

ETSI TS 137 571-1 V17.5.0 (2024-08)



**Universal Mobile Telecommunications System (UMTS);
LTE;
5G;
User Equipment (UE) conformance specification for
UE positioning;
Part 1: Conformance test specification
(3GPP TS 37.571-1 version 17.5.0 Release 17)**



Reference

RTS/TSGR-0537571-1vh50

Keywords

5G,LTE,UMTS

ETSI

650 Route des Lucioles
F-06921 Sophia Antipolis Cedex - FRANCE

Tel.: +33 4 92 94 42 00 Fax: +33 4 93 65 47 16

Siret N° 348 623 562 00017 - APE 7112B
Association à but non lucratif enregistrée à la
Sous-Préfecture de Grasse (06) N° w061004871

Important notice

The present document can be downloaded from the
ETSI [Search & Browse Standards](#) application.

The present document may be made available in electronic versions and/or in print. The content of any electronic and/or print versions of the present document shall not be modified without the prior written authorization of ETSI. In case of any existing or perceived difference in contents between such versions and/or in print, the prevailing version of an ETSI deliverable is the one made publicly available in PDF format on [ETSI deliver](#).

Users should be aware that the present document may be revised or have its status changed,
this information is available in the [Milestones listing](#).

If you find errors in the present document, please send your comments to
the relevant service listed under [Committee Support Staff](#).

If you find a security vulnerability in the present document, please report it through our
[Coordinated Vulnerability Disclosure \(CVD\)](#) program.

Notice of disclaimer & limitation of liability

The information provided in the present deliverable is directed solely to professionals who have the appropriate degree of experience to understand and interpret its content in accordance with generally accepted engineering or other professional standard and applicable regulations.

No recommendation as to products and services or vendors is made or should be implied.

No representation or warranty is made that this deliverable is technically accurate or sufficient or conforms to any law and/or governmental rule and/or regulation and further, no representation or warranty is made of merchantability or fitness for any particular purpose or against infringement of intellectual property rights.

In no event shall ETSI be held liable for loss of profits or any other incidental or consequential damages.

Any software contained in this deliverable is provided "AS IS" with no warranties, express or implied, including but not limited to, the warranties of merchantability, fitness for a particular purpose and non-infringement of intellectual property rights and ETSI shall not be held liable in any event for any damages whatsoever (including, without limitation, damages for loss of profits, business interruption, loss of information, or any other pecuniary loss) arising out of or related to the use of or inability to use the software.

Copyright Notification

No part may be reproduced or utilized in any form or by any means, electronic or mechanical, including photocopying and microfilm except as authorized by written permission of ETSI.

The content of the PDF version shall not be modified without the written authorization of ETSI.

The copyright and the foregoing restriction extend to reproduction in all media.

© ETSI 2024.
All rights reserved.

Intellectual Property Rights

Essential patents

IPRs essential or potentially essential to normative deliverables may have been declared to ETSI. The declarations pertaining to these essential IPRs, if any, are publicly available for **ETSI members and non-members**, and can be found in ETSI SR 000 314: "*Intellectual Property Rights (IPRs); Essential, or potentially Essential, IPRs notified to ETSI in respect of ETSI standards*", which is available from the ETSI Secretariat. Latest updates are available on the ETSI Web server (<https://ipr.etsi.org/>).

Pursuant to the ETSI Directives including the ETSI IPR Policy, no investigation regarding the essentiality of IPRs, including IPR searches, has been carried out by ETSI. No guarantee can be given as to the existence of other IPRs not referenced in ETSI SR 000 314 (or the updates on the ETSI Web server) which are, or may be, or may become, essential to the present document.

Trademarks

The present document may include trademarks and/or tradenames which are asserted and/or registered by their owners. ETSI claims no ownership of these except for any which are indicated as being the property of ETSI, and conveys no right to use or reproduce any trademark and/or tradename. Mention of those trademarks in the present document does not constitute an endorsement by ETSI of products, services or organizations associated with those trademarks.

DECT™, **PLUGTESTS™**, **UMTS™** and the ETSI logo are trademarks of ETSI registered for the benefit of its Members. **3GPP™** and **LTE™** are trademarks of ETSI registered for the benefit of its Members and of the 3GPP Organizational Partners. **oneM2M™** logo is a trademark of ETSI registered for the benefit of its Members and of the oneM2M Partners. **GSM®** and the GSM logo are trademarks registered and owned by the GSM Association.

Legal Notice

This Technical Specification (TS) has been produced by the ETSI 3rd Generation Partnership Project (3GPP).

The present document may refer to technical specifications or reports using their 3GPP identities. These shall be interpreted as being references to the corresponding ETSI deliverables.

The cross reference between 3GPP and ETSI identities can be found under <https://webapp.etsi.org/key/queryform.asp>.

Modal verbs terminology

In the present document "**shall**", "**shall not**", "**should**", "**should not**", "**may**", "**need not**", "**will**", "**will not**", "**can**" and "**cannot**" are to be interpreted as described in clause 3.2 of the [ETSI Drafting Rules](#) (Verbal forms for the expression of provisions).

"**must**" and "**must not**" are **NOT** allowed in ETSI deliverables except when used in direct citation.

Contents

Intellectual Property Rights	2
Legal Notice	2
Modal verbs terminology.....	2
Foreword.....	46
Introduction	46
1 Scope	47
2 References	47
3 Definitions, symbols and abbreviations	50
3.1 Definitions	50
3.2 Symbols.....	50
3.3 Abbreviations	51
4 General test conditions	52
4.1 Introduction	52
4.2 GNSS test conditions.....	53
4.2.0 General.....	53
4.2.1 GNSS signals	53
4.2.2 GNSS frequency	53
4.2.3 GNSS static propagation conditions	53
4.2.4 GNSS multi-path conditions	53
4.2.5 UEs supporting multiple satellite signals.....	54
4.2.6 GNSS multi System Time Offsets	54
4.3 UTRA test conditions.....	55
4.3.1 UTRA frequency band and frequency range	55
4.3.2 UTRA frequency	55
4.3.3 Sensors	55
4.4 E-UTRA test conditions	55
4.4.1 E-UTRA frequency band and frequency range.....	55
4.4.2 Groups of bands	55
4.4.3 Sensors	55
4.5 A-GNSS test conditions	56
4.5.1 General.....	56
4.5.2 UTRAN measurement parameters	56
4.5.2.1 UE based A-GNSS measurement parameters	56
4.5.2.2 UE assisted A-GNSS measurement parameters	56
4.5.2.3 2D position error	56
4.5.2.4 Response time	56
4.5.3 E-UTRAN and NR measurement parameters	56
4.5.3.1 UE based A-GNSS measurement parameters	56
4.5.3.2 UE assisted A-GNSS measurement parameters	56
4.5.3.3 2D Error definition.....	57
4.5.3.4 Response time	57
4.5.4 Converting A-GNSS UE-assisted measurement reports into position estimates	57
4.6 ECID test conditions	57
4.6.1 Simulated cells.....	57
4.6.2 Propagation conditions	57
4.6.2.1 Static	57
4.6.2.2 Multi-path fading	57
4.6.3 UE Rx - Tx time difference reporting range	57
4.7 OTDOA test conditions	58
4.7.1 Simulated cells.....	58
4.7.2 Propagation conditions	59
4.7.2.1 Static	59
4.7.2.2 Multi-path fading	59

4.7.3	Response time	59
4.7.4	RSTD reporting range	59
4.7.5	RSTD Carrier Aggregation Test Cases with Different Channel Bandwidth Combinations	60
4.8	MBS test conditions	60
4.8.1	MBS signals	60
4.8.2	Propagation conditions	60
4.8.2.1	Static	60
4.8.2.2	Multi-path fading	61
4.8.3	Response time	61
4.9	WLAN test conditions	61
4.9.1	Simulated WLAN Access Points	61
4.9.2	Propagation conditions	61
4.9.2.1	Static	61
4.9.3	Response time	61
4.9.4	Void	61
4.10	BLE test conditions	61
4.10.1	Simulated BLE	61
4.10.2	Propagation conditions	62
4.10.2.1	Static	62
4.10.3	Response time	62
4.11	NB-IOT test conditions	62
4.11.1	Groups of bands	62
4.11.2	NB-IOT inband mode	62
4.12	NR test conditions	62
4.12.1	NR terminology	62
4.12.2	NR frequency band and frequency range	62
4.12.3	Groups of bands	63
4.12.4	Sensors	63
4.12.5	Default signal conditions for FR2	63
4.12.6	Frequency Bands for Testing	63
4.12.6.1	EN-DC band combination groups	63
4.12.6.2	Applicable EN-DC band combinations for performing A-GNSS Sensitivity Requirements	63
4.12.6.3	Test frequencies for EN-DC band combinations	64
4.14	Multi-RTT test conditions	64
4.14.1	Simulated cells	64
4.14.2	Propagation conditions	64
4.14.3	Measurement Reporting Requirements	64
4.14.3.1	Measurement Reporting Requirements in RRC_CONNECTED state	64
4.14.3.2	Measurement Reporting Requirements in RRC_INACTIVE state	64
4.14.4	Measurement Period Requirements	64
4.14.4.1	Measurement Period Requirements within Measurement Gaps	64
4.14.4.2	Measurement Period Requirements without Measurement Gaps	67
4.14.4.3	Measurement Period Requirements in RRC_INACTIVE state	67
4.14.5	Measurement Accuracy Requirements	67
4.14.6	Reporting mapping	76
4.14.6.1	Absolute UE Rx-Tx Measurement Report Mapping	76
4.14.6.2	Differential UE Rx-Tx Measurement Report Mapping	77
4.14.6.3	Additional Path Report Mapping for UE Rx-Tx Time Difference	79
4.15	DL-TDOA test conditions	81
4.15.1	Simulated cells	81
4.15.2	Propagation conditions	81
4.15.3	Measurement Reporting Requirements	81
4.15.3.1	Measurement Reporting Requirements in RRC_CONNECTED state	81
4.15.3.2	Measurement Reporting Requirements in RRC_INACTIVE state	81
4.15.4	Measurement Period Requirements	81
4.15.4.1	Measurement Period Requirements within Measurement Gaps	81
4.15.4.2	Measurement Period Requirements without Measurement Gaps	84
4.15.4.3	Measurement Period Requirements in RRC_INACTIVE state	84
4.15.5	Measurement Accuracy Requirements	84
4.15.6	Reporting mapping	90
4.15.6.1	Absolute DL RSTD Measurement Reporting	90
4.15.6.2	Differential Reporting for DL RSTD Measurement	92

4.15.6.3	Additional Path Report Mapping for DL RSTD	94
4.16	DL-AoD test conditions	96
4.16.1	Simulated cells	96
4.16.2	Propagation conditions	96
4.16.3	Measurement Reporting Requirements	96
4.16.3.1	Measurement Reporting Requirements in RRC_CONNECTED state	96
4.16.3.2	Measurement Reporting Requirements in RRC_INACTIVE state	96
4.16.4	PRS-RSRP Measurement Period Requirements	96
4.16.4.1	Measurement Period Requirements within Measurement Gaps	96
4.16.4.2	Measurement Period Requirements without Measurement Gaps	98
4.16.4.3	Measurement Period Requirements in RRC_INACTIVE state	98
4.16.5	PRS-RSRP Measurement Accuracy Requirements	98
4.16.6	PRS-RSRP Reporting mapping	104
4.16.6.1	Absolute PRS-RSRP Measurement Report Mapping	104
4.16.6.2	Differential Report Mapping for PRS-RSRP Measurement	105
4.16.7	PRS-RSRPP Measurement Period Requirements	107
4.16.8	PRS-RSRPP Measurement Accuracy Requirements	107
4.16.9	PRS-RSRPP Reporting mapping	107
4.16.9.1	Absolute PRS-RSRPP Measurement Report Mapping	107
4.16.9.2	Differential Report Mapping for PRS-RSRPP Measurement	108
4A	Support of 4 Rx capable UEs	109
4A.0	Introduction	109
4A.1	RAT Independent Tests	109
4A.2	RAT Dependent Tests	109
4A.2.1	Principle of testing	109
4A.2.1.1	Single carrier tests	109
4A.2.1.2	Carrier Aggregation tests	109
4A.2.1.3	Antenna connection for bands where 2RX is supported	110
4A.2.1.4	Antenna connection for bands where 4RX is supported	110
4B	Applicability of tests for types and Categories of UE	110
4B.1	Introduction	110
4B.2	Applicability of requirements and tests	110
5	UTRA A-GPS Minimum Performance requirements	112
5.1	General	112
5.2	Sensitivity	112
5.2.1	Sensitivity Coarse Time Assistance	112
5.2.1.1	Definition and applicability	112
5.2.1.2	Minimum requirements	112
5.2.1.3	Test purpose	112
5.2.1.4	Method of test	113
5.2.1.4.1	Initial conditions	113
5.2.1.4.2	Procedure	113
5.2.1.5	Test Requirements	113
5.2.2	Sensitivity Fine Time Assistance	114
5.2.2.1	Definition and applicability	114
5.2.2.2	Minimum requirements	114
5.2.2.3	Test purpose	115
5.2.2.4	Method of test	115
5.2.2.4.1	Initial conditions	115
5.2.2.4.2	Procedure	115
5.2.2.5	Test Requirements	115
5.3	Nominal Accuracy	116
5.3.1	Definition and applicability	116
5.3.2	Minimum requirements	116
5.3.3	Test purpose	116
5.3.4	Method of test	117
5.3.4.1	Initial conditions	117
5.3.4.2	Procedure	117
5.3.5	Test Requirements	118
5.4	Dynamic Range	118

5.4.1	Definition and applicability	118
5.4.2	Minimum requirements.....	118
5.4.3	Test purpose.....	119
5.4.4	Method of test	119
5.4.4.1	Initial conditions	119
5.4.4.2	Procedure	119
5.4.5	Test Requirements	120
5.5	Multi-path Performance	120
5.5.1	Definition and applicability	120
5.5.2	Minimum requirements.....	120
5.5.3	Test purpose.....	121
5.5.4	Method of test.....	121
5.5.4.1	Initial conditions	121
5.5.4.2	Procedure	121
5.5.5	Test Requirements	122
5.6	Moving Scenario and Periodic Update Performance.....	122
5.6.1	Definition and applicability	122
5.6.2	Minimum requirements.....	122
5.6.3	Test purpose.....	123
5.6.4	Method of test.....	123
5.6.4.1	Initial conditions	123
5.6.4.2	Procedure	124
5.6.5	Test Requirements	124
6	UTRA A-GNSS Minimum Performance requirements	126
6.1	General	126
6.2	Sensitivity.....	126
6.2.1	Sensitivity Coarse Time Assistance.....	126
6.2.1.1	Definition and applicability.....	126
6.2.1.2	Minimum requirements.....	126
6.2.1.3	Test purpose	127
6.2.1.4	Method of test	127
6.2.1.4.1	Initial conditions	127
6.2.1.4.2	Procedure.....	127
6.2.1.5	Test Requirements.....	128
6.2.2	Sensitivity Fine Time Assistance.....	129
6.2.2.1	Definition and applicability.....	129
6.2.2.2	Minimum requirements.....	129
6.2.2.3	Test purpose	130
6.2.2.4	Method of test	130
6.2.2.4.1	Initial conditions	130
6.2.2.4.2	Procedure.....	130
6.2.2.5	Test Requirements.....	131
6.3	Nominal Accuracy.....	132
6.3.1	Definition and applicability	132
6.3.2	Minimum requirements.....	132
6.3.3	Test purpose.....	133
6.3.4	Method of test	133
6.3.4.1	Initial conditions	133
6.3.4.2	Procedure	133
6.3.5	Test Requirements	134
6.4	Dynamic Range.....	135
6.4.1	Definition and applicability	135
6.4.2	Minimum requirements.....	135
6.4.3	Test purpose.....	136
6.4.4	Method of test	136
6.4.4.1	Initial conditions	136
6.4.4.2	Procedure	136
6.4.5	Test Requirements	137
6.5	Multi-path Performance	138
6.5.1	Definition and applicability	138
6.5.2	Minimum requirements.....	138

6.5.3	Test purpose	139
6.5.4	Method of test	139
6.5.4.1	Initial conditions	139
6.5.4.2	Procedure	139
6.5.5	Test Requirements	140
6.6	Moving Scenario and Periodic Update Performance.....	141
6.6.1	Definition and applicability	141
6.6.2	Minimum requirements.....	141
6.6.3	Test purpose.....	142
6.6.4	Method of test.....	142
6.6.4.1	Initial conditions	142
6.6.4.2	Procedure	143
6.6.5	Test Requirements	144
7	E-UTRA A-GNSS minimum performance requirements	146
7.0	General	146
7.1	Sensitivity.....	146
7.1.1	Sensitivity Coarse time assistance	146
7.1.1.1	Sub-tests.....	146
7.1.1.2	Test purpose	146
7.1.1.3	Test applicability.....	146
7.1.1.4	Minimum conformance requirements	146
7.1.1.5	Test description	147
7.1.1.5.1	Initial conditions.....	147
7.1.1.5.2	Test procedure	148
7.1.1.5.3	Message contents.....	149
7.1.1.6	Test requirement	150
7.1.2	Sensitivity Fine time assistance	151
7.1.2.1	Sub-tests.....	151
7.1.2.2	Test purpose	151
7.1.2.3	Test applicability.....	151
7.1.2.4	Minimum conformance requirements	151
7.1.2.5	Test description	152
7.1.2.5.1	Initial conditions.....	152
7.1.2.5.2	Test procedure	153
7.1.2.5.3	Message contents.....	153
7.1.2.6	Test requirement	154
7.2	Nominal Accuracy.....	155
7.2.1	Sub-tests.....	155
7.2.2	Test purpose	156
7.2.3	Test applicability.....	156
7.2.4	Minimum conformance requirements	156
7.2.5	Test description	157
7.2.5.1	Initial conditions.....	157
7.2.5.2	Test procedure	157
7.2.5.3	Message contents.....	158
7.2.6	Test requirement	159
7.3	Dynamic Range	160
7.3.1	Sub-tests.....	160
7.3.2	Test purpose	161
7.3.3	Test applicability.....	161
7.3.4	Minimum conformance requirements	161
7.3.5	Test description	162
7.3.5.1	Initial conditions.....	162
7.3.5.2	Test procedure	162
7.3.5.3	Message contents.....	163
7.3.6	Test requirement	164
7.4	Multi-Path scenario	165
7.4.1	Sub-tests.....	165
7.4.2	Test purpose	166
7.4.3	Test applicability.....	166
7.4.4	Minimum conformance requirements	166

7.4.5	Test description	167
7.4.5.1	Initial conditions	167
7.4.5.2	Test procedure	167
7.4.5.3	Message contents	168
7.4.6	Test requirement	169
7.5	Moving scenario and periodic update (Rel-9 to Rel-13)	170
7.5.1	Sub-tests	170
7.5.2	Test purpose	171
7.5.3	Test applicability	171
7.5.4	Minimum conformance requirements	171
7.5.5	Test description	172
7.5.5.1	Initial conditions	172
7.5.5.2	Test procedure	173
7.5.5.3	Message contents	174
7.5.6	Test requirement	175
7.5A	Moving scenario and periodic update (Rel-14 onwards)	176
7.5A.1	Sub-tests	176
7.5A.2	Test purpose	176
7.5A.3	Test applicability	176
7.5A.4	Minimum conformance requirements	176
7.5A.5	Test description	176
7.5A.6	Test requirement	176
8	E-UTRA ECID measurement requirements	176
8.0	General	176
8.1	UE Rx – Tx Time Difference	176
8.1.1	E-UTRAN FDD UE Rx – Tx time difference case (Rel-9 to Rel-11)	176
8.1.1.1	Test purpose	176
8.1.1.2	Test applicability	176
8.1.1.3	Minimum conformance requirements	177
8.1.1.4	Test description	177
8.1.1.4.1	Initial conditions	177
8.1.1.4.2	Test procedure	178
8.1.1.4.3	Message contents	179
8.1.1.5	Test requirement	181
8.1.1A	E-UTRAN FDD UE Rx – Tx time difference case (Rel-12 onwards)	183
8.1.1A.1	Test purpose	183
8.1.1A.2	Test applicability	183
8.1.1A.3	Minimum conformance requirements	183
8.1.1A.4	Test description	183
8.1.1A.4.1	Initial conditions	184
8.1.1A.4.2	Test procedure	184
8.1.1A.4.3	Message contents	184
8.1.1A.5	Test requirement	184
8.1.1B	E-UTRAN FDD UE Rx – Tx time difference case for UE Category 1bis	184
8.1.1B.1	Test purpose	184
8.1.1B.2	Test applicability	184
8.1.1B.3	Minimum conformance requirements	184
8.1.1B.4	Test description	184
8.1.1B.4.1	Initial conditions	184
8.1.1B.4.2	Test procedure	184
8.1.1B.4.3	Message contents	184
8.1.1B.5	Test requirement	185
8.1.2	E-UTRAN TDD UE Rx – Tx time difference case (Rel-9 to Rel-11)	185
8.1.2.1	Test purpose	185
8.1.2.2	Test applicability	185
8.1.2.3	Minimum conformance requirements	185
8.1.2.4	Test description	185
8.1.2.4.1	Initial conditions	185
8.1.2.4.2	Test procedure	186
8.1.2.4.3	Message contents	186
8.1.2.5	Test requirement	189

8.1.2A	E-UTRAN TDD UE Rx – Tx time difference case (Rel-12 onwards)	191
8.1.2A.1	Test purpose	191
8.1.2A.2	Test applicability	191
8.1.2A.3	Minimum conformance requirements	191
8.1.2A.4	Test description	191
8.1.2A.4.1	Initial conditions	191
8.1.2A.4.2	Test procedure	191
8.1.2A.4.3	Message contents	191
8.1.2A.5	Test requirement	191
8.1.2B	E-UTRAN TDD UE Rx – Tx time difference case for UE Category 1bis	192
8.1.2B.1	Test purpose	192
8.1.2B.2	Test applicability	192
8.1.2B.3	Minimum conformance requirements	192
8.1.2B.4	Test description	192
8.1.2B.4.1	Initial conditions	192
8.1.2B.4.2	Test procedure	192
8.1.2B.4.3	Message contents	192
8.1.2B.5	Test requirement	192
8.1.3	E-UTRAN FDD UE Rx–Tx Time Difference under Time-Domain Measurement Resource Restriction with Non-MBSFN ABS (eICIC)	192
8.1.3.1	Test purpose	192
8.1.3.2	Test applicability	192
8.1.3.3	Minimum conformance requirements	192
8.1.3.4	Test description	193
8.1.3.4.1	Initial conditions	194
8.1.3.4.2	Test procedure	194
8.1.3.4.3	Message contents	195
8.1.3.5	Test requirement	198
8.1.4	E-UTRAN TDD UE Rx–Tx Time Difference under Time-Domain Measurement Resource Restriction with Non-MBSFN ABS (eICIC)	200
8.1.4.1	Test purpose	200
8.1.4.2	Test applicability	200
8.1.4.3	Minimum conformance requirements	200
8.1.4.4	Test description	201
8.1.4.4.1	Initial conditions	201
8.1.4.4.2	Test procedure	202
8.1.4.4.3	Message contents	203
8.1.4.5	Test requirement	205
8.1.5	E-UTRAN FDD UE Rx–Tx time difference under Time Domain Measurement Resource Restriction with CRS Assistance Information and Non-MBSFN ABS (feICIC)	207
8.1.5.1	Test purpose	207
8.1.5.2	Test applicability	207
8.1.5.3	Minimum conformance requirements	207
8.1.5.4	Test description	208
8.1.5.4.1	Initial conditions	209
8.1.5.4.2	Test procedure	210
8.1.5.4.3	Message contents	210
8.1.5.5	Test requirement	214
8.1.6	E-UTRAN TDD UE Rx–Tx time difference under Time Domain Measurement Resource Restriction with CRS Assistance Information and Non-MBSFN ABS (feICIC)	216
8.1.6.1	Test purpose	216
8.1.6.2	Test applicability	216
8.1.6.3	Minimum conformance requirements	216
8.1.6.4	Test description	217
8.1.6.4.1	Initial conditions	218
8.1.6.4.2	Test procedure	219
8.1.6.4.3	Message contents	219
8.1.6.5	Test requirement	223
8.1.7	E-UTRAN FDD UE Rx-Tx time difference case for Category M1/M2 UE in CEModeA	225
8.1.7.1	Test purpose	225
8.1.7.2	Test applicability	225
8.1.7.3	Minimum conformance requirements	225

8.1.7.4	Test description	226
8.1.7.4.1	Initial conditions	226
8.1.7.4.2	Test procedure	226
8.1.7.4.3	Message contents	227
8.1.7.5	Test requirement	229
8.1.8	E-UTRAN HD-FDD UE Rx-Tx time difference case for Category M1/M2 UE in CEModeA	230
8.1.8.1	Test purpose	230
8.1.8.2	Test applicability	230
8.1.8.3	Minimum conformance requirements	230
8.1.8.4	Test description	230
8.1.8.4.1	Initial conditions	230
8.1.8.4.2	Test procedure	230
8.1.8.4.3	Message contents	231
8.1.8.5	Test requirement	231
8.1.9	E-UTRAN TDD UE Rx-Tx time difference case for Category M1/M2 UE in CEModeA	232
8.1.9.1	Test purpose	232
8.1.9.2	Test applicability	232
8.1.9.3	Minimum conformance requirements	232
8.1.9.4	Test description	232
8.1.9.4.1	Initial conditions	232
8.1.9.4.2	Test procedure	232
8.1.9.4.3	Message contents	233
8.1.9.5	Test requirement	233
9	E-UTRA OTDOA measurement requirements	235
9.0	General	235
9.1	RSTD Intra-Frequency Measurements	235
9.1.1	FDD RSTD Measurement Reporting Delay	235
9.1.1.1	Test purpose	235
9.1.1.2	Test applicability	235
9.1.1.3	Minimum conformance requirements	235
9.1.1.4	Test description	236
9.1.1.4.1	Initial conditions	236
9.1.1.4.2	Test procedure	238
9.1.1.4.3	Message contents	239
9.1.1.5	Test requirement	242
9.1.1A	FDD RSTD Measurement Reporting Delay for UE Category 1bis	244
9.1.1A.1	Test purpose	244
9.1.1A.2	Test applicability	244
9.1.1A.3	Minimum conformance requirements	244
9.1.1A.4	Test description	245
9.1.1A.4.1	Initial conditions	245
9.1.1A.4.2	Test procedure	246
9.1.1A.4.3	Message contents	246
9.1.1A.5	Test requirement	247
9.1.2	TDD RSTD Measurement Reporting Delay	247
9.1.2.1	Test purpose	247
9.1.2.2	Test applicability	247
9.1.2.3	Minimum conformance requirements	247
9.1.2.4	Test description	248
9.1.2.4.1	Initial conditions	248
9.1.2.4.2	Test procedure	250
9.1.2.4.3	Message contents	251
9.1.2.5	Test requirement	254
9.1.2A	TDD RSTD Measurement Reporting Delay for UE Category 1bis	256
9.1.2A.1	Test purpose	256
9.1.2A.2	Test applicability	256
9.1.2A.3	Minimum conformance requirements	256
9.1.2A.4	Test description	257
9.1.2A.4.1	Initial conditions	257
9.1.2A.4.2	Test procedure	258
9.1.2A.4.3	Message contents	258

9.1.2A.5	Test requirement	259
9.1.3	FDD RSTD Measurement Accuracy	259
9.1.3.1	Test purpose	259
9.1.3.2	Test applicability	259
9.1.3.3	Minimum conformance requirements	259
9.1.3.4	Test description	260
9.1.3.4.1	Initial conditions	260
9.1.3.4.2	Test procedure.....	262
9.1.3.4.3	Message contents	263
9.1.3.5	Test requirement	266
9.1.3A	FDD RSTD Measurement Accuracy for UE Category 1bis	267
9.1.3A.1	Test purpose	267
9.1.3A.2	Test applicability	267
9.1.3A.3	Minimum conformance requirements.....	267
9.1.3A.4	Test description	267
9.1.3A.4.1	Initial conditions	267
9.1.3A.4.2	Test procedure.....	268
9.1.3A.4.3	Message contents	268
9.1.3A.5	Test requirement	269
9.1.4	TDD RSTD Measurement Accuracy	269
9.1.4.1	Test purpose	269
9.1.4.2	Test applicability	269
9.1.4.3	Minimum conformance requirements.....	269
9.1.4.4	Test description	269
9.1.4.4.1	Initial conditions	269
9.1.4.4.2	Test procedure.....	271
9.1.4.4.3	Message contents	272
9.1.4.5	Test requirement	275
9.1.4A	TDD RSTD Measurement Accuracy for UE Category 1bis	276
9.1.4A.1	Test purpose	276
9.1.4A.2	Test applicability	276
9.1.4A.3	Minimum conformance requirements.....	276
9.1.4A.4	Test description	276
9.1.4A.4.1	Initial conditions	276
9.1.4A.4.2	Test procedure.....	278
9.1.4A.4.3	Message contents	278
9.1.4A.5	Test requirement	278
9.2	RSTD Inter-Frequency Measurements.....	279
9.2.1	FDD-FDD inter-frequency RSTD measurement reporting delay	279
9.2.1.1	Test purpose	279
9.2.1.2	Test applicability	279
9.2.1.3	Minimum conformance requirements.....	279
9.2.1.4	Test description	280
9.2.1.4.1	Initial conditions	280
9.2.1.4.2	Test procedure.....	282
9.2.1.4.3	Message contents	283
9.2.1.5	Test requirement	286
9.2.1A	FDD-FDD inter-frequency RSTD Measurement Reporting Delay for UE Category 1bis	288
9.2.1A.1	Test purpose	288
9.2.1A.2	Test applicability	288
9.2.1A.3	Minimum conformance requirements.....	289
9.2.1A.4	Test description	289
9.2.1A.4.1	Initial conditions	289
9.2.1A.4.2	Test procedure.....	291
9.2.1A.4.3	Message contents	291
9.2.1A.5	Test requirement	291
9.2.2	TDD-TDD inter-frequency RSTD measurement reporting delay.....	292
9.2.2.1	Test purpose	292
9.2.2.2	Test applicability	292
9.2.2.3	Minimum conformance requirements.....	292
9.2.2.4	Test description	293
9.2.2.4.1	Initial conditions	293

9.2.2.4.2	Test procedure.....	295
9.2.2.4.3	Message contents	296
9.2.2.5	Test requirement	299
9.2.2A	TDD-TDD inter-frequency RSTD Measurement Reporting Delay for UE Category 1bis	301
9.2.2A.1	Test purpose	301
9.2.2A.2	Test applicability	302
9.2.2A.3	Minimum conformance requirements	302
9.2.2A.4	Test description	302
9.2.2A.4.1	Initial conditions	302
9.2.2A.4.2	Test procedure.....	304
9.2.2A.4.3	Message contents	304
9.2.2A.5	Test requirement	304
9.2.3	Void	305
9.2.4	FDD-FDD inter-frequency RSTD Accuracy	305
9.2.4.1	Test purpose	305
9.2.4.2	Test applicability.....	305
9.2.4.3	Minimum conformance requirements	305
9.2.4.4	Test description	306
9.2.4.4.1	Initial conditions	306
9.2.4.4.2	Test procedure.....	308
9.2.4.4.3	Message contents	309
9.2.4.5	Test requirement	312
9.2.4A	FDD-FDD inter-frequency RSTD Accuracy for UE Category 1bis	313
9.2.4A.1	Test purpose	313
9.2.4A.2	Test applicability.....	313
9.2.4A.3	Minimum conformance requirements	313
9.2.4A.4	Test description.....	313
9.2.4A.4.1	Initial conditions	313
9.2.4A.4.2	Test procedure.....	314
9.2.4A.4.3	Message contents	314
9.2.4A.5	Test requirement	315
9.2.5	TDD-TDD inter-frequency RSTD Accuracy.....	315
9.2.5.1	Test purpose	315
9.2.5.2	Test applicability.....	315
9.2.5.3	Minimum conformance requirements	315
9.2.5.4	Test description	315
9.2.5.4.1	Initial conditions	315
9.2.5.4.2	Test procedure.....	317
9.2.5.4.3	Message contents	318
9.2.5.5	Test requirement	321
9.2.5A	TDD-TDD inter-frequency RSTD Accuracy for UE Category 1bis.....	322
9.2.5A.1	Test purpose	322
9.2.5A.2	Test applicability.....	322
9.2.5A.3	Minimum conformance requirements	322
9.2.5A.4	Test description	322
9.2.5A.4.1	Initial conditions	322
9.2.5A.4.2	Test procedure.....	323
9.2.5A.4.3	Message contents	323
9.2.5A.5	Test requirement	324
9.3	RSTD Intra-Frequency Measurements for UE Category M1/M2	325
9.3.1	FDD intra-frequency RSTD Measurement Reporting Delay in CE Mode A	325
9.3.1.1	FDD intra-frequency RSTD Measurement Reporting Delay in CE Mode A for Category M1	325
9.3.1.1.1	Test purpose.....	325
9.3.1.1.2	Test applicability.....	325
9.3.1.1.3	Minimum conformance requirements	325
9.3.1.1.4	Test description.....	327
9.3.1.1.4.1	Initial conditions.....	327
9.3.1.1.4.2	Test procedure.....	329
9.3.1.1.4.3	Message contents.....	330
9.3.1.1.5	Test requirement	332
9.3.1.2	FDD intra-frequency RSTD Measurement Reporting Delay in CE Mode A for Category M2	334
9.3.1.2.1	Test purpose.....	334

9.3.1.2.2	Test applicability.....	334
9.3.1.2.3	Minimum conformance requirements.....	334
9.3.1.2.4	Test description.....	334
9.3.1.2.4.1	Initial conditions.....	334
9.3.1.2.4.2	Test procedure.....	335
9.3.1.2.4.3	Message contents.....	335
9.3.1.2.5	Test requirement.....	335
9.3.2	HD-FDD intra-frequency RSTD Measurement Reporting Delay in CE Mode A.....	336
9.3.2.1	HD-FDD intra-frequency RSTD Measurement Reporting Delay in CE Mode A for Category M1.....	336
9.3.2.1.1	Test purpose.....	336
9.3.2.1.2	Test applicability.....	336
9.3.2.1.3	Minimum conformance requirements.....	336
9.3.2.1.4	Test description.....	336
9.3.2.1.4.1	Initial conditions.....	336
9.3.2.1.4.2	Test procedure.....	337
9.3.2.1.4.3	Message contents.....	337
9.3.2.1.5	Test requirement.....	337
9.3.2.2	HD-FDD intra-frequency RSTD Measurement Reporting Delay in CE Mode A for Category M2.....	338
9.3.2.2.1	Test purpose.....	338
9.3.2.2.2	Test applicability.....	338
9.3.2.2.3	Minimum conformance requirements.....	338
9.3.2.2.4	Test description.....	338
9.3.2.2.4.1	Initial conditions.....	338
9.3.2.2.4.2	Test procedure.....	339
9.3.2.2.4.3	Message contents.....	339
9.3.2.2.5	Test requirement.....	339
9.3.3	TDD intra-frequency RSTD Measurement Reporting Delay in CE Mode A.....	340
9.3.3.1	TDD intra-frequency RSTD Measurement Reporting Delay in CE Mode A for Category M1.....	340
9.3.3.1.1	Test purpose.....	340
9.3.3.1.2	Test applicability.....	340
9.3.3.1.3	Minimum conformance requirements.....	340
9.3.3.1.4	Test description.....	340
9.3.3.1.4.1	Initial conditions.....	340
9.3.3.1.4.2	Test procedure.....	342
9.3.3.1.4.3	Message contents.....	342
9.3.3.1.5	Test requirement.....	342
9.3.3.2	TDD intra-frequency RSTD Measurement Reporting Delay in CE Mode A for Category M2.....	344
9.3.3.2.1	Test purpose.....	344
9.3.3.2.2	Test applicability.....	344
9.3.3.2.3	Minimum conformance requirements.....	344
9.3.3.2.4	Test description.....	345
9.3.3.2.4.1	Initial conditions.....	345
9.3.3.2.4.2	Test procedure.....	346
9.3.3.2.4.3	Message contents.....	346
9.3.3.2.5	Test requirement.....	346
9.3.4	FDD intra-frequency RSTD Measurement Reporting Delay in CE Mode B.....	347
9.3.4.1	FDD intra-frequency RSTD Measurement Reporting Delay in CE Mode B for Category M1.....	347
9.3.4.1.1	Test purpose.....	347
9.3.4.1.2	Test applicability.....	347
9.3.4.1.3	Minimum conformance requirements.....	347
9.3.4.1.4	Test description.....	347
9.3.4.1.4.1	Initial conditions.....	347
9.3.4.1.4.2	Test procedure.....	349
9.3.4.1.4.3	Message contents.....	349
9.3.4.1.5	Test requirement.....	349
9.3.4.2	FDD intra-frequency RSTD Measurement Reporting Delay in CE Mode B for Category M2.....	351
9.3.4.2.1	Test purpose.....	351
9.3.4.2.2	Test applicability.....	351
9.3.4.2.3	Minimum conformance requirements.....	351
9.3.4.2.4	Test description.....	351
9.3.4.2.4.1	Initial conditions.....	351
9.3.4.2.4.2	Test procedure.....	353

9.3.4.2.4.3	Message contents.....	353
9.3.4.2.5	Test requirement	353
9.3.5	HD-FDD intra-frequency RSTD Measurement Reporting Delay in CE Mode B.....	354
9.3.5.1	HD-FDD intra-frequency RSTD Measurement Reporting Delay in CE Mode B for Category M1 ...	354
9.3.5.1.1	Test purpose.....	354
9.3.5.1.2	Test applicability.....	354
9.3.5.1.3	Minimum conformance requirements	354
9.3.5.1.4	Test description.....	354
9.3.5.1.4.1	Initial conditions.....	354
9.3.5.1.4.2	Test procedure.....	356
9.3.5.1.4.3	Message contents.....	356
9.3.5.1.5	Test requirement	356
9.3.5.2	HD-FDD intra-frequency RSTD Measurement Reporting Delay in CE Mode B for Category M2 ...	356
9.3.5.2.1	Test purpose.....	356
9.3.5.2.2	Test applicability.....	356
9.3.5.2.3	Minimum conformance requirements	356
9.3.5.2.4	Test description.....	356
9.3.5.2.4.1	Initial conditions.....	356
9.3.5.2.4.2	Test procedure.....	357
9.3.5.2.4.3	Message contents.....	358
9.3.5.2.5	Test requirement	358
9.3.6	TDD intra-frequency RSTD Measurement Reporting Delay in CE Mode B	358
9.3.6.1	TDD intra-frequency RSTD Measurement Reporting Delay in CE Mode B for Category M1	358
9.3.6.1.1	Test purpose.....	358
9.3.6.1.2	Test applicability.....	358
9.3.6.1.3	Minimum conformance requirements	358
9.3.6.1.4	Test description.....	358
9.3.6.1.4.1	Initial conditions.....	358
9.3.6.1.4.2	Test procedure.....	360
9.3.6.1.4.3	Message contents.....	360
9.3.6.1.5	Test requirement	360
9.3.6.2	TDD intra-frequency RSTD Measurement Reporting Delay in CE Mode B for Category M2	362
9.3.6.2.1	Test purpose.....	362
9.3.6.2.2	Test applicability.....	362
9.3.6.2.3	Minimum conformance requirements	362
9.3.6.2.4	Test description.....	362
9.3.6.2.4.1	Initial conditions.....	362
9.3.6.2.4.2	Test procedure.....	364
9.3.6.2.4.3	Message contents.....	364
9.3.6.2.5	Test requirement	364
9.3.7	FDD intra-frequency RSTD Measurement Accuracy in CE Mode A.....	365
9.3.7.1	FDD intra-frequency RSTD Measurement Accuracy in CE Mode A for Category M1	365
9.3.7.1.1	Test purpose.....	365
9.3.7.1.2	Test applicability.....	365
9.3.7.1.3	Minimum conformance requirements	365
9.3.7.1.4	Test description.....	366
9.3.7.1.4.1	Initial conditions.....	366
9.3.7.1.4.2	Test procedure.....	368
9.3.7.1.4.3	Message contents.....	369
9.3.7.1.5	Test requirement	370
9.3.7.2	FDD intra-frequency RSTD Measurement Accuracy in CE Mode A for Category M2	371
9.3.7.2.1	Test purpose.....	371
9.3.7.2.2	Test applicability.....	371
9.3.7.2.3	Minimum conformance requirements	371
9.3.7.2.4	Test description.....	373
9.3.7.2.4.1	Initial conditions.....	373
9.3.7.2.4.2	Test procedure.....	374
9.3.7.2.4.3	Message contents.....	374
9.3.7.2.5	Test requirement	374
9.3.8	HD-FDD intra-frequency RSTD Measurement Accuracy in CE Mode A.....	375
9.3.8.1	HD-FDD intra-frequency RSTD Measurement Accuracy in CE Mode A for Category M1	375
9.3.8.1.1	Test purpose.....	375

9.3.8.1.2	Test applicability.....	375
9.3.8.1.3	Minimum conformance requirements.....	375
9.3.8.1.4	Test description.....	375
9.3.8.1.4.1	Initial conditions.....	375
9.3.8.1.4.2	Test procedure.....	376
9.3.8.1.4.3	Message contents.....	376
9.3.8.1.5	Test requirement.....	376
9.3.8.2	HD-FDD intra-frequency RSTD Measurement Accuracy in CE Mode A for Category M2.....	377
9.3.8.2.1	Test purpose.....	377
9.3.8.2.2	Test applicability.....	377
9.3.8.2.3	Minimum conformance requirements.....	377
9.3.8.2.4	Test description.....	377
9.3.8.2.4.1	Initial conditions.....	377
9.3.8.2.4.2	Test procedure.....	378
9.3.8.2.4.3	Message contents.....	378
9.3.8.2.5	Test requirement.....	378
9.3.9	TDD intra-frequency RSTD Measurement Accuracy in CE Mode A.....	379
9.3.9.1	TDD intra-frequency RSTD Measurement Accuracy in CE Mode A for Category M1.....	379
9.3.9.1.1	Test purpose.....	379
9.3.9.1.2	Test applicability.....	379
9.3.9.1.3	Minimum conformance requirements.....	379
9.3.9.1.4	Test description.....	379
9.3.9.1.4.1	Initial conditions.....	379
9.3.9.1.4.2	Test procedure.....	380
9.3.9.1.4.3	Message contents.....	381
9.3.9.1.5	Test requirement.....	381
9.3.9.2	TDD intra-frequency RSTD Measurement Accuracy in CE Mode A for Category M2.....	381
9.3.9.2.1	Test purpose.....	381
9.3.9.2.2	Test applicability.....	381
9.3.9.2.3	Minimum conformance requirements.....	381
9.3.9.2.4	Test description.....	381
9.3.9.2.4.1	Initial conditions.....	381
9.3.9.2.4.2	Test procedure.....	383
9.3.9.2.4.3	Message contents.....	383
9.3.9.2.5	Test requirement.....	383
9.3.10	FDD intra-frequency RSTD Measurement Accuracy in CE Mode B.....	383
9.3.10.1	FDD intra-frequency RSTD Measurement Accuracy in CE Mode B for Category M1.....	383
9.3.10.1.1	Test purpose.....	383
9.3.10.1.2	Test applicability.....	383
9.3.10.1.3	Minimum conformance requirements.....	383
9.3.10.1.4	Test description.....	384
9.3.10.1.4.1	Initial conditions.....	384
9.3.10.1.4.2	Test procedure.....	386
9.3.10.1.4.3	Message contents.....	386
9.3.10.1.5	Test requirement.....	386
9.3.10.2	FDD intra-frequency RSTD Measurement Accuracy in CE Mode B for Category M2.....	387
9.3.10.2.1	Test purpose.....	387
9.3.10.2.2	Test applicability.....	387
9.3.10.2.3	Minimum conformance requirements.....	388
9.3.10.2.4	Test description.....	389
9.3.10.2.4.1	Initial conditions.....	389
9.3.10.2.4.2	Test procedure.....	390
9.3.10.2.4.3	Message contents.....	390
9.3.10.2.5	Test requirement.....	391
9.3.11	HD-FDD intra-frequency RSTD Measurement Accuracy in CE Mode B.....	391
9.3.11.1	HD-FDD intra-frequency RSTD Measurement Accuracy in CE Mode B for Category M1.....	391
9.3.11.1.1	Test purpose.....	391
9.3.11.1.2	Test applicability.....	391
9.3.11.1.3	Minimum conformance requirements.....	391
9.3.11.1.4	Test description.....	392
9.3.11.1.4.1	Initial conditions.....	392
9.3.11.1.4.2	Test procedure.....	393

9.3.11.1.4.3	Message contents.....	393
9.3.11.1.5	Test requirement	393
9.3.11.2	HD-FDD intra-frequency RSTD Measurement Accuracy in CE Mode B for Category M2	393
9.3.11.2.1	Test purpose.....	393
9.3.11.2.2	Test applicability.....	393
9.3.11.2.3	Minimum conformance requirements	393
9.3.11.2.4	Test description.....	394
9.3.11.2.4.1	Initial conditions.....	394
9.3.11.2.4.2	Test procedure.....	395
9.3.11.2.4.3	Message contents.....	395
9.3.11.2.5	Test requirement	395
9.3.12	TDD intra-frequency RSTD Measurement Accuracy in CE Mode B.....	395
9.3.12.1	TDD intra-frequency RSTD Measurement Accuracy in CE Mode B for Category M1	395
9.3.12.1.1	Test purpose.....	395
9.3.12.1.2	Test applicability.....	395
9.3.12.1.3	Minimum conformance requirements	396
9.3.12.1.4	Test description.....	396
9.3.12.1.4.1	Initial conditions.....	396
9.3.12.1.4.2	Test procedure.....	397
9.3.12.1.4.3	Message contents.....	397
9.3.12.1.5	Test requirement	397
9.3.12.2	TDD intra-frequency RSTD Measurement Accuracy in CE Mode B for Category M2	397
9.3.12.2.1	Test purpose.....	397
9.3.12.2.2	Test applicability.....	398
9.3.12.2.3	Minimum conformance requirements	398
9.3.12.2.4	Test description.....	398
9.3.12.2.4.1	Initial conditions.....	398
9.3.12.2.4.2	Test procedure.....	399
9.3.12.2.4.3	Message contents.....	399
9.3.12.2.5	Test requirement	399
9.3.13	E-UTRAN FDD intra-frequency RSTD measurement period test case in CE Mode A with longer PRS occasions.....	400
9.3.13.1	Test purpose	400
9.3.13.2	Test applicability.....	400
9.3.13.3	Minimum conformance requirements	400
9.3.13.4	Test description	400
9.3.13.4.1	Initial conditions	400
9.3.13.4.2	Test procedure	402
9.3.13.4.3	Message contents.....	402
9.3.13.5	Test requirement	403
9.3.14	E-UTRAN HD-FDD intra-frequency RSTD measurement period test case in CE Mode A with longer PRS occasions.....	403
9.3.14.1	Test purpose	403
9.3.14.2	Test applicability.....	403
9.3.14.3	Minimum conformance requirements	403
9.3.14.4	Test description	403
9.3.14.4.1	Initial conditions	403
9.3.14.4.2	Test procedure	405
9.3.14.4.3	Message contents.....	405
9.3.14.5	Test requirement	405
9.3.15	E-UTRAN TDD intra-frequency RSTD measurement period test case in CE Mode A with longer PRS occasions.....	405
9.3.15.1	Test purpose	405
9.3.15.2	Test applicability.....	406
9.3.15.3	Minimum conformance requirements	406
9.3.15.4	Test description	406
9.3.15.4.1	Initial conditions	406
9.3.15.4.2	Test procedure	408
9.3.15.4.3	Message contents.....	408
9.3.15.5	Test requirement	408
9.3.16	E-UTRAN FDD intra-frequency RSTD measurement period test case in CE Mode B with longer PRS occasions.....	408

9.3.16.1	Test purpose	408
9.3.16.2	Test applicability	409
9.3.16.3	Minimum conformance requirements	409
9.3.16.4	Test description	409
9.3.16.4.1	Initial conditions	409
9.3.16.4.2	Test procedure	411
9.3.16.4.3	Message contents	411
9.3.16.5	Test requirement	411
9.3.17	E-UTRAN HD-FDD intra-frequency RSTD measurement period test case in CE Mode B with longer PRS occasions	411
9.3.17.1	Test purpose	411
9.3.17.2	Test applicability	411
9.3.17.3	Minimum conformance requirements	411
9.3.17.4	Test description	411
9.3.17.4.1	Initial conditions	411
9.3.17.4.2	Test procedure	413
9.3.17.4.3	Message contents	413
9.3.17.5	Test requirement	413
9.3.18	E-UTRAN TDD intra-frequency RSTD measurement period test case in CE Mode B with longer PRS occasions	413
9.3.18.1	Test purpose	413
9.3.18.2	Test applicability	414
9.3.18.3	Minimum conformance requirements	414
9.3.18.4	Test description	414
9.3.18.4.1	Initial conditions	414
9.3.18.4.2	Test procedure	416
9.3.18.4.3	Message contents	416
9.3.18.5	Test requirement	416
9.4	RSTD Inter-Frequency Measurements for UE Category M1/M2	417
9.4.1	FDD inter-frequency RSTD Measurement Reporting Delay in CE Mode A	417
9.4.1.1	FDD inter-frequency RSTD Measurement Reporting Delay in CE Mode A for Category M1	417
9.4.1.1.1	Test purpose	417
9.4.1.1.2	Test applicability	417
9.4.1.1.3	Minimum conformance requirements	417
9.4.1.1.4	Test description	418
9.4.1.1.4.1	Initial conditions	418
9.4.1.1.4.2	Test procedure	421
9.4.1.1.4.3	Message contents	422
9.4.1.1.5	Test requirement	422
9.4.1.2	FDD inter-frequency RSTD Measurement Reporting Delay in CE Mode A for Category M2	424
9.4.1.2.1	Test purpose	424
9.4.1.2.2	Test applicability	424
9.4.1.2.3	Minimum conformance requirements	425
9.4.1.2.4	Test description	425
9.4.1.2.4.1	Initial conditions	425
9.4.1.2.4.2	Test procedure	426
9.4.1.2.4.3	Message contents	426
9.4.1.2.5	Test requirement	427
9.4.2	HD-FDD inter-frequency RSTD Measurement Reporting Delay in CE Mode A	427
9.4.2.1	HD-FDD inter-frequency RSTD Measurement Reporting Delay in CE Mode A for Category M1	427
9.4.2.1.1	Test purpose	427
9.4.2.1.2	Test applicability	428
9.4.2.1.3	Minimum conformance requirements	428
9.4.2.1.4	Test description	428
9.4.2.1.4.1	Initial conditions	428
9.4.2.1.4.2	Test procedure	429
9.4.2.1.4.3	Message contents	429
9.4.2.1.5	Test requirement	429
9.4.2.2	HD-FDD inter-frequency RSTD Measurement Reporting Delay in CE Mode A for Category M2	430
9.4.2.2.1	Test purpose	430
9.4.2.2.2	Test applicability	430
9.4.2.2.3	Minimum conformance requirements	430

9.4.2.2.4	Test description.....	430
9.4.2.2.4.1	Initial conditions.....	430
9.4.2.2.4.2	Test procedure.....	432
9.4.2.2.4.3	Message contents.....	432
9.4.2.2.5	Test requirement	432
9.4.3	TDD inter-frequency RSTD Measurement Reporting Delay in CE Mode A	432
9.4.3.1	TDD inter-frequency RSTD Measurement Reporting Delay in CE Mode A for Category M1	432
9.4.3.1.1	Test purpose.....	432
9.4.3.1.2	Test applicability.....	432
9.4.3.1.3	Minimum conformance requirements	432
9.4.3.1.4	Test description.....	432
9.4.3.1.4.1	Initial conditions.....	432
9.4.3.1.4.2	Test procedure.....	434
9.4.3.1.4.3	Message contents.....	434
9.4.3.1.5	Test requirement	434
9.4.3.2	TDD inter-frequency RSTD Measurement Reporting Delay in CE Mode A for Category M2	436
9.4.3.2.1	Test purpose.....	436
9.4.3.2.2	Test applicability.....	436
9.4.3.2.3	Minimum conformance requirements	436
9.4.3.2.4	Test description.....	437
9.4.3.2.4.1	Initial conditions.....	437
9.4.3.2.4.2	Test procedure.....	439
9.4.3.2.4.3	Message contents.....	439
9.4.3.2.5	Test requirement	439
9.4.4	FDD inter-frequency RSTD Measurement Reporting Delay in CE Mode B.....	439
9.4.4.1	FDD inter-frequency RSTD Measurement Reporting Delay in CE Mode B for Category M1	439
9.4.4.1.1	Test purpose.....	439
9.4.4.1.2	Test applicability.....	439
9.4.4.1.3	Minimum conformance requirements	439
9.4.4.1.4	Test description.....	440
9.4.4.1.4.1	Initial conditions.....	440
9.4.4.1.4.2	Test procedure.....	441
9.4.4.1.4.3	Message contents.....	441
9.4.4.1.5	Test requirement	442
9.4.4.2	FDD inter-frequency RSTD Measurement Reporting Delay in CE Mode B for Category M2	444
9.4.4.2.1	Test purpose.....	444
9.4.4.2.2	Test applicability.....	444
9.4.4.2.3	Minimum conformance requirements	444
9.4.4.2.4	Test description.....	444
9.4.4.2.4.1	Initial conditions.....	444
9.4.4.2.4.2	Test procedure.....	445
9.4.4.2.4.3	Message contents.....	446
9.4.4.2.5	Test requirement	446
9.4.5	HD-FDD inter-frequency RSTD Measurement Reporting Delay in CE Mode B.....	447
9.4.5.1	HD-FDD inter-frequency RSTD Measurement Reporting Delay in CE Mode B for Category M1	447
9.4.5.1.1	Test purpose.....	447
9.4.5.1.2	Test applicability.....	447
9.4.5.1.3	Minimum conformance requirements	447
9.4.5.1.4	Test description.....	447
9.4.5.1.4.1	Initial conditions.....	447
9.4.5.1.4.2	Test procedure.....	448
9.4.5.1.4.3	Message contents.....	448
9.4.5.1.5	Test requirement	449
9.4.5.2	HD-FDD inter-frequency RSTD Measurement Reporting Delay in CE Mode B for Category M2	449
9.4.5.2.1	Test purpose.....	449
9.4.5.2.2	Test applicability.....	449
9.4.5.2.3	Minimum conformance requirements	449
9.4.5.2.4	Test description.....	449
9.4.5.2.4.1	Initial conditions.....	449
9.4.5.2.4.2	Test procedure.....	451
9.4.5.2.4.3	Message contents.....	451
9.4.5.2.5	Test requirement	451

9.4.6	TDD inter-frequency RSTD Measurement Reporting Delay in CE Mode B	451
9.4.6.1	TDD inter-frequency RSTD Measurement Reporting Delay in CE Mode B for Category M1	451
9.4.6.1.1	Test purpose	451
9.4.6.1.2	Test applicability	451
9.4.6.1.3	Minimum conformance requirements	451
9.4.6.1.4	Test description	451
9.4.6.1.4.1	Initial conditions	451
9.4.6.1.4.2	Test procedure	453
9.4.6.1.4.3	Message contents	453
9.4.6.1.5	Test requirement	453
9.4.6.2	TDD inter-frequency RSTD Measurement Reporting Delay in CE Mode B for Category M2	455
9.4.6.2.1	Test purpose	455
9.4.6.2.2	Test applicability	455
9.4.6.2.3	Minimum conformance requirements	455
9.4.6.2.4	Test description	455
9.4.6.2.4.1	Initial conditions	455
9.4.6.2.4.2	Test procedure	457
9.4.6.2.4.3	Message contents	457
9.4.6.2.5	Test requirement	457
9.4.7	FDD inter-frequency RSTD Measurement Accuracy in CE Mode A	458
9.4.7.1	FDD inter-frequency RSTD Measurement Accuracy in CE Mode A for Category M1	458
9.4.7.1.1	Test purpose	458
9.4.7.1.2	Test applicability	458
9.4.7.1.3	Minimum conformance requirements	458
9.4.7.1.4	Test description	459
9.4.7.1.4.1	Initial conditions	459
9.4.7.1.4.2	Test procedure	461
9.4.7.1.4.3	Message contents	461
9.4.7.1.5	Test requirement	462
9.4.7.2	FDD inter-frequency RSTD Measurement Accuracy in CE Mode A for Category M2	463
9.4.7.2.1	Test purpose	463
9.4.7.2.2	Test applicability	463
9.4.7.2.3	Minimum conformance requirements	463
9.4.7.2.4	Test description	464
9.4.7.2.4.1	Initial conditions	464
9.4.7.2.4.2	Test procedure	466
9.4.7.2.4.3	Message contents	466
9.4.7.2.5	Test requirement	466
9.4.8	HD-FDD inter-frequency RSTD Measurement Accuracy in CE Mode A	467
9.4.8.1	HD-FDD inter-frequency RSTD Measurement Accuracy in CE Mode A for Category M1	467
9.4.8.1.1	Test purpose	467
9.4.8.1.2	Test applicability	467
9.4.8.1.3	Minimum conformance requirements	467
9.4.8.1.4	Test description	467
9.4.8.1.4.1	Initial conditions	467
9.4.8.1.4.2	Test procedure	468
9.4.8.1.4.3	Message contents	469
9.4.8.1.5	Test requirement	469
9.4.8.2	HD-FDD inter-frequency RSTD Measurement Accuracy in CE Mode A for Category M2	469
9.4.8.2.1	Test purpose	469
9.4.8.2.2	Test applicability	469
9.4.8.2.3	Minimum conformance requirements	469
9.4.8.2.4	Test description	469
9.4.8.2.4.1	Initial conditions	469
9.4.8.2.4.2	Test procedure	470
9.4.8.2.4.3	Message contents	470
9.4.8.2.5	Test requirement	470
9.4.9	TDD inter-frequency RSTD Measurement Accuracy in CE Mode A	471
9.4.9.1	TDD inter-frequency RSTD Measurement Accuracy in CE Mode A for Category M1	471
9.4.9.1.1	Test purpose	471
9.4.9.1.2	Test applicability	471
9.4.9.1.3	Minimum conformance requirements	471

9.4.9.1.4	Test description.....	471
9.4.9.1.4.1	Initial conditions.....	471
9.4.9.1.4.2	Test procedure.....	472
9.4.9.1.4.3	Message contents.....	473
9.4.9.1.5	Test requirement	473
9.4.9.2	TDD inter-frequency RSTD Measurement Accuracy in CE Mode A for Category M2	474
9.4.9.2.1	Test purpose.....	474
9.4.9.2.2	Test applicability.....	474
9.4.9.2.3	Minimum conformance requirements	474
9.4.9.2.4	Test description.....	474
9.4.9.2.4.1	Initial conditions.....	474
9.4.9.2.4.2	Test procedure.....	475
9.4.9.2.4.3	Message contents.....	475
9.4.9.2.5	Test requirement	475
9.4.10	FDD inter-frequency RSTD Measurement Accuracy in CE Mode B.....	476
9.4.10.1	FDD inter-frequency RSTD Measurement Accuracy in CE Mode B for Category M1	476
9.4.10.1.1	Test purpose.....	476
9.4.10.1.2	Test applicability.....	476
9.4.10.1.3	Minimum conformance requirements	476
9.4.10.1.4	Test description.....	477
9.4.10.1.4.1	Initial conditions.....	477
9.4.10.1.4.2	Test procedure.....	478
9.4.10.1.4.3	Message contents.....	478
9.4.10.1.5	Test requirement	479
9.4.10.2	FDD inter-frequency RSTD Measurement Accuracy in CE Mode B for Category M2	480
9.4.10.2.1	Test purpose.....	480
9.4.10.2.2	Test applicability.....	480
9.4.10.2.3	Minimum conformance requirements	480
9.4.10.2.4	Test description.....	481
9.4.10.2.4.1	Initial conditions.....	481
9.4.10.2.4.2	Test procedure.....	483
9.4.10.2.4.3	Message contents.....	483
9.4.10.2.5	Test requirement	483
9.4.11	HD-FDD inter-frequency RSTD Measurement Accuracy in CE Mode B.....	484
9.4.11.1	HD-FDD inter-frequency RSTD Measurement Accuracy in CE Mode B for Category M1	484
9.4.11.1.1	Test purpose.....	484
9.4.11.1.2	Test applicability.....	484
9.4.11.1.3	Minimum conformance requirements	484
9.4.11.1.4	Test description.....	484
9.4.11.1.4.1	Initial conditions.....	484
9.4.11.1.4.2	Test procedure.....	486
9.4.11.1.4.3	Message contents.....	486
9.4.11.1.5	Test requirement	486
9.4.11.2	HD-FDD inter-frequency RSTD Measurement Accuracy in CE Mode B for Category M2	486
9.4.11.2.1	Test purpose.....	486
9.4.11.2.2	Test applicability.....	486
9.4.11.2.3	Minimum conformance requirements	486
9.4.11.2.4	Test description.....	486
9.4.11.2.4.1	Initial conditions.....	486
9.4.11.2.4.2	Test procedure.....	487
9.4.11.2.4.3	Message contents.....	487
9.4.11.2.5	Test requirement	487
9.4.12	TDD inter-frequency RSTD Measurement Accuracy in CE Mode B.....	488
9.4.12.1	TDD inter-frequency RSTD Measurement Accuracy in CE Mode B for Category M1	488
9.4.12.1.1	Test purpose.....	488
9.4.12.1.2	Test applicability.....	488
9.4.12.1.3	Minimum conformance requirements	488
9.4.12.1.4	Test description.....	488
9.4.12.1.4.1	Initial conditions.....	488
9.4.12.1.4.2	Test procedure.....	489
9.4.12.1.4.3	Message contents.....	490
9.4.12.1.5	Test requirement	490

9.4.12.2	TDD inter-frequency RSTD Measurement Accuracy in CE Mode B for Category M2	491
9.4.12.2.1	Test purpose	491
9.4.12.2.2	Test applicability	491
9.4.12.2.3	Minimum conformance requirements	491
9.4.12.2.4	Test description	491
9.4.12.2.4.1	Initial conditions	491
9.4.12.2.4.2	Test procedure	492
9.4.12.2.4.3	Message contents	492
9.4.12.2.5	Test requirement	492
9.4.13	E-UTRAN FDD inter-frequency RSTD measurement period test case in CE Mode A with longer PRS occasions	493
9.4.13.1	Test purpose	493
9.4.13.2	Test applicability	493
9.4.13.3	Minimum conformance requirements	493
9.4.13.4	Test description	493
9.4.13.4.1	Initial conditions	493
9.4.13.4.2	Test procedure	495
9.4.13.4.3	Message contents	495
9.4.13.5	Test requirement	496
9.4.14	E-UTRAN HD-FDD inter-frequency RSTD measurement period test case in CE Mode A with longer PRS occasions	496
9.4.14.1	Test purpose	496
9.4.14.2	Test applicability	496
9.4.14.3	Minimum conformance requirements	496
9.4.14.4	Test description	497
9.4.14.4.1	Initial conditions	497
9.4.14.4.2	Test procedure	498
9.4.14.4.3	Message contents	498
9.4.14.5	Test requirement	498
9.4.15	E-UTRAN TDD inter-frequency RSTD measurement period test case in CE Mode A with longer PRS occasions	499
9.4.15.1	Test purpose	499
9.4.15.2	Test applicability	499
9.4.15.3	Minimum conformance requirements	499
9.4.15.4	Test description	499
9.4.15.4.1	Initial conditions	499
9.4.15.4.2	Test procedure	501
9.4.15.4.3	Message contents	501
9.4.15.5	Test requirement	501
9.4.16	E-UTRAN FDD inter-frequency RSTD measurement period test case in CE Mode B with longer PRS occasions	501
9.4.16.1	Test purpose	501
9.4.16.2	Test applicability	501
9.4.16.3	Minimum conformance requirements	501
9.4.16.4	Test description	501
9.4.16.4.1	Initial conditions	501
9.4.16.4.2	Test procedure	503
9.4.16.4.3	Message contents	503
9.4.16.5	Test requirement	503
9.4.17	E-UTRAN HD-FDD inter-frequency RSTD measurement period test case in CE Mode B with longer PRS occasions	504
9.4.17.1	Test purpose	504
9.4.17.2	Test applicability	504
9.4.17.3	Minimum conformance requirements	504
9.4.17.4	Test description	504
9.4.17.4.1	Initial conditions	504
9.4.17.4.2	Test procedure	506
9.4.17.4.3	Message contents	506
9.4.17.5	Test requirement	506
9.4.18	E-UTRAN TDD inter-frequency RSTD measurement period test case in CE Mode B with longer PRS occasions	506
9.4.18.1	Test purpose	506

9.4.18.2	Test applicability	506
9.4.18.3	Minimum conformance requirements	506
9.4.18.4	Test description	506
9.4.18.4.1	Initial conditions	506
9.4.18.4.2	Test procedure	508
9.4.18.4.3	Message contents	508
9.4.18.5	Test requirement	509
9.5	HD-FDD RSTD Intra-Frequency Measurements for NB-IOT	510
9.5.1	HD-FDD Intra frequency RSTD Measurement Accuracy for NB-IOT Inband Mode in normal coverage	510
9.5.1.1	Test purpose	510
9.5.1.2	Test applicability	510
9.5.1.3	Minimum conformance requirements	510
9.5.1.4	Test description	512
9.5.1.4.1	Initial conditions	512
9.5.1.4.2	Test procedure	513
9.5.1.4.3	Message contents	514
9.5.1.5	Test requirement	516
9.5.2	HD-FDD Intra frequency RSTD Measurement Accuracy for NB-IOT Inband Mode in enhanced coverage	518
9.5.2.1	Test purpose	518
9.5.2.2	Test applicability	519
9.5.2.3	Minimum conformance requirements	519
9.5.2.4	Test description	519
9.5.2.4.1	Initial conditions	519
9.5.2.4.2	Test procedure	521
9.5.2.4.3	Message contents	521
9.5.2.5	Test requirement	522
9.5.3	HD-FDD Intra frequency RSTD Measurement Reporting Delay for NB-IOT Standalone Mode in enhanced coverage	523
9.5.3.1	Test purpose	523
9.5.3.2	Test applicability	524
9.5.3.3	Minimum conformance requirements	524
9.5.3.4	Test description	525
9.5.3.4.1	Initial conditions	525
9.5.3.4.2	Test procedure	527
9.5.3.4.3	Message contents	528
9.5.3.5	Test requirement	528
9.5.4	Void	531
9.6	HD-FDD RSTD Inter-Frequency Measurements for NB-IOT	531
9.6.1	HD-FDD Inter-Frequency RSTD Measurement Accuracy for NB-IOT Inband Mode in normal coverage	531
9.6.1.1	Test purpose	531
9.6.1.2	Test applicability	531
9.6.1.3	Minimum conformance requirements	531
9.6.1.4	Test description	533
9.6.1.4.1	Initial conditions	533
9.6.1.4.2	Test procedure	535
9.6.1.4.3	Message contents	535
9.6.1.5	Test requirement	536
9.6.2	HD-FDD Inter-Frequency RSTD Measurement Accuracy for NB-IOT Inband Mode in enhanced coverage	538
9.6.2.1	Test purpose	538
9.6.2.2	Test applicability	539
9.6.2.3	Minimum conformance requirements	539
9.6.2.4	Test description	539
9.6.2.4.1	Initial conditions	539
9.6.2.4.2	Test procedure	541
9.6.2.4.3	Message contents	542
9.6.2.5	Test requirement	542
9.6.3	HD-FDD Inter frequency RSTD Measurement Reporting Delay for NB-IOT Standalone Mode in enhanced coverage	543

9.6.3.1	Test purpose	543
9.6.3.2	Test applicability	544
9.6.3.3	Minimum conformance requirements	544
9.6.3.4	Test description	545
9.6.3.4.1	Initial conditions	545
9.6.3.4.2	Test procedure.....	547
9.6.3.4.3	Message contents	548
9.6.3.5	Test requirement	548
9.6.4	Void	551
9.7	TDD RSTD Intra-Frequency Measurements for NB-IOT.....	551
9.7.1	TDD Intra Frequency RSTD Measurement Accuracy for NB-IOT Inband Mode in normal coverage....	551
9.7.2	TDD Intra Frequency RSTD Measurement Accuracy for NB-IOT Inband Mode in enhanced coverage.....	556
9.7.3	TDD Intra Frequency RSTD Measurement Reporting Delay for NB-IOT Standalone Mode in enhanced coverage.....	562
9.8	TDD RSTD Inter-Frequency Measurements for NB-IOT.....	568
9.8.1	TDD Inter Frequency RSTD Measurement Accuracy for NB-IOT Inband Mode in normal coverage....	568
9.8.2	TDD Inter Frequency RSTD Measurement Accuracy for NB-IOT Inband Mode in enhanced coverage.....	574
10	E-UTRA OTDOA measurement requirements for Carrier Aggregation	586
10.0	General	586
10.1	FDD RSTD Measurement Reporting Delay for Carrier Aggregation.....	586
10.1.1	Test purpose.....	586
10.1.2	Test applicability	586
10.1.3	Minimum conformance requirements	587
10.1.3.1	Measurements on the secondary component carrier	587
10.1.3.2	Measurements on both primary component carrier and secondary component carrier	587
10.1.4	Test description.....	587
10.1.4.1	Initial conditions	587
10.1.4.2	Test procedure.....	589
10.1.4.3	Message contents	591
10.1.5	Test requirement	594
10.1A	FDD RSTD Measurement Reporting Delay for Carrier Aggregation for 20 MHz Bandwidth.....	596
10.1A.1	Test purpose.....	596
10.1A.2	Test applicability	596
10.1A.3	Minimum conformance requirements	596
10.1A.4	Test description.....	596
10.1A.4.1	Initial conditions	596
10.1A.4.2	Test procedure.....	597
10.1A.4.3	Message contents	597
10.1A.5	Test requirement	597
10.1B	FDD RSTD Measurement Reporting Delay Carrier Aggregation for 5 MHz + 5 MHz Bandwidth.....	597
10.1B.1	Test purpose.....	597
10.1B.2	Test applicability	598
10.1B.3	Minimum conformance requirements	598
10.1B.4	Test description.....	598
10.1B.4.1	Initial conditions	598
10.1B.4.2	Test procedure.....	598
10.1B.4.3	Message contents	598
10.1B.5	Test requirement	598
10.1C	FDD RSTD Measurement Reporting Delay for Carrier Aggregation for 10 MHz+5 MHz Bandwidth.....	599
10.1C.1	Test purpose.....	599
10.1C.2	Test applicability	599
10.1C.3	Minimum conformance requirements	599
10.1C.4	Test description.....	599
10.1C.4.1	Initial conditions	599
10.1C.4.2	Test procedure.....	600
10.1C.4.3	Message contents	600
10.1C.5	Test requirement	600
10.2	TDD RSTD Measurement Reporting Delay for Carrier Aggregation.....	601
10.2.1	Test purpose.....	601

10.2.2	Test applicability	601
10.2.3	Minimum conformance requirements	601
10.2.3.1	Measurements on the secondary component carrier	601
10.2.3.2	Measurements on both primary component carrier and secondary component carrier	601
10.2.4	Test description	601
10.2.4.1	Initial conditions	601
10.2.4.2	Test procedure	604
10.2.4.3	Message contents	605
10.2.5	Test requirement	608
10.2A	TDD RSTD Measurement Reporting Delay for Carrier Aggregation for 20 MHz Bandwidth	610
10.2A.1	Test purpose	610
10.2A.2	Test applicability	611
10.2A.3	Minimum conformance requirements	611
10.2A.4	Test description	611
10.2A.4.1	Initial conditions	611
10.2A.4.2	Test procedure	611
10.2A.4.3	Message contents	611
10.2A.5	Test requirement	611
10.2B	TDD RSTD Measurement Reporting Delay for Carrier Aggregation for 5 MHz + 5 MHz Bandwidth	612
10.2B.1	Test purpose	612
10.2B.2	Test applicability	612
10.2B.3	Minimum conformance requirements	612
10.2B.4	Test description	612
10.2B.4.1	Initial conditions	612
10.2B.4.2	Test procedure	613
10.2B.4.3	Message contents	613
10.2B.5	Test requirement	613
10.2C	TDD RSTD Measurement Reporting Delay for Carrier Aggregation for 10 MHz + 5 MHz Bandwidth	614
10.2C.1	Test purpose	614
10.2C.2	Test applicability	614
10.2C.3	Minimum conformance requirements	614
10.2C.4	Test description	614
10.2C.4.1	Initial conditions	614
10.2C.4.2	Test procedure	614
10.2C.4.3	Message contents	614
10.2C.5	Test requirement	615
10.2D	TDD RSTD Measurement Reporting Delay for Carrier Aggregation for 20 MHz +10 MHz Bandwidth	615
10.2D.1	Test purpose	615
10.2D.2	Test applicability	615
10.2D.3	Minimum conformance requirements	615
10.2D.4	Test description	616
10.2D.4.1	Initial conditions	616
10.2D.4.2	Test procedure	616
10.2D.4.3	Message contents	616
10.2D.5	Test requirement	616
10.3	FDD RSTD Measurement Accuracy for Carrier Aggregation	617
10.3.1	Test purpose	617
10.3.2	Test applicability	617
10.3.3	Minimum conformance requirements	617
10.3.4	Test description	617
10.3.4.1	Initial conditions	617
10.3.4.2	Test procedure	619
10.3.4.3	Message contents	620
10.3.5	Test requirement	622
10.3A	FDD RSTD Measurement Accuracy for Carrier Aggregation for 20 MHz Bandwidth (Rel-10 and Rel-11)	623
10.3A.1	Test purpose	623
10.3A.2	Test applicability	623
10.3A.3	Minimum conformance requirements	623
10.3A.4	Test description	623
10.3A.4.1	Initial conditions	623
10.3A.4.2	Test procedure	624

10.3A.4.3	Message contents	624
10.3A.5	Test requirement	624
10.3A_1	FDD RSTD Measurement Accuracy for Carrier Aggregation for 20 MHz Bandwidth (Rel-12 onwards)	624
10.3A_1.1	Test purpose.....	624
10.3A_1.2	Test applicability	624
10.3A_1.3	Minimum conformance requirements	625
10.3A_1.4	Test description.....	625
10.3A_1.4.1	Initial conditions	625
10.3A_1.4.2	Test procedure.....	625
10.3A_1.4.3	Message contents	625
10.3A_1.5	Test requirement	625
10.3B	FDD RSTD Measurement Accuracy for Carrier Aggregation for 5 MHz + 5 MHz Bandwidth.....	625
10.3B.1	Test purpose.....	625
10.3B.2	Test applicability	625
10.3B.3	Minimum conformance requirements	625
10.3B.4	Test description.....	625
10.3B.4.1	Initial conditions	625
10.3B.4.2	Test procedure.....	626
10.3B.4.3	Message contents	626
10.3B.5	Test requirement	626
10.3C	FDD RSTD Measurement Accuracy for Carrier Aggregation for 10 MHz + 5 MHz Bandwidth.....	627
10.3C.1	Test purpose.....	627
10.3C.2	Test applicability	627
10.3C.3	Minimum conformance requirements	627
10.3C.4	Test description.....	627
10.3C.4.1	Initial conditions	627
10.3C.4.2	Test procedure.....	627
10.3C.4.3	Message contents	628
10.3C.5	Test requirement	628
10.4	TDD RSTD Measurement Accuracy for Carrier Aggregation	628
10.4.1	Test purpose.....	628
10.4.2	Test applicability	628
10.4.3	Minimum conformance requirements	628
10.4.4	Test description.....	629
10.4.4.1	Initial conditions	629
10.4.4.2	Test procedure.....	630
10.4.4.3	Message contents	631
10.4.5	Test requirement	634
10.4A	TDD RSTD Measurement Accuracy for Carrier Aggregation for 20 MHz Bandwidth (Rel-10 and Rel-11)	635
10.4A.1	Test purpose.....	635
10.4A.2	Test applicability	635
10.4A.3	Minimum conformance requirements	635
10.4A.4	Test description.....	635
10.4A.4.1	Initial conditions	635
10.4A.4.2	Test procedure.....	635
10.4A.4.3	Message contents	635
10.4A.5	Test requirement	635
10.4A_1	TDD RSTD Measurement Accuracy for Carrier Aggregation for 20 MHz Bandwidth (Rel-12 onwards)	636
10.4A_1.1	Test purpose.....	636
10.4A_1.2	Test applicability	636
10.4A_1.3	Minimum conformance requirements	636
10.4A_1.4	Test description.....	636
10.4A_1.4.1	Initial conditions	636
10.4A_1.4.2	Test procedure.....	636
10.4A_1.4.3	Message contents	636
10.4A_1.5	Test requirement	636
10.4B	TDD RSTD Measurement Accuracy for Carrier Aggregation for 5 MHz + 5 MHz bandwidth	637
10.4B.1	Test purpose.....	637
10.4B.2	Test applicability	637
10.4B.3	Minimum conformance requirements	637
10.4B.4	Test description.....	637

10.4B.4.1	Initial conditions	637
10.4B.4.2	Test procedure.....	637
10.4B.4.3	Message contents	637
10.4B.5	Test requirement	638
10.4C	TDD RSTD Measurement Accuracy for Carrier Aggregation for 10 MHz + 5 MHz Bandwidth	638
10.4C.1	Test purpose.....	638
10.4C.2	Test applicability	638
10.4C.3	Minimum conformance requirements	638
10.4C.4	Test description.....	638
10.4C.4.1	Initial conditions	638
10.4C.4.2	Test procedure.....	639
10.4C.4.3	Message contents	639
10.4C.5	Test requirement	639
10.4D	TDD RSTD Measurement Accuracy for Carrier Aggregation for 20 MHz+10 MHz Bandwidth	640
10.4D.1	Test purpose.....	640
10.4D.2	Test applicability	640
10.4D.3	Minimum conformance requirements	640
10.4D.4	Test description.....	640
10.4D.4.1	Initial conditions	640
10.4D.4.2	Test procedure.....	640
10.4D.4.3	Message contents	640
10.4D.5	Test requirement	641
10.5	FDD 3 DL CA RSTD Measurement Reporting Delay	641
10.5.1	Test Purpose.....	641
10.5.2	Test applicability	641
10.5.3	Minimum conformance requirements	641
10.5.3.1	Measurements on the secondary component carrier	641
10.5.3.2	Measurements on both primary component carrier and secondary component carrier	641
10.5.3.3	Measurements on different secondary component carriers	642
10.5.4	Test description.....	642
10.5.4.1	Initial conditions	642
10.5.4.2	Test procedure.....	645
10.5.4.3	Message contents	646
10.5.5	Test Requirements	649
10.6	TDD 3 DL CA RSTD Measurement Reporting Delay	651
10.6.1	Test Purpose.....	651
10.6.2	Test applicability	652
10.6.3	Minimum conformance requirements	652
10.6.3.1	Measurements on the secondary component carrier	652
10.6.3.2	Measurements on both primary component carrier and secondary component carrier	652
10.6.3.3	Measurements on different secondary component carriers	652
10.6.4	Test description.....	653
10.6.4.1	Initial conditions	653
10.6.4.2	Test procedure.....	655
10.6.4.3	Message contents	657
10.6.5	Test Requirements	660
10.7	FDD RSTD Measurement Accuracy for 3DL Carrier Aggregation.....	662
10.7.1	Test purpose.....	662
10.7.2	Test applicability	662
10.7.3	Minimum conformance requirements	662
10.7.4	Test description.....	663
10.7.4.1	Initial conditions	663
10.7.4.2	Test procedure.....	665
10.7.4.3	Message contents	666
10.7.5	Test requirement	669
10.8	TDD RSTD Measurement Accuracy for 3DL Carrier Aggregation.....	670
10.8.1	Test purpose.....	670
10.8.2	Test applicability	670
10.8.3	Minimum conformance requirements	670
10.8.4	Test description.....	671
10.8.4.1	Initial conditions	671
10.8.4.2	Test procedure.....	673

10.8.4.3	Message contents	674
10.8.5	Test requirement	677
11	E-UTRA and NR MBS measurement requirements	678
11.0	General	678
11.1	MBS Measurement Reporting Delay (Release 13 only)	678
11.1.1	Test purpose.....	678
11.1.2	Test applicability	678
11.1.3	Minimum conformance requirements	678
11.1.4	Test description.....	679
11.1.4.1	Initial conditions	679
11.1.4.2	Test procedure.....	679
11.1.4.3	Message contents	679
11.1.5	Test requirement	681
11.1A	MBS Measurement Reporting Delay (Release 14 Onwards)	682
11.1A.1	Test purpose.....	682
11.1A.2	Test applicability	682
11.1A.3	Minimum conformance requirements	682
11.1A.4	Test description.....	682
11.1A.4.1	Initial conditions	682
11.1A.4.2	Test procedure.....	682
11.1A.4.3	Message contents	682
11.1A.5	Test requirement	683
11.1B	MBS Measurement Reporting Delay (NR)	683
11.1B.1	Test purpose.....	683
11.1B.2	Test applicability	684
11.1B.3	Minimum conformance requirements	684
11.1B.4	Test description.....	684
11.1B.4.1	Initial conditions	684
11.1B.4.2	Test procedure.....	684
11.1B.4.3	Message contents	684
11.1B.5	Test requirement	684
11.2	MBS Sensitivity Measurement Accuracy (Release 13 only).....	684
11.2.1	Test purpose.....	684
11.2.2	Test applicability	684
11.2.3	Minimum conformance requirements	684
11.2.4	Test description.....	685
11.2.4.1	Initial conditions	685
11.2.4.2	Test procedure.....	685
11.2.4.3	Message contents	685
11.2.5	Test requirement	687
11.2A	MBS Sensitivity Measurement Accuracy (Release 14 Onwards)	688
11.2A.1	Test purpose.....	688
11.2A.2	Test applicability	688
11.2A.3	Minimum conformance requirements	688
11.2A.4	Test description.....	689
11.2A.4.1	Initial conditions	689
11.2A.4.2	Test procedure.....	689
11.2A.4.3	Message contents	689
11.2A.5	Test requirement	690
11.2B	MBS Sensitivity Measurement Accuracy (NR)	690
11.2B.1	Test purpose.....	690
11.2B.2	Test applicability	690
11.2B.3	Minimum conformance requirements	691
11.2B.4	Test description.....	691
11.2B.4.1	Initial conditions	691
11.2B.4.2	Test procedure.....	691
11.2B.4.3	Message contents	691
11.2B.5	Test requirement	691
11.3	MBS Nominal Measurement Accuracy (Release 13 only).....	691
11.3.1	Test purpose.....	691
11.3.2	Test applicability	691

11.3.3	Minimum conformance requirements	691
11.3.4	Test description.....	692
11.3.4.1	Initial conditions	692
11.3.4.2	Test procedure.....	692
11.3.4.3	Message contents	692
11.3.5	Test requirement	694
11.3A	MBS Nominal Measurement Accuracy (Release 14 Onwards)	695
11.3A.1	Test purpose.....	695
11.3A.2	Test applicability	695
11.3A.3	Minimum conformance requirements	695
11.3A.4	Test description.....	696
11.3A.4.1	Initial conditions	696
11.3A.4.2	Test procedure.....	696
11.3A.4.3	Message contents	696
11.3A.5	Test requirement	697
11.3B	MBS Nominal Measurement Accuracy (NR).....	697
11.3B.1	Test purpose.....	697
11.3B.2	Test applicability	697
11.3B.3	Minimum conformance requirements	697
11.3B.4	Test description.....	698
11.3B.4.1	Initial conditions	698
11.3B.4.2	Test procedure.....	698
11.3B.4.3	Message contents	698
11.3B.5	Test requirement	698
11.4	MBS Dynamic Range Measurement Accuracy (Release 13 only)	698
11.4.1	Test purpose.....	698
11.4.2	Test applicability	698
11.4.3	Minimum conformance requirements	698
11.4.4	Test description.....	699
11.4.4.1	Initial conditions	699
11.4.4.2	Test procedure.....	699
11.4.4.3	Message contents	699
11.4.5	Test requirement	701
11.4A	MBS Dynamic Range Measurement Accuracy (Release 14 Onwards).....	703
11.4A.1	Test purpose.....	703
11.4A.2	Test applicability	703
11.4A.3	Minimum conformance requirements	703
11.4A.4	Test description.....	703
11.4A.4.1	Initial conditions	703
11.4A.4.2	Test procedure.....	703
11.4A.4.3	Message contents	703
11.4A.5	Test requirement	705
11.4B	MBS Dynamic Range Measurement Accuracy (NR).....	705
11.4B.1	Test purpose.....	705
11.4B.2	Test applicability	705
11.4B.3	Minimum conformance requirements	705
11.4B.4	Test description.....	705
11.4B.4.1	Initial conditions	705
11.4B.4.2	Test procedure.....	706
11.4B.4.3	Message contents	706
11.4B.5	Test requirement	706
11.5	MBS Measurement Accuracy in Multipath (Release 13 only).....	706
11.5.1	Test purpose.....	706
11.5.2	Test applicability	706
11.5.3	Minimum conformance requirements	706
11.5.4	Test description.....	706
11.5.4.1	Initial conditions	706
11.5.4.2	Test procedure.....	707
11.5.4.3	Message contents	707
11.5.5	Test requirement	709
11.5A	MBS Measurement Accuracy in Multipath (Release 14 Onwards).....	710
11.5A.1	Test purpose.....	710

11.5A.2	Test applicability	710
11.5A.3	Minimum conformance requirements	710
11.5A.4	Test description.....	710
11.5A.4.1	Initial conditions	710
11.5A.4.2	Test procedure.....	710
11.5A.4.3	Message contents	711
11.5A.5	Test requirement	712
11.5B	MBS Measurement Accuracy in Multipath (NR).....	712
11.5B.1	Test purpose.....	712
11.5B.2	Test applicability	712
11.5B.3	Minimum conformance requirements	712
11.5B.4	Test description.....	712
11.5B.4.1	Initial conditions	712
11.5B.4.2	Test procedure.....	712
11.5B.4.3	Message contents	712
11.5B.5	Test requirement	712
12	E-UTRA WLAN and BLE measurement requirements	712
12.0	General	712
12.1	WLAN Access Point Identification and Reporting Delay	713
12.1.1	WLAN AP Identification and reporting delay under nominal conditions	713
12.1.1.1	Test purpose	713
12.1.1.2	Test applicability.....	713
12.1.1.3	Minimum conformance requirements	713
12.1.1.4	Test description	714
12.1.1.4.1	Initial conditions	714
12.1.1.4.2	Test procedure	714
12.1.1.4.3	Message contents.....	715
12.1.1.5	Test requirement	716
12.1.2	WLAN AP Identification and reporting delay under dynamic range conditions	718
12.1.2.1	Test purpose	718
12.1.2.2	Test applicability.....	718
12.1.2.3	Minimum conformance requirements	718
12.1.2.4	Test description	719
12.1.2.4.1	Initial conditions	719
12.1.2.4.2	Test procedure	719
12.1.2.4.3	Message contents.....	719
12.1.2.5	Test requirement	719
12.2	BLE Identification and Reporting Delay.....	720
12.2.1	Bluetooth identification	720
12.2.1.1	Test purpose	720
12.2.1.2	Test applicability.....	720
12.2.1.3	Minimum conformance requirements	721
12.2.1.4	Test description	721
12.2.1.4.1	Initial conditions	721
12.2.1.4.2	Test procedure	721
12.2.1.4.3	Message contents.....	722
12.2.1.5	Test requirement	723
13	NR A-GNSS minimum performance requirements	725
13.1	General	725
13.2	Sensitivity.....	725
13.2.1	Sensitivity Coarse time assistance	725
13.2.1.1	Sub-tests.....	725
13.2.1.2	Test purpose	725
13.2.1.3	Test applicability.....	725
13.2.1.4	Minimum conformance requirements	726
13.2.1.5	Test description	727
13.2.1.5.1	Initial conditions	727
13.2.1.5.2	Test procedure	727
13.2.1.5.3	Message contents.....	728
13.2.1.6	Test requirement	729

13.2.2	Sensitivity Fine time assistance	730
13.2.2.1	Sub-tests	730
13.2.2.2	Test purpose	730
13.2.2.3	Test applicability	731
13.2.2.4	Minimum conformance requirements	731
13.2.2.5	Test description	732
13.2.2.5.1	Initial conditions	732
13.2.2.5.2	Test procedure	732
13.2.2.5.3	Message contents	733
13.2.2.6	Test requirement	734
13.3	Nominal Accuracy	735
13.3.1	Sub-tests	735
13.3.2	Test purpose	735
13.3.3	Test applicability	735
13.3.4	Minimum conformance requirements	735
13.3.5	Test description	736
13.3.5.1	Initial conditions	736
13.3.5.2	Test procedure	737
13.3.5.3	Message contents	738
13.3.6	Test requirement	739
13.4	Dynamic Range	740
13.4.1	Sub-tests	740
13.4.2	Test purpose	740
13.4.3	Test applicability	740
13.4.4	Minimum conformance requirements	740
13.4.5	Test description	741
13.4.5.1	Initial conditions	741
13.4.5.2	Test procedure	742
13.4.5.3	Message contents	743
13.4.6	Test requirement	743
13.5	Multi-Path scenario	745
13.5.1	Sub-tests	745
13.5.2	Test purpose	745
13.5.3	Test applicability	745
13.5.4	Minimum conformance requirements	745
13.5.5	Test description	746
13.5.5.1	Initial conditions	746
13.5.5.2	Test procedure	747
13.5.5.3	Message contents	748
13.5.6	Test requirement	748
13.6	Moving scenario and periodic update (Rel-9 to Rel-13)	750
13.6.1	Sub-tests	750
13.6.2	Test purpose	750
13.6.3	Test applicability	750
13.6.4	Minimum conformance requirements	750
13.6.5	Test description	751
13.6.5.1	Initial conditions	751
13.6.5.2	Test procedure	752
13.6.5.3	Message contents	753
13.6.6	Test requirement	754
13.7	Moving scenario and periodic update (Rel-14 onwards)	755
13.7.1	Sub-tests	755
13.7.2	Test purpose	755
13.7.3	Test applicability	756
13.7.4	Minimum conformance requirements	756
13.7.5	Test description	756
13.7.6	Test requirement	756
14	NR RSTD measurement requirements	756
14.1	General	756
14.2	NR RSTD measurement period test cases in RRC_CONNECTED	756
14.2.1	NR RSTD measurement period test case for single positioning frequency layer in FR1 SA	756

14.2.1.1	Test purpose	756
14.2.1.2	Test applicability	756
14.2.1.3	Minimum conformance requirements	756
14.2.1.4	Test description	758
14.2.1.4.1	Initial conditions	758
14.2.1.4.2	Test procedure	758
14.2.1.4.3	Message contents	759
14.2.1.5	Test requirement	765
14.2.2	NR RSTD measurement period test case for dual positioning frequency layer in FR1 SA	770
14.2.2.1	Test purpose	770
14.2.2.2	Test applicability	770
14.2.2.3	Minimum conformance requirements	770
14.2.2.4	Test description	770
14.2.2.4.1	Initial conditions	770
14.2.2.4.2	Test procedure	771
14.2.2.4.3	Message contents	771
14.2.2.5	Test requirement	774
14.2.3	NR RSTD measurement period test case for single positioning frequency layer in FR2 SA	778
14.2.3.1	Test purpose	779
14.2.3.2	Test applicability	779
14.2.3.3	Minimum conformance requirements	779
14.2.3.4	Test description	779
14.2.3.4.1	Initial conditions	779
14.2.3.4.2	Test procedure	779
14.2.3.4.3	Message contents	780
14.2.3.5	Test requirement	786
14.2.4	NR RSTD measurement period test case for dual positioning frequency layers in FR2 SA	791
14.2.4.1	Test purpose	791
14.2.4.2	Test applicability	791
14.2.4.3	Minimum conformance requirements	791
14.2.4.4	Test description	791
14.2.4.4.1	Initial conditions	791
14.2.4.4.2	Test procedure	791
14.2.4.4.3	Message contents	792
14.2.4.5	Test requirement	797
14.2.5	NR RSTD measurement reporting delay test case for single positioning frequency layer with reduced number of samples in FR1 SA	802
14.2.5.1	Test purpose	802
14.2.5.2	Test applicability	802
14.2.5.3	Minimum conformance requirements	802
14.2.5.4	Test description	804
14.2.5.4.1	Initial conditions	804
14.2.5.4.2	Test procedure	805
14.2.5.4.3	Message contents	806
14.2.5.5	Test requirement	812
14.2.6	NR RSTD measurement reporting delay test case for single positioning frequency layer without measurement gap in FR1 SA	815
14.2.6.1	Test purpose	815
14.2.6.2	Test applicability	815
14.2.6.3	Minimum conformance requirements	815
14.2.6.4	Test description	818
14.2.6.4.1	Initial conditions	818
14.2.6.4.2	Test procedure	818
14.2.6.4.3	Message contents	819
14.2.6.5	Test requirement	827
14.2.7	NR RSTD measurement reporting delay test case for single positioning frequency layer with Rx TEG in FR1 SA	830
14.2.7.1	Test purpose	830
14.2.7.2	Test applicability	830
14.2.7.3	Minimum conformance requirements	830
14.2.7.4	Test description	830
14.2.7.4.1	Initial conditions	830

14.2.7.4.2	Test procedure	831
14.2.7.4.3	Message contents	831
14.2.7.5	Test requirement	837
14.2.8	NR RSTD measurement reporting delay test case for single positioning frequency layer with reduced number of samples in FR2 SA	840
14.2.8.1	Test purpose	840
14.2.8.2	Test applicability	840
14.2.8.3	Minimum conformance requirements	841
14.2.8.4	Test description	843
14.2.8.4.1	Initial conditions	843
14.2.8.4.2	Test procedure	843
14.2.8.4.3	Message contents	844
14.2.8.5	Test requirement	851
14.2.9	NR RSTD measurement reporting delay test case for single positioning frequency layer without measurement gap in FR2 SA	854
14.2.9.1	Test purpose	855
14.2.9.2	Test applicability	855
14.2.9.3	Minimum conformance requirements	855
14.2.9.4	Test description	857
14.2.9.4.1	Initial conditions	857
14.2.9.4.2	Test procedure	857
14.2.9.4.3	Message contents	858
14.2.9.5	Test requirement	866
14.2.10	NR RSTD measurement reporting delay test case for single positioning frequency layer with Rx TEG in FR2 SA	870
14.2.10.1	Test purpose	870
14.2.10.2	Test applicability	870
14.2.10.3	Minimum conformance requirements	870
14.2.10.4	Test description	870
14.2.10.4.1	Initial conditions	870
14.2.10.4.2	Test procedure	871
14.2.10.4.3	Message contents	871
14.2.10.5	Test requirement	877
14.3	NR RSTD measurement accuracy test case in RRC_CONNECTED	881
14.3.1	NR RSTD measurement accuracy test case for single positioning frequency layer in FR1 SA	881
14.3.1.1	Test purpose	881
14.3.1.2	Test applicability	882
14.3.1.3	Minimum conformance requirements	882
14.3.1.4	Test description	884
14.3.1.4.1	Initial conditions	884
14.3.1.4.2	Test procedure	884
14.3.1.4.3	Message contents	885
14.3.1.5	Test requirement	891
14.3.2	NR RSTD measurement accuracy test case for dual positioning frequency layer in FR1 SA	893
14.3.2.1	Test purpose	893
14.3.2.2	Test applicability	893
14.3.2.3	Minimum conformance requirements	893
14.3.2.4	Test description	893
14.3.2.4.1	Initial conditions	893
14.3.2.4.2	Test procedure	894
14.3.2.4.3	Message contents	894
14.3.2.5	Test requirement	896
14.3.3	NR RSTD measurement accuracy test case for single positioning frequency layer in FR2 SA	898
14.3.3.1	Test purpose	898
14.3.3.2	Test applicability	898
14.3.3.3	Minimum conformance requirements	898
14.3.3.4	Test description	899
14.3.3.4.1	Initial conditions	899
14.3.3.4.2	Test procedure	899
14.3.3.4.3	Message contents	900
14.3.3.5	Test requirement	905
14.3.4	NR RSTD measurement accuracy test case for dual positioning frequency layer in FR2 SA	907

14.3.4.1	Test purpose	907
14.3.4.2	Test applicability	907
14.3.4.3	Minimum conformance requirements	907
14.3.4.4	Test description	907
14.3.4.4.1	Initial conditions	907
14.3.4.4.2	Test procedure	908
14.3.4.4.3	Message contents	908
14.3.4.5	Test requirement	913
14.3.5	NR RSTD measurement accuracy test case for single positioning frequency layer with reduced number of samples in FR1 SA	915
14.3.5.1	Test purpose	915
14.3.5.2	Test applicability	915
14.3.5.3	Minimum conformance requirements	915
14.3.5.4	Test description	917
14.3.5.4.1	Initial conditions	917
14.3.5.4.2	Test procedure	918
14.3.5.4.3	Message contents	919
14.3.5.5	Test requirement	925
14.3.6	NR RSTD measurement accuracy test case for single positioning frequency layer with Rx TEG in FR1 SA	927
14.3.6.1	Test purpose	928
14.3.6.2	Test applicability	928
14.3.6.3	Minimum conformance requirements	928
14.3.6.4	Test description	928
14.3.6.4.1	Initial conditions	928
14.3.6.4.2	Test procedure	928
14.3.6.4.3	Message contents	929
14.3.6.5	Test requirement	936
14.3.7	NR RSTD measurement accuracy test case for single positioning frequency layer with reduced number of samples in FR2 SA	938
14.3.7.1	Test purpose	938
14.3.7.2	Test applicability	938
14.3.7.3	Minimum conformance requirements	938
14.3.7.4	Test description	940
14.3.7.4.1	Initial conditions	940
14.3.7.4.2	Test procedure	940
14.3.7.4.3	Message contents	941
14.3.7.5	Test requirement	947
14.3.8	NR RSTD measurement accuracy test case for single positioning frequency layer with Rx TEG in FR2 SA	948
14.3.8.1	Test purpose	949
14.3.8.2	Test applicability	949
14.3.8.3	Minimum conformance requirements	949
14.3.8.4	Test description	949
14.3.8.4.1	Initial conditions	949
14.3.8.4.2	Test procedure	949
14.3.8.4.3	Message contents	950
14.3.8.5	Test requirement	956
14.4	NR RSTD measurement period test cases in RRC_INACTIVE	958
14.4.1	NR RSTD measurement reporting delay test case for single positioning frequency layer in FR1 SA	958
14.4.1.1	Test purpose	958
14.4.1.2	Test applicability	958
14.4.1.3	Minimum conformance requirements	958
14.4.1.4	Test description	960
14.4.1.4.1	Initial conditions	960
14.4.1.4.2	Test procedure	961
14.4.1.4.3	Message contents	962
14.4.1.5	Test requirement	970
14.4.2	NR RSTD measurement reporting delay test case for single positioning frequency layer with reduced number of samples in FR1 SA	973
14.4.2.1	Test purpose	973
14.4.2.2	Test applicability	973

14.4.2.3	Minimum conformance requirements	973
14.4.2.4	Test description	973
14.4.2.4.1	Initial conditions	973
14.4.2.4.2	Test procedure	973
14.4.2.4.3	Message contents	974
14.4.2.5	Test requirement	977
14.4.3	NR RSTD measurement reporting delay test case for single positioning frequency layer in FR2 SA	980
14.4.3.1	Test purpose	980
14.4.3.2	Test applicability	980
14.4.3.3	Minimum conformance requirements	980
14.4.3.4	Test description	982
14.4.3.4.1	Initial conditions	982
14.4.3.4.2	Test procedure	983
14.4.3.4.3	Message contents	984
14.4.3.5	Test requirement	992
14.4.4	NR RSTD measurement reporting delay test case for single positioning frequency layer with reduced number of samples in FR2 SA	992
14.4.4.1	Test purpose	992
14.4.4.2	Test applicability	992
14.4.4.3	Minimum conformance requirements	992
14.4.4.4	Test description	992
14.4.4.4.1	Initial conditions	992
14.4.4.4.2	Test procedure	993
14.4.4.4.3	Message contents	993
14.4.4.5	Test requirement	995
14.5	NR RSTD measurement accuracy test case in RRC_INACTIVE	995
14.5.1	NR RSTD measurement accuracy test case for single positioning frequency layer in FR1 SA	995
14.5.1.1	Test purpose	995
14.5.1.2	Test applicability	996
14.5.1.3	Minimum conformance requirements	996
14.5.1.4	Test description	997
14.5.1.4.1	Initial conditions	998
14.5.1.4.2	Test procedure	998
14.5.1.4.3	Message contents	999
14.5.1.5	Test requirement	1003
14.5.2	14.5.2 UE Rx-Tx time difference measurement accuracy for single positioning frequency layer with reduced number of samples in FR1 SA	1004
14.5.2.1	Test purpose	1004
14.5.2.2	Test applicability	1005
14.5.2.3	Minimum conformance requirements	1005
14.5.2.4	Test description	1006
14.5.2.4.1	Initial conditions	1007
14.5.2.4.2	Test procedure	1007
14.5.2.4.3	Message contents	1007
14.5.2.5	Test requirement	1011
14.5.3	NR RSTD measurement accuracy test case for single positioning frequency layer in FR2 SA	1012
14.5.3.1	Test purpose	1012
14.5.3.2	Test applicability	1013
14.5.3.3	Minimum conformance requirements	1013
14.5.3.4	Test description	1014
14.5.3.4.1	Initial conditions	1014
14.5.3.4.2	Test procedure	1014
14.5.3.4.3	Message contents	1015
14.5.3.5	Test requirement	1019
14.5.4	UE Rx-Tx time difference measurement accuracy for single positioning frequency layer with reduced number of samples in FR2 SA	1019
14.5.4.1	Test purpose	1019
14.5.4.2	Test applicability	1019
14.5.4.3	Minimum conformance requirements	1019
14.5.4.4	Test description	1020
14.5.4.4.1	Initial conditions	1021
14.5.4.4.2	Test procedure	1021

14.5.4.4.3	Message contents	1021
14.5.4.5	Test requirement	1024
15	UE Rx-Tx time difference measurement requirements	1024
15.1	General	1024
15.2	UE Rx-Tx time difference measurement period test cases in RRC_CONNECTED	1025
15.2.1	UE Rx-Tx time difference measurement period for single positioning frequency layer in FR1 SA	1025
15.2.1.1	Test purpose	1025
15.2.1.2	Test applicability	1025
15.2.1.3	Minimum conformance requirements	1025
15.2.1.4	Test description	1026
15.2.1.4.1	Initial conditions	1027
15.2.1.4.2	Test procedure	1027
15.2.1.4.3	Message contents	1028
15.2.1.5	Test requirement	1035
15.2.2	UE Rx-Tx time difference measurement period for dual positioning frequency layer in FR1 SA	1037
15.2.2.1	Test purpose	1037
15.2.2.2	Test applicability	1037
15.2.2.3	Minimum conformance requirements	1037
15.2.2.4	Test description	1037
15.2.2.4.1	Initial conditions	1038
15.2.2.4.2	Test procedure	1038
15.2.2.4.3	Message contents	1038
15.2.2.5	Test requirement	1045
15.2.3	UE Rx-Tx time difference measurement period for single positioning frequency layer in FR2 SA	1048
15.2.3.1	Test purpose	1048
15.2.3.2	Test applicability	1048
15.2.3.3	Minimum conformance requirements	1048
15.2.3.4	Test description	1048
15.2.3.4.1	Initial conditions	1049
15.2.3.4.2	Test procedure	1049
15.2.3.4.3	Message contents	1049
15.2.3.5	Test requirement	1056
15.2.4	UE Rx-Tx time difference measurement period for dual positioning frequency layer in FR2 SA	1058
15.2.4.1	Test purpose	1058
15.2.4.2	Test applicability	1059
15.2.4.3	Minimum conformance requirements	1059
15.2.4.4	Test description	1059
15.2.4.4.1	Initial conditions	1059
15.2.4.4.2	Test procedure	1059
15.2.4.4.3	Message contents	1059
15.2.4.5	Test requirement	1066
15.2.5	UE Rx-Tx time difference measurement reporting delay test case for single positioning frequency layer with reduced number of samples in FR1 SA	1069
15.2.5.1	Test purpose	1069
15.2.5.2	Test applicability	1069
15.2.5.3	Minimum conformance requirements	1069
15.2.5.4	Test description	1071
15.2.5.4.1	Initial conditions	1071
15.2.5.4.2	Test procedure	1072
15.2.5.4.3	Message contents	1073
15.2.5.5	Test requirement	1080
15.2.6	UE Rx-Tx time difference measurement reporting delay test case for single positioning frequency layer without measurement gap in FR1 SA	1082
15.2.6.1	Test purpose	1082
15.2.6.2	Test applicability	1082
15.2.6.3	Minimum conformance requirements	1082
15.2.6.4	Test description	1084
15.2.6.4.1	Initial conditions	1084
15.2.6.4.2	Test procedure	1085
15.2.6.4.3	Message contents	1086
15.2.6.5	Test requirement	1093

15.2.7	UE Rx-Tx time difference measurement reporting delay test case for single positioning frequency layer with RxTx TEG in FR1 SA	1095
15.2.7.1	Test purpose	1095
15.2.7.2	Test applicability	1096
15.2.7.3	Minimum conformance requirements	1096
15.2.7.4	Test description	1096
15.2.7.4.1	Initial conditions	1096
15.2.7.4.2	Test procedure	1096
15.2.7.4.3	Message contents	1096
15.2.7.5	Test requirement	1104
15.2.8	UE Rx-Tx time difference measurement reporting delay test case for single positioning frequency layer with reduced number of samples in FR2 SA	1105
15.2.8.1	Test purpose	1106
15.2.8.2	Test applicability	1106
15.2.8.3	Minimum conformance requirements	1106
15.2.8.4	Test description	1108
15.2.8.4.1	Initial conditions	1108
15.2.8.4.2	Test procedure	1109
15.2.8.4.3	Message contents	1109
15.2.8.5	Test requirement	1117
15.2.9	UE Rx-Tx time difference measurement reporting delay test case for single positioning frequency layer without measurement gap in FR2 SA	1119
15.2.9.1	Test purpose	1119
15.2.9.2	Test applicability	1119
15.2.9.3	Minimum conformance requirements	1119
15.2.9.4	Test description	1122
15.2.9.4.1	Initial conditions	1122
15.2.9.4.2	Test procedure	1122
15.2.9.4.3	Message contents	1123
15.2.9.5	Test requirement	1131
15.2.10	UE Rx-Tx time difference measurement reporting delay test case for single positioning frequency layer with RxTx TEG in FR2 SA	1133
15.2.10.1	Test purpose	1134
15.2.10.2	Test applicability	1134
15.2.10.3	Minimum conformance requirements	1134
15.2.10.4	Test description	1134
15.2.10.4.1	Initial conditions	1134
15.2.10.4.2	Test procedure	1134
15.2.10.4.3	Message contents	1134
15.2.10.5	Test requirement	1142
15.3	UE Rx-Tx time difference measurement accuracy test cases in RRC_CONNECTED	1144
15.3.1	UE Rx-Tx time difference measurement accuracy for single positioning frequency layer in FR1 SA ..	1144
15.3.1.1	Test purpose	1144
15.3.1.2	Test applicability	1144
15.3.1.3	Minimum conformance requirements	1144
15.3.1.4	Test description	1146
15.3.1.4.1	Initial conditions	1147
15.3.1.4.2	Test procedure	1147
15.3.1.4.3	Message contents	1148
15.3.1.5	Test requirement	1156
15.3.2	UE Rx-Tx time difference measurement accuracy for single positioning frequency layer in FR2 SA ..	1158
15.3.2.1	Test purpose	1158
15.3.2.2	Test applicability	1158
15.3.2.3	Minimum conformance requirements	1158
15.3.2.4	Test description	1158
15.3.2.4.1	Initial conditions	1158
15.3.2.4.2	Test procedure	1158
15.3.2.4.3	Message contents	1159
15.3.2.5	Test requirement	1165
15.3.3	UE Rx-Tx time difference measurement accuracy for single positioning frequency layer with reduced number of samples in FR1 SA	1167
15.3.3.1	Test purpose	1167

15.3.3.2	Test applicability	1167
15.3.3.3	Minimum conformance requirements	1167
15.3.3.4	Test description	1169
15.3.3.4.1	Initial conditions	1169
15.3.3.4.2	Test procedure	1169
15.3.3.4.3	Message contents	1170
15.3.3.5	Test requirement	1177
15.3.4	UE Rx-Tx time difference measurement accuracy for single positioning frequency layer with RxTx TEG in FR1 SA	1179
15.3.4.1	Test purpose	1179
15.3.4.2	Test applicability	1179
15.3.4.3	Minimum conformance requirements	1179
15.3.4.4	Test description	1181
15.3.4.4.1	Initial conditions	1181
15.3.4.4.2	Test procedure	1181
15.3.4.4.3	Message contents	1182
15.3.4.5	Test requirement	1190
15.3.5	UE Rx-Tx time difference measurement accuracy for single positioning frequency layer with reduced number of samples in FR2 SA	1192
15.3.5.1	Test purpose	1192
15.3.5.2	Test applicability	1192
15.3.5.3	Minimum conformance requirements	1192
15.3.5.4	Test description	1193
15.3.5.4.1	Initial conditions	1193
15.3.5.4.2	Test procedure	1194
15.3.5.4.3	Message contents	1194
15.3.5.5	Test requirement	1201
15.3.6	UE Rx-Tx time difference measurement accuracy for single positioning frequency layer with RxTx TEG in FR2 SA	1203
15.3.6.1	Test purpose	1203
15.3.6.2	Test applicability	1203
15.3.6.3	Minimum conformance requirements	1203
15.3.6.4	Test description	1204
15.3.6.4.1	Initial conditions	1204
15.3.6.4.2	Test procedure	1205
15.3.6.4.3	Message contents	1206
15.3.6.5	Test requirement	1213
15.4	UE Rx-Tx time difference measurement period test cases in RRC_INACTIVE	1215
15.4.1	UE Rx-Tx time difference measurement reporting delay test case for single positioning frequency layer in FR1 SA	1215
15.4.1.1	Test purpose	1215
15.4.1.2	Test applicability	1216
15.4.1.3	Minimum conformance requirements	1216
15.4.1.4	Test description	1218
15.4.1.4.1	Initial conditions	1218
15.4.1.4.2	Test procedure	1218
15.4.1.4.3	Message contents	1219
15.4.1.5	Test requirement	1228
15.4.2	UE Rx-Tx time difference measurement reporting delay test case for single positioning frequency layer with reduced number of samples in FR1 SA	1228
15.4.2.1	Test purpose	1228
15.4.2.2	Test applicability	1228
15.4.2.3	Minimum conformance requirements	1228
15.4.2.4	Test description	1228
15.4.2.4.1	Initial conditions	1228
15.4.2.4.2	Test procedure	1229
15.4.2.4.3	Message contents	1229
15.4.2.5	Test requirement	1231
15.4.3	UE Rx-Tx time difference measurement reporting delay test case for single positioning frequency layer in FR2 SA	1231
15.4.3.1	Test purpose	1231
15.4.3.2	Test applicability	1231

15.4.3.3	Minimum conformance requirements	1231
15.4.3.4	Test description	1231
15.4.3.4.1	Initial conditions	1231
15.4.3.4.2	Test procedure	1232
15.4.3.4.3	Message contents	1232
15.4.3.5	Test requirement	1235
15.4.4	UE Rx-Tx time difference measurement reporting delay test case for single positioning frequency layer with reduced number of samples in FR2 SA	1235
15.4.4.1	Test purpose	1235
15.4.4.2	Test applicability	1235
15.4.4.3	Minimum conformance requirements	1235
15.4.4.4	Test description	1235
15.4.4.4.1	Initial conditions	1235
15.4.4.4.2	Test procedure	1236
15.4.4.4.3	Message contents	1236
15.4.4.5	Test requirement	1241
15.5	UE Rx-Tx time difference measurement accuracy test cases in RRC_INACTIVE	1241
15.5.1	1241	
15.5.2	1241	
15.5.3	UE Rx-Tx time difference measurement accuracy for single positioning frequency layer in FR2 SA ..	1241
15.5.3.1	Test purpose	1241
15.5.3.2	Test applicability	1241
15.5.3.3	Minimum conformance requirements	1241
15.5.3.4	Test description	1243
15.5.3.4.1	Initial conditions	1243
15.5.3.4.2	Test procedure	1243
15.5.3.4.3	Message contents	1244
15.5.3.5	Test requirement	1248
16	NR PRS-RSRP measurement requirements	1257
16.1	General	1257
16.2	NR PRS-RSRP measurement period test cases in RRC_CONNECTED	1258
16.2.1	PRS-RSRP measurement period test case for single positioning frequency layer in FR1 SA	1258
16.2.1.1	Test purpose	1258
16.2.1.2	Test applicability	1258
16.2.1.3	Minimum conformance requirements	1258
16.2.1.4	Test description	1260
16.2.1.4.1	Initial conditions	1260
16.2.1.4.2	Test procedure	1261
16.2.1.4.3	Message contents	1262
16.2.1.5	Test requirement	1267
16.2.2	PRS-RSRP measurement period test case for dual positioning frequency layer in FR1 SA	1270
16.2.2.1	Test purpose	1270
16.2.2.2	Test applicability	1270
16.2.2.3	Minimum conformance requirements	1270
16.2.2.4	Test description	1270
16.2.2.4.1	Initial conditions	1270
16.2.2.4.2	Test procedure	1271
16.2.2.4.3	Message contents	1271
16.2.2.5	Test requirement	1277
16.2.3	PRS-RSRP measurement period test case for single positioning frequency layer in FR2 SA	1279
16.2.3.1	Test purpose	1279
16.2.3.2	Test applicability	1280
16.2.3.3	Minimum conformance requirements	1280
16.2.3.4	Test description	1281
16.2.3.4.1	Initial conditions	1281
16.2.3.4.2	Test procedure	1281
16.2.3.4.3	Message contents	1282
16.2.3.5	Test requirement	1287
16.2.4	PRS-RSRP measurement period test case for dual positioning frequency layer in FR2 SA	1291
16.2.4.1	Test purpose	1291
16.2.4.2	Test applicability	1291

16.2.4.3	Minimum conformance requirements	1291
16.2.4.4	Test description	1291
16.2.4.4.1	Initial conditions	1291
16.2.4.4.2	Test procedure	1291
16.2.4.4.3	Message contents	1291
16.2.4.5	Test requirement	1297
16.2.5	PRS-RSRP measurement reporting delay test case for single positioning frequency with reduced number of samples in FR1 SA	1300
16.2.5.1	Test purpose	1300
16.2.5.2	Test applicability	1300
16.2.5.3	Minimum conformance requirements	1300
16.2.5.4	Test description	1302
16.2.5.4.1	Initial conditions	1302
16.2.5.4.2	Test procedure	1303
16.2.5.4.3	Message contents	1303
16.2.5.5	Test requirement	1309
16.2.6	PRS-RSRP measurement reporting delay test case for single positioning frequency layer without measurement gap in FR1 SA	1311
16.2.6.1	Test purpose	1311
16.2.6.2	Test applicability	1312
16.2.6.3	Minimum conformance requirements	1312
16.2.6.4	Test description	1314
16.2.6.4.1	Initial conditions	1314
16.2.6.4.2	Test procedure	1314
16.2.6.4.3	Message contents	1315
16.2.6.5	Test requirement	1322
e16.2.7	PRS-RSRP measurement reporting delay test case for single positioning frequency with reduced number of samples in FR2 SA	1323
16.2.7.1	Test purpose	1324
16.2.7.2	Test applicability	1324
16.2.7.3	Minimum conformance requirements	1324
16.2.7.4	Test description	1326
16.2.7.4.1	Initial conditions	1326
16.2.7.4.2	Test procedure	1326
16.2.7.4.3	Message contents	1327
16.2.7.5	Test requirement	1332
16.2.8	PRS-RSRP measurement reporting delay test case for single positioning frequency layer without measurement gap in FR2 SA	1336
16.2.8.1	Test purpose	1336
16.2.8.2	Test applicability	1336
16.2.8.3	Minimum conformance requirements	1336
16.2.8.4	Test description	1338
16.2.8.4.1	Initial conditions	1338
16.2.8.4.2	Test procedure	1339
16.2.8.4.3	Message contents	1340
16.2.8.5	Test requirement	1346
16.3	NR PRS-RSRP measurement accuracy test case in RRC_CONNECTED	1349
16.3.1	PRS-RSRP measurement accuracy with PRS in FR1	1349
16.3.1.1	Test purpose	1349
16.3.1.2	Test applicability	1349
16.3.1.3	Minimum conformance requirements	1349
16.3.1.4	Test description	1351
16.3.1.4.1	Initial conditions	1351
16.3.1.4.2	Test procedure	1351
16.3.1.4.3	Message contents	1352
16.3.1.5	Test requirement	1358
16.3.2	PRS-RSRP measurement accuracy with PRS in FR2	1361
16.3.2.1	Test purpose	1361
16.3.2.2	Test applicability	1361
16.3.2.3	Minimum conformance requirements	1361
16.3.2.4	Test description	1362
16.3.2.4.1	Initial conditions	1362

16.3.2.4.2	Test procedure	1363
16.3.2.4.3	Message contents	1364
16.3.2.5	Test requirement	1369
16.3.3	PRS-RSRP measurement accuracy with PRS in FR1 with reduced sample number	1372
16.3.3.1	Test purpose	1372
16.3.3.2	Test applicability	1372
16.3.3.3	Minimum conformance requirements	1372
16.3.3.4	Test description	1374
16.3.3.4.1	Initial conditions	1374
16.3.3.4.2	Test procedure	1374
16.3.3.4.3	Message contents	1375
16.3.3.5	Test requirement	1381
16.3.4	PRS-RSRP measurement accuracy with PRS in FR2 with reduced sample number	1383
16.3.4.1	Test purpose	1383
16.3.4.2	Test applicability	1383
16.3.4.3	Minimum conformance requirements	1383
16.3.4.4	Test description	1384
16.3.4.4.1	Initial conditions	1384
16.3.4.4.2	Test procedure	1385
16.3.4.4.3	Message contents	1385
16.3.4.5	Test requirement	1391
16.4	NR PRS-RSRP measurement period test cases in RRC_INACTIVE	1393
16.4.1	PRS-RSRP measurement reporting delay test case for single positioning frequency layer in FR1 SA ..	1393
16.4.1.1	Test purpose	1393
16.4.1.2	Test applicability	1393
16.4.1.3	Minimum conformance requirements	1393
16.4.1.4	Test description	1395
16.4.1.4.1	Initial conditions	1395
16.4.1.4.2	Test procedure	1395
16.4.1.4.3	Message contents	1396
16.4.1.5	Test requirement	1404
16.4.2	PRS-RSRP measurement reporting delay test case for single positioning frequency layer with reduced number of samples in FR1 SA	1405
16.4.2.1	Test purpose	1405
16.4.2.2	Test applicability	1405
16.4.2.3	Minimum conformance requirements	1405
16.4.2.4	Test description	1405
16.4.2.4.1	Initial conditions	1405
16.4.2.4.2	Test procedure	1406
16.4.2.4.3	Message contents	1406
16.4.2.5	Test requirement	1409
16.4.3	PRS-RSRP measurement reporting delay test case for single positioning frequency layer in FR2 SA ..	1412
16.4.3.1	Test purpose	1413
16.4.3.2	Test applicability	1413
16.4.3.3	Minimum conformance requirements	1413
16.4.3.4	Test description	1414
16.4.3.4.1	Initial conditions	1414
16.4.3.4.2	Test procedure	1415
16.4.3.4.3	Message contents	1416
16.4.3.5	Test requirement	1423
16.4.4	PRS-RSRP measurement reporting delay test case for single positioning frequency layer with reduced number of samples in FR2 SA	1423
16.4.4.1	Test purpose	1423
16.4.4.2	Test applicability	1423
16.4.4.3	Minimum conformance requirements	1423
16.4.4.4	Test description	1423
16.4.4.4.1	Initial conditions	1423
16.4.4.4.2	Test procedure	1424
16.4.4.4.3	Message contents	1424
16.4.4.5	Test requirement	1426
16.5	NR PRS-RSRP measurement accuracy test case in RRC_INACTIVE	1427

16.5.1	PRS-RSRP measurement accuracy test case for single positioning frequency layer with PRS in FR1	
	SA	1427
16.5.1.1	Test purpose	1427
16.5.1.2	Test applicability	1427
16.5.1.3	Minimum conformance requirements	1427
16.5.1.4	Test description	1429
16.5.1.4.1	Initial conditions	1429
16.5.1.4.2	Test procedure	1430
16.5.1.4.3	Message contents	1431
16.5.1.5	Test requirement	1433
16.5.2	PRS-RSRP measurement accuracy test case for single positioning frequency layer with PRS in FR1	
	SA	1435
16.5.2.1	Test purpose	1435
16.5.2.2	Test applicability	1435
16.5.2.3	Minimum conformance requirements	1435
16.5.2.4	Test description	1437
16.5.2.4.1	Initial conditions	1437
16.5.2.4.2	Test procedure	1437
16.5.2.4.3	Message contents	1437
16.5.2.5	Test requirement	1440
16.5.3	PRS-RSRP measurement accuracy test case for single positioning frequency layer with PRS in FR2	
	SA	1442
16.5.3.1	Test purpose	1442
16.5.3.2	Test applicability	1442
16.5.3.3	Minimum conformance requirements	1442
16.5.3.4	Test description	1442
16.5.3.4.1	Initial conditions	1442
16.5.3.4.2	Test procedure	1442
16.5.3.4.3	Message contents	1443
16.5.3.5	Test requirement	1446
16.5.4	PRS-RSRP measurement accuracy test case for single positioning frequency layer with PRS in FR2 with reduced sample number	1446
16.5.4.1	Test purpose	1446
16.5.4.2	Test applicability	1446
16.5.4.3	Minimum conformance requirements	1446
16.5.4.4	Test description	1446
16.5.4.4.1	Initial conditions	1446
16.5.4.4.2	Test procedure	1446
16.5.4.4.3	Message contents	1447
16.5.4.5	Test requirement	1450
17	NR PRS-RSRPP measurement requirements	1450
17.1	General	1450
17.2	NR PRS-RSRPP measurement period test cases in RRC_CONNECTED	1450
17.2.1	PRS-RSRPP measurement reporting delay test case for single positioning frequency layer in FR1	
	SA	1450
17.2.1.1	Test purpose	1451
17.2.1.2	Test applicability	1451
17.2.1.3	Minimum conformance requirements	1451
17.2.1.4	Test description	1453
17.2.1.4.1	Initial conditions	1453
17.2.1.4.2	Test procedure	1453
17.2.1.4.3	Message contents	1454
17.2.1.5	Test requirement	1460
17.2.2	PRS-RSRPP measurement reporting delay test case for single positioning frequency layer with reduced number of samples in FR1 SA	1460
17.2.2.1	Test purpose	1460
17.2.2.2	Test applicability	1460
17.2.2.3	Minimum conformance requirements	1460
17.2.2.4	Test description	1460
17.2.2.4.1	Initial conditions	1460
17.2.2.4.2	Test procedure	1461

17.2.2.4.3	Message contents	1461
17.2.2.5	Test requirement	1467
17.2.3	PRS-RSRPP measurement reporting delay test case for single positioning frequency layer without measurement gap in FR1 SA	1467
17.2.3.1	Test purpose	1467
17.2.3.2	Test applicability	1467
17.2.3.3	Minimum conformance requirements	1467
17.2.3.4	Test description	1467
17.2.3.4.1	Initial conditions	1467
17.2.3.4.2	Test procedure	1468
17.2.3.4.3	Message contents	1469
17.2.3.5	Test requirement	1476
17.2.4	PRS-RSRPP measurement reporting delay test case for single positioning frequency layer in FR2 SA	1476
17.2.4.1	Test purpose	1476
17.2.4.2	Test applicability	1476
17.2.4.3	Minimum conformance requirements	1476
17.2.4.4	Test description	1476
17.2.4.4.1	Initial conditions	1476
17.2.4.4.2	Test procedure	1476
17.2.4.4.3	Message contents	1477
17.2.4.5	Test requirement	1482
17.2.5	PRS-RSRPP measurement reporting delay test case for single positioning frequency layer with reduced number of samples in FR2 SA	1483
17.2.5.1	Test purpose	1483
17.2.5.2	Test applicability	1483
17.2.5.3	Minimum conformance requirements	1483
17.2.5.4	Test description	1483
17.2.5.4.1	Initial conditions	1483
17.2.5.4.2	Test procedure	1483
17.2.5.4.3	Message contents	1484
17.2.5.5	Test requirement	1489
17.2.6	PRS-RSRPP measurement reporting delay test case for single positioning frequency layer without measurement gap in FR2 SA	1489
17.2.6.1	Test purpose	1490
17.2.6.2	Test applicability	1490
17.2.6.3	Minimum conformance requirements	1490
17.2.6.4	Test description	1490
17.2.6.4.1	Initial conditions	1490
17.2.6.4.2	Test procedure	1490
17.2.6.4.3	Message contents	1490
17.2.6.5	Test requirement	1496
17.3	NR PRS-RSRPP measurement accuracy test case in RRC_CONNECTED	1496
17.3.1	PRS-RSRPP measurement accuracy test case for single positioning frequency layer in FR1 SA	1496
17.3.1.1	Test purpose	1497
17.3.1.2	Test applicability	1497
17.3.1.3	Minimum conformance requirements	1497
17.3.1.4	Test description	1498
17.3.1.4.1	Initial conditions	1498
17.3.1.4.2	Test procedure	1498
17.3.1.4.3	Message contents	1499
17.3.1.5	Test requirement	1505
17.3.2	PRS-RSRPP measurement accuracy test case for single positioning frequency layer with reduced number of samples in FR1 SA	1505
17.3.2.1	Test purpose	1505
17.3.2.2	Test applicability	1505
17.3.2.3	Minimum conformance requirements	1506
17.3.2.4	Test description	1507
17.3.2.4.1	Initial conditions	1507
17.3.2.4.2	Test procedure	1507
17.3.2.4.3	Message contents	1507
17.3.2.5	Test requirement	1511

17.3.3	PRS-RSRPP measurement accuracy test case for single positioning frequency layer in FR2 SA.....	1511
17.3.3.1	Test purpose	1511
17.3.3.2	Test applicability.....	1511
17.3.3.3	Minimum conformance requirements	1511
17.3.3.4	Test description	1512
17.3.3.4.1	Initial conditions.....	1512
17.3.3.4.2	Test procedure	1512
17.3.3.4.3	Message contents.....	1512
17.3.3.5	Test requirement	1514
17.3.4	PRS-RSRPP measurement accuracy test case for single positioning frequency layer with reduced number of samples in FR2 SA	1514
17.3.4.1	Test purpose	1514
17.3.4.2	Test applicability.....	1514
17.3.4.3	Minimum conformance requirements	1515
17.3.4.4	Test description	1515
17.3.4.4.1	Initial conditions.....	1515
17.3.4.4.2	Test procedure	1516
17.3.4.4.3	Message contents.....	1516
17.3.4.5	Test requirement	1519
17.4	NR PRS-RSRPP measurement period test cases in RRC_INACTIVE.....	1519
17.4.1	PRS-RSRPP measurement reporting delay test case for single positioning frequency layer in FR1 SA	1519
17.4.1.1	Test purpose	1520
17.4.1.2	Test applicability.....	1520
17.4.1.3	Minimum conformance requirements	1520
17.4.1.4	Test description	1520
17.4.1.4.1	Initial conditions.....	1520
17.4.1.4.2	Test procedure	1520
17.4.1.4.3	Message contents.....	1522
17.4.1.5	Test requirement	1529
17.4.2	PRS-RSRPP measurement reporting delay test case for single positioning frequency layer with reduced number of samples in FR1 SA	1529
17.4.2.1	Test purpose	1529
17.4.2.2	Test applicability.....	1529
17.4.2.3	Minimum conformance requirements	1529
17.4.2.4	Test description	1529
17.4.2.4.1	Initial conditions.....	1529
17.4.2.4.2	Test procedure	1530
17.4.2.4.3	Message contents.....	1530
17.4.2.5	Test requirement	1533
17.4.3	PRS-RSRPP measurement reporting delay test case for single positioning frequency layer in FR2 SA	1533
17.4.3.1	Test purpose	1533
17.4.3.2	Test applicability.....	1533
17.4.3.3	Minimum conformance requirements	1533
17.4.3.4	Test description	1533
17.4.3.4.1	Initial conditions.....	1533
17.4.3.4.2	Test procedure	1533
17.4.3.4.3	Message contents.....	1534
17.4.3.5	Test requirement	1536
17.4.4	PRS-RSRPP measurement reporting delay test case for single positioning frequency layer with reduced number of samples in FR2 SA	1536
17.4.4.1	Test purpose	1536
17.4.4.2	Test applicability.....	1536
17.4.4.3	Minimum conformance requirements	1536
17.4.4.4	Test description	1536
17.4.4.4.1	Initial conditions.....	1536
17.4.4.4.2	Test procedure	1537
17.4.4.4.3	Message contents.....	1537
17.4.4.5	Test requirement	1541
17.5	NR PRS-RSRPP measurement accuracy test case in RRC_INACTIVE.....	1541
17.5.1	PRS-RSRPP measurement accuracy test case for single positioning frequency layer in FR1 SA.....	1541

17.5.1.1	Test purpose	1541
17.5.1.2	Test applicability	1541
17.5.1.3	Minimum conformance requirements	1541
17.5.1.4	Test description	1541
17.5.1.4.1	Initial conditions	1541
17.5.1.4.2	Test procedure	1542
17.5.1.4.3	Message contents	1543
17.5.1.5	Test requirement	1545
17.5.2	PRS-RSRPP measurement accuracy test case for single positioning frequency layer with reduced number of samples in FR1 SA	1545
17.5.2.1	Test purpose	1545
17.5.2.2	Test applicability	1545
17.5.2.3	Minimum conformance requirements	1545
17.5.2.4	Test description	1546
17.5.2.4.1	Initial conditions	1546
17.5.2.4.2	Test procedure	1546
17.5.2.4.3	Message contents	1546
17.5.2.5	Test requirement	1550
17.5.3	PRS-RSRPP measurement accuracy test case for single positioning frequency layer in FR2 SA	1550
17.5.3.1	Test purpose	1550
17.5.3.2	Test applicability	1550
17.5.3.3	Minimum conformance requirements	1550
17.5.3.4	Test description	1550
17.5.3.4.1	Initial conditions	1550
17.5.3.4.2	Test procedure	1550
17.5.3.4.3	Message contents	1551
17.5.3.5	Test requirement	1553
17.5.4	PRS-RSRPP measurement accuracy test case for single positioning frequency layer with reduced number of samples in FR2 SA	1553
17.5.4.1	Test purpose	1553
17.5.4.2	Test applicability	1553
17.5.4.3	Minimum conformance requirements	1553
17.5.4.4	Test description	1553
17.5.4.4.1	Initial conditions	1553
17.5.4.4.2	Test procedure	1554
17.5.4.4.3	Message contents	1554
17.5.4.5	Test requirement	1558
Annex A (informative): Connection Diagrams		1559
Annex B (normative): Converting A-GNSS UE-assisted measurement reports into position estimates.....		1570
B.1	Introduction	1570
B.2	UTRAN UE measurement reports for A-GPS L1 C/A only	1570
B.3	UTRAN UE measurement reports for A-GNSS.....	1570
B.4	E-UTRAN and NR UE measurement reports.....	1572
B.5	WLS position solution.....	1572
Annex C (normative): General test conditions and declarations.....		1575
C.1	Acceptable uncertainty of Test System	1575
C.1.1	Measurement of test environments	1575
C.1.2	A-GNSS Minimum Performance requirements	1575
C.1.3	ECID and OTDOA Measurement requirements	1576
C.1.4	MBS Minimum Performance requirements	1587
C.1.5	WLAN and BLE measurement requirements	1587
C.1.6	NR PRS-based measurement requirements	1587
C.2	Test Parameter Relaxations (This clause is informative)	1591
C.2.1	A-GNSS Minimum Performance requirements	1591
C.2.2	ECID and OTDOA Measurement requirements	1592
C.2.3	MBS Minimum Performance requirements	1598
C.2.4	WLAN and BLE measurement requirements	1599
C.2.5	NR PRS-based Measurement requirements	1599

C.3	Interpretation of measurement results	1601
C.4	Derivation of Test Requirements (This clause is informative).....	1601
Annex D (normative):	Rules for statistical testing	1618
D.1	Test Method.....	1618
D.2	Error Ratio (ER).....	1618
D.3	Test Design.....	1618
D.3.1	Confidence level	1618
D.3.2	Introduction: Supplier Risk versus Customer Risk.....	1618
D.3.3	Supplier Risk versus Customer Risk.....	1619
D.3.4	Introduction: Standard test versus early decision concept	1619
D.3.5	Standard test versus early decision concept.....	1620
D.3.6	Selectivity	1620
D.3.7	Design of the test	1621
D.4	Pass fail decisions.....	1622
D.4.1	Numerical definition of the pass fail limits for A-GNSS test cases	1622
D.4.2	Pass fail decision rules for A-GNSS test cases	1623
D.4.3	Numerical definition of the pass fail limits for ECID, OTDOA, MBS, WLAN and BLE test cases.....	1623
D.4.4	Pass fail decision rules for ECID, OTDOA, MBS, WLAN and BLE test cases.....	1624
D.4.5	Background information to the pass fail limits	1624
Annex E (normative):	Conditions for ECID and OTDOA requirements.....	1626
E.1	Conditions for E-CID UE Rx – Tx time difference Measurements.....	1626
E.1.1	Conditions for E-CID UE Rx – Tx time difference by UE Category M1/M2	1626
E.2	Conditions for OTDOA intra-frequency RSTD Measurements	1627
E.2.1	Conditions for OTDOA intra-frequency RSTD Measurements by UE Category M1 and M2.....	1627
E.3	Conditions for OTDOA inter-frequency RSTD Measurements	1628
E.3.1	Conditions for OTDOA inter-frequency RSTD Measurements by UE Category M1 and M2.....	1628
E.4	Conditions for UE Rx-Tx Time Difference Measurement under Time Domain Measurement Resource Restriction with CRS Assistance Information	1629
E.5	Conditions for NB-IOT OTDOA intra-frequency RSTD Measurements.....	1629
E.6	Conditions for NB-IOT OTDOA inter-frequency RSTD Measurements.....	1629
Annex F (normative):	UTRAN Generic procedures.....	1630
F.1	General	1630
F.2	UTRAN connection set up	1630
F.2.1	Initial conditions	1630
F.2.2	Procedures.....	1630
F.2.3	Specific message contents	1631
F.3	UTRAN connection release.....	1631
F.3.1	Procedure	1631
F.3.2	Specific message contents	1631
Annex G (normative):	Environmental conditions	1632
G.1	General	1632
G.2	Environmental requirements	1632
G.2.1	Temperature.....	1632
G.2.2	Voltage.....	1632
Annex H (informative):	MBS Beacon parameters.....	1633
H.1	General	1633
H.2	Beacon parameters	1633
Annex I (normative):	Conditions for NR PRS-based measurements.....	1634
I.1	General	1634
I.2	General	1634
Annex J (informative):	Change history	1636
History		1649

Foreword

This Technical Specification has been produced by the 3rd Generation Partnership Project (3GPP).

The contents of the present document are subject to continuing work within the TSG and may change following formal TSG approval. Should the TSG modify the contents of the present document, it will be re-released by the TSG with an identifying change of release date and an increase in version number as follows:

Version x.y.z

where:

- x the first digit:
 - 1 presented to TSG for information;
 - 2 presented to TSG for approval;
 - 3 or greater indicates TSG approved document under change control.
- y the second digit is incremented for all changes of substance, i.e. technical enhancements, corrections, updates, etc.
- z the third digit is incremented when editorial only changes have been incorporated in the document.

Introduction

The present document is part 1 of a multi-parts TS:

- 3GPP TS 37.571-1: User Equipment (UE) conformance specification for UE positioning; Part 1: Conformance test specification.
- 3GPP TS 37.571-2: User Equipment (UE) conformance specification for UE positioning; Part 2: Protocol conformance.
- 3GPP TS 37.571-3: User Equipment (UE) conformance specification for UE positioning; Part 3: Implementation Conformance Statement (ICS).
- 3GPP TS 37.571-4: User Equipment (UE) conformance specification for UE positioning; Part 4: Test suites.
- 3GPP TS 37.571-5: User Equipment (UE) conformance specification for UE positioning; Part 5: Test scenarios and assistance data.

1 Scope

The present document specifies the procedures for the conformance test of the measurement requirements for FDD or TDD mode of UTRA and FDD or TDD mode of E-UTRA, NB-IOT and NR for the User Equipment (UE) that supports one or more of the defined positioning methods. These positioning methods are:

- for UTRA: Assisted Global Positioning System (A-GPS), Assisted Global Navigation Satellite Systems (A-GNSS),
- for E-UTRA: Assisted Global Navigation Satellite System (A-GNSS), Observed Time Difference of Arrival (OTDOA), Enhanced Cell ID (ECID), Metropolitan Beacon System (MBS), Wireless Local Area Network (WLAN), Bluetooth Low Energy (BLE),
- for NB-IOT: Observed Time Difference of Arrival (OTDOA), [others FFS], and
- for NR: Assisted Global Navigation Satellite System (A-GNSS), Observed Time Difference of Arrival (OTDOA), Enhanced Cell ID (ECID), Metropolitan Beacon System (MBS), Wireless Local Area Network (WLAN), Bluetooth Low Energy (BLE).

Tests are only applicable to those mobiles that are intended to support the appropriate functionality. To indicate the circumstances in which tests apply, this is noted in the "Test applicability" part of the test.

The Implementation Conformance Statement (ICS) pro-forma could be found in the 3rd part of the present document.

2 References

The following documents contain provisions which, through reference in this text, constitute provisions of the present document.

- References are either specific (identified by date of publication, edition number, version number, etc.) or non-specific.
- For a specific reference, subsequent revisions do not apply.
- For a non-specific reference, the latest version applies. In the case of a reference to a 3GPP document (including a GSM document), a non-specific reference implicitly refers to the latest version of that document in the same Release as the present document unless the context in which the reference is made suggests a different Release is relevant (information on the applicable release in a particular context can be found in e.g. test case title, description or applicability, message description or content).

- [1] 3GPP TR 21.905: "Vocabulary for 3GPP Specifications".
- [2] 3GPP TS 36.101: "Evolved Universal Terrestrial Radio Access (E-UTRA); User Equipment (UE) radio transmission and reception".
- [3] 3GPP TS 36.171: "Evolved Universal Terrestrial Radio Access (E-UTRA); Requirements for Support of Assisted Global Navigation Satellite System (A-GNSS)".
- [4] 3GPP TS 36.355: "Evolved Universal Terrestrial Radio Access (E-UTRA); LTE Positioning Protocol (LPP)".
- [5] 3GPP TS 36.302: "Evolved Universal Terrestrial Radio Access (E-UTRA); Services provided by the physical layer".
- [6] 3GPP TS 36.214: "Evolved Universal Terrestrial Radio Access (E-UTRA); Physical layer; Measurements".
- [7] ETSI TR 102 273-1-2: "Electromagnetic compatibility and Radio spectrum Matters (ERM); Improvement on Radiated Methods of Measurement (using test site) and evaluation of the corresponding measurement uncertainties; Part 1: Uncertainties in the measurement of mobile radio equipment characteristics; Sub-part 2: Examples and annexes".

- [8] IS-GPS-200, Revision D, Navstar GPS Space Segment/Navigation User Interfaces, March 7th, 2006.
- [9] P. Axelrad, R.G. Brown, "GPS Navigation Algorithms", in Chapter 9 of "Global Positioning System: Theory and Applications", Volume 1, B.W. Parkinson, J.J. Spilker (Ed.), Am. Inst. of Aeronautics and Astronautics Inc., 1996.
- [10] S.K. Gupta, "Test and Evaluation Procedures for the GPS User Equipment", ION-GPS Red Book, Volume 1, p.119.
- [11] 3GPP TS 36.509: "Evolved Universal Terrestrial Radio Access (E-UTRA) and Evolved Packet Core (EPC); Special conformance testing functions for User Equipment (UE)".
- [12] IS-GPS-705, Navstar GPS Space Segment/User Segment L5 Interfaces, September 22, 2005.
- [13] IS-GPS-800, Navstar GPS Space Segment/User Segment L1C Interfaces, September 4, 2008.
- [14] IS-QZSS, Quasi Zenith Satellite System Navigation Service Interface Specifications for QZSS, Ver.1.1.1, July 31, 2009.
- [15] Galileo OS Signal in Space ICD (OS SIS ICD), Issue 1.2, February 2014, European Union.
- [16] Global Navigation Satellite System GLONASS Interface Control Document, Version 5.1, 2008.
- [17] Specification for the Wide Area Augmentation System (WAAS), US Department of Transportation, Federal Aviation Administration, DTFA01-96-C-00025, 2001.
- [18] 3GPP TS 36.508: "Evolved Universal Terrestrial Radio Access (E-UTRA) and Evolved Packet Core (EPC); Common test environments for User Equipment (UE) conformance testing".
- [19] 3GPP TS 25.172: "Requirements for support of Assisted Galileo and Additional Navigation Satellite Systems (A-GANSS); Frequency Division Duplex (FDD)".
- [20] 3GPP TS 37.571-5: "User Equipment (UE) conformance specification for UE positioning; Part 5: Test scenarios and assistance data
- [21] 3GPP TS 36.104: "Evolved Universal Terrestrial Radio Access (E-UTRA); Base Station (BS) radio transmission and reception".
- [22] 3GPP TS 36.331: "Evolved Universal Terrestrial Radio Access (E-UTRA); Radio Resource Control (RRC); Protocol specification".
- [23] 3GPP TS 36.133: "Evolved Universal Terrestrial Radio Access (E-UTRA); Requirements for support of radio resource management".
- [24] 3GPP TS 36.521-1: "Evolved Universal Terrestrial Radio Access (E-UTRA); User Equipment (UE) conformance specification Radio transmission and reception Part 1: Conformance Testing".
- [25] 3GPP TS 36.521-3: "Evolved Universal Terrestrial Radio Access (E-UTRA); User Equipment (UE) conformance specification; Radio transmission and reception; Part 3: Radio Resource Management (RRM) conformance testing".
- [26] 3GPP TS 36.211: "Evolved Universal Terrestrial Radio Access (E-UTRA); Physical Channels and Modulation".
- [27] 3GPP TR 25.990: "Vocabulary for UTRAN".
- [28] 3GPP TS 34.108: "Common test environments for User Equipment (UE) conformance testing".
- [29] 3GPP TS 34.109: "Terminal logical test interface; Special conformance testing functions".
- [30] 3GPP TS 25.331: "Radio Resource Control (RRC) protocol specification".
- [31] 3GPP TS 25.171: "Requirements for support of Assisted Global Positioning System (A-GPS); Frequency Division Duplex (FDD)".
- [32] 3GPP TS 25.302: "Services provided by the physical layer".

- [33] 3GPP TS 25.215: "Physical layer; Measurements (FDD)".
- [34] 3GPP TS 36.321: "Medium Access Control (MAC) protocol specification".
- [35] 3GPP TS 36.423: "X2 application protocol (X2AP)".
- [36] 3GPP TS 25.173: "Requirements for support of Assisted Galileo and Additional Navigation Satellite Systems (A-GANSS); Time Division Duplex (TDD)".
- [37] BDS-SIS-ICD-B1I-3.0: "BeiDou Navigation Satellite System Signal In Space Interface Control Document Open Service Signal B1I (Version 3.0)".
- [38] ATIS-0500027: "Recommendations for Establishing Wide Scale Indoor Location Performance", May 2015.
- [39] 3GPP TS 37.171: "Universal Terrestrial Radio Access (UTRA) and Evolved Universal Terrestrial Radio Access (E-UTRA); User Equipment (UE) performance requirements for RAT-Independent Positioning Enhancements".
- [40] IEEE Standard 802.11: Wireless LAN Medium Access Control (MAC) and Physical Layer (PHY) Specifications.
- [41] 3GPP TS 36.305: "Evolved Universal Terrestrial Radio Access Network (E-UTRAN); Stage 2 functional specification of User Equipment (UE) positioning in E-UTRAN".
- [42] 3GPP TS 23.401: "General Packet Radio Service (GPRS) enhancements for Evolved Universal Terrestrial Radio Access Network (E-UTRAN) access".
- [43] 3GPP TS 38.171: "NR; Requirements for Support of Assisted Global Navigation Satellite System (A-GNSS)".
- [44] 3GPP TS 38.509: "5GS; Special conformance testing functions for User Equipment (UE)".
- [45] 3GPP TS 38.508-1: "5GS; User Equipment (UE) conformance specification; Part 1: Common test environment".
- [46] 3GPP TS 36.212: "Evolved Universal Terrestrial Radio Access (E-UTRA); Multiplexing and channel coding".
- [47] 3GPP TS 38.533: "NR; User Equipment (UE) conformance specification; Radio Resource Management (RRM)".
- [48] BDS-SIS-ICD-B1C-1.0: "BeiDou Navigation Satellite System Signal In Space Interface Control Document Open Service Signal B1C (Version 1.0)".
- [49] 3GPP TS 37.355: "LTE Positioning Protocol (LPP)".
- [50] 3GPP TS 38.133: "NR; Requirements for support of radio resource management".
- [51] 3GPP TS 38.305: "NG Radio Access Network (NG-RAN); Stage 2 functional specification of User Equipment (UE) positioning in NG-RAN".
- [52] 3GPP TS 38.331: "NR Radio Resource Control (RRC) protocol specification".
- [53] 3GPP TS 38.211: "NR; Physical channels and modulation".
- [54] 3GPP TS 38.101-1: "NR; User Equipment (UE) radio transmission and reception; Part 1: Range 1 Standalone".
- [55] 3GPP TS 38.101-2: "NR; User Equipment (UE) radio transmission and reception; Part 2: Range 2 Standalone".
- [56] 3GPP TS 38.214: "NR; Physical layer procedures for data".
- [57] 3GPP TS 38.215: "NR; Physical layer measurements".

- [58] BDS-SIS-ICD-B2a-1.0: "BeiDou Navigation Satellite System Signal In Space Interface Control Document Open Service Signal B2a (Version 1.0)", December, 2017.
- [59] BDS-SIS-ICD-B3I-1.0: "BeiDou Navigation Satellite System Signal In Space Interface Control Document Open Service Signal B3I (Version 1.0)", February, 2018.
- [60] 3GPP TS 38.521-4: " NR; User Equipment (UE) conformance specification; Radio transmission and reception; Part 4: Performance requirements".

3 Definitions, symbols and abbreviations

3.1 Definitions

For the purposes of the present document, the terms and definitions given in TR 21.905 [1], 3GPP TR 25.990 [27], TS 36.101 [2], 3GPP TS 36.104 [21] and the following apply. A term defined in the present document takes precedence over the definition of the same term, if any, in TR 21.905 [1].

Horizontal Dilution Of Precision (HDOP): measure of position determination accuracy that is a function of the geometrical layout of the satellites used for the fix, relative to the receiver antenna

3.2 Symbols

For the purposes of the present document, the abbreviations given in TR 21.905 [1], 3GPP TR 25.990 [27] and the following apply. An abbreviation defined in the present document takes precedence over the definition of the same abbreviation, if any, in TR 21.905 [1].

B1I	BeiDou B1I navigation signal with carrier frequency of 1561.098 MHz
B1C	BeiDou B1C navigation signal with carrier frequency of 1575.420 MHz.
B2a	BeiDou B2a navigation signal with carrier frequency of 1176.450 MHz.
B3I	BeiDou B3I navigation signal with carrier frequency of 1268.520 MHz.
E1	Galileo E1 navigation signal with carrier frequency of 1575.420 MHz.
E5	Galileo E5 navigation signal with carrier frequency of 1191.795 MHz.
E6	Galileo E6 navigation signal with carrier frequency of 1278.750 MHz.
G1	GLONASS navigation signal in the L1 sub-bands with carrier frequencies $1602 \text{ MHz} \pm k \times 562.5 \text{ kHz}$.
G2	GLONASS navigation signal in the L2 sub-bands with carrier frequencies $1246 \text{ MHz} \pm k \times 437.5 \text{ kHz}$.
k	GLONASS channel number, $k = -7 \dots 13$.
L1 C/A	GPS or QZSS L1 navigation signal carrying the Coarse/Acquisition code with carrier frequency of 1575.420 MHz.
L1C	GPS or QZSS L1 Civil navigation signal with carrier frequency of 1575.420 MHz.
L2C	GPS or QZSS L2 Civil navigation signal with carrier frequency of 1227.600 MHz.
L5	GPS or QZSS L5 navigation signal with carrier frequency of 1176.450 MHz.
PRP	Received (linear) average power of the resource elements that carry E-UTRA PRS, measured at the UE antenna connector.
G	Geometry Matrix.
$\rho_{GNSS_m,i}$	Measured pseudo-range of satellite i of GNSS _m .
W	Weighting Matrix.
$\mathbf{1}_{GNSS_m,i}$	Line of sight unit vector from the user to the satellite i of GNSS _m .
x	State vector of user position and clock bias.
T_s	Basic time unit, defined in TS 36.211 [26], clause 4.
\hat{E}_s	Received energy per RE (power normalized to the subcarrier spacing) during the useful part of the symbol, i.e. excluding the cyclic prefix, at the UE antenna connector.
I_o	The total received power density, including signal and interference, as measured at the UE antenna connector.

I_{ot}	The received power spectral density of the total noise and interference for a certain RE (power integrated over the RE and normalized to the subcarrier spacing) as measured at the UE antenna connector.
N_{oc}	The power spectral density of a white noise source (average power per RE normalised to the subcarrier spacing), simulating interference from cells that are not defined in a test procedure, as measured at the UE antenna connector.
$PRS \hat{E}_s / I_{ot}$	The ratio of the average received energy per PRS RE during the useful part of the symbol to the average received power spectral density of the total noise and interference for this RE, where the ratio is measured over all REs which carry PRS.

3.3 Abbreviations

For the purposes of the present document, the following abbreviations apply:

A-GANSS	Assisted Galileo and Additional Navigation Satellite Systems
A-Galileo	Assisted-Galileo
A-GLONASS	Assisted-- GLObal'naya NAVigatsionnaya Sputnikovaya Sistema (English: Global Navigation Satellite System)
A-GNSS	Assisted Global Navigation Satellite System
A-GPS	Assisted - Global Positioning System
AP	Access Point
AWGN	Additive White Gaussian Noise
BDS	BeiDou Navigation Satellite System
BLE	Bluetooth Low Energy
BSS	Bluetooth System Simulator
BSSID	Basic Service Set IDentification
C/A	Coarse/Acquisition
DL-AoD	Downlink Angle-of-Departure
DL-PRS	Downlink Positioning Reference Signal
DL-TDOA	Downlink Time Difference Of Arrival
DRX	Discontinuous Reception
DUT	Device Under Test
ECEF	Earth Centred, Earth Fixed
ECID	Enhanced Cell Identification
EPRE	Energy Per Resource Element
EN-DC	E-UTRA-NR Dual Connectivity
E-UTRA	Evolved UMTS Terrestrial Radio Access
E-UTRAN	Evolved UMTS Terrestrial Radio Access Network
FDD	Frequency Division Duplex
GANSS	Galileo and Additional Navigation Satellite Systems
GEO	Geostationary Earth Orbit
GLONASS	GLObal'naya NAVigatsionnaya Sputnikovaya Sistema (English: Global Navigation Satellite System)
GNSS	Global Navigation Satellite System
GPS	Global Positioning System
GSS	GNSS System Simulator
HD-FDD	Half Duplex - Frequency Division Duplex
HDOP	Horizontal Dilution Of Precision
ICD	Interface Control Document
ICS	Implementation Conformance Statement
IGSO	Inclined Geosynchronous Satellite OrbitIS
IS	Interface Specification
LOS	Line Of Sight
LPP	LTE Positioning Protocol
MBS	Metropolitan Beacon System
MSS	MBS System Simulator
MEO	Medium Earth Orbit
Multi-RTT	Multi-Round Trip Time
NB-IOT	Narrow Band - Internet Of Things
NE-DC	NR-E-UTRA Dual Connectivity

NGEN-DC	NG-RAN E-UTRA-NR Dual Connectivity
NG-RAN E-UTRA	NG-RAN E-UTRA Radio Access
NG-RAN NR	NG-RAN NR Radio Access
NPRS	NB-IOT Positioning Reference Signal
NR	New Radio
NR-DC	NR-NR Dual Connectivity
NR E-CID	NR Enhanced Cell ID (positioning method)
OCNG	OFDMA Channel Noise Generator
OCNS	Orthogonal Channel Noise Simulator
OTA	Over The Air
OTDOA	Observed Time Difference Of Arrival
PBCH	Physical Broadcast Channel
PCC	Primary Component Carrier
PCell	Primary Cell
PCFICH	Physical Control Format Indicator Channel
PDCCH	Physical Downlink Control Channel
PDSCH	Physical Downlink Shared Channel
PHICH	Physical Hybrid ARQ Indicator Channel
PPM	Parts per million
PRS	Positioning Reference Signal
PRS-RSRP	Positioning Reference Signal based Reference Signal Received Power
PSS	Primary Synchronization Signal
QZSS	Quasi-Zenith Satellite System
RB	Resource Block
RE	Resource Element
RRC	Radio Resource Control
RSSI	Received Signal Strength Indicator
RSTD	Reference Signal Time Difference
SBAS	Space Based Augmentation System
SCC	Secondary Component Carrier
SCell	Secondary Cell
SFN	System Frame Number
SNR	Signal to Noise Ratio
SS	System simulator
SSS	Secondary Synchronization Signal
SV	Space Vehicle
SV ID	Space Vehicle Identity
TBS	Terrestrial Beacon System
TDD	Time Division Duplex
TOD	Time Of Day
TOW	Time Of Week
TTF	Time To First Fix
UE	User Equipment
UL-SRS	Uplink Sounding Reference Signal
UUID	Universal Unique Identifier
UTRA	Universal Terrestrial Radio Access
UTRAN	Universal Terrestrial Radio Access Network
WGS-84	World Geodetic System 1984
WLAN	Wireless Local Area Network
WLS	Weighted Least Square
WSS	WLAN System Simulator

4 General test conditions

4.1 Introduction

This clause defines the various common test conditions required for the various measurement requirements in the remainder of the document.

4.2 GNSS test conditions

4.2.0 General

In this clause the terms GNSS and A-GNSS also include the cases where the only satellite system used is GPS unless otherwise stated.

4.2.1 GNSS signals

The GNSS signal is defined at the A-GNSS antenna connector of the UE. For UE with integral antenna only, a reference antenna with a gain of 0 dBi is assumed.

4.2.2 GNSS frequency

The GNSS signals shall be transmitted with a frequency accuracy of ± 0.025 PPM.

4.2.3 GNSS static propagation conditions

The propagation for the static performance measurement is an Additive White Gaussian Noise (AWGN) environment. No fading and multi-paths exist for this propagation model.

4.2.4 GNSS multi-path conditions

Doppler frequency difference between direct and reflected signal paths is applied to the carrier and code frequencies. The Carrier and Code Doppler frequencies of LOS and multi-path for GNSS signals are defined in table 4.2.1.

Table 4.2.1: Multi-path Conditions for GNSS Signals

Initial relative Delay [GNSS chip]	Carrier Doppler frequency of tap [Hz]	Code Doppler frequency of tap [Hz]	Relative mean Power [dB]
0	F_d	F_d / N	0
X	$F_d - 0.1$	$(F_d - 0.1) / N$	Y

NOTE: Discrete Doppler frequency is used for each tap.

Where the X and Y depends on the GNSS signal type and is shown in Table 4.2.2, and N is the ratio between the transmitted carrier frequency of the signals and the transmitted chip rate as shown in Table 4.2.3 (where k in Table 4.2.3 is the GLONASS frequency channel number).

Table 4.2.2: Values of X and Y for GNSS Signals

System	Signals	X [m]	Y [dB]
Galileo	E1	125	-4.5
	E5a	15	-6
	E5b	15	-6
GPS/Modernized GPS	L1 C/A	0.5 chip / 150m	-6
	L1C	125	-4.5
	L2C	150	-6
	L5	15	-6
GLONASS	G1	275	-12.5
	G2	275	-12.5
BDS	B1I	75	-4.5
	B1C	125	-4.5
	B2a	15	-6
	B3I	15	-6

Table 4.2.3: Values of N for GNSS Signals

System	Signals	N
Galileo	E1	1540
	E5a	115
	E5b	118
GPS/Modernized GPS	L1 C/A	1540
	L1C	1540
	L2C	1200
	L5	115
GLONASS	G1	$3135.03 + k \cdot 1.10$
	G2	$2438.36 + k \cdot 0.86$
BDS	B1I	763
	B1C	1540
	B2a	115
	B3I	124

The initial carrier phase difference between taps shall be randomly selected between 0 and 2π radians. The initial value shall have uniform random distribution.

4.2.5 UEs supporting multiple satellite signals

For UEs supporting multiple satellite signals, different minimum performance requirements may be associated with different signals. The satellite simulator shall generate all signals supported by the UE. Signals not supported by the UE do not need to be simulated. The relative power levels of each signal type for each GNSS are defined in Table 4.2.4. The individual test scenarios in clauses 6, 7 and 13 define the reference signal power level for each satellite. The power level of each simulated satellite signal type shall be set to the reference signal power level defined in each test scenario in clauses 6, 7 and 13 plus the relative power level defined in Table 4.2.4.

Table 4.2.4: Relative signal power levels for each signal type for each GNSS

	Galileo		GPS/Modernized GPS		GLONASS		QZSS		SBAS		BDS		
	Signal	Power	Signal	Power	Signal	Power	Signal	Power	Signal	Power	Signal	Power	Signal
Signal power levels relative to reference power levels	E1	0 dB	L1 C/A	0 dB	G1	0 dB	L1 C/A	0 dB	L1	0 dB	B1I	D1	0 dB
	E6	+2 dB	L1C	+1.5 dB	G2	-6 dB	L1C	+1.5 dB			B1C	D1	0 dB
	E5	+2 dB	L2C	-1.5 dB			L2C	-1.5 dB			B2a	D1	0 dB
			L5	+3.6 dB			L5	+3.6 dB			B3I	D1	0 dB
												D2	+5 dB

NOTE 1: For test cases which involve "Modernized GPS", the satellite simulator shall also generate the GPS L1 C/A signal if the UE supports "GPS" in addition to "Modernized GPS".

NOTE 2: The signal power levels in the Test Parameter Tables represent the total signal power of the satellite per channel not e.g. pilot and data channels separately.

NOTE 3: For test cases which involve "BDS", D1 represents MEO/IGSO satellites for B1I, B1C, B3I and B2a signal types and D2 represents GEO satellites for B1I and B3I signal types.

4.2.6 GNSS multi System Time Offsets

If more than one GNSS is used in a test, the accuracy of the GNSS-GNSS Time Offsets used at the system simulator shall be better than 3 ns.

4.3 UTRA test conditions

4.3.1 UTRA frequency band and frequency range

The UTRA tests in clauses 5 and 6 in the present document are performed at mid range of the UTRA operating frequency band of the UE. The UARFCNs to be used for mid range are defined in 3GPP TS 34.108 [28], clause 5.1.1.

If the UE supports multiple UTRA frequency bands then the Sensitivity tests in clauses 5.2 and 6.2 shall be repeated in each supported UTRA frequency band.

4.3.2 UTRA frequency

For the UTRA tests in clause 5 the UTRA frequency shall be offset with respect to the nominal frequency by an amount equal to the sum of +0.025 PPM and the offset in PPM of the actual transmitted GPS carrier frequency with respect to the nominal GPS frequency.

4.3.3 Sensors

The UTRA tests in clause 6 shall be met without the use of any data coming from sensors that can aid the positioning. A dedicated test message 'RESET UE POSITIONING STORED INFORMATION' has been defined in TS 34.109 [29] for the purpose of disabling any such sensors.

4.4 E-UTRA test conditions

4.4.1 E-UTRA frequency band and frequency range

The E-UTRA A-GNSS tests in clause 7, MBS tests in clause 11, WLAN and BLE tests in clause 12 are performed on the mid range EARFCN of the E-UTRA operating frequency band of the UE and the channel bandwidth as defined in TS 36.508 [18] clause 4.3.1.

If the UE supports multiple E-UTRA frequency bands then the A-GNSS Sensitivity tests in clause 7.1 shall be repeated in each supported E-UTRA frequency band.

The E-UTRA ECID tests in clause 8 and the OTDOA tests in clauses 9 and 10 are performed on the EARFCN(s) of the E-UTRA operating frequency band of the UE and the channel bandwidth(s) specified in the test cases and as defined in TS 36.508 [18] clause 4.3.1 and 4.4.2.

4.4.2 Groups of bands

The E-UTRA tests use the band groupings defined in TS 36.521-3 [25] clause 3.5.1 in order to increase the readability of the specification.

Table 4.4.2-1: Void

Table 4.4.2-2: Void

Table 4.4.2-3: Void

4.4.3 Sensors

All the minimum performance requirements in clause 7 shall be met without the use of any data coming from sensors that can aid the positioning. A dedicated test message 'RESET UE POSITIONING STORED INFORMATION' has been defined in TS 36.509 [11] for the purpose of disabling any such sensors.

4.4A LPP transport mechanism for E-UTRA

The E-UTRA A-GNSS minimum performance requirements tested in this specification are agnostic as to whether the LPP session is performed over the Control Plane or the User Plane. Thus, the E-UTRA A-GNSS test cases in clause 7 support both configurations. The user can select either of the two options to run the test.

4.5 A-GNSS test conditions

4.5.1 General

Clauses 5, 6, 7 and 13 define the minimum performance requirements for both UE based and UE assisted A-GNSS UEs. If a UE supports both modes then it shall be tested in both modes.

4.5.2 UTRAN measurement parameters

4.5.2.1 UE based A-GNSS measurement parameters

In case of UE-based A-GNSS, the measurement parameters are contained in the RRC UE POSITIONING POSITION ESTIMATE INFO IE. The measurement parameter is the horizontal position estimate reported by the UE and expressed in latitude/longitude.

4.5.2.2 UE assisted A-GNSS measurement parameters

In case of UE-assisted A-GNSS, the measurement parameters are contained in the RRC UE POSITIONING GANSS MEASURED RESULTS IE and/or the RRC UE POSITIONING GPS MEASURED RESULTS IE. The measurement parameters are the UE GANSS Code Phase measurements and/or the UE GPS Code Phase measurements, as specified in 3GPP TS 25.302 [32] and 3GPP TS 25.215 [33]. The UE GANSS Code Phase measurements and/or the UE GPS Code Phase measurements are converted into a horizontal position estimate using the procedure detailed in Annex B.

4.5.2.3 2D position error

The 2D position error is defined by the horizontal difference in meters between the ellipsoid point reported or calculated from the UE Measurement Report and the actual simulated position of the UE in the test case considered.

4.5.2.4 Response time

Max Response Time is defined as the time starting from the moment that the UE has received the final RRC measurement control message containing reporting criteria different from "No Reporting" sent before the UE sends the measurement report containing the position estimate or the GANSS and/or GPS measured result, and ending when the UE starts sending the measurement report containing the position estimate or the GANSS and/or GPS measured result on the Uu interface. The response times specified for all test cases are Time-to-First-Fix (TTFF) unless otherwise stated, i.e. the UE shall not re-use any information on GNSS time, location or other aiding data that was previously acquired or calculated and stored internally in the UE. A dedicated test message 'RESET UE POSITIONING STORED INFORMATION' specified in 3GPP TS 34.109 [29], clause 5.4, has been defined for the purpose of deleting this information.

4.5.3 E-UTRAN and NR measurement parameters

4.5.3.1 UE based A-GNSS measurement parameters

In case of UE-based A-GNSS, the measurement parameters are contained in the LPP *GNSS-LocationInformation* IE which is included in the *A-GNSS-ProvideLocationInformation* IE provided in the LPP message of type PROVIDE LOCATION INFORMATION. The measurement parameter in case of UE-based A-GNSS is the horizontal position estimate reported by the UE and expressed in latitude/longitude.

4.5.3.2 UE assisted A-GNSS measurement parameters

In case of UE-assisted A-GNSS, the measurement parameters are contained in the LPP *GNSS-SignalMeasurementInformation* IE which is included in the *A-GNSS-ProvideLocationInformation* IE provided in

the LPP message of type PROVIDE LOCATION INFORMATION. The measurement parameters in case of UE-assisted A-GNSS are the UE GNSS code phase measurements, as specified in TS 36.302 [5] and TS 36.214 [6]. The UE GNSS code phase measurements are converted into a horizontal position estimate using the procedure detailed in Annex B.

4.5.3.3 2D Error definition

The 2D position error is defined by the horizontal difference in meters between the ellipsoid point reported or calculated from the LPP message of type PROVIDE LOCATION INFORMATION and the actual position of the UE in the test case considered.

4.5.3.4 Response time

Max Response Time is defined as the time starting from the moment that the UE has received the LPP message of type REQUEST LOCATION INFORMATION, and ending when the UE starts sending the LPP message of type PROVIDE LOCATION INFORMATION on the Uu interface. The response times specified for all test cases are Time-to-First-Fix (TTFF) unless otherwise stated, i.e. the UE shall not re-use any information on GNSS time, location or other aiding data that was previously acquired or calculated and stored internally in the UE. A dedicated test message 'RESET UE POSITIONING STORED INFORMATION' has been defined in TS 36.509 [11] clause 6.9 and in TS 38.509 [44] clause 6.3.5 for the purpose of deleting this information.

4.5.4 Converting A-GNSS UE-assisted measurement reports into position estimates

To convert the A-GNSS UE measurement reports in case of UE-assisted mode of A-GNSS into position errors, a transformation between the "measurement domain" (code-phases, etc.) into the "state" domain (position estimate) is necessary. Such a transformation procedure is outlined in Annex B.

4.6 ECID test conditions

4.6.1 Simulated cells

For the ECID performance test cases in clause 8.1, a cell environment as defined in 3GPP TS 36.508 [18] with Cell 1 is used. The default parameters for simulated cells are the same as specified in 3GPP TS 36.508 [18].

4.6.2 Propagation conditions

4.6.2.1 Static

See TS 36.521-1 [24] clause B.1.

4.6.2.2 Multi-path fading

See TS 36.521-1[24] clauses B.2, B.2.1 and B.2.2.

4.6.3 UE Rx - Tx time difference reporting range

The reporting range of FDD UE Rx - Tx time difference is defined from 0 to $20472T_s$ with $2T_s$ resolution for UE Rx - Tx time difference less than $4096T_s$ and $8T_s$ for UE Rx - Tx time difference equal to or greater than $4096T_s$.

The mapping of measured quantity for FDD is defined in Table 4.6.3-1.

Table 4.6.3-1: FDD UE Rx - Tx time difference measurement report mapping

Reported value	Measured quantity value	Unit
RX-TX_TIME_DIFFERENCE_FDD_0000	$T_{UE\ Rx-Tx} < 2$	T_s

RX-TX_TIME_DIFFERENCE_FDD_0001	$2 \leq T_{UE\ Rx-Tx} < 4$	T_s
RX-TX_TIME_DIFFERENCE_FDD_0002	$4 \leq T_{UE\ Rx-Tx} < 6$	T_s
...
RX-TX_TIME_DIFFERENCE_FDD_2046	$4092 \leq T_{UE\ Rx-Tx} < 4094$	T_s
RX-TX_TIME_DIFFERENCE_FDD_2047	$4094 \leq T_{UE\ Rx-Tx} < 4096$	T_s
RX-TX_TIME_DIFFERENCE_FDD_2048	$4096 \leq T_{UE\ Rx-Tx} < 4104$	T_s
RX-TX_TIME_DIFFERENCE_FDD_2049	$4104 \leq T_{UE\ Rx-Tx} < 4112$	T_s
...
RX-TX_TIME_DIFFERENCE_FDD_4093	$20456 \leq T_{UE\ Rx-Tx} < 20464$	T_s
RX-TX_TIME_DIFFERENCE_FDD_4094	$20464 \leq T_{UE\ Rx-Tx} < 20472$	T_s
RX-TX_TIME_DIFFERENCE_FDD_4095	$20472 \leq T_{UE\ Rx-Tx}$	T_s

The reporting range of TDD UE Rx - Tx time difference is defined from 624 to 21096 T_s with 2 T_s resolution for UE Rx - Tx time difference less than 4720 T_s and 8 T_s for UE Rx - Tx time difference equal to or greater than 4720 T_s .

The mapping of measured quantity for TDD is defined in Table 4.6.3-2.

Table 4.6.3-2: TDD UE Rx - Tx time difference measurement report mapping

Reported value	Measured quantity value	Unit
RX-TX_TIME_DIFFERENCE_TDD_0000	$T_{UE\ Rx-Tx} < 626$	T_s
RX-TX_TIME_DIFFERENCE_TDD_0001	$626 \leq T_{UE\ Rx-Tx} < 628$	T_s
RX-TX_TIME_DIFFERENCE_TDD_0002	$628 \leq T_{UE\ Rx-Tx} < 630$	T_s
...
RX-TX_TIME_DIFFERENCE_TDD_2046	$4716 \leq T_{UE\ Rx-Tx} < 4718$	T_s
RX-TX_TIME_DIFFERENCE_TDD_2047	$4718 \leq T_{UE\ Rx-Tx} < 4720$	T_s
RX-TX_TIME_DIFFERENCE_TDD_2048	$4720 \leq T_{UE\ Rx-Tx} < 4728$	T_s
RX-TX_TIME_DIFFERENCE_TDD_2049	$4728 \leq T_{UE\ Rx-Tx} < 4736$	T_s
...
RX-TX_TIME_DIFFERENCE_TDD_4093	$21080 \leq T_{UE\ Rx-Tx} < 21088$	T_s
RX-TX_TIME_DIFFERENCE_TDD_4094	$21088 \leq T_{UE\ Rx-Tx} < 21096$	T_s
RX-TX_TIME_DIFFERENCE_TDD_4095	$21096 \leq T_{UE\ Rx-Tx}$	T_s

4.7 OTDOA test conditions

4.7.1 Simulated cells

For the intra-frequency OTDOA measurement test cases in clause 9.1, a multi cell environment as defined in 3GPP TS 36.508 [18] with Cell 1, Cell 2, and Cell 4 (if needed in the test) is used.

For the inter-frequency OTDOA measurement test cases in clause 9.2, a multi cell environment as defined in 3GPP TS 36.508 [18] with Cell 1 (called Cell 1 in the tests), Cell 3 (called Cell 2 in the tests), and Cell 6 (called Cell 3 in the tests) (if needed in the test) is used.

For the intra-frequency OTDOA measurement test cases for UE Category M1/M2 in clause 9.3, a multi cell environment as defined in 3GPP TS 36.508 [18] with Cell 1, Cell 2, and Cell 4 (if needed in the test) is used.

For the inter-frequency OTDOA measurement test cases for UE Category M1/M2 in clause 9.4, a multi cell environment as defined in 3GPP TS 36.508 [18] with Cell 1 (called Cell 1 in the tests), Cell 3 (called Cell 2 in the tests), and Cell 6 (called Cell 3 in the tests) (if needed in the test) is used.

For the intra-frequency NB-IOT OTDOA measurement accuracy test cases in clause 9.5, a multi cell environment with LTE Cell 1 and Cell 1a (see 3GPP TS 36.508 [18] Clause 4.4.2) and NB-IOT Ncell 1 and Ncell 1a (see 3GPP TS 36.508 [18] Clause 8.1.4.2) is used.

For the intra-frequency NB-IOT OTDOA measurement reporting delay test cases in clause 9.5, a multi cell environment with NB-IOT Ncell 1, Ncell 1a and Ncell 2 (see 3GPP TS 36.508 [18] Clause 8.1.4.2) is used.

For the inter-frequency NB-IOT OTDOA measurement accuracy test cases in clause 9.6, a multi cell environment with LTE Cell 1 and Cell 1a (see 3GPP TS 36.508 [18] Clause 4.4.2) and NB-IOT Ncell 1 and Ncell 1a (see 3GPP TS 36.508 [18] Clause 8.1.4.2) is used.

For the inter-frequency NB-IOT OTDOA measurement reporting delay test cases in clause 9.9, a multi cell environment with NB-IOT Ncell 1, Ncell 1a and Ncell 2 (see 3GPP TS 36.508 [18] Clause 8.1.4.2) is used.

For the OTDOA measurement test cases for Carrier Aggregation in clause 10, a multi cell environment is used with Cell 1 as the PCell on the PCC, Cell 2 is an active SCell on the SCC, and Cell 3 is a neighbour cell on the SCC. For the OTDOA measurement test cases for 3 DL Carrier Aggregation in clause 10, a multi cell environment is used with Cell 1 as the PCell on the PCC, Cell 2 is an active SCell on SCC1, Cell 3 is an active SCell on SCC2 and Cell 4 is a neighbour cell on SCC2.

The default parameters for simulated cells are the same as specified in 3GPP TS 36.508 [18], with the following exceptions:

- All cells transmit PRS according to the PRS configuration provided in the OTDOA assistance data defined for each test. The positioning subframes are low-interference subframes, i.e. contain no PDSCH transmissions.
- The physical layer cell identities are selected such that the relative shifts of PRS patterns among cells used in the tests are as given by the test parameters of the individual test cases.
- The cells shall be synchronized and the timing offset (the RSTD) between the cells referenced to the UE's antenna input is given in the individual test cases.

4.7.2 Propagation conditions

4.7.2.1 Static

See TS 36.521-1 [24] clause B.1.

4.7.2.2 Multi-path fading

See TS 36.521-1[24] clauses B.2, B.2.1 and B.2.2.

4.7.3 Response time

The response time is defined as the time starting from the moment that the UE has received the LPP message of type REQUEST LOCATION INFORMATION, and ending when the UE starts sending the LPP message of type PROVIDE LOCATION INFORMATION on the Uu interface. The response time specified for the Measurement Reporting Delay test cases assumes that the UE shall not reuse any RSTD information or other aiding data that was previously acquired and stored internally in the UE. A dedicated test message 'RESET UE POSITIONING STORED INFORMATION' has been defined in TS 36.509 [11] clause 6.9 and in TS 38.509 [44] clause 6.3.5 for the purpose of deleting this information.

4.7.4 RSTD reporting range

The reporting range of RSTD is defined from $-15391T_s$ to $15391T_s$ with $1T_s$ resolution for absolute value of RSTD less or equal to $4096T_s$ and $5T_s$ for absolute value of RSTD greater than $4096T_s$.

The mapping of measured quantity is defined in Table 4.7.4-1.

Table 4.7.4-1: RSTD report mapping

Reported Value	Measured Quantity Value	Unit
----------------	-------------------------	------

RSTD_0000	$-15391 > \text{RSTD}$	T_s
RSTD_0001	$-15391 \leq \text{RSTD} < -15386$	T_s
...
RSTD_2258	$-4106 \leq \text{RSTD} < -4101$	T_s
RSTD_2259	$-4101 \leq \text{RSTD} < -4096$	T_s
RSTD_2260	$-4096 \leq \text{RSTD} < -4095$	T_s
RSTD_2261	$-4095 \leq \text{RSTD} < -4094$	T_s
...
RSTD_6353	$-3 \leq \text{RSTD} < -2$	T_s
RSTD_6354	$-2 \leq \text{RSTD} < -1$	T_s
RSTD_6355	$-1 \leq \text{RSTD} \leq 0$	T_s
RSTD_6356	$0 < \text{RSTD} \leq 1$	T_s
RSTD_6357	$1 < \text{RSTD} \leq 2$	T_s
RSTD_6358	$2 < \text{RSTD} \leq 3$	T_s
...
RSTD_10450	$4094 < \text{RSTD} \leq 4095$	T_s
RSTD_10451	$4095 < \text{RSTD} \leq 4096$	T_s
RSTD_10452	$4096 < \text{RSTD} \leq 4101$	T_s
RSTD_10453	$4101 < \text{RSTD} \leq 4106$	T_s
...
RSTD_12709	$15381 < \text{RSTD} \leq 15386$	T_s
RSTD_12710	$15386 < \text{RSTD} \leq 15391$	T_s
RSTD_12711	$15391 < \text{RSTD}$	T_s

4.7.5 RSTD Carrier Aggregation Test Cases with Different Channel Bandwidth Combinations

RSTD carrier aggregation test cases may be defined with different channel bandwidth combinations to verify the same requirement.

If multiple carrier aggregation test cases with different channel bandwidth combinations are defined to verify the same requirement that is channel bandwidth independent, then the UE needs to be tested only with one bandwidth combination out of the bandwidth combination sets supported by that UE.

4.8 MBS test conditions

4.8.1 MBS signals

A single or multi MBS beacon environment, depending on the test, is used.

The MBS signal is defined at the antenna connector of the UE. For UE with integral antenna only, a reference antenna with a gain of 0 dBi is assumed.

The beacons shall be synchronized, and the beacon code phase delays are defined in each test. The MBS signals shall be transmitted with a frequency accuracy of ± 2.5 PPM from the specified MBS carrier centre frequency.

4.8.2 Propagation conditions

4.8.2.1 Static

See TS 36.521-1 [24] clause B.1.

4.8.2.2 Multi-path fading

According to the Extended Pedestrian A model with a Maximum Doppler frequency of 5Hz (EPA 5Hz) in TS 36.521-1 [24] clauses B.2, B.2.1 and B.2.2.

4.8.3 Response time

The response time is defined as the time starting from the moment that the UE has received the LPP message of type REQUEST LOCATION INFORMATION, and ending when the UE starts sending the LPP message of type PROVIDE LOCATION INFORMATION on the Uu interface. The response time specified for the Measurement Reporting Delay test case assumes that the UE shall not reuse any information that was previously acquired and stored internally in the UE. A dedicated test message 'RESET UE POSITIONING STORED INFORMATION' has been defined in TS 36.509 [11] clause 6.9 and in TS 38.509 [44] clause 6.3.5 for the purpose of deleting this information.

4.9 WLAN test conditions

4.9.1 Simulated WLAN Access Points

A multi-WLAN AP environment is used.

The WLAN signal is defined at the antenna connector of the UE. For UE with integral antenna only, a reference antenna with a gain of 0 dBi is assumed.

The beacon signals from multiple WLAN APs shall be available at the UE with a periodicity of at least 102.4 ms (Beacon Interval). In order to ensure that the UE is in passive scan mode, this interval can be reduced. Beacon signals from different APs shall be received at different time slots or in non-overlapping frequency channels. Non-overlapping frequency channels shall be at least 25 MHz apart in the WLAN 2.4 GHz band and at least 20 MHz apart in the WLAN 5 GHz band.

The WLAN Test Frequency IDs to be used during the tests are specified in the test cases and are as defined in TS 36.508 [18] clause 4.3.1.6.

4.9.2 Propagation conditions

4.9.2.1 Static

See TS 36.521-1 [24] clause B.1.

4.9.3 Response time

The response time is defined as the time starting from the moment that the UE has received the LPP message of type REQUEST LOCATION INFORMATION, and ending when the UE starts sending the LPP message of type PROVIDE LOCATION INFORMATION on the Uu interface. The response time specified for the Measurement Reporting Delay test case assumes that the UE shall not reuse any information that was previously acquired and stored internally in the UE. A dedicated test message 'RESET UE POSITIONING STORED INFORMATION' has been defined in TS 36.509 [11] clause 6.9 and in TS 38.509 [44] clause 6.3.5 for the purpose of deleting this information.

4.9.4 Void

4.10 BLE test conditions

4.10.1 Simulated BLE

A multi-BLE device environment is used.

The BLE signal is defined at the antenna connector of the UE. For UE with integral antenna only, a reference antenna with a gain of 0 dBi is assumed.

The beacon signals from multiple BLE devices shall be available at the UE with a broadcast interval of 100 ms. Signals from different BLE devices shall be received at different time slots or in non-overlapping BLE advertising frequency channels. The BLE advertising channels are Channel 37 (2402 MHz), Channel 38 (2426 MHz) and Channel 39 (2480 MHz). The beacons shall be of type Non-Connectable Advertising beacons.

4.10.2 Propagation conditions

4.10.2.1 Static

See TS 36.521-1 [24] clause B.1.

4.10.3 Response time

The response time is defined as the time starting from the moment that the UE has received the LPP message of type REQUEST LOCATION INFORMATION, and ending when the UE starts sending the LPP message of type PROVIDE LOCATION INFORMATION on the Uu interface. The response time specified for the Measurement Reporting Delay test case assumes that the UE shall not reuse any information that was previously acquired and stored internally in the UE. A dedicated test message 'RESET UE POSITIONING STORED INFORMATION' has been defined in TS 36.509 [11] clause 6.9 and in TS 38.509 [44] clause 6.3.5 for the purpose of deleting this information.

4.11 NB-IOT test conditions

4.11.1 Groups of bands

The NB-IOT tests use the band groupings defined in TS 36.521-3 [25] clause 3.5.1 in order to increase the readability of the specification

Table 4.11.1-1: Void

4.11.2 NB-IOT inband mode

The E-UTRA donor cell shall use the settings defined in Clause 4.4.1 unless otherwise stated.

4.12 NR test conditions

4.12.1 NR terminology

The terminology used in this specification for NR architecture options is described below.

Table 4.12.1-1: NR terminology

Terminology	Abbreviation
NSA	
E-UTRA-NR Dual Connectivity	EN-DC
NR-E-UTRA Dual Connectivity	NE-DC
NG-RAN E-UTRA-NR Dual Connectivity	NGEN-DC
SA	
NG-RAN NR Radio Access	NG-RAN NR
NG-RAN E-UTRA Radio Access	NG-RAN E-UTRA

4.12.2 NR frequency band and frequency range

The A-GNSS tests in clause 13, MBS tests in clause 11, WLAN tests in clause 15 and BLE tests in clause 16 are, where relevant, performed on the NR test frequency and default channel bandwidth of the NR operating frequency band of the UE as defined in TS 38.508-1 [45] clause 4.3.1. .

The A-GNSS requirements and tests in clause 13 apply for NR UE in FR1 and FR2.

If connectivity is *NR* (see TS 38.508-1 [45] clause 4.5) and if the UE supports multiple NR frequency bands then the A-GNSS Sensitivity tests in clause 13.2 shall be repeated in each supported NR frequency band.

If connectivity is *EN-DC* (see TS 38.508-1 [45] clause 4.5) and if the UE supports multiple EN-DC configurations, then the A-GNSS Sensitivity tests in clause 13.2 shall be performed in one EN-DC band combination in each of the applicable frequency group combination as specified in clause 4.12.6.

The NR OTDOA tests in clause 14 are performed on the ARFCN(s) of the operating frequency band of the UE and the channel bandwidth(s) specified in the test cases and as defined in FFS.

4.12.3 Groups of bands

The NR tests use the band groupings defined in TS 38.533 [47] clause 3A.4 in order to increase the readability of the specification.

Table 4.12.3-1: Void

Table 4.12.3-2: Void

4.12.4 Sensors

All the minimum performance requirements in clause 13 shall be met without the use of any data coming from sensors that can aid the positioning. A dedicated test message 'RESET UE POSITIONING STORED INFORMATION' has been defined in TS 38.509 [44] clause 6.3.5 for the purpose of disabling any such sensors.

4.12.5 Default signal conditions for FR2

For NR FR2, the connection between the SS and the DUT shall be OTA.

For the RAT-Independent test cases defined in clause 13, the SS shall ensure that a stable OTA link between the SS and the DUT can be established and maintained throughout the test. This link shall be sufficient to provide stable LPP message transmissions between the SS and the DUT. The connection for the other technologies (i.e. non-NR) used for the tests in clause 13 (e.g. LTE, GNSS, WLAN ...) shall be conducted.

For the RAT-Dependent test cases defined in clauses 14, 15 and 16, a calibrated NR FR2 signal is required. The requirements OTA test method are defined in clause 7.1.3 of TS 38.508-1 [45].

4.12.6 Frequency Bands for Testing

4.12.6.1 EN-DC band combination groups

For the A-GNSS sensitivity requirements in EN-DC operation mode with uplink assigned to E-UTRA and NR frequency bands, the A-GNSS Sensitivity tests in clause 13.2 shall be performed in one EN-DC band combination in each of the supported frequency group combination specified in TS 38.171 [43] Table B.1.13.1-1, where the frequency groups are defined in TS 38.171 [43] Table B.1.13.1-2.

4.12.6.2 Applicable EN-DC band combinations for performing A-GNSS Sensitivity Requirements

The A-GNSS Sensitivity tests in clause 13.2 when in EN-DC operation mode shall be performed in EN-DC band combinations that can generate second or third order intermodulation products falling into the following GNSS receiver bands for the particular GNSS (where supported by the UE):

- GPS L1 C/A: 1574.3970 – 1576.4430 MHz
- Galileo E1 / GPS L1C: 1573.3740 – 1577.4660 MHz
- GLONASS G1: 1597.5515 – 1605.8860 MHz

- BDS B1I: 1559.0520 – 1563.1440 MHz

For each frequency group combination in TS 38.171 [43] Table B.1.13.2-1, in the case that the UE supports only one GNSS, only one EN-DC band combination shall be used for testing for the supported GNSS. In the case the UE supports more than one GNSS then the one EN-DC band combination used for testing shall be common across the supported GNSSs unless there is no common EN-DC band combination in which case the tests shall be repeated as necessary.

4.12.6.3 Test frequencies for EN-DC band combinations

For performing the A-GNSS Sensitivity tests in clause 13.2 in EN-DC operation mode, the E-UTRA and NR frequencies and channel configurations shall be selected to ensure the intermodulation products fall into the GNSS receiver bands as defined in TS 38.171 [43] clause B.1.13.2 for the particular GNSS.

4.13 LPP transport mechanism for NR

The NR A-GNSS minimum performance requirements tested in this specification are agnostic as to whether the LPP session is performed over the Control Plane or the User Plane. Thus, the NR A-GNSS test cases in clause 13 support both configurations. The user can select either of the two options to run the test.

4.14 Multi-RTT test conditions

4.14.1 Simulated cells

For the Multi-RTT measurement test cases in clause 15 a cell environment as defined in 3GPP TS 38.508-1 [45] with NR Cell 1 and NR cell 2 are used. The default parameters for simulated cells are the same as specified in 3GPP TS 38.508-1 [45].

4.14.2 Propagation conditions

See TS 38.533 [47] clause C 2.

4.14.3 Measurement Reporting Requirements

4.14.3.1 Measurement Reporting Requirements in RRC_CONNECTED state

This requirement assumes that the measurement report is not delayed by other LPP signalling on the DCCH. This measurement reporting delay excludes a delay uncertainty resulted when inserting the measurement report to the TTI of the uplink DCCH. The delay uncertainty is: $2 \times \text{TTIDCCH}$ where TTIDCCH is the duration of subframe or slot or subslot when the measurement report is transmitted on the PUSCH with subframe or slot or subslot duration. This measurement reporting delay excludes any delay caused by no UL resources for UE to send the measurement report.

4.14.3.2 Measurement Reporting Requirements in RRC_INACTIVE state

See TS 38.133 [50] clause 5.6.4.4.

4.14.4 Measurement Period Requirements

4.14.4.1 Measurement Period Requirements within Measurement Gaps

When physical layer receives last of *NR-Multi-RTT-ProvideAssistanceData* message and *NR-Multi-RTT-RequestLocationInformation* message from LMF via LPP [49], UE shall be able to measure multiple (up to the UE capability specified in TS 38.133 clause 9.9.4.3) UE Rx-Tx time difference measurements as defined in TS 38.215 [57] in configured positioning frequency layers within the measurement period $T_{\text{UERxTx, Total}}$ ms.

$$T_{\text{UERxTx, Total}} = \sum_{i=1}^L T_{\text{UERxTx},i} + (L - 1) * \max(T_{\text{effect},i}).$$

where i is the index of positioning frequency layer,

$T_{\text{UERxTx},i}$ is the measurement period for UE Rx-Tx time difference measurements in positioning frequency layer i as further defined in this clause,

L is total number of positioning frequency layers, and

$T_{\text{effect},i}$ is the periodicity of the UE Rx-Tx time difference measurement in positioning frequency layer i as defined further in this clause.

$$T_{\text{UERxTx},i} = \left(k_{\text{multiTEG},i} * \text{CSSF}_i * \text{ceil}(K_{\text{p,PRS},i}) * N_{\text{RxBeam},i} * \left\lfloor \frac{N_{\text{PRS},i}^{\text{slot}}}{N'} \right\rfloor \left\lfloor \frac{L_{\text{available_PRS},i}}{N} \right\rfloor * N_{\text{sample}} - 1 \right) * T_{\text{effect},i} + T_{\text{last},i}$$

Where

CSSF_i is the carrier-specific scaling factor for NR PRS-based measurement in the positioning frequency layer i as defined in TS 38.133 clause 9.1.5.2,

$k_{\text{multiTEG},i}$ is the scaling factor for measurement of same PRS resource with multiple Rx TEGs.

$k_{\text{multiTEG},i}=1$ if UE is not requested by LMF to measure a PRS resource with multiple Rx TEGs via *measureSameDL-PRS-ResourceWithDifferentRxTEGs-r17* or *measureSameDL-PRS-ResourceWithDifferentRxTxTEGs-r17* [49] in *NR-Multi-RTT-RequestLocationInformation*;

otherwise,

$k_{\text{multiTEG}}=N_{\text{TEG},i}$, if UE is not capable of receiving same DL PRS resource simultaneously from multiple Rx TEGs, and

$k_{\text{multiTEG}}=\left\lfloor \frac{N_{\text{TEG},i}}{k_{\text{TEG,simul},i}} \right\rfloor$ if UE is capable of receiving the same DL PRS resource simultaneously from multiple Rx TEGs.

where

$N_{\text{TEG},i}$ is the number of Rx TEGs or RxTx TEGs with which UE is requested to measure a PRS resource indicated via *measureSameDL-PRS-ResourceWithDifferentRxTEGs-r17* or *measureSameDL-PRS-ResourceWithDifferentRxTxTEGs-r17* [49] in *NR-Multi-RTT-RequestLocationInformation*, and in case 'n0' is indicated, $N_{\text{TEG},i}$ is the maximum number of Rx TEGs with which UE can support to measure the same PRS resource as reported in *NR-UE-TEG-Capability*, and

$k_{\text{TEG,simul},i}$ is the number of Rx TEGs UE can measure simultaneously which is reported via *measureSameDL-PRS-ResourceWithDifferentRxTEGsSimul*.

$K_{\text{p,PRS},i}$ is a scaling factor for a positioning frequency layer to be measured within the associated measurement gap pattern, which is defined as $K_{\text{p,PRS},i} = N_{\text{total}} / N_{\text{available}}$ for UE configured with concurrent measurement gap, and $K_{\text{p,PRS},i} = 1$ for UE not configured with concurrent measurement gap.

For a window W of duration $\max(T_{\text{PRS},i}, \text{MGRP_max})$, where MGRP_max is the maximum MGRP across all configured per-UE MG and per-FR MG within the same FR as the positioning frequency layer, and starting at the beginning of any associated gap occasions covering the PRS occasion:

N_{total} is the total number of associated gap occasions covering PRS occasions within the window, including both dropped and non-dropped instances of the associated measurement gap within the window, and

$N_{\text{available}}$ is the number of non-dropped associated gap occasions covering PRS occasions within the window W , after further accounting for MG collisions by applying the selected gap collision rule

Requirements do not apply if $N_{\text{available}}=0$.

$N_{\text{RxBeam},i}$ is the scaling factor for Rx beam sweeping, and $N_{\text{RxBeam},i}=1$ if positioning frequency layer i is in FR1 and if positioning frequency layer i is in FR2, $N_{\text{RxBeam},i}$ is equal to the value reported by the UE in *supportedLowerRxBeamSweepingFactor-FR2* if the UE supports the capability for the band containing positioning

frequency layer i , and the LMF indicates *lowerRxBeamSweepingFactor-FR2* in *NR-Multi-RTT-RequestLocationInformation*. $N_{RxBeam,i}$ is equal to 8, otherwise.

$L_{available_PRS,i}$ is the time duration of available PRS resources in the positioning frequency layer i , to be measured during $T_{available_PRS,i}$, and is calculated in the same way as PRS duration K defined in clause 5.1.6.5 of TS 38.214 [56]. For calculation of $L_{available_PRS,i}$, only the PRS resources unmuted and fully or partially overlapped with MG are considered.

$N_{PRS,i}^{slot}$ is the maximum number of DL PRS resources of positioning frequency layer i configured in a slot,

$\{N, T\}$ is UE capability combination per band where N is a duration of DL PRS symbols in ms corresponding to *durationOfPRS-ProcessingSymsbols* in TS 37.355 [49] processed every T ms corresponding to *durationOfPRS-ProcessingSymsbolsInEveryTms* in TS 37.355 [49] for a given maximum bandwidth supported by UE corresponding to *supportedBandwidthPRS* in clause 4.2.7.2 of TS 37.355 [49],

N' is UE capability for number of DL PRS resources that it can process in a slot corresponding to *maxNumOfDL-PRS-ResProcessedPerSlot* as specified in clause 6.4.3 of TS 37.355 [49],

N_{sample} is the number of UE Rx-Tx time difference measurement samples:

- $N_{sample} = 4$ if the UE is not capable of *supportedDL-PRS-ProcessingSamples-RRC-CONNECTED* defined in [49].
- $N_{sample} = 1$ if the UE is capable of *supportedDL-PRS-ProcessingSamples-RRC-CONNECTED* defined in [49] and LMF requests the UE to perform positioning measurements with reduced number of samples by *reducedDL-PRS-ProcessingSamples* [34] and the following conditions are met:
 - PRS bandwidth is within the active BWP and
 - Magnitude of difference between the serving cell's SS-RSRP and the neighbor cell's PRS-RSRP is within 6 dB.
- $N_{sample} = 2$ if the UE is capable of *supportedDL-PRS-ProcessingSamples-RRC-CONNECTED* defined in [49] and the LMF requests the UE to perform positioning measurements with reduced number of samples by *reducedDL-PRS-ProcessingSamples* [34] but the following conditions are not met:
 - PRS bandwidth is within the active BWP and
 - Magnitude of difference between the serving cell's SS-RSRP and the neighbor cell's PRS-RSRP is within 6 dB.
- $N_{sample} = 4$ otherwise.

$T_{last,i}$ is the measurement duration for the last UE Rx-Tx time difference measurement sample in the positioning layer i , including the sampling time and processing time, $T_{last,i} = T_i + T_{available_PRS,i}$,

$T_{effect,i}$ is periodicity of UE Rx-Tx time difference measurement in positioning frequency layer i :

$$T_{effect,i} = \left\lceil \frac{T_i}{T_{available_PRS,i}} \right\rceil * T_{available_PRS,i}$$

where

T_i corresponds to *durationOfPRS-ProcessingSymsbolsInEveryTms* in TS 37.355 [49],

$T_{available_PRS,i} = LCM(T_{PRS,i}, MGRP_i)$, the least common multiple between $T_{PRS,i}$ and $MGRP_i$

$MGRP_i$ is the measurement gap repetition periodicity in positioning frequency layer i .

$T_{PRS,i}$ is the PRS resource periodicity in positioning frequency layer i . If the positioning frequency layer i has more than one DL PRS resource sets with different PRS periodicities with muting, $T_{per}^{PRS\ with\ muting} = N_{muting} * T_{per}^{PRS}$, the least common multiple of $T_{per}^{PRS\ with\ muting}$ among DL PRS resource sets is used to derive $T_{PRS,i}$, where

T_{per}^{PRS} is the periodicity of PRS resource sets given by the higher-layer parameter *DL-PRS-Periodicity*.

N_{muting} is the scaling factor considering PRS resource muting. $N_{muting} = T_{muting}^{PRS} * L_{muting}$, where T_{muting}^{PRS} is the muting repetition factor given by the higher-layer parameter *DL-PRS-MutingBitRepetitionFactor*, and L_{muting} is the size of the bitmap $\{b^1\}$

4.14.4.2 Measurement Period Requirements without Measurement Gaps

See TS 38.133 [50] clause 9.9.4.6.

4.14.4.3 Measurement Period Requirements in RRC_INACTIVE state

See TS 38.133 [50] clause 5.6.4.5

4.14.5 Measurement Accuracy Requirements

The UE Rx-Tx time difference measurement accuracy requirements in this clause shall not apply, if:

- N_{TA_offset} defined in TS 38.133 Table 7.1.2-2 changes during the UE Rx-Tx measurement period or
- if the uplink transmission timing changes during the UE Rx-Tx measurement period due to the network-configured Timing Advance.

The UE Rx-Tx time difference measurement accuracy requirements in this clause shall apply provided that:

- The UE transmits SRS within [-160, 160] msec of at least one DL PRS resource of each of the TRPs in the assistance data.

If the uplink transmission timing changes during the UE Rx-Tx measurement period due to the autonomous timing adjustment defined in TS 38.133 clause 7.1.2 then:

- UE Rx-Tx measurement accuracy requirements shall apply for a cell, which is also the downlink reference cell (defined in TS 38.133 section 7.1.1) for SRS transmission even if the uplink transmission timing changes during the UE Rx-Tx measurement period due to autonomous adjustment.
- UE Rx-Tx measurement accuracy requirements shall not apply for a cell, which is not the downlink reference cell (defined in TS 38.133 section 7.1.1) for SRS transmission, if the uplink transmission timing changes during the UE Rx-Tx measurement period due to autonomous adjustment.

When a serving cell change occurs during the UE Rx-Tx measurement period, the UE Rx-Tx time difference measurement accuracy requirements in this clause shall apply provided that the serving cell change does not impact SRS configuration for the UE Rx-Tx measurement.

Note: The requirements for fading channel in this clause are derived based on TDL-A (30 ns delay spread, 5Hz) and TDL-C (60 ns delay spread, 300 Hz) channel models for FR1 and FR2 respectively.

The accuracy requirements in Table 4.14.5-1 for FR1 are valid under the following conditions:

Conditions defined in clause 7.3 of TS 38.101-1 [54] for reference sensitivity are fulfilled.

PRP_{dBm} according to TS 38.133 Annex B.2.14 for a corresponding Band.

AWGN propagation condition.

Table 4.14.5-1: UE Rx-Tx time difference measurement accuracy in FR1 in AWGN

Accuracy	Conditions						
	PRS Es/lot	Minimum PRS bandwidth	PRS SCS	PRS resource repetition ($T_{rep}^{PRS} * L_{PRS} / K_{comb}^{PRS}$ ^{Note 3})	NR operating band groups ^{Note 2}	Io ^{Note 4} range	
						Minimum Io ^{Note 1}	Maximum Io
Tc ^{Note 5}	dB	RB	kHz			dBm / SCS _{PRS}	dBm/BW

± 78+δ	-3	≥24	15	≥4	NR_FDD_FR1_A, NR_TDD_FR1_A, NR_SDL_FR1_A	-121	-50
					NR_FDD_FR1_B	-120.5	
					NR_TDD_FR1_C	-120	
					NR_FDD_FR1_D, NR_TDD_FR1_D	-119.5	
					NR_FDD_FR1_E, NR_TDD_FR1_E	-119	
					NR_FDD_FR1_F	-118.5	
					NR_FDD_FR1_G	-118	
					NR_FDD_FR1_H	-117.5	
± 59+δ	≥52	≥1	Note 6	Note 6	Note 6		
± 30+δ	>104	≥1	Note 6	Note 6	Note 6		
± 57+δ	-3	≥24	30	≥4	NR_FDD_FR1_A, NR_TDD_FR1_A, NR_SDL_FR1_A	-118	-50
					NR_FDD_FR1_B	-117.5	
					NR_TDD_FR1_C	-117	
					NR_FDD_FR1_D, NR_TDD_FR1_D	-116.5	
					NR_FDD_FR1_E, NR_TDD_FR1_E	-116	
					NR_FDD_FR1_F	-115.5	
					NR_FDD_FR1_G	-115	
					NR_FDD_FR1_H	-114.5	
± 30+δ	≥48	≥1	NOTE 6	NOTE 6	NOTE 6		
± 15+δ	≥132	≥1	NOTE 6	NOTE 6	NOTE 6		
± 29+δ	-3	≥24	60	≥4	NR_FDD_FR1_A, NR_TDD_FR1_A, NR_SDL_FR1_A	-115	-50
					NR_FDD_FR1_B	-114.5	
					NR_TDD_FR1_C	-114	
					NR_FDD_FR1_D, NR_TDD_FR1_D	-113.5	
					NR_FDD_FR1_E, NR_TDD_FR1_E	-113	
					NR_FDD_FR1_F	-113.5	
					NR_FDD_FR1_G	-113	
					NR_FDD_FR1_H	-111.5	
± 15+δ	≥ 64	≥1	NOTE 6	NOTE 6	NOTE 6		
± 7+δ	≥ 132	≥1	NOTE 6	NOTE 6	NOTE 6		
± 101+δ	≥24	15	≥4	NOTE 6	NOTE 6	NOTE 6	
± 75+δ	≥52		≥1	NOTE 6	NOTE 6	NOTE 6	
± 37+δ	>104		≥1	NOTE 6	NOTE 6	NOTE 6	
± 58+δ	≥24	30	≥4	NOTE 6	NOTE 6	NOTE 6	
± 39+δ	≥48		≥1	NOTE 6	NOTE 6	NOTE 6	
± 16+δ	≥132		≥1	NOTE 6	NOTE 6	NOTE 6	
± 36+δ	≥24	60	≥4	NOTE 6	NOTE 6	NOTE 6	
± 16+δ	≥ 64		≥1	NOTE 6	NOTE 6	NOTE 6	
± 8+δ	≥ 132		≥1	NOTE 6	NOTE 6	NOTE 6	
<p>NOTE 1: This minimum I_0 condition is expressed as the average I_0 per RE over all REs in an OFDM symbol.</p> <p>NOTE 2: NR operating band groups are as defined in TS 38.133 Section 3.5.</p> <p>NOTE 3: T_{rep}^{PRS}, L_{PRS}, K_{comb}^{PRS} are configured by higher layer parameter <i>dl-PRS-ResourceRepetitionFactor</i>, <i>dl-PRS-NumSymbols</i> and <i>dl-PRS-CombSizeN</i> defined in TS 37.355 [49].</p> <p>NOTE 4: The I_0 is defined in PRS slots. The same I_0 range applies to PRS and non-PRS symbols. I_0 levels are different in PRS and non-PRS symbols within the same slot.</p> <p>NOTE 5: T_c is the basic timing unit defined in TS 38.211 [53].</p> <p>NOTE 6: The same bands and the same I_0 conditions for each band apply for this requirement as for the corresponding requirement with the PRS bandwidth of the smallest RB number for the corresponding SCS.</p> <p>NOTE 7: δ is the margin determined from Table 4.14.5-5.</p>							

The accuracy requirements in Table 4.14.5-1a for FR1 are valid under the following conditions:

Conditions defined in clause 7.3 of TS 38.101-1 [54] for reference sensitivity are fulfilled.

PRP_{dBm} according to TS 38.133 Annex B.2.14 for a corresponding Band.

Number of measurement samples is less than 4

AWGN propagation condition.

Table 4.14.5-1a: UE Rx-Tx time difference measurement accuracy in FR1 in AWGN with reduced measurement samples

Accuracy	Conditions							
	PRP Es/lot	Minimum PRP bandwidth	PRP SCS	PRP resource repetition ($T_{rep}^{PRP} *$ L_{PRP}/K_{comb}^{PRP} Note 3)	NR operating band groups ^{Note 2}	I _o ^{Note 4} range		
						Minimum I _o ^{Note 1}	Maximum I _o	
T _C ^{Note 5}	dB	RB	kHz			dBm / SCS _{PRP}	dBm/BW	
± 59+δ	0	≥52	15	≥1	NR_FDD_FR1_A, NR_TDD_FR1_A, NR_SDL_FR1_A	-127	-50	
					NR_FDD_FR1_B	-126.5	-50	
					NR_TDD_FR1_C	-126	-50	
					NR_FDD_FR1_D, NR_TDD_FR1_D	-125.5	-50	
					NR_FDD_FR1_E, NR_TDD_FR1_E	-125	-50	
					NR_FDD_FR1_F	-124.5	-50	
					NR_FDD_FR1_G, NR_TDD_FR1_G	-124	-50	
				NR_FDD_FR1_H	-123.5	-50		
± 30+δ6		>104		≥1	NOTE 6	NOTE 6	NOTE 6	
± 30+δ		≥48	30	≥1	NR_FDD_FR1_A, NR_TDD_FR1_A, NR_SDL_FR1_A	-124	-50	
					NR_FDD_FR1_B	-123.5	-50	
					NR_TDD_FR1_C	-123	-50	
					NR_FDD_FR1_D, NR_TDD_FR1_D	-122.5	-50	
					NR_FDD_FR1_E, NR_TDD_FR1_E	-122	-50	
					NR_FDD_FR1_F	-121.5	-50	
					NR_FDD_FR1_G, NR_TDD_FR1_G	-121	-50	
				NR_FDD_FR1_H	-120.5	-50		
± 15+δ		≥132		≥1	NOTE 6	NOTE 6	NOTE 6	
± 15+δ		≥64	60	≥1	NR_FDD_FR1_A, NR_TDD_FR1_A, NR_SDL_FR1_A	-121	-50	
					NR_FDD_FR1_B	-120.5	-50	
					NR_TDD_FR1_C	-120	-50	
					NR_FDD_FR1_D, NR_TDD_FR1_D	-119.5	-50	
					NR_FDD_FR1_E, NR_TDD_FR1_E	-119	-50	
					NR_FDD_FR1_F	-118.5	-50	
					NR_FDD_FR1_G, NR_TDD_FR1_G	-118	-50	
				NR_FDD_FR1_H	-117.5	-50		
± 7+δ	-6	≥132	15	≥1	NOTE 6	NOTE 6	NOTE 6	
± 75+δ		≥52		≥1	NOTE 6	NOTE 6	NOTE 6	
± 37+δ		>104		≥1	NOTE 6	NOTE 6	NOTE 6	
± 39+δ		≥48		30	≥1	NOTE 6	NOTE 6	NOTE 6
± 16+δ		≥132		≥1	NOTE 6	NOTE 6	NOTE 6	
± 16+δ		≥64		60	≥1	NOTE 6	NOTE 6	NOTE 6
± 8+δ		≥132		≥1	NOTE 6	NOTE 6	NOTE 6	

NOTE 1: This minimum I_0 condition is expressed as the average I_0 per RE over all REs in an OFDM symbol.
 NOTE 2: NR operating band groups are as defined in Section 3.5.
 NOTE 3: T_{rep}^{PRS} , L_{PRS} , K_{comb}^{PRS} are configured by higher layer parameter *dl-PRS-ResourceRepetitionFactor*, *dl-PRS-NumSymbols* and *dl-PRS-CombSizeN* defined in TS 37.355 [49].
 NOTE 4: The I_0 is defined in PRS slots. The same I_0 range applies to PRS and non-PRS symbols. I_0 levels are different in PRS and non-PRS symbols within the same slot.
 NOTE 5: T_c is the basic timing unit defined in TS 38.211 [53].
 NOTE 6: The same bands and the same I_0 conditions for each band apply for this requirement as for the corresponding requirement with the PRS bandwidth of the smallest RB number for the corresponding SCS.
 NOTE 7: δ is the margin determined from Table 4.14.5-5.

The relative accuracy requirements in Table 4.14.5-1b for FR1 are valid under the following conditions:

Conditions defined in clause 7.3 of TS 38.101-1 [54] for reference sensitivity are fulfilled.

$PRP|_{dBm}$ according to TS 38.133 Annex B.2.14 for a corresponding Band.

AWGN propagation condition.

the two UE Rx-Tx time difference measurements are associated with the same RxTx TEG

Table 4.14.5-1b: UE Rx-Tx time difference relative measurement accuracy in FR1 in AWGN with TEG reporting

Accuracy	Conditions						
	PRS $\hat{\epsilon}_s$ /lot	PRS SCS	PRS bandwidth Note 1	PRS resource repetition ($T_{rep}^{PRS} * L_{PRS} / K_{comb}^{PRS}$) Note 2	I_0 Note 3 range		
					NR operating band groups Note 4	Minimum I_0	Maximum I_0
T_c Note 5	dB	kHz	RB		dBm/SCS	dBm/BW _{Channel}	
132 + Δ Note 7	(PRS $\hat{\epsilon}_s$ /lot) _i \geq -6dB	15	\geq [24	\geq 4	NR_FDD_FR1_A, NR_TDD_FR1_A, NR_SDL_FR1_A	-127	-50
					NR_FDD_FR1_B	-126.5	-50
					NR_TDD_FR1_C	-126	-50
					NR_FDD_FR1_D, NR_TDD_FR1_D	-125.5	-50
					NR_FDD_FR1_E, NR_TDD_FR1_E	-125	-50
					NR_FDD_FR1_F	-124.5	-50
					NR_FDD_FR1_G, NR_TDD_FR1_G	-124	-50
98 + Δ	(PRS $\hat{\epsilon}_s$ /lot) _i \geq -6dB		\geq 52	\geq 1	Note 6	Note 6	Note 6
42 + Δ			\geq 104	\geq 1	Note 6	Note 6	Note 6
75 + Δ	(PRS $\hat{\epsilon}_s$ /lot) _i \geq -13dB	30	\geq 24	\geq 4	NR_FDD_FR1_A, NR_TDD_FR1_A, NR_SDL_FR1_A	-124	-50
					NR_FDD_FR1_B	-123.5	-50
					NR_TDD_FR1_C	-123	-50
					NR_FDD_FR1_D, NR_TDD_FR1_D	-122.5	-50
					NR_FDD_FR1_E, NR_TDD_FR1_E	-122	-50
					NR_FDD_FR1_F	-121.5	-50
					NR_FDD_FR1_G, NR_TDD_FR1_G	-121	-50
48 + Δ	(PRS $\hat{\epsilon}_s$ /lot) _i \geq -13dB		\geq 48	\geq 1	Note 6	Note 6	Note 6
24 + Δ			\geq 132	\geq 1	Note 6	Note 6	Note 6

50 + Δ	60	≥24	≥ 4	NR_FDD_FR1_A, NR_TDD_FR1_A, NR_SDL_FR1_A	-121	-50
				NR_FDD_FR1_B	-120.5	-50
				NR_TDD_FR1_C	-120	-50
				NR_FDD_FR1_D, NR_TDD_FR1_D	-119.5	-50
				NR_FDD_FR1_E, NR_TDD_FR1_E	-119	-50
				NR_FDD_FR1_F	-118.5	-50
				NR_FDD_FR1_G, NR_TDD_FR1_G	-118	-50
				NR_FDD_FR1_H	-117.5	-50
24 + Δ		≥ 64	≥ 1	Note 6	Note 6	Note 6
10 + Δ		≥ 132	≥ 1	Note 6	Note 6	Note 6

NOTE 1: Minimum PRS bandwidth, which is minimum of the PRS bandwidths of resource j and resource i.
 NOTE 2: Minimum number of PRS resource repetitions among resource j and resource i. T_{rep}^{PRS} , L_{PRS} , K_{comb}^{PRS} are configured by higher layer parameter *dl-PRS-ResourceRepetitionFactor*, *dl-PRS-NumSymbols* and *dl-PRS-CombSizeN* defined in TS 37.355 [49], respectively.
 NOTE 3: I_0 is assumed to have constant EPRE across the bandwidth.
 NOTE 4: NR operating band groups in FR1 are as defined in TS 38.133 [50] clause 3.5.2.
 NOTE 5: T_c is the basic timing unit defined in TS 38.211 [53].
 NOTE 6: The same bands and the same I_0 conditions for each band apply for this requirement as for the corresponding requirement with the PRS bandwidth of the smallest RB number for the corresponding SCS.
 NOTE 7: Δ is the value of the timing error margin for the RxTx TEG, reported via *nr-UE-RxTxTEG-TimingErrorMargin*. Δ cannot be larger than the sum of the margins in table 4.14.5-5 (dependent on PRS/SRS BW) for any pair of individual UE Rx-Tx time difference measurements associated with the RxTx TEG. .

The accuracy requirements in Table 4.14.5-2 for FR1 are valid under the following conditions:

Conditions defined in clause 7.3 of TS 38.101-1 [54] for reference sensitivity are fulfilled.

PRP_{dBm} according to TS 38.133 Annex B.2.14 for a corresponding Band.

Fading propagation condition.

Table 4.14.5-2: UE Rx-Tx time difference measurement accuracy in FR1 in fading

Accuracy	Conditions						
	PRS Es/lot	Minimum PRS bandwidth	PRS SCS	PRS resource repetition (T_{rep}^{PRS} * L_{PRS}/K_{comb}^{PRS} Note 3)	NR operating band groups ^{Note 2}	I_0 ^{Note 4} range Minimum I_0 ^{Note 1} Maximum I_0	
± 137+δ	-3	≥24	15	≥4	NR_FDD_FR1_A, NR_TDD_FR1_A, NR_SDL_FR1_A	-121	-50
					NR_FDD_FR1_B	-120.5	
					NR_TDD_FR1_C	-120	
					NR_FDD_FR1_D, NR_TDD_FR1_D	-119.5	
					NR_FDD_FR1_E, NR_TDD_FR1_E	-119	
					NR_FDD_FR1_F	-118.5	
					NR_FDD_FR1_G, NR_TDD_FR1_G	-118	
				NR_FDD_FR1_H	-117.5		
± 96+δ		≥52		≥1	NOTE 6	NOTE 6	NOTE 6
± 62+δ		>104		≥1	NOTE 6	NOTE 6	NOTE 6
± 87+δ		≥24	30	≥4	NR_FDD_FR1_A, NR_TDD_FR1_A, NR_SDL_FR1_A	-118	-50
					NR_FDD_FR1_B	-117.5	
					NR_TDD_FR1_C	-117	

				NR_FDD_FR1_D, NR_TDD_FR1_D	-116.5	
				NR_FDD_FR1_E, NR_TDD_FR1_E	-116	
				NR_FDD_FR1_F	-115.5	
				NR_FDD_FR1_G	-115	
				NR_FDD_FR1_H	-114.5	
± 68+δ		≥48		NOTE 6	NOTE 6	NOTE 6
± 44+δ		≥132		NOTE 6	NOTE 6	NOTE 6
± 59+δ		≥24	60	NR_FDD_FR1_A, NR_TDD_FR1_A, NR_SDL_FR1_A	-115	-50
				NR_FDD_FR1_B	-114.5	
				NR_TDD_FR1_C	-114	
			≥4	NR_FDD_FR1_D, NR_TDD_FR1_D	-113.5	
				NR_FDD_FR1_E, NR_TDD_FR1_E	-113	
				NR_FDD_FR1_F	-113.5	
				NR_FDD_FR1_G	-113	
				NR_FDD_FR1_H	-111.5	
± 42+δ		≥ 64		NOTE 6	NOTE 6	NOTE 6
± 36+δ		≥ 132		NOTE 6	NOTE 6	NOTE 6
± 180+δ	-13	≥24	15	≥4	NOTE 6	NOTE 6
± 98+δ		≥52		≥1	NOTE 6	NOTE 6
± 68+δ		>104		≥1	NOTE 6	NOTE 6
± 87+δ		≥24	30	≥4	NOTE 6	NOTE 6
± 85+δ		≥48		≥1	NOTE 6	NOTE 6
± 44+δ		≥132		≥1	NOTE 6	NOTE 6
± 139+δ		≥24	60	≥4	NOTE 6	NOTE 6
± 46+δ		≥ 64		≥1	NOTE 6	NOTE 6
± 30+δ		≥ 132		≥1	NOTE 6	NOTE 6

NOTE 1: This minimum I_0 condition is expressed as the average I_0 per RE over all REs in an OFDM symbol.
 NOTE 2: NR operating band groups are as defined in TS 38.133 Section 3.5.
 NOTE 3: T_{rep}^{PRS} , L_{PRS} , K_{comb}^{PRS} are configured by higher layer parameter *dl-PRS-ResourceRepetitionFactor*, *dl-PRS-NumSymbols* and *dl-PRS-CombSizeN* defined in TS 37.355 [49].
 NOTE 4: The I_0 is defined in PRS slots. The same I_0 range applies to PRS and non-PRS symbols. I_0 levels are different in PRS and non-PRS symbols within the same slot.
 NOTE 5: T_c is the basic timing unit defined in TS 38.211 [53].
 NOTE 6: The same bands and the same I_0 conditions for each band apply for this requirement as for the corresponding requirement with the PRS bandwidth of the smallest RB number for the corresponding SCS.
 NOTE 7: δ is the margin determined from Table 4.14.5-5.

The accuracy requirements in Table 4.14.5-3 for FR2 are valid under the following conditions:

Conditions defined in clause 7.3 of TS 38.101-2 [55] for reference sensitivity are fulfilled.

PRP_{dBm} according to TS 38.133 Annex B.2.14 for a corresponding Band.

AWGN propagation condition.

Table 4.14.5-3: UE Rx-Tx time difference measurement accuracy in FR2 in AWGN

Accuracy	Conditions					
	PRS Es/lot	Minimum PRS bandwidth	PRS SCS	PRS resource repetition ($T_{rep}^{PRS} * L_{PRS} / K_{comb}^{PRS}$) Note 3	$I_0^{Note 4}$ range	
					Minimum $I_0^{Note 1}$	Maximum I_0
$T_c^{Note 5}$	dB	RB	kHz		dBm / SCS _{PRS}	dBm/BW _{Channel}
± 22+δ	-3	≥24	60	≥4	Same value as PRP in TS 38.133 Table B.2.14-2, according to UE	-50

					Power class, operating band and angle of arrival	
$\pm 15+\delta$		≥ 64	120	≥ 1	NOTE 6	NOTE 6
$\pm 7+\delta$		≥ 132		≥ 1	NOTE 6	NOTE 6
$\pm 12+\delta$		≥ 32		≥ 1	Same value as PRP in TS 38.133 Table B.2.14-2, according to UE Power class, operating band and angle of arrival	-50
$\pm 7+\delta$	-13	≥ 64	60	≥ 1	NOTE 6	NOTE 6
$\pm 4+\delta$		≥ 128		≥ 1	NOTE 6	NOTE 6
$\pm 35+\delta$		≥ 24		≥ 1	NOTE 6	NOTE 6
$\pm 15+\delta$		≥ 64		≥ 1	NOTE 6	NOTE 6
$\pm 7+\delta$		≥ 132		≥ 1	NOTE 6	NOTE 6
$\pm 14+\delta$		≥ 32	120	≥ 1	NOTE 6	NOTE 6
$\pm 9+\delta$		≥ 64		≥ 1	NOTE 6	NOTE 6
$\pm 4+\delta$		≥ 128		≥ 1	NOTE 6	NOTE 6

NOTE 1: This minimum I_0 condition is expressed as the average I_0 per RE over all REs in an OFDM symbol.
 NOTE 2: NR operating band groups are as defined in TS 38.133 Section 3.5.
 NOTE 3: T_{rep}^{PRS} , L_{PRS} , K_{comb}^{PRS} are configured by higher layer parameter *dl-PRS-ResourceRepetitionFactor*, *dl-PRS-NumSymbols* and *dl-PRS-CombSizeN* defined in TS 37.355 [49].
 NOTE 4: The I_0 is defined in PRS slots. The same I_0 range applies to PRS and non-PRS symbols. I_0 levels are different in PRS and non-PRS symbols within the same slot.
 NOTE 5: T_c is the basic timing unit defined in TS 38.211 [53].
 NOTE 6: The same bands and the same I_0 conditions for each band apply for this requirement as for the corresponding requirement with the PRS bandwidth of the smallest RB number for the corresponding SCS.
 NOTE 7: δ is the margin determined from Table 4.14.5-6.

The accuracy requirements in Table 4.14.5-3a for FR2 are valid under the following conditions:

Conditions defined in clause 7.3 of TS 38.101-2 [55] for reference sensitivity are fulfilled.

$PRP|_{dBm}$ according to TS 38.133 Annex B.2.14 for a corresponding Band

Number of measurement samples is less than 4

AWGN propagation condition.

Table 4.14.5-3a: UE Rx-Tx time difference measurement accuracy in FR2 in AWGN with reduced measurement samples

Accuracy	Conditions					
	PRS $\hat{\epsilon}$ s/lot	Minimum PRS bandwidth	PRS SCS	PRS resource repetition ($T_{rep}^{PRS} * L_{PRS} / K_{comb}^{PRS}$ Note 3)	I_0 Note 4 range	
					Minimum I_0 Note 1	Maximum I_0
T_c Note 5	dB	RB	kHz		dBm / SCS _{PRS}	dBm/BW _{Channel}
$\pm 15+\delta$	0	≥ 64	60	≥ 1	Same value as PRP in TS 38.133 Table B.2.14-2, according to UE Power class, operating band and angle of arrival	NOTE 6
$\pm 7+\delta$		≥ 132		≥ 1	NOTE 6	NOTE 6
$\pm 7+\delta$		≥ 64	120	≥ 1	Same value as PRP in TS 38.133 Table B.2.14-2, according to UE Power class, operating band and angle of arrival	NOTE 6
$\pm 4+\delta$		≥ 128		≥ 1	NOTE 6	NOTE 6
$\pm 15+\delta$	-6	≥ 64	60	≥ 1	NOTE 6	NOTE 6
$\pm 7+\delta$		≥ 132		≥ 1	NOTE 6	NOTE 6
$\pm 9+\delta$		≥ 64	120	≥ 1	NOTE 6	NOTE 6
$\pm 4+\delta$		≥ 128		≥ 1	NOTE 6	NOTE 6

NOTE 1: This minimum I_0 condition is expressed as the average I_0 per RE over all REs in an OFDM symbol.
 NOTE 2: NR operating band groups are as defined in TS 38.133 Section 3.5.

NOTE 3: $T_{rep}^{PRS}, L_{PRS}, K_{comb}^{PRS}$ are configured by higher layer parameter *dl-PRS-ResourceRepetitionFactor*, *dl-PRS-NumSymbols* and *dl-PRS-CombSizeN* defined in TS 37.355 [49].

NOTE 4: The l_o is defined in PRS slots. The same l_o range applies to PRS and non-PRS symbols. l_o levels are different in PRS and non-PRS symbols within the same slot.

NOTE 5: T_c is the basic timing unit defined in TS 38.211 [53].

NOTE 6: The same bands and the same l_o conditions for each band apply for this requirement as for the corresponding requirement with the PRS bandwidth of the smallest RB number for the corresponding SCS.

NOTE 7: δ is the margin determined from Table 4.14.5-6.

The relative accuracy requirements in Table 4.14.5-3b for FR2 are valid under the following conditions:

Conditions defined in clause 7.3 of TS 38.101-2 [55] for reference sensitivity are fulfilled.

$PRP|_{dBm}$ according to TS 38.133 Annex B.2.14 for a corresponding Band

AWGN propagation condition.

the two UE Rx-Tx time difference measurements are associated with the same RxTx TEG

Table 4.14.5-3b: UE Rx-Tx time difference relative measurement accuracy in FR2 in AWGN with TEG reporting

Accuracy	Conditions					
	PRS \hat{E}_s/lot	PRS SCS	PRS bandwidth Note 1	PRS resource repetition ($T_{rep}^{PRS} * L_{PRS} / K_{comb}^{PRS}$) Note 2	l_o Note 3 range	
					Minimum l_o	Maximum l_o
T_c Note 4	dB	kHz	RB		dBm/SCS	dBm/BW _{Channel}
$35 + \Delta$ Note 6	(PRS $\hat{E}_s/lot)_j \geq -6$ dB	60	≥ 24	≥ 4	Same value as PRS_RP in TS 38.133 Table B.2.14-2, according to UE Power class, operating band and angle of arrival	-50
$24 + \Delta$			≥ 64	≥ 1	Note 5	Note 5
$11 + \Delta$			≥ 132	≥ 1	Note 5	Note 5
$24 + \Delta$	(PRS $\hat{E}_s/lot)_i \geq -13$ dB	120	≥ 32	≥ 4	Same value as PRS_RP in TS 38.133 Table B.2.14-2, according to UE Power class, operating band and angle of arrival	-50
$13 + \Delta$			≥ 64	≥ 1	Note 5	Note 5
$6 + \Delta$			≥ 128	≥ 1	Note 5	Note 5

NOTE 1: Minimum PRS bandwidth, which is minimum of the PRS bandwidths of resource j and resource i.

NOTE 2: Minimum number of PRS resource repetitions among resource j and resource i. $T_{rep}^{PRS}, L_{PRS}, K_{comb}^{PRS}$ are configured by higher layer parameter *dl-PRS-ResourceRepetitionFactor*, *dl-PRS-NumSymbols* and *dl-PRS-CombSizeN* defined in TS 37.355 [49], respectively.

NOTE 3: l_o is assumed to have constant EPRE across the bandwidth.

NOTE 4: T_c is the basic timing unit defined in TS 38.211 [53].

NOTE 5: The same bands and the same l_o conditions for each band apply for this requirement as for the corresponding requirement with the PRS bandwidth of the smallest RB number for the corresponding SCS.

NOTE 6: Δ is the value of the timing error margin for the RxTx TEG, reported via *nr-UE-RxTxTEG-TimingErrorMargin*. Δ cannot be larger than the sum of the margins in table 4.14.5-6 (dependent on PRS/SRS BW) for any pair of individual UE Rx-Tx time difference measurements associated with the RxTx TEG.

The accuracy requirements in Table 4.14.5-4 for FR2 are valid under the following conditions:

Conditions defined in clause 7.3 of TS 38.101-2 [55] for reference sensitivity are fulfilled.

$PRP|_{dBm}$ according to TS 38.133 Annex B.2.14 for a corresponding Band.

Fading propagation condition.

Table 4.14.5-4: UE Rx-Tx time difference measurement accuracy in FR2 in fading

Accuracy	Conditions								
	PRS Es/lot	Minimum PRS bandwidth	PRS SCS	PRS resource repetition ($T_{rep}^{PRS} * L_{PRS} /$ K_{comb}^{PRS} Note 3)	Io ^{Note 4} range				
					Minimum Io ^{Note 1}	Maximum Io			
Tc ^{Note 5}	dB	RB	kHz		dBm / SCS _{PRS}	dBm/BW _{Channel}			
± 75+δ	-3	≥24	60	≥4	Same value as PRP in TS 38.133 Table B.2.14-2, according to UE Power class, operating band and angle of arrival	-50			
± 72+δ		≥64		≥1			NOTE 6	NOTE 6	
± 57+δ		≥132		≥1			NOTE 6	NOTE 6	
± 61+δ	-13	≥32	120	≥1	Same value as PRP in TS 38.133 Table B.2.14-2, according to UE Power class, operating band and angle of arrival	-50			
± 64+δ		≥64		≥1			NOTE 6	NOTE 6	
± 55+δ		≥128		≥1			NOTE 6	NOTE 6	
± 92+δ		≥24		60			≥4	NOTE 6	NOTE 6
± 70+δ		≥64					≥1	NOTE 6	NOTE 6
± 57+δ	≥132	≥1	NOTE 6		NOTE 6				
± 60+δ	≥32	120	≥1	NOTE 6	NOTE 6				
± 66+δ	≥64		≥1	NOTE 6	NOTE 6				
± 62+δ	≥128		≥1	NOTE 6	NOTE 6				

NOTE 1: This minimum Io condition is expressed as the average Io per RE over all REs in an OFDM symbol.
 NOTE 2: NR operating band groups are as defined in TS 38.133 Section 3.5.
 NOTE 3: T_{rep}^{PRS} , L_{PRS} , K_{comb}^{PRS} are configured by higher layer parameter *dl-PRS-ResourceRepetitionFactor*, *dl-PRS-NumSymbols* and *dl-PRS-CombSizeN* defined in TS 37.355 [49].
 NOTE 4: The Io is defined in PRS slots. The same Io range applies to PRS and non-PRS symbols. Io levels are different in PRS and non-PRS symbols within the same slot.
 NOTE 5: Tc is the basic timing unit defined in TS 38.211 [53].
 NOTE 6: The same bands and the same Io conditions for each band apply for this requirement as for the corresponding requirement with the PRS bandwidth of the smallest RB number for the corresponding SCS.
 NOTE 7: δ is the margin determined from Table 4.14.5-6.

Table 4.14.5-5: Margin for UE Rx-Tx time difference measurement accuracy in FR1

Min(PRS BW, SRS BW) (RB)			Margin (Tc ^{Note 1})
SCS = 15 kHz	SCS = 30 kHz	SCS = 60 kHz	
≥ 24	N/A	N/A	160
≥ 52	≥ 24	N/A	80
≥ 104	≥ 48	≥ 24	56
N/A	≥ 132	≥ 64	24
N/A	N/A	≥ 132	24

NOTE 1: Tc is the basic timing unit defined in TS 38.211 [53].
 NOTE 2: If SRS and PRS have different SCS, the margin corresponding to the smallest RS BW in MHz applies.

Table 4.14.5-6: Margin for UE Rx-Tx time difference measurement accuracy in FR2

Min(PRS BW, SRS BW) (MHz)		Margin (Tc ^{Note 1})
SCS = 60 kHz	SCS = 120 kHz	
≥ 24	N/A	76
≥ 64	≥ 32	32
≥ 132	≥ 64	24
N/A	≥ 128	20

NOTE 1: Tc is the basic timing unit defined in TS 38.211 [53].

NOTE 2: If SRS and PRS have different SCS, the margin corresponding to the smallest RS BW in MHz applies.

4.14.6 Reporting mapping

4.14.6.1 Absolute UE Rx-Tx Measurement Report Mapping

The reporting range for the absolute UE Rx-Tx time difference measurement ($T_{UE\ Rx-Tx}$) is defined from $-985024 \times T_c$ to $985024 \times T_c$ with the resolution step of $2^k \times T_c$, where:

T_c is defined in TS 38.211 [53],

$$k_{min} \leq k \leq k_{max},$$

$k_{min}=2$ and $k_{max}=5$, when at least one of the PRS and the SRS resources configured for $T_{UE\ Rx-Tx}$ is in FR1,

$k_{min}=0$ and $k_{max}=5$, when both PRS and SRS resources configured for $T_{UE\ Rx-Tx}$ are in FR2,

$k \geq \text{timingReportingGranularityFactor}$ [49] configured by LMF via LPP for the UE Rx-Tx time difference measurement.

The $T_{UE\ Rx-Tx}$ report mapping for $k = 0, 1, 2, 3, 4,$ and 5 are specified in Tables 4.14.6.1-1, 4.14.6.1-2, 4.14.6.1-3, 4.14.6.1-4, 4.14.6.1-5, and 4.14.6.1-6, respectively.

Table 4.14.6.1-1: Absolute UE Rx-Tx time difference measurement report mapping for $k=0$

Reported Quantity Value	Measured Quantity Value	Unit
RX-TX_TIME_DIFFERENCE_0000	$T_{UE\ Rx-Tx} < -985024$	T_c
RX-TX_TIME_DIFFERENCE_0001	$-985024 \leq T_{UE\ Rx-Tx} < -985023$	T_c
RX-TX_TIME_DIFFERENCE_0002	$-985023 \leq T_{UE\ Rx-Tx} < -985022$	T_c
□	□	...
RX-TX_TIME_DIFFERENCE_985024	$-1 \leq T_{UE\ Rx-Tx} < 0$	T_c
RX-TX_TIME_DIFFERENCE_985025	$0 \leq T_{UE\ Rx-Tx} < 1$	T_c
...
RX-TX_TIME_DIFFERENCE_1970047	$985022 \leq T_{UE\ Rx-Tx} < 985023$	T_c
RX-TX_TIME_DIFFERENCE_1970048	$985023 \leq T_{UE\ Rx-Tx} < 985024$	T_c
RX-TX_TIME_DIFFERENCE_1970049	$985024 \leq T_{UE\ Rx-Tx}$	T_c

Table 4.14.6.1-2: Absolute UE Rx-Tx time difference measurement report mapping for $k=1$

Reported Quantity Value	Measured Quantity Value	Unit
RX-TX_TIME_DIFFERENCE_0000	$T_{UE\ Rx-Tx} < -985024$	T_c
RX-TX_TIME_DIFFERENCE_0001	$-985024 \leq T_{UE\ Rx-Tx} < -985022$	T_c
RX-TX_TIME_DIFFERENCE_0002	$-985022 \leq T_{UE\ Rx-Tx} < -985020$	T_c
□	□	...
RX-TX_TIME_DIFFERENCE_492512	$-2 \leq T_{UE\ Rx-Tx} < 0$	T_c
RX-TX_TIME_DIFFERENCE_492513	$0 \leq T_{UE\ Rx-Tx} < 2$	T_c
...
RX-TX_TIME_DIFFERENCE_985023	$985020 \leq T_{UE\ Rx-Tx} < 985022$	T_c
RX-TX_TIME_DIFFERENCE_985024	$985022 \leq T_{UE\ Rx-Tx} < 985024$	T_c
RX-TX_TIME_DIFFERENCE_985025	$985024 \leq T_{UE\ Rx-Tx}$	T_c

Table 4.14.6.1-3: Absolute UE Rx-Tx time difference measurement report mapping for $k=2$

Reported Quantity Value	Measured Quantity Value	Unit
RX-TX_TIME_DIFFERENCE_0000	$T_{UE\ Rx-Tx} < -985024$	T_c
RX-TX_TIME_DIFFERENCE_0001	$-985024 \leq T_{UE\ Rx-Tx} < -985020$	T_c
RX-TX_TIME_DIFFERENCE_0002	$-985020 \leq T_{UE\ Rx-Tx} < -985016$	T_c
□	□	...
RX-TX_TIME_DIFFERENCE_246256	$-4 \leq T_{UE\ Rx-Tx} < 0$	T_c

RX-TX_TIME_DIFFERENCE_246257	$0 \leq T_{UE\ Rx-Tx} < 4$	T_c
...
RX-TX_TIME_DIFFERENCE_492511	$985016 \leq T_{UE\ Rx-Tx} < 985020$	T_c
RX-TX_TIME_DIFFERENCE_492512	$985020 \leq T_{UE\ Rx-Tx} < 985024$	T_c
RX-TX_TIME_DIFFERENCE_492513	$985024 \leq T_{UE\ Rx-Tx}$	T_c

Table 4.14.6.1-4: Absolute UE Rx-Tx time difference measurement report mapping for $k=3$

Reported Quantity Value	Measured Quantity Value	Unit
RX-TX_TIME_DIFFERENCE_0000	$T_{UE\ Rx-Tx} < -985024$	T_c
RX-TX_TIME_DIFFERENCE_0001	$-985024 \leq T_{UE\ Rx-Tx} < -985016$	T_c
RX-TX_TIME_DIFFERENCE_0002	$-985016 \leq T_{UE\ Rx-Tx} < -985008$	T_c
□	□	...
RX-TX_TIME_DIFFERENCE_123128	$-8 \leq T_{UE\ Rx-Tx} < 0$	T_c
RX-TX_TIME_DIFFERENCE_123129	$0 \leq T_{UE\ Rx-Tx} < 8$	T_c
...
RX-TX_TIME_DIFFERENCE_246255	$985008 \leq T_{UE\ Rx-Tx} < 985016$	T_c
RX-TX_TIME_DIFFERENCE_246256	$985016 \leq T_{UE\ Rx-Tx} < 985024$	T_c
RX-TX_TIME_DIFFERENCE_246257	$985024 \leq T_{UE\ Rx-Tx}$	T_c

Table 4.14.6.1-5: Absolute UE Rx-Tx time difference measurement report mapping for $k=4$

Reported Quantity Value	Measured Quantity Value	Unit
RX-TX_TIME_DIFFERENCE_0000	$T_{UE\ Rx-Tx} < -985024$	T_c
RX-TX_TIME_DIFFERENCE_0001	$-985024 \leq T_{UE\ Rx-Tx} < -985008$	T_c
RX-TX_TIME_DIFFERENCE_0002	$-985008 \leq T_{UE\ Rx-Tx} < -984992$	T_c
□	□	...
RX-TX_TIME_DIFFERENCE_61564	$-16 \leq T_{UE\ Rx-Tx} < 0$	T_c
RX-TX_TIME_DIFFERENCE_61565	$0 \leq T_{UE\ Rx-Tx} < 16$	T_c
...
RX-TX_TIME_DIFFERENCE_123127	$984992 \leq T_{UE\ Rx-Tx} < 985008$	T_c
RX-TX_TIME_DIFFERENCE_123128	$985008 \leq T_{UE\ Rx-Tx} < 985024$	T_c
RX-TX_TIME_DIFFERENCE_123129	$985024 \leq T_{UE\ Rx-Tx}$	T_c

Table 4.14.6.1-6: Absolute UE Rx-Tx time difference measurement report mapping for $k=5$

Reported Quantity Value	Measured Quantity Value	Unit
RX-TX_TIME_DIFFERENCE_0000	$T_{UE\ Rx-Tx} < -985024$	T_c
RX-TX_TIME_DIFFERENCE_0001	$-985024 \leq T_{UE\ Rx-Tx} < -984992$	T_c
RX-TX_TIME_DIFFERENCE_0002	$-984992 \leq T_{UE\ Rx-Tx} < -984960$	T_c
□	□	...
RX-TX_TIME_DIFFERENCE_30782	$-32 \leq T_{UE\ Rx-Tx} < 0$	T_c
RX-TX_TIME_DIFFERENCE_30783	$0 \leq T_{UE\ Rx-Tx} < 32$	T_c
...
RX-TX_TIME_DIFFERENCE_61563	$984960 \leq T_{UE\ Rx-Tx} < 984992$	T_c
RX-TX_TIME_DIFFERENCE_61564	$984992 \leq T_{UE\ Rx-Tx} < 985024$	T_c
RX-TX_TIME_DIFFERENCE_61565	$985024 \leq T_{UE\ Rx-Tx}$	T_c

4.14.6.2 Differential UE Rx-Tx Measurement Report Mapping

The reporting range for differential UE Rx-Tx time difference measurement ($\Delta T_{UE\ Rx-Tx}$) is defined from 0 up to $8191 \times T_c$ where:

$$\Delta T_{UE\ Rx-Tx} = T_{UE\ Rx-Tx1} - T_{UE\ Rx-Tx2}; \text{ where:}$$

$$T_{UE\ Rx-Tx1} > T_{UE\ Rx-Tx2},$$

$T_{UE\ Rx-Tx1}$ is the first absolute UE Rx-Tx time difference measurement,

$T_{UE\ Rx-Tx1}$ is the second absolute UE Rx-Tx time difference measurement,

T_c is defined in TS 38.211 [53],

$$k_{min} \leq k \leq k_{max},$$

$k_{min}=2$ and $k_{max}=5$, when at least one of the PRS and the SRS resources configured for $\Delta T_{UE\ Rx-Tx}$ is in FR1,

$k_{min}=0$ and $k_{max}=5$, when all the PRS and SRS resources configured for $\Delta T_{UE\ Rx-Tx}$ are in FR2,

$k \geq \text{timingReportingGranularityFactor}$ [49] configured by LMF via LPP for the UE Rx-Tx time difference measurement.

The $\Delta T_{UE\ Rx-Tx}$ report mapping for $k = 0, 1, 2, 3, 4$, and 5 are specified in Tables 4.14.6.2-1, 4.14.6.2-2, 4.14.6.2-3, 4.14.6.2-4, 4.14.6.2-5, and 4.14.6.2-6, respectively.

Table 4.14.6.2-1: Differential UE Rx-Tx time difference measurement report mapping for $k=0$

Reported Quantity Value	Measured Quantity Value	Unit
DIFF_RX-TX_TIME_DIFFERENCE_0000	$0 \leq \Delta T_{UE\ Rx-Tx} < 1$	T_c
DIFF_RX-TX_TIME_DIFFERENCE_0001	$1 \leq \Delta T_{UE\ Rx-Tx} < 2$	T_c
DIFF_RX-TX_TIME_DIFFERENCE_0002	$2 \leq \Delta T_{UE\ Rx-Tx} < 3$	T_c
□	□	...
DIFF_RX-TX_TIME_DIFFERENCE_8189	$8189 \leq \Delta T_{UE\ Rx-Tx} < 8190$	T_c
DIFF_RX-TX_TIME_DIFFERENCE_8190	$8190 \leq \Delta T_{UE\ Rx-Tx} < 8191$	T_c
DIFF_RX-TX_TIME_DIFFERENCE_8191	$8191 \leq \Delta T_{UE\ Rx-Tx}$	T_c

Table 4.14.6.2-2: Differential UE Rx-Tx time difference measurement report mapping for $k=1$

Reported Quantity Value	Measured Quantity Value	Unit
DIFF_RX-TX_TIME_DIFFERENCE_0000	$0 \leq \Delta T_{UE\ Rx-Tx} < 2$	T_c
DIFF_RX-TX_TIME_DIFFERENCE_0001	$2 \leq \Delta T_{UE\ Rx-Tx} < 4$	T_c
DIFF_RX-TX_TIME_DIFFERENCE_0002	$4 \leq \Delta T_{UE\ Rx-Tx} < 6$	T_c
□	□	...
DIFF_RX-TX_TIME_DIFFERENCE_4093	$8186 \leq \Delta T_{UE\ Rx-Tx} < 8188$	T_c
DIFF_RX-TX_TIME_DIFFERENCE_4094	$8188 \leq \Delta T_{UE\ Rx-Tx} < 8190$	T_c
DIFF_RX-TX_TIME_DIFFERENCE_4095	$8190 \leq \Delta T_{UE\ Rx-Tx}$	T_c

Table 4.14.6.2-3: Differential UE Rx-Tx time difference measurement report mapping for $k=2$

Reported Quantity Value	Measured Quantity Value	Unit
DIFF_RX-TX_TIME_DIFFERENCE_0000	$0 \leq \Delta T_{UE\ Rx-Tx} < 4$	T_c
DIFF_RX-TX_TIME_DIFFERENCE_0001	$4 \leq \Delta T_{UE\ Rx-Tx} < 8$	T_c
DIFF_RX-TX_TIME_DIFFERENCE_0002	$8 \leq \Delta T_{UE\ Rx-Tx} < 12$	T_c
□	□	...
DIFF_RX-TX_TIME_DIFFERENCE_2045	$8180 \leq \Delta T_{UE\ Rx-Tx} < 8184$	T_c
DIFF_RX-TX_TIME_DIFFERENCE_2046	$8184 \leq \Delta T_{UE\ Rx-Tx} < 8188$	T_c
DIFF_RX-TX_TIME_DIFFERENCE_2047	$8188 \leq \Delta T_{UE\ Rx-Tx}$	T_c

Table 4.14.6.2-4: Differential UE Rx-Tx time difference measurement report mapping for $k=3$

Reported Quantity Value	Measured Quantity Value	Unit
DIFF_RX-TX_TIME_DIFFERENCE_0000	$0 \leq \Delta T_{UE\ Rx-Tx} < 8$	T_c
DIFF_RX-TX_TIME_DIFFERENCE_0001	$8 \leq \Delta T_{UE\ Rx-Tx} < 16$	T_c
DIFF_RX-TX_TIME_DIFFERENCE_0002	$16 \leq \Delta T_{UE\ Rx-Tx} < 24$	T_c
□	□	...
DIFF_RX-TX_TIME_DIFFERENCE_1021	$8168 \leq \Delta T_{UE\ Rx-Tx} < 8176$	T_c
DIFF_RX-TX_TIME_DIFFERENCE_1022	$8176 \leq \Delta T_{UE\ Rx-Tx} < 8184$	T_c
DIFF_RX-TX_TIME_DIFFERENCE_1023	$8184 \leq \Delta T_{UE\ Rx-Tx}$	T_c

Table 4.14.6.2-5: Differential UE Rx-Tx time difference measurement report mapping for $k=4$

Reported Quantity Value	Measured Quantity Value	Unit
DIFF_RX-TX_TIME_DIFFERENCE_0000	$0 \leq \Delta T_{UE\ Rx-Tx} < 16$	T_c
DIFF_RX-TX_TIME_DIFFERENCE_0001	$16 \leq \Delta T_{UE\ Rx-Tx} < 32$	T_c
DIFF_RX-TX_TIME_DIFFERENCE_0002	$32 \leq \Delta T_{UE\ Rx-Tx} < 48$	T_c
□	□	...
DIFF_RX-TX_TIME_DIFFERENCE_509	$8144 \leq \Delta T_{UE\ Rx-Tx} < 8160$	T_c
DIFF_RX-TX_TIME_DIFFERENCE_510	$8160 \leq \Delta T_{UE\ Rx-Tx} < 8176$	T_c
DIFF_RX-TX_TIME_DIFFERENCE_511	$8176 \leq \Delta T_{UE\ Rx-Tx}$	T_c

Table 4.14.6.2-6: Differential UE Rx-Tx time difference measurement report mapping for $k=5$

Reported Quantity Value	Measured Quantity Value	Unit
DIFF_RX-TX_TIME_DIFFERENCE_0000	$0 \leq \Delta T_{UE\ Rx-Tx} < 32$	T_c
DIFF_RX-TX_TIME_DIFFERENCE_0001	$32 \leq \Delta T_{UE\ Rx-Tx} < 64$	T_c
DIFF_RX-TX_TIME_DIFFERENCE_0002	$64 \leq \Delta T_{UE\ Rx-Tx} < 96$	T_c
□	□	...
DIFF_RX-TX_TIME_DIFFERENCE_253	$8096 \leq \Delta T_{UE\ Rx-Tx} < 8128$	T_c
DIFF_RX-TX_TIME_DIFFERENCE_254	$8128 \leq \Delta T_{UE\ Rx-Tx} < 8160$	T_c
DIFF_RX-TX_TIME_DIFFERENCE_255	$8160 \leq \Delta T_{UE\ Rx-Tx}$	T_c

4.14.6.3 Additional Path Report Mapping for UE Rx-Tx Time Difference

The reporting range for the additional path reporting for an UE Rx-Tx time difference measurement is defined up to the range from $-8175 \times T_c$ to $8175 \times T_c$ with the resolution step of $2^k \times T_c$, where

T_c is defined in TS 38.211 [53],

$k_{min} \leq k \leq k_{max}$,

$k_{min}=2$ and $k_{max}=5$, when at least one of the PRS resource and SRS resource configured for the UE Rx-Tx time difference measurement is in FR1,

$k_{min}=0$ and $k_{max}=5$, when both of the PRS resource and SRS resource configured for the UE Rx-Tx time difference measurement is in FR2,

$k \geq \text{timingReportingGranularityFactor}$ [49] configured by LMF via LPP for the UE Rx-Tx time difference measurement.

The UE can report the timing of up to two additional paths with respect to the path timing determining the UE Rx-Tx time difference measurement.

The report mappings for different k values are specified in Tables 4.14.6.3-1 – 4.14.6.3-6.

Table 4.14.6.3-1: Report mapping for $k=0$

Reported Quantity Value, path_i	Measured Quantity Value, $\Delta path$	Unit
path_00000	$\Delta path < -8175$	T_c
path_00001	$-8175 \leq \Delta path < -8174$	T_c
path_00002	$-8174 \leq \Delta path < -8173$	T_c
...
path_08175	$-1 \leq \Delta path < 0$	T_c
path_08176	$0 \leq \Delta path < 1$	T_c
...
path_16349	$8173 \leq \Delta path < 8174$	T_c
path_16350	$8174 \leq \Delta path < 8175$	T_c
path_16351	$8175 \leq \Delta path$	T_c

Table 4.14.6.3-2: Report mapping for $k=1$

Reported Quantity Value, path_i	Measured Quantity Value, Δpath	Unit
path_0000	$\Delta\text{path} < -8175$	T_c
path_0001	$-8175 \leq \Delta\text{path} < -8173$	T_c
path_0002	$-8173 \leq \Delta\text{path} < -8171$	T_c
...
path_4088	$-1 \leq \Delta\text{path} < 1$	T_c
...
path_8174	$8171 \leq \Delta\text{path} < 8173$	T_c
path_8175	$8173 \leq \Delta\text{path} < 8175$	T_c
path_8176	$8175 \leq \Delta\text{path}$	T_c

Table 4.14.6.3-3: Report mapping for $k=2$

Reported Quantity Value, path_i	Measured Quantity Value, Δpath	Unit
path_0000	$\Delta\text{path} < -8174$	T_c
path_0001	$-8174 \leq \Delta\text{path} < -8170$	T_c
path_0002	$-8170 \leq \Delta\text{path} < -8166$	T_c
...
path_2044	$-2 \leq \Delta\text{path} < 2$	T_c
...
path_4086	$8166 \leq \Delta\text{path} < 8170$	T_c
path_4087	$8170 \leq \Delta\text{path} < 8174$	T_c
path_4088	$8174 \leq \Delta\text{path}$	T_c

Table 4.14.6.3-4: Report mapping for $k=3$

Reported Quantity Value, path_i	Measured Quantity Value, Δpath	Unit
path_0000	$\Delta\text{path} < -8172$	T_c
path_0001	$-8172 \leq \Delta\text{path} < -8164$	T_c
path_0002	$-8164 \leq \Delta\text{path} < -8156$	T_c
...
path_1022	$-4 \leq \Delta\text{path} < 4$	T_c
...
path_2042	$8156 \leq \Delta\text{path} < 8164$	T_c
path_2043	$8164 \leq \Delta\text{path} < 8172$	T_c
path_2044	$8172 \leq \Delta\text{path}$	T_c

Table 4.14.6.3-5: Report mapping for $k=4$

Reported Quantity Value, path_i	Measured Quantity Value, Δpath	Unit
path_0000	$\Delta\text{path} < -8168$	T_c
path_0001	$-8168 \leq \Delta\text{path} < -8152$	T_c
path_0002	$-8152 \leq \Delta\text{path} < -8136$	T_c
...
path_511	$-8 \leq \Delta\text{path} < 8$	T_c
...
path_1020	$8136 \leq \Delta\text{path} < 8152$	T_c
path_1021	$8152 \leq \Delta\text{path} < 8168$	T_c
path_1022	$8168 \leq \Delta\text{path}$	T_c

Table 4.14.6.3-6: Report mapping for $k=5$

Reported Quantity Value, path_i	Measured Quantity Value, Δpath	Unit
path_000	$\Delta\text{path} < -8160$	T_c
path_001	$-8160 \leq \Delta\text{path} < -8128$	T_c
path_002	$-8128 \leq \Delta\text{path} < -8096$	T_c
...
path_256	$0 \leq \Delta\text{path} < 32$	T_c
...
path_509	$8096 \leq \Delta\text{path} < 8128$	T_c
path_510	$8128 \leq \Delta\text{path} < 8160$	T_c
path_511	$8160 \leq \Delta\text{path}$	T_c

4.15 DL-TDOA test conditions

4.15.1 Simulated cells

For the DL-TDOA measurement test cases in clause 14, a multi cell environment as defined in 3GPP TS 38.508-1 [45] with NR Cell 1, NR Cell 2 and NR Cell 3 (if needed in the test) are used. The default parameters for simulated cells are the same as specified in 3GPP TS 38.508-1 [45].

4.15.2 Propagation conditions

See TS 38.533 [47] clause C 2.

4.15.3 Measurement Reporting Requirements

4.15.3.1 Measurement Reporting Requirements in RRC_CONNECTED state

The measurement reporting delay is defined as the time between the moment when the periodic measurement report is triggered and the moment when the UE starts to transmit the measurement report over the air interface. This requirement assumes that the measurement report is not delayed by other LPP signalling on the DCCH. This measurement reporting delay excludes a delay uncertainty resulted when inserting the measurement report to the TTI of the uplink DCCH. The delay uncertainty is: $2 \times TTI_{DCCH}$ where TTI_{DCCH} is the duration of subframe or slot or subslot when the measurement report is transmitted on the PUSCH with subframe or slot or subslot duration. This measurement reporting delay excludes any delay caused by no UL resources for UE to send the measurement report.

4.15.3.2 Measurement Reporting Requirements in RRC_INACTIVE state

See TS 38.133 [50] clause 5.6.2.4.

4.15.4 Measurement Period Requirements

4.15.4.1 Measurement Period Requirements within Measurement Gaps

When physical layer receives last of *NR-TDOA-ProvideAssistanceData* message and *NR-TDOA-RequestLocationInformation* message from LMF via LPP [49], the UE shall be able to measure multiple (up to the UE capability specified in TS 38.133 Clause 9.9.2.3) DL RSTD measurements, defined in TS 38.215 [57], during the measurement period $T_{RSTD,Total}$ defined as:

$$T_{RSTD,Total} = \sum_{i=1}^L T_{RSTD,i} + (L - 1) * \max(T_{effect,i})$$

Where ,

i is the index of positioning frequency layer,

L is total number of positioning frequency layers, and

$T_{\text{effect},i}$ is the periodicity of the PRS RSTD measurement in positioning frequency layer i

$T_{\text{RSTD},i}$ is the measurement period for PRS RSTD measurement in positioning frequency layer i as specified below:

$$T_{\text{RSTD},i} = \left(k_{\text{multiTEG},i} * \text{CSSF}_{\text{PRS},i} * \text{ceil}(K_{\text{p,PRS},i}) * N_{\text{RxBeam},i} * \left\lfloor \frac{N_{\text{PRS},i}^{\text{slot}}}{N'} \right\rfloor \left\lceil \frac{L_{\text{available_PRS},i}}{N} \right\rceil * N_{\text{sample}} - 1 \right) * T_{\text{effect},i} + T_{\text{last},i}$$

where:

$N_{\text{RxBeam},i}$ is the UE Rx beam sweeping factor. In FR1, $N_{\text{RxBeam},i} = 1$;

and in FR2, $N_{\text{RxBeam},i}$ is equal to the value reported by the UE in *supportedLowerRxBeamSweepingFactor-FR2* if the UE supports the capability for the band containing positioning frequency layer i , and the LMF indicates *lowerRxBeamSweepingFactor-FR2* in *NR-DL-TDOA-RequestLocationInformation*. $N_{\text{RxBeam},i}$ is equal to 8, otherwise.

$\text{CSSF}_{\text{PRS},i}$ is the carrier-specific scaling factor for NR PRS-based positioning measurements in positioning frequency layer i as defined in TS 38.133 clause 9.1.5.2.

$k_{\text{multiTEG},i}$ is the scaling factor for measurement of same PRS resource with multiple Rx TEGs.

$k_{\text{multiTEG},i} = 1$ if UE is not requested by LMF to measure a PRS resource with multiple Rx TEGs via *measureSameDL-PRS-ResourceWithDifferentRxTEGs-r17* [49] in *NR-DL-TDOA-RequestLocationInformation*;

otherwise,

$k_{\text{multiTEG},i} = N_{\text{TEG},i}$, if UE is not capable of receiving same DL PRS resource simultaneously from multiple Rx TEGs, and

$k_{\text{multiTEG},i} = \left\lfloor \frac{N_{\text{TEG},i}}{k_{\text{TEG},\text{simul},i}} \right\rfloor$ if UE is capable of receiving the same DL PRS resource simultaneously from multiple Rx TEGs.

where

$N_{\text{TEG},i}$ is the number of Rx TEGs with which UE is requested to measure a PRS resource indicated via *measureSameDL-PRS-ResourceWithDifferentRxTEGs-r17* [49] in *NR-DL-TDOA-RequestLocationInformation*, and in case 'n0' is indicated, $N_{\text{TEG},i}$ is the maximum number of Rx TEGs with which UE can support to measure the same PRS resource as reported in *NR-UE-TEG-Capability*, and

$k_{\text{TEG},\text{simul},i}$ is the number of Rx TEGs UE can measure simultaneously which is reported via *measureSameDL-PRS-ResourceWithDifferentRxTEGsSimul*.

$K_{\text{p,PRS},i}$ is a scaling factor for a positioning frequency layer to be measured within the associated measurement gap pattern, which is defined as $K_{\text{p,PRS},i} = N_{\text{total}} / N_{\text{available}}$ for UE configured with concurrent measurement gap, and $K_{\text{p,PRS},i} = 1$ for UE not configured with concurrent measurement gap.

- For a window W of duration $\max(T_{\text{PRS},j}, \text{MGRP_max})$, where MGRP_max is the maximum MGRP across all configured per-UE MG and per-FR MG within the same FR as the positioning frequency layer, and starting at the beginning of any associated gap occasions covering the PRS occasion:
 - N_{total} is the total number of associated gap occasions covering PRS occasions within the window, including both dropped and non-dropped instances of the associated measurement gap within the window, and
 - $N_{\text{available}}$ is the number of non-dropped associated gap occasions covering PRS occasions within the window W , after further accounting for MG collisions by applying the selected gap collision rule
 - Requirements do not apply if $N_{\text{available}} = 0$.

$N_{PRS,i}^{slot}$ is the maximum number of DL PRS resources in positioning frequency layer i configured in a slot.

$L_{available_PRS,i}$ is the time duration of available PRS in the positioning frequency layer i to be measured during $T_{available_PRS,i}$, and is calculated in the same way as PRS duration K defined in clause 5.1.6.5 of TS 38.214 [56]. For calculation of $L_{available_PRS,i}$, only the PRS resources unmuted and fully or partially overlapped with MG are considered.

N_{sample} is the number of PRS RSTD measurement samples, where

- $N_{sample} = 1$ if the UE supports *supportedDL-PRS-ProcessingSamples-RRC-CONNECTED* [49], and the LMF requests the UE to perform positioning measurements with reduced number of samples, and meets the following conditions:
 - PRS bandwidth is within the active BWP and
 - Magnitude of difference between the serving cell's SS-RSRP and the neighbor cell's PRS-RSRP is within 6 dB.
- $N_{sample} = 2$ if the UE supports *supportedDL-PRS-ProcessingSamples-RRC-CONNECTED* [49], and the LMF requests the UE to perform positioning measurements with reduced number of samples, and does not meet the following conditions:
 - PRS bandwidth is within the active BWP and
 - Magnitude of difference between the serving cell's SS-RSRP and the neighbor cell's PRS-RSRP is within 6 dB.
- $N_{sample} = 4$ otherwise.

$T_{last,i}$ is the measurement duration for the last PRS RSTD sample in positioning frequency layer i , including the sampling time and processing time. If all of the PRS resources to be measured are available in the same MG occasion during $T_{available}$, $T_{last,i} = T_i + MGL$. Otherwise, $T_{last,i} = T_i + T_{available_PRS,i}$,

$T_{effect,i}$ is the periodicity of the PRS RSTD measurement in positioning frequency layer i defined as:

$$T_{effect,i} = \left\lceil \frac{T_i}{T_{available_PRS,i}} \right\rceil * T_{available_PRS,i}$$

Where,

T_i corresponds to *durationOfPRS-ProcessingSymbolsInEveryTms* in TS 37.355 [49],

$T_{available_PRS,i} = LCM(T_{PRS,i}, MGRP_i)$, the least common multiple between $T_{PRS,i}$ and $MGRP_i$.

$MGRP_i$ is the repetition periodicity of the measurement gap applicable for measurement in the PRS frequency layer i . $T_{PRS,i}$ is the periodicity of DL PRS resource with muting on positioning frequency layer i .

If more than one PRS periodicities are configured in positioning frequency layer i , the least common multiple of PRS periodicities $T_{per}^{PRS \text{ with muting}}$ among all DL PRS resource sets in the positioning frequency layer is used to derive $T_{PRS,i}$, where,

$T_{per}^{PRS \text{ with muting}} = N_{muting} * T_{per}^{PRS}$, is the PRS periodicity with muting per PRS resource,

T_{per}^{PRS} is the periodicity of PRS resource sets given by the higher-layer parameter *DL-PRS-Periodicity*.

N_{muting} is the scaling factor considering PRS resource muting. $N_{muting} = T_{muting}^{PRS} * L_{muting}$, where

T_{muting}^{PRS} is the muting repetition factor given by the higher-layer parameter *DL-PRS-MutingBitRepetitionFactor*, and L_{muting} is the size of the bitmap $\{b^1\}$.

- Note: For the purpose of calculating $T_{PRS,i}$, only the PRS resources fully or partially covered by the MG are considered.

$\{N, T\}$ is UE capability combination per band where N is a duration of DL PRS symbols in ms corresponding to *durationOfPRS-ProcessingSymsbols* in TS 37.355 [49] processed every T ms corresponding to *durationOfPRS-ProcessingSymsbolsInEveryTms* in TS 37.355 [49] for a given maximum bandwidth supported by UE corresponding to *supportedBandwidthPRS* in TS 37.355 [49].

N' is UE capability for number of DL PRS resources that it can process in a slot as indicated by *maxNumOfDL-PRS-ResProcessedPerSlot* specified in TS 37.355 [49].

4.15.4.2 Measurement Period Requirements without Measurement Gaps

See TS 38.133 [50] clause 9.9.2.7.

4.15.4.3 Measurement Period Requirements in RRC_INACTIVE state

See TS 38.133 [50] clause 5.6.2.5

4.15.5 Measurement Accuracy Requirements

The accuracy requirements for RSTD measurement shall be within $\pm(X+Y+Z) T_c$.

X is defined in Table 4.15.5-1 for AWGN channel and Table 4.15.5-3 for fading channel for FR1, provided that the following conditions are met.

- Conditions defined in clause 7.3 of TS 38.101-1 [54] for reference sensitivity are fulfilled.
- Conditions for RSTD measurements are fulfilled according to TS 38.133 Annex B.2.14 for a corresponding Band for each relevant PRS resource configured for measurement.
- UE does not perform positioning measurement with reduced number of samples.

X is defined in Table 4.15.5-2 for AWGN channel and Table 4.15.5-4 for fading channel for FR2, provided that the following conditions are met.

- Conditions defined in clause 7.3 of TS 38.101-2 [55] for reference sensitivity are fulfilled.
- Conditions for RSTD measurements are fulfilled according to TS 38.133 Annex B.2.14 for a corresponding Band for each relevant PRS resource configured for measurement.
- UE does not perform positioning measurement with reduced number of samples.

X is defined in Table 4.15.5-7 for AWGN channel in FR1 provided that the following conditions are met.

- Conditions defined in clause 7.3 of TS 38.101-1 [54] for reference sensitivity are fulfilled.
- Conditions for RSTD measurements are fulfilled according to TS 38.133 Annex B.2.14 for a corresponding Band for each relevant PRS resource configured for measurement.
- UE supports positioning measurement with reduced number of sample and is indicated by LMF to perform positioning measurement with reduced number of samples.

X is defined in Table 4.15.5-8 for AWGN channel in FR2 provided that the following conditions are met.

- Conditions defined in clause 7.3 of TS 38.101-1 [54] for reference sensitivity are fulfilled.
- Conditions for RSTD measurements are fulfilled according to Annex B.2.14 for a corresponding Band for each relevant PRS resource configured for measurement.
- UE supports positioning measurement with reduced number of sample and is indicated by LMF to perform positioning measurement with reduced number of samples.

Note: The requiriements for fading channel in this clause are derived based on TDL-A (30 ns delay spread, 5Hz) and TDL-C (60 ns delay spread, 300 Hz) channel models for FR1 and FR2 respectively.

When UE measures RSTD on PRS resources belonging to different PFLs, then the RSTD accuracy is defined as the accuracy corresponding to the largest accuracy value among different PFLs.

If the UE doesn't support Rx TEG reporting for RSTD measurement or when the measurements of reference cell and neighbour cell belong to different Rx TEGs, Y, Z and Δ are defined as follows:

- When UE measures RSTD on PRS resources belonging to same PFL, $Y=32 T_c$, provided that the time offset between the two PRS resource instances from the reference cell and the neighbor cell, which are used for a single RSTD estimate, is no greater than 160 ms.
- When UE measures RSTD on PRS resources belonging different PFLs, $Y=256 T_c$, provided that the time offset between the two PRS resource instances from the reference cell and the neighbor cell, which are used for a single RSTD estimate, is no greater than 1280 ms.
- Z is defined in Table 4.15.5-5 for FR1 and Table 4.15.5-6 for FR2, respectively.
- Δ is zero for single PFL, and is defined in Table 4.15.5-5a for FR1 and Table 4.15.5-6a for FR2, respectively, for dual PFL.

If the measurements of reference cell and neighbour cell belong to the same Rx TEG, i.e. associated and reported with a common Rx TEG ID, then the sum of $Y+Z+\Delta$ is equal to the timing error margin of the Rx TEG reported in *nr-UE-RxTEG-TimingErrorMargin*. The timing error margin reported via *nr-UE-RxTEG-TimingErrorMargin* cannot be larger than the value of $(Y+Z+\Delta)$ defined when the UE does not associate the measurements with the same Rx TEG.

Table 4.15.5-1: RSTD absolute accuracy in FR1 for AWGN channel

Accuracy	Conditions							
	PRS \hat{E}_s/lot	PRS SCS	PRS bandwidth Note 1	PRS resource repetition ($T_{\text{rep}}^{\text{PRS}} * L_{\text{PRS}} / K_{\text{comb}}^{\text{PRS}}$) Note 2	Io Note 3 range			
					NR operating band groups Note 4	Minimum Io	Maximum Io	
T_c Note 5	dB	kHz	RB			dBm/SCS	dBm/BW _{channel}	
132 + Δ Note 7	(PRS \hat{E}_s/lot) _{ref} ≥ -6dB	15	≥24	≥4	NR_FDD_FR1_A, NR_TDD_FR1_A, NR_SDL_FR1_A	-121	-50	
					NR_FDD_FR1_B	-120.5	-50	
					NR_TDD_FR1_C	-120	-50	
					NR_FDD_FR1_D, NR_TDD_FR1_D	-119.5	-50	
					NR_FDD_FR1_E, NR_TDD_FR1_E	-119	-50	
					NR_FDD_FR1_F	-118.5	-50	
					NR_FDD_FR1_G	-118	-50	
98 + Δ	(PRS \hat{E}_s/lot) _i ≥ -13dB	30	≥52	≥1	Note 6	Note 6	Note 6	
42 + Δ			≥104	≥1	Note 6	Note 6	Note 6	
75 + Δ			NR_FDD_FR1_A, NR_TDD_FR1_A, NR_SDL_FR1_A	≥24	≥4	NR_FDD_FR1_A, NR_TDD_FR1_A, NR_SDL_FR1_A	-118	-50
						NR_FDD_FR1_B	-117.5	-50
						NR_TDD_FR1_C	-117	-50
						NR_FDD_FR1_D, NR_TDD_FR1_D	-116.5	-50
						NR_FDD_FR1_E, NR_TDD_FR1_E	-116	-50
	NR_FDD_FR1_F	-115.5				-50		
	NR_FDD_FR1_G	-115				-50		
48 + Δ	(PRS \hat{E}_s/lot) _i ≥ -13dB	60	≥48	≥1	Note 6	Note 6	Note 6	
24 + Δ			≥132	≥1	Note 6	Note 6	Note 6	
50 + Δ			NR_FDD_FR1_A, NR_TDD_FR1_A, NR_SDL_FR1_A	≥24	≥4	NR_FDD_FR1_A, NR_TDD_FR1_A, NR_SDL_FR1_A	-115	-50
						NR_FDD_FR1_B	-114.5	-50
						NR_TDD_FR1_C	-114	-50

					NR_FDD_FR1_D, NR_TDD_FR1_D	-113.5	-50
					NR_FDD_FR1_E, NR_TDD_FR1_E	-113	-50
					NR_FDD_FR1_F	-113.5	-50
					NR_FDD_FR1_G	-113	-50
					NR_FDD_FR1_H	-111.5	-50
24 + Δ			≥ 64	≥ 1	Note 6	Note 6	Note 6
10 + Δ			≥ 132	≥ 1	Note 6	Note 6	Note 6

NOTE 1: Minimum PRS bandwidth, which is minimum of the PRS bandwidths of the reference resource and the measured neighbour resource i.

NOTE 2: Minimum number of PRS resource repetitions among the reference resource and the measured neighbour resource i. T_{rep}^{PRS} , L_{PRS} , K_{comb}^{PRS} are configured by higher layer parameter *dl-PRS-ResourceRepetitionFactor*, *dl-PRS-NumSymbols* and *dl-PRS-CombSizeN* defined in TS 37.355 [49], respectively.

NOTE 3: l_o is assumed to have constant EPRE across the bandwidth.

NOTE 4: NR operating band groups in FR1 are as defined in TS 38.133[50] clause 3.5.2.

NOTE 5: T_c is the basic timing unit defined in TS 38.211 [53].

NOTE 6: The same bands and the same l_o conditions for each band apply for this requirement as for the corresponding requirement with the PRS bandwidth of the smallest RB number for the corresponding SCS.

NOTE 7: Δ= 0 for single PFL, Δ= TBD for dual PFL.

Table 4.15.5-2: RSTD absolute accuracy in FR2 for AWGN channel

Accuracy	Conditions						
	PRS \hat{E}_s/lot	PRS SCS	PRS bandwidth Note 1	PRS resource repetition ($T_{rep}^{PRS} * L_{PRS}/K_{comb}^{PRS}$) Note 2	l_o Note 3 range		
					Minimum l_o	Maximum l_o	
T_c Note 4	dB	kHz	RB		dBm/SCS	dBm/BW _{Channel}	
35 + Δ Note 6	(PRS $\hat{E}_s/lot)_{ref} \geq -6dB$	60	≥ 24	≥ 4	Same value as PRS_RP in TS 38.133[50] Table B.2.14-2, according to UE Power class, operating band and angle of arrival	-50	
24 + Δ			≥ 64	≥ 1	Note 5	Note 5	
11 + Δ			≥ 132	≥ 1	Note 5	Note 5	
24 + Δ	(PRS $\hat{E}_s/lot)_i \geq -13dB$	120	≥ 32	≥ 4	Same value as PRS_RP in TS 38.133[50] Table B.2.14-2, according to UE Power class, operating band and angle of arrival	-50	
13 + Δ			≥ 64	≥ 1	Note 5	Note 5	
6 + Δ			≥ 128	≥ 1	Note 5	Note 5	

NOTE 1: Minimum PRS bandwidth, which is minimum of the PRS bandwidths of the reference resource and the measured neighbour resource i.

NOTE 2: Minimum number of PRS resource repetitions among the reference resource and the measured neighbour resource i. T_{rep}^{PRS} , L_{PRS} , K_{comb}^{PRS} are configured by higher layer parameter *dl-PRS-ResourceRepetitionFactor*, *dl-PRS-NumSymbols* and *dl-PRS-CombSizeN* defined in TS 37.355 [49], respectively.

NOTE 3: l_o is assumed to have constant EPRE across the bandwidth.

NOTE 4: T_c is the basic timing unit defined in TS 38.211 [53].

NOTE 5: The same bands and the same l_o conditions for each band apply for this requirement as for the corresponding requirement with the PRS bandwidth of the smallest RB number for the corresponding SCS.

NOTE 6: Δ= 0 for single PFL, Δ= TBD for dual PFL.

Table 4.15.5-3: RSTD absolute accuracy in FR1 for fading channel

Accuracy	Conditions						
	PRS \hat{E}_s/lot	PRS SCS	PRS bandwidth Note 1	PRS resource repetition	l_o Note 3 range		
					NR operating band groups Note 4	Minimum l_o	Maximum l_o

				$(T_{rep}^{PRS} * L_{PRS} / K_{comb}^{PRS})$ Note 2			
T_c Note 5	dB	kHz	RB			dBm/SCS	dBm/BW _{Channel}
247 + Δ Note 7		15	≥ 24	≥ 4	NR_FDD_FR1_A, NR_TDD_FR1_A, NR_SDL_FR1_A	-121	-50
					NR_FDD_FR1_B	-120.5	-50
					NR_TDD_FR1_C	-120	-50
					NR_FDD_FR1_D, NR_TDD_FR1_D	-119.5	-50
					NR_FDD_FR1_E, NR_TDD_FR1_E	-119	-50
					NR_FDD_FR1_F	-118.5	-50
					NR_FDD_FR1_G	-118	-50
					NR_FDD_FR1_H	-117.5	-50
140 + Δ			≥ 52	≥ 1	Note 6	Note 6	Note 6
86 + Δ			≥ 104	≥ 1	Note 6	Note 6	Note 6
118 + Δ	(PRS $\dot{E}_s/lot)_{ref} \geq -6$ dB (PRS $\dot{E}_s/lot)_i \geq -13$ dB	30	≥ 24	≥ 4	NR_FDD_FR1_A, NR_TDD_FR1_A, NR_SDL_FR1_A	-118	-50
					NR_FDD_FR1_B	-117.5	-50
					NR_TDD_FR1_C	-117	-50
					NR_FDD_FR1_D, NR_TDD_FR1_D	-116.5	-50
					NR_FDD_FR1_E, NR_TDD_FR1_E	-116	-50
					NR_FDD_FR1_F	-115.5	-50
					NR_FDD_FR1_G	-115	-50
					NR_FDD_FR1_H	-114.5	-50
109 + Δ			≥ 48	≥ 1	Note 6	Note 6	Note 6
28 + Δ			≥ 132	≥ 1	Note 6	Note 6	Note 6
147 + Δ		60	≥ 24	≥ 4	NR_FDD_FR1_A, NR_TDD_FR1_A, NR_SDL_FR1_A	-115	-50
					NR_FDD_FR1_B	-114.5	-50
					NR_TDD_FR1_C	-114	-50
					NR_FDD_FR1_D, NR_TDD_FR1_D	-113.5	-50
					NR_FDD_FR1_E, NR_TDD_FR1_E	-113	-50
					NR_FDD_FR1_F	-113.5	-50
					NR_FDD_FR1_G	-113	-50
					NR_FDD_FR1_H	-111.5	-50
27 + Δ			≥ 64	≥ 1	Note 6	Note 6	Note 6
21 + Δ			≥ 132	≥ 1	Note 6	Note 6	Note 6

NOTE 1: Minimum PRS bandwidth, which is minimum of the PRS bandwidths of the reference resource and the measured neighbour resource i.

NOTE 2: Minimum number of PRS resource repetitions among the reference resource and the measured neighbour resource i. T_{rep}^{PRS} , L_{PRS} , K_{comb}^{PRS} are configured by higher layer parameter *dl-PRS-ResourceRepetitionFactor*, *dl-PRS-NumSymbols* and *dl-PRS-CombSizeN* defined in TS 37.355 [49], respectively.

NOTE 3: l_o is assumed to have constant EPRE across the bandwidth.

NOTE 4: NR operating band groups in FR1 are as defined in TS 38.133[50] clause 3.5.2.

NOTE 5: T_c is the basic timing unit defined in TS 38.211 [53].

NOTE 6: The same bands and the same l_o conditions for each band apply for this requirement as for the corresponding requirement with the PRS bandwidth of the smallest RB number for the corresponding SCS.

NOTE 7: $\Delta = 0$ for single PFL, $\Delta =$ TBD for dual PFL.

Table 4.15.5-4: RSTD absolute accuracy in FR2 for fading channel

Accuracy	Conditions			
				l_o Note 3 range

	PRS \hat{E}_s/lot	PRS SCS	PRS bandwidth Note 1	PRS resource repetition ($T_{\text{rep}}^{\text{PRS}} * L_{\text{PRS}}/K_{\text{comb}}^{\text{PRS}}$) Note 2	Minimum I_0	Maximum I_0
T_c Note 4	dB	kHz	RB		dBm/SCS	dBm/BW _{Channel}
$83 + \Delta$ Note 6	(PRS \hat{E}_s/lot) _{ref} \geq -6dB	60	≥ 24	≥ 4	Same value as PRS_RP in TS 38.133[50] Table B.2.14-2, according to UE Power class, operating band and angle of arrival	-50
$64 + \Delta$			≥ 64	≥ 1	Note 5	Note 5
$46 + \Delta$			≥ 132	≥ 1	Note 5	Note 5
$48 + \Delta$	(PRS \hat{E}_s/lot) _i \geq -13dB	120	≥ 32	≥ 4	Same value as PRS_RP in TS 38.133[50] Table B.2.14-2, according to UE Power class, operating band and angle of arrival	-50
$54 + \Delta$			≥ 64	≥ 1	Note 5	Note 5
$36 + \Delta$			≥ 128	≥ 1	Note 5	Note 5

NOTE 1: Minimum PRS bandwidth, which is minimum of the PRS bandwidths of the reference resource and the measured neighbour resource i.

NOTE 2: Minimum number of PRS resource repetitions among the reference resource and the measured neighbour resource i. $T_{\text{rep}}^{\text{PRS}}$, L_{PRS} , $K_{\text{comb}}^{\text{PRS}}$ are configured by higher layer parameter *dl-PRS-ResourceRepetitionFactor*, *dl-PRS-NumSymbols* and *dl-PRS-CombSizeN* defined in TS 37.355 [49], respectively.

NOTE 3: I_0 is assumed to have constant EPRE across the bandwidth.

NOTE 4: T_c is the basic timing unit defined in TS 38.211 [53].

NOTE 5: The same bands and the same I_0 conditions for each band apply for this requirement as for the corresponding requirement with the PRS bandwidth of the smallest RB number for the corresponding SCS.

NOTE 6: $\Delta = 0$ for single PFL, $\Delta = \text{TBD}$ for dual PFL.

Table 4.15.5-5: Margin for RSTD measurement accuracy in FR1

PRS BW (RB number)			Margin (T_c)
SCS=15kHz	SCS=30kHz	SCS=60kHz	
≥ 24	N/A	N/A	120
≥ 52	≥ 24	N/A	72
≥ 104	≥ 48	≥ 24	36
N/A	≥ 132	≥ 64	16
N/A	N/A	≥ 132	12

Table 4.15.5-5a: Margin Δ for RSTD measurement accuracy in FR1

PRS BW (RB number)			Margin (T_c)
SCS=15kHz	SCS=30kHz	SCS=60kHz	
≥ 24	N/A	N/A	128
≥ 52	≥ 24	N/A	64
≥ 104	≥ 48	≥ 24	32
N/A	≥ 132	≥ 64	16
N/A	N/A	≥ 132	8

Table 4.15.6-6: Margin for RSTD measurement accuracy in FR2

PRS BW (RB number)		Margin (T_c)
SCS=60kHz	SCS=120kHz	
≥ 24	N/A	72
≥ 64	≥ 32	32
≥ 132	≥ 64	16
N/A	≥ 128	12

Table 4.15.5-6a: Margin Δ for RSTD measurement accuracy in FR2

PRS BW (RB number)		Margin (Tc)
SCS=60kHz	SCS=120kHz	
≥ 24	N/A	32
≥ 64	≥ 32	16
≥ 132	≥ 64	8
N/A	≥ 128	4

Table 4.15.5-7: RSTD absolute accuracy in FR1 for AWGN channel with reduced number of samples

Accuracy	Conditions						
	PRS Ês/lot	PRS SCS	PRS bandwidth Note 1	PRS resource repetition ($T_{rep}^{PRS} * L_{PRS} / K_{comb}^{PRS}$) Note 2	Io ^{Note 3} range		
					NR operating band groups Note 4	Minimum Io	Maximum Io
Tc ^{Note 5}	dB	kHz	RB			dBm/SCS	dBm/BW _{channel}
98		15	≥ 52	≥ 1	NR_FDD_FR1_A, NR_TDD_FR1_A, NR_SDL_FR1_A	-127	-50
					NR_FDD_FR1_B	-126.5	-50
					NR_TDD_FR1_C	-126	-50
					NR_FDD_FR1_D, NR_TDD_FR1_D	-125.5	-50
					NR_FDD_FR1_E, NR_TDD_FR1_E	-125	-50
					NR_FDD_FR1_F	-124.5	-50
					NR_FDD_FR1_G, NR_TDD_FR1_G	-124	-50
					NR_FDD_FR1_H	-123.5	-50
42			≥ 104	≥ 1	Note 6	Note 6	Note 6
48	(PRS Ês/lot) _{ref} ≥ -3dB (PRS Ês/lot) _i ≥ -6dB	30	≥ 48	≥ 1	NR_FDD_FR1_A, NR_TDD_FR1_A, NR_SDL_FR1_A	-124	-50
					NR_FDD_FR1_B	-123.5	-50
					NR_TDD_FR1_C	-123	-50
					NR_FDD_FR1_D, NR_TDD_FR1_D	-122.5	-50
					NR_FDD_FR1_E, NR_TDD_FR1_E	-122	-50
					NR_FDD_FR1_F	-121.5	-50
					NR_FDD_FR1_G, NR_TDD_FR1_G	-121	-50
					NR_FDD_FR1_H	-120.5	-50
24			≥ 132	≥ 1	Note 6	Note 6	Note 6
24		60	≥ 64	≥ 1	NR_FDD_FR1_A, NR_TDD_FR1_A, NR_SDL_FR1_A	-121	-50
					NR_FDD_FR1_B	-120.5	-50
					NR_TDD_FR1_C	-120	-50
					NR_FDD_FR1_D, NR_TDD_FR1_D	-119.5	-50
					NR_FDD_FR1_E, NR_TDD_FR1_E	-119	-50
					NR_FDD_FR1_F	-118.5	-50
					NR_FDD_FR1_G, NR_TDD_FR1_G	-118	-50
					NR_FDD_FR1_H	-117.5	-50
10			≥ 132	≥ 1	Note 6	Note 6	Note 6

NOTE 1: Minimum PRS bandwidth, which is minimum of the PRS bandwidths of the reference resource and the measured neighbour resource i.

NOTE 2: Minimum number of PRS resource repetitions among the reference resource and the measured neighbour resource i . T_{rep}^{PRS} , L_{PRS} , K_{comb}^{PRS} are configured by higher layer parameter $dl-PRS-ResourceRepetitionFactor$, $dl-PRS-NumSymbols$ and $dl-PRS-CombSizeN$ defined in TS 37.355 [49], respectively.

NOTE 3: I_0 is assumed to have constant EPRE across the bandwidth.

NOTE 4: NR operating band groups in FR1 are as defined in TS 38.133 clause 3.5.2.

NOTE 5: T_c is the basic timing unit defined in TS 38.211 [53].

NOTE 6: The same bands and the same I_0 conditions for each band apply for this requirement as for the corresponding requirement with the PRS bandwidth of the smallest RB number for the corresponding SCS.

NOTE 7: Void

Table 4.15.5-8: RSTD absolute accuracy in FR2 for AWGN channel with reduced number of samples

Accuracy	Conditions					
	PRS \hat{E}_s/lot	PRS SCS	PRS bandwidth Note 1	PRS resource repetition ($T_{rep}^{PRS} * L_{PRS} / K_{comb}^{PRS}$) Note 2	I_0 Note 3 range	
					Minimum I_0	Maximum I_0
T_c Note 4	dB	kHz	RB		dBm/SCS	dBm/BW _{Channel}
24	(PRS \hat{E}_s/lot) _{ref} \geq -3dB	60	≥ 64	≥ 1	Same value as PRS_RP in TS 38.133 Table B.2.14-2, according to UE Power class, operating band and angle of arrival	Note 5
11			≥ 132	≥ 1		Note 5
13	(PRS \hat{E}_s/lot) _i \geq -6dB	120	≥ 64	≥ 1	Same value as PRS_RP in TS 38.133 Table B.2.14-2, according to UE Power class, operating band and angle of arrival	Note 5
6			≥ 128	≥ 1		Note 5

NOTE 1: Minimum PRS bandwidth, which is minimum of the PRS bandwidths of the reference resource and the measured neighbour resource i .

NOTE 2: Minimum number of PRS resource repetitions among the reference resource and the measured neighbour resource i . T_{rep}^{PRS} , L_{PRS} , K_{comb}^{PRS} are configured by higher layer parameter $dl-PRS-ResourceRepetitionFactor$, $dl-PRS-NumSymbols$ and $dl-PRS-CombSizeN$ defined in TS 37.355 [49], respectively.

NOTE 3: I_0 is assumed to have constant EPRE across the bandwidth.

NOTE 4: T_c is the basic timing unit defined in TS 38.211 [53].

NOTE 5: The same bands and the same I_0 conditions for each band apply for this requirement as for the corresponding requirement with the PRS bandwidth of the smallest RB number for the corresponding SCS.

NOTE 6: Void

4.15.6 Reporting mapping

4.15.6.1 Absolute DL RSTD Measurement Reporting

The reporting range for the DL RSTD measurement is defined from $-985024 \times T_c$ to $985024 \times T_c$ with the resolution step of $2^k \times T_c$, where

T_c is defined in TS 38.211 [53],

$$k_{min} \leq k \leq k_{max},$$

$k_{min}=2$ and $k_{max}=5$, when configured PRS resource of at least one of the reference cell and neighbour cell measured for the RSTD measurement is in FR1,

$k_{min}=0$ and $k_{max}=5$, when configured PRS resource of both the reference cell and neighbour cell measured for the RSTD measurement are in FR2,

$k \geq timingReportingGranularityFactor$ [49] configured by LMF via LPP for the RSTD measurement.

The measurement report mapping for different k values are specified in Tables 4.15.6.1-1 – 4.15.6.1-6.

Table 4.15.6.1-1: Report mapping for $k=0$

Reported Quantity Value, RSTD_i	Measured Quantity Value, RSTD	Unit
RSTD_000000	$RSTD < -985024$	T_c
RSTD_000001	$-985024 \leq RSTD < -985023$	T_c
RSTD_000002	$-985023 \leq RSTD < -985022$	T_c
...
RSTD_0985024	$-1 \leq RSTD < 0$	T_c
RSTD_0985025	$0 \leq RSTD < 1$	T_c
...
RSTD_1970047	$985022 \leq RSTD < 985023$	T_c
RSTD_1970048	$985023 \leq RSTD < 985024$	T_c
RSTD_1970049	$985024 \leq RSTD$	T_c

Table 4.15.6.1-2: Report mapping for $k=1$

Reported Quantity Value, RSTD_i	Measured Quantity Value, RSTD	Unit
RSTD_000000	$RSTD < -985024$	T_c
RSTD_000001	$-985024 \leq RSTD < -985022$	T_c
RSTD_000002	$-985022 \leq RSTD < -985020$	T_c
...
RSTD_492512	$-2 \leq RSTD < 0$	T_c
RSTD_492513	$0 \leq RSTD < 2$	T_c
...
RSTD_985023	$985020 \leq RSTD < 985022$	T_c
RSTD_985024	$985022 \leq RSTD < 985024$	T_c
RSTD_985025	$985024 \leq RSTD$	T_c

Table 4.15.6.1-3: Report mapping for $k=2$

Reported Quantity Value, RSTD_i	Measured Quantity Value, RSTD	Unit
RSTD_000000	$RSTD < -985024$	T_c
RSTD_000001	$-985024 \leq RSTD < -985020$	T_c
RSTD_000002	$-985020 \leq RSTD < -985016$	T_c
...
RSTD_246256	$-4 \leq RSTD < 0$	T_c
RSTD_246257	$0 \leq RSTD < 4$	T_c
...
RSTD_492511	$985016 \leq RSTD < 985020$	T_c
RSTD_492512	$985020 \leq RSTD < 985024$	T_c
RSTD_492513	$985024 \leq RSTD$	T_c

Table 4.15.6.1-4: Report mapping for $k=3$

Reported Quantity Value RSTD_i	Measured Quantity Value, RSTD	Unit
RSTD_000000	$RSTD < -985024$	T_c
RSTD_000001	$-985024 \leq RSTD < -985016$	T_c
RSTD_000002	$-985016 \leq RSTD < -985008$	T_c
...
RSTD_123128	$-8 \leq RSTD < 0$	T_c
RSTD_123129	$0 \leq RSTD < 8$	T_c
...
RSTD_246255	$985008 \leq RSTD < 985016$	T_c
RSTD_246256	$985016 \leq RSTD < 985024$	T_c
RSTD_246257	$985024 \leq RSTD$	T_c

Table 4.15.6.1-5: Report mapping for $k=4$

Reported Quantity Value, RSTD_i	Measured Quantity Value, RSTD	Unit
RSTD_000000	RSTD < -985024	T _c
RSTD_000001	-985024 ≤ RSTD < -985008	T _c
RSTD_000002	-985008 ≤ RSTD < -984992	T _c
...
RSTD_061564	-16 ≤ RSTD < 0	T _c
RSTD_061565	0 ≤ RSTD < 16	T _c
...
RSTD_123127	984992 ≤ RSTD < 985008	T _c
RSTD_123128	985008 ≤ RSTD < 985024	T _c
RSTD_123129	985024 ≤ RSTD	T _c

Table 4.15.6.1-6: Report mapping for $k=5$

Reported Quantity Value, RSTD_i	Measured Quantity Value, RSTD	Unit
RSTD_00000	RSTD < -985024	T _c
RSTD_00001	-985024 ≤ RSTD < -984992	T _c
RSTD_00002	-984992 ≤ RSTD < -984960	T _c
...
RSTD_30782	-32 ≤ RSTD < 0	T _c
RSTD_30783	0 ≤ RSTD < 32	T _c
...
RSTD_61563	984960 ≤ RSTD < 984992	T _c
RSTD_61564	984992 ≤ RSTD < 985024	T _c
RSTD_61565	985024 ≤ RSTD	T _c

4.15.6.2 Differential Reporting for DL RSTD Measurement

A first DL RSTD measurement is reported by means of differential reporting, i.e. as Δ RSTD, relative to a second DL RSTD measurement (RSTD2), provided that:

- the absolute measured quantity value of the second DL RSTD measurement (RSTD2) is not larger than the absolute measured quantity value of the first DL RSTD measurement (RSTD1), i.e., Δ RSTD=RSTD1-RSTD2 \geq 0, and
- the absolute value of the second DL RSTD measurement (RSTD2) is reported together with Δ RSTD for the first DL RSTD measurement.

The reporting range for differential reporting Δ RSTD of the first DL RSTD measurement is defined from 0 up to $8191 \times T_c$ with the resolution step of $2^k \times T_c$, where

T_c is defined in TS 38.211 [53],

$$k_{\min} \leq k \leq k_{\max},$$

$k_{\min}=2$ and $k_{\max}=5$, when configured PRS resource of at least one of the reference cell and neighbour cell measured for the first RSTD measurement or second RSTD measurement is in FR1,

$k_{\min}=0$ and $k_{\max}=5$, when configured PRS resource of both the reference cell and neighbour cell measured for both of the first RSTD measurement and the second RSTD measurement are in FR2,

$k \geq \text{timingReportingGranularityFactor}$ [49] configured by LMF via LPP for the RSTD measurement.

The measurement report mapping for different k values are specified in Tables 4.15.6.2-1 – 4.15.6.2-6.

Table 4.15.6.2-1: Report mapping for $k=0$

Reported Quantity Value, DIFFRSTD _i	$\Delta\text{RSTD} = \text{RSTD1} - \text{RSTD2}$	Unit
DIFFRSTD_0000	$0 \leq \Delta\text{RSTD} < 1$	T_c
DIFFRSTD_0001	$1 \leq \Delta\text{RSTD} < 2$	T_c
DIFFRSTD_0002	$2 \leq \Delta\text{RSTD} < 3$	T_c
...
DIFFRSTD_8189	$8189 \leq \Delta\text{RSTD} < 8190$	T_c
DIFFRSTD_8190	$8190 \leq \Delta\text{RSTD} < 8191$	T_c
DIFFRSTD_8191	$8191 \leq \Delta\text{RSTD}$	T_c

Table 4.15.6.2-2: Report mapping for $k=1$

Reported Quantity Value, DIFFRSTD _i	$\Delta\text{RSTD} = \text{RSTD1} - \text{RSTD2}$	Unit
DIFFRSTD_0000	$0 \leq \Delta\text{RSTD} < 2$	T_c
DIFFRSTD_0001	$2 \leq \Delta\text{RSTD} < 4$	T_c
DIFFRSTD_0002	$4 \leq \Delta\text{RSTD} < 6$	T_c
...
DIFFRSTD_4093	$8186 \leq \Delta\text{RSTD} < 8188$	T_c
DIFFRSTD_4094	$8188 \leq \Delta\text{RSTD} < 8190$	T_c
DIFFRSTD_4095	$8190 \leq \Delta\text{RSTD}$	T_c

Table 4.15.6.2-3: Report mapping for $k=2$

Reported Quantity Value, DIFFRSTD _i	$\Delta\text{RSTD} = \text{RSTD1} - \text{RSTD2}$	Unit
DIFFRSTD_0000	$0 \leq \Delta\text{RSTD} < 4$	T_c
DIFFRSTD_0001	$4 \leq \Delta\text{RSTD} < 8$	T_c
DIFFRSTD_0002	$8 \leq \Delta\text{RSTD} < 12$	T_c
...
DIFFRSTD_2045	$8180 \leq \Delta\text{RSTD} < 8184$	T_c
DIFFRSTD_2046	$8184 \leq \Delta\text{RSTD} < 8188$	T_c
DIFFRSTD_2047	$8188 \leq \Delta\text{RSTD}$	T_c

Table 4.15.6.2-4: Report mapping for $k=3$

Reported Quantity Value, DIFFRSTD _i	$\Delta\text{RSTD} = \text{RSTD1} - \text{RSTD2}$	Unit
DIFFRSTD_0000	$0 \leq \Delta\text{RSTD} < 8$	T_c
DIFFRSTD_0001	$8 \leq \Delta\text{RSTD} < 16$	T_c
DIFFRSTD_0002	$16 \leq \Delta\text{RSTD} < 24$	T_c
...
DIFFRSTD_1021	$8168 \leq \Delta\text{RSTD} < 8176$	T_c
DIFFRSTD_1022	$8176 \leq \Delta\text{RSTD} < 8184$	T_c
DIFFRSTD_1023	$8184 \leq \Delta\text{RSTD}$	T_c

Table 4.15.6.2-5: Report mapping for $k=4$

Reported Quantity Value, DIFFRSTD _i	$\Delta\text{RSTD} = \text{RSTD1} - \text{RSTD2}$	Unit
DIFFRSTD_000	$0 \leq \Delta\text{RSTD} < 16$	T_c
DIFFRSTD_001	$16 \leq \Delta\text{RSTD} < 32$	T_c
DIFFRSTD_002	$32 \leq \Delta\text{RSTD} < 48$	T_c
...
DIFFRSTD_509	$8144 \leq \Delta\text{RSTD} < 8160$	T_c
DIFFRSTD_510	$8160 \leq \Delta\text{RSTD} < 8176$	T_c

DIFFRSTD_511	$8176 \leq \Delta RSTD$	T_c
--------------	-------------------------	-------

Table 4.15.6.2-6: Report mapping for $k=5$

Reported Quantity Value, DIFFRSTD_i	$\Delta RSTD = RSTD1 - RSTD2$	Unit
DIFFRSTD_000	$0 \leq \Delta RSTD < 32$	T_c
DIFFRSTD_001	$32 \leq \Delta RSTD < 64$	T_c
DIFFRSTD_002	$64 \leq \Delta RSTD < 96$	T_c
...
DIFFRSTD_253	$8096 \leq \Delta RSTD < 8128$	T_c
DIFFRSTD_254	$8128 \leq \Delta RSTD < 8160$	T_c
DIFFRSTD_255	$8160 \leq \Delta RSTD$	T_c

4.15.6.3 Additional Path Report Mapping for DL RSTD

The reporting range for the additional path reporting for an RSTD measurement is defined up to the range from $-8175 \times T_c$ to $8175 \times T_c$ with the resolution step of $2^k \times T_c$, where

T_c is defined in TS 38.211 [53],

$k_{min} \leq k \leq k_{max}$,

$k_{min}=2$ and $k_{max}=5$, when configured PRS resource of at least one of the reference cell and neighbour cell measured for the RSTD measurement is in FR1,

$k_{min}=0$ and $k_{max}=5$, when configured PRS resource of both the reference cell and neighbour cell measured for the RSTD measurement are in FR2,

$k \geq \text{timingReportingGranularityFactor}$ [49] configured by LMF via LPP for the RSTD measurement.

The UE can report the timing of up to two additional paths with respect to the path timing determining the RSTD measurement.

The report mappings for different k values are specified in Tables 10.1.23.3.3-1 – 10.1.23.3.3-6.

Table 10.1.23.3.3-1: Report mapping for $k=0$

Reported Quantity Value, path_i	Measured Quantity Value, $\Delta path$	Unit
path_00000	$\Delta path < -8175$	T_c
path_00001	$-8175 \leq \Delta path < -8174$	T_c
path_00002	$-8174 \leq \Delta path < -8173$	T_c
...
path_08175	$-1 \leq \Delta path < 0$	T_c
path_08176	$0 \leq \Delta path < 1$	T_c
...
path_16349	$8173 \leq \Delta path < 8174$	T_c
path_16350	$8174 \leq \Delta path < 8175$	T_c
path_16351	$8175 \leq \Delta path$	T_c

Table 10.1.23.3.3-2: Report mapping for $k=1$

Reported Quantity Value, path_i	Measured Quantity Value, $\Delta path$	Unit
path_0000	$\Delta path < -8175$	T_c
path_0001	$-8175 \leq \Delta path < -8173$	T_c
path_0002	$-8173 \leq \Delta path < -8171$	T_c
...
path_4088	$-1 \leq \Delta path < 1$	T_c
...

path_8174	$8171 \leq \Delta\text{path} < 8173$	T_c
path_8175	$8173 \leq \Delta\text{path} < 8175$	T_c
path_8176	$8175 \leq \Delta\text{path}$	T_c

Table 10.1.23.3.3-3: Report mapping for $k=2$

Reported Quantity Value, path_i	Measured Quantity Value, Δpath	Unit
path_0000	$\Delta\text{path} < -8174$	T_c
path_0001	$-8174 \leq \Delta\text{path} < -8170$	T_c
path_0002	$-8170 \leq \Delta\text{path} < -8166$	T_c
...
path_2044	$-2 \leq \Delta\text{path} < 2$	T_c
...
path_4086	$8166 \leq \Delta\text{path} < 8170$	T_c
path_4087	$8170 \leq \Delta\text{path} < 8174$	T_c
path_4088	$8174 \leq \Delta\text{path}$	T_c

Table 10.1.23.3.3-4: Report mapping for $k=3$

Reported Quantity Value, path_i	Measured Quantity Value, Δpath	Unit
path_0000	$\Delta\text{path} < -8172$	T_c
path_0001	$-8172 \leq \Delta\text{path} < -8164$	T_c
path_0002	$-8164 \leq \Delta\text{path} < -8156$	T_c
...
path_1022	$-4 \leq \Delta\text{path} < 4$	T_c
...
path_2042	$8156 \leq \Delta\text{path} < 8164$	T_c
path_2043	$8164 \leq \Delta\text{path} < 8172$	T_c
path_2044	$8172 \leq \Delta\text{path}$	T_c

Table 10.1.23.3.3-5: Report mapping for $k=4$

Reported Quantity Value, path_i	Measured Quantity Value, Δpath	Unit
path_0000	$\Delta\text{path} < -8168$	T_c
path_0001	$-8168 \leq \Delta\text{path} < -8152$	T_c
path_0002	$-8152 \leq \Delta\text{path} < -8136$	T_c
...
path_511	$-8 \leq \Delta\text{path} < 8$	T_c
...
path_1020	$8136 \leq \Delta\text{path} < 8152$	T_c
path_1021	$8152 \leq \Delta\text{path} < 8168$	T_c
path_1022	$8168 \leq \Delta\text{path}$	T_c

Table 10.1.23.3.3-6: Report mapping for $k=5$

Reported Quantity Value, path_i	Measured Quantity Value, Δpath	Unit
path_000	$\Delta\text{path} < -8160$	T_c
path_001	$-8160 \leq \Delta\text{path} < -8128$	T_c
path_002	$-8128 \leq \Delta\text{path} < -8096$	T_c
...
path_256	$0 \leq \Delta\text{path} < 32$	T_c
...
path_509	$8096 \leq \Delta\text{path} < 8128$	T_c
path_510	$8128 \leq \Delta\text{path} < 8160$	T_c
path_511	$8160 \leq \Delta\text{path}$	T_c

4.16 DL-AoD test conditions

4.16.1 Simulated cells

For the DL-AoD measurement test cases in clause 16, a multi cell environment as defined in 3GPP TS 38.508-1 [45] with NR Cell 1 and NR Cell 2 are used. The default parameters for simulated cells are the same as specified in 3GPP TS 38.508-1 [45].

4.16.2 Propagation conditions

For PRS-RSRP test cases see TS 38.533 [47] clause C 2.

For PRS-RSRPP test cases see TS 38.521-4 [60] clause B.2.4.

4.16.3 Measurement Reporting Requirements

4.16.3.1 Measurement Reporting Requirements in RRC_CONNECTED state

The measurement reporting delay is defined as the time between the moment when the periodic measurement report is triggered and the moment when the UE starts to transmit the measurement report over the air interface. This requirement assumes that the measurement report is not delayed by other LPP signalling on the DCCH. This measurement reporting delay excludes a delay uncertainty resulted when inserting the measurement report to the TTI of the uplink DCCH. The delay uncertainty is: $2 \times TTI_{DCCH}$ where TTI_{DCCH} is the duration of subframe or slot or subslot when the measurement report is transmitted on the PUSCH with subframe or slot or subslot duration. This measurement reporting delay excludes any delay caused by no UL resources for UE to send the measurement report.

4.16.3.2 Measurement Reporting Requirements in RRC_INACTIVE state

See TS 38.133 [50] clause 5.6.3.4.

4.16.4 PRS-RSRP Measurement Period Requirements

4.16.4.1 Measurement Period Requirements within Measurement Gaps

When the physical layer receives *NR-DL-AoD-ProvideAssistanceData* message and *NR-DL-AoD-RequestLocationInformation* message from LMF via LPP [49], the UE shall be able to measure multiple (up to the UE capability specified in TS 38.133 Clause 9.9.3.3) PRS-RSRP measurements, defined in TS 38.215 [57], from configured PRS resources for configured TRPs on configured positioning frequency layers, within $T_{PRS-RSRP,total}$ ms.

$$T_{PRS-RSRP, total} = \sum_{i=1}^L T_{PRS-RSRP,i} + (L - 1) * \max(T_{effect,i})$$

where

i is the index of positioning frequency layer,

L is total number of positioning frequency layers,

$T_{effect,i}$ is the periodicity of the PRS-RSRP measurement in positioning frequency layer i .

$$T_{PRS-RSRP,i} = \left(CSSF_i * \text{ceil}(K_{p,PRS,i}) * N_{RxBeam,i} * \left\lceil \frac{N_{PRS,i}^{slot}}{N'} \right\rceil \left\lceil \frac{L_{available_PRS,i}}{N} \right\rceil * N_{sample} - 1 \right) * T_{effect,i} + T_{last}$$

where

$CSSF_i$ is the carrier specific scaling factor for PRS-RSRP measurements specified in TS 38.133 clause 9.1.5.2,

$K_{p,PRS,i}$ is a scaling factor for a positioning frequency layer to be measured within the associated measurement gap pattern, which is defined as $K_{p,PRS,i} = N_{total} / N_{available}$ for UE configured with concurrent measurement gap, and $K_{p,PRS,i} = 1$ for UE not configured with concurrent measurement gap.

For a window W of duration $\max(T_{PRS,i}, MGRP_max)$, where $MGRP_max$ is the maximum MGRP across all configured per-UE MG and per-FR MG within the same FR as the positioning frequency layer, and starting at the beginning of any associated gap occasions covering the PRS occasion:

N_{total} is the total number of associated gap occasions covering PRS occasions within the window, including both dropped and non-dropped instances of the associated measurement gap within the window, and

$N_{available}$ is the number of non-dropped associated gap occasions covering PRS occasions within the window W , after further accounting for MG collisions by applying the selected gap collision rule

Requirements do not apply if $N_{available} = 0$.

$N_{RxBeam,i}$ is the scaling factor for Rx beam sweeping, and $N_{RxBeam,i} = 1$ if positioning frequency layer i is in FR1 and if positioning frequency layer i is in FR2, $N_{RxBeam,i}$ is equal to the value reported by the UE in *supportedLowerRxBeamSweepingFactor-FR2* if the UE supports the capability for the band containing positioning frequency layer i , and the LMF indicates *lowerRxBeamSweepingFactor-FR2* in *NR-DL-TDOA-RequestLocationInformation*. $N_{RxBeam,i}$ is equal to 8, otherwise.

$L_{available_PRS,i}$ is the time duration of available PRS to be measured in the positioning frequency layer i to be measured during $T_{available_PRS,i}$, and is calculated in the same way as PRS duration K defined in TS 38.133 clause 5.1.6.5 of TS 38.214 [56]. For calculation of $L_{available_PRS,i}$, only the PRS resources unmuted and fully or partially overlapped with MG are considered.

$N_{PRS,i}^{slot}$ is the maximum number of DL PRS resources of positioning frequency layer i configured in a slot,

$\{N, T\}$ is UE capability combination per band where N is a duration of DL PRS symbols in ms corresponding to *durationOfPRS-ProcessingSymbols* in TS 37.355 [49] processed every T ms corresponding to *durationOfPRS-ProcessingSymbolsInEveryTms* in TS 37.355 [49] for a given maximum bandwidth supported by UE corresponding to *supportedBandwidthPRS* in TS 37.355 [49],

N' is UE capability for number of DL PRS resources that it can process in a slot as indicated by *maxNumOfDL-PRS-ResProcessedPerSlot* in clause 6.4.3 of TS 37.355 [49],

N_{sample} is the number of PRS RSRP measurement samples, where

- $N_{sample} = 1$ if the UE supports *supportedDL-PRS-ProcessingSamples-RRC-CONNECTED* [49], and the LMF requests the UE to perform positioning measurements with reduced number of samples, and meets the following conditions:
 - PRS bandwidth is within the active BWP and
 - Magnitude of difference between the serving cell's SS-RSRP and the neighbor cell's PRS-RSRP is within 6 dB.
- $N_{sample} = 2$ if the UE supports *supportedDL-PRS-ProcessingSamples-RRC-CONNECTED* [49], and the LMF requests the UE to perform positioning measurements with reduced number of samples, and does not meet the following conditions:
 - PRS bandwidth is within the active BWP and
 - Magnitude of difference between the serving cell's SS-RSRP and the neighbor cell's PRS-RSRP is within 6 dB.
- $N_{sample} = 4$ otherwise.

$T_{last,i} = T_i + T_{available_PRS,i}$ is the measurement duration for the last PRS-RSRP sample, including the sampling time and processing time, if not all PRS resources to be measured are available in the same measurement gap occasion during $T_{available_PRS,i}$, otherwise $T_{last,i} = T_i + MGL$,

$T_{effect,i} = \left\lceil \frac{T_i}{T_{available_PRS,i}} \right\rceil * T_{available_PRS,i}$ is the periodicity of PRS-RSRP measurement in positioning frequency layer i ,

T_i corresponds to durationOfPRS-ProcessingSymbolsInEveryTms in TS 37.355 [49],

$T_{available_PRS,i} = LCM(T_{PRS,i}, MGRP_i)$ is the least common multiple between $T_{PRS,i}$ and $MGRP_i$,

$T_{PRS,i}$ is the maximum PRS resource periodicity among all PRS resources in positioning frequency layer i ,

$MGRP_i$ is the measurement gap repetition period in positioning frequency layer i .

If positioning frequency layer i has more than one DL PRS resource set with different PRS periodicities with muting, $T_{per}^{PRS\ with\ muting} = N_{muting} * T_{per}^{PRS}$, the least common multiple of $T_{per}^{PRS\ with\ muting}$ among the DL PRS resource sets is used to derive $T_{PRS,i}$, where:

T_{per}^{PRS} is the periodicity of PRS resource sets given by the higher-layer parameter *DL-PRS-Periodicity*.

N_{muting} is the scaling factor considering PRS resource muting. $N_{muting} = T_{muting}^{PRS} * L_{muting}$, where T_{muting}^{PRS} is the muting repetition factor given by the higher-layer parameter *DL-PRS-MutingBitRepetitionFactor*, and L_{muting} is the size of the bitmap $\{b^1\}$.

4.16.4.2 Measurement Period Requirements without Measurement Gaps

See TS 38.133 [50] clause 9.9.3.6.

4.16.4.3 Measurement Period Requirements in RRC_INACTIVE state

See TS 38.133 [50] clause 5.6.3.5

4.16.5 PRS-RSRP Measurement Accuracy Requirements

The absolute accuracy requirements for PRS-RSRP measurement for FR1 defined in Table 4.16.5-1 are valid under the following conditions:

Conditions defined in 38.101-1 Clause 7.3 for reference sensitivity are fulfilled.

PRP 1,2_{dBm} according to TS 38.133 Annex B.2.14 for a corresponding Band

UE does not support positioning measurements with reduced number of samples, or LMF does not indicate UE to perform positioning measurements with reduced number of samples

Table 4.16.5-1: PRS-RSRP absolute accuracy for FR1

Accuracy		Conditions							
Normal condition	Extreme condition	PRS $\hat{\epsilon}$ s/lot	PRS BW	Repetition factor ($T_{rep}^{PRS} * L_{PRS} / K_{comb}^{PRS}$)	NR operating band groups Note 8	Io ^{Note 7} range			Maximum Io
						dBm / SCS _{PRS}			
dB	dB	dB	PRB	-		dBm / SCS _{PRS}			dBm/BW _{Channel}
						dBm/15k Hz Note 6	dBm/30kHz z Note 6	dBm/60kHz Note 6	
±3.5	±8	≥-3dB	≥24	All	NR_FDD_FR1_A, NR_TDD_FR1_A, NR_SDL_FR1_A	-127	-124	-121	-50
					NR_FDD_FR1_B	-126.5	-123.5	-120.5	-50

					NR_TDD_FR1_C	-126	-123	-120	-50
					NR_FDD_FR1_D, NR_TDD_FR1_D	-125.5	-122.5	-119.5	-50
					NR_FDD_FR1_E, NR_TDD_FR1_E	-125	-122	-119	-50
					NR_FDD_FR1_F	-124.5	-121.5	-118.5	-50
					NR_FDD_FR1_G	-124	-121	-118	-50
					NR_FDD_FR1_H	-123.5	-120.5	-117.5	-50
					Note 4				
					Note 4				
±8.5	±13	≥-13dB	24 ≤ BW ≤ 52	All	Note 4				
±6	±10.5		52 < BW ≤ 104	All	Note 4				
±4.5	±9		BW >104	All	Note 4				
NOTE 1: This minimum Io condition is expressed as the average Io per RE over all REs in an OFDM symbol.									
NOTE 2: Void.									
NOTE 3: PRS bandwidth is as indicated in <i>prs-Bandwidth</i> in the OTDOA or DL-AoD assistance data defined in TS 37.355 [49].									
NOTE 4: The same bands and the same Io conditions for each band apply for this requirement as for the corresponding requirement with the PRS bandwidth ≥ 24 RB.									
NOTE 5: The serving cell, the reference cell, and the measured neighbour cell i are on the same carrier frequency.									
NOTE 6: The condition level is increased by Δ>0, when applicable, as described in TS 38.133[50] Sections B.3.2 and B.3.3.									
NOTE 7: The Io is defined in PRS positioning subframes. The same Io range applies to PRS and non-PRS symbols. Io levels are different in PRS and non-PRS symbols within the same subframe.									
NOTE 8: NR operating band groups are as defined in TS 38.133[50] Section 3.5.2.									

The absolute accuracy requirements for PRS-RSRP measurement for FR2 defined in Table 4.16.5-2 are valid under the following conditions:

Conditions defined in 38.101-2 Clause 7.3 for reference sensitivity are fulfilled.

PRP 1,2_{dBm} according to TS 38.133[50] Annex B.2.14 for a corresponding Band

UE does not support positioning measurements with reduced number of samples, or LMF does not indicate UE to perform positioning measurements with reduced number of samples

Table 4.16.5-2: PRS-RSRP absolute accuracy for FR2

Accuracy		Conditions				
Normal condition	Extreme condition	PRS Ês/lot	PRS BW	Repetition factor ($T_{rep}^{PRS} * L_{PRS} / K_{comb}^{PRS}$)	Io ^{Note 7} range	
					Minimum Io ^{Note 1} dBm / SCS _{PRS}	Maximum Io
dB	dB	dB	PRB	-	dBm / SCS _{PRS}	
					dBm/120kHz ^{Note 6}	dBm/60kHz ^{Note 6}
±5	±8	≥-3dB	≥24	All	Same value as PRP in TS 38.133[50]Table B.2.14 -2, according to UE Power class, operating band and angle of arrival	
					-50	
					Note 4	
					Note 4	

± 8.5	± 11.5	≥ -13 dB	$24 \leq BW \leq 64$	All	Note 4
± 6	± 9		$BW > 64$	All	Note 4
<p>NOTE 1: This minimum I_o condition is expressed as the average I_o per RE over all REs in an OFDM symbol.</p> <p>NOTE 2: Void.</p> <p>NOTE 3: PRS bandwidth is as indicated in <i>prs-Bandwidth</i> in the OTDOA or DL-AoD assistance data defined in TS 37.355[49].</p> <p>NOTE 4: The same bands and the same I_o conditions for each band apply for this requirement as for the corresponding requirement with the PRS bandwidth ≥ 24 RB.</p> <p>NOTE 5: The serving cell, the reference cell, and the measured neighbour cell i are on the same carrier frequency.</p> <p>NOTE 6: The condition level is increased by $\Delta > 0$, when applicable, as described in TS 38.133[50] Sections B.3.2 and B.3.3.</p> <p>NOTE 7: The I_o is defined in PRS positioning subframes. The same I_o range applies to PRS and non-PRS symbols. I_o levels are different in PRS and non-PRS symbols within the same subframe.</p> <p>NOTE 8: NR operating band groups are as defined in TS 38.133[50] Section 3.5.2.</p>					

The absolute accuracy requirements for PRS-RSRP measurement for FR1 defined in Table 4.16.5-2a are valid under the following conditions:

- Conditions defined in 38.101-1 Clause 7.3 for reference sensitivity are fulfilled.
- PRP $1,2_{dBm}$ according to TS 38.133 Annex B.2.14 for a corresponding Band
- UE supports positioning measurements with reduced number of samples, and LMF indicates UE to perform positioning measurements with reduced number of samples
- AWGN channel

The absolute accuracy requirements for PRS-RSRP measurement for FR2 defined in Table 4.16.5-2b are valid under the following conditions:

- Conditions defined in 38.101-2 Clause 7.3 for reference sensitivity are fulfilled.
- PRP $1,2_{dBm}$ according to Annex B.2.14 for a corresponding Band
- UE supports positioning measurements with reduced number of samples, and LMF indicates UE to perform positioning measurements with reduced number of samples
- AWGN channel

Table 4.16.5-2a: PRS-RSRP absolute accuracy for FR1 with reduced sample number

Accuracy		Conditions							
Normal condition	Extreme condition	PRS \hat{E}_s/lot	PRS BW	Repetition factor $(T_{rep}^{PRS} * L_{PRS}/K_{comb}^{PRS})$	NR operating band groups Note 7	I_o Note 6 range			Maximum I_o
						dBm / SCS _{PRS}			
dB	dB	dB	PRB	-	dBm / SCS _{PRS}			dBm/BW _{Channel}	
					dBm/15k Hz Note 5	dBm/30k Hz Note 5	dBm/60kHz Note 5		
± 3.5	± 8	≥ 0	≥ 48	All	NR_FDD_FR1_A, NR_TDD_FR1_A, NR_SDL_FR1_A	-127	-124	-121	-50
					NR_FDD_FR1_B	-126.5	-123.5	-120.5	-50
					NR_TDD_FR1_C	-126	-123	-120	-50
					NR_FDD_FR1_D, NR_TDD_FR1_D	-125.5	-122.5	-119.5	-50
					NR_FDD_FR1_E, NR_TDD_FR1_E	-125	-122	-119	-50
					NR_FDD_FR1_F	-124.5	-121.5	-118.5	-50
					NR_FDD_FR1_G, NR_TDD_FR1_G	-124	-121	-118	-50
				NR_FDD_FR1_H	-123.5	-120.5	-117.5	-50	
± 8.5	± 13	≥ -6	$48 \leq BW \leq 52$	All	Note 3				

±6	±10.5		52 < BW ≤ 104	All	Note 3
±4.5	±9		BW >104	All	Note 3

NOTE 1: This minimum I_0 condition is expressed as the average I_0 per RE over all REs in an OFDM symbol.
 NOTE 2: PRS bandwidth is as indicated in *prs-Bandwidth* in the OTDOA or DL-AoD assistance data defined in [49].
 NOTE 3: The same bands and the same I_0 conditions for each band apply for this requirement as for the corresponding requirement with the PRS bandwidth ≥ 48 RB.
 NOTE 4: The serving cell, the reference cell, and the measured neighbour cell i are on the same carrier frequency.
 NOTE 5: The condition level is increased by $\Delta > 0$, when applicable, as described in TS 38.133 Sections B.3.2 and B.3.3.
 NOTE 6: The I_0 is defined in PRS positioning subframes. The same I_0 range applies to PRS and non-PRS symbols. I_0 levels are different in PRS and non-PRS symbols within the same subframe.
 NOTE 7: NR operating band groups are as defined in TS 38.133 Section 3.5.2.

Table 4.16.5-2b: PRS-RSRP absolute accuracy for FR2 with reduced sample number

Accuracy		Conditions				
Normal condition	Extreme condition	PRS \hat{E}_s/lot	PRS BW	Repetition factor ($T_{\text{rep}}^{\text{PRS}} * L_{\text{PRS}} / K_{\text{comb}}^{\text{PRS}}$)	I_0 ^{Note 6} range	
					Minimum I_0 ^{Note 1} dBm / SCS _{PRS}	Maximum I_0
dB	dB	dB	PRB	-	dBm / SCS _{PRS}	dBm/BW _{Channel}
					dBm/120kHz ^{Note 5}	dBm/60kHz ^{Note 5}
±5	±8	≥0	≥48	All	Same value as PRP in TS 38.133 Table B.2.14-2, according to UE Power class, operating band and angle of arrival	
±8.5	±11.5	≥-6	48 ≤ BW ≤ 64	All	Note 3	
±6	±9		BW >64	All	Note 3	

NOTE 1: This minimum I_0 condition is expressed as the average I_0 per RE over all REs in an OFDM symbol.
 NOTE 2: PRS bandwidth is as indicated in *prs-Bandwidth* in the OTDOA or DL-AoD assistance data defined in [49].
 NOTE 3: The same bands and the same I_0 conditions for each band apply for this requirement as for the corresponding requirement with the PRS bandwidth ≥ 48 RB.
 NOTE 4: The serving cell, the reference cell, and the measured neighbour cell i are on the same carrier frequency.
 NOTE 5: The condition level is increased by $\Delta > 0$, when applicable, as described in TS 38.133 Sections B.3.2 and B.3.3.
 NOTE 6: The I_0 is defined in PRS positioning subframes. The same I_0 range applies to PRS and non-PRS symbols. I_0 levels are different in PRS and non-PRS symbols within the same subframe.
 NOTE 7: NR operating band groups are as defined in TS 38.133 Section 3.5.2.

The relative accuracy of PRS-RSRP is defined as accuracy of the difference between two PRS-RSRP measurements.

The relative PRS-RSRP accuracy requirements apply for the cases when PRS-RSRP is measured from PRS resources in the same PRS resource set in FR1 or FR2, and measured with same Rx beam in case of FR2.

The accuracy requirements for PRS-RSRP measurement for FR1 defined in Table 4.16.5-3 are valid under the following conditions:

Conditions defined in 38.101-1 Clause 7.3 for reference sensitivity are fulfilled.

PRP $1,2_{\text{dBm}}$ according to TS 38.133[50] Annex B.2.14 for a corresponding Band

UE does not support positioning measurements with reduced number of samples, or LMF does not indicate UE to perform positioning measurements with reduced number of samples

Table 4.16.5-3: PRS-RSRP relative accuracy for FR1

Accuracy	Conditions	
	PRS BW	I_0 ^{Note 7} range

Normal condition	Extreme condition	PRS \hat{E}_s/lot	PRB	Repetition factor ($T_{\text{rep}}^{\text{PRS}} * L_{\text{PRS}} / K_{\text{comb}}^{\text{PRS}}$)	NR operating band groups Note 8	Minimum I_o Note 1 dBm / SCS _{PRS}			Maximum I_o
						dBm / SCS _{PRS}			
dB	dB	dB		-		dBm/15kHz z Note 6	dBm/30kHz z Note 6	dBm/60kHz Note 6	dBm/BW _{Channel}
± 3.5	± 5.0	$\geq -3\text{dB}$	≥ 24	All	NR_FDD_FR1_A, NR_TDD_FR1_A, NR_SDL_FR1_A	-127	-124	-121	-50
					NR_FDD_FR1_B	-126.5	-123.5	-120.5	-50
					NR_TDD_FR1_C	-126	-123	-120	-50
					NR_FDD_FR1_D, NR_TDD_FR1_D	-125.5	-122.5	-119.5	-50
					NR_FDD_FR1_E, NR_TDD_FR1_E	-125	-122	-119	-50
					NR_FDD_FR1_F	-124.5	-121.5	-118.5	-50
					NR_FDD_FR1_G	-124	-121	-118	-50
					NR_FDD_FR1_H	-123.5	-120.5	-117.5	-50
								Note 4	
			Note 4						
± 9.5	± 11.0	$\geq -13\text{dB}$	$24 \leq \text{BW} \leq 52$	All	Note 4				
± 6.5	± 8.0		$52 < \text{BW} \leq 104$	All	Note 4				
± 5.0	± 6.5		$\text{BW} > 104$	All	Note 4				

NOTE 1: This minimum I_o condition is expressed as the average I_o per RE over all REs in an OFDM symbol.
 NOTE 2: Void.
 NOTE 3: PRS bandwidth is as indicated in *prs-Bandwidth* in the OTDOA or DL-AoD assistance data defined in [49].
 NOTE 4: The same bands and the same I_o conditions for each band apply for this requirement as for the corresponding requirement with the PRS bandwidth ≥ 24 RB.
 NOTE 5: The serving cell, the reference cell, and the measured neighbour cell i are on the same carrier frequency.
 NOTE 6: The condition level is increased by $\Delta > 0$, when applicable, as described in TS 38.133[50] Sections B.3.2 and B.3.3.
 NOTE 7: The I_o is defined in PRS positioning subframes. The same I_o range applies to PRS and non-PRS symbols. I_o levels are different in PRS and non-PRS symbols within the same subframe.
 NOTE 8: NR operating band groups are as defined in TS 38.133[50] Section 3.5.2.

The accuracy requirements for PRS-RSRP measurement for FR2 defined in Table 4.16.5-3 are valid under the following conditions:

Conditions defined in 38.101-2 Clause 7.3 for reference sensitivity are fulfilled.

PRP $1,2_{\text{dBm}}$ according to TS 38.133[50] Annex B.2.14 for a corresponding Band

UE does not support positioning measurements with reduced number of samples, or LMF does not indicate UE to perform positioning measurements with reduced number of samples

Table 4.16.5-4: PRS-RSRP relative accuracy for FR2

Accuracy	Conditions	
	PRS BW	I_o Note 7 range

Normal condition	Extreme condition	PRS \hat{E}_s/lot	PRB	Repetition factor ($T_{\text{rep}}^{\text{PRS}} * L_{\text{PRS}} / K_{\text{comb}}^{\text{PRS}}$)	Minimum I_o ^{Note 1} dBm / SCS _{PRS}		Maximum I_o
					dBm / SCS _{PRS}		dBm/BW _{Channel}
dB	dB	dB		-	dBm/120kHz <small>Note 6</small>	dBm/60kHz <small>Note 6</small>	
± 5.0	± 8.0	$\geq -3\text{dB}$	≥ 24	All	Same value as PRP in TS 38.133[50] Table B.2.14-2, according to UE Power class, operating band and angle of arrival		-50
Note 4							
Note 4							
± 10	± 13	$\geq -13\text{dB}$	$24 \leq \text{BW} \leq 64$	All	Note 4		
± 7.5	± 10.5		$\text{BW} > 64$	All	Note 4		

NOTE 1: This minimum I_o condition is expressed as the average I_o per RE over all REs in an OFDM symbol.
 NOTE 2: Void.
 NOTE 3: PRS bandwidth is as indicated in *prs-Bandwidth* in the OTDOA or DL-AoD assistance data defined in [49].
 NOTE 4: The same bands and the same I_o conditions for each band apply for this requirement as for the corresponding requirement with the PRS bandwidth ≥ 24 RB.
 NOTE 5: The serving cell, the reference cell, and the measured neighbour cell i are on the same carrier frequency.
 NOTE 6: The condition level is increased by $\Delta > 0$, when applicable, as described in TS 38.133[50] Sections B.3.2 and B.3.3.
 NOTE 7: The I_o is defined in PRS positioning subframes. The same I_o range applies to PRS and non-PRS symbols. I_o levels are different in PRS and non-PRS symbols within the same subframe.
 NOTE 8: NR operating band groups are as defined in TS 38.133[50] Section 3.5.2.

The absolute accuracy requirements for PRS-RSRP measurement for FR1 defined in Table 4.16.5-5 are valid under the following conditions:

- Conditions defined in 38.101-1 Clause 7.3 for reference sensitivity are fulfilled.
- PRP $1,2_{\text{dBm}}$ according to TS 38.133 Annex B.2.14 for a corresponding Band
- UE supports positioning measurements with reduced number of samples, and LMF indicates UE to perform positioning measurements with reduced number of samples
- AWGN channel

The absolute accuracy requirements for PRS-RSRP measurement for FR2 defined in Table 4.16.5-6 are valid under the following conditions:

- Conditions defined in 38.101-2 Clause 7.3 for reference sensitivity are fulfilled.
- PRP $1,2_{\text{dBm}}$ according to TS 38.133 Annex B.2.14 for a corresponding Band
- UE supports positioning measurements with reduced number of samples, and LMF indicates UE to perform positioning measurements with reduced number of samples
- AWGN channel

Table 4.16.5-5: PRS-RSRP relative accuracy for FR1 with reduced sample number

Accuracy		Conditions					
Normal condition	Extreme condition	PRS \hat{E}_s/lot	PRS BW	Repetition factor ($T_{\text{rep}}^{\text{PRS}} * L_{\text{PRS}} / K_{\text{comb}}^{\text{PRS}}$)	I_o ^{Note 6} range		
					NR operating band groups <small>Note 7</small>	Minimum I_o ^{Note 1} dBm / SCS _{PRS}	Maximum I_o

dB	dB	dB	PRB	-		dBm / SCS _{PRS}			dBm/BW _{Channel}
						dBm/15k Hz <small>Note 5</small>	dBm/30kHz <small>Note 5</small>	dBm/60k Hz <small>Note 5</small>	
±3.5	±5.0	≥0	≥48	All	NR_FDD_FR1_A, NR_TDD_FR1_A, NR_SDL_FR1_A	-127	-124	-121	-50
					NR_FDD_FR1_B	-126.5	-123.5	-120.5	-50
					NR_TDD_FR1_C	-126	-123	-120	-50
					NR_FDD_FR1_D, NR_TDD_FR1_D	-125.5	-122.5	-119.5	-50
					NR_FDD_FR1_E, NR_TDD_FR1_E	-125	-122	-119	-50
					NR_FDD_FR1_F	-124.5	-121.5	-118.5	-50
					NR_FDD_FR1_G, NR_TDD_FR1_G	-124	-121	-118	-50
				NR_FDD_FR1_H	-123.5	-120.5	-117.5	-50	
±9.5	±11.0	≥-6	48 ≤ BW ≤ 52	All	Note 3				
±6.5	±8.0		52 < BW ≤ 104	All	Note 3				
±5.0	±6.5		BW > 104	All	Note 3				

NOTE 1: This minimum I_0 condition is expressed as the average I_0 per RE over all REs in an OFDM symbol.
 NOTE 2: PRS bandwidth is as indicated in *prs-Bandwidth* in the OTDOA or DL-AoD assistance data defined in [49].
 NOTE 3: The same bands and the same I_0 conditions for each band apply for this requirement as for the corresponding requirement with the PRS bandwidth ≥ 48 RB.
 NOTE 4: The serving cell, the reference cell, and the measured neighbour cell i are on the same carrier frequency.
 NOTE 5: The condition level is increased by $\Delta > 0$, when applicable, as described in Sections B.3.2 and B.3.3.
 NOTE 6: The I_0 is defined in PRS positioning subframes. The same I_0 range applies to PRS and non-PRS symbols. I_0 levels are different in PRS and non-PRS symbols within the same subframe.
 NOTE 7: NR operating band groups are as defined in Section 3.5.2.

Table 4.16.5-6: PRS-RSRP relative accuracy for FR2 with reduced sample number

Accuracy		Conditions				
Normal condition	Extreme condition	PRS \hat{E}_s/lot	PRS BW	Repetition factor $(T_{\text{rep}}^{\text{PRS}} * L_{\text{PRS}} / K_{\text{comb}}^{\text{PRS}})$	I_0 <small>Note 6</small> range	
					Minimum I_0 <small>Note 1</small> dBm / SCS _{PRS}	Maximum I_0
dB	dB	dB	PRB	-	dBm / SCS _{PRS}	
					dBm/120kHz <small>Note 5</small>	dBm/60kHz <small>Note 5</small>
±5.0	±8.0	≥0	≥48	All	Same value as PRP in Table B.2.14-2, according to UE Power class, operating band and angle of arrival	
±10	±13	≥-6	48 ≤ BW ≤ 64	All	Note 3	
±7.5	±10.5		BW > 64	All	Note 3	

NOTE 1: This minimum I_0 condition is expressed as the average I_0 per RE over all REs in an OFDM symbol.
 NOTE 2: PRS bandwidth is as indicated in *prs-Bandwidth* in the OTDOA or DL-AoD assistance data defined in [34].
 NOTE 3: The same bands and the same I_0 conditions for each band apply for this requirement as for the corresponding requirement with the PRS bandwidth ≥ 24 RB.
 NOTE 4: The serving cell, the reference cell, and the measured neighbour cell i are on the same carrier frequency.
 NOTE 5: The condition level is increased by $\Delta > 0$, when applicable, as described in Sections B.3.2 and B.3.3.
 NOTE 6: The I_0 is defined in PRS positioning subframes. The same I_0 range applies to PRS and non-PRS symbols. I_0 levels are different in PRS and non-PRS symbols within the same subframe.
 NOTE 8: NR operating band groups are as defined in Section 3.5.2.

4.16.6 PRS-RSRP Reporting mapping

4.16.6.1 Absolute PRS-RSRP Measurement Report Mapping

The reporting range of absolute PRS-RSRP measurement is defined from -156 dBm to -31 dBm with 1 dB resolution.

The mapping of measured quantity is defined in Table 4.16.6.1-1. The range in the signalling may be larger than the guaranteed accuracy range.

Table 4.16.6.1-1: Measurement report mapping for PRS-RSRP

Reported value	Measured quantity value	Unit
PRS_RSRP_0	PRS-RSRP<-156	dBm
PRS_RSRP_1	-156≤PRS-RSRP<-155	dBm
PRS_RSRP_2	-155≤PRS-RSRP<-154	dBm
PRS_RSRP_3	-154≤PRS-RSRP<-153	dBm
PRS_RSRP_4	-153≤PRS-RSRP<-152	dBm
PRS_RSRP_5	-152≤PRS-RSRP<-151	dBm
PRS_RSRP_6	-151≤PRS-RSRP<-150	dBm
PRS_RSRP_7	-150≤PRS-RSRP<-149	dBm
PRS_RSRP_8	-149≤PRS-RSRP<-148	dBm
PRS_RSRP_9	-148≤PRS-RSRP<-147	dBm
PRS_RSRP_10	-147≤PRS-RSRP<-146	dBm
PRS_RSRP_11	-146≤PRS-RSRP<-145	dBm
PRS_RSRP_12	-145≤PRS-RSRP<-144	dBm
PRS_RSRP_13	-144≤PRS-RSRP<-143	dBm
PRS_RSRP_14	-143≤PRS-RSRP<-142	dBm
PRS_RSRP_15	-142≤PRS-RSRP<-141	dBm
PRS_RSRP_16	-141≤PRS-RSRP<-140	dBm
PRS_RSRP_17	-140≤PRS-RSRP<-139	dBm
PRS_RSRP_18	-139≤PRS-RSRP<-138	dBm
...
PRS_RSRP_111	-46≤PRS-RSRP<-45	dBm
PRS_RSRP_112	-45≤PRS-RSRP<-44	dBm
PRS_RSRP_113	-44≤PRS-RSRP<-43	dBm
PRS_RSRP_114	-43≤PRS-RSRP<-42	dBm
PRS_RSRP_115	-42≤PRS-RSRP<-41	dBm
PRS_RSRP_116	-41≤PRS-RSRP<-40	dBm
PRS_RSRP_117	-40≤PRS-RSRP<-39	dBm
PRS_RSRP_118	-39≤PRS-RSRP<-38	dBm
PRS_RSRP_119	-38≤PRS-RSRP<-37	dBm
PRS_RSRP_120	-37≤PRS-RSRP<-36	dBm
PRS_RSRP_121	-36≤PRS-RSRP<-35	dBm
PRS_RSRP_122	-35≤PRS-RSRP<-34	dBm
PRS_RSRP_123	-34≤PRS-RSRP<-33	dBm
PRS_RSRP_124	-33≤PRS-RSRP<-32	dBm
PRS_RSRP_125	-32≤PRS-RSRP<-31	dBm
PRS_RSRP_126	-31≤PRS-RSRP	dBm

4.16.6.2 Differential Report Mapping for PRS-RSRP Measurement

The reporting range of differential PRS-RSRP is defined from -30 dB to 0 dB with 1 dB resolution when *nr-DL-AoD-RequestLocationInformation* message is received.

The mapping of measured quantity is defined in Table 4.16.6.2-1. The range in the signalling may be larger than the guaranteed accuracy range.

The reporting range of differential PRS-RSRP is defined from -30 dB to 30 dB with 1 dB resolution when *nr-DL-TDOA-RequestLocationInformation* or *nr-Multi-RTT-RequestLocationInformation* is received.

The mapping of measured quantity is defined in Table 4.16.6.2-2. The range in the signalling may be larger than the guaranteed accuracy range or the range supported by the UE receiver for different Δ RSRP measured on different PRS resources in frequency domain at the same time.

Table 4.16.6.2-1: Measurement report mapping for differential PRS-RSRP

Reported value	Measured quantity value	Unit
DIFFRSRP_0	-30≥ Δ RSRP	dB
DIFFRSRP_1	-29≥ Δ RSRP>-30	dB
DIFFRSRP_2	-28≥ Δ RSRP>-29	dB

DIFFRSRP_3	$-27 \geq \Delta \text{RSRP} > -28$	dB
DIFFRSRP_4	$-26 \geq \Delta \text{RSRP} > -27$	dB
DIFFRSRP_5	$-25 \geq \Delta \text{RSRP} > -26$	dB
DIFFRSRP_6	$-24 \geq \Delta \text{RSRP} > -25$	dB
DIFFRSRP_7	$-23 \geq \Delta \text{RSRP} > -24$	dB
DIFFRSRP_8	$-22 \geq \Delta \text{RSRP} > -23$	dB
DIFFRSRP_9	$-21 \geq \Delta \text{RSRP} > -22$	dB
DIFFRSRP_10	$-20 \geq \Delta \text{RSRP} > -21$	dB
DIFFRSRP_11	$-19 \geq \Delta \text{RSRP} > -20$	dB
DIFFRSRP_12	$-18 \geq \Delta \text{RSRP} > -19$	dB
DIFFRSRP_13	$-17 \geq \Delta \text{RSRP} > -18$	dB
DIFFRSRP_14	$-16 \geq \Delta \text{RSRP} > -17$	dB
DIFFRSRP_15	$-15 \geq \Delta \text{RSRP} > -16$	dB
DIFFRSRP_16	$-14 \geq \Delta \text{RSRP} > -15$	dB
DIFFRSRP_17	$-13 \geq \Delta \text{RSRP} > -14$	dB
DIFFRSRP_18	$-12 \geq \Delta \text{RSRP} > -13$	dB
DIFFRSRP_19	$-11 \geq \Delta \text{RSRP} > -12$	dB
DIFFRSRP_20	$-10 \geq \Delta \text{RSRP} > -11$	dB
DIFFRSRP_21	$-9 \geq \Delta \text{RSRP} > -10$	dB
DIFFRSRP_22	$-8 \geq \Delta \text{RSRP} > -9$	dB
DIFFRSRP_23	$-7 \geq \Delta \text{RSRP} > -8$	dB
DIFFRSRP_24	$-6 \geq \Delta \text{RSRP} > -7$	dB
DIFFRSRP_25	$-5 \geq \Delta \text{RSRP} > -6$	dB
DIFFRSRP_26	$-4 \geq \Delta \text{RSRP} > -5$	dB
DIFFRSRP_27	$-3 \geq \Delta \text{RSRP} > -4$	dB
DIFFRSRP_28	$-2 \geq \Delta \text{RSRP} > -3$	dB
DIFFRSRP_29	$-1 \geq \Delta \text{RSRP} > -2$	dB
DIFFRSRP_30	$0 \geq \Delta \text{RSRP} > -1$	dB

Table 4.16.6.2-2: Measurement report mapping for differential PRS-RSRP

Reported value	Measured quantity value	Unit
DIFFRSRP_0	$-30 \geq \Delta \text{RSRP}$	dB
DIFFRSRP_1	$-29 \geq \Delta \text{RSRP} > -30$	dB
DIFFRSRP_2	$-28 \geq \Delta \text{RSRP} > -29$	dB
DIFFRSRP_3	$-27 \geq \Delta \text{RSRP} > -28$	dB
DIFFRSRP_4	$-26 \geq \Delta \text{RSRP} > -27$	dB
DIFFRSRP_5	$-25 \geq \Delta \text{RSRP} > -26$	dB
DIFFRSRP_6	$-24 \geq \Delta \text{RSRP} > -25$	dB
DIFFRSRP_7	$-23 \geq \Delta \text{RSRP} > -24$	dB
DIFFRSRP_8	$-22 \geq \Delta \text{RSRP} > -23$	dB
DIFFRSRP_9	$-21 \geq \Delta \text{RSRP} > -22$	dB
DIFFRSRP_10	$-20 \geq \Delta \text{RSRP} > -21$	dB
DIFFRSRP_11	$-19 \geq \Delta \text{RSRP} > -20$	dB
DIFFRSRP_12	$-18 \geq \Delta \text{RSRP} > -19$	dB
DIFFRSRP_13	$-17 \geq \Delta \text{RSRP} > -18$	dB
DIFFRSRP_14	$-16 \geq \Delta \text{RSRP} > -17$	dB
...
DIFFRSRP_25	$-5 \geq \Delta \text{RSRP} > -6$	dB
DIFFRSRP_26	$-4 \geq \Delta \text{RSRP} > -5$	dB
DIFFRSRP_27	$-3 \geq \Delta \text{RSRP} > -4$	dB
DIFFRSRP_28	$-2 \geq \Delta \text{RSRP} > -3$	dB
DIFFRSRP_29	$-1 \geq \Delta \text{RSRP} > -2$	dB
DIFFRSRP_30	$0 \geq \Delta \text{RSRP} > -1$	dB
DIFFRSRP_31	$1 \geq \Delta \text{RSRP} > 0$	dB
DIFFRSRP_32	$2 \geq \Delta \text{RSRP} > 1$	dB
DIFFRSRP_33	$3 \geq \Delta \text{RSRP} > 2$	dB
DIFFRSRP_34	$4 \geq \Delta \text{RSRP} > 3$	dB
DIFFRSRP_35	$5 \geq \Delta \text{RSRP} > 4$	dB
DIFFRSRP_36	$6 \geq \Delta \text{RSRP} > 5$	dB
...
DIFFRSRP_47	$17 \geq \Delta \text{RSRP} > 16$	dB
DIFFRSRP_48	$18 \geq \Delta \text{RSRP} > 17$	dB
DIFFRSRP_49	$19 \geq \Delta \text{RSRP} > 18$	dB

DIFFRSRP_50	$20 \geq \Delta \text{RSRP} > 19$	dB
DIFFRSRP_51	$21 \geq \Delta \text{RSRP} > 20$	dB
DIFFRSRP_52	$22 \geq \Delta \text{RSRP} > 21$	dB
DIFFRSRP_53	$23 \geq \Delta \text{RSRP} > 22$	dB
DIFFRSRP_54	$24 \geq \Delta \text{RSRP} > 23$	dB
DIFFRSRP_55	$25 \geq \Delta \text{RSRP} > 24$	dB
DIFFRSRP_56	$26 \geq \Delta \text{RSRP} > 25$	dB
DIFFRSRP_57	$27 \geq \Delta \text{RSRP} > 26$	dB
DIFFRSRP_58	$28 \geq \Delta \text{RSRP} > 27$	dB
DIFFRSRP_59	$29 \geq \Delta \text{RSRP} > 28$	dB
DIFFRSRP_60	$30 \geq \Delta \text{RSRP} > 29$	dB
DIFFRSRP_61	$\Delta \text{RSRP} > 30$	dB

4.16.7 PRS-RSRPP Measurement Period Requirements

For PRS measurement within MG configured to UE, measurement period requirements for PRS-RSRP defined in 4.16.4.1 is re-used for PRS-RSRPP.

For PRS measurement without MG configured to UE, measurement period requirements for PRS-RSRP defined in 4.16.4.2 is re-used for PRS-RSRPP.

For PRS measurement in RRC_INACTIVE state, measurement period requirements for PRS-RSRP defined in 4.16.4.2 is re-used for PRS-RSRPP.

4.16.8 PRS-RSRPP Measurement Accuracy Requirements

See TS 38.133 [50] clause 10.1.38.2.

4.16.9 PRS-RSRPP Reporting mapping

4.16.9.1 Absolute PRS-RSRPP Measurement Report Mapping

The reporting range of absolute PRS-RSRPP measurement is defined from -156 dBm to -31 dBm with 1 dB resolution.

The mapping of measured quantity is defined in Table 4.16.9.1-1. The range in the signalling may be larger than the guaranteed accuracy range.

The UE capable of *additionalPathsExtSupport-r17* can report the PRS-RSRPP measurement of up to its supported number of additional paths.

Table 4.16.9.1-1: Measurement report mapping for PRS-RSRPP

Reported value	Measured quantity value	Unit
PRS_RSRPP_0	$\text{PRS-RSRPP} < -156$	dBm
PRS_RSRPP_1	$-156 \leq \text{PRS-RSRPP} < -155$	dBm
PRS_RSRPP_2	$-155 \leq \text{PRS-RSRPP} < -154$	dBm
PRS_RSRPP_3	$-154 \leq \text{PRS-RSRPP} < -153$	dBm
PRS_RSRPP_4	$-153 \leq \text{PRS-RSRPP} < -152$	dBm
PRS_RSRPP_5	$-152 \leq \text{PRS-RSRPP} < -151$	dBm
PRS_RSRPP_6	$-151 \leq \text{PRS-RSRPP} < -150$	dBm
PRS_RSRPP_7	$-150 \leq \text{PRS-RSRPP} < -149$	dBm
PRS_RSRPP_8	$-149 \leq \text{PRS-RSRPP} < -148$	dBm
PRS_RSRPP_9	$-148 \leq \text{PRS-RSRPP} < -147$	dBm
PRS_RSRPP_10	$-147 \leq \text{PRS-RSRPP} < -146$	dBm

PRS_RSRPP_11	$-146 \leq \text{PRS-RSRPP} < -145$	dBm
PRS_RSRPP_12	$-145 \leq \text{PRS-RSRPP} < -144$	dBm
PRS_RSRPP_13	$-144 \leq \text{PRS-RSRPP} < -143$	dBm
PRS_RSRPP_14	$-143 \leq \text{PRS-RSRPP} < -142$	dBm
PRS_RSRPP_15	$-142 \leq \text{PRS-RSRPP} < -141$	dBm
PRS_RSRPP_16	$-141 \leq \text{PRS-RSRPP} < -140$	dBm
PRS_RSRPP_17	$-140 \leq \text{PRS-RSRPP} < -139$	dBm
PRS_RSRPP_18	$-139 \leq \text{PRS-RSRPP} < -138$	dBm
...
PRS_RSRPP_111	$-46 \leq \text{PRS-RSRPP} < -45$	dBm
PRS_RSRPP_112	$-45 \leq \text{PRS-RSRPP} < -44$	dBm
PRS_RSRPP_113	$-44 \leq \text{PRS-RSRPP} < -43$	dBm
PRS_RSRPP_114	$-43 \leq \text{PRS-RSRPP} < -42$	dBm
PRS_RSRPP_115	$-42 \leq \text{PRS-RSRPP} < -41$	dBm
PRS_RSRPP_116	$-41 \leq \text{PRS-RSRPP} < -40$	dBm
PRS_RSRPP_117	$-40 \leq \text{PRS-RSRPP} < -39$	dBm
PRS_RSRPP_118	$-39 \leq \text{PRS-RSRPP} < -38$	dBm
PRS_RSRPP_119	$-38 \leq \text{PRS-RSRPP} < -37$	dBm
PRS_RSRPP_120	$-37 \leq \text{PRS-RSRPP} < -36$	dBm
PRS_RSRPP_121	$-36 \leq \text{PRS-RSRPP} < -35$	dBm
PRS_RSRPP_122	$-35 \leq \text{PRS-RSRPP} < -34$	dBm
PRS_RSRPP_123	$-34 \leq \text{PRS-RSRPP} < -33$	dBm
PRS_RSRPP_124	$-33 \leq \text{PRS-RSRPP} < -32$	dBm
PRS_RSRPP_125	$-32 \leq \text{PRS-RSRPP} < -31$	dBm
PRS_RSRPP_126	$-31 \leq \text{PRS-RSRPP}$	dBm

4.16.9.2 Differential Report Mapping for PRS-RSRPP Measurement

The reporting range of differential PRS-RSRPP is defined from -30 dB to 30 dB with 1 dB resolution.

The mapping of measured quantity is defined in Table 4.16.9.2-1. The range in the signalling may be larger than the guaranteed accuracy range.

For differential reporting, PRS-RSRPP is reported as the difference in dB with respect to the first reported PRS-RSRPP.

Table 4.16.9.2-1: Measurement report mapping for differential PRS-RSRPP

Reported value	Measured quantity value	Unit
DIFFRSRPP_0	$-30 \geq \Delta \text{RSRPP}$	dB
DIFFRSRPP_1	$-29 \geq \Delta \text{RSRPP} > -30$	dB
DIFFRSRPP_2	$-28 \geq \Delta \text{RSRPP} > -29$	dB
DIFFRSRPP_3	$-27 \geq \Delta \text{RSRPP} > -28$	dB
DIFFRSRPP_4	$-26 \geq \Delta \text{RSRPP} > -27$	dB
DIFFRSRPP_5	$-25 \geq \Delta \text{RSRPP} > -26$	dB
DIFFRSRPP_6	$-24 \geq \Delta \text{RSRPP} > -25$	dB
DIFFRSRPP_7	$-23 \geq \Delta \text{RSRPP} > -24$	dB
DIFFRSRPP_8	$-22 \geq \Delta \text{RSRPP} > -23$	dB
DIFFRSRPP_9	$-21 \geq \Delta \text{RSRPP} > -22$	dB
DIFFRSRPP_10	$-20 \geq \Delta \text{RSRPP} > -21$	dB
DIFFRSRPP_11	$-19 \geq \Delta \text{RSRPP} > -20$	dB
DIFFRSRPP_12	$-18 \geq \Delta \text{RSRPP} > -19$	dB
DIFFRSRPP_13	$-17 \geq \Delta \text{RSRPP} > -18$	dB

DIFFRSRPP_14	$-16 \geq \Delta \text{RSRPP} > -17$	dB
...
DIFFRSRPP_25	$-5 \geq \Delta \text{RSRPP} > -6$	dB
DIFFRSRPP_26	$-4 \geq \Delta \text{RSRPP} > -5$	dB
DIFFRSRPP_27	$-3 \geq \Delta \text{RSRPP} > -4$	dB
DIFFRSRPP_28	$-2 \geq \Delta \text{RSRPP} > -3$	dB
DIFFRSRPP_29	$-1 \geq \Delta \text{RSRPP} > -2$	dB
DIFFRSRPP_30	$0 \geq \Delta \text{RSRPP} > -1$	dB
DIFFRSRPP_31	$1 \geq \Delta \text{RSRPP} > 0$	dB
DIFFRSRPP_32	$2 \geq \Delta \text{RSRPP} > 1$	dB
DIFFRSRPP_33	$3 \geq \Delta \text{RSRPP} > 2$	dB
DIFFRSRPP_34	$4 \geq \Delta \text{RSRPP} > 3$	dB
DIFFRSRPP_35	$5 \geq \Delta \text{RSRPP} > 4$	dB
DIFFRSRPP_36	$6 \geq \Delta \text{RSRPP} > 5$	dB
...
DIFFRSRPP_47	$17 \geq \Delta \text{RSRPP} > 16$	dB
DIFFRSRPP_48	$18 \geq \Delta \text{RSRPP} > 17$	dB
DIFFRSRPP_49	$19 \geq \Delta \text{RSRPP} > 18$	dB
DIFFRSRPP_50	$20 \geq \Delta \text{RSRPP} > 19$	dB
DIFFRSRPP_51	$21 \geq \Delta \text{RSRPP} > 20$	dB
DIFFRSRPP_52	$22 \geq \Delta \text{RSRPP} > 21$	dB
DIFFRSRPP_53	$23 \geq \Delta \text{RSRPP} > 22$	dB
DIFFRSRPP_54	$24 \geq \Delta \text{RSRPP} > 23$	dB
DIFFRSRPP_55	$25 \geq \Delta \text{RSRPP} > 24$	dB
DIFFRSRPP_56	$26 \geq \Delta \text{RSRPP} > 25$	dB
DIFFRSRPP_57	$27 \geq \Delta \text{RSRPP} > 26$	dB
DIFFRSRPP_58	$28 \geq \Delta \text{RSRPP} > 27$	dB
DIFFRSRPP_59	$29 \geq \Delta \text{RSRPP} > 28$	dB
DIFFRSRPP_60	$30 \geq \Delta \text{RSRPP} > 29$	dB
DIFFRSRPP_61	$\Delta \text{RSRPP} > 30$	dB

4A Support of 4 Rx capable UEs

4A.0 Introduction

In this section, the method for applying 2RX tests to UEs supporting 4RX antenna ports is specified.

4A.1 RAT Independent Tests

All tests in Sections 5 to 7, 11 and 12 are applicable for all types of UEs independently of the number of RX antennas. Only one of the E-UTRAN/UTRAN RX antennas shall be connected to the SS.

4A.2 RAT Dependent Tests

All tests in Sections 8 to 10 are specified for UEs supporting either category 0 (1RX) or 2RX. No tests cases are currently specified in Sections 8 to 10 that are applicable only to 4RX antenna ports, so 4RX capable UEs are always tested by reusing tests that were originally specified for 2RX UEs.

4A.2.1 Principle of testing

4A.2.1.1 Single carrier tests

ECID (Section 8) and OTDOA Measurement Accuracy test cases shall be tested on all bands supported by the UE. For bands where 2RX is supported, the test shall be performed with the antenna connection specified in 4A.2.1.3. For bands where only 4RX is supported, the test shall be performed with the antenna connection specified in 4A.2.1.4.

OTDOA Measurement Reporting Delay test cases shall be tested on any band where 2RX is supported, using the antenna connection specified in 4A.2.1.3. If 2RX is not supported on any band, any 4RX band shall be tested, using the antenna connection specified in 4A.2.1.4.

4A.2.1.2 Carrier Aggregation tests

For all carrier aggregation tests, the antenna connection for each cell needs to be considered separately. If a PCell or SCell is in a band where 2RX is supported, the test shall be performed using the antenna connection specified in 4A.2.1.3 for that cell. Otherwise, the test shall be performed using the antenna connection specified in 4A.2.1.4 for that cell.

4A.2.1.3 Antenna connection for bands where 2RX is supported

For bands where 2RX is supported, it is left to the UE declaration and AP configuration to decide which 2 of the 4 Rx ports are connected with data source from system simulator. The remaining 2 Rx ports shall be connected with zero input. No test parameters or requirements are modified.

4A.2.1.4 Antenna connection for bands where 4RX is supported

For bands where 4RX is supported, all 4 Rx are connected with data source from system simulator. The system simulator shall provide independent noise and fading (low correlation) for each antenna port.

4B Applicability of tests for types and Categories of UE

4B.1 Introduction

In this clause, the applicability of the tests defined in clauses 7 to 16 of this specification are detailed for various types and Categories of UE for information.

4B.2 Applicability of requirements and tests

The applicability of the requirements for various types and Categories of UE for the tests in this specification are defined as follows:

- for the tests in clause 7 (E-UTRA A-GNSS): applicabilities are defined in TS 36.171 [3] clauses 4.1 and 4.1.1
- for the tests in clauses 8 (E-UTRA ECID), 9 (E-UTRA OTDOA), 10 (E-UTRA OTDOA for Carrier Aggregation): applicabilities are defined in TS 36.133 [23] clause 3.6.1
- for the tests in clauses 11 (E-UTRA and NR MBS), 12 (E-UTRA WLAN and BLE): applicabilities are defined in TS 37.171 [39]
- for the tests in clause 13 (NR A-GNSS): applicabilities are defined in TS 38.171 [43] clause 4.1
- for the tests in clause 14 (NR OTDOA): applicabilities are defined in TS 38.133 [23] clause 3.6
- for the tests in clauses 15 (NR WLAN), 16 (NR BLE): applicabilities are defined in TS 37.171 [39].

These are summarised below for the relevant tests in this specification.

Table 4B.2-1: Applicability of tests for various types and Categories of UE (informative)

Tests	Types and Categories of UE								
	LTE UE other than types and Categories listed here	UE Category 0 (Note 1)	UE Category 1	UE Category 1bis (Note 2)	UE Category M1	UE Category M2	UE Category NB1 and NB2 (Note 3)	UE configured with NR EN-DC	UE supporting NR SA mode or NE-DC or NGEN-DC

Clause 7 (E-UTRA A-GNSS)	All	All	All	All	All (UE must also support VoLTE)	All (UE must also support VoLTE)	None	N/A	N/A
Clause 8 (E-UTRA ECID),	All except those defined for types and Categories listed here	All	All	Only tests defined for UE Category 1bis	Only tests defined for UE Category M1	Only tests defined for UE Category M2	None	Requirements and tests defined in RAN 4. Tests here are FFS	N/A
Clause 9 (E-UTRA OTDOA)	All except those defined for types and Categories listed here	All	All	Only tests defined for UE Category 1bis	Only tests defined for UE Category M1	Only tests defined for UE Category M2	Only tests defined for NB-IOT	Requirements and tests defined in RAN 4. Tests here are FFS	N/A
Clause 10 (E-UTRA OTDOA for Carrier Aggregation)	All	All	All	None	None	None	None	Requirements and tests defined in RAN 4. Tests here are FFS	N/A
Clause 11 (E-UTRA and NR MBS)	All except those defined for NR	All except those defined for NR	All except those defined for NR	All except those defined for NR	All except those defined for NR	All except those defined for NR	FFS	All those defined for NR	All those defined for NR
Clause 12 (E-UTRA WLAN and BLE)	All	All	All	All	All	All	FFS	Requirements (only) defined in RAN 4. Tests are FFS	Requirement (only) defined in RAN 4. Tests are FFS
Clause 13 (NR A-GNSS)	N/A	N/A	N/A	N/A	N/A	N/A	N/A	All	All
Clause 14 (NR OTDOA)	N/A	N/A	N/A	N/A	N/A	N/A	N/A	N/A.	FFS
Clause 15 (NR WLAN)	N/A	N/A	N/A	N/A	N/A	N/A	N/A	FFS	FFS
Clause 16 (NR BLE)	N/A	N/A	N/A	N/A	N/A	N/A	N/A	FFS	FFS

Note 1: The requirements for a UE Category 0 are derived assuming UE Category 0 and a single antenna receiver.

Note 2: The requirements for UE Category 1bis are derived assuming UE Category 1bis and a single antenna receiver.

Note 3: The requirements for UE Category NB1/NB2 are derived assuming UE Category NB1/NB2 and a single antenna receiver.

Editor's note: the current versions of this specification and TS 37.571-3 do not accurately reflect the above table. The above table should therefore be used where it differs from the applicabilities given in this specification and TS 37.571-3.

5 UTRA A-GPS Minimum Performance requirements

5.1 General

This clause defines the minimum performance requirements for FDD UTRA UEs where the only Assisted Global Navigation Satellite System (A-GNSS) supported is Assisted Global Positioning System (A-GPS) L1 C/A. The procedures for UEs that support other or additional A-GNSSs are specified in clause 6. Note that for TDD UTRA UEs where the only Assisted Global Navigation Satellite System (A-GNSS) supported is Assisted Global Positioning System (A-GPS) L1 C/A there are no requirements.

This clause defines requirements for both UE based and UE assisted modes; if a UE supports both modes then it shall be tested in both modes

The requirements in this clause are defined for CELL_DCH and CELL_FACH states. All tests shall be performed in CELL_DCH state and the Nominal Accuracy Performance test case shall be also performed in CELL_FACH state.

5.2 Sensitivity

5.2.1 Sensitivity Coarse Time Assistance

5.2.1.1 Definition and applicability

Sensitivity with coarse time assistance is the minimum level of GPS satellite signals required for the UE to make an A-GPS position estimate to a specific accuracy and within a specific response time when the network only provides coarse time assistance.

The requirements and this test apply to all types of UTRA for the FDD UE that supports A-GPS.

5.2.1.2 Minimum requirements

The first fix position estimates shall meet the accuracy and response time requirements in table 5.2.1.2 for the parameters specified in table 5.2.1.1.

Table 5.2.1.1: Test parameters for Sensitivity Coarse Time Assistance

Parameters	Unit	Value
Number of generated satellites	-	8
HDOP Range	-	1.1 to 1.6
Propagation conditions	-	AWGN
GPS Coarse Time assistance error range	seconds	± 2
GPS Signal for one satellite	dBm	-142
GPS Signal for remaining satellites	dBm	-147

Table 5.2.1.2: Minimum requirements for Sensitivity Coarse Time Assistance

Success rate	2-D position error	Max response time
95 %	100 m	20 s

The reference for this requirement is 3GPP TS 25.171 [31], clause 5.1.1.1.

5.2.1.3 Test purpose

To verify the UE's first position estimate meets the minimum requirements under GPS satellite signal conditions that represent weak signal conditions and with only Coarse Time Assistance provided by the SS.

5.2.1.4 Method of test

5.2.1.4.1 Initial conditions

Test environment: normal; see Annex G.

1. Connect SS and GSS to the UE antenna connector or antenna connectors as shown in figures A.1 or A.2.
2. Set the GPS test parameters as specified in table 5.2.1.3 for GPS scenario #1. Select the first satellite PRN defined in the table in 3GPP TS 37.571-5 [20] clause 5.2.1.2.5 for the one satellite with the higher level.
3. Switch on the UE.
4. Set up a connection using the procedure in clause F.2.

5.2.1.4.2 Procedure

1. Start GPS scenario #1 as specified in 3GPP TS 37.571-5 [20] clause 5.2.1.2 with the UE location randomly selected to be within 3 km of the Reference Location and the altitude of the UE randomly selected between 0 m to 500 m above WGS-84 reference ellipsoid using the method described in 3GPP TS 37.571-5 [20] clause 5.2.1.2.4
2. Send a RESET UE POSITIONING STORED INFORMATION message followed by RRC MEASUREMENT CONTROL messages containing appropriate assistance data; as specified in 3GPP TS 37.571-5 [20], clauses 5.2.2 and 5.2.6 for UE based testing; or clauses 5.2.4 and 5.2.6 for UE assisted testing with the value of GPS TOW msec offset by a random value as specified in 3GPP TS 37.571-5 [20] clause 5.2.6.2; as required to obtain a fix using the procedure specified in 3GPP TS 34.108 [28], clauses 7.5.1 or 7.5.4.
3. If the UE returns a valid result in the MEASUREMENT REPORT message within the Max response time specified in table 5.2.1.4 then record the result and process it as specified in step 4. If the UE does not return a valid result within the Max response time specified in table 5.2.1.4 or reports a UE positioning error in the MEASUREMENT REPORT message then record one Bad Result.
4. For UE based testing compare the reported position estimate in the MEASUREMENT REPORT message against the simulated position of the UE used in step 1, and calculate the 2D position error as specified in clause 4.5.2.3. Compare the 2D position error against the value in table 5.2.1.4 and record one Good Result or Bad Result as appropriate; or

For UE assisted testing convert the GPS measured results reported in the MEASUREMENT REPORT message to a 2D position using the method described in Annex B and then compare the result against the simulated position of the UE, used in step 1, and calculate the 2D position error as specified in clause 4.5.2.3. Compare the 2D position error against the value in table 5.2.1.4 and record one Good Result or Bad Result as appropriate.

5. Repeat steps 1 to 4 using GPS scenario #2 instead of #1 so that the reference location changes sufficiently such that the UE shall have to use the new assistance data. Select the first satellite PRN defined in the table in 3GPP TS 37.571-5 [20] clause 5.2.1.2.5 for the one satellite with the higher level. Use new random values for the UE location and altitude in step 1 and for the GPS TOW msec offset in step 2.
6. Repeat steps 1 to 5 until the statistical requirements of clause 5.2.1.5 are met. Each time scenario #1 or #2 is used, the start time of the GPS scenario shall be advanced by 2 minutes from the time used previously for that scenario. Once a scenario reaches the end of its viable running time, restart it from its nominal start time again. Each time scenario #1 or #2 is used select the next satellite PRN from the one used previously, defined in the table in 3GPP TS 37.571-5 [20] clause 5.2.1.2.5, for the one satellite with the higher level.
7. Release the connection using the procedure in clause F.3.

5.2.1.5 Test Requirements

For the parameters specified in table 5.2.1.3 the UE shall meet the requirements and the success rate specified in table 5.2.1.4 with a confidence level of 95% according to annex D.

Table 5.2.1.3: Test parameters for Sensitivity Coarse Time Assistance

Parameters	Unit	Value
Number of generated satellites	-	8
HDOP Range	-	1.1 to 1.6
Propagation conditions	-	AWGN
GPS Coarse Time assistance error range	seconds	± 1.8
GPS Signal for one satellite	dBm	-141
GPS Signal for remaining satellites	dBm	-146

Table 5.2.1.4: Test requirements for Sensitivity Coarse Time Assistance

Success rate	2-D position error	Max response time
95 %	101.3 m	20.3 s

NOTE: If the above Test Requirement differs from the Minimum Requirement then the Test Tolerance applied for this test is non-zero. The Test Tolerance for this test is defined in clause C.2 and the explanation of how the Minimum Requirement has been relaxed by the Test Tolerance is given in clause C.4.

5.2.2 Sensitivity Fine Time Assistance

5.2.2.1 Definition and applicability

Sensitivity with fine time assistance is the minimum level of GPS satellite signals required for the UE to make an A-GPS position estimate to a specific accuracy and within a specific response time when the network provides fine time assistance in addition to coarse time assistance.

The requirements and this test apply to all types of UTRA for the FDD UE that supports only A-GPS and that is capable of providing an enhanced performance when the network provides Fine Time Assistance.

5.2.2.2 Minimum requirements

The first fix position estimates shall meet the accuracy and response time requirements in table 5.2.2.2 for the parameters specified in table 5.2.2.1.

Table 5.2.2.1: Test parameters for Sensitivity Fine Time Assistance

Parameters	Unit	Value
Number of generated satellites	-	8
HDOP Range	-	1.1 to 1.6
Propagation conditions	-	AWGN
GPS Coarse time assistance error range	seconds	± 2
GPS Fine Time assistance error range	μs	± 10
GPS Signal for all satellites	dBm	-147

Table 5.2.2.2: Minimum requirements for Sensitivity Fine Time Assistance

Success rate	2-D position error	Max response time
95 %	100 m	20 s

The reference for this requirement is 3GPP TS 25.171 [31], clause 5.1.2.1.

5.2.2.3 Test purpose

To verify the UE's first position estimate meets the minimum requirements under GPS satellite signal conditions that represent weak signal conditions and with Fine Time Assistance provided by the SS.

5.2.2.4 Method of test

5.2.2.4.1 Initial conditions

Test environment: normal; see Annex G.

1. Connect SS and GSS to the UE antenna connector or antenna connectors as shown in figures A.1 or A.2.
2. Set the GPS test parameters as specified in table 5.2.2.3 for GPS scenario #1.
3. Switch on the UE.
4. Set up a connection using the procedure in clause F.2.

5.2.2.4.2 Procedure

1. Start GPS scenario #1 as specified in 3GPP TS 37.571-5 [20] clause 5.2.1.2 with the UE location randomly selected to be within 3 km of the Reference Location and the altitude of the UE randomly selected between 0 m to 500 m above WGS-84 reference ellipsoid using the method described in 3GPP TS 37.571-5 [20] clause 5.2.1.2.4
2. Send a RESET UE POSITIONING STORED INFORMATION message followed by RRC MEASUREMENT CONTROL messages containing appropriate assistance data; as specified in 3GPP TS 37.571-5 [20], clauses 5.2.2 and 5.2.6 for UE based testing; or clauses 5.2.4 and 5.2.6 for UE assisted testing with the values of GPS TOW msec and UTRAN GPS timing of cell frames offset by random values as specified in 3GPP TS 37.571-5 [20] clause 5.2.6.2; as required to obtain a fix using the procedure specified in 3GPP TS 34.108 [28], clauses 7.5.1 or 7.5.4.
3. If the UE returns a valid result in the MEASUREMENT REPORT message within the Max response time specified in table 5.2.2.4 then record the result and process it as specified in step 4. If the UE does not return a valid result within the Max response time specified in table 5.2.2.4 or reports a UE positioning error in the MEASUREMENT REPORT message then record one Bad Result.
4. For UE based testing compare the reported position estimate in the MEASUREMENT REPORT message against the simulated position of the UE used in step 1, and calculate the 2D position error as specified in clause 4.5.2.3. Compare the 2D position error against the value in table 5.2.2.4 and record one Good Result or Bad Result as appropriate; or

For UE assisted testing convert the GPS measured results reported in the MEASUREMENT REPORT message to a 2D position using the method described in Annex B and then compare the result against the simulated position of the UE used in step 1, and calculate the 2D position error as specified in clause 4.5.2.3. Compare the 2D position error against the value in table 5.2.2.4 and record one Good Result or Bad Result as appropriate.

5. Repeat steps 1 to 4 using GPS scenario #2 instead of #1 so that the reference location changes sufficiently such that the UE shall have to use the new assistance data. Use new random values for the UE location and altitude in step 1 and for the GPS TOW msec and UTRAN GPS timing of cell frames offsets in step 2.
6. Repeat steps 1 to 5 until the statistical requirements of clause 5.2.2.5 are met. Each time scenario #1 or #2 is used, the start time of the GPS scenario shall be advanced by 2 minutes from the time used previously for that scenario. Once a scenario reaches the end of its viable running time, restart it from its nominal start time again.
7. Release the connection using the procedure in clause F.3.

5.2.2.5 Test Requirements

For the parameters specified in table 5.2.2.3 the UE shall meet the requirements and the success rate specified in table 5.2.2.4 with a confidence level of 95% according to annex D.

Table 5.2.2.3: Test parameters for Sensitivity Fine Time Assistance

Parameters	Unit	Value
Number of generated satellites	-	8
HDOP Range	-	1.1 to 1.6
Propagation conditions	-	AWGN
GPS Coarse time assistance error range	seconds	± 1.8
GPS Fine Time assistance error range	μs	± 9
GPS Signal for all satellites	dBm	-146

Table 5.2.2.4: Test requirements for Sensitivity Fine Time Assistance

Success rate	2-D position error	Max response time
95 %	101.3 m	20.3 s

NOTE: If the above Test Requirement differs from the Minimum Requirement then the Test Tolerance applied for this test is non-zero. The Test Tolerance for this test is defined in clause C.2 and the explanation of how the Minimum Requirement has been relaxed by the Test Tolerance is given in clause C.4.

5.3 Nominal Accuracy

5.3.1 Definition and applicability

Nominal accuracy is the accuracy of the UE's A-GPS position estimate under ideal GPS signal conditions.

The requirements and this test apply to all types of UTRA for the FDD UE that supports A-GPS.

5.3.2 Minimum requirements

The first fix position estimates shall meet the accuracy and response time requirements in table 5.3.2 for the parameters specified in table 5.3.1.

Table 5.3.1: Test parameters for Nominal Accuracy

Parameters	Unit	Value
Number of generated satellites	-	8
HDOP Range	-	1.1 to 1.6
Propagation conditions	-	AWGN
GPS Coarse Time assistance error range	seconds	± 2
GPS Signal for all satellites	dBm	-130

Table 5.3.2: Minimum requirements for Nominal Accuracy

Success rate	2-D position error	Max response time
95 %	30 m	20 s

The reference for this requirement is 3GPP TS 25.171 [31], clause 5.2.1.

5.3.3 Test purpose

To verify the UE's first position estimate meets the minimum requirements under GPS satellite signal conditions that represent ideal conditions.

5.3.4 Method of test

5.3.4.1 Initial conditions

Test environment: normal; see Annex G.

1. Connect SS and GSS to the UE antenna connector or antenna connectors as shown in figures A.1 or A.2.
2. Set the GPS test parameters as specified in table 5.3.3 for GPS scenario #1.
3. Switch on the UE.
4. Set up a connection using the procedure in clause F.2.

5.3.4.2 Procedure

1. Start GPS scenario #1 as specified in 3GPP TS 37.571-5 [20] clause 5.2.1.2 with the UE location randomly selected to be within 3 km of the Reference Location and the altitude of the UE randomly selected between 0 m to 500 m above WGS-84 reference ellipsoid using the method described in 3GPP TS 37.571-5 [20] clause 5.2.1.2.4
2. Send a RESET UE POSITIONING STORED INFORMATION message followed by RRC MEASUREMENT CONTROL messages containing appropriate assistance data; as specified in 3GPP TS 37.571-5 [20], clauses 5.2.2 and 5.2.6 for UE based testing; or clauses 5.2.4 and 5.2.6 for UE assisted testing with the value of GPS TOW msec offset by a random value as specified in 3GPP TS 37.571-5 [20] clause 5.2.6.2; using the exception to the RRC MEASUREMENT CONTROL message listed in table 5.3.2A; as required to obtain a fix using the procedure specified in 3GPP TS 34.108 [28], clauses 7.5.1 or 7.5.4.

Table 5.3.2A: Contents of RRC MEASUREMENT CONTROL message

Information Element	Value/Remark
- UE positioning reporting quantity - Horizontal accuracy	10 (15.9 m)

3. If the UE returns a valid result in the MEASUREMENT REPORT message within the Max response time specified in table 5.3.4 then record the result and process it as specified in step 4. If the UE does not return a valid result within the Max response time specified in table 5.3.4 or reports a UE positioning error in the MEASUREMENT REPORT message then record one Bad Result.
4. For UE based testing compare the reported position estimate in the MEASUREMENT REPORT message against the simulated position of the UE used in step 1, and calculate the 2D position error as specified in clause 4.5.2.3. Compare the 2D position error against the value in table 5.3.4 and record one Good Result or Bad Result as appropriate; or

For UE assisted testing convert the GPS measured results reported in the MEASUREMENT REPORT message to a 2D position using the method described in Annex B and then compare the result against the simulated position of the UE used in step 1, and calculate the 2D position error as specified in clause 4.5.2.3. Compare the 2D position error against the value in table 5.3.4 and record one Good Result or Bad Result as appropriate.
5. Repeat steps 1 to 4 using GPS scenario #2 instead of #1 so that the reference location changes sufficiently such that the UE shall have to use the new assistance data. Use new random values for the UE location and altitude in step 1 and for the GPS TOW msec offset in step 2.
6. Repeat steps 1 to 5 until the statistical requirements of clause 5.3.5 are met. Each time scenario #1 or #2 is used, the start time of the GPS scenario shall be advanced by 2 minutes from the time used previously for that scenario. Once a scenario reaches the end of its viable running time, restart it from its nominal start time again.
7. Release the connection using the procedure in clause F.3.

5.3.5 Test Requirements

For the parameters specified in table 5.3.3 the UE shall meet the requirements and the success rate specified in table 5.3.4 with a confidence level of 95% according to annex D.

Table 5.3.3: Test parameters for Nominal Accuracy

Parameters	Unit	Value
Number of generated satellites	-	8
HDOP Range	-	1.1 to 1.6
Propagation conditions	-	AWGN
GPS Coarse Time assistance error range	seconds	±1.8
GPS Signal for all satellites	dBm	-130

Table 5.3.4: Test requirements for Nominal Accuracy

Success rate	2-D position error	Max response time
95 %	31.3 m	20.3 s

NOTE: If the above Test Requirement differs from the Minimum Requirement then the Test Tolerance applied for this test is non-zero. The Test Tolerance for this test is defined in clause C.2 and the explanation of how the Minimum Requirement has been relaxed by the Test Tolerance is given in clause C.4.

5.4 Dynamic Range

5.4.1 Definition and applicability

Dynamic Range is the maximum difference in level of the GPS signals from a number of satellites that allows the UE to make an A-GPS position estimate with a specific accuracy and a specific response time.

The requirements and this test apply to all types of UTRA for the FDD UE that supports A-GPS.

5.4.2 Minimum requirements

The first fix position estimates shall meet the accuracy and response time requirements in table 5.4.2 for the parameters specified in table 5.4.1.

Table 5.4.1: Test parameters for Dynamic Range

Parameters	Unit	Value
Number of generated satellites	-	6
HDOP Range	-	1.4 to 2.1
GPS Coarse Time assistance error range	seconds	±2
Propagation conditions	-	AWGN
GPS Signal for 1 st satellite	dBm	-129
GPS Signal for 2 nd satellite	dBm	-135
GPS Signal for 3 rd satellite	dBm	-141
GPS Signal for 4 th satellite	dBm	-147
GPS Signal for 5 th satellite	dBm	-147
GPS Signal for 6 th satellite	dBm	-147

Table 5.4.2: Minimum requirements for Dynamic Range

Success rate	2-D position error	Max response time
95 %	100 m	20 s

The reference for this requirement is 3GPP TS 25.171 [31], clause 5.3.1.

5.4.3 Test purpose

To verify the UE's first position estimate meets the minimum requirements under GPS satellite signal conditions that have a wide dynamic range. Strong satellites are likely to degrade the acquisition of weaker satellites due to their cross-correlation products.

5.4.4 Method of test

5.4.4.1 Initial conditions

Test environment: normal; see Annex G.

1. Connect SS and GSS to the UE antenna connector or antenna connectors as shown in figures A.1 or A.2.
2. Set the GPS test parameters as specified in table 5.4.3 for GPS scenario #1. Select the first three satellite PRNs defined in the table in 3GPP TS 37.571-5 [20] clause 5.2.1.2.5 for the three satellites with the higher levels.
3. Switch on the UE.
4. Set up a connection using the procedure in clause F.2.

5.4.4.2 Procedure

1. Start GPS scenario #1 as specified in 3GPP TS 37.571-5 [20] clause 5.2.1.2 with the UE location randomly selected to be within 3 km of the Reference Location and the altitude of the UE randomly selected between 0 m to 500 m above WGS-84 reference ellipsoid using the method described in 3GPP TS 37.571-5 [20] clause 5.2.1.2.4
2. Send a RESET UE POSITIONING STORED INFORMATION message followed by RRC MEASUREMENT CONTROL messages containing appropriate assistance data; as specified in 3GPP TS 37.571-5 [20], clauses 5.2.2 and 5.2.6 for UE based testing; or clauses 5.2.4 and 5.2.6 for UE assisted testing with the value of GPS TOW msec offset by a random value as specified in 3GPP TS 37.571-5 [20] clause 5.2.6.2; as required to obtain a fix using the procedure specified in 3GPP TS 34.108 [28], clauses 7.5.1 or 7.5.4.
3. If the UE returns a valid result in the MEASUREMENT REPORT message within the Max response time specified in table 5.4.4 then record the result and process it as specified in step 4. If the UE does not return a valid result within the Max response time specified in table 5.4.4 or reports a UE positioning error in the MEASUREMENT REPORT message then record one Bad Result.
4. For UE based testing compare the reported position estimate in the MEASUREMENT REPORT message against the simulated position of the UE used in step 1, and calculate the 2D position error as specified in clause 4.5.2.3. Compare the 2D position error against the value in table 5.4.4 and record one Good Result or Bad Result as appropriate; or

For UE assisted testing convert the GPS measured results reported in the MEASUREMENT REPORT message to a 2D position using the method described in Annex B and then compare the result against the simulated position of the UE used in step 1, and calculate the 2D position error as specified in clause 4.5.2.3. Compare the 2D position error against the value in table 5.4.4 and record one Good Result or Bad Result as appropriate.

5. Repeat steps 1 to 4 using GPS scenario #2 instead of #1 so that the reference location changes sufficiently such that the UE shall have to use the new assistance data. Select the first three satellite PRNs defined in the table in 3GPP TS 37.571-5 [20] clause 5.2.1.2.5 for the three satellites with the higher levels. Use new random values for the UE location and altitude in step 1 and for the GPS TOW msec offset in step 2.
6. Repeat steps 1 to 5 until the statistical requirements of clause 5.4.5 are met. Each time scenario #1 or #2 is used, the start time of the GPS scenario shall be advanced by 2 minutes from the time used previously for that scenario. Once a scenario reaches the end of its viable running time, restart it from its nominal start time again. Each time scenario #1 or #2 is used, increment the set of three satellite PRNs by one from the ones used previously, defined in the table in 3GPP TS 37.571-5 [20] clause 5.2.1.2.5, for the three satellites with the higher

levels (i.e. if the set of satellites is a, b, c, d, e, f and the first set used was a, b, c, the second set shall be b, c, d and so on).

7. Release the connection using the procedure in clause F.3.

5.4.5 Test Requirements

For the parameters specified in table 5.4.3 the UE shall meet the requirements and the success rate specified in table 5.4.4 with a confidence level of 95% according to annex D.

Table 5.4.3: Test parameters for Dynamic Range

Parameters	Unit	Value
Number of generated satellites	-	6
HDOP Range	-	1.4 to 2.1
GPS Coarse Time assistance error range	seconds	$\pm 2+TT$
Propagation conditions	-	AWGN
GPS Signal for 1 st satellite	dBm	-128.2
GPS Signal for 2 nd satellite	dBm	-134
GPS Signal for 3 rd satellite	dBm	-140
GPS Signal for 4 th satellite	dBm	-146
GPS Signal for 5 th satellite	dBm	-146
GPS Signal for 6 th satellite	dBm	-146

Table 5.4.4: Test requirements for Dynamic Range

Success rate	2-D position error	Max response time
95 %	101.3 m	20.3 s

NOTE: If the above Test Requirement differs from the Minimum Requirement then the Test Tolerance applied for this test is non-zero. The Test Tolerance for this test is defined in clause C.2 and the explanation of how the Minimum Requirement has been relaxed by the Test Tolerance is given in clause C.4.

5.5 Multi-path Performance

5.5.1 Definition and applicability

Multi-path performance measures the accuracy and response time of the UE's A-GPS position estimate in a specific GPS signal multi-path environment.

The requirements and this test apply to all types of UTRA for the FDD UE that supports A-GPS.

5.5.2 Minimum requirements

The first fix position estimates shall meet the accuracy and response time requirements in table 5.5.2 for the parameters specified in table 5.5.1.

Table 5.5.1: Test parameters for Multi-path Performance

Parameters	Unit	Value
Number of generated satellites (see note)	-	5
GPS Coarse Time assistance error range	seconds	± 2
HDOP Range	-	1.8 to 2.5
GPS signal for Satellite 1, 2 (see note)	dBm	-130
GPS signal for Satellite 3, 4, 5 (see note)	dBm	LOS signal of -130 dBm, multi-path signal of -136 dBm
NOTE: Satellites 1, 2 no multi-path. Satellites 3, 4, 5 multi-path defined in clause 4.2.4.		

Table 5.5.2: Minimum requirements for Multi-path Performance

Success rate	2-D position error	Max response time
95 %	100 m	20 s

The reference for this requirement is 3GPP TS 25.171 [31], clause 5.4.1.

5.5.3 Test purpose

To verify the UE's first position estimate meets the minimum requirements under GPS satellite signal conditions that represent simple multi-path conditions.

5.5.4 Method of test

5.5.4.1 Initial conditions

Test environment: normal; see Annex G.

1. Connect SS and GSS to the UE antenna connector or antenna connectors as shown in figures A.1 or A.2.
2. Set the GPS test parameters as specified in table 5.5.3 for GPS scenario #1. Select the first two satellite PRNs defined in the table in 3GPP TS 37.571-5 [20] clause 5.2.1.2.5 for the two satellites with the higher levels.
3. Switch on the UE.
4. Set up a connection using the procedure in clause F.2.

5.5.4.2 Procedure

1. Start GPS scenario #1 as specified in 3GPP TS 37.571-5 [20] clause 5.2.1.2 with the UE location randomly selected to be within 3 km of the Reference Location and the altitude of the UE randomly selected between 0 m to 500 m above WGS-84 reference ellipsoid using the method described in 3GPP TS 37.571-5 [20] clause 5.2.1.2.4. The initial carrier phase difference between taps of the multi-path model shall be randomly selected between 0 and 2π radians by selecting the next random number from a standard uniform random number generator, in the range 0 to 2π , representing radians with a resolution of 0.1, representing 0.1 radians.
2. Send a RESET UE POSITIONING STORED INFORMATION message followed by RRC MEASUREMENT CONTROL messages containing appropriate assistance data; as specified in 3GPP TS 37.571-5 [20], clauses 5.2.2 and 5.2.6 for UE based testing; or clauses 5.2.4 and 5.2.6 for UE assisted testing with the value of GPS TOW msec offset by a random value as specified in 3GPP TS 37.571-5 [20] clause 5.2.6.2; as required to obtain a fix using the procedure specified in 3GPP TS 34.108 [28], clauses 7.5.1 or 7.5.4.
3. If the UE returns a valid result in the MEASUREMENT REPORT message within the Max response time specified in table 5.5.4 then record the result and process it as specified in step 4. If the UE does not return a valid result within the Max response time specified in table 5.5.4 or reports a UE positioning error in the MEASUREMENT REPORT message then record one Bad Result.
4. For UE based testing compare the reported position estimate in the MEASUREMENT REPORT message against the simulated position of the UE used in step 1, and calculate the 2D position error as specified in clause 4.5.2.3. Compare the 2D position error against the value in table 5.5.4 and record one Good Result or Bad Result as appropriate; or

For UE assisted testing convert the GPS measured results reported in the MEASUREMENT REPORT message to a 2D position using the method described in Annex B and then compare the result against the simulated position of the UE used in step 1, and calculate the 2D position error as specified in clause 4.5.2.3. Compare the 2D position error against the value in table 5.5.4 and record one Good Result or Bad Result as appropriate.

5. Repeat steps 1 to 4 using GPS scenario #2 instead of #1 so that the reference location changes sufficiently such that the UE shall have to use the new assistance data. Select the first two satellite PRNs defined in the table in 3GPP TS 37.571-5 [20] clause 5.2.1.2.5 for the two satellites with the higher levels. Use new random values for

the UE location and altitude, and the initial carrier phase difference between taps of the multi-path model in step 1 and for the GPS TOW msec offset in step 2.

6. Repeat steps 1 to 5 until the statistical requirements of clause 5.5.5 are met. Each time scenario #1 or #2 is used, the start time of the GPS scenario shall be advanced by 2 minutes from the time used previously for that scenario. Once a scenario reaches the end of its viable running time, restart it from its nominal start time again. Each time scenario #1 or #2 is used, increment the set of two satellite PRNs by one from the ones used previously, defined in the table in 3GPP TS 37.571-5 [20] clause 5.2.1.2.5, for the two satellites with the higher level (i.e. if the set of satellites is a, b, c, d, e and the first set used was a, b the second set shall be b, c and so on).
7. Release the connection using the procedure in clause F.3.

5.5.5 Test Requirements

For the parameters specified in table 5.5.3 the UE shall meet the requirements and the success rate specified in table 5.5.4 with a confidence level of 95% according to annex D.

Table 5.5.3: Test parameters for Multi-path Performance

Parameters	Unit	Value
Number of generated satellites (see note)	-	5
GPS Coarse Time assistance error range	seconds	$\pm 2+TT$
HDOP Range	-	1.8 to 2.5
GPS signal for Satellite 1, 2 (see note)	dBm	-130
GPS signal for Satellite 3, 4, 5 (see note)	dBm	LOS signal of -130 dBm, multi-path signal of -136.2 dBm
NOTE: Satellites 1, 2 no multi-path. Satellites 3, 4, 5 multi-path defined in clause 4.2.4.		

Table 5.5.4: Test requirements for Multi-path Performance

Success rate	2-D position error	Max response time
95 %	101.3 m	20.3 s

NOTE: If the above Test Requirement differs from the Minimum Requirement then the Test Tolerance applied for this test is non-zero. The Test Tolerance for this test is defined in clause C.2 and the explanation of how the Minimum Requirement has been relaxed by the Test Tolerance is given in clause C.4.

5.6 Moving Scenario and Periodic Update Performance

5.6.1 Definition and applicability

Moving scenario and periodic update performance measures the accuracy of the UE's A-GPS position estimates and the periodic update capability of the UE in a moving scenario.

The requirements and this test apply to all types of UTRA for the FDD UE that supports only A-GPS.

5.6.2 Minimum requirements

The position estimates, after the first reported position estimate, shall meet the accuracy requirement in table 5.6.2 with the periodical reporting interval of 2 seconds for the parameters specified in table 5.6.1.

NOTE: In the actual testing the UE may report error messages until it has been able to acquire GPS measured results or a position estimate. The SS shall only consider the first measurement report different from an error message as the first position estimate in the requirement in table 5.6.2.

Table 5.6.1: Test parameters for Moving Scenario and Periodic Update Performance

Parameters	Unit	Value
Number of generated satellites	-	5

Parameters	Unit	Value
HDOP Range	-	1.8 to 2.5
Propagation condition	-	AWGN
GPS signal for all satellites	dBm	-130

Table 5.6.2: Minimum requirements for Moving Scenario and Periodic Update Performance

Success Rate	2-D position error
95 %	100 m

The reference for this requirement is 3GPP TS 25.171 [31], clause 5.5.1.

5.6.3 Test purpose

To verify the UE's position estimates, after the first reported position estimate, meet the minimum requirements under GPS satellite signal conditions that simulate a moving scenario. A good tracking performance, with regular position estimate reporting is essential for certain location services.

5.6.4 Method of test

5.6.4.1 Initial conditions

Test environment: normal; see Annex G.

The UE is requested to use periodical reporting with a reporting interval of 2 seconds.

The GPS signals simulate the UE moving on a rectangular trajectory of 940 m by 1 440 m with rounded corners defined in figure 5.6.1 and table 5.6.3. The initial reference is first defined followed by acceleration to final speed of 100 km/h in 250 m. The UE then maintains the speed for 400 m. This is followed by deceleration to final speed of 25 km/h in 250 m. The UE then turn 90 degrees with turning radius of 20 m at 25 km/h. This is followed by acceleration to final speed of 100 km/h in 250 m. The sequence is repeated to complete the rectangle.

Table 5.6.3: Trajectory Parameters for Moving Scenario and Periodic Update Performance test case

Parameter	Distance (m)	Speed (km/h)
$l_{11}, l_{15}, l_{21}, l_{25}$	20	25
$l_{12}, l_{14}, l_{22}, l_{24}$	250	25 to 100 and 100 to 25
l_{13}	400	100
l_{23}	900	100

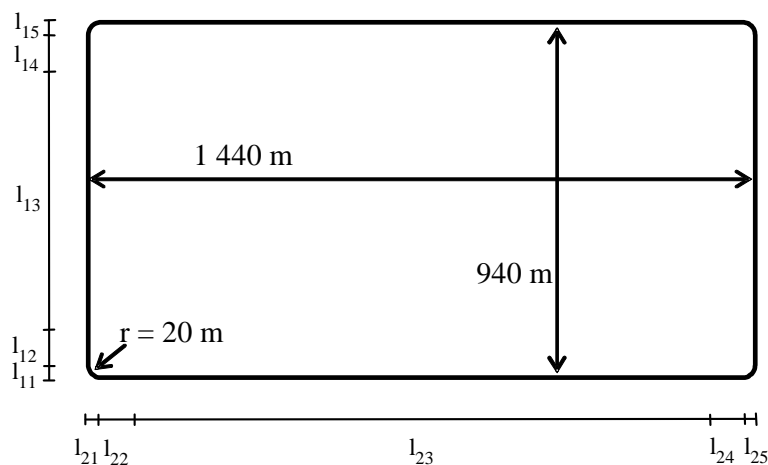

Figure 5.6.1: Rectangular Trajectory for Moving Scenario and Periodic Update Performance test case

1. Connect SS and GSS to the UE antenna connector or antenna connectors as shown in figures A.1 or A.2.
2. Set the GPS test parameters as specified in table 5.6.4 for GPS scenario #3.
3. Switch on the UE.
4. Set up a connection using the procedure in clause F.2.

5.6.4.2 Procedure

1. Start GPS scenario #3 as specified in 3GPP TS 37.571-5 [20], clause 5.2.1.2
2. Send a RESET UE POSITIONING STORED INFORMATION message followed by RRC MEASUREMENT CONTROL messages containing appropriate assistance data; as specified in 3GPP TS 37.571-5 [20], clauses 5.2.2 and 5.2.6 for UE based testing; or clauses 5.2.4 and 5.2.6 for UE assisted testing; as required to obtain fixes using the procedure specified in 3GPP TS 34.108 [28], clauses 7.5.2 or 7.5.5.
3. Ignore any error messages that the UE may report in MEASUREMENT REPORT messages until it has been able to acquire the GPS signals and reports the first GPS measured result or position estimate.
4. Discard the first GPS measured result or position estimate.
5. Record the time of reception of the next MEASUREMENT REPORT message after reception of the first GPS measured result or position estimate.
6. After the reception of the first GPS measured result or position estimate reported in a MEASUREMENT REPORT message, every time the UE returns a GPS measured result or position estimate in the MEASUREMENT REPORT message record the time of reception and the result. If the difference between the time of reception and the time of reception of the previous result is less than 1.5 seconds or greater than 2.5 seconds, or if the UE reports a UE positioning error in any MEASUREMENT REPORT messages, then record one Bad Result. Otherwise process the result as specified in step 7.
7. For UE based testing compare the reported position estimate in the MEASUREMENT REPORT message against the simulated position of the UE at the time of applicability reported in the position estimate and calculate the 2D position error as specified in clause 4.5.2.3. Compare the 2D position error against the value in table 5.6.5 and record one Good Result or Bad Result as appropriate; or

For UE assisted testing convert the GPS measured results reported in the MEASUREMENT REPORT message to a 2D position using the method described in Annex B and then compare the result against the simulated position of the UE at the time of applicability reported in the GPS measured results and calculate the 2D position error as specified in clause 4.5.2.3. Compare the 2D position error against the value in table 5.6.5 and record one Good Result or Bad Result as appropriate.
8. If the UE sends the first MEASUREMENT REPORT that contains a measured result or position estimate later than 240s after the start of the GPS scenario, fail the UE and stop the test early. Otherwise collect MEASUREMENT REPORTs during 900s, starting from the time recorded in step 5. If at any time the difference between the times of reception of two consecutive results is greater than 240s, fail the UE and stop the test early. Use the collected Good Results and Bad Results to determine the PASS/FAIL according to clause 5.6.5.
9. Release the connection using the procedure in clause F.3.

5.6.5 Test Requirements

For the parameters specified in table 5.6.4, after the first reported position estimate, the UE shall meet the accuracy requirement and the success rate specified in table 5.6.5 with a periodical reporting interval of 2 seconds +/- 20% plus measurement system uncertainty of 100ms.

NOTE: Due to the statistical nature of the results it is not possible to design a test with predefined confidence level for the success rate in Table 5.6.5, therefore a simple PASS/FAIL of the results gathered against this success rate is used.

Table 5.6.4: Test parameters for Moving Scenario and Periodic Update Performance

Parameters	Unit	Value
Number of generated satellites	-	5
HDOP Range	-	1.8 to 2.5
Propagation condition	-	AWGN
GPS signal for all satellites	dBm	-130

Table 5.6.5: Test requirements for Moving Scenario and Periodic Update Performance

Success Rate	2-D position error
95 %	101.3 m

NOTE 1: If the above Test Requirement differs from the Minimum Requirement then the Test Tolerance applied for this test is non-zero. The Test Tolerance for this test is defined in clause C.2 and the explanation of how the Minimum Requirement has been relaxed by the Test Tolerance is given in clause C.4.

NOTE 2: In the actual testing the UE may report error messages until it has been able to acquire GPS measured results or a position estimate. The test equipment shall only consider the first measurement report different from an error message as the first position estimate in the requirement in table 5.6.5.

6 UTRA A-GNSS Minimum Performance requirements

6.1 General

This clause defines the minimum performance requirements for both UE based and UE assisted A-GNSS UTRA UEs. If a UE supports both modes then it shall be tested in both modes. It excludes performance requirements for FDD UEs where the only A-GNSS supported is A-GPS L1 C/A which are specified in clause 5. It excludes performance requirements for TDD UEs where the only A-GNSS supported is A-GPS L1 C/A for which there is no requirement.

The requirements are defined for CELL_DCH and CELL_FACH states. All tests shall be performed in CELL_DCH state and the Nominal Accuracy Performance test case shall be also performed in CELL_FACH state.

6.2 Sensitivity

6.2.1 Sensitivity Coarse Time Assistance

6.2.1.1 Definition and applicability

Sensitivity with coarse time assistance is the minimum level of GNSS satellite signals required for the UE to make an A-GNSS position estimate to a specific accuracy and within a specific response time when the network only provides coarse time assistance.

The requirements and this test apply to all types of UTRA for the UE that supports A-GNSS.

This test case includes sub-test cases dependent on the GNSS supported by the UE. Each sub-test case is identified by a Sub-Test Case Number as defined in Table 6.2.1.1.

Table 6.2.1.1: Sub-Test Case Number Definition

Sub-Test Case Number	Supported GNSS
1	UE supporting A-GLONASS
2	UE supporting A-Galileo
3	UE supporting A-GPS and Modernized GPS
4	UE supporting A-GPS and A-GLONASS
8	UE supporting A-GPS and A-Galileo
9	UE supporting A-BDS
10	UE supporting A-GPS and A-BDS

6.2.1.2 Minimum requirements

The first fix position estimates shall meet the accuracy and response time requirements in table 6.2.1.2-3 for the parameters specified in table 6.2.1.2-1.

Table 6.2.1.2-1: Test parameters for Sensitivity Coarse Time Assistance

System	Parameters	Unit	Value
	Number of generated satellites per system	-	See Table 6.2.1.2-2
	Total number of generated satellites	-	6
	HDOP range		1.4 to 2.1
	Propagation conditions	-	AWGN
	GNSS coarse time assistance error range	seconds	± 2
Galileo	Reference high signal power level	dBm	-142
	Reference low signal power level	dBm	-147
GPS ⁽¹⁾	Reference high signal power level	dBm	-142
	Reference low signal power level	dBm	-147
GLONASS	Reference high signal power level	dBm	-142

System	Parameters	Unit	Value
BDS	Reference low signal power level	dBm	-147
	Reference high signal power level	dBm	-136
	Reference low signal power level	dBm	-145

NOTE 1: "GPS" here means GPS L1 C/A, Modernized GPS, or both, dependent on UE capabilities.

Table 6.2.1.2-2: Power level and satellite allocation

		Satellite allocation for each constellation		
		GNSS-1 ⁽¹⁾	GNSS-2	GNSS-3
Single constellation	High signal level	1	-	-
	Low signal level	5	-	-
Dual constellation	High signal level	1	-	-
	Low signal level	2	3	-
Triple constellation	High signal level	1	-	-
	Low signal level	1	2	2

Note: For GPS capable receivers, GNSS-1, i.e. the system having the satellite with high signal level, shall be GPS.

Table 6.2.1.2-3: Minimum requirements for Sensitivity Coarse Time Assistance

System	Success rate	2-D position error	Max response time
All	95 %	100 m	20 s

The reference for this requirement is 3GPP TS 25.172 [19], clause 5.1.1.1, and 3GPP TS 25.173 [36], clause 5.1.1.1.

6.2.1.3 Test purpose

To verify the UE's first position estimate meets the minimum requirements under GNSS satellite signal conditions that represent weak signal conditions and with only Coarse Time Assistance provided by the SS.

6.2.1.4 Method of test

6.2.1.4.1 Initial conditions

Test environment: normal; see Annex G.

1. Connect SS and GSS to the UE antenna connector or antenna connectors as shown in figures A.1 or A.2.
2. Set the GNSS test parameters as specified in table 6.2.1.5-1 for GNSS scenario #1. For GNSS-1, select the first satellite SV ID defined in the relevant table in 3GPP TS 37.571-5 [20] clause 6.2.1.2 for the one satellite with the higher level.
3. Switch on the UE.
4. Set up a connection using the procedure in clause F.2.

6.2.1.4.2 Procedure

1. Start GNSS scenario #1 as specified in 3GPP TS 37.571-5 [20] clause 6.2.1.2 with the UE location randomly selected to be within 3 km of the Reference Location and the altitude of the UE randomly selected between 0 m to 500 m above WGS-84 reference ellipsoid using the method described in 3GPP TS 37.571-5 [20] clause 6.2.1.2.6.
2. Send a RESET UE POSITIONING STORED INFORMATION message followed by RRC MEASUREMENT CONTROL messages containing appropriate assistance data; as specified in 3GPP TS 37.571-5 [20], clauses 6.2.2 and 6.2.7 for UE based testing; or clauses 6.2.4 and 6.2.7 for UE assisted testing with the value of GPS TOW msec or GANSS TOD offset by a random value as specified in 3GPP TS 37.571-5 [20] clause 6.2.7.2; as required to obtain a fix using the procedure specified in 3GPP TS 34.108 [28], clauses 7.5.6 or 7.5.8.

3. If the UE returns a valid result in the MEASUREMENT REPORT message within the Max response time specified in table 6.2.1.5-3 then record the result and process it as specified in step 4. If the UE does not return a valid result within the Max response time specified in table 6.2.1.5-3 or reports a UE positioning error in the MEASUREMENT REPORT message then record one Bad Result.
4. For UE based testing compare the reported position estimate in the MEASUREMENT REPORT message against the simulated position of the UE used in step 1, and calculate the 2D position error as specified in clause 4.5.2.3. Compare the 2D position error against the value in table 6.2.1.5-3 and record one Good Result or Bad Result as appropriate; or

For UE assisted testing convert the GNSS measured results reported in the MEASUREMENT REPORT message to a 2D position using the method described in Annex B and then compare the result against the simulated position of the UE, used in step 1, and calculate the 2D position error as specified in clause 4.5.2.3. Compare the 2D position error against the value in table 6.2.1.5-3 and record one Good Result or Bad Result as appropriate.

5. Repeat steps 1 to 4 using GNSS scenario #2 instead of #1 so that the reference location changes sufficiently such that the UE shall have to use the new assistance data. For GNSS-1, select the first satellite SV ID defined in the relevant table in 3GPP TS 37.571-5 [20] clause 6.2.1.2 for the one satellite with the higher level. Use new random values for the UE location and altitude in step 1 and for the GPS TOW msec or GANSS TOD offset in step 2.
6. Repeat steps 1 to 5 until the statistical requirements of clause 6.2.1.5 are met. Each time scenario #1 or #2 is used, the start time of the GNSS scenario shall be advanced by 2 minutes from the time used previously for that scenario. Once a scenario reaches the end of its viable running time, restart it from its nominal start time again. Each time scenario #1 or #2 is used for GNSS-1, select the next satellite SV ID from the one used previously, defined in the relevant table in 3GPP TS 37.571-5 [20] clause 6.2.1.2, for the one satellite with the higher level.
7. Release the connection using the procedure in clause F.3.

6.2.1.5 Test Requirements

For the parameters specified in table 6.2.1.5-1 the UE shall meet the requirements and the success rate specified in table 6.2.1.5-3 with a confidence level of 95% according to Annex D.

Table 6.2.1.5-1: Test parameters for Sensitivity Coarse Time Assistance

System	Parameters	Unit	Value
	Number of generated satellites per system	-	See Table 6.2.1.5-2
	Total number of generated satellites	-	6
	HDOP range		1.4 to 2.1
	Propagation conditions	-	AWGN
	GNSS coarse time assistance error range	seconds	±1.8
Galileo	Reference high signal power level	dBm	-141
	Reference low signal power level	dBm	-146
GPS ⁽¹⁾	Reference high signal power level	dBm	-141
	Reference low signal power level	dBm	-146
GLONASS	Reference high signal power level	dBm	-141
	Reference low signal power level	dBm	-146
BDS	Reference high signal power level	dBm	-135
	Reference low signal power level	dBm	-144
NOTE 1: "GPS" here means GPS L1 C/A, Modernized GPS, or both, dependent on UE capabilities.			

Table 6.2.1.5-2: Power level and satellite allocation

		Satellite allocation for each constellation		
		GNSS-1 ⁽¹⁾	GNSS-2	GNSS-3
Single constellation	High signal level	1	-	-
	Low signal level	5	-	-
Dual constellation	High signal level	1	-	-
	Low signal level	2	3	-

Triple constellation	High signal level	1	-	-
	Low signal level	1	2	2
Note: For GPS capable receivers, GNSS-1, i.e. the system having the satellite with high signal level, shall be GPS.				

Table 6.2.1.5-3: Test requirements for Sensitivity Coarse Time Assistance

System	Success rate	2-D position error	Max response time
All	95 %	101.3 m	20.3 s

NOTE: If the above Test Requirement differs from the Minimum Requirement then the Test Tolerance applied for this test is non-zero. The Test Tolerance for this test is defined in clause C.2 and the explanation of how the Minimum Requirement has been relaxed by the Test Tolerance is given in clause C.4.

6.2.2 Sensitivity Fine Time Assistance

6.2.2.1 Definition and applicability

Sensitivity with fine time assistance is the minimum level of GNSS satellite signals required for the UE to make an A-GNSS position estimate to a specific accuracy and within a specific response time when the network provides fine time assistance in addition to coarse time assistance.

The requirements and this test apply to all types of UTRA for the UE that supports A-GNSS and that is capable of providing an enhanced performance when the network provides Fine Time Assistance.

This test case includes sub-test cases dependent on the GNSS supported by the UE. Each sub-test case is identified by a Sub-Test Case Number as defined in Table 6.2.2.1.

Table 6.2.2.1: Sub-Test Case Number Definition

Sub-Test Case Number	Supported GNSS
1	UE supporting A-GLONASS
2	UE supporting A-Galileo
3	UE supporting A-GPS and Modernized GPS
4	UE supporting A-GPS and A-GLONASS
8	UE supporting A-GPS and A-Galileo
9	UE supporting A-BDS
10	UE supporting A-GPS and A-BDS

6.2.2.2 Minimum requirements

The first fix position estimates shall meet the accuracy and response time requirements in table 6.2.2.2-3 for the parameters specified in table 6.2.2.2-1.

Table 6.2.2.2-1: Test parameters for Sensitivity Fine Time Assistance

System	Parameters	Unit	Value
	Number of generated satellites per system	-	See Table 6.2.2.2-2
	Total number of generated satellites	-	6
	HDOP range		1.4 to 2.1
	Propagation conditions	-	AWGN
	GNSS coarse time assistance error range	seconds	±2
	GNSS fine time assistance error range	µs	±10
Galileo	Reference signal power level	dBm	-147
GPS ⁽¹⁾	Reference signal power level	dBm	-147
GLONASS	Reference signal power level	dBm	-147
BDS	Reference signal power level	dBm	-147

System	Parameters	Unit	Value
Note: "GPS" here means GPS L1 C/A, Modernized GPS, or both, dependent on UE capabilities.			

Table 6.2.2.2-2: Satellite allocation

	Satellite allocation for each constellation		
	GNSS-1	GNSS-2	GNSS-3
Single constellation	6	-	-
Dual constellation	3	3	-
Triple constellation	2	2	2

Table 6.2.2.2-3: Minimum requirements for Sensitivity Fine Time Assistance

System	Success rate	2-D position error	Max response time
All	95 %	100 m	20 s

The reference for this requirement is 3GPP TS 25.172 [19], clause 5.1.2.1, and 3GPP TS 25.173 [36], clause 5.1.2.1.

6.2.2.3 Test purpose

To verify the UE's first position estimate meets the minimum requirements under GNSS satellite signal conditions that represent weak signal conditions and with Fine Time Assistance provided by the SS.

6.2.2.4 Method of test

6.2.2.4.1 Initial conditions

Test environment: normal; see Annex G.

1. Connect SS and GSS to the UE antenna connector or antenna connectors as shown in figures A.1 or A.2.
2. Set the GNSS test parameters as specified in table 6.2.2.5-1 for GNSS scenario #1.
3. Switch on the UE.
4. Set up a connection using the procedure in clause F.2.

6.2.2.4.2 Procedure

1. Start GNSS scenario #1 as specified in 3GPP TS 37.571-5 [20] clause 6.2.1.2 with the UE location randomly selected to be within 3 km of the Reference Location and the altitude of the UE randomly selected between 0 m to 500 m above WGS-84 reference ellipsoid using the method described in 3GPP TS 37.571-5 [20] clause 6.2.1.2.6.
2. Send a RESET UE POSITIONING STORED INFORMATION message followed by RRC MEASUREMENT CONTROL messages containing appropriate assistance data; as specified in 3GPP TS 37.571-5 [20], clauses 6.2.2 and 6.2.7 for UE based testing; or clauses 6.2.4 and 6.2.7 for UE assisted testing with the values of GPS TOW msec or GANSS TOD, and UTRAN GPS timing of cell frames or UTRAN GANSS timing of cell frames offset by random values as specified in 3GPP TS 37.571-5 [20] clause 6.2.7.2; as required to obtain a fix using the procedure specified in 3GPP TS 34.108 [28], clauses 7.5.6 or 7.5.8.
3. If the UE returns a valid result in the MEASUREMENT REPORT message within the Max response time specified in table 6.2.2.5-3 then record the result and process it as specified in step 4. If the UE does not return a valid result within the Max response time specified in table 6.2.2.5-3 or reports a UE positioning error in the MEASUREMENT REPORT message then record one Bad Result.
4. For UE based testing compare the reported position estimate in the MEASUREMENT REPORT message against the simulated position of the UE used in step 1, and calculate the 2D position error as specified in clause

6.1.1.3. Compare the 2D position error against the value in table 6.2.2.5-3 and record one Good Result or Bad Result as appropriate; or

For UE assisted testing convert the GNSS measured results reported in the MEASUREMENT REPORT message to a 2D position using the method described in Annex B and then compare the result against the simulated position of the UE used in step 1, and calculate the 2D position error as specified in clause 6.1.1.3. Compare the 2D position error against the value in table 6.2.2.5-3 and record one Good Result or Bad Result as appropriate.

5. Repeat steps 1 to 4 using GNSS scenario #2 instead of #1 so that the reference location changes sufficiently such that the UE shall have to use the new assistance data. Use new random values for the UE location and altitude in step 1 and for the GPS TOW msec or GANSS TOD, and UTRAN GPS timing of cell frames or UTRAN GANSS timing of cell frames offsets in step 2.
6. Repeat steps 1 to 5 until the statistical requirements of clause 6.2.2.5 are met. Each time scenario #1 or #2 is used, the start time of the GNSS scenario shall be advanced by 2 minutes from the time used previously for that scenario. Once a scenario reaches the end of its viable running time, restart it from its nominal start time again.
7. Release the connection using the procedure in clause F.3.

6.2.2.5 Test Requirements

For the parameters specified in table 6.2.2.5-1 the UE shall meet the requirements and the success rate specified in table 6.2.2.5-3 with a confidence level of 95% according to Annex D.

Table 6.2.2.5-1: Test parameters for Sensitivity Fine Time Assistance

System	Parameters	Unit	Value
	Number of generated satellites per system	-	See Table 6.2.2.5-2
	Total number of generated satellites	-	6
	HDOP range		1.4 to 2.1
	Propagation conditions	-	AWGN
	GNSS coarse time assistance error range	seconds	± 1.8
	GNSS fine time assistance error range	μ s	± 9
Galileo	Reference signal power level	dBm	-146
GPS ⁽¹⁾	Reference signal power level	dBm	-146
GLONASS	Reference signal power level	dBm	-146
BDS	Reference signal power level	dBm	-146

Note: "GPS" here means GPS L1 C/A, Modernized GPS, or both, dependent on UE capabilities.

Table 6.2.2.5-2: Satellite allocation

	Satellite allocation for each constellation		
	GNSS-1	GNSS-2	GNSS-3
Single constellation	6	-	-
Dual constellation	3	3	-
Triple constellation	2	2	2

Table 6.2.2.5-3: Test requirements for Sensitivity Fine Time Assistance

System	Success rate	2-D position error	Max response time
All	95 %	101.3 m	20.3 s

NOTE: If the above Test Requirement differs from the Minimum Requirement then the Test Tolerance applied for this test is non-zero. The Test Tolerance for this test is defined in clause C.2 and the explanation of how the Minimum Requirement has been relaxed by the Test Tolerance is given in clause C.4.

6.3 Nominal Accuracy

6.3.1 Definition and applicability

Nominal accuracy is the accuracy of the UE's A-GNSS position estimate under ideal GNSS signal conditions.

The requirements and this test apply to all types of UTRA for the UE that supports A-GNSS.

This test case includes sub-test cases dependent on the GNSS supported by the UE. Each sub-test case is identified by a Sub-Test Case Number as defined in Table 6.3.1.

Table 6.3.1: Sub-Test Case Number Definition

Sub-Test Case Number	Supported GNSS
1	UE supporting A-GLONASS
2	UE supporting A-Galileo
3	UE supporting A-GPS and Modernized GPS
4	UE supporting A-GPS and A-GLONASS
8	UE supporting A-GPS and A-Galileo
9	UE supporting A-BDS
10	UE supporting A-GPS and A-BDS

6.3.2 Minimum requirements

The first fix position estimates shall meet the accuracy and response time requirements in table 6.3.2-3 for the parameters specified in table 6.3.2-1.

Table 6.3.2-1: Test parameters for Nominal Accuracy

System	Parameters	Unit	Value
	Number of generated satellites per system	-	See Table 6.3.2-2
	Total number of generated satellites	-	6 or 7 ⁽²⁾
	HDOP Range	-	1.4 to 2.1
	Propagation conditions	-	AWGN
	GNSS coarse time assistance error range	seconds	±2
GPS ⁽¹⁾	Reference signal power level for all satellites	dBm	-128.5
Galileo	Reference signal power level for all satellites	dBm	-127
GLONASS	Reference signal power level for all satellites	dBm	-131
QZSS	Reference signal power level for all satellites	dBm	-128.5
SBAS	Reference signal power level for all satellites	dBm	-131
BDS	Reference signal power level for all satellites	dBm	-133
Note 1: "GPS" here means GPS L1 C/A, Modernized GPS, or both, dependent on UE capabilities.			
Note 2: 7 satellites apply only for SBAS case.			

If SBAS is supported, the SBAS satellite with the highest elevation will be added to the scenario.

Table 6.3.2-2: Satellite allocation

	Satellite allocation for each constellation			
	GNSS 1 ⁽¹⁾	GNSS 2 ⁽¹⁾	GNSS 3 ⁽¹⁾	SBAS
Single constellation	6	--	--	1
Dual constellation	3	3	--	1
Triple constellation	2	2	2	1
Note: GNSS refers to global systems i.e., GPS, Galileo, GLONASS and BDS.				

Table 6.3.2-3: Minimum requirements for Nominal Accuracy

System	Success rate	2-D position error	Max response time
All	95 %	15 m	20 s

The reference for this requirement is 3GPP TS 25.172 [19], clause 5.2.1, and 3GPP TS 25.173 [36], clause 5.2.1.

6.3.3 Test purpose

To verify the UE's first position estimate meets the minimum requirements under GNSS satellite signal conditions that represent ideal conditions.

6.3.4 Method of test

6.3.4.1 Initial conditions

Test environment: normal; see Annex G.

1. Connect SS and GSS to the UE antenna connector or antenna connectors as shown in figures A.1 or A.2.
2. Set the GNSS test parameters as specified in table 6.3.4.2 for GNSS scenario #3.
3. Switch on the UE.
4. Set up a connection using the procedure in clause F.2.

6.3.4.2 Procedure

1. Start GNSS scenario #3 as specified in 3GPP TS 37.571-5 [20] clause 6.2.1.2 with the UE location randomly selected to be within 3 km of the Reference Location and the altitude of the UE randomly selected between 0 m to 500 m above WGS-84 reference ellipsoid using the method described in 3GPP TS 37.571-5 [20] clause 6.2.1.2.6.
2. Send a RESET UE POSITIONING STORED INFORMATION message followed by RRC MEASUREMENT CONTROL messages containing appropriate assistance data; as specified in 3GPP TS 37.571-5 [20], clauses 6.2.2 and 6.2.7 for UE based testing; or clauses 6.2.4 and 6.2.7 for UE assisted testing with the value of GPS TOW msec or GANSS TOD offset by a random value as specified in 3GPP TS 37.571-5 [20] clause 6.2.7.2; using the exception to the RRC MEASUREMENT CONTROL message listed in table 6.3.5-1; as required to obtain a fix using the procedure specified in 3GPP TS 34.108 [28], clauses 7.5.6 or 7.5.8.

Table 6.3.4.2: Contents of RRC MEASUREMENT CONTROL message

Information Element	Value/Remark
- UE positioning reporting quantity - Horizontal accuracy	'6' (7.7m)

3. If the UE returns a valid result in the MEASUREMENT REPORT message within the Max response time specified in table 6.3.5-3 then record the result and process it as specified in step 4. If the UE does not return a valid result within the Max response time specified in table 6.3.5-3 or reports a UE positioning error in the MEASUREMENT REPORT message then record one Bad Result.
4. For UE based testing compare the reported position estimate in the MEASUREMENT REPORT message against the simulated position of the UE used in step 1, and calculate the 2D position error as specified in clause 6.1.1.3. Compare the 2D position error against the value in table 6.3.5-3 and record one Good Result or Bad Result as appropriate; or

For UE assisted testing convert the GNSS measured results reported in the MEASUREMENT REPORT message to a 2D position using the method described in Annex B and then compare the result against the simulated position of the UE used in step 1, and calculate the 2D position error as specified in clause 6.1.1.3.

Compare the 2D position error against the value in table 6.3.5-3 and record one Good Result or Bad Result as appropriate.

5. Repeat steps 1 to 4 using GNSS scenario #4 instead of #3 so that the reference location changes sufficiently such that the UE shall have to use the new assistance data. Use new random values for the UE location and altitude in step 1 and for the GPS TOW msec or GANSS TOD offset in step 2.
6. Repeat steps 1 to 5 until the statistical requirements of clause 6.3.5 are met. Each time scenario #3 or #4 is used, the start time of the GNSS scenario shall be advanced by 2 minutes from the time used previously for that scenario. Once a scenario reaches the end of its viable running time, restart it from its nominal start time again.
7. Release the connection using the procedure in clause F.3.

6.3.5 Test Requirements

For the parameters specified in table 6.3.5-1 the UE shall meet the requirements and the success rate specified in table 6.3.5-3 with a confidence level of 95% according to Annex D.

Table 6.3.5-1: Test parameters for Nominal Accuracy

System	Parameters	Unit	Value
	Number of generated satellites per system	-	See Table 6.3.5-3
	Total number of generated satellites	-	6 or 7 ⁽²⁾
	HDOP Range	-	1.4 to 2.1
	Propagation conditions	-	AWGN
	GNSS coarse time assistance error range	seconds	±1.8
GPS ⁽¹⁾	Reference signal power level for all satellites	dBm	-128.5
Galileo	Reference signal power level for all satellites	dBm	-127
GLONASS	Reference signal power level for all satellites	dBm	-131
QZSS	Reference signal power level for all satellites	dBm	-128.5
SBAS	Reference signal power level for all satellites	dBm	-131
BDS	Reference signal power level for all satellites	dBm	-133
Note 1: "GPS" here means GPS L1 C/A, Modernized GPS, or both, dependent on UE capabilities.			
Note 2: 7 satellites apply only for SBAS case.			

If SBAS is supported, the SBAS satellite with the highest elevation will be added to the scenario.

Table 6.3.5-2: Satellite allocation

	Satellite allocation for each constellation			
	GNSS 1 ⁽¹⁾	GNSS 2 ⁽¹⁾	GNSS 3 ⁽¹⁾	SBAS
Single constellation	6	--	--	1
Dual constellation	3	3	--	1
Triple constellation	2	2	2	1
Note: GNSS refers to global systems i.e., GPS, Galileo, GLONASS and BDS.				

Table 6.3.5-3: Test requirements for Nominal Accuracy

System	Success rate	2-D position error	Max response time
All	95 %	16.3 m	20.3 s

NOTE: If the above Test Requirement differs from the Minimum Requirement then the Test Tolerance applied for this test is non-zero. The Test Tolerance for this test is defined in clause C.2 and the explanation of how the Minimum Requirement has been relaxed by the Test Tolerance is given in clause C.4.

6.4 Dynamic Range

6.4.1 Definition and applicability

Dynamic Range is the maximum difference in level of the GNSS signals from a number of satellites that allows the UE to make an A-GNSS position estimate with a specific accuracy and a specific response time.

The requirements and this test apply to all types of UTRA for the UE that supports A-GNSS.

This test case includes sub-test cases dependent on the GNSS supported by the UE. Each sub-test case is identified by a Sub-Test Case Number as defined in Table 6.4.1.

Table 6.4.1: Sub-Test Case Number Definition

Sub-Test Case Number	Supported GNSS
1	UE supporting A-GLONASS
2	UE supporting A-Galileo
3	UE supporting A-GPS and Modernized GPS
4	UE supporting A-GPS and A-GLONASS
8	UE supporting A-GPS and A-Galileo
9	UE supporting A-BDS
10	UE supporting A-GPS and A-BDS

6.4.2 Minimum requirements

The first fix position estimates shall meet the accuracy and response time requirements in table 6.4.2-3 for the parameters specified in table 6.4.2-1.

Table 6.4.2-1: Test parameters for Dynamic Range

System	Parameters	Unit	Value
	Number of generated satellites per system	-	See Table 6.4.2-2
	Total number of generated satellites	-	6
	HDOP Range	-	1.4 to 2.1
	Propagation conditions	-	AWGN
	GNSS coarse time assistance error range	seconds	±2
Galileo	Reference high signal power level	dBm	-127.5
	Reference low signal power level	dBm	-147
GPS ⁽¹⁾	Reference high signal power level	dBm	-129
	Reference low signal power level	dBm	-147
GLONASS	Reference high signal power level	dBm	-131.5
	Reference low signal power level	dBm	-147
BDS	Reference high signal power level	dBm	-133.5
	Reference low signal power level	dBm	-145
Note: "GPS" here means GPS L1 C/A, Modernized GPS, or both, dependent on UE capabilities.			

Table 6.4.2-2: Power level and satellite allocation

		Satellite allocation for each constellation		
		GNSS 1 ⁽¹⁾	GNSS 2 ⁽¹⁾	GNSS 3 ⁽¹⁾
Single constellation	High signal level	2	--	--
	Low signal level	4	--	--
Dual constellation	High signal level	1	1	--
	Low signal level	2	2	--
Triple constellation	High signal level	1	1	1
	Low signal level	1	1	1
Note: GNSS refers to global systems i.e., GPS, Galileo, GLONASS and BDS.				

Table 6.4.2-3: Minimum requirements for Dynamic Range

System	Success rate	2-D position error	Max response time
All	95 %	100 m	20 s

The reference for this requirement is 3GPP TS 25.172 [19], clause 5.3.1, and 3GPP TS 25.173 [36], clause 5.3.1.

6.4.3 Test purpose

To verify the UE's first position estimate meets the minimum requirements under GNSS satellite signal conditions that have a wide dynamic range. Strong satellites are likely to degrade the acquisition of weaker satellites due to their cross-correlation products.

6.4.4 Method of test

6.4.4.1 Initial conditions

Test environment: normal; see Annex G.

1. Connect SS and GSS to the UE antenna connector or antenna connectors as shown in figures A.1 or A.2.
2. Set the GNSS test parameters as specified in table 6.4.5-1 for GNSS scenario #1. Randomly select from the satellite SV IDs defined in the table in 3GPP TS 37.571-5 [20] clause 6.2.1.2 for the satellites with the higher levels.
3. Switch on the UE.
4. Set up a connection using the procedure in clause F.2.

6.4.4.2 Procedure

1. Start GNSS scenario #1 as specified in 3GPP TS 37.571-5 [20] clause 6.2.1.2 with the UE location randomly selected to be within 3 km of the Reference Location and the altitude of the UE randomly selected between 0 m to 500 m above WGS-84 reference ellipsoid using the method described in 3GPP TS 37.571-5 [20] clause 6.2.1.2.6.
2. Send a RESET UE POSITIONING STORED INFORMATION message followed by RRC MEASUREMENT CONTROL messages containing appropriate assistance data; as specified in 3GPP TS 37.571-5 [20], clauses 6.2.2 and 6.2.7 for UE based testing; or clauses 6.2.4 and 6.2.7 for UE assisted testing with the value of GPS TOW msec or GANSS TOD offset by a random value as specified in 3GPP TS 37.571-5 [20] clause 6.2.7.2; as required to obtain a fix using the procedure specified in 3GPP TS 34.108 [28], clauses 7.5.6 or 7.5.8.
3. If the UE returns a valid result in the MEASUREMENT REPORT message within the Max response time specified in table 6.4.5-3 then record the result and process it as specified in step 4. If the UE does not return a valid result within the Max response time specified in table 6.4.5-3 or reports a UE positioning error in the MEASUREMENT REPORT message then record one Bad Result.
4. For UE based testing compare the reported position estimate in the MEASUREMENT REPORT message against the simulated position of the UE used in step 1, and calculate the 2D position error as specified in clause 6.1.1.3. Compare the 2D position error against the value in table 6.4.5-3 and record one Good Result or Bad Result as appropriate; or

For UE assisted testing convert the GNSS measured results reported in the MEASUREMENT REPORT message to a 2D position using the method described in Annex B and then compare the result against the simulated position of the UE used in step 1, and calculate the 2D position error as specified in clause 6.1.1.3. Compare the 2D position error against the value in table 6.4.5-3 and record one Good Result or Bad Result as appropriate.

5. Repeat steps 1 to 4 using GNSS scenario #2 instead of #1 so that the reference location changes sufficiently such that the UE shall have to use the new assistance data. Randomly select from the satellite SV IDs defined in the

table in 3GPP TS 37.571-5 [20] clause 6.2.1.2 for the satellites with the higher levels. Use new random values for the UE location and altitude in step 1 and for the GPS TOW msec or GANSS TOD offset in step 2.

6. Repeat steps 1 to 5 until the statistical requirements of clause 6.4.5 are met. Each time scenario #1 or #2 is used, the start time of the GNSS scenario shall be advanced by 2 minutes from the time used previously for that scenario. Once a scenario reaches the end of its viable running time, restart it from its nominal start time again. Each time scenario #1 or #2 is used, randomly select from the set of satellite SV IDs defined in the table in 3GPP TS 37.571-5 [20] clause 6.2.1.2, for the satellites with the higher levels.
7. Release the connection using the procedure in clause F.3.

6.4.5 Test Requirements

For the parameters specified in table 6.4.5-1 the UE shall meet the requirements and the success rate specified in table 6.4.5-3 with a confidence level of 95% according to Annex D.

Table 6.4.5-1: Test parameters for Dynamic Range

System	Parameters	Unit	Value
	Number of generated satellites per system	-	See Table 6.4.5-2
	Total number of generated satellites	-	6
	HDOP Range	-	1.4 to 2.1
	Propagation conditions	-	AWGN
	GNSS coarse time assistance error range	seconds	±2
Galileo	Reference high signal power level	dBm	-126.7
	Reference low signal power level	dBm	-146
GPS ⁽¹⁾	Reference high signal power level	dBm	-128.2
	Reference low signal power level	dBm	-146
GLONASS	Reference high signal power level	dBm	-130.7
	Reference low signal power level	dBm	-146
BSD	Reference high signal power level	dBm	-132.7
	Reference low signal power level	dBm	-144
Note: "GPS" here means GPS L1 C/A, Modernized GPS, or both, dependent on UE capabilities.			

Table 6.4.5-2: Power level and satellite allocation

		Satellite allocation for each constellation		
		GNSS 1 ⁽¹⁾	GNSS 2 ⁽¹⁾	GNSS 3 ⁽¹⁾
Single constellation	High signal level	2	--	--
	Low signal level	4	--	--
Dual constellation	High signal level	1	1	--
	Low signal level	2	2	--
Triple constellation	High signal level	1	1	1
	Low signal level	1	1	1
Note: GNSS refers to global systems i.e., GPS, Galileo, GLONASS and BDS.				

Table 6.4.5-3: Test requirements for Dynamic Range

System	Success rate	2-D position error	Max response time
All	95 %	101.3 m	20.3 s

NOTE: If the above Test Requirement differs from the Minimum Requirement then the Test Tolerance applied for this test is non-zero. The Test Tolerance for this test is defined in clause C.2 and the explanation of how the Minimum Requirement has been relaxed by the Test Tolerance is given in clause C.4.

6.5 Multi-path Performance

6.5.1 Definition and applicability

Multi-path performance measures the accuracy and response time of the UE's A-GNSS position estimate in a specific GNSS signal multi-path environment.

The requirements and this test apply to all types of UTRA for the UE that supports A-GNSS.

This test case includes sub-test cases dependent on the GNSS supported by the UE. Each sub-test case is identified by a Sub-Test Case Number as defined in Table 6.5.1.

Table 6.5.1: Sub-Test Case Number Definition

Sub-Test Case Number	Supported GNSS
1	UE supporting A-GLONASS
2	UE supporting A-Galileo
3	UE supporting A-GPS and Modernized GPS
4	UE supporting A-GPS and A-GLONASS
8	UE supporting A-GPS and A-Galileo
9	UE supporting A-BDS
10	UE supporting A-GPS and A-BDS

6.5.2 Minimum requirements

The first fix position estimates shall meet the accuracy and response time requirements in table 6.5.2-3 for the parameters specified in table 6.5.2-1.

Table 6.5.2-1: Test parameters for Multi-path Performance

System	Parameters	Unit	Value
	Number of generated satellites per system	-	See Table 6.5.2-2
	Total number of generated satellites	-	6
	HDOP range		1.4 to 2.1
	Propagation conditions	-	AWGN
	GNSS coarse time assistance error range	seconds	±2
Galileo	Reference signal power level	dBm	-127
GPS ⁽¹⁾	Reference signal power level	dBm	-128.5
GLONASS	Reference signal power level	dBm	-131
BDS	Reference signal power level	dBm	-133
Note: "GPS" here means GPS L1 C/A, Modernized GPS, or both, dependent on UE capabilities.			

Table 6.5.2-2: Channel model allocation

		Channel model allocation for each constellation		
		GNSS-1	GNSS-2	GNSS-3
Single constellation	One-tap channel	2	--	--
	Two-tap channel	4	--	--
Dual constellation	One-tap channel	1	1	--
	Two-tap channel	2	2	--
Triple constellation	One-tap channel	1	1	1
	Two-tap channel	1	1	1
Note: One-tap channel: no multi-path. Two-tap channel: multi-path defined in clause 4.2.4				

Table 6.5.2-3: Minimum requirements for Multi-path Performance

System	Success rate	2-D position error	Max response time
All	95 %	100 m	20 s

The reference for this requirement is 3GPP TS 25.172 [19], clause 5.4.1, and 3GPP TS 25.173 [36], clause 5.4.1.

6.5.3 Test purpose

To verify the UE's first position estimate meets the minimum requirements under GNSS satellite signal conditions that represent simple multi-path conditions.

6.5.4 Method of test

6.5.4.1 Initial conditions

Test environment: normal; see Annex G.

1. Connect SS and GSS to the UE antenna connector or antenna connectors as shown in figures A.1 or A.2.
2. Set the GNSS test parameters as specified in table 6.5.5-1 for GNSS scenario #1. Randomly select from the satellite SV IDs defined in the table in 3GPP TS 37.571-5 [20] clause 6.2.1.2 for the satellites with one-tap channel.
3. Switch on the UE.
4. Set up a connection using the procedure in clause F.2.

6.5.4.2 Procedure

1. Start GNSS scenario #1 as specified in 3GPP TS 37.571-5 [20] clause 6.2.1.2 with the UE location randomly selected to be within 3 km of the Reference Location and the altitude of the UE randomly selected between 0 m to 500 m above WGS-84 reference ellipsoid using the method described in 3GPP TS 37.571-5 [20] clause 6.2.1.2.6. The initial carrier phase difference between taps of the multi-path model shall be randomly selected between 0 and 2π radians by selecting the next random number from a standard uniform random number generator, in the range 0 to 2π , representing radians with a resolution of 0.1, representing 0.1 radians.
2. Send a RESET UE POSITIONING STORED INFORMATION message followed by RRC MEASUREMENT CONTROL messages containing appropriate assistance data; as specified in 3GPP TS 37.571-5 [20], clauses 6.2.2 and 6.2.7 for UE based testing; or clauses 6.2.4 and 6.2.7 for UE assisted testing with the value of GPS TOW msec or GANSS TOD offset by a random value as specified in 3GPP TS 37.571-5 [20] clause 6.2.7.2; as required to obtain a fix using the procedure specified in 3GPP TS 34.108 [28], clauses 7.5.6 or 7.5.8.
3. If the UE returns a valid result in the MEASUREMENT REPORT message within the Max response time specified in table 6.5.5-4 then record the result and process it as specified in step 4. If the UE does not return a valid result within the Max response time specified in table 6.5.5-4 or reports a UE positioning error in the MEASUREMENT REPORT message then record one Bad Result.
4. For UE based testing compare the reported position estimate in the MEASUREMENT REPORT message against the simulated position of the UE used in step 1, and calculate the 2D position error as specified in clause 6.1.1.3. Compare the 2D position error against the value in table 6.5.5-4 and record one Good Result or Bad Result as appropriate; or

For UE assisted testing convert the GNSS measured results reported in the MEASUREMENT REPORT message to a 2D position using the method described in Annex B and then compare the result against the simulated position of the UE used in step 1, and calculate the 2D position error as specified in clause 6.1.1.3. Compare the 2D position error against the value in table 6.5.5-4 and record one Good Result or Bad Result as appropriate.

5. Repeat steps 1 to 4 using GNSS scenario #2 instead of #1 so that the reference location changes sufficiently such that the UE shall have to use the new assistance data. Randomly select from the satellite SV IDs defined in the

table in 3GPP TS 37.571-5 [20] clause 6.2.1.2 for the satellites with one-tap channel. Use new random values for the UE location and altitude, and the initial carrier phase difference between taps of the multi-path model in step 1 and for the GPS TOW msec or GANSS TOD offset in step 2.

6. Repeat steps 1 to 5 until the statistical requirements of clause 6.5.5 are met. Each time scenario #1 or #2 is used, the start time of the GNSS scenario shall be advanced by 2 minutes from the time used previously for that scenario. Once a scenario reaches the end of its viable running time, restart it from its nominal start time again. Each time scenario #1 or #2 is used, randomly select from the satellite SV IDs defined in the table in 3GPP TS 37.571-5 [20] clause 6.2.1.2, for the satellites with one-tap channel.
7. Release the connection using the procedure in clause F.3.

6.5.5 Test Requirements

For the parameters specified in table 6.5.5-1 the UE shall meet the requirements and the success rate specified in table 6.5.5-4 with a confidence level of 95% according to Annex D.

Table 6.5.5-1: Test parameters for Multi-path Performance

System	Parameters	Unit	Value
	Number of generated satellites per system	-	See Table 6.5.5-2
	Total number of generated satellites	-	6
	HDOP range		1.4 to 2.1
	Propagation conditions	-	AWGN
	GNSS coarse time assistance error range	seconds	±1.8
Galileo	Reference signal power level	dBm	-127
GPS ⁽¹⁾	Reference signal power level	dBm	-128.5
GLONASS	Reference signal power level	dBm	-131
BDS	Reference signal power level	dBm	-133
Note: "GPS" here means GPS L1 C/A, Modernized GPS, or both, dependent on UE capabilities.			

Table 6.5.5-2: Channel model allocation

		Channel model allocation for each constellation		
		GNSS-1	GNSS-2	GNSS-3
Single constellation	One-tap channel	2	--	--
	Two-tap channel	4	--	--
Dual constellation	One-tap channel	1	1	--
	Two-tap channel	2	2	--
Triple constellation	One-tap channel	1	1	1
	Two-tap channel	1	1	1
Note: One-tap channel: no multi-path. Two-tap channel: multi-path defined in clause 4.2.4 with Relative mean Power (Y) defined in Table 6.5.5-3.				

Table 6.5.5-3: Relative mean Power (Y) for use in Table 6.5.5-2

System	Signals	Y [dB]
Galileo	E1	-4.7
	E5a	-6.2
	E5b	-6.2
GPS/Modernized GPS	L1 C/A	-6.2
	L1C	-4.7
	L2C	-6.2
GLONASS	L5	-6.2
	G1	-12.7
	G2	-12.7
BDS	B1I	-4.7

Table 6.5.5-4: Test requirements for Multi-path Performance

System	Success rate	2-D position error	Max response time
All	95 %	101.3 m	20.3 s

NOTE: If the above Test Requirement differs from the Minimum Requirement then the Test Tolerance applied for this test is non-zero. The Test Tolerance for this test is defined in clause C.2 and the explanation of how the Minimum Requirement has been relaxed by the Test Tolerance is given in clause C.4.

6.6 Moving Scenario and Periodic Update Performance

6.6.1 Definition and applicability

Moving scenario and periodic update performance measures the accuracy of the UE's A-GNSS position estimates and the periodic update capability of the UE in a moving scenario.

The requirements and this test apply to all types of UTRA for the UE that supports A-GNSS.

This test case includes sub-test cases dependent on the GNSS supported by the UE. Each sub-test case is identified by a Sub-Test Case Number as defined in Table 6.6.1.

Table 6.6.1: Sub-Test Case Number Definition

Sub-Test Case Number	Supported GNSS
1	UE supporting A-GLONASS
2	UE supporting A-Galileo
3	UE supporting A-GPS and Modernized GPS
4	UE supporting A-GPS and A-GLONASS
8	UE supporting A-GPS and A-Galileo
9	UE supporting A-BDS
10	UE supporting A-GPS and A-BDS

6.6.2 Minimum requirements

The position estimates, after the first reported position estimate, shall meet the accuracy requirement in table 6.6.2-3 with the periodical reporting interval of 2 seconds for the parameters specified in table 6.6.2-1.

NOTE: In the actual testing the UE may report error messages until it has been able to acquire GNSS measured results or a position estimate. The SS shall only consider the first measurement report different from an error message as the first position estimate in the requirement in table 6.6.2-1.

Table 6.6.2-1: Test parameters for Moving Scenario and Periodic Update Performance

System	Parameters	Unit	Value
	Number of generated satellites per system	-	See Table 6.6.2-2
	Total number of generated satellites	-	6
	HDOP Range per system	-	1.4 to 2.1
	Propagation conditions	-	AWGN
	GNSS coarse time assistance error range	seconds	±2
Galileo	Reference signal power level for all satellites	dBm	-127
GPS ⁽¹⁾	Reference signal power level for all satellites	dBm	-128.5
GLONASS	Reference signal power level for all satellites	dBm	-131
BDS	Reference signal power level for all satellites	dBm	-133
Note: "GPS" here means GPS L1 C/A, Modernized GPS, or both, dependent on UE capabilities.			

Table 6.6.2-2: Satellite allocation

	Satellite allocation for each constellation		
	GNSS 1 ⁽¹⁾	GNSS 2 ⁽¹⁾	GNSS 3 ⁽¹⁾
Single constellation	6	--	--
Dual constellation	3	3	--
Triple constellation	2	2	2
Note: GNSS refers to global systems i.e., GPS, Galileo, GLONASS and BDS.			

Table 6.6.2-3: Minimum requirements for Moving Scenario and Periodic Update Performance

System	Success rate	2-D position error	Periodical reporting interval
All	95 %	50 m	2 s

The reference for this requirement is 3GPP TS 25.172 [19], clause 5.5.1, and 3GPP TS 25.173 [36], clause 5.5.1.

6.6.3 Test purpose

To verify the UE's position estimates, after the first reported position estimate, meet the minimum requirements under GNSS satellite signal conditions that simulate a moving scenario. A good tracking performance, with regular position estimate reporting is essential for certain location services.

6.6.4 Method of test

6.6.4.1 Initial conditions

Test environment: normal; see Annex G.

The UE is requested to use periodical reporting with a reporting interval of 2 seconds.

The GNSS signals simulate the UE moving on a rectangular trajectory of 940 m by 1 440 m with rounded corners defined in figure 6.6.1 and table 6.6.4.1. The initial reference is first defined followed by acceleration to final speed of 100 km/h in 250 m. The UE then maintains the speed for 400 m. This is followed by deceleration to final speed of 25 km/h in 250 m. The UE then turn 90 degrees with turning radius of 20 m at 25 km/h. This is followed by acceleration to final speed of 100 km/h in 250 m. The sequence is repeated to complete the rectangle.

Table 6.6.4.1: Trajectory Parameters for Moving Scenario and Periodic Update Performance test case

Parameter	Distance (m)	Speed (km/h)
$l_{11}, l_{15}, l_{21}, l_{25}$	20	25
$l_{12}, l_{14}, l_{22}, l_{24}$	250	25 to 100 and 100 to 25
l_{13}	400	100
l_{23}	900	100

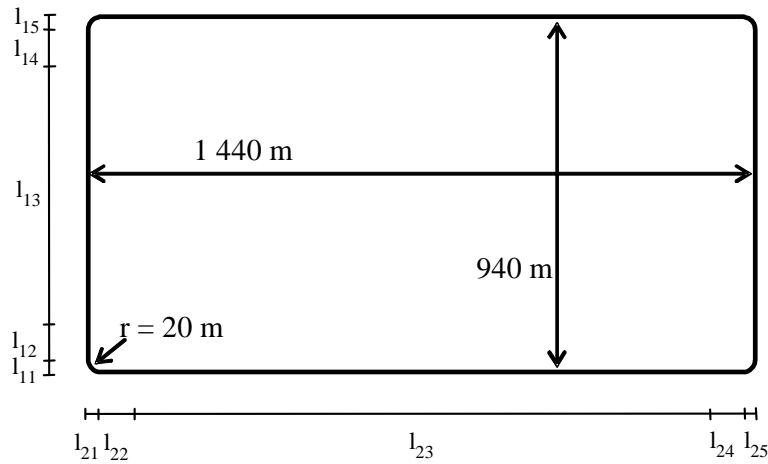

Figure 6.6.1: Rectangular Trajectory for Moving Scenario and Periodic Update Performance test case

1. Connect SS and GSS to the UE antenna connector or antenna connectors as shown in figures A.1 or A.2.
2. Set the GNSS test parameters as specified in table 6.6.5-1 for GNSS scenario #5.
3. Switch on the UE.
4. Set up a connection using the procedure in clause F.2.

6.6.4.2 Procedure

1. Start GNSS scenario #5 as specified in 3GPP TS 37.571-5 [20], clause 6.2.1.2.
2. Send a RESET UE POSITIONING STORED INFORMATION message followed by RRC MEASUREMENT CONTROL messages containing appropriate assistance data; as specified in 3GPP TS 37.571-5 [20], clauses 6.2.2 and 6.2.7 for UE based testing; or clauses 6.2.4 and 6.2.7 for UE assisted testing; using the exception to the RRC MEASUREMENT CONTROL message listed in table 6.6.4.2; as required to obtain fixes using the procedure specified in 3GPP TS 34.108 [28], clauses 7.5.7 or 7.5.9.

Table 6.6.4.2: Contents of RRC MEASUREMENT CONTROL message

Information Element	Value/Remark
- UE positioning reporting quantity - Horizontal accuracy	'13' (24.5m)

3. Ignore any error messages that the UE may report in MEASUREMENT REPORT messages until it has been able to acquire the GNSS signals and reports the first GNSS measured result or position estimate.
4. Discard the first GNSS measured result or position estimate.
5. Record the time of reception of the next MEASUREMENT REPORT message after reception of the first GNSS measured result or position estimate.
6. After the reception of the first GNSS measured result or position estimate reported in a MEASUREMENT REPORT message, every time the UE returns a GNSS measured result or position estimate in the MEASUREMENT REPORT message record the time of reception and the result. If the difference between the time of reception and the time of reception of the previous result is less than 1.5 seconds or greater than 2.5 seconds, or if the UE reports a UE positioning error in any MEASUREMENT REPORT messages, then record one Bad Result. Otherwise process the result as specified in step 7.
7. For UE based testing compare the reported position estimate in the MEASUREMENT REPORT message against the simulated position of the UE at the time of applicability reported in the position estimate and

calculate the 2D position error as specified in clause 6.1.1.3. Compare the 2D position error against the value in table 6.6.9 and record one Good Result or Bad Result as appropriate; or

For UE assisted testing convert the GNSS measured results reported in the MEASUREMENT REPORT message to a 2D position using the method described in Annex B and then compare the result against the simulated position of the UE at the time of applicability reported in the GNSS measured results and calculate the 2D position error as specified in clause 6.1.1.3. Compare the 2D position error against the value in table 6.6.9 and record one Good Result or Bad Result as appropriate.

8. If the UE sends the first MEASUREMENT REPORT that contains a measured result or position estimate later than 240s after the start of the GNSS scenario, fail the UE and stop the test early. Otherwise collect MEASUREMENT REPORTs during 900s, starting from the time recorded in step 5. If at any time the difference between the times of reception of two consecutive results is greater than 240s, fail the UE and stop the test early. Use the collected Good Results and Bad Results to determine the PASS/FAIL according to clause 6.6.5.
9. Release the connection using the procedure in clause F.3.

6.6.5 Test Requirements

For the parameters specified in table 6.6.5-1, after the first reported position estimate, the UE shall meet the accuracy requirement and the success rate specified in table 6.6.5-3 with a periodical reporting interval of 2 seconds +/- 20% plus measurement system uncertainty of 100ms.

NOTE: Due to the statistical nature of the results it is not possible to design a test with predefined confidence level for the success rate in Table 6.6.5-3; therefore a simple PASS/FAIL of the results gathered against this success rate is used.

Table 6.6.5-1: Test parameters for Moving Scenario and Periodic Update Performance

System	Parameters	Unit	Value
	Number of generated satellites per system	-	See Table 6.6.5-2
	Total number of generated satellites	-	6
	HDOP Range per system	-	1.4 to 2.1
	Propagation conditions	-	AWGN
	GNSS coarse time assistance error range	seconds	±1.8
Galileo	Reference signal power level for all satellites	dBm	-127
GPS ⁽¹⁾	Reference signal power level for all satellites	dBm	-128.5
GLONASS	Reference signal power level for all satellites	dBm	-131
BDS	Reference signal power level for all satellites	dBm	-133
Note: "GPS" here means GPS L1 C/A, Modernized GPS, or both, dependent on UE capabilities.			

Table 6.6.5-2: Satellite allocation

	Satellite allocation for each constellation		
	GNSS 1 ⁽¹⁾	GNSS 2 ⁽¹⁾	GNSS 3 ⁽¹⁾
Single constellation	6	--	--
Dual constellation	3	3	--
Triple constellation	2	2	2
Note: GNSS refers to global systems i.e., GPS, Galileo, GLONASS and BDS.			

Table 6.6.5-3: Test requirements for Moving Scenario and Periodic Update Performance

System	Success rate	2-D position error
All	95 %	51.3 m

NOTE 1: If the above Test Requirement differs from the Minimum Requirement then the Test Tolerance applied for this test is non-zero. The Test Tolerance for this test is defined in clause C.2 and the explanation of how the Minimum Requirement has been relaxed by the Test Tolerance is given in clause C.4.

NOTE 2: In the actual testing the UE may report error messages until it has been able to acquire GNSS measured results or a position estimate. The test equipment shall only consider the first measurement report different from an error message as the first position estimate in the requirement in table 6.6.5-3.

7 E-UTRA A-GNSS minimum performance requirements

7.0 General

This clause defines the minimum performance requirements for both UE based and UE assisted A-GNSS FDD and TDD E-UTRA UEs. If a UE supports both UE based and UE assisted modes then it shall be tested in both modes.

7.1 Sensitivity

7.1.1 Sensitivity Coarse time assistance

7.1.1.1 Sub-tests

This test includes sub-tests dependent on the GNSS supported by the UE. Each sub-test is identified by a Sub-Test Number as defined in Table 7.1.1.1

Table 7.1.1.1: Sub-Test Number Definition

Sub-Test Number	Supported GNSS
1	UE supporting A-GPS L1 C/A
2	UE supporting A-GLONASS
3	UE supporting A-Galileo
4	UE supporting A-GPS and Modernized GPS
5	UE supporting A-GPS and A-GLONASS (Note)
8	UE supporting A-GPS and A-Galileo (Note)
9	UE supporting A-BDS
10	UE supporting A-GPS and A-BDS (Note)
11	UE supporting A-GPS and A-GLONASS and A-BDS (Note)
12	UE supporting A-GPS and A-Galileo and A-GLONASS (Note)
13	UE supporting A-GPS and A-Galileo and A-BDS (Note)
14	UE supporting A-GPS and A-QZSS
15	UE supporting A-GPS and A-NAVIC
Note: "GPS" here means GPS L1 C/A, Modernized GPS, or both, dependent on UE capabilities.	

7.1.1.2 Test purpose

To verify the performance of the first position estimate, when the UE is provided with only coarse time assistance.

7.1.1.3 Test applicability

This test applies to all types of E-UTRA UE that supports A-GNSS except Category M1 and Category M2 devices that do not support VoLTE.

7.1.1.4 Minimum conformance requirements

The first fix position estimates shall meet the accuracy and response time requirements in table 7.1.1.2 for the parameters specified in table 7.1.1.3 or 7.1.1.4.

Table 7.1.1.2: Requirements for Sensitivity Coarse time assistance

Success rate	2-D position error	Max response time
95 %	100 m	20 s

Table 7.1.1.3: Parameters for Sensitivity Coarse time assistance - Sub-Test 1

Parameters	Unit	Value
Number of generated satellites	-	8
HDOP Range	-	1.1 to 1.6
Propagation conditions	-	AWGN
GPS Coarse time assistance error range	seconds	± 2
GPS L1 C/A Signal for one satellite	dBm	-142
GPS L1 C/A Signal for remaining satellites	dBm	-147

Table 7.1.1.4: Parameters for Sensitivity Coarse time assistance - Sub-Tests 2 to 5 and Sub-Tests 8 to 13

System	Parameters	Unit	Value
	Number of generated satellites per system	-	See Table 7.1.1.5
	Total number of generated satellites	-	6 or 7 ⁽²⁾
	HDOP range	-	1.4 to 2.1
	Propagation conditions	-	AWGN
	GNSS coarse time assistance error range	seconds	± 2
Galileo	Reference high signal power level	dBm	-142
	Reference low signal power level	dBm	-147
GPS ⁽¹⁾	Reference high signal power level	dBm	-142
	Reference low signal power level	dBm	-147
GLONASS	Reference high signal power level	dBm	-142
	Reference low signal power level	dBm	-147
BDS	Reference high signal power level	dBm	-136
	Reference low signal power level	dBm	-145
QZSS	Reference high signal power level	dBm	-142
	Reference low signal power level	dBm	-147
NAVIC	Reference high signal power level	dBm	-142
	Reference low signal power level	dBm	-147
NOTE 1: "GPS" here means GPS L1 C/A, Modernized GPS, or both, dependent on UE capabilities.			
NOTE 2: 7 satellites are used for sub-tests with 3 different GNSSs			

Table 7.1.1.5: Power level and satellite allocation

		Satellite allocation for each constellation		
		GNSS-1 ⁽¹⁾	GNSS-2	GNSS-3
Single constellation	High signal level	1	-	-
	Low signal level	5	-	-
Dual constellation	High signal level	1	-	-
	Low signal level	2	3	-
Triple constellation	High signal level	1	-	-
	Low signal level	2	2	2
Note 1: Up to Rel-14: for GPS capable receivers, GNSS-1, i.e. the system having the satellite with high signal level, shall be GPS. Rel-15 onwards: GNSS-1, i.e. the system having the satellite with high signal level, shall be selected by the device manufacturer.				

The normative reference for this requirement is TS 36.171 [3] clause 5.1.1 and 6.1.1.

7.1.1.5 Test description

7.1.1.5.1 Initial conditions

Initial conditions are a set of test configurations the UE needs to be tested in and the steps for the SS to take with the UE to reach the correct measurement state.

Test Environment: Normal, as defined in TS 36.508 [18] clause 4.1.

Frequencies to be tested: Mid Range, as defined in TS 36.508 [18] clause 4.3.1.

Channel Bandwidth to be tested: as defined in TS 36.508 [18] clause 4.3.1.

1. Connect SS and GSS to the UE antenna connector or antenna connectors as shown in Annex A.
2. Set the GNSS test parameters as specified in table 7.1.1.6 or 7.1.1.7 for GNSS scenario #1 in TS 37.571-5 [20]. For GNSS-1, select the first satellite SV ID defined in the relevant table of Satellites to be simulated in clause 6.2.1.2 in TS 37.571-5 [20] for the one satellite with the higher level.
3. The parameter settings for the cell are set up according to TS 36.508 [18] clause 4.4.3, single cell scenario.
4. Switch on the UE.
5. Establish a signalling connection according to the generic procedure in TS 36.508 [18] clause 4.5.3 (State 3, Generic RB established) on a channel in the Mid EARFCN range.

7.1.1.5.2 Test procedure

1. Start GNSS scenario #1 as specified in clause 6.2.1.2 of TS 37.571-5 [20] with the UE location randomly selected to be within 3 km of the Reference Location and the altitude of the UE randomly selected between 0 m to 500 m above WGS-84 reference ellipsoid using the method described in clause 6.2.1.2.6 of TS 37.571-5 [20]
2. Send a RESET UE POSITIONING STORED INFORMATION message.
3. Depending on how the LPP session is performed:
 - In the case of C-Plane, the SS shall send an LPP REQUEST CAPABILITIES message.
 - In the case of U-Plane, the SS shall establish a SUPL session with the UE for positioning.
4. The UE returns an LPP PROVIDE CAPABILITIES message indicating the assistance data supported by the UE in the Assistance Data Support List in the A GNSS Provide Capabilities IE.
5. Send an LPP PROVIDE ASSISTANCE DATA message to provide the assistance data that is supported by the UE as indicated in step 4 and in accordance with clause 6.2.6 of TS 37.571-5 [20], and with the values defined in clause 6.2.7 of TS 37.571-5 [20] with the value of GNSS Reference Time offset by a random value as specified in clause 6.2.7.2 of TS 37.571-5 [20]. If the LPP session is performed over C-Plane, then if the UE message at step 4 includes the ackRequested IE set to TRUE, then the SS shall send an acknowledgment in the LPP PROVIDE ASSISTANCE DATA message.
6. Send an LPP REQUEST LOCATION INFORMATION message to obtain a fix.
7. If the UE returns a valid result in the LPP PROVIDE LOCATION INFORMATION message within the Max response time specified in table 7.1.1.9 then record the result and process it as specified in step 8. If the UE does not return a valid result within the Max response time specified in table 7.1.1.9 or reports an Error in the LPP PROVIDE LOCATION INFORMATION message then record one Bad Result.
- 7a. If the UE message at step 7 includes the ackRequested IE set to TRUE, then the SS shall send a LPP acknowledgment message.
8. For UE based testing compare the reported Location Information in the LPP PROVIDE LOCATION INFORMATION message against the simulated position of the UE used in step 1, and calculate the 2D position error as specified in clause 4.5.2.3. Compare the 2D position error against the value in table 7.1.1.9 and record one Good Result or Bad Result as appropriate; or

For UE assisted testing convert the GNSS Signal Measurement Information reported in the LPP PROVIDE LOCATION INFORMATION message to a 2D position using the method described in clause 4.4.3 and then compare the result against the simulated position of the UE, used in step 1, and calculate the 2D position error as specified in clause 4.5.2.3. Compare the 2D position error against the value in table 7.1.1.9 and record one Good Result or Bad Result as appropriate.

9. Repeat steps 1 to 8 using GNSS scenario #2 instead of #1 so that the reference location changes sufficiently such that the UE shall have to use the new assistance data. For GNSS-1, select the first satellite SV ID defined in the

relevant table of Satellites to be simulated in clause 6.2.1.2 in TS 37.571-5 [20] for the one satellite with the higher level. Use new random values for the UE location and altitude in step 1 and for the GNSS Reference Time offset in step 5.

10. Repeat steps 1 to 9 until the statistical requirements of clause 7.1.1.6 are met. Each time scenario #1 or #2 is used, the start time of the GNSS scenario shall be advanced by 2 minutes from the time used previously for that scenario. Once a scenario reaches the end of its viable running time, restart it from its nominal start time again. Each time scenario #1 or #2 is used, for GNSS-1 select the next satellite SV ID from the one used previously, defined in the relevant table of Satellites to be simulated in clause 6.2.1.2 in TS 37.571-5 [20], for the one satellite with the higher level.

11. Release the signalling connection.

7.1.1.5.3 Message contents

Message contents are according to TS 36.508 [18] clauses 4.6 and 4.7 and as follows:

RESET UE POSITIONING STORED INFORMATION

Information Element	Value/remark
UE POSITIONING TECHNOLOGY	AGNSS

LPP REQUEST CAPABILITIES

Information Element	Value/remark
a-gnss-RequestCapabilities	TRUE

LPP REQUEST LOCATION INFORMATION

Information Element	Value/remark	Comment
commonIEsRequestLocationInformation		
> locationInformationType	'locationEstimateRequired' or 'locationMeasurementsRequired'	Depending on test case and UE capabilities, i.e. support for UE-based or UE-assisted
> additionalInformation	'onlyReturnInformationRequested'	
> qos		
>> horizontalAccuracy	'19' (51.2m)	
>> verticalCoordinateRequest	FALSE	
>> responseTime		
>>>time	'20'	
a-gnss-RequestLocationInformation		
> gnss-PositioningInstructions		
>> gnssMethods		
>>> gnss-ids	Sub-test 1: 'gps' Sub-test 2: 'glonass' Sub-test 3: 'galileo' Sub-test 4: 'gps' Sub-test 5: 'gps' and 'glonass' Sub-test 8: 'gps' and 'galileo' Sub-test 9: 'bds' Sub-test 10: 'gps'and'bds' Sub-test 11: 'gps' and 'glonass' and 'bds' Sub-test 12: 'gps' and 'galileo' and 'glonass' Sub-test 13: 'gps' and 'galileo' and 'bds' Sub-test 14: 'gps' and 'qzss' Sub-test 15: 'gps' and 'navic'	
>> fineTimeAssistanceMeasReq	FALSE	

>> adrMeasReq	FALSE	
>> multiFreqMeasReq	TRUE or FALSE	Depending on UE capabilities
>> assistanceAvailability	FALSE	

7.1.1.6 Test requirement

For the parameters specified in table 7.1.1.6 or 7.1.1.7 the UE shall meet the requirements and the success rate specified in table 7.1.1.9 with a confidence level of 95% according to Annex D.

Table 7.1.1.6: Test parameters for Sensitivity Coarse time assistance - Sub-Test 1

Parameters	Unit	Value
Number of generated satellites	-	8
HDOP Range	-	1.1 to 1.6
Propagation conditions	-	AWGN
GPS Coarse Time assistance error range	seconds	± 1.8
GPS L1 C/A Signal for one satellite	dBm	-141
GPS L1 C/A Signal for remaining satellites	dBm	-146

Table 7.1.1.7: Test parameters for Sensitivity Coarse time assistance - Sub-Tests 2 to 5 and Sub-Tests 8 to 13

System	Parameters	Unit	Value
	Number of generated satellites per system	-	See Table 7.1.1.8
	Total number of generated satellites	-	6 or 7 ⁽²⁾
	HDOP range	-	1.4 to 2.1
	Propagation conditions	-	AWGN
	GNSS coarse time assistance error range	seconds	± 1.8
Galileo	Reference high signal power level	dBm	-141
	Reference low signal power level	dBm	-146
GPS ⁽¹⁾	Reference high signal power level	dBm	-141
	Reference low signal power level	dBm	-146
GLONASS	Reference high signal power level	dBm	-141
	Reference low signal power level	dBm	-146
BDS	Reference high signal power level	dBm	-135
	Reference low signal power level	dBm	-144
QZSS	Reference high signal power level	dBm	-141
	Reference low signal power level	dBm	-146
Navic	Reference high signal power level	dBm	-141
	Reference low signal power level	dBm	-146
NOTE 1: "GPS" here means GPS L1 C/A, Modernized GPS, or both, dependent on UE capabilities.			
NOTE 2: 7 satellites are used for sub-tests with 3 different GNSSs			

Table 7.1.1.8: Power level and satellite allocation

		Satellite allocation for each constellation		
		GNSS-1 ⁽¹⁾	GNSS-2	GNSS-3
Single constellation	High signal level	1	-	-
	Low signal level	5	-	-
Dual constellation	High signal level	1	-	-
	Low signal level	2	3	-
Triple constellation	High signal level	1	-	-
	Low signal level	2	2	2

Note 1: Up to Rel-14: for GPS capable receivers, GNSS-1, i.e. the system having the satellite with high signal level, shall be GPS.
Rel-15 onwards: GNSS-1, i.e. the system having the satellite with high signal level, shall be selected by the device manufacturer.

Table 7.1.1.9: Test requirements for Sensitivity Coarse Time Assistance

System	Success rate	2-D position error	Max response time
All	95 %	101.3 m	20.3 s

7.1.2 Sensitivity Fine time assistance

7.1.2.1 Sub-tests

This test includes sub-tests dependent on the GNSS supported by the UE. Each sub-test is identified by a Sub-Test Number as defined in Table 7.1.2.1

Table 7.1.2.1: Sub-Test Number Definition

Sub-Test Number	Supported GNSS
1	UE supporting A-GPS L1 C/A
2	UE supporting A-GLONASS
3	UE supporting A-Galileo
4	UE supporting A-GPS and Modernized GPS
5	UE supporting A-GPS and A-GLONASS (Note)
8	UE supporting A-GPS and A-Galileo (Note)
9	UE supporting A-BDS
10	UE supporting A-GPS and A-BDS (Note)
11	UE supporting A-GPS and A-GLONASS and A-BDS (Note)
12	UE supporting A-GPS and A-Galileo and A-GLONASS (Note)
13	UE supporting A-GPS and A-Galileo and A-BDS (Note)
14	UE supporting A-GPS and A-QZSS (Note)
15	UE supporting A-GPS and A-Navic (Note)

Note: "GPS" here means GPS L1 C/A, Modernized GPS, or both, dependent on UE capabilities.

7.1.2.2 Test purpose

To verify the performance of the first position estimate, when the UE is additionally provided with fine time assistance.

7.1.2.3 Test applicability

This test applies to all types of E-UTRA UE that supports A-GNSS and that is capable of providing an enhanced performance when the network provides Fine Time Assistance, except Category M1 and Category M2 devices that do not support VoLTE.

7.1.2.4 Minimum conformance requirements

The first fix position estimates shall meet the accuracy and response time requirements in table 7.1.2.2 for the parameters specified in table 7.1.2.3 or 7.1.2.4.

Table 7.1.2.2: Requirements for Sensitivity Fine time assistance

Success rate	2-D position error	Max response time
95 %	100 m	20 s

Table 7.1.2.3: Parameters for Sensitivity Fine time assistance - Sub-Test 1

Parameters	Unit	Value
Number of generated satellites	-	8
HDOP Range	-	1.1 to 1.6
Propagation conditions	-	AWGN
GPS Coarse time assistance error range	seconds	± 2
GPS L1 C/A Fine time assistance error range	μs	± 10
GPS L1 C/A Signal for all satellites	dBm	-147

Table 7.1.2.4: Parameters for Sensitivity Fine time assistance - Sub-Tests 2 to 5 and Sub-Tests 8 to 13

System	Parameters	Unit	Value
	Number of generated satellites per system	-	See Table 7.1.2.5
	Total number of generated satellites	-	6 or 7 ⁽²⁾
	HDOP range	-	1.4 to 2.1
	Propagation conditions	-	AWGN
	GNSS coarse time assistance error range	seconds	± 2
	GNSS fine time assistance error range	μs	± 10
Galileo	Reference signal power level	dBm	-147
GPS ⁽¹⁾	Reference signal power level	dBm	-147
GLONASS	Reference signal power level	dBm	-147
BDS	Reference signal power level	dBm	-147
QZSS	Reference signal power level	dBm	-147
Navic	Reference signal power level	dBm	-147
NOTE 1: "GPS" here means GPS L1 C/A, Modernized GPS, or both, dependent on UE capabilities.			
NOTE 2: 7 satellites are used for sub-tests with 3 different GNSSs			

Table 7.1.2.5: Satellite allocation

	Satellite allocation for each constellation		
	GNSS-1	GNSS-2	GNSS-3
Single constellation	6	-	-
Dual constellation	3	3	-
Triple constellation	3	2	2

The normative reference for this requirement is TS 36.171 [3] clause 5.1.2 and 6.1.2.

7.1.2.5 Test description

7.1.2.5.1 Initial conditions

Initial conditions are a set of test configurations the UE needs to be tested in and the steps for the SS to take with the UE to reach the correct measurement state.

Test Environment: Normal, as defined in TS 36.508 [18] clause 4.1.

Frequencies to be tested: Mid Range, as defined in TS 36.508 [18] clause 4.3.1.

Channel Bandwidth to be tested: as defined in TS 36.508 [18] clause 4.3.1.

1. Connect SS and GSS to the UE antenna connector or antenna connectors as shown in Annex A.
2. Set the GNSS test parameters as specified in table 7.1.2.6 or 7.1.2.7 for GNSS scenario #1 in TS 37.571-5 [20].
3. The parameter settings for the cell are set up according to TS 36.508 [18] clause 4.4.3, single cell scenario.
4. Switch on the UE.

5. Establish a signalling connection according to the generic procedure in TS 36.508 [18] clause 4.5.3 (State 3, Generic RB established) on a channel in the Mid EARFCN range.

7.1.2.5.2 Test procedure

1. Start GNSS scenario #1 as specified in clause 6.2.1.2 of TS 37.571-5 [20] with the UE location randomly selected to be within 3 km of the Reference Location and the altitude of the UE randomly selected between 0 m to 500 m above WGS-84 reference ellipsoid using the method described in clause 6.2.1.2.6 of TS 37.571-5 [20]
2. Send a RESET UE POSITIONING STORED INFORMATION message.
3. Depending on how the LPP session is performed:
 - In the case of C-Plane, the SS shall send an LPP REQUEST CAPABILITIES message.
 - In the case of U-Plane, the SS shall establish a SUPL session with the UE for positioning.
4. The UE returns an LPP PROVIDE CAPABILITIES message indicating the assistance data supported by the UE in the Assistance Data Support List in the A GNSS Provide Capabilities IE.
5. Send an LPP PROVIDE ASSISTANCE DATA message to provide the assistance data that is supported by the UE as indicated in step 4 and in accordance with clause 6.2.6 of TS 37.571-5 [20], and with the values defined in clause 6.2.7 of TS 37.571-5 [20] with the value of GNSS Reference Time and GNSS Reference Time for one cell offset by a random value as specified in clause 6.2.7.2 of TS 37.571-5 [20]. If the LPP session is performed over C-Plane, then if the UE message at step 4 includes the ackRequested IE set to TRUE, then the SS shall send an acknowledgment in the LPP PROVIDE ASSISTANCE DATA message.
6. Send an LPP REQUEST LOCATION INFORMATION message to obtain a fix.
7. If the UE returns a valid result in the LPP PROVIDE LOCATION INFORMATION message within the Max response time specified in table 7.1.2.9 then record the result and process it as specified in step 8. If the UE does not return a valid result within the Max response time specified in table 7.1.2.9 or reports an Error in the LPP PROVIDE LOCATION INFORMATION message then record one Bad Result.
- 7a. If the UE message at step 7 includes the ackRequested IE set to TRUE, then the SS shall send a LPP acknowledgment message.
8. For UE based testing compare the reported Location Information in the LPP PROVIDE LOCATION INFORMATION message against the simulated position of the UE used in step 1, and calculate the 2D position error as specified in clause 4.5.2.3. Compare the 2D position error against the value in table 7.1.2.9 and record one Good Result or Bad Result as appropriate; or

For UE assisted testing convert the GNSS Measurement Information reported in the LPP PROVIDE LOCATION INFORMATION message to a 2D position using the method described in clause 4.4.3 and then compare the result against the simulated position of the UE used in step 1, and calculate the 2D position error as specified in clause 4.5.2.3. Compare the 2D position error against the value in table 7.1.2.9 and record one Good Result or Bad Result as appropriate.
9. Repeat steps 1 to 8 using GNSS scenario #2 instead of #1 so that the reference location changes sufficiently such that the UE shall have to use the new assistance data. Use new random values for the UE location and altitude in step 1 and for the GNSS Reference Time GNSS Reference Time for one cell offsets in step 5.
10. Repeat steps 1 to 9 until the statistical requirements of clause 7.1.2.6 are met. Each time scenario #1 or #2 is used, the start time of the GNSS scenario shall be advanced by 2 minutes from the time used previously for that scenario. Once a scenario reaches the end of its viable running time, restart it from its nominal start time again.
11. Release the signalling connection.

7.1.2.5.3 Message contents

Message contents are according to TS 36.508 [18] clauses 4.6 and 4.7 and as follows:

RESET UE POSITIONING STORED INFORMATION

Information Element	Value/remark
UE POSITIONING TECHNOLOGY	AGNSS

LPP REQUEST CAPABILITIES

Information Element	Value/remark
a-gnss-RequestCapabilities	TRUE

LPP REQUEST LOCATION INFORMATION

Information Element	Value/remark	Comment
commonEsRequestLocationInformation		
> locationInformationType	'locationEstimateRequired' or 'locationMeasurementsRequired'	Depending on test case and UE capabilities, i.e. support for UE-based or UE-assisted
> additionalInformation	'onlyReturnInformationRequested'	
> qos		
>> horizontalAccuracy	'19' (51.2m)	
>> verticalCoordinateRequest	FALSE	
>> responseTime		
>>>time	'20'	
a-gnss-RequestLocationInformation		
> gnss-PositioningInstructions		
>> gnssMethods		
>>> gnss-ids	Sub-test 1: 'gps' Sub-test 2: 'glonass' Sub-test 3: 'galileo' Sub-test 4: 'gps' Sub-test 5: 'gps' and 'glonass' Sub-test 8: 'gps' and 'galileo' Sub-test 9: 'bds' Sub-test 10: 'gps'and'bds' Sub-test 11: 'gps' and 'glonass' and 'bds' Sub-test 12: 'gps' and 'galileo' and 'glonass' Sub-test 13: 'gps' and 'galileo' and 'bds' Sub-test 14: 'gps' and 'qzss' Sub-test 15: 'gps' and 'navic'	
>> fineTimeAssistanceMeasReq	FALSE	
>> adrMeasReq	FALSE	
>> multiFreqMeasReq	TRUE or FALSE	Depending on UE capabilities
>> assistanceAvailability	FALSE	

7.1.2.6 Test requirement

For the parameters specified in table 7.1.2.6 or 7.1.2.7 the UE shall meet the requirements and the success rate specified in table 7.1.2.9 with a confidence level of 95% according to Annex D.

Table 7.1.2.6: Test parameters for Sensitivity Fine time assistance - Sub-Test 1

Parameters	Unit	Value
Number of generated satellites	-	8
HDOP Range	-	1.1 to 1.6
Propagation conditions	-	AWGN

Parameters	Unit	Value
GPS Coarse time assistance error range	seconds	±1.8
GPS Fine Time assistance error range	µs	±9
GPS L1 C/A Signal for all satellites	dBm	-146

Table 7.1.2.7: Test parameters for Sensitivity Fine time assistance - Sub-Tests 2 to 5 and Sub-Tests 8 to 13

System	Parameters	Unit	Value
	Number of generated satellites per system	-	See Table 7.1.2.8
	Total number of generated satellites	-	6 or 7 ⁽²⁾
	HDOP range		1.4 to 2.1
	Propagation conditions	-	AWGN
	GNSS coarse time assistance error range	seconds	±1.8
	GNSS fine time assistance error range	µs	±9
Galileo	Reference signal power level	dBm	-146
GPS ⁽¹⁾	Reference signal power level	dBm	-146
GLONASS	Reference signal power level	dBm	-146
BDS	Reference signal power level	dBm	-146
QZSS	Reference signal power level	dBm	-146
Navic	Reference signal power level	dBm	-146
NOTE 1: "GPS" here means GPS L1 C/A, Modernized GPS, or both, dependent on UE capabilities.			
NOTE 2: 7 satellites are used for sub-tests with 3 different GNSSs			

Table 7.1.2.8: Satellite allocation

	Satellite allocation for each constellation		
	GNSS-1	GNSS-2	GNSS-3
Single constellation	6	-	-
Dual constellation	3	3	-
Triple constellation	3	2	2

Table 7.1.2.9: Test requirements for Sensitivity Fine Time Assistance

System	Success rate	2-D position error	Max response time
All	95 %	101.3 m	20.3 s

7.2 Nominal Accuracy

7.2.1 Sub-tests

This test includes sub-tests dependent on the GNSS supported by the UE. Each sub-test is identified by a Sub-Test Number as defined in Table 7.2.1

Table 7.2.1: Sub-Test Number Definition

Sub-Test Number	Supported GNSS
1	UE supporting A-GPS L1 C/A
2	UE supporting A-GLONASS
3	UE supporting A-Galileo
4	UE supporting A-GPS and Modernized GPS
5	UE supporting A-GPS and A-GLONASS (Note)
8	UE supporting A-GPS and A-Galileo (Note)

9	UE supporting A-BDS
10	UE supporting A-GPS and A-BDS (Note)
11	UE supporting A-GPS and A-GLONASS and A-BDS (Note)
12	UE supporting A-GPS and A-Galileo and A-GLONASS (Note)
13	UE supporting A-GPS and A-Galileo and A-BDS (Note)
14	UE supporting A-GPS and A-QZSS (Note)
15	UE supporting A-GPS and A-Navic (Note)
Note: "GPS" here means GPS L1 C/A, Modernized GPS, or both, dependent on UE capabilities.	

7.2.2 Test purpose

To verify the performance of the first position estimate, when the UE is provided with ideal GNSS signal conditions.

7.2.3 Test applicability

This test applies to all types of E-UTRA UE that supports A-GNSS, except Category M1 and Category M2 devices that do not support VoLTE.

7.2.4 Minimum conformance requirements

The first fix position estimates shall meet the accuracy and response time requirements in table 7.2.2 or 7.2.3 for the parameters specified in table 7.2.4 or 7.2.5.

Table 7.2.2: Requirements for Nominal Accuracy - Sub-Test 1

Success rate	2-D position error	Max response time
95 %	30 m	20 s

Table 7.2.3: Requirements for Nominal Accuracy - Sub-Tests 2 to 5 and Sub-Tests 8 to 13

Success rate	2-D position error	Max response time
95 %	15 m	20 s

Table 7.2.4: Parameters for Nominal Accuracy - Sub-Test 1

Parameters	Unit	Value
Number of generated satellites	-	8
HDOP Range	-	1.1 to 1.6
Propagation conditions	-	AWGN
GPS Coarse Time assistance error range	seconds	± 2
GPS L1 C/A Signal for all satellites	dBm	-130

Table 7.2.5: Parameters for Nominal Accuracy - Sub-Tests 2 to 5 and Sub-Tests 8 to 13

System	Parameters	Unit	Value
	Number of generated satellites per system	-	See Table 7.2.6
	Total number of generated satellites	-	6, 7 ⁽²⁾ or 8 ⁽³⁾
	HDOP Range	-	1.4 to 2.1
	Propagation conditions	-	AWGN
	GNSS coarse time assistance error range	seconds	± 2
GPS ⁽¹⁾	Reference signal power level for all satellites	dBm	-128.5
Galileo	Reference signal power level for all satellites	dBm	-127
GLONASS	Reference signal power level for all satellites	dBm	-131
QZSS	Reference signal power level for all satellites	dBm	-128.5
SBAS	Reference signal power level for all satellites	dBm	-131
BDS	Reference signal power level for all satellites	dBm	-133

System	Parameters	Unit	Value
NOTE 1: "GPS" here means GPS L1 C/A, Modernized GPS, or both, dependent on UE capabilities.			
NOTE 2: 7 satellites apply only for SBAS case or sub-tests with 3 different GNSSs.			
NOTE 3: 8 satellites apply only for sub-tests with 3 different GNSSs and SBAS.			

If SBAS is supported, the SBAS satellite with the highest elevation will be added to the scenario.

Table 7.2.6: Satellite allocation

	Satellite allocation for each constellation			
	GNSS 1 ⁽¹⁾	GNSS 2 ⁽¹⁾	GNSS 3 ⁽¹⁾	SBAS
Single constellation	6	--	--	1
Dual constellation	3	3	--	1
Triple constellation	3	2	2	1
NOTE 1: GNSS refers to global systems i.e., GPS, Galileo, GLONASS and BDS.				

The normative reference for this requirement is TS 36.171 [3] clause 5.2 and 6.2.

7.2.5 Test description

7.2.5.1 Initial conditions

Initial conditions are a set of test configurations the UE needs to be tested in and the steps for the SS to take with the UE to reach the correct measurement state.

Test Environment: Normal, as defined in TS 36.508 [18] clause 4.1.

Frequencies to be tested: Mid Range, as defined in TS 36.508 [18] clause 4.3.1.

Channel Bandwidth to be tested: as defined in TS 36.508 [18] clause 4.3.1.

1. Connect SS and GSS to the UE antenna connector or antenna connectors as shown in Annex A.
2. Set the GNSS test parameters as specified in table 7.2.7 or 7.2.8 for GNSS scenario #3 in TS 37.571-5 [20].
3. The parameter settings for the cell are set up according to TS 36.508 [18] clause 4.4.3, single cell scenario.
4. Switch on the UE.
5. Establish a signalling connection according to the generic procedure in TS 36.508 [18] clause 4.5.3 (State 3, Generic RB established) on a channel in the Mid EARFCN range.

7.2.5.2 Test procedure

1. Start GNSS scenario #3 as specified in clause 6.2.1.2 of TS 37.571-5 [20] with the UE location randomly selected to be within 3 km of the Reference Location and the altitude of the UE randomly selected between 0 m to 500 m above WGS-84 reference ellipsoid using the method described in clause 6.2.1.2.6 of TS 37.571-5 [20]
2. Send a RESET UE POSITIONING STORED INFORMATION message.
3. Depending on how the LPP session is performed:
 - In the case of C-Plane, the SS shall send an LPP REQUEST CAPABILITIES message.
 - In the case of U-Plane, the SS shall establish a SUPL session with the UE for positioning.
4. The UE returns an LPP PROVIDE CAPABILITIES message indicating the assistance data supported by the UE in the Assistance Data Support List in the A GNSS Provide Capabilities IE.
5. Send an LPP PROVIDE ASSISTANCE DATA message to provide the assistance data that is supported by the UE as indicated in the step 4 and in accordance with clause 6.2.6 of TS 37.571-5 [20], and with the values defined in clause 6.2.7 of TS 37.571-5 [20] with the value of GNSS Reference Time offset by a random value as

specified in clause 6.2.7.2 of TS 37.571-5 [20]. If the LPP session is performed over C-Plane, then if the UE message at step 4 includes the ackRequested IE set to TRUE, then the SS shall send an acknowledgment in the (first) LPP PROVIDE ASSISTANCE DATA message.

6. Send an LPP REQUEST LOCATION INFORMATION message to obtain a fix.
7. If the UE returns a valid result in the LPP PROVIDE LOCATION INFORMATION message within the Max response time specified in table 7.2.10 then record the result and process it as specified in step 8. If the UE does not return a valid result within the Max response time specified in table 7.2.10 or reports an Error in the LPP PROVIDE LOCATION INFORMATION message then record one Bad Result.
- 7a. If the UE message at step 7 includes the ackRequested IE set to TRUE, then the SS shall send a LPP acknowledgment message.
8. For UE based testing compare the reported Location Information in the LPP PROVIDE LOCATION INFORMATION message against the simulated position of the UE used in step 1, and calculate the 2D position error as specified in clause 4.5.2.3. Compare the 2D position error against the value in table 7.2.10 and record one Good Result or Bad Result as appropriate; or

For UE assisted testing convert the GNSS Measurement Information reported in the LPP PROVIDE LOCATION INFORMATION message to a 2D position using the method described in clause 4.4.3 and then compare the result against the simulated position of the UE used in step 1, and calculate the 2D position error as specified in clause 4.5.2.3. Compare the 2D position error against the value in table 7.2.10 and record one Good Result or Bad Result as appropriate.
9. Repeat steps 1 to 8 using GNSS scenario #4 instead of #3 so that the reference location changes sufficiently such that the UE shall have to use the new assistance data. Use new random values for the UE location and altitude in step 1 and for the GNSS Reference Time offset in step 5.
10. Repeat steps 1 to 9 until the statistical requirements of clause 7.2.6 are met. Each time scenario #3 or #4 is used, the start time of the GNSS scenario shall be advanced by 2 minutes from the time used previously for that scenario. Once a scenario reaches the end of its viable running time, restart it from its nominal start time again.
11. Release the signalling connection.

7.2.5.3 Message contents

Message contents are according to TS 36.508 [18] clauses 4.6 and 4.7 and as follows:

RESET UE POSITIONING STORED INFORMATION

Information Element	Value/remark
UE POSITIONING TECHNOLOGY	AGNSS

LPP REQUEST CAPABILITIES

Information Element	Value/remark
a-gnss-RequestCapabilities	TRUE

LPP REQUEST LOCATION INFORMATION

Information Element	Value/remark	Comment
commonIEsRequestLocationInformation		
> locationInformationType	'locationEstimateRequired' or 'locationMeasurementsRequired'	Depending on test case and UE capabilities, i.e. support for UE-based or UE-assisted
> additionalInformation	'onlyReturnInformationRequested'	
> qos		
>> horizontalAccuracy (Sub-Test 1)	'10' (15.9m)	
>> horizontalAccuracy (Sub-Tests 2 to 5 and 8 to 13)	'6' (7.7m)	

>> verticalCoordinateRequest	FALSE	
>> responseTime		
>>>time	'20'	
a-gnss-RequestLocationInformation		
> gnss-PositioningInstructions		
>> gnssMethods		
>>> gnss-ids	Sub-test 1: 'gps' and possibly 'sbas' Sub-test 2: 'glonass' and possibly 'sbas' Sub-test 3: 'galileo' and possibly 'sbas' Sub-test 4: 'gps' and possibly 'sbas' Sub-test 5: 'gps' and 'glonass' and possibly 'sbas' Sub-test 8: 'gps' and 'galileo' and possibly 'sbas' Sub-test 9: 'bds' and possibly 'sbas' Sub-test 10: 'gps' and 'bds' and possibly 'sbas' Sub-test 11: 'gps' and 'glonass' and 'bds' and possibly 'sbas' Sub-test 12: 'gps' and 'galileo' and 'glonass' Sub-test 13: 'gps' and 'galileo' and 'bds' Sub-test 14: 'gps' and 'qzss' Sub-test 15: 'gps' and 'navic'	Depending on UE capabilities
>> fineTimeAssistanceMeasReq	FALSE	
>> adrMeasReq	FALSE	
>> multiFreqMeasReq	TRUE or FALSE	Depending on UE capabilities
>> assistanceAvailability	FALSE	

7.2.6 Test requirement

For the parameters specified in table 7.2.7 or 7.2.8 the UE shall meet the requirements and the success rate specified in table 7.2.10 or 7.2.11 with a confidence level of 95% according to Annex D.

Table 7.2.7: Test parameters Nominal Accuracy - Sub-Test 1

Parameters	Unit	Value
Number of generated satellites	-	8
HDOP Range	-	1.1 to 1.6
Propagation conditions	-	AWGN
GPS Coarse Time assistance error range	seconds	±1.8
GPS L1 C/A Signal for all satellites	dBm	-130

Table 7.2.8: Test parameters Nominal Accuracy - Sub-Tests 2 to 5 and Sub-Tests 8 to 13

System	Parameters	Unit	Value
	Number of generated satellites per system	-	See Table 7.2.9
	Total number of generated satellites	-	6, 7 ⁽²⁾ or 8 ⁽³⁾
	HDOP Range	-	1.4 to 2.1
	Propagation conditions	-	AWGN
	GNSS coarse time assistance error range	seconds	±1.8
GPS ⁽¹⁾	Reference signal power level for all satellites	dBm	-128.5
Galileo	Reference signal power level for all satellites	dBm	-127
GLONASS	Reference signal power level for all satellites	dBm	-131

System	Parameters	Unit	Value
QZSS	Reference signal power level for all satellites	dBm	-128.5
SBAS	Reference signal power level for all satellites	dBm	-131
BDS	Reference signal power level for all satellites	dBm	-133
Navic	Reference signal power level for all satellites	dBm	-128.5
NOTE 1: "GPS" here means GPS L1 C/A, Modernized GPS, or both, dependent on UE capabilities.			
NOTE 2: 7 satellites apply only for SBAS case or sub-tests with 3 different GNSSs.			
NOTE 3: 8 satellites apply only for sub-tests with 3 different GNSSs and SBAS.			

If SBAS is supported, the SBAS satellite with the highest elevation will be added to the scenario.

Table 7.2.9: Satellite allocation

	Satellite allocation for each constellation			
	GNSS 1 ⁽¹⁾	GNSS 2 ⁽¹⁾	GNSS 3 ⁽¹⁾	SBAS
Single constellation	6	-	-	1
Dual constellation	3	3	-	1
Triple constellation	3	2	2	1
NOTE 1: GNSS refers to global systems i.e., GPS, Galileo, GLONASS and BDS.				

Table 7.2.10: Test requirements for Nominal Accuracy – Sub-Test 1

System	Success rate	2-D position error	Max response time
All	95 %	31.3 m	20.3 s

Table 7.2.11: Test requirements for Nominal Accuracy – Sub-Tests 2 to 5 and Sub-Tests 8 to 13

System	Success rate	2-D position error	Max response time
All	95 %	16.3 m	20.3 s

7.3 Dynamic Range

7.3.1 Sub-tests

This test includes sub-tests dependent on the GNSS supported by the UE. Each sub-test is identified by a Sub-Test Number as defined in Table 7.3.1

Table 7.3.1: Sub-Test Number Definition

Sub-Test Number	Supported GNSS
1	UE supporting A-GPS L1 C/A
2	UE supporting A-GLONASS
3	UE supporting A-Galileo
4	UE supporting A-GPS and Modernized GPS
5	UE supporting A-GPS and A-GLONASS (Note)
8	UE supporting A-GPS and A-Galileo (Note)
9	UE supporting A-BDS
10	UE supporting A-GPS and A-BDS (Note)
11	UE supporting A-GPS and A-GLONASS and A-BDS (Note)
12	UE supporting A-GPS and A-Galileo and A-GLONASS (Note)
13	UE supporting A-GPS and A-Galileo and A-BDS (Note)
14	UE supporting A-GPS and A-QZSS (Note)
15	UE supporting A-GPS and A-Navic (Note)
Note: "GPS" here means GPS L1 C/A, Modernized GPS, or both, dependent on UE capabilities.	

7.3.2 Test purpose

To verify the performance of the first position estimate, when the UE is provided with GNSS signals with large dynamic ranges.

7.3.3 Test applicability

This test applies to all types of E-UTRA UE that supports A-GNSS, except Category M1 and Category M2 devices that do not support VoLTE.

7.3.4 Minimum conformance requirements

The first fix position estimates shall meet the accuracy and response time requirements in table 7.3.2 for the parameters specified in table 7.3.3 or 7.3.4.

Table 7.3.2: Requirements for Dynamic Range

Success rate	2-D position error	Max response time
95 %	100 m	20 s

Table 7.3.3: Parameters for Dynamic Range - Sub-Test 1

Parameters	Unit	Value
Number of generated satellites	-	6
HDOP Range	-	1.4 to 2.1
GPS Coarse Time assistance error range	seconds	±2
Propagation conditions	-	AWGN
GPS L1 C/A Signal for 1 st satellite	dBm	-129
GPS L1 C/A Signal for 2 nd satellite	dBm	-135
GPS L1 C/A Signal for 3 rd satellite	dBm	-141
GPS L1 C/A Signal for 4 th satellite	dBm	-147
GPS L1 C/A Signal for 5 th satellite	dBm	-147
GPS L1 C/A Signal for 6 th satellite	dBm	-147

Table 7.3.4: Parameters for Dynamic Range - Sub-Tests 2 to 5 and Sub-Tests 8 to 13

System	Parameters	Unit	Value
	Number of generated satellites per system	-	See Table 7.3.5
	Total number of generated satellites	-	6 or 7 ⁽²⁾
	HDOP Range	-	1.4 to 2.1
	Propagation conditions	-	AWGN
	GNSS coarse time assistance error range	seconds	±2
Galileo	Reference high signal power level	dBm	-127.5
	Reference low signal power level	dBm	-147
GPS ⁽¹⁾	Reference high signal power level	dBm	-129
	Reference low signal power level	dBm	-147
GLONASS	Reference high signal power level	dBm	-131.5
	Reference low signal power level	dBm	-147
BDS	Reference high signal power level	dBm	-133.5
	Reference low signal power level	dBm	-145
QZSS	Reference high signal power level	dBm	-129
	Reference low signal power level	dBm	-147
Navic	Reference high signal power level	dBm	-129
	Reference low signal power level	dBm	-147

NOTE 1: "GPS" here means GPS L1 C/A, Modernized GPS, or both, dependent on UE capabilities.

NOTE 2: 7 satellites are used for sub-tests with 3 different GNSSs

Table 7.3.5: Power level and satellite allocation

		Satellite allocation for each constellation		
		GNSS 1 ⁽¹⁾	GNSS 2 ⁽¹⁾	GNSS 3 ⁽¹⁾
Single constellation	High signal level	2	--	--
	Low signal level	4	--	--
Dual constellation	High signal level	1	1	--
	Low signal level	2	2	--
Triple constellation	High signal level	1	1	1
	Low signal level	2	1	1

NOTE 1: GNSS refers to global systems i.e., GPS, Galileo, GLONASS and BDS.

The normative reference for this requirement is TS 36.171 [3] clause 5.3 and 6.3.

7.3.5 Test description

7.3.5.1 Initial conditions

Initial conditions are a set of test configurations the UE needs to be tested in and the steps for the SS to take with the UE to reach the correct measurement state.

Test Environment: Normal, as defined in TS 36.508 [18] clause 4.1.

Frequencies to be tested: Mid Range, as defined in TS 36.508 [18] clause 4.3.1.

Channel Bandwidth to be tested: as defined in TS 36.508 [18] clause 4.3.1.

1. Connect SS and GSS to the UE antenna connector or antenna connectors as shown in Annex A.
2. Set the GNSS test parameters as specified in table 7.3.6 or 7.3.7 for GNSS scenario #1 in TS 37.571-5 [20]. Randomly select from the satellite SV IDs defined in the relevant table of Satellites to be simulated in clause 6.2.1.2 in TS 37.571-5 [20] for the satellites with the higher levels.
3. The parameter settings for the cell are set up according to TS 36.508 [18] clause 4.4.3, single cell scenario.
4. Switch on the UE.
5. Establish a signalling connection according to the generic procedure in TS 36.508 [18] clause 4.5.3 (State 3, Generic RB established) on a channel in the Mid EARFCN range.

7.3.5.2 Test procedure

1. Start GNSS scenario #1 as specified in clause 6.2.1.2 of TS 37.571-5 [20] with the UE location randomly selected to be within 3 km of the Reference Location and the altitude of the UE randomly selected between 0 m to 500 m above WGS-84 reference ellipsoid using the method described in clause 6.2.1.2.6 of TS 37.571-5 [20]
2. Send a RESET UE POSITIONING STORED INFORMATION message.
3. Depending on how the LPP session is performed:
 - In the case of C-Plane, the SS shall send an LPP REQUEST CAPABILITIES message.
 - In the case of U-Plane, the SS shall establish a SUPL session with the UE for positioning.
4. The UE returns an LPP PROVIDE CAPABILITIES message indicating the assistance data supported by the UE in the Assistance Data Support List in the A GNSS Provide Capabilities IE.
5. Send an LPP PROVIDE ASSISTANCE DATA message to provide the assistance data that is supported by the UE as indicated in the step 4 and in accordance with clause 6.2.6 of TS 37.571-5 [20], and with the values defined in clause 6.2.7 of TS 37.571-5 [20] with the value of GNSS Reference Time offset by a random value as specified in clause 6.2.7.2 of TS 37.571-5 [20]. If the LPP session is performed over C-Plane, then if the UE message at step 4 includes the ackRequested IE set to TRUE, then the SS shall send an acknowledgment in the (first) LPP PROVIDE ASSISTANCE DATA message.

6. Send an LPP REQUEST LOCATION INFORMATION message to obtain a fix.
7. If the UE returns a valid result in the LPP PROVIDE LOCATION INFORMATION message within the Max response time specified in table 7.3.9 then record the result and process it as specified in step 8. If the UE does not return a valid result within the Max response time specified in table 7.3.9 or reports an Error in the LPP PROVIDE LOCATION INFORMATION message then record one Bad Result.
- 7a. If the UE message at step 7 includes the ackRequested IE set to TRUE, then the SS shall send a LPP acknowledgment message.
8. For UE based testing compare the reported Location Information in the LPP PROVIDE LOCATION INFORMATION message against the simulated position of the UE used in step 1, and calculate the 2D position error as specified in clause 4.5.2.3. Compare the 2D position error against the value in table 7.3.9 and record one Good Result or Bad Result as appropriate; or

For UE assisted testing convert the GNSS Measurement Information reported in the LPP PROVIDE LOCATION INFORMATION message to a 2D position using the method described in clause 4.4.3 and then compare the result against the simulated position of the UE used in step 1, and calculate the 2D position error as specified in clause 4.5.2.3. Compare the 2D position error against the value in table 7.3.9 and record one Good Result or Bad Result as appropriate.
9. Repeat steps 1 to 8 using GNSS scenario #2 instead of #1 so that the reference location changes sufficiently such that the UE shall have to use the new assistance data. Randomly select from the satellite SV IDs defined in the relevant table of Satellites to be simulated in clause 6.2.1.2 in TS 37.571-5 [20] for the satellites with the higher levels. Use new random values for the UE location and altitude in step 1 and for the GNSS Reference Time offset in step 5.
10. Repeat steps 1 to 9 until the statistical requirements of clause 7.3.6 are met. Each time scenario #1 or #2 is used, the start time of the GNSS scenario shall be advanced by 2 minutes from the time used previously for that scenario. Once a scenario reaches the end of its viable running time, restart it from its nominal start time again. Each time scenario #1 or #2 is used, randomly select from the satellite SV IDs defined in the relevant table of Satellites to be simulated in clause 6.2.1.2 in TS 37.571-5 [20], for the satellites with the higher levels.
11. Release the signalling connection.

7.3.5.3 Message contents

Message contents are according to TS 36.508 [18] clauses 4.6 and 4.7 and as follows:

RESET UE POSITIONING STORED INFORMATION

Information Element	Value/remark
UE POSITIONING TECHNOLOGY	AGNSS

LPP REQUEST CAPABILITIES

Information Element	Value/remark
a-gnss-RequestCapabilities	TRUE

LPP REQUEST LOCATION INFORMATION

Information Element	Value/remark	Comment
commonIEsRequestLocationInformation		
> locationInformationType	'locationEstimateRequired' or 'locationMeasurementsRequired'	Depending on test case and UE capabilities, i.e. support for UE-based or UE-assisted
> additionalInformation	'onlyReturnInformationRequested'	
> qos		
>> horizontalAccuracy	'19' (51.2m)	
>> verticalCoordinateRequest	FALSE	

>> responseTime		
>>>time	'20'	
a-gnss-RequestLocationInformation		
> gnss-PositioningInstructions		
>> gnssMethods		
>>> gnss-ids	Sub-test 1: 'gps' Sub-test 2: 'glonass' Sub-test 3: 'galileo' Sub-test 4: 'gps' Sub-test 5: 'gps' and 'glonass' Sub-test 8: 'gps' and 'galileo' Sub-test 9: 'bds' Sub-test 10: 'gps'and'bds' Sub-test 11: 'gps' and 'glonass' and 'bds' Sub-test 12: 'gps' and 'galileo' and 'glonass' Sub-test 13: 'gps' and 'galileo' and 'bds' Sub-test 14: 'gps' and 'qzss' Sub-test 15: 'gps' and 'navic'	
>> fineTimeAssistanceMeasReq	FALSE	
>> adrMeasReq	FALSE	
>> multiFreqMeasReq	TRUE or FALSE	Depending on UE capabilities
>> assistanceAvailability	FALSE	

7.3.6 Test requirement

For the parameters specified in table 7.3.6 or 7.3.7 the UE shall meet the requirements and the success rate specified in table 7.3.9 with a confidence level of 95% according to Annex D.

Table 7.3.6: Test parameters for Dynamic Range - Sub-Test 1

Parameters	Unit	Value
Number of generated satellites	-	6
HDOP Range	-	1.4 to 2.1
GPS Coarse Time assistance error range	seconds	±1.8
Propagation conditions	-	AWGN
GPS L1 C/A Signal for 1 st satellite	dBm	-128.2
GPS L1 C/A Signal for 2 nd satellite	dBm	-134
GPS L1 C/A Signal for 3 rd satellite	dBm	-140
GPS L1 C/A Signal for 4 th satellite	dBm	-146
GPS L1 C/A Signal for 5 th satellite	dBm	-146
GPS L1 C/A Signal for 6 th satellite	dBm	-146

Table 7.3.7: Test parameters for Dynamic Range - Sub-Tests 2 to 5 and Sub-Tests 8 to 13

System	Parameters	Unit	Value
	Number of generated satellites per system	-	See Table 7.3.8
	Total number of generated satellites	-	6 or 7 ⁽²⁾
	HDOP Range	-	1.4 to 2.1
	Propagation conditions	-	AWGN
	GNSS coarse time assistance error range	seconds	±1.8
Galileo	Reference high signal power level	dBm	-126.7
	Reference low signal power level	dBm	-146
GPS ⁽¹⁾	Reference high signal power level	dBm	-128.2
	Reference low signal power level	dBm	-146
GLONASS	Reference high signal power level	dBm	-130.7
	Reference low signal power level	dBm	-146
BDS	Reference high signal power level	dBm	-132.7

System	Parameters	Unit	Value
QZSS	Reference low signal power level	dBm	-144
	Reference high signal power level	dBm	-128.2
	Reference low signal power level	dBm	-146
Navic	Reference high signal power level	dBm	-128.2
	Reference low signal power level	dBm	-146
NOTE 1: "GPS" here means GPS L1 C/A, Modernized GPS, or both, dependent on UE capabilities.			
NOTE 2: 7 satellites are used for sub-tests with 3 different GNSSs			

Table 7.3.8: Power level and satellite allocation

		Satellite allocation for each constellation		
		GNSS 1 ⁽¹⁾	GNSS 2 ⁽¹⁾	GNSS 3 ⁽¹⁾
Single constellation	High signal level	2	--	--
	Low signal level	4	--	--
Dual constellation	High signal level	1	1	--
	Low signal level	2	2	--
Triple constellation	High signal level	1	1	1
	Low signal level	2	1	1
NOTE 1: GNSS refers to global systems i.e., GPS, Galileo, GLONASS and BDS.				

Table 7.3.9: Test requirements for Dynamic Range

System	Success rate	2-D position error	Max response time
All	95 %	101.3 m	20.3 s

7.4 Multi-Path scenario

7.4.1 Sub-tests

This test includes sub-tests dependent on the GNSS supported by the UE. Each sub-test is identified by a Sub-Test Number as defined in Table 7.4.1

Table 7.4.1: Sub-Test Number Definition

Sub-Test Number	Supported GNSS		
1	UE supporting A-GPS L1 C/A		
2	UE supporting A-GLONASS		
3	UE supporting A-Galileo		
4	UE supporting A-GPS and Modernized GPS		
5	UE supporting A-GPS and A-GLONASS (Note)		
8	UE supporting A-GPS and A-Galileo (Note)		
9	UE supporting A-BDS		
10	UE supporting A-GPS and A-BDS (Note)		
11	UE supporting A-GPS and A-GLONASS and A-BDS (Note)		
12	UE supporting A-GPS and A-Galileo and A-GLONASS (Note)		
13	UE supporting A-GPS and A-Galileo and A-BDS (Note)		
QZSS	Reference high signal power level	dBm	-128.2
	Reference low signal power level	dBm	-146
Navic	Reference high signal power level	dBm	-128.2
	Reference low signal power level	dBm	-146
Note: "GPS" here means GPS L1 C/A, Modernized GPS, or both, dependent on UE capabilities.			

7.4.2 Test purpose

To verify the performance of the first position estimate, when the UE is provided with GNSS signals with multi-path components.

7.4.3 Test applicability

This test applies to all types of E-UTRA UE that supports A-GNSS, except Category M1 and Category M2 devices that do not support VoLTE.

7.4.4 Minimum conformance requirements

The first fix position estimates shall meet the accuracy and response time requirements in table 7.4.2 for the parameters specified in table 7.4.3 or 7.4.4.

Table 7.4.2: Requirements for Multi-Path scenario

Success rate	2-D position error	Max response time
95 %	100 m	20 s

Table 7.4.3: Parameters for Multi-Path scenario - Sub-Test 1

Parameters	Unit	Value
Number of generated satellites (Satellites 1, 2 unaffected by multi-path) (Satellites 3, 4, 5 affected by multi-path)	-	5
GPS Coarse time assistance error range	seconds	± 2
HDOP Range	-	1.8 to 2.5
GPS L1 C/A Signal for satellite 1, 2	dBm	-130
GPS L1 C/A Signal for satellite 3, 4, 5	dBm	LOS signal of -130 dBm, multi-path signal of -136 dBm

Table 7.4.4: Parameters for Multi-Path scenario - Sub-Tests 2 to 5 and Sub-Tests 8 to 13

System	Parameters	Unit	Value
	Number of generated satellites per system	-	See Table 7.4.5
	Total number of generated satellites	-	6 or 7 ⁽²⁾
	HDOP range		1.4 to 2.1
	Propagation conditions	-	AWGN
	GNSS coarse time assistance error range	seconds	± 2
Galileo	Reference signal power level	dBm	-127
GPS ⁽¹⁾	Reference signal power level	dBm	-128.5
GLONASS	Reference signal power level	dBm	-131
BDS	Reference signal power level	dBm	-133
QZSS	Reference signal power level	dBm	-128.5
Navic	Reference signal power level	dBm	-128.5
NOTE 1: "GPS" here means GPS L1 C/A, Modernized GPS, or both, dependent on UE capabilities.			
NOTE 2: 7 satellites are used for sub-tests with 3 different GNSSs			

Table 7.4.5: Channel model allocation

		Channel model allocation for each constellation		
		GNSS-1	GNSS-2	GNSS-3
Single constellation	One-tap channel	2	--	--
	Two-tap channel	4	--	--
Dual constellation	One-tap channel	1	1	--
	Two-tap channel	2	2	--
Triple constellation	One-tap channel	1	1	1

	Two-tap channel	2	1	1
Note: One-tap channel: no multi-path. Two-tap channel: multi-path defined in clause 4.2.4				

The normative reference for this requirement is TS 36.171 [3] clause 5.4 and 6.4.

7.4.5 Test description

7.4.5.1 Initial conditions

Initial conditions are a set of test configurations the UE needs to be tested in and the steps for the SS to take with the UE to reach the correct measurement state.

Test Environment: Normal, as defined in TS 36.508 [18] clause 4.1.

Frequencies to be tested: Mid Range, as defined in TS 36.508 [18] clause 4.3.1.

Channel Bandwidth to be tested: as defined in TS 36.508 [18] clause 4.3.1.

1. Connect SS and GSS to the UE antenna connector or antenna connectors as shown in Annex A.
2. Set the GNSS test parameters as specified in table 7.4.6 or 7.4.7 for GNSS scenario #1 in TS 37.571-5 [20]. Randomly select from the satellite SV IDs defined in the relevant table of Satellites to be simulated in clause 6.2.1.2 in TS 37.571-5 [20] for the satellites with one-tap channels.
3. The parameter settings for the cell are set up according to TS 36.508 [18] clause 4.4.3, single cell scenario.
4. Switch on the UE.
5. Establish a signalling connection according to the generic procedure in TS 36.508 [18] clause 4.5.3 (State 3, Generic RB established) on a channel in the Mid EARFCN range.

7.4.5.2 Test procedure

1. Start GNSS scenario #1 as specified in clause 6.2.1.2 of TS 37.571-5 [20] with the UE location randomly selected to be within 3 km of the Reference Location and the altitude of the UE randomly selected between 0 m to 500 m above WGS-84 reference ellipsoid using the method described in clause 6.2.1.2.6 of TS 37.571-5 [20]. The initial carrier phase difference between taps of the multi-path model shall be randomly selected between 0 and 2π radians by selecting the next random number from a standard uniform random number generator, in the range 0 to 2π , representing radians with a resolution of 0.1, representing 0.1 radians.
2. Send a RESET UE POSITIONING STORED INFORMATION message.
3. Depending on how the LPP session is performed:
 - In the case of C-Plane, the SS shall send an LPP REQUEST CAPABILITIES message.
 - In the case of U-Plane, the SS shall establish a SUPL session with the UE for positioning.
4. The UE returns an LPP PROVIDE CAPABILITIES message indicating the assistance data supported by the UE in the Assistance Data Support List in the A GNSS Provide Capabilities IE.
5. Send an LPP PROVIDE ASSISTANCE DATA message to provide the assistance data that is supported by the UE as indicated in the step 4 and in accordance with clause 6.2.6 of TS 37.571-5 [20], and with the values defined in clause 6.2.7 of TS 37.571-5 [20] with the value of GNSS Reference Time offset by a random value as specified in clause 6.2.7.2 of TS 37.571-5 [20]. If the LPP session is performed over C-Plane, then if the UE message at step 4 includes the ackRequested IE set to TRUE, then the SS shall send an acknowledgment in the LPP PROVIDE ASSISTANCE DATA message.
6. Send an LPP REQUEST LOCATION INFORMATION message to obtain a fix.
7. If the UE returns a valid result in the LPP PROVIDE LOCATION INFORMATION message within the Max response time specified in table 7.4.10 then record the result and process it as specified in step 8. If the UE does

not return a valid result within the Max response time specified in table 7.4.10 or reports an Error in the LPP PROVIDE LOCATION INFORMATION message then record one Bad Result.

- 7a. If the UE message at step 7 includes the ackRequested IE set to TRUE, then the SS shall send a LPP acknowledgment message.
- 8. For UE based testing compare the reported Location Information in the LPP PROVIDE LOCATION INFORMATION message against the simulated position of the UE used in step 1, and calculate the 2D position error as specified in clause 4.5.2.3. Compare the 2D position error against the value in table 7.4.10 and record one Good Result or Bad Result as appropriate; or

For UE assisted testing convert the GNSS Measurement Information reported in the LPP PROVIDE LOCATION INFORMATION message to a 2D position using the method described in clause 4.4.3 and then compare the result against the simulated position of the UE used in step 1, and calculate the 2D position error as specified in clause 4.5.2.3. Compare the 2D position error against the value in table 7.4.10 and record one Good Result or Bad Result as appropriate.

- 9. Repeat steps 1 to 8 using GNSS scenario #2 instead of #1 so that the reference location changes sufficiently such that the UE shall have to use the new assistance data. Randomly select from the satellite SV IDs defined in the relevant table of Satellites to be simulated in clause 6.2.1.2 in TS 37.571-5 [20] for the satellites with the one-tap channels. Use new random values for the UE location and altitude, and the initial carrier phase difference between taps of the multi-path model in step 1 and for the GNSS Reference Time offset in step 5.
- 10. Repeat steps 1 to 9 until the statistical requirements of clause 7.4.6 are met. Each time scenario #1 or #2 is used, the start time of the GNSS scenario shall be advanced by 2 minutes from the time used previously for that scenario. Once a scenario reaches the end of its viable running time, restart it from its nominal start time again. Each time scenario #1 or #2 is used, randomly select from the satellite SV IDs defined in the relevant table of Satellites to be simulated in clause 6.2.1.2 in TS 37.571-5 [20], for the satellites with the one-tap channels.
- 11. Release the signalling connection

7.4.5.3 Message contents

Message contents are according to TS 36.508 [18] clauses 4.6 and 4.7 and as follows:

RESET UE POSITIONING STORED INFORMATION

Information Element	Value/remark
UE POSITIONING TECHNOLOGY	AGNSS

LPP REQUEST CAPABILITIES

Information Element	Value/remark
a-gnss-RequestCapabilities	TRUE

LPP REQUEST LOCATION INFORMATION

Information Element	Value/remark	Comment
commonIEsRequestLocationInformation		
> locationInformationType	'locationEstimateRequired' or 'locationMeasurementsRequired'	Depending on test case and UE capabilities, i.e. support for UE-based or UE-assisted
> additionalInformation	'onlyReturnInformationRequested'	
> qos		
>> horizontalAccuracy	'19' (51.2m)	
>> verticalCoordinateRequest	FALSE	
>> responseTime		
>>>time	'20'	
a-gnss-RequestLocationInformation		
> gnss-PositioningInstructions		

>> gnssMethods		
>>> gnss-ids	Sub-test 1: 'gps' Sub-test 2: 'glonass' Sub-test 3: 'galileo' Sub-test 4: 'gps' Sub-test 5: 'gps' and 'glonass' Sub-test 8: 'gps' and 'galileo' Sub-test 9: 'bds' Sub-test 10: 'gps'and'bds' Sub-test 11: 'gps' and 'glonass' and 'bds' Sub-test 12: 'gps' and 'galileo' and 'glonass' Sub-test 13: 'gps' and 'galileo' and 'bds' Sub-test 14: 'gps' and 'qzss' Sub-test 15: 'gps' and 'navic'	
>> fineTimeAssistanceMeasReq	FALSE	
>> adrMeasReq	FALSE	
>> multiFreqMeasReq	TRUE or FALSE	Depending on UE capabilities
>> assistanceAvailability	FALSE	

7.4.6 Test requirement

For the parameters specified in table 7.4.6 or 7.4.7 the UE shall meet the requirements and the success rate specified in table 7.4.10 with a confidence level of 95% according to Annex D.

Table 7.4.6: Test parameters for Multi-Path scenario - Sub-Test 1

Parameters	Unit	Value
Number of generated satellites (see note)	-	5
GPS Coarse Time assistance error range	seconds	±1.8
HDOP Range	-	1.8 to 2.5
GPS L1 C/A Signal for Satellite 1, 2 (see note)	dBm	-130
GPS L1 C/A Signal for Satellite 3, 4, 5 (see note)	dBm	LOS signal of -130 dBm, multi-path signal of -136.2 dBm
NOTE: Satellites 1, 2 no multi-path. Satellites 3, 4, 5 multi-path defined in clause 4.2.4.		

Table 7.4.7: Test parameters for Multi-Path scenario - Sub-Tests 2 to 5 and Sub-Tests 8 to 13

System	Parameters	Unit	Value
	Number of generated satellites per system	-	See Table 7.4.8
	Total number of generated satellites	-	6 or 7 ⁽²⁾
	HDOP Range per system	-	1.4 to 2.1
	Propagation conditions	-	AWGN
	GNSS coarse time assistance error range	seconds	±2
Galileo	Reference signal power level for all satellites	dBm	-127
GPS ⁽¹⁾	Reference signal power level for all satellites	dBm	-128.5
GLONASS	Reference signal power level for all satellites	dBm	-131
BDS	Reference signal power level for all satellites	dBm	-133
QZSS	Reference signal power level for all satellites	dBm	-128.5
Navic	Reference signal power level for all satellites	dBm	-128.5
NOTE 1: "GPS" here means GPS L1 C/A, Modernized GPS, or both, dependent on UE capabilities.			
NOTE 2: 7 satellites are used for sub-tests with 3 different GNSSs			

Table 7.4.8: Channel model allocation

	Channel model allocation for each constellation		
	GNSS-1	GNSS-2	GNSS-3

Single constellation	One-tap channel	2	--	--
	Two-tap channel	4	--	--
Dual constellation	One-tap channel	1	1	--
	Two-tap channel	2	2	--
Triple constellation	One-tap channel	1	1	1
	Two-tap channel	2	1	1
Note: One-tap channel: no multi-path. Two-tap channel: multi-path defined in clause 4.2.4 with Relative mean Power (Y) defined in Table 7.4.9.				

Table 7.4.9: Relative mean Power (Y) for use in Table 7.4.8

Galileo	E1	-4.7
	E5a	-6.2
	E5b	-6.2
GPS/Modernized GPS/QZSS	L1 C/A	-6.2
	L1C	-4.7
	L2C	-6.2
GLONASS	L5	-6.2
	G1	-12.7
	G2	-12.7
BDS	B1I	-4.7
	B1C	-4.7
	B2a	-6.2
	B3I	-6.2
Navic	L5	-6,2

Table 7.4.10: Test requirements for Multi-Path scenario

System	Success rate	2-D position error	Max response time
All	95 %	101.3 m	20.3 s

7.5 Moving scenario and periodic update (Rel-9 to Rel-13)

7.5.1 Sub-tests

This test includes sub-tests dependent on the GNSS supported by the UE. Each sub-test is identified by a Sub-Test Number as defined in Table 7.5.1.

Table 7.5.1: Sub-Test Number Definition

Sub-Test Number	Supported GNSS
1	UE supporting A-GPS L1 C/A
2	UE supporting A-GLONASS
3	UE supporting A-Galileo
4	UE supporting A-GPS and Modernized GPS
5	UE supporting A-GPS and A-GLONASS (Note)
8	UE supporting A-GPS and A-Galileo (Note)
9	UE supporting A-BDS
10	UE supporting A-GPS and A-BDS (Note)
11	UE supporting A-GPS and A-GLONASS and A-BDS (Note)
12	UE supporting A-GPS and A-Galileo and A-GLONASS (Note)
13	UE supporting A-GPS and A-Galileo and A-BDS (Note)
14	UE supporting A-GPS and A-QZSS (Note)
15	UE supporting A-GPS and A-Navic (Note)
Note: "GPS" here means GPS L1 C/A, Modernized GPS, or both, dependent on UE capabilities.	

7.5.2 Test purpose

To verify the performance when the UE is requested to use periodical reporting with a reporting interval of 2 seconds.

7.5.3 Test applicability

This test applies to all types of E-UTRA UE that supports A-GNSS with LPP Release 9 to 13, except Category M1 and Category M2 devices that do not support VoLTE.

7.5.4 Minimum conformance requirements

The position estimates, after the first reported position estimate, shall meet the accuracy requirement in table 7.5.2 or 7.5.3 with the periodical reporting interval of 2 seconds for the parameters specified in table 7.5.4 or 7.5.5.

NOTE: In the actual testing the UE may report error messages until it has been able to acquire GNSS measured results or a position estimate. The SS shall only consider the first measurement report different from an error message as the first position estimate in the requirement in table 7.5.2 or 7.5.3.

Table 7.5.2: Requirements for Moving scenario and periodic update - Sub-Test 1

Success Rate	2-D position error	Periodical reporting interval
95 %	100 m	2 s

Table 7.5.3: Requirements for Moving scenario and periodic update - Sub-Tests 2 to 5 and Sub-Tests 8 to 13

Success Rate	2-D position error	Periodical reporting interval
95 %	50 m	2 s

Table 7.5.4: Parameters for Moving scenario and periodic update - Sub-Test 1

Parameters	Unit	Value
Number of generated satellites	-	5
HDOP Range	-	1.8 to 2.5
Propagation condition	-	AWGN
GPS L1 C/A signal for all satellites	dBm	-130

Table 7.5.5: Parameters for Moving scenario and periodic update - Sub-Tests 2 to 5 and Sub-Tests 8 to 13

System	Parameters	Unit	Value
	Number of generated satellites per system	-	See Table 7.5.6
	Total number of generated satellites	-	6 or 7 ⁽²⁾
	HDOP range	-	1.4 to 2.1
	Propagation conditions	-	AWGN
Galileo	Reference signal power level	dBm	-127
GPS ⁽¹⁾	Reference signal power level	dBm	-128.5
GLONASS	Reference signal power level	dBm	-131
BDS	Reference signal power level	dBm	-133
QZSS	Reference signal power level	dBm	-128.5
Navic	Reference signal power level	dBm	-128.5
NOTE 1: "GPS" here means GPS L1 C/A, Modernized GPS, or both, dependent on UE capabilities.			
NOTE 2: 7 satellites are used for sub-tests with 3 different GNSSs			

Table 7.5.6: Satellite allocation

Satellite allocation for each constellation

	GNSS 1 ⁽¹⁾	GNSS 2 ⁽¹⁾	GNSS 3 ⁽¹⁾
Single constellation	6	--	--
Dual constellation	3	3	--
Triple constellation	3	2	2
NOTE 1: GNSS refers to global systems i.e., GPS, Galileo, GLONASS and BDS.			

The normative reference for this requirement is TS 36.171 [3] clause 5.5 and 6.5.

7.5.5 Test description

7.5.5.1 Initial conditions

Initial conditions are a set of test configurations the UE needs to be tested in and the steps for the SS to take with the UE to reach the correct measurement state.

Test Environment: Normal, as defined in TS 36.508 [18] clause 4.1.

Frequencies to be tested: Mid Range, as defined in TS 36.508 [18] clause 4.3.1.

Channel Bandwidth to be tested: as defined in TS 36.508 [18] clause 4.3.1

The UE moves on a rectangular trajectory of 940 m by 1 440 m with rounded corner defined in Figure 7.1. The initial reference is first defined followed by acceleration to final speed of 100 km/h in 250 m. The UE then maintains the speed for 400 m. This is followed by deceleration to final speed of 25 km/h in 250 m. The UE then turn 90 degrees with turning radius of 20 m at 25 km/h. This is followed by acceleration to final speed of 100 km/h in 250 m. The sequence is repeated to complete the rectangle.

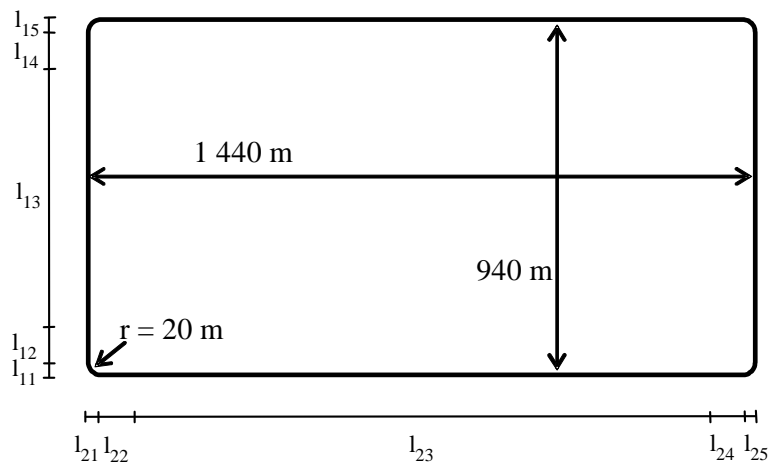

Figure 7.1: Rectangular trajectory of the moving scenario and periodic update test case

Trajectory Parameters

Parameter	Distance (m)	Speed (km/h)
$l_{11}, l_{15}, l_{21}, l_{25}$	20	25
$l_{12}, l_{14}, l_{22}, l_{24}$	250	25 to 100 and 100 to 25
l_{13}	400	100
l_{23}	900	100

1. Connect SS and GSS to the UE antenna cofor nconnector or antenna connectors as shown in Annex A.
2. Set the GNSS test parameters as specified in table 7.5.7 or 7.5.8 for GNSS scenario #5 in TS 37.571-5 [20].
3. The parameter settings for the cell are set up according to TS 36.508 [18] clause 4.4.3, single cell scenario.

4. Switch on the UE.
5. Establish a signalling connection according to the generic procedure in TS 36.508 [18] clause 4.5.3 (State 3, Generic RB established) on a channel in the Mid EARFCN range.

7.5.5.2 Test procedure

1. Start GNSS scenario #5 as specified in clause 6.2.1.2 of TS 37.571-5 [20]
2. Send a RESET UE POSITIONING STORED INFORMATION message.
3. Depending on how the LPP session is performed:
 - In the case of C-Plane, the SS shall send an LPP REQUEST CAPABILITIES message.
 - In the case of U-Plane, the SS shall establish a SUPL session with the UE for positioning.
4. The UE returns an LPP PROVIDE CAPABILITIES message indicating the assistance data supported by the UE in the Assistance Data Support List in the A GNSS Provide Capabilities IE.
5. Send an LPP PROVIDE ASSISTANCE DATA message to provide the assistance data that is supported by the UE as indicated in the step 4 and in accordance with clause 6.2.6 of TS 37.571-5 [20], and with the values defined in clause 6.2.7 of TS 37.571-5 [20]. If the LPP session is performed over C-Plane, then if the UE message at step 4 includes the ackRequested IE set to TRUE, then the SS shall send an acknowledgment in the LPP PROVIDE ASSISTANCE DATA message.
6. Send an LPP REQUEST LOCATION INFORMATION message to obtain a fix.
7. Ignore any Error messages that the UE may report in LPP PROVIDE LOCATION INFORMATION messages until it has been able to acquire the GNSS signals and reports the first GNSS Measurement Information or Location Information.
8. Discard the first GNSS Measurement Information or Location Information.
9. Record the time of reception of the next LPP PROVIDE LOCATION INFORMATION message after reception of the first GNSS Measurement Information or Location Information.
10. After the reception of the first GNSS Measurement Information or Location Information reported in a LPP PROVIDE LOCATION INFORMATION message, every time the UE returns a GNSS Measurement Information or Location Information in the LPP PROVIDE LOCATION INFORMATION message record the time of reception and the result. If the difference between the time of reception and the time of reception of the previous result is less than 1.5 seconds or greater than 2.5 seconds, or if the UE reports an Error in any LPP PROVIDE LOCATION INFORMATION messages, then record one Bad Result. Otherwise process the result as specified in step 11.
- 10a. If the UE messages at steps 7 to 10 include the ackRequested IE set to TRUE, then the SS shall send LPP acknowledgment messages as required.
11. For UE based testing compare the reported Location Information in the LPP PROVIDE LOCATION INFORMATION message against the simulated position of the UE at the time of applicability reported in the Location Information, and calculate the 2D position error as specified in clause 4.5.2.3. Compare the 2D position error against the value in table 7.5.10 or 7.5.11 and record one Good Result or Bad Result as appropriate; or

For UE assisted testing convert the GNSS Measurement Information reported in the LPP PROVIDE LOCATION INFORMATION message to a 2D position using the method described in clause 4.4.3 and then compare the result against the simulated position of the UE at the time of applicability reported in the GNSS Measurement Information, and calculate the 2D position error as specified in clause 4.5.2.3. Compare the 2D position error against the value in table 7.5.10 or 7.5.11 and record one Good Result or Bad Result as appropriate.
12. If the UE sends the first LPP PROVIDE LOCATION INFORMATION that contains GNSS Measurement Information or Location Information later than 240s after the start of the GNSS scenario, fail the UE and stop the test early. Otherwise collect LPP PROVIDE LOCATION INFORMATION results during 900s, starting from the time recorded in step 9. If at any time the difference between the times of reception of two consecutive results is

greater than 240s, fail the UE and stop the test early. Use the collected Good Results and Bad Results to determine the PASS/FAIL according to clause 7.5.6.

13. Release the signalling connection.

7.5.5.3 Message contents

Message contents are according to TS 36.508 [18] clauses 4.6 and 4.7 and as follows:

RESET UE POSITIONING STORED INFORMATION

Information Element	Value/remark
UE POSITIONING TECHNOLOGY	AGNSS

LPP REQUEST CAPABILITIES

Information Element	Value/remark
a-gnss-RequestCapabilities	TRUE

LPP REQUEST LOCATION INFORMATION

Information Element	Value/remark	Comment
commonIEsRequestLocationInformation		
> locationInformationType	'locationEstimateRequired' or 'locationMeasurementsRequired'	Depending on test case and UE capabilities, i.e. support for UE-based or UE-assisted
> periodicalReporting		
>> reportingAmount	'ra-Infinity'	Infinite means during the complete test time
>> reportingInterval	'ri0-5'	2 seconds
> additionalInformation	'onlyReturnInformationRequested'	
> qos		
>> horizontalAccuracy (Sub-Test 1)	'19' (51.2m)	
>> horizontalAccuracy (Sub-Tests 2 to 5 and 8 to 13)	'13' (24.5m)	
>> verticalCoordinateRequest	FALSE	
>> responseTime	Not present	
a-gnss-RequestLocationInformation		
> gnss-PositioningInstructions		
>> gnssMethods		
>>> gnss-ids	Sub-test 1: 'gps' Sub-test 2: 'glonass' Sub-test 3: 'galileo' Sub-test 4: 'gps' Sub-test 5: 'gps' and 'glonass' Sub-test 8: 'gps' and 'galileo' Sub-test 9: 'bds' Sub-test 10: 'gps'and'bds' Sub-test 11: 'gps' and 'glonass' and 'bds' Sub-test 12: 'gps' and 'galileo' and 'glonass' Sub-test 13: 'gps' and 'galileo' and 'bds' Sub-test 14: 'gps' and 'qzss' Sub-test 15: 'gps' and 'navic'	
>> fineTimeAssistanceMeasReq	FALSE	
>> adrMeasReq	FALSE	
>> multiFreqMeasReq	TRUE or FALSE	Depending on UE capabilities
>> assistanceAvailability	FALSE	

7.5.6 Test requirement

For the parameters specified in table 7.5.7 or 7.5.8 the UE shall meet the requirements and the success rate specified in table 7.5.10 or 7.5.11 after the first reported position estimates.

- NOTES:
1. In the testing the UE may report error messages until it has been able to acquire GNSS measured results or a position estimate. The test equipment shall only consider the first measurement report different from an error message as the first position estimate in the requirement in table 7.5.10 or 7.5.11.
 2. Due to the statistical nature of the results it is not possible to design a test with predefined confidence level for the success rate in table 7.5.10 or 7.5.11, therefore a simple PASS/FAIL of the results gathered against this success rate is used.

Table 7.5.7: Test parameters Moving scenario and periodic update - Sub-Test 1

Parameters	Unit	Value
Number of generated satellites	-	5
HDOP Range	-	1.8 to 2.5
Propagation condition	-	AWGN
GPS L1 C/A Signal for all satellites	dBm	-130

Table 7.5.8: Test parameters Moving scenario and periodic update - Sub-Tests 2 to 5 and Sub-Tests 8 to 13

System	Parameters	Unit	Value
	Number of generated satellites per system	-	See Table 7.5.9
	Total number of generated satellites	-	6 or 7 ⁽²⁾
	HDOP Range per system	-	1.4 to 2.1
	Propagation conditions	-	AWGN
Galileo	Reference signal power level for all satellites	dBm	-127
GPS ⁽¹⁾	Reference signal power level for all satellites	dBm	-128.5
GLONASS	Reference signal power level for all satellites	dBm	-131
BDS	Reference signal power level for all satellites	dBm	-133
QZSS	Reference signal power level for all satellites	dBm	-128.5
Navic	Reference signal power level for all satellites	dBm	-128.5
NOTE 1: "GPS" here means GPS L1 C/A, Modernized GPS, or both, dependent on UE capabilities.			
NOTE 2: 7 satellites are used for sub-tests with 3 different GNSSs			

Table 7.5.9: Satellite allocation

	Satellite allocation for each constellation		
	GNSS 1 ⁽¹⁾	GNSS 2 ⁽¹⁾	GNSS 3 ⁽¹⁾
Single constellation	6	--	--
Dual constellation	3	3	--
Triple constellation	3	2	2
NOTE 1: GNSS refers to global systems i.e., GPS, Galileo, GLONASS and BDS.			

Table 7.5.10: Test requirements for Moving scenario and periodic update - Sub-Test 1

System	Success rate	2-D position error	Periodical reporting interval
All	95 %	101.3 m	Between 1.5 s and 2.5s

Table 7.5.11: Test requirements for Moving scenario and periodic update - Sub-Tests 2 to 5 and Sub-Tests 8 to 13

System	Success rate	2-D position error	Periodical reporting interval
All	95 %	51.3 m	Between 1.5 s and 2.5s

7.5A Moving scenario and periodic update (Rel-14 onwards)

7.5A.1 Sub-tests

Same as defined in clause 7.5.1.

7.5A.2 Test purpose

Same as defined in clause 7.5.2.

7.5A.3 Test applicability

This test applies to all types of E-UTRA UE with LPP Release 14 onwards that supports A-GNSS with periodical reporting, except Category M1 and Category M2 devices that do not support VoLTE.

NOTE: The capability to support periodical reporting is indicated in LPP [4] by either omitting the field *periodicalReportingNotSupported-r14* in the LPP PROVIDE CAPABILITIES message, or by including the field *periodicalReportingNotSupported-r14* in the LPP PROVIDE CAPABILITIES message but with bits for UE-assisted or UE-based mode set to zero.

7.5A.4 Minimum conformance requirements

Same as defined in clause 7.5.4.

7.5A.5 Test description

Same as defined in clause 7.5.5.

7.5A.6 Test requirement

Same as defined in clause 7.5.6.

8 E-UTRA ECID measurement requirements

8.0 General

This clause defines the minimum performance requirements for ECID FDD and TDD E-UTRA UEs and UEs supporting NR EN-DC.

8.1 UE Rx – Tx Time Difference

8.1.1 E-UTRAN FDD UE Rx – Tx time difference case (Rel-9 to Rel-11)

8.1.1.1 Test purpose

The purpose of this test is to verify that the E-UTRAN FDD UE Rx – Tx time difference measurement accuracy is within the specified limits in TS 36.133 [23] clause 9.1.9.

8.1.1.2 Test applicability

This test applies to all types of E-UTRA FDD UE release 9 to release 11 that supports ECID positioning.

8.1.1.3 Minimum conformance requirements

NOTE: This measurement is used for UE positioning purposes.

The UE RX-TX time difference is measured from the PCell.

The accuracy requirements in Table 8.1.1.3-1 are valid under the following conditions:

Cell specific reference signals are transmitted either from one, two or four antenna ports.

Conditions defined in TS 36.101 [2] clause 7.3 for reference sensitivity are fulfilled.

No changes to the uplink transmission timing are applied during the measurement period.

RSRP_{dBm} according to clause E.1 for a corresponding Band.

Table 8.1.1.3-1: UE Rx – Tx time difference measurement accuracy

Accuracy	Conditions				
	Ês/lot	Downlink transmission bandwidth of PCell	I _o ^{Note 1} range		
			E-UTRA operating band groups ^{Note 6}	Minimum I _o	Maximum I _o
T _s ^{Note 2}	dB	MHz		dBm/15kHz ^{Note 5}	dBm/BW _{Channel}
±20	≥-3 dB	≤ 3 MHz	FDD_A ^{Note 7} , TDD_A	-121	-50
			FDD_B	-120.5	-50
			FDD_C, TDD_C	-120	-50
			FDD_D	-119.5	-50
			FDD_E, TDD_E	-119	-50
			FDD_F	-118.5	-50
			FDD_G ^{Note 4}	-118	-50
			FDD_H	-117.5	-50
			FDD_N	-114.5	-50
±10	≥-3 dB	≥ 5 MHz	Note 3	Note 3	Note 3

NOTE 1: When in dBm/15kHz, the minimum I_o condition is expressed as the average I_o per RE over all REs in that symbol. I_o may be different in different symbols within a subframe.
NOTE 2: T_s is the basic timing unit defined in TS 36.211 [26].
NOTE 3: The same bands and the same I_o conditions for each band apply for this requirement as for the corresponding requirement with downlink bandwidth ≤ 3 MHz.
NOTE 4: Except Band 29.
NOTE 5: The condition level is increased by Δ>0, when applicable, as described in TS 36.521-3 [25] Sections I.4.2 and I.4.3.
NOTE 6: E-UTRA operating band groups are as defined in Section 4.4.2.
NOTE 7: Except Band 32.

The normative reference for this requirement is TS 36.133 [23] clause 9.1.9 and A.9.7.1.

8.1.1.4 Test description

The test consists of two sub-tests; the difference between the sub-tests is the bandwidth, 1.4 MHz and 10 MHz. Each sub-test has two test points with time delays starting at 32 T_s and 5008 T_s respectively. There is only one active cell in the tests. The tested UE is connected with the serving cell, configured to transmit SRS signals periodically, and signalled to report UE Rx – Tx time difference measurement. The test equipment measures the transmit timing of the UE using the transmitted SRS. The test equipment then compares this timing to the UE Rx-Tx measurement reported by the UE.

8.1.1.4.1 Initial conditions

Test Environment: Normal as defined in TS 36.508 [18] clause 4.1.

Frequencies to be tested: Mid Range, as defined in TS 36.508 [18] clause 4.3.1.1.

Channel Bandwidth to be tested: 1.4 and 10 MHz. In the case that 1.4 MHz channel bandwidth is not defined for the operating band under test, as defined in TS 36.101 [2] clause 5.6.1, then the corresponding sub-test shall be omitted.

1. Connect the SS (node B emulator) and AWGN noise source to the UE antenna connectors as shown in Annex A figure A.5a for 4RX capable UE without any 2RX bands. Otherwise use Annex A figure A.5.
2. Propagation conditions are set according to clause 4.6.2.1.
3. Message contents are defined in clause 8.1.1.4.3.
4. Cell 1 is the serving cell. Cell 1 is the cell used for connection setup with the power levels set according to TS 36.521-3 [25] clauses C.0 and C.1 for this test.

8.1.1.4.2 Test procedure

1. Bring the UE to State 3A or 3A-RF according to TS 36.508 [18] clause 4.5.3A or 5.2A.2, using a value of initial timing advance command $T_A = 2$ in the Random Access Response which indicates an initial timing advance value $N_{TA} = 32 T_s$. Note that in the remainder of the test the timing advance command $T_A = 31$ which indicates a timing advance adjustment value $N_{TA} = 0 T_s$.
2. Set the parameters according to Sub-test 1 in Tables 8.1.1.5-1 and 8.1.1.5-2 as appropriate. Propagation conditions are set according to clause 4.6.2.1.
3. The SS adjusts the downlink timing for Cell 1 to a delay of $+8 T_s$, compared to the current value.
4. Wait for 1.6 s to allow for the possibility that the UE makes autonomous timing adjustments.
- 4a. The SS shall transmit an LPP REQUEST CAPABILITIES message.
- 4b. The UE shall transmit an LPP PROVIDE CAPABILITIES message indicating the ECID capabilities supported by the UE in the *ECID-ProvideCapabilities* IE.
5. The SS shall transmit an LPP REQUEST LOCATION INFORMATION message, including the *ECID-RequestLocationInformation* IE. If the UE message at step 4b includes the *ackRequested* IE set to TRUE, then the SS shall send an acknowledgment in the LPP REQUEST LOCATION INFORMATION message.
6. The UE shall transmit an LPP PROVIDE LOCATION INFORMATION message including the *ecid-SignalMeasurementInformation* IE.
7. As soon as possible after step 6 the SS shall measure the transmit timing of the UE using the transmitted SRS, relative to the current downlink timing.
8. If the UE message at step 6 includes the *ackRequested* IE set to TRUE, then the SS shall send a LPP acknowledgment message.
9. The SS shall check the reported value of *ue-RxTxTimeDiff* in the *ecid-SignalMeasurementInformation* IE provided by the UE in step 6 and compare it with the value measured in step 7. The SS shall check that the reported value is within the limits specified in table 8.1.1.5-3 for Sub-test 1 compared to the measured value. If the reported value is within the limits the number of successful results for “Sub-test 1 – Test point 1” is increased by one. If the reported value is not within the limits, or the UE reports an error in the LPP PROVIDE LOCATION INFORMATION message in step 6, or does not respond at step 6 within the time given by the *time* IE in the *ECID-RequestLocationInformation* IE in step 5, then the number of unsuccessful results for “Sub-test 1 – Test point 1” is increased by one.
10. Repeat steps 3-9 until the confidence level according to Annex D.4.3 is achieved.
NOTE: To avoid a large divergence between the sent TA and the set downlink timing, the SS may reset the downlink timing for Cell 1 to its initial value after a certain amount of loops. The loop during the reset does not count for the result statistics.
11. Repeat steps 1-10 for “Sub-test 1 – Test point 2”. Set a value of initial timing advance command $T_A = 313$ in the Random Access Response which indicates an initial timing advance value $N_{TA} = 5008 T_s$ in step 1.
12. Repeat steps 1-11 for Sub-test 2 (consisting of Test point 1 and Test point 2) in Tables 8.1.1.5-1 and 8.1.1.5-2 as appropriate. In step 3 the SS adjusts the downlink timing for Cell 1 to a delay of $+4 T_s$ compared to the current value.

If both test points of a sub-test pass, the sub-test passes. If one test point of a sub-test fails, the sub-test fails.

If all (applicable) sub-tests pass, the whole test passes. If one (applicable) sub-test fails, the whole test fails.

8.1.1.4.3 Message contents

Message contents are according to TS 36.508 [18] clause 4.6 with the following exceptions:

Table 8.1.1.4.3-1: SoundingRS-RL-ConfigCommon-DEFAULT: UE Rx – Tx time difference for E-UTRAN FDD test requirement

Derivation Path: TS 36.508 [18] clause 4.6.3, Table 4.6.3-21 SoundingRS-UL-ConfigCommon-DEFAULT			
Information Element	Value/remark	Comment	Condition
SoundingRS-UL-ConfigCommon-DEFAULT ::= SEQUENCE {			
setup SEQUENCE {			
srs-BandwidthConfig	bw7 for sub-test 1 bw5 for sub-test 2	Set according to specific sub-test	
srs-SubframeConfig	Sc1		FDD
ackNackSRS-SimultaneousTransmission	FALSE		
srsMaxUpPts	Not present		FDD
}			

Table 8.1.1.4.3-2: SoundingRS-RL-ConfigDedicated-DEFAULT: UE Rx – Tx time difference for E-UTRAN FDD test requirement

Derivation Path: TS 36.508 [18] clause 4.6.3, Table 4.6.3-22 SoundingRS-UL-ConfigDedicated-DEFAULT			
Information Element	Value/remark	Comment	Condition
SoundingRS-UL-ConfigDedicated-DEFAULT ::= CHOICE {			
setup SEQUENCE {			
srs-Bandwidth	bw0	bw0 used with no frequency hopping. bw3 used with frequency hopping	
srs-HoppingBandwidth	hbw0		
freqDomainPosition	0		
duration	TRUE	Indefinite duration	
srs-ConfigIndex	0		
transmissionComb	0		
cyclicShift	cs0	No cyclic shift	
}			

Table 8.1.1.4.3-2a: LPP REQUEST CAPABILITIES: UE Rx – Tx time difference for E-UTRAN FDD test requirement

Information Element	Value/remark
ecid-RequestCapabilities	TRUE

Table 8.1.1.4.3-3: ECID-RequestLocationInformation: UE Rx – Tx time difference for E-UTRAN FDD test requirement

Derivation Path: TS 36.355 clause 6.2			
Information Element	Value/remark	Comment	Condition
LPP-Message ::= SEQUENCE {			
transactionID SEQUENCE {			
Initiator	locationServer		
transactionNumber	1		
}			
endTransaction	FALSE		
sequenceNumber	Not present		

acknowledgement	Not present		
lpp-MessageBody CHOICE {			
c1 CHOICE {			
requestLocationInformation SEQUENCE {			
criticalExtensions CHOICE {			
c1 CHOICE {			
requestLocationInformation-r9 SEQUENCE {			
commonEsRequestLocationInformation SEQUENCE {			
locationInformationType	locationMeasurementsRequired		
triggeredReporting	Not present		
periodicalReporting	Not present		
additionalInformation	onlyReturnInformationRequested		
qos SEQUENCE {			
horizontalAccuracy	Not present		
verticalCoordinateRequest	FALSE		
verticalAccuracy	Not present		
responseTime SEQUENCE {			
time	2		
responseTimeEarlyFix-r12	Not present		Rel-12 onwards
}			
velocityRequest	FALSE		
}			
environment	Not present		
locationCoordinateTypes	Not present		
velocityTypes	Not present		
}			
a-gnss-RequestLocationInformation	Not present		
otdoa-RequestLocationInformation	Not present		
ecid-RequestLocationInformation ::= SEQUENCE {			
requestedMeasurements	0 0 1	ueRxTxReq	
}			
epdu-RequestLocationInformation	Not Present		
}			
}			
}			
}			
}			
}			
}			
}			
}			
}			

Table 8.1.1.4.3-4: ECID-ProvideLocationInformation: UE Rx – Tx time difference for E-UTRAN FDD test requirement

Derivation Path: 36.355 clause 6.2			
Information Element	Value/remark	Comment	Condition
LPP-Message ::= SEQUENCE {			
transactionID SEQUENCE {			
Initiator	locationServer		
transactionNumber	1		
}			
endTransaction	TRUE		
sequenceNumber	(0..255)		
acknowledgement			
lpp-MessageBody CHOICE {			
c1 CHOICE {			
provideLocationInformation SEQUENCE {			
criticalExtensions CHOICE {			
c1 CHOICE {			
provideLocationInformation-r9 SEQUENCE {			

commonIEsProvideLocationInformation	Not present.		
a-gnss-ProvideLocationInformation	Not present		
otdoa-ProvideLocationInformation	Not present		
ecid-ProvideLocationInformation ::= SEQUENCE {			
ecid-SignalMeasurementInformation ::= SEQUENCE {			
primaryCellMeasuredResults	Not Present		
MeasuredResultsList ::= SEQUENCE (SIZE(1..32)) OF MeasuredResultsElement			
MeasuredResultsElement ::= SEQUENCE {			
physCellId			
cellGlobalId			
arfcnEUTRA			
systemFrameNumber			
rsrp-Result	Not Present		
rsrq-Result	Not Present		
ue-RxTxTimeDiff		Set according to specific sub-test and test point.	
}			
}			
}			
epdu-ProvideLocationInformation	Not present		
}			
}			
}			
}			
}			
}			

Table 8.1.1.4.3-5: CQI-ReportConfig-DEFAULT: UE Rx – Tx time difference for E-UTRAN FDD test requirement

Derivation Path: TS 36.508 [18] clause 4.6.3, Table 4.6.3-2 CQI-ReportConfig-DEFAULT			
Information Element	Value/remark	Comment	Condition
CQI-ReportConfig-DEFAULT ::= SEQUENCE {			
cqi-ReportModeAperiodic	rm30	This IE should be omitted for Sub-test 1	
nomPDSCH-RS-EPRE-Offset	0		
cqi-ReportPeriodic CHOICE {			
release	NULL		
}			

8.1.1.5 Test requirement

Table 8.1.1.5-1 defines the primary level settings including test tolerances for all sub-tests.

Table 8.1.1.5-1: FDD UE Rx – Tx time difference test parameters

Parameter	Unit	Sub-test 1	Sub-test 2
E-UTRAN RF Channel Number		1	1
BW _{channel}	MHz	1.4	10
DRX		OFF	
PDSCH Reference measurement channel defined in TS 36.521-3 [25] clause A.1.1		R.2 FDD	R.0 FDD
PDSCH allocation	n_{PRB}	2–3	13–36

PDCCH/PCFICH/PHICH Reference measurement channel defined in TS 36.521-3 [25] clause A.2.1		R.8 FDD	R.6 FDD
OCNG Patterns defined in TS 36.521-3 [25] clause D.1		OP.3 FDD	OP.1 FDD
PBCH_RA	dB	0	0
PBCH_RB	dB		
PSS_RA	dB		
SSS_RA	dB		
PCFICH_RB	dB		
PHICH_RA	dB		
PHICH_RB	dB		
PDCCH_RA	dB		
PDCCH_RB	dB		
PDSCH_RA	dB		
PDSCH_RB	dB		
OCNG_RA ^{Note 1}	dB		
OCNG_RB ^{Note 1}	dB		
N_{oc} ^{Note 2}	dBm/15 kHz	-98	-98
RSRP ^{Note 3}	dBm/15 kHz	-101	-101
\hat{E}_s / N_{oc}	dB	2.7	2.7
I_o ^{Note 3}	dBm/1.08 MHz	-76.55	N/A
	dBm/9 MHz	N/A	-67.35
\hat{E}_s / I_{ot}	dB	-2.7	-2.7
Propagation Condition		AWGN	
<p>Note 1: OCNG shall be used such that the resources in the active cell are fully allocated and a constant total transmitted power spectral density is achieved for all OFDM symbols.</p> <p>Note 2: Interference from other cells and noise sources not specified in the test is assumed to be constant over subcarriers and time and shall be modelled as AWGN of appropriate power for N_{oc} to be fulfilled.</p> <p>Note 3: RSRP and I_o levels have been derived from other parameters for information purposes. They are not settable parameters themselves.</p>			

Table 8.1.1.5-2: Sounding Reference Symbol Configuration to be used in FDD UE Rx – Tx time difference test

Field	Sub-test 1	Sub-test 2	Comment
	Value		
srsBandwidthConfiguration	bw7	bw5	
srsSubframeConfiguration	sc1		
ackNackSrsSimultaneousTransmission	FALSE		
srsMaxUpPTS	N/A		Not applicable for FDD
srsBandwidth	0		No hopping
srsHoppingBandwidth	hbw0		
frequencyDomainPosition	0		
Duration	TRUE		Indefinite duration
Srs-ConfigurationIndex	0		SRS periodicity of 2ms.
transmissionComb	0		
cyclicShift	cs0		No cyclic shift
SRS-AntennaPort	an1		Number of antenna ports used for SRS transmission
Note:	For further information see clause 6.3.2 in 3GPP TS 36.331 [22].		

The UE Rx – Tx time difference measurement accuracy shall fulfil the requirements in Table 8.1.1.5-3.

Table 8.1.1.5-3: Test requirements UE Rx – Tx time difference measurement accuracy requirements

	Sub-test 1	Sub-test 2
Lowest reported value	(Measured value from step 7 - 23) T_s converted to RX-TX_TIME_DIFFERENCE according to Table 4.6.3-1	(Measured value from step 7 - 13) T_s converted to RX-TX_TIME_DIFFERENCE according to Table 4.6.3-1

Highest reported value	(Measured value from step 7 + 23) T_s converted to RX-TX_TIME_DIFFERENCE according to Table 4.6.3-1	(Measured value from step 7 + 13) T_s converted to RX-TX_TIME_DIFFERENCE according to Table 4.6.3-1
------------------------	---	---

NOTE: Each sub-test in table 8.1.1.5-3 has two test points starting at 32 T_s and 5008 T_s .

The test tolerances are defined in Annex C.

For the overall test to pass, the ratio of successful reported values in each test point of each sub-test shall be more than 90% with a confidence level of 95%. In the case that 1.4 MHz channel bandwidth is not defined for the operating band under test then Sub-test 1 shall be omitted.

8.1.1A E-UTRAN FDD UE Rx – Tx time difference case (Rel-12 onwards)

8.1.1A.1 Test purpose

Same as defined in clause 8.1.1.1.

8.1.1A.2 Test applicability

This test applies to all types of E-UTRA FDD UE release 12 onwards that supports ECID positioning.

8.1.1A.3 Minimum conformance requirements

Same as defined in clause 8.1.1.3 except that Table 8.1.1A.3-1 replaces Table 8.1.1.3-1.

Table 8.1.1A.3-1: UE Rx – Tx time difference measurement accuracy from Release 12 onwards

Accuracy	Conditions				
	\hat{E}_s/lot	Downlink bandwidth	I_o ^{Note 1} range		
			E-UTRA operating band groups ^{Note 6}	Minimum I_o	Maximum I_o
T_s ^{Note 2}	dB	MHz		dBm/15kHz ^{Note 5}	dBm/BW _{Channel}
±20	≥-3 dB	≥1.4 MHz	FDD_A ^{Note 7} , TDD_A	-121	-50
			FDD_B	-120.5	-50
			FDD_C, TDD_C	-120	-50
			FDD_D	-119.5	-50
			FDD_E, TDD_E	-119	-50
			FDD_F	-118.5	-50
			FDD_G ^{Note 4}	-118	-50
			FDD_H	-117.5	-50
			FDD_N	-114.5	-50
±14	≥-3 dB	≥ 3 MHz	Note 3	Note 3	Note 3
±10	≥-3 dB	≥ 5 MHz	Note 3	Note 3	Note 3
±7	≥-3 dB	≥10 MHz	Note 3	Note 3	Note 3

NOTE 1: When in dBm/15kHz, the minimum I_o condition is expressed as the average I_o per RE over all REs in that symbol. I_o may be different in different symbols within a subframe.
 NOTE 2: T_s is the basic timing unit defined in TS 36.211 [26].
 NOTE 3: The same bands and the same I_o conditions for each band apply for this requirement as for the corresponding requirement with downlink bandwidth ≥1.4 MHz.
 NOTE 4: Except Band 29.
 NOTE 5: The condition level is increased by $\Delta > 0$, when applicable, as described in TS 36.521-3 [25] Sections I.4.2 and I.4.3.
 NOTE 6: E-UTRA operating band groups are as defined in Section 4.4.2.
 NOTE 7: Except Band 32.

8.1.1A.4 Test description

Same as defined in clause 8.1.1.4.

8.1.1A.4.1 Initial conditions

Same as defined in clause 8.1.1.4.1.

8.1.1A.4.2 Test procedure

Same as defined in clause 8.1.1.4.2.

8.1.1A.4.3 Message contents

Same as defined in clause 8.1.1.4.3.

8.1.1A.5 Test requirement

Same as defined in clause 8.1.1.5 except that Table 8.1.1A.5-3 replaces Table 8.1.1.5-3.

Table 8.1.1A.5-3: Test requirements UE Rx – Tx time difference measurement accuracy requirements

	Sub-test 1	Sub-test 2
Lowest reported value	(Measured value from step 7 - 23) T_s converted to RX-TX_TIME_DIFFERENCE according to Table 4.6.3-1	(Measured value from step 7 - 10) T_s converted to RX-TX_TIME_DIFFERENCE according to Table 4.6.3-1
Highest reported value	(Measured value from step 7 + 23) T_s converted to RX-TX_TIME_DIFFERENCE according to Table 4.6.3-1	(Measured value from step 7 + 10) T_s converted to RX-TX_TIME_DIFFERENCE according to Table 4.6.3-1

8.1.1B E-UTRAN FDD UE Rx – Tx time difference case for UE Category 1bis

8.1.1B.1 Test purpose

Same as defined in clause 8.1.1.1.

8.1.1B.2 Test applicability

This test applies to all types of E-UTRA FDD UE release 13 onwards of category 1bis that supports ECID positioning.

8.1.1B.3 Minimum conformance requirements

Same as defined in clause 8.1.1A.3.

8.1.1B.4 Test description

Same as defined in clause 8.1.1.4.

8.1.1B.4.1 Initial conditions

Same as defined in clause 8.1.1.4.1.

8.1.1B.4.2 Test procedure

Same as defined in clause 8.1.1.4.2.

8.1.1B.4.3 Message contents

Same as defined in clause 8.1.1.4.3.

8.1.1B.5 Test requirement

Same as defined in clause 8.1.1A.5 except that the Cell Antenna Configuration is 1x1 instead of the default 1x2.

8.1.2 E-UTRAN TDD UE Rx – Tx time difference case (Rel-9 to Rel-11)

8.1.2.1 Test purpose

The purpose of this test is to verify that the E-UTRAN TDD UE Rx – Tx time difference measurement accuracy is within the specified limits in TS 36.133 [23] clause 9.1.9.

8.1.2.2 Test applicability

This test applies to all types of E-UTRA TDD UE release 9 to release 11 with LPP release 13 onwards that supports ECID positioning. Note that for LPP releases before release 13 the UE TDD Rx - Tx time difference measurement report mapping is ambiguous and therefore this test shall not be used.

8.1.2.3 Minimum conformance requirements

NOTE: This measurement is used for UE positioning purposes.

The UE RX-TX time difference is measured from the PCell.

The accuracy requirements in Table 8.1.1.3-1 are valid under the following conditions:

Cell specific reference signals are transmitted either from one, two or four antenna ports.

Conditions defined in TS 36.101 [2] clause 7.3 for reference sensitivity are fulfilled.

No changes to the uplink transmission timing are applied during the measurement period.

$RSRP_{dBm}$ according to clause E.1 for a corresponding Band.

The normative reference for this requirement is TS 36.133 [23] clause 9.1.9 and A.9.7.1.

8.1.2.4 Test description

The test consists of two sub-tests; the difference between the sub-tests is the bandwidth, 1.4 MHz and 10 MHz. Each sub-test has two test points with time delays starting at $32 T_s$ and $5008 T_s$ respectively. There is only one active cell in the tests. The tested UE is connected with the serving cell, configured to transmit SRS signals periodically, and signalled to report UE Rx – Tx time difference measurement. The test equipment measures the transmit timing of the UE using the transmitted SRS. The test equipment then compares this timing to the UE Rx-Tx measurement reported by the UE.

8.1.2.4.1 Initial conditions

Test Environment: Normal as defined in TS 36.508 [18] clause 4.1.

Frequencies to be tested: Mid Range, as defined in TS 36.508 [18] clause 4.3.1.2.

Channel Bandwidth to be tested: 1.4 and 10 MHz. In the case that 1.4 MHz channel bandwidth is not defined for the operating band under test, as defined in TS 36.101 [2] clause 5.6.1, then the corresponding sub-test shall be omitted.

1. Connect the SS (node B emulator) and AWGN noise source to the UE antenna connectors as shown in Annex A figure A.5a for 4RX capable UE without any 2RX bands. Otherwise use Annex A figure A.5.
2. Propagation conditions are set according to clause 4.6.2.1.
3. Message contents are defined in clause 8.1.2.4.3.
4. Cell 1 is the serving cell. Cell 1 is the cell used for connection setup with the power levels set according to TS 36.521-3 [25] clauses C.0 and C.1 for this test.

8.1.2.4.2 Test procedure

1. Bring the UE to State 3A or 3A-RF according to TS 36.508 [18] clause 4.5.3A or 5.2A.2, using a value of initial timing advance command $T_A = 2$ in the Random Access Response which indicates an initial timing advance value $N_{TA} = 32 T_s$. Note that in the remainder of the test the timing advance command $T_A = 31$ which indicates a timing advance adjustment value $N_{TA} = 0 T_s$.
2. Set the parameters according to Sub-test 1 in Tables 8.1.2.5-1 and 8.1.5.2-2 as appropriate. Propagation conditions are set according to clause 4.6.2.1.
3. The SS adjusts the downlink timing for Cell 1 to a delay of $+8 T_s$, compared to the current value.
4. Wait for 1.6 s to allow for the possibility that the UE makes autonomous timing adjustments.
- 4a. The SS shall transmit an LPP REQUEST CAPABILITIES message.
- 4b. The UE shall transmit an LPP PROVIDE CAPABILITIES message indicating the ECID capabilities supported by the UE in the *ECID-ProvideCapabilities* IE. The IE *ueRxTxSupTDD-r13* shall be present (TRUE).
5. The SS shall transmit a LPP REQUEST LOCATION INFORMATION message, including the *ECID-RequestLocationInformation* IE. If the UE message at step 4b includes the *ackRequested* IE set to TRUE, then the SS shall send an acknowledgment in the LPP REQUEST LOCATION INFORMATION message.
6. The UE shall transmit an LPP PROVIDE LOCATION INFORMATION message including the *ecid-SignalMeasurementInformation* IE.
7. As soon as possible after step 6 the SS shall measure the transmit timing of the UE using the transmitted SRS, relative to the current downlink timing.
8. If the UE message at step 6 includes the *ackRequested* IE set to TRUE, then the SS shall send a LPP acknowledgment message.
9. The SS shall check the reported value of *ue-RxTxTimeDiff* in the *ecid-SignalMeasurementInformation* IE provided by the UE in step 6 and compare it with the value measured in step 7. The SS shall check that the reported values are within the limits specified in table 8.1.2.5-3 for Sub-test 1 compared to the measured value. If the reported value is within the limits the number of successful results for “Sub-test 1 – Test point 1” is increased by one. If the reported value is not within the limits, or the UE reports an error in the LPP PROVIDE LOCATION INFORMATION message in step 6, or does not respond at step 6 within the time given by the *time* IE in the *ECID-RequestLocationInformation* IE in step 5, then the number of unsuccessful results for “Sub-test 1 – Test point 1” is increased by one.
10. Repeat steps 3-9 until the confidence level according to Annex D.4.3 is achieved.
NOTE: To avoid a large divergence between the sent TA and the set downlink timing, the SS may reset the downlink timing for Cell 1 to its initial value after a certain amount of loops. The loop during the reset does not count for the result statistics.
11. Repeat steps 1-10 for “Sub-test 1 – Test point 2”. Set a value of initial timing advance command $T_A = 313$ in the Random Access Response which indicates an initial timing advance value $N_{TA} = 5008 T_s$ in step 1.
12. Repeat steps 1-11 for Sub-test 2 (consisting of Test point 1 and Test point 2) in Tables 8.1.2.5-1 and 8.1.2.5-2 as appropriate. In step 3 the SS adjusts the downlink timing for Cell 1 to a delay of $+4 T_s$ compared to the current value.

If both test points of a sub-test pass, the sub-test passes. If one test point of a sub-test fails, the sub-test fails.

If all (applicable) sub-tests pass, the whole test passes. If one (applicable) sub-test fails, the whole test fails.

8.1.2.4.3 Message contents

Message contents are according to TS 36.508 [18] clause 4.6 with the following exceptions:

Table 8.1.2.4.3-1: SoundingRS-RL-ConfigCommon-DEFAULT: UE Rx – Tx time difference for E-UTRAN TDD test requirement

Derivation Path: TS 36.508 [18] clause 4.6.3, Table 4.6.3-21 SoundingRS-UL-ConfigCommon-DEFAULT

Information Element	Value/remark	Comment	Condition
SoundingRS-UL-ConfigCommon-DEFAULT ::= SEQUENCE {			
setup SEQUENCE {			
srs-BandwidthConfig	bw7 for sub-test 1 bw5 for sub-test 2	Set according to specific sub-test	
srs-SubframeConfig	Sc1		TDD
ackNackSRS-SimultaneousTransmission	FALSE		
srsMaxUpPts	TRUE		TDD
}			

Table 8.1.2.4.3-2: SoundingRS-RL-ConfigDedicated-DEFAULT: UE Rx – Tx time difference for E-UTRAN TDD test requirement

Derivation Path: TS 36.508 [18] clause 4.6.3, Table 4.6.3-22 SoundingRS-UL-ConfigDedicated-DEFAULT

Information Element	Value/remark	Comment	Condition
SoundingRS-UL-ConfigDedicated-DEFAULT ::= CHOICE {			
setup SEQUENCE {			
srs-Bandwidth	bw0	bw0 used with no frequency hopping. bw3 used with frequency hopping	
srs-HoppingBandwidth	hbw0		
freqDomainPosition	0		
duration	TRUE	Indefinite duration	
srs-ConfigIndex	10		
transmissionComb	0		
cyclicShift	cs0	No cyclic shift	
}			

Table 8.1.2.4.3-2a: LPP REQUEST CAPABILITIES: UE Rx – Tx time difference for E-UTRAN TDD test requirement

Information Element	Value/remark
ecid-RequestCapabilities	TRUE

Table 8.1.2.4.3-2b: LPP PROVIDE CAPABILITIES: UE Rx – Tx time difference for E-UTRAN TDD test requirement

Information Element	Value/remark
ueRxTxSupTDD-r13	TRUE

Table 8.1.2.4.3-3: ECID-RequestLocationInformation: UE Rx – Tx time difference for E-UTRAN TDD test requirement

Derivation Path: TS 36.355 clause 6.2

Information Element	Value/remark	Comment	Condition
LPP-Message ::= SEQUENCE {			
transactionID SEQUENCE {			
Initiator	locationServer		
transactionNumber	1		
}			
endTransaction	FALSE		
sequenceNumber	Not present		
acknowledgement	Not present		
lpp-MessageBody CHOICE {			
c1 CHOICE {			
requestLocationInformation SEQUENCE {			
criticalExtensions CHOICE {			

c1 CHOICE {			
requestLocationInformation-r9 SEQUENCE {			
commonIEsRequestLocationInformation SEQUENCE {			
locationInformationType	locationMeasurementsRequired		
triggeredReporting	Not present		
periodicalReporting	Not present		
additionalInformation	onlyReturnInformationRequested		
qos SEQUENCE {			
horizontalAccuracy	Not present		
verticalCoordinateRequest	FALSE		
verticalAccuracy	Not present		
responseTime SEQUENCE {			
time	2		
responseTimeEarlyFix-r12	Not present		Rel-12 onwards
}			
velocityRequest	FALSE		
}			
environment	Not present		
locationCoordinateTypes	Not present		
velocityTypes	Not present		
}			
a-gnss-RequestLocationInformation	Not present		
otdoa-RequestLocationInformation	Not present		
ecid-RequestLocationInformation ::= SEQUENCE {			
requestedMeasurements	0 0 1	ueRxTxReq	
}			
epdu-RequestLocationInformation	Not Present		
}			
}			
}			
}			
}			
}			
}			
}			
}			
}			

Table 8.1.2.4.3-4: ECID-ProvideLocationInformation: UE Rx – Tx time difference for E-UTRAN TDD test requirement

Derivation Path: 36.355 clause 6.2			
Information Element	Value/remark	Comment	Condition
LPP-Message ::= SEQUENCE {			
transactionID SEQUENCE {			
initiator	locationServer		
transactionNumber	1		
}			
endTransaction	TRUE		
sequenceNumber	(0..255)		
acknowledgement			
lpp-MessageBody CHOICE {			
c1 CHOICE {			
provideLocationInformation SEQUENCE {			
criticalExtensions CHOICE {			
c1 CHOICE {			
provideLocationInformation-r9 SEQUENCE {			
commonIEsProvideLocationInformation	Not present.		
a-gnss-ProvideLocationInformation	Not present		
otdoa-ProvideLocationInformation	Not present		
ecid-ProvideLocationInformation ::= SEQUENCE {			

acid-SignalMeasurementInformation ::= SEQUENCE {			
primaryCellMeasuredResults	Not Present		
MeasuredResultsList ::= SEQUENCE (SIZE(1..32)) OF MeasuredResultsElement			
MeasuredResultsElement ::= SEQUENCE {			
physCellId			
cellGlobalId			
arfcnEUTRA			
systemFrameNumber			
rsrp-Result	Not Present		
rsrq-Result	Not Present		
ue-RxTxTimeDiff		Set according to specific sub-test and test point.	
}			
}			
}			
epdu-ProvideLocationInformation	Not present		
}			
}			
}			
}			
}			

Table 8.1.2.4.3-5: CQI-ReportConfig-DEFAULT: UE Rx – Tx time difference for E-UTRAN TDD test requirement

Derivation Path: TS 36.508 [18] clause 4.6.3, Table 4.6.3-2 CQI-ReportConfig-DEFAULT			
Information Element	Value/remark	Comment	Condition
CQI-ReportConfig-DEFAULT ::= SEQUENCE {			
cqi-ReportModeAperiodic	rm30	This IE should be omitted for Sub-test 1	
nomPDSCH-RS-EPRE-Offset	0		
cqi-ReportPeriodic CHOICE {			
release	NULL		
}			

8.1.2.5 Test requirement

Table 8.1.2.5-1 defines the primary level settings including test tolerances for all sub-tests.

Table 8.1.2.5-1: Cell specific test parameters for UE Rx-Tx time difference measurement

Parameter	Unit	Sub-test 1	Sub-test 2
E-UTRAN RF Channel Number	-	1	1
BW _{channel}	MHz	1.4	10
Uplink-downlink configuration of cell ^{Note 1}		1	1
Special subframe configuration of cell ^{Note 1}		6	6
PDSCH Reference measurement channel defined in TS 36.521-3 [25] clause A.1.2	-	R.2 TDD	R.0 TDD
PDSCH allocation	<i>n_{PRB}</i>	2-3	13-36
PDCCH/PCFICH/PHICH Reference measurement channel defined in TS 36.521-3 [25] clause A.2.2	-	R.8 TDD	R.6 TDD
OCNG Patterns defined in TS 36.521-3 [25] clause D.2	-	OP.3 TDD	OP.1 TDD
PBCH_RA	dB	0	0
PBCH_RB	dB		
PSS_RA	dB		

SSS_RA	dB		
PCFICH_RB	dB		
PHICH_RA	dB		
PHICH_RB	dB		
PDCCH_RA	dB		
PDCCH_RB	dB		
PDSCH_RA	dB		
PDSCH_RB	dB		
OCNG_RA ^{Note 2}	dB		
OCNG_RB ^{Note 2}	dB		
N_{oc} ^{Note 3}	dBm/15 kHz	-98	-98
RSRP ^{Note 4}	dBm/15 kHz	-100.7	-100.7
\hat{E}_s/N_{oc}	dB	-2.7	-2.7
I_o ^{Note 4}	dBm/1.08 MHz	-77.55	N/A
	dBm/9 MHz	N/A	-67.35
\hat{E}_s/I_{ot}	dB	-2.7	-2.7
Propagation Condition		AWGN	
Note 1: For special subframe and uplink-downlink configurations see Tables 4.2-1 and 4.2-2 in 3GPP TS 36.211 [26].			
Note 2: OCNG shall be used such that the cell is fully allocated and a constant total transmitted power spectral density is achieved for all OFDM symbols.			
Note 3: Interference from other cells and noise sources not specified in the test is assumed to be constant over subcarriers and time and shall be modelled as AWGN of appropriate power for N_{oc} to be fulfilled.			
Note 4: RSRP and I_o levels have been derived from other parameters for information purposes. They are not settable parameters themselves.			

Table 8.1.2.5-2: Sounding Reference Symbol Configuration to be used in TDD UE Rx – Tx time difference test

Field	Sub-test 1	Sub-test 2	Comment
	Value		
srsBandwidthConfiguration	bw7	bw5	
srsSubframeConfiguration	sc1		
ackNackSrsSimultaneousTransmission	FALSE		
srsMaxUpPTS	TRUE		
srsBandwidth	0		No hopping
srsHoppingBandwidth	hbw0		
frequencyDomainPosition	0		
Duration	TRUE		Indefinite duration
Srs-ConfigurationIndex	10		SRS periodicity of 10ms.
transmissionComb	0		
cyclicShift	cs0		No cyclic shift
SRS-AntennaPort	an1		Number of antenna ports used for SRS transmission
Note: For further information see clause 6.3.2 in 3GPP TS 36.331 [22].			

The UE Rx – Tx time difference measurement accuracy shall fulfil the requirements in Table 8.1.2.5-3.

Table 8.1.2.5-3: Test requirements UE Rx – Tx time difference measurement accuracy requirements

	Sub-test 1	Sub-test 2
Lowest reported value	(Measured value from step 7 - 23) T_s converted to RX-TX_TIME_DIFFERENCE according to Table 4.6.3-2	(Measured value from step 7 - 13) T_s converted to RX-TX_TIME_DIFFERENCE according to Table 4.6.3-2
Highest reported value	(Measured value from step 7 + 23) T_s converted to RX-TX_TIME_DIFFERENCE according to Table 4.6.3-2	(Measured value from step 7 + 13) T_s converted to RX-TX_TIME_DIFFERENCE according to Table 4.6.3-2

NOTE: Each sub-test in table 8.1.2.5-3 has two test points starting at 32 T_s and 5008 T_s .

The test tolerances are defined in Annex C.

For the overall test to pass, the ratio of successful reported values in each test point of each sub-test shall be more than 90% with a confidence level of 95%. In the case that 1.4 MHz channel bandwidth is not defined for the operating band under test then Sub-test 1 shall be omitted.

8.1.2A E-UTRAN TDD UE Rx – Tx time difference case (Rel-12 onwards)

8.1.2A.1 Test purpose

Same as defined in clause 8.1.2.1.

8.1.2A.2 Test applicability

This test applies to all types of E-UTRA TDD UE release 12 onwards with LPP release 13 onwards that supports ECID positioning. Note that for LPP releases before release 13 the UE TDD Rx - Tx time difference measurement report mapping is ambiguous and therefore this test shall not be used.

8.1.2A.3 Minimum conformance requirements

Same as defined in clause 8.1.2.3 except that Table 8.1.1A.3-1 replaces Table 8.1.1.3-1.

8.1.2A.4 Test description

Same as defined in clause 8.1.2.4.

8.1.2A.4.1 Initial conditions

Same as defined in clause 8.1.2.4.1.

8.1.2A.4.2 Test procedure

Same as defined in clause 8.1.2.4.2.

8.1.2A.4.3 Message contents

Same as defined in clause 8.1.2.4.3.

8.1.2A.5 Test requirement

Same as defined in clause 8.1.2.5 except that Table 8.1.2A.5-3 replaces Table 8.1.2.5-3.

Table 8.1.2A.5-3: Test requirements UE Rx – Tx time difference measurement accuracy requirements

	Sub-test 1	Sub-test 2
Lowest reported value	(Measured value from step 7 - 23) T_s converted to RX-TX_TIME_DIFFERENCE according to Table 4.6.3-2	(Measured value from step 7 - 10) T_s converted to RX-TX_TIME_DIFFERENCE according to Table 4.6.3-2
Highest reported value	(Measured value from step 7 + 23) T_s converted to RX-TX_TIME_DIFFERENCE according to Table 4.6.3-2	(Measured value from step 7 + 10) T_s converted to RX-TX_TIME_DIFFERENCE according to Table 4.6.3-2

8.1.2B E-UTRAN TDD UE Rx – Tx time difference case for UE Category 1bis

8.1.2B.1 Test purpose

Same as defined in clause 8.1.2.1.

8.1.2B.2 Test applicability

This test applies to all types of E-UTRA TDD UE release 13 onwards of category 1bis that supports ECID positioning.

8.1.2B.3 Minimum conformance requirements

Same as defined in clause 8.1.2A.3.

8.1.2B.4 Test description

Same as defined in clause 8.1.2.4.

8.1.2B.4.1 Initial conditions

Same as defined in clause 8.1.2.4.1.

8.1.2B.4.2 Test procedure

Same as defined in clause 8.1.2.4.2.

8.1.2B.4.3 Message contents

Same as defined in clause 8.1.2.4.3.

8.1.2B.5 Test requirement

Same as defined in clause 8.1.2A.5 except that the Cell Antenna Configuration is 1x1 instead of the default 1x2.

8.1.3 E-UTRAN FDD UE Rx–Tx Time Difference under Time-Domain Measurement Resource Restriction with Non-MBSFN ABS (eICIC)

8.1.3.1 Test purpose

To verify that the E-UTRAN FDD UE Rx – Tx time difference measurement accuracy is within the specified limits under a time-domain measurement resource restriction pattern, and when non-MBSFN ABS is configured in the interfering cells.

8.1.3.2 Test applicability

This test applies to all types of E-UTRA FDD UE release 10 and ECID positioning. Applicability requires support for FGI bit 115.

8.1.3.3 Minimum conformance requirements

NOTE: This measurement is used for UE positioning purposes.

The requirements in this section apply for UE configured with a time-domain measurement resource restriction pattern for PCell measurements. The UE Rx-Tx time difference is measured from the Pcell.

The accuracy requirements in Table 8.1.3.3-1 are valid under the following conditions:

- Cell specific reference signals are transmitted either from one, two or four antenna ports,
 - Conditions defined in 36.101[2] Clause 7.3 for reference sensitivity are fulfilled,
 - No changes to the uplink transmission timing are applied during the measurement period,
- RSRP_{dBm} according to Annex E.4 for a corresponding Band,
- The time domain measurement resource restriction pattern configured for the PCell indicates at least one subframe per radio frame for performing the PCell measurements,
 - Four symbols containing CRS are available in all subframes indicated by the time domain measurement resource restriction pattern.

Table 8.1.3.3-1: UE Rx–Tx time difference measurement accuracy under time domain measurement resource restriction

Accuracy	Conditions				
	Ês/lot ^{Note 6}	Downlink transmission bandwidth of PCell	I _o ^{Note 1, 5} range		
			E-UTRA operating band groups ^{Note 8}	Minimum I _o	Maximum I _o
T _s ^{Note 2}	dB	MHz		dBm/15kHz ^{Note 7}	dBm/BW _{Channel}
±20	≥-3 dB	≤ 3 MHz	FDD_A ^{Note 9} , TDD_A	-121	-50
			FDD_B	-120.5	-50
			FDD_C, TDD_C	-120	-50
			FDD_D	-119.5	-50
			FDD_E, TDD_E	-119	-50
			FDD_F	-118.5	-50
			FDD_G ^{Note 4}	-118	-50
			FDD_H	-117.5	-50
±10	≥-3 dB	≥ 5 MHz	Note 3	Note 3	Note 3

NOTE 1: When in dBm/15kHz, the minimum I_o condition is expressed as the average I_o per RE over all REs in that symbol. I_o may be different in different symbols within a subframe.

NOTE 2: T_s is the basic timing unit defined in TS 36.211.

NOTE 3: The same bands and the same I_o conditions for each band apply for this requirement as for the corresponding requirement with downlink bandwidth ≤ 3 MHz.

NOTE 4: Except Band 29.

NOTE 5: I_o is defined for the subframes indicated by the time-domain measurement resource restriction pattern for serving cell measurements. The specified I_o range applies to CRS and non-CRS symbols. I_o may be different in different symbols within a subframe.

NOTE 6: CRS Ês/lot is in subframes indicated for PCell measurements by the time-domain measurement resource restriction pattern.

NOTE 7: The condition level is increased by Δ>0, when applicable, as described in TS 36.521-3 [25] Sections I.4.2 and I.4.3.

NOTE 8: E-UTRA operating band groups are as defined in Section 4.4.2.

NOTE 9: Except Band 32.

NOTE: It is up to the UE implementation whether the UE Rx-Tx time difference measurement is performed in any subframe or in subframes indicated by the time-domain measurement resource restriction pattern.

The normative reference for this requirement is TS 36.133 [23] clause 9.1.9.3 and A.9.7.3.

8.1.3.4 Test description

The test has two test points with time delays starting at 32 T_s and 5008 T_s, respectively.

In this test case, there are two synchronous cells, Cell 1 and Cell 2, on the same RF channel. Cell 1 is the PCell on which UE Rx-Tx is measured, and Cell 2 is the interfering cell. Non-MBSFN ABS pattern is configured in Cell 2 during the entire test.

The tested UE is connected to the PCell and configured to transmit SRS signals periodically. The SRS configuration is provided to the UE before the measurement starts. The UE is configured to report UE Rx–Tx time difference measurement. The test equipment measures the transmit timing of the UE using the transmitted SRS, and measures the

receive timing using the downlink CRS. The test equipment then compares the difference of these two timings to the UE Rx-Tx measurement reported by the UE. The UE is configured by higher layers via Cell 1 with a time-domain measurement resource restriction pattern for performing E-UTRAN FDD intra-frequency measurements on PCell. The information for both patterns shall be provided to the UE before the measurement starts.

8.1.3.4.1 Initial conditions

Test Environment: Normal as defined in TS 36.508 [18] clause 4.1.

Frequencies to be tested: According to TS 36.521-1 [24] Annex E table E-1 and TS 36.508 [18] clauses 4.4.2 and 4.3.1.

Channel Bandwidth to be tested: 10 MHz as defined in TS 36.508 [18] clause 4.3.1.

1. Connect the SS (node B emulator) and AWGN noise source to the UE antenna connectors as shown in TS 36.508 [18] Annex A figure A.54 (without faders).
2. Propagation conditions are set according to clause 4.6.2.1.
3. Message contents are defined in clause 8.1.3.4.3.
4. Cell 1 is the serving cell. Cell 1 is the cell used for connection setup with the power levels set according to TS 36.521-3 [25] clauses C.0 and C.1 for this test. Cell 2 is the neighbour cells. Both cells are on the same RF channel.

Table 8.1.3.4.1-1: General test parameters for FDD UE Rx–Tx time difference measurement under time-domain measurement resource restriction with non-MBSFN ABS

Parameter	Unit	Value	Comment
Serving cell (PCell)		Cell 1	The measured cell
Neighbour cell		Cell 2	The cell interfering to Cell 1
PCell ABS configuration		Non-MBSFN ABS	As defined in TS 36.521-3 [25] Table C.3.1.1.1-1
E-UTRA RF Channel Number		1	One FDD carrier frequency is used
Downlink Channel Bandwidth (BW _{channel})	MHz	10	For both cells in the test
CP length		Normal	For both cells in the test
DRX			OFF
Time offset between cells	μs	3	Synchronous cells
Physical cell ID PCI		$(PCI_{cell1} - PCI_{cell2}) \bmod 6 \neq 0$	Cell PCIs for Cell 1 and Cell 2 are selected randomly so that the condition is met
ABS pattern		'10000000100000001000000000001000000010000000'	Non-MBSFN ABS. FDD ABS Pattern Info IE, as defined in TS 36.423 [35], clause 9.2.54. Configured in Cell 2. The first/leftmost bit corresponds to the subframe #0 of a radio frame satisfying SFN mod 40 = 0. No MBSFN subframes are configured in Cell 1 or Cell 2 during the ABS subframes of Cell 2.
Time-domain measurement resource restriction pattern for serving cell measurements		'10000000100000001000000000001000000010000000'	Configured for measurements on Cell 1.

8.1.3.4.2 Test procedure

1. Bring the UE to State 3A or 3A-RF according to TS 36.508 [18] clause 4.5.3A or 5.2A.2 with exceptions listed in 7.2A.6, using a value of initial timing advance command $T_A = 2$ in the Random Access Response which indicates an initial timing advance value $N_{TA} = 32 T_s$. Note that in the remainder of the test the timing advance command $T_A = 31$ which indicates a timing advance adjustment value $N_{TA} = 0 T_s$.
2. Set the parameters according to Tables 8.1.3.5-1 and 8.1.3.5-2. Propagation conditions are set according to clause 4.6.2.1.
3. The SS adjusts the downlink timing for Cell 1 to a delay of $+4 T_s$, compared to the current value.

4. Wait for 1.6 s to allow for the possibility that the UE makes autonomous timing adjustments.
5. The SS shall transmit an LPP REQUEST CAPABILITIES message.
6. The UE shall transmit an LPP PROVIDE CAPABILITIES message indicating the ECID capabilities supported by the UE in the *ECID-ProvideCapabilities* IE.
7. The SS shall transmit an LPP REQUEST LOCATION INFORMATION message, including the *ECID-RequestLocationInformation* IE. If the UE message at step 6 includes the *ackRequested* IE set to TRUE, then the SS shall send an acknowledgment in the LPP REQUEST LOCATION INFORMATION message.
8. The UE shall transmit an LPP PROVIDE LOCATION INFORMATION message including the *ecid-SignalMeasurementInformation* IE.
9. As soon as possible after step 8 the SS shall measure the transmit timing of the UE using the transmitted SRS, relative to the current downlink timing.
10. If the UE message at step 8 includes the *ackRequested* IE set to TRUE, then the SS shall send a LPP acknowledgment message.
11. The SS shall check the reported value of *ue-RxTxTimeDiff* in the *ecid-SignalMeasurementInformation* IE provided by the UE in step 8 and compare it with the value measured in step 9. The SS shall check that the reported value is within the limits specified in table 8.1.3.5-3 compared to the measured value. If the reported value is within the limits the number of successful results for the test point is increased by one. If the reported value is not within the limits, or the UE reports an error in the LPP PROVIDE LOCATION INFORMATION message in step 6, or does not respond at step 8 within the time given by the *responseTime* IE in the *ECID-RequestLocationInformation* IE in step 7, then the number of unsuccessful results for the test point test is increased by one.
12. Repeat steps 3-11 until the confidence level according to Annex D.4.3 is achieved.
NOTE: To avoid a large divergence between the sent TA and the set downlink timing, the SS may reset the downlink timing for Cell 1 to its initial value after a certain amount of loops. The loop during the reset does not count for the result statistics.
13. Repeat steps 1-12 for test point 2.

8.1.3.4.3 Message contents

Table 8.1.3.4.3-1: SoundingRS-RL-ConfigCommon-DEFAULT: FDD UE Rx–Tx time difference measurement under time-domain measurement resource restriction with non-MBSFN ABS (eICIC)

Derivation Path: TS 36.508 [18] clause 4.6.3, Table 4.6.3-21 SoundingRS-UL-ConfigCommon-DEFAULT			
Information Element	Value/remark	Comment	Condition
SoundingRS-UL-ConfigCommon-DEFAULT ::= SEQUENCE {			
setup SEQUENCE {			
srs-BandwidthConfig	bw5		
srs-SubframeConfig	sc1		FDD
ackNackSRS-SimultaneousTransmission	FALSE		
srsMaxUpPts	Not present		FDD
}			
}			

Table 8.1.3.4.3-2: SoundingRS-RL-ConfigDedicated-DEFAULT: FDD UE Rx–Tx time difference measurement under time-domain measurement resource restriction with non-MBSFN ABS (eICIC)

Derivation Path: TS 36.508 [18] clause 4.6.3, Table 4.6.3-22 SoundingRS-UL-ConfigDedicated-DEFAULT			
Information Element	Value/remark	Comment	Condition
SoundingRS-UL-ConfigDedicated-DEFAULT ::= CHOICE {			
setup SEQUENCE {			
srs-Bandwidth	bw0		
srs-HoppingBandwidth	hbw0		
freqDomainPosition	0		

duration	TRUE	Indefinite duration	
srs-ConfigIndex	0		
transmissionComb	0		
cyclicShift	cs0	No cyclic shift	
}			
}			

Table 8.1.3.4.3-3: LPP REQUEST CAPABILITIES: FDD UE Rx–Tx time difference measurement under time-domain measurement resource restriction with non-MBSFN ABS (eICIC)

Information Element	Value/remark
ecid-RequestCapabilities	TRUE

Table 8.1.3.4.3-4: ECID-RequestLocationInformation: FDD UE Rx–Tx time difference measurement under time-domain measurement resource restriction with non-MBSFN ABS (eICIC)

Derivation Path: TS 36.355 [4] clause 6.2			
Information Element	Value/remark	Comment	Condition
LPP-Message ::= SEQUENCE {			
transactionID SEQUENCE {			
Initiator	locationServer		
transactionNumber	1		
}			
endTransaction	FALSE		
sequenceNumber	Not present		
acknowledgement	Not present		
lpp-MessageBody CHOICE {			
c1 CHOICE {			
requestLocationInformation SEQUENCE {			
criticalExtensions CHOICE {			
c1 CHOICE {			
requestLocationInformation-r9 SEQUENCE {			
commonEsRequestLocationInformation SEQUENCE {			
locationInformationType	locationMeasurementsRequired		
triggeredReporting	Not present		
periodicalReporting	Not present		
additionalInformation	onlyReturnInformationRequested		
qos SEQUENCE {			
horizontalAccuracy	Not present		
verticalCoordinateRequest	FALSE		
verticalAccuracy	Not present		
responseTime SEQUENCE {			
time	2		
responseTimeEarlyFix-r12	Not present		Rel-12 onwards
}			
velocityRequest	FALSE		
}			
environment	Not present		
locationCoordinateTypes	Not present		
velocityTypes	Not present		
}			
a-gnss-RequestLocationInformation	Not present		
otdoa-RequestLocationInformation	Not present		
ecid-RequestLocationInformation ::= SEQUENCE {			
requestedMeasurements	0 0 1	ueRxTxReq	
}			
epdu-RequestLocationInformation	Not Present		
}			

}			
}			
}			
}			
}			
}			

Table 8.1.3.4.3-5: ECID-ProvideLocationInformation: FDD UE Rx-Tx time difference measurement under time-domain measurement resource restriction with non-MBSFN ABS (eICIC)

Derivation Path: TS 36.355 [4] clause 6.2			
Information Element	Value/remark	Comment	Condition
LPP-Message ::= SEQUENCE {			
transactionID SEQUENCE {			
Initiator	locationServer		
transactionNumber	1		
}			
endTransaction	TRUE		
sequenceNumber	(0..255)		
acknowledgement			
lpp-MessageBody CHOICE {			
c1 CHOICE {			
provideLocationInformation SEQUENCE {			
criticalExtensions CHOICE {			
c1 CHOICE {			
provideLocationInformation-r9 SEQUENCE {			
commonIEsProvideLocationInformation	Not present.		
a-gnss-ProvideLocationInformation	Not present		
otdoa-ProvideLocationInformation	Not present		
ecid-ProvideLocationInformation ::=			
SEQUENCE {			
ecid-SignalMeasurementInformation ::=			
SEQUENCE {			
primaryCellMeasuredResults	Not Present		
MeasuredResultsList ::= SEQUENCE			
(SIZE(1..32)) OF			
MeasuredResultsElement			
MeasuredResultsElement ::= SEQUENCE {			
physCellId			
cellGlobalId			
arfcnEUTRA			
systemFrameNumber			
rsrp-Result	Not Present		
rsrq-Result	Not Present		
ue-RxTxTimeDiff		Set according to specific sub-test and test point.	
}			
}			
}			
}			
epdu-ProvideLocationInformation	Not present		
}			
}			
}			

Table 8.1.3.4.3-6: RadioResourceConfigDedicated-SRB2-DRB(n, m): Additional FDD UE Rx–Tx time difference measurement under time-domain measurement resource restriction with non-MBSFN ABS (eICIC)

Derivation Path: TS 36.508 [18] clause 4.6.3, Table 4.6.3-16 RadioResourceConfigDedicated-SRB2-DRB(n,m)			
Information Element	Value/remark	Comment	Condition
RadioResourceConfigDedicated-SRB2-DRB(n, m) ::= SEQUENCE {			
MeasSubframePatternPCell-r10 CHOICE {			
setup SEQUENCE {			
subframePatternFDD-r10	'10000000100000001000 00001000000010000000'	BIT STRING (SIZE (40))	Cell1
}			
}			
}			

8.1.3.5 Test requirement

Table 8.1.3.5-1 defines the primary level settings including test tolerances for the test.

The UE Rx – Tx time difference measurement accuracy shall fulfil the requirements in Table 8.1.3.5-3.

Table 8.1.3.5-1: Cell-specific test parameters for FDD UE Rx–Tx time difference measurement under time-domain measurement resource restriction with non-MBSFN ABS

Parameter	Unit	Cell 1	Cell 2
E-UTRAN RF Channel Number		1	1
Channel bandwidth ($BW_{channel}$)	MHz	10	10
PDSCH Reference measurement channel defined in TS 36.521-3 [25] A.1.1		R.0 FDD	N/A
PDSCH allocation	n_{PRB}	13–36	N/A
PDCCH/PCFICH/PHICH Reference measurement channel defined in TS 36.521-3 [25] A.2.1		R.6 FDD	N/A
OCNG Patterns defined in TS 36.521-3 [25] D.1.1 (OP.1 FDD) and in D.1.6 (OP.6 FDD)		OP.5 FDD	OP.6 FDD
PBCH_RA	dB	0	Non-ABS and ABS subframe channel powers defined in Table C.3.1.1.1-1 in TS 36.521-3 [25].
PBCH_RB	dB		
PSS_RA	dB		
SSS_RA	dB		
PCFICH_RB	dB		
PHICH_RA	dB		
PHICH_RB	dB		
PDCCH_RA	dB		
PDCCH_RB	dB		
PDSCH_RA	dB		
PDSCH_RB	dB		
OCNG_RA ^{Note1}	dB		
OCNG_RB ^{Note1}	dB		
N_{oc} ^{Note 2}	dBm/15 kHz		
CRS \hat{E}_s / N_{oc}	dB	-2.7	1
CRS $(\hat{E}_s / I_{ot})_{meas}$ ^{Note 3}	dB	-2.7	-0.87
CRS $(\hat{E}_s / I_{ot})_{nonABS}$ ^{Note 3}	dB	-6.24	-0.87
RSRP ^{Note 4}	dBm/15 kHz	-100.7	-97
$(I_o)_{meas}$ ^{Note 4}	dBm/9 MHz	-67.8	-67.8
$(I_o)_{nonABS}$ ^{Note 4}	dBm/9 MHz	-65.75	-65.75
Propagation condition		AWGN	

NOTE 1: OCNG shall be used such that the resources in the active cell are fully allocated and a constant total transmitted power spectral density is achieved for all OFDM symbols.

NOTE 2: Interference from other cells and noise sources not specified in the test is assumed to be constant over subcarriers and time and shall be modelled as AWGN of appropriate power for N_{oc} to be fulfilled. Applies to all subframes.

Note 3: $(\hat{E}_s / I_{ot})_{meas}$ is calculated in CRS REs in the subframes indicated for PCell measurements by measurement resource restriction pattern, whilst $(\hat{E}_s / I_{ot})_{nonABS}$ is calculated in CRS REs in the subframes not indicated for PCell measurements by measurement resource restriction pattern.

Note 4: RSRP and Io levels have been derived from other parameters for information purposes. They are not settable parameters themselves. $(Io)_{meas}$ is calculated in CRS symbols in the subframes indicated for PCell measurements by measurement resource restriction pattern, whilst $(Io)_{nonABS}$ is calculated in CRS symbols in the subframes not indicated for PCell measurements by measurement resource restriction pattern.

Table 8.1.3.5-2: Sounding Reference Symbol Configuration to be used in FDD UE Rx–Tx time difference test

Field	Value	Comment
UL bandwidth	50 RBs	Same as the DL bandwidth
srsBandwidthConfiguration	bw5	
srsSubframeConfiguration	sc1	
ackNackSrsSimultaneousTransmission	FALSE	
srsMaxUpPTS	N/A	Not applicable for FDD
srsBandwidth	0	No hopping
srsHoppingBandwidth	hbw0	
frequencyDomainPosition	0	
Duration	TRUE	Indefinite duration
srs-ConfigIndex	0	SRS periodicity of 2ms
transmissionComb	0	
cyclicShift	cs0	No cyclic shift
srsAntennaPort	an1	Number of SRS antenna ports
Note:	For further information see clause 6.3.2 in TS 36.331 [22].	

Table 8.1.3.5-3: Test requirements UE Rx – Tx time difference measurement accuracy requirements

	Test requirement
Lowest reported value	(Measured value from step 7 - 13) T_s converted to RX-TX_TIME_DIFFERENCE according to Table 4.6.3-1
Highest reported value	(Measured value from step 7 + 13) T_s converted to RX-TX_TIME_DIFFERENCE according to Table 4.6.3-1

NOTE: The test in table 8.1.3.5-3 has two test points starting at 32 T_s and 5008 T_s .

The test tolerances are defined in Annex C.

For the overall test to pass, the ratio of successful reported values in each test point shall be more than 90% with a confidence level of 95%.

8.1.4 E-UTRAN TDD UE Rx–Tx Time Difference under Time-Domain Measurement Resource Restriction with Non-MBSFN ABS (eICIC)

8.1.4.1 Test purpose

To verify that the E-UTRAN TDD UE Rx – Tx time difference measurement accuracy is within the specified limits under a time-domain measurement resource restriction pattern, and when non-MBSFN ABS is configured in the interfering cells.

8.1.4.2 Test applicability

This test applies to all types of E-UTRA TDD UE release 10 with LPP release 13 onwards and ECID positioning. Applicability requires support for FGI bit 115. Note that for LPP releases before release 13 the UE Rx - Tx time difference measurement report mapping is ambiguous and therefore this test shall not be used.

8.1.4.3 Minimum conformance requirements

NOTE: This measurement is used for UE positioning purposes.

The requirements in this section apply for UE configured with a time-domain measurement resource restriction pattern for PCell measurements. The UE Rx-Tx time difference is measured from the Pcell.

The accuracy requirements in Table 8.1.4.3-1 are valid under the following conditions:

- Cell specific reference signals are transmitted either from one, two or four antenna ports,
- Conditions defined in 36.101[2] Clause 7.3 for reference sensitivity are fulfilled,
- No changes to the uplink transmission timing are applied during the measurement period,

RSRP_{dBm} according to Annex E.4 for a corresponding Band,

- The time domain measurement resource restriction pattern configured for the PCell indicates at least one subframe per radio frame for performing the PCell measurements,
- Four symbols containing CRS are available in all subframes indicated by the time domain measurement resource restriction pattern.

Table 8.1.4.3-1: UE Rx–Tx time difference measurement accuracy under time domain measurement resource restriction

Accuracy	Conditions				
	Es/lot ^{Note 6}	Downlink transmission bandwidth of PCell	Io ^{Note 1, 5} range		
E-UTRA operating band groups ^{Note 8}			Minimum Io	Maximum Io	
Ts ^{Note 2}	dB	MHz		dBm/15kHz ^{Note 7}	dBm/BW _{Channel}
±20	≥-3 dB	≤ 3 MHz	FDD_A ^{Note 9} , TDD_A	-121	-50
			FDD_B	-120.5	-50
			FDD_C, TDD_C	-120	-50
			FDD_D	-119.5	-50
			FDD_E, TDD_E	-119	-50
			FDD_F	-118.5	-50
			FDD_G ^{Note 4}	-118	-50
			FDD_H	-117.5	-50
±10	≥-3 dB	≥ 5 MHz	Note 3	Note 3	Note 3

NOTE 1: When in dBm/15kHz, the minimum Io condition is expressed as the average Io per RE over all REs in that symbol. Io may be different in different symbols within a subframe.
 NOTE 2: Ts is the basic timing unit defined in TS 36.211.
 NOTE 3: The same bands and the same Io conditions for each band apply for this requirement as for the corresponding requirement with downlink bandwidth ≤ 3 MHz.
 NOTE 4: Except Band 29.

- NOTE 5: l_o is defined for the subframes indicated by the time-domain measurement resource restriction pattern for serving cell measurements. The specified l_o range applies to CRS and non-CRS symbols. l_o may be different in different symbols within a subframe.
- NOTE 6: CRS \bar{E}_s/l_o is in subframes indicated for PCell measurements by the time-domain measurement resource restriction pattern.
- NOTE 7: The condition level is increased by $\Delta > 0$, when applicable, as described in TS 36.521-3 [25] Sections I.4.2 and I.4.3.
- NOTE 8: E-UTRA operating band groups are as defined in Section 4.4.2.
- NOTE 9: Except Band 32.

NOTE: It is up to the UE implementation whether the UE Rx-Tx time difference measurement is performed in any subframe or in subframes indicated by the time-domain measurement resource restriction pattern.

The normative reference for this requirement is TS 36.133 [23] clause 9.1.9.3 and A.9.7.4.

8.1.4.4 Test description

The test has two test points with time delays starting at $32 T_s$ and $5008 T_s$, respectively.

In the test, there are two synchronous cells, Cell 1 and Cell 2, on the same RF channel. Cell 1 is the PCell on which UE Rx-Tx is measured, and Cell 2 is the interfering cell. Non-MBSFN ABS pattern is configured in Cell 2 during the entire test.

The tested UE is connected to the PCell and configured to transmit SRS signals periodically. The SRS configuration is provided to the UE before the measurement starts. The UE is configured to report UE Rx-Tx time difference measurement. The test equipment measures the transmit timing of the UE using the transmitted SRS, and measures the receive timing using the downlink CRS. The test equipment then compares the difference of these two timings to the UE Rx-Tx measurement reported by the UE. The UE is configured by higher layers via Cell 1 with a time-domain measurement resource restriction pattern for performing E-UTRAN TDD UE Rx-Tx time difference measurements on PCell. The information for both patterns shall be provided to the UE before the measurement starts.

8.1.4.4.1 Initial conditions

Test Environment: Normal as defined in TS 36.508 [18] clause 4.1.

Frequencies to be tested: According to TS 36.521-1 [24] Annex E table E-1 and TS 36.508 [18] clauses 4.4.2 and 4.3.1.

Channel Bandwidth to be tested: 10 MHz as defined in TS 36.508 [18] clause 4.3.1.

1. Connect the SS (node B emulator) and AWGN noise source to the UE antenna connectors as shown in TS 36.508 [18] Annex A figure A.54 (without faders).
2. Propagation conditions are set according to clause 4.6.2.1.
3. Message contents are defined in clause 8.1.4.4.3.
4. Cell 1 is the serving cell. Cell 1 is the cell used for connection setup with the power levels set according to TS 36.521-3 [25] clauses C.0 and C.1 for this test. Cell 2 is the neighbour cells. Both cells are on the same RF channel.

Table 8.1.4.4.1-1: General test parameters for E-UTRAN TDD UE Rx-Tx time difference measurement under time-domain measurement resource restriction with non-MBSFN ABS

Parameter	Unit	Value	Comment
Serving cell (PCell)		Cell 1	Cell to be measured
Neighbour cell		Cell 2	The cell interfering to Cell 1
PCell ABS configuration		Non-MBSFN ABS	As defined in TS 36.521-3 [25] Table C.3.1.1.1-1
E-UTRA RF Channel Number		1	One TDD carrier frequency is used
Downlink Channel Bandwidth ($BW_{channel}$)	MHz	10	For both cells in the test
CP length		Normal	For both cells in the test

Special subframe configuration		6	For Cell 1 and Cell 2. For special subframe configurations see Table 4.2-1 in TS 36.211 [26].
Uplink/downlink subframe configuration		1	For Cell 1 and Cell 2. For uplink-downlink subframe configurations see Table 4.2- in TS 36.211 [26].
DRX			OFF
Time offset between cells	μs	3	Synchronous cells
Physical cell ID PCI		$(\text{PCI}_{\text{cell1}} - \text{PCI}_{\text{cell2}}) \bmod 6 \neq 0$	Cell PCIs for Cell 1 and Cell 2 are selected randomly so that the condition is met.
ABS pattern		'00000000010000000001'	Non-MBSFN ABS. TDD ABS Pattern Info IE, as defined in TS 36.423 [35], clause 9.2.54. Configured in Cell 2. The first/leftmost bit corresponds to the subframe #0 of a radio frame satisfying $\text{SFN} \bmod 20 = 0$. No MBSFN subframes are configured in the ABS subframes in Cell 2.
Time-domain measurement resource restriction pattern for serving cell measurements		'00000000010000000001'	Configured for measurements on Cell 1.

8.1.4.4.2 Test procedure

1. Bring the UE to State 3A or 3A-RF according to TS 36.508 [18] clause 4.5.3A or 5.2A.2 with exceptions listed in 7.2A.6, using a value of initial timing advance command $T_A = 2$ in the Random Access Response which indicates an initial timing advance value $N_{TA} = 32 T_s$. Note that in the remainder of the test the timing advance command $T_A = 31$ which indicates a timing advance adjustment value $N_{TA} = 0 T_s$.
2. Set the parameters according to Tables 8.1.4.5-1 and 8.1.4.5-2. Propagation conditions are set according to clause 4.6.2.1.
3. The SS adjusts the downlink timing for Cell 1 to a delay of $+4 T_s$, compared to the current value.
4. Wait for 1.6 s to allow for the possibility that the UE makes autonomous timing adjustments.
5. The SS shall transmit an LPP REQUEST CAPABILITIES message.
6. The UE shall transmit an LPP PROVIDE CAPABILITIES message indicating the ECID capabilities supported by the UE in the *ECID-ProvideCapabilities* IE. The IE *ueRxTxSupTDD-r13* shall be present (TRUE).
7. The SS shall transmit an LPP REQUEST LOCATION INFORMATION message, including the *ECID-RequestLocationInformation* IE. If the UE message at step 6 includes the *ackRequested* IE set to TRUE, then the SS shall send an acknowledgment in the LPP REQUEST LOCATION INFORMATION message.
8. The UE shall transmit an LPP PROVIDE LOCATION INFORMATION message including the *ecid-SignalMeasurementInformation* IE.
9. As soon as possible after step 8 the SS shall measure the transmit timing of the UE using the transmitted SRS, relative to the current downlink timing.
10. If the UE message at step 8 includes the *ackRequested* IE set to TRUE, then the SS shall send a LPP acknowledgment message.
11. The SS shall check the reported value of *ue-RxTxTimeDiff* in the *ecid-SignalMeasurementInformation* IE provided by the UE in step 8 and compare it with the value measured in step 9. The SS shall check that the reported value is within the limits specified in table 8.1.4.5-3 compared to the measured value. If the reported value is within the limits the number of successful results for the test point is increased by one. If the reported value is not within the limits, or the UE reports an error in the LPP PROVIDE LOCATION INFORMATION message in step 6, or does not respond at step 8 within the time given by the *responseTime* IE in the *ECID-RequestLocationInformation* IE in step 7, then the number of unsuccessful results for the test point test is increased by one.
12. Repeat steps 3-11 until the confidence level according to Annex D.4.3 is achieved.

NOTE: To avoid a large divergence between the sent TA and the set downlink timing, the SS may reset the downlink timing for Cell 1 to its initial value after a certain amount of loops. The loop during the reset does not count for the result statistics.

13. Repeat steps 1-12 for test point 2.

8.1.4.4.3 Message contents

Table 8.1.4.4.3-1: SoundingRS-RL-ConfigCommon-DEFAULT: TDD UE Rx–Tx time difference measurement under time-domain measurement resource restriction with non-MBSFN ABS (eICIC)

Derivation Path: TS 36.508 [18] clause 4.6.3, Table 4.6.3-21 SoundingRS-UL-ConfigCommon-DEFAULT			
Information Element	Value/remark	Comment	Condition
SoundingRS-UL-ConfigCommon-DEFAULT ::= SEQUENCE {			
setup SEQUENCE {			
srs-BandwidthConfig	bw5		
srs-SubframeConfig	sc1		FDD
ackNackSRS-SimultaneousTransmission	FALSE		
srsMaxUpPts	Not present		FDD
}			
}			

Table 8.1.4.4.3-2: SoundingRS-RL-ConfigDedicated-DEFAULT: TDD UE Rx–Tx time difference measurement under time-domain measurement resource restriction with non-MBSFN ABS (eICIC)

Derivation Path: TS 36.508 [18] clause 4.6.3, Table 4.6.3-22 SoundingRS-UL-ConfigDedicated-DEFAULT			
Information Element	Value/remark	Comment	Condition
SoundingRS-UL-ConfigDedicated-DEFAULT ::= CHOICE {			
setup SEQUENCE {			
srs-Bandwidth	bw0		
srs-HoppingBandwidth	hbw0		
freqDomainPosition	0		
duration	TRUE	Indefinite duration	
srs-ConfigIndex	0		
transmissionComb	0		
cyclicShift	cs0	No cyclic shift	
}			
}			

Table 8.1.4.4.3-3: LPP REQUEST CAPABILITIES: TDD UE Rx–Tx time difference measurement under time-domain measurement resource restriction with non-MBSFN ABS (eICIC)

Information Element	Value/remark
ecid-RequestCapabilities	TRUE

Table 8.1.4.4.3-3a: LPP PROVIDE CAPABILITIES: TDD UE Rx–Tx time difference measurement under time-domain measurement resource restriction with non-MBSFN ABS (eICIC)

Information Element	Value/remark
ueRxTxSupTDD-r13	TRUE

Table 8.1.4.4.3-4: ECID-RequestLocationInformation: TDD UE Rx–Tx time difference measurement under time-domain measurement resource restriction with non-MBSFN ABS (eICIC)

Derivation Path: TS 36.355 [4] clause 6.2			
Information Element	Value/remark	Comment	Condition
LPP-Message ::= SEQUENCE {			
transactionID SEQUENCE {			

Initiator	locationServer		
transactionNumber	1		
}			
endTransaction	FALSE		
sequenceNumber	Not present		
acknowledgement	Not present		
lpp-MessageBody CHOICE {			
c1 CHOICE {			
requestLocationInformation SEQUENCE {			
criticalExtensions CHOICE {			
c1 CHOICE {			
requestLocationInformation-r9 SEQUENCE {			
commonEsRequestLocationInformation SEQUENCE {			
locationInformationType	locationMeasurementsRequired		
triggeredReporting	Not present		
periodicalReporting	Not present		
additionalInformation	onlyReturnInformationRequested		
qos SEQUENCE {			
horizontalAccuracy	Not present		
verticalCoordinateRequest	FALSE		
verticalAccuracy	Not present		
responseTime SEQUENCE {			
time	2		
responseTimeEarlyFix-r12	Not present		Rel-12 onwards
}			
velocityRequest	FALSE		
}			
environment	Not present		
locationCoordinateTypes	Not present		
velocityTypes	Not present		
}			
a-gnss-RequestLocationInformation	Not present		
otdoa-RequestLocationInformation	Not present		
ecid-RequestLocationInformation ::= SEQUENCE {			
requestedMeasurements	0 0 1	ueRxTxReq	
}			
epdu-RequestLocationInformation	Not Present		
}			
}			
}			
}			
}			
}			
}			
}			
}			
}			

Table 8.1.4.4.3-5: ECID-ProvideLocationInformation: TDD UE Rx-Tx time difference measurement under time-domain measurement resource restriction with non-MBSFN ABS (eICIC)

Derivation Path: TS 36.355 [4] clause 6.2			
Information Element	Value/remark	Comment	Condition
LPP-Message ::= SEQUENCE {			
transactionID SEQUENCE {			
Initiator	locationServer		
transactionNumber	1		
}			
endTransaction	TRUE		
sequenceNumber	(0..255)		
acknowledgement			
lpp-MessageBody CHOICE {			

c1 CHOICE {			
provideLocationInformation SEQUENCE {			
criticalExtensions CHOICE {			
c1 CHOICE {			
provideLocationInformation-r9 SEQUENCE {			
commonIEsProvideLocationInformation	Not present.		
a-gnss-ProvideLocationInformation	Not present		
otdoa-ProvideLocationInformation	Not present		
ecid-ProvideLocationInformation ::=			
SEQUENCE {			
ecid-SignalMeasurementInformation ::=			
SEQUENCE {			
primaryCellMeasuredResults	Not Present		
MeasuredResultsList ::= SEQUENCE			
(SIZE(1..32)) OF			
MeasuredResultsElement			
MeasuredResultsElement ::= SEQUENCE {			
physCellId			
cellGlobalId			
arfcnEUTRA			
systemFrameNumber			
rsrp-Result	Not Present		
rsrq-Result	Not Present		
ue-RxTxTimeDiff		Set according to specific sub-test and test point.	
}			
}			
}			
}			
epdu-ProvideLocationInformation	Not present		
}			
}			
}			

Table 8.1.4.4.3-6: RadioResourceConfigDedicated-SRB2-DRB(n, m): Additional TDD UE Rx–Tx time difference measurement under time-domain measurement resource restriction with non-MBSFN ABS (eICIC)

Derivation Path: TS 36.508 [18] clause 4.6.3, Table 4.6.3-16 RadioResourceConfigDedicated-SRB2-DRB(n,m)			
Information Element	Value/remark	Comment	Condition
RadioResourceConfigDedicated-SRB2-DRB(n, m) ::= SEQUENCE {			
MeasSubframePatternPCell-r10 CHOICE {			
setup SEQUENCE {			
subframePatternTDD-r10			
subframeConfig1-5-r10	'00000000010000000001'	BIT STRING (SIZE (20))	Cell 1
}			
}			
}			

8.1.4.5 Test requirement

Table 8.1.4.5-1 defines the primary level settings including test tolerances for the test.

The UE Rx – Tx time difference measurement accuracy shall fulfil the requirements in Table 8.1.4.5-3.

Table 8.1.4.5-1: Cell-specific test parameters for TDD UE Rx–Tx time difference measurement under time-domain measurement resource restriction with non-MBSFN ABS

Parameter	Unit	Cell 1	Cell 2
PDSCH Reference measurement channel defined in TS 36.521-3 [25] A.1.2		R.0 TDD	N/A
PDSCH allocation	n_{PRB}	13–36	N/A
PDCCH/PCFICH/PHICH Reference measurement channel defined in TS 36.521-3 [25] A.2.2		R.6 TDD	R.6 TDD
OCNG Patterns defined in TS 36.521-3 [25] D.2.1 (OP.1 TDD) and D.2.2 (OP.2 TDD)		OP.1 TDD	OP.2 TDD
PBCH_RA	dB	0	Non-ABS and ABS subframe channel powers defined in Table C.3.1.1.1-1 in TS 36.521-3 [25].
PBCH_RB	dB		
PSS_RA	dB		
SSS_RA	dB		
PCFICH_RB	dB		
PHICH_RA	dB		
PHICH_RB	dB		
PDCCH_RA	dB		
PDCCH_RB	dB		
PDSCH_RA	dB		
PDSCH_RB	dB		
OCNG_RA ^{Note1}	dB		
OCNG_RB ^{Note1}	dB		
N_{oc} ^{Note2}	dBm/15 kHz		
CRS \hat{E}_s / N_{oc}	dB	-2.7	1
CRS $\left(\hat{E}_s / I_{ot}\right)_{meas}$ ^{Note 3}	dB	-2.7	-0.87
CRS $\left(\hat{E}_s / I_{ot}\right)_{nonABS}$ ^{Note 3}	dB	-6.24	-0.87
RSRP ^{Note 4}	dBm/15 kHz	-100.7	-97
$(I_o)_{meas}$ ^{Note 4}	dBm/9 MHz	-67.8	-67.8
$(I_o)_{nonABS}$ ^{Note 4}	dBm/9 MHz	-65.75	-65.75
Propagation Condition		AWGN	
<p>Note 1: OCNG shall be used such that the resources in the active cell are fully allocated and a constant total transmitted power spectral density is achieved for all OFDM symbols.</p> <p>Note 2: Interference from other cells and noise sources not specified in the test is assumed to be constant over subcarriers and time and shall be modelled as AWGN of appropriate power for N_{oc} to be fulfilled.</p> <p>Note 3: $\left(\hat{E}_s / I_{ot}\right)_{meas}$ is calculated in CRS REs in the subframes indicated for PCell measurements by measurement resource restriction pattern, whilst $\left(\hat{E}_s / I_{ot}\right)_{nonABS}$ is calculated in CRS REs in the subframes not indicated for PCell measurements by measurement resource restriction pattern.</p> <p>Note 4: RSRP and I_o levels have been derived from other parameters for information purposes. They are not settable parameters themselves. $(I_o)_{meas}$ is calculated in CRS symbols in the subframes indicated for PCell measurements by measurement resource restriction pattern, whilst $(I_o)_{nonABS}$ is calculated in CRS symbols</p>			

Table 8.1.4.5-2: Sounding Reference Symbol Configuration to be used in TDD UE Rx–Tx time difference test

Field	Value	Comment
UL bandwidth	50 RBs	Same as the DL bandwidth
srsBandwidthConfiguration	bw5	

srsSubframeConfiguration	sc1	
ackNackSrsSimultaneousTransmission	FALSE	
srsMaxUpPTS	TRUE	
srsBandwidth	0	No hopping
srsHoppingBandwidth	hbw0	
frequencyDomainPosition	0	
Duration	TRUE	Indefinite duration
Srs-ConfigurationIndex	10	SRS periodicity of 10ms for all Tests.
transmissionComb	0	
cyclicShift	cs0	No cyclic shift
SRS-AntennaPort	an1	Number of antenna ports used for SRS transmission
Note:	For further information see clause 6.3.2 in TS 36.331 [22].	

Table 8.1.4.5-3: Test requirements UE Rx – Tx time difference measurement accuracy requirements

	Test requirement
Lowest reported value	(Measured value from step 7 - 13) T_s converted to RX-TX_TIME_DIFFERENCE according to Table 4.6.3-2
Highest reported value	(Measured value from step 7 + 13) T_s converted to RX-TX_TIME_DIFFERENCE according to Table 4.6.3-2

NOTE: The test in table 8.1.4.5-3 has two test points starting at $32 T_s$ and $5008 T_s$.

The test tolerances are defined in Annex C.

For the overall test to pass, the ratio of successful reported values in each test point shall be more than 90% with a confidence level of 95%.

8.1.5 E-UTRAN FDD UE Rx–Tx time difference under Time Domain Measurement Resource Restriction with CRS Assistance Information and Non-MBSFN ABS (feICIC)

8.1.5.1 Test purpose

The purpose of this test is to verify that the E-UTRAN FDD UE Rx – Tx time difference measurement accuracy is within the specified limits in TS 36.133 [23] clause 9.1.9.4 when the UE is provided with a time-domain measurement resource restriction pattern and CRS assistance information, and when non-MBSFN ABS is configured in the interfering cells.

8.1.5.2 Test applicability

This test applies to all types of E-UTRA FDD UE release 11 and forward that supports ECID positioning and CRS interference handling. Applicability requires support of FGI bit 115.

8.1.5.3 Minimum conformance requirements

NOTE: This measurement is used for UE positioning purposes.

The UE RX-TX time difference is measured from the PCell.

For UE configured with a time-domain measurement resource restriction pattern for PCell measurements, the accuracy requirements in Table 8.1.5.3-1 apply provided that the following conditions are met for the PCell:

PCell cell specific reference signals are transmitted from one, two or four antenna ports,

Conditions defined in TS 36.101 [2] clause 7.3 for reference sensitivity are fulfilled,

No changes to the uplink transmission timing are applied during the measurement period,

$RSRP_{dBm}$ according to clause E.4 for a corresponding Band,

The time domain measurement resource restriction pattern configured for the measured cell indicates at least one subframe per radio frame for performing the RSRP measurement,

Four symbols containing CRS are available in all subframes indicated by the time domain measurement resource restriction pattern, and

The UE is provided via PCell with the CRS assistance information (TS 36.331 [22]) and the CRS assistance information is valid throughout the entire evaluation period.

The requirements in this section shall also be met when the number of transmit antenna ports TS 36.211 [26] of one or more cells whose CRS assistance information is provided TS 36.331 [22] is different from the number of transmit antenna ports of the measured cell.

When the CRS assistance information is provided, the transmission bandwidth in all intra-frequency cells in the CRS assistance information is the same or larger than the transmission bandwidth of the PCell for which measurement is performed.

Table 8.1.5.3-1: UE Rx – Tx time difference measurement accuracy

Accuracy	Conditions				
	CRS \hat{E}_s/lot ^{Note 9}	Downlink transmission bandwidth of PCell	lo range ^{Note 8}		
			E-UTRA operating band groups ^{Note 6}	Minimum lo ^{Note 1}	Maximum lo
T_s ^{Note 2}	dB	MHz		dBm/15kHz ^{Note 5}	dBm/BW _{Channel}
±20	≥-7.76 dB	≤ 3 MHz	FDD_A ^{Note 7} , TDD_A	-121	-50
			FDD_B	-120.5	-50
			FDD_C, TDD_C	-120	-50
			FDD_D	-119.5	-50
			FDD_E, TDD_E	-119	-50
			FDD_F	-118.5	-50
			FDD_G ^{Note 4}	-118	-50
			FDD_H	-117.5	-50
			FDD_N	-114.5	-50
±10	≥-7.76 dB	≥ 5 MHz	Note 3	Note 3	Note 3

NOTE 1: This lo condition is expressed as the average lo per RE over all REs in an OFDM symbol.

NOTE 2: T_s is the basic timing unit defined in TS 36.211 [26].

NOTE 3: The same bands and the same lo conditions for each band apply for this requirement as for the corresponding requirement with downlink bandwidth ≤ 3 MHz.

NOTE 4: Except Band 29.

NOTE 5: The condition level is increased by $\Delta > 0$, when applicable, as described in TS 36.521-3 [25] Sections I.4.2 and I.4.3.

NOTE 6: E-UTRA operating band groups are as defined in Section 4.4.2.

NOTE 7: Except Band 32.

NOTE 8: lo is defined in subframes indicated for PCell measurements by the time domain measurement resource restriction pattern. The specified lo range applies to CRS and non-CRS symbols. lo may be different in different symbols within a subframe.

NOTE 9: CRS \hat{E}_s/lot is in subframes indicated for PCell measurements by the time-domain measurement resource restriction pattern.

NOTE: It is up to the UE implementation whether the UE Rx-Tx time difference measurement is performed in any subframe or in subframes indicated by the time-domain measurement resource restriction pattern.

The normative reference for this requirement is TS 36.133 [23] clause 9.1.9.4 and A.9.7.5.

8.1.5.4 Test description

The test has two test points with time delays starting at 32 T_s and 5008 T_s , respectively. In this test case, there are three cells, Cell 1, Cell 2 and Cell 3, on the same RF channel. Cell 1 is the PCell on which UE Rx-Tx is measured. Cell 2 and

Cell 3 are the interfering cells. A non-MBSFN ABS pattern is configured in each of the Cell 2 and Cell 3 during the entire test. The tested UE is connected to the PCell and configured to transmit SRS signals periodically. The SRS configuration is provided to the UE before the measurement starts. The UE is configured to report UE Rx–Tx time difference measurement. The test equipment measures the transmit timing of the UE using the transmitted SRS. The test equipment then compares this timing to the UE Rx–Tx measurement reported by the UE. The UE is configured by higher layers via Cell 1 with a time-domain measurement resource restriction pattern for performing E-UTRAN FDD intra-frequency measurements on PCell. The UE is also provided via higher layers with the CRS assistance information for Cell 2. The information for both measurement patterns and the CRS assistance information shall be provided via RRC to the UE before the measurement starts.

8.1.5.4.1 Initial conditions

Test Environment: Normal as defined in TS 36.508 [18] clause 4.1.

Frequencies to be tested: According to TS 36.521-1 [24] Annex E table E-1 and TS 36.508 [18] clauses 4.4.2 and 4.3.1.

Channel Bandwidth to be tested: 10 MHz as defined in TS 36.508 [18] clause 4.3.1.

1. Connect the SS (node B emulator) and AWGN noise source to the UE antenna connectors as shown in TS 36.508 [18] Annex A figure A.54 (without faders).
2. Propagation conditions are set according to clause 4.6.2.1.
3. Message contents are defined in clause 8.1.5.4.3.
4. Cell 1 is the serving cell. Cell 1 is the cell used for connection setup with the power levels set according to TS 36.521-3 [25] clauses C.0 and C.1 for this test. Cell 2 and Cell 3 are the neighbour cells. All cells are on the same RF channel. Cell 3 in the test is the Cell 4 defined in clause 4.7.1

Table 8.1.5.4.1-1: General test parameters for FDD UE Rx–Tx time difference measurement under time-domain measurement resource restriction with CRS assistance information and non-MBSFN ABS

Parameter	Unit	Value	Comment
Serving cell (PCell)		Cell 1	The measured cell
Neighbour cell		Cell 2 and Cell 3	Cell 2 is the first interfering cell to Cell 1, whilst Cell 3 is the second interfering cell to Cell 1.
ABS transmission configuration		Non-MBSFN ABS	As defined in TS 36.521-3 [25] Table C.3.1.2-1.
E-UTRA RF Channel Number		1	One FDD carrier frequency is used
Downlink Channel Bandwidth (BW _{channel})	MHz	10	For all cells in the test
CP length		Normal	For all cells in the test
DRX			OFF
Time offset between cells	μs	Cell 2 offset with respect to Cell 1: 3 Cell 3 offset with respect to Cell 1: 2	Three synchronous cells
Physical cell ID PCI		$(PCI_{cell1} - PCI_{cell2}) \bmod 6 = 0$ $(PCI_{cell1} - PCI_{cell3}) \bmod 6 \neq 0$ PCI _{cell1} not equal to PCI _{cell2}	Cell PCIs are selected so that all conditions are met
ABS pattern		'10000000100000001000 00001000000010000000'	Non-MBSFN ABS. FDD ABS Pattern Info IE, as defined in TS 36.423 [35], clause 9.2.54. The first/leftmost bit corresponds to the PCell subframe #0 of a radio frame satisfying SFN mod x = 0, where x is the size of the bit string (40) divided by 10. No MBSFN subframes are configured in the ABS subframes. Configured in Cell 2 and Cell 3 during the testing.
Time-domain measurement resource restriction pattern for PCell measurements		'10000000100000001000 00001000000010000000'	Configured for measurements on Cell 1.
	physCellId	see PCI conditions above	

CRS assistance information	antennaPortsCount		1	The CRS assistance information is provided for Cell 2 and Cell 3 in CRS-AssistanceInfo. It includes a single MBSFN-SubframeConfig element with subframe allocation one Frame='000000'.
	mbsfn-SubframeConfigList		oneFrame = '000000'	

8.1.5.4.2 Test procedure

1. Bring the UE to State 3A or 3A-RF according to TS 36.508 [18] clause 4.5.3A or 5.2A.2 with exceptions listed in 7.2A.6, using a value of initial timing advance command $T_A = 2$ in the Random Access Response which indicates an initial timing advance value $N_{TA} = 32 T_s$. Note that in the remainder of the test the timing advance command $T_A = 31$ which indicates a timing advance adjustment value $N_{TA} = 0 T_s$.
2. Set the parameters according to Tables 8.1.5.5-1 and 8.1.5.5-2. Propagation conditions are set according to clause 4.6.2.1.
3. The SS adjusts the downlink timing for Cell 1 to a delay of $+4 T_s$, compared to the current value.
4. Wait for 1.6 s to allow for the possibility that the UE makes autonomous timing adjustments.
5. The SS shall transmit an LPP REQUEST CAPABILITIES message.
6. The UE shall transmit an LPP PROVIDE CAPABILITIES message indicating the ECID capabilities supported by the UE in the *ECID-ProvideCapabilities* IE.
7. The SS shall transmit an LPP REQUEST LOCATION INFORMATION message, including the *ECID-RequestLocationInformation* IE. If the UE message at step 6 includes the *ackRequested* IE set to TRUE, then the SS shall send an acknowledgment in the LPP REQUEST LOCATION INFORMATION message.
8. The UE shall transmit an LPP PROVIDE LOCATION INFORMATION message including the *ecid-SignalMeasurementInformation* IE.
9. As soon as possible after step 8 the SS shall measure the transmit timing of the UE using the transmitted SRS, relative to the current downlink timing.
10. If the UE message at step 8 includes the *ackRequested* IE set to TRUE, then the SS shall send a LPP acknowledgment message.
11. The SS shall check the reported value of *ue-RxTxTimeDiff* in the *ecid-SignalMeasurementInformation* IE provided by the UE in step 8 and compare it with the value measured in step 9. The SS shall check that the reported value is within the limits specified in table 8.1.5.5-3 compared to the measured value. If the reported value is within the limits the number of successful results for the test point is increased by one. If the reported value is not within the limits, or the UE reports an error in the LPP PROVIDE LOCATION INFORMATION message in step 6, or does not respond at step 8 within the time given by the *time* IE in the *ECID-RequestLocationInformation* IE in step 7, then the number of unsuccessful results for the test point test is increased by one.
12. Repeat steps 3-11 until the confidence level according to Annex D.4.3 is achieved.
NOTE: To avoid a large divergence between the sent TA and the set downlink timing, the SS may reset the downlink timing for Cell 1 to its initial value after a certain amount of loops. The loop during the reset does not count for the result statistics.
13. Repeat steps 1-12 for test point 2.

8.1.5.4.3 Message contents

Message contents are according to TS 36.508 [18] clause 5.2A.5.1 with the following exceptions:

Table 8.1.5.4.3-1: SoundingRS-RL-ConfigCommon-DEFAULT: FDD UE Rx–Tx time difference measurement under time-domain measurement resource restriction with CRS assistance information and non-MBSFN ABS (feICIC)

Derivation Path: TS 36.508 [18] clause 4.6.3, Table 4.6.3-21 SoundingRS-UL-ConfigCommon-DEFAULT

Information Element	Value/remark	Comment	Condition
SoundingRS-UL-ConfigCommon-DEFAULT ::= SEQUENCE {			
setup SEQUENCE {			
srs-BandwidthConfig	bw5		
srs-SubframeConfig	sc1		FDD
ackNackSRS-SimultaneousTransmission	FALSE		
srsMaxUpPts	Not present		FDD
}			
}			

Table 8.1.5.4.3-2: SoundingRS-RL-ConfigDedicated-DEFAULT: FDD UE Rx–Tx time difference measurement under time-domain measurement resource restriction with CRS assistance information and non-MBSFN ABS (feICIC)

Derivation Path: TS 36.508 [18] clause 4.6.3, Table 4.6.3-22 SoundingRS-UL-ConfigDedicated-DEFAULT			
Information Element	Value/remark	Comment	Condition
SoundingRS-UL-ConfigDedicated-DEFAULT ::= CHOICE {			
setup SEQUENCE {			
srs-Bandwidth	bw0		
srs-HoppingBandwidth	hbw0		
freqDomainPosition	0		
duration	TRUE	Indefinite duration	
srs-ConfigIndex	0		
transmissionComb	0		
cyclicShift	cs0	No cyclic shift	
}			
}			

Table 8.1.5.4.3-3: LPP REQUEST CAPABILITIES: FDD UE Rx–Tx time difference measurement under time-domain measurement resource restriction with CRS assistance information and non-MBSFN ABS (feICIC)

Information Element	Value/remark
ecid-RequestCapabilities	TRUE

Table 8.1.5.4.3-4: ECID-RequestLocationInformation: FDD UE Rx–Tx time difference measurement under time-domain measurement resource restriction with CRS assistance information and non-MBSFN ABS (feICIC)

Derivation Path: TS 36.355 [4] clause 6.2			
Information Element	Value/remark	Comment	Condition
LPP-Message ::= SEQUENCE {			
transactionID SEQUENCE {			
Initiator	locationServer		
transactionNumber	1		
}			
endTransaction	FALSE		
sequenceNumber	Not present		
acknowledgement	Not present		
lpp-MessageBody CHOICE {			
c1 CHOICE {			
requestLocationInformation SEQUENCE {			
criticalExtensions CHOICE {			
c1 CHOICE {			
requestLocationInformation-r9 SEQUENCE {			
commonIEsRequestLocationInformation SEQUENCE {			
locationInformationType	locationMeasurementsRequired		
triggeredReporting	Not present		

periodicalReporting	Not present		
additionalInformation	onlyReturnInformationRequested		
qos SEQUENCE {			
horizontalAccuracy	Not present		
verticalCoordinateRequest	FALSE		
verticalAccuracy	Not present		
responseTime SEQUENCE {			
time	2		
responseTimeEarlyFix-r12	Not present		Rel-12 onwards
}			
velocityRequest	FALSE		
}			
environment	Not present		
locationCoordinateTypes	Not present		
velocityTypes	Not present		
}			
a-gnss-RequestLocationInformation	Not present		
otdoa-RequestLocationInformation	Not present		
ecid-RequestLocationInformation ::= SEQUENCE {			
requestedMeasurements	0 0 1	ueRxTxReq	
}			
epdu-RequestLocationInformation	Not Present		
}			
}			
}			
}			
}			
}			
}			
}			
}			
}			

Table 8.1.5.4.3-5: ECID-ProvideLocationInformation: FDD UE Rx–Tx time difference measurement under time-domain measurement resource restriction with CRS assistance information and non-MBSFN ABS (feICIC)

Derivation Path: TS 36.355 [4] clause 6.2			
Information Element	Value/remark	Comment	Condition
LPP-Message ::= SEQUENCE {			
transactionID SEQUENCE {			
Initiator	locationServer		
transactionNumber	1		
}			
endTransaction	TRUE		
sequenceNumber	(0..255)		
acknowledgement			
lpp-MessageBody CHOICE {			
c1 CHOICE {			
provideLocationInformation SEQUENCE {			
criticalExtensions CHOICE {			
c1 CHOICE {			
provideLocationInformation-r9 SEQUENCE {			
commonIEsProvideLocationInformation	Not present.		
a-gnss-ProvideLocationInformation	Not present		
otdoa-ProvideLocationInformation	Not present		
ecid-ProvideLocationInformation ::= SEQUENCE {			
ecid-SignalMeasurementInformation ::= SEQUENCE {			
primaryCellMeasuredResults	Not Present		
MeasuredResultsList ::= SEQUENCE (SIZE(1..32)) OF MeasuredResultsElement			

MeasuredResultsElement ::= SEQUENCE {			
physCellId			
cellGlobalId			
arfcnEUTRA			
systemFrameNumber			
rsrp-Result	Not Present		
rsrq-Result	Not Present		
ue-RxTxTimeDiff		Set according to specific sub-test and test point.	
}			
}			
epdu-ProvideLocationInformation	Not present		
}			
}			
}			
}			
}			
}			
}			
}			
}			
}			

Table 8.1.5.4.3-6: RadioResourceConfigDedicated-SRB2-DRB(n, m): FDD UE Rx–Tx time difference measurement under time-domain measurement resource restriction with CRS assistance information and non-MBSFN ABS (feICIC)

Derivation Path: TS 36.508 [18] clause 4.6.3, Table 4.6.3-16			
Information Element	Value/remark	Comment	Condition
neighCellsCRS-Info-r11 ::= CHOICE {			
NeighCellsCRS-Info-r11 ::= CHOICE {			
Release	NULL		
Setup	CRS-AssistanceInfoList-r11		
}			
}			

Table 8.1.5.4.3-7: RadioResourceConfigDedicated-SRB2-DRB(n, m): FDD UE Rx–Tx time difference measurement under time-domain measurement resource restriction with CRS assistance information and non-MBSFN ABS (feICIC)

Derivation Path: TS 36.508 [18] clause 4.6.3, Table 4.6.3-16			
Information Element	Value/remark	Comment	Condition
CRS-AssistanceInfoList-r11 ::= SEQUENCE (SIZE (1..maxCellReport)) OF CRS-AssistanceInfo-r11			
CRS-AssistanceInfo-r11 ::= SEQUENCE {			
physCellId-r11	($PCI_{cell1} - PCI_{cell3} \text{ mod } 6 = 0$) ($PCI_{cell2} - PCI_{cell3} \text{ mod } 6 \neq 0$)	Cell PCIs are selected so that both conditions are met	
antennaPortsCount-r11	an1		
mbsfn-SubframeConfigList-r11	MBSFN-SubframeConfigList		
}			

Table 8.1.5.4.3-8: RadioResourceConfigDedicated-SRB2-DRB(n, m): FDD UE Rx–Tx time difference measurement under time-domain measurement resource restriction with CRS assistance information and non-MBSFN ABS (feICIC)

Derivation Path: TS 36.508 [18] clause 4.6.3, Table 4.6.3-16			
Information Element	Value/remark	Comment	Condition

MBSFN-SubframeConfigList ::= SEQUENCE (SIZE (1..maxMBSFN-Allocations)) OF MBSFN-SubframeConfig			
MBSFN-SubframeConfig ::= SEQUENCE {			
subframeAllocation CHOICE {			
oneFrame	'000000'	Only the CRS information of Cell 2 is provided in CRS-AssistanceInfo. It includes a single MBSFN-SubframeConfig element with subframe allocation <i>oneFrame</i> ='000000'	BIT STRING (SIZE(6))
}			
}			

Table 8.1.5.4.3-9: RadioResourceConfigDedicated-SRB2-DRB(n, m): Additional FDD UE Rx–Tx time difference measurement under time-domain measurement resource restriction with CRS assistance information and non-MBSFN ABS (felCIC)

Derivation Path: TS 36.508 [18] clause 4.6.3, Table 4.6.3-16 RadioResourceConfigDedicated-SRB2-DRB(n,m)			
Information Element	Value/remark	Comment	Condition
RadioResourceConfigDedicated-SRB2-DRB(n, m) ::= SEQUENCE {			
MeasSubframePatternPCell-r10 CHOICE {			
setup SEQUENCE {			
subframePatternFDD-r10	'1000000010000000100000000000000010000000000000000'	BIT STRING (SIZE (40))	Cell1
}			
}			
}			

8.1.5.5 Test requirement

Table 8.1.5.5-1 defines the primary level settings including test tolerances for the test.

The UE Rx – Tx time difference measurement accuracy shall fulfil the requirements in Table 8.1.5.5-3.

Table 8.1.5.5-1: Test parameters test parameters for FDD UE Rx–Tx time difference measurement under time-domain measurement resource restriction with CRS assistance information and non-MBSFN ABS

Parameter	Unit	Cell 1	Cell 2	Cell 3
E-UTRAN RF Channel Number		1	1	1
PDSCH Reference measurement channel defined in TS 36.521-3 [25] A.1.1		R.0 FDD	N/A	N/A
PDSCH allocation	n_{PRB}	13—36	N/A	N/A
PDCCH/PCFICH/PHICH Reference measurement channel defined in TS 36.521-3 [25] A.2.1		R.6 FDD	N/A	N/A
OCNG Patterns defined in TS 36.521-3 [25] D.1.5 (OP.5 FDD) and in D.1.6 (OP.6 FDD)		OP.5 FDD	OP.6 FDD	OP.6 FDD
PBCH_RA	dB	0	Non-ABS and ABS subframe channel powers defined in Table	
PBCH_RB	dB			

PSS_RA	dB		C.3.1.1.1-1 in TS 36.521-3 [25].		
SSS_RA	dB				
PCFICH_RB	dB				
PHICH_RA	dB				
PHICH_RB	dB				
PDCCH_RA	dB				
PDCCH_RB	dB				
PDSCH_RA	dB				
PDSCH_RB	dB				
OCNG_RA ^{Note 1}	dB				
OCNG_RB ^{Note 1}	dB				
N_{oc} ^{Note 2}	dBm/15 kHz	-98			
CRS \hat{E}_s/N_{oc}	dB	-2.60	3	1	
CRS $(\hat{E}_s/I_{ot})_{meas}$ ^{Note 3}	dB	-7.36	1.10	-0.90	
CRS $(\hat{E}_s/I_{ot})_{nonABS}$ ^{Note 3}	dB	-8.89	-1.48	-4.50	
RSRP ^{Note 4}	dBm/15 kHz	-100.6	-95	-97	
$(I_o)_{meas}$ ^{Note 4}	dBm/9 MHz	-	-	-	
$(I_o)_{nonABS}$ ^{Note 4}	dBm/9 MHz	-63.40	-63.40	-63.40	
Propagation condition		AWGN			
<p>Note 1: OCNG shall be used such that the resources in the active cell are fully allocated and a constant total transmitted power spectral density is achieved for all OFDM symbols.</p> <p>Note 2: Interference from other cells and noise sources not specified in the test is assumed to be constant over subcarriers and time and shall be modelled as AWGN of appropriate power for N_{oc} to be fulfilled. Applies to all subframes.</p> <p>Note 3: $(\hat{E}_s/I_{ot})_{meas}$ is calculated in CRS REs in the subframes indicated for PCell measurements by measurement resource restriction pattern, whilst $(\hat{E}_s/I_{ot})_{nonABS}$ is calculated in CRS REs in the subframes not indicated for PCell measurements by measurement resource restriction pattern.</p> <p>Note 4: RSRP and I_o levels have been derived from other parameters for information purposes. They are not settable parameters themselves. $(I_o)_{meas}$ is calculated in CRS symbols in the subframes indicated for PCell measurements by measurement resource restriction pattern, whilst $(I_o)_{nonABS}$ is calculated in CRS symbols in the subframes not indicated for PCell measurements by measurement resource restriction pattern.</p>					

Table 8.1.5.5-2: Sounding Reference Symbol Configuration to be used in FDD UE Rx-Tx time difference test

Field	Value	Comment
UL bandwidth	50 RBs	Same as the DL bandwidth
srsBandwidthConfiguration	bw5	
srsSubframeConfiguration	sc1	
ackNackSrsSimultaneousTransmission	FALSE	
srsMaxUpPTS	N/A	Not applicable for FDD
srsBandwidth	0	No hopping
srsHoppingBandwidth	hbw0	
frequencyDomainPosition	0	
Duration	TRUE	Indefinite duration
srs-ConfigIndex	0	SRS periodicity of 2ms
transmissionComb	0	
cyclicShift	cs0	No cyclic shift
srsAntennaPort	an1	Number of SRS antenna ports
Note: For further information see clause 6.3.2 in TS 36.331 [22].		

Table 8.1.5.3-3: Test requirements UE Rx – Tx time difference measurement accuracy requirements

	Test requirement
Lowest reported value	(Measured value from step 7 - 13) T_s converted to RX-TX_TIME_DIFFERENCE according to Table 4.6.3-1
Highest reported value	(Measured value from step 7 + 13) T_s converted to RX-TX_TIME_DIFFERENCE according to Table 4.6.3-1

NOTE: The test in table 8.1.5.3-3 has two test points starting at $32 T_s$ and $5008 T_s$.

The test tolerances are defined in Annex C.

For the overall test to pass, the ratio of successful reported values in each test point shall be more than 90% with a confidence level of 95%.

8.1.6 E-UTRAN TDD UE Rx–Tx time difference under Time Domain Measurement Resource Restriction with CRS Assistance Information and Non-MBSFN ABS (feICIC)

8.1.6.1 Test purpose

The purpose of this test is to verify that the E-UTRAN TDD UE Rx – Tx time difference measurement accuracy is within the specified limits in TS 36.133 [23] clause 9.1.9.4 when the UE is provided with a time-domain measurement resource restriction pattern and CRS assistance information, and when non-MBSFN ABS is configured in the interfering cells.

8.1.6.2 Test applicability

This test applies to all types of E-UTRA TDD UE release 11 and forward with LPP release 13 onwards that supports ECID positioning and CRS interference handling. Applicability requires support of FGI bit 115. Note that for LPP releases before release 13 the UE Rx - Tx time difference measurement report mapping is ambiguous and therefore this test shall not be used.

8.1.6.3 Minimum conformance requirements

NOTE: This measurement is used for UE positioning purposes.

The UE RX-TX time difference is measured from the PCell.

For UE configured with a time-domain measurement resource restriction pattern for PCell measurements, the accuracy requirements in Table 8.1.5.3-1 apply provided that the following conditions are met for the PCell:

PCell cell specific reference signals are transmitted from one, two or four antenna ports,

Conditions defined in TS 36.101 [2] clause 7.3 for reference sensitivity are fulfilled,

No changes to the uplink transmission timing are applied during the measurement period,

$RSRP_{dBm}$ according to clause E.4 for a corresponding Band,

The time domain measurement resource restriction pattern configured for the measured cell indicates at least one subframe per radio frame for performing the RSRP measurement,

Four symbols containing CRS are available in all subframes indicated by the time domain measurement resource restriction pattern, and

The UE is provided via PCell with the CRS assistance information (TS 36.331 [22]) and the CRS assistance information is valid throughout the entire evaluation period.

The requirements in this section shall also be met when the number of transmit antenna ports TS 36.211 [26] of one or more cells whose CRS assistance information is provided TS 36.331 [22] is different from the number of transmit antenna ports of the measured cell.

When the CRS assistance information is provided, the transmission bandwidth in all intra-frequency cells in the CRS assistance information is the same or larger than the transmission bandwidth of the PCell for which measurement is performed.

Table 8.1.6.3-1: TDD UE Rx – Tx time difference measurement accuracy

Accuracy	Conditions				
	CRS \hat{E}_s/lot ^{Note 9}	Downlink transmission bandwidth of PCell	Io range ^{Note 8}		
			E-UTRA operating band groups ^{Note 6}	Minimum Io	Maximum Io
T _s ^{Note 2}	dB	MHz		dBm/15kHz ^{Note 5}	dBm/BW _{Channel}
±20	≥-7.76 dB	≤ 3 MHz	FDD_A ^{Note 7} , TDD_A	-121	-50
			FDD_B	-120.5	-50
			FDD_C, TDD_C	-120	-50
			FDD_D	-119.5	-50
			FDD_E, TDD_E	-119	-50
			FDD_F	-118.5	-50
			FDD_G ^{Note 4}	-118	-50
			FDD_H	-117.5	-50
±10	≥-7.76 dB	≥ 5 MHz	Note 3	Note 3	Note 3

NOTE 1: This Io condition is expressed as the average Io per RE over all REs in an OFDM symbol.
 NOTE 2: Ts is the basic timing unit defined in TS 36.211 [26].
 NOTE 3: The same bands and the same Io conditions for each band apply for this requirement as for the corresponding requirement with downlink bandwidth ≤ 3 MHz.
 NOTE 4: Except Band 29.
 NOTE 5: The condition level is increased by Δ>0, when applicable, as described in TS 36.521-3 [25] Sections I.4.2 and I.4.3.
 NOTE 6: E-UTRA operating band groups are as defined in Section 4.4.2.
 NOTE 7: Except Band 32.
 NOTE 8: Io is defined in subframes indicated for PCell measurements by the time domain measurement resource restriction pattern. The specified Io range applies to CRS and non-CRS symbols. Io may be different in different symbols within a subframe.
 NOTE 9: CRS \hat{E}_s/lot is in subframes indicated for PCell measurements by the time-domain measurement resource restriction pattern.

NOTE: It is up to the UE implementation whether the UE Rx-Tx time difference measurement is performed in any subframe or in subframes indicated by the time-domain measurement resource restriction pattern.

The normative reference for this requirement is TS 36.133 [23] clause 9.1.9.4 and A.9.7.6.

8.1.6.4 Test description

The test has two test points with time delays starting at 32 T_s and 5008 T_s, respectively. In this test case, there are three cells, Cell 1, Cell 2 and Cell 3, on the same RF channel. Cell 1 is the PCell on which UE Rx-Tx is measured. Cell 2 and Cell 3 are the interfering cells. A non-MBSFN ABS pattern is configured in each of the Cell 2 and Cell 3 during the entire test. The tested UE is connected to the PCell and configured to transmit SRS signals periodically. The SRS configuration is provided to the UE before the measurement starts. The UE is configured to report UE Rx-Tx time difference measurement. The test equipment measures the transmit timing of the UE using the transmitted SRS. The test equipment then compares this timing to the UE Rx-Tx measurement reported by the UE. The UE is configured by higher layers via Cell 1 with a time-domain measurement resource restriction pattern for performing E-UTRAN FDD intra-frequency measurements on PCell. The UE is also provided via higher layers with the CRS assistance information for Cell 2. The information for both measurement patterns and the CRS assistance information shall be provided via RRC to the UE before the measurement starts.

8.1.6.4.1 Initial conditions

Test Environment: Normal as defined in TS 36.508 [18] clause 4.1.

Frequencies to be tested: According to TS 36.521-1 [24] Annex E table E-1 and TS 36.508 [18] clauses 4.4.2 and 4.3.1.

Channel Bandwidth to be tested: 10 MHz as defined in TS 36.508 [18] clause 4.3.1.

1. Connect the SS (node B emulator) and AWGN noise source to the UE antenna connectors as shown in TS 36.508 [18] Annex A Figure A.54 (without faders).
2. Propagation conditions are set according to clause 4.6.2.1.
3. Message contents are defined in clause 8.1.6.4.3.
4. Cell 1 is the serving cell. Cell 1 is the cell used for connection setup with the power levels set according to TS 36.521-3 [25] clauses C.0 and C.1 for this test. Cell 2 and Cell 3 are the neighbour cells. All cells are on the same RF channel. Cell 3 in the test is the Cell 4 defined in clause 4.7.1

Table 8.1.6.4.1-1: General test parameters for TDD UE Rx–Tx time difference measurement under time-domain measurement resource restriction with CRS assistance information and non-MBSFN ABS

Parameter	Unit	Value	Comment
Serving cell (PCell)		Cell 1	Cell to be measured
Neighbour cell		Cell 2 and Cell 3	Cell 2 is the first interfering cell to Cell 1, whilst Cell 3 is the second interfering cell to Cell 1.
ABS transmission configuration		Non-MBSFN ABS	As defined in TS 36.521-3 [25] Table C.3.1.2.1-1
E-UTRA RF Channel Number		1	One TDD carrier frequency is used
Downlink Channel Bandwidth ($BW_{channel}$)	MHz	10	For all cells in the test
CP length		Normal	For all cells in the test
Special subframe configuration		6	For all cells in the test. For special subframe configurations see Table 4.2-1 in TS 36.211 [26].
Uplink/downlink subframe configuration		1	For all cells in the test. For uplink-downlink subframe configurations see Table 4.2-2 in TS 36.211 [26].
DRX			OFF
Time offset between cells	μ s	Cell 2 offset with respect to Cell 1: 3 Cell 3 offset with respect to Cell 1: 2	Three synchronous cells
Physical cell ID PCI		$(PCI_{cell1} - PCI_{cell2}) \bmod 6 = 0$ $(PCI_{cell1} - PCI_{cell3}) \bmod 6 \neq 0$ PCI_{cell1} not equal to PCI_{cell2}	Cell PCIs are selected so that both conditions are met
ABS pattern		'00000000010000000001'	Non-MBSFN ABS. TDD ABS Pattern Info IE, as defined in TS 36.423 [35], clause 9.2.54. The first/leftmost bit corresponds to the PCell subframe #0 of a radio frame satisfying $SFN \bmod x = 0$, where x is the size of the bit string (20) divided by 10. No MBSFN subframes are configured in the ABS subframes. Configured in Cell 2 and Cell 3 during the testing.
Time-domain measurement resource restriction pattern for serving cell measurements		'00000000010000000001'	Configured for measurements on Cell 1.
CRS assistance information	physCellId	see PCI conditions above	The CRS assistance information is provided for Cell 2 and Cell 3 in CRS-AssistanceInfo. It includes a single MBSFN-SubframeConfig
	antennaPortsCount	1	

	mbsfn-SubframeConfigList		oneFrame = '000000'	element with subframe allocation one Frame='000000'.
--	--------------------------	--	---------------------	--

8.1.6.4.2 Test procedure

1. Bring the UE to State 3A or 3A-RF according to TS 36.508 [18] clause 4.5.3A or 5.2A.2, with exceptions listed in 7.2A.6 using a value of initial timing advance command $T_A = 2$ in the Random Access Response which indicates an initial timing advance value $N_{TA} = 32 T_s$. Note that in the remainder of the test the timing advance command $T_A = 31$ which indicates a timing advance adjustment value $N_{TA} = 0 T_s$.
2. Set the parameters according to Tables 8.1.6.5-1 and 8.1.6.5-2 as appropriate. Propagation conditions are set according to clause 4.6.2.1.
3. The SS adjusts the downlink timing for Cell 1 to a delay of $+4 T_s$, compared to the current value.
4. Wait for 1.6s to allow for the possibility that the UE makes autonomous timing adjustments.
5. The SS shall transmit an LPP REQUEST CAPABILITIES message.
6. The UE shall transmit an LPP PROVIDE CAPABILITIES message indicating the ECID capabilities supported by the UE in the *ECID-ProvideCapabilities* IE. The IE *ueRxTxSupTDD-r13* shall be present (TRUE).
7. The SS shall transmit an LPP REQUEST LOCATION INFORMATION message, including the *ECID-RequestLocationInformation* IE. If the UE message at step 4b includes the *ackRequested* IE set to TRUE, then the SS shall send an acknowledgment in the LPP REQUEST LOCATION INFORMATION message.
8. The UE shall transmit an LPP PROVIDE LOCATION INFORMATION message including the *ecid-SignalMeasurementInformation* IE.
9. As soon as possible after step 8 the SS shall measure the transmit timing of the UE using the transmitted SRS, relative to the current downlink timing.
10. If the UE message at step 8 includes the *ackRequested* IE set to TRUE, then the SS shall send a LPP acknowledgment message.
11. The SS shall check the reported value of *ue-RxTxTimeDiff* in the *ecid-SignalMeasurementInformation* IE provided by the UE in step 8 and compare it with the value measured in step 9. The SS shall check that the reported value is within the limits specified in table 8.1.6.5-3 for test compared to the measured value. If the reported value is within the limits the number of successful results for test is increased by one. If the reported value is not within the limits, or the UE reports an error in the LPP PROVIDE LOCATION INFORMATION message in step 8, or does not respond at step 8 within the time given by the *time* IE in the *ECID-RequestLocationInformation* IE in step 7, then the number of unsuccessful results for test is increased by one.
12. Repeat steps 3-11 until the confidence level according to Annex D.4.3 is achieved.
NOTE: To avoid a large divergence between the sent TA and the set downlink timing, the SS may reset the downlink timing for Cell 1 to its initial value after a certain amount of loops. The loop during the reset does not count for the result statistics.
13. Repeat steps 1-12 for test point 2.

8.1.6.4.3 Message contents

Message contents are according to TS 36.508 [18] clause 5.2A.5.1 with the following exceptions:

Table 8.1.6.4.3-1: SoundingRS-RL-ConfigCommon-DEFAULT: TDD UE Rx-Tx time difference measurement under time-domain measurement resource restriction with CRS assistance information and non-MBSFN ABS

Derivation Path: TS 36.508 [18] clause 4.6.3, Table 4.6.3-21 SoundingRS-UL-ConfigCommon-DEFAULT			
Information Element	Value/remark	Comment	Condition
SoundingRS-UL-ConfigCommon-DEFAULT ::= SEQUENCE {			
setup SEQUENCE {			

srs-BandwidthConfig	bw0		
srs-SubframeConfig	sc1		FDD
ackNackSRS-SimultaneousTransmission	FALSE		
srsMaxUpPts	Not present		FDD
}			
}			

Table 8.1.6.4.3-2: SoundingRS-RL-ConfigDedicated-DEFAULT: TDD UE Rx–Tx time difference measurement under time-domain measurement resource restriction with CRS assistance information and non-MBSFN ABS

Derivation Path: TS 36.508 [18] clause 4.6.3, Table 4.6.3-22 SoundingRS-UL-ConfigDedicated-DEFAULT			
Information Element	Value/remark	Comment	Condition
SoundingRS-UL-ConfigDedicated-DEFAULT ::= CHOICE {			
setup SEQUENCE {			
srs-Bandwidth	bw5		
srs-HoppingBandwidth	hbw0		
freqDomainPosition	0		
duration	TRUE	Indefinite duration	
srs-ConfigIndex	0		
transmissionComb	0		
cyclicShift	cs0	No cyclic shift	
}			
}			

Table 8.1.6.4.3-3: LPP REQUEST CAPABILITIES: TDD UE Rx–Tx time difference measurement under time-domain measurement resource restriction with CRS assistance information and non-MBSFN ABS

Information Element	Value/remark
ecid-RequestCapabilities	TRUE

Table 8.1.6.4.3-3a: LPP PROVIDE CAPABILITIES: TDD UE Rx–Tx time difference measurement under time-domain measurement resource restriction with CRS assistance information and non-MBSFN ABS

Information Element	Value/remark
ueRxTxSupTDD-r13	TRUE

Table 8.1.6.4.3-4: ECID-RequestLocationInformation: TDD UE Rx–Tx time difference measurement under time-domain measurement resource restriction with CRS assistance information and non-MBSFN ABS

Derivation Path: TS 36.355 [4] clause 6.2			
Information Element	Value/remark	Comment	Condition
LPP-Message ::= SEQUENCE {			
transactionID SEQUENCE {			
Initiator	locationServer		
transactionNumber	1		
}			
endTransaction	FALSE		
sequenceNumber	Not present		
acknowledgement	Not present		
lpp-MessageBody CHOICE {			
c1 CHOICE {			
requestLocationInformation SEQUENCE {			
criticalExtensions CHOICE {			
c1 CHOICE {			
requestLocationInformation-r9 SEQUENCE {			

commonIEsRequestLocationInformation SEQUENCE {			
locationInformationType	locationMeasurementsRequired		
triggeredReporting	Not present		
periodicalReporting	Not present		
additionalInformation	onlyReturnInformationRequested		
qos SEQUENCE {			
horizontalAccuracy	Not present		
verticalCoordinateRequest	FALSE		
verticalAccuracy	Not present		
responseTime SEQUENCE {			
time	2		
responseTimeEarlyFix-r12	Not present		Rel-12 onwards
}			
velocityRequest	FALSE		
}			
environment	Not present		
locationCoordinateTypes	Not present		
velocityTypes	Not present		
}			
a-gnss-RequestLocationInformation	Not present		
otdoa-RequestLocationInformation	Not present		
ecid-RequestLocationInformation ::= SEQUENCE {			
requestedMeasurements	0 0 1	ueRxTxReq	
}			
epdu-RequestLocationInformation	Not Present		
}			
}			
}			
}			
}			
}			
}			
}			

Table 8.1.6.4.3-5: ECID-ProvideLocationInformation: TDD UE Rx-Tx time difference measurement under time-domain measurement resource restriction with CRS assistance information and non-MBSFN ABS

Derivation Path: TS 36.355 [4] clause 6.2			
Information Element	Value/remark	Comment	Condition
LPP-Message ::= SEQUENCE {			
transactionID SEQUENCE {			
Initiator	locationServer		
transactionNumber	1		
}			
endTransaction	TRUE		
sequenceNumber	(0..255)		
acknowledgement			
lpp-MessageBody CHOICE {			
c1 CHOICE {			
provideLocationInformation SEQUENCE {			
criticalExtensions CHOICE {			
c1 CHOICE {			
provideLocationInformation-r9 SEQUENCE {			
commonIEsProvideLocationInformation	Not present.		
a-gnss-ProvideLocationInformation	Not present		
otdoa-ProvideLocationInformation	Not present		
ecid-ProvideLocationInformation ::= SEQUENCE {			
ecid-SignalMeasurementInformation ::=			

SEQUENCE {			
primaryCellMeasuredResults	Not Present		
MeasuredResultsList ::= SEQUENCE (SIZE(1..32)) OF MeasuredResultsElement			
MeasuredResultsElement ::= SEQUENCE {			
physCellId			
cellGlobalId			
arfcnEUTRA			
systemFrameNumber			
rsrp-Result	Not Present		
rsrq-Result	Not Present		
ue-RxTxTimeDiff		Set according to specific sub-test and test point.	
}			
}			
}			
epdu-ProvideLocationInformation	Not present		
}			
}			
}			
}			
}			
}			

Table 8.1.6.4.3-6: RadioResourceConfigDedicated-SRB2-DRB(n, m): TDD UE Rx–Tx time difference measurement under time-domain measurement resource restriction with CRS assistance information and non-MBSFN ABS

Derivation Path: TS 36.508 [18] clause 4.6.3, Table 4.6.3-16			
Information Element	Value/remark	Comment	Condition
neighCellsCRS-Info-r11 ::= CHOICE {			
NeighCellsCRS-Info-r11 ::= CHOICE {			
Release	NULL		
Setup	CRS-AssistanceInfoList-r11		
}			
}			

Table 8.1.6.4.3-7: RadioResourceConfigDedicated-SRB2-DRB(n, m): TDD UE Rx–Tx time difference measurement under time-domain measurement resource restriction with CRS assistance information and non-MBSFN ABS

Derivation Path: TS 36.508 [18] clause 4.6.3, Table 4.6.3-16			
Information Element	Value/remark	Comment	Condition
CRS-AssistanceInfoList-r11 ::= SEQUENCE (SIZE (1..maxCellReport)) OF CRS-AssistanceInfo-r11			
CRS-AssistanceInfo-r11 ::= SEQUENCE {			
physCellId-r11	($PCI_{cell1} - PCI_{cell3} \bmod 6 = 0$) ($PCI_{cell2} - PCI_{cell3} \bmod 6 \neq 0$)	Cell PCIs are selected so that both conditions are met	
antennaPortsCount-r11	an1		
mbsfn-SubframeConfigList-r11	MBSFN-SubframeConfigList		
}			

Table 8.1.6.4.3-8: *RadioResourceConfigDedicated-SRB2-DRB(n, m)*: TDD UE Rx–Tx time difference measurement under time-domain measurement resource restriction with CRS assistance information and non-MBSFN ABS

Derivation Path: TS 36.508 [18] clause 4.6.3, Table 4.6.3-16			
Information Element	Value/remark	Comment	Condition
MBSFN-SubframeConfigList ::= SEQUENCE (SIZE (1..maxMBSFN-Allocations)) OF MBSFN-SubframeConfig			
MBSFN-SubframeConfig ::= SEQUENCE { subframeAllocation CHOICE { oneFrame	'000000'	Only the CRS information of Cell 2 is provided in CRS-AssistanceInfo. It includes a single MBSFN-SubframeConfig element with subframe allocation <i>oneFrame</i> ='000000' BIT STRING (SIZE(6))	
}			
}			

Table 8.1.6.4.3-9: *RadioResourceConfigDedicated-SRB2-DRB(n, m)*: Additional TDD UE Rx–Tx time difference measurement under time-domain measurement resource restriction with CRS assistance information and non-MBSFN ABS (felCIC)

Derivation Path: TS 36.508 [18] clause 4.6.3, Table 4.6.3-16 RadioResourceConfigDedicated-SRB2-DRB(n,m)			
Information Element	Value/remark	Comment	Condition
RadioResourceConfigDedicated-SRB2-DRB(n, m) ::= SEQUENCE { MeasSubframePatternPCell-r10 CHOICE { setup SEQUENCE { subframePatternTDD-r10 subframeConfig1-5-r10	'00000000010000000001'	BIT STRING (SIZE (20))	Cell 1
}			
}			
}			

8.1.6.5 Test requirement

Table 8.1.6.5-1 defines the primary level settings including test tolerances for the test.

The UE Rx – Tx time difference measurement accuracy shall fulfil the requirements in Table 8.1.6.5-3.

Table 8.1.6.5-1: Test parameters test parameters for TDD UE Rx–Tx time difference measurement under time-domain measurement resource restriction with CRS assistance information and non-MBSFN ABS

Parameter	Unit	Cell 1	Cell 2	Cell 3
E-UTRAN RF Channel Number		1	1	1
PDSCH Reference measurement channel defined in TS 36.521-3 [25] A.1.2		R.0 TDD	N/A	N/A

PDSCH allocation	n_{PRB}	13—36	N/A	N/A
PDCCH/PCFICH/PHICH Reference measurement channel defined in TS 36.521-3 [25] A.2.2		R.6 TDD	N/A	N/A
OCNG Patterns defined in TS 36.521-3 [25] D.2.1 (OP.1 TDD) and D.2.2 (OP.2 TDD)		OP.1 TDD	OP.2 TDD	OP.2 TDD
PBCH_RA	dB	0	Non-ABS and ABS subframe channel powers defined in TS 36.521-3 [25] Table C.3.1.2.1-1	
PBCH_RB	dB			
PSS_RA	dB			
SSS_RA	dB			
PCFICH_RB	dB			
PHICH_RA	dB			
PHICH_RB	dB			
PDCCH_RA	dB			
PDCCH_RB	dB			
PDSCH_RA	dB			
PDSCH_RB	dB			
OCNG_RA ^{Note1}	dB			
OCNG_RB ^{Note1}	dB			
N_{oc} ^{Note2}	dBm/15 kHz	-98	-98	-98
CRS \hat{E}_s/N_{oc}	dB	-2.60	3	1
CRS $\left(\hat{E}_s/I_{ot}\right)_{meas}$ ^{Note 3}	dB	-7.36	1.10	-0.90
CRS $\left(\hat{E}_s/I_{ot}\right)_{nonABS}$ ^{Note 3}	dB	-8.89	-1.48	-4.50
RSRP ^{Note 4}	dBm/15 kHz	-100.6	-95	-97
$(I_o)_{meas}$ ^{Note 4}	dBm/9 MHz	-	-	-
$(I_o)_{nonABS}$ ^{Note 4}	dBm/9 MHz	-63.40	-63.40	-63.40
Propagation Condition		AWGN		
<p>Note 1: OCNG shall be used such that the resources in the active cell are fully allocated and a constant total transmitted power spectral density is achieved for all OFDM symbols.</p> <p>Note 2: Interference from other cells and noise sources not specified in the test is assumed to be constant over subcarriers and time and shall be modelled as AWGN of appropriate power for N_{oc} to be fulfilled.</p> <p>Note 3: $\left(\hat{E}_s/I_{ot}\right)_{meas}$ is calculated in CRS REs in the subframes indicated for PCell measurements by measurement resource restriction pattern, whilst $\left(\hat{E}_s/I_{ot}\right)_{nonABS}$ is calculated in CRS REs in the subframes not indicated for PCell measurements by measurement resource restriction pattern.</p> <p>Note 4: RSRP and I_o levels have been derived from other parameters for information purposes. They are not settable parameters themselves. $(I_o)_{meas}$ is calculated in CRS symbols in the subframes indicated for PCell measurements by measurement resource restriction pattern, whilst $(I_o)_{nonABS}$ is calculated in CRS symbols</p>				

Table 8.1.6.5-2: Sounding Reference Symbol Configuration to be used in FDD UE Rx–Tx time difference test

Field	Value	Comment
UL bandwidth	50 RBs	Same as the DL bandwidth
srsBandwidthConfiguration	bw5	
srsSubframeConfiguration	sc1	
ackNackSrsSimultaneousTransmission	FALSE	
srsMaxUpPTS	TRUE	
srsBandwidth	0	No hopping
srsHoppingBandwidth	hbw0	

frequencyDomainPosition	0	
Duration	TRUE	Indefinite duration
Srs-ConfigurationIndex	10	SRS periodicity of 10ms for all Tests.
transmissionComb	0	
cyclicShift	cs0	No cyclic shift
SRS-AntennaPort	an1	Number of antenna ports used for SRS transmission
Note: For further information see clause 6.3.2 in TS 36.331 [22].		

Table 8.1.6.5-3: Test requirements UE Rx – Tx time difference measurement accuracy requirements

	Test requirement
Lowest reported value	(Measured value from step 7 - 13) T_s converted to RX-TX_TIME_DIFFERENCE according to Table 4.6.3-2
Highest reported value	(Measured value from step 7 + 13) T_s converted to RX-TX_TIME_DIFFERENCE according to Table 4.6.3-2

NOTE: The test in table 8.1.6.5-3 has two test points starting at 32 T_s and 5008 T_s .

The test tolerances are defined in Annex C.

For the overall test to pass, the ratio of successful reported values in each test point shall be more than 90% with a confidence level of 95%.

8.1.7 E-UTRAN FDD UE Rx-Tx time difference case for Category M1/M2 UE in CEModeA

8.1.7.1 Test purpose

The purpose of this test is to verify that the E-UTRAN FDD UE Rx – Tx time difference measurement accuracy for Category M1/M2 UEs is within the specified limits in TS 36.133 [23] clause 9.1.21.19 and 9.1.25.3.

8.1.7.2 Test applicability

This test applies to E-UTRA FDD UE Category M1/M2 release 14 and forward that supports ECID positioning.

8.1.7.3 Minimum conformance requirements

NOTE: This measurement is used for UE positioning purposes.

The UE RX-TX time difference is measured from the PCell.

The accuracy requirements in Table 8.1.7.3-1 are valid under the following conditions:

Conditions defined in TS 36.101 [2] clause 7.3 for reference sensitivity are fulfilled.

No changes to the uplink transmission timing are applied during the measurement period.

$RSRP_{dBm}$ according to clause E.1-1 for a corresponding Band.

Table 8.1.7.3-1: UE Rx – Tx time difference measurement accuracy for CEModeA

Accuracy	Conditions				
	\hat{E}_s/lot	Downlink transmission bandwidth of PCell	$I_o^{Note 1}$ range		
			E-UTRA operating band groups <small>Note 6</small>	Minimum I_o	Maximum I_o

T_s ^{Note 2}	dB	MHz		dBm/15kHz ^{Note 5}	dBm/BW _{Channel}
± 20	≥ -3 dB	≥ 6	FDD-M1_A, TDD-M1_A	-121	-50
			FDD-M1_B	-120.5	-50
			FDD-M1_C, TDD-M1_C	-120	-50
			FDD-M1_D	-119.5	-50
			FDD-M1_E, TDD-M1_E	-119	-50
			FDD-M1_F	-118.5	-50
			FDD-M1_G	-118	-50
			FDD-M1_H	-117.5	-50
			FDD-M1_N	-114.5	-50
± 10 ^{Note 8}	≥ -3 dB	≥ 24	Note 3	Note 3	Note 3
<p>NOTE 1: When in dBm/15kHz, the minimum Io condition is expressed as the average Io per RE over all REs in that symbol. Io may be different in different symbols within a subframe.</p> <p>NOTE 2: T_s is the basic timing unit defined in TS 36.211 [26].</p> <p>NOTE 3: The same bands and the same Io conditions for each band apply for this requirement as for the corresponding requirement with downlink bandwidth ≤ 3 MHz.</p> <p>NOTE 4: Except Band 29.</p> <p>NOTE 5: The condition level is increased by $\Delta > 0$, when applicable, as described in TS 36.521-3 [25] Sections I.4.2 and I.4.3.</p> <p>NOTE 6: E-UTRA operating band groups are as defined in Section 4.4.2.</p> <p>NOTE 7: Except Band 32.</p> <p>NOTE 8: Only for Category M2.</p>					

The normative reference for this requirement is TS 36.133 [23] clause 9.1.21.19, 9.1.25.3 and A.9.7.7.

8.1.7.4 Test description

There is only one active cell in the tests. The tested UE is connected with the serving cell, configured to transmit SRS signals periodically, and signalled to report UE Rx – Tx time difference measurement. The test equipment measures the transmit timing of the UE using the transmitted SRS. The test equipment then compares this timing to the UE Rx-Tx measurement reported by the UE.

8.1.7.4.1 Initial conditions

Test Environment: Normal as defined in TS 36.508 [18] clause 4.1.

Frequencies to be tested: Mid Range, as defined in TS 36.508 [18] clause 4.3.1.1.

Channel Bandwidth to be tested: 10 MHz as defined in TS 36.508 [18] clause 4.3.1.

1. Connect the SS (node B emulator) and AWGN noise source to the UE antenna connectors as shown in Annex A figure A.5.
2. Propagation conditions are set according to clause 4.6.2.1.
3. Message contents are defined in clause 8.1.7.4.3.
4. Cell 1 is the serving cell. Cell 1 is the cell used for connection setup with the power levels set according to TS 36.521-3 [25] clauses C.0 and C.1 for this test.

8.1.7.4.2 Test procedure

1. Bring the UE to Generic RB Established State 3A-RF-CE according to 3GPP TS 36.508 [18] clause 7.2A.3AA, using a value of initial timing advance command $T_A = 2$ in the Random Access Response which indicates an initial timing advance value $N_{TA} = 32 T_s$. Note that in the remainder of the test the timing advance command $T_A = 31$ which indicates a timing advance adjustment value $N_{TA} = 0 T_s$.
2. Set the parameters according to Table 8.1.7.5-1 and 8.1.7.5-2 as appropriate. Propagation conditions are set according to clause 4.6.2.1.
3. The SS adjusts the downlink timing for Cell 1 to a delay of $+8 T_s$, compared to the current value.
4. Wait for 1.6 s to allow for the possibility that the UE makes autonomous timing adjustments.

- 4a. The SS shall transmit an LPP REQUEST CAPABILITIES message.
- 4b. The UE shall transmit an LPP PROVIDE CAPABILITIES message indicating the ECID capabilities supported by the UE in the *ECID-ProvideCapabilities* IE.
5. The SS shall transmit an LPP REQUEST LOCATION INFORMATION message, including the *ECID-RequestLocationInformation* IE. If the UE message at step 4b includes the *ackRequested* IE set to TRUE, then the SS shall send an acknowledgment in the LPP REQUEST LOCATION INFORMATION message.
6. The UE shall transmit an LPP PROVIDE LOCATION INFORMATION message including the *ecid-SignalMeasurementInformation* IE.
7. As soon as possible after step 6 the SS shall measure the transmit timing of the UE using the transmitted SRS, relative to the current downlink timing.
8. If the UE message at step 6 includes the *ackRequested* IE set to TRUE, then the SS shall send a LPP acknowledgment message.
9. The SS shall check the reported value of *ue-RxTxTimeDiff* in the *ecid-SignalMeasurementInformation* IE provided by the UE in step 6 and compare it with the value measured in step 7. The SS shall check that the reported value is within the limits specified in table 8.1.7.5-3 compared to the measured value. If the reported value is within the limits the number of successful results is increased by one. If the reported value is not within the limits, or the UE reports an error in the LPP PROVIDE LOCATION INFORMATION message in step 6, or does not respond at step 6 within the time given by the *time* IE in the *ECID-RequestLocationInformation* IE in step 5, then the number of unsuccessful results is increased by one.
10. Repeat steps 3-9 until the confidence level according to Annex D.4.3 is achieved.
NOTE: To avoid a large divergence between the sent TA and the set downlink timing, the SS may reset the downlink timing for Cell 1 to its initial value after a certain amount of loops. The loop during the reset does not count for the result statistics.

8.1.7.4.3 Message contents

Message contents are according to TS 36.508 [18] clause 4.6 with the following exceptions:

Table 8.1.7.4.3-1: SoundingRS-RL-ConfigCommon-DEFAULT: UE Rx – Tx time difference for E-UTRAN FDD test requirement

Derivation Path: TS 36.508 [18] clause 4.6.3, Table 4.6.3-21 SoundingRS-UL-ConfigCommon-DEFAULT			
Information Element	Value/remark	Comment	Condition
SoundingRS-UL-ConfigCommon-DEFAULT ::= SEQUENCE {			
setup SEQUENCE {			
srs-BandwidthConfig	bw5		
srs-SubframeConfig	sc1		FDD
ackNackSRS-SimultaneousTransmission	FALSE		
srsMaxUpPts	Not present		FDD
}			

Table 8.1.7.4.3-2: SoundingRS-RL-ConfigDedicated-DEFAULT: UE Rx – Tx time difference for E-UTRAN FDD test requirement

Derivation Path: TS 36.508 [18] clause 4.6.3, Table 4.6.3-22 SoundingRS-UL-ConfigDedicated-DEFAULT			
Information Element	Value/remark	Comment	Condition
SoundingRS-UL-ConfigDedicated-DEFAULT ::= CHOICE {			
setup SEQUENCE {			
srs-Bandwidth	bw0	bw0 used with no frequency hopping. bw3 used with frequency hopping	
srs-HoppingBandwidth	hbw0		
freqDomainPosition	0		
duration	TRUE	Indefinite duration	

srs-ConfigIndex	0		
transmissionComb	0		
cyclicShift	cs0	No cyclic shift	
}			
}			

Table 8.1.7.4.3-2a: LPP REQUEST CAPABILITIES: UE Rx – Tx time difference for E-UTRAN FDD test requirement

Information Element	Value/remark
ecid-RequestCapabilities	TRUE

Table 8.1.7.4.3-3: ECID-RequestLocationInformation: UE Rx – Tx time difference for E-UTRAN FDD test requirement

Derivation Path: TS 36.355 clause 6.2			
Information Element	Value/remark	Comment	Condition
LPP-Message ::= SEQUENCE {			
transactionID SEQUENCE {			
Initiator	locationServer		
transactionNumber	1		
}			
endTransaction	FALSE		
sequenceNumber	Not present		
acknowledgement	Not present		
lpp-MessageBody CHOICE {			
c1 CHOICE {			
requestLocationInformation SEQUENCE {			
criticalExtensions CHOICE {			
c1 CHOICE {			
requestLocationInformation-r9 SEQUENCE {			
commonIEsRequestLocationInformation SEQUENCE {			
locationInformationType	locationMeasurementsRequired		
triggeredReporting	Not present		
periodicalReporting	Not present		
additionalInformation	onlyReturnInformationRequested		
qos SEQUENCE {			
horizontalAccuracy	Not present		
verticalCoordinateRequest	FALSE		
verticalAccuracy	Not present		
responseTime SEQUENCE {			
time	2		
responseTimeEarlyFix-r12	Not present		Rel-12 onwards
}			
velocityRequest	FALSE		
}			
environment	Not present		
locationCoordinateTypes	Not present		
velocityTypes	Not present		
}			
a-gnss-RequestLocationInformation	Not present		
otdoa-RequestLocationInformation	Not present		
ecid-RequestLocationInformation ::= SEQUENCE {			
requestedMeasurements	0 0 1	ueRxTxReq	
}			
epdu-RequestLocationInformation	Not Present		
}			
}			
}			
}			

}			
}			
}			
}			
}			

8.1.7.5 Test requirement

Table 8.1.7.5-1 defines the primary level settings including test tolerances.

Table 8.1.7.5-1: FDD UE Rx – Tx time difference test parameters

Parameter	Unit	Test 1
E-UTRAN RF Channel Number		1
Channel Bandwidth ($BW_{channel}$)	MHz	10
DRX		OFF
PRACH Configuration		PRACH_4CE As specified in TS 36.133 [23] A.3.16
MPDCCH Reference measurement channel ^{Note1}		R.16 FDD
OCNG Pattern ^{Note2}		OP.21 FDD
PBCH_RA	dB	0
PBCH_RB	dB	
PSS_RA	dB	
SSS_RA	dB	
PHICH_RA	dB	
PHICH_RB	dB	
MPDCCH_RA	dB	
MPDCCH_RB	dB	
OCNG_RA ^{Note3}	dB	
OCNG_RB ^{Note3}	dB	
N_{oc}	dBm/15 kHz	-98
\hat{E}_s / N_{oc}	dB	-2.7
\hat{E}_s / I_{ot}	dB	-2.7
I_o ^{Note4}	dBm/9 MHz	-65.5
Propagation Condition		AWGN
Note 1: For the reference measurement channels, see TS 36.521-3 [25] A.7.1 Note 2: For the OCNG pattern, see clause A.3.2. Note 3: OCNG shall be used such that both cells are fully allocated and a constant total transmitted power spectral density is achieved for all OFDM symbols. Note 4: I_o level has been derived from other parameters for information purpose. It is not a settable parameter.		

Table 8.1.7.5-2: Sounding Reference Symbol Configuration to be used in FDD UE Rx – Tx time difference test

Field	Test 1	Comment
srsBandwidthConfiguration	bw5	
srsSubframeConfiguration	sc1	
ackNackSrsSimultaneousTransmission	FALSE	
srsMaxUpPTS	N/A	Not applicable for FDD
srsBandwidth	0	No hopping
srsHoppingBandwidth	hbw0	
frequencyDomainPosition	0	
Duration	TRUE	Indefinite duration
Srs-ConfigurationIndex	0	SRS periodicity of 2ms for all Tests.
transmissionComb	0	

cyclicShift	cs0	No cyclic shift
SRS-AntennaPort	an1	Number of antenna ports used for SRS transmission
Note: For further information see clause 6.3.2 in TS 36.331 [22].		

The UE Rx – Tx time difference measurement accuracy shall fulfil the requirements in Table 8.1.7.5-3.

Table 8.1.7.5-3: Test requirements UE Rx – Tx time difference measurement accuracy requirements

Lowest reported value	Category M1: (Measured value from step 7 – 23) T_s converted to RX-TX_TIME_DIFFERENCE according to Table 4.6.3-1 Category M2: (Measured value from step 7 – 13) T_s converted to RX-TX_TIME_DIFFERENCE according to Table 4.6.3-1
Highest reported value	Category M1: (Measured value from step 7 + 23) T_s converted to RX-TX_TIME_DIFFERENCE according to Table 4.6.3-1 Category M2: (Measured value from step 7 + 13) T_s converted to RX-TX_TIME_DIFFERENCE according to Table 4.6.3-1

The test tolerances are defined in Annex C.

The rate of successful tests during repeated tests shall be at least 90% with a confidence level of 95%.

8.1.8 E-UTRAN HD-FDD UE Rx-Tx time difference case for Category M1/M2 UE in CEModeA

8.1.8.1 Test purpose

The purpose of this test is to verify that the E-UTRAN HD-FDD UE Rx – Tx time difference measurement accuracy for Category M1/M2 UEs is within the specified limits in TS 36.133 [23] clause 9.1.21.19 and 9.1.25.3.

8.1.8.2 Test applicability

This test applies to E-UTRA HD-FDD UE Category M1/M2 release 14 and forward that supports ECID positioning.

8.1.8.3 Minimum conformance requirements

Same in section 8.1.7.3.

The normative reference for this requirement is TS 36.133 [23] clause 9.1.21.19, 9.1.25.3 and A.9.7.8.

8.1.8.4 Test description

Same as in clause 8.1.7.4.

8.1.8.4.1 Initial conditions

Same as in clause 8.1.7.4.1.

8.1.8.4.2 Test procedure

Same as in clause 8.1.7.4.2.

8.1.8.4.3 Message contents

Same as in clause 8.1.7.4.3.

8.1.8.5 Test requirement

Table 8.1.8.5-1 defines the primary level settings including test tolerances.

Table 8.1.8.5-1: HD-FDD UE Rx – Tx time difference test parameters

Parameter	Unit	Test 1
E-UTRAN RF Channel Number		1
Channel Bandwidth ($BW_{channel}$)	MHz	10
DRX		OFF
PRACH Configuration		PRACH_4CE As specified in TS 36.133 [23] A.3.16
MPDCCH Reference measurement channel ^{Note1}		R.6 HD-FDD
OCNG Pattern ^{Note2}		OP.21 FDD
PBCH_RA	dB	0
PBCH_RB	dB	
PSS_RA	dB	
SSS_RA	dB	
PHICH_RA	dB	
PHICH_RB	dB	
MPDCCH_RA	dB	
MPDCCH_RB	dB	
OCNG_RA ^{Note3}	dB	
OCNG_RB ^{Note3}	dB	
N_{oc}	dBm/15 kHz	-98
\hat{E}_s / N_{oc}	dB	-2.7
\hat{E}_s / I_{ot}	dB	-2.7
I_o ^{Note4}	dBm/9 MHz	-65.5
Propagation Condition		AWGN
Note 1: For the reference measurement channels, see TS 36.521-3 [25] A.7.2 Note 2: For the OCNG pattern, see clause A.3.2. Note 3: OCNG shall be used such that both cells are fully allocated and a constant total transmitted power spectral density is achieved for all OFDM symbols. Note 4: I_o level has been derived from other parameters for information purpose. It is not a settable parameter.		

Table 8.1.8.5-2: Sounding Reference Symbol Configuration to be used in HD-FDD UE Rx – Tx time difference test

Field	Test 1	Comment
srsBandwidthConfiguration	bw5	
srsSubframeConfiguration	sc1	
ackNackSrsSimultaneousTransmission	FALSE	
srsMaxUpPTS	N/A	Not applicable for FDD
srsBandwidth	0	No hopping
srsHoppingBandwidth	hbw0	
frequencyDomainPosition	0	
Duration	TRUE	Indefinite duration
Srs-ConfigurationIndex	0	SRS periodicity of 2ms for all Tests.
transmissionComb	0	
cyclicShift	cs0	No cyclic shift
SRS-AntennaPort	an1	Number of antenna ports used for SRS transmission

Note: For further information see clause 6.3.2 in TS 36.331 [22].

The UE Rx – Tx time difference measurement accuracy shall fulfil the requirements in Table 8.1.8.5-3.

Table 8.1.8.5-3: Test requirements UE Rx – Tx time difference measurement accuracy requirements

Lowest reported value	Category M1: (Measured value from step 7 – 23) T_s converted to RX-TX_TIME_DIFFERENCE according to Table 4.6.3-1 Category M2: (Measured value from step 7 - 13) T_s converted to RX-TX_TIME_DIFFERENCE according to Table 4.6.3-1
Highest reported value	Category M1: (Measured value from step 7 + 23) T_s converted to RX-TX_TIME_DIFFERENCE according to Table 4.6.3-1 Category M2: (Measured value from step 7 + 13) T_s converted to RX-TX_TIME_DIFFERENCE according to Table 4.6.3-1

The test tolerances are defined in Annex C.

The rate of successful tests during repeated tests shall be at least 90% with a confidence level of 95%.

8.1.9 E-UTRAN TDD UE Rx-Tx time difference case for Category M1/M2 UE in CEModeA

8.1.9.1 Test purpose

The purpose of this test is to verify that the E-UTRAN TDD UE Rx – Tx time difference measurement accuracy for Category M1/M2 UEs is within the specified limits in TS 36.133 [23] clause 9.1.21.19 and 9.1.25.3.

8.1.9.2 Test applicability

This test applies to E-UTRA TDD UE Category M1/M2 release 14 and forward that supports ECID positioning.

8.1.9.3 Minimum conformance requirements

Same in section 8.1.7.3.

The normative reference for this requirement is TS 36.133 [23] clause 9.1.21.19, 9.1.25.3 and A.9.7.9.

8.1.9.4 Test description

Same as in clause 8.1.7.4.

8.1.9.4.1 Initial conditions

Same as in clause 8.1.7.4.1.

8.1.9.4.2 Test procedure

Same as in clause 8.1.7.4.2.

8.1.9.4.3 Message contents

Same as in clause 8.1.7.4.3 with the following exceptions:

Table 8.1.9.4.3-1: SoundingRS-RL-ConfigCommon-DEFAULT: UE Rx – Tx time difference for E-UTRAN TDD test requirement

Derivation Path: TS 36.508 [18] clause 4.6.3, Table 4.6.3-21 SoundingRS-UL-ConfigCommon-DEFAULT			
Information Element	Value/remark	Comment	Condition
SoundingRS-UL-ConfigCommon-DEFAULT ::= SEQUENCE {			
setup SEQUENCE {			
srs-BandwidthConfig	bw5		
srs-SubframeConfig	Sc3		TDD
ackNackSRS-SimultaneousTransmission	FALSE		
srsMaxUpPts	FALSE		TDD
}			

Table 8.1.9.4.3-2: SoundingRS-RL-ConfigDedicated-DEFAULT: UE Rx – Tx time difference for E-UTRAN TDD test requirement

Derivation Path: TS 36.508 [18] clause 4.6.3, Table 4.6.3-22 SoundingRS-UL-ConfigDedicated-DEFAULT			
Information Element	Value/remark	Comment	Condition
SoundingRS-UL-ConfigDedicated-DEFAULT ::= CHOICE {			
setup SEQUENCE {			
srs-Bandwidth	bw0	bw0 used with no frequency hopping. bw3 used with frequency hopping	
srs-HoppingBandwidth	hbw0		
freqDomainPosition	0		
duration	TRUE	Indefinite duration	
srs-ConfigIndex	15		
transmissionComb	0		
cyclicShift	cs0	No cyclic shift	
}			

8.1.9.5 Test requirement

Table 8.1.9.5-1 defines the primary level settings including test tolerances.

Table 8.1.9.5-1: TDD UE Rx – Tx time difference test parameters

Parameter	Unit	Test 1
E-UTRAN RF Channel Number		1
Channel Bandwidth (BW _{channel})	MHz	10
DRX		OFF
PRACH Configuration		PRACH_4CE As specified in TS 36.133 [23] A.3.16
MPDCCH Reference measurement channel ^{Note1}		R.14 TDD
OCNG Pattern ^{Note2}		OP.11 TDD
PBCH_RA	dB	0
PBCH_RB	dB	
PSS_RA	dB	
SSS_RA	dB	
PHICH_RA	dB	
PHICH_RB	dB	
MPDCCH_RA	dB	

MPDCCH_RB	dB	
OCNG_RA ^{Note3}	dB	
OCNG_RB ^{Note3}	dB	
N_{oc}	dBm/15 kHz	-98
\hat{E}_s / N_{oc}	dB	-2.7
\hat{E}_s / I_{ot}	dB	-2.7
I_o ^{Note4}	dBm/9 MHz	-65.5
Propagation Condition		AWGN
<p>Note 1: For the reference measurement channels, see TS 36.521-3 [25] A.7.3</p> <p>Note 2: For the OCNG pattern, see clause A.3.2.</p> <p>Note 3: OCNG shall be used such that both cells are fully allocated and a constant total transmitted power spectral density is achieved for all OFDM symbols.</p> <p>Note 4: I_o level has been derived from other parameters for information purpose. It is not a settable parameter.</p>		

Table 8.1.9.5-2: Sounding Reference Symbol Configuration to be used in TDD UE Rx – Tx time difference test

Field	Test 1	Comment
srsBandwidthConfiguration	bw5	
srsSubframeConfiguration	sc3	
ackNackSrsSimultaneousTransmission	FALSE	
srsMaxUpPTS	FALSE	
srsBandwidth	0	No hopping
srsHoppingBandwidth	hbw0	
frequencyDomainPosition	0	
Duration	TRUE	Indefinite duration
Srs-ConfigurationIndex	15	SRS periodicity of 10ms
transmissionComb	0	
cyclicShift	cs0	No cyclic shift
SRS-AntennaPort	an1	Number of antenna ports used for SRS transmission
<p>Note: For further information see clause 6.3.2 in TS 36.331 [22].</p>		

The UE Rx – Tx time difference measurement accuracy shall fulfil the requirements in Table 8.1.9.5-3.

Table 8.1.9.5-3: Test requirements UE Rx – Tx time difference measurement accuracy requirements

Lowest reported value	<p>Category M1: (Measured value from step 7 – 23) T_s converted to RX-TX_TIME_DIFFERENCE according to Table 4.6.3-2</p> <p>Category M2: (Measured value from step 7 – 13) T_s converted to RX-TX_TIME_DIFFERENCE according to Table 4.6.3-2</p>
Highest reported value	<p>Category M1: (Measured value from step 7 + 23) T_s converted to RX-TX_TIME_DIFFERENCE according to Table 4.6.3-2</p> <p>Category M2: (Measured value from step 7 + 13) T_s converted to RX-TX_TIME_DIFFERENCE according to Table 4.6.3-2</p>

The test tolerances are defined in Annex C.

The rate of successful tests during repeated tests shall be at least 90% with a confidence level of 95%.

9 E-UTRA OTDOA measurement requirements

9.0 General

This clause defines the minimum performance requirements for OTDOA FDD and TDD E-UTRA UEs and UEs supporting NR EN-DC.

9.1 RSTD Intra-Frequency Measurements

9.1.1 FDD RSTD Measurement Reporting Delay

9.1.1.1 Test purpose

To verify that the RSTD measurement reporting delay meets the requirements in an environment with fading propagation conditions.

9.1.1.2 Test applicability

This test applies to all types of E-UTRA FDD UE release 9 and forward that supports UE-assisted OTDOA except UE Category 1bis.

9.1.1.3 Minimum conformance requirements

When the physical layer cell identities of neighbour cells together with the OTDOA assistance data are provided, the UE shall be able to detect and measure intra-frequency RSTD, specified in 3GPP TS 36.214 [6], for at least $n=16$ cells, including the reference cell, on the same carrier frequency f_1 as that of the reference cell within

$T_{\text{RSTDIntraFreqFDD,E-UTRAN}}$ ms as given below (see also Figure 9.1.1.3-1):

$$T_{\text{RSTDIntraFreqFDD,E-UTRAN}} = T_{\text{PRS}} \cdot (M - 1) + \Delta \quad \text{ms}$$

where

$T_{\text{RSTDIntraFreqFDD,E-UTRAN}}$ is the total time for detecting and measuring at least n cells,

T_{PRS} is the cell-specific positioning subframe configuration period as defined in 3GPP TS 36.211 [26],

M is the number of PRS positioning occasions as defined in Table 9.1.1.3-1, where each PRS positioning occasion comprises of N_{PRS} ($1 \leq N_{\text{PRS}} \leq 6$) consecutive downlink positioning subframes defined in 3GPP TS 36.211 [26], and

$\Delta = 160 \cdot \left\lceil \frac{n}{M} \right\rceil$ ms is the measurement time for a single PRS positioning occasion which includes the sampling time and the processing time.

Table 9.1.1.3-1: Number of PRS positioning occasions within $T_{\text{RSTDIntraFreqFDD,E-UTRAN}}$

Positioning subframe configuration period T_{PRS}	Number of PRS positioning occasions M
	f_1 <small>Note 1</small>
160 ms	16
>160 ms	8
Note 1: When only intra-frequency RSTD measurements are performed over cells belonging to the serving FDD carrier frequency f_1 .	

The UE physical layer shall be capable of reporting RSTD for the reference cell and all the neighbour cells i out of at least $(n-1)$ neighbour cells within $T_{RSTDIntraFreqFDD,E-UTRAN}$ provided:

$$\left(PRS \hat{E}_s / Iot \right)_{ref} \geq -6 \text{ dB for all Frequency Bands for the reference cell,}$$

$$\left(PRS \hat{E}_s / Iot \right)_i \geq -13 \text{ dB for all Frequency Bands for neighbour cell } i,$$

$\left(PRS \hat{E}_s / Iot \right)_{ref}$ and $\left(PRS \hat{E}_s / Iot \right)_i$ conditions apply for all subframes of at least $L = \frac{M}{2}$ PRS positioning occasions,

PRP 1,2_{dBm} according to clause E.2 for a corresponding Band.

The time $T_{RSTDIntraFreqFDD,E-UTRAN}$ starts from the first subframe of the PRS positioning occasion closest in time after both the OTDOA-RequestLocationInformation message and the OTDOA assistance data in the OTDOA-ProvideAssistanceData message as specified in 3GPP TS 36.355 [4], are delivered to the physical layer of the UE as illustrated in Figure 9.1.1.3-1.

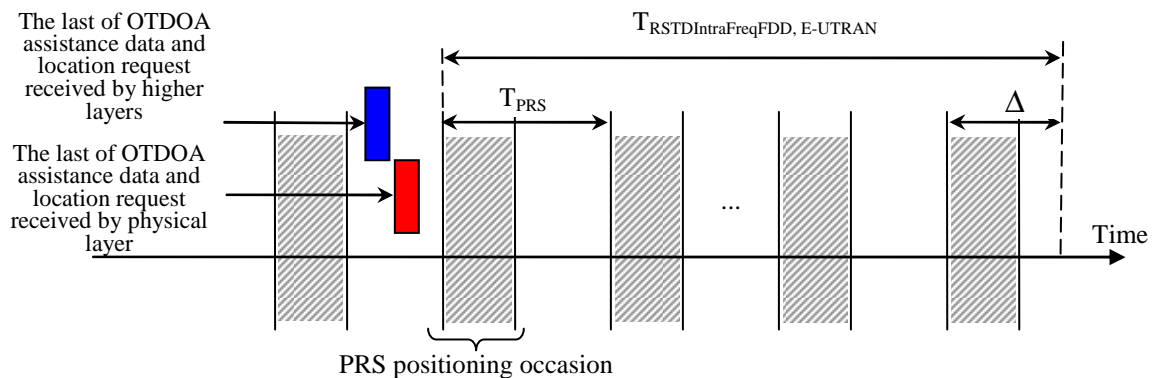

Figure 9.1.1.3-1: Illustration of the RSTD reporting time requirement in an FDD system

This requirement assumes that the measurement report is not delayed by other LPP signalling on the DCCH. This measurement reporting delay excludes a delay uncertainty resulted when inserting the measurement report to the TTI of the uplink DCCH. The delay uncertainty is: $2 \times TTI_{DCCH}$. This measurement reporting delay excludes any delay caused by no UL resources for UE to send the measurement report.

The normative reference for this requirement is TS 36.133 [23] clause 8.1.2.5.1 and A.8.12.1.

9.1.1.4 Test description

9.1.1.4.1 Initial conditions

Test Environment: Normal; as defined in TS 36.508 [18] clause 4.1.

Frequencies to be tested: Mid Range, as defined in TS 36.508 [18] clause 4.3.1.1.

Channel bandwidth to be tested: 10 MHz as defined in TS 36.508 [18] clause 4.3.1.

1. Connect the SS, faders and AWGN noise sources to the UE antenna connector or antenna connectors as shown in Annex A, Figure A.4.

2. The general test parameter settings are set up according to Table 9.1.1.4.1-1.
3. Propagation conditions are set according to clause 4.7.2.1.
4. Message contents are defined in clause 9.1.1.4.3.
5. In the test there are three synchronized cells: Cell 1, Cell 2 and Cell 3. Cell 1 is the OTDOA assistance data reference as well as the serving cell. Cell 2 and Cell 3 are the neighbour cells. All cells are on the same RF channel. Cell 3 in the test is the Cell 4 defined in clause 4.7.1. The assistance data neighbour cell list includes in total 15 cells, where 13 of the cells are not simulated (dummy cells; as defined in 3GPP TS 37.571-5 clause 7.2.2).
6. The true RSTD (which is the receive time difference for frame 0 between two cells as seen at the UE antenna connector) is set to 31 Ts (about 1 μ s) between neighbour Cell 2 and serving Cell 1; and set to -31 Ts (about -1 μ s) between neighbour Cell 3 and serving Cell 1.

Table 9.1.1.4.1-1: General test parameters for E-UTRAN FDD intra-frequency RSTD measurement reporting delay under fading propagation conditions

Parameter	Unit	Value	Comment
Reference cell		Cell 1	Reference cell is the cell in the OTDOA assistance data with respect to which the RSTD measurement is defined, as specified in 3GPP TS 36.214 [6] and 3GPP TS 36.355 [4]. The reference cell is the serving cell in this test case.
Neighbour cells		Cell 2 and Cell 3	Cell 2 and Cell 3 appear at random places in the neighbour cell list in the OTDOA assistance data, but Cell 2 always appears in the first half of the list, whilst Cell 3 appears in the second half of the list.
PCFICH/PDCCH/PHICH parameters		DL Reference Measurement Channel R.6 FDD	As specified in TS 36.521-3 [25] clause A.2.1
Channel Bandwidth (BW_{channel})	MHz	10	
PRS Transmission Bandwidth ^{Note 2}	RB	50	PRS are transmitted over the system bandwidth
PRS configuration index I_{PRS} ^{Note 2}		171	This corresponds to periodicity of 320 ms and PRS subframe offset of $I_{\text{PRS}} - 160$ DL subframes, as defined in 3GPP TS 36.211 [26], Table 6.10.4.3-1
Number of consecutive downlink positioning subframes N_{PRS} ^{Note 2}		1	As defined in 3GPP TS 36.211 [26]. The number of subframes in a positioning occasion
Physical cell ID PCI ^{Note 2}		(PCI of Cell 1 – PCI of Cell 2) mod 6 = 0 and (PCI of Cell 1 – PCI of Cell 3) mod 6 = 0	The cell PCIs are selected such that the relative shifts of PRS patterns among cells are as given by the test parameters
CP length ^{Note 2}		Normal	
DRX		ON	DRX parameters are further specified in Table 9.1.1.4.1-2
Radio frame receive time offset between the cells at the UE antenna connector ^{Note 3}	μ s	Cell 2 to Cell 1: 1 Cell 3 to Cell 1: -1	PRS are transmitted from synchronous cells
Expected RSTD ^{Note 1}	μ s	Cell 2: 3 Cell 3: 3 Other neighbour cells: randomly between -3 and 3	The expected RSTD is what is expected at the receiver. The corresponding parameter in the OTDOA assistance data specified in TS 36.355 [4] is the expectedRSTD indicator

Expected RSTD uncertainty for all neighbour cells ^{Note 1}	µs	5	The corresponding parameter in the OTDOA assistance data specified in TS 36.355 [4] is the expectedRSTD-Uncertainty index
Number of cells provided in OTDOA assistance data		16	Including the reference cell
PRS muting info ^{Note 2}		Cell 1: '11110000' Cell 2: '00001111' Cell 3: '11110000'	Corresponds to prs-MutingInfo defined in TS 36.355 [4]
T1	s	3	The length of the time interval from the beginning of each test
T2	s	1.28	The length of the time interval that follows immediately after time interval T1
T3	s	1.28	The length of the time interval that follows immediately after time interval T2
<p>Note 1: Parameters "Expected RSTD" and "Expected RSTD uncertainty for all neighbour cells" are not settable parameters. These are parameters signalled in LPP only. For the values to be used in LPP see Table 9.1.1.4.3-5 and TS 37.571-5 [20], clause 7.2.2.</p> <p>Note 2: Parameters "PRS Transmission Bandwidth", "PRS configuration index", "Number of consecutive downlink positioning subframes", "Physical cell ID PCI", "CP length", and "PRS muting info" are settable parameters and also parameters signalled in LPP. The values to be used for "Physical cell ID PCI" are as follows: Cell 1: 0, Cell 2: 6, Cell 3: 12. For all the values to be used in LPP see Table 9.1.1.4.3-5 and TS 37.571-5 [20], clause 7.2.2.</p> <p>Note 3: The parameter "Radio frame receive time offset between the cells at the UE antenna connector" is not a settable parameter but is used to set the "true RSTD" values in step 6 of clause 9.1.1.4.1.</p>			

Table 9.1.1.4.1-2: DRX parameters for E-UTRAN FDD intra-frequency RSTD measurement reporting delay under fading propagation conditions

Field	Value	Comment
onDurationTimer	psf1	As specified in 3GPP TS 36.331 [22], clause 6.3.2
drx-InactivityTimer	psf1	
drx-RetransmissionTimer	sf1	
longDRX-CycleStartOffset	sf320	
shortDRX	Disable	

9.1.1.4.2 Test procedure

The test consists of three consecutive time intervals, with duration of T1, T2 and T3 defined in Table 9.1.1.4.1-1. Cell 1 is active in T1, T2 and T3, whilst Cell 2 and Cell 3 are activated only in the beginning of T2. Cell 2 is active until the end of T3, and Cell 3 is active until the end of T2. The beginning of the time interval T2 shall be aligned 5 ms before the first PRS positioning subframe of a positioning occasion in the reference cell, where 5 ms is the necessary test tolerance. Cell 1 transmits PRS in T2, while Cell 2 transmits PRS only in T3, and Cell 3 transmits PRS only in T2.

NOTE: The information on when PRS is muted is conveyed to the UE using PRS muting information in the OTDOA assistance data.

The OTDOA-RequestLocationInformation message and the OTDOA assistance data as defined in clause 9.1.1.4.3 shall be provided to the UE during T1. The last TTI containing the OTDOA-RequestLocationInformation message shall be provided to the UE ΔT ms before the start of T2, where $\Delta T = 150$ ms is the maximum processing time of the OTDOA-RequestLocationInformation message and the OTDOA assistance data.

1. Ensure that the UE is in state Generic RB Established State 3A-RF according to 3GPP TS 36.508 [18] clause 7.2A.3.
2. The SS shall send a RESET UE POSITIONING STORED INFORMATION message.

3. Set the parameters according to Table 9.1.1.5-1. Propagation conditions are set according to clause 4.7.2.2 (ETU30).
4. T1 starts.
5. The SS shall transmit an RRCConnectionReconfiguration message with the DRX configuration. PDCCHs indicating new transmissions shall be sent continuously until the start of T2 to ensure that the UE would not enter the DRX state before T2.
6. The UE shall transmit RRCConnectionReconfigurationComplete message.
- 6a. The SS shall transmit an LPP REQUEST CAPABILITIES message.
- 6b. The UE shall transmit an LPP PROVIDE CAPABILITIES message indicating the OTDOA capabilities supported by the UE in the *OTDOA-ProvideCapabilities* IE.
7. The SS shall send a LPP PROVIDE ASSISTANCE DATA message, including the *OTDOA-ProvideAssistanceData* IE. The position of neighbour Cell 2 in the *OTDOA-NeighbourCellInfoList* is randomly selected to be in the first 7 elements of the sequence, and the position of neighbour Cell 3 is randomly selected to be in the last 8 elements of the sequence, as described in 3GPP TS 37.571-5 [20], clause 7.2.3. If the UE message at step 6b includes the *ackRequested* IE set to TRUE, then the SS shall send an acknowledgment in the LPP PROVIDE ASSISTANCE DATA message.
8. The SS shall send a LPP REQUEST LOCATION INFORMATION message, including the *OTDOA-RequestLocationInformation* IE such that the UE receives the message ΔT ms before the start of T2, where $\Delta T = 150$ ms.
9. When T1 expires, the SS shall switch the power setting from T1 to T2 as specified in Table 9.1.1.5-2.
10. When T2 expires, the SS shall switch the power setting from T2 to T3 as specified in Table 9.1.1.5-2.
11. The UE shall transmit a LPP PROVIDE LOCATION INFORMATION message including the *OTDOA-ProvideLocationInformation* IE within the response time (see clause 4.7.3) specified in clause 9.1.1.5. The UE shall perform and report the RSTD measurements for both Cell 2 and Cell 3 with respect to the reference cell in the OTDOA assistance data, Cell 1. If the UE transmits an *OTDOA-ProvideLocationInformation* IE including the *rstd* field for both Cell 2 and Cell 3 within the response time then the number of successful tests is increased by one. If the UE fails to report the *OTDOA-ProvideLocationInformation* IE with both the *rstd* fields included within the response time then the number of failure tests is increased by one.
12. If the UE message at step 11 includes the *ackRequested* IE set to TRUE, the SS shall send a LPP acknowledgement message.
13. Repeat steps 2-12 until the confidence level according to Annex D is achieved. For each iteration, at step 7 change the random position of the Cells 2 and 3 in the *OTDOA-NeighbourCellInfoList*.

9.1.1.4.3 Message contents

Table 9.1.1.4.3-1: RESET UE POSITIONING STORED INFORMATION

Derivation Path: 36.509 [11] clause 6.9			
Information Element	Value/remark	Comment	Condition
UE Positioning Technology	0 0 0 0 0 0 1	OTDOA	

Table 9.1.1.4.3-2: MAC-MainConfig-RBC: FDD RSTD Measurement Reporting Delay

Derivation Path: TS 36.508 [18] clause 4.8.2.1.5, Table 4.8.2.1.5-1 MAC-MainConfig-RBC			
Information Element	Value/remark	Comment	Condition
MAC-MainConfig-RBC ::= SEQUENCE {			
drx-Config CHOICE {			
setup SEQUENCE {			
onDurationTimer	psf1		
drx-InactivityTimer	psf1		
drx-RetransmissionTimer	sf1		

longDRX-CycleStartOffset CHOICE {			
sf320	0		
}			
shortDRX	Not present		
}			
}			

Table 9.1.1.4.3-2a: LPP Request Capabilities

Information Element	Value/remark
otdoa-RequestCapabilities	TRUE

Table 9.1.1.4.3-3: LPP RequestLocationInformation

Derivation Path: 36.355 clause 6.2			
Information Element	Value/remark	Comment	Condition
LPP-Message ::= SEQUENCE {			
transactionID SEQUENCE {			
initiator	locationServer		
transactionNumber	1		
}			
endTransaction	FALSE		
sequenceNumber	Not present		
acknowledgement	Not present		
lpp-MessageBody CHOICE {			
c1 CHOICE {			
requestLocationInformation SEQUENCE {			
criticalExtensions CHOICE {			
c1 CHOICE {			
requestLocationInformation-r9 SEQUENCE {			
commonIEsRequestLocationInformation SEQUENCE {			
locationInformationType	locationMeasurementsRequired		
triggeredReporting	Not present		
periodicalReporting	Not present		
additionalInformation	onlyReturnInformationRequested		
qos SEQUENCE {			
horizontalAccuracy	Not present		
verticalCoordinateRequest	FALSE		
verticalAccuracy	Not present		
responseTime SEQUENCE {			
time	3	See clause 9.1.1.5	
responseTimeEarlyFix-r12	Not present		Rel-12 onwards
}			
velocityRequest	FALSE		
}			
environment	Not present		
locationCoordinateTypes	Not present		
velocityTypes	Not present		
}			
a-gnss-RequestLocationInformation	Not present		
otdoa-RequestLocationInformation SEQUENCE {			
assistanceAvailability	FALSE		
}			
ecid-RequestLocationInformation	Not present		
epdu-RequestLocationInformation	Not Present		
}			
}			

}			
}			
}			
}			
}			

Table 9.1.1.4.3-4: Void

Table 9.1.1.4.3-5: LPP ProvideAssistanceData

Derivation Path: 36.355 clause 6.2			
Information Element	Value/remark	Comment	Condition
LPP-Message ::= SEQUENCE {			
transactionID SEQUENCE {			
Initiator	locationServer		
transactionNumber	(0..255)		
}			
endTransaction	TRUE		
sequenceNumber	Not present		
acknowledgement	Not present		
lpp-MessageBody CHOICE {			
c1 CHOICE {			
provideAssistanceData SEQUENCE {			
criticalExtensions CHOICE {			
c1 CHOICE {			
provideAssistanceData-r9 SEQUENCE {			
commonEsProvideAssistanceData	Not present		
a-gnss-ProvideAssistanceData	Not present		
otdoa-ProvideAssistanceData SEQUENCE {			
otdoa-ReferenceCellInfo	As defined in TS 37.571-5 [20], clause 7.2.2.		
otdoa-NeighbourCellInfo	As defined in TS 37.571-5 [20], clause 7.2.2.		
otdoa-Error	Not present		
}			
epdu-ProvideAssistanceData	Not present		
}			
}			
}			
}			
}			

Table 9.1.1.4.3-6: LPP ProvideLocation Information

Derivation Path: 36.355 clause 6.2			
Information Element	Value/remark	Comment	Condition
LPP-Message ::= SEQUENCE {			
transactionID SEQUENCE {			
initiator	locationServer		
transactionNumber	1		
}			
endTransaction	TRUE		
sequenceNumber	(0..255)		
acknowledgement			
lpp-MessageBody CHOICE {			
c1 CHOICE {			
provideLocationInformation SEQUENCE {			
criticalExtensions CHOICE {			
c1 CHOICE {			
provideLocationInformation-r9 SEQUENCE {			

commonIEsProvideLocationInformation	Not present.		
a-gnss-ProvideLocationInformation	Not present		
otdoa-ProvideLocationInformation			
SEQUENCE {			
otdoaSignalMeasurementInformation			
SEQUENCE {			
systemFrameNumber			
physCellIdRef	Cell 1		
cellGlobalIdRef			
earfcnRef			
referenceQuality			
neighbourMeasurementList			
SEQUENCE (SIZE(n)) {			
physCellIdNeighbor	Cell 2		
cellGlobalIdNeighbour			
earfcnNeighbour			
rstd	Present		
rstd-Quality			
}			
neighbourMeasurementList			
SEQUENCE (SIZE(n)) {			
physCellIdNeighbor	Cell 3		
cellGlobalIdNeighbour			
earfcnNeighbour			
rstd	Present		
rstd-Quality			
}			
}			
otdoa-Error	May be present with error reason 'undefined' or 'attemptedButUnableToMeasureSomeNeighbourCells'		
}			
ecid-ProvideLocationInformation	Not present		
epdu-ProvideLocationInformation	Not present		
}			
}			
}			
}			
}			
}			

9.1.1.5 Test requirement

Table 9.1.1.5-1 and 9.1.1.5-2 define the primary level settings including test tolerances for the test.

Table 9.1.1.5-1: Cell-specific test parameters for E-UTRAN FDD intra-frequency RSTD measurement reporting delay under fading propagation conditions during T1

Parameter	Unit	Cell 1	Cell 2	Cell 3
E-UTRA RF Channel Number		1	1	1
Correlation Matrix and Antenna Configuration		1x2 Low	1x2 Low	1x2 Low
OCNG patterns defined in TS 36.521-3 [25] clause D.1		OP.5 FDD	N/A	N/A
PBCH_RA	dB	0	N/A	N/A
PBCH_RB				
PSS_RA				
SSS_RA				

PCFICH_RB				
PHICH_RA				
PHICH_RB				
PDCCH_RA				
PDCCH_RB				
OCNG_RA ^{Note 1}				
OCNG_RB ^{Note 1}				
N_{oc} ^{Note 3}	dBm/ 15 kHz	-95		
PRS \hat{E}_s/N_{oc}	dB	-Infinity	-Infinity	-Infinity
I_o ^{Note 4}	dBm/ 9 MHz	-67.22	N/A	N/A
\hat{E}_s/N_{oc}	dB	0	-Infinity	-Infinity
Propagation Condition		ETU30		
<p>Note 1: OCNG shall be used such that active cell (Cell 1) is fully allocated and a constant total transmitted power spectral density is achieved for all OFDM symbols.</p> <p>Note 2: The resources for uplink transmission are assigned to the UE prior to the start of time period T2.</p> <p>Note 3: Interference from other cells and noise sources not specified in the test are assumed to be constant over subcarriers and time and shall be modelled as AWGN of appropriate power for N_{oc} to be fulfilled.</p> <p>Note 4: I_o levels have been derived from other parameters and are given for information purpose. These are not settable test parameters.</p>				

Table 9.1.1.5-2: Cell-specific test parameters for E-UTRAN FDD intra-frequency RSTD measurement reporting delay under fading propagation conditions during T2 and T3

Parameter	Unit	Cell 1		Cell 2		Cell 3	
		T2	T3	T2	T3	T2	T3
E-UTRA RF Channel Number		1		1		1	
Correlation Matrix and Antenna Configuration		1x2 Low		1x2 Low		1x2 Low	
OCNG patterns defined in TS 36.521-3 [25] clause D.1		OP.5 FDD		OP.6 FDD		OP.6 FDD	N/A
PBCH_RA	dB	0		0		0	N/A
PBCH_RB							
PSS_RA							
SSS_RA							
PCFICH_RB							
PHICH_RA							
PHICH_RB							
PDCCH_RA							
PDCCH_RB							
OCNG_RA ^{Note 1}							
OCNG_RB ^{Note 1}							
PRS_RA	dB	-3	N/A	N/A	3	3	N/A
N_{oc} ^{Note 3}	dBm/ 15 kHz	-98	-95	-98	-95	-98	-95
PRS \hat{E}_s/N_{oc}	dB	-1	-Infinity	-Infinity	-7	-7	-Infinity
PRS \hat{E}_s/I_{ot} ^{Note 4}	dB	-1.79	-Infinity	-Infinity	-7	-9.54	-Infinity

I_o ^{Note 4}	dBm/ 9 MHz	-69.55	-67.08	-69.55	-67.08	-69.55	N/A
PRP ^{Note 4}	dBm/ 15 kHz	-99	-Infinity	-Infinity	-102	-105	-Infinity
RSRP ^{Note 4}	dBm/ 15 kHz	-96	-93	-105	-105	-108	-Infinity
\hat{E}_s/N_{oc} ^{Note 4}	dB	2	2	-7	-10	-10	-Infinity
Propagation Condition		ETU30					
<p>Note 1: OCNB shall be used such that active cells (all, except Cell 3 in T3) are fully allocated and a constant total transmitted power spectral density is achieved for all OFDM symbols other than those in the subframes with transmitted PRS.</p> <p>Note 2: The resources for uplink transmission are assigned to the UE prior to the start of time period T2.</p> <p>Note 3: Interference from other cells and noise sources not specified in the test are assumed to be constant over subcarriers and time and shall be modelled as AWGN of appropriate power for N_{oc} to be fulfilled.</p> <p>Note 4: If PRS_RA is not "N/A", \hat{E}_s/N_{oc}, PRS \hat{E}_s/I_{ot}, I_o, RSRP and PRP levels have been derived from other parameters and are given for information purpose. If PRS_RA is "N/A", I_o and RSRP levels have been derived from other parameters and are given for information purpose. These are not settable test parameters. Interference conditions shall be applied to all PRS symbols of DL positioning subframes.</p>							

The response time including test tolerance is 3.3 s. The response time is equal to the LPP time IE value plus the test tolerance. The LPP time IE value is derived from the RSTD reporting delay plus ΔT , where $\Delta T = 150$ ms, giving a value of 2710 ms. This is rounded up to the next allowed LPP value of 3 seconds. The RSTD measurement reporting delay in the test is derived from the following expression, $T_{PRS}(M - 1) + 160 \left\lceil \frac{n}{M} \right\rceil$, where $M=8$ and $n=16$ are the parameters specified in clause 9.1.1.3 and Table 9.1.1.3-1. This gives the total RSTD reporting delay of 2560 ms for the 15 neighbour cells including Cell 2 and Cell 3 with respect to the reference cell, Cell 1.

The test tolerances are defined in clauses C.1.3 and C4.

The rate of successful tests during repeated tests shall be at least 90% with a confidence level of 95%.

9.1.1A FDD RSTD Measurement Reporting Delay for UE Category 1bis

9.1.1A.1 Test purpose

To verify that the RSTD measurement reporting delay meets the requirements in an environment with fading propagation conditions.

9.1.1A.2 Test applicability

This test applies to E-UTRA FDD UE Category 1bis release 13 and forward that supports UE-assisted OTDOA.

9.1.1A.3 Minimum conformance requirements

Same as 9.1.1.3 but using Table 9.1.1A.3-1 instead of Table 9.1.1.3-1.

Table 9.1.1A.3-1: Number of PRS positioning occasions within $T_{RSTDIntraFreqE-UTRA}$

Positioning subframe configuration period T_{PRS}	Number of PRS positioning occasions M
	$f1$ ^{Note 1}
160 ms	32

>160 ms	16
Note 1: When only intra-frequency RSTD measurements are performed over cells belonging to the serving FDD carrier frequency f1.	

The normative reference for this requirement is TS 36.133 [23] clause 8.1.2.5.3 and A.8.12.1.

9.1.1A.4 Test description

9.1.1A.4.1 Initial conditions

Same as 9.1.1.4.1 with the following exceptions:

1. Connect the SS, faders and AWGN noise sources to the UE antenna connector or antenna connectors as shown in Annex A, Figure A.4, using only the main Tx/Rx path.
2. The general test parameter settings are set up according to Table 9.1.1A.4.1-1.

Table 9.1.1A.4.1-1: General test parameters for E-UTRAN FDD intra-frequency RSTD measurement reporting delay under fading propagation conditions

Parameter	Unit	Value	Comment
Reference cell		Cell 1	Reference cell is the cell in the OTDOA assistance data with respect to which the RSTD measurement is defined, as specified in 3GPP TS 36.214 [6] and 3GPP TS 36.355 [4]. The reference cell is the serving cell in this test case.
Neighbour cells		Cell 2 and Cell 3	Cell 2 and Cell 3 appear at random places in the neighbour cell list in the OTDOA assistance data, but Cell 2 always appears in the first half of the list, whilst Cell 3 appears in the second half of the list.
PCFICH/PDCCH/PHICH parameters		DL Reference Measurement Channel R.6 FDD	As specified in TS 36.521-3 [25] clause A.2.1
Channel Bandwidth (BW_{channel})	MHz	10	
PRS Transmission Bandwidth ^{Note 2}	RB	50	PRS are transmitted over the system bandwidth
PRS configuration index I_{PRS} ^{Note 2}		171	This corresponds to periodicity of 320 ms and PRS subframe offset of $I_{\text{PRS}} - 160$ DL subframes, as defined in 3GPP TS 36.211 [26], Table 6.10.4.3-1
Number of consecutive downlink positioning subframes N_{PRS} ^{Note 2}		1	As defined in 3GPP TS 36.211 [26]. The number of subframes in a positioning occasion
Physical cell ID PCI ^{Note 2}		(PCI of Cell 1 – PCI of Cell 2) mod 6 = 0 and (PCI of Cell 1 – PCI of Cell 3) mod 6 = 0	The cell PCIs are selected such that the relative shifts of PRS patterns among cells are as given by the test parameters
CP length ^{Note 2}		Normal	
DRX		ON	DRX parameters are further specified in Table 9.1.1.4.1-2
Radio frame receive time offset between the cells at the UE antenna connector ^{Note 3}	μs	Cell 2 to Cell 1: 1 Cell 3 to Cell 1: -1	PRS are transmitted from synchronous cells

Expected RSTD ^{Note 1}	µs	Cell 2: 3 Cell 3: 3 Other neighbour cells: randomly between -3 and 3	The expected RSTD is what is expected at the receiver. The corresponding parameter in the OTDOA assistance data specified in TS 36.355 [4] is the expectedRSTD indicator
Expected RSTD uncertainty for all neighbour cells ^{Note 1}	µs	5	The corresponding parameter in the OTDOA assistance data specified in TS 36.355 [4] is the expectedRSTD-Uncertainty index
Number of cells provided in OTDOA assistance data		16	Including the reference cell
PRS muting info ^{Note 2}		Cell 1: '1111111100000000' Cell 2: '0000000011111111' Cell 3: '1111111100000000'	Corresponds to prs-MutingInfo defined in TS 36.355 [4]
T1	s	3	The length of the time interval from the beginning of each test
T2	s	2.56	The length of the time interval that follows immediately after time interval T1
T3	s	2.56	The length of the time interval that follows immediately after time interval T2
<p>Note 1: Parameters "Expected RSTD" and "Expected RSTD uncertainty for all neighbour cells" are not settable parameters. These are parameters signalled in LPP only. For the values to be used in LPP see Table 9.1.1.4.3-5 and TS 37.571-5 [20], clause 7.2.2.</p> <p>Note 2: Parameters "PRS Transmission Bandwidth", "PRS configuration index", "Number of consecutive downlink positioning subframes", "Physical cell ID PCI", "CP length", and "PRS muting info" are settable parameters and also parameters signalled in LPP. The values to be used for "Physical cell ID PCI" are as follows: Cell 1: 0, Cell 2: 6, Cell 3: 12. For all the values to be used in LPP see Table 9.1.1.4.3-5 and TS 37.571-5 [20], clause 7.2.2.</p> <p>Note 3: The parameter "Radio frame receive time offset between the cells at the UE antenna connector" is not a settable parameter but is used to set the "true RSTD" values in step 6 of clause 9.1.1.4.1.</p>			

9.1.1A.4.2 Test procedure

Same as 9.1.1.4.2.

9.1.1A.4.3 Message contents

Same as 9.1.1.4.3 with the following exceptions:

Table 9.1.1A.4.3-1: LPP RequestLocationInformation

Derivation Path: Table 9.1.1.4.3-3			
Information Element	Value/remark	Comment	Condition
LPP-Message ::= SEQUENCE {			
lpp-MessageBody CHOICE {			
c1 CHOICE {			
requestLocationInformation SEQUENCE {			
criticalExtensions CHOICE {			
c1 CHOICE {			
requestLocationInformation-r9 SEQUENCE {			
commonIEsRequestLocationInformation SEQUENCE {			
qos SEQUENCE {			
responseTime SEQUENCE {			
time	6	See clause 9.1.1A.5	
}			
}			
}			
}			
}			
}			
}			

}			
}			
}			
}			

9.1.1A.5 Test requirement

Table 9.1.1.5-1 and 9.1.1.5-2 define the primary level settings including test tolerances for the test.

The response time including test tolerance is 6.3 s. The response time is equal to the LPP time IE value plus the test tolerance. The LPP time IE value is derived from the RSTD reporting delay plus ΔT , where $\Delta T = 150$ ms, giving a value of 5110 ms. This is rounded up to the next allowed LPP value of 6 seconds. The RSTD measurement reporting

delay in the test is derived from the following expression, $T_{PRS}(M-1) + 160 \left\lceil \frac{n}{M} \right\rceil$, where $M=8$ and $n=16$ are the parameters specified in clause 9.1.1A.3 and Table 9.1.1A.3-1. This gives the total RSTD reporting delay of 4960 ms for the 15 neighbour cells including Cell 2 and Cell 3 with respect to the reference cell, Cell 1.

The test tolerances are defined in clauses C.1.3 and C4.

The rate of successful tests during repeated tests shall be at least 90% with a confidence level of 95%.

9.1.2 TDD RSTD Measurement Reporting Delay

9.1.2.1 Test purpose

To verify that the RSTD measurement reporting delay meets the requirements in an environment with fading propagation conditions.

9.1.2.2 Test applicability

This test applies to all types of E-UTRA TDD UE release 9 and forward that supports UE-assisted OTDOA except UE Category 1bis.

9.1.2.3 Minimum conformance requirements

When the physical layer cell identities of neighbour cells together with the OTDOA assistance data are provided, the UE shall be able to detect and measure intra-frequency RSTD, specified in 3GPP TS 36.214 [6], for at least $n=16$ cells, including the reference cell, on the same carrier frequency f_1 as that of the reference cell within

$T_{\text{RSTDIntraFreqDD,E-UTRAN}}$ ms as given below:

$$T_{\text{RSTDIntraFreqDD,E-UTRAN}} = T_{\text{PRS}} \cdot (M - 1) + \Delta \quad \text{ms}$$

where

$T_{\text{RSTDIntraFreqDD,E-UTRAN}}$ is the total time for detecting and measuring at least n cells,

T_{PRS} is the cell-specific positioning subframe configuration period as defined in 3GPP TS 36.211 [26],

M is the number of PRS positioning occasions as defined in Table 9.1.2.3-1, where each PRS positioning occasion comprises of N_{PRS} ($1 \leq N_{\text{PRS}} \leq 6$) consecutive downlink positioning subframes defined in 3GPP TS 36.211 [26], and

$\Delta = 160 \cdot \left\lceil \frac{n}{M} \right\rceil$ ms is the measurement time for a single PRS positioning occasion which includes the sampling time and the processing time.

Table 9.1.2.3-1: Number of PRS positioning occasions within $T_{\text{RSTDIntraFreq}}^{\text{DE-UTRAN}}$

Positioning subframe configuration period T_{PRS}	Number of PRS positioning occasions M
	f1 Note 1
160 ms	16
>160 ms	8
Note 1: When only intra-frequency RSTD measurements are performed over cells belonging to the serving FDD carrier frequency f1.	

The UE physical layer shall be capable of reporting RSTD for the reference cell and all the neighbour cells i out of at least $(n-1)$ neighbour cells within $T_{\text{RSTDIntraFreq}}^{\text{DE-UTRAN}}$ provided:

$$\left(\text{PRS } \hat{E}_s / \text{Iot} \right)_{\text{ref}} \geq -6 \text{ dB for all Frequency Bands for the reference cell,}$$

$$\left(\text{PRSE}_s / \text{Iot} \right)_i \geq -13 \text{ dB for all Frequency Bands for neighbour cell } i,$$

$\left(\text{PRS } \hat{E}_s / \text{Iot} \right)_{\text{ref}}$ and $\left(\text{PRSE}_s / \text{Iot} \right)_i$ conditions apply for all subframes of at least $L = \frac{M}{2}$ PRS positioning occasions,

PRP 1,2_{dBm} according to clause E.2 for a corresponding Band.

The time $T_{\text{RSTDIntraFreq}}^{\text{DE-UTRAN}}$ starts from the first subframe of the PRS positioning occasion closest in time after both the OTDOA-RequestLocationInformation message and the OTDOA assistance data in the OTDOA-ProvideAssistanceData message as specified in 3GPP TS 36.355 [4], are delivered to the physical layer of the UE.

The requirements shall apply for all TDD special subframe configurations specified in 3GPP TS 36.211 [26] and for the TDD uplink-downlink configurations as specified in Table 9.1.2.3-2.

Table 9.1.2.3-2: TDD uplink-downlink subframe configurations applicable for TDD intra-frequency requirements

PRS Transmission Bandwidth [RB]	Applicable TDD uplink-downlink configurations
6, 15	1, 2, 3, 4 and 5
25, 50, 75, 100	0, 1, 2, 3, 4, 5 and 6
Note: Uplink-downlink configurations are specified in Table 4.2-2 in 3GPP TS 36.211 [26].	

This requirement assumes that the measurement report is not delayed by other LPP signalling on the DCCH. This measurement reporting delay excludes a delay uncertainty resulted when inserting the measurement report to the TTI of the uplink DCCH. The delay uncertainty is: $2 \times \text{TTI}_{\text{DCCH}}$. This measurement reporting delay excludes any delay caused by no UL resources for UE to send the measurement report.

The normative reference for this requirement is TS 36.133 [23] clause 8.1.2.5.2 and A.8.12.2.

9.1.2.4 Test description

9.1.2.4.1 Initial conditions

Test Environment: Normal; as defined in TS 36.508 [18] clause 4.1.

Frequencies to be tested: Mid Range, as defined in TS 36.508 [18] clause 4.3.1.2.

Channel bandwidth to be tested: 10 MHz as defined in TS 36.508 [18] clause 4.3.1.

1. Connect the SS, faders and AWGN noise sources to the UE antenna connector or antenna connectors as shown in Annex A, Figure A.4.

2. The general test parameter settings are set up according to Table 9.1.2.4.1-1.
3. Propagation conditions are set according to clause 4.7.2.1.
4. Message contents are defined in clause 9.1.2.4.3.
5. In the test there are three synchronized cells: Cell 1, Cell 2 and Cell 3. Cell 1 is the OTDOA assistance data reference as well as the serving cell. Cell 2 and Cell 3 are the neighbour cells. All cells are on the same RF channel. Cell 3 in the test is the Cell 4 defined in clause 4.7.1. The assistance data neighbour cell list includes in total 15 cells, where 13 of the cells are not simulated (dummy cells; as defined in 3GPP TS 37.571-5 clause 7.2.2).
6. The true RSTD (which is the receive time difference for frame 0 between two cells as seen at the UE antenna connector) is set to 31 Ts (about 1 μ s) between neighbour Cell 2 and serving Cell 1; and set to -31 Ts (about -1 μ s) between neighbour Cell 3 and serving Cell 1.

Table 9.1.2.4-1: General test parameters for E-UTRAN TDD intra-frequency RSTD measurement reporting delay under fading propagation conditions

Parameter	Unit	Value	Comment
Reference cell		Cell 1	Reference is the cell in the OTDOA assistance data with respect to which the RSTD measurement is defined, as specified in 3GPP TS 36.214 [6] and 3GPP TS 36.355 [4]. The reference cell is the serving cell in this test case.
Neighbour cells		Cell 2 and Cell 3	Cell 2 and Cell 3 appear at random places in the neighbour cell list in the OTDOA assistance data, but Cell 2 always appears in the first half of the list, whilst Cell 3 appears in the second half of the list.
PCFICH/PDCCH/PHICH parameters		DL Reference Measurement Channel R.6 TDD	As specified in TS 36.521-3 [25] clause A.2.2
Channel Bandwidth (BW_{channel})	MHz	10	
PRS Transmission Bandwidth ^{Note 2}	RB	50	PRS are transmitted over the system bandwidth
PRS configuration index I_{PRS} ^{Note 2}		174	This corresponds to periodicity of 320 ms and PRS subframe offset of $I_{\text{PRS}} - 160$ DL subframes, as defined in 3GPP TS 36.211 [26], Table 6.10.4.3-1
Number of consecutive downlink positioning subframes N_{PRS} ^{Note 2}		1	As defined in 3GPP TS 36.211 [26]. The number of subframes in a positioning occasion
Physical cell ID PCI ^{Note 2}		(PCI of Cell 1 – PCI of Cell 2) mod 6 = 0 and (PCI of Cell 1 – PCI of Cell 3) mod 6 = 0	The cell PCIs are selected such that the relative shifts of PRS patterns among cells are as given by the test parameters
TDD uplink-downlink configuration		1	As specified in TS 36.211 [26], Section 4.2; corresponds to a configuration with 5 ms switch-point periodicity and two downlink consecutive subframes
TDD special subframe configuration		6	As specified in TS 36.211 [26], Section 4.2; corresponds to DwPTS of $19760 \cdot T_s$ and UpPTS of $4384 \cdot T_s$
CP length ^{Note 2}		Normal	The same CP length applies for DL and UL
DRX		ON	DRX parameters are further specified in Table 9.1.2.4-2
Radio frame receive time offset between the cells at the UE antenna connector ^{Note 3}	μ s	Cell 2 to Cell 1: 1 Cell 3 to Cell 1: -1	PRS are transmitted from synchronous cells

Expected RSTD ^{Note 1}	μs	Cell 2: 3 Cell 3: 3 Other neighbour cells: randomly between -3 and 3	The expected RSTD is what is expected at the receiver. The corresponding parameter in the OTDOA assistance data specified in TS 36.355 [4] is the expectedRSTD indicator
Expected RSTD uncertainty for all neighbour cells ^{Note 1}	μs	5	The corresponding parameter in the OTDOA assistance data specified in TS 36.355 [4] is the expectedRSTD-Uncertainty index
Number of cells provided in OTDOA assistance data		16	Including the reference cell
PRS muting info ^{Note 2}		Cell 1: '11110000' Cell 2: '00001111' Cell 3: '11110000'	Corresponds to prs-MutingInfo defined in TS 36.355 [4]
T1	s	3	The length of the time interval from the beginning of each test
T2	s	1.28	The length of the time interval that follows immediately after time interval T1
T3	s	1.28	The length of the time interval that follows immediately after time interval T2
<p>Note 1: Parameters "Expected RSTD" and "Expected RSTD uncertainty for all neighbour cells" are not settable parameters. These are parameters signalled in LPP only. For the values to be used in LPP see Table 9.1.2.4.3-5 and TS 37.571-5 [20], clause 7.2.2.</p> <p>Note 2: Parameters "PRS Transmission Bandwidth", "PRS configuration index", "Number of consecutive downlink positioning subframes", "Physical cell ID PCI", "CP length", and "PRS muting info" are settable parameters and also parameters signalled in LPP. The values to be used for "Physical cell ID PCI" are as follows: Cell 1: 0, Cell 2: 6, Cell 3: 12. For all the values to be used in LPP see Table 9.1.2.4.3-5 and TS 37.571-5 [20], clause 7.2.2.</p> <p>Note 3: The parameter "Radio frame receive time offset between the cells at the UE antenna connector" is not a settable parameter but is used to set the "true RSTD" values in step 6 of clause 9.1.2.4.1.</p>			

Table 9.1.2.4-2: DRX parameters for E-UTRAN TDD intra-frequency RSTD measurement reporting delay under fading propagation conditions

Field	Value	Comment
onDurationTimer	psf1	As specified in 3GPP TS 36.331 [22], clause 6.3.2.
drx-InactivityTimer	psf1	
drx-RetransmissionTimer	sf1	
longDRX-CycleStartOffset	sf320	
shortDRX	disable	

9.1.2.4.2 Test procedure

The test consists of three consecutive time intervals, with duration of T1, T2 and T3 defined in Table 9.1.2.4-1. Cell 1 is active in T1, T2 and T3, whilst Cell 2 and Cell 3 are activated only in the beginning of T2. Cell 2 is active until the end of T3, and Cell 3 is active until the end of T2. The beginning of the time interval T2 shall be aligned 5 ms before the first PRS positioning subframe of a positioning occasion in the reference cell, where 5 ms is the necessary test tolerance. Cell 1 transmits PRS in T2, while Cell 2 transmits PRS only in T3, and Cell 3 transmits PRS only in T2.

NOTE: The information on when PRS is muted is conveyed to the UE using PRS muting information in the OTDOA assistance data.

The OTDOA-RequestLocationInformation message and the OTDOA assistance data as defined in clause 9.1.2.4.3 shall be provided to the UE during T1. The last TTI containing the OTDOA-RequestLocationInformation message shall be provided to the UE ΔT ms before the start of T2, where $\Delta T = 150$ ms is the maximum processing time of the OTDOA-RequestLocationInformation message and the OTDOA assistance data.

1. Ensure that the UE is in state Generic RB Established State 3A-RF according to 3GPP TS 36.508 [18] clause 7.2A.3.
2. The SS shall send a RESET UE POSITIONING STORED INFORMATION message.
3. Set the parameters according to Table 9.1.2.5-1. Propagation conditions are set according to clause 4.7.2.2 (ETU30).

4. T1 starts.
5. The SS shall transmit an RRCConnectionReconfiguration message with the DRX configuration. PDCCHs indicating new transmissions shall be sent continuously until the start of T2 to ensure that the UE would not enter the DRX state before T2.
6. The UE shall transmit RRCConnectionReconfigurationComplete message.
- 6a. The SS shall transmit an LPP REQUEST CAPABILITIES message.
- 6b. The UE shall transmit an LPP PROVIDE CAPABILITIES message indicating the OTDOA capabilities supported by the UE in the *OTDOA-ProvideCapabilities* IE.
7. The SS shall send a LPP PROVIDE ASSISTANCE DATA message, including the *OTDOA-ProvideAssistanceData* IE. The position of neighbour Cell 2 in the *OTDOA-NeighbourCellInfoList* is randomly selected to be in the first 7 elements of the sequence, and the position of neighbour Cell 3 is randomly selected to be in the last 8 elements of the sequence, as described in 3GPP TS 37.571-5 [20], clause 7.2.3. If the UE message at step 6b includes the *ackRequested* IE set to TRUE, then the SS shall send an acknowledgment in the LPP PROVIDE ASSISTANCE DATA message.
8. The SS shall send a LPP REQUEST LOCATION INFORMATION message, including the *OTDOA-RequestLocationInformation* IE such that the UE receives the message ΔT ms before the start of T2, where $\Delta T = 150$ ms.
9. When T1 expires, the SS shall switch the power setting from T1 to T2 as specified in Table 9.1.2.5-3.
10. When T2 expires, the SS shall switch the power setting from T2 to T3 as specified in Table 9.1.2.5-3.
11. The UE shall transmit a LPP PROVIDE LOCATION INFORMATION including the *OTDOA-ProvideLocationInformation* IE within the response time (see clause 4.7.3) specified in clause 9.1.1.5. The UE shall perform and report the RSTD measurements for both Cell 2 and Cell 3 with respect to the reference cell in the OTDOA assistance data, Cell 1. If the UE transmits an *OTDOA-ProvideLocationInformation* IE including the *rstd* field for both Cell 2 and Cell 3 within the response time then the number of successful tests is increased by one. If the UE fails to report the *OTDOA-ProvideLocationInformation* IE with both the *rstd* fields included within the response time then the number of failure tests is increased by one.
12. If the UE message at step 11 includes the *ackRequested* IE set to TRUE, the SS shall send a LPP acknowledgement message.
13. Repeat steps 2-12 until the confidence level according to Annex D is achieved. For each iteration, at step 9 change the random position of the Cells 2 and 3 in the *OTDOA-NeighbourCellInfoList*.

9.1.2.4.3 Message contents

Table 9.1.2.4.3-1: RESET UE POSITIONING STORED INFORMATION

Derivation Path: 36.509 [11] clause 6.9			
Information Element	Value/remark	Comment	Condition
UE Positioning Technology	0 0 0 0 0 0 1	OTDOA	

Table 9.1.2.4.3-2: MAC-MainConfig-RBC: TDD RSTD Measurement Reporting Delay

Derivation Path: TS 36.508 [18] clause 4.8.2.1.5, Table 4.8.2.1.5-1 MAC-MainConfig-RBC			
Information Element	Value/remark	Comment	Condition
MAC-MainConfig-RBC ::= SEQUENCE {			
drx-Config CHOICE {			
setup SEQUENCE {			
onDurationTimer	psf1		
drx-InactivityTimer	psf1		
drx-RetransmissionTimer	sf1		
longDRX-CycleStartOffset CHOICE {			
sf320	0		
}			

shortDRX	Not present		
}			
}			

Table 9.1.2.4.3-2a: LPP Request Capabilities

Information Element	Value/remark
otdoa-RequestCapabilities	TRUE

Table 9.1.2.4.3-3: LPP RequestLocationInformation

Derivation Path: 36.355 clause 6.2			
Information Element	Value/remark	Comment	Condition
LPP-Message ::= SEQUENCE {			
transactionID SEQUENCE {			
initiator	locationServer		
transactionNumber	1		
}			
endTransaction	FALSE		
sequenceNumber	Not present		
acknowledgement	Not present		
lpp-MessageBody CHOICE {			
c1 CHOICE {			
requestLocationInformation SEQUENCE {			
criticalExtensions CHOICE {			
c1 CHOICE {			
requestLocationInformation-r9 SEQUENCE {			
commonIEsRequestLocationInformation SEQUENCE {			
locationInformationType	locationMeasurementsRequired		
triggeredReporting	Not present		
periodicalReporting	Not present		
additionalInformation	onlyReturnInformationRequested		
qos SEQUENCE {			
horizontalAccuracy	Not present		
verticalCoordinateRequest	FALSE		
verticalAccuracy	Not present		
responseTime SEQUENCE {			
time	3	See clause 9.1.2.5	
responseTimeEarlyFix-r12	Not present		Rel-12 onwards
}			
velocityRequest	FALSE		
}			
environment	Not present		
locationCoordinateTypes	Not present		
velocityTypes	Not present		
}			
a-gnss-RequestLocationInformation	Not present		
otdoa-RequestLocationInformation SEQUENCE {			
assistanceAvailability	FALSE		
}			
ecid-RequestLocationInformation	Not present		
epdu-RequestLocationInformation	Not Present		
}			
}			
}			
}			
}			
}			

}			
}			

Table 9.1.2.4.3-4: Void

Table 9.1.2.4.3-5: LPP ProvideAssistanceData

Derivation Path: 36.355 clause 6.2			
Information Element	Value/remark	Comment	Condition
LPP-Message ::= SEQUENCE {			
transactionID SEQUENCE {			
Initiator	locationServer		
transactionNumber	(0..255)		
}			
endTransaction	TRUE		
sequenceNumber	Not present		
acknowledgement	Not present		
lpp-MessageBody CHOICE {			
c1 CHOICE {			
provideAssistanceData SEQUENCE {			
criticalExtensions CHOICE {			
c1 CHOICE {			
provideAssistanceData-r9 SEQUENCE {			
commonIEsProvideAssistanceData	Not present		
a-gnss-ProvideAssistanceData	Not present		
otdoa-ProvideAssistanceData SEQUENCE {			
otdoa-ReferenceCellInfo	As defined in TS 37.571-5 [20], clause 7.2.2.		
otdoa-NeighbourCellInfo	As defined in TS 37.571-5 [20], clause 7.2.2.		
otdoa-Error	Not present		
}			
epdu-ProvideAssistanceData	Not present		
}			
}			
}			
}			
}			
}			

Table 9.1.2.4.3-6: LPP ProvideLocation Information

Derivation Path: 36.355 clause 6.2			
Information Element	Value/remark	Comment	Condition
LPP-Message ::= SEQUENCE {			
transactionID SEQUENCE {			
initiator	locationServer		
transactionNumber	1		
}			
endTransaction	TRUE		
sequenceNumber	(0..255)		
acknowledgement			
lpp-MessageBody CHOICE {			
c1 CHOICE {			
provideLocationInformation SEQUENCE {			
criticalExtensions CHOICE {			
c1 CHOICE {			
provideLocationInformation-r9 SEQUENCE {			
commonIEsProvideLocationInformation	Not present.		
a-gnss-ProvideLocationInformation	Not present		
}			
}			
}			
}			
}			

otdoa-ProvideLocationInformation SEQUENCE {			
otdoaSignalMeasurementInformation SEQUENCE {			
systemFrameNumber			
physCellIdRef	Cell 1		
cellGlobalIdRef			
earfcnRef			
referenceQuality			
neighbourMeasurementList SEQUENCE (SIZE(n)) {			
physCellIdNeighbor	Cell 2		
cellGlobalIdNeighbour			
earfcnNeighbour			
rstd	Present		
rstd-Quality			
}			
neighbourMeasurementList SEQUENCE (SIZE(n)) {			
physCellIdNeighbor	Cell 3		
cellGlobalIdNeighbour			
earfcnNeighbour			
rstd	Present		
rstd-Quality			
}			
}			
otdoa-Error	May be present with error reason 'undefined' or 'attemptedButUnableToMeasureSomeNeighbourCells'		
}			
ecid-ProvideLocationInformation	Not present		
epdu-ProvideLocationInformation	Not present		
}			
}			
}			
}			
}			
}			

9.1.2.5 Test requirement

Table 9.1.2.5-1 and 9.1.2.5-2 define the primary level settings including test tolerances for the test.

Table 9.1.2.5-1: Cell-specific test parameters for E-UTRAN TDD intra-frequency RSTD measurement reporting delay under fading propagation conditions during T1

Parameter	Unit	Cell 1	Cell 2	Cell 3
E-UTRA RF Channel Number		1	1	1
Correlation Matrix and Antenna Configuration		1x2 Low	1x2 Low	1x2 Low
OCNG patterns defined in TS 36.521-3 [25] clause D.2		OP.1 TDD	N/A	N/A
PBCH_RA	dB	0	N/A	N/A
PBCH_RB				
PSS_RA				
SSS_RA				
PCFICH_RB				
PHICH_RA				

PHICH_RB				
PDCCH_RA				
PDCCH_RB				
OCNG_RA ^{Note 1}				
OCNG_RB ^{Note 1}				
N_{oc} ^{Note 3}	dBm/ 15 kHz	-95		
PRS \hat{E}_s/N_{oc}	dB	-Infinity	-Infinity	-Infinity
I_o ^{Note 4}	dBm/ 9 MHz	-67.22	N/A	N/A
\hat{E}_s/N_{oc}	dB	0	-Infinity	-Infinity
Propagation Condition		ETU30		
<p>Note 1: OCNG shall be used such that active cell (Cell 1) is fully allocated and a constant total transmitted power spectral density is achieved for all OFDM symbols.</p> <p>Note 2: The resources for uplink transmission are assigned to the UE prior to the start of time period T2.</p> <p>Note 3: Interference from other cells and noise sources not specified in the test are assumed to be constant over subcarriers and time and shall be modelled as AWGN of appropriate power for N_{oc} to be fulfilled.</p> <p>Note 4: I_o levels have been derived from other parameters and are given for information purpose. These are not settable test parameters.</p>				

Table 9.1.2.5-2: Cell-specific test parameters for E-UTRAN TDD intra-frequency RSTD measurement reporting delay under fading propagation conditions

Parameter	Unit	Cell 1		Cell 2		Cell 3		
		T2	T3	T2	T3	T2	T3	
E-UTRA RF Channel Number		1		1		1		
Correlation Matrix and Antenna Configuration		1x2 Low		1x2 Low		1x2 Low		
OCNG patterns defined in TS 36.521-3 [25] clause D.2		OP.1 TDD		OP.2 TDD		OP.2 TDD	N/A	
PBCH_RA	dB	0		0		0		N/A
PBCH_RB								
PSS_RA								
SSS_RA								
PCFICH_RB								
PHICH_RA								
PHICH_RB								
PDCCH_RA								
PDCCH_RB								
OCNG_RA ^{Note 1}								
OCNG_RB ^{Note 1}								
PRS_RA	dB	-3	N/A	N/A	3	3	N/A	
N_{oc} ^{Note 3}	dBm/ 15 kHz	-98	-95	-98	-95	-98	-95	
PRS \hat{E}_s/N_{oc}	dB	-1	-Infinity	-Infinity	-7	-7	-Infinity	
PRS \hat{E}_s/I_{ot} ^{Note 4}	dB	-1.79	-Infinity	-Infinity	-7	-9.54	-Infinity	
I_o ^{Note 4}	dBm/ 9 MHz	-69.55	-67.08	-69.55	-67.08	-69.55	N/A	

PRP ^{Note 4}	dBm/ 15 kHz	-99	-Infinity	-Infinity	-102	-105	-Infinity
RSRP ^{Note 4}	dBm/ 15 kHz	-96	-93	-105	-105	-108	-Infinity
\hat{E}_s/N_{oc} ^{Note 4}	dB	2	2	-7	-10	-10	-Infinity
Propagation Condition		ETU30					
<p>Note 1: OCNG shall be used such that active cells (all, except Cell 3 in T3) are fully allocated and a constant total transmitted power spectral density is achieved for all OFDM symbols other than those in the subframes with transmitted PRS.</p> <p>Note 2: The resources for uplink transmission are assigned to the UE prior to the start of time period T2.</p> <p>Note 3: Interference from other cells and noise sources not specified in the test are assumed to be constant over subcarriers and time and shall be modelled as AWGN of appropriate power for N_{oc} to be fulfilled.</p> <p>Note 4: If PRS_RA is not "N/A", \hat{E}_s/N_{oc}, PRS \hat{E}_s/I_{ot}, lo, RSRP and PRP levels have been derived from other parameters and are given for information purpose. If PRS_RA is "N/A", lo and RSRP levels have been derived from other parameters and are given for information purpose. These are not settable test parameters. Interference conditions shall be applied to all PRS symbols of DL positioning subframes.</p>							

The response time including test tolerance is 3.3 s. The response time is equal to the LPP time IE value plus the test tolerance. The LPP time IE value is derived from the RSTD reporting delay plus ΔT , where $\Delta T = 150$ ms, giving a value of 2710 ms. This is rounded up to the next allowed LPP value of 3 seconds. The RSTD measurement reporting delay in the test is derived from the following expression, $T_{PRS}(M - 1) + 160 \left\lceil \frac{n}{M} \right\rceil$, where $M=8$ and $n=16$ are the parameters specified in clause 9.1.2.3 and Table 9.1.2.3-1. This gives the total RSTD reporting delay of 2560 ms for the 15 neighbour cells including Cell 2 and Cell 3 with respect to the reference cell, Cell 1.

The test tolerances are defined in clauses C.1.3 and C4.

The rate of successful tests during repeated tests shall be at least 90% with a confidence level of 95%.

9.1.2A TDD RSTD Measurement Reporting Delay for UE Category 1bis

9.1.2A.1 Test purpose

To verify that the RSTD measurement reporting delay meets the requirements in an environment with fading propagation conditions.

9.1.2A.2 Test applicability

This test applies to E-UTRA TDD UE Category 1bis release 13 and forward that supports UE-assisted OTDOA.

9.1.2A.3 Minimum conformance requirements

Same as 9.1.2.3 but using Table 9.1.2A.3-1 instead of Table 9.1.2.3-1.

Table 9.1.2A.3-1: Number of PRS positioning occasions within $T_{RSTDIntraFreqDDE-UTRAN}$

Positioning subframe configuration period T_{PRS}	Number of PRS positioning occasions M
	f_1 ^{Note 1}
160 ms	32
>160 ms	16

Note 1: When only intra-frequency RSTD measurements are performed over cells belonging to the serving TDD carrier frequency f1

The normative reference for this requirement is TS 36.133 [23] clause 8.1.2.5.4 and A.8.12.2.

9.1.2A.4 Test description

9.1.2A.4.1 Initial conditions

Same as 9.1.2.4.1 with the following exceptions:

1. Connect the SS, faders and AWGN noise sources to the UE antenna connector or antenna connectors as shown in Annex A, Figure A.4, using only the main Tx/Rx path.
2. The general test parameter settings are set up according to Table 9.1.2A.4.1-1.

Table 9.1.2.4A-1: General test parameters for E-UTRAN TDD intra-frequency RSTD measurement reporting delay under fading propagation conditions

Parameter	Unit	Value	Comment
Reference cell		Cell 1	Reference is the cell in the OTDOA assistance data with respect to which the RSTD measurement is defined, as specified in 3GPP TS 36.214 [6] and 3GPP TS 36.355 [4]. The reference cell is the serving cell in this test case.
Neighbour cells		Cell 2 and Cell 3	Cell 2 and Cell 3 appear at random places in the neighbour cell list in the OTDOA assistance data, but Cell 2 always appears in the first half of the list, whilst Cell 3 appears in the second half of the list.
PCFICH/PDCCH/PHICH parameters		DL Reference Measurement Channel R.6 TDD	As specified in TS 36.521-3 [25] clause A.2.2
Channel Bandwidth (BW _{channel})	MHz	10	
PRS Transmission Bandwidth ^{Note 2}	RB	50	PRS are transmitted over the system bandwidth
PRS configuration index I_{PRS} ^{Note 2}		174	This corresponds to periodicity of 320 ms and PRS subframe offset of $I_{PRS} - 160$ DL subframes, as defined in 3GPP TS 36.211 [26], Table 6.10.4.3-1
Number of consecutive downlink positioning subframes N_{PRS} ^{Note 2}		1	As defined in 3GPP TS 36.211 [26]. The number of subframes in a positioning occasion
Physical cell ID PCI ^{Note 2}		(PCI of Cell 1 – PCI of Cell 2) mod 6 = 0 and (PCI of Cell 1 – PCI of Cell 3) mod 6 = 0	The cell PCIs are selected such that the relative shifts of PRS patterns among cells are as given by the test parameters
TDD uplink-downlink configuration		1	As specified in TS 36.211 [26], Section 4.2; corresponds to a configuration with 5 ms switch-point periodicity and two downlink consecutive subframes
TDD special subframe configuration		6	As specified in TS 36.211 [26], Section 4.2; corresponds to DwPTS of $19760 \cdot T_s$ and UpPTS of $4384 \cdot T_s$
CP length ^{Note 2}		Normal	The same CP length applies for DL and UL
DRX		ON	DRX parameters are further specified in Table 9.1.2.4-2
Radio frame receive time offset between the cells at the UE antenna connector ^{Note 3}	µs	Cell 2 to Cell 1: 1 Cell 3 to Cell 1: -1	PRS are transmitted from synchronous cells

Expected RSTD ^{Note 1}	µs	Cell 2: 3 Cell 3: 3 Other neighbour cells: randomly between -3 and 3	The expected RSTD is what is expected at the receiver. The corresponding parameter in the OTDOA assistance data specified in TS 36.355 [4] is the expectedRSTD indicator
Expected RSTD uncertainty for all neighbour cells ^{Note 1}	µs	5	The corresponding parameter in the OTDOA assistance data specified in TS 36.355 [4] is the expectedRSTD-Uncertainty index
Number of cells provided in OTDOA assistance data		16	Including the reference cell
PRS muting info ^{Note 2}		Cell 1: '1111111100000000' Cell 2: '0000000011111111' Cell 3: '1111111100000000'	Corresponds to prs-MutingInfo defined in TS 36.355 [4]
T1	s	3	The length of the time interval from the beginning of each test
T2	s	2.56	The length of the time interval that follows immediately after time interval T1
T3	s	2.56	The length of the time interval that follows immediately after time interval T2
<p>Note 1: Parameters "Expected RSTD" and "Expected RSTD uncertainty for all neighbour cells" are not settable parameters. These are parameters signalled in LPP only. For the values to be used in LPP see Table 9.1.2.4.3-5 and TS 37.571-5 [20], clause 7.2.2.</p> <p>Note 2: Parameters "PRS Transmission Bandwidth", "PRS configuration index", "Number of consecutive downlink positioning subframes", "Physical cell ID PCI", "CP length", and "PRS muting info" are settable parameters and also parameters signalled in LPP. The values to be used for "Physical cell ID PCI" are as follows: Cell 1: 0, Cell 2: 6, Cell 3: 12. For all the values to be used in LPP see Table 9.1.2.4.3-5 and TS 37.571-5 [20], clause 7.2.2.</p> <p>Note 3: The parameter "Radio frame receive time offset between the cells at the UE antenna connector" is not a settable parameter but is used to set the "true RSTD" values in step 6 of clause 9.1.2.4.1.</p>			

9.1.2A.4.2 Test procedure

Same as 9.1.2.4.2

9.1.2A.4.3 Message contents

Same as 9.1.2.4.3 with the following exceptions:

Table 9.1.2A.4.3-1: LPP RequestLocationInformation

Derivation Path: Table 9.1.2.4.3-3			
Information Element	Value/remark	Comment	Condition
LPP-Message ::= SEQUENCE {			
lpp-MessageBody CHOICE {			
c1 CHOICE {			
requestLocationInformation SEQUENCE {			
criticalExtensions CHOICE {			
c1 CHOICE {			
requestLocationInformation-r9 SEQUENCE {			
commonIEsRequestLocationInformation SEQUENCE {			
qos SEQUENCE {			
responseTime SEQUENCE {			
time	6	See clause 9.1.2A.5	
}			
}			
}			
}			
}			
}			
}			
}			

}			
}			

9.1.2A.5 Test requirement

Table 9.1.2.5-1 and 9.1.2.5-2 define the primary level settings including test tolerances for the test.

The response time including test tolerance is 6.3 s. The response time is equal to the LPP time IE value plus the test tolerance. The LPP time IE value is derived from the RSTD reporting delay plus ΔT, where ΔT = 150 ms, giving a value of 5110 ms. This is rounded up to the next allowed LPP value of 6 seconds. The RSTD measurement reporting

delay in the test is derived from the following expression, $T_{PRS}(M - 1) + 160 \left\lceil \frac{n}{M} \right\rceil$, where $M=8$ and $n=16$ are the parameters specified in clause 9.1.2A.3 and Table 9.1.2A.3-1. This gives the total RSTD reporting delay of 4960 ms for the 15 neighbour cells including Cell 2 and Cell 3 with respect to the reference cell, Cell 1.

The test tolerances are defined in clauses C.1.3 and C4.

The rate of successful tests during repeated tests shall be at least 90% with a confidence level of 95%.

9.1.3 FDD RSTD Measurement Accuracy

9.1.3.1 Test purpose

To verify that the RSTD FDD intra-frequency measurement accuracy is within the specified limits.

9.1.3.2 Test applicability

This test applies to all types of E-UTRA FDD UE release 9 and forward that supports UE-assisted OTDOA except UE Category 1bis.

9.1.3.3 Minimum conformance requirements

The accuracy requirements in Table 9.1.3.3-1 are valid under the following conditions:

Conditions defined in TS 36.101 [2] clause 7.3 for reference sensitivity are fulfilled.

PRP 1,2_{dBm} according to clause E.2 for a corresponding Band.

There are no measurement gaps overlapping with the PRS subframes of the measured cell.

The parameter *expectedRSTDUncertainty* signalled over LPP as defined in 3GPP TS 36.355 [4] is less than 5 μs.

Table 9.1.3.3-1: RSTD measurement accuracy

Accuracy	Conditions					
	PRS $\hat{\epsilon}_s$ /lot	Minimum PRS bandwidth, which is minimum of serving cell channel bandwidth and the PRS bandwidths of the reference cell and the measured neighbour	Minimum number of available measurement subframes among the reference cell and the measured neighbour cell i	Io ^{Note 9} range		
				E-UTRA operating band groups ^{Note 10}	Minimum Io ^{Note 1}	Maximum Io

		cell i ^{Notes 3, 6}				
T_s ^{Note 2}	dB	RB			dBm/15kHz z ^{Note 8}	dBm/BW _{Chan} _{nel}
± 15	(PRS \hat{E}_s/I_{ot}) _{ref} ≥ -6 dB and (PRS \hat{E}_s/I_{ot}) _{i} ≥ -13 dB	≥ 6	6	FDD_A, TDD_A	-121	-50
				FDD_B	-120.5	-50
				FDD_C, TDD_C	-120	-50
				FDD_D	-119.5	-50
				FDD_E, TDD_E	-119	-50
				FDD_F	-118.5	-50
				FDD_G	-118	-50
				FDD_H	-117.5	-50
				FDD_N	-114.5	-50
± 10 Note 11	(PRS \hat{E}_s/I_{ot}) _{ref} ≥ -6 dB and (PRS \hat{E}_s/I_{ot}) _{i} ≥ -13 dB	≥ 15	6	Note 5	Note 5	Note 5
± 6	(PRS \hat{E}_s/I_{ot}) _{ref} ≥ -6 dB and (PRS \hat{E}_s/I_{ot}) _{i} ≥ -13 dB	≥ 25	≥ 2	Note 5	Note 5	Note 5
± 5	(PRS \hat{E}_s/I_{ot}) _{ref} ≥ -6 dB and (PRS \hat{E}_s/I_{ot}) _{i} ≥ -13 dB	≥ 50	≥ 1	Note 5	Note 5	Note 5
± 4 Note 11	(PRS \hat{E}_s/I_{ot}) _{ref} ≥ -6 dB and (PRS \hat{E}_s/I_{ot}) _{i} ≥ -13 dB	≥ 75	≥ 1	Note 5	Note 5	Note 5
<p>NOTE 1: This minimum I_{o} condition is expressed as the average I_{o} per RE over all REs in an OFDM symbol.</p> <p>NOTE 2: T_s is the basic timing unit defined in TS 36.211 [26].</p> <p>NOTE 3: PRS bandwidth is as indicated in <i>prs-Bandwidth</i> in the OTDOA assistance data defined in TS 36.355 [4].</p> <p>NOTE 4: Void.</p> <p>NOTE 5: The same bands and the same I_{o} conditions for each band apply for this requirement as for the corresponding requirement with the PRS bandwidth ≥ 6 RB.</p> <p>NOTE 6: The serving cell, the reference cell, and the measured neighbour cell i are on the same carrier frequency.</p> <p>NOTE 7: Void.</p> <p>NOTE 8: The condition level is increased by $\Delta > 0$, when applicable, as described in TS 36.521-3 [25] Sections I.4.2 and I.4.3.</p> <p>NOTE 9: The I_{o} is defined in PRS positioning subframes. The same I_{o} range applies to PRS and non-PRS symbols. I_{o} levels are different in PRS and non-PRS symbols within the same subframe.</p> <p>NOTE 10: E-UTRA operating band groups are as defined in clause 4.4.2.</p> <p>NOTE 11: Only applicable from Rel-12 onwards</p>						

The normative reference for this requirement is TS 36.133 [23] clause 9.1.10.1 and A.9.8.1.

9.1.3.4 Test description

9.1.3.4.1 Initial conditions

Test Environment: Normal; as defined in TS 36.508 [18] clause 4.1.

Frequencies to be tested: Mid Range, as defined in TS 36.508 [18] clause 4.3.1.1.

Channel bandwidth to be tested: 1.4 MHz (Test 1 and 2) and 10 MHz (Test 3 and 4). In the case that 1.4 MHz channel bandwidth is not defined for the operating band under test, as defined in TS 36.101 [2] clause 5.6.1, then this part of the test shall be omitted.

1. Connect the SS and AWGN noise sources to the UE antenna connector or antenna connectors as shown in Annex A, Figure A.3a for 4RX capable UE without any 2RX bands. Otherwise use Annex A figure A.3.

2. The general test parameter settings are set up according to Table 9.1.3.4.1-1.

3. Propagation conditions are set according to clause 4.7.2.1.

4. Message contents are defined in clause 9.1.3.4.3.
5. All cells are on the same carrier frequency. Cell 1 is the serving cell and OTDOA assistance data reference cell; Cell 2 is the neighbour cell. The assistance data neighbour cell list includes in total 15 cells, where 14 of the cells are not simulated (dummy cells; as defined in 3GPP TS 37.571-5 [20], clause 7.2.2).
6. The true RSTD (which is the receive time difference for frame 0 between cell 2 and cell 1 as seen at the UE antenna connector) is set to the following values:
 - Test 1: -92 Ts (about -3 μ s)
 - Test 2: 92 Ts (about 3 μ s)
 - Test 3: 92 Ts (about 3 μ s)
 - Test 4: -92 Ts (about -3 μ s)

Note that the related expectedRSTD values to be signalled over LPP are defined in Table 9.1.3.4-1 for each test.

Table 9.1.3.4.1-1: General Test Parameters for intra frequency RSTD Tests for E-UTRAN FDD

Parameter	Unit	Value				Comment
		Test 1	Test 2	Test 3	Test 4	
PCFICH/PDCCH/PHICH parameters		R.14 FDD		R.6 FDD		As specified in TS 36.521-3 [25] clause A.2.1.
OCNG Patterns defined in TS 36.521-3 [25] clause D.1		OP.7 FDD		OP.6 FDD		OCNG shall be used such that both cells are fully allocated and a constant total transmitted power spectral density is achieved for all OFDM symbols (other than those in the PRS subframes).
Reference cell		Cell 1				
Neighbour cell		Cell 2				
E-UTRA RF Channel Number		1				One FDD carrier frequency is used.
Channel Bandwidth ($BW_{channel}$)	MHz	1.4		10		
PRS Transmission Bandwidth ^{Note 2}	RB	6		50		
PRS configuration Index I_{PRS} ^{Note 2}		12		2		As defined in 3GPP TS 36.211 [26]
Number of consecutive positioning downlink subframes N_{PRS} ^{Note 2}		6		1		As defined in 3GPP TS 36.211 [26]
prs-MutingInfo ^{Note 2}		Cell 1: '11110000' Cell 2: '11110000'				See section 6.5.1.2 in 3GPP TS 36.355 [4] for more information
Cell ID ^{Note 2}		(Cell ID of cell 1 – Cell ID of cell 2) mod 6 = 0	(Cell ID of cell 1 – Cell ID of cell 2) mod 6 = 1	(Cell ID of cell 1 – Cell ID of cell 2) mod 6 = 0	(Cell ID of cell 1 – Cell ID of cell 2) mod 6 = 3	
Expected RSTD ^{Note 1}	us	Cell 2: 1 Other neighbour cells: randomly between -3 and 3	Cell 2: -1 Other neighbour cells: randomly between -3 and 3	Cell 2: -1 Other neighbour cells: randomly between -3 and 3	Cell 2: 1 Other neighbour cells: randomly between -3 and 3	
Expected RSTD uncertainty for all neighbour cells ^{Note 1}	us	5	5	5	5	
CP length ^{Note 2}		Normal				
DRX		OFF				

Radio frame receive time offset between the cells at the UE antenna connector Note 3	us	Cell 2 to Cell 1: -3	Cell 2 to Cell 1: 3	Cell 2 to Cell 1: 3	Cell 2 to Cell 1: -3	PRS are transmitted from synchronous cells
Number of cells provided in OTDOA assistance data		16				The number of cells includes the reference cell
$T_{RSTDIntraFreqFDE-UTRAN}$ Note 4	ms	2560				Derived according to the RSTD measurement requirements specified in Section 9.1.1.3
<p>NOTE 1: Parameters “Expected RSTD” and “Expected RSTD uncertainty for all neighbour cells” are not settable parameters. These are parameters signalled in LPP only. For the values to be used in LPP see Table 9.1.3.4.3-4 and TS 37.571-5 [20], clause 7.2.2.</p> <p>NOTE 2: Parameters “PRS Transmission Bandwidth”, “PRS configuration index”, “Number of consecutive positioning downlink subframes”, “prs-MutingInfo”, “Cell ID” and “CP length” are settable parameters and also parameters signalled in LPP. The values to be used for “Cell ID” are as follows: Cell 1: 0, Cell 2: Test 1: 6, Test 2: 7, Test 3: 6, Test 4: 9. For all the values to be used in LPP see Table 9.1.3.4.3-4 and TS 37.571-5 [20], clause 7.2.2.</p> <p>NOTE 3: The parameter “Radio frame receive time offset between the cells at the UE antenna connector” is not a settable parameter but is used to set the “true RSTD” values in step 6 of clause 9.1.3.4.1.</p> <p>NOTE 4: The parameter “$T_{RSTDIntraFreqFDE-UTRAN}$” is not a settable parameter but is used to set the LPP “time” value in Table 9.1.3.4.3-2. The value of the LPP time IE is set to $T_{RSTDIntraFreqFDE-UTRAN} + \Delta T$ ms, where $\Delta T = 150$ ms, giving a value of 2710 ms. This is rounded up to the next allowed LPP value of 3 seconds.</p>						

9.1.3.4.2 Test procedure

The test consists of a set-up period and a measurement period. Cell 1 and Cell 2 are both active during the complete test. The beginning of the measurement period shall be aligned with the first PRS positioning subframe of a positioning occasion in the reference cell.

NOTE: The information on when PRS is muted is conveyed to the UE using PRS muting information in the OTDOA assistance data.

The OTDOA-RequestLocationInformation message and the OTDOA assistance data as defined in clause 9.1.3.4.3 shall be provided to the UE during the set-up period. The last TTI containing the OTDOA-RequestLocationInformation message shall be provided to the UE ΔT ms before the start of the measurement period, where $\Delta T = 150$ ms is the maximum processing time of the OTDOA-RequestLocationInformation message and the OTDOA assistance data in the UE.

1. Ensure that the UE is in state Generic RB Established State 3A-RF according to 3GPP TS 36.508 [18] clause 7.2A.3.
2. The SS shall send a RESET UE POSITIONING STORED INFORMATION message.
3. Set the parameters according to Table 9.1.3.5-1 as appropriate. Propagation conditions are set according to clause 4.7.2.1.
 - 3a. The SS shall send an LPP REQUEST CAPABILITIES message.
 - 3b. The UE shall send an LPP PROVIDE CAPABILITIES message indicating the OTDOA capabilities supported by the UE in the *OTDOA-ProvideCapabilities* IE.
4. The SS shall send a LPP PROVIDE ASSISTANCE DATA message, including the *OTDOA-ProvideAssistanceData* IE. If the UE message at step 3b includes the *ackRequested* IE set to TRUE, then the SS shall send an acknowledgment in the LPP PROVIDE ASSISTANCE DATA message.
5. The SS shall send a LPP REQUEST LOCATION INFORMATION message, including the *OTDOA-RequestLocationInformation* IE such that the UE receives the message ΔT ms before the start of the measurement period, where $\Delta T = 150$ ms.

6. The UE shall transmit a LPP PROVIDE LOCATION INFORMATION message, including the *OTDOA-ProvideLocationInformation* IE.
7. If the UE message at step 6 includes the *ackRequested* IE set to TRUE, the SS shall send a LPP acknowledgement message.
8. The SS shall check the *rstd* value for Cell 2 in the *OTDOA-SignalMeasurementInformation* IE according to Table 9.1.3.5-2.
9. Repeat step 2-8 until the confidence level according to Annex D is achieved.
10. Repeat step 1-9 for each sub-test in Table 9.1.3.5-1 as appropriate.

9.1.3.4.3 Message contents

Table 9.1.3.4.3-1: RESET UE POSITIONING STORED INFORMATION

Derivation Path: 36.509 [11] clause 6.9			
Information Element	Value/remark	Comment	Condition
UE Positioning Technology	0 0 0 0 0 0 1	OTDOA	

Table 9.1.3.4.3-1a: LPP Request Capabilities

Information Element	Value/remark
otdoa-RequestCapabilities	TRUE

Table 9.1.3.4.3-2: LPP RequestLocationInformation

Derivation Path: 36.355 clause 6.2			
Information Element	Value/remark	Comment	Condition
LPP-Message ::= SEQUENCE {			
transactionID SEQUENCE {			
initiator	locationServer		
transactionNumber	1		
}			
endTransaction	FALSE		
sequenceNumber	Not present		
acknowledgement	Not present		
lpp-MessageBody CHOICE {			
c1 CHOICE {			
requestLocationInformation SEQUENCE {			
criticalExtensions CHOICE {			
c1 CHOICE {			
requestLocationInformation-r9 SEQUENCE {			
commonEsRequestLocationInformation SEQUENCE {			
locationInformationType	locationMeasurementsRequired		
triggeredReporting	Not present		
periodicalReporting	Not present		
additionalInformation	onlyReturnInformationRequested		
qos SEQUENCE {			
horizontalAccuracy	Not present		
verticalCoordinateRequest	FALSE		
verticalAccuracy	Not present		
responseTime SEQUENCE {			
time	3	See Note 4 of Table 9.1.3.4.1-1	
responseTimeEarlyFix-r12	Not present		Rel-12 onwards
}			
velocityRequest	FALSE		

}			
environment	Not present		
locationCoordinateTypes	Not present		
velocityTypes	Not present		
}			
a-gnss-RequestLocationInformation	Not present		
otdoa-RequestLocationInformation SEQUENCE {			
assistanceAvailability	FALSE		
}			
ecid-RequestLocationInformation	Not present		
epdu-RequestLocationInformation	Not Present		
}			
}			
}			
}			
}			
}			
}			
}			
}			

Table 9.1.3.4.3-3: Void

Table 9.1.3.4.3-4: LPP ProvideAssistanceData

Derivation Path: 36.355 clause 6.2			
Information Element	Value/remark	Comment	Condition
LPP-Message ::= SEQUENCE {			
transactionID SEQUENCE {			
Initiator	locationServer		
transactionNumber	(0..255)		
}			
endTransaction	TRUE		
sequenceNumber	Not present		
acknowledgement	Not present		
lpp-MessageBody CHOICE {			
c1 CHOICE {			
provideAssistanceData SEQUENCE {			
criticalExtensions CHOICE {			
c1 CHOICE {			
provideAssistanceData-r9 SEQUENCE {			
commonEsProvideAssistanceData	Not present		
a-gnss-ProvideAssistanceData	Not present		
otdoa-ProvideAssistanceData SEQUENCE {			
otdoa-ReferenceCellInfo	As defined in TS 37.571-5 [20], clause 7.2.2.		
otdoa-NeighbourCellInfo	As defined in TS 37.571-5 [20], clause 7.2.2.		
otdoa-Error	Not present		
}			
epdu-ProvideAssistanceData	Not present		
}			
}			
}			
}			
}			
}			
}			

Table 9.1.3.4.3-5: LPP ProvideLocation Information

Derivation Path: 36.355 clause 6.2			
Information Element	Value/remark	Comment	Condition

LPP-Message ::= SEQUENCE {			
transactionID SEQUENCE {			
initiator	locationServer		
transactionNumber	1		
}			
endTransaction	TRUE		
sequenceNumber	(0..255)		
acknowledgement			
lpp-MessageBody CHOICE {			
c1 CHOICE {			
provideLocationInformation SEQUENCE {			
criticalExtensions CHOICE {			
c1 CHOICE {			
provideLocationInformation-r9 SEQUENCE {			
commonIEsProvideLocationInformation	Not present.		
a-gnss-ProvideLocationInformation	Not present		
otdoa-ProvideLocationInformation			
SEQUENCE {			
otdoaSignalMeasurementInformation			
SEQUENCE {			
systemFrameNumber			
physCellIdRef	Cell 1		
cellGlobalIdRef			
earfcnRef			
referenceQuality			
neighbourMeasurementList			
SEQUENCE (SIZE(1)) {			
physCellIdNeighbor	Cell 2		
cellGlobalIdNeighbour			
earfcnNeighbour			
rstd	Set according to Table 9.1.3.5-2 for each specific test		
rstd-Quality			
}			
}			
otdoa-Error	May be present with error reason 'undefined' or 'attemptedButUnableToMeasureSomeNeighbourCells'		
}			
ecid-ProvideLocationInformation	Not present		
epdu-ProvideLocationInformation	Not present		
}			
}			

Table 9.1.3.4.3-6: CQI-ReportConfig-DEFAULT: FDD RSTD Measurement Accuracy

Derivation Path: TS 36.508 [18] clause 4.6.3, Table 4.6.3-2 CQI-ReportConfig-DEFAULT			
Information Element	Value/remark	Comment	Condition
CQI-ReportConfig-DEFAULT ::= SEQUENCE {			
cqi-ReportModeAperiodic	rm30	This IE should be omitted for Test 1 and Test 2	
nomPDSCH-RS-EPRE-Offset	0		
cqi-ReportPeriodic CHOICE {			
release	NULL		
}			

9.1.3.5 Test requirement

Table 9.1.3.5-1 defines the primary level settings including test tolerances for all tests.

The RSTD FDD intra-frequency accuracy test shall meet the reported values in Table 9.1.3.5-2.

Table 9.1.3.5-1: Cell Specific Test Parameters for intra frequency RSTD Tests for E-UTRAN FDD

Parameter	Unit	Test 1		Test 2		Test 3		Test 4	
		Cell 1	Cell 2	Cell 1	Cell 2	Cell 1	Cell 2	Cell 1	Cell 2
E-UTRA RF Channel Number		1							
PBCH_RA	dB	0	0	0	0	0	0	0	0
PBCH_RB									
PSS_RA									
SSS_RA									
PCFICH_RB									
PHICH_RA									
PHICH_RB									
PDCCH_RA									
PDCCH_RB									
OCNG_RA ^{Note 1}									
OCNG_RB ^{Note 1}									
PRS_RA	dB	0	0	-2.7	0.3	0	0	-2.7	0.3
N_{oc} ^{Note 2}	dBm/15 kHz	-98	-98	-98	-98	-98	-98	-98	-98
$PRS \hat{E}_s/N_{oc}$	dB	-2.37	-8.02	-5.7	-12.7	-2.37	-8.02	-5.7	-12.7
$PRS \hat{E}_s/I_{ot}$ ^{Note 3}	dB	-3	-10	-5.7	-12.7	-3	-10	-5.7	-12.7
I_o ^{Note 3}	dBm/1.08 MHz	-78.92	-78.92	-79.2	-79.2	N/A	N/A	N/A	N/A
	dBm/9 MHz	N/A	N/A	N/A	N/A	-69.72	-69.72	-69.99	-69.99
PRP ^{Note 3}	dBm/15kHz	-100.37	-106.02	-103.7	-110.7	-100.37	-106.02	-103.7	-110.7
\hat{E}_s/N_{oc} ^{Note 3}	dB	-2.37	-8.02	-3	-13	-2.37	-8.02	-3	-13
RSRP ^{Note 3}	dBm/15kHz	-100.37	-106.02	-101	-111	-100.37	-106.02	-101	-111
Propagation condition		AWGN							
<p>Note 1: OCNG shall be used such that both cells are fully allocated and a constant total transmitted power spectral density is achieved for all OFDM symbols (other than those in the PRS subframes).</p> <p>Note 2: Interference from other cells and noise sources not specified in the test is assumed to be constant over subcarriers and time and shall be modelled as AWGN of appropriate power for N_{oc} to be fulfilled.</p> <p>Note 3: \hat{E}_s/N_{oc}, $PRS \hat{E}_s/I_{ot}$, I_o, RSRP and PRP levels have been derived from other parameters for information purposes. They are not settable parameters themselves. I_o values are derived in the case that there is no PBCH, PSS or SSS in the OFDM symbols carrying PRS.</p>									

Table 9.1.3.5-2: RSTD FDD intra-frequency accuracy requirements for the reported values

	Test 1	Test 2	Test 3	Test 4
Lowest reported value	RSTD_6248	RSTD_6431	RSTD_6441	RSTD_6258

Highest reported value	RSTD_6280	RSTD_6463	RSTD_6453	RSTD_6270
------------------------	-----------	-----------	-----------	-----------

For the overall test to pass, the ratio of successful reported values in each sub-test shall be more than 90% with a confidence level of 95%. In the case that 1.4 MHz channel bandwidth is not defined for the operating band under test then Test 1 and Test 2 shall be omitted.

9.1.3A FDD RSTD Measurement Accuracy for UE Category 1bis

9.1.3A.1 Test purpose

To verify that the RSTD FDD intra-frequency measurement accuracy is within the specified limits.

9.1.3A.2 Test applicability

This test applies to E-UTRA FDD UE Category 1bis release 13 and forward that supports UE-assisted OTDOA.

9.1.3A.3 Minimum conformance requirements

Same as 9.1.3.3

The normative reference for this requirement is TS 36.133 [23] clause 9.1.10.5 and A.9.8.1.2A.

9.1.3A.4 Test description

9.1.3A.4.1 Initial conditions

Same as 9.1.3.4.1 with the following exceptions:

1. Connect the SS, faders and AWGN noise sources to the UE antenna connector or antenna connectors as shown in Annex A, Figure A.3, using only the main Tx/Rx path.
2. The general test parameter settings are set up according to Table 9.1.3A.4.1-1

Table 9.1.3A.4.1-1: General Test Parameters for intra frequency RSTD Tests for E-UTRAN FDD for UE Category 1bis

Parameter	Unit	Value				Comment
		Test 1	Test 2	Test 3	Test 4	
PCFICH/PDCCH/PHICH parameters		R.14 FDD		R.6 FDD		As specified in TS 36.521-3 [25] clause A.2.1.
OCNG Patterns defined in TS 36.521-3 [25] clause D.1		OP.7 FDD		OP.6 FDD		OCNG shall be used such that both cells are fully allocated and a constant total transmitted power spectral density is achieved for all OFDM symbols (other than those in the PRS subframes).
Reference cell		Cell 1				
Neighbour cell		Cell 2				
E-UTRA RF Channel Number		1				One FDD carrier frequency is used.
Channel Bandwidth (BW _{channel})	MHz	1.4		10		
PRS Transmission Bandwidth ^{Note 2}	RB	6		50		
PRS configuration Index I _{PRS} ^{Note 2}		12		2		As defined in 3GPP TS 36.211 [26]

Number of consecutive positioning downlink subframes N_{PRS} ^{Note 2}		6		1		As defined in 3GPP TS 36.211 [26]
prs-MutingInfo ^{Note 2}		Cell 1: '1111111100000000' Cell 2: '1111111100000000'				See section 6.5.1.2 in 3GPP TS 36.355 [4] for more information
Cell ID ^{Note 2}		(Cell ID of cell 1 – Cell ID of cell 2) mod 6 = 0	(Cell ID of cell 1 – Cell ID of cell 2) mod 6 = 1	(Cell ID of cell 1 – Cell ID of cell 2) mod 6 = 0	(Cell ID of cell 1 – Cell ID of cell 2) mod 6 = 3	
Expected RSTD ^{Note 1}	us	Cell 2: 1 Other neighbour cells: randomly between -3 and 3	Cell 2: -1 Other neighbour cells: randomly between -3 and 3	Cell 2: -1 Other neighbour cells: randomly between -3 and 3	Cell 2: 1 Other neighbour cells: randomly between -3 and 3	
Expected RSTD uncertainty for all neighbour cells ^{Note 1}	us	5	5	5	5	
CP length ^{Note 2}		Normal				
DRX		OFF				
Radio frame receive time offset between the cells at the UE antenna connector ^{Note 3}	us	Cell 2 to Cell 1: -3	Cell 2 to Cell 1: 3	Cell 2 to Cell 1: 3	Cell 2 to Cell 1: -3	PRS are transmitted from synchronous cells
Number of cells provided in OTDOA assistance data		16				The number of cells includes the reference cell
T_{RSTD} IntraFreqFDD, E-UTRAN ^{Note 4}	ms	5120				Derived according to the RSTD measurement requirements specified in Section 9.1.1A.3
<p>NOTE 1: Parameters “Expected RSTD” and “Expected RSTD uncertainty for all neighbour cells” are not settable parameters. These are parameters signalled in LPP only. For the values to be used in LPP see Table 9.1.3.4.3-4 and TS 37.571-5 [20], clause 7.2.2.</p> <p>NOTE 2: Parameters “PRS Transmission Bandwidth”, “PRS configuration index”, “Number of consecutive positioning downlink subframes”, “prs-MutingInfo”, “Cell ID” and “CP length” are settable parameters and also parameters signalled in LPP. The values to be used for “Cell ID” are as follows: Cell 1: 0, Cell 2: Test 1: 6, Test 2: 7, Test 3: 6, Test 4: 9. For all the values to be used in LPP see Table 9.1.3.4.3-4 and TS 37.571-5 [20], clause 7.2.2.</p> <p>NOTE 3: The parameter “Radio frame receive time offset between the cells at the UE antenna connector” is not a settable parameter but is used to set the “true RSTD” values in step 6 of clause 9.1.3.4.1.</p> <p>NOTE 4: The parameter “T_{RSTD} IntraFreqFDD, E-UTRAN ” is not a settable parameter but is used to set the LPP “time” value in Table 9.1.3A.4.3-2. The value of the LPP time IE is set to T_{RSTD} IntraFreqFDD, E-UTRAN + ΔT ms, where $\Delta T = 150$ ms, giving a value of 5270 ms. This is rounded up to the next allowed LPP value of 6 seconds.</p>						

9.1.3A.4.2 Test procedure

Same as 9.1.3.4.2.

9.1.3A.4.3 Message contents

Same as 9.1.3.4.3 with the following exceptions

Table 9.1.3A.4.3-1: LPP RequestLocationInformation

Derivation Path: Table 9.1.3.4.3-2			
Information Element	Value/remark	Comment	Condition
LPP-Message ::= SEQUENCE {			

lpp-MessageBody CHOICE {			
c1 CHOICE {			
requestLocationInformation SEQUENCE {			
criticalExtensions CHOICE {			
c1 CHOICE {			
requestLocationInformation-r9 SEQUENCE {			
commonEsRequestLocationInformation SEQUENCE {			
qos SEQUENCE {			
responseTime SEQUENCE {			
time	6	See Note 4 of Table 9.1.3A.4.1-1	
}			
}			
}			
}			
}			
}			
}			
}			

9.1.3A.5 Test requirement

Same as 9.1.3.5.

9.1.4 TDD RSTD Measurement Accuracy

9.1.4.1 Test purpose

To verify that the RSTD TDD intra-frequency measurement accuracy is within the specified limits.

9.1.4.2 Test applicability

This test applies to all types of E-UTRA TDD UE release 9 and forward that supports UE-assisted OTDOA except UE Category 1bis.

9.1.4.3 Minimum conformance requirements

The accuracy requirements in Table 9.1.3.3-1 are valid under the following conditions:

Conditions defined in TS 36.101 [2] clause 7.3 for reference sensitivity are fulfilled.

PRP 1,2_{dBm} according to clause E.2 for a corresponding Band.

There are no measurement gaps overlapping with the PRS subframes of the measured cell.

The parameter *expectedRSTDUncertainty* signalled over LPP as defined in 3GPP TS 36.355 [4] is less than 5 μs.

The normative reference for this requirement is TS 36.133 [23] clause 9.1.10.1 and A.9.8.2.

9.1.4.4 Test description

9.1.4.4.1 Initial conditions

Test Environment: Normal; as defined in TS 36.508 [18] clause 4.1.

Frequencies to be tested: Mid Range, as defined in TS 36.508 [18] clause 4.3.1.2.

Channel bandwidth to be tested: 1.4 MHz (Test 1 and 2) and 10 MHz (Test 3 and 4). In the case that 1.4 MHz channel bandwidth is not defined for the operating band under test, as defined in TS 36.101 [2] clause 5.6.1, then this part of the test shall be omitted.

1. Connect the SS and AWGN noise sources to the UE antenna connector or antenna connectors as shown in Annex A, Figure A.3a for 4RX capable UE without any 2RX bands. Otherwise use Annex A figure A.3.

2. The general test parameter settings are set up according to Table 9.1.4.4.1-1.

3. Propagation conditions are set according to clause 4.7.2.1.

4. Message contents are defined in clause 9.1.4.4.3.

5. All cells are on the same carrier frequency. Cell 1 is the serving cell and OTDOA assistance data reference cell; Cell 2 is the neighbour cell. The assistance data neighbour cell list includes in total 15 cells, where 14 of the cells are not simulated (dummy cells; as defined in 3GPP TS 37.571-5 clause 7.2.2).

6. The true RSTD (which is the receive time difference for frame 0 between cell 2 and cell 1 as seen at the UE antenna connector) is set to the following values:

Test 1: -92 Ts (about -3 μ s)

Test 2: 92 Ts (about 3 μ s)

Test 3: 92 Ts (about 3 μ s)

Test 4: -92 Ts (about -3 μ s)

Note that the related expectedRSTD values to be signalled over LPP are defined in Table 9.1.4.4-1 for each test.

Table 9.1.4.4.1-1: General Test Parameters for intra frequency RSTD Tests for E-UTRAN TDD

Parameter	Unit	Value				Comment	
		Test 1	Test 2	Test 3	Test 4		
PCFICH/PDCCH/PHICH parameters		R.14 TDD		R.6 TDD		As specified in TS 36.521-3 [25] clause A.2.2.	
OCNG Patterns defined in TS 36.521-3 [25] clause D.2		OP.4 TDD		OP.2 TDD		OCNG shall be used such that both cells are fully allocated and a constant total transmitted power spectral density is achieved for all OFDM symbols (other than those in the PRS subframes).	
Reference cell		Cell 1					
Neighbour cell		Cell 2					
E-UTRA RF Channel Number		1					One TDD carrier frequency is used.
Channel Bandwidth (BW_{channel})	MHz	1.4		10			
Special subframe configuration		6		6		As specified in table 4.2-1 in TS 36.211 [26]. The same configuration in both cells.	
Uplink-downlink configuration		3		1		As specified in table 4.2-2 in TS 36.211 [26] and table 9.1.2.3-2. The same configuration in both cells.	
PRS Transmission Bandwidth ^{Note 2}	RB	6		50			
PRS configuration Index I_{PRS} ^{Note 2}		9		14		As defined in 3GPP TS 36.211 [26].	

Number of consecutive positioning downlink subframes N_{PRS} ^{Note 2}		6	1			As defined in 3GPP TS 36.211 [26].
prs-MutingInfo ^{Note 2}		Cell 1: '11110000' Cell 2: '11110000'				See section 6.5.1.2 in 3GPP TS 36.355 [4] for more information
Cell ID ^{Note 2}		(Cell ID of cell 1 – Cell ID of cell 2) mod 6 = 0	(Cell ID of cell 1 – Cell ID of cell 2) mod 6 = 1	(Cell ID of cell 1 – Cell ID of cell 2) mod 6 = 0	(Cell ID of cell 1 – Cell ID of cell 2) mod 6 = 3	
Expected RSTD ^{Note 1}	us	Cell 2: 1 Other neighbour cells: randomly between -3 and 3	Cell 2: -1 Other neighbour cells: randomly between -3 and 3	Cell 2: -1 Other neighbour cells: randomly between -3 and 3	Cell 2: 1 Other neighbour cells: randomly between -3 and 3	
Expected RSTD uncertainty for all neighbour cells ^{Note 1}	us	5	5	5	5	
CP length ^{Note 2}		Normal				
DRX		OFF				
Radio frame receive time offset between the cells at the UE antenna connector ^{Note 3}	us	Cell 2 to Cell 1: -3	Cell 2 to Cell 1: 3	Cell 2 to Cell 1: 3	Cell 2 to Cell 1: -3	PRS are transmitted from synchronous cells
Number of cells provided in OTDOA assistance data		16				The number of cells includes the reference cell
$T_{RSTDIntraFreqDDE-UTRAN}$ ^{Note 4}	ms	2560				Derived according to the RSTD measurement requirements specified in Section 9.1.2.3
<p>NOTE 1: Parameters "Expected RSTD" and "Expected RSTD uncertainty for all neighbour cells" are not settable parameters. These are parameters signalled in LPP only. For the values to be used in LPP see Table 9.1.4.4.3-4 and TS 37.571-5 [20], clause 7.2.2.</p> <p>NOTE 2: Parameters "PRS Transmission Bandwidth", "PRS configuration index", "Number of consecutive positioning downlink subframes", "prs-MutingInfo", "Cell ID" and "CP length" are settable parameters and also parameters signalled in LPP. The values to be used for "Cell ID" are as follows: Cell 1: 0, Cell 2: Test 1: 6, Test 2: 7, Test 3: 6, Test 4: 9. For all the values to be used in LPP see Table 9.1.4.4.3-4 and TS 37.571-5 [20], clause 7.2.2.</p> <p>NOTE 3: The parameter "Radio frame receive time offset between the cells at the UE antenna connector" is not a settable parameter but is used to set the "true RSTD" values in step 6 of clause 9.1.4.4.1.</p> <p>NOTE 4: The parameter "$T_{RSTDIntraFreqDDE-UTRAN}$" is not a settable parameter but is used to set the LPP "time" value in Table 9.1.4.4.3-2. The value of the LPP time IE is set to $T_{RSTDIntraFreqDDE-UTRAN} + \Delta T$ ms, where $\Delta T = 150$ ms, giving a value of 2710 ms. This is rounded up to the next allowed LPP value of 3 seconds.</p>						

9.1.4.4.2 Test procedure

The test consists of a set-up period and a measurement period. Cell 1 and Cell 2 are both active during the complete test. The beginning of the measurement period shall be aligned with the first PRS positioning subframe of a positioning occasion in the reference cell.

NOTE: The information on when PRS is muted is conveyed to the UE using PRS muting information in the OTDOA assistance data.

The OTDOA-RequestLocationInformation message and the OTDOA assistance data as defined in clause 9.1.4.4.3 shall be provided to the UE during the set-up period. The last TTI containing the OTDOA-RequestLocationInformation message shall be provided to the UE ΔT ms before the start of the measurement period, where $\Delta T = 150$ ms is the maximum processing time of the OTDOA-RequestLocationInformation message and the OTDOA assistance data in the UE.

1. Ensure that the UE is in state Generic RB Established State 3A-RF according to 3GPP TS 36.508 [18] clause 7.2A.3.
2. The SS shall send a RESET UE POSITIONING STORED INFORMATION message.
3. Set the parameters according to Table 9.1.4.5-1 as appropriate. Propagation conditions are set according to clause 4.7.2.1.
 - 3a. The SS shall send an LPP REQUEST CAPABILITIES message.
 - 3b. The UE shall send an LPP PROVIDE CAPABILITIES message indicating the OTDOA capabilities supported by the UE in the *OTDOA-ProvideCapabilities* IE.
4. The SS shall send a LPP PROVIDE ASSISTANCE DATA message, including the *OTDOA-ProvideAssistanceData* IE. If the UE message at step 3b includes the *ackRequested* IE set to TRUE, then the SS shall send an acknowledgment in the LPP PROVIDE ASSISTANCE DATA message.
5. The SS shall send a LPP REQUEST LOCATION INFORMATION message, including the *OTDOA-RequestLocationInformation* IE such that the UE receives the message ΔT ms before the start of measurement period, where $\Delta T = 150$ ms.
6. The UE shall transmit a LPP PROVIDE LOCATION INFORMATION message, including the *OTDOA-ProvideLocationInformation* IE.
7. If the UE message at step 6 includes the *ackRequested* IE set to TRUE, the SS shall send a LPP acknowledgement message.
8. The SS shall check the *rstd* value for Cell 2 in the *OTDOA-SignalMeasurementInformation* IE according to Table 9.1.4.5-2.
9. Repeat step 2-8 until the confidence level according to Annex D is achieved.
10. Repeat step 1-9 for each sub-test in Table 9.1.4.5-1 as appropriate.

9.1.4.4.3 Message contents

Table 9.1.4.4.3-1: RESET UE POSITIONING STORED INFORMATION

Derivation Path: 36.509 [11] clause 6.9			
Information Element	Value/remark	Comment	Condition
UE Positioning Technology	0 0 0 0 0 0 1	OTDOA	

Table 9.1.4.4.3-1a: LPP Request Capabilities

Information Element	Value/remark
otdoa-RequestCapabilities	TRUE

Table 9.1.4.4.3-2: LPP RequestLocationInformation

Derivation Path: 36.355 clause 6.2			
Information Element	Value/remark	Comment	Condition
LPP-Message ::= SEQUENCE {			
transactionID SEQUENCE {			
initiator	locationServer		
transactionNumber	1		
}			
endTransaction	FALSE		
sequenceNumber	Not present		
acknowledgement	Not present		
lpp-MessageBody CHOICE {			
c1 CHOICE {			
requestLocationInformation SEQUENCE {			
criticalExtensions CHOICE {			

c1 CHOICE {			
requestLocationInformation-r9 SEQUENCE {			
commonEsRequestLocationInformation SEQUENCE {			
locationInformationType	locationMeasurementsRe quired		
triggeredReporting	Not present		
periodicalReporting	Not present		
additionalInformation	onlyReturnInformationRe quested		
qos SEQUENCE {			
horizontalAccuracy	Not present		
verticalCoordinateRequest	FALSE		
verticalAccuracy	Not present		
responseTime SEQUENCE {			
time	3	See Note 4 of Table 9.1.4.4.1-1	
responseTimeEarlyFix-r12	Not present		Rel-12 onwards
}			
velocityRequest	FALSE		
}			
environment	Not present		
locationCoordinateTypes	Not present		
velocityTypes	Not present		
}			
a-gnss-RequestLocationInformation	Not present		
otdoa-RequestLocationInformation SEQUENCE {			
assistanceAvailability	FALSE		
}			
ecid-RequestLocationInformation	Not present		
epdu-RequestLocationInformation	Not Present		
}			
}			
}			
}			
}			
}			
}			
}			
}			
}			
}			

Table 9.1.4.4.3-3: Void

Table 9.1.4.4.3-4: LPP ProvideAssistanceData

Derivation Path: 36.355 clause 6.2			
Information Element	Value/remark	Comment	Condition
LPP-Message ::= SEQUENCE {			
transactionID SEQUENCE {			
Initiator	locationServer		
transactionNumber	(0..255)		
}			
endTransaction	TRUE		
sequenceNumber	Not present		
acknowledgement	Not present		
lpp-MessageBody CHOICE {			
c1 CHOICE {			
provideAssistanceData SEQUENCE {			
criticalExtensions CHOICE {			
c1 CHOICE {			
provideAssistanceData-r9 SEQUENCE {			
commonEsProvideAssistanceData	Not present		

a-gnss-ProvideAssistanceData	Not present		
otdoa-ProvideAssistanceData SEQUENCE {			
otdoa-ReferenceCellInfo	As defined in TS 37.571-5 [20], clause 7.2.2.		
otdoa-NeighbourCellInfo	As defined in TS 37.571-5 [20], clause 7.2.2.		
otdoa-Error	Not present		
}			
epdu-ProvideAssistanceData	Not present		
}			
}			
}			
}			
}			
}			
}			
}			

Table 9.1.4.4.3-5: LPP ProvideLocation Information

Derivation Path: 36.355 clause 6.2			
Information Element	Value/remark	Comment	Condition
LPP-Message ::= SEQUENCE {			
transactionID SEQUENCE {			
initiator	locationServer		
transactionNumber	1		
}			
endTransaction	TRUE		
sequenceNumber	(0..255)		
acknowledgement			
lpp-MessageBody CHOICE {			
c1 CHOICE {			
provideLocationInformation SEQUENCE {			
criticalExtensions CHOICE {			
c1 CHOICE {			
provideLocationInformation-r9 SEQUENCE {			
commonIEsProvideLocationInformation	Not present.		
a-gnss-ProvideLocationInformation	Not present		
otdoa-ProvideLocationInformation SEQUENCE {			
otdoaSignalMeasurementInformation SEQUENCE {			
systemFrameNumber			
physCellIdRef	Cell 1		
cellGlobalIdRef			
earfcnRef			
referenceQuality			
neighbourMeasurementList SEQUENCE (SIZE(1)) {			
physCellIdNeighbor	Cell 2		
cellGlobalIdNeighbour			
earfcnNeighbour			
rstd	Set according to Table 9.1.4.5-2 for each specific test		
rstd-Quality			
}			
}			
otdoa-Error	May be present with error reason 'undefined' or 'attemptedButUnableToMeasureSomeNeighbourCells'		
}			
}			
}			
ecid-ProvideLocationInformation	Not present		

epdu-ProvideLocationInformation	Not present		
}			
}			
}			
}			
}			

Table 9.1.4.4.3-6: CQI-ReportConfig-DEFAULT: TDD RSTD Measurement Accuracy

Derivation Path: TS 36.508 [18] clause 4.6.3, Table 4.6.3-2 CQI-ReportConfig-DEFAULT			
Information Element	Value/remark	Comment	Condition
CQI-ReportConfig-DEFAULT ::= SEQUENCE {			
cqi-ReportModeAperiodic	rm30	This IE should be omitted for Test 1 and Test 2	
nomPDSCH-RS-EPRE-Offset	0		
cqi-ReportPeriodic CHOICE {			
release	NULL		
}			

9.1.4.5 Test requirement

Table 9.1.4.5-1 defines the primary level settings including test tolerances for all tests.

Each RSTD TDD intra-frequency accuracy test shall meet the reported values in Table 9.1.4.5-2.

Table 9.1.4.5-1: Cell Specific Test Parameters for intra frequency RSTD Tests for E-UTRAN TDD

Parameter	Unit	Test 1		Test 2		Test 3		Test 4	
		Cell 1	Cell 2	Cell 1	Cell 2	Cell 1	Cell 2	Cell 1	Cell 2
E-UTRA RF Channel Number		1							
PBCH_RA	dB	0	0	0	0	0	0	0	0
PBCH_RB									
PSS_RA									
SSS_RA									
PCFICH_RB									
PHICH_RA									
PHICH_RB									
PDCCH_RA									
PDCCH_RB									
OCNG_RA ^{Note 1}									
OCNG_RB ^{Note 1}									
PRS_RA	dB	0	0	-2.7	0.3	0	0	-2.7	0.3
N_{oc} ^{Note 2}	dBm/15 kHz	-98	-98	-98	-98	-98	-98	-98	-98
\hat{E}_s/N_{oc} ^{PRS}	dB	-2.37	-8.02	-5.7	-12.7	-2.37	-8.02	-5.7	-12.7
\hat{E}_s/I_{ot} ^{Note 3}	dB	-3	-10	-5.7	-12.7	-3	-10	-5.7	-12.7
I_o ^{Note 3}	dBm/1.08 MHz	-78.92	-78.92	-79.2	-79.2	N/A	N/A	N/A	N/A
	dBm/9 MHz	N/A	N/A	N/A	N/A	-69.72	-69.72	-69.99	-69.99
PRP ^{Note 3}	dBm/15kHz	-100.37	-106.02	-103.7	-110.7	-100.37	-106.02	-103.7	-110.7
\hat{E}_s/N_{oc} ^{Note 3}	dB	-2.37	-8.02	-3	-13	-2.37	-8.02	-3	-13
RSRP ^{Note 3}	dBm/15kHz	-100.37	-106.02	-101	-111	-100.37	-106.02	-101	-111
Propagation condition		AWGN							
Note 1: OCNG shall be used such that both cells are fully allocated and a constant total transmitted power spectral density is achieved for all OFDM symbols (other than those in the PRS subframes).									

Note 2: Interference from other cells and noise sources not specified in the test is assumed to be constant over subcarriers and time and shall be modelled as AWGN of appropriate power for N_{oc} to be fulfilled.

Note 3: \hat{E}_s/N_{oc} , PRS \hat{E}_s/I_{ot} , I_o , RSRP and PRP levels have been derived from other parameters for information purposes. They are not settable parameters themselves. I_o values are derived in the case that there is no PBCH, PSS or SSS in the OFDM symbols carrying PRS.

Table 9.1.4.5-2: RSTD TDD intra-frequency accuracy requirements for the reported values

	Test 1	Test 2	Test 3	Test 4
Lowest reported value	RSTD_6248	RSTD_6431	RSTD_6441	RSTD_6258
Highest reported value	RSTD_6280	RSTD_6463	RSTD_6453	RSTD_6270

For the overall test to pass, the ratio of successful reported values in each sub-test shall be more than 90% with a confidence level of 95%. In the case that 1.4 MHz channel bandwidth is not defined for the operating band under test then Test 1 and Test 2 shall be omitted.

9.1.4A TDD RSTD Measurement Accuracy for UE Category 1bis

9.1.4A.1 Test purpose

To verify that the RSTD TDD intra-frequency measurement accuracy is within the specified limits.

9.1.4A.2 Test applicability

This test applies to E-UTRA TDD UE Category 1bis release 13 and forward that supports UE-assisted OTDOA.

9.1.4A.3 Minimum conformance requirements

Same as 9.1.4.3

The normative reference for this requirement is TS 36.133 [23] clause 9.1.10.6 and A.9.8.2.2A.

9.1.4A.4 Test description

9.1.4A.4.1 Initial conditions

Same as 9.1.4.4.1 with the following exceptions:

1. Connect the SS, faders and AWGN noise sources to the UE antenna connector or antenna connectors as shown in Annex A, Figure A.3, using only the main Tx/Rx path.
2. The general test parameter settings are set up according to Table 9.1.4A.4.1-1

Table 9.1.4A.4.1-1: General Test Parameters for intra frequency RSTD Tests for E-UTRAN TDD for UE Category 1bis

Parameter	Unit	Value				Comment
		Test 1	Test 2	Test 3	Test 4	
PCFICH/PDCCH/PHICH parameters		R.14 TDD		R.6 TDD		As specified in TS 36.521-3 [25] clause A.2.2.

OCNG Patterns defined in TS 36.521-3 [25] clause D.2		OP.4 TDD	OP.2 TDD			OCNG shall be used such that both cells are fully allocated and a constant total transmitted power spectral density is achieved for all OFDM symbols (other than those in the PRS subframes).
Reference cell		Cell 1				
Neighbour cell		Cell 2				
E-UTRA RF Channel Number		1				One TDD carrier frequency is used.
Channel Bandwidth (BW _{channel})	MHz	1.4	10			
Special subframe configuration		6	6			As specified in table 4.2-1 in TS 36.211 [26]. The same configuration in both cells.
Uplink-downlink configuration		3	1			As specified in table 4.2-2 in TS 36.211 [26] and table 9.1.2.3-2. The same configuration in both cells.
PRS Transmission Bandwidth ^{Note 2}	RB	6	50			
PRS configuration Index I _{PRS} ^{Note 2}		9	14			As defined in 3GPP TS 36.211 [26].
Number of consecutive positioning downlink subframes N _{PRS} ^{Note 2}		6	1			As defined in 3GPP TS 36.211 [26].
prs-MutingInfo ^{Note 2}		Cell 1: '1111111100000000' Cell 2: '1111111100000000'				See section 6.5.1.2 in 3GPP TS 36.355 [4] for more information
Cell ID ^{Note 2}		(Cell ID of cell 1 – Cell ID of cell 2) mod 6 = 0	(Cell ID of cell 1 – Cell ID of cell 2) mod 6 = 1	(Cell ID of cell 1 – Cell ID of cell 2) mod 6 = 0	(Cell ID of cell 1 – Cell ID of cell 2) mod 6 = 3	
Expected RSTD ^{Note 1}	us	Cell 2: 1 Other neighbour cells: randomly between -3 and 3	Cell 2: -1 Other neighbour cells: randomly between -3 and 3	Cell 2: -1 Other neighbour cells: randomly between -3 and 3	Cell 2: 1 Other neighbour cells: randomly between -3 and 3	
Expected RSTD uncertainty for all neighbour cells ^{Note 1}	us	5	5	5	5	
CP length ^{Note 2}		Normal				
DRX		OFF				
Radio frame receive time offset between the cells at the UE antenna connector ^{Note 3}	us	Cell 2 to Cell 1: -3	Cell 2 to Cell 1: 3	Cell 2 to Cell 1: 3	Cell 2 to Cell 1: -3	PRS are transmitted from synchronous cells
Number of cells provided in OTDOA assistance data		16				The number of cells includes the reference cell
T _{RSTDIntraFreqDDE-UTRAN} ^{Note 4}	ms	5120				Derived according to the RSTD measurement requirements specified in Section 9.1.2A.3

NOTE 1: Parameters “Expected RSTD” and “Expected RSTD uncertainty for all neighbour cells” are not settable parameters. These are parameters signalled in LPP only. For the values to be used in LPP see Table 9.1.4.4.3-4 and TS 37.571-5 [20], clause 7.2.2.

NOTE 2: Parameters “PRS Transmission Bandwidth”, “PRS configuration index”, “Number of consecutive positioning downlink subframes”, “prs-MutingInfo”, “Cell ID” and “CP length” are settable parameters and also parameters signalled in LPP. The values to be used for “Cell ID” are as follows: Cell 1: 0, Cell 2: Test 1: 6, Test 2: 7, Test 3: 6, Test 4: 9. For all the values to be used in LPP see Table 9.1.4.4.3-4 and TS 37.571-5 [20], clause 7.2.2.

NOTE 3: The parameter “Radio frame receive time offset between the cells at the UE antenna connector” is not a settable parameter but is used to set the “true RSTD” values in step 6 of clause 9.1.4.4.1.

NOTE 4: The parameter “ $T_{RSTD_{IntraFreq_{DDE-UTRAN}}}$ ” is not a settable parameter but is used to set the LPP “time” value in Table 9.1.4A.4.3-1. The value of the LPP time IE is set to $T_{RSTD_{IntraFreq_{DDE-UTRAN}} + \Delta T$ ms, where $\Delta T = 150$ ms, giving a value of 5270 ms. This is rounded up to the next allowed LPP value of 6 seconds.

9.1.4A.4.2 Test procedure

Same as 9.1.3.4.2.

9.1.4A.4.3 Message contents

Same as 9.1.4.4.3 with the following exceptions

Table 9.1.4A.4.3-1: LPP RequestLocationInformation

Derivation Path: Table 9.1.4.4.3-2			
Information Element	Value/remark	Comment	Condition
LPP-Message ::= SEQUENCE {			
lpp-MessageBody CHOICE {			
c1 CHOICE {			
requestLocationInformation SEQUENCE {			
criticalExtensions CHOICE {			
c1 CHOICE {			
requestLocationInformation-r9 SEQUENCE {			
commonIEsRequestLocationInformation SEQUENCE {			
qos SEQUENCE {			
responseTime SEQUENCE {			
time	6	See Note 4 of Table 9.1.3A.4.1-1	
}			
}			
}			
}			
}			
}			
}			
}			
}			

9.1.4A.5 Test requirement

Same as 9.1.4.5.

9.2 RSTD Inter-Frequency Measurements

9.2.1 FDD-FDD inter-frequency RSTD measurement reporting delay

9.2.1.1 Test purpose

To verify that the FDD-FDD inter-frequency RSTD measurement reporting delay meets the requirements in an environment with fading propagation conditions.

9.2.1.2 Test applicability

This test applies to all types of E-UTRA FDD UE release 10 and forward that support inter-frequency RSTD measurements except UE Category 1bis.

9.2.1.3 Minimum conformance requirements

When the physical layer cell identities of neighbour cells together with the OTDOA assistance data are provided, the UE shall be able to detect and measure inter-frequency RSTD, specified in 3GPP TS 36.214 [6], for at least $n=16$ cells, including the reference cell, within $T_{\text{RSTDInterFreqFDD,E-UTRA}} \text{ ms}$ as given below:

$$T_{\text{RSTDInterFreqFDD,E-UTRA}} = T_{\text{PRS}} \cdot (M - 1) + \Delta \quad \text{ms}$$

where

$T_{\text{RSTDInterFreqFDD,E-UTRA}}$ is the total time for detecting and measuring at least n cells,

T_{PRS} is the largest value of the cell-specific positioning subframe configuration period, defined in 3GPP TS 36.211 [26], among the measured n cells including the reference cell,

M is the number of PRS positioning occasions as defined in Table 9.2.1.3-1, where each PRS positioning occasion comprises of N_{PRS} ($1 \leq N_{\text{PRS}} \leq 6$) consecutive downlink positioning subframes defined in 3GPP TS 36.211 [26], and

$\Delta = 160 \cdot \left\lceil \frac{n}{M} \right\rceil \text{ ms}$ is the measurement time for a single PRS positioning occasion which includes the sampling time and the processing time.

Table 9.2.1.3-1: Number of PRS positioning occasions within $T_{\text{RSTDInterFreqFDD,E-UTRA}}$

Positioning subframe configuration period T_{PRS}	Number of PRS positioning occasions M	
	f2 <small>Note 1</small>	f1 and f2 <small>Note 2</small>
160 ms	16	32
>160 ms	8	16
Note 1: When inter-frequency RSTD measurements are performed over the reference cell and neighbour cells, which belong to the FDD inter-frequency carrier frequency f2. Note 2: When inter-frequency RSTD measurements are performed over the reference cell and the neighbour cells, which belong to the serving FDD carrier frequency f1 and the FDD inter-frequency carrier frequency f2 respectively.		

The UE physical layer shall be capable of reporting RSTD for the reference cell and all the neighbour cells i out of at least $(n-1)$ neighbour cells within $T_{\text{RSTDInterFreqFDD,E-UTRA}}$ provided:

$$\left(\text{PRS } \hat{E}_s / \text{Iot} \right)_{\text{ref}} \geq -6 \text{ dB for all Frequency Bands for the reference cell,}$$

$(\text{PRSE}_s / \text{Iot})_i \geq -13$ dB for all Frequency Bands for neighbour cell i ,

$(\text{PRS } \hat{E}_s / \text{Iot})_{ref}$ and $(\text{PRSE}_s / \text{Iot})_i$ conditions apply for all subframes of at least $L = \frac{M}{2}$ PRS positioning occasions,

PRP 1,2_{dBm} according to E.3 for a corresponding Band.

$\text{PRSE}_s / \text{Iot}$ is as defined in Section 9.1.1.3.

The time $T_{\text{RSTDInterFreq}}^{\text{E-UTRAN}}$ starts from the first subframe of the PRS positioning occasion closest in time after both the OTDOA-RequestLocationInformation message and the OTDOA assistance data in the OTDOA-ProvideAssistanceData message as specified in 3GPP TS 36.355 [4], are delivered to the physical layer of the UE.

This requirement assumes that the measurement report is not delayed by other LPP signalling on the DCCH. This measurement reporting delay excludes a delay uncertainty resulted when inserting the measurement report to the TTI of the uplink DCCH. The delay uncertainty is: $2 \times TTI_{\text{DCCH}}$. This measurement reporting delay excludes any delay caused by no UL resources for UE to send the measurement report.

The normative reference for this requirement is TS 36.133 [23] clause 8.1.2.6.1 and A.8.13.1.

9.2.1.4 Test description

9.2.1.4.1 Initial conditions

Test Environment: Normal; as defined in TS 36.508 [18] clause 4.1.

Frequencies to be tested: Mid Range, as defined in TS 36.508 [18] clause 4.3.1.1.

Channel bandwidth to be tested: 10 MHz as defined in TS 36.508 [18] clause 4.3.1.

1. Connect the SS, faders and AWGN noise sources to the UE antenna connector or antenna connectors as shown in Annex A, Figure A.4.
2. The general test parameter settings are set up according to Table 9.2.1.4.1-1.
3. Propagation conditions are set according to clause 4.7.2.1.
4. Message contents are defined in clause 9.2.1.4.3.
5. In the test there are three synchronized cells: Cell 1, Cell 2 and Cell 3. Cell 1 is the OTDOA assistance data reference as well as the serving cell. Cell 2 and Cell 3 are the neighbour cells. Cell 1 is on FDD RF channel 1. Cell 2 and Cell 3 are on a FDD RF channel 2. The assistance data neighbour cell list includes in total 15 cells, where 13 of the cells are not simulated (dummy cells; as defined in 3GPP TS 37.571-5 clause 7.2.2).
6. The true RSTD (which is the receive time difference for frame 0 between two cells as seen at the UE antenna connector) is set to 31 Ts (about 1 μ s) between neighbour Cell 2 and serving Cell 1; and set to -31 Ts (about -1 μ s) between neighbour Cell 3 and serving Cell 1.
7. The gap pattern configuration # 0 as defined in Table 8.1.2.1-1 in 3GPP TS 36.133 [23] is configured and does not overlap with PRS subframes of Cell 1.

Table 9.2.1.4.1-1: General test parameters for E-UTRAN FDD-FDD inter-frequency RSTD measurement reporting delay under fading propagation conditions

Parameter	Unit	Value	Comment
-----------	------	-------	---------

Reference cell		Cell 1	Reference cell is the cell with respect to which the RSTD measurement is defined, as specified in 3GPP TS 36.214 [6] and 3GPP TS 36.355 [4]. The reference cell is the serving cell on RF channel 1 in this test case.
Neighbour cells		Cell 2 and Cell 3	Cells on RF channel 2. The cells appear at random places in the neighbour cell list in the OTDOA assistance data, but Cell 2 always appears in the first half of the list, whilst Cell 3 appears in the second half of the list.
PCFICH/PDCCH/PHICH parameters		DL Reference Measurement Channel R.6 FDD	As specified in TS 36.521-3 [25] clause A.2.1
Channel Bandwidth (BW _{channel})	MHz	10	
PRS Bandwidth ^{Note 2}	RB	50	PRS are transmitted over the system bandwidth
Gap pattern Id		0	As specified in Table 8.1.2.1-1 in TS 36.133[23].
Gap offset		9	As specified in 36.331 [22], Section 6.3.5
PRS configuration index I_{PRS} ^{Note 2}		Cell 1: 181, Cell 2, Cell 3: 171	This corresponds to periodicity of 320 ms and PRS subframe offset of $I_{PRS} - 160$ DL subframes, as defined in 3GPP TS 36.211 [26], Table 6.10.4.3-1
Number of consecutive downlink positioning subframes N_{PRS} ^{Note 2}		1	As defined in TS 36.211 [26]. The number of subframes in a positioning occasion
Physical cell ID PCI ^{Note 2}		(PCI of Cell 1 – PCI of Cell 2) mod 6 = 0 and (PCI of Cell 1 – PCI of Cell 3) mod 6 = 0	The cell PCIs are selected such that the relative shifts of PRS patterns among cells are as given by the test parameters
CP length ^{Note 2}		Normal	
DRX		ON	DRX parameters are further specified in Table 9.2.1.4.1-2
prs-SubframeOffset ^{Note 2}		310	Number of subframes rounded to the closest integer. The corresponding parameter in the OTDOA assistance data is prs-SubframeOffset specified in TS 36.355 [4]
slotNumberOffset ^{Note 2}		0	The slot number offset at the transmitter between a neighbour cell and the assistance data reference cell specified in TS 36.355 [4]
Radio frame receive time offset between the cells at the UE antenna connector ^{Note 3}	µs	Cell 2 to Cell 1: 1 Cell 3 to Cell 1: -1	PRS are transmitted from synchronous cells
Expected RSTD ^{Note 1}	µs	Cell 2: -2 Cell 3: 2 Other neighbour cells: randomly between -3 and 3	The expected RSTD is what is expected at the receiver. The corresponding parameter in the OTDOA assistance data specified in TS 36.355 [4] is the expectedRSTD indicator
Expected RSTD uncertainty for all neighbour cells ^{Note 1}	µs	5	The corresponding parameter in the OTDOA assistance data specified in TS 36.355 [4] is the expectedRSTD-Uncertainty index

Number of cells provided in OTDOA assistance data		16	The list includes the reference cell (received in <i>OTDOA-ReferenceCellInfo</i> [4]) on RF channel 1 and 15 other cells on RF channel 2, all received in <i>OTDOA-ProvideAssistanceData</i> [4].
PRS muting info ^{Note 2}		Cell 1: '1111111100000000' Cell 2: '0000000011111111' Cell 3: '1111111100000000'	Corresponds to <i>prs-MutingInfo</i> defined in TS 36.355 [4]
T1	s	3	The length of the time interval from the beginning of each test
T2	s	2.48	The length of the time interval that follows immediately after time interval T1
T3	s	2.48	The length of the time interval that follows immediately after time interval T2
<p>Note 1: Parameters "Expected RSTD" and "Expected RSTD uncertainty for all neighbour cells" are not settable parameters. These are parameters signalled in LPP only. For the values to be used in LPP see Table 9.2.1.4.3-5 and TS 37.571-5 [20], clause 7.2.2.</p> <p>Note 2: Parameters "PRS Bandwidth", "PRS configuration index", "Number of consecutive downlink positioning subframes", "Physical cell ID PCI", "CP length", "prs-SubframeOffset", "slotNumberOffset" and "PRS muting info" are settable parameters and also parameters signalled in LPP. The values to be used for "Physical cell ID PCI" are as follows: Cell 1: 0, Cell 2: 6, Cell 3: 12. For all the values to be used in LPP see Table 9.2.1.4.3-5 and TS 37.571-5 [20], clause 7.2.2.</p> <p>Note 3: The parameter "Radio frame receive time offset between the cells at the UE antenna connector" is not a settable parameter but is used to set the "true RSTD" values in step 6 of clause 9.2.1.4.1.</p>			

Table 9.2.1.4.1-2: DRX parameters for E-UTRAN FDD-FDD inter-frequency RSTD measurement reporting delay under fading propagation conditions

Field	Value	Comment
<i>onDurationTimer</i>	psf1	As specified in 3GPP TS 36.331 [22], clause 6.3.2
<i>drx-InactivityTimer</i>	psf1	
<i>drx-RetransmissionTimer</i>	sf1	
<i>longDRX-CycleStartOffset</i>	sf320	
<i>shortDRX</i>	Disable	

9.2.1.4.2 Test procedure

The test consists of three consecutive time intervals, with duration of T1, T2 and T3 defined in Table 9.2.1.4.1-1. Cell 1 is active in T1, T2 and T3, whilst Cell 2 and Cell 3 are activated only in the beginning of T2. Cell 2 is active until the end of T3, and Cell 3 is active until the end of T2. The beginning of the time interval T2 shall be aligned 5 ms before the first PRS positioning subframe of a positioning occasion in the reference cell, where 5 ms is the necessary test tolerance. Cell 1 transmits PRS only in T2, Cell 2 transmits PRS only in T3, and Cell 3 transmits PRS only in T2.

NOTE: The information on when PRS is muted is conveyed to the UE using PRS muting information in the OTDOA assistance data.

The OTDOA-RequestLocationInformation message and the OTDOA assistance data as defined in clause 9.2.1.4.3 shall be provided to the UE during T1. The last TTI containing the OTDOA-RequestLocationInformation message shall be provided to the UE ΔT ms before the start of T2, where $\Delta T = 150$ ms is the maximum processing time of the OTDOA-RequestLocationInformation message and the OTDOA assistance data.

1. Ensure that the UE is in state Generic RB Established State 3A-RF according to 3GPP TS 36.508 [18] clause 7.2A.3.
2. The SS shall send a RESET UE POSITIONING STORED INFORMATION message.
3. Set the parameters according to Table 9.2.1.5-1. Propagation conditions are set according to clause 4.7.2.2 (ETU30).
4. T1 starts.

5. The SS shall transmit an RRCConnectionReconfiguration message with the DRX configuration and the measurement gap configuration. PDCCHs indicating new transmissions shall be sent continuously until the start of T2 to ensure that the UE would not enter the DRX state before T2.
6. The UE shall transmit RRCConnectionReconfigurationComplete message.
- 6a. The SS shall transmit an LPP REQUEST CAPABILITIES message.
- 6b. The UE shall transmit an LPP PROVIDE CAPABILITIES message indicating the OTDOA capabilities supported by the UE in the *OTDOA-ProvideCapabilities* IE.
7. The SS shall send a LPP PROVIDE ASSISTANCE DATA message, including the *OTDOA-ProvideAssistanceData* IE. The position of neighbour Cell 2 in the *OTDOA-NeighbourCellInfoList* is randomly selected to be in the first 7 elements of the sequence, and the position of neighbour Cell 3 is randomly selected to be in the last 8 elements of the sequence, as described in 3GPP TS 37.571-5 [20], clause 7.2.3. If the UE message at step 6b includes the *ackRequested* IE set to TRUE, then the SS shall send an acknowledgment in the LPP PROVIDE ASSISTANCE DATA message.
8. The SS shall send a LPP REQUEST LOCATION INFORMATION message, including the *OTDOA-RequestLocationInformation* IE such that the UE receives the message ΔT ms before the start of T2, where $\Delta T = 150$ ms.
9. When T1 expires, the SS shall switch the power setting from T1 to T2 as specified in Table 9.2.1.5-2.
10. When T2 expires, the SS shall switch the power setting from T2 to T3 as specified in Table 9.2.1.5-2.
11. The UE shall transmit a LPP PROVIDE LOCATION INFORMATION message including the *OTDOA-ProvideLocationInformation* IE within the response time (see clause 4.7.3) specified in clause 9.2.1.5. The UE shall perform and report the RSTD measurements for both Cell 2 and Cell 3 with respect to the reference cell in the OTDOA assistance data, Cell 1. If the UE transmits an *OTDOA-ProvideLocationInformation* IE including the *rstd* field for both Cell 2 and Cell 3 within the response time then the number of successful tests is increased by one. If the UE fails to report the *OTDOA-ProvideLocationInformation* IE with both the *rstd* fields included within the response time then the number of failure tests is increased by one.
12. If the UE message at step 11 includes the *ackRequested* IE set to TRUE, the SS shall send a LPP acknowledgement message.
13. Repeat steps 2-12 until the confidence level according to Annex D is achieved. For each iteration, at step 7 change the random position of the Cells 2 and 3 in the *OTDOA-NeighbourCellInfoList*.

9.2.1.4.3 Message contents

Table 9.2.1.4.3-1: RESET UE POSITIONING STORED INFORMATION

Derivation Path: 36.509 [11] clause 6.9			
Information Element	Value/remark	Comment	Condition
UE Positioning Technology	0 0 0 0 0 0 1	OTDOA	

Table 9.2.1.4.3-2: MAC-MainConfig-RBC: FDD-FDD Inter-frequency RSTD Measurement Reporting Delay

Derivation Path: TS 36.508 [18] clause 4.8.2.1.5, Table 4.8.2.1.5-1 MAC-MainConfig-RBC			
Information Element	Value/remark	Comment	Condition
MAC-MainConfig-RBC ::= SEQUENCE {			
drx-Config CHOICE {			
setup SEQUENCE {			
onDurationTimer	psf1		
drx-InactivityTimer	psf1		
drx-RetransmissionTimer	sf1		
longDRX-CycleStartOffset CHOICE {			
sf320	0		
}			

shortDRX	Not present		
}			
}			

Table 9.2.1.4.3-3: MeasGapConfig-GP1: FDD-FDD inter-frequency RSTD Measurement Reporting Delay

Derivation Path: TS 36.508 [18] clause 4.6.6, Table 4.6.6-1A: MeasGapConfig-GP1			
Information Element	Value/remark	Comment	Condition
MeasGapConfig-GP1 ::= CHOICE {			
setup SEQUENCE {			
gapOffset CHOICE {			
gp0	9	TGRP = 40 ms	
}			
}			
}			

Table 9.2.1.4.3-3a: LPP Request Capabilities

Information Element	Value/remark
otdoa-RequestCapabilities	TRUE

Table 9.2.1.4.3-4: LPP RequestLocationInformation

Derivation Path: 36.355 clause 6.2			
Information Element	Value/remark	Comment	Condition
LPP-Message ::= SEQUENCE {			
transactionID SEQUENCE {			
initiator	locationServer		
transactionNumber	1		
}			
endTransaction	FALSE		
sequenceNumber	Not present		
acknowledgement	Not present		
lpp-MessageBody CHOICE {			
c1 CHOICE {			
requestLocationInformation SEQUENCE {			
criticalExtensions CHOICE {			
c1 CHOICE {			
requestLocationInformation-r9 SEQUENCE {			
commonIEsRequestLocationInformation SEQUENCE {			
locationInformationType	locationMeasurementsRequired		
triggeredReporting	Not present		
periodicalReporting	Not present		
additionalInformation	onlyReturnInformationRequested		
qos SEQUENCE {			
horizontalAccuracy	Not present		
verticalCoordinateRequest	FALSE		
verticalAccuracy	Not present		
responseTime SEQUENCE {			
time	6	See clause 9.2.1.5	
responseTimeEarlyFix-r12	Not present		Rel-12 onwards
}			
}			
}			
}			
}			
}			
}			
environment	Not present		
locationCoordinateTypes	Not present		

velocityTypes	Not present		
}			
a-gnss-RequestLocationInformation	Not present		
otdoa-RequestLocationInformation			
SEQUENCE {			
assistanceAvailability	FALSE		
}			
ecid-RequestLocationInformation	Not present		
epdu-RequestLocationInformation	Not Present		
}			
}			
}			
}			
}			
}			
}			
}			

Table 9.2.1.4.3-5: LPP ProvideAssistanceData

Derivation Path: 36.355 clause 6.2			
Information Element	Value/remark	Comment	Condition
LPP-Message ::= SEQUENCE {			
transactionID SEQUENCE {			
Initiator	locationServer		
transactionNumber	(0..255)		
}			
endTransaction	TRUE		
sequenceNumber	Not present		
acknowledgement	Not present		
lpp-MessageBody CHOICE {			
c1 CHOICE {			
provideAssistanceData SEQUENCE {			
criticalExtensions CHOICE {			
c1 CHOICE {			
provideAssistanceData-r9 SEQUENCE {			
commonIEsProvideAssistanceData	Not present		
a-gnss-ProvideAssistanceData	Not present		
otdoa-ProvideAssistanceData SEQUENCE {			
otdoa-ReferenceCellInfo	As defined in TS 37.571-5 [20], clause 7.2.2.		
otdoa-NeighbourCellInfo	As defined in TS 37.571-5 [20], clause 7.2.2.		
otdoa-Error	Not present		
}			
epdu-ProvideAssistanceData	Not present		
}			
}			
}			
}			
}			
}			

Table 9.2.1.4.3-6: LPP ProvideLocation Information

Derivation Path: 36.355 clause 6.2			
Information Element	Value/remark	Comment	Condition
LPP-Message ::= SEQUENCE {			
transactionID SEQUENCE {			
initiator	locationServer		
transactionNumber	1		
}			

endTransaction	TRUE		
sequenceNumber	(0..255)		
acknowledgement			
lpp-MessageBody CHOICE {			
c1 CHOICE {			
provideLocationInformation SEQUENCE {			
criticalExtensions CHOICE {			
c1 CHOICE {			
provideLocationInformation-r9 SEQUENCE {			
commonIEsProvideLocationInformation	Not present.		
a-gnss-ProvideLocationInformation	Not present		
otdoa-ProvideLocationInformation SEQUENCE {			
otdoaSignalMeasurementInformation SEQUENCE {			
systemFrameNumber			
physCellIdRef	Cell 1		
cellGlobalIdRef			
earfcnRef			
referenceQuality			
neighbourMeasurementList SEQUENCE (SIZE(n)) {			
physCellIdNeighbor	Cell 2		
cellGlobalIdNeighbour			
earfcnNeighbour	RF channel 2		
rstd	Present		
rstd-Quality			
}			
neighbourMeasurementList SEQUENCE (SIZE(n)) {			
physCellIdNeighbor	Cell 3		
cellGlobalIdNeighbour			
earfcnNeighbour	RF channel 2		
rstd	Present		
rstd-Quality			
}			
}			
otdoa-Error	May be present with error reason 'undefined' or 'attemptedButUnableToMeasureSomeNeighbourCells'		
}			
ecid-ProvideLocationInformation	Not present		
epdu-ProvideLocationInformation	Not present		
}			
}			
}			
}			
}			
}			

9.2.1.5 Test requirement

Table 9.2.1.5-1 and 9.2.1.5-2 define the primary level settings including test tolerances for the test.

Table 9.2.1.5-1: Cell-specific test parameters for E-UTRAN FDD-FDD inter-frequency RSTD measurement reporting delay under fading propagation conditions during T1

Parameter	Unit	Cell 1	Cell 2	Cell 3
E-UTRA RF Channel Number		1	N/A	N/A

Correlation Matrix and Antenna Configuration		1x2 Low	1x2 Low	1x2 Low
OCNG patterns defined in TS 36.521-3 [25] clause D.1		OP.5 FDD	N/A	N/A
PBCH_RA	dB	0	N/A	N/A
PBCH_RB				
PSS_RA				
SSS_RA				
PCFICH_RB				
PHICH_RA				
PHICH_RB				
PDCCH_RA				
PDCCH_RB				
OCNG_RA ^{Note 1}				
OCNG_RB ^{Note 1}				
N_{oc} ^{Note 3}	dBm/ 15 kHz	-95	N/A	N/A
PRS \hat{E}_s/N_{oc}	dB	-Infinity	-Infinity	-Infinity
I_o ^{Note 4}	dBm/ 9 MHz	-67.22	N/A	N/A
\hat{E}_s/N_{oc}	dB	0	-Infinity	-Infinity
Propagation Condition		ETU30		
<p>Note 1: OCNG shall be used such that the active cell (Cell 1) is fully allocated and a constant total transmitted power spectral density is achieved for all OFDM symbols.</p> <p>Note 2: The resources for uplink transmission are assigned to the UE prior to the start of time period T2.</p> <p>Note 3: Interference from other cells and noise sources not specified in the test are assumed to be constant over subcarriers and time and shall be modelled as AWGN of appropriate power for N_{oc} to be fulfilled.</p> <p>Note 4: I_o levels have been derived from other parameters and are given for information purpose. These are not settable test parameters.</p>				

Table 9.2.1.5-2: Cell-specific test parameters for E-UTRAN FDD-FDD inter-frequency RSTD measurement reporting delay under fading propagation conditions during T2 and T3

Parameter	Unit	Cell 1		Cell 2		Cell 3	
		T2	T3	T2	T3	T2	T3
E-UTRA RF Channel Number		1		2		2	N/A
Correlation Matrix and Antenna Configuration		1x2 Low		1x2 Low		1x2 Low	
OCNG patterns defined in TS 36.521-3 [25] clause D.1		OP.5 FDD		OP.6 FDD		OP.6 FDD	N/A
PBCH_RA	dB	0		0		0	N/A
PBCH_RB							
PSS_RA							
SSS_RA							
PCFICH_RB							
PHICH_RA							
PHICH_RB							
PDCCH_RA							
PDCCH_RB							
OCNG_RA ^{Note 1}							

OCNG_RB ^{Note 1}							
PRS_RA	dB	-3	N/A	N/A	3	3	N/A
N_{oc} ^{Note 3}	dBm/ 15 kHz	-98	-98	-98	-95	-98	N/A
PRS \hat{E}_s/N_{oc}	dB	-1	-Infinity	-Infinity	-7	-8	-Infinity
PRS \hat{E}_s/I_{ot} ^{Note 4}	dB	-1	-Infinity	-Infinity	-7	-8	-Infinity
I_o ^{Note 4}	dBm/ 9 MHz	-69.68	-70.22	-70.11	-67.08	-70.11	N/A
PRP ^{Note 4}	dBm/ 15 kHz	-99	-Infinity	-Infinity	-102	-106	-Infinity
RSRP ^{Note 4}	dBm/ 15 kHz	-96	-96	-105	-105	-109	-Infinity
\hat{E}_s/N_{oc} ^{Note 4}	dB	2	2	-7	-10	-11	-Infinity
Propagation Condition		ETU30					
<p>Note 1: OCNG shall be used such that active cells (all, except Cell 3 in T3) are fully allocated and a constant total transmitted power spectral density is achieved for all OFDM symbols other than those in the subframes with transmitted PRS.</p> <p>Note 2: The resources for uplink transmission are assigned to the UE prior to the start of time period T2.</p> <p>Note 3: Interference from other cells and noise sources not specified in the test and assumed to be constant over subcarriers and time and shall be modelled as AWGN of appropriate power for N_{oc} to be fulfilled.</p> <p>Note 4: If PRS_RA is not "N/A", \hat{E}_s/N_{oc}, PRS \hat{E}_s/I_{ot}, I_o, RSRP and PRP levels have been derived from other parameters and are given for information purpose. If PRS_RA is "N/A", I_o and RSRP levels have been derived from other parameters and are given for information purpose. These are not settable test parameters. Interference conditions shall be applied to all PRS symbols of DL positioning subframes.</p>							

The response time including test tolerance is 6.3 s. The response time is equal to the LPP time IE value plus the test tolerance. The LPP time IE value is derived from the RSTD reporting delay plus ΔT , where $\Delta T = 150$ ms, giving a value of 5110 ms. This is rounded up to the next allowed LPP value of 6 seconds. The RSTD measurement reporting

delay in the test is derived from the following expression, $T_{PRS}(M-1) + 160 \left\lceil \frac{n}{M} \right\rceil$, where $M=16$ and $n=16$ are the parameters specified in clause 9.2.1.3 and Table 9.2.1.3-1. This gives the total RSTD reporting delay of 4960 ms for the 15 neighbour cells including Cell 2 and Cell 3 with respect to the reference cell, Cell 1.

The test tolerances are defined in clauses C.1.3 and C4.

The rate of successful tests during repeated tests shall be at least 90% with a confidence level of 95%.

9.2.1A FDD-FDD inter-frequency RSTD Measurement Reporting Delay for UE Category 1bis

9.2.1A.1 Test purpose

To verify that the FDD-FDD inter-frequency RSTD measurement reporting delay meets the requirements in an environment with fading propagation conditions.

9.2.1A.2 Test applicability

This test applies to E-UTRA FDD UE Category 1bis release 13 and forward that support inter-frequency RSTD measurements.

9.2.1A.3 Minimum conformance requirements

Same as 9.2.1.3 but using Table 9.2.1A.3-1 instead of Table 9.2.1.3-1.

Table 9.2.1A.3-1: Number of PRS positioning occasions within $T_{\text{RSTDInterFreqFDD,E-UTRAN}}$

Positioning subframe configuration period T_{PRS}	Number of PRS positioning occasions M	
	$f2$ ^{Note 1}	$f1$ and $f2$ ^{Note 2}
160 ms	32	64
>160 ms	16	32
Note 1: When inter-frequency RSTD measurements are performed over the reference cell and neighbour cells, which belong to the FDD inter-frequency carrier frequency $f2$. Note 2: When inter-frequency RSTD measurements are performed over the reference cell and the neighbour cells, which belong to the serving FDD carrier frequency $f1$ and the FDD inter-frequency carrier frequency $f2$ respectively.		

The normative reference for this requirement is TS 36.133 [23] clause 8.1.2.6.5 and A.8.13.1.

9.2.1A.4 Test description

9.2.1A.4.1 Initial conditions

Same as 9.2.1.4.1 with the following exceptions:

1. Connect the SS, faders and AWGN noise sources to the UE antenna connector or antenna connectors as shown in Annex A, Figure A.4, using only the main Tx/Rx path.
2. The general test parameter settings are set up according to Table 9.2.1A.4.1-1.

Table 9.2.1A.4.1-1: General test parameters for E-UTRAN FDD-FDD inter-frequency RSTD measurement reporting delay under fading propagation conditions for UE Category 1bis

Parameter	Unit	Value	Comment
Reference cell		Cell 1	Reference cell is the cell with respect to which the RSTD measurement is defined, as specified in 3GPP TS 36.214 [6] and 3GPP TS 36.355 [4]. The reference cell is the serving cell on RF channel 1 in this test case.
Neighbour cells		Cell 2 and Cell 3	Cells on RF channel 2. The cells appear at random places in the neighbour cell list in the OTDOA assistance data, but Cell 2 always appears in the first half of the list, whilst Cell 3 appears in the second half of the list.
PCFICH/PDCCH/PHICH parameters		DL Reference Measurement Channel R.6 FDD	As specified in TS 36.521-3 [25] clause A.2.1
Channel Bandwidth (BW_{channel})	MHz	10	
PRS Bandwidth ^{Note 2}	RB	50	PRS are transmitted over the system bandwidth
Gap pattern Id		0	As specified in Table 8.1.2.1-1 in TS 36.133[23].
Gap offset		9	As specified in 36.331 [22], Section 6.3.5

PRs configuration index I_{PRS} ^{Note 2}		Cell 1: 181, Cell 2, Cell 3: 171	This corresponds to periodicity of 320 ms and PRs subframe offset of $I_{PRS} - 160$ DL subframes, as defined in 3GPP TS 36.211 [26], Table 6.10.4.3-1
Number of consecutive downlink positioning subframes N_{PRS} ^{Note 2}		1	As defined in TS 36.211 [26]. The number of subframes in a positioning occasion
Physical cell ID PCI ^{Note 2}		(PCI of Cell 1 – PCI of Cell 2) mod 6 = 0 and (PCI of Cell 1 – PCI of Cell 3) mod 6 = 0	The cell PCIs are selected such that the relative shifts of PRs patterns among cells are as given by the test parameters
CP length ^{Note 2}		Normal	
DRX		ON	DRX parameters are further specified in Table 9.2.1.4.1-2
prs-SubframeOffset ^{Note 2}		310	Number of subframes rounded to the closest integer. The corresponding parameter in the OTDOA assistance data is prs-SubframeOffset specified in TS 36.355 [4]
slotNumberOffset ^{Note 2}		0	The slot number offset at the transmitter between a neighbour cell and the assistance data reference cell specified in TS 36.355 [4]
Radio frame receive time offset between the cells at the UE antenna connector ^{Note 3}	μs	Cell 2 to Cell 1: 1 Cell 3 to Cell 1: -1	PRs are transmitted from synchronous cells
Expected RSTD ^{Note 1}	μs	Cell 2: -2 Cell 3: 2 Other neighbour cells: randomly between -3 and 3	The expected RSTD is what is expected at the receiver. The corresponding parameter in the OTDOA assistance data specified in TS 36.355 [4] is the expectedRSTD indicator
Expected RSTD uncertainty for all neighbour cells ^{Note 1}	μs	5	The corresponding parameter in the OTDOA assistance data specified in TS 36.355 [4] is the expectedRSTD-Uncertainty index
Number of cells provided in OTDOA assistance data		16	The list includes the reference cell (received in <i>OTDOA-ReferenceCellInfo</i> [4]) on RF channel 1 and 15 other cells on RF channel 2, all received in <i>OTDOA-ProvideAssistanceData</i> [4].
PRs muting info ^{Note 2}		Cell 1: '1111111111111111111100000000000000' Cell 2: '0000000000000000000011111111111111' Cell 3: '1111111111111111111100000000000000'	Corresponds to prs-MutingInfo defined in TS 36.355 [4]
T1	s	3	The length of the time interval from the beginning of each test
T2	s	4.96	The length of the time interval that follows immediately after time interval T1
T3	s	4.96	The length of the time interval that follows immediately after time interval T2

Note 1: Parameters “Expected RSTD” and “Expected RSTD uncertainty for all neighbour cells” are not settable parameters. These are parameters signalled in LPP only. For the values to be used in LPP see Table 9.2.1.4.3-5 and TS 37.571-5 [20], clause 7.2.2.

Note 2: Parameters “PRS Bandwidth”, “PRS configuration index”, “Number of consecutive downlink positioning subframes”, “Physical cell ID PCI”, “CP length”, “prs-SubframeOffset”, “slotNumberOffset” and “PRS muting info” are settable parameters and also parameters signalled in LPP. The values to be used for “Physical cell ID PCI” are as follows: Cell 1: 0, Cell 2: 6, Cell 3: 12. For all the values to be used in LPP see Table 9.2.1.4.3-5 and TS 37.571-5 [20], clause 7.2.2.

Note 3: The parameter “Radio frame receive time offset between the cells at the UE antenna connector” is not a settable parameter but is used to set the “true RSTD” values in step 6 of clause 9.2.1.4.1.

9.2.1A.4.2 Test procedure

Same as 9.2.1.4.2.

9.2.1A.4.3 Message contents

Same as 9.2.1.4.3 with the following exceptions:

Table 9.2.1A.4.3-1: LPP RequestLocationInformation

Derivation Path: Table 9.2.1.4.3-4			
Information Element	Value/remark	Comment	Condition
LPP-Message ::= SEQUENCE {			
lpp-MessageBody CHOICE {			
c1 CHOICE {			
requestLocationInformation SEQUENCE {			
criticalExtensions CHOICE {			
c1 CHOICE {			
requestLocationInformation-r9 SEQUENCE {			
commonIEsRequestLocationInformation SEQUENCE {			
qos SEQUENCE {			
responseTime SEQUENCE {			
time	11	See clause 9.2.1A.5	
}			
}			
}			
}			
}			
}			
}			
}			
}			
}			

9.2.1A.5 Test requirement

Table 9.2.1.5-1 and 9.2.1.5-2 define the primary level settings including test tolerances for the test.

The response time including test tolerance is 11.3 s. The response time is equal to the LPP time IE value plus the test tolerance. The LPP time IE value is derived from the RSTD reporting delay plus ΔT, where ΔT = 150 ms, giving a value of 10230 ms. This is rounded up to the next allowed LPP value of 11 seconds. The RSTD measurement reporting

delay in the test is derived from the following expression, $T_{PRS} (M - 1) + 160 \left\lceil \frac{n}{M} \right\rceil$, where $M=32$ and $n=16$ are the

parameters specified in clause 9.2.1A.3 and Table 9.2.1A.3-1. This gives the total RSTD reporting delay of 10080 ms for the 15 neighbour cells including Cell 2 and Cell 3 with respect to the reference cell, Cell 1.

The test tolerances are defined in clauses C.1.3 and C4.

The rate of successful tests during repeated tests shall be at least 90% with a confidence level of 95%.

9.2.2 TDD-TDD inter-frequency RSTD measurement reporting delay

9.2.2.1 Test purpose

To verify that the TDD-TDD inter-frequency RSTD measurement reporting delay meets the requirements in an environment with fading propagation conditions.

9.2.2.2 Test applicability

This test applies to all types of E-UTRA TDD UE release 10 and forward that support inter-frequency RSTD measurements except UE Category 1bis.

9.2.2.3 Minimum conformance requirements

When the physical layer cell identities of neighbour cells together with the OTDOA assistance data are provided, the UE shall be able to detect and measure inter-frequency RSTD, specified in 3GPP TS 36.214 [6], for at least $n=16$ cells, including the reference cell, within $T_{\text{RSTDInterFreqDD,E-UTRAN}}$ ms as given below:

$$T_{\text{RSTDInterFreqDD,E-UTRAN}} = T_{\text{PRS}} \cdot (M - 1) + \Delta \quad \text{ms}$$

where

$T_{\text{RSTDInterFreqDD,E-UTRAN}}$ is the total time for detecting and measuring at least n cells,

T_{PRS} is the largest value of the cell-specific positioning subframe configuration period, defined in 3GPP TS 36.211 [26], among the measured n cells including the reference cell,

M is the number of PRS positioning occasions as defined in Table 9.2.2.3-1, where each PRS positioning occasion comprises of N_{PRS} ($1 \leq N_{\text{PRS}} \leq 6$) consecutive downlink positioning subframes defined in 3GPP TS 36.211 [26], and

$\Delta = 160 \cdot \left[\frac{n}{M} \right]$ ms is the measurement time for a single PRS positioning occasion which includes the sampling time and the processing time.

Table 9.2.2.3-1: Number of PRS positioning occasions within $T_{\text{RSTDInterFreqDD,E-UTRAN}}$

Positioning subframe configuration period T_{PRS}	Number of PRS positioning occasions M	
	f2 <small>Note 1</small>	f1 and f2 <small>Note 2</small>
160 ms	16	32
>160 ms	8	16
Note 1: When inter-frequency RSTD measurements are performed over the reference cell and neighbour cells, which belong to the TDD inter-frequency carrier frequency f2. Note 2: When inter-frequency RSTD measurements are performed over the reference cell and the neighbour cells, which belong to the serving TDD carrier frequency f1 and the TDD inter-frequency carrier frequency f2 respectively.		

The UE physical layer shall be capable of reporting RSTD for the reference cell and all the neighbour cells i out of at least $(n-1)$ neighbour cells within $T_{\text{RSTDInterFreqDD,E-UTRAN}}$ provided:

$$\left(\text{PRS } \hat{E}_s / \text{Iot} \right)_{\text{ref}} \geq -6 \text{ dB for all Frequency Bands for the reference cell,}$$

$(\widehat{\text{PRSE}}_s / \text{Iot})_i \geq -13$ dB for all Frequency Bands for neighbour cell i ,

$(\widehat{\text{PRS}} \widehat{\text{E}}_s / \text{Iot})_{ref}$ and $(\widehat{\text{PRSE}}_s / \text{Iot})_i$ conditions apply for all subframes of at least $L = \frac{M}{2}$ PRS positioning occasions,

PRP 1,2_{dBm} according to E.3 for a corresponding Band.

$\widehat{\text{PRSE}}_s / \text{Iot}$ is as defined in Section 9.1.1.3.

The time $T_{\text{RSTD}_{\text{InterFreq}}^{\text{DD,E-UTRAN}}}$ starts from the first subframe of the PRS positioning occasion closest in time after both the OTDOA-RequestLocationInformation message and the OTDOA assistance data in the OTDOA-ProvideAssistanceData message as specified in 3GPP TS 36.355 [4], are delivered to the physical layer of the UE.

This requirement assumes that the measurement report is not delayed by other LPP signalling on the DCCH. This measurement reporting delay excludes a delay uncertainty resulted when inserting the measurement report to the TTI of the uplink DCCH. The delay uncertainty is: $2 \times TTI_{\text{DCCH}}$. This measurement reporting delay excludes any delay caused by no UL resources for UE to send the measurement report.

The normative reference for this requirement is TS 36.133 [23] clause 8.1.2.6.3 and A.8.13.2.

9.2.2.4 Test description

9.2.2.4.1 Initial conditions

Test Environment: Normal; as defined in TS 36.508 [18] clause 4.1.

Frequencies to be tested: Mid Range, as defined in TS 36.508 [18] clause 4.3.1.1.

Channel bandwidth to be tested: 10 MHz as defined in TS 36.508 [18] clause 4.3.1.

1. Connect the SS, faders and AWGN noise sources to the UE antenna connector or antenna connectors as shown in Annex A, Figure A.4.
2. The general test parameter settings are set up according to Table 9.2.2.4.1-1.
3. Propagation conditions are set according to clause 4.7.2.1.
4. Message contents are defined in clause 9.2.2.4.3.
5. In the test there are three synchronized cells: Cell 1, Cell 2 and Cell 3. Cell 1 is the OTDOA assistance data reference as well as the serving cell. Cell 2 and Cell 3 are the neighbour cells. Cell 1 is on TDD RF channel 1. Cell 2 and Cell 3 are on a TDD RF channel 2. The assistance data neighbour cell list includes in total 15 cells, where 13 of the cells are not simulated (dummy cells; as defined in 3GPP TS 37.571-5 clause 7.2.2).
6. The true RSTD (which is the receive time difference for frame 0 between two cells as seen at the UE antenna connector) is set to 31 Ts (about 1 μ s) between neighbour Cell 2 and serving Cell 1; and set to -31 Ts (about -1 μ s) between neighbour Cell 3 and serving Cell 1.
7. The gap pattern configuration # 0 as defined in Table 8.1.2.1-1 in 3GPP TS 36.133 [23] is configured and does not overlap with PRS subframes of Cell 1.

Table 9.2.2.4.1-1: General test parameters for E-UTRAN TDD-TDD inter-frequency RSTD measurement reporting delay under fading propagation conditions

Parameter	Unit	Value	Comment
-----------	------	-------	---------

Reference cell		Cell 1	Reference cell is the cell with respect to which the RSTD measurement is defined, as specified in 3GPP TS 36.214 [6] and 3GPP TS 36.355 [4]. The reference cell is the serving cell on RF channel 1 in this test case.
Neighbour cells		Cell 2 and Cell 3	Cells on RF channel 2. The cells appear at random places in the neighbour cell list in the OTDOA assistance data, but Cell 2 always appears in the first half of the list, whilst Cell 3 appears in the second half of the list.
PCFICH/PDCCH/PHICH parameters		DL Reference Measurement Channel R.6 TDD	As specified in TS 36.521-3 [25] clause A.2.2
Channel Bandwidth (BW_{channel})	MHz	10	
PRS Bandwidth ^{Note 2}	RB	50	PRS are transmitted over the system bandwidth
Gap pattern Id		0	As specified in Table 8.1.2.1-1 in TS 36.133 [23].
Gap offset		12	As specified in 36.331 [22], Section 6.3.5
PRS configuration index I_{PRS} ^{Note 2}		Cell 1: 184, Cell 2, Cell 3: 174	This corresponds to periodicity of 320 ms and PRS subframe offset of $I_{\text{PRS}} - 160$ DL subframes, as defined in 3GPP TS 36.211 [26], Table 6.10.4.3-1
Number of consecutive downlink positioning subframes N_{PRS} ^{Note 2}		1	As defined in TS 36.211 [26]. The number of subframes in a positioning occasion
Physical cell ID PCI ^{Note 2}		$(\text{PCI of Cell 1} - \text{PCI of Cell 2}) \bmod 6 = 0$ and $(\text{PCI of Cell 1} - \text{PCI of Cell 3}) \bmod 6 = 0$	The cell PCIs are selected such that the relative shifts of PRS patterns among cells are as given by the test parameters
TDD uplink-downlink configuration		1	As specified in TS 36.211 [26], Section 4.2; corresponds to a configuration with 5 ms switch-point periodicity and two downlink consecutive subframes
TDD special subframe configuration		6	As specified in TS 36.211 [26], Section 4.2; corresponds to DwPTS of $19760 \cdot T_s$ and UpPTS of $4384 \cdot T_s$
CP length ^{Note 2}		Normal	
DRX		ON	DRX parameters are further specified in Table 9.2.2.4.1-2
prs-SubframeOffset ^{Note 2}		310	Number of subframes rounded to the closest integer. The corresponding parameter in the OTDOA assistance data is prs-SubframeOffset specified in TS 36.355 [4]
slotNumberOffset ^{Note 2}		0	The slot number offset at the transmitter between a neighbour cell and the assistance data reference cell specified in TS 36.355 [4]
Radio frame receive time offset between the cells at the UE antenna connector ^{Note 3}	μs	Cell 2 to Cell 1: 1 Cell 3 to Cell 1: -1	PRS are transmitted from synchronous cells

Expected RSTD ^{Note 1}	µs	Cell 2: -2 Cell 3: 2 Other neighbour cells: randomly between -3 and 3	The expected RSTD is what is expected at the receiver. The corresponding parameter in the OTDOA assistance data specified in TS 36.355 [4] is the expectedRSTD indicator
Expected RSTD uncertainty for all neighbour cells ^{Note 1}	µs	5	The corresponding parameter in the OTDOA assistance data specified in TS 36.355 [4] is the expectedRSTD-Uncertainty index
Number of cells provided in OTDOA assistance data		16	The list includes the reference cell (received in <i>OTDOA-ReferenceCellInfo</i> [4]) on RF channel 1 and 15 other cells on RF channel 2, all received in <i>OTDOA-ProvideAssistanceData</i> [4].
PRS muting info ^{Note 2}		Cell 1: '1111111100000000' Cell 2: '0000000011111111' Cell 3: '1111111100000000'	Corresponds to prs-MutingInfo defined in TS 36.355 [4]
T1	s	3	The length of the time interval from the beginning of each test
T2	s	2.48	The length of the time interval that follows immediately after time interval T1
T3	s	2.48	The length of the time interval that follows immediately after time interval T2
Note 1:	Parameters "Expected RSTD" and "Expected RSTD uncertainty for all neighbour cells" are not settable parameters. These are parameters signalled in LPP only. For the values to be used in LPP see Table 9.2.2.4.3-5 and TS 37.571-5 [20], clause 7.2.2.		
Note 2:	Parameters "PRS Bandwidth", "PRS configuration index", "Number of consecutive downlink positioning subframes", "Physical cell ID PCI", "CP length", "prs-SubframeOffset", "slotNumberOffset" and "PRS muting info" are settable parameters and also parameters signalled in LPP. The values to be used for "Physical cell ID PCI" are as follows: Cell 1: 0, Cell 2: 6, Cell 3: 12. For all the values to be used in LPP see Table 9.2.2.4.3-5 and TS 37.571-5 [20], clause 7.2.2.		
Note 3:	The parameter "Radio frame receive time offset between the cells at the UE antenna connector" is not a settable parameter but is used to set the "true RSTD" values in step 6 of clause 9.2.2.4.1.		

Table 9.2.2.4.1-2: DRX parameters for E-UTRAN TDD-TDD inter-frequency RSTD measurement reporting delay under fading propagation conditions

Field	Value	Comment
onDurationTimer	psf1	As specified in 3GPP TS 36.331 [22], clause 6.3.2
drx-InactivityTimer	psf1	
drx-RetransmissionTimer	sf1	
longDRX-CycleStartOffset	sf320	
shortDRX	Disable	

9.2.2.4.2 Test procedure

The test consists of three consecutive time intervals, with duration of T1, T2 and T3 defined in Table 9.2.2.4.1-1. Cell 1 is active in T1, T2 and T3, whilst Cell 2 and Cell 3 are activated only in the beginning of T2. Cell 2 is active until the end of T3, and Cell 3 is active until the end of T2. The beginning of the time interval T2 shall be aligned 5 ms before the first PRS positioning subframe of a positioning occasion in the reference cell, where 5 ms is the necessary test tolerance. Cell 1 transmits PRS only in T2, Cell 2 transmits PRS only in T3, and Cell 3 transmits PRS only in T2.

NOTE: The information on when PRS is muted is conveyed to the UE using PRS muting information in the OTDOA assistance data.

The OTDOA-RequestLocationInformation message and the OTDOA assistance data as defined in clause 9.2.2.4.3 shall be provided to the UE during T1. The last TTI containing the OTDOA-RequestLocationInformation message shall be provided to the UE ΔT ms before the start of T2, where $\Delta T = 150$ ms is the maximum processing time of the OTDOA-RequestLocationInformation message and the OTDOA assistance data.

1. Ensure that the UE is in state Generic RB Established State 3A-RF according to 3GPP TS 36.508 [18] clause 7.2A.3.
2. The SS shall send a RESET UE POSITIONING STORED INFORMATION message.
3. Set the parameters according to Table 9.2.2.5-1. Propagation conditions are set according to clause 4.7.2.2 (ETU30).
4. T1 starts.
5. The SS shall transmit an RRCConnectionReconfiguration message with the DRX configuration and the measurement gap configuration. PDCCHs indicating new transmissions shall be sent continuously until the start of T2 to ensure that the UE would not enter the DRX state before T2.
6. The UE shall transmit RRCConnectionReconfigurationComplete message.
- 6a. The SS shall transmit an LPP REQUEST CAPABILITIES message.
- 6b. The UE shall transmit an LPP PROVIDE CAPABILITIES message indicating the OTDOA capabilities supported by the UE in the *OTDOA-ProvideCapabilities* IE.
7. The SS shall send a LPP PROVIDE ASSISTANCE DATA message, including the *OTDOA-ProvideAssistanceData* IE. The position of neighbour Cell 2 in the *OTDOA-NeighbourCellInfoList* is randomly selected to be in the first 7 elements of the sequence, and the position of neighbour Cell 3 is randomly selected to be in the last 8 elements of the sequence, as described in 3GPP TS 37.571-5 [20], clause 7.2.3. If the UE message at step 6b includes the *ackRequested* IE set to TRUE, then the SS shall send an acknowledgment in the LPP PROVIDE ASSISTANCE DATA message.
8. The SS shall send a LPP REQUEST LOCATION INFORMATION message, including the *OTDOA-RequestLocationInformation* IE such that the UE receives the message ΔT ms before the start of T2, where $\Delta T = 150$ ms.
9. When T1 expires, the SS shall switch the power setting from T1 to T2 as specified in Table 9.2.2.5-2.
10. When T2 expires, the SS shall switch the power setting from T2 to T3 as specified in Table 9.2.2.5-2.
11. The UE shall transmit a LPP PROVIDE LOCATION INFORMATION message including the *OTDOA-ProvideLocationInformation* IE within the response time (see clause 4.7.3) specified in clause 9.2.2.5. The UE shall perform and report the RSTD measurements for both Cell 2 and Cell 3 with respect to the reference cell in the OTDOA assistance data, Cell 1. If the UE transmits an *OTDOA-ProvideLocationInformation* IE including the *rstd* field for both Cell 2 and Cell 3 within the response time then the number of successful tests is increased by one. If the UE fails to report the *OTDOA-ProvideLocationInformation* IE with both the *rstd* fields included within the response time then the number of failure tests is increased by one.
12. If the UE message at step 11 includes the *ackRequested* IE set to TRUE, the SS shall send a LPP acknowledgement message.
13. Repeat steps 2-12 until the confidence level according to Annex D is achieved. For each iteration, at step 7 change the random position of the Cells 2 and 3 in the *OTDOA-NeighbourCellInfoList*.

9.2.2.4.3 Message contents

Table 9.2.2.4.3-1: RESET UE POSITIONING STORED INFORMATION

Derivation Path: 36.509 [11] clause 6.9			
Information Element	Value/remark	Comment	Condition
UE Positioning Technology	0 0 0 0 0 0 1	OTDOA	

Table 9.2.2.4.3-2: MAC-MainConfig-RBC: TDD-TDD Inter-frequency RSTD Measurement Reporting Delay

Derivation Path: TS 36.508 [18] clause 4.8.2.1.5, Table 4.8.2.1.5-1 MAC-MainConfig-RBC			
Information Element	Value/remark	Comment	Condition

MAC-MainConfig-RBC ::= SEQUENCE {			
drx-Config CHOICE {			
setup SEQUENCE {			
onDurationTimer	psf1		
drx-InactivityTimer	psf1		
drx-RetransmissionTimer	sf1		
longDRX-CycleStartOffset CHOICE {			
sf320	0		
}			
shortDRX	Not present		
}			
}			
}			

Table 9.2.2.4.3-3: MeasGapConfig-GP1: TDD-TDD inter-frequency RSTD Measurement Reporting Delay

Derivation Path: TS 36.508 [18] clause 4.6.6, Table 4.6.6-1A: MeasGapConfig-GP1			
Information Element	Value/remark	Comment	Condition
MeasGapConfig-GP1 ::= CHOICE {			
setup SEQUENCE {			
gapOffset CHOICE {			
gp0	12	TGRP = 40 ms	
}			
}			
}			

Table 9.2.2.4.3-3a: LPP Request Capabilities

Information Element	Value/remark
otdoa-RequestCapabilities	TRUE

Table 9.2.2.4.3-4: LPP RequestLocationInformation

Derivation Path: 36.355 clause 6.2			
Information Element	Value/remark	Comment	Condition
LPP-Message ::= SEQUENCE {			
transactionID SEQUENCE {			
initiator	locationServer		
transactionNumber	1		
}			
endTransaction	FALSE		
sequenceNumber	Not present		
acknowledgement	Not present		
lpp-MessageBody CHOICE {			
c1 CHOICE {			
requestLocationInformation SEQUENCE {			
criticalExtensions CHOICE {			
c1 CHOICE {			
requestLocationInformation-r9 SEQUENCE {			
commonEsRequestLocationInformation SEQUENCE {			
locationInformationType	locationMeasurementsRequired		
triggeredReporting	Not present		
periodicalReporting	Not present		
additionalInformation	onlyReturnInformationRequested		
qos SEQUENCE {			
horizontalAccuracy	Not present		
verticalCoordinateRequest	FALSE		
verticalAccuracy	Not present		
responseTime SEQUENCE {			

time	6	See clause 9.2.2.5	
responseTimeEarlyFix-r12	Not present		Rel-12 onwards
}			
velocityRequest	FALSE		
}			
environment	Not present		
locationCoordinateTypes	Not present		
velocityTypes	Not present		
}			
a-gnss-RequestLocationInformation	Not present		
otdoa-RequestLocationInformation SEQUENCE {			
assistanceAvailability	FALSE		
}			
ecid-RequestLocationInformation	Not present		
epdu-RequestLocationInformation	Not Present		
}			
}			
}			
}			
}			
}			
}			
}			
}			
}			

Table 9.2.2.4.3-5: LPP ProvideAssistanceData

Derivation Path: 36.355 clause 6.2			
Information Element	Value/remark	Comment	Condition
LPP-Message ::= SEQUENCE {			
transactionID SEQUENCE {			
Initiator	locationServer		
transactionNumber	(0..255)		
}			
endTransaction	TRUE		
sequenceNumber	Not present		
acknowledgement	Not present		
lpp-MessageBody CHOICE {			
c1 CHOICE {			
provideAssistanceData SEQUENCE {			
criticalExtensions CHOICE {			
c1 CHOICE {			
provideAssistanceData-r9 SEQUENCE {			
commonIEsProvideAssistanceData	Not present		
a-gnss-ProvideAssistanceData	Not present		
otdoa-ProvideAssistanceData SEQUENCE {			
otdoa-ReferenceCellInfo	As defined in TS 37.571-5 [20], clause 7.2.2.		
otdoa-NeighbourCellInfo	As defined in TS 37.571-5 [20], clause 7.2.2.		
otdoa-Error	Not present		
}			
epdu-ProvideAssistanceData	Not present		
}			
}			
}			
}			
}			
}			
}			
}			

Table 9.2.2.4.3-6: LPP ProvideLocation Information

Derivation Path: 36.355 clause 6.2			
Information Element	Value/remark	Comment	Condition
LPP-Message ::= SEQUENCE {			
transactionID SEQUENCE {			
initiator	locationServer		
transactionNumber	1		
}			
endTransaction	TRUE		
sequenceNumber	(0..255)		
acknowledgement			
lpp-MessageBody CHOICE {			
c1 CHOICE {			
provideLocationInformation SEQUENCE {			
criticalExtensions CHOICE {			
c1 CHOICE {			
provideLocationInformation-r9 SEQUENCE {			
commonIEsProvideLocationInformation	Not present.		
a-gnss-ProvideLocationInformation	Not present		
otdoa-ProvideLocationInformation			
SEQUENCE {			
otdoaSignalMeasurementInformation			
SEQUENCE {			
systemFrameNumber			
physCellIdRef	Cell 1		
cellGlobalIdRef			
earfcnRef			
referenceQuality			
neighbourMeasurementList			
SEQUENCE (SIZE(n)) {			
physCellIdNeighbor	Cell 2		
cellGlobalIdNeighbour			
earfcnNeighbour	RF channel 2		
rstd	Present		
rstd-Quality			
}			
neighbourMeasurementList			
SEQUENCE (SIZE(n)) {			
physCellIdNeighbor	Cell 3		
cellGlobalIdNeighbour			
earfcnNeighbour	RF channel 2		
rstd	Present		
rstd-Quality			
}			
}			
otdoa-Error	May be present with error reason 'undefined' or 'attemptedButUnableToMeasureSomeNeighbourCells'		
}			
ecid-ProvideLocationInformation	Not present		
epdu-ProvideLocationInformation	Not present		
}			
}			
}			
}			
}			

9.2.2.5 Test requirement

Table 9.2.2.5-1 and 9.2.2.5-2 define the primary level settings including test tolerances for the test.

Table 9.2.2.5-1: Cell-specific test parameters for E-UTRAN TDD-TDD inter-frequency RSTD measurement reporting delay under fading propagation conditions during T1

Parameter	Unit	Cell 1	Cell 2	Cell 3
E-UTRA RF Channel Number		1	N/A	N/A
Correlation Matrix and Antenna Configuration		1x2 Low	1x2 Low	1x2 Low
OCNG patterns defined in TS 36.521-3 [25] clause D.2		OP.1 TDD	N/A	N/A
PBCH_RA	dB	0	N/A	N/A
PBCH_RB				
PSS_RA				
SSS_RA				
PCFICH_RB				
PHICH_RA				
PHICH_RB				
PDCCH_RA				
PDCCH_RB				
OCNG_RA ^{Note 1}				
OCNG_RB ^{Note 1}				
N_{oc} ^{Note 3}	dBm/15 kHz	-95	N/A	N/A
PRS \hat{E}_s/N_{oc}	dB	-Infinity	-Infinity	-Infinity
I_o ^{Note 4}	dBm/9 MHz	-67.22	N/A	N/A
\hat{E}_s/N_{oc}	dB	0	-Infinity	-Infinity
Propagation Condition		ETU30		
<p>Note 1: OCNG shall be used such that the active cell (Cell 1) is fully allocated and a constant total transmitted power spectral density is achieved for all OFDM symbols.</p> <p>Note 2: The resources for uplink transmission are assigned to the UE prior to the start of time period T2.</p> <p>Note 3: Interference from other cells and noise sources not specified in the test are assumed to be constant over subcarriers and time and shall be modelled as AWGN of appropriate power for N_{oc} to be fulfilled.</p> <p>Note 4: I_o levels have been derived from other parameters and are given for information purpose. These are not settable test parameters.</p>				

Table 9.2.2.5-2: Cell-specific test parameters for E-UTRAN TDD-TDD inter-frequency RSTD measurement reporting delay under fading propagation conditions during T2 and T3

Parameter	Unit	Cell 1		Cell 2		Cell 3	
		T2	T3	T2	T3	T2	T3
E-UTRA RF Channel Number		1		2		2	N/A
Correlation Matrix and Antenna Configuration		1x2 Low		1x2 Low		1x2 Low	
OCNG patterns defined in TS 36.521-3 [25] clause D.2		OP.1 TDD		OP.2 TDD		OP.2 TDD	N/A
PBCH_RA	dB	0		0		0	N/A
PBCH_RB							
PSS_RA							
SSS_RA							

PCFICH_RB							
PHICH_RA							
PHICH_RB							
PDCCH_RA							
PDCCH_RB							
OCNG_RA ^{Note 1}							
OCNG_RB ^{Note 1}							
PRS_RA	dB	-3	N/A	N/A	3	3	N/A
N_{oc} ^{Note 3}	dBm/ 15 kHz	-98	-98	-98	-95	-98	N/A
$\text{PRS } \hat{E}_s/N_{oc}$	dB	-1	-Infinity	-Infinity	-7	-8	-Infinity
$\text{PRS } \hat{E}_s/I_{ot}$ ^{Note 4}	dB	-1	-Infinity	-Infinity	-7	-8	-Infinity
I_o ^{Note 4}	dBm/ 9 MHz	-69.68	-70.22	-70.11	-67.08	-70.11	N/A
PRP ^{Note 4}	dBm/ 15 kHz	-99	-Infinity	-Infinity	-102	-106	-Infinity
RSRP ^{Note 4}	dBm/ 15 kHz	-96	-96	-105	-105	-109	-Infinity
\hat{E}_s/N_{oc} ^{Note 4}	dB	2	2	-7	-10	-11	-Infinity
Propagation Condition		ETU30					
<p>Note 1: OCNG shall be used such that active cells (all, except Cell 3 in T3) are fully allocated and a constant total transmitted power spectral density is achieved for all OFDM symbols other than those in the subframes with transmitted PRS.</p> <p>Note 2: The resources for uplink transmission are assigned to the UE prior to the start of time period T2.</p> <p>Note 3: Interference from other cells and noise sources not specified in the test are assumed to be constant over subcarriers and time and shall be modelled as AWGN of appropriate power for N_{oc} to be fulfilled.</p> <p>Note 4: If PRS_RA is not "N/A", \hat{E}_s/N_{oc}, $\text{PRS } \hat{E}_s/I_{ot}$, I_o, RSRP and PRP levels have been derived from other parameters and are given for information purpose. If PRS_RA is "N/A", I_o and RSRP levels have been derived from other parameters and are given for information purpose. These are not settable test parameters. Interference conditions shall be applied to all PRS symbols of DL positioning subframes</p>							

The response time including test tolerance is 6.3 s. The response time is equal to the LPP time IE value plus the test tolerance. The LPP time IE value is derived from the RSTD reporting delay plus ΔT , where $\Delta T = 150$ ms, giving a value of 5110 ms. This is rounded up to the next allowed LPP value of 6 seconds. The RSTD measurement reporting

delay in the test is derived from the following expression, $T_{PRS}(M-1) + 160 \left\lceil \frac{n}{M} \right\rceil$, where $M=16$ and $n=16$ are the

parameters specified in clause 9.2.2.3 and Table 9.2.2.3-1. This gives the total RSTD reporting delay of 4960 ms for the 15 neighbour cells including Cell 2 and Cell 3 with respect to the reference cell, Cell 1.

The test tolerances are defined in clauses C.1.3 and C4.

The rate of successful tests during repeated tests shall be at least 90% with a confidence level of 95%.

9.2.2A TDD-TDD inter-frequency RSTD Measurement Reporting Delay for UE Category 1bis

9.2.2A.1 Test purpose

To verify that the TDD-TDD inter-frequency RSTD measurement reporting delay meets the requirements in an environment with fading propagation conditions.

9.2.2A.2 Test applicability

This test applies to E-UTRA TDD UE Category 1bis release 13 and forward that support inter-frequency RSTD measurements.

9.2.2A.3 Minimum conformance requirements

Same as 9.2.2.3 but using Table 9.2.2A.3-1 instead of Table 9.2.2.3-1.

Table 9.2.2A.3-1: Number of PRS positioning occasions within $T_{\text{RSTDInterFreqDD,E-UTRAN}}$

Positioning subframe configuration period T_{PRS}	Number of PRS positioning occasions M	
	$f2$ ^{Note 1}	$f1$ and $f2$ ^{Note 2}
160 ms	32	64
>160 ms	16	32
Note 1: When inter-frequency RSTD measurements are performed over the reference cell and neighbour cells, which belong to the TDD inter-frequency carrier frequency $f2$. Note 2: When inter-frequency RSTD measurements are performed over the reference cell and the neighbour cells, which belong to the serving TDD carrier frequency $f1$ and the FDD inter-frequency carrier frequency $f2$ respectively.		

The normative reference for this requirement is TS 36.133 [23] clause 8.1.2.6.7 and A.8.13.2.

9.2.2A.4 Test description

9.2.2A.4.1 Initial conditions

Same as 9.2.2.4.1 with the following exceptions:

1. Connect the SS, faders and AWGN noise sources to the UE antenna connector or antenna connectors as shown in Annex A, Figure A.4, using only the main Tx/Rx path.
2. The general test parameter settings are set up according to Table 9.2.2A.4.1-1.

Table 9.2.2A.4.1-1: General test parameters for E-UTRAN TDD-TDD inter-frequency RSTD measurement reporting delay under fading propagation conditions for UE Category 1bis

Parameter	Unit	Value	Comment
Reference cell		Cell 1	Reference cell is the cell with respect to which the RSTD measurement is defined, as specified in 3GPP TS 36.214 [6] and 3GPP TS 36.355 [4]. The reference cell is the serving cell on RF channel 1 in this test case.
Neighbour cells		Cell 2 and Cell 3	Cells on RF channel 2. The cells appear at random places in the neighbour cell list in the OTDOA assistance data, but Cell 2 always appears in the first half of the list, whilst Cell 3 appears in the second half of the list.
PCFICH/PDCCH/PHICH parameters		DL Reference Measurement Channel R.6 TDD	As specified in TS 36.521-3 [25] clause A.2.2
Channel Bandwidth (BW_{channel})	MHz	10	
PRS Bandwidth ^{Note 2}	RB	50	PRS are transmitted over the system bandwidth
Gap pattern Id		0	As specified in Table 8.1.2.1-1 in TS 36.133[23].

Gap offset		12	As specified in 36.331 [22], Section 6.3.5
PRS configuration index I_{PRS} ^{Note 2}		Cell 1: 184, Cell 2, Cell 3: 174	This corresponds to periodicity of 320 ms and PRS subframe offset of $I_{\text{PRS}} - 160$ DL subframes, as defined in 3GPP TS 36.211 [26], Table 6.10.4.3-1
Number of consecutive downlink positioning subframes N_{PRS} ^{Note 2}		1	As defined in TS 36.211 [26]. The number of subframes in a positioning occasion
Physical cell ID PCI ^{Note 2}		(PCI of Cell 1 – PCI of Cell 2) mod 6 = 0 and (PCI of Cell 1 – PCI of Cell 3) mod 6 = 0	The cell PCIs are selected such that the relative shifts of PRS patterns among cells are as given by the test parameters
TDD uplink-downlink configuration		1	As specified in TS 36.211 [26], Section 4.2; corresponds to a configuration with 5 ms switch-point periodicity and two downlink consecutive subframes
TDD special subframe configuration		6	As specified in TS 36.211 [26], Section 4.2; corresponds to DwPTS of $19760 \cdot T_s$ and UpPTS of $4384 \cdot T_s$
CP length ^{Note 2}		Normal	
DRX		ON	DRX parameters are further specified in Table 9.2.1.4.1-2
prs-SubframeOffset ^{Note 2}		310	Number of subframes rounded to the closest integer. The corresponding parameter in the OTDOA assistance data is prs-SubframeOffset specified in TS 36.355 [4]
slotNumberOffset ^{Note 2}		0	The slot number offset at the transmitter between a neighbour cell and the assistance data reference cell specified in TS 36.355 [4]
Radio frame receive time offset between the cells at the UE antenna connector ^{Note 3}	μs	Cell 2 to Cell 1: 1 Cell 3 to Cell 1: -1	PRS are transmitted from synchronous cells
Expected RSTD ^{Note 1}	μs	Cell 2: -2 Cell 3: 2 Other neighbour cells: randomly between -3 and 3	The expected RSTD is what is expected at the receiver. The corresponding parameter in the OTDOA assistance data specified in TS 36.355 [4] is the expectedRSTD indicator
Expected RSTD uncertainty for all neighbour cells ^{Note 1}	μs	5	The corresponding parameter in the OTDOA assistance data specified in TS 36.355 [4] is the expectedRSTD-Uncertainty index
Number of cells provided in OTDOA assistance data		16	The list includes the reference cell (received in <i>OTDOA-ReferenceCellInfo</i> [4]) on RF channel 1 and 15 other cells on RF channel 2, all received in <i>OTDOA-ProvideAssistanceData</i> [4].
PRS muting info ^{Note 2}		Cell 1: '11111111111111111100000000000000' Cell 2: '00000000000000000011111111111111' Cell 3: '11111111111111111100000000000000' 00'	Corresponds to prs-MutingInfo defined in TS 36.355 [4]

T1	s	3	The length of the time interval from the beginning of each test
T2	s	4.96	The length of the time interval that follows immediately after time interval T1
T3	s	4.96	The length of the time interval that follows immediately after time interval T2
<p>Note 1: Parameters “Expected RSTD” and “Expected RSTD uncertainty for all neighbour cells” are not settable parameters. These are parameters signalled in LPP only. For the values to be used in LPP see Table 9.2.1.4.3-5 and TS 37.571-5 [20], clause 7.2.2.</p> <p>Note 2: Parameters “PRS Bandwidth”, “PRS configuration index”, “Number of consecutive downlink positioning subframes”, “Physical cell ID PCI”, “CP length”, “prs-SubframeOffset”, “slotNumberOffset” and “PRS muting info” are settable parameters and also parameters signalled in LPP. The values to be used for “Physical cell ID PCI” are as follows: Cell 1: 0, Cell 2: 6, Cell 3: 12. For all the values to be used in LPP see Table 9.2.1.4.3-5 and TS 37.571-5 [20], clause 7.2.2.</p> <p>Note 3: The parameter “Radio frame receive time offset between the cells at the UE antenna connector” is not a settable parameter but is used to set the “true RSTD” values in step 6 of clause 9.2.1.4.1.</p>			

9.2.2A.4.2 Test procedure

Same as 9.2.2.4.2.

9.2.2A.4.3 Message contents

Same as 9.2.2.4.3 with the following exceptions:

Table 9.2.2A.4.3-1: LPP RequestLocationInformation

Derivation Path: Table 9.2.2.4.3-4			
Information Element	Value/remark	Comment	Condition
LPP-Message ::= SEQUENCE {			
lpp-MessageBody CHOICE {			
c1 CHOICE {			
requestLocationInformation SEQUENCE {			
criticalExtensions CHOICE {			
c1 CHOICE {			
requestLocationInformation-r9 SEQUENCE {			
commonIEsRequestLocationInformation SEQUENCE {			
qos SEQUENCE {			
responseTime SEQUENCE {			
time	11	See clause 9.2.2A.5	
}			
}			
}			
}			
}			
}			
}			
}			
}			
}			

9.2.2A.5 Test requirement

Table 9.2.2.5-1 and 9.2.2.5-2 define the primary level settings including test tolerances for the test.

The response time including test tolerance is 11.3 s. The response time is equal to the LPP time IE value plus the test tolerance. The LPP time IE value is derived from the RSTD reporting delay plus ΔT, where ΔT = 150 ms, giving a value of 10230 ms. This is rounded up to the next allowed LPP value of 11 seconds. The RSTD measurement reporting

delay in the test is derived from the following expression, $T_{PRS}(M - 1) + 160 \left\lceil \frac{n}{M} \right\rceil$, where $M=32$ and $n=16$ are the parameters specified in clause 9.2.2A.3 and Table 9.2.2A.3-1. This gives the total RSTD reporting delay of 10080 ms for the 15 neighbour cells including Cell 2 and Cell 3 with respect to the reference cell, Cell 1.

The test tolerances are defined in clauses C.1.3 and C4.

The rate of successful tests during repeated tests shall be at least 90% with a confidence level of 95%.

9.2.3 Void

9.2.4 FDD-FDD inter-frequency RSTD Accuracy

9.2.4.1 Test purpose

To verify that the Reference Signal Time Difference (RSTD) FDD-FDD inter-frequency measurement accuracy is within the specified limit for all bands in AWGN channels.

9.2.4.2 Test applicability

This test applies to all types of E-UTRA FDD UE release 10 and forward that support inter-frequency RSTD measurements except UE Category 1bis.

9.2.4.3 Minimum conformance requirements

The accuracy of FDD-FDD inter-frequency RSTD measurement shall meet the requirement defined in the Table 9.2.4.3-1 without DRX as well as for all the DRX cycles specified in TS 36.331 [22].

The accuracy requirements in Table 9.2.4.3-1 are valid under the following conditions:

Conditions defined in TS 36.101 [2] Section 7.3 for reference sensitivity are fulfilled.

PRP 1,2_{dBm} according to clause E.3 for a corresponding Band.

There are no measurement gaps overlapping with the PRS subframes in cells belonging to the serving carrier frequency.

The parameter expectedRSTDUncertainty signalled over LPP by E-SMLC as defined in TS 36.355 [4] is less than 5 μs.

Table 9.2.4.3-1: RSTD measurement accuracy

Accuracy	Conditions					
	PRS \hat{E}_s/lot	Minimum PRS bandwidth which is minimum of serving cell channel bandwidth ^{Note 9} and the PRS bandwidths of the reference cell and the measured neighbour cell i ^{Note 3}	Minimum number of available measurement subframes among the reference cell and the measured neighbour cell i	Io ^{Note 8} range		
				E-UTRA operating band groups ^{Note 10}	Minimum Io ^{Note 1}	Maximum Io
T_s ^{Note 2}	dB	RB			dBm/15kHz ^{Note 7}	dBm/BW _{Chan} nel
± 21	$(\text{PRS } \hat{E}_s/\text{lot})_{\text{ref}} \geq -6\text{dB}$ and	≥ 6	4	FDD_A, TDD_A FDD_B	-121 -120.5	-50 -50

	$(\text{PRS } \hat{E}_s/\text{lot})_i \geq -13\text{dB}$			FDD_C, TDD_C	-120	-50
				FDD_D	-119.5	-50
				FDD_E, TDD_E	-119	-50
				FDD_F	-118.5	-50
				FDD_G	-118	-50
				FDD_H	-117.5	-50
				FDD_N	-114.5	-50
± 16 Note 11	$(\text{PRS } \hat{E}_s/\text{lot})_{\text{ref}} \geq -6\text{dB}$ and $(\text{PRS } \hat{E}_s/\text{lot})_i \geq -13\text{dB}$	≥ 15	4	Note 5	Note 5	Note 5
± 10	$(\text{PRS } \hat{E}_s/\text{lot})_{\text{ref}} \geq -6\text{dB}$ and $(\text{PRS } \hat{E}_s/\text{lot})_i \geq -13\text{dB}$	≥ 25	≥ 2	Note 5	Note 5	Note 5
± 9	$(\text{PRS } \hat{E}_s/\text{lot})_{\text{ref}} \geq -6\text{dB}$ and $(\text{PRS } \hat{E}_s/\text{lot})_i \geq -13\text{dB}$	≥ 50	≥ 1	Note 5	Note 5	Note 5
± 8 Note 11	$(\text{PRS } \hat{E}_s/\text{lot})_{\text{ref}} \geq -6\text{dB}$ and $(\text{PRS } \hat{E}_s/\text{lot})_i \geq -13\text{dB}$	≥ 75	≥ 1	Note 5	Note 5	Note 5
<p>NOTE 1: This minimum l_0 condition is expressed as the average l_0 per RE over all REs in an OFDM symbol.</p> <p>NOTE 2: T_s is the basic timing unit defined in TS 36.211 [26].</p> <p>NOTE 3: PRS bandwidth is as indicated in <i>prs-Bandwidth</i> in the OTDOA assistance data defined in [24].</p> <p>NOTE 4: Void.</p> <p>NOTE 5: The same bands and the same l_0 conditions for each band apply for this requirement as for the corresponding requirement with the PRS bandwidth ≥ 6 RB.</p> <p>NOTE 6: Void.</p> <p>NOTE 7: The condition level is increased by $\Delta > 0$, when applicable, as described in TS 36.521-3 [25] Sections I.4.2 and I.4.3.</p> <p>NOTE 8: The l_0 is defined in PRS positioning subframes. The same l_0 range applies to PRS and non-PRS symbols. l_0 levels are different in PRS and non-PRS symbols within the same subframe.</p> <p>NOTE 9: If a CA capable UE is configured with SCell, the serving cell channel bandwidth is the minimum of the serving cell channel bandwidths in the component carriers involved in the RSTD measurement. If one of the serving cells is not involved in this RSTD measurement for CA, the channel bandwidth of that serving cell is not included in the determination of the minimum PRS bandwidth.</p> <p>NOTE 10: E-UTRA operating band groups are as defined in clause 4.4.2.</p> <p>NOTE 11: Only applicable from Rel-12 onwards</p>						

The normative reference for this requirement is TS 36.133 [23] clause 9.1.10.2 and A.9.8.3.

9.2.4.4 Test description

9.2.4.4.1 Initial conditions

Test Environment: Normal; as defined in TS 36.508 [18] clause 4.1.

Frequencies to be tested: Mid Range, as defined in TS 36.508 [18] clause 4.3.1.1.

Channel bandwidth to be tested: 1.4 MHz (Test 1) and 10 MHz (Test 2). In the case that 1.4 MHz channel bandwidth is not defined for the operating band under test, as defined in TS 36.101 [2] clause 5.6.1, then this part of the test shall be omitted.

1. Connect the SS and AWGN noise sources to the UE antenna connector or antenna connectors as shown in Annex A, Figure A.3a for 4RX capable UE without any 2RX bands. Otherwise use Annex A figure A.3.
2. The general test parameter settings are set up according to Table 9.2.4.4.1-1.
3. Propagation conditions are set according to clause 4.7.2.1.
4. Message contents are defined in clause 9.2.4.4.3.
5. Two cells are on the different carrier frequencies. Cell 1 is the serving cell and OTDOA assistance data reference cell; Cell 2 is the neighbour cell. The assistance data neighbour cell list includes in total 15 cells, where 14 of the cells are not simulated (dummy cells; as defined in 3GPP TS 37.571-5 [20], clause 7.2.2).
6. The true RSTD (which is the receive time difference for frame 0 between the two cells as seen at the UE antenna connector) is set to 92 T_s (about 3 μs) between neighbour cell 2 and serving cell 1 for Test 1 and -92 T_s (about -

3 μ s) for Test 2.

Note that the related expectedRSTD values to be signalled over LPP are defined in Table 9.2.4.4-1.

7. The gap pattern configuration # 0 as defined in Table 8.1.2.1-1 in 3GPP TS 36.133 [23] is configured and does not overlap with PRS subframes of Cell 1.

Table 9.2.4.4-1: General Test Parameters for inter-frequency RSTD Tests for E-UTRAN FDD

Parameter	Unit	Value		Comment
		Test 1	Test 2	
PCFICH/PDCCH/PHICH parameters		R.14 FDD	R.6 FDD	As specified in TS 36.521-3 [25] clause A.2.1.
OCNG Patterns defined in TS 36.521-3 [25] clause D.1		OP.7 FDD	OP.6 FDD	OCNG shall be used such that both cells are fully allocated and a constant total transmitted power spectral density is achieved for all OFDM symbols (other than those in the PRS subframes).
Reference cell		Cell 1		Cell 1 on RF channel number 1
Neighbour cell		Cell 2		Cell 2 on RF channel number 2
E-UTRA RF Channel Number		1,2		Two FDD carrier frequencies are used.
Channel Bandwidth ($BW_{channel}$)	MHz	1.4	10	
GapOffset		18	11	For Cell 1
Gap Pattern ID		0	0	For Cell 1
PRS Bandwidth	RB	6	50	
PRS configuration Index I_{PRS} Note 2		Cell 1: 12 Cell 2: 19	Cell 1: 2 Cell 2: 12	As defined in 3GPP TS 36.211 [26]
PRS subframe offset		7	10	For Cell 2
Number of consecutive positioning downlink subframes N_{PRS} Note 2		6	1	As defined in 3GPP TS 36.211 [26]
prs-MutingInfo Note 2		Cell 1: '11110000' Cell 2: '11110000'		See section 6.5.1.2 in 3GPP TS 36.355 [4] for more information
Cell ID Note 2		Cell 1: 0 Cell 2: 1		
Expected RSTD Note 1	μ s	Cell 2: 1 Other neighbour cells: randomly between -3 and 3		The expected RSTD is what is expected at the receiver. The corresponding parameter in the OTDOA assistance data specified in TS 36.355 [4] is the expectedRSTD indicator
Expected RSTD uncertainty for all neighbour cells Note 1	μ s	5		The corresponding parameter in the OTDOA assistance data specified in TS 36.355 [4] is the expectedRSTD-Uncertainty index
CP length Note 2		Normal		
DRX		OFF		
Radio frame receive time offset between the cells at the UE antenna connector Note 3	μ s	Cell 2 to Cell 1: 3	Cell 2 to Cell 1: -3	PRS are transmitted from synchronous cells
Number of cells provided in OTDOA assistance data		16		The list includes the reference cell (received in <i>OTDOA-ReferenceCellInfo</i> [4]) on RF channel 1 and 15 other cells on RF channel 2, all received in <i>OTDOA-ProvideAssistanceData</i> [4].
$T_{RSTD}^{InterFreqE-UTRAN}$ Note 4	ms	5120		Derived according to the RSTD measurement requirements specified in Section 8.1.2.6.1 in TS 36.133 [23].

<p>NOTE 1: Parameters “Expected RSTD” and “Expected RSTD uncertainty for all neighbour cells” in Table 9.2.4.4.1-1 are not settable parameters. These are parameters signalled in LPP only. For the values to be used in LPP see Table 9.2.4.4.3-4 and TS 37.571-5 [20], clause 7.2.2.</p> <p>NOTE 2: Parameters “PRS Bandwidth”, “PRS configuration index”, “Number of consecutive positioning downlink subframes”, “prs-MutingInfo”, “Cell ID” and “CP length” in Table 9.2.4.4.1-1 are settable parameters and also parameters signalled in LPP. For all the values to be used in LPP see Table 9.2.4.4.3-4 and TS 37.571-5 [20], clause 7.2.2.</p> <p>NOTE 3: The parameter “Radio frame receive time offset between the cells at the UE antenna connector” is not a settable parameter but is used to set the “true RSTD” values in step 6 of clause 9.2.4.4.1.</p> <p>NOTE 4: The parameter “$T_{\text{RSTDInterFreq}}^{\text{FDD-E-UTRAN}}$” is not a settable parameter but is used to set the LPP “time” value in Table 9.2.4.4.3-3. The value of the LPP time IE is set to $T_{\text{RSTDInterFreq}}^{\text{FDD-E-UTRAN}} + \Delta T$ ms, where $\Delta T = 150$ ms, giving a value of 5270 ms. This is rounded up to the next allowed LPP value of 6 seconds.</p>

9.2.4.4.2 Test procedure

The test consists of a set-up period and a measurement period. Cell 1 and Cell 2 are both active during the complete test. The beginning of the measurement period shall be aligned with the first PRS positioning subframe of a positioning occasion in the reference cell.

NOTE: The information on when PRS is muted is conveyed to the UE using PRS muting information in the OTDOA assistance data.

The OTDOA-RequestLocationInformation message and the OTDOA assistance data as defined in clause 9.2.4.4.3 shall be provided to the UE during the set-up period. The last TTI containing the OTDOA-RequestLocationInformation message shall be provided to the UE ΔT ms before the start of the measurement period, where $\Delta T = 150$ ms is the maximum processing time of the OTDOA-RequestLocationInformation message and the OTDOA assistance data in the UE.

1. Ensure that the UE is in state Generic RB Established State 3A-RF according to 3GPP TS 36.508 [18] clause 7.2A.3.
2. The SS shall send a RESET UE POSITIONING STORED INFORMATION message.
3. Set the parameters according to Table 9.2.4.5-1 as appropriate. Propagation conditions are set according to clause 4.7.2.1.
4. The SS shall transmit an RRCConnectionReconfiguration message with the measurement gap configuration.
5. The UE shall transmit RRCConnectionReconfigurationComplete message.
- 5a. The SS shall transmit an LPP REQUEST CAPABILITIES message.
- 5b. The UE shall transmit an LPP PROVIDE CAPABILITIES message indicating the OTDOA capabilities supported by the UE in the *OTDOA-ProvideCapabilities* IE.
6. The SS shall send a LPP PROVIDE ASSISTANCE DATA message, including the *OTDOA-ProvideAssistanceData* IE. If the UE message at step 5b includes the *ackRequested* IE set to TRUE, then the SS shall send an acknowledgment in the LPP PROVIDE ASSISTANCE DATA message.
7. The SS shall send a LPP REQUEST LOCATION INFORMATION message, including the *OTDOA-RequestLocationInformation* IE such that the UE receives the message ΔT ms before the start of the measurement period, where $\Delta T = 150$ ms.
8. The UE shall transmit a LPP PROVIDE LOCATION INFORMATION message, including the *OTDOA-ProvideLocationInformation* IE.
9. If the UE message at step 8 includes the *ackRequested* IE set to TRUE, the SS shall send a LPP acknowledgement message.
10. The SS shall check the *rstd* value for Cell 2 in the *OTDOA-SignalMeasurementInformation* IE according to Table 9.2.4.5-2.
11. Repeat step 2-10 until the confidence level according to Annex D is achieved.

12. Repeat step 1-11 for each sub-test in Table 9.2.4.5-1 as appropriate.

9.2.4.4.3 Message contents

Table 9.2.4.4.3-1: RESET UE POSITIONING STORED INFORMATION

Derivation Path: 36.509 [11] clause 6.9			
Information Element	Value/remark	Comment	Condition
UE Positioning Technology	0 0 0 0 0 0 1	OTDOA	

Table 9.2.4.4.3-2: MeasGapConfig-GP1: FDD-FDD inter-frequency RSTD Accuracy

Derivation Path: TS 36.508 [18] clause 4.6.6, Table 4.6.6-1A: MeasGapConfig-GP1			
Information Element	Value/remark	Comment	Condition
MeasGapConfig-GP1 ::= CHOICE {			
setup SEQUENCE {			
gapOffset CHOICE {			
gp0	18 (Test 1) 11 (Test 2)	TGRP = 40 ms	
}			
}			
}			

Table 9.2.4.4.3-2a: LPP Request Capabilities

Information Element	Value/remark
otdoa-RequestCapabilities	TRUE

Table 9.2.4.4.3-3: LPP RequestLocationInformation

Derivation Path: 36.355 clause 6.2			
Information Element	Value/remark	Comment	Condition
LPP-Message ::= SEQUENCE {			
transactionID SEQUENCE {			
initiator	locationServer		
transactionNumber	1		
}			
endTransaction	FALSE		
sequenceNumber	Not present		
acknowledgement	Not present		
lpp-MessageBody CHOICE {			
c1 CHOICE {			
requestLocationInformation SEQUENCE {			
criticalExtensions CHOICE {			
c1 CHOICE {			
requestLocationInformation-r9 SEQUENCE {			
commonIEsRequestLocationInformation SEQUENCE {			
locationInformationType	locationMeasurementsRe quired		
triggeredReporting	Not present		
periodicalReporting	Not present		
additionalInformation	onlyReturnInformationRe quested		
qos SEQUENCE {			
horizontalAccuracy	Not present		
verticalCoordinateRequest	FALSE		
verticalAccuracy	Not present		
responseTime SEQUENCE {			
time	6	See Note 4 of Table 9.2.4.4.1-1	

responseTimeEarlyFix-r12	Not present		Rel-12 onwards
}			
velocityRequest	FALSE		
}			
environment	Not present		
locationCoordinateTypes	Not present		
velocityTypes	Not present		
}			
a-gnss-RequestLocationInformation	Not present		
otdoa-RequestLocationInformation SEQUENCE {			
assistanceAvailability	FALSE		
}			
ecid-RequestLocationInformation	Not present		
epdu-RequestLocationInformation	Not Present		
}			
}			
}			
}			
}			
}			
}			
}			
}			

Table 9.2.4.4.3-4: LPP ProvideAssistanceData

Derivation Path: 36.355 clause 6.2			
Information Element	Value/remark	Comment	Condition
LPP-Message ::= SEQUENCE {			
transactionID SEQUENCE {			
Initiator	locationServer		
transactionNumber	(0..255)		
}			
endTransaction	TRUE		
sequenceNumber	Not present		
acknowledgement	Not present		
lpp-MessageBody CHOICE {			
c1 CHOICE {			
provideAssistanceData SEQUENCE {			
criticalExtensions CHOICE {			
c1 CHOICE {			
provideAssistanceData-r9 SEQUENCE {			
commonIEsProvideAssistanceData	Not present		
a-gnss-ProvideAssistanceData	Not present		
otdoa-ProvideAssistanceData SEQUENCE {			
otdoa-ReferenceCellInfo	As defined in TS 37.571-5 [20], clause 7.2.2.		
otdoa-NeighbourCellInfo	As defined in TS 37.571-5 [20], clause 7.2.2.		
otdoa-Error	Not present		
}			
epdu-ProvideAssistanceData	Not present		
}			
}			
}			
}			
}			
}			

Table 9.2.4.4.3-5: LPP ProvideLocation Information

Derivation Path: 36.355 clause 6.2			
Information Element	Value/remark	Comment	Condition
LPP-Message ::= SEQUENCE {			
transactionID SEQUENCE {			
initiator	locationServer		
transactionNumber	1		
}			
endTransaction	TRUE		
sequenceNumber	(0..255)		
acknowledgement			
lpp-MessageBody CHOICE {			
c1 CHOICE {			
provideLocationInformation SEQUENCE {			
criticalExtensions CHOICE {			
c1 CHOICE {			
provideLocationInformation-r9 SEQUENCE {			
commonIEsProvideLocationInformation	Not present.		
a-gnss-ProvideLocationInformation	Not present		
otdoa-ProvideLocationInformation SEQUENCE {			
otdoaSignalMeasurementInformation SEQUENCE {			
systemFrameNumber			
physCellIdRef	Cell 1		
cellGlobalIdRef			
earfcnRef			
referenceQuality			
neighbourMeasurementList SEQUENCE (SIZE(1)) {			
physCellIdNeighbor	Cell 2		
cellGlobalIdNeighbour			
earfcnNeighbour	RF channel 2		
rstd	Set according to Table 9.2.4.5-2 for each specific test		
rstd-Quality			
}			
}			
otdoa-Error	May be present with error reason 'undefined' or 'attemptedButUnableToMeasureSomeNeighbourCells'		
}			
ecid-ProvideLocationInformation	Not present		
epdu-ProvideLocationInformation	Not present		
}			
}			
}			
}			
}			

Table 9.2.4.4.3-6: CQI-ReportConfig-DEFAULT: FDD-FDD inter-frequency RSTD Accuracy

Derivation Path: TS 36.508 [18] clause 4.6.3, Table 4.6.3-2 CQI-ReportConfig-DEFAULT			
Information Element	Value/remark	Comment	Condition
CQI-ReportConfig-DEFAULT ::= SEQUENCE {			
cqi-ReportModeAperiodic	rm30	This IE should be omitted for Test 1	
nomPDSCH-RS-EPRE-Offset	0		
cqi-ReportPeriodic CHOICE {			
release	NULL		

--	--	--

9.2.4.5 Test requirement

Table 9.2.4.5-1 defines the primary level settings including test tolerances for all tests.

RSTD FDD-FDD inter-frequency accuracy test shall meet the reported values in Table 9.2.4.5-2.

Table 9.2.4.5-1: Cell Specific Test Parameters for inter-frequency RSTD Tests for E-UTRAN FDD

Parameter	Unit	Test 1		Test 2	
		Cell 1	Cell 2	Cell 1	Cell 2
E-UTRA RF Channel Number		1	2	1	2
PBCH_RA	dB	0	0	0	0
PBCH_RB					
PSS_RA					
SSS_RA					
PCFICH_RB					
PHICH_RA					
PHICH_RB					
PDCCH_RA					
PDCCH_RB					
OCNG_RA ^{Note 1}					
OCNG_RB ^{Note 1}					
PRS_RA					
N_{oc} ^{Note 2}	dBm/15 kHz	-98			
PRS \hat{E}_s/N_{oc}	dB	-5.7	-12.7	-5.7	-12.7
PRS \hat{E}_s/I_{ot} ^{Note 3}	dB	-5.7	-12.7	-5.7	-12.7
I_o ^{Note 3}	dBm/1.08 MHz	-79.24	-79.39	N/A	N/A
	dBm/9 MHz	N/A	N/A	-70.03	-70.18
PRP ^{Note 3}	dBm/15kHz	-103.7	-110.7	-103.7	-110.7
\hat{E}_s/N_{oc} ^{Note 3}	dB	-3	-13	-3	-13
RSRP ^{Note 3}	dBm/15kHz	-101	-111	-101	-111
Propagation condition		AWGN			
<p>Note 1: OCNG shall be used such that both cells are fully allocated and a constant total transmitted power spectral density is achieved for all OFDM symbols (other than those in the PRS subframes).</p> <p>Note 2: Interference from other cells and noise sources not specified in the test is assumed to be constant over subcarriers and time and shall be modelled as AWGN of appropriate power for N_{oc} to be fulfilled.</p> <p>Note 3: \hat{E}_s/N_{oc}, PRS \hat{E}_s/I_{ot}, RSRP, I_o and PRP levels have been derived from other parameters for information purposes. They are not settable parameters themselves. I_o values are derived in the case that there is no PBCH, PSS or SSS in the OFDM symbols carrying PRS</p>					

Table 9.2.4.5-2: RSTD FDD inter-frequency accuracy requirements for the reported values

	Test 1	Test 2
Lowest reported value	RSTD_6424	RSTD_6253
Highest reported value	RSTD_6470	RSTD_6275

For the overall test to pass, the ratio of successful reported values in each sub-test shall be more than 90% with a confidence level of 95%. In the case that 1.4 MHz channel bandwidth is not defined for the operating band under test then Test 1 shall be omitted.

9.2.4A FDD-FDD inter-frequency RSTD Accuracy for UE Category 1bis

9.2.4A.1 Test purpose

To verify that the Reference Signal Time Difference (RSTD) FDD-FDD inter-frequency measurement accuracy is within the specified limit for all bands in AWGN channels.

9.2.4A.2 Test applicability

This test applies to E-UTRA FDD UE Category 1bis release 13 and forward that support inter-frequency RSTD measurements.

9.2.4A.3 Minimum conformance requirements

Same as 9.2.4.3

The normative reference for this requirement is TS 36.133 [23] clause 9.1.10.6 and A.9.8.3.2A.

9.2.4A.4 Test description

9.2.4A.4.1 Initial conditions

Same as 9.2.4.4.1 with the following exceptions:

1. Connect the SS, faders and AWGN noise sources to the UE antenna connector or antenna connectors as shown in Annex A, Figure A.3, using only the main Tx/Rx path.
2. The general test parameter settings are set up according to Table 9.2.4A.4.1-1

Table 9.2.4A.4.1-1: General Test Parameters for inter-frequency RSTD Tests for E-UTRAN FDD for UE Category 1bis

Parameter	Unit	Value		Comment
		Test 1	Test 2	
PCFICH/PDCCH/PHICH parameters		R.14 FDD	R.6 FDD	As specified in TS 36.521-3 [25] clause A.2.1.
OCNG Patterns defined in TS 36.521-3 [25] clause D.1		OP.7 FDD	OP.6 FDD	OCNG shall be used such that both cells are fully allocated and a constant total transmitted power spectral density is achieved for all OFDM symbols (other than those in the PRS subframes).
Reference cell		Cell 1		Cell 1 on RF channel number 1
Neighbour cell		Cell 2		Cell 2 on RF channel number 2
E-UTRA RF Channel Number		1,2		Two FDD carrier frequencies are used.
Channel Bandwidth (BW _{channel})	MHz	1.4	10	
GapOffset		18	11	For Cell 1
Gap Pattern ID		0	0	For Cell 1
PRS Bandwidth	RB	6	50	
PRS configuration Index I_{PRS} Note 2		Cell 1: 12 Cell 2: 19	Cell 1: 2 Cell 2: 12	As defined in 3GPP TS 36.211 [26]
PRS subframe offset		7	10	For Cell 2
Number of consecutive positioning downlink subframes N_{PRS} Note 2		6	1	As defined in 3GPP TS 36.211 [26]
prs-MutingInfo ^{Note 2}		Cell 1: '1111111100000000' Cell 2: '1111111100000000'		See section 6.5.1.2 in 3GPP TS 36.355 [4] for more information
Cell ID ^{Note 2}		Cell 1: 0 Cell 2: 1		
Expected RSTD ^{Note 1}	µs	Cell 2: 1 Other neighbour cells: randomly between -3 and 3		The expected RSTD is what is expected at the receiver. The corresponding parameter in the OTDOA assistance data specified in TS 36.355 [4] is the expectedRSTD indicator

Expected RSTD uncertainty for all neighbour cells ^{Note 1}	μs	5		The corresponding parameter in the OTDOA assistance data specified in TS 36.355 [4] is the expectedRSTD-Uncertainty index
CP length ^{Note 2}		Normal		
DRX		OFF		
Radio frame receive time offset between the cells at the UE antenna connector ^{Note 3}	μs	Cell 2 to Cell 1: 3	Cell 2 to Cell 1: -3	PRS are transmitted from synchronous cells
Number of cells provided in OTDOA assistance data		16		The list includes the reference cell (received in <i>OTDOA-ReferenceCellInfo</i> [4]) on RF channel 1 and 15 other cells on RF channel 2, all received in <i>OTDOA-ProvideAssistanceData</i> [4].
$T_{RSTD,InterFreq,FD,DE-UTRAN}$ ^{Note 4}	ms	10240		Derived according to the RSTD measurement requirements specified in Section 8.1.2.6.5 in TS 36.133 [23].
<p>NOTE 1: Parameters “Expected RSTD” and “Expected RSTD uncertainty for all neighbour cells” in Table 9.2.4.4.1-1 are not settable parameters. These are parameters signalled in LPP only. For the values to be used in LPP see Table 9.2.4.4.3-4 and TS 37.571-5 [20], clause 7.2.2.</p> <p>NOTE 2: Parameters “PRS Bandwidth”, “PRS configuration index”, “Number of consecutive positioning downlink subframes”, “prs-MutingInfo”, “Cell ID” and “CP length” in Table 9.2.4.4.1-1 are settable parameters and also parameters signalled in LPP. For all the values to be used in LPP see Table 9.2.4.4.3-4 and TS 37.571-5 [20], clause 7.2.2.</p> <p>NOTE 3: The parameter “Radio frame receive time offset between the cells at the UE antenna connector” is not a settable parameter but is used to set the “true RSTD” values in step 6 of clause 9.2.4.4.1.</p> <p>NOTE 4: The parameter “$T_{RSTD,InterFreq,FD,DE-UTRAN}$” is not a settable parameter but is used to set the LPP “time” value in Table 9.2.4.4.3-3. The value of the LPP time IE is set to $T_{RSTD,InterFreq,FD,DE-UTRAN} + \Delta T$ ms, where $\Delta T = 150$ ms, giving a value of 10390 ms. This is rounded up to the next allowed LPP value of 11 seconds.</p>				

9.2.4A.4.2 Test procedure

Same as 9.2.4.4.2.

9.2.4A.4.3 Message contents

Same as 9.2.4.4.3 with the following exceptions

Table 9.2.4A.4.3-1: LPP RequestLocationInformation

Derivation Path: Table 9.2.4.4.3-2			
Information Element	Value/remark	Comment	Condition
LPP-Message ::= SEQUENCE {			
lpp-MessageBody CHOICE {			
c1 CHOICE {			
requestLocationInformation SEQUENCE {			
criticalExtensions CHOICE {			
c1 CHOICE {			
requestLocationInformation-r9 SEQUENCE {			
commonIEsRequestLocationInformation SEQUENCE {			
qos SEQUENCE {			
responseTime SEQUENCE {			
time	11	See Note 4 of Table 9.2.4A.4.1-1	
}			
}			
}			
}			
}			
}			
}			
}			
}			
}			

}			
---	--	--	--

9.2.4A.5 Test requirement

Same as 9.2.4.5.

9.2.5 TDD-TDD inter-frequency RSTD Accuracy

9.2.5.1 Test purpose

To verify that the Reference Signal Time Difference (RSTD) of TDD-TDD inter-frequency measurement accuracy is within the specified limit for all bands in AWGN channels

9.2.5.2 Test applicability

This test applies to all types of E-UTRA TDD UE release 10 and forward that support inter-frequency RSTD measurements except UE Category 1bis.

9.2.5.3 Minimum conformance requirements

This RSTD measurement is used for UE positioning purposes.

The accuracy of TDD-TDD inter-frequency RSTD measurement shall meet the requirement defined in the Table 9.2.4.3-1 without DRX as well as for all the DRX cycles specified in TS 36.331 [22].

The accuracy requirements in Table 9.2.4.3-1 are valid under the following conditions:

Conditions defined in TS 36.101 [2] Section 7.3 for reference sensitivity are fulfilled.

PRP 1,2_{dBm} according to clause E.3 for a corresponding Band

There are no measurement gaps overlapping with the PRS subframes in cells belonging to the serving carrier frequency.

The parameter expectedRSTDUncertainty signalled over LPP by E-SMLC as defined in TS 36.355 [4] is less than 5 μ s.

The normative reference for this requirement is TS 36.133 [23] clause 9.1.10.2 and A.9.8.4.

9.2.5.4 Test description

9.2.5.4.1 Initial conditions

Test Environment: Normal; as defined in TS 36.508 [18] clause 4.1.

Frequencies to be tested: Mid Range, as defined in TS 36.508 [18] clause 4.3.1.2.

Channel bandwidth to be tested: 1.4 MHz (Test 1) and 10 MHz (Test 2). In the case that 1.4 MHz channel bandwidth is not defined for the operating band under test, as defined in TS 36.101 [2] clause 5.6.1, then this part of the test shall be omitted.

1. Connect the SS and AWGN noise sources to the UE antenna connector or antenna connectors as shown in Annex A, Figure A.3a for 4RX capable UE without any 2RX bands. Otherwise use Annex A figure A.3.
2. The general test parameter settings are set up according to Table 9.2.5.4.1-1.
3. Propagation conditions are set according to clause 4.7.2.1.
4. Message contents are defined in clause 9.2.5.4.3.
5. Two cells are on the different carrier frequencies. Cell 1 is the serving cell and OTDOA assistance data reference cell; Cell 2 is the neighbour cell. The assistance data neighbour cell list includes in total 15 cells, where 14 of the cells are not simulated (dummy cells; as defined in 3GPP TS 37.571-5 [20], clause 7.2.2).

6. The true RSTD (which is the receive time difference for frame 0 between the two cells as seen at the UE antenna connector) is set to 92 Ts (about 3 μ s) between neighbour cell 2 and serving cell 1 for Test 1 and -92 Ts (about -3 μ s) for Test 2.

Note that the related expectedRSTD values to be signalled over LPP are defined in Table 9.2.5.4-1.

7. The gap pattern configuration # 0 as defined in Table 8.1.2.1-1 in 3GPP TS 36.133 [23] is configured and does not overlap with PRS subframes of Cell 1.

Table 9.2.5.4.1-1: General Test Parameters for inter-frequency RSTD Tests for E-UTRAN TDD-TDD

Parameter	Unit	Value		Comment
		Test 1	Test 2	
PCFICH/PDCCH/PHICH parameters		R.14 TDD	R.6 TDD	As specified in TS 36.521-3 [25] clause A.2.2.
OCNG Patterns defined in TS 36.521-3 [25] clause D.2		OP.4 TDD	OP.2 TDD	OCNG shall be used such that both cells are fully allocated and a constant total transmitted power spectral density is achieved for all OFDM symbols (other than those in the PRS subframes).
Reference cell		Cell 1		Cell 1 on RF channel number 1
Neighbour cell		Cell 2		Cell 2 on RF channel number 2
E-UTRA RF Channel Number		1,2		Two TDD carrier frequencies are used.
Channel Bandwidth ($BW_{channel}$)	MHz	1.4	10	
PRS Bandwidth ^{Note 2}	RB	6	50	
GapOffset		34	13	For Cell 1
Gap Pattern ID		0		For Cell 1
Special subframe configuration		6		As specified in table 4.2-1 in TS 36.211 [26]. The same configuration in both cells.
Uplink-downlink configuration		3	1	As specified in table 4.2-2 in TS 36.211 [26] and table 9.1.2.3-2. The same configuration in both cells.
PRS configuration Index I_{PRS} ^{Note 2}		Cell 1: 15 Cell 2: 35	Cell 1: 4 Cell 2: 14	As defined in 3GPP TS 36.211 [26]
PRS subframe offset		20	10	For Cell 2
Number of consecutive positioning downlink subframes N_{PRS} ^{Note 2}		6	1	As defined in 3GPP TS 36.211 [26]
prs-MutingInfo ^{Note 2}		Cell 1:'11110000' Cell 2:'11110000'		See section 6.5.1.2 in 3GPP TS 36.355 [4] for more information
Cell ID ^{Note 2}		Cell 1: 0 Cell 2: 1		
Expected RSTD ^{Note 1}	μ s	Cell 2: 1 Other neighbour cells: randomly between -3 and 3		The expected RSTD is what is expected at the receiver. The corresponding parameter in the OTDOA assistance data specified in TS 36.355 [4] is the expectedRSTD indicator
Expected RSTD uncertainty for all neighbour cells ^{Note 1}	μ s	5		The corresponding parameter in the OTDOA assistance data specified in TS 36.355 [4] is the expectedRSTD-Uncertainty index
CP length ^{Note 2}		Normal		
DRX		OFF		
Radio frame receive time offset between the cells at the UE antenna connector ^{Note 3}	μ s	Cell 2 to Cell 1: 3	Cell 2 to Cell 1: -3	PRS are transmitted from synchronous cells
Number of cells provided in OTDOA assistance data		16		The list includes the reference cell (received in <i>OTDOA-ReferenceCellInfo</i> [4]) on RF channel 1 and 15 other cells on RF channel 2, all received in <i>OTDOA-ProvideAssistanceData</i> [4].
$T_{RSTDInterFreqDD,E-UTRAN}$ ^{Note 4}	ms	5120		Derived according to the RSTD measurement requirements specified in Section 8.1.2.6.3 in TS 36.133 [23].

<p>NOTE 1: Parameters “Expected RSTD” and “Expected RSTD uncertainty for all neighbour cells” are not settable parameters. These are parameters signalled in LPP only. For the values to be used in LPP see Table 9.2.5.4.3-4 and TS 37.571-5 [20], clause 7.2.2.</p> <p>NOTE 2: Parameters “PRS Bandwidth”, “PRS configuration index”, “Number of consecutive positioning downlink subframes”, “prs-MutingInfo”, “Cell ID” and “CP length” are settable parameters and also parameters signalled in LPP. For all the values to be used in LPP see Table 9.2.5.4.3-4 and TS 37.571-5 [20], clause 7.2.2.</p> <p>NOTE 3: The parameter “Radio frame receive time offset between the cells at the UE antenna connector” is not a settable parameter but is used to set the “true RSTD” values in step 6 of clause 9.2.5.4.1.</p> <p>NOTE 4: The parameter “$T_{\text{RSTDInterFreqDDE-UTRAN}}$” is not a settable parameter but is used to set the LPP “time” value in Table 9.2.5.4.3-3. The value of the LPP time IE is set to $T_{\text{RSTDInterFreqDDE-UTRAN}} + \Delta T$ ms, where $\Delta T = 150$ ms, giving a value of 5270 ms. This is rounded up to the next allowed LPP value of 6 seconds.</p>

9.2.5.4.2 Test procedure

The test consists of a set-up period and a measurement period. Cell 1 and Cell 2 are both active during the complete test. The beginning of the measurement period shall be aligned with the first PRS positioning subframe of a positioning occasion in the reference cell.

NOTE: The information on when PRS is muted is conveyed to the UE using PRS muting information in the OTDOA assistance data.

The OTDOA-RequestLocationInformation message and the OTDOA assistance data as defined in clause 9.2.5.4.3 shall be provided to the UE during the set-up period. The last TTI containing the OTDOA-RequestLocationInformation message shall be provided to the UE ΔT ms before the start of the measurement period, where $\Delta T = 150$ ms is the maximum processing time of the OTDOA-RequestLocationInformation message and the OTDOA assistance data in the UE.

1. Ensure that the UE is in state Generic RB Established State 3A-RF according to 3GPP TS 36.508 [18] clause 7.2A.3.
2. The SS shall send a RESET UE POSITIONING STORED INFORMATION message.
3. Set the parameters according to Table 9.2.5.5-1 as appropriate. Propagation conditions are set according to clause 4.7.2.1.
 4. The SS shall transmit an RRCConnectionReconfiguration message with the measurement gap configuration.
 5. The UE shall transmit RRCConnectionReconfigurationComplete message.
 - 5a. The SS shall transmit an LPP REQUEST CAPABILITIES message.
 - 5b. The UE shall transmit an LPP PROVIDE CAPABILITIES message indicating the OTDOA capabilities supported by the UE in the *OTDOA-ProvideCapabilities* IE.
6. The SS shall send a LPP PROVIDE ASSISTANCE DATA message, including the *OTDOA-ProvideAssistanceData* IE. If the UE message at step 5b includes the *ackRequested* IE set to TRUE, then the SS shall send an acknowledgment in the LPP PROVIDE ASSISTANCE DATA message.
 7. The SS shall send a LPP REQUEST LOCATION INFORMATION message, including the *OTDOA-RequestLocationInformation* IE such that the UE receives the message ΔT ms before the start of the measurement period, where $\Delta T = 150$ ms.
 8. The UE shall transmit a LPP PROVIDE LOCATION INFORMATION message, including the *OTDOA-ProvideLocationInformation* IE.
 9. If the UE message at step 8 includes the *ackRequested* IE set to TRUE, the SS shall send a LPP acknowledgement message.
 10. The SS shall check the *rstd* value for Cell 2 in the *OTDOA-SignalMeasurementInformation* IE according to Table 9.2.5.5-2.
 11. Repeat step 2-10 until the confidence level according to Annex D is achieved.

12. Repeat step 1-11 for each sub-test in Table 9.2.5.5-1 as appropriate.

9.2.5.4.3 Message contents

Table 9.2.5.4.3-1: RESET UE POSITIONING STORED INFORMATION

Derivation Path: 36.509 [11] clause 6.9			
Information Element	Value/remark	Comment	Condition
UE Positioning Technology	0 0 0 0 0 0 1	OTDOA	

Table 9.2.5.4.3-2: MeasGapConfig-GP1: TDD-TDD inter-frequency RSTD Accuracy

Derivation Path: TS 36.508 [18] clause 4.6.6, Table 4.6.6-1A: MeasGapConfig-GP1			
Information Element	Value/remark	Comment	Condition
MeasGapConfig-GP1 ::= CHOICE {			
setup SEQUENCE {			
gapOffset CHOICE {			
gp0	34 (Test 1) 13 (Test 2)	TGRP = 40 ms	
}			
}			
}			

Table 9.2.5.4.3-2a: LPP Request Capabilities

Information Element	Value/remark
otdoa-RequestCapabilities	TRUE

Table 9.2.5.4.3-3: LPP RequestLocationInformation

Derivation Path: 36.355 clause 6.2			
Information Element	Value/remark	Comment	Condition
LPP-Message ::= SEQUENCE {			
transactionID SEQUENCE {			
initiator	locationServer		
transactionNumber	1		
}			
endTransaction	FALSE		
sequenceNumber	Not present		
acknowledgement	Not present		
lpp-MessageBody CHOICE {			
c1 CHOICE {			
requestLocationInformation SEQUENCE {			
criticalExtensions CHOICE {			
c1 CHOICE {			
requestLocationInformation-r9 SEQUENCE {			
commonIEsRequestLocationInformation SEQUENCE {			
locationInformationType	locationMeasurementsRequired		
triggeredReporting	Not present		
periodicalReporting	Not present		
additionalInformation	onlyReturnInformationRequested		
qos SEQUENCE {			
horizontalAccuracy	Not present		
verticalCoordinateRequest	FALSE		
verticalAccuracy	Not present		
responseTime SEQUENCE {			
time	6	See Note 4 of Table 9.2.5.4.1-1	

responseTimeEarlyFix-r12	Not present		Rel-12 onwards
}			
velocityRequest	FALSE		
}			
environment	Not present		
locationCoordinateTypes	Not present		
velocityTypes	Not present		
}			
a-gnss-RequestLocationInformation	Not present		
otdoa-RequestLocationInformation			
SEQUENCE {			
assistanceAvailability	FALSE		
}			
ecid-RequestLocationInformation	Not present		
epdu-RequestLocationInformation	Not Present		
}			
}			
}			
}			
}			
}			
}			
}			
}			
}			

Table 9.2.5.4.3-4: LPP ProvideAssistanceData

Derivation Path: 36.355 clause 6.2			
Information Element	Value/remark	Comment	Condition
LPP-Message ::= SEQUENCE {			
transactionID SEQUENCE {			
Initiator	locationServer		
transactionNumber	(0..255)		
}			
endTransaction	TRUE		
sequenceNumber	Not present		
acknowledgement	Not present		
lpp-MessageBody CHOICE {			
c1 CHOICE {			
provideAssistanceData SEQUENCE {			
criticalExtensions CHOICE {			
c1 CHOICE {			
provideAssistanceData-r9 SEQUENCE {			
commonIEsProvideAssistanceData	Not present		
a-gnss-ProvideAssistanceData	Not present		
otdoa-ProvideAssistanceData SEQUENCE {			
otdoa-ReferenceCellInfo	As defined in TS 37.571-5 [20], clause 7.2.2.		
otdoa-NeighbourCellInfo	As defined in TS 37.571-5 [20], clause 7.2.2.		
otdoa-Error	Not present		
}			
epdu-ProvideAssistanceData	Not present		
}			
}			
}			
}			
}			
}			
}			

Table 9.2.5.4.3-5: LPP ProvideLocation Information

Derivation Path: 36.355 clause 6.2			
Information Element	Value/remark	Comment	Condition
LPP-Message ::= SEQUENCE {			
transactionID SEQUENCE {			
initiator	locationServer		
transactionNumber	1		
}			
endTransaction	TRUE		
sequenceNumber	(0..255)		
acknowledgement			
lpp-MessageBody CHOICE {			
c1 CHOICE {			
provideLocationInformation SEQUENCE {			
criticalExtensions CHOICE {			
c1 CHOICE {			
provideLocationInformation-r9 SEQUENCE {			
commonIEsProvideLocationInformation	Not present.		
a-gnss-ProvideLocationInformation	Not present		
otdoa-ProvideLocationInformation SEQUENCE {			
otdoaSignalMeasurementInformation SEQUENCE {			
systemFrameNumber			
physCellIdRef	Cell 1		
cellGlobalIdRef			
earfcnRef			
referenceQuality			
neighbourMeasurementList SEQUENCE (SIZE(1)) {			
physCellIdNeighbor	Cell 2		
cellGlobalIdNeighbour			
earfcnNeighbour	RF channel 2		
rstd	Set according to Table 9.2.5.5-2 for each specific test		
rstd-Quality			
}			
}			
otdoa-Error	May be present with error reason 'undefined' or 'attemptedButUnableToMeasureSomeNeighbourCells'		
}			
ecid-ProvideLocationInformation	Not present		
epdu-ProvideLocationInformation	Not present		
}			
}			
}			
}			
}			

Table 9.2.5.4.3-6: CQI-ReportConfig-DEFAULT: TDD-TDD inter-frequency RSTD Accuracy

Derivation Path: TS 36.508 [18] clause 4.6.3, Table 4.6.3-2 CQI-ReportConfig-DEFAULT			
Information Element	Value/remark	Comment	Condition
CQI-ReportConfig-DEFAULT ::= SEQUENCE {			
cqi-ReportModeAperiodic	rm30	This IE should be omitted for Test 1	
nomPDSCH-RS-EPRE-Offset	0		
cqi-ReportPeriodic CHOICE {			
release	NULL		

--	--	--

9.2.5.5 Test requirement

Table 9.2.5.5-1 defines the primary level settings including test tolerances for all tests.

The RSTD TDD-TDD inter frequency measurement accuracy test shall meet the reported values in Table 9.2.5.5-2.

Table 9.2.5.5-1: Cell Specific Test Parameters for inter frequency RSTD Tests for E-UTRAN TDD-TDD

Parameter	Unit	Test 1		Test 2	
		Cell 1	Cell 2	Cell 1	Cell 2
E-UTRA RF Channel Number		1	2	1	2
PBCH_RA	dB	0			
PBCH_RB					
PSS_RA					
SSS_RA					
PCFICH_RB					
PHICH_RA					
PHICH_RB					
PDCCH_RA					
PDCCH_RB					
OCNG_RA ^{Note 1}					
OCNG_RB ^{Note 1}					
PRS_RA					
N_{oc} ^{Note 2}	dBm/15 kHz	-98			
PRS \hat{E}_s/N_{oc}	dB	-5.7	-12.7	-5.7	-12.7
PRS \hat{E}_s/I_{ot} ^{Note 3}	dB	-5.7	-12.7	-5.7	-12.7
I_o ^{Note 3}	dBm/1.08 MHz	-79.24	-79.39	N/A	N/A
	dBm/9 MHz	N/A	N/A	-70.03	-70.18
PRP ^{Note 3}	dBm/15kHz	-103.7	-110.7	-103.7	-110.7
\hat{E}_s/N_{oc} ^{Note 3}	dB	-3	-13	-3	-13
RSRP ^{Note 3}	dBm/15kHz	-101	-111	-101	-111
Propagation condition		AWGN			
<p>Note 1: OCNG shall be used such that both cells are fully allocated and a constant total transmitted power spectral density is achieved for all OFDM symbols (other than those in the PRS subframes).</p> <p>Note 2: Interference from other cells and noise sources not specified in the test is assumed to be constant over subcarriers and time and shall be modelled as AWGN of appropriate power for N_{oc} to be fulfilled.</p> <p>Note 3: \hat{E}_s/N_{oc}, PRS \hat{E}_s/I_{ot}, I_o, RSRP and PRP levels have been derived from other parameters for information purposes. They are not settable parameters themselves. I_o values are derived in the case that there is no PBCH, PSS or SSS in the OFDM symbols carrying PRS.</p>					

Table 9.2.5.5-2: RSTD TDD inter-frequency accuracy requirements for the reported values

	Test 1	Test 2
Lowest reported value	RSTD_6424	RSTD_6253
Highest reported value	RSTD_6470	RSTD_6275

For the overall test to pass, the ratio of successful reported values in each sub-test shall be more than 90% with a confidence level of 95%. In the case that 1.4 MHz channel bandwidth is not defined for the operating band under test then Test 1 shall be omitted.

9.2.5A TDD-TDD inter-frequency RSTD Accuracy for UE Category 1bis

9.2.5A.1 Test purpose

To verify that the Reference Signal Time Difference (RSTD) TDD-TDD inter-frequency measurement accuracy is within the specified limit for all bands in AWGN channels.

9.2.5A.2 Test applicability

This test applies to E-UTRA TDD UE Category 1bis release 13 and forward that support inter-frequency RSTD measurements.

9.2.5A.3 Minimum conformance requirements

Same as 9.2.5.3

The normative reference for this requirement is TS 36.133 [23] clause 9.1.10.6 and A.9.8.4.2A.

9.2.5A.4 Test description

9.2.5A.4.1 Initial conditions

Same as 9.2.5.4.1 with the following exceptions:

1. Connect the SS, faders and AWGN noise sources to the UE antenna connector or antenna connectors as shown in Annex A, Figure A.3, using only the main Tx/Rx path.
2. The general test parameter settings are set up according to Table 9.2.5A.4.1-1

Table 9.2.5A.4.1-1: General Test Parameters for inter-frequency RSTD Tests for E-UTRAN TDD-TDD for UE Category 1bis

Parameter	Unit	Value		Comment
		Test 1	Test 2	
PCFICH/PDCCH/PHICH parameters		R.14 TDD	R.6 TDD	As specified in TS 36.521-3 [25] clause A.2.2.
OCNG Patterns defined in TS 36.521-3 [25] clause D.2		OP.4 TDD	OP.2 TDD	OCNG shall be used such that both cells are fully allocated and a constant total transmitted power spectral density is achieved for all OFDM symbols (other than those in the PRS subframes).
Reference cell		Cell 1		Cell 1 on RF channel number 1
Neighbour cell		Cell 2		Cell 2 on RF channel number 2
E-UTRA RF Channel Number		1,2		Two TDD carrier frequencies are used.
Channel Bandwidth (BW_{channel})	MHz	1.4	10	
PRS Bandwidth ^{Note 2}	RB	6	50	
GapOffset		34	13	For Cell 1
Gap Pattern ID		0		For Cell 1
Special subframe configuration		6		As specified in table 4.2-1 in TS 36.211 [26]. The same configuration in both cells.
Uplink-downlink configuration		3	1	As specified in table 4.2-2 in TS 36.211 [26] and table 9.1.2.3-2. The same configuration in both cells.
PRS configuration Index I_{PRS} ^{Note 2}		Cell 1: 15 Cell 2: 35	Cell 1: 4 Cell 2: 14	As defined in 3GPP TS 36.211 [26]
PRS subframe offset		20	10	For Cell 2
Number of consecutive positioning downlink subframes N_{PRS} ^{Note 2}		6	1	As defined in 3GPP TS 36.211 [26]
prs-MutingInfo ^{Note 2}		Cell 1:'1111111100000000' Cell 2:'1111111100000000'		See section 6.5.1.2 in 3GPP TS 36.355 [4] for more information

Cell ID ^{Note 2}		Cell 1: 0 Cell 2: 1		
Expected RSTD ^{Note 1}	μs	Cell 2: 1 Other neighbour cells: randomly between -3 and 3	The expected RSTD is what is expected at the receiver. The corresponding parameter in the OTDOA assistance data specified in TS 36.355 [4] is the expectedRSTD indicator	
Expected RSTD uncertainty for all neighbour cells ^{Note 1}	μs	5	The corresponding parameter in the OTDOA assistance data specified in TS 36.355 [4] is the expectedRSTD-Uncertainty index	
CP length ^{Note 2}		Normal		
DRX		OFF		
Radio frame receive time offset between the cells at the UE antenna connector ^{Note 3}	μs	Cell 2 to Cell 1: 3	Cell 2 to Cell 1: -3	PRS are transmitted from synchronous cells
Number of cells provided in OTDOA assistance data		16		The list includes the reference cell (received in <i>OTDOA-ReferenceCellInfo</i> [4]) on RF channel 1 and 15 other cells on RF channel 2, all received in <i>OTDOA-ProvideAssistanceData</i> [4].
$T_{RSTD}^{InterFreqDD-E-UTRAN}$ ^{Note 4}	ms	10240		Derived according to the RSTD measurement requirements specified in Section 8.1.2.6.7 in TS 36.133 [23].
<p>NOTE 1: Parameters “Expected RSTD” and “Expected RSTD uncertainty for all neighbour cells” are not settable parameters. These are parameters signalled in LPP only. For the values to be used in LPP see Table 9.2.5.4.3-4 and TS 37.571-5 [20], clause 7.2.2.</p> <p>NOTE 2: Parameters “PRS Bandwidth”, “PRS configuration index”, “Number of consecutive positioning downlink subframes”, “prs-MutingInfo”, “Cell ID” and “CP length” are settable parameters and also parameters signalled in LPP. For all the values to be used in LPP see Table 9.2.5.4.3-4 and TS 37.571-5 [20], clause 7.2.2.</p> <p>NOTE 3: The parameter “Radio frame receive time offset between the cells at the UE antenna connector” is not a settable parameter but is used to set the “true RSTD” values in step 6 of clause 9.2.5.4.1.</p> <p>NOTE 4: The parameter “$T_{RSTD}^{InterFreqDD-E-UTRAN}$” is not a settable parameter but is used to set the LPP “time” value in Table 9.2.5A.4.3-3. The value of the LPP time IE is set to $T_{RSTD}^{InterFreqDD-E-UTRAN} + \Delta T$ ms, where $\Delta T = 150$ ms, giving a value of 10390 ms. This is rounded up to the next allowed LPP value of 11 seconds.</p>				

9.2.5A.4.2 Test procedure

Same as 9.2.5.4.2.

9.2.5A.4.3 Message contents

Same as 9.2.5.4.3 with the following exceptions

Table 9.2.5A.4.3-1: LPP RequestLocationInformation

Derivation Path: Table 9.2.5.4.3-2			
Information Element	Value/remark	Comment	Condition
LPP-Message ::= SEQUENCE {			
lpp-MessageBody CHOICE {			
c1 CHOICE {			
requestLocationInformation SEQUENCE {			
criticalExtensions CHOICE {			
c1 CHOICE {			
requestLocationInformation-r9 SEQUENCE {			
commonIEsRequestLocationInformation SEQUENCE {			
qos SEQUENCE {			
responseTime SEQUENCE {			
time	11	See Note 4 of Table 9.2.5A.4.1-1	
}			
}			
}			
}			
}			

}			
}			
}			
}			
}			

9.2.5A.5 Test requirement

Same as 9.2.5.5.

9.3 RSTD Intra-Frequency Measurements for UE Category M1/M2

9.3.1 FDD intra-frequency RSTD Measurement Reporting Delay in CE Mode A

9.3.1.1 FDD intra-frequency RSTD Measurement Reporting Delay in CE Mode A for Category M1

9.3.1.1.1 Test purpose

To verify that the RSTD measurement reporting delay for UE Category M1 meets the performance requirements in normal coverage mode in an environment with fading propagation conditions.

9.3.1.1.2 Test applicability

This test applies to E-UTRA FDD UE Category M1 release 14 and forward that supports UE-assisted OTDOA.

9.3.1.1.3 Minimum conformance requirements

When the physical layer cell identities of neighbour cells together with the OTDOA assistance data are provided, the UE shall be able to detect and measure intra-frequency RSTD, specified in 3GPP TS 36.214 [6], for at least $n=16$ cells, including the reference cell, on the same carrier frequency f_1 as that of the reference cell within $T_{\text{RSTD IntraFreqFDD, Cat_M}}$ ms as given below (see also Figure 9.3.1.1.3-1):

$$T_{\text{RSTD IntraFreqFDD, Cat_M}} = T_{\text{PRS}} \cdot (M - 1) + \Delta + T_{\text{MIB}} \text{ ms,}$$

where

$T_{\text{RSTD IntraFreqFDD, Cat_M}}$ is the total time for detecting and measuring at least n cells,

T_{PRS} is the cell-specific positioning subframe configuration period as defined in 3GPP TS 36.211 [26] for UE not configured with measurement gaps for intra-frequency RSTD. For UE configured with measurement gaps for intra-frequency RSTD measurements, $T_{\text{PRS}} = \max(T_{\text{PRS}}, \text{MGRP})$, where MGRP is the Measurement Gap Repetition Period as defined in section 8.1.2.1 of TS 36.133 [23].

M is the number of PRS positioning occasions as defined in Table 9.3.1.1.3-1, , where downlink positioning subframes defined in TS 36.211 [16],

$\Delta = T_{\text{PRS}} \cdot \left\lceil \frac{n}{M} \right\rceil$ ms is the measurement time for a single PRS positioning occasion which includes the sampling time and the processing time,

N_{PRS} is the cell-specific number of PRS subframes within a PRS occasion as defined in TS36.355 [4],

$N_{\text{actual_PRS}}$ is the cell-specific number of PRS subframes within a PRS occasion; $N_{\text{actual_PRS}} = N_{\text{PRS}}$ for UE not configured with measurement gaps for intra-frequency RSTD measurements; for UE configured with measurement gaps for intra-frequency RSTD measurements $N_{\text{actual_PRS}}$ is the number of PRS subframes which can be measured by UE within MGL, where $N_{\text{actual_PRS}} = (MGL-2)$ if $\text{MGRP} \geq N_{\text{PRS}} > (MGL-2)$, $N_{\text{actual_PRS}} = (MGL-2) \cdot \left\lfloor \frac{N_{\text{PRS}}}{\text{MGRP}} \right\rfloor$ if $N_{\text{PRS}} > \text{MGRP}$, and $N_{\text{actual_PRS}} = N_{\text{PRS}}$ if $N_{\text{PRS}} \leq (MGL-2)$.

$N_{\text{PRS_total}}$ is the minimum number of PRS subframes per cell measurement as specified in TS 36.133 [23] Section 9.1.21.20.

T_{PRS} , N_{PRS} , and N_{PRS_total} are the parameters of the same cell, for which $T_{PRS} \cdot \left\lceil \frac{N_{PRS_total}}{N_{actual_PRS}} \right\rceil$ is the largest among all the measured cells.

T_{MIB} is the time required for acquiring the MIB information of the target cell. $T_{MIB} = 0$ if the SFN of at least one cell in OTDOA assistance data is known to the UE.

Table 9.3.1.1.3-1: Number of PRS positioning occasions within $T_{RSTD \text{ IntraFreqFDD, Cat}_M}$

Positioning subframe configuration period T_{PRS}	Number of PRS positioning occasions M
	f1 <small>Note 1</small>
160 ms	$16 \cdot \left\lceil \frac{N_{PRS_Total}}{N_{actual_PRS}} \right\rceil$
>160 ms	$8 \cdot \left\lceil \frac{N_{PRS_Total}}{N_{actual_PRS}} \right\rceil$
Note 1: When only intra-frequency RSTD measurements are performed over cells belonging to the serving FDD carrier frequency f1.	

The UE physical layer shall be capable of reporting RSTD for the reference cell and all the neighbour cells i out of at least $(n-1)$ neighbour cells within $T_{RSTD \text{ IntraFreqFDD, Cat}_M}$ provided:

$$\left(\text{PRS } \hat{E}_s / \text{Iot} \right)_{ref} \geq -6 \text{ dB for all Frequency Bands for the reference cell,}$$

$$\left(\text{PRS } \hat{E}_s / \text{Iot} \right)_i \geq -13 \text{ dB for all Frequency Bands for neighbour cell } i,$$

$$\left(\text{PRS } \hat{E}_s / \text{Iot} \right)_{ref} \text{ and } \left(\text{PRS } \hat{E}_s / \text{Iot} \right)_i \text{ conditions apply for all subframes of at least } L = \frac{M}{2} \text{ PRS positioning}$$

occasions,

PRP 1,2_{dBm} according to clause E.2 for a corresponding Band.

$\text{PRS } \hat{E}_s / \text{Iot}$ is defined as the ratio of the average received energy per PRS RE during the useful part of the symbol to the average received power spectral density of the total noise and interference for this RE, where the ratio is measured over all REs which carry PRS.

The time $T_{RSTD \text{ IntraFreqFDD, Cat}_M}$ starts from the first subframe of the PRS positioning occasion closest in time after both the OTDOA-RequestLocationInformation message and the OTDOA assistance data in the OTDOA-ProvideAssistanceData message as specified in 3GPP TS 36.355 [4], are delivered to the physical layer of the UE as illustrated in Figure 9.3.1.1.3-1.

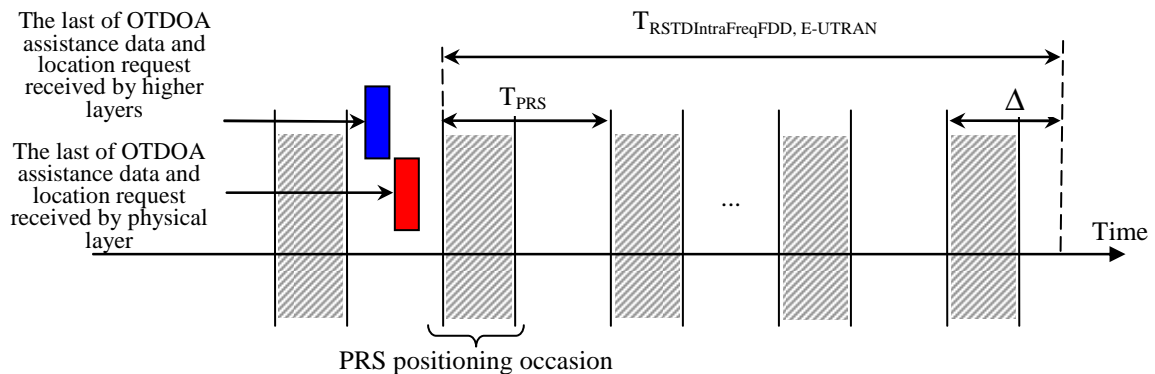

Figure 9.3.1.1.3-1: Illustration of the RSTD reporting time requirement in an FDD system

This requirement assumes that the measurement report is not delayed by other LPP signalling on the DCCH. This measurement reporting delay excludes a delay uncertainty resulted when inserting the measurement report to the TTI of the uplink DCCH. The delay uncertainty is $N_{rep} \times TTI_{DCCH}$, where N_{rep} is the maximum number of PUSCH repetitions configured for the UE, otherwise uncertainty is defined as $2 \times TTI_{DCCH}$. This measurement reporting delay excludes any delay caused by no UL resources for UE to send the measurement report.

The normative reference for this requirement is TS 36.133 [23] clause 8.13.2.3.1 and A.8.12.3.

9.3.1.1.4 Test description

9.3.1.1.4.1 Initial conditions

Test Environment: Normal; as defined in TS 36.508 [18] clause 4.1.

Frequencies to be tested: Mid Range, as defined in TS 36.508 [18] clause 4.3.1.1.

Channel bandwidth to be tested: 10 MHz as defined in TS 36.508 [18] clause 4.3.1.

1. Connect the SS, faders and AWGN noise sources to the UE antenna connector or antenna connectors as shown in Annex A, Figure A.4 using only the main Tx/Rx antenna of the UE.
2. The general test parameter settings are set up according to Table 9.3.1.1.4.1-1.
3. Propagation conditions are set according to clause 4.7.2.1.
4. Message contents are defined in clause 9.3.1.1.4.3.
5. In the test there are three synchronized cells: Cell 1, Cell 2 and Cell 3. Cell 1 is the OTDOA assistance data reference as well as the serving cell. Cell 2 and Cell 3 are the neighbour cells. All cells are on the same RF channel. Cell 3 in the test is the Cell 4 defined in clause 4.7.1. The assistance data neighbour cell list includes in total 15 cells, where 13 of the cells are not simulated (dummy cells; as defined in 3GPP TS 37.571-5 clause 7.2.5).
6. The true RSTD (which is the receive time difference for frame 0 between two cells as seen at the UE antenna connector) is set to 31 Ts (about 1 μ s) between neighbour Cell 2 and serving Cell 1; and set to -31 Ts (about -1 μ s) between neighbour Cell 3 and serving Cell 1.

Table 9.3.1.1.4.1-1: General test parameters for E-UTRAN FDD intra-frequency RSTD measurement reporting delay under fading propagation conditions

Parameter	Unit	Value	Comment
Reference cell		Cell 1	Reference cell is the cell in the OTDOA assistance data with respect to which the RSTD measurement is defined, as specified in 3GPP TS 36.214 [6] and 3GPP TS 36.355 [4]. The reference cell is the serving cell in this test case.
Neighbour cells		Cell 2 and Cell 3	Cell 2 and Cell 3 appear at random places in the neighbour cell list in the OTDOA assistance data, but Cell 2 always appears in the first half of the list, whilst Cell 3 appears in the second half of the list.
MPDCCH		DL Reference Measurement Channel R.16 FDD	As specified in TS 36.521-3 [25] clause A.7.1
$mPDCCH\text{-startSF-U ESS}$		10	Parameter G in $T = r_{\max} \cdot G$ which determines subframe $k0$ in which MPDCCH starts
Channel Bandwidth (BW _{channel})	MHz	10	

PRS Transmission Bandwidth ^{Note 2}	RB	50 ^{Note 4}	PRS are transmitted over the system bandwidth
PRS configuration index I_{PRS} ^{Note 2}		311	This corresponds to periodicity of 320 ms and PRS subframe offset of $I_{PRS} - 160$ DL subframes, as defined in 3GPP TS 36.211 [26], Table 6.10.4.3-1
Number of consecutive downlink positioning subframes N_{PRS} ^{Note 2}		6	As defined in 3GPP TS 36.211 [26]. The number of subframes in a positioning occasion
Physical cell ID PCI ^{Note 2}		(PCI of Cell 1 – PCI of Cell 2) mod 6 = 0 and (PCI of Cell 1 – PCI of Cell 3) mod 6 = 0	The cell PCIs are selected such that the relative shifts of PRS patterns among cells are as given by the test parameters
CP length ^{Note 2}		Normal	
DRX		ON	DRX parameters are further specified in Table 9.3.1.1.4.1-2
Radio frame receive time offset between the cells at the UE antenna connector ^{Note 3}	µs	Cell 2 to Cell 1: 1 Cell 3 to Cell 1: -1	PRS are transmitted from synchronous cells
Expected RSTD ^{Note 1}	µs	Cell 2: 3 Cell 3: 3 Other neighbour cells: randomly between -3 and 3	The expected RSTD is what is expected at the receiver. The corresponding parameter in the OTDOA assistance data specified in TS 36.355 [4] is the expectedRSTD indicator
Expected RSTD uncertainty for all neighbour cells ^{Note 1}	µs	5	The corresponding parameter in the OTDOA assistance data specified in TS 36.355 [4] is the expectedRSTD-Uncertainty index
Number of cells provided in OTDOA assistance data		16	Including the reference cell
PRS muting info ^{Note 2}		Cell 1: '11110000' Cell 2: '00001111' Cell 3: '11110000'	Corresponds to prs-MutingInfo defined in TS 36.355 [4]
T1	s	3	The length of the time interval from the beginning of each test
T2	s	2.56	The length of the time interval that follows immediately after time interval T1
T3	s	2.56	The length of the time interval that follows immediately after time interval T2
<p>Note 1: Parameters “Expected RSTD” and “Expected RSTD uncertainty for all neighbour cells” are not settable parameters. These are parameters signalled in LPP only. For the values to be used in LPP see Table 9.3.1.1.4.3-5 and TS 37.571-5 [20], clause 7.2.5.</p> <p>Note 2: Parameters “PRS Transmission Bandwidth”, “PRS configuration index”, “Number of consecutive downlink positioning subframes”, “Physical cell ID PCI”, “CP length”, and “PRS muting info” are settable parameters and also parameters signalled in LPP. The values to be used for “Physical cell ID PCI” are as follows: Cell 1: 0, Cell 2: 6, Cell 3: 12. For all the values to be used in LPP see Table 9.3.1.1.4.3-5 and TS 37.571-5 [20], clause 7.2.5.</p> <p>Note 3: The parameter “Radio frame receive time offset between the cells at the UE antenna connector” is not a settable parameter but is used to set the “true RSTD” values in step 6 of clause 9.3.1.1.4.1.</p> <p>Note 4: If the PRS transmission bandwidth is larger than the UE RF bandwidth, the UE is measuring RSTD within its RF bandwidth.</p>			

Table 9.3.1.1.4.1-2: DRX parameters for E-UTRAN FDD intra-frequency RSTD measurement reporting delay under fading propagation conditions

Field	Value	Comment
onDurationTimer	psf1	As specified in 3GPP TS 36.331 [22], clause 6.3.2
drx-InactivityTimer	psf1	
drx-RetransmissionTimer	sf1	
longDRX-CycleStartOffset	sf320	

shortDRX	Disable	
----------	---------	--

9.3.1.1.4.2 Test procedure

The test consists of three consecutive time intervals, with duration of T1, T2 and T3 defined in Table 9.3.1.1.4.1-1. Cell 1 is active in T1, T2 and T3, whilst Cell 2 and Cell 3 are activated only in the beginning of T2. Cell 2 is active until the end of T3, and Cell 3 is active until the end of T2. The beginning of the time interval T2 shall be aligned 5 ms before the first PRS positioning subframe of a positioning occasion in the reference cell, where 5 ms is the necessary test tolerance. Cell 1 transmits PRS in T2, while Cell 2 transmits PRS only in T3, and Cell 3 transmits PRS only in T2.

NOTE: The information on when PRS is muted is conveyed to the UE using PRS muting information in the OTDOA assistance data.

The OTDOA-RequestLocationInformation message and the OTDOA assistance data as defined in clause 9.3.1.1.4.3 shall be provided to the UE during T1. The last TTI containing the OTDOA-RequestLocationInformation message shall be provided to the UE ΔT ms before the start of T2, where $\Delta T = 150$ ms is the maximum processing time of the OTDOA-RequestLocationInformation message and the OTDOA assistance data.

1. Ensure that the UE is in state Generic RB Established State 3A-RF-CE according to 3GPP TS 36.508 [18] clause 7.2A.3AA.
2. The SS shall send a RESET UE POSITIONING STORED INFORMATION message.
3. Set the parameters according to Table 9.3.1.1.5-1. Propagation conditions are set according to clause 4.7.2.2 (ETU30).
4. T1 starts.
5. The SS shall transmit an RRCConnectionReconfiguration message with the DRX configuration. PDCCHs indicating new transmissions shall be sent continuously until the start of T2 to ensure that the UE would not enter the DRX state before T2.
6. The UE shall transmit RRCConnectionReconfigurationComplete message.
- 6a. The SS shall transmit an LPP REQUEST CAPABILITIES message.
- 6b. The UE shall transmit an LPP PROVIDE CAPABILITIES message indicating the OTDOA capabilities supported by the UE in the *OTDOA-ProvideCapabilities* IE.
7. The SS shall send a LPP PROVIDE ASSISTANCE DATA message, including the *OTDOA-ProvideAssistanceData* IE. The position of neighbour Cell 2 in the *OTDOA-NeighbourCellInfoList* is randomly selected to be in the first 7 elements of the sequence, and the position of neighbour Cell 3 is randomly selected to be in the last 8 elements of the sequence, as described in 3GPP TS 37.571-5 [20], clause 7.2.3. If the UE message at step 6b includes the *ackRequested* IE set to TRUE, then the SS shall send an acknowledgment in the LPP PROVIDE ASSISTANCE DATA message.
8. The SS shall send a LPP REQUEST LOCATION INFORMATION message, including the *OTDOA-RequestLocationInformation* IE such that the UE receives the message ΔT ms before the start of T2, where $\Delta T = 150$ ms.
9. When T1 expires, the SS shall switch the power setting from T1 to T2 as specified in Table 9.3.1.1.5-2.
10. When T2 expires, the SS shall switch the power setting from T2 to T3 as specified in Table 9.3.1.1.5-2.
11. The UE shall transmit a LPP PROVIDE LOCATION INFORMATION message including the *OTDOA-ProvideLocationInformation* IE within the response time (see clause 4.7.3) specified in clause 9.3.1.1.5. The UE shall perform and report the RSTD measurements for both Cell 2 and Cell 3 with respect to the reference cell in the OTDOA assistance data, Cell 1. If the UE transmits an *OTDOA-ProvideLocationInformation* IE including the *rstd* field for both Cell 2 and Cell 3 within the response time then the number of successful tests is increased by one. If the UE fails to report the *OTDOA-ProvideLocationInformation* IE with both the *rstd* fields included within the response time then the number of failure tests is increased by one.

- 12. If the UE message at step 11 includes the *ackRequested* IE set to TRUE, the SS shall send a LPP acknowledgement message.
- 13. Repeat steps 2-12 until the confidence level according to Annex D is achieved. For each iteration, at step 7 change the random position of the Cells 2 and 3 in the *OTDOA-NeighbourCellInfoList*.

9.3.1.1.4.3 Message contents

Table 9.3.1.1.4.3-1: RESET UE POSITIONING STORED INFORMATION

Derivation Path: 36.509 [11] clause 6.9			
Information Element	Value/remark	Comment	Condition
UE Positioning Technology	0 0 0 0 0 0 1	OTDOA	

Table 9.3.1.1.4.3-2: MAC-MainConfig-RBC: FDD RSTD Measurement Reporting Delay

Derivation Path: TS 36.508 [18] clause 4.8.2.1.5, Table 4.8.2.1.5-1 MAC-MainConfig-RBC			
Information Element	Value/remark	Comment	Condition
MAC-MainConfig-RBC ::= SEQUENCE {			
drx-Config CHOICE {			
setup SEQUENCE {			
onDurationTimer	psf1		
drx-InactivityTimer	psf1		
drx-RetransmissionTimer	sf1		
longDRX-CycleStartOffset CHOICE {			
sf320	0		
}			
shortDRX	Not present		
}			
}			
}			

Table 9.3.1.1.4.3-3: LPP Request Capabilities

Information Element	Value/remark
<i>otdoa-RequestCapabilities</i>	TRUE

Table 9.3.1.1.4.3-4: LPP RequestLocationInformation

Derivation Path: 36.355 clause 6.2			
Information Element	Value/remark	Comment	Condition
LPP-Message ::= SEQUENCE {			
transactionID SEQUENCE {			
initiator	locationServer		
transactionNumber	1		
}			
endTransaction	FALSE		
sequenceNumber	Not present		
acknowledgement	Not present		
lpp-MessageBody CHOICE {			
c1 CHOICE {			
requestLocationInformation SEQUENCE {			
criticalExtensions CHOICE {			
c1 CHOICE {			
requestLocationInformation-r9 SEQUENCE {			
commonIEsRequestLocationInformation SEQUENCE {			
locationInformationType	locationMeasurementsRequired		
triggeredReporting	Not present		
periodicalReporting	Not present		
additionalInformation	onlyReturnInformationRequested		
}			
}			
}			
}			
}			
}			

qos SEQUENCE {			
horizontalAccuracy	Not present		
verticalCoordinateRequest	FALSE		
verticalAccuracy	Not present		
responseTime SEQUENCE {			
time	6	See clause 9.3.1.1.5	
responseTimeEarlyFix-r12	Not present		Rel-12 onwards
}			
velocityRequest	FALSE		
}			
environment	Not present		
locationCoordinateTypes	Not present		
velocityTypes	Not present		
}			
a-gnss-RequestLocationInformation	Not present		
otdoa-RequestLocationInformation			
SEQUENCE {			
assistanceAvailability	FALSE		
}			
ecid-RequestLocationInformation	Not present		
epdu-RequestLocationInformation	Not Present		
}			
}			
}			
}			
}			
}			
}			
}			
}			

Table 9.3.1.1.4.3-5: LPP ProvideAssistanceData

Derivation Path: 36.355 clause 6.2			
Information Element	Value/remark	Comment	Condition
LPP-Message ::= SEQUENCE {			
transactionID SEQUENCE {			
Initiator	locationServer		
transactionNumber	(0..255)		
}			
endTransaction	TRUE		
sequenceNumber	Not present		
acknowledgement	Not present		
lpp-MessageBody CHOICE {			
c1 CHOICE {			
provideAssistanceData SEQUENCE {			
criticalExtensions CHOICE {			
c1 CHOICE {			
provideAssistanceData-r9 SEQUENCE {			
commonIEsProvideAssistanceData	Not present		
a-gnss-ProvideAssistanceData	Not present		
otdoa-ProvideAssistanceData SEQUENCE {			
otdoa-ReferenceCellInfo	As defined in TS 37.571-5 [20], clause 7.2.5.		
otdoa-NeighbourCellInfo	As defined in TS 37.571-5 [20], clause 7.2.5.		
otdoa-Error	Not present		
}			
epdu-ProvideAssistanceData	Not present		
}			
}			
}			
}			

}		
}		

9.3.1.1.5 Test requirement

Table 9.3.1.1.5-1 and 9.3.1.1.5-2 define the primary level settings including test tolerances for the test.

Table 9.3.1.1.5-1: Cell-specific test parameters for E-UTRAN FDD intra-frequency RSTD measurement reporting delay under fading propagation conditions during T1

Parameter	Unit	Cell 1	Cell 2	Cell 3
E-UTRA RF Channel Number		1	1	1
Correlation Matrix and Antenna Configuration		1x1	1x1	1x1
OCNG patterns defined in TS 36.521-3 [25] clause D.1		OP.21 FDD	N/A	N/A
PBCH_RA	dB	0	N/A	N/A
PBCH_RB				
PSS_RA				
SSS_RA				
PCFICH_RB				
PHICH_RA				
PHICH_RB				
PDCCH_RA				
PDCCH_RB				
OCNG_RA ^{Note 1}				
OCNG_RB ^{Note 1}				
N_{oc} ^{Note 3}	dBm/15 kHz	-95		
PRS \hat{E}_s/N_{oc}	dB	-Infinity	-Infinity	-Infinity
I_0 ^{Note 4}	dBm/9 MHz	-67.22	N/A	N/A
\hat{E}_s/N_{oc}	dB	0	-Infinity	-Infinity
Propagation Condition		ETU30		
Note 1: OCNG shall be used such that active cell (Cell 1) is fully allocated and a constant total transmitted power spectral density is achieved for all OFDM symbols. Note 2: The resources for uplink transmission are assigned to the UE prior to the start of time period T2. Note 3: Interference from other cells and noise sources not specified in the test are assumed to be constant over subcarriers and time and shall be modelled as AWGN of appropriate power for N_{oc} to be fulfilled. Note 4: I_0 levels have been derived from other parameters and are given for information purpose. These are not settable test parameters.				

Table 9.3.1.1.5-2: Cell-specific test parameters for E-UTRAN FDD intra-frequency RSTD measurement reporting delay under fading propagation conditions during T2 and T3

Parameter	Unit	Cell 1		Cell 2		Cell 3	
		T2	T3	T2	T3	T2	T3
E-UTRA RF Channel Number		1		1		1	
Correlation Matrix and Antenna Configuration		1x1		1x1		1x1	

OCNG patterns defined in TS 36.521-3 [25] clause D.1		OP.21 FDD		OP.6 FDD		OP.6 FDD	N/A
PBCH_RA	dB	0		0		0	N/A
PBCH_RB							
PSS_RA							
SSS_RA							
PCFICH_RB							
PHICH_RA							
PHICH_RB							
PDCCH_RA							
PDCCH_RB							
OCNG_RA ^{Note 1}							
OCNG_RB ^{Note 1}							
PRS_RA	dB	-3	N/A	N/A	3	3	N/A
N_{oc} ^{Note 3}	dBm/15 kHz	-98	-95	-98	-95	-98	-95
$PRS \hat{E}_s/N_{oc}$	dB	-1	-Infinity	-Infinity	-7	-7	-Infinity
$PRS \hat{E}_s/I_{ot}$ ^{Note 4}	dB	-1.79	-Infinity	-Infinity	-7	-9.54	-Infinity
I_o ^{Note 4}	dBm/9 MHz	-69.55	-67.08	-69.55	-67.08	-69.55	N/A
PRP ^{Note 4}	dBm/15 kHz	-99	-Infinity	-Infinity	-102	-105	-Infinity
RSRP ^{Note 4}	dBm/15 kHz	-96	-93	-105	-105	-108	-Infinity
\hat{E}_s/N_{oc} ^{Note 4}	dB	2	2	-7	-10	-10	-Infinity
Propagation Condition		ETU30					
<p>Note 1: OCNG shall be used such that active cells (all, except Cell 3 in T3) are fully allocated and a constant total transmitted power spectral density is achieved for all OFDM symbols other than those in the subframes with transmitted PRS.</p> <p>Note 2: The resources for uplink transmission are assigned to the UE prior to the start of time period T2.</p> <p>Note 3: Interference from other cells and noise sources not specified in the test are assumed to be constant over subcarriers and time and shall be modelled as AWGN of appropriate power for N_{oc} to be fulfilled.</p> <p>Note 4: If PRS_RA is not "N/A", \hat{E}_s/N_{oc}, $PRS \hat{E}_s/I_{ot}$, I_o, RSRP and PRP levels have been derived from other parameters and are given for information purpose. If PRS_RA is "N/A", I_o and RSRP levels have been derived from other parameters and are given for information purpose. These are not settable test parameters. Interference conditions shall be applied to all PRS symbols of DL positioning subframes.</p>							

The response time including test tolerance is 6.3 s. The response time is equal to the LPP time IE value plus the test tolerance. The LPP time IE value is derived from the RSTD reporting delay plus ΔT , where $\Delta T = N_{rep} \times TTI_{DCCH} = N_{rep} \times 75$ ms, giving a value of 5270 ms. This is rounded up to the next allowed LPP value of 6 seconds. The RSTD

measurement reporting delay in the test is derived from the following expression $T_{PRS} (M - 1) + 320 \cdot \left\lceil \frac{n}{M} \right\rceil$, where

$M = 16$ and $n = 16$ are the parameters specified in clause 9.3.1.1.3, Table 9.3.1.1.3-1 and Note 4 of Table 9.3.1.1.4.1-1. This gives the total RSTD reporting delay of 5210 ms for the 15 neighbour cells including Cell 2 and Cell 3 with respect to the reference cell, Cell 1.

The test tolerances are defined in clauses C.1.3 and C4.

The rate of successful tests during repeated tests shall be at least 90% with a confidence level of 95%.

9.3.1.2 FDD intra-frequency RSTD Measurement Reporting Delay in CE Mode A for Category M2

9.3.1.2.1 Test purpose

To verify that the RSTD measurement reporting delay for UE Category M2 meets the performance requirements in normal coverage mode in an environment with fading propagation conditions.

9.3.1.2.2 Test applicability

This test applies to E-UTRA FDD UE Category M2 release 14 and forward that supports UE-assisted OTDOA.

9.3.1.2.3 Minimum conformance requirements

Same as in clause 9.3.1.1.3.

The normative reference for this requirement is TS 36.133 [23] clause 8.16.2.3.1 and A.8.12.3.

9.3.1.2.4 Test description

9.3.1.2.4.1 Initial conditions

Same as in clause 9.3.1.1.4.1 but replacing Table 9.3.1.1.4.1-1 with Table 9.3.1.2.4.1-1.

Table 9.3.1.2.4.1-1: General test parameters for E-UTRAN FDD intra-frequency RSTD measurement reporting delay under fading propagation conditions

Parameter	Unit	Value		Comment
		Test 1	Test 2	
Reference cell		Cell 1		Reference cell is the cell in the OTDOA assistance data with respect to which the RSTD measurement is defined, as specified in 3GPP TS 36.214 [6] and 3GPP TS 36.355 [4]. The reference cell is the serving cell in this test case.
Neighbour cells		Cell 2 and Cell 3		Cell 2 and Cell 3 appear at random places in the neighbour cell list in the OTDOA assistance data, but Cell 2 always appears in the first half of the list, whilst Cell 3 appears in the second half of the list.
MPDCCH		DL Reference Measurement Channel R.16 FDD		As specified in TS 36.521-3 [25] clause A.7.1
$mPDCCH\text{-startSF-U ESS}$		10		Parameter G in $T = r_{\max} \cdot G$ which determines subframe k_0 in which MPDCCH starts
Channel Bandwidth (BW _{channel})	MHz	10		
PRS Transmission Bandwidth ^{Note 2}	RB	50 ^{Note 4}		PRS are transmitted over the system bandwidth
PRS configuration index I_{PRS} ^{Note 2}		311		This corresponds to periodicity of 320 ms and PRS subframe offset of $I_{\text{PRS}} - 160$ DL subframes, as defined in 3GPP TS 36.211 [26], Table 6.10.4.3-1
Number of consecutive downlink positioning subframes N_{PRS} ^{Note 2}		6	2	As defined in 3GPP TS 36.211 [26]. The number of subframes in a positioning occasion

Physical cell ID PCI ^{Note 2}		(PCI of Cell 1 – PCI of Cell 2) mod 6 = 0 and (PCI of Cell 1 – PCI of Cell 3) mod 6 = 0	The cell PCIs are selected such that the relative shifts of PRS patterns among cells are as given by the test parameters
CP length ^{Note 2}		Normal	
DRX		ON	DRX parameters are further specified in Table 9.3.1.1.4.1-2
Radio frame receive time offset between the cells at the UE antenna connector ^{Note 3}	μs	Cell 2 to Cell 1: 1 Cell 3 to Cell 1: -1	PRS are transmitted from synchronous cells
Expected RSTD ^{Note 1}	μs	Cell 2: 3 Cell 3: 3 Other neighbour cells: randomly between -3 and 3	The expected RSTD is what is expected at the receiver. The corresponding parameter in the OTDOA assistance data specified in TS 36.355 [4] is the expectedRSTD indicator
Expected RSTD uncertainty for all neighbour cells ^{Note 1}	μs	5	The corresponding parameter in the OTDOA assistance data specified in TS 36.355 [4] is the expectedRSTD-Uncertainty index
Number of cells provided in OTDOA assistance data		16	Including the reference cell
PRS muting info ^{Note 2}		Cell 1: '11110000' Cell 2: '00001111' Cell 3: '11110000'	Corresponds to prs-MutingInfo defined in TS 36.355 [4]
T1	s	3	The length of the time interval from the beginning of each test
T2	s	2.56	The length of the time interval that follows immediately after time interval T1
T3	s	2.56	The length of the time interval that follows immediately after time interval T2
<p>Note 1: Parameters "Expected RSTD" and "Expected RSTD uncertainty for all neighbour cells" are not settable parameters. These are parameters signalled in LPP only. For the values to be used in LPP see Table 9.3.1.1.4.3-5 and TS 37.571-5 [20], clause 7.2.5.</p> <p>Note 2: Parameters "PRS Transmission Bandwidth", "PRS configuration index", "Number of consecutive downlink positioning subframes", "Physical cell ID PCI", "CP length", and "PRS muting info" are settable parameters and also parameters signalled in LPP. The values to be used for "Physical cell ID PCI" are as follows: Cell 1: 0, Cell 2: 6, Cell 3: 12. For all the values to be used in LPP see Table 9.3.1.1.4.3-5 and TS 37.571-5 [20], clause 7.2.5.</p> <p>Note 3: The parameter "Radio frame receive time offset between the cells at the UE antenna connector" is not a settable parameter but is used to set the "true RSTD" values in step 6 of clause 9.3.1.1.4.1.</p> <p>Note 4: If the PRS transmission bandwidth is larger than the UE RF bandwidth, the UE is measuring RSTD within its RF bandwidth.</p>			

9.3.1.2.4.2 Test procedure

Same as in clause 9.3.1.1.4.2 but with the following additional step:

14. Repeat step 1-13 for each sub-test in Table 9.3.1.2.4.1-1 as appropriate

9.3.1.2.4.3 Message contents

Same as in clause 9.3.1.1.4.3.

9.3.1.2.5 Test requirement

Same as in clause 9.3.1.1.5.

For the overall test to pass, the ratio of successful reported values in each sub-test shall be more than 90% with a confidence level of 95%.

9.3.2 HD-FDD intra-frequency RSTD Measurement Reporting Delay in CE Mode A

9.3.2.1 HD-FDD intra-frequency RSTD Measurement Reporting Delay in CE Mode A for Category M1

9.3.2.1.1 Test purpose

To verify that the RSTD measurement reporting delay for UE Category M1 meets the performance requirements normal coverage mode in an environment with fading propagation conditions.

9.3.2.1.2 Test applicability

This test applies to E-UTRA HD-FDD UE Category M1 release 14 and forward that supports UE-assisted OTDOA.

9.3.2.1.3 Minimum conformance requirements

Same as in clause 9.3.1.1.3.

The normative reference for this requirement is TS 36.133 [23] clause 8.13.2.3.3 and A.8.12.4.

9.3.2.1.4 Test description

9.3.2.1.4.1 Initial conditions

Same as in clause 9.3.1.1.4.1 but replacing Table 9.3.1.1.4.1-1 with Table 9.3.2.1.4.1-1

Table 9.3.2.1.4.1-1: General test parameters for E-UTRAN HD-FDD intra-frequency RSTD measurement reporting delay under fading propagation conditions

Parameter	Unit	Value	Comment
Reference cell		Cell 1	Reference cell is the cell in the OTDOA assistance data with respect to which the RSTD measurement is defined, as specified in 3GPP TS 36.214 [6] and 3GPP TS 36.355 [4]. The reference cell is the serving cell in this test case.
Neighbour cells		Cell 2 and Cell 3	Cell 2 and Cell 3 appear at random places in the neighbour cell list in the OTDOA assistance data, but Cell 2 always appears in the first half of the list, whilst Cell 3 appears in the second half of the list.
MPDCCH		DL Reference Measurement Channel R.6 HD-FDD	As specified in TS 36.521-3 [25] clause A.7.2
$mPDCCH\text{-startSF-UeSS}$		10	Parameter G in $T = r_{\max} \cdot G$ which determines subframe $k0$ in which MPDCCH starts
Channel Bandwidth (BW_{channel})	MHz	10	
PRS Transmission Bandwidth ^{Note 2}	RB	50 ^{Note 4}	PRS are transmitted over the system bandwidth
PRS configuration index I_{PRS} ^{Note 2}		311	This corresponds to periodicity of 320 ms and PRS subframe offset of $I_{\text{PRS}} - 160$ DL subframes, as defined in 3GPP TS 36.211 [26], Table 6.10.4.3-1

Number of consecutive downlink positioning subframes N_{PRS} ^{Note 2}		6	As defined in 3GPP TS 36.211 [26]. The number of subframes in a positioning occasion
Physical cell ID PCI ^{Note 2}		(PCI of Cell 1 – PCI of Cell 2) mod 6 = 0 and (PCI of Cell 1 – PCI of Cell 3) mod 6 = 0	The cell PCIs are selected such that the relative shifts of PRS patterns among cells are as given by the test parameters
CP length ^{Note 2}		Normal	
DRX		ON	DRX parameters are further specified in Table 9.3.1.1.4.1-2
Radio frame receive time offset between the cells at the UE antenna connector ^{Note 3}	μs	Cell 2 to Cell 1: 1 Cell 3 to Cell 1: -1	PRS are transmitted from synchronous cells
Expected RSTD ^{Note 1}	μs	Cell 2: 3 Cell 3: 3 Other neighbour cells: randomly between -3 and 3	The expected RSTD is what is expected at the receiver. The corresponding parameter in the OTDOA assistance data specified in TS 36.355 [4] is the expectedRSTD indicator
Expected RSTD uncertainty for all neighbour cells ^{Note 1}	μs	5	The corresponding parameter in the OTDOA assistance data specified in TS 36.355 [4] is the expectedRSTD-Uncertainty index
Number of cells provided in OTDOA assistance data		16	Including the reference cell
PRS muting info ^{Note 2}		Cell 1: '11110000' Cell 2: '00001111' Cell 3: '11110000'	Corresponds to prs-MutingInfo defined in TS 36.355 [4]
T1	s	3	The length of the time interval from the beginning of each test
T2	s	2.56	The length of the time interval that follows immediately after time interval T1
T3	s	2.56	The length of the time interval that follows immediately after time interval T2
<p>Note 1: Parameters "Expected RSTD" and "Expected RSTD uncertainty for all neighbour cells" are not settable parameters. These are parameters signalled in LPP only. For the values to be used in LPP see Table 9.3.1.1.4.3-5 and TS 37.571-5 [20], clause 7.2.5.</p> <p>Note 2: Parameters "PRS Transmission Bandwidth", "PRS configuration index", "Number of consecutive downlink positioning subframes", "Physical cell ID PCI", "CP length", and "PRS muting info" are settable parameters and also parameters signalled in LPP. The values to be used for "Physical cell ID PCI" are as follows: Cell 1: 0, Cell 2: 6, Cell 3: 12. For all the values to be used in LPP see Table 9.3.1.1.4.3-5 and TS 37.571-5 [20], clause 7.2.5.</p> <p>Note 3: The parameter "Radio frame receive time offset between the cells at the UE antenna connector" is not a settable parameter but is used to set the "true RSTD" values in step 6 of clause 9.3.1.1.4.1.</p> <p>Note 4: If the PRS transmission bandwidth is larger than the UE RF bandwidth, the UE is measuring RSTD within its RF bandwidth.</p>			

9.3.2.1.4.2 Test procedure

Same as in clause 9.3.1.1.4.2.

9.3.2.1.4.3 Message contents

Same as in clause 9.3.1.1.4.3

9.3.2.1.5 Test requirement

Same as in clause 9.3.1.1.5.

9.3.2.2 HD-FDD intra-frequency RSTD Measurement Reporting Delay in CE Mode A for Category M2

9.3.2.2.1 Test purpose

To verify that the RSTD measurement reporting delay for UE Category M2 meets the performance requirements normal coverage mode in an environment with fading propagation conditions.

9.3.2.2.2 Test applicability

This test applies to E-UTRA HD-FDD UE Category M2 release 14 and forward that supports UE-assisted OTDOA.

9.3.2.2.3 Minimum conformance requirements

Same as in clause 9.3.1.1.3.

The normative reference for this requirement is TS 36.133 [23] clause 8.16.2.3.3 and A.8.12.4.

9.3.2.2.4 Test description

9.3.2.2.4.1 Initial conditions

Same as in clause 9.3.1.1.4.1 but replacing Table 9.3.1.1.4.1-1 with Table 9.3.2.2.4.1-1.

Table 9.3.2.2.4.1-1: General test parameters for E-UTRAN HD-FDD intra-frequency RSTD measurement reporting delay under fading propagation conditions

Parameter	Unit	Value		Comment
		Test 1	Test 2	
Reference cell		Cell 1		Reference cell is the cell in the OTDOA assistance data with respect to which the RSTD measurement is defined, as specified in 3GPP TS 36.214 [6] and 3GPP TS 36.355 [4]. The reference cell is the serving cell in this test case.
Neighbour cells		Cell 2 and Cell 3		Cell 2 and Cell 3 appear at random places in the neighbour cell list in the OTDOA assistance data, but Cell 2 always appears in the first half of the list, whilst Cell 3 appears in the second half of the list.
MPDCCH		DL Reference Measurement Channel R.6 HD-FDD		As specified in TS 36.521-3 [25] clause A.7.2
$mPDCCH\text{-startSF-U ESS}$		10		Parameter G in $T = r_{\max} \cdot G$ which determines subframe k_0 in which MPDCCH starts
Channel Bandwidth (BW_{channel})	MHz	10		
PRS Transmission Bandwidth ^{Note 2}	RB	50 ^{Note 4}		PRS are transmitted over the system bandwidth
PRS configuration index I_{PRS} ^{Note 2}		311		This corresponds to periodicity of 320 ms and PRS subframe offset of $I_{\text{PRS}} - 160$ DL subframes, as defined in 3GPP TS 36.211 [26], Table 6.10.4.3-1
Number of consecutive downlink positioning subframes N_{PRS} ^{Note 2}		6	2	As defined in 3GPP TS 36.211 [26]. The number of subframes in a positioning occasion

Physical cell ID PCI ^{Note 2}		(PCI of Cell 1 – PCI of Cell 2) mod 6 = 0 and (PCI of Cell 1 – PCI of Cell 3) mod 6 = 0	The cell PCIs are selected such that the relative shifts of PRS patterns among cells are as given by the test parameters
CP length ^{Note 2}		Normal	
DRX		ON	DRX parameters are further specified in Table 9.3.1.1.4.1-2
Radio frame receive time offset between the cells at the UE antenna connector ^{Note 3}	μs	Cell 2 to Cell 1: 1 Cell 3 to Cell 1: -1	PRS are transmitted from synchronous cells
Expected RSTD ^{Note 1}	μs	Cell 2: 3 Cell 3: 3 Other neighbour cells: randomly between -3 and 3	The expected RSTD is what is expected at the receiver. The corresponding parameter in the OTDOA assistance data specified in TS 36.355 [4] is the expectedRSTD indicator
Expected RSTD uncertainty for all neighbour cells ^{Note 1}	μs	5	The corresponding parameter in the OTDOA assistance data specified in TS 36.355 [4] is the expectedRSTD-Uncertainty index
Number of cells provided in OTDOA assistance data		16	Including the reference cell
PRS muting info ^{Note 2}		Cell 1: '11110000' Cell 2: '00001111' Cell 3: '11110000'	Corresponds to prs-MutingInfo defined in TS 36.355 [4]
T1	s	3	The length of the time interval from the beginning of each test
T2	s	2.56	The length of the time interval that follows immediately after time interval T1
T3	s	2.56	The length of the time interval that follows immediately after time interval T2
<p>Note 1: Parameters "Expected RSTD" and "Expected RSTD uncertainty for all neighbour cells" are not settable parameters. These are parameters signalled in LPP only. For the values to be used in LPP see Table 9.3.1.1.4.3-5 and TS 37.571-5 [20], clause 7.2.5.</p> <p>Note 2: Parameters "PRS Transmission Bandwidth", "PRS configuration index", "Number of consecutive downlink positioning subframes", "Physical cell ID PCI", "CP length", and "PRS muting info" are settable parameters and also parameters signalled in LPP. The values to be used for "Physical cell ID PCI" are as follows: Cell 1: 0, Cell 2: 6, Cell 3: 12. For all the values to be used in LPP see Table 9.3.1.1.4.3-5 and TS 37.571-5 [20], clause 7.2.5.</p> <p>Note 3: The parameter "Radio frame receive time offset between the cells at the UE antenna connector" is not a settable parameter but is used to set the "true RSTD" values in step 6 of clause 9.3.1.1.4.1.</p> <p>Note 4: If the PRS transmission bandwidth is larger than the UE RF bandwidth, the UE is measuring RSTD within its RF bandwidth.</p>			

9.3.2.2.4.2 Test procedure

Same as in clause 9.3.1.1.4.2 but with the following additional step:

14. Repeat step 1-13 for each sub-test in Table 9.3.2.2.4.1-1 as appropriate.

9.3.2.2.4.3 Message contents

Same as in clause 9.3.1.1.4.3.

9.3.2.2.5 Test requirement

Same as in clause 9.3.2.1.5.

For the overall test to pass, the ratio of successful reported values in each sub-test shall be more than 90% with a confidence level of 95%.

9.3.3 TDD intra-frequency RSTD Measurement Reporting Delay in CE Mode A

9.3.3.1 TDD intra-frequency RSTD Measurement Reporting Delay in CE Mode A for Category M1

9.3.3.1.1 Test purpose

To verify that the RSTD measurement reporting delay for UE Category M1 meets the performance requirements in normal coverage mode in an environment with fading propagation conditions.

9.3.3.1.2 Test applicability

This test applies to E-UTRA TDD UE Category M1 release 14 and forward that supports UE-assisted OTDOA.

9.3.3.1.3 Minimum conformance requirements

Same as in clause 9.3.1.1.3.

The intra-frequency requirements in this clause shall apply for all TDD special subframe configurations specified in TS 36.211 [26] and for the TDD uplink-downlink configurations as specified in Table 9.3.3.1.3-1.

Table 9.3.3.1.3-1: TDD uplink-downlink subframe configurations applicable for TDD intra-frequency requirements

PRS Transmission Bandwidth [RB]	Applicable TDD uplink-downlink configurations
6	1, 2, 3, 4 and 5
Note: Uplink-downlink configurations are specified in Table 4.2-2 in TS 36.211 [26].	

The normative reference for this requirement is TS 36.133 [23] clause 8.13.2.3.2 and A.8.12.5.

9.3.3.1.4 Test description

9.3.3.1.4.1 Initial conditions

Same as in clause 9.3.1.1.4.1 but replacing Table 9.3.1.1.4.1-1 with Table 9.3.3.1.4.1-1

Table 9.3.3.1.4.1-1: General test parameters for E-UTRAN TDD intra-frequency RSTD measurement reporting delay under fading propagation conditions

Parameter	Unit	Value	Comment
Reference cell		Cell 1	Reference cell is the cell in the OTDOA assistance data with respect to which the RSTD measurement is defined, as specified in 3GPP TS 36.214 [6] and 3GPP TS 36.355 [4]. The reference cell is the serving cell in this test case.
Neighbour cells		Cell 2 and Cell 3	Cell 2 and Cell 3 appear at random places in the neighbour cell list in the OTDOA assistance data, but Cell 2 always appears in the first half of the list, whilst Cell 3 appears in the second half of the list.
MPDCCH		DL Reference Measurement Channel R.14 TDD	As specified in TS 36.521-3 [25] clause A.7.3

<i>mPDCCH-startSF-UeSS</i>		10	Parameter G in $T = r_{\max} \cdot G$ which determines subframe $k0$ in which MPDCCH starts
Channel Bandwidth (BW_{channel})	MHz	10	
PRS Transmission Bandwidth ^{Note 2}	RB	50 ^{Note 4}	PRS are transmitted over the system bandwidth
PRS configuration index I_{PRS} ^{Note 2}		304	This corresponds to periodicity of 320 ms and PRS subframe offset of $I_{\text{PRS}} - 160$ DL subframes, as defined in 3GPP TS 36.211 [26], Table 6.10.4.3-1
Number of consecutive downlink positioning subframes N_{PRS} ^{Note 2}		6	As defined in 3GPP TS 36.211 [26]. The number of subframes in a positioning occasion
Physical cell ID PCI ^{Note 2}		(PCI of Cell 1 – PCI of Cell 2) mod 6 = 0 and (PCI of Cell 1 – PCI of Cell 3) mod 6 = 0	The cell PCIs are selected such that the relative shifts of PRS patterns among cells are as given by the test parameters
TDD uplink-downlink configuration		1	As specified in TS 36.211 [26], Clause 4.2; corresponds to a configuration with 5 ms switch-point periodicity and two downlink consecutive subframes
TDD special subframe configuration		6	As specified in TS 36.211 [26], Clause 4.2; corresponds to DwPTS of $19760 \cdot T_s$ and UpPTS of $4384 \cdot T_s$
CP length ^{Note 2}		Normal	
DRX		ON	DRX parameters are further specified in Table 9.3.1.1.4.1-2
Radio frame receive time offset between the cells at the UE antenna connector ^{Note 3}	μs	Cell 2 to Cell 1: 1 Cell 3 to Cell 1: -1	PRS are transmitted from synchronous cells
Expected RSTD ^{Note 1}	μs	Cell 2: 3 Cell 3: 3 Other neighbour cells: randomly between -3 and 3	The expected RSTD is what is expected at the receiver. The corresponding parameter in the OTDOA assistance data specified in TS 36.355 [4] is the expectedRSTD indicator
Expected RSTD uncertainty for all neighbour cells ^{Note 1}	μs	5	The corresponding parameter in the OTDOA assistance data specified in TS 36.355 [4] is the expectedRSTD-Uncertainty index
Number of cells provided in OTDOA assistance data		16	Including the reference cell
PRS muting info ^{Note 2}		Cell 1: '11110000' Cell 2: '00001111' Cell 3: '11110000'	Corresponds to prs-MutingInfo defined in TS 36.355 [4]
T1	s	3	The length of the time interval from the beginning of each test
T2	s	2.56	The length of the time interval that follows immediately after time interval T1
T3	s	2.56	The length of the time interval that follows immediately after time interval T2

Note 1:	Parameters “Expected RSTD” and “Expected RSTD uncertainty for all neighbour cells” are not settable parameters. These are parameters signalled in LPP only. For the values to be used in LPP see Table 9.3.1.1.4.3-5 and TS 37.571-5 [20], clause 7.2.5.
Note 2:	Parameters “PRS Transmission Bandwidth”, “PRS configuration index”, “Number of consecutive downlink positioning subframes”, “Physical cell ID PCI”, “CP length”, and “PRS muting info” are settable parameters and also parameters signalled in LPP. The values to be used for “Physical cell ID PCI” are as follows: Cell 1: 0, Cell 2: 6, Cell 3: 12. For all the values to be used in LPP see Table 9.3.1.1.4.3-5 and TS 37.571-5 [20], clause 7.2.5.
Note 3:	The parameter “Radio frame receive time offset between the cells at the UE antenna connector” is not a settable parameter but is used to set the “true RSTD” values in step 6 of clause 9.3.1.1.4.1.
Note 4:	If the PRS transmission bandwidth is larger than the UE RF bandwidth, the UE is measuring RSTD within its RF bandwidth.

9.3.3.1.4.2 Test procedure

Same as in clause 9.3.1.1.4.2.

9.3.3.1.4.3 Message contents

Same as in clause 9.3.1.1.4.3

9.3.3.1.5 Test requirement

Table 9.3.3.1.5-1 and 9.3.3.1.5-2 define the primary level settings including test tolerances for the test.

Table 9.3.3.1.5-1: Cell-specific test parameters for E-UTRAN TDD intra-frequency RSTD measurement reporting delay under fading propagation conditions during T1

Parameter	Unit	Cell 1	Cell 2	Cell 3
E-UTRA RF Channel Number		1	1	1
Correlation Matrix and Antenna Configuration		1x1	1x1	1x1
OCNG patterns defined in TS 36.521-3 [25] clause D.1		OP.11 TDD	N/A	N/A
PBCH_RA	dB	0	N/A	N/A
PBCH_RB				
PSS_RA				
SSS_RA				
PCFICH_RB				
PHICH_RA				
PHICH_RB				
PDCCH_RA				
PDCCH_RB				
OCNG_RA ^{Note 1}				
OCNG_RB ^{Note 1}				
N_{oc} ^{Note 3}	dBm/15 kHz	-95		
$PRS \hat{E}_s / N_{oc}$	dB	-Infinity	-Infinity	-Infinity
I_0 ^{Note 4}	dBm/9 MHz	-67.22	N/A	N/A
\hat{E}_s / N_{oc}	dB	0	-Infinity	-Infinity
Propagation Condition		ETU30		

Note 1:	OCNG shall be used such that active cell (Cell 1) is fully allocated and a constant total transmitted power spectral density is achieved for all OFDM symbols.
Note 2:	The resources for uplink transmission are assigned to the UE prior to the start of time period T2.
Note 3:	Interference from other cells and noise sources not specified in the test are assumed to be constant over subcarriers and time and shall be modelled as AWGN of appropriate power for N_{oc} to be fulfilled.
Note 4:	Io levels have been derived from other parameters and are given for information purpose. These are not settable test parameters.

Table 9.3.3.1.5-2: Cell-specific test parameters for E-UTRAN TDD intra-frequency RSTD measurement reporting delay under fading propagation conditions during T2 and T3

Parameter	Unit	Cell 1		Cell 2		Cell 3	
		T2	T3	T2	T3	T2	T3
E-UTRA RF Channel Number		1		1		1	
Correlation Matrix and Antenna Configuration		1x1		1x1		1x1	
OCNG patterns defined in TS 36.521-3 [25] clause D.1		OP.11 TDD		OP.2 TDD		OP.2 TDD	N/A
PBCH_RA	dB	0		0		0	N/A
PBCH_RB							
PSS_RA							
SSS_RA							
PCFICH_RB							
PHICH_RA							
PHICH_RB							
PDCCH_RA							
PDCCH_RB							
OCNG_RA ^{Note 1}							
OCNG_RB ^{Note 1}							
PRS_RA	dB	-3	N/A	N/A	3	3	N/A
N_{oc} ^{Note 3}	dBm/15 kHz	-98	-95	-98	-95	-98	-95
$PRS \hat{E}_s / N_{oc}$	dB	-1	-Infinity	-Infinity	-7	-7	-Infinity
$PRS \hat{E}_s / I_{ot}$ ^{Note 4}	dB	-1.79	-Infinity	-Infinity	-7	-9.54	-Infinity
I_o ^{Note 4}	dBm/9 MHz	-69.55	-67.08	-69.55	-67.08	-69.55	N/A
PRP ^{Note 4}	dBm/15 kHz	-99	-Infinity	-Infinity	-102	-105	-Infinity
RSRP ^{Note 4}	dBm/15 kHz	-96	-93	-105	-105	-108	-Infinity
\hat{E}_s / N_{oc} ^{Note 4}	dB	2	2	-7	-10	-10	-Infinity
Propagation Condition		ETU30					

Note 1:	OCNG shall be used such that active cells (all, except Cell 3 in T3) are fully allocated and a constant total transmitted power spectral density is achieved for all OFDM symbols other than those in the subframes with transmitted PRS.
Note 2:	The resources for uplink transmission are assigned to the UE prior to the start of time period T2.
Note 3:	Interference from other cells and noise sources not specified in the test are assumed to be constant over subcarriers and time and shall be modelled as AWGN of appropriate power for N_{oc} to be fulfilled.
Note 4:	If PRS_RA is not "N/A", \hat{E}_s/N_{oc} , PRS \hat{E}_s/I_{ot} , I_o , RSRP and PRP levels have been derived from other parameters and are given for information purpose. If PRS_RA is "N/A", I_o and RSRP levels have been derived from other parameters and are given for information purpose. These are not settable test parameters. Interference conditions shall be applied to all PRS symbols of DL positioning subframes.

The response time including test tolerance is 6.3 s. The response time is equal to the LPP time IE value plus the test tolerance. The LPP time IE value is derived from the RSTD reporting delay plus ΔT , where $\Delta T = N_{rep} \times TTI_{DCCH} = N_{rep} \times 75$ ms, giving a value of [5270] ms. This is rounded up to the next allowed LPP value of 6 seconds. The RSTD

measurement reporting delay in the test is derived from the following expression $T_{PRS} (M - 1) + 320 \cdot \left\lceil \frac{n}{M} \right\rceil$, where

$M = 16$ and $n = 16$ are the parameters specified in clause 9.3.1.1.3, Table 9.3.1.1.3-1 and Note 4 of Table 9.3.3.1.4.1-1. This gives the total RSTD reporting delay of [5210] ms for the 15 neighbour cells including Cell 2 and Cell 3 with respect to the reference cell, Cell 1.

The test tolerances are defined in clauses C.1.3 and C4.

The rate of successful tests during repeated tests shall be at least 90% with a confidence level of 95%.

9.3.3.2 TDD intra-frequency RSTD Measurement Reporting Delay in CE Mode A for Category M2

9.3.3.2.1 Test purpose

To verify that the RSTD measurement reporting delay for UE Category M2 meets the performance requirements in normal coverage mode in an environment with fading propagation conditions.

9.3.3.2.2 Test applicability

This test applies to E-UTRA TDD UE Category M2 release 14 and forward that supports UE-assisted OTDOA.

9.3.3.2.3 Minimum conformance requirements

Same as in clause 9.3.3.1.3.

The intra-frequency requirements in this clause shall apply for all TDD special subframe configurations specified in TS 36.211 [26] and for the TDD uplink-downlink configurations as specified in Table 9.3.3.2.3-1.

Table 9.3.3.2.3-1: TDD uplink-downlink subframe configurations applicable for TDD intra-frequency requirements

PRS Transmission Bandwidth [RB]	Applicable TDD uplink-downlink configurations
6	1, 2, 3, 4 and 5
24	0, 1, 2, 3, 4, 5 and 6
Note:	Uplink-downlink configurations are specified in Table 4.2-2 in TS 36.211 [26].

The normative reference for this requirement is TS 36.133 [23] clause 8.16.2.3.2 and A.8.12.5.

9.3.3.2.4 Test description

9.3.3.2.4.1 Initial conditions

Same as in clause 9.3.1.1.4.1 but replacing Table 9.3.1.1.4.1-1 with Table 9.3.3.2.4.1-1.

Table 9.3.3.2.4.1-1: General test parameters for E-UTRAN TDD intra-frequency RSTD measurement reporting delay under fading propagation conditions

Parameter	Unit	Value		Comment
		Test 1	Test 2	
Reference cell		Cell 1		Reference cell is the cell in the OTDOA assistance data with respect to which the RSTD measurement is defined, as specified in 3GPP TS 36.214 [6] and 3GPP TS 36.355 [4]. The reference cell is the serving cell in this test case.
Neighbour cells		Cell 2 and Cell 3		Cell 2 and Cell 3 appear at random places in the neighbour cell list in the OTDOA assistance data, but Cell 2 always appears in the first half of the list, whilst Cell 3 appears in the second half of the list.
MPDCCH		DL Reference Measurement Channel R.14 TDD		As specified in TS 36.521-3 [25] clause A.7.3
$mPDCCH\text{-startSF-UeSS}$		10		Parameter G in $T = r_{\max} \cdot G$ which determines subframe $k0$ in which MPDCCH starts
Channel Bandwidth (BW_{channel})	MHz	10		
PRS Transmission Bandwidth ^{Note 2}	RB	50 ^{Note 4}		PRS are transmitted over the system bandwidth
PRS configuration index I_{PRS} ^{Note 2}		304		This corresponds to periodicity of 320 ms and PRS subframe offset of $I_{\text{PRS}} - 160$ DL subframes, as defined in 3GPP TS 36.211 [26], Table 6.10.4.3-1
Number of consecutive downlink positioning subframes N_{PRS} ^{Note 2}		6	2	As defined in 3GPP TS 36.211 [26]. The number of subframes in a positioning occasion
Physical cell ID PCI ^{Note 2}		(PCI of Cell 1 – PCI of Cell 2) mod 6 = 0 and (PCI of Cell 1 – PCI of Cell 3) mod 6 = 0		The cell PCIs are selected such that the relative shifts of PRS patterns among cells are as given by the test parameters
TDD uplink-downlink configuration		1		As specified in TS 36.211 [26], Clause 4.2; corresponds to a configuration with 5 ms switch-point periodicity and two downlink consecutive subframes
TDD special subframe configuration		6		As specified in TS 36.211 [26], Clause 4.2; corresponds to DwPTS of $19760 \cdot T_s$ and UpPTS of $4384 \cdot T_s$
CP length ^{Note 2}		Normal		
DRX		ON		DRX parameters are further specified in Table 9.3.1.1.4.1-2
Radio frame receive time offset between the cells at the UE antenna connector ^{Note 3}	μs	Cell 2 to Cell 1: 1 Cell 3 to Cell 1: -1		PRS are transmitted from synchronous cells

Expected RSTD ^{Note 1}	μs	Cell 2: 3 Cell 3: 3 Other neighbour cells: randomly between -3 and 3	The expected RSTD is what is expected at the receiver. The corresponding parameter in the OTDOA assistance data specified in TS 36.355 [4] is the expectedRSTD indicator
Expected RSTD uncertainty for all neighbour cells ^{Note 1}	μs	5	The corresponding parameter in the OTDOA assistance data specified in TS 36.355 [4] is the expectedRSTD-Uncertainty index
Number of cells provided in OTDOA assistance data		16	Including the reference cell
PRS muting info ^{Note 2}		Cell 1: '11110000' Cell 2: '00001111' Cell 3: '11110000'	Corresponds to prs-MutingInfo defined in TS 36.355 [4]
T1	s	3	The length of the time interval from the beginning of each test
T2	s	2.56	The length of the time interval that follows immediately after time interval T1
T3	s	2.56	The length of the time interval that follows immediately after time interval T2
<p>Note 1: Parameters "Expected RSTD" and "Expected RSTD uncertainty for all neighbour cells" are not settable parameters. These are parameters signalled in LPP only. For the values to be used in LPP see Table 9.3.1.1.4.3-5 and TS 37.571-5 [20], clause 7.2.5.</p> <p>Note 2: Parameters "PRS Transmission Bandwidth", "PRS configuration index", "Number of consecutive downlink positioning subframes", "Physical cell ID PCI", "CP length", and "PRS muting info" are settable parameters and also parameters signalled in LPP. The values to be used for "Physical cell ID PCI" are as follows: Cell 1: 0, Cell 2: 6, Cell 3: 12. For all the values to be used in LPP see Table 9.3.1.1.4.3-5 and TS 37.571-5 [20], clause 7.2.5.</p> <p>Note 3: The parameter "Radio frame receive time offset between the cells at the UE antenna connector" is not a settable parameter but is used to set the "true RSTD" values in step 6 of clause 9.3.1.1.4.1.</p> <p>Note 4: If the PRS transmission bandwidth is larger than the UE RF bandwidth, the UE is measuring RSTD within its RF bandwidth.</p>			

9.3.3.2.4.2 Test procedure

Same as in clause 9.3.1.1.4.2 but with the following additional step:

14. Repeat step 1-13 for each sub-test in Table 9.3.2.2.4.1-1 as appropriate.

9.3.3.2.4.3 Message contents

Same as in clause 9.3.1.1.4.3.

9.3.3.2.5 Test requirement

Same as in clause 9.3.3.1.5.

For the overall test to pass, the ratio of successful reported values in each sub-test shall be more than 90% with a confidence level of 95%.

9.3.4 FDD intra-frequency RSTD Measurement Reporting Delay in CE Mode B

9.3.4.1 FDD intra-frequency RSTD Measurement Reporting Delay in CE Mode B for Category M1

9.3.4.1.1 Test purpose

To verify that the RSTD measurement reporting delay for UE Category M1 meets the performance requirements in enhanced coverage mode in an environment with fading propagation conditions.

9.3.4.1.2 Test applicability

This test applies to E-UTRA FDD UE Category M1 release 14 and forward that supports UE-assisted OTDOA and CE Mode B.

9.3.4.1.3 Minimum conformance requirements

Same as 9.3.1.1.3 with the following exceptions:

The conditions under which the UE physical layer shall be capable of reporting RSTD for the reference cell and all the neighbour cells i out of at least $(n-1)$ neighbour cells within $T_{RSTD \text{ IntraFreqFDD, Cat_M}}$ are changed:

$$\begin{aligned} & \left(PRS \hat{E}_s / Iot \right)_{ref} \geq -15 \text{ dB for all Frequency Bands for the reference cell,} \\ & \left(PRS \hat{E}_s / Iot \right)_i \geq -15 \text{ dB for all Frequency Bands for neighbour cell } i, \\ & \left(PRS \hat{E}_s / Iot \right)_{ref} \text{ and } \left(PRS \hat{E}_s / Iot \right)_i \text{ conditions apply for all subframes of at least } L = \frac{M}{2} \text{ PRS positioning} \end{aligned}$$

occasions,
PRP 1,2_{dBm} according to clause E.2 for a corresponding Band.

The normative reference for this requirement is TS 36.133 [23] clause 8.13.3.3.1 and A.8.12.6.

9.3.4.1.4 Test description

9.3.4.1.4.1 Initial conditions

Same as in clause 9.3.1.1.4.1 but replacing Table 9.3.1.1.4.1-1 with Table 9.3.4.1.4.1-1.

Table 9.3.4.1.4.1-1: General test parameters for E-UTRAN FDD intra-frequency RSTD measurement reporting delay under fading propagation conditions

Parameter	Unit	Value	Comment
Reference cell		Cell 1	Reference cell is the cell in the OTDOA assistance data with respect to which the RSTD measurement is defined, as specified in 3GPP TS 36.214 [6] and 3GPP TS 36.355 [4]. The reference cell is the serving cell in this test case.
Neighbour cells		Cell 2 and Cell 3	Cell 2 and Cell 3 appear at random places in the neighbour cell list in the OTDOA assistance data, but Cell 2 always appears in the first half of the list, whilst Cell 3 appears in the second half of the list.
MPDCCH		DL Reference Measurement Channel R.18 FDD	As specified in TS 36.521-3 [25] clause A.7.1

<i>mPDCCH-startSF-UeSS</i>		10	Parameter G in $T = r_{\max} \cdot G$ which determines subframe $k0$ in which MPDCCH starts
Channel Bandwidth (BW_{channel})	MHz	10	
PRS Transmission Bandwidth ^{Note 2}	RB	50 ^{Note 4}	PRS are transmitted over the system bandwidth
PRS configuration index I_{PRS} ^{Note 2}		311	This corresponds to periodicity of 320 ms and PRS subframe offset of $I_{\text{PRS}} - 160$ DL subframes, as defined in 3GPP TS 36.211 [26], Table 6.10.4.3-1
Number of consecutive downlink positioning subframes N_{PRS} ^{Note 2}		6	As defined in 3GPP TS 36.211 [26]. The number of subframes in a positioning occasion
Physical cell ID PCI ^{Note 2}		(PCI of Cell 1 – PCI of Cell 2) mod 6 = 0 and (PCI of Cell 1 – PCI of Cell 3) mod 6 = 0	The cell PCIs are selected such that the relative shifts of PRS patterns among cells are as given by the test parameters
CP length ^{Note 2}		Normal	
DRX		ON	DRX parameters are further specified in Table 9.3.1.1.4.1-2
Radio frame receive time offset between the cells at the UE antenna connector ^{Note 3}	μs	Cell 2 to Cell 1: 1 Cell 3 to Cell 1: -1	PRS are transmitted from synchronous cells
Expected RSTD ^{Note 1}	μs	Cell 2: 3 Cell 3: 3 Other neighbour cells: randomly between -3 and 3	The expected RSTD is what is expected at the receiver. The corresponding parameter in the OTDOA assistance data specified in TS 36.355 [4] is the expectedRSTD indicator
Expected RSTD uncertainty for all neighbour cells ^{Note 1}	μs	5	The corresponding parameter in the OTDOA assistance data specified in TS 36.355 [4] is the expectedRSTD-Uncertainty index
Number of cells provided in OTDOA assistance data		16	Including the reference cell
PRS muting info ^{Note 2}		Cell 1: '11110000' Cell 2: '00001111' Cell 3: '11110000'	Corresponds to prs-MutingInfo defined in TS 36.355 [4]
T1	s	3	The length of the time interval from the beginning of each test
T2	s	6.4	The length of the time interval that follows immediately after time interval T1
T3	s	6.4	The length of the time interval that follows immediately after time interval T2
Note 1:	Parameters "Expected RSTD" and "Expected RSTD uncertainty for all neighbour cells" are not settable parameters. These are parameters signalled in LPP only. For the values to be used in LPP see Table 9.3.1.1.4.3-5 and TS 37.571-5 [20], clause 7.2.5.		
Note 2:	Parameters "PRS Transmission Bandwidth", "PRS configuration index", "Number of consecutive downlink positioning subframes", "Physical cell ID PCI", "CP length", and "PRS muting info" are settable parameters and also parameters signalled in LPP. The values to be used for "Physical cell ID PCI" are as follows: Cell 1: 0, Cell 2: 6, Cell 3: 12. For all the values to be used in LPP see Table 9.3.1.1.4.3-5 and TS 37.571-5 [20], clause 7.2.5.		
Note 3:	The parameter "Radio frame receive time offset between the cells at the UE antenna connector" is not a settable parameter but is used to set the "true RSTD" values in step 6 of clause 9.3.1.1.4.1.		
Note 4:	If the PRS transmission bandwidth is larger than the UE RF bandwidth, the UE is measuring RSTD within its RF bandwidth.		

9.3.4.1.4.2 Test procedure

Same as in clause 9.3.1.1.4.2 but using condition CEModeB.

9.3.4.1.4.3 Message contents

Same as in clause 9.3.1.1.4.3 with the following exceptions:

Table 9.3.4.1.4.3-1: LPP RequestLocationInformation

Derivation Path: Table 9.3.1.1.4.3-4			
Information Element	Value/remark	Comment	Condition
LPP-Message ::= SEQUENCE {			
lpp-MessageBody CHOICE {			
c1 CHOICE {			
requestLocationInformation SEQUENCE {			
criticalExtensions CHOICE {			
c1 CHOICE {			
requestLocationInformation-r9 SEQUENCE {			
commonIEsRequestLocationInformation SEQUENCE {			
qos SEQUENCE {			
responseTime SEQUENCE {			
time	13	See clause 9.3.4.1.5	
}			
}			
}			
}			
}			
}			
}			
}			
}			

9.3.4.1.5 Test requirement

Table 9.3.4.1.5-1 and 9.3.4.1.5-2 define the primary level settings including test tolerances for the test.

Table 9.3.4.1.5-1: Cell-specific test parameters for E-UTRAN FDD intra-frequency RSTD measurement reporting delay under fading propagation conditions during T1

Parameter	Unit	Cell 1	Cell 2	Cell 3
E-UTRA RF Channel Number		1	1	1
Correlation Matrix and Antenna Configuration		1x1	1x1	1x1
OCNG patterns defined in TS 36.521-3 [25] clause D.1		OP.21 FDD	N/A	N/A
PBCH_RA	dB	0	N/A	N/A
PBCH_RB				
PSS_RA				
SSS_RA				
PCFICH_RB				
PHICH_RA				
PHICH_RB				
PDCCH_RA				
PDCCH_RB				
OCNG_RA ^{Note 1}				

OCNG_RB ^{Note 1}				
N_{oc} ^{Note 3}	dBm/ 15 kHz	-95		
PRS \hat{E}_s/N_{oc}	dB	-Infinity	-Infinity	-Infinity
I_o ^{Note 4}	dBm/ 9 MHz	-67.22	N/A	N/A
\hat{E}_s/N_{oc}	dB	0	-Infinity	-Infinity
Propagation Condition		ETU30		
<p>Note 1: OCNG shall be used such that active cell (Cell 1) is fully allocated and a constant total transmitted power spectral density is achieved for all OFDM symbols.</p> <p>Note 2: The resources for uplink transmission are assigned to the UE prior to the start of time period T2.</p> <p>Note 3: Interference from other cells and noise sources not specified in the test are assumed to be constant over subcarriers and time and shall be modelled as AWGN of appropriate power for N_{oc} to be fulfilled.</p> <p>Note 4: I_o levels have been derived from other parameters and are given for information purpose. These are not settable test parameters.</p>				

Table 9.3.4.1.5-2: Cell-specific test parameters for E-UTRAN FDD intra-frequency RSTD measurement reporting delay under fading propagation conditions during T2 and T3

Parameter	Unit	Cell 1		Cell 2		Cell 3	
		T2	T3	T2	T3	T2	T3
E-UTRA RF Channel Number		1		1		1	
Correlation Matrix and Antenna Configuration		1x1		1x1		1x1	
OCNG patterns defined in TS 36.521-3 [25] clause D.1		OP.21 FDD		OP.6 FDD		OP.6 FDD	N/A
PBCH_RA	dB	0		0		0	N/A
PBCH_RB							
PSS_RA							
SSS_RA							
PCFICH_RB							
PHICH_RA							
PHICH_RB							
PDCCH_RA							
PDCCH_RB							
OCNG_RA ^{Note 1}							
OCNG_RB ^{Note 1}							
PRS_RA	dB	-3	N/A	N/A	3	3	N/A
N_{oc} ^{Note 3}	dBm/ 15 kHz	-98	-95	-98	-95	-98	-95
PRS \hat{E}_s/N_{oc}	dB	-12	-Infinity	-Infinity	-13	-13	-Infinity
PRS \hat{E}_s/I_{ot} ^{Note 4}	dB	-12.21	-Infinity	-Infinity	-13	-13.27	-Infinity
I_o ^{Note 4}	dBm/ 9 MHz	-69.92	-67.18	-69.92	-67.18	-69.92	N/A
PRP ^{Note 4}	dBm/ 15 kHz	-110	-Infinity	-Infinity	-108	-111	-Infinity
RSRP ^{Note 4}	dBm/ 15 kHz	-107	-104	-111	-111	-114	-Infinity
\hat{E}_s/N_{oc} ^{Note 4}	dB	-9	-9	-13	-16	-16	-Infinity

Propagation Condition	ETU30
Note 1:	OCNG shall be used such that active cells (all, except Cell 3 in T3) are fully allocated and a constant total transmitted power spectral density is achieved for all OFDM symbols other than those in the subframes with transmitted PRS.
Note 2:	The resources for uplink transmission are assigned to the UE prior to the start of time period T2.
Note 3:	Interference from other cells and noise sources not specified in the test are assumed to be constant over subcarriers and time and shall be modelled as AWGN of appropriate power for N_{oc} to be fulfilled.
Note 4:	If PRS_RA is not "N/A", \hat{E}_s/N_{oc} , PRS \hat{E}_s/I_{ot} , I_o , RSRP and PRP levels have been derived from other parameters and are given for information purpose. If PRS_RA is "N/A", I_o and RSRP levels have been derived from other parameters and are given for information purpose. These are not settable test parameters. Interference conditions shall be applied to all PRS symbols of DL positioning subframes.

The response time including test tolerance is 13.3 s. The response time is equal to the LPP time IE value plus the test tolerance. The LPP time IE value is derived from the RSTD reporting delay plus ΔT , where $\Delta T = N_{rep} \times TTI_{DCCH} = N_{rep} \times 75$ ms, giving a value of 12950 ms. This is rounded up to the next allowed LPP value of 13 seconds. The RSTD

measurement reporting delay in the test is derived from the following expression $T_{PRS} (M - 1) + 320 \cdot \left\lceil \frac{n}{M} \right\rceil$, where

$M = 16$ and $n = 16$ are the parameters specified in clause 9.3.1.1.3, Table 9.3.1.1.3-1 and Note 4 of Table 9.3.4.1.4.1-1. This gives the total RSTD reporting delay of 12800 ms for the 15 neighbour cells including Cell 2 and Cell 3 with respect to the reference cell, Cell 1.

The test tolerances are defined in clauses C.1.3 and C4.

The rate of successful tests during repeated tests shall be at least 90% with a confidence level of 95%.

9.3.4.2 FDD intra-frequency RSTD Measurement Reporting Delay in CE Mode B for Category M2

9.3.4.2.1 Test purpose

To verify that the RSTD measurement reporting delay for UE Category M2 meets the performance requirements in enhanced coverage mode in an environment with fading propagation conditions.

9.3.4.2.2 Test applicability

This test applies to E-UTRA FDD UE Category M2 release 14 and forward that supports UE-assisted OTDOA and CE Mode B.

9.3.4.2.3 Minimum conformance requirements

Same as in clause 9.3.4.1.3.

The normative reference for this requirement is TS 36.133 [23] clause 8.16.3.1.1 and A.8.12.6.

9.3.4.2.4 Test description

9.3.4.2.4.1 Initial conditions

Same as in clause 9.3.1.1.4.1 but replacing Table 9.3.1.1.4.1-1 with Table 9.3.4.2.4.1-1.

Table 9.3.4.2.4.1-1: General test parameters for E-UTRAN FDD intra-frequency RSTD measurement reporting delay under fading propagation conditions

Parameter	Unit	Value		Comment
		Test 1	Test 2	

Reference cell		Cell 1	Reference cell is the cell in the OTDOA assistance data with respect to which the RSTD measurement is defined, as specified in 3GPP TS 36.214 [6] and 3GPP TS 36.355 [4]. The reference cell is the serving cell in this test case.	
Neighbour cells		Cell 2 and Cell 3	Cell 2 and Cell 3 appear at random places in the neighbour cell list in the OTDOA assistance data, but Cell 2 always appears in the first half of the list, whilst Cell 3 appears in the second half of the list.	
MPDCCH		DL Reference Measurement Channel R.18 FDD	As specified in TS 36.521-3 [25] clause A.7.1	
$mPDCCH\text{-startSF-UeSS}$		10	Parameter G in $T = r_{\max} \cdot G$ which determines subframe $k0$ in which MPDCCH starts	
Channel Bandwidth (BW_{channel})	MHz	10		
PRS Transmission Bandwidth ^{Note 2}	RB	50 ^{Note 4}	PRS are transmitted over the system bandwidth	
PRS configuration index I_{PRS} ^{Note 2}		311	This corresponds to periodicity of 320 ms and PRS subframe offset of $I_{\text{PRS}} - 160$ DL subframes, as defined in 3GPP TS 36.211 [26], Table 6.10.4.3-1	
Number of consecutive downlink positioning subframes N_{PRS} ^{Note 2}		6	4	As defined in 3GPP TS 36.211 [26]. The number of subframes in a positioning occasion
Physical cell ID PCI ^{Note 2}		(PCI of Cell 1 – PCI of Cell 2) mod 6 = 0 and (PCI of Cell 1 – PCI of Cell 3) mod 6 = 0	The cell PCIs are selected such that the relative shifts of PRS patterns among cells are as given by the test parameters	
CP length ^{Note 2}		Normal		
DRX		ON		DRX parameters are further specified in Table 9.3.1.1.4.1-2
Radio frame receive time offset between the cells at the UE antenna connector ^{Note 3}	μs	Cell 2 to Cell 1: 1 Cell 3 to Cell 1: -1	PRS are transmitted from synchronous cells	
Expected RSTD ^{Note 1}	μs	Cell 2: 3 Cell 3: 3 Other neighbour cells: randomly between -3 and 3	The expected RSTD is what is expected at the receiver. The corresponding parameter in the OTDOA assistance data specified in TS 36.355 [4] is the expectedRSTD indicator	
Expected RSTD uncertainty for all neighbour cells ^{Note 1}	μs	5		The corresponding parameter in the OTDOA assistance data specified in TS 36.355 [4] is the expectedRSTD-Uncertainty index
Number of cells provided in OTDOA assistance data		16		Including the reference cell
PRS muting info ^{Note 2}		Cell 1: '11110000' Cell 2: '00001111' Cell 3: '11110000'	Corresponds to prs-MutingInfo defined in TS 36.355 [4]	
T1	s	3		The length of the time interval from the beginning of each test
T2	s	6.4	2.56	The length of the time interval that follows immediately after time interval T1
T3	s	6.4	2.56	The length of the time interval that follows immediately after time interval T2

Note 1: Parameters “Expected RSTD” and “Expected RSTD uncertainty for all neighbour cells” are not settable parameters. These are parameters signalled in LPP only. For the values to be used in LPP see Table 9.3.1.1.4.3-5 and TS 37.571-5 [20], clause 7.2.5.

Note 2: Parameters “PRS Transmission Bandwidth”, “PRS configuration index”, “Number of consecutive downlink positioning subframes”, “Physical cell ID PCI”, “CP length”, and “PRS muting info” are settable parameters and also parameters signalled in LPP. The values to be used for “Physical cell ID PCI” are as follows: Cell 1: 0, Cell 2: 6, Cell 3: 12. For all the values to be used in LPP see Table 9.3.1.1.4.3-5 and TS 37.571-5 [20], clause 7.2.5.

Note 3: The parameter “Radio frame receive time offset between the cells at the UE antenna connector” is not a settable parameter but is used to set the “true RSTD” values in step 6 of clause 9.3.1.1.4.1.

Note 4: If the PRS transmission bandwidth is larger than the UE RF bandwidth, the UE is measuring RSTD within its RF bandwidth.

9.3.4.2.4.2 Test procedure

Same as in clause 9.3.1.1.4.2 but using condition CEModeB and with the following additional step:

14. Repeat step 1-13 for each sub-test in Table 9.3.4.2.4.1-1 as appropriate

9.3.4.2.4.3 Message contents

Same as in clause 9.3.1.1.4.3 with the following exceptions:

Table 9.3.4.2.4.3-1: LPP RequestLocationInformation

Derivation Path: Table 9.3.1.1.4.3-4			
Information Element	Value/remark	Comment	Condition
LPP-Message ::= SEQUENCE {			
lpp-MessageBody CHOICE {			
c1 CHOICE {			
requestLocationInformation SEQUENCE {			
criticalExtensions CHOICE {			
c1 CHOICE {			
requestLocationInformation-r9 SEQUENCE {			
commonIEsRequestLocationInformation SEQUENCE {			
qos SEQUENCE {			
responseTime SEQUENCE {			
time	13	See clause 9.3.4.1.5	Test 1
time	6	See clause 9.3.4.2.5	Test 2
}			
}			
}			
}			
}			
}			
}			
}			
}			
}			

9.3.4.2.5 Test requirement

The primary level settings including test tolerances for the test are defined in clause 9.3.4.1.5.

For Test 1, the response time is defined in clause 9.3.4.1.5.

For Test 2, the response time including test tolerance is 6.3 s. The response time is equal to the LPP time IE value plus the test tolerance. The LPP time IE value is derived from the RSTD reporting delay plus ΔT , where $\Delta T = N_{rep} \times TTI_{DCCCH} = N_{rep} \times 75$ ms, giving a value of 5270 ms. This is rounded up to the next allowed LPP value of 6 seconds. The RSTD

measurement reporting delay in the test is derived from the following expression $T_{PRS}(M-1) + 320 \cdot \left\lceil \frac{n}{M} \right\rceil$, where

$M=40$ and $n=16$ are the parameters specified in clause 9.3.1.1.3, Table 9.3.1.1.3-1 and Note 4 of Table 9.3.4.2.4.1-1. This gives the total RSTD reporting delay of 5210 ms for the 15 neighbour cells including Cell 2 and Cell 3 with respect to the reference cell, Cell 1.

The test tolerances are defined in clauses C.1.3 and C4.

For the overall test to pass, the ratio of successful reported values in each sub-test shall be more than 90% with a confidence level of 95%.

9.3.5 HD-FDD intra-frequency RSTD Measurement Reporting Delay in CE Mode B

9.3.5.1 HD-FDD intra-frequency RSTD Measurement Reporting Delay in CE Mode B for Category M1

9.3.5.1.1 Test purpose

To verify that the RSTD measurement reporting delay for UE Category M1 meets the performance requirements in an environment with fading propagation conditions.

9.3.5.1.2 Test applicability

This test applies to E-UTRA HD-FDD UE Category M1 release 14 and forward that supports UE-assisted OTDOA and CE Mode B.

9.3.5.1.3 Minimum conformance requirements

Same as in clause 9.3.4.1.3.

The normative reference for this requirement is TS 36.133 [23] clause 8.13.3.3 and A.8.12.7.

9.3.5.1.4 Test description

9.3.5.1.4.1 Initial conditions

Same as in clause 9.3.1.1.4.1 but replacing Table 9.3.1.1.4.1-1 with Table 9.3.5.1.4.1-1

Table 9.3.5.1.4.1-1: General test parameters for E-UTRAN HD-FDD intra-frequency RSTD measurement reporting delay under fading propagation conditions

Parameter	Unit	Value	Comment
Reference cell		Cell 1	Reference cell is the cell in the OTDOA assistance data with respect to which the RSTD measurement is defined, as specified in 3GPP TS 36.214 [6] and 3GPP TS 36.355 [4]. The reference cell is the serving cell in this test case.
Neighbour cells		Cell 2 and Cell 3	Cell 2 and Cell 3 appear at random places in the neighbour cell list in the OTDOA assistance data, but Cell 2 always appears in the first half of the list, whilst Cell 3 appears in the second half of the list.
MPDCCH		DL Reference Measurement Channel R.8 HD-FDD	As specified in TS 36.521-3 [25] clause A.7.2

<i>mPDCCH-startSF-UeSS</i>		10	Parameter G in $T = r_{\max} \cdot G$ which determines subframe $k0$ in which MPDCCH starts
Channel Bandwidth (BW_{channel})	MHz	10	
PRS Transmission Bandwidth Note 2	RB	50 Note 4	PRS are transmitted over the system bandwidth
PRS configuration index I_{PRS} Note 2		311	This corresponds to periodicity of 320 ms and PRS subframe offset of $I_{\text{PRS}} - 160$ DL subframes, as defined in 3GPP TS 36.211 [26], Table 6.10.4.3-1
Number of consecutive downlink positioning subframes N_{PRS} Note 2		6	As defined in 3GPP TS 36.211 [26]. The number of subframes in a positioning occasion
Physical cell ID PCI Note 2		(PCI of Cell 1 – PCI of Cell 2) mod 6 = 0 and (PCI of Cell 1 – PCI of Cell 3) mod 6 = 0	The cell PCIs are selected such that the relative shifts of PRS patterns among cells are as given by the test parameters
CP length Note 2		Normal	
DRX		ON	DRX parameters are further specified in Table 9.3.1.1.4.1-2
Radio frame receive time offset between the cells at the UE antenna connector Note 3	μs	Cell 2 to Cell 1: 1 Cell 3 to Cell 1: -1	PRS are transmitted from synchronous cells
Expected RSTD Note 1	μs	Cell 2: 3 Cell 3: 3 Other neighbour cells: randomly between -3 and 3	The expected RSTD is what is expected at the receiver. The corresponding parameter in the OTDOA assistance data specified in TS 36.355 [4] is the expectedRSTD indicator
Expected RSTD uncertainty for all neighbour cells Note 1	μs	5	The corresponding parameter in the OTDOA assistance data specified in TS 36.355 [4] is the expectedRSTD-Uncertainty index
Number of cells provided in OTDOA assistance data		16	Including the reference cell
PRS muting info Note 2		Cell 1: '11110000' Cell 2: '00001111' Cell 3: '11110000'	Corresponds to prs-MutingInfo defined in TS 36.355 [4]
T1	s	3	The length of the time interval from the beginning of each test
T2	s	6.4	The length of the time interval that follows immediately after time interval T1
T3	s	6.4	The length of the time interval that follows immediately after time interval T2
Note 1:	Parameters "Expected RSTD" and "Expected RSTD uncertainty for all neighbour cells" are not settable parameters. These are parameters signalled in LPP only. For the values to be used in LPP see Table 9.3.1.1.4.3-5 and TS 37.571-5 [20], clause 7.2.5.		
Note 2:	Parameters "PRS Transmission Bandwidth", "PRS configuration index", "Number of consecutive downlink positioning subframes", "Physical cell ID PCI", "CP length", and "PRS muting info" are settable parameters and also parameters signalled in LPP. The values to be used for "Physical cell ID PCI" are as follows: Cell 1: 0, Cell 2: 6, Cell 3: 12. For all the values to be used in LPP see Table 9.3.1.1.4.3-5 and TS 37.571-5 [20], clause 7.2.5.		
Note 3:	The parameter "Radio frame receive time offset between the cells at the UE antenna connector" is not a settable parameter but is used to set the "true RSTD" values in step 6 of clause 9.3.1.1.4.1.		
Note 4:	If the PRS transmission bandwidth is larger than the UE RF bandwidth, the UE is measuring RSTD within its RF bandwidth.		

9.3.5.1.4.2 Test procedure

Same as in clause 9.3.1.1.4.2 but using condition CEModeB.

9.3.5.1.4.3 Message contents

Same as in clause 9.3.4.1.4.3

9.3.5.1.5 Test requirement

Same as in clause 9.3.4.1.5.

9.3.5.2 HD-FDD intra-frequency RSTD Measurement Reporting Delay in CE Mode B for Category M2

9.3.5.2.1 Test purpose

To verify that the RSTD measurement reporting delay for UE Category M2 meets the performance requirements in an environment with fading propagation conditions.

9.3.5.2.2 Test applicability

This test applies to E-UTRA HD-FDD UE Category M2 release 14 and forward that supports UE-assisted OTDOA and CE Mode B.

9.3.5.2.3 Minimum conformance requirements

Same as in clause 9.3.4.1.3.

The normative reference for this requirement is TS 36.133 [23] clause 8.16.3.1.3 and A.8.12.7.

9.3.5.2.4 Test description

9.3.5.2.4.1 Initial conditions

Same as in clause 9.3.1.1.4.1 but replacing Table 9.3.1.1.4.1-1 with Table 9.3.5.2.4.1-1.

Table 9.3.5.2.4.1-1: General test parameters for E-UTRAN HD-FDD intra-frequency RSTD measurement reporting delay under fading propagation conditions

Parameter	Unit	Value		Comment
		Test 1	Test 2	
Reference cell		Cell 1		Reference cell is the cell in the OTDOA assistance data with respect to which the RSTD measurement is defined, as specified in 3GPP TS 36.214 [6] and 3GPP TS 36.355 [4]. The reference cell is the serving cell in this test case.
Neighbour cells		Cell 2 and Cell 3		Cell 2 and Cell 3 appear at random places in the neighbour cell list in the OTDOA assistance data, but Cell 2 always appears in the first half of the list, whilst Cell 3 appears in the second half of the list.
MPDCCH		DL Reference Measurement Channel R.8 HD-FDD		As specified in TS 36.521-3 [25] clause A.7.2
<i>mPDCCH-startSF-U ESS</i>		10		Parameter G in $T = r_{\max} \cdot G$ which determines subframe $k0$ in which MPDCCH starts

Channel Bandwidth ($BW_{channel}$)	MHz	10		
PRS Transmission Bandwidth <small>Note 2</small>	RB	50 <small>Note 4</small>		PRS are transmitted over the system bandwidth
PRS configuration index I_{PRS} <small>Note 2</small>		311		This corresponds to periodicity of 320 ms and PRS subframe offset of $I_{PRS} - 160$ DL subframes, as defined in 3GPP TS 36.211 [26], Table 6.10.4.3-1
Number of consecutive downlink positioning subframes N_{PRS} <small>Note 2</small>		6	4	As defined in 3GPP TS 36.211 [26]. The number of subframes in a positioning occasion
Physical cell ID PCI <small>Note 2</small>		(PCI of Cell 1 – PCI of Cell 2) mod 6 = 0 and (PCI of Cell 1 – PCI of Cell 3) mod 6 = 0		The cell PCIs are selected such that the relative shifts of PRS patterns among cells are as given by the test parameters
CP length <small>Note 2</small>		Normal		
DRX		ON		DRX parameters are further specified in Table 9.3.1.1.4.1-2
Radio frame receive time offset between the cells at the UE antenna connector <small>Note 3</small>	μ s	Cell 2 to Cell 1: 1 Cell 3 to Cell 1: -1		PRS are transmitted from synchronous cells
Expected RSTD <small>Note 1</small>	μ s	Cell 2: 3 Cell 3: 3 Other neighbour cells: randomly between -3 and 3		The expected RSTD is what is expected at the receiver. The corresponding parameter in the OTDOA assistance data specified in TS 36.355 [4] is the expectedRSTD indicator
Expected RSTD uncertainty for all neighbour cells <small>Note 1</small>	μ s	5		The corresponding parameter in the OTDOA assistance data specified in TS 36.355 [4] is the expectedRSTD-Uncertainty index
Number of cells provided in OTDOA assistance data		16		Including the reference cell
PRS muting info <small>Note 2</small>		Cell 1: '11110000' Cell 2: '00001111' Cell 3: '11110000'		Corresponds to prs-MutingInfo defined in TS 36.355 [4]
T1	s	3		The length of the time interval from the beginning of each test
T2	s	6.4	2.56	The length of the time interval that follows immediately after time interval T1
T3	s	6.4	2.56	The length of the time interval that follows immediately after time interval T2
<p>Note 1: Parameters "Expected RSTD" and "Expected RSTD uncertainty for all neighbour cells" are not settable parameters. These are parameters signalled in LPP only. For the values to be used in LPP see Table 9.3.1.1.4.3-5 and TS 37.571-5 [20], clause 7.2.5.</p> <p>Note 2: Parameters "PRS Transmission Bandwidth", "PRS configuration index", "Number of consecutive downlink positioning subframes", "Physical cell ID PCI", "CP length", and "PRS muting info" are settable parameters and also parameters signalled in LPP. The values to be used for "Physical cell ID PCI" are as follows: Cell 1: 0, Cell 2: 6, Cell 3: 12. For all the values to be used in LPP see Table 9.3.1.1.4.3-5 and TS 37.571-5 [20], clause 7.2.5.</p> <p>Note 3: The parameter "Radio frame receive time offset between the cells at the UE antenna connector" is not a settable parameter but is used to set the "true RSTD" values in step 6 of clause 9.3.1.1.4.1.</p> <p>Note 4: If the PRS transmission bandwidth is larger than the UE RF bandwidth, the UE is measuring RSTD within its RF bandwidth.</p>				

9.3.5.2.4.2 Test procedure

Same as in clause 9.3.1.1.4.2 but using condition CEModeB and with the following additional step:

14. Repeat step 1-13 for each sub-test in Table 9.3.2.2.4.1-1 as appropriate.

9.3.5.2.4.3 Message contents

Same as in clause 9.3.4.2.4.3.

9.3.5.2.5 Test requirement

Same as in clause 9.3.4.2.5.

For the overall test to pass, the ratio of successful reported values in each sub-test shall be more than 90% with a confidence level of 95%.

9.3.6 TDD intra-frequency RSTD Measurement Reporting Delay in CE Mode B

9.3.6.1 TDD intra-frequency RSTD Measurement Reporting Delay in CE Mode B for Category M1

9.3.6.1.1 Test purpose

To verify that the RSTD measurement reporting delay for UE Category M1 meets the performance requirements in an environment with fading propagation conditions.

9.3.6.1.2 Test applicability

This test applies to E-UTRA TDD UE Category M1 release 14 and forward that supports UE-assisted OTDOA and CE Mode B.

9.3.6.1.3 Minimum conformance requirements

Same as in clause 9.3.4.1.3.

The intra-frequency requirements in this clause shall apply for all TDD special subframe configurations specified in TS 36.211 [26] and for the TDD uplink-downlink configurations as specified in Table 9.3.6.1.3-1.

Table 9.3.6.1.3-1: TDD uplink-downlink subframe configurations applicable for TDD intra-frequency requirements

PRS Transmission Bandwidth [RB]	Applicable TDD uplink-downlink configurations
6	1, 2, 3, 4 and 5
Note: Uplink-downlink configurations are specified in Table 4.2-2 in TS 36.211 [26].	

The normative reference for this requirement is TS 36.133 [23] clause 8.13.3.3.2 and A.8.12.8.

9.3.6.1.4 Test description

9.3.6.1.4.1 Initial conditions

Same as in clause 9.3.1.1.4.1 but replacing Table 9.3.1.1.4.1-1 with Table 9.3.6.1.4.1-1

Table 9.3.6.1.4.1-1: General test parameters for E-UTRAN TDD intra-frequency RSTD measurement reporting delay under fading propagation conditions

Parameter	Unit	Value	Comment
-----------	------	-------	---------

Reference cell		Cell 1	Reference cell is the cell in the OTDOA assistance data with respect to which the RSTD measurement is defined, as specified in 3GPP TS 36.214 [6] and 3GPP TS 36.355 [4]. The reference cell is the serving cell in this test case.
Neighbour cells		Cell 2 and Cell 3	Cell 2 and Cell 3 appear at random places in the neighbour cell list in the OTDOA assistance data, but Cell 2 always appears in the first half of the list, whilst Cell 3 appears in the second half of the list.
MPDCCH		DL Reference Measurement Channel R.16 TDD	As specified in TS 36.521-3 [25] clause A.7.3
<i>mPDCCH-startSF-UeSS</i>		10	Parameter G in $T = r_{\max} \cdot G$ which determines subframe $k0$ in which MPDCCH starts
Channel Bandwidth (BW_{channel})	MHz	10	
PRS Transmission Bandwidth ^{Note 2}	RB	50 ^{Note 4}	PRS are transmitted over the system bandwidth
PRS configuration index I_{PRS} ^{Note 2}		304	This corresponds to periodicity of 320 ms and PRS subframe offset of $I_{\text{PRS}} - 160$ DL subframes, as defined in 3GPP TS 36.211 [26], Table 6.10.4.3-1
Number of consecutive downlink positioning subframes N_{PRS} ^{Note 2}		6	As defined in 3GPP TS 36.211 [26]. The number of subframes in a positioning occasion
Physical cell ID PCI ^{Note 2}		(PCI of Cell 1 – PCI of Cell 2) mod 6 = 0 and (PCI of Cell 1 – PCI of Cell 3) mod 6 = 0	The cell PCIs are selected such that the relative shifts of PRS patterns among cells are as given by the test parameters
TDD uplink-downlink configuration		1	As specified in TS 36.211 [26], Clause 4.2; corresponds to a configuration with 5 ms switch-point periodicity and two downlink consecutive subframes
TDD special subframe configuration		6	As specified in TS 36.211 [26], Clause 4.2; corresponds to DwPTS of $19760 \cdot T_s$ and UpPTS of $4384 \cdot T_s$
CP length ^{Note 2}		Normal	
DRX		ON	DRX parameters are further specified in Table 9.3.1.1.4.1-2
Radio frame receive time offset between the cells at the UE antenna connector ^{Note 3}	μs	Cell 2 to Cell 1: 1 Cell 3 to Cell 1: -1	PRS are transmitted from synchronous cells
Expected RSTD ^{Note 1}	μs	Cell 2: 3 Cell 3: 3 Other neighbour cells: randomly between -3 and 3	The expected RSTD is what is expected at the receiver. The corresponding parameter in the OTDOA assistance data specified in TS 36.355 [4] is the expectedRSTD indicator
Expected RSTD uncertainty for all neighbour cells ^{Note 1}	μs	5	The corresponding parameter in the OTDOA assistance data specified in TS 36.355 [4] is the expectedRSTD-Uncertainty index
Number of cells provided in OTDOA assistance data		16	Including the reference cell

PRS muting info ^{Note 2}		Cell 1: '11110000' Cell 2: '00001111' Cell 3: '11110000'	Corresponds to prs-MutingInfo defined in TS 36.355 [4]
T1	s	3	The length of the time interval from the beginning of each test
T2	s	6.4	The length of the time interval that follows immediately after time interval T1
T3	s	6.4	The length of the time interval that follows immediately after time interval T2
<p>Note 1: Parameters "Expected RSTD" and "Expected RSTD uncertainty for all neighbour cells" are not settable parameters. These are parameters signalled in LPP only. For the values to be used in LPP see Table 9.3.1.1.4.3-5 and TS 37.571-5 [20], clause 7.2.5.</p> <p>Note 2: Parameters "PRS Transmission Bandwidth", "PRS configuration index", "Number of consecutive downlink positioning subframes", "Physical cell ID PCI", "CP length", and "PRS muting info" are settable parameters and also parameters signalled in LPP. The values to be used for "Physical cell ID PCI" are as follows: Cell 1: 0, Cell 2: 6, Cell 3: 12. For all the values to be used in LPP see Table 9.3.1.1.4.3-5 and TS 37.571-5 [20], clause 7.2.5.</p> <p>Note 3: The parameter "Radio frame receive time offset between the cells at the UE antenna connector" is not a settable parameter but is used to set the "true RSTD" values in step 6 of clause 9.3.1.1.4.1.</p> <p>Note 4: If the PRS transmission bandwidth is larger than the UE RF bandwidth, the UE is measuring RSTD within its RF bandwidth.</p>			

9.3.6.1.4.2 Test procedure

Same as in clause 9.3.1.1.4.2 but using condition CEModeB.

9.3.6.1.4.3 Message contents

Same as in clause 9.3.4.1.4.3

9.3.6.1.5 Test requirement

Table 9.3.6.1.5-1 and 9.3.6.1.5-2 define the primary level settings including test tolerances for the test.

Table 9.3.6.1.5-1: Cell-specific test parameters for E-UTRAN TDD intra-frequency RSTD measurement reporting delay under fading propagation conditions during T1

Parameter	Unit	Cell 1	Cell 2	Cell 3
E-UTRA RF Channel Number		1	1	1
Correlation Matrix and Antenna Configuration		1x1	1x1	1x1
OCNG patterns defined in TS 36.521-3 [25] clause D.1		OP.11 TDD	N/A	N/A
PBCH_RA	dB	0	N/A	N/A
PBCH_RB				
PSS_RA				
SSS_RA				
PCFICH_RB				
PHICH_RA				
PHICH_RB				
PDCCH_RA				
PDCCH_RB				
OCNG_RA ^{Note 1}				
OCNG_RB ^{Note 1}				
N_{oc} ^{Note 3}				

$PRS \hat{E}_s / N_{oc}$	dB	-Infinity	-Infinity	-Infinity
I_o ^{Note 4}	dBm/ 9 MHz	-67.22	N/A	N/A
\hat{E}_s / N_{oc}	dB	0	-Infinity	-Infinity
Propagation Condition		ETU30		
<p>Note 1: OCNG shall be used such that active cell (Cell 1) is fully allocated and a constant total transmitted power spectral density is achieved for all OFDM symbols.</p> <p>Note 2: The resources for uplink transmission are assigned to the UE prior to the start of time period T2.</p> <p>Note 3: Interference from other cells and noise sources not specified in the test are assumed to be constant over subcarriers and time and shall be modelled as AWGN of appropriate power for N_{oc} to be fulfilled.</p> <p>Note 4: I_o levels have been derived from other parameters and are given for information purpose. These are not settable test parameters.</p>				

Table 9.3.6.1.5-2: Cell-specific test parameters for E-UTRAN TDD intra-frequency RSTD measurement reporting delay under fading propagation conditions during T2 and T3

Parameter	Unit	Cell 1		Cell 2		Cell 3		
		T2	T3	T2	T3	T2	T3	
E-UTRA RF Channel Number		1		1		1		
Correlation Matrix and Antenna Configuration		1x1		1x1		1x1		
OCNG patterns defined in TS 36.521-3 [25] clause D.1		OP.11 TDD		OP.2 TDD		OP.2 TDD	N/A	
PBCH_RA	dB	0		0		0		N/A
PBCH_RB								
PSS_RA								
SSS_RA								
PCFICH_RB								
PHICH_RA								
PHICH_RB								
PDCCH_RA								
PDCCH_RB								
OCNG_RA ^{Note 1}								
OCNG_RB ^{Note 1}								
PRS_RA	dB	-3	N/A	N/A	3	3	N/A	
N_{oc} ^{Note 3}	dBm/ 15 kHz	-98	-95	-98	-95	-98	-95	
$PRS \hat{E}_s / N_{oc}$	dB	-12	-Infinity	-Infinity	-13	-13	-Infinity	
$PRS \hat{E}_s / I_{ot}$ ^{Note 4}	dB	-12.21	-Infinity	-Infinity	-13	-13.27	-Infinity	
I_o ^{Note 4}	dBm/ 9 MHz	-69.92	-67.18	-69.92	-67.18	-69.92	-67.18	
PRP ^{Note 4}	dBm/ 15 kHz	-110	-Infinity	-Infinity	-108	-111	-Infinity	
RSRP ^{Note 4}	dBm/ 15 kHz	-107	-104	-111	-111	-114	-Infinity	
\hat{E}_s / N_{oc} ^{Note 4}	dB	-9	-9	-13	-16	-16	-Infinity	
Propagation Condition		ETU30						

Note 1:	OCNG shall be used such that active cells (all, except Cell 3 in T3) are fully allocated and a constant total transmitted power spectral density is achieved for all OFDM symbols other than those in the subframes with transmitted PRS.
Note 2:	The resources for uplink transmission are assigned to the UE prior to the start of time period T2.
Note 3:	Interference from other cells and noise sources not specified in the test are assumed to be constant over subcarriers and time and shall be modelled as AWGN of appropriate power for N_{oc} to be fulfilled.
Note 4:	If PRS_RA is not "N/A", \hat{E}_s/N_{oc} , PRS \hat{E}_s/I_{ot} , I_o , RSRP and PRP levels have been derived from other parameters and are given for information purpose. If PRS_RA is "N/A", I_o and RSRP levels have been derived from other parameters and are given for information purpose. These are not settable test parameters. Interference conditions shall be applied to all PRS symbols of DL positioning subframes.

The response time is defined in clause 9.3.4.1.5.

The test tolerances are defined in clauses C.1.3 and C4.

The rate of successful tests during repeated tests shall be at least 90% with a confidence level of 95%.

9.3.6.2 TDD intra-frequency RSTD Measurement Reporting Delay in CE Mode B for Category M2

9.3.6.2.1 Test purpose

To verify that the RSTD measurement reporting delay for UE Category M2 meets the performance requirements in an environment with fading propagation conditions.

9.3.6.2.2 Test applicability

This test applies to E-UTRA TDD UE Category M2 release 14 and forward that supports UE-assisted OTDOA and CE Mode B.

9.3.6.2.3 Minimum conformance requirements

Same as in clause 9.3.6.1.3.

The intra-frequency requirements in this clause shall apply for all TDD special subframe configurations specified in TS 36.211 [26] and for the TDD uplink-downlink configurations as specified in Table 9.3.6.2.3-1.

Table 9.3.6.2.3-1: TDD uplink-downlink subframe configurations applicable for TDD intra-frequency requirements

PRS Transmission Bandwidth [RB]	Applicable TDD uplink-downlink configurations
6	1, 2, 3, 4 and 5
24	0, 1, 2, 3, 4, 5 and 6
Note:	Uplink-downlink configurations are specified in Table 4.2-2 in TS 36.211 [26].

The normative reference for this requirement is TS 36.133 [23] clause 8.16.3.1.2 and A.8.12.8.

9.3.6.2.4 Test description

9.3.6.2.4.1 Initial conditions

Same as in clause 9.3.1.1.4.1 but replacing Table 9.3.1.1.4.1-1 with Table 9.3.6.2.4.1-1.

Table 9.3.6.2.4.1-1: General test parameters for E-UTRAN TDD intra-frequency RSTD measurement reporting delay under fading propagation conditions

Parameter	Unit	Value		Comment
		Test 1	Test 2	
Reference cell		Cell 1		Reference cell is the cell in the OTDOA assistance data with respect to which the RSTD measurement is defined, as specified in 3GPP TS 36.214 [6] and 3GPP TS 36.355 [4]. The reference cell is the serving cell in this test case.
Neighbour cells		Cell 2 and Cell 3		Cell 2 and Cell 3 appear at random places in the neighbour cell list in the OTDOA assistance data, but Cell 2 always appears in the first half of the list, whilst Cell 3 appears in the second half of the list.
MPDCCH		DL Reference Measurement Channel R.16 TDD		As specified in TS 36.521-3 [25] clause A.7.3
$mPDCCH\text{-startSF-UeSS}$		10		Parameter G in $T = r_{\max} \cdot G$ which determines subframe $k0$ in which MPDCCH starts
Channel Bandwidth (BW_{channel})	MHz	10		
PRS Transmission Bandwidth Note 2	RB	50 ^{Note 4}		PRS are transmitted over the system bandwidth
PRS configuration index I_{PRS} ^{Note 2}		304		This corresponds to periodicity of 320 ms and PRS subframe offset of $I_{\text{PRS}} - 160$ DL subframes, as defined in 3GPP TS 36.211 [26], Table 6.10.4.3-1
Number of consecutive downlink positioning subframes N_{PRS} ^{Note 2}		6	4	As defined in 3GPP TS 36.211 [26]. The number of subframes in a positioning occasion
Physical cell ID PCI ^{Note 2}		(PCI of Cell 1 – PCI of Cell 2) mod 6 = 0 and (PCI of Cell 1 – PCI of Cell 3) mod 6 = 0		The cell PCIs are selected such that the relative shifts of PRS patterns among cells are as given by the test parameters
TDD uplink-downlink configuration		1		As specified in TS 36.211 [26], Clause 4.2; corresponds to a configuration with 5 ms switch-point periodicity and two downlink consecutive subframes
TDD special subframe configuration		6		As specified in TS 36.211 [26], Clause 4.2; corresponds to DwPTS of $19760 \cdot T_s$ and UpPTS of $4384 \cdot T_s$
CP length ^{Note 2}		Normal		
DRX		ON		DRX parameters are further specified in Table 9.3.1.1.4.1-2
Radio frame receive time offset between the cells at the UE antenna connector Note 3	μs	Cell 2 to Cell 1: 1 Cell 3 to Cell 1: -1		PRS are transmitted from synchronous cells
Expected RSTD ^{Note 1}	μs	Cell 2: 3 Cell 3: 3 Other neighbour cells: randomly between -3 and 3		The expected RSTD is what is expected at the receiver. The corresponding parameter in the OTDOA assistance data specified in TS 36.355 [4] is the expectedRSTD indicator

Expected RSTD uncertainty for all neighbour cells ^{Note 1}	μs	5		The corresponding parameter in the OTDOA assistance data specified in TS 36.355 [4] is the expectedRSTD-Uncertainty index
Number of cells provided in OTDOA assistance data		16		Including the reference cell
PRS muting info ^{Note 2}		Cell 1: '11110000' Cell 2: '00001111' Cell 3: '11110000'		Corresponds to prs-MutingInfo defined in TS 36.355 [4]
T1	s	3		The length of the time interval from the beginning of each test
T2	s	6.4	2.56	The length of the time interval that follows immediately after time interval T1
T3	s	6.4	2.56	The length of the time interval that follows immediately after time interval T2
<p>Note 1: Parameters "Expected RSTD" and "Expected RSTD uncertainty for all neighbour cells" are not settable parameters. These are parameters signalled in LPP only. For the values to be used in LPP see Table 9.3.1.1.4.3-5 and TS 37.571-5 [20], clause 7.2.5.</p> <p>Note 2: Parameters "PRS Transmission Bandwidth", "PRS configuration index", "Number of consecutive downlink positioning subframes", "Physical cell ID PCI", "CP length", and "PRS muting info" are settable parameters and also parameters signalled in LPP. The values to be used for "Physical cell ID PCI" are as follows: Cell 1: 0, Cell 2: 6, Cell 3: 12. For all the values to be used in LPP see Table 9.3.1.1.4.3-5 and TS 37.571-5 [20], clause 7.2.5.</p> <p>Note 3: The parameter "Radio frame receive time offset between the cells at the UE antenna connector" is not a settable parameter but is used to set the "true RSTD" values in step 6 of clause 9.3.1.1.4.1.</p> <p>Note 4: If the PRS transmission bandwidth is larger than the UE RF bandwidth, the UE is measuring RSTD within its RF bandwidth.</p>				

9.3.6.2.4.2 Test procedure

Same as in clause 9.3.1.1.4.2 but using condition CEModeB and with the following additional step:

14. Repeat step 1-13 for each sub-test in Table 9.3.2.2.4.1-1 as appropriate.

9.3.6.2.4.3 Message contents

Same as in clause 9.3.4.2.4.3.

9.3.6.2.5 Test requirement

The primary level settings including test tolerances for the test are defined in clause 9.3.6.1.5.

For Test 1, the response time is defined in clause 9.3.6.1.5.

For Test 2, the response time including test tolerance is 6.3 s. The response time is equal to the LPP time IE value plus the test tolerance. The LPP time IE value is derived from the RSTD reporting delay plus ΔT , where $\Delta T = N_{rep} \times TTI_{DCCCH} = N_{rep} \times 75$ ms, giving a value of 5270 ms. This is rounded up to the next allowed LPP value of 6 seconds. The RSTD

measurement reporting delay in the test is derived from the following expression $T_{PRS} (M - 1) + 320 \cdot \left\lceil \frac{n}{M} \right\rceil$, where

$M = 40$ and $n = 16$ are the parameters specified in clause 9.3.1.1.3, Table 9.3.1.1.3-1 and Note 4 of Table 9.3.6.2.4.1-1. This gives the total RSTD reporting delay of 5210 ms for the 15 neighbour cells including Cell 2 and Cell 3 with respect to the reference cell, Cell 1.

The test tolerances are defined in clauses C.1.3 and C4.

For the overall test to pass, the ratio of successful reported values in each sub-test shall be more than 90% with a confidence level of 95%. 9.3.7 FDD intra-frequency RSTD Measurement Accuracy in CE Mode A.

9.3.7 FDD intra-frequency RSTD Measurement Accuracy in CE Mode A

9.3.7.1 FDD intra-frequency RSTD Measurement Accuracy in CE Mode A for Category M1

9.3.7.1.1 Test purpose

To verify that the RSTD measurement accuracy for UE Category M1 is within the specified limits in normal coverage mode in an environment with fading propagation conditions.

9.3.7.1.2 Test applicability

This test applies to E-UTRA FDD UE Category M1 release 14 and forward that supports UE-assisted OTDOA.

9.3.7.1.3 Minimum conformance requirements

The accuracy requirements in Table 9.3.7.1.3-1 are valid under the following conditions:

Conditions defined in 36.101 [2] Clause 7.3 for reference sensitivity are fulfilled.

PRP $1,2_{\text{dBm}}$ according to Annex E.2 for a corresponding Band

For a UE that does not need a measurement gap for intra-frequency RSTD measurement, there are no measurement gaps overlapping with the PRS subframes of the measured serving cell and PRS are available within the UE measurement bandwidth in all PRS subframes

For a UE that needs a measurement gap for intra-frequency RSTD measurement, the measurement gaps are configured to contain PRS subframes

The parameter expectedRSTDUncertainty signalled over LPP by E-SMLC as defined in TS 36.355 [4] is less than 5 μs .

Table 9.3.7.1.3-1: RSTD intra-frequency measurement accuracy for CE Mode A

Accuracy	Conditions						
	PRS \hat{E}_s/lot	Minimum PRS bandwidth, which is minimum of serving cell channel bandwidth and the PRS bandwidths of the reference cell and the measured neighbour cell i Notes 3, 6	Minimum number of available measurement subframes among the reference cell and the measured neighbour cell i	The number of consecutive downlink subframes N_{PRS} among the reference cell and the measured neighbour cell i as defined in [24]	E-UTRA operating band groups ^{Note 5}	I_0 ^{Note 4} range	
T_s ^{Note 2}	dB	RB				dBm/15kHz	dBm/BW _{Channel}
± 15	(PRS \hat{E}_s/lot) _{ref} $\geq -6\text{dB}$ and (PRS \hat{E}_s/lot) _{i} $\geq -13\text{dB}$	≥ 6	≥ 12	≥ 6	FDD-M1_A, TDD-M1_A	-121	-50
					FDD-M1_B	-120.5	-50
					FDD-M1_C, TDD-M1_C	-120	-50
					FDD-M1_D	-119.5	-50
					FDD-M1_E, TDD-M1_E	-119	-50

					FDD-M1_F	-118.5	-50
					FDD-M1_G	-118	-50
					FDD-M1_H	-117.5	-50
					FDD-M1_N	-114.5	-50
<p>NOTE 1: This minimum l_0 condition is expressed as the average l_0 per RE over all REs in an OFDM symbol.</p> <p>NOTE 2: T_s is the basic timing unit defined in TS 36.211 [26].</p> <p>NOTE 3: PRS bandwidth is as indicated in <i>prs-Bandwidth</i> in the OTDOA assistance data defined in TS 36.355 [4].</p> <p>NOTE 4: The l_0 is defined in PRS positioning subframes. The same l_0 range applies to PRS and non-PRS symbols. l_0 levels are different in PRS and non-PRS symbols within the same subframe.</p> <p>NOTE 5: E-UTRA operating band groups are as defined in Section 4.4.2.</p> <p>NOTE 6: The serving cell, the reference cell, and the measured neighbour cell i are on the same carrier frequency.</p>							

The normative reference for this requirement is TS 36.133 [23] clause 9.1.21.20 and A.9.8.20.

9.3.7.1.4 Test description

9.3.7.1.4.1 Initial conditions

Test Environment: Normal; as defined in TS 36.508 [18] clause 4.1.

Frequencies to be tested: Mid Range, as defined in TS 36.508 [18] clause 4.3.1.1.

Channel bandwidth to be tested: 10 MHz as defined in TS 36.508 [18] clause 4.3.1.

1. Connect the SS, faders and AWGN noise sources to the UE antenna connector or antenna connectors as shown in Annex A, Figure A.3 using only the main Tx/Rx antenna of the UE.
2. The general test parameter settings are set up according to Table 9.3.7.1.4.1-1.
3. Propagation conditions are set according to clause 4.7.2.1.
4. Message contents are defined in clause 9.3.7.1.4.3.
5. All cells are on the same carrier frequency. Cell 1 is the serving cell and OTDOA assistance data reference cell; Cell 2 is the neighbour cell. The assistance data neighbour cell list includes in total 15 cells, where 14 of the cells are not simulated (dummy cells; as defined in 3GPP TS 37.571-5 [20], clause 7.2.5).
6. The true RSTD (which is the receive time difference for frame 0 between cell 2 and cell 1 as seen at the UE antenna connector) is set to the following values:
 - Test 1: $-92 T_s$ (about $-3 \mu s$)
 - Test 2: $92 T_s$ (about $3 \mu s$)

Note that the related expectedRSTD values to be signalled over LPP are defined in Table 9.3.7.1.4-1 for each test.

Table 9.3.7.1.4.1-1: General test parameters for E-UTRAN FDD intra-frequency RSTD measurement Accuracy under fading propagation conditions.

Parameter	Unit	Value		Comment
		Test 1	Test 2	
MPDCCH		R.16 FDD		As specified in TS 36.521-3 [25] clause A.7.1
<i>mPDCCH-startSF-U ESS</i>		10		Parameter G in $T = r_{max} \cdot G$ which determines subframe $k0$ in which MPDCCH starts

OCNG Patterns defined in TS 36.521-3 [25] clause D.1		OP.21 FDD		OCNG shall be used such that both cells are fully allocated and a constant total transmitted power spectral density is achieved for all OFDM symbols (other than those in the PRS subframes).
Reference cell		Cell 1		Reference cell is the cell in the OTDOA assistance data with respect to which the RSTD measurement is defined, as specified in 3GPP TS 36.214 [6] and 3GPP TS 36.355 [4]. The reference cell is the serving cell in this test case.
Neighbour cell		Cell 2		One carrier frequency is used.
E-UTRA RF Channel Number		1		
Channel Bandwidth (BW_{channel})	MHz	10		
PRS Transmission Bandwidth ^{Note 2}	RB	50 ^{Note 4}		PRS are transmitted over the system bandwidth
PRS configuration index I_{PRS} ^{Note 2}		151		This corresponds to periodicity of 320 ms and PRS subframe offset of $I_{\text{PRS}} - 160$ DL subframes, as defined in 3GPP TS 36.211 [26], Table 6.10.4.3-1
Number of consecutive downlink positioning subframes N_{PRS} ^{Note 2}		6		As defined in 3GPP TS 36.211 [26]. The number of subframes in a positioning occasion
PRS muting info ^{Note 2}		Cell 1: '11110000' Cell 2: '11110000'		Corresponds to prs-MutingInfo defined in TS 36.355 [4]
Physical cell ID PCI ^{Note 2}		(Cell ID of cell 1 – Cell ID of cell 2) mod 6 = 0	(Cell ID of cell 1 – Cell ID of cell 2) mod 6 = 1	
Expected RSTD ^{Note 1}	μs	Cell 2: 1 Other neighbour cells: randomly between -3 and 3	Cell 2: -1 Other neighbour cells: randomly between -3 and 3	The expected RSTD is what is expected at the receiver. The corresponding parameter in the OTDOA assistance data specified in TS 36.355 [4] is the expectedRSTD indicator
Expected RSTD uncertainty for all neighbour cells ^{Note 1}	μs	5	5	The corresponding parameter in the OTDOA assistance data specified in TS 36.355 [4] is the expectedRSTD-Uncertainty index
CP length ^{Note 2}		Normal		
DRX		OFF		
Radio frame receive time offset between the cells at the UE antenna connector ^{Note 3}	μs	Cell 2 to Cell 1: -3	Cell 2 to Cell 1: 3	PRS are transmitted from synchronous cells
Number of cells provided in OTDOA assistance data		16		Including the reference cell
$T_{\text{RSTD IntraFreqFDD, E-UTRAN}}$	ms	5120		Derived according to the RSTD measurement requirements specified in section 9.3.7.1.3

Note 1:	Parameters “Expected RSTD” and “Expected RSTD uncertainty for all neighbour cells” are not settable parameters. These are parameters signalled in LPP only. For the values to be used in LPP see Table 9.3.7.1.4.3-5 and TS 37.571-5 [20], clause 7.2.5.
Note 2:	Parameters “PRS Transmission Bandwidth”, “PRS configuration index”, “Number of consecutive positioning downlink subframes”, “prs-MutingInfo”, “Cell ID” and “CP length” are settable parameters and also parameters signalled in LPP. The values to be used for “Cell ID” are as follows: Cell 1: 0, Cell 2: Test 1: 6, Test 2: 7, Test 3: 6, Test 4: 9. For all the values to be used in LPP see Table 9.3.7.1.4.3-4 and TS 37.571-5 [20], clause 7.2.5.
Note 3:	The parameter “Radio frame receive time offset between the cells at the UE antenna connector” is not a settable parameter but is used to set the “true RSTD” values in step 6 of clause 9.3.7.1.4.1.
Note 4:	If the PRS transmission bandwidth is larger than the UE RF bandwidth, the UE is measuring RSTD within its RF bandwidth.
Note 5:	The parameter “ $T_{\text{RSTD IntraFreqFDD, E-UTRAN}}$ ” is not a settable parameter but is used to set the LPP “time” value in Table 9.3.7.1.4.3-3. The value of the LPP time IE is set to $T_{\text{RSTD IntraFreqFDD, E-UTRAN}} + \Delta T$ ms, where $\Delta T = 150$ ms, giving a value of 5270 ms. This is rounded up to the next allowed LPP value of 6 seconds.

9.3.7.1.4.2 Test procedure

The test consists of a set-up period and a measurement period. Cell 1 and Cell 2 are both active during the complete test. The beginning of the measurement period shall be aligned with the first PRS positioning subframe of a positioning occasion in the reference cell.

NOTE: The information on when PRS is muted is conveyed to the UE using PRS muting information in the OTDOA assistance data.

The OTDOA-RequestLocationInformation message and the OTDOA assistance data as defined in clause 9.3.7.1.4.3 shall be provided to the UE during the set-up period. The last TTI containing the OTDOA-RequestLocationInformation message shall be provided to the UE ΔT ms before the start of the measurement period, where $\Delta T = 150$ ms is the maximum processing time of the OTDOA-RequestLocationInformation message and the OTDOA assistance data in the UE.

1. Ensure that the UE is in state Generic RB Established State 3A-RF-CE according to 3GPP TS 36.508 [18] clause 7.2A.3AA.
2. The SS shall send a RESET UE POSITIONING STORED INFORMATION message.
3. Set the parameters according to Table 9.3.7.1.5-1. Propagation conditions are set according to clause 4.7.2.1.
4. The SS shall transmit an LPP REQUEST CAPABILITIES message.
5. The UE shall transmit an LPP PROVIDE CAPABILITIES message indicating the OTDOA capabilities supported by the UE in the *OTDOA-ProvideCapabilities* IE.
6. The SS shall send a LPP PROVIDE ASSISTANCE DATA message, including the *OTDOA-ProvideAssistanceData* IE. If the UE message at step 5 includes the *ackRequested* IE set to TRUE, then the SS shall send an acknowledgment in the LPP PROVIDE ASSISTANCE DATA message.
7. The SS shall send a LPP REQUEST LOCATION INFORMATION message, including the *OTDOA-RequestLocationInformation* IE such that the UE receives the message ΔT ms before the start of T2, where $\Delta T = 150$ ms.
8. The UE shall transmit a LPP PROVIDE LOCATION INFORMATION message, including the *OTDOA-ProvideLocationInformation* IE.
9. If the UE message at step 8 includes the *ackRequested* IE set to TRUE, the SS shall send a LPP acknowledgement message.
11. The SS shall check the *rstd* value for Cell 2 in the *OTDOA-SignalMeasurementInformation* IE according to Table 9.3.7.1.5-2.
12. Repeat steps 2-10 until the confidence level according to Annex D is achieved.

13. Repeat step 1-12 for each sub-test in Table 9.3.7.1.5-1 as appropriate.

9.3.7.1.4.3 Message contents

Table 9.3.7.1.4.3-1: RESET UE POSITIONING STORED INFORMATION

Derivation Path: 36.509 [11] clause 6.9			
Information Element	Value/remark	Comment	Condition
UE Positioning Technology	0 0 0 0 0 0 1	OTDOA	

Table 9.3.7.1.4.3-2: LPP Request Capabilities

Information Element	Value/remark
<i>otdoa-RequestCapabilities</i>	TRUE

Table 9.3.7.1.4.3-3: LPP RequestLocationInformation

Derivation Path: 36.355 clause 6.2			
Information Element	Value/remark	Comment	Condition
LPP-Message ::= SEQUENCE {			
transactionID SEQUENCE {			
initiator	locationServer		
transactionNumber	1		
}			
endTransaction	FALSE		
sequenceNumber	Not present		
acknowledgement	Not present		
lpp-MessageBody CHOICE {			
c1 CHOICE {			
requestLocationInformation SEQUENCE {			
criticalExtensions CHOICE {			
c1 CHOICE {			
requestLocationInformation-r9 SEQUENCE {			
commonIEsRequestLocationInformation SEQUENCE {			
locationInformationType	locationMeasurementsRequired		
triggeredReporting	Not present		
periodicalReporting	Not present		
additionalInformation	onlyReturnInformationRequested		
qos SEQUENCE {			
horizontalAccuracy	Not present		
verticalCoordinateRequest	FALSE		
verticalAccuracy	Not present		
responseTime SEQUENCE {			
time	6	See Note 4 of Table 9.3.7.1.4.1-1	
responseTimeEarlyFix-r12	Not present		Rel-12 onwards
}			
velocityRequest	FALSE		
}			
environment	Not present		
locationCoordinateTypes	Not present		
velocityTypes	Not present		
}			
a-gnss-RequestLocationInformation	Not present		
otdoa-RequestLocationInformation SEQUENCE {			
assistanceAvailability	FALSE		
}			

ecid-RequestLocationInformation	Not present		
epdu-RequestLocationInformation	Not Present		
}			
}			
}			
}			
}			
}			
}			

Table 9.3.7.1.4.3-4: LPP ProvideAssistanceData

Derivation Path: 36.355 clause 6.2			
Information Element	Value/remark	Comment	Condition
LPP-Message ::= SEQUENCE {			
transactionID SEQUENCE {			
Initiator	locationServer		
transactionNumber	(0..255)		
}			
endTransaction	TRUE		
sequenceNumber	Not present		
acknowledgement	Not present		
lpp-MessageBody CHOICE {			
c1 CHOICE {			
provideAssistanceData SEQUENCE {			
criticalExtensions CHOICE {			
c1 CHOICE {			
provideAssistanceData-r9 SEQUENCE {			
commonIEsProvideAssistanceData	Not present		
a-gnss-ProvideAssistanceData	Not present		
otdoa-ProvideAssistanceData SEQUENCE {			
otdoa-ReferenceCellInfo	As defined in TS 37.571-5 [20], clause 7.2.5.		
otdoa-NeighbourCellInfo	As defined in TS 37.571-5 [20], clause 7.2.5.		
otdoa-Error	Not present		
}			
epdu-ProvideAssistanceData	Not present		
}			
}			
}			
}			

9.3.7.1.5 Test requirement

Table 9.3.7.1.5-1 defines the primary level settings including test tolerances for the test.

The RSTD FDD intra-frequency accuracy test shall meet the reported values in Table 9.3.7.1.5-2

Table 9.3.7.1.5-1: Cell Specific Test Parameters for intra frequency RSTD Tests for E-UTRAN FDD

Parameter	Unit	Test1		Test2		Test3 ^{Note 4}		Test4 ^{Note 4}	
		Cell1	Cell2	Cell1	Cell2	Cell1	Cell2	Cell1	Cell2
E-UTRA RF Channel Number		1							
PBCH_RA	dB	0	0	0	0	0	0	0	0
PBCH_RB									
PSS_RA									
SSS_RA									

MPDCCH_RA									
MPDCCH_RB									
OCNG_RA ^{Note1}									
OCNG_RB ^{Note1}									
PRS_RA	dB	0	0	-2.7	0.3	0	0	-2.7	0.3
N_{oc} ^{Note2}	dBm/15 kHz	-98	-98	-98	-98	-98	-98	-98	-98
PRS \hat{E}_s/N_{oc}	dB	-2.37	-8.02	-5.7	-12.7	-2.37	-8.02	-5.7	-12.7
PRS \hat{E}_s/I_{ot} ^{Note3}	dB	-3.01	-10.01	-5.7	-12.7	-3.01	-10.01	-5.7	-12.7
I_o ^{Note3}	dBm/9 MHz	-69.23	-69.23	-70	-70	-69.23	-69.23	-70	-70
PRP ^{Note3}	dBm/15kHz	-100.37	-106.02	-103.7	-110.7	-100.37	-106.02	-103.7	-110.7
\hat{E}_s/N_{oc} ^{Note 3}	dB	-2.37	-8.02	-3	-13	-2.37	-8.02	-3	-13
RSRP ^{Note 3}	dBm/15kHz	-100.37	-106.02	-101	-111	-100.37	-106.02	-101	-111
Propagation condition		AWGN							
<p>Note 1: OCNG shall be used such that both cells are fully allocated and a constant total transmitted power spectral density is achieved for all OFDM symbols (other than those in the PRS subframes).</p> <p>Note 2: Interference from other cells and noise sources not specified in the test is assumed to be constant over subcarriers and time and shall be modelled as AWGN of appropriate power for N_{oc} to be fulfilled.</p> <p>Note 3: \hat{E}_s/N_{oc}, PRS \hat{E}_s/I_{ot}, I_o, RSRP and PRP levels have been derived from other parameters for information purposes. They are not settable parameters themselves. I_o values are derived in the case that there is no PBCH, PSS or SSS in the OFDM symbols carrying PRS</p> <p>Note 4: Test3 and Test4 are not used for test 9.3.7.1</p>									

Table 9.3.7.1.5-2: RSTD FDD intra-frequency accuracy requirements for the reported values

	Test 1	Test 2
Lowest reported value	RSTD_6248	RSTD_6431
Highest reported value	RSTD_6280	RSTD_6463

The test tolerances are defined in clauses C.1.3 and C4.

For the overall test to pass, the ratio of successful reported values in each sub-test shall be more than 90% with a confidence level of 95%.

9.3.7.2 FDD intra-frequency RSTD Measurement Accuracy in CE Mode A for Category M2

9.3.7.2.1 Test purpose

To verify that the RSTD measurement accuracy for UE Category M2 is within the specified limits in normal coverage mode in an environment with fading propagation conditions.

9.3.7.2.2 Test applicability

This test applies to E-UTRA FDD UE Category M2 release 14 and forward that supports UE-assisted OTDOA.

9.3.7.2.3 Minimum conformance requirements

The accuracy requirements in Table 9.3.7.2.3-1 are valid under the following conditions:

Conditions defined in 36.101 [2] Clause 7.3 for reference sensitivity are fulfilled.

PRP $1,2_{dBm}$ according to Annex E.2 for a corresponding Band

For a UE that does not need a measurement gap for intra-frequency RSTD measurement, there are no measurement gaps overlapping with the PRS subframes of the measured serving cell and PRS are available within the UE measurement bandwidth in all PRS subframes

For a UE that needs a measurement gap for intra-frequency RSTD measurement, the measurement gaps are configured to contain PRS subframes

The parameter expectedRSTDUncertainty signalled over LPP by E-SMLC as defined in TS 36.355 [4] is less than 5 μ s.

Table 9.3.7.2.3-1: RSTD intra-frequency measurement accuracy for CEModeA

Accuracy	Conditions				Io ^{Note 4} range		
	PRS \hat{E}_s/lot	Minimum PRS bandwidth, which is minimum of serving cell channel bandwidth and the PRS bandwidths of the reference cell and the measured neighbour cell i Notes 3, 6	Minimum number of available measurement subframes among the reference cell and the measured neighbour cell i	The number of consecutive downlink subframes N_{PRS} among the reference cell and the measured neighbour cell i as defined in [24]	E-UTRA operating band groups ^{Note 5}	Minimum Io ^{Note 1}	Maximum Io
Ts ^{Note 2}	dB	RB				dBm/15kHz	dBm/BW _{Channel}
± 15	(PRS \hat{E}_s/lot) _{ref} ≥ -6 dB and (PRS \hat{E}_s/lot) _{i} ≥ -13 dB	≥ 6	≥ 12	≥ 6	FDD-M1_A, TDD-M1_A	-121	-50
					FDD-M1_B	-120.5	-50
					FDD-M1_C, TDD-M1_C	-120	-50
					FDD-M1_D	-119.5	-50
					FDD-M1_E, TDD-M1_E	-119	-50
					FDD-M1_F	-118.5	-50
					FDD-M1_G	-118	-50
					FDD-M1_H	-117.5	-50
					FDD-M1_N	-114.5	-50
± 6	(PRS \hat{E}_s/lot) _{ref} ≥ -6 dB and (PRS \hat{E}_s/lot) _{i} ≥ -13 dB	≥ 24	≥ 4	≥ 2	Note 7	Note 7	Note 7

NOTE 1: This minimum Io condition is expressed as the average Io per RE over all REs in an OFDM symbol.
 NOTE 2: Ts is the basic timing unit defined in TS 36.211 [26].
 NOTE 3: PRS bandwidth is as indicated in *prs-Bandwidth* in the OTDOA assistance data defined in TS 36.355 [4].
 NOTE 4: The Io is defined in PRS positioning subframes. The same Io range applies to PRS and non-PRS symbols. Io levels are different in PRS and non-PRS symbols within the same subframe.
 NOTE 5: E-UTRA operating band groups are as defined in Section 4.4.2.
 NOTE 6: The serving cell, the reference cell, and the measured neighbour cell i are on the same carrier frequency.
 NOTE 7: The same bands and the same Io conditions for each band apply for this requirement as for the corresponding requirement with the PRS bandwidth ≥ 6 RB.

The normative reference for this requirement is TS 36.133 [23] clause 9.1.25.4 and A.9.8.20.

9.3.7.2.4 Test description

9.3.7.2.4.1 Initial conditions

Same as in clause 9.3.7.1.4.1 adding Test 3 and Test 4 and replacing Table 9.3.7.1.4.1-1 with Table 9.3.7.2.4.1-1.

The true RSTD (which is the receive time difference for frame 0 between cell 2 and cell 1 as seen at the UE antenna connector) is set to the following values:

- Test 1: -92 Ts (about -3 μs)
- Test 2: 92 Ts (about 3 μs)
- Test 3: 92 Ts (about 3 μs)
- Test 4: -92 Ts (about -3 μs)

Note that the related expectedRSTD values to be signalled over LPP are defined in Table 9.3.7.2.4-1 for each test.

Table 9.3.7.2.4.1-1: General test parameters for E-UTRAN FDD intra-frequency RSTD measurement Accuracy under fading propagation conditions

Parameter	Unit	Value				Comment
		Test1	Test2	Test3	Test4	
M-PDCCH parameters		R.16 FDD		R.16 FDD		As specified in TS 36.521-3 [25] clause A.7.1.
<i>mPDCCH-startSF-UESS</i>		10		10		Parameter <i>G</i> in $T = r_{max} \cdot G$ which determines subframe <i>k0</i> in which MPDCCH starts
OCNG Patterns defined in TS 36.521-3 [25] clause D.1		OP.21 FDD		OP.21 FDD		OCNG shall be used such that both cells are fully allocated and a constant total transmitted power spectral density is achieved for all OFDM symbols (other than those in the PRS subframes).
Reference cell		Cell 1				
Neighbour cell		Cell 2				
E-UTRA RF Channel Number		1				One carrier frequency is used.
System channel Bandwidth (<i>BW_{channel}</i>)	MHz	10		10		
PRS Transmission Bandwidth ^{Note 2}	RB	50 ^{Note 4}		50 ^{Note 4}		PRS bandwidth is as indicated in <i>prs-Bandwidth</i> in the OTDOA assistance data defined in TS 36.355 [4].
PRS configuration Index ^{Note 2} <i>I_{PRS}</i>		151		151		As defined in TS 36.211 [26]
Number of consecutive positioning downlink subframes <i>N_{PRS}</i> ^{Note 2}		6		2		As defined in TS 36.211 [26]
<i>prs-MutingInfo</i> ^{Note 2}		Cell 1: '11110000' Cell 2: '11110000'				See section 6.5.1.2 in 3GPP TS 36.355 [4] for more information
Cell ID ^{Note 2}		(Cell ID of cell 1 – Cell ID of cell 2) mod 6 = 0	(Cell ID of cell 1 – Cell ID of cell 2) mod 6 = 1	(Cell ID of cell 1 – Cell ID of cell 2) mod 6 = 0	(Cell ID of cell 1 – Cell ID of cell 2) mod 6 = 3	

Expected RSTD ^{Note 1}	μs	Cell 2: 1 Other neighbour cells: randomly between -3 and 3	Cell 2: -1 Other neighbour cells: randomly between -3 and 3	Cell 2: -1 Other neighbour cells: randomly between -3 and 3	Cell 2: 1 Other neighbour cells: randomly between -3 and 3	
Expected RSTD uncertainty for all neighbour cells ^{Note 1}	μs	5	5	5	5	
CP length ^{Note 2}		Normal				
DRX		OFF				
Radio frame receive time offset between the cells at the UE antenna connector ^{Note 3}	μs	Cell 2 to Cell 1: -3	Cell 2 to Cell 1: 3	Cell 2 to Cell 1: 3	Cell 2 to Cell 1: -3	PRS are transmitted from synchronous cells
Number of cells provided in OTDOA assistance data		16				The number of cells includes the reference cell
T_{RSTD} IntraFreqFDD, E-UTRAN ^{Note 5}	ms	5120				Derived according to the RSTD measurement requirements specified in section 9.3.7.2.3

NOTE 1: Parameters “Expected RSTD” and “Expected RSTD uncertainty for all neighbour cells” are not settable parameters. These are parameters signalled in LPP only. For the values to be used in LPP see Table 9.3.7.1.4.3-4 and TS 37.571-5 [20], clause 7.2.5.

NOTE 2: Parameters “PRS Transmission Bandwidth”, “PRS configuration index”, “Number of consecutive positioning downlink subframes”, “prs-MutingInfo”, “Cell ID” and “CP length” are settable parameters and also parameters signalled in LPP. The values to be used for “Cell ID” are as follows: Cell 1: 0, Cell 2: Test 1: 6, Test 2: 7, Test 3: 6, Test 4: 9. For all the values to be used in LPP see Table 9.3.7.1.4.3-4 and TS 37.571-5 [20], clause 7.2.5.

NOTE 3: The parameter “Radio frame receive time offset between the cells at the UE antenna connector” is not a settable parameter but is used to set the “true RSTD” values in step 6 of clause 9.1.3.4.1.

NOTE 4: If the PRS transmission bandwidth is larger than the UE RF bandwidth, the UE is measuring RSTD within its RF bandwidth.

NOTE 5: The parameter “ T_{RSTD} IntraFreqFDD, E-UTRAN ” is not a settable parameter but is used to set the LPP “time” value in Table 9.3.7.1.4.3-3. The value of the LPP time IE is set to T_{RSTD} IntraFreqFDD, E-UTRAN + ΔT ms, where ΔT = 150 ms, giving a value of 5270 ms. This is rounded up to the next allowed LPP value of 6 seconds.

9.3.7.2.4.2 Test procedure

Same as in clause 9.3.7.1.4.2.

9.3.7.2.4.3 Message contents

Same as in clause 9.3.7.1.4.3.

9.3.7.2.5 Test requirement

Same as in clause 9.3.7.1.5 adding Test 3 and Test 4 and replacing Table 9.3.7.1.5-2 with Table 9.3.7.2.5-1:

Table 9.3.7.2.5-1: RSTD FDD intra-frequency accuracy requirements for the reported values

	Test 1	Test 2	Test 3	Test 4
Lowest reported value	RSTD_6257	RSTD_6440	RSTD_6440	RSTD_6257
Highest reported value	RSTD_6271	RSTD_6454	RSTD_6454	RSTD_6271

For the overall test to pass, the ratio of successful reported values in each sub-test shall be more than 90% with a confidence level of 95%.

9.3.8 HD-FDD intra-frequency RSTD Measurement Accuracy in CE Mode A

9.3.8.1 HD-FDD intra-frequency RSTD Measurement Accuracy in CE Mode A for Category M1

9.3.8.1.1 Test purpose

To verify that the RSTD measurement accuracy for UE Category M1 is within the specified limits normal coverage mode in an environment with fading propagation conditions.

9.3.8.1.2 Test applicability

This test applies to E-UTRA HD-FDD UE Category M1 release 14 and forward that supports UE-assisted OTDOA.

9.3.8.1.3 Minimum conformance requirements

Same as in clause 9.3.7.1.3.

The normative reference for this requirement is TS 36.133 [23] clause 9.1.21.20 and A.9.8.21.

9.3.8.1.4 Test description

9.3.8.1.4.1 Initial conditions

Same as in clause 9.3.7.1.4.1 but replacing Table 9.3.7.1.4.1-1 with Table 9.3.8.1.4.1-1

Table 9.3.8.1.4.1-1: General test parameters for E-UTRAN HD-FDD intra-frequency RSTD measurement Accuracy under fading propagation conditions

Parameter	Unit	Value		Comment
		Test 1	Test 2	
MPDCCH		R.6 HD-FDD		As specified in TS 36.521-3 [25] clause A.7.2
<i>mPDCCH-startSF-UeSS</i>		10		Parameter G in $T = r_{\max} \cdot G$ which determines subframe $k0$ in which MPDCCH starts
OCNG Patterns defined in TS 36.521-3 [25] clause D.1		OP.21 FDD		OCNG shall be used such that both cells are fully allocated and a constant total transmitted power spectral density is achieved for all OFDM symbols (other than those in the PRS subframes).
Reference cell		Cell 1		Reference cell is the cell in the OTDOA assistance data with respect to which the RSTD measurement is defined, as specified in 3GPP TS 36.214 [6] and 3GPP TS 36.355 [4]. The reference cell is the serving cell in this test case.
Neighbour cell		Cell 2		One carrier frequency is used.
E-UTRA RF Channel Number		1		
Channel Bandwidth (BW_{channel})	MHz	10		
PRS Transmission Bandwidth ^{Note 2}	RB	50 ^{Note 4}		PRS are transmitted over the system bandwidth

PRS configuration index I_{PRS} ^{Note 2}		151		This corresponds to periodicity of 320 ms and PRS subframe offset of $I_{PRS} - 160$ DL subframes, as defined in 3GPP TS 36.211 [26], Table 6.10.4.3-1
Number of consecutive downlink positioning subframes N_{PRS} ^{Note 2}		6		As defined in 3GPP TS 36.211 [26]. The number of subframes in a positioning occasion
PRS muting info ^{Note 2}		Cell 1: '11110000' Cell 2: '11110000'		Corresponds to prs-MutingInfo defined in TS 36.355 [4]
Physical cell ID PCI ^{Note 2}		(Cell ID of cell 1 – Cell ID of cell 2) mod 6 = 0	(Cell ID of cell 1 – Cell ID of cell 2) mod 6 = 1	
Expected RSTD ^{Note 1}	μs	Cell 2: 1 Other neighbour cells: randomly between -3 and 3	Cell 2: -1 Other neighbour cells: randomly between -3 and 3	The expected RSTD is what is expected at the receiver. The corresponding parameter in the OTDOA assistance data specified in TS 36.355 [4] is the expectedRSTD indicator
Expected RSTD uncertainty for all neighbour cells ^{Note 1}	μs	5	5	The corresponding parameter in the OTDOA assistance data specified in TS 36.355 [4] is the expectedRSTD-Uncertainty index
CP length ^{Note 2}		Normal		
DRX		OFF		
Radio frame receive time offset between the cells at the UE antenna connector ^{Note 3}	μs	Cell 2 to Cell 1: -3	Cell 2 to Cell 1: 3	PRS are transmitted from synchronous cells
Number of cells provided in OTDOA assistance data		16		Including the reference cell
$T_{RSTD \text{ IntraFreqHD-FDD, E-UTRAN}}$	ms	5120		Derived according to the RSTD measurement requirements specified in section 9.3.7.1.3
<p>Note 1: Parameters “Expected RSTD” and “Expected RSTD uncertainty for all neighbour cells” are not settable parameters. These are parameters signalled in LPP only. For the values to be used in LPP see Table 9.3.7.1.4.3-5 and TS 37.571-5 [20], clause 7.2.5.</p> <p>Note 2: Parameters “PRS Transmission Bandwidth”, “PRS configuration index”, “Number of consecutive positioning downlink subframes”, “prs-MutingInfo”, “Cell ID” and “CP length” are settable parameters and also parameters signalled in LPP. The values to be used for “Cell ID” are as follows: Cell 1: 0, Cell 2: Test 1: 6, Test 2: 7, Test 3: 6, Test 4: 9. For all the values to be used in LPP see Table 9.3.7.1.4.3-4 and TS 37.571-5 [20], clause 7.2.5.</p> <p>Note 3: The parameter “Radio frame receive time offset between the cells at the UE antenna connector” is not a settable parameter but is used to set the “true RSTD” values in step 6 of clause 9.3.7.1.4.1.</p> <p>Note 4: If the PRS transmission bandwidth is larger than the UE RF bandwidth, the UE is measuring RSTD within its RF bandwidth.</p> <p>Note 5: The parameter “$T_{RSTD \text{ IntraFreqHD-FDD, E-UTRAN}}$” is not a settable parameter but is used to set the LPP “time” value in Table 9.3.7.1.4.3-3. The value of the LPP time IE is set to $T_{RSTD \text{ IntraFreqHD-FDD, E-UTRAN}} + \Delta T$ ms, where $\Delta T = 150$ ms, giving a value of 5270 ms. This is rounded up to the next allowed LPP value of 6 seconds.</p>				

9.3.8.1.4.2 Test procedure

Same as in clause 9.3.7.1.4.2.

9.3.8.1.4.3 Message contents

Same as in clause 9.3.7.1.4.3

9.3.8.1.5 Test requirement

Same as in clause 9.3.7.1.5.

9.3.8.2 HD-FDD intra-frequency RSTD Measurement Accuracy in CE Mode A for Category M2

9.3.8.2.1 Test purpose

To verify that the RSTD measurement accuracy for UE Category M2 is within the specified limits normal coverage mode in an environment with fading propagation conditions.

9.3.8.2.2 Test applicability

This test applies to E-UTRA HD-FDD UE Category M2 release 14 and forward that supports UE-assisted OTDOA.

9.3.8.2.3 Minimum conformance requirements

Same as in clause 9.3.7.2.3.

The normative reference for this requirement is TS 36.133 [23] clause 9.1.25.4 and A.9.8.21.

9.3.8.2.4 Test description

9.3.8.2.4.1 Initial conditions

Same as in clause 9.3.7.2.4.1 but replacing Table 9.3.7.2.4.1-1 with Table 9.3.8.2.4.1-1.

Table 9.3.8.2.4.1-1: General test parameters for E-UTRAN HD-FDD intra-frequency RSTD measurement Accuracy under fading propagation conditions

Parameter	Unit	Value				Comment
		Test1	Test2	Test3	Test4	
M-PDCCH parameters		R.6 HD-FDD		R.6 HD-FDD		As specified in TS 36.521-3 [25] clause A.7.2.
<i>mPDCCH-startSF-UESS</i>		10		10		Parameter G in $T = r_{\max} \cdot G$ which determines subframe <i>k0</i> in which MPDCCH starts
OCNG Patterns defined in TS 36.521-3 [25] clause D.1		OP.21 FDD		OP.21 FDD		OCNG shall be used such that both cells are fully allocated and a constant total transmitted power spectral density is achieved for all OFDM symbols (other than those in the PRS subframes).
Reference cell		Cell 1				
Neighbour cell		Cell 2				
E-UTRA RF Channel Number		1				One carrier frequency is used.
System channel Bandwidth (BW_{channel})	MHz	10		10		
PRS Transmission Bandwidth Note 2	RB	50 ^{Note 4}		50 ^{Note 4}		PRS bandwidth is as indicated in <i>prs-Bandwidth</i> in the OTDOA assistance data defined in TS 36.355 [4].
PRS configuration Index I_{PRS} Note 2		151		151		As defined in TS 36.211 [26]

Number of consecutive positioning downlink subframes N_{PRS} ^{Note 2}		6		2		As defined in TS 36.211 [26]
prs-MutingInfo ^{Note 2}		Cell 1: '11110000' Cell 2: '11110000'				See section 6.5.1.2 in 3GPP TS 36.355 [4] for more information
Cell ID ^{Note 2}		(Cell ID of cell 1 – Cell ID of cell 2) mod 6 = 0	(Cell ID of cell 1 – Cell ID of cell 2) mod 6 = 1	(Cell ID of cell 1 – Cell ID of cell 2) mod 6 = 0	(Cell ID of cell 1 – Cell ID of cell 2) mod 6 = 3	
Expected RSTD ^{Note 1}	μs	Cell 2: 1 Other neighbour cells: randomly between -3 and 3	Cell 2: -1 Other neighbour cells: randomly between -3 and 3	Cell 2: -1 Other neighbour cells: randomly between -3 and 3	Cell 2: 1 Other neighbour cells: randomly between -3 and 3	
Expected RSTD uncertainty for all neighbour cells ^{Note 1}	μs	5	5	5	5	
CP length ^{Note 2}		Normal				
DRX		OFF				
Radio frame receive time offset between the cells at the UE antenna connector ^{Note 3}	μs	Cell 2 to Cell 1: -3	Cell 2 to Cell 1: 3	Cell 2 to Cell 1: 3	Cell 2 to Cell 1: -3	PRS are transmitted from synchronous cells
Number of cells provided in OTDOA assistance data		16				The number of cells includes the reference cell
T_{RSTD} IntraFreqHD-FDD, E-UTRAN ^{Note 5}	ms	5120				Derived according to the RSTD measurement requirements specified in section 9.3.7.2.3
<p>NOTE 1: Parameters “Expected RSTD” and “Expected RSTD uncertainty for all neighbour cells” are not settable parameters. These are parameters signalled in LPP only. For the values to be used in LPP see Table 9.3.7.1.4.3-4 and TS 37.571-5 [20], clause 7.2.5.</p> <p>NOTE 2: Parameters “PRS Transmission Bandwidth”, “PRS configuration index”, “Number of consecutive positioning downlink subframes”, “prs-MutingInfo”, “Cell ID” and “CP length” are settable parameters and also parameters signalled in LPP. The values to be used for “Cell ID” are as follows: Cell 1: 0, Cell 2: Test 1: 6, Test 2: 7, Test 3: 6, Test 4: 9. For all the values to be used in LPP see Table 9.3.7.1.4.3-4 and TS 37.571-5 [20], clause 7.2.5.</p> <p>NOTE 3: The parameter “Radio frame receive time offset between the cells at the UE antenna connector” is not a settable parameter but is used to set the “true RSTD” values in step 6 of clause 9.1.3.4.1.</p> <p>NOTE 4: If the PRS transmission bandwidth is larger than the UE RF bandwidth, the UE is measuring RSTD within its RF bandwidth.</p> <p>NOTE 5: The parameter “T_{RSTD} IntraFreqHD-FDD, E-UTRAN” is not a settable parameter but is used to set the LPP “time” value in Table 9.3.7.1.4.3-3. The value of the LPP time IE is set to T_{RSTD} IntraFreqHD-FDD, E-UTRAN + ΔT ms, where ΔT = 150 ms, giving a value of 5270 ms. This is rounded up to the next allowed LPP value of 6 seconds.</p>						

9.3.8.2.4.2 Test procedure

Same as in clause 9.3.7.1.4.2.

9.3.8.2.4.3 Message contents

Same as in clause 9.3.7.1.4.3.

9.3.8.2.5 Test requirement

Same as in clause 9.3.7.2.5.

For the overall test to pass, the ratio of successful reported values in each sub-test shall be more than 90% with a confidence level of 95%.

9.3.9 TDD intra-frequency RSTD Measurement Accuracy in CE Mode A

9.3.9.1 TDD intra-frequency RSTD Measurement Accuracy in CE Mode A for Category M1

9.3.9.1.1 Test purpose

To verify that the RSTD measurement accuracy for UE Category M1 is within the specified limits in normal coverage mode in an environment with fading propagation conditions.

9.3.9.1.2 Test applicability

This test applies to E-UTRA TDD UE Category M1 release 14 and forward that supports UE-assisted OTDOA.

9.3.9.1.3 Minimum conformance requirements

Same as in clause 9.3.7.1.3.

The normative reference for this requirement is TS 36.133 [23] clause 9.1.21.20 and A.9.8.22.

9.3.9.1.4 Test description

9.3.9.1.4.1 Initial conditions

Same as in clause 9.3.7.1.4.1 but replacing Table 9.3.7.1.4.1-1 with Table 9.3.9.1.4.1-1

Table 9.3.9.1.4.1-1: General test parameters for E-UTRAN TDD intra-frequency RSTD measurement Accuracy under fading propagation conditions

Parameter	Unit	Value		Comment
		Test 1	Test 2	
MPDCCH		R.14 TDD		As specified in TS 36.521-3 [25] clause A.7.3
<i>mPDCCH-startSF-UESS</i>		10		Parameter G in $T = r_{\max} \cdot G$ which determines subframe $k0$ in which MPDCCH starts
OCNG Patterns defined in TS 36.521-3 [25] clause D.1		OP.11 TDD		OCNG shall be used such that both cells are fully allocated and a constant total transmitted power spectral density is achieved for all OFDM symbols (other than those in the PRS subframes).
Reference cell		Cell 1		Reference cell is the cell in the OTDOA assistance data with respect to which the RSTD measurement is defined, as specified in 3GPP TS 36.214 [6] and 3GPP TS 36.355 [4]. The reference cell is the serving cell in this test case.
Neighbour cell		Cell 2		One carrier frequency is used.
E-UTRA RF Channel Number		1		
Channel Bandwidth (BW_{channel})	MHz	10		
Special subframe configuration		6		As specified in table 4.2-1 in TS 36.211 [26]. The same configuration in both cells.

Uplink-downlink configuration		1		As specified in table 4.2-2 in TS 36.211 [26] and table 8.1.2.5.2-2. The same configuration in both cells.
PRS Transmission Bandwidth ^{Note 2}	RB	50 ^{Note 4}		PRS are transmitted over the system bandwidth
PRS configuration index I_{PRS} ^{Note 2}		154		This corresponds to periodicity of 320 ms and PRS subframe offset of $I_{PRS} - 160$ DL subframes, as defined in 3GPP TS 36.211 [26], Table 6.10.4.3-1
Number of consecutive downlink positioning subframes N_{PRS} ^{Note 2}		6		As defined in 3GPP TS 36.211 [26]. The number of subframes in a positioning occasion
PRS muting info ^{Note 2}		Cell 1: '11110000' Cell 2: '11110000'		Corresponds to prs-MutingInfo defined in TS 36.355 [4]
Physical cell ID PCI ^{Note 2}		(Cell ID of cell 1 – Cell ID of cell 2) mod 6 = 0	(Cell ID of cell 1 – Cell ID of cell 2) mod 6 = 1	
Expected RSTD ^{Note 1}	μs	Cell 2: 1 Other neighbour cells: randomly between -3 and 3	Cell 2: -1 Other neighbour cells: randomly between -3 and 3	The expected RSTD is what is expected at the receiver. The corresponding parameter in the OTDOA assistance data specified in TS 36.355 [4] is the expectedRSTD indicator
Expected RSTD uncertainty for all neighbour cells ^{Note 1}	μs	5	5	The corresponding parameter in the OTDOA assistance data specified in TS 36.355 [4] is the expectedRSTD-Uncertainty index
CP length ^{Note 2}		Normal		
DRX		OFF		
Radio frame receive time offset between the cells at the UE antenna connector ^{Note 3}	μs	Cell 2 to Cell 1: -3	Cell 2 to Cell 1: 3	PRS are transmitted from synchronous cells
Number of cells provided in OTDOA assistance data		16		Including the reference cell
$T_{RSTD \text{ IntraFreqTDD, E-UTRAN}}$	ms	5120		Derived according to the RSTD measurement requirements specified in section 9.3.7.1.3
<p>Note 1: Parameters “Expected RSTD” and “Expected RSTD uncertainty for all neighbour cells” are not settable parameters. These are parameters signalled in LPP only. For the values to be used in LPP see Table 9.3.7.1.4.3-5 and TS 37.571-5 [20], clause 7.2.5.</p> <p>Note 2: Parameters “PRS Transmission Bandwidth”, “PRS configuration index”, “Number of consecutive positioning downlink subframes”, “prs-MutingInfo”, “Cell ID” and “CP length” are settable parameters and also parameters signalled in LPP. The values to be used for “Cell ID” are as follows: Cell 1: 0, Cell 2: Test 1: 6, Test 2: 7, Test 3: 6, Test 4: 9. For all the values to be used in LPP see Table 9.3.7.1.4.3-4 and TS 37.571-5 [20], clause 7.2.5.</p> <p>Note 3: The parameter “Radio frame receive time offset between the cells at the UE antenna connector” is not a settable parameter but is used to set the “true RSTD” values in step 6 of clause 9.3.7.1.4.1.</p> <p>Note 4: If the PRS transmission bandwidth is larger than the UE RF bandwidth, the UE is measuring RSTD within its RF bandwidth.</p> <p>Note 5: The parameter “$T_{RSTD \text{ IntraFreqTDD, E-UTRAN}}$” is not a settable parameter but is used to set the LPP “time” value in Table 9.3.7.1.4.3-3. The value of the LPP time IE is set to $T_{RSTD \text{ IntraFreqTDD, E-UTRAN}} + \Delta T$ ms, where $\Delta T = 150$ ms, giving a value of 5270 ms. This is rounded up to the next allowed LPP value of 6 seconds.</p>				

9.3.9.1.4.2 Test procedure

Same as in clause 9.3.7.1.4.2.

9.3.9.1.4.3 Message contents

Same as in clause 9.3.7.1.4.3

9.3.9.1.5 Test requirement

Same as in clause 9.3.7.1.5.

9.3.9.2 TDD intra-frequency RSTD Measurement Accuracy in CE Mode A for Category M2

9.3.9.2.1 Test purpose

To verify that the RSTD measurement accuracy for UE Category M2 is within the specified limits in normal coverage mode in an environment with fading propagation conditions.

9.3.9.2.2 Test applicability

This test applies to E-UTRA TDD UE Category M2 release 14 and forward that supports UE-assisted OTDOA.

9.3.9.2.3 Minimum conformance requirements

Same as in clause 9.3.7.2.3.

The normative reference for this requirement is TS 36.133 [23] clause 9.1.25.4 and A.9.8.22.

9.3.9.2.4 Test description

9.3.9.2.4.1 Initial conditions

Same as in clause 9.3.7.2.4.1 but replacing Table 9.3.7.2.4.1-1 with Table 9.3.9.2.4.1-1.

Table 9.3.9.2.4.1-1: General test parameters for E-UTRAN TDD intra-frequency RSTD measurement Accuracy under fading propagation conditions

Parameter	Unit	Value				Comment
		Test1	Test2	Test3	Test4	
M-PDCCH parameters		R.14 TDD		R.14 TDD		As specified in TS 36.521-3 [25] clause A.7.3.
<i>mPDCCH-startSF-UESS</i>		10		10		Parameter G in $T = r_{\max} \cdot G$ which determines subframe $k0$ in which MPDCCH starts
OCNG Patterns defined in TS 36.521-3 [25] clause D.1		OP.11 TDD		OP.11 FTDD		OCNG shall be used such that both cells are fully allocated and a constant total transmitted power spectral density is achieved for all OFDM symbols (other than those in the PRS subframes).
Reference cell		Cell 1				
Neighbour cell		Cell 2				
E-UTRA RF Channel Number		1				One carrier frequency is used.
System channel Bandwidth (BW_{channel})	MHz	10		10		

Special subframe configuration		6				As specified in table 4.2-1 in TS 36.211 [26]. The same configuration in both cells.
Uplink-downlink configuration		1				As specified in table 4.2-2 in TS 36.211 [26] and table 8.1.2.5.2-2. The same configuration in both cells.
PRS Transmission Bandwidth ^{Note 2}	RB	50 ^{Note 4}	50 ^{Note 4}			PRS bandwidth is as indicated in <i>prs-Bandwidth</i> in the OTDOA assistance data defined in TS 36.355 [4].
PRS configuration Index I_{PRS} ^{Note 2}		154	154			As defined in TS 36.211 [26]
Number of consecutive positioning downlink subframes N_{PRS} ^{Note 2}		6	2			As defined in TS 36.211 [26]
prs-MutingInfo ^{Note 2}		Cell 1: '11110000' Cell 2: '11110000'				See section 6.5.1.2 in 3GPP TS 36.355 [4] for more information
Cell ID ^{Note 2}		(Cell ID of cell 1 – Cell ID of cell 2) mod 6 = 0	(Cell ID of cell 1 – Cell ID of cell 2) mod 6 = 1	(Cell ID of cell 1 – Cell ID of cell 2) mod 6 = 0	(Cell ID of cell 1 – Cell ID of cell 2) mod 6 = 3	
Expected RSTD ^{Note 1}	μs	Cell 2: 1 Other neighbour cells: randomly between -3 and 3	Cell 2: -1 Other neighbour cells: randomly between -3 and 3	Cell 2: -1 Other neighbour cells: randomly between -3 and 3	Cell 2: 1 Other neighbour cells: randomly between -3 and 3	
Expected RSTD uncertainty for all neighbour cells ^{Note 1}	μs	5	5	5	5	
CP length ^{Note 2}		Normal				
DRX		OFF				
Radio frame receive time offset between the cells at the UE antenna connector ^{Note 3}	μs	Cell 2 to Cell 1: -3	Cell 2 to Cell 1: 3	Cell 2 to Cell 1: 3	Cell 2 to Cell 1: -3	PRS are transmitted from synchronous cells
Number of cells provided in OTDOA assistance data		16				The number of cells includes the reference cell
T_{RSTD} IntraFreqTDD, E-UTRAN ^{Note 5}	ms	5120				Derived according to the RSTD measurement requirements specified in section 9.3.7.2.3

NOTE 1: Parameters "Expected RSTD" and "Expected RSTD uncertainty for all neighbour cells" are not settable parameters. These are parameters signalled in LPP only. For the values to be used in LPP see Table 9.3.7.1.4.3-4 and TS 37.571-5 [20], clause 7.2.5.

NOTE 2: Parameters "PRS Transmission Bandwidth", "PRS configuration index", "Number of consecutive positioning downlink subframes", "prs-MutingInfo", "Cell ID" and "CP length" are settable parameters and also parameters signalled in LPP. The values to be used for "Cell ID" are as follows: Cell 1: 0, Cell 2: Test 1: 6, Test 2: 7, Test 3: 6, Test 4: 9. For all the values to be used in LPP see Table 9.3.7.1.4.3-4 and TS 37.571-5 [20], clause 7.2.5.

NOTE 3: The parameter "Radio frame receive time offset between the cells at the UE antenna connector" is not a settable parameter but is used to set the "true RSTD" values in step 6 of clause 9.1.3.4.1.

NOTE 4: If the PRS transmission bandwidth is larger than the UE RF bandwidth, the UE is measuring RSTD within its RF bandwidth.

NOTE 5: The parameter " $T_{\text{RSTD IntraFreqTDD, E-UTRAN}}$ " is not a settable parameter but is used to set the LPP "time" value in Table 9.3.7.1.4.3-3. The value of the LPP time IE is set to $T_{\text{RSTD IntraFreqTDD, E-UTRAN}} + \Delta T$ ms, where $\Delta T = 150$ ms, giving a value of 5270 ms. This is rounded up to the next allowed LPP value of 6 seconds.

9.3.9.2.4.2 Test procedure

Same as in clause 9.3.7.1.4.2.

9.3.9.2.4.3 Message contents

Same as in clause 9.3.7.1.4.3.

9.3.9.2.5 Test requirement

Same as in clause 9.3.7.2.5.

For the overall test to pass, the ratio of successful reported values in each sub-test shall be more than 90% with a confidence level of 95%.

9.3.10 FDD intra-frequency RSTD Measurement Accuracy in CE Mode B

9.3.10.1 FDD intra-frequency RSTD Measurement Accuracy in CE Mode B for Category M1

9.3.10.1.1 Test purpose

To verify that the RSTD measurement accuracy for UE Category M1 is within the specified limits in enhanced coverage mode in an environment with fading propagation conditions.

9.3.10.1.2 Test applicability

This test applies to E-UTRA FDD UE Category M1 release 14 and forward that supports UE-assisted OTDOA and CE Mode B.

9.3.10.1.3 Minimum conformance requirements

The accuracy requirements in Table 9.3.10.1.3-1 are valid under the following conditions:

Conditions defined in 36.101 [2] Clause 7.3 for reference sensitivity are fulfilled.

PRP $1,2_{\text{dBm}}$ according to Annex E.2 for a corresponding Band

For a UE that does not need a measurement gap for intra-frequency RSTD measurement, there are no measurement gaps overlapping with the PRS subframes of the measured serving cell and PRS are available within the UE measurement bandwidth in all PRS subframes

For a UE that needs a measurement gap for intra-frequency RSTD measurement, the measurement gaps are configured to contain PRS subframes

The parameter expectedRSTDUncertainty signalled over LPP by E-SMLC as defined in TS 36.355 [4] is less than 5 μ s.

Table 9.3.10.1.3-1: RSTD intra-frequency measurement accuracy for CEModeB

Accuracy	Conditions						
	PRS \hat{E}_s/lot	Minimum PRS bandwidth, which is minimum of serving cell channel bandwidth and the PRS bandwidths of the reference cell and the measured neighbour cell i <small>Notes 3, 6</small>	Minimum number of available measurement subframes among the reference cell and the measured neighbour cell i	The number of consecutive downlink subframes N_{PRS} among the reference cell and the measured neighbour cell i as defined in [24]	l_o <small>Note 4</small> range		
T_s <small>Note 2</small>	dB	RB			E-UTRA operating band groups <small>Note 5</small>	Minimum l_o <small>Note 1</small>	Maximum l_o
						dBm/15kHz	dBm/BW _{Channel}
± 15	(PRS \hat{E}_s/lot) _{ref} ≥ -15 dB and (PRS \hat{E}_s/lot) _{i} ≥ -15 dB	≥ 6	≥ 12	≥ 6	FDD-M1_A, TDD-M1_A	-121	-50
					FDD-M1_B	-120.5	-50
					FDD-M1_C, TDD-M1_C	-120	-50
					FDD-M1_D	-119.5	-50
					FDD-M1_E, TDD-M1_E	-119	-50
					FDD-M1_F	-118.5	-50
					FDD-M1_G	-118	-50
					FDD-M1_H	-117.5	-50
					FDD-M1_N	-114.5	-50

NOTE 1: This minimum l_o condition is expressed as the average l_o per RE over all REs in an OFDM symbol.
 NOTE 2: T_s is the basic timing unit defined in TS 36.211 [26].
 NOTE 3: PRS bandwidth is as indicated in *prs-Bandwidth* in the OTDOA assistance data defined in TS 36.355 [4].
 NOTE 4: The l_o is defined in PRS positioning subframes. The same l_o range applies to PRS and non-PRS symbols. l_o levels are different in PRS and non-PRS symbols within the same subframe.
 NOTE 5: E-UTRA operating band groups are as defined in Section 4.4.2.
 NOTE 6: The serving cell, the reference cell, and the measured neighbour cell i are on the same carrier frequency.

The normative reference for this requirement is TS 36.133 [23] clause 9.1.21.21 and A.9.8.23.

9.3.10.1.4 Test description

9.3.10.1.4.1 Initial conditions

Same as in clause 9.3.7.1.4.1 but replacing Table 9.3.7.1.4.1-1 with Table 9.3.10.1.4.1-1.

Table 9.3.10.1.4.1-1: General test parameters for E-UTRAN FDD intra-frequency RSTD measurement Accuracy under fading propagation conditions.

Parameter	Unit	Value		Comment
		Test 1	Test 2	

MPDCCH		R.18 FDD		As specified in TS 36.521-3 [25] clause A.7.1
$mPDCCH\text{-startSF-U ESS}$		10		Parameter G in $T = r_{\max} \cdot G$ which determines subframe $k0$ in which MPDCCH starts
OCNG Patterns defined in TS 36.521-3 [25] clause D.1		OP.21 FDD		OCNG shall be used such that both cells are fully allocated and a constant total transmitted power spectral density is achieved for all OFDM symbols (other than those in the PRS subframes).
Reference cell		Cell 1		Reference cell is the cell in the OTDOA assistance data with respect to which the RSTD measurement is defined, as specified in 3GPP TS 36.214 [6] and 3GPP TS 36.355 [4]. The reference cell is the serving cell in this test case.
Neighbour cell		Cell 2		One carrier frequency is used.
E-UTRA RF Channel Number		1		
Channel Bandwidth (BW_{channel})	MHz	10		
PRS Transmission Bandwidth ^{Note 2}	RB	50 ^{Note 4}		PRS are transmitted over the system bandwidth
PRS configuration index I_{PRS} ^{Note 2}		151		This corresponds to periodicity of 320 ms and PRS subframe offset of $I_{\text{PRS}} - 160$ DL subframes, as defined in 3GPP TS 36.211 [26], Table 6.10.4.3-1
Number of consecutive downlink positioning subframes N_{PRS} ^{Note 2}		6		As defined in 3GPP TS 36.211 [26]. The number of subframes in a positioning occasion
PRS muting info ^{Note 2}		Cell 1: '11110000' Cell 2: '11110000'		Corresponds to prs-MutingInfo defined in TS 36.355 [4]
Physical cell ID PCI ^{Note 2}		(Cell ID of cell 1 – Cell ID of cell 2) mod 6 = 0	(Cell ID of cell 1 – Cell ID of cell 2) mod 6 = 1	
Expected RSTD ^{Note 1}	μs	Cell 2: 1 Other neighbour cells: randomly between -3 and 3	Cell 2: -1 Other neighbour cells: randomly between -3 and 3	The expected RSTD is what is expected at the receiver. The corresponding parameter in the OTDOA assistance data specified in TS 36.355 [4] is the expectedRSTD indicator
Expected RSTD uncertainty for all neighbour cells ^{Note 1}	μs	5	5	The corresponding parameter in the OTDOA assistance data specified in TS 36.355 [4] is the expectedRSTD-Uncertainty index
CP length ^{Note 2}		Normal		
DRX		OFF		
Radio frame receive time offset between the cells at the UE antenna connector ^{Note 3}	μs	Cell 2 to Cell 1: -3	Cell 2 to Cell 1: 3	PRS are transmitted from synchronous cells
Number of cells provided in OTDOA assistance data		16		Including the reference cell
$T_{\text{RSTD IntraFreqFDD, E-UTRAN}}$	ms	12800		Derived according to the RSTD measurement requirements specified in section 9.3.10.1.3

- Note 1: Parameters “Expected RSTD” and “Expected RSTD uncertainty for all neighbour cells” are not settable parameters. These are parameters signalled in LPP only. For the values to be used in LPP see Table 9.3.10.1.4.3-5 and TS 37.571-5 [20], clause 7.2.5.
- Note 2: Parameters “PRS Transmission Bandwidth”, “PRS configuration index”, “Number of consecutive positioning downlink subframes”, “prs-MutingInfo”, “Cell ID” and “CP length” are settable parameters and also parameters signalled in LPP. The values to be used for “Cell ID” are as follows: Cell 1: 0, Cell 2: Test 1: 6, Test 2: 7, Test 3: 6, Test 4: 9. For all the values to be used in LPP see Table 9.3.10.1.4.3-4 and TS 37.571-5 [20], clause 7.2.5.
- Note 3: The parameter “Radio frame receive time offset between the cells at the UE antenna connector” is not a settable parameter but is used to set the “true RSTD” values in step 6 of clause 9.3.10.1.4.1.
- Note 4: If the PRS transmission bandwidth is larger than the UE RF bandwidth, the UE is measuring RSTD within its RF bandwidth.
- Note 5: The parameter “ $T_{RSTD \text{ IntraFreqFDD, E-UTRAN}}$ ” is not a settable parameter but is used to set the LPP “time” value in Table 9.3.10.1.4.3-3. The value of the LPP time IE is set to $T_{RSTD \text{ IntraFreqFDD, E-UTRAN}} + \Delta T$ ms, where $\Delta T = 150$ ms, giving a value of 12950 ms. This is rounded up to the next allowed LPP value of 13 seconds.

9.3.10.1.4.2 Test procedure

Same as in clause 9.3.7.1.4.2 but using condition CEModeB.

9.3.10.1.4.3 Message contents

Same as in clause 9.3.7.1.4.3 with the following exceptions

Table 9.3.10.1.4.3-1: LPP RequestLocationInformation

Derivation Path: Table 9.3.7.1.4.3-4			
Information Element	Value/remark	Comment	Condition
LPP-Message ::= SEQUENCE {			
lpp-MessageBody CHOICE {			
c1 CHOICE {			
requestLocationInformation SEQUENCE {			
criticalExtensions CHOICE {			
c1 CHOICE {			
requestLocationInformation-r9 SEQUENCE {			
commonIEsRequestLocationInformation SEQUENCE {			
qos SEQUENCE {			
responseTime SEQUENCE {			
time	13	See Note 4 in Table 9.3.10.1.4.1-1	
}			
}			
}			
}			
}			
}			
}			
}			
}			

9.3.10.1.5 Test requirement

Table 9.3.10.1.5-1 defines the primary level settings including test tolerances for the test.

The RSTD FDD intra-frequency accuracy test shall meet the reported values in Table 9.3.10.1.5-2

Table 9.3.10.1.5-1: Cell Specific Test Parameters for intra frequency RSTD Tests for E-UTRAN FDD

Parameter	Unit	Test1		Test2		Test3 ^{Note4}		Test4 ^{Note4}	
		Cell1	Cell2	Cell1	Cell2	Cell1	Cell2	Cell1	Cell2
E-UTRA RF Channel Number		1							
PBCH_RA	dB	0	0	0	0	0	0	0	0
PBCH_RB									
PSS_RA									
SSS_RA									
MPDCCH_RA									
MPDCCH_RB									
OCNG_RA ^{Note1}									
OCNG_RB ^{Note1}									
PRS_RA	dB	0	0	-2.7	0.3	0	0	-2.7	0.3
N_{oc} ^{Note2}	dBm/15 kHz	-98	-98	-98	-98	-98	-98	-98	-98
$PRS \hat{E}_s / N_{oc}$	dB	-5	-13	-14.7	-14.7	-5	-13	-14.7	-14.7
$PRS \hat{E}_s / I_{ot}$ ^{Note3}	dB	-5.21	-14.19	-14.7	-14.7	-5.21	-14.19	-14.7	-14.7
I_o ^{Note3}	dBm/9 MHz	-69.79	-69.79	-70.06	-70.06	-69.79	-69.79	-70.06	-70.06
PRP ^{Note3}	dBm/15kHz	-103	-111	-112.7	-112.7	-103	-111	-112.7	-112.7
\hat{E}_s / N_{oc} ^{Note 3}	dB	-5	-13	-12	-15	-5	-13	-12	-15
RSRP ^{Note 3}	dBm/15kHz	-103	-111	-110	-113	-103	-111	-110	-113
Propagation condition		AWGN							
<p>Note 1: OCNG shall be used such that both cells are fully allocated and a constant total transmitted power spectral density is achieved for all OFDM symbols (other than those in the PRS subframes).</p> <p>Note 2: Interference from other cells and noise sources not specified in the test is assumed to be constant over subcarriers and time and shall be modelled as AWGN of appropriate power for N_{oc} to be fulfilled.</p> <p>Note 3: \hat{E}_s / N_{oc}, $PRS \hat{E}_s / I_{ot}$, I_o, RSRP and PRP levels have been derived from other parameters for information purposes. They are not settable parameters themselves. I_o values are derived in the case that there is no PBCH, PSS or SSS in the OFDM symbols carrying PRS</p> <p>Note 4: Test3 and Test4 are not used for test 9.3.10.1</p>									

Table 9.3.10.1.5-2: RSTD FDD intra-frequency accuracy requirements for the reported values

	Test 1	Test 2
Lowest reported value	RSTD_6248	RSTD_6431
Highest reported value	RSTD_6280	RSTD_6463

The test tolerances are defined in clauses C.1.3 and C4.

For the overall test to pass, the ratio of successful reported values in each sub-test shall be more than 90% with a confidence level of 95%.

9.3.10.2 FDD intra-frequency RSTD Measurement Accuracy in CE Mode B for Category M2

9.3.10.2.1 Test purpose

To verify that the RSTD measurement accuracy for UE Category M2 is within the specified limits in enhanced coverage mode in an environment with fading propagation conditions.

9.3.10.2.2 Test applicability

This test applies to E-UTRA FDD UE Category M2 release 14 and forward that supports UE-assisted OTDOA and CE Mode B.

9.3.10.2.3 Minimum conformance requirements

The accuracy requirements in Table 9.3.10.2.3-1 are valid under the following conditions:

Conditions defined in 36.101 [2] Clause 7.3 for reference sensitivity are fulfilled.

PRP $1,2_{dBm}$ according to Annex E.2 for a corresponding Band

For a UE that does not need a measurement gap for intra-frequency RSTD measurement, there are no measurement gaps overlapping with the PRS subframes of the measured serving cell and PRS are available within the UE measurement bandwidth in all PRS subframes

For a UE that needs a measurement gap for intra-frequency RSTD measurement, the measurement gaps are configured to contain PRS subframes

The parameter $expectedRSTDUncertainty$ signalled over LPP by E-SMLC as defined in TS 36.355 [4] is less than 5 μs .

Table 9.3.10.2.3-1: RSTD intra-frequency measurement accuracy for CEModeB

Accuracy	PRS \hat{E}_s/lot	Minimum PRS bandwidth, which is minimum of serving cell channel bandwidth and the PRS bandwidths of the reference cell and the measured neighbour cell i Notes 3, 6	Conditions		Io ^{Note 4} range		
			Minimum number of available measurement subframes among the reference cell and the measured neighbour cell i	The number of consecutive downlink subframes N_{PRS} among the reference cell and the measured neighbour cell i as defined in [24]	E-UTRA operating band groups ^{Note 5}	Minimum Io ^{Note 1}	Maximum Io
Ts ^{Note 2}	dB	RB				dBm/15kHz	dBm/BW _{Channel}
± 15	(PRS $\hat{E}_s/lot)_{ref} \geq -15dB$ and (PRS $\hat{E}_s/lot)_i \geq -15dB$	≥ 6	≥ 12	≥ 6	FDD-M1_A, TDD-M1_A	-121	-50
					FDD-M1_B	-120.5	-50
					FDD-M1_C, TDD-M1_C	-120	-50
					FDD-M1_D	-119.5	-50
					FDD-M1_E, TDD-M1_E	-119	-50
					FDD-M1_F	-118.5	-50
					FDD-M1_G	-118	-50
					FDD-M1_H	-117.5	-50
					FDD-M1_N	-114.5	-50
± 6	(PRS $\hat{E}_s/lot)_{ref} \geq -15dB$ and (PRS $\hat{E}_s/lot)_i \geq -15dB$	≥ 24	≥ 4	≥ 4	Note 7	Note 7	Note 7

NOTE 1: This minimum Io condition is expressed as the average Io per RE over all REs in an OFDM symbol.

NOTE 2: T_s is the basic timing unit defined in TS 36.211 [26].
NOTE 3: PRS bandwidth is as indicated in <i>prs-Bandwidth</i> in the OTDOA assistance data defined in TS 36.355 [4].
NOTE 4: The l_0 is defined in PRS positioning subframes. The same l_0 range applies to PRS and non-PRS symbols. l_0 levels are different in PRS and non-PRS symbols within the same subframe.
NOTE 5: E-UTRA operating band groups are as defined in Section 4.4.2.
NOTE 6: The serving cell, the reference cell, and the measured neighbour cell i are on the same carrier frequency.
NOTE 7: The same bands and the same l_0 conditions for each band apply for this requirement as for the corresponding requirement with the PRS bandwidth ≥ 6 RB.

The normative reference for this requirement is TS 36.133 [23] clause 9.1.25.5 and A.9.8.23.

9.3.10.2.4 Test description

9.3.10.2.4.1 Initial conditions

Same as in clause 9.3.10.1.4.1 adding Test 3 and Test 4 and replacing Table 9.3.10.1.4.1-1 with Table 9.3.10.2.4.1-1.

The true RSTD (which is the receive time difference for frame 0 between cell 2 and cell 1 as seen at the UE antenna connector) is set to the following values:

- Test 1: $-92 T_s$ (about $-3 \mu s$)
- Test 2: $92 T_s$ (about $3 \mu s$)
- Test 3: $92 T_s$ (about $3 \mu s$)
- Test 4: $-92 T_s$ (about $-3 \mu s$)

Note that the related expectedRSTD values to be signalled over LPP are defined in Table 9.3.10.2.4-1 for each test.

Table 9.3.10.2.4.1-1: General test parameters for E-UTRAN FDD intra-frequency RSTD measurement Accuracy under fading propagation conditions

Parameter	Unit	Value				Comment
		Test1	Test2	Test3	Test4	
M-PDCCH parameters		R.18 FDD		R.18 FDD		As specified in TS 36.521-3 [25] clause A.7.1.
<i>mPDCCH-startSF-UESS</i>		10		10		Parameter G in $T = r_{\max} \cdot G$ which determines subframe k_0 in which MPDCCH starts
OCNG Patterns defined in TS 36.521-3 [25] clause D.1		OP.21 FDD		OP.21 FDD		OCNG shall be used such that both cells are fully allocated and a constant total transmitted power spectral density is achieved for all OFDM symbols (other than those in the PRS subframes).
Reference cell		Cell 1				
Neighbour cell		Cell 2				
E-UTRA RF Channel Number		1				One carrier frequency is used.
System channel Bandwidth (BW_{channel})	MHz	10		10		
PRS Transmission Bandwidth ^{Note 2}	RB	50 ^{Note 4}		50 ^{Note 4}		PRS bandwidth is as indicated in <i>prs-Bandwidth</i> in the OTDOA assistance data defined in TS 36.355 [4].
PRS configuration Index ^{Note 2} I_{PRS}		151		151		As defined in TS 36.211 [26]

Number of consecutive positioning downlink subframes N_{PRS} ^{Note 2}		6		4		As defined in TS 36.211 [26]
prs-MutingInfo ^{Note 2}		Cell 1: '11110000' Cell 2: '11110000'				See section 6.5.1.2 in 3GPP TS 36.355 [4] for more information
Cell ID ^{Note 2}		(Cell ID of cell 1 – Cell ID of cell 2) mod 6 = 0	(Cell ID of cell 1 – Cell ID of cell 2) mod 6 = 1	(Cell ID of cell 1 – Cell ID of cell 2) mod 6 = 0	(Cell ID of cell 1 – Cell ID of cell 2) mod 6 = 3	
Expected RSTD ^{Note 1}	μs	Cell 2: 1 Other neighbour cells: randomly between -3 and 3	Cell 2: -1 Other neighbour cells: randomly between -3 and 3	Cell 2: -1 Other neighbour cells: randomly between -3 and 3	Cell 2: 1 Other neighbour cells: randomly between -3 and 3	
Expected RSTD uncertainty for all neighbour cells ^{Note 1}	μs	5	5	5	5	
CP length ^{Note 2}		Normal				
DRX		OFF				
Radio frame receive time offset between the cells at the UE antenna connector ^{Note 3}	μs	Cell 2 to Cell 1: -3	Cell 2 to Cell 1: 3	Cell 2 to Cell 1: 3	Cell 2 to Cell 1: -3	PRS are transmitted from synchronous cells
Number of cells provided in OTDOA assistance data		16				The number of cells includes the reference cell
$T_{RSTD \text{ IntraFreqFDD, E-UTRAN}}$ ^{Note 5}	ms	12800		5120		Derived according to the RSTD measurement requirements specified in section 9.3.10.2.3

NOTE 1: Parameters “Expected RSTD” and “Expected RSTD uncertainty for all neighbour cells” are not settable parameters. These are parameters signalled in LPP only. For the values to be used in LPP see Table 9.3.10.1.4.3-4 and TS 37.571-5 [20], clause 7.2.5.

NOTE 2: Parameters “PRS Transmission Bandwidth”, “PRS configuration index”, “Number of consecutive positioning downlink subframes”, “prs-MutingInfo”, “Cell ID” and “CP length” are settable parameters and also parameters signalled in LPP. The values to be used for “Cell ID” are as follows: Cell 1: 0, Cell 2: Test 1: 6, Test 2: 7, Test 3: 6, Test 4: 9. For all the values to be used in LPP see Table 9.3.10.1.4.3-4 and TS 37.571-5 [20], clause 7.2.5.

NOTE 3: The parameter “Radio frame receive time offset between the cells at the UE antenna connector” is not a settable parameter but is used to set the “true RSTD” values in step 6 of clause 9.1.3.4.1.

NOTE 4: If the PRS transmission bandwidth is larger than the UE RF bandwidth, the UE is measuring RSTD within its RF bandwidth.

NOTE 5: The parameter “ $T_{RSTD \text{ IntraFreqFDD, E-UTRAN}}$ ” is not a settable parameter but is used to set the LPP “time” value in Table 9.3.10.2.4.3-1. The value of the LPP time IE is set to $T_{RSTD \text{ IntraFreqFDD, E-UTRAN}} + \Delta T$ ms, where $\Delta T = 150$ ms, giving a value of 12950 ms for Test 1 and 2 and 5270 ms for Test 3 and 4. This is rounded up to the next allowed LPP value of 13 or 6 seconds, respectively.

9.3.10.2.4.2 Test procedure

Same as in clause 9.3.7.1.4.2 but using condition CEModeB.

9.3.10.2.4.3 Message contents

Same as in clause 9.3.7.1.4.3 with the following exceptions:

Table 9.3.10.2.4.3-1: LPP RequestLocationInformation

Derivation Path: Table 9.3.7.1.4.3-4			
Information Element	Value/remark	Comment	Condition

LPP-Message ::= SEQUENCE {			
lpp-MessageBody CHOICE {			
c1 CHOICE {			
requestLocationInformation SEQUENCE {			
criticalExtensions CHOICE {			
c1 CHOICE {			
requestLocationInformation-r9 SEQUENCE {			
commonIEsRequestLocationInformation SEQUENCE {			
qos SEQUENCE {			
responseTime SEQUENCE {			
time	13	See Note 4 in Table 9.3.10.2.4.1-1	Test 1 or Test 2
time	6	See Note 4 in Table 9.3.10.2.4.1-1	Test 3 or Test 4
}			
}			
}			
}			
}			
}			

9.3.10.2.5 Test requirement

Same as in clause 9.3.10.1.5 but replacing Table 9.3.10.1.5-2 with Table 9.3.10.2.5-1:

Table 9.3.10.2.5-1: RSTD FDD intra-frequency accuracy requirements for the reported values

	Test 1	Test 2	Test 3	Test 4
Lowest reported value	RSTD_6257	RSTD_6440	RSTD_6440	RSTD_6257
Highest reported value	RSTD_6271	RSTD_6454	RSTD_6454	RSTD_6271

For the overall test to pass, the ratio of successful reported values in each sub-test shall be more than 90% with a confidence level of 95%.

9.3.11 HD-FDD intra-frequency RSTD Measurement Accuracy in CE Mode B

9.3.11.1 HD-FDD intra-frequency RSTD Measurement Accuracy in CE Mode B for Category M1

9.3.11.1.1 Test purpose

To verify that the RSTD measurement accuracy for UE Category M1 is within the specified limits enhanced coverage mode in an environment with fading propagation conditions.

9.3.11.1.2 Test applicability

This test applies to E-UTRA HD-FDD UE Category M1 release 14 and forward that supports UE-assisted OTDOA and CE Mode B.

9.3.11.1.3 Minimum conformance requirements

Same as in clause 9.3.10.1.3.

The normative reference for this requirement is TS 36.133 [23] clause 9.1.21.21 and A.9.8.24.

9.3.11.1.4 Test description

9.3.11.1.4.1 Initial conditions

Same as in clause 9.3.10.1.4.1 but replacing Table 9.3.10.1.4.1-1 with Table 9.3.11.1.4.1-1

Table 9.3.11.1.4.1-1: General test parameters for E-UTRAN HD-FDD intra-frequency RSTD measurement Accuracy under fading propagation conditions

Parameter	Unit	Value		Comment
		Test 1	Test 2	
MPDCCH		R.8 HD-FDD		As specified in TS 36.521-3 [25] clause A.7.2
<i>mPDCCH-startSF-UeSS</i>		10		Parameter G in $T = r_{\max} \cdot G$ which determines subframe $k0$ in which MPDCCH starts
OCNG Patterns defined in TS 36.521-3 [25] clause D.1		OP.21 FDD		OCNG shall be used such that both cells are fully allocated and a constant total transmitted power spectral density is achieved for all OFDM symbols (other than those in the PRS subframes).
Reference cell		Cell 1		Reference cell is the cell in the OTDOA assistance data with respect to which the RSTD measurement is defined, as specified in 3GPP TS 36.214 [6] and 3GPP TS 36.355 [4]. The reference cell is the serving cell in this test case.
Neighbour cell		Cell 2		One carrier frequency is used.
E-UTRA RF Channel Number		1		
Channel Bandwidth (BW_{channel})	MHz	10		
PRS Transmission Bandwidth ^{Note 2}	RB	50 ^{Note 4}		PRS are transmitted over the system bandwidth
PRS configuration index I_{PRS} ^{Note 2}		151		This corresponds to periodicity of 320 ms and PRS subframe offset of $I_{\text{PRS}} - 160$ DL subframes, as defined in 3GPP TS 36.211 [26], Table 6.10.4.3-1
Number of consecutive downlink positioning subframes N_{PRS} ^{Note 2}		6		As defined in 3GPP TS 36.211 [26]. The number of subframes in a positioning occasion
PRS muting info ^{Note 2}		Cell 1: '11110000' Cell 2: '11110000'		Corresponds to prs-MutingInfo defined in TS 36.355 [4]
Physical cell ID PCI ^{Note 2}		(Cell ID of cell 1 – Cell ID of cell 2) mod 6 = 0	(Cell ID of cell 1 – Cell ID of cell 2) mod 6 = 1	
Expected RSTD ^{Note 1}	μs	Cell 2: 1 Other neighbour cells: randomly between -3 and 3	Cell 2: -1 Other neighbour cells: randomly between -3 and 3	The expected RSTD is what is expected at the receiver. The corresponding parameter in the OTDOA assistance data specified in TS 36.355 [4] is the expectedRSTD indicator
Expected RSTD uncertainty for all neighbour cells ^{Note 1}	μs	5	5	The corresponding parameter in the OTDOA assistance data specified in TS 36.355 [4] is the expectedRSTD-Uncertainty index
CP length ^{Note 2}		Normal		
DRX		OFF		

Radio frame receive time offset between the cells at the UE antenna connector Note 3	μs	Cell 2 to Cell 1: -3	Cell 2 to Cell 1: 3	PRS are transmitted from synchronous cells
Number of cells provided in OTDOA assistance data		16		Including the reference cell
$T_{\text{RSTD IntraFreqHD-FDD, E-UTRAN}}$	ms	12800		Derived according to the RSTD measurement requirements specified in section 9.3.10.1.3
<p>Note 1: Parameters "Expected RSTD" and "Expected RSTD uncertainty for all neighbour cells" are not settable parameters. These are parameters signalled in LPP only. For the values to be used in LPP see Table 9.3.10.1.4.3-5 and TS 37.571-5 [20], clause 7.2.5.</p> <p>Note 2: Parameters "PRS Transmission Bandwidth", "PRS configuration index", "Number of consecutive positioning downlink subframes", "prs-MutingInfo", "Cell ID" and "CP length" are settable parameters and also parameters signalled in LPP. The values to be used for "Cell ID" are as follows: Cell 1: 0, Cell 2: Test 1: 6, Test 2: 7, Test 3: 6, Test 4: 9. For all the values to be used in LPP see Table 9.3.10.1.4.3-4 and TS 37.571-5 [20], clause 7.2.5.</p> <p>Note 3: The parameter "Radio frame receive time offset between the cells at the UE antenna connector" is not a settable parameter but is used to set the "true RSTD" values in step 6 of clause 9.3.10.1.4.1.</p> <p>Note 4: If the PRS transmission bandwidth is larger than the UE RF bandwidth, the UE is measuring RSTD within its RF bandwidth.</p> <p>Note 5: The parameter "$T_{\text{RSTD IntraFreqHD-FDD, E-UTRAN}}$" is not a settable parameter but is used to set the LPP "time" value in Table 9.3.10.1.4.3-3. The value of the LPP time IE is set to $T_{\text{RSTD IntraFreqHD-FDD, E-UTRAN}} + \Delta T$ ms, where $\Delta T = 150$ ms, giving a value of 12950 ms. This is rounded up to the next allowed LPP value of 13 seconds.</p>				

9.3.11.1.4.2 Test procedure

Same as in clause 9.3.7.1.4.2 but using condition CEModeB.

9.3.11.1.4.3 Message contents

Same as in clause 9.3.10.1.4.3.

9.3.11.1.5 Test requirement

Same as in clause 9.3.10.1.5.

9.3.11.2 HD-FDD intra-frequency RSTD Measurement Accuracy in CE Mode B for Category M2

9.3.11.2.1 Test purpose

To verify that the RSTD measurement accuracy for UE Category M2 is within the specified limits enhanced coverage mode in an environment with fading propagation conditions.

9.3.11.2.2 Test applicability

This test applies to E-UTRA HD-FDD UE Category M2 release 14 and forward that supports UE-assisted OTDOA and CE Mode B.

9.3.11.2.3 Minimum conformance requirements

Same as in clause 9.3.10.2.3.

The normative reference for this requirement is TS 36.133 [23] clause 9.1.25.5 and A.9.8.24.

9.3.11.2.4 Test description

9.3.11.2.4.1 Initial conditions

Same as in clause 9.3.10.2.4.1 but replacing Table 9.3.10.2.4.1-1 with Table 9.3.11.2.4.1-1.

Table 9.3.11.2.4.1-1: General test parameters for E-UTRAN HD-FDD intra-frequency RSTD measurement Accuracy under fading propagation conditions

Parameter	Unit	Value				Comment
		Test1	Test2	Test3	Test4	
M-PDCCH parameters		R.8 HD-FDD		R.8 HD-FDD		As specified in TS 36.521-3 [25] clause A.7.2.
<i>mPDCCH-startSF-U ESS</i>		10		10		Parameter G in $T = r_{max} \cdot G$ which determines subframe <i>k0</i> in which MPDCCH starts
OCNG Patterns defined in TS 36.521-3 [25] clause D.1		OP.21 FDD		OP.21 FDD		OCNG shall be used such that both cells are fully allocated and a constant total transmitted power spectral density is achieved for all OFDM symbols (other than those in the PRS subframes).
Reference cell		Cell 1				
Neighbour cell		Cell 2				
E-UTRA RF Channel Number		1				One carrier frequency is used.
System channel Bandwidth ($BW_{channel}$)	MHz	10		10		
PRS Transmission Bandwidth <small>Note 2</small>	RB	50 <small>Note 4</small>		50 <small>Note 4</small>		PRS bandwidth is as indicated in <i>prs-Bandwidth</i> in the OTDOA assistance data defined in TS 36.355 [4].
PRS configuration Index I_{PRS} <small>Note 2</small>		151		151		As defined in TS 36.211 [26]
Number of consecutive positioning downlink subframes N_{PRS} <small>Note 2</small>		6		4		As defined in TS 36.211 [26]
<i>prs-MutingInfo</i> <small>Note 2</small>		Cell 1: '11110000' Cell 2: '11110000'				See section 6.5.1.2 in 3GPP TS 36.355 [4] for more information
Cell ID <small>Note 2</small>		(Cell ID of cell 1 – Cell ID of cell 2) mod 6 = 0	(Cell ID of cell 1 – Cell ID of cell 2) mod 6 = 1	(Cell ID of cell 1 – Cell ID of cell 2) mod 6 = 0	(Cell ID of cell 1 – Cell ID of cell 2) mod 6 = 3	
Expected RSTD <small>Note 1</small>	µs	Cell 2: 1 Other neighbour cells: randomly between -3 and 3	Cell 2: -1 Other neighbour cells: randomly between -3 and 3	Cell 2: -1 Other neighbour cells: randomly between -3 and 3	Cell 2: 1 Other neighbour cells: randomly between -3 and 3	
Expected RSTD uncertainty for all neighbour cells <small>Note 1</small>	µs	5	5	5	5	
CP length <small>Note 2</small>		Normal				
DRX		OFF				

Radio frame receive time offset between the cells at the UE antenna connector ^{Note 3}	µs	Cell 2 to Cell 1: -3	Cell 2 to Cell 1: 3	Cell 2 to Cell 1: 3	Cell 2 to Cell 1: -3	PRS are transmitted from synchronous cells
Number of cells provided in OTDOA assistance data		16				The number of cells includes the reference cell
$T_{\text{RSTD IntraFreqHD-FDD, E-UTRAN}}$ ^{Note 5}	ms	12800		5120		Derived according to the RSTD measurement requirements specified in section 9.3.10.2.3
<p>NOTE 1: Parameters “Expected RSTD” and “Expected RSTD uncertainty for all neighbour cells” are not settable parameters. These are parameters signalled in LPP only. For the values to be used in LPP see Table 9.3.10.1.4.3-4 and TS 37.571-5 [20], clause 7.2.5.</p> <p>NOTE 2: Parameters “PRS Transmission Bandwidth”, “PRS configuration index”, “Number of consecutive positioning downlink subframes”, “prs-MutingInfo”, “Cell ID” and “CP length” are settable parameters and also parameters signalled in LPP. The values to be used for “Cell ID” are as follows: Cell 1: 0, Cell 2: Test 1: 6, Test 2: 7, Test 3: 6, Test 4: 9. For all the values to be used in LPP see Table 9.3.10.1.4.3-4 and TS 37.571-5 [20], clause 7.2.5.</p> <p>NOTE 3: The parameter “Radio frame receive time offset between the cells at the UE antenna connector” is not a settable parameter but is used to set the “true RSTD” values in step 6 of clause 9.1.3.4.1.</p> <p>NOTE 4: If the PRS transmission bandwidth is larger than the UE RF bandwidth, the UE is measuring RSTD within its RF bandwidth.</p> <p>NOTE 5: The parameter “$T_{\text{RSTD IntraFreqHD-FDD, E-UTRAN}}$” is not a settable parameter but is used to set the LPP “time” value in Table 9.3.10.2.4.3-1. The value of the LPP time IE is set to $T_{\text{RSTD IntraFreqHD-FDD, E-UTRAN}} + \Delta T$ ms, where $\Delta T = 150$ ms, giving a value of 12950 ms for Test 1 and 2 and 5270 ms for Test 3 and 4. This is rounded up to the next allowed LPP value of 13 or 6 seconds, respectively.</p>						

9.3.11.2.4.2 Test procedure

Same as in clause 9.3.7.1.4.2 but using condition CEModeB.

9.3.11.2.4.3 Message contents

Same as in clause 9.3.10.2.4.3.

9.3.11.2.5 Test requirement

Same as in clause 9.3.10.2.5.

For the overall test to pass, the ratio of successful reported values in each sub-test shall be more than 90% with a confidence level of 95%.

9.3.12 TDD intra-frequency RSTD Measurement Accuracy in CE Mode B

9.3.12.1 TDD intra-frequency RSTD Measurement Accuracy in CE Mode B for Category M1

9.3.12.1.1 Test purpose

To verify that the RSTD measurement accuracy for UE Category M1 is within the specified limits in enhanced coverage mode in an environment with fading propagation conditions.

9.3.12.1.2 Test applicability

This test applies to E-UTRA TDD UE Category M1 release 14 and forward that supports UE-assisted OTDOA and CE Mode B.

9.3.12.1.3 Minimum conformance requirements

Same as in clause 9.3.10.1.3.

The normative reference for this requirement is TS 36.133 [23] clause 9.1.21.21 and A.9.8.25.

9.3.12.1.4 Test description

9.3.12.1.4.1 Initial conditions

Same as in clause 9.3.10.1.4.1 but replacing Table 9.3.10.1.4.1-1 with Table 9.3.12.1.4.1-1

Table 9.3.12.1.4.1-1: General test parameters for E-UTRAN TDD intra-frequency RSTD measurement Accuracy under fading propagation conditions

Parameter	Unit	Value		Comment
		Test 1	Test 2	
MPDCCH		R.16 TDD		As specified in TS 36.521-3 [25] clause A.7.3
$mPDCCH\text{-startSF-U ESS}$		10		Parameter G in $T = r_{\max} \cdot G$ which determines subframe $k0$ in which MPDCCH starts
OCNG Patterns defined in TS 36.521-3 [25] clause D.1		OP.11 TDD		OCNG shall be used such that both cells are fully allocated and a constant total transmitted power spectral density is achieved for all OFDM symbols (other than those in the PRS subframes).
Reference cell		Cell 1		Reference cell is the cell in the OTDOA assistance data with respect to which the RSTD measurement is defined, as specified in 3GPP TS 36.214 [6] and 3GPP TS 36.355 [4]. The reference cell is the serving cell in this test case.
Neighbour cell		Cell 2		One carrier frequency is used.
E-UTRA RF Channel Number		1		
Channel Bandwidth (BW_{channel})	MHz	10		
Special subframe configuration		6		As specified in table 4.2-1 in TS 36.211 [26]. The same configuration in both cells.
Uplink-downlink configuration		1		As specified in table 4.2-2 in TS 36.211 [26] and table 8.1.2.5.2-2. The same configuration in both cells.
PRS Transmission Bandwidth ^{Note 2}	RB	50 ^{Note 4}		PRS are transmitted over the system bandwidth
PRS configuration index I_{PRS} ^{Note 2}		154		This corresponds to periodicity of 320 ms and PRS subframe offset of $I_{\text{PRS}} - 160$ DL subframes, as defined in 3GPP TS 36.211 [26], Table 6.10.4.3-1
Number of consecutive downlink positioning subframes N_{PRS} ^{Note 2}		6		As defined in 3GPP TS 36.211 [26]. The number of subframes in a positioning occasion
PRS muting info ^{Note 2}		Cell 1: '11110000' Cell 2: '11110000'		Corresponds to prs-MutingInfo defined in TS 36.355 [4]
Physical cell ID PCI ^{Note 2}		(Cell ID of cell 1 – Cell ID of cell 2) mod 6 = 0	(Cell ID of cell 1 – Cell ID of cell 2) mod 6 = 1	

Expected RSTD ^{Note 1}	μs	Cell 2: 1 Other neighbour cells: randomly between -3 and 3	Cell 2: -1 Other neighbour cells: randomly between -3 and 3	The expected RSTD is what is expected at the receiver. The corresponding parameter in the OTDOA assistance data specified in TS 36.355 [4] is the expectedRSTD indicator
Expected RSTD uncertainty for all neighbour cells ^{Note 1}	μs	5	5	The corresponding parameter in the OTDOA assistance data specified in TS 36.355 [4] is the expectedRSTD-Uncertainty index
CP length ^{Note 2}		Normal		
DRX		OFF		
Radio frame receive time offset between the cells at the UE antenna connector ^{Note 3}	μs	Cell 2 to Cell 1: -3	Cell 2 to Cell 1: 3	PRS are transmitted from synchronous cells
Number of cells provided in OTDOA assistance data		16		Including the reference cell
$T_{\text{RSTD IntraFreqTDD, E-UTRAN}}$	ms	12800		Derived according to the RSTD measurement requirements specified in section 9.3.10.1.3
<p>Note 1: Parameters "Expected RSTD" and "Expected RSTD uncertainty for all neighbour cells" are not settable parameters. These are parameters signalled in LPP only. For the values to be used in LPP see Table 9.3.10.1.4.3-5 and TS 37.571-5 [20], clause 7.2.5.</p> <p>Note 2: Parameters "PRS Transmission Bandwidth", "PRS configuration index", "Number of consecutive positioning downlink subframes", "prs-MutingInfo", "Cell ID" and "CP length" are settable parameters and also parameters signalled in LPP. The values to be used for "Cell ID" are as follows: Cell 1: 0, Cell 2: Test 1: 6, Test 2: 7, Test 3: 6, Test 4: 9. For all the values to be used in LPP see Table 9.3.10.1.4.3-4 and TS 37.571-5 [20], clause 7.2.5.</p> <p>Note 3: The parameter "Radio frame receive time offset between the cells at the UE antenna connector" is not a settable parameter but is used to set the "true RSTD" values in step 6 of clause 9.3.10.1.4.1.</p> <p>Note 4: If the PRS transmission bandwidth is larger than the UE RF bandwidth, the UE is measuring RSTD within its RF bandwidth.</p> <p>Note 5: The parameter "$T_{\text{RSTD IntraFreqTDD, E-UTRAN}}$" is not a settable parameter but is used to set the LPP "time" value in Table 9.3.10.1.4.3-3. The value of the LPP time IE is set to $T_{\text{RSTD IntraFreqTDD, E-UTRAN}} + \Delta T$ ms, where $\Delta T = 150$ ms, giving a value of 12950 ms. This is rounded up to the next allowed LPP value of 13 seconds.</p>				

9.3.12.1.4.2 Test procedure

Same as in clause 9.3.7.1.4.2 but using condition CEModeB.

9.3.12.1.4.3 Message contents

Same as in clause 9.3.10.1.4.3.

9.3.12.1.5 Test requirement

Same as in clause 9.3.10.1.5.

9.3.12.2 TDD intra-frequency RSTD Measurement Accuracy in CE Mode B for Category M2

9.3.12.2.1 Test purpose

To verify that the RSTD measurement accuracy for UE Category M2 is within the specified limits in enhanced coverage mode in an environment with fading propagation conditions.

9.3.12.2.2 Test applicability

This test applies to E-UTRA TDD UE Category M2 release 14 and forward that supports UE-assisted OTDOA and CE Mode B.

9.3.12.2.3 Minimum conformance requirements

Same as in clause 9.3.20.1.3.

The normative reference for this requirement is TS 36.133 [23] clause 9.1.25.5 and A.9.8.25.

9.3.12.2.4 Test description

9.3.12.2.4.1 Initial conditions

Same as in clause 9.3.10.2.4.1 but replacing Table 9.3.10.2.4.1-1 with Table 9.3.12.2.4.1-1.

Table 9.3.12.2.4.1-1: General test parameters for E-UTRAN TDD intra-frequency RSTD measurement Accuracy under fading propagation conditions

Parameter	Unit	Value				Comment
		Test1	Test2	Test3	Test4	
M-PDCCH parameters		R.16 TDD		R.16 TDD		As specified in TS 36.521-3 [25] clause A.7.3.
<i>mPDCCH-startSF-UESS</i>		10		10		Parameter G in $T = r_{\max} \cdot G$ which determines subframe $k0$ in which MPDCCH starts
OCNG Patterns defined in TS 36.521-3 [25] clause D.1		OP.11 TDD		OP.11 TDD		OCNG shall be used such that both cells are fully allocated and a constant total transmitted power spectral density is achieved for all OFDM symbols (other than those in the PRS subframes).
Reference cell		Cell 1				
Neighbour cell		Cell 2				
E-UTRA RF Channel Number		1				One carrier frequency is used.
System channel Bandwidth (BW_{channel})	MHz	10		10		
Special subframe configuration		6				As specified in table 4.2-1 in TS 36.211 [26]. The same configuration in both cells.
Uplink-downlink configuration		1				As specified in table 4.2-2 in TS 36.211 [26] and table 8.1.2.5.2-2. The same configuration in both cells.
PRS Transmission Bandwidth ^{Note 2}	RB	50 ^{Note 4}		50 ^{Note 4}		PRS bandwidth is as indicated in <i>prs-Bandwidth</i> in the OTDOA assistance data defined in TS 36.355 [4].
PRS configuration Index ^{Note 2} I_{PRS}		154		154		As defined in TS 36.211 [26]

Number of consecutive positioning downlink subframes N_{PRS} ^{Note 2}		6		4		As defined in TS 36.211 [26]
prs-MutingInfo ^{Note 2}		Cell 1: '11110000' Cell 2: '11110000'				See section 6.5.1.2 in 3GPP TS 36.355 [4] for more information
Cell ID ^{Note 2}		(Cell ID of cell 1 – Cell ID of cell 2) mod 6 = 0	(Cell ID of cell 1 – Cell ID of cell 2) mod 6 = 1	(Cell ID of cell 1 – Cell ID of cell 2) mod 6 = 0	(Cell ID of cell 1 – Cell ID of cell 2) mod 6 = 3	
Expected RSTD ^{Note 1}	μs	Cell 2: 1 Other neighbour cells: randomly between -3 and 3	Cell 2: -1 Other neighbour cells: randomly between -3 and 3	Cell 2: -1 Other neighbour cells: randomly between -3 and 3	Cell 2: 1 Other neighbour cells: randomly between -3 and 3	
Expected RSTD uncertainty for all neighbour cells ^{Note 1}	μs	5	5	5	5	
CP length ^{Note 2}		Normal				
DRX		OFF				
Radio frame receive time offset between the cells at the UE antenna connector ^{Note 3}	μs	Cell 2 to Cell 1: -3	Cell 2 to Cell 1: 3	Cell 2 to Cell 1: 3	Cell 2 to Cell 1: -3	PRS are transmitted from synchronous cells
Number of cells provided in OTDOA assistance data		16				The number of cells includes the reference cell
$T_{RSTD \text{ IntraFreqTDD, E-UTRAN}}$ ^{Note 5}	ms	12800		5120		Derived according to the RSTD measurement requirements specified in section 9.3.10.2.3
<p>NOTE 1: Parameters “Expected RSTD” and “Expected RSTD uncertainty for all neighbour cells” are not settable parameters. These are parameters signalled in LPP only. For the values to be used in LPP see Table 9.3.10.1.4.3-4 and TS 37.571-5 [20], clause 7.2.5.</p> <p>NOTE 2: Parameters “PRS Transmission Bandwidth”, “PRS configuration index”, “Number of consecutive positioning downlink subframes”, “prs-MutingInfo”, “Cell ID” and “CP length” are settable parameters and also parameters signalled in LPP. The values to be used for “Cell ID” are as follows: Cell 1: 0, Cell 2: Test 1: 6, Test 2: 7, Test 3: 6, Test 4: 9. For all the values to be used in LPP see Table 9.3.10.1.4.3-4 and TS 37.571-5 [20], clause 7.2.5.</p> <p>NOTE 3: The parameter “Radio frame receive time offset between the cells at the UE antenna connector” is not a settable parameter but is used to set the “true RSTD” values in step 6 of clause 9.1.3.4.1.</p> <p>NOTE 4: If the PRS transmission bandwidth is larger than the UE RF bandwidth, the UE is measuring RSTD within its RF bandwidth.</p> <p>NOTE 5: The parameter “$T_{RSTD \text{ IntraFreqTDD, E-UTRAN}}$” is not a settable parameter but is used to set the LPP “time” value in Table 9.3.10.2.4.3-3. The value of the LPP time IE is set to $T_{RSTD \text{ IntraFreqTDD, E-UTRAN}} + \Delta T$ ms, where $\Delta T = 150$ ms, giving a value of 12950 ms for Test 1 and 2 and 5270 ms for Test 3 and 4. This is rounded up to the next allowed LPP value of 13 or 6 seconds, respectively.</p>						

9.3.12.2.4.2 Test procedure

Same as in clause 9.3.7.1.4.2 but using condition CEModeB.

9.3.12.2.4.3 Message contents

Same as in clause 9.3.10.1.4.3.

9.3.12.2.5 Test requirement

Same as in clause 9.3.10.2.5.

For the overall test to pass, the ratio of successful reported values in each sub-test shall be more than 90% with a confidence level of 95%.

9.3.13 E-UTRAN FDD intra-frequency RSTD measurement period test case in CE Mode A with longer PRS occasions

9.3.13.1 Test purpose

To verify that the RSTD measurement reporting delay with longer PRS occasions for UE Category M1 and M2 meets the performance requirements in normal coverage mode in an environment with fading propagation conditions.

9.3.13.2 Test applicability

This test applies to E-UTRA FDD UE Category M1 and M2 release 15 and forward that supports UE-assisted OTDOA and dense PRS configuration or additional PRS configuration.

9.3.13.3 Minimum conformance requirements

Same as in clause 9.3.1.1.3

The normative reference for this requirement is TS 36.133 [23] clause 8.13.2.3.1, 8.16.2.3.1 and A.8.12.9.

9.3.13.4 Test description

9.3.13.4.1 Initial conditions

Test Environment: Normal; as defined in TS 36.508 [18] clause 4.1.

Frequencies to be tested: Mid Range, as defined in TS 36.508 [18] clause 4.3.1.1.

Channel bandwidth to be tested: 10 MHz as defined in TS 36.508 [18] clause 4.3.1.

1. Connect the SS, faders and AWGN noise sources to the UE antenna connector or antenna connectors as shown in Annex A, Figure A.4 using only the main Tx/Rx antenna of the UE.
2. The general test parameter settings are set up according to Table 9.3.13.4.1-1.
3. Propagation conditions are set according to clause 4.7.2.1.
4. Message contents are defined in clause 9.3.13.4.3.
5. In the test there are three synchronized cells: Cell 1, Cell 2 and Cell 3. Cell 1 is the OTDOA assistance data reference as well as the serving cell. Cell 2 and Cell 3 are the neighbour cells. All cells are on the same RF channel. Cell 3 in the test is the Cell 4 defined in clause 4.7.1. The assistance data neighbour cell list includes in total 15 cells, where 13 of the cells are not simulated (dummy cells; as defined in 3GPP TS 37.571-5 clause 7.2.5).
6. The true RSTD (which is the receive time difference for frame 0 between two cells as seen at the UE antenna connector) is set to 31 Ts (about 1 μ s) between neighbour Cell 2 and serving Cell 1; and set to -31 Ts (about -1 μ s) between neighbour Cell 3 and serving Cell 1.

Table 9.3.13.4.1-1: General test parameters

Parameter	Unit	Value	Comment
Reference cell		Cell 1	Reference cell is the cell in the OTDOA assistance data with respect to which the RSTD measurement is defined, as specified in 3GPP TS 36.214 [6] and 3GPP TS 36.355 [4]. The reference cell is the serving cell in this test case.

Neighbour cells		Cell 2 and Cell 3	Cell 2 and Cell 3 appear at random places in the neighbour cell list in the OTDOA assistance data, but Cell 2 always appears in the first half of the list, whilst Cell 3 appears in the second half of the list.
MPDCCH		DL Reference Measurement Channel R.16 FDD	As specified in TS 36.521-3 [25] clause A.7.1
$mPDCCH\text{-startSF-UeSS}$		10	Parameter G in $T = r_{\max} \cdot G$ which determines subframe $k0$ in which MPDCCH starts
Channel Bandwidth (BW_{channel})	MHz	10	
PRS Transmission Bandwidth ^{Note 2}	RB	6	PRS are transmitted in the centre RBs
PRS configuration index I_{PRS} ^{Note 2}		311	This corresponds to periodicity of 320 ms and PRS subframe offset of $I_{\text{PRS}} - 160$ DL subframes, as defined in 3GPP TS 36.211 [26], Table 6.10.4.3-1
Gap pattern Id		rstd6	As specified in TS 36.133 [23] Table 8.1.2.1-3. Applies for measurements on Cell 1, Cell 2, and Cell 3
Gap offset		150	As specified in TS 36.331 [22], Clause 6.3.5
Number of consecutive downlink positioning subframes N_{PRS} ^{Note 2}		12	As defined in 3GPP TS 36.211 [26]. The number of subframes in a positioning occasion. Corresponds to parameter <i>add-numDL-Frames</i> in TS 36.355 [4], for UE with <i>additional-prs-config</i> capability
		20	As defined in 3GPP TS 36.211 [26]. The number of subframes in a positioning occasion. Corresponds to parameter <i>add-numDL-Frames</i> in TS 36.355 [4], for UE with <i>densePrsConfig</i> capability
Physical cell ID PCI ^{Note 2}		(PCI of Cell 1 – PCI of Cell 2) mod 6 = 0 and (PCI of Cell 1 – PCI of Cell 3) mod 6 = 0	The cell PCIs are selected such that the relative shifts of PRS patterns among cells are as given by the test parameters
CP length ^{Note 2}		Normal	
DRX		ON	DRX parameters are further specified in Table 9.3.13.4.1-2
Radio frame receive time offset between the cells at the UE antenna connector ^{Note 3}	μs	Cell 2 to Cell 1: 1 Cell 3 to Cell 1: -1	PRS are transmitted from synchronous cells
Expected RSTD ^{Note 1}	μs	Cell 2: 3 Cell 3: 3 Other neighbour cells: randomly between -3 and 3	The expected RSTD is what is expected at the receiver. The corresponding parameter in the OTDOA assistance data specified in TS 36.355 [4] is the <i>expectedRSTD</i> indicator
Expected RSTD uncertainty for all neighbour cells ^{Note 1}	μs	5	The corresponding parameter in the OTDOA assistance data specified in TS 36.355 [4] is the <i>expectedRSTD-Uncertainty</i> index
Number of cells provided in OTDOA assistance data		16	Including the reference cell

PRS muting info ^{Note 2}		Cell 1: '11110000' Cell 2: '00001111' Cell 3: '11110000'	Corresponds to prs-MutingInfo defined in TS 36.355 [4]
T1	s	3	The length of the time interval from the beginning of each test
T2	s	1.28	The length of the time interval that follows immediately after time interval T1
T3	s	1.60	The length of the time interval that follows immediately after time interval T2
<p>Note 1: Parameters "Expected RSTD" and "Expected RSTD uncertainty for all neighbour cells" are not settable parameters. These are parameters signalled in LPP only. For the values to be used in LPP see Table 9.3.13.4.3-5 and TS 37.571-5 [20], clause 7.2.5.</p> <p>Note 2: Parameters "PRS Transmission Bandwidth", "PRS configuration index", "Number of consecutive downlink positioning subframes", "Physical cell ID PCI", "CP length", and "PRS muting info" are settable parameters and also parameters signalled in LPP. The values to be used for "Physical cell ID PCI" are as follows: Cell 1: 0, Cell 2: 6, Cell 3: 12. For all the values to be used in LPP see Table 9.3.13.4.3-5 and TS 37.571-5 [20], clause 7.2.5.</p> <p>Note 3: The parameter "Radio frame receive time offset between the cells at the UE antenna connector" is not a settable parameter but is used to set the "true RSTD" values in step 6 of clause 9.3.13.4.1.</p> <p>Note 4: If the PRS transmission bandwidth is larger than the UE RF bandwidth, the UE is measuring RSTD within its RF bandwidth.</p>			

Table 9.3.13.4.1-2: DRX parameters

Field	Value	Comment
onDurationTimer	psf1	As specified in 3GPP TS 36.331 [22], clause 6.3.2
drx-InactivityTimer	psf1	
drx-RetransmissionTimer	sf1	
longDRX-CycleStartOffset	sf320	
shortDRX	Disable	

9.3.13.4.2 Test procedure

Same as in clause 9.3.1.1.4.2.

9.3.13.4.3 Message contents

Same as in clause 9.3.1.1.4.3 with the following exceptions:

Table 9.3.13.4.3-1: LPP RequestLocationInformation

Derivation Path: Table 9.3.1.1.4.3-4			
Information Element	Value/remark	Comment	Condition
LPP-Message ::= SEQUENCE {			
lpp-MessageBody CHOICE {			
c1 CHOICE {			
requestLocationInformation SEQUENCE {			
criticalExtensions CHOICE {			
c1 CHOICE {			
requestLocationInformation-r9 SEQUENCE {			
commonIEsRequestLocationInformation SEQUENCE {			
qos SEQUENCE {			
responseTime SEQUENCE {			
time	3	See clause 9.3.13.5	
}			
}			
}			
}			
}			
}			
}			
}			
}			
}			

}			
}			
}			
}			
}			

9.3.13.5 Test requirement

Table 9.3.1.1.5-1 and 9.3.1.1.5-2 define the primary level settings including test tolerances for the test.

The response time including test tolerance is 3300ms. The response time is equal to the LPP time IE value plus the test tolerance. The LPP time IE value is derived from the RSTD reporting delay plus ΔT , where $\Delta T = N_{rep} \times TTI_{DCCH} = N_{rep} \times 75$ ms, giving a value of 2955 ms. This is rounded up to the next allowed LPP value of 3 seconds. The RSTD measurement reporting delay in the test is derived from the following expression

$T_{RSTD \text{ IntraFreqFDD, Cat}_M} = T_{PRS} \cdot (M - 1) + \Delta + T_{MIB}$, where $T_{PRS}=320\text{ms}$, $M=8$, $\Delta = T_{PRS} \cdot \left\lceil \frac{n}{M} \right\rceil$ and $n=16$ are the parameters specified in clause 9.3.13.3, Table 9.3.1.1.3-1 and Note 4 of Table 9.3.13.4.1-1. This gives the total RSTD reporting delay of 2880 ms for the 15 neighbour cells including Cell 2 and Cell 3 with respect to the reference cell, Cell 1.

The test tolerances are defined in clauses C.1.3 and C4.

The rate of successful tests during repeated tests shall be at least 90% with a confidence level of 95%.

9.3.14 E-UTRAN HD-FDD intra-frequency RSTD measurement period test case in CE Mode A with longer PRS occasions

9.3.14.1 Test purpose

To verify that the RSTD measurement reporting delay with longer PRS occasions for UE Category M1 and M2 meets the performance requirements in normal coverage mode in an environment with fading propagation conditions.

9.3.14.2 Test applicability

This test applies to E-UTRA HD-FDD UE Category M1 and M2 release 15 and forward that supports UE-assisted OTDOA and dense PRS configuration or additional PRS configuration.

9.3.14.3 Minimum conformance requirements

Same as in clause 9.3.2.1.3

The normative reference for this requirement is TS 36.133 [23] clause 8.13.2.3.3, 8.16.2.3.3 and A.8.12.10.

9.3.14.4 Test description

9.3.14.4.1 Initial conditions

Same as in clause 9.3.13.4.1 but replacing Table 9.3.13.4.1-1 with Table 9.3.14.4.1-1

Table 9.3.14.4.1-1: General test parameters

Parameter	Unit	Value	Comment
-----------	------	-------	---------

Reference cell		Cell 1	Reference cell is the cell in the OTDOA assistance data with respect to which the RSTD measurement is defined, as specified in 3GPP TS 36.214 [6] and 3GPP TS 36.355 [4]. The reference cell is the serving cell in this test case.
Neighbour cells		Cell 2 and Cell 3	Cell 2 and Cell 3 appear at random places in the neighbour cell list in the OTDOA assistance data, but Cell 2 always appears in the first half of the list, whilst Cell 3 appears in the second half of the list.
MPDCCH		DL Reference Measurement Channel R.6 HD-FDD	As specified in TS 36.521-3 [25] clause A.7.1
$mPDCCH\text{-startSF-UeSS}$		10	Parameter G in $T = r_{\max} \cdot G$ which determines subframe $k0$ in which MPDCCH starts
Channel Bandwidth (BW _{channel})	MHz	10	
PRS Transmission Bandwidth ^{Note 2}	RB	6	PRS are transmitted in the centre RBs
PRS configuration index I_{PRS} ^{Note 2}		311	This corresponds to periodicity of 320 ms and PRS subframe offset of $I_{\text{PRS}} - 160$ DL subframes, as defined in 3GPP TS 36.211 [26], Table 6.10.4.3-1
Gap pattern Id		rstd6	As specified in TS 36.133 [23] Table 8.1.2.1-3. Applies for measurements on Cell 1, Cell 2, and Cell 3
Gap offset		150	As specified in TS 36.331 [22], Clause 6.3.5
Number of consecutive downlink positioning subframes N_{PRS} ^{Note 2}		12	As defined in 3GPP TS 36.211 [26]. The number of subframes in a positioning occasion. Corresponds to parameter <i>add-numDL-Frames</i> in TS 36.355 [4], for UE with <i>additional-prs-config</i> capability
		20	As defined in 3GPP TS 36.211 [26]. The number of subframes in a positioning occasion. Corresponds to parameter <i>add-numDL-Frames</i> in TS 36.355 [4], for UE with <i>densePrsConfig</i> capability
Physical cell ID PCI ^{Note 2}		(PCI of Cell 1 – PCI of Cell 2)mod6=0 and (PCI of Cell 1 – PCI of Cell 3)mod6=0	The cell PCIs are selected such that the relative shifts of PRS patterns among cells are as given by the test parameters
CP length ^{Note 2}		Normal	
DRX		ON	DRX parameters are further specified in Table 9.3.14.4.1-2
Radio frame receive time offset between the cells at the UE antenna connector ^{Note 3}	μs	Cell 2 to Cell 1: 1 Cell 3 to Cell 1: -1	PRS are transmitted from synchronous cells
Expected RSTD ^{Note 1}	μs	Cell 2: 3 Cell 3: 3 Other neighbour cells: randomly between -3 and 3	The expected RSTD is what is expected at the receiver. The corresponding parameter in the OTDOA assistance data specified in TS 36.355 [4] is the expectedRSTD indicator

Expected RSTD uncertainty for all neighbour cells ^{Note 1}	μs	5	The corresponding parameter in the OTDOA assistance data specified in TS 36.355 [4] is the expectedRSTD-Uncertainty index
Number of cells provided in OTDOA assistance data		16	Including the reference cell
PRS muting info ^{Note 2}		Cell 1: '11110000' Cell 2: '00001111' Cell 3: '11110000'	Corresponds to prs-MutingInfo defined in TS 36.355 [4]
T1	s	3	The length of the time interval from the beginning of each test
T2	s	1.28	The length of the time interval that follows immediately after time interval T1
T3	s	1.60	The length of the time interval that follows immediately after time interval T2
<p>Note 1: Parameters "Expected RSTD" and "Expected RSTD uncertainty for all neighbour cells" are not settable parameters. These are parameters signalled in LPP only. For the values to be used in LPP see Table 9.3.14.4.3-5 and TS 37.571-5 [20], clause 7.2.5.</p> <p>Note 2: Parameters "PRS Transmission Bandwidth", "PRS configuration index", "Number of consecutive downlink positioning subframes", "Physical cell ID PCI", "CP length", and "PRS muting info" are settable parameters and also parameters signalled in LPP. The values to be used for "Physical cell ID PCI" are as follows: Cell 1: 0, Cell 2: 6, Cell 3: 12. For all the values to be used in LPP see Table 9.3.14.4.3-5 and TS 37.571-5 [20], clause 7.2.5.</p> <p>Note 3: The parameter "Radio frame receive time offset between the cells at the UE antenna connector" is not a settable parameter but is used to set the "true RSTD" values in step 6 of clause 9.3.14.4.1.</p> <p>Note 4: If the PRS transmission bandwidth is larger than the UE RF bandwidth, the UE is measuring RSTD within its RF bandwidth.</p>			

Table 9.3.14.4.1-2: DRX parameters

Field	Value	Comment
onDurationTimer	psf1	As specified in 3GPP TS 36.331 [22], clause 6.3.2
drx-InactivityTimer	psf1	
drx-RetransmissionTimer	sf1	
longDRX-CycleStartOffset	sf320	
shortDRX	Disable	

9.3.14.4.2 Test procedure

Same as in clause 9.3.1.1.4.2.

9.3.14.4.3 Message contents

Same as in clause 9.3.13.4.3.

9.3.14.5 Test requirement

Same as in clause 9.3.13.5.

9.3.15 E-UTRAN TDD intra-frequency RSTD measurement period test case in CE Mode A with longer PRS occasions

9.3.15.1 Test purpose

To verify that the RSTD measurement reporting delay with longer PRS occasions for UE Category M1 and M2 meets the performance requirements in normal coverage mode in an environment with fading propagation conditions.

9.3.15.2 Test applicability

This test applies to E-UTRA TDD UE Category M1 and M2 release 15 and forward that supports UE-assisted OTDOA and dense PRS configuration or additional PRS configuration.

9.3.15.3 Minimum conformance requirements

Same as in clause 9.3.2.1.3

The intra-frequency requirements in this clause shall apply for all TDD special subframe configurations specified in TS 36.211 [26] and for the TDD uplink-downlink configurations as specified in Table 9.3.3.1.3-1.

Table 9.3.3.1.3-1: TDD uplink-downlink subframe configurations applicable for TDD intra-frequency requirements

PRS Transmission Bandwidth [RB]	Applicable TDD uplink-downlink configurations
6	1, 2, 3, 4 and 5
Note: Uplink-downlink configurations are specified in Table 4.2-2 in TS 36.211 [26].	

The normative reference for this requirement is TS 36.133 [23] clause 8.13.2.3.2, 8.16.2.3.2 and A.8.12.11.

9.3.15.4 Test description

9.3.15.4.1 Initial conditions

Same as in clause 9.3.13.4.1 but replacing Table 9.3.13.4.1-1 with Table 9.3.15.4.1-1

Table 9.3.15.4.1-1: General test parameters

Parameter	Unit	Value	Comment
Reference cell		Cell 1	Reference cell is the cell in the OTDOA assistance data with respect to which the RSTD measurement is defined, as specified in 3GPP TS 36.214 [6] and 3GPP TS 36.355 [4]. The reference cell is the serving cell in this test case.
Neighbour cells		Cell 2 and Cell 3	Cell 2 and Cell 3 appear at random places in the neighbour cell list in the OTDOA assistance data, but Cell 2 always appears in the first half of the list, whilst Cell 3 appears in the second half of the list.
MPDCCH		DL Reference Measurement Channel R.14 TDD	As specified in TS 36.521-3 [25] clause A.7.1
$mPDCCH\text{-startSF-U ESS}$		10	Parameter G in $T = r_{\max} \cdot G$ which determines subframe $k0$ in which MPDCCH starts
Channel Bandwidth (BW_{channel})	MHz	10	
PRS Transmission Bandwidth ^{Note 2}	RB	6	PRS are transmitted in the center RBs
PRS configuration index I_{PRS} ^{Note 2}		304	This corresponds to periodicity of 320 ms and PRS subframe offset of $I_{\text{PRS}} - 160$ DL subframes, as defined in 3GPP TS 36.211 [26], Table 6.10.4.3-1

Gap pattern Id		rstd6	As specified in TS 36.133 [23] Table 8.1.2.1-3. Applies for measurements on Cell 1, Cell 2, and Cell 3
Gap offset		143	As specified in TS 36.331 [22], Clause 6.3.5
Number of consecutive downlink positioning subframes N_{PRS} ^{Note 2}		12	As defined in 3GPP TS 36.211 [26]. The number of subframes in a positioning occasion. Corresponds to parameter <i>add-numDL-Frames</i> in TS 36.355 [4], for UE with <i>additional-prs-config</i> capability
		20	As defined in 3GPP TS 36.211 [26]. The number of subframes in a positioning occasion. Corresponds to parameter <i>add-numDL-Frames</i> in TS 36.355 [4], for UE with <i>densePrsConfig</i> capability
Physical cell ID PCI ^{Note 2}		(PCI of Cell 1 – PCI of Cell 2) mod 6 = 0 and (PCI of Cell 1 – PCI of Cell 3) mod 6 = 0	The cell PCIs are selected such that the relative shifts of PRS patterns among cells are as given by the test parameters
CP length ^{Note 2}		Normal	
TDD uplink-downlink configuration		1	As specified in TS 36.211 [16], Clause 4.2; corresponds to a configuration with 5 ms switch-point periodicity and two downlink consecutive subframes
TDD special subframe configuration		6	As specified in TS 36.211 [16], Clause 4.2; corresponds to DwPTS of $19760 \cdot T_s$ and UpPTS of $4384 \cdot T_s$
DRX		ON	DRX parameters are further specified in Table 9.3.15.4.1-2
Radio frame receive time offset between the cells at the UE antenna connector ^{Note 3}	μs	Cell 2 to Cell 1: 1 Cell 3 to Cell 1: -1	PRS are transmitted from synchronous cells
Expected RSTD ^{Note 1}	μs	Cell 2: 3 Cell 3: 3 Other neighbour cells: randomly between -3 and 3	The expected RSTD is what is expected at the receiver. The corresponding parameter in the OTDOA assistance data specified in TS 36.355 [4] is the <i>expectedRSTD</i> indicator
Expected RSTD uncertainty for all neighbour cells ^{Note 1}	μs	5	The corresponding parameter in the OTDOA assistance data specified in TS 36.355 [4] is the <i>expectedRSTD-Uncertainty</i> index
Number of cells provided in OTDOA assistance data		16	Including the reference cell
PRS muting info ^{Note 2}		Cell 1: '11110000' Cell 2: '00001111' Cell 3: '11110000'	Corresponds to <i>prs-MutingInfo</i> defined in TS 36.355 [4]
T1	s	3	The length of the time interval from the beginning of each test
T2	s	1.28	The length of the time interval that follows immediately after time interval T1
T3	s	1.60	The length of the time interval that follows immediately after time interval T2

Note 1:	Parameters “Expected RSTD” and “Expected RSTD uncertainty for all neighbour cells” are not settable parameters. These are parameters signalled in LPP only. For the values to be used in LPP see Table 9.3.15.4.3-5 and TS 37.571-5 [20], clause 7.2.5.
Note 2:	Parameters “PRS Transmission Bandwidth”, “PRS configuration index”, “Number of consecutive downlink positioning subframes”, “Physical cell ID PCI”, “CP length”, and “PRS muting info” are settable parameters and also parameters signalled in LPP. The values to be used for “Physical cell ID PCI” are as follows: Cell 1: 0, Cell 2: 6, Cell 3: 12. For all the values to be used in LPP see Table 9.3.15.4.3-5 and TS 37.571-5 [20], clause 7.2.5.
Note 3:	The parameter “Radio frame receive time offset between the cells at the UE antenna connector” is not a settable parameter but is used to set the “true RSTD” values in step 6 of clause 9.3.15.4.1.
Note 4:	If the PRS transmission bandwidth is larger than the UE RF bandwidth, the UE is measuring RSTD within its RF bandwidth.

Table 9.3.15.4.1-2: DRX parameters

Field	Value	Comment
onDurationTimer	psf1	As specified in 3GPP TS 36.331 [22], clause 6.3.2
drx-InactivityTimer	psf1	
drx-RetransmissionTimer	sf1	
longDRX-CycleStartOffset	sf320	
shortDRX	Disable	

9.3.15.4.2 Test procedure

Same as in clause 9.3.1.1.4.2.

9.3.15.4.3 Message contents

Same as in clause 9.3.13.4.3.

9.3.15.5 Test requirement

Table 9.3.3.1.5-1 and 9.3.3.1.5-2 define the primary level settings including test tolerances for the test.

The response time including test tolerance is 3300ms. The response time is equal to the LPP time IE value plus the test tolerance. The LPP time IE value is derived from the RSTD reporting delay plus ΔT , where $\Delta T = N_{rep} \times TTI_{DCCH} = N_{rep} \times 75$ ms, giving a value of 2955 ms. This is rounded up to the next allowed LPP value of 3 seconds. The RSTD measurement reporting delay in the test is derived from the following expression

$$T_{RSTD \text{ IntraFreqFDD, Cat}_M} = T_{PRS} \cdot (M - 1) + \Delta + T_{MIB}, \text{ where } T_{PRS}=320\text{ms}, M=8, \Delta = T_{PRS} \cdot \left\lceil \frac{n}{M} \right\rceil \text{ and } n=16 \text{ are the}$$

parameters specified in clause 9.3.13.3, Table 9.3.1.1.3-1 and Note 4 of Table 9.3.13.4.1-1. This gives the total RSTD reporting delay of 2880 ms for the 15 neighbour cells including Cell 2 and Cell 3 with respect to the reference cell, Cell 1.

The test tolerances are defined in clauses C.1.3 and C4.

The rate of successful tests during repeated tests shall be at least 90% with a confidence level of 95%.

9.3.16 E-UTRAN FDD intra-frequency RSTD measurement period test case in CE Mode B with longer PRS occasions

9.3.16.1 Test purpose

To verify that the RSTD measurement reporting delay with longer PRS occasions for UE Category M1 and M2 meets the performance requirements in normal coverage mode in an environment with fading propagation conditions.

9.3.16.2 Test applicability

This test applies to E-UTRA FDD UE Category M1 and M2 release 15 and forward that supports UE-assisted OTDOA and dense PRS configuration or additional PRS configuration and CE Mode B. Test 2 is applicable only to UE Category M2.

9.3.16.3 Minimum conformance requirements

Same as in clause 9.3.4.1.3

The normative reference for this requirement is TS 36.133 [23] clause 8.13.3.3.1, 8.16.3.3.1 and A.8.12.12.

9.3.16.4 Test description

9.3.16.4.1 Initial conditions

Same as in clause 9.3.13.4.1 but replacing Table 9.3.13.4.1-1 with Table 9.3.16.4.1-1

Table 9.3.16.4.1-1: General test parameters

Parameter	Unit	Value		Comment
		Test 1	Test 2	
Reference cell		Cell 1		Reference cell is the cell in the OTDOA assistance data with respect to which the RSTD measurement is defined, as specified in 3GPP TS 36.214 [6] and 3GPP TS 36.355 [4]. The reference cell is the serving cell in this test case.
Neighbour cells		Cell 2 and Cell 3		Cell 2 and Cell 3 appear at random places in the neighbour cell list in the OTDOA assistance data, but Cell 2 always appears in the first half of the list, whilst Cell 3 appears in the second half of the list.
MPDCCH		DL Reference Measurement Channel R.18 FDD		As specified in TS 36.521-3 [25] clause A.7.1
<i>mPDCCH-startSF-UESS</i>		10		Parameter G in $T = r_{\max} \cdot G$ which determines subframe $k0$ in which MPDCCH starts
Channel Bandwidth (BW_{channel})	MHz	10		
PRS Transmission Bandwidth ^{Note 2}	RB	6	24	PRS are transmitted in the centre RBs
PRS configuration index I_{PRS} ^{Note 2}		311		This corresponds to periodicity of 320 ms and PRS subframe offset of $I_{\text{PRS}} - 160$ DL subframes, as defined in 3GPP TS 36.211 [26], Table 6.10.4.3-1
Gap pattern Id		rstd12	rstd2	As specified in TS 36.133 [23] Table 8.1.2.1-3. Applies for measurements on Cell 1, Cell 2, and Cell 3
Gap offset		150		As specified in TS 36.331 [22], Clause 6.3.5
Number of consecutive downlink positioning subframes N_{PRS} ^{Note 2}		30	8	As defined in 3GPP TS 36.211 [26]. The number of subframes in a positioning occasion. Corresponds to parameter <i>add-numDL-Frames</i> in TS 36.355 [4], for UE with <i>additional-prs-config</i> capability

		40	10	As defined in 3GPP TS 36.211 [26]. The number of subframes in a positioning occasion. Corresponds to parameter <i>add-numDL-Frames</i> in TS 36.355 [4], for UE with <i>densePrsConfig</i> capability
Physical cell ID PCI ^{Note 2}		(PCI of Cell 1 – PCI of Cell 2) mod 6 = 0 and (PCI of Cell 1 – PCI of Cell 3) mod 6 = 0		The cell PCIs are selected such that the relative shifts of PRS patterns among cells are as given by the test parameters
CP length ^{Note 2}		Normal		
DRX		ON		DRX parameters are further specified in Table 9.3.16.4.1-2
Radio frame receive time offset between the cells at the UE antenna connector ^{Note 3}	µs	Cell 2 to Cell 1: 1 Cell 3 to Cell 1: -1		PRS are transmitted from synchronous cells
Expected RSTD ^{Note 1}	µs	Cell 2: 3 Cell 3: 3 Other neighbour cells: randomly between -3 and 3		The expected RSTD is what is expected at the receiver. The corresponding parameter in the OTDOA assistance data specified in TS 36.355 [4] is the <i>expectedRSTD</i> indicator
Expected RSTD uncertainty for all neighbour cells ^{Note 1}	µs	5		The corresponding parameter in the OTDOA assistance data specified in TS 36.355 [4] is the <i>expectedRSTD-Uncertainty</i> index
Number of cells provided in OTDOA assistance data		16		Including the reference cell
PRS muting info ^{Note 2}		Cell 1: '11110000' Cell 2: '00001111' Cell 3: '11110000'		Corresponds to <i>prs-MutingInfo</i> defined in TS 36.355 [4]
T1	s	3		The length of the time interval from the beginning of each test
T2	s	1.28		The length of the time interval that follows immediately after time interval T1
T3	s	1.60		The length of the time interval that follows immediately after time interval T2
<p>Note 1: Parameters "Expected RSTD" and "Expected RSTD uncertainty for all neighbour cells" are not settable parameters. These are parameters signalled in LPP only. For the values to be used in LPP see Table 9.3.16.4.3-5 and TS 37.571-5 [20], clause 7.2.5.</p> <p>Note 2: Parameters "PRS Transmission Bandwidth", "PRS configuration index", "Number of consecutive downlink positioning subframes", "Physical cell ID PCI", "CP length", and "PRS muting info" are settable parameters and also parameters signalled in LPP. The values to be used for "Physical cell ID PCI" are as follows: Cell 1: 0, Cell 2: 6, Cell 3: 12. For all the values to be used in LPP see Table 9.3.16.4.3-5 and TS 37.571-5 [20], clause 7.2.5.</p> <p>Note 3: The parameter "Radio frame receive time offset between the cells at the UE antenna connector" is not a settable parameter but is used to set the "true RSTD" values in step 6 of clause 9.3.16.4.1.</p> <p>Note 4: If the PRS transmission bandwidth is larger than the UE RF bandwidth, the UE is measuring RSTD within its RF bandwidth.</p>				

Table 9.3.16.4.1-2: DRX parameters

Field	Value	Comment
onDurationTimer	psf1	As specified in 3GPP TS 36.331 [22], clause 6.3.2
drx-InactivityTimer	psf1	
drx-RetransmissionTimer	sf1	
longDRX-CycleStartOffset	sf320	
shortDRX	Disable	

9.3.16.4.2 Test procedure

Same as in clause 9.3.13.4.2 but with the following additional step:

14. Repeat step 1-13 for each sub-test in Table 9.3.16.4.1-1 as appropriate

9.3.16.4.3 Message contents

Same as in clause 9.3.13.4.3

9.3.16.5 Test requirement

Table 9.3.1.1.5-1 and 9.3.1.1.5-2 define the primary level settings including test tolerances for the test.

The response time including test tolerance is 3300ms. The response time is equal to the LPP time IE value plus the test tolerance. The LPP time IE value is derived from the RSTD reporting delay plus ΔT , where $\Delta T = N_{rep} \times TTI_{DCCH} = N_{rep} \times 75$ ms, giving a value of 2955 ms. This is rounded up to the next allowed LPP value of 3 seconds. The RSTD measurement reporting delay in the test is derived from the following expression

$$T_{RSTD \text{ IntraFreqFDD, Cat}_M} = T_{PRS} \cdot (M - 1) + \Delta + T_{MIB}, \text{ where } T_{PRS}=320\text{ms}, M=8, \Delta = T_{PRS} \cdot \left\lceil \frac{n}{M} \right\rceil \text{ and } n=16 \text{ are the}$$

parameters specified in clause 9.3.16.3, Table 9.3.1.1.3-1 and Note 4 of Table 9.3.16.4.1-1. This gives the total RSTD reporting delay of 2880 ms for the 15 neighbour cells including Cell 2 and Cell 3 with respect to the reference cell, Cell 1.

The test tolerances are defined in clauses C.1.3 and C4.

The rate of successful tests during repeated tests shall be at least 90% with a confidence level of 95%.

9.3.17 E-UTRAN HD-FDD intra-frequency RSTD measurement period test case in CE Mode B with longer PRS occasions

9.3.17.1 Test purpose

To verify that the RSTD measurement reporting delay with longer PRS occasions for UE Category M1 and M2 meets the performance requirements in normal coverage mode in an environment with fading propagation conditions.

9.3.17.2 Test applicability

This test applies to E-UTRA HD-FDD UE Category M1 and M2 release 15 and forward that supports UE-assisted OTDOA and dense PRS configuration or additional PRS configuration and CE Mode B. Test 2 is applicable only to UE Category M2.

9.3.17.3 Minimum conformance requirements

Same as in clause 9.3.4.1.3

The normative reference for this requirement is TS 36.133 [23] clause 8.13.3.3, 8.16.3.3 and A.8.12.13.

9.3.17.4 Test description

9.3.17.4.1 Initial conditions

Same as in clause 9.3.13.4.1 but replacing Table 9.3.13.4.1-1 with Table 9.3.17.4.1-1

Table 9.3.17.4.1-1: General test parameters

Parameter	Unit	Value		Comment
		Test 1	Test 2	

Reference cell		Cell 1		Reference cell is the cell in the OTDOA assistance data with respect to which the RSTD measurement is defined, as specified in 3GPP TS 36.214 [6] and 3GPP TS 36.355 [4]. The reference cell is the serving cell in this test case.
Neighbour cells		Cell 2 and Cell 3		Cell 2 and Cell 3 appear at random places in the neighbour cell list in the OTDOA assistance data, but Cell 2 always appears in the first half of the list, whilst Cell 3 appears in the second half of the list.
MPDCCH		DL Reference Measurement Channel R.8 HD-FDD		As specified in TS 36.521-3 [25] clause A.7.1
<i>mPDCCH-startSF-UeSS</i>		10		Parameter G in $T = r_{\max} \cdot G$ which determines subframe $k0$ in which MPDCCH starts
Channel Bandwidth (BW _{channel})	MHz	10		
PRS Transmission Bandwidth ^{Note 2}	RB	6	24	PRS are transmitted in the centre RBs
PRS configuration index I_{PRS} ^{Note 2}		311		This corresponds to periodicity of 320 ms and PRS subframe offset of $I_{\text{PRS}} - 160$ DL subframes, as defined in 3GPP TS 36.211 [26], Table 6.10.4.3-1
Gap pattern Id		rstd12	rstd2	As specified in TS 36.133 [23] Table 8.1.2.1-3. Applies for measurements on Cell 1, Cell 2, and Cell 3
Gap offset		150		As specified in TS 36.331 [22], Clause 6.3.5
Number of consecutive downlink positioning subframes N_{PRS} ^{Note 2}		30	8	As defined in 3GPP TS 36.211 [26]. The number of subframes in a positioning occasion. Corresponds to parameter <i>add-numDL-Frames</i> in TS 36.355 [4], for UE with <i>additional-prs-config</i> capability
		40	10	As defined in 3GPP TS 36.211 [26]. The number of subframes in a positioning occasion. Corresponds to parameter <i>add-numDL-Frames</i> in TS 36.355 [4], for UE with <i>densePrsConfig</i> capability
Physical cell ID PCI ^{Note 2}		(PCI of Cell 1 – PCI of Cell 2) mod 6 = 0 and (PCI of Cell 1 – PCI of Cell 3) mod 6 = 0		The cell PCIs are selected such that the relative shifts of PRS patterns among cells are as given by the test parameters
CP length ^{Note 2}		Normal		
DRX		ON		DRX parameters are further specified in Table 9.3.17.4.1-2
Radio frame receive time offset between the cells at the UE antenna connector ^{Note 3}	μs	Cell 2 to Cell 1: 1 Cell 3 to Cell 1: -1		PRS are transmitted from synchronous cells
Expected RSTD ^{Note 1}	μs	Cell 2: 3 Cell 3: 3 Other neighbour cells: randomly between -3 and 3		The expected RSTD is what is expected at the receiver. The corresponding parameter in the OTDOA assistance data specified in TS 36.355 [4] is the expectedRSTD indicator

Expected RSTD uncertainty for all neighbour cells ^{Note 1}	μs	5	The corresponding parameter in the OTDOA assistance data specified in TS 36.355 [4] is the expectedRSTD-Uncertainty index
Number of cells provided in OTDOA assistance data		16	Including the reference cell
PRS muting info ^{Note 2}		Cell 1: '11110000' Cell 2: '00001111' Cell 3: '11110000'	Corresponds to prs-MutingInfo defined in TS 36.355 [4]
T1	s	3	The length of the time interval from the beginning of each test
T2	s	1.28	The length of the time interval that follows immediately after time interval T1
T3	s	1.60	The length of the time interval that follows immediately after time interval T2
<p>Note 1: Parameters "Expected RSTD" and "Expected RSTD uncertainty for all neighbour cells" are not settable parameters. These are parameters signalled in LPP only. For the values to be used in LPP see Table 9.3.17.4.3-5 and TS 37.571-5 [20], clause 7.2.5.</p> <p>Note 2: Parameters "PRS Transmission Bandwidth", "PRS configuration index", "Number of consecutive downlink positioning subframes", "Physical cell ID PCI", "CP length", and "PRS muting info" are settable parameters and also parameters signalled in LPP. The values to be used for "Physical cell ID PCI" are as follows: Cell 1: 0, Cell 2: 6, Cell 3: 12. For all the values to be used in LPP see Table 9.3.17.4.3-5 and TS 37.571-5 [20], clause 7.2.5.</p> <p>Note 3: The parameter "Radio frame receive time offset between the cells at the UE antenna connector" is not a settable parameter but is used to set the "true RSTD" values in step 6 of clause 9.3.17.4.1.</p> <p>Note 4: If the PRS transmission bandwidth is larger than the UE RF bandwidth, the UE is measuring RSTD within its RF bandwidth.</p>			

Table 9.3.17.4.1-2: DRX parameters

Field	Value	Comment
onDurationTimer	psf1	As specified in 3GPP TS 36.331 [22], clause 6.3.2
drx-InactivityTimer	psf1	
drx-RetransmissionTimer	sf1	
longDRX-CycleStartOffset	sf320	
shortDRX	Disable	

9.3.17.4.2 Test procedure

Same as in clause 9.3.13.4.2 but with the following additional step:

14. Repeat step 1-13 for each sub-test in Table 9.3.17.4.1-1 as appropriate

9.3.17.4.3 Message contents

Same as in clause 9.3.13.4.3

9.3.17.5 Test requirement

Same as in clause 9.3.16.5.

9.3.18 E-UTRAN TDD intra-frequency RSTD measurement period test case in CE Mode B with longer PRS occasions

9.3.18.1 Test purpose

To verify that the RSTD measurement reporting delay with longer PRS occasions for UE Category M1 and M2 meets the performance requirements in normal coverage mode in an environment with fading propagation conditions.

9.3.18.2 Test applicability

This test applies to E-UTRA TDD UE Category M1 and M2 release 15 and forward that supports UE-assisted OTDOA and dense PRS configuration or additional PRS configuration and CE Mode B. Test 2 is applicable only to UE Category M2.

9.3.18.3 Minimum conformance requirements

Same as in clause 9.3.4.1.3

The normative reference for this requirement is TS 36.133 [23] clause 8.13.3.3.2, 8.16.3.3.2 and A.8.12.14.

9.3.18.4 Test description

9.3.18.4.1 Initial conditions

Same as in clause 9.3.13.4.1 but replacing Table 9.3.13.4.1-1 with Table 9.3.18.4.1-1

Table 9.3.18.4.1-1: General test parameters

Parameter	Unit	Value		Comment
		Test 1	Test 2	
Reference cell		Cell 1		Reference cell is the cell in the OTDOA assistance data with respect to which the RSTD measurement is defined, as specified in 3GPP TS 36.214 [6] and 3GPP TS 36.355 [4]. The reference cell is the serving cell in this test case.
Neighbour cells		Cell 2 and Cell 3		Cell 2 and Cell 3 appear at random places in the neighbour cell list in the OTDOA assistance data, but Cell 2 always appears in the first half of the list, whilst Cell 3 appears in the second half of the list.
MPDCCH		DL Reference Measurement Channel R.16 TDD		As specified in TS 36.521-3 [25] clause A.7.1
<i>mPDCCH-startSF-UESS</i>		10		Parameter G in $T = r_{\max} \cdot G$ which determines subframe $k0$ in which MPDCCH starts
Channel Bandwidth (BW_{channel})	MHz	10		
PRS Transmission Bandwidth ^{Note 2}	RB	6	24	PRS are transmitted in the centre RBs
PRS configuration index I_{PRS} ^{Note 2}		624		This corresponds to periodicity of 320 ms and PRS subframe offset of $I_{\text{PRS}} - 160$ DL subframes, as defined in 3GPP TS 36.211 [26], Table 6.10.4.3-1
Gap pattern Id		rstd15	rstd10	As specified in TS 36.133 [23] Table 8.1.2.1-3. Applies for measurements on Cell 1, Cell 2, and Cell 3
Gap offset		143		As specified in TS 36.331 [22], Clause 6.3.5
Number of consecutive downlink positioning subframes N_{PRS} ^{Note 2}		30	8	As defined in 3GPP TS 36.211 [26]. The number of subframes in a positioning occasion. Corresponds to parameter <i>add-numDL-Frames</i> in TS 36.355 [4], for UE with <i>additional-prs-config</i> capability

		40	10	As defined in 3GPP TS 36.211 [26]. The number of subframes in a positioning occasion. Corresponds to parameter <i>add-numDL-Frames</i> in TS 36.355 [4], for UE with <i>densePrsConfig</i> capability
Physical cell ID PCI ^{Note 2}		(PCI of Cell 1 – PCI of Cell 2) mod 6 = 0 and (PCI of Cell 1 – PCI of Cell 3) mod 6 = 0		The cell PCIs are selected such that the relative shifts of PRS patterns among cells are as given by the test parameters
TDD uplink-downlink configuration		2	1	As specified in TS 36.211 [16], Clause 4.2; corresponds to a configuration with 5 ms switch-point periodicity and two downlink consecutive subframes
TDD special subframe configuration		6		As specified in TS 36.211 [16], Clause 4.2; corresponds to DwPTS of $19760 \cdot T_s$ and UpPTS of $4384 \cdot T_s$
Radio frame receive time offset between the cells at the UE antenna connector ^{Note 3}	µs	Cell 2 to Cell 1: 1 Cell 3 to Cell 1: -1		PRS are transmitted from synchronous cells
Expected RSTD ^{Note 1}	µs	Cell 2: 3 Cell 3: 3 Other neighbour cells: randomly between -3 and 3		The expected RSTD is what is expected at the receiver. The corresponding parameter in the OTDOA assistance data specified in TS 36.355 [4] is the <i>expectedRSTD</i> indicator
Expected RSTD uncertainty for all neighbour cells ^{Note 1}	µs	5		The corresponding parameter in the OTDOA assistance data specified in TS 36.355 [4] is the <i>expectedRSTD-Uncertainty</i> index
Number of cells provided in OTDOA assistance data		16		Including the reference cell
PRS muting info ^{Note 2}		Cell 1: '11110000' Cell 2: '00001111' Cell 3: '11110000'		Corresponds to <i>prs-MutingInfo</i> defined in TS 36.355 [4]
T1	s	3		The length of the time interval from the beginning of each test
T2	s	2.56		The length of the time interval that follows immediately after time interval T1
T3	s	2.56		The length of the time interval that follows immediately after time interval T2
<p>Note 1: Parameters "Expected RSTD" and "Expected RSTD uncertainty for all neighbour cells" are not settable parameters. These are parameters signalled in LPP only. For the values to be used in LPP see Table 9.3.18.4.3-5 and TS 37.571-5 [20], clause 7.2.5.</p> <p>Note 2: Parameters "PRS Transmission Bandwidth", "PRS configuration index", "Number of consecutive downlink positioning subframes", "Physical cell ID PCI", "CP length", and "PRS muting info" are settable parameters and also parameters signalled in LPP. The values to be used for "Physical cell ID PCI" are as follows: Cell 1: 0, Cell 2: 6, Cell 3: 12. For all the values to be used in LPP see Table 9.3.18.4.3-5 and TS 37.571-5 [20], clause 7.2.5.</p> <p>Note 3: The parameter "Radio frame receive time offset between the cells at the UE antenna connector" is not a settable parameter but is used to set the "true RSTD" values in step 6 of clause 9.3.18.4.1.</p> <p>Note 4: If the PRS transmission bandwidth is larger than the UE RF bandwidth, the UE is measuring RSTD within its RF bandwidth.</p>				

Table 9.3.18.4.1-2: DRX parameters

Field	Value	Comment
onDurationTimer	psf1	As specified in 3GPP TS 36.331 [22], clause 6.3.2
drx-InactivityTimer	psf1	

drx-RetransmissionTimer	sf1	
longDRX-CycleStartOffset	sf320	
shortDRX	Disable	

9.3.18.4.2 Test procedure

Same as in clause 9.3.13.4.2 but with the following additional step:

14. Repeat step 1-13 for each sub-test in Table 9.3.18.4.1-1 as appropriate

9.3.18.4.3 Message contents

Same as in clause 9.3.1.1.4.3 with the following exceptions:

Table 9.3.18.4.3-1: LPP RequestLocationInformation

Derivation Path: Table 9.3.1.1.4.3-4			
Information Element	Value/remark	Comment	Condition
LPP-Message ::= SEQUENCE {			
lpp-MessageBody CHOICE {			
c1 CHOICE {			
requestLocationInformation SEQUENCE {			
criticalExtensions CHOICE {			
c1 CHOICE {			
requestLocationInformation-r9 SEQUENCE {			
commonIEsRequestLocationInformation SEQUENCE {			
qos SEQUENCE {			
responseTime SEQUENCE {			
time	6	See clause 9.3.18.5	
}			
}			
}			
}			
}			
}			
}			
}			
}			
}			

9.3.18.5 Test requirement

Table 9.3.3.1.5-1 and 9.3.3.1.5-2 define the primary level settings including test tolerances for the test.

The response time including test tolerance is 6300ms. The response time is equal to the LPP time IE value plus the test tolerance. The LPP time IE value is derived from the RSTD reporting delay plus ΔT, where ΔT = N_{rep}X TTI_{DCCH} = N_{rep}X 75 ms, giving a value of 5285 ms. This is rounded up to the next allowed LPP value of 6 seconds. The RSTD measurement reporting delay in the test is derived from the following expression

$T_{RSTD \text{ IntraFreqFDD, Cat_M}} = T_{PRS} \cdot (M - 1) + \Delta + T_{MIB}$, where $T_{PRS}=640\text{ms}$, $M=8$, $\Delta = T_{PRS} \cdot \left\lceil \frac{n}{M} \right\rceil$ and $n=16$ are the parameters specified in clause 9.3.13.3, Table 9.3.1.1.3-1 and Note 4 of Table 9.3.13.4.1-1. This gives the total RSTD reporting delay of 5210 ms for the 15 neighbour cells including Cell 2 and Cell 3 with respect to the reference cell, Cell 1.

The test tolerances are defined in clauses C.1.3 and C4.

The rate of successful tests during repeated tests shall be at least 90% with a confidence level of 95%.

9.4 RSTD Inter-Frequency Measurements for UE Category M1/M2

9.4.1 FDD inter-frequency RSTD Measurement Reporting Delay in CE Mode A

9.4.1.1 FDD inter-frequency RSTD Measurement Reporting Delay in CE Mode A for Category M1

9.4.1.1.1 Test purpose

To verify that the RSTD measurement reporting delay for UE Category M1 meets the performance requirements in normal coverage mode in an environment with fading propagation conditions.

9.4.1.1.2 Test applicability

This test applies to E-UTRA FDD UE Category M1 release 14 and forward that supports UE-assisted OTDOA and inter-frequency RSTD measurements.

9.4.1.1.3 Minimum conformance requirements

When the physical layer cell identities of neighbour cells together with the OTDOA assistance data are provided, the UE shall be able to detect and measure inter-frequency RSTD, specified in 3GPP TS 36.214 [6], for at least $n=16$ cells, including the reference cell, on the same carrier frequency f_1 as that of the reference cell within $T_{\text{RSTD InterFreqFDD, Cat_M}}$ ms as given below (see also Figure 9.4.1.1.3-1):

$$T_{\text{RSTD InterFreqFDD, Cat_M}} = T_{\text{PRS}} \cdot (M - 1) + \Delta + T_{\text{MIB}} \text{ ms,}$$

where

$T_{\text{RSTD InterFreqFDD, Cat_M}}$ is the total time for detecting and measuring at least n cells,

T_{PRS} is the cell-specific positioning subframe configuration period as defined in 3GPP TS 36.211 [26]; if

$T_{\text{PRS}} < \text{MGRP}$, T_{PRS} equals to MGRP; MGRP is the Measurement Gap Repetition Period as defined in 3GPP TS 36.133 [23] section 8.1.2.1,

M is the number of PRS positioning occasions as defined in Table 9.4.1.1.3-1, , where downlink positioning subframes defined in TS 36.211 [16],

$\Delta = T_{\text{PRS}} \cdot \left\lceil \frac{n}{M} \right\rceil$ ms is the measurement time for a single PRS positioning occasion which includes the sampling time and the processing time,

N_{PRS} is the cell-specific number of PRS subframes within a PRS occasion as defined in TS36.355 [4],

$N_{\text{actual_PRS}}$ is the cell-specific number of PRS subframes within a PRS occasion and can be measured by UE within

MGL; if $\text{MGRP} \geq N_{\text{PRS}} > (\text{MGL} - 2\text{ms})$, $N_{\text{actual_PRS}}$ equals to $(\text{MGL} - 2\text{ms})$; if $N_{\text{PRS}} > \text{MGRP}$, $N_{\text{actual_PRS}}$ equals to

$$(\text{MGL} - 2) \cdot \left\lceil \frac{N_{\text{PRS}}}{\text{MGRP}} \right\rceil;$$

$N_{\text{PRS_total}}$ is the minimum number of PRS subframes per cell measurement as specified in TS 36.133 [23] Section 9.1.21.17.

T_{PRS} , N_{PRS} , N_{actual_PRS} and N_{PRS_total} are the parameters of the same cell, for which $T_{PRS} \cdot \left\lceil \frac{N_{PRS_total}}{N_{actual_PRS}} \right\rceil$ is the largest among all the measured cells.

T_{MIB} is the time required for acquiring the MIB information of the target cell. $T_{MIB} = 0$ if the SFN of at least one cell in OTDOA assistance data is known to the UE.

Table 9.4.1.1.3-1: Number of PRS positioning occasions within $T_{RSTD_InterFreqFDD, Cat_M}$

Positioning subframe configuration period T_{PRS}	Number of PRS positioning occasions M
	f1 and f2 ^{Note 1}
160 ms	$32 \cdot \left\lceil \frac{N_{PRS_Total}}{N_{actual_PRS}} \right\rceil$
>160 ms	$16 \cdot \left\lceil \frac{N_{PRS_Total}}{N_{actual_PRS}} \right\rceil$
Note 1: When intra-frequency RSTD and inter-frequency RSTD measurements are performed over cells belonging to the serving FDD carrier frequency f1 and one inter-frequency carrier frequency f2, respectively.	

The UE physical layer shall be capable of reporting RSTD for the reference cell and all the neighbour cells i out of at least $(n-1)$ neighbour cells within $T_{RSTD_InterFreqFDD, Cat_M}$ provided:

$(PRS \hat{E}_s / Iot)_{ref} \geq -6$ dB for all Frequency Bands for the reference cell,

$(PRS \hat{E}_s / Iot)_i \geq -13$ dB for all Frequency Bands for neighbour cell i ,

$(PRS \hat{E}_s / Iot)_{ref}$ and $(PRS \hat{E}_s / Iot)_i$ conditions apply for all subframes of at least $L = \frac{M}{2}$ PRS positioning

occasions,

PRP 1,2_{dBm} according to clause E.3.1 for a corresponding Band.

$PRS \hat{E}_s / Iot$ is defined as the ratio of the average received energy per PRS RE during the useful part of the symbol to the average received power spectral density of the total noise and interference for this RE, where the ratio is measured over all REs which carry PRS.

The time $T_{RSTD_InterFreqFDD, Cat_M}$ starts from the first subframe of the PRS positioning occasion closest in time after both the OTDOA-RequestLocationInformation message and the OTDOA assistance data in the OTDOA-ProvideAssistanceData message as specified in 3GPP TS 36.355 [4], are delivered to the physical layer of the UE.

This requirement assumes that the measurement report is not delayed by other LPP signalling on the DCCH. This measurement reporting delay excludes a delay uncertainty resulted when inserting the measurement report to the TTI of the uplink DCCH. The delay uncertainty is $N_{rep} \times TTI_{DCCH}$, where N_{rep} is the maximum number of PUSCH repetitions configured for the UE, otherwise uncertainty is defined as $2 \times TTI_{DCCH}$. This measurement reporting delay excludes any delay caused by no UL resources for UE to send the measurement report.

The normative reference for this requirement is TS 36.133 [23] clause 8.13.2.4.1 and A.8.13.3.

9.4.1.1.4 Test description

9.4.1.1.4.1 Initial conditions

Test Environment: Normal; as defined in TS 36.508 [18] clause 4.1.

Frequencies to be tested: Mid Range, as defined in TS 36.508 [18] clause 4.3.1.1.

Channel bandwidth to be tested: 10 MHz as defined in TS 36.508 [18] clause 4.3.1.

1. Connect the SS, faders and AWGN noise sources to the UE antenna connector or antenna connectors as shown in Annex A, Figure A.4 using only the main Tx/Rx antenna of the UE.
2. The general test parameter settings are set up according to Table 9.4.1.1.4.1-1.
3. Propagation conditions are set according to clause 4.7.2.1.
4. Message contents are defined in clause 9.4.1.1.4.3.
5. In the test there are three synchronized cells: Cell 1, Cell 2 and Cell 3. Cell 1 is the OTDOA assistance data reference as well as the serving cell. Cell 2 and Cell 3 are the neighbour cells. Cell 1 is on FDD RF channel 1. Cell 2 and Cell 3 are on a FDD RF channel 2. The assistance data neighbour cell list includes in total 15 cells, where 13 of the cells are not simulated (dummy cells; as defined in 3GPP TS 37.571-5 clause 7.2.5).
6. The true RSTD (which is the receive time difference for frame 0 between two cells as seen at the UE antenna connector) is set to 31 Ts (about 1 μ s) between neighbour Cell 2 and serving Cell 1; and set to -31 Ts (about -1 μ s) between neighbour Cell 3 and serving Cell 1.

Table 9.4.1.1.4.1-1: General test parameters for E-UTRAN FDD inter-frequency RSTD measurement reporting delay under fading propagation conditions

Parameter	Unit	Value	Comment
Reference cell		Cell 1	Reference cell is the cell in the OTDOA assistance data with respect to which the RSTD measurement is defined, as specified in 3GPP TS 36.214 [6] and 3GPP TS 36.355 [4]. The reference cell is the serving cell in this test case.
Neighbour cells		Cell 2 and Cell 3	Cell 2 and Cell 3 appear at random places in the neighbour cell list in the OTDOA assistance data, but Cell 2 always appears in the first half of the list, whilst Cell 3 appears in the second half of the list.
MPDCCH		DL Reference Measurement Channel R.16 FDD	As specified in TS 36.521-3 [25] clause A.7.1
$mPDCCH\text{-startSF-UeSS}$		10	Parameter G in $T = r_{\max} \cdot G$ which determines subframe $k0$ in which MPDCCH starts
Channel Bandwidth (BW_{channel})	MHz	10	
Gap pattern Id		0	As specified in TS 36.133 [23] Table 8.1.2.1-1. Applies for measurements on Cell 2 and Cell 3
Gap offset		9	As specified in TS 36.331 [22], Clause 6.3.5
PRS Transmission Bandwidth <small>Note 2</small>	RB	50 <small>Note 4</small>	PRS are transmitted over the system bandwidth
PRS configuration index I_{PRS} <small>Note 2</small>		Cell 1: 142, Cell 2, Cell 3: 152	This corresponds to periodicity of 320 ms and PRS subframe offset of $I_{\text{PRS}} - 160$ DL subframes, as defined in 3GPP TS 36.211 [26], Table 6.10.4.3-1
Number of consecutive downlink positioning subframes N_{PRS} <small>Note 2</small>		4	As defined in 3GPP TS 36.211 [26]. The number of subframes in a positioning occasion

Physical cell ID PCI ^{Note 2}		(PCI of Cell 1 – PCI of Cell 2)mod6=0 and (PCI of Cell 1 – PCI of Cell 3)mod6=0	The cell PCIs are selected such that the relative shifts of PRS patterns among cells are as given by the test parameters
CP length ^{Note 2}		Normal	
DRX		ON	DRX parameters are further specified in Table 9.4.1.1.4.1-2
prs-SubframeOffset		10	Number of subframes rounded to the closest integer. The corresponding parameter in the OTDOA assistance data is prs-SubframeOffset specified in TS 36.355 [4]
slotNumberOffset		0	The slot number offset at the transmitter between a neighbour cell and the assistance data reference cell specified in TS 36.355 [4]
Radio frame receive time offset between the cells at the UE antenna connector ^{Note 3}	µs	Cell 2 to Cell 1: 1 Cell 3 to Cell 1: -1	PRS are transmitted from synchronous cells
Expected RSTD ^{Note 1}	µs	Cell 2: -2 Cell 3: 2 Other neighbour cells: randomly between -3 and 3	The expected RSTD is what is expected at the receiver. The corresponding parameter in the OTDOA assistance data specified in TS 36.355 [4] is the expectedRSTD indicator
Expected RSTD uncertainty for all neighbour cells ^{Note 1}	µs	5	The corresponding parameter in the OTDOA assistance data specified in TS 36.355 [4] is the expectedRSTD-Uncertainty index
Number of cells provided in OTDOA assistance data		16	Including the reference cell
PRS muting info ^{Note 2}		Cell 1: '1111111100000000' Cell 2: '0000000011111111' Cell 3: '1111111100000000'	Corresponds to prs-MutingInfo defined in TS 36.355 [4]
T1	s	3	The length of the time interval from the beginning of each test
T2	s	7.68	The length of the time interval that follows immediately after time interval T1
T3	s	7.68	The length of the time interval that follows immediately after time interval T2
<p>Note 1: Parameters “Expected RSTD” and “Expected RSTD uncertainty for all neighbour cells” are not settable parameters. These are parameters signalled in LPP only. For the values to be used in LPP see Table 9.4.1.1.4.3-5 and TS 37.571-5 [20], clause 7.2.5.</p> <p>Note 2: Parameters “PRS Transmission Bandwidth”, “PRS configuration index”, “Number of consecutive downlink positioning subframes”, “Physical cell ID PCI”, “CP length”, and “PRS muting info” are settable parameters and also parameters signalled in LPP. The values to be used for “Physical cell ID PCI” are as follows: Cell 1: 0, Cell 2: 6, Cell 3: 12. For all the values to be used in LPP see Table 9.4.1.1.4.3-5 and TS 37.571-5 [20], clause 7.2.5.</p> <p>Note 3: The parameter “Radio frame receive time offset between the cells at the UE antenna connector” is not a settable parameter but is used to set the “true RSTD” values in step 6 of clause 9.4.1.1.4.1.</p> <p>Note 4: If the PRS transmission bandwidth is larger than the UE RF bandwidth, the UE is measuring RSTD within its RF bandwidth.</p>			

Table 9.4.1.1.4.1-2: DRX parameters for E-UTRAN FDD inter-frequency RSTD measurement reporting delay under fading propagation conditions

Field	Value	Comment
onDurationTimer	psf1	As specified in 3GPP TS 36.331 [22], clause 6.3.2
drx-InactivityTimer	psf1	
drx-RetransmissionTimer	sf1	
longDRX-CycleStartOffset	sf320	

shortDRX	Disable	
----------	---------	--

9.4.1.1.4.2 Test procedure

The test consists of three consecutive time intervals, with duration of T1, T2 and T3 defined in Table 9.4.1.1.4.1-1. Cell 1 is active in T1, T2 and T3, whilst Cell 2 and Cell 3 are activated only in the beginning of T2. Cell 2 is active until the end of T3, and Cell 3 is active until the end of T2. The beginning of the time interval T2 shall be aligned 5 ms before the first PRS positioning subframe of a positioning occasion in the reference cell, where 5 ms is the necessary test tolerance. Cell 1 transmits PRS in T2, while Cell 2 transmits PRS only in T3, and Cell 3 transmits PRS only in T2.

NOTE: The information on when PRS is muted is conveyed to the UE using PRS muting information in the OTDOA assistance data.

The OTDOA-RequestLocationInformation message and the OTDOA assistance data as defined in clause 9.4.1.1.4.3 shall be provided to the UE during T1. The last TTI containing the OTDOA-RequestLocationInformation message shall be provided to the UE ΔT ms before the start of T2, where $\Delta T = 150$ ms is the maximum processing time of the OTDOA-RequestLocationInformation message and the OTDOA assistance data.

1. Ensure that the UE is in state Generic RB Established State 3A-RF-CE according to 3GPP TS 36.508 [18] clause 7.2A.3AA.
2. The SS shall send a RESET UE POSITIONING STORED INFORMATION message.
3. Set the parameters according to Table 9.4.1.1.5-1. Propagation conditions are set according to clause 4.7.2.2 (ETU30).
4. T1 starts.
5. The SS shall transmit an RRCConnectionReconfiguration message with the DRX configuration and the measurement gap configuration. PDCCHs indicating new transmissions shall be sent continuously until the start of T2 to ensure that the UE would not enter the DRX state before T2.
6. The UE shall transmit RRCConnectionReconfigurationComplete message.
- 6a. The SS shall transmit an LPP REQUEST CAPABILITIES message.
- 6b. The UE shall transmit an LPP PROVIDE CAPABILITIES message indicating the OTDOA capabilities supported by the UE in the *OTDOA-ProvideCapabilities* IE.
7. The SS shall send a LPP PROVIDE ASSISTANCE DATA message, including the *OTDOA-ProvideAssistanceData* IE. The position of neighbour Cell 2 in the *OTDOA-NeighbourCellInfoList* is randomly selected to be in the first 7 elements of the sequence, and the position of neighbour Cell 3 is randomly selected to be in the last 8 elements of the sequence, as described in 3GPP TS 37.571-5 [20], clause 7.2.5. If the UE message at step 6b includes the *ackRequested* IE set to TRUE, then the SS shall send an acknowledgment in the LPP PROVIDE ASSISTANCE DATA message.
8. The SS shall send a LPP REQUEST LOCATION INFORMATION message, including the *OTDOA-RequestLocationInformation* IE such that the UE receives the message ΔT ms before the start of T2, where $\Delta T = 150$ ms.
9. When T1 expires, the SS shall switch the power setting from T1 to T2 as specified in Table 9.4.1.1.5-2.
10. When T2 expires, the SS shall switch the power setting from T2 to T3 as specified in Table 9.4.1.1.5-2.
11. The UE shall transmit a LPP PROVIDE LOCATION INFORMATION message including the *OTDOA-ProvideLocationInformation* IE within the response time (see clause 4.7.3) specified in clause 9.4.1.1.5. The UE shall perform and report the RSTD measurements for both Cell 2 and Cell 3 with respect to the reference cell in the OTDOA assistance data, Cell 1. If the UE transmits an *OTDOA-ProvideLocationInformation* IE including the *rstd* field for both Cell 2 and Cell 3 within the response time then the number of successful tests is increased by one. If the UE fails to report the *OTDOA-ProvideLocationInformation* IE with both the *rstd* fields included within the response time then the number of failure tests is increased by one.

- 12. If the UE message at step 11 includes the *ackRequested* IE set to TRUE, the SS shall send a LPP acknowledgement message.
- 13. Repeat steps 2-12 until the confidence level according to Annex D is achieved. For each iteration, at step 7 change the random position of the Cells 2 and 3 in the *OTDOA-NeighbourCellInfoList*.

9.4.1.1.4.3 Message contents

Same as in clause 9.3.1.1.4.3 with the following exceptions.

Table 9.4.1.1.4.3-1: MeasGapConfig-GP1: FDD-FDD inter-frequency RSTD Measurement Reporting Delay

Derivation Path: TS 36.508 [18] clause 4.6.6, Table 4.6.6-1A: MeasGapConfig-GP1			
Information Element	Value/remark	Comment	Condition
MeasGapConfig-GP1 ::= CHOICE {			
setup SEQUENCE {			
gapOffset CHOICE {			
gp0	9	TGRP = 40 ms	
}			
}			
}			

Table 9.4.1.1.4.3-2: LPP RequestLocationInformation

Derivation Path: Table 9.3.1.1.4.3-4			
Information Element	Value/remark	Comment	Condition
LPP-Message ::= SEQUENCE {			
lpp-MessageBody CHOICE {			
c1 CHOICE {			
requestLocationInformation SEQUENCE {			
criticalExtensions CHOICE {			
c1 CHOICE {			
requestLocationInformation-r9 SEQUENCE {			
commonIEsRequestLocationInformation SEQUENCE {			
qos SEQUENCE {			
responseTime SEQUENCE {			
time	16	See clause 9.4.1.1.5	
}			
}			
}			
}			
}			
}			
}			

9.4.1.1.5 Test requirement

Table 9.4.1.1.5-1 and 9.4.1.1.5-2 define the primary level settings including test tolerances for the test.

Table 9.4.1.1.5-1: Cell-specific test parameters for E-UTRAN FDD inter-frequency RSTD measurement reporting delay under fading propagation conditions during T1

Parameter	Unit	Cell 1	Cell 2	Cell 3
E-UTRA RF Channel Number		1	2	2

Correlation Matrix and Antenna Configuration		1x1	1x1	1x1
OCNG patterns defined in TS 36.521-3 [25] clause D.1		OP.21 FDD	N/A	N/A
PBCH_RA	dB	0	N/A	N/A
PBCH_RB				
PSS_RA				
SSS_RA				
PCFICH_RB				
PHICH_RA				
PHICH_RB				
PDCCH_RA				
PDCCH_RB				
OCNG_RA ^{Note 1}				
OCNG_RB ^{Note 1}				
N_{oc} ^{Note 3}				
$PRS \hat{E}_s / N_{oc}$	dB	-Infinity	-Infinity	-Infinity
I_o ^{Note 4}	dBm/9 MHz	-67.22	N/A	N/A
\hat{E}_s / N_{oc}	dB	0	-Infinity	-Infinity
Propagation Condition		ETU30		
<p>Note 1: OCNG shall be used such that active cell (Cell 1) is fully allocated and a constant total transmitted power spectral density is achieved for all OFDM symbols.</p> <p>Note 2: The resources for uplink transmission are assigned to the UE prior to the start of time period T2.</p> <p>Note 3: Interference from other cells and noise sources not specified in the test are assumed to be constant over subcarriers and time and shall be modelled as AWGN of appropriate power for N_{oc} to be fulfilled.</p> <p>Note 4: I_o levels have been derived from other parameters and are given for information purpose. These are not settable test parameters.</p>				

Table 9.4.1.1.5-2: Cell-specific test parameters for E-UTRAN FDD inter-frequency RSTD measurement reporting delay under fading propagation conditions during T2 and T3

Parameter	Unit	Cell 1		Cell 2		Cell 3	
		T2	T3	T2	T3	T2	T3
E-UTRA RF Channel Number		1		2		2	
Correlation Matrix and Antenna Configuration		1x1		1x1		1x1	
OCNG patterns defined in TS 36.521-3 [25] clause D.1		OP.21 FDD		OP.6 FDD		OP.6 FDD	N/A
PBCH_RA	dB	0	0	0	0	0	N/A
PBCH_RB							
PSS_RA							
SSS_RA							
PCFICH_RB							
PHICH_RA							
PHICH_RB							
PDCCH_RA							
PDCCH_RB							
OCNG_RA ^{Note 1}							

OCNG_RB ^{Note 1}							
PRS_RA	dB	-3	N/A	N/A	3	3	N/A
N_{oc} ^{Note 3}	dBm/ 15 kHz	-98	-98	-98	-95	-98	-95
PRS \hat{E}_s/N_{oc}	dB	-1	-Infinity	-Infinity	-7	-8	-Infinity
PRS \hat{E}_s/I_{ot} ^{Note 4}	dB	-1	-Infinity	-Infinity	-7	-8	-Infinity
I_o ^{Note 4}	dBm/ 9 MHz	-69.68	-70.22	-70.11	-67.08	-70.11	-67.08
PRP ^{Note 4}	dBm/ 15 kHz	-99	-Infinity	-Infinity	-102	-106	-Infinity
RSRP ^{Note 4}	dBm/ 15 kHz	-96	-96	-105	-105	-109	-Infinity
\hat{E}_s/N_{oc} ^{Note 4}	dB	2	2	-7	-10	-11	-Infinity
Propagation Condition		ETU30					
<p>Note 1: OCNG shall be used such that active cells (all, except Cell 3 in T3) are fully allocated and a constant total transmitted power spectral density is achieved for all OFDM symbols other than those in the subframes with transmitted PRS.</p> <p>Note 2: The resources for uplink transmission are assigned to the UE prior to the start of time period T2.</p> <p>Note 3: Interference from other cells and noise sources not specified in the test are assumed to be constant over subcarriers and time and shall be modelled as AWGN of appropriate power for N_{oc} to be fulfilled.</p> <p>Note 4: If PRS_RA is not "N/A", \hat{E}_s/N_{oc}, PRS \hat{E}_s/I_{ot}, I_o, RSRP and PRP levels have been derived from other parameters and are given for information purpose. If PRS_RA is "N/A", I_o and RSRP levels have been derived from other parameters and are given for information purpose. These are not settable test parameters. Interference conditions shall be applied to all PRS symbols of DL positioning subframes.</p>							

The response time including test tolerance is 16.3 s. The response time is equal to the LPP time IE value plus the test tolerance. The LPP time IE value is derived from the RSTD reporting delay plus ΔT , where $\Delta T = N_{rep} \times TTI_{DCCH} = N_{rep} \times 75$ ms, giving a value of 15510 ms. This is rounded up to the next allowed LPP value of 16 seconds. The RSTD

measurement reporting delay in the test is derived from the following expression $T_{PRS} (M - 1) + 320 \cdot \left\lceil \frac{n}{M} \right\rceil$, where

$M = 48$ and $n = 16$ are the parameters specified in clause 9.4.1.1.3, Table 9.4.1.1.3-1 and Note 4 of Table 9.4.1.1.4.1-1. This gives the total RSTD reporting delay of 15360 ms for the 15 neighbour cells including Cell 2 and Cell 3 with respect to the reference cell, Cell 1.

The test tolerances are defined in clauses C.1.3 and C4.

The rate of successful tests during repeated tests shall be at least 90% with a confidence level of 95%.

9.4.1.2 FDD inter-frequency RSTD Measurement Reporting Delay in CE Mode A for Category M2

9.4.1.2.1 Test purpose

To verify that the RSTD measurement reporting delay for UE Category M2 meets the performance requirements in normal coverage mode in an environment with fading propagation conditions.

9.4.1.2.2 Test applicability

This test applies to E-UTRA FDD UE Category M2 release 14 and forward that supports UE-assisted OTDOA and inter-frequency RSTD measurements.

9.4.1.2.3 Minimum conformance requirements

Same as in clause 9.4.1.1.3.

The normative reference for this requirement is TS 36.133 [23] clause 8.16.2.4.1 and A.8.13.3.

9.4.1.2.4 Test description

9.4.1.2.4.1 Initial conditions

Same as in clause 9.4.1.1.4.1 but replacing Table 9.4.1.1.4.1-1 with Table 9.4.1.2.4.1-1.

Table 9.4.1.2.4.1-1: General test parameters for E-UTRAN FDD inter-frequency RSTD measurement reporting delay under fading propagation conditions

Parameter	Unit	Value		Comment
Reference cell		Cell 1		Reference cell is the cell in the OTDOA assistance data with respect to which the RSTD measurement is defined, as specified in 3GPP TS 36.214 [6] and 3GPP TS 36.355 [4]. The reference cell is the serving cell in this test case.
Neighbour cells		Cell 2 and Cell 3		Cell 2 and Cell 3 appear at random places in the neighbour cell list in the OTDOA assistance data, but Cell 2 always appears in the first half of the list, whilst Cell 3 appears in the second half of the list.
MPDCCH		DL Reference Measurement Channel R.16 FDD		As specified in TS 36.521-3 [25] clause A.7.1
<i>mPDCCH-startSF-UeSS</i>		10		Parameter G in $T = r_{\max} \cdot G$ which determines subframe $k0$ in which MPDCCH starts
Channel Bandwidth (BW_{channel})	MHz	10		
Gap pattern Id		0		As specified in TS 36.133 [23] Table 8.1.2.1-1. Applies for measurements on Cell 2 and Cell 3
Gap offset		9		As specified in TS 36.331 [22], Clause 6.3.5
PRS Transmission Bandwidth ^{Note 2}	RB	50 ^{Note 4}		PRS are transmitted over the system bandwidth
PRS configuration index I_{PRS} ^{Note 2}		Cell 1: 142, Cell 2, Cell 3: 152		This corresponds to periodicity of 320 ms and PRS subframe offset of $I_{\text{PRS}} - 160$ DL subframes, as defined in 3GPP TS 36.211 [26], Table 6.10.4.3-1
Number of consecutive downlink positioning subframes N_{PRS} ^{Note 2}		4	2	As defined in 3GPP TS 36.211 [26]. The number of subframes in a positioning occasion
Physical cell ID PCI ^{Note 2}		(PCI of Cell 1 – PCI of Cell 2) mod 6 = 0 and (PCI of Cell 1 – PCI of Cell 3) mod 6 = 0		The cell PCIs are selected such that the relative shifts of PRS patterns among cells are as given by the test parameters
CP length ^{Note 2}		Normal		
DRX		ON		DRX parameters are further specified in Table 9.4.1.1.4.1-2

prs-SubframeOffset		10	Number of subframes rounded to the closest integer. The corresponding parameter in the OTDOA assistance data is prs-SubframeOffset specified in TS 36.355 [4]	
slotNumberOffset		0	The slot number offset at the transmitter between a neighbour cell and the assistance data reference cell specified in TS 36.355 [4]	
Radio frame receive time offset between the cells at the UE antenna connector <small>Note 3</small>	µs	Cell 2 to Cell 1: 1 Cell 3 to Cell 1: -1	PRS are transmitted from synchronous cells	
Expected RSTD <small>Note 1</small>	µs	Cell 2: -2 Cell 3: 2 Other neighbour cells: randomly between -3 and 3	The expected RSTD is what is expected at the receiver. The corresponding parameter in the OTDOA assistance data specified in TS 36.355 [4] is the expectedRSTD indicator	
Expected RSTD uncertainty for all neighbour cells <small>Note 1</small>	µs	5	The corresponding parameter in the OTDOA assistance data specified in TS 36.355 [4] is the expectedRSTD-Uncertainty index	
Number of cells provided in OTDOA assistance data		16	Including the reference cell	
PRS muting info <small>Note 2</small>		Cell 1: '1111111100000000' Cell 2: '0000000011111111' Cell 3: '1111111100000000'	Corresponds to prs-MutingInfo defined in TS 36.355 [4]	
T1	s	3	The length of the time interval from the beginning of each test	
T2	s	7.68	5.12	The length of the time interval that follows immediately after time interval T1
T3	s	7.68	5.12	The length of the time interval that follows immediately after time interval T2
<p>Note 1: Parameters "Expected RSTD" and "Expected RSTD uncertainty for all neighbour cells" are not settable parameters. These are parameters signalled in LPP only. For the values to be used in LPP see Table 9.4.1.1.4.3-5 and TS 37.571-5 [20], clause 7.2.5.</p> <p>Note 2: Parameters "PRS Transmission Bandwidth", "PRS configuration index", "Number of consecutive downlink positioning subframes", "Physical cell ID PCI", "CP length", and "PRS muting info" are settable parameters and also parameters signalled in LPP. The values to be used for "Physical cell ID PCI" are as follows: Cell 1: 0, Cell 2: 6, Cell 3: 12. For all the values to be used in LPP see Table 9.4.1.1.4.3-5 and TS 37.571-5 [20], clause 7.2.5.</p> <p>Note 3: The parameter "Radio frame receive time offset between the cells at the UE antenna connector" is not a settable parameter but is used to set the "true RSTD" values in step 6 of clause 9.4.1.1.4.1.</p> <p>Note 4: If the PRS transmission bandwidth is larger than the UE RF bandwidth, the UE is measuring RSTD within its RF bandwidth.</p>				

9.4.1.2.4.2 Test procedure

Same as in clause 9.4.1.1.4.2 but with the following additional step:

- 14. Repeat step 1-13 for each sub-test in Table 9.4.1.2.4.1-1 as appropriate

9.4.1.2.4.3 Message contents

Same as in clause 9.4.1.1.4.3 with the following exceptions:

Table 9.4.2.1.4.3-1: LPP RequestLocationInformation

Derivation Path: Table 9.3.1.1.4.3-4			
Information Element	Value/remark	Comment	Condition

LPP-Message ::= SEQUENCE {			
lpp-MessageBody CHOICE {			
c1 CHOICE {			
requestLocationInformation SEQUENCE {			
criticalExtensions CHOICE {			
c1 CHOICE {			
requestLocationInformation-r9 SEQUENCE {			
commonIEsRequestLocationInformation SEQUENCE {			
qos SEQUENCE {			
responseTime SEQUENCE {			
time	16	See clause 9.4.1.1.5	Test 1
time	11	See clause 9.4.1.1.5	Test 2
}			
}			
}			
}			
}			
}			
}			

9.4.1.2.5 Test requirement

The primary level settings including test tolerances for the test are defined in clause 9.4.1.1.5.

For Test 1, the response time is defined in clause 9.4.1.1.5.

For Test 2, the response time including test tolerance is 11.3 s. The response time is equal to the LPP time IE value plus the test tolerance. The LPP time IE value is derived from the RSTD reporting delay plus ΔT , where $\Delta T = N_{rep} \times TTI_{DCCH} = N_{rep} \times 75$ ms, giving a value of 10390 ms. This is rounded up to the next allowed LPP value of 11 seconds. The RSTD

measurement reporting delay in the test is derived from the following expression $T_{PRS} (M - 1) + 320 \cdot \left\lceil \frac{n}{M} \right\rceil$, where

$M = 32$ and $n = 16$ are the parameters specified in clause 9.4.1.1.3, Table 9.4.1.1.3-1 and Note 4 of Table 9.4.1.2.4.1-1. This gives the total RSTD reporting delay of 10240 ms for the 15 neighbour cells including Cell 2 and Cell 3 with respect to the reference cell, Cell 1.

The test tolerances are defined in clauses C.1.3 and C4.

For the overall test to pass, the ratio of successful reported values in each sub-test shall be more than 90% with a confidence level of 95%.

9.4.2 HD-FDD inter-frequency RSTD Measurement Reporting Delay in CE Mode A

9.4.2.1 HD-FDD inter-frequency RSTD Measurement Reporting Delay in CE Mode A for Category M1

9.4.2.1.1 Test purpose

To verify that the RSTD measurement reporting delay for UE Category M1 meets the performance requirements normal coverage mode in an environment with fading propagation conditions.

9.4.2.1.2 Test applicability

This test applies to E-UTRA HD-FDD UE Category M1 release 14 and forward that supports UE-assisted OTDOA and inter-frequency RSTD measurements.

9.4.2.1.3 Minimum conformance requirements

Same as in clause 9.4.1.1.3.

The normative reference for this requirement is TS 36.133 [23] clause 8.13.2.4.3 and A.8.13.4.

9.4.2.1.4 Test description

9.4.2.1.4.1 Initial conditions

Same as in clause 9.4.1.1.4.1 but replacing Table 9.4.1.1.4.1-1 with Table 9.4.2.1.4.1-1

Table 9.4.2.1.4.1-1: General test parameters for E-UTRAN HD-FDD inter-frequency RSTD measurement reporting delay under fading propagation conditions

Parameter	Unit	Value	Comment
Reference cell		Cell 1	Reference cell is the cell in the OTDOA assistance data with respect to which the RSTD measurement is defined, as specified in 3GPP TS 36.214 [6] and 3GPP TS 36.355 [4]. The reference cell is the serving cell in this test case.
Neighbour cells		Cell 2 and Cell 3	Cell 2 and Cell 3 appear at random places in the neighbour cell list in the OTDOA assistance data, but Cell 2 always appears in the first half of the list, whilst Cell 3 appears in the second half of the list.
MPDCCH		DL Reference Measurement Channel R.6 HD-FDD	As specified in TS 36.521-3 [25] clause A.7.2
$mPDCCH\text{-startSF-U ESS}$		10	Parameter G in $T = r_{\max} \cdot G$ which determines subframe $k0$ in which MPDCCH starts
Channel Bandwidth (BW_{channel})	MHz	10	
Gap pattern Id		0	As specified in TS 36.133 [23] Table 8.1.2.1-1. Applies for measurements on Cell 2 and Cell 3
Gap offset		9	As specified in TS 36.331 [22], Clause 6.3.5
PRS Transmission Bandwidth ^{Note 2}	RB	50 ^{Note 4}	PRS are transmitted over the system bandwidth
PRS configuration index I_{PRS} ^{Note 2}		Cell 1: 142, Cell 2, Cell 3: 152	This corresponds to periodicity of 320 ms and PRS subframe offset of $I_{\text{PRS}} - 160$ DL subframes, as defined in 3GPP TS 36.211 [26], Table 6.10.4.3-1
Number of consecutive downlink positioning subframes N_{PRS} ^{Note 2}		4	As defined in 3GPP TS 36.211 [26]. The number of subframes in a positioning occasion
Physical cell ID PCI ^{Note 2}		(PCI of Cell 1 – PCI of Cell 2) mod 6 = 0 and (PCI of Cell 1 – PCI of Cell 3) mod 6 = 0	The cell PCIs are selected such that the relative shifts of PRS patterns among cells are as given by the test parameters
CP length ^{Note 2}		Normal	

DRX		ON	DRX parameters are further specified in Table 9.4.1.1.4.1-2
prs-SubframeOffset		10	Number of subframes rounded to the closest integer. The corresponding parameter in the OTDOA assistance data is prs-SubframeOffset specified in TS 36.355 [4]
slotNumberOffset		0	The slot number offset at the transmitter between a neighbour cell and the assistance data reference cell specified in TS 36.355 [4]
Radio frame receive time offset between the cells at the UE antenna connector Note 3	μs	Cell 2 to Cell 1: 1 Cell 3 to Cell 1: -1	PRS are transmitted from synchronous cells
Expected RSTD Note 1	μs	Cell 2: -2 Cell 3: 2 Other neighbour cells: randomly between -3 and 3	The expected RSTD is what is expected at the receiver. The corresponding parameter in the OTDOA assistance data specified in TS 36.355 [4] is the expectedRSTD indicator
Expected RSTD uncertainty for all neighbour cells Note 1	μs	5	The corresponding parameter in the OTDOA assistance data specified in TS 36.355 [4] is the expectedRSTD-Uncertainty index
Number of cells provided in OTDOA assistance data		16	Including the reference cell
PRS muting info Note 2		Cell 1: '1111111100000000' Cell 2: '0000000011111111' Cell 3: '1111111100000000'	Corresponds to prs-MutingInfo defined in TS 36.355 [4]
T1	s	3	The length of the time interval from the beginning of each test
T2	s	7.68	The length of the time interval that follows immediately after time interval T1
T3	s	7.68	The length of the time interval that follows immediately after time interval T2
<p>Note 1: Parameters "Expected RSTD" and "Expected RSTD uncertainty for all neighbour cells" are not settable parameters. These are parameters signalled in LPP only. For the values to be used in LPP see Table 9.4.1.1.4.3-5 and TS 37.571-5 [20], clause 7.2.5.</p> <p>Note 2: Parameters "PRS Transmission Bandwidth", "PRS configuration index", "Number of consecutive downlink positioning subframes", "Physical cell ID PCI", "CP length", and "PRS muting info" are settable parameters and also parameters signalled in LPP. The values to be used for "Physical cell ID PCI" are as follows: Cell 1: 0, Cell 2: 6, Cell 3: 12. For all the values to be used in LPP see Table 9.4.1.1.4.3-5 and TS 37.571-5 [20], clause 7.2.5.</p> <p>Note 3: The parameter "Radio frame receive time offset between the cells at the UE antenna connector" is not a settable parameter but is used to set the "true RSTD" values in step 6 of clause 9.4.1.1.4.1.</p> <p>Note 4: If the PRS transmission bandwidth is larger than the UE RF bandwidth, the UE is measuring RSTD within its RF bandwidth.</p>			

9.4.2.1.4.2 Test procedure

Same as in clause 9.4.1.1.4.2.

9.4.2.1.4.3 Message contents

Same as in clause 9.4.1.1.4.3

9.4.2.1.5 Test requirement

Same as in clause 9.4.1.1.5.

9.4.2.2 HD-FDD inter-frequency RSTD Measurement Reporting Delay in CE Mode A for Category M2

9.4.2.2.1 Test purpose

To verify that the RSTD measurement reporting delay for UE Category M2 meets the performance requirements normal coverage mode in an environment with fading propagation conditions.

9.4.2.2.2 Test applicability

This test applies to E-UTRA HD-FDD UE Category M2 release 14 and forward that supports UE-assisted OTDOA and inter-frequency RSTD measurements.

9.4.2.2.3 Minimum conformance requirements

Same as in clause 9.4.1.1.3.

The normative reference for this requirement is TS 36.133 [23] clause 8.16.2.4.3 and A.8.13.4.

9.4.2.2.4 Test description

9.4.2.2.4.1 Initial conditions

Same as in clause 9.4.1.1.4.1 but replacing Table 9.4.1.1.4.1-1 with Table 9.4.2.2.4.1-1.

Table 9.4.2.2.4.1-1: General test parameters for E-UTRAN HD-FDD inter-frequency RSTD measurement reporting delay under fading propagation conditions

Parameter	Unit	Value	Comment
Reference cell		Cell 1	Reference cell is the cell in the OTDOA assistance data with respect to which the RSTD measurement is defined, as specified in 3GPP TS 36.214 [6] and 3GPP TS 36.355 [4]. The reference cell is the serving cell in this test case.
Neighbour cells		Cell 2 and Cell 3	Cell 2 and Cell 3 appear at random places in the neighbour cell list in the OTDOA assistance data, but Cell 2 always appears in the first half of the list, whilst Cell 3 appears in the second half of the list.
MPDCCH		DL Reference Measurement Channel R.6 HD-FDD	As specified in TS 36.521-3 [25] clause A.7.2
$mPDCCH\text{-startSF}\text{-UESS}$		10	Parameter G in $T = r_{\max} \cdot G$ which determines subframe k_0 in which MPDCCH starts
Channel Bandwidth (BW _{channel})	MHz	10	
Gap pattern Id		0	As specified in TS 36.133 [23] Table 8.1.2.1-1. Applies for measurements on Cell 2 and Cell 3
Gap offset		9	As specified in TS 36.331 [22], Clause 6.3.5
PRS Transmission Bandwidth ^{Note 2}	RB	50 ^{Note 4}	PRS are transmitted over the system bandwidth

PRs configuration index I_{PRS} ^{Note 2}		Cell 1: 142, Cell 2, Cell 3: 152		This corresponds to periodicity of 320 ms and PRs subframe offset of $I_{PRS} - 160$ DL subframes, as defined in 3GPP TS 36.211 [26], Table 6.10.4.3-1
Number of consecutive downlink positioning subframes N_{PRS} ^{Note 2}		4	2	As defined in 3GPP TS 36.211 [26]. The number of subframes in a positioning occasion
Physical cell ID PCI ^{Note 2}		(PCI of Cell 1 – PCI of Cell 2)mod6=0 and (PCI of Cell 1 – PCI of Cell 3)mod6=0		The cell PCIs are selected such that the relative shifts of PRs patterns among cells are as given by the test parameters
CP length ^{Note 2}		Normal		
DRX		ON		DRX parameters are further specified in Table 9.4.1.1.4.1-2
prs-SubframeOffset		10		Number of subframes rounded to the closest integer. The corresponding parameter in the OTDOA assistance data is prs-SubframeOffset specified in TS 36.355 [4]
slotNumberOffset		0		The slot number offset at the transmitter between a neighbour cell and the assistance data reference cell specified in TS 36.355 [4]
Radio frame receive time offset between the cells at the UE antenna connector ^{Note 3}	μs	Cell 2 to Cell 1: 1 Cell 3 to Cell 1: -1		PRs are transmitted from synchronous cells
Expected RSTD ^{Note 1}	μs	Cell 2: -2 Cell 3: 2 Other neighbour cells: randomly between -3 and 3		The expected RSTD is what is expected at the receiver. The corresponding parameter in the OTDOA assistance data specified in TS 36.355 [4] is the expectedRSTD indicator
Expected RSTD uncertainty for all neighbour cells ^{Note 1}	μs	5		The corresponding parameter in the OTDOA assistance data specified in TS 36.355 [4] is the expectedRSTD-Uncertainty index
Number of cells provided in OTDOA assistance data		16		Including the reference cell
PRs muting info ^{Note 2}		Cell 1: '1111111100000000' Cell 2: '0000000011111111' Cell 3: '1111111100000000'		Corresponds to prs-MutingInfo defined in TS 36.355 [4]
T1	s	3		The length of the time interval from the beginning of each test
T2	s	7.68	5.12	The length of the time interval that follows immediately after time interval T1
T3	s	7.68	5.12	The length of the time interval that follows immediately after time interval T2
<p>Note 1: Parameters "Expected RSTD" and "Expected RSTD uncertainty for all neighbour cells" are not settable parameters. These are parameters signalled in LPP only. For the values to be used in LPP see Table 9.4.1.1.4.3-5 and TS 37.571-5 [20], clause 7.2.5.</p> <p>Note 2: Parameters "PRs Transmission Bandwidth", "PRs configuration index", "Number of consecutive downlink positioning subframes", "Physical cell ID PCI", "CP length", and "PRs muting info" are settable parameters and also parameters signalled in LPP. The values to be used for "Physical cell ID PCI" are as follows: Cell 1: 0, Cell 2: 6, Cell 3: 12. For all the values to be used in LPP see Table 9.4.1.1.4.3-5 and TS 37.571-5 [20], clause 7.2.5.</p> <p>Note 3: The parameter "Radio frame receive time offset between the cells at the UE antenna connector" is not a settable parameter but is used to set the "true RSTD" values in step 6 of clause 9.4.1.1.4.1.</p> <p>Note 4: If the PRs transmission bandwidth is larger than the UE RF bandwidth, the UE is measuring RSTD within its RF bandwidth.</p>				

9.4.2.2.4.2 Test procedure

Same as in clause 9.4.1.1.4.2 but with the following additional step:

14. Repeat step 1-13 for each sub-test in Table 9.4.2.2.4.1-1 as appropriate.

9.4.2.2.4.3 Message contents

Same as in clause 9.4.1.2.4.3.

9.4.2.2.5 Test requirement

Same as in clause 9.4.1.2.5.

For the overall test to pass, the ratio of successful reported values in each sub-test shall be more than 90% with a confidence level of 95%.

9.4.3 TDD inter-frequency RSTD Measurement Reporting Delay in CE Mode A

9.4.3.1 TDD inter-frequency RSTD Measurement Reporting Delay in CE Mode A for Category M1

9.4.3.1.1 Test purpose

To verify that the RSTD measurement reporting delay for UE Category M1 meets the performance requirements in normal coverage mode in an environment with fading propagation conditions.

9.4.3.1.2 Test applicability

This test applies to E-UTRA TDD UE Category M1 release 14 and forward that supports UE-assisted OTDOA and inter-frequency RSTD measurements.

9.4.3.1.3 Minimum conformance requirements

Same as in clause 9.4.1.1.3.

The inter-frequency requirements in this clause shall apply for all TDD special subframe configurations specified in TS 36.211 [26] and for the TDD uplink-downlink configurations as specified in Table 9.4.3.1.3-1.

Table 9.4.3.1.3-1: TDD uplink-downlink subframe configurations applicable for TDD inter-frequency requirements

PRS Transmission Bandwidth [RB]	Applicable TDD uplink-downlink configurations
6	1, 2, 3, 4 and 5
Note:	Uplink-downlink configurations are specified in Table 4.2-2 in TS 36.211 [26].

The normative reference for this requirement is TS 36.133 [23] clause 8.13.2.4.2 and A.8.13.5.

9.4.3.1.4 Test description

9.4.3.1.4.1 Initial conditions

Same as in clause 9.4.1.1.4.1 but replacing Table 9.4.1.1.4.1-1 with Table 9.4.3.1.4.1-1

Table 9.4.2.1.4.1-1: General test parameters for E-UTRAN TDD inter-frequency RSTD measurement reporting delay under fading propagation conditions

Parameter	Unit	Value	Comment
-----------	------	-------	---------

Reference cell		Cell 1	Reference cell is the cell in the OTDOA assistance data with respect to which the RSTD measurement is defined, as specified in 3GPP TS 36.214 [6] and 3GPP TS 36.355 [4]. The reference cell is the serving cell in this test case.
Neighbour cells		Cell 2 and Cell 3	Cell 2 and Cell 3 appear at random places in the neighbour cell list in the OTDOA assistance data, but Cell 2 always appears in the first half of the list, whilst Cell 3 appears in the second half of the list.
MPDCCH		DL Reference Measurement Channel R.14 TDD	As specified in TS 36.521-3 [25] clause A.7.3
$mPDCCH\text{-startSF-UeSS}$		10	Parameter G in $T = r_{\max} \cdot G$ which determines subframe $k0$ in which MPDCCH starts
Channel Bandwidth (BW _{channel})	MHz	10	
Gap pattern Id		0	As specified in TS 36.133 [23] Table 8.1.2.1-1. Applies for measurements on Cell 2 and Cell 3
Gap offset		9	As specified in TS 36.331 [22], Clause 6.3.5
PRS Transmission Bandwidth ^{Note 2}	RB	50 ^{Note 4}	PRS are transmitted over the system bandwidth
PRS configuration index I_{PRS} ^{Note 2}		Cell 1: 142, Cell 2, Cell 3: 152	This corresponds to periodicity of 320 ms and PRS subframe offset of $I_{\text{PRS}} - 160$ DL subframes, as defined in 3GPP TS 36.211 [26], Table 6.10.4.3-1
Number of consecutive downlink positioning subframes N_{PRS} ^{Note 2}		4	As defined in 3GPP TS 36.211 [26]. The number of subframes in a positioning occasion
Physical cell ID PCI ^{Note 2}		(PCI of Cell 1 – PCI of Cell 2) mod 6 = 0 and (PCI of Cell 1 – PCI of Cell 3) mod 6 = 0	The cell PCIs are selected such that the relative shifts of PRS patterns among cells are as given by the test parameters
TDD uplink-downlink configuration		1	As specified in TS 36.211 [26], Clause 4.2; corresponds to a configuration with 5 ms switch-point periodicity and two downlink consecutive subframes
TDD special subframe configuration		6	As specified in TS 36.211 [26], Clause 4.2; corresponds to DwPTS of $19760 \cdot T_s$ and UpPTS of $4384 \cdot T_s$
CP length ^{Note 2}		Normal	
DRX		ON	DRX parameters are further specified in Table 9.4.1.1.4.1-2
prs-SubframeOffset		10	Number of subframes rounded to the closest integer. The corresponding parameter in the OTDOA assistance data is prs-SubframeOffset specified in TS 36.355 [4]
slotNumberOffset		0	The slot number offset at the transmitter between a neighbour cell and the assistance data reference cell specified in TS 36.355 [4]

Radio frame receive time offset between the cells at the UE antenna connector <small>Note 3</small>	µs	Cell 2 to Cell 1: 1 Cell 3 to Cell 1: -1	PRS are transmitted from synchronous cells
Expected RSTD <small>Note 1</small>	µs	Cell 2: -2 Cell 3: 2 Other neighbour cells: randomly between -3 and 3	The expected RSTD is what is expected at the receiver. The corresponding parameter in the OTDOA assistance data specified in TS 36.355 [4] is the expectedRSTD indicator
Expected RSTD uncertainty for all neighbour cells <small>Note 1</small>	µs	5	The corresponding parameter in the OTDOA assistance data specified in TS 36.355 [4] is the expectedRSTD-Uncertainty index
Number of cells provided in OTDOA assistance data		16	Including the reference cell
PRS muting info <small>Note 2</small>		Cell 1: '1111111100000000' Cell 2: '0000000011111111' Cell 3: '1111111100000000'	Corresponds to prs-MutingInfo defined in TS 36.355 [4]
T1	s	3	The length of the time interval from the beginning of each test
T2	s	7.68	The length of the time interval that follows immediately after time interval T1
T3	s	7.68	The length of the time interval that follows immediately after time interval T2
<p>Note 1: Parameters "Expected RSTD" and "Expected RSTD uncertainty for all neighbour cells" are not settable parameters. These are parameters signalled in LPP only. For the values to be used in LPP see Table 9.4.1.1.4.3-5 and TS 37.571-5 [20], clause 7.2.5.</p> <p>Note 2: Parameters "PRS Transmission Bandwidth", "PRS configuration index", "Number of consecutive downlink positioning subframes", "Physical cell ID PCI", "CP length", and "PRS muting info" are settable parameters and also parameters signalled in LPP. The values to be used for "Physical cell ID PCI" are as follows: Cell 1: 0, Cell 2: 6, Cell 3: 12. For all the values to be used in LPP see Table 9.4.1.1.4.3-5 and TS 37.571-5 [20], clause 7.2.5.</p> <p>Note 3: The parameter "Radio frame receive time offset between the cells at the UE antenna connector" is not a settable parameter but is used to set the "true RSTD" values in step 6 of clause 9.4.1.1.4.1.</p> <p>Note 4: If the PRS transmission bandwidth is larger than the UE RF bandwidth, the UE is measuring RSTD within its RF bandwidth.</p>			

9.4.3.1.4.2 Test procedure

Same as in clause 9.4.1.1.4.2.

9.4.3.1.4.3 Message contents

Same as in clause 9.4.1.1.4.3

9.4.3.1.5 Test requirement

Table 9.4.3.1.5-1 and 9.4.3.1.5-2 define the primary level settings including test tolerances for the test.

Table 9.4.3.1.5-1: Cell-specific test parameters for E-UTRAN TDD inter-frequency RSTD measurement reporting delay under fading propagation conditions during T1

Parameter	Unit	Cell 1	Cell 2	Cell 3
E-UTRA RF Channel Number		1	2	2
Correlation Matrix and Antenna Configuration		1x1	1x1	1x1
OCNG patterns defined in TS 36.521-3 [25] clause D.1		OP.11 TDD	N/A	N/A

PBCH_RA	dB	0	N/A	N/A
PBCH_RB				
PSS_RA				
SSS_RA				
PCFICH_RB				
PHICH_RA				
PHICH_RB				
PDCCH_RA				
PDCCH_RB				
OCNG_RA ^{Note 1}				
OCNG_RB ^{Note 1}				
N_{oc} ^{Note 3}	dBm/ 15 kHz	-95		
$PRS \hat{E}_s / N_{oc}$	dB	-Infinity	-Infinity	-Infinity
I_o ^{Note 4}	dBm/ 9 MHz	-67.22	N/A	N/A
\hat{E}_s / N_{oc}	dB	0	-Infinity	-Infinity
Propagation Condition	ETU30			
<p>Note 1: OCNG shall be used such that active cell (Cell 1) is fully allocated and a constant total transmitted power spectral density is achieved for all OFDM symbols.</p> <p>Note 2: The resources for uplink transmission are assigned to the UE prior to the start of time period T2.</p> <p>Note 3: Interference from other cells and noise sources not specified in the test are assumed to be constant over subcarriers and time and shall be modelled as AWGN of appropriate power for N_{oc} to be fulfilled.</p> <p>Note 4: I_o levels have been derived from other parameters and are given for information purpose. These are not settable test parameters.</p>				

Table 9.4.3.1.5-2: Cell-specific test parameters for E-UTRAN TDD inter-frequency RSTD measurement reporting delay under fading propagation conditions during T2 and T3

Parameter	Unit	Cell 1		Cell 2		Cell 3	
		T2	T3	T2	T3	T2	T3
E-UTRA RF Channel Number		1		2		2	
Correlation Matrix and Antenna Configuration		1x1		1x1		1x1	
OCNG patterns defined in TS 36.521-3 [25] clause D.1		OP.11 TDD		OP.2 TDD		OP.2 TDD	N/A
PBCH_RA	dB	0	0	0	0	0	N/A
PBCH_RB							
PSS_RA							
SSS_RA							
PCFICH_RB							
PHICH_RA							
PHICH_RB							
PDCCH_RA							
PDCCH_RB							
OCNG_RA ^{Note 1}							
OCNG_RB ^{Note 1}							
PRS_RA	dB	-3	N/A	N/A	3	3	N/A
N_{oc} ^{Note 3}	dBm/ 15 kHz	-98	-95	-98	-95	-98	-95
$PRS \hat{E}_s / N_{oc}$	dB	-1	-Infinity	-Infinity	-7	-7	-Infinity

$\text{PRS } \hat{E}_s / I_{ot}$ Note 4	dB	-1.79	-Infinity	-Infinity	-7	-9.54	-Infinity
I_o Note 4	dBm/ 9 MHz	-69.55	-67.08	-69.55	-67.08	-69.55	N/A
PRP Note 4	dBm/ 15 kHz	-99	-Infinity	-Infinity	-102	-105	-Infinity
RSRP Note 4	dBm/ 15 kHz	-96	-93	-105	-105	-108	-Infinity
\hat{E}_s / N_{oc} Note 4	dB	2	2	-7	-10	-10	-Infinity
Propagation Condition		ETU30					
<p>Note 1: OCNG shall be used such that active cells (all, except Cell 3 in T3) are fully allocated and a constant total transmitted power spectral density is achieved for all OFDM symbols other than those in the subframes with transmitted PRS.</p> <p>Note 2: The resources for uplink transmission are assigned to the UE prior to the start of time period T2.</p> <p>Note 3: Interference from other cells and noise sources not specified in the test are assumed to be constant over subcarriers and time and shall be modelled as AWGN of appropriate power for N_{oc} to be fulfilled.</p> <p>Note 4: If PRS_RA is not "N/A", \hat{E}_s / N_{oc}, PRS \hat{E}_s / I_{ot}, I_o, RSRP and PRP levels have been derived from other parameters and are given for information purpose. If PRS_RA is "N/A", I_o and RSRP levels have been derived from other parameters and are given for information purpose. These are not settable test parameters. Interference conditions shall be applied to all PRS symbols of DL positioning subframes.</p>							

The response time including test tolerance is 16.3 s. The response time is equal to the LPP time IE value plus the test tolerance. The LPP time IE value is derived from the RSTD reporting delay plus ΔT , where $\Delta T = N_{rep} \times TTI_{DCCH} = N_{rep} \times 75$ ms, giving a value of 15510 ms. This is rounded up to the next allowed LPP value of 16 seconds. The RSTD

measurement reporting delay in the test is derived from the following expression $T_{PRS} (M - 1) + 320 \cdot \left\lceil \frac{n}{M} \right\rceil$, where

$M = 48$ and $n = 16$ are the parameters specified in clause 9.4.1.1.3, Table 9.4.1.1.3-1 and Note 4 of Table 9.4.1.1.4.1-1. This gives the total RSTD reporting delay of 15360 ms for the 15 neighbour cells including Cell 2 and Cell 3 with respect to the reference cell, Cell 1.

The test tolerances are defined in clauses C.1.3 and C4.

The rate of successful tests during repeated tests shall be at least 90% with a confidence level of 95%.

9.4.3.2 TDD inter-frequency RSTD Measurement Reporting Delay in CE Mode A for Category M2

9.4.3.2.1 Test purpose

To verify that the RSTD measurement reporting delay for UE Category M2 meets the performance requirements in normal coverage mode in an environment with fading propagation conditions.

9.4.3.2.2 Test applicability

This test applies to E-UTRA TDD UE Category M2 release 14 and forward that supports UE-assisted OTDOA and inter-frequency RSTD measurements.

9.4.3.2.3 Minimum conformance requirements

Same as in clause 9.4.3.1.3.

The intra-frequency requirements in this clause shall apply for all TDD special subframe configurations specified in TS 36.211 [26] and for the TDD uplink-downlink configurations as specified in Table 9.4.3.2.3-1.

Table 9.4.3.2.3-1: TDD uplink-downlink subframe configurations applicable for TDD intra-frequency requirements

PRS Transmission Bandwidth [RB]	Applicable TDD uplink-downlink configurations
6	1, 2, 3, 4 and 5
24	0, 1, 2, 3, 4, 5 and 6
Note: Uplink-downlink configurations are specified in Table 4.2-2 in TS 36.211 [26].	

The normative reference for this requirement is TS 36.133 [23] clause 8.16.2.4.2 and A.8.13.5.

9.4.3.2.4 Test description

9.4.3.2.4.1 Initial conditions

Same as in clause 9.4.1.1.4.1 but replacing Table 9.4.1.1.4.1-1 with Table 9.4.3.2.4.1-1.

Table 9.4.3.2.4.1-1: General test parameters for E-UTRAN TDD inter-frequency RSTD measurement reporting delay under fading propagation conditions

Parameter	Unit	Value		Comment
Reference cell		Cell 1		Reference cell is the cell in the OTDOA assistance data with respect to which the RSTD measurement is defined, as specified in 3GPP TS 36.214 [6] and 3GPP TS 36.355 [4]. The reference cell is the serving cell in this test case.
Neighbour cells		Cell 2 and Cell 3		Cell 2 and Cell 3 appear at random places in the neighbour cell list in the OTDOA assistance data, but Cell 2 always appears in the first half of the list, whilst Cell 3 appears in the second half of the list.
MPDCCH		DL Reference Measurement Channel R.14 TDD		As specified in TS 36.521-3 [25] clause A.7.3
$mPDCCH\text{-startSF-U ESS}$		10		Parameter G in $T = r_{\max} \cdot G$ which determines subframe $k0$ in which MPDCCH starts
Channel Bandwidth (BW_{channel})	MHz	10		
Gap pattern Id		0		As specified in TS 36.133 [23] Table 8.1.2.1-1. Applies for measurements on Cell 2 and Cell 3
Gap offset		9		As specified in TS 36.331 [22], Clause 6.3.5
PRS Transmission Bandwidth ^{Note 2}	RB	50 ^{Note 4}		PRS are transmitted over the system bandwidth
PRS configuration index I_{PRS} ^{Note 2}		Cell 1: 142, Cell 2, Cell 3: 152		This corresponds to periodicity of 320 ms and PRS subframe offset of $I_{\text{PRS}} - 160$ DL subframes, as defined in 3GPP TS 36.211 [26], Table 6.10.4.3-1
Number of consecutive downlink positioning subframes N_{PRS} ^{Note 2}		4	2	As defined in 3GPP TS 36.211 [26]. The number of subframes in a positioning occasion
Physical cell ID PCI ^{Note 2}		(PCI of Cell 1 – PCI of Cell 2) mod 6 = 0 and (PCI of Cell 1 – PCI of Cell 3) mod 6 = 0		The cell PCIs are selected such that the relative shifts of PRS patterns among cells are as given by the test parameters

TDD uplink-downlink configuration		1	As specified in TS 36.211 [26], Clause 4.2; corresponds to a configuration with 5 ms switch-point periodicity and two downlink consecutive subframes	
TDD special subframe configuration		6	As specified in TS 36.211 [26], Clause 4.2; corresponds to DwPTS of $19760 \cdot T_s$ and UpPTS of $4384 \cdot T_s$	
CP length ^{Note 2}		Normal		
DRX		ON	DRX parameters are further specified in Table 9.4.1.1.4.1-2	
prs-SubframeOffset		10	Number of subframes rounded to the closest integer. The corresponding parameter in the OTDOA assistance data is prs-SubframeOffset specified in TS 36.355 [4]	
slotNumberOffset		0	The slot number offset at the transmitter between a neighbour cell and the assistance data reference cell specified in TS 36.355 [4]	
Radio frame receive time offset between the cells at the UE antenna connector ^{Note 3}	μs	Cell 2 to Cell 1: 1 Cell 3 to Cell 1: -1	PRS are transmitted from synchronous cells	
Expected RSTD ^{Note 1}	μs	Cell 2: -2 Cell 3: 2 Other neighbour cells: randomly between -3 and 3	The expected RSTD is what is expected at the receiver. The corresponding parameter in the OTDOA assistance data specified in TS 36.355 [4] is the expectedRSTD indicator	
Expected RSTD uncertainty for all neighbour cells ^{Note 1}	μs	5	The corresponding parameter in the OTDOA assistance data specified in TS 36.355 [4] is the expectedRSTD-Uncertainty index	
Number of cells provided in OTDOA assistance data		16	Including the reference cell	
PRS muting info ^{Note 2}		Cell 1: '1111111100000000' Cell 2: '0000000011111111' Cell 3: '1111111100000000'	Corresponds to prs-MutingInfo defined in TS 36.355 [4]	
T1	s	3	The length of the time interval from the beginning of each test	
T2	s	7.68	5.12	The length of the time interval that follows immediately after time interval T1
T3	s	7.68	5.12	The length of the time interval that follows immediately after time interval T2
Note 1:	Parameters "Expected RSTD" and "Expected RSTD uncertainty for all neighbour cells" are not settable parameters. These are parameters signalled in LPP only. For the values to be used in LPP see Table 9.4.1.1.4.3-5 and TS 37.571-5 [20], clause 7.2.5.			
Note 2:	Parameters "PRS Transmission Bandwidth", "PRS configuration index", "Number of consecutive downlink positioning subframes", "Physical cell ID PCI", "CP length", and "PRS muting info" are settable parameters and also parameters signalled in LPP. The values to be used for "Physical cell ID PCI" are as follows: Cell 1: 0, Cell 2: 6, Cell 3: 12. For all the values to be used in LPP see Table 9.4.1.1.4.3-5 and TS 37.571-5 [20], clause 7.2.5.			
Note 3:	The parameter "Radio frame receive time offset between the cells at the UE antenna connector" is not a settable parameter but is used to set the "true RSTD" values in step 6 of clause 9.4.1.1.4.1.			
Note 4:	If the PRS transmission bandwidth is larger than the UE RF bandwidth, the UE is measuring RSTD within its RF bandwidth.			

9.4.3.2.4.2 Test procedure

Same as in clause 9.4.1.1.4.2 but with the following additional step:

14. Repeat step 1-13 for each sub-test in Table 9.4.2.2.4.1-1 as appropriate.

9.4.3.2.4.3 Message contents

Same as in clause 9.4.1.2.4.3.

9.4.3.2.5 Test requirement

The primary level settings including test tolerances for the test are defined in clause 9.4.3.1.5.

For Test 1, the response time is defined in clause 9.4.3.1.5.

For Test 2, the response time including test tolerance is 11.3 s. The response time is equal to the LPP time IE value plus the test tolerance. The LPP time IE value is derived from the RSTD reporting delay plus ΔT , where $\Delta T = N_{rep} \times TTI_{DCCH} = N_{rep} \times 75$ ms, giving a value of 10390 ms. This is rounded up to the next allowed LPP value of 11 seconds. The RSTD

measurement reporting delay in the test is derived from the following expression $T_{PRS} (M - 1) + 320 \cdot \left\lceil \frac{n}{M} \right\rceil$, where

$M = 32$ and $n = 16$ are the parameters specified in clause 9.4.1.1.3, Table 9.4.1.1.3-1 and Note 4 of Table 9.4.3.2.4.1-1. This gives the total RSTD reporting delay of 10240 ms for the 15 neighbour cells including Cell 2 and Cell 3 with respect to the reference cell, Cell 1.

For the overall test to pass, the ratio of successful reported values in each sub-test shall be more than 90% with a confidence level of 95%.

9.4.4 FDD inter-frequency RSTD Measurement Reporting Delay in CE Mode B

9.4.4.1 FDD inter-frequency RSTD Measurement Reporting Delay in CE Mode B for Category M1

9.4.4.1.1 Test purpose

To verify that the RSTD measurement reporting delay for UE Category M1 meets the performance requirements in enhanced coverage mode in an environment with fading propagation conditions.

9.4.4.1.2 Test applicability

This test applies to E-UTRA FDD UE Category M1 release 14 and forward that supports UE-assisted OTDOA, inter-frequency RSTD measurements and CE Mode B.

9.4.4.1.3 Minimum conformance requirements

Same as 9.4.1.1.3 with the following exceptions:

The conditions under which the UE physical layer shall be capable of reporting RSTD for the reference cell and all the neighbour cells i out of at least $(n-1)$ neighbour cells within $T_{RSTD, IntraFreqFDD, Cat_M}$ are changed:

$(PRS \hat{E}_s / Iot)_{ref} \geq -15$ dB for all Frequency Bands for the reference cell,

$(PRS \hat{E}_s / Iot)_i \geq -15$ dB for all Frequency Bands for neighbour cell i ,

$(PRS \hat{E}_s / Iot)_{ref}$ and $(PRS \hat{E}_s / Iot)_i$ conditions apply for all subframes of at least $L = \frac{M}{2}$ PRS positioning

occasions,

PRP 1,2|dBm according to clause E.3.1 for a corresponding Band.

The normative reference for this requirement is TS 36.133 [23] clause 8.13.3.7.1 and A.8.13.6.

9.4.4.1.4 Test description

9.4.4.1.4.1 Initial conditions

Same as in clause 9.4.1.1.4.1 but replacing Table 9.4.1.1.4.1-1 with Table 9.4.4.1.4.1-1.

Table 9.4.4.1.4.1-1: General test parameters for E-UTRAN FDD inter-frequency RSTD measurement reporting delay under fading propagation conditions

Parameter	Unit	Value	Comment
Reference cell		Cell 1	Reference cell is the cell in the OTDOA assistance data with respect to which the RSTD measurement is defined, as specified in 3GPP TS 36.214 [6] and 3GPP TS 36.355 [4]. The reference cell is the serving cell in this test case.
Neighbour cells		Cell 2 and Cell 3	Cell 2 and Cell 3 appear at random places in the neighbour cell list in the OTDOA assistance data, but Cell 2 always appears in the first half of the list, whilst Cell 3 appears in the second half of the list.
MPDCCH		DL Reference Measurement Channel R.16 FDD	As specified in TS 36.521-3 [25] clause A.7.1
$mPDCCH\text{-startSF-UeSS}$		10	Parameter G in $T = r_{\max} \cdot G$ which determines subframe $k0$ in which MPDCCH starts
Channel Bandwidth (BW_{channel})	MHz	10	
Gap pattern Id		0	As specified in TS 36.133 [23] Table 8.1.2.1-1. Applies for measurements on Cell 2 and Cell 3
Gap offset		9	As specified in TS 36.331 [22], Clause 6.3.5
PRS Transmission Bandwidth ^{Note 2}	RB	50 ^{Note 4}	PRS are transmitted over the system bandwidth
PRS configuration index I_{PRS} ^{Note 2}		Cell 1: 142, Cell 2, Cell 3: 152	This corresponds to periodicity of 320 ms and PRS subframe offset of $I_{\text{PRS}} - 160$ DL subframes, as defined in 3GPP TS 36.211 [26], Table 6.10.4.3-1
Number of consecutive downlink positioning subframes N_{PRS} ^{Note 2}		4	As defined in 3GPP TS 36.211 [26]. The number of subframes in a positioning occasion
Physical cell ID PCI ^{Note 2}		(PCI of Cell 1 – PCI of Cell 2) mod 6 = 0 and (PCI of Cell 1 – PCI of Cell 3) mod 6 = 0	The cell PCIs are selected such that the relative shifts of PRS patterns among cells are as given by the test parameters
CP length ^{Note 2}		Normal	
DRX		ON	DRX parameters are further specified in Table 9.4.1.1.4.1-2
Radio frame receive time offset between the cells at the UE antenna connector ^{Note 3}	µs	Cell 2 to Cell 1: 1 Cell 3 to Cell 1: -1	PRS are transmitted from synchronous cells

Expected RSTD ^{Note 1}	µs	Cell 2: 3 Cell 3: 3 Other neighbour cells: randomly between -3 and 3	The expected RSTD is what is expected at the receiver. The corresponding parameter in the OTDOA assistance data specified in TS 36.355 [4] is the expectedRSTD indicator
Expected RSTD uncertainty for all neighbour cells ^{Note 1}	µs	5	The corresponding parameter in the OTDOA assistance data specified in TS 36.355 [4] is the expectedRSTD-Uncertainty index
Number of cells provided in OTDOA assistance data		16	Including the reference cell
PRS muting info ^{Note 2}		Cell 1: '1111111100000000' Cell 2: '0000000011111111' Cell 3: '1111111100000000'	Corresponds to prs-MutingInfo defined in TS 36.355 [4]
T1	s	3	The length of the time interval from the beginning of each test
T2	s	20.48	The length of the time interval that follows immediately after time interval T1
T3	s	20.48	The length of the time interval that follows immediately after time interval T2
<p>Note 1: Parameters "Expected RSTD" and "Expected RSTD uncertainty for all neighbour cells" are not settable parameters. These are parameters signalled in LPP only. For the values to be used in LPP see Table 9.4.1.1.4.3-5 and TS 37.571-5 [20], clause 7.2.5.</p> <p>Note 2: Parameters "PRS Transmission Bandwidth", "PRS configuration index", "Number of consecutive downlink positioning subframes", "Physical cell ID PCI", "CP length", and "PRS muting info" are settable parameters and also parameters signalled in LPP. The values to be used for "Physical cell ID PCI" are as follows: Cell 1: 0, Cell 2: 6, Cell 3: 12. For all the values to be used in LPP see Table 9.4.1.1.4.3-5 and TS 37.571-5 [20], clause 7.2.5.</p> <p>Note 3: The parameter "Radio frame receive time offset between the cells at the UE antenna connector" is not a settable parameter but is used to set the "true RSTD" values in step 6 of clause 9.4.1.1.4.1.</p> <p>Note 4: If the PRS transmission bandwidth is larger than the UE RF bandwidth, the UE is measuring RSTD within its RF bandwidth.</p>			

9.4.4.1.4.2 Test procedure

Same as in clause 9.4.1.4.2 but using condition CEModeB.

9.4.4.1.4.3 Message contents

Same as in clause 9.4.1.1.4.3 with the following exceptions:

Table 9.4.4.1.4.3-1: LPP RequestLocationInformation

Derivation Path: Table 9.4.1.1.4.3-4			
Information Element	Value/remark	Comment	Condition
LPP-Message ::= SEQUENCE {			
lpp-MessageBody CHOICE {			
c1 CHOICE {			
requestLocationInformation SEQUENCE {			
criticalExtensions CHOICE {			
c1 CHOICE {			
requestLocationInformation-r9 SEQUENCE {			
commonIEsRequestLocationInformation SEQUENCE {			
qos SEQUENCE {			
responseTime SEQUENCE {			
time	42	See clause 9.4.4.1.5	
}			
}			
}			
}			
}			
}			
}			

}			
}			
}			
}			
}			
}			

9.4.4.1.5 Test requirement

Table 9.4.4.1.5-1 and 9.4.4.1.5-2 define the primary level settings including test tolerances for the test.

Table 9.4.4.1.5-1: Cell-specific test parameters for E-UTRAN FDD inter-frequency RSTD measurement reporting delay under fading propagation conditions during T1

Parameter	Unit	Cell 1	Cell 2	Cell 3
E-UTRA RF Channel Number		1	2	2
Correlation Matrix and Antenna Configuration		1x1	1x1	1x1
OCNG patterns defined in TS 36.521-3 [25] clause D.1		OP.21 FDD	N/A	N/A
PBCH_RA	dB	0	N/A	N/A
PBCH_RB				
PSS_RA				
SSS_RA				
PCFICH_RB				
PHICH_RA				
PHICH_RB				
PDCCH_RA				
PDCCH_RB				
OCNG_RA ^{Note 1}				
OCNG_RB ^{Note 1}				
N_{oc} ^{Note 3}	dBm/15 kHz	-95		
$PRS \hat{E}_s / N_{oc}$	dB	-Infinity	-Infinity	-Infinity
I_o ^{Note 4}	dBm/9 MHz	-67.22	N/A	N/A
\hat{E}_s / N_{oc}	dB	0	-Infinity	-Infinity
Propagation Condition		ETU30		
Note 1: OCNG shall be used such that active cell (Cell 1) is fully allocated and a constant total transmitted power spectral density is achieved for all OFDM symbols. Note 2: The resources for uplink transmission are assigned to the UE prior to the start of time period T2. Note 3: Interference from other cells and noise sources not specified in the test are assumed to be constant over subcarriers and time and shall be modelled as AWGN of appropriate power for N_{oc} to be fulfilled. Note 4: I_o levels have been derived from other parameters and are given for information purpose. These are not settable test parameters.				

Table 9.4.4.1.5-2: Cell-specific test parameters for E-UTRAN FDD inter-frequency RSTD measurement reporting delay under fading propagation conditions during T2 and T3

Parameter	Unit	Cell 1		Cell 2		Cell 3	
		T2	T3	T2	T3	T2	T3

E-UTRA RF Channel Number		1		2		2	
Correlation Matrix and Antenna Configuration		1x1		1x1		1x1	
OCNG patterns defined in TS 36.521-3 [25] clause D.1		OP.21 FDD		OP.6 FDD		OP.6 FDD	N/A
PBCH_RA	dB	0		0	0	0	N/A
PBCH_RB							
PSS_RA							
SSS_RA							
PCFICH_RB							
PHICH_RA							
PHICH_RB							
PDCCH_RA							
PDCCH_RB							
OCNG_RA ^{Note 1}							
OCNG_RB ^{Note 1}							
PRS_RA	dB	0	N/A	N/A	0	0	N/A
N_{oc} ^{Note 3}	dBm/15 kHz	-98	-95	-98	-95	-98	-95
$PRS \hat{E}_s / N_{oc}$	dB	-12	-Infinity	-Infinity	-13	-14	-Infinity
$PRS \hat{E}_s / I_{ot}$ ^{Note 4}	dB	-12	-Infinity	-Infinity	-13	-14	-Infinity
I_o ^{Note 4}	dBm/9 MHz	-70.17	-67.13	-70.19	-70.18	-70.19	-70.18
PRP ^{Note 4}	dBm/15 kHz	-110	-Infinity	-Infinity	-108	-112	-Infinity
RSRP ^{Note 4}	dBm/15 kHz	-110	-110	-114	-108	-112	-Infinity
\hat{E}_s / N_{oc} ^{Note 4}	dB	-9	-9	-14	-13	-14	-Infinity
Propagation Condition		ETU30					
<p>Note 1: OCNG shall be used such that active cells (all, except Cell 3 in T3) are fully allocated and a constant total transmitted power spectral density is achieved for all OFDM symbols other than those in the subframes with transmitted PRS.</p> <p>Note 2: The resources for uplink transmission are assigned to the UE prior to the start of time period T2.</p> <p>Note 3: Interference from other cells and noise sources not specified in the test are assumed to be constant over subcarriers and time and shall be modelled as AWGN of appropriate power for N_{oc} to be fulfilled.</p> <p>Note 4: If PRS_RA is not "N/A", \hat{E}_s / N_{oc}, $PRS \hat{E}_s / I_{ot}$, I_o, RSRP and PRP levels have been derived from other parameters and are given for information purpose. If PRS_RA is "N/A", I_o and RSRP levels have been derived from other parameters and are given for information purpose. These are not settable test parameters. Interference conditions shall be applied to all PRS symbols of DL positioning subframes.</p>							

The response time including test tolerance is 42.3 s. The response time is equal to the LPP time IE value plus the test tolerance. The LPP time IE value is derived from the RSTD reporting delay plus ΔT , where $\Delta T = N_{rep} \times TTI_{DCCH} = N_{rep} \times 75$ ms, giving a value of 41110 ms. This is rounded up to the next allowed LPP value of 42 seconds. The RSTD

measurement reporting delay in the test is derived from the following expression $T_{PRS} (M - 1) + 320 \cdot \left\lceil \frac{n}{M} \right\rceil$, where

$M = 128$ and $n = 16$ are the parameters specified in clause 9.4.1.1.3, Table 9.4.1.1.3-1 and Note 4 of Table 9.4.4.1.4.1-1. This gives the total RSTD reporting delay of 40960 ms for the 15 neighbour cells including Cell 2 and Cell 3 with respect to the reference cell, Cell 1.

The test tolerances are defined in clauses C.1.3 and C4.

The rate of successful tests during repeated tests shall be at least 90% with a confidence level of 95%.

9.4.4.2 FDD inter-frequency RSTD Measurement Reporting Delay in CE Mode B for Category M2

9.4.4.2.1 Test purpose

To verify that the RSTD measurement reporting delay for UE Category M2 meets the performance requirements in enhanced coverage mode in an environment with fading propagation conditions.

9.4.4.2.2 Test applicability

This test applies to E-UTRA FDD UE Category M2 release 14 and forward that supports UE-assisted OTDOA, inter-frequency RSTD measurements and CE Mode B.

9.4.4.2.3 Minimum conformance requirements

Same as in clause 9.4.4.1.3.

The normative reference for this requirement is TS 36.133 [23] clause 8.16.3.2.1 and A.8.13.6.

9.4.4.2.4 Test description

9.4.4.2.4.1 Initial conditions

Same as in clause 9.4.1.1.4.1 but replacing Table 9.4.1.1.4.1-1 with Table 9.4.4.2.4.1-1.

Table 9.4.4.2.4.1-1: General test parameters for E-UTRAN FDD inter-frequency RSTD measurement reporting delay under fading propagation conditions

Parameter	Unit	Value		Comment
		Test 1	Test 2	
Reference cell		Cell 1		Reference cell is the cell in the OTDOA assistance data with respect to which the RSTD measurement is defined, as specified in 3GPP TS 36.214 [6] and 3GPP TS 36.355 [4]. The reference cell is the serving cell in this test case.
Neighbour cells		Cell 2 and Cell 3		Cell 2 and Cell 3 appear at random places in the neighbour cell list in the OTDOA assistance data, but Cell 2 always appears in the first half of the list, whilst Cell 3 appears in the second half of the list.
MPDCCH		DL Reference Measurement Channel R.16 FDD		As specified in TS 36.521-3 [25] clause A.7.1
<i>mPDCCH-startSF-UESS</i>		10		Parameter G in $T = r_{\max} \cdot G$ which determines subframe $k0$ in which MPDCCH starts
Channel Bandwidth (BW _{channel})	MHz	10		
Gap pattern Id		0		As specified in TS 36.133 [23] Table 8.1.2.1-1. Applies for measurements on Cell 2 and Cell 3
Gap offset		9		As specified in TS 36.331 [22], Clause 6.3.5

PRS Transmission Bandwidth ^{Note 2}	RB	50 ^{Note 4}		PRS are transmitted over the system bandwidth
PRS configuration index I_{PRS} ^{Note 2}		Cell 1: 142, Cell 2, Cell 3: 152		This corresponds to periodicity of 320 ms and PRS subframe offset of $I_{PRS} - 160$ DL subframes, as defined in 3GPP TS 36.211 [26], Table 6.10.4.3-1
Number of consecutive downlink positioning subframes N_{PRS} ^{Note 2}		4	4	As defined in 3GPP TS 36.211 [26]. The number of subframes in a positioning occasion
Physical cell ID PCI ^{Note 2}		(PCI of Cell 1 – PCI of Cell 2) mod 6 = 0 and (PCI of Cell 1 – PCI of Cell 3) mod 6 = 0		The cell PCIs are selected such that the relative shifts of PRS patterns among cells are as given by the test parameters
CP length ^{Note 2}		Normal		
DRX		ON		DRX parameters are further specified in Table 9.4.1.1.4.1-2
Radio frame receive time offset between the cells at the UE antenna connector ^{Note 3}	µs	Cell 2 to Cell 1: 1 Cell 3 to Cell 1: -1		PRS are transmitted from synchronous cells
Expected RSTD ^{Note 1}	µs	Cell 2: 3 Cell 3: 3 Other neighbour cells: randomly between -3 and 3		The expected RSTD is what is expected at the receiver. The corresponding parameter in the OTDOA assistance data specified in TS 36.355 [4] is the expectedRSTD indicator
Expected RSTD uncertainty for all neighbour cells ^{Note 1}	µs	5		The corresponding parameter in the OTDOA assistance data specified in TS 36.355 [4] is the expectedRSTD-Uncertainty index
Number of cells provided in OTDOA assistance data		16		Including the reference cell
PRS muting info ^{Note 2}		Cell 1: '1111111100000000' Cell 2: '0000000011111111' Cell 3: '1111111100000000'		Corresponds to prs-MutingInfo defined in TS 36.355 [4]
T1	s	3		The length of the time interval from the beginning of each test
T2	s	20.48	5.12	The length of the time interval that follows immediately after time interval T1
T3	s	20.48	5.12	The length of the time interval that follows immediately after time interval T2
<p>Note 1: Parameters “Expected RSTD” and “Expected RSTD uncertainty for all neighbour cells” are not settable parameters. These are parameters signalled in LPP only. For the values to be used in LPP see Table 9.4.1.1.4.3-5 and TS 37.571-5 [20], clause 7.2.5.</p> <p>Note 2: Parameters “PRS Transmission Bandwidth”, “PRS configuration index”, “Number of consecutive downlink positioning subframes”, “Physical cell ID PCI”, “CP length”, and “PRS muting info” are settable parameters and also parameters signalled in LPP. The values to be used for “Physical cell ID PCI” are as follows: Cell 1: 0, Cell 2: 6, Cell 3: 12. For all the values to be used in LPP see Table 9.4.1.1.4.3-5 and TS 37.571-5 [20], clause 7.2.5.</p> <p>Note 3: The parameter “Radio frame receive time offset between the cells at the UE antenna connector” is not a settable parameter but is used to set the “true RSTD” values in step 6 of clause 9.4.1.1.4.1.</p> <p>Note 4: If the PRS transmission bandwidth is larger than the UE RF bandwidth, the UE is measuring RSTD within its RF bandwidth.</p>				

9.4.4.2.4.2 Test procedure

Same as in clause 9.4.1.1.4.2 but using condition CEModeB and with the following additional step:

14. Repeat step 1-13 for each sub-test in Table 9.4.4.2.4.1-1 as appropriate

9.4.4.2.4.3 Message contents

Same as in clause 9.4.1.1.4.3 with the following exceptions:

Table 9.4.4.2.4.3-1: LPP RequestLocationInformation

Derivation Path: Table 9.4.1.1.4.3-4			
Information Element	Value/remark	Comment	Condition
LPP-Message ::= SEQUENCE {			
lpp-MessageBody CHOICE {			
c1 CHOICE {			
requestLocationInformation SEQUENCE {			
criticalExtensions CHOICE {			
c1 CHOICE {			
requestLocationInformation-r9 SEQUENCE {			
commonIEsRequestLocationInformation SEQUENCE {			
qos SEQUENCE {			
responseTime SEQUENCE {			
time	42	See clause 9.4.4.1.5	Test 1
time	11	See clause 9.4.4.1.5	Test 2
}			
}			
}			
}			
}			
}			
}			
}			
}			
}			

9.4.4.2.5 Test requirement

The primary level settings including test tolerances for the test are defined in clause 9.4.4.1.5.

For Test 1, the response time is defined in clause 9.4.4.1.5.

For Test 2, the response time including test tolerance is 11.3 s. The response time is equal to the LPP time IE value plus the test tolerance. The LPP time IE value is derived from the RSTD reporting delay plus ΔT, where ΔT = N_{rep} × TTI_{DCCH} = N_{rep} × 75 ms, giving a value of 10390 ms. This is rounded up to the next allowed LPP value of 11 seconds. The RSTD

measurement reporting delay in the test is derived from the following expression $T_{PRS} (M - 1) + 320 \cdot \left\lceil \frac{n}{M} \right\rceil$, where

M = 32 and n = 16 are the parameters specified in clause 9.4.1.1.3, Table 9.4.1.1.3-1 and Note 4 of Table 9.4.4.2.4.1-1. This gives the total RSTD reporting delay of 10240 ms for the 15 neighbour cells including Cell 2 and Cell 3 with respect to the reference cell, Cell 1.

The test tolerances are defined in clauses C.1.3 and C4.

For the overall test to pass, the ratio of successful reported values in each sub-test shall be more than 90% with a confidence level of 95%.

9.4.5 HD-FDD inter-frequency RSTD Measurement Reporting Delay in CE Mode B

9.4.5.1 HD-FDD inter-frequency RSTD Measurement Reporting Delay in CE Mode B for Category M1

9.4.5.1.1 Test purpose

To verify that the RSTD measurement reporting delay for UE Category M1 meets the performance requirements in an environment with fading propagation conditions.

9.4.5.1.2 Test applicability

This test applies to E-UTRA HD-FDD UE Category M1 release 14 and forward that supports UE-assisted OTDOA, inter-frequency RSTD measurements and CE Mode B.

9.4.5.1.3 Minimum conformance requirements

Same as in clause 9.4.4.1.3.

The normative reference for this requirement is TS 36.133 [23] clause 8.13.3.7.3 and A.8.13.7.

9.4.5.1.4 Test description

9.4.5.1.4.1 Initial conditions

Same as in clause 9.4.1.1.4.1 but replacing Table 9.4.1.1.4.1-1 with Table 9.4.5.1.4.1-1

Table 9.4.5.1.4.1-1: General test parameters for E-UTRAN HD-FDD inter-frequency RSTD measurement reporting delay under fading propagation conditions

Parameter	Unit	Value	Comment
Reference cell		Cell 1	Reference cell is the cell in the OTDOA assistance data with respect to which the RSTD measurement is defined, as specified in 3GPP TS 36.214 [6] and 3GPP TS 36.355 [4]. The reference cell is the serving cell in this test case.
Neighbour cells		Cell 2 and Cell 3	Cell 2 and Cell 3 appear at random places in the neighbour cell list in the OTDOA assistance data, but Cell 2 always appears in the first half of the list, whilst Cell 3 appears in the second half of the list.
MPDCCH		DL Reference Measurement Channel R.8 HD-FDD	As specified in TS 36.521-3 [25] clause A.7.2
$mPDCCH\text{-startSF-U ESS}$		10	Parameter G in $T = r_{\max} \cdot G$ which determines subframe $k0$ in which MPDCCH starts
Channel Bandwidth (BW _{channel})	MHz	10	
Gap pattern Id		0	As specified in TS 36.133 [23] Table 8.1.2.1-1. Applies for measurements on Cell 2 and Cell 3
Gap offset		9	As specified in TS 36.331 [22], Clause 6.3.5
PRS Transmission Bandwidth ^{Note 2}	RB	50 ^{Note 4}	PRS are transmitted over the system bandwidth

PRs configuration index I_{PRS} ^{Note 2}		Cell 1: 142, Cell 2, Cell 3: 152	This corresponds to periodicity of 320 ms and PRS subframe offset of $I_{PRS} - 160$ DL subframes, as defined in 3GPP TS 36.211 [26], Table 6.10.4.3-1
Number of consecutive downlink positioning subframes N_{PRS} ^{Note 2}		4	As defined in 3GPP TS 36.211 [26]. The number of subframes in a positioning occasion
Physical cell ID PCI ^{Note 2}		(PCI of Cell 1 – PCI of Cell 2) mod 6 = 0 and (PCI of Cell 1 – PCI of Cell 3) mod 6 = 0	The cell PCIs are selected such that the relative shifts of PRS patterns among cells are as given by the test parameters
CP length ^{Note 2}		Normal	
DRX		ON	DRX parameters are further specified in Table 9.4.1.1.4.1-2
Radio frame receive time offset between the cells at the UE antenna connector ^{Note 3}	μs	Cell 2 to Cell 1: 1 Cell 3 to Cell 1: -1	PRS are transmitted from synchronous cells
Expected RSTD ^{Note 1}	μs	Cell 2: 3 Cell 3: 3 Other neighbour cells: randomly between -3 and 3	The expected RSTD is what is expected at the receiver. The corresponding parameter in the OTDOA assistance data specified in TS 36.355 [4] is the expectedRSTD indicator
Expected RSTD uncertainty for all neighbour cells ^{Note 1}	μs	5	The corresponding parameter in the OTDOA assistance data specified in TS 36.355 [4] is the expectedRSTD-Uncertainty index
Number of cells provided in OTDOA assistance data		16	Including the reference cell
PRS muting info ^{Note 2}		Cell 1: '1111111100000000' Cell 2: '0000000011111111' Cell 3: '1111111100000000'	Corresponds to prs-MutingInfo defined in TS 36.355 [4]
T1	s	3	The length of the time interval from the beginning of each test
T2	s	20.48	The length of the time interval that follows immediately after time interval T1
T3	s	20.48	The length of the time interval that follows immediately after time interval T2
<p>Note 1: Parameters "Expected RSTD" and "Expected RSTD uncertainty for all neighbour cells" are not settable parameters. These are parameters signalled in LPP only. For the values to be used in LPP see Table 9.4.1.1.4.3-5 and TS 37.571-5 [20], clause 7.2.5.</p> <p>Note 2: Parameters "PRS Transmission Bandwidth", "PRS configuration index", "Number of consecutive downlink positioning subframes", "Physical cell ID PCI", "CP length", and "PRS muting info" are settable parameters and also parameters signalled in LPP. The values to be used for "Physical cell ID PCI" are as follows: Cell 1: 0, Cell 2: 6, Cell 3: 12. For all the values to be used in LPP see Table 9.4.1.1.4.3-5 and TS 37.571-5 [20], clause 7.2.5.</p> <p>Note 3: The parameter "Radio frame receive time offset between the cells at the UE antenna connector" is not a settable parameter but is used to set the "true RSTD" values in step 6 of clause 9.4.1.1.4.1.</p> <p>Note 4: If the PRS transmission bandwidth is larger than the UE RF bandwidth, the UE is measuring RSTD within its RF bandwidth.</p>			

9.4.5.1.4.2 Test procedure

Same as in clause 9.4.1.1.4.2 but using condition CEModeB.

9.4.5.1.4.3 Message contents

Same as in clause 9.4.4.1.4.3

9.4.5.1.5 Test requirement

Same as in clause 9.4.4.1.5.

9.4.5.2 HD-FDD inter-frequency RSTD Measurement Reporting Delay in CE Mode B for Category M2

9.4.5.2.1 Test purpose

To verify that the RSTD measurement reporting delay for UE Category M2 meets the performance requirements in an environment with fading propagation conditions.

9.4.5.2.2 Test applicability

This test applies to E-UTRA HD-FDD UE Category M2 release 14 and forward that supports UE-assisted OTDOA, inter-frequency RSTD measurements and CE Mode B.

9.4.5.2.3 Minimum conformance requirements

Same as in clause 9.4.4.1.3.

The normative reference for this requirement is TS 36.133 [23] clause 8.16.3.2.3 and A.8.13.7.

9.4.5.2.4 Test description

9.4.5.2.4.1 Initial conditions

Same as in clause 9.4.1.1.4.1 but replacing Table 9.4.1.1.4.1-1 with Table 9.4.5.2.4.1-1.

Table 9.4.5.2.4.1-1: General test parameters for E-UTRAN HD-FDD inter-frequency RSTD measurement reporting delay under fading propagation conditions

Parameter	Unit	Value		Comment
		Test 1	Test 2	
Reference cell		Cell 1		Reference cell is the cell in the OTDOA assistance data with respect to which the RSTD measurement is defined, as specified in 3GPP TS 36.214 [6] and 3GPP TS 36.355 [4]. The reference cell is the serving cell in this test case.
Neighbour cells		Cell 2 and Cell 3		Cell 2 and Cell 3 appear at random places in the neighbour cell list in the OTDOA assistance data, but Cell 2 always appears in the first half of the list, whilst Cell 3 appears in the second half of the list.
MPDCCH		DL Reference Measurement Channel R.8 HD-FDD		As specified in TS 36.521-3 [25] clause A.7.2
<i>mPDCCH-startSF-UESS</i>		10		Parameter G in $T = r_{\max} \cdot G$ which determines subframe $k0$ in which MPDCCH starts
Channel Bandwidth (BW_{channel})	MHz	10		
Gap pattern Id		0		As specified in TS 36.133 [23] Table 8.1.2.1-1. Applies for measurements on Cell 2 and Cell 3
Gap offset		9		As specified in TS 36.331 [22], Clause 6.3.5

PRS Transmission Bandwidth ^{Note 2}	RB	50 ^{Note 4}		PRS are transmitted over the system bandwidth
PRS configuration index I_{PRS} ^{Note 2}		Cell 1: 142, Cell 2, Cell 3: 152		This corresponds to periodicity of 320 ms and PRS subframe offset of $I_{PRS} - 160$ DL subframes, as defined in 3GPP TS 36.211 [26], Table 6.10.4.3-1
PRS Transmission Bandwidth ^{Note 2}	RB	50 ^{Note 4}		PRS are transmitted over the system bandwidth
PRS configuration index I_{PRS} ^{Note 2}		311		This corresponds to periodicity of 320 ms and PRS subframe offset of $I_{PRS} - 160$ DL subframes, as defined in 3GPP TS 36.211 [26], Table 6.10.4.3-1
Number of consecutive downlink positioning subframes N_{PRS} ^{Note 2}		4	4	As defined in 3GPP TS 36.211 [26]. The number of subframes in a positioning occasion
Physical cell ID PCI ^{Note 2}		(PCI of Cell 1 – PCI of Cell 2) mod 6 = 0 and (PCI of Cell 1 – PCI of Cell 3) mod 6 = 0		The cell PCIs are selected such that the relative shifts of PRS patterns among cells are as given by the test parameters
CP length ^{Note 2}		Normal		
DRX		ON		DRX parameters are further specified in Table 9.4.1.1.4.1-2
Radio frame receive time offset between the cells at the UE antenna connector ^{Note 3}	µs	Cell 2 to Cell 1: 1 Cell 3 to Cell 1: -1		PRS are transmitted from synchronous cells
Expected RSTD ^{Note 1}	µs	Cell 2: 3 Cell 3: 3 Other neighbour cells: randomly between -3 and 3		The expected RSTD is what is expected at the receiver. The corresponding parameter in the OTDOA assistance data specified in TS 36.355 [4] is the expectedRSTD indicator
Expected RSTD uncertainty for all neighbour cells ^{Note 1}	µs	5		The corresponding parameter in the OTDOA assistance data specified in TS 36.355 [4] is the expectedRSTD-Uncertainty index
Number of cells provided in OTDOA assistance data		16		Including the reference cell
PRS muting info ^{Note 2}		Cell 1: '1111111100000000' Cell 2: '0000000011111111' Cell 3: '1111111100000000'		Corresponds to prs-MutingInfo defined in TS 36.355 [4]
T1	s	3		The length of the time interval from the beginning of each test
T2	s	20.48	5.12	The length of the time interval that follows immediately after time interval T1
T3	s	20.48	5.12	The length of the time interval that follows immediately after time interval T2
Note 1:	Parameters "Expected RSTD" and "Expected RSTD uncertainty for all neighbour cells" are not settable parameters. These are parameters signalled in LPP only. For the values to be used in LPP see Table 9.4.1.1.4.3-5 and TS 37.571-5 [20], clause 7.2.5.			
Note 2:	Parameters "PRS Transmission Bandwidth", "PRS configuration index", "Number of consecutive downlink positioning subframes", "Physical cell ID PCI", "CP length", and "PRS muting info" are settable parameters and also parameters signalled in LPP. The values to be used for "Physical cell ID PCI" are as follows: Cell 1: 0, Cell 2: 6, Cell 3: 12. For all the values to be used in LPP see Table 9.4.1.1.4.3-5 and TS 37.571-5 [20], clause 7.2.5.			
Note 3:	The parameter "Radio frame receive time offset between the cells at the UE antenna connector" is not a settable parameter but is used to set the "true RSTD" values in step 6 of clause 9.4.1.1.4.1.			
Note 4:	If the PRS transmission bandwidth is larger than the UE RF bandwidth, the UE is measuring RSTD within its RF bandwidth.			

9.4.5.2.4.2 Test procedure

Same as in clause 9.4.1.1.4.2 but using condition CEModeB and with the following additional step:

14. Repeat step 1-13 for each sub-test in Table 9.4.2.2.4.1-1 as appropriate.

9.4.5.2.4.3 Message contents

Same as in clause 9.4.4.2.4.3.

9.4.5.2.5 Test requirement

Same as in clause 9.4.4.2.5.

For the overall test to pass, the ratio of successful reported values in each sub-test shall be more than 90% with a confidence level of 95%.

9.4.6 TDD inter-frequency RSTD Measurement Reporting Delay in CE Mode B

9.4.6.1 TDD inter-frequency RSTD Measurement Reporting Delay in CE Mode B for Category M1

9.4.6.1.1 Test purpose

To verify that the RSTD measurement reporting delay for UE Category M1 meets the performance requirements in an environment with fading propagation conditions.

9.4.6.1.2 Test applicability

This test applies to E-UTRA TDD UE Category M1 release 14 and forward that supports UE-assisted OTDOA, inter-frequency RSTD measurements and CE Mode B.

9.4.6.1.3 Minimum conformance requirements

Same as in clause 9.4.4.1.3.

The inter-frequency requirements in this clause shall apply for all TDD special subframe configurations specified in TS 36.211 [26] and for the TDD uplink-downlink configurations as specified in Table 9.4.6.1.3-1.

Table 9.4.6.1.3-1: TDD uplink-downlink subframe configurations applicable for TDD inter-frequency requirements

PRS Transmission Bandwidth [RB]	Applicable TDD uplink-downlink configurations
6	1, 2, 3, 4 and 5
Note: Uplink-downlink configurations are specified in Table 4.2-2 in TS 36.211 [26].	

The normative reference for this requirement is TS 36.133 [23] clause 8.13.3.7.2 and A.8.13.8.

9.4.6.1.4 Test description

9.4.6.1.4.1 Initial conditions

Same as in clause 9.4.1.1.4.1 but replacing Table 9.4.1.1.4.1-1 with Table 9.4.6.1.4.1-1

Table 9.4.6.1.4.1-1: General test parameters for E-UTRAN TDD inter-frequency RSTD measurement reporting delay under fading propagation conditions

Parameter	Unit	Value	Comment
-----------	------	-------	---------

Reference cell		Cell 1	Reference cell is the cell in the OTDOA assistance data with respect to which the RSTD measurement is defined, as specified in 3GPP TS 36.214 [6] and 3GPP TS 36.355 [4]. The reference cell is the serving cell in this test case.
Neighbour cells		Cell 2 and Cell 3	Cell 2 and Cell 3 appear at random places in the neighbour cell list in the OTDOA assistance data, but Cell 2 always appears in the first half of the list, whilst Cell 3 appears in the second half of the list.
MPDCCH		DL Reference Measurement Channel R.16 TDD	As specified in TS 36.521-3 [25] clause A.7.3
$mPDCCH\text{-startSF}\text{-UESS}$		10	Parameter G in $T = r_{\max} \cdot G$ which determines subframe $k0$ in which MPDCCH starts
Channel Bandwidth (BW _{channel})	MHz	10	
Gap pattern Id		0	As specified in TS 36.133 [23] Table 8.1.2.1-1. Applies for measurements on Cell 2 and Cell 3
Gap offset		9	As specified in TS 36.331 [22], Clause 6.3.5
PRS Transmission Bandwidth ^{Note 2}	RB	50 ^{Note 4}	PRS are transmitted over the system bandwidth
PRS configuration index I_{PRS} ^{Note 2}		Cell 1: 142, Cell 2, Cell 3: 152	This corresponds to periodicity of 320 ms and PRS subframe offset of $I_{\text{PRS}} - 160$ DL subframes, as defined in 3GPP TS 36.211 [26], Table 6.10.4.3-1
Number of consecutive downlink positioning subframes N_{PRS} ^{Note 2}		4	As defined in 3GPP TS 36.211 [26]. The number of subframes in a positioning occasion
Physical cell ID PCI ^{Note 2}		(PCI of Cell 1 – PCI of Cell 2) mod 6 = 0 and (PCI of Cell 1 – PCI of Cell 3) mod 6 = 0	The cell PCIs are selected such that the relative shifts of PRS patterns among cells are as given by the test parameters
CP length ^{Note 2}		Normal	
DRX		ON	DRX parameters are further specified in Table 9.4.1.1.4.1-2
Radio frame receive time offset between the cells at the UE antenna connector ^{Note 3}	µs	Cell 2 to Cell 1: 1 Cell 3 to Cell 1: -1	PRS are transmitted from synchronous cells
Expected RSTD ^{Note 1}	µs	Cell 2: 3 Cell 3: 3 Other neighbour cells: randomly between -3 and 3	The expected RSTD is what is expected at the receiver. The corresponding parameter in the OTDOA assistance data specified in TS 36.355 [4] is the expectedRSTD indicator
Expected RSTD uncertainty for all neighbour cells ^{Note 1}	µs	5	The corresponding parameter in the OTDOA assistance data specified in TS 36.355 [4] is the expectedRSTD-Uncertainty index
Number of cells provided in OTDOA assistance data		16	Including the reference cell
PRS muting info ^{Note 2}		Cell 1: '1111111100000000' Cell 2: '0000000011111111' Cell 3: '1111111100000000'	Corresponds to prs-MutingInfo defined in TS 36.355 [4]
T1	s	3	The length of the time interval from the beginning of each test

T2	s	20.48	The length of the time interval that follows immediately after time interval T1
T3	s	20.48	The length of the time interval that follows immediately after time interval T2
<p>Note 1: Parameters “Expected RSTD” and “Expected RSTD uncertainty for all neighbour cells” are not settable parameters. These are parameters signalled in LPP only. For the values to be used in LPP see Table 9.4.1.1.4.3-5 and TS 37.571-5 [20], clause 7.2.5.</p> <p>Note 2: Parameters “PRS Transmission Bandwidth”, “PRS configuration index”, “Number of consecutive downlink positioning subframes”, “Physical cell ID PCI”, “CP length”, and “PRS muting info” are settable parameters and also parameters signalled in LPP. The values to be used for “Physical cell ID PCI” are as follows: Cell 1: 0, Cell 2: 6, Cell 3: 12. For all the values to be used in LPP see Table 9.4.1.1.4.3-5 and TS 37.571-5 [20], clause 7.2.5.</p> <p>Note 3: The parameter “Radio frame receive time offset between the cells at the UE antenna connector” is not a settable parameter but is used to set the “true RSTD” values in step 6 of clause 9.4.1.1.4.1.</p> <p>Note 4: If the PRS transmission bandwidth is larger than the UE RF bandwidth, the UE is measuring RSTD within its RF bandwidth.</p>			

9.4.6.1.4.2 Test procedure

Same as in clause 9.4.1.1.4.2 but using condition CEModeB.

9.4.6.1.4.3 Message contents

Same as in clause 9.4.4.1.4.3

9.4.6.1.5 Test requirement

Table 9.4.6.1.5-1 and 9.4.6.1.5-2 define the primary level settings including test tolerances for the test.

Table 9.4.6.1.5-1: Cell-specific test parameters for E-UTRAN TDD inter-frequency RSTD measurement reporting delay under fading propagation conditions during T1

Parameter	Unit	Cell 1	Cell 2	Cell 3
E-UTRA RF Channel Number		1	2	2
Correlation Matrix and Antenna Configuration		1x1	1x1	1x1
OCNG patterns defined in TS 36.521-3 [25] clause D.1		OP.11 TDD	N/A	N/A
PBCH_RA	dB	0	N/A	N/A
PBCH_RB				
PSS_RA				
SSS_RA				
PCFICH_RB				
PHICH_RA				
PHICH_RB				
PDCCH_RA				
PDCCH_RB				
OCNG_RA ^{Note 1}				
OCNG_RB ^{Note 1}				
N_{oc} ^{Note 3}	dBm/15 kHz	-95		
$PRS \hat{E}_s / N_{oc}$	dB	-Infinity	-Infinity	-Infinity
I_o ^{Note 4}	dBm/9 MHz	-67.22	N/A	N/A
\hat{E}_s / N_{oc}	dB	0	-Infinity	-Infinity

Propagation Condition	ETU30
Note 1:	OCNG shall be used such that active cell (Cell 1) is fully allocated and a constant total transmitted power spectral density is achieved for all OFDM symbols.
Note 2:	The resources for uplink transmission are assigned to the UE prior to the start of time period T2.
Note 3:	Interference from other cells and noise sources not specified in the test are assumed to be constant over subcarriers and time and shall be modelled as AWGN of appropriate power for N_{oc} to be fulfilled.
Note 4:	I_o levels have been derived from other parameters and are given for information purpose. These are not settable test parameters.

Table 9.4.6.1.5-2: Cell-specific test parameters for E-UTRAN TDD inter-frequency RSTD measurement reporting delay under fading propagation conditions during T2 and T3

Parameter	Unit	Cell 1		Cell 2		Cell 3	
		T2	T3	T2	T3	T2	T3
E-UTRA RF Channel Number		1		2		2	
Correlation Matrix and Antenna Configuration		1x1		1x1		1x1	
OCNG patterns defined in TS 36.521-3 [25] clause D.1		OP.11 TDD		OP.2 TDD		OP.2 TDD	N/A
PBCH_RA	dB	0		0		0	N/A
PBCH_RB							
PSS_RA							
SSS_RA							
PCFICH_RB							
PHICH_RA							
PHICH_RB							
PDCCH_RA							
PDCCH_RB							
OCNG_RA ^{Note 1}							
OCNG_RB ^{Note 1}							
PRS_RA	dB	-3	N/A	N/A	3	3	N/A
N_{oc} ^{Note 3}	dBm/15 kHz	-98	-95	-98	-95	-98	-95
$PRS \hat{E}_s / N_{oc}$	dB	-12	-Infinity	-Infinity	-13	-14	-Infinity
$PRS \hat{E}_s / I_{ot}$ ^{Note 4}	dB	-12	-Infinity	-Infinity	-13	-14	-Infinity
I_o ^{Note 4}	dBm/9 MHz	-70.17	-67.13	-70.19	-70.18	-70.19	-70.18
PRP ^{Note 4}	dBm/15 kHz	-110	-Infinity	-Infinity	-108	-112	-Infinity
RSRP ^{Note 4}	dBm/15 kHz	-110	-110	-114	-108	-112	-Infinity
\hat{E}_s / N_{oc} ^{Note 4}	dB	-9	-9	-14	-13	-14	-Infinity
Propagation Condition		ETU30					

Note 1:	OCNG shall be used such that active cells (all, except Cell 3 in T3) are fully allocated and a constant total transmitted power spectral density is achieved for all OFDM symbols other than those in the subframes with transmitted PRS.
Note 2:	The resources for uplink transmission are assigned to the UE prior to the start of time period T2.
Note 3:	Interference from other cells and noise sources not specified in the test are assumed to be constant over subcarriers and time and shall be modelled as AWGN of appropriate power for N_{oc} to be fulfilled.
Note 4:	If PRS_RA is not "N/A", \hat{E}_s/N_{oc} , PRS \hat{E}_s/I_{ot} , I_o , RSRP and PRP levels have been derived from other parameters and are given for information purpose. If PRS_RA is "N/A", I_o and RSRP levels have been derived from other parameters and are given for information purpose. These are not settable test parameters. Interference conditions shall be applied to all PRS symbols of DL positioning subframes.

The response time is defined in clause 9.4.4.1.5.

The test tolerances are defined in clauses C.1.3 and C4.

The rate of successful tests during repeated tests shall be at least 90% with a confidence level of 95%.

9.4.6.2 TDD inter-frequency RSTD Measurement Reporting Delay in CE Mode B for Category M2

9.4.6.2.1 Test purpose

To verify that the RSTD measurement reporting delay for UE Category M2 meets the performance requirements in an environment with fading propagation conditions.

9.4.6.2.2 Test applicability

This test applies to E-UTRA TDD UE Category M2 release 14 and forward that supports UE-assisted OTDOA, inter-frequency RSTD measurements and CE Mode B.

9.4.6.2.3 Minimum conformance requirements

Same as in clause 9.4.6.1.3.

The inter-frequency requirements in this clause shall apply for all TDD special subframe configurations specified in TS 36.211 [26] and for the TDD uplink-downlink configurations as specified in Table 9.4.6.2.3-1.

Table 9.4.6.2.3-1: TDD uplink-downlink subframe configurations applicable for TDD inter-frequency requirements

PRS Transmission Bandwidth [RB]	Applicable TDD uplink-downlink configurations
6	1, 2, 3, 4 and 5
24	0, 1, 2, 3, 4, 5 and 6
Note:	Uplink-downlink configurations are specified in Table 4.2-2 in TS 36.211 [26].

The normative reference for this requirement is TS 36.133 [23] clause 8.16.3.2.2 and A.8.13.8.

9.4.6.2.4 Test description

9.4.6.2.4.1 Initial conditions

Same as in clause 9.4.1.1.4.1 but replacing Table 9.4.1.1.4.1-1 with Table 9.4.6.2.4.1-1.

Table 9.4.6.2.4.1-1: General test parameters for E-UTRAN TDD inter-frequency RSTD measurement reporting delay under fading propagation conditions

Parameter	Unit	Value		Comment
		Test 1	Test 2	
Reference cell		Cell 1		Reference cell is the cell in the OTDOA assistance data with respect to which the RSTD measurement is defined, as specified in 3GPP TS 36.214 [6] and 3GPP TS 36.355 [4]. The reference cell is the serving cell in this test case.
Neighbour cells		Cell 2 and Cell 3		Cell 2 and Cell 3 appear at random places in the neighbour cell list in the OTDOA assistance data, but Cell 2 always appears in the first half of the list, whilst Cell 3 appears in the second half of the list.
MPDCCH		DL Reference Measurement Channel R.16 TDD		As specified in TS 36.521-3 [25] clause A.7.3
<i>mPDCCH-startSF-UeSS</i>		10		Parameter G in $T = r_{\max} \cdot G$ which determines subframe $k0$ in which MPDCCH starts
Channel Bandwidth (BW_{channel})	MHz	10		
Gap pattern Id		0		As specified in TS 36.133 [23] Table 8.1.2.1-1. Applies for measurements on Cell 2 and Cell 3
Gap offset		9		As specified in TS 36.331 [22], Clause 6.3.5
PRS Transmission Bandwidth ^{Note 2}	RB	50 ^{Note 4}		PRS are transmitted over the system bandwidth
PRS configuration index I_{PRS} ^{Note 2}		Cell 1: 142, Cell 2, Cell 3: 152		This corresponds to periodicity of 320 ms and PRS subframe offset of $I_{\text{PRS}} - 160$ DL subframes, as defined in 3GPP TS 36.211 [26], Table 6.10.4.3-1
Number of consecutive downlink positioning subframes N_{PRS} ^{Note 2}		4	4	As defined in 3GPP TS 36.211 [26]. The number of subframes in a positioning occasion
Physical cell ID PCI ^{Note 2}		(PCI of Cell 1 – PCI of Cell 2) mod 6 = 0 and (PCI of Cell 1 – PCI of Cell 3) mod 6 = 0		The cell PCIs are selected such that the relative shifts of PRS patterns among cells are as given by the test parameters
CP length ^{Note 2}		Normal		
DRX		ON		DRX parameters are further specified in Table 9.4.1.1.4.1-2
Radio frame receive time offset between the cells at the UE antenna connector ^{Note 3}	μs	Cell 2 to Cell 1: 1 Cell 3 to Cell 1: -1		PRS are transmitted from synchronous cells
Expected RSTD ^{Note 1}	μs	Cell 2: 3 Cell 3: 3 Other neighbour cells: randomly between -3 and 3		The expected RSTD is what is expected at the receiver. The corresponding parameter in the OTDOA assistance data specified in TS 36.355 [4] is the expectedRSTD indicator
Expected RSTD uncertainty for all neighbour cells ^{Note 1}	μs	5		The corresponding parameter in the OTDOA assistance data specified in TS 36.355 [4] is the expectedRSTD-Uncertainty index
Number of cells provided in OTDOA assistance data		16		Including the reference cell

PRS muting info ^{Note 2}		Cell 1: '1111111100000000' Cell 2: '0000000011111111' Cell 3: '1111111100000000'	Corresponds to prs-MutingInfo defined in TS 36.355 [4]
T1	s	3	
T2	s	20.48	5.12
T3	s	20.48	5.12
Note 1:	Parameters "Expected RSTD" and "Expected RSTD uncertainty for all neighbour cells" are not settable parameters. These are parameters signalled in LPP only. For the values to be used in LPP see Table 9.4.1.1.4.3-5 and TS 37.571-5 [20], clause 7.2.5.		
Note 2:	Parameters "PRS Transmission Bandwidth", "PRS configuration index", "Number of consecutive downlink positioning subframes", "Physical cell ID PCI", "CP length", and "PRS muting info" are settable parameters and also parameters signalled in LPP. The values to be used for "Physical cell ID PCI" are as follows: Cell 1: 0, Cell 2: 6, Cell 3: 12. For all the values to be used in LPP see Table 9.4.1.1.4.3-5 and TS 37.571-5 [20], clause 7.2.5.		
Note 3:	The parameter "Radio frame receive time offset between the cells at the UE antenna connector" is not a settable parameter but is used to set the "true RSTD" values in step 6 of clause 9.4.1.1.4.1.		
Note 4:	If the PRS transmission bandwidth is larger than the UE RF bandwidth, the UE is measuring RSTD within its RF bandwidth.		

9.4.6.2.4.2 Test procedure

Same as in clause 9.4.1.1.4.2 but using condition CEModeB and with the following additional step:

14. Repeat step 1-13 for each sub-test in Table 9.4.2.2.4.1-1 as appropriate.

9.4.6.2.4.3 Message contents

Same as in clause 9.4.4.2.4.3.

9.4.6.2.5 Test requirement

The primary level settings including test tolerances for the test are defined in clause 9.4.6.1.5.

For Test 1, the response time is defined in clause 9.4.6.1.5.

For Test 2, the response time including test tolerance is 11.3 s. The response time is equal to the LPP time IE value plus the test tolerance. The LPP time IE value is derived from the RSTD reporting delay plus ΔT , where $\Delta T = N_{rep} \times TTI_{DCCH} = N_{rep} \times 75$ ms, giving a value of 10390 ms. This is rounded up to the next allowed LPP value of 11 seconds. The RSTD

measurement reporting delay in the test is derived from the following expression $T_{PRS} (M - 1) + 320 \cdot \left\lceil \frac{n}{M} \right\rceil$, where

$M = 40$ and $n = 16$ are the parameters specified in clause 9.4.1.1.3, Table 9.4.1.1.3-1 and Note 4 of Table 9.4.6.2.4.1-1. This gives the total RSTD reporting delay of 10240 ms for the 15 neighbour cells including Cell 2 and Cell 3 with respect to the reference cell, Cell 1.

The test tolerances are defined in clauses C.1.3 and C4.

For the overall test to pass, the ratio of successful reported values in each sub-test shall be more than 90% with a confidence level of 95%.

9.4.7 FDD inter-frequency RSTD Measurement Accuracy in CE Mode A

9.4.7.1 FDD inter-frequency RSTD Measurement Accuracy in CE Mode A for Category M1

9.4.7.1.1 Test purpose

To verify that the RSTD measurement accuracy for UE Category M1 is within the specified limits in normal coverage mode in an environment with fading propagation conditions.

9.4.7.1.2 Test applicability

This test applies to E-UTRA FDD UE Category M1 release 14 and forward that supports UE-assisted OTDOA and inter-frequency RSTD measurements.

9.4.7.1.3 Minimum conformance requirements

The accuracy requirements in Table 9.4.7.1.3-1 are valid under the following conditions:

Conditions defined in 36.101 [2] Clause 7.3 for reference sensitivity are fulfilled.

PRP $1,2_{dBm}$ according to Annex E.3.1 for a corresponding Band

There are no measurement gaps overlapping with the PRS subframes of the measured serving cell.

The parameter expectedRSTDUncertainty signalled over LPP by E-SMLC as defined in TS 36.355 [4] is less than 5 μs .

Table 9.4.7.1.3-1: RSTD inter-frequency measurement accuracy for CEModeA

Accuracy	Conditions						
	PRS \hat{E}_s/lot	Minimum PRS bandwidth, which is minimum of serving cell channel bandwidth and the PRS bandwidths of the reference cell and the measured neighbour cell i <small>Note 3</small>	Minimum number of available measurement subframes among the reference cell and the measured neighbour cell i	The number of consecutive downlink subframes N_{PRS} among the reference cell and the measured neighbour cell i as defined in [24]	lo <small>Note 4</small> range		
					E-UTRA operating band groups <small>Note 5</small>	Minimum lo <small>Note 1</small>	Maximum lo
T_s <small>Note 2</small>	dB	RB			dBm/15kHz	dBm/BW _{Channel}	
± 21	(PRS \hat{E}_s/lot) _{ref} $\geq -6dB$ and (PRS \hat{E}_s/lot) _i $\geq -13dB$	≥ 6	≥ 12	≥ 4	FDD-M1_A, TDD-M1_A	-121	-50
					FDD-M1_B	-120.5	-50
					FDD-M1_C, TDD-M1_C	-120	-50
					FDD-M1_D	-119.5	-50
					FDD-M1_E, TDD-M1_E	-119	-50
					FDD-M1_F	-118.5	-50
					FDD-M1_G	-118	-50

				FDD-M1_H	-117.5	-50
				FDD-M1_N	-114.5	-50
<p>NOTE 1: This minimum l_0 condition is expressed as the average l_0 per RE over all REs in an OFDM symbol.</p> <p>NOTE 2: T_s is the basic timing unit defined in TS 36.211 [26].</p> <p>NOTE 3: PRS bandwidth is as indicated in <i>prs-Bandwidth</i> in the OTDOA assistance data defined in TS 36.355 [4].</p> <p>NOTE 4: The l_0 is defined in PRS positioning subframes. The same l_0 range applies to PRS and non-PRS symbols. l_0 levels are different in PRS and non-PRS symbols within the same subframe.</p> <p>NOTE 5: E-UTRA operating band groups are as defined in Section 4.4.2.</p>						

The normative reference for this requirement is TS 36.133 [23] clause 9.1.21.17 and A.9.8.26.

9.4.7.1.4 Test description

9.4.7.1.4.1 Initial conditions

Test Environment: Normal; as defined in TS 36.508 [18] clause 4.1.

Frequencies to be tested: Mid Range, as defined in TS 36.508 [18] clause 4.3.1.1.

Channel bandwidth to be tested: 10 MHz as defined in TS 36.508 [18] clause 4.3.1.

1. Connect the SS, faders and AWGN noise sources to the UE antenna connector or antenna connectors as shown in Annex A, Figure A.3 using only the main Tx/Rx antenna of the UE.
2. The general test parameter settings are set up according to Table 9.4.7.1.4.1-1.
3. Propagation conditions are set according to clause 4.7.2.1.
4. Message contents are defined in clause 9.4.7.1.4.3.
5. Cell 1 is the serving cell and OTDOA assistance data reference cell; Cell 2 is the neighbour cell. Cell 1 is on RF channel 1 and Cell 2 is on RF channel 2. The assistance data neighbour cell list includes in total 15 cells, where 14 of the cells are not simulated (dummy cells; as defined in 3GPP TS 37.571-5 [20], clause 7.2.5).
6. The true RSTD (which is the receive time difference for frame 0 between cell 2 and cell 1 as seen at the UE antenna connector) is set to the following values:

Test 1: $-92 T_s$ (about $-3 \mu s$)

Note that the related expectedRSTD values to be signalled over LPP are defined in Table 9.4.7.1.4-1 for each test.

Table 9.4.7.1.4.1-1: General test parameters for E-UTRAN FDD inter-frequency RSTD measurement Accuracy under fading propagation conditions.

Parameter	Unit	Value	Comment
		Test 1	
MPDCCH		R.16 FDD	As specified in TS 36.521-3 [25] clause A.7.1
<i>mPDCCH-startSF-UeSS</i>		10	Parameter G in $T = r_{max} \cdot G$ which determines subframe $k0$ in which MPDCCH starts
Reference cell		Cell 1	Reference cell is the cell in the OTDOA assistance data with respect to which the RSTD measurement is defined, as specified in 3GPP TS 36.214 [6] and 3GPP TS 36.355 [4]. The reference cell is the serving cell in this test case.
Neighbour cell		Cell 2	One carrier frequency is used.
E-UTRA RF Channel Number		Cell 1: 1 Cell 2: 2	The two cells are on different frequencies.

Channel Bandwidth ($BW_{channel}$)	MHz	10	
PRS Transmission Bandwidth <small>Note 2</small>	RB	50 <small>Note 4</small>	PRS are transmitted over the system bandwidth
Number of consecutive downlink positioning subframes N_{PRS} <small>Note 2</small>		4	As defined in 3GPP TS 36.211 [26]. The number of subframes in a positioning occasion
PRS muting info <small>Note 2</small>		Cell 1: '11110000' Cell 2: '11110000'	Corresponds to prs-MutingInfo defined in TS 36.355 [4]
Physical cell ID PCI <small>Note 2</small>		(Cell ID of cell 1 – Cell ID of cell 2) mod 6 = 0	
prs-SubframeOffset		10	Number of subframes rounded to the closest integer. The corresponding parameter in the OTDOA assistance data is prs-SubframeOffset specified in TS 36.355 [4]
slotNumberOffset		0	The slot number offset at the transmitter between a neighbour cell and the assistance data reference cell specified in TS 36.355 [4]
Expected RSTD <small>Note 1</small>	μ s	Cell 2: 1 Other neighbour cells: randomly between -3 and 3	The expected RSTD is what is expected at the receiver. The corresponding parameter in the OTDOA assistance data specified in TS 36.355 [4] is the expectedRSTD indicator
Expected RSTD uncertainty for all neighbour cells <small>Note 1</small>	μ s	5	The corresponding parameter in the OTDOA assistance data specified in TS 36.355 [4] is the expectedRSTD-Uncertainty index
CP length <small>Note 2</small>		Normal	
DRX		OFF	
Radio frame receive time offset between the cells at the UE antenna connector <small>Note 3</small>	μ s	Cell 2 to Cell 1: -3	PRS are transmitted from synchronous cells
Number of cells provided in OTDOA assistance data		16	Including the reference cell
$T_{RSTD InterFreqFDD-FDD, E-UTRAN}$	ms	15360	Derived according to the RSTD measurement requirements specified in section 9.4.7.1.3
<p>Note 1: Parameters "Expected RSTD" and "Expected RSTD uncertainty for all neighbour cells" are not settable parameters. These are parameters signalled in LPP only. For the values to be used in LPP see Table 9.4.7.1.4.3-5 and TS 37.571-5 [20], clause 7.2.5.</p> <p>Note 2: Parameters "PRS Transmission Bandwidth", "PRS configuration index", "Number of consecutive positioning downlink subframes", "prs-MutingInfo", "Cell ID" and "CP length" are settable parameters and also parameters signalled in LPP. The values to be used for "Cell ID" are as follows: Cell 1: 0, Cell 2: 6. For all the values to be used in LPP see Table 9.4.7.1.4.3-4 and TS 37.571-5 [20], clause 7.2.5.</p> <p>Note 3: The parameter "Radio frame receive time offset between the cells at the UE antenna connector" is not a settable parameter but is used to set the "true RSTD" values in step 6 of clause 9.4.7.1.4.1.</p> <p>Note 4: If the PRS transmission bandwidth is larger than the UE RF bandwidth, the UE is measuring RSTD within its RF bandwidth.</p> <p>Note 5: The parameter "$T_{RSTD InterFreqFDD-FDD, E-UTRAN}$" is not a settable parameter but is used to set the LPP "time" value in Table 9.4.7.1.4.3-3. The value of the LPP time IE is set to $T_{RSTD InterFreqFDD-FDD, E-UTRAN} + \Delta T$ ms, where $\Delta T = 150$ ms, giving a value of 15510 ms. This is rounded up to the next allowed LPP value of 16 seconds.</p>			

9.4.7.1.4.2 Test procedure

The test consists of a set-up period and a measurement period. Cell 1 and Cell 2 are both active during the complete test. The beginning of the measurement period shall be aligned with the first PRS positioning subframe of a positioning occasion in the reference cell.

NOTE: The information on when PRS is muted is conveyed to the UE using PRS muting information in the OTDOA assistance data.

The OTDOA-RequestLocationInformation message and the OTDOA assistance data as defined in clause 9.4.7.1.4.3 shall be provided to the UE during the set-up period. The last TTI containing the OTDOA-RequestLocationInformation message shall be provided to the UE ΔT ms before the start of the measurement period, where $\Delta T = 150$ ms is the maximum processing time of the OTDOA-RequestLocationInformation message and the OTDOA assistance data in the UE.

1. Ensure that the UE is in state Generic RB Established State 3A-RF-CE according to 3GPP TS 36.508 [18] clause 7.2A.3AA.
2. The SS shall send a RESET UE POSITIONING STORED INFORMATION message.
3. Set the parameters according to Table 9.4.7.1.5-1. Propagation conditions are set according to clause 4.7.2.1.
4. The SS shall transmit an RRCConnectionReconfiguration message with the measurement gap configuration.
5. The UE shall transmit RRCConnectionReconfigurationComplete message.
6. The SS shall transmit an LPP REQUEST CAPABILITIES message.
7. The UE shall transmit an LPP PROVIDE CAPABILITIES message indicating the OTDOA capabilities supported by the UE in the *OTDOA-ProvideCapabilities* IE.
8. The SS shall send a LPP PROVIDE ASSISTANCE DATA message, including the *OTDOA-ProvideAssistanceData* IE. If the UE message at step 7 includes the *ackRequested* IE set to TRUE, then the SS shall send an acknowledgment in the LPP PROVIDE ASSISTANCE DATA message.
9. The SS shall send a LPP REQUEST LOCATION INFORMATION message, including the *OTDOA-RequestLocationInformation* IE such that the UE receives the message ΔT ms before the start of T2, where $\Delta T = 150$ ms.
10. The UE shall transmit a LPP PROVIDE LOCATION INFORMATION message, including the *OTDOA-ProvideLocationInformation* IE.
11. If the UE message at step 10 includes the *ackRequested* IE set to TRUE, the SS shall send a LPP acknowledgement message.
12. The SS shall check the *rstd* value for Cell 2 in the *OTDOA-SignalMeasurementInformation* IE according to Table 9.4.7.1.5-2.
13. Repeat steps 2-12 until the confidence level according to Annex D is achieved.
14. Repeat step 1-13 for each sub-test in Table 9.4.7.1.5-1 as appropriate.

9.4.7.1.4.3 Message contents

Same as in clause 9.3.7.1.4.3 with the following exceptions.

Table 9.4.7.1.4.3-1: MeasGapConfig-GP1: FDD-FDD inter-frequency RSTD Measurement Accuracy

Derivation Path: TS 36.508 [18] clause 4.6.6, Table 4.6.6-1A: MeasGapConfig-GP1			
Information Element	Value/remark	Comment	Condition
MeasGapConfig-GP1 ::= CHOICE {			
setup SEQUENCE {			
gapOffset CHOICE {			
gp0	9	TGRP = 40 ms	
}			
}			

}		
---	--	--

Table 9.4.7.1.4.3-2: LPP RequestLocationInformation

Derivation Path: Table 9.3.7.1.4.3-4			
Information Element	Value/remark	Comment	Condition
LPP-Message ::= SEQUENCE {			
lpp-MessageBody CHOICE {			
c1 CHOICE {			
requestLocationInformation SEQUENCE {			
criticalExtensions CHOICE {			
c1 CHOICE {			
requestLocationInformation-r9 SEQUENCE {			
commonIEsRequestLocationInformation SEQUENCE {			
qos SEQUENCE {			
responseTime SEQUENCE {			
time	16	See Note 5 in Table 9.4.7.1.4.1-1	
}			
}			
}			
}			
}			
}			
}			
}			
}			

9.4.7.1.5 Test requirement

Table 9.4.7.1.5-1 defines the primary level settings including test tolerances for the test.

The RSTD FDD inter-frequency accuracy test shall meet the reported values in Table 9.4.7.1.5-2

Table 9.4.7.1.5-1: Cell Specific Test Parameters for inter frequency RSTD Tests for E-UTRAN FDD

Parameter	Unit	Test1		Test2 ^{Note4}	
		Cell1	Cell2	Cell1	Cell2
E-UTRA RF Channel Number		1	2	1	2
Gap offset		9	N/A	9	N/A
Gap pattern		#0	N/A	#0	N/A
OCNG Patterns defined in TS 36.521-3 [25] clause D.1		OP.21 FDD	OP.6 FDD	OP.21 FDD	OP.6 FDD
PRS configuration Index I_{PRS} , as defined in TS 36.211		142	152	142	152
PBCH_RA	dB	0	0	0	0
PBCH_RB					
PSS_RA					
SSS_RA					
MPDCCH_RA					
MPDCCH_RB					
OCNG_RA ^{Note1}					
OCNG_RB ^{Note1}					
PRS_RA	dB	0	0	0	0
N_{oc} ^{Note2}	dBm/15 kHz	-98	-98	-98	-98
PRS \hat{E}_s/N_{oc}	dB	-1	-11	-1	-11
PRS \hat{E}_s/I_{ot} ^{Note3}	dB	-1	-11	-1	-11

I_o ^{Note 3}	dBm/9 MHz	-69.68	-70.16	-69.68	-70.16
PRP ^{Note 3}	dBm/15kHz	-99	-109	-99	-109
\hat{E}_s/N_{oc} ^{Note 3}	dB	-1	-11	-1	-11
RSRP ^{Note 3}	dBm/15kHz	-99	-109	-99	-109
Propagation condition		AWGN			
<p>Note 1: OCNG shall be used such that both cells are fully allocated and a constant total transmitted power spectral density is achieved for all OFDM symbols (other than those in the PRS subframes).</p> <p>Note 2: Interference from other cells and noise sources not specified in the test is assumed to be constant over subcarriers and time and shall be modelled as AWGN of appropriate power for N_{oc} to be fulfilled.</p> <p>Note 3: \hat{E}_s/N_{oc}, PRS \hat{E}_s/I_{ot}, I_o, RSRP and PRP levels have been derived from other parameters for information purposes. They are not settable parameters themselves. I_o values are derived in the case that there is no PBCH, PSS or SSS in the OFDM symbols carrying PRS</p> <p>Note 4: Test2 is not used for test 9.4.7.1</p>					

Table 9.4.7.1.5-2: RSTD FDD inter-frequency accuracy requirements for the reported values

	Test 1
Lowest reported value	RSTD_6241
Highest reported value	RSTD_6287

The test tolerances are defined in clauses C.1.3 and C4.

For the overall test to pass, the ratio of successful reported values in each sub-test shall be more than 90% with a confidence level of 95%.

9.4.7.2 FDD inter-frequency RSTD Measurement Accuracy in CE Mode A for Category M2

9.4.7.2.1 Test purpose

To verify that the RSTD measurement accuracy for UE Category M2 is within the specified limits in normal coverage mode in an environment with fading propagation conditions.

9.4.7.2.2 Test applicability

This test applies to E-UTRA FDD UE Category M2 release 14 and forward that supports UE-assisted OTDOA and inter-frequency RSTD measurements.

9.4.7.2.3 Minimum conformance requirements

The accuracy requirements in Table 9.4.7.2.3-1 are valid under the following conditions:

Conditions defined in 36.101 [2] Clause 7.3 for reference sensitivity are fulfilled.

PRP $1,2_{dBm}$ according to Annex E.2 for a corresponding Band

There are no measurement gaps overlapping with the PRS subframes of the measured serving cell.

The parameter expectedRSTDUncertainty signalled over LPP by E-SMLC as defined in TS 36.355 [4] is less than 5 μs .

Table 9.4.7.2.3-1: RSTD inter-frequency measurement accuracy for CE Mode A

Accuracy	Conditions						
	PRS \hat{E}_s/I_{ot}	Minimum PRS bandwidth, which is minimum of serving cell channel	Minimum number of available measurement subframes among the reference cell	The number of consecutive downlink subframes N_{PRS} among the reference cell	I_o ^{Note 4} range		
					E-UTRA operating band groups ^{Note 5}	Minimum I_o ^{Note 1}	Maximum I_o

		bandwidth and the PRS bandwidths of the reference cell and the measured neighbour cell <i>i</i> <small>Note 3</small>	and the measured neighbour cell <i>i</i>	and the measured neighbour cell <i>i</i> as defined in [24]			
T_s <small>Note 2</small>	dB	RB				dBm/15kHz	dBm/BW _{Channel}
±21	(PRS $\hat{E}_s/lot)_{ref} \geq -6dB$ and (PRS $\hat{E}_s/lot)_i \geq -13dB$	≥ 6	≥ 12	≥ 4	FDD-M1_A, TDD-M1_A	-121	-50
					FDD-M1_B	-120.5	-50
					FDD-M1_C, TDD-M1_C	-120	-50
					FDD-M1_D	-119.5	-50
					FDD-M1_E, TDD-M1_E	-119	-50
					FDD-M1_F	-118.5	-50
					FDD-M1_G	-118	-50
					FDD-M1_H	-117.5	-50
					FDD-M1_N	-114.5	-50
±10	(PRS $\hat{E}_s/lot)_{ref} \geq -6dB$ and (PRS $\hat{E}_s/lot)_i \geq -13dB$	≥ 24	≥ 4	≥ 2	Note 6	Note 6	Note 6
<p>NOTE 1: This minimum l_o condition is expressed as the average l_o per RE over all REs in an OFDM symbol.</p> <p>NOTE 2: T_s is the basic timing unit defined in TS 36.211 [26].</p> <p>NOTE 3: PRS bandwidth is as indicated in <i>prs-Bandwidth</i> in the OTDOA assistance data defined in TS 36.355 [4].</p> <p>NOTE 4: The l_o is defined in PRS positioning subframes. The same l_o range applies to PRS and non-PRS symbols. l_o levels are different in PRS and non-PRS symbols within the same subframe.</p> <p>NOTE 5: E-UTRA operating band groups are as defined in Section 4.4.2.</p> <p>NOTE 6: The same bands and the same l_o conditions for each band apply for this requirement as for the corresponding requirement with the PRS bandwidth ≥ 6 RB.</p>							

The normative reference for this requirement is TS 36.133 [23] clause 9.1.25.1 and A.9.8.26.

9.4.7.2.4 Test description

9.4.7.2.4.1 Initial conditions

Same as in clause 9.4.7.1.4.1 adding Test 2 and replacing Table 9.4.7.1.4.1-1 with Table 9.4.7.2.4.1-1.

The true RSTD (which is the receive time difference for frame 0 between cell 2 and cell 1 as seen at the UE antenna connector) is set to the following values:

Test 1: -92 T_s (about -3 μs)

Test 2: 92 T_s (about 3 μs)

Note that the related expectedRSTD values to be signalled over LPP are defined in Table 9.4.7.2.4-1 for each test.

Table 9.4.7.2.4.1-1: General test parameters for E-UTRAN FDD inter-frequency RSTD measurement Accuracy under fading propagation conditions

Parameter	Unit	Value		Comment
		Test1	Test2	
M-PDCCH parameters		R.16 FDD	R.16 FDD	As specified in TS 36.521-3 [25] clause A.7.1.
<i>mPDCCH-startSF-UESS</i>		10	10	Parameter G in $T = r_{\max} \cdot G$ which determines subframe $k0$ in which MPDCCH starts
Reference cell		Cell 1		
Neighbour cell		Cell 2		
E-UTRA RF Channel Number		Cell 1: 1 Cell 2: 2		The two cells are on different frequencies.
System channel Bandwidth (BW_{channel})	MHz	10	10	
PRS Transmission Bandwidth ^{Note 2}	RB	50 ^{Note 4}	50 ^{Note 4}	PRS bandwidth is as indicated in <i>prs-Bandwidth</i> in the OTDOA assistance data defined in TS 36.355 [4].
Number of consecutive positioning downlink subframes N_{PRS} ^{Note 2}		4	2	As defined in TS 36.211 [26]
<i>prs-MutingInfo</i> ^{Note 2}		Cell 1: '11110000' Cell 2: '11110000'		See section 6.5.1.2 in 3GPP TS 36.355 [4] for more information
Cell ID ^{Note 2}		(Cell ID of cell 1 – Cell ID of cell 2) mod 6 = 0	(Cell ID of cell 1 – Cell ID of cell 2) mod 6 = 0	
<i>prs-SubframeOffset</i>		10	10	Number of subframes rounded to the closest integer. The corresponding parameter in the OTDOA assistance data is <i>prs-SubframeOffset</i> specified in TS 36.355 [4]
<i>slotNumberOffset</i>		0	0	The slot number offset at the transmitter between a neighbour cell and the assistance data reference cell specified in TS 36.355 [4]
Expected RSTD ^{Note 1}	μs	Cell 2: 1 Other neighbour cells: randomly between -3 and 3	Cell 2: -1 Other neighbour cells: randomly between -3 and 3	
Expected RSTD uncertainty for all neighbour cells ^{Note 1}	μs	5	5	
CP length ^{Note 2}		Normal		
DRX		OFF		
Radio frame receive time offset between the cells at the UE antenna connector ^{Note 3}	μs	Cell 2 to Cell 1: -3	Cell 2 to Cell 1: 3	PRS are transmitted from synchronous cells
Number of cells provided in OTDOA assistance data		16		The number of cells includes the reference cell
$T_{\text{RSTD InterFreqFDD-FDD, E-UTRAN}}$ ^{Note 5}	ms	15360	10240	Derived according to the RSTD measurement requirements specified in section 9.4.7.2.3

NOTE 1: Parameters “Expected RSTD” and “Expected RSTD uncertainty for all neighbour cells” are not settable parameters. These are parameters signalled in LPP only. For the values to be used in LPP see Table 9.4.7.1.4.3-4 and TS 37.571-5 [20], clause 7.2.5.

NOTE 2: Parameters “PRS Transmission Bandwidth”, “PRS configuration index”, “Number of consecutive positioning downlink subframes”, “prs-MutingInfo”, “Cell ID” and “CP length” are settable parameters and also parameters signalled in LPP. The values to be used for “Cell ID” are as follows: Cell 1: 0, Cell 2: 6. For all the values to be used in LPP see Table 9.4.7.1.4.3-4 and TS 37.571-5 [20], clause 7.2.5.

NOTE 3: The parameter “Radio frame receive time offset between the cells at the UE antenna connector” is not a settable parameter but is used to set the “true RSTD” values in step 6 of clause 9.1.3.4.1.

NOTE 4: If the PRS transmission bandwidth is larger than the UE RF bandwidth, the UE is measuring RSTD within its RF bandwidth.

NOTE 5: The parameter “ $T_{RSTD \text{ InterFreqFDD-FDD, E-UTRAN}}$ ” is not a settable parameter but is used to set the LPP “time” value in Table 9.4.7.2.4.3-1. The value of the LPP time IE is set to $T_{RSTD \text{ InterFreqFDD-FDD, E-UTRAN}} + \Delta T$ ms, where $\Delta T = 150$ ms, giving a value of 15510 ms for Test 1 and 10390 ms for Test 2. This is rounded up to the next allowed LPP value of 16 and 11 seconds, respectively.

9.4.7.2.4.2 Test procedure

Same as in clause 9.4.7.1.4.2.

9.4.7.2.4.3 Message contents

Same as in clause 9.4.7.1.4.3 with the following exceptions:

Table 9.4.7.2.4.3-1: LPP RequestLocationInformation

Derivation Path: Table 9.4.7.1.4.3-4			
Information Element	Value/remark	Comment	Condition
LPP-Message ::= SEQUENCE {			
lpp-MessageBody CHOICE {			
c1 CHOICE {			
requestLocationInformation SEQUENCE {			
criticalExtensions CHOICE {			
c1 CHOICE {			
requestLocationInformation-r9 SEQUENCE {			
commonIEsRequestLocationInformation SEQUENCE {			
qos SEQUENCE {			
responseTime SEQUENCE {			
time	16	See Note 5 in Table 9.4.7.2.4.1-1	Test 1
time	11	See Note 5 in Table 9.4.7.2.4.1-1	Test 2
}			
}			
}			
}			
}			
}			
}			

9.4.7.2.5 Test requirement

Same as in clause 9.4.7.1.5 adding Test 2 and replacing Table 9.4.7.1.5-2 with Table 9.4.7.2.5-1:

Table 9.4.7.2.5-1: RSTD FDD inter-frequency accuracy requirements for the reported values

	Test 1	Test 2
Lowest reported value	RSTD_6252	RSTD_6435
Highest reported value	RSTD_6276	RSTD_6459

For the overall test to pass, the ratio of successful reported values in each sub-test shall be more than 90% with a confidence level of 95%.

9.4.8 HD-FDD inter-frequency RSTD Measurement Accuracy in CE Mode A

9.4.8.1 HD-FDD inter-frequency RSTD Measurement Accuracy in CE Mode A for Category M1

9.4.8.1.1 Test purpose

To verify that the RSTD measurement accuracy for UE Category M1 is within the specified limits normal coverage mode in an environment with fading propagation conditions.

9.4.8.1.2 Test applicability

This test applies to E-UTRA HD-FDD UE Category M1 release 14 and forward that supports UE-assisted OTDOA and inter-frequency RSTD measurements.

9.4.8.1.3 Minimum conformance requirements

Same as in clause 9.4.7.1.3.

The normative reference for this requirement is TS 36.133 [23] clause 9.1.21.17 and A.9.8.27.

9.4.8.1.4 Test description

9.4.8.1.4.1 Initial conditions

Same as in clause 9.4.7.1.4.1 but replacing Table 9.4.7.1.4.1-1 with Table 9.4.8.1.4.1-1

Table 9.4.8.1.4.1-1: General test parameters for E-UTRAN HD-FDD inter-frequency RSTD measurement Accuracy under fading propagation conditions

Parameter	Unit	Value	Comment
		Test 1	
MPDCCH		R.6 HD-FDD	As specified in TS 36.521-3 [25] clause A.7.2
<i>mPDCCH-startSF-UESS</i>		10	Parameter G in $T = r_{\max} \cdot G$ which determines subframe $k0$ in which MPDCCH starts
Reference cell		Cell 1	Reference cell is the cell in the OTDOA assistance data with respect to which the RSTD measurement is defined, as specified in 3GPP TS 36.214 [6] and 3GPP TS 36.355 [4]. The reference cell is the serving cell in this test case.
Neighbour cell		Cell 2	One carrier frequency is used.
E-UTRA RF Channel Number		Cell 1: 1 Cell 2: 2	The two cells are on different frequencies.
Channel Bandwidth (BW_{channel})	MHz	10	

PRS Transmission Bandwidth ^{Note 2}	RB	50 ^{Note 4}	PRS are transmitted over the system bandwidth
Number of consecutive downlink positioning subframes N_{PRS} ^{Note 2}		4	As defined in 3GPP TS 36.211 [26]. The number of subframes in a positioning occasion
PRS muting info ^{Note 2}		Cell 1: '11110000' Cell 2: '11110000'	Corresponds to prs-MutingInfo defined in TS 36.355 [4]
Physical cell ID PCI ^{Note 2}		(Cell ID of cell 1 – Cell ID of cell 2) mod 6 = 0	
prs-SubframeOffset		10	Number of subframes rounded to the closest integer. The corresponding parameter in the OTDOA assistance data is prs-SubframeOffset specified in TS 36.355 [4]
slotNumberOffset		0	The slot number offset at the transmitter between a neighbour cell and the assistance data reference cell specified in TS 36.355 [4]
Expected RSTD ^{Note 1}	μs	Cell 2: 1 Other neighbour cells: randomly between -3 and 3	The expected RSTD is what is expected at the receiver. The corresponding parameter in the OTDOA assistance data specified in TS 36.355 [4] is the expectedRSTD indicator
Expected RSTD uncertainty for all neighbour cells ^{Note 1}	μs	5	The corresponding parameter in the OTDOA assistance data specified in TS 36.355 [4] is the expectedRSTD-Uncertainty index
CP length ^{Note 2}		Normal	
DRX		OFF	
Radio frame receive time offset between the cells at the UE antenna connector ^{Note 3}	μs	Cell 2 to Cell 1: -3	PRS are transmitted from synchronous cells
Number of cells provided in OTDOA assistance data		16	Including the reference cell
$T_{RSTD \text{ InterFreqHD-FDD, E-UTRAN}}$	ms	15360	Derived according to the RSTD measurement requirements specified in section 9.4.7.1.3
<p>Note 1: Parameters “Expected RSTD” and “Expected RSTD uncertainty for all neighbour cells” are not settable parameters. These are parameters signalled in LPP only. For the values to be used in LPP see Table 9.4.7.1.4.3-5 and TS 37.571-5 [20], clause 7.2.5.</p> <p>Note 2: Parameters “PRS Transmission Bandwidth”, “PRS configuration index”, “Number of consecutive positioning downlink subframes”, “prs-MutingInfo”, “Cell ID” and “CP length” are settable parameters and also parameters signalled in LPP. The values to be used for “Cell ID” are as follows: Cell 1: 0, Cell 2: 6. For all the values to be used in LPP see Table 9.4.7.1.4.3-4 and TS 37.571-5 [20], clause 7.2.5.</p> <p>Note 3: The parameter “Radio frame receive time offset between the cells at the UE antenna connector” is not a settable parameter but is used to set the “true RSTD” values in step 6 of clause 9.4.7.1.4.1.</p> <p>Note 4: If the PRS transmission bandwidth is larger than the UE RF bandwidth, the UE is measuring RSTD within its RF bandwidth.</p> <p>Note 5: The parameter “$T_{RSTD \text{ InterFreqHD-FDD, E-UTRAN}}$” is not a settable parameter but is used to set the LPP “time” value in Table 9.4.7.1.4.3-3. The value of the LPP time IE is set to $T_{RSTD \text{ InterFreqHD-FDD, E-UTRAN}} + \Delta T$ ms, where $\Delta T = 150$ ms, giving a value of 15510 ms. This is rounded up to the next allowed LPP value of 16 seconds.</p>			

9.4.8.1.4.2 Test procedure

Same as in clause 9.4.7.1.4.2.

9.4.8.1.4.3 Message contents

Same as in clause 9.4.7.1.4.3

9.4.8.1.5 Test requirement

Same as in clause 9.4.7.1.5.

9.4.8.2 HD-FDD inter-frequency RSTD Measurement Accuracy in CE Mode A for Category M2

9.4.8.2.1 Test purpose

To verify that the RSTD measurement accuracy for UE Category M2 is within the specified limits normal coverage mode in an environment with fading propagation conditions.

9.4.8.2.2 Test applicability

This test applies to E-UTRA HD-FDD UE Category M2 release 14 and forward that supports UE-assisted OTDOA and inter-frequency RSTD measurements.

9.4.8.2.3 Minimum conformance requirements

Same as in clause 9.4.7.2.3.

The normative reference for this requirement is TS 36.133 [23] clause 9.1.25.1 and A.9.8.27.

9.4.8.2.4 Test description

9.4.8.2.4.1 Initial conditions

Same as in clause 9.4.7.2.4.1 but replacing Table 9.4.7.2.4.1-1 with Table 9.4.8.2.4.1-1.

Table 9.4.8.2.4.1-1: General test parameters for E-UTRAN HD-FDD inter-frequency RSTD measurement accuracy under fading propagation conditions

Parameter	Unit	Value		Comment
		Test1	Test2	
M-PDCCH parameters		R.6 HD-FDD	R.6 HD-FDD	As specified in TS 36.521-3 [25] clause A.7.2.
$mPDCCH\text{-startSF}\text{-UESS}$		10	10	Parameter G in $T = r_{\max} \cdot G$ which determines subframe $k0$ in which MPDCCH starts
Reference cell		Cell 1		
Neighbour cell		Cell 2		
E-UTRA RF Channel Number		Cell 1: 1 Cell 2: 2		The two cells are on different frequencies.
System channel Bandwidth (BW_{channel})	MHz	10	10	
PRS Transmission Bandwidth ^{Note 2}	RB	50 ^{Note 4}	50 ^{Note 4}	PRS bandwidth is as indicated in <i>prs-Bandwidth</i> in the OTDOA assistance data defined in TS 36.355 [4].
Number of consecutive positioning downlink subframes N_{PRS} ^{Note 2}		4	2	As defined in TS 36.211 [26]
prs-MutingInfo ^{Note 2}		Cell 1: '11110000' Cell 2: '11110000'		See section 6.5.1.2 in 3GPP TS 36.355 [4] for more information
Cell ID ^{Note 2}		(Cell ID of cell 1 – Cell ID of cell 2) mod 6 = 0	(Cell ID of cell 1 – Cell ID of cell 2) mod 6 = 0	

prs-SubframeOffset		10	10	Number of subframes rounded to the closest integer. The corresponding parameter in the OTDOA assistance data is prs-SubframeOffset specified in TS 36.355 [4]
slotNumberOffset		0	0	The slot number offset at the transmitter between a neighbour cell and the assistance data reference cell specified in TS 36.355 [4]
Expected RSTD ^{Note 1}	μs	Cell 2: 1 Other neighbour cells: randomly between -3 and 3	Cell 2: -1 Other neighbour cells: randomly between -3 and 3	
Expected RSTD uncertainty for all neighbour cells ^{Note 1}	μs	5	5	
CP length ^{Note 2}		Normal		
DRX		OFF		
Radio frame receive time offset between the cells at the UE antenna connector ^{Note 3}	μs	Cell 2 to Cell 1: -3	Cell 2 to Cell 1: 3	PRS are transmitted from synchronous cells
Number of cells provided in OTDOA assistance data		16		The number of cells includes the reference cell
$T_{\text{RSTD InterFreqFDD-FDD, E-UTRAN}}$ ^{Note 5}	ms	15360	10240	Derived according to the RSTD measurement requirements specified in section 9.4.7.2.3
<p>NOTE 1: Parameters “Expected RSTD” and “Expected RSTD uncertainty for all neighbour cells” are not settable parameters. These are parameters signalled in LPP only. For the values to be used in LPP see Table 9.4.7.1.4.3-4 and TS 37.571-5 [20], clause 7.2.5.</p> <p>NOTE 2: Parameters “PRS Transmission Bandwidth”, “PRS configuration index”, “Number of consecutive positioning downlink subframes”, “prs-MutingInfo”, “Cell ID” and “CP length” are settable parameters and also parameters signalled in LPP. The values to be used for “Cell ID” are as follows: Cell 1: 0, Cell 2: 6. For all the values to be used in LPP see Table 9.4.7.1.4.3-4 and TS 37.571-5 [20], clause 7.2.5.</p> <p>NOTE 3: The parameter “Radio frame receive time offset between the cells at the UE antenna connector” is not a settable parameter but is used to set the “true RSTD” values in step 6 of clause 9.1.3.4.1.</p> <p>NOTE 4: If the PRS transmission bandwidth is larger than the UE RF bandwidth, the UE is measuring RSTD within its RF bandwidth.</p> <p>NOTE 5: The parameter “$T_{\text{RSTD InterFreqFDD-FDD, E-UTRAN}}$” is not a settable parameter but is used to set the LPP “time” value in Table 9.4.7.2.4.3-1. The value of the LPP time IE is set to $T_{\text{RSTD InterFreqFDD-FDD, E-UTRAN}} + \Delta T$ ms, where $\Delta T = 150$ ms, giving a value of 15510 ms for Test 1 and 10390 ms for Test 2. This is rounded up to the next allowed LPP value of 16 and 11 seconds, respectively.</p>				

9.4.8.2.4.2 Test procedure

Same as in clause 9.4.7.1.4.2.

9.4.8.2.4.3 Message contents

Same as in clause 9.4.7.1.4.3.

9.4.8.2.5 Test requirement

Same as in clause 9.4.7.2.5.

For the overall test to pass, the ratio of successful reported values in each sub-test shall be more than 90% with a confidence level of 95%.

9.4.9 TDD inter-frequency RSTD Measurement Accuracy in CE Mode A

9.4.9.1 TDD inter-frequency RSTD Measurement Accuracy in CE Mode A for Category M1

9.4.9.1.1 Test purpose

To verify that the RSTD measurement accuracy for UE Category M1 is within the specified limits in normal coverage mode in an environment with fading propagation conditions.

9.4.9.1.2 Test applicability

This test applies to E-UTRA TDD UE Category M1 release 14 and forward that supports UE-assisted OTDOA and inter-frequency RSTD measurements.

9.4.9.1.3 Minimum conformance requirements

Same as in clause 9.4.7.1.3.

The normative reference for this requirement is TS 36.133 [23] clause 9.1.21.17 and A.9.8.28.

9.4.9.1.4 Test description

9.4.9.1.4.1 Initial conditions

Same as in clause 9.4.7.1.4.1 but replacing Table 9.4.7.1.4.1-1 with Table 9.4.9.1.4.1-1

Table 9.4.9.1.4.1-1: General test parameters for E-UTRAN TDD inter-frequency RSTD measurement Accuracy under fading propagation conditions

Parameter	Unit	Value	Comment
		Test 1	
MPDCCH		R.14 TDD	As specified in TS 36.521-3 [25] clause A.7.3
<i>mPDCCH-startSF-U ESS</i>		10	Parameter G in $T = r_{\max} \cdot G$ which determines subframe $k0$ in which MPDCCH starts
Reference cell		Cell 1	Reference cell is the cell in the OTDOA assistance data with respect to which the RSTD measurement is defined, as specified in 3GPP TS 36.214 [6] and 3GPP TS 36.355 [4]. The reference cell is the serving cell in this test case.
Neighbour cell		Cell 2	One carrier frequency is used.
E-UTRA RF Channel Number		Cell 1: 1 Cell 2: 2	The two cells are on different frequencies.
Channel Bandwidth (BW_{channel})	MHz	10	
PRS Transmission Bandwidth ^{Note 2}	RB	50 ^{Note 4}	PRS are transmitted over the system bandwidth
Number of consecutive downlink positioning subframes N_{PRS} ^{Note 2}		4	As defined in 3GPP TS 36.211 [26]. The number of subframes in a positioning occasion
PRS muting info ^{Note 2}		Cell 1: '11110000' Cell 2: '11110000'	Corresponds to prs-MutingInfo defined in TS 36.355 [4]
Physical cell ID PCI ^{Note 2}		(Cell ID of cell 1 – Cell ID of cell 2) mod 6 = 0	

prs-SubframeOffset		10	Number of subframes rounded to the closest integer. The corresponding parameter in the OTDOA assistance data is prs-SubframeOffset specified in TS 36.355 [4]
slotNumberOffset		0	The slot number offset at the transmitter between a neighbour cell and the assistance data reference cell specified in TS 36.355 [4]
Expected RSTD ^{Note 1}	μs	Cell 2: 1 Other neighbour cells: randomly between -3 and 3	The expected RSTD is what is expected at the receiver. The corresponding parameter in the OTDOA assistance data specified in TS 36.355 [4] is the expectedRSTD indicator
Expected RSTD uncertainty for all neighbour cells ^{Note 1}	μs	5	The corresponding parameter in the OTDOA assistance data specified in TS 36.355 [4] is the expectedRSTD-Uncertainty index
TDD uplink-downlink configuration		1	As specified in TS 36.211 [26], Clause 4.2; corresponds to a configuration with 5 ms switch-point periodicity and two downlink consecutive subframes
TDD special subframe configuration		6	As specified in TS 36.211 [26], Clause 4.2; corresponds to DwPTS of $19760 \cdot T_s$ and UpPTS of $4384 \cdot T_s$
CP length ^{Note 2}		Normal	
DRX		OFF	
Radio frame receive time offset between the cells at the UE antenna connector ^{Note 3}	μs	Cell 2 to Cell 1: -3	PRS are transmitted from synchronous cells
Number of cells provided in OTDOA assistance data		16	Including the reference cell
$T_{\text{RSTD InterFreqTDD, E-UTRAN}}$	ms	15360	Derived according to the RSTD measurement requirements specified in section 9.4.7.1.3
<p>Note 1: Parameters "Expected RSTD" and "Expected RSTD uncertainty for all neighbour cells" are not settable parameters. These are parameters signalled in LPP only. For the values to be used in LPP see Table 9.4.7.1.4.3-5 and TS 37.571-5 [20], clause 7.2.5.</p> <p>Note 2: Parameters "PRS Transmission Bandwidth", "PRS configuration index", "Number of consecutive positioning downlink subframes", "prs-MutingInfo", "Cell ID" and "CP length" are settable parameters and also parameters signalled in LPP. The values to be used for "Cell ID" are as follows: Cell 1: 0, Cell 2: 6. For all the values to be used in LPP see Table 9.4.7.1.4.3-4 and TS 37.571-5 [20], clause 7.2.5.</p> <p>Note 3: The parameter "Radio frame receive time offset between the cells at the UE antenna connector" is not a settable parameter but is used to set the "true RSTD" values in step 6 of clause 9.4.7.1.4.1.</p> <p>Note 4: If the PRS transmission bandwidth is larger than the UE RF bandwidth, the UE is measuring RSTD within its RF bandwidth.</p> <p>Note 5: The parameter "$T_{\text{RSTD InterFreqTDD, E-UTRAN}}$" is not a settable parameter but is used to set the LPP "time" value in Table 9.4.7.1.4.3-3. The value of the LPP time IE is set to $T_{\text{RSTD InterFreqTDD, E-UTRAN}} + \Delta T$ ms, where $\Delta T = 150$ ms, giving a value of 15510 ms. This is rounded up to the next allowed LPP value of 16 seconds.</p>			

9.4.9.1.4.2 Test procedure

Same as in clause 9.4.7.1.4.2.

9.4.9.1.4.3 Message contents

Same as in clause 9.4.7.1.4.3

9.4.9.1.5 Test requirement

Table 9.4.9.1.5-1 defines the primary level settings including test tolerances for the test.

The RSTD TDD inter-frequency accuracy test shall meet the reported values in Table 9.4.9.1.5-2

Table 9.4.9.1.5-1: Cell Specific Test Parameters for inter frequency RSTD Tests for E-UTRAN TDD

Parameter	Unit	Test1		Test2 ^{Note4}	
		Cell1	Cell2	Cell1	Cell2
E-UTRA RF Channel Number		1	2	1	2
Gap offset		9	N/A	9	N/A
Gap pattern		#0	N/A	#0	N/A
OCNG Patterns defined in TS 36.521-3 [25] clause D.1		OP.11 TDD	OP.2 TDD	OP.11 TDD	OP.2 TDD
PRS configuration Index I_{PRS} , as defined in TS 36.211		140	150	140	150
PBCH_RA	dB	0	0	0	0
PBCH_RB					
PSS_RA					
SSS_RA					
MPDCCH_RA					
MPDCCH_RB					
OCNG_RA ^{Note1}					
OCNG_RB ^{Note1}					
PRS_RA	dB	0	0	0	0
N_{oc} ^{Note2}	dBm/15 kHz	-98	-98	-98	-98
$PRS \hat{E}_s / N_{oc}$	dB	-1	-11	-1	-11
$PRS \hat{E}_s / I_{ot}$ ^{Note3}	dB	-1	-11	-1	-11
I_o ^{Note3}	dBm/9 MHz	-69.68	-70.16	-69.68	-70.16
PRP ^{Note3}	dBm/15kHz	-99	-109	-99	-109
\hat{E}_s / N_{oc} ^{Note 3}	dB	-1	-11	-1	-11
RSRP ^{Note 3}	dBm/15kHz	-99	-109	-99	-109
Propagation condition		AWGN			
Note 1: OCNG shall be used such that both cells are fully allocated and a constant total transmitted power spectral density is achieved for all OFDM symbols (other than those in the PRS subframes). Note 2: Interference from other cells and noise sources not specified in the test is assumed to be constant over subcarriers and time and shall be modelled as AWGN of appropriate power for N_{oc} to be fulfilled. Note 3: \hat{E}_s / N_{oc} , $PRS \hat{E}_s / I_{ot}$, I_o , RSRP and PRP levels have been derived from other parameters for information purposes. They are not settable parameters themselves. I_o values are derived in the case that there is no PBCH, PSS or SSS in the OFDM symbols carrying PRS Note 4: Test2 is not used for test 9.4.9.1					

Table 9.4.9.1.5-2: RSTD TDD inter-frequency accuracy requirements for the reported values

	Test 1
Lowest reported value	RSTD_6241
Highest reported value	RSTD_6287

The test tolerances are defined in clauses C.1.3 and C4.

For the overall test to pass, the ratio of successful reported values in each sub-test shall be more than 90% with a confidence level of 95%.

9.4.9.2 TDD inter-frequency RSTD Measurement Accuracy in CE Mode A for Category M2

9.4.9.2.1 Test purpose

To verify that the RSTD measurement accuracy for UE Category M2 is within the specified limits in normal coverage mode in an environment with fading propagation conditions.

9.4.9.2.2 Test applicability

This test applies to E-UTRA TDD UE Category M2 release 14 and forward that supports UE-assisted OTDOA and inter-frequency RSTD measurements.

9.4.9.2.3 Minimum conformance requirements

Same as in clause 9.4.7.2.3.

The normative reference for this requirement is TS 36.133 [23] clause 9.1.25.1 and A.9.8.28.

9.4.9.2.4 Test description

9.4.9.2.4.1 Initial conditions

Same as in clause 9.4.7.2.4.1 but replacing Table 9.4.7.2.4.1-1 with Table 9.4.9.2.4.1-1.

Table 9.4.9.2.4.1-1: General test parameters for E-UTRAN TDD inter-frequency RSTD measurement Accuracy under fading propagation conditions

Parameter	Unit	Value		Comment
		Test1	Test2	
M-PDCCH parameters		R.14 TDD	R.14 TDD	As specified in TS 36.521-3 [25] clause A.7.3.
<i>mPDCCH-startSF-UESS</i>		10	10	Parameter G in $T = r_{\max} \cdot G$ which determines subframe $k0$ in which MPDCCH starts
Reference cell		Cell 1		
Neighbour cell		Cell 2		
E-UTRA RF Channel Number		Cell 1: 1 Cell 2: 2		The two cells are on different frequencies.
System channel Bandwidth (BW_{channel})	MHz	10	10	
PRS Transmission Bandwidth ^{Note 2}	RB	50 ^{Note 4}	50 ^{Note 4}	PRS bandwidth is as indicated in <i>prs-Bandwidth</i> in the OTDOA assistance data defined in TS 36.355 [4].
Number of consecutive positioning downlink subframes N_{PRS} ^{Note 2}		4	2	As defined in TS 36.211 [26]
<i>prs-MutingInfo</i> ^{Note 2}		Cell 1: '11110000' Cell 2: '11110000'		See section 6.5.1.2 in 3GPP TS 36.355 [4] for more information
Cell ID ^{Note 2}		(Cell ID of cell 1 – Cell ID of cell 2) mod 6 = 0	(Cell ID of cell 1 – Cell ID of cell 2) mod 6 = 0	
<i>prs-SubframeOffset</i>		10	10	Number of subframes rounded to the closest integer. The corresponding parameter in the OTDOA assistance data is <i>prs-SubframeOffset</i> specified in TS 36.355 [4]

slotNumberOffset		0	0	The slot number offset at the transmitter between a neighbour cell and the assistance data reference cell specified in TS 36.355 [4]
Expected RSTD ^{Note 1}	μs	Cell 2: 1 Other neighbour cells: randomly between -3 and 3	Cell 2: -1 Other neighbour cells: randomly between -3 and 3	
Expected RSTD uncertainty for all neighbour cells ^{Note 1}	μs	5	5	
TDD uplink-downlink configuration		1		As specified in TS 36.211 [26], Clause 4.2; corresponds to a configuration with 5 ms switch-point periodicity and two downlink consecutive subframes
TDD special subframe configuration		6		As specified in TS 36.211 [26], Clause 4.2; corresponds to DwPTS of $19760 \cdot T_s$ and UpPTS of $4384 \cdot T_s$
CP length ^{Note 2}		Normal		
DRX		OFF		
Radio frame receive time offset between the cells at the UE antenna connector ^{Note 3}	μs	Cell 2 to Cell 1: -3	Cell 2 to Cell 1: 3	PRS are transmitted from synchronous cells
Number of cells provided in OTDOA assistance data		16		The number of cells includes the reference cell
$T_{\text{RSTD InterFreqFDD-FDD, E-UTRAN}}$ ^{Note 5}	ms	15360	10240	Derived according to the RSTD measurement requirements specified in section 9.4.7.2.3

NOTE 1: Parameters "Expected RSTD" and "Expected RSTD uncertainty for all neighbour cells" are not settable parameters. These are parameters signalled in LPP only. For the values to be used in LPP see Table 9.4.7.1.4.3-4 and TS 37.571-5 [20], clause 7.2.5.

NOTE 2: Parameters "PRS Transmission Bandwidth", "PRS configuration index", "Number of consecutive positioning downlink subframes", "prs-MutingInfo", "Cell ID" and "CP length" are settable parameters and also parameters signalled in LPP. The values to be used for "Cell ID" are as follows: Cell 1: 0, Cell 2: 6. For all the values to be used in LPP see Table 9.4.7.1.4.3-4 and TS 37.571-5 [20], clause 7.2.5.

NOTE 3: The parameter "Radio frame receive time offset between the cells at the UE antenna connector" is not a settable parameter but is used to set the "true RSTD" values in step 6 of clause 9.1.3.4.1.

NOTE 4: If the PRS transmission bandwidth is larger than the UE RF bandwidth, the UE is measuring RSTD within its RF bandwidth.

NOTE 5: The parameter " $T_{\text{RSTD InterFreqFDD-FDD, E-UTRAN}}$ " is not a settable parameter but is used to set the LPP "time" value in Table 9.4.7.2.4.3-1. The value of the LPP time IE is set to $T_{\text{RSTD InterFreqFDD-FDD, E-UTRAN}} + \Delta T$ ms, where $\Delta T = 150$ ms, giving a value of 15510 ms for Test 1 and 10390 ms for Test 2. This is rounded up to the next allowed LPP value of 16 and 11 seconds, respectively.

9.4.9.2.4.2 Test procedure

Same as in clause 9.4.7.1.4.2.

9.4.9.2.4.3 Message contents

Same as in clause 9.4.7.1.4.3.

9.4.9.2.5 Test requirement

Same as in clause 9.4.9.1.5 adding Test 2 and replacing Table 9.4.9.1.5-2 with Table 9.4.9.2.5-1:

Table 9.4.9.2.5-1: RSTD TDD inter-frequency accuracy requirements for the reported values

	Test 1	Test 2
Lowest reported value	RSTD_6252	RSTD_6435
Highest reported value	RSTD_6276	RSTD_6459

For the overall test to pass, the ratio of successful reported values in each sub-test shall be more than 90% with a confidence level of 95%.

9.4.10 FDD inter-frequency RSTD Measurement Accuracy in CE Mode B

9.4.10.1 FDD inter-frequency RSTD Measurement Accuracy in CE Mode B for Category M1

Editor’s note: This test is incomplete. The following aspects are missing:

The core requirements in TS 36.133 contain square brackets

9.4.10.1.1 Test purpose

To verify that the RSTD measurement accuracy for UE Category M1 is within the specified limits in enhanced coverage mode in an environment with fading propagation conditions.

9.4.10.1.2 Test applicability

This test applies to E-UTRA FDD UE Category M1 release 14 and forward that supports UE-assisted OTDOA, inter-frequency RSTD measurements and CE Mode B.

9.4.10.1.3 Minimum conformance requirements

The accuracy requirements in Table 9.4.10.1.3-1 are valid under the following conditions:

Conditions defined in 36.101 [2] Clause 7.3 for reference sensitivity are fulfilled.

PRP $1,2_{dBm}$ according to Annex E.3.1 for a corresponding Band

There are no measurement gaps overlapping with the PRS subframes of the measured serving cell.

The parameter expectedRSTDUncertainty signalled over LPP by E-SMLC as defined in TS 36.355 [4] is less than 5 μs .

Table 9.4.10.1.3-1: RSTD inter-frequency measurement accuracy for CE Mode B

Accuracy	PRS \hat{E}_s/lot	Minimum PRS bandwidth, which is minimum of serving cell channel bandwidth and the PRS bandwidths of the reference cell and the measured neighbour cell i <small>Note 3</small>	Conditions			Io <small>Note 4</small> range	
			Minimum number of available measurement subframes among the reference cell and the measured neighbour cell i	The number of consecutive downlink subframes N_{PRS} among the reference cell and the measured neighbour cell i as defined in [24]	E-UTRA operating band groups <small>Note 5</small>	Minimum Io <small>Note 1</small>	Maximum Io
T_s <small>Note 2</small>	dB	RB				dBm/15kHz	dBm/BW _{Channel}
[±21]	(PRS \hat{E}_s/lot) _{ref} ≥ -15dB and (PRS	≥ 6	≥ 30	≥ 4	FDD-M1_A, TDD-M1_A	-121	-50
)				FDD-	-120.5	-50

	$\hat{E}_s/lot)_i$ $\geq -15\text{dB}$			M1_B		
				FDD-M1_C, TDD-M1_C	-120	-50
				FDD-M1_D	-119.5	-50
				FDD-M1_E, TDD-M1_E	-119	-50
				FDD-M1_F	-118.5	-50
				FDD-M1_G	-118	-50
				FDD-M1_H	-117.5	-50
				FDD-M1_N	-114.5	-50

NOTE 1: This minimum l_0 condition is expressed as the average l_0 per RE over all REs in an OFDM symbol.
 NOTE 2: T_s is the basic timing unit defined in TS 36.211 [26].
 NOTE 3: PRS bandwidth is as indicated in *prs-Bandwidth* in the OTDOA assistance data defined in TS 36.355 [4].
 NOTE 4: The l_0 is defined in PRS positioning subframes. The same l_0 range applies to PRS and non-PRS symbols. l_0 levels are different in PRS and non-PRS symbols within the same subframe.
 NOTE 5: E-UTRA operating band groups are as defined in Section 4.4.2.

The normative reference for this requirement is TS 36.133 [23] clause 9.1.21.18 and A.9.8.29.

9.4.10.1.4 Test description

9.4.10.1.4.1 Initial conditions

Same as in clause 9.4.7.1.4.1 but replacing Table 9.4.7.1.4.1-1 with Table 9.4.10.1.4.1-1.

Table 9.4.10.1.4.1-1: General test parameters for E-UTRAN FDD inter-frequency RSTD measurement Accuracy under fading propagation conditions.

Parameter	Unit	Value	Comment
		Test 1	
MPDCCH		R.18 FDD	As specified in TS 36.521-3 [25] clause A.7.1
<i>mPDCCH-startSF-UCESS</i>		10	Parameter G in $T = r_{\max} \cdot G$ which determines subframe $k0$ in which MPDCCH starts
Reference cell		Cell 1	Reference cell is the cell in the OTDOA assistance data with respect to which the RSTD measurement is defined, as specified in 3GPP TS 36.214 [6] and 3GPP TS 36.355 [4]. The reference cell is the serving cell in this test case.
Neighbour cell		Cell 2	One carrier frequency is used.
E-UTRA RF Channel Number		1	
Channel Bandwidth (BW_{channel})	MHz	10	
PRS Transmission Bandwidth ^{Note 2}	RB	50 ^{Note 4}	PRS are transmitted over the system bandwidth
Number of consecutive downlink positioning subframes N_{PRS} ^{Note 2}		4	As defined in 3GPP TS 36.211 [26]. The number of subframes in a positioning occasion

PRS muting info ^{Note 2}		Cell 1: '11110000' Cell 2: '11110000'	Corresponds to prs-MutingInfo defined in TS 36.355 [4]
Physical cell ID PCI ^{Note 2}		(Cell ID of cell 1 – Cell ID of cell 2) mod 6 = 0	
prs-SubframeOffset		10	Number of subframes rounded to the closest integer. The corresponding parameter in the OTDOA assistance data is prs-SubframeOffset specified in TS 36.355 [4]
slotNumberOffset		0	The slot number offset at the transmitter between a neighbour cell and the assistance data reference cell specified in TS 36.355 [4]
Expected RSTD ^{Note 1}	µs	Cell 2: 1 Other neighbour cells: randomly between -3 and 3	The expected RSTD is what is expected at the receiver. The corresponding parameter in the OTDOA assistance data specified in TS 36.355 [4] is the expectedRSTD indicator
Expected RSTD uncertainty for all neighbour cells ^{Note 1}	µs	5	The corresponding parameter in the OTDOA assistance data specified in TS 36.355 [4] is the expectedRSTD-Uncertainty index
CP length ^{Note 2}		Normal	
DRX		OFF	
Radio frame receive time offset between the cells at the UE antenna connector ^{Note 3}	µs	Cell 2 to Cell 1: -3	PRS are transmitted from synchronous cells
Number of cells provided in OTDOA assistance data		16	Including the reference cell
$T_{RSTD \text{ InterFreqFDD-FDD, E-UTRAN}}$	ms	40960	Derived according to the RSTD measurement requirements specified in section 9.4.10.1.3
<p>Note 1: Parameters “Expected RSTD” and “Expected RSTD uncertainty for all neighbour cells” are not settable parameters. These are parameters signalled in LPP only. For the values to be used in LPP see Table 9.4.10.1.4.3-5 and TS 37.571-5 [20], clause 7.2.5.</p> <p>Note 2: Parameters “PRS Transmission Bandwidth”, “PRS configuration index”, “Number of consecutive positioning downlink subframes”, “prs-MutingInfo”, “Cell ID” and “CP length” are settable parameters and also parameters signalled in LPP. The values to be used for “Cell ID” are as follows: Cell 1: 0, Cell 2: Test 1: 6, Test 2: 7, Test 3: 6, Test 4: 9. For all the values to be used in LPP see Table 9.4.10.1.4.3-4 and TS 37.571-5 [20], clause 7.2.5.</p> <p>Note 3: The parameter “Radio frame receive time offset between the cells at the UE antenna connector” is not a settable parameter but is used to set the “true RSTD” values in step 6 of clause 9.4.10.1.4.1.</p> <p>Note 4: If the PRS transmission bandwidth is larger than the UE RF bandwidth, the UE is measuring RSTD within its RF bandwidth.</p> <p>Note 5: The parameter “$T_{RSTD \text{ InterFreqFDD-FDD, E-UTRAN}}$” is not a settable parameter but is used to set the LPP “time” value in Table 9.4.10.1.4.3-3. The value of the LPP time IE is set to $T_{RSTD \text{ InterFreqFDD-FDD, E-UTRAN}} + \Delta T$ ms, where $\Delta T = 150$ ms, giving a value of 41210 ms. This is rounded up to the next allowed LPP value of 42 seconds.</p>			

9.4.10.1.4.2 Test procedure

Same as in clause 9.4.7.1.4.2 but using condition CEModeB.

9.4.10.1.4.3 Message contents

Same as in clause 9.4.7.1.4.3 with the following exceptions

Table 9.4.10.1.4.3-1: LPP RequestLocationInformation

Derivation Path: Table 9.4.7.1.4.3-4

Information Element	Value/remark	Comment	Condition
LPP-Message ::= SEQUENCE {			
lpp-MessageBody CHOICE {			
c1 CHOICE {			
requestLocationInformation SEQUENCE {			
criticalExtensions CHOICE {			
c1 CHOICE {			
requestLocationInformation-r9 SEQUENCE {			
commonIEsRequestLocationInformation SEQUENCE {			
qos SEQUENCE {			
responseTime SEQUENCE {			
time	42	See Note 5 in Table 9.4.10.1.4.1-1	
}			
}			
}			
}			
}			
}			
}			
}			
}			
}			

9.4.10.1.5 Test requirement

Table 9.4.10.1.5-1 defines the primary level settings including test tolerances for the test.

The RSTD FDD inter-frequency accuracy test shall meet the reported values in Table 9.4.10.1.5-2

Table 9.4.10.1.5-1: Cell Specific Test Parameters for inter frequency RSTD Tests for E-UTRAN FDD

Parameter	Unit	Test1		Test2 ^{Note4}	
		Cell1	Cell2	Cell1	Cell2
E-UTRA RF Channel Number		1	2	1	2
Gap offset		9	N/A	9	N/A
Gap pattern		#0	N/A	#0	N/A
OCNG Patterns defined in TS 36.521-3 [25] clause D.1		OP.21 FDD	OP.6 FDD	OP.21 FDD	OP.6 FDD
PRS configuration Index I_{PRS} , as defined in TS 36.211 [26]		142	152	142	152
PBCH_RA	dB	0	0	0	0
PBCH_RB					
PSS_RA					
SSS_RA					
MPDCCH_RA					
MPDCCH_RB					
OCNG_RA ^{Note1}					
OCNG_RB ^{Note1}					
PRS_RA	dB	0	0	0	0
N_{oc} ^{Note2}	dBm/15 kHz	-98	-98	-98	-98
PRS \hat{E}_s/N_{oc}	dB	-11	-14	-11	-14
PRS \hat{E}_s/I_{ot} ^{Note3}	dB	-11	-14	-11	-14
I_o ^{Note3}	dBm/9 MHz	-70.16	-70.19	-70.16	-70.19
PRP ^{Note3}	dBm/15kHz	-109	-112	-109	-112
\hat{E}_s/N_{oc} ^{Note 3}	dB	-11	-14	-11	-14
RSRP ^{Note 3}	dBm/15kHz	-109	-112	-109	-112
Propagation condition		AWGN			

Note 1:	OCNG shall be used such that both cells are fully allocated and a constant total transmitted power spectral density is achieved for all OFDM symbols (other than those in the PRS subframes).
Note 2:	Interference from other cells and noise sources not specified in the test is assumed to be constant over subcarriers and time and shall be modelled as AWGN of appropriate power for N_{oc} to be fulfilled.
Note 3:	\hat{E}_s/N_{oc} , PRS \hat{E}_s/I_{ot} , I_o , RSRP and PRP levels have been derived from other parameters for information purposes. They are not settable parameters themselves. I_o values are derived in the case that there is no PBCH, PSS or SSS in the OFDM symbols carrying PRS
Note 4:	Test2 is not used for test 9.4.10.1

Table 9.4.10.1.5-2: RSTD FDD inter-frequency accuracy requirements for the reported values

	Test 1
Lowest reported value	[RSTD_6241]
Highest reported value	[RSTD_6287]

The test tolerances are defined in clauses C.1.3 and C4.

For the overall test to pass, the ratio of successful reported values in each sub-test shall be more than 90% with a confidence level of 95%.

9.4.10.2 FDD inter-frequency RSTD Measurement Accuracy in CE Mode B for Category M2

9.4.10.2.1 Test purpose

To verify that the RSTD measurement accuracy for UE Category M2 is within the specified limits in enhanced coverage mode in an environment with fading propagation conditions.

9.4.10.2.2 Test applicability

This test applies to E-UTRA FDD UE Category M2 release 14 and forward that supports UE-assisted OTDOA, inter-frequency RSTD measurements and CE Mode B.

9.4.10.2.3 Minimum conformance requirements

The accuracy requirements in Table 9.4.10.2.3-1 are valid under the following conditions:

Conditions defined in 36.101 [2] Clause 7.3 for reference sensitivity are fulfilled.

PRP $1,2_{dBm}$ according to Annex E.2 for a corresponding Band

There are no measurement gaps overlapping with the PRS subframes of the measured serving cell.

The parameter expectedRSTDUncertainty signalled over LPP by E-SMLC as defined in TS 36.355 [4] is less than 5 μ s.

Table 9.4.10.2.3-1: RSTD inter-frequency measurement accuracy for CEModeB

Accuracy	Conditions						
	PRS \hat{E}_s/I_{ot}	Minimum PRS bandwidth, which is minimum of serving cell channel bandwidth and the PRS bandwidths of the reference cell and the measured neighbour cell i	Minimum number of available measurement subframes among the reference cell and the measured neighbour cell i	The number of consecutive downlink subframes N_{PRS} among the reference cell and the measured neighbour cell i as defined in [24]	Io ^{Note 4} range		
					E-UTRA operating band groups ₅ ^{Note 5}	Minimum Io ^{Note 1}	Maximum Io

Ts <small>Note 2</small>	dB	Note 3				dBm/15kHz	dBm/BW _{Channel}
		RB					
±21	(PRS \hat{E}_s/I_{ot}) _{ref} ≥ -15dB and (PRS \hat{E}_s/I_{ot}) _i ≥ -[13]dB	≥ 6	≥ 30	≥ 4	FDD-M1_A, TDD-M1_A	-121	-50
					FDD-M1_B	-120.5	-50
					FDD-M1_C, TDD-M1_C	-120	-50
					FDD-M1_D	-119.5	-50
					FDD-M1_E, TDD-M1_E	-119	-50
					FDD-M1_F	-118.5	-50
					FDD-M1_G	-118	-50
					FDD-M1_H	-117.5	-50
					FDD-M1_N	-114.5	-50
±10	(PRS \hat{E}_s/I_{ot}) _{ref} ≥ -15dB and (PRS \hat{E}_s/I_{ot}) _i ≥ -[13]dB	≥ 24	≥ 8	≥ 2	Note 6	Note 6	Note 6

NOTE 1: This minimum Io condition is expressed as the average Io per RE over all REs in an OFDM symbol.
 NOTE 2: Ts is the basic timing unit defined in TS 36.211 [26].
 NOTE 3: PRS bandwidth is as indicated in *prs-Bandwidth* in the OTDOA assistance data defined in TS 36.355 [4].
 NOTE 4: The Io is defined in PRS positioning subframes. The same Io range applies to PRS and non-PRS symbols. Io levels are different in PRS and non-PRS symbols within the same subframe.
 NOTE 5: E-UTRA operating band groups are as defined in Section 4.4.2.
 NOTE 6: **FFS?**
 NOTE 7: The same bands and the same Io conditions for each band apply for this requirement as for the corresponding requirement with the PRS bandwidth ≥ 6 RB.

Editor’s note: The values of (PRS \hat{E}_s/I_{ot})_i in the above table are inconsistent with other similar values and are therefore placed in square brackets pending further review.

The normative reference for this requirement is TS 36.133 [23] clause 9.1.25.2 and A.9.8.29.

9.4.10.2.4 Test description

9.4.10.2.4.1 Initial conditions

Same as in clause 9.4.10.1.4.1 adding Test 2 and replacing Table 9.4.10.1.4.1-1 with Table 9.4.10.2.4.1-1.

The true RSTD (which is the receive time difference for frame 0 between cell 2 and cell 1 as seen at the UE antenna connector) is set to the following values:

Test 1: -92 Ts (about -3 μs)

Test 2: 92 Ts (about 3 μs)

Note that the related expectedRSTD values to be signalled over LPP are defined in Table 9.4.10.2.4-1 for each test.

Table 9.4.10.2.4.1-1: General test parameters for E-UTRAN FDD inter-frequency RSTD measurement Accuracy under fading propagation conditions

Parameter	Unit	Value	Comment
-----------	------	-------	---------

		Test1	Test2	
M-PDCCH parameters		R.18 FDD	R.18 FDD	As specified in TS 36.521-3 [25] clause A.7.1.
$mPDCCH\text{-startSF}\text{-UESS}$		10	10	Parameter G in $T = r_{\max} \cdot G$ which determines subframe $k0$ in which MPDCCH starts
Reference cell		Cell 1		
Neighbour cell		Cell 2		
E-UTRA RF Channel Number		1		One carrier frequency is used.
System channel Bandwidth (BW_{channel})	MHz	10	10	
PRS Transmission Bandwidth ^{Note 2}	RB	50 ^{Note 4}	50 ^{Note 4}	PRS bandwidth is as indicated in <i>prs-Bandwidth</i> in the OTDOA assistance data defined in TS 36.355 [4].
Number of consecutive positioning downlink subframes N_{PRS} ^{Note 2}		4	2	As defined in TS 36.211 [26]
<i>prs-MutingInfo</i> ^{Note 2}		Cell 1: '11110000' Cell 2: '11110000'		See section 6.5.1.2 in 3GPP TS 36.355 [4] for more information
Cell ID ^{Note 2}		(Cell ID of cell 1 – Cell ID of cell 2) mod 6 = 0	(Cell ID of cell 1 – Cell ID of cell 2) mod 6 = 0	
<i>prs-SubframeOffset</i>		10	10	Number of subframes rounded to the closest integer. The corresponding parameter in the OTDOA assistance data is <i>prs-SubframeOffset</i> specified in TS 36.355 [4]
<i>slotNumberOffset</i>		0	0	The slot number offset at the transmitter between a neighbour cell and the assistance data reference cell specified in TS 36.355 [4]
Expected RSTD ^{Note 1}	μs	Cell 2: 1 Other neighbour cells: randomly between -3 and 3	Cell 2: -1 Other neighbour cells: randomly between -3 and 3	
Expected RSTD uncertainty for all neighbour cells ^{Note 1}	μs	5	5	
CP length ^{Note 2}		Normal		
DRX		OFF		
Radio frame receive time offset between the cells at the UE antenna connector ^{Note 3}	μs	Cell 2 to Cell 1: -3	Cell 2 to Cell 1: 3	PRS are transmitted from synchronous cells
Number of cells provided in OTDOA assistance data		16		The number of cells includes the reference cell
$T_{\text{RSTD InterFreqFDD-FDD, E-UTRAN}}$ ^{Note 5}	ms	40960	10240	Derived according to the RSTD measurement requirements specified in section 9.4.10.2.3

NOTE 1: Parameters “Expected RSTD” and “Expected RSTD uncertainty for all neighbour cells” are not settable parameters. These are parameters signalled in LPP only. For the values to be used in LPP see Table 9.4.10.1.4.3-4 and TS 37.571-5 [20], clause 7.2.5.

NOTE 2: Parameters “PRS Transmission Bandwidth”, “PRS configuration index”, “Number of consecutive positioning downlink subframes”, “prs-MutingInfo”, “Cell ID” and “CP length” are settable parameters and also parameters signalled in LPP. The values to be used for “Cell ID” are as follows: Cell 1: 0, Cell 2: Test 1: 6, Test 2: 7, Test 3: 6, Test 4: 9. For all the values to be used in LPP see Table 9.4.10.1.4.3-4 and TS 37.571-5 [20], clause 7.2.5.

NOTE 3: The parameter “Radio frame receive time offset between the cells at the UE antenna connector” is not a settable parameter but is used to set the “true RSTD” values in step 6 of clause 9.1.3.4.1.

NOTE 4: If the PRS transmission bandwidth is larger than the UE RF bandwidth, the UE is measuring RSTD within its RF bandwidth.

NOTE 5: The parameter “ $T_{\text{RSTD InterFreqFDD-FDD, E-UTRAN}}$ ” is not a settable parameter but is used to set the LPP “time” value in Table 9.4.10.2.4.3-1. The value of the LPP time IE is set to $T_{\text{RSTD InterFreqFDD-FDD, E-UTRAN}} + \Delta T$ ms, where $\Delta T = 150$ ms, giving a value of 41210 ms for Test and 10390 ms for Test 2. This is rounded up to the next allowed LPP value of 42 and 11 seconds, respectively.

9.4.10.2.4.2 Test procedure

Same as in clause 9.4.7.1.4.2 but using condition CEModeB.

9.4.10.2.4.3 Message contents

Same as in clause 9.4.7.1.4.3 with the following exceptions:

Table 9.4.10.2.4.3-1: LPP RequestLocationInformation

Derivation Path: Table 9.4.7.1.4.3-4			
Information Element	Value/remark	Comment	Condition
LPP-Message ::= SEQUENCE {			
lpp-MessageBody CHOICE {			
c1 CHOICE {			
requestLocationInformation SEQUENCE {			
criticalExtensions CHOICE {			
c1 CHOICE {			
requestLocationInformation-r9 SEQUENCE {			
commonIEsRequestLocationInformation SEQUENCE {			
qos SEQUENCE {			
responseTime SEQUENCE {			
time	42	See Note 5 in Table 9.4.10.2.4.1-1	Test 1
time	11	See Note 5 in Table 9.4.10.2.4.1-1	Test 2
}			
}			
}			
}			
}			
}			
}			
}			
}			
}			

9.4.10.2.5 Test requirement

Same as in clause 9.4.10.1.5 adding Test 2 and replacing Table 9.4.10.1.5-2 with Table 9.4.10.2.5-1:

Table 9.4.10.2.5-1: RSTD FDD inter-frequency accuracy requirements for the reported values

	Test 1	Test 2
Lowest reported value	RSTD_6252	RSTD_6435
Highest reported value	RSTD_6276	RSTD_6459

For the overall test to pass, the ratio of successful reported values in each sub-test shall be more than 90% with a confidence level of 95%.

9.4.11 HD-FDD inter-frequency RSTD Measurement Accuracy in CE Mode B

9.4.11.1 HD-FDD inter-frequency RSTD Measurement Accuracy in CE Mode B for Category M1

Editor's note: This test is incomplete. The following aspects are missing:

The core requirements in TS 36.133 contain square brackets

9.4.11.1.1 Test purpose

To verify that the RSTD measurement accuracy for UE Category M1 is within the specified limits enhanced coverage mode in an environment with fading propagation conditions.

9.4.11.1.2 Test applicability

This test applies to E-UTRA HD-FDD UE Category M1 release 14 and forward that supports UE-assisted OTDOA, inter-frequency RSTD measurements and CE Mode B.

9.4.11.1.3 Minimum conformance requirements

Same as in clause 9.4.10.1.3.

The normative reference for this requirement is TS 36.133 [23] clause 9.1.21.18 and A.9.8.30.

9.4.11.1.4 Test description

9.4.11.1.4.1 Initial conditions

Same as in clause 9.4.10.1.4.1 but replacing Table 9.4.10.1.4.1-1 with Table 9.4.11.1.4.1-1

Table 9.4.11.1.4.1-1: General test parameters for E-UTRAN HD-FDD inter-frequency RSTD measurement Accuracy under fading propagation conditions

Parameter	Unit	Value	Comment
		Test 1	
MPDCCH		R.8 HD-FDD	As specified in TS 36.521-3 [25] clause A.7.2
<i>mPDCCH-startSF-U ESS</i>		10	Parameter G in $T = r_{\max} \cdot G$ which determines subframe $k0$ in which MPDCCH starts
Reference cell		Cell 1	Reference cell is the cell in the OTDOA assistance data with respect to which the RSTD measurement is defined, as specified in 3GPP TS 36.214 [6] and 3GPP TS 36.355 [4]. The reference cell is the serving cell in this test case.
Neighbour cell		Cell 2	One carrier frequency is used.

E-UTRA RF Channel Number		1	
Channel Bandwidth (BW_{channel})	MHz	10	
PRS Transmission Bandwidth ^{Note 2}	RB	50 ^{Note 4}	PRS are transmitted over the system bandwidth
Number of consecutive downlink positioning subframes N_{PRS} ^{Note 2}		4	As defined in 3GPP TS 36.211 [26]. The number of subframes in a positioning occasion
PRS muting info ^{Note 2}		Cell 1: '11110000' Cell 2: '11110000'	Corresponds to prs-MutingInfo defined in TS 36.355 [4]
Physical cell ID PCI ^{Note 2}		(Cell ID of cell 1 – Cell ID of cell 2) mod 6 = 0	
prs-SubframeOffset		10	Number of subframes rounded to the closest integer. The corresponding parameter in the OTDOA assistance data is prs-SubframeOffset specified in TS 36.355 [4]
slotNumberOffset		0	The slot number offset at the transmitter between a neighbour cell and the assistance data reference cell specified in TS 36.355 [4]
Expected RSTD ^{Note 1}	μs	Cell 2: 1 Other neighbour cells: randomly between -3 and 3	The expected RSTD is what is expected at the receiver. The corresponding parameter in the OTDOA assistance data specified in TS 36.355 [4] is the expectedRSTD indicator
Expected RSTD uncertainty for all neighbour cells ^{Note 1}	μs	5	The corresponding parameter in the OTDOA assistance data specified in TS 36.355 [4] is the expectedRSTD-Uncertainty index
CP length ^{Note 2}		Normal	
DRX		OFF	
Radio frame receive time offset between the cells at the UE antenna connector ^{Note 3}	μs	Cell 2 to Cell 1: -3	PRS are transmitted from synchronous cells
Number of cells provided in OTDOA assistance data		16	Including the reference cell
$T_{\text{RSTD InterFreqHD-FDD, E-UTRAN}}$	ms	40960	Derived according to the RSTD measurement requirements specified in section 9.4.10.1.3
<p>Note 1: Parameters "Expected RSTD" and "Expected RSTD uncertainty for all neighbour cells" are not settable parameters. These are parameters signalled in LPP only. For the values to be used in LPP see Table 9.4.10.1.4.3-5 and TS 37.571-5 [20], clause 7.2.5.</p> <p>Note 2: Parameters "PRS Transmission Bandwidth", "PRS configuration index", "Number of consecutive positioning downlink subframes", "prs-MutingInfo", "Cell ID" and "CP length" are settable parameters and also parameters signalled in LPP. The values to be used for "Cell ID" are as follows: Cell 1: 0, Cell 2: Test 1: 6, Test 2: 7, Test 3: 6, Test 4: 9. For all the values to be used in LPP see Table 9.4.10.1.4.3-4 and TS 37.571-5 [20], clause 7.2.5.</p> <p>Note 3: The parameter "Radio frame receive time offset between the cells at the UE antenna connector" is not a settable parameter but is used to set the "true RSTD" values in step 6 of clause 9.4.10.1.4.1.</p> <p>Note 4: If the PRS transmission bandwidth is larger than the UE RF bandwidth, the UE is measuring RSTD within its RF bandwidth.</p> <p>Note 5: The parameter "$T_{\text{RSTD InterFreqHD-FDD, E-UTRAN}}$" is not a settable parameter but is used to set the LPP "time" value in Table 9.4.10.2.4.3-1. The value of the LPP time IE is set to $T_{\text{RSTD InterFreqHD-FDD, E-UTRAN}} + \Delta T$ ms, where $\Delta T = 150$ ms, giving a value of 41210 ms. This is rounded up to the next allowed LPP value of 42 seconds.</p>			

9.4.11.1.4.2 Test procedure

Same as in clause 9.4.7.1.4.2 but using condition CEModeB.

9.4.11.1.4.3 Message contents

Same as in clause 9.4.10.1.4.3.

9.4.11.1.5 Test requirement

Same as in clause 9.4.10.1.5.

9.4.11.2 HD-FDD inter-frequency RSTD Measurement Accuracy in CE Mode B for Category M2

9.4.11.2.1 Test purpose

To verify that the RSTD measurement accuracy for UE Category M2 is within the specified limits enhanced coverage mode in an environment with fading propagation conditions.

9.4.11.2.2 Test applicability

This test applies to E-UTRA HD-FDD UE Category M2 release 14 and forward that supports UE-assisted OTDOA, inter-frequency RSTD measurements and CE Mode B.

9.4.11.2.3 Minimum conformance requirements

Same as in clause 9.4.10.2.3.

The normative reference for this requirement is TS 36.133 [23] clause 9.1.25.2 and A.9.8.30.

9.4.11.2.4 Test description

9.4.11.2.4.1 Initial conditions

Same as in clause 9.4.10.2.4.1 but replacing Table 9.4.10.2.4.1-1 with Table 9.4.11.2.4.1-1.

Table 9.4.11.2.4.1-1: General test parameters for E-UTRAN HD-FDD inter-frequency RSTD measurement Accuracy under fading propagation conditions

Parameter	Unit	Value		Comment
		Test1	Test2	
M-PDCCH parameters		R.8 HD-FDD	R.8 HD-FDD	As specified in TS 36.521-3 [25] clause A.7.1.
<i>mPDCCH-startSF-UESS</i>		10	10	Parameter G in $T = r_{\max} \cdot G$ which determines subframe $k0$ in which MPDCCH starts
Reference cell		Cell 1		
Neighbour cell		Cell 2		
E-UTRA RF Channel Number		1		One carrier frequency is used.
System channel Bandwidth (BW_{channel})	MHz	10	10	
PRS Transmission Bandwidth ^{Note 2}	RB	50 ^{Note 4}	50 ^{Note 4}	PRS bandwidth is as indicated in <i>prs-Bandwidth</i> in the OTDOA assistance data defined in TS 36.355 [4].
Number of consecutive positioning downlink subframes N_{PRS} ^{Note 2}		4	2	As defined in TS 36.211 [26]
<i>prs-MutingInfo</i> ^{Note 2}		Cell 1: '11110000' Cell 2: '11110000'		See section 6.5.1.2 in 3GPP TS 36.355 [4] for more information

Cell ID ^{Note 2}		(Cell ID of cell 1 – Cell ID of cell 2) mod 6 = 0	(Cell ID of cell 1 – Cell ID of cell 2) mod 6 = 0	
prs-SubframeOffset		10	10	Number of subframes rounded to the closest integer. The corresponding parameter in the OTDOA assistance data is prs-SubframeOffset specified in TS 36.355 [4]
slotNumberOffset		0	0	The slot number offset at the transmitter between a neighbour cell and the assistance data reference cell specified in TS 36.355 [4]
Expected RSTD ^{Note 1}	µs	Cell 2: 1 Other neighbour cells: randomly between -3 and 3	Cell 2: -1 Other neighbour cells: randomly between -3 and 3	
Expected RSTD uncertainty for all neighbour cells ^{Note 1}	µs	5	5	
CP length ^{Note 2}		Normal		
DRX		OFF		
Radio frame receive time offset between the cells at the UE antenna connector ^{Note 3}	µs	Cell 2 to Cell 1: -3	Cell 2 to Cell 1: 3	PRS are transmitted from synchronous cells
Number of cells provided in OTDOA assistance data		16		The number of cells includes the reference cell
$T_{\text{RSTD InterFreqHD-FDD, E-UTRAN}}$ ^{Note 5}	ms	40960	10240	Derived according to the RSTD measurement requirements specified in section 9.4.10.2.3
<p>NOTE 1: Parameters “Expected RSTD” and “Expected RSTD uncertainty for all neighbour cells” are not settable parameters. These are parameters signalled in LPP only. For the values to be used in LPP see Table 9.4.10.1.4.3-4 and TS 37.571-5 [20], clause 7.2.5.</p> <p>NOTE 2: Parameters “PRS Transmission Bandwidth”, “PRS configuration index”, “Number of consecutive positioning downlink subframes”, “prs-MutingInfo”, “Cell ID” and “CP length” are settable parameters and also parameters signalled in LPP. The values to be used for “Cell ID” are as follows: Cell 1: 0, Cell 2: Test 1: 6, Test 2: 7, Test 3: 6, Test 4: 9. For all the values to be used in LPP see Table 9.4.10.1.4.3-4 and TS 37.571-5 [20], clause 7.2.5.</p> <p>NOTE 3: The parameter “Radio frame receive time offset between the cells at the UE antenna connector” is not a settable parameter but is used to set the “true RSTD” values in step 6 of clause 9.1.3.4.1.</p> <p>NOTE 4: If the PRS transmission bandwidth is larger than the UE RF bandwidth, the UE is measuring RSTD within its RF bandwidth.</p> <p>NOTE 5: The parameter “$T_{\text{RSTD InterFreqHD-FDD, E-UTRAN}}$” is not a settable parameter but is used to set the LPP “time” value in Table 9.4.10.1.4.3-3. The value of the LPP time IE is set to $T_{\text{RSTD InterFreqHD-FDD, E-UTRAN}} + \Delta T$ ms, where $\Delta T = 150$ ms, giving a value of 41210 ms for Test and 10390 ms for Test 2. This is rounded up to the next allowed LPP value of 42 and 11 seconds, respectively.</p>				

9.4.11.2.4.2 Test procedure

Same as in clause 9.4.7.1.4.2 but using condition CEModeB.

9.4.11.2.4.3 Message contents

Same as in clause 9.4.10.2.4.3.

9.4.11.2.5 Test requirement

Same as in clause 9.4.10.2.5.

For the overall test to pass, the ratio of successful reported values in each sub-test shall be more than 90% with a confidence level of 95%.

9.4.12 TDD inter-frequency RSTD Measurement Accuracy in CE Mode B

9.4.12.1 TDD inter-frequency RSTD Measurement Accuracy in CE Mode B for Category M1

Editor's note: This test is incomplete. The following aspects are missing:

The core requirements in TS 36.133 contain square brackets

9.4.12.1.1 Test purpose

To verify that the RSTD measurement accuracy for UE Category M1 is within the specified limits in enhanced coverage mode in an environment with fading propagation conditions.

9.4.12.1.2 Test applicability

This test applies to E-UTRA TDD UE Category M1 release 14 and forward that supports UE-assisted OTDOA, inter-frequency RSTD measurements and CE Mode B.

9.4.12.1.3 Minimum conformance requirements

Same as in clause 9.4.10.1.3.

The normative reference for this requirement is TS 36.133 [23] clause 9.1.21.18 and A.9.8.31.

9.4.12.1.4 Test description

9.4.12.1.4.1 Initial conditions

Same as in clause 9.4.10.1.4.1 but replacing Table 9.4.10.1.4.1-1 with Table 9.4.12.1.4.1-1

Table 9.4.12.1.4.1-1: General test parameters for E-UTRAN TDD inter-frequency RSTD measurement Accuracy under fading propagation conditions

Parameter	Unit	Value	Comment
		Test 1	
MPDCCH		R.16 TDD	As specified in TS 36.521-3 [25] clause A.7.3
<i>mPDCCH-startSF-UeSS</i>		10	Parameter G in $T = r_{\max} \cdot G$ which determines subframe $k0$ in which MPDCCH starts
Reference cell		Cell 1	Reference cell is the cell in the OTDOA assistance data with respect to which the RSTD measurement is defined, as specified in 3GPP TS 36.214 [6] and 3GPP TS 36.355 [4]. The reference cell is the serving cell in this test case.
Neighbour cell		Cell 2	One carrier frequency is used.
E-UTRA RF Channel Number		1	
Channel Bandwidth (BW_{channel})	MHz	10	
PRS Transmission Bandwidth ^{Note 2}	RB	50 ^{Note 4}	PRS are transmitted over the system bandwidth
Number of consecutive downlink positioning subframes N_{PRS} ^{Note 2}		4	As defined in 3GPP TS 36.211 [26]. The number of subframes in a positioning occasion
PRS muting info ^{Note 2}		Cell 1: '11110000' Cell 2: '11110000'	Corresponds to prs-MutingInfo defined in TS 36.355 [4]

Physical cell ID PCI ^{Note 2}		(Cell ID of cell 1 – Cell ID of cell 2) mod 6 = 0	
prs-SubframeOffset		10	Number of subframes rounded to the closest integer. The corresponding parameter in the OTDOA assistance data is prs-SubframeOffset specified in TS 36.355 [4]
slotNumberOffset		0	The slot number offset at the transmitter between a neighbour cell and the assistance data reference cell specified in TS 36.355 [4]
Expected RSTD ^{Note 1}	μs	Cell 2: 1 Other neighbour cells: randomly between -3 and 3	The expected RSTD is what is expected at the receiver. The corresponding parameter in the OTDOA assistance data specified in TS 36.355 [4] is the expectedRSTD indicator
Expected RSTD uncertainty for all neighbour cells ^{Note 1}	μs	5	The corresponding parameter in the OTDOA assistance data specified in TS 36.355 [4] is the expectedRSTD-Uncertainty index
TDD uplink-downlink configuration		1	As specified in TS 36.211 [26], Clause 4.2; corresponds to a configuration with 5 ms switch-point periodicity and two downlink consecutive subframes
TDD special subframe configuration		6	As specified in TS 36.211 [26], Clause 4.2; corresponds to DwPTS of $19760 \cdot T_s$ and UpPTS of $4384 \cdot T_s$
CP length ^{Note 2}		Normal	
DRX		OFF	
Radio frame receive time offset between the cells at the UE antenna connector ^{Note 3}	μs	Cell 2 to Cell 1: -3	PRS are transmitted from synchronous cells
Number of cells provided in OTDOA assistance data		16	Including the reference cell
$T_{\text{RSTD InterFreqTDD, E-UTRAN}}$	ms	40960	Derived according to the RSTD measurement requirements specified in section 9.4.10.1.3
<p>Note 1: Parameters “Expected RSTD” and “Expected RSTD uncertainty for all neighbour cells” are not settable parameters. These are parameters signalled in LPP only. For the values to be used in LPP see Table 9.4.10.1.4.3-5 and TS 37.571-5 [20], clause 7.2.5.</p> <p>Note 2: Parameters “PRS Transmission Bandwidth”, “PRS configuration index”, “Number of consecutive positioning downlink subframes”, “prs-MutingInfo”, “Cell ID” and “CP length” are settable parameters and also parameters signalled in LPP. The values to be used for “Cell ID” are as follows: Cell 1: 0, Cell 2: Test 1: 6, Test 2: 7, Test 3: 6, Test 4: 9. For all the values to be used in LPP see Table 9.4.10.1.4.3-4 and TS 37.571-5 [20], clause 7.2.5.</p> <p>Note 3: The parameter “Radio frame receive time offset between the cells at the UE antenna connector” is not a settable parameter but is used to set the “true RSTD” values in step 6 of clause 9.4.10.1.4.1.</p> <p>Note 4: If the PRS transmission bandwidth is larger than the UE RF bandwidth, the UE is measuring RSTD within its RF bandwidth.</p> <p>Note 5: The parameter “$T_{\text{RSTD InterFreqTDD, E-UTRAN}}$” is not a settable parameter but is used to set the LPP “time” value in Table 9.4.10.1.4.3-3. The value of the LPP time IE is set to $T_{\text{RSTD InterFreqTDD, E-UTRAN}} + \Delta T$ ms, where $\Delta T = 150$ ms, giving a value of 41210 ms. This is rounded up to the next allowed LPP value of 42 seconds.</p>			

9.4.12.1.4.2 Test procedure

Same as in clause 9.4.7.1.4.2 but using condition CEModeB.

9.4.12.1.4.3 Message contents

Same as in clause 9.4.10.1.4.3.

9.4.12.1.5 Test requirement

Table 9.4.12.1.5-1 defines the primary level settings including test tolerances for the test.

The RSTD TDD inter-frequency accuracy test shall meet the reported values in Table 9.4.12.1.5-2

Table 9.4.12.1.5-1: Cell Specific Test Parameters for inter frequency RSTD Tests for E-UTRAN TDD

Parameter	Unit	Test1		Test2 ^{Note4}	
		Cell1	Cell2	Cell1	Cell2
E-UTRA RF Channel Number		1	2	1	2
Gap offset		9	N/A	9	N/A
Gap pattern		#0	N/A	#0	N/A
OCNG Patterns defined in TS 36.521-3 [25] clause D.1		OP.11 TDD	OP.2 TDD	OP.11 TDD	OP.2 TDD
PRS configuration Index I_{PRS} , as defined in TS 36.211 [26]		140	150	140	150
PBCH_RA	dB	0	0	0	0
PBCH_RB					
PSS_RA					
SSS_RA					
MPDCCH_RA					
MPDCCH_RB					
OCNG_RA ^{Note1}					
OCNG_RB ^{Note1}					
PRS_RA	dB	0	0	0	0
N_{oc} ^{Note2}	dBm/15 kHz	-98	-98	-98	-98
PRS \hat{E}_s/N_{oc}	dB	-11	-14	-11	-14
PRS \hat{E}_s/I_{ot} ^{Note3}	dB	-11	-14	-11	-14
I_o ^{Note3}	dBm/9 MHz	-70.16	-70.19	-70.16	-70.19
PRP ^{Note3}	dBm/15kHz	-109	-112	-109	-112
\hat{E}_s/N_{oc} ^{Note 3}	dB	-11	-14	-11	-14
RSRP ^{Note 3}	dBm/15kHz	-109	-112	-109	-112
Propagation condition		AWGN			
<p>Note 1: OCNG shall be used such that both cells are fully allocated and a constant total transmitted power spectral density is achieved for all OFDM symbols (other than those in the PRS subframes).</p> <p>Note 2: Interference from other cells and noise sources not specified in the test is assumed to be constant over subcarriers and time and shall be modelled as AWGN of appropriate power for N_{oc} to be fulfilled.</p> <p>Note 3: \hat{E}_s/N_{oc}, PRS \hat{E}_s/I_{ot}, I_o, RSRP and PRP levels have been derived from other parameters for information purposes. They are not settable parameters themselves. I_o values are derived in the case that there is no PBCH, PSS or SSS in the OFDM symbols carrying PRS</p> <p>Note 4: Test2 is not used for test 9.4.12.1</p>					

Table 9.4.12.1.5-2: RSTD TDD inter-frequency accuracy requirements for the reported values

	Test 1
Lowest reported value	[RSTD_6241]
Highest reported value	[RSTD_6287]

The test tolerances are defined in clauses C.1.3 and C4.

For the overall test to pass, the ratio of successful reported values in each sub-test shall be more than 90% with a confidence level of 95%.

9.4.12.2 TDD inter-frequency RSTD Measurement Accuracy in CE Mode B for Category M2

9.4.12.2.1 Test purpose

To verify that the RSTD measurement accuracy for UE Category M2 is within the specified limits in enhanced coverage mode in an environment with fading propagation conditions.

9.4.12.2.2 Test applicability

This test applies to E-UTRA TDD UE Category M2 release 14 and forward that supports UE-assisted OTDOA, inter-frequency RSTD measurements and CE Mode B.

9.4.12.2.3 Minimum conformance requirements

Same as in clause 9.4.20.1.3.

The normative reference for this requirement is TS 36.133 [23] clause 9.1.25.2 and A.9.8.31.

9.4.12.2.4 Test description

9.4.12.2.4.1 Initial conditions

Same as in clause 9.4.10.2.4.1 but replacing Table 9.4.10.2.4.1-1 with Table 9.4.12.2.4.1-1.

Table 9.4.12.2.4.1-1: General test parameters for E-UTRAN TDD inter-frequency RSTD measurement Accuracy under fading propagation conditions

Parameter	Unit	Value		Comment
		Test1	Test2	
M-PDCCH parameters		R.16 TDD	R.16 TDD	As specified in TS 36.521-3 [25] clause A.7.3.
<i>mPDCCH-startSF-UESS</i>		10	10	Parameter G in $T = r_{\max} \cdot G$ which determines subframe $k0$ in which MPDCCH starts
Reference cell		Cell 1		
Neighbour cell		Cell 2		
E-UTRA RF Channel Number		1		One carrier frequency is used.
System channel Bandwidth (BW_{channel})	MHz	10	10	
PRS Transmission Bandwidth ^{Note 2}	RB	50 ^{Note 4}	50 ^{Note 4}	PRS bandwidth is as indicated in <i>prs-Bandwidth</i> in the OTDOA assistance data defined in TS 36.355 [4].
Number of consecutive positioning downlink subframes N_{PRS} ^{Note 2}		4	2	As defined in TS 36.211 [26]
<i>prs-MutingInfo</i> ^{Note 2}		Cell 1: '11110000' Cell 2: '11110000'		See section 6.5.1.2 in 3GPP TS 36.355 [4] for more information
Cell ID ^{Note 2}		(Cell ID of cell 1 – Cell ID of cell 2) mod 6 = 0	(Cell ID of cell 1 – Cell ID of cell 2) mod 6 = 0	
<i>prs-SubframeOffset</i>		10	10	Number of subframes rounded to the closest integer. The corresponding parameter in the OTDOA assistance data is <i>prs-SubframeOffset</i> specified in TS 36.355 [4]
<i>slotNumberOffset</i>		0	0	The slot number offset at the transmitter between a neighbour cell and the assistance data reference cell specified in TS 36.355 [4]

Expected RSTD ^{Note 1}	μs	Cell 2: 1 Other neighbour cells: randomly between -3 and 3	Cell 2: -1 Other neighbour cells: randomly between -3 and 3	
Expected RSTD uncertainty for all neighbour cells ^{Note 1}	μs	5	5	
TDD uplink-downlink configuration		1		As specified in TS 36.211 [26], Clause 4.2; corresponds to a configuration with 5 ms switch-point periodicity and two downlink consecutive subframes
TDD special subframe configuration		6		As specified in TS 36.211 [26], Clause 4.2; corresponds to DwPTS of $19760 \cdot T_s$ and UpPTS of $4384 \cdot T_s$
CP length ^{Note 2}		Normal		
DRX		OFF		
Radio frame receive time offset between the cells at the UE antenna connector ^{Note 3}	μs	Cell 2 to Cell 1: -3	Cell 2 to Cell 1: 3	PRS are transmitted from synchronous cells
Number of cells provided in OTDOA assistance data		16		The number of cells includes the reference cell
$T_{RSTD \text{ InterFreqTDD, E-UTRAN}}$ ^{Note 5}	ms	40960	10240	Derived according to the RSTD measurement requirements specified in section 9.4.10.2.3
<p>NOTE 1: Parameters “Expected RSTD” and “Expected RSTD uncertainty for all neighbour cells” are not settable parameters. These are parameters signalled in LPP only. For the values to be used in LPP see Table 9.4.10.1.4.3-4 and TS 37.571-5 [20], clause 7.2.5.</p> <p>NOTE 2: Parameters “PRS Transmission Bandwidth”, “PRS configuration index”, “Number of consecutive positioning downlink subframes”, “prs-MutingInfo”, “Cell ID” and “CP length” are settable parameters and also parameters signalled in LPP. The values to be used for “Cell ID” are as follows: Cell 1: 0, Cell 2: Test 1: 6, Test 2: 7, Test 3: 6, Test 4: 9. For all the values to be used in LPP see Table 9.4.10.1.4.3-4 and TS 37.571-5 [20], clause 7.2.5.</p> <p>NOTE 3: The parameter “Radio frame receive time offset between the cells at the UE antenna connector” is not a settable parameter but is used to set the “true RSTD” values in step 6 of clause 9.1.3.4.1.</p> <p>NOTE 4: If the PRS transmission bandwidth is larger than the UE RF bandwidth, the UE is measuring RSTD within its RF bandwidth.</p> <p>NOTE 5: The parameter “$T_{RSTD \text{ InterFreqTDD, E-UTRAN}}$” is not a settable parameter but is used to set the LPP “time” value in Table 9.4.10.2.4.3-1. The value of the LPP time IE is set to $T_{RSTD \text{ InterFreqTDD, E-UTRAN}} + \Delta T$ ms, where $\Delta T = 150$ ms, giving a value of 41210 ms for Test and 10390 ms for Test 2. This is rounded up to the next allowed LPP value of 42 and 11 seconds, respectively.</p>				

9.4.12.2.4.2 Test procedure

Same as in clause 9.4.7.1.4.2 but using condition CEModeB.

9.4.12.2.4.3 Message contents

Same as in clause 9.4.10.1.4.3.

9.4.12.2.5 Test requirement

Same as in clause 9.4.12.1.5 adding Test 2 and replacing Table 9.4.12.1.5-2 with Table 9.4.12.2.5-1:

Table 9.4.12.2.5-1: RSTD TDD inter-frequency accuracy requirements for the reported values

	Test 1	Test 2
Lowest reported value	RSTD_6252	RSTD_6435
Highest reported value	RSTD_6276	RSTD_6459

For the overall test to pass, the ratio of successful reported values in each sub-test shall be more than 90% with a confidence level of 95%.

9.4.13 E-UTRAN FDD inter-frequency RSTD measurement period test case in CE Mode A with longer PRS occasions

9.4.13.1 Test purpose

To verify that the RSTD measurement reporting delay with longer PRS occasions for UE Category M1 and M2 meets the performance requirements in normal coverage mode in an environment with fading propagation conditions.

9.4.13.2 Test applicability

This test applies to E-UTRA FDD UE Category M1 and M2 release 15 and forward that supports UE-assisted OTDOA, inter-frequency RSTD measurements and dense PRS configuration or additional PRS configuration.

9.4.13.3 Minimum conformance requirements

Same as in clause 9.4.1.1.3

The normative reference for this requirement is TS 36.133 [23] clause 8.13.2.4.1, 8.16.2.1.1 and A.8.13.9.

9.4.13.4 Test description

9.4.13.4.1 Initial conditions

Test Environment: Normal; as defined in TS 36.508 [18] clause 4.1.

Frequencies to be tested: Mid Range, as defined in TS 36.508 [18] clause 4.3.1.1.

Channel bandwidth to be tested: 10 MHz as defined in TS 36.508 [18] clause 4.3.1.

1. Connect the SS, faders and AWGN noise sources to the UE antenna connector or antenna connectors as shown in Annex A, Figure A.4 using only the main Tx/Rx antenna of the UE.
2. The general test parameter settings are set up according to Table 9.4.13.4.1-1.
3. Propagation conditions are set according to clause 4.7.2.1.
4. Message contents are defined in clause 9.4.13.4.3.
5. In the test there are three synchronized cells: Cell 1, Cell 2 and Cell 3. Cell 1 is the OTDOA assistance data reference as well as the serving cell. Cell 2 and Cell 3 are the neighbour cells. Cell 1 is on RF channel 1. Cell 2 and Cell 3 are on RF channel 2. Cell 3 in the test is the Cell 4 defined in clause 4.7.1. The assistance data neighbour cell list includes in total 15 cells, where 13 of the cells are not simulated (dummy cells; as defined in 3GPP TS 37.571-5 clause 7.2.5).
6. The true RSTD (which is the receive time difference for frame 0 between two cells as seen at the UE antenna connector) is set to 31 Ts (about 1 μ s) between neighbour Cell 2 and serving Cell 1; and set to -31 Ts (about -1 μ s) between neighbour Cell 3 and serving Cell 1.

Table 9.4.13.4.1-1: General test parameters

Parameter	Unit	Value	Comment
Reference cell		Cell 1	Reference cell is the cell in the OTDOA assistance data with respect to which the RSTD measurement is defined, as specified in 3GPP TS 36.214 [6] and 3GPP TS 36.355 [4]. The reference cell is the serving cell in this test case.

Neighbour cells		Cell 2 and Cell 3	Cell 2 and Cell 3 appear at random places in the neighbour cell list in the OTDOA assistance data, but Cell 2 always appears in the first half of the list, whilst Cell 3 appears in the second half of the list.
MPDCCH		DL Reference Measurement Channel R.16 FDD	As specified in TS 36.521-3 [25] clause A.7.1
<i>mPDCCH-startSF-U ESS</i>		10	Parameter G in $T = r_{\max} \cdot G$ which determines subframe $k0$ in which MPDCCH starts
Channel Bandwidth (BW_{channel})	MHz	10	
PRS Transmission Bandwidth	RB	50	PRS are transmitted over the system bandwidth
PRS configuration index I_{PRS} ^{Note 2}		Cell 1: 232, Cell 2, Cell 3: 252	This corresponds to periodicity of 320 ms and PRS subframe offset of $I_{\text{PRS}} - 160$ DL subframes, as defined in 3GPP TS 36.211 [26], Table 6.10.4.3-1
Gap pattern Id		rstd6	As specified in TS 36.133 [23] Table 8.1.2.1-3. Applies for measurements on Cell 1, Cell 2, and Cell 3
Gap offset		91	As specified in TS 36.331 [22], Clause 6.3.5
Number of consecutive downlink positioning subframes N_{PRS} ^{Note 2}		12	As defined in 3GPP TS 36.211 [26]. The number of subframes in a positioning occasion. Corresponds to parameter <i>add-numDL-Frames</i> in TS 36.355 [4], for UE with <i>additional-prs-config</i> capability
		20	As defined in 3GPP TS 36.211 [26]. The number of subframes in a positioning occasion. Corresponds to parameter <i>add-numDL-Frames</i> in TS 36.355 [4], for UE with <i>densePrsConfig</i> capability
Physical cell ID PCI ^{Note 2}		(PCI of Cell 1 – PCI of Cell 2) mod 6 = 0 and (PCI of Cell 1 – PCI of Cell 3) mod 6 = 0	The cell PCIs are selected such that the relative shifts of PRS patterns among cells are as given by the test parameters
CP length ^{Note 2}		Normal	
DRX		ON	DRX parameters are further specified in Table 9.4.13.4.1-2
prs-SubframeOffset		20	Number of subframes rounded to the closest integer. The corresponding parameter in the OTDOA assistance data is prs-SubframeOffset specified in TS 36.355 [4]
slotNumberOffset		0	The slot number offset at the transmitter between a neighbour cell and the assistance data reference cell specified in TS 36.355 [4]
Radio frame receive time offset between the cells at the UE antenna connector ^{Note 3}	µs	Cell 2 to Cell 1: 1 Cell 3 to Cell 1: -1	PRS are transmitted from synchronous cells

Expected RSTD ^{Note 1}	µs	Cell 2: -2 Cell 3: 2 Other neighbour cells: randomly between -3 and 3	The expected RSTD is what is expected at the receiver. The corresponding parameter in the OTDOA assistance data specified in TS 36.355 [4] is the expectedRSTD indicator
Expected RSTD uncertainty for all neighbour cells ^{Note 1}	µs	5	The corresponding parameter in the OTDOA assistance data specified in TS 36.355 [4] is the expectedRSTD-Uncertainty index
Number of cells provided in OTDOA assistance data		16	Including the reference cell
PRS muting info ^{Note 2}		Cell 1: '1111111100000000' Cell 2: '0000000011111111' Cell 3: '1111111100000000'	Corresponds to prs-MutingInfo defined in TS 36.355 [4]
T1	s	3	The length of the time interval from the beginning of each test
T2	s	2.56	The length of the time interval that follows immediately after time interval T1
T3	s	2.56	The length of the time interval that follows immediately after time interval T2
<p>Note 1: Parameters "Expected RSTD" and "Expected RSTD uncertainty for all neighbour cells" are not settable parameters. These are parameters signalled in LPP only. For the values to be used in LPP see Table 9.4.13.4.3-5 and TS 37.571-5 [20], clause 7.2.5.</p> <p>Note 2: Parameters "PRS Transmission Bandwidth", "PRS configuration index", "Number of consecutive downlink positioning subframes", "Physical cell ID PCI", "CP length", and "PRS muting info" are settable parameters and also parameters signalled in LPP. The values to be used for "Physical cell ID PCI" are as follows: Cell 1: 0, Cell 2: 6, Cell 3: 12. For all the values to be used in LPP see Table 9.4.13.4.3-5 and TS 37.571-5 [20], clause 7.2.5.</p> <p>Note 3: The parameter "Radio frame receive time offset between the cells at the UE antenna connector" is not a settable parameter but is used to set the "true RSTD" values in step 6 of clause 9.4.13.4.1.</p> <p>Note 4: If the PRS transmission bandwidth is larger than the UE RF bandwidth, the UE is measuring RSTD within its RF bandwidth.</p>			

Table 9.4.13.4.1-2: DRX parameters

Field	Value	Comment
onDurationTimer	psf1	As specified in 3GPP TS 36.331 [22], clause 6.3.2
drx-InactivityTimer	psf1	
drx-RetransmissionTimer	sf1	
longDRX-CycleStartOffset	sf320	
shortDRX	Disable	

9.4.13.4.2 Test procedure

Same as in clause 9.4.1.1.4.2.

9.4.13.4.3 Message contents

Same as in clause 9.4.1.1.4.3 with the following exceptions:

Table 9.4.13.4.3-1: LPP RequestLocationInformation

Derivation Path: Table 9.3.1.1.4.3-4			
Information Element	Value/remark	Comment	Condition
LPP-Message ::= SEQUENCE {			
lpp-MessageBody CHOICE {			
c1 CHOICE {			
requestLocationInformation SEQUENCE {			
criticalExtensions CHOICE {			
c1 CHOICE {			

9.4.14.4 Test description

9.4.14.4.1 Initial conditions

Same as in clause 9.4.13.4.1 but replacing Table 9.4.13.4.1-1 with Table 9.4.14.4.1-1.

Table 9.4.14.4.1-1: General test parameters

Parameter	Unit	Value	Comment
Reference cell		Cell 1	Reference cell is the cell in the OTDOA assistance data with respect to which the RSTD measurement is defined, as specified in 3GPP TS 36.214 [6] and 3GPP TS 36.355 [4]. The reference cell is the serving cell in this test case.
Neighbour cells		Cell 2 and Cell 3	Cell 2 and Cell 3 appear at random places in the neighbour cell list in the OTDOA assistance data, but Cell 2 always appears in the first half of the list, whilst Cell 3 appears in the second half of the list.
MPDCCH		DL Reference Measurement Channel R.6 HD-FDD	As specified in TS 36.521-3 [25] clause A.7.1
<i>mPDCCH-startSF-U ESS</i>		10	Parameter G in $T = r_{\max} \cdot G$ which determines subframe $k0$ in which MPDCCH starts
Channel Bandwidth (BW_{channel})	MHz	10	
PRS Transmission Bandwidth	RB	50	PRS are transmitted over the system bandwidth
PRS configuration index I_{PRS} ^{Note 2}		Cell 1: 232, Cell 2, Cell 3: 252	This corresponds to periodicity of 320 ms and PRS subframe offset of $I_{\text{PRS}} - 160$ DL subframes, as defined in 3GPP TS 36.211 [26], Table 6.10.4.3-1
Gap pattern Id		rstd6	As specified in TS 36.133 [23] Table 8.1.2.1-3. Applies for measurements on Cell 1, Cell 2, and Cell 3
Gap offset		91	As specified in TS 36.331 [22], Clause 6.3.5
Number of consecutive downlink positioning subframes N_{PRS} ^{Note 2}		12	As defined in 3GPP TS 36.211 [26]. The number of subframes in a positioning occasion. Corresponds to parameter <i>add-numDL-Frames</i> in TS 36.355 [4], for UE with <i>additional-prs-config</i> capability
		20	As defined in 3GPP TS 36.211 [26]. The number of subframes in a positioning occasion. Corresponds to parameter <i>add-numDL-Frames</i> in TS 36.355 [4], for UE with <i>densePrsConfig</i> capability
Physical cell ID PCI ^{Note 2}		(PCI of Cell 1 – PCI of Cell 2) mod 6 = 0 and (PCI of Cell 1 – PCI of Cell 3) mod 6 = 0	The cell PCIs are selected such that the relative shifts of PRS patterns among cells are as given by the test parameters
CP length ^{Note 2}		Normal	
DRX		ON	DRX parameters are further specified in Table 9.4.14.4.1-2

prs-SubframeOffset		20	Number of subframes rounded to the closest integer. The corresponding parameter in the OTDOA assistance data is prs-SubframeOffset specified in TS 36.355 [4]
slotNumberOffset		0	The slot number offset at the transmitter between a neighbour cell and the assistance data reference cell specified in TS 36.355 [4]
Radio frame receive time offset between the cells at the UE antenna connector Note 3	μs	Cell 2 to Cell 1: 1 Cell 3 to Cell 1: -1	PRS are transmitted from synchronous cells
Expected RSTD Note 1	μs	Cell 2: -2 Cell 3: 2 Other neighbour cells: randomly between -3 and 3	The expected RSTD is what is expected at the receiver. The corresponding parameter in the OTDOA assistance data specified in TS 36.355 [4] is the expectedRSTD indicator
Expected RSTD uncertainty for all neighbour cells Note 1	μs	5	The corresponding parameter in the OTDOA assistance data specified in TS 36.355 [4] is the expectedRSTD-Uncertainty index
Number of cells provided in OTDOA assistance data		16	Including the reference cell
PRS muting info Note 2		Cell 1: '1111111100000000' Cell 2: '0000000011111111' Cell 3: '1111111100000000'	Corresponds to prs-MutingInfo defined in TS 36.355 [4]
T1	s	3	The length of the time interval from the beginning of each test
T2	s	2.56	The length of the time interval that follows immediately after time interval T1
T3	s	2.56	The length of the time interval that follows immediately after time interval T2
<p>Note 1: Parameters "Expected RSTD" and "Expected RSTD uncertainty for all neighbour cells" are not settable parameters. These are parameters signalled in LPP only. For the values to be used in LPP see Table 9.4.14.4.3-5 and TS 37.571-5 [20], clause 7.2.5.</p> <p>Note 2: Parameters "PRS Transmission Bandwidth", "PRS configuration index", "Number of consecutive downlink positioning subframes", "Physical cell ID PCI", "CP length", and "PRS muting info" are settable parameters and also parameters signalled in LPP. The values to be used for "Physical cell ID PCI" are as follows: Cell 1: 0, Cell 2: 6, Cell 3: 12. For all the values to be used in LPP see Table 9.4.14.4.3-5 and TS 37.571-5 [20], clause 7.2.5.</p> <p>Note 3: The parameter "Radio frame receive time offset between the cells at the UE antenna connector" is not a settable parameter but is used to set the "true RSTD" values in step 6 of clause 9.4.14.4.1.</p> <p>Note 4: If the PRS transmission bandwidth is larger than the UE RF bandwidth, the UE is measuring RSTD within its RF bandwidth.</p>			

9.4.14.4.2 Test procedure

Same as in clause 9.4.1.1.4.2.

9.4.14.4.3 Message contents

Same as in clause 9.4.13.4.3.

9.4.14.5 Test requirement

Same as in clause 9.4.13.5.

9.4.15 E-UTRAN TDD inter-frequency RSTD measurement period test case in CE Mode A with longer PRS occasions

9.4.15.1 Test purpose

To verify that the RSTD measurement reporting delay with longer PRS occasions for UE Category M1 and M2 meets the performance requirements in normal coverage mode in an environment with fading propagation conditions.

9.4.15.2 Test applicability

This test applies to E-UTRA TDD UE Category M1 and M2 release 15 and forward that supports UE-assisted OTDOA, inter-frequency RSTD measurements and dense PRS configuration or additional PRS configuration.

9.4.15.3 Minimum conformance requirements

Same as in clause 9.4.3.1.3

The normative reference for this requirement is TS 36.133 [23] clause 8.13.2.4.2, 8.16.2.1.2 and A.8.13.11.

9.4.15.4 Test description

9.4.15.4.1 Initial conditions

Same as in clause 9.4.13.4.1 but replacing Table 9.4.13.4.1-1 with Table 9.4.15.4.1-1.

Table 9.4.15.4.1-1: General test parameters

Parameter	Unit	Value	Comment
Reference cell		Cell 1	Reference cell is the cell in the OTDOA assistance data with respect to which the RSTD measurement is defined, as specified in 3GPP TS 36.214 [6] and 3GPP TS 36.355 [4]. The reference cell is the serving cell in this test case.
Neighbour cells		Cell 2 and Cell 3	Cell 2 and Cell 3 appear at random places in the neighbour cell list in the OTDOA assistance data, but Cell 2 always appears in the first half of the list, whilst Cell 3 appears in the second half of the list.
MPDCCH		DL Reference Measurement Channel R.14 TDD	As specified in TS 36.521-3 [25] clause A.7.1
$mPDCCH\text{-startSF}\text{-UESS}$		10	Parameter G in $T = r_{\max} \cdot G$ which determines subframe $k0$ in which MPDCCH starts
Channel Bandwidth (BW_{channel})	MHz	10	
PRS Transmission Bandwidth	RB	50	PRS are transmitted over the system bandwidth
PRS configuration index I_{PRS} ^{Note 2}		Cell 1: 212, Cell 2, Cell 3: 252	This corresponds to periodicity of 320 ms and PRS subframe offset of $I_{\text{PRS}} - 160$ DL subframes, as defined in 3GPP TS 36.211 [26], Table 6.10.4.3-1
Gap pattern Id		rstd12	As specified in TS 36.133 [23] Table 8.1.2.1-3. Applies for measurements on Cell 1, Cell 2, and Cell 3

Gap offset		91	As specified in TS 36.331 [22], Clause 6.3.5
Number of consecutive downlink positioning subframes N_{PRS} ^{Note 2}		12	As defined in 3GPP TS 36.211 [26]. The number of subframes in a positioning occasion. Corresponds to parameter <i>add-numDL-Frames</i> in TS 36.355 [4], for UE with <i>additional-prs-config</i> capability
		20	As defined in 3GPP TS 36.211 [26]. The number of subframes in a positioning occasion. Corresponds to parameter <i>add-numDL-Frames</i> in TS 36.355 [4], for UE with <i>densePrsConfig</i> capability
Physical cell ID PCI ^{Note 2}		(PCI of Cell 1 – PCI of Cell 2) mod 6 = 0 and (PCI of Cell 1 – PCI of Cell 3) mod 6 = 0	The cell PCIs are selected such that the relative shifts of PRS patterns among cells are as given by the test parameters
CP length ^{Note 2}		Normal	
TDD uplink-downlink configuration		1	As specified in TS 36.211 [26], Clause 4.2; corresponds to a configuration with 5 ms switch-point periodicity and two downlink consecutive subframes
TDD special subframe configuration		6	As specified in TS 36.211 [26], Clause 4.2; corresponds to DwPTS of $19760 \cdot T_s$ and UpPTS of $4384 \cdot T_s$
DRX		ON	DRX parameters are further specified in Table 9.4.15.4.1-2
prs-SubframeOffset		40	Number of subframes rounded to the closest integer. The corresponding parameter in the OTDOA assistance data is prs-SubframeOffset specified in TS 36.355 [4]
slotNumberOffset		0	The slot number offset at the transmitter between a neighbour cell and the assistance data reference cell specified in TS 36.355 [4]
Radio frame receive time offset between the cells at the UE antenna connector ^{Note 3}	μs	Cell 2 to Cell 1: 1 Cell 3 to Cell 1: -1	PRS are transmitted from synchronous cells
Expected RSTD ^{Note 1}	μs	Cell 2: -2 Cell 3: 2 Other neighbour cells: randomly between -3 and 3	The expected RSTD is what is expected at the receiver. The corresponding parameter in the OTDOA assistance data specified in TS 36.355 [4] is the expectedRSTD indicator
Expected RSTD uncertainty for all neighbour cells ^{Note 1}	μs	5	The corresponding parameter in the OTDOA assistance data specified in TS 36.355 [4] is the expectedRSTD-Uncertainty index
Number of cells provided in OTDOA assistance data		16	Including the reference cell
PRS muting info ^{Note 2}		Cell 1: '1111111100000000' Cell 2: '0000000011111111' Cell 3: '1111111100000000'	Corresponds to prs-MutingInfo defined in TS 36.355 [4]
T1	s	3	The length of the time interval from the beginning of each test
T2	s	2.56	The length of the time interval that follows immediately after time interval T1

T3	s	2.56	The length of the time interval that follows immediately after time interval T2
Note 1:	Parameters “Expected RSTD” and “Expected RSTD uncertainty for all neighbour cells” are not settable parameters. These are parameters signalled in LPP only. For the values to be used in LPP see Table 9.4.15.4.3-5 and TS 37.571-5 [20], clause 7.2.5.		
Note 2:	Parameters “PRS Transmission Bandwidth”, “PRS configuration index”, “Number of consecutive downlink positioning subframes”, “Physical cell ID PCI”, “CP length”, and “PRS muting info” are settable parameters and also parameters signalled in LPP. The values to be used for “Physical cell ID PCI” are as follows: Cell 1: 0, Cell 2: 6, Cell 3: 12. For all the values to be used in LPP see Table 9.4.15.4.3-5 and TS 37.571-5 [20], clause 7.2.5.		
Note 3:	The parameter “Radio frame receive time offset between the cells at the UE antenna connector” is not a settable parameter but is used to set the “true RSTD” values in step 6 of clause 9.4.15.4.1.		
Note 4:	If the PRS transmission bandwidth is larger than the UE RF bandwidth, the UE is measuring RSTD within its RF bandwidth.		

9.4.15.4.2 Test procedure

Same as in clause 9.4.1.1.4.2.

9.4.15.4.3 Message contents

Same as in clause 9.4.13.4.3.

9.4.15.5 Test requirement

Same as in clause 9.4.13.5.

9.4.16 E-UTRAN FDD inter-frequency RSTD measurement period test case in CE Mode B with longer PRS occasions

9.4.16.1 Test purpose

To verify that the RSTD measurement reporting delay with longer PRS occasions for UE Category M1 and M2 meets the performance requirements in normal coverage mode in an environment with fading propagation conditions.

9.4.16.2 Test applicability

This test applies to E-UTRA FDD UE Category M1 and M2 release 15 and forward that supports UE-assisted OTDOA, CE Mode B, inter-frequency RSTD measurements and dense PRS configuration or additional PRS configuration. Test 2 is applicable only to UE Category M2.

9.4.16.3 Minimum conformance requirements

Same as in clause 9.4.4.1.3

The normative reference for this requirement is TS 36.133 [23] clause 8.13.3.7.1, 8.16.3.2.1 and A.8.13.12.

9.4.16.4 Test description

9.4.16.4.1 Initial conditions

Same as in clause 9.4.13.4.1 but replacing Table 9.4.13.4.1-1 with Table 9.4.16.4.1-1.

Table 9.4.16.4.1-1: General test parameters

Parameter	Unit	Value		Comment
		Test 1	Test 2	

Reference cell		Cell 1	Reference cell is the cell in the OTDOA assistance data with respect to which the RSTD measurement is defined, as specified in 3GPP TS 36.214 [6] and 3GPP TS 36.355 [4]. The reference cell is the serving cell in this test case.	
Neighbour cells		Cell 2 and Cell 3	Cell 2 and Cell 3 appear at random places in the neighbour cell list in the OTDOA assistance data, but Cell 2 always appears in the first half of the list, whilst Cell 3 appears in the second half of the list.	
MPDCCH		DL Reference Measurement Channel R.18 FDD	As specified in TS 36.521-3 [25] clause A.7.1	
<i>mPDCCH-startSF-UeSS</i>		10	Parameter G in $T = r_{\max} \cdot G$ which determines subframe $k0$ in which MPDCCH starts	
Channel Bandwidth (BW _{channel})	MHz	10		
Gap pattern Id		rstd12	rstd2	As specified in TS 36.133 [23] Table 8.1.2.1-3. Applies for measurements on Cell 1, Cell 2, and Cell 3
Gap offset		151		As specified in TS 36.331 [22], Clause 6.3.5
PRS Transmission Bandwidth ^{Note 2}	RB	50		PRS are transmitted over the system bandwidth
PRS configuration index I_{PRS} ^{Note 2}		Cell 1: 232, Cell 2, Cell 3: 312		This corresponds to periodicity of 320 ms and PRS subframe offset of $I_{\text{PRS}} - 160$ DL subframes, as defined in 3GPP TS 36.211 [26], Table 6.10.4.3-1
Number of consecutive downlink positioning subframes N_{PRS} ^{Note 2}		30	8	As defined in 3GPP TS 36.211 [26]. The number of subframes in a positioning occasion. Corresponds to parameter <i>add-numDL-Frames</i> in TS 36.355 [4], for UE with <i>additional-prs-config</i> capability
		40	10	As defined in 3GPP TS 36.211 [26]. The number of subframes in a positioning occasion. Corresponds to parameter <i>add-numDL-Frames</i> in TS 36.355 [4], for UE with <i>densePrsConfig</i> capability
Physical cell ID PCI ^{Note 2}		(PCI of Cell 1 – PCI of Cell 2) mod 6 = 0 and (PCI of Cell 1 – PCI of Cell 3) mod 6 = 0		The cell PCIs are selected such that the relative shifts of PRS patterns among cells are as given by the test parameters
CP length ^{Note 2}		Normal		
DRX		ON		DRX parameters are further specified in Table 9.3.16.4.1-2
prs-SubframeOffset		80		Number of subframes rounded to the closest integer. The corresponding parameter in the OTDOA assistance data is prs-SubframeOffset specified in TS 36.355 [4]

slotNumberOffset		0	The slot number offset at the transmitter between a neighbour cell and the assistance data reference cell specified in TS 36.355 [4]
Radio frame receive time offset between the cells at the UE antenna connector Note 3	μs	Cell 2 to Cell 1: 1 Cell 3 to Cell 1: -1	PRS are transmitted from synchronous cells
Expected RSTD Note 1	μs	Cell 2: -2 Cell 3: 2 Other neighbour cells: randomly between -3 and 3	The expected RSTD is what is expected at the receiver. The corresponding parameter in the OTDOA assistance data specified in TS 36.355 [4] is the expectedRSTD indicator
Expected RSTD uncertainty for all neighbour cells Note 1	μs	5	The corresponding parameter in the OTDOA assistance data specified in TS 36.355 [4] is the expectedRSTD-Uncertainty index
Number of cells provided in OTDOA assistance data		16	Including the reference cell
PRS muting info Note 2		Cell 1: '1111111100000000' Cell 2: '0000000011111111' Cell 3: '1111111100000000'	Corresponds to prs-MutingInfo defined in TS 36.355 [4]
T1	s	3	The length of the time interval from the beginning of each test
T2	s	2.56	The length of the time interval that follows immediately after time interval T1
T3	s	2.56	The length of the time interval that follows immediately after time interval T2
<p>Note 1: Parameters "Expected RSTD" and "Expected RSTD uncertainty for all neighbour cells" are not settable parameters. These are parameters signalled in LPP only. For the values to be used in LPP see Table 9.3.16.4.3-5 and TS 37.571-5 [20], clause 7.2.5.</p> <p>Note 2: Parameters "PRS Transmission Bandwidth", "PRS configuration index", "Number of consecutive downlink positioning subframes", "Physical cell ID PCI", "CP length", and "PRS muting info" are settable parameters and also parameters signalled in LPP. The values to be used for "Physical cell ID PCI" are as follows: Cell 1: 0, Cell 2: 6, Cell 3: 12. For all the values to be used in LPP see Table 9.3.16.4.3-5 and TS 37.571-5 [20], clause 7.2.5.</p> <p>Note 3: The parameter "Radio frame receive time offset between the cells at the UE antenna connector" is not a settable parameter but is used to set the "true RSTD" values in step 6 of clause 9.3.16.4.1.</p> <p>Note 4: If the PRS transmission bandwidth is larger than the UE RF bandwidth, the UE is measuring RSTD within its RF bandwidth.</p>			

9.4.16.4.2 Test procedure

Same as in clause 9.4.14.4.2 but with the following additional step:

- For UE Category M2, repeat step 1-13 for sub-test 2 in Table 9.4.16.4.1-1.

9.4.16.4.3 Message contents

Same as in clause 9.4.13.4.3.

9.4.16.5 Test requirement

Same as in clause 9.4.13.5 except that for a UE Category M2 for the overall test to pass, the ratio of successful reported values in each sub-test shall be more than 90% with a confidence level of 95%.

9.4.17 E-UTRAN HD-FDD inter-frequency RSTD measurement period test case in CE Mode B with longer PRS occasions

9.4.17.1 Test purpose

To verify that the RSTD measurement reporting delay with longer PRS occasions for UE Category M1 and M2 meets the performance requirements in normal coverage mode in an environment with fading propagation conditions.

9.4.17.2 Test applicability

This test applies to E-UTRA HD-FDD UE Category M1 and M2 release 15 and forward that supports UE-assisted OTDOA, CE Mode B, inter-frequency RSTD measurements and dense PRS configuration or additional PRS configuration. Test 2 is applicable only to UE Category M2.

9.4.17.3 Minimum conformance requirements

Same as in clause 9.4.4.1.3

The normative reference for this requirement is TS 36.133 [23] clause 8.13.3.7.3, 8.16.3.2.3 and A.8.13.13.

9.4.17.4 Test description

9.4.17.4.1 Initial conditions

Same as in clause 9.4.13.4.1 but replacing Table 9.4.13.4.1-1 with Table 9.4.17.4.1-1.

Table 9.4.17.4.1-1: General test parameters

Parameter	Unit	Value		Comment
		Test 1	Test 2	
Reference cell		Cell 1		Reference cell is the cell in the OTDOA assistance data with respect to which the RSTD measurement is defined, as specified in 3GPP TS 36.214 [6] and 3GPP TS 36.355 [4]. The reference cell is the serving cell in this test case.
Neighbour cells		Cell 2 and Cell 3		Cell 2 and Cell 3 appear at random places in the neighbour cell list in the OTDOA assistance data, but Cell 2 always appears in the first half of the list, whilst Cell 3 appears in the second half of the list.
MPDCCH		DL Reference Measurement Channel R.8 HD-FDD		As specified in TS 36.521-3 [25] clause A.7.1
<i>mPDCCH-startSF-UESS</i>		10		Parameter G in $T = r_{\max} \cdot G$ which determines subframe $k0$ in which MPDCCH starts
Channel Bandwidth (BW _{channel})	MHz	10		
Gap pattern Id		rstd12	rstd2	As specified in TS 36.133 [23] Table 8.1.2.1-3. Applies for measurements on Cell 1, Cell 2, and Cell 3
Gap offset		151		As specified in TS 36.331 [22], Clause 6.3.5
PRS Transmission Bandwidth ^{Note 2}	RB	50		PRS are transmitted over the system bandwidth

PRs configuration index I_{PRS} ^{Note 2}		Cell 1: 232, Cell 2, Cell 3: 312		This corresponds to periodicity of 320 ms and PRs subframe offset of $I_{PRS} - 160$ DL subframes, as defined in 3GPP TS 36.211 [26], Table 6.10.4.3-1
Number of consecutive downlink positioning subframes N_{PRS} ^{Note 2}		30	8	As defined in 3GPP TS 36.211 [26]. The number of subframes in a positioning occasion. Corresponds to parameter <i>add-numDL-Frames</i> in TS 36.355 [4], for UE with <i>additional-prs-config</i> capability
		40	10	As defined in 3GPP TS 36.211 [26]. The number of subframes in a positioning occasion. Corresponds to parameter <i>add-numDL-Frames</i> in TS 36.355 [4], for UE with <i>densePrsConfig</i> capability
Physical cell ID PCI ^{Note 2}		(PCI of Cell 1 – PCI of Cell 2) mod 6 = 0 and (PCI of Cell 1 – PCI of Cell 3) mod 6 = 0		The cell PCIs are selected such that the relative shifts of PRs patterns among cells are as given by the test parameters
CP length ^{Note 2}		Normal		
DRX		ON		DRX parameters are further specified in Table 9.3.16.4.1-2
prs-SubframeOffset		80		Number of subframes rounded to the closest integer. The corresponding parameter in the OTDOA assistance data is prs-SubframeOffset specified in TS 36.355 [4]
slotNumberOffset		0		The slot number offset at the transmitter between a neighbour cell and the assistance data reference cell specified in TS 36.355 [4]
Radio frame receive time offset between the cells at the UE antenna connector ^{Note 3}	µs	Cell 2 to Cell 1: 1 Cell 3 to Cell 1: -1		PRs are transmitted from synchronous cells
Expected RSTD ^{Note 1}	µs	Cell 2: -2 Cell 3: 2 Other neighbour cells: randomly between -3 and 3		The expected RSTD is what is expected at the receiver. The corresponding parameter in the OTDOA assistance data specified in TS 36.355 [4] is the expectedRSTD indicator
Expected RSTD uncertainty for all neighbour cells ^{Note 1}	µs	5		The corresponding parameter in the OTDOA assistance data specified in TS 36.355 [4] is the expectedRSTD-Uncertainty index
Number of cells provided in OTDOA assistance data		16		Including the reference cell
PRs muting info ^{Note 2}		Cell 1: '1111111100000000' Cell 2: '0000000011111111' Cell 3: '1111111100000000'		Corresponds to prs-MutingInfo defined in TS 36.355 [4]
T1	s	3		The length of the time interval from the beginning of each test
T2	s	2.56		The length of the time interval that follows immediately after time interval T1
T3	s	2.56		The length of the time interval that follows immediately after time interval T2

Note 1:	Parameters "Expected RSTD" and "Expected RSTD uncertainty for all neighbour cells" are not settable parameters. These are parameters signalled in LPP only. For the values to be used in LPP see Table 9.3.16.4.3-5 and TS 37.571-5 [20], clause 7.2.5.
Note 2:	Parameters "PRS Transmission Bandwidth", "PRS configuration index", "Number of consecutive downlink positioning subframes", "Physical cell ID PCI", "CP length", and "PRS muting info" are settable parameters and also parameters signalled in LPP. The values to be used for "Physical cell ID PCI" are as follows: Cell 1: 0, Cell 2: 6, Cell 3: 12. For all the values to be used in LPP see Table 9.3.16.4.3-5 and TS 37.571-5 [20], clause 7.2.5.
Note 3:	The parameter "Radio frame receive time offset between the cells at the UE antenna connector" is not a settable parameter but is used to set the "true RSTD" values in step 6 of clause 9.3.16.4.1.
Note 4:	If the PRS transmission bandwidth is larger than the UE RF bandwidth, the UE is measuring RSTD within its RF bandwidth.

9.4.17.4.2 Test procedure

Same as in clause 9.4.14.4.2 but with the following additional step:

14. For UE Category M2, repeat step 1-13 for sub-test 2 in Table 9.4.17.4.1-1.

9.4.17.4.3 Message contents

Same as in clause 9.4.13.4.3.

9.4.17.5 Test requirement

Same as in clause 9.4.13.5 except that for a UE Category M2 for the overall test to pass, the ratio of successful reported values in each sub-test shall be more than 90% with a confidence level of 95%.

9.4.18 E-UTRAN TDD inter-frequency RSTD measurement period test case in CE Mode B with longer PRS occasions

9.4.18.1 Test purpose

To verify that the RSTD measurement reporting delay with longer PRS occasions for UE Category M1 and M2 meets the performance requirements in normal coverage mode in an environment with fading propagation conditions.

9.4.18.2 Test applicability

This test applies to E-UTRA TDD UE Category M1 and M2 release 15 and forward that supports UE-assisted OTDOA, CE Mode B, inter-frequency RSTD measurements and dense PRS configuration or additional PRS configuration. Test 2 is applicable only to UE Category M2.

9.4.18.3 Minimum conformance requirements

Same as in clause 9.4.4.1.3.

The normative reference for this requirement is TS 36.133 [23] clause 8.13.3.7.2, 8.16.3.2.2 and A.8.13.14.

9.4.18.4 Test description

9.4.18.4.1 Initial conditions

Same as in clause 9.4.13.4.1 but replacing Table 9.4.13.4.1-1 with Table 9.4.18.4.1-1.

Table 9.4.18.4.1-1: General test parameters

Parameter	Unit	Value		Comment
		Test 1	Test 2	

Reference cell		Cell 1		Reference cell is the cell in the OTDOA assistance data with respect to which the RSTD measurement is defined, as specified in 3GPP TS 36.214 [6] and 3GPP TS 36.355 [4]. The reference cell is the serving cell in this test case.
Neighbour cells		Cell 2 and Cell 3		Cell 2 and Cell 3 appear at random places in the neighbour cell list in the OTDOA assistance data, but Cell 2 always appears in the first half of the list, whilst Cell 3 appears in the second half of the list.
MPDCCH		DL Reference Measurement Channel R.16 TDD		As specified in TS 36.521-3 [25] clause A.7.1
$mPDCCH\text{-startSF-UeSS}$		10		Parameter G in $T = r_{\max} \cdot G$ which determines subframe $k0$ in which MPDCCH starts
Channel Bandwidth (BW _{channel})	MHz	10		
Gap pattern Id		rstd15	rstd10	As specified in TS 36.133 [23] Table 8.1.2.1-3. Applies for measurements on Cell 1, Cell 2, and Cell 3
Gap offset		131		As specified in TS 36.331 [22], Clause 6.3.5
PRS Transmission Bandwidth ^{Note 2}	RB	50		PRS are transmitted over the system bandwidth
PRS configuration index I_{PRS} ^{Note 2}		Cell 1: 532, Cell 2, Cell 3: 612		This corresponds to periodicity of 320 ms and PRS subframe offset of $I_{\text{PRS}} - 160$ DL subframes, as defined in 3GPP TS 36.211 [26], Table 6.10.4.3-1
Number of consecutive downlink positioning subframes N_{PRS} ^{Note 2}		30	8	As defined in 3GPP TS 36.211 [26]. The number of subframes in a positioning occasion. Corresponds to parameter <i>add-numDL-Frames</i> in TS 36.355 [4], for UE with <i>additional-prs-config</i> capability
		40	10	As defined in 3GPP TS 36.211 [26]. The number of subframes in a positioning occasion. Corresponds to parameter <i>add-numDL-Frames</i> in TS 36.355 [4], for UE with <i>densePrsConfig</i> capability
Physical cell ID PCI ^{Note 2}		(PCI of Cell 1 – PCI of Cell 2) mod 6 = 0 and (PCI of Cell 1 – PCI of Cell 3) mod 6 = 0		The cell PCIs are selected such that the relative shifts of PRS patterns among cells are as given by the test parameters
TDD uplink-downlink configuration		2	1	As specified in TS 36.211 [26], Clause 4.2; corresponds to a configuration with 5 ms switch-point periodicity and two downlink consecutive subframes
TDD special subframe configuration		6		As specified in TS 36.211 [26], Clause 4.2; corresponds to DwPTS of $19760 \cdot T_s$ and UpPTS of $4384 \cdot T_s$
CP length ^{Note 2}		Normal		
DRX		ON		DRX parameters are further specified in Table 9.3.16.4.1-2

prs-SubframeOffset		80	Number of subframes rounded to the closest integer. The corresponding parameter in the OTDOA assistance data is prs-SubframeOffset specified in TS 36.355 [4]
slotNumberOffset		0	The slot number offset at the transmitter between a neighbour cell and the assistance data reference cell specified in TS 36.355 [4]
Radio frame receive time offset between the cells at the UE antenna connector <small>Note 3</small>	µs	Cell 2 to Cell 1: 1 Cell 3 to Cell 1: -1	PRS are transmitted from synchronous cells
Expected RSTD <small>Note 1</small>	µs	Cell 2: -2 Cell 3: 2 Other neighbour cells: randomly between -3 and 3	The expected RSTD is what is expected at the receiver. The corresponding parameter in the OTDOA assistance data specified in TS 36.355 [4] is the expectedRSTD indicator
Expected RSTD uncertainty for all neighbour cells <small>Note 1</small>	µs	5	The corresponding parameter in the OTDOA assistance data specified in TS 36.355 [4] is the expectedRSTD-Uncertainty index
Number of cells provided in OTDOA assistance data		16	Including the reference cell
PRS muting info <small>Note 2</small>		Cell 1: '1111111100000000' Cell 2: '0000000011111111' Cell 3: '1111111100000000'	Corresponds to prs-MutingInfo defined in TS 36.355 [4]
T1	s	3	The length of the time interval from the beginning of each test
T2	s	5.12	The length of the time interval that follows immediately after time interval T1
T3	s	5.12	The length of the time interval that follows immediately after time interval T2
<p>Note 1: Parameters "Expected RSTD" and "Expected RSTD uncertainty for all neighbour cells" are not settable parameters. These are parameters signalled in LPP only. For the values to be used in LPP see Table 9.3.16.4.3-5 and TS 37.571-5 [20], clause 7.2.5.</p> <p>Note 2: Parameters "PRS Transmission Bandwidth", "PRS configuration index", "Number of consecutive downlink positioning subframes", "Physical cell ID PCI", "CP length", and "PRS muting info" are settable parameters and also parameters signalled in LPP. The values to be used for "Physical cell ID PCI" are as follows: Cell 1: 0, Cell 2: 6, Cell 3: 12. For all the values to be used in LPP see Table 9.3.16.4.3-5 and TS 37.571-5 [20], clause 7.2.5.</p> <p>Note 3: The parameter "Radio frame receive time offset between the cells at the UE antenna connector" is not a settable parameter but is used to set the "true RSTD" values in step 6 of clause 9.3.16.4.1.</p> <p>Note 4: If the PRS transmission bandwidth is larger than the UE RF bandwidth, the UE is measuring RSTD within its RF bandwidth.</p>			

9.4.18.4.2 Test procedure

Same as in clause 9.4.14.4.2 but with the following additional step:

14. For UE Category M2, repeat step 1-13 for sub-test 2 in Table 9.4.18.4.1-1.

9.4.18.4.3 Message contents

Same as in clause 9.4.13.4.3 with the following exceptions:

Table 9.4.18.4.3-1: LPP RequestLocationInformation

Derivation Path: Table 9.4.13.4.3-2			
Information Element	Value/remark	Comment	Condition

LPP-Message ::= SEQUENCE {			
lpp-MessageBody CHOICE {			
c1 CHOICE {			
requestLocationInformation SEQUENCE {			
criticalExtensions CHOICE {			
c1 CHOICE {			
requestLocationInformation-r9 SEQUENCE {			
commonIEsRequestLocationInformation SEQUENCE {			
qos SEQUENCE {			
responseTime SEQUENCE {			
time	11	See test requirement in Section 9.4.18.5	
}			
}			
}			
}			
}			
}			
}			
}			
}			
}			

9.4.18.5 Test requirement

Table 9.4.1.1.5-1 and 9.4.1.1.5-2 define the primary level settings including test tolerances for the test.

The response time including test tolerance is 11300ms. The response time is equal to the LPP time IE value plus the test tolerance. The LPP time IE value is derived from the RSTD reporting delay plus ΔT , where $\Delta T = N_{rep} \times TTI_{DCCH} = N_{rep} \times 75$ ms, giving a value of 10315 ms. This is rounded up to the next allowed LPP value of 11 seconds. The RSTD measurement reporting delay in the test is derived from the following expression $T_{PRS}(M - 1) + 640 \cdot \left\lceil \frac{n}{M} \right\rceil$, where $M=16$ and $n=16$ are the parameters specified in clause 9.4.13.3, Table 9.4.1.1.3-1 and Note 4 of Table 9.4.13.4.1-1. This gives the total RSTD reporting delay of 10240 ms for the 15 neighbour cells including Cell 2 and Cell 3 with respect to the reference cell, Cell 1.

The test tolerances are defined in clauses C.1.3 and C4.

For a UE Category M1 the rate of successful tests during repeated tests shall be at least 90% with a confidence level of 95%. For a UE Category M2 for the overall test to pass, the ratio of successful reported values in each sub-test shall be more than 90% with a confidence level of 95%.

9.5 HD-FDD RSTD Intra-Frequency Measurements for NB-IOT

9.5.1 HD-FDD Intra frequency RSTD Measurement Accuracy for NB-IOT Inband Mode in normal coverage

9.5.1.1 Test purpose

To verify that the RSTD HD-FDD intra-frequency measurement accuracy is within the specified limits for NB-IOT Inband Mode in normal coverage.

9.5.1.2 Test applicability

This test applies to NB-IOT E-UTRA HD-FDD UE release 14 and forward that supports UE-assisted OTDOA.

9.5.1.3 Minimum conformance requirements

The UE shall follow the procedure for RRC_IDLE state positioning measurement as defined in TS 36.305 [41] section 7.1.3.

When the physical layer cell identities of the neighbour cells together with the OTDOA assistance data have been provided and the UE has entered the RRC_IDLE state, the UE shall be able to detect and measure intra-frequency RSTD, specified in TS 36.214 [6], for at least $n = 16$ cells, including the reference cell, on the same carrier frequency f_1 as that of the reference cell within $T_{\text{RSTD IntraFreq, NB}}$ ms as given below:

$$T_{\text{RSTD IntraFreq, NB}} = T_{\text{NPRS}} \cdot (M - 1) + \Delta \quad \text{ms},$$

where

$T_{\text{RSTD IntraFreq, NB}}$ is the total time for detecting and measuring at least n cells;

T_{NPRS} is the cell-specific positioning subframe configuration period as defined in TS 36.355 [4] if Part B subframe configuration is provided; otherwise if only Part A subframe configuration is provided, the T_{NPRS} equals to the length of the subframe pattern,

M is the number of NPRS positioning occasions as defined in Table 9.5.1.3-1,

$\Delta = T_{\text{NPRS}} \cdot \left\lceil \frac{n}{M} \right\rceil$ ms is the measurement time for a single NPRS positioning occasion which includes the sampling time and the processing time;

N_{NPRS} is the cell-specific number of NPRS subframes within a NPRS occasion as defined in TS 36.355 [4] if Part B subframe configuration is provided; if only Part A subframe configuration is provided, the NPRS occasion length is 10 ms,

$N_{\text{NPRS_total}}$ is the minimum number of NPRS subframes per cell measurement as defined in Table 9.5.1.3-2.

T_{NPRS} , N_{NPRS} , and $N_{\text{NPRS_total}}$ are the parameters of the same cell, for which $T_{\text{NPRS}} \cdot \left\lceil \frac{N_{\text{NPRS_total}}}{N_{\text{NPRS}}} \right\rceil$ is the

largest among all the measured cells.

Table 9.5.1.3-1: Number of NPRS positioning occasions within $T_{\text{RSTD IntraFreq, NB}}$

	Number of NPRS positioning occasions M
--	--

Positioning subframe configuration period T_{NPRS}	f1 ^{Note1}	f1 and f2 ^{Note2}
160 ms	16* $ N_{NPRS_total} / N_{NPRS} $	32* $ N_{NPRS_total} / N_{NPRS} $
>160 ms	8* $ N_{NPRS_total} / N_{NPRS} $	16* $ N_{NPRS_total} / N_{NPRS} $
Note 1: When only intra-frequency RSTD measurements are performed over cells belonging to the serving carrier frequency f1. Note 2: When intra-frequency RSTD and inter-frequency RSTD measurements are performed over cells belonging to the serving carrier frequency f1 and one inter-frequency carrier frequency f2, respectively.		

The UE physical layer shall be capable of reporting RSTD for the reference cell and all the neighbour cells i out of at least $(n-1)$ neighbour cells within $T_{RSTD\ IntraFreq, NB}$ provided:

$$\left(NPRS \hat{E}_s / Iot \right)_{ref} \geq -6 \text{ dB for all Frequency Bands for the reference cell,}$$

$$\left(NPRS \hat{E}_s / Iot \right)_i \geq -13 \text{ dB for all Frequency Bands for neighbour cell } i,$$

$$\left(NPRS \hat{E}_s / Iot \right)_{ref} \text{ and } \left(NPRS \hat{E}_s / Iot \right)_i \text{ conditions apply for all subframes of at least } L = \frac{M}{2} \text{ NPRS}$$

positioning occasions,

NPRP 1,2_{dBm} according to Annex E.5 for a corresponding Band

$NPRS \hat{E}_s / Iot$ is defined as the ratio of the average received energy per PRS RE during the useful part of the symbol to the average received power spectral density of the total noise and interference for this RE, where the ratio is measured over all REs which carry NPRS.

The time $T_{RSTD\ IntraFreq, NB}$ starts from the point when the UE has received both the OTDOA-

RequestLocationInformation message and the OTDOA assistance data in the OTDOA-ProvideAssistanceData message as specified in TS 36.355 [4], and the message and data have been delivered to the physical layer of the UE and the UE has entered the RRC_IDLE state.

The accuracy requirements in Table 9.5.1.3-2 are valid under the following conditions:

Conditions defined in 36.101 [2] Clause 7.3 for reference sensitivity are fulfilled.

NPRP 1,2_{dBm} according to Annex E.5 for a corresponding Band

There are no measurement gaps overlapping with the NPRS subframes of the measured serving cell.

The parameter expectedRSTDUncertainty signalled over LPP by E-SMLC as defined in TS 36.355 [4] is less than 5 μ s.

Table 9.5.1.3-2: Intra RSTD measurement accuracy for normal coverage

Accuracy	Conditions					
	NPRS \hat{E}_s/Iot	UE NPRS measurement bandwidth on the reference cell and the measured neighbour cell i ^{Note 3}	Minimum number of available measurement subframes among the reference cell and the measured neighbour cell i , N_{NPRS_total} ^{Note 6}	I_o ^{Note 4} range		
				E-UTRA operating band groups ^{Note 5}	Minimum I_o ^{Note 1}	Maximum I_o
T_s ^{Note 2}	dB	RB			dBm/15kHz	dBm/BW _{Channel}

±20	(NPRS \hat{E}_s/lot) _{ref} ≥ -6dB and (NPRS \hat{E}_s/lot) _i ≥ -13dB	1	320	NFDD_G	-118	-70
-----	--	---	-----	--------	------	-----

NOTE 1: This minimum lo condition is expressed as the average lo per RE over all REs in an OFDM symbol.
 NOTE 2: Ts is the basic timing unit defined in TS 36.211 [26].
 NOTE 3: The serving cell, the reference cell, and the measured neighbour cell i are on the same carrier frequency.
 NOTE 4: The lo is defined in NPRS positioning subframes. The same lo range applies to NPRS and non-NPRS symbols. lo levels are different in NPRS and non-NPRS symbols within the same subframe.
 NOTE 5: E-UTRA operating band groups for NB-IoT are as defined in Section 4.11.1.
 NOTE 6: N_{NPRS_total} can be in one or more NPRS positioning occasions.

The normative reference for this requirement is TS 36.133 [23] clauses 4.8.1, 9.1.22.10, A.3.23.2 and A.9.8.16.

9.5.1.4 Test description

9.5.1.4.1 Initial conditions

Test Environment: Normal; as defined in TS 36.508 [18] clause 8.1.1.

Frequencies to be tested: Mid Range, as defined in TS 36.508 [18] clause 8.1.3.1.1.

Channel bandwidth to be tested: 10 MHz. If the band under test does not support 10 MHz bandwidth, 5 MHz shall be used.

1. Connect the SS and AWGN noise sources to the UE antenna connector or antenna connectors as shown in Annex A, Figure A.3 but using only the main TX/RX antenna.
2. The general test parameter settings are set up according to Table 9.5.1.4.1-1.
3. Propagation conditions are set according to clause 4.7.2.1.
4. Message contents are defined in clause 9.5.1.4.3.
5. All cells are on the same carrier frequency. nCell 1 is the serving cell and OTDOA assistance data reference cell; nCell 2 is the neighbour cell. eCell 1 and eCell 2 are the LTE donor cells to nCell 1 and nCell 2, respectively. The assistance data neighbour cell list includes in total 15 cells, where 14 of the cells are not simulated (dummy cells; as defined in TS 37.571-5 [20], clause 7.2.2).
6. The true RSTD (which is the receive time difference for frame 0 between nCell 2 and nCell 1 as seen at the UE antenna connector) is set to 92 Ts (about 3 µs). Note that the related expectedRSTD values to be signalled over LPP are defined in Table 9.5.1.4-1.

Table 9.5.1.4-1: General test parameters

Parameter	Unit	Value	Comment
NB-IoT operational mode		Inband	
Reference cell		nCell 1	
Neighbor cells		nCell 2, eCell 2 and eCell 1	
NPDCCH parameters		R.26 HD-FDD	As defined in TS 36.133 [23] section A.3.1.6.1
nprsID		Test1: (nprsID of Cell 1 – nprsID of Cell 2) mod 6 = 1	As defined in TS36.355 [4]
nprs-period	ms	1280	As defined in TS36.355 [4]
nprs-startSF		sf0	Subframe offset of the NPRS positioning occasion as defined in TS36.355 [4]

Number of consecutive downlink positioning subframes nprs-NumSF		640	As defined in TS36.355 [4]
NPRS muting info		nCell 1: '11110000' nCell 2: '11110000'	Corresponds to nprs-MutingInfoB defined in TS 36.355 [4]
PartA Configuration		as in the following 2 rows	
subframePattern10		'0111001110'	Corresponds to subframePattern10-r14 defined in TS 36.355 [4]
nprsSequenceInfo		BW _{channel} 5MHz: 54 BW _{channel} 10MHz: 130	Corresponds to nprsSequenceInfo defined in TS 36.355 [4]
CP length		Normal	
NPRACH Configuration		NPRACH.R-1	Refer to TS 36.133 [23] section A.3.18
DRX cycle length		1.28	The value shall be used for all cells in the test.
Expected RSTD	μs	nCell 2: 3 Other neighbour cells: randomly between -3 and 3	The expected RSTD is what is expected at the receiver. The corresponding parameter in the OTDOA assistance data specified in TS 36.355 [4] is the expectedRSTD indicator
Expected RSTD uncertainty for all neighbour cells	μs	5	The corresponding parameter in the OTDOA assistance data specified in TS 36.355 [4] is the expectedRSTD-Uncertainty index
Number of cells provided in OTDOA assistance data		16	Including the reference cell
Measurement period	s	11.52	Derived according to the RSTD measurement period in clause 9.5.1.3

9.5.1.4.2 Test procedure

The test consists of a set-up period and a measurement period. nCell 1 and nCell 2 (and their LTE donor cells eCell 1 and eCell 2) are active during the complete test. The beginning of the measurement period shall be aligned with the first PRS positioning subframe of a positioning occasion in the reference cell.

NOTE: The information on when PRS is muted is conveyed to the UE using PRS muting information in the OTDOA assistance data.

The OTDOA-RequestLocationInformation message and the OTDOA assistance data as defined in clause 9.5.1.4.3 shall be provided to the UE during the set-up period. The last TTI containing the OTDOA-RequestLocationInformation message shall be provided to the UE ΔT ms before the start of the measurement period, where $\Delta T = 150$ ms is the maximum processing time of the OTDOA-RequestLocationInformation message and the OTDOA assistance data in the UE.

1. Ensure that the UE is in state Generic RB Established State 3A-NB with CP CIoT optimisation according to TS 36.508 [18] clause 8.1.5 in nCell 1.
2. The SS shall send a RESET UE POSITIONING STORED INFORMATION message.
3. Set the parameters according to Table 9.5.1.5-1 and Table 9.5.1.5-2 as appropriate. Propagation conditions are set according to clause 4.7.2.1.
4. The SS shall send an LPP REQUEST CAPABILITIES message.
5. The UE shall send an LPP PROVIDE CAPABILITIES message indicating the OTDOA capabilities supported by the UE in the *OTDOA-ProvideCapabilities* IE.
6. The SS shall send a LPP PROVIDE ASSISTANCE DATA message, including the *OTDOA-ProvideAssistanceData* IE. If the UE message at step 5 includes the ackRequested IE set to TRUE, then the SS shall send an acknowledgment in the LPP PROVIDE ASSISTANCE DATA message.

7. The SS shall send a LPP REQUEST LOCATION INFORMATION message, including the *OTDOA-RequestLocationInformation* IE such that the UE receives the message ΔT ms before the start of the measurement period, where $\Delta T = 150$ ms.
8. When the Inactivity Timer expires, the SS shall send a RRC Connection Release to send the UE to RRC_IDLE state.
9. The UE shall perform location measurements in RRC_IDLE state start a Mobile Originated Data Transport according to TS 23.401 [42] clause 5.3.4B.2.
10. When the signalling connection between the UE and SS is re-established, the UE shall transmit a LPP PROVIDE LOCATION INFORMATION message, including the *OTDOA-ProvideLocationInformation* IE.
11. If the UE message at step 10 includes the *ackRequested* IE set to TRUE, the SS shall send a LPP acknowledgement message.
12. The SS shall check the *rstd* value for nCell 2 in the *OTDOA-SignalMeasurementInformation* IE according to Table 9.5.1.5-3.
13. Repeat step 2-12 until the confidence level according to Annex D is achieved.

9.5.1.4.3 Message contents

Message contents are according to TS 36.508 [18] clause 8.1.4.3 and clause 8.1.6 using condition "Inband_Same" with the following exceptions:

Table 9.5.1.4.3-1: RESET UE POSITIONING STORED INFORMATION

Derivation Path: 36.509 [11] clause 6.9			
Information Element	Value/remark	Comment	Condition
UE Positioning Technology	0 0 0 0 0 0 1	OTDOA	

Table 9.5.1.4.3-1a: LPP Request Capabilities

Information Element	Value/remark
<i>otdoa-RequestCapabilities</i>	TRUE

Table 9.5.1.4.3-2: LPP RequestLocationInformation

Derivation Path: 36.355 clause 6.2			
Information Element	Value/remark	Comment	Condition
LPP-Message ::= SEQUENCE {			
transactionID SEQUENCE {			
initiator	locationServer		
transactionNumber	1		
}			
endTransaction	FALSE		
sequenceNumber	Not present		
acknowledgement	Not present		
lpp-MessageBody CHOICE {			
c1 CHOICE {			
requestLocationInformation SEQUENCE {			
criticalExtensions CHOICE {			
c1 CHOICE {			
requestLocationInformation-r9 SEQUENCE {			
commonEsRequestLocationInformation SEQUENCE {			
locationInformationType	locationMeasurementsRequired		
triggeredReporting	Not present		
periodicalReporting	Not present		
additionalInformation	onlyReturnInformationRequested		

qos SEQUENCE {			
horizontalAccuracy	Not present		
verticalCoordinateRequest	FALSE		
verticalAccuracy	Not present		
responseTime SEQUENCE {			
time	12	See Measurement Period of Table 9.5.1.4.1-1	
responseTimeEarlyFix-r12	Not present		
}			
velocityRequest	FALSE		
responseTimeNB-r14	Not present	Only required if response time shall be >128s	
}			
environment	Not present		
locationCoordinateTypes	Not present		
velocityTypes	Not present		
messageSizeLimitNB-r14	Not present		
}			
a-gnss-RequestLocationInformation	Not present		
otdoa-RequestLocationInformation SEQUENCE {			
assistanceAvailability	FALSE		
}			
ecid-RequestLocationInformation	Not present		
epdu-RequestLocationInformation	Not Present		
sensor-RequestLocationInformation-r13	Not Present		
tbs-RequestLocationInformation-r13	Not Present		
wlan-RequestLocationInformation-r13	Not Present		
bt-RequestLocationInformation-r13	Not Present		
}			
}			
}			
}			
}			
}			
}			
}			

Table 9.5.1.4.3-1: LPP ProvideAssistanceData

Derivation Path: 36.355 clause 6.2			
Information Element	Value/remark	Comment	Condition
LPP-Message ::= SEQUENCE {			
transactionID SEQUENCE {			
Initiator	locationServer		
transactionNumber	(0..255)		
}			
endTransaction	TRUE		
sequenceNumber	Not present		
acknowledgement	Not present		
lpp-MessageBody CHOICE {			
c1 CHOICE {			
provideAssistanceData SEQUENCE {			
criticalExtensions CHOICE {			
c1 CHOICE {			
provideAssistanceData-r9 SEQUENCE {			
commonIEsProvideAssistanceData	Not present		
a-gnss-ProvideAssistanceData	Not present		
otdoa-ProvideAssistanceData SEQUENCE {			
otdoa-ReferenceCellInfo	Not present		
otdoa-NeighbourCellInfo	Not present		
otdoa-Error	Not present		

otdoa-ReferenceCellInfoNB-r14	As defined in TS 37.571-5 [20], clause 7.4.2.		
otdoa-NeighbourCellInfoNB-r14	As defined in TS 37.571-5 [20], clause 7.4.2.		
}			
epdu-ProvideAssistanceData	Not present		
sensor-ProvideAssistanceData-r14	Not present		
tbs-ProvideAssistanceData-r14	Not present		
wlan-ProvideAssistanceData-r14	Not present		
}			
}			
}			
}			
}			
}			

9.5.1.5 Test requirement

Table 9.5.1.5-1 and 9.5.1.5-2 define the primary level settings including test tolerances for all tests.

The RSTD FDD intra-frequency accuracy test shall meet the reported values in Table 9.5.1.5-3.

Table 9.5.1.5-1: Cell Specific Test Parameters for intra frequency RSTD Tests for NB-IOT Cells

Parameter	Unit	Test 1	
		nCell 1	nCell 2
$BW_{channel}$	kHz	180	180
PRB location within eCell		eCell 1 $BW_{channel}$ 5MHz: 17 eCell 1 $BW_{channel}$ 10MHz: 30	eCell 2 $BW_{channel}$ 5MHz: 17 eCell 2 $BW_{channel}$ 10MHz: 30
NPBCH_RA	dB	0	0
NPBCH_RB			
NPSS_RA			
NSSS_RA			
NPDCCH_RA			
NPDCCH_RB			
NPDSCH_RA			
NPDSCH_RB			
OCNG_RA ^{Note 1}			
OCNG_RB ^{Note 1}			
N_{oc} ^{Note 2}	dBm/ 15 kHz	-98	-98
NPRS_RA	dB	-7.2	-8.7
$NPRS \hat{E}_s / N_{oc}$	dB	-0.2	-4.7
$NPRS \hat{E}_s / I_{ot}$ ^{Note 3}	dB	-5.66	-12.49
I_o ^{Note 3}	dBm/ 180kHz	-78.40	-78.40
NPRP ^{Note 3}	dBm/ 15 kHz	-98.2	-102.7
NRSRP ^{Note 3}	dBm/ 15 kHz	-91	-94
\hat{E}_s / N_{oc} ^{Note 3}	dB	7	4
Propagation Condition		AWGN	AWGN
Antenna Configuration		1x1	1x1
Timing offset to nCell 1	us	N/A	3

Note 1: OCNG shall be used such that active cells are fully allocated and a constant total transmitted power spectral density is achieved for all OFDM symbols other than those in the subframes with transmitted NPRS.

Note 2: Interference from other cells and noise sources not specified in the test are assumed to be constant over subcarriers and time and shall be modelled as AWGN of appropriate power for N_{oc} to be fulfilled.

Note 3: If NPRS_RA is not "N/A", \hat{E}_s/N_{oc} , NPRS \hat{E}_s/I_{ot} , I_o , NRSRP and NPRP levels have been derived from other parameters and are given for information purpose. If NPRS_RA is "N/A", I_o and NRSRP levels have been derived from other parameters and are given for information purpose. These are not settable test parameters. Interference conditions shall be applied to all PRS symbols of DL positioning subframes.

Table 9.5.1.5-2: Cell Specific Test Parameters for intra frequency RSTD Tests for E-UTRA Cells

Parameter	Unit	eCell 1			eCell 2		
		T1	T2	T3	T1	T2	T3
$BW_{channel}$	MHz	5 or 10			5 or 10		
NOCNG Pattern defined in TS 36.133 [23] section A.3.2.3	-	$BW_{channel}$ 5MHz: NOP.4 FDD $BW_{channel}$ 10MHz: NOP.1 FDD			$BW_{channel}$ 5MHz: NOP.4 FDD $BW_{channel}$ 10MHz: NOP.1 FDD		
PBCH_RA	dB	-3			-3		
PBCH_RB	dB						
PSS_RA	dB						
SSS_RA	dB						
PDCCH_RA	dB						
PDCCH_RB	dB						
PDSCH_RA	dB						
PDSCH_RB	dB						
OCNG_RA ^{Note 1}	dB						
OCNG_RB ^{Note 1}	dB						
N_{oc} ^{Note2}	dBm/15 kHz	-98			-98		
\hat{E}_s / N_{oc} ^{Note2}	dBm	7	7	7	4	4	4
Propagation Condition		AWGN			AWGN		
Antenna Configuration		1x1			1x1		
Timing offset to eCell 1	ms	-			3		
Note 1: OCNG shall be used such that the Cell is fully allocated and a constant total transmitted power spectral density is achieved for all OFDM symbols. Note 2: Interference from other cells and noise sources not specified in the test is assumed to be constant over subcarriers and time and shall be modelled as AWGN of appropriate power N_{oc} .							

Table 9.5.1.5-3: RSTD HD-FDD intra-frequency accuracy requirements for the reported values

Lowest reported value	RSTD_6426
Highest reported value	RSTD_6468

For the overall test to pass, the ratio of successful reported values shall be more than 90% with a confidence level of 95%.

The expected response time is 12 s. The response time is equal to the LPP time IE value. The LPP time IE value is derived from the RSTD reporting delay plus ΔT , where $\Delta T = 150$ ms, giving a value of 11670 ms. This is rounded up to the next allowed LPP value of 12 seconds. The RSTD measurement reporting delay in the test is derived from the following expression, $T_{RSTD \text{ IntraFreq,NB}} = T_{NPRS} \cdot (M - 1) + \Delta$ ms, where $T_{NPRS} = 1280$ ms, $M = 8$

$\left| N_{NPRS_total} / N_{NPRS} \right|$, $\Delta = T_{NPRS} \cdot \left[\frac{n}{M} \right]$, $N_{NPRS_total} = 320$ ms, $N_{NPRS} = 640$ ms and $n = 16$. All the parameters are specified in clause 9.5.1.3 and Table 9.5.1.3-1. This gives the total RSTD reporting delay of 11520 ms for the 15 neighbour cells including nCell 2 with respect to the reference cell, nCell 1. This expected response time excludes any delay caused by RRC connection release before the RRC_IDLE mode measurement. This expected response time excludes any delay caused by establishing a signalling connection with the SS (including random access procedure) as defined in TS 36.305 [41] for LPP measurement reporting. The response time is not explicitly evaluated for this test; hence, no test tolerance values need to be applied.

9.5.2 HD-FDD Intra frequency RSTD Measurement Accuracy for NB-IOT Inband Mode in enhanced coverage

9.5.2.1 Test purpose

To verify that the RSTD HD-FDD intra-frequency measurement accuracy is within the specified limits for NB-IOT Inband Mode in enhanced coverage.

9.5.2.2 Test applicability

This test applies to NB-IOT E-UTRA HD-FDD UE release 14 and forward that supports UE-assisted OTDOA.

9.5.2.3 Minimum conformance requirements

Same as clause 9.5.1.3, replacing Table 9.5.1.3-1 with Table 9.5.2.3-1 and Table 9.5.1.3-2 with Table 9.5.2.3-2.

Table 9.5.2.3-1: Number of NPRS positioning occasions within T_{RSTD} IntraFreq, NB

Positioning subframe configuration period T_{NPRS}	Number of NPRS positioning occasions M			
	f1 ^{Note1}		f1 and f2 ^{Note2}	
160 ms	16*	$N_{NPRS_total} / N_{NPRS}$	32*	$N_{NPRS_total} / N_{NPRS}$
>160 ms	8*	$N_{NPRS_total} / N_{NPRS}$	16*	$N_{NPRS_total} / N_{NPRS}$

Note 1: When only intra-frequency RSTD measurements are performed over cells belonging to the serving carrier frequency f1.
 Note 2: When intra-frequency RSTD and inter-frequency RSTD measurements are performed over cells belonging to the serving carrier frequency f1 and one inter-frequency carrier frequency f2, respectively.

Table 9.5.2.3-2: Intra RSTD measurement accuracy for enhanced coverage

Accuracy	Conditions					
	NPRS \hat{E}_s/lot	UE NPRS measurement bandwidth on the reference cell and the measured neighbour cell i ^{Note 3}	Minimum number of available measurement subframes among the reference cell and the measured neighbour cell i , N_{NPRS_total} ^{Note 6}	Io ^{Note 4} range		
E-UTRA operating band groups ^{Note 5}				Minimum Io ^{Note 1}	Maximum Io	
T_s ^{Note 2}	dB	RB		dBm/15kHz	dBm/BW _{Channel} _{i}	
± 32	$(NPRS \hat{E}_s/lot)_{ref} \geq -15dB$ and $(NPRS \hat{E}_s/lot)_i \geq -15dB$	1	320	NFDD_G	-118	-70

NOTE 1: This minimum Io condition is expressed as the average Io per RE over all REs in an OFDM symbol.
 NOTE 2: T_s is the basic timing unit defined in TS 36.211 [26].
 NOTE 3: The serving cell, the reference cell, and the measured neighbour cell i are on the same carrier frequency.
 NOTE 4: The Io is defined in NPRS positioning subframes. The same Io range applies to NPRS and non-NPRS symbols. Io levels are different in NPRS and non-NPRS symbols within the same subframe.
 NOTE 5: E-UTRA operating band groups for NB-IoT are as defined in Section 4.11.1.
 NOTE 6: N_{NPRS_total} can be in one or more NPRS positioning occasions.

The normative reference for this requirement is TS 36.133 [23] clauses 4.8.2, 9.1.22.12, A.3.23.2 and A.9.8.18.

9.5.2.4 Test description

9.5.2.4.1 Initial conditions

Test Environment: Normal; as defined in TS 36.508 [18] clause 8.1.1.

Frequencies to be tested: Mid Range, as defined in TS 36.508 [18] clause 8.1.3.1.1.

Channel bandwidth to be tested: 10 MHz. If the band under test does not support 10 MHz bandwidth, 5 MHz shall be used.

1. Connect the SS and AWGN noise sources to the UE antenna connector or antenna connectors as shown in Annex A, Figure A.3 but using only the main TX/RX antenna.
2. The general test parameter settings are set up according to Table 9.5.2.4.1-1.
3. Propagation conditions are set according to clause 4.7.2.1.
4. Message contents are defined in clause 9.5.2.4.3.
5. All cells are on the same carrier frequency. nCell 1 is the serving cell and OTDOA assistance data reference cell; nCell 2 is the neighbour cell. eCell 1 and eCell 2 are the LTE donor cells to nCell 1 and nCell 2, respectively. The assistance data neighbour cell list includes in total 15 cells, where 14 of the cells are not simulated (dummy cells; as defined in TS 37.571-5 [20], clause 7.2.2).
6. The true RSTD (which is the receive time difference for frame 0 between nCell 2 and nCell 1 as seen at the UE antenna connector) is set to 92 Ts (about 3 μ s). Note that the related expectedRSTD values to be signalled over LPP are defined in Table 9.5.2.4-1.

Table 9.5.2.4-1: General test parameters

Parameter	Unit	Value	Comment
NB-IoT operational mode		Inband	
Reference cell		nCell 1	
Neighbor cells		nCell 2, eCell 2 and eCell 1	
NPDCCH parameters		R.26 HD-FDD	As defined in TS 36.133 [23] section A.3.1.6.1
nprsID		Test1: (nprsID of Cell 1 – nprsID of Cell 2)mod6=1	As defined in TS36.355 [4]
nprs-period	ms	1280	As defined in TS36.355 [4]
nprs-startSF		sf0	Subframe offset of the NPRS positioning occasion as defined in TS36.355 [4]
Number of consecutive downlink positioning subframes nprs-NumSF		640	As defined in TS36.355 [4]
NPRS muting info		nCell 1: '11110000' nCell 2: '11110000'	Corresponds to nprs-MutingInfoB defined in TS 36.355 [4]
PartA Configuration		as in the following two rows	
subframePattern10		'0111001110'	Corresponds to subframePattern10-r14 defined in TS 36.355 [4]
nprsSequenceInfo		BW _{channel} 5MHz: 54 BW _{channel} 10MHz: 130	Corresponds to nprsSequenceInfo defined in TS 36.355 [4]
CP length		Normal	
NPRACH Configuration		NPRACH.R-1	Refer to TS 36.133 [23] section A.3.18
DRX cycle length		1.28	The value shall be used for all cells in the test.
Expected RSTD	μ s	nCell 2: 3 Other neighbour cells: randomly between -3 and 3	The expected RSTD is what is expected at the receiver. The corresponding parameter in the OTDOA assistance data specified in TS 36.355 [4] is the expectedRSTD indicator
Expected RSTD uncertainty for all neighbour cells	μ s	5	The corresponding parameter in the OTDOA assistance data specified in TS 36.355 [4] is the expectedRSTD-Uncertainty index
Number of cells provided in OTDOA assistance data		16	Including the reference cell

Measurement period	s	11.52	Derived according to the RSTD measurement period in clause 9.5.2.3
--------------------	---	-------	--

9.5.2.4.2 Test procedure

The test consists of a set-up period and a measurement period. nCell 1 and nCell 2 (and their LTE donor cells eCell 1 and eCell 2) are active during the complete test. The beginning of the measurement period shall be aligned with the first PRS positioning subframe of a positioning occasion in the reference cell.

NOTE: The information on when PRS is muted is conveyed to the UE using PRS muting information in the OTDOA assistance data.

The OTDOA-RequestLocationInformation message and the OTDOA assistance data as defined in clause 9.5.2.4.3 shall be provided to the UE during the set-up period. The last TTI containing the OTDOA-RequestLocationInformation message of the last NPDCCH repetition shall be provided to the UE ΔT ms before the start of the measurement period, where $\Delta T = 150$ ms is the maximum processing time of the OTDOA-RequestLocationInformation message and the OTDOA assistance data in the UE.

1. Ensure that the UE is in state Generic RB Established State 3A-NB with CP ClIoT optimisation according to TS 36.508 [18] clause 8.1.5 in nCell 1.
2. The SS shall send a RESET UE POSITIONING STORED INFORMATION message.
3. Set the parameters according to Table 9.5.2.5-1 and Table 9.5.2.5-2 as appropriate. Propagation conditions are set according to clause 4.7.2.1.
4. The SS shall send an LPP REQUEST CAPABILITIES message.
5. The UE shall send an LPP PROVIDE CAPABILITIES message indicating the OTDOA capabilities supported by the UE in the *OTDOA-ProvideCapabilities* IE.
6. The SS shall send a LPP PROVIDE ASSISTANCE DATA message, including the *OTDOA-ProvideAssistanceData* IE. If the UE message at step 5 includes the *ackRequested* IE set to TRUE, then the SS shall send an acknowledgment in the LPP PROVIDE ASSISTANCE DATA message.
7. The SS shall send a LPP REQUEST LOCATION INFORMATION message, including the *OTDOA-RequestLocationInformation* IE such that the UE receives the message ΔT ms before the start of the measurement period, where $\Delta T = 150$ ms.
8. When the Inactivity Timer expires, the SS shall send a RRC Connection Release to send the UE to RRC_IDLE state.
9. The UE shall perform location measurements in RRC_IDLE state start a Mobile Originated Data Transport according to TS 23.401 [42] clause 5.3.4B.2.
10. When the signalling connection between the UE and SS is re-established, the UE shall transmit a LPP PROVIDE LOCATION INFORMATION message, including the *OTDOA-ProvideLocationInformation* IE.
11. If the UE message at step 10 includes the *ackRequested* IE set to TRUE, the SS shall send a LPP acknowledgement message.
12. The SS shall check the *rstd* value for nCell 2 in the *OTDOA-SignalMeasurementInformation* IE according to Table 9.5.1.5-3.
13. Repeat step 2-12 until the confidence level according to Annex D is achieved.

9.5.2.4.3 Message contents

Same as clause 9.5.1.4.3.

9.5.2.5 Test requirement

Table 9.5.2.5-1 and 9.5.2.5-2 define the primary level settings including test tolerances for all tests.

The RSTD FDD intra-frequency accuracy test shall meet the reported values in Table 9.5.2.5-3.

Table 9.5.2.5-1: Cell Specific Test Parameters for intra frequency RSTD Tests for NB-IOT Cells

Parameter	Unit	Test 1	
		nCell 1	nCell 2
BW_{channel}	kHz	180	180
PRB location within eCell		eCell 1 BW_{channel} 5MHz: 17 eCell 1 BW_{channel} 10MHz: 30	eCell 2 BW_{channel} 5MHz: 17 eCell 2 BW_{channel} 10MHz: 30
NPBCH_RA	dB	0	0
NPBCH_RB			
NPSS_RA			
NSSS_RA			
NPDCCH_RA			
NPDCCH_RB			
NPDSCH_RA			
NPDSCH_RB			
OCNG_RA ^{Note 1}			
OCNG_RB ^{Note 1}			
N_{oc} ^{Note 2}	dBm/ 15 kHz	-110	-110
NPRS_RA	dB	-12.4	-0.4
$NPRS \hat{E}_s / N_{oc}$	dB	-14.4	-12.4
$NPRS \hat{E}_s / I_{ot}$ ^{Note 3}	dB	-14.67	-14.52
I_o ^{Note 3}	dBm/ 180kHz	-100.8	-110.8
NPRP ^{Note 3}	dBm/ 15 kHz	-124.4	-122.4
NRSRP ^{Note 3}	dBm/ 15 kHz	-112	-122
\hat{E}_s / N_{oc} ^{Note 3}	dB	-2	-12
Propagation Condition		AWGN	AWGN
Antenna Configuration		1x1	1x1
Timing offset to nCell 1	us	N/A	3
<p>Note 1: OCNG shall be used such that active cells are fully allocated and a constant total transmitted power spectral density is achieved for all OFDM symbols other than those in the subframes with transmitted NPRS.</p> <p>Note 2: Interference from other cells and noise sources not specified in the test are assumed to be constant over subcarriers and time and shall be modelled as AWGN of appropriate power for N_{oc} to be fulfilled.</p> <p>Note 3: If NPRS_RA is not "N/A", \hat{E}_s / N_{oc}, $NPRS \hat{E}_s / I_{ot}$, I_o, NRSRP and NPRP levels have been derived from other parameters and are given for information purpose. If NPRS_RA is "N/A", I_o and NRSRP levels have been derived from other parameters and are given for information purpose. These are not settable test parameters. Interference conditions shall be applied to all PRS symbols of DL positioning subframes.</p>			

Table 9.5.2.5-2: Cell Specific Test Parameters for intra frequency RSTD Tests for E-UTRA Cells

Parameter	Unit	eCell 1			eCell 2		
		T1	T2	T3	T1	T2	T3
$BW_{channel}$	MHz	5 or 10			5 or 10		
NOCNG Pattern defined in TS 36.133 [23] section A.3.2.3	-	$BW_{channel}$ 5MHz: NOP.4 FDD $BW_{channel}$ 10MHz: NOP.1 FDD			$BW_{channel}$ 5MHz: NOP.4 FDD $BW_{channel}$ 10MHz: NOP.1 FDD		
PBCH_RA	dB	-3			-3		
PBCH_RB	dB						
PSS_RA	dB						
SSS_RA	dB						
PDCCH_RA	dB						
PDCCH_RB	dB						
PDSCH_RA	dB						
PDSCH_RB	dB						
OCNG_RA ^{Note 1}	dB						
OCNG_RB ^{Note 1}	dB						
N_{oc} ^{Note2}	dBm/15 kHz	-110			-110		
\hat{E}_s / N_{oc} ^{Note2}	dBm	-2	-2	-2	-2	-2	-2
Propagation Condition		AWGN			AWGN		
Antenna Configuration		1x1			1x1		
Timing offset to eCell 1	ms	-			3		
Note 1: OCNG shall be used such that the Cell is fully allocated and a constant total transmitted power spectral density is achieved for all OFDM symbols. Note 2: Interference from other cells and noise sources not specified in the test is assumed to be constant over subcarriers and time and shall be modelled as AWGN of appropriate power N_{oc} .							

Table 9.5.2.5-3: RSTD HD-FDD intra-frequency accuracy requirements for the reported values

Lowest reported value	RSTD_6414
Highest reported value	RSTD_6480

For the overall test to pass, the ratio of successful reported values shall be more than 90% with a confidence level of 95%.

The expected response time is 12 s. The response time is equal to the LPP time IE value. The LPP time IE value is derived from the RSTD reporting delay plus ΔT , where $\Delta T = 150$ ms, giving a value of 11670 ms. This is rounded up to the next allowed LPP value of 12 seconds. The RSTD measurement reporting delay in the test is derived from the following expression, $T_{RSTD \text{ IntraFreq,NB}} = T_{NPRS} \cdot (M - 1) + \Delta$ ms, where $T_{NPRS} = 1280$ ms, $M = 8$

$\left| N_{NPRS_total} / N_{NPRS} \right|$, $\Delta = T_{NPRS} \cdot \left[\frac{n}{M} \right]$, $N_{NPRS_total} = 320$ ms, $N_{NPRS} = 640$ ms and $n = 16$. All the parameters are specified in clause 9.5.2.3 and Table 9.5.2.3-1. This gives the total RSTD reporting delay of 11520 ms for the 15 neighbour cells including nCell 2 with respect to the reference cell, nCell 1. This expected response time excludes any delay caused by RRC connection release before the RRC_IDLE mode measurement. This expected response time excludes any delay caused by establishing a signalling connection with the SS (including random access procedure) as defined in TS 36.305 [41] for LPP measurement reporting. The response time is not explicitly evaluated for this test; hence, no test tolerance values need to be applied.

9.5.3 HD-FDD Intra frequency RSTD Measurement Reporting Delay for NB-IOT Standalone Mode in enhanced coverage

9.5.3.1 Test purpose

To verify that the RSTD HD-FDD intra-frequency measurement reporting delay is within the specified limits for NB-IOT Standalone Mode in enhanced coverage.

9.5.3.2 Test applicability

This test applies to NB-IOT E-UTRA HD-FDD UE release 14 and forward that supports UE-assisted OTDOA.

9.5.3.3 Minimum conformance requirements

The UE shall follow the procedure for RRC_IDLE state positioning measurement as defined in TS 36.305 [41] section 7.1.3.

When the physical layer cell identities of neighbour cells together with the OTDOA assistance data have been provided and the UE has entered the RRC_IDLE state, the UE shall be able to detect and measure intra-frequency RSTD, specified in TS 36.214 [6], for at least $n = 16$ cells, including the reference cell, on the same carrier frequency f_1 as that of the reference cell within $T_{\text{RSTD IntraFreq, NB}}$ ms as given below:

$$T_{\text{RSTD IntraFreq, NB}} = T_{\text{NPRS}} \cdot (M - 1) + \Delta \quad \text{ms},$$

where

$T_{\text{RSTD IntraFreq, NB}}$ is the total time for detecting and measuring at least n cells;

T_{NPRS} is the cell-specific positioning subframe configuration period as defined in TS 36.355 [4] if Part B subframe configuration is provided; otherwise if only Part A subframe configuration is provided, the T_{NPRS} equals to the length of the subframe pattern,

M is the number of NPRS positioning occasions as defined in Table 9.5.3.3-1,

$\Delta = T_{\text{NPRS}} \cdot \left\lceil \frac{n}{M} \right\rceil$ ms is the measurement time for a single NPRS positioning occasion which includes the sampling time and the processing time;

N_{NPRS} is the cell-specific number of NPRS subframes within a NPRS occasion as defined in TS 36.355 [4] if Part B subframe configuration is provided; if only Part A subframe configuration is provided, the NPRS occasion length is 10 ms,

$N_{\text{NPRS_total}}$ is the minimum number of NPRS subframes per cell measurement as defined in Table 9.5.2.3-2.

T_{NPRS} , N_{NPRS} , and $N_{\text{NPRS_total}}$ are the parameters of the same cell, for which $T_{\text{NPRS}} \cdot \left\lceil \frac{N_{\text{NPRS_total}}}{N_{\text{NPRS}}} \right\rceil$ is the largest among all the measured cells.

Table 9.5.3.3-1: Number of NPRS positioning occasions within $T_{\text{RSTD IntraFreq, NB}}$

Positioning subframe configuration period T_{NPRS}	Number of NPRS positioning occasions M	
	f_1 ^{Note1}	f_1 and f_2 ^{Note2}
160 ms	$16^* \left\lceil \frac{N_{\text{NPRS_total}}}{N_{\text{NPRS}}} \right\rceil$	$32^* \left\lceil \frac{N_{\text{NPRS_total}}}{N_{\text{NPRS}}} \right\rceil$
>160 ms	$8^* \left\lceil \frac{N_{\text{NPRS_total}}}{N_{\text{NPRS}}} \right\rceil$	$16^* \left\lceil \frac{N_{\text{NPRS_total}}}{N_{\text{NPRS}}} \right\rceil$
Note 1:	When only intra-frequency RSTD measurements are performed over cells belonging to the serving carrier frequency f_1 .	
Note 2:	When intra-frequency RSTD and inter-frequency RSTD measurements are performed over cells belonging to the serving carrier frequency f_1 and one inter-frequency carrier frequency f_2 , respectively.	

The UE physical layer shall be capable of reporting RSTD for the reference cell and all the neighbour cells i out of at least $(n-1)$ neighbour cells within $T_{\text{RSTD IntraFreq, NB}}$ provided:

$$\left(\text{NPRS} \hat{E}_s / \text{Iot} \right)_{\text{ref}} \geq -15 \text{ dB for all Frequency Bands for the reference cell,}$$

$$\left(\text{NPRS} \hat{E}_s / \text{Iot} \right)_i \geq -15 \text{ dB for all Frequency Bands for neighbour cell } i,$$

$$\left(\text{NPRS} \hat{E}_s / \text{Iot} \right)_{\text{ref}} \text{ and } \left(\text{NPRS} \hat{E}_s / \text{Iot} \right)_i \text{ conditions apply for all subframes of at least } L = \frac{M}{2} \text{ NPRS}$$

positioning occasions,

NPRP 1,2_{dBm} according to Annex E.5 for a corresponding Band

$\text{NPRS} \hat{E}_s / \text{Iot}$ is defined as the ratio of the average received energy per PRS RE during the useful part of the symbol to the average received power spectral density of the total noise and interference for this RE, where the ratio is measured over all REs which carry NPRS.

The time $T_{\text{RSTD IntraFreq, NB}}$ starts from the point when the UE has received both the OTDOA-RequestLocationInformation message and the OTDOA assistance data in the OTDOA-ProvideAssistanceData message as specified in TS 36.355 [4], and the message and data have been delivered to the physical layer of the UE, and the UE has entered the RRC_IDLE state.

After receiving both the OTDOA-RequestLocationInformation message and the OTDOA assistance data in the OTDOA-ProvideAssistanceData message as specified in TS 36.355 [4], the UE shall be sent to RRC_IDLE state. The maximum allowed RSTD reporting delay is defined as the time between the point when the UE has entered the RRC_IDLE state, and the point when the UE is ready to transmit the measurement report over the air interface and starts to establish a signalling connection with the MME.

The maximum allowed RSTD reporting delay shall be less than $T_{\text{RSTD IntraFreq, NB}} + T_{\text{RandomAccess_NB-IoT-EC}}$.

The normative reference for this requirement is TS 36.133 [23] clauses 4.8.2, 4.8.2.1, A.3.23.2 and A.4.7.1.

9.5.3.4 Test description

9.5.3.4.1 Initial conditions

Test Environment: Normal; as defined in TS 36.508 [18] clause 8.1.1.

Frequencies to be tested: Mid Range, as defined in TS 36.508 [18] clause 8.1.3.1.1.

Channel bandwidth to be tested: 200 kHz as defined in TS 36.508 [18] clause 8.1.3.1.

1. Connect the SS and AWGN noise sources to the UE antenna connector or antenna connectors as shown in Annex A, Figure A.3 but using only the main TX/RX antenna.
2. The general test parameter settings are set up according to Table 9.5.3.4.1-1.
3. Propagation conditions are set according to clause 4.7.2.1.
4. Message contents are defined in clause 9.5.3.4.3.
5. There are three synchronous cells: nCell 1, nCell 2 and nCell 3. nCell 1 is the reference as well as the serving cell. nCell 2 and nCell 3 are the neighbour cells. All cells are on the same RF channel. The assistance data neighbour cell list includes in total 15 cells, where 13 of the cells are not simulated (dummy cells; as defined in TS 37.571-5 [20], clause 7.2.2).
6. The true RSTD (which is the received time difference for frame 0 between two cells as seen at the UE antenna connector) is set to 31 Ts (about 1 μ s) between neighbour nCell 2 and serving nCell 1; and set to -31 Ts (about -1 μ s) between neighbour nCell 3 and serving nCell 1.

Table 9.5.3.4-1: General test parameters

Parameter	Unit	Value	Comment
NB-IoT operational mode		Standalone	
Reference cell		nCell 1	Reference cell is the cell in the OTDOA assistance data with respect to which the RSTD measurement is defined, as specified in TS 36.214 [6] and TS 36.355 [4]. The reference cell is the PCell in this test case.
Neighbor cells		nCell 2 and nCell 3	Cell 2 and Cell 3 appear at random places in the neighbour cell list in the OTDOA assistance data, but Cell 2 always appears in the first half of the list, whilst Cell 3 appears in the second half of the list.
nprsID		(nprsID of Cell 1 – nprsID of Cell 2)mod6=1 and (nprsID of Cell 1 – nprsID of Cell 3)mod6=2	As defined in TS 36.355 [4]
nprs-period	ms	1280	As defined in TS 36.355 [4]
nprs-startSF		sf0	Subframe offset of the NPRS positioning occasion as defined in TS 36.355 [4]
Number of consecutive downlink positioning subframes nprs-NumSF		320	As defined in TS 36.355 [4]
NPRS muting info		nCell 1: '11110000' nCell 2: '00001111' nCell 3: '11110000'	Corresponds to nprs-MutingInfoB defined in TS 36.355 [4]
Part A Configuration		N/A	NPRS is configured based on Part B but not Part A.
CP length		Normal	
NPRACH Configuration		NPRACH.R-1	Refer to A.3.18
DRX cycle length		1.28	The value shall be used for all cells in the test.
Radio frame receive time offset between the cells at the UE antenna connector	µs	nCell 2 to nCell 1: 1 nCell 3 to nCell 1: -1	PRS are transmitted from synchronous cells
Expected RSTD	µs	nCell 2: 3 nCell 3: 3 Other neighbour cells: randomly between -3 and 3	The expected RSTD is what is expected at the receiver. The corresponding parameter in the OTDOA assistance data specified in TS 36.355 [4] is the expectedRSTD indicator
Expected RSTD uncertainty for all neighbour cells	µs	5	The corresponding parameter in the OTDOA assistance data specified in TS 36.355 [4] is the expectedRSTD-Uncertainty index
Number of cells provided in OTDOA assistance data		16	Including the reference cell
T1	s	-	The length of the time interval from the beginning of the test until T2
T2	s	5.12	The length of the time interval that follows immediately after time interval T1
T3	s	5.12	The length of the time interval that follows immediately after time interval T2
T4	s	5.12	The length of the time interval that follows immediately after time interval T3

T5	s	5.12	The length of the time interval that follows immediately after time interval T4
T6	s	≥ 57	The length of the time interval that follows immediately after time interval T5

9.5.3.4.2 Test procedure

The test consists of six consecutive time intervals, with durations of T1, T2, T3, T4, T5 and T6. nCell 1 is active throughout T1, T2, T3, T4, T5 and T6, whilst nCell 2 and nCell 3 are activated only in the beginning of T2. nCell 2 is active until the end of T5 and nCell 3 is active until the end of T4. nCell 1 transmits NPRS in T2 and T4, while nCell 2 transmits NPRS in T3 and T5 and nCell 3 transmits NPRS only in T2 and T4. Note: The information on when NPRS is muted is conveyed to the UE using PRS muting information.

NOTE: The information on when PRS is muted is conveyed to the UE using PRS muting information in the OTDOA assistance data.

The OTDOA-RequestLocationInformation message and the OTDOA assistance data as defined in clause 9.5.3.4.3 shall be provided to the UE during the set-up period, T1. After the receipt of the OTDOA assistance data and *OTDOA-RequestLocationInformation*, the UE is provided with a RRC connection release command. The last TTI containing the RRC connection release command shall be provided to the UE ΔT ms before the start of T2 where $\Delta T = 150$ ms. The UE is then expected to enter RRC_IDLE state before T4.

1. Ensure that the UE is in state Generic RB Established State 3A-NB with CP CIoT optimisation according to TS 36.508 [18] clause 8.1.5 in nCell 1.
2. T1 starts.
3. The SS shall send a RESET UE POSITIONING STORED INFORMATION message.
4. Set the parameters according to Table 9.5.3.5-1 and Table 9.5.3.5-2 as appropriate. Propagation conditions are set according to clause 4.7.2.1.
5. The SS shall send an LPP REQUEST CAPABILITIES message.
6. The UE shall send an LPP PROVIDE CAPABILITIES message indicating the OTDOA capabilities supported by the UE in the *OTDOA-ProvideCapabilities* IE.
7. The SS shall send a LPP PROVIDE ASSISTANCE DATA message, including the *OTDOA-ProvideAssistanceData* IE. If the UE message at step 6 includes the ackRequested IE set to TRUE, then the SS shall send an acknowledgment in the LPP PROVIDE ASSISTANCE DATA message.
8. The SS shall send a LPP REQUEST LOCATION INFORMATION message, including the *OTDOA-RequestLocationInformation* IE.
9. The SS shall send a RRC Connection Release to send the UE to RRC_IDLE state and ΔT ms after the last TTI containing the RRC connection release command, T2 starts, where $\Delta T = 150$ ms.
10. At the start of T2, the SS shall switch the power setting from T1 to T2 as specified in Table 9.5.3.5-2.
11. When T2 expires, the SS shall switch the power setting from T2 to T3 as specified in Table 9.5.3.5-2.
12. When T3 expires, the SS shall switch the power setting from T3 to T4 as specified in Table 9.5.3.5-2.
13. When T4 expires, the SS shall switch the power setting from T4 to T5 as specified in Table 9.5.3.5-2.
14. When T5 expires, the SS shall switch the power setting from T5 to T6 as specified in Table 9.5.3.5-1.
15. The UE shall perform location measurements in RRC_IDLE state and then start a Mobile Originated Data Transport according to TS 23.401 [42] clause 5.3.4B.2.
16. When the signalling connection between the UE and SS is re-established, the UE shall transmit a LPP PROVIDE LOCATION INFORMATION message, including the *OTDOA-ProvideLocationInformation* IE. The LPP PROVIDE LOCATION INFORMATION shall be transmitted within the response time (see clause 4.7.3)

specified in clause 9.5.3.5. The UE shall perform and report the RSTD measurements for both nCell 2 and nCell 3 with respect to the reference cell in the OTDOA assistance data, nCell 1. If the UE transmits an *OTDOA-ProvideLocationInformation* IE including the *rstd* field for both nCell 2 and nCell 3 within the response time then the number of successful tests is increased by one. If the UE fails to report the *OTDOA-ProvideLocationInformation* IE with both the *rstd* fields included within the response time then the number of failure tests is increased by one.

17. If the UE message at step 16 includes the *ackRequested* IE set to TRUE, the SS shall send a LPP acknowledgement message.

18. Repeat step 2-17 until the confidence level according to Annex D is achieved.

9.5.3.4.3 Message contents

Same as in Clause 9.5.1.3.4.3 with the following exceptions:

Table 9.5.3.4.3-1: LPP RequestLocationInformation

Derivation Path: Table 9.5.1.4.3-2			
Information Element	Value/remark	Comment	Condition
LPP-Message ::= SEQUENCE {			
lpp-MessageBody CHOICE {			
c1 CHOICE {			
requestLocationInformation SEQUENCE {			
criticalExtensions CHOICE {			
c1 CHOICE {			
requestLocationInformation-r9 SEQUENCE {			
commonIEsRequestLocationInformation SEQUENCE {			
qos SEQUENCE {			
responseTime SEQUENCE {			
time	78	See test requirement in Section 9.5.3.5	
}			
}			
}			
}			
}			
}			
}			
}			
}			
}			

9.5.3.5 Test requirement

Table 9.5.3.5-1 and 9.5.3.5-2 define the primary level settings including test tolerances for all tests.

Table 9.5.3.5-1: Cell Specific Test Parameters for intra frequency RSTD Tests for T1 and T6

Parameter	Unit	nCell 1	nCell 2	nCell 3
NB-IoT RF Channel Number		1	1	1
NB-IoT Channel Bandwidth (BW _{channel})	kHz	200	200	200
OCNG Pattern ^{Note 1}		NOP.3 FDD	N/A	N/A
NPDSCH parameters ^{Note 2}		R.18 HD-FDD	N/A	N/A
NPDCCH parameters ^{Note 2}		R.30 HD-FDD	N/A	N/A
NPBCH_RA	dB	0	N/A	N/A
NPBCH_RB				

NPSS_RA				
NSSS_RA				
NPDCCH_RA				
NPDCCH_RB				
NPDSCH_RA				
NPDSCH_RB				
OCNG_RA ^{Note 1}				
OCNG_RB ^{Note 1}				
N_{oc} ^{Note 3}	dBm/ 15 kHz	-98		
$NPRS \hat{E}_s/N_{oc}$	dB	-Infinity	-Infinity	-Infinity
\hat{E}_s/N_{oc}	dB	-2	-Infinity	-Infinity
Propagation Condition		AWGN		
Antenna Configuration		1x1		
Timing offset to nCell 1	μ s	N/A	1	-1
<p>Note 1: OCNG shall be used such that the cell is fully allocated and a constant total transmitted power spectral density is achieved for all OFDM symbols. The OCNG pattern is chosen during the test according to the presence of a DL reference measurement channel.</p> <p>Note 2: The NPDSCH and NPDCCH reference measurement channels are used in the test only when a downlink transmission dedicated to the UE under test is required.</p> <p>Note 3: Interference from other cells and noise sources not specified in the test are assumed to be constant over subcarriers and time and shall be modelled as AWGN of appropriate power for N_{oc} to be fulfilled.</p>				

Table 9.5.3.5-2: Cell Specific Test Parameters for intra frequency RSTD Tests for T2 to T5

Parameter	Unit	nCell 1		nCell 2		nCell 3		
		T2 and T4	T3 and T5	T2 and T4	T3 and T5	T2 and T4	T3 and T5	
$BW_{channel}$	kHz	200		200		200		
NB-IoT RF Channel Number		1		1		1		
OCNG patterns		NOP.3 FDD		N/A	NOP.3 FDD	NOP.3 FDD	N/A	
NPBCH_RA	dB	0		0		0		N/A
NPBCH_RB								
NPSS_RA								
NSSS_RA								
NPDCCH_RA								
NPDCCH_RB								
NPDSCH_RA								
NPDSCH_RB								
OCNG_RA ^{Note 1}								
OCNG_RB ^{Note 1}								
NPRS_RA	dB	-3	N/A	N/A	0	0	N/A	
N_{oc} ^{Note 3}	dBm/15 kHz	-98	-95	-98	-95	-98	-95	
$NPRS \hat{E}_s / N_{oc}$	dB	-15	-Infinity	-Infinity	-15	-15	-Infinity	
$NPRS \hat{E}_s / I_{ot}$ ^{Note 4}	dB	-15	-Infinity	-Infinity	-15	-15	-Infinity	
Io ^{Note 4}	dBm/180kHz	-87.14	-87.12	-87.14	-87.12	-87.14	-87.12	
NPRP ^{Note 4}	dBm/15 kHz	-113	-Infinity	-Infinity	-110	-113	-Infinity	
NRSRP ^{Note 4}	dBm/15 kHz	-110	-107	-113	-110	-113	-Infinity	
\hat{E}_s / N_{oc} ^{Note 4}	dB	-12	-12	-15	-15	-15	-Infinity	
Propagation Condition		AWGN						
Antenna Configuration		1x1						
Timing offset to nCell 1	μ s	N/A		1		-1		
Note 1:	OCNG shall be used such that active cells (all, except nCell 3 in T3) are fully allocated and a constant total transmitted power spectral density is achieved for all OFDM symbols other than those in the subframes with transmitted NPRS.							
Note 3:	Interference from other cells and noise sources not specified in the test are assumed to be constant over subcarriers and time and shall be modelled as AWGN of appropriate power for N_{oc} to be fulfilled.							
Note 4:	If NPRS_RA is not "N/A", \hat{E}_s / N_{oc} , $NPRS \hat{E}_s / I_{ot}$, Io , NRSRP and NPRP levels have been derived from other parameters and are given for information purpose. If NPRS_RA is "N/A", Io and NRSRP levels have been derived from other parameters and are given for information purpose. These are not settable test parameters. Interference conditions shall be applied to all PRS symbols of DL positioning subframes.							

The response time including test tolerance is 78.3 s. The response time is equal to the LPP time IE value plus the test tolerance.

The LPP time IE value is derived from the maximum allowed RSTD reporting delay plus T2 and T3 plus ΔT , where $\Delta T = 150$ ms, giving a value of 77550 ms. This is rounded up to the next allowed LPP value of 78 seconds.

The maximum allowed RSTD reporting delay is 67.16 s. This time is measured starting from the beginning of time interval T4, to the moment when the UE starts to send preambles on the PRACH for sending the positioning

measurement report message to nCell1. The maximum allowed RSTD reporting delay is equal to $T_{\text{RSTD_intra_NB-IoT-EC}} + T_{\text{RandomAccess_NB-IoT-EC}}$.

The RSTD measurement time $T_{\text{RSTD_intra_NB-IoT-EC}}$ in the test is derived according to section 9.5.3.3 where it is equal to $T_{\text{RSTD_IntraFreq_NB}}$. This gives the total RSTD measurement time of 11.52s for nCell 2 and nCell 3 with respect to the reference nCell 1

The random access to an already detected cell $T_{\text{RandomAccess_NB-IoT-EC}}$ can be expressed as: $T_{\text{evaluate_NB_intra_NB-IoT-EC}} + T_{\text{SI}} + T_{\text{PRACH_NB-IoT}}$,

Where:

$T_{\text{evaluate_NB_intra_NB-IoT-EC}} = 12800$ ms: see Table 4.6.2.4-1 in clause 4.6.2.4 in TS 36.133 [23].

$T_{\text{SI}} = 41560$ ms and is the time required for receiving all the relevant system information as defined in TS 36.331 [22] for the target NB-IoT FDD cell.

$T_{\text{PRACH_NB-IoT}} = 1280$ ms and is the additional delay caused by the random access procedure.

This gives $T_{\text{RandomAccess_NB-IoT-EC}} = 55.64$ s for the random access delay to an already detected cell in the test case.

The test tolerances are defined in clauses C.1.3 and C4.

The rate of the correct events for each neighbour cell observed during repeated tests shall be at least 90% with a confidence level of 95%, where the reported RSTD measurement for each correct event shall be within the RSTD reporting range specified in Clause 9.1.10.3, i.e., between RSTD_0000 and RSTD_12711.

9.5.4 Void

9.6 HD-FDD RSTD Inter-Frequency Measurements for NB-IOT

9.6.1 HD-FDD Inter-Frequency RSTD Measurement Accuracy for NB-IOT Inband Mode in normal coverage

9.6.1.1 Test purpose

To verify that the RSTD HD-FDD inter-frequency measurement accuracy is within the specified limits for NB-IOT Mode in normal coverage.

9.6.1.2 Test applicability

This test applies to NB-IOT E-UTRA HD-FDD UE release 14 and forward that supports UE-assisted OTDOA and inter-frequency RSTD measurements.

9.6.1.3 Minimum conformance requirements

The UE shall follow the procedure for RRC_IDLE state positioning measurement as defined in TS 36.305 [41] section 7.1.3.

When the physical layer cell identities of neighbour cells together with the OTDOA assistance data have been provided and the UE has entered the RRC_IDLE state, the UE shall be able to detect and measure inter-frequency RSTD, specified in TS 36.214 [6], for at least $n = 16$ cells, including the reference cell, on the same carrier frequency f_1 as that of the reference cell within $T_{\text{RSTD_InterFreq_NB}}$ ms as given below:

$$T_{\text{RSTD_InterFreq_NB}} = T_{\text{NPRS}} \cdot (M - 1) + \Delta \quad ms ,$$

where

$T_{\text{RSTD_InterFreq_NB}}$ is the total time for detecting and measuring at least n cells;

T_{NPRS} is the cell-specific positioning subframe configuration period as defined in TS 36.355 [4] if Part B subframe configuration is provided; otherwise if only Part A subframe configuration is provided, the T_{NPRS} equals to the length of the subframe pattern,

M is the number of NPRS positioning occasions as defined in Table 9.6.1.3-1,

$\Delta = T_{\text{NPRS}} \cdot \left\lceil \frac{n}{M} \right\rceil$ ms is the measurement time for a single NPRS positioning occasion which includes the sampling time and the processing time;

N_{NPRS} is the cell-specific number of NPRS subframes within a NPRS occasion as defined in TS 36.355 [4] if Part B subframe configuration is provided; if only Part A subframe configuration is provided, the NPRS occasion length is 10 ms,

$N_{\text{NPRS_total}}$ is the minimum number of NPRS subframes per cell measurement as defined in Table 9.6.1.3-2.

T_{NPRS} , N_{NPRS} , and $N_{\text{NPRS_total}}$ are the parameters of the same cell, for which $T_{\text{NPRS}} \cdot \left\lceil \frac{N_{\text{NPRS_total}}}{N_{\text{NPRS}}} \right\rceil$ is the largest among all the measured cells.

Table 9.6.1.3-1: Number of NPRS positioning occasions within $T_{\text{RSTD InterFreq, NB}}$

Positioning subframe configuration period T_{NPRS}	Number of NPRS positioning occasions M	
	f1 ^{Note1}	f1 and f2 ^{Note2}
160 ms	16* $\lceil N_{\text{NPRS_total}} / N_{\text{NPRS}} \rceil$	32* $\lceil N_{\text{NPRS_total}} / N_{\text{NPRS}} \rceil$
>160 ms	8* $\lceil N_{\text{NPRS_total}} / N_{\text{NPRS}} \rceil$	16* $\lceil N_{\text{NPRS_total}} / N_{\text{NPRS}} \rceil$
Note 1:	When only intra-frequency RSTD measurements are performed over cells belonging to the serving carrier frequency f1.	
Note 2:	When intra-frequency RSTD and inter-frequency RSTD measurements are performed over cells belonging to the serving carrier frequency f1 and one inter-frequency carrier frequency f2, respectively.	

The UE physical layer shall be capable of reporting RSTD for the reference cell and all the neighbour cells i out of at least $(n-1)$ neighbour cells within $T_{\text{RSTD InterFreq, NB}}$ provided:

$$\left(\text{NPRS } \hat{E}_s / \text{Iot} \right)_{\text{ref}} \geq -6 \text{ dB for all Frequency Bands for the reference cell,}$$

$$\left(\text{NPRS } \hat{E}_s / \text{Iot} \right)_i \geq -13 \text{ dB for all Frequency Bands for neighbour cell } i,$$

$$\left(\text{NPRS } \hat{E}_s / \text{Iot} \right)_{\text{ref}} \text{ and } \left(\text{NPRS } \hat{E}_s / \text{Iot} \right)_i \text{ conditions apply for all subframes of at least } L = \frac{M}{2} \text{ NPRS positioning occasions,}$$

NPRP 1,2_{dBm} according to Annex E.5 for a corresponding Band

$\text{NPRS } \hat{E}_s / \text{Iot}$ is defined as the ratio of the average received energy per PRS RE during the useful part of the symbol to the average received power spectral density of the total noise and interference for this RE, where the ratio is measured over all REs which carry NPRS.

The time $T_{\text{RSTD InterFreq, NB}}$ starts from the point when the UE has received both the OTDOA-RequestLocationInformation message and the OTDOA assistance data in the OTDOA-ProvideAssistanceData message

as specified in TS 36.355 [4], and the message and data have been delivered to the physical layer of the UE and the UE has entered the RRC_IDLE state.

The accuracy requirements in Table 9.6.1.3-2 are valid under the following conditions:

Conditions defined in 36.101 [2] Clause 7.3 for reference sensitivity are fulfilled.

NPRP $1,2|_{dBm}$ according to Annex E.5 for a corresponding Band

There are no measurement gaps overlapping with the NPRS subframes of the measured serving cell.

The parameter expectedRSTDUncertainty signalled over LPP by E-SMLC as defined in TS 36.355 [4] is less than 5 μ s.

Table 9.6.1.3-2: Inter RSTD measurement accuracy for normal coverage

Accuracy	Conditions					
	NPRS \hat{E}_s/lot	UE NPRS measurement bandwidth on the reference cell and the measured neighbour cell i ^{Note 3}	Minimum number of available measurement subframes among the reference cell and the measured neighbour cell i , N_{NPRS_total} ^{Note 6}	lo ^{Note 4} range		
				E-UTRA operating band groups ^{Note 5}	Minimum lo ^{Note 1}	Maximum lo
T_s ^{Note 2}	dB	RB		dBm/15kHz	dBm/BW _{Channel}	
± 28	(NPRS \hat{E}_s/lot) _{ref} ≥ -6 dB and (NPRS \hat{E}_s/lot) _i ≥ -13 dB	1	320	NFDD_G	-118	-70

NOTE 1: This minimum lo condition is expressed as the average lo per RE over all REs in an OFDM symbol.
 NOTE 2: T_s is the basic timing unit defined in TS 36.211 [26].
 NOTE 3: The serving cell, the reference cell, and the measured neighbour cell i are on the same carrier frequency.
 NOTE 4: The lo is defined in NPRS positioning subframes. The same lo range applies to NPRS and non-NPRS symbols. lo levels are different in NPRS and non-NPRS symbols within the same subframe.
 NOTE 5: E-UTRA operating band groups for NB-IoT are as defined in Section 4.11.1.
 NOTE 6: N_{NPRS_total} can be in one or more NPRS positioning occasions.

The normative reference for this requirement is TS 36.133 [23] clauses 4.8.3, 9.1.22.11, A.3.23.2 and A.9.8.17.

9.6.1.4 Test description

9.6.1.4.1 Initial conditions

Test Environment: Normal; as defined in TS 36.508 [18] clause 8.1.1.

Frequencies to be tested: Mid Range, as defined in TS 36.508 [18] clause 8.1.3.1.1.

Channel bandwidth to be tested: 10 MHz. If the band under test does not support 10 MHz bandwidth, 5 MHz shall be used.

1. Connect the SS and AWGN noise sources to the UE antenna connector or antenna connectors as shown in Annex A, Figure A.3 but using only the main TX/RX antenna.
2. The general test parameter settings are set up according to Table 9.6.1.4.1-1.
3. Propagation conditions are set according to clause 4.7.2.1.

4. Message contents are defined in clause 9.6.1.4.3.
5. The two NB-IOT cells are on different PRBs of the same LTE carrier frequency. The two LTE Cells are on the same carrier frequency. nCell 1 is the serving cell and OTDOA assistance data reference cell; nCell 2 is the neighbour cell. eCell 1 and eCell 2 are the LTE donor cells to nCell 1 and nCell 2, respectively. The assistance data neighbour cell list includes in total 15 cells, where 14 of the cells are not simulated (dummy cells; as defined in TS 37.571-5 [20], clause 7.2.2).
6. The true RSTD (which is the receive time difference for frame 0 between nCell 2 and nCell 1 as seen at the UE antenna connector) is set to 92 Ts (about 3 μ s). Note that the related expectedRSTD values to be signalled over LPP are defined in Table 9.6.1.4-1.

Table 9.6.1.4-1: General test parameters

Parameter	Unit	Value	Comment
NB-IoT operational mode		Inband	
Reference cell		nCell 1	
Neighbor cells		nCell 2, eCell 2 and eCell 1	
NPDCCH parameters		R.26 HD-FDD	As defined in TS 36.133 [23] section A.3.1.6.1
nprsID		Test1: (nprsID of Cell 1 – nprsID of Cell 2)mod6=1	As defined in TS36.355 [4]
nprs-period	ms	1280	As defined in TS36.355 [4]
nprs-startSF		sf0	Subframe offset of the NPRS positioning occasion as defined in TS36.355 [4]
nprs-slotNumberOffset		0	As defined in TS36.355 [4]
nprs-SubframeOffset		640	As defined in TS36.355 [4]
Number of consecutive downlink positioning subframes nprs-NumSF		640	As defined in TS36.355 [4]
NPRS muting info		nCell 1: '1111111100000000' nCell 2: '1111111100000000'	Corresponds to nprs-MutingInfoB defined in TS 36.355 [4]
PartA Configuration		as in the following 3 rows	
subframePattern10		'0111001110'	Corresponds to subframePattern10-r14 defined in TS 36.355 [4]
nprsSequenceInfo nCell1		BW _{channel} 5MHz: 54 BW _{channel} 10MHz: 130	Corresponds to nprsSequenceInfo defined in TS 36.355 [4]
nprsSequenceInfo nCell2		BW _{channel} 5MHz: 59 BW _{channel} 10MHz: 135	Corresponds to nprsSequenceInfo defined in TS 36.355 [4]
CP length		Normal	
NPRACH Configuration		NPRACH.R-1	Refer to TS 36.133 [23] section A.3.18
DRX cycle length		1.28	The value shall be used for all cells in the test.
Expected RSTD	μ s	nCell 2: 3 Other neighbour cells: randomly between -3 and 3	The expected RSTD is what is expected at the receiver. The corresponding parameter in the OTDOA assistance data specified in TS 36.355 [4] is the expectedRSTD indicator
Expected RSTD uncertainty for all neighbour cells	μ s	5	The corresponding parameter in the OTDOA assistance data specified in TS 36.355 [4] is the expectedRSTD-Uncertainty index
Number of cells provided in OTDOA assistance data		16	Including the reference cell
Measurement period	s	20.48	Derived according to the RSTD measurement period in clause 9.6.1.3

9.6.1.4.2 Test procedure

The test consists of a set-up period and a measurement period. nCell 1 and nCell 2 (and their LTE donor cells eCell 1 and eCell 2) are active during the complete test. The beginning of the measurement period shall be aligned with the first PRS positioning subframe of a positioning occasion in the reference cell.

NOTE: The information on when PRS is muted is conveyed to the UE using PRS muting information in the OTDOA assistance data.

The OTDOA-RequestLocationInformation message and the OTDOA assistance data as defined in clause 9.6.1.4.3 shall be provided to the UE during the set-up period. The last TTI containing the OTDOA-RequestLocationInformation message shall be provided to the UE ΔT ms before the start of the measurement period, where $\Delta T = 150$ ms is the maximum processing time of the OTDOA-RequestLocationInformation message and the OTDOA assistance data in the UE.

1. Ensure that the UE is in state Generic RB Established State 3A-NB with CP ClIoT optimisation according to TS 36.508 [18] clause 8.1.5 in nCell 1.
2. The SS shall send a RESET UE POSITIONING STORED INFORMATION message.
3. Set the parameters according to Table 9.6.1.5-1 and Table 9.6.1.5-2 as appropriate. Propagation conditions are set according to clause 4.7.2.1.
4. The SS shall send an LPP REQUEST CAPABILITIES message.
5. The UE shall send an LPP PROVIDE CAPABILITIES message indicating the OTDOA capabilities supported by the UE in the *OTDOA-ProvideCapabilities* IE.
6. The SS shall send a LPP PROVIDE ASSISTANCE DATA message, including the *OTDOA-ProvideAssistanceData* IE. If the UE message at step 5 includes the *ackRequested* IE set to TRUE, then the SS shall send an acknowledgment in the LPP PROVIDE ASSISTANCE DATA message.
7. The SS shall send a LPP REQUEST LOCATION INFORMATION message, including the *OTDOA-RequestLocationInformation* IE such that the UE receives the message ΔT ms before the start of the measurement period, where $\Delta T = 150$ ms.
8. When the Inactivity Timer expires, the SS shall send a RRC Connection Release to send the UE to RRC_IDLE state.
9. The UE shall perform location measurements in RRC_IDLE state start a Mobile Originated Data Transport according to TS 23.401 [42] clause 5.3.4B.2.
10. When the signalling connection between the UE and SS is re-established, the UE shall transmit a LPP PROVIDE LOCATION INFORMATION message, including the *OTDOA-ProvideLocationInformation* IE.
11. If the UE message at step 10 includes the *ackRequested* IE set to TRUE, the SS shall send a LPP acknowledgement message.
12. The SS shall check the *rstd* value for nCell 2 in the *OTDOA-SignalMeasurementInformation* IE according to Table 9.6.1.5-3.
13. Repeat step 2-12 until the confidence level according to Annex D is achieved.

9.6.1.4.3 Message contents

Same as clause 9.5.1.4.3 with the following exceptions:

Table 9.6.1.4.3-1: LPP RequestLocationInformation

Derivation Path: Table 9.5.1.4.3-2			
Information Element	Value/remark	Comment	Condition
LPP-Message ::= SEQUENCE {			
lpp-MessageBody CHOICE {			
c1 CHOICE {			
requestLocationInformation SEQUENCE {			

criticalExtensions CHOICE {			
c1 CHOICE {			
requestLocationInformation-r9 SEQUENCE {			
commonIEsRequestLocationInformation			
SEQUENCE {			
qos SEQUENCE {			
responseTime SEQUENCE {			
time	21	See Measurement	
}		Period of Table	
}		9.6.1.4.1-1	
}			
}			
}			
}			

9.6.1.5 Test requirement

Table 9.6.1.5-1 and 9.6.1.5-2 define the primary level settings including test tolerances for all tests.

The RSTD FDD inter-frequency accuracy test shall meet the reported values in Table 9.6.1.5-3.

Table 9.6.1.5-1: Cell Specific Test Parameters for inter frequency RSTD Tests for NB-IOT Cells

Parameter	Unit	Test 1	
		nCell 1	nCell 2
BW _{channel}	kHz	180	180
PRB location within eCell		eCell 1 BW _{channel} 5MHz: 17 eCell 1 BW _{channel} 10MHz: 30	eCell 2 BW _{channel} 5MHz: 22 eCell 2 BW _{channel} 10MHz: 35
NPBCH_RA	dB	0	0
NPBCH_RB			
NPSS_RA			
NSSS_RA			
NPDCCH_RA			
NPDCCH_RB			
NPDSCH_RA			
NPDSCH_RB			
OCNG_RA <small>Note 1</small>			
OCNG_RB <small>Note 1</small>			
N_{oc} <small>Note 2</small>	dBm/ 15 kHz	-98	-98
NPRS_RA	dB	-12.7	-16.7
$NPRS \hat{E}_s / N_{oc}$	dB	-5.7	-12.7
$NPRS \hat{E}_s / I_{ot}$ <small>Note 3</small>	dB	-5.7	-12.7
I_o <small>Note 3</small>	dBm/ 180kHz	-79.90	-82.90
NPRP <small>Note 3</small>	dBm/ 15 kHz	-103.7	-110.7
NRSRP <small>Note 3</small>	dBm/ 15 kHz	-91	-94
\hat{E}_s / N_{oc} <small>Note 3</small>	dB	7	4
Propagation Condition		AWGN	AWGN
Antenna Configuration		1x1	1x1
Timing offset to nCell 1	us	N/A	3

Note 1: OCNG shall be used such that active cells are fully allocated and a constant total transmitted power spectral density is achieved for all OFDM symbols other than those in the subframes with transmitted NPRS.

Note 2: Interference from other cells and noise sources not specified in the test are assumed to be constant over subcarriers and time and shall be modelled as AWGN of appropriate power for N_{oc} to be fulfilled.

Note 3: If NPRS_RA is not "N/A", \hat{E}_s/N_{oc} , NPRS \hat{E}_s/I_{ot} , I_o , NRSRP and NPRP levels have been derived from other parameters and are given for information purpose. If NPRS_RA is "N/A", I_o and NRSRP levels have been derived from other parameters and are given for information purpose. These are not settable test parameters. Interference conditions shall be applied to all PRS symbols of DL positioning subframes.

Table 9.6.1.5-2: Cell Specific Test Parameters for inter frequency RSTD Tests for E-UTRA Cells

Parameter	Unit	eCell 1			eCell 2		
		T1	T2	T3	T1	T2	T3
$BW_{channel}$	MHz	5 or 10			5 or 10		
NOCNG Pattern defined in TS 36.133 [23] section A.3.2.3	-	$BW_{channel}$ 5MHz: NOP.4 FDD $BW_{channel}$ 10MHz: NOP.1 FDD			$BW_{channel}$ 5MHz: NOP.4 FDD $BW_{channel}$ 10MHz: NOP.1 FDD		
PBCH_RA	dB	-3			-3		
PBCH_RB	dB						
PSS_RA	dB						
SSS_RA	dB						
PDCCH_RA	dB						
PDCCH_RB	dB						
PDSCH_RA	dB						
PDSCH_RB	dB						
OCNG_RA ^{Note 1}	dB						
OCNG_RB ^{Note 1}	dB						
N_{oc} ^{Note2}	dBm/15 kHz	-98			-98		
\hat{E}_s / N_{oc} ^{Note2}	dBm	7	7	7	4	4	4
Propagation Condition		AWGN			AWGN		
Antenna Configuration		1x1			1x1		
Timing offset to eCell 1	ms	-			3		
Note 1: OCNG shall be used such that the Cell is fully allocated and a constant total transmitted power spectral density is achieved for all OFDM symbols. Note 2: Interference from other cells and noise sources not specified in the test is assumed to be constant over subcarriers and time and shall be modelled as AWGN of appropriate power N_{oc} .							

Table 9.6.1.5-3: RSTD HD-FDD inter-frequency accuracy requirements for the reported values

Lowest reported value	RSTD_6417
Highest reported value	RSTD_6477

For the overall test to pass, the ratio of successful reported values shall be more than 90% with a confidence level of 95%.

The expected response time is 21 s. The response time is equal to the LPP time IE value. The LPP time IE value is derived from the RSTD reporting delay plus ΔT , where $\Delta T = 150$ ms, giving a value of 20630 ms. This is rounded up to the next allowed LPP value of 21 seconds. The RSTD measurement reporting delay in the test is derived from the following expression, $T_{RSTD \text{ IntraFreq,NB}} = T_{NPRS} \cdot (M - 1) + \Delta$ ms, where $T_{NPRS} = 1280$ ms, $M = 16$

$\left| N_{NPRS_total} / N_{NPRS} \right|$, $\Delta = T_{NPRS} \cdot \left[\frac{n}{M} \right]$, $N_{NPRS_total} = 320$ ms, $N_{NPRS} = 640$ ms and $n = 16$. All the parameters are specified in clause 9.6.1.3 and Table 9.6.1.3-1. This gives the total RSTD reporting delay of 20480 ms for the 15 neighbour cells including nCell 2 with respect to the reference cell, nCell 1. This expected response time excludes any delay caused by RRC connection release before the RRC_IDLE mode measurement. This expected response time excludes any delay caused by establishing a signalling connection with the SS (including random access procedure) as defined in TS 36.305 [41] for LPP measurement reporting. The response time is not explicitly evaluated for this test; hence, no test tolerance values need to be applied.

9.6.2 HD-FDD Inter-Frequency RSTD Measurement Accuracy for NB-IOT Inband Mode in enhanced coverage

9.6.2.1 Test purpose

To verify that the RSTD HD-FDD inter-frequency measurement accuracy is within the specified limits for NB-IOT Inband Mode in enhanced coverage.

9.6.2.2 Test applicability

This test applies to NB-IOT E-UTRA HD-FDD UE release 14 and forward that supports UE-assisted OTDOA and inter-frequency RSTD measurements.

9.6.2.3 Minimum conformance requirements

Same as clause 9.6.1.3, replacing Table 9.6.1.3-1 with Table 9.6.2.3-1 and Table 9.6.1.3-2 with Table 9.6.2.3-2.

Table 9.6.2.3-1: Number of NPRS positioning occasions within $T_{RSTD \text{ InterFreq, NB}}$

Positioning subframe configuration period T_{NPRS}	Number of NPRS positioning occasions M			
	$f1$ ^{Note1}		$f1$ and $f2$ ^{Note2}	
160 ms	16*	$N_{NPRS_total} / N_{NPRS}$	32*	$N_{NPRS_total} / N_{NPRS}$
>160 ms	8*	$N_{NPRS_total} / N_{NPRS}$	16*	$N_{NPRS_total} / N_{NPRS}$
Note 1: When only intra-frequency RSTD measurements are performed over cells belonging to the serving carrier frequency $f1$. Note 2: When intra-frequency RSTD and inter-frequency RSTD measurements are performed over cells belonging to the serving carrier frequency $f1$ and one inter-frequency carrier frequency $f2$, respectively.				

Table 9.6.2.3-2: Inter RSTD measurement accuracy for normal coverage

Accuracy	Conditions					
	NPRS \hat{E}_s/lot	UE NPRS measurement bandwidth on the reference cell and the measured neighbour cell i ^{Note 3}	Minimum number of available measurement subframes among the reference cell and the measured neighbour cell i , N_{NPRS_total} ^{Note 6}	Io ^{Note 4} range		
				E-UTRA operating band groups ^{Note 5}	Minimum Io ^{Note 1}	Maximum Io
T_s ^{Note 2}	dB	RB		dBm/15kHz	dBm/BW _{Channel} _{i}	
± 40	$(NPRS \hat{E}_s/lot)_{ref} \geq -15\text{dB}$ and $(NPRS \hat{E}_s/lot)_i \geq -15\text{dB}$	1	320	NFDD_G	-118	-70
NOTE 1: This minimum Io condition is expressed as the average Io per RE over all REs in an OFDM symbol. NOTE 2: T_s is the basic timing unit defined in TS 36.211 [26]. NOTE 3: The serving cell, the reference cell, and the measured neighbour cell i are on the same carrier frequency. NOTE 4: The Io is defined in NPRS positioning subframes. The same Io range applies to NPRS and non-NPRS symbols. Io levels are different in NPRS and non-NPRS symbols within the same subframe. NOTE 5: E-UTRA operating band groups for NB-IoT are as defined in Section 4.11.1. NOTE 6: N_{NPRS_total} can be in one or more NPRS positioning occasions.						

The normative reference for this requirement is TS 36.133 [23] clauses 4.8.4, 9.1.22.13, A.3.23.2 and A.9.8.19.

9.6.2.4 Test description

9.6.2.4.1 Initial conditions

Test Environment: Normal; as defined in TS 36.508 [18] clause 8.1.1.

Frequencies to be tested: Mid Range, as defined in TS 36.508 [18] clause 8.1.3.1.1.

Channel bandwidth to be tested: 10 MHz. If the band under test does not support 10 MHz bandwidth, 5 MHz shall be used.

1. Connect the SS and AWGN noise sources to the UE antenna connector or antenna connectors as shown in Annex A, Figure A.3 but using only the main TX/RX antenna.
2. The general test parameter settings are set up according to Table 9.6.2.4.1-1.
3. Propagation conditions are set according to clause 4.7.2.1.
4. Message contents are defined in clause 9.6.2.4.3.
5. The two NB-IOT cells are on different PRBs of the same LTE carrier frequency. The two LTE Cells are on the same carrier frequency. nCell 1 is the serving cell and OTDOA assistance data reference cell; nCell 2 is the neighbour cell. eCell 1 and eCell 2 are the LTE donor cells to nCell 1 and nCell 2, respectively. The assistance data neighbour cell list includes in total 15 cells, where 14 of the cells are not simulated (dummy cells; as defined in TS 37.571-5 [20], clause 7.2.2).
6. The true RSTD (which is the receive time difference for frame 0 between nCell 2 and nCell 1 as seen at the UE antenna connector) is set to 92 Ts (about 3 μs). Note that the related expectedRSTD values to be signalled over LPP are defined in Table 9.6.2.4-1.

Table 9.6.2.4-1: General test parameters

Parameter	Unit	Value	Comment
NB-IoT operational mode		Inband	
Reference cell		nCell 1	
Neighbor cells		nCell 2, eCell 2 and eCell 1	
NPDCCH parameters		R.26 HD-FDD	As defined in TS 36.133 [23] section A.3.1.6.1
nprsID		Test1: (nprsID of Cell 1 – nprsID of Cell 2)mod6=1	As defined in TS36.355 [4]
nprs-period	ms	1280	As defined in TS36.355 [4]
nprs-startSF		sf0	Subframe offset of the NPRS positioning occasion as defined in TS36.355 [4]
nprs-slotNumberOffset		0	As defined in TS36.355 [4]
nprs-SubframeOffset		640	As defined in TS36.355 [4]
Number of consecutive downlink positioning subframes nprs-NumSF		640	As defined in TS36.355 [4]
NPRS muting info		nCell 1: '1111111100000000' nCell 2: '1111111100000000'	Corresponds to nprs-MutingInfoB defined in TS 36.355 [4]
PartA Configuration		as in the following 3 rows	
subframePattern10		'0111001110'	Corresponds to subframePattern10-r14 defined in TS 36.355 [4]
nprsSequenceInfo nCell1		BW _{channel} 5MHz: 54 BW _{channel} 10MHz: 130	Corresponds to nprsSequenceInfo defined in TS 36.355 [4]
nprsSequenceInfo nCell2		BW _{channel} 5MHz: 59 BW _{channel} 10MHz: 135	Corresponds to nprsSequenceInfo defined in TS 36.355 [4]
CP length		Normal	
NPRACH Configuration		NPRACH.R-1	Refer to TS 36.133 [23] section A.3.18
DRX cycle length		1.28	The value shall be used for all cells in the test.

Expected RSTD	μs	nCell 2: 3 Other neighbour cells: randomly between -3 and 3	The expected RSTD is what is expected at the receiver. The corresponding parameter in the OTDOA assistance data specified in TS 36.355 [4] is the expectedRSTD indicator
Expected RSTD uncertainty for all neighbour cells	μs	5	The corresponding parameter in the OTDOA assistance data specified in TS 36.355 [4] is the expectedRSTD-Uncertainty index
Number of cells provided in OTDOA assistance data		16	Including the reference cell
Measurement period	s	20.48	Derived according to the RSTD measurement period in clause 9.6.2.3

9.6.2.4.2 Test procedure

The test consists of a set-up period and a measurement period. nCell 1 and nCell 2 (and their LTE donor cells eCell 1 and eCell 2) are active during the complete test. The beginning of the measurement period shall be aligned with the first PRS positioning subframe of a positioning occasion in the reference cell.

NOTE: The information on when PRS is muted is conveyed to the UE using PRS muting information in the OTDOA assistance data.

The OTDOA-RequestLocationInformation message and the OTDOA assistance data as defined in clause 9.6.2.4.3 shall be provided to the UE during the set-up period. The last TTI containing the OTDOA-RequestLocationInformation message of the last NPDCCH repetition shall be provided to the UE ΔT ms before the start of the measurement period, where $\Delta T = 150$ ms is the maximum processing time of the OTDOA-RequestLocationInformation message and the OTDOA assistance data in the UE.

1. Ensure that the UE is in state Generic RB Established State 3A-NB with CP CIoT optimisation according to TS 36.508 [18] clause 8.1.5 in nCell 1.
2. The SS shall send a RESET UE POSITIONING STORED INFORMATION message.
3. Set the parameters according to Table 9.6.2.5-1 and Table 9.6.2.5-2 as appropriate. Propagation conditions are set according to clause 4.7.2.1.
4. The SS shall send an LPP REQUEST CAPABILITIES message.
5. The UE shall send an LPP PROVIDE CAPABILITIES message indicating the OTDOA capabilities supported by the UE in the *OTDOA-ProvideCapabilities* IE.
6. The SS shall send a LPP PROVIDE ASSISTANCE DATA message, including the *OTDOA-ProvideAssistanceData* IE. If the UE message at step 5 includes the *ackRequested* IE set to TRUE, then the SS shall send an acknowledgment in the LPP PROVIDE ASSISTANCE DATA message.
7. The SS shall send a LPP REQUEST LOCATION INFORMATION message, including the *OTDOA-RequestLocationInformation* IE such that the UE receives the message ΔT ms before the start of the measurement period, where $\Delta T = 150$ ms.
8. When the Inactivity Timer expires, the SS shall send a RRC Connection Release to send the UE to RRC_IDLE state.
9. The UE shall perform location measurements in RRC_IDLE state start a Mobile Originated Data Transport according to TS 23.401 [42] clause 5.3.4B.2.
10. When the signalling connection between the UE and SS is re-established, the UE shall transmit a LPP PROVIDE LOCATION INFORMATION message, including the *OTDOA-ProvideLocationInformation* IE.
11. If the UE message at step 10 includes the *ackRequested* IE set to TRUE, the SS shall send a LPP acknowledgement message.

12. The SS shall check the *rstd* value for nCell 2 in the *OTDOA-SignalMeasurementInformation* IE according to Table 9.6.2.5-3.

13. Repeat step 2-12 until the confidence level according to Annex D is achieved.

9.6.2.4.3 Message contents

Same as clause 9.6.1.4.3.

9.6.2.5 Test requirement

Table 9.6.2.5-1 and 9.6.2.5-2 define the primary level settings including test tolerances for all tests.

The RSTD FDD inter-frequency accuracy test shall meet the reported values in Table 9.6.2.5-3.

Table 9.6.2.5-1: Cell Specific Test Parameters for inter frequency RSTD Tests for NB-IOT Cells

Parameter	Unit	Test 1	
		nCell 1	nCell 2
$BW_{channel}$	kHz	180	180
PRB location within eCell		eCell 1 $BW_{channel}$ 5MHz: 17 eCell 1 $BW_{channel}$ 10MHz: 30	eCell 2 $BW_{channel}$ 5MHz: 22 eCell 2 $BW_{channel}$ 10MHz: 35
NPBCH_RA	dB	0	0
NPBCH_RB			
NPSS_RA			
NSSS_RA			
NPDCCH_RA			
NPDCCH_RB			
NPDSCH_RA			
NPDSCH_RB			
OCNG_RA ^{Note 1}			
OCNG_RB ^{Note 1}			
N_{oc} ^{Note 2}	dBm/ 15 kHz	-110	-110
NPRS_RA	dB	-12.7	-2.7
$NPRS \hat{E}_s / N_{oc}$	dB	-14.7	-14.7
$NPRS \hat{E}_s / I_{ot}$ ^{Note 3}	dB	-14.7	-14.7
I_o ^{Note 3}	dBm/ 180kHz	-101.20	-111.20
NPRP ^{Note 3}	dBm/ 15 kHz	-124.7	-124.7
NRSRP ^{Note 3}	dBm/ 15 kHz	-112	-122
\hat{E}_s / N_{oc} ^{Note 3}	dB	-2	-12
Propagation Condition		AWGN	AWGN
Antenna Configuration		1x1	1x1
Timing offset to nCell 1	us	N/A	3
<p>Note 1: OCNG shall be used such that active cells are fully allocated and a constant total transmitted power spectral density is achieved for all OFDM symbols other than those in the subframes with transmitted NPRS.</p> <p>Note 2: Interference from other cells and noise sources not specified in the test are assumed to be constant over subcarriers and time and shall be modelled as AWGN of appropriate power for N_{oc} to be fulfilled.</p> <p>Note 3: If NPRS_RA is not "N/A", \hat{E}_s / N_{oc}, $NPRS \hat{E}_s / I_{ot}$, I_o, NRSRP and NPRP levels have been derived from other parameters and are given for information purpose. If NPRS_RA is "N/A", I_o and NRSRP levels have been derived from other parameters and are given for information purpose. These are not settable test parameters. Interference conditions shall be applied to all PRS symbols of DL positioning subframes.</p>			

Table 9.6.2.5-2: Cell Specific Test Parameters for inter frequency RSTD Tests for E-UTRA Cells

Parameter	Unit	eCell 1			eCell 2		
		T1	T2	T3	T1	T2	T3
$BW_{channel}$	MHz	5 or 10			5 or 10		
NOCNG Pattern defined in TS 36.133 [23] section A.3.2.3	-	$BW_{channel}$ 5MHz: NOP.4 FDD $BW_{channel}$ 10MHz: NOP.1 FDD			$BW_{channel}$ 5MHz: NOP.4 FDD $BW_{channel}$ 10MHz: NOP.1 FDD		
PBCH_RA	dB	-3			-3		
PBCH_RB	dB						
PSS_RA	dB						
SSS_RA	dB						
PDCCH_RA	dB						
PDCCH_RB	dB						
PDSCH_RA	dB						
PDSCH_RB	dB						
OCNG_RA ^{Note 1}	dB						
OCNG_RB ^{Note 1}	dB						
N_{oc} ^{Note2}	dBm/15 kHz	-110			-110		
\hat{E}_s / N_{oc} ^{Note2}	dBm	-2	-2	-2	-12	-12	-12
Propagation Condition		AWGN			AWGN		
Antenna Configuration		1x1			1x1		
Timing offset to eCell 1	ms	-			3		
Note 1: OCNG shall be used such that the Cell is fully allocated and a constant total transmitted power spectral density is achieved for all OFDM symbols. Note 2: Interference from other cells and noise sources not specified in the test is assumed to be constant over subcarriers and time and shall be modelled as AWGN of appropriate power N_{oc} .							

Table 9.6.2.5-3: RSTD HD-FDD inter-frequency accuracy requirements for the reported values

Lowest reported value	RSTD_6405
Highest reported value	RSTD_6489

For the overall test to pass, the ratio of successful reported values shall be more than 90% with a confidence level of 95%.

The expected response time is 21 s. The response time is equal to the LPP time IE value. The LPP time IE value is derived from the RSTD reporting delay plus ΔT , where $\Delta T = 150$ ms, giving a value of 20630 ms. This is rounded up to the next allowed LPP value of 21 seconds. The RSTD measurement reporting delay in the test is derived from the following expression, $T_{RSTD \text{ IntraFreq,NB}} = T_{NPRS} \cdot (M - 1) + \Delta$ ms, where $T_{NPRS} = 1280$ ms, $M = 16$

$\left| N_{NPRS_total} / N_{NPRS} \right|$, $\Delta = T_{NPRS} \cdot \left[\frac{n}{M} \right]$, $N_{NPRS_total} = 320$ ms, $N_{NPRS} = 640$ ms and $n = 16$. All the parameters are specified in clause 9.6.2.3 and Table 9.6.2.3-1. This gives the total RSTD reporting delay of 20480 ms for the 15 neighbour cells including nCell 2 with respect to the reference cell, nCell 1. This expected response time excludes any delay caused by RRC connection release before the RRC_IDLE mode measurement. This expected response time excludes any delay caused by establishing a signalling connection with the SS (including random access procedure) as defined in TS 36.305 [41] for LPP measurement reporting. The response time is not explicitly evaluated for this test; hence, no test tolerance values need to be applied.

9.6.3 HD-FDD Inter frequency RSTD Measurement Reporting Delay for NB-IOT Standalone Mode in enhanced coverage

9.6.3.1 Test purpose

To verify that the RSTD HD-FDD inter-frequency measurement reporting delay is within the specified limits for NB-IOT Standalone Mode in enhanced coverage.

9.6.3.2 Test applicability

This test applies to NB-IOT E-UTRA HD-FDD UE release 14 and forward that supports UE-assisted OTDOA and inter-frequency RSTD measurements.

9.6.3.3 Minimum conformance requirements

The UE shall follow the procedure for RRC_IDLE state positioning measurement as defined in TS 36.305 [41] section 7.1.3.

When the physical layer cell identities of neighbour cells together with the OTDOA assistance data have been provided and the UE has entered the RRC_IDLE state, the UE shall be able to detect and measure inter-frequency RSTD, specified in TS 36.214 [6], for at least $n = 16$ cells, including the reference cell, on the same carrier frequency f_1 as that of the reference cell within $T_{RSTD \text{ IntraFreq, NB}}$ ms as given below:

$$T_{RSTD \text{ InterFreq, NB}} = T_{NPRS} \cdot (M - 1) + \Delta \quad \text{ms},$$

where

$T_{RSTD \text{ InterFreq, NB}}$ is the total time for detecting and measuring at least n cells;

T_{NPRS} is the cell-specific positioning subframe configuration period as defined in TS 36.355 [4] if Part B subframe configuration is provided; otherwise if only Part A subframe configuration is provided, the T_{NPRS} equals to the length of the subframe pattern,

M is the number of NPRS positioning occasions as defined in Table 9.6.3.3-1,

$\Delta = T_{NPRS} \cdot \left\lceil \frac{n}{M} \right\rceil$ ms is the measurement time for a single NPRS positioning occasion which includes the sampling time and the processing time;

N_{NPRS} is the cell-specific number of NPRS subframes within a NPRS occasion as defined in TS 36.355 [4] if Part B subframe configuration is provided; if only Part A subframe configuration is provided, the NPRS occasion length is 10 ms,

N_{NPRS_total} is the minimum number of NPRS subframes per cell measurement as defined in Table 9.6.2.3-2.

T_{NPRS} , N_{NPRS} , and N_{NPRS_total} are the parameters of the same cell, for which $T_{NPRS} \cdot \left\lceil \frac{N_{NPRS_total}}{N_{NPRS}} \right\rceil$ is the largest among all the measured cells.

Table 9.6.3.3-1: Number of NPRS positioning occasions within $T_{RSTD \text{ InterFreq, NB}}$

Positioning subframe configuration period T_{NPRS}	Number of NPRS positioning occasions M	
	f1 ^{Note1}	f1 and f2 ^{Note2}
160 ms	16* $\lceil N_{NPRS_total} / N_{NPRS} \rceil$	32* $\lceil N_{NPRS_total} / N_{NPRS} \rceil$
>160 ms	8* $\lceil N_{NPRS_total} / N_{NPRS} \rceil$	16* $\lceil N_{NPRS_total} / N_{NPRS} \rceil$
Note 1: When only intra-frequency RSTD measurements are performed over cells belonging to the serving carrier frequency f1. Note 2: When intra-frequency RSTD and inter-frequency RSTD measurements are performed over cells belonging to the serving carrier frequency f1 and one inter-frequency carrier frequency f2, respectively.		

The UE physical layer shall be capable of reporting RSTD for the reference cell and all the neighbour cells i out of at least $(n-1)$ neighbour cells within $T_{\text{RSTD InterFreq, NB}}$ provided:

$$\left(\text{NPRS} \hat{E}_s / \text{Iot} \right)_{\text{ref}} \geq -15 \text{ dB for all Frequency Bands for the reference cell,}$$

$$\left(\text{NPRS} \hat{E}_s / \text{Iot} \right)_i \geq -15 \text{ dB for all Frequency Bands for neighbour cell } i,$$

$$\left(\text{NPRS} \hat{E}_s / \text{Iot} \right)_{\text{ref}} \text{ and } \left(\text{NPRS} \hat{E}_s / \text{Iot} \right)_i \text{ conditions apply for all subframes of at least } L = \frac{M}{2} \text{ NPRS}$$

positioning occasions,

NPRP 1,2_{dBm} according to Annex E.5 for a corresponding Band

$\text{NPRS} \hat{E}_s / \text{Iot}$ is defined as the ratio of the average received energy per PRS RE during the useful part of the symbol to the average received power spectral density of the total noise and interference for this RE, where the ratio is measured over all REs which carry NPRS.

The time $T_{\text{RSTD InterFreq, NB}}$ starts from the point when the UE has received both the OTDOA-RequestLocationInformation message and the OTDOA assistance data in the OTDOA-ProvideAssistanceData message as specified in TS 36.355 [4], and the message and data have been delivered to the physical layer of the UE and the UE has entered the RRC_IDLE state.

After receiving both the OTDOA-RequestLocationInformation message and the OTDOA assistance data in the OTDOA-ProvideAssistanceData message as specified in TS 36.355 [4], the UE shall be sent to RRC_IDLE state. The maximum allowed RSTD reporting delay is defined as the time between the point when the UE has entered the RRC_IDLE state, and the point when the UE is ready to transmit the measurement report over the air interface and starts to establish a signalling connection with the MME.

The maximum allowed RSTD reporting delay shall be less than $T_{\text{RSTD InterFreq, NB}} + T_{\text{RandomAccess_NB-IoT-EC}}$.

The normative reference for this requirement is TS 36.133 [23] clauses 4.8.4, 4.8.4.1, A.3.23.2 and A.4.7.2.

9.6.3.4 Test description

9.6.3.4.1 Initial conditions

Test Environment: Normal; as defined in TS 36.508 [18] clause 8.1.1.

Frequencies to be tested: Mid Range, as defined in TS 36.508 [18] clause 8.1.3.1.1.

Channel bandwidth to be tested: 200 kHz as defined in TS 36.508 [18] clause 8.1.3.1.

1. Connect the SS and AWGN noise sources to the UE antenna connector or antenna connectors as shown in Annex A, Figure A.3 but using only the main TX/RX antenna.
2. The general test parameter settings are set up according to Table 9.6.3.4.1-1.
3. Propagation conditions are set according to clause 4.7.2.1.
4. Message contents are defined in clause 9.6.3.4.3.
5. There are three synchronous cells: nCell 1, nCell 2 and nCell 3. nCell 1 is the reference as well as the serving cell. nCell 2 and nCell 3 are the neighbour cells. nCell 1 is on one RF channel, nCell 2 and 3 are on a different RF channel. The assistance data neighbour cell list includes in total 15 cells, where 13 of the cells are not simulated (dummy cells; as defined in TS 37.571-5 [20], clause 7.2.2).
6. The true RSTD (which is the received time difference for frame 0 between two cells as seen at the UE antenna connector) is set to 31 Ts (about 1 μ s) between neighbour nCell 2 and serving nCell 1; and set to -31 Ts (about -1 μ s) between neighbour nCell 3 and serving nCell 1.

Table 9.6.3.4-1: General test parameters

Parameter	Unit	Value	Comment
NB-IoT operational mode		Standalone	
Reference cell		nCell 1	Reference cell is the cell in the OTDOA assistance data with respect to which the RSTD measurement is defined, as specified in TS 36.214 [6] and TS 36.355 [4]. The reference cell is the PCell in this test case.
Neighbor cells		nCell 2 and nCell 3	Cell 2 and Cell 3 appear at random places in the neighbour cell list in the OTDOA assistance data, but Cell 2 always appears in the first half of the list, whilst Cell 3 appears in the second half of the list.
nprsID		(nprsID of Cell 1 – nprsID of Cell 2)mod6=1 and (nprsID of Cell 1 – nprsID of Cell 3)mod6=2	As defined in TS 36.355 [4]
nprs-period	ms	640	As defined in TS 36.355 [4]
nprs-startSF		sf0	Subframe offset of the NPRS positioning occasion as defined in TS36.355 [4]
Number of consecutive downlink positioning subframes nprs-NumSF		320	As defined in TS36.355 [4]
nprs-SubframeOffset		0	As defined in TS36.355 [4]
NPRS muting info		Cell 1: '1111111100000000' Cell 2: '0000000011111111' Cell 3: '1111111100000000'	Corresponds to nprs-MutingInfoB defined in TS 36.355 [4]
Part A Configuration		N/A	NPRS is configured based on Part B but not Part A.
CP length		Normal	
NPRACH Configuration		NPRACH.R-1	Refer to A.3.18
DRX cycle length		1.28	The value shall be used for all cells in the test.
Radio frame receive time offset between the cells at the UE antenna connector	µs	nCell 2 to nCell 1: 1 nCell 3 to nCell 1: -1	PRS are transmitted from synchronous cells
Expected RSTD	µs	Cell 2: -2 Cell 3: 2 Other neighbour cells: randomly between -3 and 3	The expected RSTD is what is expected at the receiver. The corresponding parameter in the OTDOA assistance data specified in TS 36.355 [4] is the expectedRSTD indicator
Expected RSTD uncertainty for all neighbour cells	µs	5	The corresponding parameter in the OTDOA assistance data specified in TS 36.355 [4] is the expectedRSTD-Uncertainty index
Number of cells provided in OTDOA assistance data		16	Including the reference cell
T1	s	-	The length of the time interval from the beginning of the test until T2
T2	s	5.12	The length of the time interval that follows immediately after time interval T1
T3	s	5.12	The length of the time interval that follows immediately after time interval T2

T4	s	5.12	The length of the time interval that follows immediately after time interval T3
T5	s	5.12	The length of the time interval that follows immediately after time interval T4
T6	s	≥ 57	The length of the time interval that follows immediately after time interval T5

9.6.3.4.2 Test procedure

The test consists of six consecutive time intervals, with durations of T1, T2, T3, T4, T5 and T6. nCell 1 is active throughout T1, T2, T3, T4, T5 and T6, whilst nCell 2 and nCell 3 are activated only in the beginning of T2. nCell 2 is active until the end of T5 and nCell 3 is active until the end of T4. nCell 1 transmits NPRS in T2 and T4, while nCell 2 transmits NPRS in T3 and T5 and nCell 3 transmits NPRS only in T2 and T4. Note: The information on when NPRS is muted is conveyed to the UE using PRS muting information.

NOTE: The information on when PRS is muted is conveyed to the UE using PRS muting information in the OTDOA assistance data.

The OTDOA-RequestLocationInformation message and the OTDOA assistance data as defined in clause 9.6.3.4.3 shall be provided to the UE during the set-up period, T1. After the receipt of the OTDOA assistance data and *OTDOA-RequestLocationInformation*, the UE is provided with a RRC connection release command. The last TTI containing the RRC connection release command shall be provided to the UE ΔT ms before the start of T2 where $\Delta T = 150$ ms. The UE is then expected to enter RRC_IDLE state before T4.

1. Ensure that the UE is in state Generic RB Established State 3A-NB with CP CIoT optimisation according to TS 36.508 [18] clause 8.1.5 in nCell 1.
2. T1 starts.
3. The SS shall send a RESET UE POSITIONING STORED INFORMATION message.
4. Set the parameters according to Table 9.6.3.5-1 and Table 9.6.3.5-2 as appropriate. Propagation conditions are set according to clause 4.7.2.1.
5. The SS shall send an LPP REQUEST CAPABILITIES message.
6. The UE shall send an LPP PROVIDE CAPABILITIES message indicating the OTDOA capabilities supported by the UE in the *OTDOA-ProvideCapabilities* IE.
7. The SS shall send a LPP PROVIDE ASSISTANCE DATA message, including the *OTDOA-ProvideAssistanceData* IE. If the UE message at step 6 includes the *ackRequested* set to TRUE, then the SS shall send an acknowledgment in the LPP PROVIDE ASSISTANCE DATA message.
8. The SS shall send a LPP REQUEST LOCATION INFORMATION message, including the *OTDOA-RequestLocationInformation* IE.
9. The SS shall send a RRC Connection Release to send the UE to RRC_IDLE state and ΔT ms after the last TTI containing the RRC connection release command, T2 starts, where $\Delta T = 150$ ms.
10. At the start of T2, the SS shall switch the power setting from T1 to T2 as specified in Table 9.6.3.5-2.
11. When T2 expires, the SS shall switch the power setting from T2 to T3 as specified in Table 9.6.3.5-2.
12. When T3 expires, the SS shall switch the power setting from T3 to T4 as specified in Table 9.6.3.5-2.
13. When T4 expires, the SS shall switch the power setting from T4 to T5 as specified in Table 9.6.3.5-2.
14. When T5 expires, the SS shall switch the power setting from T5 to T6 as specified in Table 9.6.3.5-1.
15. The UE shall perform location measurements in RRC_IDLE state and then start a Mobile Originated Data Transport according to TS 23.401 [42] clause 5.3.4B.2.

16. When the signalling connection between the UE and SS is re-established, the UE shall transmit a LPP PROVIDE LOCATION INFORMATION message, including the *OTDOA-ProvideLocationInformation* IE. The LPP PROVIDE LOCATION INFORMATION shall be transmitted within the response time (see clause 4.7.3) specified in clause 9.6.3.5. The UE shall perform and report the RSTD measurements for both nCell 2 and nCell 3 with respect to the reference cell in the OTDOA assistance data, nCell 1. If the UE transmits an *OTDOA-ProvideLocationInformation* IE including the *rstd* field for both nCell 2 and nCell 3 within the response time then the number of successful tests is increased by one. If the UE fails to report the *OTDOA-ProvideLocationInformation* IE with both the *rstd* fields included within the response time then the number of failure tests is increased by one.

17. If the UE message at step 16 includes the *ackRequested* IE set to TRUE, the SS shall send a LPP acknowledgement message.

18. Repeat step 2-17 until the confidence level according to Annex D is achieved.

9.6.3.4.3 Message contents

Same as in Clause 9.5.3.4.3.

9.6.3.5 Test requirement

Table 9.6.3.5-1 and 9.6.3.5-2 define the primary level settings including test tolerances for all tests.

Table 9.6.3.5-1: Cell Specific Test Parameters for Inter frequency RSTD Tests for T1 and T6

Parameter	Unit	nCell 1	nCell 2	nCell 3
NB-IoT RF Channel Number		1	2	2
NB-IoT Channel Bandwidth ($BW_{channel}$)	kHz	200	200	200
OCNG Pattern ^{Note 1}		NOP.3 FDD	N/A	N/A
NPDSCH parameters ^{Note 2}		R.18 HD-FDD	N/A	N/A
NPDCCH parameters ^{Note 2}		R.30 HD-FDD	N/A	N/A
NPBCH_RA	dB	0	N/A	N/A
NPBCH_RB				
NPSS_RA				
NSSS_RA				
NPDCCH_RA				
NPDCCH_RB				
NPDSCH_RA				
NPDSCH_RB				
OCNG_RA ^{Note 1}				
OCNG_RB ^{Note 1}				
N_{oc} ^{Note 3}	dBm/ 15 kHz	-98		
$NPRS \hat{E}_s / N_{oc}$	dB	-Infinity	-Infinity	-Infinity
\hat{E}_s / N_{oc}	dB	-2	-Infinity	-Infinity
Propagation Condition		AWGN		
Antenna Configuration		1x1		
Timing offset to nCell 1	µs	N/A	1	-1

- Note 1: OCNG shall be used such that the cell is fully allocated and a constant total transmitted power spectral density is achieved for all OFDM symbols. The OCNG pattern is chosen during the test according to the presence of a DL reference measurement channel.
- Note 2: The NPDSCH and NPDCCH reference measurement channels are used in the test only when a downlink transmission dedicated to the UE under test is required.
- Note 3: Interference from other cells and noise sources not specified in the test are assumed to be constant over subcarriers and time and shall be modelled as AWGN of appropriate power for N_{oc} to be fulfilled.

Table 9.6.3.5-2: Cell Specific Test Parameters for Inter frequency RSTD Tests for T2 to T5

Parameter	Unit	nCell 1		nCell 2		nCell 3		
		T2 and T4	T3 and T5	T2 and T4	T3 and T5	T2 and T4	T3 and T5	
$BW_{channel}$	kHz	200		200		200		
NB-IoT RF Channel Number		1		1		1		
OCNG patterns		NOP.3 FDD		N/A	NOP.3 FDD	NOP.3 FDD	N/A	
NPBCH_RA	dB	0		0		0		N/A
NPBCH_RB								
NPSS_RA								
NSSS_RA								
NPDCCH_RA								
NPDCCH_RB								
NPDSCH_RA								
NPDSCH_RB								
OCNG_RA ^{Note 1}								
OCNG_RB ^{Note 1}								
NPRS_RA	dB	-3	N/A	N/A	0	0	N/A	
N_{oc} ^{Note 2}	dBm/ 15 kHz	-98	-95	-98	-95	-98	-95	
$NPRS \hat{E}_s / N_{oc}$	dB	-15	-Infinity	-Infinity	-15	-15	-Infinity	
$NPRS \hat{E}_s / I_{ot}$ ^{Note 3}	dB	-15	-Infinity	-Infinity	-15	-15	-Infinity	
I_o ^{Note 3}	dBm/ 180kHz	-87.17	-87.20	-87.17	-87.15	-87.17	-87.15	
NPRP ^{Note 3}	dBm/ 15 kHz	-113	-Infinity	-Infinity	-110	-113	-Infinity	
NRSRP ^{Note 3}	dBm/ 15 kHz	-110	-107	-113	-110	-113	-Infinity	
\hat{E}_s / N_{oc} ^{Note 3}	dB	-12	-12	-15	-15	-15	-Infinity	
Propagation Condition		AWGN						
Antenna Configuration		1x1						
Timing offset to nCell 1	μ s	N/A		1		-1		
Note 1:	OCNG shall be used such that active cells (all, except nCell 3 in T3) are fully allocated and a constant total transmitted power spectral density is achieved for all OFDM symbols other than those in the subframes with transmitted NPRS.							
Note 2:	Interference from other cells and noise sources not specified in the test are assumed to be constant over subcarriers and time and shall be modelled as AWGN of appropriate power for N_{oc} to be fulfilled.							
Note 3:	If NPRS_RA is not "N/A", \hat{E}_s / N_{oc} , $NPRS \hat{E}_s / I_{ot}$, I_o , NRSRP and NPRP levels have been derived from other parameters and are given for information purpose. If NPRS_RA is "N/A", I_o and NRSRP levels have been derived from other parameters and are given for information purpose. These are not settable test parameters. Interference conditions shall be applied to all PRS symbols of DL positioning subframes.							

The response time including test tolerance is 78.3 s. The response time is equal to the LPP time IE value plus the test tolerance.

The LPP time IE value is derived from the maximum allowed RSTD reporting delay plus T2 and T3 plus ΔT , where $\Delta T = 150$ ms, giving a value of 77550 ms. This is rounded up to the next allowed LPP value of 78 seconds.

The maximum allowed RSTD reporting delay is 67.16 s. This time is measured starting from the beginning of time interval T4, to the moment when the UE starts to send preambles on the PRACH for sending the positioning

measurement report message to nCell1. The maximum allowed RSTD reporting delay is equal to $T_{\text{RSTD_inter_NB-IoT-EC}} + T_{\text{RandomAccess_NB-IoT-EC}}$.

The RSTD measurement time $T_{\text{RSTD_inter_NB-IoT-EC}}$ in the test is derived according to section 9.6.3.3 where it is equal to $T_{\text{RSTD_InterFreq_NB}}$. This gives the total RSTD measurement time of 11.52s for nCell 2 and nCell 3 with respect to the reference nCell 1

The random access to an already detected cell $T_{\text{RandomAccess_NB-IoT-EC}}$ can be expressed as: $T_{\text{evaluate_NB_inter_NB-IoT-EC}} + T_{\text{SI}} + T_{\text{PRACH_NB-IoT}}$,

Where:

$T_{\text{evaluate_NB_inter_NB-IoT-EC}} = 12800$ ms: see Table 4.6.2.4-1 in clause 4.6.2.4 in TS 36.133 [23].

$T_{\text{SI}} = 41560$ ms and is the time required for receiving all the relevant system information as defined in TS 36.331 [22] for the target NB-IoT FDD cell.

$T_{\text{PRACH_NB-IoT}} = 1280$ ms and is the additional delay caused by the random access procedure.

This gives $T_{\text{RandomAccess_NB-IoT-EC}} = 55.64$ s for the random access delay to an already detected cell in the test case.

The test tolerances are defined in clauses C.1.3 and C4.

The rate of the correct events for each neighbour cell observed during repeated tests shall be at least 90% with a confidence level of 95%, where the reported RSTD measurement for each correct event shall be within the RSTD reporting range specified in Clause 9.1.10.3, i.e., between RSTD_0000 and RSTD_12711.

9.6.4 Void

9.7 TDD RSTD Intra-Frequency Measurements for NB-IOT

9.7.1 TDD Intra Frequency RSTD Measurement Accuracy for NB-IOT Inband Mode in normal coverage

9.7.1.1 Test purpose

To verify that the RSTD TDD intra-frequency measurement accuracy is within the specified limits for NB-IOT Mode in normal coverage.

9.7.1.2 Test applicability

This test applies to all types of NB-IoT TDD UE release 15 and forward that supports UE-assisted OTDOA.

9.7.1.3 Minimum conformance requirements

The UE shall follow the procedure for RRC_IDLE state positioning measurement as defined in TS 36.305 [41] section 7.1.3.

When the physical layer cell identities of the neighbour cells together with the OTDOA assistance data have been provided and the UE has entered the RRC_IDLE state, the UE shall be able to detect and measure intra-frequency RSTD, specified in TS 36.214 [6], for at least $n = 16$ cells, including the reference cell, on the same carrier frequency f_1 as that of the reference cell within $T_{\text{RSTDIntraFreq,NB}}$ ms as given below:

$$T_{\text{RSTD IntraFreq,NB}} = T_{\text{NPRS}} \cdot (M-1) + \Delta \quad \text{ms}$$

where

$T_{\text{RSTDIntraFreq,NB}}$ is the total time for detecting and measuring at least n cells;

T_{NPRS} is the cell-specific positioning subframe configuration period as defined in TS 36.355 [4] if Part B subframe configuration is provided; otherwise if only Part A subframe configuration is provided, the T_{NPRS} equals to the length of the subframe pattern,

M is the number of NPRS positioning occasions as defined in Table 9.7.1.3-1,

$\Delta = T_{\text{NPRS}} \cdot \left\lceil \frac{n}{M} \right\rceil$ ms is the measurement time for a single NPRS positioning occasion which includes the sampling time and the processing time;

N_{NPRS} is the cell-specific number of NPRS subframes within a NPRS occasion as defined in TS 36.355 [4] if Part B subframe configuration is provided; if only Part A subframe configuration is provided, the NPRS occasion length is 10 ms,

$N_{\text{NPRS_total}}$ is the minimum number of NPRS subframes per cell measurement as defined in Table 9.7.1.3-2.

T_{NPRS} , N_{NPRS} , and $N_{\text{NPRS_total}}$ are the parameters of the same cell, for which $T_{\text{NPRS}} \cdot \left\lceil \frac{N_{\text{NPRS_total}}}{N_{\text{NPRS}}} \right\rceil$ is the largest among all the measured cells.

Table 9.7.1.3-1: Number of NPRS positioning occasions within $T_{\text{RSTDIntraFreq,NB}}$

Positioning subframe configuration period T_{NPRS}	Number of NPRS positioning occasions M	
	f1 ^{Note1}	f1 and f2 ^{Note2}
160 ms	16* $\left\lceil \frac{N_{\text{NPRS_total}}}{N_{\text{NPRS}}} \right\rceil$	32* $\left\lceil \frac{N_{\text{NPRS_total}}}{N_{\text{NPRS}}} \right\rceil$
>160 ms	8* $\left\lceil \frac{N_{\text{NPRS_total}}}{N_{\text{NPRS}}} \right\rceil$	16* $\left\lceil \frac{N_{\text{NPRS_total}}}{N_{\text{NPRS}}} \right\rceil$
Note 1: When only intra-frequency RSTD measurements are performed over cells belonging to the serving carrier frequency f1. Note 2: When intra-frequency RSTD and inter-frequency RSTD measurements are performed over cells belonging to the serving carrier frequency f1 and one inter-frequency carrier frequency f2, respectively.		

The UE physical layer shall be capable of reporting RSTD for the reference cell and all the neighbour cells i out of at least $(n-1)$ neighbour cells within $T_{\text{RSTDIntraFreq,NB}}$ provided:

$$\left(\text{NPRS } \hat{E}_s / \text{Iot} \right)_{\text{ref}} \geq -6 \text{ dB for all Frequency Bands for the reference cell,}$$

$$\left(\text{NPRS } \hat{E}_s / \text{Iot} \right)_i \geq -13 \text{ dB for all Frequency Bands for neighbour cell } i,$$

$$\left(\text{NPRS } \hat{E}_s / \text{Iot} \right)_{\text{ref}} \text{ and } \left(\text{NPRS } \hat{E}_s / \text{Iot} \right)_i \text{ conditions apply for all subframes of at least } L = \frac{M}{2} \text{ NPRS}$$

positioning occasions,

NPRP 1,2_{dBm} according to Annex E.5 for a corresponding Band

$\text{NPRS } \hat{E}_s / \text{Iot}$ is defined as the ratio of the average received energy per PRS RE during the useful part of the symbol to the average received power spectral density of the total noise and interference for this RE, where the ratio is measured over all REs which carry NPRS.

The time $T_{\text{RSTDIntraFreq,NB}}$ starts from the point when the UE has received both the OTDOA-RequestLocationInformation message and the OTDOA assistance data in the OTDOA-ProvideAssistanceData message

as specified in TS 36.355 [4], and the message and data have been delivered to the physical layer of the UE and the UE has entered the RRC_IDLE state.

The accuracy requirements in Table 9.7.1.3-2 are valid under the following conditions:

Conditions defined in 36.101 [2] Clause 7.3 for reference sensitivity are fulfilled.

NPRP 1,2_{dBm} according to Annex E.5 for a corresponding Band

There are no measurement gaps overlapping with the NPRS subframes of the measured serving cell.

The parameter expectedRSTDUncertainty signalled over LPP by E-SMLC as defined in TS 36.355 [4] is less than 5 μs.

Table 9.7.1.3-2: Intra RSTD measurement accuracy for normal coverage

Accuracy	Conditions					
	NPRS Ês/lot	UE NPRS measurement bandwidth on the reference cell and the measured neighbour cell <i>i</i> ^{Note 3}	Minimum number of available measurement subframes among the reference cell and the measured neighbour cell <i>i</i> , N_{NPRS_total} ^{Note 6}	lo ^{Note 4} range		
				E-UTRA operating band groups ^{Note 5}	Minimum lo ^{Note 1}	Maximum lo
T_s ^{Note 2}	dB	RB			dBm/15kHz	dBm/BW _{Channel}
±20	$(NPRS \hat{E}s/lot)_{ref} \geq -6dB$ and $(NPRS \hat{E}s/lot)_i \geq -13dB$	1	320	NTDD_G	-118	-70

NOTE 1: This minimum lo condition is expressed as the average lo per RE over all REs in an OFDM symbol.
 NOTE 2: T_s is the basic timing unit defined in TS 36.211 [26].
 NOTE 3: The serving cell, the reference cell, and the measured neighbour cell *i* are on the same carrier frequency.
 NOTE 4: The lo is defined in NPRS positioning subframes. The same lo range applies to NPRS and non-NPRS symbols. lo levels are different in NPRS and non-NPRS symbols within the same subframe.
 NOTE 5: E-UTRA operating band groups are as defined in Section 4.11.1.
 NOTE 6: N_{NPRS_total} can be in one or more NPRS positioning occasions.

The normative reference for this requirement is TS 36.133 [23] clauses 4.8.1, 9.1.22.10, A.3.23.2 and A.9.8.32.

9.7.1.4 Test description

9.7.1.4.1 Initial conditions

Test Environment: Normal; as defined in TS 36.508 [18] clause 8.1.1.

Frequencies to be tested: Mid Range, as defined in TS 36.508 [18] clause 8.1.3.1.1.

Channel bandwidth to be tested: 10 MHz.

1. Connect the SS and AWGN noise sources to the UE antenna connector or antenna connectors as shown in Annex A, Figure A.3 but using only the main TX/RX antenna.
2. The general test parameter settings are set up according to Table 9.7.1.4.1-1.

3. Propagation conditions are set according to clause 4.7.2.1.
4. Message contents are defined in clause 9.7.1.4.3.
5. All cells are on the same carrier frequency. nCell 1 is the serving cell and OTDOA assistance data reference cell; nCell 2 is the neighbour cell. eCell 1 and eCell 2 are the LTE donor cells to nCell 1 and nCell 2, respectively. The assistance data neighbour cell list includes in total 15 cells, where 14 of the cells are not simulated (dummy cells; as defined in TS 37.571-5 [20], clause 7.2.2).
6. The true RSTD (which is the receive time difference for frame 0 between nCell 2 and nCell 1 as seen at the UE antenna connector) is set to 92 Ts (about 3 μ s). Note that the related expectedRSTD values to be signalled over LPP are defined in Table 9.7.1.4-1.

Table 9.7.1.4-1: General test parameters

Parameter	Unit	Value	Comment
NB-IoT operational mode		Inband	
Reference cell		nCell 1	
Neighbor cells		nCell 2, eCell 2 and eCell 1	
NPDCCH parameters		R.26 NB-TDD	Specified in TS 36.133 [23] section A.3.1.6.1
nprsID		Test1: (nprsID of Cell 1 – nprsID of Cell 2)mod6=1	As defined in TS 36.355 [4]
nprs-period	ms	1280	As defined in TS 36.355 [4]
nprs-startSF		sf0	Subframe offset of the NPRS positioning occasion as defined in TS 36.355 [4]
Number of consecutive downlink positioning subframes nprs-NumSF		640	As defined in TS 36.355 [4]
NPRS muting info		nCell 1: '11110000' nCell 2: '11110000'	Corresponds to nprs-MutingInfoB defined in TS 36.355 [4]
PartA Configuration: subframePattern10-TDD		'01100011'	Corresponds to subframePattern10-TDD-r15 defined in TS 36.355 [4]
nprsSequenceInfo		BW _{channel} 10MHz: 130	Corresponds to nprsSequenceInfo defined in TS 36.355 [4]
CP length		Normal	
NPRACH Configuration		NPRACH.R-2	Refer to TS 36.133 [23] section A.3.18
DRX cycle length		1.28	The value shall be used for all cells in the test.
Expected RSTD	μ s	nCell 2: 3 Other neighbour cells: randomly between -3 and 3	The expected RSTD is what is expected at the receiver. The corresponding parameter in the OTDOA assistance data specified in TS 36.355 [4] is the expectedRSTD indicator
Expected RSTD uncertainty for all neighbour cells	μ s	5	The corresponding parameter in the OTDOA assistance data specified in TS 36.355 [4] is the expectedRSTD-Uncertainty index
Number of cells provided in OTDOA assistance data		16	Including the reference cell
Special subframe configuration		6	As specified in table 4.2-1 in TS 36.211 [26]
Uplink-downlink configuration		2	As specified in table 4.2-2 in TS 36.211 [26]
Measurement period	s	11.52	Derived according to the RSTD measurement period in clause 9.7.1.3

9.7.1.4.2 Test procedure

Same as in clause 9.5.1.4.2.

9.7.1.4.3 Message contents

Same as in clause 9.5.1.4.3.

9.7.1.5 Test requirement

Table 9.7.1.5-1 and 9.7.1.5-2 define the primary level settings including test tolerances for the test.

The RSTD TDD intra-frequency accuracy test shall meet the reported values in Table 9.7.1.5-3.

Table 9.7.1.5-1: Cell Specific Test Parameters for intra frequency RSTD Tests for NB-IOT Cells

Parameter	Unit	Test1	
		nCell 1	nCell 2
$BW_{channel}$	kHz	180	180
PRB location within eCell		eCell 1 $BW_{channel}$ 10MHz: 30	eCell 2 $BW_{channel}$ 10MHz: 30
NPBCH_RA	dB	0	0
NPBCH_RB			
NPSS_RA			
NSSS_RA			
NPDCCH_RA			
NPDCCH_RB			
NPDSCH_RA			
NPDSCH_RB			
OCNG_RA ^{Note 1}			
OCNG_RB ^{Note 1}			
NPRS_RA	dB	0.3	0.3
N_{oc} ^{Note 2}	dBm/ 15 kHz	-98	-98
$NPRS \hat{E}_s / N_{oc}$	dB	-5.7	-12.7
$NPRS \hat{E}_s / I_{ot}$ ^{Note 3}	dB	-5.7	-12.7
I_o ^{Note 3}	dBm/ 180kHz	-86.89	-86.89
NPRP ^{Note 3}	dBm/ 15 kHz	-103.7	-110.7
NRSRP ^{Note 3}	dBm/ 15 kHz	-104	-111
\hat{E}_s / N_{oc} ^{Note 3}	dB	-6	-13
Propagation Condition		AWGN	AWGN
Antenna Configuration		1x1	1x1
Timing offset to nCell 1	us	N/A	3
<p>Note 1: OCNG shall be used such that active cells are fully allocated and a constant total transmitted power spectral density is achieved for all OFDM symbols other than those in the subframes with transmitted NPRS.</p> <p>Note 2: Interference from other cells and noise sources not specified in the test are assumed to be constant over subcarriers and time and shall be modelled as AWGN of appropriate power for N_{oc} to be fulfilled.</p> <p>Note 3: If NPRS_RA is not "N/A", \hat{E}_s / N_{oc}, $NPRS \hat{E}_s / I_{ot}$, I_o, NRSRP and NPRP levels have been derived from other parameters and are given for information purpose. If NPRS_RA is "N/A", I_o and NRSRP levels have been derived from other parameters and are given for information purpose. These are not settable test parameters. Interference conditions shall be applied to all PRS symbols of DL positioning subframes.</p>			

Table 9.7.1.5-2: Cell Specific Test Parameters for intra frequency RSTD Tests for E-UTRA Cells

Parameter	Unit	eCell 1	eCell 2
-----------	------	---------	---------

		T1	T2	T3	T1	T2	T3
BW _{channel}	MHz	10			10		
NOCNG Pattern defined in TS 36.133 [23] section A.3.2.3.6	-	NOP.1 TDD			NOP.1 TDD		
PBCH_RA	dB	-3			-3		
PBCH_RB	dB						
PSS_RA	dB						
SSS_RA	dB						
PDCCH_RA	dB						
PDCCH_RB	dB						
PDSCH_RA	dB						
PDSCH_RB	dB						
OCNG_RA ^{Note 1}	dB						
OCNG_RB ^{Note 1}	dB						
N_{oc} ^{Note2}	dBm/15 kHz	-98			-98		
\hat{E}_s / N_{oc} ^{Note2}	dBm	0	0	0	-7	-7	-7
Propagation Condition		AWGN			AWGN		
Antenna Configuration		1x1			1x1		
Timing offset to eCell 1	us	-			3		
<p>Note 1: OCNG shall be used such that the Cell is fully allocated and a constant total transmitted power spectral density is achieved for all OFDM symbols.</p> <p>Note 2: Interference from other cells and noise sources not specified in the test is assumed to be constant over subcarriers and time and shall be modelled as AWGN of appropriate power N_{oc}.</p>							

Table 9.7.1.5-3: RSTD TDD intra-frequency accuracy requirements for the reported values

Lowest reported value	RSTD_6426
Highest reported value	RSTD_6468

For the overall test to pass, the ratio of successful reported values shall be more than 90% with a confidence level of 95%.

The expected response time is 12 s. The response time is equal to the LPP time IE value. The LPP time IE value is derived from the RSTD reporting delay plus ΔT , where $\Delta T = 150$ ms, giving a value of 11670 ms. This is rounded up to the next allowed LPP value of 12 seconds. The RSTD measurement reporting delay in the test is derived from the following expression, $T_{\text{RSTD IntraFreq,NB}} = T_{\text{NPRS}} \cdot (M - 1) + \Delta$ ms, where $T_{\text{NPRS}} = 1280$ ms, $M = 8$

$\left| N_{\text{NPRS_total}} / N_{\text{NPRS}} \right|$, $\Delta = T_{\text{NPRS}} \cdot \left[\frac{n}{M} \right]$, $N_{\text{NPRS_total}} = 320$ ms, $N_{\text{NPRS}} = 640$ ms and $n = 16$. All the parameters are

specified in clause 9.7.1.3 and Table 9.7.1.3-1. This gives the total RSTD reporting delay of 11520 ms for the 15 neighbour cells including nCell 2 with respect to the reference cell, nCell 1. This expected response time excludes any delay caused by RRC connection release before the RRC_IDLE mode measurement. This expected response time excludes any delay caused by establishing a signalling connection with the SS (including random access procedure) as defined in TS 36.305 [41] for LPP measurement reporting. The response time is not explicitly evaluated for this test; hence, no test tolerance values need to be applied.

9.7.2 TDD Intra Frequency RSTD Measurement Accuracy for NB-IOT Inband Mode in enhanced coverage

9.7.2.1 Test purpose

To verify that the RSTD TDD intra-frequency measurement accuracy is within the specified limits for NB-IOT Mode in enhanced coverage.

9.7.2.2 Test applicability

This test applies to all types of NB-IoT TDD UE release 15 and forward that supports UE-assisted OTDOA.

9.7.2.3 Minimum conformance requirements

Same as clause 9.7.1.3, replacing Table 9.7.1.3-1 with Table 9.7.2.3-1 and Table 9.7.1.3-2 with Table 9.7.2.3-2.

Table 9.7.2.3-1: Number of NPRS positioning occasions within $T_{RSTD \text{ IntraFreq, NB}}$

Positioning subframe configuration period T_{NPRS}	Number of NPRS positioning occasions M	
	f1 ^{Note1}	f1 and f2 ^{Note2}
160 ms	16* $N_{NPRS_total} / N_{NPRS}$	32* $N_{NPRS_total} / N_{NPRS}$
>160 ms	8* $N_{NPRS_total} / N_{NPRS}$	16* $N_{NPRS_total} / N_{NPRS}$
Note 1: When only intra-frequency RSTD measurements are performed over cells belonging to the serving carrier frequency f1. Note 2: When intra-frequency RSTD and inter-frequency RSTD measurements are performed over cells belonging to the serving carrier frequency f1 and one inter-frequency carrier frequency f2, respectively.		

The UE physical layer shall be capable of reporting RSTD for the reference cell and all the neighbour cells i out of at least $(n-1)$ neighbour cells within $T_{RSTD \text{ IntraFreq, NB}}$ provided:

$$\left(\text{NPRS } \hat{E}_s / \text{Iot} \right)_{ref} \geq -15 \text{ dB for all Frequency Bands for the reference cell,}$$

$$\left(\text{NPRS } \hat{E}_s / \text{Iot} \right)_i \geq -15 \text{ dB for all Frequency Bands for neighbour cell } i,$$

$$\left(\text{NPRS } \hat{E}_s / \text{Iot} \right)_{ref} \text{ and } \left(\text{NPRS } \hat{E}_s / \text{Iot} \right)_i \text{ conditions apply for all subframes of at least } L = \frac{M}{2} \text{ NPRS positioning occasions,}$$

NPRP 1,2_{dBm} according to Annex E.5 for a corresponding Band

$\text{NPRS } \hat{E}_s / \text{Iot}$ is defined as the ratio of the average received energy per PRS RE during the useful part of the symbol to the average received power spectral density of the total noise and interference for this RE, where the ratio is measured over all REs which carry NPRS.

Table 9.7.2.3-2: Intra RSTD measurement accuracy for normal coverage

Accuracy	Conditions					
	NPRS \hat{E}_s/Iot	UE NPRS measurement bandwidth on the reference cell and the measured neighbour cell i ^{Note 3}	Minimum number of available measurement subframes among the reference cell and the measured neighbour cell i , N_{NPRS_total} ^{Note 6}	I_0 ^{Note 4} range		
E-UTRA operating band groups ^{Note 5}				Minimum I_0 ^{Note 1}	Maximum I_0	
T_s ^{Note 2}	dB	RB		dBm/15kHz	dBm/BW _{Channel}	
± 32	$(\text{NPRS } \hat{E}_s/\text{Iot})_{ref} \geq -15\text{dB}$ and $(\text{NPRS } \hat{E}_s/\text{Iot})_i \geq -15\text{dB}$	1	320	NTDD_G	-118	-70

NOTE 1: This minimum I_0 condition is expressed as the average I_0 per RE over all REs in an OFDM symbol.

NOTE 2: T_s is the basic timing unit defined in TS 36.211 [26].
 NOTE 3: The serving cell, the reference cell, and the measured neighbour cell i are on the same carrier frequency.
 NOTE 4: The l_o is defined in NPRS positioning subframes. The same l_o range applies to NPRS and non-NPRS symbols. l_o levels are different in NPRS and non-NPRS symbols within the same subframe.
 NOTE 5: E-UTRA operating band groups are as defined in Section 4.11.1.
 NOTE 6: N_{NPRS_total} can be in one or more NPRS positioning occasions.

The normative reference for this requirement is TS 36.133 [23] clauses 4.8.2, 9.1.22.12, A.3.23.2 and A.9.8.34.

9.7.2.4 Test description

9.7.2.4.1 Initial conditions

Test Environment: Normal; as defined in TS 36.508 [18] clause 8.1.1.

Frequencies to be tested: Mid Range, as defined in TS 36.508 [18] clause 8.1.3.1.1.

Channel bandwidth to be tested: 10 MHz.

1. Connect the SS and AWGN noise sources to the UE antenna connector or antenna connectors as shown in Annex A, Figure A.3 but using only the main TX/RX antenna.
2. The general test parameter settings are set up according to Table 9.7.2.4.1-1.
3. Propagation conditions are set according to clause 4.7.2.1.
4. Message contents are defined in clause 9.7.2.4.3.
5. All cells are on the same carrier frequency. nCell 1 is the serving cell and OTDOA assistance data reference cell; nCell 2 is the neighbour cell. eCell 1 and eCell 2 are the LTE donor cells to nCell 1 and nCell 2, respectively. The assistance data neighbour cell list includes in total 15 cells, where 14 of the cells are not simulated (dummy cells; as defined in TS 37.571-5 [20], clause 7.2.2).
6. The true RSTD (which is the receive time difference for frame 0 between nCell 2 and nCell 1 as seen at the UE antenna connector) is set to 92 T_s (about 3 μs). Note that the related expectedRSTD values to be signalled over LPP are defined in Table 9.7.2.4-1.

Table 9.7.2.4-1: General test parameters

Parameter	Unit	Value	Comment
NB-IoT operational mode		Inband	
Reference cell		nCell 1	
Neighbor cells		nCell 2, eCell 2 and eCell 1	
NPDCCH parameters		R.26 NB-TDD	Specified in TS 36.133 [23] section A.3.1.6.1
nprsID		Test1: (nprsID of Cell 1 – nprsID of Cell 2) mod 6 = 1	As defined in TS 36.355 [4]
nprs-period	ms	1280	As defined in TS 36.355 [4]
nprs-startSF		sf0	Subframe offset of the NPRS positioning occasion as defined in TS 36.355 [4]
Number of consecutive downlink positioning subframes nprs-NumSF		640	As defined in TS 36.355 [4]
NPRS muting info		nCell 1: '11110000' nCell 2: '11110000'	Corresponds to nprs-MutingInfoB defined in TS 36.355 [4]
PartA Configuration: subframePattern10-TDD		'01100011'	Corresponds to subframePattern10-TDD-r15 defined in TS 36.355 [4]
nprsSequenceInfo		BW _{channel} 10MHz: 130	Corresponds to nprsSequenceInfo defined in TS 36.355 [4]
CP length		Normal	

NPRACH Configuration		NPRACH.R-2	Refer to TS 36.133 [23] section A.3.18
DRX cycle length		1.28	The value shall be used for all cells in the test.
Expected RSTD	μs	nCell 2: 3 Other neighbour cells: randomly between -3 and 3	The expected RSTD is what is expected at the receiver. The corresponding parameter in the OTDOA assistance data specified in TS 36.355 [4] is the expectedRSTD indicator
Expected RSTD uncertainty for all neighbour cells	μs	5	The corresponding parameter in the OTDOA assistance data specified in TS 36.355 [4] is the expectedRSTD-Uncertainty index
Number of cells provided in OTDOA assistance data		16	Including the reference cell
Special subframe configuration		6	As specified in table 4.2-1 in TS 36.211 [26]
Uplink-downlink configuration		2	As specified in table 4.2-2 in TS 36.211 [26]
Measurement period	s	11.52	Derived according to the RSTD measurement period in clause 9.7.2.3

9.7.2.4.2 Test procedure

Same as in clause 9.5.2.4.2.

9.7.2.4.3 Message contents

Same as in clause 9.5.2.4.3.

9.7.2.5 Test requirement

Table 9.7.2.5-1 and 9.7.2.5-2 define the primary level settings including test tolerances for the test.

The RSTD TDD intra-frequency accuracy test shall meet the reported values in Table 9.7.2.5-3.

Table 9.7.2.5-1: Cell Specific Test Parameters for intra frequency RSTD Tests for NB-IOT Cells

Parameter	Unit	Test1	
		nCell 1	nCell 2
BW_{channel}	kHz	180	180
PRB location within eCell		eCell 1 BW_{channel} 10MHz: 30	eCell 2 BW_{channel} 10MHz: 30
NPBCH_RA	dB	0	0
NPBCH_RB			
NPSS_RA			
NSSS_RA			
NPDCCH_RA			
NPDCCH_RB			
NPDSCH_RA			
NPDSCH_RB			
OCNG_RA ^{Note 1}			
OCNG_RB ^{Note 1}			
NPRS_RA	dB	0.3	0.3
N_{oc} ^{Note 2}	dBm/ 15 kHz	-98	-98
$NPRS \hat{E}_s / N_{oc}$	dB	-14.3	-14.3
$NPRS \hat{E}_s / I_{ot}$ ^{Note 3}	dB	-14.3	-14.3
I_o ^{Note 3}	dBm/ 180kHz	-87.14	-87.14

NPRP ^{Note 3}	dBm/ 15 kHz	-112.7	-112.7
NRSRP ^{Note 3}	dBm/ 15 kHz	-113	-113
\hat{E}_s/N_{oc} ^{Note 3}	dB	-15	-15
Propagation Condition		AWGN	AWGN
Antenna Configuration		1x1	1x1
Timing offset to nCell 1	us	N/A	3
Note 1:	OCNG shall be used such that active cells are fully allocated and a constant total transmitted power spectral density is achieved for all OFDM symbols other than those in the subframes with transmitted NPRS.		
Note 2:	Interference from other cells and noise sources not specified in the test are assumed to be constant over subcarriers and time and shall be modelled as AWGN of appropriate power for N_{oc} to be fulfilled.		
Note 3:	If NPRS_RA is not "N/A", \hat{E}_s/N_{oc} , NPRS \hat{E}_s/I_{ot} , lo, NRSRP and NPRP levels have been derived from other parameters and are given for information purpose. If NPRS_RA is "N/A", lo and NRSRP levels have been derived from other parameters and are given for information purpose. These are not settable test parameters. Interference conditions shall be applied to all PRS symbols of DL positioning subframes.		

Table 9.7.2.5-2: Cell Specific Test Parameters for intra frequency RSTD Tests for E-UTRA Cells

Parameter	Unit	eCell 1			eCell 2		
		T1	T2	T3	T1	T2	T3
$BW_{channel}$	MHz	10			10		
NOCNG Pattern defined in TS 36.133 [23] section A.3.2.3.6	-	NOP.1 TDD			NOP.1 TDD		
PBCH_RA	dB	-3			-3		
PBCH_RB	dB						
PSS_RA	dB						
SSS_RA	dB						
PDCCH_RA	dB						
PDCCH_RB	dB						
PDSCH_RA	dB						
PDSCH_RB	dB						
OCNG_RA ^{Note 1}	dB						
OCNG_RB ^{Note 1}	dB						
N_{oc} ^{Note2}	dBm/15 kHz	-98			-98		
\hat{E}_s / N_{oc} ^{Note2}	dBm	-9	-9	-9	-9	-9	-9
Propagation Condition		AWGN			AWGN		
Antenna Configuration		1x1			1x1		
Timing offset to eCell 1	us	-			3		
Note 1: OCNG shall be used such that the Cell is fully allocated and a constant total transmitted power spectral density is achieved for all OFDM symbols. Note 2: Interference from other cells and noise sources not specified in the test is assumed to be constant over subcarriers and time and shall be modelled as AWGN of appropriate power N_{oc} .							

Table 9.7.2.5-3: RSTD TDD intra-frequency accuracy requirements for the reported values

Lowest reported value	RSTD_6414
Highest reported value	RSTD_6480

For the overall test to pass, the ratio of successful reported values shall be more than 90% with a confidence level of 95%.

The expected response time is 12 s. The response time is equal to the LPP time IE value. The LPP time IE value is derived from the RSTD reporting delay plus ΔT , where $\Delta T = 150$ ms, giving a value of 11670 ms. This is rounded up to the next allowed LPP value of 12 seconds. The RSTD measurement reporting delay in the test is derived from the following expression, $T_{RSTD\ IntraFreq,NB} = T_{NPRS} \cdot (M - 1) + \Delta$ ms, where $T_{NPRS} = 1280$ ms, $M = 8$

$$\left\lfloor N_{NPRS_total} / N_{NPRS} \right\rfloor, \Delta = T_{NPRS} \cdot \left\lceil \frac{n}{M} \right\rceil, N_{NPRS_total} = 320 \text{ ms}, N_{NPRS} = 640 \text{ ms and } n = 16. \text{ All the parameters are}$$

specified in clause 9.7.2.3 and Table 9.7.2.3-1. This gives the total RSTD reporting delay of 11520 ms for the 15 neighbour cells including nCell 2 with respect to the reference cell, nCell 1. This expected response time excludes any delay caused by RRC connection release before the RRC_IDLE mode measurement. This expected response time excludes any delay caused by establishing a signalling connection with the SS (including random access procedure) as defined in TS 36.305 [41] for LPP measurement reporting. The response time is not explicitly evaluated for this test; hence, no test tolerance values need to be applied.

9.7.3 TDD Intra Frequency RSTD Measurement Reporting Delay for NB-IOT Standalone Mode in enhanced coverage

9.7.3.1 Test purpose

To verify that the RSTD TDD intra-frequency measurement reporting delay is within the specified limits for NB-IOT Standalone Mode in enhanced coverage.

9.7.3.2 Test applicability

This test applies to all types of NB-IoT TDD UE release 15 and forward that supports UE-assisted OTDOA.

9.7.3.3 Minimum conformance requirements

The UE shall follow the procedure for RRC_IDLE state positioning measurement as defined in TS 36.305 [41] section 7.1.3.

When the physical layer cell identities of neighbour cells together with the OTDOA assistance data have been provided and the UE has entered the RRC_IDLE state, the UE shall be able to detect and measure intra-frequency RSTD, specified in TS 36.214 [6], for at least $n = 16$ cells, including the reference cell, on the same carrier frequency $f1$ as that of the reference cell within $T_{RSTD \text{ IntraFreq, NB}}$ ms as given below:

$$T_{RSTD \text{ IntraFreq, NB}} = T_{NPRS} \cdot (M - 1) + \Delta \quad \text{ms} ,$$

where

$T_{RSTD \text{ IntraFreq, NB}}$ is the total time for detecting and measuring at least n cells;

T_{NPRS} is the cell-specific positioning subframe configuration period as defined in TS 36.355 [4] if Part B subframe configuration is provided; otherwise if only Part A subframe configuration is provided, the T_{NPRS} equals to the length of the subframe pattern,

M is the number of NPRS positioning occasions as defined in Table 9.7.3.3-1,

$\Delta = T_{NPRS} \cdot \left\lceil \frac{n}{M} \right\rceil$ ms is the measurement time for a single NPRS positioning occasion which includes the sampling time and the processing time;

N_{NPRS} is the cell-specific number of NPRS subframes within a NPRS occasion as defined in TS 36.355 [4] if Part B subframe configuration is provided; if only Part A subframe configuration is provided, the NPRS occasion length is 10 ms,

N_{NPRS_total} is the minimum number of NPRS subframes per cell measurement as defined in Table 9.7.3.3-2.

T_{NPRS} , N_{NPRS} , and N_{NPRS_total} are the parameters of the same cell, for which $T_{NPRS} \cdot \left\lceil \frac{N_{NPRS_total}}{N_{NPRS}} \right\rceil$ is the largest among all the measured cells.

Table 9.7.3.3-1: Number of NPRS positioning occasions within $T_{RSTD \text{ IntraFreq, NB}}$

Positioning subframe configuration period T_{NPRS}	Number of NPRS positioning occasions M	
	$f1$ ^{Note1}	$f1$ and $f2$ ^{Note2}
160 ms	$16^* \left\lceil \frac{N_{NPRS_total}}{N_{NPRS}} \right\rceil$	$32^* \left\lceil \frac{N_{NPRS_total}}{N_{NPRS}} \right\rceil$

>160 ms	$8^* \left N_{NPRS_total} / N_{NPRS} \right $	$16^* \left N_{NPRS_total} / N_{NPRS} \right $
Note 1:	When only intra-frequency RSTD measurements are performed over cells belonging to the serving carrier frequency f1.	
Note 2:	When intra-frequency RSTD and inter-frequency RSTD measurements are performed over cells belonging to the serving carrier frequency f1 and one inter-frequency carrier frequency f2, respectively.	

The UE physical layer shall be capable of reporting RSTD for the reference cell and all the neighbour cells i out of at least $(n-1)$ neighbour cells within $T_{RSTD_IntraFreq_NB}$ provided:

$$\left(NPRS \hat{E}_s / Iot \right)_{ref} \geq -15 \text{ dB for all Frequency Bands for the reference cell,}$$

$$\left(NPRS \hat{E}_s / Iot \right)_i \geq -15 \text{ dB for all Frequency Bands for neighbour cell } i,$$

$$\left(NPRS \hat{E}_s / Iot \right)_{ref} \text{ and } \left(NPRS \hat{E}_s / Iot \right)_i \text{ conditions apply for all subframes of at least } L = \frac{M}{2} \text{ NPRS}$$

positioning occasions,

NPRP 1,2_{dBm} according to Annex E.5 for a corresponding Band

$NPRS \hat{E}_s / Iot$ is defined as the ratio of the average received energy per PRS RE during the useful part of the symbol to the average received power spectral density of the total noise and interference for this RE, where the ratio is measured over all REs which carry NPRS.

The time $T_{RSTD_IntraFreq_NB}$ starts from the point when the UE has received both the OTDOA-

RequestLocationInformation message and the OTDOA assistance data in the OTDOA-ProvideAssistanceData message as specified in TS 36.355 [4], and the message and data have been delivered to the physical layer of the UE, and the UE has entered the RRC_IDLE state.

After receiving both the OTDOA-RequestLocationInformation message and the OTDOA assistance data in the OTDOA-ProvideAssistanceData message as specified in TS 36.355 [4], the UE shall be sent to RRC IDLE state. The maximum allowed RSTD reporting delay is defined as the time between the point when the UE has entered the RRC_IDLE state, and the point when the UE is ready to transmit the measurement report over the air interface and starts to establish a signalling connection with the MME.

The maximum allowed RSTD reporting delay shall be less than $T_{RSTD_IntraFreq_NB} + T_{RandomAccess_NB-IoT-EC}$.

The normative reference for this requirement is TS 36.133 [23] clauses 4.8.2, 4.8.2.1, A.3.23.2 and A.4.7.3.

9.7.3.4 Test description

9.7.3.4.1 Initial conditions

Test Environment: Normal; as defined in TS 36.508 [18] clause 8.1.1.

Frequencies to be tested: Mid Range, as defined in TS 36.508 [18] clause 8.1.3.1.1.

Channel bandwidth to be tested: 200 kHz as defined in TS 36.508 [18] clause 8.1.3.1.

1. Connect the SS and AWGN noise sources to the UE antenna connector or antenna connectors as shown in Annex A, Figure A.3 but using only the main TX/RX antenna.
2. The general test parameter settings are set up according to Table 9.7.3.4.1-1.
3. Propagation conditions are set according to clause 4.7.2.1.
4. Message contents are defined in clause 9.7.3.4.3.

5. There are three synchronous cells: nCell 1, nCell 2 and nCell 3. nCell 1 is the reference as well as the serving cell. nCell 2 and nCell 3 are the neighbour cells. All cells are on the same RF channel. The assistance data neighbour cell list includes in total 15 cells, where 13 of the cells are not simulated (dummy cells; as defined in TS 37.571-5 [20], clause 7.2.2).
6. The true RSTD (which is the receive time difference for frame 0 between nCell 2 and nCell 1 as seen at the UE antenna connector) is set to 31 Ts (about 1 μ s between neighbour nCell 2 and serving nCell 1; and set to -31 Ts (about -1 μ s) between neighbour nCell 3 and serving nCell 1

Table 9.7.3.4-1: General test parameters

Parameter	Unit	Value	Comment
NB-IoT operational mode		Standalone	
Reference cell		nCell 1	Reference cell is the cell in the OTDOA assistance data with respect to which the RSTD measurement is defined, as specified in TS 36.214 [6] and TS 36.355 [4]. The reference cell is the PCell in this test case.
Neighbor cells		nCell 2 and nCell 3	Cell 2 and Cell 3 appear at random places in the neighbour cell list in the OTDOA assistance data, but Cell 2 always appears in the first half of the list, whilst Cell 3 appears in the second half of the list.
nprsID		(nprsID of Cell 1 – nprsID of Cell 2)mod6=1 and (nprsID of Cell 1 – nprsID of Cell 3)mod6=2	As defined in TS 36.355 [4]
nprs-period	ms	1280	As defined in TS 36.355 [4]
nprs-startSF		sf0	Subframe offset of the NPRS positioning occasion as defined in TS 36.355 [4]
Number of consecutive downlink positioning subframes nprs-NumSF		640	As defined in TS 36.355 [4]
NPRS muting info		nCell 1: '11110000' nCell 2: '00001111' nCell 3: '11110000'	Corresponds to nprs-MutingInfoB defined in TS 36.355 [4]
Part A Configuration		N/A	NPRS is configured based on Part B but not Part A.
CP length		Normal	
NPRACH Configuration		NPRACH.R-2	Refer to A.3.18
DRX cycle length		1.28	The value shall be used for all cells in the test.
Radio frame receive time offset between the cells at the UE antenna connector	μ s	nCell 2 to nCell 1: 1 nCell 3 to nCell 1: -1	PRS are transmitted from synchronous cells
Expected RSTD	μ s	nCell 2: 3 nCell 3: 3 Other neighbour cells: randomly between -3 and 3	The expected RSTD is what is expected at the receiver. The corresponding parameter in the OTDOA assistance data specified in TS 36.355 [4] is the expectedRSTD indicator
Expected RSTD uncertainty for all neighbour cells	μ s	5	The corresponding parameter in the OTDOA assistance data specified in TS 36.355 [4] is the expectedRSTD-Uncertainty index
Number of cells provided in OTDOA assistance data		16	Including the reference cell
Special subframe configuration		6	As specified in table 4.2-1 in TS 36.211 [26]

Uplink-downlink configuration		2	As specified in table 4.2-2 in TS 36.211 [26]
T2	s	5.12	The length of the time interval that follows immediately after time interval T1
T3	s	5.12	The length of the time interval that follows immediately after time interval T2
T4	s	5.12	The length of the time interval that follows immediately after time interval T3
T5	s	5.12	The length of the time interval that follows immediately after time interval T4
T6	s	≥ 58.2	The length of the time interval that follows immediately after time interval T5

9.7.3.4.2 Test procedure

Same as in clause 9.5.3.4.2.

9.7.3.4.3 Message contents

Same as in clause 9.5.3.4.3.

9.7.3.5 Test requirement

Table 9.7.3.5-1 and 9.7.3.5-2 define the primary level settings including test tolerances for the test.

Table 9.7.3.5-1: Cell Specific Test Parameters for intra frequency RSTD Tests for T1 and T6

Parameter	Unit	nCell 1	nCell 2	nCell 3
NB-IoT RF Channel Number		1	1	1
NB-IoT Channel Bandwidth (BW_{channel})	kHz	200	200	200
OCNG Pattern ^{Note 1}		NOP.3 TDD	N/A	N/A
NPDSCH parameters ^{Note 2}		R.18 NB-TDD	N/A	N/A
NPDCCH parameters ^{Note 2}		R.30 NB-TDD	N/A	N/A
NPBCH_RA	dB	0	N/A	N/A
NPBCH_RB				
NPSS_RA				
NSSS_RA				
NPDCCH_RA				
NPDCCH_RB				
NPDSCH_RA				
NPDSCH_RB				
OCNG_RA ^{Note 1}				
OCNG_RB ^{Note 1}				
N_{oc} ^{Note 3}	dBm/ 15 kHz	-98		
$NPRS \hat{E}_s / N_{oc}$	dB	-Infinity	-Infinity	-Infinity
\hat{E}_s / N_{oc}	dB	-2	-Infinity	-Infinity
Propagation Condition		AWGN		
Antenna Configuration		1x1		

Timing offset to nCell 1	μs	N/A	1	-1
Note 1:	OCNG shall be used such that the cell is fully allocated and a constant total transmitted power spectral density is achieved for all OFDM symbols. The OCNG pattern is chosen during the test according to the presence of a DL reference measurement channel.			
Note 2:	The NPDSCH and NPDCCH reference measurement channels are used in the test only when a downlink transmission dedicated to the UE under test is required.			
Note 3:	Interference from other cells and noise sources not specified in the test are assumed to be constant over subcarriers and time and shall be modelled as AWGN of appropriate power for N_{oc} to be fulfilled.			

Table 9.7.3.5-2: Cell Specific Test Parameters for intra frequency RSTD Tests for T2 to T5

Parameter	Unit	nCell 1		nCell 2		nCell 3		
		T2 and T4	T3 and T5	T2 and T4	T3 and T5	T2 and T4	T3 and T5	
BW _{channel}	kHz	200		200		200		
NB-IoT RF Channel Number		1		1		1		
OCNG patterns		NOP.3 TDD		N/A	NOP.3 TDD	NOP.3 TDD	N/A	
NPBCH_RA	dB	0		0		0		N/A
NPBCH_RB								
NPSS_RA								
NSSS_RA								
NPDCCH_RA								
NPDCCH_RB								
NPDSCH_RA								
NPDSCH_RB								
OCNG_RA ^{Note 1}								
OCNG_RB ^{Note 1}								
NPRS_RA	dB	-3	N/A	N/A	0	0	N/A	
N_{oc} ^{Note 3}	dBm/ 15 kHz	-98	-95	-98	-95	-98	-95	
$NPRS \hat{E}_s/N_{oc}$	dB	-15	-Infinity	-Infinity	-15	-15	-Infinity	
$NPRS \hat{E}_s/I_{ot}$ ^{Note 4}	dB	-15	-Infinity	-Infinity	-15	-15	-Infinity	
I_o ^{Note 4}	dBm/ 180kHz	-87.14	-87.12	-87.14	-87.12	-87.14	-87.12	
NPRP ^{Note 4}	dBm/ 15 kHz	-113	-Infinity	-Infinity	-110	-113	-Infinity	
NRSRP ^{Note 4}	dBm/ 15 kHz	-110	-107	-113	-110	-113	-Infinity	
\hat{E}_s/N_{oc} ^{Note 4}	dB	-12	-12	-15	-15	-15	-Infinity	
Propagation Condition		AWGN						
Antenna Configuration		1x1						
Timing offset to nCell 1	μs	N/A		1		-1		
<p>Note 1: OCNG shall be used such that active cells (all, except Cell 3 in T3) are fully allocated and a constant total transmitted power spectral density is achieved for all OFDM symbols other than those in the subframes with transmitted NPRS.</p> <p>Note 3: Interference from other cells and noise sources not specified in the test are assumed to be constant over subcarriers and time and shall be modelled as AWGN of appropriate power for N_{oc} to be fulfilled.</p> <p>Note 4: If NPRS_RA is not "N/A", \hat{E}_s/N_{oc}, $NPRS \hat{E}_s/I_{ot}$, I_o, NRSRP and NPRP levels have been derived from other parameters and are given for information purpose. If NPRS_RA is "N/A", I_o and NRSRP levels have been derived from other parameters and are given for information purpose. These are not settable test parameters. Interference conditions shall be applied to all PRS symbols of DL positioning subframes.</p>								

The response time including test tolerance is 79.3 s. The response time is equal to the LPP time IE value plus the test tolerance.

The LPP time IE value is derived from the maximum allowed RSTD reporting delay plus T2 and T3 plus ΔT , where $\Delta T = 150$ ms, giving a value of 78830 ms. This is rounded up to the next allowed LPP value of 79 seconds.

The maximum allowed RSTD reporting delay is 68.44 s. This time is measured starting from the beginning of time interval T4, to the moment when the UE starts to send preambles on the PRACH for sending the positioning

measurement report message to nCell1. The maximum allowed RSTD reporting delay is equal to $T_{\text{RSTD_intra_NB-IoT-EC}} + T_{\text{RandomAccess_NB-IoT-EC}}$.

The RSTD measurement time $T_{\text{RSTD_intra_NB-IoT-EC}}$ in the test is derived according to section 9.7.3.3 where it is equal to $T_{\text{RSTD_IntraFreq_NB}}$. This gives the total RSTD measurement time of 11.52s for nCell 2 and nCell 3 with respect to the reference nCell 1

The random access to an already detected cell $T_{\text{RandomAccess_NB-IoT-EC}}$ can be expressed as: $T_{\text{evaluate_NB_intra_NB-IoT-EC}} + T_{\text{SI}} + T_{\text{PRACH_NB-IoT}}$,

Where:

$T_{\text{evaluate_NB_intra_NB-IoT-EC}} = 12800$ ms: see Table 4.6.2.4-1 in clause 4.6.2.4 in TS 36.133 [23].

$T_{\text{SI}} = 41560$ ms and is the time required for receiving all the relevant system information as defined in TS 36.331 [22] for the target NB-IoT TDD cell.

$T_{\text{PRACH_NB-IoT}} = 2560$ ms and is the additional delay caused by the random access procedure.

This gives $T_{\text{RandomAccess_NB-IoT-EC}} = 56.92$ s for the random access delay to an already detected cell in the test case.

The test tolerances are defined in clauses C.1.3 and C4.

The rate of the correct events for each neighbour cell observed during repeated tests shall be at least 90% with a confidence level of 95%, where the reported RSTD measurement for each correct event shall be within the RSTD reporting range specified in Clause 9.1.10.3, i.e., between RSTD_0000 and RSTD_12711.

9.8 TDD RSTD Inter-Frequency Measurements for NB-IOT

9.8.1 TDD Inter Frequency RSTD Measurement Accuracy for NB-IOT Inband Mode in normal coverage

9.8.1.1 Test purpose

To verify that the RSTD TDD inter-frequency measurement accuracy is within the specified limits for NB-IOT Mode in normal coverage.

9.8.1.2 Test applicability

This test applies to all types of NB-IoT TDD UE release 15 and forward that supports UE-assisted OTDOA and inter-frequency RSTD measurements.

9.8.1.3 Minimum conformance requirements

The UE shall follow the procedure for RRC_IDLE state positioning measurement as defined in TS 36.305 [41] section 7.1.3.

All positioning subframes indicated in the OTDOA assistance data and specified in sub-clause 9.1.22.11 are available for RSTD measurements in the measured and reference cell.

When the physical layer cell identities of neighbour cells together with the OTDOA assistance data have been provided and the UE has entered the RRC_IDLE state, the UE shall be able to detect and measure inter-frequency RSTD, specified in TS 36.214 [6], for at least $n = 16$ cells, including the reference cell within $T_{\text{RSTD_InterFreq_NB}}$ ms as given below:

$$T_{\text{RSTD_InterFreq_NB}} = T_{\text{NPRS}} \cdot (M-1) + \Delta \quad \text{ms},$$

where

$T_{\text{RSTD_InterFreq_NB}}$ is the total time for detecting and measuring at least n cells;

T_{NPRS} is the cell-specific positioning subframe configuration period as defined in TS 36.355 [4] if Part B subframe configuration is provided; otherwise if only Part A subframe configuration is provided, the T_{NPRS} equals to the length of the subframe pattern,

M is the number of NPRS positioning occasions as defined in Table 9.8.1.3-1,

$\Delta = T_{\text{NPRS}} \cdot \left\lceil \frac{n}{M} \right\rceil$ ms is the measurement time for a single NPRS positioning occasion which includes the sampling time and the processing time;

N_{NPRS} is the cell-specific number of NPRS subframes within a NPRS occasion as defined in TS 36.355 [4] if Part B subframe configuration is provided; if only Part A subframe configuration is provided, the NPRS occasion length is 10 ms,

$N_{\text{NPRS_total}}$ is the minimum number of NPRS subframes per cell measurement as defined in Table 9.8.1.3-2.

T_{NPRS} , N_{NPRS} , and $N_{\text{NPRS_total}}$ are the parameters of the same cell, for which $T_{\text{NPRS}} \cdot \left\lceil \frac{N_{\text{NPRS_total}}}{N_{\text{NPRS}}} \right\rceil$ is the largest among all the measured cells.

Table 9.8.1.3-1: Number of NPRS positioning occasions within $T_{\text{RSTD InterFreq, NB}}$

Positioning subframe configuration period T_{NPRS}	Number of NPRS positioning occasions M	
	f1 ^{Note1}	f1 and f2 ^{Note2}
160 ms	16* $\left\lceil \frac{N_{\text{NPRS_total}}}{N_{\text{NPRS}}} \right\rceil$	32* $\left\lceil \frac{N_{\text{NPRS_total}}}{N_{\text{NPRS}}} \right\rceil$
>160 ms	8* $\left\lceil \frac{N_{\text{NPRS_total}}}{N_{\text{NPRS}}} \right\rceil$	16* $\left\lceil \frac{N_{\text{NPRS_total}}}{N_{\text{NPRS}}} \right\rceil$
Note 1:	When only intra-frequency RSTD measurements are performed over cells belonging to the serving carrier frequency f1.	
Note 2:	When intra-frequency RSTD and inter-frequency RSTD measurements are performed over cells belonging to the serving carrier frequency f1 and one inter-frequency carrier frequency f2, respectively.	

The UE physical layer shall be capable of reporting RSTD for the reference cell and all the neighbour cells i out of at least $(n-1)$ neighbour cells within $T_{\text{RSTD InterFreq, NB}}$ provided:

$$\left(\text{NPRS } \hat{E}_s / \text{Iot} \right)_{\text{ref}} \geq -6 \text{ dB for all Frequency Bands for the reference cell,}$$

$$\left(\text{NPRS } \hat{E}_s / \text{Iot} \right)_i \geq -13 \text{ dB for all Frequency Bands for neighbour cell } i,$$

$$\left(\text{NPRS } \hat{E}_s / \text{Iot} \right)_{\text{ref}} \text{ and } \left(\text{NPRS } \hat{E}_s / \text{Iot} \right)_i \text{ conditions apply for all subframes of at least } L = \frac{M}{2} \text{ NPRS positioning occasions,}$$

NPRP 1,2_{dBm} according to Annex E.5 for a corresponding Band

$\text{NPRS } \hat{E}_s / \text{Iot}$ is defined as the ratio of the average received energy per PRS RE during the useful part of the symbol to the average received power spectral density of the total noise and interference for this RE, where the ratio is measured over all REs which carry NPRS.

The time $T_{\text{RSTD InterFreq, NB}}$ starts from the point when the UE has received both the OTDOA-RequestLocationInformation message and the OTDOA assistance data in the OTDOA-ProvideAssistanceData message

as specified in TS 36.355 [4], and the message and data have been delivered to the physical layer of the UE and the UE has entered the RRC_IDLE state.

The accuracy requirements in Table 9.8.1.3-2 are valid under the following conditions:

Conditions defined in 36.101 [2] Clause 7.3 for reference sensitivity are fulfilled.

NPRP $1,2|_{dBm}$ according to Annex E.5 for a corresponding Band

There are no measurement gaps overlapping with the NPRS subframes of the measured serving cell.

The parameter expectedRSTDUncertainty signalled over LPP by E-SMLC as defined in TS 36.355 [4] is less than 5 μ s.

Table 9.8.1.3-2: Inter RSTD measurement accuracy for normal coverage

Accuracy	Conditions					
	NPRS \hat{E}_s/lot	UE NPRS measurement bandwidth on the reference cell and the measured neighbour cell i ^{Note 3}	Minimum number of available measurement subframes among the reference cell and the measured neighbour cell i , N_{NPRS_total} ^{Note 6}	lo ^{Note 4} range		
				E-UTRA operating band groups ^{Note 5}	Minimum lo ^{Note 1}	Maximum lo
T_s ^{Note 2}	dB	RB		dBm/15kHz	dBm/BW _{Channel}	
± 28	(NPRS \hat{E}_s/lot) _{ref} ≥ -6 dB and (NPRS \hat{E}_s/lot) _i ≥ -13 dB	1	320	NTDD_G	-118	-70

NOTE 1: This minimum lo condition is expressed as the average lo per RE over all REs in an OFDM symbol.
 NOTE 2: T_s is the basic timing unit defined in TS 36.211 [26].
 NOTE 3: The serving cell, the reference cell, and the measured neighbour cell i are on the same carrier frequency.
 NOTE 4: The lo is defined in NPRS positioning subframes. The same lo range applies to NPRS and non-NPRS symbols. lo levels are different in NPRS and non-NPRS symbols within the same subframe.
 NOTE 5: E-UTRA operating band groups for NB-IoT are as defined in Section 4.11.1.
 NOTE 6: N_{NPRS_total} can be in one or more NPRS positioning occasions.

The normative reference for this requirement is TS 36.133 [23] clauses 4.8.3, 9.1.22.11, A.3.23.2 and A.9.8.33.

9.8.1.4 Test description

9.8.1.4.1 Initial conditions

Test Environment: Normal; as defined in TS 36.508 [18] clause 8.1.1.

Frequencies to be tested: Mid Range, as defined in TS 36.508 [18] clause 8.1.3.1.1.

Channel bandwidth to be tested: 10 MHz.

1. Connect the SS and AWGN noise sources to the UE antenna connector or antenna connectors as shown in Annex A, Figure A.3 but using only the main TX/RX antenna.
2. The general test parameter settings are set up according to Table 9.8.1.4.1-1.
3. Propagation conditions are set according to clause 4.7.2.1.

4. Message contents are defined in clause 9.8.1.4.3.
5. The two NB-IOT cells are on different PRBs of the same LTE carrier frequency. The two LTE Cells are on the same carrier frequency. nCell 1 is the serving cell and OTDOA assistance data reference cell; nCell 2 is the neighbour cell. eCell 1 and eCell 2 are the LTE donor cells to nCell 1 and nCell 2, respectively. The assistance data neighbour cell list includes in total 15 cells, where 14 of the cells are not simulated (dummy cells; as defined in TS 37.571-5 [20], clause 7.2.2).
6. The true RSTD (which is the receive time difference for frame 0 between nCell 2 and nCell 1 as seen at the UE antenna connector) is set to 92 Ts (about 3 μ s). Note that the related expectedRSTD values to be signalled over LPP are defined in Table 9.8.1.4-1.

Table 9.8.1.4-1: General test parameters

Parameter	Unit	Value	Comment
NB-IoT operational mode		Inband	
Reference cell		nCell 1	
Neighbor cells		nCell 2, eCell 1 and eCell 2	
NPDCCH parameters		R.26 NB-TDD	Specified in TS 36.133 [23] section A.3.1.6.1
nprsID		Test1: (nprsID of Cell 1 – nprsID of Cell 2)mod6=1	As defined in TS 36.355 [4]
nprs-period	ms	1280	As defined in TS 36.355 [4]
nprs-startSF		sf0	Subframe offset of the NPRS positioning occasion as defined in TS 36.355 [4]
Number of consecutive downlink positioning subframes nprs-NumSF		640	As defined in TS 36.355 [4]
nprs-slotNumberOffset		0	As defined in TS 36.355 [4]
nprs-SubframeOffset		640	As defined in TS 36.355 [4]
Number of consecutive downlink positioning subframes nprs-NumSF		640	As defined in TS 36.355 [4]
NPRS muting info		nCell 1: '1111111100000000' nCell 2: '1111111100000000'	Corresponds to nprs-MutingInfoB defined in TS 36.355 [4]
PartA Configuration: subframePattern10-TDD		'01100011'	Corresponds to subframePattern10-TDD-r15 defined in TS 36.355 [4]
nprsSequenceInfo nCell1		BW _{channel} 10MHz: 130	Corresponds to nprsSequenceInfo defined in TS 36.355 [4]
nprsSequenceInfo nCell2		BW _{channel} 10MHz: 135	Corresponds to nprsSequenceInfo defined in TS36.355 [4]
CP length		Normal	
NPRACH Configuration		NPRACH.R-2	Refer to TS 36.133 [23] section A.3.18
DRX cycle length		1.28	The value shall be used for all cells in the test.
Expected RSTD	μ s	nCell 2: 3 Other neighbour cells: randomly between -3 and 3	The expected RSTD is what is expected at the receiver. The corresponding parameter in the OTDOA assistance data specified in TS 36.355 [4] is the expectedRSTD indicator
Expected RSTD uncertainty for all neighbour cells	μ s	5	The corresponding parameter in the OTDOA assistance data specified in TS 36.355 [4] is the expectedRSTD-Uncertainty index
Number of cells provided in OTDOA assistance data		16	Including the reference cell
Special subframe configuration		6	As specified in table 4.2-1 in TS 36.211 [26]

Uplink-downlink configuration		2	As specified in table 4.2-2 in TS 36.211 [26]
Measurement period	s	20.48	Derived according to the RSTD measurement period in TS 36.133 [23] 4.8.3

9.8.1.4.2 Test procedure

Same as in clause 9.6.1.4.2.

9.8.1.4.3 Message contents

Same as in clause 9.6.1.4.3.

9.8.1.5 Test requirement

Table 9.8.1.5-1 and 9.8.1.5-2 define the primary level settings including test tolerances for the test.

The RSTD TDD inter-frequency accuracy test shall meet the reported values in Table 9.8.1.5-3.

Table 9.8.1.5-1: Cell Specific Test Parameters for inter-frequency RSTD Tests for NB-IOT Cells

Parameter	Unit	Test1	
		nCell 1	nCell 2
BW_{channel}	kHz	180	180
PRB location within eCell		eCell 1 BW_{channel} 10MHz: 30	eCell 2 BW_{channel} 10MHz: 35
NPBCH_RA	dB	0	0
NPBCH_RB			
NPSS_RA			
NSSS_RA			
NPDCCH_RA			
NPDCCH_RB			
NPDSCH_RA			
NPDSCH_RB			
OCNG_RA ^{Note 1}			
OCNG_RB ^{Note 1}			
NPRS_RA	dB	0.3	0.3
N_{oc} ^{Note 2}	dBm/ 15 kHz	-98	-98
$NPRS \hat{E}_s / N_{oc}$	dB	-5.7	-12.7
$NPRS \hat{E}_s / I_{ot}$ ^{Note 3}	dB	-5.7	-12.7
I_o ^{Note 3}	dBm/ 15kHz	-86.93	-86.93
NPRP ^{Note 3}	dBm/ 15 kHz	-103.7	-110.7
NRSRP ^{Note 3}	dBm/ 15 kHz	-104	-111
\hat{E}_s / N_{oc} ^{Note 3}	dB	-6	-13
Propagation Condition		AWGN	AWGN
Antenna Configuration		1x1	1x1
Timing offset to nCell 1	us	N/A	3

- Note 1: OCNG shall be used such that active cells are fully allocated and a constant total transmitted power spectral density is achieved for all OFDM symbols other than those in the subframes with transmitted NPRS.
- Note 2: Interference from other cells and noise sources not specified in the test are assumed to be constant over subcarriers and time and shall be modelled as AWGN of appropriate power for N_{oc} to be fulfilled.
- Note 3: If NPRS_RA is not "N/A", \hat{E}_s/N_{oc} , NPRS \hat{E}_s/I_{ot} , I_o , NRSRP and NPRP levels have been derived from other parameters and are given for information purpose. If NPRS_RA is "N/A", I_o and NRSRP levels have been derived from other parameters and are given for information purpose. These are not settable test parameters. Interference conditions shall be applied to all PRS symbols of DL positioning subframes.

Table 9.8.1.5-2: Cell Specific Test Parameters for inter-frequency RSTD Tests for E-UTRA Cells

Parameter	Unit	eCell 1			eCell 2		
		T1	T2	T3	T1	T2	T3
$BW_{channel}$	MHz	10			10		
NOCNG Pattern defined in TS 36.133 [23] section A.3.2.3.6	-	NOP.1 TDD			NOP.1 TDD		
PBCH_RA	dB	-3			-3		
PBCH_RB	dB						
PSS_RA	dB						
SSS_RA	dB						
PDCCH_RA	dB						
PDCCH_RB	dB						
PDSCH_RA	dB						
PDSCH_RB	dB						
OCNG_RA ^{Note 1}	dB						
OCNG_RB ^{Note 1}	dB						
N_{oc} ^{Note2}	dBm/15 kHz	-98			-98		
\hat{E}_s / N_{oc} ^{Note2}	dBm	3	3	3	3	3	3
Propagation Condition		AWGN			AWGN		
Antenna Configuration		1x1			1x1		
Timing offset to eCell 1	us	-			3		
Note 1: OCNG shall be used such that the Cell is fully allocated and a constant total transmitted power spectral density is achieved for all OFDM symbols. Note 2: Interference from other cells and noise sources not specified in the test is assumed to be constant over subcarriers and time and shall be modelled as AWGN of appropriate power N_{oc} .							

Table 9.8.1.5-3: RSTD TDD inter-frequency accuracy requirements for the reported values

Lowest reported value	RSTD_6417
Highest reported value	RSTD_6477

For the overall test to pass, the ratio of successful reported values shall be more than 90% with a confidence level of 95%.

The expected response time is 21 s. The response time is equal to the LPP time IE value. The LPP time IE value is derived from the RSTD reporting delay plus ΔT , where $\Delta T = 150$ ms, giving a value of 20630 ms. This is rounded up to the next allowed LPP value of 21 seconds. The RSTD measurement reporting delay in the test is derived from the following expression, $T_{RSTD\ InterFreq,NB} = T_{NPRS} \cdot (M-1) + \Delta$ ms, where $T_{NPRS} = 1280$ ms, $M = 16$

$\left| N_{NPRS_total} / N_{NPRS} \right|$, $\Delta = T_{NPRS} \cdot \left\lceil \frac{n}{M} \right\rceil$, $N_{NPRS_total} = 320$ ms, $N_{NPRS} = 640$ ms and $n = 16$. All the parameters are specified in clause 9.8.1.3 and Table 9.8.1.3-1. This gives the total RSTD reporting delay of 20480 ms for the 15 neighbour cells including nCell 2 with respect to the reference cell, nCell 1. This expected response time excludes any delay caused by RRC connection release before the RRC_IDLE mode measurement. This expected response time excludes any delay caused by establishing a signalling connection with the SS (including random access procedure) as defined in TS 36.305 [41] for LPP measurement reporting. The response time is not explicitly evaluated for this test; hence, no test tolerance values need to be applied.

9.8.2 TDD Inter Frequency RSTD Measurement Accuracy for NB-IOT Inband Mode in enhanced coverage

9.8.2.1 Test purpose

To verify that the RSTD TDD inter-frequency measurement accuracy is within the specified limits for NB-IOT Mode in enhanced coverage.

9.8.2.2 Test applicability

This test applies to all types of NB-IoT TDD UE release 15 and forward that supports UE-assisted OTDOA and inter-frequency RSTD measurements.

9.8.2.3 Minimum conformance requirements

Same as clause 9.8.1.3, replacing Table 9.8.1.3-1 with Table 9.8.2.3-1 and Table 9.8.1.3-2 with Table 9.8.2.3-2.

Table 9.8.2.3-1: Number of NPRS positioning occasions within $T_{RSTD \text{ InterFreq, NB}}$

Positioning subframe configuration period T_{NPRS}	Number of NPRS positioning occasions M	
	f1 ^{Note1}	f1 and f2 ^{Note2}
160 ms	16* $N_{NPRS_total} / N_{NPRS}$	32* $N_{NPRS_total} / N_{NPRS}$
>160 ms	8* $N_{NPRS_total} / N_{NPRS}$	16* $N_{NPRS_total} / N_{NPRS}$
Note 1: When only intra-frequency RSTD measurements are performed over cells belonging to the serving carrier frequency f1. Note 2: When intra-frequency RSTD and inter-frequency RSTD measurements are performed over cells belonging to the serving carrier frequency f1 and one inter-frequency carrier frequency f2, respectively.		

The UE physical layer shall be capable of reporting RSTD for the reference cell and all the neighbour cells i out of at least $(n-1)$ neighbour cells within $T_{RSTD \text{ InterFreq, NB}}$ provided:

$$\left(\text{NPRS} \hat{E}_s / \text{Iot} \right)_{ref} \geq -15 \text{ dB for all Frequency Bands for the reference cell,}$$

$$\left(\text{NPRS} \hat{E}_s / \text{Iot} \right)_i \geq -15 \text{ dB for all Frequency Bands for neighbour cell } i,$$

$$\left(\text{NPRS} \hat{E}_s / \text{Iot} \right)_{ref} \text{ and } \left(\text{NPRS} \hat{E}_s / \text{Iot} \right)_i \text{ conditions apply for all subframes of at least } L = \frac{M}{2} \text{ NPRS positioning occasions,}$$

NPRP 1,2_{dBm} according to Annex E.5 for a corresponding Band

$\text{NPRS} \hat{E}_s / \text{Iot}$ is defined as the ratio of the average received energy per PRS RE during the useful part of the symbol to the average received power spectral density of the total noise and interference for this RE, where the ratio is measured over all REs which carry NPRS.

Table 9.8.2.3-2: Inter RSTD measurement accuracy for enhanced coverage

Accuracy	Conditions					
	NPRS \hat{E}_s / Iot	UE NPRS measurement bandwidth on the reference cell and the measured neighbour cell i ^{Note 3}	Minimum number of available measurement subframes among the reference cell and the measured neighbour cell i , N_{NPRS_total} ^{Note 6}	I_o ^{Note 4} range		
				E-UTRA operating band groups ^{Note 5}	Minimum I_o ^{Note 1}	Maximum I_o
T_s ^{Note 2}	dB	RB			dBm/15kHz	dBm/BW _{Channel}

± 40	$(\text{NPRS } \hat{E}_s/\text{lot})_{\text{ref}} \geq -15\text{dB}$ and $(\text{NPRS } \hat{E}_s/\text{lot})_i \geq -15\text{dB}$	1	320	NTDD_G	-118	-70
<p>NOTE 1: This minimum l_0 condition is expressed as the average l_0 per RE over all REs in an OFDM symbol.</p> <p>NOTE 2: T_s is the basic timing unit defined in TS 36.211 [26].</p> <p>NOTE 3: The serving cell, the reference cell, and the measured neighbour cell i are on the same carrier frequency.</p> <p>NOTE 4: The l_0 is defined in NPRS positioning subframes. The same l_0 range applies to NPRS and non-NPRS symbols. l_0 levels are different in NPRS and non-NPRS symbols within the same subframe.</p> <p>NOTE 5: E-UTRA operating band groups for NB-IoT are as defined in Section 4.11.1.</p> <p>NOTE 6: $N_{\text{NPRS total}}$ can be in one or more NPRS positioning occasions.</p>						

The normative reference for this requirement is TS 36.133 [23] clauses 4.8.4, 9.1.22.13, A.3.23.2 and A.9.8.35.

9.8.2.4 Test description

9.8.2.4.1 Initial conditions

Test Environment: Normal; as defined in TS 36.508 [18] clause 8.1.1.

Frequencies to be tested: Mid Range, as defined in TS 36.508 [18] clause 8.1.3.1.1.

Channel bandwidth to be tested: 10 MHz.

1. Connect the SS and AWGN noise sources to the UE antenna connector or antenna connectors as shown in Annex A, Figure A.3 but using only the main TX/RX antenna.
2. The general test parameter settings are set up according to Table 9.8.2.4.1-1.
3. Propagation conditions are set according to clause 4.7.2.1.
4. Message contents are defined in clause 9.8.2.4.3.
5. The two NB-IOT cells are on different PRBs of the same LTE carrier frequency. The two LTE Cells are on the same carrier frequency. nCell 1 is the serving cell and OTDOA assistance data reference cell; nCell 2 is the neighbour cell. eCell 1 and eCell 2 are the LTE donor cells to nCell 1 and nCell 2, respectively. The assistance data neighbour cell list includes in total 15 cells, where 14 of the cells are not simulated (dummy cells; as defined in TS 37.571-5 [20], clause 7.2.2).
6. The true RSTD (which is the receive time difference for frame 0 between nCell 2 and nCell 1 as seen at the UE antenna connector) is set to 92 T_s (about 3 μs). Note that the related expectedRSTD values to be signalled over LPP are defined in Table 9.8.2.4-1.

Table 9.8.2.4-1: General test parameters

Parameter	Unit	Value	Comment
NB-IoT operational mode		Inband	
Reference cell		nCell 1	
Neighbor cells		nCell 2, eCell 1 and eCell 2	
NPDCCH parameters		R.26 NB-TDD	Specified in TS 36.133 [23] section A.3.1.6.1
nprsID		Test1: (nprsID of Cell 1 – nprsID of Cell 2) mod 6 = 1	As defined in TS 36.355 [4]
nprs-period	ms	1280	As defined in TS 36.355 [4]
nprs-startSF		sf0	Subframe offset of the NPRS positioning occasion as defined in TS 36.355 [4]

Number of consecutive downlink positioning subframes nprs-NumSF		640	As defined in TS 36.355 [4]
NPRS muting info		nCell 1: '1111111100000000' nCell 2: '1111111100000000'	Corresponds to nprs-MutingInfoB defined in TS 36.355 [4]
PartA Configuration: subframePattern10-TDD		'01100011'	Corresponds to subframePattern10-TDD-r15 defined in TS 36.355 [4]
nprsSequenceInfo nCell1		BW _{channel} 10MHz: 130	Corresponds to nprsSequenceInfo defined in TS 36.355 [4]
nprsSequenceInfo nCell2		BW _{channel} 10MHz: 135	Corresponds to nprsSequenceInfo defined in TS36.355 [4]
CP length		Normal	
NPRACH Configuration		NPRACH.R-2	Refer to TS 36.133 [23] section A.3.18
DRX cycle length		1.28	The value shall be used for all cells in the test.
Expected RSTD	μs	nCell 2: 3 Other neighbour cells: randomly between -3 and 3	The expected RSTD is what is expected at the receiver. The corresponding parameter in the OTDOA assistance data specified in TS 36.355 [4] is the expectedRSTD indicator
Expected RSTD uncertainty for all neighbour cells	μs	5	The corresponding parameter in the OTDOA assistance data specified in TS 36.355 [4] is the expectedRSTD-Uncertainty index
Number of cells provided in OTDOA assistance data		16	Including the reference cell
Special subframe configuration		6	As specified in table 4.2-1 in TS 36.211 [26]
Uplink-downlink configuration		2	As specified in table 4.2-2 in TS 36.211 [26]
Measurement period	s	20.48	Derived according to the RSTD measurement period in TS 36.133 [23] 4.8.1

9.8.2.4.2 Test procedure

Same as in clause 9.6.2.4.2.

9.8.2.4.3 Message contents

Same as in clause 9.6.2.4.3.

9.8.2.5 Test requirement

Table 9.8.2.5-1 and 9.8.2.5-2 define the primary level settings including test tolerances for the test.

The RSTD TDD inter-frequency accuracy test shall meet the reported values in Table 9.8.2.5-3.

Table 9.8.2.5-1: Cell Specific Test Parameters for inter-frequency RSTD Tests for NB-IOT Cells

Parameter	Unit	Test1	
		nCell 1	nCell 2
BW _{channel}	kHz	180	180
PRB location within eCell		eCell 1 BW _{channel} 10MHz: 30	eCell 2 BW _{channel} 10MHz: 35
NPBCH_RA	dB	0	0
NPBCH_RB			
NPSS_RA			
NSSS_RA			

NPDCCH_RA			
NPDCCH_RB			
NPDSCH_RA			
NPDSCH_RB			
OCNG_RA ^{Note 1}			
OCNG_RB ^{Note 1}			
NPRS_RA	dB	0.3	0.3
N_{oc} ^{Note 2}	dBm/ 15 kHz	-98	-98
$NPRS \hat{E}_s / N_{oc}$	dB	-14.7	-14.7
$NPRS \hat{E}_s / I_{ot}$ ^{Note 3}	dB	-14.7	-14.7
I_o ^{Note 3}	dBm/ 15kHz	-87.14	-87.14
NPRP ^{Note 3}	dBm/ 15 kHz	-112.7	-112.7
NRSRP ^{Note 3}	dBm/ 15 kHz	-113	-113
\hat{E}_s / N_{oc} ^{Note 3}	dB	-15	-15
Propagation Condition		AWGN	AWGN
Antenna Configuration		1x1	1x1
Timing offset to nCell 1	us	N/A	3
<p>Note 1: OCNG shall be used such that active cells are fully allocated and a constant total transmitted power spectral density is achieved for all OFDM symbols other than those in the subframes with transmitted NPRS.</p> <p>Note 2: Interference from other cells and noise sources not specified in the test are assumed to be constant over subcarriers and time and shall be modelled as AWGN of appropriate power for N_{oc} to be fulfilled.</p> <p>Note 3: If NPRS_RA is not "N/A", \hat{E}_s / N_{oc}, $NPRS \hat{E}_s / I_{ot}$, I_o, NRSRP and NPRP levels have been derived from other parameters and are given for information purpose. If NPRS_RA is "N/A", I_o and NRSRP levels have been derived from other parameters and are given for information purpose. These are not settable test parameters. Interference conditions shall be applied to all PRS symbols of DL positioning subframes.</p>			

Table 9.8.2.5-2: Cell Specific Test Parameters for inter-frequency RSTD Tests for E-UTRA Cells

Parameter	Unit	eCell 1			eCell 2		
		T1	T2	T3	T1	T2	T3
$BW_{channel}$	MHz	10			10		
NOCNG Pattern defined in TS 36.133 [23] section A.3.2.3.6	-	NOP.1 TDD			NOP.1 TDD		
PBCH_RA	dB	-3			-3		
PBCH_RB	dB						
PSS_RA	dB						
SSS_RA	dB						
PDCCH_RA	dB						
PDCCH_RB	dB						
PDSCH_RA	dB						
PDSCH_RB	dB						
OCNG_RA ^{Note 1}	dB						
OCNG_RB ^{Note 1}	dB						
N_{oc} ^{Note2}	dBm/15 kHz	-98			-98		
\hat{E}_s / N_{oc} ^{Note2}	dBm	-9	-9	-9	-9	-9	-9
Propagation Condition		AWGN			AWGN		
Antenna Configuration		1x1			1x1		
Timing offset to eCell 1	us	-			3		
Note 1: OCNG shall be used such that the Cell is fully allocated and a constant total transmitted power spectral density is achieved for all OFDM symbols. Note 2: Interference from other cells and noise sources not specified in the test is assumed to be constant over subcarriers and time and shall be modelled as AWGN of appropriate power N_{oc} .							

Table 9.8.2.5-3: RSTD TDD inter-frequency accuracy requirements for the reported values

Lowest reported value	RSTD_6405
Highest reported value	RSTD_6489

For the overall test to pass, the ratio of successful reported values shall be more than 90% with a confidence level of 95%.

The expected response time is 21 s. The response time is equal to the LPP time IE value. The LPP time IE value is derived from the RSTD reporting delay plus ΔT , where $\Delta T = 150$ ms, giving a value of 20630 ms. This is rounded up to the next allowed LPP value of 21 seconds. The RSTD measurement reporting delay in the test is derived from the following expression, $T_{RSTD\ InterFreq,NB} = T_{NPRS} \cdot (M - 1) + \Delta$ ms, where $T_{NPRS} = 1280$ ms, $M = 16$

$\left| N_{NPRS_total} / N_{NPRS} \right|$, $\Delta = T_{NPRS} \cdot \left[\frac{n}{M} \right]$, $N_{NPRS_total} = 320$ ms, $N_{NPRS} = 640$ ms and $n = 16$. All the parameters are specified in clause 9.8.2.3 and Table 9.8.2.3-1. This gives the total RSTD reporting delay of 20480 ms for the 15 neighbour cells including nCell 2 with respect to the reference cell, nCell 1. This expected response time excludes any delay caused by RRC connection release before the RRC_IDLE mode measurement. This expected response time excludes any delay caused by establishing a signalling connection with the SS (including random access procedure) as defined in TS 36.305 [41] for LPP measurement reporting. The response time is not explicitly evaluated for this test; hence, no test tolerance values need to be applied.

9.8.3 TDD Inter-Frequency RSTD Measurement Reporting Delay for NB-IOT Standalone Mode in enhanced coverage

9.8.3.1 Test purpose

To verify that the RSTD TDD inter-frequency measurement reporting delay is within the specified limits for NB-IOT Standalone Mode in enhanced coverage.

9.8.3.2 Test applicability

This test applies to all types of NB-IoT TDD UE release 15 and forward that supports UE-assisted OTDOA and inter-frequency RSTD measurements.

9.8.3.3 Minimum conformance requirements

The UE shall follow the procedure for RRC_IDLE state positioning measurement as defined in TS 36.305 [41] section 7.1.3.

When the physical layer cell identities of neighbour cells together with the OTDOA assistance data have been provided and the UE has entered the RRC_IDLE state, the UE shall be able to detect and measure inter-frequency RSTD, specified in TS 36.214 [6], for at least $n = 16$ cells, including the reference cell within $T_{RSTD\ InterFreq, NB}$ ms as given below:

$$T_{RSTD\ InterFreq, NB} = T_{NPRS} \cdot (M - 1) + \Delta \quad ms,$$

where

$T_{RSTD\ InterFreq, NB}$ is the total time for detecting and measuring at least n cells;

T_{NPRS} is the cell-specific positioning subframe configuration period as defined in TS 36.355 [4] if Part B subframe configuration is provided; otherwise if only Part A subframe configuration is provided, the T_{NPRS} equals to the length of the subframe pattern,

M is the number of NPRS positioning occasions as defined in Table 9.8.3.3-1,

$\Delta = T_{NPRS} \cdot \left\lceil \frac{n}{M} \right\rceil$ ms is the measurement time for a single NPRS positioning occasion which includes the sampling time and the processing time;

N_{NPRS} is the cell-specific number of NPRS subframes within a NPRS occasion as defined in TS 36.355 [4] if Part B subframe configuration is provided; if only Part A subframe configuration is provided, the NPRS occasion length is 10 ms,

N_{NPRS_total} is the minimum number of NPRS subframes per cell measurement as defined in Table 9.8.3.3-2.

T_{NPRS} , N_{NPRS} , and N_{NPRS_total} are the parameters of the same cell, for which $T_{NPRS} \cdot \left\lceil \frac{N_{NPRS_total}}{N_{NPRS}} \right\rceil$ is the largest among all the measured cells.

Table 9.8.3.3-1: Number of NPRS positioning occasions within $T_{RSTD\ InterFreq, NB}$

Positioning subframe configuration period T_{NPRS}	Number of NPRS positioning occasions M	
	f1 <small>Note1</small>	f1 and f2 <small>Note2</small>
160 ms	16* $\left\lceil \frac{N_{total_NPRS}}{N_{NPRS}} \right\rceil$	32* $\left\lceil \frac{N_{total_NPRS}}{N_{NPRS}} \right\rceil$
>160 ms	8* $\left\lceil \frac{N_{total_NPRS}}{N_{NPRS}} \right\rceil$	16* $\left\lceil \frac{N_{total_NPRS}}{N_{NPRS}} \right\rceil$
Note 1:	When only intra-frequency RSTD measurements are performed over cells belonging to the serving carrier frequency f1.	
Note 2:	When intra-frequency RSTD and inter-frequency RSTD measurements are performed over cells belonging to the serving carrier frequency f1 and one inter-frequency carrier frequency f2, respectively.	

The UE physical layer shall be capable of reporting RSTD for the reference cell and all the neighbour cells i out of at least $(n-1)$ neighbour cells within $T_{\text{RSTD InterFreq, NB}}$ provided:

$$\left(\text{NPRS } \hat{E}_s / \text{Iot} \right)_{\text{ref}} \geq -15 \text{ dB for all Frequency Bands for the reference cell,}$$

$$\left(\text{NPRS } \hat{E}_s / \text{Iot} \right)_i \geq -15 \text{ dB for all Frequency Bands for neighbour cell } i,$$

$$\left(\text{NPRS } \hat{E}_s / \text{Iot} \right)_{\text{ref}} \text{ and } \left(\text{NPRS } \hat{E}_s / \text{Iot} \right)_i \text{ conditions apply for all subframes of at least } L = \frac{M}{2} \text{ NPRS}$$

positioning occasions,

NPRP 1,2|dBm according to Annex E.5 for a corresponding Band

$\text{NPRS } \hat{E}_s / \text{Iot}$ is defined as the ratio of the average received energy per PRS RE during the useful part of the symbol to the average received power spectral density of the total noise and interference for this RE, where the ratio is measured over all REs which carry NPRS.

The time $T_{\text{RSTD InterFreq, NB}}$ starts from the point when the UE has received both the OTDOA-RequestLocationInformation message and the OTDOA assistance data in the OTDOA-ProvideAssistanceData message as specified in TS 36.355 [4], and the message and data have been delivered to the physical layer of the UE and the UE has entered the RRC_IDLE state.

After receiving both the OTDOA-RequestLocationInformation message and the OTDOA assistance data in the OTDOA-ProvideAssistanceData message as specified in TS 36.355 [4], the UE shall be sent to RRC_IDLE state. The maximum allowed RSTD reporting delay is defined as the time between the point when the UE has entered the RRC_IDLE state, and the point when the UE is ready to transmit the measurement report over the air interface and starts to establish a signalling connection with the MME.

The maximum allowed RSTD reporting delay shall be less than $T_{\text{RSTD InterFreq, NB}} + T_{\text{RandomAccess_NB-IoT-EC}}$.

The normative reference for this requirement is TS 36.133 [23] clauses 4.8.4, 4.8.4.1, A.3.23.2 and A.4.7.4.

9.8.3.4 Test description

9.8.3.4.1 Initial conditions

Test Environment: Normal; as defined in TS 36.508 [18] clause 8.1.1.

Frequencies to be tested: Mid Range, as defined in TS 36.508 [18] clause 8.1.3.1.1.

Channel bandwidth to be tested: 200 kHz as defined in TS 36.508 [18] clause 8.1.3.1.

1. Connect the SS and AWGN noise sources to the UE antenna connector or antenna connectors as shown in Annex A, Figure A.3 but using only the main TX/RX antenna.
2. The general test parameter settings are set up according to Table 9.8.3.4.1-1.
3. Propagation conditions are set according to clause 4.7.2.1.
4. Message contents are defined in clause 9.8.3.4.3.
5. There are three synchronous cells: nCell 1, nCell 2 and nCell 3. nCell 1 is the reference as well as the serving cell. nCell 2 and nCell 3 are the neighbour cells. All cells are on the same RF channel. The assistance data neighbour cell list includes in total 15 cells, where 13 of the cells are not simulated (dummy cells; as defined in TS 37.571-5 [20], clause 7.2.2).
6. The true RSTD (which is the receive time difference for frame 0 between nCell 2 and nCell 1 as seen at the UE antenna connector) is set to 31 Ts (about 1 μ s between neighbour nCell 2 and serving nCell 1; and set to -31 Ts (about -1 μ s) between neighbour nCell 3 and serving nCell 1

Table 9.8.3.4-1: General test parameters

Parameter	Unit	Value	Comment
NB-IoT operational mode		Standalone	
Reference cell		nCell 1	Reference cell is the cell in the OTDOA assistance data with respect to which the RSTD measurement is defined, as specified in TS 36.214 [6] and TS 36.355 [4]. The reference cell is the PCell in this test case.
Neighbor cells		nCell 2 and nCell 3	Cell 2 and Cell 3 appear at random places in the neighbour cell list in the OTDOA assistance data, but Cell 2 always appears in the first half of the list, whilst Cell 3 appears in the second half of the list.
nprsID		(nprsID of Cell 1 – nprsID of Cell 2)mod6=1 and (nprsID of Cell 1 – nprsID of Cell 3)mod6=2	As defined in TS 36.355 [4]
nprs-period	ms	1280	As defined in TS 36.355 [4]
nprs-startSF		sf0	Subframe offset of the NPRS positioning occasion as defined in TS 36.355 [4]
Number of consecutive downlink positioning subframes nprs-NumSF		640	As defined in TS 36.355 [4]
nprs-SubframeOffset		0	As defined in TS 36.355 [24]
NPRS muting info		Cell 1: '1111111100000000' Cell 2: '0000000011111111' Cell 3: '1111111100000000'	Corresponds to nprs-MutingInfoB defined in TS 36.355 [24]
Part A Configuration		N/A	NPRS is configured based on Part B but not Part A.
CP length		Normal	
NPRACH Configuration		NPRACH.R-2	Refer to A.3.18
DRX cycle length		1.28	The value shall be used for all cells in the test.
Radio frame receive time offset between the cells at the UE antenna connector	µs	nCell 2 to nCell 1: 1 nCell 3 to nCell 1: -1	PRS are transmitted from synchronous cells
Expected RSTD	µs	Cell 2: -2 Cell 3: 2 Other neighbour cells: randomly between -3 and 3	The expected RSTD is what is expected at the receiver. The corresponding parameter in the OTDOA assistance data specified in TS 36.355 [4] is the expectedRSTD indicator
Expected RSTD uncertainty for all neighbour cells	µs	5	The corresponding parameter in the OTDOA assistance data specified in TS 36.355 [4] is the expectedRSTD-Uncertainty index
Number of cells provided in OTDOA assistance data		16	Including the reference cell
Special subframe configuration		6	As specified in table 4.2-1 in TS 36.211 [26]
Uplink-downlink configuration		2	As specified in table 4.2-2 in TS 36.211 [26]
T2	s	5.12	The length of the time interval that follows immediately after time interval T1
T3	s	5.12	The length of the time interval that follows immediately after time interval T2

T4	s	10.24	The length of the time interval that follows immediately after time interval T3
T5	s	10.24	The length of the time interval that follows immediately after time interval T4
T6	s	≥ 58.2	The length of the time interval that follows immediately after time interval T5

9.8.3.4.2 Test procedure

Same as in clause 9.6.3.4.2.

9.8.3.4.3 Message contents

Same as in clause 9.6.3.4.3.

9.8.3.5 Test requirement

Table 9.8.3.5-1 and 9.8.3.5-2 define the primary level settings including test tolerances for the test.

Table 9.8.3.5-1: Cell Specific Test Parameters during T1 and T6

Parameter	Unit	nCell 1	nCell 2	nCell 3
NB-IoT RF Channel Number		1	2	2
NB-IoT Channel Bandwidth (BW _{channel})	kHz	200	200	200
OCNG Pattern ^{Note 1}		NOP.3 TDD	N/A	N/A
NPDSCH parameters ^{Note 2}		R.18 NB-TDD	N/A	N/A
NPDCCH parameters ^{Note 2}		R.30 NB-TDD	N/A	N/A
NPBCH_RA	dB	0	N/A	N/A
NPBCH_RB				
NPSS_RA				
NSSS_RA				
NPDCCH_RA				
NPDCCH_RB				
NPDSCH_RA				
NPDSCH_RB				
OCNG_RA ^{Note 1}				
OCNG_RB ^{Note 1}				
N_{oc} ^{Note 3}	dBm/ 15 kHz	-98		
$NPRS \hat{E}_s / N_{oc}$	dB	-Infinity	-Infinity	-Infinity
\hat{E}_s / N_{oc}	dB	-2	-Infinity	-Infinity
Propagation Condition		AWGN		
Antenna Configuration		1x1		
Timing offset to nCell 1	μs	N/A	1	-1

- Note 1: OCNG shall be used such that the cell is fully allocated and a constant total transmitted power spectral density is achieved for all OFDM symbols. The OCNG pattern is chosen during the test according to the presence of a DL reference measurement channel.
- Note 2: The NPDSCH and NPDCCH reference measurement channels are used in the test only when a downlink transmission dedicated to the UE under test is required.
- Note 3: Interference from other cells and noise sources not specified in the test are assumed to be constant over subcarriers and time and shall be modelled as AWGN of appropriate power for N_{oc} to be fulfilled.

Table 9.8.3.5-2: Cell Specific Test Parameters from T2 to T5

Parameter	Unit	nCell 1		nCell 2		nCell 3		
		T2 and T4	T3 and T5	T2 and T4	T3 and T5	T2 and T4	T3 and T5	
$BW_{channel}$	kHz	200		200		200		
NB-IoT RF Channel Number		1		2		2		
NPDSCH parameters ^{Note 2}		R.18 NB-TDD		N/A		N/A		
NPDCCH parameters ^{Note 2}		R.30 NB-TDD		N/A		N/A		
OCNG patterns		NOP.3 TDD		N/A	NOP.3 TDD	NOP.3 TDD	N/A	
NPBCH_RA	dB	0		0		0		N/A
NPBCH_RB								
NPSS_RA								
NSSS_RA								
NPDCCH_RA								
NPDCCH_RB								
NPDSCH_RA								
NPDSCH_RB								
OCNG_RA ^{Note 1}								
OCNG_RB ^{Note 1}								
NPRS_RA	dB	-3	N/A	N/A	0	0	N/A	
N_{oc} ^{Note 3}	dBm/15 kHz	-98	-98	-98	-95	-98	-95	
$NPRS \hat{E}_s / N_{oc}$	dB	-15	-Infinity	-Infinity	-15	-15	-Infinity	
$NPRS \hat{E}_s / I_{ot}$ ^{Note 4}	dB	-15	-Infinity	-Infinity	-15	-15	-Infinity	
I_o ^{Note 4}	dBm/180kHz	-87.17	-87.20	-87.17	-87.15	-87.17	-87.15	
NPRP ^{Note 4}	dBm/15 kHz	-113	-Infinity	-Infinity	-110	-113	-Infinity	
NRSRP ^{Note 4}	dBm/15 kHz	-110	-110	-113	-110	-113	-Infinity	
\hat{E}_s / N_{oc} ^{Note 4}	dB	-12	-12	-15	-15	-15	-Infinity	
Propagation Condition		AWGN						
Antenna Configuration		1x1						
Timing offset to nCell 1	μ s	N/A		1		-1		
Note 1:	OCNG shall be used such that active cells (all, except Cell 3 in T3) are fully allocated and a constant total transmitted power spectral density is achieved for all OFDM symbols other than those in the subframes with transmitted NPRS.							
Note 3:	Interference from other cells and noise sources not specified in the test are assumed to be constant over subcarriers and time and shall be modelled as AWGN of appropriate power for N_{oc} to be fulfilled.							
Note 4:	If NPRS_RA is not "N/A", \hat{E}_s / N_{oc} , $NPRS \hat{E}_s / I_{ot}$, I_o , NRSRP and NPRP levels have been derived from other parameters and are given for information purpose. If NPRS_RA is "N/A", I_o and NRSRP levels have been derived from other parameters and are given for information purpose. These are not settable test parameters. Interference conditions shall be applied to all PRS symbols of DL positioning subframes.							

The response time including test tolerance is 90.3 s. The response time is equal to the LPP time IE value plus the test tolerance.

The LPP time IE value is derived from the maximum allowed RSTD reporting delay plus T2 and T3 plus ΔT , where $\Delta T = 150$ ms, giving a value of 89070 ms. This is rounded up to the next allowed LPP value of 90 seconds.

The maximum allowed RSTD reporting delay is 78.68 s. This time is measured starting from the beginning of time interval T4, to the moment when the UE starts to send preambles on the PRACH for sending the positioning measurement report message to nCell1. The maximum allowed RSTD reporting delay is equal to $T_{\text{RSTD_inter_NB-IoT-EC}} + T_{\text{RandomAccess_NB-IoT-EC}}$.

The RSTD measurement time $T_{\text{RSTD_inter_NB-IoT-EC}}$ in the test is derived according to section 9.8.3.3 where it is equal to $T_{\text{RSTD_InterFreq_NB}}$. This gives the total RSTD measurement time of 21.76s for nCell 2 and nCell 3 with respect to the reference nCell 1

The random access to an already detected cell $T_{\text{RandomAccess_NB-IoT-EC}}$ can be expressed as: $T_{\text{evaluate_NB_inter_NB-IoT-EC}} + T_{\text{SI}} + T_{\text{PRACH_NB-IoT}}$,

Where:

$T_{\text{evaluate_NB_inter_NB-IoT-EC}} = 12800$ ms: see Table 4.6.2.4-1 in clause 4.6.2.4 in TS 36.133 [23].

$T_{\text{SI}} = 41560$ ms and is the time required for receiving all the relevant system information as defined in TS 36.331 [22] for the target NB-IoT TDD cell.

$T_{\text{PRACH_NB-IoT}} = 2560$ ms and is the additional delay caused by the random access procedure.

This gives $T_{\text{RandomAccess_NB-IoT-EC}} = 56.92$ s for the random access delay to an already detected cell in the test case.

The test tolerances are defined in clauses C.1.3 and C4.

The rate of the correct events for each neighbour cell observed during repeated tests shall be at least 90% with a confidence level of 95%, where the reported RSTD measurement for each correct event shall be within the RSTD reporting range specified in Clause 9.1.10.3, i.e., between RSTD_0000 and RSTD_12711.

10 E-UTRA OTDOA measurement requirements for Carrier Aggregation

10.0 General

This clause defines the minimum performance requirements for OTDOA FDD and TDD E-UTRA UEs and UEs supporting NR EN-DC, with Carrier Aggregation.

10.1 FDD RSTD Measurement Reporting Delay for Carrier Aggregation

10.1.1 Test purpose

To verify that the RSTD measurement reporting delay meets the requirements in an environment with fading propagation conditions. This test case verifies the measurement period requirements for RSTD measurements performed on the secondary component carrier and also the measurement period requirements for RSTD measurements performed on both the primary and secondary component carriers.

10.1.2 Test applicability

This test applies to all types of E-UTRA FDD UE release 10 and forward that supports UE-assisted OTDOA for Carrier Aggregation.

10.1.3 Minimum conformance requirements

10.1.3.1 Measurements on the secondary component carrier

The RSTD measurements when all cells are on the configured secondary component carrier shall meet all applicable requirements (FDD) specified in TS 36.133 [23] section 8.1.2.5, i.e., E-UTRAN intra-frequency RSTD measurement period applies, regardless of whether the SCell on the corresponding frequency is activated or deactivated by the MAC-CE commands as specified in 3GPP TS 36.321 [34].

10.1.3.2 Measurements on both primary component carrier and secondary component carrier

The RSTD measurements of cells on both primary component carrier and configured secondary component carrier shall meet all applicable requirements (FDD) specified in TS 36.133 [23] section 8.1.2.6, i.e., E-UTRAN inter-frequency RSTD measurement period applies regardless of whether the SCell on the corresponding frequency is activated or deactivated by the MAC-CE commands as specified in 3GPP TS 36.321 [34], with the following exception

- the number of PRS positioning occasions is as specified in Table 10.1.3.2-1 shall apply.

Table 10.1.3.2-1: Number of PRS positioning occasions within measurement period

Positioning subframe configuration period T_{PRS}	Number of PRS positioning occasions M
160 ms	32
>160 ms	16

The normative reference for this requirement is TS 36.133 [23] clause 8.4.3, 8.4.4 and A.8.17.1.

10.1.4 Test description

10.1.4.1 Initial conditions

Test Environment: Normal; as defined in TS 36.508 [18] clause 4.1.

Frequencies to be tested: Mid Range, as defined in TS 36.508 [18] clause 4.3.1.1.

Channel bandwidth to be tested: 10 MHz as defined in TS 36.508 [18] clause 4.3.1.

1. Connect the SS, faders and AWGN noise sources to the UE antenna connector or antenna connectors as shown in TS 36.508 [18] Annex A, Figure group A.42 as appropriate.
2. The general test parameter settings are set up according to Table 10.1.4.1-1.
3. Propagation conditions are set according to clause 4.7.2.1.
4. Message contents are defined in clause 10.1.4.3.
5. In the tests, there are two configured component carriers: PCC and SCC, and three synchronized cells: Cell 1, Cell 2 and Cell 3. Cell 1 is PCell on the PCC, Cell 2 is an active SCell on the SCC, and Cell 3 is a neighbour cell on the SCC. In both tests, Cell 2 is the OTDOA assistance data reference cell. The assistance data neighbour cell list includes in total 15 cells, where 14 of the cells are not simulated (dummy cells; as defined in 3GPP TS 37.571-5 clause 7.3.2) for Test 1 and where 13 of the cells are not simulated for Test 2. PCell (Cell 1) is the cell used for connection setup with the power level and mapping set according to TS 36.521-1 [24] Annex C.0 and C.1 as appropriate for this test. Cell 2 and Cell 3 are powered OFF.
6. The true RSTD (which is the receive time difference for frame 0 between two cells as seen at the UE antenna connector) is set to 31 Ts (about 1 μ s) between Cell 1 and OTDOA assistance data reference cell, Cell 2; and set to -31 Ts (about -1 μ s) between neighbour Cell 3 and OTDOA assistance data reference cell, Cell 2.

Table 10.1.4.1-1: General test parameters for E-UTRAN FDD RSTD measurement reporting delay under fading propagation conditions for Carrier Aggregation

Parameter	Unit	Value		Comment
		Test 1	Test 2	
PCell		Cell 1		PCell is on RF channel 1 (PCC).
SCell		Cell 2		SCell on RF channel 2 (SCC). Cell 2 is the assistance data reference cell.
Other neighbour cell		Cell 3		Neighbour cell on RF channel 2 (SCC).
PCFICH/PDCCH/PHICH parameters		DL Reference Measurement Channel R.6 FDD		As specified in TS 36.521-3 [25] clause A.2.1
Channel Bandwidth (BW_{channel})	MHz	10		
PRS Transmission Bandwidth ^{Note 2}	RB	50		PRS are transmitted over the system bandwidth
PRS configuration index I_{PRS} ^{Note 2}		171 for all cells on PCC 181 for all cells on SCC		This corresponds to periodicity of 320 ms and PRS subframe offset of $I_{\text{PRS}} - 160$ DL subframes, as defined in 3GPP TS 36.211 [26], Table 6.10.4.3-1
Number of consecutive downlink positioning subframes N_{PRS} ^{Note 2}		1		As defined in 3GPP TS 36.211 [26]. The number of subframes in a positioning occasion
Physical cell ID PCI ^{Note 2}		(PCI of Cell 2 – PCI of Cell 3) mod 6 = 0		The PCI of Cell 1 is selected randomly. PCIs of Cell 2 and Cell 3 are selected randomly such that the relative subcarrier shifts of PRS patterns among these cells are as given by the condition.
CP length ^{Note 2}		Normal		
DRX		ON		DRX parameters are further specified in Table 10.1.4.1-2
Radio frame receive time offset between the cells at the UE antenna connector ^{Note 3}	μs	Cell 1 to Cell 2: 1 Cell 3 to Cell 2: -1	Cell 1 to Cell 2: 1 Cell 3 to Cell 2: -1	PRS are transmitted from synchronous cells
Expected RSTD ^{Note 1}	μs	Cell 3: 2 Other neighbour cells: randomly between -3 and 3	Cell 1: -2 Cell 3: 2 Other neighbour cells: randomly between -3 and 3	The expected RSTD is what is expected at the receiver. The corresponding parameter in the OTDOA assistance data specified in TS 36.355 [4] is the expectedRSTD indicator
Expected RSTD uncertainty for all neighbour cells ^{Note 1}	μs	5		The corresponding parameter in the OTDOA assistance data specified in TS 36.355 [4] is the expectedRSTD-Uncertainty index
Number of cells provided in OTDOA assistance data		16 cells in total		The list includes the reference cell and 15 other cells. Cell 1 (when included) appears at random places in the first half of the neighbour cell list in the OTDOA assistance data. Cell 3 always appears at random places in the second half of the list
		OTDOA neighbour cells include Cell 3 and other 14 cells on SCC	OTDOA neighbour cells include Cell 1 and other 7 cells on PCC, and Cell 3 and other 6 cells on SCC	

prs-SubframeOffset ^{Note 2}		Cells on PCC: 310 Cells on SCC, except reference cell: 0		Subframe offset, counted in full subframes. The corresponding parameter in the OTDOA assistance data is prs-SubframeOffset specified in TS 36.355 [4]
slotNumberOffset ^{Note 2}		Cells on PCC: 0 Cells on SCC, except reference cell: 0		The slot number offset at the transmitter between a neighbour cell and the assistance data reference cell. The corresponding parameter in the OTDOA assistance data is slotNumberOffset specified in TS 36.355 [4].
PRS muting info ^{Note 2}		Cell 1: '11110000' Cell 2: '00001111' Cell 3: '11110000'	Cell 1: '1111111100000000' Cell 2: '0000000111111111' Cell 3: '1111111100000000'	Corresponds to prs-MutingInfo defined in TS 36.355 [4]
T1	S	3		The length of the time interval from the beginning of each test
T2	S	1.28	2.48	The length of the time interval that follows immediately after time interval T1
T3	S	1.28	2.48	The length of the time interval that follows immediately after time interval T2
Note 1:	Parameters "Expected RSTD" and "Expected RSTD uncertainty for all neighbour cells" are not settable parameters. These are parameters signalled in LPP only. For the values to be used in LPP see Table 10.1.4.3-4 and TS 37.571-5 [20], clause 7.3.2.			
Note 2:	Parameters "PRS Transmission Bandwidth", "PRS configuration index", "Number of consecutive downlink positioning subframes", "Physical cell ID PCI", "CP length", "prs-SubframeOffset", "slotNumberOffset" and "PRS muting info" are settable parameters and also parameters signalled in LPP. The values to be used for "Physical cell ID PCI" are as follows: Cell 1: 0, Cell 2: 6, Cell 3: 12. For the values to be used in LPP see Table 10.1.4.3-4 and TS 37.571-5 [20], clause 7.3.2.			
Note 3:	The parameter "Radio frame receive time offset between the cells at the UE antenna connector" is used to set the "true RSTD" values in step 6 of clause 10.1.4.1.			

Table 10.1.4.1-2: DRX parameters for E-UTRAN FDD RSTD measurement reporting delay under fading propagation conditions for Carrier Aggregation

Field	Value	Comment
onDurationTimer	psf1	As specified in 3GPP TS 36.331 [22], clause 6.3.2
drx-InactivityTimer	psf1	
drx-RetransmissionTimer	sf1	
longDRX-CycleStartOffset	sf320	
shortDRX	Disable	

10.1.4.2 Test procedure

The test case includes two tests. Test 1 is designed for the scenario where the UE receives OTDOA assistance data with cells on SCC, and the UE is expected to report RSTD measurements performed on SCC only. Test 2 is designed for the scenario where the UE receives OTDOA assistance data with cells on PCC and SCC, and the UE is expected to report RSTD measurements performed on PCC and on SCC.

Each test consists of three consecutive time intervals, with duration of T1, T2 and T3 defined in Table 10.1.4.1-1. Cell 1 is active in T1, T2 and T3, whilst Cell 2 is active only in T2 and T3, and Cell 3 is active only during T2. The beginning of the time interval T2 shall be aligned 5 ms before the first PRS positioning subframe of a positioning occasion in the OTDOA assistance data reference cell, where 5 ms is the necessary test tolerance. Cell 1 transmits PRS in T2, while Cell 2 transmits PRS only in T3, and Cell 3 transmits PRS only in T2.

NOTE: The information on when PRS is muted is conveyed to the UE using PRS muting information in the OTDOA assistance data.

The OTDOA-RequestLocationInformation message and the OTDOA assistance data as defined in clause 10.1.4.3 shall be provided to the UE during T1. The last TTI containing the OTDOA-RequestLocationInformation message shall be provided to the UE ΔT ms before the start of T2, where $\Delta T = 150$ ms is the maximum processing time of the OTDOA-RequestLocationInformation message and the OTDOA assistance data.

1. Ensure that the UE is in state Generic RB Established State 3A-RF according to 3GPP TS 36.508 [18] clause 7.2A.3.
2. Configure Cell 2 and Cell 3 on the SCC according to TS 36.521-3 [25] Annex C.0 and C.1 for all downlink physical channels.
3. The SS shall configure the SCell (Cell 2) on the SCC as per TS 36.508 [18] clause 5.2A.4.
4. The SS activates the SCell (Cell 2) by sending the Activation/Deactivation MAC control element according to TS 36.321 [34] clauses 5.13 and 6.1.3.8. Wait for at least 2 seconds as per TS 36.133 [23] clause 8.3.3.2.
5. The SS shall send a RESET UE POSITIONING STORED INFORMATION message.
6. Set the parameters according to Table 10.1.5-1. Propagation conditions are set according to clause 4.7.2.2 (ETU30).
7. T1 starts.
8. The SS shall transmit an RRCConnectionReconfiguration message with the DRX configuration. PDCCHs indicating new transmissions shall be sent continuously until the start of T2 to ensure that the UE would not enter the DRX state before T2.
9. The UE shall transmit RRCConnectionReconfigurationComplete message.
- 9a. The SS shall transmit an LPP REQUEST CAPABILITIES message.
- 9b. The UE shall transmit an LPP PROVIDE CAPABILITIES message indicating the OTDOA capabilities supported by the UE in the *OTDOA-ProvideCapabilities* IE.
10. The SS shall send a LPP PROVIDE ASSISTANCE DATA message, including the *OTDOA-ProvideAssistanceData* IE. The position of neighbour Cell 3 in the *OTDOA-NeighbourCellInfoList* is randomly selected to be in the last 8 elements of the sequence for Test 1 and in the 7 elements of the relevant sequence for Test 2, and the position of neighbour Cell 1 is randomly selected to be in the first 7 elements of the relevant sequence for Test 2, as described in 3GPP TS 37.571-5 [20], clause 7.3.2. If the UE message at step 9b includes the *ackRequested* IE set to TRUE, then the SS shall send an acknowledgment in the LPP PROVIDE ASSISTANCE DATA message.
11. The SS shall send a LPP REQUEST LOCATION INFORMATION message, including the *OTDOA-RequestLocationInformation* IE such that the UE receives the message ΔT ms before the start of T2, where $\Delta T = 150$ ms.
12. When T1 expires, the SS shall switch the power setting from T1 to T2 as specified in Table 10.1.5-2.
13. When T2 expires, the SS shall switch the power setting from T2 to T3 as specified in Table 10.1.5-2.
14. The UE shall transmit a LPP PROVIDE LOCATION INFORMATION message including the *OTDOA-ProvideLocationInformation* IE within the response time (see clause 4.7.3) specified in clause 10.1.5.

For Test 1 the UE shall perform and report the RSTD measurement for Cell 3 with respect to the reference cell in the OTDOA assistance data, Cell 2. If the UE transmits an *OTDOA-ProvideLocationInformation* IE including the *rstd* field for Cell 3 within the response time then the number of successful tests is increased by one. If the UE fails to report the *OTDOA-ProvideLocationInformation* IE with the *rstd* field included within the response time then the number of failure tests is increased by one.

For Test 2 the UE shall perform and report the RSTD measurements for Cell 1 with respect to the reference cell in the OTDOA assistance data, Cell 2 and also Cell 3 with respect to the reference cell in the OTDOA assistance data, Cell 2. If the UE transmits an *OTDOA-ProvideLocationInformation* IE including the *rstd* field for Cell 1 (with respect to Cell 2) and Cell 3 (with respect to Cell 2) within the response time then the number of successful tests is increased by one. If the UE fails to report the *OTDOA-ProvideLocationInformation* IE with both the *rstd* fields included within the response time then the number of failure tests is increased by one.

- 15. If the UE message at step 14 includes the *ackRequested* IE set to TRUE, the SS shall send a LPP acknowledgement message.
- 16. Repeat steps 5-15 until the confidence level according to Annex D is achieved. For each iteration, at step 10 change the random positions of the Cell 3 and Cell 1(for Test 2 only) in the relevant sequence in the *OTDOA-NeighbourCellInfoList*.
- 17. Repeat from clause 10.1.4.1 for Test 2.

10.1.4.3 Message contents

Table 10.1.4.3-1: RESET UE POSITIONING STORED INFORMATION

Derivation Path: 36.509 [11] clause 6.9			
Information Element	Value/remark	Comment	Condition
UE Positioning Technology	0 0 0 0 0 0 1	OTDOA	

Table 10.1.4.3-2: MAC-MainConfig-RBC: FDD RSTD Measurement Reporting Delay for Carrier Aggregation

Derivation Path: TS 36.508 [18] clause 4.8.2.1.5, Table 4.8.2.1.5-1 MAC-MainConfig-RBC			
Information Element	Value/remark	Comment	Condition
MAC-MainConfig-RBC ::= SEQUENCE {			
drx-Config CHOICE {			
setup SEQUENCE {			
onDurationTimer	psf1		
drx-InactivityTimer	psf1		
drx-RetransmissionTimer	sf1		
longDRX-CycleStartOffset CHOICE {			
sf320	0		
}			
shortDRX	Not present		
}			
}			

Table 10.1.4.3-2a: LPP Request Capabilities

Information Element	Value/remark
<i>otdoa-RequestCapabilities</i>	TRUE

Table 10.1.4.3-3: LPP RequestLocationInformation

Derivation Path: 36.355 clause 6.2			
Information Element	Value/remark	Comment	Condition
LPP-Message ::= SEQUENCE {			
transactionID SEQUENCE {			
Initiator	locationServer		
transactionNumber	1		
}			
endTransaction	FALSE		
sequenceNumber	Not present		
acknowledgement	Not present		
lpp-MessageBody CHOICE {			
c1 CHOICE {			
requestLocationInformation SEQUENCE {			
criticalExtensions CHOICE {			
c1 CHOICE {			
requestLocationInformation-r9 SEQUENCE {			
commonIEsRequestLocationInformation SEQUENCE {			

locationInformationType	locationMeasurementsRequired		
triggeredReporting	Not present		
periodicalReporting	Not present		
additionalInformation	onlyReturnInformationRequested		
qos SEQUENCE {			
horizontalAccuracy	Not present		
verticalCoordinateRequest	FALSE		
verticalAccuracy	Not present		
responseTime SEQUENCE {			
time	Test 1: 3 Test 2: 6	See clause 10.1.5	
responseTimeEarlyFix-r12	Not present		Rel-12 onwards
}			
velocityRequest	FALSE		
}			
environment	Not present		
locationCoordinateTypes	Not present		
velocityTypes	Not present		
}			
a-gnss-RequestLocationInformation	Not present		
otdoa-RequestLocationInformation SEQUENCE {			
assistanceAvailability	FALSE		
}			
ecid-RequestLocationInformation	Not present		
epdu-RequestLocationInformation	Not Present		
}			
}			
}			
}			
}			
}			
}			
}			
}			
}			
}			
}			

Table 10.1.4.3-4: LPP ProvideAssistanceData

Derivation Path: 36.355 clause 6.2			
Information Element	Value/remark	Comment	Condition
LPP-Message ::= SEQUENCE {			
transactionID SEQUENCE {			
Initiator	locationServer		
transactionNumber	(0..255)		
}			
endTransaction	TRUE		
sequenceNumber	Not present		
acknowledgement	Not present		
lpp-MessageBody CHOICE {			
c1 CHOICE {			
provideAssistanceData SEQUENCE {			
criticalExtensions CHOICE {			
c1 CHOICE {			
provideAssistanceData-r9 SEQUENCE {			
commonIEsProvideAssistanceData	Not present		
a-gnss-ProvideAssistanceData	Not present		
otdoa-ProvideAssistanceData SEQUENCE {			
otdoa-ReferenceCellInfo	As defined in TS 37.571-5 [20], clause 7.3.2.		
otdoa-NeighbourCellInfo	As defined in TS 37.571-5 [20], clause 7.3.2.		
otdoa-Error	Not present		

}			
epdu-ProvideAssistanceData	Not present		
}			
}			
}			
}			
}			

Table 10.1.4.3-5: LPP ProvideLocation Information

Derivation Path: 36.355 clause 6.2			
Information Element	Value/remark	Comment	Condition
LPP-Message ::= SEQUENCE {			
transactionID SEQUENCE {			
Initiator	locationServer		
transactionNumber	1		
}			
endTransaction	TRUE		
sequenceNumber	(0..255)		
acknowledgement			
lpp-MessageBody CHOICE {			
c1 CHOICE {			
provideLocationInformation SEQUENCE {			
criticalExtensions CHOICE {			
c1 CHOICE {			
provideLocationInformation-r9 SEQUENCE {			
commonIEsProvideLocationInformation	Not present.		
a-gnss-ProvideLocationInformation	Not present		
otdoa-ProvideLocationInformation			
SEQUENCE {			
otdoaSignalMeasurementInformation			
SEQUENCE {			
systemFrameNumber			
physCellIdRef	Cell 2		
cellGlobalIdRef			
earfcnRef			
referenceQuality			
neighbourMeasurementList			
SEQUENCE (SIZE(n)) {			
physCellIdNeighbour	Cell 3		
cellGlobalIdNeighbour			
earfcnNeighbour			
rstd	Present	With respect to Cell 2	
rstd-Quality			
}			
neighbourMeasurementList			
SEQUENCE (SIZE(n)) {			
physCellIdNeighbour	Cell 1	Test 2 only	
cellGlobalIdNeighbour			
earfcnNeighbour			
rstd	Present	Test 2 only With respect to Cell 2	
rstd-Quality			
}			
}			
}			
otdoa-Error	May be present with error reason 'undefined' or 'attemptedButUnableToMeasureSomeNeighbourCells'		
}			
}			
ecid-ProvideLocationInformation	Not present		

epdu-ProvideLocationInformation	Not present		
}			
}			
}			
}			
}			

10.1.5 Test requirement

Table 10.1.5-1 and 10.1.5-2 define the primary level settings including test tolerances for the tests.

Table 10.1.5-1: Cell-specific test parameters for E-UTRAN FDD RSTD measurement reporting delay under fading propagation conditions during T1 for Carrier Aggregation

Parameter	Unit	Cell 1	Cell 2	Cell 3
E-UTRA RF Channel Number		1	N/A	N/A
Correlation Matrix and Antenna Configuration		1x2 Low	1x2 Low	1x2 Low
OCNG patterns defined in TS 36.521-3 [25] clause D.1		OP.5 FDD	N/A	N/A
PBCH_RA	dB	0	N/A	N/A
PBCH_RB				
PSS_RA				
SSS_RA				
PCFICH_RB				
PHICH_RA				
PHICH_RB				
PDCCH_RA				
PDCCH_RB				
OCNG_RA ^{Note 1}				
OCNG_RB ^{Note 1}				
N_{oc} ^{Note 3}	dBm/15 kHz	-95	N/A	N/A
$PR_S \hat{E}_s / N_{oc}$	dB	-Infinity	-Infinity	-Infinity
I_o ^{Note 4}	dBm/9 MHz	-67.22	N/A	N/A
\hat{E}_s / N_{oc}	dB	0	-Infinity	-Infinity
Propagation Condition		ETU30		
<p>Note 1: OCNG shall be used such that active cell (Cell 1) is fully allocated and a constant total transmitted power spectral density is achieved for all OFDM symbols.</p> <p>Note 2: The resources for uplink transmission are assigned to the UE prior to the start of time period T2.</p> <p>Note 3: Interference from other cells and noise sources not specified in the test are assumed to be constant over subcarriers and time and shall be modelled as AWGN of appropriate power for N_{oc} to be fulfilled.</p> <p>Note 4: I_o levels have been derived from other parameters and are given for information purpose. These are not settable test parameters.</p>				

Table 10.1.5-2: Cell-specific test parameters for E-UTRAN FDD RSTD measurement reporting delay under fading propagation conditions during T2 and T3 for Carrier Aggregation

Parameter	Unit	Cell 1		Cell 2		Cell 3	
		T2	T3	T2	T3	T2	T3

E-UTRA RF Channel Number		1		2		2	
Correlation Matrix and Antenna Configuration		1x2 Low		1x2 Low		1x2 Low	
OCNG patterns defined in TS 36.521-3 [25] clause D.1		OP.5 FDD		OP.6 FDD		OP.6 FDD	N/A
PBCH_RA	dB	0		0		0	N/A
PBCH_RB							
PSS_RA							
SSS_RA							
PCFICH_RB							
PHICH_RA							
PHICH_RB							
PDCCH_RA							
PDCCH_RB							
OCNG_RA ^{Note 1}							
OCNG_RB ^{Note 1}							
PRS_RA	dB	-6	N/A	N/A	3	3	N/A
N_{oc} ^{Note 3}	dBm/15 kHz	-98	-98	-98	-95	-98	-95
$PRS \hat{E}_s / N_{oc}$	dB	-4	-Infinity	-Infinity	-1	-8	-Infinity
$PRS \hat{E}_s / I_{ot}$ ^{Note 4}	dB	-4	-Infinity	-Infinity	-1	-8	-Infinity
I_o ^{Note 4}	dBm/9 MHz	-69.94	N/A	N/A	-66.68	-70.11	N/A
PRP ^{Note 4}	dBm/15 kHz	-102	-Infinity	-Infinity	-96	-106	-Infinity
RSRP ^{Note 4}	dBm/15 kHz	-96	-96	-105	-99	-109	-Infinity
\hat{E}_s / N_{oc} ^{Note 4}	dB	2	2	-7	-4	-11	-Infinity
Propagation Condition		ETU30					
<p>Note 1: OCNG shall be used such that active cells (all, except Cell 3 in T3) are fully allocated and a constant total transmitted power spectral density is achieved for all OFDM symbols other than those in the subframes with transmitted PRS.</p> <p>Note 2: The resources for uplink transmission are assigned to the UE prior to the start of time period T2.</p> <p>Note 3: Interference from other cells and noise sources not specified in the test are assumed to be constant over subcarriers and time and shall be modelled as AWGN of appropriate power for N_{oc} to be fulfilled.</p> <p>Note 4: If PRS_RA is not "N/A", \hat{E}_s / N_{oc}, $PRS \hat{E}_s / I_{ot}$, I_o, RSRP and PRP levels have been derived from other parameters and are given for information purpose. If PRS_RA is "N/A", I_o and RSRP levels have been derived from other parameters and are given for information purpose. These are not settable test parameters. Interference conditions shall be applied to all PRS symbols of DL positioning subframes.</p>							

The response time including test tolerance is 3.3s for Test 1 and 6.3s for Test 2. The response time is equal to the LPP time IE value plus the test tolerance. The LPP time IE value is derived from the RSTD reporting delay plus ΔT , where $\Delta T = 150$ ms, giving a value of 2710 ms for Test 1 and 5110ms for Test 2. This is rounded up to the next allowed LPP value of 3 seconds for Test 1 and 6 seconds for Test 2.

The RSTD measurement reporting delay in the tests is derived from the following expression,

$$T_{PRS} (M - 1) + 160 \left\lceil \frac{n}{M} \right\rceil$$

where $M = 8$ and $n = 16$ for Test 1, and $M = 16$ and $n = 16$ for Test 2 are the parameters specified in clause 10.1.3.1 for Test 1 and clause 10.1.3.2 for Test 2.

This gives the total RSTD reporting delay of 2560 ms for Test 1 for the 15 neighbour cells including Cell 3 with respect to the reference cell, Cell 2.

This gives the total RSTD reporting delay of 4960 ms for Test 2 for the 15 neighbour cells including Cell 1 and Cell 3 with respect to the reference cell, Cell 2.

The test tolerances are defined in clauses C.1.3 and C.4.

For the overall test to pass, the rate of successful tests during repeated tests in both Test 1 and Test 2 shall be more than 90% with a confidence level of 95%.

10.1A FDD RSTD Measurement Reporting Delay for Carrier Aggregation for 20 MHz Bandwidth

10.1A.1 Test purpose

Same as defined in clause 10.1.1.

NOTE: This test verifies the requirement which is independent of channel bandwidth and is performed according to the principle defined in clause 4.7.5.

10.1A.2 Test applicability

This test applies to all types of E-UTRA FDD UE release 10 and forward that supports UE-assisted OTDOA for Carrier Aggregation.

10.1A.3 Minimum conformance requirements

Same as defined in clause 10.1.3.

The normative reference for this requirement is TS 36.133 [23] clause 8.4.3, 8.4.4 and A.8.17.3.

10.1A.4 Test description

10.1A.4.1 Initial conditions

Same as defined in clause 10.1.4.1 except that the values of the parameters in Table 10.1A.4.1-1 will replace the values of the corresponding parameters in Table 10.1.4.1-1.

Channel bandwidth to be tested: 20 MHz.

Table 10.1A.4.1-1: General test parameters for E-UTRAN FDD RSTD measurement reporting delay under fading propagation conditions for carrier aggregation for 20 MHz

Parameter	Unit	Value		Comment
		Test 1	Test 2	
PCFICH/PDCCH/PHICH parameters		DL Reference Measurement Channel R.10 FDD		As specified in TS 36.521-3 [25] clause A.2.1
Channel Bandwidth (BW _{channel})	MHz	20		
PRS Transmission Bandwidth	RB	100		PRS are transmitted over the system bandwidth
Note 1:	See Table 10.1.4.1-1 for the other parameters.			
Note 2:	This test verifies the requirement which is independent of channel bandwidth and is performed according to the principle defined in clause 4.7.5.			

10.1A.4.2 Test procedure

Same as defined in clause 10.1.4.2.

10.1A.4.3 Message contents

Same as defined in clause 10.1.4.3.

10.1A.5 Test requirement

Same as defined in clause 10.1.5 except that the values of the parameters in Table 10.1A.5-1 and Table 10.1A.5-2 will replace the values of the corresponding parameters in Table 10.1.5-1 and Table 10.1.5-2, respectively.

Table 10.1A.5-1: Cell-specific test parameters for E-UTRAN FDD RSTD measurement reporting delay under fading propagation conditions during T1 for carrier aggregation for 20 MHz

Parameter	Unit	Cell 1	Cell 2	Cell 3
OCNG patterns defined in TS 36.521-3 [25] clause D.1		OP.13 FDD	N/A	N/A
I_o ^{Note 1}	dBm/ 18 MHz	-64.21	N/A	N/A
Note 1: I_o levels have been derived from other parameters for information purposes. They are not settable parameters themselves.				
Note 2: See Table 10.1.5-1 for the other parameters.				

Table 10.1A.5-2: Cell-specific test parameters for E-UTRAN FDD RSTD measurement reporting delay under fading propagation conditions during T2 and T3 for carrier aggregation for 20 MHz

Parameter	Unit	Cell 1		Cell 2		Cell 3	
		T2	T3	T2	T3	T2	T3
OCNG patterns defined in TS 36.521-3 [25] clause D.1		OP.13 FDD		OP.14 FDD		OP.14 FDD	N/A
I_o ^{Note 1}	dBm/ 18 MHz	-66.93	N/A	N/A	-63.67	-67.09	N/A
Note 1: I_o levels have been derived from other parameters for information purposes. They are not settable parameters themselves.							
Note 2: See Table 10.1.5-2 for the other parameters.							

10.1B FDD RSTD Measurement Reporting Delay Carrier Aggregation for 5 MHz + 5 MHz Bandwidth

10.1B.1 Test purpose

Same as defined in clause 10.1.1.

NOTE: This test verifies the requirement which is independent of channel bandwidth and is performed according to the principle defined in clause 4.7.5.

10.1B.2 Test applicability

This test applies to all types of E-UTRA FDD UE release 12 and forward that supports UE-assisted OTDOA for Carrier Aggregation.

10.1B.3 Minimum conformance requirements

Same as defined in clause 10.1.3.

The normative reference for this requirement is TS 36.133 [23] clause 8.4.3, 8.4.4 and A.8.17.7.

10.1B.4 Test description

10.1B.4.1 Initial conditions

Same as defined in clause 10.1.4.1 except that the values of the parameters in Table 10.1B.4.1-1 will replace the values of the corresponding parameters in Table 10.1.4.1-1.

Channel bandwidth to be tested: 5 MHz.

Table 10.1B.4.1-1: General test parameters for E-UTRAN FDD RSTD measurement reporting delay under fading propagation conditions for carrier aggregation for 5 MHz + 5 MHz

Parameter	Unit	Value		Comment
		Test 1	Test 2	
PCFICH/PDCCH/PHICH parameters		DL Reference Measurement Channel R.11 FDD		As specified in TS 36.521-3 [25] clause A.2.1
Channel Bandwidth ($BW_{channel}$)	MHz	5		
PRS Transmission Bandwidth	RB	25		PRS are transmitted over the system bandwidth
PRS occasion length N_{PRS}		2		
Note 1:	See Table 10.1.4.1-1 for the other parameters.			
Note 2:	This test verifies the requirement which is independent of channel bandwidth and is performed according to the principle defined in section 4.7.5.			

10.1B.4.2 Test procedure

Same as defined in clause 10.1.4.2.

10.1B.4.3 Message contents

Same as defined in clause 10.1.4.3.

10.1B.5 Test requirement

Same as defined in clause 10.1.5 except that the values of the parameters in Table 10.1B.5-1 and Table 10.1B.5-2 will replace the values of the corresponding parameters in Table 10.1.5-1 and Table 10.1.5-2, respectively.

Table 10.1B.5-1: Cell-specific test parameters for E-UTRAN FDD RSTD measurement reporting delay under fading propagation conditions during T1 for carrier aggregation for 5 MHz + 5 MHz

Parameter	Unit	Cell 1	Cell 2	Cell 3
OCNG patterns defined in TS 36.521-3 [25] clause D.1.18		OP.18 FDD	N/A	N/A

I_{o} ^{Note 1}	dBm/ 4.5 MHz	-70.23	N/A	N/A
Note 1: I_{o} levels have been derived from other parameters for information purposes. They are not settable parameters themselves.				
Note 2: See Table 10.1.5-1 for the other parameters.				

Table 10.1B.5-2: Cell-specific test parameters for E-UTRAN FDD RSTD measurement reporting delay under fading propagation conditions during T2 and T3 for carrier aggregation for 5 MHz + 5 MHz

Parameter	Unit	Cell 1		Cell 2		Cell 3	
		T2	T3	T2	T3	T2	T3
OCNG patterns defined in TS 36.521-3 [25] clause D.1		OP.18 FDD		OP.19 FDD		OP.19 FDD	N/A
I_{o} ^{Note 1}	dBm/ 4.5 MHz	-72.95	N/A	N/A	-69.69	-73.12	N/A
Note 1: I_{o} levels have been derived from other parameters for information purposes. They are not settable parameters themselves.							
Note 2: See Table 10.1.5-2 for the other parameters.							

10.1C FDD RSTD Measurement Reporting Delay for Carrier Aggregation for 10 MHz+5 MHz Bandwidth

10.1C.1 Test purpose

Same as defined in clause 10.1.1.

NOTE: This test verifies the requirement which is independent of channel bandwidth and is performed according to the principle defined in clause 4.7.5.

10.1C.2 Test applicability

This test applies to all types of E-UTRA FDD UE release 12 and forward that supports UE-assisted OTDOA for Carrier Aggregation.

10.1C.3 Minimum conformance requirements

Same as defined in clause 10.1.3.

The normative reference for this requirement is TS 36.133 [23] clause 8.4.3, 8.4.4 and A.8.17.5.

10.1C.4 Test description

10.1C.4.1 Initial conditions

Same as defined in clause 10.1.4.1 except that the values of the parameters in Table 10.1C.4.1-1 will replace the values of the corresponding parameters in Table 10.1.4.1-1.

Channel bandwidth to be tested: Cell 1: 10 MHz, Cell 2 and Cell 3: 5 MHz.

Table 10.1C.4.1-1: General test parameters for E-UTRAN FDD RSTD measurement reporting delay under fading propagation conditions for carrier aggregation for 10 MHz + 5 MHz

Parameter	Unit	Value	Comment
-----------	------	-------	---------

		Test 1	Test 2	
PCFICH/PDCCH/PHICH parameters		Cell 1: R.6 FDD Cell 2: R.11 FDD Cell 3: R.11 FDD	Cell 1: R.6 FDD Cell 2: R.11 FDD Cell 3: R.11 FDD	As specified in TS 36.521-3 [25] clause A.2.1
Channel Bandwidth ($BW_{channel}$)	MHz	Cell 1: 10 Cell 2: 5 Cell 3: 5	Cell 1: 10 Cell 2: 5 Cell 3: 5	
PRS Transmission Bandwidth	RB	Cell 1: 50 Cell 2: 25 Cell 3: 25	Cell 1: 50 Cell 2: 25 Cell 3: 25	PRS are transmitted over the system bandwidth
PRS occasion length N_{PRS}		Cell 1: 1 Cell 2: 2 Cell 3: 2	Cell 1: 1 Cell 2: 2 Cell 3: 2	
Note 1: See Table 10.1.4.1-1 for the other parameters.				
Note 2: This test verifies the requirement which is independent of channel bandwidth and is performed according to the principle defined in section 4.7.5.				

10.1C.4.2 Test procedure

Same as defined in clause 10.1.4.2.

10.1C.4.3 Message contents

Same as defined in clause 10.1.4.3.

10.1C.5 Test requirement

Same as defined in clause 10.1.5 except that the values of the parameters in Table 10.1C.5-1 and Table 10.1C.5-2 will replace the values of the corresponding parameters in Table 10.1.5-1 and Table 10.1.5-2, respectively.

Table 10.1C.5-1: Cell-specific test parameters for E-UTRAN FDD RSTD measurement reporting delay under fading propagation conditions during T1 for carrier aggregation for 10 MHz + 5 MHz

Parameter	Unit	Cell 1	Cell 2	Cell 3
I_o ^{Note 1}	dBm/9 MHz	-67.22	N/A	N/A
	dBm/4.5 MHz	N/A	N/A	N/A
Note 1: I_o levels have been derived from other parameters for information purposes. They are not settable parameters themselves.				
Note 2: See Table 10.1.5-1 for the other parameters.				

Table 10.1C.5-2: Cell-specific test parameters for E-UTRAN FDD RSTD measurement reporting delay under fading propagation conditions during T2 and T3 for carrier aggregation for 10 MHz + 5 MHz

Parameter	Unit	Cell 1		Cell 2		Cell 3	
		T2	T3	T2	T3	T2	T3
OCNG patterns defined in TS 36.521-3 [25] clause D.1		OP.5 FDD		OP.19 FDD		OP.19 FDD	N/A
I_o ^{Note 1}	dBm/9 MHz	-69.94	N/A	N/A	N/A	N/A	N/A
	dBm/4.5 MHz	N/A	N/A	N/A	-69.69	-73.12	N/A
Note 1: I_o levels have been derived from other parameters for information purposes. They are not settable parameters themselves.							
Note 2: See Table 10.1.5-2 for the other parameters.							

10.2 TDD RSTD Measurement Reporting Delay for Carrier Aggregation

10.2.1 Test purpose

To verify that the RSTD measurement reporting delay meets the requirements in an environment with fading propagation conditions. This test case verifies the measurement period requirements for RSTD measurements performed on the secondary component carrier and also the measurement period requirements for RSTD measurements performed on both the primary and secondary component carriers.

10.2.2 Test applicability

This test applies to all types of E-UTRA TDD UE release 10 and forward that supports UE-assisted OTDOA for Carrier Aggregation.

10.2.3 Minimum conformance requirements

10.2.3.1 Measurements on the secondary component carrier

The RSTD measurements when all cells are on the configured secondary component carrier shall meet all applicable requirements (TDD) specified in TS 36.133 [23] section 8.1.2.5, i.e., E-UTRAN intra-frequency RSTD measurement period applies, regardless of whether the SCell on the corresponding frequency is activated or deactivated by the MAC-CE commands as specified in 3GPP TS 36.321 [34].

10.2.3.2 Measurements on both primary component carrier and secondary component carrier

The RSTD measurements of cells on both primary component carrier and configured secondary component carrier shall meet all applicable requirements (TDD) specified in TS 36.133 [23] section 8.1.2.6, i.e., E-UTRAN inter-frequency RSTD measurement period applies regardless of whether the SCell on the corresponding frequency is activated or deactivated by the MAC-CE commands as specified in 3GPP TS 36.321 [34], with the following exceptions

- the number of PRS positioning occasions is as specified in Table 10.2.3.2-1 shall apply, and
- TDD uplink-downlink subframes configurations as specified in TS 36.133 [23] section 8.1.2.5.2, Table 8.1.2.5.2-2 shall apply.

Table 10.2.3.2-1: Number of PRS positioning occasions within measurement period

Positioning subframe configuration period T_{PRS}	Number of PRS positioning occasions M
160 ms	32
>160 ms	16

The normative reference for this requirement is TS 36.133 [23] clause 8.4.3, 8.4.4 and A.8.17.2.

10.2.4 Test description

10.2.4.1 Initial conditions

Test Environment: Normal; as defined in TS 36.508 [18] clause 4.1.

Frequencies to be tested: Mid Range, as defined in TS 36.508 [18] clause 4.3.1.2.

Channel bandwidth to be tested: 10 MHz as defined in TS 36.508 [18] clause 4.3.1.

1. Connect the SS, faders and AWGN noise sources to the UE antenna connector or antenna connectors as shown in TS 36.508 [18] Annex A, Figure group A.42 as appropriate.
2. The general test parameter settings are set up according to Table 10.2.4.1-1.
3. Propagation conditions are set according to clause 4.7.2.1.
4. Message contents are defined in clause 10.2.4.3.
5. In the tests, there are two configured component carriers: PCC and SCC, and three synchronized cells: Cell 1, Cell 2 and Cell 3. Cell 1 is PCell on the PCC, Cell 2 is an active SCell on the SCC, and Cell 3 is a neighbour cell on the SCC. In both tests, Cell 2 is the OTDOA assistance data reference cell. The assistance data neighbour cell list includes in total 15 cells, where 14 of the cells are not simulated (dummy cells; as defined in 3GPP TS 37.571-5 clause 7.3.2) for Test 1 and where 13 of the cells are not simulated for Test 2. PCell (Cell 1) is the cell used for connection setup with the power level and mapping set according to TS 36.521-1 [24] Annex C.0 and C.1 as appropriate for this test. Cell 2 and Cell 3 are powered OFF.
6. The true RSTD (which is the receive time difference for frame 0 between two cells as seen at the UE antenna connector) is set to 31 Ts (about 1 μ s) between Cell 1 and OTDOA assistance data reference cell, Cell 2; and set to -31 Ts (about -1 μ s) between neighbour Cell 3 and OTDOA assistance data reference cell, Cell 2.

Table 10.2.4.1-1: General test parameters for E-UTRAN TDD RSTD measurement reporting delay under fading propagation conditions for Carrier Aggregation

Parameter	Unit	Value		Comment
		Test 1	Test 2	
PCell		Cell 1		PCell is on RF channel 1 (PCC).
SCell		Cell 2		SCell on RF channel 2 (SCC). Cell 2 is the assistance data reference cell.
Other neighbour cell		Cell 3		Neighbour cell on RF channel 2 (SCC).
PCFICH/PDCCH/PHICH parameters		DL Reference Measurement Channel R.6 TDD		As specified in TS 36.521-3 [25] clause A.2.2
Channel Bandwidth (BW _{channel})	MHz	10		
PRS Transmission Bandwidth ^{Note 2}	RB	50		PRS are transmitted over the system bandwidth
PRS configuration index I_{PRS} ^{Note 2}		174 for all cells on PCC 184 for all cells on SCC		This corresponds to periodicity of 320 ms and PRS subframe offset of $I_{PRS} - 160$ DL subframes, as defined in 3GPP TS 36.211 [26], Table 6.10.4.3-1
Number of consecutive downlink positioning subframes N_{PRS} ^{Note 2}		1		As defined in 3GPP TS 36.211 [26]. The number of subframes in a positioning occasion
Physical cell ID PCI ^{Note 2}		(PCI of Cell 2 – PCI of Cell 3) mod 6 = 0		The PCI of Cell 1 is selected randomly. PCIs of Cell 2 and Cell 3 are selected randomly such that the relative subcarrier shifts of PRS patterns among these cells are as given by the condition
TDD uplink-downlink configuration		1		As specified in TS 36.211 [26], Section 4.2; corresponds to a configuration with 5 ms switch-point periodicity and two downlink consecutive subframes

TDD special subframe configuration		6		As specified in TS 36.211 [26], Section 4.2; corresponds to DwPTS of $19760 \cdot T_s$ and UpPTS of $4384 \cdot T_s$
CP length ^{Note 2}		Normal		
DRX		ON		DRX parameters are further specified in Table 10.2.4.1-2
Radio frame receive time offset between the cells at the UE antenna connector ^{Note 3}	µs	Cell 1 to Cell 2: 1 Cell 3 to Cell 2: -1	Cell 1 to Cell 2: 1 Cell 3 to Cell 2: -1	PRS are transmitted from synchronous cells
Expected RSTD ^{Note 1}	µs	Cell 3: 2 Other neighbour cells: randomly between -3 and 3	Cell 1: -2 Cell 3: 2 Other neighbour cells: randomly between -3 and 3	The expected RSTD is what is expected at the receiver. The corresponding parameter in the OTDOA assistance data specified in TS 36.355 [4] is the expectedRSTD indicator
Expected RSTD uncertainty for all neighbour cells ^{Note 1}	µs	5		The corresponding parameter in the OTDOA assistance data specified in TS 36.355 [4] is the expectedRSTD-Uncertainty index
Number of cells provided in OTDOA assistance data		16 cells in total		The list includes the reference cell and 15 other cells. Cell 1 (when included) appears at random places in the first half of the neighbour cell list in the OTDOA assistance data. Cell 3 always appears at random places in the second half of the list
		OTDOA neighbour cells include Cell 3 and other 14 cells on SCC	OTDOA neighbour cells include Cell 1 and other 7 cells on PCC, and Cell 3 and other 6 cells on SCC	
prs-SubframeOffset ^{Note2}		Cells on PCC: 310 Cells on SCC, except reference cell: 0		Subframe offset, counted in full subframes. The corresponding parameter in the OTDOA assistance data is prs-SubframeOffset specified in TS 36.355 [4]
slotNumberOffset ^{Note 2}		Cells on PCC: 0 Cells on SCC, except reference cell: 0		The slot number offset at the transmitter between a neighbour cell and the assistance data reference cell. The corresponding parameter in the OTDOA assistance data is slotNumberOffset specified in TS 36.355 [4].
PRS muting info ^{Note 2}		Cell 1: '11110000' Cell 2: '00001111' Cell 3: '11110000'	Cell 1: '1111111100000000' Cell 2: '0000000011111111' Cell 3: '1111111100000000'	Corresponds to prs-MutingInfo defined in TS 36.355 [4]
T1	s	3		The length of the time interval from the beginning of each test
T2	s	1.28	2.48	The length of the time interval that follows immediately after time interval T1
T3	s	1.28	2.48	The length of the time interval that follows immediately after time interval T2

Note 1:	Parameters "Expected RSTD" and "Expected RSTD uncertainty for all neighbour cells" are not settable parameters. These are parameters signalled in LPP only. For the values to be used in LPP see Table 10.2.4.3-4 and TS 37.571-5 [20], clause 7.3.2.
Note 2:	Parameters "PRS Transmission Bandwidth", "PRS configuration index", "Number of consecutive downlink positioning subframes", "Physical cell ID PCI", "CP length", "prs-SubframeOffset", "slotNumberOffset" and "PRS muting info" are settable parameters and also parameters signalled in LPP. The values to be used for "Physical cell ID PCI" are as follows: Cell 1: 0, Cell 2: 6, Cell 3: 12. For the values to be used in LPP see Table 10.2.4.3-4 and TS 37.571-5 [20], clause 7.3.2.
Note 3:	The parameter "Radio frame receive time offset between the cells at the UE antenna connector" is used to set the "true RSTD" values in step 6 of clause 10.2.4.1.

Table 10.2.4.1-2: DRX parameters for E-UTRAN TDD RSTD measurement reporting delay under fading propagation conditions for Carrier Aggregation

Field	Value	Comment
onDurationTimer	psf1	As specified in 3GPP TS 36.331 [22], clause 6.3.2.
drx-InactivityTimer	psf1	
drx-RetransmissionTimer	sf1	
longDRX-CycleStartOffset	sf320	
shortDRX	disable	

10.2.4.2 Test procedure

The test case includes two tests. Test 1 is designed for the scenario where the UE receives OTDOA assistance data with cells on SCC, and the UE is expected to report RSTD measurements performed on SCC only. Test 2 is designed for the scenario where the UE receives OTDOA assistance data with cells on PCC and SCC, and the UE is expected to report RSTD measurements performed on PCC and on SCC.

Each test consists of three consecutive time intervals, with duration of T1, T2 and T3 defined in Table 10.2.4-1. Cell 1 is active in T1, T2 and T3, whilst Cell 2 and Cell 3 are activated only in the beginning of T2. Cell 2 is active until the end of T3, and Cell 3 is active until the end of T2. The beginning of the time interval T2 shall be aligned 5 ms before the first PRS positioning subframe of a positioning occasion in the reference cell, where 5 ms is the necessary test tolerance. Cell 1 transmits PRS in T2, while Cell 2 transmits PRS only in T3, and Cell 3 transmits PRS only in T2.

NOTE: The information on when PRS is muted is conveyed to the UE using PRS muting information in the OTDOA assistance data.

The OTDOA-RequestLocationInformation message and the OTDOA assistance data as defined in clause 10.2.4.3 shall be provided to the UE during T1. The last TTI containing the OTDOA-RequestLocationInformation message shall be provided to the UE ΔT ms before the start of T2, where $\Delta T = 150$ ms is the maximum processing time of the OTDOA-RequestLocationInformation message and the OTDOA assistance data.

1. Ensure that the UE is in state Generic RB Established State 3A-RF according to 3GPP TS 36.508 [18] clause 7.2A.3.
2. Configure Cell 2 and Cell 3 on the SCC according to TS 36.521-3 [25] Annex C.0 and C.1 for all downlink physical channels.
3. The SS shall configure the SCell (Cell 2) on the SCC as per TS 36.508 [18] clause 5.2A.4.
4. The SS activates the SCell (Cell 2) by sending the Activation/Deactivation MAC control element according to TS 36.321 [34] clauses 5.13 and 6.1.3.8. Wait for at least 2 seconds as per TS 36.133 [23] clause 8.3.3.2.
5. The SS shall send a RESET UE POSITIONING STORED INFORMATION message.
6. Set the parameters according to Table 10.2.5-1. Propagation conditions are set according to clause 4.7.2.2 (ETU30).
7. T1 starts.
8. The SS shall transmit an RRCConnectionReconfiguration message with the DRX configuration. PDCCHs indicating new transmissions shall be sent continuously until the start of T2 to ensure that the UE would not enter the DRX state before T2.

- 9. The UE shall transmit RRCConnectionReconfigurationComplete message.
- 9a. The SS shall transmit an LPP REQUEST CAPABILITIES message.
- 9b. The UE shall transmit an LPP PROVIDE CAPABILITIES message indicating the OTDOA capabilities supported by the UE in the *OTDOA-ProvideCapabilities* IE.
- 10. The SS shall send a LPP PROVIDE ASSISTANCE DATA message, including the *OTDOA-ProvideAssistanceData* IE. The position of neighbour Cell 3 in the *OTDOA-NeighbourCellInfoList* is randomly selected to be in the last 8 elements of the sequence for Test 1 and in the 7 elements of the relevant sequence for Test 2, and the position of neighbour Cell 1 is randomly selected to be in the first 7 elements of the relevant sequence for Test 2, as described in 3GPP TS 37.571-5 [20], clause 7.3.2. If the UE message at step 9b includes the *ackRequested* IE set to TRUE, then the SS shall send an acknowledgment in the LPP PROVIDE ASSISTANCE DATA message.
- 11. The SS shall send a LPP REQUEST LOCATION INFORMATION message, including the *OTDOA-RequestLocationInformation* IE such that the UE receives the message ΔT ms before the start of T2, where $\Delta T = 150$ ms.
- 12. When T1 expires, the SS shall switch the power setting from T1 to T2 as specified in Table 10.2.5-3.
- 13. When T2 expires, the SS shall switch the power setting from T2 to T3 as specified in Table 10.2.5-3.
- 14. The UE shall transmit a LPP PROVIDE LOCATION INFORMATION including the *OTDOA-ProvideLocationInformation* IE within the response time (see clause 4.7.3) specified in clause 10.2.5.

For Test 1 the UE shall perform and report the RSTD measurement for Cell 3 with respect to the reference cell in the OTDOA assistance data, Cell 2. If the UE transmits an *OTDOA-ProvideLocationInformation* IE including the *rstd* field for Cell 3 within the response time then the number of successful tests is increased by one. If the UE fails to report the *OTDOA-ProvideLocationInformation* IE with the *rstd* field included within the response time then the number of failure tests is increased by one.

For Test 2 the UE shall perform and report the RSTD measurements for Cell 1 with respect to the reference cell in the OTDOA assistance data, Cell 2 and also Cell 3 with respect to the reference cell in the OTDOA assistance data, Cell 2. If the UE transmits an *OTDOA-ProvideLocationInformation* IE including the *rstd* field for Cell 1 (with respect to Cell 2) and Cell 3 (with respect to Cell 2) within the response time then the number of successful tests is increased by one. If the UE fails to report the *OTDOA-ProvideLocationInformation* IE with both the *rstd* fields included within the response time then the number of failure tests is increased by one.
- 15. If the UE message at step 14 includes the *ackRequested* IE set to TRUE, the SS shall send a LPP acknowledgement message.
- 16. Repeat steps 5-15 until the confidence level according to Annex D is achieved. For each iteration, at step 10 change the random positions of the Cell 3 and Cell 1(for Test 2 only) in the relevant sequence in the *OTDOA-NeighbourCellInfoList*.
- 17. Repeat from clause 10.2.4.1 for Test 2.

10.2.4.3 Message contents

Table 10.2.4.3-1: RESET UE POSITIONING STORED INFORMATION

Derivation Path: 36.509 [11] clause 6.9			
Information Element	Value/remark	Comment	Condition
UE Positioning Technology	0 0 0 0 0 0 1	OTDOA	

Table 10.2.4.3-2: MAC-MainConfig-RBC: TDD RSTD Measurement Reporting Delay for Carrier Aggregation

Derivation Path: TS 36.508 [18] clause 4.8.2.1.5, Table 4.8.2.1.5-1 MAC-MainConfig-RBC			
Information Element	Value/remark	Comment	Condition
MAC-MainConfig-RBC ::= SEQUENCE {			
drx-Config CHOICE {			

setup SEQUENCE {			
onDurationTimer	psf1		
drx-InactivityTimer	psf1		
drx-RetransmissionTimer	sf1		
longDRX-CycleStartOffset CHOICE {			
sf320	0		
}			
shortDRX	Not present		
}			
}			

Table 10.2.4.3-2a: LPP Request Capabilities

Information Element	Value/remark
<i>otdoa-RequestCapabilities</i>	TRUE

Table 10.2.4.3-3: LPP RequestLocationInformation

Derivation Path: 36.355 clause 6.2			
Information Element	Value/remark	Comment	Condition
LPP-Message ::= SEQUENCE {			
transactionID SEQUENCE {			
Initiator	locationServer		
transactionNumber	1		
}			
endTransaction	FALSE		
sequenceNumber	Not present		
acknowledgement	Not present		
lpp-MessageBody CHOICE {			
c1 CHOICE {			
requestLocationInformation SEQUENCE {			
criticalExtensions CHOICE {			
c1 CHOICE {			
requestLocationInformation-r9 SEQUENCE {			
commonIEsRequestLocationInformation SEQUENCE {			
locationInformationType	locationMeasurementsRequired		
triggeredReporting	Not present		
periodicalReporting	Not present		
additionalInformation	onlyReturnInformationRequested		
qos SEQUENCE {			
horizontalAccuracy	Not present		
verticalCoordinateRequest	FALSE		
verticalAccuracy	Not present		
responseTime SEQUENCE {			
time	Test 1: 3 Test 2: 6	See clause 10.2.5	
responseTimeEarlyFix-r12	Not present		Rel-12 onwards
}			
velocityRequest	FALSE		
}			
environment	Not present		
locationCoordinateTypes	Not present		
velocityTypes	Not present		
}			
a-gnss-RequestLocationInformation	Not present		
otdoa-RequestLocationInformation SEQUENCE {			
assistanceAvailability	FALSE		
}			

ecid-RequestLocationInformation	Not present		
epdu-RequestLocationInformation	Not Present		
}			
}			
}			
}			
}			
}			

Table 10.2.4.3-4: LPP ProvideAssistanceData

Derivation Path: 36.355 clause 6.2			
Information Element	Value/remark	Comment	Condition
LPP-Message ::= SEQUENCE {			
transactionID SEQUENCE {			
Initiator	locationServer		
transactionNumber	(0..255)		
}			
endTransaction	TRUE		
sequenceNumber	Not present		
acknowledgement	Not present		
lpp-MessageBody CHOICE {			
c1 CHOICE {			
provideAssistanceData SEQUENCE {			
criticalExtensions CHOICE {			
c1 CHOICE {			
provideAssistanceData-r9 SEQUENCE {			
commonIEsProvideAssistanceData	Not present		
a-gnss-ProvideAssistanceData	Not present		
otdoa-ProvideAssistanceData SEQUENCE {			
otdoa-ReferenceCellInfo	As defined in TS 37.571-5 [20], clause 7.3.2.		
otdoa-NeighbourCellInfo	As defined in TS 37.571-5 [20], clause 7.3.2.		
otdoa-Error	Not present		
}			
}			
}			
}			
}			
}			
}			
}			

Table 10.2.4.3-5: LPP ProvideLocation Information

Derivation Path: 36.355 clause 6.2			
Information Element	Value/remark	Comment	Condition
LPP-Message ::= SEQUENCE {			
transactionID SEQUENCE {			
Initiator	locationServer		
transactionNumber	1		
}			
endTransaction	TRUE		
sequenceNumber	(0..255)		
acknowledgement			
lpp-MessageBody CHOICE {			
c1 CHOICE {			
provideLocationInformation SEQUENCE {			
criticalExtensions CHOICE {			

c1 CHOICE {			
provideLocationInformation-r9 SEQUENCE {			
commonIEsProvideLocationInformation	Not present.		
a-gnss-ProvideLocationInformation	Not present		
otdoa-ProvideLocationInformation			
SEQUENCE {			
otdoaSignalMeasurementInformation			
SEQUENCE {			
systemFrameNumber			
physCellIdRef	Cell 2		
cellGlobalIdRef			
earfcnRef			
referenceQuality			
neighbourMeasurementList			
SEQUENCE (SIZE(n)) {			
physCellIdNeighbour	Cell 3		
cellGlobalIdNeighbour			
earfcnNeighbour			
rstd	Present	With respect to Cell 2	
rstd-Quality			
}			
neighbourMeasurementList			
SEQUENCE (SIZE(n)) {			
physCellIdNeighbour	Cell 1	Test 2 only	
cellGlobalIdNeighbour			
earfcnNeighbour			
rstd	Present	Test 2 only With respect to Cell 2	
rstd-Quality			
}			
}			
otdoa-Error	May be present with error reason 'undefined' or 'attemptedButUnableToMeasureSomeNeighbourCells'		
}			
ecid-ProvideLocationInformation	Not present		
epdu-ProvideLocationInformation	Not present		
}			
}			
}			
}			
}			
}			
}			

10.2.5 Test requirement

Table 10.2.5-1 and 10.2.5-2 define the primary level settings including test tolerances for the test.

Table 10.2.5-1: Cell-specific test parameters for E-UTRAN TDD RSTD measurement reporting delay under fading propagation conditions during T1 for Carrier Aggregation

Parameter	Unit	Cell 1	Cell 2	Cell 3
E-UTRA RF Channel Number		1	N/A	N/A
Correlation Matrix and Antenna Configuration		1x2 Low	1x2 Low	1x2 Low

OCNG patterns defined in TS 36.521-3 [25] clause D.2		OP.1 TDD	N/A	N/A
PBCH_RA	dB	0	N/A	N/A
PBCH_RB				
PSS_RA				
SSS_RA				
PCFICH_RB				
PHICH_RA				
PHICH_RB				
PDCCH_RA				
PDCCH_RB				
OCNG_RA <small>Note 1</small>				
OCNG_RB <small>Note 1</small>				
N_{oc} <small>Note 3</small>	dBm/ 15 kHz	-95	N/A	N/A
$PRS \hat{E}_s / N_{oc}$	dB	-Infinity	-Infinity	-Infinity
I_o <small>Note 4</small>	dBm/ 9 MHz	-67.22	N/A	N/A
\hat{E}_s / N_{oc}	dB	0	-Infinity	-Infinity
Propagation Condition		ETU30		
<p>Note 1: OCNG shall be used such that active cell (Cell 1) is fully allocated and a constant total transmitted power spectral density is achieved for all OFDM symbols.</p> <p>Note 2: The resources for uplink transmission are assigned to the UE prior to the start of time period T2.</p> <p>Note 3: Interference from other cells and noise sources not specified in the test are assumed to be constant over subcarriers and time and shall be modelled as AWGN of appropriate power for N_{oc} to be fulfilled.</p> <p>Note 4: I_o levels have been derived from other parameters and are given for information purpose. These are not settable test parameters.</p>				

Table 10.2.5-2: Cell-specific test parameters for E-UTRAN TDD RSTD measurement reporting delay under fading propagation conditions during T2 and T3 for Carrier Aggregation

Parameter	Unit	Cell 1		Cell 2		Cell 3	
		T2	T3	T2	T3	T2	T3
E-UTRA RF Channel Number		1		2		2	
Correlation Matrix and Antenna Configuration		1x2 Low		1x2 Low		1x2 Low	
OCNG patterns defined in TS 36.521-3 [25] clause D.2		OP.1 TDD		OP.2 TDD		OP.2 TDD	N/A
PBCH_RA	dB	0		0	0	0	N/A
PBCH_RB							
PSS_RA							
SSS_RA							
PCFICH_RB							
PHICH_RA							
PHICH_RB							
PDCCH_RA							
PDCCH_RB							
OCNG_RA <small>Note 1</small>							
OCNG_RB <small>Note 1</small>							
PRS_RA	dB	-6	N/A	N/A	3	3	N/A

N_{oc} ^{Note 3}	dBm/ 15 kHz	-98	-98	-98	-95	-98	-95
PRS \hat{E}_s/N_{oc}	dB	-4	-Infinity	-Infinity	-1	-8	-Infinity
PRS \hat{E}_s/I_{ot} ^{Note 4}	dB	-4	-Infinity	-Infinity	-1	-8	-Infinity
I_o ^{Note 4}	dBm/ 9 MHz	-69.94	N/A	N/A	-66.68	-70.11	N/A
PRP ^{Note 4}	dBm/ 15 kHz	-102	-Infinity	-Infinity	-96	-106	-Infinity
RSRP ^{Note 4}	dBm/ 15 kHz	-96	-96	-105	-99	-109	-Infinity
\hat{E}_s/N_{oc} ^{Note 4}	dB	2	2	-7	-4	-11	-Infinity
Propagation Condition		ETU30					
<p>Note 1: OCNG shall be used such that active cells (all, except Cell 3 in T3) are fully allocated and a constant total transmitted power spectral density is achieved for all OFDM symbols other than those in the subframes with transmitted PRS.</p> <p>Note 2: The resources for uplink transmission are assigned to the UE prior to the start of time period T2.</p> <p>Note 3: Interference from other cells and noise sources not specified in the test are assumed to be constant over subcarriers and time and shall be modelled as AWGN of appropriate power for N_{oc} to be fulfilled.</p> <p>Note 4: If PRS_RA is not "N/A", \hat{E}_s/N_{oc}, PRS \hat{E}_s/I_{ot}, I_o, RSRP and PRP levels have been derived from other parameters and are given for information purpose. If PRS_RA is "N/A", I_o and RSRP levels have been derived from other parameters and are given for information purpose. These are not settable test parameters. Interference conditions shall be applied to all PRS symbols of DL positioning subframes.</p>							

The response time including test tolerance is 3.3s for Test 1 and 6.3s for Test 2. The response time is equal to the LPP time IE value plus the test tolerance. The LPP time IE value is derived from the RSTD reporting delay plus ΔT , where $\Delta T = 150$ ms, giving a value of 2710 ms for Test 1 and 5110ms for Test 2. This is rounded up to the next allowed LPP value of 3 seconds for Test 1 and 6 seconds for Test 2.

The RSTD measurement reporting delay in the tests is derived from the following expression,

$T_{PRS} (M - 1) + 160 \left\lceil \frac{n}{M} \right\rceil$, where $M = 8$ and $n = 16$ for Test 1, and $M = 16$ and $n = 16$ for Test 2 are the parameters specified in clause 10.2.3.1 for Test 1 and clause 10.2.3.2 for Test 2.

This gives the total RSTD reporting delay of 2560 ms for Test 1 for the 15 neighbour cells including Cell 3 with respect to the reference cell, Cell 2.

This gives the total RSTD reporting delay of 4960 ms for Test 2 for the 15 neighbour cells including Cell 1 and Cell 3 with respect to the reference cell, Cell 2.

The test tolerances are defined in clauses C.1.3 and C.4.

For the overall test to pass, the rate of successful tests during repeated tests in both Test 1 and Test 2 shall be more than 90% with a confidence level of 95%.

10.2A TDD RSTD Measurement Reporting Delay for Carrier Aggregation for 20 MHz Bandwidth

10.2A.1 Test purpose

Same as defined in clause 10.2.1.

NOTE: This test verifies the requirement which is independent of channel bandwidth and is performed according to the principle defined in clause 4.7.5.

10.2A.2 Test applicability

This test applies to all types of E-UTRA TDD UE release 10 and forward that supports UE-assisted OTDOA for Carrier Aggregation.

10.2A.3 Minimum conformance requirements

Same as defined in clause 10.2.3.

The normative reference for this requirement is TS 36.133 [23] clause 8.4.3, 8.4.4 and A.8.17.4.

10.2A.4 Test description

10.2A.4.1 Initial conditions

Same as defined in clause 10.2.4.1 except that the values of the parameters in Table 10.2A.4.1-1 will replace the values of the corresponding parameters in Table 10.2.4.1-1.

Channel bandwidth to be tested: 20 MHz.

Table 10.2A.4.1-1: General test parameters for E-UTRAN TDD RSTD measurement reporting delay under fading propagation conditions for carrier aggregation for 20 MHz

Parameter	Unit	Value		Comment
		Test 1	Test 2	
PCFICH/PDCCH/PHICH parameters		DL Reference Measurement Channel R.10 TDD		As specified in TS 36.521-3 [25] clause A.2.2
Channel Bandwidth (BW_{channel})	MHz	20		
PRS Transmission Bandwidth	RB	100		PRS are transmitted over the system bandwidth
Note 1: See Table 10.2.4.1-1 for the other parameters.				
Note 2: This test verifies the requirement which is independent of channel bandwidth and is performed according to the principle defined in clause 4.7.5.				

10.2A.4.2 Test procedure

Same as defined in clause 10.2.4.2.

10.2A.4.3 Message contents

Same as defined in clause 10.2.4.3.

10.2A.5 Test requirement

Same as defined in clause 10.2.5 except that the values of the parameters in Table 10.2A.5-1 and Table 10.2A.5-2 will replace the values of the corresponding parameters in Table 10.2.5-1 and Table 10.2.5-2, respectively.

Table 10.2A.5-1: Cell-specific test parameters for E-UTRAN TDD RSTD measurement reporting delay under fading propagation conditions during T1 for carrier aggregation for 20 MHz

Parameter	Unit	Cell 1	Cell 2	Cell 3
OCNG patterns defined in TS 36.521-3 [25] clause D.2		OP.7 TDD	N/A	N/A

I_o ^{Note 1}	dBm/ 18 MHz	-64.21	N/A	N/A
Note 1: I_o levels have been derived from other parameters for information purposes. They are not settable parameters themselves.				
Note 2: See Table 10.2.5-1 for the other parameters.				

Table 10.2A.5-2: Cell-specific test parameters for E-UTRAN TDD RSTD measurement reporting delay under fading propagation conditions during T2 and T3 for carrier aggregation for 20 MHz

Parameter	Unit	Cell 1		Cell 2		Cell 3	
		T2	T3	T2	T3	T2	T3
OCNG patterns defined in TS 36.521-3 [25] clause D.2		OP.7 TDD		OP.8 TDD		OP.8 TDD	N/A
I_o ^{Note 1}	dBm/ 18 MHz	-66.93	N/A	N/A	-63.67	-67.09	N/A
Note 1: I_o levels have been derived from other parameters for information purposes. They are not settable parameters themselves.							
Note 2: See Table 10.2.5-2 for the other parameters.							

10.2B TDD RSTD Measurement Reporting Delay for Carrier Aggregation for 5 MHz + 5 MHz Bandwidth

10.2B.1 Test purpose

Same as defined in clause 10.2.1.

NOTE: This test verifies the requirement which is independent of channel bandwidth and is performed according to the principle defined in clause 4.7.5.

10.2B.2 Test applicability

This test applies to all types of E-UTRA TDD UE release 12 and forward that supports UE-assisted OTDOA for Carrier Aggregation.

10.2B.3 Minimum conformance requirements

Same as defined in clause 10.2.3.

The normative reference for this requirement is TS 36.133 [23] clause 8.4.3, 8.4.4 and A.8.17.8.

10.2B.4 Test description

10.2B.4.1 Initial conditions

Same as defined in clause 10.2.4.1 except that the values of the parameters in Table 10.2B.4.1-1 will replace the values of the corresponding parameters in Table 10.2.4.1-1.

Channel bandwidth to be tested: 5 MHz.

Table 10.2B.4.1-1: General test parameters for E-UTRAN TDD RSTD measurement reporting delay under fading propagation conditions for carrier aggregation for 5 MHz + 5 MHz

Parameter	Unit	Value	Comment
-----------	------	-------	---------

		Test 1	Test 2	
PCFICH/PDCCH/PHICH parameters		DL Reference Measurement Channel R.11 TDD		As specified in TS 36.521-3 [25] clause A.2.2
Channel Bandwidth (BW_{channel})	MHz	5		
PRS Transmission Bandwidth	RB	25		PRS are transmitted over the system bandwidth
PRS occasion length N_{PRS}		2		
Note 1: See Table 10.2.4.1-1 for the other parameters.				
Note 2: This test verifies the requirement which is independent of channel bandwidth and is performed according to the principle defined in section 4.7.5.				

10.2B.4.2 Test procedure

Same as defined in clause 10.2.4.2.

10.2B.4.3 Message contents

Same as defined in clause 10.2.4.3.

10.2B.5 Test requirement

Same as defined in clause 10.2.5 except that the values of the parameters in Table 10.2B.5-1 and Table 10.2B.5-2 will replace the values of the corresponding parameters in Table 10.2.5-1 and Table 10.2.5-2, respectively.

Table 10.2B.5-1: Cell-specific test parameters for E-UTRAN TDD RSTD measurement reporting delay under fading propagation conditions during T1 for carrier aggregation for 5 MHz + 5 MHz

Parameter	Unit	Cell 1	Cell 2	Cell 3
OCNG patterns defined in TS 36.521-3 [25] clause D.2		OP.9 TDD	N/A	N/A
I_0 ^{Note 1}	dBm/ 4.5 MHz	-70.23	N/A	N/A
Note 1: I_0 levels have been derived from other parameters for information purposes. They are not settable parameters themselves.				
Note 2: See Table 10.2.5-1 for the other parameters.				

Table 10.2B.5-2: Cell-specific test parameters for E-UTRAN TDD RSTD measurement reporting delay under fading propagation conditions during T2 and T3 for carrier aggregation for 5 MHz + 5 MHz

Parameter	Unit	Cell 1		Cell 2		Cell 3	
		T2	T3	T2	T3	T2	T3
OCNG patterns defined in TS 36.521-3 [25] clause D.2		OP.9 TDD		OP.10 TDD		OP.10 TDD	N/A
I_0 ^{Note 1}	dBm/ 4.5 MHz	-72.95	N/A	N/A	-69.69	-73.12	N/A
Note 1: I_0 levels have been derived from other parameters for information purposes. They are not settable parameters themselves.							
Note 2: See Table 10.2.5-2 for the other parameters.							

10.2C TDD RSTD Measurement Reporting Delay for Carrier Aggregation for 10 MHz + 5 MHz Bandwidth

10.2C.1 Test purpose

Same as defined in clause 10.2.1.

NOTE: This test verifies the requirement which is independent of channel bandwidth and is performed according to the principle defined in clause 4.7.5.

10.2C.2 Test applicability

This test applies to all types of E-UTRA TDD UE release 12 and forward that supports UE-assisted OTDOA for Carrier Aggregation.

10.2C.3 Minimum conformance requirements

Same as defined in clause 10.2.3.

The normative reference for this requirement is TS 36.133 [23] clause 8.4.3, 8.4.4 and A.8.17.6.

10.2C.4 Test description

10.2C.4.1 Initial conditions

Same as defined in clause 10.2.4.1 except that the values of the parameters in Table 10.2C.4.1-1 will replace the values of the corresponding parameters in Table 10.2.4.1-1.

Channel bandwidth to be tested: Cell 1: 10 MHz, Cell 2 and Cell 3: 5 MHz.

Table 10.2C.4.1-1: General test parameters for E-UTRAN TDD RSTD measurement reporting delay under fading propagation conditions for carrier aggregation for 10 MHz + 5 MHz

Parameter	Unit	Value		Comment
		Test 1	Test 2	
PCFICH/PDCCH/PHICH parameters		Cell 1: R.6 TDD Cell 2: R.11 TDD Cell 3: R.11 TDD	Cell 1: R.6 TDD Cell 2: R.11 TDD Cell 3: R.11 TDD	As specified in TS 36.521-3 [25] clause A.2.2
Channel Bandwidth (BW_{channel})	MHz	Cell 1: 10 Cell 2: 5 Cell 3: 5	Cell 1: 10 Cell 2: 5 Cell 3: 5	
PRS Transmission Bandwidth	RB	Cell 1: 50 Cell 2: 25 Cell 3: 25	Cell 1: 50 Cell 2: 25 Cell 3: 25	PRS are transmitted over the system bandwidth
PRS occasion length N_{PRS}		Cell 1: 1 Cell 2: 2 Cell 3: 2	Cell 1: 1 Cell 2: 2 Cell 3: 2	
Note 1:	See Table 10.2.4.1-1 for the other parameters.			
Note 2:	This test verifies the requirement which is independent of channel bandwidth and is performed according to the principle defined in section 4.7.5.			

10.2C.4.2 Test procedure

Same as defined in clause 10.2.4.2.

10.2C.4.3 Message contents

Same as defined in clause 10.2.4.3.

10.2C.5 Test requirement

Same as defined in clause 10.2.5 except that the values of the parameters in Table 10.2C.5-1 and Table 10.2C.5-2 will replace the values of the corresponding parameters in Table 10.2.5-1 and Table 10.2.5-2, respectively.

Table 10.2C.5-1: Cell-specific test parameters for E-UTRAN TDD RSTD measurement reporting delay under fading propagation conditions during T1 for carrier aggregation for 10 MHz + 5 MHz

Parameter	Unit	Cell 1	Cell 2	Cell 3
I _o ^{Note 1}	dBm/ 9 MHz	-67.22	N/A	N/A
	dBm/ 4.5 MHz	N/A	N/A	N/A
Note 1: I _o levels have been derived from other parameters for information purposes. They are not settable parameters themselves.				
Note 2: See Table 10.2.5-1 for the other parameters.				

Table 10.2C.5-2: Cell-specific test parameters for E-UTRAN TDD RSTD measurement reporting delay under fading propagation conditions during T2 and T3 for carrier aggregation for 10 MHz + 5 MHz

Parameter	Unit	Cell 1		Cell 2		Cell 3	
		T2	T3	T2	T3	T2	T3
OCNG patterns defined in TS 36.521-3 [25] clause D.2		OP.1 TDD		OP.10 TDD		OP.10 TDD	N/A
I _o ^{Note 1}	dBm/ 9 MHz	-69.94	N/A	N/A	N/A	N/A	N/A
	dBm/ 4.5 MHz	N/A	N/A	N/A	-69.69	-73.12	N/A
Note 1: I _o levels have been derived from other parameters for information purposes. They are not settable parameters themselves.							
Note 2: See Table 10.2.5-2 for the other parameters.							

10.2D TDD RSTD Measurement Reporting Delay for Carrier Aggregation for 20 MHz +10 MHz Bandwidth

10.2D.1 Test purpose

Same as defined in clause 10.2.1

NOTE: This test verifies the requirement which is independent of channel bandwidth and is performed according to the principle defined in clause 4.7.5.

10.2D.2 Test applicability

This test applies to all types of E-UTRA TDD UE release 10 and forward that supports UE-assisted OTDOA for Carrier Aggregation.

10.2D.3 Minimum conformance requirements

Same as defined in clause 10.2.3

The normative reference for this requirement is TS 36.133 [23] clause 8.4.3, 8.4.4 and A.8.17.9.

10.2D.4 Test description

10.2D.4.1 Initial conditions

Same as defined in clause 10.2.4.1 except that the values of the parameters in Table 10.2D.4.1-1 will replace the values of the corresponding parameters in Table 10.2.4.1-1.

Channel bandwidth to be tested: Cell 1: 20 MHz, Cell 2 and Cell 3: 10 MHz.

Table 10.2D.4.1-1: General test parameters for E-UTRAN TDD RSTD measurement reporting delay under fading propagation conditions for carrier aggregation for 20 MHz+10 MHz

Parameter	Unit	Value		Comment
		Test 1	Test 2	
PCFICH/PDCCH/PHICH parameters		Cell 1: R.10 TDD Cell 2: R.6 TDD Cell 3: R.6 TDD	Cell 1: R.10 TDD Cell 2: R.6 TDD Cell 3: R.6 TDD	As specified in TS 36.521-3 [25] clause A.2.2
Channel Bandwidth (BW _{channel})	MHz	Cell 1: 20 Cell 2: 10 Cell 3: 10	Cell 1: 20 Cell 2: 10 Cell 3: 10	
PRS Transmission Bandwidth	RB	Cell 1: 100 Cell 2: 50 Cell 3: 50	Cell 1: 100 Cell 2: 50 Cell 3: 50	PRS are transmitted over the system bandwidth
Note 1: See Table 10.2.4.1-1 for the other parameters.				
Note 2: This test verifies the requirement which is independent of channel bandwidth and is performed according to the principle defined in section 4.7.5.				

10.2D.4.2 Test procedure

Same as defined in clause 10.2.4.2

10.2D.4.3 Message contents

Same as defined in clause 10.2.4.3

10.2D.5 Test requirement

Same as defined in clause 10.2.5 except that the values of the parameters in Table 10.2D.5-1 and Table 10.2D.5-2 will replace the values of the corresponding parameters in Table 10.2.5-1 and Table 10.2.5-2, respectively.

Table 10.2D.5-1: Cell-specific test parameters for E-UTRAN TDD RSTD measurement reporting delay under fading propagation conditions during T1 for carrier aggregation for 20 MHz+10 MHz

Parameter	Unit	Cell 1	Cell 2	Cell 3
I ₀ ^{Note 1}	dBm/ 18 MHz	-64.21	N/A	N/A
	dBm/ 9 MHz	N/A	N/A	N/A
Note 1: I ₀ levels have been derived from other parameters for information purposes. They are not settable parameters themselves.				
Note 2: See Table 10.2.5-1 for the other parameters.				

Table 10.2D.5-2: Cell-specific test parameters for E-UTRAN TDD RSTD measurement reporting delay under fading propagation conditions during T2 and T3 for carrier aggregation for 20 MHz+10 MHz

Parameter	Unit	Cell 1		Cell 2		Cell 3	
		T2	T3	T2	T3	T2	T3

OCNG patterns defined in TS36.521-3 clause D.2		OP.7 TDD		OP.2 TDD		OP.2 TDD	N/A
I _o ^{Note 1}	dBm/18 MHz	-66.93	N/A	N/A	N/A	N/A	N/A
	dBm/9 MHz	N/A	N/A	N/A	-66.68	-70.11	N/A
<p>Note 1: I_o levels have been derived from other parameters for information purposes. They are not settable parameters themselves.</p> <p>Note 2: See Table 10.2.5-2 for the other parameters.</p>							

10.3 FDD RSTD Measurement Accuracy for Carrier Aggregation

10.3.1 Test purpose

To verify that the FDD RSTD measurement accuracy is within the specified limits when both the reference cell and neighbouring cell belong to the secondary component carrier.

10.3.2 Test applicability

This test applies to all types of E-UTRA FDD UE release 10 and forward that supports UE-assisted OTDOA for Carrier Aggregation.

10.3.3 Minimum conformance requirements

The UE may operate in either E-UTRA inter-band or intra-band carrier aggregation mode. The requirements in this section shall apply regardless whether the configured downlink secondary cell is activated or deactivated by the MAC-CE command (3GPP TS 36.321 [34]). The requirements apply for bandwidths defined in the bandwidth combination set for the CA configurations supported by the UE as defined in TS 36.101 [2].

The RSTD measurements, which are obtained when both the reference cell and neighbouring cell belong to the secondary component carrier, shall meet the intra-frequency RSTD accuracy requirements defined in TS 36.133 [23] section 9.1.3.

The normative reference for this requirement is TS 36.133 [23] clause 9.1.12 and A.9.8.5.

10.3.4 Test description

10.3.4.1 Initial conditions

Test Environment: Normal; as defined in TS 36.508 [18] clause 4.1.

Frequencies to be tested: Mid Range, as defined in TS 36.508 [18] clause 4.3.1.1.

Channel bandwidth to be tested: 10 MHz.

1. Connect the SS (node B emulator) and AWGN noise sources to the UE antenna connectors as follows:
 - For UEs supporting only 2Rx in all the bands under test, use TS 36.508 [18] Annex A, Figure group A.41 as appropriate.
 - For UEs supporting 4Rx in any of the bands under test use TS 36.508 [18] Annex A, Figure A.90. Use the 2Rx module for cells on bands supporting 2Rx and the 4Rx module for cells on bands supporting 4Rx.
2. The general test parameter settings are set up according to Table 10.3.4.1-1.
3. Propagation conditions are set according to clause 4.7.2.1.
4. Message contents are defined in clause 10.3.4.3.

5. There are three synchronized cells on two different carrier frequencies. Cell 1 is the PCell on primary component carrier F1 (RF channel number 1), Cell 2 is the SCell and OTDOA assistance data reference cell on secondary component carrier F2 (RF channel number 2), and Cell 3 is the neighbour cell on F2. PCell (Cell 1) is the cell used for connection setup with the power level and mapping set according to TS 36.521-1 [24] Annex C.0 and C.1 as appropriate for this test. Cell 2 and Cell 3 are powered OFF.

Cell 3 is included in the OTDOA assistance data neighbour cell list, whilst Cell 1 is not included in the OTDOA assistance data. The assistance data neighbour cell list includes in total 15 cells, where 14 of the cells are not simulated (dummy cells; as defined in 3GPP TS 37.571-5 [20], clause 7.3.2).

Note that the measurement gap is not configured in the test because of UE carrier aggregation capability.

6. The true RSTD (which is the receive time difference for frame 0 between the two cells as seen at the UE antenna connector) is set to 31 Ts (about 1 μ s) between neighbour Cell 3 and OTDOA assistance data reference cell, Cell 2.

Note that the related expectedRSTD value to be signalled over LPP is defined in Table 10.3.4.1-1.

Table 10.3.4.1-1: General Test Parameters for RSTD Test for E-UTRAN FDD for Carrier Aggregation

Parameter	Unit	Value	Comment
PCFICH/PDCCH/PHICH parameters		R.6 FDD	As specified in TS 36.521-3 [25] clause A.2.1
OCNG Patterns defined in TS 36.521-3 [25] clause D.1		OP.6 FDD	OCNG shall be used such that both cells are fully allocated and a constant total transmitted power spectral density is achieved for all OFDM symbols (other than those in the PRS subframes).
Assistance data reference cell		Cell 2	Cell 2 is the SCell on RF channel number 2
PCell		Cell 1	Cell 1 on RF channel number 1
Neighbour cell		Cell 3	Cell 3 on RF channel number 2
E-UTRA RF Channel Number		1,2	Two FDD carrier frequencies are used.
Channel Bandwidth (BW_{channel})	MHz	10	
PRS Transmission Bandwidth ^{Note 2}	RB	50	PRS Bandwidth: bandwidth is as indicated in <i>prs-Bandwidth</i> in the OTDOA assistance data defined in 3GPP TS 36.355 [4].
PRS configuration Index I_{PRS} ^{Note 2}		2	As defined in 3GPP TS 36.211 [26]
Number of consecutive positioning downlink subframes N_{PRS} ^{Note 2}		1	As defined in 3GPP TS 36.211 [26]
prs-MutingInfo ^{Note 2}		Cell 1: '11110000' Cell 2: '11110000' Cell 3: '11110000'	See section 6.5.1.2 in 3GPP TS 36.355 [4] for more information
Cell ID ^{Note 2}		(Cell ID of cell 2 – Cell ID of cell 3) mod 6 = 3	PCI of cell 1 is selected randomly.
Expected RSTD ^{Note 1}	μ s	Cell 3: -2 Other neighbour cells: randomly between -3 and 3	The expected RSTD is what is expected at the receiver. The corresponding parameter in the OTDOA assistance data specified in TS 36.355 [4] is the expectedRSTD indicator
Expected RSTD uncertainty for all neighbour cells ^{Note 1}	μ s	5	The corresponding parameter in the OTDOA assistance data specified in TS 36.355 [4] is the expectedRSTD-Uncertainty index
CP length ^{Note 2}		Normal	
DRX		OFF	
Radio frame receive time offset between the cells at the UE antenna connector ^{Note 3}	μ s	Cell 1 to Cell 2: -1 Cell 3 to Cell 2: 1	PRS are transmitted from synchronous cells
Number of cells provided in OTDOA assistance data		16	The list includes the assistance-data-reference cell and 15 other cells. All cells provided in OTDOA assistance data are on RF channel 2.
$T_{\text{RSTD IntraFreqFDD, E-UTRAN}}$ ^{Note 4}	ms	2560	Derived according to the RSTD measurement requirements specified in Section 10.1.3

<p>NOTE 1: Parameters “Expected RSTD” and “Expected RSTD uncertainty for all neighbour cells” are not settable parameters. These are parameters signalled in LPP only. For the values to be used in LPP see Table 10.3.4.3-3 and TS 37.571-5 [20], clause 7.3.2.</p> <p>NOTE 2: Parameters “PRS Transmission Bandwidth”, “PRS configuration index”, “Number of consecutive positioning downlink subframes”, “prs-MutingInfo”, “Cell ID” and “CP length” are settable parameters and also parameters signalled in LPP. The values to be used for “Cell ID” are as follows: Cell 1: 0, Cell 2: 7, Cell 3: 10. For the values to be used in LPP see Table 10.3.4.3-3 and TS 37.571-5 [20], clause 7.3.2.</p> <p>NOTE 3: The parameter “Radio frame receive time offset between the cells at the UE antenna connector” is used to set the “true RSTD” value in step 6 of clause 10.3.4.1.</p> <p>NOTE 4: The parameter “$T_{\text{RSTD IntraFreqFDD, E-UTRAN}}$” is not a settable parameter but is used to set the LPP “time” value in Table 10.3.4.3-2. The value of the LPP time IE is set to $T_{\text{RSTD IntraFreqFDD, E-UTRAN}} + \Delta T$ ms, where $\Delta T = 150$ ms, giving a value of 2710 ms. This is rounded up to the next allowed LPP value of 3 seconds.</p>

10.3.4.2 Test procedure

The RSTD measurements are performed between Cell 2 and Cell 3 to verify that when both the reference cell and neighbouring cell belong to the secondary component carrier the RSTD measurement accuracy can meet the intra-frequency RSTD accuracy requirements defined in section 10.3.3.

The test consists of a set-up period and a measurement period. All cells are active during the complete test. The beginning of the measurement period shall be aligned with the first PRS positioning subframe of a positioning occasion in the reference cell.

NOTE: The information on when PRS is muted is conveyed to the UE using PRS muting information in the OTDOA assistance data.

The OTDOA-RequestLocationInformation message and the OTDOA assistance data as defined in clause 10.3.4.3 shall be provided to the UE during the set-up period. The last TTI containing the OTDOA-RequestLocationInformation message shall be provided to the UE ΔT ms before the start of the measurement period, where $\Delta T = 150$ ms is the maximum processing time of the OTDOA-RequestLocationInformation message and the OTDOA assistance data in the UE.

1. Ensure that the UE is in state Generic RB Established State 3A-RF according to 3GPP TS 36.508 [18] clause 7.2A.3.
2. Configure Cell 2 and Cell 3 on the SCC according to TS 36.521-3 [25] Annex C.0 and C.1 for all downlink physical channels.
3. The SS shall configure the SCell (Cell 2) on the SCC as per TS 36.508 [18] clause 5.2A.4.
4. The SS activates the SCell (Cell 2) by sending the Activation/Deactivation MAC control element according to TS 36.321 [34] clauses 5.13 and 6.1.3.8. Wait for at least 2 seconds as per TS 36.133 [23] clause 8.3.3.2.
5. The SS shall send a RESET UE POSITIONING STORED INFORMATION message.
6. Set the parameters according to Table 10.3.5-1 as appropriate. Propagation conditions are set according to clause 4.7.2.1.
- 6a. The SS shall send an LPP REQUEST CAPABILITIES message.
- 6b. The UE shall send an LPP PROVIDE CAPABILITIES message indicating the OTDOA capabilities supported by the UE in the *OTDOA-ProvideCapabilities* IE
7. The SS shall send a LPP PROVIDE ASSISTANCE DATA message, including the *OTDOA-ProvideAssistanceData* IE. If the UE message at step 6b includes the *ackRequested* IE set to TRUE, then the SS shall send an acknowledgment in the LPP PROVIDE ASSISTANCE DATA message.
8. The SS shall send a LPP REQUEST LOCATION INFORMATION message, including the *OTDOA-RequestLocationInformation* IE such that the UE receives the message ΔT ms before the start of the measurement period, where $\Delta T = 150$ ms.
9. The UE shall transmit a LPP PROVIDE LOCATION INFORMATION message, including the *OTDOA-ProvideLocationInformation* IE.

- 10. If the UE message at step 9 includes the *ackRequested* IE set to TRUE, the SS shall send a LPP acknowledgement message.
- 11. The SS shall check the *rstd* value for Cell 3 in the *OTDOA-SignalMeasurementInformation* IE according to Table 10.3.5-2.
- 12. Repeat step 5-11 until the confidence level according to Annex D is achieved.

10.3.4.3 Message contents

Table 10.3.4.3-1: RESET UE POSITIONING STORED INFORMATION

Derivation Path: 36.509 [11] clause 6.9			
Information Element	Value/remark	Comment	Condition
UE Positioning Technology	0 0 0 0 0 0 1	OTDOA	

Table 10.3.4.3-1a: LPP Request Capabilities

Information Element	Value/remark
<i>otdoa-RequestCapabilities</i>	TRUE

Table 10.3.4.3-2: LPP RequestLocationInformation

Derivation Path: 36.355 clause 6.2			
Information Element	Value/remark	Comment	Condition
LPP-Message ::= SEQUENCE {			
transactionID SEQUENCE {			
Initiator	locationServer		
transactionNumber	1		
}			
endTransaction	FALSE		
sequenceNumber	Not present		
acknowledgement	Not present		
lpp-MessageBody CHOICE {			
c1 CHOICE {			
requestLocationInformation SEQUENCE {			
criticalExtensions CHOICE {			
c1 CHOICE {			
requestLocationInformation-r9 SEQUENCE {			
commonEsRequestLocationInformation SEQUENCE {			
locationInformationType	locationMeasurementsRequired		
triggeredReporting	Not present		
periodicalReporting	Not present		
additionalInformation	onlyReturnInformationRequested		
qos SEQUENCE {			
horizontalAccuracy	Not present		
verticalCoordinateRequest	FALSE		
verticalAccuracy	Not present		
responseTime SEQUENCE {			
time	3	See Note 4 of Table 10.3.4.1-1	
responseTimeEarlyFix-r12	Not present		Rel-12 onwards
}			
velocityRequest	FALSE		
}			
environment	Not present		
locationCoordinateTypes	Not present		
velocityTypes	Not present		
}			

a-gnss-RequestLocationInformation	Not present		
otdoa-RequestLocationInformation			
SEQUENCE {			
assistanceAvailability	FALSE		
}			
ecid-RequestLocationInformation	Not present		
epdu-RequestLocationInformation	Not Present		
}			
}			
}			
}			
}			
}			
}			
}			

Table 10.3.4.3-3: LPP ProvideAssistanceData

Derivation Path: 36.355 clause 6.2			
Information Element	Value/remark	Comment	Condition
LPP-Message ::= SEQUENCE {			
transactionID SEQUENCE {			
Initiator	locationServer		
transactionNumber	(0..255)		
}			
endTransaction	TRUE		
sequenceNumber	Not present		
acknowledgement	Not present		
lpp-MessageBody CHOICE {			
c1 CHOICE {			
provideAssistanceData SEQUENCE {			
criticalExtensions CHOICE {			
c1 CHOICE {			
provideAssistanceData-r9 SEQUENCE {			
commonIEsProvideAssistanceData	Not present		
a-gnss-ProvideAssistanceData	Not present		
otdoa-ProvideAssistanceData SEQUENCE {			
otdoa-ReferenceCellInfo	As defined in TS 37.571-5 [20], clause 7.3.2.		
otdoa-NeighbourCellInfo	As defined in TS 37.571-5 [20], clause 7.3.2.		
otdoa-Error	Not present		
}			
epdu-ProvideAssistanceData	Not present		
}			
}			
}			
}			
}			
}			

Table 10.3.4.3-4: LPP ProvideLocation Information

Derivation Path: 36.355 clause 6.2			
Information Element	Value/remark	Comment	Condition
LPP-Message ::= SEQUENCE {			
transactionID SEQUENCE {			
Initiator	locationServer		
transactionNumber	1		
}			
endTransaction	TRUE		
sequenceNumber	(0..255)		

acknowledgement			
lpp-MessageBody CHOICE {			
c1 CHOICE {			
provideLocationInformation SEQUENCE {			
criticalExtensions CHOICE {			
c1 CHOICE {			
provideLocationInformation-r9 SEQUENCE {			
commonIEsProvideLocationInformation	Not present.		
a-gnss-ProvideLocationInformation	Not present		
otdoa-ProvideLocationInformation			
SEQUENCE {			
otdoaSignalMeasurementInformation			
SEQUENCE {			
systemFrameNumber			
physCellIdRef	Cell 2		
cellGlobalIdRef			
earfcnRef			
referenceQuality			
neighbourMeasurementList			
SEQUENCE (SIZE(1)) {			
physCellIdNeighbour	Cell 3		
cellGlobalIdNeighbour			
earfcnNeighbour			
rstd	Set according to Table 10.3.5-2		
rstd-Quality			
}			
}			
otdoa-Error	May be present with error reason 'undefined' or 'attemptedButUnableToMeasureSomeNeighbourCells'		
}			
ecid-ProvideLocationInformation	Not present		
epdu-ProvideLocationInformation	Not present		
}			
}			
}			
}			
}			
}			

10.3.5 Test requirement

Table 10.3.5-1 defines the primary level settings including test tolerances for the test.

The FDD RSTD accuracy test shall meet the reported values in Table 10.3.5-2.

Table 10.3.5-1: Cell Specific Test Parameters for RSTD Test for E-UTRAN FDD for Carrier Aggregation

Parameter	Unit	Cell 1	Cell 2	Cell 3
E-UTRA RF Channel Number		1	2	2
PBCH_RA	dB	0	0	0
PBCH_RB				
PSS_RA				
SSS_RA				
PCFICH_RB				
PHICH_RA				
PHICH_RB				
PDCCH_RA				
PDCCH_RB				
OCNG_RA ^{Note 1}				

OCNG_RB ^{Note 1}				
PRS_RA	dB	-3	0.3	0.3
N_{oc} ^{Note 2}	dBm/15 kHz	-98		
PRS \hat{E}_s/N_{oc}	dB	-6	-5.7	-12.7
PRS \hat{E}_s/I_{ot} ^{Note 3}	dB	-6	-5.7	-12.7
I_o ^{Note 3}	dBm/9 MHz	-70.04	-69.99	-69.99
PRP ^{Note 3}	dBm/15 kHz	-104	-103.7	-110.7
\hat{E}_s/N_{oc} ^{Note 3}	dB	-3	-6	-13
RSRP ^{Note 3}	dBm/15 kHz	-101	-104	-111
Propagation condition		AWGN		
<p>Note 1: OCNG shall be used such that both cells are fully allocated and a constant total transmitted power spectral density is achieved for all OFDM symbols (other than those in the PRS subframes).</p> <p>Note 2: Interference from other cells and noise sources not specified in the test is assumed to be constant over subcarriers and time and shall be modelled as AWGN of appropriate power for N_{oc} to be fulfilled.</p> <p>Note 3: \hat{E}_s/N_{oc}, PRS \hat{E}_s/I_{ot}, I_o, RSRP and PRP levels have been derived from other parameters for information purposes. They are not settable parameters themselves. I_o values are derived in the case that there is no PBCH, PSS or SSS in the OFDM symbols carrying PRS.</p>				

Table 10.3.5-2: RSTD FDD accuracy requirements for the reported values for Carrier Aggregation

	Value
Lowest reported value	RSTD_6380
Highest reported value	RSTD_6392

For the test to pass, the ratio of successful reported values shall be more than 90% with a confidence level of 95%.

10.3A FDD RSTD Measurement Accuracy for Carrier Aggregation for 20 MHz Bandwidth (Rel-10 and Rel-11)

10.3A.1 Test purpose

Same as defined in clause 10.3.1.

10.3A.2 Test applicability

This test applies to all types of E-UTRA FDD UE release 10 and 11 that supports UE-assisted OTDOA for Carrier Aggregation.

10.3A.3 Minimum conformance requirements

Same as defined in clause 10.3.3.

The normative reference for this requirement is TS 36.133 [23] clause 9.1.12 and A.9.8.7.

10.3A.4 Test description

10.3A.4.1 Initial conditions

Same as defined in clause 10.3.4.1 except that the values of the parameters in Table 10.3A.4.1-1 will replace the values of the corresponding parameters in Table 10.3.4.1-1.

Channel bandwidth to be tested: 20 MHz.

Table 10.3A.4.1-1: General Test Parameters for RSTD Test for E-UTRAN FDD for Carrier Aggregation for 20 MHz

Parameter	Unit	Value	Comment
PCFICH/PDCCH/PHICH parameters		R.10 FDD	As specified in clause TS 36.521-3 [25] clause A.2.1
OCNG Patterns defined in TS 36.521-3 [25] clause D.1		OP.14 FDD	OCNG shall be used such that both cells are fully allocated and a constant total transmitted power spectral density is achieved for all OFDM symbols (other than those in the PRS subframes).
Channel Bandwidth (BW _{channel})	MHz	20	
PRS Bandwidth	RB	100	PRS Bandwidth bandwidth is as indicated in <i>prs-Bandwidth</i> in the OTDOA assistance data defined in 3GPP TS 36.355 [4].

Note 1: See Table 10.3.4.1-1 for other general test parameters.

10.3A.4.2 Test procedure

Same as defined in clause 10.3.4.2.

10.3A.4.3 Message contents

Same as defined in clause 10.3.4.3.

10.3A.5 Test requirement

Same as defined in clause 10.3.5 except that the value of the parameter in Table 10.3A.5-1 will replace the value of the corresponding parameter in Table 10.3.5-1.

Table 10.3A.5-1: Cell Specific Test Parameters for RSTD Test for E-UTRAN FDD for Carrier Aggregation for 20 MHz

Parameter	Unit	Cell1	Cell2	Cell3
I ₀ ^{Note1}	dBm/18 MHz	-67.03	-66.98	-66.98

Note 1: I₀ level has been derived from other parameters for information purposes. It is not settable parameter itself. I₀ values are derived in the case that there is no PBCH, PSS or SSS in the OFDM symbols carrying PRS

Note 2: See Table 10.3.5-1 for other cell specific test parameters.

10.3A_1 FDD RSTD Measurement Accuracy for Carrier Aggregation for 20 MHz Bandwidth (Rel-12 onwards)

10.3A_1.1 Test purpose

Same as defined in clause 10.3A.1.

10.3A_1.2 Test applicability

This test applies to all types of E-UTRA FDD UE release 12 and forward that supports UE-assisted OTDOA for Carrier Aggregation.

10.3A_1.3 Minimum conformance requirements

Same as defined in clause 10.3A.3.

The normative reference for this requirement is TS 36.133 [23] clause 9.1.12 and A.9.8.7.

10.3A_1.4 Test description

10.3A_1.4.1 Initial conditions

Same as defined in clause 10.3A.4.1.

10.3A_1.4.2 Test procedure

Same as defined in clause 10.3A.4.2.

10.3A_1.4.3 Message contents

Same as defined in clause 10.3A.4.3.

10.3A_1.5 Test requirement

Same as defined in clause 10.3A.5 except that in addition Table 10.3A_1.5-1 will replace Table 10.3.5-2.

Table 10.3A_1.5-1: RSTD FDD accuracy requirements for the reported values for Carrier Aggregation

	Value
Lowest reported value	RSTD_6381
Highest reported value	RSTD_6391

10.3B FDD RSTD Measurement Accuracy for Carrier Aggregation for 5 MHz + 5 MHz Bandwidth

10.3B.1 Test purpose

Same as defined in clause 10.3.1.

10.3B.2 Test applicability

This test applies to all types of E-UTRA FDD UE release 10 and forward that supports UE-assisted OTDOA for Carrier Aggregation.

10.3B.3 Minimum conformance requirements

Same as defined in clause 10.3.3.

The normative reference for this requirement is TS 36.133 [23] clause 9.1.12 and A.9.8.11.

10.3B.4 Test description

10.3B.4.1 Initial conditions

Same as defined in clause 10.3.4.1 except that the values of the parameters in Table 10.3B.4.1-1 will replace the values of the corresponding parameters in Table 10.3.4.1-1.

Channel bandwidth to be tested: 5 MHz.

Table 10.3B.4.1-1: General Test Parameters for RSTD Test for E-UTRAN FDD for Carrier Aggregation for 5 MHz + 5 MHz

Parameter	Unit	Value	Comment
PCFICH/PDCCH/PHICH parameters		R.11 FDD	As specified in TS 36.521-3 [25] clause A.2.1
OCNG Patterns defined in TS 36.521-3 [25] clause D.1		OP.19 FDD	OCNG shall be used such that both cells are fully allocated and a constant total transmitted power spectral density is achieved for all OFDM symbols (other than those in the PRS subframes). There is no PDSCH allocated in the subframe transmitting PRS.
Channel Bandwidth ($BW_{channel}$)	MHz	5	
PRS Bandwidth	RB	25	PRS Bandwidth bandwidth is as indicated in <i>prs-Bandwidth</i> in the OTDOA assistance data defined in 3GPP TS 36.355 [4].
Number of consecutive positioning downlink subframes N_{PRS}		2	As defined in 3GPP TS 36.211 [26]
Note 1: See Table 10.3.4.1-1 for other general test parameters.			

10.3B.4.2 Test procedure

Same as defined in clause 10.3.4.2.

10.3B.4.3 Message contents

Same as defined in clause 10.3.4.3.

10.3B.5 Test requirement

Same as defined in clause 10.3.5 except that the value of the parameter in Table 10.3B.5-1 will replace the value of the corresponding parameter in Table 10.3.5-1 and the FDD RSTD accuracy shall meet the reported values in Table 10.3B.5-2.

Table 10.3B.5-1: Cell Specific Test Parameters for RSTD Test for E-UTRAN FDD for Carrier Aggregation for 5 MHz + 5 MHz

Parameter	Unit	Cell1	Cell2	Cell3
I_0 ^{Note1}	dBm/4.5 MHz	-73.05	-73.00	-73.00
Note 1: I_0 level has been derived from other parameters for information purposes. It is not settable parameter itself. I_0 values are derived in the case that there is no PBCH, PSS or SSS in the OFDM symbols carrying PRS				
Note 2: See Table 10.3.5-1 for other cell specific test parameters.				

Table 10.3B.5-2: RSTD FDD accuracy requirements for the reported values for Carrier Aggregation for 5 MHz+5 MHz bandwidth

	Value
Lowest reported value	RSTD_6379
Highest reported value	RSTD_6393

10.3C FDD RSTD Measurement Accuracy for Carrier Aggregation for 10 MHz + 5 MHz Bandwidth

10.3C.1 Test purpose

Same as defined in clause 10.3.1.

10.3C.2 Test applicability

This test applies to all types of E-UTRA FDD UE release 11 and forward that supports UE-assisted OTDOA for Carrier Aggregation.

10.3C.3 Minimum conformance requirements

Same as defined in clause 10.3.3.

The normative reference for this requirement is TS 36.133 [23] clause 9.1.12 and A.9.8.9.

10.3C.4 Test description

10.3C.4.1 Initial conditions

Same as defined in clause 10.3.4.1 except that the values of the parameters in Table 10.3C.4.1-1 will replace the values of the corresponding parameters in Table 10.3.4.1-1.

Channel bandwidth to be tested: Cell 1: 10 MHz, Cell 2 and Cell 3: 5 MHz.

Table 10.3C.4.1-1: General Test Parameters for RSTD Test for E-UTRAN FDD for Carrier Aggregation for 10 MHz + 5 MHz

Parameter	Unit	Value	Comment
PCFICH/PDCCH/PHICH parameters		Cell1: R.6 FDD Cell2: R.11 FDD Cell3: R.11 FDD	As specified in TS 36.521-3 [25] clause A.2.1
OCNG Patterns defined in TS 36.521-3 [25] clause D.1		Cell1: OP.6 FDD Cell2: OP.19 FDD Cell3: OP.19 FDD	OCNG shall be used such that both cells are fully allocated and a constant total transmitted power spectral density is achieved for all OFDM symbols (other than those in the PRS subframes). There is no PDSCH allocated in the subframe transmitting PRS.
Channel Bandwidth (BW_{channel})	MHz	Cell1: 10 Cell2: 5 Cell3: 5	
PRS Bandwidth	RB	Cell1: 50 Cell2: 25 Cell3: 25	PRS Bandwidth bandwidth is as indicated in <i>prs-Bandwidth</i> in the OTDOA assistance data defined in 3GPP TS 36.355 [4].
Number of consecutive positioning downlink subframes N_{PRS}		2	As defined in 3GPP TS 36.211 [26]
Note 1: See Table 10.3.4.1-1 for other general test parameters.			

10.3C.4.2 Test procedure

Same as defined in clause 10.3.4.2.

10.3C.4.3 Message contents

Same as defined in clause 10.3.4.3.

10.3C.5 Test requirement

Same as defined in clause 10.3.5 except that the value of the parameter in Table 10.3C.5-1 will replace the value of the corresponding parameter in Table 10.3.5-1 and the FDD RSTD accuracy shall meet the reported values in Table 10.3C.5-2.

Table 10.3C.5-1: Cell Specific Test Parameters for RSTD Test for E-UTRAN FDD for Carrier Aggregation for 10 MHz +5 MHz

Parameter	Unit	Cell1	Cell2	Cell3
I _o ^{Note1}	dBm/9 MHz	-70.04	N/A	N/A
	dBm/4.5 MHz	N/A	-73.00	-73.00
Note 1:	I _o level has been derived from other parameters for information purposes. It is not settable parameter itself. I _o values are derived in the case that there is no PBCH, PSS or SSS in the OFDM symbols carrying PRS			
Note 2:	See Table 10.3.5-1 for other cell specific test parameters.			

Table 10.3C.5-2: RSTD FDD accuracy requirements for the reported values for Carrier Aggregation for 10 MHz+5 MHz bandwidth

	Value
Lowest reported value	RSTD_6379
Highest reported value	RSTD_6393

10.4 TDD RSTD Measurement Accuracy for Carrier Aggregation

10.4.1 Test purpose

To verify that the TDD RSTD measurement accuracy is within the specified limits when both the reference cell and neighbouring cell belong to the secondary component carrier.

10.4.2 Test applicability

This test applies to all types of E-UTRA TDD UE release 10 and forward that supports UE-assisted OTDOA for Carrier Aggregation.

10.4.3 Minimum conformance requirements

The UE may operate in either E-UTRA inter-band or intra-band carrier aggregation mode. The requirements in this section shall apply regardless whether the configured downlink secondary cell is activated or deactivated by the MAC-CE command (3GPP TS 36.321 [34]). The requirements apply for bandwidths defined in the bandwidth combination set for the CA configurations supported by the UE as defined in TS 36.101 [2].

The RSTD measurements, which are obtained when both the reference cell and neighbouring cell belong to the secondary component carrier, shall meet the intra-frequency RSTD accuracy requirements defined in TS 36.133 [23] section 9.1.3.

The normative reference for this requirement is TS 36.133 [23] clause 9.1.12 and A.9.8.6.

10.4.4 Test description

10.4.4.1 Initial conditions

Test Environment: Normal; as defined in TS 36.508 [18] clause 4.1.

Frequencies to be tested: Mid Range, as defined in TS 36.508 [18] clause 4.3.1.2.

Channel bandwidth to be tested: 10 MHz.

1. Connect the SS (node B emulator) and AWGN noise sources to the UE antenna connectors as follows:
 - For UEs supporting only 2Rx in all the bands under test, use TS 36.508 [18] Annex A, Figure group A.41 as appropriate.
 - For UEs supporting 4Rx in any of the bands under test use TS 36.508 [18] Annex A, Figure A.90. Use the 2Rx module for cells on bands supporting 2Rx and the 4Rx module for cells on bands supporting 4Rx.
2. The general test parameter settings are set up according to Table 10.4.4.1-1.
3. Propagation conditions are set according to clause 4.7.2.1.
4. Message contents are defined in clause 10.4.4.3.
5. There are three synchronized cells on two different carrier frequencies. Cell 1 is the PCell on primary component carrier F1 (RF channel number 1), Cell 2 is the SCell and OTDOA assistance data reference cell on secondary component carrier F2 (RF channel number 2), and Cell 3 is the neighbour cell on F2. PCell (Cell 1) is the cell used for connection setup with the power level and mapping set according to TS 36.521-1 [24] Annex C.0 and C.1 as appropriate for this test. Cell 2 and Cell 3 are powered OFF.

Cell 3 is included in the OTDOA assistance data neighbour cell list, whilst Cell 1 is not included in the OTDOA assistance data. The assistance data neighbour cell list includes in total 15 cells, where 14 of the cells are not simulated (dummy cells; as defined in 3GPP TS 37.571-5 [20], clause 7.3.2).

Note that the measurement gap is not configured in the test because of UE carrier aggregation capability.

6. The true RSTD (which is the receive time difference for frame 0 between the two cells as seen at the UE antenna connector) is set to 31 Ts (about 1 μ s) between neighbour Cell 3 and OTDOA assistance data reference cell, Cell 2.

Note that the related expectedRSTD value to be signalled over LPP is defined in Table 10.4.4.1-1.

Table 10.4.4.1-1: General Test Parameters for RSTD Test for E-UTRAN TDD for Carrier Aggregation

Parameter	Unit	Value	Comment
PCFICH/PDCCH/PHICH parameters		R.6 TDD	As specified in TS 36.521-3 [25] clause A.2.2
OCNG Patterns defined in TS 36.521-3 [25] clause D.2		OP.2 TDD	OCNG shall be used such that both cells are fully allocated and a constant total transmitted power spectral density is achieved for all OFDM symbols (other than those in the PRS subframes).
Assistance data reference cell		Cell 2	Cell 2 is the SCell on RF channel number 2
PCell		Cell 1	Cell 1 on RF channel number 1
Neighbour cell		Cell 3	Cell 3 on RF channel number 2
E-UTRA RF Channel Number		1,2	Two TDD carrier frequencies are used.
Channel Bandwidth (BW _{channel})	MHz	10	
Special subframe configuration		6	As specified in table 4.2-1 in TS 36.211 [26]. The same configuration in both cells.
Uplink-downlink configuration		1	As specified in table 4.2-2 in TS 36.211 [26] and table 8.1.2.5.2-2 in TS 36.133 [23]. The same configuration in both cells.
PRS Transmission Bandwidth ^{Note 2}	RB	50	PRS Bandwidth: bandwidth is as indicated in <i>prs-Bandwidth</i> in the OTDOA assistance data defined in 3GPP TS 36.355 [4].

PRS configuration Index I_{PRS} ^{Note 2}		Cell 1: 14 Cell 2: 14 Cell 3: 14	As defined in 3GPP TS 36.211 [26]
Number of consecutive positioning downlink subframes N_{PRS} ^{Note 2}		1	As defined in 3GPP TS 36.211 [26]
prs-MutingInfo ^{Note 2}		Cell 1: '11110000' Cell 2: '11110000' Cell 3: '11110000'	See section 6.5.1.2 in 3GPP TS 36.355 [4] for more information
Cell ID ^{Note 2}		(Cell ID of cell 2 – Cell ID of cell 3) mod 6 = 3	PCI of cell 1 is selected randomly.
Expected RSTD ^{Note 1}	μs	Cell 3: -2 Other neighbour cells: randomly between -3 and 3	The expected RSTD is what is expected at the receiver. The corresponding parameter in the OTDOA assistance data specified in TS 36.355 [4] is the expectedRSTD indicator
Expected RSTD uncertainty for all neighbour cells ^{Note 1}	μs	5	The corresponding parameter in the OTDOA assistance data specified in TS 36.355 [4] is the expectedRSTD-Uncertainty index
CP length ^{Note 2}		Normal	
DRX		OFF	
Radio frame receive time offset between the cells at the UE antenna connector ^{Note 3}	μs	Cell 1 to Cell 2: -1 Cell 3 to Cell 2: 1	PRS are transmitted from synchronous cells
Number of cells provided in OTDOA assistance data		16	The list includes the assistance-data-reference cell and 15 other cells. All cells provided in OTDOA assistance data are on RF channel 2.
$T_{RSTD \text{ IntraFreqFDD, E-UTRAN}}$ ^{Note 4}	ms	2560	Derived according to the RSTD measurement requirements specified in Section 10.2.3
<p>NOTE 1: Parameters “Expected RSTD” and “Expected RSTD uncertainty for all neighbour cells” are not settable parameters. These are parameters signalled in LPP only. For the values to be used in LPP see Table 10.4.4.3-3 and TS 37.571-5 [20], clause 7.3.2.</p> <p>NOTE 2: Parameters “PRS Transmission Bandwidth”, “PRS configuration index”, “Number of consecutive positioning downlink subframes”, “prs-MutingInfo”, “Cell ID” and “CP length” are settable parameters and also parameters signalled in LPP. The values to be used for “Cell ID” are as follows: Cell 1: 0, Cell 2: 7, Cell 3: 10. For the values to be used in LPP see Table 10.4.4.3-3 and TS 37.571-5 [20], clause 7.3.2.</p> <p>NOTE 3: The parameter “Radio frame receive time offset between the cells at the UE antenna connector” is used to set the “true RSTD” value in step 6 of clause 10.4.4.1.</p> <p>NOTE 4: The parameter “$T_{RSTD \text{ IntraFreqFDD, E-UTRAN}}$” is not a settable parameter but is used to set the LPP “time” value in Table 10.4.4.3-2. The value of the LPP time IE is set to $T_{RSTD \text{ IntraFreqFDD, E-UTRAN}} + \Delta T$ ms, where $\Delta T = 150$ ms, giving a value of 2710 ms. This is rounded up to the next allowed LPP value of 3 seconds.</p>			

10.4.4.2 Test procedure

The RSTD measurements are performed between Cell 2 and Cell 3 to verify that when both the reference cell and neighbouring cell belong to the secondary component carrier the RSTD measurement accuracy can meet the intra-frequency RSTD accuracy requirements defined in section 10.4.3.

The test consists of a set-up period and a measurement period. All Cells are active during the complete test. The beginning of the measurement period shall be aligned with the first PRS positioning subframe of a positioning occasion in the reference cell.

NOTE: The information on when PRS is muted is conveyed to the UE using PRS muting information in the OTDOA assistance data.

The OTDOA-RequestLocationInformation message and the OTDOA assistance data as defined in clause 10.4.4.3 shall be provided to the UE during the set-up period. The last TTI containing the OTDOA-RequestLocationInformation message shall be provided to the UE ΔT ms before the start of the measurement period, where $\Delta T = 150$ ms is the maximum processing time of the OTDOA-RequestLocationInformation message and the OTDOA assistance data in the UE.

1. Ensure that the UE is in state Generic RB Established State 3A-RF according to 3GPP TS 36.508 [18] clause 7.2A.3.

2. Configure Cell 2 and Cell 3 on the SCC according to TS 36.521-3 [25] Annex C.0 and C.1 for all downlink physical channels.
3. The SS shall configure the SCell (Cell 2) on the SCC as per TS 36.508 [18] clause 5.2A.
4. The SS activates the SCell (Cell 2) by sending the Activation/Deactivation MAC control element according to TS 36.321 [34] clauses 5.13 and 6.1.3.8. Wait for at least 2 seconds as per TS 36.133 [23] clause 8.3.3.2.
5. The SS shall send a RESET UE POSITIONING STORED INFORMATION message.
6. Set the parameters according to Table 10.4.5-1 as appropriate. Propagation conditions are set according to clause 4.7.2.1.
- 6a. The SS shall send an LPP REQUEST CAPABILITIES message.
- 6b. The UE shall send an LPP PROVIDE CAPABILITIES message indicating the OTDOA capabilities supported by the UE in the *OTDOA-ProvideCapabilities* IE.
7. The SS shall send a LPP PROVIDE ASSISTANCE DATA message, including the *OTDOA-ProvideAssistanceData* IE. If the UE message at step 6b includes the *ackRequested* IE set to TRUE, then the SS shall send an acknowledgment in the LPP PROVIDE ASSISTANCE DATA message.
8. The SS shall send a LPP REQUEST LOCATION INFORMATION message, including the *OTDOA-RequestLocationInformation* IE such that the UE receives the message ΔT ms before the start of the measurement period, where $\Delta T = 150$ ms.
9. The UE shall transmit a LPP PROVIDE LOCATION INFORMATION message, including the *OTDOA-ProvideLocationInformation* IE.
10. If the UE message at step 9 includes the *ackRequested* IE set to TRUE, the SS shall send a LPP acknowledgement message.
11. The SS shall check the *rstd* value for Cell 3 in the *OTDOA-SignalMeasurementInformation* IE according to Table 10.4.5-2.
12. Repeat step 5-11 until the confidence level according to Annex D is achieved.

10.4.4.3 Message contents

Table 10.4.4.3-1: RESET UE POSITIONING STORED INFORMATION

Derivation Path: 36.509 [11] clause 6.9			
Information Element	Value/remark	Comment	Condition
UE Positioning Technology	0 0 0 0 0 0 1	OTDOA	

Table 10.4.4.3-1a: LPP Request Capabilities

Information Element	Value/remark
<i>otdoa-RequestCapabilities</i>	TRUE

Table 10.4.4.3-2: LPP RequestLocationInformation

Derivation Path: 36.355 clause 6.2			
Information Element	Value/remark	Comment	Condition
LPP-Message ::= SEQUENCE {			
transactionID SEQUENCE {			
Initiator	locationServer		
transactionNumber	1		
}			
endTransaction	FALSE		
sequenceNumber	Not present		
acknowledgement	Not present		
lpp-MessageBody CHOICE {			

otdoa-ProvideAssistanceData SEQUENCE {			
otdoa-ReferenceCellInfo	As defined in TS 37.571-5 [20], clause 7.3.2.		
otdoa-NeighbourCellInfo	As defined in TS 37.571-5 [20], clause 7.3.2.		
otdoa-Error	Not present		
}			
epdu-ProvideAssistanceData	Not present		
}			
}			
}			
}			
}			
}			

Table 10.4.4.3-4: LPP ProvideLocation Information

Derivation Path: 36.355 clause 6.2			
Information Element	Value/remark	Comment	Condition
LPP-Message ::= SEQUENCE {			
transactionID SEQUENCE {			
initiator	locationServer		
transactionNumber	1		
}			
endTransaction	TRUE		
sequenceNumber	(0..255)		
acknowledgement			
lpp-MessageBody CHOICE {			
c1 CHOICE {			
provideLocationInformation SEQUENCE {			
criticalExtensions CHOICE {			
c1 CHOICE {			
provideLocationInformation-r9 SEQUENCE {			
commonIEsProvideLocationInformation	Not present.		
a-gnss-ProvideLocationInformation	Not present		
otdoa-ProvideLocationInformation SEQUENCE {			
otdoaSignalMeasurementInformation SEQUENCE {			
systemFrameNumber			
physCellIdRef	Cell 2		
cellGlobalIdRef			
earfcnRef			
referenceQuality			
neighbourMeasurementList SEQUENCE (SIZE(1)) {			
physCellIdNeighbour	Cell 3		
cellGlobalIdNeighbour			
earfcnNeighbour			
rstd	Set according to Table 10.4.5-2		
rstd-Quality			
}			
}			
otdoa-Error	May be present with error reason 'undefined' or 'attemptedButUnableToMeasureSomeNeighbourCells'		
}			
ecid-ProvideLocationInformation	Not present		
epdu-ProvideLocationInformation	Not present		
}			

}			
}			
}			
}			
}			

10.4.5 Test requirement

Table 10.4.5-1 defines the primary level settings including test tolerances for the test.

The TDD RSTD accuracy test shall meet the reported values in Table 10.4.5-2.

Table 10.4.5-1: Cell Specific Test Parameters for RSTD Test for E-UTRAN TDD for Carrier Aggregation

Parameter	Unit	Cell 1	Cell 2	Cell 3				
E-UTRA RF Channel Number		1	2	2				
PBCH_RA								
PBCH_RB								
PSS_RA								
SSS_RA								
PCFICH_RB								
PHICH_RA	dB	0	0	0				
PHICH_RB								
PDCCH_RA								
PDCCH_RB								
OCNG_RA ^{Note 1}								
OCNG_RB ^{Note 1}								
PRS_RA					-3	0.3	0.3	
N_{oc} ^{Note 2}					dBm/15 kHz			-98
PRS \hat{E}_s/N_{oc}					-6	-5.7	-12.7	
PRS \hat{E}_s/I_{ot} ^{Note 3}					-6	-5.7	-12.7	
I_o ^{Note 3}	dBm/9 MHz			-70.04				
PRP ^{Note 3}	dBm/15 kHz			-104				
\hat{E}_s/N_{oc} ^{Note 3}	dB			-3				
RSRP ^{Note 3}	dBm/15 kHz			-101				
Propagation condition	AWGN							
Note 1: OCNG shall be used such that both cells are fully allocated and a constant total transmitted power spectral density is achieved for all OFDM symbols (other than those in the PRS subframes). Note 2: Interference from other cells and noise sources not specified in the test is assumed to be constant over subcarriers and time and shall be modelled as AWGN of appropriate power for N_{oc} to be fulfilled. Note 3: \hat{E}_s/N_{oc} , PRS \hat{E}_s/I_{ot} , I_o , RSRP and PRP levels have been derived from other parameters for information purposes. They are not settable parameters themselves. I_o values are derived in the case that there is no PBCH, PSS or SSS in the OFDM symbols carrying PRS.								

Table 10.4.5-2: RSTD TDD accuracy requirements for the reported values for Carrier Aggregation

	Value
Lowest reported value	RSTD_6380
Highest reported value	RSTD_6392

For the test to pass, the ratio of successful reported values shall be more than 90% with a confidence level of 95%.

10.4A TDD RSTD Measurement Accuracy for Carrier Aggregation for 20 MHz Bandwidth (Rel-10 and Rel-11)

10.4A.1 Test purpose

Same as defined in clause 10.4.1.

10.4A.2 Test applicability

This test applies to all types of E-UTRA TDD UE release 10 and 11 that supports UE-assisted OTDOA for Carrier Aggregation.

10.4A.3 Minimum conformance requirements

Same as defined in clause 10.4.3.

The normative reference for this requirement is TS 36.133 [23] clause 9.1.12 and A.9.8.8.

10.4A.4 Test description

10.4A.4.1 Initial conditions

Same as defined in clause 10.4.4.1 except that the values of the parameters in Table 10.4A.4.1-1 will replace the values of the corresponding parameters in Table 10.4.4.1-1.

Channel bandwidth to be tested: 20 MHz.

Table 10.4A.4.1-1: General Test Parameters for RSTD Test for E-UTRAN TDD for Carrier Aggregation for 20 MHz

Parameter	Unit	Value	Comment
PCFICH/PDCCH/PHICH parameters		R.10 TDD	As specified in clause TS 36.521-3 [25] clause A.2.2
OCNG Patterns defined in TS 36.521-3 [25] clause D.2		OP.8 TDD	OCNG shall be used such that both cells are fully allocated and a constant total transmitted power spectral density is achieved for all OFDM symbols (other than those in the PRS subframes).
Channel Bandwidth ($BW_{channel}$)	MHz	20	
PRS Bandwidth	RB	100	PRS Bandwidth: bandwidth is as indicated in <i>prs-Bandwidth</i> in the OTDOA assistance data defined in 3GPP TS 36.355 [4].

Note 1: See Table 10.4.4.1-1 for other general test parameters.

10.4A.4.2 Test procedure

Same as defined in clause 10.4.4.2.

10.4A.4.3 Message contents

Same as defined in clause 10.4.4.3.

10.4A.5 Test requirement

Same as defined in clause 10.4.5 except that the value of the parameter in Table 10.4A.5-1 will replace the value of the corresponding parameter in Table 10.4.5-1.

Table 10.4A.5-1: Cell Specific Test Parameters for RSTD Test for E-UTRAN TDD for Carrier Aggregation for 20 MHz

Parameter	Unit	Cell1	Cell2	Cell3
I_0 ^{Note1}	dBm/18 MHz	-67.03	-66.98	-66.98
Note 1: I_0 level has been derived from other parameters for information purposes. It is not settable parameter itself. I_0 values are derived in the case that there is no PBCH, PSS or SSS in the OFDM symbols carrying PRS				
Note 2: See Table 10.4.5-1 for other cell specific test parameters.				

10.4A_1 TDD RSTD Measurement Accuracy for Carrier Aggregation for 20 MHz Bandwidth (Rel-12 onwards)

10.4A_1.1 Test purpose

Same as defined in clause 10.4A.1.

10.4A_1.2 Test applicability

This test applies to all types of E-UTRA TDD UE release 12 and forward that supports UE-assisted OTDOA for Carrier Aggregation.

10.4A_1.3 Minimum conformance requirements

Same as defined in clause 10.4A.3.

The normative reference for this requirement is TS 36.133 [23] clause 9.1.12 and A.9.8.8.

10.4A_1.4 Test description

10.4A_1.4.1 Initial conditions

Same as defined in clause 10.4A.4.1.

10.4A_1.4.2 Test procedure

Same as defined in clause 10.4A.4.2.

10.4A_1.4.3 Message contents

Same as defined in clause 10.4A.4.3.

10.4A_1.5 Test requirement

Same as defined in clause 10.4A.5 except that in addition Table 10.4A_1.5-1 will replace Table 10.4.5-2.

Table 10.4A_1.5-1: RSTD FDD accuracy requirements for the reported values for Carrier Aggregation

	Value
Lowest reported value	RSTD_6381
Highest reported value	RSTD_6391

10.4B TDD RSTD Measurement Accuracy for Carrier Aggregation for 5 MHz + 5 MHz bandwidth

10.4B.1 Test purpose

Same as defined in clause 10.4.1.

10.4B.2 Test applicability

This test applies to all types of E-UTRA TDD UE release 10 and forward that supports UE-assisted OTDOA for Carrier Aggregation.

10.4B.3 Minimum conformance requirements

Same as defined in clause 10.4.3.

The normative reference for this requirement is TS 36.133 [23] clause 9.1.12 and A.9.8.12.

10.4B.4 Test description

10.4B.4.1 Initial conditions

Same as defined in clause 10.4.4.1 except that the values of the parameters in Table 10.4B.4.1-1 will replace the values of the corresponding parameters in Table 10.4.4.1-1.

Channel bandwidth to be tested: 5 MHz.

Table 10.4B.4.1-1: General Test Parameters for RSTD Test for E-UTRAN TDD for Carrier Aggregation for 5 MHz + 5 MHz

Parameter	Unit	Value	Comment
PCFICH/PDCCH/PHICH parameters		R.11 TDD	As specified in clause TS 36.521-3 [25] clause A.2.2
OCNG Patterns defined in TS 36.521-3 [25] clause D.2		OP.10 TDD	OCNG shall be used such that both cells are fully allocated and a constant total transmitted power spectral density is achieved for all OFDM symbols (other than those in the PRS subframes). There is no PDSCH allocated in the subframe transmitting PRS.
Channel Bandwidth (BW_{channel})	MHz	5	
PRS Bandwidth	RB	25	PRS Bandwidth bandwidth is as indicated in <i>prs-Bandwidth</i> in the OTDOA assistance data defined in 3GPP TS 36.355 [4].
Number of consecutive positioning downlink subframes N_{PRS}		2	As defined in 3GPP TS 36.211 [26]
Note 1: See Table 10.4.4.1-1 for other general test parameters.			

10.4B.4.2 Test procedure

Same as defined in clause 10.4.4.2.

10.4B.4.3 Message contents

Same as defined in clause 10.4.4.3.

10.4B.5 Test requirement

Same as defined in clause 10.4.5 except that the value of the parameter in Table 10.4B.5-1 will replace the value of the corresponding parameter in Table 10.4.5-1 and the TDD RSTD accuracy shall meet the reported values in Table 10.4B.5-2.

Table 10.4B.5-1: Cell Specific Test Parameters for RSTD Test for E-UTRAN TDD for Carrier Aggregation for 5 MHz + 5 MHz bandwidth

Parameter	Unit	Cell1	Cell2	Cell3
I_0 ^{Note1}	dBm/4.5 MHz	-73.05	-73.00	-73.00
Note 1: I_0 level has been derived from other parameters for information purposes. It is not settable parameter itself. I_0 values are derived in the case that there is no PBCH, PSS or SSS in the OFDM symbols carrying PRS				
Note 2: See Table 10.4.5-1 for other cell specific test parameters.				

Table 10.4B.5-2: RSTD TDD accuracy requirements for the reported values for Carrier Aggregation for 5 MHz+5 MHz bandwidth

	Value
Lowest reported value	RSTD_6379
Highest reported value	RSTD_6393

10.4C TDD RSTD Measurement Accuracy for Carrier Aggregation for 10 MHz + 5 MHz Bandwidth

10.4C.1 Test purpose

Same as defined in clause 10.4.1.

10.4C.2 Test applicability

This test applies to all types of E-UTRA TDD UE release 11 and forward that supports UE-assisted OTDOA for Carrier Aggregation.

10.4C.3 Minimum conformance requirements

Same as defined in clause 10.4.3.

The normative reference for this requirement is TS 36.133 [23] clause 9.1.12 and A.9.8.10.

10.4C.4 Test description

10.4C.4.1 Initial conditions

Same as defined in clause 10.4.4.1 except that the values of the parameters in Table 10.4C.4.1-1 will replace the values of the corresponding parameters in Table 10.4.4.1-1.

Channel bandwidth to be tested: Cell 1: 10 MHz, Cell 2 and Cell 3: 5 MHz.

Table 10.4C.4.1-1: General Test Parameters for RSTD Test for E-UTRAN TDD for Carrier Aggregation for 10 MHz + 5 MHz

Parameter	Unit	Value	Comment
-----------	------	-------	---------

PCFICH/PDCCH/PHICH parameters		Cell1: R.6 TDD Cell2: R.11 TDD Cell3: R.11 TDD	As specified in clause TS 36.521-3 [25] clause A.2.2
OCNG Patterns defined in TS 36.521-3 [25] clause D.2		Cell1: OP.2 TDD Cell2: OP.10 TDD Cell3: OP.10 TDD	OCNG shall be used such that both cells are fully allocated and a constant total transmitted power spectral density is achieved for all OFDM symbols (other than those in the PRS subframes). There is no PDSCH allocated in the subframe transmitting PRS.
Channel Bandwidth (BW _{channel})	MHz	Cell1: 10 Cell2: 5 Cell3: 5	
PRS Bandwidth	RB	Cell1: 50 Cell2: 25 Cell3: 25	PRS Bandwidth bandwidth is as indicated in <i>prs-Bandwidth</i> in the OTDOA assistance data defined in 3GPP TS 36.355 [4].
Number of consecutive positioning downlink subframes N_{PRS}		2	As defined in 3GPP TS 36.211 [26]
Note 1: See Table 10.4.4.1-1 for other general test parameters.			

10.4C.4.2 Test procedure

Same as defined in clause 10.4.4.2.

10.4C.4.3 Message contents

Same as defined in clause 10.4.4.3.

10.4C.5 Test requirement

Same as defined in clause 10.4.5 except that the value of the parameter in Table 10.4C.5-1 will replace the value of the corresponding parameter in Table 10.4.5-1 and the TDD RSTD accuracy shall meet the reported values in Table 10.4C.5-2.

Table 10.4C.5-1: Cell Specific Test Parameters for RSTD Test for E-UTRAN TDD for Carrier Aggregation for 10 MHz + 5 MHz

Parameter	Unit	Cell1	Cell2	Cell3
I ₀ ^{Note1}	dBm/9 MHz	-70.04	N/A	N/A
	dBm/4.5 MHz	N/A	-73.00	-73.00
Note 1: I ₀ level has been derived from other parameters for information purposes. It is not settable parameter itself. I ₀ values are derived in the case that there is no PBCH, PSS or SSS in the OFDM symbols carrying PRS				
Note 2: See Table 10.4.5-1 for other cell specific test parameters.				

Table 10.4C.5-2: RSTD TDD accuracy requirements for the reported values for Carrier Aggregation for 10 MHz+5 MHz bandwidth

	Value
Lowest reported value	RSTD_6379
Highest reported value	RSTD_6393

10.4D TDD RSTD Measurement Accuracy for Carrier Aggregation for 20 MHz+10 MHz Bandwidth

10.4D.1 Test purpose

Same as defined in clause 10.4.1

10.4D.2 Test applicability

This test applies to all types of E-UTRA TDD UE release 10 and forward that supports UE-assisted OTDOA for Carrier Aggregation.

10.4D.3 Minimum conformance requirements

Same as defined in clause 10.4.3

The normative reference for this requirement is TS 36.133 [23] clause 9.1.12 and A.9.8.13.

10.4D.4 Test description

10.4D.4.1 Initial conditions

Same as defined in clause 10.4.4.1 except that the values of the parameters in Table 10.4D.4.1-1 will replace the values of the corresponding parameters in Table 10.4.4.1-1.

Channel bandwidth to be tested: Cell 1: 20 MHz, Cell 2 and Cell 3: 10 MHz.

Table 10.4D.4.1-1: General Test Parameters for RSTD Test for E-UTRAN TDD for Carrier Aggregation for 20 MHz+10 MHz

Parameter	Unit	Value	Comment
PCFICH/PDCCH/PHICH parameters		Cell 1: R.10 TDD Cell 2: R.6 TDD Cell 3: R.6 TDD	As specified in clause TS 36.521-3 [25] clause A.2.2
OCNG Patterns defined in TS 36.521-3 [25] clause D.2		Cell 1: OP.8 TDD Cell 2: OP.2 TDD Cell 3: OP.2 TDD	OCNG shall be used such that both cells are fully allocated and a constant total transmitted power spectral density is achieved for all OFDM symbols (other than those in the PRS subframes). There is no PDSCH allocated in the subframe transmitting PRS.
Channel Bandwidth (BW_{channel})	MHz	Cell 1: 20 Cell 2: 10 Cell 3: 10	
PRS Bandwidth	RB	Cell 1: 100 Cell 2: 50 Cell 3: 50	PRS Bandwidth bandwidth is as indicated in <i>prs-Bandwidth</i> in the OTDOA assistance data defined in 3GPP TS36.355 [4].
Note 1: See Table 10.4.4.1-1 for other general test parameters.			

10.4D.4.2 Test procedure

Same as defined in clause 10.4.4.2

10.4D.4.3 Message contents

Same as defined in clause 10.4.4.3

10.4D.5 Test requirement

Same as defined in clause 10.4.5 except that the value of the parameter in Table 10.4D.5-1 will replace the value of the corresponding parameter in Table 10.4.5-1.

Table 10.4D.5-1: Cell Specific Test Parameters for RSTD Test for E-UTRAN TDD for Carrier Aggregation for 20 MHz+10 MHz

Parameter	Unit	Cell 1	Cell 2	Cell 3
I_0 ^{Note1}	dBm/ 18 MHz	-67.03	N/A	N/A
	dBm/ 9 MHz	N/A	-69.99	-69.99
Note 1: I_0 level has been derived from other parameters for information purposes. It is not settable parameter itself. I_0 values are derived in the case that there is no PBCH, PSS or SSS in the OFDM symbols carrying PRS				
Note 2: See Table 10.4.5-1 for other cell specific test parameters.				

10.5 FDD 3 DL CA RSTD Measurement Reporting Delay

10.5.1 Test Purpose

The purpose of the test case is to verify that the RSTD measurement reporting delay meets the requirements in an environment with fading propagation conditions. This test case verifies the measurement period requirements for RSTD measurements performed on the same secondary component carrier, the measurement period requirements for RSTD measurements performed on both the primary and secondary component carriers, and also the measurement period requirements for RSTD measurements performed on different secondary component carriers.

10.5.2 Test applicability

This test applies to all types of E-UTRA FDD UE release 12 and forward that supports UE-assisted OTDOA for 3DL Carrier Aggregation.

10.5.3 Minimum conformance requirements

10.5.3.1 Measurements on the secondary component carrier

The RSTD measurements when all cells are on the configured secondary component carrier shall meet all applicable requirements (FDD) specified in TS 36.133 [23] section 8.1.2.5, i.e., E-UTRAN intra-frequency RSTD measurement period applies, regardless of whether the SCell on the corresponding frequency is activated or deactivated by the MAC-CE commands as specified in 3GPP TS 36.321 [34].

10.5.3.2 Measurements on both primary component carrier and secondary component carrier

The RSTD measurements of cells on both primary component carrier and configured secondary component carrier shall meet all applicable requirements (FDD) specified in TS 36.133 [23] section 8.1.2.6, i.e., E-UTRAN inter-frequency RSTD measurement period applies regardless of whether the SCell on the corresponding frequency is activated or deactivated by the MAC-CE commands as specified in 3GPP TS 36.321 [34], with the following exception

- the number of PRS positioning occasions is as specified in Table 10.5.3.2-1 shall apply.

Table 10.5.3.2-1: Number of PRS positioning occasions within measurement period

Positioning subframe configuration period T_{PRS}	Number of PRS positioning occasions M
160 ms	32

>160 ms	16
---------	----

10.5.3.3 Measurements on different secondary component carriers

The RSTD measurements of cells on a configured secondary component carrier and another configured secondary component carrier shall meet all applicable requirements (FDD-FDD inter-Frequency OTDOA) specified in TS 36.133 [23] section 8.1.2.6, i.e., E-UTRAN inter-frequency RSTD measurement period applies regardless of whether the SCell on the corresponding frequency is activated or deactivated by the MAC-CE commands as specified in 3GPP TS 36.321 [34], with the following exceptions

- the number of PRS positioning occasions is as specified in Table 10.5.3.3-1 shall apply.

Table 10.5.3.3-1: Number of PRS positioning occasions within measurement period

Positioning subframe configuration period T_{PRS}	Number of PRS positioning occasions M
160 ms	32
>160 ms	16

The normative reference for this requirement is TS 36.133 [23] clause 8.4.3, 8.4.4, 8.4.5 and A.8.17.10.

10.5.4 Test description

10.5.4.1 Initial conditions

Test Environment: Normal; as defined in TS 36.508 [18] clause 4.1.

Frequencies to be tested: Mid Range, as defined in TS 36.508 [18] clause 4.3.1.1.

Channel bandwidth to be tested: the largest aggregated bandwidth combination supported by the UE of the Channel bandwidths defined in Table 10.5.4.1-1. The Channel bandwidths for CA Intra-Band combinations are, as defined in TS 36.508 [18] clause 4.3.1 and for CA Inter-Band combinations are defined in TS 36.521-1 [24] clause 5.4.2A. In case of multiple possible Channel bandwidth combinations, the first combination listed in the above mentioned clauses shall be selected.

1. Connect the SS, faders and AWGN noise sources to the UE antenna connector or antenna connectors as shown in TS 36.508 [18] Annex A, Figure A.68 as appropriate.
2. The general test parameter settings are set up according to Table 10.5.4.1-1.
3. Propagation conditions are set according to clause 4.7.2.1.
4. Message contents are defined in clause 10.5.4.3.
5. In the tests, there are three configured component carriers: PCC, SCC1 and SCC2, and four synchronized cells: Cell 1, Cell 2, Cell 3 and Cell 4. Cell 1 is PCell on the PCC, Cell 2 is SCell on the SCC1, Cell 3 is SCell on the SCC2 and Cell 4 is a neighbour cell on the SCC2. In all tests, Cell 3 is the OTDOA assistance data reference cell. The assistance data neighbour cell list includes in total 15 cells, where 14 of the cells are not simulated (dummy cells; as defined in 3GPP TS 37.571-5 clause 7.3.2) for Test 1 and where 12 of the cells are not simulated for Test 2. PCell (Cell 1) is the cell used for connection setup with the power level and mapping set according to TS 36.521-1 [24] Annex C.0 and C.1 as appropriate for this test. Cell 2, Cell 3 and Cell 4 are powered OFF.
6. The true RSTD (which is the receive time difference for frame 0 between two cells as seen at the UE antenna connector) is set to 31 Ts (about 1 μ s) between Cell 1 and OTDOA assistance data reference cell, Cell 3, and set to -31 Ts (about -1 μ s) between Cell 2 and OTDOA assistance data reference cell, Cell 3, and set to 92 Ts (about 3 μ s) between neighbour Cell 4 and OTDOA assistance data reference cell, Cell 3.

Table 10.5.4.1-1: General test parameters for E-UTRAN FDD RSTD measurement reporting delay under fading propagation conditions for carrier aggregation

Parameter	Unit	Value		Comment
		Test 1	Test 2	
PCell		Cell 1		PCell is on RF channel 1 (PCC).
SCell 1		Cell 2		SCell 1 on RF channel 2 (SCC1).
SCell 2		Cell 3		SCell 2 on RF channel 3 (SCC2). Cell 3 is the assistance data reference cell.
Other neighbour cell		Cell 4		Neighbour cell on RF channel 3 (SCC2).
PCFICH/PDCCH/PHICH parameters (PCFICH/PDCCH/PHICH parameters depend on selected channel bandwidth)		5MHz: R.11 FDD 10MHz: R.6 FDD 20MHz: R.10 FDD		As specified in TS 36.521-3 [25] clause A.2.1
Channel Bandwidth ($BW_{channel}$)	MHz	5,10,20		
PRS Transmission Bandwidth (PRS transmission bandwidth depends on selected channel bandwidth) ^{Note 2}	RB	5MHz: 25 10MHz: 50 20MHz:100		PRS are transmitted over the system bandwidth
Number of consecutive downlink positioning subframes N_{PRS} . (N_{PRS} depends on selected channel bandwidth) ^{Note 2}		5MHz: 2 10MHz: 1 20MHz:1		As defined in TS 36.211 [26]. The number of subframes in a positioning occasion
PRS configuration index I_{PRS} ^{Note 2}		171 for all cells on PCC 181 for all cells on SCC1 191 for all cells on SCC2		This corresponds to periodicity of 320 ms and PRS subframe offset of $I_{PRS} - 160$ DL subframes, as defined in TS 36.211 [26], Table 6.10.4.3-1
Physical cell ID PCI ^{Note 2}		(PCI of Cell 3 – PCI of Cell 4)mod6=0		The PCIs of Cell 1 and Cell 2 are selected randomly. PCIs of Cell 3 and Cell 4 are selected randomly such that the relative subcarrier shifts of PRS patterns among these cells are as given by the condition
CP length ^{Note 2}		Normal		
DRX		ON		DRX parameters are further specified in Table 10.5.4.1-2
Radio frame receive time offset between the cells at the UE antenna connector ^{Note 3}	μ s	Cell 1 to Cell 3: 1 Cell 2 to Cell 3: -1 Cell 4 to Cell 3: 3	Cell 1 to Cell 3: 1 Cell 2 to Cell 3: -1 Cell 4 to Cell 3:	PRS are transmitted from synchronous cells
Expected RSTD ^{Note 1}	μ s	Cell 4: 2 Other neighbour cells: randomly between -3 and 3	Cell 1: -2 Cell 2: 0 Cell 4: 2 Other neighbour cells: randomly between -3 and 3	The expected RSTD is what is expected at the receiver. The corresponding parameter in the OTDOA assistance data specified in TS 36.355 [4] is the expectedRSTD indicator
Expected RSTD uncertainty for all neighbour cells ^{Note 1}	μ s	5		The corresponding parameter in the OTDOA assistance data specified in TS 36.355 [4] is the expectedRSTD-Uncertainty index
		16 cells in total		

Number of cells provided in OTDOA assistance data		OTDOA neighbour cells include Cell 4 and other 14 cells on SCC2	OTDOA neighbour cells include Cell 1 and other 3 cells on PCC, Cell 2 and other 3 cells on SCC1 and Cell 4 and other 6 cells on SCC2	The list includes the reference cell and 15 other cells. Cell 1 and Cell 2 (when included) appears at random places in the first half of the neighbour cell list in the OTDOA assistance data. Cell 4 always appears at random places in the second half of the list.
prs-SubframeOffset ^{Note 2}		Cells on PCC: 300 Cells on SCC1: 310 Cells on SCC2, except reference cell: 0		Subframe offset, counted in full subframes. The corresponding parameter in the OTDOA assistance data is prs-SubframeOffset specified in TS 36.355 [4]
slotNumberOffset ^{Note 2}		Cells on PCC: 0 Cells on SCC1: 0 Cells on SCC2, except reference cell: 0		The slot number offset at the transmitter between a neighbour cell and the assistance data reference cell. The corresponding parameter in the OTDOA assistance data is slotNumberOffset specified in TS 36.355 [4].
PRS muting info ^{Note 2}		Cell 1: '11110000' Cell 2: '00001111' Cell 3: '11110000' Cell 4: '00001111'	Cell 1: '1111111100000000' Cell 2: '0000000011111111' Cell 3: '1111111100000000' Cell 4: '0000000011111111'	Corresponds to prs-MutingInfo defined in TS 36.355 [4]
T1	s	3		The length of the time interval from the beginning of each test
T2	s	1.28	2.48	The length of the time interval that follows immediately after time interval T1
T3	s	1.28	2.48	The length of the time interval that follows immediately after time interval T2
<p>Note 1: Parameters "Expected RSTD" and "Expected RSTD uncertainty for all neighbour cells" are not settable parameters. These are parameters signalled in LPP only. For the values to be used in LPP see Table 10.5.4.3-4 and TS 37.571-5 [20], clause 7.3.2.</p> <p>Note 2: Parameters "PRS Transmission Bandwidth", "PRS configuration index", "Number of consecutive downlink positioning subframes", "Physical cell ID PCI", "CP length", "prs-SubframeOffset", "slotNumberOffset" and "PRS muting info" are settable parameters and also parameters signalled in LPP. The values to be used for "Physical cell ID PCI" are as follows: Cell 1: 0, Cell 2: 3, Cell 3: 6, Cell 4: 12. For the values to be used in LPP see Table 10.5.4.3-4 and TS 37.571-5 [20], clause 7.3.2.</p> <p>Note 3: The parameter "Radio frame receive time offset between the cells at the UE antenna connector" is used to set the "true RSTD" values in step 6 of clause 10.5.4.1.</p>				

Table 10.5.4.1-2: DRX parameters for the test of E-UTRAN FDD intra-frequency RSTD measurement reporting delay under fading propagation conditions for carrier aggregation

Field	Value	Comment
onDurationTimer	psf1	As specified in TS 36.331 [22], Clause 6.3.2
Drx-InactivityTimer	psf1	
drx-RetransmissionTimer	sf1	
longDRX-CycleStartOffset	sf320	
shortDRX	Disable	

10.5.4.2 Test procedure

The test case includes two tests. Test 1 is designed for the scenario where the UE receives OTDOA assistance data with cells only on SCC2, and the UE is expected to report RSTD measurements performed on SCC2 only. Test 2 is designed for the scenario where the UE receives OTDOA assistance data with cells on PCC, SCC1 and SCC2, and the UE is expected to report RSTD measurements performed on PCC, SCC1 and SCC2.

Each test consists of three consecutive time intervals, with duration of T1, T2 and T3. Cell 1 is active in T1, T2 and T3, Cell 2 is active only in T2 and T3, Cell 3 is active only during T2 and T3, and Cell 4 is active only during T2. The beginning of the time interval T2 shall be aligned 5 ms before the first PRS positioning subframe of a positioning occasion in the OTDOA assistance data reference cell, where 5 ms is the necessary test tolerance. Cell 1 transmits PRS in T2, Cell 2 transmits PRS only in T3, Cell 3 transmits PRS only in T3, and Cell 4 transmits PRS only in T2.

NOTE: The information on when PRS is muted is conveyed to the UE using PRS muting information in the OTDOA assistance data.

The OTDOA-RequestLocationInformation message and the OTDOA assistance data as defined in 10.5.4.3 shall be provided to the UE during T1. The last TTI containing the OTDOA-RequestLocationInformation message shall be provided to the UE ΔT ms before the start of T2, where $\Delta T = 150$ ms is the maximum processing time of the OTDOA-RequestLocationInformation message and the OTDOA assistance data.

1. Ensure that the UE is in state Generic RB Established State 3A-RF according to 3GPP TS 36.508 [18] clause 7.2A.3.
2. Configure Cell 2 on SCC1 and Cell 3 and Cell 4 on SCC2 according to TS 36.521-3 [25] Annex C.0 and C.1 for all downlink physical channels.
3. The SS shall configure the SCells (Cell 2 and Cell 3) on the SCCs as per TS 36.508 [18] clause 5.2A.4.
4. The SS activates the SCells (Cell 2 and Cell 3) by sending the Activation/Deactivation MAC control element according to TS 36.321 [34] clauses 5.13 and 6.1.3.8. Wait for at least 2 seconds as per TS 36.133 [23] clause 8.3.3.2.
5. The SS shall send a RESET UE POSITIONING STORED INFORMATION message.
6. Set the parameters according to Table 10.5.5-1. Propagation conditions are set according to clause 4.7.2.2 (ETU30).
7. T1 starts.
8. The SS shall transmit an RRCConnectionReconfiguration message with the DRX configuration. PDCCHs indicating new transmissions shall be sent continuously until the start of T2 to ensure that the UE would not enter the DRX state before T2.
9. The UE shall transmit RRCConnectionReconfigurationComplete message.
- 9a. The SS shall transmit an LPP REQUEST CAPABILITIES message.
- 9b. The UE shall transmit an LPP PROVIDE CAPABILITIES message indicating the OTDOA capabilities supported by the UE in the *OTDOA-ProvideCapabilities* IE.
10. The SS shall send a LPP PROVIDE ASSISTANCE DATA message, including the *OTDOA-ProvideAssistanceData* IE. The position of neighbour Cell 4 in the *OTDOA-NeighbourCellInfoList* is randomly selected to be in the last 8 elements of the sequence for Test 1 and in the 7 elements of the relevant sequence for Test 2, and the position of Cell 1 and the position of Cell 2 are randomly selected to be in the 4 elements of the relevant sequence for Test 2, as described in 3GPP TS 37.571-5 [20], clause 7.3.2. If the UE message at step 9b includes the *ackRequested* IE set to TRUE, then the SS shall send an acknowledgment in the LPP PROVIDE ASSISTANCE DATA message.
11. The SS shall send a LPP REQUEST LOCATION INFORMATION message, including the *OTDOA-RequestLocationInformation* IE such that the UE receives the message ΔT ms before the start of T2, where $\Delta T = 150$ ms.
12. When T1 expires, the SS shall switch the power setting from T1 to T2 as specified in Table 10.5.5-2.

13. When T2 expires, the SS shall switch the power setting from T2 to T3 as specified in Table 10.5.5-2.

14. The UE shall transmit a LPP PROVIDE LOCATION INFORMATION message including the *OTDOA-ProvideLocationInformation* IE within the response time (see clause 4.7.3) specified in clause 10.5.5.

For Test 1 the UE shall perform and report the RSTD measurement for Cell 4 with respect to the reference cell in the OTDOA assistance data, Cell 3. If the UE transmits an *OTDOA-ProvideLocationInformation* IE including the *rstd* field for Cell 4 within the response time then the number of successful tests is increased by one. If the UE fails to report the *OTDOA-ProvideLocationInformation* IE with the *rstd* field included within the response time then the number of failure tests is increased by one.

For Test 2 the UE shall perform and report the RSTD measurements for Cell 1 with respect to the reference cell in the OTDOA assistance data, Cell 3 and also Cell 2 with respect to the reference cell in the OTDOA assistance data, Cell 3 and also Cell 4 with respect to the reference cell in the OTDOA assistance data, Cell 3. If the UE transmits an *OTDOA-ProvideLocationInformation* IE including the *rstd* field for Cell 1 (with respect to Cell 3) and Cell 2 (with respect to Cell 3) and Cell 4 (with respect to Cell 3) within the response time then the number of successful tests is increased by one. If the UE fails to report the *OTDOA-ProvideLocationInformation* IE with the three *rstd* fields included within the response time then the number of failure tests is increased by one.

15. If the UE message at step 14 includes the *ackRequested* IE set to TRUE, the SS shall send a LPP acknowledgement message.

16. Repeat steps 5-15 until the confidence level according to Annex D is achieved. For each iteration, at step 10 change the random positions of Cell 4 and Cell 1(for Test 2 only) and Cell 2(for Test 2 only) in the relevant sequence in the *OTDOA-NeighbourCellInfoList*.

17. Repeat from clause 10.5.4.1 for Test 2.

10.5.4.3 Message contents

Table 10.5.4.3-1: RESET UE POSITIONING STORED INFORMATION

Derivation Path: 36.509 [11] clause 6.9			
Information Element	Value/remark	Comment	Condition
UE Positioning Technology	0 0 0 0 0 0 1	OTDOA	

Table 10.5.4.3-2: MAC-MainConfig-RBC: FDD RSTD Measurement Reporting Delay for Carrier Aggregation

Derivation Path: TS 36.508 [18] clause 4.8.2.1.5, Table 4.8.2.1.5-1 MAC-MainConfig-RBC			
Information Element	Value/remark	Comment	Condition
MAC-MainConfig-RBC ::= SEQUENCE {			
drx-Config CHOICE {			
setup SEQUENCE {			
onDurationTimer	psf1		
drx-InactivityTimer	psf1		
drx-RetransmissionTimer	sf1		
longDRX-CycleStartOffset CHOICE {			
sf320	0		
}			
shortDRX	Not present		
}			
}			

Table 10.5.4.3-2a: LPP Request Capabilities

Information Element	Value/remark
<i>otdoa-RequestCapabilities</i>	TRUE

Table 10.5.4.3-3: LPP RequestLocationInformation

Derivation Path: 36.355 clause 6.2			
Information Element	Value/remark	Comment	Condition
LPP-Message ::= SEQUENCE {			
transactionID SEQUENCE {			
Initiator	locationServer		
transactionNumber	1		
}			
endTransaction	FALSE		
sequenceNumber	Not present		
acknowledgement	Not present		
lpp-MessageBody CHOICE {			
c1 CHOICE {			
requestLocationInformation SEQUENCE {			
criticalExtensions CHOICE {			
c1 CHOICE {			
requestLocationInformation-r9 SEQUENCE {			
commonIEsRequestLocationInformation SEQUENCE {			
locationInformationType	locationMeasurementsRequired		
triggeredReporting	Not present		
periodicalReporting	Not present		
additionalInformation	onlyReturnInformationRequested		
qos SEQUENCE {			
horizontalAccuracy	Not present		
verticalCoordinateRequest	FALSE		
verticalAccuracy	Not present		
responseTime SEQUENCE {			
time	Test 1: 3 Test 2: 6	See clause 10.5.5	
responseTimeEarlyFix-r12	Not present		Rel-12 onwards
}			
velocityRequest	FALSE		
}			
environment	Not present		
locationCoordinateTypes	Not present		
velocityTypes	Not present		
}			
a-gnss-RequestLocationInformation	Not present		
otdoa-RequestLocationInformation SEQUENCE {			
assistanceAvailability	FALSE		
}			
ecid-RequestLocationInformation	Not present		
epdu-RequestLocationInformation	Not Present		
}			
}			
}			
}			

Table 10.5.4.3-4: LPP ProvideAssistanceData

Derivation Path: 36.355 clause 6.2			
Information Element	Value/remark	Comment	Condition
LPP-Message ::= SEQUENCE {			
transactionID SEQUENCE {			
Initiator	locationServer		
transactionNumber	(0..255)		

}			
endTransaction	TRUE		
sequenceNumber	Not present		
acknowledgement	Not present		
lpp-MessageBody CHOICE {			
c1 CHOICE {			
provideAssistanceData SEQUENCE {			
criticalExtensions CHOICE {			
c1 CHOICE {			
provideAssistanceData-r9 SEQUENCE {			
commonIEsProvideAssistanceData	Not present		
a-gnss-ProvideAssistanceData	Not present		
otdoa-ProvideAssistanceData SEQUENCE {			
otdoa-ReferenceCellInfo	As defined in TS 37.571-5 [20], clause 7.3.2.		
otdoa-NeighbourCellInfo	As defined in TS 37.571-5 [20], clause 7.3.2.		
otdoa-Error	Not present		
}			
epdu-ProvideAssistanceData	Not present		
}			
}			
}			
}			
}			
}			
}			

Table 10.5.4.3-5: LPP ProvideLocation Information

Derivation Path: 36.355 clause 6.2			
Information Element	Value/remark	Comment	Condition
LPP-Message ::= SEQUENCE {			
transactionID SEQUENCE {			
Initiator	locationServer		
transactionNumber	1		
}			
endTransaction	TRUE		
sequenceNumber	(0..255)		
acknowledgement			
lpp-MessageBody CHOICE {			
c1 CHOICE {			
provideLocationInformation SEQUENCE {			
criticalExtensions CHOICE {			
c1 CHOICE {			
provideLocationInformation-r9 SEQUENCE {			
commonIEsProvideLocationInformation	Not present.		
a-gnss-ProvideLocationInformation	Not present		
otdoa-ProvideLocationInformation			
SEQUENCE {			
otdoaSignalMeasurementInformation			
SEQUENCE {			
systemFrameNumber			
physCellIdRef	Cell 3		
cellGlobalIdRef			
earfcnRef			
referenceQuality			
neighbourMeasurementList			
SEQUENCE{			
NeighbourMeasurementElement			
SEQUENCE {			
physCellIdNeighbour	Cell 4		
cellGlobalIdNeighbour			
earfcnNeighbour			

rstd	Present	With respect to Cell 3	
rstd-Quality			
}			
NeighbourMeasurementElement SEQUENCE {		Test 2 only	
physCellIdNeighbour	Cell 1		
cellGlobalIdNeighbour			
earfcnNeighbour			
rstd	Present	Test 2 only With respect to Cell 3	
rstd-Quality			
}			
NeighbourMeasurementElement SEQUENCE {		Test 2 only	
physCellIdNeighbour	Cell 2		
cellGlobalIdNeighbour			
earfcnNeighbour			
rstd	Present	Test 2 only With respect to Cell 3	
rstd-Quality			
}			
}			
}			
otdoa-Error	May be present with error reason 'undefined' or 'attemptedButUnableToMeasureSomeNeighbourCells'		
}			
ecid-ProvideLocationInformation	Not present		
epdu-ProvideLocationInformation	Not present		
}			
}			
}			
}			
}			
}			

10.5.5 Test Requirements

Table 10.5.5-1 and 10.5.5-2 define the primary level settings including test tolerances for the tests.

Table 10.5.5-1: Cell-specific test parameters for E-UTRAN FDD RSTD measurement reporting delay under fading propagation conditions during T1 for carrier aggregation

Parameter	Unit	Cell 1	Cell 2	Cell 3	Cell 4
E-UTRA RF Channel Number		1	N/A	N/A	N/A
Correlation Matrix and Antenna Configuration		1x2 Low	1x2 Low	1x2 Low	1x2 Low
OCNG patterns defined in TS 36.521-3 [25] clause D.1. (OCNG patterns depend on selected channel bandwidth)		5MHz: OP.18 FDD 10MHz: OP.5 FDD 20MHz: OP.13 FDD	N/A	N/A	N/A
PBCH_RA	dB	0	N/A	N/A	N/A
PBCH_RB					
PSS_RA					
SSS_RA					
PCFICH_RB					

PHICH_RA					
PHICH_RB					
PDCCH_RA					
PDCCH_RB					
OCNG_RA ^{Note 1}					
OCNG_RB ^{Note 1}					
N_{oc} ^{Note 3}	dBm/ 15 kHz	-95	N/A	N/A	N/A
PRS \hat{E}_s/N_{oc}	dB	-Infinity	-Infinity	-Infinity	-Infinity
I_o ^{Note 4}	dBm/ 9 MHz	-67.22 +10log ($N_{RB,c}/50$)	N/A	N/A	N/A
\hat{E}_s/N_{oc}	dB	0	-Infinity	-Infinity	-Infinity
Propagation Condition		ETU30			
<p>Note 1: OCNG shall be used such that active cell (Cell 1) is fully allocated and a constant total transmitted power spectral density is achieved for all OFDM symbols.</p> <p>Note 2: The resources for uplink transmission are assigned to the UE prior to the start of time period T2.</p> <p>Note 3: Interference from other cells and noise sources not specified in the test are assumed to be constant over subcarriers and time and shall be modelled as AWGN of appropriate power for N_{oc} to be fulfilled.</p> <p>Note 4: I_o levels have been derived from other parameters and are given for information purpose. These are not settable test parameters.</p>					

Table 10.5.5-2: Cell-specific test parameters for E-UTRAN FDD RSTD measurement reporting delay under fading propagation conditions during T2 and T3 for carrier aggregation

Parameter	Unit	Cell 1		Cell 2		Cell 3		Cell 4	
		T2	T3	T2	T3	T2	T3	T2	T3
E-UTRA RF Channel Number		1		2		3		3	
Correlation Matrix and Antenna Configuration		1x2 Low		1x2 Low		1x2 Low		1x2 Low	
OCNG patterns defined in TS 36.521-3 [25] clause D.1 (There is no PDSCH allocated in the subframe transmitting PRS) (OCNG patterns depend on selected channel bandwidth)		5MHz: OP.18 FDD 10MHz: OP.5 FDD 20MHz: OP.13 FDD		5MHz: OP.19 FDD 10MHz: OP.6 FDD 20MHz: OP.14 FDD		5MHz: OP.19 FDD 10MHz: OP.6 FDD 20MHz: OP.14 FDD		5MHz: OP.19 FDD 10MHz: OP.6 FDD 20MHz: OP.14 FDD	N/A
PBCH_RA	dB								
PBCH_RB									
PSS_RA									
SSS_RA									
PCFICH_RB									
PHICH_RA		0		0		0		0	
PHICH_RB									
PDCCH_RA									
PDCCH_RB									
OCNG_RA ^{Note 1}									
OCNG_RB ^{Note 1}									
PRS_RA	dB	-6	N/A	N/A	3	N/A	3	3	N/A
N_{oc} ^{Note 3}	dBm/ 15 kHz	-98	-98	-98	-95	-98	-95	-98	-95

PRS \hat{E}_s/N_{oc}	dB	-4	-	-	-1	-	-1	-8	-
PRS \hat{E}_s/I_{ot} Note 4	dB	-4	-	-	-1	-	-1	-8	-
I_o Note 4	dBm/ 9 MHz	-69.94 +10log ($N_{RB,c}$ /50)	N/A	N/A	-66.68 +10log ($N_{RB,c}$ /50)	N/A	-66.68 +10log ($N_{RB,c}$ /50)	-70.11 +10log ($N_{RB,c}$ /50)	N/A
PRP Note 4	dBm/ 15 kHz	-102	-	-	-96	-	-96	-106	-
RSRP Note 4	dBm/ 15 kHz	-96	-96	-105	-99	-105	-99	-109	-
\hat{E}_s/N_{oc} Note 4	dB	2	2	-7	-4	-7	-4	-11	-
Propagation Condition		ETU30							
<p>Note 1: OCNG shall be used such that active cells (all, except Cell 3 in T3) are fully allocated and a constant total transmitted power spectral density is achieved for all OFDM symbols other than those in the subframes with transmitted PRS.</p> <p>Note 2: The resources for uplink transmission are assigned to the UE prior to the start of time period T2.</p> <p>Note 3: Interference from other cells and noise sources not specified in the test are assumed to be constant over subcarriers and time and shall be modelled as AWGN of appropriate power for N_{oc} to be fulfilled.</p> <p>Note 4: If PRS_RA is not "N/A", \hat{E}_s/N_{oc}, PRS \hat{E}_s/I_{ot}, I_o, RSRP and PRP levels have been derived from other parameters and are given for information purpose. If PRS_RA is "N/A", I_o and RSRP levels have been derived from other parameters and are given for information purpose. These are not settable test parameters. Interference conditions shall be applied to all PRS symbols of DL positioning subframes.</p>									

The response time including test tolerance is 3.3 s for Test 1 and 6.3 s for Test 2. The response time is equal to the LPP time IE value plus the test tolerance. The LPP time IE value is derived from the RSTD reporting delay plus ΔT , where $\Delta T = 150$ ms, giving a value of 2710 ms for Test 1 and 5110ms for Test 2. This is rounded up to the next allowed LPP value of 3 seconds for Test 1 and 6 seconds for Test 2.

The RSTD measurement reporting delay in the tests are derived from the following expression,

$T_{PRS} (M - 1) + 160 \left\lceil \frac{n}{M} \right\rceil$, where $M=8$ and $n=16$ for Test 1, and $M=16$ and $n=16$ for Test 2 are the parameters specified in clause 10.5.3.1 for Test 1 and clause 10.5.3.2 for Test 2.

This gives the total RSTD reporting delay of 2560 ms for Test 1 for the 15 neighbour cells including Cell 4 with respect to the reference cell, Cell 3.

This gives the total RSTD reporting delay of 4960 ms for Test 2 for the 15 neighbour cells including Cell 1, Cell 2 and Cell 4 with respect to the reference cell, Cell 3.

The test tolerances are defined in clauses C.1.3 and C.4.

For the overall test to pass, the rate of successful tests during repeated tests in both Test 1 and Test 2 shall be more than 90% with a confidence level of 95%.

10.6 TDD 3 DL CA RSTD Measurement Reporting Delay

10.6.1 Test Purpose

The purpose of the test case is to verify that the RSTD measurement reporting delay meets the requirements in an environment with fading propagation conditions. This test case verifies the measurement period requirements for RSTD measurements performed on the same secondary component carrier, the measurement period requirements for RSTD

measurements performed on both the primary and secondary component carriers, and also the measurement period requirements for RSTD measurements performed on different secondary component carriers.

10.6.2 Test applicability

This test applies to all types of E-UTRA TDD UE release 12 and forward that supports UE-assisted OTDOA for 3DL Carrier Aggregation.

10.6.3 Minimum conformance requirements

10.6.3.1 Measurements on the secondary component carrier

The RSTD measurements when all cells are on the configured secondary component carrier shall meet all applicable requirements (TDD) specified in TS 36.133 [23] section 8.1.2.5, i.e., E-UTRAN intra-frequency RSTD measurement period applies, regardless of whether the SCell on the corresponding frequency is activated or deactivated by the MAC-CE commands as specified in 3GPP TS 36.321 [34].

10.6.3.2 Measurements on both primary component carrier and secondary component carrier

The RSTD measurements of cells on both primary component carrier and configured secondary component carrier shall meet all applicable requirements (TDD) specified in TS 36.133 [23] section 8.1.2.6, i.e., E-UTRAN inter-frequency RSTD measurement period applies regardless of whether the SCell on the corresponding frequency is activated or deactivated by the MAC-CE commands as specified in 3GPP TS 36.321 [34], with the following exception

- the number of PRS positioning occasions is as specified in Table 10.6.3.2-1 shall apply.
- TDD uplink-downlink subframes configurations as specified in TS 36.133 [23] section 8.1.2.5.2, Table 8.1.2.5.2-2 shall apply.

Table 10.6.3.2-1: Number of PRS positioning occasions within measurement period

Positioning subframe configuration period T_{PRS}	Number of PRS positioning occasions M
160 ms	32
>160 ms	16

10.6.3.3 Measurements on different secondary component carriers

The RSTD measurements of cells on a configured secondary component carrier and another configured secondary component carrier shall meet all applicable requirements (TDD-TDD inter-Frequency OTDOA) specified in TS 36.133 [23] section 8.1.2.6, i.e., E-UTRAN inter-frequency RSTD measurement period applies regardless of whether the SCell on the corresponding frequency is activated or deactivated by the MAC-CE commands as specified in 3GPP TS 36.321 [34], with the following exceptions

- the number of PRS positioning occasions is as specified in Table 10.6.3.3-1 shall apply.
- TDD uplink-downlink subframes configurations as specified in TS 36.133 [23] section 8.1.2.5.2, Table 8.1.2.5.2-2 shall apply.

Table 10.6.3.3-1: Number of PRS positioning occasions within measurement period

Positioning subframe configuration period T_{PRS}	Number of PRS positioning occasions M
160 ms	32
>160 ms	16

The normative reference for this requirement is TS 36.133 [23] clause 8.4.3, 8.4.4, 8.4.5 and A.8.17.11.

10.6.4 Test description

10.6.4.1 Initial conditions

Test Environment: Normal; as defined in TS 36.508 [18] clause 4.1.

Frequencies to be tested: Mid Range, as defined in TS 36.508 [18] clause 4.3.1.1.

Channel bandwidth to be tested: the largest aggregated bandwidth combination (where all channels have the same bandwidth) supported by the UE of the Channel bandwidths defined in Table 10.6.4.1-1. The Channel bandwidths for CA Intra-Band combinations are defined in TS 36.508 [18] clause 4.3.1 and for CA Inter-Band combinations are defined in TS 36.521-1 [24] clause 5.4.2A. In case of multiple possible Channel bandwidth combinations, the first combination listed in the above mentioned clauses shall be selected.

1. Connect the SS, faders and AWGN noise sources to the UE antenna connector or antenna connectors as shown in TS 36.508 [18] Annex A, Figure A.68 as appropriate.
2. The general test parameter settings are set up according to Table 10.6.4.1-1.
3. Propagation conditions are set according to clause 4.7.2.1.
4. Message contents are defined in clause 10.6.4.3.
5. In the tests, there are three configured component carriers: PCC, SCC1 and SCC2, and four synchronized cells: Cell 1, Cell 2, Cell 3 and Cell 4. Cell 1 is PCell on the PCC, Cell 2 is SCell on the SCC1, Cell 3 is SCell on the SCC2 and Cell 4 is a neighbour cell on the SCC2. In all tests, Cell 3 is the OTDOA assistance data reference cell. The assistance data neighbour cell list includes in total 15 cells, where 14 of the cells are not simulated (dummy cells; as defined in 3GPP TS 37.571-5 clause 7.3.2) for Test 1 and where 12 of the cells are not simulated for Test 2. PCell (Cell 1) is the cell used for connection setup with the power level and mapping set according to TS 36.521-1 [24] Annex C.0 and C.1 as appropriate for this test. Cell 2, Cell 3 and Cell 4 are powered OFF.
6. The true RSTD (which is the receive time difference for frame 0 between two cells as seen at the UE antenna connector) is set to 31 Ts (about 1 μ s) between Cell 1 and OTDOA assistance data reference cell, Cell 3, and set to -31 Ts (about -1 μ s) between Cell 2 and OTDOA assistance data reference cell, Cell 3, and set to 92 Ts (about 3 μ s) between neighbour Cell 4 and OTDOA assistance data reference cell, Cell 3.

Table 10.6.4.1-1: General test parameters for E-UTRAN TDD RSTD measurement reporting delay under fading propagation conditions for carrier aggregation

Parameter	Unit	Value		Comment
		Test 1	Test 2	
PCell		Cell 1		PCell is on RF channel 1 (PCC).
SCell 1		Cell 2		SCell 1 on RF channel 2 (SCC1).
SCell 2		Cell 3		SCell 2 on RF channel 3 (SCC2). Cell 3 is the assistance data reference cell.
Other neighbour cell		Cell 4		Neighbour cell on RF channel 3 (SCC2).
PCFICH/PDCCH/PHICH parameters (PCFICH/PDCCH/PHICH parameters depend on selected channel bandwidth)		5MHz: R.11 TDD 10MHz: R.6 TDD 20MHz: R.10 TDD		As specified in TS 36.521-3 [25] clause A.2.1
Channel Bandwidth (BW _{channel})	MHz	5MHz or 10MHz or 20MHz		All channels in a test have the same bandwidth.

PRs Transmission Bandwidth (PRs transmission bandwidth depends on selected channel bandwidth) ^{Note 2}	RB	5MHz: 25 10MHz: 50 20MHz:100		PRs are transmitted over the system bandwidth
Number of consecutive downlink positioning subframes N_{PRs} . (N_{PRs} depends on selected channel bandwidth) ^{Note 2}		5MHz: 2 10MHz: 1 20MHz:1		As defined in TS 36.211 [26]. The number of subframes in a positioning occasion
PRs configuration index I_{PRs} ^{Note 2}		174 for all cells on PCC 184 for all cells on SCC1 194 for all cells on SCC2		This corresponds to periodicity of 320 ms and PRs subframe offset of $I_{PRs} - 160$ DL subframes, as defined in TS 36.211 [26], Table 6.10.4.3-1
Physical cell ID PCI ^{Note 2}		(PCI of Cell 3 – PCI of Cell 4)mod6=0		The PCIs of Cell 1 and Cell 2 are selected randomly. PCIs of Cell 3 and Cell 4 are selected randomly such that the relative subcarrier shifts of PRs patterns among these cells are as given by the condition
TDD uplink-downlink configuration		1		As specified in TS 36.211 [26], Clause 4.2; corresponds to a configuration with 5 ms switch-point periodicity and two downlink consecutive subframes
TDD special subframe configuration		6		As specified in TS 36.211 [26], Clause 4.2; corresponds to DwPTS of $19760 \cdot T_s$ and UpPTS of $4384 \cdot T_s$
CP length ^{Note 2}		Normal		
DRX		ON		DRX parameters are further specified in Table 10.6.4.1-2
Radio frame receive time offset between the cells at the UE antenna connector ^{Note 3}	μs	Cell 1 to Cell 3: 1 Cell 2 to Cell 3: -1 Cell 4 to Cell 3: 3	Cell 1 to Cell 3: 1 Cell 2 to Cell 3: -1 Cell 4 to Cell 3:	PRs are transmitted from synchronous cells
Expected RSTD ^{Note 1}	μs	Cell 4: 2 Other neighbour cells: randomly between -3 and 3	Cell 1: -2 Cell 2: 0 Cell 4: 2 Other neighbour cells: randomly between -3 and 3	The expected RSTD is what is expected at the receiver. The corresponding parameter in the OTDOA assistance data specified in TS 36.355 [4] is the expectedRSTD indicator
Expected RSTD uncertainty for all neighbour cells ^{Note 1}	μs	5		The corresponding parameter in the OTDOA assistance data specified in TS 36.355 [4] is the expectedRSTD-Uncertainty index
Number of cells provided in OTDOA assistance data		16 cells in total		The list includes the reference cell and 15 other cells. Cell 1 and Cell 2 (when included) appears at random places in the first half of the neighbour cell list in the OTDOA assistance data. Cell 4 always appears at random places in the second half of the list.
		OTDOA neighbour cells include Cell 4 and other 14 cells on SCC2	OTDOA neighbour cells include Cell 1 and other 3 cells on PCC, Cell 2 and other 3 cells on SCC1 and Cell 4 and other 6 cells on SCC2	

prs-SubframeOffset ^{Note 2}		Cells on PCC: 300 Cells on SCC1: 310 Cells on SCC2, except reference cell: 0		Subframe offset, counted in full subframes. The corresponding parameter in the OTDOA assistance data is prs-SubframeOffset specified in TS 36.355 [4]
slotNumberOffset ^{Note 2}		Cells on PCC: 0 Cells on SCC1: 0 Cells on SCC2, except reference cell: 0		The slot number offset at the transmitter between a neighbour cell and the assistance data reference cell. The corresponding parameter in the OTDOA assistance data is slotNumberOffset specified in TS 36.355 [4].
PRS muting info ^{Note 2}		Cell 1: '11110000' Cell 2: '00001111' Cell 3: '11110000' Cell 4: '00001111'	Cell 1: '1111111100000000' Cell 2: '0000000011111111' Cell 3: '1111111100000000' Cell 4: '0000000011111111'	Corresponds to prs-MutingInfo defined in TS 36.355 [4]
T1	s	3		The length of the time interval from the beginning of each test
T2	s	1.28	2.48	The length of the time interval that follows immediately after time interval T1
T3	s	1.28	2.48	The length of the time interval that follows immediately after time interval T2
<p>Note 1: Parameters "Expected RSTD" and "Expected RSTD uncertainty for all neighbour cells" are not settable parameters. These are parameters signalled in LPP only. For the values to be used in LPP see Table 10.6.4.3-4 and TS 37.571-5 [20], clause 7.3.2.</p> <p>Note 2: Parameters "PRS Transmission Bandwidth", "PRS configuration index", "Number of consecutive downlink positioning subframes", "Physical cell ID PCI", "CP length", "prs-SubframeOffset", "slotNumberOffset" and "PRS muting info" are settable parameters and also parameters signalled in LPP. The values to be used for "Physical cell ID PCI" are as follows: Cell 1: 0, Cell 2: 3, Cell 3: 6, Cell 4: 12. For the values to be used in LPP see Table 10.6.4.3-4 and TS 37.571-5 [20], clause 7.3.2.</p> <p>Note 3: The parameter "Radio frame receive time offset between the cells at the UE antenna connector" is used to set the "true RSTD" values in step 6 of clause 10.6.4.1.</p>				

Table 10.6.4.1-2: DRX parameters for the test of E-UTRAN TDD intra-frequency RSTD measurement reporting delay under fading propagation conditions for carrier aggregation

Field	Value	Comment
onDurationTimer	psf1	As specified in TS 36.331 [22], Clause 6.3.2
Drx-InactivityTimer	psf1	
drx-RetransmissionTimer	sf1	
longDRX-CycleStartOffset	sf320	
shortDRX	Disable	

10.6.4.2 Test procedure

The test case includes two tests. Test 1 is designed for the scenario where the UE receives OTDOA assistance data with cells only on SCC2, and the UE is expected to report RSTD measurements performed on SCC2 only. Test 2 is designed for the scenario where the UE receives OTDOA assistance data with cells on PCC, SCC1 and SCC2, and the UE is expected to report RSTD measurements performed on PCC, SCC1 and SCC2.

Each test consists of three consecutive time intervals, with duration of T1, T2 and T3. Cell 1 is active in T1, T2 and T3, Cell 2 is active only in T2 and T3, Cell 3 is active only during T2 and T3, and Cell 4 is active only during T2. The beginning of the time interval T2 shall be aligned 5 ms before the first PRS positioning subframe of a positioning occasion in the OTDOA assistance data reference cell, where 5 ms is the necessary test tolerance. Cell 1 transmits PRS in T2, Cell 2 transmits PRS only in T3, Cell 3 transmits PRS only in T3, and Cell 4 transmits PRS only in T2.

NOTE: The information on when PRS is muted is conveyed to the UE using PRS muting information in the OTDOA assistance data.

The OTDOA-RequestLocationInformation message and the OTDOA assistance data as defined in 10.6.4.3 shall be provided to the UE during T1. The last TTI containing the OTDOA-RequestLocationInformation message shall be provided to the UE ΔT ms before the start of T2, where $\Delta T = 150$ ms is the maximum processing time of the OTDOA-RequestLocationInformation message and the OTDOA assistance data.

1. Ensure that the UE is in state Generic RB Established State 3A-RF according to 3GPP TS 36.508 [18] clause 7.2A.3.
2. Configure Cell 2 on SCC1 and Cell 3 and Cell 4 on SCC2 according to TS 36.521-3 [25] Annex C.0 and C.1 for all downlink physical channels.
3. The SS shall configure the SCells (Cell 2 and Cell 3) on the SCCs as per TS 36.508 [18] clause 5.2A.4.
4. The SS activates the SCells (Cell 2 and Cell 3) by sending the Activation/Deactivation MAC control element according to TS 36.321 [34] clauses 5.13 and 6.1.3.8. Wait for at least 2 seconds as per TS 36.133 [23] clause 8.3.3.2.
5. The SS shall send a RESET UE POSITIONING STORED INFORMATION message.
6. Set the parameters according to Table 10.6.5-1. Propagation conditions are set according to clause 4.7.2.2 (ETU30).
7. T1 starts.
8. The SS shall transmit an RRCConnectionReconfiguration message with the DRX configuration. PDCCHs indicating new transmissions shall be sent continuously until the start of T2 to ensure that the UE would not enter the DRX state before T2.
9. The UE shall transmit RRCConnectionReconfigurationComplete message.
- 9a. The SS shall transmit an LPP REQUEST CAPABILITIES message.
- 9b. The UE shall transmit an LPP PROVIDE CAPABILITIES message indicating the OTDOA capabilities supported by the UE in the *OTDOA-ProvideCapabilities* IE.
10. The SS shall send a LPP PROVIDE ASSISTANCE DATA message, including the *OTDOA-ProvideAssistanceData* IE. The position of neighbour Cell 4 in the *OTDOA-NeighbourCellInfoList* is randomly selected to be in the last 8 elements of the sequence for Test 1 and in the 7 elements of the relevant sequence for Test 2, and the position of Cell 1 and the position of Cell 2 are randomly selected to be in the 4 elements of the relevant sequence for Test 2, as described in 3GPP TS 37.571-5 [20], clause 7.3.2. If the UE message at step 9b includes the *ackRequested* IE set to TRUE, then the SS shall send an acknowledgment in the LPP PROVIDE ASSISTANCE DATA message.
11. The SS shall send a LPP REQUEST LOCATION INFORMATION message, including the *OTDOA-RequestLocationInformation* IE such that the UE receives the message ΔT ms before the start of T2, where $\Delta T = 150$ ms.
12. When T1 expires, the SS shall switch the power setting from T1 to T2 as specified in Table 10.6.5-2.
13. When T2 expires, the SS shall switch the power setting from T2 to T3 as specified in Table 10.6.5-2.
14. The UE shall transmit a LPP PROVIDE LOCATION INFORMATION message including the *OTDOA-ProvideLocationInformation* IE within the response time (see clause 4.7.3) specified in clause 10.6.5.

For Test 1 the UE shall perform and report the RSTD measurement for Cell 4 with respect to the reference cell in the OTDOA assistance data, Cell 3. If the UE transmits an *OTDOA-ProvideLocationInformation* IE including the *rstd* field for Cell 4 within the response time then the number of successful tests is increased by one. If the UE fails to report the *OTDOA-ProvideLocationInformation* IE with the *rstd* field included within the response time then the number of failure tests is increased by one.

For Test 2 the UE shall perform and report the RSTD measurements for Cell 1 with respect to the reference cell in the OTDOA assistance data, Cell 3 and also Cell 2 with respect to the reference cell in the OTDOA assistance data, Cell 3 and also Cell 4 with respect to the reference cell in the OTDOA assistance data, Cell 3. If the UE

transmits an *OTDOA-ProvideLocationInformation* IE including the *rstd* field for Cell 1 (with respect to Cell 3) and Cell 2 (with respect to Cell 3) and Cell 4 (with respect to Cell 3) within the response time then the number of successful tests is increased by one. If the UE fails to report the *OTDOA-ProvideLocationInformation* IE with the three *rstd* fields included within the response time then the number of failure tests is increased by one.

- 15. If the UE message at step 14 includes the *ackRequested* IE set to TRUE, the SS shall send a LPP acknowledgement message.
- 16. Repeat steps 5-15 until the confidence level according to Annex D is achieved. For each iteration, at step 10 change the random positions of Cell 4 and Cell 1(for Test 2 only) and Cell 2(for Test 2 only) in the relevant sequence in the *OTDOA-NeighbourCellInfoList*.
- 17. Repeat from clause 10.6.4.1 for Test 2.

10.6.4.3 Message contents

Table 10.6.4.3-1: RESET UE POSITIONING STORED INFORMATION

Derivation Path: 36.509 [11] clause 6.9			
Information Element	Value/remark	Comment	Condition
UE Positioning Technology	0 0 0 0 0 0 1	OTDOA	

Table 10.6.4.3-2: MAC-MainConfig-RBC: TDD RSTD Measurement Reporting Delay for Carrier Aggregation

Derivation Path: TS 36.508 [18] clause 4.8.2.1.5, Table 4.8.2.1.5-1 MAC-MainConfig-RBC			
Information Element	Value/remark	Comment	Condition
MAC-MainConfig-RBC ::= SEQUENCE {			
drx-Config CHOICE {			
setup SEQUENCE {			
onDurationTimer	psf1		
drx-InactivityTimer	psf1		
drx-RetransmissionTimer	sf1		
longDRX-CycleStartOffset CHOICE {			
sf320	0		
}			
shortDRX	Not present		
}			
}			
}			

Table 10.6.4.3-2a: LPP Request Capabilities

Information Element	Value/remark
<i>otdoa-RequestCapabilities</i>	TRUE

Table 10.6.4.3-3: LPP RequestLocationInformation

Derivation Path: 36.355 clause 6.2			
Information Element	Value/remark	Comment	Condition
LPP-Message ::= SEQUENCE {			
transactionID SEQUENCE {			
Initiator	locationServer		
transactionNumber	1		
}			
endTransaction	FALSE		
sequenceNumber	Not present		
acknowledgement	Not present		
lpp-MessageBody CHOICE {			
c1 CHOICE {			
requestLocationInformation SEQUENCE {			
criticalExtensions CHOICE {			

c1 CHOICE {			
requestLocationInformation-r9 SEQUENCE {			
commonIEsRequestLocationInformation SEQUENCE {			
locationInformationType	locationMeasurementsRequired		
triggeredReporting	Not present		
periodicalReporting	Not present		
additionalInformation	onlyReturnInformationRequested		
qos SEQUENCE {			
horizontalAccuracy	Not present		
verticalCoordinateRequest	FALSE		
verticalAccuracy	Not present		
responseTime SEQUENCE {			
time	Test 1: 3 Test 2: 6	See clause 10.6.5	
responseTimeEarlyFix-r12	Not present		Rel-12 onwards
}			
velocityRequest	FALSE		
}			
environment	Not present		
locationCoordinateTypes	Not present		
velocityTypes	Not present		
}			
a-gnss-RequestLocationInformation	Not present		
otdoa-RequestLocationInformation SEQUENCE {			
assistanceAvailability	FALSE		
}			
ecid-RequestLocationInformation	Not present		
epdu-RequestLocationInformation	Not Present		
}			
}			
}			
}			
}			
}			
}			
}			
}			
}			
}			
}			
}			
}			
}			
}			

Table 10.6.4.3-4: LPP ProvideAssistanceData

Derivation Path: 36.355 clause 6.2			
Information Element	Value/remark	Comment	Condition
LPP-Message ::= SEQUENCE {			
transactionID SEQUENCE {			
Initiator	locationServer		
transactionNumber	(0..255)		
}			
endTransaction	TRUE		
sequenceNumber	Not present		
acknowledgement	Not present		
lpp-MessageBody CHOICE {			
c1 CHOICE {			
provideAssistanceData SEQUENCE {			
criticalExtensions CHOICE {			
c1 CHOICE {			
provideAssistanceData-r9 SEQUENCE {			
commonIEsProvideAssistanceData	Not present		
a-gnss-ProvideAssistanceData	Not present		
otdoa-ProvideAssistanceData SEQUENCE {			
otdoa-ReferenceCellInfo	As defined in TS 37.571-5 [20], clause 7.3.2.		

otdoa-NeighbourCellInfo	As defined in TS 37.571-5 [20], clause 7.3.2.		
otdoa-Error	Not present		
}			
epdu-ProvideAssistanceData	Not present		
}			
}			
}			
}			
}			
}			

Table 10.6.4.3-5: LPP ProvideLocation Information

Derivation Path: 36.355 clause 6.2			
Information Element	Value/remark	Comment	Condition
LPP-Message ::= SEQUENCE {			
transactionID SEQUENCE {			
Initiator	locationServer		
transactionNumber	1		
}			
endTransaction	TRUE		
sequenceNumber	(0..255)		
acknowledgement			
lpp-MessageBody CHOICE {			
c1 CHOICE {			
provideLocationInformation SEQUENCE {			
criticalExtensions CHOICE {			
c1 CHOICE {			
provideLocationInformation-r9 SEQUENCE {			
commonIEsProvideLocationInformation	Not present.		
a-gnss-ProvideLocationInformation	Not present		
otdoa-ProvideLocationInformation SEQUENCE {			
otdoaSignalMeasurementInformation SEQUENCE {			
systemFrameNumber			
physCellIdRef	Cell 3		
cellGlobalIdRef			
earfcnRef			
referenceQuality			
neighbourMeasurementList SEQUENCE {			
NeighbourMeasurementElement SEQUENCE {			
physCellIdNeighbour	Cell 4		
cellGlobalIdNeighbour			
earfcnNeighbour			
rstd	Present	With respect to Cell 3	
rstd-Quality			
}			
NeighbourMeasurementElement SEQUENCE {		Test 2 only	
physCellIdNeighbour	Cell 1		
cellGlobalIdNeighbour			
earfcnNeighbour			
rstd	Present	Test 2 only With respect to Cell 3	
rstd-Quality			
}			
NeighbourMeasurementElement SEQUENCE {		Test 2 only	

physCellIdNeighbour	Cell 2		
cellGlobalIdNeighbour			
earfcnNeighbour			
rstd	Present	Test 2 only With respect to Cell 3	
rstd-Quality			
}			
}			
}			
otdoa-Error	May be present with error reason 'undefined' or 'attemptedButUnableToM easureSomeNeighbourC ells'		
}			
ecid-ProvideLocationInformation	Not present		
epdu-ProvideLocationInformation	Not present		
}			
}			
}			
}			
}			
}			

10.6.5 Test Requirements

Table 10.6.5-1 and 10.6.5-2 define the primary level settings including test tolerances for the tests.

Table 10.6.5-1: Cell-specific test parameters for E-UTRAN TDD RSTD measurement reporting delay under fading propagation conditions during T1 for carrier aggregation

Parameter	Unit	Cell 1	Cell 2	Cell 3	Cell 4
E-UTRA RF Channel Number		1	N/A	N/A	N/A
Correlation Matrix and Antenna Configuration		1x2 Low	1x2 Low	1x2 Low	1x2 Low
OCNG patterns defined in TS 36.521-3 [25] clause D.1. (OCNG patterns depend on selected channel bandwidth)		5MHz: OP.10 TDD 10MHz: OP.1 TDD 20MHz: OP.7 TDD	N/A	N/A	N/A
PBCH_RA	dB	0	N/A	N/A	N/A
PBCH_RB					
PSS_RA					
SSS_RA					
PCFICH_RB					
PHICH_RA					
PHICH_RB					
PDCCH_RA					
PDCCH_RB					
OCNG_RA ^{Note 1}					
OCNG_RB ^{Note 1}					
N_{oc} ^{Note 3}	dBm/ 15 kHz	-95	N/A	N/A	N/A
$PRS \hat{E}_s / N_{oc}$	dB	-Infinity	-Infinity	-Infinity	-Infinity
I_0 ^{Note 4}	dBm/ 9 MHz	-67.22 +10log ($N_{RB,c} / 50$)	N/A	N/A	N/A

\hat{E}_s/N_{oc}	dB	0	-Infinity	-Infinity	-Infinity
Propagation Condition		ETU30			
Note 1:	OCNG shall be used such that active cell (Cell 1) is fully allocated and a constant total transmitted power spectral density is achieved for all OFDM symbols.				
Note 2:	The resources for uplink transmission are assigned to the UE prior to the start of time period T2.				
Note 3:	Interference from other cells and noise sources not specified in the test are assumed to be constant over subcarriers and time and shall be modelled as AWGN of appropriate power for N_{oc} to be fulfilled.				
Note 4:	Io levels have been derived from other parameters and are given for information purpose. These are not settable test parameters.				

Table 10.6.5-2: Cell-specific test parameters for E-UTRAN TDD RSTD measurement reporting delay under fading propagation conditions during T2 and T3 for carrier aggregation

Parameter	Unit	Cell 1		Cell 2		Cell 3		Cell 4	
		T2	T3	T2	T3	T2	T3	T2	T3
E-UTRA RF Channel Number		1		2		3		3	
Correlation Matrix and Antenna Configuration		1x2 Low		1x2 Low		1x2 Low		1x2 Low	
OCNG patterns defined in TS 36.521-3 [25] clause D.1 (There is no PDSCH allocated in the subframe transmitting PRS) (OCNG patterns depend on selected channel bandwidth)		5MHz: OP.10 TDD 10MHz: OP.1 TDD 20MHz: OP.7 TDD		5MHz: OP.10 TDD 10MHz: OP.1 TDD 20MHz: OP.7 TDD		5MHz: OP.10 TDD 10MHz: OP.1 TDD 20MHz: OP.7 TDD		5MHz: OP.10 TDD 10MHz: OP.1 TDD 20MHz: OP.7 TDD	
PBCH_RA	dB								
PBCH_RB									
PSS_RA									
SSS_RA									
PCFICH_RB									
PHICH_RA		0		0		0		0	
PHICH_RB									
PDCCH_RA									
PDCCH_RB									
OCNG_RA ^{Note 1}									
OCNG_RB ^{Note 1}									
PRS_RA	dB	-6	N/A	N/A	3	N/A	3	3	N/A
N_{oc} ^{Note 3}	dBm/15 kHz	-98	-98	-98	-95	-98	-95	-98	-95
PRS \hat{E}_s/N_{oc}	dB	-4	-Infinity	-Infinity	-1	-Infinity	-1	-8	-Infinity
PRS \hat{E}_s/I_{ot} ^{Note 4}	dB	-4	-Infinity	-Infinity	-1	-Infinity	-1	-8	-Infinity
I_o ^{Note 4}	dBm/9 MHz	-69.94 +10log($N_{RB,c}/50$)	N/A	N/A	-66.68 +10log($N_{RB,c}/50$)	N/A	-66.68 +10log($N_{RB,c}/50$)	-70.11 +10log($N_{RB,c}/50$)	N/A
PRP ^{Note 4}	dBm/15 kHz	-102	-Infinity	-Infinity	-96	-Infinity	-96	-106	-Infinity
RSRP ^{Note 4}	dBm/15 kHz	-96	-96	-105	-99	-105	-99	-109	-Infinity

\hat{E}_s/N_{oc} Note 4	dB	2	2	-7	-4	-7	-4	-11	-	Infinity
Propagation Condition		ETU30								
Note 1:	OCNG shall be used such that active cells (all, except Cell 3 in T3) are fully allocated and a constant total transmitted power spectral density is achieved for all OFDM symbols other than those in the subframes with transmitted PRS.									
Note 2:	The resources for uplink transmission are assigned to the UE prior to the start of time period T2.									
Note 3:	Interference from other cells and noise sources not specified in the test are assumed to be constant over subcarriers and time and shall be modelled as AWGN of appropriate power for N_{oc} to be fulfilled.									
Note 4:	If PRS_RA is not "N/A", \hat{E}_s/N_{oc} , PRS \hat{E}_s/I_{ot} , I_o , RSRP and PRP levels have been derived from other parameters and are given for information purpose. If PRS_RA is "N/A", I_o and RSRP levels have been derived from other parameters and are given for information purpose. These are not settable test parameters. Interference conditions shall be applied to all PRS symbols of DL positioning subframes.									

The response time including test tolerance is 3.3 s for Test 1 and 6.3 s for Test 2. The response time is equal to the LPP time IE value plus the test tolerance. The LPP time IE value is derived from the RSTD reporting delay plus ΔT , where $\Delta T = 150$ ms, giving a value of 2710 ms for Test 1 and 5110ms for Test 2. This is rounded up to the next allowed LPP value of 3 seconds for Test 1 and 6 seconds for Test 2.

The RSTD measurement reporting delay in the tests are derived from the following expression,

$T_{PRS}(M-1) + 160 \left\lceil \frac{n}{M} \right\rceil$, where $M=8$ and $n=16$ for Test 1, and $M=16$ and $n=16$ for Test 2 are the parameters specified in clause 10.6.3.1 for Test 1 and clause 10.6.3.2 for Test 2.

This gives the total RSTD reporting delay of 2560 ms for Test 1 for the 15 neighbour cells including Cell 4 with respect to the reference cell, Cell 3.

This gives the total RSTD reporting delay of 4960 ms for Test 2 for the 15 neighbour cells including Cell 1, Cell 2 and Cell 4 with respect to the reference cell, Cell 3.

The test tolerances are defined in clauses C.1.3 and C.4.

For the overall test to pass, the rate of successful tests during repeated tests in both Test 1 and Test 2 shall be more than 90% with a confidence level of 95%.

10.7 FDD RSTD Measurement Accuracy for 3DL Carrier Aggregation

10.7.1 Test purpose

To verify that the FDD RSTD measurement accuracy is within the specified limits.

10.7.2 Test applicability

This test applies to all types of E-UTRA FDD UE release 12 and forward that supports UE-assisted OTDOA for 3DL Carrier Aggregation.

10.7.3 Minimum conformance requirements

This section contains RSTD measurement accuracy requirements for a UE configured with one or two downlink SCell(s). The UE may operate in one of the E-UTRA carrier aggregations listed in TS 36.133 [23] section 8.3.1. The requirements in this section shall apply regardless of whether the configured downlink secondary cell is activated or deactivated by the MAC-CE command [34]. The requirements apply for bandwidths defined in the bandwidth combination set for the CA configurations supported by the UE defined in TS 36.101 [2].

The RSTD measurements, which are obtained when both the reference cell and neighbouring cell belong to the primary component carrier, shall meet the intra-frequency RSTD accuracy requirements defined in TS 36.133 [23] section 9.1.10.1.

The RSTD measurements, which are obtained when both the reference cell and neighbouring cell belong to the same secondary component carrier, shall meet the intra-frequency RSTD accuracy requirements defined in TS 36.133 [23] section 9.1.10.1.

The RSTD measurements, which are obtained when the reference cell and neighbouring cell do not belong to the same carrier, shall meet the inter-frequency RSTD accuracy requirements defined in TS 36.133 [23] section 9.1.10.2.

The normative reference for this requirement is TS 36.133 [23] clause 9.1.12 and A.9.8.14.

10.7.4 Test description

10.7.4.1 Initial conditions

Test Environment: Normal; as defined in TS 36.508 [18] clause 4.1.

Frequencies to be tested: Mid Range, as defined in TS 36.508 [18] clause 4.3.1.1.

Channel bandwidths to be tested: the largest and the smallest aggregated bandwidth combinations supported by the UE of the Channel bandwidths defined in Table 10.7.4.1-1. The Channel bandwidths for CA Intra-Band combinations are as defined in TS 36.508 [18] clause 4.3.1 and for CA Inter-Band combinations are defined in TS 36.521-1 [24] clause 5.4.2A. In case of multiple possible Channel bandwidth combinations, the first combination listed in the above mentioned clauses shall be selected.

1. Connect the SS (node B emulator) and AWGN noise sources to the UE antenna connectors as follows:
 - For UEs supporting only 2Rx in all the bands under test, use TS 36.508 [18] Annex A, Figure group A.68 as appropriate.
 - For UEs supporting 4Rx in any of the bands under test use TS 36.508 [18] Annex A, Figure A.90. Use the 2Rx module for cells on bands supporting 2Rx and the 4Rx module for cells on bands supporting 4Rx.
2. The general test parameter settings are set up according to Table 10.7.4.1-1.
3. Propagation conditions are set according to clause 4.7.2.1.
4. Message contents are defined in clause 10.7.4.3.
5. There are four synchronized cells on three different carrier frequencies. Cell 1 is the PCell on primary component carrier F1 (RF channel number 1), Cell 2 is an SCell on secondary component carrier F2 (RF channel number 2), Cell 3 is an SCell and reference cell on secondary component carrier F3 (RF channel number 3), and Cell 4 is the neighbour cell on F3. PCell (Cell 1) is the cell used for connection setup with the power level and mapping set according to TS 36.521-1 [24] Annex C.0 and C.1 as appropriate for this test. Cell 2, Cell 3 and Cell 4 are powered OFF.

Cell 1, Cell 2, Cell 3, and Cell 4 are included in the OTDOA assistance data neighbour cell list.

The assistance data neighbour cell list includes in total 15 cells, where 12 of the cells are not simulated (dummy cells; as defined in 3GPP TS 37.571-5 [20], clause 7.3.2).

Note that the measurement gap is not configured in the test because of UE carrier aggregation capability.

6. The true RSTD (which is the receive time difference for frame 0 between the two cells as seen at the UE antenna connector) is set to 31 Ts (about 1 μ s) between Cell 1 and OTDOA assistance data reference cell, Cell 3, and set to -31 Ts (about -1 μ s) between Cell 2 and OTDOA assistance data reference cell, Cell 3, and set to 92 Ts (about 3 μ s) between neighbour Cell 4 and OTDOA assistance data reference cell, Cell 3.

Note that the related expectedRSTD values to be signalled over LPP are defined in Table 10.7.4.1-1.

Table 10.7.4.1-1: General Test Parameters for RSTD Test for E-UTRAN FDD for Carrier Aggregation

Parameter	Unit	Value	Comment
PCell		Cell 1	Cell 1 on RF channel number 1
SCell 1		Cell 2	Cell 2 is an SCell on RF channel number 2
SCell 2 (Assistance data reference cell)		Cell 3	Cell 3 is an SCell on RF channel number 3
Neighbour cell		Cell 4	Cell 4 on RF channel number 3
Channel Bandwidth (BW_{channel})	MHz	5,10,20	
PRS Transmission Bandwidth (PRS transmission bandwidth depends on selected channel bandwidth) ^{Note 2}	RB	5MHz: 25 10MHz: 50 20MHz:100	PRS are transmitted over the system bandwidth. PRS Bandwidth: bandwidth is as indicated in <i>prs-Bandwidth</i> in the OTDOA assistance data defined in 3GPP TS 36.355 [4].
PCFICH/PDCCH/PHICH parameters (PCFICH/PDCCH/PHICH parameters depend on selected channel bandwidth)		5MHz: R.11 FDD 10MHz: R.6 FDD 20MHz: R.10 FDD	As specified in TS 36.521-3 [25] clause A.2.1
OCNG Patterns defined in TS 36.521-3 [25] clause D.1 (There is no PDSCH allocated in the subframe transmitting PRS) (OCNG Patterns depend on selected channel bandwidth)		5MHz: OP.18 FDD 10MHz: OP.5 FDD 20MHz: OP.13 FDD	OCNG shall be used such that all cells are fully allocated and a constant total transmitted power spectral density is achieved for all OFDM symbols (other than those in the PRS subframes).
PRS configuration Index I_{PRS} ^{Note 2}		171 for all cells on PCC 181 for all cells on SCC1 191 for all cells on SCC2	This corresponds to periodicity of 320 ms and PRS subframe offset of $I_{\text{PRS}} - 160$ _{DL} subframes, as defined in TS 36.211 [26], Table 6.10.4.3-1
Number of consecutive positioning downlink subframes N_{PRS} (N_{PRS} depends on selected channel bandwidth) ^{Note 2}		5MHz: 2 10MHz: 1 20MHz:1	As defined in 3GPP TS 36.211 [26]
prs-SubframeOffset ^{Note 2}		Cells on PCC: 300 Cells on SCC1: 310 Cells on SCC2, except reference cell: 0	Subframe offset, counted in full subframes. The corresponding parameter in the OTDOA assistance data is prs-SubframeOffset specified in TS 36.355 [4]
slotNumberOffset ^{Note 2}		Cells on PCC: 0 Cells on SCC1: 0 Cells on SCC2, except reference cell: 0	The slot number offset at the transmitter between a neighbour cell and the assistance data reference cell. The corresponding parameter in the OTDOA assistance data is slotNumberOffset specified in TS 36.355 [4].
prs-MutingInfo ^{Note 2}		Cell 1:'11110000' Cell 2:'11110000' Cell 3:'11110000' Cell 4:'11110000'	See section 6.5.1.2 in 3GPP TS 36.355 [4] for more information
Cell ID ^{Note 2}		(Cell ID of cell 4 – Cell ID of cell 3) mod 6 = 3	PCIs of cell 1 and cell 2 are selected randomly.
Radio frame receive time offset between the cells at the UE antenna connector ^{Note 3}	µs	Cell 1 to Cell 3: 1 Cell 2 to Cell 3: -1 Cell 4 to Cell 3: 3	PRS are transmitted from synchronous cells

Expected RSTD ^{Note 1}	μs	Cell 1: -2 Cell 2: 0 Cell 4: 2 Other neighbour cells: randomly between -3 and 3	The expected RSTD is what is expected at the receiver. The corresponding parameter in the OTDOA assistance data specified in TS 36.355 [4] is the expectedRSTD indicator
Expected RSTD uncertainty for all neighbour cells ^{Note 1}	μs	5	The corresponding parameter in the OTDOA assistance data specified in TS 36.355 [4] is the expectedRSTD-Uncertainty index
CP length ^{Note 2}		Normal	
DRX		OFF	
Number of cells provided in OTDOA assistance data		16	The list includes the assistance-data-reference cell and 15 other cells. Cell 1 and Cell 2 appear at random places in the first half of the neighbour cell list in the OTDOA assistance data. Cell 4 always appears at random places in the second half of the list.
$T_{\text{RSTDInterFreqIDD,E-UTRAN}}$ ^{Note 4}	ms	4960	Derived according to the RSTD measurement requirements specified in Section 10.5.3
<p>NOTE 1: Parameters "Expected RSTD" and "Expected RSTD uncertainty for all neighbour cells" are not settable parameters. These are parameters signalled in LPP only. For the values to be used in LPP see Table 10.7.4.3-3 and TS 37.571-5 [20], clause 7.3.2.</p> <p>NOTE 2: Parameters "PRS Transmission Bandwidth", "PRS configuration index", "Number of consecutive positioning downlink subframes", "prs-SubframeOffset", "slotNumberOffset", "prs-MutingInfo", "Cell ID" and "CP length" are settable parameters and also parameters signalled in LPP. The values to be used for "Cell ID" are as follows: Cell 1: 0, Cell 2: 3, Cell 3: 7, Cell 4: 10. For the values to be used in LPP see Table 10.7.4.3-3 and TS 37.571-5 [20], clause 7.3.2.</p> <p>NOTE 3: The parameter "Radio frame receive time offset between the cells at the UE antenna connector" is used to set the "true RSTD" value in step 6 of clause 10.7.4.1.</p> <p>NOTE 4: The parameter "$T_{\text{RSTDInterFreqIDD,E-UTRAN}}$" is not a settable parameter but is used to set the LPP "time" value in Table 10.7.4.3-2. The value of the LPP time IE is set to $T_{\text{RSTDInterFreqIDD,E-UTRAN}} + \Delta T$ ms, where $\Delta T = 150$ ms, giving a value of 5110 ms. This is rounded up to the next allowed LPP value of 6 seconds.</p>			

10.7.4.2 Test procedure

The RSTD measurements are performed:

- between Cell 4 and Cell 3 to verify the accuracy of RSTD measurement when the reference cell and neighbouring cell belong to the same secondary component carrier can meet the intra-frequency RSTD accuracy requirements defined in section 10.7.3.
- between Cell 1 and Cell 3 to verify the accuracy of RSTD measurement between the PCell and an SCell can meet the inter-frequency RSTD accuracy requirements defined in section 10.7.3.
- between Cell 2 and Cell 3 to verify the accuracy of RSTD measurement between two SCells can meet the inter-frequency RSTD accuracy requirements defined in section 10.7.3.

The test consists of a set-up period and a measurement period. All cells are active during the complete test. The beginning of the measurement period shall be aligned with the first PRS positioning subframe of a positioning occasion in the reference cell.

NOTE: The information on when PRS is muted is conveyed to the UE using PRS muting information in the OTDOA assistance data.

The OTDOA-RequestLocationInformation message and the OTDOA assistance data as defined in clause 10.7.4.3 shall be provided to the UE during the set-up period. The last TTI containing the OTDOA-RequestLocationInformation message shall be provided to the UE ΔT ms before the start of the measurement period, where $\Delta T = 150$ ms is the maximum processing time of the OTDOA-RequestLocationInformation message and the OTDOA assistance data in the UE.

1. Ensure that the UE is in state Generic RB Established State 3A-RF according to 3GPP TS 36.508 [18] clause 7.2A.3.
2. Configure Cell 2 on SCC1 and Cell 3 and Cell 4 on SCC2 according to TS 36.521-3 [25] Annex C.0 and C.1 for all downlink physical channels.
3. The SS shall configure the SCells (Cell 2 and Cell 3) on the SCCs as per TS 36.508 [18] clause 5.2A.4.
4. The SS activates the SCells (Cell 2 and Cell 3) by sending the Activation/Deactivation MAC control element according to TS 36.321 [34] clauses 5.13 and 6.1.3.8. Wait for at least 2 seconds as per TS 36.133 [23] clause 8.3.3.2.
5. The SS shall send a RESET UE POSITIONING STORED INFORMATION message.
6. Set the parameters according to Table 10.7.5-1 as appropriate. Propagation conditions are set according to clause 4.7.2.1.
- 6a. The SS shall send an LPP REQUEST CAPABILITIES message.
- 6b. The UE shall send an LPP PROVIDE CAPABILITIES message indicating the OTDOA capabilities supported by the UE in the *OTDOA-ProvideCapabilities* IE
7. The SS shall send a LPP PROVIDE ASSISTANCE DATA message, including the *OTDOA-ProvideAssistanceData* IE. The position of Cell 1 in the *OTDOA-NeighbourCellInfoList* and the position of Cell 2 are randomly selected in the relevant sequence and the position of Cell 4 is randomly selected in the relevant sequence as described in 3GPP TS 37.571-5 [20], clause 7.3.2. If the UE message at step 6b includes the *ackRequested* IE set to TRUE, then the SS shall send an acknowledgment in the LPP PROVIDE ASSISTANCE DATA message.
8. The SS shall send a LPP REQUEST LOCATION INFORMATION message, including the *OTDOA-RequestLocationInformation* IE such that the UE receives the message ΔT ms before the start of the measurement period, where $\Delta T = 150$ ms.
9. The UE shall transmit a LPP PROVIDE LOCATION INFORMATION message, including the *OTDOA-ProvideLocationInformation* IE.
10. If the UE message at step 9 includes the *ackRequested* IE set to TRUE, the SS shall send a LPP acknowledgement message.
11. The SS shall check the *rstd* values for Cell 1, Cell 2 and Cell 4 in the *OTDOA-SignalMeasurementInformation* IE according to Table 10.7.5-2.
12. Repeat step 5-11 until the confidence level according to Annex D is achieved. For each iteration, at step 7 change the random positions of Cell 1 and Cell 2 and Cell 4 in the relevant sequence in the *OTDOA-NeighbourCellInfoList*.
13. Repeat complete test for the other channel bandwidth(s) supported by the UE (if any).

10.7.4.3 Message contents

Table 10.7.4.3-1: RESET UE POSITIONING STORED INFORMATION

Derivation Path: 36.509 [11] clause 6.9			
Information Element	Value/remark	Comment	Condition
UE Positioning Technology	0 0 0 0 0 0 1	OTDOA	

Table 10.7.4.3-1a: LPP Request Capabilities

Information Element	Value/remark
<i>otdoa-RequestCapabilities</i>	TRUE

Table 10.7.4.3-2: LPP RequestLocationInformation

Derivation Path: 36.355 clause 6.2			
Information Element	Value/remark	Comment	Condition
LPP-Message ::= SEQUENCE {			
transactionID SEQUENCE {			
Initiator	locationServer		
transactionNumber	1		
}			
endTransaction	FALSE		
sequenceNumber	Not present		
acknowledgement	Not present		
lpp-MessageBody CHOICE {			
c1 CHOICE {			
requestLocationInformation SEQUENCE {			
criticalExtensions CHOICE {			
c1 CHOICE {			
requestLocationInformation-r9 SEQUENCE {			
commonIEsRequestLocationInformation SEQUENCE {			
locationInformationType	locationMeasurementsRequired		
triggeredReporting	Not present		
periodicalReporting	Not present		
additionalInformation	onlyReturnInformationRequested		
qos SEQUENCE {			
horizontalAccuracy	Not present		
verticalCoordinateRequest	FALSE		
verticalAccuracy	Not present		
responseTime SEQUENCE {			
time	6	See Note 4 of Table 10.7.4.1-1	
responseTimeEarlyFix-r12	Not present		Rel-12 onwards
}			
velocityRequest	FALSE		
}			
environment	Not present		
locationCoordinateTypes	Not present		
velocityTypes	Not present		
}			
a-gnss-RequestLocationInformation	Not present		
otdoa-RequestLocationInformation SEQUENCE {			
assistanceAvailability	FALSE		
}			
ecid-RequestLocationInformation	Not present		
epdu-RequestLocationInformation	Not Present		
}			
}			
}			
}			
}			
}			

Table 10.7.4.3-3: LPP ProvideAssistanceData

Derivation Path: 36.355 clause 6.2			
Information Element	Value/remark	Comment	Condition
LPP-Message ::= SEQUENCE {			
transactionID SEQUENCE {			
Initiator	locationServer		
transactionNumber	(0..255)		

}			
endTransaction	TRUE		
sequenceNumber	Not present		
acknowledgement	Not present		
lpp-MessageBody CHOICE {			
c1 CHOICE {			
provideAssistanceData SEQUENCE {			
criticalExtensions CHOICE {			
c1 CHOICE {			
provideAssistanceData-r9 SEQUENCE {			
commonIEsProvideAssistanceData	Not present		
a-gnss-ProvideAssistanceData	Not present		
otdoa-ProvideAssistanceData SEQUENCE {			
otdoa-ReferenceCellInfo	As defined in TS 37.571-5 [20], clause 7.3.2.		
otdoa-NeighbourCellInfo	As defined in TS 37.571-5 [20], clause 7.3.2.		
otdoa-Error	Not present		
}			
epdu-ProvideAssistanceData	Not present		
}			
}			
}			
}			
}			
}			
}			

Table 10.7.4.3-4: LPP ProvideLocation Information

Derivation Path: 36.355 clause 6.2			
Information Element	Value/remark	Comment	Condition
LPP-Message ::= SEQUENCE {			
transactionID SEQUENCE {			
Initiator	locationServer		
transactionNumber	1		
}			
endTransaction	TRUE		
sequenceNumber	(0..255)		
acknowledgement			
lpp-MessageBody CHOICE {			
c1 CHOICE {			
provideLocationInformation SEQUENCE {			
criticalExtensions CHOICE {			
c1 CHOICE {			
provideLocationInformation-r9 SEQUENCE {			
commonIEsProvideLocationInformation	Not present.		
a-gnss-ProvideLocationInformation	Not present		
otdoa-ProvideLocationInformation			
SEQUENCE {			
otdoaSignalMeasurementInformation			
SEQUENCE {			
systemFrameNumber			
physCellIdRef	Cell 3		
cellGlobalIdRef			
earfcnRef			
referenceQuality			
neighbourMeasurementList			
SEQUENCE{			
NeighbourMeasurementElement			
SEQUENCE {			
physCellIdNeighbour	Cell 1		
cellGlobalIdNeighbour			
earfcnNeighbour			

rstd	Set according to Table 10.7.5-2	With respect to Cell 3	
rstd-Quality			
}			
NeighbourMeasurementElement SEQUENCE {			
physCellIdNeighbour	Cell 2		
cellGlobalIdNeighbour			
earfcnNeighbour			
rstd	Set according to Table 10.7.5-2	With respect to Cell 3	
rstd-Quality			
}			
NeighbourMeasurementElement SEQUENCE {			
physCellIdNeighbour	Cell 4		
cellGlobalIdNeighbour			
earfcnNeighbour			
rstd	Set according to Table 10.7.5-2	With respect to Cell 3	
rstd-Quality			
}			
}			
}			
otdoa-Error	May be present with error reason 'undefined' or 'attemptedButUnableToMeasureSomeNeighbourCells'		
}			
ecid-ProvideLocationInformation	Not present		
epdu-ProvideLocationInformation	Not present		
}			
}			
}			
}			
}			
}			

10.7.5 Test requirement

Table 10.7.5-1 defines the primary level settings including test tolerances for the test.

The FDD RSTD accuracy test shall meet the reported values in Table 10.7.5-2.

Table 10.7.5-1: Cell Specific Test Parameters for RSTD Test for E-UTRAN FDD for Carrier Aggregation

Parameter	Unit	Cell 1	Cell 2	Cell 3	Cell 4
E-UTRA RF Channel Number		1	2	3	3
PBCH_RA	dB	0	0	0	0
PBCH_RB					
PSS_RA					
SSS_RA					
PCFICH_RB					
PHICH_RA					
PHICH_RB					
PDCCH_RA					
PDCCH_RB					
OCNG_RA ^{Note1}					
OCNG_RB ^{Note1}					
PRS_RA	dB	-3	0	0.3	0.3
N_{oc} ^{Note2}	dBm/15 kHz	-98			

PRS \hat{E}_s/N_{oc}	dB	-6	-6	-5.7	-12.7
PRS \hat{E}_s/I_{ot} ^{Note3}	dB	-6	-6	-5.7	-12.7
I_o ^{Note3}	dBm/9 MHz	-70.04 +10log ($N_{RB,c}/50$)	-70.04 +10log ($N_{RB,c}/50$)	-69.99 +10log ($N_{RB,c}/50$)	-69.99 +10log ($N_{RB,c}/50$)
PRP ^{Note3}	dBm/15kHz	-104	-104	-103.7	-110.7
RSRP ^{Note3}	dBm/15kHz	-101	-104	-104	-111
\hat{E}_s/N_{oc} ^{Note3}	dB	-3	-6	-6	-13
Propagation condition		AWGN			
Note 1:	OCNG shall be used such that all cells are fully allocated and a constant total transmitted power spectral density is achieved for all OFDM symbols (other than those in the PRS subframes).				
Note 2:	Interference from other cells and noise sources not specified in the test is assumed to be constant over subcarriers and time and shall be modelled as AWGN of appropriate power for N_{oc} to be fulfilled.				
Note 3:	\hat{E}_s/N_{oc} , PRS \hat{E}_s/I_{ot} , RSRP, I_o and PRP levels have been derived from other parameters for information purposes. They are not settable parameters themselves. I_o values are derived in the case that there is no PBCH, PSS or SSS in the OFDM symbols carrying PRS.				

Table 10.7.5-2: RSTD FDD accuracy requirements for the reported values for Carrier Aggregation

	Value Cell 1	Value Cell 2	Value Cell 4
Lowest reported value (depends on selected channel bandwidth)	5MHz: RSTD_6374 10MHz: RSTD_6375 20MHz: RSTD_6376	5MHz: RSTD_6313 10MHz: RSTD_6314 20MHz: RSTD_6315	5MHz: RSTD_6440 10MHz: RSTD_6441 20MHz: RSTD_6442
Highest reported value (depends on selected channel bandwidth)	5MHz: RSTD_6398 10MHz: RSTD_6397 20MHz: RSTD_6396	5MHz: RSTD_6337 10MHz: RSTD_6336 20MHz: RSTD_6335	5MHz: RSTD_6454 10MHz: RSTD_6453 20MHz: RSTD_6452

For the test to pass, the ratio of successful reported values shall be more than 90% with a confidence level of 95% for each of Cell 1, Cell 2 and Cell 4 for each supported channel bandwidth.

10.8 TDD RSTD Measurement Accuracy for 3DL Carrier Aggregation

10.8.1 Test purpose

To verify that the TDD RSTD measurement accuracy is within the specified limits.

10.8.2 Test applicability

This test applies to all types of E-UTRA TDD UE release 12 and forward that supports UE-assisted OTDOA for 3DL Carrier Aggregation.

10.8.3 Minimum conformance requirements

This section contains RSTD measurement accuracy requirements for a UE configured with one or two downlink SCell(s). The UE may operate in one of the E-UTRA carrier aggregations listed in TS 36.133 [23] section 8.3.1. The requirements in this section shall apply regardless of whether the configured downlink secondary cell is activated or deactivated by the MAC-CE command [34]. The requirements apply for bandwidths defined in the bandwidth combination set for the CA configurations supported by the UE defined in TS 36.101 [2].

The RSTD measurements, which are obtained when both the reference cell and neighbouring cell belong to the primary component carrier, shall meet the intra-frequency RSTD accuracy requirements defined in TS 36.133 [23] section 9.1.10.1.

The RSTD measurements, which are obtained when both the reference cell and neighbouring cell belong to the same secondary component carrier, shall meet the intra-frequency RSTD accuracy requirements defined in TS 36.133 [23] section 9.1.10.1.

The RSTD measurements, which are obtained when the reference cell and neighbouring cell do not belong to the same carrier, shall meet the inter-frequency RSTD accuracy requirements defined in TS 36.133 [23] section 9.1.10.2.

The normative reference for this requirement is TS 36.133 [23] clause 9.1.12 and A.9.8.15.

10.8.4 Test description

10.8.4.1 Initial conditions

Test Environment: Normal; as defined in TS 36.508 [18] clause 4.1.

Frequencies to be tested: Mid Range, as defined in TS 36.508 [18] clause 4.3.1.1.

Channel bandwidths to be tested: the largest and the smallest aggregated bandwidth combinations supported by the UE of the Channel bandwidths defined in Table 10.8.4.1-1. The Channel bandwidths for CA Intra-Band combinations are as defined in TS 36.508 [18] clause 4.3.1 and for CA Inter-Band combinations are defined in TS 36.521-1 [24] clause 5.4.2A. In case of multiple possible Channel bandwidth combinations, the first combination listed in the above mentioned clauses shall be selected.

1. Connect the SS (node B emulator) and AWGN noise sources to the UE antenna connectors as follows:
 - For UEs supporting only 2Rx in all the bands under test, use TS 36.508 [18] Annex A, Figure group A.68 as appropriate.
 - For UEs supporting 4Rx in any of the bands under test use TS 36.508 [18] Annex A, Figure A.90. Use the 2Rx module for cells on bands supporting 2Rx and the 4Rx module for cells on bands supporting 4Rx.
2. The general test parameter settings are set up according to Table 10.8.4.1-1.
3. Propagation conditions are set according to clause 4.7.2.1.
4. Message contents are defined in clause 10.8.4.3.
5. There are four synchronized cells on three different carrier frequencies. Cell 1 is the PCell on primary component carrier F1 (RF channel number 1), Cell 2 is an SCell on secondary component carrier F2 (RF channel number 2), Cell 3 is an SCell and reference cell on secondary component carrier F3 (RF channel number 3), and Cell 4 is the neighbour cell on F3. PCell (Cell 1) is the cell used for connection setup with the power level and mapping set according to TS 36.521-1 [24] Annex C.0 and C.1 as appropriate for this test. Cell 2, Cell 3 and Cell 4 are powered OFF.

Cell 1, Cell 2, Cell 3, and Cell 4 are included in the OTDOA assistance data neighbour cell list.

The assistance data neighbour cell list includes in total 15 cells, where 12 of the cells are not simulated (dummy cells; as defined in 3GPP TS 37.571-5 [20], clause 7.3.2).

Note that the measurement gap is not configured in the test because of UE carrier aggregation capability.

6. The true RSTD (which is the receive time difference for frame 0 between the two cells as seen at the UE antenna connector) is set to 31 Ts (about 1 μ s) between Cell 1 and OTDOA assistance data reference cell, Cell 3, and set to -31 Ts (about -1 μ s) between Cell 2 and OTDOA assistance data reference cell, Cell 3, and set to 92 Ts (about 3 μ s) between neighbour Cell 4 and OTDOA assistance data reference cell, Cell 3.

Note that the related expected RSTD values to be signalled over LPP are defined in Table 10.8.4.1-1.

Table 10.8.4.1-1: General Test Parameters for RSTD Test for E-UTRAN TDD for Carrier Aggregation

Parameter	Unit	Value	Comment
PCell		Cell 1	Cell 1 on RF channel number 1
SCell 1		Cell 2	Cell 2 is an SCell on RF channel number 2
SCell 2 (Assistance data reference cell)		Cell 3	Cell 3 is an SCell on RF channel number 3

Neighbour cell		Cell 4	Cell 4 on RF channel number 3
Channel Bandwidth (BW_{channel})	MHz	5,10,20	
PRS Transmission Bandwidth (PRS transmission bandwidth depends on selected channel bandwidth) ^{Note 2}	RB	5MHz: 25 10MHz: 50 20MHz: 100	PRS are transmitted over the system bandwidth. PRS Bandwidth: bandwidth is as indicated in <i>prs-Bandwidth</i> in the OTDOA assistance data defined in 3GPP TS 36.355 [4].
PCFICH/PDCCH/PHICH parameters (PCFICH/PDCCH/PHICH parameters depend on selected channel bandwidth)		5MHz: R.11 TDD 10MHz: R.6 TDD 20MHz: R.10 TDD	As specified in TS 36.521-3 [25] clause A.2.1
OCNG Patterns defined in TS 36.521-3 [25] clause D.1 (There is no PDSCH allocated in the subframe transmitting PRS) (OCNG Patterns depend on selected channel bandwidth)		5MHz: OP.10 TDD 10MHz: OP.2 TDD 20MHz: OP.8 TDD	OCNG shall be used such that all cells are fully allocated and a constant total transmitted power spectral density is achieved for all OFDM symbols (other than those in the PRS subframes).
PRS configuration Index I_{PRS} ^{Note 2}		171 for all cells on PCC 181 for all cells on SCC1 191 for all cells on SCC2	This corresponds to periodicity of 320 ms and PRS subframe offset of $I_{\text{PRS}} - 160$ DL subframes, as defined in TS 36.211 [26], Table 6.10.4.3-1
Number of consecutive positioning downlink subframes N_{PRS} (N_{PRS} depends on selected channel bandwidth) ^{Note 2}		5MHz: 2 10MHz: 1 20MHz: 1	As defined in 3GPP TS 36.211 [26]
prs-SubframeOffset ^{Note 2}		Cells on PCC: 300 Cells on SCC1: 310 Cells on SCC2, except reference cell: 0	Subframe offset, counted in full subframes. The corresponding parameter in the OTDOA assistance data is prs-SubframeOffset specified in TS 36.355 [4]
slotNumberOffset ^{Note 2}		Cells on PCC: 0 Cells on SCC1: 0 Cells on SCC2, except reference cell: 0	The slot number offset at the transmitter between a neighbour cell and the assistance data reference cell. The corresponding parameter in the OTDOA assistance data is slotNumberOffset specified in TS 36.355 [4].
prs-MutingInfo ^{Note 2}		Cell 1: '11110000' Cell 2: '11110000' Cell 3: '11110000' Cell 4: '11110000'	See section 6.5.1.2 in 3GPP TS 36.355 [4] for more information
Special subframe configuration		6	As specified in table 4.2-1 in TS 36.211 [26]. The same configuration in both cells.
Uplink-downlink configuration		1	As specified in table 4.2-2 in TS 36.211 [26] and table 8.1.2.5.2-2 in TS 36.133 [23]. The same configuration in both cells.
Cell ID ^{Note 2}		(Cell ID of cell 4 – Cell ID of cell 3) mod 6 = 3	PCIs of cell 1 and cell 2 are selected randomly.
Radio frame receive time offset between the cells at the UE antenna connector ^{Note 3}	μs	Cell 1 to Cell 3: 1 Cell 2 to Cell 3: -1 Cell 4 to Cell 3: 3	PRS are transmitted from synchronous cells
Expected RSTD ^{Note 1}	μs	Cell 1: -2 Cell 2: 0 Cell 4: 2 Other neighbour cells: randomly between -3 and 3	The expected RSTD is what is expected at the receiver. The corresponding parameter in the OTDOA assistance data specified in TS 36.355 [4] is the expectedRSTD indicator

Expected RSTD uncertainty for all neighbour cells ^{Note 1}	μs	5	The corresponding parameter in the OTDOA assistance data specified in TS 36.355 [4] is the expectedRSTD-Uncertainty index
CP length ^{Note 2}		Normal	
DRX		OFF	
Number of cells provided in OTDOA assistance data		16	The list includes the assistance-data-reference cell and 15 other cells. Cell 1 and Cell 2 appear at random places in the first half of the neighbour cell list in the OTDOA assistance data. Cell 4 always appears at random places in the second half of the list.
$T_{\text{RSTDInterFreqTDD,E-UTRAN}}$ ^{Note 4}	ms	4960	Derived according to the RSTD measurement requirements specified in Section 10.6.3
<p>NOTE 1: Parameters “Expected RSTD” and “Expected RSTD uncertainty for all neighbour cells” are not settable parameters. These are parameters signalled in LPP only. For the values to be used in LPP see Table 10.8.4.3-3 and TS 37.571-5 [20], clause 7.3.2.</p> <p>NOTE 2: Parameters “PRS Transmission Bandwidth”, “PRS configuration index”, “Number of consecutive positioning downlink subframes”, “prs-SubframeOffset”, “slotNumberOffset”, “prs-MutingInfo”, “Cell ID” and “CP length” are settable parameters and also parameters signalled in LPP. The values to be used for “Cell ID” are as follows: Cell 1: 0, Cell 2: 3, Cell 3: 7, Cell 4: 10. For the values to be used in LPP see Table 10.8.4.3-3 and TS 37.571-5 [20], clause 7.3.2.</p> <p>NOTE 3: The parameter “Radio frame receive time offset between the cells at the UE antenna connector” is used to set the “true RSTD” value in step 6 of clause 10.8.4.1.</p> <p>NOTE 4: The parameter “$T_{\text{RSTD InterFreqTDD,E-UTRAN}}$” is not a settable parameter but is used to set the LPP “time” value in Table 10.8.4.3-2. The value of the LPP time IE is set to $T_{\text{RSTDInterFreqTDD,E-UTRAN}} + \Delta T$ ms, where $\Delta T = 150$ ms, giving a value of 5110 ms. This is rounded up to the next allowed LPP value of 6 seconds.</p>			

10.8.4.2 Test procedure

The RSTD measurements are performed:

- between Cell 4 and Cell 3 to verify the accuracy of RSTD measurement when the reference cell and neighbouring cell belong to the same secondary component carrier can meet the intra-frequency RSTD accuracy requirements defined in section 10.8.3.
- between Cell 1 and Cell 3 to verify the accuracy of RSTD measurement between the PCell and an SCell can meet the inter-frequency RSTD accuracy requirements defined in section 10.8.3.
- between Cell 2 and Cell 3 to verify the accuracy of RSTD measurement between two SCells can meet the inter-frequency RSTD accuracy requirements defined in section 10.8.3.

The test consists of a set-up period and a measurement period. All cells are active during the complete test. The beginning of the measurement period shall be aligned with the first PRS positioning subframe of a positioning occasion in the reference cell.

NOTE: The information on when PRS is muted is conveyed to the UE using PRS muting information in the OTDOA assistance data.

The OTDOA-RequestLocationInformation message and the OTDOA assistance data as defined in clause 10.8.4.3 shall be provided to the UE during the set-up period. The last TTI containing the OTDOA-RequestLocationInformation message shall be provided to the UE ΔT ms before the start of the measurement period, where $\Delta T = 150$ ms is the maximum processing time of the OTDOA-RequestLocationInformation message and the OTDOA assistance data in the UE.

1. Ensure that the UE is in state Generic RB Established State 3A-RF according to 3GPP TS 36.508 [18] clause 7.2A.3.
2. Configure Cell 2 on SCC1 and Cell 3 and Cell 4 on SCC2 according to TS 36.521-3 [25] Annex C.0 and C.1 for all downlink physical channels.
3. The SS shall configure the SCells (Cell 2 and Cell 3) on the SCCs as per TS 36.508 [18] clause 5.2A.4.

4. The SS activates the SCells (Cell 2 and Cell 3) by sending the Activation/Deactivation MAC control element according to TS 36.321 [34] clauses 5.13 and 6.1.3.8. Wait for at least 2 seconds as per TS 36.133 [23] clause 8.3.3.2.
5. The SS shall send a RESET UE POSITIONING STORED INFORMATION message.
6. Set the parameters according to Table 10.8.5-1 as appropriate. Propagation conditions are set according to clause 4.7.2.1.
- 6a. The SS shall send an LPP REQUEST CAPABILITIES message.
- 6b. The UE shall send an LPP PROVIDE CAPABILITIES message indicating the OTDOA capabilities supported by the UE in the *OTDOA-ProvideCapabilities* IE
7. The SS shall send a LPP PROVIDE ASSISTANCE DATA message, including the *OTDOA-ProvideAssistanceData* IE. The position of Cell 1 in the *OTDOA-NeighbourCellInfoList* and the position of Cell 2 are randomly selected in the relevant sequence and the position of Cell 4 is randomly selected in the relevant sequence as described in 3GPP TS 37.571-5 [20], clause 7.3.2. If the UE message at step 6b includes the *ackRequested* IE set to TRUE, then the SS shall send an acknowledgment in the LPP PROVIDE ASSISTANCE DATA message.
8. The SS shall send a LPP REQUEST LOCATION INFORMATION message, including the *OTDOA-RequestLocationInformation* IE such that the UE receives the message ΔT ms before the start of the measurement period, where $\Delta T = 150$ ms.
9. The UE shall transmit a LPP PROVIDE LOCATION INFORMATION message, including the *OTDOA-ProvideLocationInformation* IE.
10. If the UE message at step 9 includes the *ackRequested* IE set to TRUE, the SS shall send a LPP acknowledgement message.
11. The SS shall check the *rstd* values for Cell 1, Cell 2 and Cell 4 in the *OTDOA-SignalMeasurementInformation* IE according to Table 10.8.5-2.
12. Repeat step 5-11 until the confidence level according to Annex D is achieved. For each iteration, at step 7 change the random positions of Cell 1 and Cell 2 and Cell 4 in the relevant sequence in the *OTDOA-NeighbourCellInfoList*.
13. Repeat complete test for the other channel bandwidth(s) supported by the UE (if any).

10.8.4.3 Message contents

Table 10.8.4.3-1: RESET UE POSITIONING STORED INFORMATION

Derivation Path: 36.509 [11] clause 6.9			
Information Element	Value/remark	Comment	Condition
UE Positioning Technology	0 0 0 0 0 0 1	OTDOA	

Table 10.8.4.3-1a: LPP Request Capabilities

Information Element	Value/remark
<i>otdoa-RequestCapabilities</i>	TRUE

Table 10.8.4.3-2: LPP RequestLocationInformation

Derivation Path: 36.355 clause 6.2			
Information Element	Value/remark	Comment	Condition
LPP-Message ::= SEQUENCE {			
transactionID SEQUENCE {			
Initiator	locationServer		
transactionNumber	1		
}			
endTransaction	FALSE		

sequenceNumber	Not present		
acknowledgement	Not present		
lpp-MessageBody CHOICE {			
c1 CHOICE {			
requestLocationInformation SEQUENCE {			
criticalExtensions CHOICE {			
c1 CHOICE {			
requestLocationInformation-r9 SEQUENCE {			
commonEsRequestLocationInformation SEQUENCE {			
locationInformationType	locationMeasurementsRequired		
triggeredReporting	Not present		
periodicalReporting	Not present		
additionalInformation	onlyReturnInformationRequested		
qos SEQUENCE {			
horizontalAccuracy	Not present		
verticalCoordinateRequest	FALSE		
verticalAccuracy	Not present		
responseTime SEQUENCE {			
time	6	See Note 4 of Table 10.8.4.1-1	
responseTimeEarlyFix-r12	Not present		Rel-12 onwards
}			
velocityRequest	FALSE		
}			
environment	Not present		
locationCoordinateTypes	Not present		
velocityTypes	Not present		
}			
a-gnss-RequestLocationInformation	Not present		
otdoa-RequestLocationInformation SEQUENCE {			
assistanceAvailability	FALSE		
}			
ecid-RequestLocationInformation	Not present		
epdu-RequestLocationInformation	Not Present		
}			
}			
}			
}			
}			
}			
}			
}			
}			
}			

Table 10.8.4.3-3: LPP ProvideAssistanceData

Derivation Path: 36.355 clause 6.2			
Information Element	Value/remark	Comment	Condition
LPP-Message ::= SEQUENCE {			
transactionID SEQUENCE {			
Initiator	locationServer		
transactionNumber	(0..255)		
}			
endTransaction	TRUE		
sequenceNumber	Not present		
acknowledgement	Not present		
lpp-MessageBody CHOICE {			
c1 CHOICE {			
provideAssistanceData SEQUENCE {			
criticalExtensions CHOICE {			
c1 CHOICE {			

provideAssistanceData-r9 SEQUENCE {			
commonIEsProvideAssistanceData	Not present		
a-gnss-ProvideAssistanceData	Not present		
otdoa-ProvideAssistanceData SEQUENCE {			
otdoa-ReferenceCellInfo	As defined in TS 37.571-5 [20], clause 7.3.2.		
otdoa-NeighbourCellInfo	As defined in TS 37.571-5 [20], clause 7.3.2.		
otdoa-Error	Not present		
}			
epdu-ProvideAssistanceData	Not present		
}			
}			
}			
}			
}			
}			
}			
}			
}			
}			
}			

Table 10.8.4.3-4: LPP ProvideLocation Information

Derivation Path: 36.355 clause 6.2			
Information Element	Value/remark	Comment	Condition
LPP-Message ::= SEQUENCE {			
transactionID SEQUENCE {			
Initiator	locationServer		
transactionNumber	1		
}			
endTransaction	TRUE		
sequenceNumber	(0..255)		
acknowledgement			
lpp-MessageBody CHOICE {			
c1 CHOICE {			
provideLocationInformation SEQUENCE {			
criticalExtensions CHOICE {			
c1 CHOICE {			
provideLocationInformation-r9 SEQUENCE {			
commonIEsProvideLocationInformation	Not present.		
a-gnss-ProvideLocationInformation	Not present		
otdoa-ProvideLocationInformation SEQUENCE {			
otdoaSignalMeasurementInformation SEQUENCE {			
systemFrameNumber			
physCellIdRef	Cell 3		
cellGlobalIdRef			
earfcnRef			
referenceQuality			
neighbourMeasurementList SEQUENCE{			
NeighbourMeasurementElement SEQUENCE {			
physCellIdNeighbour	Cell 1		
cellGlobalIdNeighbour			
earfcnNeighbour			
rstd	Set according to Table 10.8.5-2	With respect to Cell 3	
rstd-Quality			
}			
NeighbourMeasurementElement SEQUENCE {			
physCellIdNeighbour	Cell 2		
cellGlobalIdNeighbour			
earfcnNeighbour			

rstd	Set according to Table 10.8.5-2	With respect to Cell 3	
rstd-Quality			
} NeighbourMeasurementElement SEQUENCE {			
physCellIdNeighbour	Cell 4		
cellGlobalIdNeighbour			
earfcnNeighbour			
rstd	Set according to Table 10.8.5-2	With respect to Cell 3	
rstd-Quality			
}			
}			
otdoa-Error	May be present with error reason 'undefined' or 'attemptedButUnableToMeasureSomeNeighbourCells'		
}			
ecid-ProvideLocationInformation	Not present		
epdu-ProvideLocationInformation	Not present		
}			
}			
}			
}			
}			
}			

10.8.5 Test requirement

Table 10.8.5-1 defines the primary level settings including test tolerances for the test.

The TDD RSTD accuracy test shall meet the reported values in Table 10.8.5-2.

Table 10.8.5-1: Cell Specific Test Parameters for RSTD Test for E-UTRAN TDD for Carrier Aggregation

Parameter	Unit	Cell 1	Cell 2	Cell 3	Cell 4
E-UTRA RF Channel Number		1	2	3	3
PBCH_RA	dB	0	0	0	0
PBCH_RB					
PSS_RA					
SSS_RA					
PCFICH_RB					
PHICH_RA					
PHICH_RB					
PDCCH_RA					
PDCCH_RB					
OCNG_RA ^{Note1}					
OCNG_RB ^{Note1}					
PRS_RA	dB	-3	0	0.3	0.3
N_{oc} ^{Note2}	dBm/15 kHz	-98			
$PRS \hat{E}_s / N_{oc}$	dB	-6	-6	-5.7	-12.7
$PRS \hat{E}_s / I_{ot}$ ^{Note3}	dB	-6	-6	-5.7	-12.7
I_o ^{Note3}	dBm/9 MHz	-70.04 +10log ($N_{RB,c}/50$)	-70.04 +10log ($N_{RB,c}/50$)	-69.99 +10log ($N_{RB,c}/50$)	-69.99 +10log ($N_{RB,c}/50$)
PRP ^{Note3}	dBm/15kHz	-104	-104	-103.7	-110.7
RSRP ^{Note3}	dBm/15kHz	-101	-104	-104	-111

\hat{E}_s / N_{oc} ^{Note3}	dB	-3	-6	-6	-13
Propagation condition	AWGN				
Note 1:	OCNG shall be used such that all cells are fully allocated and a constant total transmitted power spectral density is achieved for all OFDM symbols (other than those in the PRS subframes).				
Note 2:	Interference from other cells and noise sources not specified in the test is assumed to be constant over subcarriers and time and shall be modelled as AWGN of appropriate power for N_{oc} to be fulfilled.				
Note 3:	\hat{E}_s / N_{oc} , PRS \hat{E}_s / I_{ot} , RSRP, I_o and PRP levels have been derived from other parameters for information purposes. They are not settable parameters themselves. I_o values are derived in the case that there is no PBCH, PSS or SSS in the OFDM symbols carrying PRS.				

Table 10.8.5-2: RSTD TDD accuracy requirements for the reported values for Carrier Aggregation

	Value Cell 1	Value Cell 2	Value Cell 4
Lowest reported value (depends on selected channel bandwidth)	5MHz: RSTD_6374 10MHz: RSTD_6375 20MHz: RSTD_6376	5MHz: RSTD_6313 10MHz: RSTD_6314 20MHz: RSTD_6315	5MHz: RSTD_6440 10MHz: RSTD_6441 20MHz: RSTD_6442
Highest reported value (depends on selected channel bandwidth)	5MHz: RSTD_6398 10MHz: RSTD_6397 20MHz: RSTD_6396	5MHz: RSTD_6337 10MHz: RSTD_6336 20MHz: RSTD_6335	5MHz: RSTD_6454 10MHz: RSTD_6453 20MHz: RSTD_6452

For the test to pass, the ratio of successful reported values shall be more than 90% with a confidence level of 95% for each of Cell 1, Cell 2 and Cell 4 for each supported channel bandwidth.

11 E-UTRA and NR MBS measurement requirements

11.0 General

This clause defines the minimum performance requirements for MBS FDD and TDD E-UTRA UEs, and NR UEs.

The requirements in this clause that apply for NR UE include NG-RAN NR, EN-DC, NE-DC, NG-RAN E-UTRA and NGEN-DC.

Editor's Note: For NR tests, the initial test conditions apply for NR UE in FR1. For FR2, initial test conditions are FFS.

11.1 MBS Measurement Reporting Delay (Release 13 only)

11.1.1 Test purpose

The purpose of the test is to verify that the MBS measurements meet the measurement time requirements specified in clause 4.2.3 of TS 37.171 [39] in an environment with fading propagation conditions specified in clause 4.8.2.2 (EPA 5 Hz).

11.1.2 Test applicability

This test applies to all types of E-UTRA UE that supports UE-assisted MBS with LPP Release 13 only.

11.1.3 Minimum conformance requirements

The MBS measurement reporting delay (response time) shall be ≤ 12000 msec.

The normative reference for this requirement is TS 37.171 [39] clauses 4.2.3 and A.3.1.

11.1.4 Test description

11.1.4.1 Initial conditions

Test environment: normal; see Annex G.

1. Connect SS and MSS to the UE antenna connector or antenna connectors as shown in figures A.6 or A.7.
2. Switch on the UE.
3. Establish a signalling connection according to the generic procedure in TS 36.508 [18] clause 4.5.3 (State 3, Generic RB established) on a channel in the Mid EARFCN range.

11.1.4.2 Test procedure

1. Set the MSS test parameters as specified in clause 11.1.5.
2. The SS shall send a RESET UE POSITIONING STORED INFORMATION message.
3. The SS shall send an LPP REQUEST CAPABILITIES message.
4. The UE shall transmit an LPP PROVIDE CAPABILITIES message indicating the TBS capabilities supported by the UE in the *TBS-ProvideCapabilities* IE.
5. The SS shall send a LPP REQUEST LOCATION INFORMATION message, including the *TBS-RequestLocationInformation* IE. If the UE message at step 4 includes the *ackRequested* IE set to TRUE, then the SS shall send an acknowledgment in the LPP REQUEST LOCATION INFORMATION message.
6. The UE shall perform and report the code phase measurement for the simulated beacon. If the UE transmits a *TBS-ProvideLocationInformation* IE including the *transmitterID* and *codePhase* fields for the simulated beacon within the required response time in 11.1.5, then the number of successful tests is increased by one. Otherwise the number of failure tests is increased by one.
7. If the UE message at step 6 includes the *ackRequested* IE set to TRUE, the SS shall send a LPP acknowledgement message.
8. Repeat steps 1-7 until the confidence level according to Annex D is achieved. For each iteration, at step 1 reselect the PN code assigned to the MBS beacon.
9. Release the signalling connection.

11.1.4.3 Message contents

Table 11.1.4.3-1: RESET UE POSITIONING STORED INFORMATION

Derivation Path: TS 36.509 [11] clause 6.9			
Information Element	Value/remark	Comment	Condition
UE Positioning Technology	0 0 0 0 0 1 0	MBS	

Table 11.1.4.3-2: LPP RequestCapabilities

Information Element	Value/remark
<i>tbs-RequestCapabilities-r13</i>	TRUE

Table 11.1.4.3-3: LPP RequestLocationInformation

Derivation Path: TS 36.355 [4] clause 6.2			
Information Element	Value/remark	Comment	Condition
LPP-Message ::= SEQUENCE {			
transactionID SEQUENCE {			
Initiator	locationServer		
transactionNumber	1		

}			
endTransaction	FALSE		
sequenceNumber	Not present		
acknowledgement	Not present		
lpp-MessageBody CHOICE {			
c1 CHOICE {			
requestLocationInformation SEQUENCE {			
criticalExtensions CHOICE {			
c1 CHOICE {			
requestLocationInformation-r9 SEQUENCE {			
commonIEsRequestLocationInformation SEQUENCE {			
locationInformationType	locationMeasurementsRequired		
triggeredReporting	Not present		
periodicalReporting	Not present		
additionalInformation	onlyReturnInformationRequested		
qos SEQUENCE {			
horizontalAccuracy	Not present		
verticalCoordinateRequest	FALSE		
verticalAccuracy	Not present		
responseTime SEQUENCE {			
Time	12		
responseTimeEarlyFix-r12	Not present		
}			
velocityRequest	FALSE		
}			
Environment	Not present		
locationCoordinateTypes	Not present		
velocityTypes	Not present		
}			
a-gnss-RequestLocationInformation	Not present		
otdoa-RequestLocationInformation	Not present		
ecid-RequestLocationInformation	Not present		
epdu-RequestLocationInformation	Not present		
sensor-RequestLocationInformation-r13	Not present		
tbs-RequestLocationInformation-r13 SEQUENCE {			
mbsSgnMeasListReq-r13	TRUE		
}			
wlan-RequestLocationInformation-r13	Not present		
bt-RequestLocationInformation-r13	Not Present		
}			
}			
}			
}			
}			
}			
}			
}			

Table 11.1.4.3-4: LPP ProvideLocationInformation

Derivation Path: TS 36.355 [4] clause 6.2			
Information Element	Value/remark	Comment	Condition
LPP-Message ::= SEQUENCE {			
transactionID SEQUENCE {			
Initiator	locationServer		
transactionNumber	1		
}			
endTransaction	TRUE		
sequenceNumber	(0..255)		
Acknowledgement			
lpp-MessageBody CHOICE {			

c1 CHOICE {			
provideLocationInformation SEQUENCE {			
criticalExtensions CHOICE {			
c1 CHOICE {			
provideLocationInformation-r9 SEQUENCE {			
commonIEsProvideLocationInformation	Not present.		
a-gnss-ProvideLocationInformation	Not present		
otdoa-ProvideLocationInformation	Not present		
ecid-ProvideLocationInformation	Not present		
epdu-ProvideLocationInformation	Not present		
sensor-ProvideLocationInformation-r13	Not present		
tbs-ProvideLocationInformation-r13			
SEQUENCE {			
tbs-MeasurementInformation-r13			
SEQUENCE {			
measurementReferenceTime-r13			
mbs-SgnMeasList-r13			
SEQUENCE (SIZE(n)) {			
transmitterID-r13	Present		
codePhase-r13	Present		
codePhaseRMSError-r13			
}			
}			
tbs-Error-r13	May be present with error reason 'undefined' or 'thereWereNotEnoughMBSBeaconsReceived'		
}			
wlan-ProvideLocationInformation-r13	Not present		
bt-ProvideLocationInformation-r13	Not present		
}			
}			
}			

11.1.5 Test requirement

The details of the beacon parameters are in Table 11.1.5-1 and Table 11.1.5-2.

Table 11.1.5-1: General test parameters for the beacon to be simulated for the measurement reporting delay test

Parameter	Unit	Value	Comment
Number of beacons	Integer	1	Beacon transmitted in any beacon slot, but static for the test, in the MBS beacon transmission period. Other slots contain no simulated beacons ^{Note 1}
Centre Frequency	MHz	925.977	
RF Channel	N/A	EPA 5Hz	
MBS Beacon Configuration	N/A	TB1 (2 MHz)	For details see Annex H
MBS Packet Type	N/A	Type 2	For details see Annex H
Beacon PN Code	Integer	Chosen for the beacon from the PN code list for TB1	For details see Annex H ^{Note 1}
Transmit power	dBm	-30	
Response time	Seconds	12	Value of Time used in LPP RequestLocationInformation message in Table 11.1.4.3-3
Note 1: The slots and PN codes are chosen at random, such that the UE does not and cannot have advanced knowledge of what that slot/PN code might be.			

Table 11.1.5-2: MBS Beacon Payload fields for the beacon to be simulated for the measurement reporting delay test

MBS Tx ID (see Annex H)	Slot Index (see Annex H)	All Other fields (see Annex H)
Equal to Slot number	Equal to Slot number	min value (bit_value = 0) ^{Note 1}
Note 1: bit_value is the conversion of the binary number represented by the corresponding bits in the payload to decimal.		

The MBS measurement reporting delay (response time) shall be ≤ 12300 msec.

The test tolerances are defined in clauses C.1.4 and C.4.

The rate of successful tests during repeated tests shall be at least 90% with a confidence level of 95%.

11.1A MBS Measurement Reporting Delay (Release 14 Onwards)

11.1A.1 Test purpose

Same as defined in clause 11.1.1

11.1A.2 Test applicability

This test applies to all types of E-UTRA UE that supports UE-assisted MBS with LPP Release 14 onwards.

11.1A.3 Minimum conformance requirements

Same as defined in clause 11.1.3

11.1A.4 Test description

11.1A.4.1 Initial conditions

Same as defined in clause 11.1.4.1

11.1A.4.2 Test procedure

Same as defined in clause 11.1.4.2, except step 4a is introduced and step 5 is modified as follows:

- 4a. The SS shall send an LPP PROVIDE ASSISTANCE DATA message to provide the MBS assistance data in accordance with TS 37.571-5 [20], and with the values defined therein. If the UE message at step 4 includes the *ackRequested* IE set to TRUE, then the SS shall send an acknowledgment in the LPP PROVIDE ASSISTANCE DATA message.
5. The SS shall send a LPP REQUEST LOCATION INFORMATION message, including the *TBS-RequestLocationInformation* IE.

11.1A.4.3 Message contents

Same as defined in clause 11.1.4.3, with the addition of the LPP Provide Assistance Data.

Table 11.1A.4.3-5: LPP ProvideAssistanceData

Derivation Path: TS 36.355 [4] clause 6.2			
Information Element	Value/remark	Comment	Condition

LPP-Message ::= SEQUENCE {			
transactionID SEQUENCE {			
Initiator	locationServer		
transactionNumber	(0..255)		
}			
endTransaction	TRUE		
sequenceNumber	Not present		
acknowledgement			
lpp-MessageBody CHOICE {			
c1 CHOICE {			
provideAssistanceData SEQUENCE {			
criticalExtensions CHOICE {			
c1 CHOICE {			
provideAssistanceData-r9 SEQUENCE {			
commonEsProvideAssistanceData	Not present		
a-gnss-ProvideAssistanceData	Not present		
otdoa-ProvideAssistanceData	Not present		
epdu-ProvideAssistanceData	Not present		
sensor-ProvideAssistanceData-r14	Not present		Rel-14 onwards
tbs-ProvideAssistanceData-r14 SEQUENCE {			Rel-14 onwards
tbs-AssistanceDataList-r14 SEQUENCE {			
mbs-AssistanceDataList-r14 SEQUENCE {			
mbs-AssistanceDataElement-r14 SEQUENCE {		Beacon 1 tb1	
mbs-AlmanacAssistance-r14	Not Present		
mbs-AcquisitionAssistance-r14	As defined in TS 37.571-5 [20], clause 8		
}			
mbs-AssistanceDataElement-r14 SEQUENCE {		Beacon 1 tb2	
mbs-AlmanacAssistance-r14	Not Present		
mbs-AcquisitionAssistance-r14	As defined in TS 37.571-5 [20], clause 8		
}			
}			
}			
tbs-Error-r14	Not Present		
}			
wlan-ProvideAssistanceData-r14	Not Present		Rel-14 onwards
}			
}			
}			
}			
}			

11.1A.5 Test requirement

Same as defined in clause 11.1.5, with the beacon parameters set according to the assistance data in TS 37.571-5 [20] clause 8.

11.1B MBS Measurement Reporting Delay (NR)

11.1B.1 Test purpose

Same as defined in clause 11.1.1

11.1B.2 Test applicability

This test applies to all types of NR UE that supports UE-assisted MBS with LPP Release 13 onwards.

11.1B.3 Minimum conformance requirements

Same as defined in clause 11.1.3

11.1B.4 Test description

11.1B.4.1 Initial conditions

Same as defined in clause 11.1.4.1, except in the case of NR UE, step 3 is modified as follows:

3. Establish a signalling connection according to the generic procedure in TS 38.508-1 [45] clause 4.5.4.

11.1B.4.2 Test procedure

For NR UE that supports LPP Release 13 only, same as defined in clause 11.1.4.2. For NR UE that supports LPP Release 14 onwards, same as defined in clause 11.1A.4.2.

11.1B.4.3 Message contents

For NR UE that supports LPP Release 13 only, same as defined in clause 11.1.4.3. For NR UE that supports LPP Release 14 onwards, same as defined in clause 11.1A.4.3.

11.1B.5 Test requirement

For NR UE that supports LPP Release 13 only, same as defined in clause 11.1.5. For NR UE that supports LPP Release 14 onwards, same as defined in clause 11.1A.5.

11.2 MBS Sensitivity Measurement Accuracy (Release 13 only)

11.2.1 Test purpose

The purpose of this test is to verify that the MBS Code Phase measurement accuracy is within the specified limits under target sensitivity conditions. This test will verify the requirements in clause 5.2 of TS 37.171 [39] for MBS measurements. The channel type for this test is AWGN, as specified in clause 4.8.2.1.

11.2.2 Test applicability

This test applies to all types of E-UTRA UE that supports UE-assisted MBS with LPP Release 13 only.

11.2.3 Minimum conformance requirements

The MBS code phase measurement accuracy shall fulfil the requirement given in Table 11.2.3-1.

Table 11.2.3-1: Accuracy requirements for sensitivity scenario

Signal Strength (dBm)	Code phase measurement accuracy (ms) ^{Note 1}	Accuracy requirement for the difference of code phase measurements (ms) ^{Note 2}
-130	1.66×10^{-4}	2.35×10^{-4}
Note 1: Provided for reference only		
Note 2: To be used for testing		

The accuracy requirement for the difference of code phase measurements is derived from the requirement for the code phase measurement accuracy, assuming a scaling factor of $\sqrt{2}$ due to the compounding of two error distributions.

The normative reference for this requirement is TS 37.171 [39] clause 5.2 (Sensitivity) and clause A.4.2.

11.2.4 Test description

11.2.4.1 Initial conditions

Test environment: normal; see Annex G.

1. Connect SS and MSS to the UE antenna connector or antenna connectors as shown in figures A.6 or A.7.
2. Switch on the UE.
3. Establish a signalling connection according to the generic procedure in TS 36.508 [18] clause 4.5.3 (State 3, Generic RB established) on a channel in the Mid EARFCN range.

11.2.4.2 Test procedure

1. Set the MSS test parameters as specified in clause 11.2.5.
2. The SS shall send a RESET UE POSITIONING STORED INFORMATION message.
3. The SS shall send an LPP REQUEST CAPABILITIES message.
4. The UE shall transmit an LPP PROVIDE CAPABILITIES message indicating the TBS capabilities supported by the UE in the *TBS-ProvideCapabilities* IE.
5. The SS shall send a LPP REQUEST LOCATION INFORMATION message, including the *TBS-RequestLocationInformation* IE. If the UE message at step 4 includes the *ackRequested* IE set to TRUE, then the SS shall send an acknowledgment in the LPP REQUEST LOCATION INFORMATION message.
6. The UE shall perform and report the code phase measurement for each simulated beacon. If the UE transmits a *TBS-ProvideLocationInformation* IE including the *transmitterID* and *codePhase* field for the two simulated beacons and the difference between *codePhase* field values for the two beacons meet the corresponding requirements in Table 11.2.5-3, then the number of successful tests is increased by one. Otherwise the number of failure tests is increased by one.
7. If the UE message at step 6 includes the *ackRequested* IE set to TRUE, the SS shall send a LPP acknowledgement message.
8. Repeat steps 1-7 until the confidence level according to Annex D is achieved. For each iteration, at step 1 reselect the PN code assigned to each MBS beacon.
9. Release the signalling connection.

11.2.4.3 Message contents

Table 11.2.4.3-1: RESET UE POSITIONING STORED INFORMATION

Derivation Path: TS 36.509 [11] clause 6.9			
Information Element	Value/remark	Comment	Condition
UE Positioning Technology	0 0 0 0 0 1 0	MBS	

Table 11.2.4.3-2: LPP RequestCapabilities

Information Element	Value/remark
<i>tbs-RequestCapabilities-r13</i>	TRUE

Table 11.2.4.3-3: LPP RequestLocationInformation

Derivation Path: TS 36.355 [4] clause 6.2			
Information Element	Value/remark	Comment	Condition
LPP-Message ::= SEQUENCE {			
transactionID SEQUENCE {			
Initiator	locationServer		
transactionNumber	1		
}			
endTransaction	FALSE		
sequenceNumber	Not present		
acknowledgement	Not present		
lpp-MessageBody CHOICE {			
c1 CHOICE {			
requestLocationInformation SEQUENCE {			
criticalExtensions CHOICE {			
c1 CHOICE {			
requestLocationInformation-r9 SEQUENCE {			
commonIEsRequestLocationInformation SEQUENCE {			
locationInformationType	locationMeasurementsRequired		
triggeredReporting	Not present		
periodicalReporting	Not present		
additionalInformation	onlyReturnInformationRequested		
qos SEQUENCE {			
horizontalAccuracy	Not present		
verticalCoordinateRequest	FALSE		
verticalAccuracy	Not present		
responseTime SEQUENCE {			
Time	12		
responseTimeEarlyFix-r12	Not present		
}			
velocityRequest	FALSE		
}			
Environment	Not present		
locationCoordinateTypes	Not present		
velocityTypes	Not present		
}			
a-gnss-RequestLocationInformation	Not present		
otdoa-RequestLocationInformation	Not present		
ecid-RequestLocationInformation	Not present		
epdu-RequestLocationInformation	Not present		
sensor-RequestLocationInformation-r13	Not present		
tbs-RequestLocationInformation-r13 SEQUENCE {			
mbsSgnMeasListReq-r13	TRUE		
}			
wlan-RequestLocationInformation-r13	Not present		
bt-RequestLocationInformation-r13	Not Present		
}			
}			
}			
}			
}			
}			

Table 11.2.4.3-4: LPP ProvideLocationInformation

Derivation Path: TS 36.355 [4] clause 6.2			
Information Element	Value/remark	Comment	Condition
LPP-Message ::= SEQUENCE {			
transactionID SEQUENCE {			

Initiator	locationServer		
transactionNumber	1		
}			
endTransaction	TRUE		
sequenceNumber	(0..255)		
Acknowledgement			
lpp-MessageBody CHOICE {			
c1 CHOICE {			
provideLocationInformation SEQUENCE {			
criticalExtensions CHOICE {			
c1 CHOICE {			
provideLocationInformation-r9 SEQUENCE {			
commonIEsProvideLocationInformation	Not present.		
a-gnss-ProvideLocationInformation	Not present		
otdoa-ProvideLocationInformation	Not present		
ecid-ProvideLocationInformation	Not present		
epdu-ProvideLocationInformation	Not present		
sensor-ProvideLocationInformation-r13	Not present		
tbs-ProvideLocationInformation-r13			
SEQUENCE {			
tbs-MeasurementInformation-r13			
SEQUENCE {			
measurementReferenceTime-r13			
mbs-SgnMeasList-r13			
SEQUENCE (SIZE(n)) {			
transmitterID-r13	Present		
codePhase-r13	Present		
codePhaseRMSError-r13			
}			
mbs-SgnMeasList-r13			
SEQUENCE (SIZE(n)) {			
transmitterID-r13	Present		
codePhase-r13	Present		
codePhaseRMSError-r13			
}			
}			
tbs-Error-r13	May be present with error reason 'undefined' or 'thereWereNotEnoughMBSBeaconsReceived'		
}			
wlan-ProvideLocationInformation-r13	Not present		
bt-ProvideLocationInformation-r13	Not present		
}			
}			
}			
}			
}			
}			

11.2.5 Test requirement

The details of the beacon parameters are in Table 11.2.5-1 and Table 11.2.5-2.

Table 11.2.5-1: General test parameters for the beacons to be simulated for measurement accuracy in Sensitivity test

Parameter	Unit	Value	Comment
Number of Beacons		2	Beacons transmitted in any two beacon slots in the beacon transmission period, but static for the test. Other slots contain no simulated beacons ^{Note 1}

Centre Frequency	MHz	925.977	
RF Channel	N/A	AWGN	
MBS Beacon Configuration	N/A	TB1 (2 MHz)	For details see Annex H
MBS Packet Type	N/A	Type 2	For details see Annex H\
Beacon PN Code	Integer	Chosen for each beacon from the PN code list for TB1	Each of the 2 beacons uses a different PN code. For details see Annex H ^{Note 1}
Response time	Seconds	12	Value of Time used in LPP RequestLocationInformation message in Table 11.2.4.3-3
Note 1: The slots and PN codes are chosen at random, such that the UE does not and cannot have advanced knowledge of what that slot/PN code might be.			

Table 11.2.5-2: MBS Beacon Payload fields, code phase delay difference and transmit powers for the beacons to be simulated for measurement accuracy in sensitivity test

MBS Tx ID (See Annex H)	Slot Index (See Annex H)	All Other fields (See Annex H)	Code phase delay difference between beacons (ms)	Transmit Power (dBm)
Equal to Slot number	Equal to Slot number	min value (bit_value = 0) ^{Note 1}	0	-128
Note 1: bit_value is the conversion of the binary number represented by the corresponding bits in the payload to decimal.				

The MBS code phase measurement accuracy shall fulfil the requirements given in Table 11.2.5-3.

Table 11.2.5-3: Accuracy requirements for Sensitivity scenario

Code phase measurement accuracy (ms) ^{Note 1}	Accuracy requirement for the difference of code phase measurements (ms) ^{Note 2}
1.66×10^{-4}	2.40×10^{-4}
Note 1: Provided for reference only Note 2: To be used for testing	

The test tolerances are defined in clauses C.1.4 and C.4.

The rate of successful tests during repeated tests shall be at least 90% with a confidence level of 95%.

11.2A MBS Sensitivity Measurement Accuracy (Release 14 Onwards)

11.2A.1 Test purpose

Same as defined in clause 11.2.1

11.2A.2 Test applicability

This test applies to all types of E-UTRA UE that supports UE-assisted MBS with LPP Release 14 onwards.

11.2A.3 Minimum conformance requirements

Same as defined in clause 11.2.3 except that the accuracy requirements are:

Table 11.2A.3-1: Accuracy requirements for sensitivity scenario

MBS Configuration	Signal Strength (dBm)	Code phase measurement accuracy (ms) ^{Note 1}	Accuracy requirement for the difference of code phase measurements (ms) ^{Note 2}
TB1 (2 MHz)	-130	1.66×10^{-4}	2.35×10^{-4}
TB2 (5 MHz)	-130	6.6×10^{-5}	9.3×10^{-5}
Note 1: Provided for reference only			
Note 2: To be used for testing			

11.2A.4 Test description

11.2A.4.1 Initial conditions

Same as defined in clause 11.2.4.1

11.2A.4.2 Test procedure

Same as defined in clause 11.2.4.2, except step 4a is introduced and step 5 is modified as follows:

- 4a. The SS shall send an LPP PROVIDE ASSISTANCE DATA message to provide the MBS assistance data in accordance with TS 37.571-5 [20], and with the values defined therein. If the UE message at step 4 includes the *ackRequested* IE set to TRUE, then the SS shall send an acknowledgment in the LPP PROVIDE ASSISTANCE DATA message.
5. The SS shall send a LPP REQUEST LOCATION INFORMATION message, including the *TBS-RequestLocationInformation* IE.

11.2A.4.3 Message contents

Same as defined in clause 11.2.4.3, with the addition of the LPP Provide Assistance Data

Table 11.2A.4.3-5: LPP ProvideAssistanceData

Derivation Path: TS 36.355 [4] clause 6.2			
Information Element	Value/remark	Comment	Condition
LPP-Message ::= SEQUENCE {			
transactionID SEQUENCE {			
Initiator	locationServer		
transactionNumber	(0..255)		
}			
endTransaction	TRUE		
sequenceNumber	Not present		
acknowledgement			
lpp-MessageBody CHOICE {			
c1 CHOICE {			
provideAssistanceData SEQUENCE {			
criticalExtensions CHOICE {			
c1 CHOICE {			
provideAssistanceData-r9 SEQUENCE {			
commonIEsProvideAssistanceData	Not present		
a-gnss-ProvideAssistanceData	Not present		
otdoa-ProvideAssistanceData	Not present		
epdu-ProvideAssistanceData	Not present		
sensor-ProvideAssistanceData-r14	Not present		Rel-14 onwards
tbs-ProvideAssistanceData-r14 SEQUENCE {			Rel-14 onwards
tbs-AssistanceDataList-r14 SEQUENCE {			
mbs-AssistanceDataList-r14 SEQUENCE {			
mbs-AssistanceDataElement-r14 SEQUENCE {		Beacon 1 tb1	

mbs-AlmanacAssistance-r14	Not Present		
mbs-AcquisitionAssistance-r14	As defined in TS 37.571-5 [20], clause 8		
}			
mbs-AssistanceDataElement-r14 SEQUENCE {		Beacon 2 tb1	
mbs-AlmanacAssistance-r14	Not Present		
mbs-AcquisitionAssistance-r14	As defined in TS 37.571-5 [20], clause 8		
}			
mbs-AssistanceDataElement-r14 SEQUENCE {		Beacon 1 tb2	
mbs-AlmanacAssistance-r14	Not Present		
mbs-AcquisitionAssistance-r14	As defined in TS 37.571-5 [20], clause 8		
}			
mbs-AssistanceDataElement-r14 SEQUENCE {		Beacon 2 tb2	
mbs-AlmanacAssistance-r14	Not Present		
mbs-AcquisitionAssistance-r14	As defined in TS 37.571-5 [20], clause 8		
}			
}			
}			
tbs-Error-r14	Not Present		
}			
}			
wlan-ProvideAssistanceData-r14	Not Present		Rel-14 onwards
}			
}			
}			
}			
}			

11.2A.5 Test requirement

Same as defined in clause 11.2.5, with the beacon parameters set according to the assistance data in TS 37.571-5 [20] clause 8 and with the measurement accuracy requirement in Table 11.2A.5-1.

Table 11.2A.5-1: Accuracy requirements for Sensitivity scenario

MBS Configuration	Code phase measurement accuracy (ms) ^{Note 1}	Accuracy requirement for the difference of code phase measurements (ms) ^{Note 2}
TB1 (2 MHz)	1.66×10^{-4}	2.40×10^{-4}
TB2 (5 MHz)	6.6×10^{-5}	9.8×10^{-5}
Note 1: Provided for reference only		
Note 2: To be used for testing		

11.2B MBS Sensitivity Measurement Accuracy (NR)

11.2B.1 Test purpose

Same as defined in clause 11.2.1

11.2B.2 Test applicability

This test applies to all types of NR UE that supports UE-assisted MBS with LPP Release 13 onwards.

11.2B.3 Minimum conformance requirements

For NR UE that supports LPP Release 13 only, same as defined in clause 11.2.3. For NR UE that supports LPP Release 14 onwards, same as defined in clause 11.2A.3

11.2B.4 Test description

11.2B.4.1 Initial conditions

Same as defined in clause 11.2.4.1, except in the case of NR UE, step 3 is modified as follows:

3. Establish a signalling connection according to the generic procedure in TS 38.508-1 [45] clause 4.5.4.

11.2B.4.2 Test procedure

For NR UE that supports LPP Release 13 only, same as defined in clause 11.2.4.2. For NR UE that supports LPP Release 14 onwards, same as defined in clause 11.2A.4.2.

11.2B.4.3 Message contents

For NR UE that supports LPP Release 13 only, same as defined in clause 11.2.4.3. For NR UE that supports LPP Release 14 onwards, same as defined in clause 11.2A.4.3

11.2B.5 Test requirement

For NR UE that supports LPP Release 13 only, same as defined in clause 11.2.5. For NR UE that supports LPP Release 14 onwards, same as defined in clause 11.2A.5

11.3 MBS Nominal Measurement Accuracy (Release 13 only)

11.3.1 Test purpose

The purpose of this test is to verify that the MBS Code Phase measurement accuracy is within the specified limits under ideal conditions. This test will verify the requirements in clauses 5.3 of 37.171 [39] for MBS measurements. The channel type for this test is AWGN, as specified in clause 4.8.2.1.

11.3.2 Test applicability

This test applies to all types of E-UTRA UE that supports UE-assisted MBS with LPP Release 13 only.

11.3.3 Minimum conformance requirements

The MBS code phase measurement accuracy shall fulfil the requirement given in Table 11.3.3-1.

Table 11.3.3-1: Accuracy requirements for Nominal scenario

Signal Strength (dBm)	Code phase measurement accuracy (ms) ^{Note 1}	Accuracy requirement for the difference of code phase measurements (ms) ^{Note 2}
-30	5.0×10^{-5}	7.1×10^{-5}
Note 1: Provided for reference only Note 2: To be used for testing		

The accuracy requirement for the difference of code phase measurements is derived from the requirement for the code phase measurement accuracy, assuming a scaling factor of $\sqrt{2}$ due to the compounding of two error distributions.

The normative reference for this requirement is TS 37.171 [39] clause 5.3 (Nominal) and clause A.4.2.

11.3.4 Test description

11.3.4.1 Initial conditions

Test environment: normal; see Annex G.

1. Connect SS and MSS to the UE antenna connector or antenna connectors as shown in figures A.6 or A.7.
2. Switch on the UE.
3. Establish a signalling connection according to the generic procedure in TS 36.508 [18] clause 4.5.3 (State 3, Generic RB established) on a channel in the Mid EARFCN range.

11.3.4.2 Test procedure

1. Set the MSS test parameters as specified in clause 11.3.5.
2. The SS shall send a RESET UE POSITIONING STORED INFORMATION message.
3. The SS shall send an LPP REQUEST CAPABILITIES message.
4. The UE shall transmit an LPP PROVIDE CAPABILITIES message indicating the TBS capabilities supported by the UE in the *TBS-ProvideCapabilities* IE.
5. The SS shall send a LPP REQUEST LOCATION INFORMATION message, including the *TBS-RequestLocationInformation* IE. If the UE message at step 4 includes the *ackRequested* IE set to TRUE, then the SS shall send an acknowledgment in the LPP REQUEST LOCATION INFORMATION message.
6. The UE shall perform and report the code phase measurement for each simulated beacon. If the UE transmits a *TBS-ProvideLocationInformation* IE including the *transmitterID* and *codePhase* field for the two simulated beacons and the difference between *codePhase* field values for the two beacons meet the corresponding requirements in Table 11.3.5-3, then the number of successful tests is increased by one. Otherwise the number of failure tests is increased by one.
7. If the UE message at step 6 includes the *ackRequested* IE set to TRUE, the SS shall send a LPP acknowledgement message.
8. Repeat steps 1-7 until the confidence level according to Annex D is achieved. For each iteration, at step 1 reselect the PN code assigned to each MBS beacon.
9. Release the signalling connection.

11.3.4.3 Message contents

Table 11.3.4.3-1: RESET UE POSITIONING STORED INFORMATION

Derivation Path: TS 36.509 [11] clause 6.9			
Information Element	Value/remark	Comment	Condition
UE Positioning Technology	0 0 0 0 0 1 0	MBS	

Table 11.3.4.3-2: LPP RequestCapabilities

Information Element	Value/remark
<i>tbs-RequestCapabilities-r13</i>	TRUE

Table 11.3.4.3-3: LPP RequestLocationInformation

Derivation Path: TS 36.355 [4] clause 6.2			
Information Element	Value/remark	Comment	Condition
LPP-Message ::= SEQUENCE {			
transactionID SEQUENCE {			
Initiator	locationServer		

transactionNumber	1		
}			
endTransaction	FALSE		
sequenceNumber	Not present		
acknowledgement	Not present		
lpp-MessageBody CHOICE {			
c1 CHOICE {			
requestLocationInformation SEQUENCE {			
criticalExtensions CHOICE {			
c1 CHOICE {			
requestLocationInformation-r9 SEQUENCE {			
commonEsRequestLocationInformation SEQUENCE {			
locationInformationType	locationMeasurementsRequired		
triggeredReporting	Not present		
periodicalReporting	Not present		
additionalInformation	onlyReturnInformationRequested		
qos SEQUENCE {			
horizontalAccuracy	Not present		
verticalCoordinateRequest	FALSE		
verticalAccuracy	Not present		
responseTime SEQUENCE {			
Time	12		
responseTimeEarlyFix-r12	Not present		
}			
velocityRequest	FALSE		
}			
Environment	Not present		
locationCoordinateTypes	Not present		
velocityTypes	Not present		
}			
a-gnss-RequestLocationInformation	Not present		
otdoa-RequestLocationInformation	Not present		
ecid-RequestLocationInformation	Not present		
epdu-RequestLocationInformation	Not present		
sensor-RequestLocationInformation-r13	Not present		
tbs-RequestLocationInformation-r13 SEQUENCE {			
mbsSgnMeasListReq-r13	TRUE		
}			
wlan-RequestLocationInformation-r13	Not present		
bt-RequestLocationInformation-r13	Not Present		
}			
}			
}			
}			
}			
}			
}			
}			

Table 11.3.4.3-4: LPP ProvideLocationInformation

Derivation Path: TS 36.355 [4] clause 6.2			
Information Element	Value/remark	Comment	Condition
LPP-Message ::= SEQUENCE {			
transactionID SEQUENCE {			
Initiator	locationServer		
transactionNumber	1		
}			
endTransaction	TRUE		
sequenceNumber	(0..255)		
Acknowledgement			

lpp-MessageBody CHOICE {			
c1 CHOICE {			
provideLocationInformation SEQUENCE {			
criticalExtensions CHOICE {			
c1 CHOICE {			
provideLocationInformation-r9 SEQUENCE {			
commonIEsProvideLocationInformation	Not present.		
a-gnss-ProvideLocationInformation	Not present		
otdoa-ProvideLocationInformation	Not present		
ecid-ProvideLocationInformation	Not present		
epdu-ProvideLocationInformation	Not present		
sensor-ProvideLocationInformation-r13	Not present		
tbs-ProvideLocationInformation-r13			
SEQUENCE {			
tbs-MeasurementInformation-r13			
SEQUENCE {			
measurementReferenceTime-r13			
mbs-SgnMeasList-r13			
SEQUENCE (SIZE(n)) {			
transmitterID-r13	Present		
codePhase-r13	Present		
codePhaseRMSError-r13			
}			
mbs-SgnMeasList-r13			
SEQUENCE (SIZE(n)) {			
transmitterID-r13	Present		
codePhase-r13	Present		
codePhaseRMSError-r13			
}			
}			
tbs-Error-r13	May be present with error reason 'undefined' or 'thereWereNotEnoughMBSBeaconsReceived'		
}			
wlan-ProvideLocationInformation-r13	Not present		
bt-ProvideLocationInformation-r13	Not present		
}			
}			

11.3.5 Test requirement

The details of the beacon parameters are in Table 11.3.5-1 and Table 11.3.5-2.

Table 11.3.5-1: General test parameters for the beacons to be simulated for measurement accuracy in Nominal test

Parameter	Unit	Value	Comment
Number of Beacons		2	Beacons transmitted in any two beacon slots in the beacon transmission period, but static for the test. Other slots contain no simulated beacons ^{Note 1}
Centre Frequency	MHz	925.977	
RF Channel	N/A	AWGN	
MBS Beacon Configuration	N/A	TB1 (2 MHz)	For details see Annex H
MBS Packet Type	N/A	Type 2	For details see Annex H

Beacon PN Code	Integer	Chosen for each beacon from the PN code list for TB1	Each of the 2 beacons uses a different PN code. For details see Annex H ^{Note 1}
Response time	Seconds	12	Value of Time used in LPP RequestLocationInformation message in Table 11.3.4.3-3
Note 1: The slots and PN codes are chosen at random, such that the UE does not and cannot have advanced knowledge of what that slot/PN code might be.			

Table 11.3.5-2: MBS Beacon Payload fields, code phase delay difference and transmit powers for the beacons to be simulated for measurement accuracy in Nominal test

MBS Tx ID (See Annex H)	Slot Index (See Annex H)	All Other fields (See Annex H)	Code phase delay difference between beacons (ms)	Transmit Power (dBm)
Equal to Slot number	Equal to Slot number	min value (bit_value = 0) ^{Note 1}	0	-30
Note: bit_value is the conversion of the binary number represented by the corresponding bits in the payload to decimal.				

The MBS code phase measurement accuracy shall fulfil the requirements given in Table 11.3.5-3.

Table 11.3.5-3: Accuracy requirements for Nominal scenario

Code phase measurement accuracy (ms) ^{Note 1}	Accuracy requirement for the difference of code phase measurements (ms) ^{Note 2}
5.0×10^{-5}	7.6×10^{-5}
Note 1: Provided for reference only Note 2: To be used for testing	

The test tolerances are defined in clauses C.1.4 and C.4.

The rate of successful tests during repeated tests shall be at least 90% with a confidence level of 95%.

11.3A MBS Nominal Measurement Accuracy (Release 14 Onwards)

11.3A.1 Test purpose

Same as defined in clause 11.3.1

11.3A.2 Test applicability

This test applies to all types of E-UTRA UE supports UE-assisted MBS with LPP Release 14 onwards.

11.3A.3 Minimum conformance requirements

Same as defined in clause 11.3.3 except that the accuracy requirements are:

Table 11.3A.3-1: Accuracy requirements for Nominal scenario

MBS Configuration	Signal Strength (dBm)	Code phase measurement accuracy (ms) ^{Note 1}	Accuracy requirement for the difference of code phase measurements (ms) ^{Note 2}
TB1 (2 MHz)	-30	5.0×10^{-5}	7.1×10^{-5}
TB2 (5 MHz)	-30	2.0×10^{-5}	2.8×10^{-5}
Note 1: Provided for reference only.			

Note 2: To be used for testing.

11.3A.4 Test description

11.3A.4.1 Initial conditions

Same as defined in clause 11.3.4.1

11.3A.4.2 Test procedure

Same as defined in clause 11.3.4.2, except step 4a is introduced and step 5 is modified as follows:

- 4a. The SS shall send an LPP PROVIDE ASSISTANCE DATA message to provide the MBS assistance data in accordance with TS 37.571-5 [20], and with the values defined therein. If the UE message at step 4 includes the *ackRequested* IE set to TRUE, then the SS shall send an acknowledgment in the LPP PROVIDE ASSISTANCE DATA message.
5. The SS shall send a LPP REQUEST LOCATION INFORMATION message, including the *TBS-RequestLocationInformation* IE.

11.3A.4.3 Message contents

Same as defined in clause 11.3.4.3, with the addition of the LPP Provide Assistance Data.

Table 11.3A.4.3-5: LPP ProvideAssistanceData

Derivation Path: TS 36.355 [4] clause 6.2			
Information Element	Value/remark	Comment	Condition
LPP-Message ::= SEQUENCE {			
transactionID SEQUENCE {			
Initiator	locationServer		
transactionNumber	(0..255)		
}			
endTransaction	TRUE		
sequenceNumber	Not present		
acknowledgement			
lpp-MessageBody CHOICE {			
c1 CHOICE {			
provideAssistanceData SEQUENCE {			
criticalExtensions CHOICE {			
c1 CHOICE {			
provideAssistanceData-r9 SEQUENCE {			
commonIEsProvideAssistanceData	Not present		
a-gnss-ProvideAssistanceData	Not present		
otdoa-ProvideAssistanceData	Not present		
epdu-ProvideAssistanceData	Not present		
sensor-ProvideAssistanceData-r14	Not present		Rel-14 onwards
tbs-ProvideAssistanceData-r14 SEQUENCE {			Rel-14 onwards
tbs-AssistanceDataList-r14 SEQUENCE {			
mbs-AssistanceDataList-r14 SEQUENCE {			
mbs-AssistanceDataElement-r14 SEQUENCE {		Beacon 1 tb1	
mbs-AlmanacAssistance-r14	Not Present		
mbs-AcquisitionAssistance-r14	As defined in TS 37.571-5 [20], clause 8		
}			
mbs-AssistanceDataElement-r14 SEQUENCE {		Beacon 2 tb1	
mbs-AlmanacAssistance-r14	Not Present		

mbs-AcquisitionAssistance-r14	As defined in TS 37.571-5 [20], clause 8		
}			
mbs-AssistanceDataElement-r14 SEQUENCE {		Beacon 1 tb2	
mbs-AlmanacAssistance-r14	Not Present		
mbs-AcquisitionAssistance-r14	As defined in TS 37.571-5 [20], clause 8		
}			
mbs-AssistanceDataElement-r14 SEQUENCE {		Beacon 2 tb2	
mbs-AlmanacAssistance-r14	Not Present		
mbs-AcquisitionAssistance-r14	As defined in TS 37.571-5 [20], clause 8		
}			
}			
}			
tbs-Error-r14	Not Present		
}			
}			
wlan-ProvideAssistanceData-r14	Not Present		Rel-14 onwards
}			
}			
}			
}			
}			

11.3A.5 Test requirement

Same as defined in clause 11.3.5, with the beacon parameters set according to the assistance data in TS 37.571-5 [20] clause 8 and with the measurement accuracy requirement in Table 11.3A.5-1.

Table 11.3A.5-1: Accuracy requirements for Nominal scenario

MBS Configuration	Code phase measurement accuracy (ms) ^{Note 1}	Accuracy requirement for the difference of code phase measurements (ms) ^{Note 2}
TB1 (2 MHz)	5.0×10^{-5}	7.6×10^{-5}
TB2 (5 MHz)	2.0×10^{-5}	3.3×10^{-5}
Note 1: Provided for reference only.		
Note 2: To be used for testing.		

11.3B MBS Nominal Measurement Accuracy (NR)

11.3B.1 Test purpose

Same as defined in clause 11.3.1

11.3B.2 Test applicability

This test applies to all types of NR UE that supports UE-assisted MBS with LPP Release 13 onwards.

11.3B.3 Minimum conformance requirements

For NR UE that supports LPP Release 13 only, same as defined in clause 11.3.3. For NR UE that supports LPP Release 14 onwards, same as defined in clause 11.3A.3

11.3B.4 Test description

11.3B.4.1 Initial conditions

Same as defined in clause 11.3.4.1, except in the case of NR UE, step 3 is modified as follows:

3. Establish a signalling connection according to the generic procedure in TS 38.508-1 [45] clause 4.5.4.

11.3B.4.2 Test procedure

For NR UE that supports LPP Release 13 only, same as defined in clause 11.3.4.2. For NR UE that supports LPP Release 14 onwards, same as defined in clause 11.3A.4.2

11.3B.4.3 Message contents

For NR UE that supports LPP Release 13 only, same as defined in clause 11.3.4.3. For NR UE that supports LPP Release 14 onwards, same as defined in clause 11.3A.4.3

11.3B.5 Test requirement

For NR UE that supports LPP Release 13 only, same as defined in clause 11.3.5. For NR UE that supports LPP Release 14 onwards, same as defined in clause 11.3A.5

11.4 MBS Dynamic Range Measurement Accuracy (Release 13 only)

11.4.1 Test purpose

The purpose of this test is to verify that the MBS Code Phase measurement accuracy is within the specified limits under maximum dynamic range conditions. This test will verify the requirements in clauses 5.4 of TS 37.171 [39] for MBS measurements. The channel type for this test is AWGN, as specified in clause 4.8.2.1.

11.4.2 Test applicability

This test applies to all types of E-UTRA UE that supports UE-assisted MBS with LPP Release 13 only.

11.4.3 Minimum conformance requirements

The MBS code phase measurement accuracy shall fulfil the requirements given in Table 11.4.3-1.

Table 11.4.3-1: Accuracy requirements for Dynamic Range scenario

Signal Strength (dBm)	Code phase measurement accuracy (ms) ^{Note 1}	Accuracy requirement for the difference of code phase measurements (ms) ^{Note 2}
-30	5.0×10^{-5}	7.1×10^{-5}
-130	1.66×10^{-4}	2.35×10^{-4}

Note 1: Provided for reference only
Note 2: To be used for testing

The accuracy requirement for the difference of code phase measurements is derived from the requirement for the code phase measurement accuracy, assuming a scaling factor of $\sqrt{2}$ due to the compounding of two error distributions.

The normative reference for this requirement is TS 37.171 [39] clause 5.4 (Dynamic Range) and clause A.4.2.

11.4.4 Test description

11.4.4.1 Initial conditions

Test environment: normal; see Annex G.

1. Connect SS and MSS to the UE antenna connector or antenna connectors as shown in figures A.6 or A.7.
2. Switch on the UE.
3. Establish a signalling connection according to the generic procedure in TS 36.508 [18] clause 4.5.3 (State 3, Generic RB established) on a channel in the Mid EARFCN range.

11.4.4.2 Test procedure

1. Set the MSS test parameters as specified in clause 11.4.5.
2. The SS shall send a RESET UE POSITIONING STORED INFORMATION message.
3. The SS shall send an LPP REQUEST CAPABILITIES message.
4. The UE shall transmit an LPP PROVIDE CAPABILITIES message indicating the TBS capabilities supported by the UE in the *TBS-ProvideCapabilities* IE.
5. The SS shall send a LPP REQUEST LOCATION INFORMATION message, including the *TBS-RequestLocationInformation* IE. If the UE message at step 4 includes the *ackRequested* IE set to TRUE, then the SS shall send an acknowledgment in the LPP REQUEST LOCATION INFORMATION message.
6. The UE shall perform and report the code phase measurement for each simulated beacon. If the UE transmits a *TBS-ProvideLocationInformation* IE including the *transmitterID* and *codePhase* field for the four simulated beacons and the difference between *codePhase* field values for the two high power beacons and the difference in the *codePhase* field values for the two low power beacons meet the corresponding requirements in Table 11.4.5-3, then the number of successful tests is increased by one. Otherwise the number of failure tests is increased by one.
7. If the UE message at step 6 includes the *ackRequested* IE set to TRUE, the SS shall send a LPP acknowledgement message.
8. Repeat steps 1-7 until the confidence level according to Annex D is achieved. For each iteration, at step 1 reselect the PN code assigned to each MBS beacon.
9. Release the signalling connection.

11.4.4.3 Message contents

Table 11.4.4.3-1: RESET UE POSITIONING STORED INFORMATION

Derivation Path: TS 36.509 [11] clause 6.9			
Information Element	Value/remark	Comment	Condition
UE Positioning Technology	0 0 0 0 0 1 0	MBS	

Table 11.4.4.3-2: LPP RequestCapabilities

Information Element	Value/remark
<i>tbs-RequestCapabilities-r13</i>	TRUE

Table 11.4.4.3-3: LPP RequestLocationInformation

Derivation Path: TS 36.355 [4] clause 6.2			
Information Element	Value/remark	Comment	Condition
LPP-Message ::= SEQUENCE {			

transactionID SEQUENCE {			
Initiator	locationServer		
transactionNumber	1		
}			
endTransaction	FALSE		
sequenceNumber	Not present		
acknowledgement	Not present		
lpp-MessageBody CHOICE {			
c1 CHOICE {			
requestLocationInformation SEQUENCE {			
criticalExtensions CHOICE {			
c1 CHOICE {			
requestLocationInformation-r9 SEQUENCE {			
commonEsRequestLocationInformation SEQUENCE {			
locationInformationType	locationMeasurementsRequired		
triggeredReporting	Not present		
periodicalReporting	Not present		
additionalInformation	onlyReturnInformationRequested		
qos SEQUENCE {			
horizontalAccuracy	Not present		
verticalCoordinateRequest	FALSE		
verticalAccuracy	Not present		
responseTime SEQUENCE {			
Time	12		
responseTimeEarlyFix-r12	Not present		
}			
velocityRequest	FALSE		
}			
Environment	Not present		
locationCoordinateTypes	Not present		
velocityTypes	Not present		
}			
a-gnss-RequestLocationInformation	Not present		
otdoa-RequestLocationInformation	Not present		
ecid-RequestLocationInformation	Not present		
epdu-RequestLocationInformation	Not present		
sensor-RequestLocationInformation-r13	Not present		
tbs-RequestLocationInformation-r13 SEQUENCE {			
mbsSgnMeasListReq-r13	TRUE		
}			
wlan-RequestLocationInformation-r13	Not present		
bt-RequestLocationInformation-r13	Not Present		
}			
}			
}			
}			

Table 11.4.4.3-4: LPP ProvideLocationInformation

Derivation Path: TS 36.355 [4] clause 6.2			
Information Element	Value/remark	Comment	Condition
LPP-Message ::= SEQUENCE {			
transactionID SEQUENCE {			
Initiator	locationServer		
transactionNumber	1		
}			
endTransaction	TRUE		

sequenceNumber	(0..255)		
Acknowledgement			
lpp-MessageBody CHOICE {			
c1 CHOICE {			
provideLocationInformation SEQUENCE {			
criticalExtensions CHOICE {			
c1 CHOICE {			
provideLocationInformation-r9 SEQUENCE {			
commonIEsProvideLocationInformation	Not present.		
a-gnss-ProvideLocationInformation	Not present		
otdoa-ProvideLocationInformation	Not present		
ecid-ProvideLocationInformation	Not present		
epdu-ProvideLocationInformation	Not present		
sensor-ProvideLocationInformation-r13	Not present		
tbs-ProvideLocationInformation-r13			
SEQUENCE {			
tbs-MeasurementInformation-r13			
SEQUENCE {			
measurementReferenceTime-r13			
mbs-SgnMeasList-r13			
SEQUENCE (SIZE(n)) {			
transmitterID-r13	Present		
codePhase-r13	Present		
codePhaseRMSError-r13			
}			
mbs-SgnMeasList-r13			
SEQUENCE (SIZE(n)) {			
transmitterID-r13	Present		
codePhase-r13	Present		
codePhaseRMSError-r13			
}			
mbs-SgnMeasList-r13			
SEQUENCE (SIZE(n)) {			
transmitterID-r13	Present		
codePhase-r13	Present		
codePhaseRMSError-r13			
}			
mbs-SgnMeasList-r13			
SEQUENCE (SIZE(n)) {			
transmitterID-r13	Present		
codePhase-r13	Present		
codePhaseRMSError-r13			
}			
}			
tbs-Error-r13	May be present with error reason 'undefined' or 'thereWereNotEnoughMBSBeaconsReceived'		
}			
wlan-ProvideLocationInformation-r13	Not present		
bt-ProvideLocationInformation-r13	Not present		
}			
}			
}			
}			

11.4.5 Test requirement

The details of the beacon parameters are in Table 11.4.5-1 and Table 11.4.5-2.

Table 11.4.5-1: General test parameters for the beacons to be simulated for measurement accuracy in Dynamic Range test

Parameter	Unit	Value	Comment
Number of Beacons		4	Beacons 1 to 4. Transmitted in any four consecutive beacon slots in the beacon transmission period, but static for the test. Other slots contain no simulated beacons ^{Note 1}
Centre Frequency	MHz	925.977	
RF Channel	N/A	AWGN	
MBS Beacon Configuration	N/A	TB1 (2 MHz)	For details see Annex H
MBS Packet Type	N/A	Type 2	For details see Annex H
Beacon PN Code	Integer	Chosen for each beacon from the PN code list for TB1	Each of the 4 beacons uses a different PN code. For details see Annex H ^{Note 1}
Response time	Seconds	12	Value of Time used in LPP RequestLocationInformation message in Table 11.4.4.3-3
Note 1: The slots and PN codes are chosen at random, such that the UE does not and cannot have advanced knowledge of what that slot/PN code might be.			

Table 11.4.5-2: MBS Beacon Payload fields, code phase delay difference and transmit powers for the beacons to be simulated for measurement accuracy in Dynamic Range test

Beacon	MBS Tx ID (See Annex H)	Slot Index (See Annex H)	All Other fields (See Annex H)	Code phase delay difference between beacons (ms)	Transmit Power (dBm)
1	Equal to Slot number	Equal to Slot number	min value (bit_value = 0) ^{Note 1}	Beacon 1 to beacon 3: 0 ^{Note 2}	-30 (high power)
2	Equal to Slot number	Equal to Slot number	min value (bit_value = 0) ^{Note 1}	Beacon 2 to beacon 4: 0 ^{Note 2}	-128 (low power)
3	Equal to Slot number	Equal to Slot number	min value (bit_value = 0) ^{Note 1}	Beacon 1 to beacon 3: 0 ^{Note 2}	-30 (high power)
4	Equal to Slot number	Equal to Slot number	min value (bit_value = 0) ^{Note 1}	Beacon 2 to beacon 4: 0 ^{Note 2}	-128 (low power)
Note 1: bit_value is the conversion of the binary number represented by the corresponding bits in the payload to decimal. Note 2: The code phase delay difference between beacon 1 and 3 and beacon 2 and 4 shall be set to some non-zero value.					

The MBS code phase measurement accuracy shall fulfil the requirements given in Table 11.4.5-3.

Table 11.4.5-3: Accuracy requirements for Dynamic Range scenario

Beacon Signal Strength	Code phase measurement accuracy (ms) ^{Note 1}	Accuracy requirement for the difference of code phase measurements (ms) ^{Note 2}
High Power (-30 dBm)	5.0×10^{-5}	7.6×10^{-5}
Low Power (-130 dBm)	1.66×10^{-4}	2.40×10^{-4}
Note 1: Provided for reference only Note 2: To be used for testing		

The test tolerances are defined in clauses C.1.4 and C.4.

The rate of successful tests during repeated tests shall be at least 90% with a confidence level of 95%.

11.4A MBS Dynamic Range Measurement Accuracy (Release 14 Onwards)

11.4A.1 Test purpose

Same as defined in clause 11.4.1

11.4A.2 Test applicability

This test applies to all types of E-UTRA UE that supports UE-assisted MBS with LPP Release 14 onwards.

11.4A.3 Minimum conformance requirements

Same as defined in clause 11.4.3 except that the accuracy requirements are:

Table 11.4A.3-1: Accuracy requirements for Dynamic Range scenario

MBS Configuration	Signal Strength (dBm)	Code phase measurement accuracy (ms) ^{Note 1}	Accuracy requirement for the difference of code phase measurements (ms) ^{Note 2}
TB1 (2 MHz)	-30	5.0×10^{-5}	7.1×10^{-5}
	-130	1.66×10^{-4}	2.35×10^{-4}
TB2 (5 MHz)	-30	2.0×10^{-5}	2.8×10^{-5}
	-130	6.6×10^{-5}	9.3×10^{-5}
Note 1: Provided for reference only.			
Note 2: To be used for testing.			

11.4A.4 Test description

11.4A.4.1 Initial conditions

Same as defined in clause 11.4.4.1

11.4A.4.2 Test procedure

Same as defined in clause 11.4.4.2, except step 4a is introduced and step 5 is modified as follows:

- 4a. The SS shall send an LPP PROVIDE ASSISTANCE DATA message to provide the MBS assistance data in accordance with TS 37.571-5 [20], and with the values defined therein. If the UE message at step 4 includes the *ackRequested* IE set to TRUE, then the SS shall send an acknowledgment in the LPP PROVIDE ASSISTANCE DATA message.
5. The SS shall send a LPP REQUEST LOCATION INFORMATION message, including the *TBS-RequestLocationInformation* IE.

11.4A.4.3 Message contents

Same as defined in clause 11.4.4.3, with the addition of the LPP Provide Assistance Data.

Table 11.4A.4.3-5: LPP ProvideAssistanceData

Derivation Path: TS 36.355 [4] clause 6.2			
Information Element	Value/remark	Comment	Condition
LPP-Message ::= SEQUENCE {			
transactionID SEQUENCE {			
Initiator	locationServer		
transactionNumber	(0..255)		
}			

endTransaction	TRUE		
sequenceNumber	Not present		
acknowledgement			
lpp-MessageBody CHOICE {			
c1 CHOICE {			
provideAssistanceData SEQUENCE {			
criticalExtensions CHOICE {			
c1 CHOICE {			
provideAssistanceData-r9 SEQUENCE {			
commonEsProvideAssistanceData	Not present		
a-gnss-ProvideAssistanceData	Not present		
otdoa-ProvideAssistanceData	Not present		
epdu-ProvideAssistanceData	Not present		
sensor-ProvideAssistanceData-r14	Not present		Rel-14 onwards
tbs-ProvideAssistanceData-r14 SEQUENCE {			Rel-14 onwards
tbs-AssistanceDataList-r14 SEQUENCE {			
mbs-AssistanceDataList-r14 SEQUENCE {			
mbs-AssistanceDataElement-r14 SEQUENCE {		Beacon 1 tb1	
mbs-AlmanacAssistance-r14	Not Present		
mbs-AcquisitionAssistance-r14	As defined in TS 37.571-5 [20], clause 8		
}			
mbs-AssistanceDataElement-r14 SEQUENCE {		Beacon 2 tb1	
mbs-AlmanacAssistance-r14	Not Present		
mbs-AcquisitionAssistance-r14	As defined in TS 37.571-5 [20], clause 8		
}			
mbs-AssistanceDataElement-r14 SEQUENCE {		Beacon 3 tb1	
mbs-AlmanacAssistance-r14	Not Present		
mbs-AcquisitionAssistance-r14	As defined in TS 37.571-5 [20], clause 8		
}			
mbs-AssistanceDataElement-r14 SEQUENCE {		Beacon 4 tb1	
mbs-AlmanacAssistance-r14	Not Present		
mbs-AcquisitionAssistance-r14	As defined in TS 37.571-5 [20], clause 8		
}			
mbs-AssistanceDataElement-r14 SEQUENCE {		Beacon 1 tb2	
mbs-AlmanacAssistance-r14	Not Present		
mbs-AcquisitionAssistance-r14	As defined in TS 37.571-5 [20], clause 8		
}			
mbs-AssistanceDataElement-r14 SEQUENCE {		Beacon 2 tb2	
mbs-AlmanacAssistance-r14	Not Present		
mbs-AcquisitionAssistance-r14	As defined in TS 37.571-5 [20], clause 8		
}			
mbs-AssistanceDataElement-r14 SEQUENCE {		Beacon 3 tb2	
mbs-AlmanacAssistance-r14	Not Present		
mbs-AcquisitionAssistance-r14	As defined in TS 37.571-5 [20], clause 8		
}			
mbs-AssistanceDataElement-r14 SEQUENCE {		Beacon 4 tb2	
mbs-AlmanacAssistance-r14	Not Present		
mbs-AcquisitionAssistance-r14	As defined in TS 37.571-5 [20], clause 8		

}			
}			
}			
tbs-Error-r14	Not Present		
}			
wlan-ProvideAssistanceData-r14	Not Present		Rel-14 onwards
}			
}			
}			
}			
}			
}			

11.4A.5 Test requirement

Same as defined in clause 11.4.5, with the beacon parameters set according to the assistance data in TS 37.571-5 [20] clause 8 and with the measurement accuracy requirements in Table 11.4A.5-1.

Table 11.4A.5-1: Accuracy requirements for Dynamic Range scenario

MBS Configuration	Beacon Signal Strength	Code phase measurement accuracy (ms) ^{Note 1}	Accuracy requirement for the difference of code phase measurements (ms) ^{Note 2}
TB1 (2 MHz)	High Power (-30 dBm)	5.0×10^{-5}	7.6×10^{-5}
	Low Power (-130 dBm)	1.66×10^{-4}	2.40×10^{-4}
TB2 (5 MHz)	High Power (-30 dBm)	2.0×10^{-5}	3.3×10^{-5}
	Low Power (-130 dBm)	6.6×10^{-5}	9.8×10^{-5}
Note 1: Provided for reference only			
Note 2: To be used for testing			

11.4B MBS Dynamic Range Measurement Accuracy (NR)

11.4B.1 Test purpose

Same as defined in clause 11.4.1

11.4B.2 Test applicability

This test applies to all types of NR UE that supports UE-assisted MBS with LPP Release 13 onwards.

11.4B.3 Minimum conformance requirements

For NR UE that supports LPP Release 13 only, same as defined in clause 11.4.3. For NR UE that supports LPP Release 14 onwards, same as defined in clause 11.4A.3

11.4B.4 Test description

11.4B.4.1 Initial conditions

Same as defined in clause 11.4.4.1, except in the case of NR UE, step 3 is modified as follows:

3. Establish a signalling connection according to the generic procedure in TS 38.508-1 [45] clause 4.5.4.

11.4B.4.2 Test procedure

For NR UE that supports LPP Release 13 only, same as defined in clause 11.4.4.2. For NR UE that supports LPP Release 14 onwards, same as defined in clause 11.4A.4.2

11.4B.4.3 Message contents

For NR UE that supports LPP Release 13 only, same as defined in clause 11.4.4.3. For NR UE that supports LPP Release 14 onwards, same as defined in clause 11.4A.4.3

11.4B.5 Test requirement

For NR UE that supports LPP Release 13 only, same as defined in clause 11.4.5. For NR UE that supports LPP Release 14 onwards, same as defined in clause 11.4A.5

11.5 MBS Measurement Accuracy in Multipath (Release 13 only)

11.5.1 Test purpose

The purpose of this test is to verify that the MBS Code Phase measurement accuracy is within the specified limits in a multipath environment. This test will verify the requirements in clause 5.5 of TS 37.171 [39] for MBS measurements. The channel type for the test is EPA 5 Hz, as specified in clause 4.8.2.2.

11.5.2 Test applicability

This test applies to all types of E-UTRA UE that supports UE-assisted MBS with LPP Release 13 only.

11.5.3 Minimum conformance requirements

The MBS code phase measurement accuracy shall fulfil the requirements in Table 11.5.3-1.

Table 11.5.3-1: Accuracy requirements for Multipath scenario

Direct Path Signal Strength (dBm)	Code phase measurement accuracy (ms) ^{Note 1}	Accuracy requirement for the difference of code phase measurements (ms) ^{Note 2}
-30	1.66×10^{-4}	2.35×10^{-4}
Note 1: Provided for reference only Note 2: To be used for testing		

The accuracy requirement for the difference of code phase measurements is derived from the requirement for the code phase measurement accuracy, assuming a scaling factor of $\sqrt{2}$ due to the compounding of two error distributions.

The normative reference for this requirement is TS 37.171 [39] clause 5.5 (Multipath) and clause A.4.3.

11.5.4 Test description

11.5.4.1 Initial conditions

Test environment: normal; see Annex G.

1. Connect SS and MSS to the UE antenna connector or antenna connectors as shown in figures A.6 or A.7.
2. Switch on the UE.
3. Establish a signalling connection according to the generic procedure in TS 36.508 [18] clause 4.5.3 (State 3, Generic RB established) on a channel in the Mid EARFCN range.

11.5.4.2 Test procedure

1. Set the MSS test parameters as specified in clause 11.5.5.
2. The SS shall send a RESET UE POSITIONING STORED INFORMATION message.
3. The SS shall send an LPP REQUEST CAPABILITIES message.
4. The UE shall transmit an LPP PROVID CAPABILITIES message indicating the TBS capabilities supported by the UE in the *TBS-ProvideCapabilities* IE.
5. The SS shall send a LPP REQUEST LOCATION INFORMATION message, including the *TBS-RequestLocationInformation*. If the UE message at step 4 includes the *ackRequested* IE set to TRUE, then the SS shall send an acknowledgment in the LPP REQUEST LOCATION INFORMATION message.
6. The UE shall perform and report the code phase measurement for each simulated beacon. If the UE transmits a *TBS-ProvideLocationInformation* IE including the *transmitterID* and *codePhase* field for the two simulated and the difference between *codePhase* field values for the two beacons meets the requirement in Table 11.5.5-3, then the number of successful tests is increased by one. Otherwise the number of failure tests is increased by one.
7. If the UE message at step 6 includes the *ackRequested* IE set to TRUE, the SS shall send a LPP acknowledgement message.
8. Repeat steps 1-7 until the confidence level according to Annex D is achieved. For each iteration, at step 1 reselect the PN code assigned to each MBS beacon.
9. Release the signalling connection.

11.5.4.3 Message contents

Table 11.5.4.3-1: RESET UE POSITIONING STORED INFORMATION

Derivation Path: TS 36.509 [11] clause 6.9			
Information Element	Value/remark	Comment	Condition
UE Positioning Technology	0 0 0 0 0 1 0	MBS	

Table 11.5.4.3-2: LPP Request Capabilities

Information Element	Value/remark
<i>tbs-RequestCapabilities-r13</i>	TRUE

Table 11.5.4.3-3: LPP RequestLocationInformation

Derivation Path: TS 36.355 [4] clause 6.2			
Information Element	Value/remark	Comment	Condition
LPP-Message ::= SEQUENCE {			
transactionID SEQUENCE {			
Initiator	locationServer		
transactionNumber	1		
}			
endTransaction	FALSE		
sequenceNumber	Not present		
acknowledgement	Not present		
lpp-MessageBody CHOICE {			
c1 CHOICE {			
requestLocationInformation SEQUENCE {			
criticalExtensions CHOICE {			
c1 CHOICE {			
requestLocationInformation-r9 SEQUENCE {			
commonIEsRequestLocationInformation SEQUENCE {			
locationInformationType	locationMeasurementsRequired		

triggeredReporting	Not present		
periodicalReporting	Not present		
additionalInformation	onlyReturnInformationRequested		
qos SEQUENCE {			
horizontalAccuracy	Not present		
verticalCoordinateRequest	FALSE		
verticalAccuracy	Not present		
responseTime SEQUENCE {			
Time	12		
responseTimeEarlyFix-r12	Not present		
}			
velocityRequest	FALSE		
}			
Environment	Not present		
locationCoordinateTypes	Not present		
velocityTypes	Not present		
}			
a-gnss-RequestLocationInformation	Not present		
otdoa-RequestLocationInformation	Not present		
ecid-RequestLocationInformation	Not present		
epdu-RequestLocationInformation	Not present		
sensor-RequestLocationInformation-r13	Not present		
tbs-RequestLocationInformation-r13 SEQUENCE {			
mbsSgnMeasListReq-r13	TRUE		
}			
wan-RequestLocationInformation-r13	Not present		
bt-RequestLocationInformation-r13	Not Present		
}			
}			
}			
}			
}			
}			
}			
}			
}			

Table 11.5.4.3-4: LPP ProvideLocationInformation

Derivation Path: TS 36.355 [4] clause 6.2			
Information Element	Value/remark	Comment	Condition
LPP-Message ::= SEQUENCE {			
transactionID SEQUENCE {			
Initiator	locationServer		
transactionNumber	1		
}			
endTransaction	TRUE		
sequenceNumber	(0..255)		
Acknowledgement			
lpp-MessageBody CHOICE {			
c1 CHOICE {			
provideLocationInformation SEQUENCE {			
criticalExtensions CHOICE {			
c1 CHOICE {			
provideLocationInformation-r9 SEQUENCE {			
commonIEsProvideLocationInformation	Not present.		
a-gnss-ProvideLocationInformation	Not present		
otdoa-ProvideLocationInformation	Not present		
ecid-ProvideLocationInformation	Not present		
epdu-ProvideLocationInformation	Not present		
sensor-ProvideLocationInformation-r13	Not present		
tbs-ProvideLocationInformation-r13 SEQUENCE {			
}			
}			
}			
}			
}			
}			
}			
}			
}			
}			

tbs-MeasurementInformation-r13 SEQUENCE {			
measurementReferenceTime-r13			
mbs-SgnMeasList-r13 SEQUENCE (SIZE(n)) {			
transmitterID-r13	Present		
codePhase-r13	Present		
codePhaseRMSError-r13			
}			
mbs-SgnMeasList-r13 SEQUENCE (SIZE(n)) {			
transmitterID-r13	Present		
codePhase-r13	Present		
codePhaseRMSError-r13			
}			
}			
tbs-Error-r13	May be present with error reason 'undefined' or 'thereWereNotEnoughMBSBeaconsReceived'		
}			
wlan-ProvideLocationInformation-r13	Not present		
bt-ProvideLocationInformation-r13	Not present		
}			
}			
}			
}			
}			
}			

11.5.5 Test requirement

The details of the beacon parameters are in Table 11.5.5-1 and Table 11.5.5-2.

Table 11.5.5-1: General test parameters for the beacons to be simulated for measurement accuracy in Multipath test

Parameter	Unit	Value	Comment
Number of beacons	Integer	2	Beacons transmitted in the any two beacon slots in the beacon transmission period, but static for the test. Other slots contain no simulated beacons. ^{Note 1}
Centre Frequency	MHz	925.977	
RF Channel	N/A	EPA 5 Hz	
MBS Beacon Configuration	N/A	TB1 (2 MHz)	For details see Annex H
MBS Packet Type	N/A	Type 2	For details see Annex H
Beacon PN Code	Integer	Chosen for each beacon from the PN code list for TB1	Each of the 2 beacons uses a different PN code For details see Annex H ^{Note 1}
Response time	Seconds	12	Value of Time used in LPP RequestLocationInformation message in Table 11.5.4.3-3
Note 1: The slots and PN codes are chosen at random, such that the UE does not and cannot have advanced knowledge of what that slot/PN code might be.			

Table 11.5.5-2: MBS Beacon Payload fields, and code phase delay difference and transmit powers for the beacons to be simulated for measurement accuracy in Multipath test

MBS Tx ID (See Annex H)	Slot Index (See Annex H)	All Other fields (See Annex H)	Code phase delay difference between beacons (ms)	Transmit Power (dBm)
Equal to Slot number	Equal to Slot number	min value (bit_value = 0) ^{Note 1}	0	-30
Note 1: bit_value is the conversion of the binary number represented by the corresponding bits in the payload to decimal.				

The MBS code phase measurement accuracy shall fulfil the requirements in Table 11.5.5-3.

Table 11.5.5-3: Accuracy requirements for Multipath scenario

Code phase measurement accuracy (ms) ^{Note 1}	Accuracy requirement for the difference of code phase measurements (ms) ^{Note 2}
1.66×10^{-4}	2.40×10^{-4}
Note 1: Provided for reference only Note 2: To be used for testing	

The test tolerances are defined in clauses C.1.4 and C.4.

The rate of successful tests during repeated tests shall be at least 90% with a confidence level of 95%.

11.5A MBS Measurement Accuracy in Multipath (Release 14 Onwards)

11.5A.1 Test purpose

Same as defined in clause 11.5.1

11.5A.2 Test applicability

This test applies to all types of E-UTRA UE that supports UE-assisted MBS with LPP Release 14 onwards.

11.5A.3 Minimum conformance requirements

Same as defined in clause 11.5.3

11.5A.4 Test description

11.5A.4.1 Initial conditions

Same as defined in clause 11.5.4.1

11.5A.4.2 Test procedure

Same as defined in clause 11.5.4.2, except step 4a is introduced and step 5 is modified as follows:

- 4a. The SS shall send an LPP PROVIDE ASSISTANCE DATA message to provide the MBS assistance data in accordance with TS 37.571-5 [20], and with the values defined therein. If the UE message at step 4 includes the *ackRequested* IE set to TRUE, then the SS shall send an acknowledgment in the LPP PROVIDE ASSISTANCE DATA message.
5. The SS shall send a LPP REQUEST LOCATION INFORMATION message, including the TBS RequestLocationInformation.

11.5A.4.3 Message contents

Same as defined in clause 11.5.4.3, with the addition of the LPP Provide Assistance Data.

Table 11.5A.4.3-5: LPP ProvideAssistanceData

Derivation Path: TS 36.355 [4] clause 6.2			
Information Element	Value/remark	Comment	Condition
LPP-Message ::= SEQUENCE {			
transactionID SEQUENCE {			
Initiator	locationServer		
transactionNumber	(0..255)		
}			
endTransaction	TRUE		
sequenceNumber	Not present		
acknowledgement			
lpp-MessageBody CHOICE {			
c1 CHOICE {			
provideAssistanceData SEQUENCE {			
criticalExtensions CHOICE {			
c1 CHOICE {			
provideAssistanceData-r9 SEQUENCE {			
commonEsProvideAssistanceData	Not present		
a-gnss-ProvideAssistanceData	Not present		
otdoa-ProvideAssistanceData	Not present		
epdu-ProvideAssistanceData	Not present		
sensor-ProvideAssistanceData-r14	Not present		Rel-14 onwards
tbs-ProvideAssistanceData-r14 SEQUENCE {			Rel-14 onwards
tbs-AssistanceDataList-r14 SEQUENCE {			
mbs-AssistanceDataList-r14 SEQUENCE {			
mbs-AssistanceDataElement-r14 SEQUENCE {		Beacon 1 tb1	
mbs-AlmanacAssistance-r14	Not Present		
mbs-AcquisitionAssistance-r14	As defined in TS 37.571-5 [20], clause 8		
}			
mbs-AssistanceDataElement-r14 SEQUENCE {		Beacon 2 tb1	
mbs-AlmanacAssistance-r14	Not Present		
mbs-AcquisitionAssistance-r14	As defined in TS 37.571-5 [20], clause 8		
}			
mbs-AssistanceDataElement-r14 SEQUENCE {		Beacon 1 tb2	
mbs-AlmanacAssistance-r14	Not Present		
mbs-AcquisitionAssistance-r14	As defined in TS 37.571-5 [20], clause 8		
}			
mbs-AssistanceDataElement-r14 SEQUENCE {		Beacon 2 tb2	
mbs-AlmanacAssistance-r14	Not Present		
mbs-AcquisitionAssistance-r14	As defined in TS 37.571-5 [20], clause 8		
}			
}			
}			
tbs-Error-r14	Not Present		
}			
wlan-ProvideAssistanceData-r14	Not Present		Rel-14 onwards
}			
}			
}			
}			

}			
}			
}			

11.5A.5 Test requirement

Same as defined in clause 11.5.5, with the beacon parameters set according to the assistance data in TS 37.571-5 [20] clause 8.

11.5B MBS Measurement Accuracy in Multipath (NR)

11.5B.1 Test purpose

Same as defined in clause 11.5.1.

11.5B.2 Test applicability

This test applies to all types of NR UE that supports UE-assisted MBS with LPP Release 13 onwards.

11.5B.3 Minimum conformance requirements

Same as defined in clause 11.5.3.

11.5B.4 Test description

11.5B.4.1 Initial conditions

For NR UE that supports LPP Release 13 only, same as defined in clause 11.5.4.1. For NR UE that supports LPP Release 14 onwards, same as defined in clause 11.5A.4.1.

11.5B.4.2 Test procedure

For NR UE that supports LPP Release 13 only, same as defined in clause 11.5.4.2. For NR UE that supports LPP Release 14 onwards, same as defined in clause 11.5A.4.2.

11.5B.4.3 Message contents

For NR UE that supports LPP Release 13 only, same as defined in clause 11.5.4.3. For NR UE that supports LPP Release 14 onwards, same as defined in clause 11.5A.4.3.

11.5B.5 Test requirement

For NR UE that supports LPP Release 13 only, same as defined in clause 11.5.5. For NR UE that supports LPP Release 14 onwards, same as defined in clause 11.5A.5.

12 E-UTRA WLAN and BLE measurement requirements

12.0 General

This clause defines the minimum performance requirements for WLAN and/or BLE FDD and TDD E-UTRA UEs and NR UEs. Details for NR UEs are FFS.

12.1 WLAN Access Point Identification and Reporting Delay

12.1.1 WLAN AP Identification and reporting delay under nominal conditions

12.1.1.1 Test purpose

The purpose of this test is to verify that the E-UTRAN UE WLAN AP measurements fulfil the performance requirements for WLAN AP identification under nominal conditions in TS 37.171 [39] clause 7.3 and reporting delay in TS 37.171 [39] clause 4.3.

12.1.1.2 Test applicability

This test applies to all types of E-UTRA UE that support LPP release 14 and forward and WLAN positioning. Optionally, this test can be run by LPP release 13 UEs.

12.1.1.3 Minimum conformance requirements

Under nominal conditions of the WLAN signal, the UE shall be able to identify 6 WLAN APs. The minimum requirements for Nominal conditions are shown in Table 12.1.1.3-1. In these requirements, AWGN channel model is used and the signal level is above the noise floor.

Table 12.1.1.3-1: Requirements for WLAN Access Point Identification under Nominal conditions

Number of WLAN APs	Signal Strength (dBm)	% of reported Access Points
6	-60	90

For LTE, the WLAN measurement time is defined as the time starting from the moment that the UE has received the LPP message of type REQUEST LOCATION INFORMATION, and ending when the UE starts sending the LPP message of type PROVIDE LOCATION INFORMATION on the Uu interface. The response times specified for all test cases are based on new measurements unless otherwise stated, i.e. the UE shall not re use any information on measurements or other aiding data that was previously acquired or calculated and stored internally in the UE. A dedicated test message 'RESET UE POSITIONING STORED INFORMATION' has been defined in TS 36.509 [11] clause 6.9 for the purpose of deleting this information. No WLAN assistance data is provided to the UE.

The signals from the WLAN APs shall be available at the UE for the duration of the measurement time. Each WLAN AP transmits a beacon signal with a beacon interval smaller or equal to 102.4 ms. The beacon frames from different access points shall be transmitted in different time slots or non-overlapping frequency channels. The beacon frames have variable time duration of ~1ms.

The WLAN Measurement Reporting Delay is given as:

$$T_{\text{WLAN_meas}} = \tau + 20 \text{ sec}$$

where:

$T_{\text{WLAN_meas}}$ is the total time for detecting and measuring the WLAN Access Points

τ is the elapsed time from the trigger of the measurement to the start of the first WLAN transmission period and is shown in Figure 12.1.1.3-1.

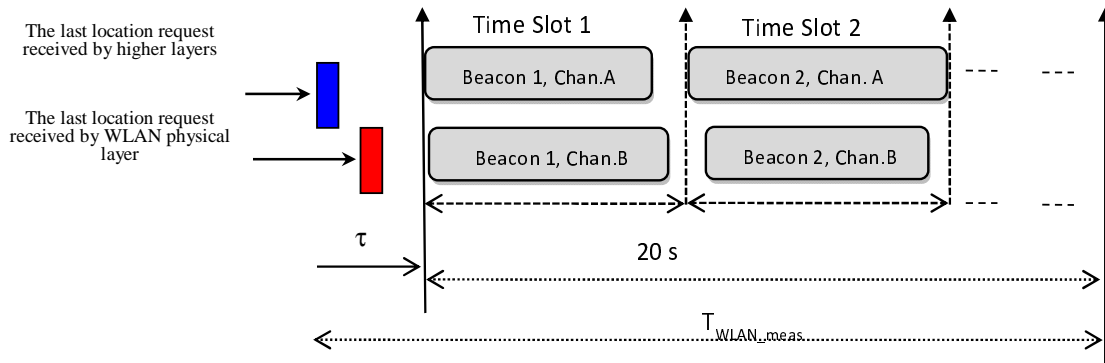

Figure 12.1.1.3-1: Illustration of the WLAN Measurement Time

The normative reference for the WLAN reporting delay requirement is 3GPP TS 37.171 [39] clause 4.3 and the normative reference for the WLAN AP Identification under nominal conditions requirement is 3GPP TS 37.171 [39] clause 7.3.

12.1.1.4 Test description

There is one active LTE cell and 6 WLAN APs transmitting beacon signals at least every 102.4 ms. The APs are transmitting in 3 non-overlapping frequency channels in the same WLAN Frequency Band. Non-overlapping frequency channels are those whose centre frequencies are separated by at least 25 MHz in the WLAN 2.4 GHz band and by at least 20 MHz in the WLAN 5 GHz band. There are 2 APs in every channel. The tested UE is connected to the serving cell and signalled to report WLAN AP measurements. The test consists of two successive time periods, with duration of T1 and T2, respectively. WLAN-RequestLocationInformation message shall be provided to the UE during T1. WLAN Access Points only transmit signal during T2. The test equipment compares the BSSID reported by the UE in the WLAN AP measurements with the BSSID of the APs simulated in the test.

12.1.1.4.1 Initial conditions

Test Environment: Normal as defined in TS 36.508 [18] clause 4.1.

E-UTRA frequencies to be tested: Mid Range, as defined in TS 36.508 [18] clause 4.3.1.

WLAN Channel Numbers to be tested: as specified in Table 12.1.1.5-2 and as defined in TS 36.508 [18] clause 4.3.1.6.

1. Connect the SS (node B emulator) and AWGN noise source to the UE antenna connectors as shown in Annex A figure A.8.
2. Propagation conditions are set according to clause 4.9.2.1.
3. Message contents are defined in clause 12.1.1.4.3.
4. Cell 1 is the serving cell. Cell 1 is the cell used for connection setup with the power levels set according to TS 36.521-3 [25] clauses C.0 and C.1 for this test. After the connection is established, the parameter settings for the cell are set according to Table 12.1.1.5-2.
5. Switch on the UE.
6. Establish a signalling connection according to the generic procedure in TS 36.508 [18] clause 4.5.3 (State 3, Generic RB established) on a channel in the Mid EARFCN range.

12.1.1.4.2 Test procedure

1. Set the SS test parameters as specified in clause 12.1.1.5. The BSSID of the simulated APs shall be generated in a random manner.

2. The SS shall send a RESET UE POSITIONING STORED INFORMATION message.
3. T1 starts.
4. The SS shall send an LPP REQUEST CAPABILITIES message.
5. The UE shall transmit an LPP PROVIDE CAPABILITIES message indicating the WLAN capabilities supported by the UE in the *WLAN-ProvideCapabilities* IE.
6. The SS shall send a LPP REQUEST LOCATION INFORMATION message, including the *WLAN-RequestLocationInformation* IE such that the UE receives the message ΔT ms before the start of T2, where $\Delta T = 150$ ms. If the UE message at step 5 includes the *ackRequested* IE set to TRUE, then the SS shall send an acknowledgment in the LPP REQUEST LOCATION INFORMATION message.
- 6a. If the UE sends a LPP REQUEST ASSISTANCE DATA message requesting WLAN assistance data, the SS shall send a LPP PROVIDE ASSISTANCE DATA message, including *wlan-ProvideAssistanceData-r14* IE with no WLAN assistance data and the *wlan-Error-r14* IE with *WLAN-LocationServerErrorCauses-r13* with *cause-r13* set to *requestedADNotAvailable-v1420*.

If the UE message includes the *ackRequested* IE set to TRUE, then the SS shall send an acknowledgment in the LPP PROVIDE ASSISTANCE DATA message.
7. When T1 expires, the SS shall switch the WLAN power setting from T1 to T2 as specified in Table 12.1.1.5-2.
8. The UE shall perform and report the WLAN AP measurements for the simulated WLAN APs. The UE shall transmit a *WLAN-ProvideLocationInformation* IE including the *wlan-MeasurementList-r13* field. If the report is sent within the maximum response time specified in Clause 12.1.1.5 and it includes WLAN Measurements for at least the percentage of the simulated APs indicated in Table 12.1.1.3-1, the number of successful tests is increased by one. Otherwise, the number of failure tests is increased by one. The verification shall be done by comparing the reported list of *bssid-r13* against the simulated BSSIDs.
9. If the UE message at step 8 includes the *ackRequested* IE set to TRUE, the SS shall send a LPP acknowledgement message.
10. Repeat steps 1-9 until the confidence level according to Annex D, clauses D.4.3 and D.4.4 is achieved. For each iteration, at step 1 reselect a new list of WLAN APs. The BSSID of the new APs shall be different from the previous set of simulated BSSIDs.
- 10a. The test is repeated for both the 2.4GHz and 5GHz WLAN bands if supported by the UE.
11. Release the signalling connection.

12.1.1.4.3 Message contents

Message contents are according to TS 36.508 [18] clause 4.6 with the following exceptions:

Table 12.1.1.4.3-1: RESET UE POSITIONING STORED INFORMATION

Derivation Path: 36.509 [11] clause 6.9			
Information Element	Value/remark	Comment	Condition
UE Positioning Technology	0 0 0 0 0 1 1	WLAN	

Table 12.1.1.4.3-2: LPP-RequestCapabilities

Derivation Path: 36.355 [4] clause 6.3	
Information Element	Value/remark
<i>wlan-RequestCapabilities-r13</i>	TRUE

Table 12.1.1.4.3-3: LPP-RequestLocationInformation

Derivation Path: TS 36.355 clause 6.3			
Information Element	Value/remark	Comment	Condition
LPP-Message ::= SEQUENCE {			

lpp-MessageBody CHOICE {			
c1 CHOICE {			
requestLocationInformation SEQUENCE {			
criticalExtensions CHOICE {			
c1 CHOICE {			
requestLocationInformation-r9 SEQUENCE {			
commonEsRequestLocationInformation SEQUENCE {			
locationInformationType	locationMeasurementsRequired		
additionalInformation	onlyReturnInformationRequested		
qos SEQUENCE {			
verticalCoordinateRequest	FALSE		
responseTime SEQUENCE {			
time	21	See clause 12.1.1.5	
}			
velocityRequest	FALSE		
}			
}			
}			
}			
}			
}			
}			

12.1.1.5 Test requirement

The UE shall send *WLAN-ProvideLocationInformation* within a maximum response time of 21.15 seconds (including test tolerance of 300ms) from the beginning of T2. The maximum response time is equal to the LPP time IE value of 21 seconds, minus ΔT, where ΔT = 150 ms, plus the test tolerance of 300ms. The LPP time IE value is derived from T_{WLAN_meas} , where $T_{WLAN_meas} = \tau + 20$ seconds as described in clause 12.1.1.3, and where the value of τ is equal to ΔT, where ΔT = 150 ms, plus one beacon interval, which is taken as 100 ms, giving a value for τ of 250 ms. This value for T_{WLAN_meas} of 20.25 seconds is then rounded up to the next allowed LPP value of 21 seconds.

The *wlan-MeasurementInformation* IE shall include WLAN measurements for each AP indicating at least wlan-AP-Identifier (BSSID) and RSSI (if reporting of RSSI is supported by the UE as indicated by the UE in the LPP PROVIDE CAPABILITIES message). The list of reported BSSIDs shall contain at least the BSSID of 90% of the WLAN APs simulated in the test, as defined in Table 12.1.1.3-1.

The rate of correct events observed during repeated tests shall be at least 90% with a confidence level of 95%.

Table 12.1.1.5-1: General WLAN AP test parameters for WLAN AP Identification and reporting delay under nominal conditions test

Parameter	Unit	Value	Comment
Number of Access Points	N/A	6	AP 1-AP 6
Time Slot 1	ms	1	AP 1, AP 2

Time Slot 2	ms	1	AP 3, AP 4
Time Slot 3	ms	1	AP 5
Time Slot 4	ms	1	AP 6
T1	s	5	During this time the WLAN signals are not transmitted
T2	s	25	UE should report WLAN measurement information within 21.15s (including test tolerance)

Table 12.1.1.5-2: Cell specific and WLAN AP specific test parameters for WLAN AP Identification and reporting delay under nominal conditions test

Parameter	Unit	Cell 1		AP.1, 4		AP.2, 5		AP.3, 6	
		T1	T2	T1	T2	T1	T2	T1	T2
WLAN Test Frequency ID		N/A		1		2		3	
PDSCH parameters: DL Reference Measurement Channel ^{Note 6}		R.0 FDD R.0 TDD		N/A		N/A		N/A	
PCFICH/PDCCH/PHICH parameters: DL Reference Measurement Channel ^{Note 6}		R.6 FDD R.6 TDD		N/A		N/A		N/A	
OCNG Patterns ^{Note 6}		OP.1 FDD OP.1 TDD		N/A		N/A		N/A	
PBCH_RA	dB	0		N/A		N/A		N/A	
PBCH_RB	dB								
PSS_RA	dB								
SSS_RA	dB								
PCFICH_RB	dB								
PHICH_RA	dB								
PHICH_RB	dB								
PDCCH_RA	dB								
PDCCH_RB	dB								
PDSCH_RA	dB								
PDSCH_RB	dB								
OCNG_RA ^{Note 1}	dB								
OCNG_RB ^{Note 1}	dB								
N_{oc1} ^{Note 2}	dBm/15 KHz								
N_{oc2} ^{Note 3}	dBm/20 MHz	N/A		-75		-75		-75	
\hat{E}_s/N_{oc1}	dB	3	3	N/A		N/A		N/A	
\hat{E}_s/I_{ot} ^{Note 4}	dB	3	3						
RSRP ^{Note 4}	dBm/15 kHz	-95	-95						
SCH_RP ^{Note 4}	dBm/15 kHz	-95	-95						
I_o ^{Note 3}	dBm/Ch BW	-65.5	-65.5						
WLAN Received Power Level	dBm	N/A	N/A	-	-60	-	-60	-	-60
WLAN SNR ^{Note 4}	dB	N/A		15		15		15	
Propagation Condition		AWGN							
Antenna Configuration		1x2		-		-		-	
Note 1:	OCNG shall be used such that all cells are fully allocated and a constant total transmitted power spectral density is achieved for all OFDM symbols.								
Note 2:	Interference from other cells and noise sources not specified in the test is assumed to be constant over subcarriers and time and shall be modelled as AWGN of appropriate power for N_{oc1} to be fulfilled.								
Note 3:	Interference from other cells and noise sources not specified in the test is assumed to be constant over the bandwidth and time and shall be modelled as AWGN of appropriate power for N_{oc2} to be fulfilled.								
Note 4:	Es/Iot, RSRP, SCH_RP, Io and WLAN SNR have been derived from other parameters for information purposes. They are not settable parameters themselves.								
Note 5:	The resources for uplink transmission are assigned to the UE prior to the start of time period T2.								
Note 6:	If Cell 1 is LTE FDD, the FDD OCNG and RMCs shall be used. If Cell 1 is LTE TDD, the TDD OCNG and RMCs shall be used.								

12.1.2 WLAN AP Identification and reporting delay under dynamic range conditions

12.1.2.1 Test purpose

The purpose of this test is to verify that the E-UTRAN UE WLAN AP measurements fulfil the performance requirements for WLAN AP identification under dynamic range conditions in TS 37.171 [39] clause 7.4 and reporting delay in TS 37.171 [39] clause 4.3.

12.1.2.2 Test applicability

This test applies to all types of E-UTRA UE that support LPP release 14 and forward and WLAN positioning. Optionally, this test can be run by LPP release 13 UEs.

12.1.2.3 Minimum conformance requirements

The WLAN Access Point identification under dynamic range conditions verifies the UE capability to identify and report WLAN APs when the received power difference between WLAN APs is large. The power difference between APs follows the adjacent channel rejection criteria defined by IEEE in [40].

The UE shall be able to identify at least 3 WLAN AP located in 3 adjacent channels where the separation between channels is ≥ 20 MHz and the middle channel is received with high power and the side channels are received with low power.

Table 12.1.2.3-1: Requirements for WLAN Access Point Identification under Dynamic Range conditions

Number of WLAN APs	Signal Strength (dBm)	% of reported Access Points
3	See [40]	100

For LTE, the WLAN measurement time is defined as the time starting from the moment that the UE has received the LPP message of type REQUEST LOCATION INFORMATION, and ending when the UE starts sending the LPP message of type PROVIDE LOCATION INFORMATION on the Uu interface. The response times specified for all test cases are based on new measurements unless otherwise stated, i.e. the UE shall not re use any information on measurements or other aiding data that was previously acquired or calculated and stored internally in the UE. A dedicated test message 'RESET UE POSITIONING STORED INFORMATION' has been defined in TS 36.509 [11] clause 6.9 for the purpose of deleting this information. No WLAN assistance data is provided to the UE.

The signals from the WLAN APs shall be available at the UE for the duration of the measurement time. Each WLAN AP transmits a beacon signal with a beacon interval smaller or equal to T_{WLAN_TP} (102.4 ms). The beacon frames from different access points shall be transmitted in different time slots or non-overlapping frequency channels. The beacon frames have variable time duration of ~ 1 ms.

The WLAN Measurement Reporting Delay is given as:

$$T_{WLAN_meas} = \tau + 20 \text{ .sec}$$

where:

T_{WLAN_meas} is the total time for detecting and measuring the WLAN Access Points

τ is the elapsed time from the trigger of the measurement to the start of the first WLAN transmission period and is shown in Figure 12.1.1.3-1.

The normative reference for the WLAN reporting delay requirement is 3GPP TS 37.171 [39] clause 4.3 and the normative reference for the WLAN AP Identification under dynamic range requirement is 3GPP TS 37.171 [39] clause 7.4.

12.1.2.4 Test description

In this test, there are LTE cell1 and 3 WLAN APs transmitting beacon signals at least every 102.4 ms. The APs are transmitting in 3 non-overlapping frequency channels in the same WLAN Frequency Band. Non-overlapping frequency channels are those whose centre frequencies are separated by at least 25 MHz in the WLAN 2.4 GHz band and by at least 20 MHz in the WLAN 5 GHz band. There is 1 AP in every channel. The tested UE is connected to the serving cell and signalled to report WLAN AP measurements. The test consists of two successive time periods, with duration of T1 and T2, respectively. WLAN-RequestLocationInformation message shall be provided to the UE during T1. WLAN Access Points only transmit signal during T2. The test equipment compares the BSSID reported by the UE in the WLAN AP measurements with the BSSID of the APs simulated in the test.

12.1.2.4.1 Initial conditions

Same as in Clause 12.1.1.4.1

12.1.2.4.2 Test procedure

Same as in clause 12.1.1.4.2 with the exception that SS test parameters are specified in clause 12.1.2.5 and the percentage of reported WLAN APs to count an iteration as successful is defined in Table 12.1.2.3-1

12.1.2.4.3 Message contents

Same as in clause 12.1.1.4.3.

12.1.2.5 Test requirement

The UE shall send *WLAN-ProvideLocationInformation* within a maximum response time of 21.15 seconds (including test tolerance of 300ms) from the beginning of T2. See clause 12.1.1.5 for more details.

The *wlan-MeasurementInformation* IE shall include WLAN measurements for each AP indicating at least wlan-AP-Identifier (BSSID) and RSSI (if reporting of RSSI is supported by the UE as indicated by the UE in the LPP PROVIDE CAPABILITIES message). The list of reported BSSIDs shall contain the BSSID of 100% of the WLAN APs simulated in the test, as defined in Table 12.1.2.3-1.

The rate of correct events observed during repeated tests shall be at least 90% with a confidence level of 95%.

Table 12.1.2.5-1: General test parameters for WLAN AP Identification and reporting delay under dynamic range conditions test

Parameter	Unit	Value	Comment
Number of Access Points	N/A	3	AP 1-AP 3
Time Slot 1	ms	1	AP 1, AP 2, AP 3
T1	s	5	During this time the WLAN signals are not transmitted
T2	s	25	UE should report WLAN measurement information within 21.15s (including test tolerance)

Table 12.1.2.5-2: Cell specific test parameters for WLAN AP Identification and reporting delay under dynamic range conditions test

Parameter	Unit	Cell 1		AP 1		AP 2		AP 3	
		T1	T2	T1	T2	T1	T2	T1	T2
WLAN Channel Number		N/A		1		2		3	
PDSCH parameters: DL Reference Measurement Channel ^{Note 6}		R.0 FDD R.0 TDD		N/A		N/A		N/A	
PCFICH/PDCCH/PHICH parameters: DL Reference Measurement Channel ^{Note 6}		R.6 FDD R.6 TDD		N/A		N/A		N/A	
OCNG Patterns ^{Note 6}		OP.1 FDD OP.1 TDD		N/A		N/A		N/A	

PBCH_RA	dB								
PBCH_RB	dB								
PSS_RA	dB								
SSS_RA	dB								
PCFICH_RB	dB								
PHICH_RA	dB								
PHICH_RB	dB	0		N/A		N/A		N/A	
PDCCH_RA	dB								
PDCCH_RB	dB								
PDSCH_RA	dB								
PDSCH_RB	dB								
OCNG_RA ^{Note 1}	dB								
OCNG_RB ^{Note 1}	dB								
N_{oc1} ^{Note 2}	dBm/15 kHz	-98		N/A		N/A		N/A	
N_{oc2} ^{Note 3}	dBm/20 MHz	N/A		-85		-85		-85	
\bar{E}_s/N_{oc1}	dB	3	3						
\bar{E}_s/I_{ot} ^{Note 4}	dB	3	3						
RSRP ^{Note 4}	dBm/15 kHz	-95	-95						
SCH_RP ^{Note 4}	dBm/15 kHz	-95	-95						
I_o ^{Note 3}	dBm/Ch BW	-	-						
WLAN Received Power Level	dBm	N/A	N/A	- inf	WLAN 2.4 GHz band: -73 WLAN 5 GHz band: -78	- inf	WLAN 2.4 GHz band: -39 WLAN 5 GHz band: -63	- inf	WLAN 2.4 GHz band: -73 WLAN 5 GHz band: -78
WLAN SNR ^{Note 4}	db	N/A		WLAN 2.4 GHz band: 12 WLAN 5 GHz band: 7		WLAN 2.4 GHz band: 46 WLAN 5 GHz band: 22		WLAN 2.4 GHz band: 12 WLAN 5 GHz band: 7	
Propagation Condition		AWGN							
Antenna Configuration		1x2		-		-		-	
Note 1:	OCNG shall be used such that all cells are fully allocated and a constant total transmitted power spectral density is achieved for all OFDM symbols.								
Note 2:	Interference from other cells and noise sources not specified in the test is assumed to be constant over subcarriers and time and shall be modelled as AWGN of appropriate power for N_{oc1} to be fulfilled.								
Note 3:	Interference from other cells and noise sources not specified in the test is assumed to be constant over the bandwidth and time and shall be modelled as AWGN of appropriate power for N_{oc2} to be fulfilled.								
Note 4:	\bar{E}_s/I_{ot} , RSRP, SCH_RP, I_o and WLAN SNR have been derived from other parameters for information purposes. They are not settable parameters themselves.								
Note 5:	The resources for uplink transmission are assigned to the UE prior to the start of time period T2.								
Note 6:	If Cell 1 is LTE FDD, the FDD OCNG and RMCs shall be used. If Cell 1 is LTE TDD, the TDD OCNG and RMCs shall be used.								

12.2 BLE Identification and Reporting Delay

12.2.1 Bluetooth identification

12.2.1.1 Test purpose

The purpose of this test is to verify that the E-UTRAN UE BLE measurements fulfil the performance requirements for Bluetooth Access Point identification and reporting delay in TS 37.171 [39] clause 4.4.

12.2.1.2 Test applicability

This test applies to all types of E-UTRA UE that support LPP release 14 and forward and BLE positioning. Optionally, this test can be run by LPP release 13 UEs.

12.2.1.3 Minimum conformance requirements

In the RRC_CONNECTED state the measurement period for Bluetooth Access Point identification shall be T_{BT_meas} . The value of T_{BT_meas} is 10.24s, and can be extended to 40.96s if extended inquiry is allowed, provided that the following conditions are met:

- At least one Bluetooth beacon signal is transmitted on one of the Bluetooth advertising channels with a broadcast interval of 100 ms.

The UE physical layer shall be capable of reporting Bluetooth Access Point(s) measurements to higher layers within the measurement period of T_{BT_meas} . For LTE, the BLE measurement time is defined as the time starting from the moment that the UE has received the LPP message of type REQUEST LOCATION INFORMATION, and ending when the UE starts sending the LPP message of type PROVIDE LOCATION INFORMATION on the Uu interface. The response times specified for all test cases are based on new measurements unless otherwise stated, i.e. the UE shall not re use any information on measurements or other aiding data that was previously acquired or calculated and stored internally in the UE. A dedicated test message 'RESET UE POSITIONING STORED INFORMATION' has been defined in TS 36.509 [11] clause 6.9 for deleting this information.

The signals from the BLE devices shall be available at the UE for the duration of the measurement time. Each BLE device transmits a beacon signal with a broadcast interval of T_{BLE_TP} of 100 ms. Beacon frames from different BLE devices shall be transmitted in different time slots or non-overlapping frequency channels.

The normative reference for this requirement is 3GPP TS 37.171 [39] clause 4.4.

12.2.1.4 Test description

There is one active LTE cell and 6 BLE devices transmitting advertising non-connectable beacon signals at least every 100 ms. The BLE devices are transmitting in 3 non-overlapping BLE advertising frequency channels. The BLE advertising channels are Channel 37 (2402 MHz), Channel 38 (2426 MHz) and Channel 39 (2480 MHz). There are 2 BLE devices transmitting in each channel. The tested UE is connected to the serving cell and signalled to report BLE measurements. The test consists of two successive time periods, with duration of T1 and T2, respectively. BT-RequestLocationInformation message shall be provided to the UE during T1. BLE devices only transmit signal during T2. The test equipment compares the UUID reported by the UE in the BLE measurements with the UUID of the BLE devices simulated in the test.

12.2.1.4.1 Initial conditions

Test Environment: Normal as defined in TS 36.508 [18] clause 4.1.

E-UTRA frequencies to be tested: Mid Range, as defined in TS 36.508 [18] clause 4.3.1.

1. Connect the SS (node B emulator) and AWGN noise source to the UE antenna connectors as shown in Annex A figure A.9.
2. Propagation conditions are set according to clause 4.10.2.1.
3. Message contents are defined in clause 12.2.1.4.3.
4. Cell 1 is the serving cell. Cell 1 is the cell used for connection setup with the power levels set according to TS 36.521-3 [25] clauses C.0 and C.1 for this test. After the connection is established, the parameter settings for the cell are set according to Table 12.2.1.5-2.
5. Switch on the UE.
6. Establish a signalling connection according to the generic procedure in TS 36.508 [18] clause 4.5.3 (State 3, Generic RB established) on a channel in the Mid EARFCN range.

12.2.1.4.2 Test procedure

1. Set the SS test parameters as specified in clause 12.2.1.5. The UUID of the simulated BLE devices shall be generated in a random manner.
2. The SS shall send a RESET UE POSITIONING STORED INFORMATION message.

3. T1 starts.
4. The SS shall send an LPP REQUEST CAPABILITIES message.
5. The UE shall transmit an LPP PROVIDE CAPABILITIES message indicating the BLE capabilities supported by the UE in the *BT-ProvideCapabilities* IE.
6. The SS shall send a LPP REQUEST LOCATION INFORMATION message, including the *BT-RequestLocationInformation* IE such that the UE receives the message ΔT ms before the start of T2, where $\Delta T = 150$ ms. If the UE message at step 5 includes the *ackRequested* IE set to TRUE, then the SS shall send an acknowledgment in the LPP REQUEST LOCATION INFORMATION message.
7. When T1 expires, the SS shall switch the BLE power setting from T1 to T2 as specified in Table 12.2.1.5-2.
8. The UE shall perform and report the BLE measurements for the simulated BLE devices. The UE shall transmit a *BT-ProvideLocationInformation* IE including the *BT-MeasurementList-r13* field. If the report is sent within the maximum response time specified in Clause 12.2.1.5 and it includes BT Measurements for all of the simulated BLE devices, the number of successful tests is increased by one. Otherwise, the number of failure tests is increased by one. The verification shall be done by comparing the reported list of *btAddr-r13* against the simulated UUIDs.
9. If the UE message at step 8 includes the *ackRequested* IE set to TRUE, the SS shall send a LPP acknowledgement message.
10. Repeat steps 1-9 until the confidence level according to Annex D, clauses D.4.3 and D.4.4 is achieved. For each iteration, at step 1 reselect a new list of BLE devices. The UUID of the new BLE devices shall be different from the previous set of simulated UUIDs.
11. Release the signalling connection.

12.2.1.4.3 Message contents

Message contents are according to TS 36.508 [18] clause 4.6 with the following exceptions:

Table 12.2.1.4.3-1: RESET UE POSITIONING STORED INFORMATION

Derivation Path: 36.509 [11] clause 6.9			
Information Element	Value/remark	Comment	Condition
UE Positioning Technology	0 0 0 0 1 0 0	BLE	

Table 12.2.1.4.3-2: LPP-RequestCapabilities

Derivation Path: 36.355 [4] clause 6.3	
Information Element	Value/remark
<i>bt-RequestCapabilities-r13</i>	TRUE

Table 12.2.1.4.3-3: LPP-RequestLocationInformation

Derivation Path: TS 36.355 clause 6.3			
Information Element	Value/remark	Comment	Condition
LPP-Message ::= SEQUENCE {			
lpp-MessageBody CHOICE {			
c1 CHOICE {			
requestLocationInformation SEQUENCE {			
criticalExtensions CHOICE {			
c1 CHOICE {			
requestLocationInformation-r9 SEQUENCE {			
commonIEsRequestLocationInformation SEQUENCE {			
locationInformationType	locationMeasurementsRequired		
additionalInformation	onlyReturnInformationRequested		

qos SEQUENCE {			
verticalCoordinateRequest	FALSE		
responseTime SEQUENCE {			
time	11	See clause 12.2.1.5	
}			
velocityRequest	FALSE		
}			
}			
BT-RequestLocationInformation-r13 ::= SEQUENCE {			
requestedMeasurements-r13	If reporting of RSSI is supported by the UE: 1 If reporting of RSSI is not supported by the UE: 0	RSSI Requested if reporting of RSSI is supported by the UE as indicated by IE rssi-r13 in the LPP PROVIDE CAPABILITIES message	
}			
}			
}			
}			
}			
}			
}			
}			
}			

12.2.1.5 Test requirement

The UE shall send *BT-ProvideLocationInformation*, within a maximum response time of 11.15 seconds (including test tolerance of 300ms) from the beginning of time period T2. The maximum response time is equal to the LPP time IE value of 11 seconds, minus ΔT, where ΔT = 150 ms, plus the test tolerance of 300ms. The LPP time IE value is derived from T_{BT_meas}, where T_{BT_meas} is 10.24 seconds as described in clause 12.2.1.3, plus one broadcast interval, which is taken as 100 ms, giving a total value of 10.34 seconds which is then rounded up to the next allowed LPP value of 11 seconds.

The *BT-ProvideLocationInformation* IE shall include BT Measurements for all of the simulated BLE devices identified by the corresponding UUID.

The rate of correct events observed during repeated tests shall be at least 90% with a confidence level of 95%.

Table 12.2.1.5-1: General test parameters for Bluetooth Identification

Parameter	Unit	Value	Comment
Bluetooth Low Energy (BLE) Devices		BLE 1, BLE 2, BLE 3, BLE 4, BLE 5 and BLE 6	BLE 1 and BLE 2 are on Bluetooth Advertising Channel 1 (2402 MHz). BLE 3 and BLE 4 are on Bluetooth Advertising Channel 2 (2426 MHz). BLE 5 and BLE 6 are on Bluetooth Advertising Channel 3 (2480 MHz).
Bluetooth Advertising Channel Numbers and frequencies		Channel 37:2402 MHz, Channel 38:2426 MHz, Channel 39:2480 MHz	
Bluetooth beacon signal broadcast interval	ms	100 ms	
T1	s	5	During this time the BLE signals are not transmitted
T2	s	15	UE should report Bluetooth measurement information within 10.54s.

Table 12.2.1.5-2: Cell specific test parameters for Bluetooth Identification

Parameter	Unit	Cell 1		BLE 1, BLE 2		BLE 3, BLE 4		BLE 5, BLE 6	
		T1	T2	T1	T2	T1	T2	T1	T2
Bluetooth Advertising Channel Number		N/A		37		38		39	
PDSCH parameters: DL Reference Measurement Channel ^{Note 6}		R.0 FDD R.0 TDD		N/A		N/A		N/A	
PCFICH/PDCCH/PHICH parameters: DL Reference Measurement Channel ^{Note 6}		R.6 FDD R.6 TDD		N/A		N/A		N/A	
OCNG Patterns ^{Note 6}		OP.1 FDD OP.1 TDD		N/A		N/A		N/A	
PBCH_RA	dB	0		N/A		N/A		N/A	
PBCH_RB	dB								
PSS_RA	dB								
SSS_RA	dB								
PCFICH_RB	dB								
PHICH_RA	dB								
PHICH_RB	dB								
PDCCH_RA	dB								
PDCCH_RB	dB								
PDSCH_RA	dB								
PDSCH_RB	dB								
OCNG_RA ^{Note 1}	dB								
OCNG_RB ^{Note 1}	dB								
N_{oc1} ^{Note 2}	dBm/15 KHz								
N_{oc2} ^{Note 3}	dBm/2MHz	N/A		-84		-84		-84	
E_s/N_{oc1}	dB	3	3	N/A		N/A		N/A	
E_s/I_{ot} ^{Note 4}	dB	3	3						
RSRP ^{Note 4}	dBm/15 kHz	-95	-95						
SCH_RP ^{Note 4}	dBm/15 kHz	-95	-95						
I_o ^{Note 3}	dBm/Ch BW	-65.5	-65.5						
Bluetooth RSSI ^{Note 4}	dBm/2 MHz	N/A	N/A	-infinity	-60	-infinity	-60	-infinity	-60
SINR ^{Note 4}	dB	N/A	N/A	-infinity	63.2	-infinity	63.2	-infinity	63.2
Propagation Condition		AWGN							
Antenna Configuration		1x2		-		-		-	
<p>Note 1: OCNG shall be used such that all cells are fully allocated and a constant total transmitted power spectral density is achieved for all OFDM symbols.</p> <p>Note 2: Interference from other cells and noise sources not specified in the test is assumed to be constant over subcarriers and time and shall be modelled as AWGN of appropriate power for N_{oc1} to be fulfilled.</p> <p>Note 3: Interference from other cells and noise sources not specified in the test is assumed to be constant over the bandwidth and time and shall be modelled as AWGN of appropriate power for N_{oc2} to be fulfilled.</p> <p>Note 4: E_s/I_{ot}, RSRP, SCH_RP, I_o and Bluetooth RSSI have been derived from other parameters for information purposes. They are not settable parameters themselves.</p> <p>Note 5: The resources for uplink transmission are assigned to the UE prior to the start of time period T2.</p> <p>Note 6: If Cell 1 is LTE FDD, the FDD OCNG and RMCs shall be used. If Cell 1 is LTE TDD, the TDD OCNG and RMCs shall be used</p>									

13 NR A-GNSS minimum performance requirements

13.1 General

This clause defines the minimum performance requirements for both UE based and UE assisted A-GNSS FDD and TDD NR UEs. If a UE supports both UE based and UE assisted modes then it shall be tested in both modes.

The requirements in this section apply for NR UE in FR1.

For ease of use of this document a number of Test Configurations corresponding to Network Deployment Types are defined in Table 13.1.1.

Table 13.1.1: Test Configuration

Test Configuration	Network Deployment Type
A	EN-DC
B	NG-RAN NR
FFS	NE-DC

13.2 Sensitivity

13.2.1 Sensitivity Coarse time assistance

13.2.1.1 Sub-tests

This test includes sub-tests dependent on the GNSS supported by the UE. Each sub-test is identified by a Sub-Test Number as defined in Table 13.2.1.1

Table 13.2.1.1: Sub-Test Number Definition

Sub-Test Number	Supported GNSS
1	UE supporting A-GPS L1 C/A
2	UE supporting A-GLONASS
3	UE supporting A-Galileo
4	UE supporting A-GPS and Modernized GPS
5	UE supporting A-GPS and A-GLONASS (Note)
8	UE supporting A-GPS and A-Galileo (Note)
9	UE supporting A-BDS
10	UE supporting A-GPS and A-BDS (Note)
11	UE supporting A-GPS and A-GLONASS and A-BDS (Note)
12	UE supporting A-GPS and A-Galileo and A-GLONASS (Note)
13	UE supporting A-GPS and A-Galileo and A-BDS (Note)
14	UE supporting A-GPS and A-QZSS
15	UE supporting A-GPS and A-NAVIC
Note: "GPS" here means GPS L1 C/A, Modernized GPS, or both, dependent on UE capabilities.	

13.2.1.2 Test purpose

To verify the performance of the first position estimate, when the UE is provided with only coarse time assistance.

13.2.1.3 Test applicability

This test applies to all types of NR UE that support EN-DC or NG-RAN NR, and A-GNSS.

13.2.1.4 Minimum conformance requirements

The first fix position estimates shall meet the accuracy and response time requirements in table 13.2.1.2 for the parameters specified in table 13.2.1.3 or 13.2.1.4.

Table 13.2.1.2: Requirements for Sensitivity Coarse time assistance

Success rate	2-D position error	Max response time
95 %	100 m	20 s

Table 13.2.1.3: Parameters for Sensitivity Coarse time assistance - Sub-Test 1

Parameters	Unit	Value
Number of generated satellites	-	8
HDOP Range	-	1.1 to 1.6
Propagation conditions	-	AWGN
GPS Coarse time assistance error range	seconds	±2
GPS L1 C/A Signal for one satellite	dBm	-142
GPS L1 C/A Signal for remaining satellites	dBm	-147

Table 13.2.1.4: Parameters for Sensitivity Coarse time assistance - Sub-Tests 2 to 5 and Sub-Tests 8 to 13

System	Parameters	Unit	Value
	Number of generated satellites per system	-	See Table 13.2.1.5
	Total number of generated satellites	-	6 or 7 ⁽²⁾
	HDOP range	-	1.4 to 2.1
	Propagation conditions	-	AWGN
	GNSS coarse time assistance error range	seconds	±2
Galileo	Reference high signal power level	dBm	-142
	Reference low signal power level	dBm	-147
GPS ⁽¹⁾	Reference high signal power level	dBm	-142
	Reference low signal power level	dBm	-147
GLONASS	Reference high signal power level	dBm	-142
	Reference low signal power level	dBm	-147
BDS	Reference high signal power level	dBm	-136
	Reference low signal power level	dBm	-145
QZSS	Reference high signal power level	dBm	-142
	Reference low signal power level	dBm	-147
NAVIC	Reference high signal power level	dBm	-142
	Reference low signal power level	dBm	-147
NOTE 1: "GPS" here means GPS L1 C/A, Modernized GPS, or both, dependent on UE capabilities.			
NOTE 2: 7 satellites are used for sub-tests with 3 different GNSSs.			

Table 13.2.1.5: Power level and satellite allocation

		Satellite allocation for each constellation		
		GNSS-1 ⁽¹⁾	GNSS-2	GNSS-3
Single constellation	High signal level	1	-	-
	Low signal level	5	-	-
Dual constellation	High signal level	1	-	-
	Low signal level	2	3	-
Triple constellation	High signal level	1	-	-
	Low signal level	2	2	2

Note 1: Up to Rel-14: for GPS capable receivers, GNSS-1, i.e. the system having the satellite with high signal level, shall be GPS.
Rel-15 onwards: GNSS-1, i.e. the system having the satellite with high signal level, shall be selected by the device manufacturer.

The normative reference for this requirement is TS 38.171 [43] clause 5.1.1 and 6.1.1.

13.2.1.5 Test description

13.2.1.5.1 Initial conditions

Initial conditions are a set of test configurations the UE needs to be tested in and the steps for the SS to take with the UE to reach the correct measurement state.

Test Environment: Normal, as defined in TS 38.508-1 [45] clause 4.1.

Frequencies to be tested: as defined in TS 38.508-1 [45] clause 4.3.1.

Channel Bandwidth to be tested: as defined in TS 38.508-1 [45] clause 4.3.1.

1. Connect SS and GSS to the UE antenna connector or antenna connectors as shown in Annex A.
2. Set the GNSS test parameters as specified in table 13.2.1.7 or 13.2.1.8 for GNSS scenario #1 in TS 37.571-5 [20]. For GNSS-1, select the first satellite SV ID defined in the relevant table of Satellites to be simulated in clause 6.2.1.2 in TS 37.571-5 [20] for the one satellite with the higher level.
3. For Test Configuration A (Table 13.1.1), the parameter settings for the cell are set up according to TS 38.508-1 [45] clause 4.4.1.2, non-standalone E-UTRA single cell and NR single cell network scenarios.

For Test Configuration B (Table 13.1.1), the parameter settings for the cell are set up according to TS 38.508-1 [45] clause 4.4.1.1, standalone NR single cell network scenarios.

4. Switch on the UE.
5. Establish a signalling connection according to the generic procedure in TS 38.508-1 [45] clause 4.5.4 (RRC_CONNECTED).

13.2.1.5.2 Test procedure

1. Start GNSS scenario #1 as specified in clause 6.2.1.2 of TS 37.571-5 [20] with the UE location randomly selected to be within 3 km of the Reference Location and the altitude of the UE randomly selected between 0 m to 500 m above WGS-84 reference ellipsoid using the method described in clause 6.2.1.2.6 of TS 37.571-5 [20]
2. Send a RESET UE POSITIONING STORED INFORMATION message.
3. Depending on how the LPP session is performed:
 - In the case of C-Plane, the SS shall send an LPP REQUEST CAPABILITIES message.
 - In the case of U-Plane, the SS shall establish a SUPL session with the UE for positioning.
4. The UE returns an LPP PROVIDE CAPABILITIES message indicating the assistance data supported by the UE in the Assistance Data Support List in the A GNSS Provide Capabilities IE.
5. Send an LPP PROVIDE ASSISTANCE DATA message to provide the assistance data that is supported by the UE as indicated in step 4 and in accordance with clause 6.2.6 of TS 37.571-5 [20], and with the values defined in clause 6.2.7 of TS 37.571-5 [20] with the value of GNSS Reference Time offset by a random value as specified in clause 6.2.7.2 of TS 37.571-5 [20]. If the LPP session is performed over C-Plane, then if the UE message at step 4 includes the ackRequested IE set to TRUE, then the SS shall send an acknowledgment in the LPP PROVIDE ASSISTANCE DATA message.
6. Send an LPP REQUEST LOCATION INFORMATION message to obtain a fix.

7. If the UE returns a valid result in the LPP PROVIDE LOCATION INFORMATION message within the Max response time specified in table 13.2.1.10 then record the result and process it as specified in step 9. If the UE does not return a valid result within the Max response time specified in table 13.2.1.10 or reports an Error in the LPP PROVIDE LOCATION INFORMATION message then record one Bad Result.
8. If the UE message at step 7 includes the ackRequested IE set to TRUE, then the SS shall send a LPP acknowledgment message.
9. For UE based testing compare the reported Location Information in the LPP PROVIDE LOCATION INFORMATION message against the simulated position of the UE used in step 1, and calculate the 2D position error as specified in clause 4.5.2.3. Compare the 2D position error against the value in table 13.2.1.10 and record one Good Result or Bad Result as appropriate; or

For UE assisted testing convert the GNSS Signal Measurement Information reported in the LPP PROVIDE LOCATION INFORMATION message to a 2D position using the method described in clause 4.4.3 and then compare the result against the simulated position of the UE, used in step 1, and calculate the 2D position error as specified in clause 4.5.2.3. Compare the 2D position error against the value in table 13.2.1.10 and record one Good Result or Bad Result as appropriate.

10. Repeat steps 1 to 9 using GNSS scenario #2 instead of #1 so that the reference location changes sufficiently such that the UE shall have to use the new assistance data. For GNSS-1, select the first satellite SV ID defined in the relevant table of Satellites to be simulated in clause 6.2.1.2 in TS 37.571-5 [20] for the one satellite with the higher level. Use new random values for the UE location and altitude in step 1 and for the GNSS Reference Time offset in step 5.
11. Repeat steps 1 to 10 until the statistical requirements of clause 13.2.1.7 are met. Each time scenario #1 or #2 is used, the start time of the GNSS scenario shall be advanced by 2 minutes from the time used previously for that scenario. Once a scenario reaches the end of its viable running time, restart it from its nominal start time again. Each time scenario #1 or #2 is used, for GNSS-1 select the next satellite SV ID from the one used previously, defined in the relevant table of Satellites to be simulated in clause 6.2.1.2 in TS 37.571-5 [20], for the one satellite with the higher level.
12. Release the signalling connection.

13.2.1.5.3 Message contents

Message contents are according to TS 38.508-1 [45] clauses 4.6 and 4.7 and as follows:

RESET UE POSITIONING STORED INFORMATION

Information Element	Value/remark
UE POSITIONING TECHNOLOGY	AGNSS

LPP REQUEST CAPABILITIES

Information Element	Value/remark
<i>a-gnss-RequestCapabilities</i>	TRUE

LPP REQUEST LOCATION INFORMATION

Information Element	Value/remark	Comment
commonIEsRequestLocationInformation		
> locationInformationType	'locationEstimateRequired' or 'locationMeasurementsRequired'	Depending on test case and UE capabilities, i.e. support for UE-based or UE-assisted
> additionalInformation	'onlyReturnInformationRequested'	
> qos		
>> horizontalAccuracy	'19' (51.2m)	
>> verticalCoordinateRequest	FALSE	

>> responseTime		
>>>time	'20'	
a-gnss-RequestLocationInformation		
> gnss-PositioningInstructions		
>> gnssMethods		
>>> gnss-ids	Sub-test 1: 'gps' Sub-test 2: 'glonass' Sub-test 3: 'galileo' Sub-test 4: 'gps' Sub-test 5: 'gps' and 'glonass' Sub-test 8: 'gps' and 'galileo' Sub-test 9: 'bds' Sub-test 10: 'gps'and'bds' Sub-test 11: 'gps' and 'glonass' and 'bds' Sub-test 12: 'gps' and 'galileo' and 'glonass' Sub-test 13: 'gps' and 'galileo' and 'bds' Sub-test 14: 'gps' and 'qzss' Sub-test 15: 'gps' and 'navic'	
>> fineTimeAssistanceMeasReq	FALSE	
>> adrMeasReq	FALSE	
>> multiFreqMeasReq	TRUE or FALSE	Depending on UE capabilities
>> assistanceAvailability	FALSE	

13.2.1.6 Test requirement

For the parameters specified in table 13.2.1.7 or 13.2.1.8 the UE shall meet the requirements and the success rate specified in table 13.2.1.10 with a confidence level of 95% according to Annex D.

Table 13.2.1.7: Test parameters for Sensitivity Coarse time assistance - Sub-Test 1

Parameters	Unit	Value
Number of generated satellites	-	8
HDOP Range	-	1.1 to 1.6
Propagation conditions	-	AWGN
GPS Coarse Time assistance error range	seconds	±1.8
GPS L1 C/A Signal for one satellite	dBm	-141
GPS L1 C/A Signal for remaining satellites	dBm	-146

Table 13.2.1.8: Test parameters for Sensitivity Coarse time assistance - Sub-Tests 2 to 5 and Sub-Tests 8 to 13

System	Parameters	Unit	Value
	Number of generated satellites per system	-	See Table 13.2.1.9
	Total number of generated satellites	-	6 or 7 ⁽²⁾
	HDOP range		1.4 to 2.1
	Propagation conditions	-	AWGN
	GNSS coarse time assistance error range	seconds	±1.8
Galileo	Reference high signal power level	dBm	-141
	Reference low signal power level	dBm	-146
GPS ⁽¹⁾	Reference high signal power level	dBm	-141
	Reference low signal power level	dBm	-146
GLONASS	Reference high signal power level	dBm	-141
	Reference low signal power level	dBm	-146
BDS	Reference high signal power level	dBm	-135
	Reference low signal power level	dBm	-144
QZSS	Reference high signal power level	dBm	-141

System	Parameters	Unit	Value
	Reference low signal power level	dBm	-146
Navic	Reference high signal power level	dBm	-141
	Reference low signal power level	dBm	-146
NOTE 1: "GPS" here means GPS L1 C/A, Modernized GPS, or both, dependent on UE capabilities.			
NOTE 2: 7 satellites are used for sub-tests with 3 different GNSSs			

Table 13.2.1.9: Power level and satellite allocation

		Satellite allocation for each constellation		
		GNSS-1 ⁽¹⁾	GNSS-2	GNSS-3
Single constellation	High signal level	1	-	-
	Low signal level	5	-	-
Dual constellation	High signal level	1	-	-
	Low signal level	2	3	-
Triple constellation	High signal level	1	-	-
	Low signal level	2	2	2
Note 1: Up to Rel-14: for GPS capable receivers, GNSS-1, i.e. the system having the satellite with high signal level, shall be GPS. Rel-15 onwards: GNSS-1, i.e. the system having the satellite with high signal level, shall be selected by the device manufacturer.				

Table 13.2.1.10: Test requirements for Sensitivity Coarse Time Assistance

System	Success rate	2-D position error	Max response time
All	95 %	101.3 m	20.3 s

13.2.2 Sensitivity Fine time assistance

13.2.2.1 Sub-tests

This test includes sub-tests dependent on the GNSS supported by the UE. Each sub-test is identified by a Sub-Test Number as defined in Table 13.2.2.1

Table 13.2.2.1: Sub-Test Number Definition

Sub-Test Number	Supported GNSS
1	UE supporting A-GPS L1 C/A
2	UE supporting A-GLONASS
3	UE supporting A-Galileo
4	UE supporting A-GPS and Modernized GPS
5	UE supporting A-GPS and A-GLONASS (Note)
8	UE supporting A-GPS and A-Galileo (Note)
9	UE supporting A-BDS
10	UE supporting A-GPS and A-BDS (Note)
11	UE supporting A-GPS and A-GLONASS and A-BDS (Note)
12	UE supporting A-GPS and A-Galileo and A-GLONASS (Note)
13	UE supporting A-GPS and A-Galileo and A-BDS (Note)
14	UE supporting A-GPS and A-QZSS (Note)
15	UE supporting A-GPS and A-Navic (Note)
Note: "GPS" here means GPS L1 C/A, Modernized GPS, or both, dependent on UE capabilities.	

13.2.2.2 Test purpose

To verify the performance of the first position estimate, when the UE is additionally provided with fine time assistance.

13.2.2.3 Test applicability

This test applies to all types of NR UE that support EN-DC and A-GNSS and that are capable of providing an enhanced performance when the network provides Fine Time Assistance.

This test applies to all types of NR UE with LPP Release 15 onwards that support NG-RAN NR and A-GNSS and that are capable of providing an enhanced performance when the network provides Fine Time Assistance.

13.2.2.4 Minimum conformance requirements

The first fix position estimates shall meet the accuracy and response time requirements in table 13.2.2.2 for the parameters specified in table 13.2.2.3 or 13.2.2.4.

Table 13.2.2.2: Requirements for Sensitivity Fine time assistance

Success rate	2-D position error	Max response time
95 %	100 m	20 s

Table 13.2.2.3: Parameters for Sensitivity Fine time assistance - Sub-Test 1

Parameters	Unit	Value
Number of generated satellites	-	8
HDOP Range	-	1.1 to 1.6
Propagation conditions	-	AWGN
GPS Coarse time assistance error range	seconds	± 2
GPS L1 C/A Fine time assistance error range	μs	± 10
GPS L1 C/A Signal for all satellites	dBm	-147

Table 13.2.2.4: Parameters for Sensitivity Fine time assistance - Sub-Tests 2 to 5 and Sub-Tests 8 to 13

System	Parameters	Unit	Value
	Number of generated satellites per system	-	See Table 13.2.2.5
	Total number of generated satellites	-	6 or 7 ⁽²⁾
	HDOP range	-	1.4 to 2.1
	Propagation conditions	-	AWGN
	GNSS coarse time assistance error range	seconds	± 2
	GNSS fine time assistance error range	μs	± 10
Galileo	Reference signal power level	dBm	-147
GPS ⁽¹⁾	Reference signal power level	dBm	-147
GLONASS	Reference signal power level	dBm	-147
BDS	Reference signal power level	dBm	-147
QZSS	Reference signal power level	dBm	-147
Navic	Reference signal power level	dBm	-147
NOTE 1: "GPS" here means GPS L1 C/A, Modernized GPS, or both, dependent on UE capabilities.			
NOTE 2: 7 satellites are used for sub-tests with 3 different GNSSs			

Table 13.2.2.5: Satellite allocation

	Satellite allocation for each constellation		
	GNSS-1	GNSS-2	GNSS-3
Single constellation	6	-	-
Dual constellation	3	3	-
Triple constellation	3	2	2

The normative reference for this requirement is TS 38.171 [43] clause 5.1.2 and 6.1.2.

13.2.2.5 Test description

13.2.2.5.1 Initial conditions

Initial conditions are a set of test configurations the UE needs to be tested in and the steps for the SS to take with the UE to reach the correct measurement state.

Test Environment: Normal, as defined in TS 38.508-1 [45] clause 4.1.

Frequencies to be tested: Mid Range, as defined in TS 38.508-1 [45] clause 4.3.1.

Channel Bandwidth to be tested: as defined in TS 38.508-1 [45] clause 4.3.1.

1. Connect SS and GSS to the UE antenna connector or antenna connectors as shown in Annex A.
2. Set the GNSS test parameters as specified in table 13.2.2.7 or 13.2.2.8 for GNSS scenario #1 in TS 37.571-5 [20].
3. For Test Configuration A (Table 13.1.1), the parameter settings for the cell are set up according to TS 38.508-1 [45] clause 4.4.1.2, non-standalone E-UTRA single cell and NR single cell network scenarios.
For Test Configuration B (Table 13.1.1), the parameter settings for the cell are set up according to TS 38.508-1 [45] clause 4.4.1.1, standalone NR single cell network scenarios.
4. Switch on the UE.
5. Establish a signalling connection according to the generic procedure in TS 38.508-1 [45] clause 4.5.4 (RRC_CONNECTED).

13.2.2.5.2 Test procedure

1. Start GNSS scenario #1 as specified in clause 6.2.1.2 of TS 37.571-5 [20] with the UE location randomly selected to be within 3 km of the Reference Location and the altitude of the UE randomly selected between 0 m to 500 m above WGS-84 reference ellipsoid using the method described in clause 6.2.1.2.6 of TS 37.571-5 [20]
2. Send a RESET UE POSITIONING STORED INFORMATION message.
3. Depending on how the LPP session is performed:
 - In the case of C-Plane, the SS shall send an LPP REQUEST CAPABILITIES message.
 - In the case of U-Plane, the SS shall establish a SUPL session with the UE for positioning.
4. The UE returns an LPP PROVIDE CAPABILITIES message indicating the assistance data supported by the UE in the Assistance Data Support List in the A GNSS Provide Capabilities IE.
5. Send an LPP PROVIDE ASSISTANCE DATA message to provide the assistance data that is supported by the UE as indicated in step 4 and in accordance with clause 6.2.6 of TS 37.571-5 [20], and with the values defined in clause 6.2.7 of TS 37.571-5 [20] with the value of GNSS Reference Time and GNSS Reference Time for one cell offset by a random value as specified in clause 6.2.7.2 of TS 37.571-5 [20]. If the LPP session is performed over C-Plane, then if the UE message at step 4 includes the ackRequested IE set to TRUE, then the SS shall send an acknowledgment in the LPP PROVIDE ASSISTANCE DATA message.
6. Send an LPP REQUEST LOCATION INFORMATION message to obtain a fix.
7. If the UE returns a valid result in the LPP PROVIDE LOCATION INFORMATION message within the Max response time specified in table 13.2.2.10 then record the result and process it as specified in step 9. If the UE does not return a valid result within the Max response time specified in table 13.2.2.10 or reports an Error in the LPP PROVIDE LOCATION INFORMATION message then record one Bad Result.
8. If the UE message at step 7 includes the ackRequested IE set to TRUE, then the SS shall send a LPP acknowledgment message.
9. For UE based testing compare the reported Location Information in the LPP PROVIDE LOCATION INFORMATION message against the simulated position of the UE used in step 1, and calculate the 2D position

error as specified in clause 4.5.2.3. Compare the 2D position error against the value in table 13.2.2.10 and record one Good Result or Bad Result as appropriate; or

For UE assisted testing convert the GNSS Measurement Information reported in the LPP PROVIDE LOCATION INFORMATION message to a 2D position using the method described in clause 4.4.3 and then compare the result against the simulated position of the UE used in step 1, and calculate the 2D position error as specified in clause 4.5.2.3. Compare the 2D position error against the value in table 13.2.2.10 and record one Good Result or Bad Result as appropriate.

10. Repeat steps 1 to 9 using GNSS scenario #2 instead of #1 so that the reference location changes sufficiently such that the UE shall have to use the new assistance data. Use new random values for the UE location and altitude in step 1 and for the GNSS Reference Time GNSS Reference Time for one cell offsets in step 5.
11. Repeat steps 1 to 10 until the statistical requirements of clause 13.2.2.7 are met. Each time scenario #1 or #2 is used, the start time of the GNSS scenario shall be advanced by 2 minutes from the time used previously for that scenario. Once a scenario reaches the end of its viable running time, restart it from its nominal start time again.
12. Release the signalling connection.

13.2.2.5.3 Message contents

Message contents are according to TS 38.508-1 [45] clauses 4.6 and 4.7 and as follows:

RESET UE POSITIONING STORED INFORMATION

Information Element	Value/remark
UE POSITIONING TECHNOLOGY	AGNSS

LPP REQUEST CAPABILITIES

Information Element	Value/remark
<i>a-gnss-RequestCapabilities</i>	TRUE

LPP REQUEST LOCATION INFORMATION

Information Element	Value/remark	Comment
commonIEsRequestLocationInformation		
> locationInformationType	'locationEstimateRequired' or 'locationMeasurementsRequired'	Depending on test case and UE capabilities, i.e. support for UE-based or UE-assisted
> additionalInformation	'onlyReturnInformationRequested'	
> qos		
>> horizontalAccuracy	'19' (51.2m)	
>> verticalCoordinateRequest	FALSE	
>> responseTime		
>>>time	'20'	
a-gnss-RequestLocationInformation		
> gnss-PositioningInstructions		
>> gnssMethods		
>>> gnss-ids	Sub-test 1: 'gps' Sub-test 2: 'glonass' Sub-test 3: 'galileo' Sub-test 4: 'gps' Sub-test 5: 'gps' and 'glonass' Sub-test 8: 'gps' and 'galileo' Sub-test 9: 'bds' Sub-test 10: 'gps' and 'bds' Sub-test 11: 'gps' and 'glonass' and 'bds'	

	Sub-test 12: 'gps' and 'galileo' and 'glonass' Sub-test 13: 'gps' and 'galileo' and 'bds' Sub-test 14: 'gps' and 'qzss' Sub-test 15: 'gps' and 'navic'	
>> fineTimeAssistanceMeasReq	FALSE	
>> adrMeasReq	FALSE	
>> multiFreqMeasReq	TRUE or FALSE	Depending on UE capabilities
>> assistanceAvailability	FALSE	

13.2.2.6 Test requirement

For the parameters specified in table 13.2.2.7 or 13.2.2.8 the UE shall meet the requirements and the success rate specified in table 13.2.2.10 with a confidence level of 95% according to Annex D.

Table 13.2.2.7: Test parameters for Sensitivity Fine time assistance - Sub-Test 1

Parameters	Unit	Value
Number of generated satellites	-	8
HDOP Range	-	1.1 to 1.6
Propagation conditions	-	AWGN
GPS Coarse time assistance error range	seconds	±1.8
GPS Fine Time assistance error range	µs	±9
GPS L1 C/A Signal for all satellites	dBm	-146

Table 13.2.2.8: Test parameters for Sensitivity Fine time assistance - Sub-Tests 2 to 5 and Sub-Tests 8 to 13

System	Parameters	Unit	Value
	Number of generated satellites per system	-	See Table 13.2.2.9
	Total number of generated satellites	-	6 or 7 ⁽²⁾
	HDOP range	-	1.4 to 2.1
	Propagation conditions	-	AWGN
	GNSS coarse time assistance error range	seconds	±1.8
	GNSS fine time assistance error range	µs	±9
Galileo	Reference signal power level	dBm	-146
GPS ⁽¹⁾	Reference signal power level	dBm	-146
GLONASS	Reference signal power level	dBm	-146
BDS	Reference signal power level	dBm	-146
QZSS	Reference signal power level	dBm	-146
Navic	Reference signal power level	dBm	-146
NOTE 1: "GPS" here means GPS L1 C/A, Modernized GPS, or both, dependent on UE capabilities.			
NOTE 2: 7 satellites are used for sub-tests with 3 different GNSSs			

Table 13.2.2.9: Satellite allocation

	Satellite allocation for each constellation		
	GNSS-1	GNSS-2	GNSS-3
Single constellation	6	-	-
Dual constellation	3	3	-
Triple constellation	3	2	2

Table 13.2.2.10: Test requirements for Sensitivity Fine Time Assistance

System	Success rate	2-D position error	Max response time
All	95 %	101.3 m	20.3 s

13.3 Nominal Accuracy

13.3.1 Sub-tests

This test includes sub-tests dependent on the GNSS supported by the UE. Each sub-test is identified by a Sub-Test Number as defined in Table 13.3.1

Table 13.3.1: Sub-Test Number Definition

Sub-Test Number	Supported GNSS
1	UE supporting A-GPS L1 C/A
2	UE supporting A-GLONASS
3	UE supporting A-Galileo
4	UE supporting A-GPS and Modernized GPS
5	UE supporting A-GPS and A-GLONASS (Note)
8	UE supporting A-GPS and A-Galileo (Note)
9	UE supporting A-BDS
10	UE supporting A-GPS and A-BDS (Note)
11	UE supporting A-GPS and A-GLONASS and A-BDS (Note)
12	UE supporting A-GPS and A-Galileo and A-GLONASS (Note)
13	UE supporting A-GPS and A-Galileo and A-BDS (Note)
14	UE supporting A-GPS and A-QZSS (Note)
15	UE supporting A-GPS and A-Navic (Note)

Note: "GPS" here means GPS L1 C/A, Modernized GPS, or both, dependent on UE capabilities.

13.3.2 Test purpose

To verify the performance of the first position estimate, when the UE is provided with ideal GNSS signal conditions.

13.3.3 Test applicability

This test applies to all types of NR UE that support EN-DC or NG-RAN NR, and A-GNSS.

13.3.4 Minimum conformance requirements

The first fix position estimates shall meet the accuracy and response time requirements in table 13.3.2 or 13.3.3 for the parameters specified in table 13.3.4 or 13.3.5.

Table 13.3.2: Requirements for Nominal Accuracy - Sub-Test 1

Success rate	2-D position error	Max response time
95 %	30 m	20 s

Table 13.3.3: Requirements for Nominal Accuracy - Sub-Tests 2 to 5 and Sub-Tests 8 to 13

Success rate	2-D position error	Max response time
95 %	15 m	20 s

Table 13.3.4: Parameters for Nominal Accuracy - Sub-Test 1

Parameters	Unit	Value
Number of generated satellites	-	8
HDOP Range	-	1.1 to 1.6
Propagation conditions	-	AWGN
GPS Coarse Time assistance error range	seconds	±2
GPS L1 C/A Signal for all satellites	dBm	-130

Table 13.3.5: Parameters for Nominal Accuracy - Sub-Tests 2 to 5 and Sub-Tests 8 to 13

System	Parameters	Unit	Value
	Number of generated satellites per system	-	See Table 13.3.6
	Total number of generated satellites	-	6, 7 ⁽²⁾ or 8 ⁽³⁾
	HDOP Range	-	1.4 to 2.1
	Propagation conditions	-	AWGN
	GNSS coarse time assistance error range	seconds	±2
GPS ⁽¹⁾	Reference signal power level for all satellites	dBm	-128.5
Galileo	Reference signal power level for all satellites	dBm	-127
GLONASS	Reference signal power level for all satellites	dBm	-131
QZSS	Reference signal power level for all satellites	dBm	-128.5
SBAS	Reference signal power level for all satellites	dBm	-131
BDS	Reference signal power level for all satellites	dBm	-133
NOTE 1: "GPS" here means GPS L1 C/A, Modernized GPS, or both, dependent on UE capabilities.			
NOTE 2: 7 satellites apply only for SBAS case or sub-tests with 3 different GNSSs.			
NOTE 3: 8 satellites apply only for sub-tests with 3 different GNSSs and SBAS.			

If SBAS is supported, the SBAS satellite with the highest elevation will be added to the scenario.

Table 13.3.6: Satellite allocation

	Satellite allocation for each constellation			
	GNSS 1 ⁽¹⁾	GNSS 2 ⁽¹⁾	GNSS 3 ⁽¹⁾	SBAS
Single constellation	6	--	--	1
Dual constellation	3	3	--	1
Triple constellation	3	2	2	1
NOTE 1: GNSS refers to global systems i.e., GPS, Galileo, GLONASS and BDS.				

The normative reference for this requirement is TS 38.171 [43] clause 5.2 and 6.2.

13.3.5 Test description

13.3.5.1 Initial conditions

Initial conditions are a set of test configurations the UE needs to be tested in and the steps for the SS to take with the UE to reach the correct measurement state.

Test Environment: Normal, as defined in TS 38.508-1 [45] clause 4.1.

Frequencies to be tested: as defined in TS 38.508-1 [45] clause 4.3.1.

Channel Bandwidth to be tested: as defined in TS 38.508-1 [45] clause 4.3.1.

1. Connect SS and GSS to the UE antenna connector or antenna connectors as shown in Annex A.
2. Set the GNSS test parameters as specified in table 13.3.8 or 13.3.9 for GNSS scenario #3 in TS 37.571-5 [20].
3. For Test Configuration A (Table 13.1.1), the parameter settings for the cell are set up according to TS 38.508-1 [45] clause 4.4.1.2, non-standalone E-UTRA single cell and NR single cell network scenarios.

For Test Configuration B (Table 13.1.1), the parameter settings for the cell are set up according to TS 38.508-1 [45] clause 4.4.1.1, standalone NR single cell network scenarios.

4. Switch on the UE.
5. Establish a signalling connection according to the generic procedure in TS 38.508-1 [45] clause 4.5.4 (RRC_CONNECTED).

13.3.5.2 Test procedure

1. Start GNSS scenario #3 as specified in clause 6.2.1.2 of TS 37.571-5 [20] with the UE location randomly selected to be within 3 km of the Reference Location and the altitude of the UE randomly selected between 0 m to 500 m above WGS-84 reference ellipsoid using the method described in clause 6.2.1.2.6 of TS 37.571-5 [20]
2. Send a RESET UE POSITIONING STORED INFORMATION message.
3. Depending on how the LPP session is performed:
 - In the case of C-Plane, the SS shall send an LPP REQUEST CAPABILITIES message.
 - In the case of U-Plane, the SS shall establish a SUPL session with the UE for positioning.
4. The UE returns an LPP PROVIDE CAPABILITIES message indicating the assistance data supported by the UE in the Assistance Data Support List in the A GNSS Provide Capabilities IE.
5. Send an LPP PROVIDE ASSISTANCE DATA message to provide the assistance data that is supported by the UE as indicated in the step 4 and in accordance with clause 6.2.6 of TS 37.571-5 [20], and with the values defined in clause 6.2.7 of TS 37.571-5 [20] with the value of GNSS Reference Time offset by a random value as specified in clause 6.2.7.2 of TS 37.571-5 [20]. If the LPP session is performed over C-Plane, then if the UE message at step 4 includes the ackRequested IE set to TRUE, then the SS shall send an acknowledgment in the (first) LPP PROVIDE ASSISTANCE DATA message.
6. Send an LPP REQUEST LOCATION INFORMATION message to obtain a fix.
7. If the UE returns a valid result in the LPP PROVIDE LOCATION INFORMATION message within the Max response time specified in table 13.3.11 then record the result and process it as specified in step 9. If the UE does not return a valid result within the Max response time specified in table 13.3.11 or reports an Error in the LPP PROVIDE LOCATION INFORMATION message then record one Bad Result.
8. If the UE message at step 7 includes the ackRequested IE set to TRUE, then the SS shall send a LPP acknowledgment message.
9. For UE based testing compare the reported Location Information in the LPP PROVIDE LOCATION INFORMATION message against the simulated position of the UE used in step 1, and calculate the 2D position error as specified in clause 4.5.2.3. Compare the 2D position error against the value in table 13.3.11 and record one Good Result or Bad Result as appropriate; or

For UE assisted testing convert the GNSS Measurement Information reported in the LPP PROVIDE LOCATION INFORMATION message to a 2D position using the method described in clause 4.4.3 and then compare the result against the simulated position of the UE used in step 1, and calculate the 2D position error as specified in clause 4.5.2.3. Compare the 2D position error against the value in table 13.3.11 and record one Good Result or Bad Result as appropriate.
10. Repeat steps 1 to 9 using GNSS scenario #4 instead of #3 so that the reference location changes sufficiently such that the UE shall have to use the new assistance data. Use new random values for the UE location and altitude in step 1 and for the GNSS Reference Time offset in step 5.
11. Repeat steps 1 to 10 until the statistical requirements of clause 13.3.6 are met. Each time scenario #3 or #4 is used, the start time of the GNSS scenario shall be advanced by 2 minutes from the time used previously for that scenario. Once a scenario reaches the end of its viable running time, restart it from its nominal start time again.
12. Release the signalling connection.

13.3.5.3 Message contents

Message contents are according to TS 38.508-1 [45] clauses 4.6 and 4.7 and as follows:

RESET UE POSITIONING STORED INFORMATION

Information Element	Value/remark
UE POSITIONING TECHNOLOGY	AGNSS

LPP REQUEST CAPABILITIES

Information Element	Value/remark
<i>a-gnss-RequestCapabilities</i>	TRUE

LPP REQUEST LOCATION INFORMATION

Information Element	Value/remark	Comment
commonEsRequestLocationInformation		
> locationInformationType	'locationEstimateRequired' or 'locationMeasurementsRequired'	Depending on test case and UE capabilities, i.e. support for UE-based or UE-assisted
> additionalInformation	'onlyReturnInformationRequested'	
> qos		
>> horizontalAccuracy (Sub-Test 1)	'10' (15.9m)	
>> horizontalAccuracy (Sub-Tests 2 to 5 and 8 to 13)	'6' (7.7m)	
>> verticalCoordinateRequest	FALSE	
>> responseTime		
>>>time	'20'	
a-gnss-RequestLocationInformation		
> gnss-PositioningInstructions		
>> gnssMethods		
>>> gnss-ids	Sub-test 1: 'gps' and possibly 'sbas' Sub-test 2: 'glonass' and possibly 'sbas' Sub-test 3: 'galileo' and possibly 'sbas' Sub-test 4: 'gps' and possibly 'sbas' Sub-test 5: 'gps' and 'glonass' and possibly 'sbas' Sub-test 8: 'gps' and 'galileo' and possibly 'sbas' Sub-test 9: 'bds' and possibly 'sbas' Sub-test 10: 'gps' and 'bds' and possibly 'sbas' Sub-test 11: 'gps' and 'glonass' and 'bds' and possibly 'sbas' Sub-test 12: 'gps' and 'galileo' and 'glonass' Sub-test 13: 'gps' and 'galileo' and 'bds' Sub-test 14: 'gps' and 'qzss' Sub-test 15: 'gps' and 'navic'	Depending on UE capabilities
>> fineTimeAssistanceMeasReq	FALSE	
>> adrMeasReq	FALSE	
>> multiFreqMeasReq	TRUE or FALSE	Depending on UE capabilities
>> assistanceAvailability	FALSE	

13.3.6 Test requirement

For the parameters specified in table 13.3.8 or 13.3.9 the UE shall meet the requirements and the success rate specified in table 13.3.11 or 13.3.12 with a confidence level of 95% according to Annex D.

Table 13.3.8: Test parameters for Nominal Accuracy - Sub-Test 1

Parameters	Unit	Value
Number of generated satellites	-	8
HDOP Range	-	1.1 to 1.6
Propagation conditions	-	AWGN
GPS Coarse Time assistance error range	seconds	±1.8
GPS L1 C/A Signal for all satellites	dBm	-130

Table 13.3.9: Test parameters for Nominal Accuracy - Sub-Tests 2 to 5 and Sub-Tests 8 to 13

System	Parameters	Unit	Value
	Number of generated satellites per system	-	See Table 13.3.10
	Total number of generated satellites	-	6, 7 ⁽²⁾ or 8 ⁽³⁾
	HDOP Range	-	1.4 to 2.1
	Propagation conditions	-	AWGN
	GNSS coarse time assistance error range	seconds	±1.8
GPS ⁽¹⁾	Reference signal power level for all satellites	dBm	-128.5
Galileo	Reference signal power level for all satellites	dBm	-127
GLONASS	Reference signal power level for all satellites	dBm	-131
QZSS	Reference signal power level for all satellites	dBm	-128.5
SBAS	Reference signal power level for all satellites	dBm	-131
BDS	Reference signal power level for all satellites	dBm	-133
Navic	Reference signal power level for all satellites	dBm	-128.5
NOTE 1: "GPS" here means GPS L1 C/A, Modernized GPS, or both, dependent on UE capabilities.			
NOTE 2: 7 satellites apply only for SBAS case or sub-tests with 3 different GNSSs.			
NOTE 3: 8 satellites apply only for sub-tests with 3 different GNSSs and SBAS.			

If SBAS is supported, the SBAS satellite with the highest elevation will be added to the scenario.

Table 13.3.10: Satellite allocation

	Satellite allocation for each constellation			
	GNSS 1 ⁽¹⁾	GNSS 2 ⁽¹⁾	GNSS 3 ⁽¹⁾	SBAS
Single constellation	6	-	-	1
Dual constellation	3	3	-	1
Triple constellation	3	2	2	1
NOTE 1: GNSS refers to global systems i.e., GPS, Galileo, GLONASS and BDS.				

Table 13.3.11: Test requirements for Nominal Accuracy – Sub-Test 1

System	Success rate	2-D position error	Max response time
All	95 %	31.3 m	20.3 s

Table 13.3.12: Test requirements for Nominal Accuracy – Sub-Tests 2 to 5 and Sub-Tests 8 to 13

System	Success rate	2-D position error	Max response time
All	95 %	16.3 m	20.3 s

13.4 Dynamic Range

13.4.1 Sub-tests

This test includes sub-tests dependent on the GNSS supported by the UE. Each sub-test is identified by a Sub-Test Number as defined in Table 13.4.1

Table 13.4.1: Sub-Test Number Definition

Sub-Test Number	Supported GNSS
1	UE supporting A-GPS L1 C/A
2	UE supporting A-GLONASS
3	UE supporting A-Galileo
4	UE supporting A-GPS and Modernized GPS
5	UE supporting A-GPS and A-GLONASS (Note)
8	UE supporting A-GPS and A-Galileo (Note)
9	UE supporting A-BDS
10	UE supporting A-GPS and A-BDS (Note)
11	UE supporting A-GPS and A-GLONASS and A-BDS (Note)
12	UE supporting A-GPS and A-Galileo and A-GLONASS (Note)
13	UE supporting A-GPS and A-Galileo and A-BDS (Note)
14	UE supporting A-GPS and A-QZSS (Note)
15	UE supporting A-GPS and A-Navic (Note)

Note: "GPS" here means GPS L1 C/A, Modernized GPS, or both, dependent on UE capabilities.

13.4.2 Test purpose

To verify the performance of the first position estimate, when the UE is provided with GNSS signals with large dynamic ranges.

13.4.3 Test applicability

This test applies to all types of NR UE that support EN-DC or NG-RAN NR, and A-GNSS.

13.4.4 Minimum conformance requirements

The first fix position estimates shall meet the accuracy and response time requirements in table 13.4.2 for the parameters specified in table 13.4.3 or 13.4.4.

Table 13.4.2: Requirements for Dynamic Range

Success rate	2-D position error	Max response time
95 %	100 m	20 s

Table 13.4.3: Parameters for Dynamic Range - Sub-Test 1

Parameters	Unit	Value
Number of generated satellites	-	6
HDOP Range	-	1.4 to 2.1
GPS Coarse Time assistance error range	seconds	±2
Propagation conditions	-	AWGN
GPS L1 C/A Signal for 1 st satellite	dBm	-129
GPS L1 C/A Signal for 2 nd satellite	dBm	-135
GPS L1 C/A Signal for 3 rd satellite	dBm	-141
GPS L1 C/A Signal for 4 th satellite	dBm	-147
GPS L1 C/A Signal for 5 th satellite	dBm	-147
GPS L1 C/A Signal for 6 th satellite	dBm	-147

Table 13.4.4: Parameters for Dynamic Range - Sub-Tests 2 to 5 and Sub-Tests 8 to 13

System	Parameters	Unit	Value
	Number of generated satellites per system	-	See Table 13.4.6
	Total number of generated satellites	-	6 or 7 ⁽²⁾
	HDOP Range	-	1.4 to 2.1
	Propagation conditions	-	AWGN
	GNSS coarse time assistance error range	seconds	±2
Galileo	Reference high signal power level	dBm	-127.5
	Reference low signal power level	dBm	-147
GPS ⁽¹⁾	Reference high signal power level	dBm	-129
	Reference low signal power level	dBm	-147
GLONASS	Reference high signal power level	dBm	-131.5
	Reference low signal power level	dBm	-147
BDS	Reference high signal power level	dBm	-133.5
	Reference low signal power level	dBm	-145
QZSS	Reference high signal power level	dBm	-129
	Reference low signal power level	dBm	-147
Navic	Reference high signal power level	dBm	-129
	Reference low signal power level	dBm	-147
NOTE 1: "GPS" here means GPS L1 C/A, Modernized GPS, or both, dependent on UE capabilities.			
NOTE 2: 7 satellites are used for sub-tests with 3 different GNSSs			

Table 13.4.5: Power level and satellite allocation

		Satellite allocation for each constellation		
		GNSS 1 ⁽¹⁾	GNSS 2 ⁽¹⁾	GNSS 3 ⁽¹⁾
Single constellation	High signal level	2	--	--
	Low signal level	4	--	--
Dual constellation	High signal level	1	1	--
	Low signal level	2	2	--
Triple constellation	High signal level	1	1	1
	Low signal level	2	1	1
NOTE 1: GNSS refers to global systems i.e., GPS, Galileo, GLONASS and BDS.				

The normative reference for this requirement is TS 38.171 [43] clause 5.3 and 6.3.

13.4.5 Test description

13.4.5.1 Initial conditions

Initial conditions are a set of test configurations the UE needs to be tested in and the steps for the SS to take with the UE to reach the correct measurement state.

Test Environment: Normal, as defined in TS 38.508-1 [45] clause 4.1.

Frequencies to be tested: as defined in TS 38.508-1 [45] clause 4.3.1.

Channel Bandwidth to be tested: as defined in TS 38.508-1 [45] clause 4.3.1.

1. Connect SS and GSS to the UE antenna connector or antenna connectors as shown in Annex A.
2. Set the GNSS test parameters as specified in table 13.4.7 or 13.4.8 for GNSS scenario #1 in TS 37.571-5 [20]. Randomly select from the satellite SV IDs defined in the relevant table of Satellites to be simulated in clause 6.2.1.2 in TS 37.571-5 [20] for the satellites with the higher levels.
3. For Test Configuration A (Table 13.1.1), the parameter settings for the cell are set up according to TS 38.508-1 [45] clause 4.4.1.2, non-standalone E-UTRA single cell and NR single cell network scenarios.

For Test Configuration B (Table 13.1.1), the parameter settings for the cell are set up according to TS 38.508-1 [45] clause 4.4.1.1, standalone NR single cell network scenarios.

4. Switch on the UE.
5. Establish a signalling connection according to the generic procedure in TS 38.508-1 [45] clause 4.5.4 (RRC_CONNECTED).

13.4.5.2 Test procedure

1. Start GNSS scenario #1 as specified in clause 6.2.1.2 of TS 37.571-5 [20] with the UE location randomly selected to be within 3 km of the Reference Location and the altitude of the UE randomly selected between 0 m to 500 m above WGS-84 reference ellipsoid using the method described in clause 6.2.1.2.6 of TS 37.571-5 [20]
2. Send a RESET UE POSITIONING STORED INFORMATION message.
3. Depending on how the LPP session is performed:
 - In the case of C-Plane, the SS shall send an LPP REQUEST CAPABILITIES message.
 - In the case of U-Plane, the SS shall establish a SUPL session with the UE for positioning.
4. The UE returns an LPP PROVIDE CAPABILITIES message indicating the assistance data supported by the UE in the Assistance Data Support List in the A GNSS Provide Capabilities IE.
5. Send an LPP PROVIDE ASSISTANCE DATA message to provide the assistance data that is supported by the UE as indicated in the step 4 and in accordance with clause 6.2.6 of TS 37.571-5 [20], and with the values defined in clause 6.2.7 of TS 37.571-5 [20] with the value of GNSS Reference Time offset by a random value as specified in clause 6.2.7.2 of TS 37.571-5 [20]. If the LPP session is performed over C-Plane, then if the UE message at step 4 includes the ackRequested IE set to TRUE, then the SS shall send an acknowledgment in the (first) LPP PROVIDE ASSISTANCE DATA message.
6. Send an LPP REQUEST LOCATION INFORMATION message to obtain a fix.
7. If the UE returns a valid result in the LPP PROVIDE LOCATION INFORMATION message within the Max response time specified in table 13.4.10 then record the result and process it as specified in step 9. If the UE does not return a valid result within the Max response time specified in table 13.4.10 or reports an Error in the LPP PROVIDE LOCATION INFORMATION message then record one Bad Result.
8. If the UE message at step 7 includes the ackRequested IE set to TRUE, then the SS shall send a LPP acknowledgment message.
9. For UE based testing compare the reported Location Information in the LPP PROVIDE LOCATION INFORMATION message against the simulated position of the UE used in step 1, and calculate the 2D position error as specified in clause 4.5.2.3. Compare the 2D position error against the value in table 7.3.9 and record one Good Result or Bad Result as appropriate; or

For UE assisted testing convert the GNSS Measurement Information reported in the LPP PROVIDE LOCATION INFORMATION message to a 2D position using the method described in clause 4.4.3 and then compare the result against the simulated position of the UE used in step 1, and calculate the 2D position error as specified in clause 4.5.2.3. Compare the 2D position error against the value in table 13.4.10 and record one Good Result or Bad Result as appropriate.

10. Repeat steps 1 to 9 using GNSS scenario #2 instead of #1 so that the reference location changes sufficiently such that the UE shall have to use the new assistance data. Randomly select from the satellite SV IDs defined in the relevant table of Satellites to be simulated in clause 6.2.1.2 in TS 37.571-5 [20] for the satellites with the higher levels. Use new random values for the UE location and altitude in step 1 and for the GNSS Reference Time offset in step 5.
11. Repeat steps 1 to 10 until the statistical requirements of clause 13.4.6 are met. Each time scenario #1 or #2 is used, the start time of the GNSS scenario shall be advanced by 2 minutes from the time used previously for that scenario. Once a scenario reaches the end of its viable running time, restart it from its nominal start time again. Each time scenario #1 or #2 is used, randomly select from the satellite SV IDs defined in the relevant table of Satellites to be simulated in clause 6.2.1.2 in TS 37.571-5 [20], for the satellites with the higher levels.

12. Release the signalling connection.

13.4.5.3 Message contents

Message contents are according to TS 38.508-1 [45] clauses 4.6 and 4.7 and as follows:

RESET UE POSITIONING STORED INFORMATION

Information Element	Value/remark
UE POSITIONING TECHNOLOGY	AGNSS

LPP REQUEST CAPABILITIES

Information Element	Value/remark
<i>a-gnss-RequestCapabilities</i>	TRUE

LPP REQUEST LOCATION INFORMATION

Information Element	Value/remark	Comment
commonIEsRequestLocationInformation		
> locationInformationType	'locationEstimateRequired' or 'locationMeasurementsRequired'	Depending on test case and UE capabilities, i.e. support for UE-based or UE-assisted
> additionalInformation	'onlyReturnInformationRequested'	
> qos		
>> horizontalAccuracy	'19' (51.2m)	
>> verticalCoordinateRequest	FALSE	
>> responseTime		
>>>time	'20'	
a-gnss-RequestLocationInformation		
> gnss-PositioningInstructions		
>> gnssMethods		
>>> gnss-ids	Sub-test 1: 'gps' Sub-test 2: 'glonass' Sub-test 3: 'galileo' Sub-test 4: 'gps' Sub-test 5: 'gps' and 'glonass' Sub-test 8: 'gps' and 'galileo' Sub-test 9: 'bds' Sub-test 10: 'gps'and'bds' Sub-test 11: 'gps' and 'glonass' and 'bds' Sub-test 12: 'gps' and 'galileo' and 'glonass' Sub-test 13: 'gps' and 'galileo' and 'bds' Sub-test 14: 'gps' and 'qzss' Sub-test 15: 'gps' and 'navic'	
>> fineTimeAssistanceMeasReq	FALSE	
>> adrMeasReq	FALSE	
>> multiFreqMeasReq	TRUE or FALSE	Depending on UE capabilities
>> assistanceAvailability	FALSE	

13.4.6 Test requirement

For the parameters specified in table 13.4.7 or 13.4.8 the UE shall meet the requirements and the success rate specified in table 13.4.10 with a confidence level of 95% according to Annex D.

Table 13.4.7: Test parameters for Dynamic Range - Sub-Test 1

Parameters	Unit	Value
Number of generated satellites	-	6
HDOP Range	-	1.4 to 2.1
GPS Coarse Time assistance error range	seconds	±1.8
Propagation conditions	-	AWGN
GPS L1 C/A Signal for 1 st satellite	dBm	-128.2
GPS L1 C/A Signal for 2 nd satellite	dBm	-134
GPS L1 C/A Signal for 3 rd satellite	dBm	-140
GPS L1 C/A Signal for 4 th satellite	dBm	-146
GPS L1 C/A Signal for 5 th satellite	dBm	-146
GPS L1 C/A Signal for 6 th satellite	dBm	-146

Table 13.4.8: Test parameters for Dynamic Range - Sub-Tests 2 to 5 and Sub-Tests 8 to 13

System	Parameters	Unit	Value
	Number of generated satellites per system	-	See Table 13.4.9
	Total number of generated satellites	-	6 or 7 ⁽²⁾
	HDOP Range	-	1.4 to 2.1
	Propagation conditions	-	AWGN
	GNSS coarse time assistance error range	seconds	±1.8
Galileo	Reference high signal power level	dBm	-126.7
	Reference low signal power level	dBm	-146
GPS ⁽¹⁾	Reference high signal power level	dBm	-128.2
	Reference low signal power level	dBm	-146
GLONASS	Reference high signal power level	dBm	-130.7
	Reference low signal power level	dBm	-146
BDS	Reference high signal power level	dBm	-132.7
	Reference low signal power level	dBm	-144
QZSS	Reference high signal power level	dBm	-128.2
	Reference low signal power level	dBm	-146
Navic	Reference high signal power level	dBm	-128.2
	Reference low signal power level	dBm	-146
NOTE 1: "GPS" here means GPS L1 C/A, Modernized GPS, or both, dependent on UE capabilities.			
NOTE 2: 7 satellites are used for sub-tests with 3 different GNSSs			

Table 13.4.9: Power level and satellite allocation

		Satellite allocation for each constellation		
		GNSS 1 ⁽¹⁾	GNSS 2 ⁽¹⁾	GNSS 3 ⁽¹⁾
Single constellation	High signal level	2	--	--
	Low signal level	4	--	--
Dual constellation	High signal level	1	1	--
	Low signal level	2	2	--
Triple constellation	High signal level	1	1	1
	Low signal level	2	1	1
NOTE 1: GNSS refers to global systems i.e., GPS, Galileo, GLONASS and BDS.				

Table 13.4.10: Test requirements for Dynamic Range

System	Success rate	2-D position error	Max response time
All	95 %	101.3 m	20.3 s

13.5 Multi-Path scenario

13.5.1 Sub-tests

This test includes sub-tests dependent on the GNSS supported by the UE. Each sub-test is identified by a Sub-Test Number as defined in Table 13.5.1

Table 13.5.1: Sub-Test Number Definition

Sub-Test Number	Supported GNSS
1	UE supporting A-GPS L1 C/A
2	UE supporting A-GLONASS
3	UE supporting A-Galileo
4	UE supporting A-GPS and Modernized GPS
5	UE supporting A-GPS and A-GLONASS (Note)
8	UE supporting A-GPS and A-Galileo (Note)
9	UE supporting A-BDS
10	UE supporting A-GPS and A-BDS (Note)
11	UE supporting A-GPS and A-GLONASS and A-BDS (Note)
12	UE supporting A-GPS and A-Galileo and A-GLONASS (Note)
13	UE supporting A-GPS and A-Galileo and A-BDS (Note)
14	UE supporting A-GPS and A-QZSS (Note)
15	UE supporting A-GPS and A-Navic (Note)

Note: "GPS" here means GPS L1 C/A, Modernized GPS, or both, dependent on UE capabilities.

13.5.2 Test purpose

To verify the performance of the first position estimate, when the UE is provided with GNSS signals with multi-path components.

13.5.3 Test applicability

This test applies to all types of NR UE that support EN-DC or NG-RAN NR, and A-GNSS.

13.5.4 Minimum conformance requirements

The first fix position estimates shall meet the accuracy and response time requirements in table 13.5.2 for the parameters specified in table 13.5.3 or 13.5.4.

Table 13.5.2: Requirements for Multi-Path scenario

Success rate	2-D position error	Max response time
95 %	100 m	20 s

Table 13.5.3: Parameters for Multi-Path scenario - Sub-Test 1

Parameters	Unit	Value
Number of generated satellites (Satellites 1, 2 unaffected by multi-path) (Satellites 3, 4, 5 affected by multi-path)	-	5
GPS Coarse time assistance error range	seconds	± 2
HDOP Range	-	1.8 to 2.5
GPS L1 C/A Signal for satellite 1, 2	dBm	-130
GPS L1 C/A Signal for satellite 3, 4, 5	dBm	LOS signal of -130 dBm, multi-path signal of -136 dBm

Table 13.5.4: Parameters for Multi-Path scenario - Sub-Tests 2 to 5 and Sub-Tests 8 to 13

System	Parameters	Unit	Value
	Number of generated satellites per system	-	See Table 13.5.5
	Total number of generated satellites	-	6 or 7 ⁽²⁾
	HDOP range		1.4 to 2.1
	Propagation conditions	-	AWGN
	GNSS coarse time assistance error range	seconds	±2
Galileo	Reference signal power level	dBm	-127
GPS ⁽¹⁾	Reference signal power level	dBm	-128.5
GLONASS	Reference signal power level	dBm	-131
BDS	Reference signal power level	dBm	-133
QZSS	Reference signal power level	dBm	-128.5
Navic	Reference signal power level	dBm	-128.5
NOTE 1: "GPS" here means GPS L1 C/A, Modernized GPS, or both, dependent on UE capabilities.			
NOTE 2: 7 satellites are used for sub-tests with 3 different GNSSs			

Table 13.5.5: Channel model allocation

		Channel model allocation for each constellation		
		GNSS-1	GNSS-2	GNSS-3
Single constellation	One-tap channel	2	--	--
	Two-tap channel	4	--	--
Dual constellation	One-tap channel	1	1	--
	Two-tap channel	2	2	--
Triple constellation	One-tap channel	1	1	1
	Two-tap channel	2	1	1
Note: One-tap channel: no multi-path. Two-tap channel: multi-path defined in clause 4.2.4				

The normative reference for this requirement is TS 38.171 [43] clause 5.4 and 6.4.

13.5.5 Test description

13.5.5.1 Initial conditions

Initial conditions are a set of test configurations the UE needs to be tested in and the steps for the SS to take with the UE to reach the correct measurement state.

Test Environment: Normal, as defined in TS 38.508-1 [45] clause 4.1.

Frequencies to be tested: as defined in TS 38.508-1 [45] clause 4.3.1.

Channel Bandwidth to be tested: as defined in TS 38.508-1 [45] clause 4.3.1.

1. Connect SS and GSS to the UE antenna connector or antenna connectors as shown in Annex A.
2. Set the GNSS test parameters as specified in table 13.5.7 or 13.5.8 for GNSS scenario #1 in TS 37.571-5 [20]. Randomly select from the satellite SV IDs defined in the relevant table of Satellites to be simulated in clause 6.2.1.2 in TS 37.571-5 [20] for the satellites with one-tap channels.
3. For Test Configuration A (Table 13.1.1), the parameter settings for the cell are set up according to TS 38.508-1 [45] clause 4.4.1.2, non-standalone E-UTRA single cell and NR single cell network scenarios.

For Test Configuration B (Table 13.1.1), the parameter settings for the cell are set up according to TS 38.508-1 [45] clause 4.4.1.1, standalone NR single cell network scenarios.

4. Switch on the UE.
5. Establish a signalling connection according to the generic procedure in TS 38.508-1 [18] clause 4.5. 4 (RRC_CONNECTED).

13.5.5.2 Test procedure

1. Start GNSS scenario #1 as specified in clause 6.2.1.2 of TS 37.571-5 [20] with the UE location randomly selected to be within 3 km of the Reference Location and the altitude of the UE randomly selected between 0 m to 500 m above WGS-84 reference ellipsoid using the method described in clause 6.2.1.2.6 of TS 37.571-5 [20]. The initial carrier phase difference between taps of the multi-path model shall be randomly selected between 0 and 2π radians by selecting the next random number from a standard uniform random number generator, in the range 0 to 2π , representing radians with a resolution of 0.1, representing 0.1 radians.
2. Send a RESET UE POSITIONING STORED INFORMATION message.
3. Depending on how the LPP session is performed:
 - In the case of C-Plane, the SS shall send an LPP REQUEST CAPABILITIES message.
 - In the case of U-Plane, the SS shall establish a SUPL session with the UE for positioning.
4. The UE returns an LPP PROVIDE CAPABILITIES message indicating the assistance data supported by the UE in the Assistance Data Support List in the A GNSS Provide Capabilities IE.
5. Send an LPP PROVIDE ASSISTANCE DATA message to provide the assistance data that is supported by the UE as indicated in the step 4 and in accordance with clause 6.2.6 of TS 37.571-5 [20], and with the values defined in clause 6.2.7 of TS 37.571-5 [20] with the value of GNSS Reference Time offset by a random value as specified in clause 6.2.7.2 of TS 37.571-5 [20]. If the LPP session is performed over C-Plane, then if the UE message at step 4 includes the ackRequested IE set to TRUE, then the SS shall send an acknowledgment in the LPP PROVIDE ASSISTANCE DATA message.
6. Send an LPP REQUEST LOCATION INFORMATION message to obtain a fix.
7. If the UE returns a valid result in the LPP PROVIDE LOCATION INFORMATION message within the Max response time specified in table 13.5.10 then record the result and process it as specified in step 9. If the UE does not return a valid result within the Max response time specified in table 13.5.10 or reports an Error in the LPP PROVIDE LOCATION INFORMATION message then record one Bad Result.
8. If the UE message at step 7 includes the ackRequested IE set to TRUE, then the SS shall send a LPP acknowledgment message.
9. For UE based testing compare the reported Location Information in the LPP PROVIDE LOCATION INFORMATION message against the simulated position of the UE used in step 1, and calculate the 2D position error as specified in clause 4.5.2.3. Compare the 2D position error against the value in table 13.5.10 and record one Good Result or Bad Result as appropriate; or

For UE assisted testing convert the GNSS Measurement Information reported in the LPP PROVIDE LOCATION INFORMATION message to a 2D position using the method described in clause 4.4.3 and then compare the result against the simulated position of the UE used in step 1, and calculate the 2D position error as specified in clause 4.5.2.3. Compare the 2D position error against the value in table 13.5.10 and record one Good Result or Bad Result as appropriate.
10. Repeat steps 1 to 9 using GNSS scenario #2 instead of #1 so that the reference location changes sufficiently such that the UE shall have to use the new assistance data. Randomly select from the satellite SV IDs defined in the relevant table of Satellites to be simulated in clause 6.2.1.2 in TS 37.571-5 [20] for the satellites with the one-tap channels. Use new random values for the UE location and altitude, and the initial carrier phase difference between taps of the multi-path model in step 1 and for the GNSS Reference Time offset in step 5.
11. Repeat steps 1 to 10 until the statistical requirements of clause 13.5.6 are met. Each time scenario #1 or #2 is used, the start time of the GNSS scenario shall be advanced by 2 minutes from the time used previously for that scenario. Once a scenario reaches the end of its viable running time, restart it from its nominal start time again. Each time scenario #1 or #2 is used, randomly select from the satellite SV IDs defined in the relevant table of Satellites to be simulated in clause 6.2.1.2 in TS 37.571-5 [20], for the satellites with the one-tap channels.
12. Release the signalling connection

13.5.5.3 Message contents

Message contents are according to TS 38.508-1 [45] clauses 4.6 and 4.7 and as follows:

RESET UE POSITIONING STORED INFORMATION

Information Element	Value/remark
UE POSITIONING TECHNOLOGY	AGNSS

LPP REQUEST CAPABILITIES

Information Element	Value/remark
<i>a-gnss-RequestCapabilities</i>	TRUE

LPP REQUEST LOCATION INFORMATION

Information Element	Value/remark	Comment
commonEsRequestLocationInformation		
> locationInformationType	'locationEstimateRequired' or 'locationMeasurementsRequired'	Depending on test case and UE capabilities, i.e. support for UE-based or UE-assisted
> additionalInformation	'onlyReturnInformationRequested'	
> qos		
>> horizontalAccuracy	'19' (51.2m)	
>> verticalCoordinateRequest	FALSE	
>> responseTime		
>>>time	'20'	
a-gnss-RequestLocationInformation		
> gnss-PositioningInstructions		
>> gnssMethods		
>>> gnss-ids	Sub-test 1: 'gps' Sub-test 2: 'glonass' Sub-test 3: 'galileo' Sub-test 4: 'gps' Sub-test 5: 'gps' and 'glonass' Sub-test 8: 'gps' and 'galileo' Sub-test 9: 'bds' Sub-test 10: 'gps'and'bds' Sub-test 11: 'gps' and 'glonass' and 'bds' Sub-test 12: 'gps' and 'galileo' and 'glonass' Sub-test 13: 'gps' and 'galileo' and 'bds' Sub-test 14: 'gps' and 'qzss' Sub-test 15: 'gps' and 'navic'	
>> fineTimeAssistanceMeasReq	FALSE	
>> adrMeasReq	FALSE	
>> multiFreqMeasReq	TRUE or FALSE	Depending on UE capabilities
>> assistanceAvailability	FALSE	

13.5.6 Test requirement

For the parameters specified in table 13.5.7 or 13.5.8 the UE shall meet the requirements and the success rate specified in table 13.5.10 with a confidence level of 95% according to Annex D.

Table 13.5.7: Test parameters for Multi-Path scenario - Sub-Test 1

Parameters	Unit	Value
Number of generated satellites (see note)	-	5
GPS Coarse Time assistance error range	seconds	±1.8
HDOP Range	-	1.8 to 2.5
GPS L1 C/A Signal for Satellite 1, 2 (see note)	dBm	-130
GPS L1 C/A Signal for Satellite 3, 4, 5 (see note)	dBm	LOS signal of -130 dBm, multi-path signal of -136.2 dBm
NOTE: Satellites 1, 2 no multi-path. Satellites 3, 4, 5 multi-path defined in clause 4.2.4.		

Table 13.5.8: Test parameters for Multi-Path scenario - Sub-Tests 2 to 5 and Sub-Tests 8 to 13

System	Parameters	Unit	Value
	Number of generated satellites per system	-	See Table 13.5.9
	Total number of generated satellites	-	6 or 7 ⁽²⁾
	HDOP Range per system	-	1.4 to 2.1
	Propagation conditions	-	AWGN
	GNSS coarse time assistance error range	seconds	±2
Galileo	Reference signal power level for all satellites	dBm	-127
GPS ⁽¹⁾	Reference signal power level for all satellites	dBm	-128.5
GLONASS	Reference signal power level for all satellites	dBm	-131
BDS	Reference signal power level for all satellites	dBm	-133
QZSS	Reference signal power level for all satellites	dBm	-128.5
Navic	Reference signal power level for all satellites	dBm	-128.5
NOTE 1: "GPS" here means GPS L1 C/A, Modernized GPS, or both, dependent on UE capabilities.			
NOTE 2: 7 satellites are used for sub-tests with 3 different GNSSs.			

Table 13.5.9: Channel model allocation

		Channel model allocation for each constellation		
		GNSS-1	GNSS-2	GNSS-3
Single constellation	One-tap channel	2	--	--
	Two-tap channel	4	--	--
Dual constellation	One-tap channel	1	1	--
	Two-tap channel	2	2	--
Triple constellation	One-tap channel	1	1	1
	Two-tap channel	2	1	1
Note: One-tap channel: no multi-path. Two-tap channel: multi-path defined in clause 4.2.4 with Relative mean Power (Y) defined in Table 13.5.9A.				

Table 13.5.9A: Relative mean Power (Y) for use in Table 13.5.9

System	Signals	Y [dB]
Galileo	E1	-4.7
	E5a	-6.2
	E5b	-6.2
GPS/Modernized GPS/QZSS	L1 C/A	-6.2
	L1C	-4.7
	L2C	-6.2
GLONASS	L5	-6.2
	G1	-12.7
	G2	-12.7
BDS	B1I	-4.7
	B1C	-4.7
	B2a	-6.2
Navic	B3I	-6.2
	L5	-6,2

Table 13.5.10: Test requirements for Multi-Path scenario

System	Success rate	2-D position error	Max response time
All	95 %	101.3 m	20.3 s

13.6 Moving scenario and periodic update (Rel-9 to Rel-13)

13.6.1 Sub-tests

This test includes sub-tests dependent on the GNSS supported by the UE. Each sub-test is identified by a Sub-Test Number as defined in Table 13.6.1

Table 13.6.1: Sub-Test Number Definition

Sub-Test Number	Supported GNSS
1	UE supporting A-GPS L1 C/A
2	UE supporting A-GLONASS
3	UE supporting A-Galileo
4	UE supporting A-GPS and Modernized GPS
5	UE supporting A-GPS and A-GLONASS (Note)
8	UE supporting A-GPS and A-Galileo (Note)
9	UE supporting A-BDS
10	UE supporting A-GPS and A-BDS (Note)
11	UE supporting A-GPS and A-GLONASS and A-BDS (Note)
12	UE supporting A-GPS and A-Galileo and A-GLONASS (Note)
13	UE supporting A-GPS and A-Galileo and A-BDS (Note)
14	UE supporting A-GPS and A-QZSS (Note)
15	UE supporting A-GPS and A-Navic (Note)

Note: "GPS" here means GPS L1 C/A, Modernized GPS, or both, dependent on UE capabilities.

13.6.2 Test purpose

To verify the performance when the UE is requested to use periodical reporting with a reporting interval of 2 seconds.

13.6.3 Test applicability

This test applies to all types of NR UE that support EN-DC or NG-RAN NR, and A-GNSS, with LPP Release 9 to 13.

13.6.4 Minimum conformance requirements

The position estimates, after the first reported position estimate, shall meet the accuracy requirement in table 13.6.2 or 13.6.3 with the periodical reporting interval of 2 seconds for the parameters specified in table 13.6.4 or 13.6.5.

NOTE: In the actual testing the UE may report error messages until it has been able to acquire GNSS measured results or a position estimate. The SS shall only consider the first measurement report different from an error message as the first position estimate in the requirement in table 13.6.2 or 13.6.3.

Table 13.6.2: Requirements for Moving scenario and periodic update - Sub-Test 1

Success Rate	2-D position error	Periodical reporting interval
95 %	100 m	2 s

Table 13.6.3: Requirements for Moving scenario and periodic update - Sub-Tests 2 to 5 and Sub-Tests 8 to 13

Success Rate	2-D position error	Periodical reporting interval
95 %	50 m	2 s

Table 13.6.4: Parameters for Moving scenario and periodic update - Sub-Test 1

Parameters	Unit	Value
Number of generated satellites	-	5
HDOP Range	-	1.8 to 2.5
Propagation condition	-	AWGN
GPS L1 C/A signal for all satellites	dBm	-130

Table 13.6.5: Parameters for Moving scenario and periodic update - Sub-Tests 2 to 5 and Sub-Tests 8 to 13

System	Parameters	Unit	Value
	Number of generated satellites per system	-	See Table 13.6.6
	Total number of generated satellites	-	6 or 7 ⁽²⁾
	HDOP range	-	1.4 to 2.1
	Propagation conditions	-	AWGN
Galileo	Reference signal power level	dBm	-127
GPS ⁽¹⁾	Reference signal power level	dBm	-128.5
GLONASS	Reference signal power level	dBm	-131
BDS	Reference signal power level	dBm	-133
QZSS	Reference signal power level	dBm	-128.5
Navic	Reference signal power level	dBm	-128.5
NOTE 1: "GPS" here means GPS L1 C/A, Modernized GPS, or both, dependent on UE capabilities.			
NOTE 2: 7 satellites are used for sub-tests with 3 different GNSSs.			

Table 13.6.6: Satellite allocation

	Satellite allocation for each constellation		
	GNSS 1 ⁽¹⁾	GNSS 2 ⁽¹⁾	GNSS 3 ⁽¹⁾
Single constellation	6	--	--
Dual constellation	3	3	--
Triple constellation	3	2	2
NOTE 1: GNSS refers to global systems i.e., GPS, Galileo, GLONASS and BDS.			

The normative reference for this requirement is TS 38.171 [43] clause 5.5 and 6.5.

13.6.5 Test description

13.6.5.1 Initial conditions

Initial conditions are a set of test configurations the UE needs to be tested in and the steps for the SS to take with the UE to reach the correct measurement state.

Test Environment: Normal, as defined in TS 38.508-1 [45] clause 4.1.

Frequencies to be tested: as defined in TS 38.508-1 [45] clause 4.3.1.

Channel Bandwidth to be tested: as defined in TS 38.508-1 [45] clause 4.3.1.

The UE moves on a rectangular trajectory of 940 m by 1 440 m with rounded corner defined in Figure 13.1. The initial reference is first defined followed by acceleration to final speed of 100 km/h in 250 m. The UE then maintains the speed for 400 m. This is followed by deceleration to final speed of 25 km/h in 250 m. The UE then turn 90 degrees with turning radius of 20 m at 25 km/h. This is followed by acceleration to final speed of 100 km/h in 250 m. The sequence is repeated to complete the rectangle.

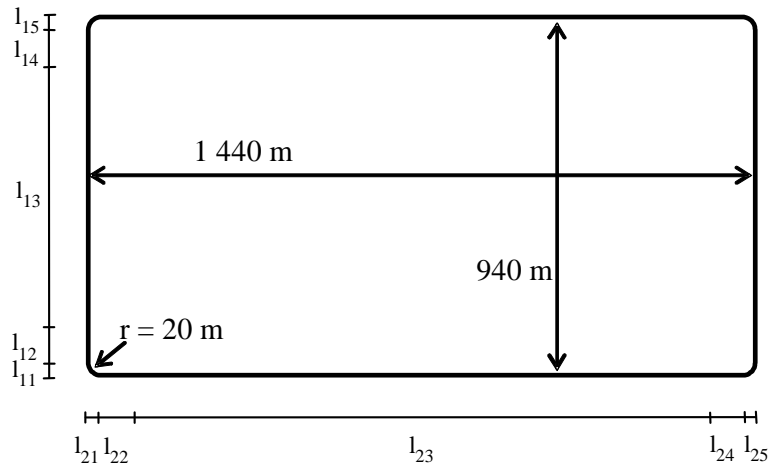

Figure 13.1: Rectangular trajectory of the moving scenario and periodic update test case

Trajectory Parameters

Parameter	Distance (m)	Speed (km/h)
$l_{11}, l_{15}, l_{21}, l_{25}$	20	25
$l_{12}, l_{14}, l_{22}, l_{24}$	250	25 to 100 and 100 to 25
l_{13}	400	100
l_{23}	900	100

1. Connect SS and GSS to the UE antenna connector or antenna connectors as shown in Annex A.
2. Set the GNSS test parameters as specified in table 13.6.8 or 13.6.9 for GNSS scenario #5 in TS 37.571-5 [20].
3. For Test Configuration A (Table 13.1.1), the parameter settings for the cell are set up according to TS 38.508-1 [45] clause 4.4.1.2, non-standalone E-UTRA single cell and NR single cell network scenarios.
For Test Configuration B (Table 13.1.1), the parameter settings for the cell are set up according to TS 38.508-1 [45] clause 4.4.1.1, standalone NR single cell network scenarios.
4. Switch on the UE.
5. Establish a signalling connection according to the generic procedure in TS 38.508-1 [45] clause 4.5. 4 (RRC_CONNECTED).

13.6.5.2 Test procedure

1. Start GNSS scenario #5 as specified in clause 6.2.1.2 of TS 37.571-5 [20]
2. Send a RESET UE POSITIONING STORED INFORMATION message.
3. Depending on how the LPP session is performed:
 - In the case of C-Plane, the SS shall send an LPP REQUEST CAPABILITIES message.
 - In the case of U-Plane, the SS shall establish a SUPL session with the UE for positioning.
4. The UE returns an LPP PROVIDE CAPABILITIES message indicating the assistance data supported by the UE in the Assistance Data Support List in the A GNSS Provide Capabilities IE.
5. Send an LPP PROVIDE ASSISTANCE DATA message to provide the assistance data that is supported by the UE as indicated in the step 4 and in accordance with clause 6.2.6 of TS 37.571-5 [20], and with the values defined in clause 6.2.7 of TS 37.571-5 [20]. If the LPP session is performed over C-Plane, then if the UE

message at step 4 includes the `ackRequested` IE set to TRUE, then the SS shall send an acknowledgment in the LPP PROVIDE ASSISTANCE DATA message.

6. Send an LPP REQUEST LOCATION INFORMATION message to obtain a fix.
7. Ignore any Error messages that the UE may report in LPP PROVIDE LOCATION INFORMATION messages until it has been able to acquire the GNSS signals and reports the first GNSS Measurement Information or Location Information.
8. Discard the first GNSS Measurement Information or Location Information.
9. Record the time of reception of the next LPP PROVIDE LOCATION INFORMATION message after reception of the first GNSS Measurement Information or Location Information.
10. After the reception of the first GNSS Measurement Information or Location Information reported in a LPP PROVIDE LOCATION INFORMATION message, every time the UE returns a GNSS Measurement Information or Location Information in the LPP PROVIDE LOCATION INFORMATION message record the time of reception and the result. If the difference between the time of reception and the time of reception of the previous result is less than 1.5 seconds or greater than 2.5 seconds, or if the UE reports an Error in any LPP PROVIDE LOCATION INFORMATION messages, then record one Bad Result. Otherwise process the result as specified in step 12.
11. If the UE messages at steps 7 to 10 include the `ackRequested` IE set to TRUE, then the SS shall send LPP acknowledgment messages as required.
12. For UE based testing compare the reported Location Information in the LPP PROVIDE LOCATION INFORMATION message against the simulated position of the UE at the time of applicability reported in the Location Information, and calculate the 2D position error as specified in clause 4.5.2.3. Compare the 2D position error against the value in table 13.6.11 or 13.6.12 and record one Good Result or Bad Result as appropriate; or

For UE assisted testing convert the GNSS Measurement Information reported in the LPP PROVIDE LOCATION INFORMATION message to a 2D position using the method described in clause 4.4.3 and then compare the result against the simulated position of the UE at the time of applicability reported in the GNSS Measurement Information, and calculate the 2D position error as specified in clause 4.5.2.3. Compare the 2D position error against the value in table 13.6.11 or 13.6.12 and record one Good Result or Bad Result as appropriate.
13. If the UE sends the first LPP PROVIDE LOCATION INFORMATION that contains GNSS Measurement Information or Location Information later than 240s after the start of the GNSS scenario, fail the UE and stop the test early. Otherwise collect LPP PROVIDE LOCATION INFORMATION results during 900s, starting from the time recorded in step 9. If at any time the difference between the times of reception of two consecutive results is greater than 240s, fail the UE and stop the test early. Use the collected Good Results and Bad Results to determine the PASS/FAIL according to clause 13.6.6.
14. Release the signalling connection.

13.6.5.3 Message contents

Message contents are according to TS 38.508-1 [45] clauses 4.6 and 4.7 and as follows:

RESET UE POSITIONING STORED INFORMATION

Information Element	Value/remark
UE POSITIONING TECHNOLOGY	AGNSS

LPP REQUEST CAPABILITIES

Information Element	Value/remark
<i>a-gnss-RequestCapabilities</i>	TRUE

LPP REQUEST LOCATION INFORMATION

Information Element	Value/remark	Comment
commonEsRequestLocationInformation		
> locationInformationType	'locationEstimateRequired' or 'locationMeasurementsRequired'	Depending on test case and UE capabilities, i.e. support for UE-based or UE-assisted
> periodicalReporting		
>> reportingAmount	'ra-Infinity'	Infinite means during the complete test time
>> reportingInterval	'ri0-5'	2 seconds
> additionalInformation	'onlyReturnInformationRequested'	
> qos		
>> horizontalAccuracy (Sub-Test 1)	'19' (51.2m)	
>> horizontalAccuracy (Sub-Tests 2 to 5 and 8 to 13)	'13' (24.5m)	
>> verticalCoordinateRequest	FALSE	
>> responseTime	Not present	
a-gnss-RequestLocationInformation		
> gnss-PositioningInstructions		
>> gnssMethods		
>>> gnss-ids	Sub-test 1: 'gps' Sub-test 2: 'glonass' Sub-test 3: 'galileo' Sub-test 4: 'gps' Sub-test 5: 'gps' and 'glonass' Sub-test 8: 'gps' and 'galileo' Sub-test 9: 'bds' Sub-test 10: 'gps'and'bds' Sub-test 11: 'gps' and 'glonass' and 'bds' Sub-test 12: 'gps' and 'galileo' and 'glonass' Sub-test 13: 'gps' and 'galileo' and 'bds' Sub-test 14: 'gps' and 'qzss' Sub-test 15: 'gps' and 'navic'	
>> fineTimeAssistanceMeasReq	FALSE	
>> adrMeasReq	FALSE	
>> multiFreqMeasReq	TRUE or FALSE	Depending on UE capabilities
>> assistanceAvailability	FALSE	

13.6.6 Test requirement

For the parameters specified in table 13.6.8 or 13.6.9 the UE shall meet the requirements and the success rate specified in table 13.6.11 or 13.6.12 after the first reported position estimates.

NOTES: 1. In the testing the UE may report error messages until it has been able to acquire GNSS measured results or a position estimate. The test equipment shall only consider the first measurement report different from an error message as the first position estimate in the requirement in table 13.6.11 or 13.6.12.

2. Due to the statistical nature of the results it is not possible to design a test with predefined confidence level for the success rate in table 13.6.11 or 13.6.12, therefore a simple PASS/FAIL of the results gathered against this success rate is used.

Table 13.6.8: Test parameters for Moving scenario and periodic update - Sub-Test 1

Parameters	Unit	Value
Number of generated satellites	-	5
HDOP Range	-	1.8 to 2.5
Propagation condition	-	AWGN

Parameters	Unit	Value
GPS L1 C/A Signal for all satellites	dBm	-130

Table 13.6.9: Test parameters for Moving scenario and periodic update - Sub-Tests 2 to 5 and Sub-Tests 8 to 13

System	Parameters	Unit	Value
	Number of generated satellites per system	-	See Table 13.6.10
	Total number of generated satellites	-	6 or 7 ⁽²⁾
	HDOP Range per system	-	1.4 to 2.1
	Propagation conditions	-	AWGN
Galileo	Reference signal power level for all satellites	dBm	-127
GPS ⁽¹⁾	Reference signal power level for all satellites	dBm	-128.5
GLONASS	Reference signal power level for all satellites	dBm	-131
BDS	Reference signal power level for all satellites	dBm	-133
QZSS	Reference signal power level for all satellites	dBm	-128.5
Navic	Reference signal power level for all satellites	dBm	-128.5
NOTE 1: "GPS" here means GPS L1 C/A, Modernized GPS, or both, dependent on UE capabilities.			
NOTE 2: 7 satellites are used for sub-tests with 3 different GNSSs.			

Table 13.6.10: Satellite allocation

	Satellite allocation for each constellation		
	GNSS 1 ⁽¹⁾	GNSS 2 ⁽¹⁾	GNSS 3 ⁽¹⁾
Single constellation	6	--	--
Dual constellation	3	3	--
Triple constellation	3	2	2
NOTE 1: GNSS refers to global systems i.e., GPS, Galileo, GLONASS and BDS.			

Table 13.6.11: Test requirements for Moving scenario and periodic update - Sub-Test 1

System	Success rate	2-D position error	Periodical reporting interval
All	95 %	101.3 m	Between 1.5 s and 2.5s

Table 13.6.12: Test requirements for Moving scenario and periodic update - Sub-Tests 2 to 5 and Sub-Tests 8 to 13

System	Success rate	2-D position error	Periodical reporting interval
All	95 %	51.3 m	Between 1.5 s and 2.5s

13.7 Moving scenario and periodic update (Rel-14 onwards)

13.7.1 Sub-tests

Same as defined in clause 13.6.1.

13.7.2 Test purpose

Same as defined in clause 13.6.2.

13.7.3 Test applicability

This test applies to all types of NR UE that support EN-DC or NG-RAN NR, and A-GNSS with periodical reporting with LPP Release 14 onwards.

NOTE: The capability to support periodical reporting is indicated in LPP [4] by either omitting the field *periodicalReportingNotSupported-r14* in the LPP PROVIDE CAPABILITIES message, or by including the field *periodicalReportingNotSupported-r14* in the LPP PROVIDE CAPABILITIES message but with bits for UE-assisted or UE-based mode set to zero.

13.7.4 Minimum conformance requirements

Same as defined in clause 13.6.4.

13.7.5 Test description

Same as defined in clause 13.6.5.

13.7.6 Test requirement

Same as defined in clause 13.6.6.

14 NR RSTD measurement requirements

14.1 General

This clause defines the minimum performance requirements for NR UEs capable of performing NR RSTD measurements for DL-TDOA.

14.2 NR RSTD measurement period test cases in RRC_CONNECTED

14.2.1 NR RSTD measurement period test case for single positioning frequency layer in FR1 SA

14.2.1.1 Test purpose

The purpose of the test is to verify that the RSTD measurement meets the requirements specified in TS 38.133 [50] Clause 9.9.2 in an environment with AWGN propagation conditions in FR1 in standalone scenario when single positioning frequency layer is configured.

14.2.1.2 Test applicability

This test applies to all types of NR UE release 16 onwards that supports DL-TDOA positioning.

14.2.1.3 Minimum conformance requirements

When physical layer receives last of *NR-TDOA-ProvideAssistanceData* message and *NR-TDOA-RequestLocationInformation* message from LMF via LPP [49], the UE shall be able to measure and report multiple (up to the UE capability specified in TS 38.133 [50] Clause 9.9.2.3) DL RSTD measurements, during the measurement period $T_{RSTD,Total}$ defined as:

$$T_{RSTD,Total} = \sum_{i=1}^L T_{RSTD,i} + (L - 1) * \max(T_{effect,i})$$

Where ,

i is the index of positioning frequency layer,

L is total number of positioning frequency layers, and

$T_{\text{effect},i}$ is the periodicity of the PRS RSTD measurement in positioning frequency layer i

$T_{\text{RSTD},i}$ is the measurement period for PRS RSTD measurement in positioning frequency layer i as specified below:

$$T_{\text{RSTD},i} = \left(\text{CSSF}_{\text{PRS},i} * N_{\text{RxBeam},i} * \left\lfloor \frac{N_{\text{PRS},i}^{\text{slot}}}{N'} \right\rfloor \left\lceil \frac{L_{\text{available_PRS},i}}{N} \right\rceil * N_{\text{sample}} - 1 \right) * T_{\text{effect},i} + T_{\text{last}},$$

where:

$N_{\text{RxBeam},i}$ is the UE Rx beam sweeping factor. In FR1, $N_{\text{RxBeam},i} = 1$; and in FR2, $N_{\text{RxBeam},i} = 8$.

$\text{CSSF}_{\text{PRS},i}$ is the carrier-specific scaling factor for NR PRS-based positioning measurements in positioning frequency layer i as defined in TS 38.133[50] clause 9.1.5.2.

$N_{\text{PRS},i}^{\text{slot}}$ is the maximum number of DL PRS resources in positioning frequency layer i configured in a slot.

$L_{\text{available_PRS},i}$ is the time duration of available PRS to be measured in the positioning frequency layer i , and is calculated in the same way as PRS duration K defined in clause 5.1.6.5 of TS 38.214 [56].

N_{sample} is the number of PRS RSTD samples and $N_{\text{sample}} = 4$.

T_{last} is the measurement duration for the last PRS RSTD sample, including the sampling time and processing time, $T_{\text{last}} = T_i + T_{\text{available_PRS},i}$,

$T_{\text{effect},i}$ is the periodicity of the PRS RSTD measurement in positioning frequency layer i defined as:

$$T_{\text{effect},i} = \left\lceil \frac{T_i}{T_{\text{available_PRS},i}} \right\rceil * T_{\text{available_PRS},i}$$

Where,

T_i corresponds to *durationOfPRS-ProcessingSymbolsInEveryTms* in TS 37.355 [49],

$T_{\text{available_PRS},i} = \text{LCM}(T_{\text{PRS},i}, \text{MGRP}_i)$, the least common multiple between $T_{\text{PRS},i}$ and MGRP_i .

MGRP_i is the repetition periodicity of the measurement gap applicable for measurement in the PRS frequency layer i .

$T_{\text{PRS},i}$ is the periodicity of DL PRS resource with muting on positioning frequency layer i .

If more than one PRS periodicities are configured in positioning frequency layer i , the least common multiple of PRS periodicities $T_{\text{per}}^{\text{PRS with muting}}$ among all DL PRS resource sets in the positioning frequency layer is used to derive the measurement period of that positioning frequency layer i . Where,

$T_{\text{per}}^{\text{PRS with muting}} = N_{\text{muting}} * T_{\text{per}}^{\text{PRS}}$, is the PRS periodicity with muting per PRS resource,

$T_{\text{per}}^{\text{PRS}}$ is the periodicity of PRS resource sets given by the higher-layer parameter *DL-PRS-Periodicity*.

N_{muting} is the scaling factor considering PRS resource muting. If bitmap $\{b^1\}$ for higher-layer parameter *DL-PRS-MutingPattern* is provided, and $T_{\text{per}}^{\text{PRS}} * T_{\text{muting}}^{\text{PRS}} \leq 10240\text{ms}$, then $N_{\text{muting}} = T_{\text{muting}}^{\text{PRS}} * \min(L, \frac{10240}{T_{\text{per}}^{\text{PRS}} * T_{\text{muting}}^{\text{PRS}}})$; otherwise, if bitmap $\{b^1\}$ is not provided or $T_{\text{per}}^{\text{PRS}} * T_{\text{muting}}^{\text{PRS}} > 10240\text{ms}$, then $N_{\text{muting}} = 1$.

$T_{\text{muting}}^{\text{PRS}}$ is the muting repetition factor given by the higher-layer parameter *DL-PRS-MutingBitRepetitionFactor*, and L is the size of the bitmap $\{b^1\}$.

- Note: For the purpose of calculating $T_{\text{PRS},i}$, only the PRS resources fully or partially covered by the MG are considered.

$\{N, T\}$ is UE capability combination per band where N is a duration of DL PRS symbols in ms corresponding to *durationOfPRS-ProcessingSyms* in TS 37.355 [49] processed every T ms corresponding to *durationOfPRS-*

$ProcessingSymbolsInEveryTms$ in TS 37.355 [49] for a given maximum bandwidth supported by UE corresponding to $supportedBandwidthPRS$ in TS 37.355 [49].

N' is UE capability for number of DL PRS resources that it can process in a slot as indicated by $maxNumOfDL-PRS-ResProcessedPerSlot$ specified in TS 37.355 [49].

The time $T_{RSTD,i}$ starts from the first MG instance aligned with a DL PRS resource(s) of positioning frequency layer i closest in time after both the $NR-TDOA-ProvideAssistanceData$ message and $NR-TDOA-RequestLocationInformation$ message are delivered from LMF to the physical layer of UE via LPP.

14.2.1.4 Test description

14.2.1.4.1 Initial conditions

The test is defined with three possible Test Configurations. In the case that the UE supports more than one of these Test Configurations, then the UE is only required to be tested in one of the Test Configurations, chosen by the UE. The defined Test Configurations are specified in Table 14.2.1.4.1-1.

Table 14.2.1.4.1-1: Test Configurations

Configuration	Description
1	15 kHz SSB SCS, 10 MHz bandwidth, FDD duplex mode
2	15 kHz SSB SCS, 10 MHz bandwidth, TDD duplex mode
3	30 kHz SSB SCS, 40 MHz bandwidth, TDD duplex mode

Test Environment: Normal, as defined in TS 38.508-1 [45] clause 4.1.

Frequencies to be tested: Mid, as defined in TS 38.508-1 [45] clause 4.3.1.

Channel bandwidth to be tested: are specified in Table 14.2.1.4-1.

1. Connect the SS and AWGN noise sources to the UE antenna connector or antenna connectors as shown in Annex A, Figure A.12.
2. The general test parameter settings are set up according to Table 14.2.1.5-1, Table 14.2.1.5-2 and Table 14.2.1.5-3.
3. Propagation conditions are set according to clause 4.15.2.
4. Message contents are defined in clause 14.2.4.1.3.
5. In the test there are three synchronous cells: Cell 1, Cell 2 and Cell 3. Cell 1 is the RSTD reference as well as the PCell. Cell 2 and Cell 3 are the neighbour cells. All 3 cells are on the same RF channel in FR1

14.2.1.4.2 Test procedure

The test consists of two consecutive time intervals, with duration of T1 and T2. Cell 1 is active in T1 and T2, whilst Cell 2 and Cell 3 are activated only in the beginning of T2. The beginning of the time interval T2 shall be aligned with the first PRS positioning subframe of a positioning occasion in the reference cell.

The $NR-DL-TDOA-ProvideAssistanceData$ and $NR-DL-TDOA-RequestLocationInformation$ as defined in TS 37.355 [49] clause 6.5.10.1, shall be provided to the UE during T1. The last TTI containing the $NR-DL-TDOA-RequestLocationInformation$ shall be provided to the UE ΔT ms before the start of T2, where $\Delta T = 50$ ms is the maximum processing time of the $DL-TDOA$ assistance data and location information request.

The UE is configured with measurement gap pattern ID # 24 or #0 before T2.

1. Ensure the UE is in State RRC_CONNECTED with generic procedure parameters Connectivity NR, Connected without release On, according to TS 38.508-1 [45] clause 4.5.
2. The SS shall send a RESET UE POSITIONING STORED INFORMATION message.

3. Set the parameters according to Table 14.2.1.5-1, Table 14.2.1.5-2 and Table 14.2.1.5-3. Propagation conditions are set according to clause 4.15.2.
4. T1 starts.
5. The SS shall transmit an LPP REQUEST CAPABILITIES message.
6. The UE shall transmit an LPP PROVIDE CAPABILITIES message indicating the DL-TDOA capabilities supported by the UE in the *NR-DL-TDOA-ProvideCapabilities* IE.
7. The SS shall send a LPP PROVIDE ASSISTANCE DATA message, including the *NR-DL-TDOA-ProvideAssistanceData* IE. The position of neighbour Cell 2 and the position of neighbour Cell 3 are described in 3GPP TS 37.571-5 [20]. If the UE message at step 6 includes the *ackRequested* IE set to TRUE, then the SS shall send an acknowledgment in the LPP PROVIDE ASSISTANCE DATA message.
8. The SS shall send a LPP REQUEST LOCATION INFORMATION message, including the *NR-DL-TDOA-RequestLocationInformation* IE such that the UE receives the message ΔT ms before the start of T2, where $\Delta T = 50$ ms.
9. When T1 expires, the SS shall switch the power setting from T1 to T2 as specified in Table 14.2.1.5-2 and Table 14.2.1.5-3.
10. The UE shall transmit a LPP PROVIDE LOCATION INFORMATION message including the *NR-DL-TDOA-ProvideLocationInformation* IE within the response time (see clause 4.15.3). The UE shall perform and report the RSTD measurements for both Cell 2 and Cell 3 with respect to the reference cell in the DL-TDOA assistance data, Cell 1. If the UE transmits an *NR-DL-TDOA-ProvideLocationInformation* IE including the *nr-RSTD* field for both Cell 2 and Cell 3 within the response time then the number of successful tests is increased by one. If the UE fails to report the *NR-DL-TDOA-ProvideLocationInformation* IE with both the *nr-RSTD* fields included within the response time then the number of failure tests is increased by one.
11. If the UE message at step 10 includes the *ackRequested* IE set to TRUE, the SS shall send a LPP acknowledgement message.
12. Repeat steps 2-11 in Tables 14.2.1.4-1 until the confidence level according to Annex D is achieved.

14.2.1.4.3 Message contents

Table 14.2.1.4.3-1: RESET UE POSITIONING STORED INFORMATION

Derivation Path: 38.509 [44] clause 6.6			
Information Element	Value/remark	Comment	Condition
UE Positioning Technology	0 0 0 0 1 1 1	DL-TDOA	

Table 14.2.1.4.3-2: LPP Request Capabilities

Information Element	Value/remark
<i>nr-DL-TDOA-RequestCapabilities-r16</i>	TRUE

Table 14.2.1.4.3-3: LPP RequestLocationInformation

Derivation Path: TS 37.355 [49] clause 6.2			
Information Element	Value/remark	Comment	Condition
LPP-Message ::= SEQUENCE {			
transactionID SEQUENCE {			
initiator	locationServer		
transactionNumber	1		
}			
endTransaction	FALSE		
sequenceNumber	Not present		
acknowledgement	Not present		
lpp-MessageBody CHOICE {			
c1 CHOICE {			
requestLocationInformation SEQUENCE {			

criticalExtensions CHOICE {			
c1 CHOICE {			
requestLocationInformation-r9 SEQUENCE {			
commonEsRequestLocationInformation SEQUENCE {			
locationInformationType	locationMeasurementsPreferred		
triggeredReporting	Not present		
periodicalReporting	Not present		
additionalInformation	onlyReturnInformationRequested		
qos SEQUENCE {			
horizontalAccuracy	Not present		
verticalCoordinateRequest	FALSE		
verticalAccuracy	Not present		
responseTime SEQUENCE {			
time	See 14.2.1.5	Result of the response time calculation rounded up to the next second if response time <= 128s. Result of the response time calculation rounded up to the next multiple of ten seconds if response time > 128s	
responseTimeEarlyFix-r12	Not present		Rel-12 onwards
unit-r15	Not present ten-seconds		Calculated response time >128s
}			
velocityRequest	FALSE		
}			
environment	Not present		
locationCoordinateTypes	Not present		
velocityTypes	Not present		
}			
a-gnss-RequestLocationInformation	Not present		
otdoa-RequestLocationInformation	Not present		
ecid-RequestLocationInformation	Not present		
epdu-RequestLocationInformation	Not Present		
sensor-RequestLocationInformation-r13	Not present		
tbs-RequestLocationInformation-r13	Not present		
wlan-RequestLocationInformation-r13	Not present		
bt-RequestLocationInformation-r13	Not present		
nr-ECID-RequestLocationInformation-r16	Not present		
nr-Multi-RTT-RequestLocationInformation-r16	Not present		
nr-DL-AoD-RequestLocationInformation-r16	Not present		
nr-DL-TDOA-RequestLocationInformation-r16 SEQUENCE {			
r16 nr-DL-PRS-RstdMeasurementInfoRequest-	Not present		
nr-RequestedMeasurements-r16	bit 0 = 0 (prsrspReq)		
nr-AssistanceAvailability-r16	FALSE		
nr-DL-TDOA-ReportConfig-r16	Not present		
additionalPaths-r16	Not present		
}			
}			
}			
}			

}			
}			
}			

Table 14.2.1.4.3-4: LPP ProvideAssistanceData

Derivation Path: TS 37.355 [49] clause 6.2			
Information Element	Value/remark	Comment	Condition
LPP-Message ::= SEQUENCE {			
transactionID SEQUENCE {			
initiator	locationServer		
transactionNumber	(0..255)		
}			
endTransaction	TRUE		
sequenceNumber	Not present		
acknowledgement	Not present		
lpp-MessageBody CHOICE {			
c1 CHOICE {			
provideAssistanceData SEQUENCE {			
criticalExtensions CHOICE {			
c1 CHOICE {			
provideAssistanceData-r9 SEQUENCE {			
commonEsProvideAssistanceData	Not present		
a-gnss-ProvideAssistanceData	Not present		
otdoa-ProvideAssistanceData	Not present		
epdu-ProvideAssistanceData	Not present		
sensor-ProvideAssistanceData-r14	Not present		
tbs-ProvideAssistanceData-r14	Not present		
wlan-ProvideAssistanceData-r14	Not present		
nr-Multi-RTT-ProvideAssistanceData-r16	Not present		
nr-DL-AoD-ProvideAssistanceData-r16	Not present		
nr-DL-TDOA-ProvideAssistanceData-r16			
SEQUENCE {			
nr-DL-PRS-AssistanceData-r16	As defined in Table 14.2.1.4.3-5		
nr-SelectedDL-PRS-IndexList-r16	Not present		
nr-PositionCalculationAssistance-r16			Depending on UE capabilities, i.e. support for UE-based DL-TDOA
SEQUENCE {			
nr-TRP-LocationInfo-r16	As defined in TS 37.571-5 [20]		
nr-DL-PRS-BeamInfo-r16	Not present		
nr-RTD-Info-r16	Not present		
}			
nr-DL-TDOA-Error-r16	Not present		
}			
}			
}			
}			

Table 14.2.1.4.3-5: NR-DL-PRS-AssistanceData

Derivation Path: TS 37.355 [49] clause 6.4.3			
Information Element	Value/remark	Comment	Condition
NR-DL-PRS-AssistanceData-r16 ::= SEQUENCE {			
nr-DL-PRS-ReferenceInfo-r16 SEQUENCE {			
dl-PRS-ID-r16	0		

nr-DL-PRS-ResourceID-List-r16	Not present		
nr-DL-PRS-ResourceSetID-r16	Not present		
}			
nr-DL-PRS-AssistanceDataList-r16 SEQUENCE (SIZE (1..nrMaxFreqLayers-r16)) OF NR-DL-PRS-AssistanceDataPerFreq-r16 {	1 entry		
NR-DL-PRS-AssistanceDataPerFreq-r16[1] SEQUENCE {		entry 1	
nr-DL-PRS-PositioningFrequencyLayer-r16 SEQUENCE {			
dl-PRS-SubcarrierSpacing-r16	kHz15		Config 1 and Config 2
	kHz30		Config 3
dl-PRS-ResourceBandwidth-r16	1	24 PRBs	
dl-PRS-StartPRB-r16	0		
dl-PRS-PointA-r16	absoluteFrequencyPointA as defined for the DL frequency of the Cell 1		
dl-PRS-CombSizeN-r16	n2		
dl-PRS-CyclicPrefix-r16	normal		
}			
nr-DL-PRS-AssistanceDataPerFreq-r16 SEQUENCE (SIZE (1..nrMaxTRPsPerFreq-r16)) OF NR-DL-PRS-AssistanceDataPerTRP-r16{	16 entries		
NR-DL-PRS-AssistanceDataPerTRP-r16[1] SEQUENCE {		entry 1	Cell 1
dl-PRS-ID-r16	0		
nr-PhysCellID-r16	Cell 1		
nr-CellGlobalID-r16	Cell 1		
nr-ARFCN-r16	Cell 1		
nr-DL-PRS-SFN0-Offset-r16 SEQUENCE {			
sfn-Offset-r16	0		
integerSubframeOffset-r16	0		
}			
nr-DL-PRS-ExpectedRSTD-r16	0		
nr-DL-PRS-ExpectedRSTD-Uncertainty-r16	0		
nr-DL-PRS-Info-r16	As specified in Table 14.2.1.4.3-6		
}			
NR-DL-PRS-AssistanceDataPerTRP-r16[2] SEQUENCE {		entry 2	Cell 2
dl-PRS-ID-r16	1		
nr-PhysCellID-r16	Cell 2		
nr-CellGlobalID-r16	Cell 2		
nr-ARFCN-r16	Cell 2		
nr-DL-PRS-SFN0-Offset-r16 SEQUENCE {			
sfn-Offset-r16	0		
integerSubframeOffset-r16	0		
}			
nr-DL-PRS-ExpectedRSTD-r16	0	0 μ s	
nr-DL-PRS-ExpectedRSTD-Uncertainty-r16	38	About 5 μ s	
nr-DL-PRS-Info-r16	As specified in Table 14.2.1.4.3-6		
}			
NR-DL-PRS-AssistanceDataPerTRP-r16[3] SEQUENCE {		entry 3	Cell 3
dl-PRS-ID-r16	2		
nr-PhysCellID-r16	Cell 3		
nr-CellGlobalID-r16 SEQUENCE {			
mcc-r15	Cell 3		
mnc-r15	Cell 3		
nr-cellidentity-r15	Cell 3		
}			
nr-ARFCN-r16	Cell 3		
nr-DL-PRS-SFN0-Offset-r16 SEQUENCE {			

sfn-Offset-r16	0		
integerSubframeOffset-r16	0		
}			
nr-DL-PRS-ExpectedRSTD-r16	23	About 3 μs	
nr-DL-PRS-ExpectedRSTD-Uncertainty-r16	38	About 5 μs	
nr-DL-PRS-Info-r16	As specified in Table 14.2.1.4.3-6		
}			
NR-DL-PRS-AssistanceDataPerTRP-r16[4-16]	As specified in TS 37.571-5 [20]		
}			
}			
}			
}			

Table 14.2.1.4.3-6: NR-DL-PRS-Info

Derivation Path: TS 37.355 [49] clause 6.4.3			
Information Element	Value/remark	Comment	Condition
NR-DL-PRS-Info-r16 ::= SEQUENCE {			
nr-DL-PRS-ResourceSetList-r16 SEQUENCE (SIZE (1..nrMaxSetsPerTrp-r16)) OF NR-DL-PRS-ResourceSet-r16 {	1 entry		
NR-DL-PRS-ResourceSet-r16[1] SEQUENCE {		entry 1	
nr-DL-PRS-ResourceSetID-r16	0		
dl-PRS-Periodicity-and-ResourceSetSlotOffset-r16 CHOICE {			
scs15-r16 CHOICE {			Config 1 and Config 2
n160-r16	10		
}			
scs30-r16 CHOICE {			Config 3
n320-r16	20		
}			
dl-PRS-ResourceRepetitionFactor-r16	n2		
dl-PRS-ResourceTimeGap-r16	s1		
dl-PRS-NumSymbols-r16	n4		
dl-PRS-MutingOption1-r16 SEQUENCE {			
dl-prs-MutingBitRepetitionFactor-r16	Not present		
nr-option1-muting-r16 CHOICE {			
po2-r16	10		Cell 1 and Cell 3
	01		Cell 2
}			
}			
dl-PRS-MutingOption2-r16	Not present		
dl-PRS-ResourcePower-r16	27		
dl-PRS-ResourceList-r16 SEQUENCE (SIZE (1..nrMaxResourcesPerSet-r16)) OF NR-DL-PRS-Resource-r16 {	1 entry		
NR-DL-PRS-Resource-r16[1] SEQUENCE {		entry 1	
nr-DL-PRS-ResourceID-r16	0		
dl-PRS-SequenceID-r16	0		
dl-PRS-CombSizeN-AndReOffset-r16 CHOICE {			
n2-r16	0		Cell 1 and Cell 3
	1		Cell 2
}			
dl-PRS-ResourceSlotOffset-r16	0		
dl-PRS-ResourceSymbolOffset-r16	0		
dl-PRS-QCL-Info-r16	Not present		

}			
}			
}			
}			
}			

Table 14.2.1.4.3-7: LPP ProvideLocation Information

Derivation Path: TS 37.355 [49] clause 6.2			
Information Element	Value/remark	Comment	Condition
LPP-Message ::= SEQUENCE {			
transactionID SEQUENCE {			
initiator	locationServer		
transactionNumber	1		
}			
endTransaction	TRUE		
sequenceNumber	(0..255)		
acknowledgement			
lpp-MessageBody CHOICE {			
c1 CHOICE {			
provideLocationInformation SEQUENCE {			
criticalExtensions CHOICE {			
c1 CHOICE {			
provideLocationInformation-r9 SEQUENCE {			
commonIEsProvideLocationInformation	Not present.		
a-gnss-ProvideLocationInformation	Not present		
otdoa-ProvideLocationInformation	Not present		
ecid-ProvideLocationInformation	Not present		
epdu-ProvideLocationInformation	Not present		
sensor-ProvideLocationInformation-r13	Not present		
tbs-ProvideLocationInformation-r13	Not present		
wlan-ProvideLocationInformation-r13	Not present		
bt-ProvideLocationInformation-r13	Not present		
nr-ECID-ProvideLocationInformation-r16	Not present		
nr-Multi-RTT-ProvideLocationInformation-	Not present		
r16			
nr-DL-AoD-ProvideLocationInformation-r16	Not present		
nr-DL-TDOA-ProvideLocationInformation-			
r16 SEQUENCE {			
nr-DL-TDOA-			
SignalMeasurementInformation-r16 SEQUENCE {			
dl-PRS-ReferenceInfo-r16			
nr-DL-TDOA-MeasList-r16 SEQUENCE	3 entries		
(SIZE(1..nrMaxTRPs-r16)) OF NR-DL-TDOA-			
MeasElement-r16 {			
NR-DL-TDOA-MeasElement-r16[1]		entry 1	
SEQUENCE {			
dl-PRS-ID-r16			
nr-PhysCellID-r16	Cell 1		
nr-CellGlobalID-r16			
nr-ARFCN-r16			
nr-DL-PRS-ResourceID-r16			
nr-DL-PRS-ResourceSetID-r16			
nr-TimeStamp-r16			
nr-RSTD-r16	Present		
nr-AdditionalPathList-r16			
nr-TimingQuality-r16			
nr-DL-PRS-RSRP-Result-r16			
nr-DL-TDOA-AdditionalMeasurements-			
r16			
}			
NR-DL-TDOA-MeasElement-r16[2]		entry 2	
SEQUENCE {			
dl-PRS-ID-r16			
nr-PhysCellID-r16	Cell 2		

nr-CellGlobalID-r16			
nr-ARFCN-r16			
nr-DL-PRS-ResourceID-r16			
nr-DL-PRS-ResourceSetID-r16			
nr-TimeStamp-r16			
nr-RSTD-r16	Present		
nr-AdditionalPathList-r16			
nr-TimingQuality-r16			
nr-DL-PRS-RSRP-Result-r16			
nr-DL-TDOA-AdditionalMeasurements- r16			
}			
NR-DL-TDOA-MeasElement-r16[3]		entry 3	
SEQUENCE {			
dl-PRS-ID-r16			
nr-PhysCellID-r16	Cell 3		
nr-CellGlobalID-r16			
nr-ARFCN-r16			
nr-DL-PRS-ResourceID-r16			
nr-DL-PRS-ResourceSetID-r16			
nr-TimeStamp-r16			
nr-RSTD-r16	Present		
nr-AdditionalPathList-r16			
nr-TimingQuality-r16			
nr-DL-PRS-RSRP-Result-r16			
nr-DL-TDOA-AdditionalMeasurements- r16			
}			
nr-dl-tdoa-LocationInformation-r16			
nr-DL-TDOA-Error-r16			
}			
}			
}			
}			
}			
}			
}			

14.2.1.5 Test requirement

Table 14.2.1.5-1, Table 14.2.1.5-2 and Table 14.2.1.5-3 define the primary level settings including test tolerances for the test.

Table 14.2.1.5-1: General test parameters for RSTD measurement reporting delay

Parameter	Unit	Value	Comment
Reference cell		Cell 1	Reference cell is the cell in the DL-TDOA assistance data with respect to which the RSTD measurement is defined, as specified in TS 36.214 [6] and TS 37.355 [49]. The reference cell is the PCell in this test case.
Neighbor cells		Cell 2 and Cell 3	Cell 2 and Cell 3 appear at random places in the neighbour cell list in the DL-TDOA assistance data, but Cell 2 always appears in the first half of the list, whilst Cell 3 appears in the second half of the list.
SSB configuration	Config 1	SSB.1 FR1	
	Config 2	SSB.1 FR1	
	Config 3	SSB.2 FR1	

SMTC configuration	Config 1		SMTC.2	
	Config 2		SMTC.1	
	Config 3		SMTC.1	
PDSCH RMC configuration	Config 1		SR.1.1 FDD	
	Config 2		SR.1.1 TDD	
	Config 3		SR.2.1 TDD	
RMSI CORESET RMC configuration	Config 1		CR.1.1 FDD	
	Config 2		CR.1.1 TDD	
	Config 3		CR.2.1 TDD	
Dedicated CORESET RMC configuration	Config 1		CCR.1.1 FDD	
	Config 2		CCR.1.1 TDD	
	Config 3		CCR.2.1 TDD	
Initial BWP configuration	Config 1,2,3		DLBWP.0.1 ULBWP.0.1	
Active DL BWP configuration	Config 1,2,3		DLBWP.1.1	
Active UL BWP configuration	Config 1,2,3		ULBWP.1.1	
PRS Configuration	Config 1		PRS.1.1 FR1	
	Config 2		PRS.1.1 FR1	
	Config 3		PRS.2.1 FR1	
Physical cell ID PCI			(PCI of Cell 1 – PCI of Cell 2) mod 6 = 0 and (PCI of Cell 1 – PCI of Cell 3) mod 6 = 0	The cell PCIs are selected such that the relative shifts of PRS patterns among cells are as given by the test parameters
CP length			Normal	
DRX			OFF	
Measurement gap			GP#24 or GP#0	GP#24 is configured if UE supports MG#24, otherwise GP#0 is configured
Radio frame receive time offset between the cells at the UE antenna connector	μs		Cell 2 to Cell 1: 0 Cell 3 to Cell 1: 3	PRS are transmitted from synchronous cells
Expected RSTD	μs		Cell 2: 3 Cell 3: 3 Other neighbour cells: randomly between -3 and 3	The expected RSTD is what is expected at the receiver. The corresponding parameter in the DL-TDOA assistance data specified in TS 37.355 [49] is the expectedRSTD indicator
Expected RSTD uncertainty for all neighbour cells	μs		5	The corresponding parameter in the OTDOA assistance data specified in TS 37.355 [49] is the expectedRSTD-Uncertainty index
Number of cells provided in OTDOA assistance data			16	Including the reference cell
PRS muting info			Cell 1: '10' Cell 2: '01' Cell 3: '10'	Corresponds to prs-MutingInfo defined in TS 37.355 [49] Cell 1 and Cell 3 will be configured with different Comb patterns or resource offsets
PRS resource RE offset			Cell 1: 0 Cell 2: 0 Cell 3: 1	Cell 1 and Cell 3 are configured with different resource offsets
T1	s		3	The length of the time interval from the beginning of each test
T2	s		1.28	The length of the time interval that follows immediately after time interval T1

Table 14.2.1.5-2: Cell-specific test parameters for RSTD measurement reporting delay during T1

Parameter		Unit	Cell 1	Cell 2	Cell 3
NR RF Channel Number			1	1	1
Positioning frequency layer			1	1	1
Correlation Matrix and Antenna Configuration			1x2 Low	1x2 Low	1x2 Low
OCNG patterns defined in A.3.2.1			OP.1	N/A	N/A
EPRE ratio of PSS to SSS		dB	0	N/A	N/A
EPRE ratio of PBCH DMRS to SSS					
EPRE ratio of PBCH to PBCH DMRS					
EPRE ratio of PDCCH DMRS to SSS					
EPRE ratio of PDCCH to PDCCH DMRS					
EPRE ratio of PDSCH DMRS to SSS					
EPRE ratio of PDSCH to PDSCH DMRS					
EPRE ratio of OCNG DMRS to SSS ^{Note 1}					
EPRE ratio of OCNG to OCNG DMRS ^{Note 1}					
N_{oc} ^{Note 3}	Config 1	dBm/SCS	-98		
	Config 2	dBm/SCS	-98		
	Config 3	dBm/SCS	-95		
PRS \hat{E}_s/N_{oc}		dB	-Infinity	-Infinity	-Infinity
SSB \hat{E}_s/N_{oc}		dB	10	-Infinity	-Infinity
I_o ^{Note 4}	Config 1	dBm/9.36MHz	-59.63	-59.63	-59.63
	Config 2	dBm/9.36MHz	-59.63	-59.63	-59.63
	Config 3	dBm/38.16MHz	-53.54	-53.54	-53.54
SSB RP ^{Note4}	Config 1	dBm/SCS	-88	-Infinity	-Infinity
	Config 2	dBm/SCS	-88	-Infinity	-Infinity
	Config 3	dBm/SCS	-85	-Infinity	-Infinity
Propagation Condition			AWGN		
<p>Note 1: OCNG shall be used such that active cell (Cell 1) is fully allocated and a constant total transmitted power spectral density is achieved for all OFDM symbols other than those in the slots with transmitted PRS.</p> <p>Note 2: The resources for uplink transmission are assigned to the UE prior to the start of time period T2.</p> <p>Note 3: Interference from other cells and noise sources not specified in the test are assumed to be constant over subcarriers and time and shall be modelled as AWGN of appropriate power for N_{oc} to be fulfilled.</p> <p>Note 4: SSB RP and I_o levels have been derived from other parameters and are given for information purpose. These are not settable test parameters. The I_o is calculated based only on the symbols where PRS is transmitted.</p>					

Table 14.2.1.5-3: Cell-specific test parameters for RSTD measurement reporting delay during T2

Parameter	Unit	Cell 1	Cell 2	Cell 3
		T2	T2	T2
NR RF Channel Number		1	1	1

Correlation Matrix and Antenna Configuration			1x2 Low	1x2 Low	1x2 Low
OCNG patterns defined in A.3.2.1			OP.1	OP.1	OP.1
PRACH configuration			FR1 PRACH configuration 1	FR1 PRACH configuration 1	FR1 PRACH configuration 1
EPRE ratio of PSS to SSS		dB	0	0	0
EPRE ratio of PBCH DMRS to SSS					
EPRE ratio of PBCH to PBCH DMRS					
EPRE ratio of PDCCH DMRS to SSS					
EPRE ratio of PDCCH to PDCCH DMRS					
EPRE ratio of PDSCH DMRS to SSS					
EPRE ratio of PDSCH to PDSCH DMRS					
EPRE ratio of OCNG DMRS to SSS ^{Note 1}					
EPRE ratio of OCNG to OCNG DMRS ^{Note 1}					
N_{oc} ^{Note 3}	Config 1	dBm/SCS	-98	-98	-98
	Config 2	dBm/SCS	-98	-98	-98
	Config 3	dBm/SCS	-95	-95	-95
PRS \hat{E}_s/N_{oc}	Config 1	dB	-5	-11.20	-11.20
	Config 2	dB	-5	-11.20	-11.20
	Config 3	dB	-5	-11.20	-11.20
SSB \hat{E}_s/N_{oc}	Config 1~3	dB	10	3	3
I_o ^{Note 4}	Config 1	dBm/9.36MHz	-68.38	-68.38	-68.38
	Config 2	dBm/9.36MHz	-68.38	-68.38	-68.38
	Config 3	dBm/38.16MHz	-62.28	-62.28	-62.28
SSB_RP ^{Note4}	Config 1	dBm/SCS	-88	-95	-95
	Config 2	dBm/SCS	-88	-95	-95
	Config 3	dBm/SCS	-85	-92	-92
PRS \hat{E}_s/I_{ot}		dB	-5.61	-12.64	-12.64
Propagation Condition			AWGN		

Note 1:	OCNG shall be used such that active cells (all, except Cell 3 in T3) are fully allocated and a constant total transmitted power spectral density is achieved for all OFDM symbols other than those in the slots with transmitted PRS.
Note 2:	The resources for uplink transmission are assigned to the UE prior to the start of time period T2.
Note 3:	Interference from other cells and noise sources not specified in the test are assumed to be constant over subcarriers and time and shall be modelled as AWGN of appropriate power for N_{oc} to be fulfilled.
Note 4:	SSB RP and lo levels have been derived from other parameters and are given for information purpose. These are not settable test parameters.

The RSTD measurement time fulfils the requirements specified in clause 14.2.1.3.

The UE shall perform and report the RSTD measurements for Cell 2 and Cell 3 with respect to the reference cell in the DL-TDOA assistance data, Cell 1, within the time duration specified in clause 14.2.1.3 starting from the beginning of time interval T2.

The rate of the correct events for each neighbour cell observed during repeated tests shall be at least 90%, where the reported RSTD measurement for each correct event shall be within the RSTD reporting range specified in TS 38.133[50] Clause 10.1.23.3, i.e., between RSTD_0000000 and RSTD_1970049.

The response time is equal to the LPP time IE value plus the test tolerance. The LPP time IE value is derived from the RSTD measurement period plus ΔT, where ΔT = 50 ms. The RSTD measurement period follows the equation:

$$T_{RSTD,i} = \left(CSSF_{PRS,i} * N_{RxBeam,i} * \left\lceil \frac{N_{PRS,i}^{slot}}{N'} \right\rceil \left\lceil \frac{L_{available_PRS,i}}{N} \right\rceil * N_{sample} - 1 \right) * T_{effect,i} + T_{last,i}$$

Where $CSSF_{PRS,i} = 1$, $N_{RxBeam,i} = 1$, $N_{PRS,i}^{slot} = 16$, $L_{available_PRS,i} = 1$, $N_{sample} = 4$. N is the parameter *durationOfPRS-ProcessingSymbols* from TS 37.355 [49], N' is the parameter *maxNumOfDL-PRS-ResProcessedPerSlot* from TS 37.355 [49], $T_{last,i} = T_i + T_{available_PRS,i}$ and $T_{effect,i} = \left\lceil \frac{T_i}{T_{available_PRS,i}} \right\rceil * T_{available_PRS,i}$.

$T_{available_PRS,i} = LCM(T_{PRS,i}, MGRP_i)$; where $T_{prs} = 160$ ms, and MGRP is 80 (for GP#24) or 40 (for GP#0) depending on UE capabilities. Therefore, $T_{available_PRS,i} = 160$ ms.

T_i depends on the UE parameter *durationOfPRS-ProcessingSymbolsInEveryTms* from TS 37.355 [49]

Finally, it results in the following equation:

$$\left(\left\lceil \frac{16}{N'} \right\rceil \left\lceil \frac{1}{N} \right\rceil * 4 - 1 \right) * T_{effect} + T_{last}$$

Where the remaining parameters depend on the UE capabilities. The LPP time IE ranges between 0.698s and 655.57s. The value of the LPP time IE is rounded up to the next second (if the value is >128s, it should be rounded up to the next multiple of ten seconds). The result is transmitted in the response time IE in the LPP-RequestLocationInformation in Table 14.2.1.4.3-3. The LPP time IE ranges between 1s and 660s.

The test tolerance for the response time is 300ms. Therefore, the response time ranges between 1.3s and 660.3s.

The values of N', N and Ti and the effect in the response time equation are defined in Table 14.2.1.5-4, Table 14.2.1.5-5 and Table 14.2.1.5-6 for reference.

Table 14.2.1.5-4: value of N' based on *maxNumOfDL-PRS-ResProcessedPerSlot*

<i>maxNumOfDL-PRS-ResProcessedPerSlot</i>	$\left\lceil \frac{16}{N'} \right\rceil$
n1	16
n2	8
n4	4
n8	2
>=n16	1

Table 14.2.1.5-5: value of N based on *durationOfPRS-ProcessingSymbols*

<i>durationOfPRS-ProcessingSymbols</i>	$\lceil \frac{1}{N} \rceil$
nDot125	8
nDot25	4
nDot5	2
>=n1	1

Table 14.2.1.5-6: value of T_{effect} and T_{last} based on *durationOfPRS-ProcessingSymbolsInEveryTms*

<i>durationOfPRS-ProcessingSymbolsInEveryTms</i>	T_{effect}	T_{last}
n8	160	168
n16	160	176
n20	160	180
n30	160	190
n40	160	200
n80	160	240
n160	160	320
n320	320	480
n640	640	800
n1280	1280	1440

The test tolerances are defined in clauses C.1.6, C 2.5 and C4.

The rate of successful tests during repeated tests shall be at least 90% with a confidence level of 95%.

14.2.2 NR RSTD measurement period test case for dual positioning frequency layer in FR1 SA

14.2.2.1 Test purpose

The purpose of the test is to verify that the RSTD measurement meets the requirements specified in TS 38.133 [50] Clause 9.9.2 in an environment with AWGN propagation conditions in FR1 in standalone scenario when dual positioning frequency layer is configured.

14.2.2.2 Test applicability

This test applies to all types of NR UE release 16 onwards that supports DL-TDOA positioning.

14.2.2.3 Minimum conformance requirements

Same as in clause 14.2.1.3.

14.2.2.4 Test description

14.2.2.4.1 Initial conditions

The test is defined with three possible Test Configurations. In the case that the UE supports more than one of these Test Configurations, then the UE is only required to be tested in one of the Test Configurations, chosen by the UE. The defined Test Configurations are specified in Table 14.2.2.4.1-1.

Table 14.2.2.4.1-1: Test Configurations

Configuration	Description
1	15 kHz SSB SCS, 10 MHz bandwidth, FDD duplex mode
2	15 kHz SSB SCS, 10 MHz bandwidth, TDD duplex mode
3	30 kHz SSB SCS, 40 MHz bandwidth, TDD duplex mode

Test Environment: Normal, as defined in TS 38.508-1 [45] clause 4.1.

Frequencies to be tested: Low for RF channel #1 and High for RF channel #2, as defined in TS 38.508-1 [45] clause 4.3.1.

Channel bandwidth to be tested: are specified in Table 14.2.2.4-1.

1. Connect the SS and AWGN noise sources to the UE antenna connector or antenna connectors as shown in Annex A, Figure A.12.
2. The general test parameter settings are set up according to Table 14.2.2.5-1, Table 14.2.2.5-2 and Table 14.2.2.5-3.
3. Propagation conditions are set according to clause 4.15.2.
4. Message contents are defined in clause 14.2.4.1.3.
5. In the test there are three synchronous cells: Cell 1, Cell 2 and Cell 3. Cell 1 is the RSTD reference as well as the PCell. Cell 2 and Cell 3 are the neighbour cells. Cell 1 and Cell 2 are on RF channel #1 in FR1, Cell 3 on RF channel #2 on FR1.

14.2.2.4.2 Test procedure

Same as clause 14.2.1.4.2.

14.2.2.4.3 Message contents

Same as 14.2.4.1.3 except that Table 14.2.2.4.3-1 replaces 14.2.4.1.3-5 and Table 14.2.2.4.3-2 replaces 14.2.4.1.3-6.

Table 14.2.2.4.3-1: NR-DL-PRS-AssistanceData

Derivation Path: 37.355 clause 6.4.3			
Information Element	Value/remark	Comment	Condition
NR-DL-PRS-AssistanceData-r16 ::= SEQUENCE {			
nr-DL-PRS-ReferenceInfo-r16 SEQUENCE {			
dl-PRS-ID-r16	0		
nr-DL-PRS-ResourceID-List-r16	Not present		
nr-DL-PRS-ResourceSetID-r16	Not present		
}			
nr-DL-PRS-AssistanceDataList-r16 SEQUENCE (SIZE (1..nrMaxFreqLayers-r16)) OF NR-DL-PRS-AssistanceDataPerFreq-r16 {	2 entries		
NR-DL-PRS-AssistanceDataPerFreq-r16[1] SEQUENCE {		entry 1	
nr-DL-PRS-PositioningFrequencyLayer-r16 SEQUENCE {			
dl-PRS-SubcarrierSpacing-r16	kHz15		Config 1 and Config 2
	kHz30		Config 3
dl-PRS-ResourceBandwidth-r16	1	24 PRBs	
dl-PRS-StartPRB-r16	0		
dl-PRS-PointA-r16	absoluteFrequencyPointA as defined for the DL frequency of the Cell 1		
dl-PRS-CombSizeN-r16	n2		Config 1 and Config 3
	n4		Config 2
dl-PRS-CyclicPrefix-r16	normal		
}			
nr-DL-PRS-AssistanceDataPerFreq-r16 SEQUENCE (SIZE (1..nrMaxTRPsPerFreq-r16)) OF NR-DL-PRS-AssistanceDataPerTRP-r16{	2 entries		

NR-DL-PRS-AssistanceDataPerTRP-r16[1] SEQUENCE {		entry 1	Cell 1
dl-PRS-ID-r16	0		
nr-PhysCellID-r16	Cell 1		
nr-CellGlobalID-r16	Cell 1		
nr-ARFCN-r16	Cell 1		
nr-DL-PRS-SFN0-Offset-r16 SEQUENCE {			
sfn-Offset-r16	0		
integerSubframeOffset-r16	0		
}			
nr-DL-PRS-ExpectedRSTD-r16	0		
nr-DL-PRS-ExpectedRSTD-Uncertainty-r16	0		
nr-DL-PRS-Info-r16	As specified in Table 14.2.2.4.3-2		
}			
NR-DL-PRS-AssistanceDataPerTRP-r16[2] SEQUENCE {		entry 2	Cell 2
dl-PRS-ID-r16	1		
nr-PhysCellID-r16	Cell 2		
nr-CellGlobalID-r16	Cell 2		
nr-ARFCN-r16	Cell 2		
nr-DL-PRS-SFN0-Offset-r16 SEQUENCE {			
sfn-Offset-r16	0		
integerSubframeOffset-r16	0		
}			
nr-DL-PRS-ExpectedRSTD-r16	23	About 3 μ s	
nr-DL-PRS-ExpectedRSTD-Uncertainty-r16	39	About 5 μ s	
nr-DL-PRS-Info-r16	As specified in Table 14.2.2.4.3-2		
}			
}			
NR-DL-PRS-AssistanceDataPerFreq-r16[2] SEQUENCE {		entry 2	
nr-DL-PRS-PositioningFrequencyLayer-r16 SEQUENCE {			
dl-PRS-SubcarrierSpacing-r16	kHz15		Config 1 and Config 2
	kHz30		Config 3
dl-PRS-ResourceBandwidth-r16	1	24 PRBs	
dl-PRS-StartPRB-r16	0		
dl-PRS-PointA-r16	absoluteFrequencyPointA as defined for the DL frequency of the Cell 3		
dl-PRS-CombSizeN-r16	n2		Config 1 and Config 3
	n4		Config 2
dl-PRS-CyclicPrefix-r16	normal		
}			
nr-DL-PRS-AssistanceDataPerFreq-r16 SEQUENCE (SIZE (1..nrMaxTRPsPerFreq-r16)) OF NR-DL-PRS-AssistanceDataPerTRP-r16{	1 entry		
NR-DL-PRS-AssistanceDataPerTRP-r16[1] SEQUENCE {		entry 1	Cell 3
dl-PRS-ID-r16	3		
nr-PhysCellID-r16	Cell 3		
nr-CellGlobalID-r16 SEQUENCE {			
mcc-r15	Cell 3		
mnc-r15	Cell 3		
nr-cellidentity-r15	Cell 3		
}			
nr-ARFCN-r16	Cell 3		
nr-DL-PRS-SFN0-Offset-r16 SEQUENCE {			

sfn-Offset-r16	0		
integerSubframeOffset-r16	0		
}			
nr-DL-PRS-ExpectedRSTD-r16	23	About 3 μs	
nr-DL-PRS-ExpectedRSTD-Uncertainty-r16	39	About 5 μs	
nr-DL-PRS-Info-r16	As specified in Table 14.2.2.4.3-2		
}			
}			
}			
}			
}			

Table 14.2.2.4.3-2: NR-DL-PRS-Info

Derivation Path: 37.355 clause 6.4.3			
Information Element	Value/remark	Comment	Condition
NR-DL-PRS-Info-r16 ::= SEQUENCE {			
nr-DL-PRS-ResourceSetList-r16 SEQUENCE (SIZE (1..nrMaxSetsPerTrp-r16)) OF NR-DL-PRS-ResourceSet-r16 {	1 entry		
NR-DL-PRS-ResourceSet-r16[1] SEQUENCE {		entry 1	
nr-DL-PRS-ResourceSetID-r16	0		
dl-PRS-Periodicity-and-ResourceSetSlotOffset-r16 CHOICE {			
scs15-r16 CHOICE {			Config 1 and Config 2
n160-r16	10		
}			
scs30-r16 CHOICE {			Config 3
n320-r16	20		
}			
dl-PRS-ResourceRepetitionFactor-r16	Not present n2		Config 2 Config 1 and Config 3
dl-PRS-ResourceTimeGap-r16	s1		
dl-PRS-NumSymbols-r16	n4		
dl-PRS-MutingOption1-r16 SEQUENCE {			
dl-prs-MutingBitRepetitionFactor-r16	Not present		
nr-option1-muting-r16 CHOICE {			
po2-r16	10		Cell 1 and Cell 3
	01		Cell 2
}			
}			
dl-PRS-MutingOption2-r16	Not present		
dl-PRS-ResourcePower-r16	27		
dl-PRS-ResourceList-r16 SEQUENCE (SIZE (1..nrMaxResourcesPerSet-r16)) OF NR-DL-PRS-Resource-r16 {	1 entry		
NR-DL-PRS-Resource-r16[1] SEQUENCE {		entry 1	
nr-DL-PRS-ResourceID-r16	0		
dl-PRS-SequenceID-r16	0		
dl-PRS-CombSizeN-AndReOffset-r16 CHOICE {			
n2-r16	0		Cell 1 and Cell 3
	1		Config 2
}			
dl-PRS-ResourceSlotOffset-r16	0		Config 1 and Config 3
	4		Config 2
dl-PRS-ResourceSymbolOffset-r16	0		

dl-PRS-QCL-Info-r16	Not present		
}			
}			
}			
}			

14.2.2.5 Test requirement

Table 14.2.2.5-1, Table 14.2.2.5-2 and Table 14.2.2.5-3 define the primary level settings including test tolerances for the test.

Table 14.2.2.5-1: General test parameters for RSTD measurement reporting delay

Parameter		Unit	Value	Comment
Reference cell			Cell 1	Reference cell is the cell in the DL-TDOA assistance data with respect to which the RSTD measurement is defined, as specified in TS 36.214 [6] and TS 37.355 [49]. The reference cell is the PCell in this test case.
Neighbor cells			Cell 2 and Cell 3	Cell 2 and Cell 3 appear at random places in the neighbour cell list in the DL-TDOA assistance data, but Cell 2 always appears in the first half of the list, whilst Cell 3 appears in the second half of the list.
SSB configuration	Config 1		SSB.1 FR1	
	Config 2		SSB.1 FR1	
	Config 3		SSB.2 FR1	
SMTC configuration	Config 1		SMTC.2	
	Config 2		SMTC.1	
	Config 3		SMTC.1	
PDSCH RMC configuration	Config 1		SR.1.1 FDD	
	Config 2		SR.1.1 TDD	
	Config 3		SR.2.1 TDD	
RMSI CORESET RMC configuration	Config 1		CR.1.1 FDD	
	Config 2		CR.1.1 TDD	
	Config 3		CR.2.1 TDD	
Dedicated CORESET RMC configuration	Config 1		CCR.1.1 FDD	
	Config 2		CCR.1.1 TDD	
	Config 3		CCR.2.1 TDD	
Initial BWP configuration	Config 1,2,3		DLBWP.0.1 ULBWP.0.1	
Active DL BWP configuration	Config 1,2,3		DLBWP.1.1	
Active UL BWP configuration	Config 1,2,3		ULBWP.1.1	
PRS Configuration	Config 1		PRS.1.1 FR1	
	Config 2		PRS.1.1 FR1	
	Config 3		PRS.2.1 FR1	

Physical cell ID PCI		(PCI of Cell 1 – PCI of Cell 2)mod6=0 and (PCI of Cell 1 – PCI of Cell 3)mod6=0	The cell PCIs are selected such that the relative shifts of PRS patterns among cells are as given by the test parameters
CP length		Normal	
DRX		OFF	
Measurement gap		GP#24 or GP#0	GP#24 is configured if UE supports MG#24, otherwise GP#0 is configured
Radio frame receive time offset between the cells at the UE antenna connector	µs	Cell 2 to Cell 1: 0 Cell 3 to Cell 1: 3	PRS are transmitted from synchronous cells
Expected RSTD	µs	Cell 2: 3 Cell 3: 3 Other neighbour cells: randomly between -3 and 3	The expected RSTD is what is expected at the receiver. The corresponding parameter in the DL-TDOA assistance data specified in TS 37.355 [49] is the expectedRSTD indicator
Expected RSTD uncertainty for all neighbour cells	µs	5	The corresponding parameter in the OTDOA assistance data specified in TS 37.355 [49] is the expectedRSTD-Uncertainty index
Number of cells provided in OTDOA assistance data		16	Including the reference cell
PRS muting info		Cell 1: '10' Cell 2: '01' Cell 3: '10'	Corresponds to prs-MutingInfo defined in TS 37.355 [49] Cell 1 and Cell 3 will be configured with different Comb patterns or resource offsets
T1	s	3	The length of the time interval from the beginning of each test
T2	s	1.28	The length of the time interval that follows immediately after time interval T1

Table 14.2.2.5-2: Cell-specific test parameters for RSTD measurement reporting delay during T1

Parameter	Unit	Cell 1	Cell 2	Cell 3
NR RF Channel Number		1	1	2
Positioning frequency layer		1	1	2
Correlation Matrix and Antenna Configuration		1x2 Low	1x2 Low	1x2 Low
OCNG patterns defined in A.3.2.1		OP.1	N/A	N/A
EPRE ratio of PSS to SSS	dB	0	N/A	N/A
EPRE ratio of PBCH DMRS to SSS				
EPRE ratio of PBCH to PBCH DMRS				
EPRE ratio of PDCCH DMRS to SSS				
EPRE ratio of PDCCH to PDCCH DMRS				
EPRE ratio of PDSCH DMRS to SSS				
EPRE ratio of PDSCH to PDSCH DMRS				
EPRE ratio of OCNG DMRS to SSS ^{Note 1}				
EPRE ratio of OCNG to OCNG DMRS ^{Note 1}				
Config 1				

N_{oc} <small>Note 3</small>	Config 2	dBm/SCS	-98		
	Config 3	dBm/SCS	-95		
PRS \hat{E}_s/N_{oc}		dB	-Infinity	-Infinity	-Infinity
SSB \hat{E}_s/N_{oc}		dB	10	-Infinity	-Infinity
I_o <small>Note 4</small>	Config 1	dBm/ 9.36MHz	-59.63	-59.63	-70.05
	Config 2	dBm/ 9.36MHz	-59.63	-59.63	-70.05
	Config 3	dBm/ 38.16MHz	-53.54	-53.54	-63.96
SSB RP <small>Note 4</small>	Config 1	dBm/SCS	-88	-Infinity	-Infinity
	Config 2	dBm/SCS	-88	-Infinity	-Infinity
	Config 3	dBm/SCS	-85	-Infinity	-Infinity
Propagation Condition			AWGN		
<p>Note 1: OCNG shall be used such that active cell (Cell 1) is fully allocated and a constant total transmitted power spectral density is achieved for all OFDM symbols other than those in the slots with transmitted PRS.</p> <p>Note 2: The resources for uplink transmission are assigned to the UE prior to the start of time period T2.</p> <p>Note 3: Interference from other cells and noise sources not specified in the test are assumed to be constant over subcarriers and time and shall be modelled as AWGN of appropriate power for N_{oc} to be fulfilled.</p> <p>Note 4: SSB RP and I_o levels have been derived from other parameters and are given for information purpose. These are not settable test parameters.</p>					

Table 14.2.2.5-3: Cell-specific test parameters for RSTD measurement reporting delay during T2

Parameter	Unit	Cell 1	Cell 2	Cell 3	
		T2	T2	T2	
NR RF Channel Number		1	1	2	
Positioning frequency layer		1	1	2	
Correlation Matrix and Antenna Configuration		1x2 Low	1x2 Low	1x2 Low	
OCNG patterns defined in A.3.2.1		OP.1	OP.1	OP.1	
EPRE ratio of PSS to SSS	dB	0	0	0	
EPRE ratio of PBCH DMRS to SSS					
EPRE ratio of PBCH to PBCH DMRS					
EPRE ratio of PDCCH DMRS to SSS					
EPRE ratio of PDCCH to PDCCH DMRS					
EPRE ratio of PDSCH DMRS to SSS					
EPRE ratio of PDSCH to PDSCH DMRS					
EPRE ratio of OCNG DMRS to SSS <small>Note 1</small>					
EPRE ratio of OCNG to OCNG DMRS <small>Note 1</small>					
EPRE ratio of PRS to SSS					
PRACH configuration		FR1 PRACH configuration 1	FR1 PRACH configuration 1	FR1 PRACH configuration 1	
N_{oc} <small>Note 3</small>	Config 1	dBm/SCS	-98	-98	-98
	Config 2	dBm/SCS	-98	-98	-98
	Config 3	dBm/SCS	-95	-95	-95

PRS \hat{E}_s/N_{oc}	Config 1	dB	-5.0	-11.20	-11.20
	Config 2	dB	-5.0	-11.20	-11.20
	Config 3	dB	-5.0	-11.20	-11.20
I _o Note 4	Config 1	dBm/ 9.36MHz	-68.61	-68.61	-69.73
	Config 2	dBm/ 9.36MHz	-68.61	-68.61	-69.73
	Config 3	dBm/ 38.16MHz	-62.51	-62.51	-63.63
PRS \hat{E}_s/I_{ot}		dB	-5.61	-12.64	-11.20
Propagation Condition		AWGN			
<p>Note 1: OCNG shall be used such that active cells (all, except Cell 3 in T3) are fully allocated and a constant total transmitted power spectral density is achieved for all OFDM symbols other than those in the slots with transmitted PRS.</p> <p>Note 2: The resources for uplink transmission are assigned to the UE prior to the start of time period T2.</p> <p>Note 3: Interference from other cells and noise sources not specified in the test are assumed to be constant over subcarriers and time and shall be modelled as AWGN of appropriate power for N_{oc} to be fulfilled.</p> <p>Note 4: SSB RP and I_o levels have been derived from other parameters and are given for information purpose. These are not settable test parameters. The I_o is calculated based only on the symbols where PRS is transmitted.</p>					

The RSTD measurement time fulfils the requirements specified in clause 14.2.2.3.

The UE shall perform and report the RSTD measurements for Cell 2 and Cell 3 with respect to the reference cell in the DL-TDOA assistance data, Cell 1, within the time duration specified in clause 14.2.2.3 starting from the beginning of time interval T2.

The rate of the correct events for each neighbour cell observed during repeated tests shall be at least 90%, where the reported RSTD measurement for each correct event shall be within the RSTD reporting range specified in TS 38.133[50] Clause 10.1.23.3, i.e., between RSTD_000000 and RSTD_1970049.

The response time is equal to the LPP time IE value plus the test tolerance. The LPP time IE value is derived from the RSTD measurement period plus ΔT , where $\Delta T = 50$ ms. The RSTD measurement period follows the equation:

$$T_{RSTD,Total} = T_{RSTD,1} + T_{RSTD,2} + \text{Max}(T_{effect,i})$$

Given that both PFLs have the same settings, it can be simplified:

$$T_{RSTD,Total} = 2 * T_{RSTD,i} + T_{effect,i}$$

$$T_{RSTD,i} = \left(\text{CSSF}_{PRS,i} * N_{RxBeam,i} * \left\lceil \frac{N_{PRS,i}^{slot}}{N'} \right\rceil \left\lfloor \frac{L_{available_PRS,i}}{N} \right\rfloor * N_{sample} - 1 \right) * T_{effect,i} + T_{last,i}$$

Where $\text{CSSF}_{PRS,i} = 1$, $N_{RxBeam,i} = 1$, $N_{PRS,i}^{slot} = 8$, $L_{available_PRS,i} = 1$, $N_{sample} = 4$. N is the parameter *durationOfPRS-ProcessingSymbols* from TS 37.355 [49], N' is the parameter *maxNumOfDL-PRS-ResProcessedPerSlot* from TS 37.355 [49], $T_{last,i} = T_i + T_{available_PRS,i}$ and $T_{effect,i} = \left\lceil \frac{T_i}{T_{available_PRS,i}} \right\rceil * T_{available_PRS,i}$.

$T_{available_PRS,i} = \text{LCM}(T_{PRS,i}, \text{MGRP}_i)$; where $T_{prs} = 160$ ms, and MGRP is 80 (for GP#24) or 40 (for GP#0) depending on UE capabilities. Therefore, $T_{available_PRS,i} = 160$ ms.

T_i depends on the UE parameter *durationOfPRS-ProcessingSymbolsInEveryTms* from TS 37.355 [49]

Finally, it results in the following equation:

$$T_{RSTD,i} = \left(\left\lceil \frac{16}{N'} \right\rceil \left\lfloor \frac{1}{N} \right\rfloor * 4 - 1 \right) * T_{effect} + T_{last}$$

Where the remaining parameters depend on the UE capabilities. The LPP time IE ranges between 1.506s and 657.01s. The value of the LPP time IE is rounded up to the next second (if the value is >128s, it should be rounded up to the next

multiple of ten seconds). The result is transmitted in the response time IE in the LPP-RequestLocationInformation in Table 14.2.2.4.3-3. The LPP time IE ranges between 2s and 660s.

The test tolerance for the response time is 300ms. Therefore, the response time ranges between 2.3s and 660.3s.

The values of N' , N and T_i and the effect in the response time equation are defined in Table 14.2.2.5-4, Table 14.2.2.5-5 and Table 14.2.2.5-6 for reference.

Table 14.2.2.5-4: value of N' based on *maxNumOfDL-PRS-ResProcessedPerSlot*

<i>maxNumOfDL-PRS-ResProcessedPerSlot</i>	$\left\lceil \frac{8}{N'} \right\rceil$
n1	8
n2	4
n4	2
$\geq n8$	1

Table 14.2.2.5-5: value of N based on *durationOfPRS-ProcessingSysmbols*

<i>durationOfPRS-ProcessingSysmbols</i>	$\left\lceil \frac{1}{N} \right\rceil$
nDot125	8
nDot25	4
nDot5	2
$\geq n1$	1

Table 14.2.2.5-6: value of T_{effect} and T_{last} based on *durationOfPRS-ProcessingSymbolsInEveryTms*

<i>durationOfPRS-ProcessingSymbolsInEveryTms</i>	T_{effect}	T_{last}
n8	160	168
n16	160	176
n20	160	180
n30	160	190
n40	160	200
n80	160	240
n160	160	320
n320	320	480
n640	640	800
n1280	1280	1440

The test tolerances are defined in clauses C.1.6, C 2.5 and C4.

The rate of successful tests during repeated tests shall be at least 90% with a confidence level of 95%.

14.2.3 NR RSTD measurement period test case for single positioning frequency layer in FR2 SA

Editor's Note: This test case has been completed for the following configurations:

- Test frequency $f \leq 40.8$ GHz
- UE PC3

This test case is incomplete for UE power classes other than PC3

This test case is incomplete for test frequencies > 40.8 GHz

14.2.3.1 Test purpose

The purpose of the test is to verify that the RSTD measurement meets the accuracy requirements specified in TS 38.133 [50] clause 9.9.2 in an environment with AWGN propagation conditions. The test is conducted in AWGN propagation condition in FR2 in standalone scenario when single positioning frequency layer is configured.

14.2.3.2 Test applicability

This test applies to all types of NR UE release 16 onwards that supports DL-TDOA positioning.

14.2.3.3 Minimum conformance requirements

Same as in clause 14.2.1.3.

14.2.3.4 Test description

The supported test configurations are listed in Table 14.2.3.4-1. **Table 14.2.3.4-1: Test Configurations**

Test Configuration	Description
1	120 kHz SSB and PRS SCS, 200 MHz bandwidth, TDD duplex mode

14.2.3.4.1 Initial conditions

Test Environment: Normal, as defined in TS 38.508-1 [45] clause 4.1.

Frequencies to be tested: Mid Range, as defined in TS 38.508-1 [45] clause 4.3.1.

Channel bandwidth to be tested: are specified in Table 14.2.3.4-1.

1. Connect the SS and AWGN noise sources to the UE antenna connector or antenna connectors as shown in Annex A, Figure A.14.
2. The general test parameter settings are set up according to Table 14.2.3.5-1, Table 14.2.3.5-2 and Table 14.2.3.5-3.
3. Propagation conditions are set according to clause 4.15.2.
4. Message contents are defined in clause 14.2.3.4.3.
5. In the test there are three synchronous cells: Cell 1, Cell 2 and Cell 3. Cell 1 is the RSTD reference as well as the PCell. Cell 2 and Cell 3 are the neighbour cells. All 3 cells are on the same RF channel in FR2.

14.2.3.4.2 Test procedure

The test consists of two consecutive time intervals, with duration of T1 and T2. Cell 1 is active in T1 and T2, whilst Cell 2 and Cell 3 are activated only in the beginning of T2. The beginning of the time interval T2 shall be aligned with the first PRS positioning subframe of a positioning occasion in the reference cell.

The *NR-DL-TDOA-ProvideAssistanceData* and *NR-DL-TDOA-RequestLocationInformation* as defined in TS 37.355 [49] clause 6.5.10.1 shall be provided to the UE during T1. The last TTI containing the *NR-DL-TDOA-RequestLocationInformation* shall be provided to the UE ΔT ms before the start of T2, where $\Delta T = 50$ ms is the maximum processing time of the *DL-TDOA assistance* data and location information request.

The UE is configured with measurement gap pattern ID # 24 or #13 before T2.

1. Ensure the UE is in State RRC_CONNECTED with generic procedure parameters Connectivity NR, Connected without release *On*, according to TS 38.508-1 [45] clause 4.5.
2. The SS shall send a RESET UE POSITIONING STORED INFORMATION message.
3. Set the parameters according to Table 14.2.3.5-1, Table 14.2.3.5-2 and Table 14.2.3.5-3. Propagation conditions are set according to clause 4.15.2.

4. T1 starts.
5. The SS shall transmit an LPP REQUEST CAPABILITIES message.
6. The UE shall transmit an LPP PROVIDE CAPABILITIES message indicating the DL-TDOA capabilities supported by the UE in the *NR-DL-TDOA-ProvideCapabilities* IE.
7. The SS shall send a LPP PROVIDE ASSISTANCE DATA message, including the *NR-DL-TDOA-ProvideAssistanceData* IE. The position of neighbour Cell 2 and the position of neighbour Cell 3 are described in 3GPP TS 37.571-5 [20]. If the UE message at step 6 includes the *ackRequested* IE set to TRUE, then the SS shall send an acknowledgment in the LPP PROVIDE ASSISTANCE DATA message.
8. The SS shall send a LPP REQUEST LOCATION INFORMATION message, including the *NR-DL-TDOA-RequestLocationInformation* IE such that the UE receives the message ΔT ms before the start of T2, where $\Delta T = 50$ ms.
9. When T1 expires, the SS shall switch the power setting from T1 to T2 as specified in Table 14.2.3.5-2 and Table 14.2.3.5-3.
10. The UE shall transmit a LPP PROVIDE LOCATION INFORMATION message including the *NR-DL-TDOA-ProvideLocationInformation* IE within the response time (see clause 4.15.3). The UE shall perform and report the RSTD measurements for both Cell 2 and Cell 3 with respect to the reference cell in the DL-TDOA assistance data, Cell 1. If the UE transmits an *NR-DL-TDOA-ProvideLocationInformation* IE including the *nr-RSTD* field for both Cell 2 and Cell 3 within the response time then the number of successful tests is increased by one. If the UE fails to report the *NR-DL-TDOA-ProvideLocationInformation* IE with both the *nr-RSTD* fields included within the response time then the number of failure tests is increased by one.
11. If the UE message at step 10 includes the *ackRequested* IE set to TRUE, the SS shall send a LPP acknowledgement message.
12. Repeat steps 2-11 in Tables 14.2.3.4-1 until the confidence level according to Annex D is achieved.

14.2.3.4.3 Message contents

Table 14.2.3.4.3-1: RESET UE POSITIONING STORED INFORMATION

Derivation Path: 38.509 [44] clause 6.6			
Information Element	Value/remark	Comment	Condition
UE Positioning Technology	0 0 0 0 1 1 1	DL-TDOA	

Table 14.2.3.4.3-2: LPP Request Capabilities

Information Element	Value/remark
nr-DL-TDOA-RequestCapabilities-r16	TRUE

Table 14.2.3.4.3-3: LPP RequestLocationInformation

Derivation Path: 37.355 clause 6.2			
Information Element	Value/remark	Comment	Condition
LPP-Message ::= SEQUENCE {			
transactionID SEQUENCE {			
initiator	locationServer		
transactionNumber	1		
}			
endTransaction	FALSE		
sequenceNumber	Not present		
acknowledgement	Not present		
lpp-MessageBody CHOICE {			
c1 CHOICE {			
requestLocationInformation SEQUENCE {			
criticalExtensions CHOICE {			
c1 CHOICE {			

requestLocationInformation-r9 SEQUENCE {			
commonEsRequestLocationInformation SEQUENCE {			
locationInformationType	locationMeasurementsPreferred		
triggeredReporting	Not present		
periodicalReporting	Not present		
additionalInformation	onlyReturnInformationRequested		
qos SEQUENCE {			
horizontalAccuracy	Not present		
verticalCoordinateRequest	FALSE		
verticalAccuracy	Not present		
responseTime SEQUENCE {			
time	See 14.2.3.5	Result of the response time calculation rounded up to the next second if response time <= 128s. Result of the response time calculation rounded up to the next multiple of ten seconds if response time > 128s	
responseTimeEarlyFix-r12	Not present		Rel-12 onwards
unit-r15	Not present		
	ten-seconds		Calculated response time >128s
}			
velocityRequest	FALSE		
}			
environment	Not present		
locationCoordinateTypes	Not present		
velocityTypes	Not present		
}			
a-gnss-RequestLocationInformation	Not present		
otdoa-RequestLocationInformation	Not present		
ecid-RequestLocationInformation	Not present		
epdu-RequestLocationInformation	Not Present		
sensor-RequestLocationInformation-r13	Not present		
tbs-RequestLocationInformation-r13	Not present		
wlan-RequestLocationInformation-r13	Not present		
bt-RequestLocationInformation-r13	Not present		
nr-ECID-RequestLocationInformation-r16	Not present		
nr-Multi-RTT-RequestLocationInformation-r16	Not present		
nr-DL-AoD-RequestLocationInformation-r16	Not present		
nr-DL-TDOA-RequestLocationInformation-r16			
SEQUENCE {			
nr-DL-PRS-RstdMeasurementInfoRequest-r16	Not present		
nr-RequestedMeasurements-r16	bit 0 = 0 (prsrsrpReq)		
nr-AssistanceAvailability-r16	FALSE		
nr-DL-TDOA-ReportConfig-r16	Not present		
additionalPaths-r16	Not present		
}			
}			
}			
}			
}			
}			
}			

}		
---	--	--

Table 14.2.3.4.3-4: LPP ProvideAssistanceData

Derivation Path: 37.355 clause 6.2			
Information Element	Value/remark	Comment	Condition
LPP-Message ::= SEQUENCE {			
transactionID SEQUENCE {			
initiator	locationServer		
transactionNumber	(0..255)		
}			
endTransaction	TRUE		
sequenceNumber	Not present		
acknowledgement	Not present		
lpp-MessageBody CHOICE {			
c1 CHOICE {			
provideAssistanceData SEQUENCE {			
criticalExtensions CHOICE {			
c1 CHOICE {			
provideAssistanceData-r9 SEQUENCE {			
commonEsProvideAssistanceData	Not present		
a-gnss-ProvideAssistanceData	Not present		
otdoa-ProvideAssistanceData	Not present		
epdu-Provide-AssistanceData	Not present		
sensor-ProvideAssistanceData-r15	Not present		
tbs-ProvideAssistanceData-r15	Not present		
wlan-ProvideAssistanceData-r15	Not present		
nr-Multi-RTT-ProvideAssistanceData-r16	Not present		
nr-DL-AoD-ProvideAssistanceData-r16	Not present		
nr-DL-TDOA-ProvideAssistanceData-r16	Not present		
SEQUENCE {			
nr-DL-PRS-AssistanceData-r16	As defined in Table 14.2.3.4.3-5		
nr-SelectedDL-PRS-IndexList-r16	Not present		
nr-PositionCalculationAssistance-r16			Depending on UE capabilities, i.e. support for UE-based DL-TDOA
SEQUENCE {			
nr-TRP-LocationInfo-r16	As defined in TS 37.571-5 [20]		
nr-DL-PRS-BeamInfo-r16	Not present		
nr-RTD-Info-r16	Not present		
}			
nr-DL-TDOA-Error-r16	Not present		
}			
}			
}			
}			
}			
}			

Table 14.2.3.4.3-5: NR-DL-PRS-AssistanceData

Derivation Path: 37.355 clause 6.4.3			
Information Element	Value/remark	Comment	Condition
NR-DL-PRS-AssistanceData-r16 ::= SEQUENCE {			
nr-DL-PRS-ReferenceInfo-r16 SEQUENCE {			
dl-PRS-ID-r16	0		
nr-DL-PRS-ResourceID-List-r16	Not present		
nr-DL-PRS-ResourceSetID-r16	Not present		

}			
nr-DL-PRS-AssistanceDataList-r16 SEQUENCE (SIZE (1..nrMaxFreqLayers-r16)) OF NR-DL-PRS-AssistanceDataPerFreq-r16 {	1 entry		
NR-DL-PRS-AssistanceDataPerFreq-r16[1] SEQUENCE {		entry 1	
nr-DL-PRS-PositioningFrequencyLayer-r16 SEQUENCE {			
dl-PRS-SubcarrierSpacing-r16	kHz120		
dl-PRS-ResourceBandwidth-r16	3	32 PRBs	
dl-PRS-StartPRB-r16	0		
dl-PRS-PointA-r16	absoluteFrequencyPointA as defined for the DL frequency of the Cell 1		
dl-PRS-CombSizeN-r16	n2		
dl-PRS-CyclicPrefix-r16	normal		
}			
nr-DL-PRS-AssistanceDataPerFreq-r16 SEQUENCE (SIZE (1..nrMaxTRPsPerFreq-r16)) OF NR-DL-PRS-AssistanceDataPerTRP-r16{	3 entries		
NR-DL-PRS-AssistanceDataPerTRP-r16[1] SEQUENCE {		entry 1	Cell 1
dl-PRS-ID-r16	0		
nr-PhysCellID-r16	Cell 1		
nr-CellGlobalID-r16	Cell 1		
nr-ARFCN-r16	Cell 1		
nr-DL-PRS-SFN0-Offset-r16 SEQUENCE {			
sfn-Offset-r16	0		
integerSubframeOffset-r16	0		
}			
nr-DL-PRS-ExpectedRSTD-r16	0		
nr-DL-PRS-ExpectedRSTD-Uncertainty-r16	0		
nr-DL-PRS-Info-r16	As specified in Table 14.2.3.4.3-6		
}			
NR-DL-PRS-AssistanceDataPerTRP-r16[2] SEQUENCE {		entry 2	Cell 2
dl-PRS-ID-r16	1		
nr-PhysCellID-r16	Cell 2		
nr-CellGlobalID-r16	Cell 2		
nr-ARFCN-r16	Cell 2		
nr-DL-PRS-SFN0-Offset-r16 SEQUENCE {			
sfn-Offset-r16	0		
integerSubframeOffset-r16	0		
}			
nr-DL-PRS-ExpectedRSTD-r16	23	About 3 μs	
nr-DL-PRS-ExpectedRSTD-Uncertainty-r16	154	About 5 μs	
nr-DL-PRS-Info-r16	As specified in Table 14.2.3.4.3-6		
}			
NR-DL-PRS-AssistanceDataPerTRP-r16[3] SEQUENCE {		entry 3	Cell 3
dl-PRS-ID-r16	2		
nr-PhysCellID-r16	Cell 3		
nr-CellGlobalID-r16	Cell 3		
nr-ARFCN-r16	Cell 3		
nr-DL-PRS-SFN0-Offset-r16 SEQUENCE {			
sfn-Offset-r16	0		
integerSubframeOffset-r16	0		
}			
nr-DL-PRS-ExpectedRSTD-r16	23	About 3 μs	
nr-DL-PRS-ExpectedRSTD-Uncertainty-r16	154	About 5 μs	
nr-DL-PRS-Info-r16	As specified in Table 14.2.3.4.3-6		
}			
}			

}			
}			
}			

Table 14.2.3.4.3-6: NR-DL-PRS-Info

Derivation Path: 37.355 clause 6.4.3			
Information Element	Value/remark	Comment	Condition
NR-DL-PRS-Info-r16 ::= SEQUENCE {			
nr-DL-PRS-ResourceSetList-r16 SEQUENCE (SIZE (1..nrMaxSetsPerTrp-r16)) OF NR-DL-PRS-ResourceSet-r16 {	1 entry		
NR-DL-PRS-ResourceSet-r16[1] SEQUENCE {		entry 1	
nr-DL-PRS-ResourceSetID-r16	0		
dl-PRS-Periodicity-and-ResourceSetSlotOffset-r16 CHOICE {			
Scs120-r16 CHOICE {			
n1280-r16	80		
}			
dl-PRS-ResourceRepetitionFactor-r16	Not present		
dl-PRS-ResourceTimeGap-r16	s1		
dl-PRS-NumSymbols-r16	n4		
dl-PRS-MutingOption1-r16 SEQUENCE {			
dl-prs-MutingBitRepetitionFactor-r16	Not present		
nr-option1-muting-r16 CHOICE {			
po2-r16	10		Cell 1
	01		Cell 2
	10		Cell 3
}			
}			
dl-PRS-MutingOption2-r16	Not present		
dl-PRS-ResourcePower-r16	27		
dl-PRS-ResourceList-r16 SEQUENCE (SIZE (1..nrMaxResourcesPerSet-r16)) OF NR-DL-PRS-Resource-r16 {	1 entry		
NR-DL-PRS-Resource-r16[1] SEQUENCE {		entry 1	
nr-DL-PRS-ResourceID-r16	0		
dl-PRS-SequenceID-r16	0		
dl-PRS-CombSizeN-AndReOffset-r16 CHOICE {			
n2-r16	0		Cell 1 and Cell 2
	1		Cell 3
}			
dl-PRS-ResourceSlotOffset-r16	0		
dl-PRS-ResourceSymbolOffset-r16	0		
dl-PRS-QCL-Info-r16	Not present		
}			
}			
}			
}			
}			

Table 14.2.3.4.3-7: LPP ProvideLocation Information

Derivation Path: TS 37.355 [49] clause 6.2			
Information Element	Value/remark	Comment	Condition
LPP-Message ::= SEQUENCE {			
transactionID SEQUENCE {			
initiator	locationServer		
transactionNumber	1		
}			
endTransaction	TRUE		
sequenceNumber	(0..255)		

acknowledgement			
lpp-MessageBody CHOICE {			
c1 CHOICE {			
provideLocationInformation SEQUENCE {			
criticalExtensions CHOICE {			
c1 CHOICE {			
provideLocationInformation-r9 SEQUENCE {			
commonIEsProvideLocationInformation	Not present.		
a-gnss-ProvideLocationInformation	Not present		
otdoa-ProvideLocationInformation	Not present		
ecid-ProvideLocationInformation	Not present		
epdu-ProvideLocationInformation	Not present		
sensor-ProvideLocationInformation-r13	Not present		
tbs-ProvideLocationInformation-r13	Not present		
wlan-ProvideLocationInformation-r13	Not present		
bt-ProvideLocationInformation-r13	Not present		
nr-ECID-ProvideLocationInformation-r16	Not present		
nr-Multi-RTT-ProvideLocationInformation-	Not present		
r16			
nr-DL-AoD-ProvideLocationInformation-r16	Not present		
nr-DL-TDOA-ProvideLocationInformation-			
r16 SEQUENCE {			
nr-DL-TDOA-			
SignalMeasurementInformation-r16 SEQUENCE {			
dl-PRS-ReferenceInfo-r16			
nr-DL-TDOA-MeasList-r16 SEQUENCE	3 entries		
(SIZE(1..nrMaxTRPs-r16)) OF NR-DL-TDOA-			
MeasElement-r16 {			
NR-DL-TDOA-MeasElement-r16[1]		entry 1	
SEQUENCE {			
dl-PRS-ID-r16			
nr-PhysCellID-r16	Cell 1		
nr-CellGlobalID-r16			
nr-ARFCN-r16			
nr-DL-PRS-ResourceID-r16			
nr-DL-PRS-ResourceSetID-r16			
nr-TimeStamp-r16			
nr-RSTD-r16	Present		
nr-AdditionalPathList-r16			
nr-TimingQuality-r16			
nr-DL-PRS-RSRP-Result-r16			
nr-DL-TDOA-AdditionalMeasurements-			
r16			
}			
NR-DL-TDOA-MeasElement-r16[2]		entry 2	
SEQUENCE {			
dl-PRS-ID-r16			
nr-PhysCellID-r16	Cell 2		
nr-CellGlobalID-r16			
nr-ARFCN-r16			
nr-DL-PRS-ResourceID-r16			
nr-DL-PRS-ResourceSetID-r16			
nr-TimeStamp-r16			
nr-RSTD-r16	Present		
nr-AdditionalPathList-r16			
nr-TimingQuality-r16			
nr-DL-PRS-RSRP-Result-r16			
nr-DL-TDOA-AdditionalMeasurements-			
r16			
}			
NR-DL-TDOA-MeasElement-r16[3]		entry 3	
SEQUENCE {			
dl-PRS-ID-r16			
nr-PhysCellID-r16	Cell 3		
nr-CellGlobalID-r16			
nr-ARFCN-r16			

nr-DL-PRS-ResourceID-r16			
nr-DL-PRS-ResourceSetID-r16			
nr-TimeStamp-r16			
nr-RSTD-r16	Present		
nr-AdditionalPathList-r16			
nr-TimingQuality-r16			
nr-DL-PRS-RSRP-Result-r16			
nr-DL-TDOA-AdditionalMeasurements-r16			
}			
nr-dl-tdoa-LocationInformation-r16			
nr-DL-TDOA-Error-r16			
}			
}			
}			
}			
}			
}			

14.2.3.5 Test requirement

Table 14.2.3.5-1, Table 14.2.3.5-2 and Table 14.2.3.5-3 define the primary level settings including test tolerances for the test.

Table 14.2.3.5-1: General test parameters for RSTD measurement reporting delay

Parameter		Unit	Value	Comment
Reference cell			Cell 1	Reference cell is the cell in the DL-TDOA assistance data with respect to which the RSTD measurement is defined, as specified in TS 38.215 [57] and TS 37.355[49]. The reference cell is the PCell in this test case.
Neighbour cells			Cell 2 and Cell 3	Cell 2 and Cell 3 appear at the first and second places in the neighbour cell list in the DL-TDOA assistance data.
SSB configuration	Config 1		SSB.2 FR2	
SMTC configuration	Config 1		SMTC.1	
PDSCH RMC configuration	Config 1		SR.1.1 FDD	
RMSI CORESET RMC configuration	Config 1		CR.3.1 TDD	As specified in TS 38.133 [50] clause A.3.1.2.1
Dedicated CORESET RMC configuration	Config 1		CR.1.1 FDD	
PRS Configuration	Config 1		PRS.1.1 FR2	As specified in TS 38.133 [50] clause A.3.31

Physical cell ID PCI		(PCI of Cell 1 – PCI of Cell 2)mod6=0 and (PCI of Cell 1 – PCI of Cell 3)mod6=0	The cell PCIs are selected such that the relative shifts of PRS patterns among cells are as given by the test parameters
CP length		Normal	
DRX		OFF	
Measurement gap		GP#24 or GP#13	GP#24 is configured if UE supports MG#24, otherwise GP#13 is configured
Radio frame receive time offset between the cells at the UE antenna connector	µs	Cell 2 to Cell 1: 0 Cell 3 to Cell 1: 3	PRS are transmitted from synchronous cells
Expected RSTD	µs	Cell 2: 3 Cell 3: 3 Other neighbour cells: randomly between -3 and 3	The expected RSTD is what is expected at the receiver. The corresponding parameter in the DL-TDOA assistance data specified in TS 37.355 [49] is the expectedRSTD indicator
Expected RSTD uncertainty for all neighbour cells	µs	5	The corresponding parameter in the DL-TDOA assistance data specified in TS 37.355 [49] is the expectedRSTD-Uncertainty index
Number of cells provided in DL-TDOA assistance data		4	Including the reference cell
PRS muting info		Cell 1: '10' Cell 2: '01' Cell 3: '10'	Corresponds to prs-MutingInfo defined in TS 37.355 [49]
PRS resource RE offset		Cell 1: 0 Cell 2: 0 Cell 3: 1	Cell 1 and Cell 3 are configured with different resource offsets
T1	s	3	The length of the time interval from the beginning of each test
T2	s	1.28	The length of the time interval that follows immediately after time interval T1
AoA setup		Setup 1	As defined in TS 38.133 [50] A.3.15.1
Beam assumption		Rough	Information about types of UE beam is given in TS 38.133 [50] B.2.1.3, and does not limit UE implementation or test system implementation

Table 14.2.3.5-2: Cell-specific test parameters for RSTD measurement reporting delay during T1

Parameter	Unit	Cell 1	Cell 2	Cell 3
NR RF Channel Number		1	1	1
Positioning frequency layer		1	1	1
BW _{channel}	MHz	200: N _{RB,c} = 132	200: N _{RB,c} = 132	200: N _{RB,c} = 132
Correlation Matrix and Antenna Configuration		1x2 Low	1x2 Low	1x2 Low
OCNG patterns defined in A.3.2.1		OP.1	N/A	N/A
EPRE ratio of PSS to SSS	dB	0	0	0
EPRE ratio of PBCH DMRS to SSS				

EPRE ratio of PBCH to PBCH DMRS					
EPRE ratio of PDCCH DMRS to SSS					
EPRE ratio of PDCCH to PDCCH DMRS					
EPRE ratio of PDSCH DMRS to SSS					
EPRE ratio of PDSCH to PDSCH					
EPRE ratio of OCNG DMRS to SSS(Note 1)					
EPRE ratio of OCNG to OCNG DMRS (Note 1)					
N_{oc} ^{Note 3}	Config 1	dBm/SCS	-89		
$PR_S \hat{E}_s / N_{oc}$		dB	-Infinity	-Infinity	-Infinity
I_o ^{Note 4}	Config 1	dBm/190.08MHz	-57	-57	-57
SSB RP ^{Note4}	Config 1	dBm/SCS	-89	-Infinity	-Infinity
\hat{E}_s / N_{oc}		dB	0	-Infinity	-Infinity
Propagation Condition			AWGN		
<p>Note 1: OCNG shall be used such that active cell (Cell 1) is fully allocated and a constant total transmitted power spectral density is achieved for all OFDM symbols.</p> <p>Note 2: The resources for uplink transmission are assigned to the UE prior to the start of time period T2.</p> <p>Note 3: Interference from other cells and noise sources not specified in the test are assumed to be constant over subcarriers and time and shall be modelled as AWGN of appropriate power for N_{oc} to be fulfilled.</p> <p>Note 4: SSB RP and I_o levels have been derived from other parameters and are given for information purpose. These are not settable test parameters.</p>					

Table 14.2.3.5-3: Cell-specific test parameters for RSTD measurement reporting delay during T2

Parameter	Unit	Cell 1	Cell 2	Cell 3
		T2	T2	T2
RF Channel Number		1	1	1
Positioning frequency layer		1	1	1
$BW_{channel}$	MHz	200: NRB,c = 132	200: NRB,c = 132	200: NRB,c = 132
Correlation Matrix and Antenna Configuration		1x2 Low	1x2 Low	1x2 Low
OCNG patterns defined in A.3.2.1		OP.1	OP.1	OP.1
PRACH configuration		FR2 PRACH configuration 1	FR2 PRACH configuration 1	FR2 PRACH configuration 1
EPRE ratio of PSS to SSS	dB	0	0	0
EPRE ratio of PBCH DMRS to SSS				
EPRE ratio of PBCH to PBCH DMRS				
EPRE ratio of PDCCH DMRS to SSS				

EPRE ratio of PDCCH to PDCCH DMRS					
EPRE ratio of PDSCH DMRS to SSS					
EPRE ratio of PDSCH to PDSCH					
EPRE ratio of OCNG DMRS to SSS(Note 1)					
EPRE ratio of OCNG to OCNG DMRS (Note 1)					
EPRE ratio of PRS to SSS					
N_{oc} Note 3	Config 1	dBm/SCS	-89.41	-89.41	-89.41
PRS \hat{E}_s/N_{oc}	Config 1	dB	-4.844	-11.02	-11.02
I_o	Config 1	dBm/190.08MHz	-55.66	-55.66	-55.66
PRS \hat{E}_s/I_{ot}		dB	-5.7	-12.7	-12.7
PRP Note 4		dBm/SCS	-94.2	-100.4	-100.4
Propagation Condition			AWGN		
Note 1:	OCNG shall be used such that active cells are fully allocated and a constant total transmitted power spectral density is achieved for all OFDM symbols other than those in the subframes with transmitted PRS.				
Note 2:	The resources for uplink transmission are assigned to the UE prior to the start of time period T2.				
Note 3:	Interference from other cells and noise sources not specified in the test are assumed to be constant over subcarriers and time and shall be modelled as AWGN of appropriate power for N_{oc} to be fulfilled. The I_o is calculated based only on the symbols in which PRS is transmitted.				
Note 4:	PRP and I_o levels have been derived from other parameters and are given for information purpose. These are not settable test parameters. The I_o is calculated based only on the symbols in which PRS is transmitted.				
Note 5:	Calculation of E_s/I_{ot} includes the effect of UE internal noise up to the value assumed for the associated Refsens requirement in clause 7.3.2 of TS 38.101-2 [19], and an allowance of 1dB for UE multi-band relaxation factor ΔMB_P from TS 38.101-2 [19] Table 6.2.1.3-4.				

The RSTD measurement time fulfils the requirements specified in clause 14.2.3.3.

The UE shall perform and report the RSTD measurements for Cell 2 and Cell 3 with respect to the reference cell in the DL-TDOA assistance data, Cell 1, within the time duration specified in clause 14.2.3.3 starting from the beginning of time interval T2.

The rate of the correct events for each neighbour cell observed during repeated tests shall be at least 90%, where the reported RSTD measurement for each correct event shall be within the RSTD reporting range specified in TS 38.133[50] Clause 10.1.23.3, i.e., between RSTD_000000 and RSTD_1970049.

The response time is equal to the LPP time IE value plus the test tolerance. The LPP time IE value is derived from the RSTD measurement period plus ΔT , where $\Delta T = 50ms$. The RSTD measurement period follows the equation:

$$T_{RSTD,i} = \left(CSSF_{PRS,i} * N_{RxBeam,i} * \left\lceil \frac{N_{PRS,i}^{slot}}{N'} \right\rceil \left\lceil \frac{L_{available_PRS,i}}{N} \right\rceil * N_{sample} - 1 \right) * T_{effect,i} + T_{last,i}$$

Where $CSSF_{PRS,i} = 1$, $N_{RxBeam,i} = 8$, $N_{PRS,i}^{slot} = 3$, $L_{available_PRS,i} = 1$, $N_{sample} = 4$. N is the parameter *durationOfPRS-ProcessingSymsbols* from TS 37.355 [49], N' is the parameter *maxNumOfDL-PRS-ResProcessedPerSlot* from TS 37.355 [49], $T_{last,i} = T_i + T_{available_PRS,i}$ and $T_{effect,i} = \left\lceil \frac{T_i}{T_{available_PRS,i}} \right\rceil * T_{available_PRS,i}$.

$T_{available_PRS,i} = LCM(T_{PRS,i}, MGRP_i)$; where $T_{prs} = 160$ ms, and $MGRP$ is 80 (for GP#24) or 40 (for GP#13) depending on UE capabilities. Therefore, $T_{available_PRS,i} = 160$ ms.

T_i depends on the UE parameter *durationOfPRS-ProcessingSymsbolsInEveryTms* from TS 37.355 [49]

Finally, it results in the following equation:

$$\left(1 * 8 * \left\lceil \frac{3}{N'} \right\rceil \left\lceil \frac{0.214}{N} \right\rceil * 4 - 1 \right) * T_{effect} + T_{last}$$

Where the remaining parameters depend on the UE capabilities. The LPP time IE ranges between 5.178s and 245.97s. The value of the LPP time IE is rounded up to the next second (if the value is >128s, it should be rounded up to the next multiple of ten seconds). The result is transmitted in the response time IE in the LPP-RequestLocationInformation in Table 14.2.3.4.3-3. The LPP time IE ranges between 6s and 250s.

The test tolerance for the response time is 300ms. Therefore, the response time ranges between 6.3s and 250.3s.

The values of N' , N and T_i and the effect in the response time equation are defined in Table 14.2.3.5-4, Table 14.2.3.5-5 and Table 14.2.3.5-6 for reference.

Table 14.2.3.5-4: value of N' based on *maxNumOfDL-PRS-ResProcessedPerSlot*

<i>maxNumOfDL-PRS-ResProcessedPerSlot</i>	$\left\lceil \frac{3}{N'} \right\rceil$
n1	3
n2	2
>=n4	1

Table 14.2.3.5-5: value of N based on *durationOfPRS-ProcessingSymsbols*

<i>durationOfPRS-ProcessingSymsbols</i>	$\left\lceil \frac{0.214}{N} \right\rceil$
nDot125	2
>= nDot25	1

Table 14.2.3.5-6: value of T_{effect} and T_{last} based on *durationOfPRS-ProcessingSymsbolsInEveryTms*

<i>durationOfPRS-ProcessingSymsbolsInEveryTms</i>	T_{effect}	T_{last}
n8	160	168
n16	160	176
n20	160	180
n30	160	190
n40	160	200
n80	160	240
n160	160	320
n320	320	480
n640	640	800
n1280	1280	1440

The test tolerances are defined in clauses C.1.6 and C.2.5.

The rate of successful tests during repeated tests shall be at least 90% with a confidence level of 95%.

14.2.4 NR RSTD measurement period test case for dual positioning frequency layers in FR2 SA

Editor's Note: This test case has been completed for the following configurations:

- Test frequency $f \leq 40.8$ GHz

- UE PC3

This test case is incomplete for UE power classes other than PC3

This test case is incomplete for test frequencies > 40.8 GHz

14.2.4.1 Test purpose

The purpose of the test is to verify that the RSTD measurement meets the accuracy requirements specified in TS 38.133 [50] clause 9.9.2 in an environment with AWGN propagation conditions. The test is conducted in AWGN propagation condition in FR2 in standalone scenario when dual positioning frequency layers are configured.

14.2.4.2 Test applicability

This test applies to all types of NR UE release 16 onwards that supports DL-TDOA positioning.

14.2.4.3 Minimum conformance requirements

Same as in clause 14.2.1.3.

14.2.4.4 Test description

The supported test configurations in listed in Table 14.2.4.4-1.

Table 14.2.4.4-1: Test Configurations

Test Configuration	Description
1	120 kHz SSB and PRS SCS, 200 MHz bandwidth, TDD duplex mode

14.2.4.4.1 Initial conditions

Test Environment: Normal, as defined in TS 38.508-1 [45] clause 4.1.

Frequencies to be tested: Mid Range, as defined in TS 38.508-1 [45] clause 4.3.1.

Channel bandwidth to be tested: are specified in Table 14.2.4.4-1.

1. Connect the SS and AWGN noise sources to the UE antenna connector or antenna connectors as shown in Annex A, Figure A.14.
2. The general test parameter settings are set up according to Table 14.2.4.5-1, Table 14.2.4.5-2 and Table 14.2.4.5-3.
3. Propagation conditions are set according to clause 4.15.2.
4. Message contents are defined in clause 14.2.4.4.3.
5. In the test there are three synchronous cells: Cell 1, Cell 2 and Cell 3. Cell 1 is the reference as well as the PCell. Cell 2 and Cell 3 are the neighbour cells. All cells are on the 2 RF channels distributed in dual positioning frequency layers.

14.2.4.4.2 Test procedure

Same as in clause 14.2.3.4.2.

14.2.4.4.3 Message contents

Table 14.2.4.4.3-1: RESET UE POSITIONING STORED INFORMATION

Derivation Path: 38.509 [44] clause 6.6			
Information Element	Value/remark	Comment	Condition
UE Positioning Technology	0 0 0 0 1 1 1	DL-TDOA	

Table 14.2.4.4.3-2: LPP Request Capabilities

Information Element	Value/remark
nr-DL-TDOA-RequestCapabilities-r16	TRUE

Table 14.2.4.4.3-3: LPP RequestLocationInformation

Derivation Path: 37.355 clause 6.2			
Information Element	Value/remark	Comment	Condition
LPP-Message ::= SEQUENCE {			
transactionID SEQUENCE {			
initiator	locationServer		
transactionNumber	1		
}			
endTransaction	FALSE		
sequenceNumber	Not present		
acknowledgement	Not present		
lpp-MessageBody CHOICE {			
c1 CHOICE {			
requestLocationInformation SEQUENCE {			
criticalExtensions CHOICE {			
c1 CHOICE {			
requestLocationInformation-r9 SEQUENCE {			
commonEsRequestLocationInformation SEQUENCE {			
locationInformationType	locationMeasurementsPreferred		
triggeredReporting	Not present		
periodicalReporting	Not present		
additionalInformation	onlyReturnInformationRequested		
qos SEQUENCE {			
horizontalAccuracy	Not present		
verticalCoordinateRequest	FALSE		
verticalAccuracy	Not present		
responseTime SEQUENCE {			
time	See 14.2.4.5	Result of the response time calculation rounded up to the next second if response time <= 128s. Result of the response time calculation rounded up to the next multiple of ten seconds if response time > 128s	
} responseTimeEarlyFix-r12	Not present		Rel-12 onwards
} unit-r15	Not present		
ten-seconds			Calculated response time >128s

}			
velocityRequest	FALSE		
}			
environment	Not present		
locationCoordinateTypes	Not present		
velocityTypes	Not present		
}			
a-gnss-RequestLocationInformation	Not present		
otdoa-RequestLocationInformation	Not present		
ecid-RequestLocationInformation	Not present		
epdu-RequestLocationInformation	Not Present		
sensor-RequestLocationInformation-r13	Not present		
tbs-RequestLocationInformation-r13	Not present		
wlan-RequestLocationInformation-r13	Not present		
bt-RequestLocationInformation-r13	Not present		
nr-ECID-RequestLocationInformation-r16	Not present		
nr-Multi-RTT-RequestLocationInformation-r16	Not present		
nr-DL-AoD-RequestLocationInformation-r16	Not present		
nr-DL-TDOA-RequestLocationInformation-r16			
SEQUENCE {			
nr-DL-PRS-RstdMeasurementInfoRequest-r16	Not present		
nr-RequestedMeasurements-r16	bit 0 = 0 (prsrsrpReq)		
nr-AssistanceAvailability-r16	FALSE		
nr-DL-TDOA-ReportConfig-r16	Not present		
additionalPaths-r16	Not present		
}			
}			
}			
}			
}			
}			
}			
}			
}			

Table 14.2.4.4.3-4: LPP ProvideAssistanceData

Derivation Path: 37.355 clause 6.2			
Information Element	Value/remark	Comment	Condition
LPP-Message ::= SEQUENCE {			
transactionID SEQUENCE {			
initiator	locationServer		
transactionNumber	(0..255)		
}			
endTransaction	TRUE		
sequenceNumber	Not present		
acknowledgement	Not present		
lpp-MessageBody CHOICE {			
c1 CHOICE {			
provideAssistanceData SEQUENCE {			
criticalExtensions CHOICE {			
c1 CHOICE {			
provideAssistanceData-r9 SEQUENCE {			
commonEsProvideAssistanceData	Not present		
a-gnss-ProvideAssistanceData	Not present		
otdoa-ProvideAssistanceData	Not present		
epdu-Provide-AssistanceData	Not present		
sensor-ProvideAssistanceData-r15	Not present		
tbs-ProvideAssistanceData-r15	Not present		
wlan-ProvideAssistanceData-r15	Not present		
nr-Multi-RTT-ProvideAssistanceData-r16	Not present		
nr-DL-AoD-ProvideAssistanceData-r16	Not present		
nr-DL-TDOA-ProvideAssistanceData-r16	Not present		
}			
}			
}			
}			
}			
}			
SEQUENCE {			

nr-DL-PRS-AssistanceData-r16	As defined in Table 14.2.4.4.3-5		
nr-SelectedDL-PRS-IndexList-r16	Not present		
nr-PositionCalculationAssistance-r16			Depending on UE capabilities, i.e. support for UE-based DL-TDOA
SEQUENCE {			
nr-TRP-LocationInfo-r16	As defined in TS 37.571-5 [20]		
nr-DL-PRS-BeamInfo-r16	Not present		
nr-RTD-Info-r16	Not present		
}			
nr-DL-TDOA-Error-r16	Not present		
}			
}			
}			
}			
}			
}			
}			

Table 14.2.4.4.3-5: NR-DL-PRS-AssistanceData

Derivation Path: 37.355 clause 6.4.3			
Information Element	Value/remark	Comment	Condition
NR-DL-PRS-AssistanceData-r16 ::= SEQUENCE {			
nr-DL-PRS-ReferenceInfo-r16 SEQUENCE {			
dl-PRS-ID-r16	0		
nr-DL-PRS-ResourceID-List-r16	Not present		
nr-DL-PRS-ResourceSetID-r16	Not present		
}			
nr-DL-PRS-AssistanceDataList-r16 SEQUENCE (SIZE (1..nrMaxFreqLayers-r16)) OF NR-DL-PRS-AssistanceDataPerFreq-r16 {	1 entry		
NR-DL-PRS-AssistanceDataPerFreq-r16[1] SEQUENCE {		entry 1	
nr-DL-PRS-PositioningFrequencyLayer-r16 SEQUENCE {			
dl-PRS-SubcarrierSpacing-r16	kHz120		
dl-PRS-ResourceBandwidth-r16	3	32 PRBs	
dl-PRS-StartPRB-r16	0		
dl-PRS-PointA-r16	absoluteFrequencyPointA as defined for the DL frequency of the Cell 1		
dl-PRS-CombSizeN-r16	n2		
dl-PRS-CyclicPrefix-r16	normal		
}			
nr-DL-PRS-AssistanceDataPerFreq-r16 SEQUENCE (SIZE (1..nrMaxTRPsPerFreq-r16)) OF NR-DL-PRS-AssistanceDataPerTRP-r16{	3 entries		
NR-DL-PRS-AssistanceDataPerTRP-r16[1] SEQUENCE {		entry 1	Cell 1
dl-PRS-ID-r16	0		
nr-PhysCellID-r16	Cell 1		
nr-CellGlobalID-r16	Cell 1		
nr-ARFCN-r16	Cell 1		
nr-DL-PRS-SFN0-Offset-r16 SEQUENCE {			
sfn-Offset-r16	0		
integerSubframeOffset-r16	0		
}			
nr-DL-PRS-ExpectedRSTD-r16	0		
nr-DL-PRS-ExpectedRSTD-Uncertainty-r16	0		

nr-DL-PRS-Info-r16	As specified in Table 14.2.4.4.3-6		
}			
NR-DL-PRS-AssistanceDataPerTRP-r16[2] SEQUENCE {		entry 2	Cell 2
dl-PRS-ID-r16	1		
nr-PhysCellID-r16	Cell 2		
nr-CellGlobalID-r16	Cell 2		
nr-ARFCN-r16	Cell 2		
nr-DL-PRS-SFN0-Offset-r16 SEQUENCE {			
sfn-Offset-r16	0		
integerSubframeOffset-r16	0		
}			
nr-DL-PRS-ExpectedRSTD-r16	23	About 3 μs	
nr-DL-PRS-ExpectedRSTD-Uncertainty-r16	154	About 5 μs	
nr-DL-PRS-Info-r16	As specified in Table 14.2.4.4.3-6		
}			
NR-DL-PRS-AssistanceDataPerTRP-r16[3] SEQUENCE {		entry 3	Cell 3
dl-PRS-ID-r16	2		
nr-PhysCellID-r16	Cell 3		
nr-CellGlobalID-r16	Cell 3		
nr-ARFCN-r16	Cell 3		
nr-DL-PRS-SFN0-Offset-r16 SEQUENCE {			
sfn-Offset-r16	0		
integerSubframeOffset-r16	0		
}			
nr-DL-PRS-ExpectedRSTD-r16	23	About 3 μs	
nr-DL-PRS-ExpectedRSTD-Uncertainty-r16	154	About 5 μs	
nr-DL-PRS-Info-r16	As specified in Table 14.2.4.4.3-6		
}			
}			
}			
}			
}			

Table 14.2.4.4.3-6: NR-DL-PRS-Info

Derivation Path: 37.355 clause 6.4.3			
Information Element	Value/remark	Comment	Condition
NR-DL-PRS-Info-r16 ::= SEQUENCE {			
nr-DL-PRS-ResourceSetList-r16 SEQUENCE (SIZE (1..nrMaxSetsPerTrp-r16)) OF NR-DL-PRS-ResourceSet-r16 {	1 entry		
NR-DL-PRS-ResourceSet-r16[1] SEQUENCE {		entry 1	
nr-DL-PRS-ResourceSetID-r16	0		
dl-PRS-Periodicity-and-ResourceSetSlotOffset-r16 CHOICE {			
scs120-r16 CHOICE {			
n1280-r16	80		
}			
dl-PRS-ResourceRepetitionFactor-r16	Not present		
dl-PRS-ResourceTimeGap-r16	s1		
dl-PRS-NumSymbols-r16	n4		
dl-PRS-MutingOption1-r16 SEQUENCE {			
dl-prs-MutingBitRepetitionFactor-r16	Not present		
nr-option1-muting-r16 CHOICE {			
po2-r16	10		Cell 1 and Cell 3
	01		Cell 2
}			
}			
}			

dl-PRS-MutingOption2-r16	Not present		
dl-PRS-ResourcePower-r16	27		
dl-PRS-ResourceList-r16 SEQUENCE (SIZE (1..nrMaxResourcesPerSet-r16)) OF NR-DL-PRS-Resource-r16 {	1 entry		
NR-DL-PRS-Resource-r16[1] SEQUENCE {		entry 1	
nr-DL-PRS-ResourceID-r16	0		
dl-PRS-SequenceID-r16	0		
dl-PRS-CombSizeN-AndReOffset-r16 CHOICE {			
n2-r16	0		Cell 1 and Cell 2
	1		Cell 3
}			
dl-PRS-ResourceSlotOffset-r16	0		
dl-PRS-ResourceSymbolOffset-r16	0		
dl-PRS-QCL-Info-r16	Not present		
}			
}			
}			
}			
}			

Table 14.2.4.4.3-7: LPP ProvideLocation Information

Derivation Path: TS 37.355 [49] clause 6.2			
Information Element	Value/remark	Comment	Condition
LPP-Message ::= SEQUENCE {			
transactionID SEQUENCE {			
initiator	locationServer		
transactionNumber	1		
}			
endTransaction	TRUE		
sequenceNumber	(0..255)		
acknowledgement			
lpp-MessageBody CHOICE {			
c1 CHOICE {			
provideLocationInformation SEQUENCE {			
criticalExtensions CHOICE {			
c1 CHOICE {			
provideLocationInformation-r9 SEQUENCE {			
commonIEsProvideLocationInformation	Not present.		
a-gnss-ProvideLocationInformation	Not present		
otdoa-ProvideLocationInformation	Not present		
ecid-ProvideLocationInformation	Not present		
epdu-ProvideLocationInformation	Not present		
sensor-ProvideLocationInformation-r13	Not present		
tbs-ProvideLocationInformation-r13	Not present		
wlan-ProvideLocationInformation-r13	Not present		
bt-ProvideLocationInformation-r13	Not present		
nr-ECID-ProvideLocationInformation-r16	Not present		
nr-Multi-RTT-ProvideLocationInformation-r16	Not present		
nr-DL-AoD-ProvideLocationInformation-r16	Not present		
nr-DL-TDOA-ProvideLocationInformation-r16 SEQUENCE {			
nr-DL-TDOA-SignalMeasurementInformation-r16 SEQUENCE {			
dl-PRS-ReferenceInfo-r16			
nr-DL-TDOA-MeasList-r16 SEQUENCE (SIZE(1..nrMaxTRPs-r16)) OF NR-DL-TDOA-MeasElement-r16 {	3 entries		
NR-DL-TDOA-MeasElement-r16[1] SEQUENCE {		entry 1	
dl-PRS-ID-r16			
nr-PhysCellID-r16	Cell 1		

nr-CellGlobalID-r16			
nr-ARFCN-r16			
nr-DL-PRS-ResourceID-r16			
nr-DL-PRS-ResourceSetID-r16			
nr-TimeStamp-r16			
nr-RSTD-r16	Present		
nr-AdditionalPathList-r16			
nr-TimingQuality-r16			
nr-DL-PRS-RSRP-Result-r16			
nr-DL-TDOA-AdditionalMeasurements- r16			
}			
NR-DL-TDOA-MeasElement-r16[2]		entry 2	
SEQUENCE {			
dl-PRS-ID-r16			
nr-PhysCellID-r16	Cell 2		
nr-CellGlobalID-r16			
nr-ARFCN-r16			
nr-DL-PRS-ResourceID-r16			
nr-DL-PRS-ResourceSetID-r16			
nr-TimeStamp-r16			
nr-RSTD-r16	Present		
nr-AdditionalPathList-r16			
nr-TimingQuality-r16			
nr-DL-PRS-RSRP-Result-r16			
nr-DL-TDOA-AdditionalMeasurements- r16			
}			
NR-DL-TDOA-MeasElement-r16[3]		entry 3	
SEQUENCE {			
dl-PRS-ID-r16			
nr-PhysCellID-r16	Cell 3		
nr-CellGlobalID-r16			
nr-ARFCN-r16			
nr-DL-PRS-ResourceID-r16			
nr-DL-PRS-ResourceSetID-r16			
nr-TimeStamp-r16			
nr-RSTD-r16	Present		
nr-AdditionalPathList-r16			
nr-TimingQuality-r16			
nr-DL-PRS-RSRP-Result-r16			
nr-DL-TDOA-AdditionalMeasurements- r16			
}			
nr-dl-tdoa-LocationInformation-r16			
nr-DL-TDOA-Error-r16			
}			
}			
}			
}			
}			

14.2.4.5 Test requirement

Table 14.2.4.5-1, Table 14.2.4.5-2 and Table 14.2.4.5-3 define the primary level settings including test tolerances for the test.

Table 14.2.4.5-1: General test parameters for RSTD measurement reporting delay

Parameter	Unit	Value	Comment
-----------	------	-------	---------

Reference cell			Cell 1	Reference cell is the cell in the DL-TDOA assistance data with respect to which the RSTD measurement is defined, as specified in TS 38.215 [57] and TS 37.355 49]. The reference cell is the PCell in this test case.
Neighbour cells			Cell 2 and Cell 3	Cell 2 and Cell 3 appear at the first and second places in the neighbour cell list in the DL-TDOA assistance data.
SSB configuration	Config 1		SSB.2 FR2	
SMTc configuration	Config 1		SMTc.1	
PDSCH RMC configuration	Config 1		SR.1.1 FDD	
RMSI CORESET RMC configuration	Config 1		CR.3.1 TDD	As specified in TS 38.133 [50] clause A.3.1.2.1
Dedicated CORESET RMC configuration	Config 1		CCR.1.1 FDD	
PRS Configuration	Config 1		PRS.1.1 FR2	As specified in TS 38.133 [50] clause A.3.31
Physical cell ID PCI			(PCI of Cell 1 – PCI of Cell 2)mod6=0 and (PCI of Cell 1 – PCI of Cell 3)mod6=0	The cell PCIs are selected such that the relative shifts of PRS patterns among cells are as given by the test parameters
CP length			Normal	
DRX			OFF	
Measurement gap			GP#24 or GP#13	GP#24 is configured if UE supports MG#24, otherwise GP#13 is configured
Radio frame receive time offset between the cells at the UE antenna connector		µs	Cell 2 to Cell 1: 0 Cell 3 to Cell 1: 3	PRS are transmitted from synchronous cells
Expected RSTD		µs	Cell 2: 3 Cell 3: 3 Other neighbour cells: randomly between -3 and 3	The expected RSTD is what is expected at the receiver. The corresponding parameter in the DL-TDOA assistance data specified in TS 37.355[49] is the expectedRSTD indicator
Expected RSTD uncertainty for all neighbour cells		µs	5	The corresponding parameter in the DL-TDOA assistance data specified in TS 37.355[49] is the expectedRSTD-Uncertainty index
Number of cells provided in DL-TDOA assistance data			4	Including the reference cell
PRS muting info			Cell 1: '10' Cell 2: '01' Cell 3: '10'	Corresponds to prs-MutingInfo defined in TS 37.355 [49]
PRS resource RE offset			Cell 1: 0 Cell 2: 0 Cell 3: 1	Cell 1 and Cell 3 are configured with different resource offsets
T1		s	3	The length of the time interval from the beginning of each test

T2	s	1.28	The length of the time interval that follows immediately after time interval T1
AoA setup		Setup 1	As defined in TS 38.133 [50] A.3.15.1
Beam assumption		Rough	Information about types of UE beam is given in TS 38.133 [50] B.2.1.3, and does not limit UE implementation or test system implementation

Table 14.2.4.5-2: Cell-specific test parameters for RSTD measurement reporting delay during T1

Parameter	Unit	Cell 1	Cell 2	Cell 3
NR RF Channel Number		1	1	2
Positioning frequency layer		1	1	2
BWchannel	MHz	200: NRB,c = 132	200: NRB,c = 132	200: NRB,c = 132
Correlation Matrix and Antenna Configuration		1x2 Low	1x2 Low	1x2 Low
OCNG patterns defined in A.3.2.1		OP.1	N/A	N/A
EPRE ratio of PBCH DMRS to SSS				
EPRE ratio of PBCH to PBCH DMRS				
EPRE ratio of PDCCH DMRS to SSS				
EPRE ratio of PDCCH to PDCCH DMRS				
EPRE ratio of PDSCH DMRS to SSS				
EPRE ratio of PDSCH to PDSCH				
EPRE ratio of OCNG DMRS to SSS(Note 1)				
EPRE ratio of OCNG to OCNG DMRS (Note 1)				
N_{oc} Note 3	Config 1	dBm/SCS		
\hat{E}_s/N_{oc}		-89		
PRS \hat{E}_s/N_{oc}	dB	-Infinity	-Infinity	-Infinity
I_o Note 4	Config 1	dBm/190.08MHz		
SSB _{RP} Note4	Config 1	dBm/SCS		
SSB \hat{E}_s/N_{oc}		0	-Infinity	-Infinity
Propagation Condition		AWGN		
<p>Note 1: OCNG shall be used such that active cell (Cell 1) is fully allocated and a constant total transmitted power spectral density is achieved for all OFDM symbols.</p> <p>Note 2: The resources for uplink transmission are assigned to the UE prior to the start of time period T2.</p> <p>Note 3: Interference from other cells and noise sources not specified in the test are assumed to be constant over subcarriers and time and shall be modelled as AWGN of appropriate power for N_{oc} to be fulfilled.</p> <p>Note 4: SSB_{RP} and I_o levels have been derived from other parameters and are given for information purpose. These are not settable test parameters.</p>				

Table 14.2.4.5-3: Cell-specific test parameters for RSTD measurement reporting delay during T2

Parameter	Unit	Cell 1	Cell 2	Cell 3
-----------	------	--------	--------	--------

			T2	T2	T2
RF Channel Number			1	1	2
Positioning frequency layer			1	1	2
Correlation Matrix and Antenna Configuration			1x2 Low	1x2 Low	1x2 Low
OCNG patterns defined in A.3.2.1			OP.1	OP.1	OP.1
PRACH configuration			FR2 PRACH configuration 1	FR2 PRACH configuration 1	FR2 PRACH configuration 1
EPRE ratio of PBCH DMRS to SSS		dB	0	0	0
EPRE ratio of PBCH to PBCH DMRS					
EPRE ratio of PDCCH DMRS to SSS					
EPRE ratio of PDCCH to PDCCH DMRS					
EPRE ratio of PDSCH DMRS to SSS					
EPRE ratio of PDSCH to PDSCH					
EPRE ratio of OCNG DMRS to SSS(Note 1)					
EPRE ratio of OCNG to OCNG DMRS (Note 1)					
EPRE ratio of PRS to SSS					
N_{oc} ^{Note 3}	Config 1				
PRS \hat{E}_s/N_{oc}	Config 1	dB	-5.17	-11.36	-12.47
I_o	Config 1	dBm/190.08MHz	-55.68	-55.68	-56.73
PRS \hat{E}_s/I_{ot}		dB	-5.7	-12.7	-12.7
PRP ^{Note 4}		dBm/SCS kHz	-94.2	-100.4	-101.4
Propagation Condition			AWGN		
<p>Note 1: OCNG shall be used such that active cells are fully allocated and a constant total transmitted power spectral density is achieved for all OFDM symbols other than those in the slots with transmitted PRS.</p> <p>Note 2: The resources for uplink transmission are assigned to the UE prior to the start of time period T2.</p> <p>Note 3: Interference from other cells and noise sources not specified in the test are assumed to be constant over subcarriers and time and shall be modelled as AWGN of appropriate power for N_{oc} to be fulfilled.</p> <p>Note 4: SSB RP and I_o levels have been derived from other parameters and are given for information purpose. These are not settable test parameters. The I_o is calculated based only on the symbols in which PRS is transmitted.</p> <p>Note 5: Calculation of E_s/I_{ot} includes the effect of UE internal noise up to the value assumed for the associated Refsens requirement in clause 7.3.2 of TS 38.101-2 [19], and an allowance of 1dB for UE multi-band relaxation factor ΔMB_P from TS 38.101-2 [19] Table 6.2.1.3-4.</p>					

The RSTD measurement time fulfils the requirements specified in clause 14.2.4.3.

The UE shall perform and report the RSTD measurements for Cell 2 and Cell 3 with respect to the reference cell in the DL-TDOA assistance data, Cell 1, within the time duration specified in clause 14.2.4.3 starting from the beginning of time interval T2.

The rate of the correct events for each neighbour cell observed during repeated tests shall be at least 90%, where the reported RSTD measurement for each correct event shall be within the RSTD reporting range specified in TS 38.133[50] Clause 10.1.23.3, i.e., between RSTD_000000 and RSTD_1970049.

The response time is equal to the LPP time IE value plus the test tolerance. The LPP time IE value is derived from the RSTD measurement period plus ΔT, where ΔT = 50ms. The RSTD measurement period follows the equation:

$$T_{RSTD,i} = \left(CSSF_{PRS,i} * N_{RxBeam,i} * \left\lceil \frac{N_{PRS,i}^{slot}}{N'} \right\rceil \left\lceil \frac{L_{available_PRS,i}}{N} \right\rceil * N_{sample} - 1 \right) * T_{effect,i} + T_{last,i}$$

Where $CSSF_{PRS,i} = 1$, $N_{RxBeam,i} = 8$, $N_{PRS,i}^{slot} = 2$ for $T_{RSTD,1}$, $N_{PRS,i}^{slot} = 1$ for $T_{RSTD,2}$, $L_{available_PRS,i} = 0.142$, $N_{sample} = 4$. N is the parameter durationOfPRS-ProcessingSymsbols from TS 37.355 [49], N' is the parameter maxNumOfDL-PRS-ResProcessedPerSlot from TS 37.355 [49], $T_{last,i} = T_i + T_{available_PRS,i}$ and $T_{effect,i} = \left\lceil \frac{T_i}{T_{available_PRS,i}} \right\rceil * T_{available_PRS,i}$.

$T_{available_PRS,i} = LCM(T_{PRS,i}, MGRP_i)$; where $T_{prs} = 160$ ms, and MGRP is 80 (for GP#24) or 40 (for GP#13) depending on UE capabilities. Therefore, $T_{available_PRS,i} = 160$ ms.

T_i depends on the UE parameter durationOfPRS-ProcessingSymsbolsInEveryTms from TS 37.355 [49]

Finally, it results in the following equation:

$$\left(1 * 8 * \left\lceil \frac{2}{N'} \right\rceil \left\lceil \frac{0.142}{N} \right\rceil * 4 - 1 \right) * T_{effect} + T_{last}$$

Where the remaining parameters depend on the UE capabilities. The LPP time IE ranges between 10.456s and 206.45s. The value of the LPP time IE is rounded up to the next second (if the value is >128s, it should be rounded up to the next multiple of ten seconds). The result is transmitted in the response time IE in the LPP-RequestLocationInformation in Table 14.2.3.4.3-3. The LPP time IE ranges between 11s and 210s.

The test tolerance for the response time is 300ms. Therefore, the response time ranges between 11.3s and 210.3s.

The values of N', N and Ti and the effect in the response time equation are defined in Table 14.2.4.5-4, Table 14.2.4.5-5 and Table 14.2.3.5-6 for reference.

Table 14.2.4.5-4: value of N' based on maxNumOfDL-PRS-ResProcessedPerSlot

maxNumOfDL-PRS-ResProcessedPerSlot	$\left\lceil \frac{2}{N'} \right\rceil$
n1	2
>=n2	1

Table 14.2.4.5-5: value of N based on durationOfPRS-ProcessingSymsbols

durationOfPRS-ProcessingSymsbols	$\left\lceil \frac{0.142}{N} \right\rceil$
nDot125	2
>= nDot25	1

Table 14.2.3.4-6: value of T_{effect} and T_{last} based on durationOfPRS-ProcessingSymsbolsInEveryTms

durationOfPRS-ProcessingSymsbolsInEveryTms	T_{effect}	T_{last}
n8	160	168
n16	160	176
n20	160	180
n30	160	190

n40	160	200
n80	160	240
n160	160	320
n320	320	480
n640	640	800
n1280	1280	1440

The test tolerances are defined in clauses C.1.6 and C.2.5.

The rate of successful tests during repeated tests shall be at least 90% with a confidence level of 95%.

14.2.5 NR RSTD measurement reporting delay test case for single positioning frequency layer with reduced number of samples in FR1 SA

Editor's note: This test case is incomplete. The following aspect is either missing or TBD:

- Test tolerance is missing

14.2.5.1 Test purpose

The purpose of the test is to verify that the RSTD measurement meets the requirements specified in TS 38.133 [50] Clause 9.9.2 in an environment with AWGN propagation conditions in FR1 in standalone scenario when single positioning frequency layer is configured.

14.2.5.2 Test applicability

This test applies to all types of NR UE release 17 onwards that supports DL-TDOA positioning and supportedDL-PRS-ProcessingSamples-RRC-CONNECTED.

14.2.5.3 Minimum conformance requirements

When physical layer receives last of *NR-TDOA-ProvideAssistanceData* message and *NR-TDOA-RequestLocationInformation* message from LMF via LPP [34], the UE shall be able to measure multiple (up to the UE capability specified in Clause 9.9.2.3) DL RSTD measurements, defined in TS 38.215 [4], during the measurement period $T_{RSTD,Total}$ defined as:

$$T_{RSTD,Total} = \sum_{i=1}^L T_{RSTD,i} + (L - 1) * \max(T_{effect,i})$$

Where ,

i is the index of positioning frequency layer,

L is total number of positioning frequency layers, and

$T_{effect,i}$ is the periodicity of the PRS RSTD measurement in positioning frequency layer i

$T_{RSTD,i}$ is the measurement period for PRS RSTD measurement in positioning frequency layer i as specified below:

$$T_{RSTD,i} = \left(k_{multiTEG,i} * CSSF_{PRS,i} * \text{ceil}(K_{p,PRS,i}) * N_{RxBeam,i} * \left\lceil \frac{N_{PRS,i}^{slot}}{N'} \right\rceil \left\lceil \frac{L_{available_PRS,i}}{N} \right\rceil * N_{sample} - 1 \right) * T_{effect,i} + T_{last,i}$$

where:

$N_{RxBeam,i}$ is the UE Rx beam sweeping factor. In FR1, $N_{RxBeam,i} = 1$;

and in FR2, $N_{RxBeam,i}$ is equal to the value reported by the UE in *supportedLowerRxBeamSweepingFactor-FR2* if the UE supports the capability for the band containing positioning frequency layer i , and the LMF indicates *lowerRxBeamSweepingFactor-FR2* in *NR-DL-TDOA-RequestLocationInformation*. $N_{RxBeam,i}$ is equal to 8, otherwise.

$CSSF_{PRS,i}$ is the carrier-specific scaling factor for NR PRS-based positioning measurements in positioning frequency layer i as defined in TS 38.133[50] clause 9.1.5.2.

$k_{multiTEG,i}$ is the scaling factor for measurement of same PRS resource with multiple Rx TEGs.

$k_{multiTEG,i}=1$ if UE is not requested by LMF to measure a PRS resource with multiple Rx TEGs via *measureSameDL-PRS-ResourceWithDifferentRxTEGs-r17* [34] in *NR-DL-TDOA-RequestLocationInformation*;

otherwise,

$k_{multiTEG,i}=N_{TEG,i}$, if UE is not capable of receiving same DL PRS resource simultaneously from multiple Rx TEGs, and

$k_{multiTEG,i}=\left\lfloor \frac{N_{TEG,i}}{k_{TEG,simul,i}} \right\rfloor$ if UE is capable of receiving the same DL PRS resource simultaneously from multiple Rx TEGs.

where

$N_{TEG,i}$ is the number of Rx TEGs with which UE is requested to measure a PRS resource indicated via *measureSameDL-PRS-ResourceWithDifferentRxTEGs-r17* [34] in *NR-DL-TDOA-RequestLocationInformation*, and in case 'n0' is indicated, $N_{TEG,i}$ is the maximum number of Rx TEGs with which UE can support to measure the same PRS resource as reported in *NR-UE-TEG-Capability*, and

$k_{TEG,simul,i}$ is the number of Rx TEGs UE can measure simultaneously which is reported via *measureSameDL-PRS-ResourceWithDifferentRxTEGsSimul*.

$K_{p,PRS,i}$ is a scaling factor for a positioning frequency layer to be measured within the associated measurement gap pattern, which is defined as $K_{p,PRS,i} = N_{total} / N_{available}$ for UE configured with concurrent measurement gap, and $K_{p,PRS,i} = 1$ for UE not configured with concurrent measurement gaps.

- For a window W of duration $\max(T_{PRS,i}, MGRP_max)$, where $MGRP_max$ is the maximum MGRP across all configured per-UE MG and per-FR MG within the same FR as the positioning frequency layer, and starting at the beginning of any associated gap occasions covering the PRS occasion:
 - N_{total} is the total number of associated gap occasions covering PRS occasions within the window, including both dropped and non-dropped instances of the associated measurement gap within the window, and
 - $N_{available}$ is the number of non-dropped associated gap occasions covering PRS occasions within the window W , after further accounting for MG collisions by applying the selected gap collision rule
 - Requirements do not apply if $N_{available} = 0$.

$N_{PRS,i}^{slot}$ is the maximum number of DL PRS resources in positioning frequency layer i configured in a slot.

$L_{available_PRS,i}$ is the time duration of available PRS in the positioning frequency layer i to be measured during $T_{available_PRS,i}$, and is calculated in the same way as PRS duration K defined in clause 5.1.6.5 of TS 38.214 [26]. For calculation of $L_{available_PRS,i}$, only the PRS resources unmuted and fully or partially overlapped with MG are considered.

N_{sample} is the number of PRS RSTD measurement samples, where

- $N_{sample} = 1$ if the UE supports *supportedDL-PRS-ProcessingSamples-RRC-CONNECTED* [34], and the LMF requests the UE to perform positioning measurements with reduced number of samples, and meets the following conditions:
 - PRS bandwidth is within the active BWP and
 - Magnitude of difference between the serving cell's SS-RSRP and the neighbour cell's PRS-RSRP is within 6 dB.

- $N_{sample} = 2$ if the UE supports *supportedDL-PRS-ProcessingSamples-RRC-CONNECTED* [34], and the LMF requests the UE to perform positioning measurements with reduced number of samples, and does not meet the following conditions:
 - PRS bandwidth is within the active BWP and
 - Magnitude of difference between the serving cell's SS-RSRP and the neighbour cell's PRS-RSRP is within 6 dB.
- $N_{sample} = 4$ otherwise.

$T_{last,i}$ is the measurement duration for the last PRS RSTD sample in positioning frequency layer i , including the sampling time and processing time. If all of the PRS resources to be measured are available in the same MG occasion during $T_{available}$, $T_{last,i} = T_i + MGL$. Otherwise, $T_{last,i} = T_i + T_{available_PRS,i}$,

$T_{effect,i}$ is the periodicity of the PRS RSTD measurement in positioning frequency layer i defined as:

$$T_{effect,i} = \left\lceil \frac{T_i}{T_{available_PRS,i}} \right\rceil * T_{available_PRS,i}$$

Where,

T_i corresponds to *durationOfPRS-ProcessingSymbolsInEveryTms* in TS 37.355 [49],

$T_{available_PRS,i} = LCM(T_{PRS,i}, MGRP_i)$, the least common multiple between $T_{PRS,i}$ and $MGRP_i$.

$MGRP_i$ is the repetition periodicity of the measurement gap applicable for measurement in the PRS frequency layer i . $T_{PRS,i}$ is the periodicity of DL PRS resource with muting on positioning frequency layer i .

If more than one PRS periodicities are configured in positioning frequency layer i , the least common multiple of PRS periodicities $T_{per}^{PRS \text{ with muting}}$ among all DL PRS resource sets in the positioning frequency layer is used to derive $T_{PRS,i}$, where,

$T_{per}^{PRS \text{ with muting}} = N_{muting} * T_{per}^{PRS}$, is the PRS periodicity with muting per PRS resource,

T_{per}^{PRS} is the periodicity of PRS resource sets given by the higher-layer parameter *DL-PRS-Periodicity*.

N_{muting} is the scaling factor considering PRS resource muting. $N_{muting} = T_{muting}^{PRS} * L_{muting}$, where

T_{muting}^{PRS} is the muting repetition factor given by the higher-layer parameter *DL-PRS-MutingBitRepetitionFactor*, and L_{muting} is the size of the bitmap $\{b^1\}$.

- Note: For the purpose of calculating $T_{PRS,i}$, only the PRS resources fully or partially covered by the MG are considered.

$\{N, T\}$ is UE capability combination per band where N is a duration of DL PRS symbols in ms corresponding to *durationOfPRS-ProcessingSymbols* in TS 37.355 [49] processed every T ms corresponding to *durationOfPRS-ProcessingSymbolsInEveryTms* in TS 37.355 [49] for a given maximum bandwidth supported by UE corresponding to *supportedBandwidthPRS* in TS 37.355 [49].

N' is UE capability for number of DL PRS resources that it can process in a slot as indicated by *maxNumOfDL-PRS-ResProcessedPerSlot* specified in TS 37.355 [49].

14.2.5.4 Test description

14.2.5.4.1 Initial conditions

The supported test configuration is listed in Table 14.2.5.4-1.

Table 14.2.5.4-1: Test Configuration

Configuration	Description
1	15 kHz SSB SCS, 20 MHz bandwidth, FDD duplex mode
2	15 kHz SSB SCS, 20 MHz bandwidth, TDD duplex mode
3	30 kHz SSB SCS, 50 MHz bandwidth, TDD duplex mode
Note:	The UE is only required to be tested in one of the supported test configurations.

Test Environment: Normal, as defined in TS 38.508-1 [45] clause 4.1.

Frequencies to be tested: Mid Range, as defined in TS 38.508-1 [45] clause 4.3.1.

Channel bandwidth to be tested: are specified in Table 14.2.5.4-1.

1. Connect the SS and AWGN noise sources to the UE antenna connector or antenna connectors as shown in Annex A, Figure A.12.
2. The general test parameter settings are set up according to Table 14.2.5.5-1, Table 14.2.5.5-2 and Table 14.2.5.5-3.
3. Propagation conditions are set according to clause 4.15.2.
4. Message contents are defined in clause 14.2.5.4.3.
5. In the test there are three synchronous cells: Cell 1, Cell 2 and Cell 3. Cell 1 is the reference as well as the PCell. Cell 2 and Cell 3 are the neighbour cells. All 3 cells are on the same RF channel in FR1.

14.2.5.4.2 Test procedure

The test consists of two consecutive time intervals, with duration of T1 and T2. During time duration T1, the UE shall not have any timing information of Cell 2 and Cell 3. All three cells transmit PRS during T2. The beginning of the time interval T2 shall be aligned with the beginning of the first MG instance containing the PRS resources.

The NR-DL-TDOA-ProvideAssistanceData and nr-DL-TDOA-RequestLocationInformation as defined in TS 37.355 [49] clause 6.5.12.1, shall be provided to the UE during T1. The last TTI containing the two messages shall be provided to the UE ΔT ms before the start of T2, where $\Delta T = 50$ ms is the maximum processing time of the *DL-TDOA assistance* data and location information request.

The UE is configured with measurement gap pattern ID # 24 or #0 before T2.

1. Ensure the UE is in State RRC_CONNECTED with generic procedure parameters Connectivity NR, Connected without release On, according to TS 38.508-1 [45] clause 4.5.
2. The SS shall send a RESET UE POSITIONING STORED INFORMATION message.
3. Set the parameters according to Table 14.2.5.5-1, Table 14.2.5.5-2 and Table 14.2.5.5-3. Propagation conditions are set according to clause 4.15.2.
4. T1 starts.
5. The SS shall transmit an LPP REQUEST CAPABILITIES message.
6. The UE shall transmit an LPP PROVIDE CAPABILITIES message indicating the UE supports *supportedDL-PRS-ProcessingSamples-RRC-CONNECTED* in the *NR-DL-PRS-ProcessingCapability* IE and DL-TDOA capabilities supported by the UE in the *NR-DL-TDOA-ProvideCapabilities* IE.
7. The SS shall send a LPP PROVIDE ASSISTANCE DATA message, including the *NR-DL-TDOA-ProvideAssistanceData* IE. The position of neighbour Cell 2 and the position of neighbour Cell 3 are described in 3GPP TS 37.571-5 [20]. If the UE message at step 6 includes the *ackRequested* IE set to TRUE, then the SS shall send an acknowledgment in the LPP PROVIDE ASSISTANCE DATA message.
8. The SS shall send a LPP REQUEST LOCATION INFORMATION message, including the *reducedDL-PRS-ProcessingSamples-r17* in the *NR-DL-TDOA-RequestLocationInformation* IE such that the UE receives the message ΔT ms before the start of T2, where $\Delta T = 50$ ms.

9. When T1 expires, the SS shall switch the power setting from T1 to T2 as specified in Table 14.2.5.5-3.
10. The UE shall transmit a LPP PROVIDE LOCATION INFORMATION message including the *NR-DL-TDOA-ProvideLocationInformation* IE within the response time (see clause 4.15.3). The UE shall perform and report the RSTD measurements for both Cell 2 and Cell 3 with respect to the reference cell in the DL-TDOA assistance data, Cell 1. If the UE transmits an *NR-DL-TDOA-ProvideLocationInformation* IE including the nr-RSTD field for both Cell 2 and Cell 3 within the response time then the number of successful tests is increased by one. If the UE fails to report the *NR-DL-TDOA-ProvideLocationInformation* IE with both the nr-RSTD fields included within the response time then the number of failure tests is increased by one.
11. If the UE message at step 10 includes the *ackRequested* IE set to TRUE, the SS shall send a LPP acknowledgement message.
12. Repeat steps 2-11 in Table 14.2.5.4-1 until the confidence level according to Annex D is achieved.

14.2.5.4.3 Message contents

Table 14.2.5.4.3-1: RESET UE POSITIONING STORED INFORMATION

Derivation Path: 38.509 [44] clause 6.6			
Information Element	Value/remark	Comment	Condition
UE Positioning Technology	0 0 0 0 1 1 1	DL-TDOA	

Table 14.2.5.4.3-2: LPP Request Capabilities

Information Element	Value/remark
nr-DL-TDOA-RequestCapabilities-r16	TRUE

Table 14.2.5.4.3-3: LPP RequestLocationInformation

Derivation Path: TS 37.355 [49] clause 6.2			
Information Element	Value/remark	Comment	Condition
LPP-Message ::= SEQUENCE {			
transactionID SEQUENCE {			
initiator	locationServer		
transactionNumber	1		
}			
endTransaction	FALSE		
sequenceNumber	Not present		
acknowledgement	Not present		
lpp-MessageBody CHOICE {			
c1 CHOICE {			
requestLocationInformation SEQUENCE {			
criticalExtensions CHOICE {			
c1 CHOICE {			
requestLocationInformation-r9 SEQUENCE {			
commonEsRequestLocationInformation SEQUENCE {			
locationInformationType	locationMeasurementsPreferred		
triggeredReporting	Not present		
periodicalReporting	Not present		
additionalInformation	onlyReturnInformationRequested		
}			
}			
}			
}			
}			
qos SEQUENCE {			
horizontalAccuracy	Not present		
verticalCoordinateRequest	FALSE		
verticalAccuracy	Not present		
responseTime SEQUENCE {			
time	See 14.2.5.5	Result of the response time calculation rounded	

		up to the next second	
responseTimeEarlyFix-r12	Not present		Rel-12 onwards
unit-r15	Not present		
}			
velocityRequest	FALSE		
}			
environment	Not present		
locationCoordinateTypes	Not present		
velocityTypes	Not present		
}			
a-gnss-RequestLocationInformation	Not present		
otdoa-RequestLocationInformation	Not present		
ecid-RequestLocationInformation	Not present		
epdu-RequestLocationInformation	Not Present		
sensor-RequestLocationInformation-r13	Not present		
tbs-RequestLocationInformation-r13	Not present		
wlan-RequestLocationInformation-r13	Not present		
bt-RequestLocationInformation-r13	Not present		
nr-ECID-RequestLocationInformation-r16	Not present		
nr-Multi-RTT-RequestLocationInformation-r16	Not present		
nr-DL-AoD-RequestLocationInformation-r16	Not present		
nr-DL-TDOA-RequestLocationInformation-r16			
SEQUENCE {			
nr-DL-PRS-RstdMeasurementInfoRequest-r16	Not present		
nr-RequestedMeasurements-r16	bit 0 = 0 (prsrsrpReq)		
nr-AssistanceAvailability-r16	FALSE		
nr-DL-TDOA-ReportConfig-r16 SEQUENCE {			
maxDL-PRS-RSTD-MeasurementsPerTRPPair-r16	Not present		
timingReportingGranularityFactor-r16	Not present		
measureSameDL-PRS-ResourceWithDifferentRxTEGs-r17	Not present		
reducedDL-PRS-ProcessingSamples-r17	requested		
lowerRxBeamSweepingFactor-FR2-r17	Not present		
}			
additionalPaths-r16	Not present		
nr-UE-RxTEG-Request-r17	Not present		
nr-los-nlos-IndicatorRequest-r17	Not present		
additionalPathsExt-r17	Not present		
additionalPathsDL-PRS-RSRP-Request-r17	Not present		
multiMeasInSameReport-r17	Not present		
}			
}			
}			
}			
}			
}			
}			

Table 14.2.5.4.3-4: LPP ProvideAssistanceData

Derivation Path: TS 37.355 [49] clause 6.2			
Information Element	Value/remark	Comment	Condition
LPP-Message ::= SEQUENCE {			
transactionID SEQUENCE {			
initiator	locationServer		
transactionNumber	(0..255)		
}			
endTransaction	TRUE		
sequenceNumber	Not present		
acknowledgement	Not present		

lpp-MessageBody CHOICE {			
c1 CHOICE {			
provideAssistanceData SEQUENCE {			
criticalExtensions CHOICE {			
c1 CHOICE {			
provideAssistanceData-r9 SEQUENCE {			
commonEsProvideAssistanceData	Not present		
a-gnss-ProvideAssistanceData	Not present		
otdoa-ProvideAssistanceData	Not present		
epdu-Provide-AssistanceData	Not present		
sensor-ProvideAssistanceData-r14	Not present		
tbs-ProvideAssistanceData-r14	Not present		
wlan-ProvideAssistanceData-r14	Not present		
nr-Multi-RTT-ProvideAssistanceData-r16	Not present		
nr-DL-AoD-ProvideAssistanceData-r16	Not present		
nr-DL-TDOA-ProvideAssistanceData-r16			
SEQUENCE {			
nr-DL-PRS-AssistanceData-r16	As defined in Table 14.2.5.4.3-5		
nr-SelectedDL-PRS-IndexList-r16	Not present		
nr-PositionCalculationAssistance-r16			Depending on UE capabilities, i.e. support for UE-based DL-TDOA
SEQUENCE {			
nr-TRP-LocationInfo-r16	As defined in TS 37.571-5 [20]		
nr-DL-PRS-BeamInfo-r16	Not present		
nr-RTD-Info-r16	Not present		
nr-TRP-BeamAntennaInfo-r17	Not present		
nr-DL-PRS-Expected-LOS-NLOS-Assistance-r17	Not present		
nr-DL-PRS-TRP-TEG-Info-r17	Not present		
}			
nr-DL-TDOA-Error-r16	Not present		
nr-On-Demand-DL-PRS-Configurations-r17	Not present		
nr-On-Demand-DL-PRS-Configurations-Selected-IndexList-r17	Not present		
assistanceDataValidityArea-r17	Not present		
}			
}			
}			
}			
}			
}			

Table 14.2.5.4.3-5: NR-DL-PRS-AssistanceData

Derivation Path: TS 37.355 [49] clause 6.4.3			
Information Element	Value/remark	Comment	Condition
NR-DL-PRS-AssistanceData-r16 ::= SEQUENCE {			
nr-DL-PRS-ReferenceInfo-r16 SEQUENCE {			
dl-PRS-ID-r16	0		
nr-DL-PRS-ResourceID-List-r16	Not present		
nr-DL-PRS-ResourceSetID-r16	Not present		
}			
nr-DL-PRS-AssistanceDataList-r16 SEQUENCE (SIZE (1..nrMaxFreqLayers-r16)) OF NR-DL-PRS-AssistanceDataPerFreq-r16 {	1 entry		
NR-DL-PRS-AssistanceDataPerFreq-r16[1]		entry 1	
SEQUENCE {			

nr-DL-PRS-PositioningFrequencyLayer-r16 SEQUENCE {			
dl-PRS-SubcarrierSpacing-r16	kHz15		Config 1 and Config 2
	kHz30		Config 3
dl-PRS-ResourceBandwidth-r16	21	104 PRBs	Config 1 and Config 2
	28	132 PRBs	Config 3
dl-PRS-StartPRB-r16	0		
dl-PRS-PointA-r16	absoluteFrequencyPointA as defined for the DL frequency of the Cell 1		
dl-PRS-CombSizeN-r16	n4		
dl-PRS-CyclicPrefix-r16	normal		
}			
nr-DL-PRS-AssistanceDataPerFreq-r16 SEQUENCE (SIZE (1..nrMaxTRPsPerFreq-r16)) OF NR-DL-PRS-AssistanceDataPerTRP-r16{	3 entries		
NR-DL-PRS-AssistanceDataPerTRP-r16[1] SEQUENCE {		entry 1	Cell 1
dl-PRS-ID-r16	0		
nr-PhysCellID-r16	Cell 1		
nr-CellGlobalID-r16	Cell 1		
nr-ARFCN-r16	Cell 1		
nr-DL-PRS-SFN0-Offset-r16 SEQUENCE {			
sfn-Offset-r16	0		
integerSubframeOffset-r16	0		
}			
nr-DL-PRS-ExpectedRSTD-r16	0		
nr-DL-PRS-ExpectedRSTD-Uncertainty-r16	0		
nr-DL-PRS-Info-r16	As specified in Table 14.2.1.4.3-6		
}			
NR-DL-PRS-AssistanceDataPerTRP-r16[2] SEQUENCE {		entry 2	Cell 2
dl-PRS-ID-r16	1		
nr-PhysCellID-r16	Cell 2		
nr-CellGlobalID-r16	Cell 2		
nr-ARFCN-r16	Cell 2		
nr-DL-PRS-SFN0-Offset-r16 SEQUENCE {			
sfn-Offset-r16	0		
integerSubframeOffset-r16	0		
}			
nr-DL-PRS-ExpectedRSTD-r16	23	About 3 μ s	
nr-DL-PRS-ExpectedRSTD-Uncertainty-r16	39	About 5 μ s	
nr-DL-PRS-Info-r16	As specified in Table 14.2.1.4.3-6		
}			
NR-DL-PRS-AssistanceDataPerTRP-r16[3] SEQUENCE {		entry 3	Cell 3
dl-PRS-ID-r16	2		
nr-PhysCellID-r16	Cell 3		
nr-CellGlobalID-r16 SEQUENCE {			
mcc-r15	Cell 3		
mnc-r15	Cell 3		
nr-cellidentity-r15	Cell 3		
}			
nr-ARFCN-r16	Cell 3		
nr-DL-PRS-SFN0-Offset-r16 SEQUENCE {			
sfn-Offset-r16	0		
integerSubframeOffset-r16	0		
}			
nr-DL-PRS-ExpectedRSTD-r16	23	About 3 μ s	
nr-DL-PRS-ExpectedRSTD-Uncertainty-r16	38	About 5 μ s	

nr-DL-PRS-Info-r16	As specified in Table 14.2.1.4.3-6		
}			
NR-DL-PRS-AssistanceDataPerTRP-r16[4-16]	As specified in TS 37.571-5 [20]		
}			
}			
}			
}			

Table 14.2.5.4.3-6: NR-DL-PRS-Info

Derivation Path: TS 37.355 [49] clause 6.4.3			
Information Element	Value/remark	Comment	Condition
NR-DL-PRS-Info-r16 ::= SEQUENCE {			
nr-DL-PRS-ResourceSetList-r16 SEQUENCE (SIZE (1..nrMaxSetsPerTrp-r16)) OF NR-DL-PRS-ResourceSet-r16 {	1 entry		
NR-DL-PRS-ResourceSet-r16[1] SEQUENCE {		entry 1	
nr-DL-PRS-ResourceSetID-r16	0		
dl-PRS-Periodicity-and-ResourceSetSlotOffset-r16 CHOICE {			
scs15-r16 CHOICE {			Config 1 and Config 2
n160-r16	10		
}			
scs30-r16 CHOICE {			Config 3
n160-r16	20		
}			
dl-PRS-ResourceRepetitionFactor-r16	Not present		
dl-PRS-ResourceTimeGap-r16	s1		
dl-PRS-NumSymbols-r16	n4		
dl-PRS-MutingOption1-r16 SEQUENCE {			
dl-prs-MutingBitRepetitionFactor-r16	Not present		
nr-option1-muting-r16 CHOICE {			
po2-r16	10		Cell 1 and Cell 3
	01		Cell 2
}			
}			
dl-PRS-MutingOption2-r16	Not present		
dl-PRS-ResourcePower-r16	27		
dl-PRS-ResourceList-r16 SEQUENCE (SIZE (1..nrMaxResourcesPerSet-r16)) OF NR-DL-PRS-Resource-r16 {	1 entry		
NR-DL-PRS-Resource-r16[1] SEQUENCE {		entry 1	
nr-DL-PRS-ResourceID-r16	0		
dl-PRS-SequenceID-r16	0		
dl-PRS-CombSizeN-AndReOffset-r16 CHOICE {			
n4-r16	0		Cell 1 and Cell 2
	1		Cell 3
}			
dl-PRS-ResourceSlotOffset-r16	4		
dl-PRS-ResourceSymbolOffset-r16	0		
dl-PRS-QCL-Info-r16	Not present		
}			
}			
}			
}			
}			

Table 14.2.5.4.3-7: LPP ProvideLocation Information

Derivation Path: TS 37.355 [49] clause 6.2			
Information Element	Value/remark	Comment	Condition
LPP-Message ::= SEQUENCE {			
transactionID SEQUENCE {			
initiator	locationServer		
transactionNumber	1		
}			
endTransaction	TRUE		
sequenceNumber	(0..255)		
acknowledgement			
lpp-MessageBody CHOICE {			
c1 CHOICE {			
provideLocationInformation SEQUENCE {			
criticalExtensions CHOICE {			
c1 CHOICE {			
provideLocationInformation-r9 SEQUENCE {			
commonIEsProvideLocationInformation	Not present.		
a-gnss-ProvideLocationInformation	Not present		
otdoa-ProvideLocationInformation	Not present		
ecid-ProvideLocationInformation	Not present		
epdu-ProvideLocationInformation	Not present		
sensor-ProvideLocationInformation-r13	Not present		
tbs-ProvideLocationInformation-r13	Not present		
wlan-ProvideLocationInformation-r13	Not present		
bt-ProvideLocationInformation-r13	Not present		
nr-ECID-ProvideLocationInformation-r16	Not present		
nr-Multi-RTT-ProvideLocationInformation-	Not present		
r16			
nr-DL-AoD-ProvideLocationInformation-r16	Not present		
nr-DL-TDOA-ProvideLocationInformation-			
r16 SEQUENCE {			
nr-DL-TDOA-			
SignalMeasurementInformation-r16 SEQUENCE {			
dl-PRS-ReferenceInfo-r16			
nr-DL-TDOA-MeasList-r16 SEQUENCE	3 entries		
(SIZE(1..nrMaxTRPs-r16)) OF NR-DL-TDOA-			
MeasElement-r16 {			
NR-DL-TDOA-MeasElement-r16[1]		entry 1	
SEQUENCE {			
dl-PRS-ID-r16			
nr-PhysCellID-r16	Cell 1		
nr-CellGlobalID-r16			
nr-ARFCN-r16			
nr-DL-PRS-ResourceID-r16			
nr-DL-PRS-ResourceSetID-r16			
nr-TimeStamp-r16			
nr-RSTD-r16	Present		
nr-AdditionalPathList-r16			
nr-TimingQuality-r16			
nr-DL-PRS-RSRP-Result-r16			
nr-DL-TDOA-AdditionalMeasurements-			
r16			
nr-UE-Rx-TEG-ID-r17			
nr-DL-PRS-FirstPathRSRP-Result-r17			
nr-los-nlos-Indicator-r17			
nr-AdditionalPathListExt-r17			
nr-DL-TDOA-			
AdditionalMeasurementsExt-r17			
}			
NR-DL-TDOA-MeasElement-r16[2]		entry 2	
SEQUENCE {			
dl-PRS-ID-r16			
nr-PhysCellID-r16	Cell 2		
nr-CellGlobalID-r16			

nr-ARFCN-r16			
nr-DL-PRS-ResourceID-r16			
nr-DL-PRS-ResourceSetID-r16			
nr-TimeStamp-r16			
nr-RSTD-r16	Present		
nr-AdditionalPathList-r16			
nr-TimingQuality-r16			
nr-DL-PRS-RSRP-Result-r16			
nr-DL-TDOA-AdditionalMeasurements-			
r16			
nr-UE-Rx-TEG-ID-r17			
nr-DL-PRS-FirstPathRSRP-Result-r17			
nr-los-nlos-Indicator-r17			
nr-AdditionalPathListExt-r17			
nr-DL-TDOA-			
AdditionalMeasurementsExt-r17			
}			
NR-DL-TDOA-MeasElement-r16[3]		entry 3	
SEQUENCE {			
dl-PRS-ID-r16			
nr-PhysCellID-r16	Cell 3		
nr-CellGlobalID-r16			
nr-ARFCN-r16			
nr-DL-PRS-ResourceID-r16			
nr-DL-PRS-ResourceSetID-r16			
nr-TimeStamp-r16			
nr-RSTD-r16	Present		
nr-AdditionalPathList-r16			
nr-TimingQuality-r16			
nr-DL-PRS-RSRP-Result-r16			
nr-DL-TDOA-AdditionalMeasurements-			
r16			
nr-UE-Rx-TEG-ID-r17			
nr-DL-PRS-FirstPathRSRP-Result-r17			
nr-los-nlos-Indicator-r17			
nr-AdditionalPathListExt-r17			
nr-DL-TDOA-			
AdditionalMeasurementsExt-r17			
}			
}			
nr-UE-RxTEG-TimingErrorMargin-r17			
}			
nr-dl-tdoa-LocationInformation-r16			
nr-DL-TDOA-Error-r16			
nr-DL-TDOA-			
SignalMeasurementInstances-r17			
nr-DL-TDOA-			
LocationInformationInstances-r17			
}			
}			
}			
}			
}			
}			

14.2.5.5 Test requirement

Table 14.2.5.5-1, Table 14.2.5.5-2 and Table 14.2.5.5-3 define the primary level settings including test tolerances for the test.

Table 14.2.5.5-1: General test parameters for RSTD measurement reporting delay

Parameter	Unit	Value	Comment
-----------	------	-------	---------

Reference cell			Cell 1	Reference cell is the cell in the DL-TDOA assistance data with respect to which the RSTD measurement is defined, as specified in TS 38.215 [4] and TS 37.355 [34]. The reference cell is the PCell in this test case.
Neighbor cells			Cell 2 and Cell 3	Cell 2 and Cell 3 appear at the first and second places in the neighbour cell list in the DL-TDOA assistance data.
SSB configuration	Config 1		SSB.1 FR1	
	Config 2		SSB.1 FR1	
	Config 3		SSB.2 FR1	
SMTC configuration	Config 1		SMTC.2	
	Config 2		SMTC.1	
	Config 3		SMTC.1	
PDSCH RMC configuration	Config 1		SR.1.1 FDD	
	Config 2		SR.1.1 TDD	
	Config 3		SR.2.1 TDD	
RMSI CORESET RMC configuration	Config 1		CR.1.1 FDD	As specified in clause A.3.1.2.1
	Config 2		CR.1.1 TDD	
	Config 3		CR.2.1 TDD	
Dedicated CORESET RMC configuration	Config 1		CR.1.1 FDD	
	Config 2		CR.1.1 TDD	
	Config 3		CR.2.1 TDD	
Initial BWP configuration	Config 1,2,3		DLBWP.0.1 ULBWP.0.1	
Active DL BWP configuration	Config 1,2,3		DLBWP.1.1	
Active UL BWP configuration	Config 1,2,3		ULBWP.1.1	
PRS Configuration	Config 1		PRS.1.2 FR1	As specified in clause A.3.31
	Config 2		PRS.1.2 FR1	
	Config 3		PRS.2.2 FR1	
Physical cell ID PCI			(PCI of Cell 1 – PCI of Cell 2)mod6=0 and (PCI of Cell 1 – PCI of Cell 3)mod6=0	The cell PCIs are selected such that the relative shifts of PRS patterns among cells are as given by the test parameters
CP length			Normal	
DRX			OFF	
Measurement gap			GP#24 or GP#0	GP#24 is configured if UE supports MG#24, otherwise GP#0 is configured
Radio frame receive time offset between the cells at the UE antenna connector	µs		Cell 2 to Cell 1: 0 Cell 3 to Cell 1: 3	PRS are transmitted from synchronous cells
Expected RSTD	µs		Cell 2: 3 Cell 3: 3 Other neighbour cells: randomly between -3 and 3	The expected RSTD is what is expected at the receiver. The corresponding parameter in the DL-TDOA assistance data specified in TS 37.355 [34] is the expectedRSTD indicator
Expected RSTD uncertainty for all neighbour cells	µs		5	The corresponding parameter in the DL-TDOA assistance data specified in TS 37.355 [34] is the expectedRSTD-Uncertainty index

Number of cells provided in DL-TDOA assistance data		4	Including the reference cell
PRS muting info		Cell 1: '10' Cell 2: '01' Cell 3: '10'	Corresponds to prs-MutingInfo defined in TS 37.355 [34]
PRS resource RE offset		Cell 1: 0 Cell 2: 0 Cell 3: 1	Cell 1 and Cell 3 are configured with different resource offsets
T1	s	3	The length of the time interval from the beginning of each test
T2	s	1.28	The length of the time interval that follows immediately after time interval T1

Table 14.2.5.5-2: Cell-specific test parameters for RSTD measurement reporting delay during T1

Parameter		Unit	Cell 1	Cell 2	Cell 3
NR RF Channel Number			1	1	1
Positioning frequency layer			1	1	1
Correlation Matrix and Antenna Configuration			1x2 Low	1x2 Low	1x2 Low
OCNG patterns defined in A.3.2.1			OP.1	N/A	N/A
N_{oc} ^{Note 3}	Config 1	dBm/SCS	-98		
	Config 2	dBm/SCS	-98		
	Config 3	dBm/SCS	-95		
PRS \hat{E}_s/N_{oc}		dB	-Infinity	-Infinity	-Infinity
SSB \hat{E}_s/N_{oc}		dB	10	-Infinity	-Infinity
I_o ^{Note 4}	Config 1	dBm/19.08MHz	-56.54+TT	-56.54+TT	-56.54+TT
	Config 2	dBm/19.08MHz	-56.54+TT	-56.54+TT	-56.54+TT
	Config 3	dBm/47.88MHz	-52.56+TT	-52.56+TT	-52.56+TT
SSB RP ^{Note4}	Config 1	dBm/SCS	-88+TT	-Infinity	-Infinity
	Config 2	dBm/SCS	-88+TT	-Infinity	-Infinity
	Config 3	dBm/SCS	-88+TT	-Infinity	-Infinity
Propagation Condition			AWGN		
<p>Note 1: OCNG shall be used such that active cell (Cell 1) is fully allocated and a constant total transmitted power spectral density is achieved for all OFDM symbols.</p> <p>Note 2: The resources for uplink transmission are assigned to the UE prior to the start of time period T2.</p> <p>Note 3: Interference from other cells and noise sources not specified in the test are assumed to be constant over subcarriers and time and shall be modelled as AWGN of appropriate power for N_{oc} to be fulfilled.</p> <p>Note 4: SSB RP and I_o levels have been derived from other parameters and are given for information purpose. These are not settable test parameters.</p>					

Table 14.2.5.5-2: Cell-specific test parameters for RSTD measurement reporting delay during T2

Parameter	Unit	Cell 1	Cell 2	Cell 3
		T2	T2	T2
NR RF Channel Number		1	1	1
Correlation Matrix and Antenna Configuration		1x2 Low	1x2 Low	1x2 Low
OCNG patterns defined in A.3.2.1		OP.1	OP.1	OP.1

PRACH configuration			FR1 PRACH configuration 1	FR1 PRACH configuration 1	FR1 PRACH configuration 1
N_{oc} Note 3	Config 1	dBm/SCS	-98	-98	-98
	Config 2	dBm/SCS	-98	-98	-98
	Config 3	dBm/SCS	-95	-95	-95
PRS \hat{E}_s/N_{oc}	Config 1	dB	1	-1.2	-1.2
	Config 2	dB	1	-1.2	-1.2
	Config 3	dB	1	-1.2	-1.2
I_0 Note 4	Config 1	dBm/19.08MHz	-61.18+TT	-61.18+TT	-61.18+TT
	Config 2	dBm/19.08MHz	-61.18+TT	-61.18+TT	-61.18+TT
	Config 3	dBm/47.88MHz	-57.20+TT	-57.20+TT	-57.20+TT
PRS \hat{E}_s/I_{ot}		dB	-3	-6	-6
Propagation Condition			AWGN		
<p>Note 1: OCNG shall be used such that active cells (all, except Cell 3 in T3) are fully allocated and a constant total transmitted power spectral density is achieved for all OFDM symbols other than those in the subframes with transmitted PRS.</p> <p>Note 2: The resources for uplink transmission are assigned to the UE prior to the start of time period T2.</p> <p>Note 3: Interference from other cells and noise sources not specified in the test are assumed to be constant over subcarriers and time and shall be modelled as AWGN of appropriate power for N_{oc} to be fulfilled.</p>					

The RSTD measurement time fulfils the requirements specified in clause 14.2.5.3.

The test tolerances are FFS

14.2.6 NR RSTD measurement reporting delay test case for single positioning frequency layer without measurement gap in FR1 SA

Editor's Note: This test case has been completed for the following configurations:

- Test tolerance is missing

14.2.6.1 Test purpose

The purpose of the test is to verify that the RSTD measurement meets the gapless RSTD measurement period requirement specified in TS 38.133[50] Clause 9.9.2.7 in an environment with AWGN propagation conditions in FR1 in standalone scenario when single positioning frequency layer is configured.

14.2.6.2 Test applicability

This test applies to all types of NR UE release 17 onwards that supports DL-TDOA positioning and prs-Processing Window.

14.2.6.3 Minimum conformance requirements

When physical layer receives last of *NR-DL-TDOA-ProvideAssistanceData* message and *NR-DL-TDOA-RequestLocationInformation* message from LMF via LPP [34], the UE shall be able to measure multiple (up to the UE capability specified in TS 38.133[50] Clause 9.9.2.3) DL RSTD measurements, defined in TS 38.215 [4], during the measurement period $T_{RSTD,Total}$ defined as:

$T_{RSTD,Total} = \sum_{i=1}^L T_{RSTD,wo_gap,i} + (L - 1) * \max(T_{effect,i})$, if any of the positioning frequency layers are in Case 1, or

$T_{\text{RSTD,Total}} = \max(T_{\text{RSTD_wo_gap},i} + T_{\text{uncertainty},i})$, if all the positioning frequency layers are in Case 2,

Where,

i is the index of positioning frequency layer, and

L is total number of positioning frequency layers, and

$T_{\text{effect},i}$ is the periodicity of the PRS RSTD measurement in positioning frequency layer i , and

$T_{\text{uncertainty},i}$ is the time from the start of the first PPW occasion for positioning frequency layer i to the start of measurement period $T_{\text{RSTD,Total}}$.

A positioning frequency layer is in Case 1 if UE reports *ppw-durationOfPRS-Processing1-r17* for the band containing the positioning frequency layer, and a positioning frequency layer is in Case 2 if UE reports *ppw-durationOfPRS-Processing2-r17* for the band containing the positioning frequency layer.

$T_{\text{RSTD_wo_gap},i}$ is the measurement period for PRS RSTD measurement in positioning frequency layer i as specified below.

$$T_{\text{RSTD_wo_gap},i} = \left(k_{\text{multiTEG},i} * N_{\text{RxBeam},i} * \left\lceil \frac{N_{\text{PRS},i}^{\text{slot}}}{N'} \right\rceil \left\lfloor \frac{L_{\text{available_PRS},i}}{N} \right\rfloor * N_{\text{sample}} - 1 \right) * T_{\text{effect},i} + T_{\text{last},i},$$

where:

$N_{\text{RxBeam},i}$ is the UE Rx beam sweeping factor. In FR1, $N_{\text{RxBeam},i} = 1$; and in FR2, $N_{\text{RxBeam},i}$ is equal to the value reported by the UE in *supportedLowerRxBeamSweepingFactor-FR2* if the UE supports the capability for the band containing positioning frequency layer i , and the LMF indicates *lowerRxBeamSweepingFactor-FR2* in *NR-DL-TDOA-RequestLocationInformation*. $N_{\text{RxBeam},i}$ is equal to 8, otherwise.

$k_{\text{multiTEG},i}$ is the scaling factor for measurement of same PRS resource with multiple Rx TEGs.

$k_{\text{multiTEG},i} = 1$ if UE is not supported *measureSameDL-PRS-ResourceWithDifferentRxTEGs-r17* or not requested by LMF to measure a PRS resource with multiple Rx TEGs via *measureSameDL-PRS-ResourceWithDifferentRxTEGs-r17* [34] in *NR-DL-TDOA-RequestLocationInformation*;

otherwise,

$k_{\text{multiTEG},i} = N_{\text{TEG},i}$, if the UE is not capable of receiving same DL PRS resource simultaneously from multiple Rx TEGs, and

$k_{\text{multiTEG},i} = \left\lfloor \frac{N_{\text{TEG},i}}{k_{\text{TEG},\text{simul},i}} \right\rfloor$ if the UE is capable of receiving the same DL PRS resource simultaneously from multiple Rx TEGs.

where

$N_{\text{TEG},i}$ is the number of Rx TEGs with which UE is requested to measure a PRS resource indicated via *measureSameDL-PRS-ResourceWithDifferentRxTEGs-r17* [34] in *NR-DL-TDOA-RequestLocationInformation*, and in case 'n0' is indicated, $N_{\text{TEG},i}$ is the maximum number of Rx TEGs with which UE can support to measure the same PRS resource as reported in *NR-UE-TEG-Capability*, and

$k_{\text{TEG},\text{simul},i}$ is the number of Rx TEGs UE can measure simultaneously which is reported via *measureSameDL-PRS-ResourceWithDifferentRxTEGsSimul*.

$N_{\text{PRS},i}^{\text{slot}}$ is the maximum number of DL PRS resources in positioning frequency layer i configured in a slot.

$L_{\text{available_PRS},i}$ is the time duration of available PRS in the positioning frequency layer i to be measured during $T_{\text{available_PRS},i}$, and is calculated in the same way as PRS duration K defined in clause 5.1.6.5 of TS 38.214 [26].

For calculation of $L_{\text{available_PRS},i}$,

only the PRS resources unmuted and fully or partially overlapped with PPW are considered, if positioning frequency layer i is in Case 1, or

only the PRS resources unmuted and fully or partially overlapped with the first (PPWL-T2) ms of PPW are considered, if positioning frequency layer i is in Case 2, where PPWL is the PPW length and T2 corresponds to $ppw\text{-}durationOfPRS\text{-}ProcessingSymbolsT2$.

N_{sample} is the number of PRS RSTD measurement samples, where

- $N_{sample} = 1$ if the UE supports *supportedDL-PRS-ProcessingSamples-RRC-CONNECTED* [34], and the LMF requests the UE to perform positioning measurements with reduced number of samples, and meets the following conditions:
 - PRS bandwidth is within the active BWP and
 - Magnitude of difference between the serving cell's SS-RSRP and the neighbour cell's PRS-RSRP is within 6 dB.
- $N_{sample} = 2$ if the UE supports *supportedDL-PRS-ProcessingSamples-RRC-CONNECTED* [34], and the LMF requests the UE to perform positioning measurements with reduced number of samples, and does not meet the following conditions:
 - PRS bandwidth is within the active BWP and
 - Magnitude of difference between the serving cell's SS-RSRP and the neighbour cell's PRS-RSRP is within 6 dB.

$T_{last,i}$ is the measurement duration for the last PRS RSTD sample in positioning frequency layer i , including the sampling time and processing time.

If positioning frequency layer i is in Case 1 and all of the PRS resources to be measured are available in the same PPW occasion during $T_{available}$, then $T_{last,i} = T_i + PPWL$, else

if positioning frequency layer i is in Case 2 and all of the PRS resources to be measured are available in the same PPW occasion during $T_{available}$, then $T_{last,i} = PPWL$;

otherwise, $T_{last,i} = T_i + T_{available_PRS,i}$.

$T_{effect,i}$ is the periodicity of the PRS RSTD measurement in positioning frequency layer i defined as:

$$T_{effect,i} = \left\lceil \frac{T_i}{T_{available_PRS,i}} \right\rceil * T_{available_PRS,i}$$

Where,

T_i corresponds to $ppw\text{-}durationOfPRS\text{-}ProcessingSymbolsT$ in TS 37.355 [34] if positioning frequency layer i is in Case 1, or corresponds to the sum of $ppw\text{-}durationOfPRS\text{-}ProcessingSymbolsT2$ and $ppw\text{-}durationOfPRS\text{-}ProcessingSymbolsN2$ in TS 37.355 [34] if positioning frequency layer i is in Case 2,

$T_{available_PRS,i} = LCM(T_{PRS,i}, PPWRP_i)$, the least common multiple between $T_{PRS,i}$ and $PPWRP_i$.

$PPWRP_i$ is the repetition periodicity of the PRS processing window applicable for measurements in the positioning frequency layer i .

$T_{PRS,i}$ is the periodicity of DL PRS resource with muting on positioning frequency layer i .

If more than one PRS periodicities are configured in positioning frequency layer i , the least common multiple of PRS periodicities $T_{per}^{PRS\text{ with muting}}$ among all DL PRS resource sets in the positioning frequency layer is used to derive $T_{PRS,i}$, where,

$T_{per}^{PRS\text{ with muting}} = N_{muting} * T_{per}^{PRS}$, is the PRS periodicity with muting per PRS resource,

T_{per}^{PRS} is the periodicity of PRS resource sets given by the higher-layer parameter *DL-PRS-Periodicity*,

N_{muting} is the scaling factor considering PRS resource muting. $N_{muting} = T_{muting}^{PRS} * L_{muting}$, where T_{muting}^{PRS} is the muting repetition factor given by the higher-layer parameter *DL-PRS-MutingBitRepetitionFactor*, and L_{muting} is the size of the bitmap $\{b^1\}$.

Note: For the purpose of calculating $T_{PRS,i}$, only the PRS resources that meet the conditions for PRS measurement outside measurement gaps as defined in clause TS 38.133[50] 9.9.1.2 are considered.

N is a duration of DL PRS symbols in ms corresponding to *ppw-durationOfPRS-ProcessingSymbolsN* in TS 37.355 [34] if positioning frequency layer i is in Case 1, or corresponding to *ppw-durationOfPRS-ProcessingSymbolsN2* in TS 37.355 [34] if positioning frequency layer i is in Case 2.

N' is UE capability for number of DL PRS resources that it can process in a slot as indicated by *ppw-maxNumOfDL-PRS-ResProcessedPerSlot* specified in TS 37.355 [34].

14.2.6.4 Test description

14.2.6.4.1 Initial conditions

The supported test configurations in listed in Table 14.2.6.4-1.

Table 14.2.6.4-1: Test Configurations

Configuration	Description
1	15 kHz SSB SCS, 20 MHz bandwidth, FDD duplex mode
2	15 kHz SSB SCS, 20 MHz bandwidth, TDD duplex mode
3	30 kHz SSB SCS, 50 MHz bandwidth, TDD duplex mode
Note:	The UE is only required to be tested in one of the supported test configurations.

Test Environment: Normal, as defined in TS 38.508-1 [45] clause 4.1.

Frequencies to be tested: Mid Range, as defined in TS 38.508-1 [45] clause 4.3.1.

Channel bandwidth to be tested: are specified in Table 14.2.6.4-1.

1. Connect the SS and AWGN noise sources to the UE antenna connector or antenna connectors as shown in Annex A, Figure A.12.
2. The general test parameter settings are set up according to Table 14.2.6.5-1, Table 14.2.6.5-2 and Table 14.2.6.5-3.
3. Propagation conditions are set according to clause 4.15.2.
4. Message contents are defined in clause 14.2.6.4.3.
5. In the test there are three synchronous cells: Cell 1, Cell 2 and Cell 3. Cell 1 is the reference as well as the PCell. Cell 2 and Cell 3 are the neighbour cells. All cells are on the same RF channel distributed in single positioning frequency layer.

14.2.6.4.2 Test procedure

The test consists of two sub-tests; Sub-test 1 is for $N_{\text{sample}} = 4$ and sub-test 2 is for $N_{\text{sample}} = 1$. Sub-test 2 is only conducted when UE also supporting supported DL-PRS-ProcessingSamples-RRC-CONNECTED. The test consists of two consecutive time intervals, with duration of T1 and T2. During time duration T1, the UE shall not have any timing information of Cell 2 and Cell 3. All three cells transmit PRS during T2. The beginning of the time interval T2 shall be aligned with the beginning of the first PRS processing window instance containing the PRS resources.

The *NR-DL-TDOA-ProvideAssistanceData* and *nr-DL-TDOA-RequestLocationInformation* as defined in TS 37.355 [49] clause 6.5.12.1, shall be provided to the UE during T1. The last TTI containing the two messages shall be provided to the UE ΔT ms before the start of T2, where $\Delta T = 50$ ms is the maximum processing time of the *DL-TDOA assistance* data and location information request.

2. Ensure the UE is in State RRC_CONNECTED with generic procedure parameters Connectivity NR, Connected without release On, according to TS 38.508-1 [45] clause 4.5.
2. The SS shall send a RESET UE POSITIONING STORED INFORMATION message.

3. Set the parameters according to Table 14.2.6.5-1, Table 14.2.6.5-2 and Table 14.2.6.5-3. Propagation conditions are set according to clause 4.15.2.
 4. T1 starts.
 5. The SS shall transmit an LPP REQUEST CAPABILITIES message.
 6. The UE shall transmit an LPP PROVIDE CAPABILITIES message indicating the DL-TDOA capabilities supported by the UE in the *NR-DL-TDOA-ProvideCapabilities* IE.
 7. The SS shall transmit an RRCReconfiguration message with the PPW configuration.
 8. The UE shall transmit RRCReconfigurationComplete message.
 9. The SS shall send a LPP PROVIDE ASSISTANCE DATA message, including the *NR-DL-TDOA-ProvideAssistanceData* IE. The position of neighbour Cell 2 and the position of neighbour Cell 3 are described in 3GPP TS 37.571-5 [20]. If the UE message at step 6 includes the *ackRequested* IE set to TRUE, then the SS shall send an acknowledgment in the LPP PROVIDE ASSISTANCE DATA message.
 10. The SS shall send a LPP REQUEST LOCATION INFORMATION message, including the *NR-DL-TDOA-RequestLocationInformation* IE such that the UE receives the message ΔT ms before the start of T2, where $\Delta T = 50$ ms.
 11. The SS sends a Positioning Measurement Gap Activation command containing an ID to activate the associated measurement gap
 12. When T1 expires, the SS shall switch the power setting from T1 to T2 as specified in Table 14.2.6.5-2 and Table 14.2.6.5-3.
 13. The UE shall transmit a LPP PROVIDE LOCATION INFORMATION message including the *NR-DL-TDOA-ProvideLocationInformation* IE within the response time (see clause 4.15.3). The UE shall perform and report the RSTD measurements for both Cell 2 and Cell 3 with respect to the reference cell in the DL-TDOA assistance data, Cell 1. If the UE transmits an *NR-DL-TDOA-ProvideLocationInformation* IE including the *nr-RSTD* field for both Cell 2 and Cell 3 within the response time, then the number of successful tests is increased by one. If the UE fails to report the *NR-DL-TDOA-ProvideLocationInformation* IE with the *nr-RSTD* fields included within the response time then the number of failure tests is increased by one.
 14. If the UE message at step 13 includes the *ackRequested* IE set to TRUE, the SS shall send a LPP acknowledgement message.
 15. Repeat steps 2-14 in Table 14.2.6.4-1 until the confidence level according to Annex D is achieved.
- If all (applicable) sub-tests pass, the whole test passes. If one (applicable) sub-test fails, the whole test fails.

14.2.6.4.3 Message contents

Table 14.2.6.4.3-1: RESET UE POSITIONING STORED INFORMATION

Derivation Path: 38.509 [44] clause 6.6			
Information Element	Value/remark	Comment	Condition
UE Positioning Technology	0 0 0 0 1 1 1	DL-TDOA	

Table 14.2.6.4.3-2: LPP Request Capabilities

Information Element	Value/remark
nr-DL-TDOA-RequestCapabilities-r16	TRUE

Table 14.6.9.4.3-3: RRCReconfiguration

Derivation Path: TS 38.508-1 [45], table 4.6.1-13			
Information Element	Value/remark	Comment	Condition
RRCReconfiguration ::= SEQUENCE {			

rrc-TransactionIdentifier	RRC-TransactionIdentifier		
criticalExtensions CHOICE {			
rrcReconfiguration SEQUENCE {			
nonCriticalExtension SEQUENCE {			
masterCellGroup	OCTET STRING (CONTAINING CellGroupConfig)		
}			
}			
}			
}			

Table 14.2.6.4.3-4: CellGroupConfig (RRCReconfiguration, Table 14.2.9.4.3-3)

Derivation Path: 38.508-1 [45], Table 4.6.3-19			
Information Element	Value/remark	Comment	Condition
CellGroupConfig ::= SEQUENCE {			
spCellConfig SEQUENCE {			
spCellConfigDedicated SEQUENCE {			
initialDownlinkBWP SEQUENCE {			
dl-PPW-PreConfigToAddModList-r17 SEQUENCE (SIZE (1..maxNrofPPW-Config-r17)) OF DL-PPW-PreConfig-r17 {	1 entry		
DL-PPW-PreConfig-r17[1] SEQUENCE {		entry 1	
dl-PPW-ID-r17	0		
dl-PPW-PeriodicityAndStartSlot-r17 CHOICE {	The periodicity is 160ms and the starting slot offset is 11 ms for any SCS configuration		
scs15-r16 CHOICE {			Config 1 and Config 2
n160-r16	10		
}			
scs30-r16 CHOICE {			Config 3
n320-r16	20		
}			
}			
length-r17	10		
type-r17	type1A		
priority-r17	st1		
}			
}			
}			
}			
}			
}			

Table 14.2.6.4.3-5: LPP RequestLocationInformation

Derivation Path: TS 37.355 [49] clause 6.			
Information Element	Value/remark	Comment	Condition
LPP-Message ::= SEQUENCE {			
transactionID SEQUENCE {			
initiator	locationServer		
transactionNumber	1		
}			
endTransaction	FALSE		
sequenceNumber	Not present		
acknowledgement	Not present		
lpp-MessageBody CHOICE {			
c1 CHOICE {			

requestLocationInformation SEQUENCE {			
criticalExtensions CHOICE {			
c1 CHOICE {			
requestLocationInformation-r9 SEQUENCE {			
commonEsRequestLocationInformation SEQUENCE {			
locationInformationType	locationMeasurementsPreferred		
triggeredReporting	Not present		
periodicalReporting	Not present		
additionalInformation	onlyReturnInformationRequested		
qos SEQUENCE {			
horizontalAccuracy	Not present		
verticalCoordinateRequest	FALSE		
verticalAccuracy	Not present		
responseTime SEQUENCE {			
time	See 14.2.6.5	Result of the response time calculation rounded up to the next second	
responseTimeEarlyFix-r12	Not present		Rel-12 onwards
unit-r15	Not present		
ten-seconds			Calculated response time >128s
}			
velocityRequest	FALSE		
}			
environment	Not present		
locationCoordinateTypes	Not present		
velocityTypes	Not present		
}			
a-gnss-RequestLocationInformation	Not present		
otdoa-RequestLocationInformation	Not present		
ecid-RequestLocationInformation	Not present		
epdu-RequestLocationInformation	Not Present		
sensor-RequestLocationInformation-r13	Not present		
tbs-RequestLocationInformation-r13	Not present		
wlan-RequestLocationInformation-r13	Not present		
bt-RequestLocationInformation-r13	Not present		
nr-ECID-RequestLocationInformation-r16	Not present		
nr-Multi-RTT-RequestLocationInformation-r16	Not present		
nr-DL-AoD-RequestLocationInformation-r16	Not present		
nr-DL-TDOA-RequestLocationInformation-r16			
SEQUENCE {			
nr-DL-PRS-RstdMeasurementInfoRequest-r16	Not present		
nr-RequestedMeasurements-r16	bit 0 = 0 (prsrsrpReq)		
nr-AssistanceAvailability-r16	FALSE		
nr-DL-TDOA-ReportConfig-r16 SEQUENCE {			
maxDL-PRS-RSTD-MeasurementsPerTRPPair-r16	Not present		
timingReportingGranularityFactor-r16	Not present		
measureSameDL-PRS-ResourceWithDifferentRxTEGs-r17	Not present		
reducedDL-PRS-ProcessingSamples-r17	Not present		Sub-test 1
requested			Sub-test 2
lowerRxBeamSweepingFactor-FR2-r17	Not present		
}			
additionalPaths-r16	Not present		
nr-UE-RxTEG-Request-r17	Not present		
nr-los-nlos-IndicatorRequest-r17	Not present		
additionalPathsExt-r17	Not present		

additionalPathsDL-PRS-RSRP-Request-r17	Not present		
multiMeasInSameReport-r17	Not present		
}			
}			
}			
}			
}			
}			
}			

Table 14.2.6.4.3-6: LPP ProvideAssistanceData

Derivation Path: TS 37.355 [49] clause 6.2			
Information Element	Value/remark	Comment	Condition
LPP-Message ::= SEQUENCE {			
transactionID SEQUENCE {			
initiator	locationServer		
transactionNumber	(0..255)		
}			
endTransaction	TRUE		
sequenceNumber	Not present		
acknowledgement	Not present		
lpp-MessageBody CHOICE {			
c1 CHOICE {			
provideAssistanceData SEQUENCE {			
criticalExtensions CHOICE {			
c1 CHOICE {			
provideAssistanceData-r9 SEQUENCE {			
commonEsProvideAssistanceData	Not present		
a-gnss-ProvideAssistanceData	Not present		
otdoa-ProvideAssistanceData	Not present		
epdu-Provide-AssistanceData	Not present		
sensor-ProvideAssistanceData-r14	Not present		
tbs-ProvideAssistanceData-r14	Not present		
wlan-ProvideAssistanceData-r14	Not present		
nr-Multi-RTT-ProvideAssistanceData-r16	Not present		
nr-DL-AoD-ProvideAssistanceData-r16	Not present		
nr-DL-TDOA-ProvideAssistanceData-r16			
SEQUENCE {			
nr-DL-PRS-AssistanceData-r16	As defined in Table 14.2.6.4.3-5		
nr-SelectedDL-PRS-IndexList-r16	Not present		
nr-PositionCalculationAssistance-r16			Depending on UE capabilities, i.e. support for UE-based DL-TDOA
nr-TRP-LocationInfo-r16	As defined in TS 37.571-5 [20]		
nr-DL-PRS-BeamInfo-r16	Not present		
nr-RTD-Info-r16	Not present		
nr-TRP-BeamAntennaInfo-r17	Not present		
nr-DL-PRS-Expected-LOS-NLOS-Assistance-r17	Not present		
nr-DL-PRS-TRP-TEG-Info-r17	Not present		
}			
nr-DL-TDOA-Error-r16	Not present		
nr-On-Demand-DL-PRS-Configurations-r17	Not present		
nr-On-Demand-DL-PRS-Configurations-Selected-IndexList-r17	Not present		
assistanceDataValidityArea-r17	Not present		
}			
}			
}			
}			

}			
}			
}			
}			
}			

Table 14.2.6.4.3-7: NR-DL-PRS-AssistanceData

Derivation Path: 37.355 clause 6.4.3			
Information Element	Value/remark	Comment	Condition
NR-DL-PRS-AssistanceData-r16 ::= SEQUENCE {			
nr-DL-PRS-ReferenceInfo-r16 SEQUENCE {			
dl-PRS-ID-r16	0		
nr-DL-PRS-ResourceID-List-r16	Not present		
nr-DL-PRS-ResourceSetID-r16	Not present		
}			
nr-DL-PRS-AssistanceDataList-r16 SEQUENCE (SIZE (1..nrMaxFreqLayers-r16)) OF NR-DL-PRS-AssistanceDataPerFreq-r16 {	1 entry		
NR-DL-PRS-AssistanceDataPerFreq-r16[1] SEQUENCE {		entry 1	
nr-DL-PRS-PositioningFrequencyLayer-r16 SEQUENCE {			
dl-PRS-SubcarrierSpacing-r16	kHz15		Config 1 and Config 2
	kHz30		Config 3
dl-PRS-ResourceBandwidth-r16	21	104 PRBs	Config 1 and Config 2
	28	132 PRBs	Config 3
dl-PRS-StartPRB-r16	0		
dl-PRS-PointA-r16	absoluteFrequencyPointA as defined for the DL frequency of the Cell 1		
dl-PRS-CombSizeN-r16	n4		
dl-PRS-CyclicPrefix-r16	normal		
}			
nr-DL-PRS-AssistanceDataPerFreq-r16 SEQUENCE (SIZE (1..nrMaxTRPsPerFreq-r16)) OF NR-DL-PRS-AssistanceDataPerTRP-r16{	3 entries		
NR-DL-PRS-AssistanceDataPerTRP-r16[1] SEQUENCE {		entry 1	Cell 1
dl-PRS-ID-r16	0		
nr-PhysCellID-r16	Cell 1		
nr-CellGlobalID-r16	Cell 1		
nr-ARFCN-r16	Cell 1		
nr-DL-PRS-SFN0-Offset-r16 SEQUENCE {			
sfn-Offset-r16	0		
integerSubframeOffset-r16	0		
}			
nr-DL-PRS-ExpectedRSTD-r16	0		
nr-DL-PRS-ExpectedRSTD-Uncertainty-r16	0		
nr-DL-PRS-Info-r16	As specified in Table 14.2.6.4.3-6		
}			
NR-DL-PRS-AssistanceDataPerTRP-r16[2] SEQUENCE {		entry 2	Cell 2
dl-PRS-ID-r16	1		
nr-PhysCellID-r16	Cell 2		
nr-CellGlobalID-r16	Cell 2		
nr-ARFCN-r16	Cell 2		
nr-DL-PRS-SFN0-Offset-r16 SEQUENCE {			
sfn-Offset-r16	0		
integerSubframeOffset-r16	0		

}			
nr-DL-PRS-ExpectedRSTD-r16	0		
nr-DL-PRS-ExpectedRSTD-Uncertainty-r16	As specified in Table 14.2.6.5-1		
nr-DL-PRS-Info-r16	As specified in Table 14.2.6.4.3-6		
}			
NR-DL-PRS-AssistanceDataPerTRP-r16[3] SEQUENCE {		entry 3	Cell 3
dl-PRS-ID-r16	2		
nr-PhysCellID-r16	Cell 3		
nr-CellGlobalID-r16	Cell 3		
nr-ARFCN-r16	Cell 3		
nr-DL-PRS-SFN0-Offset-r16 SEQUENCE {			
sfn-Offset-r16	0		
integerSubframeOffset-r16	0		
}			
nr-DL-PRS-ExpectedRSTD-r16	0		
nr-DL-PRS-ExpectedRSTD-Uncertainty-r16	As specified in Table 14.2.6.5-1		
nr-DL-PRS-Info-r16	As specified in Table 14.2.6.4.3-6		
}			
}			
}			
}			
}			

Table 14.2.6.4.3-8: NR-DL-PRS-Info

Derivation Path: 37.355 clause 6.4.3			
Information Element	Value/remark	Comment	Condition
NR-DL-PRS-Info-r16 ::= SEQUENCE {			
nr-DL-PRS-ResourceSetList-r16 SEQUENCE (SIZE (1..nrMaxSetsPerTrp-r16)) OF NR-DL-PRS-ResourceSet-r16 {	1 entry		
NR-DL-PRS-ResourceSet-r16[1] SEQUENCE {		entry 1	
nr-DL-PRS-ResourceSetID-r16	0		
dl-PRS-Periodicity-and-ResourceSetSlotOffset-r16 CHOICE {			
scs15-r16 CHOICE {			Config 1 and Config 2
n160-r16	10		
}			
scs30-r16 CHOICE {			Config 3
n320-r16	20		
}			
dl-PRS-ResourceRepetitionFactor-r16	Not present		
dl-PRS-ResourceTimeGap-r16	s1		
dl-PRS-NumSymbols-r16	n4		
dl-PRS-MutingOption1-r16 SEQUENCE {			
dl-prs-MutingBitRepetitionFactor-r16	Not present		
nr-option1-muting-r16 CHOICE {			
po2-r16	10		Cell 1 and cell 3
	01		Cell 2
}			
}			
dl-PRS-MutingOption2-r16	Not present		
dl-PRS-ResourcePower-r16	27		
dl-PRS-ResourceList-r16 SEQUENCE (SIZE (1..nrMaxResourcesPerSet-r16)) OF NR-DL-PRS-Resource-r16 {	2 entries		
NR-DL-PRS-Resource-r16[1] SEQUENCE {		entry 1	

nr-DL-PRS-ResourceID-r16	0		
dl-PRS-SequenceID-r16	0		
dl-PRS-CombSizeN-AndReOffset-r16 CHOICE {			
n4-r16	0		Cell 1 and Cell 2
	1		Cell 3
}			
dl-PRS-ResourceSlotOffset-r16	4		
dl-PRS-ResourceSymbolOffset-r16	0		
dl-PRS-QCL-Info-r16	Not present		
}			
NR-DL-PRS-Resource-r16[2] SEQUENCE {		entry 2	
nr-DL-PRS-ResourceID-r16	1		
dl-PRS-SequenceID-r16	1		
dl-PRS-CombSizeN-AndReOffset-r16 CHOICE {			
n4-r16	0		Cell 1 and Cell 2
	1		Cell 3
}			
dl-PRS-ResourceSlotOffset-r16	4		
dl-PRS-ResourceSymbolOffset-r16	0		
dl-PRS-QCL-Info-r16	Not present		
}			
}			
}			
}			
}			

Table 14.2.6.4.3-9: LPP ProvideLocation Information

Derivation Path: TS 37.355 [49] clause 6.2			
Information Element	Value/remark	Comment	Condition
LPP-Message ::= SEQUENCE {			
transactionID SEQUENCE {			
initiator	locationServer		
transactionNumber	1		
}			
endTransaction	TRUE		
sequenceNumber	(0..255)		
acknowledgement			
lpp-MessageBody CHOICE {			
c1 CHOICE {			
provideLocationInformation SEQUENCE {			
criticalExtensions CHOICE {			
c1 CHOICE {			
provideLocationInformation-r9 SEQUENCE {			
commonIEsProvideLocationInformation	Not present.		
a-gnss-ProvideLocationInformation	Not present		
otdoa-ProvideLocationInformation	Not present		
ecid-ProvideLocationInformation	Not present		
epdu-ProvideLocationInformation	Not present		
sensor-ProvideLocationInformation-r13	Not present		
tbs-ProvideLocationInformation-r13	Not present		
wlan-ProvideLocationInformation-r13	Not present		
bt-ProvideLocationInformation-r13	Not present		
nr-ECID-ProvideLocationInformation-r16	Not present		
nr-Multi-RTT-ProvideLocationInformation-r16	Not present		
nr-DL-AoD-ProvideLocationInformation-r16	Not present		
nr-DL-TDOA-ProvideLocationInformation-r16 SEQUENCE {			
nr-DL-TDOA-SignalMeasurementInformation-r16 SEQUENCE {			
dl-PRS-ReferenceInfo-r16			

nr-DL-TDOA-MeasList-r16 SEQUENCE (SIZE(1..nrMaxTRPs-r16)) OF NR-DL-TDOA-MeasElement-r16 {	3 entries		
NR-DL-TDOA-MeasElement-r16[1] SEQUENCE {		entry 1	
dl-PRS-ID-r16			
nr-PhysCellID-r16	Cell 1		
nr-CellGlobalID-r16			
nr-ARFCN-r16			
nr-DL-PRS-ResourceID-r16			
nr-DL-PRS-ResourceSetID-r16			
nr-TimeStamp-r16			
nr-RSTD-r16	Present		
nr-AdditionalPathList-r16			
nr-TimingQuality-r16			
nr-DL-PRS-RSRP-Result-r16			
nr-DL-TDOA-AdditionalMeasurements-r16			
nr-UE-Rx-TEG-ID-r17			
nr-DL-PRS-FirstPathRSRP-Result-r17			
nr-los-nlos-Indicator-r17			
nr-AdditionalPathListExt-r17			
nr-DL-TDOA-AdditionalMeasurementsExt-r17			
}			
NR-DL-TDOA-MeasElement-r16[2] SEQUENCE {		entry 2	
dl-PRS-ID-r16			
nr-PhysCellID-r16	Cell 2		
nr-CellGlobalID-r16			
nr-ARFCN-r16			
nr-DL-PRS-ResourceID-r16			
nr-DL-PRS-ResourceSetID-r16			
nr-TimeStamp-r16			
nr-RSTD-r16	Present		
nr-AdditionalPathList-r16			
nr-TimingQuality-r16			
nr-DL-PRS-RSRP-Result-r16			
nr-DL-TDOA-AdditionalMeasurements-r16			
nr-UE-Rx-TEG-ID-r17			
nr-DL-PRS-FirstPathRSRP-Result-r17			
nr-los-nlos-Indicator-r17			
nr-AdditionalPathListExt-r17			
nr-DL-TDOA-AdditionalMeasurementsExt-r17			
}			
NR-DL-TDOA-MeasElement-r16[3] SEQUENCE {		entry 3	
dl-PRS-ID-r16			
nr-PhysCellID-r16	Cell 3		
nr-CellGlobalID-r16			
nr-ARFCN-r16			
nr-DL-PRS-ResourceID-r16			
nr-DL-PRS-ResourceSetID-r16			
nr-TimeStamp-r16			
nr-RSTD-r16	Present		
nr-AdditionalPathList-r16			
nr-TimingQuality-r16			
nr-DL-PRS-RSRP-Result-r16			
nr-DL-TDOA-AdditionalMeasurements-r16			
nr-UE-Rx-TEG-ID-r17			
nr-DL-PRS-FirstPathRSRP-Result-r17			
nr-los-nlos-Indicator-r17			
nr-AdditionalPathListExt-r17			

nr-DL-TDOA-AdditionalMeasurementsExt-r17			
}			
}			
nr-UE-RxTEG-TimingErrorMargin-r17			
}			
nr-dl-tdoa-LocationInformation-r16			
nr-DL-TDOA-Error-r16			
nr-DL-TDOA-SignalMeasurementInstances-r17			
nr-DL-TDOA-LocationInformationInstances-r17			
}			
}			
}			
}			
}			
}			

14.2.6.5 Test requirement

Table 14.2.6.5-1, Table 14.2.6.5-2 and Table 14.2.6.5-3 define the primary level settings including test tolerances for the test.

Table 14.2.6.5-1: General test parameters for RSTD measurement reporting delay

Parameter		Unit	Value	Comment
Reference cell			Cell 1	Reference cell is the cell in the DL-TDOA assistance data with respect to which the RSTD measurement is defined, as specified in TS 38.215 [4] and TS 37.355 [34]. The reference cell is the PCell in this test case.
Neighbor cells			Cell 2 and Cell 3	Cell 2 and Cell 3 appear at the first and second places in the neighbour cell list in the DL-TDOA assistance data.
BW _{channel}	Config 1	MHz	20: N _{RB,c} = 106	
	Config 2		20: N _{RB,c} = 106	
	Config 3		50: N _{RB,c} = 133	
SSB configuration	Config 1		SSB.1 FR1	
	Config 2		SSB.1 FR1	
	Config 3		SSB.2 FR1	
SMTC configuration	Config 1		SMTC.2	
	Config 2		SMTC.1	
	Config 3		SMTC.1	
PDSCH RMC configuration	Config 1		SR.1.1 FDD	
	Config 2		SR.1.1 TDD	
	Config 3		SR.2.1 TDD	
RMSI CORESET RMC configuration	Config 1		CR.1.1 FDD	As specified in clause A.3.1.2.1
	Config 2		CR.1.1 TDD	
	Config 3		CR.2.1 TDD	
Dedicated CORESET	Config 1		CR.1.1 FDD	
	Config 2		CR.1.1 TDD	
	Config 3		CR.2.1 TDD	

RMC configuration				
Initial BWP configuration	Config 1,2,3		DLBWP.0.1 ULBWP.0.1	
Active DL BWP configuration	Config 1,2,3		DLBWP.1.1	Cell 2 and cell 3 also transmit PRS on active DL BWP configured to the UE
Active UL BWP configuration	Config 1,2,3		ULBWP.1.1	
PRS Configuration	Config 1		PRS.1.4 FR1	As specified in clause A.3.31
	Config 2		PRS.1.4 FR1	
	Config 3		PRS.2.4 FR1	
Physical cell ID PCI			(PCI of Cell 1 – PCI of Cell 2)mod6=0 and (PCI of Cell 1 – PCI of Cell 3)mod6=0	The cell PCIs are selected such that the relative shifts of PRS patterns among cells are as given by the test parameters
CP length			Normal	
DRX			OFF	
PPW configuration			PPW.1	As defined in A.3.33
Time offset between serving and neighbour cells	μs		<ul style="list-style-type: none"> – set to the UE reported capability for receive time difference threshold if the UE reported value is < 3μs – 3μs otherwise 	PRS are transmitted from synchronous cells
Expected RSTD	μs		0	The expected RSTD is what is expected at the receiver. The corresponding parameter in the DL-TDOA assistance data specified in TS 37.355 [34] is the expectedRSTD indicator
Expected RSTD uncertainty for all neighbour cells	μs		Same as time offset	The corresponding parameter in the DL-TDOA assistance ta specified in TS 37.355 [34] is the expectedRSTD-Uncertainty index
Number of cells provided in DL-TDOA assistance data			4	Including the reference cell
PRS muting info			Cell 1: '10' Cell 2: '01' Cell 3: '10'	Corresponds to prs-MutingInfo defined in TS 37.355 [34]
PRS resource RE offset			Cell 1: 0 Cell 2: 0 Cell 3: 1	Cell 1 and Cell 3 are configured with different resource offsets
T1	s		3	The length of the time interval from the beginning of each test
T2	ms		10	The length of the time interval that follows after time interval T1 and processing time of assistance data. In this test UE is configured to measure single PFL within the configured PPW.

Table 14.2.6.5-2: Cell-specific test parameters for RSTD measurement reporting delay during T1

Parameter	Unit	Cell 1	Cell 2	Cell 3
NR RF Channel Number		1	1	1
Positioning frequency layer		1	1	1
Correlation Matrix and Antenna Configuration		1x2 Low	1x2 Low	1x2 Low

OCNG patterns defined in A.3.2.1			OP.1	N/A	N/A
N_{oc} ^{Note 3}	Config 1	dBm/SCS	-98		
	Config 2	dBm/SCS	-98		
	Config 3	dBm/SCS	-95		
PRS \hat{E}_s/N_{oc}		dB	-Infinity	-Infinity	-Infinity
SSB \hat{E}_s/N_{oc}		dB	10	-Infinity	-Infinity
I_o ^{Note 4}	Config 1	dBm/ 19.08MHz	-56.54	-56.54	-56.54
	Config 2	dBm/ 19.08MHz	-56.54	-56.54	-56.54
	Config 3	dBm/ 47.88MHz	-52.56	-52.56	-52.56
SSB RP ^{Note 4}	Config 1	dBm/SCS	-88	-Infinity	-Infinity
	Config 2	dBm/SCS	-88	-Infinity	-Infinity
	Config 3	dBm/SCS	-88	-Infinity	-Infinity
Propagation Condition			AWGN		
<p>Note 1: OCNG shall be used such that active cell is fully allocated and a constant total transmitted power spectral density is achieved for all OFDM symbols.</p> <p>Note 2: The resources for uplink transmission are assigned to the UE prior to the start of time period T2.</p> <p>Note 3: Interference from other cells and noise sources not specified in the test are assumed to be constant over subcarriers and time and shall be modelled as AWGN of appropriate power for N_{oc} to be fulfilled.</p> <p>Note 4: SSB RP and I_o levels have been derived from other parameters and are given for information purpose. These are not settable test parameters.</p>					

Table 14.2.6.5-3: Cell-specific test parameters for RSTD measurement reporting delay during T2

Parameter	Unit	Cell 1		Cell 2		Cell 3	
		Sub-test 1	Sub-test 2	Sub-test 1	Sub-test 2	Sub-test 1	Sub-test 2
NR RF Channel Number		1		1		1	
Correlation Matrix and Antenna Configuration		1x2 Low		1x2 Low		1x2 Low	
OCNG patterns defined in A.3.2.1		OP.1		OP.1		OP.1	
PRACH configuration		FR1 PRACH configuration 1		FR1 PRACH configuration 1		FR1 PRACH configuration 1	
N_{oc} ^{Note 3}	Config 1,2	-98		-98		-98	
	Config 3	-95		-95		-95	
PRS \hat{E}_s/N_{oc}	Config 1,2,3	-5.45	1	-11.67	-1.2	-11.67	-1.2
I_o ^{Note 4}	Config 1,2	-65.43	-61.18	-65.43	-61.18	-65.43	-61.18
	Config 3	-61.44		-57.20		-61.44	
PRS \hat{E}_s/I_{ot}	Config 1,2,3	-6	-3	-13	-6	-13	-6
PRS-RSRP ^{Note 4}	Config 1,2	-103.45	-97	-109.67	-99.2	-109.67	-99.2
	Config 3	-100.45	-94	-106.67	-96.2	-106.67	-96.2
SS-RSRP ^{Note 4}	Config 1,2	-88	-97	-88	-99.2	-88	-99.2
	Config 3	-85	-94	-85	-96.2	-85	-96.2
Propagation Condition		AWGN					

Note 1:	OCNG shall be used such that active cells are fully allocated and a constant total transmitted power spectral density is achieved for all OFDM symbols other than those in the subframes with transmitted PRS.
Note 2:	The resources for uplink transmission are assigned to the UE prior to the start of time period T2.
Note 3:	Interference from other cells and noise sources not specified in the test are assumed to be constant over subcarriers and time and shall be modelled as AWGN of appropriate power for N_{oc} to be fulfilled.
Note 4:	RSRP and Io levels have been derived from other parameters for information purposes. They are not settable parameters themselves.

The RSTD measurement time fulfils the requirements specified in clause 14.2.6.3.

14.2.7 NR RSTD measurement reporting delay test case for single positioning frequency layer with Rx TEG in FR1 SA

Editor's Note: This test case has been completed for the following configurations:

- Test tolerance is missing

14.2.7.1 Test purpose

The purpose of the test is to verify that the RSTD measurement meets the Rx TEG based measurement period requirements specified in TS 38.133 [50] Clause 9.9.2.5 in an environment with AWGN propagation conditions in FR1 in standalone scenario when single positioning frequency layer is configured.

14.2.7.2 Test applicability

This test applies to all types of NR UE release 17 onwards that supports UE assisted DL-TDOA positioning and nr-UE-RxTEG-ID-MaxSupport.

14.2.7.3 Minimum conformance requirements

Same as defined in clause 14.2.5.3.

14.2.7.4 Test description

14.2.7.4.1 Initial conditions

The supported test configurations in listed in Table 14.2.7.4-1.

Table 14.2.7.4-1: Test Configurations

Configuration	Description
1	15 kHz SSB SCS, 20 MHz bandwidth, FDD duplex mode
2	15 kHz SSB SCS, 20 MHz bandwidth, TDD duplex mode
3	30 kHz SSB SCS, 50 MHz bandwidth, TDD duplex mode
Note:	The UE is only required to be tested in one of the supported test configurations.

Test Environment: Normal, as defined in TS 38.508-1 [45] clause 4.1.

Frequencies to be tested: Mid Range, as defined in TS 38.508-1 [45] clause 4.3.1.

Channel bandwidth to be tested: are specified in Table 14.2.7.4-1.

1. Connect the SS and AWGN noise sources to the UE antenna connector or antenna connectors as shown in Annex A, Figure A.12.
2. The general test parameter settings are set up according to Table 14.2.7.5-1, Table 14.2.7.5-2 and Table 14.2.7.5-3.

- 3. Propagation conditions are set according to clause 4.15.2.
- 4. Message contents are defined in clause 14.2.7.4.3.
- 5. In the test there are three synchronous cells: Cell 1, Cell 2 and Cell 3. Cell 1 is the reference as well as the PCell. Cell 2 and Cell 3 are the neighbour cells. All cells are on the same RF channel distributed in single positioning frequency layer.

14.2.7.4.2 Test procedure

Same as defined in clause 14.2.5.4.2.

14.2.7.4.3 Message contents

Table 14.2.7.4.3-1: RESET UE POSITIONING STORED INFORMATION

Derivation Path: 38.509 [44] clause 6.6			
Information Element	Value/remark	Comment	Condition
UE Positioning Technology	0 0 0 0 1 1 1	DL-TDOA	

Table 14.2.7.4.3-2: LPP Request Capabilities

Information Element	Value/remark
nr-DL-TDOA-RequestCapabilities-r16	TRUE

Table 14.2.7.4.3-3: LPP RequestLocationInformation

Derivation Path: TS 37.355 [49] clause 6.2			
Information Element	Value/remark	Comment	Condition
LPP-Message ::= SEQUENCE {			
transactionID SEQUENCE {			
initiator	locationServer		
transactionNumber	1		
}			
endTransaction	FALSE		
sequenceNumber	Not present		
acknowledgement	Not present		
lpp-MessageBody CHOICE {			
c1 CHOICE {			
requestLocationInformation SEQUENCE {			
criticalExtensions CHOICE {			
c1 CHOICE {			
requestLocationInformation-r9 SEQUENCE {			
commonEsRequestLocationInformation SEQUENCE {			
locationInformationType	locationMeasurementsPreferred		
triggeredReporting	Not present		
periodicalReporting	Not present		
additionalInformation	onlyReturnInformationRequested		
}			
}			
}			
}			
responseTime SEQUENCE {			
time	See 14.2.7.5	Result of the response time calculation rounded up to the next second	
responseTimeEarlyFix-r12	Not present		Rel-12 onwards

unit-r15	Not present		
	ten-seconds		Calculated response time >128s
}			
velocityRequest	FALSE		
}			
environment	Not present		
locationCoordinateTypes	Not present		
velocityTypes	Not present		
}			
a-gnss-RequestLocationInformation	Not present		
otdoa-RequestLocationInformation	Not present		
ecid-RequestLocationInformation	Not present		
epdu-RequestLocationInformation	Not Present		
sensor-RequestLocationInformation-r13	Not present		
tbs-RequestLocationInformation-r13	Not present		
wlan-RequestLocationInformation-r13	Not present		
bt-RequestLocationInformation-r13	Not present		
nr-ECID-RequestLocationInformation-r16	Not present		
nr-Multi-RTT-RequestLocationInformation-r16	Not present		
nr-DL-AoD-RequestLocationInformation-r16	Not present		
nr-DL-TDOA-RequestLocationInformation-r16			
SEQUENCE {			
nr-DL-PRS-RstdMeasurementInfoRequest-r16	Not present		
nr-RequestedMeasurements-r16	bit 0 = 0 (prsrspReq)		
nr-AssistanceAvailability-r16	FALSE		
nr-DL-TDOA-ReportConfig-r16 SEQUENCE {			
maxDL-PRS-RSTD-MeasurementsPerTRPPair-r16	Not present		
timingReportingGranularityFactor-r16	Not present		
measureSameDL-PRS-ResourceWithDifferentRxTEGs-r17	n2		
reducedDL-PRS-ProcessingSamples-r17	Not present		
lowerRxBeamSweepingFactor-FR2-r17	Not present		
}			
additionalPaths-r16	Not present		
nr-UE-RxTEG-Request-r17	requested		
nr-los-nlos-IndicatorRequest-r17	Not present		
additionalPathsExt-r17	Not present		
additionalPathsDL-PRS-RSRP-Request-r17	Not present		
multiMeasInSameReport-r17	Not present		
}			
}			
}			
}			
}			
}			
}			

Table 14.2.7.4.3-4: LPP ProvideAssistanceData

Derivation Path: TS 37.355 [49] clause 6.2			
Information Element	Value/remark	Comment	Condition
LPP-Message ::= SEQUENCE {			
transactionID SEQUENCE {			
initiator	locationServer		
transactionNumber	(0..255)		
}			
endTransaction	TRUE		
sequenceNumber	Not present		
acknowledgement	Not present		
lpp-MessageBody CHOICE {			

c1 CHOICE {			
provideAssistanceData SEQUENCE {			
criticalExtensions CHOICE {			
c1 CHOICE {			
provideAssistanceData-r9 SEQUENCE {			
commonEsProvideAssistanceData	Not present		
a-gnss-ProvideAssistanceData	Not present		
otdoa-ProvideAssistanceData	Not present		
epdu-Provide-AssistanceData	Not present		
sensor-ProvideAssistanceData-r14	Not present		
tbs-ProvideAssistanceData-r14	Not present		
wlan-ProvideAssistanceData-r14	Not present		
nr-Multi-RTT-ProvideAssistanceData-r16	Not present		
nr-DL-AoD-ProvideAssistanceData-r16	Not present		
nr-DL-TDOA-ProvideAssistanceData-r16			
SEQUENCE {			
nr-DL-PRS-AssistanceData-r16	As defined in Table 14.2.7.4.3-5		
nr-SelectedDL-PRS-IndexList-r16	Not present		
nr-PositionCalculationAssistance-r16	Not present		
nr-DL-TDOA-Error-r16	Not present		
nr-On-Demand-DL-PRS-Configurations-r17	Not present		
nr-On-Demand-DL-PRS-Configurations-Selected-IndexList-r17	Not present		
assistanceDataValidityArea-r17	Not present		
}			
}			
}			
}			
}			

Table 14.2.7.4.3-5: NR-DL-PRS-AssistanceData

Derivation Path: 37.355 clause 6.4.3			
Information Element	Value/remark	Comment	Condition
NR-DL-PRS-AssistanceData-r16 ::= SEQUENCE {			
nr-DL-PRS-ReferenceInfo-r16 SEQUENCE {			
dl-PRS-ID-r16	0		
nr-DL-PRS-ResourceID-List-r16	Not present		
nr-DL-PRS-ResourceSetID-r16	Not present		
}			
nr-DL-PRS-AssistanceDataList-r16 SEQUENCE (SIZE (1..nrMaxFreqLayers-r16)) OF NR-DL-PRS-AssistanceDataPerFreq-r16 {	1 entry		
NR-DL-PRS-AssistanceDataPerFreq-r16[1] SEQUENCE {		entry 1	
nr-DL-PRS-PositioningFrequencyLayer-r16 SEQUENCE {			
dl-PRS-SubcarrierSpacing-r16	kHz15		Config 1 and Config 2
	kHz30		Config 3
dl-PRS-ResourceBandwidth-r16	21	104 PRBs	Config 1 and Config 2
	28	132 PRBs	Config 3
dl-PRS-StartPRB-r16	0		
dl-PRS-PointA-r16	absoluteFrequencyPointA as defined for the DL frequency of the Cell 1		
dl-PRS-CombSizeN-r16	n4		
dl-PRS-CyclicPrefix-r16	normal		
}			
}			
}			

nr-DL-PRS-AssistanceDataPerFreq-r16 SEQUENCE (SIZE (1..nrMaxTRPsPerFreq-r16)) OF NR-DL-PRS-AssistanceDataPerTRP-r16{	3 entries		
NR-DL-PRS-AssistanceDataPerTRP-r16[1] SEQUENCE {		entry 1	Cell 1
dl-PRS-ID-r16	0		
nr-PhysCellID-r16	Cell 1		
nr-CellGlobalID-r16	Cell 1		
nr-ARFCN-r16	Cell 1		
nr-DL-PRS-SFN0-Offset-r16 SEQUENCE {			
sfn-Offset-r16	0		
integerSubframeOffset-r16	0		
}			
nr-DL-PRS-ExpectedRSTD-r16	0		
nr-DL-PRS-ExpectedRSTD-Uncertainty-r16	0		
nr-DL-PRS-Info-r16	As specified in Table 14.2.7.4.3-6		
}			
NR-DL-PRS-AssistanceDataPerTRP-r16[2] SEQUENCE {		entry 2	Cell 2
dl-PRS-ID-r16	1		
nr-PhysCellID-r16	Cell 2		
nr-CellGlobalID-r16	Cell 2		
nr-ARFCN-r16	Cell 2		
nr-DL-PRS-SFN0-Offset-r16 SEQUENCE {			
sfn-Offset-r16	0		
integerSubframeOffset-r16	0		
}			
nr-DL-PRS-ExpectedRSTD-r16	As specified in Table 14.2.7.5-1		
nr-DL-PRS-ExpectedRSTD-Uncertainty-r16	As specified in Table 14.2.7.5-1		
nr-DL-PRS-Info-r16	As specified in Table 14.2.7.4.3-6		
}			
NR-DL-PRS-AssistanceDataPerTRP-r16[3] SEQUENCE {		entry 3	Cell 3
dl-PRS-ID-r16	2		
nr-PhysCellID-r16	Cell 3		
nr-CellGlobalID-r16	Cell 3		
nr-ARFCN-r16	Cell 3		
nr-DL-PRS-SFN0-Offset-r16 SEQUENCE {			
sfn-Offset-r16	0		
integerSubframeOffset-r16	0		
}			
nr-DL-PRS-ExpectedRSTD-r16	As specified in Table 14.2.7.5-1		
nr-DL-PRS-ExpectedRSTD-Uncertainty-r16	As specified in Table 14.2.7.5-1		
nr-DL-PRS-Info-r16	As specified in Table 14.2.7.4.3-6		
}			
}			
}			
}			
}			

Table 14.2.7.4.3-6: NR-DL-PRS-Info

Derivation Path: 37.355 clause 6.4.3			
Information Element	Value/remark	Comment	Condition
NR-DL-PRS-Info-r16 ::= SEQUENCE {			
nr-DL-PRS-ResourceSetList-r16 SEQUENCE (SIZE (1..nrMaxSetsPerTrp-r16)) OF NR-DL-PRS-ResourceSet-r16 {	1 entry		

NR-DL-PRS-ResourceSet-r16[1] SEQUENCE {		entry 1	
nr-DL-PRS-ResourceSetID-r16	0		
dl-PRS-Periodicity-and-ResourceSetSlotOffset-r16 CHOICE {			
scs15-r16 CHOICE {			Config 1 and Config 2
n160-r16	10		
}			
scs30-r16 CHOICE {			Config 3
n320-r16	20		
}			
dl-PRS-ResourceRepetitionFactor-r16	Not present		
dl-PRS-ResourceTimeGap-r16	s1		
dl-PRS-NumSymbols-r16	n4		
dl-PRS-MutingOption1-r16 SEQUENCE {			
dl-prs-MutingBitRepetitionFactor-r16	Not present		
nr-option1-muting-r16 CHOICE {			
po2-r16	10		Cell 1
	01		Cell 2
	10		Cell 3
}			
}			
dl-PRS-MutingOption2-r16	Not present		
dl-PRS-ResourcePower-r16	27		
dl-PRS-ResourceList-r16 SEQUENCE (SIZE (1..nrMaxResourcesPerSet-r16)) OF NR-DL-PRS-Resource-r16 {	2 entries		
NR-DL-PRS-Resource-r16[1] SEQUENCE {		entry 1	
nr-DL-PRS-ResourceID-r16	0		
dl-PRS-SequenceID-r16	0		
dl-PRS-CombSizeN-AndReOffset-r16 CHOICE {			
n4-r16	0		Cell 1 and Cell 2
	1		Cell 3
}			
dl-PRS-ResourceSlotOffset-r16	4		
dl-PRS-ResourceSymbolOffset-r16	0		
dl-PRS-QCL-Info-r16	Not present		
}			
NR-DL-PRS-Resource-r16[2] SEQUENCE {		entry 2	
nr-DL-PRS-ResourceID-r16	1		
dl-PRS-SequenceID-r16	1		
dl-PRS-CombSizeN-AndReOffset-r16 CHOICE {			
n4-r16	0		Cell 1 and Cell 2
	1		Cell 3
}			
dl-PRS-ResourceSlotOffset-r16	4		
dl-PRS-ResourceSymbolOffset-r16	0		
dl-PRS-QCL-Info-r16	Not present		
}			
}			
}			
}			
}			

Table 14.2.7.4.3-7: LPP ProvideLocation Information

Derivation Path: TS 37.355 [49] clause 6.2			
Information Element	Value/remark	Comment	Condition
LPP-Message ::= SEQUENCE {			
transactionID SEQUENCE {			
initiator	locationServer		
transactionNumber	1		

}			
endTransaction	TRUE		
sequenceNumber	(0..255)		
acknowledgement			
lpp-MessageBody CHOICE {			
c1 CHOICE {			
provideLocationInformation SEQUENCE {			
criticalExtensions CHOICE {			
c1 CHOICE {			
provideLocationInformation-r9 SEQUENCE {			
commonIEsProvideLocationInformation	Not present.		
a-gnss-ProvideLocationInformation	Not present		
otdoa-ProvideLocationInformation	Not present		
ecid-ProvideLocationInformation	Not present		
epdu-ProvideLocationInformation	Not present		
sensor-ProvideLocationInformation-r13	Not present		
tbs-ProvideLocationInformation-r13	Not present		
wlan-ProvideLocationInformation-r13	Not present		
bt-ProvideLocationInformation-r13	Not present		
nr-ECID-ProvideLocationInformation-r16	Not present		
nr-Multi-RTT-ProvideLocationInformation-	Not present		
r16			
nr-DL-AoD-ProvideLocationInformation-r16	Not present		
nr-DL-TDOA-ProvideLocationInformation-			
r16 SEQUENCE {			
nr-DL-TDOA-			
SignalMeasurementInformation-r16 SEQUENCE {			
dl-PRS-ReferenceInfo-r16			
nr-DL-TDOA-MeasList-r16 SEQUENCE	3 entries		
(SIZE(1..nrMaxTRPs-r16)) OF NR-DL-TDOA-			
MeasElement-r16 {			
NR-DL-TDOA-MeasElement-r16[1]		entry 1	
SEQUENCE {			
dl-PRS-ID-r16			
nr-PhysCellID-r16	Cell 1		
nr-CellGlobalID-r16			
nr-ARFCN-r16			
nr-DL-PRS-ResourceID-r16			
nr-DL-PRS-ResourceSetID-r16			
nr-TimeStamp-r16			
nr-RSTD-r16	Present		
nr-AdditionalPathList-r16			
nr-TimingQuality-r16			
nr-DL-PRS-RSRP-Result-r16			
nr-DL-TDOA-AdditionalMeasurements-			
r16			
nr-UE-Rx-TEG-ID-r17	Present		
nr-DL-PRS-FirstPathRSRP-Result-r17			
nr-los-nlos-Indicator-r17			
nr-AdditionalPathListExt-r17			
nr-DL-TDOA-			
AdditionalMeasurementsExt-r17			
}			
NR-DL-TDOA-MeasElement-r16[2]		entry 2	
SEQUENCE {			
dl-PRS-ID-r16			
nr-PhysCellID-r16	Cell 2		
nr-CellGlobalID-r16			
nr-ARFCN-r16			
nr-DL-PRS-ResourceID-r16			
nr-DL-PRS-ResourceSetID-r16			
nr-TimeStamp-r16			
nr-RSTD-r16	Present		
nr-AdditionalPathList-r16			
nr-TimingQuality-r16			
nr-DL-PRS-RSRP-Result-r16			

r16	nr-DL-TDOA-AdditionalMeasurements-			
	nr-UE-Rx-TEG-ID-r17	Present		
	nr-DL-PRS-FirstPathRSRP-Result-r17			
	nr-los-nlos-Indicator-r17			
	nr-AdditionalPathListExt-r17			
	nr-DL-TDOA-AdditionalMeasurementsExt-r17			
	}			
	NR-DL-TDOA-MeasElement-r16[3]		entry 3	
SEQUENCE {	dl-PRS-ID-r16			
	nr-PhysCellID-r16	Cell 3		
	nr-CellGlobalID-r16			
	nr-ARFCN-r16			
	nr-DL-PRS-ResourceID-r16			
	nr-DL-PRS-ResourceSetID-r16			
	nr-TimeStamp-r16			
	nr-RSTD-r16	Present		
	nr-AdditionalPathList-r16			
	nr-TimingQuality-r16			
	nr-DL-PRS-RSRP-Result-r16			
r16	nr-DL-TDOA-AdditionalMeasurements-			
	nr-UE-Rx-TEG-ID-r17	Present		
	nr-DL-PRS-FirstPathRSRP-Result-r17			
	nr-los-nlos-Indicator-r17			
	nr-AdditionalPathListExt-r17			
	nr-DL-TDOA-AdditionalMeasurementsExt-r17			
	}			
	}			
	nr-UE-RxTEG-TimingErrorMargin-r17			
	}			
	nr-dl-tdoa-LocationInformation-r16			
	nr-DL-TDOA-Error-r16			
	nr-DL-TDOA-SignalMeasurementInstances-r17			
	nr-DL-TDOA-LocationInformationInstances-r17			
	}			
	}			
	}			
	}			
	}			
	}			

14.2.7.5 Test requirement

Table 14.2.7.5-1, Table 14.2.7.5-2 and Table 14.2.7.5-3 define the primary level settings including test tolerances for the test.

Table 14.2.7.5-1: General test parameters for RSTD measurement reporting delay

Parameter	Unit	Value	Comment
Reference cell		Cell 1	Reference cell is the cell in the DL-TDOA assistance data with respect to which the RSTD measurement is defined, as specified in TS 38.215 [4] and TS 37.355 [34]. The reference cell is the PCell in this test case.
Neighbor cells		Cell 2 and Cell 3	Cell 2 and Cell 3 appear at the first and second places in the

			neighbour cell list in the DL-TDOA assistance data.	
BW _{channel}	Config 1	MHz	20: N _{RB,c} = 106	
	Config 2		20: N _{RB,c} = 106	
	Config 3		50: N _{RB,c} = 133	
SSB configuration	Config 1		SSB.1 FR1	
	Config 2		SSB.1 FR1	
	Config 3		SSB.2 FR1	
SMTc configuration	Config 1		SMTc.2	
	Config 2		SMTc.1	
	Config 3		SMTc.1	
PDSCH RMC configuration	Config 1		SR.1.1 FDD	
	Config 2		SR.1.1 TDD	
	Config 3		SR.2.1 TDD	
RMSI CORESET RMC configuration	Config 1		CR.1.1 FDD	As specified in clause A.3.1.2.1
	Config 2		CR.1.1 TDD	
	Config 3		CR.2.1 TDD	
Dedicated CORESET RMC configuration	Config 1		CR.1.1 FDD	
	Config 2		CR.1.1 TDD	
	Config 3		CR.2.1 TDD	
Initial BWP configuration	Config 1,2,3		DLBWP.0.1 ULBWP.0.1	
Active DL BWP configuration	Config 1,2,3		DLBWP.1.1	
Active UL BWP configuration	Config 1,2,3		ULBWP.1.1	
PRS Configuration	Config 1		PRS.1.4 FR1	As specified in clause A.3.31
	Config 2		PRS.1.4 FR1	
	Config 3		PRS.2.4 FR1	
Physical cell ID PCI			(PCI of Cell 1 – PCI of Cell 2) mod 6 = 0 and (PCI of Cell 1 – PCI of Cell 3) mod 6 = 0	The cell PCIs are selected such that the relative shifts of PRS patterns among cells are as given by the test parameters
CP length			Normal	
DRX			OFF	
Measurement gap			GP#24 or GP#0	GP#24 is configured if UE supports MG#24, otherwise GP#0 is configured
Radio frame receive time offset between the cells at the UE antenna connector	µs		Cell 2 to Cell 1: 0 Cell 3 to Cell 1: 3	PRS are transmitted from synchronous cells
Expected RSTD	µs		Cell 2: 3 Cell 3: 3 Other neighbour cells: randomly between -3 and 3	The expected RSTD is what is expected at the receiver. The corresponding parameter in the DL-TDOA assistance data specified in TS 37.355 [34] is the expectedRSTD indicator
Expected RSTD uncertainty for all neighbour cells	µs		5	The corresponding parameter in the DL-TDOA assistance data specified in TS 37.355 [34] is the expectedRSTD-Uncertainty index
Number of cells provided in DL-TDOA assistance data			4	Including the reference cell
PRS muting info			Cell 1: '10' Cell 2: '01' Cell 3: '10'	Corresponds to prs-MutingInfo defined in TS 37.355 [34]

PRS resource RE offset		Cell 1: 0 Cell 2: 0 Cell 3: 1	Cell 1 and Cell 3 are configured with different resource offsets
T1	s	3	The length of the time interval from the beginning of each test
T2	s	$[1.28 * k_{multiTEG}]^{Note\ 1}$	The length of the time interval that follows immediately after time interval T1
<p>Note 1:</p> <ul style="list-style-type: none"> $k_{multiTEG} = \left\lceil \frac{N_{TEG}}{k_{TEG, simul}} \right\rceil$ if UE is capable of receiving the same DL PRS resource from the same TRP simultaneously from multiple Rx TEGs, where N_{TEG} is the maximum number of Rx TEGs with which UE can support to measure the same PRS resource, and $k_{TEG, simul}$ is the number of Rx TEGs UE can measure simultaneously which is reported via <i>measureSameDL-PRS-ResourceWithDifferentRxTEGsSimul</i>. 			

Table 14.2.7.5-2: Cell-specific test parameters for RSTD measurement reporting delay during T1

Parameter		Unit	Cell 1	Cell 2	Cell 3
NR RF Channel Number			1	1	1
Positioning frequency layer			1	1	1
Correlation Matrix and Antenna Configuration			1x2 Low	1x2 Low	1x2 Low
OCNG patterns defined in A.3.2.1			OP.1	N/A	N/A
N_{oc} ^{Note 3}	Config 1	dBm/SCS	-98		
	Config 2	dBm/SCS	-98		
	Config 3	dBm/SCS	-95		
PRS \hat{E}_s / N_{oc}		dB	-Infinity	-Infinity	-Infinity
SSB \hat{E}_s / N_{oc}		dB	10	-Infinity	-Infinity
I_o ^{Note 4}	Config 1	dBm/ 19.08MHz	-56.54	-56.54	-56.54
	Config 2	dBm/ 19.08MHz	-56.54	-56.54	-56.54
	Config 3	dBm/ 47.88MHz	-52.56	-52.56	-52.56
SSB RP ^{Note 4}	Config 1	dBm/SCS	-88	-Infinity	-Infinity
	Config 2	dBm/SCS	-88	-Infinity	-Infinity
	Config 3	dBm/SCS	-88	-Infinity	-Infinity
Propagation Condition			AWGN		
<p>Note 1: OCNG shall be used such that active cell (Cell 1) is fully allocated and a constant total transmitted power spectral density is achieved for all OFDM symbols.</p> <p>Note 2: The resources for uplink transmission are assigned to the UE prior to the start of time period T2.</p> <p>Note 3: Interference from other cells and noise sources not specified in the test are assumed to be constant over subcarriers and time and shall be modelled as AWGN of appropriate power for N_{oc} to be fulfilled.</p> <p>Note 4: SSB RP and I_o levels have been derived from other parameters and are given for information purpose. These are not settable test parameters.</p>					

Table 14.2.7.5-3: Cell-specific test parameters for RSTD measurement reporting delay during T2

Parameter	Unit	Cell 1	Cell 2	Cell 3
		T2	T2	T2
NR RF Channel Number		1	1	1
Correlation Matrix and Antenna Configuration		1x2 Low	1x2 Low	1x2 Low

OCNG patterns defined in A.3.2.1			OP.1	OP.1	OP.1
PRACH configuration			FR1 PRACH configuration 1	FR1 PRACH configuration 1	FR1 PRACH configuration 1
N_{oc} ^{Note 3}	Config 1	dBm/SCS	-98	-98	-98
	Config 2	dBm/SCS	-98	-98	-98
	Config 3	dBm/SCS	-95	-95	-95
PRS \hat{E}_s/N_{oc}	Config 1	dB	-5.45	-11.67	-11.67
	Config 2	dB	-5.45	-11.67	-11.67
	Config 3	dB	-5.45	-11.67	-11.67
I_o ^{Note 4}	Config 1	dBm/19.08MHz	-65.43	-65.43	-65.43
	Config 2	dBm/19.08MHz	-65.43	-65.43	-65.43
	Config 3	dBm/47.88MHz	-61.44	-61.44	-61.44
PRS \hat{E}_s/I_{ot}		dB	-6	-13	-13
Propagation Condition			AWGN		
<p>Note 1: OCNG shall be used such that active cells are fully allocated and a constant total transmitted power spectral density is achieved for all OFDM symbols other than those in the subframes with transmitted PRS.</p> <p>Note 2: The resources for uplink transmission are assigned to the UE prior to the start of time period T2.</p> <p>Note 3: Interference from other cells and noise sources not specified in the test are assumed to be constant over subcarriers and time and shall be modelled as AWGN of appropriate power for N_{oc} to be fulfilled.</p>					

The RSTD measurement time fulfils the requirements specified in clause 14.2.7.3.

14.2.8 NR RSTD measurement reporting delay test case for single positioning frequency layer with reduced number of samples in FR2 SA

Editor's Note: This test case has been completed for the following configurations:

- Test frequency $f \leq 40.8$ GHz

- UE PC3

This test case is incomplete for UE power classes other than PC3

This test case is incomplete for test frequencies > 40.8 GHz

14.2.8.1 Test purpose

The purpose of the test is to verify that the RSTD measurement meets the requirements specified in TS 38.133 [50] Clause 9.9.2 in an environment with AWGN propagation conditions in FR2 in standalone scenario when single positioning frequency layer is configured. In this test PRS is transmitted within the active BWP of the UE.

14.2.8.2 Test applicability

This test applies to all types of NR UE release 17 onwards that supports DL-TDOA positioning and supportedDL-PRS-ProcessingSamples-RRC-CONNECTED.

14.2.8.3 Minimum conformance requirements

When physical layer receives last of *NR-TDOA-ProvideAssistanceData* message and *NR-TDOA-RequestLocationInformation* message from LMF via LPP [49], the UE shall be able to measure multiple DL RSTD measurements, defined in TS 38.215 [57], during the measurement period $T_{RSTD,Total}$ defined as:

$$T_{RSTD,Total} = \sum_{i=1}^L T_{RSTD,i} + (L - 1) * \max(T_{effect,i})$$

Where ,

i is the index of positioning frequency layer,

L is total number of positioning frequency layers, and

$T_{effect,i}$ is the periodicity of the PRS RSTD measurement in positioning frequency layer i

$T_{RSTD,i}$ is the measurement period for PRS RSTD measurement in positioning frequency layer i as specified below:

$$T_{RSTD,i} = \left(k_{multiTEG,i} * CSSF_{PRS,i} * \text{ceil}(K_{p,PRS,i}) * N_{RxBeam,i} * \left\lceil \frac{N_{PRS,i}^{slot}}{N'} \right\rceil \left\lceil \frac{L_{available_PRS,i}}{N} \right\rceil * N_{sample} - 1 \right) * T_{effect,i} + T_{last,i}$$

where:

$N_{RxBeam,i}$ is the UE Rx beam sweeping factor. In FR1, $N_{RxBeam,i} = 1$;

and in FR2, $N_{RxBeam,i}$ is equal to the value reported by the UE in *supportedLowerRxBeamSweepingFactor-FR2* if the UE supports the capability for the band containing positioning frequency layer i , and the LMF indicates *lowerRxBeamSweepingFactor-FR2* in *NR-TDOA-RequestLocationInformation*. $N_{RxBeam,i}$ is equal to 8, otherwise.

$CSSF_{PRS,i}$ is the carrier-specific scaling factor for NR PRS-based positioning measurements in positioning frequency layer i as defined in TS 38.133[50] clause 9.1.5.2.

$k_{multiTEG,i}$ is the scaling factor for measurement of same PRS resource with multiple Rx TEGs.

$k_{multiTEG,i}=1$ if UE is not requested by LMF to measure a PRS resource with multiple Rx TEGs via *measureSameDL-PRS-ResourceWithDifferentRxTEGs-r17* [49] in *NR-DL-TDOA-RequestLocationInformation*;

otherwise,

$k_{multiTEG} = N_{TEG,i}$, if UE is not capable of receiving same DL PRS resource simultaneously from multiple Rx TEGs, and

$k_{multiTEG} = \left\lceil \frac{N_{TEG,i}}{k_{TEG,simul,i}} \right\rceil$ if UE is capable of receiving the same DL PRS resource simultaneously from multiple Rx TEGs.

where

$N_{TEG,i}$ is the number of Rx TEGs with which UE is requested to measure a PRS resource indicated via *measureSameDL-PRS-ResourceWithDifferentRxTEGs-r17* [49] in *NR-DL-TDOA-RequestLocationInformation*, and in case 'n0' is indicated, $N_{TEG,i}$ is the maximum number of Rx TEGs with which UE can support to measure the same PRS resource as reported in *NR-UE-TEG-Capability*, and

$k_{TEG,simul,i}$ is the number of Rx TEGs UE can measure simultaneously which is reported via *measureSameDL-PRS-ResourceWithDifferentRxTEGsSimul*.

$K_{p,PRS,i}$ is a scaling factor for a positioning frequency layer to be measured within the associated measurement gap pattern, which is defined as $K_{p,PRS,i} = N_{total} / N_{available}$ for UE configured with concurrent measurement gap, and $K_{p,PRS,i} = 1$ for UE not configured with concurrent measurement gap.

- For a window W of duration $\max(T_{PRS,i}, MGRP_max)$, where $MGRP_max$ is the maximum $MGRP$ across all configured per-UE MG and per-FR MG within the same FR as the positioning frequency layer, and starting at the beginning of any associated gap occasions covering the PRS occasion:
 - N_{total} is the total number of associated gap occasions covering PRS occasions within the window, including those overlapped with other MG occasions within the window, and
 - $N_{available}$ is the number of non-dropped associated gap occasions covering PRS occasions within the window W , after further accounting for MG collisions by applying the selected gap collision rule
 - Requirements do not apply if $N_{available} = 0$.

$N_{PRS,i}^{slot}$ is the maximum number of DL PRS resources in positioning frequency layer i configured in a slot.

$L_{available_PRS,i}$ is the time duration of available PRS in the positioning frequency layer i to be measured during $T_{available_PRS,i}$, and is calculated in the same way as PRS duration K defined in clause 5.1.6.5 of TS 38.214 [56]. For calculation of $L_{available_PRS,i}$, only the PRS resources unmuted and fully or partially overlapped with MG are considered.

N_{sample} is the number of PRS RSTD measurement samples, where

- $N_{sample} = 1$ if the UE supports *supportedDL-PRS-ProcessingSamples* [34], and the LMF requests the UE to perform positioning measurements with reduced number of samples, and meets the following conditions:
 - PRS bandwidth is within the active BWP and
 - Magnitude of difference between the serving cell's SS-RSRP and the neighbour cell's PRS-RSRP is within 6 dB.
- $N_{sample} = 2$ if the UE supports *supportedDL-PRS-ProcessingSamples* [34], and the LMF requests the UE to perform positioning measurements with reduced number of samples, and does not meet the following conditions:
 - PRS bandwidth is within the active BWP and
 - Magnitude of difference between the serving cell's SS-RSRP and the neighbour cell's PRS-RSRP is within 6 dB.
- $N_{sample} = 4$ otherwise.

$T_{last,i}$ is the measurement duration for the last PRS RSTD sample in positioning frequency layer i , including the sampling time and processing time. If all of the PRS resources to be measured are available in the same MG occasion during $T_{available}$, $T_{last,i} = T_i + MGL$. Otherwise, $T_{last,i} = T_i + T_{available_PRS,i}$,

$T_{effect,i}$ is the periodicity of the PRS RSTD measurement in positioning frequency layer i defined as:

$$T_{effect,i} = \left\lceil \frac{T_i}{T_{available_PRS,i}} \right\rceil * T_{available_PRS,i}$$

Where,

T_i corresponds to *durationOfPRS-ProcessingSymbolsInEveryTms* in TS 37.355 [49],

$T_{available_PRS,i} = LCM(T_{PRS,i}, MGRP_i)$, the least common multiple between $T_{PRS,i}$ and $MGRP_i$.

$MGRP_i$ is the repetition periodicity of the measurement gap applicable for measurement in the PRS frequency layer i . $T_{PRS,i}$ is the periodicity of DL PRS resource with muting on positioning frequency layer i .

If more than one PRS periodicities are configured in positioning frequency layer i , the least common multiple of PRS periodicities $T_{per}^{PRS\ with\ muting}$ among all DL PRS resource sets in the positioning frequency layer is used to derive $T_{PRS,i}$, where,

$T_{per}^{PRS \text{ with muting}} = N_{muting} * T_{per}^{PRS}$, is the PRS periodicity with muting per PRS resource,

T_{per}^{PRS} is the periodicity of PRS resource sets given by the higher-layer parameter *DL-PRS-Periodicity*.

N_{muting} is the scaling factor considering PRS resource muting. $N_{muting} = T_{muting}^{PRS} * L_{muting}$, where

T_{muting}^{PRS} is the muting repetition factor given by the higher-layer parameter *DL-PRS-MutingBitRepetitionFactor*, and

L_{muting} is the size of the bitmap $\{b^1\}$.

- Note: For the purpose of calculating $T_{PRS,i}$, only the PRS resources fully or partially covered by the MG are considered.

$\{N, T\}$ is UE capability combination per band where N is a duration of DL PRS symbols in ms corresponding to *durationOfPRS-ProcessingSymsbols* in TS 37.355 [49] processed every T ms corresponding to *durationOfPRS-ProcessingSymsbolsInEveryTms* in TS 37.355 [49] for a given maximum bandwidth supported by UE corresponding to *supportedBandwidthPRS* in TS 37.355 [49].

N' is UE capability for number of DL PRS resources that it can process in a slot as indicated by *maxNumOfDL-PRS-ResProcessedPerSlot* specified in TS 37.355 [49].

14.2.8.4 Test description

14.2.8.4.1 Initial conditions

The supported test configuration is listed in Table 14.2.8.4-1.

Table 14.2.8.4-1: Test Configuration

Test Configuration	Description
1	120 kHz SSB and PRS SCS, 200 MHz bandwidth, TDD duplex mode

Test Environment: Normal, as defined in TS 38.508-1 [45] clause 4.1.

Frequencies to be tested: Mid Range, as defined in TS 38.508-1 [45] clause 4.3.1.

Channel bandwidth to be tested: are specified in Table 14.2.8.4-1.

1. Connect the SS and AWGN noise sources to the UE antenna connector or antenna connectors as shown in Annex A, Figure A.14.
2. The general test parameter settings are set up according to Table 14.2.8.5-1, Table 14.2.8.5-2 and Table 14.2.8.5-3.
3. Propagation conditions are set according to clause 4.15.2.
4. Message contents are defined in clause 14.2.8.4.3.
5. In the test there are three synchronous cells: Cell 1, Cell 2 and Cell 3. Cell 1 is the reference as well as the PCell. Cell 2 and Cell 3 are the neighbour cells. All cells are on the same RF channel distributed in single positioning frequency layer.

14.2.8.4.2 Test procedure

The test consists of two consecutive time intervals, with duration of T1 and T2. During time duration T1, the UE shall not have any timing information of Cell 2 and Cell 3. All three cells transmit PRS during T2. The beginning of the time interval T2 shall be aligned with the beginning of the first MG instance containing the PRS resources.

The *NR-DL-TDOA-ProvideAssistanceData* and *nr-DL-TDOA-RequestLocationInformation* as defined in TS 37.355 [49] clause 6.5.12.1, shall be provided to the UE during T1. The last TTI containing the two messages shall be provided to the UE ΔT ms before the start of T2, where $\Delta T = 50$ ms is the maximum processing time of the *DL-TDOA assistance data* and location information request.

The UE is configured with measurement gap pattern ID # 24 or #13 before T2.

2. Ensure the UE is in State RRC_CONNECTED with generic procedure parameters Connectivity NR, Connected without release On, according to TS 38.508-1 [45] clause 4.5.
2. The SS shall send a RESET UE POSITIONING STORED INFORMATION message.
3. Set the parameters according to Table 14.2.8.5-1, Table 14.2.8.5-2 and Table 14.2.8.5-3. Propagation conditions are set according to clause 4.15.2.
4. T1 starts.
5. The SS shall transmit an LPP REQUEST CAPABILITIES message.
6. The UE shall transmit an LPP PROVIDE CAPABILITIES message indicating the UE supports supportedDL-PRS-ProcessingSamples-RRC-CONNECTED in the NR-DL-PRS-ProcessingCapability IE and DL-TDOA capabilities supported by the UE in the NR-DL-TDOA-ProvideCapabilities IE.
7. The SS shall send a LPP PROVIDE ASSISTANCE DATA message, including the NR-DL-TDOA-ProvideAssistanceData IE. The position of neighbour Cell 2 and the position of neighbour Cell 3 are described in 3GPP TS 37.571-5 [20]. If the UE message at step 6 includes the ackRequested IE set to TRUE, then the SS shall send an acknowledgment in the LPP PROVIDE ASSISTANCE DATA message.
8. The SS shall send a LPP REQUEST LOCATION INFORMATION message, including the reducedDL-PRS-ProcessingSamples-r17 in the NR-DL-TDOA-RequestLocationInformation IE such that the UE receives the message ΔT ms before the start of T2, where ΔT = 50 ms.
9. When T1 expires, the SS shall switch the power setting from T1 to T2 as specified in Table 14.2.8.5-3.
10. The UE shall transmit a LPP PROVIDE LOCATION INFORMATION message including the NR-DL-TDOA-ProvideLocationInformation IE within the response time (see clause 4.15.3). The UE shall perform and report the RSTD measurements for both Cell 2 and Cell 3 with respect to the reference cell in the DL-TDOA assistance data, Cell 1. If the UE transmits an NR-DL-TDOA-ProvideLocationInformation IE including the nr-RSTD field for both Cell 2 and Cell 3 within the response time then the number of successful tests is increased by one. If the UE fails to report the NR-DL-TDOA-ProvideLocationInformation IE with both the nr-RSTD fields included within the response time then the number of failure tests is increased by one.
11. If the UE message at step 10 includes the ackRequested IE set to TRUE, the SS shall send a LPP acknowledgement message.
12. Repeat steps 2-11 in Table 14.2.8.4-1 until the confidence level according to Annex D is achieved.

14.2.8.4.3 Message contents

Table 14.2.8.4.3-1: RESET UE POSITIONING STORED INFORMATION

Derivation Path: 38.509 [44] clause 6.6			
Information Element	Value/remark	Comment	Condition
UE Positioning Technology	0 0 0 0 1 1 1	DL-TDOA	

Table 14.2.8.4.3-2: LPP Request Capabilities

Information Element	Value/remark
nr-DL-TDOA-RequestCapabilities-r16	TRUE

Table 14.2.8.4.3-3: LPP RequestLocationInformation

Derivation Path: TS 37.355 [49] clause 6.2			
Information Element	Value/remark	Comment	Condition
LPP-Message ::= SEQUENCE {			
transactionID SEQUENCE {			
initiator	locationServer		
transactionNumber	1		

}			
endTransaction	FALSE		
sequenceNumber	Not present		
acknowledgement	Not present		
lpp-MessageBody CHOICE {			
c1 CHOICE {			
requestLocationInformation SEQUENCE {			
criticalExtensions CHOICE {			
c1 CHOICE {			
requestLocationInformation-r9 SEQUENCE {			
commonEsRequestLocationInformation SEQUENCE {			
locationInformationType	locationMeasurementsPreferred		
triggeredReporting	Not present		
periodicalReporting	Not present		
additionalInformation	onlyReturnInformationRequested		
qos SEQUENCE {			
horizontalAccuracy	Not present		
verticalCoordinateRequest	FALSE		
verticalAccuracy	Not present		
responseTime SEQUENCE {			
time	See 14.2.8.5	Result of the response time calculation rounded up to the next second	
responseTimeEarlyFix-r12	Not present		Rel-12 onwards
unit-r15	Not present		
}			
velocityRequest	FALSE		
}			
environment	Not present		
locationCoordinateTypes	Not present		
velocityTypes	Not present		
}			
a-gnss-RequestLocationInformation	Not present		
otdoa-RequestLocationInformation	Not present		
ecid-RequestLocationInformation	Not present		
epdu-RequestLocationInformation	Not present		
sensor-RequestLocationInformation-r13	Not present		
tbs-RequestLocationInformation-r13	Not present		
wlan-RequestLocationInformation-r13	Not present		
bt-RequestLocationInformation-r13	Not present		
nr-ECID-RequestLocationInformation-r16	Not present		
nr-Multi-RTT-RequestLocationInformation-r16	Not present		
nr-DL-AoD-RequestLocationInformation-r16	Not present		
nr-DL-TDOA-RequestLocationInformation-r16 SEQUENCE {			
nr-DL-PRS-RstdMeasurementInfoRequest-r16	Not present		
nr-RequestedMeasurements-r16	bit 0 = 0 (prsrspReq)		
nr-AssistanceAvailability-r16	FALSE		
nr-DL-TDOA-ReportConfig-r16 SEQUENCE {			
maxDL-PRS-RSTD-MeasurementsPerTRPPair-r16	Not present		
timingReportingGranularityFactor-r16	Not present		
measureSameDL-PRS-ResourceWithDifferentRxTEGs-r17	Not present		
reducedDL-PRS-ProcessingSamples-r17	requested		
lowerRxBeamSweepingFactor-FR2-r17	Not present		
}			
additionalPaths-r16	Not present		
nr-UE-RxTEG-Request-r17	Not present		

nr-los-nlos-IndicatorRequest-r17	Not present		
additionalPathsExt-r17	Not present		
additionalPathsDL-PRS-RSRP-Request-r17	Not present		
multiMeasInSameReport-r17	Not present		
}			
}			
}			
}			
}			
}			
}			

Table 14.2.8.4.3-4: LPP ProvideAssistanceData

Derivation Path: TS 37.355 [49] clause 6.2			
Information Element	Value/remark	Comment	Condition
LPP-Message ::= SEQUENCE {			
transactionID SEQUENCE {			
initiator	locationServer		
transactionNumber	(0..255)		
}			
endTransaction	TRUE		
sequenceNumber	Not present		
acknowledgement	Not present		
lpp-MessageBody CHOICE {			
c1 CHOICE {			
provideAssistanceData SEQUENCE {			
criticalExtensions CHOICE {			
c1 CHOICE {			
provideAssistanceData-r9 SEQUENCE {			
commonEsProvideAssistanceData	Not present		
a-gnss-ProvideAssistanceData	Not present		
otdoa-ProvideAssistanceData	Not present		
epdu-Provide-AssistanceData	Not present		
sensor-ProvideAssistanceData-r14	Not present		
tbs-ProvideAssistanceData-r14	Not present		
wlan-ProvideAssistanceData-r14	Not present		
nr-Multi-RTT-ProvideAssistanceData-r16	Not present		
nr-DL-AoD-ProvideAssistanceData-r16	Not present		
nr-DL-TDOA-ProvideAssistanceData-r16			
SEQUENCE {			
nr-DL-PRS-AssistanceData-r16	As defined in Table 14.2.8.4.3-5		
nr-SelectedDL-PRS-IndexList-r16	Not present		
nr-PositionCalculationAssistance-r16			Depending on UE capabilities, i.e. support for UE-based DL-TDOA
nr-TRP-LocationInfo-r16	As defined in TS 37.571-5 [20]		
nr-DL-PRS-BeamInfo-r16	Not present		
nr-RTD-Info-r16	Not present		
nr-TRP-BeamAntennaInfo-r17	Not present		
nr-DL-PRS-Expected-LOS-NLOS-Assistance-r17	Not present		
nr-DL-PRS-TRP-TEG-Info-r17	Not present		
}			
nr-DL-TDOA-Error-r16	Not present		
nr-On-Demand-DL-PRS-Configurations-r17	Not present		
nr-On-Demand-DL-PRS-Configurations-Selected-IndexList-r17	Not present		
assistanceDataValidityArea-r17	Not present		

}			
}			
}			
}			
}			
}			
}			
}			

Table 14.2.8.4.3-5: NR-DL-PRS-AssistanceData

Derivation Path: 37.355 clause 6.4.3			
Information Element	Value/remark	Comment	Condition
NR-DL-PRS-AssistanceData-r16 ::= SEQUENCE {			
nr-DL-PRS-ReferenceInfo-r16 SEQUENCE {			
dl-PRS-ID-r16	0		
nr-DL-PRS-ResourceID-List-r16	Not present		
nr-DL-PRS-ResourceSetID-r16	Not present		
}			
nr-DL-PRS-AssistanceDataList-r16 SEQUENCE (SIZE (1..nrMaxFreqLayers-r16)) OF NR-DL-PRS-AssistanceDataPerFreq-r16 {	1 entry		
NR-DL-PRS-AssistanceDataPerFreq-r16[1] SEQUENCE {		entry 1	
nr-DL-PRS-PositioningFrequencyLayer-r16 SEQUENCE {			
dl-PRS-SubcarrierSpacing-r16	kHz120		
dl-PRS-ResourceBandwidth-r16	27	128 PRBs	
dl-PRS-StartPRB-r16	0		
dl-PRS-PointA-r16	absoluteFrequencyPointA as defined for the DL frequency of the Cell 1		
dl-PRS-CombSizeN-r16	n4		
dl-PRS-CyclicPrefix-r16	normal		
}			
nr-DL-PRS-AssistanceDataPerFreq-r16 SEQUENCE (SIZE (1..nrMaxTRPsPerFreq-r16)) OF NR-DL-PRS-AssistanceDataPerTRP-r16{	3 entries		
NR-DL-PRS-AssistanceDataPerTRP-r16[1] SEQUENCE {		entry 1	Cell 1
dl-PRS-ID-r16	0		
nr-PhysCellID-r16	Cell 1		
nr-CellGlobalID-r16	Cell 1		
nr-ARFCN-r16	Cell 1		
nr-DL-PRS-SFN0-Offset-r16 SEQUENCE {			
sfn-Offset-r16	0		
integerSubframeOffset-r16	0		
}			
nr-DL-PRS-ExpectedRSTD-r16	0		
nr-DL-PRS-ExpectedRSTD-Uncertainty-r16	0		
nr-DL-PRS-Info-r16	As specified in Table 14.2.8.4.3-6		
}			
NR-DL-PRS-AssistanceDataPerTRP-r16[2] SEQUENCE {		entry 2	Cell 2
dl-PRS-ID-r16	1		
nr-PhysCellID-r16	Cell 2		
nr-CellGlobalID-r16	Cell 2		
nr-ARFCN-r16	Cell 2		
nr-DL-PRS-SFN0-Offset-r16 SEQUENCE {			
sfn-Offset-r16	0		
integerSubframeOffset-r16	0		
}			
nr-DL-PRS-ExpectedRSTD-r16	23	About 3 μs	
nr-DL-PRS-ExpectedRSTD-Uncertainty-r16	154	About 5 μs	

nr-DL-PRS-Info-r16	As specified in Table 14.2.8.4.3-6		
}			
NR-DL-PRS-AssistanceDataPerTRP-r16[3] SEQUENCE {		entry 3	Cell 3
dl-PRS-ID-r16	2		
nr-PhysCellID-r16	Cell 3		
nr-CellGlobalID-r16	Cell 3		
nr-ARFCN-r16	Cell 3		
nr-DL-PRS-SFN0-Offset-r16 SEQUENCE {			
sfn-Offset-r16	0		
integerSubframeOffset-r16	0		
}			
nr-DL-PRS-ExpectedRSTD-r16	23	About 3 μs	
nr-DL-PRS-ExpectedRSTD-Uncertainty-r16	154	About 5 μs	
nr-DL-PRS-Info-r16	As specified in Table 14.2.8.4.3-6		
}			
}			
}			
}			
}			

Table 14.2.8.4.3-6: NR-DL-PRS-Info

Derivation Path: 37.355 clause 6.4.3			
Information Element	Value/remark	Comment	Condition
NR-DL-PRS-Info-r16 ::= SEQUENCE {			
nr-DL-PRS-ResourceSetList-r16 SEQUENCE (SIZE (1..nrMaxSetsPerTrp-r16)) OF NR-DL-PRS-ResourceSet-r16 {	1 entry		
NR-DL-PRS-ResourceSet-r16[1] SEQUENCE {		entry 1	
nr-DL-PRS-ResourceSetID-r16	0		
dl-PRS-Periodicity-and-ResourceSetSlotOffset-r16 CHOICE {			
scs120-r16 CHOICE {			
n1280-r16	80		
}			
dl-PRS-ResourceRepetitionFactor-r16	Not present		
dl-PRS-ResourceTimeGap-r16	s1		
dl-PRS-NumSymbols-r16	n4		
dl-PRS-MutingOption1-r16 SEQUENCE {			
dl-prs-MutingBitRepetitionFactor-r16	Not present		
nr-option1-muting-r16 CHOICE {			
po2-r16	10		Cell 1
	01		Cell 2
	10		Cell 3
}			
}			
dl-PRS-MutingOption2-r16	Not present		
dl-PRS-ResourcePower-r16	27		
dl-PRS-ResourceList-r16 SEQUENCE (SIZE (1..nrMaxResourcesPerSet-r16)) OF NR-DL-PRS-Resource-r16 {	1 entry		
NR-DL-PRS-Resource-r16[1] SEQUENCE {		entry 1	
nr-DL-PRS-ResourceID-r16	0		
dl-PRS-SequenceID-r16	0		
dl-PRS-CombSizeN-AndReOffset-r16 CHOICE {			
n4-r16	0		Cell 1 and Cell 2
	1		Cell 3
}			
}			
dl-PRS-ResourceSlotOffset-r16	4		
dl-PRS-ResourceSymbolOffset-r16	0		
dl-PRS-QCL-Info-r16	Not present		

}			
}			
}			
}			
}			

Table 14.2.8.4.3-7: LPP ProvideLocation Information

Derivation Path: TS 37.355 [49] clause 6.2			
Information Element	Value/remark	Comment	Condition
LPP-Message ::= SEQUENCE {			
transactionID SEQUENCE {			
initiator	locationServer		
transactionNumber	1		
}			
endTransaction	TRUE		
sequenceNumber	(0..255)		
acknowledgement			
lpp-MessageBody CHOICE {			
c1 CHOICE {			
provideLocationInformation SEQUENCE {			
criticalExtensions CHOICE {			
c1 CHOICE {			
provideLocationInformation-r9 SEQUENCE {			
commonIEsProvideLocationInformation	Not present.		
a-gnss-ProvideLocationInformation	Not present		
otdoa-ProvideLocationInformation	Not present		
ecid-ProvideLocationInformation	Not present		
epdu-ProvideLocationInformation	Not present		
sensor-ProvideLocationInformation-r13	Not present		
tbs-ProvideLocationInformation-r13	Not present		
wlan-ProvideLocationInformation-r13	Not present		
bt-ProvideLocationInformation-r13	Not present		
nr-ECID-ProvideLocationInformation-r16	Not present		
nr-Multi-RTT-ProvideLocationInformation-	Not present		
r16			
nr-DL-AoD-ProvideLocationInformation-r16	Not present		
nr-DL-TDOA-ProvideLocationInformation-			
r16 SEQUENCE {			
nr-DL-TDOA-			
SignalMeasurementInformation-r16 SEQUENCE {			
dl-PRS-ReferenceInfo-r16			
nr-DL-TDOA-MeasList-r16 SEQUENCE	3 entries		
(SIZE(1..nrMaxTRPs-r16)) OF NR-DL-TDOA-			
MeasElement-r16 {			
NR-DL-TDOA-MeasElement-r16[1]		entry 1	
SEQUENCE {			
dl-PRS-ID-r16			
nr-PhysCellID-r16	Cell 1		
nr-CellGlobalID-r16			
nr-ARFCN-r16			
nr-DL-PRS-ResourceID-r16			
nr-DL-PRS-ResourceSetID-r16			
nr-TimeStamp-r16			
nr-RSTD-r16	Present		
nr-AdditionalPathList-r16			
nr-TimingQuality-r16			
nr-DL-PRS-RSRP-Result-r16			
nr-DL-TDOA-AdditionalMeasurements-			
r16			
nr-UE-Rx-TEG-ID-r17			
nr-DL-PRS-FirstPathRSRP-Result-r17			
nr-los-nlos-Indicator-r17			
nr-AdditionalPathListExt-r17			

nr-DL-TDOA-AdditionalMeasurementsExt-r17			
}			
NR-DL-TDOA-MeasElement-r16[2]		entry 2	
SEQUENCE {			
dl-PRS-ID-r16			
nr-PhysCellID-r16	Cell 2		
nr-CellGlobalID-r16			
nr-ARFCN-r16			
nr-DL-PRS-ResourceID-r16			
nr-DL-PRS-ResourceSetID-r16			
nr-TimeStamp-r16			
nr-RSTD-r16	Present		
nr-AdditionalPathList-r16			
nr-TimingQuality-r16			
nr-DL-PRS-RSRP-Result-r16			
nr-DL-TDOA-AdditionalMeasurements-r16			
nr-UE-Rx-TEG-ID-r17			
nr-DL-PRS-FirstPathRSRP-Result-r17			
nr-los-nlos-Indicator-r17			
nr-AdditionalPathListExt-r17			
nr-DL-TDOA-AdditionalMeasurementsExt-r17			
}			
NR-DL-TDOA-MeasElement-r16[3]		entry 3	
SEQUENCE {			
dl-PRS-ID-r16			
nr-PhysCellID-r16	Cell 3		
nr-CellGlobalID-r16			
nr-ARFCN-r16			
nr-DL-PRS-ResourceID-r16			
nr-DL-PRS-ResourceSetID-r16			
nr-TimeStamp-r16			
nr-RSTD-r16	Present		
nr-AdditionalPathList-r16			
nr-TimingQuality-r16			
nr-DL-PRS-RSRP-Result-r16			
nr-DL-TDOA-AdditionalMeasurements-r16			
nr-UE-Rx-TEG-ID-r17			
nr-DL-PRS-FirstPathRSRP-Result-r17			
nr-los-nlos-Indicator-r17			
nr-AdditionalPathListExt-r17			
nr-DL-TDOA-AdditionalMeasurementsExt-r17			
}			
}			
nr-UE-RxTEG-TimingErrorMargin-r17			
}			
nr-dl-tdoa-LocationInformation-r16			
nr-DL-TDOA-Error-r16			
nr-DL-TDOA-SignalMeasurementInstances-r17			
nr-DL-TDOA-LocationInformationInstances-r17			
}			
}			
}			
}			
}			
}			

14.2.8.5 Test requirement

Table 14.2.8.5-1, Table 14.2.8.5-2 and Table 14.2.8.5-3 define the primary level settings including test tolerances for the test.

Table 14.2.8.5-1: General test parameters for RSTD measurement reporting delay

Parameter	Unit	Value	Comment	
Reference cell		Cell 1	Reference cell is the cell in the DL-TDOA assistance data with respect to which the RSTD measurement is defined, as specified in TS 38.215 [57] and TS 37.355 [49]. The reference cell is the PCell in this test case.	
Neighbor cells		Cell 2 and Cell 3	Cell 2 and Cell 3 appear at the first and second places in the neighbour cell list in the DL-TDOA assistance data.	
SSB configuration	Config 1	SSB.3 FR2		
BW _{channel}	Config 1	MHz	200: N _{RB,c} = 132	
SMTC configuration	Config 1		SMTC.1	
PDSCH RMC configuration	Config 1		SR.1.1 FDD	
RMSI CORESET RMC configuration	Config 1		CR.3.1 TDD	As specified in TS 38.133 [50] clause A.3.1.2.1
Dedicated CORESET RMC configuration	Config 1		CR.1.1 FDD	
PRS Configuration	Config 1		PRS.1.2 FR2	As specified in TS 38.133 [50] clause A.3. 31
Physical cell ID PCI			(PCI of Cell 1 – PCI of Cell 2)mod6=0 and (PCI of Cell 1 – PCI of Cell 3)mod6=0	The cell PCIs are selected such that the relative shifts of PRS patterns among cells are as given by the test parameters
CP length			Normal	
DRX			OFF	
Measurement gap			GP#24 or GP#13	GP#24 is configured if UE supports MG#24, otherwise GP#13 is configured
Radio frame receive time offset between the cells at the UE antenna connector	μs		Cell 2 to Cell 1: 0 Cell 3 to Cell 1: 3	PRS are transmitted from synchronous cells
Expected RSTD	μs		Cell 2: 3 Cell 3: 3 Other neighbour cells: randomly between -3 and 3	The expected RSTD is what is expected at the receiver. The corresponding parameter in the DL-TDOA assistance data specified in TS 37.355 [49] is the expectedRSTD indicator

Expected RSTD uncertainty for all neighbour cells	μs	5	The corresponding parameter in the DL-TDOA assistance data specified in TS 37.355 [49] is the expectedRSTD-Uncertainty index
Number of cells provided in DL-TDOA assistance data		4	Including the reference cell
PRS muting info		Cell 1: '10' Cell 2: '01' Cell 3: '10'	Corresponds to prs-MutingInfo defined in TS 37.355 [49]
PRS resource RE offset		Cell 1: 0 Cell 2: 0 Cell 3: 1	Cell 1 and Cell 3 are configured with different resource offsets
T1	s	3	The length of the time interval from the beginning of each test
T2	s	1.28	The length of the time interval that follows immediately after time interval T1
AoA setup		Setup 1	As defined in TS 38.133 [50] A.3.15.1
Beam assumption		Rough	Information about types of UE beam is given in TS 38.133 [50] B.2.1.3, and does not limit UE implementation or test system implementation

Table 14.2.8.5-2: Cell-specific test parameters for RSTD measurement reporting delay during T1

Parameter	Unit	Cell 1	Cell 2	Cell 3	
NR RF Channel Number		1	1	1	
Positioning frequency layer		1	1	1	
Correlation Matrix and Antenna Configuration		1x2 Low	1x2 Low	1x2 Low	
OCNG patterns defined in A.3.2.1		OP.5 FDD	N/A	N/A	
N_{oc} ^{Note 3}	Config 1	dBm/SCS	-89		
PRS \hat{E}_s/N_{oc}		dB	-Infinity	-Infinity	-Infinity
I_o ^{Note 4}	Config 1	dBm/190.08MHz	-57.00	-57.00	-57.00
SSB RP ^{Note 4}	Config 1	dBm/SCS	-89	-Infinity	-Infinity
SSB \hat{E}_s/N_{oc}		dB	0	-Infinity	-Infinity
Propagation Condition		AWGN			
Note 1:	OCNG shall be used such that active cell (Cell 1) is fully allocated and a constant total transmitted power spectral density is achieved for all OFDM symbols.				
Note 2:	The resources for uplink transmission are assigned to the UE prior to the start of time period T2.				
Note 3:	Interference from other cells and noise sources not specified in the test are assumed to be constant over subcarriers and time and shall be modelled as AWGN of appropriate power for N_{oc} to be fulfilled.				
Note 4:	SSB RP and I_o levels have been derived from other parameters and are given for information purpose. These are not settable test parameters.				

Table 14.2.8.5-2: Cell-specific test parameters for RSTD measurement reporting delay during T2

Parameter		Unit	Cell 1	Cell 2	Cell 3
			T2	T2	T2
RF Channel Number			1	1	1
Positioning frequency layer			1	1	1
Correlation Matrix and Antenna Configuration			1x2 Low	1x2 Low	1x2 Low
OCNG patterns defined in A.3.2.1			OP.1	OP.1	OP.1
PRACH configuration			FR2 PRACH configuration 1	FR2 PRACH configuration 1	FR2 PRACH configuration 1
N_{oc} ^{Note 3}	Config 1	dBm/SCS	-95	-95	-95
PRS \hat{E}_s/N_{oc}	Config 1	dB	2.9	0.75	0.75
Io	Config 1	dBm/190.08MHz	-55.71	-55.71	-55.71
PRS \hat{E}_s/I_{ot}		dB	-2.7	-5.6	-5.6
PRP ^{Note 4}		dBm/SCS	-92.1	-94.2	-94.2
Propagation Condition			AWGN		
<p>Note 1: OCNG shall be used such that active cells (all, except Cell 3 in T3) are fully allocated and a constant total transmitted power spectral density is achieved for all OFDM symbols other than those in the subframes with transmitted PRS.</p> <p>Note 2: The resources for uplink transmission are assigned to the UE prior to the start of time period T2.</p> <p>Note 3: Interference from other cells and noise sources not specified in the test are assumed to be constant over subcarriers and time and shall be modelled as AWGN of appropriate power for N_{oc} to be fulfilled.</p> <p>Note 4: PRP and Io levels have been derived from other parameters and are given for information purpose. These are not settable test parameters. The Io is calculated based only on the symbols in which PRS is transmitted.</p> <p>Note 5: Calculation of E_s/I_{ot} includes the effect of UE internal noise up to the value assumed for the associated Refsens requirement in clause 7.3.2 of TS 38.101-2 [55], and an allowance of 1dB for UE multi-band relaxation factor ΔMB_P from TS 38.101-2 [55] Table 6.2.1.3-4.</p>					

The RSTD measurement time fulfils the requirements specified in clause 14.2.8.3.

The UE shall perform and report the RSTD measurements for Cell 2 and Cell 3 with respect to the reference cell in the DL-TDOA assistance data, Cell 1, within the time duration specified in clause 14.2.8.3 starting from the beginning of time interval T2.

The rate of the correct events for each neighbour cell observed during repeated tests shall be at least 90%, where the reported RSTD measurement for each correct event shall be within the RSTD reporting range specified in TS 38.133[50] Clause 10.1.23.3, i.e., between RSTD_000000 and RSTD_1970049.

The response time is equal to the LPP time IE value plus the test tolerance. The LPP time IE value is derived from the RSTD measurement period plus ΔT , where $\Delta T = 50$ ms. The RSTD measurement period follows the equation:

$$T_{RSTD,i} = \left(CSSF_{PRS,i} * N_{RxBeam,i} * \left[\frac{N_{PRS,i}^{slot}}{N'} \right] \left[\frac{L_{available_PRS,i}}{N} \right] * N_{sample} - 1 \right) * T_{effect,i} + T_{last,i}$$

Where $CSSF_{PRS,i} = 1$, $N_{RxBeam,i} = 8$, $N_{PRS,i}^{slot} = 3$, $L_{available_PRS,i} = 1$, $N_{sample} = 1$. N is the parameter *durationOfPRS-ProcessingSymbols* from TS 37.355 [49], N' is the parameter *maxNumOfDL-PRS-ResProcessedPerSlot* from TS 37.355 [49], $T_{last,i} = T_i + T_{available_PRS,i}$ and $T_{effect,i} = \left[\frac{T_i}{T_{available_PRS,i}} \right] * T_{available_PRS,i}$

$T_{available_PRS,i} = LCM(T_{PRS,i}, MGRP_i)$; where $T_{prs} = 160$ ms, and MGRP is 80 (for GP#24) or 40 (for GP#13) depending on UE capabilities. Therefore, $T_{available_PRS,i} = 160$ ms.

T_i depends on the UE parameter *durationOfPRS-ProcessingSymbolsInEveryTms* from TS 37.355 [49]

Finally, it results in the following equation:

$$\left(1 * 8 * \left\lceil \frac{3}{N'} \right\rceil \left\lceil \frac{0.107}{N} \right\rceil * 1 - 1 \right) * T_{effect} + T_{last}$$

Where the remaining parameters depend on the UE capabilities. The LPP time IE ranges between 1.288s and 30.88s. The value of the LPP time IE is rounded up to the next second (if the value is >128s, it should be rounded up to the next multiple of ten seconds). The result is transmitted in the response time IE in the LPP-RequestLocationInformation in Table 14.2.8.4.3-3. The LPP time IE ranges between 2s and 31s.

The test tolerance for the response time is 300ms. Therefore, the response time ranges between 2.3s and 31.3s.

The values of N' , N and T_i and the effect in the response time equation are defined in Table 14.2.8.5-4, Table 14.2.8.5-5 and Table 14.2.8.5-6 for reference.

Table 14.2.8.5-4: value of N' based on *maxNumOfDL-PRS-ResProcessedPerSlot*

<i>maxNumOfDL-PRS-ResProcessedPerSlot</i>	$\left\lceil \frac{3}{N'} \right\rceil$
n1	3
n2	3
>=n4	1

Table 14.2.8.5-5: value of N based on *durationOfPRS-ProcessingSymsbols*

<i>durationOfPRS-ProcessingSymsbols</i>	$\left\lceil \frac{0.107}{N} \right\rceil$
>=nDot125	1

Table 14.2.8.5-6: value of T_{effect} and T_{last} based on *durationOfPRS-ProcessingSymbolsInEveryTms*

<i>durationOfPRS-ProcessingSymbolsInEveryTms</i>	T_{effect}	T_{last}
n8	160	168
n16	160	176
n20	160	180
n30	160	190
n40	160	200
n80	160	240
n160	160	320
n320	320	480
n640	640	800
n1280	1280	1440

The test tolerances are defined in clauses C.1.6 and C.2.5.

The rate of successful tests during repeated tests shall be at least 90% with a confidence level of 95%.

14.2.9 NR RSTD measurement reporting delay test case for single positioning frequency layer without measurement gap in FR2 SA

Editor's Note: This test case has been completed for the following configurations:

- Test frequency $f \leq 40.8$ GHz

- UE PC3

This test case is incomplete for UE power classes other than PC3

This test case is incomplete for test frequencies > 40.8 GHz

14.2.9.1 Test purpose

The purpose of the test is to verify that the RSTD measurement meets the gapless RSTD measurement requirements specified in TS 38.133 [50] Clause 9.9.2.7 in an environment with AWGN propagation conditions in FR2 in standalone scenario when single positioning frequency layer is configured.

14.2.9.2 Test applicability

This test applies to all types of NR UE release 17 onwards that supports DL-TDOA positioning and prs-Processing Window.

14.2.9.3 Minimum conformance requirements

When physical layer receives last of *NR-TDOA-ProvideAssistanceData* message and *NR-TDOA-RequestLocationInformation* message from LMF via LPP [34], the UE shall be able to measure multiple (up to the UE capability specified in Clause 9.9.2.3) DL RSTD measurements, defined in TS 38.215 [4], during the measurement period $T_{RSTD,Total}$ defined as:

$T_{RSTD,Total} = \sum_{i=1}^L T_{RSTD_wo_gap,i} + (L - 1) * \max(T_{effect,i})$, if any of the positioning frequency layers are in Case 1, or

$T_{RSTD,Total} = \max(T_{RSTD_wo_gap,i} + T_{uncertainty,i})$, if all the positioning frequency layers are in Case 2,

Where,

i is the index of positioning frequency layer, and

L is total number of positioning frequency layers, and

$T_{effect,i}$ is the periodicity of the PRS RSTD measurement in positioning frequency layer i , and

$T_{uncertainty,i}$ is the time from the start of the first PPW occasion for positioning frequency layer i to the start of measurement period $T_{RSTD,Total}$.

A positioning frequency layer is in Case 1 if UE reports *ppw-durationOfPRS-Processing1-r17* for the band containing the positioning frequency layer, and a positioning frequency layer is in Case 2 if UE reports *ppw-durationOfPRS-Processing2-r17* for the band containing the positioning frequency layer.

$T_{RSTD_wo_gap,i}$ is the measurement period for PRS RSTD measurement in positioning frequency layer i as specified below.

$$T_{RSTD_wo_gap,i} = \left(k_{multiTEG,i} * N_{RxBeam,i} * \left\lceil \frac{N_{slot}^{PRs,i}}{N'} \right\rceil \left\lfloor \frac{L_{available_PRS,i}}{N} \right\rfloor * N_{sample} - 1 \right) * T_{effect,i} + T_{last,i},$$

where:

$N_{RxBeam,i}$ is the UE Rx beam sweeping factor. In FR1, $N_{RxBeam,i} = 1$; and in FR2, $N_{RxBeam,i}$ is equal to the value reported by the UE in *supportedLowerRxBeamSweepingFactor-FR2* if the UE supports the capability for the band containing positioning frequency layer i , and the LMF indicates *lowerRxBeamSweepingFactor-FR2* in *NR-TDOA-RequestLocationInformation*. $N_{RxBeam,i}$ is equal to 8, otherwise.

$k_{multiTEG,i}$ is the scaling factor for measurement of same PRS resource with multiple Rx TEGs.

$k_{multiTEG,i} = 1$ if UE is not supported *measureSameDL-PRS-ResourceWithDifferentRxTEGs-r17* or not requested by LMF to measure a PRS resource with multiple Rx TEGs via *measureSameDL-PRS-ResourceWithDifferentRxTEGs-r17* [34] in *NR-DL-TDOA-RequestLocationInformation*;

otherwise,

$k_{multiTEG} = N_{TEG,i}$, if the UE is not capable of receiving same DL PRS resource simultaneously from multiple Rx TEGs, and

$k_{multiTEG} = \left\lfloor \frac{N_{TEG,i}}{k_{TEG,simul,i}} \right\rfloor$ if the UE is capable of receiving the same DL PRS resource simultaneously from multiple Rx TEGs.

where

$N_{TEG,i}$ is the number of Rx TEGs with which UE is requested to measure a PRS resource indicated via *measureSameDL-PRS-ResourceWithDifferentRxTEGs-r17* [34] in *NR-DL-TDOA-RequestLocationInformation*, and in case 'n0' is indicated, $N_{TEG,i}$ is the maximum number of Rx TEGs with which UE can support to measure the same PRS resource as reported in *NR-UE-TEG-Capability*, and

$k_{TEG,simul,i}$ is the number of Rx TEGs UE can measure simultaneously which is reported via *measureSameDL-PRS-ResourceWithDifferentRxTEGsSimul*.

$N_{PRS,i}^{slot}$ is the maximum number of DL PRS resources in positioning frequency layer i configured in a slot.

$L_{available_PRS,i}$ is the time duration of available PRS in the positioning frequency layer i to be measured during $T_{available_PRS,i}$, and is calculated in the same way as PRS duration K defined in clause 5.1.6.5 of TS 38.214 [26]. For calculation of $L_{available_PRS,i}$,

only the PRS resources unmuted and fully or partially overlapped with PPW are considered, if positioning frequency layer i is in Case 1, or

only the PRS resources unmuted and fully or partially overlapped with the first (PPWL-T2) ms of PPW are considered, if positioning frequency layer i is in Case 2, where PPWL is the PPW length and T2 corresponds to *ppw-durationOfPRS-ProcessingSymbolsT2*.

N_{sample} is the number of PRS RSTD measurement samples, where

- $N_{sample} = 1$ if the UE supports *supportedDL-PRS-ProcessingSamples* [34], and the LMF requests the UE to perform positioning measurements with reduced number of samples, and meets the following conditions:
 - PRS bandwidth is within the active BWP and
 - Magnitude of difference between the serving cell's SS-RSRP and the neighbour cell's PRS-RSRP is within 6 dB.
- $N_{sample} = 2$ if the UE supports *supportedDL-PRS-ProcessingSamples* [34], and the LMF requests the UE to perform positioning measurements with reduced number of samples, and does not meet the following conditions:
 - PRS bandwidth is within the active BWP and
 - Magnitude of difference between the serving cell's SS-RSRP and the neighbour cell's PRS-RSRP is within 6 dB.

$T_{last,i}$ is the measurement duration for the last PRS RSTD sample in positioning frequency layer i , including the sampling time and processing time.

If positioning frequency layer i is in Case 1 and all of the PRS resources to be measured are available in the same PPW occasion during $T_{available}$, then $T_{last,i} = T_i + PPWL$, else

if positioning frequency layer i is in Case 2 and all of the PRS resources to be measured are available in the same PPW occasion during $T_{available}$, then $T_{last,i} = PPWL$;

otherwise, $T_{last,i} = T_i + T_{available_PRS,i}$.

$T_{effect,i}$ is the periodicity of the PRS RSTD measurement in positioning frequency layer i defined as:

$$T_{effect,i} = \left\lceil \frac{T_i}{T_{available_PRS,i}} \right\rceil * T_{available_PRS,i}$$

Where,

T_i corresponds to *ppw-durationOfPRS-ProcessingSymbolsT* in TS 37.355 [34] if positioning frequency layer i is in Case 1, or corresponds to the sum of *ppw-durationOfPRS-ProcessingSymbolsT2* and *ppw-durationOfPRS-ProcessingSymbolsN2* in TS 37.355 [34] if positioning frequency layer i is in Case 2,

$T_{available_PRS,i} = LCM(T_{PRS,i}, PPWRP_i)$, the least common multiple between $T_{PRS,i}$ and $PPWRP_i$.

$PPWRP_i$ is the repetition periodicity of the PRS processing window applicable for measurements in the positioning frequency layer i .

$T_{PRS,i}$ is the periodicity of DL PRS resource with muting on positioning frequency layer i .

If more than one PRS periodicities are configured in positioning frequency layer i , the least common multiple of PRS periodicities $T_{per}^{PRS \text{ with muting}}$ among all DL PRS resource sets in the positioning frequency layer is used to derive $T_{PRS,i}$, where,

$T_{per}^{PRS \text{ with muting}} = N_{muting} * T_{per}^{PRS}$, is the PRS periodicity with muting per PRS resource,

T_{per}^{PRS} is the periodicity of PRS resource sets given by the higher-layer parameter *DL-PRS-Periodicity*,

N_{muting} is the scaling factor considering PRS resource muting. $N_{muting} = T_{muting}^{PRS} * L_{muting}$, where T_{muting}^{PRS} is the muting repetition factor given by the higher-layer parameter *DL-PRS-MutingBitRepetitionFactor*, and L_{muting} is the size of the bitmap $\{b^1\}$.

Note: For the purpose of calculating $T_{PRS,i}$, only the PRS resources that meet the conditions for PRS measurement outside measurement gaps as defined in clause 9.9.1.2 are considered.

N is a duration of DL PRS symbols in ms corresponding to *ppw-durationOfPRS-ProcessingSymbolsN* in TS 37.355 [34] if positioning frequency layer i is in Case 1, or corresponding to *ppw-durationOfPRS-ProcessingSymbolsN2* in TS 37.355 [34] if positioning frequency layer i is in Case 2.

N' is UE capability for number of DL PRS resources that it can process in a slot as indicated by *ppw-maxNumOfDL-PRS-ResProcessedPerSlot* specified in TS 37.355 [34].

14.2.9.4 Test description

14.2.9.4.1 Initial conditions

The supported test configurations in listed in Table 14.2.9.4-1.

Table 14.2.9.4-1: Test Configurations

Test Configuration	Description
1	120 kHz SSB and PRS SCS, 200 MHz bandwidth, TDD duplex mode

Test Environment: Normal, as defined in TS 38.508-1 [45] clause 4.1.

Frequencies to be tested: Mid Range, as defined in TS 38.508-1 [45] clause 4.3.1.

Channel bandwidth to be tested: are specified in Table 14.2.9.4-1.

1. Connect the SS and AWGN noise sources to the UE antenna connector or antenna connectors as shown in Annex A, Figure A.14.
2. The general test parameter settings are set up according to Table 14.2.9.5-1, Table 14.2.9.5-2 and Table 14.2.9.5-3.
3. Propagation conditions are set according to clause 4.15.2.
4. Message contents are defined in clause 14.2.9.4.3.
5. In the test there are three synchronous cells: Cell 1, Cell 2 and Cell 3. Cell 1 is the reference as well as the PCell. Cell 2 and Cell 3 are the neighbour cells. All cells are on the same RF channel distributed in single positioning frequency layer.

14.2.9.4.2 Test procedure

The test consists of two sub-tests; Sub-test 1 is for $N_{sample} = 4$ and sub-test 2 is for $N_{sample} = 1$. Sub-test 2 is only conducted when UE also supporting supportedDL-PRS-ProcessingSamples-RRC-CONNECTED. The test consists of

two consecutive time intervals, with duration of T1 and T2. During time duration T1, the UE shall not have any timing information of Cell 2 and Cell 3. All three cells transmit PRS during T2. The beginning of the time interval T2 shall be aligned with the beginning of the first PRS processing window instance containing the PRS resources.

The *NR-DL-TDOA-ProvideAssistanceData* and *nr-DL-TDOA-RequestLocationInformation* as defined in TS 37.355 [49] clause 6.5.12.1, shall be provided to the UE during T1. The last TTI containing the two messages shall be provided to the UE ΔT ms before the start of T2, where $\Delta T = 50$ ms is the maximum processing time of the *DL-TDOA assistance* data and location information request.

3. Ensure the UE is in State RRC_CONNECTED with generic procedure parameters Connectivity NR, Connected without release On, according to TS 38.508-1 [45] clause 4.5.
2. The SS shall send a RESET UE POSITIONING STORED INFORMATION message.
3. Set the parameters according to Table 14.2.9.5-1, Table 14.2.9.5-2 and Table 14.2.9.5-3. Propagation conditions are set according to clause 4.15.2.
4. T1 starts.
5. The SS shall transmit an LPP REQUEST CAPABILITIES message.
6. The UE shall transmit an LPP PROVIDE CAPABILITIES message indicating the DL-TDOA capabilities supported by the UE in the *NR-DL-TDOA-ProvideCapabilities* IE.
7. The SS shall transmit an RRCReconfiguration message with the PPW configuration.
8. The UE shall transmit RRCReconfigurationComplete message.
9. The SS shall send a LPP PROVIDE ASSISTANCE DATA message, including the *NR-DL-TDOA-ProvideAssistanceData* IE. The position of neighbour Cell 2 and the position of neighbour Cell 3 are described in 3GPP TS 37.571-5 [20]. If the UE message at step 6 includes the *ackRequested* IE set to TRUE, then the SS shall send an acknowledgment in the LPP PROVIDE ASSISTANCE DATA message.
10. The SS shall send a LPP REQUEST LOCATION INFORMATION message, including the *NR-DL-TDOA-RequestLocationInformation* IE such that the UE receives the message ΔT ms before the start of T2, where $\Delta T = 50$ ms.
11. The SS sends a Positioning Measurement Gap Activation command containing an ID to activate the associated measurement gap
12. When T1 expires, the SS shall switch the power setting from T1 to T2 as specified in Table 14.2.9.5-2 and Table 14.2.9.5-3.
13. The UE shall transmit a LPP PROVIDE LOCATION INFORMATION message including the *NR-DL-TDOA-ProvideLocationInformation* IE within the response time (see clause 4.15.3). The UE shall perform and report the RSTD measurements for both Cell 2 and Cell 3 with respect to the reference cell in the DL-TDOA assistance data, Cell 1. If the UE transmits an *NR-DL-TDOA-ProvideLocationInformation* IE including the *nr-RSTD* field for both Cell 2 and Cell 3 within the response time, then the number of successful tests is increased by one. If the UE fails to report the *NR-DL-TDOA-ProvideLocationInformation* IE with the *nr-RSTD* fields included within the response time then the number of failure tests is increased by one.
14. If the UE message at step 13 includes the *ackRequested* IE set to TRUE, the SS shall send a LPP acknowledgement message.
15. Repeat steps 2-14 in Table 14.2.9.4-1 until the confidence level according to Annex D is achieved.

If all (applicable) sub-tests pass, the whole test passes. If one (applicable) sub-test fails, the whole test fails.

14.2.9.4.3 Message contents

Table 14.2.9.4.3-1: RESET UE POSITIONING STORED INFORMATION

Derivation Path: 38.509 [44] clause 6.6			
Information Element	Value/remark	Comment	Condition
UE Positioning Technology	0 0 0 0 1 1 1	DL-TDOA	

Table 14.2.9.4.3-2: LPP Request Capabilities

Information Element	Value/remark
nr-DL-TDOA-RequestCapabilities-r16	TRUE

Table 14.2.9.4.3-3: RRCReconfiguration

Derivation Path: TS 38.508-1 [45], table 4.6.1-13			
Information Element	Value/remark	Comment	Condition
RRCReconfiguration ::= SEQUENCE {			
rrc-TransactionIdentifier	RRC-TransactionIdentifier		
criticalExtensions CHOICE {			
rrcReconfiguration SEQUENCE {			
nonCriticalExtension SEQUENCE {			
masterCellGroup	OCTET STRING (CONTAINING CellGroupConfig)		
}			
}			
}			
}			

Table 14.2.9.4.3-4: CellGroupConfig (RRCReconfiguration, Table 14.2.9.4.3-3)

Derivation Path: 38.508-1 [45], Table 4.6.3-19			
Information Element	Value/remark	Comment	Condition
CellGroupConfig ::= SEQUENCE {			
spCellConfig SEQUENCE {			
spCellConfigDedicated SEQUENCE {			
initialDownlinkBWP SEQUENCE {			
dl-PPW-PreConfigToAddModList-r17 SEQUENCE (SIZE (1..maxNrofPPW-Config-r17)) OF DL-PPW-PreConfig-r17 {	1 entry		
DL-PPW-PreConfig-r17[1] SEQUENCE {		entry 1	
dl-PPW-ID-r17	0		
dl-PPW-PeriodicityAndStartSlot-r17 CHOICE {	The periodicity is 160ms and the starting slot offset is 11 ms for any SCS configuration		
scs120 CHOICE {			
n1280	4		
}			
}			
length-r17	80		
type-r17	type1A		
priority-r17	st1		
}			
}			
}			
}			
}			
}			

Table 14.2.9.4.3-5: LPP ProvideAssistanceData

Derivation Path: TS 37.355 [49] clause 6.2			
Information Element	Value/remark	Comment	Condition
LPP-Message ::= SEQUENCE {			

transactionID SEQUENCE {			
initiator	locationServer		
transactionNumber	(0..255)		
}			
endTransaction	TRUE		
sequenceNumber	Not present		
acknowledgement	Not present		
lpp-MessageBody CHOICE {			
c1 CHOICE {			
provideAssistanceData SEQUENCE {			
criticalExtensions CHOICE {			
c1 CHOICE {			
provideAssistanceData-r9 SEQUENCE {			
commonEsProvideAssistanceData	Not present		
a-gnss-ProvideAssistanceData	Not present		
otdoa-ProvideAssistanceData	Not present		
epdu-Provide-AssistanceData	Not present		
sensor-ProvideAssistanceData-r14	Not present		
tbs-ProvideAssistanceData-r14	Not present		
wlan-ProvideAssistanceData-r14	Not present		
nr-Multi-RTT-ProvideAssistanceData-r16	Not present		
nr-DL-AoD-ProvideAssistanceData-r16	Not present		
nr-DL-TDOA-ProvideAssistanceData-r16			
SEQUENCE {			
nr-DL-PRS-AssistanceData-r16	As defined in Table 14.2.9.4.3-6		
nr-SelectedDL-PRS-IndexList-r16	Not present		
nr-PositionCalculationAssistance-r16			Depending on UE capabilities, i.e. support for UE-based DL-TDOA
SEQUENCE {			
nr-TRP-LocationInfo-r16	As defined in TS 37.571-5 [20]		
nr-DL-PRS-BeamInfo-r16	Not present		
nr-RTD-Info-r16	Not present		
nr-TRP-BeamAntennaInfo-r17	Not present		
nr-DL-PRS-Expected-LOS-NLOS-Assistance-r17	Not present		
nr-DL-PRS-TRP-TEG-Info-r17	Not present		
}			
nr-DL-TDOA-Error-r16	Not present		
nr-On-Demand-DL-PRS-Configurations-r17	Not present		
nr-On-Demand-DL-PRS-Configurations-Selected-IndexList-r17	Not present		
assistanceDataValidityArea-r17	Not present		
}			
}			
}			
}			
}			

Table 14.2.9.4.3-6: NR-DL-PRS-AssistanceData

Derivation Path: 37.355 clause 6.4.3			
Information Element	Value/remark	Comment	Condition
NR-DL-PRS-AssistanceData-r16 ::= SEQUENCE {			
nr-DL-PRS-ReferenceInfo-r16 SEQUENCE {			
dl-PRS-ID-r16	0		
nr-DL-PRS-ResourceID-List-r16	Not present		
nr-DL-PRS-ResourceSetID-r16	Not present		

}			
nr-DL-PRS-AssistanceDataList-r16 SEQUENCE (SIZE (1..nrMaxFreqLayers-r16)) OF NR-DL-PRS-AssistanceDataPerFreq-r16 {	1 entry		
NR-DL-PRS-AssistanceDataPerFreq-r16[1] SEQUENCE {		entry 1	
nr-DL-PRS-PositioningFrequencyLayer-r16 SEQUENCE {			
dl-PRS-SubcarrierSpacing-r16	kHz120		
dl-PRS-ResourceBandwidth-r16	27	128 PRBs	
dl-PRS-StartPRB-r16	0		
dl-PRS-PointA-r16	absoluteFrequencyPointA as defined for the DL frequency of the Cell 1		
dl-PRS-CombSizeN-r16	n4		
dl-PRS-CyclicPrefix-r16	normal		
}			
nr-DL-PRS-AssistanceDataPerFreq-r16 SEQUENCE (SIZE (1..nrMaxTRPsPerFreq-r16)) OF NR-DL-PRS-AssistanceDataPerTRP-r16{	3 entries		
NR-DL-PRS-AssistanceDataPerTRP-r16[1] SEQUENCE {		entry 1	Cell 1
dl-PRS-ID-r16	0		
nr-PhysCellID-r16	Cell 1		
nr-CellGlobalID-r16	Cell 1		
nr-ARFCN-r16	Cell 1		
nr-DL-PRS-SFN0-Offset-r16 SEQUENCE {			
sfn-Offset-r16	0		
integerSubframeOffset-r16	0		
}			
nr-DL-PRS-ExpectedRSTD-r16	0		
nr-DL-PRS-ExpectedRSTD-Uncertainty-r16	0		
nr-DL-PRS-Info-r16	As specified in Table 14.2.9.4.3-7		
}			
NR-DL-PRS-AssistanceDataPerTRP-r16[2] SEQUENCE {		entry 2	Cell 2
dl-PRS-ID-r16	1		
nr-PhysCellID-r16	Cell 2		
nr-CellGlobalID-r16	Cell 2		
nr-ARFCN-r16	Cell 2		
nr-DL-PRS-SFN0-Offset-r16 SEQUENCE {			
sfn-Offset-r16	0		
integerSubframeOffset-r16	0		
}			
nr-DL-PRS-ExpectedRSTD-r16	0	About 0 μ s	
nr-DL-PRS-ExpectedRSTD-Uncertainty-r16	17	About 0.58 μ s	
nr-DL-PRS-Info-r16	As specified in Table 14.2.9.4.3-7		
}			
NR-DL-PRS-AssistanceDataPerTRP-r16[3] SEQUENCE {		entry 3	Cell 3
dl-PRS-ID-r16	2		
nr-PhysCellID-r16	Cell 3		
nr-CellGlobalID-r16	Cell 3		
nr-ARFCN-r16	Cell 3		
nr-DL-PRS-SFN0-Offset-r16 SEQUENCE {			
sfn-Offset-r16	0		
integerSubframeOffset-r16	0		
}			
nr-DL-PRS-ExpectedRSTD-r16	0	About 0 μ s	
nr-DL-PRS-ExpectedRSTD-Uncertainty-r16	17	About 0.58 μ s	
nr-DL-PRS-Info-r16	As specified in Table 14.2.9.4.3-7		
}			
}			

}			
}			
}			

Table 14.2.9.4.3-7: NR-DL-PRS-Info

Derivation Path: 37.355 clause 6.4.3			
Information Element	Value/remark	Comment	Condition
NR-DL-PRS-Info-r16 ::= SEQUENCE {			
nr-DL-PRS-ResourceSetList-r16 SEQUENCE (SIZE (1..nrMaxSetsPerTrp-r16)) OF NR-DL-PRS-ResourceSet-r16 {	1 entry		
NR-DL-PRS-ResourceSet-r16[1] SEQUENCE {		entry 1	
nr-DL-PRS-ResourceSetID-r16	0		
dl-PRS-Periodicity-and-ResourceSetSlotOffset-r16 CHOICE {			
Scs120-r16 CHOICE {			
n1280-r16	80		
}			
dl-PRS-ResourceRepetitionFactor-r16	Not present		
dl-PRS-ResourceTimeGap-r16	s1		
dl-PRS-NumSymbols-r16	n4		
dl-PRS-MutingOption1-r16 SEQUENCE {			
dl-prs-MutingBitRepetitionFactor-r16	Not present		
nr-option1-muting-r16 CHOICE {			
po2-r16	10		Cell 1
	01		Cell 2
	10		Cell 3
}			
}			
dl-PRS-MutingOption2-r16	Not present		
dl-PRS-ResourcePower-r16	27		
dl-PRS-ResourceList-r16 SEQUENCE (SIZE (1..nrMaxResourcesPerSet-r16)) OF NR-DL-PRS-Resource-r16 {	2 entries		
NR-DL-PRS-Resource-r16[1] SEQUENCE {		entry 1	
nr-DL-PRS-ResourceID-r16	0		
dl-PRS-SequenceID-r16	0		
dl-PRS-CombSizeN-AndReOffset-r16 CHOICE {			
n4-r16	0		Cell 1 and Cell 2
	1		Cell 3
}			
dl-PRS-ResourceSlotOffset-r16	4		
dl-PRS-ResourceSymbolOffset-r16	0		
dl-PRS-QCL-Info-r16	Not present		
}			
NR-DL-PRS-Resource-r16[2] SEQUENCE {		entry 2	
nr-DL-PRS-ResourceID-r16	1		
dl-PRS-SequenceID-r16	1		
dl-PRS-CombSizeN-AndReOffset-r16 CHOICE {			
n4-r16	0		Cell 1 and Cell 2
	1		Cell 3
}			
dl-PRS-ResourceSlotOffset-r16	4		
dl-PRS-ResourceSymbolOffset-r16	0		
dl-PRS-QCL-Info-r16	Not present		
}			
}			
}			
}			
}			

Table 14.2.9.4.3-8: LPP RequestLocationInformation

Derivation Path: TS 37.355 [49] clause 6.2			
Information Element	Value/remark	Comment	Condition
LPP-Message ::= SEQUENCE {			
transactionID SEQUENCE {			
initiator	locationServer		
transactionNumber	1		
}			
endTransaction	FALSE		
sequenceNumber	Not present		
acknowledgement	Not present		
lpp-MessageBody CHOICE {			
c1 CHOICE {			
requestLocationInformation SEQUENCE {			
criticalExtensions CHOICE {			
c1 CHOICE {			
requestLocationInformation-r9 SEQUENCE {			
commonEsRequestLocationInformation SEQUENCE {			
locationInformationType	locationMeasurementsPreferred		
triggeredReporting	Not present		
periodicalReporting	Not present		
additionalInformation	onlyReturnInformationRequested		
qos SEQUENCE {			
horizontalAccuracy	Not present		
verticalCoordinateRequest	FALSE		
verticalAccuracy	Not present		
responseTime SEQUENCE {			
time	See 14.2.9.5	Result of the response time calculation rounded up to the next second if response time <= 128s. Result of the response time calculation rounded up to the next multiple of ten seconds if response time > 128s	
responseTimeEarlyFix-r12	Not present		Rel-12 onwards
unit-r15	Not present ten-seconds		Calculated response time >128s
}			
velocityRequest	FALSE		
}			
environment	Not present		
locationCoordinateTypes	Not present		
velocityTypes	Not present		
}			
a-gnss-RequestLocationInformation	Not present		
otdoa-RequestLocationInformation	Not present		
ecid-RequestLocationInformation	Not present		
epdu-RequestLocationInformation	Not Present		
sensor-RequestLocationInformation-r13	Not present		
tbs-RequestLocationInformation-r13	Not present		
wlan-RequestLocationInformation-r13	Not present		
bt-RequestLocationInformation-r13	Not present		

nr-ECID-RequestLocationInformation-r16	Not present		
nr-Multi-RTT-RequestLocationInformation-r16	Not present		
nr-DL-AoD-RequestLocationInformation-r16	Not present		
nr-DL-TDOA-RequestLocationInformation-r16			
SEQUENCE {			
nr-DL-PRS-RstdMeasurementInfoRequest-r16	Not present		
nr-RequestedMeasurements-r16	bit 0 = 0 (prsrsrpReq)		
nr-AssistanceAvailability-r16	FALSE		
nr-DL-TDOA-ReportConfig-r16 SEQUENCE {			
maxDL-PRS-RSTD-MeasurementsPerTRPPair-r16	Not present		
timingReportingGranularityFactor-r16	Not present		
measureSameDL-PRS-ResourceWithDifferentRxTEGs-r17	Not present		
reducedDL-PRS-ProcessingSamples-r17	Not present		Sub-test 1
	requested		Sub-test 2
lowerRxBeamSweepingFactor-FR2-r17	Not present		
}			
additionalPaths-r16	Not present		
nr-UE-RxTEG-Request-r17	Not present		
nr-los-nlos-IndicatorRequest-r17	Not present		
additionalPathsExt-r17	Not present		
additionalPathsDL-PRS-RSRP-Request-r17	Not present		
multiMeasInSameReport-r17	Not present		
}			
}			
}			
}			
}			
}			
}			
}			

Table 14.2.9.4.3-9: LPP ProvideLocation Information

Derivation Path: TS 37.355 [49] clause 6.2			
Information Element	Value/remark	Comment	Condition
LPP-Message ::= SEQUENCE {			
transactionID SEQUENCE {			
initiator	locationServer		
transactionNumber	1		
}			
endTransaction	TRUE		
sequenceNumber	(0..255)		
acknowledgement			
lpp-MessageBody CHOICE {			
c1 CHOICE {			
provideLocationInformation SEQUENCE {			
criticalExtensions CHOICE {			
c1 CHOICE {			
provideLocationInformation-r9 SEQUENCE {			
commonIEsProvideLocationInformation	Not present.		
a-gnss-ProvideLocationInformation	Not present		
otdoa-ProvideLocationInformation	Not present		
ecid-ProvideLocationInformation	Not present		
epdu-ProvideLocationInformation	Not present		
sensor-ProvideLocationInformation-r13	Not present		
tbs-ProvideLocationInformation-r13	Not present		
wlan-ProvideLocationInformation-r13	Not present		
bt-ProvideLocationInformation-r13	Not present		
nr-ECID-ProvideLocationInformation-r16	Not present		
nr-Multi-RTT-ProvideLocationInformation-r16	Not present		
nr-DL-AoD-ProvideLocationInformation-r16	Not present		

nr-DL-TDOA-ProvideLocationInformation-r16 SEQUENCE {			
nr-DL-TDOA-SignalMeasurementInformation-r16 SEQUENCE {			
dl-PRS-ReferenceInfo-r16			
nr-DL-TDOA-MeasList-r16 SEQUENCE (SIZE(1..nrMaxTRPs-r16)) OF NR-DL-TDOA-MeasElement-r16 {	3 entries		
NR-DL-TDOA-MeasElement-r16[1] SEQUENCE {		entry 1	
dl-PRS-ID-r16			
nr-PhysCellID-r16	Cell 1		
nr-CellGlobalID-r16			
nr-ARFCN-r16			
nr-DL-PRS-ResourceID-r16			
nr-DL-PRS-ResourceSetID-r16			
nr-TimeStamp-r16			
nr-RSTD-r16	Present		
nr-AdditionalPathList-r16			
nr-TimingQuality-r16			
nr-DL-PRS-RSRP-Result-r16			
nr-DL-TDOA-AdditionalMeasurements-r16			
nr-UE-Rx-TEG-ID-r17			
nr-DL-PRS-FirstPathRSRP-Result-r17			
nr-los-nlos-Indicator-r17			
nr-AdditionalPathListExt-r17			
nr-DL-TDOA-AdditionalMeasurementsExt-r17			
}			
NR-DL-TDOA-MeasElement-r16[2] SEQUENCE {		entry 2	
dl-PRS-ID-r16			
nr-PhysCellID-r16	Cell 2		
nr-CellGlobalID-r16			
nr-ARFCN-r16			
nr-DL-PRS-ResourceID-r16			
nr-DL-PRS-ResourceSetID-r16			
nr-TimeStamp-r16			
nr-RSTD-r16	Present		
nr-AdditionalPathList-r16			
nr-TimingQuality-r16			
nr-DL-PRS-RSRP-Result-r16			
nr-DL-TDOA-AdditionalMeasurements-r16			
nr-UE-Rx-TEG-ID-r17			
nr-DL-PRS-FirstPathRSRP-Result-r17			
nr-los-nlos-Indicator-r17			
nr-AdditionalPathListExt-r17			
nr-DL-TDOA-AdditionalMeasurementsExt-r17			
}			
NR-DL-TDOA-MeasElement-r16[3] SEQUENCE {		entry 3	
dl-PRS-ID-r16			
nr-PhysCellID-r16	Cell 3		
nr-CellGlobalID-r16			
nr-ARFCN-r16			
nr-DL-PRS-ResourceID-r16			
nr-DL-PRS-ResourceSetID-r16			
nr-TimeStamp-r16			
nr-RSTD-r16	Present		
nr-AdditionalPathList-r16			
nr-TimingQuality-r16			
nr-DL-PRS-RSRP-Result-r16			

r16	nr-DL-TDOA-AdditionalMeasurements-			
	nr-UE-Rx-TEG-ID-r17			
	nr-DL-PRS-FirstPathRSRP-Result-r17			
	nr-los-nlos-Indicator-r17			
	nr-AdditionalPathListExt-r17			
	nr-DL-TDOA-AdditionalMeasurementsExt-r17			
	}			
	}			
	nr-UE-RxTEG-TimingErrorMargin-r17			
	}			
	nr-dl-tdoa-LocationInformation-r16			
	nr-DL-TDOA-Error-r16			
	nr-DL-TDOA-SignalMeasurementInstances-r17			
	nr-DL-TDOA-LocationInformationInstances-r17			
	}			
	}			
	}			
	}			
	}			
	}			

14.2.9.5 Test requirement

Table 14.2.9.5-1, Table 14.2.9.5-2 and Table 14.2.9.5-3 define the primary level settings including test tolerances for the test.

Table 14.2.9.5-1: General test parameters for RSTD measurement reporting delay

Parameter		Unit	Value	Comment
Reference cell			Cell 1	Reference cell is the cell in the DL-TDOA assistance data with respect to which the RSTD measurement is defined, as specified in TS 38.215 [57] and TS 37.355 [49]. The reference cell is the PCell in this test case.
Neighbor cells			Cell 2 and Cell 3	Cell 2 and Cell 3 appear at the first and second places in the neighbour cell list in the DL-TDOA assistance data.
BW _{channel}	Config 1	MHz	200: N _{RB,c} = 132	
SSB configuration	Config 1		SSB.3 FR2	
SMTC configuration	Config 1		SMTC.1	
PDSCH RMC configuration	Config 1		SR.1.1 FDD	
RMSI CORESET RMC configuration	Config 1		CR.3.1 TDD	As specified in TS 38.133 [50] clause A.3.1.2.1

Dedicated CORESET RMC configuration	Config 1		CR.1.1 FDD	
PRS Configuration	Config 1		PRS.1.4. FR2	As specified in TS 38.133 [50] clause A.3. 31
Physical cell ID PCI			(PCI of Cell 1 – PCI of Cell 2)mod6=0 and (PCI of Cell 1 – PCI of Cell 3)mod6=0	The cell PCIs are selected such that the relative shifts of PRS patterns among cells are as given by the test parameters
CP length			Normal	
DRX			OFF	
PPW configuration			Table A.3.X33-1: Reference PPW configuration	As defined in TS 38.133 [50] A.3.33
Time offset between serving and neighbour cells	μs		set to the UE reported capability for receive time difference threshold if the UE reported value is $< 3\mu\text{s}$ $3\mu\text{s}$ otherwise	PRS are transmitted from synchronous cells
Expected RSTD	μs		0	The expected RSTD is what is expected at the receiver. The corresponding parameter in the DL-TDOA assistance data specified in TS 37.355 [49] is the expectedRSTD indicator
Expected RSTD uncertainty for all neighbour cells	μs		Same as time offset between serving and neighbour cells	The corresponding parameter in the DL-TDOA assistance data specified in TS 37.355 [49] is the expectedRSTD-Uncertainty index
Number of cells provided in DL-TDOA assistance data			4	Including the reference cell
PRS muting info			Cell 1: '10' Cell 2: '01' Cell 3: '10'	Corresponds to prs-MutingInfo defined in TS 37.355 [49]
PRS resource RE offset			Cell 1: 0 Cell 2: 0 Cell 3: 1	Cell 1 and Cell 3 are configured with different resource offsets
T1	s		3	The length of the time interval from the beginning of each test
T2	ms		10	The length of the time interval that follows after time interval T1 and processing time of assistance data. In this test UE is configured to measure single PFL within the configured PPW.
AoA setup			Setup 1	As defined in TS 38.133 [50] A.3.15.1
Beam assumption			Rough	Information about types of UE beam is given in TS 38.133 [50] B.2.1.3, and does not limit UE implementation or test system implementation

Table 14.2.9.5-2: Cell-specific test parameters for RSTD measurement reporting delay during T1

Parameter	Unit	Cell 1	Cell 2	Cell 3
NR RF Channel Number		1	1	1
Positioning frequency layer		1	1	1

Correlation Matrix and Antenna Configuration			1x2 Low	1x2 Low	1x2 Low
OCNG patterns defined in A.3.2.1			OP.5 FDD	N/A	N/A
N_{oc} ^{Note 3}	Config 1	dBm/SCS	-89		
PRS \hat{E}_s/N_{oc}		dB	-Infinity	-Infinity	-Infinity
I_o ^{Note 4}	Config 1	dBm/190.08MHz	-57.00	-57.00	-57.00
SSB RP ^{Note 4}	Config 1	dBm/SCS	-89	-Infinity	-Infinity
SSB \hat{E}_s/N_{oc}		dB	0	-Infinity	-Infinity
Propagation Condition			AWGN		
<p>Note 1: OCNG shall be used such that active cell (Cell 1) is fully allocated and a constant total transmitted power spectral density is achieved for all OFDM symbols.</p> <p>Note 2: The resources for uplink transmission are assigned to the UE prior to the start of time period T2.</p> <p>Note 3: Interference from other cells and noise sources not specified in the test are assumed to be constant over subcarriers and time and shall be modelled as AWGN of appropriate power for N_{oc} to be fulfilled.</p> <p>Note 4: SSB RP and I_o levels have been derived from other parameters and are given for information purpose. These are not settable test parameters.</p>					

Table 14.2.9.5-3: Cell-specific test parameters for RSTD measurement reporting delay during T2

Parameter	Unit	Cell 1		Cell 2		Cell 3		
		Sub-test 1	Sub-test 2	Sub-test 1	Sub-test 2	Sub-test 1	Sub-test 2	
RF Channel Number		1		1		1		
Positioning frequency layer		1		1		1		
Correlation Matrix and Antenna Configuration		1x2 Low		1x2 Low		1x2 Low		
OCNG patterns defined in A.3.2.1		OP.1		OP.1		OP.1		
PRACH configuration		FR2 PRACH configuration 1		FR2 PRACH configuration 1		FR2 PRACH configuration 1		
N_{oc} ^{Note 3}	Config 1	dBm/SCS	-89.41	-95	-89.41	-95	-84.41	-95
PRS \hat{E}_s/N_{oc}	Config 1	dB	-4.84	42.9	-11.02	0.75	-11.02	0.75
I_o	Config 1	dBm/190.08MHz	-55.66	-55.71	-55.66	-55.71	-55.66	-55.71
PRS \hat{E}_s/I_{ot}		dB	-5.7	-276	-12.7	-5.6	-12.7	-5.6
PRS-RSRP ^{Note 4}		dBm/SCS	-94.2	-92.1	-100.4	-94.2	-100.4	-94.2
Propagation Condition			AWGN					
<p>Note 1: OCNG shall be used such that active cells are fully allocated and a constant total transmitted power spectral density is achieved for all OFDM symbols other than those in the slots with transmitted PRS.</p> <p>Note 2: The resources for uplink transmission are assigned to the UE prior to the start of time period T2.</p> <p>Note 3: Interference from other cells and noise sources not specified in the test are assumed to be constant over subcarriers and time and shall be modelled as AWGN of appropriate power for N_{oc} to be fulfilled.</p>								

Note 4: PRP and Io levels have been derived from other parameters and are given for information purpose. These are not settable test parameters. The Io is calculated based only on the symbols in which PRS is transmitted.

Note 5: Calculation of Es/Iot includes the effect of UE internal noise up to the value assumed for the associated Refsens requirement in clause 7.3.2 of TS 38.101-2 [55], and an allowance of 1dB for UE multi-band relaxation factor ΔMB_P from TS 38.101-2 [55] Table 6.2.1.3-4.

The RSTD measurement time fulfils the requirements specified in clause 14.2.9.3.

The UE shall perform and report the RSTD measurements for Cell 2 and Cell 3 with respect to the reference cell in the DL-TDOA assistance data, Cell 1, within the time duration specified in clause 14.2.9.3 starting from the beginning of time interval T2.

The rate of the correct events for each neighbour cell observed during repeated tests shall be at least 90%, where the reported RSTD measurement for each correct event shall be within the RSTD reporting range specified in TS 38.133[50] Clause 10.1.23.3, i.e., between RSTD_000000 and RSTD_1970049.

The response time is equal to the LPP time IE value plus the test tolerance. The LPP time IE value is derived from the RSTD measurement period plus ΔT, where ΔT = 50ms. The LPP response time calculation procedure could be divided into two situations based on whether the UE support ppw-durationOfPRS-Processing1-r17 or ppw-durationOfPRS-Processing2-r17. The RSTD measurement period follows the equation:

$$T_{RSTD,Total} = \sum_{i=1}^L T_{RSTD_wo_gap,i} + (L - 1) * \max(T_{effect,i}), \text{ if any of the positioning frequency layers are in Case 1, or}$$

$$T_{RSTD,Total} = \max(T_{RSTD_wo_gap,i} + T_{uncertainty,i}), \text{ if all the positioning frequency layers are in Case 2,}$$

Where $N_{RxBeam,i} = 8, k_{multiTEG,i}=1, N_{PRS,i}^{slot} = 3, L_{available_PRS,i} = 0.214, N_{sample} = 4, T_{uncertainty,i} = 0$. N is the parameter *ppw-durationOfPRS-ProcessingSymbolsN* from TS 37.355 [49], N' is the parameter *ppw-maxNumOfDL-PRS-ResProcessedPerSlot* from TS 37.355 [49], $T_{last,i} = T_i + PPWL$ and $T_{effect,i} = \left\lceil \frac{T_i}{T_{available_PRS,i}} \right\rceil * T_{available_PRS,i}$

$T_{available_PRS,i} = LCM(T_{PRS,i}, PPWRP_i)$; where $T_{prs} = 160$ ms, and the repetition periodicity $PPWRP_i=160$ ms. Therefore, $T_{available_PRS,i} = 160$

T_i depends on the UE parameter *ppw-durationOfPRS-ProcessingSymbolsT* from TS 37.355 [49]

Finally, it results in the following equation:

$$\left(8 * \left\lceil \frac{3}{N'} \right\rceil \left\lceil \frac{0.214}{N} \right\rceil * 4 - 1 \right) * T_{effect} + T_{last}$$

Where the remaining parameters depend on the UE capabilities. The LPP time IE ranges between 4.971s and 245.77s. The value of the LPP time IE is rounded up to the next second (if the value is >128s, it should be rounded up to the next multiple of ten seconds). The result is transmitted in the response time IE in the LPP-RequestLocationInformation in Table 14.2.9.4.3-3. The LPP time IE ranges between 5s and 250s.

The test tolerance for the response time is 300ms. Therefore, the response time ranges between 5.3s and 25.3s.

The values of N', N and Ti and the effect in the response time equation are defined in Table 14.2.9.5-4, Table 14.2.9.5-5 and Table 14.2.9.5-6 for reference.

Table 14.2.9.5-4: value of N' based on ppw-maxNumOfDL-PRS-ResProcessedPerSlot

maxNumOfDL-PRS-ResProcessedPerSlot	$\left\lceil \frac{3}{N'} \right\rceil$
n1	3
n2	3
>=n4	1

Table 14.2.9.5-5: value of N based on ppw-durationOfPRS-ProcessingSymbolsN

durationOfPRS-ProcessingSysmbols	$\left\lceil \frac{0.214}{N} \right\rceil$
---	--

nDot125	2
>= nDot25	1

Table 14.2.9.5-6: value of T_{effect} and T_{last} based on ppw-durationOfPRS-ProcessingSymbolsT-r17

ppw-durationOfPRS-ProcessingSymbolsT-r17	T_{effect}	T_{last}
ms1	160	11
ms2	160	12
ms4	160	14
ms8	160	18
ms16	160	26
ms20	160	30
ms30	160	40
ms40	160	50
ms80	160	90
ms160	160	170
ms320	320	330
ms640	640	650
ms1280	1280	1290

The test tolerances are defined in clauses C.1.6 and C.2.5.

The rate of successful tests during repeated tests shall be at least 90% with a confidence level of 95%.

14.2.10 NR RSTD measurement reporting delay test case for single positioning frequency layer with Rx TEG in FR2 SA

Editor's Note: This test case has been completed for the following configurations:

- Test frequency $f \leq 40.8$ GHz

- UE PC3

This test case is incomplete for UE power classes other than PC3

This test case is incomplete for test frequencies > 40.8 GHz

14.2.10.1 Test purpose

The purpose of the test is to verify that the RSTD measurement meets the Rx TEG based measurement period requirements specified in TS 38.133 [50] Clause 9.9.2.5 in an environment with AWGN propagation conditions in FR2 in standalone scenario when single positioning frequency layer is configured.

14.2.10.2 Test applicability

This test applies to all types of NR UE release 17 onwards that supports UE assisted DL-TDOA positioning and nr-UE-RxTEG-ID-MaxSupport.

14.2.10.3 Minimum conformance requirements

Same as defined in clause 14.2.8.3.

14.2.10.4 Test description

14.2.10.4.1 Initial conditions

The supported test configurations in listed in Table 14.2.10.4-1.

Table 14.2.10.4-1: Test Configurations

Test Configuration	Description
1	120 kHz SSB and PRS SCS, 200 MHz bandwidth, TDD duplex mode

Test Environment: Normal, as defined in TS 38.508-1 [45] clause 4.1.

Frequencies to be tested: Mid Range, as defined in TS 38.508-1 [45] clause 4.3.1.

Channel bandwidth to be tested: are specified in Table 14.2.10.4-1.

1. Connect the SS and AWGN noise sources to the UE antenna connector or antenna connectors as shown in Annex A, Figure A.14.
2. The general test parameter settings are set up according to Table 14.2.10.5-1, Table 14.2.10.5-2 and Table 14.2.10.5-3.
3. Propagation conditions are set according to clause 4.15.2.
4. Message contents are defined in clause 14.2.10.4.3.
5. In the test there are three synchronous cells: Cell 1, Cell 2 and Cell 3. Cell 1 is the reference as well as the PCell. Cell 2 and Cell 3 are the neighbour cells. All cells are on the same RF channel distributed in single positioning frequency layer.

14.2.10.4.2 Test procedure

Same as defined in clause 14.2.8.4.2.

14.2.10.4.3 Message contents

Table 14.2.10.4.3-1: RESET UE POSITIONING STORED INFORMATION

Derivation Path: 38.509 [44] clause 6.6			
Information Element	Value/remark	Comment	Condition
UE Positioning Technology	0 0 0 0 1 1 1	DL-TDOA	

Table 14.2.10.4.3-2: LPP Request Capabilities

Information Element	Value/remark
nr-DL-TDOA-RequestCapabilities-r16	TRUE

Table 14.2.10.4.3-3: LPP RequestLocationInformation

Derivation Path: TS 37.355 [49] clause 6.2			
Information Element	Value/remark	Comment	Condition
LPP-Message ::= SEQUENCE {			
transactionID SEQUENCE {			
initiator	locationServer		
transactionNumber	1		
}			
endTransaction	FALSE		
sequenceNumber	Not present		
acknowledgement	Not present		
lpp-MessageBody CHOICE {			
c1 CHOICE {			
requestLocationInformation SEQUENCE {			
criticalExtensions CHOICE {			
c1 CHOICE {			
requestLocationInformation-r9 SEQUENCE {			
commonEsRequestLocationInformation SEQUENCE {			

locationInformationType	locationMeasurementsPreferred		
triggeredReporting	Not present		
periodicalReporting	Not present		
additionalInformation	onlyReturnInformationRequested		
qos SEQUENCE {			
horizontalAccuracy	Not present		
verticalCoordinateRequest	FALSE		
verticalAccuracy	Not present		
responseTime SEQUENCE {			
time	See 14.2.10.5	Result of the response time calculation rounded up to the next second if response time <= 128s. Result of the response time calculation rounded up to the next multiple of ten seconds if response time > 128s	
responseTimeEarlyFix-r12	Not present		Rel-12 onwards
unit-r15	Not present ten-seconds		Calculated response time >128s
}			
velocityRequest	FALSE		
}			
environment	Not present		
locationCoordinateTypes	Not present		
velocityTypes	Not present		
}			
a-gnss-RequestLocationInformation	Not present		
otdoa-RequestLocationInformation	Not present		
ecid-RequestLocationInformation	Not present		
epdu-RequestLocationInformation	Not Present		
sensor-RequestLocationInformation-r13	Not present		
tbs-RequestLocationInformation-r13	Not present		
wlan-RequestLocationInformation-r13	Not present		
bt-RequestLocationInformation-r13	Not present		
nr-ECID-RequestLocationInformation-r16	Not present		
nr-Multi-RTT-RequestLocationInformation-r16	Not present		
nr-DL-AoD-RequestLocationInformation-r16	Not present		
nr-DL-TDOA-RequestLocationInformation-r16			
SEQUENCE {			
nr-DL-PRS-RstdMeasurementInfoRequest-r16	Not present		
nr-RequestedMeasurements-r16	bit 0 = 0 (prsrsrpReq)		
nr-AssistanceAvailability-r16	FALSE		
nr-DL-TDOA-ReportConfig-r16 SEQUENCE {			
maxDL-PRS-RSTD-MeasurementsPerTRPPair-r16	Not present		
timingReportingGranularityFactor-r16	Not present		
measureSameDL-PRS-ResourceWithDifferentRxTEGs-r17	n2		
reducedDL-PRS-ProcessingSamples-r17	Not present		
lowerRxBeamSweepingFactor-FR2-r17	Not present		
}			
additionalPaths-r16	Not present		
nr-UE-RxTEG-Request-r17	requested		

nr-los-nlos-IndicatorRequest-r17	Not present		
additionalPathsExt-r17	Not present		
additionalPathsDL-PRS-RSRP-Request-r17	Not present		
multiMeasInSameReport-r17	Not present		
}			
}			
}			
}			
}			
}			
}			

Table 14.2.10.4.3-4: LPP ProvideAssistanceData

Derivation Path: TS 37.355 [49] clause 6.2			
Information Element	Value/remark	Comment	Condition
LPP-Message ::= SEQUENCE {			
transactionID SEQUENCE {			
initiator	locationServer		
transactionNumber	(0..255)		
}			
endTransaction	TRUE		
sequenceNumber	Not present		
acknowledgement	Not present		
lpp-MessageBody CHOICE {			
c1 CHOICE {			
provideAssistanceData SEQUENCE {			
criticalExtensions CHOICE {			
c1 CHOICE {			
provideAssistanceData-r9 SEQUENCE {			
commonEsProvideAssistanceData	Not present		
a-gnss-ProvideAssistanceData	Not present		
otdoa-ProvideAssistanceData	Not present		
epdu-Provide-AssistanceData	Not present		
sensor-ProvideAssistanceData-r14	Not present		
tbs-ProvideAssistanceData-r14	Not present		
wlan-ProvideAssistanceData-r14	Not present		
nr-Multi-RTT-ProvideAssistanceData-r16	Not present		
nr-DL-AoD-ProvideAssistanceData-r16	Not present		
nr-DL-TDOA-ProvideAssistanceData-r16			
SEQUENCE {			
nr-DL-PRS-AssistanceData-r16	As defined in Table 14.2.10.4.3-5		
nr-SelectedDL-PRS-IndexList-r16	Not present		
nr-PositionCalculationAssistance-r16	Not present		
nr-DL-TDOA-Error-r16	Not present		
nr-On-Demand-DL-PRS-Configurations-r17	Not present		
nr-On-Demand-DL-PRS-Configurations-Selected-IndexList-r17	Not present		
assistanceDataValidityArea-r17	Not present		
}			
}			
}			
}			
}			
}			
}			

Table 14.2.10.4.3-5: NR-DL-PRS-AssistanceData

Derivation Path: 37.355 clause 6.4.3			
Information Element	Value/remark	Comment	Condition
NR-DL-PRS-AssistanceData-r16 ::= SEQUENCE {			

nr-DL-PRS-ReferenceInfo-r16 SEQUENCE {			
dl-PRS-ID-r16	0		
nr-DL-PRS-ResourceID-List-r16	Not present		
nr-DL-PRS-ResourceSetID-r16	Not present		
}			
nr-DL-PRS-AssistanceDataList-r16 SEQUENCE (SIZE (1..nrMaxFreqLayers-r16)) OF NR-DL-PRS-AssistanceDataPerFreq-r16 {	1 entry		
NR-DL-PRS-AssistanceDataPerFreq-r16[1] SEQUENCE {		entry 1	
nr-DL-PRS-PositioningFrequencyLayer-r16 SEQUENCE {			
dl-PRS-SubcarrierSpacing-r16	kHz120		
dl-PRS-ResourceBandwidth-r16	27	128 PRBs	
dl-PRS-StartPRB-r16	0		
dl-PRS-PointA-r16	absoluteFrequencyPointA as defined for the DL frequency of the Cell 1		
dl-PRS-CombSizeN-r16	n4		
dl-PRS-CyclicPrefix-r16	normal		
}			
}			
nr-DL-PRS-AssistanceDataPerFreq-r16 SEQUENCE (SIZE (1..nrMaxTRPsPerFreq-r16)) OF NR-DL-PRS-AssistanceDataPerTRP-r16{	3 entries		
NR-DL-PRS-AssistanceDataPerTRP-r16[1] SEQUENCE {		entry 1	Cell 1
dl-PRS-ID-r16	0		
nr-PhysCellID-r16	Cell 1		
nr-CellGlobalID-r16	Cell 1		
nr-ARFCN-r16	Cell 1		
nr-DL-PRS-SFN0-Offset-r16 SEQUENCE {			
sfn-Offset-r16	0		
integerSubframeOffset-r16	0		
}			
nr-DL-PRS-ExpectedRSTD-r16	0		
nr-DL-PRS-ExpectedRSTD-Uncertainty-r16	0		
nr-DL-PRS-Info-r16	As specified in Table 14.2.10.4.3-6		
}			
NR-DL-PRS-AssistanceDataPerTRP-r16[2] SEQUENCE {		entry 2	Cell 2
dl-PRS-ID-r16	1		
nr-PhysCellID-r16	Cell 2		
nr-CellGlobalID-r16	Cell 2		
nr-ARFCN-r16	Cell 2		
nr-DL-PRS-SFN0-Offset-r16 SEQUENCE {			
sfn-Offset-r16	0		
integerSubframeOffset-r16	0		
}			
nr-DL-PRS-ExpectedRSTD-r16	23	About 3 μ s	
nr-DL-PRS-ExpectedRSTD-Uncertainty-r16	154	About 5 μ s	
nr-DL-PRS-Info-r16	As specified in Table 14.2.10.4.3-6		
}			
NR-DL-PRS-AssistanceDataPerTRP-r16[3] SEQUENCE {		entry 3	Cell 3
dl-PRS-ID-r16	2		
nr-PhysCellID-r16	Cell 3		
nr-CellGlobalID-r16	Cell 3		
nr-ARFCN-r16	Cell 3		
nr-DL-PRS-SFN0-Offset-r16 SEQUENCE {			
sfn-Offset-r16	0		
integerSubframeOffset-r16	0		
}			
nr-DL-PRS-ExpectedRSTD-r16	23	About 3 μ s	
nr-DL-PRS-ExpectedRSTD-Uncertainty-r16	154	About 5 μ s	

nr-DL-PRS-Info-r16	As specified in Table 14.2.10.4.3-6		
}			
}			
}			
}			
}			

Table 14.2.10.4.3-6: NR-DL-PRS-Info

Derivation Path: 37.355 clause 6.4.3			
Information Element	Value/remark	Comment	Condition
NR-DL-PRS-Info-r16 ::= SEQUENCE {			
nr-DL-PRS-ResourceSetList-r16 SEQUENCE (SIZE (1..nrMaxSetsPerTrp-r16)) OF NR-DL-PRS-ResourceSet-r16 {	1 entry		
NR-DL-PRS-ResourceSet-r16[1] SEQUENCE {		entry 1	
nr-DL-PRS-ResourceSetID-r16	0		
dl-PRS-Periodicity-and-ResourceSetSlotOffset-r16 CHOICE {			
Scs120-r16 CHOICE {			
n1280-r16	80		
}			
dl-PRS-ResourceRepetitionFactor-r16	Not present		
dl-PRS-ResourceTimeGap-r16	s1		
dl-PRS-NumSymbols-r16	n4		
dl-PRS-MutingOption1-r16 SEQUENCE {			
dl-prs-MutingBitRepetitionFactor-r16	Not present		
nr-option1-muting-r16 CHOICE {			
po2-r16	10		Cell 1
	01		Cell 2
	10		Cell 3
}			
}			
dl-PRS-MutingOption2-r16	Not present		
dl-PRS-ResourcePower-r16	27		
dl-PRS-ResourceList-r16 SEQUENCE (SIZE (1..nrMaxResourcesPerSet-r16)) OF NR-DL-PRS-Resource-r16 {	2 entries		
NR-DL-PRS-Resource-r16[1] SEQUENCE {		entry 1	
nr-DL-PRS-ResourceID-r16	0		
dl-PRS-SequenceID-r16	0		
dl-PRS-CombSizeN-AndReOffset-r16 CHOICE {			
n4-r16	0		Cell 1 and Cell 2
	1		Cell 3
}			
dl-PRS-ResourceSlotOffset-r16	4		
dl-PRS-ResourceSymbolOffset-r16	0		
dl-PRS-QCL-Info-r16	Not present		
}			
NR-DL-PRS-Resource-r16[2] SEQUENCE {		entry 2	
nr-DL-PRS-ResourceID-r16	1		
dl-PRS-SequenceID-r16	1		
dl-PRS-CombSizeN-AndReOffset-r16 CHOICE {			
n4-r16	0		Cell 1 and Cell 2
	1		Cell 3
}			
dl-PRS-ResourceSlotOffset-r16	4		
dl-PRS-ResourceSymbolOffset-r16	0		
dl-PRS-QCL-Info-r16	Not present		
}			
}			
}			

--	--	--

Table 14.2.10.4.3-7: LPP ProvideLocation Information

Derivation Path: TS 37.355 [49] clause 6.2			
Information Element	Value/remark	Comment	Condition
LPP-Message ::= SEQUENCE {			
transactionID SEQUENCE {			
initiator	locationServer		
transactionNumber	1		
}			
endTransaction	TRUE		
sequenceNumber	(0..255)		
acknowledgement			
lpp-MessageBody CHOICE {			
c1 CHOICE {			
provideLocationInformation SEQUENCE {			
criticalExtensions CHOICE {			
c1 CHOICE {			
provideLocationInformation-r9 SEQUENCE {			
commonIEsProvideLocationInformation	Not present.		
a-gnss-ProvideLocationInformation	Not present		
otdoa-ProvideLocationInformation	Not present		
ecid-ProvideLocationInformation	Not present		
epdu-ProvideLocationInformation	Not present		
sensor-ProvideLocationInformation-r13	Not present		
tbs-ProvideLocationInformation-r13	Not present		
wlan-ProvideLocationInformation-r13	Not present		
bt-ProvideLocationInformation-r13	Not present		
nr-ECID-ProvideLocationInformation-r16	Not present		
nr-Multi-RTT-ProvideLocationInformation-r16	Not present		
nr-DL-AoD-ProvideLocationInformation-r16	Not present		
nr-DL-TDOA-ProvideLocationInformation-r16 SEQUENCE {			
nr-DL-TDOA-SignalMeasurementInformation-r16 SEQUENCE {			
dl-PRS-ReferenceInfo-r16			
nr-DL-TDOA-MeasList-r16 SEQUENCE (SIZE(1..nrMaxTRPs-r16)) OF NR-DL-TDOA-MeasElement-r16 {	3 entries		
NR-DL-TDOA-MeasElement-r16[1] SEQUENCE {		entry 1	
dl-PRS-ID-r16			
nr-PhysCellID-r16	Cell 1		
nr-CellGlobalID-r16			
nr-ARFCN-r16			
nr-DL-PRS-ResourceID-r16			
nr-DL-PRS-ResourceSetID-r16			
nr-TimeStamp-r16			
nr-RSTD-r16	Present		
nr-AdditionalPathList-r16			
nr-TimingQuality-r16			
nr-DL-PRS-RSRP-Result-r16			
nr-DL-TDOA-AdditionalMeasurements-r16			
nr-UE-Rx-TEG-ID-r17	Present		
nr-DL-PRS-FirstPathRSRP-Result-r17			
nr-los-nlos-Indicator-r17			
nr-AdditionalPathListExt-r17			
nr-DL-TDOA-AdditionalMeasurementsExt-r17			
}			
}			
}			
}			
}			
}			

NR-DL-TDOA-MeasElement-r16[2]		entry 2	
SEQUENCE {			
dl-PRS-ID-r16			
nr-PhysCellID-r16	Cell 2		
nr-CellGlobalID-r16			
nr-ARFCN-r16			
nr-DL-PRS-ResourceID-r16			
nr-DL-PRS-ResourceSetID-r16			
nr-TimeStamp-r16			
nr-RSTD-r16	Present		
nr-AdditionalPathList-r16			
nr-TimingQuality-r16			
nr-DL-PRS-RSRP-Result-r16			
nr-DL-TDOA-AdditionalMeasurements-			
r16			
nr-UE-Rx-TEG-ID-r17	Present		
nr-DL-PRS-FirstPathRSRP-Result-r17			
nr-los-nlos-Indicator-r17			
nr-AdditionalPathListExt-r17			
nr-DL-TDOA-			
AdditionalMeasurementsExt-r17			
}			
NR-DL-TDOA-MeasElement-r16[3]		entry 3	
SEQUENCE {			
dl-PRS-ID-r16			
nr-PhysCellID-r16	Cell 3		
nr-CellGlobalID-r16			
nr-ARFCN-r16			
nr-DL-PRS-ResourceID-r16			
nr-DL-PRS-ResourceSetID-r16			
nr-TimeStamp-r16			
nr-RSTD-r16	Present		
nr-AdditionalPathList-r16			
nr-TimingQuality-r16			
nr-DL-PRS-RSRP-Result-r16			
nr-DL-TDOA-AdditionalMeasurements-			
r16			
nr-UE-Rx-TEG-ID-r17	Present		
nr-DL-PRS-FirstPathRSRP-Result-r17			
nr-los-nlos-Indicator-r17			
nr-AdditionalPathListExt-r17			
nr-DL-TDOA-			
AdditionalMeasurementsExt-r17			
}			
}			
nr-UE-RxTEG-TimingErrorMargin-r17			
}			
nr-dl-tdoa-LocationInformation-r16			
nr-DL-TDOA-Error-r16			
nr-DL-TDOA-			
SignalMeasurementInstances-r17			
nr-DL-TDOA-			
LocationInformationInstances-r17			
}			
}			
}			
}			
}			
}			

14.2.10.5 Test requirement

Table 14.2.10.5-1, Table 14.2.10.5-2 and Table 14.2.10.5-3 define the primary level settings including test tolerances for the test.

Table 14.2.10.5-1: General test parameters for RSTD measurement reporting delay

Parameter		Unit	Value	Comment
Reference cell			Cell 1	Reference cell is the cell in the DL-TDOA assistance data with respect to which the RSTD measurement is defined, as specified in TS 38.215 [57] and TS 37.355 [49]. The reference cell is the PCell in this test case.
Neighbor cells			Cell 2 and Cell 3	Cell 2 and Cell 3 appear at the first and second places in the neighbour cell list in the DL-TDOA assistance data.
BW_{channel}	Config 1	MHz	200: $N_{RB,c} = 132$	
SSB configuration	Config 1		SSB.3 FR2	
SMTTC configuration	Config 1		SMTTC.1	
PDSCH RMC configuration	Config 1		SR.1.1 FDD	
RMSI CORESET RMC configuration	Config 1		CR.3.1 TDD	As specified in TS 38.133 [50] clause A.3.1.2.1
Dedicated CORESET RMC configuration	Config 1		CR.1.1 FDD	
PRS Configuration	Config 1		PRS.1.4. FR2	As specified in TS 38.133 [50] clause A.3. 31
Physical cell ID PCI			(PCI of Cell 1 – PCI of Cell 2)mod6=0 and (PCI of Cell 1 – PCI of Cell 3)mod6=0	The cell PCIs are selected such that the relative shifts of PRS patterns among cells are as given by the test parameters
CP length			Normal	
DRX			OFF	
Measurement gap			GP#24 or GP#13	GP#24 is configured if UE supports MG#24, otherwise GP#13 is configured
Radio frame receive time offset between the cells at the UE antenna connector		μs	Cell 2 to Cell 1: 0 Cell 3 to Cell 1: 3	PRS are transmitted from synchronous cells
Expected RSTD		μs	Cell 2: 3 Cell 3: 3 Other neighbour cells: randomly between -3 and 3	The expected RSTD is what is expected at the receiver. The corresponding parameter in the DL-TDOA assistance data specified in TS 37.355 [49] is the expectedRSTD indicator
Expected RSTD uncertainty for all neighbour cells		μs	5	The corresponding parameter in the DL-TDOA assistance data specified in TS 37.355 [49] is the expectedRSTD-Uncertainty index
Number of cells provided in DL-TDOA assistance data			4	Including the reference cell

PRS muting info		Cell 1: '10' Cell 2: '01' Cell 3: '10'	Corresponds to prs-MutingInfo defined in TS 37.355 [49]
PRS resource RE offset		Cell 1: 0 Cell 2: 0 Cell 3: 1	Cell 1 and Cell 3 are configured with different resource offsets
T1	s	3	The length of the time interval from the beginning of each test
T2	s	$1.28 * k_{multiTEG}$ ^{Note 1}	The length of the time interval that follows immediately after time interval T1
AoA setup		Setup 1	As defined in TS 38.133 [50] A.3.15.1
Beam assumption		Rough	Information about types of UE beam is given in TS 38.133 [50] B.2.1.3, and does not limit UE implementation or test system implementation
<p>Note 1: $k_{multiTEG} = \left\lfloor \frac{N_{TEG}}{k_{TEG,simul}} \right\rfloor$ if UE is capable of receiving the same DL PRS resource from the same TRP simultaneously from multiple Rx TEGs, where N_{TEG} is the maximum number of Rx TEGs with which UE can support to measure the same PRS resource, and $k_{TEG,simul}$ is the number of Rx TEGs UE can measure simultaneously which is reported via <i>measureSameDL-PRS-ResourceWithDifferentRxTEGsSimul</i>.</p>			

Table 14.2.10.5-2: Cell-specific test parameters for RSTD measurement reporting delay during T1

Parameter	Unit	Cell 1	Cell 2	Cell 3
NR RF Channel Number		1	1	1
Positioning frequency layer		1	1	1
Correlation Matrix and Antenna Configuration		1x2 Low	1x2 Low	1x2 Low
OCNG patterns defined in A.3.2.1		OP.5 FDD	N/A	N/A
N_{oc} ^{Note 3} Config 1	dBm/SCS	-89		
PRS \hat{E}_s / N_{oc}	dB	-Infinity	-Infinity	-Infinity
I_o ^{Note 4} Config 1	dBm/190.08MHz	-57.00	-57.00	-57.00
SSB RP ^{Note 4} Config 1	dBm/SCS	-89	-Infinity	-Infinity
SSB \hat{E}_s / N_{oc}	dB	0	-Infinity	-Infinity
Propagation Condition		AWGN		
<p>Note 1: OCNG shall be used such that active cell is fully allocated and a constant total transmitted power spectral density is achieved for all OFDM symbols.</p> <p>Note 2: The resources for uplink transmission are assigned to the UE prior to the start of time period T2.</p> <p>Note 3: Interference from other cells and noise sources not specified in the test are assumed to be constant over subcarriers and time and shall be modelled as AWGN of appropriate power for N_{oc} to be fulfilled.</p> <p>Note 4: SSB RP and I_o levels have been derived from other parameters and are given for information purpose. These are not settable test parameters.</p>				

Table 14.2.10.5-3: Cell-specific test parameters for RSTD measurement reporting delay during T2

Parameter	Unit	Cell 1	Cell 2	Cell 3
-----------	------	--------	--------	--------

			T2	T2	T2
RF Channel Number			1	1	1
Positioning frequency layer			1	1	1
Correlation Matrix and Antenna Configuration			1x2 Low	1x2 Low	1x2 Low
OCNG patterns defined in A.3.2.1			OP.1	OP.1	OP.1
PRACH configuration			FR2 PRACH configuration 1	FR2 PRACH configuration 1	FR2 PRACH configuration 1
N_{oc} Note 3	Config 1	dBm/SCS	-89.41	-89.41	-89.41
PRS \hat{E}_s/N_{oc}	Config 1	dB	-4.84	-11.02	-11.02
Io	Config 1	dBm/190.08MHz	-55.66	-55.66	-55.66
PRS \hat{E}_s/I_{ot}		dB	-5.7	-12.7	-12.7
PRP Note 4		dBm/SCS	-93.8	-100	-100
Propagation Condition			AWGN		
<p>Note 1: OCNG shall be used such that active cells are fully allocated and a constant total transmitted power spectral density is achieved for all OFDM symbols other than those in the subframes with transmitted PRS.</p> <p>Note 2: The resources for uplink transmission are assigned to the UE prior to the start of time period T2.</p> <p>Note 3: Interference from other cells and noise sources not specified in the test are assumed to be constant over subcarriers and time and shall be modelled as AWGN of appropriate power for N_{oc} to be fulfilled.</p> <p>Note 4: PRP and Io levels have been derived from other parameters and are given for information purpose. These are not settable test parameters. The Io is calculated based only on the symbols in which PRS is transmitted.</p> <p>Note 5: Calculation of E_s/I_{ot} includes the effect of UE internal noise up to the value assumed for the associated Refsens requirement in clause 7.3.2 of TS 38.101-2 [55], and an allowance of 1dB for UE multi-band relaxation factor ΔMB_P from TS 38.101-2 [55] Table 6.2.1.3-4.</p>					

The RSTD measurement time fulfils the requirements specified in clause 14.2.10.3.

The UE shall perform and report the RSTD measurements for Cell 2 and Cell 3 with respect to the reference cell in the DL-TDOA assistance data, Cell 1, within the time duration specified in clause 14.2.10.3 starting from the beginning of time interval T2.

The rate of the correct events for each neighbour cell observed during repeated tests shall be at least 90%, where the reported RSTD measurement for each correct event shall be within the RSTD reporting range specified in TS 38.133[50] Clause 10.1.23.3, i.e., between RSTD_0000000 and RSTD_1970049.

The response time is equal to the LPP time IE value plus the test tolerance. The LPP time IE value is derived from the RSTD measurement period plus ΔT , where $\Delta T = 50$ ms. The RSTD measurement period follows the equation:

$$T_{RSTD,i} = \left(k_{multiTEG,i} * CSSF_{PRS,i} * \text{ceil}(K_{p,PRS,i}) * N_{RxBeam,i} * \left\lceil \frac{N_{PRS,i}^{slot}}{N'} \right\rceil \left\lceil \frac{L_{available_PRS,i}}{N} \right\rceil * N_{sample} - 1 \right) * T_{effect,i} + T_{last,i}$$

Where $CSSF_{PRS,i} = 1$, $N_{RxBeam,i} = 8$, $N_{PRS,i}^{slot} = 3$, $L_{available_PRS,i} = 0.214$, $N_{sample} = 4k_{multiTEG} = 2$. N is the parameter *durationOfPRS-ProcessingSymbols* from TS 37.355 [49], N' is the parameter *maxNumOfDL-PRS-ResProcessedPerSlot* from TS 37.355 [49], $T_{last,i} = T_i + T_{available_PRS,i}$ and $T_{effect,i} = \left\lceil \frac{T_i}{T_{available_PRS,i}} \right\rceil * T_{available_PRS,i}$

$T_{available_PRS,i} = LCM(T_{PRS,i}, MGRP_i)$; where $T_{prs} = 160$ ms, and MGRP is 80 (for GP#24) or 40 (for GP#13) depending on UE capabilities. Therefore, $T_{available_PRS,i} = 160$ ms.

T_i depends on the UE parameter *durationOfPRS-ProcessingSymbolsInEveryTms* from TS 37.355 [49]

Finally, it results in the following equation:

$$\left(2 * 1 * 8 * \left\lceil \frac{3}{N'} \right\rceil \left\lceil \frac{0.214}{N} \right\rceil * 4 - 1 \right) * T_{effect} + T_{last}$$

Where the remaining parameters depend on the UE capabilities. The LPP time IE ranges between 10.248s and 491.68s. The value of the LPP time IE is rounded up to the next second (if the value is >128s, it should be rounded up to the next multiple of ten seconds). The result is transmitted in the response time IE in the LPP-RequestLocationInformation in Table 14.2.10.4.3-3. The LPP time IE ranges between 11s and 500s.

The test tolerance for the response time is 300ms. Therefore, the response time ranges between 11.3s and 500.3s.

The values of N', N and Ti and the effect in the response time equation are defined in Table 14.2.10.5-4, Table 14.2.10.5-5 and Table 14.2.10.5-6 for reference.

Table 14.2.10.5-4: value of N' based on *maxNumOfDL-PRS-ResProcessedPerSlot*

<i>maxNumOfDL-PRS-ResProcessedPerSlot</i>	$\left\lceil \frac{3}{N'} \right\rceil$
n1	3
n2	3
>=n4	1

Table 14.2.10.5-5: value of N based on *durationOfPRS-ProcessingSymsbols*

<i>durationOfPRS-ProcessingSymsbols</i>	$\left\lceil \frac{0.214}{N} \right\rceil$
nDot125	2
>= nDot25	1

Table 14.2.10.5-6: value of T_{effect} and T_{last} based on *durationOfPRS-ProcessingSymsbolsInEveryTms*

<i>durationOfPRS-ProcessingSymsbolsInEveryTms</i>	T _{effect}	T _{last}
n8	160	168
n16	160	176
n20	160	180
n30	160	190
n40	160	200
n80	160	240
n160	160	320
n320	320	480
n640	640	800
n1280	1280	1440

The test tolerances are defined in clauses C.1.6 and C.2.5.

The rate of successful tests during repeated tests shall be at least 90% with a confidence level of 95%.

14.3 NR RSTD measurement accuracy test case in RRC_CONNECTED

14.3.1 NR RSTD measurement accuracy test case for single positioning frequency layer in FR1 SA

14.3.1.1 Test purpose

The purpose of the test is to verify that the RSTD measurement meets the accuracy requirements specified in TS 38.133 [50] clause 10.1.23.2 in an environment with AWGN propagation conditions.

14.3.1.2 Test applicability

This test applies to all types of NR UE release 16 onwards that supports DL-TDOA positioning.

14.3.1.3 Minimum conformance requirements

The RSTD measurement reported by the UE shall fulfil the accuracy requirements defined by $\pm(X+Y+Z) T_c$.

X is defined in Table 14.3.1.3-1 for AWGN channel, provided that the following conditions are met.

- Conditions defined in clause 7.3 of TS 38.101-1 [54] for reference sensitivity are fulfilled.
- Conditions for RSTD measurements are fulfilled according to Annex I.2 for a corresponding Band for each relevant PRS resource configured for measurement.

The RSTD measurement reported by the UE shall fulfil the accuracy requirements defined in Table 14.3.1.3-2 for AWGN channel, provided that the following conditions are met.

- Conditions defined in clause 7.3 of TS 38.101-2 [55] for reference sensitivity are fulfilled.
- Conditions for RSTD measurements are fulfilled according to Annex I.2 for a corresponding Band for each relevant PRS resource configured for measurement.

When UE measures RSTD on PRS resources belonging to different PFLs, then the RSTD accuracy is defined as the accuracy corresponding to the largest accuracy value among different PFLs.

When UE measures RSTD on PRS resources belonging to same PFL, $Y=32 T_c$, provided that the time offset between the two PRS resource instances from the reference cell and the neighbour cell, which are used for a single RSTD estimate, is no greater than 160 ms.

When UE measures RSTD on PRS resources belonging different PFLs, $Y=256 T_c$, provided that the time offset between the two PRS resource instances from the reference cell and the neighbour cell, which are used for a single RSTD estimate, is no greater than 1280 ms

Z is defined in Table 14.3.1.3-2 a for FR1.

Table 14.3.1.3-1: RSTD absolute accuracy in FR1 for AWGN channel

Accuracy	Conditions						
	PRS \hat{E}_s/lot	PRS SCS	PRS bandwidth Note 1	PRS resource repetition ($T_{\text{rep}}^{\text{PRS}} * L_{\text{PRS}} / K_{\text{comb}}^{\text{PRS}}$) Note 2	I_0 Note 3 range		
					NR operating band groups Note 4	Minimum I_0	Maximum I_0
T_c Note 5	dB	kHz	RB			dBm/SCS	dBm/BW _{channel}
132 + Δ Note 7	(PRS $\hat{E}_s/\text{lot})_{\text{ref}} \geq -6\text{dB}$ (PRS $\hat{E}_s/\text{lot})_j \geq -13\text{dB}$	15	≥ 24	≥ 4	NR_FDD_FR1_A, NR_TDD_FR1_A, NR_SDL_FR1_A	-121	-50
					NR_FDD_FR1_B	-120.5	-50
					NR_TDD_FR1_C	-120	-50
					NR_FDD_FR1_D, NR_TDD_FR1_D	-119.5	-50
					NR_FDD_FR1_E, NR_TDD_FR1_E	-119	-50
					NR_FDD_FR1_F	-118.5	-50
					NR_FDD_FR1_G NR_FDD_FR1_H	-118 -117.5	-50 -50
98 + Δ			≥ 52	≥ 1	Note 6	Note 6	Note 6
42 + Δ			≥ 104	≥ 1	Note 6	Note 6	Note 6
75 + Δ		30	≥ 24	≥ 4	NR_FDD_FR1_A, NR_TDD_FR1_A, NR_SDL_FR1_A	-118	-50
	NR_FDD_FR1_B				-117.5	-50	

					NR_TDD_FR1_C	-117	-50		
					NR_FDD_FR1_D, NR_TDD_FR1_D	-116.5	-50		
					NR_FDD_FR1_E, NR_TDD_FR1_E	-116	-50		
					NR_FDD_FR1_F	-115.5	-50		
					NR_FDD_FR1_G	-115	-50		
					NR_FDD_FR1_H	-114.5	-50		
48 + Δ			≥ 48	≥ 1	Note 6	Note 6	Note 6		
24 + Δ			≥ 132	≥ 1	Note 6	Note 6	Note 6		
50 + Δ		60	≥ 24	≥ 4	NR_FDD_FR1_A, NR_TDD_FR1_A, NR_SDL_FR1_A	-115	-50		
							NR_FDD_FR1_B	-114.5	-50
							NR_TDD_FR1_C	-114	-50
							NR_FDD_FR1_D, NR_TDD_FR1_D	-113.5	-50
							NR_FDD_FR1_E, NR_TDD_FR1_E	-113	-50
							NR_FDD_FR1_F	-113.5	-50
							NR_FDD_FR1_G	-113	-50
							NR_FDD_FR1_H	-111.5	-50
24 + Δ			≥ 64	≥ 1	Note 6	Note 6	Note 6		
10 + Δ			≥ 132	≥ 1	Note 6	Note 6	Note 6		

NOTE 1: Minimum PRS bandwidth, which is minimum of the PRS bandwidths of the reference resource and the measured neighbour resource i.

NOTE 2: Minimum number of PRS resource repetitions among the reference resource and the measured neighbour resource i. T_{rep}^{PRS} , L_{PRS} , K_{comb}^{PRS} are configured by higher layer parameter *dl-PRS-ResourceRepetitionFactor*, *dl-PRS-NumSymbols* and *dl-PRS-CombSizeN* defined in TS 37.355 [34], respectively.

NOTE 3: l_0 is assumed to have constant EPRE across the bandwidth.

NOTE 4: NR operating band groups in FR1 are as defined in clause 3.5.2.

NOTE 5: T_c is the basic timing unit defined in TS 38.211 [6].

NOTE 6: The same bands and the same l_0 conditions for each band apply for this requirement as for the corresponding requirement with the PRS bandwidth of the smallest RB number for the corresponding SCS.

NOTE 7: $\Delta = 0$ for single PFL, Δ is defined in Table 14.3.1.3-3 for dual PFL.

Table 14.3.1.3-2: Void

Table 14.3.1.3-2a: Margin for RSTD measurement accuracy in FR1

PRS BW (RB number)			Margin (T_c)
SCS=15kHz	SCS=30kHz	SCS=60kHz	
≥ 24	N/A	N/A	120
≥ 52	≥ 24	N/A	72
≥ 104	≥ 48	≥ 24	36
N/A	≥ 132	≥ 64	16
N/A	N/A	≥ 132	12

Table 14.3.1.3-3: Margin Δ for RSTD measurement accuracy in FR1

PRS BW (RB number)			Margin (T_c)
SCS=15kHz	SCS=30kHz	SCS=60kHz	
≥ 24	N/A	N/A	128
≥ 52	≥ 24	N/A	64
≥ 104	≥ 48	≥ 24	32
N/A	≥ 132	≥ 64	16
N/A	N/A	≥ 132	8

14.3.1.4 Test description

14.3.1.4.1 Initial conditions

The test is defined with three possible Test Configurations. In the case that the UE supports more than one of these Test Configurations, then the UE is only required to be tested in one of the Test Configurations, chosen by the UE. The defined Test Configurations are specified in Table 14.3.1.4.1-1.

Table 14.3.1.4-1: Test Configurations

Configuration	Description
1	15 kHz SSB SCS, 10 MHz bandwidth, FDD duplex mode
2	15 kHz SSB SCS, 10 MHz bandwidth, TDD duplex mode
3	30 kHz SSB SCS, 40 MHz bandwidth, TDD duplex mode

Test Environment: Normal, as defined in TS 38.508-1 [45] clause 4.1.

Frequencies to be tested: Mid as defined in TS 38.508-1 [45] clause 4.3.1.

Channel bandwidth to be tested: are specified in Table 14.2.1.4-1.

1. Connect the SS and AWGN noise sources to the UE antenna connector or antenna connectors as shown in Annex A, Figure A.13.
2. The general test parameter settings are set up according to Table 14.3.1.5-1.
3. Propagation conditions are set according to clause 4.15.2.
4. Message contents are defined in clause 14.3.1.4.3.
5. In the test there are two synchronous cells: Cell 1 and Cell 2. Cell 1 is the RSTD reference as well as the PCell. Cell 2 is a neighbour cell. Both cells are on the same NR RF channel in FR1. GP#24 is configured if UE supports MG#24, otherwise GP#0 is configured.
6. The true RSTD (which is the receive time difference for frame 0 between cell 2 and cell 1 as seen at the UE antenna connector) is set to $5898 T_c$ (about $3 \mu s$)

14.3.1.4.2 Test procedure

The test consists of a set-up period and a measurement period. Cell 1 and Cell 2 are both active during the complete test. The beginning of the measurement period shall be aligned with the first PRS positioning subframe of a positioning occasion in the reference cell.

The NR-DL-TDOA-RequestLocationInformation message and the DL-TDOA assistance data as defined in clause 14.3.1.4.3 shall be provided to the UE during the set-up period. The last TTI containing the NR-DL-TDOA-RequestLocationInformation message shall be provided to the UE ΔT ms before the start of the measurement period, where $\Delta T = 50$ ms is the maximum processing time of the NR-DL-TDOA-RequestLocationInformation message and the DL-TDOA assistance data in the UE.

1. Ensure the UE is in State RRC_CONNECTED with generic procedure parameters Connectivity NR, Connected without release *On* according to TS 38.508-1 [45] clause 4.5.
2. The SS shall send a RESET UE POSITIONING STORED INFORMATION message.
3. Set the parameters according to Table 14.3.1.5-1 as appropriate. Propagation conditions are set according to clause 4.15.2.
4. The SS shall send an LPP REQUEST CAPABILITIES message.
5. The UE shall transmit an LPP PROVIDE CAPABILITIES message indicating the DL-TDOA capabilities supported by the UE in the NR-DL-TDOA-ProvideCapabilities IE.

6. The SS shall send a LPP PROVIDE ASSISTANCE DATA message, including the nr-DL-TDOA-ProvideAssistanceData-r16 IE. If the UE message at step 5 includes the ackRequested IE set to TRUE, then the SS shall send an acknowledgment in the LPP PROVIDE ASSISTANCE DATA message.
7. The SS shall send a LPP REQUEST LOCATION INFORMATION message, including the nr-DL-TDOA-RequestLocationInformation-r16 IE such that the UE receives the message ΔT ms before the start of the measurement period, where $\Delta T = 50$ ms.
8. The UE shall transmit a LPP PROVIDE LOCATION INFORMATION message, including the nr-DL-TDOA-ProvideLocationInformation-r16 IE.
9. If the UE message at step 8 includes the *ackRequested* IE set to TRUE, the SS shall send a LPP acknowledgement message.
10. The SS shall check the nr-RSTD-r16 value for Cell 2 in the nr-DL-TDOA-SignalMeasurementInformation-r16 according to Table 14.3.1.5-2.
11. Repeat step 2-10 until the confidence level according to Annex D is achieved.
12. Repeat step 1-11 for the other sub-test defined in Table 14.3.1.4-1 as appropriate.

If all (applicable) sub-tests pass, the whole test passes. If one (applicable) sub-test fails, the whole test fails.

14.3.1.4.3 Message contents

Table 14.3.1.4.3-1: RESET UE POSITIONING STORED INFORMATION

Derivation Path: 38.509 [44] clause 6.6			
Information Element	Value/remark	Comment	Condition
UE Positioning Technology	0 0 0 0 0 1 1 1	DL-TDOA	

Table 14.3.1.4.3-2: LPP Request Capabilities

Information Element	Value/remark
nr-DL-TDOA-RequestCapabilities-r16	TRUE

Table 14.3.1.4.3-3: LPP RequestLocationInformation

Derivation Path: TS 37.355 [49] clause 6.2			
Information Element	Value/remark	Comment	Condition
LPP-Message ::= SEQUENCE {			
transactionID SEQUENCE {			
initiator	locationServer		
transactionNumber	1		
}			
endTransaction	FALSE		
sequenceNumber	Not present		
acknowledgement	Not present		
lpp-MessageBody CHOICE {			
c1 CHOICE {			
requestLocationInformation SEQUENCE {			
criticalExtensions CHOICE {			
c1 CHOICE {			
requestLocationInformation-r9 SEQUENCE {			
commonEsRequestLocationInformation SEQUENCE {			
locationInformationType	locationMeasurementsPreferred		
triggeredReporting	Not present		
periodicalReporting	Not present		
additionalInformation	onlyReturnInformationRequested		
}			
}			
}			
}			
qos SEQUENCE {			

horizontalAccuracy	Not present		
verticalCoordinateRequest	FALSE		
verticalAccuracy	Not present		
responseTime SEQUENCE { time	See 14.3.1.5	Result of the response time calculation rounded up to the next second	
responseTimeEarlyFix-r12	Not present		Rel-12 onwards
}			
velocityRequest	FALSE		
}			
environment	Not present		
locationCoordinateTypes	Not present		
velocityTypes	Not present		
}			
a-gnss-RequestLocationInformation	Not present		
otdoa-RequestLocationInformation	Not present		
ecid-RequestLocationInformation	Not present		
epdu-RequestLocationInformation	Not Present		
sensor-RequestLocationInformation-r13	Not present		
tbs-RequestLocationInformation-r13	Not present		
wlan-RequestLocationInformation-r13	Not present		
bt-RequestLocationInformation-r13	Not present		
nr-ECID-RequestLocationInformation-r16	Not present		
nr-Multi-RTT-RequestLocationInformation-r16	Not present		
nr-DL-AoD-RequestLocationInformation-r16	Not present		
nr-DL-TDOA-RequestLocationInformation-r16			
SEQUENCE {			
nr-DL-PRS-RstdMeasurementInfoRequest-r16	Not present		
nr-RequestedMeasurements-r16	bit 0 = 0 (prsrsrpReq)		
nr-AssistanceAvailability-r16	FALSE		
nr-DL-TDOA-ReportConfig-r16	Not present		
additionalPaths-r16	Not present		
}			
}			
}			
}			
}			
}			
}			
}			

Table 14.3.1.4.3-4: LPP ProvideAssistanceData

Derivation Path: TS 37.355 [49] clause 6.2			
Information Element	Value/remark	Comment	Condition
LPP-Message ::= SEQUENCE {			
transactionID SEQUENCE {			
initiator	locationServer		
transactionNumber	(0..255)		
}			
endTransaction	TRUE		
sequenceNumber	Not present		
acknowledgement	Not present		
lpp-MessageBody CHOICE {			
c1 CHOICE {			
provideAssistanceData SEQUENCE {			
criticalExtensions CHOICE {			
c1 CHOICE {			
provideAssistanceData-r9 SEQUENCE {			
commonEsProvideAssistanceData	Not present		
a-gnss-ProvideAssistanceData	Not present		

otdoa-ProvideAssistanceData	Not present		
epdu-Provide-AssistanceData	Not present		
sensor-ProvideAssistanceData-r14	Not present		
tbs-ProvideAssistanceData-r14	Not present		
wlan-ProvideAssistanceData-r14	Not present		
nr-Multi-RTT-ProvideAssistanceData-r16	Not present		
nr-DL-AoD-ProvideAssistanceData-r16	Not present		
nr-DL-TDOA-ProvideAssistanceData-r16			
SEQUENCE {			
nr-DL-PRS-AssistanceData-r16	As defined in Table 14.3.1.4.3-5		
nr-SelectedDL-PRS-IndexList-r16	Not present		
nr-PositionCalculationAssistance-r16			Depending on UE capabilities, i.e. support for UE-based DL-TDOA
SEQUENCE {			
nr-TRP-LocationInfo-r16	As defined in TS 37.571-5 [20]		
nr-DL-PRS-BeamInfo-r16	Not present		
nr-RTD-Info-r16	Not present		
}			
nr-DL-TDOA-Error-r16	Not present		
}			
}			
}			
}			
}			
}			
}			
}			
}			
}			
}			

Table 14.3.1.4.3-5: NR-DL-PRS-AssistanceData

Derivation Path: TS 37.355 [49] clause 6.4.3			
Information Element	Value/remark	Comment	Condition
NR-DL-PRS-AssistanceData-r16 ::= SEQUENCE {			
nr-DL-PRS-ReferenceInfo-r16 SEQUENCE {			
dl-PRS-ID-r16	0		
nr-DL-PRS-ResourceID-List-r16	Not present		
nr-DL-PRS-ResourceSetID-r16	Not present		
}			
nr-DL-PRS-AssistanceDataList-r16 SEQUENCE (SIZE (1..nrMaxFreqLayers-r16)) OF NR-DL-PRS-AssistanceDataPerFreq-r16 {	1 entry		
NR-DL-PRS-AssistanceDataPerFreq-r16[1]		entry 1	
SEQUENCE {			
nr-DL-PRS-PositioningFrequencyLayer-r16 SEQUENCE {			
dl-PRS-SubcarrierSpacing-r16	kHz15		Sub-test 1-1, Sub-test 1-2, Sub-test 2-1 and Sub-test 2-2
	kHz30		Sub-test 3-1 and Sub-test 3-2
dl-PRS-ResourceBandwidth-r16	1	24 PRBs	Sub-test 1-1, Sub-test 2-1 and Sub-test 3-1

	21	104 PRBs	Sub-test 1-2 and Sub-test 2-2
	28	132 PRBs	Sub-test 3-2
dl-PRS-StartPRB-r16	0		
dl-PRS-PointA-r16	absoluteFrequencyPointA as defined for the DL frequency of the Cell 1		
dl-PRS-CombSizeN-r16	n2		Sub-test 1-1, Sub-test 2-1 and Sub-test 3-1
	n4		Sub-test 1-2, Sub-test 2-2 and Sub-test 3-2
dl-PRS-CyclicPrefix-r16	normal		
}			
nr-DL-PRS-AssistanceDataPerFreq-r16 SEQUENCE (SIZE (1..nrMaxTRPsPerFreq-r16)) OF NR-DL-PRS-AssistanceDataPerTRP-r16{	2 entries		
NR-DL-PRS-AssistanceDataPerTRP-r16[1] SEQUENCE {		entry 1	Cell 1
dl-PRS-ID-r16	0		
nr-PhysCellID-r16	Cell 1		
nr-CellGlobalID-r16	Cell 1		
nr-ARFCN-r16	Cell 1		
nr-DL-PRS-SFN0-Offset-r16 SEQUENCE {			
sfn-Offset-r16	0		
integerSubframeOffset-r16	0		
}			
nr-DL-PRS-ExpectedRSTD-r16	0		
nr-DL-PRS-ExpectedRSTD-Uncertainty-r16	0		
nr-DL-PRS-Info-r16	As specified in Table 14.3.1.4.3-6		
}			
NR-DL-PRS-AssistanceDataPerTRP-r16[2] SEQUENCE {		entry 2	Cell 2
dl-PRS-ID-r16	1		
nr-PhysCellID-r16	Cell 2		
nr-CellGlobalID-r16	Cell 2		
nr-ARFCN-r16	Cell 2		
nr-DL-PRS-SFN0-Offset-r16 SEQUENCE {			
sfn-Offset-r16	0		
integerSubframeOffset-r16	0		
}			
nr-DL-PRS-ExpectedRSTD-r16	23	About 3 μs	
nr-DL-PRS-ExpectedRSTD-Uncertainty-r16	39	About 5 μs	
nr-DL-PRS-Info-r16	As specified in Table 14.3.1.4.3-6		
}			
}			
}			
}			
}			

Table 14.3.1.4.3-6: NR-DL-PRS-Info

Derivation Path: TS 37.355 [49] clause 6.4.3			
Information Element	Value/remark	Comment	Condition
NR-DL-PRS-Info-r16 ::= SEQUENCE {			

nr-DL-PRS-ResourceSetList-r16 SEQUENCE (SIZE (1..nrMaxSetsPerTrp-r16)) OF NR-DL-PRS-ResourceSet-r16 {	1 entry		
NR-DL-PRS-ResourceSet-r16[1] SEQUENCE {		entry 1	
nr-DL-PRS-ResourceSetID-r16	0		
dl-PRS-Periodicity-and-ResourceSetSlotOffset-r16 CHOICE {			
scs15-r16 CHOICE {			Sub-tests 1-1, Sub-test 1-2, Sub-test 2-1 and Sub-test 2-2
N320-r16	20		
}			
scs30-r16 CHOICE {			Sub-tests 3-1 and Sub-test 3-2
n160-r16	10		
}			
dl-PRS-ResourceRepetitionFactor-r16	Not present		Sub-tests 1-2, Sub-test 2-2 and Sub-test 3-2
	n2		Sub-tests 1-1, Sub-test 2-1 and Sub-test 3-1
dl-PRS-ResourceTimeGap-r16	s1		
dl-PRS-NumSymbols-r16	n4		
dl-PRS-MutingOption1-r16	Not present		
dl-PRS-MutingOption2-r16	Not present		
dl-PRS-ResourcePower-r16	27		
dl-PRS-ResourceList-r16 SEQUENCE (SIZE (1..nrMaxResourcesPerSet-r16)) OF NR-DL-PRS-Resource-r16 {	1 entry		
NR-DL-PRS-Resource-r16[1] SEQUENCE {		entry 1	
nr-DL-PRS-ResourceID-r16	0		
dl-PRS-SequenceID-r16	0		
dl-PRS-CombSizeN-AndReOffset-r16 CHOICE {			
n2-r16	0		Sub-tests 1-1, Sub-test 2-1 and Sub-test 3-1
n4-r16	0		Sub-tests 1-2, Sub-test 2-2 and Sub-test 3-2
}			
dl-PRS-ResourceSlotOffset-r16	0		Sub-test 1-1 Cell 1, Sub-test 1-2 Cell 1, Sub-test 2-1 Cell 1, Sub-test 2-2 Cell 1, Sub-test 3-1 Cell 1, and Sub-test 3-2 Cell 1

	4		Sub-test 1-1 Cell 2, Sub-test 1-2 Cell 2, Sub-test 2-1 Cell 2, Sub-test 2-2 Cell 2, Sub-test 3-1 Cell 2, and Sub-test 3-2 Cell 2.
dl-PRS-ResourceSymbolOffset-r16	0		
dl-PRS-QCL-Info-r16	Not present		
}			
}			
}			
}			
}			

Table 14.3.1.4.3-7: LPP ProvideLocation Information

Derivation Path: TS 37.355 [49] clause 6.2			
Information Element	Value/remark	Comment	Condition
LPP-Message ::= SEQUENCE {			
transactionID SEQUENCE {			
initiator	locationServer		
transactionNumber	1		
}			
endTransaction	TRUE		
sequenceNumber	(0..255)		
acknowledgement			
lpp-MessageBody CHOICE {			
c1 CHOICE {			
provideLocationInformation SEQUENCE {			
criticalExtensions CHOICE {			
c1 CHOICE {			
provideLocationInformation-r9 SEQUENCE {			
commonIEsProvideLocationInformation	Not present.		
a-gnss-ProvideLocationInformation	Not present		
otdoa-ProvideLocationInformation	Not present		
ecid-ProvideLocationInformation	Not present		
epdu-ProvideLocationInformation	Not present		
sensor-ProvideLocationInformation-r13	Not present		
tbs-ProvideLocationInformation-r13	Not present		
wlan-ProvideLocationInformation-r13	Not present		
bt-ProvideLocationInformation-r13	Not present		
nr-ECID-ProvideLocationInformation-r16	Not present		
nr-Multi-RTT-ProvideLocationInformation-r16	Not present		
nr-DL-AoD-ProvideLocationInformation-r16	Not present		
nr-DL-TDOA-ProvideLocationInformation-r16 SEQUENCE {			
nr-DL-TDOA-SignalMeasurementInformation-r16 SEQUENCE {			
dl-PRS-ReferenceInfo-r16			
nr-DL-TDOA-MeasList-r16 SEQUENCE (SIZE(1..nrMaxTRPs-r16)) OF NR-DL-TDOA-MeasElement-r16 {	2 entries		
NR-DL-TDOA-MeasElement-r16[1] SEQUENCE {		entry 1	
dl-PRS-ID-r16			
nr-PhysCellID-r16	Cell 1		
nr-CellGlobalID-r16			

nr-ARFCN-r16			
nr-DL-PRS-ResourceID-r16			
nr-DL-PRS-ResourceSetID-r16			
nr-TimeStamp-r16			
nr-RSTD-r16	Present		
nr-AdditionalPathList-r16			
nr-TimingQuality-r16			
nr-DL-PRS-RSRP-Result-r16			
nr-DL-TDOA-AdditionalMeasurements- r16			
}			
NR-DL-TDOA-MeasElement-r16[2]		entry 2	
SEQUENCE {			
dl-PRS-ID-r16			
nr-PhysCellID-r16	Cell 2		
nr-CellGlobalID-r16			
nr-ARFCN-r16			
nr-DL-PRS-ResourceID-r16			
nr-DL-PRS-ResourceSetID-r16			
nr-TimeStamp-r16			
nr-RSTD-r16	Present		
nr-AdditionalPathList-r16			
nr-TimingQuality-r16			
nr-DL-PRS-RSRP-Result-r16			
nr-DL-TDOA-AdditionalMeasurements- r16			
}			
nr-dl-tdoa-LocationInformation-r16			
nr-DL-TDOA-Error-r16			
}			
}			
}			
}			
}			
}			
}			

14.3.1.5 Test requirement

The RSTD measurement accuracy for Cell 2 shall fulfil the absolute requirement in clause 14.3.1.3.

Table 14.3.1.5-1: RSTD accuracy test parameters

Parameter	Config	Unit	Test 1		Test 2	
			Cell 1	Cell 2	Cell 1	Cell 2
PRS ARFCN	1~3		freq1	Freq1	freq1	Freq1
BW _{channel}	1	MHZ	10: N _{RB,c} = 52		10: N _{RB,c} = 52	
	2		10: N _{RB,c} = 52		10: N _{RB,c} = 52	
	3		40: N _{RB,c} = 106		40: N _{RB,c} = 106	
Duplex mode	1		FDD		FDD	
	2		TDD		TDD	
	3		TDD		TDD	
TDD configuration	1		N/A		N/A	
	2		TDDConf.1.1		TDDConf.1.1	
	3		TDDConf.2.1		TDDConf.2.1	
Measurement gap	1, 2, 3		GP#24 or GP#0		GP#24 or GP#0	
PDSCH Reference measurement channel	1		SR.1.1 FDD	-	SR.1.1 FDD	-
	2		SR.1.1 TDD		SR.1.1 TDD	
	3		SR.2.1 FDD		SR.2.1 FDD	
RMSI CORESET Reference Channel	1		CR.1.1 FDD	-	CR.1.1 FDD	-
	2		CR.1.1 TDD	-	CR.1.1 TDD	-

	3		CR.2.1 FDD	-	CR.2.1 FDD	-
Dedicated CORESET Reference Channel	1		CCR.1.1 FDD	-	CCR.1.1 FDD	-
	2		CCR.1.1 TDD	-	CCR.1.1 TDD	-
	3		CCR.2.1 TDD	-	CCR.2.1 TDD	-
SSB configuration	1		SSB.1 FR1		SSB.1 FR1	
	2		SSB.1 FR1		SSB.1 FR1	
	3		SSB.2 FR1		SSB.2 FR1	
OCNG Patterns	1~3		OP.1		OP.1	
TRS configuration	1		TRS.1.1 FDD	-	TRS.1.1 FDD	
	2		TRS.1.1 TDD		TRS.1.1 TDD	
	3		TRS.1.2 TDD		TRS.1.2 TDD	
Initial BWP Configuration	1~3		DLBWP.0.1 ULBWP.0.1		DLBWP.0.1 ULBWP.0.1	
Dedicated BWP configuration	1~3		DLBWP.1.1 ULBWP.1.1		DLBWP.1.1 ULBWP.1.1	
Time offset with Cell 1	1	μs	-	3	-	3
	2,3		-	3	-	3
SMTC configuration	1		SMTC.2		SMTC.2	
	2,3		SMTC.1		SMTC.1	
PRS configuration	1		PRS.1.1 FR1		PRS.1.2 FR1	
	2		PRS.1.1 FR1		PRS.1.2 FR1	
	3		PRS.2.1 FR1		PRS.2.2 FR1	
PRS Resource slot offset	slot	1, 2, 3	0	4	0	4
Expected RSTD	1, 2, 3	μs	N/A		3	
Expected RSTD uncertainty	1, 2, 3	μs	N/A		5	
EPRE ratio of PSS to SSS	1~3	dB	0	0	0	0
EPRE ratio of PBCH DMRS to SSS						
EPRE ratio of PBCH to PBCH DMRS						
EPRE ratio of PDCCH DMRS to SSS						
EPRE ratio of PDCCH to PDCCH DMRS						
EPRE ratio of PDSCH DMRS to SSS						
EPRE ratio of PDSCH to PDSCH DMRS						
EPRE ratio of OCNG DMRS to SSS ^{Note 1}						
EPRE ratio of OCNG to OCNG DMRS ^{Note 1}						
EPRE ratio of PRS to SSS						
N_{oc} ^{Note2}	1,2	dBm/SCS	-98		-98	
	3		-95		-95	
$PRS \hat{E}_s / I_{ot}$	1~3	dB	-5.7	-12.6	-5.7	-12.6
PRP ^{Note3}	1,2	dBm/SCS	-103.4	-109.5	-103.4	-109.5
	3	S	-100.4	-106.5	-100.4	-106.5
I_o ^{Note3}	1,2	dBm/9.36MHz	-68.72	-68.72	-68.72	-68.72
	3	dBm/38.16MHz	-62.69	-62.69	-62.69	-62.69
$PRS \hat{E}_s / N_{oc}$	1~3	dB	-5.4	-11.5	-5.4	-11.5
$SSB \hat{E}_s / N_{oc}$	1~3	dB	-5.4	-11.5	-5.4	-11.5
Propagation condition	1~3	-	AWGN		AWGN	
Antenna configuration	1~3		1x2		1x2	

Note 1:	OCNG shall be used such that both cells are fully allocated and a constant total transmitted power spectral density is achieved for all OFDM symbols other than those in the slots with transmitted PRS.
Note 2:	Interference from other cells and noise sources not specified in the test is assumed to be constant over subcarriers and time and shall be modelled as AWGN of appropriate power for N_{oc} to be fulfilled.
Note 3:	PRP and I_o levels have been derived from other parameters for information purposes. They are not settable parameters themselves. The I_o is calculated based only on the symbols where PRS is transmitted.
Note 4:	RSRP minimum requirements are specified assuming independent interference and noise at each receiver antenna port.
Note 5:	The test configuration excludes support for band n51 and it is not required to run this test on band n51 in this release of the specification.

The value of the LPP Time IE depends on the UE capabilities. The calculation is the same as in clause 14.2.1.5 with the following difference: $N_{PRS,i}^{slot} = 2$. Therefore, the value of the LPP Time IE is given by the following equation:

$$\left(\left\lceil \frac{16}{N'} \right\rceil \left\lfloor \frac{1}{N} \right\rfloor * 4 - 1 \right) * T_{effect} + T_{last}$$

The resulting value shall be rounded up to the next integer and transmitted in the LPP-RequestLocationInformation (see Table 14.3.1.4.3-3).

Table 14.3.1.5-2: RSTD accuracy requirements for the reported values

Test Configuration	Subtest	Lowest reported value [T _c]	Highest reported value [T _c]
1 & 2	Test 1	5582	6214
	Test 2	5756	6040
3	Test 1	5687	6109
	Test 2	5794	6002

For the overall test to pass, the ratio of successful reported values in each sub-test shall be more than 90% with a confidence level of 95%.

14.3.2 NR RSTD measurement accuracy test case for dual positioning frequency layer in FR1 SA

14.3.2.1 Test purpose

The purpose of the test is to verify that the RSTD measurement meets the accuracy requirements specified in TS 38.133 [50] clause 10.1.23.2 in an environment with AWGN propagation conditions.

14.3.2.2 Test applicability

This test applies to all types of NR UE release 16 onwards that supports DL-TDOA positioning.

14.3.2.3 Minimum conformance requirements

Same as in clause 14.3.1.3.

14.3.2.4 Test description

14.3.2.4.1 Initial conditions

The test is defined with three possible Test Configurations. In the case that the UE supports more than one of these Test Configurations, then the UE is only required to be tested in one of the Test Configurations, chosen by the UE. The defined Test Configurations are specified in Table 14.3.2.4.1-1.

Table 14.3.2.4-1: Test Configurations

Configuration	Description
1	15 kHz SSB SCS, 10 MHz bandwidth, FDD duplex mode
2	15 kHz SSB SCS, 10 MHz bandwidth, TDD duplex mode
3	30 kHz SSB SCS, 40 MHz bandwidth, TDD duplex mode

Test Environment: Normal, as defined in TS 38.508-1 [45] clause 4.1.

Frequencies to be tested: Low for RF channel #1 and High for RF channel #2 as defined in TS 38.508-1 [45] clause 4.3.1.

Channel bandwidth to be tested: are specified in Table 14.2.1.4-1.

1. Connect the SS and AWGN noise sources to the UE antenna connector or antenna connectors as shown in Annex A, Figure A.13.
2. The general test parameter settings are set up according to Table 14.3.2.5-1.
3. Propagation conditions are set according to clause 4.15.2.
4. Message contents are defined in clause 14.3.2.4.3.
5. In the test there are two synchronous cells: Cell 1 and Cell 2. Cell 1 is the RSTD reference as well as the PCell on NR RF channel #1 in FR1. Cell 2 is a neighbour cell on a different NR RF channel #2 in FR1. GP#24 is configured if UE supports MG#24, otherwise GP#0 is configured.
6. The true RSTD (which is the receive time difference for frame 0 between cell 2 and cell 1 as seen at the UE antenna connector) is set to 5898 Tc (about 3 μ s)

14.3.2.4.2 Test procedure

Same as clause 14.3.1.4.2.

14.3.2.4.3 Message contents

Same as clause 14.3.1.4.3 except that Table 14.3.2.4.3-1 replaces Table 14.3.1.4.3-5.

Table 14.3.2.4.3-1: NR-DL-PRS-AssistanceData

Derivation Path: TS 37.355 [49] clause 6.4.3			
Information Element	Value/remark	Comment	Condition
NR-DL-PRS-AssistanceData-r16 ::= SEQUENCE {			
nr-DL-PRS-ReferenceInfo-r16 SEQUENCE {			
dl-PRS-ID-r16	0		
nr-DL-PRS-ResourceID-List-r16	Not present		
nr-DL-PRS-ResourceSetID-r16	Not present		
}			
nr-DL-PRS-AssistanceDataList-r16 SEQUENCE (SIZE (1..nrMaxFreqLayers-r16)) OF NR-DL-PRS-AssistanceDataPerFreq-r16 {	2 entries		
NR-DL-PRS-AssistanceDataPerFreq-r16[1] SEQUENCE {		entry 1	
nr-DL-PRS-PositioningFrequencyLayer-r16 SEQUENCE {			
dl-PRS-SubcarrierSpacing-r16	kHz15		Sub-test 1-1, Sub-test 1-2, Sub-test 2-1 and Sub-test 2-2
	kHz30		Sub-test 3-1 and Sub-test 3-2

dl-PRS-ResourceBandwidth-r16	1	24 PRBs	Sub-test 1-1, Sub-test 1-2 and Sub-test 1-3
	21	104 PRBs	Sub-test 1-2 and Sub-test 2-2
	28	132 PRBs	Sub-test 3-2
dl-PRS-StartPRB-r16	0		
dl-PRS-PointA-r16	absoluteFrequencyPointA as defined for the DL frequency of the Cell 1		
dl-PRS-CombSizeN-r16	n2		Sub-tests 1-1, Sub-test 2-1 and Sub-test 3-1
	n4		Sub-tests 1-2, Sub-test 2-2 and Sub-test 3-2
dl-PRS-CyclicPrefix-r16	normal		
}			
nr-DL-PRS-AssistanceDataPerFreq-r16 SEQUENCE (SIZE (1..nrMaxTRPsPerFreq-r16)) OF NR-DL-PRS-AssistanceDataPerTRP-r16{	1 entry		
NR-DL-PRS-AssistanceDataPerTRP-r16[1] SEQUENCE {		entry 1	Cell 1
dl-PRS-ID-r16	0		
nr-PhysCellID-r16	Cell 1		
nr-CellGlobalID-r16	Cell 1		
nr-ARFCN-r16	Cell 1		
nr-DL-PRS-SFN0-Offset-r16 SEQUENCE {			
sfm-Offset-r16	0		
integerSubframeOffset-r16	0		
}			
nr-DL-PRS-ExpectedRSTD-r16	0		
nr-DL-PRS-ExpectedRSTD-Uncertainty-r16	0		
nr-DL-PRS-Info-r16	As specified in Table 14.3.1.4.3-6		
}			
}			
}			
NR-DL-PRS-AssistanceDataPerFreq-r16[2] SEQUENCE {		entry 2	
nr-DL-PRS-PositioningFrequencyLayer-r16 SEQUENCE {			
dl-PRS-SubcarrierSpacing-r16	kHz15		Sub-test 1-1, Sub-test 1-2, Sub test 2-1 and Sub-test 2-2
	kHz30		Sub-test 3-1 and Sub-test 3-2
dl-PRS-ResourceBandwidth-r16	1	24 PRBs	Sub-test 1-1, Sub-test 2-1 and Sub-test 3-1
	21	104 PRBs	Sub-test 1-2 and Sub-test 2-2

	28	132 PRBs	Sub-test 3-2
dl-PRS-StartPRB-r16	0		
dl-PRS-PointA-r16	absoluteFrequencyPointA as defined for the DL frequency of the Cell 2		
dl-PRS-CombSizeN-r16	n2		Sub-tests 1-1, Sub-test 2-1 and Sub-test 3-1
	n4		Sub-tests 1-2, Sub-test 2-2 and Sub-test 3-2
dl-PRS-CyclicPrefix-r16	normal		
}			
nr-DL-PRS-AssistanceDataPerFreq-r16 SEQUENCE (SIZE (1..nrMaxTRPsPerFreq-r16)) OF NR-DL-PRS-AssistanceDataPerTRP-r16{	1 entry		
NR-DL-PRS-AssistanceDataPerTRP-r16[1] SEQUENCE {		entry 1	Cell 2
dl-PRS-ID-r16	1		
nr-PhysCellID-r16	Cell 2		
nr-CellGlobalID-r16	Cell 2		
nr-ARFCN-r16	Cell 2		
nr-DL-PRS-SFN0-Offset-r16 SEQUENCE {			
sfn-Offset-r16	0		
integerSubframeOffset-r16	0		
}			
nr-DL-PRS-ExpectedRSTD-r16	23	About 3 μ s	
nr-DL-PRS-ExpectedRSTD-Uncertainty-r16	39	About 5 μ s	
nr-DL-PRS-Info-r16	As specified in Table 14.3.1.4.3-6		
}			
}			
}			
}			
}			
}			

14.3.2.5 Test requirement

The RSTD measurement accuracy for Cell 2 shall fulfil the absolute requirement in clause 14.3.2.3.

Table 14.3.2.5-1: RSTD accuracy test parameters

Parameter	Config	Unit	Test 1		Test 2	
			Cell 1	Cell 2	Cell 1	Cell 2
PRS ARFCN	1~3		freq1	freq2	freq1	freq2
BW _{channel}	1	MHz	10: N _{RB,c} = 52		10: N _{RB,c} = 52	
	2		10: N _{RB,c} = 52		10: N _{RB,c} = 52	
	3		40: N _{RB,c} = 106		40: N _{RB,c} = 106	
Duplex mode	1		FDD		FDD	
	2		TDD		TDD	
	3		TDD		TDD	
TDD configuration	1		N/A		N/A	
	2		TDDConf.1.1		TDDConf.1.1	
	3		TDDConf.2.1		TDDConf.2.1	
PDSCH Reference measurement channel	1		SR.1.1 FDD	-	SR.1.1 FDD	-
	2		SR.1.1 TDD		SR.1.1 TDD	
	3		SR.2.1 FDD		SR.2.1 FDD	
RMSI CORESET Reference Channel	1		CR.1.1 FDD	-	CR.1.1 FDD	-
	2		CR.1.1 TDD	-	CR.1.1 TDD	-

	3		CR.2.1 FDD	-	CR.2.1 FDD	-
Dedicated CORESET Reference Channel	1		CCR.1.1 FDD	-	CCR.1.1 FDD	-
	2		CCR.1.1 TDD	-	CCR.1.1 TDD	-
	3		CCR.2.1 TDD	-	CCR.2.1 TDD	-
SSB configuration	1		SSB.1 FR1		SSB.1 FR1	
	2		SSB.1 FR1		SSB.1 FR1	
	3		SSB.2 FR1		SSB.2 FR1	
OCNG Patterns	1~3		OP.1		OP.1	
TRS configuration	1		TRS.1.1 FDD	-	TRS.1.1 FDD	
	2		TRS.1.1 TDD		TRS.1.1 TDD	
	3		TRS.1.2 TDD		TRS.1.2 TDD	
Initial BWP Configuration	1~3		DLBWP.0.1 ULBWP.0.1		DLBWP.0.1 ULBWP.0.1	
Dedicated BWP configuration	1~3		DLBWP.1.1 ULBWP.1.1		DLBWP.1.1 ULBWP.1.1	
Time offset with Cell 1	1	μs	-	3	-	3
	2,3		-	3	-	3
SMTC configuration	1		SMTC.2		SMTC.2	
	2,3		SMTC.1		SMTC.1	
PRS configuration	1		PRS.1.1 FR1		PRS.1.2 FR1	
	2		PRS.1.1 FR1		PRS.1.2 FR1	
	3		PRS.2.1 FR1		PRS.2.2 FR1	
PRS Resource slot offset	1, 2, 3	slot	0	4	0	4
Expected RSTD	1, 2, 3	μs	N/A	3	N/A	3
Expected RSTD uncertainty	1, 2, 3	μs	N/A	5	N/A	5
EPRE ratio of PSS to SSS	1~3	dB	0	0	0	0
EPRE ratio of PBCH DMRS to SSS						
EPRE ratio of PBCH to PBCH DMRS						
EPRE ratio of PDCCH DMRS to SSS						
EPRE ratio of PDCCH to PDCCH DMRS						
EPRE ratio of PDSCH DMRS to SSS						
EPRE ratio of PDSCH to PDSCH DMRS						
EPRE ratio of OCNG DMRS to SSS ^{Note 1}						
EPRE ratio of OCNG to OCNG DMRS ^{Note 1}						
EPRE ratio of PRS to SSS						
N_{oc} ^{Note2}	1,2	dBm/SCS	-98		-98	
	3		-95		-95	
$PRS \hat{E}_s / I_{ot}$	1~3	dB	-5.7	-12.7	-5.7	-12.7
$PRS-RSRP$ ^{Note3}	1,2	dBm/SCS	-103.7	-110.7	-103.7	-110.7
	3		-100.7	-107.7	-100.7	-107.7
I_o ^{Note3}	1,2	dBm/9.36MHz	-69.01	-69.82	-69.01	-69.82
	3	dBm/38.16MHz	-62.91	-63.72	-62.91	-63.72
$PRS \hat{E}_s / N_{oc}$	1~3	dB	-5.7	-12.7	-5.7	-12.7
Propagation condition	1~3	-	AWGN		AWGN	
Antenna configuration	1~3		1x2		1x2	
Note 1: OCNG shall be used such that both cells are fully allocated and a constant total transmitted power spectral density is achieved for all OFDM symbols.						

Note 2:	Interference from other cells and noise sources not specified in the test is assumed to be constant over subcarriers and time and shall be modelled as AWGN of appropriate power for N_{oc} to be fulfilled.
Note 3:	RSRP and Io levels have been derived from other parameters for information purposes. They are not settable parameters themselves. The Io is calculated based only on the symbols where PRS is transmitted.
Note 4:	RSRP minimum requirements are specified assuming independent interference and noise at each receiver antenna port.
Note 5:	The test configuration excludes support for band n51 and it is not required to run this test on band n51 in this release of the specification.

The value of the LPP Time IE depends on the UE capabilities. The calculation is the same as in clause 14.3.1.5 with the following difference: $N_{PRS,i}^{slot} = 2$. Therefore, the value of the LPP Time IE is given by the following equation:

$$T_{RSTD} = 2 * \left(\left\lceil \frac{2}{N'} \right\rceil \left\lceil \frac{1}{N} \right\rceil * 4 - 1 \right) * T_{effect} + T_{last} + T_{effect}$$

The resulting value shall be rounded up to the next integer and transmitted in the LPP-RequestLocationInformation (see Table 14.3.1.4.3-3).

Table 14.3.2.5-2: RSTD accuracy requirements for the reported values

Test Configuration	Subtest	Lowest reported value [Tc]	Highest reported value [Tc]
1 & 2	Test 1	5230	6566
	Test 2	5500	6296
3	Test 1	5399	6397
	Test 2	5554	6242

For the overall test to pass, the ratio of successful reported values in each sub-test shall be more than 90% with a confidence level of 95%.

14.3.3 NR RSTD measurement accuracy test case for single positioning frequency layer in FR2 SA

Editor's Note: This test case has been completed for the following configurations:

- Test frequency $f \leq 40.8$ GHz
- UE PC3

This test case is incomplete for UE power classes other than PC3

This test case is incomplete for test frequencies > 40.8 GHz

14.3.3.1 Test purpose

The purpose of the test is to verify that the RSTD measurement meets the accuracy requirements specified in TS 38.133 [50] clause 10.1.23.2 in an environment with AWGN propagation conditions. The test is conducted in AWGN propagation condition in FR2 in standalone scenario when dsingle positioning frequency layers are configured.

14.3.3.2 Test applicability

This test applies to all types of NR UE release 16 onwards that supports DL-TDOA positioning.

14.3.3.3 Minimum conformance requirements

Same as in clause 14.3.1.3.

14.3.3.4 Test description

The supported test configurations are listed in Table 14.3.3.4-1.

Table 14.3.3.4-1: Test Configurations

Configuration	Description
1	120 kHz SSB SCS, 200 MHz bandwidth, TDD duplex mode

14.3.3.4.1 Initial conditions

Test Environment: Normal, as defined in TS 38.508-1 [45] clause 4.1.

Frequencies to be tested: Mid Range, as defined in TS 38.508-1 [45] clause 4.3.1.

Channel bandwidth to be tested: are specified in Table 14.3.3.4-1.

1. Connect the SS and AWGN noise sources to the UE antenna connector or antenna connectors as shown in Annex A, Figure A.14.
2. The general test parameter settings are set up according to Table 14.3.3.5-1 and Table 14.3.3.5-2.
3. Propagation conditions are set according to clause 4.15.2.
4. Message contents are defined in clause 14.3.3.4.3.
5. In the test there are two synchronous cells: Cell 1 and Cell 2. Cell 1 is the reference as well as the PCell. Cell 2 is a neighbour cell. Both cells are on the same NR RF channel in FR2. GP#13 is configured for the test.
6. The true RSTD (which is the receive time difference for frame 0 between cell 2 and cell 1 as seen at the UE antenna connector) is set to $5898 T_c$ (about $3 \mu s$)

14.3.3.4.2 Test procedure

The test consists of two sub-tests; the difference between the sub-tests is the PRS configuration, PRS.1.1 FR2 and PRS.1.2 FR2. The test consists of a set-up period and a measurement period. Cell 1 and Cell 2 are both active during the complete test. The beginning of the measurement period shall be aligned with the first PRS positioning subframe of a positioning occasion in the reference cell. The NR-DL-TDOA-RequestLocationInformation message and the DL-TDOA assistance data as defined in clause 14.3.3.4.3 shall be provided to the UE during the set-up period. The last TTI containing the NR-DL-TDOA-RequestLocationInformation message shall be provided to the UE ΔT ms before the start of the measurement period, where $\Delta T = 50$ ms is the maximum processing time of the NR-DL-TDOA-RequestLocationInformation message and the DL-TDOA assistance data in the UE.

1. Ensure the UE is in State RRC_CONNECTED with generic procedure parameters Connectivity *NR*, Connected without release *On*, according to TS 38.508-1 [45] clause 4.5.
2. The SS shall send a RESET UE POSITIONING STORED INFORMATION message.
3. Set the parameters according to Table 14.3.3.5-1 and Table 14.3.3.5-2 as appropriate. Propagation conditions are set according to clause 4.15.2.
4. The SS shall send an LPP REQUEST CAPABILITIES message.
5. The UE shall transmit an LPP PROVIDE CAPABILITIES message indicating the DL-TDOA capabilities supported by the UE in the *NR-DL-TDOA-ProvideCapabilities* IE.
6. The SS shall send a LPP PROVIDE ASSISTANCE DATA message, including the *nr-DL-TDOA-ProvideAssistanceData-r16* IE. If the UE message at step 5 includes the *ackRequested* IE set to TRUE, then the SS shall send an acknowledgment in the LPP PROVIDE ASSISTANCE DATA message.
7. The SS shall send a LPP REQUEST LOCATION INFORMATION message, including the *nr-DL-TDOA-RequestLocationInformation-r16* IE such that the UE receives the message ΔT ms before the start of the measurement period, where $\Delta T = 50$ ms.

8. The UE shall transmit a LPP PROVIDE LOCATION INFORMATION message, including the nr-DL-TDOA-ProvideLocationInformation-r16 IE.
9. If the UE message at step 8 includes the *ackRequested* IE set to TRUE, the SS shall send a LPP acknowledgement message.
10. The SS shall check the nr-RSTD-r16 value for Cell 2 in the nr-DL-TDOA-SignalMeasurementInformation-r16 according to Table 14.3.3.5-3.
11. Repeat step 2-10 until the confidence level according to Annex D is achieved.
12. Repeat step 1-11 for the other sub-test defined in Table 14.3.3.5-1 as appropriate.

If all (applicable) sub-tests pass, the whole test passes. If one (applicable) sub-test fails, the whole test fails.

14.3.3.4.3 Message contents

Table 14.3.3.4.3-1: RESET UE POSITIONING STORED INFORMATION

Derivation Path: 38.509 [44] clause 6.6			
Information Element	Value/remark	Comment	Condition
UE Positioning Technology	0 0 0 0 1 1 1	DL-TDOA	

Table 14.3.3.4.3-2: LPP Request Capabilities

Information Element	Value/remark
nr-DL-TDOA-RequestCapabilities-r16	TRUE

Table 14.3.3.4.3-3: LPP RequestLocationInformation

Derivation Path: TS 37.355 [49] clause 6.2			
Information Element	Value/remark	Comment	Condition
LPP-Message ::= SEQUENCE {			
transactionID SEQUENCE {			
initiator	locationServer		
transactionNumber	1		
}			
endTransaction	FALSE		
sequenceNumber	Not present		
acknowledgement	Not present		
lpp-MessageBody CHOICE {			
c1 CHOICE {			
requestLocationInformation SEQUENCE {			
criticalExtensions CHOICE {			
c1 CHOICE {			
requestLocationInformation-r9 SEQUENCE {			
commonEsRequestLocationInformation SEQUENCE {			
locationInformationType	locationMeasurementsPreferred		
triggeredReporting	Not present		
periodicalReporting	Not present		
additionalInformation	onlyReturnInformationRequested		
}			
}			
}			
}			
}			
responseTime SEQUENCE {			
time	See 14.3.3.5	Result of the response time calculation rounded	

		up to the next second	
responseTimeEarlyFix-r12	Not present		Rel-12 onwards
}			
velocityRequest	FALSE		
}			
environment	Not present		
locationCoordinateTypes	Not present		
velocityTypes	Not present		
}			
a-gnss-RequestLocationInformation	Not present		
otdoa-RequestLocationInformation	Not present		
ecid-RequestLocationInformation	Not present		
epdu-RequestLocationInformation	Not Present		
sensor-RequestLocationInformation-r13	Not present		
tbs-RequestLocationInformation-r13	Not present		
wlan-RequestLocationInformation-r13	Not present		
bt-RequestLocationInformation-r13	Not present		
nr-ECID-RequestLocationInformation-r16	Not present		
nr-Multi-RTT-RequestLocationInformation-r16	Not present		
nr-DL-AoD-RequestLocationInformation-r16	Not present		
nr-DL-TDOA-RequestLocationInformation-r16			
SEQUENCE {			
nr-DL-PRS-RstdMeasurementInfoRequest-r16	Not present		
nr-RequestedMeasurements-r16	bit 0 = 0 (prsrsrpReq)		
nr-AssistanceAvailability-r16	FALSE		
nr-DL-TDOA-ReportConfig-r16	Not present		
additionalPaths-r16	Not present		
}			
}			
}			
}			
}			
}			
}			
}			

Table 14.3.3.4.3-4: LPP ProvideAssistanceData

Derivation Path: TS 37.355 [49] clause 6.2			
Information Element	Value/remark	Comment	Condition
LPP-Message ::= SEQUENCE {			
transactionID SEQUENCE {			
initiator	locationServer		
transactionNumber	(0..255)		
}			
endTransaction	TRUE		
sequenceNumber	Not present		
acknowledgement	Not present		
lpp-MessageBody CHOICE {			
c1 CHOICE {			
provideAssistanceData SEQUENCE {			
criticalExtensions CHOICE {			
c1 CHOICE {			
provideAssistanceData-r9 SEQUENCE {			
commonEsProvideAssistanceData	Not present		
a-gnss-ProvideAssistanceData	Not present		
otdoa-ProvideAssistanceData	Not present		
epdu-Provide-AssistanceData	Not present		
sensor-ProvideAssistanceData-r14	Not present		
tbs-ProvideAssistanceData-r14	Not present		
wlan-ProvideAssistanceData-r14	Not present		
nr-Multi-RTT-ProvideAssistanceData-r16	Not present		

nr-DL-AoD-ProvideAssistanceData-r16	Not present		
nr-DL-TDOA-ProvideAssistanceData-r16			
SEQUENCE {			
nr-DL-PRS-AssistanceData-r16	As defined in Table 14.3.3.4.3-5		
nr-SelectedDL-PRS-IndexList-r16	Not present		
nr-PositionCalculationAssistance-r16			Depending on UE capabilities, i.e. support for UE-based DL-TDOA
SEQUENCE {			
nr-TRP-LocationInfo-r16	As defined in TS 37.571-5 [20]		
nr-DL-PRS-BeamInfo-r16	Not present		
nr-RTD-Info-r16	Not present		
}			
nr-DL-TDOA-Error-r16	Not present		
}			
}			
}			
}			
}			
}			
}			
}			

Table 14.3.3.4.3-5: NR-DL-PRS-AssistanceData

Derivation Path: 37.355 clause 6.4.3			
Information Element	Value/remark	Comment	Condition
NR-DL-PRS-AssistanceData-r16 ::= SEQUENCE {			
nr-DL-PRS-ReferenceInfo-r16 SEQUENCE {			
dl-PRS-ID-r16	0		
nr-DL-PRS-ResourceID-List-r16	Not present		
nr-DL-PRS-ResourceSetID-r16	Not present		
}			
nr-DL-PRS-AssistanceDataList-r16 SEQUENCE (SIZE (1..nrMaxFreqLayers-r16)) OF NR-DL-PRS-AssistanceDataPerFreq-r16 {	1 entry		
NR-DL-PRS-AssistanceDataPerFreq-r16[1] SEQUENCE {		entry 1	
nr-DL-PRS-PositioningFrequencyLayer-r16 SEQUENCE {			
dl-PRS-SubcarrierSpacing-r16	kHz120		
dl-PRS-ResourceBandwidth-r16	3	32 PRBs	Sub-test 1
	27	128 PRBs	Sub-test 2
dl-PRS-StartPRB-r16	0		
dl-PRS-PointA-r16	absoluteFrequencyPointA as defined for the DL frequency of the Cell 1		
dl-PRS-CombSizeN-r16	n2		Sub-test 1
	n4		Sub-test 2
dl-PRS-CyclicPrefix-r16	normal		
}			
nr-DL-PRS-AssistanceDataPerFreq-r16 SEQUENCE (SIZE (1..nrMaxTRPsPerFreq-r16)) OF NR-DL-PRS-AssistanceDataPerTRP-r16{	2 entries		
NR-DL-PRS-AssistanceDataPerTRP-r16[1] SEQUENCE {		entry 1	Cell 1
dl-PRS-ID-r16	0		
nr-PhysCellID-r16	Cell 1		
nr-CellGlobalID-r16	Cell 1		
nr-ARFCN-r16	Cell 1		
nr-DL-PRS-SFN0-Offset-r16 SEQUENCE {			

sfn-Offset-r16	0		
integerSubframeOffset-r16	0		
}			
nr-DL-PRS-ExpectedRSTD-r16	0		
nr-DL-PRS-ExpectedRSTD-Uncertainty-r16	0		
nr-DL-PRS-Info-r16	As specified in Table 14.3.3.4.3-6		
}			
NR-DL-PRS-AssistanceDataPerTRP-r16[2] SEQUENCE {		entry 2	Cell 2
dl-PRS-ID-r16	1		
nr-PhysCellID-r16	Cell 2		
nr-CellGlobalID-r16	Cell 2		
nr-ARFCN-r16	Cell 2		
nr-DL-PRS-SFN0-Offset-r16 SEQUENCE {			
sfn-Offset-r16	0		
integerSubframeOffset-r16	0		
}			
nr-DL-PRS-ExpectedRSTD-r16	23	About 3 μs	
nr-DL-PRS-ExpectedRSTD-Uncertainty-r16	154	About 5 μs	
nr-DL-PRS-Info-r16	As specified in Table 14.3.3.4.3-6		
}			
}			
}			
}			
}			
}			

Table 14.3.3.4.3-6: NR-DL-PRS-Info

Derivation Path: 37.355 clause 6.4.3			
Information Element	Value/remark	Comment	Condition
NR-DL-PRS-Info-r16 ::= SEQUENCE {			
nr-DL-PRS-ResourceSetList-r16 SEQUENCE (SIZE (1..nrMaxSetsPerTrp-r16)) OF NR-DL-PRS-ResourceSet-r16 {	1 entry		
NR-DL-PRS-ResourceSet-r16[1] SEQUENCE {		entry 1	
nr-DL-PRS-ResourceSetID-r16	0		
dl-PRS-Periodicity-and-ResourceSetSlotOffset-r16 CHOICE {			
scs120-r16 CHOICE {			
n160-r16	80		
}			
dl-PRS-ResourceRepetitionFactor-r16	n2		Sub-test 1
	Not present		Sub-test 2
dl-PRS-ResourceTimeGap-r16	s1		
dl-PRS-NumSymbols-r16	n4		
dl-PRS-MutingOption1-r16	Not present		
dl-PRS-MutingOption2-r16	Not present		
dl-PRS-ResourcePower-r16	27		
dl-PRS-ResourceList-r16 SEQUENCE (SIZE (1..nrMaxResourcesPerSet-r16)) OF NR-DL-PRS-Resource-r16 {	1 entry		
NR-DL-PRS-Resource-r16[1] SEQUENCE {		entry 1	
nr-DL-PRS-ResourceID-r16	0		
dl-PRS-SequenceID-r16	0		
dl-PRS-CombSizeN-AndReOffset-r16 CHOICE {			
n2-r16	0		Sub-test 1
n4-r16	0		Sub-test 2
}			
dl-PRS-ResourceSlotOffset-r16	0		Sub-test 1
	4		Sub-test 2
dl-PRS-ResourceSymbolOffset-r16	0		
dl-PRS-QCL-Info-r16	Not present		

}			
}			
}			
}			
}			

Table 14.3.3.4.3-7: LPP ProvideLocation Information

Derivation Path: TS 37.355 [49] clause 6.2			
Information Element	Value/remark	Comment	Condition
LPP-Message ::= SEQUENCE {			
transactionID SEQUENCE {			
initiator	locationServer		
transactionNumber	1		
}			
endTransaction	TRUE		
sequenceNumber	(0..255)		
acknowledgement			
lpp-MessageBody CHOICE {			
c1 CHOICE {			
provideLocationInformation SEQUENCE {			
criticalExtensions CHOICE {			
c1 CHOICE {			
provideLocationInformation-r9 SEQUENCE {			
commonIEsProvideLocationInformation	Not present.		
a-gnss-ProvideLocationInformation	Not present		
otdoa-ProvideLocationInformation	Not present		
ecid-ProvideLocationInformation	Not present		
epdu-ProvideLocationInformation	Not present		
sensor-ProvideLocationInformation-r13	Not present		
tbs-ProvideLocationInformation-r13	Not present		
wlan-ProvideLocationInformation-r13	Not present		
bt-ProvideLocationInformation-r13	Not present		
nr-ECID-ProvideLocationInformation-r16	Not present		
nr-Multi-RTT-ProvideLocationInformation-r16	Not present		
nr-DL-AoD-ProvideLocationInformation-r16	Not present		
nr-DL-TDOA-ProvideLocationInformation-r16 SEQUENCE {			
nr-DL-TDOA-SignalMeasurementInformation-r16 SEQUENCE {			
dl-PRS-ReferenceInfo-r16			
nr-DL-TDOA-MeasList-r16 SEQUENCE (SIZE(1..nrMaxTRPs-r16)) OF NR-DL-TDOA-MeasElement-r16 {	2 entries		
NR-DL-TDOA-MeasElement-r16[1] SEQUENCE {		entry 1	
dl-PRS-ID-r16			
nr-PhysCellID-r16	Cell 1		
nr-CellGlobalID-r16			
nr-ARFCN-r16			
nr-DL-PRS-ResourceID-r16			
nr-DL-PRS-ResourceSetID-r16			
nr-TimeStamp-r16			
nr-RSTD-r16	Present		
nr-AdditionalPathList-r16			
nr-TimingQuality-r16			
nr-DL-PRS-RSRP-Result-r16			
nr-DL-TDOA-AdditionalMeasurements-r16			
}			
NR-DL-TDOA-MeasElement-r16[2] SEQUENCE {		entry 2	
dl-PRS-ID-r16			
nr-PhysCellID-r16	Cell 2		

nr-CellGlobalID-r16			
nr-ARFCN-r16			
nr-DL-PRS-ResourceID-r16			
nr-DL-PRS-ResourceSetID-r16			
nr-TimeStamp-r16			
nr-RSTD-r16	Present		
nr-AdditionalPathList-r16			
nr-TimingQuality-r16			
nr-DL-PRS-RSRP-Result-r16			
nr-DL-TDOA-AdditionalMeasurements- r16			
}			
nr-dl-tdoa-LocationInformation-r16			
nr-DL-TDOA-Error-r16			
}			
}			
}			
}			
}			

14.3.3.5 Test requirement

The RSTD measurement accuracy for Cell 2 shall fulfil the absolute requirement in clause 14.3.3.3.

Table 14.3.3.5-1: RSTD accuracy test parameters

Parameter	Unit	Test 1		Test 2	
		Cell 1	Cell 2	Cell 1	Cell 2
PRS ARFCN		freq1		freq1	
Duplex mode		TDD		TDD	
TDD configuration		TDDConf.3.1		TDDConf.3.1	
BW _{channel}	MHz	200: N _{RB,C} = 132		200: N _{RB,C} = 132	
Downlink initial BWP configuration		DLBWP.0.1	-	DLBWP.0.1	-
Measurement gap		GP#24 or GP#13		GP#24 or GP#13	
Downlink dedicated BWP configuration		DLBWP.1.1	-	DLBWP.1.1	-
Uplink initial BWP configuration		ULBWP.0.1	-	ULBWP.0.1	-
Uplink dedicated BWP configuration		ULBWP.1.1	-	ULBWP.1.1	-
DRX cycle configuration		Not applicable	-	Not applicable	-
TRS configuration		TRS.2.1 TDD	-	TRS.2.1 TDD	-
TCI state		TCI.State.0	-	TCI.State.0	-
PDSCH Reference measurement channel		SR.3.1 TDD	-	SR.3.1 TDD	-
RMSI CORESET Reference Channel		CR.3.1 TDD	-	CR.3.1 TDD	-
Control channel RMC		CCR.3.1 TDD	-	CCR.3.1 TDD	-
OCNG Patterns		OP.1	OP.1	OP.1	OP.1
SSB configuration		SSB.3 FR2	SSB.3 FR2	SSB.3 FR2	SSB.3 FR2
SMTC configuration		SMTC.1	SMTC.1	SMTC.1	SMTC.1
PRS configuration		PRS.1.1 FR2	PRS.1.1 FR2	PRS.1.2 FR2	PRS.1.2 FR2
PRS Resource slot offset	slot	0	4	0	4
Expected RSTD	μs	N/A	3	N/A	3
Expected RSTD uncertainty	μs	N/A	5	N/A	5
Time offset with Cell 1	μs	-	3	-	3
PDSCH/PDCCH subcarrier spacing	kHz	120	120	120	120
EPRE ratio of PSS to SSS	dB	0	0	0	0
EPRE ratio of PBCH_DMRS to SSS					
EPRE ratio of PBCH to PBCH_DMRS					
EPRE ratio of PDCCH_DMRS to SSS					
EPRE ratio of PDCCH to PDCCH_DMRS					

EPRE ratio of PDSCH_DMRS to SSS					
EPRE ratio of PDSCH to PDSCH_DMRS					
EPRE ratio of OCNG DMRS to SSS ^{Note 1}					
EPRE ratio of OCNG to OCNG DMRS ^{Note 1}					
EPRE ratio of PRS to SSS	dB	0	0	0	0
Propagation conditions		AWGN	AWGN	AWGN	AWGN
Antenna configuration		1x2	1x2	1x2	1x2
Note 1: OCNG shall be used such that both cells are fully allocated and a constant total transmitted power spectral density is achieved for all OFDM symbols other than those in the slots with transmitted PRS..					

Table 14.3.3.5-2: RSTD accuracy OTA related test parameters

Parameter	Unit	Test 1		Test 2	
		Cell 1	Cell 2	Cell 1	Cell 2
Angle of arrival configuration		Setup 1 according to TS 38.133 [50] clause A.3.15.1			
Assumption for UE beams ^{Note 5}		Rough		Rough	
N_{oc} ^{Note1}	dBm/SCS ^{Note3}	-89.1		-89.1	
PRS \hat{E}_s / N_{oc}	dB	-5.17	-11.36	-5.17	-11.36
PRP ^{Note2}	dBm/SCS	-94.2	-100.4	-94.2	-100.4
PRS \hat{E}_s / I_{ot}	dB	-5.7	-12.7	-5.7	-12.7
I_o ^{Note2}	dBm/190.0 8 MHz ^{Note3}	-55.68	-55.68	-55.68	-55.68
<p>Note 1: Where used, interference from other cells and noise sources not specified in the test is assumed to be constant over subcarriers and time and shall be modelled as AWGN of appropriate power for N_{oc} to be fulfilled.</p> <p>Note 2: PRP, E_s/I_{ot} and I_o levels have been derived from other parameters for information purposes. They are not settable parameters themselves. The I_o is calculated based only on the symbols in which PRS is transmitted.</p> <p>Note 3: Equivalent power received by an antenna with 0 dBi gain at the centre of the quiet zone</p> <p>Note 4: Calculation of E_s/I_{ot} includes the effect of UE internal noise up to the value assumed for the associated Refsens requirement in clause 7.3.2 of TS 38.101-2 [2], and an allowance of 1dB for UE multi-band relaxation factor ΔMB_P from TS 38.101-2 [55] Table 6.2.1.3-4.</p> <p>Note 5: Information about types of UE beam is given in TS 38.133 [50] B.2.1.3, and does not limit UE implementation or test system implementation</p>					

The value of the LPP Time IE depends on the UE capabilities. The calculation is the same as in clause 14.2.3.5 with the following difference: $N_{PRS,i}^{slot} = 2$. Therefore, the value of the LPP Time IE is given by the following equation:

$$\left(1 * 8 * \left\lceil \frac{2}{N'} \right\rceil \left\lceil \frac{0.142}{N} \right\rceil * 4 - 1 \right) * T_{effect} + T_{last}$$

The resulting value shall be rounded up to the next integer and transmitted in the LPP-RequestLocationInformation (see Table 14.3.3.4.3-3).

Table 14.3.3.5-3: RSTD accuracy requirements for the reported values

Test Configuration	Lowest reported value	Highest reported value
--------------------	-----------------------	------------------------

Sub-test 1	(5898 – 120) T _c converted to RSTD measurement according to clause 4.15.6	(5898 + 120) T _c converted to RSTD measurement according to clause 4.15.6
Sub-test 2	(5898 – 82) T _c converted to RSTD measurement according to clause 4.15.6	(5898 + 82) T _c converted to RSTD measurement according to clause 4.15.6

The test tolerances are defined in clauses C.1.6 and C.2.5.

The rate of successful tests during repeated tests shall be at least 90% with a confidence level of 95%.

14.3.4 NR RSTD measurement accuracy test case for dual positioning frequency layer in FR2 SA

Editor's Note: This test case has been completed for the following configurations:

- Test frequency $f \leq 40.8$ GHz

- UE PC3

This test case is incomplete for UE power classes other than PC3

This test case is incomplete for test frequencies > 40.8 GHz

14.3.4.1 Test purpose

The purpose of the test is to verify that the RSTD measurement meets the accuracy requirements specified in TS 38.133 [50] clause 10.1.23.2 in an environment with AWGN propagation conditions. The test is conducted in AWGN propagation condition in FR2 in standalone scenario when dual positioning frequency layers are configured.

14.3.4.2 Test applicability

This test applies to all types of NR UE release 16 onwards that supports DL-TDOA positioning.

14.3.4.3 Minimum conformance requirements

Same as in clause 14.3.1.3.

14.3.4.4 Test description

The supported test configurations in listed in Table 14.3.4.4-1.

Table 14.3.4.4-1: Test Configurations

Configuration	Description
1	120 kHz SSB SCS, 200 MHz bandwidth, TDD duplex mode

14.3.4.4.1 Initial conditions

Test Environment: Normal, as defined in TS 38.508-1 [45] clause 4.1.

Frequencies to be tested: Mid Range, as defined in TS 38.508-1 [45] clause 4.3.1.

Channel bandwidth to be tested: are specified in Table 14.3.4.4-1.

1. Connect the SS and AWGN noise sources to the UE antenna connector or antenna connectors as shown in Annex A, Figure A.14.
2. The general test parameter settings are set up according to Table 14.3.4.5-1 and Table 14.3.4.5-2.
3. Propagation conditions are set according to clause 4.15.2.
4. Message contents are defined in clause 14.3.4.4.3.

5. In the test there are two synchronous cells: Cell 1 and Cell 2. Cell 1 is the reference as well as the PCell on NR RF channel #1 in FR2. Cell 2 is a neighbour cell on a different NR RF channel #2 in FR2. GP#13 is configured for the test.
6. The true RSTD (which is the receive time difference for frame 0 between cell 2 and cell 1 as seen at the UE antenna connector) is set to 5898 Tc (about 3 μs)

14.3.4.4.2 Test procedure

Same as clause 14.3.3.4.2.

14.3.4.4.3 Message contents

Table 14.3.4.4.3-1: RESET UE POSITIONING STORED INFORMATION

Derivation Path: 38.509 [44] clause 6.6			
Information Element	Value/remark	Comment	Condition
UE Positioning Technology	0 0 0 0 0 1 1 1	DL-TDOA	

Table 14.3.4.4.3-2: LPP Request Capabilities

Information Element	Value/remark
nr-DL-TDOA-RequestCapabilities-r16	TRUE

Table 14.3.4.4.3-3: LPP RequestLocationInformation

Derivation Path: TS 37.355 [49] clause 6.2			
Information Element	Value/remark	Comment	Condition
LPP-Message ::= SEQUENCE {			
transactionID SEQUENCE {			
initiator	locationServer		
transactionNumber	1		
}			
endTransaction	FALSE		
sequenceNumber	Not present		
acknowledgement	Not present		
lpp-MessageBody CHOICE {			
c1 CHOICE {			
requestLocationInformation SEQUENCE {			
criticalExtensions CHOICE {			
c1 CHOICE {			
requestLocationInformation-r9 SEQUENCE {			
commonEsRequestLocationInformation SEQUENCE {			
locationInformationType	locationMeasurementsPreferred		
triggeredReporting	Not present		
periodicalReporting	Not present		
additionalInformation	onlyReturnInformationRequested		
}			
}			
}			
}			
}			
}			
}			
responseTime SEQUENCE {			
time	see 14.3.4.5	Result of the response time calculation rounded up to the next second	
}			
responseTimeEarlyFix-r12	Not present		Rel-12 onwards

}			
velocityRequest	FALSE		
}			
environment	Not present		
locationCoordinateTypes	Not present		
velocityTypes	Not present		
}			
a-gnss-RequestLocationInformation	Not present		
otdoa-RequestLocationInformation	Not present		
ecid-RequestLocationInformation	Not present		
epdu-RequestLocationInformation	Not Present		
sensor-RequestLocationInformation-r13	Not present		
tbs-RequestLocationInformation-r13	Not present		
wlan-RequestLocationInformation-r13	Not present		
bt-RequestLocationInformation-r13	Not present		
nr-ECID-RequestLocationInformation-r16	Not present		
nr-Multi-RTT-RequestLocationInformation-r16	Not present		
nr-DL-AoD-RequestLocationInformation-r16	Not present		
nr-DL-TDOA-RequestLocationInformation-r16			
SEQUENCE {			
nr-DL-PRS-RstdMeasurementInfoRequest-r16	Not present		
nr-RequestedMeasurements-r16	bit 0 = 0 (prsrsrpReq)		
nr-AssistanceAvailability-r16	FALSE		
nr-DL-TDOA-ReportConfig-r16	Not present		
additionalPaths-r16	Not present		
}			
}			
}			
}			
}			
}			
}			
}			

Table 14.3.4.4.3-4: LPP ProvideAssistanceData

Derivation Path: TS 37.355 [49] clause 6.2			
Information Element	Value/remark	Comment	Condition
LPP-Message ::= SEQUENCE {			
transactionID SEQUENCE {			
initiator	locationServer		
transactionNumber	(0..255)		
}			
endTransaction	TRUE		
sequenceNumber	Not present		
acknowledgement	Not present		
lpp-MessageBody CHOICE {			
c1 CHOICE {			
provideAssistanceData SEQUENCE {			
criticalExtensions CHOICE {			
c1 CHOICE {			
provideAssistanceData-r9 SEQUENCE {			
commonEsProvideAssistanceData	Not present		
a-gnss-ProvideAssistanceData	Not present		
otdoa-ProvideAssistanceData	Not present		
epdu-Provide-AssistanceData	Not present		
sensor-ProvideAssistanceData-r14	Not present		
tbs-ProvideAssistanceData-r14	Not present		
wlan-ProvideAssistanceData-r14	Not present		
nr-Multi-RTT-ProvideAssistanceData-r16	Not present		
nr-DL-AoD-ProvideAssistanceData-r16	Not present		
nr-DL-TDOA-ProvideAssistanceData-r16			
}			
}			
}			
}			
}			
}			

nr-DL-PRS-AssistanceData-r16	As defined in Table 14.3.4.4.3-5		
nr-SelectedDL-PRS-IndexList-r16	Not present		
nr-PositionCalculationAssistance-r16			Depending on UE capabilities, i.e. support for UE-based DL-TDOA
SEQUENCE {			
nr-TRP-LocationInfo-r16	As defined in TS 37.571-5 [20]		
nr-DL-PRS-BeamInfo-r16	Not present		
nr-RTD-Info-r16	Not present		
}			
nr-DL-TDOA-Error-r16	Not present		
}			
}			
}			
}			
}			
}			
}			
}			

Table 14.3.4.4.3-5: NR-DL-PRS-AssistanceData

Derivation Path: 37.355 clause 6.4.3			
Information Element	Value/remark	Comment	Condition
NR-DL-PRS-AssistanceData-r16 ::= SEQUENCE {			
nr-DL-PRS-ReferenceInfo-r16 SEQUENCE {			
dl-PRS-ID-r16	0		
nr-DL-PRS-ResourceID-List-r16	Not present		
nr-DL-PRS-ResourceSetID-r16	Not present		
}			
nr-DL-PRS-AssistanceDataList-r16 SEQUENCE (SIZE (1..nrMaxFreqLayers-r16)) OF NR-DL-PRS-AssistanceDataPerFreq-r16 {	2 entries		
NR-DL-PRS-AssistanceDataPerFreq-r16[1] SEQUENCE {		entry 1	
nr-DL-PRS-PositioningFrequencyLayer-r16 SEQUENCE {			
dl-PRS-SubcarrierSpacing-r16	kHz120		
dl-PRS-ResourceBandwidth-r16	3	32 PRBs	Sub-test 1
	27	128 PRBs	Sub-test 2
dl-PRS-StartPRB-r16	0		
dl-PRS-PointA-r16	absoluteFrequencyPointA as defined for the DL frequency of the Cell 1		
dl-PRS-CombSizeN-r16	n2		Sub-test 1
	n4		Sub-test 2
dl-PRS-CyclicPrefix-r16	normal		
}			
nr-DL-PRS-AssistanceDataPerFreq-r16 SEQUENCE (SIZE (1..nrMaxTRPsPerFreq-r16)) OF NR-DL-PRS-AssistanceDataPerTRP-r16{	1 entry		
NR-DL-PRS-AssistanceDataPerTRP-r16[1] SEQUENCE {		entry 1	Cell 1
dl-PRS-ID-r16	0		
nr-PhysCellID-r16	Cell 1		
nr-CellGlobalID-r16	Cell 1		
nr-ARFCN-r16	Cell 1		
nr-DL-PRS-SFN0-Offset-r16 SEQUENCE {			
sfn-Offset-r16	0		
integerSubframeOffset-r16	0		
}			

nr-DL-PRS-ExpectedRSTD-r16	0		
nr-DL-PRS-ExpectedRSTD-Uncertainty-r16	0		
nr-DL-PRS-Info-r16	As specified in Table 14.3.4.4.3-6		
}			
}			
NR-DL-PRS-AssistanceDataPerFreq-r16[2] SEQUENCE {		entry 2	
nr-DL-PRS-PositioningFrequencyLayer-r16 SEQUENCE {			
dl-PRS-SubcarrierSpacing-r16	kHz120		
dl-PRS-ResourceBandwidth-r16	3	32 PRBs	Sub-test 1
	27	128 PRBs	Sub-test 2
dl-PRS-StartPRB-r16	0		
dl-PRS-PointA-r16	absoluteFrequencyPointA as defined for the DL frequency of the Cell 2		
dl-PRS-CombSizeN-r16	n2		Sub-test 1
	n4		Sub-test 2
dl-PRS-CyclicPrefix-r16	normal		
}			
nr-DL-PRS-AssistanceDataPerFreq-r16 SEQUENCE (SIZE (1..nrMaxTRPsPerFreq-r16)) OF NR-DL-PRS-AssistanceDataPerTRP-r16{	1 entry		
NR-DL-PRS-AssistanceDataPerTRP-r16[1] SEQUENCE {		entry 1	Cell 2
dl-PRS-ID-r16	1		
nr-PhysCellID-r16	Cell 2		
nr-CellGlobalID-r16	Cell 2		
nr-ARFCN-r16	Cell 2		
nr-DL-PRS-SFN0-Offset-r16 SEQUENCE {			
sfn-Offset-r16	0		
integerSubframeOffset-r16	0		
}			
nr-DL-PRS-ExpectedRSTD-r16	23	About 3 μs	
nr-DL-PRS-ExpectedRSTD-Uncertainty-r16	154	About 5 μs	
nr-DL-PRS-Info-r16	As specified in Table 14.3.4.4.3-6		
}			
}			
}			
}			
}			
}			

Table 14.3.4.4.3-6: NR-DL-PRS-Info

Derivation Path: 37.355 clause 6.4.3			
Information Element	Value/remark	Comment	Condition
NR-DL-PRS-Info-r16 ::= SEQUENCE {			
nr-DL-PRS-ResourceSetList-r16 SEQUENCE (SIZE (1..nrMaxSetsPerTrp-r16)) OF NR-DL-PRS-ResourceSet-r16 {	1 entry		
NR-DL-PRS-ResourceSet-r16[1] SEQUENCE {		entry 1	
nr-DL-PRS-ResourceSetID-r16	0		
dl-PRS-Periodicity-and-ResourceSetSlotOffset-r16 CHOICE {			
scs120-r16 CHOICE {			
n160-r16	80		
}			
dl-PRS-ResourceRepetitionFactor-r16	n2		Sub-test 1
	Not present		Sub-test 2
dl-PRS-ResourceTimeGap-r16	s1		
dl-PRS-NumSymbols-r16	n4		
dl-PRS-MutingOption1-r16	Not present		
dl-PRS-MutingOption2-r16	Not present		

dl-PRS-ResourcePower-r16	27		
dl-PRS-ResourceList-r16 SEQUENCE (SIZE (1..nrMaxResourcesPerSet-r16)) OF NR-DL-PRS-Resource-r16 {	1 entry		
NR-DL-PRS-Resource-r16[1] SEQUENCE {		entry 1	
nr-DL-PRS-ResourceID-r16	0		
dl-PRS-SequenceID-r16	0		
dl-PRS-CombSizeN-AndReOffset-r16 CHOICE {			
n2-r16	0		Sub-test 1
n4-r16	0		Sub-test 2
}			
dl-PRS-ResourceSlotOffset-r16	0		Sub-test 1 Cell 1 and Sub-test 2 Cell 1
	4		Sub-test 1 Cell 2 and Sub-test 2 Cell 2
dl-PRS-ResourceSymbolOffset-r16	0		
dl-PRS-QCL-Info-r16	Not present		
}			
}			
}			
}			
}			

Table 14.3.4.4.3-7: LPP ProvideLocation Information

Derivation Path: TS 37.355 [49] clause 6.2			
Information Element	Value/remark	Comment	Condition
LPP-Message ::= SEQUENCE {			
transactionID SEQUENCE {			
initiator	locationServer		
transactionNumber	1		
}			
endTransaction	TRUE		
sequenceNumber	(0..255)		
acknowledgement			
lpp-MessageBody CHOICE {			
c1 CHOICE {			
provideLocationInformation SEQUENCE {			
criticalExtensions CHOICE {			
c1 CHOICE {			
provideLocationInformation-r9 SEQUENCE {			
commonIEsProvideLocationInformation	Not present.		
a-gnss-ProvideLocationInformation	Not present		
otdoa-ProvideLocationInformation	Not present		
ecid-ProvideLocationInformation	Not present		
epdu-ProvideLocationInformation	Not present		
sensor-ProvideLocationInformation-r13	Not present		
tbs-ProvideLocationInformation-r13	Not present		
wlan-ProvideLocationInformation-r13	Not present		
bt-ProvideLocationInformation-r13	Not present		
nr-ECID-ProvideLocationInformation-r16	Not present		
nr-Multi-RTT-ProvideLocationInformation-r16	Not present		
nr-DL-AoD-ProvideLocationInformation-r16	Not present		
nr-DL-TDOA-ProvideLocationInformation-r16 SEQUENCE {			
nr-DL-TDOA-SignalMeasurementInformation-r16 SEQUENCE {			
dl-PRS-ReferenceInfo-r16			

nr-DL-TDOA-MeasList-r16 SEQUENCE (SIZE(1..nrMaxTRPs-r16)) OF NR-DL-TDOA-MeasElement-r16 {	2 entries		
NR-DL-TDOA-MeasElement-r16[1] SEQUENCE {		entry 1	
dl-PRS-ID-r16			
nr-PhysCellID-r16	Cell 1		
nr-CellGlobalID-r16			
nr-ARFCN-r16			
nr-DL-PRS-ResourceID-r16			
nr-DL-PRS-ResourceSetID-r16			
nr-TimeStamp-r16			
nr-RSTD-r16	Present		
nr-AdditionalPathList-r16			
nr-TimingQuality-r16			
nr-DL-PRS-RSRP-Result-r16			
nr-DL-TDOA-AdditionalMeasurements-r16			
}			
NR-DL-TDOA-MeasElement-r16[2] SEQUENCE {		entry 2	
dl-PRS-ID-r16			
nr-PhysCellID-r16	Cell 2		
nr-CellGlobalID-r16			
nr-ARFCN-r16			
nr-DL-PRS-ResourceID-r16			
nr-DL-PRS-ResourceSetID-r16			
nr-TimeStamp-r16			
nr-RSTD-r16	Present		
nr-AdditionalPathList-r16			
nr-TimingQuality-r16			
nr-DL-PRS-RSRP-Result-r16			
nr-DL-TDOA-AdditionalMeasurements-r16			
}			
nr-dl-tdoa-LocationInformation-r16			
nr-DL-TDOA-Error-r16			
}			
}			
}			
}			
}			

14.3.4.5 Test requirement

The RSTD measurement accuracy for Cell 2 shall fulfil the absolute requirement in clause 14.3.4.3.

Table 14.3.4.5-1: RSTD accuracy test parameters

Parameter	Unit	Test 1		Test 2	
		Cell 1	Cell 2	Cell 1	Cell 2
PRS ARFCN		freq1	freq2	freq1	freq2
Duplex mode		TDD		TDD	
TDD configuration		TDDConf.3.1		TDDConf.3.1	
BW _{channel}	MHz	200: N _{RB,c} = 132		200: N _{RB,c} = 132	
Measurement gap		GP#24 or GP#13			
Downlink initial BWP configuration		DLBWP.0.1	-	DLBWP.0.1	-
Downlink dedicated BWP configuration		DLBWP.1.1	-	DLBWP.1.1	-
Uplink initial BWP configuration		ULBWP.0.1	-	ULBWP.0.1	-
Uplink dedicated BWP configuration		ULBWP.1.1	-	ULBWP.1.1	-
DRX cycle configuration		Not applicable	-	Not applicable	-
TRS configuration		TRS.2.1 TDD	-	TRS.2.1 TDD	-

TCI state		TCI.State.0	-	TCI.State.0	-
PDSCH Reference measurement channel		SR.3.1 TDD	-	SR.3.1 TDD	-
RMSI CORESET Reference Channel		CR.3.1 TDD	-	CR.3.1 TDD	-
Control channel RMC		CCR.3.1 TDD	-	CCR.3.1 TDD	-
OCNG Patterns		OP.1	OP.1	OP.1	OP.1
SSB configuration		SSB.3 FR2	SSB.3 FR2	SSB.3 FR2	SSB.3 FR2
SMTC configuration		SMTC.1	SMTC.1	SMTC.1	SMTC.1
PRS configuration		PRS.1.1 FR2	PRS.1.1 FR2	PRS.1.2 FR2	PRS.1.2 FR2
PRS Resource slot offset	slot	0	4	0	4
Expected RSTD	μs	N/A	3	N/A	3
Expected RSTD uncertainty	μs	N/A	5	N/A	5
Time offset with Cell 1	μs	-	3	-	3
PDSCH/PDCCH subcarrier spacing	kHz	120	120	120	120
EPRE ratio of PSS to SSS	dB	0	0	0	0
EPRE ratio of PBCH_DMRS to SSS					
EPRE ratio of PBCH to PBCH_DMRS					
EPRE ratio of PDCCH_DMRS to SSS					
EPRE ratio of PDCCH to PDCCH_DMRS					
EPRE ratio of PDSCH_DMRS to SSS					
EPRE ratio of PDSCH to PDSCH_DMRS					
EPRE ratio of OCNG DMRS to SSS ^{Note 1}					
EPRE ratio of OCNG to OCNG DMRS ^{Note 1}					
Propagation conditions					
Antenna configuration		1x2	1x2	1x2	1x2
EPRE ratio of PRS to SSS	dB	0	0	0	0
Note 1: OCNG shall be used such that both cells are fully allocated and a constant total transmitted power spectral density is achieved for all OFDM symbols other than those in the slots with transmitted PRS.					

Table 14.3.4.5-2: RSTD accuracy OTA related test parameters

Parameter	Unit	Test 1		Test 2	
		Cell 1	Cell 2	Cell 1	Cell 2
Angle of arrival configuration		Setup 1 according to clause A.3.15.1			
Assumption for UE beams ^{Note 5}		Rough		Rough	
N_{oc} ^{Note1}	dBm/SCS ^{Note3}	-89		-89	
PRS \hat{E}_s / N_{oc}	dB	-5.47	-12.47	-5.47	-12.47
PRP ^{Note2}	dBm/SCS	-94.4	-101.4	-94.4	-101.4
\hat{E}_s / I_{ot_BB} ^{Note4}	dB	-5.7	-12.7	-5.7	-12.7
I_o ^{Note2}	dBm/190.0 8 MHz ^{Note3}	-55.89	-55.89	-55.89	-55.89
Note 1: Where used, interference from other cells and noise sources not specified in the test is assumed to be constant over subcarriers and time and shall be modelled as AWGN of appropriate power for N_{oc} to be fulfilled.					

Note 2:	PRP, Es/lot and Io levels have been derived from other parameters for information purposes. They are not settable parameters themselves. The Io is calculated based only on the symbols in which PRS is transmitted.
Note 3:	Equivalent power received by an antenna with 0 dBi gain at the centre of the quiet zone
Note 4:	Calculation of Es/lot includes the effect of UE internal noise up to the value assumed for the associated Refsens requirement in clause 7.3.2 of TS 38.101-2 [19], and an allowance of 1dB for UE multi-band relaxation factor ΔMB_P from TS 38.101-2 [19] Table 6.2.1.3-4.
Note 5:	Information about types of UE beam is given in B.2.1.3, and does not limit UE implementation or test system implementation

The value of the LPP Time IE depends on the UE capabilities. The calculation is the same as in clause 14.2.4.5 with the following difference: $N_{PRS,i}^{slot} = 1$. Therefore, the value of the LPP Time IE is given by the following equation:

$$\left(1 * 8 * \left\lfloor \frac{1}{N_f} \right\rfloor \left\lceil \frac{0.071}{N} \right\rceil * 4 - 1 \right) * T_{effect} + T_{last}$$

The resulting value shall be rounded up to the next integer and transmitted in the LPP-RequestLocationInformation (see Table 14.3.4.4.3-3).

Table 14.3.4.5-3: RSTD accuracy requirements for the reported values

Test Configuration	Lowest reported value	Highest reported value
Sub-test 1	[5898 – 360] T _c converted to RSTD measurement according to clause 4.15.6	[5898 + 360] T _c converted to RSTD measurement according to clause 4.15.6
Sub-test 2	[5898 – 310] T _c converted to RSTD measurement according to clause 4.15.6	[5898 + 310] T _c converted to RSTD measurement according to clause 4.15.6

The test tolerances are defined in clauses C.1.6 and C.2.5.

The rate of successful tests during repeated tests shall be at least 90% with a confidence level of 95%.

14.3.5 NR RSTD measurement accuracy test case for single positioning frequency layer with reduced number of samples in FR1 SA

Editor's note: This test case is incomplete. The following aspect is either missing or TBD:

- Test tolerance is missing
- Message contents require update

14.3.5.1 Test purpose

The purpose of the test is to verify that the RSTD measurement meets the accuracy requirements specified in TS 38.133 [50] clause 10.1.23.2 in an environment with AWGN propagation conditions.

14.3.5.2 Test applicability

This test applies to all types of NR UE release 17 onwards that supports DL-TDOA positioning and supportedDL-PRS-ProcessingSamples.

14.3.5.3 Minimum conformance requirements

The accuracy requirements for RSTD measurement shall be within $\pm(X+Y+Z+\Delta)$ T_c.

X is defined in TS 38.133 [50] Table 10.1.23.2-7 for AWGN channel in FR1 provided that the following conditions are met.

- Conditions defined in clause 7.3 of TS 38.101-1 [18] for reference sensitivity are fulfilled.
- Conditions for RSTD measurements are fulfilled according to Annex B.2.14 for a corresponding Band for each relevant PRS resource configured for measurement.
- UE supports positioning measurement with reduced number of sample and is indicated by LMF to perform positioning measurement with reduced number of samples.

Note: The requirements for fading channel in this clause are derived based on TDL-A (30 ns delay spread, 5Hz) and TDL-C (60 ns delay spread, 300 Hz) channel models for FR1 and FR2 respectively.

When UE measures RSTD on PRS resources belonging to different PFLs, then the RSTD accuracy is defined as the accuracy corresponding to the largest accuracy value among different PFLs.

If the UE doesn't support Rx TEG reporting for RSTD measurement or when the measurements of reference cell and neighbour cell belong to different Rx TEGs, Y, Z and Δ are defined as follows:

- When UE measures RSTD on PRS resources belonging to same PFL, $Y=32 T_c$, provided that the time offset between the two PRS resource instances from the reference cell and the neighbour cell, which are used for a single RSTD estimate, is no greater than 160 ms.
- When UE measures RSTD on PRS resources belonging different PFLs, $Y=256 T_c$, provided that the time offset between the two PRS resource instances from the reference cell and the neighbour cell, which are used for a single RSTD estimate, is no greater than 1280 ms.
- Z is defined in Table 14.3.5.3-1
- Δ is zero for single PFL, and is defined in Table 14.3.5.3-1, for dual PFL.

Table 14.3.5.3-1: Margin for RSTD measurement accuracy in FR1

PRS BW (RB number)			Margin (Tc)
SCS=15kHz	SCS=30kHz	SCS=60kHz	
≥ 24	N/A	N/A	120
≥ 52	≥ 24	N/A	72
≥ 104	≥ 48	≥ 24	36
N/A	≥ 132	≥ 64	16
N/A	N/A	≥ 132	12

Table 14.3.5.3-2: Margin Δ for RSTD measurement accuracy in FR1

PRS BW (RB number)			Margin (Tc)
SCS=15kHz	SCS=30kHz	SCS=60kHz	
≥ 24	N/A	N/A	128
≥ 52	≥ 24	N/A	64
≥ 104	≥ 48	≥ 24	32
N/A	≥ 132	≥ 64	16
N/A	N/A	≥ 132	8

Table 14.3.5.3-3: RSTD absolute accuracy in FR1 for AWGN channel with reduced number of samples

Accuracy	Conditions						
	PRS $\hat{\epsilon}_s/\text{lot}$	PRS SCS	PRS bandwidth Note 1	PRS resource repetition ($T_{\text{rep}}^{\text{PRS}} * L_{\text{PRS}} / K_{\text{comb}}^{\text{PRS}}$) Note 2	I_o Note 3 range		
					NR operating band groups Note 4	Minimum I_o	Maximum I_o
T_c Note 5	dB	kHz	RB		dBm/SCS	dBm/BW _{Channel}	
98	(PRS $\hat{\epsilon}_s/\text{lot}$) _{ref} ≥ -3dB	15	≥ 52	≥ 1	NR_FDD_FR1_A, NR_TDD_FR1_A, NR_SDL_FR1_A	-127	-50
					NR_FDD_FR1_B	-126.5	-50

	(PRS \hat{E}_s/lot) _i ≥ -6dB				NR_TDD_FR1_C	-126	-50
					NR_FDD_FR1_D, NR_TDD_FR1_D	-125.5	-50
					NR_FDD_FR1_E, NR_TDD_FR1_E	-125	-50
					NR_FDD_FR1_F	-124.5	-50
					NR_FDD_FR1_G, NR_TDD_FR1_G	-124	-50
					NR_FDD_FR1_H	-123.5	-50
42			≥ 104	≥ 1	Note 6	Note 6	Note 6
48		30	≥ 48	≥ 1	NR_FDD_FR1_A, NR_TDD_FR1_A, NR_SDL_FR1_A	-124	-50
	NR_FDD_FR1_B				-123.5	-50	
	NR_TDD_FR1_C				-123	-50	
	NR_FDD_FR1_D, NR_TDD_FR1_D				-122.5	-50	
	NR_FDD_FR1_E, NR_TDD_FR1_E				-122	-50	
	NR_FDD_FR1_F				-121.5	-50	
					NR_FDD_FR1_G, NR_TDD_FR1_G	-121	-50
					NR_FDD_FR1_H	-120.5	-50
24			≥ 132	≥ 1	Note 6	Note 6	Note 6
24		60	≥ 64	≥ 1	NR_FDD_FR1_A, NR_TDD_FR1_A, NR_SDL_FR1_A	-121	-50
	NR_FDD_FR1_B				-120.5	-50	
	NR_TDD_FR1_C				-120	-50	
	NR_FDD_FR1_D, NR_TDD_FR1_D				-119.5	-50	
	NR_FDD_FR1_E, NR_TDD_FR1_E				-119	-50	
	NR_FDD_FR1_F				-118.5	-50	
					NR_FDD_FR1_G, NR_TDD_FR1_G	-118	-50
					NR_FDD_FR1_H	-117.5	-50
10			≥ 132	≥ 1	Note 6	Note 6	Note 6
<p>NOTE 1: Minimum PRS bandwidth, which is minimum of the PRS bandwidths of the reference resource and the measured neighbour resource <i>i</i>.</p> <p>NOTE 2: Minimum number of PRS resource repetitions among the reference resource and the measured neighbour resource <i>i</i>. $T_{\text{rep}}^{\text{PRS}}$, L_{PRS}, $K_{\text{comb}}^{\text{PRS}}$ are configured by higher layer parameter <i>dl-PRS-ResourceRepetitionFactor</i>, <i>dl-PRS-NumSymbols</i> and <i>dl-PRS-CombSizeN</i> defined in TS 37.355 [49], respectively.</p> <p>NOTE 3: I_0 is assumed to have constant EPRE across the bandwidth.</p> <p>NOTE 4: NR operating band groups in FR1 are as defined in clause 3.5.2.</p> <p>NOTE 5: T_c is the basic timing unit defined in TS 38.211 [53].</p> <p>NOTE 6: The same bands and the same I_0 conditions for each band apply for this requirement as for the corresponding requirement with the PRS bandwidth of the smallest RB number for the corresponding SCS.</p> <p>NOTE 7: Void</p>							

14.3.5.4 Test description

14.3.5.4.1 Initial conditions

The supported test configuration is listed in Table 14.3.5.4-1.

Table 14.3.5.4-1: Test Configuration

Configuration	Description
1	15 kHz SSB SCS, 20 MHz bandwidth, FDD duplex mode
2	15 kHz SSB SCS, 20 MHz bandwidth, TDD duplex mode
3	30 kHz SSB SCS, 50 MHz bandwidth, TDD duplex mode
Note:	The UE is only required to be tested in one of the supported test configurations.

Test Environment: Normal, as defined in TS 38.508-1 [45] clause 4.1.

Frequencies to be tested: Mid-Range, as defined in TS 38.508-1 [45] clause 4.3.1.

Channel bandwidth to be tested: are specified in Table 14.3.5.4-1.

1. Connect the SS and AWGN noise sources to the UE antenna connector or antenna connectors as shown in Annex A, Figure A.13.
2. The general test parameter settings are set up according to Table 14.3.5.5-1.
3. Propagation conditions are set according to clause 4.15.2.
4. Message contents are defined in clause 14.3.5.4.3.
5. In the test there are two synchronous cells: Cell 1 and Cell 2. Cell 1 is the reference as well as the PCell. Cell 2 is a neighbour cell. Both cells are on the same NR RF channel in FR1. GP#24 is configured if UE supports MG#24, otherwise GP#0 is configured for the test.
6. The true RSTD (which is the receive time difference for frame 0 between cell 2 and cell 1 as seen at the UE antenna connector) is set to 5898 Tc (about 3 μ s)

14.3.5.4.2 Test procedure

The test consists of two sub-tests; the difference between the sub-tests is the PRS configuration. The test consists of a set-up period and a measurement period. Cell 1 and Cell 2 are both active during the complete test. The beginning of the measurement period shall be aligned with the first PRS positioning subframe of a positioning occasion in the reference cell. The NR-DL-TDOA-RequestLocationInformation message and the DL-TDOA assistance data as defined in clause 14.3.5.4.3 shall be provided to the UE during the set-up period.

The UE is configured with measurement gap pattern ID # 24 if UE supports MG#24, otherwise #0 before T2.

1. Ensure the UE is in State RRC_CONNECTED with generic procedure parameters Connectivity NR, Connected without release On, according to TS 38.508-1 [45] clause 4.5.
2. The SS shall send a RESET UE POSITIONING STORED INFORMATION message.
3. Set the parameters according to Table 14.3.5.5-1. Propagation conditions are set according to clause 4.15.2.
4. The SS shall transmit an LPP REQUEST CAPABILITIES message.
5. The UE shall transmit an LPP PROVIDE CAPABILITIES message indicating the UE supports *supportedDL-PRS-ProcessingSamples-RRC-CONNECTED* in the *NR-DL-PRS-ProcessingCapability* IE and DL-TDOA capabilities supported by the UE in the *NR-DL-TDOA-ProvideCapabilities* IE.
6. The SS shall send a LPP PROVIDE ASSISTANCE DATA message, including the *NR-DL-TDOA-ProvideAssistanceData* IE. If the UE message at step 5 includes the *ackRequested* IE set to TRUE, then the SS shall send an acknowledgment in the LPP PROVIDE ASSISTANCE DATA message.
7. The SS shall send a LPP REQUEST LOCATION INFORMATION message, including the *reducedDL-PRS-ProcessingSamples-r17* in the *NR-DL-TDOA-RequestLocationInformation* IE such that the UE receives the message ΔT ms before the start of the measurement period, where $\Delta T = 50$ ms.
8. The UE shall transmit a LPP PROVIDE LOCATION INFORMATION message including the *NR-DL-TDOA-ProvideLocationInformation* IE within the response time (see clause 4.15.3).
9. If the UE message at step 8 includes the *ackRequested* IE set to TRUE, the SS shall send a LPP acknowledgement message.
10. The SS shall check the *nr-RSTD-r16* value for Cell 2 in the *nr-DL-TDOA-SignalMeasurementInformation-r16* according to Table 14.3.5.5-2.
11. Repeat steps 2-10 in Table 14.3.5.4-1 until the confidence level according to Annex D is achieved.
12. Repeat step 1-11 for the other sub-test defined in Table 14.3.5.5-1 as appropriate.

If all (applicable) sub-tests pass, the whole test passes. If one (applicable) sub-test fails, the whole test fails.

14.3.5.4.3 Message contents

Table 14.2.3.7.3-1: RESET UE POSITIONING STORED INFORMATION

Derivation Path: 38.509 [44] clause 6.6			
Information Element	Value/remark	Comment	Condition
UE Positioning Technology	0 0 0 0 1 1 1	DL-TDOA	

Table 14.3.5.4.3-2: LPP Request Capabilities

Information Element	Value/remark
nr-DL-TDOA-RequestCapabilities-r16	TRUE

Table 14.3.5.4.3-3: LPP RequestLocationInformation

Derivation Path: TS 37.355 [49] clause 6.2			
Information Element	Value/remark	Comment	Condition
LPP-Message ::= SEQUENCE {			
transactionID SEQUENCE {			
initiator	locationServer		
transactionNumber	1		
}			
endTransaction	FALSE		
sequenceNumber	Not present		
acknowledgement	Not present		
lpp-MessageBody CHOICE {			
c1 CHOICE {			
requestLocationInformation SEQUENCE {			
criticalExtensions CHOICE {			
c1 CHOICE {			
requestLocationInformation-r9 SEQUENCE {			
commonEsRequestLocationInformation SEQUENCE {			
locationInformationType	locationMeasurementsPreferred		
triggeredReporting	Not present		
periodicalReporting	Not present		
additionalInformation	onlyReturnInformationRequested		
qos SEQUENCE {			
horizontalAccuracy	Not present		
verticalCoordinateRequest	FALSE		
verticalAccuracy	Not present		
responseTime SEQUENCE {			
time	See 14.3.5.5	Result of the response time calculation rounded up to the next second	
responseTimeEarlyFix-r12	Not present		Rel-12 onwards
unit-r15	Not present		
}			
velocityRequest	FALSE		
}			
environment	Not present		
locationCoordinateTypes	Not present		
velocityTypes	Not present		
}			
a-gnss-RequestLocationInformation	Not present		
otdoa-RequestLocationInformation	Not present		

ecid-RequestLocationInformation	Not present		
epdu-RequestLocationInformation	Not Present		
sensor-RequestLocationInformation-r13	Not present		
tbs-RequestLocationInformation-r13	Not present		
wlan-RequestLocationInformation-r13	Not present		
bt-RequestLocationInformation-r13	Not present		
nr-ECID-RequestLocationInformation-r16	Not present		
nr-Multi-RTT-RequestLocationInformation-r16	Not present		
nr-DL-AoD-RequestLocationInformation-r16	Not present		
nr-DL-TDOA-RequestLocationInformation-r16			
SEQUENCE {			
nr-DL-PRS-RstdMeasurementInfoRequest-r16	Not present		
nr-RequestedMeasurements-r16	bit 0 = 0 (prsrsrpReq)		
nr-AssistanceAvailability-r16	FALSE		
nr-DL-TDOA-ReportConfig-r16 SEQUENCE {			
maxDL-PRS-RSTD-MeasurementsPerTRPPair-r16	Not present		
timingReportingGranularityFactor-r16	Not present		
measureSameDL-PRS-ResourceWithDifferentRxTEGs-r17	Not present		
reducedDL-PRS-ProcessingSamples-r17	requested		
lowerRxBeamSweepingFactor-FR2-r17	Not present		
}			
additionalPaths-r16	Not present		
nr-UE-RxTEG-Request-r17	Not present		
nr-los-nlos-IndicatorRequest-r17	Not present		
additionalPathsExt-r17	Not present		
additionalPathsDL-PRS-RSRP-Request-r17	Not present		
multiMeasInSameReport-r17	Not present		
}			
}			
}			
}			
}			
}			
}			
}			
}			
}			

Table 14.3.5.4.3-4: LPP ProvideAssistanceData

Derivation Path: TS 37.355 [49] clause 6.2			
Information Element	Value/remark	Comment	Condition
LPP-Message ::= SEQUENCE {			
transactionID SEQUENCE {			
initiator	locationServer		
transactionNumber	(0..255)		
}			
endTransaction	TRUE		
sequenceNumber	Not present		
acknowledgement	Not present		
lpp-MessageBody CHOICE {			
c1 CHOICE {			
provideAssistanceData SEQUENCE {			
criticalExtensions CHOICE {			
c1 CHOICE {			
provideAssistanceData-r9 SEQUENCE {			
commonEsProvideAssistanceData	Not present		
a-gnss-ProvideAssistanceData	Not present		
otdoa-ProvideAssistanceData	Not present		
epdu-Provide-AssistanceData	Not present		
sensor-ProvideAssistanceData-r14	Not present		
tbs-ProvideAssistanceData-r14	Not present		
wlan-ProvideAssistanceData-r14	Not present		
nr-Multi-RTT-ProvideAssistanceData-r16	Not present		

nr-DL-AoD-ProvideAssistanceData-r16	Not present		
nr-DL-TDOA-ProvideAssistanceData-r16			
SEQUENCE {			
nr-DL-PRS-AssistanceData-r16	As defined in Table 14.3.5.4.3-5		
nr-SelectedDL-PRS-IndexList-r16	Not present		
nr-PositionCalculationAssistance-r16			Depending on UE capabilities, i.e. support for UE-based DL-TDOA
SEQUENCE {			
nr-TRP-LocationInfo-r16	As defined in TS 37.571-5 [20]		
nr-DL-PRS-BeamInfo-r16	Not present		
nr-RTD-Info-r16	Not present		
nr-TRP-BeamAntennaInfo-r17	Not present		
nr-DL-PRS-Expected-LOS-NLOS-Assistance-r17	Not present		
nr-DL-PRS-TRP-TEG-Info-r17	Not present		
}			
nr-DL-TDOA-Error-r16	Not present		
nr-On-Demand-DL-PRS-Configurations-r17	Not present		
nr-On-Demand-DL-PRS-Configurations-Selected-IndexList-r17	Not present		
assistanceDataValidityArea-r17	Not present		
}			
}			
}			
}			
}			
}			
}			
}			
}			
}			

Table 14.3.5.4.3-5: NR-DL-PRS-AssistanceData

Derivation Path: TS 37.355 [49] clause 6.4.3			
Information Element	Value/remark	Comment	Condition
NR-DL-PRS-AssistanceData-r16 ::= SEQUENCE {			
nr-DL-PRS-ReferenceInfo-r16 SEQUENCE {			
dl-PRS-ID-r16	0		
nr-DL-PRS-ResourceID-List-r16	Not present		
nr-DL-PRS-ResourceSetID-r16	Not present		
}			
nr-DL-PRS-AssistanceDataList-r16 SEQUENCE (SIZE (1..nrMaxFreqLayers-r16)) OF NR-DL-PRS-AssistanceDataPerFreq-r16 {	1 entry		
NR-DL-PRS-AssistanceDataPerFreq-r16[1] SEQUENCE {		entry 1	
nr-DL-PRS-PositioningFrequencyLayer-r16 SEQUENCE {			
dl-PRS-SubcarrierSpacing-r16	kHz15		Sub-test 1-1, Sub-test 1-2, Sub test 2-1 and Sub-test 2-2
	kHz30		Sub-test 3-1 and Sub-test 3-2
dl-PRS-ResourceBandwidth-r16	8	52 PRBs	Config 1 and Config 2
	7	48 PRBs	Config 3

dl-PRS-StartPRB-r16	0		
dl-PRS-PointA-r16	absoluteFrequencyPointA as defined for the DL frequency of the Cell 1		
dl-PRS-CombSizeN-r16	n2		Sub-test 1-1, Sub-test 2-1 and Sub-test 3-1
	n4		Sub-test 1-2, Sub-test 2-2 and Sub-test 3-2
dl-PRS-CyclicPrefix-r16	normal		
}			
nr-DL-PRS-AssistanceDataPerFreq-r16 SEQUENCE (SIZE (1..nrMaxTRPsPerFreq-r16)) OF NR-DL-PRS-AssistanceDataPerTRP-r16{	2 entries		
NR-DL-PRS-AssistanceDataPerTRP-r16[1] SEQUENCE {		entry 1	Cell 1
dl-PRS-ID-r16	0		
nr-PhysCellID-r16	Cell 1		
nr-CellGlobalID-r16	Cell 1		
nr-ARFCN-r16	Cell 1		
nr-DL-PRS-SFN0-Offset-r16 SEQUENCE {			
sfn-Offset-r16	0		
integerSubframeOffset-r16	0		
}			
nr-DL-PRS-ExpectedRSTD-r16	0		
nr-DL-PRS-ExpectedRSTD-Uncertainty-r16	0		
nr-DL-PRS-Info-r16	As specified in Table 14.3.1.4.3-6		
}			
NR-DL-PRS-AssistanceDataPerTRP-r16[2] SEQUENCE {		entry 2	Cell 2
dl-PRS-ID-r16	1		
nr-PhysCellID-r16	Cell 2		
nr-CellGlobalID-r16	Cell 2		
nr-ARFCN-r16	Cell 2		
nr-DL-PRS-SFN0-Offset-r16 SEQUENCE {			
sfn-Offset-r16	0		
integerSubframeOffset-r16	0		
}			
nr-DL-PRS-ExpectedRSTD-r16	23	About 3 μs	
nr-DL-PRS-ExpectedRSTD-Uncertainty-r16	39	About 5 μs	
nr-DL-PRS-Info-r16	As specified in Table 14.3.1.4.3-6		
}			
}			
}			
}			
}			

Table 14.3.5.4.3-6: NR-DL-PRS-Info

Derivation Path: TS 37.355 [49] clause 6.4.3			
Information Element	Value/remark	Comment	Condition
NR-DL-PRS-Info-r16 ::= SEQUENCE {			
nr-DL-PRS-ResourceSetList-r16 SEQUENCE (SIZE (1..nrMaxSetsPerTrp-r16)) OF NR-DL-PRS-ResourceSet-r16 {	1 entry		
NR-DL-PRS-ResourceSet-r16[1] SEQUENCE {		entry 1	
nr-DL-PRS-ResourceSetID-r16	0		

dl-PRS-Periodicity-and-ResourceSetSlotOffset-r16 CHOICE {			
scs15-r16 CHOICE {			Sub-tests 1-1, Sub-test 1-2, Sub-test 2-1 and Sub-test 2-2
n160-r16	10		
}			
scs30-r16 CHOICE {			Sub-tests 3-1 and Sub-test 3-2
n320-r16	20		
}			
dl-PRS-ResourceRepetitionFactor-r16	Not present		Sub-tests 1-2, Sub-test 2-2 and Sub-test 3-2
	n2		Sub-tests 1-1, Sub-test 2-1 and Sub-test 3-1
dl-PRS-ResourceTimeGap-r16	s1		
dl-PRS-NumSymbols-r16	n4		
dl-PRS-MutingOption1-r16	Not present		
dl-PRS-MutingOption2-r16	Not present		
dl-PRS-ResourcePower-r16	27		
dl-PRS-ResourceList-r16 SEQUENCE (SIZE (1..nrMaxResourcesPerSet-r16)) OF NR-DL-PRS-Resource-r16 {	1 entry		
NR-DL-PRS-Resource-r16[1] SEQUENCE {		entry 1	
nr-DL-PRS-ResourceID-r16	0		
dl-PRS-SequenceID-r16	0		
dl-PRS-CombSizeN-AndReOffset-r16 CHOICE {			
n2-r16	0		Sub-tests 1-1, Sub-test 2-1 and Sub-test 3-1
n4-r16	0		Sub-tests 1-2, Sub-test 2-2 and Sub-test 3-2
}			
dl-PRS-ResourceSlotOffset-r16	0		Sub-test 1-1 Cell 1, Sub-test 1-2 Cell 1, Sub-test 2-1 Cell 1, Sub-test 2-2 Cell 1, Sub-test 3-1 Cell 1, and Sub-test 3-2 Cell 1
	4		Sub-test 1-1 Cell 2, Sub-test 1-2 Cell 2, Sub-test 2-1 Cell 2,

			Sub-test 2-2 Cell 2, Sub-test 3-1 Cell 2, and Sub-test 3-2 Cell 2.
dl-PRS-ResourceSymbolOffset-r16	0		
dl-PRS-QCL-Info-r16	Not present		
}			
}			
}			
}			
}			

Table 14.3.5.4.3-7: LPP ProvideLocation Information

Derivation Path: TS 37.355 [49] clause 6.2			
Information Element	Value/remark	Comment	Condition
LPP-Message ::= SEQUENCE {			
transactionID SEQUENCE {			
initiator	locationServer		
transactionNumber	1		
}			
endTransaction	TRUE		
sequenceNumber	(0..255)		
acknowledgement			
lpp-MessageBody CHOICE {			
c1 CHOICE {			
provideLocationInformation SEQUENCE {			
criticalExtensions CHOICE {			
c1 CHOICE {			
provideLocationInformation-r9 SEQUENCE {			
commonIEsProvideLocationInformation	Not present.		
a-gnss-ProvideLocationInformation	Not present		
otdoa-ProvideLocationInformation	Not present		
ecid-ProvideLocationInformation	Not present		
epdu-ProvideLocationInformation	Not present		
sensor-ProvideLocationInformation-r13	Not present		
tbs-ProvideLocationInformation-r13	Not present		
wlan-ProvideLocationInformation-r13	Not present		
bt-ProvideLocationInformation-r13	Not present		
nr-ECID-ProvideLocationInformation-r16	Not present		
nr-Multi-RTT-ProvideLocationInformation-r16	Not present		
nr-DL-AoD-ProvideLocationInformation-r16	Not present		
nr-DL-TDOA-ProvideLocationInformation-r16 SEQUENCE {			
nr-DL-TDOA-SignalMeasurementInformation-r16 SEQUENCE {			
dl-PRS-ReferenceInfo-r16			
nr-DL-TDOA-MeasList-r16 SEQUENCE (SIZE(1..nrMaxTRPs-r16)) OF NR-DL-TDOA-MeasElement-r16 {	2 entries		
NR-DL-TDOA-MeasElement-r16[1] SEQUENCE {		entry 1	
dl-PRS-ID-r16			
nr-PhysCellID-r16	Cell 1		
nr-CellGlobalID-r16			
nr-ARFCN-r16			
nr-DL-PRS-ResourceID-r16			
nr-DL-PRS-ResourceSetID-r16			
nr-TimeStamp-r16			
nr-RSTD-r16	Present		
nr-AdditionalPathList-r16			

	nr-TimingQuality-r16			
	nr-DL-PRS-RSRP-Result-r16			
r16	nr-DL-TDOA-AdditionalMeasurements-			
	nr-UE-Rx-TEG-ID-r17			
	nr-DL-PRS-FirstPathRSRP-Result-r17			
	nr-los-nlos-Indicator-r17			
	nr-AdditionalPathListExt-r17			
	nr-DL-TDOA-			
	AdditionalMeasurementsExt-r17			
	}			
	NR-DL-TDOA-MeasElement-r16[2]		entry 2	
SEQUENCE {				
	dl-PRS-ID-r16			
	nr-PhysCellID-r16	Cell 2		
	nr-CellGlobalID-r16			
	nr-ARFCN-r16			
	nr-DL-PRS-ResourceID-r16			
	nr-DL-PRS-ResourceSetID-r16			
	nr-TimeStamp-r16			
	nr-RSTD-r16	Present		
	nr-AdditionalPathList-r16			
	nr-TimingQuality-r16			
	nr-DL-PRS-RSRP-Result-r16			
r16	nr-DL-TDOA-AdditionalMeasurements-			
	nr-UE-Rx-TEG-ID-r17			
	nr-DL-PRS-FirstPathRSRP-Result-r17			
	nr-los-nlos-Indicator-r17			
	nr-AdditionalPathListExt-r17			
	nr-DL-TDOA-			
	AdditionalMeasurementsExt-r17			
	}			
	}			
	nr-UE-RxTEG-TimingErrorMargin-r17			
	}			
	nr-dl-tdoa-LocationInformation-r16			
	nr-DL-TDOA-Error-r16			
	nr-DL-TDOA-			
	SignalMeasurementInstances-r17			
	nr-DL-TDOA-			
	LocationInformationInstances-r17			
	}			
	}			
	}			
	}			
	}			
	}			

14.3.5.5 Test requirement

Table 14.3.5.5-1 defines the primary level settings including test tolerances for the test.

Table 14.3.5.5-1: RSTD accuracy test parameters

Parameter	Config	Unit	Test 1		Test 2	
			Cell 1	Cell 2	Cell 1	Cell 2
PRS ARFCN	1~3		freq1	Freq1	freq1	Freq1
BW _{channel}	1	MHz	20: N _{RB,c} = 106		20: N _{RB,c} = 106	
	2		20: N _{RB,c} = 106		20: N _{RB,c} = 106	
	3		50: N _{RB,c} = 133		50: N _{RB,c} = 133	
Duplex mode	1		FDD		FDD	
	2		TDD		TDD	

	3		TDD		TDD	
TDD configuration	1		N/A		N/A	
	2		TDDConf.1.1		TDDConf.1.1	
	3		TDDConf.2.1		TDDConf.2.1	
PDSCH Reference measurement channel	1		SR.1.1 FDD	-	SR.1.1 FDD	-
	2		SR.1.1 TDD		SR.1.1 TDD	
	3		SR.2.1 FDD		SR.2.1 FDD	
RMSI CORESET Reference Channel	1		CR.1.1 FDD	-	CR.1.1 FDD	-
	2		CR.1.1 TDD	-	CR.1.1 TDD	-
	3		CR.2.1 FDD	-	CR.2.1 FDD	-
Dedicated CORESET Reference Channel	1		CCR.1.1 FDD	-	CCR.1.1 FDD	-
	2		CCR.1.1 TDD	-	CCR.1.1 TDD	-
	3		CCR.2.1 TDD	-	CCR.2.1 TDD	-
SSB configuration	1		SSB.1 FR1		SSB.1 FR1	
	2		SSB.1 FR1		SSB.1 FR1	
	3		SSB.2 FR1		SSB.2 FR1	
OCNG Patterns	1~3		OP.1		OP.1	
TRS configuration	1		TRS.1.1 FDD	-	TRS.1.1 FDD	
	2		TRS.1.1 TDD		TRS.1.1 TDD	
	3		TRS.1.2 TDD		TRS.1.2 TDD	
Initial BWP Configuration	1~3		DLBWP.0.1 ULBWP.0.1		DLBWP.0.1 ULBWP.0.1	
Dedicated BWP configuration	1~3		DLBWP.1.1 ULBWP.1.1		DLBWP.1.1 ULBWP.1.1	
Time offset with Cell 1	1	μs	-	3	-	3
	2,3		-	3	-	3
SMTC configuration	1		SMTC.2		SMTC.2	
	2,3		SMTC.1		SMTC.1	
PRS configuration	1		PRS.1.3 FR1		PRS.1.4 FR1	
	2		PRS.1.3 FR1		PRS.1.4 FR1	
	3		PRS.2.3 FR1		PRS.2.4 FR1	
PRS BW	1,2		52 PRBs		-	
	3		48 PRBs		-	
PRS muting info	1~3		'10'	'01'	'10'	'01'
Expected RSTD	1, 2, 3	μs	N/A	3	N/A	3
Expected RSTD uncertainty	1, 2, 3	μs	N/A	5	N/A	5
EPRE ratio of PSS to SSS	1~3	dB	0	0	0	0
EPRE ratio of PBCH DMRS to SSS						
EPRE ratio of PBCH to PBCH DMRS						
EPRE ratio of PDCCH DMRS to SSS						
EPRE ratio of PDCCH to PDCCH DMRS						
EPRE ratio of PDSCH DMRS to SSS						
EPRE ratio of PDSCH to PDSCH DMRS						
EPRE ratio of OCNG DMRS to SSS ^{Note 1}						
EPRE ratio of OCNG to OCNG DMRS ^{Note 1}						
N_{oc} ^{Note2}						
	3	-95		-95		
\hat{E}_s/I_{ot}	1~3	dB	-3	-6	-3	-6

The	PRS-RSRP ^{Note3}	1,2	dBm/SC	-99.44	-101.65	-99.44	-101.65
		3	S	-96.44	-98.65	-96.44	-98.65
	SS-RSRP ^{Note3}	1,2	dBm/SC S	-99.44+TT	- 101.65+ TT	-99.44+TT	- 101.65 +TT
		3		-96.44+TT	- 98.65+ TT	-96.44+TT	- 98.65+ TT
	I _o ^{Note3}	1,2	dBm/ 19.08M Hz	-63.63+TT	- 63.63+ TT	-63.63+TT	- 63.63+ TT
		3	dBm/ 47.88M Hz	-59.65+TT	- 59.65+ TT	-59.65+TT	- 59.65+ TT
	\hat{E}_s / N_{oc}	1~3	dB	-1.44	-3.65	-1.44	-3.65
	Propagation condition	1~3	-	AWGN		AWGN	
	Antenna configuration	1~3		1x2		1x2	
<p>Note 1: OCNG shall be used such that both cells are fully allocated and a constant total transmitted power spectral density is achieved for all OFDM symbols.</p> <p>Note 2: Interference from other cells and noise sources not specified in the test is assumed to be constant over subcarriers and time and shall be modelled as AWGN of appropriate power for N_{oc} to be fulfilled.</p> <p>Note 3: RSRP and I_o levels have been derived from other parameters for information purposes. They are not settable parameters themselves.</p> <p>Note 4: RSRP minimum requirements are specified assuming independent interference and noise at each receiver antenna port.</p> <p>Note 5: The test configuration excludes support for band n51 and it is not required to run this test on band n51 in this release of the specification.</p>							

RSTD measurement accuracy for Cell 2 shall fulfil the absolute requirement in clause 14.3.5.3.

The value of the LPP Time IE depends on the UE capabilities. The calculation is FFS

The resulting value shall be rounded up to the next integer and transmitted in the LPP-RequestLocationInformation (see Table 14.3.3.4.3-3).

Table 14.3.5.5-2: RSTD accuracy requirements for the reported values

Test Configuration	Subtest	Lowest reported value	Highest reported value
1	Sub-test 1	FFS	FFS
	Sub-test 2	FFS	FFS
2	Sub-test 1	FFS	FFS
	Sub-test 2	FFS	FFS
3	Sub-test 1	FFS	FFS
	Sub-test 2	FFS	FFSw

The test tolerances are defined in clauses C.1.6 and C.2.5.

The rate of successful tests during repeated tests shall be at least 90% with a confidence level of 95%.

14.3.6 NR RSTD measurement accuracy test case for single positioning frequency layer with Rx TEG in FR1 SA

Editor’s note: This test case is incomplete. The following aspect is either missing or TBD:

- Test tolerance is missing
- Message contents require update

14.3.6.1 Test purpose

The purpose of the test is to verify that the RSTD measurements when the measurements are within the same Rx TEG meets the accuracy requirements specified in TS 38.133 [50] clause 10.1.23.2 in an environment with AWGN propagation conditions.

14.3.6.2 Test applicability

This test applies to all types of NR UE release 17 onwards that supports UE assisted DL-TDOA positioning and nr-UE-RxTEG-ID-MaxSupport.

14.3.6.3 Minimum conformance requirements

Same as defined in clause 14.3.5.3.

14.3.6.4 Test description

14.3.6.4.1 Initial conditions

The supported test configuration is listed in Table 14.3.6-1.

Table 14.3.6.4-1: Test Configuration

Configuration	Description
1	15 kHz SSB SCS, 20 MHz bandwidth, FDD duplex mode
2	15 kHz SSB SCS, 20 MHz bandwidth, TDD duplex mode
3	30 kHz SSB SCS, 50 MHz bandwidth, TDD duplex mode
Note:	The UE is only required to be tested in one of the supported test configurations.

Test Environment: Normal, as defined in TS 38.508-1 [45] clause 4.1.

Frequencies to be tested: Mid-Range, as defined in TS 38.508-1 [45] clause 4.3.1.

Channel bandwidth to be tested: are specified in Table 14.3.6.4-1.

1. Connect the SS and AWGN noise sources to the UE antenna connector or antenna connectors as shown in Annex A, Figure A.13.
2. The general test parameter settings are set up according to Table 14.3.6.5-1.
3. Propagation conditions are set according to clause 4.15.2.
4. Message contents are defined in clause 14.3.6.4.3.
5. In the test there are two synchronous cells: Cell 1 and Cell 2. Cell 1 is the reference as well as the PCell. Cell 2 is a neighbour cell. Both cells are on the same NR RF channel in FR2. GP#24 is configured if UE supports GP#24. otherwise, GP#0 is configured for the test.
6. The true RSTD (which is the receive time difference for frame 0 between cell 2 and cell 1 as seen at the UE antenna connector) is set to 5898 T_c (about 3 μs)

14.3.6.4.2 Test procedure

The test consists of two sub-tests; the difference between the sub-tests is the PRS configuration. The test consists of a set-up period and a measurement period. Cell 1 and Cell 2 are both active during the complete test. The beginning of the measurement period shall be aligned with the first PRS positioning subframe of a positioning occasion in the reference cell. The NR-DL-TDOA-RequestLocationInformation message and the DL-TDOA assistance data as defined in clause 14.3.6.4.3 shall be provided to the UE during the set-up period.

The UE is configured with measurement gap pattern ID # 24 if UE supports MG#24, otherwise #0 before T2.

1. Ensure the UE is in State RRC_CONNECTED with generic procedure parameters Connectivity NR, Connected without release On, to TS 38.508-1 [45] clause 4.5.
2. The SS shall send a RESET UE POSITIONING STORED INFORMATION message.
3. Set the parameters according to Table 14.3.6.5-1 as appropriate. Propagation conditions are set according to clause 4.15.2.
4. The SS shall transmit an LPP REQUEST CAPABILITIES message.
5. The UE shall transmit an LPP PROVIDE CAPABILITIES message indicating the UE supports nr-UE-RxTEG-ID-MaxSupport in the NR-UE-TEG-Capability IE and DL-TDOA capabilities supported by the UE in the NR-DL-TDOA-ProvideCapabilities IE.
6. The SS shall send a LPP PROVIDE ASSISTANCE DATA message, including the NR-DL-TDOA-ProvideAssistanceData IE. If the UE message at step 5 includes the ackRequested IE set to TRUE, then the SS shall send an acknowledgment in the LPP PROVIDE ASSISTANCE DATA message.
7. The SS shall send a LPP REQUEST LOCATION INFORMATION message, including the nr-UE-RxTEG-Request-r17 in the NR-DL-TDOA-RequestLocationInformation IE such that the UE receives the message ΔT ms before the start of the measurement period, where $\Delta T = 50$ ms.
8. The UE shall transmit a LPP PROVIDE LOCATION INFORMATION message including the NR-DL-TDOA-ProvideLocationInformation IE within the response time (see clause 4.15.3).
9. If the UE message at step 8 includes the ackRequested IE set to TRUE, the SS shall send a LPP acknowledgement message.
10. The SS shall check the nr-RSTD-r16 value for Cell 2 in the nr-DL-TDOA-SignalMeasurementInformation-r16 according to Table 14.3.6.5-3.
11. Repeat steps 2-10 in Table 14.3.6.4-1 until the confidence level according to Annex D is achieved.
12. Repeat step 1-11 for the other sub-test defined in Table 14.3.6.5-1 as appropriate.

If all (applicable) sub-tests pass, the whole test passes. If one (applicable) sub-test fails, the whole test fails.

14.3.6.4.3 Message contents

Table 14.3.6.4.3-1: RESET UE POSITIONING STORED INFORMATION

Derivation Path: 38.509 [44] clause 6.6			
Information Element	Value/remark	Comment	Condition
UE Positioning Technology	0 0 0 0 1 1 1	DL-TDOA	

Table 14.3.6.4.3-2: LPP Request Capabilities

Information Element	Value/remark
nr-DL-TDOA-RequestCapabilities-r16	TRUE

Table 14.3.6.4.3-3: LPP RequestLocationInformation

Derivation Path: TS 37.355 [49] clause 6.2			
Information Element	Value/remark	Comment	Condition
LPP-Message ::= SEQUENCE {			
transactionID SEQUENCE {			
initiator	locationServer		
transactionNumber	1		
}			
endTransaction	FALSE		
sequenceNumber	Not present		
acknowledgement	Not present		
lpp-MessageBody CHOICE {			

c1 CHOICE {			
requestLocationInformation SEQUENCE {			
criticalExtensions CHOICE {			
c1 CHOICE {			
requestLocationInformation-r9 SEQUENCE {			
commonEsRequestLocationInformation SEQUENCE {			
locationInformationType	locationMeasurementsPreferred		
triggeredReporting	Not present		
periodicalReporting	Not present		
additionalInformation	onlyReturnInformationRequested		
qos SEQUENCE {			
horizontalAccuracy	Not present		
verticalCoordinateRequest	FALSE		
verticalAccuracy	Not present		
responseTime SEQUENCE {			
time	See 14.3.6.5	Result of the response time calculation rounded up to the next second if response time <= 128s. Result of the response time calculation rounded up to the next multiple of ten seconds if response time > 128s	
responseTimeEarlyFix-r12	Not present		Rel-12 onwards
unit-r15	Not present		
	ten-seconds		Calculated response time >128s
}			
velocityRequest	FALSE		
}			
environment	Not present		
locationCoordinateTypes	Not present		
velocityTypes	Not present		
}			
a-gnss-RequestLocationInformation	Not present		
otdoa-RequestLocationInformation	Not present		
ecid-RequestLocationInformation	Not present		
epdu-RequestLocationInformation	Not Present		
sensor-RequestLocationInformation-r13	Not present		
tbs-RequestLocationInformation-r13	Not present		
wlan-RequestLocationInformation-r13	Not present		
bt-RequestLocationInformation-r13	Not present		
nr-ECID-RequestLocationInformation-r16	Not present		
nr-Multi-RTT-RequestLocationInformation-r16	Not present		
nr-DL-AoD-RequestLocationInformation-r16	Not present		
nr-DL-TDOA-RequestLocationInformation-r16			
SEQUENCE {			
nr-DL-PRS-RstdMeasurementInfoRequest-r16	Not present		
nr-RequestedMeasurements-r16	bit 0 = 0 (prsrsrpReq)		
nr-AssistanceAvailability-r16	FALSE		
nr-DL-TDOA-ReportConfig-r16 SEQUENCE {			
maxDL-PRS-RSTD-MeasurementsPerTRPPair-r16	Not present		
timingReportingGranularityFactor-r16	Not present		

measureSameDL-PRS-ResourceWithDifferentRxTEGs-r17			
reducedDL-PRS-ProcessingSamples-r17	Not present		
lowerRxBeamSweepingFactor-FR2-r17	Not present		
}			
additionalPaths-r16	Not present		
nr-UE-RxTEG-Request-r17	requested		
nr-los-nlos-IndicatorRequest-r17	Not present		
additionalPathsExt-r17	Not present		
additionalPathsDL-PRS-RSRP-Request-r17	Not present		
multiMeasInSameReport-r17	Not present		
}			
}			
}			
}			
}			
}			
}			
}			

Table 14.3.6.4.3-4: LPP ProvideAssistanceData

Derivation Path: TS 37.355 [49] clause 6.2			
Information Element	Value/remark	Comment	Condition
LPP-Message ::= SEQUENCE {			
transactionID SEQUENCE {			
initiator	locationServer		
transactionNumber	(0..255)		
}			
endTransaction	TRUE		
sequenceNumber	Not present		
acknowledgement	Not present		
lpp-MessageBody CHOICE {			
c1 CHOICE {			
provideAssistanceData SEQUENCE {			
criticalExtensions CHOICE {			
c1 CHOICE {			
provideAssistanceData-r9 SEQUENCE {			
commonIEsProvideAssistanceData	Not present		
a-gnss-ProvideAssistanceData	Not present		
otdoa-ProvideAssistanceData	Not present		
epdu-Provide-AssistanceData	Not present		
sensor-ProvideAssistanceData-r14	Not present		
tbs-ProvideAssistanceData-r14	Not present		
wlan-ProvideAssistanceData-r14	Not present		
nr-Multi-RTT-ProvideAssistanceData-r16	Not present		
nr-DL-AoD-ProvideAssistanceData-r16	Not present		
nr-DL-TDOA-ProvideAssistanceData-r16			
SEQUENCE {			
nr-DL-PRS-AssistanceData-r16	As defined in Table 14.3.6.4.3-5		
nr-SelectedDL-PRS-IndexList-r16	Not present		
nr-PositionCalculationAssistance-r16	Not present		
nr-DL-TDOA-Error-r16	Not present		
nr-On-Demand-DL-PRS-Configurations-r17	Not present		
nr-On-Demand-DL-PRS-Configurations-Selected-IndexList-r17	Not present		
assistanceDataValidityArea-r17	Not present		
}			
}			
}			
}			
}			
}			
}			

Table 14.3.6.4.3-5: NR-DL-PRS-AssistanceData

Derivation Path: TS 37.355 [49] clause 6.4.3			
Information Element	Value/remark	Comment	Condition
NR-DL-PRS-AssistanceData-r16 ::= SEQUENCE {			
nr-DL-PRS-ReferenceInfo-r16 SEQUENCE {			
dl-PRS-ID-r16	0		
nr-DL-PRS-ResourceID-List-r16	Not present		
nr-DL-PRS-ResourceSetID-r16	Not present		
}			
nr-DL-PRS-AssistanceDataList-r16 SEQUENCE (SIZE (1..nrMaxFreqLayers-r16)) OF NR-DL-PRS-AssistanceDataPerFreq-r16 {	1 entry		
NR-DL-PRS-AssistanceDataPerFreq-r16[1] SEQUENCE {		entry 1	
nr-DL-PRS-PositioningFrequencyLayer-r16 SEQUENCE {			
dl-PRS-SubcarrierSpacing-r16	kHz15		Sub-test 1-1, Sub-test 1-2, Sub-test 2-1 and Sub-test 2-2
	kHz30		Sub-test 3-1 and Sub-test 3-2
dl-PRS-ResourceBandwidth-r16	1	24 PRBs	Sub-test 1-1, Sub-test 2-1 and Sub-test 3-1
	21	104 PRBs	Sub-test 1-2 and Sub-test 2-2
	28	132 PRBs	Sub-test 3-2
dl-PRS-StartPRB-r16	0		
dl-PRS-PointA-r16	absoluteFrequencyPointA as defined for the DL frequency of the Cell 1		
dl-PRS-CombSizeN-r16	n2		Sub-test 1-1, Sub-test 2-1 and Sub-test 3-1
	n4		Sub-test 1-2, Sub-test 2-2 and Sub-test 3-2
dl-PRS-CyclicPrefix-r16	normal		
}			
nr-DL-PRS-AssistanceDataPerFreq-r16 SEQUENCE (SIZE (1..nrMaxTRPsPerFreq-r16)) OF NR-DL-PRS-AssistanceDataPerTRP-r16{	2 entries		
NR-DL-PRS-AssistanceDataPerTRP-r16[1] SEQUENCE {		entry 1	Cell 1
dl-PRS-ID-r16	0		
nr-PhysCellID-r16	Cell 1		
nr-CellGlobalID-r16	Cell 1		
nr-ARFCN-r16	Cell 1		
nr-DL-PRS-SFN0-Offset-r16 SEQUENCE {			
sfn-Offset-r16	0		
integerSubframeOffset-r16	0		
}			

nr-DL-PRS-ExpectedRSTD-r16	0		
nr-DL-PRS-ExpectedRSTD-Uncertainty-r16	0		
nr-DL-PRS-Info-r16	As specified in Table 14.3.1.4.3-6		
}			
NR-DL-PRS-AssistanceDataPerTRP-r16[2]		entry 2	Cell 2
SEQUENCE {			
dl-PRS-ID-r16	1		
nr-PhysCellID-r16	Cell 2		
nr-CellGlobalID-r16	Cell 2		
nr-ARFCN-r16	Cell 2		
nr-DL-PRS-SFN0-Offset-r16 SEQUENCE {			
sfn-Offset-r16	0		
integerSubframeOffset-r16	0		
}			
nr-DL-PRS-ExpectedRSTD-r16	23	About 3 μ s	
nr-DL-PRS-ExpectedRSTD-Uncertainty-r16	39	About 5 μ s	
nr-DL-PRS-Info-r16	As specified in Table 14.3.1.4.3-6		
}			
}			
}			
}			
}			

Table 14.3.6.4.3-6: NR-DL-PRS-Info

Derivation Path: TS 37.355 [49] clause 6.4.3			
Information Element	Value/remark	Comment	Condition
NR-DL-PRS-Info-r16 ::= SEQUENCE {			
nr-DL-PRS-ResourceSetList-r16 SEQUENCE (SIZE (1..nrMaxSetsPerTrp-r16)) OF NR-DL-PRS-ResourceSet-r16 {	1 entry		
NR-DL-PRS-ResourceSet-r16[1] SEQUENCE {		entry 1	
nr-DL-PRS-ResourceSetID-r16	0		
dl-PRS-Periodicity-and-ResourceSetSlotOffset-r16 CHOICE {			
scs15-r16 CHOICE {			Sub-tests 1-1, Sub-test 1-2, Sub-test 2-1 and Sub-test 2-2
n160-r16	10		
}			
scs30-r16 CHOICE {			Sub-tests 3-1 and Sub-test 3-2
n320-r16	20		
}			
dl-PRS-ResourceRepetitionFactor-r16	Not present		Sub-tests 1-2, Sub-test 2-2 and Sub-test 3-2
	n2		Sub-tests 1-1, Sub-test 2-1 and Sub-test 3-1
dl-PRS-ResourceTimeGap-r16	s1		
dl-PRS-NumSymbols-r16	n4		
dl-PRS-MutingOption1-r16	Not present		
dl-PRS-MutingOption2-r16	Not present		

dl-PRS-ResourcePower-r16	27		
dl-PRS-ResourceList-r16 SEQUENCE (SIZE (1..nrMaxResourcesPerSet-r16)) OF NR-DL-PRS-Resource-r16 {	1 entry		
NR-DL-PRS-Resource-r16[1] SEQUENCE {		entry 1	
nr-DL-PRS-ResourceID-r16	0		
dl-PRS-SequenceID-r16	0		
dl-PRS-CombSizeN-AndReOffset-r16 CHOICE {			
n2-r16	0		Sub-tests 1-1, Sub-test 2-1 and Sub-test 3-1
n4-r16	0		Sub-tests 1-2, Sub-test 2-2 and Sub-test 3-2
}			
dl-PRS-ResourceSlotOffset-r16	0		Sub-test 1-1 Cell 1, Sub-test 1-2 Cell 1, Sub-test 2-1 Cell 1, Sub-test 2-2 Cell 1, Sub-test 3-1 Cell 1, and Sub-test 3-2 Cell 1
	4		Sub-test 1-1 Cell 2, Sub-test 1-2 Cell 2, Sub-test 2-1 Cell 2, Sub-test 2-2 Cell 2, Sub-test 3-1 Cell 2, and Sub-test 3-2 Cell 2.
dl-PRS-ResourceSymbolOffset-r16	0		
dl-PRS-QCL-Info-r16	Not present		
}			
}			
}			
}			
}			

Table 14.3.6.4.3-7: LPP ProvideLocation Information

Derivation Path: TS 37.355 [49] clause 6.2			
Information Element	Value/remark	Comment	Condition
LPP-Message ::= SEQUENCE {			
transactionID SEQUENCE {			
initiator	locationServer		
transactionNumber	1		
}			
endTransaction	TRUE		
sequenceNumber	(0..255)		
acknowledgement			
lpp-MessageBody CHOICE {			
c1 CHOICE {			

provideLocationInformation SEQUENCE {			
criticalExtensions CHOICE {			
c1 CHOICE {			
provideLocationInformation-r9 SEQUENCE {			
commonIEsProvideLocationInformation	Not present.		
a-gnss-ProvideLocationInformation	Not present		
otdoa-ProvideLocationInformation	Not present		
ecid-ProvideLocationInformation	Not present		
epdu-ProvideLocationInformation	Not present		
sensor-ProvideLocationInformation-r13	Not present		
tbs-ProvideLocationInformation-r13	Not present		
wlan-ProvideLocationInformation-r13	Not present		
bt-ProvideLocationInformation-r13	Not present		
nr-ECID-ProvideLocationInformation-r16	Not present		
nr-Multi-RTT-ProvideLocationInformation-	Not present		
r16			
nr-DL-AoD-ProvideLocationInformation-r16	Not present		
nr-DL-TDOA-ProvideLocationInformation-			
r16 SEQUENCE {			
nr-DL-TDOA-			
SignalMeasurementInformation-r16 SEQUENCE {			
dl-PRS-ReferenceInfo-r16			
nr-DL-TDOA-MeasList-r16 SEQUENCE	2 entries		
(SIZE(1..nrMaxTRPs-r16)) OF NR-DL-TDOA-			
MeasElement-r16 {			
NR-DL-TDOA-MeasElement-r16[1]		entry 1	
SEQUENCE {			
dl-PRS-ID-r16			
nr-PhysCellID-r16	Cell 1		
nr-CellGlobalID-r16			
nr-ARFCN-r16			
nr-DL-PRS-ResourceID-r16			
nr-DL-PRS-ResourceSetID-r16			
nr-TimeStamp-r16			
nr-RSTD-r16	Present		
nr-AdditionalPathList-r16			
nr-TimingQuality-r16			
nr-DL-PRS-RSRP-Result-r16			
nr-DL-TDOA-AdditionalMeasurements-			
r16			
nr-UE-Rx-TEG-ID-r17	Present		
nr-DL-PRS-FirstPathRSRP-Result-r17			
nr-los-nlos-Indicator-r17			
nr-AdditionalPathListExt-r17			
nr-DL-TDOA-			
AdditionalMeasurementsExt-r17			
}			
NR-DL-TDOA-MeasElement-r16[2]		entry 2	
SEQUENCE {			
dl-PRS-ID-r16			
nr-PhysCellID-r16	Cell 2		
nr-CellGlobalID-r16			
nr-ARFCN-r16			
nr-DL-PRS-ResourceID-r16			
nr-DL-PRS-ResourceSetID-r16			
nr-TimeStamp-r16			
nr-RSTD-r16	Present		
nr-AdditionalPathList-r16			
nr-TimingQuality-r16			
nr-DL-PRS-RSRP-Result-r16			
nr-DL-TDOA-AdditionalMeasurements-			
r16			
nr-UE-Rx-TEG-ID-r17	Present		
nr-DL-PRS-FirstPathRSRP-Result-r17			
nr-los-nlos-Indicator-r17			
nr-AdditionalPathListExt-r17			

nr-DL-TDOA-AdditionalMeasurementsExt-r17			
}			
nr-UE-RxTEG-TimingErrorMargin-r17			
}			
nr-dl-tdoa-LocationInformation-r16			
nr-DL-TDOA-Error-r16			
nr-DL-TDOA-SignalMeasurementInstances-r17			
nr-DL-TDOA-LocationInformationInstances-r17			
}			
}			
}			
}			
}			

14.3.6.5 Test requirement

Table 14.3.6.5-1 define the primary level settings including test tolerances for the test.

Table 14.3.6.5-1: RSTD accuracy test parameters

Parameter	Config	Unit	Test 1		Test 2	
			Cell 1	Cell 2	Cell 1	Cell 2
PRS ARFCN	1~3		freq1	Freq1	freq1	Freq1
BW _{channel}	1	MHz	20: N _{RB,c} = 106		20: N _{RB,c} = 106	
	2		20: N _{RB,c} = 106		20: N _{RB,c} = 106	
	3		50: N _{RB,c} = 133		50: N _{RB,c} = 133	
Duplex mode	1		FDD		FDD	
	2		TDD		TDD	
	3		TDD		TDD	
TDD configuration	1		N/A		N/A	
	2		TDDConf.1.1		TDDConf.1.1	
	3		TDDConf.2.1		TDDConf.2.1	
PDSCH Reference measurement channel	1		SR.1.1 FDD	-	SR.1.1 FDD	-
	2		SR.1.1 TDD		SR.1.1 TDD	
	3		SR.2.1 FDD		SR.2.1 FDD	
RMSI CORESET Reference Channel	1		CR.1.1 FDD	-	CR.1.1 FDD	-
	2		CR.1.1 TDD	-	CR.1.1 TDD	-
	3		CR.2.1 FDD	-	CR.2.1 FDD	-
Dedicated CORESET Reference Channel	1		CCR.1.1 FDD	-	CCR.1.1 FDD	-
	2		CCR.1.1 TDD	-	CCR.1.1 TDD	-
	3		CCR.2.1 TDD	-	CCR.2.1 TDD	-
SSB configuration	1		SSB.1 FR1		SSB.1 FR1	
	2		SSB.1 FR1		SSB.1 FR1	
	3		SSB.2 FR1		SSB.2 FR1	
OCNG Patterns	1~3		OP.1		OP.1	
EPRE ratio of PSS to SSS	1~3	dB	0		0	
EPRE ratio of PBCH DMRS to SSS						

EPRE ratio of PBCH to PBCH DMRS						
EPRE ratio of PDCCH DMRS to SSS						
EPRE ratio of PDCCH to PDCCH DMRS						
EPRE ratio of PDSCH DMRS to SSS						
EPRE ratio of PDSCH to PDSCH DMRS						
EPRE ratio of OCNG DMRS to SSS ^{Note 1}						
EPRE ratio of OCNG to OCNG DMRS ^{Note 1}						
EPRE ratio of PRS to SSS						
TRS configuration	1		TRS.1.1 FDD	-	TRS.1.1 FDD	
	2		TRS.1.1 TDD		TRS.1.1 TDD	
	3		TRS.1.2 TDD		TRS.1.2 TDD	
Initial BWP Configuration	1~3		DLBWP.0.1 ULBWP.0.1		DLBWP.0.1 ULBWP.0.1	
Dedicated BWP configuration	1~3		DLBWP.1.1 ULBWP.1.1		DLBWP.1.1 ULBWP.1.1	
Time offset with Cell 1	1	μs	-	3	-	3
	2,3		-	3	-	3
SMTC configuration	1		SMTC.2		SMTC.2	
	2,3		SMTC.1		SMTC.1	
PRS configuration	1		PRS.1.1 FR1		PRS.1.2 FR1	
	2		PRS.1.1 FR1		PRS.1.2 FR1	
	3		PRS.2.1 FR1		PRS.2.2 FR1	
PRS Resource slot offset	1~3	slot	0	4	0	4
Expected RSTD	1, 2, 3	μs	N/A	3	N/A	3
Expected RSTD uncertainty	1, 2, 3	μs	N/A	5	N/A	5
N_{oc} ^{Note2}	1,2	dBm/SCS	-98		-98	
	3		-95		-95	
$PRS \hat{E}_s / I_{ot}$	1~3	dB	-6	-13	-6	-13
PRP ^{Note3}	1,2	dBm/SC	-103.7	-109.9	-103.7	-109.9
	3	S	-100.7	-106.9	-100.7	-106.9
I_o ^{Note3}	1,2	dBm/19.08M Hz	-65.70	-65.70	-65.70	-65.70
	3	dBm/47.88M Hz	-61.72	-61.72	-61.72	-61.72
$PRS \hat{E}_s / N_{oc}$	1~3	dB	-5.7	-11.9	-5.7	-11.9
Propagation condition	1~3	-	AWGN		AWGN	
Antenna configuration	1~3		1x2		1x2	
<p>Note 1: OCNG shall be used such that both cells are fully allocated and a constant total transmitted power spectral density is achieved for all OFDM symbols.</p> <p>Note 2: Interference from other cells and noise sources not specified in the test is assumed to be constant over subcarriers and time and shall be modelled as AWGN of appropriate power for N_{oc} to be fulfilled.</p> <p>Note 3: RRP and I_o levels have been derived from other parameters for information purposes. They are not settable parameters themselves.</p> <p>Note 4: RSRP minimum requirements are specified assuming independent interference and noise at each receiver antenna port.</p> <p>Note 5: The test configuration excludes support for band n51 and it is not required to run this test on band n51 in this release of the specification.</p>						

The RSTD measurement accuracy for Cell 2 shall fulfil the absolute requirement in clause 14.3.6.3.

The value of the LPP Time IE depends on the UE capabilities. The calculation is FFS

Table 14.3.6.5-2: RSTD accuracy requirements for the reported values

Test Configuration	Lowest reported value	Highest reported value
Sub-test 1	FFS	FFS
Sub-test 2	FFS	FFS

The test tolerances are defined in clauses C.1.6 and C.2.5.

The rate of successful tests during repeated tests shall be at least 90% with a confidence level of 95%.

14.3.7 NR RSTD measurement accuracy test case for single positioning frequency layer with reduced number of samples in FR2 SA

Editor's Note: This test case has been completed for the following configurations:

- Test frequency $f \leq 40.8$ GHz

- UE PC3

This test case is incomplete for UE power classes other than PC3

This test case is incomplete for test frequencies > 40.8 GHz

14.3.7.1 Test purpose

The purpose of the test is to verify that the RSTD measurement meets the accuracy requirements specified in TS 38.133 [50] clause 10.1.23.2 in an environment with AWGN propagation conditions.

14.3.7.2 Test applicability

This test applies to all types of NR UE release 17 onwards that supports DL-TDOA positioning and supportedDL-PRS-ProcessingSamples-RRC-CONNECTED.

14.3.7.3 Minimum conformance requirements

The accuracy requirements for RSTD measurement shall be within $\pm(X+Y+Z+\Delta)$ T_c.

...

X is defined in Table 10.1.23.2-8 for AWGN channel in FR2 provided that the following conditions are met.

- Conditions defined in clause 7.3 of TS 38.101-1 [18] for reference sensitivity are fulfilled.
- Conditions for RSTD measurements are fulfilled according to Annex B.2.14 for a corresponding Band for each relevant PRS resource configured for measurement.
- UE supports positioning measurement with reduced number of sample and is indicated by LMF to perform positioning measurement with reduced number of samples.

Note: The requirements for fading channel in this clause are derived based on TDL-A (30 ns delay spread, 5Hz) and TDL-C (60 ns delay spread, 300 Hz) channel models for FR1 and FR2 respectively.

When UE measures RSTD on PRS resources belonging to different PFLs, then the RSTD accuracy is defined as the accuracy corresponding to the largest accuracy value among different PFLs.

If the UE doesn't support Rx TEG reporting for RSTD measurement or when the measurements of reference cell and neighbour cell belong to different Rx TEGs, Y, Z and Δ are defined as follows:

- When UE measures RSTD on PRS resources belonging to same PFL, $Y=32 T_c$, provided that the time offset between the two PRS resource instances from the reference cell and the neighbour cell, which are used for a single RSTD estimate, is no greater than 160 ms.
- When UE measures RSTD on PRS resources belonging different PFLs, $Y=256 T_c$, provided that the time offset between the two PRS resource instances from the reference cell and the neighbour cell, which are used for a single RSTD estimate, is no greater than 1280 ms.
- Z is defined in Table 10.1.23.2-5 for FR1 and Table 10.1.23.2-6 for FR2, respectively.
- Δ is zero for single PFL, and is defined in Table 10.1.23.2-5a for FR1 and Table 10.1.23.2-6a for FR2, respectively, for dual PFL.

...

Table 10.1.23.2-6: Margin for RSTD measurement accuracy in FR2

PRS BW (RB number)		Margin (T_c)
SCS=60kHz	SCS=120kHz	
≥ 24	N/A	72
≥ 64	≥ 32	32
≥ 132	≥ 64	16
N/A	≥ 128	12

Table 10.1.23.2-6a: Margin Δ for RSTD measurement accuracy in FR2

PRS BW (RB number)		Margin (T_c)
SCS=60kHz	SCS=120kHz	
≥ 24	N/A	32
≥ 64	≥ 32	16
≥ 132	≥ 64	8
N/A	≥ 128	4

...

Table 10.1.23.2-8: RSTD absolute accuracy in FR2 for AWGN channel with reduced number of samples

Accuracy	Conditions					
	PRS \hat{E}_s/lot	PRS SCS	PRS bandwidth Note 1	PRS resource repetition ($T_{rep}^{PRS} * L_{PRS} / K_{comb}^{PRS}$) Note 2	I_o Note 3 range	
					Minimum I_o	Maximum I_o
T_c Note 4	dB	kHz	RB		dBm/SCS	dBm/BW _{Channel}
24	(PRS $\hat{E}_s/lot)_{ref} \geq -3dB$	60	≥ 64	≥ 1	Same value as PRS_RP in Table B.2.14-2, according to UE Power class, operating band and angle of arrival	Note 5
11			≥ 132	≥ 1		
13	(PRS $\hat{E}_s/lot)_i \geq -6dB$	120	≥ 64	≥ 1	Same value as PRS_RP in Table B.2.14-2, according to UE Power class, operating band and angle of arrival	Note 5
6			≥ 128	≥ 1		

NOTE 1: Minimum PRS bandwidth, which is minimum of the PRS bandwidths of the reference resource and the measured neighbour resource i .

NOTE 2: Minimum number of PRS resource repetitions among the reference resource and the measured neighbour resource i . T_{rep}^{PRS} , L_{PRS} , K_{comb}^{PRS} are configured by higher layer parameter $dl-PRS-ResourceRepetitionFactor$, $dl-PRS-NumSymbols$ and $dl-PRS-CombSizeN$ defined in TS 37.355 [34], respectively.

NOTE 3: I_o is assumed to have constant EPRE across the bandwidth.

NOTE 4: T_c is the basic timing unit defined in TS 38.211 [6].

NOTE 5: The same bands and the same I_o conditions for each band apply for this requirement as for the corresponding requirement with the PRS bandwidth of the smallest RB number for the corresponding SCS.

NOTE 6: Void

14.3.7.4 Test description

14.3.7.4.1 Initial conditions

The supported test configuration is listed in Table 14.3.7.4-1.

Table 14.3.7.4-1: Test Configuration

Test Configuration	Description
1	120 kHz SSB and PRS SCS, 200 MHz bandwidth, TDD duplex mode

Test Environment: Normal, as defined in TS 38.508-1 [45] clause 4.1.

Frequencies to be tested: Mid-Range, as defined in TS 38.508-1 [45] clause 4.3.1.

Channel bandwidth to be tested: are specified in Table 14.3.7.4-1.

1. Connect the SS and AWGN noise sources to the UE antenna connector or antenna connectors as shown in Annex A, Figure A.14.
2. The general test parameter settings are set up according to Table 14.3.7.5-1 and Table 14.3.7.5-2.
3. Propagation conditions are set according to clause 4.15.2.
4. Message contents are defined in clause 14.3.7.4.3.
5. In the test there are two synchronous cells: Cell 1 and Cell 2. Cell 1 is the reference as well as the PCell. Cell 2 is a neighbour cell. Both cells are on the same NR RF channel in FR2. GP#24 is configured if UE supports GP#24, otherwise, GP#13 is configured for the test.
6. The true RSTD (which is the receive time difference for frame 0 between cell 2 and cell 1 as seen at the UE antenna connector) is set to 5898 T_c (about 3 μs)

14.3.7.4.2 Test procedure

The test consists of two sub-tests; the difference between the sub-tests is the PRS configuration, PRS.1.1 FR2 and PRS.1.2 FR2. The test consists of a set-up period and a measurement period. Cell 1 and Cell 2 are both active during the complete test. The beginning of the measurement period shall be aligned with the first PRS positioning subframe of a positioning occasion in the reference cell. The NR-DL-TDOA-RequestLocationInformation message and the DL-TDOA assistance data as defined in clause 14.3.7.4.3 shall be provided to the UE during the set-up period.

The UE is configured with measurement gap pattern ID # 24 or #13 before T₂.

2. Ensure the UE is in State RRC_CONNECTED with generic procedure parameters Connectivity NR, Connected without release On, according to TS 38.508-1 [45] clause 4.5.
2. The SS shall send a RESET UE POSITIONING STORED INFORMATION message.
3. Set the parameters according to Table 14.3.7.5-1 and Table 14.3.7.5-2 as appropriate. Propagation conditions are set according to clause 4.15.2.
4. The SS shall transmit an LPP REQUEST CAPABILITIES message.
5. The UE shall transmit an LPP PROVIDE CAPABILITIES message indicating the UE supports *supportedDL-PRS-ProcessingSamples-RRC-CONNECTED* in the *NR-DL-PRS-ProcessingCapability* IE and DL-TDOA capabilities supported by the UE in the *NR-DL-TDOA-ProvideCapabilities* IE.
6. The SS shall send a LPP PROVIDE ASSISTANCE DATA message, including the *NR-DL-TDOA-ProvideAssistanceData* IE. If the UE message at step 5 includes the *ackRequested* IE set to TRUE, then the SS shall send an acknowledgment in the LPP PROVIDE ASSISTANCE DATA message.
7. The SS shall send a LPP REQUEST LOCATION INFORMATION message, including the *reducedDL-PRS-ProcessingSamples-r17* in the *NR-DL-TDOA-RequestLocationInformation* IE such that the UE receives the message ΔT ms before the start of the measurement period, where ΔT = 50 ms.

8. The UE shall transmit a LPP PROVIDE LOCATION INFORMATION message including the *NR-DL-TDOA-ProvideLocationInformation* IE within the response time (see clause 4.15.3).
9. If the UE message at step 8 includes the *ackRequested* IE set to TRUE, the SS shall send a LPP acknowledgement message.
10. The SS shall check the *nr-RSTD-r16* value for Cell 2 in the *nr-DL-TDOA-SignalMeasurementInformation-r16* according to Table 14.3.7.5-3.
11. Repeat steps 2-11 in Table 14.3.7.4-1 until the confidence level according to Annex D is achieved.
12. Repeat step 1-11 for the other sub-test defined in Table 14.3.7.5-1 as appropriate.

If all (applicable) sub-tests pass, the whole test passes. If one (applicable) sub-test fails, the whole test fails.

14.3.7.4.3 Message contents

Table 14.2.3.7.3-1: RESET UE POSITIONING STORED INFORMATION

Derivation Path: 38.509 [44] clause 6.6			
Information Element	Value/remark	Comment	Condition
UE Positioning Technology	0 0 0 0 1 1 1	DL-TDOA	

Table 14.3.7.4.3-2: LPP Request Capabilities

Information Element	Value/remark
<i>nr-DL-TDOA-RequestCapabilities-r16</i>	TRUE

Table 14.3.7.4.3-3: LPP RequestLocationInformation

Derivation Path: TS 37.355 [49] clause 6.2			
Information Element	Value/remark	Comment	Condition
LPP-Message ::= SEQUENCE {			
transactionID SEQUENCE {			
initiator	locationServer		
transactionNumber	1		
}			
endTransaction	FALSE		
sequenceNumber	Not present		
acknowledgement	Not present		
lpp-MessageBody CHOICE {			
c1 CHOICE {			
requestLocationInformation SEQUENCE {			
criticalExtensions CHOICE {			
c1 CHOICE {			
requestLocationInformation-r9 SEQUENCE {			
commonEsRequestLocationInformation SEQUENCE {			
locationInformationType	locationMeasurementsPreferred		
triggeredReporting	Not present		
periodicalReporting	Not present		
additionalInformation	onlyReturnInformationRequested		
qos SEQUENCE {			
horizontalAccuracy	Not present		
verticalCoordinateRequest	FALSE		
verticalAccuracy	Not present		
responseTime SEQUENCE {			
time	See 14.3.7.5	Result of the response time calculation rounded	

		up to the next second	
responseTimeEarlyFix-r12	Not present		Rel-12 onwards
unit-r15	Not present		
}			
velocityRequest	FALSE		
}			
environment	Not present		
locationCoordinateTypes	Not present		
velocityTypes	Not present		
}			
a-gnss-RequestLocationInformation	Not present		
otdoa-RequestLocationInformation	Not present		
ecid-RequestLocationInformation	Not present		
epdu-RequestLocationInformation	Not Present		
sensor-RequestLocationInformation-r13	Not present		
tbs-RequestLocationInformation-r13	Not present		
wlan-RequestLocationInformation-r13	Not present		
bt-RequestLocationInformation-r13	Not present		
nr-ECID-RequestLocationInformation-r16	Not present		
nr-Multi-RTT-RequestLocationInformation-r16	Not present		
nr-DL-AoD-RequestLocationInformation-r16	Not present		
nr-DL-TDOA-RequestLocationInformation-r16			
SEQUENCE {			
nr-DL-PRS-RstdMeasurementInfoRequest-r16	Not present		
nr-RequestedMeasurements-r16	bit 0 = 0 (prsrsrpReq)		
nr-AssistanceAvailability-r16	FALSE		
nr-DL-TDOA-ReportConfig-r16 SEQUENCE {			
maxDL-PRS-RSTD-MeasurementsPerTRPPair-r16	Not present		
timingReportingGranularityFactor-r16	Not present		
measureSameDL-PRS-ResourceWithDifferentRxTEGs-r17	Not present		
reducedDL-PRS-ProcessingSamples-r17	requested		
lowerRxBeamSweepingFactor-FR2-r17	Not present		
}			
additionalPaths-r16	Not present		
nr-UE-RxTEG-Request-r17	Not present		
nr-los-nlos-IndicatorRequest-r17	Not present		
additionalPathsExt-r17	Not present		
additionalPathsDL-PRS-RSRP-Request-r17	Not present		
multiMeasInSameReport-r17	Not present		
}			
}			
}			
}			
}			
}			
}			
}			

Table 14.3.7.4.3-4: LPP ProvideAssistanceData

Derivation Path: TS 37.355 [49] clause 6.2			
Information Element	Value/remark	Comment	Condition
LPP-Message ::= SEQUENCE {			
transactionID SEQUENCE {			
initiator	locationServer		
transactionNumber	(0..255)		
}			
endTransaction	TRUE		
sequenceNumber	Not present		
acknowledgement	Not present		

nr-DL-PRS-PositioningFrequencyLayer-r16 SEQUENCE {			
dl-PRS-SubcarrierSpacing-r16	kHz120		
dl-PRS-ResourceBandwidth-r16	11	64 PRBs	Sub-test 1
	27	128 PRBs	Sub-test 2
dl-PRS-StartPRB-r16	0		
dl-PRS-PointA-r16	absoluteFrequencyPointA as defined for the DL frequency of the Cell 1		
dl-PRS-CombSizeN-r16	n2		Sub-test 1
	n4		Sub-test 2
dl-PRS-CyclicPrefix-r16	normal		
}			
nr-DL-PRS-AssistanceDataPerFreq-r16 SEQUENCE (SIZE (1..nrMaxTRPsPerFreq-r16)) OF NR-DL-PRS-AssistanceDataPerTRP-r16{	2 entries		
NR-DL-PRS-AssistanceDataPerTRP-r16[1] SEQUENCE {		entry 1	Cell 1
dl-PRS-ID-r16	0		
nr-PhysCellID-r16	Cell 1		
nr-CellGlobalID-r16	Cell 1		
nr-ARFCN-r16	Cell 1		
nr-DL-PRS-SFN0-Offset-r16 SEQUENCE {			
sfn-Offset-r16	0		
integerSubframeOffset-r16	0		
}			
nr-DL-PRS-ExpectedRSTD-r16	0		
nr-DL-PRS-ExpectedRSTD-Uncertainty-r16	0		
nr-DL-PRS-Info-r16	As specified in Table 14.3.7.4.3-6		
}			
NR-DL-PRS-AssistanceDataPerTRP-r16[2] SEQUENCE {		entry 2	Cell 2
dl-PRS-ID-r16	1		
nr-PhysCellID-r16	Cell 2		
nr-CellGlobalID-r16	Cell 2		
nr-ARFCN-r16	Cell 2		
nr-DL-PRS-SFN0-Offset-r16 SEQUENCE {			
sfn-Offset-r16	0		
integerSubframeOffset-r16	0		
}			
nr-DL-PRS-ExpectedRSTD-r16	23	About 3 μs	
nr-DL-PRS-ExpectedRSTD-Uncertainty-r16	154	About 5 μs	
nr-DL-PRS-Info-r16	As specified in Table 14.3.7.4.3-6		
}			
}			
}			
}			
}			

Table 14.3.7.4.3-6: NR-DL-PRS-Info

Derivation Path: 37.355 clause 6.4.3			
Information Element	Value/remark	Comment	Condition
NR-DL-PRS-Info-r16 ::= SEQUENCE {			
nr-DL-PRS-ResourceSetList-r16 SEQUENCE (SIZE (1..nrMaxSetsPerTrp-r16)) OF NR-DL-PRS-ResourceSet-r16 {	1 entry		
NR-DL-PRS-ResourceSet-r16[1] SEQUENCE {		entry 1	
nr-DL-PRS-ResourceSetID-r16	0		
dl-PRS-Periodicity-and-ResourceSetSlotOffset-r16 CHOICE {			
scs120-r16 CHOICE {			
n160-r16	80		

}			
dl-PRS-ResourceRepetitionFactor-r16	n2		Sub-test 1
	Not present		Sub-test 2
dl-PRS-ResourceTimeGap-r16	s1		
dl-PRS-NumSymbols-r16	n4		
dl-PRS-MutingOption1-r16	Not present		
dl-PRS-MutingOption2-r16	Not present		
dl-PRS-ResourcePower-r16	27		
dl-PRS-ResourceList-r16 SEQUENCE (SIZE (1..nrMaxResourcesPerSet-r16)) OF NR-DL-PRS-Resource-r16 {	1 entry		
NR-DL-PRS-Resource-r16[1] SEQUENCE {		entry 1	
nr-DL-PRS-ResourceID-r16	0		
dl-PRS-SequenceID-r16	0		
dl-PRS-CombSizeN-AndReOffset-r16 CHOICE {			
n2-r16	0		Sub-test 1
n4-r16	0		Sub-test 2
}			
dl-PRS-ResourceSlotOffset-r16	0		Sub-test 1
	4		Sub-test 2
dl-PRS-ResourceSymbolOffset-r16	0		
dl-PRS-QCL-Info-r16	Not present		
}			
}			
}			
}			
}			

Table 14.3.7.4.3-7: LPP ProvideLocation Information

Derivation Path: TS 37.355 [49] clause 6.2			
Information Element	Value/remark	Comment	Condition
LPP-Message ::= SEQUENCE {			
transactionID SEQUENCE {			
initiator	locationServer		
transactionNumber	1		
}			
endTransaction	TRUE		
sequenceNumber	(0..255)		
acknowledgement			
lpp-MessageBody CHOICE {			
c1 CHOICE {			
provideLocationInformation SEQUENCE {			
criticalExtensions CHOICE {			
c1 CHOICE {			
provideLocationInformation-r9 SEQUENCE {			
commonIEsProvideLocationInformation	Not present.		
a-gnss-ProvideLocationInformation	Not present		
otdoa-ProvideLocationInformation	Not present		
ecid-ProvideLocationInformation	Not present		
epdu-ProvideLocationInformation	Not present		
sensor-ProvideLocationInformation-r13	Not present		
tbs-ProvideLocationInformation-r13	Not present		
wlan-ProvideLocationInformation-r13	Not present		
bt-ProvideLocationInformation-r13	Not present		
nr-ECID-ProvideLocationInformation-r16	Not present		
nr-Multi-RTT-ProvideLocationInformation-r16	Not present		
nr-DL-AoD-ProvideLocationInformation-r16	Not present		
nr-DL-TDOA-ProvideLocationInformation-r16 SEQUENCE {			
nr-DL-TDOA-SignalMeasurementInformation-r16 SEQUENCE {			
dl-PRS-ReferenceInfo-r16			

nr-DL-TDOA-MeasList-r16 SEQUENCE (SIZE(1..nrMaxTRPs-r16)) OF NR-DL-TDOA-MeasElement-r16 {	2 entries		
NR-DL-TDOA-MeasElement-r16[1] SEQUENCE {		entry 1	
dl-PRS-ID-r16			
nr-PhysCellID-r16	Cell 1		
nr-CellGlobalID-r16			
nr-ARFCN-r16			
nr-DL-PRS-ResourceID-r16			
nr-DL-PRS-ResourceSetID-r16			
nr-TimeStamp-r16			
nr-RSTD-r16	Present		
nr-AdditionalPathList-r16			
nr-TimingQuality-r16			
nr-DL-PRS-RSRP-Result-r16			
nr-DL-TDOA-AdditionalMeasurements-r16			
nr-UE-Rx-TEG-ID-r17			
nr-DL-PRS-FirstPathRSRP-Result-r17			
nr-los-nlos-Indicator-r17			
nr-AdditionalPathListExt-r17			
nr-DL-TDOA-AdditionalMeasurementsExt-r17			
}			
NR-DL-TDOA-MeasElement-r16[2] SEQUENCE {		entry 2	
dl-PRS-ID-r16			
nr-PhysCellID-r16	Cell 2		
nr-CellGlobalID-r16			
nr-ARFCN-r16			
nr-DL-PRS-ResourceID-r16			
nr-DL-PRS-ResourceSetID-r16			
nr-TimeStamp-r16			
nr-RSTD-r16	Present		
nr-AdditionalPathList-r16			
nr-TimingQuality-r16			
nr-DL-PRS-RSRP-Result-r16			
nr-DL-TDOA-AdditionalMeasurements-r16			
nr-UE-Rx-TEG-ID-r17			
nr-DL-PRS-FirstPathRSRP-Result-r17			
nr-los-nlos-Indicator-r17			
nr-AdditionalPathListExt-r17			
nr-DL-TDOA-AdditionalMeasurementsExt-r17			
}			
}			
nr-UE-RxTEG-TimingErrorMargin-r17			
}			
nr-dl-tdoa-LocationInformation-r16			
nr-DL-TDOA-Error-r16			
nr-DL-TDOA-SignalMeasurementInstances-r17			
nr-DL-TDOA-LocationInformationInstances-r17			
}			
}			
}			
}			
}			
}			

14.3.7.5 Test requirement

Table 14.3.7.5-1 and Table 14.3.7.5-2 define the primary level settings including test tolerances for the test.

Table 14.3.7.5-1: RSTD accuracy test parameters

Parameter	Unit	Test 1		Test 2	
		Cell 1	Cell 2	Cell 1	Cell 2
PRS ARFCN		freq1		freq1	
Duplex mode		TDD		TDD	
TDD configuration		TDDConf.3.1		TDDConf.3.1	
BW _{channel}	MHz	200: N _{RB,c} = 132		200: N _{RB,c} = 132	
Downlink initial BWP configuration		DLBWP.0.1	-	DLBWP.0.1	-
Downlink dedicated BWP configuration		DLBWP.1.1	-	DLBWP.1.1	-
Uplink initial BWP configuration		ULBWP.0.1	-	ULBWP.0.1	-
Uplink dedicated BWP configuration		ULBWP.1.1	-	ULBWP.1.1	-
DRX cycle configuration		Not applicable	-	Not applicable	-
TRS configuration		TRS.2.1 TDD	-	TRS.2.1 TDD	-
TCI state		TCI.State.0	-	TCI.State.0	-
PDSCH Reference measurement channel		SR.3.1 TDD	-	SR.3.1 TDD	-
RMSI CORESET Reference Channel		CR.3.1 TDD	-	CR.3.1 TDD	-
Control channel RMC		CCR.3.1 TDD	-	CCR.3.1 TDD	-
OCNG Patterns		OP.3	OP.3	OP.3	OP.3
SSB configuration		SSB.3 FR2	SSB.3 FR2	SSB.3 FR2	SSB.3 FR2
SMTc configuration		SMTc.1	SMTc.1	SMTc.1	SMTc.1
PRS configuration		PRS.1.2 FR2	PRS.1.2 FR2	PRS.1.2 FR2	PRS.1.2 FR2
PRS BW		64 PRBs	64 PRBs	128 PRBs	128 PRBs
PRS Resource slot offset	slot	0	4	0	4
Expected RSTD	μs	N/A	3	N/A	3
Expected RSTD uncertainty	μs	N/A	5	N/A	5
Time offset with Cell 1	μs	-	3	-	3
PDSCH/PDCCH subcarrier spacing	kHz	120	120	120	120
EPRE ratio of PSS to SSS	dB	0	0	0	0
EPRE ratio of PBCH_DMRS to SSS					
EPRE ratio of PBCH to PBCH_DMRS					
EPRE ratio of PDCCH_DMRS to SSS					
EPRE ratio of PDCCH to PDCCH_DMRS					
EPRE ratio of PDSCH_DMRS to SSS					
EPRE ratio of PDSCH to PDSCH_DMRS					
EPRE ratio of OCNG DMRS to SSS ^{Note 1}					
EPRE ratio of OCNG to OCNG DMRS ^{Note 1}					
Propagation conditions					
Antenna configuration		1x2	1x2	1x2	1x2
Note 1: OCNG shall be used such that both cells are fully allocated and a constant total transmitted power spectral density is achieved for all OFDM symbols.					

Table 14.3.7.5-2: RSTD accuracy OTA related test parameters

Parameter	Unit	Test 1		Test 2	
		Cell 1	Cell 2	Cell 1	Cell 2
Angle of arrival configuration		Setup 1 according to clause A.3.15.1			
Assumption for UE beams ^{Note 5}		Rough		Rough	
N_{oc} ^{Note1}	dBm/15kHz Z ^{Note3}	-91.6		-91.6	
PRS	dB	-0.56	-2.72	-0.56	-2.72

\hat{E}_s / N_{oc}					
PRS-RSRP ^{Note2}	dBm/SCS	-92.1	-94.3	-92.1	-94.3
SS-RSRP ^{Note2}	dBm/SCS	-89.7	N/A	-89.7	N/A
PRS \hat{E}_s / I_{ot_BB} ^{Note4}	dB	-2.96	-5.68	-2.69	-5.68
I_o ^{Note2}	dBm/190.0 8 MHz ^{Note3}	-55.74	-55.74	-55.74	-55.74
<p>Note 1: Where used, interference from other cells and noise sources not specified in the test is assumed to be constant over subcarriers and time and shall be modelled as AWGN of appropriate power for N_{oc} to be fulfilled.</p> <p>Note 2: SSB_RP, Es/Iot and Io levels have been derived from other parameters for information purposes. They are not settable parameters themselves.</p> <p>Note 3: Equivalent power received by an antenna with 0 dBi gain at the centre of the quiet zone</p> <p>Note 4: Calculation of Es/Iot_{BB} includes the effect of UE internal noise up to the value assumed for the associated Refsens requirement in clause 7.3.2 of TS 38.101-2 [2], and an allowance of 1dB for UE multi-band relaxation factor ΔMB_P from TS 38.101-2 [19] Table 6.2.1.3-4.</p> <p>Note 5: Information about types of UE beam is given in TS 38.133 [50] B.2.1.3, and does not limit UE implementation or test system implementation</p>					

The RSTD measurement accuracy for Cell 2 shall fulfil the absolute requirement in clause 14.3.7.3.

The value of the LPP Time IE depends on the UE capabilities. The calculation is the same as in clause 14.2.8.5 with the following difference: $N_{PRS,t}^{sIot} = 2$. Therefore, the value of the LPP Time IE is given by the following equation:

$$\left(1 * 8 * \left[\frac{2}{N'} \right] \left[\frac{0.107}{N} \right] * 1 - 1 \right) * T_{effect} + T_{last}$$

The resulting value shall be rounded up to the next integer and transmitted in the LPP-RequestLocationInformation (see Table 14.3.3.4.3-3).

Table 14.3.7.5-3: RSTD accuracy requirements for the reported values

Test Configuration	Lowest reported value	Highest reported value
Sub-test 1	(5898 – 93) T _c converted to RSTD measurement according to clause 4.15.6	(5898 + 93) T _c converted to RSTD measurement according to clause 4.15.6
Sub-test 2	(5898 – 82) T _c converted to RSTD measurement according to clause 4.15.6	(5898 + 82) T _c converted to RSTD measurement according to clause 4.15.6

The test tolerances are defined in clauses C.1.6 and C.2.5.

The rate of successful tests during repeated tests shall be at least 90% with a confidence level of 95%.

14.3.8 NR RSTD measurement accuracy test case for single positioning frequency layer with Rx TEG in FR2 SA

Editor's Note: This test case has been completed for the following configurations:

- Test frequency $f \leq 40.8$ GHz
- UE PC3

This test case is incomplete for UE power classes other than PC3

This test case is incomplete for test frequencies > 40.8 GHz

14.3.8.1 Test purpose

The purpose of the test is to verify that the RSTD measurements when the measurements are within the same Rx TEG meets the accuracy requirements specified in TS 38.133 [50] clause 10.1.23.2 in an environment with AWGN propagation conditions.

14.3.8.2 Test applicability

This test applies to all types of NR UE release 17 onwards that supports UE assisted DL-TDOA positioning and nr-UE-RxTEG-ID-MaxSupport.

14.3.8.3 Minimum conformance requirements

Same as defined in clause 14.3.7.3.

14.3.8.4 Test description

14.3.8.4.1 Initial conditions

The supported test configuration is listed in Table 14.3.8-1.

Table 14.3.8.4-1: Test Configuration

Test Configuration	Description
1	120 kHz SSB and PRS SCS, 200 MHz bandwidth, TDD duplex mode

Test Environment: Normal, as defined in TS 38.508-1 [45] clause 4.1.

Frequencies to be tested: Mid-Range, as defined in TS 38.508-1 [45] clause 4.3.1.

Channel bandwidth to be tested: are specified in Table 14.3.8.4-1.

1. Connect the SS and AWGN noise sources to the UE antenna connector or antenna connectors as shown in Annex A, Figure A.14.
2. The general test parameter settings are set up according to Table 14.3.8.5-1 and Table 14.3.8.5-2.
3. Propagation conditions are set according to clause 4.15.2.
4. Message contents are defined in clause 14.3.8.4.3.
5. In the test there are two synchronous cells: Cell 1 and Cell 2. Cell 1 is the reference as well as the PCell. Cell 2 is a neighbour cell. Both cells are on the same NR RF channel in FR2. GP#24 is configured if UE supports GP#24. otherwise, GP#13 is configured for the test.
6. The true RSTD (which is the receive time difference for frame 0 between cell 2 and cell 1 as seen at the UE antenna connector) is set to $5898 T_c$ (about $3 \mu s$)

14.3.8.4.2 Test procedure

The test consists of two sub-tests; the difference between the sub-tests is the PRS configuration, PRS.1.1 FR2 and PRS.1.2 FR2. The test consists of a set-up period and a measurement period. Cell 1 and Cell 2 are both active during the complete test. The beginning of the measurement period shall be aligned with the first PRS positioning subframe of a positioning occasion in the reference cell. The NR-DL-TDOA-RequestLocationInformation message and the DL-TDOA assistance data as defined in clause 14.3.8.4.3 shall be provided to the UE during the set-up period.

The UE is configured with measurement gap pattern ID # 24 or #13 before T2.

2. Ensure the UE is in State RRC_CONNECTED with generic procedure parameters Connectivity NR, Connected without release On, to TS 38.508-1 [45] clause 4.5.
2. The SS shall send a RESET UE POSITIONING STORED INFORMATION message.

3. Set the parameters according to Table 14.3.8.5-1 and Table 14.3.8.5-2 as appropriate. Propagation conditions are set according to clause 4.15.2.
4. The SS shall transmit an LPP REQUEST CAPABILITIES message.
5. The UE shall transmit an LPP PROVIDE CAPABILITIES message indicating the UE supports nr-UE-RxTEG-ID-MaxSupport in the *NR-UE-TEG-Capability* IE and DL-TDOA capabilities supported by the UE in the *NR-DL-TDOA-ProvideCapabilities* IE.
6. The SS shall send a LPP PROVIDE ASSISTANCE DATA message, including the *NR-DL-TDOA-ProvideAssistanceData* IE. If the UE message at step 5 includes the *ackRequested* IE set to TRUE, then the SS shall send an acknowledgment in the LPP PROVIDE ASSISTANCE DATA message.
7. The SS shall send a LPP REQUEST LOCATION INFORMATION message, including the *nr-UE-RxTEG-Request-r17* in the *NR-DL-TDOA-RequestLocationInformation* IE such that the UE receives the message ΔT ms before the start of the measurement period, where $\Delta T = 50$ ms.
8. The UE shall transmit a LPP PROVIDE LOCATION INFORMATION message including the *NR-DL-TDOA-ProvideLocationInformation* IE within the response time (see clause 4.15.3).
9. If the UE message at step 8 includes the *ackRequested* IE set to TRUE, the SS shall send a LPP acknowledgement message.
10. The SS shall check the *nr-RSTD-r16* value for Cell 2 in the *nr-DL-TDOA-SignalMeasurementInformation-r16* according to Table 14.3.8.5-3.
11. Repeat steps 2-11 in Table 14.3.8.4-1 until the confidence level according to Annex D is achieved.
12. Repeat step 1-11 for the other sub-test defined in Table 14.3.8.5-1 as appropriate.

If all (applicable) sub-tests pass, the whole test passes. If one (applicable) sub-test fails, the whole test fails.

14.3.8.4.3 Message contents

Table 14.3.8.4.3-1: RESET UE POSITIONING STORED INFORMATION

Derivation Path: 38.509 [44] clause 6.6			
Information Element	Value/remark	Comment	Condition
UE Positioning Technology	0 0 0 0 1 1 1	DL-TDOA	

Table 14.3.8.4.3-2: LPP Request Capabilities

Information Element	Value/remark
nr-DL-TDOA-RequestCapabilities-r16	TRUE

Table 14.3.8.4.3-3: LPP RequestLocationInformation

Derivation Path: TS 37.355 [49] clause 6.2			
Information Element	Value/remark	Comment	Condition
LPP-Message ::= SEQUENCE {			
transactionID SEQUENCE {			
initiator	locationServer		
transactionNumber	1		
}			
endTransaction	FALSE		
sequenceNumber	Not present		
acknowledgement	Not present		
lpp-MessageBody CHOICE {			
c1 CHOICE {			
requestLocationInformation SEQUENCE {			
criticalExtensions CHOICE {			
c1 CHOICE {			
requestLocationInformation-r9 SEQUENCE {			

commonEsRequestLocationInformation SEQUENCE {			
locationInformationType	locationMeasurementsPreferred		
triggeredReporting	Not present		
periodicalReporting	Not present		
additionalInformation	onlyReturnInformationRequested		
qos SEQUENCE {			
horizontalAccuracy	Not present		
verticalCoordinateRequest	FALSE		
verticalAccuracy	Not present		
responseTime SEQUENCE {			
time	See 14.3.8.5	Result of the response time calculation rounded up to the next second if response time <= 128s. Result of the response time calculation rounded up to the next multiple of ten seconds if response time > 128s	
responseTimeEarlyFix-r12	Not present		Rel-12 onwards
unit-r15	Not present		
	ten-seconds		Calculated response time >128s
}			
velocityRequest	FALSE		
}			
environment	Not present		
locationCoordinateTypes	Not present		
velocityTypes	Not present		
}			
a-gnss-RequestLocationInformation	Not present		
otdoa-RequestLocationInformation	Not present		
ecid-RequestLocationInformation	Not present		
epdu-RequestLocationInformation	Not Present		
sensor-RequestLocationInformation-r13	Not present		
tbs-RequestLocationInformation-r13	Not present		
wlan-RequestLocationInformation-r13	Not present		
bt-RequestLocationInformation-r13	Not present		
nr-ECID-RequestLocationInformation-r16	Not present		
nr-Multi-RTT-RequestLocationInformation-r16	Not present		
nr-DL-AoD-RequestLocationInformation-r16	Not present		
nr-DL-TDOA-RequestLocationInformation-r16			
SEQUENCE {			
nr-DL-PRS-RstdMeasurementInfoRequest-r16	Not present		
nr-RequestedMeasurements-r16	bit 0 = 0 (prsrsrpReq)		
nr-AssistanceAvailability-r16	FALSE		
nr-DL-TDOA-ReportConfig-r16 SEQUENCE {			
maxDL-PRS-RSTD-MeasurementsPerTRPPair-r16	Not present		
timingReportingGranularityFactor-r16	Not present		
measureSameDL-PRS-ResourceWithDifferentRxTEGs-r17			
reducedDL-PRS-ProcessingSamples-r17	Not present		
lowerRxBeamSweepingFactor-FR2-r17	Not present		
}			

additionalPaths-r16	Not present		
nr-UE-RxTEG-Request-r17	requested		
nr-los-nlos-IndicatorRequest-r17	Not present		
additionalPathsExt-r17	Not present		
additionalPathsDL-PRS-RSRP-Request-r17	Not present		
multiMeasInSameReport-r17	Not present		
}			
}			
}			
}			
}			
}			
}			
}			

Table 14.3.8.4.3-4: LPP ProvideAssistanceData

Derivation Path: TS 37.355 [49] clause 6.2			
Information Element	Value/remark	Comment	Condition
LPP-Message ::= SEQUENCE {			
transactionID SEQUENCE {			
initiator	locationServer		
transactionNumber	(0..255)		
}			
endTransaction	TRUE		
sequenceNumber	Not present		
acknowledgement	Not present		
lpp-MessageBody CHOICE {			
c1 CHOICE {			
provideAssistanceData SEQUENCE {			
criticalExtensions CHOICE {			
c1 CHOICE {			
provideAssistanceData-r9 SEQUENCE {			
commonEsProvideAssistanceData	Not present		
a-gnss-ProvideAssistanceData	Not present		
otdoa-ProvideAssistanceData	Not present		
epdu-Provide-AssistanceData	Not present		
sensor-ProvideAssistanceData-r14	Not present		
tbs-ProvideAssistanceData-r14	Not present		
wlan-ProvideAssistanceData-r14	Not present		
nr-Multi-RTT-ProvideAssistanceData-r16	Not present		
nr-DL-AoD-ProvideAssistanceData-r16	Not present		
nr-DL-TDOA-ProvideAssistanceData-r16			
} SEQUENCE {			
nr-DL-PRS-AssistanceData-r16	As defined in Table 14.3.8.4.3-5		
nr-SelectedDL-PRS-IndexList-r16	Not present		
nr-PositionCalculationAssistance-r16	Not present		
nr-DL-TDOA-Error-r16	Not present		
nr-On-Demand-DL-PRS-Configurations-r17	Not present		
nr-On-Demand-DL-PRS-Configurations-Selected-IndexList-r17	Not present		
assistanceDataValidityArea-r17	Not present		
}			
}			
}			
}			
}			
}			
}			

Table 14.3.8.4.3-5: NR-DL-PRS-AssistanceData

Derivation Path: 37.355 clause 6.4.3

Information Element	Value/remark	Comment	Condition
NR-DL-PRS-AssistanceData-r16 ::= SEQUENCE {			
nr-DL-PRS-ReferenceInfo-r16 SEQUENCE {			
dl-PRS-ID-r16	0		
nr-DL-PRS-ResourceID-List-r16	Not present		
nr-DL-PRS-ResourceSetID-r16	Not present		
}			
nr-DL-PRS-AssistanceDataList-r16 SEQUENCE (SIZE (1..nrMaxFreqLayers-r16)) OF NR-DL-PRS-AssistanceDataPerFreq-r16 {	1 entry		
NR-DL-PRS-AssistanceDataPerFreq-r16[1] SEQUENCE {		entry 1	
nr-DL-PRS-PositioningFrequencyLayer-r16 SEQUENCE {			
dl-PRS-SubcarrierSpacing-r16	kHz120		
dl-PRS-ResourceBandwidth-r16	3	32 PRBs	Sub-test 1
	27	128 PRBs	Sub-test 2
dl-PRS-StartPRB-r16	0		
dl-PRS-PointA-r16	absoluteFrequencyPointA as defined for the DL frequency of the Cell 1		
dl-PRS-CombSizeN-r16	n2		Sub-test 1
	n4		Sub-test 2
dl-PRS-CyclicPrefix-r16	normal		
}			
nr-DL-PRS-AssistanceDataPerFreq-r16 SEQUENCE (SIZE (1..nrMaxTRPsPerFreq-r16)) OF NR-DL-PRS-AssistanceDataPerTRP-r16{	2 entries		
NR-DL-PRS-AssistanceDataPerTRP-r16[1] SEQUENCE {		entry 1	Cell 1
dl-PRS-ID-r16	0		
nr-PhysCellID-r16	Cell 1		
nr-CellGlobalID-r16	Cell 1		
nr-ARFCN-r16	Cell 1		
nr-DL-PRS-SFN0-Offset-r16 SEQUENCE {			
sfn-Offset-r16	0		
integerSubframeOffset-r16	0		
}			
nr-DL-PRS-ExpectedRSTD-r16	0		
nr-DL-PRS-ExpectedRSTD-Uncertainty-r16	0		
nr-DL-PRS-Info-r16	As specified in Table 14.3.8.4.3-6		
}			
NR-DL-PRS-AssistanceDataPerTRP-r16[2] SEQUENCE {		entry 2	Cell 2
dl-PRS-ID-r16	1		
nr-PhysCellID-r16	Cell 2		
nr-CellGlobalID-r16	Cell 2		
nr-ARFCN-r16	Cell 2		
nr-DL-PRS-SFN0-Offset-r16 SEQUENCE {			
sfn-Offset-r16	0		
integerSubframeOffset-r16	0		
}			
nr-DL-PRS-ExpectedRSTD-r16	23	About 3 μ s	
nr-DL-PRS-ExpectedRSTD-Uncertainty-r16	154	About 5 μ s	
nr-DL-PRS-Info-r16	As specified in Table 14.3.8.4.3-6		
}			
}			
}			
}			
}			

Table 14.3.8.4.3-6: NR-DL-PRS-Info

Derivation Path: 37.355 clause 6.4.3			
Information Element	Value/remark	Comment	Condition
NR-DL-PRS-Info-r16 ::= SEQUENCE {			
nr-DL-PRS-ResourceSetList-r16 SEQUENCE (SIZE (1..nrMaxSetsPerTrp-r16)) OF NR-DL-PRS-ResourceSet-r16 {	1 entry		
NR-DL-PRS-ResourceSet-r16[1] SEQUENCE {		entry 1	
nr-DL-PRS-ResourceSetID-r16	0		
dl-PRS-Periodicity-and-ResourceSetSlotOffset-r16 CHOICE {			
scs120-r16 CHOICE {			
n160-r16	80		
}			
dl-PRS-ResourceRepetitionFactor-r16	n2		Sub-test 1
	Not present		Sub-test 2
dl-PRS-ResourceTimeGap-r16	s1		
dl-PRS-NumSymbols-r16	n4		
dl-PRS-MutingOption1-r16	Not present		
dl-PRS-MutingOption2-r16	Not present		
dl-PRS-ResourcePower-r16	27		
dl-PRS-ResourceList-r16 SEQUENCE (SIZE (1..nrMaxResourcesPerSet-r16)) OF NR-DL-PRS-Resource-r16 {	1 entry		
NR-DL-PRS-Resource-r16[1] SEQUENCE {		entry 1	
nr-DL-PRS-ResourceID-r16	0		
dl-PRS-SequenceID-r16	0		
dl-PRS-CombSizeN-AndReOffset-r16 CHOICE {			
n2-r16	0		Sub-test 1
n4-r16	0		Sub-test 2
}			
dl-PRS-ResourceSlotOffset-r16	0		Sub-test 1
	4		Sub-test 2
dl-PRS-ResourceSymbolOffset-r16	0		
dl-PRS-QCL-Info-r16	Not present		
}			
}			
}			
}			
}			

Table 14.3.8.4.3-7: LPP ProvideLocation Information

Derivation Path: TS 37.355 [49] clause 6.2			
Information Element	Value/remark	Comment	Condition
LPP-Message ::= SEQUENCE {			
transactionID SEQUENCE {			
initiator	locationServer		
transactionNumber	1		
}			
endTransaction	TRUE		
sequenceNumber	(0..255)		
acknowledgement			
lpp-MessageBody CHOICE {			
c1 CHOICE {			
provideLocationInformation SEQUENCE {			
criticalExtensions CHOICE {			
c1 CHOICE {			
provideLocationInformation-r9 SEQUENCE {			
commonIEsProvideLocationInformation	Not present.		
a-gnss-ProvideLocationInformation	Not present		
otdoa-ProvideLocationInformation	Not present		
ecid-ProvideLocationInformation	Not present		
epdu-ProvideLocationInformation	Not present		

	sensor-ProvideLocationInformation-r13	Not present		
	tbs-ProvideLocationInformation-r13	Not present		
	wlan-ProvideLocationInformation-r13	Not present		
	bt-ProvideLocationInformation-r13	Not present		
	nr-ECID-ProvideLocationInformation-r16	Not present		
r16	nr-Multi-RTT-ProvideLocationInformation-	Not present		
	nr-DL-AoD-ProvideLocationInformation-r16	Not present		
	nr-DL-TDOA-ProvideLocationInformation-			
	r16 SEQUENCE {			
	nr-DL-TDOA-			
	SignalMeasurementInformation-r16 SEQUENCE {			
	dl-PRS-ReferenceInfo-r16			
	nr-DL-TDOA-MeasList-r16 SEQUENCE	2 entries		
	(SIZE(1..nrMaxTRPs-r16)) OF NR-DL-TDOA-			
	MeasElement-r16 {			
	NR-DL-TDOA-MeasElement-r16[1]		entry 1	
	SEQUENCE {			
	dl-PRS-ID-r16			
	nr-PhysCellID-r16	Cell 1		
	nr-CellGlobalID-r16			
	nr-ARFCN-r16			
	nr-DL-PRS-ResourceID-r16			
	nr-DL-PRS-ResourceSetID-r16			
	nr-TimeStamp-r16			
	nr-RSTD-r16	Present		
	nr-AdditionalPathList-r16			
	nr-TimingQuality-r16			
	nr-DL-PRS-RSRP-Result-r16			
r16	nr-DL-TDOA-AdditionalMeasurements-			
	nr-UE-Rx-TEG-ID-r17	Present		
	nr-DL-PRS-FirstPathRSRP-Result-r17			
	nr-los-nlos-Indicator-r17			
	nr-AdditionalPathListExt-r17			
	nr-DL-TDOA-			
	AdditionalMeasurementsExt-r17			
	}			
	NR-DL-TDOA-MeasElement-r16[2]		entry 2	
	SEQUENCE {			
	dl-PRS-ID-r16			
	nr-PhysCellID-r16	Cell 2		
	nr-CellGlobalID-r16			
	nr-ARFCN-r16			
	nr-DL-PRS-ResourceID-r16			
	nr-DL-PRS-ResourceSetID-r16			
	nr-TimeStamp-r16			
	nr-RSTD-r16	Present		
	nr-AdditionalPathList-r16			
	nr-TimingQuality-r16			
	nr-DL-PRS-RSRP-Result-r16			
r16	nr-DL-TDOA-AdditionalMeasurements-			
	nr-UE-Rx-TEG-ID-r17	Present		
	nr-DL-PRS-FirstPathRSRP-Result-r17			
	nr-los-nlos-Indicator-r17			
	nr-AdditionalPathListExt-r17			
	nr-DL-TDOA-			
	AdditionalMeasurementsExt-r17			
	}			
	}			
	nr-UE-RxTEG-TimingErrorMargin-r17			
	}			
	nr-dl-tdoa-LocationInformation-r16			
	nr-DL-TDOA-Error-r16			

nr-DL-TDOA-SignalMeasurementInstances-r17			
nr-DL-TDOA-LocationInformationInstances-r17			
}			
}			
}			
}			
}			

14.3.8.5 Test requirement

Table 14.3.8.5-1 and Table 14.3.8.5-2 define the primary level settings including test tolerances for the test.

Table 14.3.8.5-1: RSTD accuracy test parameters

Parameter	Unit	Test 1		Test 2	
		Cell 1	Cell 2	Cell 1	Cell 2
PRS ARFCN		freq1		freq1	
Duplex mode		TDD		TDD	
TDD configuration		TDDConf.3.1		TDDConf.3.1	
BW _{channel}	MHz	200: N _{RB,c} = 132		200: N _{RB,c} = 132	
Downlink initial BWP configuration		DLBWP.0.1	-	DLBWP.0.1	-
Downlink dedicated BWP configuration		DLBWP.1.1	-	DLBWP.1.1	-
Uplink initial BWP configuration		ULBWP.0.1	-	ULBWP.0.1	-
Uplink dedicated BWP configuration		ULBWP.1.1	-	ULBWP.1.1	-
DRX cycle configuration		Not applicable	-	Not applicable	-
TRS configuration		TRS.2.1 TDD	-	TRS.2.1 TDD	-
TCI state		TCI.State.0	-	TCI.State.0	-
PDSCH Reference measurement channel		SR.3.1 TDD	-	SR.3.1 TDD	-
RMSI CORESET Reference Channel		CR.3.1 TDD	-	CR.3.1 TDD	-
Control channel RMC		CCR.3.1 TDD	-	CCR.3.1 TDD	-
OCNG Patterns		OP.1	OP.1	OP.1	OP.1
SSB configuration		SSB.3 FR2	SSB.3 FR2	SSB.3 FR2	SSB.3 FR2
SMTC configuration		SMTC.1	SMTC.1	SMTC.1	SMTC.1
PRS configuration		PRS.1.1 FR2	PRS.1.1 FR2	PRS.1.2 FR2	PRS.1.2 FR2
PRS Resource slot offset	slot	0	4	0	4
Expected RSTD	μs	N/A	3	N/A	3
Expected RSTD uncertainty	μs	N/A	5	N/A	5
Time offset with Cell 1	μs	-	3	-	3
PDSCH/PDCCH subcarrier spacing	kHz	120	120	120	120
EPRE ratio of PSS to SSS	dB	0	0	0	0
EPRE ratio of PBCH_DMRS to SSS					
EPRE ratio of PBCH to PBCH_DMRS					
EPRE ratio of PDCCH_DMRS to SSS					
EPRE ratio of PDCCH to PDCCH_DMRS					
EPRE ratio of PDSCH_DMRS to SSS					
EPRE ratio of PDSCH to PDSCH_DMRS					
EPRE ratio of OCNG DMRS to SSS ^{Note 1}					
EPRE ratio of OCNG to OCNG DMRS ^{Note 1}					
EPRE ratio of PRS to SSS					
Propagation conditions		AWGN	AWGN	AWGN	AWGN
Antenna configuration		1x2	1x2	1x2	1x2

Note 1: OCNG shall be used such that both cells are fully allocated and a constant total transmitted power spectral density is achieved for all OFDM symbols.

Table 14.3.8.5-2: RSTD accuracy OTA related test parameters

Parameter	Unit	Test 1		Test 2	
		Cell 1	Cell 2	Cell 1	Cell 2
Angle of arrival configuration		Setup 1 according to clause A.3.15.1			
Assumption for UE beams ^{Note 5}		Rough		Rough	
N_{oc} ^{Note1}	dBm/SCS ^{Note3}	-89.1		-89.1	
PRS \hat{E}_s / N_{oc}	dB	-5.17	-11.36	-5.17	-11.36
PRP ^{Note2}	dBm/SCS	-94.2	-100.4	-94.28	-100.4
PRS \hat{E}_s / I_{ot} ^{Note4}	dB	-5.7	-12.7	-5.7	-12.7
I_o ^{Note2}	dBm/190.0 8 MHz ^{Note3}	-55.68	-55.68	-55.68	-55.68
<p>Note 1: Where used, interference from other cells and noise sources not specified in the test is assumed to be constant over subcarriers and time and shall be modelled as AWGN of appropriate power for N_{oc} to be fulfilled.</p> <p>Note 2: PRP, E_s/I_{ot} and I_o levels have been derived from other parameters for information purposes. They are not settable parameters themselves.</p> <p>Note 3: Equivalent power received by an antenna with 0 dBi gain at the centre of the quiet zone</p> <p>Note 4: Calculation of E_s/I_{ot} includes the effect of UE internal noise up to the value assumed for the associated Refsens requirement in clause 7.3.2 of TS 38.101-2 [55], and an allowance of 1dB for UE multi-band relaxation factor ΔMB_p from TS 38.101-2 [55] Table 6.2.1.3-4.</p> <p>Note 5: Information about types of UE beam is given in TS 38.133 [50] B.2.1.3, and does not limit UE implementation or test system implementation</p>					

The RSTD measurement accuracy for Cell 2 shall fulfil the absolute requirement in clause 14.3.8.3.

The value of the LPP Time IE depends on the UE capabilities. The calculation is the same as in clause 14.2.10.5 with the following difference: $N_{PRS,i}^{slot} = 2$. Therefore, the value of the LPP Time IE is given by the following equation:

$$\left(k_{multiTEG} * 8 * \left\lceil \frac{2}{N'} \right\rceil \left\lceil \frac{0.071}{N} \right\rceil * 4 - 1 \right)$$

Where the remaining parameters depend on the UE capabilities. The LPP time IE ranges between 10.248s and 164s. The value of the LPP time IE is rounded up to the next second (if the value is >128s, it should be rounded up to the next multiple of ten seconds). The result is transmitted in the response time IE in the LPP-RequestLocationInformation in Table 14.3.8.4.3-3. The LPP time IE ranges between 11s and 170s.

Table 14.3.8.5-3: RSTD accuracy requirements for the reported values

Test Configuration	Lowest reported value	Highest reported value
Sub-test 1	(5898 – 120) T_c converted to RSTD measurement according to clause 4.15.6	(5898 + 120) T_c converted to RSTD measurement according to clause 4.15.6
Sub-test 2	(5898 – 86) T_c converted to RSTD measurement according to clause 4.15.6	(5898 + 86) T_c converted to RSTD measurement according to clause 4.15.6

The test tolerances are defined in clauses C.1.6 and C.2.5.

The rate of successful tests during repeated tests shall be at least 90% with a confidence level of 95%.

14.4 NR RSTD measurement period test cases in RRC_INACTIVE

14.4.1 NR RSTD measurement reporting delay test case for single positioning frequency layer in FR1 SA

Editor's note: This test case is incomplete. The following aspect is either missing or TBD:

- Test tolerance is missing

14.4.1.1 Test purpose

The purpose of the test is to verify that the RSTD measurement meets the requirements specified in TS 38.133 [50] clause 5.6.2.5 in an environment with AWGN propagation conditions in FR1 in standalone scenario when single positioning frequency layer is configured.

14.4.1.2 Test applicability

This test applies to all types of NR UE release 17 onwards that supports DL-TDOA positioning and DL-PRS measurement in RRC_INACTIVE.

14.4.1.3 Minimum conformance requirements

After receiving both *NR-DL-TDOA-ProvideAssistanceData* message and *NR-DL-TDOA-RequestLocationInformation* message from the LMF via LPP [34], the UE shall be able to measure multiple (up to the UE capability specified in Clause 5.6.2.3) DL RSTD measurements, defined in TS 38.215 [4], during the measurement period $T_{RSTD,Total}$ defined as:

$$T_{RSTD,Total} = \sum_{i=1}^L T_{RSTD,i} + (L - 1) * \max(T_{effect,i})$$

Where:

- i is the index of positioning frequency layer,
- L is total number of positioning frequency layers, and
- $T_{effect,i}$ is the periodicity of the PRS RSTD measurement in positioning frequency layer i

$T_{RSTD,i}$ is the measurement period for PRS RSTD measurement in positioning frequency layer i as specified below:

$$T_{RSTD,i} = \left(K_{carrier_PRS} * N_{Rx,TEG,i} * N_{RxBeam,i} * \left\lceil \frac{N_{slot_PRS,i}}{N'} \right\rceil * \left\lceil \frac{L_{available_PRS,i}}{N} \right\rceil * N_{sample} - 1 \right) * T_{effect,i} + T_{last,i}$$

Where:

- $N_{RxBeam,i}$ is the UE Rx beam sweeping factor:
- $N_{RxBeam,i} = 1$ if positioning frequency layer i is in FR1, and if positioning frequency layer i is in FR2
- $N_{RxBeam,i}$ equals to the value as UE reported in *supportedLowerRxBeamSweepingFactor-FR2* if the capability is reported by the UE for the band containing positioning frequency layer i , and LMF indicates *lowerRxBeamSweepingFactor-FR2* in *NR-DL-TDOA-RequestLocationInformation*.
- $N_{RxBeam,i}$ equals to 8, otherwise.
- $K_{carrier_PRS}$ is a scaling factor for PRS-based NR positioning measurements in RRC_INACTIVE. If the UE supports *parallelPRS-MeasRRC-Inactive-r17*, $K_{carrier_PRS} = 1$; otherwise,
- If $S_{rxlev} \leq S_{nonIntraSearchP}$ or $S_{qual} \leq S_{nonIntraSearchQ}$, $K_{carrier_PRS} = K_{carrier} + 1$, where $K_{carrier}$ is defined in clause 4.2.2.4

- If $S_{rxlev} > S_{nonIntraSearchP}$ and $S_{qual} > S_{nonIntraSearchQ}$, $K_{carrier_PRS} = N_{layers} + 1$, where N_{layers} is defined in clause 4.2.2.7.
- $N_{Rx,TEG,i}$ is the Rx TEG specific scaling factor:
 - $N_{Rx,TEG,i} = 1$ if the UE is not configured by the LMF to measure a PRS resource with multiple Rx TEGs via *measureSameDL-PRS-ResourceWithDifferentRxTEGs-r17* [34].
 - $N_{Rx,TEG,i}$ is defined as follows if the UE is configured by the LMF with *measureSameDL-PRS-ResourceWithDifferentRxTEGs-r17* [34] to perform measurement on same DL PRS resource of a TRP using different Rx TEGs in *NR-DL-TDOA-RequestLocationInformation* [34]:
 - $N_{Rx,TEG,i} = P$, if the UE is not capable of measuring same DL PRS resource simultaneously from multiple Rx TEGs, where P is the number of UE Rx TEGs that the UE is requested by LMF to measure the same DL-PRS Resource of a TRP indicated by *measureSameDL-PRS-ResourceWithDifferentRxTEGs-r17* in [34], and in case 'n0' is indicated, P is the maximum number of Rx TEGs with which UE can support to measure the same PRS resource as reported in *NR-UE-TEG-Capability*.
 - $N_{Rx,TEG,i} = \left\lfloor \frac{P}{Q} \right\rfloor$, if the UE is capable of measuring the same DL PRS resource simultaneously from multiple Rx TEGs, where Q is the number of UE Rx TEGs for measuring the same DL-PRS Resource simultaneously indicated by *measureSameDL-PRS-ResourceWithDifferentRxTEGsSimul-r17* in [34].
- $N_{PRS,i}^{slot}$ is the maximum number of DL PRS resources in positioning frequency layer i configured in a slot.
- $L_{available_PRS,i}$ is the time duration of available PRS in positioning frequency layer i to be measured within $T_{PRS,i}$, and is calculated in the same way as PRS duration K defined in clause 5.1.6.5 of TS 38.214 [26]. For calculation of $L_{available_PRS,i}$, only unmuted PRS resources that are not fully overlapped with other higher-priority DL signals/channels are considered.
- N_{sample} is the number of PRS RSTD samples, where
 - $N_{sample} = 1$ if the UE supports *supportedDL-PRS-ProcessingSamples-RRC-Inactive* [34], and the LMF requests the UE to perform positioning measurements with reduced number of samples, and meets the following conditions:
 - PRS bandwidth is within the initial BWP and
 - Magnitude of difference between the serving cell's SS-RSRP and the neighbour cell's PRS-RSRP is within 6 dB.
 - $N_{sample} = 2$ if the UE supports *supportedDL-PRS-ProcessingSamples-RRC-Inactive* [34], and the LMF requests the UE to perform positioning measurements with reduced number of samples, and does not meet the following conditions:
 - PRS bandwidth is within the initial BWP and
 - Magnitude of difference between the serving cell's SS-RSRP and the neighbour cell's PRS-RSRP is within 6 dB.
 - $N_{sample} = 4$ otherwise.
- $T_{last,i}$ is the measurement duration for the last PRS RSTD sample in positioning frequency layer i , including the sampling time and processing time, $T_{last,i} = T_i + T_{available_PRS,i}$,
- $T_{effect,i}$ is the periodicity of the PRS RSTD measurement in positioning frequency layer i defined as:

$$T_{effect,i} = \left\lceil \frac{T_i}{T_{available_PRS,i}} \right\rceil * T_{available_PRS,i}$$

Where:

- T_i corresponds to *durationOfPRS-ProcessingSymbolsInEveryTms-r17* in TS 37.355 [34],

- $T_{available_PRS,i} = LCM(T_{PRS,i}, T_{DRX})$, the least common multiple between $T_{PRS,i}$ and the DRX cycle length T_{DRX}
- $T_{PRS,i}$ is the periodicity of DL PRS resource with muting on positioning frequency layer i .

If more than one PRS periodicities are configured in positioning frequency layer i , the least common multiple of PRS periodicities $T_{per}^{PRS \text{ with muting}}$ among all DL PRS resource sets in the positioning frequency layer is used to derive $T_{PRS,i}$, where,

- $T_{per}^{PRS \text{ with muting}} = N_{muting} * T_{per}^{PRS}$, is the PRS periodicity with muting per PRS resource,
- T_{per}^{PRS} is the periodicity of PRS resource sets given by the higher-layer parameter *DL-PRS-Periodicity*.
- N_{muting} is the scaling factor considering PRS resource muting. $N_{muting} = T_{muting}^{PRS} * L_{muting}$, where
- T_{muting}^{PRS} is the muting repetition factor given by the higher-layer parameter *DL-PRS-MutingBitRepetitionFactor*, and L_{muting} is the size of the bitmap $\{b^1\}$.
- $\{N, T\}$ is the UE capability combination per band for RRC_INACTIVE state where N is a duration of DL PRS symbols in ms corresponding to *durationOfPRS-ProcessingSymbols-r17* in TS 37.355 [34], T (ms) corresponds to *durationOfPRS-ProcessingSymbolsInEveryTms-r17* in TS 37.355 [34], [and T-N (>0) is the time required to process duration N of DL PRS symbols already buffered in memory], for a given maximum bandwidth supported by UE corresponding to *supportedBandwidthPRS* in TS 37.355 [34],
- N' is UE capability for number of DL PRS resources that it can process in a slot [in RRC_INACTIVE state as indicated by *maxNumOfDL-PRS-ResProcessedPerSlot-RRC-Inactive-r17* specified in TS 37.355 [34].

The time $T_{RSTD,Total}$ starts from the first DRX cycle containing the DL PRS resource(s) in the assistance data after both the *NR-DL-TDOA-ProvideAssistanceData* message and *NR-DL-TDOA-RequestLocationInformation* message are delivered from LMF to the UE via LPP [34].

14.4.1.4 Test description

The supported test configurations in listed in Table 14.4.1.4-1

Table 14.4.1.4-1: Test Configurations

Configuration	Description
1	15 kHz SSB SCS, 20 MHz bandwidth, FDD duplex mode
2	15 kHz SSB SCS, 20 MHz bandwidth, TDD duplex mode
3	30 kHz SSB SCS, 50 MHz bandwidth, TDD duplex mode
Note:	The UE is only required to be tested in one of the supported test configurations.

14.4.1.4.1 Initial conditions

Test Environment: Normal, as defined in TS 38.508-1 [45] clause 4.1.

Frequencies to be tested: Mid Range, as defined in TS 38.508-1 [45] clause 4.3.1.

Channel bandwidth to be tested: are specified in Table 14.4.1.4-1.

1. Connect the SS and AWGN noise sources to the UE antenna connector or antenna connectors as shown in Annex A, Figure A.12.
2. The general test parameter settings are set up according to Table 14.4.1.5-1, Table 14.4.1.5-2 and Table 14.4.1.5-3.
3. Propagation conditions are set according to clause 4.15.2.
4. Message contents are defined in clause 14.4.1.4.3.
5. In the test there are three synchronous cells: Cell 1, Cell 2 and Cell 3. Cell 1 is the RSTD reference as well as the PCell. Cell 2 and Cell 3 are the neighbour cells. All 3 cells are on the same RF channel in FR1.

14.4.1.4.2 Test procedure

The test consists of two consecutive time intervals, with duration of T1 and T2. During time duration T1, the UE shall be in RRC_CONNECTED state and shall not have any timing information of Cell 2 and Cell3. During T2 UE shall be in RRC_INACTIVE state and all cells transmit PRS resources within initial DL BWP of the UE and with the same numerology as the initial DL BWP.

The *NR-DL-TDOA-ProvideAssistanceData* as defined in TS 37.355 [49] clause 6.5.10.1 shall be provided to the UE during T1. The last TTI containing the *NR-DL-TDOA-ProvideAssistanceData* and *NR-DL-TDOA-RequestLocationInformation* shall be provided to the UE ΔT ms before the start of T2, where $\Delta T = 50$ ms is the maximum processing time of the *DL-TDOA assistance* data and location information request.

The beginning of the time interval T2 shall be aligned with the first DRX cycle containing a DL PRS resource(s).

0. Configure the Cell for RA-SDT with SIB1 configured according to TS 38.508-1 [45], clause 4.6.1 with condition SDT.
1. Ensure the UE is in State RRC_CONNECTED with generic procedure parameters Connectivity NR, Connected without release On, according to TS 38.508-1 [45] clause 4.5.
2. The SS shall send a RESET UE POSITIONING STORED INFORMATION message.
3. Set the parameters according to Table 14.4.1.5-1, Table 14.4.1.5-2 and Table 14.4.1.5-3. Propagation conditions are set according to clause 4.15.2.
4. T1 starts.
5. The SS shall transmit an RRCReconfiguration message with the DRX configuration.
6. The UE shall transmit RRCReconfigurationComplete message.
7. The SS shall transmit an LPP REQUEST CAPABILITIES message.
8. The UE shall transmit an LPP PROVIDE CAPABILITIES message indicating the DL-TDOA capabilities supported by the UE in the *NR-DL-TDOA-ProvideCapabilities* IE.
9. The SS shall send a LPP PROVIDE ASSISTANCE DATA message, including the *NR-DL-TDOA-ProvideAssistanceData* IE. The position of neighbour Cell 2 and the position of neighbour Cell 3 are described in 3GPP TS 37.571-5 [20]. If the UE message at step 8 includes the ackRequested IE set to TRUE, then the SS shall send an acknowledgment in the LPP PROVIDE ASSISTANCE DATA message.
10. The SS shall transmit LCS Periodic-Triggered Invoke Request message with LPP REQUEST LOCATION INFORMATION embedded to start the periodic reporting procedure, including the *NR-DL-TDOA-RequestLocationInformation* IE such that the UE receives the message ΔT ms before the start of T2, where $\Delta T = 50$ ms.
11. The UE shall transmit an LCS Periodic-Triggered Invoke Return Result message.
12. When T1 expires, the SS shall transmit an RRCRelease message with SDT configuration to transit the UE to RRC_INACTIVE state and switch the power setting from T1 to T2 as specified in Table 14.4.1.5-2 and Table 14.4.1.5-3.
13. Wait for the UE monitors for occurrence of the periodic event requested.
14. The UE shall transmit the UE transmit an *RRCResumeRequest* message. If the UE also supporting SDT feature, the UE shall include LPP PROVIDE LOCATION INFORMATION message in the *RRCResumeRequest* message and then go to step 18.
15. The SS transmits an *RRCResume* message.
16. The UE transmits an *RRCResumeComplete* message.
17. The UE shall transmit a LPP PROVIDE LOCATION INFORMATION message including the *NR-DL-TDOA-ProvideLocationInformation* IE within the response time (see clause 4.15.3).

18. The UE shall perform and report the RSTD measurements for both Cell 2 and Cell 3 with respect to the reference cell in the DL-TDOA assistance data, Cell 1. If the UE transmits an *NR-DL-TDOA-ProvideLocationInformation* IE including the nr-RSTD field for both Cell 2 and Cell 3 within the response time then the number of successful tests is increased by one. If the UE fails to report the *NR-DL-TDOA-ProvideLocationInformation* IE with both the nr-RSTD fields included within the response time then the number of failure tests is increased by one.

19. Repeat steps 2-17 in Tables 14.4.1.4-1 until the confidence level according to Annex D is achieved.

14.4.1.4.3 Message contents

Table 14.4.1.4.3-1: RESET UE POSITIONING STORED INFORMATION

Derivation Path: 38.509 [44] clause 6.6			
Information Element	Value/remark	Comment	Condition
UE Positioning Technology	0 0 0 0 1 1 1	DL-TDOA	

Table 14.4.1.4.3-2: RRCReconfiguration

Derivation Path: TS 38.508-1 [45], table 4.6.1-13			
Information Element	Value/remark	Comment	Condition
RRCReconfiguration ::= SEQUENCE {			
criticalExtensions CHOICE {			
rrcReconfiguration SEQUENCE {			
nonCriticalExtension SEQUENCE {			
masterCellGroup	CellGroupConfig		
}			
}			
}			
}			

Table 14.4.1.4.3-3: CellGroupConfig (Table 14.4.1.4.3-2)

Derivation Path: 38.508-1 [45], Table 4.6.3-19			
Information Element	Value/remark	Comment	Condition
CellGroupConfig ::= SEQUENCE {			
mac-CellGroupConfig SEQUENCE {			
drx-Config CHOICE {			
setup SEQUENCE {			
drx-onDurationTimer	ms6		
drx-InactivityTimer	ms1		
drx-HARQ-RTT-TimerDL	sl64		
drx-HARQ-RTT-TimerUL	sl64		
drx-RetransmissionTimerDL	sl1		
drx-RetransmissionTimerUL	sl1		
drx-LongCycleStartOffset CHOICE {			
ms1280	0		
}			
shortDRX	not present		
drx-SlotOffset	0		
}			
}			
}			
}			

Table 14.4.1.4.3-4: LPP Request Capabilities

Information Element	Value/remark
nr-DL-TDOA-RequestCapabilities-r16	TRUE

Table 14.4.1.4.3-5: LPP ProvideAssistanceData

Derivation Path: TS 37.355 [49] clause 6.2			
Information Element	Value/remark	Comment	Condition
LPP-Message ::= SEQUENCE {			
transactionID SEQUENCE {			
initiator	locationServer		
transactionNumber	(0..255)		
}			
endTransaction	TRUE		
sequenceNumber	Not present		
acknowledgement	Not present		
lpp-MessageBody CHOICE {			
c1 CHOICE {			
provideAssistanceData SEQUENCE {			
criticalExtensions CHOICE {			
c1 CHOICE {			
provideAssistanceData-r9 SEQUENCE {			
commonEsProvideAssistanceData	Not present		
a-gnss-ProvideAssistanceData	Not present		
otdoa-ProvideAssistanceData	Not present		
epdu-Provide-AssistanceData	Not present		
sensor-ProvideAssistanceData-r14	Not present		
tbs-ProvideAssistanceData-r14	Not present		
wlan-ProvideAssistanceData-r14	Not present		
nr-Multi-RTT-ProvideAssistanceData-r16	Not present		
nr-DL-AoD-ProvideAssistanceData-r16	Not present		
nr-DL-TDOA-ProvideAssistanceData-r16			
SEQUENCE {			
nr-DL-PRS-AssistanceData-r16	As defined in Table 14.4.1.4.3-6		
nr-SelectedDL-PRS-IndexList-r16	Not present		
nr-PositionCalculationAssistance-r16			Depending on UE capabilities, i.e. support for UE-based DL-TDOA
SEQUENCE {			
nr-TRP-LocationInfo-r16	As defined in TS 37.571-5 [20]		
nr-DL-PRS-BeamInfo-r16	Not present		
nr-RTD-Info-r16	Not present		
nr-TRP-BeamAntennaInfo-r17	Not present		
nr-DL-PRS-Expected-LOS-NLOS-Assistance-r17	Not present		
nr-DL-PRS-TRP-TEG-Info-r17	Not present		
}			
nr-DL-TDOA-Error-r16	Not present		
nr-On-Demand-DL-PRS-Configurations-r17	Not present		
nr-On-Demand-DL-PRS-Configurations-Selected-IndexList-r17	Not present		
assistanceDataValidityArea-r17	Not present		
}			
}			
}			
}			
}			
}			

Table 14.4.1.4.3-6: NR-DL-PRS-AssistanceData

Derivation Path: 37.355 clause 6.4.3			
Information Element	Value/remark	Comment	Condition

NR-DL-PRS-AssistanceData-r16 ::= SEQUENCE {			
nr-DL-PRS-ReferenceInfo-r16 SEQUENCE {			
dl-PRS-ID-r16	0		
nr-DL-PRS-ResourceID-List-r16	Not present		
nr-DL-PRS-ResourceSetID-r16	Not present		
}			
nr-DL-PRS-AssistanceDataList-r16 SEQUENCE (SIZE (1..nrMaxFreqLayers-r16)) OF NR-DL-PRS-AssistanceDataPerFreq-r16 {	1 entry		
NR-DL-PRS-AssistanceDataPerFreq-r16[1] SEQUENCE {		entry 1	
nr-DL-PRS-PositioningFrequencyLayer-r16 SEQUENCE {			
}			
dl-PRS-SubcarrierSpacing-r16	kHz15		Config 1 and Config 2
	kHz30		Config 3
dl-PRS-ResourceBandwidth-r16	1	24 PRBs	
dl-PRS-StartPRB-r16	0		
dl-PRS-PointA-r16	absoluteFrequencyPointA as defined for the DL frequency of the Cell 1		
dl-PRS-CombSizeN-r16	n2		
dl-PRS-CyclicPrefix-r16	normal		
}			
nr-DL-PRS-AssistanceDataPerFreq-r16 SEQUENCE (SIZE (1..nrMaxTRPsPerFreq-r16)) OF NR-DL-PRS-AssistanceDataPerTRP-r16{	3 entries		
NR-DL-PRS-AssistanceDataPerTRP-r16[1] SEQUENCE {		entry 1	Cell 1
dl-PRS-ID-r16	0		
nr-PhysCellID-r16	Cell 1		
nr-CellGlobalID-r16	Cell 1		
nr-ARFCN-r16	Cell 1		
nr-DL-PRS-SFN0-Offset-r16 SEQUENCE {			
sfn-Offset-r16	0		
integerSubframeOffset-r16	0		
}			
nr-DL-PRS-ExpectedRSTD-r16	0		
nr-DL-PRS-ExpectedRSTD-Uncertainty-r16	0		
nr-DL-PRS-Info-r16	As specified in Table 14.4.1.4.3-7		
}			
NR-DL-PRS-AssistanceDataPerTRP-r16[2] SEQUENCE {		entry 2	Cell 2
dl-PRS-ID-r16	1		
nr-PhysCellID-r16	Cell 2		
nr-CellGlobalID-r16	Cell 2		
nr-ARFCN-r16	Cell 2		
nr-DL-PRS-SFN0-Offset-r16 SEQUENCE {			
sfn-Offset-r16	0		
integerSubframeOffset-r16	0		
}			
nr-DL-PRS-ExpectedRSTD-r16	92	About 3 μ s	
nr-DL-PRS-ExpectedRSTD-Uncertainty-r16	154	About 5 μ s	
nr-DL-PRS-Info-r16	As specified in Table 14.4.1.4.3-7		
}			
NR-DL-PRS-AssistanceDataPerTRP-r16[3] SEQUENCE {		entry 3	Cell 3
dl-PRS-ID-r16	2		
nr-PhysCellID-r16	Cell 3		
nr-CellGlobalID-r16	Cell 3		
nr-ARFCN-r16	Cell 3		
nr-DL-PRS-SFN0-Offset-r16 SEQUENCE {			
sfn-Offset-r16	0		
}			

integerSubframeOffset-r16	0		
}			
nr-DL-PRS-ExpectedRSTD-r16	92	About 3 μs	
nr-DL-PRS-ExpectedRSTD-Uncertainty-r16	154	About 5 μs	
nr-DL-PRS-Info-r16	As specified in Table 14.4.1.4.3-7		
}			
}			
}			
}			
}			

Table 14.4.1.4.3-7: NR-DL-PRS-Info

Derivation Path: 37.355 clause 6.4.3			
Information Element	Value/remark	Comment	Condition
NR-DL-PRS-Info-r16 ::= SEQUENCE {			
nr-DL-PRS-ResourceSetList-r16 SEQUENCE (SIZE (1..nrMaxSetsPerTrp-r16)) OF NR-DL-PRS-ResourceSet-r16 {	1 entry		
NR-DL-PRS-ResourceSet-r16[1] SEQUENCE {		entry 1	
nr-DL-PRS-ResourceSetID-r16	0		
dl-PRS-Periodicity-and-ResourceSetSlotOffset-r16 CHOICE {			
scs15-r16 CHOICE {			Config 1 and Config 2
n160-r16	10		
}			
scs30-r16 CHOICE {			Config 3
n320-r16	20		
}			
dl-PRS-ResourceRepetitionFactor-r16	n2		
dl-PRS-ResourceTimeGap-r16	s1		
dl-PRS-NumSymbols-r16	n4		
dl-PRS-MutingOption1-r16 SEQUENCE {			
dl-prs-MutingBitRepetitionFactor-r16	Not present		
nr-option1-muting-r16 CHOICE {			
po2-r16	10		Cell 1
	01		Cell 2
	10		Cell 3
}			
}			
dl-PRS-MutingOption2-r16	Not present		
dl-PRS-ResourcePower-r16	27		
dl-PRS-ResourceList-r16 SEQUENCE (SIZE (1..nrMaxResourcesPerSet-r16)) OF NR-DL-PRS-Resource-r16 {	2 entries		
NR-DL-PRS-Resource-r16[1] SEQUENCE {		entry 1	
nr-DL-PRS-ResourceID-r16	0		
dl-PRS-SequenceID-r16	0		
dl-PRS-CombSizeN-AndReOffset-r16 CHOICE {			
N2-r16	0		Cell 1 and Cell 2
	1		Cell 3
}			
dl-PRS-ResourceSlotOffset-r16	0		
dl-PRS-ResourceSymbolOffset-r16	0		
dl-PRS-QCL-Info-r16	Not present		
}			
NR-DL-PRS-Resource-r16[2] SEQUENCE {		entry 2	
nr-DL-PRS-ResourceID-r16	1		
dl-PRS-SequenceID-r16	1		
dl-PRS-CombSizeN-AndReOffset-r16 CHOICE {			

N2-r16	0		Cell 1 and Cell 2
	1		Cell 3
}			
dl-PRS-ResourceSlotOffset-r16	0		
dl-PRS-ResourceSymbolOffset-r16	0		
dl-PRS-QCL-Info-r16	Not present		
}			
}			
}			
}			
}			

Table 14.4.1.4.3-8: lcs-PeriodicTriggeredInvoke

Derivation Path: 24.080 clause 4.4.2			
Information Element	Value/remark	Comment	Condition
LCS-PeriodicTriggeredInvokeArg ::= SEQUENCE {			
referenceNumber	LCS-ReferenceNumber		
h-gmlc-address	GSN-Address		
qoS	Not present		
reportingPLMNList	Not present		
periodicLocation SEQUENCE {			
periodicLDRInfo SEQUENCE {			
reportingAmount	5		
reportingInterval	1		
reportingOptionMilliseconds	Not present		
}			
}			
areaEventReporting	Not present		
motionEventReporting	Not present		
referenceNumberExt	LCS-ReferenceNumberExt		
h-gmlc-callBackUri	Not present		
supportedGADShapes	Not present		
deferredRoutingIdentifier	Not present		
reportingAccessTypes	00000001	NR	
multiplePositioningProtocolPDUs SIZE (1..maxNumLPPMsg) OF PositioningProtocolPDU {	1 entry		
PositioningProtocolPDU[1] SEQUENCE {		entry 1	
PositioningProtocolPDU	Contains a LPP RequestLocationInformation message defined in Table 14.4.1.4.3-9		
}			
}			
controlPlane-CIoT-5GS-Optimisation	Not present		
scheduledLocTime	Not present		
eventReportAllowedArea	Not present		
}			

Table 14.4.1.4.3-9: LPP RequestLocationInformation

Derivation Path: TS 37.355 [49] clause 6.2			
Information Element	Value/remark	Comment	Condition
LPP-Message ::= SEQUENCE {			
transactionID SEQUENCE {			
initiator	locationServer		
transactionNumber	1		
}			
endTransaction	FALSE		
sequenceNumber	Not present		
acknowledgement	Not present		

lpp-MessageBody CHOICE {			
c1 CHOICE {			
requestLocationInformation SEQUENCE {			
criticalExtensions CHOICE {			
c1 CHOICE {			
requestLocationInformation-r9 SEQUENCE {			
commonEsRequestLocationInformation SEQUENCE {			
locationInformationType	locationMeasurementsPreferred		
triggeredReporting	Not present		
periodicalReporting	Not present		
additionalInformation	onlyReturnInformationRequested		
qos SEQUENCE {			
horizontalAccuracy	Not present		
verticalCoordinateRequest	FALSE		
verticalAccuracy	Not present		
responseTime SEQUENCE {			
time	See 14.4.1.5	Result of the response time calculation rounded up to the next second if response time <= 128s. Result of the response time calculation rounded up to the next multiple of ten seconds if response time > 128s	
responseTimeEarlyFix-r12	Not present		Rel-12 onwards
unit-r15	Not present ten-seconds		Calculated response time >128s
}			
velocityRequest	FALSE		
}			
environment	Not present		
locationCoordinateTypes	Not present		
velocityTypes	Not present		
}			
a-gnss-RequestLocationInformation	Not present		
otdoa-RequestLocationInformation	Not present		
ecid-RequestLocationInformation	Not present		
epdu-RequestLocationInformation	Not Present		
sensor-RequestLocationInformation-r13	Not present		
tbs-RequestLocationInformation-r13	Not present		
wlan-RequestLocationInformation-r13	Not present		
bt-RequestLocationInformation-r13	Not present		
nr-ECID-RequestLocationInformation-r16	Not present		
nr-Multi-RTT-RequestLocationInformation-r16	Not present		
nr-DL-AoD-RequestLocationInformation-r16	Not present		
nr-DL-TDOA-RequestLocationInformation-r16			
SEQUENCE {			
nr-DL-PRS-RstdMeasurementInfoRequest-r16	Not present		
nr-RequestedMeasurements-r16	bit 0 = 0 (prsrsrpReq)		
nr-AssistanceAvailability-r16	FALSE		
nr-DL-TDOA-ReportConfig-r16 SEQUENCE {			

maxDL-PRS-RSTD-MeasurementsPerTRPPair-r16	Not present		
timingReportingGranularityFactor-r16	Not present		
measureSameDL-PRS-ResourceWithDifferentRxTEGs-r17	Not present		
reducedDL-PRS-ProcessingSamples-r17	Not present		
lowerRxBeamSweepingFactor-FR2-r17	Not present		
}			
additionalPaths-r16	Not present		
nr-UE-RxTEG-Request-r17	Not present		
nr-los-nlos-IndicatorRequest-r17	Not present		
additionalPathsExt-r17	Not present		
additionalPathsDL-PRS-RSRP-Request-r17	Not present		
multiMeasInSameReport-r17	Not present		
}			
}			
}			
}			
}			
}			
}			
}			

Table 14.4.1.4.3-10: RRCRelease

Derivation Path: TS 38.508-1 [45], Table 4.6.1-16 with condition NR_RRC_INACTIVE and SDT

Table 14.4.1.4.3-11: LPP ProvideLocation Information

Derivation Path: TS 37.355 [49] clause 6.2			
Information Element	Value/remark	Comment	Condition
LPP-Message ::= SEQUENCE {			
transactionID SEQUENCE {			
initiator	locationServer		
transactionNumber	1		
}			
endTransaction	TRUE		
sequenceNumber	(0..255)		
acknowledgement			
lpp-MessageBody CHOICE {			
c1 CHOICE {			
provideLocationInformation SEQUENCE {			
criticalExtensions CHOICE {			
c1 CHOICE {			
provideLocationInformation-r9 SEQUENCE {			
commonIEsProvideLocationInformation	Not present.		
a-gnss-ProvideLocationInformation	Not present		
otdoa-ProvideLocationInformation	Not present		
ecid-ProvideLocationInformation	Not present		
epdu-ProvideLocationInformation	Not present		
sensor-ProvideLocationInformation-r13	Not present		
tbs-ProvideLocationInformation-r13	Not present		
wlan-ProvideLocationInformation-r13	Not present		
bt-ProvideLocationInformation-r13	Not present		
nr-ECID-ProvideLocationInformation-r16	Not present		
nr-Multi-RTT-ProvideLocationInformation-r16	Not present		
nr-DL-AoD-ProvideLocationInformation-r16	Not present		
nr-DL-TDOA-ProvideLocationInformation-r16 SEQUENCE {			
nr-DL-TDOA-SignalMeasurementInformation-r16 SEQUENCE {			
dl-PRS-ReferenceInfo-r16			

nr-DL-TDOA-MeasList-r16 SEQUENCE (SIZE(1..nrMaxTRPs-r16)) OF NR-DL-TDOA-MeasElement-r16 {	3 entries		
NR-DL-TDOA-MeasElement-r16[1] SEQUENCE {		entry 1	
dl-PRS-ID-r16			
nr-PhysCellID-r16	Cell 1		
nr-CellGlobalID-r16			
nr-ARFCN-r16			
nr-DL-PRS-ResourceID-r16			
nr-DL-PRS-ResourceSetID-r16			
nr-TimeStamp-r16			
nr-RSTD-r16	Present		
nr-AdditionalPathList-r16			
nr-TimingQuality-r16			
nr-DL-PRS-RSRP-Result-r16			
nr-DL-TDOA-AdditionalMeasurements-r16			
nr-UE-Rx-TEG-ID-r17			
nr-DL-PRS-FirstPathRSRP-Result-r17			
nr-los-nlos-Indicator-r17			
nr-AdditionalPathListExt-r17			
nr-DL-TDOA-AdditionalMeasurementsExt-r17			
}			
NR-DL-TDOA-MeasElement-r16[2] SEQUENCE {		entry 2	
dl-PRS-ID-r16			
nr-PhysCellID-r16	Cell 2		
nr-CellGlobalID-r16			
nr-ARFCN-r16			
nr-DL-PRS-ResourceID-r16			
nr-DL-PRS-ResourceSetID-r16			
nr-TimeStamp-r16			
nr-RSTD-r16	Present		
nr-AdditionalPathList-r16			
nr-TimingQuality-r16			
nr-DL-PRS-RSRP-Result-r16			
nr-DL-TDOA-AdditionalMeasurements-r16			
nr-UE-Rx-TEG-ID-r17			
nr-DL-PRS-FirstPathRSRP-Result-r17			
nr-los-nlos-Indicator-r17			
nr-AdditionalPathListExt-r17			
nr-DL-TDOA-AdditionalMeasurementsExt-r17			
}			
NR-DL-TDOA-MeasElement-r16[3] SEQUENCE {		entry 3	
dl-PRS-ID-r16			
nr-PhysCellID-r16	Cell 3		
nr-CellGlobalID-r16			
nr-ARFCN-r16			
nr-DL-PRS-ResourceID-r16			
nr-DL-PRS-ResourceSetID-r16			
nr-TimeStamp-r16			
nr-RSTD-r16	Present		
nr-AdditionalPathList-r16			
nr-TimingQuality-r16			
nr-DL-PRS-RSRP-Result-r16			
nr-DL-TDOA-AdditionalMeasurements-r16			
nr-UE-Rx-TEG-ID-r17			
nr-DL-PRS-FirstPathRSRP-Result-r17			
nr-los-nlos-Indicator-r17			
nr-AdditionalPathListExt-r17			

nr-DL-TDOA-AdditionalMeasurementsExt-r17			
}			
}			
nr-UE-RxTEG-TimingErrorMargin-r17			
}			
nr-dl-tdoa-LocationInformation-r16			
nr-DL-TDOA-Error-r16			
nr-DL-TDOA-SignalMeasurementInstances-r17			
nr-DL-TDOA-LocationInformationInstances-r17			
}			
}			
}			
}			
}			
}			

14.4.1.5 Test requirement

Table 14.4.1.5-1, Table 14.4.1.5-2 and Table 14.4.1.5-3 define the primary level settings including test tolerances for the test.

Table.14.4.1.5-1: General test parameters for RSTD measurement reporting delay

Parameter		Unit	Value	Comment
Reference cell			Cell 1	Reference cell is the cell in the DL-TDOA assistance data with respect to which the RSTD measurement is defined, as specified in TS 38.215 [4] and TS 37.355 [34]. The reference cell is the PCell in this test case.
Neighbor cells			Cell 2 and Cell 3	Cell 2 and Cell 3 appear at the first and second places in the neighbour cell list in the DL-TDOA assistance data.
SSB configuration	Config 1		SSB.1 FR1	
	Config 2		SSB.1 FR1	
	Config 3		SSB.2 FR1	
SMTC configuration	Config 1		SMTC.2	
	Config 2		SMTC.1	
	Config 3		SMTC.1	
PDSCH RMC configuration	Config 1		SR.1.1 FDD	
	Config 2		SR.1.1 TDD	
	Config 3		SR.2.1 TDD	
RMSI CORESET RMC configuration	Config 1		CR.1.1 FDD	As specified in clause A.3.1.2.1
	Config 2		CR.1.1 TDD	
	Config 3		CR.2.1 TDD	
Dedicated CORESET RMC configuration	Config 1		CR.1.1 FDD	
	Config 2		CR.1.1 TDD	
	Config 3		CR.2.1 TDD	
Initial BWP configuration	Config 1,2,3		DLBWP.0.1 ULBWP.0.1	

Active UL BWP configuration	Config 1,2,3		ULBWP.1.1	
PRS Configuration	Config 1		PRS.1.1 FR1	As specified in clause A.3.31
	Config 2		PRS.1.1 FR1	
	Config 3		PRS.2.1 FR1	
Physical cell ID PCI			(PCI of Cell 1 – PCI of Cell 2)mod6=0 and (PCI of Cell 1 – PCI of Cell 3)mod6=0	The cell PCIs are selected such that the relative shifts of PRS patterns among cells are as given by the test parameters
CP length			Normal	
DRX		s	1.28	
Radio frame receive time offset between the cells at the UE antenna connector		μs	Cell 2 to Cell 1: 0 Cell 3 to Cell 1: 3	PRS are transmitted from synchronous cells
Expected RSTD		μs	Cell 2: 3 Cell 3: 3 Other neighbour cells: randomly between -3 and 3	The expected RSTD is what is expected at the receiver. The corresponding parameter in the DL-TDOA assistance data specified in TS 37.355 [34] is the expectedRSTD indicator
Expected RSTD uncertainty for all neighbour cells		μs	5	The corresponding parameter in the DL-TDOA assistance data specified in TS 37.355 [34] is the expectedRSTD-Uncertainty index
Number of cells provided in DL-TDOA assistance data			4	Including the reference cell
PRS muting info			Cell 1: '10' Cell 2: '01' Cell 3: '10'	Corresponds to prs-MutingInfo defined in TS 37.355 [34]
PRS resource RE offset			Cell 1: 0 Cell 2: 0 Cell 3: 1	Cell 1 and Cell 3 are configured with different resource offsets
T1		s	3	The length of the time interval from the beginning of each test
T2		s	5	The length of the time interval that follows immediately after time interval T1.

Table Table.14.4.1.5-2: Cell-specific test parameters for RSTD measurement reporting delay during T1

Parameter	Unit	Cell 1	Cell 2	Cell 3	
NR RF Channel Number		1	1	1	
Positioning frequency layer		1	1	1	
Correlation Matrix and Antenna Configuration		1x2 Low	1x2 Low	1x2 Low	
OCNG patterns defined in A.3.2.1		OP.1	N/A	N/A	
N_{oc} ^{Note 3}	Config 1	dBm/SCS	-98		
	Config 2	dBm/SCS	-98		
	Config 3	dBm/SCS	-95		
PRS \hat{E}_s/N_{oc}	dB	-Infinity	-Infinity	-Infinity	
SSB \hat{E}_s/N_{oc}	dB	10	-Infinity	-Infinity	
I_o ^{Note 4}	Config 1	dBm/ 19.08MHz	-56.54	-56.54	-56.54
	Config 2	dBm/ 19.08MHz	-56.54	-56.54	-56.54
	Config 3	dBm/ 47.88MHz	-52.56	-52.56	-52.56
SSB RP ^{Note4}	Config 1	dBm/SCS	-88	-Infinity	-Infinity

	Config 2	dBm/SCS	-88	-Infinity	-Infinity
	Config 3	dBm/SCS	-85	-Infinity	-Infinity
Propagation Condition			AWGN		
<p>Note 1: OCNG shall be used such that active cell (Cell 1) is fully allocated and a constant total transmitted power spectral density is achieved for all OFDM symbols.</p> <p>Note 2: The resources for uplink transmission are assigned after the end of time period T2 to UEs that do not support SDT for measurement reporting.</p> <p>Note 3: Interference from other cells and noise sources not specified in the test are assumed to be constant over subcarriers and time and shall be modelled as AWGN of appropriate power for N_{oc} to be fulfilled.</p> <p>Note 4: SSB RP and Io levels have been derived from other parameters and are given for information purpose. These are not settable test parameters.</p>					

Table 14.4.1.5-3: Cell-specific test parameters for RSTD measurement reporting delay during T2

Parameter		Unit	Cell 1	Cell 2	Cell 3
			T2	T2	T2
NR RF Channel Number			1	1	1
Correlation Matrix and Antenna Configuration			1x2 Low	1x2 Low	1x2 Low
OCNG patterns defined in A.3.2.1			OP.1	OP.1	OP.1
PRACH configuration			FR1 PRACH configuration 1	FR1 PRACH configuration 1	FR1 PRACH configuration 1
N_{oc} ^{Note 3}	Config 1	dBm/SCS	-98	-98	-98
	Config 2	dBm/SCS	-98	-98	-98
	Config 3	dBm/SCS	-95	-95	-95
PRS \hat{E}_s/N_{oc}	Config 1	dB	-5.45	-11.67	-11.67
	Config 2	dB	-5.45	-11.67	-11.67
	Config 3	dB	-5.45	-11.67	-11.67
I_o ^{Note 4}	Config 1	dBm/19.08MHz	-65.43	-65.43	-65.43
	Config 2	dBm/96.48MHz	-65.43	-65.43	-65.43
	Config 3	dBm/47.88MHz	-61.44	-61.44	-61.44
PRS \hat{E}_s/I_{ot}		dB	-6	-13	-13
Propagation Condition			AWGN		
<p>Note 1: OCNG shall be used such that active cells (all, except Cell 3 in T2) are fully allocated and a constant total transmitted power spectral density is achieved for all OFDM symbols other than those in the subframes with transmitted PRS.</p> <p>Note 2: The resources for uplink transmission are assigned after the end of time period T2 to UEs that do not support SDT for measurement reporting.</p> <p>Note 3: Interference from other cells and noise sources not specified in the test are assumed to be constant over subcarriers and time and shall be modelled as AWGN of appropriate power for N_{oc} to be fulfilled.</p>					

FFS

14.4.2 NR RSTD measurement reporting delay test case for single positioning frequency layer with reduced number of samples in FR1 SA

Editor's note: This test case is incomplete. The following aspect is either missing or TBD:

- Test tolerance is missing

14.4.2.1 Test purpose

The purpose of the test is to verify that the RSTD measurement meets the requirements specified in TS 38.133 [50] Clause 5.6.2 in an environment with AWGN propagation conditions in FR1 in standalone scenario when single positioning frequency layer is configured.

14.4.2.2 Test applicability

This test applies to all types of NR UE release 17 onwards that supports DL-TDOA positioning, DL-PRS measurement in RRC_INACTIVE and reduced number of samples for PRS measurement in RRC_INACTIVE state.

14.4.2.3 Minimum conformance requirements

Same as in clause 14.4.1.3.

14.4.2.4 Test description

The supported test configurations in listed in Table 14.4.2.4-1

Table 14.4.2.4-1: Test Configurations

Configuration	Description
1	15 kHz SSB SCS, 20 MHz bandwidth, FDD duplex mode
2	15 kHz SSB SCS, 20 MHz bandwidth, TDD duplex mode
3	30 kHz SSB SCS, 50 MHz bandwidth, TDD duplex mode
Note:	The UE is only required to be tested in one of the supported test configurations.

14.4.2.4.1 Initial conditions

Test Environment: Normal, as defined in TS 38.508-1 [45] clause 4.1.

Frequencies to be tested: Mid Range, as defined in TS 38.508-1 [45] clause 4.3.1.

Channel bandwidth to be tested: are specified in Table 14.4.2.4-1.

1. Connect the SS and AWGN noise sources to the UE antenna connector or antenna connectors as shown in Annex A, Figure A.12.
2. The general test parameter settings are set up according to Table 14.4.2.5-1, Table 14.4.2.5-2 and Table 14.4.2.5-3.
3. Propagation conditions are set according to clause 4.15.2.
4. Message contents are defined in clause 14.4.2.4.3.
5. In the test there are three synchronous cells: Cell 1, Cell 2 and Cell 3. Cell 1 is the RSTD reference as well as the PCell. Cell 2 and Cell 3 are the neighbour cells. All 3 cells are on the same RF channel in FR1.

14.4.2.4.2 Test procedure

Same as in clause 14.4.3.4.2.

14.4.2.4.3 Message contents

As defined in clause 14.4.1.4.3, with the following exceptions:

Table 14.4.2.4.3-1 replaces Table 14.4.1.4.3-6 and Table 14.4.2.4.3-2 replaces Table 14.4.1.4.3-7 and Table 14.4.2.4.3-3 replaces Table 14.4.1.4.3-9..

Table 14.4.2.4.3-1: NR-DL-PRS-AssistanceData

Derivation Path: 37.355 clause 6.4.3			
Information Element	Value/remark	Comment	Condition
NR-DL-PRS-AssistanceData-r16 ::= SEQUENCE {			
nr-DL-PRS-ReferenceInfo-r16 SEQUENCE {			
dl-PRS-ID-r16	0		
nr-DL-PRS-ResourceID-List-r16	Not present		
nr-DL-PRS-ResourceSetID-r16	Not present		
}			
nr-DL-PRS-AssistanceDataList-r16 SEQUENCE (SIZE (1..nrMaxFreqLayers-r16)) OF NR-DL-PRS-AssistanceDataPerFreq-r16 {	1 entry		
NR-DL-PRS-AssistanceDataPerFreq-r16[1] SEQUENCE {		entry 1	
nr-DL-PRS-PositioningFrequencyLayer-r16 SEQUENCE {			
dl-PRS-SubcarrierSpacing-r16	kHz15		Config 1 and Config 2
	kHz30		Config 3
dl-PRS-ResourceBandwidth-r16	21	104 PRBs	Config 1 and Config 2
	28	24 PRBs	Config 3
dl-PRS-StartPRB-r16	0		
dl-PRS-PointA-r16	absoluteFrequencyPointA as defined for the DL frequency of the Cell 1		
dl-PRS-CombSizeN-r16	n4		
dl-PRS-CyclicPrefix-r16	normal		
}			
nr-DL-PRS-AssistanceDataPerFreq-r16 SEQUENCE (SIZE (1..nrMaxTRPsPerFreq-r16)) OF NR-DL-PRS-AssistanceDataPerTRP-r16{	3 entries		
NR-DL-PRS-AssistanceDataPerTRP-r16[1] SEQUENCE {		entry 1	Cell 1
dl-PRS-ID-r16	0		
nr-PhysCellID-r16	Cell 1		
nr-CellGlobalID-r16	Cell 1		
nr-ARFCN-r16	Cell 1		
nr-DL-PRS-SFN0-Offset-r16 SEQUENCE {			
sfn-Offset-r16	0		
integerSubframeOffset-r16	0		
}			
nr-DL-PRS-ExpectedRSTD-r16	0		
nr-DL-PRS-ExpectedRSTD-Uncertainty-r16	0		
nr-DL-PRS-Info-r16	As specified in Table 14.4.1.4.3-7		
}			
NR-DL-PRS-AssistanceDataPerTRP-r16[2] SEQUENCE {		entry 2	Cell 2
dl-PRS-ID-r16	1		
nr-PhysCellID-r16	Cell 2		
nr-CellGlobalID-r16	Cell 2		
nr-ARFCN-r16	Cell 2		
nr-DL-PRS-SFN0-Offset-r16 SEQUENCE {			
sfn-Offset-r16	0		
integerSubframeOffset-r16	0		

}			
nr-DL-PRS-ExpectedRSTD-r16	92	About 3 μs	
nr-DL-PRS-ExpectedRSTD-Uncertainty-r16	154	About 5 μs	
nr-DL-PRS-Info-r16	As specified in Table 14.4.1.4.3-7		
}			
NR-DL-PRS-AssistanceDataPerTRP-r16[3] SEQUENCE {		entry 3	Cell 3
dl-PRS-ID-r16	2		
nr-PhysCellID-r16	Cell 3		
nr-CellGlobalID-r16	Cell 3		
nr-ARFCN-r16	Cell 3		
nr-DL-PRS-SFN0-Offset-r16 SEQUENCE {			
sfn-Offset-r16	0		
integerSubframeOffset-r16	0		
}			
nr-DL-PRS-ExpectedRSTD-r16	92	About 3 μs	
nr-DL-PRS-ExpectedRSTD-Uncertainty-r16	154	About 5 μs	
nr-DL-PRS-Info-r16	As specified in Table 14.4.1.4.3-7		
}			
}			
}			
}			
}			

Table 14.4.2.4.3-2: NR-DL-PRS-Info

Derivation Path: 37.355 clause 6.4.3			
Information Element	Value/remark	Comment	Condition
NR-DL-PRS-Info-r16 ::= SEQUENCE {			
nr-DL-PRS-ResourceSetList-r16 SEQUENCE (SIZE (1..nrMaxSetsPerTrp-r16)) OF NR-DL-PRS-ResourceSet-r16 {	1 entry		
NR-DL-PRS-ResourceSet-r16[1] SEQUENCE {		entry 1	
nr-DL-PRS-ResourceSetID-r16	0		
dl-PRS-Periodicity-and-ResourceSetSlotOffset-r16 CHOICE {			
scs15-r16 CHOICE {			Config 1 and Config 2
n160-r16	10		
}			
scs30-r16 CHOICE {			Config 3
n320-r16	20		
}			
dl-PRS-ResourceRepetitionFactor-r16	Not present		
dl-PRS-ResourceTimeGap-r16	s1		
dl-PRS-NumSymbols-r16	n4		
dl-PRS-MutingOption1-r16 SEQUENCE {			
dl-prs-MutingBitRepetitionFactor-r16	Not present		
nr-option1-muting-r16 CHOICE {			
po2-r16	10		Cell 1
	01		Cell 2
	10		Cell 3
}			
}			
dl-PRS-MutingOption2-r16	Not present		
dl-PRS-ResourcePower-r16	27		
dl-PRS-ResourceList-r16 SEQUENCE (SIZE (1..nrMaxResourcesPerSet-r16)) OF NR-DL-PRS-Resource-r16 {	1 entry		
NR-DL-PRS-Resource-r16[1] SEQUENCE {		entry 1	
nr-DL-PRS-ResourceID-r16	0		

dl-PRS-SequenceID-r16	0		
dl-PRS-CombSizeN-AndReOffset-r16 CHOICE {			
n4-r16	0		Cell 1 and Cell 2
	1		Cell 3
}			
dl-PRS-ResourceSlotOffset-r16	4		
dl-PRS-ResourceSymbolOffset-r16	0		
dl-PRS-QCL-Info-r16	Not present		
}			
}			
}			
}			
}			

Table 14.4.2.4.3-3: LPP RequestLocationInformation

Derivation Path: TS 37.355 [49] clause 6.2			
Information Element	Value/remark	Comment	Condition
LPP-Message ::= SEQUENCE {			
transactionID SEQUENCE {			
initiator	locationServer		
transactionNumber	1		
}			
endTransaction	FALSE		
sequenceNumber	Not present		
acknowledgement	Not present		
lpp-MessageBody CHOICE {			
c1 CHOICE {			
requestLocationInformation SEQUENCE {			
criticalExtensions CHOICE {			
c1 CHOICE {			
requestLocationInformation-r9 SEQUENCE {			
commonEsRequestLocationInformation SEQUENCE {			
locationInformationType	locationMeasurementsPreferred		
triggeredReporting	Not present		
periodicalReporting	Not present		
additionalInformation	onlyReturnInformationRequested		
qos SEQUENCE {			
horizontalAccuracy	Not present		
verticalCoordinateRequest	FALSE		
verticalAccuracy	Not present		
responseTime SEQUENCE {			
time	See 14.4.2.5	Result of the response time calculation rounded up to the next second if response time <= 128s. Result of the response time calculation rounded up to the next multiple of ten seconds if response time > 128s	
responseTimeEarlyFix-r12	Not present		Rel-12 onwards
unit-r15	Not present		

	ten-seconds		Calculated response time >128s
}			
velocityRequest	FALSE		
}			
environment	Not present		
locationCoordinateTypes	Not present		
velocityTypes	Not present		
}			
a-gnss-RequestLocationInformation	Not present		
otdoa-RequestLocationInformation	Not present		
ecid-RequestLocationInformation	Not present		
epdu-RequestLocationInformation	Not Present		
sensor-RequestLocationInformation-r13	Not present		
tbs-RequestLocationInformation-r13	Not present		
wlan-RequestLocationInformation-r13	Not present		
bt-RequestLocationInformation-r13	Not present		
nr-ECID-RequestLocationInformation-r16	Not present		
nr-Multi-RTT-RequestLocationInformation-r16	Not present		
nr-DL-AoD-RequestLocationInformation-r16	Not present		
nr-DL-TDOA-RequestLocationInformation-r16			
SEQUENCE {			
nr-DL-PRS-RstdMeasurementInfoRequest-r16	Not present		
nr-RequestedMeasurements-r16	bit 0 = 0 (prsrspReq)		
nr-AssistanceAvailability-r16	FALSE		
nr-DL-TDOA-ReportConfig-r16 SEQUENCE {			
maxDL-PRS-RSTD-MeasurementsPerTRPPair-r16	Not present		
timingReportingGranularityFactor-r16	Not present		
measureSameDL-PRS-ResourceWithDifferentRxTEGs-r17	Not present		
reducedDL-PRS-ProcessingSamples-r17	requested		
lowerRxBeamSweepingFactor-FR2-r17	Not present		
}			
additionalPaths-r16	Not present		
nr-UE-RxTEG-Request-r17	Not present		
nr-los-nlos-IndicatorRequest-r17	Not present		
additionalPathsExt-r17	Not present		
additionalPathsDL-PRS-RSRP-Request-r17	Not present		
multiMeasInSameReport-r17	Not present		
}			
}			
}			
}			
}			
}			
}			

14.4.2.5 Test requirement

Table 14.4.2.5-1, Table 14.4.2.5-2 and Table 14.4.2.5-3 define the primary level settings including test tolerances for the test.

Table 14.4.2.5-1: General test parameters for RSTD measurement reporting delay

Parameter	Unit	Value	Comment
-----------	------	-------	---------

Reference cell			Cell 1	Reference cell is the cell in the DL-TDOA assistance data with respect to which the RSTD measurement is defined, as specified in TS 38.215 [4] and TS 37.355 [34]. The reference cell is the PCell in this test case.
Neighbor cells			Cell 2 and Cell 3	Cell 2 and Cell 3 appear at the first and second places in the neighbour cell list in the DL-TDOA assistance data.
SSB configuration	Config 1		SSB.1 FR1	
	Config 2		SSB.1 FR1	
	Config 3		SSB.2 FR1	
SMTC configuration	Config 1		SMTC.2	
	Config 2		SMTC.1	
	Config 3		SMTC.1	
PDSCH RMC configuration	Config 1		SR.1.1 FDD	
	Config 2		SR.1.1 TDD	
	Config 3		SR.2.1 TDD	
RMSI CORESET RMC configuration	Config 1		CR.1.1 FDD	As specified in clause A.3.1.2.1
	Config 2		CR.1.1 TDD	
	Config 3		CR.2.1 TDD	
Dedicated CORESET RMC configuration	Config 1		CR.1.1 FDD	
	Config 2		CR.1.1 TDD	
	Config 3		CR.2.1 TDD	
Initial BWP configuration	Config 1,2,3		DLBWP.0.1 ULBWP.0.1	
PRS Configuration	Config 1		PRS.1.2 FR1	As specified in clause A.3.31.
	Config 2		PRS.1.2 FR1	
	Config 3		PRS.2.2 FR1	
PRS Resource slot offset	Config 1, 2, 3	slots	Cell 1, 2, 3: 0	
Physical cell ID PCI			(PCI of Cell 1 – PCI of Cell 2) mod 6 = 0 and (PCI of Cell 1 – PCI of Cell 3) mod 6 = 0	The cell PCIs are selected such that the relative shifts of PRS patterns among cells are as given by the test parameters
CP length			Normal	
DRX cycle length		s	1.28	
Radio frame receive time offset between the cells at the UE antenna connector		µs	Cell 2 to Cell 1: 0 Cell 3 to Cell 1: 3	PRS are transmitted from synchronous cells
Expected RSTD		µs	Cell 2: 3 Cell 3: 3 Other neighbour cells: randomly between -3 and 3	The expected RSTD is what is expected at the receiver. The corresponding parameter in the DL-TDOA assistance data specified in TS 37.355 [34] is the expectedRSTD indicator
Expected RSTD uncertainty for all neighbour cells		µs	5	The corresponding parameter in the DL-TDOA assistance data specified in TS 37.355 [34] is the expectedRSTD-Uncertainty index
Number of cells provided in DL-TDOA assistance data			4	Including the reference cell

PRS muting info		Cell 1: '10' Cell 2: '01' Cell 3: '10'	Corresponds to prs-MutingInfo defined in TS 37.355 [34]
PRS resource RE offset		Cell 1: 0 Cell 2: 0 Cell 3: 1	Cell 1 and Cell 3 are configured with different resource offsets
T1	s	3	The length of the time interval from the beginning of each test
T2	s	5	The length of the time interval that follows immediately after time interval T1

Table 14.4.2.5-2: Cell-specific test parameters for RSTD measurement reporting delay during T1

Parameter		Unit	Cell 1	Cell 2	Cell 3
NR RF Channel Number			1	1	1
Positioning frequency layer			1	1	1
Correlation Matrix and Antenna Configuration			1x2 Low	1x2 Low	1x2 Low
OCNG patterns defined in A.3.2.1			OP.1	N/A	N/A
N_{oc} <small>Note 3</small>	Config 1	dBm/SCS	-98		
	Config 2	dBm/SCS	-98		
	Config 3	dBm/SCS	-95		
PRS \hat{E}_s/N_{oc}		dB	-Infinity	-Infinity	-Infinity
SSB \hat{E}_s/N_{oc}		dB	0	-Infinity	-Infinity
I_o <small>Note 4</small>	Config 1	dBm/ 19.08MHz	-63.94	-63.94	-63.94
	Config 2	dBm/ 19.08MHz	-63.94	-63.94	-63.94
	Config 3	dBm/ 47.88MHz	-59.96	-59.96	-59.96
SSB RP <small>Note 4</small>	Config 1	dBm/SCS	-98	-Infinity	-Infinity
	Config 2	dBm/SCS	-98	-Infinity	-Infinity
	Config 3	dBm/SCS	-95	-Infinity	-Infinity
Propagation Condition			AWGN		
<p>Note 1: OCNG shall be used such that active cell (Cell 1) is fully allocated and a constant total transmitted power spectral density is achieved for all OFDM symbols.</p> <p>Note 2: The resources for uplink transmission are assigned to the UE prior to the start of time period T2.</p> <p>Note 3: Interference from other cells and noise sources not specified in the test are assumed to be constant over subcarriers and time and shall be modelled as AWGN of appropriate power for N_{oc} to be fulfilled.</p> <p>Note 4: SSB RP and I_o levels have been derived from other parameters and are given for information purpose. These are not settable test parameters.</p>					

Table 14.4.2.5-3: Cell-specific test parameters for RSTD measurement reporting delay during T2

Parameter	Unit	Cell 1	Cell 2	Cell 3
		T2	T2	T2
NR RF Channel Number		1	1	1
Correlation Matrix and Antenna Configuration		1x2 Low	1x2 Low	1x2 Low
OCNG patterns defined in A.3.2.1		OP.1	OP.1	OP.1

PRACH configuration			FR1 PRACH configuration 1	FR1 PRACH configuration 1	FR1 PRACH configuration 1
N_{oc} ^{Note 3}	Config 1	dBm/SCS	-98	-98	-98
	Config 2	dBm/SCS	-98	-98	-98
	Config 3	dBm/SCS	-95	-95	-95
PRS \hat{E}_s/N_{oc}	Config 1	dB	1	-1.2	-1.2
	Config 2	dB	1	-1.2	-1.2
	Config 3	dB	1	-1.2	-1.2
I_o ^{Note 4}	Config 1	dBm/19.08MHz	-61.18	-61.18	-61.18
	Config 2	dBm/19.08MHz	-61.18	-61.18	-61.18
	Config 3	dBm/47.88MHz	-57.20	-57.20	-57.20

FFS

14.4.3 NR RSTD measurement reporting delay test case for single positioning frequency layer in FR2 SA

Editor's note: This test case is incomplete. The following aspect is either missing or TBD:

- Test tolerance are not added in and analysis is missing

14.4.3.1 Test purpose

The purpose of the test is to verify that the RSTD measurement meets the requirements specified in TS 38.133 [50] clause 5.6.2.5 in an environment with AWGN propagation conditions in FR2 in standalone scenario when single positioning frequency layer is configured.

14.4.3.2 Test applicability

This test applies to all types of NR UE release 17 onwards that supports DL-TDOA positioning and DL-PRS measurement in RRC_INACTIVE.

14.4.3.3 Minimum conformance requirements

After receiving both *NR-DL-TDOA-ProvideAssistanceData* message and *NR-DL-TDOA-RequestLocationInformation* message from the LMF via LPP [49], the UE shall be able to measure multiple (up to the UE capability specified in Clause 5.6.2.3) DL RSTD measurements, defined in TS 38.215 [57], during the measurement period $T_{RSTD,Total}$ defined as:

$$T_{RSTD,Total} = \sum_{i=1}^L T_{RSTD,i} + (L - 1) * \max(T_{effect,i})$$

Where:

- i is the index of positioning frequency layer,
- L is total number of positioning frequency layers, and
- $T_{effect,i}$ is the periodicity of the PRS RSTD measurement in positioning frequency layer i

$T_{RSTD,i}$ is the measurement period for PRS RSTD measurement in positioning frequency layer i as specified below:

$$T_{RSTD,i} = \left(K_{\text{carrier_PRS}} * N_{Rx,TEG,i} * N_{RxBeam,i} * \left\lfloor \frac{N_{PRS,i}^{\text{slot}}}{N'} \right\rfloor * \left\lfloor \frac{L_{\text{available_PRS},i}}{N} \right\rfloor * N_{\text{sample}} - 1 \right) * T_{\text{effect},i} + T_{\text{last},i} ,$$

Where:

- $N_{RxBeam,i}$ is the UE Rx beam sweeping factor:
- $N_{RxBeam,i} = 1$ if positioning frequency layer i is in FR1, and if positioning frequency layer i is in FR2
- $N_{RxBeam,i}$ equals to the value as UE reported in *supportedLowerRxBeamSweepingFactor-FR2* if the capability is reported by the UE for the band containing positioning frequency layer i , and LMF indicates *lowerRxBeamSweepingFactor-FR2* in *NR-DL-TDOA-RequestLocationInformation*.
- $N_{RxBeam,i}$ equals to 8, otherwise.
- $K_{\text{carrier_PRS}}$ is a scaling factor for PRS-based NR positioning measurements in RRC_INACTIVE. If the UE supports *parallelPRS-MeasRRC-Inactive-r17*, $K_{\text{carrier_PRS}} = 1$; otherwise,
- If $S_{\text{rxlev}} \leq S_{\text{nonIntraSearchP}}$ or $S_{\text{qual}} \leq S_{\text{nonIntraSearchQ}}$, $K_{\text{carrier_PRS}} = K_{\text{carrier}} + 1$, where K_{carrier} is defined in clause 4.2.2.4
- If $S_{\text{rxlev}} > S_{\text{nonIntraSearchP}}$ and $S_{\text{qual}} > S_{\text{nonIntraSearchQ}}$, $K_{\text{carrier_PRS}} = N_{\text{layers}} + 1$, where N_{layers} is defined in clause 4.2.2.7.
- $N_{Rx,TEG,i}$ is the Rx TEG specific scaling factor:
 - $N_{Rx,TEG,i} = 1$ if the UE is not configured by the LMF to measure a PRS resource with multiple Rx TEGs via *measureSameDL-PRS-ResourceWithDifferentRxTEGs-r17* [49].
 - $N_{Rx,TEG,i}$ is defined as follows if the UE is configured by the LMF with *measureSameDL-PRS-ResourceWithDifferentRxTEGs-r17* [49] to perform measurement on same DL PRS resource of a TRP using different Rx TEGs in *NR-DL-TDOA-RequestLocationInformation* [49]:
 - $N_{Rx,TEG,i} = P$, if the UE is not capable of receiving same DL PRS resource simultaneously from multiple Rx TEGs, where P is the number of UE Rx TEGs that the UE is requested by LMF to measure the same DL-PRS Resource of a TRP indicated by *measureSameDL-PRS-ResourceWithDifferentRxTEGs-r17* in [49], and in case 'n0' is indicated, P is the maximum number of Rx TEGs with which UE can support to measure the same PRS resource as reported in *NR-UE-TEG-Capability*.
 - $N_{Rx,TEG,i} = \left\lfloor \frac{P}{Q} \right\rfloor$, if the UE is capable of receiving the same DL PRS resource simultaneously from multiple Rx TEGs, where Q is the number of UE Rx TEGs for measuring the same DL-PRS Resource simultaneously indicated by *measureSameDL-PRS-ResourceWithDifferentRxTEGsSimul-r17* in [49].
- $N_{PRS,i}^{\text{slot}}$ is the maximum number of DL PRS resources in positioning frequency layer i configured in a slot.
- $L_{\text{available_PRS},i}$ is the time duration of available PRS in positioning frequency layer i to be measured $T_{PRS,i}$, and is calculated in the same way as PRS duration K defined in clause 5.1.6.5 of TS 38.214 [56]. For calculation of $L_{\text{available_PRS},i}$, only unmuted PRS resources that are not fully overlapped with other higher-priority DL signals/channels are considered.
- N_{sample} is the number of PRS RSTD samples, where
 - $N_{\text{sample}} = 1$ if the UE supports *supportedDL-PRS-ProcessingSamples-RRC-Inactive* [49], and the LMF requests the UE to perform positioning measurements with reduced number of samples, and meets the following conditions:
 - PRS bandwidth is within the initial BWP and
 - Magnitude of difference between the serving cell's SS-RSRP and the neighbour cell's PRS-RSRP is within 6 dB.
 - $N_{\text{sample}} = 2$ if the UE supports *supportedDL-PRS-ProcessingSamples-RRC-Inactive* [49], and the LMF requests the UE to perform positioning measurements with reduced number of samples, and does not meet the following conditions:

- PRS bandwidth is within the initial BWP and
- Magnitude of difference between the serving cell's SS-RSRP and the neighbour cell's PRS-RSRP is within 6 dB.
- $N_{sample} = 4$ otherwise.
- $T_{last,i}$ is the measurement duration for the last PRS RSTD sample in positioning frequency layer i , including the sampling time and processing time, $T_{last,i} = T_i + T_{available_PRS,i}$,
- $T_{effect,i}$ is the periodicity of the PRS RSTD measurement in positioning frequency layer i defined as:

$$T_{effect,i} = \left\lceil \frac{T_i}{T_{available_PRS,i}} \right\rceil * T_{available_PRS,i}$$

Where:

- T_i corresponds to *durationOfPRS-ProcessingSymbolsInEveryTms-r17* in TS 37.355 [49],
- $T_{available_PRS,i} = LCM(T_{PRS,i}, T_{DRX})$, the least common multiple between $T_{PRS,i}$ and the DRX cycle length T_{DRX}
- $T_{PRS,i}$ is the periodicity of DL PRS resource with muting on positioning frequency layer i .

If more than one PRS periodicities are configured in positioning frequency layer i , the least common multiple of PRS periodicities $T_{per}^{PRS \text{ with muting}}$ among all DL PRS resource sets in the positioning frequency layer is used to derive $T_{PRS,i}$, where,

- $T_{per}^{PRS \text{ with muting}} = N_{muting} * T_{per}^{PRS}$, is the PRS periodicity with muting per PRS resource,
- T_{per}^{PRS} is the periodicity of PRS resource sets given by the higher-layer parameter *DL-PRS-Periodicity*.
- N_{muting} is the scaling factor considering PRS resource muting. $N_{muting} = T_{muting}^{PRS} * L_{muting}$, where
- T_{muting}^{PRS} is the muting repetition factor given by the higher-layer parameter *DL-PRS-MutingBitRepetitionFactor*, and L_{muting} is the size of the bitmap $\{b^1\}$.
- $\{N, T\}$ is the UE capability combination per band for RRC_INACTIVE state where N is a duration of DL PRS symbols in ms corresponding to *durationOfPRS-ProcessingSymbols-r17* in TS 37.355 [49], T (ms) corresponds to *durationOfPRS-ProcessingSymbolsInEveryTms-r17* in TS 37.355 [49], [T and $T-N (>0)$ is the time required to process duration N of DL PRS symbols already buffered in memory], for a given maximum bandwidth supported by UE corresponding to *supportedBandwidthPRS* in TS 37.355 [49],
- N' is UE capability for number of DL PRS resources that it can process in a slot [in RRC_INACTIVE state as indicated by *maxNumOfDL-PRS-ResProcessedPerSlot-RRC-Inactive-r17* specified in TS 37.355 [49].

14.4.3.4 Test description

The supported test configurations in listed in Table 14.4.3.4-1

Table 14.4.3.4-1: Test Configurations

Test Configuration	Description
1	120 kHz SSB and PRS SCS, 100 MHz bandwidth, TDD duplex mode

14.4.3.4.1 Initial conditions

Test Environment: Normal, as defined in TS 38.508-1 [45] clause 4.1.

Frequencies to be tested: Mid Range, as defined in TS 38.508-1 [45] clause 4.3.1.

Channel bandwidth to be tested: are specified in Table 14.4.3.4-1.

1. Connect the SS and AWGN noise sources to the UE antenna connector or antenna connectors as shown in Annex A, Figure A.14.
2. The general test parameter settings are set up according to Table 14.4.3.5-1, Table 14.4.3.5-2 and Table 14.4.3.5-3.
3. Propagation conditions are set according to clause 4.15.2.
4. Message contents are defined in clause 14.4.3.4.3.
5. In the test there are three synchronous cells: Cell 1, Cell 2 and Cell 3. Cell 1 is the RSTD reference as well as the PCell. Cell 2 and Cell 3 are the neighbour cells. All 3 cells are on the same RF channel in FR2.

14.4.3.4.2 Test procedure

The test consists of two consecutive time intervals, with duration of T1 and T2. During time duration T1, the UE shall be in RRC_CONNECTED state and shall not have any timing information of Cell 2 and Cell3. During T2 UE shall be in RRC_INACTIVE state and all cells transmit PRS resources within initial DL BWP of the UE and with the same numerology as the initial DL BWP.

The *NR-DL-TDOA-ProvideAssistanceData* as defined in TS 37.355 [49] clause 6.5.10.1 shall be provided to the UE during T1. The last TTI containing the *NR-DL-TDOA-ProvideAssistanceData* and *NR-DL-TDOA-RequestLocationInformation* shall be provided to the UE ΔT ms before the start of T2, where $\Delta T = 50$ ms is the maximum processing time of the *DL-TDOA assistance* data and location information request.

The beginning of the time interval T2 shall be aligned with the first DRX cycle containing a DL PRS resource(s).

2. Ensure the UE is in State RRC_CONNECTED with generic procedure parameters Connectivity *NR*, Connected without release *On*, according to TS 38.508-1 [45] clause 4.5.
2. The SS shall send a RESET UE POSITIONING STORED INFORMATION message.
3. Set the parameters according to Table 14.4.3.5-1, Table 14.4.3.5-2 and Table 14.4.3.5-3. Propagation conditions are set according to clause 4.15.2.
4. T1 starts.
5. The SS shall transmit an RRCReconfiguration message with the DRX configuration.
6. The UE shall transmit RRCReconfigurationComplete message.
7. The SS shall transmit an LPP REQUEST CAPABILITIES message.
8. The UE shall transmit an LPP PROVIDE CAPABILITIES message indicating the DL-TDOA capabilities supported by the UE in the *NR-DL-TDOA-ProvideCapabilities* IE.
9. The SS shall send a LPP PROVIDE ASSISTANCE DATA message, including the *NR-DL-TDOA-ProvideAssistanceData* IE. The position of neighbour Cell 2 and the position of neighbour Cell 3 are described in 3GPP TS 37.571-5 [20]. If the UE message at step 8 includes the *ackRequested* IE set to TRUE, then the SS shall send an acknowledgment in the LPP PROVIDE ASSISTANCE DATA message.
10. The SS shall transmit LCS Periodic-Triggered Invoke Request message with LPP REQUEST LOCATION INFORMATION embedded to start the periodic reporting procedure, including the *NR-DL-TDOA-RequestLocationInformation* IE such that the UE receives the message ΔT ms before the start of T2, where $\Delta T = 50$ ms.
11. The UE shall transmit an LCS Periodic-Triggered Invoke Return Result message.
12. When T1 expires, the SS shall transmit an RRCRelease message to transit the UE to RRC_INACTIVE state and switch the power setting from T1 to T2 as specified in Table 14.4.3.5-2 and Table 14.4.3.5-3.
13. Wait for the UE monitors for occurrence of the periodic event requested.
14. The UE shall transmit the UE transmit an *RRCResumeRequest* message.
15. The SS transmits an *RRCResume* message.

16. The UE transmits an *RRCResumeComplete* message.

17. The UE shall transmit a LPP PROVIDE LOCATION INFORMATION message including the *NR-DL-TDOA-ProvideLocationInformation* IE within the response time (see clause 4.15.3). The UE shall perform and report the RSTD measurements for both Cell 2 and Cell 3 with respect to the reference cell in the DL-TDOA assistance data, Cell 1. If the UE transmits an *NR-DL-TDOA-ProvideLocationInformation* IE including the nr-RSTD field for both Cell 2 and Cell 3 within the response time then the number of successful tests is increased by one. If the UE fails to report the *NR-DL-TDOA-ProvideLocationInformation* IE with both the nr-RSTD fields included within the response time then the number of failure tests is increased by one.

18. Repeat steps 2-17 in Tables 14.4.3.4-1 until the confidence level according to Annex D is achieved.

14.4.3.4.3 Message contents

Table 14.4.3.4.3-1: RESET UE POSITIONING STORED INFORMATION

Derivation Path: 38.509 [44] clause 6.6			
Information Element	Value/remark	Comment	Condition
UE Positioning Technology	0 0 0 0 1 1 1	DL-TDOA	

Table 14.4.3.4.3-2: RRCReconfiguration

Derivation Path: TS 38.508-1 [45], table 4.6.1-13			
Information Element	Value/remark	Comment	Condition
RRCReconfiguration ::= SEQUENCE {			
criticalExtensions CHOICE {			
rrcReconfiguration SEQUENCE {			
nonCriticalExtension SEQUENCE {			
masterCellGroup	CellGroupConfig		
}			
}			
}			
}			

Table 14.4.3.4.3-3: CellGroupConfig (Table 14.4.3.4.3-2)

Derivation Path: 38.508-1 [45], Table 4.6.3-19			
Information Element	Value/remark	Comment	Condition
CellGroupConfig ::= SEQUENCE {			
mac-CellGroupConfig SEQUENCE {			
drx-Config CHOICE {			
setup SEQUENCE {			
drx-onDurationTimer	ms6		
drx-InactivityTimer	ms1		
drx-HARQ-RTT-TimerDL	sl64		
drx-HARQ-RTT-TimerUL	sl64		
drx-RetransmissionTimerDL	sl1		
drx-RetransmissionTimerUL	sl1		
drx-LongCycleStartOffset CHOICE {			
ms640	0		
}			
shortDRX	not present		
drx-SlotOffset	0		
}			
}			
}			
}			

Table 14.4.3.4.3-4: LPP Request Capabilities

Information Element	Value/remark
---------------------	--------------

Table 14.4.3.4.3-6: NR-DL-PRS-AssistanceData

Derivation Path: 37.355 clause 6.4.3			
Information Element	Value/remark	Comment	Condition
NR-DL-PRS-AssistanceData-r16 ::= SEQUENCE {			
nr-DL-PRS-ReferenceInfo-r16 SEQUENCE {			
dl-PRS-ID-r16	0		
nr-DL-PRS-ResourceID-List-r16	Not present		
nr-DL-PRS-ResourceSetID-r16	Not present		
}			
nr-DL-PRS-AssistanceDataList-r16 SEQUENCE (SIZE (1..nrMaxFreqLayers-r16)) OF NR-DL-PRS-AssistanceDataPerFreq-r16 {	1 entry		
NR-DL-PRS-AssistanceDataPerFreq-r16[1] SEQUENCE {		entry 1	
nr-DL-PRS-PositioningFrequencyLayer-r16 SEQUENCE {			
dl-PRS-SubcarrierSpacing-r16	kHz120		
dl-PRS-ResourceBandwidth-r16	27	128 PRBs	
dl-PRS-StartPRB-r16	0		
dl-PRS-PointA-r16	absoluteFrequencyPointA as defined for the DL frequency of the Cell 1		
dl-PRS-CombSizeN-r16	n4		
dl-PRS-CyclicPrefix-r16	normal		
}			
nr-DL-PRS-AssistanceDataPerFreq-r16 SEQUENCE (SIZE (1..nrMaxTRPsPerFreq-r16)) OF NR-DL-PRS-AssistanceDataPerTRP-r16{	3 entries		
NR-DL-PRS-AssistanceDataPerTRP-r16[1] SEQUENCE {		entry 1	Cell 1
dl-PRS-ID-r16	0		
nr-PhysCellID-r16	Cell 1		
nr-CellGlobalID-r16	Cell 1		
nr-ARFCN-r16	Cell 1		
nr-DL-PRS-SFN0-Offset-r16 SEQUENCE {			
sfn-Offset-r16	0		
integerSubframeOffset-r16	0		
}			
nr-DL-PRS-ExpectedRSTD-r16	0		
nr-DL-PRS-ExpectedRSTD-Uncertainty-r16	0		
nr-DL-PRS-Info-r16	As specified in Table 14.4.3.4.3-7		
}			
NR-DL-PRS-AssistanceDataPerTRP-r16[2] SEQUENCE {		entry 2	Cell 2
dl-PRS-ID-r16	1		
nr-PhysCellID-r16	Cell 2		
nr-CellGlobalID-r16	Cell 2		
nr-ARFCN-r16	Cell 2		
nr-DL-PRS-SFN0-Offset-r16 SEQUENCE {			
sfn-Offset-r16	0		
integerSubframeOffset-r16	0		
}			
nr-DL-PRS-ExpectedRSTD-r16	23	About 3 μ s	
nr-DL-PRS-ExpectedRSTD-Uncertainty-r16	154	About 5 μ s	
nr-DL-PRS-Info-r16	As specified in Table 14.4.3.4.3-7		
}			
NR-DL-PRS-AssistanceDataPerTRP-r16[3] SEQUENCE {		entry 3	Cell 3
dl-PRS-ID-r16	2		
nr-PhysCellID-r16	Cell 3		
nr-CellGlobalID-r16	Cell 3		
nr-ARFCN-r16	Cell 3		
nr-DL-PRS-SFN0-Offset-r16 SEQUENCE {			

sfn-Offset-r16	0		
integerSubframeOffset-r16	0		
}			
nr-DL-PRS-ExpectedRSTD-r16	23	About 3 μs	
nr-DL-PRS-ExpectedRSTD-Uncertainty-r16	154	About 5 μs	
nr-DL-PRS-Info-r16	As specified in Table 14.4.3.4.3-7		
}			
}			
}			
}			
}			

Table 14.4.3.4.3-7: NR-DL-PRS-Info

Derivation Path: 37.355 clause 6.4.3			
Information Element	Value/remark	Comment	Condition
NR-DL-PRS-Info-r16 ::= SEQUENCE {			
nr-DL-PRS-ResourceSetList-r16 SEQUENCE (SIZE (1..nrMaxSetsPerTrp-r16)) OF NR-DL-PRS-ResourceSet-r16 {	1 entry		
NR-DL-PRS-ResourceSet-r16[1] SEQUENCE {		entry 1	
nr-DL-PRS-ResourceSetID-r16	0		
dl-PRS-Periodicity-and-ResourceSetSlotOffset-r16 CHOICE {			
Scs120-r16 CHOICE {			
n1280-r16	80		
}			
dl-PRS-ResourceRepetitionFactor-r16	Not present		
dl-PRS-ResourceTimeGap-r16	s1		
dl-PRS-NumSymbols-r16	n4		
dl-PRS-MutingOption1-r16 SEQUENCE {			
dl-prs-MutingBitRepetitionFactor-r16	Not present		
nr-option1-muting-r16 CHOICE {			
po2-r16	10		Cell 1
	01		Cell 2
	10		Cell 3
}			
}			
dl-PRS-MutingOption2-r16	Not present		
dl-PRS-ResourcePower-r16	27		
dl-PRS-ResourceList-r16 SEQUENCE (SIZE (1..nrMaxResourcesPerSet-r16)) OF NR-DL-PRS-Resource-r16 {	2 entries		
NR-DL-PRS-Resource-r16[1] SEQUENCE {		entry 1	
nr-DL-PRS-ResourceID-r16	0		
dl-PRS-SequenceID-r16	0		
dl-PRS-CombSizeN-AndReOffset-r16 CHOICE {			
n4-r16	0		Cell 1 and Cell 2
	1		Cell 3
}			
dl-PRS-ResourceSlotOffset-r16	4		
dl-PRS-ResourceSymbolOffset-r16	0		
dl-PRS-QCL-Info-r16	Not present		
}			
NR-DL-PRS-Resource-r16[2] SEQUENCE {		entry 2	
nr-DL-PRS-ResourceID-r16	1		
dl-PRS-SequenceID-r16	1		
dl-PRS-CombSizeN-AndReOffset-r16 CHOICE {			
n4-r16	0		Cell 1 and Cell 2
	1		Cell 3
}			

dl-PRS-ResourceSlotOffset-r16	4		
dl-PRS-ResourceSymbolOffset-r16	0		
dl-PRS-QCL-Info-r16	Not present		
}			
}			
}			
}			
}			

Table 14.4.3.4.3-8: lcs-PeriodicTriggeredInvoke

Derivation Path: 24.080 clause 4.4.2			
Information Element	Value/remark	Comment	Condition
LCS-PeriodicTriggeredInvokeArg ::= SEQUENCE {			
referenceNumber	LCS-ReferenceNumber		
h-gmlc-address	GSN-Address		
qoS	Not present		
reportingPLMNList	Not present		
periodicLocation SEQUENCE {			
periodicLDRInfo SEQUENCE {			
reportingAmount	5		
reportingInterval	1		
reportingOptionMilliseconds	Not present		
}			
}			
areaEventReporting	Not present		
motionEventReporting	Not present		
referenceNumberExt	LCS-ReferenceNumberExt		
h-gmlc-callBackUri	Not present		
supportedGADShapes	Not present		
deferredRoutingIdentifier	Not present		
reportingAccessTypes	00000001	NR	
multiplePositioningProtocolPDUs SIZE (1..maxNumLPPMsg) OF PositioningProtocolPDU {	1 entry		
PositioningProtocolPDU[1] SEQUENCE {		entry 1	
PositioningProtocolPDU	Contains a LPP RequestLocationInformation message defined in Table 14.4.3.4.3-9		
}			
}			
}			
controlPlane-CIoT-5GS-Optimisation	Not present		
scheduledLocTime	Not present		
eventReportAllowedArea	Not present		
}			

Table 14.4.3.4.3-9: LPP RequestLocationInformation

Derivation Path: TS 37.355 [49] clause 6.2			
Information Element	Value/remark	Comment	Condition
LPP-Message ::= SEQUENCE {			
transactionID SEQUENCE {			
initiator	locationServer		
transactionNumber	1		
}			
endTransaction	FALSE		
sequenceNumber	Not present		
acknowledgement	Not present		
lpp-MessageBody CHOICE {			
c1 CHOICE {			
requestLocationInformation SEQUENCE {			
criticalExtensions CHOICE {			

c1 CHOICE {			
requestLocationInformation-r9 SEQUENCE {			
commonEsRequestLocationInformation SEQUENCE {			
locationInformationType	locationMeasurementsPreferred		
triggeredReporting	Not present		
periodicalReporting	Not present		
additionalInformation	onlyReturnInformationRequested		
qos SEQUENCE {			
horizontalAccuracy	Not present		
verticalCoordinateRequest	FALSE		
verticalAccuracy	Not present		
responseTime SEQUENCE {			
time	See 14.4.3.5	Result of the response time calculation rounded up to the next second if response time <= 128s. Result of the response time calculation rounded up to the next multiple of ten seconds if response time > 128s	
responseTimeEarlyFix-r12	Not present		Rel-12 onwards
unit-r15	Not present		Calculated response time >128s
ten-seconds			
}			
velocityRequest	FALSE		
}			
environment	Not present		
locationCoordinateTypes	Not present		
velocityTypes	Not present		
}			
a-gnss-RequestLocationInformation	Not present		
otdoa-RequestLocationInformation	Not present		
ecid-RequestLocationInformation	Not present		
epdu-RequestLocationInformation	Not Present		
sensor-RequestLocationInformation-r13	Not present		
tbs-RequestLocationInformation-r13	Not present		
wlan-RequestLocationInformation-r13	Not present		
bt-RequestLocationInformation-r13	Not present		
nr-ECID-RequestLocationInformation-r16	Not present		
nr-Multi-RTT-RequestLocationInformation-r16	Not present		
nr-DL-AoD-RequestLocationInformation-r16	Not present		
nr-DL-TDOA-RequestLocationInformation-r16			
SEQUENCE {			
nr-DL-PRS-RstdMeasurementInfoRequest-r16	Not present		
nr-RequestedMeasurements-r16	bit 0 = 0 (prsrsrpReq)		
nr-AssistanceAvailability-r16	FALSE		
nr-DL-TDOA-ReportConfig-r16 SEQUENCE {			
maxDL-PRS-RSTD-MeasurementsPerTRPPair-r16	Not present		
timingReportingGranularityFactor-r16	Not present		
measureSameDL-PRS-ResourceWithDifferentRxTEGs-r17	Not present		
reducedDL-PRS-ProcessingSamples-r17	Not present		

lowerRxBearingSweepingFactor-FR2-r17	Not present		
}			
additionalPaths-r16	Not present		
nr-UE-RxTEG-Request-r17	Not present		
nr-los-nlos-IndicatorRequest-r17	Not present		
additionalPathsExt-r17	Not present		
additionalPathsDL-PRS-RSRP-Request-r17	Not present		
multiMeasInSameReport-r17	Not present		
}			
}			
}			
}			
}			
}			
}			

Table 14.4.3.4.3-10: RRCRelease

Derivation Path: TS 38.508-1 [45], Table 4.6.1-16 with condition NR_RRC_INACTIVE

Table 14.4.3.4.3-11: LPP ProvideLocation Information

Derivation Path: TS 37.355 [49] clause 6.2			
Information Element	Value/remark	Comment	Condition
LPP-Message ::= SEQUENCE {			
transactionID SEQUENCE {			
initiator	locationServer		
transactionNumber	1		
}			
endTransaction	TRUE		
sequenceNumber	(0..255)		
acknowledgement			
lpp-MessageBody CHOICE {			
c1 CHOICE {			
provideLocationInformation SEQUENCE {			
criticalExtensions CHOICE {			
c1 CHOICE {			
provideLocationInformation-r9 SEQUENCE {			
commonIEsProvideLocationInformation	Not present.		
a-gnss-ProvideLocationInformation	Not present		
otdoa-ProvideLocationInformation	Not present		
ecid-ProvideLocationInformation	Not present		
epdu-ProvideLocationInformation	Not present		
sensor-ProvideLocationInformation-r13	Not present		
tbs-ProvideLocationInformation-r13	Not present		
wlan-ProvideLocationInformation-r13	Not present		
bt-ProvideLocationInformation-r13	Not present		
nr-ECID-ProvideLocationInformation-r16	Not present		
nr-Multi-RTT-ProvideLocationInformation-r16	Not present		
nr-DL-AoD-ProvideLocationInformation-r16	Not present		
nr-DL-TDOA-ProvideLocationInformation-r16 SEQUENCE {			
nr-DL-TDOA-SignalMeasurementInformation-r16 SEQUENCE {			
dl-PRS-ReferenceInfo-r16			
nr-DL-TDOA-MeasList-r16 SEQUENCE (SIZE(1..nrMaxTRPs-r16)) OF NR-DL-TDOA-MeasElement-r16 {	3 entries		
NR-DL-TDOA-MeasElement-r16[1] SEQUENCE {		entry 1	
dl-PRS-ID-r16			
nr-PhysCellID-r16	Cell 1		

	nr-CellGlobalID-r16			
	nr-ARFCN-r16			
	nr-DL-PRS-ResourceID-r16			
	nr-DL-PRS-ResourceSetID-r16			
	nr-TimeStamp-r16			
	nr-RSTD-r16	Present		
	nr-AdditionalPathList-r16			
	nr-TimingQuality-r16			
	nr-DL-PRS-RSRP-Result-r16			
r16	nr-DL-TDOA-AdditionalMeasurements-			
	nr-UE-Rx-TEG-ID-r17			
	nr-DL-PRS-FirstPathRSRP-Result-r17			
	nr-los-nlos-Indicator-r17			
	nr-AdditionalPathListExt-r17			
	nr-DL-TDOA-AdditionalMeasurementsExt-r17			
	}			
SEQUENCE {	NR-DL-TDOA-MeasElement-r16[2]		entry 2	
	dl-PRS-ID-r16			
	nr-PhysCellID-r16	Cell 2		
	nr-CellGlobalID-r16			
	nr-ARFCN-r16			
	nr-DL-PRS-ResourceID-r16			
	nr-DL-PRS-ResourceSetID-r16			
	nr-TimeStamp-r16			
	nr-RSTD-r16	Present		
	nr-AdditionalPathList-r16			
	nr-TimingQuality-r16			
	nr-DL-PRS-RSRP-Result-r16			
r16	nr-DL-TDOA-AdditionalMeasurements-			
	nr-UE-Rx-TEG-ID-r17			
	nr-DL-PRS-FirstPathRSRP-Result-r17			
	nr-los-nlos-Indicator-r17			
	nr-AdditionalPathListExt-r17			
	nr-DL-TDOA-AdditionalMeasurementsExt-r17			
	}			
SEQUENCE {	NR-DL-TDOA-MeasElement-r16[3]		entry 3	
	dl-PRS-ID-r16			
	nr-PhysCellID-r16	Cell 3		
	nr-CellGlobalID-r16			
	nr-ARFCN-r16			
	nr-DL-PRS-ResourceID-r16			
	nr-DL-PRS-ResourceSetID-r16			
	nr-TimeStamp-r16			
	nr-RSTD-r16	Present		
	nr-AdditionalPathList-r16			
	nr-TimingQuality-r16			
	nr-DL-PRS-RSRP-Result-r16			
r16	nr-DL-TDOA-AdditionalMeasurements-			
	nr-UE-Rx-TEG-ID-r17			
	nr-DL-PRS-FirstPathRSRP-Result-r17			
	nr-los-nlos-Indicator-r17			
	nr-AdditionalPathListExt-r17			
	nr-DL-TDOA-AdditionalMeasurementsExt-r17			
	}			
	nr-UE-RxTEG-TimingErrorMargin-r17			
	}			
	nr-dl-tdoa-LocationInformation-r16			

nr-DL-TDOA-Error-r16			
nr-DL-TDOA-SignalMeasurementInstances-r17			
nr-DL-TDOA-LocationInformationInstances-r17			
}			
}			
}			
}			
}			
}			

14.4.3.5 Test requirement

FFS

14.4.4 NR RSTD measurement reporting delay test case for single positioning frequency layer with reduced number of samples in FR2 SA

Editor’s note: This test case is incomplete. The following aspect is either missing or TBD:

- Test tolerance are not added in and analysis is missing

14.4.4.1 Test purpose

The purpose of the test is to verify that the RSTD measurement meets the requirements specified in TS 38.133 [50] Clause 5.6.2 in an environment with AWGN propagation conditions in FR2 in standalone scenario when single positioning frequency layer is configured.

14.4.4.2 Test applicability

This test applies to all types of NR UE release 17 onwards that supports DL-TDOA positioning, DL-PRS measurement in RRC_INACTIVE and reduced number of samples for PRS measurement in RRC_INACTIVE state.

14.4.4.3 Minimum conformance requirements

Same as in clause 14.4.3.3.

14.4.4.4 Test description

The supported test configurations in listed in Table 14.4.4.4-1

Table 14.4.4.4-1: Test Configurations

Test Configuration	Description
1	120 kHz SSB and PRS SCS, 100 MHz bandwidth, TDD duplex mode

14.4.4.4.1 Initial conditions

Test Environment: Normal, as defined in TS 38.508-1 [45] clause 4.1.

Frequencies to be tested: Mid Range, as defined in TS 38.508-1 [45] clause 4.3.1.

Channel bandwidth to be tested: are specified in Table 14.4.4.4-1.

1. Connect the SS and AWGN noise sources to the UE antenna connector or antenna connectors as shown in Annex A, Figure A.14.

2. The general test parameter settings are set up according to Table 14.4.4.5-1, Table 14.4.4.5-2 and Table 14.4.4.5-3.
3. Propagation conditions are set according to clause 4.15.2.
4. Message contents are defined in clause 14.4.4.4.3.
5. In the test there are three synchronous cells: Cell 1, Cell 2 and Cell 3. Cell 1 is the RSTD reference as well as the PCell. Cell 2 and Cell 3 are the neighbour cells. All 3 cells are on the same RF channel in FR2.

14.4.4.4.2 Test procedure

Same as in clause 14.4.3.4.2.

14.4.4.4.3 Message contents

As defined in clause 14.4.3.4.3, with the following exceptions:

Table 14.4.4.4.3-1 replaces Table 14.4.3.4.3-7 and Table 14.4.4.4.3-2 replaces Table 14.4.3.4.3-9.

Table 14.4.4.4.3-1: NR-DL-PRS-Info

Derivation Path: 37.355 clause 6.4.3			
Information Element	Value/remark	Comment	Condition
NR-DL-PRS-Info-r16 ::= SEQUENCE {			
nr-DL-PRS-ResourceSetList-r16 SEQUENCE (SIZE (1..nrMaxSetsPerTrp-r16)) OF NR-DL-PRS-ResourceSet-r16 {	1 entry		
NR-DL-PRS-ResourceSet-r16[1] SEQUENCE {		entry 1	
nr-DL-PRS-ResourceSetID-r16	0		
dl-PRS-Periodicity-and-ResourceSetSlotOffset-r16 CHOICE {			
Scs120-r16 CHOICE {			
n1280-r16	80		
}			
dl-PRS-ResourceRepetitionFactor-r16	Not present		
dl-PRS-ResourceTimeGap-r16	s1		
dl-PRS-NumSymbols-r16	n4		
dl-PRS-MutingOption1-r16 SEQUENCE {			
dl-prs-MutingBitRepetitionFactor-r16	Not present		
nr-option1-muting-r16 CHOICE {			
po2-r16	10		Cell 1
	01		Cell 2
	10		Cell 3
}			
}			
dl-PRS-MutingOption2-r16	Not present		
dl-PRS-ResourcePower-r16	27		
dl-PRS-ResourceList-r16 SEQUENCE (SIZE (1..nrMaxResourcesPerSet-r16)) OF NR-DL-PRS-Resource-r16 {	1 entry		
NR-DL-PRS-Resource-r16[1] SEQUENCE {		entry 1	
nr-DL-PRS-ResourceID-r16	0		
dl-PRS-SequenceID-r16	0		
dl-PRS-CombSizeN-AndReOffset-r16 CHOICE {			
n4-r16	0		Cell 1 and Cell 2
	1		Cell 3
}			
dl-PRS-ResourceSlotOffset-r16	0		
dl-PRS-ResourceSymbolOffset-r16	0		
dl-PRS-QCL-Info-r16	Not present		
}			
}			
}			

}			
}			

Table 14.4.4.3-2: LPP RequestLocationInformation

Derivation Path: TS 37.355 [49] clause 6.2			
Information Element	Value/remark	Comment	Condition
LPP-Message ::= SEQUENCE {			
transactionID SEQUENCE {			
initiator	locationServer		
transactionNumber	1		
}			
endTransaction	FALSE		
sequenceNumber	Not present		
acknowledgement	Not present		
lpp-MessageBody CHOICE {			
c1 CHOICE {			
requestLocationInformation SEQUENCE {			
criticalExtensions CHOICE {			
c1 CHOICE {			
requestLocationInformation-r9 SEQUENCE {			
commonEsRequestLocationInformation SEQUENCE {			
locationInformationType	locationMeasurementsPreferred		
triggeredReporting	Not present		
periodicalReporting	Not present		
additionalInformation	onlyReturnInformationRequested		
qos SEQUENCE {			
horizontalAccuracy	Not present		
verticalCoordinateRequest	FALSE		
verticalAccuracy	Not present		
responseTime SEQUENCE {			
time	See 14.4.4.5	Result of the response time calculation rounded up to the next second if response time <= 128s. Result of the response time calculation rounded up to the next multiple of ten seconds if response time > 128s	
responseTimeEarlyFix-r12	Not present		Rel-12 onwards
unit-r15	Not present ten-seconds		Calculated response time >128s
}			
velocityRequest	FALSE		
}			
environment	Not present		
locationCoordinateTypes	Not present		
velocityTypes	Not present		
}			
a-gnss-RequestLocationInformation	Not present		
otdoa-RequestLocationInformation	Not present		
ecid-RequestLocationInformation	Not present		
epdu-RequestLocationInformation	Not Present		

sensor-RequestLocationInformation-r13	Not present		
tbs-RequestLocationInformation-r13	Not present		
wlan-RequestLocationInformation-r13	Not present		
bt-RequestLocationInformation-r13	Not present		
nr-ECID-RequestLocationInformation-r16	Not present		
nr-Multi-RTT-RequestLocationInformation-r16	Not present		
nr-DL-AoD-RequestLocationInformation-r16	Not present		
nr-DL-TDOA-RequestLocationInformation-r16			
SEQUENCE {			
nr-DL-PRS-RstdMeasurementInfoRequest-r16	Not present		
nr-RequestedMeasurements-r16	bit 0 = 0 (prsrsrpReq)		
nr-AssistanceAvailability-r16	FALSE		
nr-DL-TDOA-ReportConfig-r16 SEQUENCE {			
maxDL-PRS-RSTD-MeasurementsPerTRPPair-r16	Not present		
timingReportingGranularityFactor-r16	Not present		
measureSameDL-PRS-ResourceWithDifferentRxTEGs-r17	Not present		
reducedDL-PRS-ProcessingSamples-r17	requested		
lowerRxBeamSweepingFactor-FR2-r17	Not present		
}			
additionalPaths-r16	Not present		
nr-UE-RxTEG-Request-r17	Not present		
nr-los-nlos-IndicatorRequest-r17	Not present		
additionalPathsExt-r17	Not present		
additionalPathsDL-PRS-RSRP-Request-r17	Not present		
multiMeasInSameReport-r17	Not present		
}			
}			
}			
}			
}			
}			
}			
}			
}			
}			
}			

14.4.4.5 Test requirement

FFS

14.5 NR RSTD measurement accuracy test case in RRC_INACTIVE

14.5.1 NR RSTD measurement accuracy test case for single positioning frequency layer in FR1 SA

Editor's note: This test case is incomplete. The following aspect is either missing or TBD:

- Test tolerance is missing

14.5.1.1 Test purpose

The purpose of the test is to verify that the RSTD measurement in RRC_INACTIVE state meets the accuracy requirements specified in TS 38.133 [50] clause 10.1.23.2 in an environment with AWGN propagation conditions in FR1 in standalone scenario when single positioning frequency layer is configured.

14.5.1.2 Test applicability

This test applies to all types of NR UE release 17 onwards that supports DL-TDOA positioning and DL-PRS measurement in RRC_INACTIVE.

14.5.1.3 Minimum conformance requirements

The accuracy requirements for RSTD measurement shall be within $\pm(X+Y+Z+\Delta) T_c$.

X is defined in TS 38.133[50] Table 10.1.23.2-1 for AWGN channel and TS 38.133[50] Table 10.1.23.2-3 for fading channel for FR1, provided that the following conditions are met.

- Conditions defined in clause 7.3 of TS 38.101-1 [18] for reference sensitivity are fulfilled.
- Conditions for RSTD measurements are fulfilled according to Annex B.2.14 for a corresponding Band for each relevant PRS resource configured for measurement.
- UE does not perform positioning measurement with reduced number of samples.

...

X is defined in Table TS 38.133[50]10.1.23.2-7 for AWGN channel in FR1 provided that the following conditions are met.

- Conditions defined in clause 7.3 of TS 38.101-1 [18] for reference sensitivity are fulfilled.
- Conditions for RSTD measurements are fulfilled according to Annex B.2.14 for a corresponding Band for each relevant PRS resource configured for measurement.
- UE supports positioning measurement with reduced number of sample and is indicated by LMF to perform positioning measurement with reduced number of samples.

If the UE doesn't support Rx TEG reporting for RSTD measurement or when the measurements of reference cell and neighbour cell belong to different Rx TEGs, Y, Z and Δ are defined as follows:

- When UE measures RSTD on PRS resources belonging to same PFL, $Y=32 T_c$, provided that the time offset between the two PRS resource instances from the reference cell and the neighbour cell, which are used for a single RSTD estimate, is no greater than 160 ms.
- When UE measures RSTD on PRS resources belonging different PFLs, $Y=256 T_c$, provided that the time offset between the two PRS resource instances from the reference cell and the neighbour cell, which are used for a single RSTD estimate, is no greater than 1280 ms.
- Z is defined in TS 38.133[50] Table 10.1.23.2-5 for FR1.
- Δ is zero for single PFL, and is defined in TS 38.133[50] Table 10.1.23.2-5a for FR1, respectively, for dual PFL.

Table 14.5.1.3-1: RSTD absolute accuracy in FR1 for AWGN channel

c	Conditions						
	PRS \hat{E}_s/lot	PRS SCS	PRS bandwidth Note 1	PRS resource repetition ($T_{\text{rep}}^{\text{PRS}} * L_{\text{PRS}} / K_{\text{comb}}^{\text{PRS}}$) Note 2	I _o Note 3 range		
NR operating band groups Note 4					Minimum I _o	Maximum I _o	
T _c Note 5	dB	kHz	RB			dBm/SCS	dBm/BW _{Channel}
132	(PRS \hat{E}_s/lot) _{ref} ≥ -6dB (PRS \hat{E}_s/lot) _i ≥ -13dB	15	≥ 24	≥ 4	NR_FDD_FR1_A, NR_TDD_FR1_A, NR_SDL_FR1_A	-127	-50
					NR_FDD_FR1_B	-126.5	-50
					NR_TDD_FR1_C	-126	-50
					NR_FDD_FR1_D, NR_TDD_FR1_D	-125.5	-50

					NR_FDD_FR1_E, NR_TDD_FR1_E	-125	-50
					NR_FDD_FR1_F	-124.5	-50
					NR_FDD_FR1_G, NR_TDD_FR1_G	-124	-50
					NR_FDD_FR1_H	-123.5	-50
98			≥ 52	≥ 1	Note 6	Note 6	Note 6
42			≥ 104	≥ 1	Note 6	Note 6	Note 6
75	30	≥ 24	≥ 4		NR_FDD_FR1_A, NR_TDD_FR1_A, NR_SDL_FR1_A	-124	-50
					NR_FDD_FR1_B	-123.5	-50
					NR_TDD_FR1_C	-123	-50
					NR_FDD_FR1_D, NR_TDD_FR1_D	-122.5	-50
					NR_FDD_FR1_E, NR_TDD_FR1_E	-122	-50
					NR_FDD_FR1_F	-121.5	-50
					NR_FDD_FR1_G, NR_TDD_FR1_G	-121	-50
					NR_FDD_FR1_H	-120.5	-50
48		≥ 48	≥ 1	Note 6	Note 6	Note 6	
24		≥ 132	≥ 1	Note 6	Note 6	Note 6	
50	60	≥ 24	≥ 4		NR_FDD_FR1_A, NR_TDD_FR1_A, NR_SDL_FR1_A	-121	-50
					NR_FDD_FR1_B	-120.5	-50
					NR_TDD_FR1_C	-120	-50
					NR_FDD_FR1_D, NR_TDD_FR1_D	-119.5	-50
					NR_FDD_FR1_E, NR_TDD_FR1_E	-119	-50
					NR_FDD_FR1_F	-118.5	-50
					NR_FDD_FR1_G, NR_TDD_FR1_G	-118	-50
					NR_FDD_FR1_H	-117.5	-50
24		≥ 64	≥ 1	Note 6	Note 6	Note 6	
10		≥ 132	≥ 1	Note 6	Note 6	Note 6	
NOTE 1: Minimum PRS bandwidth, which is minimum of the PRS bandwidths of the reference resource and the measured neighbour resource <i>i</i> .							
NOTE 2: Minimum number of PRS resource repetitions among the reference resource and the measured neighbour resource <i>i</i> . T_{rep}^{PRS} , L_{PRS} , K_{comb}^{PRS} are configured by higher layer parameter <i>dl-PRS-ResourceRepetitionFactor</i> , <i>dl-PRS-NumSymbols</i> and <i>dl-PRS-CombSizeN</i> defined in TS 37.355 [34], respectively.							
NOTE 3: I_0 is assumed to have constant EPRE across the bandwidth.							
NOTE 4: NR operating band groups in FR1 are as defined in clause 3.5.2.							
NOTE 5: T_c is the basic timing unit defined in TS 38.211 [6].							
NOTE 6: The same bands and the same I_0 conditions for each band apply for this requirement as for the corresponding requirement with the PRS bandwidth of the smallest RB number for the corresponding SCS.							
NOTE 7: Void							

Table 14.5.1.3-1: Margin for RSTD measurement accuracy in FR1

PRS BW (RB number)			Margin (T_c)
SCS=15kHz	SCS=30kHz	SCS=60kHz	
≥ 24	N/A	N/A	120
≥ 52	≥ 24	N/A	72
≥ 104	≥ 48	≥ 24	36
N/A	≥ 132	≥ 64	16
N/A	N/A	≥ 132	12

14.5.1.4 Test description

The supported test configurations in listed in Table 14.5.1.4-1

Table 14.5.1.4-1: Test Configurations

Configuration	Description
1	15 kHz SSB SCS, 20 MHz bandwidth, FDD duplex mode
2	15 kHz SSB SCS, 20 MHz bandwidth, TDD duplex mode
3	30 kHz SSB SCS, 50 MHz bandwidth, TDD duplex mode
Note:	The UE is only required to be tested in one of the supported test configurations.

14.5.1.4.1 Initial conditions

Test Environment: Normal, as defined in TS 38.508-1 [45] clause 4.1.

Frequencies to be tested: Mid Range, as defined in TS 38.508-1 [45] clause 4.3.1.

Channel bandwidth to be tested: are specified in Table 14.5.1.4-1.

1. Connect the SS and AWGN noise sources to the UE antenna connector or antenna connectors as shown in Annex A, Figure A.13.
2. The general test parameter settings are set up according to Table 14.5.1.5-1 and Table 14.5.1.5-2.
3. Propagation conditions are set according to clause 4.15.2.
4. Message contents are defined in clause 14.5.1.4.3.
5. In the test there are two synchronous cells: Cell 1 and Cell 2. Cell 1 is the reference as well as the PCell. Cell 2 is a neighbour cell. Both cells are on the same NR RF channel in FR1. The UE is configured with DRX cycle of 0.64s.
6. The true RSTD (which is the receive time difference for frame 0 between cell 2 and cell 1 as seen at the UE antenna connector) is set to 5898 T_c (about 3 μs)

14.5.1.4.2 Test procedure

The test consists of two sub-tests; the difference between the sub-tests is the PRS configuration, PRS.1.1 FR1 and PRS.1.2 FR1. The test consists of a set-up period and a measurement period. During the set-up period, the UE shall be in RRC_CONNECTED state and shall not have any timing information of Cell 2. During the measurement period UE shall be in RRC_INACTIVE state and all cells start to transmit PRS resources within initial DL BWP of the UE and with the same numerology as the initial DL BWP.

The NR-DL-TDOA-RequestLocationInformation message and the DL-TDOA assistance data as defined in clause 14.5.1.4.3 shall be provided to the UE during the set-up period. The beginning of the measurement period shall be aligned with the first DRX cycle containing a DL PRS resource(s).

0. Configure the Cell for RA-SDT with SIB1 configured according to TS 38.508-1 [45], clause 4.6.1 with condition SDT.
1. Ensure the UE is in State RRC_CONNECTED with generic procedure parameters Connectivity *NR*, Connected without release *On*, according to TS 38.508-1 [45] clause 4.5.
2. The SS shall send a RESET UE POSITIONING STORED INFORMATION message.
3. Set parameters other than PRSconfiguration according to the Table 14.5.1.5-1 and Table 14.5.1.5-2. Propagation conditions are set according to clause 4.15.2.
4. Set-up period starts.
5. The SS shall transmit an RRCReconfiguration message with the DRX configuration.
6. The UE shall transmit RRCReconfigurationComplete message.
7. The SS shall transmit an LPP REQUEST CAPABILITIES message.
8. The UE shall transmit an LPP PROVIDE CAPABILITIES message indicating the DL-TDOA capabilities supported by the UE in the *NR-DL-TDOA-ProvideCapabilities* IE.

9. The SS shall send a LPP PROVIDE ASSISTANCE DATA message, including the *NR-DL-TDOA-ProvideAssistanceData* IE. The position of neighbour Cell 2 is described in 3GPP TS 37.571-5 [20]. If the UE message at step 8 includes the *ackRequested* IE set to TRUE, then the SS shall send an acknowledgment in the LPP PROVIDE ASSISTANCE DATA message.
10. The SS shall transmit LCS Periodic-Triggered Invoke Request message with LPP REQUEST LOCATION INFORMATION embedded to start the periodic reporting procedure, including the *NR-DL-TDOA-RequestLocationInformation* IE such that the UE receives the message ΔT ms before the start of measurement period, where $\Delta T = 50$ ms.
11. The UE shall transmit an LCS Periodic-Triggered Invoke Return Result message.
12. When set-up period ends, the SS shall transmit an RRCRelease message with SDT configuration to transit the UE to RRC_INACTIVE state and set the PRS parameters as specified in Table 14.5.1.5-1 and Table 14.5.1.5-2.
13. Wait for the UE monitors for occurrence of the periodic event requested.
14. The UE shall transmit the UE transmit an *RRCResumeRequest* message. If the UE also supporting SDT feature, the UE shall include LPP PROVIDE LOCATION INFORMATION message in the *RRCResumeRequest* message and then go to step 17.
15. The SS transmits an *RRCResume* message.
16. The UE transmits an *RRCResumeComplete* message.
17. The UE shall transmit a LPP PROVIDE LOCATION INFORMATION message including the *NR-DL-TDOA-ProvideLocationInformation* IE within the response time (see clause 4.15.3) plus the maximum RRC processing time 10ms between *RRCResume* message and *RRCResumeComplete* message.
18. If the UE message at step 17 includes the *ackRequested* IE set to TRUE, the SS shall send a LPP acknowledgement message.
19. The SS shall check the *nr-RSTD-r16* value for Cell 2 in the *nr-DL-TDOA-SignalMeasurementInformation-r16* according to Table 14.5.1.5-3.
20. Repeat steps 2-19 in Table 14.5.1.4-1 until the confidence level according to Annex D is achieved.
21. Repeat step 2-20 for the other sub-test defined in Table 14.5.1.5-1 as appropriate.

If all (applicable) sub-tests pass, the whole test passes. If one (applicable) sub-test fails, the whole test fails.

14.5.1.4.3 Message contents

As defined in clause 14.4.1.4.3, with the following exceptions:

Table 14.5.1.4.3-1 replaces Table 14.4.1.4.3-6, Table 14.5.1.4.3-2 replaces Table 14.4.1.4.3-7 and Table 14.5.1.4.3-3 replaces Table 14.4.1.4.3-11.

Table 14.5.1.4.3-1: NR-DL-PRS-AssistanceData

Derivation Path: 37.355 clause 6.4.3			
Information Element	Value/remark	Comment	Condition
NR-DL-PRS-AssistanceData-r16 ::= SEQUENCE {			
nr-DL-PRS-ReferenceInfo-r16 SEQUENCE {			
dl-PRS-ID-r16	0		
nr-DL-PRS-ResourceID-List-r16	Not present		
nr-DL-PRS-ResourceSetID-r16	Not present		
}			
nr-DL-PRS-AssistanceDataList-r16 SEQUENCE (SIZE (1..nrMaxFreqLayers-r16)) OF NR-DL-PRS-AssistanceDataPerFreq-r16 {	1 entry		
NR-DL-PRS-AssistanceDataPerFreq-r16[1] SEQUENCE {		entry 1	
nr-DL-PRS-PositioningFrequencyLayer-r16 SEQUENCE {			

dl-PRS-SubcarrierSpacing-r16	kHz15		Config 1 and Config 2
	kHz30		Config 3
dl-PRS-ResourceBandwidth-r16	1	24 PRBs	Sub-test 1 Config 1, 2 & 3
	21	104 PRBs	Sub-test 2 && config 1, 2
	28	132 PRBs	Sub-test 2 && config 3
dl-PRS-StartPRB-r16	0		
dl-PRS-PointA-r16	absoluteFrequencyPointA as defined for the DL frequency of the Cell 1		
dl-PRS-CombSizeN-r16	n2		Sub-test 1
	n4		Sub-test 2
dl-PRS-CyclicPrefix-r16	normal		
}			
nr-DL-PRS-AssistanceDataPerFreq-r16 SEQUENCE (SIZE (1..nrMaxTRPsPerFreq-r16)) OF NR-DL-PRS-AssistanceDataPerTRP-r16{	2 entries		
NR-DL-PRS-AssistanceDataPerTRP-r16[1] SEQUENCE {		entry 1	Cell 1
dl-PRS-ID-r16	0		
nr-PhysCellID-r16	Cell 1		
nr-CellGlobalID-r16	Cell 1		
nr-ARFCN-r16	Cell 1		
nr-DL-PRS-SFN0-Offset-r16 SEQUENCE {			
sfn-Offset-r16	0		
integerSubframeOffset-r16	0		
}			
nr-DL-PRS-ExpectedRSTD-r16	0		
nr-DL-PRS-ExpectedRSTD-Uncertainty-r16	0		
nr-DL-PRS-Info-r16	As specified in Table 14.5.1.4.3-2		
}			
NR-DL-PRS-AssistanceDataPerTRP-r16[2] SEQUENCE {		entry 2	Cell 2
dl-PRS-ID-r16	1		
nr-PhysCellID-r16	Cell 2		
nr-CellGlobalID-r16	Cell 2		
nr-ARFCN-r16	Cell 2		
nr-DL-PRS-SFN0-Offset-r16 SEQUENCE {			
sfn-Offset-r16	0		
integerSubframeOffset-r16	0		
}			
nr-DL-PRS-ExpectedRSTD-r16	92	About 3 μs	
nr-DL-PRS-ExpectedRSTD-Uncertainty-r16	154	About 5 μs	
nr-DL-PRS-Info-r16	As specified in Table 14.5.1.4.3-2		
}			
}			
}			
}			
}			

Table 14.5.1.4.3-2: NR-DL-PRS-Info

Derivation Path: 37.355 clause 6.4.3			
Information Element	Value/remark	Comment	Condition
NR-DL-PRS-Info-r16 ::= SEQUENCE {			

nr-DL-PRS-ResourceSetList-r16 SEQUENCE (SIZE (1..nrMaxSetsPerTrp-r16)) OF NR-DL-PRS-ResourceSet-r16 {	1 entry		
NR-DL-PRS-ResourceSet-r16[1] SEQUENCE {		entry 1	
nr-DL-PRS-ResourceSetID-r16	0		
dl-PRS-Periodicity-and-ResourceSetSlotOffset-r16 CHOICE {			
scs15-r16 CHOICE {			Config 1 and Config 2
n160-r16	10		
}			
scs30-r16 CHOICE {			Config 3
n320-r16	20		
}			
dl-PRS-ResourceRepetitionFactor-r16	n2		Sub-test 1
	Not present		Sub-test 2
dl-PRS-ResourceTimeGap-r16	s1		
dl-PRS-NumSymbols-r16	n4		
dl-PRS-MutingOption1-r16	Not present		
dl-PRS-MutingOption2-r16	Not present		
dl-PRS-ResourcePower-r16	27		
dl-PRS-ResourceList-r16 SEQUENCE (SIZE (1..nrMaxResourcesPerSet-r16)) OF NR-DL-PRS-Resource-r16 {	1 entry		
NR-DL-PRS-Resource-r16[1] SEQUENCE {		entry 1	
nr-DL-PRS-ResourceID-r16	0		
dl-PRS-SequenceID-r16	0		
dl-PRS-CombSizeN-AndReOffset-r16 CHOICE {			
n2-r16	0		Sub-test 1
	1		Sub-test 1
n4-r16	0		Sub-test 2
	1		Sub-test 2
}			
dl-PRS-ResourceSlotOffset-r16	0		Sub-test 1
	4		Sub-test 2
dl-PRS-ResourceSymbolOffset-r16	0		
dl-PRS-QCL-Info-r16	Not present		
}			
}			
}			
}			
}			

Table 14.5.1.4.3-3: LPP ProvideLocation Information

Derivation Path: TS 37.355 [49] clause 6.2			
Information Element	Value/remark	Comment	Condition
LPP-Message ::= SEQUENCE {			
transactionID SEQUENCE {			
initiator	locationServer		
transactionNumber	1		
}			
endTransaction	TRUE		
sequenceNumber	(0..255)		
acknowledgement			
lpp-MessageBody CHOICE {			
c1 CHOICE {			
provideLocationInformation SEQUENCE {			
criticalExtensions CHOICE {			
c1 CHOICE {			
provideLocationInformation-r9 SEQUENCE {			
commonIEsProvideLocationInformation	Not present.		
a-gnss-ProvideLocationInformation	Not present		
otdoa-ProvideLocationInformation	Not present		

ecid-ProvideLocationInformation	Not present		
epdu-ProvideLocationInformation	Not present		
sensor-ProvideLocationInformation-r13	Not present		
tbs-ProvideLocationInformation-r13	Not present		
wlan-ProvideLocationInformation-r13	Not present		
bt-ProvideLocationInformation-r13	Not present		
nr-ECID-ProvideLocationInformation-r16	Not present		
nr-Multi-RTT-ProvideLocationInformation-r16	Not present		
nr-DL-AoD-ProvideLocationInformation-r16	Not present		
nr-DL-TDOA-ProvideLocationInformation-r16 SEQUENCE {			
nr-DL-TDOA-SignalMeasurementInformation-r16 SEQUENCE {			
dl-PRS-ReferenceInfo-r16			
nr-DL-TDOA-MeasList-r16 SEQUENCE (SIZE(1..nrMaxTRPs-r16)) OF NR-DL-TDOA-MeasElement-r16 {	2 entries		
NR-DL-TDOA-MeasElement-r16[1] SEQUENCE {		entry 1	
dl-PRS-ID-r16			
nr-PhysCellID-r16	Cell 1		
nr-CellGlobalID-r16			
nr-ARFCN-r16			
nr-DL-PRS-ResourceID-r16			
nr-DL-PRS-ResourceSetID-r16			
nr-TimeStamp-r16			
nr-RSTD-r16	Present		
nr-AdditionalPathList-r16			
nr-TimingQuality-r16			
nr-DL-PRS-RSRP-Result-r16			
nr-DL-TDOA-AdditionalMeasurements-r16			
nr-UE-Rx-TEG-ID-r17			
nr-DL-PRS-FirstPathRSRP-Result-r17			
nr-los-nlos-Indicator-r17			
nr-AdditionalPathListExt-r17			
nr-DL-TDOA-AdditionalMeasurementsExt-r17			
NR-DL-TDOA-MeasElement-r16[2] SEQUENCE {		entry 2	
dl-PRS-ID-r16			
nr-PhysCellID-r16	Cell 2		
nr-CellGlobalID-r16			
nr-ARFCN-r16			
nr-DL-PRS-ResourceID-r16			
nr-DL-PRS-ResourceSetID-r16			
nr-TimeStamp-r16			
nr-RSTD-r16	Present		
nr-AdditionalPathList-r16			
nr-TimingQuality-r16			
nr-DL-PRS-RSRP-Result-r16			
nr-DL-TDOA-AdditionalMeasurements-r16			
nr-UE-Rx-TEG-ID-r17			
nr-DL-PRS-FirstPathRSRP-Result-r17			
nr-los-nlos-Indicator-r17			
nr-AdditionalPathListExt-r17			
nr-DL-TDOA-AdditionalMeasurementsExt-r17			
nr-UE-RxTEG-TimingErrorMargin-r17			
nr-dl-tdoa-LocationInformation-r16			

nr-DL-TDOA-Error-r16			
nr-DL-TDOA-SignalMeasurementInstances-r17			
nr-DL-TDOA-LocationInformationInstances-r17			
}			
}			
}			
}			
}			
}			

14.5.1.5 Test requirement

Table 14.5.1.5-1, define the primary level settings for the test.

Table14.5.1.5-1: RSTD accuracy test parameters

Parameter	Config	Unit	Test 1		Test 2	
			Cell 1	Cell 2	Cell 1	Cell 2
PRS ARFCN	1~3		freq1	Freq1	freq1	Freq1
BW _{channel}	1	MHz	20: N _{RB,c} = 106		20: N _{RB,c} = 106	
	2		20: N _{RB,c} = 106		20: N _{RB,c} = 106	
	3		50: N _{RB,c} = 133		50: N _{RB,c} = 133	
Duplex mode	1		FDD		FDD	
	2		TDD		TDD	
	3		TDD		TDD	
TDD configuration	1		N/A		N/A	
	2		TDDConf.1.1		TDDConf.1.1	
	3		TDDConf.2.1		TDDConf.2.1	
PDSCH Reference measurement channel	1		SR.1.1 FDD	-	SR.1.1 FDD	-
	2		SR.1.1 TDD		SR.1.1 TDD	
	3		SR.2.1 FDD		SR.2.1 FDD	
RMSI CORESET Reference Channel	1		CR.1.1 FDD	-	CR.1.1 FDD	-
	2		CR.1.1 TDD	-	CR.1.1 TDD	-
	3		CR.2.1 FDD	-	CR.2.1 FDD	-
Dedicated CORESET Reference Channel	1		CCR.1.1 FDD	-	CCR.1.1 FDD	-
	2		CCR.1.1 TDD	-	CCR.1.1 TDD	-
	3		CCR.2.1 TDD	-	CCR.2.1 TDD	-
SSB configuration	1		SSB.1 FR1		SSB.1 FR1	
	2		SSB.1 FR1		SSB.1 FR1	
	3		SSB.2 FR1		SSB.2 FR1	
OCNG Patterns	1~3		OP.1		OP.1	
TRS configuration	1		TRS.1.1 FDD	-	TRS.1.1 FDD	
	2		TRS.1.1 TDD		TRS.1.1 TDD	
	3		TRS.1.2 TDD		TRS.1.2 TDD	
Initial BWP Configuration	1~3		DLBWP.0.1		DLBWP.0.1	
Time offset with Cell 1	1	µs	-	3	-	3
	2,3		-	3	-	3
SMTC configuration	1		SMTC.2		SMTC.2	
	2,3		SMTC.1		SMTC.1	
PRS configuration	1		PRS.1.3 FR1		PRS.1.4 FR1	
	2		PRS.1.3 FR1		PRS.1.4 FR1	
	3		PRS.2.3 FR1		PRS.2.4 FR1	
PRS muting info	1~3		'10'	'01'	'10'	'01'
Expected RSTD	1, 2, 3	µs	N/A	3	N/A	3

FFS	Expected RSTD uncertainty	1, 2, 3	μs	N/A	5	N/A	5
	EPRE ratio of PSS to SSS	1~3	dB	0	0	0	0
	EPRE ratio of PBCH DMRS to SSS						
	EPRE ratio of PBCH to PBCH DMRS						
	EPRE ratio of PDCCH DMRS to SSS						
	EPRE ratio of PDCCH to PDCCH DMRS						
	EPRE ratio of PDSCH DMRS to SSS						
	EPRE ratio of PDSCH to PDSCH DMRS						
	EPRE ratio of OCNG DMRS to SSS ^{Note 1}						
	EPRE ratio of OCNG to OCNG DMRS ^{Note 1}						
	N_{oc} ^{Note2}	1,2	dBm/ SCS	-98		-98	
		3		-95		-95	
	\hat{E}_s/I_{ot}	1~3	dB	-6	-13	-6	-13
	PRRS-RSRP ^{Note3}	1,2	dBm/SC S	-103.7	-109.9	-103.7	-109.9
		3		-100.7	-106.9	-100.7	-106.9
I_o ^{Note3}	1,2	dBm/ 19.08M Hz	-65.70	-65.70	-65.70	-65.70	
	3		dBm/ 47.88M Hz	-61.72	-61.72	-61.72	-61.72
\hat{E}_s/N_{oc}	1~3	dB		-5.7	-11.9	-5.7	-11.9
Propagation condition	1~3	-	AWGN		AWGN		
Antenna configuration	1~3		1x2		1x2		
Note 1:	OCNG shall be used such that both cells are fully allocated and a constant total transmitted power spectral density is achieved for all OFDM symbols.						
Note 2:	Interference from other cells and noise sources not specified in the test is assumed to be constant over subcarriers and time and shall be modelled as AWGN of appropriate power for N_{oc} to be fulfilled.						
Note 3:	RSRP and I_o levels have been derived from other parameters for information purposes. They are not settable parameters themselves.						
Note 4:	RSRP minimum requirements are specified assuming independent interference and noise at each receiver antenna port.						
Note 5:	Void.						

14.5.2 14.5.2 UE Rx-Tx time difference measurement accuracy for single positioning frequency layer with reduced number of samples in FR1 SA

Editor's note: This test case is incomplete. The following aspect is either missing or TBD:

- Test tolerance is missing

14.5.2.1 Test purpose

The purpose of the test is to verify that the RSTD measurement in RRC_INACTIVE state with reduced number of samples meets the accuracy requirements specified in TS 38.133 [50] clause 10.1.23.2 in an environment with AWGN propagation conditions in FR1 in standalone scenario when single positioning frequency layer is configured.

14.5.2.2 Test applicability

This test applies to all types of NR UE release 17 onwards that supports DL-TDOA positioning, DL-PRS measurement in RRC_INACTIVE and reduced number of samples for PRS measurement in RRC_INACTIVE state.

14.5.2.3 Minimum conformance requirements

The

The accuracy requirements for RSTD measurement shall be within $\pm(X+Y+Z+\Delta) T_c$.

X is defined in TS 38.133[50] Table 10.1.23.2-1 for AWGN channel and TS 38.133[50] Table 10.1.23.2-3 for fading channel for FR1, provided that the following conditions are met.

- Conditions defined in clause 7.3 of TS 38.101-1 [18] for reference sensitivity are fulfilled.
- Conditions for RSTD measurements are fulfilled according to Annex B.2.14 for a corresponding Band for each relevant PRS resource configured for measurement.
- UE does not perform positioning measurement with reduced number of samples.

...

X is defined in Table TS 38.133[50]10.1.23.2-7 for AWGN channel in FR1 provided that the following conditions are met.

- Conditions defined in clause 7.3 of TS 38.101-1 [18] for reference sensitivity are fulfilled.
- Conditions for RSTD measurements are fulfilled according to Annex B.2.14 for a corresponding Band for each relevant PRS resource configured for measurement.
- UE supports positioning measurement with reduced number of sample and is indicated by LMF to perform positioning measurement with reduced number of samples.

If the UE doesn't support Rx TEG reporting for RSTD measurement or when the measurements of reference cell and neighbour cell belong to different Rx TEGs, Y, Z and Δ are defined as follows:

- When UE measures RSTD on PRS resources belonging to same PFL, $Y=32 T_c$, provided that the time offset between the two PRS resource instances from the reference cell and the neighbour cell, which are used for a single RSTD estimate, is no greater than 160 ms.
- When UE measures RSTD on PRS resources belonging different PFLs, $Y=256 T_c$, provided that the time offset between the two PRS resource instances from the reference cell and the neighbour cell, which are used for a single RSTD estimate, is no greater than 1280 ms.
- Z is defined in TS 38.133[50] Table 10.1.23.2-5 for FR1.
- Δ is zero for single PFL, and is defined in TS 38.133[50] Table 10.1.23.2-5a for FR1, respectively, for dual PFL.

...

Table 14.5.2.3-1: RSTD absolute accuracy in FR1 for AWGN channel with reduced number of samples

Accuracy	Conditions						
	PRS \hat{E}_s/lot	PRS SCS	PRS bandwidth Note 1	PRS resource repetition ($T_{\text{rep}}^{\text{PRS}} * L_{\text{PRS}} / K_{\text{comb}}^{\text{PRS}}$) Note 2	I_0 Note 3 range		
					NR operating band groups Note 4	Minimum I_0	Maximum I_0
T_c Note 5	dB	kHz	RB		dBm/SCS	dBm/BW _{channel}	
98	(PRS \hat{E}_s/lot) _{ref} ≥ -3 dB	15	≥ 52	≥ 1	NR_FDD_FR1_A, NR_TDD_FR1_A, NR_SDL_FR1_A	-127	-50
					NR_FDD_FR1_B	-126.5	-50

	(PRS $\hat{E}_s/lot)_i \geq -6$ dB				NR_TDD_FR1_C	-126	-50
					NR_FDD_FR1_D, NR_TDD_FR1_D	-125.5	-50
					NR_FDD_FR1_E, NR_TDD_FR1_E	-125	-50
					NR_FDD_FR1_F	-124.5	-50
					NR_FDD_FR1_G, NR_TDD_FR1_G	-124	-50
					NR_FDD_FR1_H	-123.5	-50
42			≥ 104	≥ 1	Note 6	Note 6	Note 6
48		30	≥ 48	≥ 1	NR_FDD_FR1_A, NR_TDD_FR1_A, NR_SDL_FR1_A	-124	-50
	NR_FDD_FR1_B				-123.5	-50	
	NR_TDD_FR1_C				-123	-50	
	NR_FDD_FR1_D, NR_TDD_FR1_D				-122.5	-50	
	NR_FDD_FR1_E, NR_TDD_FR1_E				-122	-50	
	NR_FDD_FR1_F				-121.5	-50	
	NR_FDD_FR1_G, NR_TDD_FR1_G				-121	-50	
					NR_FDD_FR1_H	-120.5	-50
24			≥ 132	≥ 1	Note 6	Note 6	Note 6
24		60	≥ 64	≥ 1	NR_FDD_FR1_A, NR_TDD_FR1_A, NR_SDL_FR1_A	-121	-50
	NR_FDD_FR1_B				-120.5	-50	
	NR_TDD_FR1_C				-120	-50	
	NR_FDD_FR1_D, NR_TDD_FR1_D				-119.5	-50	
	NR_FDD_FR1_E, NR_TDD_FR1_E				-119	-50	
	NR_FDD_FR1_F				-118.5	-50	
	NR_FDD_FR1_G, NR_TDD_FR1_G				-118	-50	
					NR_FDD_FR1_H	-117.5	-50
10			≥ 132	≥ 1	Note 6	Note 6	Note 6

NOTE 1: Minimum PRS bandwidth, which is minimum of the PRS bandwidths of the reference resource and the measured neighbour resource i .

NOTE 2: Minimum number of PRS resource repetitions among the reference resource and the measured neighbour resource i . T_{rep}^{PRS} , L_{PRS} , K_{comb}^{PRS} are configured by higher layer parameter $dl-PRS-ResourceRepetitionFactor$, $dl-PRS-NumSymbols$ and $dl-PRS-CombSizeN$ defined in TS 37.355 [34], respectively.

NOTE 3: l_0 is assumed to have constant EPRE across the bandwidth.

NOTE 4: NR operating band groups in FR1 are as defined in clause 3.5.2.

NOTE 5: T_c is the basic timing unit defined in TS 38.211 [6].

NOTE 6: The same bands and the same l_0 conditions for each band apply for this requirement as for the corresponding requirement with the PRS bandwidth of the smallest RB number for the corresponding SCS.

NOTE 7: Void

Table 14.5.2.3-2: Margin for RSTD measurement accuracy in FR1

PRS BW (RB number)			Margin (T_c)
SCS=15kHz	SCS=30kHz	SCS=60kHz	
≥ 24	N/A	N/A	120
≥ 52	≥ 24	N/A	72
≥ 104	≥ 48	≥ 24	36
N/A	≥ 132	≥ 64	16
N/A	N/A	≥ 132	12

14.5.2.4 Test description

The supported test configurations in listed in Table 14.5.2.4-1

Table 14.5.2.4-1: Test Configurations

Configuration	Description
1	15 kHz SSB SCS, 20 MHz bandwidth, FDD duplex mode
2	15 kHz SSB SCS, 20 MHz bandwidth, TDD duplex mode
3	30 kHz SSB SCS, 50 MHz bandwidth, TDD duplex mode
Note:	The UE is only required to be tested in one of the supported test configurations.

14.5.2.4.1 Initial conditions

Test Environment: Normal, as defined in TS 38.508-1 [45] clause 4.1.

Frequencies to be tested: Mid Range, as defined in TS 38.508-1 [45] clause 4.3.1.

Channel bandwidth to be tested: are specified in Table 14.5.2.4-1.

1. Connect the SS and AWGN noise sources to the UE antenna connector or antenna connectors as shown in Annex A, Figure A.13.
2. The general test parameter settings are set up according to Table 14.5.2.5-1 and Table 14.5.2.5-2.
3. Propagation conditions are set according to clause 4.15.2.
4. Message contents are defined in clause 14.5.2.4.3.
5. In the test there are two synchronous cells: Cell 1 and Cell 2. Cell 1 is the reference as well as the PCell. Cell 2 is a neighbour cell. Both cells are on the same NR RF channel in FR2. The UE is configured with DRX cycle of 0.64s.
6. The true RSTD (which is the receive time difference for frame 0 between cell 2 and cell 1 as seen at the UE antenna connector) is set to 5898 T_c (about 3 μs)

14.5.2.4.2 Test procedure

Same as in clause 14.5.1.4.2.

14.5.2.4.3 Message contents

As defined in clause 14.4.1.4.3, with the following exceptions:

Table 14.5.2.4.3-1 replaces Table 14.4.1.4.3-6, Table 14.5.2.4.3-2 replaces Table 14.4.1.4.3-7 and Table 14.5.2.4.3-3 replaces Table 14.4.1.4.3-11.

Table 14.5.2.4.3-1: NR-DL-PRS-AssistanceData

Derivation Path: 37.355 clause 6.4.3			
Information Element	Value/remark	Comment	Condition
NR-DL-PRS-AssistanceData-r16 ::= SEQUENCE {			
nr-DL-PRS-ReferenceInfo-r16 SEQUENCE {			
dl-PRS-ID-r16	0		
nr-DL-PRS-ResourceID-List-r16	Not present		
nr-DL-PRS-ResourceSetID-r16	Not present		
}			
nr-DL-PRS-AssistanceDataList-r16 SEQUENCE (SIZE (1..nrMaxFreqLayers-r16)) OF NR-DL-PRS-AssistanceDataPerFreq-r16 {	1 entry		
NR-DL-PRS-AssistanceDataPerFreq-r16[1] SEQUENCE {		entry 1	
nr-DL-PRS-PositioningFrequencyLayer-r16 SEQUENCE {			
dl-PRS-SubcarrierSpacing-r16	kHz15		Config 1 and Config 2
	kHz30		Config 3

dl-PRS-ResourceBandwidth-r16	1	24 PRBs	Sub-test 1
	21	104 PRBs	Sub-test 2 Config 1& 2
	28	132 PRBs	Sub-test 2 Config 3
dl-PRS-StartPRB-r16	0		
dl-PRS-PointA-r16	absoluteFrequencyPointA as defined for the DL frequency of the Cell 1		
dl-PRS-CombSizeN-r16	n2		Sub-test 1
	n4		Sub-test 2
dl-PRS-CyclicPrefix-r16	normal		
}			
nr-DL-PRS-AssistanceDataPerFreq-r16 SEQUENCE (SIZE (1..nrMaxTRPsPerFreq-r16)) OF NR-DL-PRS-AssistanceDataPerTRP-r16{	2 entries		
NR-DL-PRS-AssistanceDataPerTRP-r16[1] SEQUENCE {		entry 1	Cell 1
dl-PRS-ID-r16	0		
nr-PhysCellID-r16	Cell 1		
nr-CellGlobalID-r16	Cell 1		
nr-ARFCN-r16	Cell 1		
nr-DL-PRS-SFN0-Offset-r16 SEQUENCE {			
sfn-Offset-r16	0		
integerSubframeOffset-r16	0		
}			
nr-DL-PRS-ExpectedRSTD-r16	0		
nr-DL-PRS-ExpectedRSTD-Uncertainty-r16	0		
nr-DL-PRS-Info-r16	As specified in Table 14.5.2.4.3-2		
}			
NR-DL-PRS-AssistanceDataPerTRP-r16[2] SEQUENCE {		entry 2	Cell 2
dl-PRS-ID-r16	1		
nr-PhysCellID-r16	Cell 2		
nr-CellGlobalID-r16	Cell 2		
nr-ARFCN-r16	Cell 2		
nr-DL-PRS-SFN0-Offset-r16 SEQUENCE {			
sfn-Offset-r16	0		
integerSubframeOffset-r16	0		
}			
nr-DL-PRS-ExpectedRSTD-r16	92	About 3 μs	
nr-DL-PRS-ExpectedRSTD-Uncertainty-r16	154	About 5 μs	
nr-DL-PRS-Info-r16	As specified in Table 14.5.2.4.3-2		
}			
}			
}			
}			
}			

Table 14.5.2.4.3-2: NR-DL-PRS-Info

Derivation Path: 37.355 clause 6.4.3			
Information Element	Value/remark	Comment	Condition
NR-DL-PRS-Info-r16 ::= SEQUENCE {			
nr-DL-PRS-ResourceSetList-r16 SEQUENCE (SIZE (1..nrMaxSetsPerTrp-r16)) OF NR-DL-PRS-ResourceSet-r16 {	1 entry		
NR-DL-PRS-ResourceSet-r16[1] SEQUENCE {		entry 1	
nr-DL-PRS-ResourceSetID-r16	0		
dl-PRS-Periodicity-and-ResourceSetSlotOffset-r16 CHOICE {			

scs15-r16 CHOICE {			Config 1 and Config 2
n160-r16	10		
}			
scs30-r16 CHOICE {			Config 3
n320-r16	20		
}			
dl-PRS-ResourceRepetitionFactor-r16	n2		Sub-test 1
	Not present		Sub-test 2
dl-PRS-ResourceTimeGap-r16	s1		
dl-PRS-NumSymbols-r16	n4		
dl-PRS-MutingOption1-r16	Not present		
dl-PRS-MutingOption2-r16	Not present		
dl-PRS-ResourcePower-r16	27		
dl-PRS-ResourceList-r16 SEQUENCE (SIZE (1..nrMaxResourcesPerSet-r16)) OF NR-DL-PRS-Resource-r16 {	1 entry		
NR-DL-PRS-Resource-r16[1] SEQUENCE {		entry 1	
nr-DL-PRS-ResourceID-r16	0		
dl-PRS-SequenceID-r16	0		
dl-PRS-CombSizeN-AndReOffset-r16 CHOICE {			
n2-r16	0		Sub-test 1
	1		Sub-test 1
n4-r16	0		Sub-test 2
	1		Sub-test 2
}			
dl-PRS-ResourceSlotOffset-r16	0		Sub-test 1
	4		Sub-test 2
dl-PRS-ResourceSymbolOffset-r16	0		
dl-PRS-QCL-Info-r16	Not present		
}			
}			
}			
}			
}			

Table 14.5.2.4.3-3: LPP ProvideLocation Information

Derivation Path: TS 37.355 [49] clause 6.2			
Information Element	Value/remark	Comment	Condition
LPP-Message ::= SEQUENCE {			
transactionID SEQUENCE {			
initiator	locationServer		
transactionNumber	1		
}			
endTransaction	TRUE		
sequenceNumber	(0..255)		
acknowledgement			
lpp-MessageBody CHOICE {			
c1 CHOICE {			
provideLocationInformation SEQUENCE {			
criticalExtensions CHOICE {			
c1 CHOICE {			
provideLocationInformation-r9 SEQUENCE {			
commonIEsProvideLocationInformation	Not present.		
a-gnss-ProvideLocationInformation	Not present		
otdoa-ProvideLocationInformation	Not present		
ecid-ProvideLocationInformation	Not present		
epdu-ProvideLocationInformation	Not present		
sensor-ProvideLocationInformation-r13	Not present		
tbs-ProvideLocationInformation-r13	Not present		
wlan-ProvideLocationInformation-r13	Not present		
bt-ProvideLocationInformation-r13	Not present		

nr-ECID-ProvideLocationInformation-r16	Not present		
nr-Multi-RTT-ProvideLocationInformation-r16	Not present		
nr-DL-AoD-ProvideLocationInformation-r16	Not present		
nr-DL-TDOA-ProvideLocationInformation-r16 SEQUENCE {			
nr-DL-TDOA-SignalMeasurementInformation-r16 SEQUENCE {			
dl-PRS-ReferenceInfo-r16			
nr-DL-TDOA-MeasList-r16 SEQUENCE (SIZE(1..nrMaxTRPs-r16)) OF NR-DL-TDOA-MeasElement-r16 {	2 entries		
NR-DL-TDOA-MeasElement-r16[1] SEQUENCE {		entry 1	
dl-PRS-ID-r16			
nr-PhysCellID-r16	Cell 1		
nr-CellGlobalID-r16			
nr-ARFCN-r16			
nr-DL-PRS-ResourceID-r16			
nr-DL-PRS-ResourceSetID-r16			
nr-TimeStamp-r16			
nr-RSTD-r16	Present		
nr-AdditionalPathList-r16			
nr-TimingQuality-r16			
nr-DL-PRS-RSRP-Result-r16			
nr-DL-TDOA-AdditionalMeasurements-r16			
nr-UE-Rx-TEG-ID-r17			
nr-DL-PRS-FirstPathRSRP-Result-r17			
nr-los-nlos-Indicator-r17			
nr-AdditionalPathListExt-r17			
nr-DL-TDOA-AdditionalMeasurementsExt-r17			
} NR-DL-TDOA-MeasElement-r16[2] SEQUENCE {		entry 2	
dl-PRS-ID-r16			
nr-PhysCellID-r16	Cell 2		
nr-CellGlobalID-r16			
nr-ARFCN-r16			
nr-DL-PRS-ResourceID-r16			
nr-DL-PRS-ResourceSetID-r16			
nr-TimeStamp-r16			
nr-RSTD-r16	Present		
nr-AdditionalPathList-r16			
nr-TimingQuality-r16			
nr-DL-PRS-RSRP-Result-r16			
nr-DL-TDOA-AdditionalMeasurements-r16			
nr-UE-Rx-TEG-ID-r17			
nr-DL-PRS-FirstPathRSRP-Result-r17			
nr-los-nlos-Indicator-r17			
nr-AdditionalPathListExt-r17			
nr-DL-TDOA-AdditionalMeasurementsExt-r17			
}			
}			
nr-UE-RxTEG-TimingErrorMargin-r17			
}			
nr-dl-tdoa-LocationInformation-r16			
nr-DL-TDOA-Error-r16			
nr-DL-TDOA-SignalMeasurementInstances-r17			
nr-DL-TDOA-LocationInformationInstances-r17			
}			

}			
}			
}			
}			
}			

14.5.2.5 Test requirement

Table 14.5.2.5-1, define the primary level settings for the test.

Table 14.5.2.5-1 RSTD accuracy test parameters

Parameter	Config	Unit	Test 1		Test 2	
			Cell 1	Cell 2	Cell 1	Cell 2
PRS ARFCN	1~3		freq1	Freq1	freq1	Freq1
BW _{channel}	1	MHz	20: N _{RB,c} = 106		20: N _{RB,c} = 106	
	2		20: N _{RB,c} = 106		20: N _{RB,c} = 106	
	3		50: N _{RB,c} = 133		50: N _{RB,c} = 133	
Duplex mode	1		FDD		FDD	
	2		TDD		TDD	
	3		TDD		TDD	
TDD configuration	1		N/A		N/A	
	2		TDDConf.1.1		TDDConf.1.1	
	3		TDDConf.2.1		TDDConf.2.1	
PDSCH Reference measurement channel	1		SR.1.1 FDD	-	SR.1.1 FDD	-
	2		SR.1.1 TDD		SR.1.1 TDD	
	3		SR.2.1 FDD		SR.2.1 FDD	
RMSI CORESET Reference Channel	1		CR.1.1 FDD	-	CR.1.1 FDD	-
	2		CR.1.1 TDD	-	CR.1.1 TDD	-
	3		CR.2.1 FDD	-	CR.2.1 FDD	-
Dedicated CORESET Reference Channel	1		CCR.1.1 FDD	-	CCR.1.1 FDD	-
	2		CCR.1.1 TDD	-	CCR.1.1 TDD	-
	3		CCR.2.1 TDD	-	CCR.2.1 TDD	-
SSB configuration	1		SSB.1 FR1		SSB.1 FR1	
	2		SSB.1 FR1		SSB.1 FR1	
	3		SSB.2 FR1		SSB.2 FR1	
OCNG Patterns	1~3		OP.1		OP.1	
TRS configuration	1		TRS.1.1 FDD	-	TRS.1.1 FDD	
	2		TRS.1.1 TDD		TRS.1.1 TDD	
	3		TRS.1.2 TDD		TRS.1.2 TDD	
Initial BWP Configuration	1~3		DLBWP.0.1 ULBWP.0.1		-	
Time offset with Cell 1	1	µs	-	3	-	3
	2,3		-	3	-	3
SMTC configuration	1		SMTC.2		SMTC.2	
	2,3		SMTC.1		SMTC.1	
PRS configuration	1		PRS.1.3 FR1		PRS.1.4 FR1	
	2		PRS.1.3 FR1		PRS.1.4 FR1	
	3		PRS.2.3 FR1		PRS.2.4 FR1	
PRS BW	1,2,3		52 PRBs for test 1			
PRS muting info	1~3		'10'	'01'	'10'	'01'
Expected RSTD	1, 2, 3	µs	N/A	3	N/A	3
Expected RSTD uncertainty	1, 2, 3	µs	N/A	5	N/A	5
EPRE ratio of PSS to SSS	1~3	dB	0	0	0	0
EPRE ratio of PBCH DMRS to SSS						

FFS	EPRE ratio of PBCH to PBCH DMRS						
	EPRE ratio of PDCCH DMRS to SSS						
	EPRE ratio of PDCCH to PDCCH DMRS						
	EPRE ratio of PDSCH DMRS to SSS						
	EPRE ratio of PDSCH to PDSCH DMRS						
	EPRE ratio of OCNG DMRS to SSS ^{Note 1}						
	EPRE ratio of OCNG to OCNG DMRS ^{Note 1}						
	N_{oc} ^{Note2}	1,2	dBm/	-98		-98	
		3	SCS	-95		-95	
	\hat{E}_s/I_{ot}	1~3	dB	-3	-6	-3	-6
	PRS-RSRP ^{Note3}	1,2	dBm/SCS	-99.44	-	-99.44	-101.65
		3		-96.44	101.65	-96.44	-98.65
	SS-RSRP ^{Note3}	1,2	dBm/SCS	-99.44	-	-99.44	-101.65
		3		-96.44	101.65	-96.44	-98.65
I_o ^{Note3}	1,2	dBm/19.08M Hz	-63.63	-63.63	-63.63	-63.63	
	3	dBm/47.88M Hz	-59.65	-59.65	-59.65	-59.65	
\hat{E}_s/N_{oc}	1~3	dB	-1.44	-3.65	-1.44	-3.65	
Propagation condition	1~3	-	AWGN		AWGN		
Antenna configuration	1~3		1x2		1x2		
<p>Note 1: OCNG shall be used such that both cells are fully allocated and a constant total transmitted power spectral density is achieved for all OFDM symbols.</p> <p>Note 2: Interference from other cells and noise sources not specified in the test is assumed to be constant over subcarriers and time and shall be modelled as AWGN of appropriate power for N_{oc} to be fulfilled.</p> <p>Note 3: RSRP and I_o levels have been derived from other parameters for information purposes. They are not settable parameters themselves.</p> <p>Note 4: RSRP minimum requirements are specified assuming independent interference and noise at each receiver antenna port.</p> <p>Note 5: Void.</p>							

14.5.3 NR RSTD measurement accuracy test case for single positioning frequency layer in FR2 SA

Editor’s note: This test case is incomplete. The following aspect is either missing or TBD:

- Test tolerance are not added in and analysis is missing

14.5.3.1 Test purpose

The purpose of the test is to verify that the RSTD measurement in RRC_INACTIVE state meets the accuracy requirements specified in TS 38.133 [50] clause 10.1.23.2 in an environment with AWGN propagation conditions in FR2 in standalone scenario when single positioning frequency layer is configured.

14.5.3.2 Test applicability

This test applies to all types of NR UE release 17 onwards that supports DL-TDOA positioning and DL-PRS measurement in RRC_INACTIVE.

14.5.3.3 Minimum conformance requirements

The accuracy requirements for RSTD measurement shall be within $\pm(X+Y+Z+\Delta) T_c$.

...

X is defined in Table 10.1.23.2-2 for AWGN channel and Table 10.1.23.2-4 for fading channel for FR2, provided that the following conditions are met.

- Conditions defined in clause 7.3 of TS 38.101-2 [19] for reference sensitivity are fulfilled.
- Conditions for RSTD measurements are fulfilled according to Annex B.2.14 for a corresponding Band for each relevant PRS resource configured for measurement.
- UE does not perform positioning measurement with reduced number of samples.

...

If the UE doesn't support Rx TEG reporting for RSTD measurement or when the measurements of reference cell and neighbour cell belong to different Rx TEGs, Y, Z and Δ are defined as follows:

- When UE measures RSTD on PRS resources belonging to same PFL, $Y=32 T_c$, provided that the time offset between the two PRS resource instances from the reference cell and the neighbour cell, which are used for a single RSTD estimate, is no greater than 160 ms.
- When UE measures RSTD on PRS resources belonging different PFLs, $Y=256 T_c$, provided that the time offset between the two PRS resource instances from the reference cell and the neighbour cell, which are used for a single RSTD estimate, is no greater than 1280 ms.
- Z is defined in Table 10.1.23.2-5 for FR1 and Table 10.1.23.2-6 for FR2, respectively.
- Δ is zero for single PFL, and is defined in Table 10.1.23.2-5a for FR1 and Table 10.1.23.2-6a for FR2, respectively, for dual PFL.

...

Table 10.1.23.2-2: RSTD absolute accuracy in FR2 for AWGN channel

Accuracy	Conditions					
	PRS \hat{E}_s/lot	PRS SCS	PRS bandwidth Note 1	PRS resource repetition ($T_{\text{rep}}^{\text{PRS}} * L_{\text{PRS}} / K_{\text{comb}}^{\text{PRS}}$) Note 2	Io ^{Note 3} range	
Minimum Io					Maximum Io	
T_c ^{Note 4}	dB	kHz	RB		dBm/SCS	
35	(PRS $\hat{E}_s/\text{lot})_{\text{ref}} \geq -6\text{dB}$	60	≥ 24	≥ 4	Same value as PRS_RP in Table B.2.14-2, according to UE Power class, operating band and angle of arrival	
24			≥ 64	≥ 1	Note 5	
11			≥ 132	≥ 1	Note 5	
24	(PRS $\hat{E}_s/\text{lot})_i \geq -13\text{dB}$	120	≥ 32	≥ 4	Same value as PRS_RP in Table B.2.14-2, according to UE Power class, operating band and angle of arrival	
13			≥ 64	≥ 1	Note 5	
6			≥ 128	≥ 1	Note 5	

NOTE 1: Minimum PRS bandwidth, which is minimum of the PRS bandwidths of the reference resource and the measured neighbour resource i.

NOTE 2: Minimum number of PRS resource repetitions among the reference resource and the measured neighbour resource i . T_{rep}^{PRS} , L_{PRS} , K_{comb}^{PRS} are configured by higher layer parameter *dl-PRS-ResourceRepetitionFactor*, *dl-PRS-NumSymbols* and *dl-PRS-CombSizeN* defined in TS 37.355 [34], respectively.

NOTE 3: I_0 is assumed to have constant EPRE across the bandwidth.

NOTE 4: T_c is the basic timing unit defined in TS 38.211 [6].

NOTE 5: The same bands and the same I_0 conditions for each band apply for this requirement as for the corresponding requirement with the PRS bandwidth of the smallest RB number for the corresponding SCS.

NOTE 6: Void

...

Table 10.1.23.2-6: Margin for RSTD measurement accuracy in FR2

PRS BW (RB number)		Margin (T_c)
SCS=60kHz	SCS=120kHz	
≥ 24	N/A	72
≥ 64	≥ 32	32
≥ 132	≥ 64	16
N/A	≥ 128	12

14.5.3.4 Test description

The supported test configurations in listed in Table 14.5.3.4-1

Table 14.5.3.4-1: Test Configurations

Test Configuration	Description
1	120 kHz SSB and PRS SCS, 100 MHz bandwidth, TDD duplex mode

14.5.3.4.1 Initial conditions

Test Environment: Normal, as defined in TS 38.508-1 [45] clause 4.1.

Frequencies to be tested: Mid Range, as defined in TS 38.508-1 [45] clause 4.3.1.

Channel bandwidth to be tested: are specified in Table 14.5.3.4-1.

1. Connect the SS and AWGN noise sources to the UE antenna connector or antenna connectors as shown in Annex A, Figure A.14.
2. The general test parameter settings are set up according to Table 14.5.3.5-1 and Table 14.5.3.5-2.
3. Propagation conditions are set according to clause 4.15.2.
4. Message contents are defined in clause 14.5.3.4.3.
5. In the test there are two synchronous cells: Cell 1 and Cell 2. Cell 1 is the reference as well as the PCell. Cell 2 is a neighbour cell. Both cells are on the same NR RF channel in FR2. The UE is configured with DRX cycle of 0.64s.
6. The true RSTD (which is the receive time difference for frame 0 between cell 2 and cell 1 as seen at the UE antenna connector) is set to 5898 T_c (about 3 μ s)

14.5.3.4.2 Test procedure

The test consists of two sub-tests; the difference between the sub-tests is the PRS configuration, PRS.1.1 FR2 and PRS.1.2 FR2. The test consists of a set-up period and a measurement period. During the set-up period, the UE shall be in RRC_CONNECTED state and shall not have any timing information of Cell 2. During the measurement period UE shall be in RRC_INACTIVE state and all cells start to transmit PRS resources within initial DL BWP of the UE and with the same numerology as the initial DL BWP.

The NR-DL-TDOA-RequestLocationInformation message and the DL-TDOA assistance data as defined in clause 14.5.3.4.3 shall be provided to the UE during the set-up period. The beginning of the measurement period shall be aligned with the first DRX cycle containing a DL PRS resource(s).

2. Ensure the UE is in State RRC_CONNECTED with generic procedure parameters Connectivity NR, Connected without release On, according to TS 38.508-1 [45] clause 4.5.
2. The SS shall send a RESET UE POSITIONING STORED INFORMATION message.
3. Set parameters other than PRSconfiguration according to the Table 14.5.3.5-1 and Table 14.5.3.5-2. Propagation conditions are set according to clause 4.15.2.
4. Set-up period starts.
5. The SS shall transmit an RRCReconfiguration message with the DRX configuration.
6. The UE shall transmit RRCReconfigurationComplete message.
7. The SS shall transmit an LPP REQUEST CAPABILITIES message.
8. The UE shall transmit an LPP PROVIDE CAPABILITIES message indicating the DL-TDOA capabilities supported by the UE in the NR-DL-TDOA-ProvideCapabilities IE.
9. The SS shall send a LPP PROVIDE ASSISTANCE DATA message, including the NR-DL-TDOA-ProvideAssistanceData IE. The position of neighbour Cell 2 is described in 3GPP TS 37.571-5 [20]. If the UE message at step 8 includes the ackRequested IE set to TRUE, then the SS shall send an acknowledgment in the LPP PROVIDE ASSISTANCE DATA message.
10. The SS shall transmit LCS Periodic-Triggered Invoke Request message with LPP REQUEST LOCATION INFORMATION embedded to start the periodic reporting procedure, including the NR-DL-TDOA-RequestLocationInformation IE such that the UE receives the message ΔT ms before the start of measurement period, where $\Delta T = 50$ ms.
11. The UE shall transmit an LCS Periodic-Triggered Invoke Return Result message.
12. When set-up period ends, the SS shall transmit an RRCRelease message to transit the UE to RRC_INACTIVE state and set the PRS parameters as specified in Table 14.5.3.5-1 and Table 14.5.3.5-2.
13. Wait for the UE monitors for occurrence of the periodic event requested.
14. The UE shall transmit the UE transmit an RRCResumeRequest message.
15. The SS transmits an RRCResume message.
16. The UE transmits an RRCResumeComplete message.
17. The UE shall transmit a LPP PROVIDE LOCATION INFORMATION message including the NR-DL-TDOA-ProvideLocationInformation IE within the response time (see clause 4.15.3) plus the maximum RRC processing time 10ms between RRCResume message and RRCResumeComplete message.
18. If the UE message at step 17 includes the ackRequested IE set to TRUE, the SS shall send a LPP acknowledgement message.
19. The SS shall check the nr-RSTD-r16 value for Cell 2 in the nr-DL-TDOA-SignalMeasurementInformation-r16 according to Table 14.5.3.5-3.
20. Repeat steps 2-19 in Table 14.5.3.4-1 until the confidence level according to Annex D is achieved.
21. Repeat step 2-20 for the other sub-test defined in Table 14.5.3.5-1 as appropriate.

If all (applicable) sub-tests pass, the whole test passes. If one (applicable) sub-test fails, the whole test fails.

14.5.3.4.3 Message contents

As defined in clause 14.4.3.4.3, with the following exceptions:

Table 14.5.3.4.3-1 replaces Table 14.4.3.4.3-7, Table 14.5.3.4.3-2 replaces Table 14.4.3.4.3-9 and Table 14.5.3.4.3-3 replaces Table 14.4.3.4.3-11.

Table 14.5.3.4.3-1: NR-DL-PRS-AssistanceData

Derivation Path: 37.355 clause 6.4.3			
Information Element	Value/remark	Comment	Condition
NR-DL-PRS-AssistanceData-r16 ::= SEQUENCE {			
nr-DL-PRS-ReferenceInfo-r16 SEQUENCE {			
dl-PRS-ID-r16	0		
nr-DL-PRS-ResourceID-List-r16	Not present		
nr-DL-PRS-ResourceSetID-r16	Not present		
}			
nr-DL-PRS-AssistanceDataList-r16 SEQUENCE (SIZE (1..nrMaxFreqLayers-r16)) OF NR-DL-PRS-AssistanceDataPerFreq-r16 {	1 entry		
NR-DL-PRS-AssistanceDataPerFreq-r16[1] SEQUENCE {		entry 1	
nr-DL-PRS-PositioningFrequencyLayer-r16 SEQUENCE {			
dl-PRS-SubcarrierSpacing-r16	kHz120		
dl-PRS-ResourceBandwidth-r16	3	32 PRBs	Sub-test 1
	27	128 PRBs	Sub-test 2
dl-PRS-StartPRB-r16	0		
dl-PRS-PointA-r16	absoluteFrequencyPointA as defined for the DL frequency of the Cell 1		
dl-PRS-CombSizeN-r16	n2		Sub-test 1
	n4		Sub-test 2
dl-PRS-CyclicPrefix-r16	normal		
}			
nr-DL-PRS-AssistanceDataPerFreq-r16 SEQUENCE (SIZE (1..nrMaxTRPsPerFreq-r16)) OF NR-DL-PRS-AssistanceDataPerTRP-r16{	2 entries		
NR-DL-PRS-AssistanceDataPerTRP-r16[1] SEQUENCE {		entry 1	Cell 1
dl-PRS-ID-r16	0		
nr-PhysCellID-r16	Cell 1		
nr-CellGlobalID-r16	Cell 1		
nr-ARFCN-r16	Cell 1		
nr-DL-PRS-SFN0-Offset-r16 SEQUENCE {			
sfn-Offset-r16	0		
integerSubframeOffset-r16	0		
}			
nr-DL-PRS-ExpectedRSTD-r16	0		
nr-DL-PRS-ExpectedRSTD-Uncertainty-r16	0		
nr-DL-PRS-Info-r16	As specified in Table 14.5.3.4.3-2		
}			
NR-DL-PRS-AssistanceDataPerTRP-r16[2] SEQUENCE {		entry 2	Cell 2
dl-PRS-ID-r16	1		
nr-PhysCellID-r16	Cell 2		
nr-CellGlobalID-r16	Cell 2		
nr-ARFCN-r16	Cell 2		
nr-DL-PRS-SFN0-Offset-r16 SEQUENCE {			
sfn-Offset-r16	0		
integerSubframeOffset-r16	0		
}			
nr-DL-PRS-ExpectedRSTD-r16	23	About 3 μs	
nr-DL-PRS-ExpectedRSTD-Uncertainty-r16	154	About 5 μs	
nr-DL-PRS-Info-r16	As specified in Table 14.5.3.4.3-2		
}			
}			
}			
}			
}			

Table 14.5.3.4.3-2: NR-DL-PRS-Info

Derivation Path: 37.355 clause 6.4.3			
Information Element	Value/remark	Comment	Condition
NR-DL-PRS-Info-r16 ::= SEQUENCE {			
nr-DL-PRS-ResourceSetList-r16 SEQUENCE (SIZE (1..nrMaxSetsPerTrp-r16)) OF NR-DL-PRS-ResourceSet-r16 {	1 entry		
NR-DL-PRS-ResourceSet-r16[1] SEQUENCE {		entry 1	
nr-DL-PRS-ResourceSetID-r16	0		
dl-PRS-Periodicity-and-ResourceSetSlotOffset-r16 CHOICE {			
scs120-r16 CHOICE {			
n160-r16	80		
}			
dl-PRS-ResourceRepetitionFactor-r16	n2		Sub-test 1
	Not present		Sub-test 2
dl-PRS-ResourceTimeGap-r16	s1		
dl-PRS-NumSymbols-r16	n4		
dl-PRS-MutingOption1-r16	Not present		
dl-PRS-MutingOption2-r16	Not present		
dl-PRS-ResourcePower-r16	27		
dl-PRS-ResourceList-r16 SEQUENCE (SIZE (1..nrMaxResourcesPerSet-r16)) OF NR-DL-PRS-Resource-r16 {	1 entry		
NR-DL-PRS-Resource-r16[1] SEQUENCE {		entry 1	
nr-DL-PRS-ResourceID-r16	0		
dl-PRS-SequenceID-r16	0		
dl-PRS-CombSizeN-AndReOffset-r16 CHOICE {			
n2-r16	0		Sub-test 1
n4-r16	0		Sub-test 2
}			
dl-PRS-ResourceSlotOffset-r16	0		Cell 1
	4		Cell 2
dl-PRS-ResourceSymbolOffset-r16	0		
dl-PRS-QCL-Info-r16	Not present		
}			
}			
}			
}			
}			

Table 14.5.3.4.3-3: LPP ProvideLocation Information

Derivation Path: TS 37.355 [49] clause 6.2			
Information Element	Value/remark	Comment	Condition
LPP-Message ::= SEQUENCE {			
transactionID SEQUENCE {			
initiator	locationServer		
transactionNumber	1		
}			
endTransaction	TRUE		
sequenceNumber	(0..255)		
acknowledgement			
lpp-MessageBody CHOICE {			
c1 CHOICE {			
provideLocationInformation SEQUENCE {			
criticalExtensions CHOICE {			
c1 CHOICE {			
provideLocationInformation-r9 SEQUENCE {			
commonIEsProvideLocationInformation	Not present.		
a-gnss-ProvideLocationInformation	Not present		
otdoa-ProvideLocationInformation	Not present		
ecid-ProvideLocationInformation	Not present		
epdu-ProvideLocationInformation	Not present		

	sensor-ProvideLocationInformation-r13	Not present		
	tbs-ProvideLocationInformation-r13	Not present		
	wlan-ProvideLocationInformation-r13	Not present		
	bt-ProvideLocationInformation-r13	Not present		
	nr-ECID-ProvideLocationInformation-r16	Not present		
r16	nr-Multi-RTT-ProvideLocationInformation-	Not present		
	nr-DL-AoD-ProvideLocationInformation-r16	Not present		
	nr-DL-TDOA-ProvideLocationInformation-			
	r16 SEQUENCE {			
	nr-DL-TDOA-			
	SignalMeasurementInformation-r16 SEQUENCE {			
	dl-PRS-ReferenceInfo-r16			
	nr-DL-TDOA-MeasList-r16 SEQUENCE	2 entries		
	(SIZE(1..nrMaxTRPs-r16)) OF NR-DL-TDOA-			
	MeasElement-r16 {			
	NR-DL-TDOA-MeasElement-r16[1]		entry 1	
	SEQUENCE {			
	dl-PRS-ID-r16			
	nr-PhysCellID-r16	Cell 1		
	nr-CellGlobalID-r16			
	nr-ARFCN-r16			
	nr-DL-PRS-ResourceID-r16			
	nr-DL-PRS-ResourceSetID-r16			
	nr-TimeStamp-r16			
	nr-RSTD-r16	Present		
	nr-AdditionalPathList-r16			
	nr-TimingQuality-r16			
	nr-DL-PRS-RSRP-Result-r16			
r16	nr-DL-TDOA-AdditionalMeasurements-			
	nr-UE-Rx-TEG-ID-r17			
	nr-DL-PRS-FirstPathRSRP-Result-r17			
	nr-los-nlos-Indicator-r17			
	nr-AdditionalPathListExt-r17			
	nr-DL-TDOA-			
	AdditionalMeasurementsExt-r17			
	}			
	NR-DL-TDOA-MeasElement-r16[2]		entry 2	
	SEQUENCE {			
	dl-PRS-ID-r16			
	nr-PhysCellID-r16	Cell 2		
	nr-CellGlobalID-r16			
	nr-ARFCN-r16			
	nr-DL-PRS-ResourceID-r16			
	nr-DL-PRS-ResourceSetID-r16			
	nr-TimeStamp-r16			
	nr-RSTD-r16	Present		
	nr-AdditionalPathList-r16			
	nr-TimingQuality-r16			
	nr-DL-PRS-RSRP-Result-r16			
r16	nr-DL-TDOA-AdditionalMeasurements-			
	nr-UE-Rx-TEG-ID-r17			
	nr-DL-PRS-FirstPathRSRP-Result-r17			
	nr-los-nlos-Indicator-r17			
	nr-AdditionalPathListExt-r17			
	nr-DL-TDOA-			
	AdditionalMeasurementsExt-r17			
	}			
	}			
	nr-UE-RxTEG-TimingErrorMargin-r17			
	}			
	nr-dl-tdoa-LocationInformation-r16			
	nr-DL-TDOA-Error-r16			

nr-DL-TDOA-SignalMeasurementInstances-r17			
nr-DL-TDOA-LocationInformationInstances-r17			
}			
}			
}			
}			
}			
}			

14.5.3.5 Test requirement

FFS

14.5.4 UE Rx-Tx time difference measurement accuracy for single positioning frequency layer with reduced number of samples in FR2 SA

Editor’s note: This test case is incomplete. The following aspect is either missing or TBD:

- Test tolerance are not added in and analysis is missing

14.5.4.1 Test purpose

The purpose of the test is to verify that the RSTD measurement in RRC_INACTIVE state with reduced number of samples meets the accuracy requirements specified in TS 38.133 [50] clause 10.1.23.2 in an environment with AWGN propagation conditions in FR2 in standalone scenario when single positioning frequency layer is configured.

14.5.4.2 Test applicability

This test applies to all types of NR UE release 17 onwards that supports DL-TDOA positioning, DL-PRS measurement in RRC_INACTIVE and reduced number of samples for PRS measurement in RRC_INACTIVE state.

14.5.4.3 Minimum conformance requirements

The accuracy requirements for RSTD measurement shall be within $\pm(X+Y+Z+\Delta) T_c$.

...

X is defined in Table 10.1.23.2-8 for AWGN channel in FR2 provided that the following conditions are met.

- Conditions defined in clause 7.3 of TS 38.101-1 [18] for reference sensitivity are fulfilled.
- Conditions for RSTD measurements are fulfilled according to Annex B.2.14 for a corresponding Band for each relevant PRS resource configured for measurement.
- UE supports positioning measurement with reduced number of sample and is indicated by LMF to perform positioning measurement with reduced number of samples.

...

If the UE doesn’t support Rx TEG reporting for RSTD measurement or when the measurements of reference cell and neighbour cell belong to different Rx TEGs, Y, Z and Δ are defined as follows:

- When UE measures RSTD on PRS resources belonging to same PFL, $Y=32 T_c$, provided that the time offset between the two PRS resource instances from the reference cell and the neighbour cell, which are used for a single RSTD estimate, is no greater than 160 ms.

- When UE measures RSTD on PRS resources belonging different PFLs, $Y=256 T_c$, provided that the time offset between the two PRS resource instances from the reference cell and the neighbour cell, which are used for a single RSTD estimate, is no greater than 1280 ms.
- Z is defined in Table 10.1.23.2-5 for FR1 and Table 10.1.23.2-6 for FR2, respectively.
- Δ is zero for single PFL, and is defined in Table 10.1.23.2-5a for FR1 and Table 10.1.23.2-6a for FR2, respectively, for dual PFL.

...

Table 10.1.23.2-8: RSTD absolute accuracy in FR2 for AWGN channel with reduced number of samples

Accuracy	Conditions					
	PRS \hat{E}_s/lot	PRS SCS	PRS bandwidth Note 1	PRS resource repetition ($T_{\text{rep}}^{\text{PRS}} * L_{\text{PRS}} / K_{\text{comb}}^{\text{PRS}}$) Note 2	I_0 Note 3 range	
T_c Note 4	dB	kHz	RB		dBm/SCS	dBm/BW _{Channel}
24	(PRS \hat{E}_s/lot) _{ref} \geq -3dB	60	≥ 64	≥ 1	Same value as PRS_RP in Table B.2.14-2, according to UE Power class, operating band and angle of arrival	Note 5
11			≥ 132	≥ 1	Note 5	Note 5
13	(PRS \hat{E}_s/lot) _i \geq -6dB	120	≥ 64	≥ 1	Same value as PRS_RP in Table B.2.14-2, according to UE Power class, operating band and angle of arrival	Note 5
6			≥ 128	≥ 1	Note 5	Note 5

NOTE 1: Minimum PRS bandwidth, which is minimum of the PRS bandwidths of the reference resource and the measured neighbour resource i .

NOTE 2: Minimum number of PRS resource repetitions among the reference resource and the measured neighbour resource i . $T_{\text{rep}}^{\text{PRS}}, L_{\text{PRS}}, K_{\text{comb}}^{\text{PRS}}$ are configured by higher layer parameter *dl-PRS-ResourceRepetitionFactor*, *dl-PRS-NumSymbols* and *dl-PRS-CombSizeN* defined in TS 37.355 [34], respectively.

NOTE 3: I_0 is assumed to have constant EPRE across the bandwidth.

NOTE 4: T_c is the basic timing unit defined in TS 38.211 [6].

NOTE 5: The same bands and the same I_0 conditions for each band apply for this requirement as for the corresponding requirement with the PRS bandwidth of the smallest RB number for the corresponding SCS.

NOTE 6: Void

...

Table 10.1.23.2-6: Margin for RSTD measurement accuracy in FR2

PRS BW (RB number)		Margin (T_c)
SCS=60kHz	SCS=120kHz	
≥ 24	N/A	72
≥ 64	≥ 32	32
≥ 132	≥ 64	16
N/A	≥ 128	12

14.5.4.4 Test description

The supported test configurations in listed in Table 14.5.4.4-1

Table 14.5.4.4-1: Test Configurations

Test Configuration	Description
1	120 kHz SSB and PRS SCS, 100 MHz bandwidth, TDD duplex mode

14.5.4.4.1 Initial conditions

Test Environment: Normal, as defined in TS 38.508-1 [45] clause 4.1.

Frequencies to be tested: Mid Range, as defined in TS 38.508-1 [45] clause 4.3.1.

Channel bandwidth to be tested: are specified in Table 14.5.4.4-1.

1. Connect the SS and AWGN noise sources to the UE antenna connector or antenna connectors as shown in Annex A, Figure A.14.
2. The general test parameter settings are set up according to Table 14.5.4.5-1 and Table 14.5.4.5-2.
3. Propagation conditions are set according to clause 4.15.2.
4. Message contents are defined in clause 14.5.4.4.3.
5. In the test there are two synchronous cells: Cell 1 and Cell 2. Cell 1 is the reference as well as the PCell. Cell 2 is a neighbour cell. Both cells are on the same NR RF channel in FR2. The UE is configured with DRX cycle of 0.64s.
6. The true RSTD (which is the receive time difference for frame 0 between cell 2 and cell 1 as seen at the UE antenna connector) is set to 5898 Tc (about 3 μ s)

14.5.4.4.2 Test procedure

Same as in clause 14.5.3.4.2.

14.5.4.4.3 Message contents

As defined in clause 14.4.3.4.3, with the following exceptions:

Table 14.5.4.4.3-1 replaces Table 14.4.3.4.3-7, Table 14.5.4.4.3-2 replaces Table 14.4.3.4.3-9 and Table 14.5.4.4.3-3 replaces Table 14.4.3.4.3-11.

Table 14.5.4.4.3-1: NR-DL-PRS-AssistanceData

Derivation Path: 37.355 clause 6.4.3			
Information Element	Value/remark	Comment	Condition
NR-DL-PRS-AssistanceData-r16 ::= SEQUENCE {			
nr-DL-PRS-ReferenceInfo-r16 SEQUENCE {			
dl-PRS-ID-r16	0		
nr-DL-PRS-ResourceID-List-r16	Not present		
nr-DL-PRS-ResourceSetID-r16	Not present		
}			
nr-DL-PRS-AssistanceDataList-r16 SEQUENCE (SIZE (1..nrMaxFreqLayers-r16)) OF NR-DL-PRS-AssistanceDataPerFreq-r16 {	1 entry		
NR-DL-PRS-AssistanceDataPerFreq-r16[1] SEQUENCE {		entry 1	
nr-DL-PRS-PositioningFrequencyLayer-r16 SEQUENCE {			
dl-PRS-SubcarrierSpacing-r16	kHz120		
dl-PRS-ResourceBandwidth-r16	3	32 PRBs	Sub-test 1
	27	128 PRBs	Sub-test 2
dl-PRS-StartPRB-r16	0		
dl-PRS-PointA-r16	absoluteFrequencyPointA as defined for the DL frequency of the Cell 1		
dl-PRS-CombSizeN-r16	n2		Sub-test 1
	n4		Sub-test 2
dl-PRS-CyclicPrefix-r16	normal		
}			

nr-DL-PRS-AssistanceDataPerFreq-r16 SEQUENCE (SIZE (1..nrMaxTRPsPerFreq-r16)) OF NR-DL-PRS-AssistanceDataPerTRP-r16{	2 entries		
NR-DL-PRS-AssistanceDataPerTRP-r16[1] SEQUENCE {		entry 1	Cell 1
dl-PRS-ID-r16	0		
nr-PhysCellID-r16	Cell 1		
nr-CellGlobalID-r16	Cell 1		
nr-ARFCN-r16	Cell 1		
nr-DL-PRS-SFN0-Offset-r16 SEQUENCE {			
sfn-Offset-r16	0		
integerSubframeOffset-r16	0		
}			
nr-DL-PRS-ExpectedRSTD-r16	0		
nr-DL-PRS-ExpectedRSTD-Uncertainty-r16	0		
nr-DL-PRS-Info-r16	As specified in Table 14.5.4.4.3-2		
}			
NR-DL-PRS-AssistanceDataPerTRP-r16[2] SEQUENCE {		entry 2	Cell 2
dl-PRS-ID-r16	1		
nr-PhysCellID-r16	Cell 2		
nr-CellGlobalID-r16	Cell 2		
nr-ARFCN-r16	Cell 2		
nr-DL-PRS-SFN0-Offset-r16 SEQUENCE {			
sfn-Offset-r16	0		
integerSubframeOffset-r16	0		
}			
nr-DL-PRS-ExpectedRSTD-r16	23	About 3 μs	
nr-DL-PRS-ExpectedRSTD-Uncertainty-r16	154	About 5 μs	
nr-DL-PRS-Info-r16	As specified in Table 14.5.4.4.3-2		
}			
}			
}			
}			
}			

Table 14.5.4.4.3-2: NR-DL-PRS-Info

Derivation Path: 37.355 clause 6.4.3			
Information Element	Value/remark	Comment	Condition
NR-DL-PRS-Info-r16 ::= SEQUENCE {			
nr-DL-PRS-ResourceSetList-r16 SEQUENCE (SIZE (1..nrMaxSetsPerTrp-r16)) OF NR-DL-PRS-ResourceSet-r16 {	1 entry		
NR-DL-PRS-ResourceSet-r16[1] SEQUENCE {		entry 1	
nr-DL-PRS-ResourceSetID-r16	0		
dl-PRS-Periodicity-and-ResourceSetSlotOffset-r16 CHOICE {			
scs120-r16 CHOICE {			
n160-r16	80		
}			
dl-PRS-ResourceRepetitionFactor-r16	n2		Sub-test 1
	Not present		Sub-test 2
dl-PRS-ResourceTimeGap-r16	s1		
dl-PRS-NumSymbols-r16	n4		
dl-PRS-MutingOption1-r16	Not present		
dl-PRS-MutingOption2-r16	Not present		
dl-PRS-ResourcePower-r16	27		
dl-PRS-ResourceList-r16 SEQUENCE (SIZE (1..nrMaxResourcesPerSet-r16)) OF NR-DL-PRS-Resource-r16 {	1 entry		
NR-DL-PRS-Resource-r16[1] SEQUENCE {		entry 1	
nr-DL-PRS-ResourceID-r16	0		

dl-PRS-SequenceID-r16	0		
dl-PRS-CombSizeN-AndReOffset-r16 CHOICE {			
n2-r16	0		Sub-test 1
n4-r16	0		Sub-test 2
}			
dl-PRS-ResourceSlotOffset-r16	0		Cell 1
	4		Cell 2
dl-PRS-ResourceSymbolOffset-r16	0		
dl-PRS-QCL-Info-r16	Not present		
}			
}			
}			
}			
}			

Table 14.5.4.4.3-3: LPP ProvideLocation Information

Derivation Path: TS 37.355 [49] clause 6.2			
Information Element	Value/remark	Comment	Condition
LPP-Message ::= SEQUENCE {			
transactionID SEQUENCE {			
initiator	locationServer		
transactionNumber	1		
}			
endTransaction	TRUE		
sequenceNumber	(0..255)		
acknowledgement			
lpp-MessageBody CHOICE {			
c1 CHOICE {			
provideLocationInformation SEQUENCE {			
criticalExtensions CHOICE {			
c1 CHOICE {			
provideLocationInformation-r9 SEQUENCE {			
commonIEsProvideLocationInformation	Not present.		
a-gnss-ProvideLocationInformation	Not present		
otdoa-ProvideLocationInformation	Not present		
ecid-ProvideLocationInformation	Not present		
epdu-ProvideLocationInformation	Not present		
sensor-ProvideLocationInformation-r13	Not present		
tbs-ProvideLocationInformation-r13	Not present		
wlan-ProvideLocationInformation-r13	Not present		
bt-ProvideLocationInformation-r13	Not present		
nr-ECID-ProvideLocationInformation-r16	Not present		
nr-Multi-RTT-ProvideLocationInformation-r16	Not present		
nr-DL-AoD-ProvideLocationInformation-r16	Not present		
nr-DL-TDOA-ProvideLocationInformation-r16 SEQUENCE {			
nr-DL-TDOA-SignalMeasurementInformation-r16 SEQUENCE {			
dl-PRS-ReferenceInfo-r16			
nr-DL-TDOA-MeasList-r16 SEQUENCE (SIZE(1..nrMaxTRPs-r16)) OF NR-DL-TDOA-MeasElement-r16 {	2 entries		
NR-DL-TDOA-MeasElement-r16[1] SEQUENCE {		entry 1	
dl-PRS-ID-r16			
nr-PhysCellID-r16	Cell 1		
nr-CellGlobalID-r16			
nr-ARFCN-r16			
nr-DL-PRS-ResourceID-r16			
nr-DL-PRS-ResourceSetID-r16			
nr-TimeStamp-r16			
nr-RSTD-r16	Present		

	nr-AdditionalPathList-r16			
	nr-TimingQuality-r16			
	nr-DL-PRS-RSRP-Result-r16			
r16	nr-DL-TDOA-AdditionalMeasurements-			
	nr-UE-Rx-TEG-ID-r17			
	nr-DL-PRS-FirstPathRSRP-Result-r17			
	nr-los-nlos-Indicator-r17			
	nr-AdditionalPathListExt-r17			
	nr-DL-TDOA-			
	AdditionalMeasurementsExt-r17			
	}			
	NR-DL-TDOA-MeasElement-r16[2]		entry 2	
SEQUENCE {				
	dl-PRS-ID-r16			
	nr-PhysCellID-r16	Cell 2		
	nr-CellGlobalID-r16			
	nr-ARFCN-r16			
	nr-DL-PRS-ResourceID-r16			
	nr-DL-PRS-ResourceSetID-r16			
	nr-TimeStamp-r16			
	nr-RSTD-r16	Present		
	nr-AdditionalPathList-r16			
	nr-TimingQuality-r16			
	nr-DL-PRS-RSRP-Result-r16			
r16	nr-DL-TDOA-AdditionalMeasurements-			
	nr-UE-Rx-TEG-ID-r17			
	nr-DL-PRS-FirstPathRSRP-Result-r17			
	nr-los-nlos-Indicator-r17			
	nr-AdditionalPathListExt-r17			
	nr-DL-TDOA-			
	AdditionalMeasurementsExt-r17			
	}			
	}			
	nr-UE-RxTEG-TimingErrorMargin-r17			
	}			
	nr-dl-tdoa-LocationInformation-r16			
	nr-DL-TDOA-Error-r16			
	nr-DL-TDOA-			
	SignalMeasurementInstances-r17			
	nr-DL-TDOA-			
	LocationInformationInstances-r17			
	}			
	}			
	}			
	}			
	}			
	}			

14.5.4.5 Test requirement

FFS

15 UE Rx-Tx time difference measurement requirements

15.1 General

This clause defines the minimum performance requirements for Multi-RTT NR UEs.

15.2 UE Rx-Tx time difference measurement period test cases in RRC_CONNECTED

15.2.1 UE Rx-Tx time difference measurement period for single positioning frequency layer in FR1 SA

15.2.1.1 Test purpose

The purpose of the test is to verify that the UE Rx-Tx measurement period meets the requirements specified in TS 38.133 [50] clause 9.9.4.5 in AWGN propagation condition in FR1 in standalone scenario when single positioning frequency layer is configured.

15.2.1.2 Test applicability

This test applies to all types of NR UE release 16 onwards that supports Multi-RTT positioning.

15.2.1.3 Minimum conformance requirements

When physical layer receives last of *NR-Multi-RTT-ProvideAssistanceData* message and *NR-Multi-RTT-RequestLocationInformation* message from LMF via LPP [49], UE shall be able to measure multiple (up to the UE capability specified in TS 38.133 [50] clause 9.9.4.3) UE Rx-Tx time difference measurements as defined in TS 38.215 [4] in configured positioning frequency layers within the measurement period $T_{\text{UERxTx, Total}}$ ms.

$$T_{\text{UERxTx, Total}} = \sum_{i=1}^L T_{\text{UERxTx, }i} + (L - 1) * \max(T_{\text{effect, }i}).$$

where i is the index of positioning frequency layer,

$T_{\text{UERxTx, }i}$ is the measurement period for UE Rx-Tx time difference measurements in positioning frequency layer i as further defined in this clause,

L is total number of positioning frequency layers, and

$T_{\text{effect, }i}$ is the periodicity of the UE Rx-Tx time difference measurement in positioning frequency layer i as defined further in this clause.

$$T_{\text{UERxTx, }i} = \left(\text{CSSF}_i * N_{\text{RxBeam, }i} * \left\lceil \frac{N_{\text{PRS, }i}^{\text{slot}}}{N'} \right\rceil \left\lfloor \frac{L_{\text{available_PRS, }i}}{N} \right\rfloor * N_{\text{sample}} - 1 \right) * T_{\text{effect, }i} + T_{\text{last, }i}$$

Where

CSSF_i is the carrier-specific scaling factor for NR PRS-based measurement in the positioning frequency layer i as defined in TS 38.133 [50] clause 9.1.5.2,

$N_{\text{RxBeam, }i}$ is the scaling factor for Rx beam sweeping, and $N_{\text{RxBeam, }i}=1$ if positioning frequency layer i is in FR1 and $N_{\text{RxBeam, }i}=8$ if positioning frequency layer i is in FR2,

$L_{\text{available_PRS, }i}$ is the time duration of available PRS resources in the positioning frequency layer i , to be measured during $T_{\text{available_PRS, }i}$, and is calculated in the same way as PRS duration K defined in clause 5.1.6.5 of TS 38.214 [56]. For calculation of $L_{\text{available_PRS, }i}$, only the PRS resources unmuted and fully or partially overlapped with MG are considered.

$N_{\text{PRS, }i}^{\text{slot}}$ is the maximum number of DL PRS resources of positioning frequency layer i configured in a slot,

$\{N, T\}$ is UE capability combination per band where N is a duration of DL PRS symbols in ms corresponding to *durationOfPRS-ProcessingSymbols* in TS 37.355 [49] processed every T ms corresponding to *durationOfPRS-ProcessingSymbolsInEveryTms* in TS 37.355 [49] for a given maximum bandwidth supported by UE corresponding to *supportedBandwidthPRS* in clause 4.2.7.2 of TS 37.355 [49],

N' is UE capability for number of DL PRS resources that it can process in a slot corresponding to *maxNumOfDL-PRS-ResProcessedPerSlot* as specified in clause 6.4.3 of TS 37.355 [49],

N_{sample} is the number of UE Rx-Tx time difference measurement samples and $N_{sample} = 4$,

$T_{last,i}$ is the measurement duration for the last UE Rx-Tx time difference measurement sample in the positioning layer i , including the sampling time and processing time, $T_{last,i} = T_i + T_{available_PRS,i}$,

$T_{effect,i}$ is periodicity of UE Rx-Tx time difference measurement in positioning frequency layer i :

$$T_{effect,i} = \left\lceil \frac{T_i}{T_{available_PRS,i}} \right\rceil * T_{available_PRS,i}$$

where

T_i corresponds to durationOfPRS-ProcessingSymbolsInEveryTms in TS 37.355 [49],

$T_{available_PRS,i} = LCM(T_{PRS,i}, MGRP_i)$, the least common multiple between $T_{PRS,i}$ and $MGRP_i$

$MGRP_i$ is the measurement gap repetition periodicity in positioning frequency layer i .

$T_{PRS,i}$ is the PRS resource periodicity in positioning frequency layer i . If the positioning frequency layer i has more than one DL PRS resource sets with different PRS periodicities with muting, $T_{per}^{PRS \text{ with muting}} = N_{muting} * T_{per}^{PRS}$, the least common multiple of $T_{per}^{PRS \text{ with muting}}$ among DL PRS resource sets is used to derive $T_{PRS,i}$, where

T_{per}^{PRS} is the periodicity of PRS resource sets given by the higher-layer parameter *DL-PRS-Periodicity*.

N_{muting} is the scaling factor considering PRS resource muting. $N_{muting} = T_{muting}^{PRS} * L_{muting}$, where T_{muting}^{PRS} is the muting repetition factor given by the higher-layer parameter *DL-PRS-MutingBitRepetitionFactor*, and L_{muting} is the size of the bitmap $\{b^1\}$.

Note: For the purpose of calculating $T_{PRS,i}$, only the PRS resources fully or partially covered by the MG are considered.

The time $T_{UERxTx,Total}$ starts from the first MG instance aligned with DL PRS resources in the assistance data after both the *NR-Multi-RTT-RequestLocationInformation* message and *NR-Multi-RTT-ProvideAssistanceData* message from LMF via LPP [34] are delivered to the physical layer of UE.

Note: No per-positioning frequency layer requirement is applied in scenarios when multiple positioning frequency layers are configured.

The UE Rx-Tx time difference measurement period is restarted if HO occurs during the measurement period and after SRS reconfiguration on the target cell is complete.

The measurement requirements do not apply for a PRS resource:

- if the PRS resource is across two sampling duration of N within duration $L_{available_PRS,i}$ OR
- if time span of the PRS resource instance (including at least the minimum number of repetitions specified in the accuracy requirements) is greater than UE reported capability N .

The normative reference for this requirement is TS 38.133 [50] clause 9.9.4.5.

15.2.1.4 Test description

The test defines three possible test configurations; specified in Table 15.2.1.4-1. The UE is only required to be tested in one of the supported test configurations.

Table 15.2.1.4-1: Test Configurations

Test Configuration	Description
1	15 kHz SSB SCS, 20 MHz bandwidth, FDD duplex mode
2	15 kHz SSB SCS, 20 MHz bandwidth, TDD duplex mode
3	30 kHz SSB SCS, 50 MHz bandwidth, TDD duplex mode
Note:	The UE is only required to be tested in one of the supported test configurations.

15.2.1.4.1 Initial conditions

Test Environment: Normal, as defined in TS 38.508-1 [45] clause 4.1.

Frequencies to be tested: Mid-Range, as defined in TS 38.508-1 [45] clause 4.3.1.

Channel bandwidth to be tested: are specified in Table 15.2.1.4-1.

1. Connect the SS and AWGN noise sources to the UE antenna connector or antenna connectors as shown in Annex A, Figure A.13.
2. The general test parameter settings are set up according to Table 15.2.1.5-1 and Table 15.2.1.5-2.
3. Propagation conditions are set according to clause 4.14.2.
4. Message contents are defined in clause 15.2.1.4.3.
5. There are two cells in the test: PCell (Cell 1) and a neighbour cell (Cell 2). All cells are on the same RF channel in FR1.

15.2.1.4.2 Test procedure

The test consists of two consecutive time intervals, with duration of T1 and T2. Cell 1 and Cell 2 mute PRS transmission during T1 and transmit PRS during T2. The beginning of the time interval T2 shall be aligned with the beginning of the first MG instance containing the PRS resources. The UE is configured to transmit SRS during T2.

1. Ensure the UE is in State RRC_CONNECTED with generic procedure parameters Connectivity NR, Connected without release On, according to TS 38.508-1 [45] clause 4.5. Note that in the remainder of the test the timing advance command $T_A = 31$ which indicates a timing advance adjustment value $N_{TA} = 0 T_c$.
2. The SS shall send a RESET UE POSITIONING STORED INFORMATION message.
3. The SS adjusts the downlink timing for Cell 1 to a delay of $+512 T_c$, compared to the current value.
4. Wait for 1.6 s to allow for the possibility that the UE makes autonomous timing adjustments.
5. T1 starts.
6. The SS shall transmit an RRCReconfiguration message with the SRS configuration.
7. The UE shall transmit RRCReconfigurationComplete message.
8. The SS shall transmit an LPP REQUEST CAPABILITIES message.
9. The UE shall transmit an LPP PROVIDE CAPABILITIES message indicating the Multi-RTT capabilities supported by the UE in the NR-Multi-RTT-ProvideCapabilities IE.
10. The SS shall send a LPP PROVIDE ASSISTANCE DATA message, including the NR-Multi-RTT-ProvideAssistanceData IE such that the UE receives the message ΔT ms before the start of T2, where $\Delta T = 50$ MS. If the UE message at step 9 includes the ackRequested IE set to TRUE, then the SS shall send an acknowledgment in the LPP PROVIDE ASSISTANCE DATA message.
11. The SS shall send a LPP REQUEST LOCATION INFORMATION message, including the NR-Multi-RTT-RequestLocationInformation IE.
12. When T1 expires, the SS shall switch the power setting from T1 to T2 as specified in Table 15.2.1.5-2.
13. The UE shall transmit a LPP PROVIDE LOCATION INFORMATION message including the NR-Multi-RTT-ProvideLocationInformation IE within the response time (see clause 15.2.1.4.3). The UE shall perform and report the UE rx-tx time difference measurements for Cell 1 and Cell 2. If the UE transmits an NR-Multi-RTT-ProvideLocationInformation IE including the nr-UE-RxTxTimeDiff field for Cell 1 and Cell 2 within the response time then the number of successful tests is increased by one. If the UE fails to report the NR-Multi-RTT-ProvideLocationInformation IE with both the nr-UE-RxTxTimeDiff field included within the response time then the number of failure tests is increased by one.

14. If the UE message at step 13 includes the *ackRequested* IE set to TRUE, the SS shall send a LPP acknowledgement message.

15. Repeat steps 1-14 until the confidence level according to Annex D is achieved.

NOTE: To avoid a large divergence between the sent TA and the set downlink timing, the SS may reset the downlink timing for Cell 1 to its initial value after a certain amount of loops. The loop during the reset does not count for the result statistics.

15.2.1.4.3 Message contents

Table 15.2.1.4.3-1: RESET UE POSITIONING STORED INFORMATION

Derivation Path: 38.509 [44] clause 6.6			
Information Element	Value/remark	Comment	Condition
UE Positioning Technology	0 0 0 0 1 1 0	Multi-RTT	

Table 15.2.1.4.3-2: RRCReconfiguration

Derivation Path: TS 38.508-1 [45], table 4.6.1-13			
Information Element	Value/remark	Comment	Condition
RRCReconfiguration ::= SEQUENCE {			
criticalExtensions CHOICE {			
rrcReconfiguration SEQUENCE {			
radioBearerConfig			
nonCriticalExtension SEQUENCE {			
masterCellGroup SEQUENCE {	CellGroupConfig		
spCellConfig SEQUENCE {			
spCellConfigDedicated SEQUENCE {			
uplinkConfig SEQUENCE {			
initialUplinkBWP SEQUENCE {			
srs-Config CHOICE {			
setup	As defined in Table 15.2.1.4.3-3		
}			
}			
}			
}			
}			
}			
}			
}			
}			
}			

Table 15.2.1.4.3-3: SRS-Config (Table 15.2.1.4.3-2)

Derivation Path: TS 38.508-1 [45], Table 4.6.3-182			
Information Element	Value/remark	Comment	Condition
SRS-Config ::= SEQUENCE {			
srs-ResourceSetToReleaseList	Not present		
srs-ResourceSetToAddModList	Not present		
srs-ResourceToReleaseList	Not present		
srs-ResourceToAddModList	Not present		
tpc-Accumulation	Not present		
srs-RequestDCI-1-2-r16	Not present		
srs-RequestDCI-0-2-r16	Not present		
srs-ResourceSetToAddModListDCI-0-2-r16	Not present		
srs-ResourceSetToReleaseListDCI-0-2-r16	Not present		
srs-PosResourceSetToReleaseList-r16	Not present		
srs-PosResourceSetToAddModList-r16 SEQUENCE (SIZE(1..maxNrofSRS-PosResourceSets-r16)) OF SRS-PosResourceSet-r16 {	1 entry		

SRS-PosResourceSet-r16[1] SEQUENCE {		entry 1	
srs-PosResourceSetId-r16	0		
srs-PosResourceCidList-r16 SEQUENCE (SIZE(1..maxNrofSRS-ResourcesPerSet)) OF SRS-PosResourceCid-r16 {	1 entry		
SRS-PosResourceCid-r16	0	1 entry	
}			
resourceType CHOICE {			
periodic SEQUENCE {			
}			
}			
alpha-r16	alpha0		
p0-r16	0		
pathlossReferenceRS-Pos-r16	Not present		
}			
srs-PosResourceToReleaseList-r16	Not present		
srs-PosResourceToAddModList-r16 SEQUENCE (SIZE(1..maxNrofSRS-PosResources-r16)) OF SRS-PosResource-r16 {	1 entry		
SRS-PosResource-r16[1] SEQUENCE {		entry 1	
srs-PosResourceCid-r16	0		
transmissionComb-r16 CHOICE {			
n4-r16 SEQUENCE {			
combOffset-n4-r16	0		
cyclicShift-n4-r16	0		
}			
}			
resourceMapping-r16 SEQUENCE {			
startPosition-r16	0		
nrofSymbols-r16	n4		
}			
freqDomainShift-r16	0		
freqHopping-r16 SEQUENCE {			
c-SRS-r16	Matches $N_{RB,c}$ Table 15.2.1.5-1		
}			
groupOrSequenceHopping-r16	neither		
resourceType-r16 CHOICE {			
periodic-r16 SEQUENCE {			
periodicityAndOffset-p-r16 CHOICE {			
sl160	20		Configuration 1 and Configuration 2
sl320	40		Configuration 3
}			
}			
}			
sequenceId-r16	0		
spatialRelationInfoPos-r16	Not present		
}			
}			
}			

Table 15.2.1.4.3-4: LPP Request Capabilities

Information Element	Value/remark
nr-Multi-RTT-RequestCapabilities-r16	TRUE

Table 15.2.1.4.3-5: LPP RequestLocationInformation

Derivation Path: 37.355 clause 6.2			
Information Element	Value/remark	Comment	Condition

LPP-Message ::= SEQUENCE {			
transactionID SEQUENCE {			
initiator	locationServer		
transactionNumber	1		
}			
endTransaction	FALSE		
sequenceNumber	Not present		
acknowledgement	Not present		
lpp-MessageBody CHOICE {			
c1 CHOICE {			
requestLocationInformation SEQUENCE {			
criticalExtensions CHOICE {			
c1 CHOICE {			
requestLocationInformation-r9 SEQUENCE {			
commonEsRequestLocationInformation SEQUENCE {			
locationInformationType	locationMeasurementsRequired		
triggeredReporting	Not present		
periodicalReporting	Not present		
additionalInformation	onlyReturnInformationRequested		
qos SEQUENCE {			
horizontalAccuracy	Not present		
verticalCoordinateRequest	FALSE		
verticalAccuracy	Not present		
responseTime SEQUENCE {			
time	See 15.2.1.5	Result of the response time calculation rounded up to the next second if response time <= 128s.	
responseTimeEarlyFix-r12	Not present		Rel-12 onwards
}			
velocityRequest	FALSE		
}			
environment	Not present		
locationCoordinateTypes	Not present		
velocityTypes	Not present		
}			
a-gnss-RequestLocationInformation	Not present		
otdoa-RequestLocationInformation	Not present		
ecid-RequestLocationInformation	Not present		
epdu-RequestLocationInformation	Not Present		
sensor-RequestLocationInformation-r13	Not present		
tbs-RequestLocationInformation-r13	Not present		
wlan-RequestLocationInformation-r13	Not present		
bt-RequestLocationInformation-r13	Not present		
nr-ECID-RequestLocationInformation-r16	Not present		
nr-Multi-RTT-RequestLocationInformation-r16 SEQUENCE {			
nr-UE-RxTxTimeDiffMeasurementInfoRequest-r16	Not present		
nr-RequestedMeasurements-r16	bit 0 = 1 (prsrsrpReq)		
nr-AssistanceAvailability-r16	FALSE		
nr-Multi-RTT-ReportConfig-r16 SEQUENCE {			
maxDL-PRS-RxTxTimeDiffMeasPerTRP-r16	Not present		
timingReportingGranularityFactor-r16	Not present		
}			
additionalPaths-r16	Not present		
}			
nr-DL-AoD-RequestLocationInformation-r16	Not present		
nr-DL-TDOA-RequestLocationInformation-r16	Not present		
}			

}			
}			
}			
}			
}			

Table 15.2.1.4.3-6: LPP ProvideAssistanceData

Derivation Path: 37.355 clause 6.2			
Information Element	Value/remark	Comment	Condition
LPP-Message ::= SEQUENCE {			
transactionID SEQUENCE {			
initiator	locationServer		
transactionNumber	(0..255)		
}			
endTransaction	TRUE		
sequenceNumber	Not present		
acknowledgement	Not present		
lpp-MessageBody CHOICE {			
c1 CHOICE {			
provideAssistanceData SEQUENCE {			
criticalExtensions CHOICE {			
c1 CHOICE {			
provideAssistanceData-r9 SEQUENCE {			
commonEsProvideAssistanceData	Not present		
a-gnss-ProvideAssistanceData	Not present		
otdoa-ProvideAssistanceData	Not present		
epdu-Provide-AssistanceData	Not present		
sensor-ProvideAssistanceData-r15	Not present		
tbs-ProvideAssistanceData-r15	Not present		
wlan-ProvideAssistanceData-r15	Not present		
nr-Multi-RTT-ProvideAssistanceData-r16			
} SEQUENCE {			
nr-DL-PRS-AssistanceData	As defined in Table 15.2.1.4.3-7		
nr-SelectedDL-PRS-IndexList-r16	Not present		
nr-Multi-RTT-Error-r16	Not present		
}			
nr-DL-AoD-ProvideAssistanceData-r16	Not present		
nr-DL-TDOA-ProvideAssistanceData-r16	Not present		
}			
}			
}			
}			
}			
}			

Table 15.2.1.4.3-7: NR-DL-PRS-AssistanceData

Derivation Path: 37.355 clause 6.4.3			
Information Element	Value/remark	Comment	Condition
NR-DL-PRS-AssistanceData-r16 ::= SEQUENCE {			
nr-DL-PRS-ReferenceInfo-r16 SEQUENCE {			
dl-PRS-ID-r16	0		
nr-DL-PRS-ResourceID-List-r16	Not present		
nr-DL-PRS-ResourceSetID-r16	Not present		
}			
nr-DL-PRS-AssistanceDataList-r16 SEQUENCE (SIZE (1..nrMaxFreqLayers-r16)) OF NR-DL-PRS-AssistanceDataPerFreq-r16 {	1 entry		
NR-DL-PRS-AssistanceDataPerFreq-r16[1] SEQUENCE {		entry 1	
}			

nr-DL-PRS-PositioningFrequencyLayer-r16 SEQUENCE {			
dl-PRS-SubcarrierSpacing-r16	kHz15		Configurati on 1 and Configurati on 2
	kHz30		Configurati on 3
dl-PRS-ResourceBandwidth-r16	21	104 PRBs	Configurati on 1 and Configurati on 2
	28	132 PRBs	Configurati on 3
dl-PRS-StartPRB-r16	0		
dl-PRS-PointA-r16	absoluteFrequencyPointA as defined for the DL frequency of the Cell 1		
dl-PRS-CombSizeN-r16	n4		
dl-PRS-CyclicPrefix-r16	normal		
}			
nr-DL-PRS-AssistanceDataPerFreq-r16 SEQUENCE (SIZE (1..nrMaxTRPsPerFreq-r16)) OF NR-DL-PRS-AssistanceDataPerTRP-r16{	2 entries		
NR-DL-PRS-AssistanceDataPerTRP-r16[1] SEQUENCE {		entry 1	Cell 1
dl-PRS-ID-r16	0		
nr-PhysCellID-r16	Cell 1		
nr-CellGlobalID-r16	Cell 1		
nr-ARFCN-r16	Cell 1		
nr-DL-PRS-SFN0-Offset-r16 SEQUENCE {			
sfn-Offset-r16	0		
integerSubframeOffset-r16	0		
}			
nr-DL-PRS-ExpectedRSTD-r16	0		
nr-DL-PRS-ExpectedRSTD-Uncertainty-r16	0		
nr-DL-PRS-Info-r16	As specified in Table 15.2.1.4.3-8		
}			
NR-DL-PRS-AssistanceDataPerTRP-r16[2] SEQUENCE {		entry 2	Cell 2
dl-PRS-ID-r16	1		
nr-PhysCellID-r16	Cell 2		
nr-CellGlobalID-r16	Cell 2		
nr-ARFCN-r16	Cell 2		
nr-DL-PRS-SFN0-Offset-r16 SEQUENCE {			
sfn-Offset-r16	0		
integerSubframeOffset-r16	0		
}			
nr-DL-PRS-ExpectedRSTD-r16	23	About 3 μs	
nr-DL-PRS-ExpectedRSTD-Uncertainty-r16	39	About 5 μs	
nr-DL-PRS-Info-r16	As specified in Table 15.2.1.4.3-8		
}			
}			
}			
}			
}			

Table 15.2.1.4.3-8: NR-DL-PRS-Info

Derivation Path: 37.355 clause 6.4.3			
Information Element	Value/remark	Comment	Condition
NR-DL-PRS-Info-r16 ::= SEQUENCE {			

nr-DL-PRS-ResourceSetList-r16 SEQUENCE (SIZE (1..nrMaxSetsPerTrp-r16)) OF NR-DL-PRS-ResourceSet-r16 {	1 entry		
NR-DL-PRS-ResourceSet-r16[1] SEQUENCE {		entry 1	
nr-DL-PRS-ResourceSetID-r16	0		
dl-PRS-Periodicity-and-ResourceSetSlotOffset-r16 CHOICE {			
scs15-r16 CHOICE {			Configurati on 1 and Configurati on 2
n160-r16	10		
}			
scs30-r16 CHOICE {			Configurati on 3
N320-r16	20		
}			
dl-PRS-ResourceRepetitionFactor-r16	Not present		
dl-PRS-ResourceTimeGap-r16	s1		
dl-PRS-NumSymbols-r16	n4		
dl-PRS-MutingOption1-r16 SEQUENCE {			
dl-prs-MutingBitRepetitionFactor-r16	Not present		
nr-option1-muting-r16 CHOICE {			
po2-r16	10 01		Cell 1 Cell 2
}			
}			
dl-PRS-MutingOption2-r16	Not present		
dl-PRS-ResourcePower-r16	27		
dl-PRS-ResourceList-r16 SEQUENCE (SIZE (1..nrMaxResourcesPerSet-r16)) OF NR-DL-PRS-Resource-r16 {	1 entry		
NR-DL-PRS-Resource-r16[1] SEQUENCE {		entry 1	
nr-DL-PRS-ResourceID-r16	0		
dl-PRS-SequenceID-r16	0		
dl-PRS-CombSizeN-AndReOffset-r16 CHOICE {			
n4-r16	0		
}			
dl-PRS-ResourceSlotOffset-r16	4		
dl-PRS-ResourceSymbolOffset-r16	0		
dl-PRS-QCL-Info-r16	Not present		
}			
}			
}			
}			

Table 15.2.1.4.3-9: LPP ProvideLocation Information

Derivation Path: 37.355 clause 6.5.12			
Information Element	Value/remark	Comment	Condition
LPP-Message ::= SEQUENCE {			
transactionID SEQUENCE {			
initiator	locationServer		
transactionNumber	1		
}			
endTransaction	TRUE		
sequenceNumber	(0..255)		
acknowledgement			
lpp-MessageBody CHOICE {			
c1 CHOICE {			
provideLocationInformation SEQUENCE {			
criticalExtensions CHOICE {			
c1 CHOICE {			
provideLocationInformation-r9 SEQUENCE {			

commonEsProvideLocationInformation	Not present.		
a-gnss-ProvideLocationInformation	Not present		
otdoa-ProvideLocationInformation	Not present		
ecid-ProvideLocationInformation	Not present		
epdu-ProvideLocationInformation	Not present		
sensor-ProvideLocationInformation-r13	Not present		
tbs-ProvideLocationInformation-r13	Not present		
wlan-ProvideLocationInformation-r13	Not present		
bt-ProvideLocationInformation-r13	Not present		
nr-ECID-ProvideLocationInformation-r16	Not present		
nr-Multi-RTT-ProvideLocationInformation-r16 SEQUENCE {			
nr-Multi-RTT-SignalMeasurementInformation-r16 SEQUENCE {			
nr-Multi-RTT-MeasList-r16 SEQUENCE (SIZE(1..nrMaxTRPs-r16)) OF NR-Multi-RTT-MeasElement-r16 {	2 entries		
NR-Multi-RTT-MeasElement-r16[1] SEQUENCE {		entry 1	
dl-PRS-ID-r16	INTEGER (0..255)		
nr-PhysCellID-r16			
nr-CellGlobalID-r16			
nr-ARFCN-r16			
nr-DL-PRS-ResourceID-r16			
nr-DL-PRS-ResourceSetID-r16			
nr-UE-RxTxTimeDiff-r16	Present. Any value acceptable.		
nr-AdditionalPathList-r16			
nr-TimeStamp-r16			
nr-TimingQuality-r16			
nr-DL-PRS-RSRP-Result-r16			
nr-Multi-RTT-AdditionalMeasurements-r16			
NR-Multi-RTT-MeasElement-r16[2] SEQUENCE {		entry 2	
dl-PRS-ID-r16	INTEGER (0..255)		
nr-PhysCellID-r16			
nr-CellGlobalID-r16			
nr-ARFCN-r16			
nr-DL-PRS-ResourceID-r16			
nr-DL-PRS-ResourceSetID-r16			
nr-UE-RxTxTimeDiff-r16	Present. Any value acceptable.		
nr-AdditionalPathList-r16			
nr-TimeStamp-r16			
nr-TimingQuality-r16			
nr-DL-PRS-RSRP-Result-r16			
nr-Multi-RTT-AdditionalMeasurements-r16			
nr-NTA-Offset-r16			
nr-Multi-RTT-Error-r16			
nr-DL-AoD-ProvideLocationInformation-r16	Not present		

15.2.1.5 Test requirement

Table 15.2.1.5-1 and Table 15.2.1.5-2 define the primary level settings not including the test tolerances for the test.

Table 15.2.1.5-1: General test parameters

Parameter	Unit	Test configuration	Value	Comment
Active cell		1, 2, 3	Cell 1	Cell 1 is the PCell in <i>NR-Multi-RTT-ProvideAssistanceData</i> [49].
Neighbour cell		1, 2, 3	Cell 2	Cell 2 is a neighbour cell in <i>NR-Multi-RTT-ProvideAssistanceData</i> [49].
RF Channel Number		1, 2, 3	1	For both Cell 1 and Cell 2
BW _{channel}	MHz	1	20: N _{RB,c} = 106	
		2	20: N _{RB,c} = 106	
		3	50: N _{RB,c} = 133	
SSB configuration		1	SSB.1 FR1	
		2	SSB.1 FR1	
		3	SSB.2 FR1	
SMTC configuration		1	SMTC.2	
		2	SMTC.1	
		3	SMTC.1	
Measurement gap		1, 2, 3	GP#24 or GP#0 ^{Note 1}	
CP length		1, 2, 3	Normal	
DRX		1, 2, 3	OFF	
Time offset between serving and neighbour cells	µs	1, 2, 3	3	Synchronous cells
T1	s	1, 2, 3	5	
T2	s	1, 2, 3	10	

Note 1: GP#24 is configured if UE supports MG#24, otherwise GP#0 is configured.

Table 15.2.1.5-2: Cell specific test parameters

Parameter	Unit	Test configuration	Cell 1		Cell 2	
			T1	T2	T1	T2
TDD configuration		1	N/A		N/A	
		2	TDDConf.1.1		TDDConf.1.1	
		3	TDDConf.2.1		TDDConf.2.1	
PDSCH RMC configuration		1	SR.1.1 FDD		N/A	
		2	SR.1.1 TDD			
		3	SR.2.1 TDD			
RMSI CORESET RMC configuration		1	CR.1.1 FDD		N/A	
		2	CR.1.1 TDD			
		3	CR.2.1 TDD			
Dedicated CORESET RMC configuration		1	CCR.1.1 FDD		N/A	
		2	CCR.1.1 TDD			
		3	CCR.2.1 TDD			
OCNG Patterns		1, 2, 3	OP.1		OP.1	
TRS Configuration		1	TRS.1.1 FDD		N/A	
		2	TRS.1.1 TDD			
		3	TRS.1.2 TDD			
Initial BWP configuration		1, 2, 3	DLBWP.0.1 ULBWP.0.1		N/A	
Active DL BWP configuration		1, 2, 3	DLBWP.1.1		N/A	
Active UL BWP configuration		1, 2, 3	ULBWP.1.1		N/A	
PRS configuration		1	PRS.1.2 FR1		PRS.1.2 FR1	
		2	PRS.1.2 FR1		PRS.1.2 FR1	
		3	PRS.2.2 FR1		PRS.2.2 FR1	
PRS muting info		1, 2, 3	'10'		'01'	
SRS configuration		1	POS-SRS.1		N/A	
		2	POS-SRS.1		N/A	

		3	POS-SRS.2	N/A		
N_{oc} Note 2	dBm/SCS	1	-98			
		2	-98			
		3	-95			
N_{oc} Note 2	dBm/15 kHz	1	-98			
		2				
		3				
PRS \hat{E}_s/I_{ot}	dB	1	-Infinity	-2.41	-Infinity	-12.12
		2				
		3				
PRS \hat{E}_s/N_{oc}	dB	1	-Infinity	-1.98	-Infinity	-10
		2				
		3				
PRS-RSRP Note 3	dBm/SCS kHz	1	-Infinity	-100	-Infinity	-108
		2	-Infinity	-100	-Infinity	-108
		3	-Infinity	-97	-Infinity	-105
Io	dBm/19.08 MHz	1	N/A	-64.56	N/A	-64.56
		2		-64.56		-64.56
		3		-60.58		-60.58
Propagation Condition		1, 2, 3	AWGN			
<p>Note 1: The resources for uplink transmission are assigned to the UE prior to the start of time period T2.</p> <p>Note 2: Interference from other cells and noise sources not specified in the test is assumed to be constant over subcarriers and time and shall be modelled as AWGN of appropriate power for N_{oc} to be fulfilled.</p> <p>Note 3: PRS-RSRP levels have been derived from other parameters for information purposes. They are not settable parameters themselves.</p>						

The UE Rx-Tx time difference measurement period fulfils the requirements specified in clause 15.2.1.3.

The response time is equal to the LPP time IE value plus the test tolerance. The LPP time IE value is derived from the UE Rx-Tx time difference measurement period plus ΔT , where $\Delta T = 50\text{ms}$. The UE Rx-Tx time difference measurement period follows the equation:

$$T_{UERxTx,i} = \left(\text{CSSF}_i * N_{RxBeam,i} * \left\lceil \frac{N_{PRS,i}^{slot}}{N'} \right\rceil \left\lfloor \frac{L_{available_PRS,i}}{N} \right\rfloor * N_{sample} - 1 \right) * T_{effect,i} + T_{last,i}$$

Where $\text{CSSF}_{PRS,i} = 1$, $N_{RxBeam,i} = 1$, $N_{PRS,i}^{slot} = 2$, $L_{available_PRS,i} = 1.142$, $N_{sample} = 4$. N is the parameter durationOfPRS-ProcessingSymbols from TS 37.355 [49], N' is the parameter maxNumOfDL-PRS-ResProcessedPerSlot from TS 37.355 [49], $T_{last,i} = T_i + T_{available_PRS,i}$ and $T_{effect,i} = \left\lceil \frac{T_i}{T_{available_PRS,i}} \right\rceil * T_{available_PRS,i}$

$T_{available_PRS,i} = LCM(T_{PRS,i}, MGRP_i)$; where $T_{prs} = 160$ ms, and MGRP is 80 (for GP#24) or 40 (for GP#13) depending on UE capabilities. Therefore, $T_{available_PRS,i} = 160$ ms.

T_i depends on the UE parameter durationOfPRS-ProcessingSymbolsInEveryTms from TS 37.355 [49]

Finally, it results in the following equation:

$$\left(1 * \left\lceil \frac{2}{N'} \right\rceil \left\lfloor \frac{1.142}{N} \right\rfloor * 4 - 1 \right) * T_{effect} + T_{last}$$

Where the remaining parameters depend on the UE capabilities. The LPP time IE ranges between 0.648s and 102.56s. The value of the LPP time IE is rounded up to the next second (if the value is >128s, it should be rounded up to the next multiple of ten seconds). The result is transmitted in the response time IE in the LPP-RequestLocationInformation in Table 15.2.1.4.3-5. The LPP time IE ranges between 1s and 103s.

The test tolerance for the response time is 300ms. Therefore, the response time ranges between 1.3s and 103.3s.

The values of N' , N and T_i and the effect in the response time equation are defined in Table 15.2.1.5-3, Table 15.2.1.5-4 and Table 15.2.1.5-5 for reference.

Table 15.2.1.5-3: value of N' based on *maxNumOfDL-PRS-ResProcessedPerSlot*

<i>maxNumOfDL-PRS-ResProcessedPerSlot</i>	$\lceil \frac{2}{N'} \rceil$
n1	2
n2	1
$\geq n4$	1

Table 15.2.1.5-4: value of N based on *durationOfPRS-ProcessingSymbols*

<i>durationOfPRS-ProcessingSymbols</i>	$\lceil \frac{1.142}{N} \rceil$
nDot125	10
nDot25	5
nDot5	3
n2	2
$\geq n2$	1

Table 15.2.1.5-5: value of T_{effect} and T_{last} based on *durationOfPRS-ProcessingSymbolsInEveryTms*

<i>durationOfPRS-ProcessingSymbolsInEveryTms</i>	T_{effect}	T_{last}
n8	160	168
n16	160	176
n20	160	180
n30	160	190
n40	160	200
n80	160	240
n160	160	320
n320	320	480
n640	640	800
n1280	1280	1440

The rate of successful tests during repeated tests shall be at least 90% with a confidence level of 95%.

15.2.2 UE Rx-Tx time difference measurement period for dual positioning frequency layer in FR1 SA

15.2.2.1 Test purpose

The purpose of the test is to verify that the UE Rx-Tx measurement period meets the requirements specified in TS 38.133 [50] clause 9.9.4.5 in AWGN propagation condition in FR1 in standalone scenario when dual positioning frequency layers are configured.

15.2.2.2 Test applicability

This test applies to all types of NR UE release 16 onwards that supports Multi-RTT positioning.

15.2.2.3 Minimum conformance requirements

Same as defined in clause 15.2.1.3.

15.2.2.4 Test description

The test defines three possible test configurations; specified in Table 15.2.2.4-1. The UE is only required to be tested in one of the supported test configurations.

Table 15.2.2.4-1: Test Configurations

Test Configuration	Description
1	15 kHz SSB SCS, 20 MHz bandwidth, FDD duplex mode
2	15 kHz SSB SCS, 20 MHz bandwidth, TDD duplex mode
3	30 kHz SSB SCS, 50 MHz bandwidth, TDD duplex mode
Note: The UE is only required to be tested in one of the supported test configurations.	

15.2.2.4.1 Initial conditions

Test Environment: Normal, as defined in TS 38.508-1 [45] clause 4.1.

Frequencies to be tested: Low Range for Cell 1 and High Range for Cell2, as defined in TS 38.508-1 [45] clause 4.3.1.

Channel bandwidth to be tested: are specified in Table 15.2.2.4-1.

1. Connect the SS and AWGN noise sources to the UE antenna connector or antenna connectors as shown in Annex A, Figure A.13.
2. The general test parameter settings are set up according to Table 15.2.2.5-1 and Table 15.2.2.5-2.
3. Propagation conditions are set according to clause 4.14.2.
4. Message contents are defined in clause 15.2.2.4.3.
5. There are two cells in the test: PCell (Cell 1) and a neighbour cell (Cell 2). Cell 1 and Cell2 are on different RF channels in FR1.

15.2.2.4.2 Test procedure

Same as defined in clause 15.2.1.4.2.

15.2.2.4.3 Message contents

Table 15.2.2.4.3-1: RESET UE POSITIONING STORED INFORMATION

Derivation Path: 38.509 [44] clause 6.6			
Information Element	Value/remark	Comment	Condition
UE Positioning Technology	0 0 0 0 1 1 0	Multi-RTT	

Table 15.2.2.4.3-2: RRCReconfiguration

Derivation Path: TS 38.508-1 [45],, table 4.6.1-13			
Information Element	Value/remark	Comment	Condition
RRCReconfiguration ::= SEQUENCE {			
criticalExtensions CHOICE {			
rrcReconfiguration SEQUENCE {			
radioBearerConfig			
nonCriticalExtension SEQUENCE {			
masterCellGroup SEQUENCE {	CellGroupConfig		
spCellConfig SEQUENCE {			
spCellConfigDedicated SEQUENCE {			
uplinkConfig SEQUENCE {			
initialUplinkBWP SEQUENCE {			
srs-Config CHOICE {			
setup	As defined in Table 15.2.2.4.3-3		
}			
}			
}			
}			
}			
}			

}			
}			
}			
}			
}			

Table 15.2.2.4.3-3: SRS-Config (Table 15.2.2.4.3-2)

Derivation Path: TS 38.508-1 [45], Table 4.6.3-182			
Information Element	Value/remark	Comment	Condition
SRS-Config ::= SEQUENCE {			
srs-ResourceSetToReleaseList	Not present		
srs-ResourceSetToAddModList	Not present		
srs-ResourceToReleaseList	Not present		
srs-ResourceToAddModList	Not present		
tpc-Accumulation	Not present		
srs-RequestDCI-1-2-r16	Not present		
srs-RequestDCI-0-2-r16	Not present		
srs-ResourceSetToAddModListDCI-0-2-r16	Not present		
srs-ResourceSetToReleaseListDCI-0-2-r16	Not present		
srs-PosResourceSetToReleaseList-r16	Not present		
srs-PosResourceSetToAddModList-r16 SEQUENCE (SIZE(1..maxNrofSRS-PosResourceSets-r16)) OF SRS-PosResourceSet-r16 {	1 entry		
SRS-PosResourceSet-r16[1] SEQUENCE {		entry 1	
srs-PosResourceSetId-r16	0		
srs-PosResourceCidList-r16 SEQUENCE (SIZE(1..maxNrofSRS-ResourcesPerSet)) OF SRS-PosResourceCid-r16 {	1 entry		
SRS-PosResourceCid-r16	0	1 entry	
}			
resourceType CHOICE {			
periodic SEQUENCE {			
}			
}			
alpha-r16	alpha0		
p0-r16	0		
pathlossReferenceRS-Pos-r16	Not present		
}			
srs-PosResourceToReleaseList-r16	Not present		
srs-PosResourceToAddModList-r16 SEQUENCE (SIZE(1..maxNrofSRS-PosResources-r16)) OF SRS-PosResource-r16 {	1 entry		
SRS-PosResource-r16[1] SEQUENCE {		entry 1	
srs-PosResourceCid-r16	0		
transmissionComb-r16 CHOICE {			
n4-r16 SEQUENCE {			
combOffset-n4-r16	0		
cyclicShift-n4-r16	0		
}			
}			
resourceMapping-r16 SEQUENCE {			
startPosition-r16	0		
nrofSymbols-r16	n4		
}			
freqDomainShift-r16	0		
freqHopping-r16 SEQUENCE {			
c-SRS-r16	Matches N _{RB,c} Table 15.2.2.5-1		
}			
groupOrSequenceHopping-r16	neither		
resourceType-r16 CHOICE {			
periodic-r16 SEQUENCE {			
periodicityAndOffset-p-r16 CHOICE {			

sl160	20		Configuratio n 1 and Configuratio n 2
sl320	40		Configuratio n 3
}			
}			
}			
sequenceId-r16	0		
spatialRelationInfoPos-r16	Not present		
}			
}			
}			

Table 15.2.2.4.3-4: LPP Request Capabilities

Information Element	Value/remark
nr-Multi-RTT-RequestCapabilities-r16	TRUE

Table 15.2.2.4.3-5: LPP RequestLocationInformation

Derivation Path: 37.355 clause 6.2			
Information Element	Value/remark	Comment	Condition
LPP-Message ::= SEQUENCE {			
transactionID SEQUENCE {			
initiator	locationServer		
transactionNumber	1		
}			
endTransaction	FALSE		
sequenceNumber	Not present		
acknowledgement	Not present		
lpp-MessageBody CHOICE {			
c1 CHOICE {			
requestLocationInformation SEQUENCE {			
criticalExtensions CHOICE {			
c1 CHOICE {			
requestLocationInformation-r9 SEQUENCE {			
commonEsRequestLocationInformation SEQUENCE {			
locationInformationType	locationMeasurementsRe quired		
triggeredReporting	Not present		
periodicalReporting	Not present		
additionalInformation	onlyReturnInformationReq uested		
qos SEQUENCE {			
horizontalAccuracy	Not present		
verticalCoordinateRequest	FALSE		
verticalAccuracy	Not present		
responseTime SEQUENCE {			
time	20		
responseTimeEarlyFix-r12	Not present		Rel-12 onwards
}			
velocityRequest	FALSE		
}			
environment	Not present		
locationCoordinateTypes	Not present		
velocityTypes	Not present		
}			
a-gnss-RequestLocationInformation	Not present		
otdoa-RequestLocationInformation	Not present		

ecid-RequestLocationInformation	Not present		
epdu-RequestLocationInformation	Not Present		
sensor-RequestLocationInformation-r13	Not present		
tbs-RequestLocationInformation-r13	Not present		
wlan-RequestLocationInformation-r13	Not present		
bt-RequestLocationInformation-r13	Not present		
nr-ECID-RequestLocationInformation-r16	Not present		
nr-Multi-RTT-RequestLocationInformation-r16			
SEQUENCE {			
nr-UE-RxTxTimeDiffMeasurementInfoRequest-r16	Not present		
nr-RequestedMeasurements-r16	bit 0 = 1 (prsrsrpReq)		
nr-AssistanceAvailability-r16	FALSE		
nr-Multi-RTT-ReportConfig-r16 SEQUENCE {			
maxDL-PRS-RxTxTimeDiffMeasPerTRP-r16	Not present		
timingReportingGranularityFactor-r16	Not present		
}			
additionalPaths-r16	Not present		
}			
nr-DL-AoD-RequestLocationInformation-r16	Not present		
nr-DL-TDOA-RequestLocationInformation-r16	Not present		
}			
}			
}			
}			
}			
}			
}			
}			
}			
}			
}			

Table 15.2.2.4.3-6: LPP ProvideAssistanceData

Derivation Path: 37.355 clause 6.2			
Information Element	Value/remark	Comment	Condition
LPP-Message ::= SEQUENCE {			
transactionID SEQUENCE {			
initiator	locationServer		
transactionNumber	(0..255)		
}			
endTransaction	TRUE		
sequenceNumber	Not present		
acknowledgement	Not present		
lpp-MessageBody CHOICE {			
c1 CHOICE {			
provideAssistanceData SEQUENCE {			
criticalExtensions CHOICE {			
c1 CHOICE {			
provideAssistanceData-r9 SEQUENCE {			
commonEsProvideAssistanceData	Not present		
a-gnss-ProvideAssistanceData	Not present		
otdoa-ProvideAssistanceData	Not present		
epdu-Provide-AssistanceData	Not present		
sensor-ProvideAssistanceData-r15	Not present		
tbs-ProvideAssistanceData-r15	Not present		
wlan-ProvideAssistanceData-r15	Not present		
nr-Multi-RTT-ProvideAssistanceData-r16			
SEQUENCE {			
nr-DL-PRS-AssistanceData	As defined in Table 15.2.2.4.3-7		
nr-SelectedDL-PRS-IndexList-r16	Not present		
nr-Multi-RTT-Error-r16	Not present		
}			
nr-DL-AoD-ProvideAssistanceData-r16	Not present		
nr-DL-TDOA-ProvideAssistanceData-r16	Not present		
}			
}			
}			
}			
}			

}			
}			
}			
}			

Table 15.2.2.4.3-7: NR-DL-PRS-AssistanceData

Derivation Path: 37.355 clause 6.4.3			
Information Element	Value/remark	Comment	Condition
NR-DL-PRS-AssistanceData-r16 ::= SEQUENCE {			
nr-DL-PRS-ReferenceInfo-r16 SEQUENCE {			
dl-PRS-ID-r16	0		
nr-DL-PRS-ResourceID-List-r16	Not present		
nr-DL-PRS-ResourceSetID-r16	Not present		
}			
nr-DL-PRS-AssistanceDataList-r16 SEQUENCE (SIZE (1..nrMaxFreqLayers-r16)) OF NR-DL-PRS-AssistanceDataPerFreq-r16 {	2 entries		
NR-DL-PRS-AssistanceDataPerFreq-r16[1] SEQUENCE {		entry 1	
nr-DL-PRS-PositioningFrequencyLayer-r16 SEQUENCE {			
dl-PRS-SubcarrierSpacing-r16	kHz15		Configuration 1 and Configuration 2
	kHz30		Configuration 3
dl-PRS-ResourceBandwidth-r16	21	104 PRBs	Configuration 1 and Configuration 2
	28	132 PRBs	Configuration 3
dl-PRS-StartPRB-r16	0		
dl-PRS-PointA-r16	absoluteFrequencyPointA as defined for the DL frequency of the Cell 1		
dl-PRS-CombSizeN-r16	n4		
dl-PRS-CyclicPrefix-r16	normal		
}			
nr-DL-PRS-AssistanceDataPerFreq-r16 SEQUENCE (SIZE (1..nrMaxTRPsPerFreq-r16)) OF NR-DL-PRS-AssistanceDataPerTRP-r16{	1 entry		
NR-DL-PRS-AssistanceDataPerTRP-r16[1] SEQUENCE {		entry 1	Cell 1
dl-PRS-ID-r16	0		
nr-PhysCellID-r16	Cell 1		
nr-CellGlobalID-r16	Cell 1		
nr-ARFCN-r16	Cell 1		
nr-DL-PRS-SFN0-Offset-r16 SEQUENCE {			
sfn-Offset-r16	0		
integerSubframeOffset-r16	0		
}			
nr-DL-PRS-ExpectedRSTD-r16	0		
nr-DL-PRS-ExpectedRSTD-Uncertainty-r16	0		
nr-DL-PRS-Info-r16	As specified in Table 15.2.2.4.3-8		
}			
}			
}			
NR-DL-PRS-AssistanceDataPerFreq-r16[2] SEQUENCE {		entry 2	
nr-DL-PRS-PositioningFrequencyLayer-r16 SEQUENCE {			

dl-PRS-SubcarrierSpacing-r16	kHz15		Configurati on 1 and Configurati on 2
	kHz30		Configurati on 3
dl-PRS-ResourceBandwidth-r16	21	104 PRBs	Configurati on 1 and Configurati on 2
	28	132 PRBs	Configurati on 3
dl-PRS-StartPRB-r16	0		
dl-PRS-PointA-r16	absoluteFrequencyPointA as defined for the DL frequency of the Cell 2		
dl-PRS-CombSizeN-r16	n4		
dl-PRS-CyclicPrefix-r16	normal		
}			
nr-DL-PRS-AssistanceDataPerFreq-r16 SEQUENCE (SIZE (1..nrMaxTRPsPerFreq-r16)) OF NR-DL-PRS-AssistanceDataPerTRP-r16{	1 entry		
NR-DL-PRS-AssistanceDataPerTRP-r16[1] SEQUENCE {		entry 1	Cell 2
dl-PRS-ID-r16	1		
nr-PhysCellID-r16	Cell 2		
nr-CellGlobalID-r16	Cell 2		
nr-ARFCN-r16	Cell 2		
nr-DL-PRS-SFN0-Offset-r16 SEQUENCE {			
sfn-Offset-r16	0		
integerSubframeOffset-r16	0		
}			
nr-DL-PRS-ExpectedRSTD-r16	23	About 3 μs	
nr-DL-PRS-ExpectedRSTD-Uncertainty-r16	39	About 5 μs	
nr-DL-PRS-Info-r16	As specified in Table 15.2.2.4.3-8		
}			
}			
}			
}			
}			
}			

Table 15.2.2.4.3-8: NR-DL-PRS-Info

Derivation Path: 37.355 clause 6.4.3			
Information Element	Value/remark	Comment	Condition
NR-DL-PRS-Info-r16 ::= SEQUENCE {			
nr-DL-PRS-ResourceSetList-r16 SEQUENCE (SIZE (1..nrMaxSetsPerTrp-r16)) OF NR-DL-PRS-ResourceSet-r16 {	1 entry		
NR-DL-PRS-ResourceSet-r16[1] SEQUENCE {		entry 1	
nr-DL-PRS-ResourceSetID-r16	0		
dl-PRS-Periodicity-and-ResourceSetSlotOffset-r16 CHOICE {			
scs15-r16 CHOICE {			Configurati on 1 and Configurati on 2
n160-r16	10		
}			
scs30-r16 CHOICE {			Configurati on 3
n320-r16	20		
}			
dl-PRS-ResourceRepetitionFactor-r16	Not present		

dl-PRS-ResourceTimeGap-r16	s1		
dl-PRS-NumSymbols-r16	n4		
dl-PRS-MutingOption1-r16 SEQUENCE {			
dl-prs-MutingBitRepetitionFactor-r16	Not present		
nr-option1-muting-r16 CHOICE {			
po2-r16	10		Cell 1
	01		Cell 2
}			
}			
dl-PRS-MutingOption2-r16	Not present		
dl-PRS-ResourcePower-r16	27		
dl-PRS-ResourceList-r16 SEQUENCE (SIZE (1..nrMaxResourcesPerSet-r16)) OF NR-DL-PRS-Resource-r16 {	1 entry		
NR-DL-PRS-Resource-r16[1] SEQUENCE {		entry 1	
nr-DL-PRS-ResourceID-r16	0		
dl-PRS-SequenceID-r16	0		
dl-PRS-CombSizeN-AndReOffset-r16 CHOICE {			
n4-r16	0		
}			
dl-PRS-ResourceSlotOffset-r16	4		
dl-PRS-ResourceSymbolOffset-r16	0		
dl-PRS-QCL-Info-r16	Not present		
}			
}			
}			
}			
}			

Table 15.2.2.4.3-9: LPP ProvideLocation Information

Derivation Path: 37.355 clause 6.5.12			
Information Element	Value/remark	Comment	Condition
LPP-Message ::= SEQUENCE {			
transactionID SEQUENCE {			
initiator	locationServer		
transactionNumber	1		
}			
endTransaction	TRUE		
sequenceNumber	(0..255)		
acknowledgement			
lpp-MessageBody CHOICE {			
c1 CHOICE {			
provideLocationInformation SEQUENCE {			
criticalExtensions CHOICE {			
c1 CHOICE {			
provideLocationInformation-r9 SEQUENCE {			
commonIEsProvideLocationInformation	Not present.		
a-gnss-ProvideLocationInformation	Not present		
otdoa-ProvideLocationInformation	Not present		
ecid-ProvideLocationInformation	Not present		
epdu-ProvideLocationInformation	Not present		
sensor-ProvideLocationInformation-r13	Not present		
tbs-ProvideLocationInformation-r13	Not present		
wlan-ProvideLocationInformation-r13	Not present		
bt-ProvideLocationInformation-r13	Not present		
nr-ECID-ProvideLocationInformation-r16	Not present		
nr-Multi-RTT-ProvideLocationInformation-r16 SEQUENCE {			
nr-Multi-RTT-SignalMeasurementInformation-r16 SEQUENCE {			
nr-Multi-RTT-MeasList-r16 SEQUENCE (SIZE(1..nrMaxTRPs-r16)) OF NR-Multi-RTT-MeasElement-r16 {	2 entries		

NR-Multi-RTT-MeasElement-r16[1]		entry 1	
SEQUENCE {			
dl-PRS-ID-r16	INTEGER (0..255)		
nr-PhysCellID-r16			
nr-CellGlobalID-r16			
nr-ARFCN-r16			
nr-DL-PRS-ResourceID-r16			
nr-DL-PRS-ResourceSetID-r16			
nr-UE-RxTxTimeDiff-r16	Present. Any value acceptable.		
nr-AdditionalPathList-r16			
nr-TimeStamp-r16			
nr-TimingQuality-r16			
nr-DL-PRS-RSRP-Result-r16			
nr-Multi-RTT-AdditionalMeasurements-r16			
}			
NR-Multi-RTT-MeasElement-r16[2]		entry 2	
SEQUENCE {			
dl-PRS-ID-r16	INTEGER (0..255)		
nr-PhysCellID-r16			
nr-CellGlobalID-r16			
nr-ARFCN-r16			
nr-DL-PRS-ResourceID-r16			
nr-DL-PRS-ResourceSetID-r16			
nr-UE-RxTxTimeDiff-r16	Present. Any value acceptable.		
nr-AdditionalPathList-r16			
nr-TimeStamp-r16			
nr-TimingQuality-r16			
nr-DL-PRS-RSRP-Result-r16			
nr-Multi-RTT-AdditionalMeasurements-r16			
}			
}			
nr-NTA-Offset-r16			
}			
nr-Multi-RTT-Error-r16			
}			
nr-DL-AoD-ProvideLocationInformation-r16	Not present		
}			
}			
}			
}			
}			
}			
}			

15.2.2.5 Test requirement

Table 15.2.2.5-1 and Table 15.2.2.5-2 define the primary level settings not including the test tolerances for the test.

Table 15.2.2.5-1: General test parameters

Parameter	Unit	Test configuration	Value	Comment
Active cell		1, 2, 3	Cell 1	Cell 1 is the PCell in <i>NR-Multi-RTT-ProvideAssistanceData</i> [49].
Neighbour cell		1, 2, 3	Cell 2	Cell 2 is a neighbour cell in <i>NR-Multi-RTT-ProvideAssistanceData</i> [49].
RF Channel Number		1, 2, 3	1	For Cell 1
RF Channel Number		1, 2, 3	2	For Cell 2

BW _{channel}	MHz	1	20: N _{RB,c} = 106	
		2	20: N _{RB,c} = 106	
		3	50: N _{RB,c} = 133	
SSB configuration		1	SSB.1 FR1	
		2	SSB.1 FR1	
		3	SSB.2 FR1	
SMTTC configuration		1	SMTTC.2	
		2	SMTTC.1	
		3	SMTTC.1	
Measurement gap		1, 2, 3	GP#24 or GP#0 ^{Note 1}	
CP length		1, 2, 3	Normal	
DRX		1, 2, 3	OFF	
Time offset between serving and neighbour cells	µs	1, 2, 3	3	Synchronous cells
T1	s	1, 2, 3	5	
T2	s	1, 2, 3	10	
Note 1: GP#24 is configured if UE supports MG#24, otherwise GP#0 is configured.				

Table 15.2.2.5-2: Cell specific test parameters

Parameter	Unit	Test configuration	Cell 1		Cell 2	
			T1	T2	T1	T2
TDD configuration		1	N/A		N/A	
		2	TDDConf.1.1		TDDConf.1.1	
		3	TDDConf.2.1		TDDConf.2.1	
PDSCH RMC configuration		1	SR.1.1 FDD		N/A	
		2	SR.1.1 TDD			
		3	SR.2.1 TDD			
RMSI CORESET RMC configuration		1	CR.1.1 FDD		N/A	
		2	CR.1.1 TDD			
		3	CR.2.1 TDD			
Dedicated CORESET RMC configuration		1	CCR.1.1 FDD		N/A	
		2	CCR.1.1 TDD			
		3	CCR.2.1 TDD			
OCNG Patterns		1, 2, 3	OP.1		OP.1	
TRS Configuration		1	TRS.1.1 FDD		N/A	
		2	TRS.1.1 TDD			
		3	TRS.1.2 TDD			
Initial BWP configuration		1, 2, 3	DLBWP.0.1 ULBWP.0.1		N/A	
Active DL BWP configuration		1, 2, 3	DLBWP.1.1		N/A	
Active UL BWP configuration		1, 2, 3	ULBWP.1.1		N/A	
PRS configuration		1	PRS.1.2 FR1		PRS.1.2 FR1	
		2	PRS.1.2 FR1		PRS.1.2 FR1	
		3	PRS.2.2 FR1		PRS.2.2 FR1	
PRS muting info		1, 2, 3	'10'		'01'	
SRS configuration		1	POS-SRS.1		N/A	
		2	POS-SRS.1		N/A	
		3	POS-SRS.2		N/A	
N _{oc} ^{Note 2}	dBm/SCS	1	-98			
		2	-98			
		3	-95			
N _{oc} ^{Note 2}	dBm/15 kHz	1	-98			
		2				
		3				
PRS \hat{E}_s / I_{ot}	dB	1	-Infinity	-3	-Infinity	-13
		2				
		3				
PRS \hat{E}_s / N_{oc}	dB	1	-Infinity	-2.4	-Infinity	-12.4
		2				
		3				
PRS-RSRP ^{Note 3}	dBm/SCS kHz	1	-Infinity	-100.4	-Infinity	-110.4

		2	-Infinity	-100.4	-Infinity	-110.4
		3	-Infinity	-97.4	-Infinity	-107.4
Io	dBm/19.08 MHz	1	N/A	-64.98	N/A	-66.71
	dBm/19.08 MHz	2		-64.98		-66.71
	dBm/47.88 MHz	3		-61.00		-62.73
Propagation Condition		1, 2, 3		AWGN		
<p>Note 1: The resources for uplink transmission are assigned to the UE prior to the start of time period T2.</p> <p>Note 2: Interference from other cells and noise sources not specified in the test is assumed to be constant over subcarriers and time and shall be modelled as AWGN of appropriate power for N_{oc} to be fulfilled.</p> <p>Note 3: PRS-RSRP levels have been derived from other parameters for information purposes. They are not settable parameters themselves.</p>						

The UE Rx-Tx time difference measurement period fulfils the requirements specified in clause 15.2.2.2.

The response time is equal to the LPP time IE value plus the test tolerance. The LPP time IE value is derived from the UE Rx-Tx time difference measurement period plus ΔT, where ΔT = 50ms. The UE Rx-Tx time difference measurement period follows the equation:

$$T_{UERxTx, Total} = T_{UERxTx, 1} + T_{UERxTx, 2} + Max(T_{effect,i}).$$

$$T_{UERxTx,i} = \left(CSSF_1 * N_{RxBeam,i} * \left\lceil \frac{N_{PRS,i}^{slot}}{N'} \right\rceil \left\lfloor \frac{L_{available_PRS,i}}{N} \right\rfloor * N_{sample} - 1 \right) * T_{effect,i} + T_{last,i}$$

Where $CSSF_{PRS,i} = 1$, $N_{RxBeam,i} = 1$, $N_{PRS,i}^{slot} = 1$, $L_{available_PRS,i} = 0.571$, $N_{sample} = 4$. N is the parameter durationOfPRS-ProcessingSymbols from TS 37.355 [49], N' is the parameter maxNumOfDL-PRS-ResProcessedPerSlot from TS 37.355 [49], $T_{last,i} = T_i + T_{available_PRS,i}$ and $T_{effect,i} = \left\lfloor \frac{T_i}{T_{available_PRS,i}} \right\rfloor * T_{available_PRS,i}$

$T_{available_PRS,i} = LCM(T_{PRS,i}, MGRP_i)$; where $T_{prs} = 160$ ms, and MGRP is 80 (for GP#24) or 40 (for GP#13) depending on UE capabilities. Therefore, $T_{available_PRS,i} = 160$ ms.

T_i depends on the UE parameter durationOfPRS-ProcessingSymbolsInEveryTms from TS 37.355 [49]

Finally, it results in the following equation:

$$\left(1 * \left\lceil \frac{1}{N'} \right\rceil \left\lfloor \frac{0.571}{N} \right\rfloor * 4 - 1 \right) * T_{effect} + T_{last}$$

Where the remaining parameters depend on the UE capabilities. The LPP time IE ranges between 1.456s and 52.8s. The value of the LPP time IE is rounded up to the next second (if the value is >128s, it should be rounded up to the next multiple of ten seconds). The result is transmitted in the response time IE in the LPP-RequestLocationInformation in Table 15.2.2.4.3-5. The LPP time IE ranges between 2s and 53s.

The test tolerance for the response time is 300ms. Therefore, the response time ranges between 2.3s and 53.3s.

The values of N', N and Ti and the effect in the response time equation are defined in Table 15.2.2.5-3, Table 15.2.2.5-4 and Table 15.2.2.5-5 for reference.

Table 15.2.2.5-3: value of N' based on maxNumOfDL-PRS-ResProcessedPerSlot

maxNumOfDL-PRS-ResProcessedPerSlot	$\left\lceil \frac{1}{N'} \right\rceil$
>=n1	1

Table 15.2.2.5-4: value of N based on *durationOfPRS-ProcessingSymbols*

<i>durationOfPRS-ProcessingSymbols</i>	[0, 571]
	N
nDot125	5
nDot25	3
nDot5	2
>=n2	1

Table 15.2.2.5-5: value of T_{effect} and T_{last} based on *durationOfPRS-ProcessingSymbolsInEveryTms*

<i>durationOfPRS-ProcessingSymbolsInEveryTms</i>	T_{effect}	T_{last}
n8	160	168
n16	160	176
n20	160	180
n30	160	190
n40	160	200
n80	160	240
n160	160	320
n320	320	480
n640	640	800
n1280	1280	1440

The rate of successful tests during repeated tests shall be at least 90% with a confidence level of 95%.

15.2.3 UE Rx-Tx time difference measurement period for single positioning frequency layer in FR2 SA

Editor's Note: This test case has been completed for the following configurations:

- Test frequency $f \leq 40.8$ GHz

- UE PC3

This test case is incomplete for UE power classes other than PC3

This test case is incomplete for test frequencies > 40.8 GHz

15.2.3.1 Test purpose

The purpose of the test is to verify that the UE Rx-Tx measurement period meets the requirements specified in TS 38.133 [50] clause 9.9.4.5 in AWGN propagation condition in FR2 in standalone scenario when single positioning frequency layer is configured.

15.2.3.2 Test applicability

This test applies to all types of NR UE release 16 onwards that supports Multi-RTT positioning.

15.2.3.3 Minimum conformance requirements

Same as defined in clause 15.2.1.3.

15.2.3.4 Test description

The supported test configurations in listed in Table 15.2.3.4-1.

Table 15.2.3.4-1: Test Configurations

Test Configuration	Description
--------------------	-------------

1	120 kHz SSB and PRS SCS, 200 MHz bandwidth, TDD duplex mode
---	---

15.2.3.4.1 Initial conditions

Test Environment: Normal, as defined in TS 38.508-1 [45] clause 4.1.

Frequencies to be tested: Mid Range, as defined in TS 38.508-1 [45] clause 4.3.1.

Channel bandwidth to be tested: are specified in Table 15.2.3.4-1.

1. Connect the SS and AWGN noise sources to the UE antenna connector or antenna connectors as shown in Annex A, Figure A.14.
2. The general test parameter settings are set up according to Table 15.2.3.5-1 and Table 15.2.3.5-2.
3. Propagation conditions are set according to clause 4.14.2.
4. Message contents are defined in clause 15.2.3.4.3.
5. There are two cells in the test: PCell (Cell 1) and a neighbour cell (Cell 2). All cells are on the same RF channel in FR2.

15.2.3.4.2 Test procedure

Same as defined in clause 15.2.1.4.2.

15.2.3.4.3 Message contents

Table 15.2.3.4.3-1: RESET UE POSITIONING STORED INFORMATION

Derivation Path: 38.509 [44] clause 6.6			
Information Element	Value/remark	Comment	Condition
UE Positioning Technology	0 0 0 0 1 1 0	Multi-RTT	

Table 15.2.3.4.3-2: RRCReconfiguration

Derivation Path: TS 38.508-1 [45],, table 4.6.1-13			
Information Element	Value/remark	Comment	Condition
RRCReconfiguration ::= SEQUENCE {			
criticalExtensions CHOICE {			
rrcReconfiguration SEQUENCE {			
radioBearerConfig			
nonCriticalExtension SEQUENCE {			
masterCellGroup SEQUENCE {	CellGroupConfig		
spCellConfig SEQUENCE {			
spCellConfigDedicated SEQUENCE {			
uplinkConfig SEQUENCE {			
initialUplinkBWP SEQUENCE {			
srs-Config CHOICE {			
setup	As defined in Table 15.2.3.4.3-3		
}			
}			
}			
}			
}			
}			

Table 15.2.3.4.3-3: SRS-Config (Table 15.2.3.4.3-2)

Derivation Path: TS 38.508-1 [45], Table 4.6.3-182			
Information Element	Value/remark	Comment	Condition
SRS-Config ::= SEQUENCE {			
srs-ResourceSetToReleaseList	Not present		
srs-ResourceSetToAddModList	Not present		
srs-ResourceToReleaseList	Not present		
srs-ResourceToAddModList	Not present		
tpc-Accumulation	Not present		
srs-RequestDCI-1-2-r16	Not present		
srs-RequestDCI-0-2-r16	Not present		
srs-ResourceSetToAddModListDCI-0-2-r16	Not present		
srs-ResourceSetToReleaseListDCI-0-2-r16	Not present		
srs-PosResourceSetToReleaseList-r16	Not present		
srs-PosResourceSetToAddModList-r16 SEQUENCE (SIZE(1..maxNrofSRS-PosResourceSets-r16)) OF SRS-PosResourceSet-r16 {	1 entry		
SRS-PosResourceSet-r16[1] SEQUENCE {		entry 1	
srs-PosResourceSetId-r16	0		
srs-PosResourceCidList-r16 SEQUENCE (SIZE(1..maxNrofSRS-ResourcesPerSet)) OF SRS-PosResourceCid-r16 {	1 entry		
SRS-PosResourceCid-r16	0	1 entry	
}			
resourceType CHOICE {			
periodic SEQUENCE {			
}			
}			
alpha-r16	alpha0		
p0-r16	0		
pathlossReferenceRS-Pos-r16	Not present		
}			
srs-PosResourceToReleaseList-r16	Not present		
srs-PosResourceToAddModList-r16 SEQUENCE (SIZE(1..maxNrofSRS-PosResources-r16)) OF SRS-PosResource-r16 {	1 entry		
SRS-PosResource-r16[1] SEQUENCE {		entry 1	
srs-PosResourceCid-r16	0		
transmissionComb-r16 CHOICE {			
n4-r16 SEQUENCE {			
combOffset-n4-r16	0		
cyclicShift-n4-r16	0		
}			
}			
resourceMapping-r16 SEQUENCE {			
startPosition-r16	0		
nrofSymbols-r16	n4		
}			
freqDomainShift-r16	0		
freqHopping-r16 SEQUENCE {			
c-SRS-r16	Matches N _{RB,c} Table 15.3.2.5-1		
}			
groupOrSequenceHopping-r16	neither		
resourceType-r16 CHOICE {			
periodic-r16 SEQUENCE {			
periodicityAndOffset-p-r16 CHOICE {			
sl1280	160		
}			
}			
}			
sequencId-r16	0		
spatialRelationInfoPos-r16	Not present		
}			
}			

}		
---	--	--

Table 15.2.3.4.3-4: LPP Request Capabilities

Information Element	Value/remark
nr-Multi-RTT-RequestCapabilities-r16	TRUE

Table 15.2.3.4.3-5: LPP RequestLocationInformation

Derivation Path: 37.355 clause 6.2			
Information Element	Value/remark	Comment	Condition
LPP-Message ::= SEQUENCE {			
transactionID SEQUENCE {			
initiator	locationServer		
transactionNumber	1		
}			
endTransaction	FALSE		
sequenceNumber	Not present		
acknowledgement	Not present		
lpp-MessageBody CHOICE {			
c1 CHOICE {			
requestLocationInformation SEQUENCE {			
criticalExtensions CHOICE {			
c1 CHOICE {			
requestLocationInformation-r9 SEQUENCE {			
commonEsRequestLocationInformation SEQUENCE {			
locationInformationType	locationMeasurementsRequired		
triggeredReporting	Not present		
periodicalReporting	Not present		
additionalInformation	onlyReturnInformationRequested		
qos SEQUENCE {			
horizontalAccuracy	Not present		
verticalCoordinateRequest	FALSE		
verticalAccuracy	Not present		
responseTime SEQUENCE {			
time	See 15.2.3.5	Result of the response time calculation rounded up to the next second if response time <= 128s. Result of the response time calculation rounded up to the next multiple of ten seconds if response time > 128s	
responseTimeEarlyFix-r12	Not present		Rel-12 onwards
}			
velocityRequest	FALSE		
}			
environment	Not present		
locationCoordinateTypes	Not present		
velocityTypes	Not present		
}			
a-gnss-RequestLocationInformation	Not present		
otdoa-RequestLocationInformation	Not present		
ecid-RequestLocationInformation	Not present		

epdu-RequestLocationInformation	Not Present		
sensor-RequestLocationInformation-r13	Not present		
tbs-RequestLocationInformation-r13	Not present		
wlan-RequestLocationInformation-r13	Not present		
bt-RequestLocationInformation-r13	Not present		
nr-ECID-RequestLocationInformation-r16	Not present		
nr-Multi-RTT-RequestLocationInformation-r16			
SEQUENCE {			
nr-UE-	Not present		
RxTxTimeDiffMeasurementInfoRequest-r16			
nr-RequestedMeasurements-r16	bit 0 = 1 (prsrspReq)		
nr-AssistanceAvailability-r16	FALSE		
nr-Multi-RTT-ReportConfig-r16 SEQUENCE {			
maxDL-PRS-RxTxTimeDiffMeasPerTRP-r16	Not present		
timingReportingGranularityFactor-r16	Not present		
}			
additionalPaths-r16	Not present		
}			
nr-DL-AoD-RequestLocationInformation-r16	Not present		
nr-DL-TDOA-RequestLocationInformation-r16	Not present		
}			
}			
}			
}			
}			
}			
}			

Table 15.2.3.4.3-6: LPP ProvideAssistanceData

Derivation Path: 37.355 clause 6.2			
Information Element	Value/remark	Comment	Condition
LPP-Message ::= SEQUENCE {			
transactionID SEQUENCE {			
initiator	locationServer		
transactionNumber	(0..255)		
}			
endTransaction	TRUE		
sequenceNumber	Not present		
acknowledgement	Not present		
lpp-MessageBody CHOICE {			
c1 CHOICE {			
provideAssistanceData SEQUENCE {			
criticalExtensions CHOICE {			
c1 CHOICE {			
provideAssistanceData-r9 SEQUENCE {			
commonEsProvideAssistanceData	Not present		
a-gnss-ProvideAssistanceData	Not present		
otdoa-ProvideAssistanceData	Not present		
epdu-Provide-AssistanceData	Not present		
sensor-ProvideAssistanceData-r15	Not present		
tbs-ProvideAssistanceData-r15	Not present		
wlan-ProvideAssistanceData-r15	Not present		
nr-Multi-RTT-ProvideAssistanceData-r16			
SEQUENCE {			
nr-DL-PRS-AssistanceData	As defined in Table 15.2.3.4.3-7		
nr-SelectedDL-PRS-IndexList-r16	Not present		
nr-Multi-RTT-Error-r16	Not present		
}			
nr-DL-AoD-ProvideAssistanceData-r16	Not present		
nr-DL-TDOA-ProvideAssistanceData-r16	Not present		
}			
}			
}			
}			
}			

}			
}			
}			

Table 15.2.3.4.3-7: NR-DL-PRS-AssistanceData

Derivation Path: 37.355 clause 6.4.3			
Information Element	Value/remark	Comment	Condition
NR-DL-PRS-AssistanceData-r16 ::= SEQUENCE {			
nr-DL-PRS-ReferenceInfo-r16 SEQUENCE {			
dl-PRS-ID-r16	0		
nr-DL-PRS-ResourceID-List-r16	Not present		
nr-DL-PRS-ResourceSetID-r16	Not present		
}			
nr-DL-PRS-AssistanceDataList-r16 SEQUENCE (SIZE (1..nrMaxFreqLayers-r16)) OF NR-DL-PRS-AssistanceDataPerFreq-r16 {	1 entry		
NR-DL-PRS-AssistanceDataPerFreq-r16[1] SEQUENCE {		entry 1	
nr-DL-PRS-PositioningFrequencyLayer-r16 SEQUENCE {			
dl-PRS-SubcarrierSpacing-r16	kHz120		
dl-PRS-ResourceBandwidth-r16	3	32 PRBs	
dl-PRS-StartPRB-r16	0		
dl-PRS-PointA-r16	absoluteFrequencyPointA as defined for the DL frequency of the Cell 1		
dl-PRS-CombSizeN-r16	n2		
dl-PRS-CyclicPrefix-r16	normal		
}			
nr-DL-PRS-AssistanceDataPerFreq-r16 SEQUENCE (SIZE (1..nrMaxTRPsPerFreq-r16)) OF NR-DL-PRS-AssistanceDataPerTRP-r16{	2 entries		
NR-DL-PRS-AssistanceDataPerTRP-r16[1] SEQUENCE {		entry 1	Cell 1
dl-PRS-ID-r16	0		
nr-PhysCellID-r16	Cell 1		
nr-CellGlobalID-r16	Cell 1		
nr-ARFCN-r16	Cell 1		
nr-DL-PRS-SFN0-Offset-r16 SEQUENCE {			
sfn-Offset-r16	0		
integerSubframeOffset-r16	0		
}			
nr-DL-PRS-ExpectedRSTD-r16	0		
nr-DL-PRS-ExpectedRSTD-Uncertainty-r16	0		
nr-DL-PRS-Info-r16	As specified in Table 15.2.3.4.3-8		
}			
NR-DL-PRS-AssistanceDataPerTRP-r16[2] SEQUENCE {		entry 2	Cell 2
dl-PRS-ID-r16	1		
nr-PhysCellID-r16	Cell 2		
nr-CellGlobalID-r16	Cell 2		
nr-ARFCN-r16	Cell 2		
nr-DL-PRS-SFN0-Offset-r16 SEQUENCE {			
sfn-Offset-r16	0		
integerSubframeOffset-r16	0		
}			
nr-DL-PRS-ExpectedRSTD-r16	23	About 3 μs	
nr-DL-PRS-ExpectedRSTD-Uncertainty-r16	154	About 5 μs	
nr-DL-PRS-Info-r16	As specified in Table 15.2.3.4.3-8		
}			
}			
}			
}			

}			
}			

Table 15.2.3.4.3-8: NR-DL-PRS-Info

Derivation Path: 37.355 clause 6.4.3			
Information Element	Value/remark	Comment	Condition
NR-DL-PRS-Info-r16 ::= SEQUENCE {			
nr-DL-PRS-ResourceSetList-r16 SEQUENCE (SIZE (1..nrMaxSetsPerTrp-r16)) OF NR-DL-PRS-ResourceSet-r16 {	1 entry		
NR-DL-PRS-ResourceSet-r16[1] SEQUENCE {		entry 1	
nr-DL-PRS-ResourceSetID-r16	0		
dl-PRS-Periodicity-and-ResourceSetSlotOffset-r16 CHOICE {			
scs120-r16 CHOICE {			
n160-r16	80		
}			
dl-PRS-ResourceRepetitionFactor-r16	n2		
dl-PRS-ResourceTimeGap-r16	s1		
dl-PRS-NumSymbols-r16	n4		
dl-PRS-MutingOption1-r16 CHOICE {			
po2-r16	10		Cell 1
	01		Cell 2
}			
dl-PRS-MutingOption2-r16	Not present		
dl-PRS-ResourcePower-r16	27		
dl-PRS-ResourceList-r16 SEQUENCE (SIZE (1..nrMaxResourcesPerSet-r16)) OF NR-DL-PRS-Resource-r16 {	1 entry		
NR-DL-PRS-Resource-r16[1] SEQUENCE {		entry 1	
nr-DL-PRS-ResourceID-r16	0		
dl-PRS-SequenceID-r16	0		
dl-PRS-CombSizeN-AndReOffset-r16 CHOICE {			
n4-r16	0		
}			
dl-PRS-ResourceSlotOffset-r16	0		
dl-PRS-ResourceSymbolOffset-r16	0		
dl-PRS-QCL-Info-r16	Not present		
}			
}			
}			
}			
}			

Table 15.2.3.4.3-9: LPP ProvideLocation Information

Derivation Path: 37.355 clause 6.5.12			
Information Element	Value/remark	Comment	Condition
LPP-Message ::= SEQUENCE {			
transactionID SEQUENCE {			
initiator	locationServer		
transactionNumber	1		
}			
endTransaction	TRUE		
sequenceNumber	(0..255)		
acknowledgement			
lpp-MessageBody CHOICE {			
c1 CHOICE {			
provideLocationInformation SEQUENCE {			
criticalExtensions CHOICE {			
c1 CHOICE {			

provideLocationInformation-r9 SEQUENCE {			
commonIEsProvideLocationInformation	Not present.		
a-gnss-ProvideLocationInformation	Not present		
otdoa-ProvideLocationInformation	Not present		
ecid-ProvideLocationInformation	Not present		
epdu-ProvideLocationInformation	Not present		
sensor-ProvideLocationInformation-r13	Not present		
tbs-ProvideLocationInformation-r13	Not present		
wlan-ProvideLocationInformation-r13	Not present		
bt-ProvideLocationInformation-r13	Not present		
nr-ECID-ProvideLocationInformation-r16	Not present		
nr-Multi-RTT-ProvideLocationInformation-r16 SEQUENCE {			
nr-Multi-RTT-SignalMeasurementInformation-r16 SEQUENCE {			
nr-Multi-RTT-MeasList-r16 SEQUENCE (SIZE(1..nrMaxTRPs-r16)) OF NR-Multi-RTT-MeasElement-r16 {	2 entries		
NR-Multi-RTT-MeasElement-r16[1] SEQUENCE {		entry 1	
dl-PRS-ID-r16	INTEGER (0..255)		
nr-PhysCellID-r16			
nr-CellGlobalID-r16			
nr-ARFCN-r16			
nr-DL-PRS-ResourceID-r16			
nr-DL-PRS-ResourceSetID-r16			
nr-UE-RxTxTimeDiff-r16	Present. Any value acceptable.		
nr-AdditionalPathList-r16			
nr-TimeStamp-r16			
nr-TimingQuality-r16			
nr-DL-PRS-RSRP-Result-r16			
nr-Multi-RTT-AdditionalMeasurements-r16			
} NR-Multi-RTT-MeasElement-r16[1]			
NR-Multi-RTT-MeasElement-r16[2] SEQUENCE {		entry 2	
dl-PRS-ID-r16	INTEGER (0..255)		
nr-PhysCellID-r16			
nr-CellGlobalID-r16			
nr-ARFCN-r16			
nr-DL-PRS-ResourceID-r16			
nr-DL-PRS-ResourceSetID-r16			
nr-UE-RxTxTimeDiff-r16	Present. Any value acceptable.		
nr-AdditionalPathList-r16			
nr-TimeStamp-r16			
nr-TimingQuality-r16			
nr-DL-PRS-RSRP-Result-r16			
nr-Multi-RTT-AdditionalMeasurements-r16			
} NR-Multi-RTT-MeasElement-r16[2]			
} nr-Multi-RTT-MeasList-r16			
} nr-Multi-RTT-ProvideLocationInformation-r16			
nr-DL-AoD-ProvideLocationInformation-r16	Not present		
} provideLocationInformation-r9			
}			

15.2.3.5 Test requirement

Table 15.2.3.5-1 and Table 15.2.3.5-2 define the primary level settings including the test tolerances for the test.

Table 15.2.3.5-1: General test parameters

Parameter	Unit	Test configuration	Value	Comment
Active cell		1	Cell 1	Cell 1 is the PCell in <i>NR-Multi-RTT-ProvideAssistanceData</i> [49].
Neighbour cell		1	Cell 2	Cell 2 is a neighbour cell in <i>NR-Multi-RTT-ProvideAssistanceData</i> [49].
RF Channel Number		1	1	For both Cell 1 and Cell 2
BW _{channel}	MHz	1	200: N _{RB,c} = 132	
SSB configuration		1	SSB.2 FR2	
SMTC configuration		1	SMTC.1	
Measurement gap		1	GP#24 or GP#13 ^{Note 1}	
CP length		1	Normal	
DRX		1	OFF	
Time offset between serving and neighbour cells	µs	1	3	Synchronous cells
Expected RSTD	µs	1	3	
Expected RSTD uncertainty	µs	1	5	
T1	s	1	5	
T2	s	1	20	

NOTE 1: GP#24 is configured if UE supports MG#24, otherwise GP#13 is configured.

Table 15.2.3.5-2: Cell specific test parameters

Parameter	Unit	Test configuration	Cell 1		Cell 2	
			T1	T2	T1	T2
AoA setup		1	Setup 1 as specified in clause A.3.15			
Beam Assumption ^{Note 7}		1	Rough		Rough	
TDD configuration		1	TDDConf.3.1		TDDConf.3.1	
PDSCH RMC configuration		1	SR.3.1 TDD		N/A	
RMSI CORESET RMC configuration		1	CR.3.1 TDD		N/A	
Dedicated CORESET RMC configuration		1	CCR.3.1 TDD		N/A	
OCNG Patterns		1	OP.1		OP.1	
EPRE ratio of PSS to SSS	dB	1	0		0	
EPRE ratio of PBCH DMRS to SSS						
EPRE ratio of PBCH to PBCH DMRS						
EPRE ratio of PDCCH DMRS to SSS						
EPRE ratio of PDCCH to PDCCH DMRS						
EPRE ratio of PDSCH DMRS to SSS						
EPRE ratio of PDSCH to PDSCH DMRS						
EPRE ratio of OCNG DMRS to SSS ^{Note 1}						
EPRE ratio of OCNG to OCNG DMRS ^{Note 1}						

EPRE ratio of PRS to SSS						
TRS Configuration		1	TRS.2.1 TDD	N/A		
Initial BWP configuration		1	DLBWP.0.1 ULBWP.0.1	N/A		
Active DL BWP configuration		1	DLBWP.1.1	N/A		
Active UL BWP configuration		1	ULBWP.1.1	N/A		
PRS configuration		1	PRS.1.1 FR2	PRS.1.1 FR2		
PRS muting info		1	'10'	'01'		
SRS configuration		1	POS-SRS.3	N/A		
N_{oc} ^{Note 2}	dBm/SCS	1	-90.3			
N_{oc} ^{Note 2}	dBm/15 kHz	1	-99.3			
PRS \hat{E}_s/I_{ot}	dB	1	-Infinity	-2.69	-Infinity	-12.31
PRS \hat{E}_s/N_{oc}	dB	1	-Infinity	-2	-Infinity	-10
SSB \hat{E}_s/N_{oc}	dB	1	-2	-2	-Infinity	-10
PRP ^{Note 3}	dBm/SCS kHz	1	-Infinity	-92.3	-Infinity	-100.3
Io	dBm/190.08 MHz	1	N/A	-55.89	N/A	-55.89
Propagation Condition		1	AWGN			
Note 1:	The resources for uplink transmission are assigned to the UE prior to the start of time period T2.					
Note 2:	Interference from other cells and noise sources not specified in the test is assumed to be constant over subcarriers and time and shall be modelled as AWGN of appropriate power for N_{oc} to be fulfilled.					
Note 3:	PRS-RSRP and Io levels have been derived from other parameters for information purposes. They are not settable parameters themselves.					
Note 4:	PRS-RSRP minimum requirements are specified assuming independent interference and noise at each receiver antenna port.					
Note 5:	Equivalent power received by an antenna with 0 dBi gain at the centre of the quiet zone					
Note 6:	As observed with 0 dBi gain antenna at the centre of the quiet zone					
Note 7:	Information about types of UE beam is given in TS 38.133 [50] B.2.1.3, and does not limit UE implementation or test system implementation					

The UE Rx-Tx time difference measurement period fulfils the requirements specified in clause 15.2.3.3.

The response time is equal to the LPP time IE value plus the test tolerance. The LPP time IE value is derived from the UE Rx-Tx time difference measurement period plus ΔT , where $\Delta T = 50$ ms. The UE Rx-Tx time difference measurement period follows the equation:

$$T_{UERxTx,i} = \left(CSSF_i * N_{RxBeam,i} * \left\lceil \frac{N_{PRS,i}^{slot}}{N'} \right\rceil \left\lceil \frac{L_{available_PRS,i}}{N} \right\rceil * N_{sample} - 1 \right) * T_{effect,i} + T_{last,i}$$

Where $CSSF_{PRS,i} = 1$, $N_{RxBeam,i} = 8$, $N_{PRS,i}^{slot} = 2$, $L_{available_PRS,i} = 0.142$, $N_{sample} = 4$. N is the parameter durationOfPRS-ProcessingSymbols from TS 37.355 [49], N' is the parameter maxNumOfDL-PRS-ResProcessedPerSlot from TS 37.355 [49], $T_{last,i} = T_i + T_{available_PRS,i}$ and $T_{effect,i} = \left\lceil \frac{T_i}{T_{available_PRS,i}} \right\rceil * T_{available_PRS,i}$

$T_{available_PRS,i} = LCM(T_{PRS,i}, MGRP_i)$; where $T_{prs} = 160$ ms, and MGRP is 80 (for GP#24) or 40 (for GP#13) depending on UE capabilities. Therefore, $T_{available_PRS,i} = 160$ ms.

T_i depends on the UE parameter durationOfPRS-ProcessingSymbolsInEveryTms from TS 37.355 [49]

Finally, it results in the following equation:

$$\left(8 * \left\lceil \frac{2}{N'} \right\rceil \left\lceil \frac{0.142}{N} \right\rceil * 4 - 1 \right) * T_{effect} + T_{last}$$

Where the remaining parameters depend on the UE capabilities. The LPP time IE ranges between 5.128s and 164s. The value of the LPP time IE is rounded up to the next second (if the value is >128s, it should be rounded up to the next multiple of ten seconds). The result is transmitted in the response time IE in the LPP-RequestLocationInformation in Table 14.2.1.4.3-3. The LPP time IE ranges between 6s and 170s.

The test tolerance for the response time is 300ms. Therefore, the response time ranges between 6.3s and 170.3s.

The values of N' , N and T_i and the effect in the response time equation are defined in Table 15.2.3.5-3, Table 15.2.3.5-4 and Table 15.2.3.5-5 for reference.

Table 15.2.3.5-3: value of N' based on *maxNumOfDL-PRS-ResProcessedPerSlot*

<i>maxNumOfDL-PRS-ResProcessedPerSlot</i>	$\lceil \frac{2}{N'} \rceil$
n1	2
n2	1
$\geq n4$	1

Table 15.2.3.5-4: value of N based on *durationOfPRS-ProcessingSysmbols*

<i>durationOfPRS-ProcessingSysmbols</i>	$\lceil \frac{0.142}{N} \rceil$
nDot125	2
$\geq nDot25$	1

Table 15.2.3.5-5: value of T_{effect} and T_{last} based on *durationOfPRS-ProcessingSymbolsInEveryTms*

<i>durationOfPRS-ProcessingSymbolsInEveryTms</i>	T_{effect}	T_{last}
n8	160	168
n16	160	176
n20	160	180
n30	160	190
n40	160	200
n80	160	240
n160	160	320
n320	320	480
n640	640	800
n1280	1280	1440

The rate of successful tests during repeated tests shall be at least 90% with a confidence level of 95%.

15.2.4 UE Rx-Tx time difference measurement period for dual positioning frequency layer in FR2 SA

Editor's Note: This test case has been completed for the following configurations:

- Test frequency $f \leq 40.8$ GHz

- UE PC3

This test case is incomplete for UE power classes other than PC3

This test case is incomplete for test frequencies > 40.8 GHz

15.2.4.1 Test purpose

The purpose of the test is to verify that the UE Rx-Tx measurement period meets the requirements specified in TS 38.133 [50] clause 9.9.4.5 in AWGN propagation condition in FR2 in standalone scenario when dual positioning frequency layers are configured.

15.2.4.2 Test applicability

This test applies to all types of NR UE release 16 onwards that supports Multi-RTT positioning.

15.2.4.3 Minimum conformance requirements

Same as defined in clause 15.2.1.3.

15.2.4.4 Test description

The supported test configurations in listed in Table 15.2.4.4-1.

Table 15.2.4.4-1: Test Configurations

Test Configuration	Description
1	120 kHz SSB and PRS SCS, 200 MHz bandwidth, TDD duplex mode

15.2.4.4.1 Initial conditions

Test Environment: Normal, as defined in TS 38.508-1 [45] clause 4.1.

Frequencies to be tested: Low Range for Cell 1 and High Range for Cell2, as defined in TS 38.508-1 [45] clause 4.3.1.

Channel bandwidth to be tested: are specified in Table 15.2.4.4-1.

1. Connect the SS and AWGN noise sources to the UE antenna connector or antenna connectors as shown in Annex A, Figure A.14.
2. The general test parameter settings are set up according to Table 15.2.4.5-1 and Table 15.2.4.5-2.
3. Propagation conditions are set according to clause 4.14.2.
4. Message contents are defined in clause 15.2.4.4.3.
5. There are two cells in the test: PCell (Cell 1) and a neighbour cell (Cell 2). Cell 1 and Cell2 are on different RF channels in FR2.

15.2.4.4.2 Test procedure

Same as defined in clause 15.2.1.4.2.

15.2.4.4.3 Message contents

Table 15.2.4.4.3-1: RESET UE POSITIONING STORED INFORMATION

Derivation Path: 38.509 [44] clause 6.6			
Information Element	Value/remark	Comment	Condition
UE Positioning Technology	0 0 0 0 0 1 1 0	Multi-RTT	

Table 15.2.4.4.3-2: RRCReconfiguration

Derivation Path: TS 38.508-1 [45],, table 4.6.1-13			
Information Element	Value/remark	Comment	Condition
RRCReconfiguration ::= SEQUENCE {			
criticalExtensions CHOICE {			
rrcReconfiguration SEQUENCE {			
radioBearerConfig			
nonCriticalExtension SEQUENCE {			
masterCellGroup SEQUENCE {	CellGroupConfig		
spCellConfig SEQUENCE {			
spCellConfigDedicated SEQUENCE {			

uplinkConfig SEQUENCE {			
initialUplinkBWP SEQUENCE {			
srs-Config CHOICE {			
setup	As defined in Table 15.2.4.4.3-3		
}			
}			
}			

Table 15.2.4.4.3-3: SRS-Config (Table 15.2.4.4.3-2)

Derivation Path: TS 38.508-1 [45], Table 4.6.3-182			
Information Element	Value/remark	Comment	Condition
SRS-Config ::= SEQUENCE {			
srs-ResourceSetToReleaseList	Not present		
srs-ResourceSetToAddModList	Not present		
srs-ResourceToReleaseList	Not present		
srs-ResourceToAddModList	Not present		
tpc-Accumulation	Not present		
srs-RequestDCI-1-2-r16	Not present		
srs-RequestDCI-0-2-r16	Not present		
srs-ResourceSetToAddModListDCI-0-2-r16	Not present		
srs-ResourceSetToReleaseListDCI-0-2-r16	Not present		
srs-PosResourceSetToReleaseList-r16	Not present		
srs-PosResourceSetToAddModList-r16 SEQUENCE (SIZE(1..maxNrofSRS-PosResourceSets-r16)) OF SRS-PosResourceSet-r16 {	1 entry		
SRS-PosResourceSet-r16[1] SEQUENCE {		entry 1	
srs-PosResourceSetId-r16	0		
srs-PosResourceCidList-r16 SEQUENCE (SIZE(1..maxNrofSRS-ResourcesPerSet)) OF SRS-PosResourceCid-r16 {	1 entry		
SRS-PosResourceCid-r16	0	1 entry	
}			
resourceType CHOICE {			
periodic SEQUENCE {			
}			
}			
alpha-r16	alpha0		
p0-r16	0		
pathlossReferenceRS-Pos-r16	Not present		
}			
srs-PosResourceToReleaseList-r16	Not present		
srs-PosResourceToAddModList-r16 SEQUENCE (SIZE(1..maxNrofSRS-PosResources-r16)) OF SRS-PosResource-r16 {	1 entry		
SRS-PosResource-r16[1] SEQUENCE {		entry 1	
srs-PosResourceCid-r16	0		
transmissionComb-r16 CHOICE {			
n4-r16 SEQUENCE {			
combOffset-n4-r16	0		
cyclicShift-n4-r16	0		
}			
}			
resourceMapping-r16 SEQUENCE {			
startPosition-r16	0		
nrofSymbols-r16	n4		
}			

freqDomainShift-r16	0		
freqHopping-r16 SEQUENCE {			
c-SRS-r16	Matches N _{RB,c} Table 15.3.2.5-1		
}			
groupOrSequenceHopping-r16	neither		
resourceType-r16 CHOICE {			
periodic-r16 SEQUENCE {			
periodicityAndOffset-p-r16 CHOICE {			
sl1280	160		
}			
}			
}			
sequenceId-r16	0		
spatialRelationInfoPos-r16	Not present		
}			
}			
}			

Table 15.2.4.4.3-4: LPP Request Capabilities

Information Element	Value/remark
nr-Multi-RTT-RequestCapabilities-r16	TRUE

Table 15.2.4.4.3-5: LPP RequestLocationInformation

Derivation Path: 37.355 clause 6.2			
Information Element	Value/remark	Comment	Condition
LPP-Message ::= SEQUENCE {			
transactionID SEQUENCE {			
initiator	locationServer		
transactionNumber	1		
}			
endTransaction	FALSE		
sequenceNumber	Not present		
acknowledgement	Not present		
lpp-MessageBody CHOICE {			
c1 CHOICE {			
requestLocationInformation SEQUENCE {			
criticalExtensions CHOICE {			
c1 CHOICE {			
requestLocationInformation-r9 SEQUENCE {			
commonEsRequestLocationInformation SEQUENCE {			
locationInformationType	locationMeasurementsRequired		
triggeredReporting	Not present		
periodicalReporting	Not present		
additionalInformation	onlyReturnInformationRequested		
qos SEQUENCE {			
horizontalAccuracy	Not present		
verticalCoordinateRequest	FALSE		
verticalAccuracy	Not present		
responseTime SEQUENCE {			
time	See 15.2.4.5		
responseTimeEarlyFix-r12	Not present		Rel-12 onwards
}			
velocityRequest	FALSE		
}			
}			
}			
}			
}			
}			
environment	Not present		
locationCoordinateTypes	Not present		

velocityTypes	Not present		
}			
a-gnss-RequestLocationInformation	Not present		
otdoa-RequestLocationInformation	Not present		
ecid-RequestLocationInformation	Not present		
epdu-RequestLocationInformation	Not Present		
sensor-RequestLocationInformation-r13	Not present		
tbs-RequestLocationInformation-r13	Not present		
wlan-RequestLocationInformation-r13	Not present		
bt-RequestLocationInformation-r13	Not present		
nr-ECID-RequestLocationInformation-r16	Not present		
nr-Multi-RTT-RequestLocationInformation-r16			
SEQUENCE {			
nr-UE-	Not present		
RxTxTimeDiffMeasurementInfoRequest-r16			
nr-RequestedMeasurements-r16	bit 0 = 1 (prsrspReq)		
nr-AssistanceAvailability-r16	FALSE		
nr-Multi-RTT-ReportConfig-r16 SEQUENCE {			
maxDL-PRS-RxTxTimeDiffMeasPerTRP-r16	Not present		
timingReportingGranularityFactor-r16	Not present		
}			
additionalPaths-r16	Not present		
}			
nr-DL-AoD-RequestLocationInformation-r16	Not present		
nr-DL-TDOA-RequestLocationInformation-r16	Not present		
}			
}			
}			
}			
}			
}			

Table 15.2.4.4.3-6: LPP ProvideAssistanceData

Derivation Path: 37.355 clause 6.2			
Information Element	Value/remark	Comment	Condition
LPP-Message ::= SEQUENCE {			
transactionID SEQUENCE {			
initiator	locationServer		
transactionNumber	(0..255)		
}			
endTransaction	TRUE		
sequenceNumber	Not present		
acknowledgement	Not present		
lpp-MessageBody CHOICE {			
c1 CHOICE {			
provideAssistanceData SEQUENCE {			
criticalExtensions CHOICE {			
c1 CHOICE {			
provideAssistanceData-r9 SEQUENCE {			
commonEsProvideAssistanceData	Not present		
a-gnss-ProvideAssistanceData	Not present		
otdoa-ProvideAssistanceData	Not present		
epdu-Provide-AssistanceData	Not present		
sensor-ProvideAssistanceData-r15	Not present		
tbs-ProvideAssistanceData-r15	Not present		
wlan-ProvideAssistanceData-r15	Not present		
nr-Multi-RTT-ProvideAssistanceData-r16			
SEQUENCE {			
nr-DL-PRS-AssistanceData	As defined in Table 15.2.4.4.3-7		
nr-SelectedDL-PRS-IndexList-r16	Not present		
nr-Multi-RTT-Error-r16	Not present		
}			
}			
}			
}			
}			
}			

nr-DL-AoD-ProvideAssistanceData-r16	Not present		
nr-DL-TDOA-ProvideAssistanceData-r16	Not present		
}			
}			
}			
}			
}			
}			

Table 15.2.4.4.3-7: NR-DL-PRS-AssistanceData

Derivation Path: 37.355 clause 6.4.3			
Information Element	Value/remark	Comment	Condition
NR-DL-PRS-AssistanceData-r16 ::= SEQUENCE {			
nr-DL-PRS-ReferenceInfo-r16 SEQUENCE {			
dl-PRS-ID-r16	0		
nr-DL-PRS-ResourceID-List-r16	Not present		
nr-DL-PRS-ResourceSetID-r16	Not present		
}			
nr-DL-PRS-AssistanceDataList-r16 SEQUENCE (SIZE (1..nrMaxFreqLayers-r16)) OF NR-DL-PRS-AssistanceDataPerFreq-r16 {	2 entries		
NR-DL-PRS-AssistanceDataPerFreq-r16[1] SEQUENCE {		entry 1	
nr-DL-PRS-PositioningFrequencyLayer-r16 SEQUENCE {			
dl-PRS-SubcarrierSpacing-r16	kHz120		
dl-PRS-ResourceBandwidth-r16	1	24 PRBs	
dl-PRS-StartPRB-r16	0		
dl-PRS-PointA-r16	absoluteFrequencyPointA as defined for the DL frequency of the Cell 1		
dl-PRS-CombSizeN-r16	n2		
dl-PRS-CyclicPrefix-r16	normal		
}			
nr-DL-PRS-AssistanceDataPerFreq-r16 SEQUENCE (SIZE (1..nrMaxTRPsPerFreq-r16)) OF NR-DL-PRS-AssistanceDataPerTRP-r16{	1 entry		
NR-DL-PRS-AssistanceDataPerTRP-r16[1] SEQUENCE {		entry 1	Cell 1
dl-PRS-ID-r16	0		
nr-PhysCellID-r16	Cell 1		
nr-CellGlobalID-r16	Cell 1		
nr-ARFCN-r16	Cell 1		
nr-DL-PRS-SFN0-Offset-r16 SEQUENCE {			
sfn-Offset-r16	0		
integerSubframeOffset-r16	0		
}			
nr-DL-PRS-ExpectedRSTD-r16	0		
nr-DL-PRS-ExpectedRSTD-Uncertainty-r16	0		
nr-DL-PRS-Info-r16	As specified in Table 15.2.4.4.3-8		
}			
}			
NR-DL-PRS-AssistanceDataPerFreq-r16[2] SEQUENCE {		entry 2	
nr-DL-PRS-PositioningFrequencyLayer-r16 SEQUENCE {			
dl-PRS-SubcarrierSpacing-r16	kHz120		
dl-PRS-ResourceBandwidth-r16	3	32 PRBs	
dl-PRS-StartPRB-r16	0		
dl-PRS-PointA-r16	absoluteFrequencyPointA as defined for the DL frequency of the Cell 2		
dl-PRS-CombSizeN-r16	n2		

dl-PRS-CyclicPrefix-r16	normal		
}			
nr-DL-PRS-AssistanceDataPerFreq-r16 SEQUENCE (SIZE (1..nrMaxTRPsPerFreq-r16)) OF NR-DL-PRS-AssistanceDataPerTRP-r16{	1 entry		
NR-DL-PRS-AssistanceDataPerTRP-r16[1] SEQUENCE {		entry 1	Cell 2
dl-PRS-ID-r16	1		
nr-PhysCellID-r16	Cell 2		
nr-CellGlobalID-r16	Cell 2		
nr-ARFCN-r16	Cell 2		
nr-DL-PRS-SFN0-Offset-r16 SEQUENCE {			
sfn-Offset-r16	0		
integerSubframeOffset-r16	0		
}			
nr-DL-PRS-ExpectedRSTD-r16	23	About 3 μs	
nr-DL-PRS-ExpectedRSTD-Uncertainty-r16	154	About 5 μs	
nr-DL-PRS-Info-r16	As specified in Table 15.2.4.4.3-8		
}			
}			
}			
}			
}			

Table 15.2.4.4.3-8: NR-DL-PRS-Info

Derivation Path: 37.355 clause 6.4.3			
Information Element	Value/remark	Comment	Condition
NR-DL-PRS-Info-r16 ::= SEQUENCE {			
nr-DL-PRS-ResourceSetList-r16 SEQUENCE (SIZE (1..nrMaxSetsPerTrp-r16)) OF NR-DL-PRS-ResourceSet-r16 {	1 entry		
NR-DL-PRS-ResourceSet-r16[1] SEQUENCE {		entry 1	
nr-DL-PRS-ResourceSetID-r16	0		
dl-PRS-Periodicity-and-ResourceSetSlotOffset-r16 CHOICE {			
scs120-r16 CHOICE {			
n160-r16	80		
}			
dl-PRS-ResourceRepetitionFactor-r16	n2		
dl-PRS-ResourceTimeGap-r16	s1		
dl-PRS-NumSymbols-r16	n4		
dl-PRS-MutingOption1-r16 SEQUENCE {			
dl-prs-MutingBitRepetitionFactor-r16	Not present		
nr-option1-muting-r16 CHOICE {			
po2-r16	10		Cell 1
po2-r16	01		Cell 2
}			
}			
dl-PRS-MutingOption2-r16	Not present		
dl-PRS-ResourcePower-r16	27		
dl-PRS-ResourceList-r16 SEQUENCE (SIZE (1..nrMaxResourcesPerSet-r16)) OF NR-DL-PRS-Resource-r16 {	1 entry		
NR-DL-PRS-Resource-r16[1] SEQUENCE {		entry 1	
nr-DL-PRS-ResourceID-r16	0		
dl-PRS-SequenceID-r16	0		
dl-PRS-CombSizeN-AndReOffset-r16 CHOICE {			
n4-r16	0		
}			
dl-PRS-ResourceSlotOffset-r16	0		
dl-PRS-ResourceSymbolOffset-r16	0		
dl-PRS-QCL-Info-r16	Not present		
}			

}			
}			
}			
}			

Table 15.2.4.4.3-9: LPP ProvideLocation Information

Derivation Path: 37.355 clause 6.5.12			
Information Element	Value/remark	Comment	Condition
LPP-Message ::= SEQUENCE {			
transactionID SEQUENCE {			
initiator	locationServer		
transactionNumber	1		
}			
endTransaction	TRUE		
sequenceNumber	(0..255)		
acknowledgement			
lpp-MessageBody CHOICE {			
c1 CHOICE {			
provideLocationInformation SEQUENCE {			
criticalExtensions CHOICE {			
c1 CHOICE {			
provideLocationInformation-r9 SEQUENCE {			
commonIEsProvideLocationInformation	Not present.		
a-gnss-ProvideLocationInformation	Not present		
otdoa-ProvideLocationInformation	Not present		
ecid-ProvideLocationInformation	Not present		
epdu-ProvideLocationInformation	Not present		
sensor-ProvideLocationInformation-r13	Not present		
tbs-ProvideLocationInformation-r13	Not present		
wlan-ProvideLocationInformation-r13	Not present		
bt-ProvideLocationInformation-r13	Not present		
nr-ECID-ProvideLocationInformation-r16	Not present		
nr-Multi-RTT-ProvideLocationInformation-r16 SEQUENCE {			
nr-Multi-RTT-SignalMeasurementInformation-r16 SEQUENCE {			
nr-Multi-RTT-MeasList-r16 SEQUENCE (SIZE(1..nrMaxTRPs-r16)) OF NR-Multi-RTT-MeasElement-r16 {	2 entries		
NR-Multi-RTT-MeasElement-r16[1] SEQUENCE {		entry 1	
dl-PRS-ID-r16	INTEGER (0..255)		
nr-PhysCellID-r16			
nr-CellGlobalID-r16			
nr-ARFCN-r16			
nr-DL-PRS-ResourceID-r16			
nr-DL-PRS-ResourceSetID-r16			
nr-UE-RxTxTimeDiff-r16	Present. Any value acceptable.		
nr-AdditionalPathList-r16			
nr-TimeStamp-r16			
nr-TimingQuality-r16			
nr-DL-PRS-RSRP-Result-r16			
nr-Multi-RTT-AdditionalMeasurements-r16			
}			
}			
}			
}			
}			
}			
}			
}			
}			
}			

nr-UE-RxTxTimeDiff-r16	Present. Any value acceptable.		
nr-AdditionalPathList-r16			
nr-TimeStamp-r16			
nr-TimingQuality-r16			
nr-DL-PRS-RSRP-Result-r16			
nr-Multi-RTT-AdditionalMeasurements-r16			
}			
}			
nr-NTA-Offset-r16			
}			
nr-Multi-RTT-Error-r16			
}			
nr-DL-AoD-ProvideLocationInformation-r16	Not present		
}			
}			
}			
}			
}			
}			
}			

15.2.4.5 Test requirement

Table 15.2.4.5-1 and Table 15.2.4.5-2 define the primary level settings including the test tolerances for the test.

Table 15.2.4.5-1: General test parameters

Parameter	Unit	Test configuration	Value	Comment
Active cell		1	Cell 1	Cell 1 is the PCell in <i>NR-Multi-RTT-ProvideAssistanceData</i> [49].
Neighbour cell		1	Cell 2	Cell 2 is a neighbour cell in <i>NR-Multi-RTT-ProvideAssistanceData</i> [49].
RF Channel Number		1	1	For Cell 1
RF Channel Number		1	2	For Cell 2
BW _{channel}	MHz	1	200: N _{RB,c} = 132	
SSB configuration		1	SSB.2 FR2	
SMTTC configuration		1	SMTTC.1	
Measurement gap		1	GP#24 or GP#13 Note 1	
CP length		1	Normal	
DRX		1	OFF	
Time offset between serving and neighbour cells	µs	1	3	Synchronous cells
Expected RSTD	µs	1	3	
Expected RSTD uncertainty	µs	1	5	
T1	s	1	5	
T2	s	1	20	

Note 1: GP#24 is configured if UE supports MG#24, otherwise GP#13 is configured.

Table 15.2.4.5-2: Cell specific test parameters

Parameter	Unit	Test configuration	Cell 1		Cell 2	
			T1	T2	T1	T2
AoA setup		1	Setup 1 as specified in clause A.3.15			
Beam Assumption ^{Note 7}		1	Rough		Rough	
TDD configuration		1	TDDConf.3.1		TDDConf.3.1	
PDSCH RMC configuration		1	SR.3.1 TDD		N/A	

RMSI CORESET RMC configuration		1	CR.3.1 TDD	N/A			
Dedicated CORESET RMC configuration		1	CCR.3.1 TDD	N/A			
OCNG Patterns		1	OP.1	OP.1			
EPRE ratio of PSS to SSS	dB	1	0	0			
EPRE ratio of PBCH DMRS to SSS							
EPRE ratio of PBCH to PBCH DMRS							
EPRE ratio of PDCCH DMRS to SSS							
EPRE ratio of PDCCH to PDCCH DMRS							
EPRE ratio of PDSCH DMRS to SSS							
EPRE ratio of PDSCH to PDSCH DMRS							
EPRE ratio of OCNG DMRS to SSS ^{Note 1}							
EPRE ratio of OCNG to OCNG DMRS ^{Note 1}							
EPRE ratio of PRS to SSS							
TRS Configuration							
Initial BWP configuration		1	DLBWP.0.1 ULBWP.0.1	N/A			
Active DL BWP configuration		1	DLBWP.1.1	N/A			
Active UL BWP configuration		1	ULBWP.1.1	N/A			
PRS configuration		1	PRS.1.1 FR2	PRS.1.1 FR2			
PRS muting info		1	'10'	'01'			
SRS configuration		1	POS-SRS.3	N/A			
N_{oc} ^{Note 2}	dBm/SCS	1	-89	-89.65	-89	-89	
N_{oc} ^{Note 2}	dBm/15 kHz	1	-98	-98.65	-98	-98	
PRS \hat{E}_s/I_{ot}	dB	1	-Infinity	-2.69	-Infinity	-12.7	
PRS \hat{E}_s/N_{oc}	dB	1	-Infinity	-2.43	-Infinity	-11.82	
SSB \hat{E}_s/N_{oc}	dB	1	-2	-2	-Infinity	-10	
PRP ^{Note 3}	dBm/SCS kHz	1	-Infinity	-92	-Infinity	-101.4	
Io	dBm/190.08 MHz	1	N/A	-55.66	N/A	-56.73	
Propagation Condition		1	AWGN				
<p>Note 1: The resources for uplink transmission are assigned to the UE prior to the start of time period T2.</p> <p>Note 2: Interference from other cells and noise sources not specified in the test is assumed to be constant over subcarriers and time and shall be modelled as AWGN of appropriate power for N_{oc} to be fulfilled.</p> <p>Note 3: PRS-RSRP and Io levels have been derived from other parameters for information purposes. They are not settable parameters themselves.</p> <p>Note 4: PRS-RSRP minimum requirements are specified assuming independent interference and noise at each receiver antenna port.</p> <p>Note 5: Equivalent power received by an antenna with 0 dBi gain at the centre of the quiet zone</p> <p>Note 6: As observed with 0 dBi gain antenna at the centre of the quiet zone</p> <p>Note 7: Information about types of UE beam is given in TS 38.133 [50] B.2.1.3, and does not limit UE implementation or test system implementation</p>							

The UE Rx-Tx time difference measurement period fulfils the requirements specified in clause 15.2.4.2.

The response time is equal to the LPP time IE value plus the test tolerance. The LPP time IE value is derived from the UE Rx-Tx time difference measurement period plus ΔT, where ΔT = 50ms. The UE Rx-Tx time difference measurement period follows the equation:

$$T_{UERxTx,i} = \left(CSSF_1 * N_{RxBeam,i} * \left\lceil \frac{N_{PRS,i}^{slot}}{N'} \right\rceil \left\lceil \frac{L_{available_PRS,i}}{N} \right\rceil * N_{sample} - 1 \right) * T_{effect,i} + T_{last,i}$$

Where $CSSF_{PRS,i} = 1$, $N_{RxBeam,i} = 8$, $N_{PRS,i}^{slot} = 1$, $L_{available_PRS,i} = 0.071$, $N_{sample} = 4$. N is the parameter durationOfPRS-ProcessingSymsbols from TS 37.355 [49], N' is the parameter maxNumOfDL-PRS-ResProcessedPerSlot from TS 37.355 [49], $T_{last,i} = T_i + T_{available_PRS,i}$ and $T_{effect,i} = \left\lceil \frac{T_i}{T_{available_PRS,i}} \right\rceil * T_{available_PRS,i}$

$T_{available_PRS,i} = LCM(T_{PRS,i}, MGRP_i)$; where Tprs = 160 ms, and MGRP is 80 (for GP#24) or 40 (for GP#13) depending on UE capabilities. Therefore, $T_{available_PRS,i} = 160$ ms.

T_i depends on the UE parameter durationOfPRS-ProcessingSymsbolsInEveryTms from TS 37.355 [49]

Finally, it results in the following equation:

$$\left(8 * \left\lceil \frac{1}{N'} \right\rceil \left\lceil \frac{0.071}{N} \right\rceil * 4 - 1 \right) * T_{effect} + T_{last}$$

Where the remaining parameters depend on the UE capabilities. The LPP time IE ranges between 11s and 84s. The result is transmitted in the response time IE in the LPP-RequestLocationInformation in Table 15.2.4.4.3-5.

The test tolerance for the response time is 300ms. Therefore, the response time ranges between 11.3s and 84.3s.

The values of N', N and Ti and the effect in the response time equation are defined in Table 15.2.4.5-3, Table 15.2.4.5-4 and Table 15.2.4.5-5 for reference.

Table 15.2.4.5-3: value of N' based on maxNumOfDL-PRS-ResProcessedPerSlot

maxNumOfDL-PRS-ResProcessedPerSlot	$\left\lceil \frac{1}{N'} \right\rceil$
>=n1	1

Table 15.2.4.5-4: value of N based on durationOfPRS-ProcessingSymsbols

durationOfPRS-ProcessingSymsbols	$\left\lceil \frac{0.071}{N} \right\rceil$
>=nDot125	1

Table 15.2.4.5-5: value of T_{effect} and T_{last} based on durationOfPRS-ProcessingSymsbolsInEveryTms

durationOfPRS-ProcessingSymsbolsInEveryTms	T_{effect}	T_{last}
n8	160	168
n16	160	176
n20	160	180
n30	160	190
n40	160	200
n80	160	240
n160	160	320
n320	320	480
n640	640	800
n1280	1280	1440

The rate of successful tests during repeated tests shall be at least 90% with a confidence level of 95%.

15.2.5 UE Rx-Tx time difference measurement reporting delay test case for single positioning frequency layer with reduced number of samples in FR1 SA

Editor's Note: This test case is incomplete. The following aspect is either missing or TBD:

- Test tolerance is missing

15.2.5.1 Test purpose

The purpose of the test is to verify that the UE Rx-Tx measurement meets the requirements specified in TS 38.133 [50] clause 9.9.4.5 with $N_{\text{sample}} = 1$ in AWGN propagation condition in FR1 in standalone scenario when single positioning frequency layer is configured

15.2.5.2 Test applicability

This test applies to all types of NR UE release 17 onwards that supports Multi-RTT positioning and supportedDL-PRS-ProcessingSamples-RRC-CONNECTED.

15.2.5.3 Minimum conformance requirements

When physical layer receives last of *NR-Multi-RTT-ProvideAssistanceData* message and *NR-Multi-RTT-RequestLocationInformation* message from LMF via LPP [34], UE shall be able to measure multiple (up to the UE capability specified in clause 9.9.4.3) UE Rx-Tx time difference measurements as defined in TS 38.215 [4] in configured positioning frequency layers within the measurement period $T_{\text{UERxTx,Total}}$ ms.

$$T_{\text{UERxTx, Total}} = \sum_{i=1}^L T_{\text{UERxTx},i} + (L - 1) * \max(T_{\text{effect},i}).$$

where i is the index of positioning frequency layer,

$T_{\text{UERxTx},i}$ is the measurement period for UE Rx-Tx time difference measurements in positioning frequency layer i as further defined in this clause,

L is total number of positioning frequency layers, and

$T_{\text{effect},i}$ is the periodicity of the UE Rx-Tx time difference measurement in positioning frequency layer i as defined further in this clause.

$$T_{\text{UERxTx},i} = \left(k_{\text{multiTEG},i} * \text{CSSF}_i * \text{ceil}(K_{\text{p,PRS},i}) * N_{\text{RxBeam},i} * \left\lceil \frac{N_{\text{PRS},i}^{\text{slot}}}{N'} \right\rceil \left\lfloor \frac{L_{\text{available_PRS},i}}{N} \right\rfloor * N_{\text{sample}} - 1 \right) * T_{\text{effect},i} + T_{\text{last},i}$$

Where

CSSF_i is the carrier-specific scaling factor for NR PRS-based measurement in the positioning frequency layer i as defined in clause 9.1.5.2,

$k_{\text{multiTEG},i}$ is the scaling factor for measurement of same PRS resource with multiple Rx TEGs.

$k_{\text{multiTEG},i}=1$ if UE is not requested by LMF to measure a PRS resource with multiple Rx TEGs via *measureSameDL-PRS-ResourceWithDifferentRxTEGs-r17* or *measureSameDL-PRS-ResourceWithDifferentRxTxTEGs-r17* [34] in *NR-Multi-RTT-RequestLocationInformation*;

otherwise,

$k_{\text{multiTEG},i}=N_{\text{TEG},i}$, if UE is not capable of receiving same DL PRS resource simultaneously from multiple Rx TEGs, and

$k_{\text{multiTEG},i} = \left\lfloor \frac{N_{\text{TEG},i}}{k_{\text{TEG,simul},i}} \right\rfloor$ if UE is capable of receiving the same DL PRS resource simultaneously from multiple Rx TEGs.

where

$N_{TEG,i}$ is the number of Rx TEGs or RxTx TEGs with which UE is requested to measure a PRS resource indicated via *measureSameDL-PRS-ResourceWithDifferentRxTEGs-r17* or *measureSameDL-PRS-ResourceWithDifferentRxTxTEGs-r17* [34] in *NR-Multi-RTT-RequestLocationInformation*, and in case 'n0' is indicated, $N_{TEG,i}$ is the maximum number of Rx TEGs with which UE can support to measure the same PRS resource as reported in *NR-UE-TEG-Capability*, and

$k_{TEG,simul,i}$ is the number of Rx TEGs UE can measure simultaneously which is reported via *measureSameDL-PRS-ResourceWithDifferentRxTEGsSimul*.

$K_{p,PRS,i}$ is a scaling factor for a positioning frequency layer to be measured within the associated measurement gap pattern, which is defined as $K_{p,PRS,i} = N_{total} / N_{available}$ for UE configured with concurrent measurement gap, and $K_{p,PRS,i} = 1$ for UE not configured with concurrent measurement gap.

For a window W of duration $\max(T_{PRS,i}, MGRP_max)$, where $MGRP_max$ is the maximum MGRP across all configured per-UE MG and per-FR MG within the same FR as the positioning frequency layer, and starting at the beginning of any associated gap occasions covering the PRS occasion:

N_{total} is the total number of associated gap occasions covering PRS occasions within the window, including both dropped and non-dropped instances of the associated measurement gap within the window, and

$N_{available}$ is the number of non-dropped associated gap occasions covering PRS occasions within the window W , after further accounting for MG collisions by applying the selected gap collision rule

Requirements do not apply if $N_{available} = 0$.

$N_{RxBeam,i}$ is the scaling factor for Rx beam sweeping, and $N_{RxBeam,i} = 1$ if positioning frequency layer i is in FR1 and if positioning frequency layer i is in FR2, $N_{RxBeam,i}$ is equal to the value reported by the UE in *supportedLowerRxBeamSweepingFactor-FR2* if the UE supports the capability for the band containing positioning frequency layer i , and the LMF indicates *lowerRxBeamSweepingFactor-FR2* in *NR-Multi-RTT-RequestLocationInformation*. $N_{RxBeam,i}$ is equal to 8, otherwise.

$L_{available_PRS,i}$ is the time duration of available PRS resources in the positioning frequency layer i , to be measured during $T_{available_PRS,i}$, and is calculated in the same way as PRS duration K defined in clause 5.1.6.5 of TS 38.214 [26]. For calculation of $L_{available_PRS,i}$, only the PRS resources unmuted and fully or partially overlapped with MG are considered.

$N_{PRS,i}^{slot}$ is the maximum number of DL PRS resources of positioning frequency layer i configured in a slot,

$\{N, T\}$ is UE capability combination per band where N is a duration of DL PRS symbols in ms corresponding to *durationOfPRS-ProcessingSymsbols* in TS 37.355 [34] processed every T ms corresponding to *durationOfPRS-ProcessingSymsbolsInEveryTms* in TS 37.355 [34] for a given maximum bandwidth supported by UE corresponding to *supportedBandwidthPRS* in clause 4.2.7.2 of TS 37.355 [34],

N' is UE capability for number of DL PRS resources that it can process in a slot corresponding to *maxNumOfDL-PRS-ResProcessedPerSlot* as specified in clause 6.4.3 of TS 37.355 [34],

N_{sample} is the number of UE Rx-Tx time difference measurement samples:

- $N_{sample} = 1$ if the UE is capable of *supportedDL-PRS-ProcessingSamples-RRC-CONNECTED* defined in [34] and LMF requests the UE to perform positioning measurements with reduced number of samples by *reducedDL-PRS-ProcessingSamples* [34] and the following conditions are met:
 - PRS bandwidth is within the active BWP and
 - Magnitude of difference between the serving cell's SS-RSRP and the neighbour cell's PRS-RSRP is within 6 dB.
- $N_{sample} = 2$ if the UE is capable of *supportedDL-PRS-ProcessingSamples-RRC-CONNECTED* defined in [34] and the LMF requests the UE to perform positioning measurements with reduced number of samples by *reducedDL-PRS-ProcessingSamples* [34] but the following conditions are not met:

- PRS bandwidth is within the active BWP and
- Magnitude of difference between the serving cell's SS-RSRP and the neighbour cell's PRS-RSRP is within 6 dB.
- $N_{sample} = 4$ otherwise.

$T_{last,i}$ is the measurement duration for the last UE Rx-Tx time difference measurement sample in the positioning layer i , including the sampling time and processing time, $T_{last,i} = T_i + T_{available_PRS,i}$,

$T_{effect,i}$ is periodicity of UE Rx-Tx time difference measurement in positioning frequency layer i :

$$T_{effect,i} = \left\lceil \frac{T_i}{T_{available_PRS,i}} \right\rceil * T_{available_PRS,i}$$

where

T_i corresponds to *durationOfPRS-ProcessingSymbolsInEveryTms* in TS 37.355 [34],

$T_{available_PRS,i} = LCM(T_{PRS,i}, MGRP_i)$, the least common multiple between $T_{PRS,i}$ and $MGRP_i$

$MGRP_i$ is the measurement gap repetition periodicity in positioning frequency layer i .

$T_{PRS,i}$ is the PRS resource periodicity in positioning frequency layer i . If the positioning frequency layer i has more than one DL PRS resource sets with different PRS periodicities with muting, $T_{per}^{PRS\ with\ muting} = N_{muting} * T_{per}^{PRS}$, the least common multiple of $T_{per}^{PRS\ with\ muting}$ among DL PRS resource sets is used to derive $T_{PRS,i}$, where

T_{per}^{PRS} is the periodicity of PRS resource sets given by the higher-layer parameter *DL-PRS-Periodicity*.

N_{muting} is the scaling factor considering PRS resource muting. $N_{muting} = T_{muting}^{PRS} * L_{muting}$, where T_{muting}^{PRS} is the muting repetition factor given by the higher-layer parameter *DL-PRS-MutingBitRepetitionFactor*, and L_{muting} is the size of the bitmap $\{b^1\}$

15.2.5.4 Test description

15.2.5.4.1 Initial conditions

The supported test configuration is listed in Table 15.2.5.4-1.

Table 15.2.5.4-1: Test Configuration

Configuration	Description
1	15 kHz SSB SCS, 20 MHz bandwidth, FDD duplex mode
2	15 kHz SSB SCS, 20 MHz bandwidth, TDD duplex mode
3	30 kHz SSB SCS, 50 MHz bandwidth, TDD duplex mode
Note:	The UE is only required to be tested in one of the supported test configurations.

Test Environment: Normal, as defined in TS 38.508-1 [45] clause 4.1.

Frequencies to be tested: Mid Range, as defined in TS 38.508-1 [45] clause 4.3.1.

Channel bandwidth to be tested: are specified in Table 15.2.5.4-1.

1. Connect the SS and AWGN noise sources to the UE antenna connector or antenna connectors as shown in Annex A, Figure A.13.
2. The general test parameter settings are set up according to Table 15.2.5.5-1 and Table 15.2.5.5-2.
3. Propagation conditions are set according to clause 4.14.2.
4. Message contents are defined in clause 15.2.5.4.3.

5. In the test there are two cells in the test: PCell (Cell 1) and a neighbour cell (Cell 2). All cells are on the same RF channel in FR1.

15.2.5.4.2 Test procedure

The test consists of two consecutive time intervals, with duration of T1 and T2. Cell 1 and Cell 2 mute PRS transmission during T1 and transmit PRS during T2. The beginning of the time interval T2 shall be aligned with the beginning of the first MG instance containing the PRS resources. The UE is configured to transmit SRS during T2.

The UE is configured with measurement gap pattern ID # 24 or #13 before T2.

1. Ensure the UE is in State RRC_CONNECTED with generic procedure parameters Connectivity NR, Connected without release On, according to TS 38.508-1 [45] clause 4.5. Note that in the remainder of the test the timing advance command $T_A = 31$ which indicates a timing advance adjustment value $N_{TA} = 0 T_c$.
2. The SS shall send a RESET UE POSITIONING STORED INFORMATION message.
3. The SS adjusts the downlink timing for Cell 1 to a delay of $+512 T_c$, compared to the current value.
4. Wait for 1.6 s to allow for the possibility that the UE makes autonomous timing adjustments.
5. T1 starts.
6. The SS shall transmit an RRCReconfiguration message with the SRS configuration.
7. The UE shall transmit RRCReconfigurationComplete message.
8. The SS shall transmit an LPP REQUEST CAPABILITIES message.
9. The UE shall transmit an LPP PROVIDE CAPABILITIES message indicating the UE supports *supportedDL-PRS-ProcessingSamples-RRC-CONNECTED* in the *NR-DL-PRS-ProcessingCapability* IE and the Multi-RTT capabilities supported by the UE in the *NR-Multi-RTT-ProvideCapabilities* IE.
10. The SS shall send a LPP PROVIDE ASSISTANCE DATA message, including the *NR-Multi-RTT-ProvideAssistanceData* IE. The position of neighbour Cell 2 is described in 3GPP TS 37.571-5 [20]. If the UE message at step 9 includes the *ackRequested* IE set to TRUE, then the SS shall send an acknowledgment in the LPP PROVIDE ASSISTANCE DATA message.
11. The SS shall send a LPP REQUEST LOCATION INFORMATION message, including the *reducedDL-PRS-ProcessingSamples-r17* in the *NR-Multi-RTT-RequestLocationInformation* IE such that the UE receives the message ΔT ms before the start of T2, where $\Delta T = 50$ ms.
12. When T1 expires, the SS shall switch the power setting from T1 to T2 as specified in Table 15.2.5.5-2.
13. The UE shall transmit a LPP PROVIDE LOCATION INFORMATION message including the *NR-Multi-RTT-ProvideLocationInformation* IE within the response time (see clause 15.2.5.4.3). The UE shall perform and report the UE rx-tx time difference measurements for Cell 1 and Cell 2. If the UE transmits an *NR-Multi-RTT-ProvideLocationInformation* IE including the *nr-UE-RxTxTimeDiff* field for Cell 1 and Cell 2 within the response time, then the number of successful tests is increased by one. If the UE fails to report the *NR-Multi-RTT-ProvideLocationInformation* IE with the *nr-UE-RxTxTimeDiff* field included within the response time then the number of failure tests is increased by one.
14. If the UE message at step 13 includes the *ackRequested* IE set to TRUE, the SS shall send a LPP acknowledgement message.
15. Repeat steps 1-14 until the confidence level according to Annex D is achieved.

NOTE: To avoid a large divergence between the sent TA and the set downlink timing, the SS may reset the downlink timing for Cell 1 to its initial value after a certain amount of loops. The loop during the reset does not count for the result statistics.

15.2.5.4.3 Message contents

Table 15.2.5.4.3-1: RESET UE POSITIONING STORED INFORMATION

Derivation Path: 38.509 [44] clause 6.6			
Information Element	Value/remark	Comment	Condition
UE Positioning Technology	0 0 0 0 1 1 0	Multi-RTT	

Table 15.2.5.4.3-2: RRCReconfiguration

Derivation Path: TS 38.508-1 [45], table 4.6.1-13			
Information Element	Value/remark	Comment	Condition
RRCReconfiguration ::= SEQUENCE {			
criticalExtensions CHOICE {			
rrcReconfiguration SEQUENCE {			
radioBearerConfig			
nonCriticalExtension SEQUENCE {			
masterCellGroup SEQUENCE {	CellGroupConfig		
spCellConfig SEQUENCE {			
spCellConfigDedicated SEQUENCE {			
uplinkConfig SEQUENCE {			
initialUplinkBWP SEQUENCE {			
srs-Config CHOICE {			
setup	As defined in Table 15.2.5.4.3-3		
}			
}			
}			
}			
}			
}			

Table 15.2.5.4.3-3: SRS-Config

Derivation Path: TS 38.508-1 [45], Table 4.6.3-182			
Information Element	Value/remark	Comment	Condition
SRS-Config ::= SEQUENCE {			
srs-ResourceSetToReleaseList	Not present		
srs-ResourceSetToAddModList	Not present		
srs-ResourceToReleaseList	Not present		
srs-ResourceToAddModList	Not present		
tpc-Accumulation	Not present		
srs-RequestDCI-1-2-r16	Not present		
srs-RequestDCI-0-2-r16	Not present		
srs-ResourceSetToAddModListDCI-0-2-r16	Not present		
srs-ResourceSetToReleaseListDCI-0-2-r16	Not present		
srs-PosResourceSetToReleaseList-r16	Not present		
srs-PosResourceSetToAddModList-r16 SEQUENCE (SIZE(1..maxNrofSRS-PosResourceSets-r16)) OF SRS-PosResourceSet-r16 {	1 entry		
SRS-PosResourceSet-r16[1] SEQUENCE {		entry 1	
srs-PosResourceSetId-r16	0		
srs-PosResourceSetList-r16 SEQUENCE (SIZE(1..maxNrofSRS-ResourcesPerSet)) OF SRS-PosResourceSet-r16 {	1 entry		
SRS-PosResourceSet-r16	0	1 entry	
}			
resourceType CHOICE {			
periodic SEQUENCE {			

}			
}			
alpha-r16	alpha0		
p0-r16	0		
pathlossReferenceRS-Pos-r16	Not present		
}			
srs-PosResourceToReleaseList-r16	Not present		
srs-PosResourceToAddModList-r16 SEQUENCE (SIZE(1..maxNrofSRS-PosResources-r16)) OF SRS-PosResource-r16 {	1 entry		
SRS-PosResource-r16[1] SEQUENCE {		entry 1	
srs-PosResourceId-r16	0		
transmissionComb-r16 CHOICE {			
n4-r16 SEQUENCE {			
combOffset-n4-r16	0		
cyclicShift-n4-r16	0		
}			
}			
resourceMapping-r16 SEQUENCE {			
startPosition-r16	0		
nrofSymbols-r16	n4		
}			
freqDomainShift-r16	0		
freqHopping-r16 SEQUENCE {			
c-SRS-r16	Matches N _{RB,c} Table 15.2.5.5-1		
}			
groupOrSequenceHopping-r16	neither		
resourceType-r16 CHOICE {			
periodic-r16 SEQUENCE {			
periodicityAndOffset-p-r16 CHOICE {			
sl160	20		Config 1 and Config 2
sl320	40		Config 3
}			
}			
}			
sequenceId-r16	0		
spatialRelationInfoPos-r16	Not present		
}			
}			
}			

Table 15.2.5.4.3-4: LPP Request Capabilities

Information Element	Value/remark
nr-Multi-RTT-RequestCapabilities-r16	TRUE

Table 15.2.5.4.3-5: LPP RequestLocationInformation

Derivation Path: TS 37.355 [49] clause 6.2			
Information Element	Value/remark	Comment	Condition
LPP-Message ::= SEQUENCE {			
transactionID SEQUENCE {			
initiator	locationServer		
transactionNumber	1		
}			
endTransaction	FALSE		
sequenceNumber	Not present		
acknowledgement	Not present		
lpp-MessageBody CHOICE {			
c1 CHOICE {			
requestLocationInformation SEQUENCE {			

criticalExtensions CHOICE {			
c1 CHOICE {			
requestLocationInformation-r9 SEQUENCE {			
commonEsRequestLocationInformation SEQUENCE {			
locationInformationType	locationMeasurementsPreferred		
triggeredReporting	Not present		
periodicalReporting	Not present		
additionalInformation	onlyReturnInformationRequested		
qos SEQUENCE {			
horizontalAccuracy	Not present		
verticalCoordinateRequest	FALSE		
verticalAccuracy	Not present		
responseTime SEQUENCE {			
time	See 15.2.5.5		
responseTimeEarlyFix-r12	Not present	Result of the response time calculation rounded up to the next second	Rel-12 onwards
unit-r15	Not present ten-seconds		Calculated response time >128s
}			
velocityRequest	FALSE		
}			
environment	Not present		
locationCoordinateTypes	Not present		
velocityTypes	Not present		
}			
a-gnss-RequestLocationInformation	Not present		
otdoa-RequestLocationInformation	Not present		
ecid-RequestLocationInformation	Not present		
epdu-RequestLocationInformation	Not Present		
sensor-RequestLocationInformation-r13	Not present		
tbs-RequestLocationInformation-r13	Not present		
wlan-RequestLocationInformation-r13	Not present		
bt-RequestLocationInformation-r13	Not present		
nr-ECID-RequestLocationInformation-r16	Not present		
nr-Multi-RTT-RequestLocationInformation-r16 SEQUENCE {			
nr-UE-RxTxTimeDiffMeasurementInfoRequest-r16	Not present		
nr-RequestedMeasurements-r16	bit 0 = 1 (prsrsrpReq)		
nr-AssistanceAvailability-r16	FALSE		
nr-Multi-RTT-ReportConfig-r16 SEQUENCE {			
maxDL-PRS-RxTxTimeDiffMeasPerTRP-r16	Not present		
timingReportingGranularityFactor-r16	Not present		
}			
additionalPaths-r16	Not present		
nr-UE-RxTxTEG-Request-r17			
measureSameDL-PRS-ResourceWithDifferentRxTxTEGs-r17	Not present		
measureSameDL-PRS-ResourceWithDifferentRxTEGs-r17	Not present		
reducedDL-PRS-ProcessingSamples-r17	requested		
nr-los-nlos-IndicatorRequest-r17	Not present		
additionalPathsExt-r17	Not present		
additionalPathsDL-PRS-RSRP-Request-r17	Not present		
multiMeasInSameReport-r17	Not present		
lowerRxBeamSweepingFactor-FR2-r17	Not present		
}			
nr-DL-AoD-RequestLocationInformation-r16	Not present		

nr-DL-TDOA-RequestLocationInformation-r16	Not present		
}			
}			
}			
}			
}			
}			
}			

Table 15.2.5.4.3-6: LPP ProvideAssistanceData

Derivation Path: 37.355 clause 6.2			
Information Element	Value/remark	Comment	Condition
LPP-Message ::= SEQUENCE {			
transactionID SEQUENCE {			
initiator	locationServer		
transactionNumber	(0..255)		
}			
endTransaction	TRUE		
sequenceNumber	Not present		
acknowledgement	Not present		
lpp-MessageBody CHOICE {			
c1 CHOICE {			
provideAssistanceData SEQUENCE {			
criticalExtensions CHOICE {			
c1 CHOICE {			
provideAssistanceData-r9 SEQUENCE {			
commonEsProvideAssistanceData	Not present		
a-gnss-ProvideAssistanceData	Not present		
otdoa-ProvideAssistanceData	Not present		
epdu-Provide-AssistanceData	Not present		
sensor-ProvideAssistanceData-r15	Not present		
tbs-ProvideAssistanceData-r15	Not present		
wlan-ProvideAssistanceData-r15	Not present		
nr-Multi-RTT-ProvideAssistanceData-r16			
} SEQUENCE {			
nr-DL-PRS-AssistanceData	As defined in Table 15.2.5.4.3-7		
nr-SelectedDL-PRS-IndexList-r16	Not present		
nr-Multi-RTT-Error-r16	Not present		
nr-On-Demand-DL-PRS-Configurations-r17	Not present		
nr-On-Demand-DL-PRS-Configurations-Selected-IndexList-r17	Not present		
assistanceDataValidityArea-r17	Not present		
}			
nr-DL-AoD-ProvideAssistanceData-r16	Not present		
nr-DL-TDOA-ProvideAssistanceData-r16	Not present		
}			
}			
}			
}			
}			

Table 15.2.5.4.3-7: NR-DL-PRS-AssistanceData

Derivation Path: 37.355 clause 6.4.3			
Information Element	Value/remark	Comment	Condition
NR-DL-PRS-AssistanceData-r16 ::= SEQUENCE {			
nr-DL-PRS-ReferenceInfo-r16 SEQUENCE {			
dl-PRS-ID-r16	0		
nr-DL-PRS-ResourceID-List-r16	Not present		
nr-DL-PRS-ResourceSetID-r16	Not present		

}			
nr-DL-PRS-AssistanceDataList-r16 SEQUENCE (SIZE (1..nrMaxFreqLayers-r16)) OF NR-DL-PRS-AssistanceDataPerFreq-r16 {	1 entry		
NR-DL-PRS-AssistanceDataPerFreq-r16[1] SEQUENCE {		entry 1	
nr-DL-PRS-PositioningFrequencyLayer-r16 SEQUENCE {			
dl-PRS-SubcarrierSpacing-r16	kHz15		Config 1 and Config 2
	kHz30		Config 3
dl-PRS-ResourceBandwidth-r16	21	104 PRBs	Config 1 and Config 2
	28	132 PRBs	Config 3
dl-PRS-StartPRB-r16	0		
dl-PRS-PointA-r16	absoluteFrequencyPointA as defined for the DL frequency of the Cell 1		
dl-PRS-CombSizeN-r16	n4		
dl-PRS-CyclicPrefix-r16	normal		
}			
nr-DL-PRS-AssistanceDataPerFreq-r16 SEQUENCE (SIZE (1..nrMaxTRPsPerFreq-r16)) OF NR-DL-PRS-AssistanceDataPerTRP-r16{	2 entries		
NR-DL-PRS-AssistanceDataPerTRP-r16[1] SEQUENCE {		entry 1	Cell 1
dl-PRS-ID-r16	0		
nr-PhysCellID-r16	Cell 1		
nr-CellGlobalID-r16	Cell 1		
nr-ARFCN-r16	Cell 1		
nr-DL-PRS-SFN0-Offset-r16 SEQUENCE {			
sfn-Offset-r16	0		
integerSubframeOffset-r16	0		
}			
nr-DL-PRS-ExpectedRSTD-r16	0		
nr-DL-PRS-ExpectedRSTD-Uncertainty-r16	0		
nr-DL-PRS-Info-r16	As specified in Table 15.2.5.4.3-8		
}			
NR-DL-PRS-AssistanceDataPerTRP-r16[2] SEQUENCE {		entry 2	Cell 2
dl-PRS-ID-r16	1		
nr-PhysCellID-r16	Cell 2		
nr-CellGlobalID-r16	Cell 2		
nr-ARFCN-r16	Cell 2		
nr-DL-PRS-SFN0-Offset-r16 SEQUENCE {			
sfn-Offset-r16	0		
integerSubframeOffset-r16	0		
}			
nr-DL-PRS-ExpectedRSTD-r16	0		
nr-DL-PRS-ExpectedRSTD-Uncertainty-r16	154	About 5 μs	
nr-DL-PRS-Info-r16	As specified in Table 15.2.5.4.3-8		
}			
}			
}			
}			
}			

Table 15.2.5.4.3-8: NR-DL-PRS-Info

Derivation Path: 37.355 clause 6.4.3			
Information Element	Value/remark	Comment	Condition

NR-DL-PRS-Info-r16 ::= SEQUENCE {			
nr-DL-PRS-ResourceSetList-r16 SEQUENCE (SIZE (1..nrMaxSetsPerTrp-r16)) OF NR-DL-PRS-ResourceSet-r16 {	1 entry		
NR-DL-PRS-ResourceSet-r16[1] SEQUENCE {		entry 1	
nr-DL-PRS-ResourceSetID-r16	0		
dl-PRS-Periodicity-and-ResourceSetSlotOffset-r16 CHOICE {			
scs15-r16 CHOICE {			Config 1 and Config 2
n160-r16	10		
}			
scs30-r16 CHOICE {			Config 3
n320-r16	20		
}			
dl-PRS-ResourceRepetitionFactor-r16	Not present		
dl-PRS-ResourceTimeGap-r16	s1		
dl-PRS-NumSymbols-r16	n4		
dl-PRS-MutingOption1-r16 CHOICE {			
po2-r16	10		Cell 1
	01		Cell 2
}			
}			
dl-PRS-MutingOption2-r16	Not present		
dl-PRS-ResourcePower-r16	27		
dl-PRS-ResourceList-r16 SEQUENCE (SIZE (1..nrMaxResourcesPerSet-r16)) OF NR-DL-PRS-Resource-r16 {	1 entry		
NR-DL-PRS-Resource-r16[1] SEQUENCE {		entry 1	
nr-DL-PRS-ResourceID-r16	0		
dl-PRS-SequenceID-r16	0		
dl-PRS-CombSizeN-AndReOffset-r16 CHOICE {			
n4-r16	0		
}			
dl-PRS-ResourceSlotOffset-r16	4		
dl-PRS-ResourceSymbolOffset-r16	0		
dl-PRS-QCL-Info-r16	Not present		
}			
}			
}			
}			
}			

Table 15.2.5.4.3-9: LPP ProvideLocation Information

Derivation Path: 37.355 clause 6.5.12			
Information Element	Value/remark	Comment	Condition
LPP-Message ::= SEQUENCE {			
transactionID SEQUENCE {			
initiator	locationServer		
transactionNumber	1		
}			
endTransaction	TRUE		
sequenceNumber	(0..255)		
acknowledgement			
lpp-MessageBody CHOICE {			
c1 CHOICE {			
provideLocationInformation SEQUENCE {			
criticalExtensions CHOICE {			
c1 CHOICE {			
provideLocationInformation-r9 SEQUENCE {			
commonIEsProvideLocationInformation	Not present.		
a-gnss-ProvideLocationInformation	Not present		
otdoa-ProvideLocationInformation	Not present		

ecid-ProvideLocationInformation	Not present		
epdu-ProvideLocationInformation	Not present		
sensor-ProvideLocationInformation-r13	Not present		
tbs-ProvideLocationInformation-r13	Not present		
wlan-ProvideLocationInformation-r13	Not present		
bt-ProvideLocationInformation-r13	Not present		
nr-ECID-ProvideLocationInformation-r16	Not present		
nr-Multi-RTT-ProvideLocationInformation-r16 SEQUENCE {			
nr-Multi-RTT-SignalMeasurementInformation-r16 SEQUENCE {			
nr-Multi-RTT-MeasList-r16 SEQUENCE (SIZE(1..nrMaxTRPs-r16)) OF NR-Multi-RTT-MeasElement-r16 {	2 entries		
NR-Multi-RTT-MeasElement-r16[1] SEQUENCE {		entry 1	
dl-PRS-ID-r16	INTEGER (0..255)		
nr-PhysCellID-r16			
nr-CellGlobalID-r16			
nr-ARFCN-r16			
nr-DL-PRS-ResourceID-r16			
nr-DL-PRS-ResourceSetID-r16			
nr-UE-RxTxTimeDiff-r16	Present. Any value acceptable.		
nr-AdditionalPathList-r16			
nr-TimeStamp-r16			
nr-TimingQuality-r16			
nr-DL-PRS-RSRP-Result-r16			
nr-Multi-RTT-AdditionalMeasurements-r16			
nr-UE-RxTx-TEG-Info-r17			
nr-DL-PRS-FirstPathRSRP-Result-r17			
nr-los-nlos-Indicator-r17			
nr-AdditionalPathListExt-r17			
nr-Multi-RTT-AdditionalMeasurementsExt-r17			
NR-Multi-RTT-MeasElement-r16[2] SEQUENCE {		entry 2	
dl-PRS-ID-r16	INTEGER (0..255)		
nr-PhysCellID-r16			
nr-CellGlobalID-r16			
nr-ARFCN-r16			
nr-DL-PRS-ResourceID-r16			
nr-DL-PRS-ResourceSetID-r16			
nr-UE-RxTxTimeDiff-r16	Present. Any value acceptable.		
nr-AdditionalPathList-r16			
nr-TimeStamp-r16			
nr-TimingQuality-r16			
nr-DL-PRS-RSRP-Result-r16			
nr-Multi-RTT-AdditionalMeasurements-r16			
nr-UE-RxTx-TEG-Info-r17			
nr-DL-PRS-FirstPathRSRP-Result-r17			
nr-los-nlos-Indicator-r17			
nr-AdditionalPathListExt-r17			
nr-Multi-RTT-AdditionalMeasurementsExt-r17			
}			
nr-NTA-Offset-r16			
nr-SRS-TxTEG-Set-r17			
nr-UE-RxTEG-TimingErrorMargin-r17			
nr-UE-TxTEG-TimingErrorMargin-r17			

nr-UE-RxTxTEG-TimingErrorMargin-r17			
}			
nr-Multi-RTT-Error-r16			
nr-Multi-RTT-SignalMeasurementInstances-r17			
}			
nr-DL-AoD-ProvideLocationInformation-r16	Not present		
}			
}			
}			
}			
}			
}			
}			

15.2.5.5 Test requirement

Table 15.2.5.5-1 and Table 15.2.5.5-2 define the primary level settings including test tolerances for the test.

Table 15.2.5.5-1: General test parameters

Parameter	Unit	Test configuration	Value	Comment
Active cell		1, 2, 3	Cell 1	Cell 1 is the PCell in <i>NR-Multi-RTT-ProvideAssistanceData</i> [34].
Neighbour cell		1, 2, 3	Cell 2	Cell 2 is a neighbour cell in <i>NR-Multi-RTT-ProvideAssistanceData</i> [34].
RF Channel Number		1, 2, 3	1	For both Cell 1 and Cell 2
BW _{channel}	MHz	1	20: N _{RB,c} = 106	
		2	20: N _{RB,c} = 106	
		3	50: N _{RB,c} = 133	
SSB configuration		1	SSB.1 FR1	
		2	SSB.1 FR1	
		3	SSB.2 FR1	
SMTC configuration		1	SMTC.2	
		2	SMTC.1	
		3	SMTC.1	
Measurement gap		1, 2, 3	GP#24 or GP#0 ^{Note 1}	
CP length		1, 2, 3	Normal	
DRX		1, 2, 3	OFF	
Time offset between serving and neighbour cells	µs	1, 2, 3	3	Synchronous cells
T1	s	1, 2, 3	5	
T2	s	1, 2, 3	10	

Note 1: GP#24 is configured if UE supports MG#24, otherwise GP#0 is configured.

Table 15.2.5.5-2: Cell specific test parameters

Parameter	Unit	Test configuration	Cell 1		Cell 2	
			T1	T2	T1	T2
TDD configuration		1	N/A		N/A	
		2	TDDConf.1.1		TDDConf.1.1	
		3	TDDConf.2.1		TDDConf.2.1	
PDSCH RMC configuration		1	SR.1.1 FDD		N/A	
		2	SR.1.1 TDD			
		3	SR.2.1 TDD			
RMSI CORESET RMC configuration		1	CR.1.1 FDD		N/A	
		2	CR.1.1 TDD			
		3	CR.2.1 TDD			

Dedicated CORESET RMC configuration		1	CCR.1.1 FDD		N/A	
		2	CCR.1.1 TDD			
		3	CCR.2.1 TDD			
OCNG Patterns		1, 2, 3	OP.1		OP.1	
TRS Configuration		1	TRS.1.1 FDD		N/A	
		2	TRS.1.1 TDD			
		3	TRS.1.2 TDD			
Initial BWP configuration		1, 2, 3	DLBWP.0.1 ULBWP.0.1		N/A	
Active DL BWP configuration		1, 2, 3	DLBWP.1.1		N/A	
Active UL BWP configuration		1, 2, 3	ULBWP.1.1		N/A	
PRS configuration		1	PRS.1.2 FR1		PRS.1.2 FR1	
		2	PRS.1.2 FR1		PRS.1.2 FR1	
		3	PRS.2.2 FR1		PRS.2.2 FR1	
PRS muting info		1, 2, 3	'10'		'01'	
SRS configuration		1	POS-SRS.1		N/A	
		2	POS-SRS.1		N/A	
		3	POS-SRS.2		N/A	
N_{oc} <small>Note 2</small>	dBm/SCS	1	-98			
		2	-98			
		3	-95			
N_{oc} <small>Note 2</small>	dBm/15 kHz	1	-98			
		2				
		3				
PRS \hat{E}_s/I_{ot}	dB	1	-Infinity	0	-Infinity	-6
		2				
		3				
PRS \hat{E}_s/N_{oc}	dB	1	-Infinity	2.23	-Infinity	-1.73
		2				
		3				
PRS-RSRP <small>Note 3</small>	dBm/SCS kHz	1	-Infinity	-95.77	-Infinity	-99.73
		2	-Infinity	-95.77	-Infinity	-99.73
		3	-Infinity	-92.77	-Infinity	-96.73
SS-RSRP <small>Note 3</small>	dBm/SCS kHz	1	-100	-100	-Infinity	-104
		2	-100	-100	-Infinity	-104
		3	-97	-97	-Infinity	-101
Io	dBm/19.08 MHz	1	N/A	-61.71	N/A	-61.71
	dBm/19.08 MHz	2		-61.71		-61.71
	dBm/47.88 MHz	3		-57.73		-57.73
Propagation Condition		1, 2, 3	AWGN			
<p>Note 1: The resources for uplink transmission are assigned to the UE prior to the start of time period T2.</p> <p>Note 2: Interference from other cells and noise sources not specified in the test is assumed to be constant over subcarriers and time and shall be modelled as AWGN of appropriate power for N_{oc} to be fulfilled.</p> <p>Note 3: SS-RSRP and PRS-RSRP levels have been derived from other parameters for information purposes. They are not settable parameters themselves.</p>						

FFS

15.2.6 UE Rx-Tx time difference measurement reporting delay test case for single positioning frequency layer without measurement gap in FR1 SA

Editor's note: This test case is incomplete. The following aspect is either missing or TBD:

- Test tolerance is missing

15.2.6.1 Test purpose

The purpose of the test is to verify that the UE Rx-Tx measurement meets the requirements specified in TS 38.133 [50] clause 9.9.4.6 in AWGN propagation condition in FR1 in standalone scenario.

15.2.6.2 Test applicability

This test applies to all types of NR UE release 17 onwards that supports Multi-RTT positioning and prs Processing Window.

15.2.6.3 Minimum conformance requirements

When physical layer receives last of *NR-Multi-RTT-ProvideAssistanceData* message and *NR-Multi-RTT-RequestLocationInformation* message from LMF via LPP [34], UE shall be able to measure multiple (up to the UE capability specified in clause 9.9.4.3) UE Rx-Tx time difference measurements as defined in TS 38.215 [4] in configured positioning frequency layers within the measurement period $T_{\text{UERxTx_wo_gap,Total}}$ ms.

$T_{\text{UERxTx_wo_gap,Total}} = \sum_{i=1}^L T_{\text{UERxTx_wo_gap},i} + (L - 1) * \max(T_{\text{effect},i})$, if any of the positioning frequency layers are in Case 1, or

$T_{\text{UERxTx_wo_gap,Total}} = \max(T_{\text{UERxTx_wo_gap},i} + T_{\text{uncertainty},i})$, if all the positioning frequency layers are in Case 2.

Where,

i is the index of positioning frequency layer, and

L is total number of positioning frequency layers, and

$T_{\text{effect},i}$ is the periodicity of the PRS RSTD measurement in positioning frequency layer i , and

$T_{\text{uncertainty},i}$ is the time from the start of the first PPW occasion for positioning frequency layer i to the start of measurement period $T_{\text{UERxTx_wo_gap,Total}}$.

A positioning frequency layer is in Case 1 if UE reports *ppw-durationOfPRS-Processing1-r17* for the band containing the positioning frequency layer, and a positioning frequency layer is in Case 2 if UE reports *ppw-durationOfPRS-Processing2-r17* for the band containing the positioning frequency layer.

$T_{\text{UERxTx_wo_gap},i}$ is the measurement period for UE Rx-Tx time difference measurement in positioning frequency layer i as specified below.

$$T_{\text{UERxTx_wo_gap},i} = \left(k_{\text{multiTEG},i} * N_{\text{RxBeam},i} * \left\lceil \frac{N_{\text{slot}}^{\text{PRS},i}}{N'} \right\rceil \left\lfloor \frac{L_{\text{available_PRS},i}}{N} \right\rfloor * N_{\text{sample}} - 1 \right) * T_{\text{effect},i} + T_{\text{last},i}$$

Where

$T_{\text{effect},i}$ is the periodicity of the UE Rx-Tx time difference measurement in positioning frequency layer i as defined further in this clause.

$k_{\text{multiTEG},i}$ is the scaling factor for measurement of same PRS resource with multiple Rx TEGs.

$k_{\text{multiTEG},i}=1$ if UE is not supported *measureSameDL-PRS-ResourceWithDifferentRxTEGs-r17* or not requested by LMF to measure a PRS resource with multiple Rx TEGs via *measureSameDL-PRS-ResourceWithDifferentRxTEGs-r17* or *measureSameDL-PRS-ResourceWithDifferentRxTxTEGs-r17* [34] in *NR-Multi-RTT-RequestLocationInformation*;

otherwise,

$k_{multiTEG,i} = N_{TEG,i}$, if UE is not capable of receiving same DL PRS resource simultaneously from multiple Rx TEGs, and

$k_{multiTEG,i} = \left\lfloor \frac{N_{TEG,i}}{k_{TEG,simul,i}} \right\rfloor$ if UE is capable of receiving the same DL PRS resource simultaneously from multiple Rx TEGs.

where

$N_{TEG,i}$ is the number of Rx TEGs or RxTx TEGs with which UE is requested to measure a PRS resource indicated via *measureSameDL-PRS-ResourceWithDifferentRxTEGs-r17* or *measureSameDL-PRS-ResourceWithDifferentRxTxTEGs-r17* [34] in *NR-Multi-RTT-RequestLocationInformation*, and in case 'n0' is indicated, $N_{TEG,i}$ is the maximum number of Rx TEGs with which UE can support to measure the same PRS resource as reported in *NR-UE-TEG-Capability*, and

$k_{TEG,simul,i}$ is the number of Rx TEGs UE can measure simultaneously which is reported via *measureSameDL-PRS-ResourceWithDifferentRxTEGsSimul*.

$N_{RxBeam,i}$ is the scaling factor for Rx beam sweeping, and $N_{RxBeam,i} = 1$ if positioning frequency layer i is in FR1. If positioning frequency layer i is in FR2, $N_{RxBeam,i}$ is equal to the value reported by the UE in *supportedLowerRxBeamSweepingFactor-FR2* if the UE supports the capability for the band containing positioning frequency layer i , and the LMF indicates *lowerRxBeamSweepingFactor-FR2* in *NR-Multi-RTT-RequestLocationInformation*. $N_{RxBeam,i}$ is equal to 8, otherwise.

$L_{available_PRS,i}$ is the time duration of available PRS resources in the positioning frequency layer i , to be measured during $T_{available_PRS,i}$, and is calculated in the same way as PRS duration K defined in clause 5.1.6.5 of TS 38.214 [26]. For calculation of $L_{available_PRS,i}$,

only the unmuted PRS resources that meet the applicability conditions and fully or partially overlapped with PRS processing window are considered, if positioning frequency layer i is in Case 1, or

only the PRS resources unmuted and fully or partially overlapped with the first (PPWL-T2) ms of PPW are considered, if positioning frequency layer i is in Case 2, where PPWL is the PPW length and T2 corresponds to *ppw-durationOfPRS-ProcessingSymbolsT2*.

$N_{PRS,i}^{slot}$ is the maximum number of DL PRS resources of positioning frequency layer i configured in a slot,

{N, T} is UE capability combination per band where N is a duration of DL PRS symbols in ms corresponding to *ppw-durationOfPRS-ProcessingSymbolsN* in TS 37.355 [34] if positioning frequency layer i is in Case 1, or corresponding to *ppw-durationOfPRS-ProcessingSymbolsN2* in TS 37.355 [34] if positioning frequency layer i is in Case 2,

- N' is UE capability for number of DL PRS resources that it can process in a slot corresponding to *ppw-maxNumOfDL-PRS-ResProcessedPerSlot* as specified in clause 6.4.3 of TS 37.355 [34],
- N_{sample} is the number of UE Rx-Tx time difference measurement samples:
 - $N_{sample} = 4$ if the UE is not capable of *supportedDL-PRS-ProcessingSamples-RRC-CONNECTED* defined in [34].
 - $N_{sample} = 1$ if the UE is capable of *supportedDL-PRS-ProcessingSamples-RRC-CONNECTED* defined in [34] and LMF requests the UE to perform positioning measurements with reduced number of samples by *reducedDL-PRS-ProcessingSamples* [34] and the following conditions are met:
 - PRS bandwidth is within the active BWP and
 - Magnitude of difference between the serving cell's SS-RSRP and the neighbour cell's PRS-RSRP is within 6 dB.
 - $N_{sample} = 2$ if the UE is capable of *supportedDL-PRS-ProcessingSamples-RRC-CONNECTED* defined in [34] and the LMF requests the UE to perform positioning measurements with reduced number of samples by *reducedDL-PRS-ProcessingSamples* [34] but the following conditions are not met:

- PRS bandwidth is within the active BWP and
- Magnitude of difference between the serving cell's SS-RSRP and the neighbour cell's PRS-RSRP is within 6 dB.
- $N_{sample} = 4$ otherwise.
- $T_{last,i}$ is the measurement duration for the last UE Rx-Tx time difference measurement sample in the positioning layer i , including the sampling time and processing time.

If positioning frequency layer i is in Case 1 and all of the PRS resources to be measured are available in the same PPW occasion during $T_{available}$, then $T_{last,i} = T_i + PPWL$, else

if positioning frequency layer i is in Case 2 and all of the PRS resources to be measured are available in the same PPW occasion during $T_{available}$, then $T_{last,i} = PPWL$;

otherwise, $T_{last,i} = T_i + T_{available_PRS,i}$.

- $T_{effect,i}$ is periodicity of UE Rx-Tx time difference measurement in positioning frequency layer i :

$$T_{effect,i} = \left\lceil \frac{T_i}{T_{available_PRS,i}} \right\rceil * T_{available_PRS,i}$$

where

T_i corresponds to *ppw-durationOfPRS-ProcessingSymbolsT* in TS 37.355 [34] if positioning frequency layer i is in Case 1, or corresponds to the sum of *ppw-durationOfPRS-ProcessingSymbolsT2* and *ppw-durationOfPRS-ProcessingSymbolsN2* in TS 37.355 [34] if positioning frequency layer i is in Case 2,

$T_{available_PRS,i} = LCM(T_{PRS,i}, PPWRP_i)$, the least common multiple between $T_{PRS,i}$ and $PPWRP_i$

$PPWRP_i$ is the PRS processing window repetition periodicity in positioning frequency layer i .

$T_{PRS,i}$ is the PRS resource periodicity in positioning frequency layer i . If the positioning frequency layer i has more than one DL PRS resource sets with different PRS periodicities with muting, $T_{per}^{PRS\ with\ muting} = N_{muting} * T_{per}^{PRS}$, the least common multiple of $T_{per}^{PRS\ with\ muting}$ among DL PRS resource sets is used to derive $T_{PRS,i}$, where

T_{per}^{PRS} is the periodicity of PRS resource sets given by the higher-layer parameter *DL-PRS-Periodicity*.

N_{muting} is the scaling factor considering PRS resource muting. $N_{muting} = T_{muting}^{PRS} * L_{muting}$, where T_{muting}^{PRS} is the muting repetition factor given by the higher-layer parameter *DL-PRS-MutingBitRepetitionFactor*, and L_{muting} is the size of the bitmap $\{b^1\}$

15.2.6.4 Test description

15.2.6.4.1 Initial conditions

The supported test configuration is listed in Table 15.2.6.4-1.

Table 15.2.6.4-1: Test Configuration

Configuration	Description
1	15 kHz SSB SCS, 20 MHz bandwidth, FDD duplex mode
2	15 kHz SSB SCS, 20 MHz bandwidth, TDD duplex mode
3	30 kHz SSB SCS, 50 MHz bandwidth, TDD duplex mode
Note:	The UE is only required to be tested in one of the supported test configurations.

Test Environment: Normal, as defined in TS 38.508-1 [45] clause 4.1.

Frequencies to be tested: Mid Range, as defined in TS 38.508-1 [45] clause 4.3.1.

Channel bandwidth to be tested: are specified in Table 15.2.6.4-1.

1. Connect the SS and AWGN noise sources to the UE antenna connector or antenna connectors as shown in Annex A, Figure A.13.
2. The general test parameter settings are set up according to Table 15.2.6.5-1 and Table 15.2.6.5-2.
3. Propagation conditions are set according to clause 4.14.2.
4. Message contents are defined in clause 15.2.6.4.3.
5. In the test there are two cells in the test: PCell (Cell 1) and a neighbour cell (Cell 2). All cells are on the same RF channel in FR1.

15.2.6.4.2 Test procedure

The test consists of two sub-tests; Sub-test 1 is for $N_{\text{sample}} = 4$ and sub-test 2 is for $N_{\text{sample}} = 1$. Sub-test 2 is only conducted when UE also supporting supportedDL-PRS-ProcessingSamples-RRC-CONNECTED. The test consists of two consecutive time intervals, with duration of T1 and T2. Cell 1 and Cell 2 mute PRS transmission during T1 and transmit PRS during T2. The beginning of the time interval T2 shall be aligned with the beginning of the first MG instance containing the PRS resources. The UE is configured to transmit SRS during T2.

The UE is configured with measurement gap pattern ID # 24 or #13 before T2.

1. Ensure the UE is in State RRC_CONNECTED with generic procedure parameters Connectivity NR, Connected without release On, according to TS 38.508-1 [45] clause 4.5. Note that in the remainder of the test the timing advance command $T_A = 31$ which indicates a timing advance adjustment value $N_{TA} = 0 T_c$.
2. The SS shall send a RESET UE POSITIONING STORED INFORMATION message.
3. The SS adjusts the downlink timing for Cell 1 to a delay of $+512 T_c$, compared to the current value.
4. Wait for 1.6 s to allow for the possibility that the UE makes autonomous timing adjustments.
5. T1 starts.
6. The SS shall transmit an LPP REQUEST CAPABILITIES message.
7. The UE shall transmit an LPP PROVIDE CAPABILITIES message indicating the Multi-RTT capabilities supported by the UE in the NR-Multi-RTT-ProvideCapabilities IE.
8. The SS shall transmit an RRCReconfiguration message with SRS configuration and PPW configuration.
9. The UE shall transmit RRCReconfigurationComplete message.
10. The SS shall send a LPP PROVIDE ASSISTANCE DATA message, including the NR-Multi-RTT-ProvideAssistanceData IE. The position of neighbour Cell 2 is described in 3GPP TS 37.571-5 [20]. If the UE message at step 7 includes the ackRequested IE set to TRUE, then the SS shall send an acknowledgment in the LPP PROVIDE ASSISTANCE DATA message.
11. The SS shall send a LPP REQUEST LOCATION INFORMATION message, including the NR-Multi-RTT-RequestLocationInformation IE such that the UE receives the message ΔT ms before the start of T2, where $\Delta T = 50$ ms.
12. When T1 expires, the SS shall switch the power setting from T1 to T2 as specified in Table 15.2.6.5-2.
13. The UE shall transmit a LPP PROVIDE LOCATION INFORMATION message including the NR-Multi-RTT-ProvideLocationInformation IE within the response time (see clause 15.2.6.4.3). The UE shall perform and report the UE rx-tx time difference measurements for Cell 1 and Cell 2. If the UE transmits an NR-Multi-RTT-ProvideLocationInformation IE including the nr-UE-RxTxTimeDiff field for Cell 1 and Cell 2 within the response time, then the number of successful tests is increased by one. If the UE fails to report the NR-Multi-RTT-ProvideLocationInformation IE with the nr-UE-RxTxTimeDiff field included within the response time then the number of failure tests is increased by one.
14. If the UE message at step 13 includes the ackRequested IE set to TRUE, the SS shall send a LPP acknowledgement message.
15. Repeat steps 1-14 until the confidence level according to Annex D is achieved.

If all (applicable) sub-tests pass, the whole test passes. If one (applicable) sub-test fails, the whole test fails.

NOTE: To avoid a large divergence between the sent TA and the set downlink timing, the SS may reset the downlink timing for Cell 1 to its initial value after a certain amount of loops. The loop during the reset does not count for the result statistics.

15.2.6.4.3 Message contents

Table 15.2.6.4.3-1: RESET UE POSITIONING STORED INFORMATION

Derivation Path: 38.509 [44] clause 6.6			
Information Element	Value/remark	Comment	Condition
UE Positioning Technology	0 0 0 0 1 1 0	Multi-RTT	

Table 15.2.6.4.3-2: RRCReconfiguration

Derivation Path: TS 38.508-1 [45],, table 4.6.1-13			
Information Element	Value/remark	Comment	Condition
RRCReconfiguration ::= SEQUENCE {			
criticalExtensions CHOICE {			
rrcReconfiguration SEQUENCE {			
radioBearerConfig			
nonCriticalExtension SEQUENCE {			
masterCellGroup SEQUENCE {	CellGroupConfig		
spCellConfig SEQUENCE {			
spCellConfigDedicated SEQUENCE {			
initialDownlinkBWP SEQUENCE {			
dl-PPW-PreConfigToAddModList-r17 SEQUENCE (SIZE (1..maxNrofPPW-Config-r17)) OF DL-PPW-PreConfig-r17 {	1 entry		
DL-PPW-PreConfig-r17[1] SEQUENCE {		entry 1	
dl-PPW-ID-r17	0		
dl-PPW-PeriodicityAndStartSlot-r17 CHOICE {	The periodicity is 160ms and the starting slot offset is 11 ms for any SCS configuration		
scs15-r16 CHOICE {			Config 1 and Config 2
n160-r16	10		
scs30-r16 CHOICE {			Config 3
n320-r16	20		
length-r17	80		
type-r17	type1A		
priority-r17	st1		
uplinkConfig SEQUENCE {			
initialUplinkBWP SEQUENCE {			
srs-Config CHOICE {			
setup	As defined in Table 15.2.6.4.3-3		

--	--	--

Table 15.2.6.4.3-3: SRS-Config (Table 15.2.6.4.3-2)

Derivation Path: TS 38.508-1 [45], Table 4.6.3-182			
Information Element	Value/remark	Comment	Condition
SRS-Config ::= SEQUENCE {			
srs-ResourceSetToReleaseList	Not present		
srs-ResourceSetToAddModList	Not present		
srs-ResourceToReleaseList	Not present		
srs-ResourceToAddModList	Not present		
tpc-Accumulation	Not present		
srs-RequestDCI-1-2-r16	Not present		
srs-RequestDCI-0-2-r16	Not present		
srs-ResourceSetToAddModListDCI-0-2-r16	Not present		
srs-ResourceSetToReleaseListDCI-0-2-r16	Not present		
srs-PosResourceSetToReleaseList-r16	Not present		
srs-PosResourceSetToAddModList-r16 SEQUENCE (SIZE(1..maxNrofSRS-PosResourceSets-r16)) OF SRS-PosResourceSet-r16 {	1 entry		
SRS-PosResourceSet-r16[1] SEQUENCE {		entry 1	
srs-PosResourceSetId-r16	0		
srs-PosResourceCidList-r16 SEQUENCE (SIZE(1..maxNrofSRS-ResourcesPerSet)) OF SRS-PosResourceCid-r16 {	1 entry		
SRS-PosResourceCid-r16	0	1 entry	
}			
resourceType CHOICE {			
periodic SEQUENCE {			
}			
}			
alpha-r16	alpha0		
p0-r16	0		
pathlossReferenceRS-Pos-r16	Not present		
}			
srs-PosResourceToReleaseList-r16	Not present		
srs-PosResourceToAddModList-r16 SEQUENCE (SIZE(1..maxNrofSRS-PosResources-r16)) OF SRS-PosResource-r16 {	1 entry		
SRS-PosResource-r16[1] SEQUENCE {		entry 1	
srs-PosResourceCid-r16	0		
transmissionComb-r16 CHOICE {			
n4-r16 SEQUENCE {			
combOffset-n4-r16	0		
cyclicShift-n4-r16	0		
}			
}			
resourceMapping-r16 SEQUENCE {			
startPosition-r16	0		
nrofSymbols-r16	n4		
}			
freqDomainShift-r16	0		
freqHopping-r16 SEQUENCE {			
c-SRS-r16	Matches N _{RB,c} Table 15.2.6.5-1		
}			
groupOrSequenceHopping-r16	neither		
resourceType-r16 CHOICE {			
periodic-r16 SEQUENCE {			
periodicityAndOffset-p-r16 CHOICE {			
sl160	20		Config 1 and Config 2
sl320	40		Config 3
}			
}			
}			

}			
sequenceId-r16	0		
spatialRelationInfoPos-r16	Not present		
}			
}			

Table 15.2.6.4.3-4: LPP Request Capabilities

Information Element	Value/remark
nr-Multi-RTT-RequestCapabilities-r16	TRUE

Table 15.2.6.4.3-5: LPP RequestLocationInformation

Derivation Path: TS 37.355 [49] clause 6.2			
Information Element	Value/remark	Comment	Condition
LPP-Message ::= SEQUENCE {			
transactionID SEQUENCE {			
initiator	locationServer		
transactionNumber	1		
}			
endTransaction	FALSE		
sequenceNumber	Not present		
acknowledgement	Not present		
lpp-MessageBody CHOICE {			
c1 CHOICE {			
requestLocationInformation SEQUENCE {			
criticalExtensions CHOICE {			
c1 CHOICE {			
requestLocationInformation-r9 SEQUENCE {			
commonEsRequestLocationInformation SEQUENCE {			
locationInformationType	locationMeasurementsPreferred		
triggeredReporting	Not present		
periodicalReporting	Not present		
additionalInformation	onlyReturnInformationRequested		
qos SEQUENCE {			
horizontalAccuracy	Not present		
verticalCoordinateRequest	FALSE		
verticalAccuracy	Not present		
responseTime SEQUENCE {			
time	See 15.2.6.5	Result of the response time calculation rounded up to the next second if response time <= 128s. Result of the response time calculation rounded up to the next multiple of ten seconds if response time > 128s	
responseTimeEarlyFix-r12	Not present		Rel-12 onwards
unit-r15	Not present		
	ten-seconds		Calculated response time >128s
}			
}			
}			
}			

velocityRequest	FALSE		
}			
environment	Not present		
locationCoordinateTypes	Not present		
velocityTypes	Not present		
}			
a-gnss-RequestLocationInformation	Not present		
otdoa-RequestLocationInformation	Not present		
ecid-RequestLocationInformation	Not present		
epdu-RequestLocationInformation	Not Present		
sensor-RequestLocationInformation-r13	Not present		
tbs-RequestLocationInformation-r13	Not present		
wlan-RequestLocationInformation-r13	Not present		
bt-RequestLocationInformation-r13	Not present		
nr-ECID-RequestLocationInformation-r16	Not present		
nr-Multi-RTT-RequestLocationInformation-r16			
SEQUENCE {			
nr-UE-RxTxTimeDiffMeasurementInfoRequest-r16	Not present		
nr-RequestedMeasurements-r16	bit 0 = 1 (prsrsrpReq)		
nr-AssistanceAvailability-r16	FALSE		
nr-Multi-RTT-ReportConfig-r16 SEQUENCE {			
maxDL-PRS-RxTxTimeDiffMeasPerTRP-r16	Not present		
timingReportingGranularityFactor-r16	Not present		
}			
additionalPaths-r16	Not present		
nr-UE-RxTxTEG-Request-r17			
measureSameDL-PRS-ResourceWithDifferentRxTxTEGs-r17	Not present		
measureSameDL-PRS-ResourceWithDifferentRxTEGs-r17	Not present		
reducedDL-PRS-ProcessingSamples-r17	Not present		Sub-test 1
	requested		Sub-test 2
nr-los-nlos-IndicatorRequest-r17	Not present		
additionalPathsExt-r17	Not present		
additionalPathsDL-PRS-RSRP-Request-r17	Not present		
multiMeasInSameReport-r17	Not present		
lowerRxBeamSweepingFactor-FR2-r17	Not present		
}			
nr-DL-AoD-RequestLocationInformation-r16	Not present		
nr-DL-TDOA-RequestLocationInformation-r16	Not present		
}			
}			
}			
}			
}			
}			
}			
}			
}			

Table 15.2.6.4.3-6: LPP ProvideAssistanceData

Derivation Path: 37.355 clause 6.2			
Information Element	Value/remark	Comment	Condition
LPP-Message ::= SEQUENCE {			
transactionID SEQUENCE {			
initiator	locationServer		
transactionNumber	(0..255)		
}			
endTransaction	TRUE		
sequenceNumber	Not present		
acknowledgement	Not present		
lpp-MessageBody CHOICE {			
c1 CHOICE {			
provideAssistanceData SEQUENCE {			

criticalExtensions CHOICE {			
c1 CHOICE {			
provideAssistanceData-r9 SEQUENCE {			
commonEsProvideAssistanceData	Not present		
a-gnss-ProvideAssistanceData	Not present		
otdoa-ProvideAssistanceData	Not present		
epdu-ProvideAssistanceData	Not present		
sensor-ProvideAssistanceData-r15	Not present		
tbs-ProvideAssistanceData-r15	Not present		
wlan-ProvideAssistanceData-r15	Not present		
nr-Multi-RTT-ProvideAssistanceData-r16			
SEQUENCE {			
nr-DL-PRS-AssistanceData	As defined in Table 15.2.6.4.3-7		
nr-SelectedDL-PRS-IndexList-r16	Not present		
nr-Multi-RTT-Error-r16	Not present		
nr-On-Demand-DL-PRS-Configurations-r17	Not present		
nr-On-Demand-DL-PRS-Configurations-Selected-IndexList-r17	Not present		
assistanceDataValidityArea-r17	Not present		
}			
nr-DL-AoD-ProvideAssistanceData-r16	Not present		
nr-DL-TDOA-ProvideAssistanceData-r16	Not present		
}			
}			
}			

Table 15.2.6.4.3-7: NR-DL-PRS-AssistanceData

Derivation Path: 37.355 clause 6.4.3			
Information Element	Value/remark	Comment	Condition
NR-DL-PRS-AssistanceData-r16 ::= SEQUENCE {			
nr-DL-PRS-ReferenceInfo-r16 SEQUENCE {			
dl-PRS-ID-r16	0		
nr-DL-PRS-ResourceID-List-r16	Not present		
nr-DL-PRS-ResourceSetID-r16	Not present		
}			
nr-DL-PRS-AssistanceDataList-r16 SEQUENCE (SIZE (1..nrMaxFreqLayers-r16)) OF NR-DL-PRS-AssistanceDataPerFreq-r16 {	1 entry		
NR-DL-PRS-AssistanceDataPerFreq-r16[1] SEQUENCE {		entry 1	
nr-DL-PRS-PositioningFrequencyLayer-r16 SEQUENCE {			
dl-PRS-SubcarrierSpacing-r16	kHz15		Config 1 and Config 2
	kHz30		Config 3
dl-PRS-ResourceBandwidth-r16	21	104 PRBs	Config 1 and Config 2
	28	132 PRBs	Config 3
dl-PRS-StartPRB-r16	0		
dl-PRS-PointA-r16	absoluteFrequencyPointA as defined for the DL frequency of the Cell 1		
dl-PRS-CombSizeN-r16	n4		
dl-PRS-CyclicPrefix-r16	normal		
}			
nr-DL-PRS-AssistanceDataPerFreq-r16 SEQUENCE (SIZE (1..nrMaxTRPsPerFreq-r16)) OF NR-DL-PRS-AssistanceDataPerTRP-r16{	2 entries		

NR-DL-PRS-AssistanceDataPerTRP-r16[1] SEQUENCE {		entry 1	Cell 1
dl-PRS-ID-r16	0		
nr-PhysCellID-r16	Cell 1		
nr-CellGlobalID-r16	Cell 1		
nr-ARFCN-r16	Cell 1		
nr-DL-PRS-SFN0-Offset-r16 SEQUENCE {			
sfn-Offset-r16	0		
integerSubframeOffset-r16	0		
}			
nr-DL-PRS-ExpectedRSTD-r16	0		
nr-DL-PRS-ExpectedRSTD-Uncertainty-r16	0		
nr-DL-PRS-Info-r16	As specified in Table 15.2.6.4.3-8		
}			
NR-DL-PRS-AssistanceDataPerTRP-r16[2] SEQUENCE {		entry 2	Cell 2
dl-PRS-ID-r16	1		
nr-PhysCellID-r16	Cell 2		
nr-CellGlobalID-r16	Cell 2		
nr-ARFCN-r16	Cell 2		
nr-DL-PRS-SFN0-Offset-r16 SEQUENCE {			
sfn-Offset-r16	0		
integerSubframeOffset-r16	0		
}			
nr-DL-PRS-ExpectedRSTD-r16	As defined in Table 15.2.6.5-1		
nr-DL-PRS-ExpectedRSTD-Uncertainty-r16	As defined in Table 15.2.6.5-1		
nr-DL-PRS-Info-r16	As specified in Table 15.2.6.4.3-8		
}			
}			
}			
}			
}			

Table 15.2.6.4.3-8: NR-DL-PRS-Info

Derivation Path: 37.355 clause 6.4.3			
Information Element	Value/remark	Comment	Condition
NR-DL-PRS-Info-r16 ::= SEQUENCE {			
nr-DL-PRS-ResourceSetList-r16 SEQUENCE (SIZE (1..nrMaxSetsPerTrp-r16)) OF NR-DL-PRS-ResourceSet-r16 {	1 entry		
NR-DL-PRS-ResourceSet-r16[1] SEQUENCE {		entry 1	
nr-DL-PRS-ResourceSetID-r16	0		
dl-PRS-Periodicity-and-ResourceSetSlotOffset-r16 CHOICE {			
scs15-r16 CHOICE {			Config 1 and Config 2
n160-r16	10		
}			
scs30-r16 CHOICE {			Config 3
n320-r16	20		
}			
dl-PRS-ResourceRepetitionFactor-r16	Not present		
dl-PRS-ResourceTimeGap-r16	s1		
dl-PRS-NumSymbols-r16	n4		
dl-PRS-MutingOption1-r16 CHOICE {			
po2-r16	10		Cell 1
	01		Cell 2
}			
}			
}			
}			

dl-PRS-MutingOption2-r16	Not present		
dl-PRS-ResourcePower-r16	27		
dl-PRS-ResourceList-r16 SEQUENCE (SIZE (1..nrMaxResourcesPerSet-r16)) OF NR-DL-PRS-Resource-r16 {	1 entry		
NR-DL-PRS-Resource-r16[1] SEQUENCE {		entry 1	
nr-DL-PRS-ResourceID-r16	0		
dl-PRS-SequenceID-r16	0		
dl-PRS-CombSizeN-AndReOffset-r16 CHOICE {			
n4-r16	0		
}			
dl-PRS-ResourceSlotOffset-r16	4		
dl-PRS-ResourceSymbolOffset-r16	0		
dl-PRS-QCL-Info-r16	Not present		
}			
}			
}			
}			
}			

Table 15.2.6.4.3-9: LPP ProvideLocation Information

Derivation Path: 37.355 clause 6.5.12			
Information Element	Value/remark	Comment	Condition
LPP-Message ::= SEQUENCE {			
transactionID SEQUENCE {			
initiator	locationServer		
transactionNumber	1		
}			
endTransaction	TRUE		
sequenceNumber	(0..255)		
acknowledgement			
lpp-MessageBody CHOICE {			
c1 CHOICE {			
provideLocationInformation SEQUENCE {			
criticalExtensions CHOICE {			
c1 CHOICE {			
provideLocationInformation-r9 SEQUENCE {			
commonIEsProvideLocationInformation	Not present.		
a-gnss-ProvideLocationInformation	Not present		
otdoa-ProvideLocationInformation	Not present		
ecid-ProvideLocationInformation	Not present		
epdu-ProvideLocationInformation	Not present		
sensor-ProvideLocationInformation-r13	Not present		
tbs-ProvideLocationInformation-r13	Not present		
wlan-ProvideLocationInformation-r13	Not present		
bt-ProvideLocationInformation-r13	Not present		
nr-ECID-ProvideLocationInformation-r16	Not present		
nr-Multi-RTT-ProvideLocationInformation-r16 SEQUENCE {			
nr-Multi-RTT-SignalMeasurementInformation-r16 SEQUENCE {			
nr-Multi-RTT-MeasList-r16 SEQUENCE (SIZE(1..nrMaxTRPs-r16)) OF NR-Multi-RTT-MeasElement-r16 {	2 entries		
NR-Multi-RTT-MeasElement-r16[1] SEQUENCE {		entry 1	
dl-PRS-ID-r16	INTEGER (0..255)		
nr-PhysCellID-r16			
nr-CellGlobalID-r16			
nr-ARFCN-r16			
nr-DL-PRS-ResourceID-r16			
nr-DL-PRS-ResourceSetID-r16			
nr-UE-RxTxTimeDiff-r16	Present. Any value acceptable.		

	nr-AdditionalPathList-r16			
	nr-TimeStamp-r16			
	nr-TimingQuality-r16			
	nr-DL-PRS-RSRP-Result-r16			
r16	nr-Multi-RTT-AdditionalMeasurements-			
	nr-UE-RxTx-TEG-Info-r17			
	nr-DL-PRS-FirstPathRSRP-Result-r17			
	nr-los-nlos-Indicator-r17			
	nr-AdditionalPathListExt-r17			
	nr-Multi-RTT-AdditionalMeasurementsExt-r17			
	}			
	NR-Multi-RTT-MeasElement-r16[2]		entry 2	
SEQUENCE {				
	dl-PRS-ID-r16	INTEGER (0..255)		
	nr-PhysCellID-r16			
	nr-CellGlobalID-r16			
	nr-ARFCN-r16			
	nr-DL-PRS-ResourceID-r16			
	nr-DL-PRS-ResourceSetID-r16			
	nr-UE-RxTxTimeDiff-r16	Present. Any value acceptable.		
	nr-AdditionalPathList-r16			
	nr-TimeStamp-r16			
	nr-TimingQuality-r16			
	nr-DL-PRS-RSRP-Result-r16			
	}			
r16	nr-Multi-RTT-AdditionalMeasurements-			
	nr-UE-RxTx-TEG-Info-r17			
	nr-DL-PRS-FirstPathRSRP-Result-r17			
	nr-los-nlos-Indicator-r17			
	nr-AdditionalPathListExt-r17			
	nr-Multi-RTT-AdditionalMeasurementsExt-r17			
	}			
	}			
	nr-NTA-Offset-r16			
	nr-SRS-TxTEG-Set-r17			
	nr-UE-RxTEG-TimingErrorMargin-r17			
	nr-UE-TxTEG-TimingErrorMargin-r17			
	nr-UE-RxTxTEG-TimingErrorMargin-r17			
	}			
	nr-Multi-RTT-Error-r16			
	nr-Multi-RTT-SignalMeasurementInstances-r17			
	}			
	nr-DL-AoD-ProvideLocationInformation-r16	Not present		
	}			
	}			
	}			
	}			
	}			
	}			
	}			

15.2.6.5 Test requirement

Table 15.2.6.5-1 and Table 15.2.6.5-2 define the primary level settings including test tolerances for the test.

Table 15.2.6.5-1: General test parameters

Parameter	Unit	Test configuration	Value	Comment
Active cell		1, 2, 3	Cell 1	Cell 1 is the PCell in NR-Multi-RTT-ProvideAssistanceData [34].
Neighbour cell		1, 2, 3	Cell 2	Cell 2 is a neighbour cell in NR-Multi-RTT-ProvideAssistanceData [34].
RF Channel Number		1, 2, 3	1	For both Cell 1 and Cell 2
BW _{channel}	MHz	1	20: N _{RB,c} = 106	
		2	20: N _{RB,c} = 106	
		3	50: N _{RB,c} = 133	
SSB configuration		1	SSB.1 FR1	
		2	SSB.1 FR1	
		3	SSB.2 FR1	
SMTC configuration		1	SMTC.2	
		2	SMTC.1	
		3	SMTC.1	
PRS processing window		1,2,3	PPW.1	As defined in A.3.33
CP length		1, 2, 3	Normal	
DRX		1, 2, 3	OFF	
Time offset between serving and neighbour cells	µs	1	3 ^{Note1}	
		2	3 ^{Note1}	
		3	3 or 2.34 ^{Note1}	
Expected RSTD	µs	1,2,3	0	
Expected RSTD uncertainty	µs	1,2,3	Same as time offset between serving and neighbour cells	
T1	s	1, 2, 3	5	
T2	s	1, 2, 3	10	

NOTE 1: The value is up to the UE capability. The possible UE capability value: (1/4 symbol, 1/2 symbol, CP length, half of slot). When the UE reported value is > 3µs, the time offset between serving and neighbour cells is set to 3µs; when the UE reported value is < 3µs, the time offset between serving and neighbour cells is set to the UE reported value.

Table 15.2.6.5-2: Cell specific test parameters

Parameter	Unit	Test configuration	Cell 1		Cell 2	
			Sub-test 1	Sub-test 2	Sub-tests 1	Sub-test 2
TDD configuration		1	N/A		N/A	
		2	TDDConf.1.1		TDDConf.1.1	
		3	TDDConf.2.1		TDDConf.2.1	
PDSCH RMC configuration		1	SR.1.1 FDD		N/A	
		2	SR.1.1 TDD			
		3	SR.2.1 TDD			
RMSI CORESET RMC configuration		1	CR.1.1 FDD		N/A	
		2	CR.1.1 TDD			
		3	CR.2.1 TDD			
Dedicated CORESET RMC configuration		1	CCR.1.1 FDD		N/A	
		2	CCR.1.1 TDD			
		3	CCR.2.1 TDD			
OCNG Patterns		1, 2, 3	OP.1		OP.1	
TRS Configuration		1	TRS.1.1 FDD		N/A	
		2	TRS.1.1 TDD			
		3	TRS.1.2 TDD			

Initial BWP configuration		1, 2, 3	DLBWP.0.1 ULBWP.0.1	N/A		
Active DL BWP configuration		1, 2, 3	DLBWP.1.1	N/A		
Active UL BWP configuration		1, 2, 3	ULBWP.1.1	N/A		
PRS configuration		1	PRS.1.2 FR1	PRS.1.2 FR1		
		2	PRS.1.2 FR1	PRS.1.2 FR1		
		3	PRS.2.2 FR1	PRS.2.2 FR1		
PRS muting info		1, 2, 3	'10'	'01'		
SRS configuration		1	POS-SRS.1	N/A		
		2	POS-SRS.1	N/A		
		3	POS-SRS.2	N/A		
N_{oc} Note 2	dBm/SCS	1	-98			
		2	-98			
		3	-95			
N_{oc} Note 2	dBm/15 kHz	1	-98			
		2				
		3				
PRS \hat{E}_s/I_{ot}	dB	1	0	-2.41	-6	-12.12
		2				
		3				
PRS \hat{E}_s/N_{oc}	dB	1	2.23	-2	-1.73	-10
		2				
		3				
PRS-RSRP Note 3	dBm/SCS kHz	1	-95.77	-100	-99.73	-108
		2	-95.77	-100	-99.73	-108
		3	-92.77	-97	-96.73	-105
Io	dBm/19.08 MHz	1	-61.71	-64.57	-61.71	-64.57
		2	-61.71	-64.57	-61.71	-64.57
		3	-57.73	-60.59	-57.73	-60.59
Propagation Condition		1, 2, 3	AWGN			
<p>Note 1: The resources for uplink transmission are assigned to the UE prior to the start of time period T2.</p> <p>Note 2: Interference from other cells and noise sources not specified in the test is assumed to be constant over subcarriers and time and shall be modelled as AWGN of appropriate power for N_{oc} to be fulfilled.</p> <p>Note 3: PRS-RSRP levels have been derived from other parameters for information purposes. They are not settable parameters themselves.</p>						

FFS

15.2.7 UE Rx-Tx time difference measurement reporting delay test case for single positioning frequency layer with RxTx TEG in FR1 SA

Editor's note: This test case is incomplete. The following aspect is either missing or TBD:

- Test tolerance is missing

15.2.7.1 Test purpose

The purpose of the test is to verify that the UE Rx-Tx measurement meets the requirements specified in TS 38.133 [50] clause 9.9.4.5 in AWGN propagation condition in FR1 in standalone scenario when single positioning frequency layer is configured, and when UE is requested to measure a PRS resource with RxTx TEG.

15.2.7.2 Test applicability

This test applies to all types of NR UE release 17 onwards that supports Multi-RTT positioning and nr-UE-RxTxTEG-ID-MaxSupport-r17.

15.2.7.3 Minimum conformance requirements

Same as defined in clause 15.2.5.3.

15.2.7.4 Test description

15.2.7.4.1 Initial conditions

The supported test configuration is listed in Table 15.2.7.4-1.

Table 15.2.7.4-1: Test Configuration

Configuration	Description
1	15 kHz SSB SCS, 20 MHz bandwidth, FDD duplex mode
2	15 kHz SSB SCS, 20 MHz bandwidth, TDD duplex mode
3	30 kHz SSB SCS, 50 MHz bandwidth, TDD duplex mode
Note: The UE is only required to be tested in one of the supported test configurations.	

Test Environment: Normal, as defined in TS 38.508-1 [45] clause 4.1.

Frequencies to be tested: Mid Range, as defined in TS 38.508-1 [45] clause 4.3.1.

Channel bandwidth to be tested: are specified in Table 15.2.7.4-1.

1. Connect the SS and AWGN noise sources to the UE antenna connector or antenna connectors as shown in Annex A, Figure A.13.
2. The general test parameter settings are set up according to Table 15.2.7.5-1 and Table 15.2.7.5-2.
3. Propagation conditions are set according to clause 4.14.2.
4. Message contents are defined in clause 15.2.7.4.3.
5. In the test there are two cells in the test: PCell (Cell 1) and a neighbour cell (Cell 2). All cells are on the same RF channel in FR1.

15.2.7.4.2 Test procedure

Same as defined in clause 15.2.5.4.2.

15.2.7.4.3 Message contents

Table 15.2.7.4.3-1: RESET UE POSITIONING STORED INFORMATION

Derivation Path: 38.509 [44] clause 6.6			
Information Element	Value/remark	Comment	Condition
UE Positioning Technology	0 0 0 0 1 1 0	Multi-RTT	

Table 15.2.7.4.3-2: RRCReconfiguration

Derivation Path: TS 38.508-1 [45],, table 4.6.1-13			
Information Element	Value/remark	Comment	Condition
RRCReconfiguration ::= SEQUENCE {			
criticalExtensions CHOICE {			
rrcReconfiguration SEQUENCE {			
radioBearerConfig			

nonCriticalExtension SEQUENCE {			
masterCellGroup SEQUENCE {	CellGroupConfig		
spCellConfig SEQUENCE {			
spCellConfigDedicated SEQUENCE {			
uplinkConfig SEQUENCE {			
initialUplinkBWP SEQUENCE {			
srs-Config CHOICE {			
setup	As defined in Table 15.2.7.4.3-3		
}			
}			
}			
}			
}			
}			

Table 15.2.7.4.3-3: SRS-Config (Table 15.2.7.4.3-2)

Derivation Path: TS 38.508-1 [45], Table 4.6.3-182			
Information Element	Value/remark	Comment	Condition
SRS-Config ::= SEQUENCE {			
srs-ResourceSetToReleaseList	Not present		
srs-ResourceSetToAddModList	Not present		
srs-ResourceToReleaseList	Not present		
srs-ResourceToAddModList	Not present		
tpc-Accumulation	Not present		
srs-RequestDCI-1-2-r16	Not present		
srs-RequestDCI-0-2-r16	Not present		
srs-ResourceSetToAddModListDCI-0-2-r16	Not present		
srs-ResourceSetToReleaseListDCI-0-2-r16	Not present		
srs-PosResourceSetToReleaseList-r16	Not present		
srs-PosResourceSetToAddModList-r16 SEQUENCE (SIZE(1..maxNrofSRS-PosResourceSets-r16)) OF SRS-PosResourceSet-r16 {	1 entry		
SRS-PosResourceSet-r16[1] SEQUENCE {		entry 1	
srs-PosResourceSetId-r16	0		
srs-PosResourceCidList-r16 SEQUENCE (SIZE(1..maxNrofSRS-ResourcesPerSet)) OF SRS-PosResourceCid-r16 {	1 entry		
SRS-PosResourceCid-r16	0	1 entry	
}			
resourceType CHOICE {			
periodic SEQUENCE {			
}			
}			
alpha-r16	alpha0		
p0-r16	0		
pathlossReferenceRS-Pos-r16	Not present		
}			
srs-PosResourceToReleaseList-r16	Not present		
srs-PosResourceToAddModList-r16 SEQUENCE (SIZE(1..maxNrofSRS-PosResources-r16)) OF SRS-PosResource-r16 {	1 entry		
SRS-PosResource-r16[1] SEQUENCE {		entry 1	
srs-PosResourceCid-r16	0		
transmissionComb-r16 CHOICE {			
n4-r16 SEQUENCE {			
combOffset-n4-r16	0		
cyclicShift-n4-r16	0		
}			
}			
}			

resourceMapping-r16 SEQUENCE {			
startPosition-r16	0		
nrofSymbols-r16	n4		
}			
freqDomainShift-r16	0		
freqHopping-r16 SEQUENCE {			
c-SRS-r16	Matches N _{RB,c} Table 15.2.5.5-1		
}			
groupOrSequenceHopping-r16	neither		
resourceType-r16 CHOICE {			
periodic-r16 SEQUENCE {			
periodicityAndOffset-p-r16 CHOICE {			
sl160	20		Config 1 and Config 2
sl320	40		Config 3
}			
}			
}			
sequenceId-r16	0		
spatialRelationInfoPos-r16	Not present		
}			
}			
}			

Table 15.2.7.4.3-4: LPP Request Capabilities

Information Element	Value/remark
nr-Multi-RTT-RequestCapabilities-r16	TRUE

Table 15.2.7.4.3-5: LPP RequestLocationInformation

Derivation Path: TS 37.355 [49] clause 6.2			
Information Element	Value/remark	Comment	Condition
LPP-Message ::= SEQUENCE {			
transactionID SEQUENCE {			
initiator	locationServer		
transactionNumber	1		
}			
endTransaction	FALSE		
sequenceNumber	Not present		
acknowledgement	Not present		
lpp-MessageBody CHOICE {			
c1 CHOICE {			
requestLocationInformation SEQUENCE {			
criticalExtensions CHOICE {			
c1 CHOICE {			
requestLocationInformation-r9 SEQUENCE {			
commonEsRequestLocationInformation SEQUENCE {			
locationInformationType	locationMeasurementsPreferred		
triggeredReporting	Not present		
periodicalReporting	Not present		
additionalInformation	onlyReturnInformationRequested		
qos SEQUENCE {			
horizontalAccuracy	Not present		
verticalCoordinateRequest	FALSE		
verticalAccuracy	Not present		
responseTime SEQUENCE {			
time	See 15.2.7.5	Result of the response time	

		calculation rounded up to the next second if response time <= 128s. Result of the response time calculation rounded up to the next multiple of ten seconds if response time > 128s	
responseTimeEarlyFix-r12	Not present		Rel-12 onwards
unit-r15	Not present ten-seconds		Calculated response time >128s
}			
velocityRequest	FALSE		
}			
environment	Not present		
locationCoordinateTypes	Not present		
velocityTypes	Not present		
}			
a-gnss-RequestLocationInformation	Not present		
otdoa-RequestLocationInformation	Not present		
ecid-RequestLocationInformation	Not present		
epdu-RequestLocationInformation	Not Present		
sensor-RequestLocationInformation-r13	Not present		
tbs-RequestLocationInformation-r13	Not present		
wlan-RequestLocationInformation-r13	Not present		
bt-RequestLocationInformation-r13	Not present		
nr-ECID-RequestLocationInformation-r16	Not present		
nr-Multi-RTT-RequestLocationInformation-r16			
SEQUENCE {			
nr-UE-RxTxTimeDiffMeasurementInfoRequest-r16	Not present		
nr-RequestedMeasurements-r16	bit 0 = 1 (prsrsrpReq)		
nr-AssistanceAvailability-r16	FALSE		
nr-Multi-RTT-ReportConfig-r16 SEQUENCE {			
maxDL-PRS-RxTxTimeDiffMeasPerTRP-r16	Not present		
timingReportingGranularityFactor-r16	Not present		
}			
additionalPaths-r16	Not present		
nr-UE-RxTxTEG-Request-r17	case1		
measureSameDL-PRS-ResourceWithDifferentRxTxTEGs-r17	Not present		
measureSameDL-PRS-ResourceWithDifferentRxTEGs-r17	n0		
reducedDL-PRS-ProcessingSamples-r17	Not present		
nr-los-nlos-IndicatorRequest-r17	Not present		
additionalPathsExt-r17	Not present		
additionalPathsDL-PRS-RSRP-Request-r17	Not present		
multiMeasInSameReport-r17	Not present		
lowerRxBeamSweepingFactor-FR2-r17	Not present		
}			
nr-DL-AoD-RequestLocationInformation-r16	Not present		
nr-DL-TDOA-RequestLocationInformation-r16	Not present		
}			
}			
}			
}			
}			
}			
}			

Table 15.2.7.4.3-6: LPP ProvideAssistanceData

Derivation Path: 37.355 clause 6.2			
Information Element	Value/remark	Comment	Condition
LPP-Message ::= SEQUENCE {			
transactionID SEQUENCE {			
initiator	locationServer		
transactionNumber	(0..255)		
}			
endTransaction	TRUE		
sequenceNumber	Not present		
acknowledgement	Not present		
lpp-MessageBody CHOICE {			
c1 CHOICE {			
provideAssistanceData SEQUENCE {			
criticalExtensions CHOICE {			
c1 CHOICE {			
provideAssistanceData-r9 SEQUENCE {			
commonEsProvideAssistanceData	Not present		
a-gnss-ProvideAssistanceData	Not present		
otdoa-ProvideAssistanceData	Not present		
epdu-Provide-AssistanceData	Not present		
sensor-ProvideAssistanceData-r15	Not present		
tbs-ProvideAssistanceData-r15	Not present		
wlan-ProvideAssistanceData-r15	Not present		
nr-Multi-RTT-ProvideAssistanceData-r16			
} SEQUENCE {			
nr-DL-PRS-AssistanceData	As defined in Table 15.2.7.4.3-7		
nr-SelectedDL-PRS-IndexList-r16	Not present		
nr-Multi-RTT-Error-r16	Not present		
nr-On-Demand-DL-PRS-Configurations-r17	Not present		
nr-On-Demand-DL-PRS-Configurations-Selected-IndexList-r17	Not present		
assistanceDataValidityArea-r17	Not present		
}			
nr-DL-AoD-ProvideAssistanceData-r16	Not present		
nr-DL-TDOA-ProvideAssistanceData-r16	Not present		
}			
}			
}			
}			

Table 15.2.7.4.3-7: NR-DL-PRS-AssistanceData

Derivation Path: 37.355 clause 6.4.3			
Information Element	Value/remark	Comment	Condition
NR-DL-PRS-AssistanceData-r16 ::= SEQUENCE {			
nr-DL-PRS-ReferenceInfo-r16 SEQUENCE {			
dl-PRS-ID-r16	0		
nr-DL-PRS-ResourceID-List-r16	Not present		
nr-DL-PRS-ResourceSetID-r16	Not present		
}			
nr-DL-PRS-AssistanceDataList-r16 SEQUENCE (SIZE (1..nrMaxFreqLayers-r16)) OF NR-DL-PRS-AssistanceDataPerFreq-r16 {	1 entry		
NR-DL-PRS-AssistanceDataPerFreq-r16[1] SEQUENCE {		entry 1	
nr-DL-PRS-PositioningFrequencyLayer-r16 SEQUENCE {			

dl-PRS-SubcarrierSpacing-r16	kHz15		Config 1 and Config 2
	kHz30		Config 3
dl-PRS-ResourceBandwidth-r16	21	104 PRBs	Config 1 and Config 2
	28	132 PRBs	Config 3
dl-PRS-StartPRB-r16	0		
dl-PRS-PointA-r16	absoluteFrequencyPointA as defined for the DL frequency of the Cell 1		
dl-PRS-CombSizeN-r16	n4		
dl-PRS-CyclicPrefix-r16	normal		
}			
nr-DL-PRS-AssistanceDataPerFreq-r16 SEQUENCE (SIZE (1..nrMaxTRPsPerFreq-r16)) OF NR-DL-PRS-AssistanceDataPerTRP-r16{	2 entries		
NR-DL-PRS-AssistanceDataPerTRP-r16[1] SEQUENCE {		entry 1	Cell 1
dl-PRS-ID-r16	0		
nr-PhysCellID-r16	Cell 1		
nr-CellGlobalID-r16	Cell 1		
nr-ARFCN-r16	Cell 1		
nr-DL-PRS-SFN0-Offset-r16 SEQUENCE {			
sfn-Offset-r16	0		
integerSubframeOffset-r16	0		
}			
nr-DL-PRS-ExpectedRSTD-r16	0		
nr-DL-PRS-ExpectedRSTD-Uncertainty-r16	0		
nr-DL-PRS-Info-r16	As specified in Table 15.2.5.4.3-8		
}			
NR-DL-PRS-AssistanceDataPerTRP-r16[2] SEQUENCE {		entry 2	Cell 2
dl-PRS-ID-r16	1		
nr-PhysCellID-r16	Cell 2		
nr-CellGlobalID-r16	Cell 2		
nr-ARFCN-r16	Cell 2		
nr-DL-PRS-SFN0-Offset-r16 SEQUENCE {			
sfn-Offset-r16	0		
integerSubframeOffset-r16	0		
}			
nr-DL-PRS-ExpectedRSTD-r16	0		
nr-DL-PRS-ExpectedRSTD-Uncertainty-r16	154	About 5 μs	
nr-DL-PRS-Info-r16	As specified in Table 15.2.5.4.3-8		
}			
}			
}			
}			

Table 15.2.7.4.3-8: NR-DL-PRS-Info

Derivation Path: 37.355 clause 6.4.3			
Information Element	Value/remark	Comment	Condition
NR-DL-PRS-Info-r16 ::= SEQUENCE {			
nr-DL-PRS-ResourceSetList-r16 SEQUENCE (SIZE (1..nrMaxSetsPerTrp-r16)) OF NR-DL-PRS-ResourceSet-r16 {	1 entry		
NR-DL-PRS-ResourceSet-r16[1] SEQUENCE {		entry 1	
nr-DL-PRS-ResourceSetID-r16	0		
dl-PRS-Periodicity-and-ResourceSetSlotOffset-r16 CHOICE {			

nr-Multi-RTT-ProvideLocationInformation-r16 SEQUENCE {			
nr-Multi-RTT-SignalMeasurementInformation-r16 SEQUENCE {			
nr-Multi-RTT-MeasList-r16 SEQUENCE (SIZE(1..nrMaxTRPs-r16)) OF NR-Multi-RTT-MeasElement-r16 {	2 entries		
NR-Multi-RTT-MeasElement-r16[1] SEQUENCE {		entry 1	
dl-PRS-ID-r16	INTEGER (0..255)		
nr-PhysCellID-r16			
nr-CellGlobalID-r16			
nr-ARFCN-r16			
nr-DL-PRS-ResourceID-r16			
nr-DL-PRS-ResourceSetID-r16			
nr-UE-RxTxTimeDiff-r16	Present. Any value acceptable.		
nr-AdditionalPathList-r16			
nr-TimeStamp-r16			
nr-TimingQuality-r16			
nr-DL-PRS-RSRP-Result-r16			
nr-Multi-RTT-AdditionalMeasurements-r16			
nr-UE-RxTx-TEG-Info-r17 CHOICE {			
case1-r17 SEQUENCE {			
nr-UE-RxTx-TEG-ID-r17	INTEGER (0..255)		
}			
}			
nr-DL-PRS-FirstPathRSRP-Result-r17			
nr-los-nlos-Indicator-r17			
nr-AdditionalPathListExt-r17			
nr-Multi-RTT-AdditionalMeasurementsExt-r17			
}			
NR-Multi-RTT-MeasElement-r16[2] SEQUENCE {		entry 2	
dl-PRS-ID-r16	INTEGER (0..255)		
nr-PhysCellID-r16			
nr-CellGlobalID-r16			
nr-ARFCN-r16			
nr-DL-PRS-ResourceID-r16			
nr-DL-PRS-ResourceSetID-r16			
nr-UE-RxTxTimeDiff-r16	Present. Any value acceptable.		
nr-AdditionalPathList-r16			
nr-TimeStamp-r16			
nr-TimingQuality-r16			
nr-DL-PRS-RSRP-Result-r16			
nr-Multi-RTT-AdditionalMeasurements-r16			
nr-UE-RxTx-TEG-Info-r17 CHOICE {			
case1-r17 SEQUENCE {			
nr-UE-RxTx-TEG-ID-r17	INTEGER (0..255)		
}			
}			
nr-DL-PRS-FirstPathRSRP-Result-r17			
nr-los-nlos-Indicator-r17			
nr-AdditionalPathListExt-r17			
nr-Multi-RTT-AdditionalMeasurementsExt-r17			
}			
}			
nr-NTA-Offset-r16			
nr-SRS-TxTEG-Set-r17			
nr-UE-RxTEG-TimingErrorMargin-r17			

nr-UE-TxTEG-TimingErrorMargin-r17			
nr-UE-RxTxTEG-TimingErrorMargin-r17			
}			
nr-Multi-RTT-Error-r16			
nr-Multi-RTT-SignalMeasurementInstances-r17			
}			
nr-DL-AoD-ProvideLocationInformation-r16	Not present		
}			
}			
}			
}			
}			
}			
}			

15.2.7.5 Test requirement

Table 15.2.7.5-1 and Table 15.2.7.5-2 define the primary level settings including test tolerances for the test.

Table 15.2.7.5-1: General test parameters

Parameter	Unit	Test configuration	Value	Comment
Active cell		1, 2, 3	Cell 1	Cell 1 is the PCell in NR-Multi-RTT-ProvideAssistanceData [34].
Neighbour cell		1, 2, 3	Cell 2	Cell 2 is a neighbour cell in NR-Multi-RTT-ProvideAssistanceData [34].
RF Channel Number		1, 2, 3	1	For both Cell 1 and Cell 2
BW _{channel}	MHz	1	20: N _{RB,c} = 106	
		2	20: N _{RB,c} = 106	
		3	50: N _{RB,c} = 133	
SSB configuration		1	SSB.1 FR1	
		2	SSB.1 FR1	
		3	SSB.2 FR1	
SMTC configuration		1	SMTC.2	
		2	SMTC.1	
		3	SMTC.1	
Measurement gap		1, 2, 3	GP#24 or GP#0 ^{Note 1}	
CP length		1, 2, 3	Normal	
DRX		1, 2, 3	OFF	
Time offset between serving and neighbour cells	µs	1, 2, 3	3	Synchronous cells
T1	s	1, 2, 3	5	
T2	s	1, 2, 3	10	

Note 1: GP#24 is configured if UE supports MG#24, otherwise GP#0 is configured.

Table 15.2.7.5-2: Cell specific test parameters

Parameter	Unit	Test configuration	Cell 1		Cell 2	
			T1	T2	T1	T2
TDD configuration		1	N/A		N/A	
		2	TDDConf.1.1		TDDConf.1.1	
		3	TDDConf.2.1		TDDConf.2.1	
PDSCH RMC configuration		1	SR.1.1 FDD		N/A	
		2	SR.1.1 TDD			
		3	SR.2.1 TDD			
RMSI CORESET RMC configuration		1	CR.1.1 FDD		N/A	
		2	CR.1.1 TDD			
		3	CR.2.1 TDD			
		1	CCR.1.1 FDD		N/A	

Dedicated CORESET RMC configuration		2	CCR.1.1 TDD			
		3	CCR.2.1 TDD			
OCNG Patterns		1, 2, 3	OP.1			OP.1
TRS Configuration		1	TRS.1.1 FDD			N/A
		2	TRS.1.1 TDD			
		3	TRS.1.2 TDD			
Initial BWP configuration		1, 2, 3	DLBWP.0.1 ULBWP.0.1		N/A	
Active DL BWP configuration		1, 2, 3	DLBWP.1.1		N/A	
Active UL BWP configuration		1, 2, 3	ULBWP.1.1		N/A	
PRS configuration		1	PRS.1.2 FR1		PRS.1.2 FR1	
		2	PRS.1.2 FR1		PRS.1.2 FR1	
		3	PRS.2.2 FR1		PRS.2.2 FR1	
PRS muting info		1, 2, 3	'10'		'01'	
SRS configuration		1	POS-SRS.1		N/A	
		2	POS-SRS.1		N/A	
		3	POS-SRS.2		N/A	
N_{oc} <small>Note 2</small>	dBm/SCS	1	-98			
		2	-98			
		3	-95			
N_{oc} <small>Note 2</small>	dBm/15 kHz	1	-98			
		2				
		3				
PRS \hat{E}_s/I_{ot}	dB	1	-Infinity	-2.41	-Infinity	-12.12
		2				
		3				
PRS \hat{E}_s/N_{oc}	dB	1	-Infinity	-2	-Infinity	-10
		2				
		3				
PRS-RSRP <small>Note 3</small>	dBm/SCS kHz	1	-Infinity	-100	-Infinity	-108
		2	-Infinity	-100	-Infinity	-108
		3	-Infinity	-97	-Infinity	-105
I _o	dBm/19.08 MHz	1	N/A	-64.57	N/A	-64.57
	dBm/19.08 MHz	2		-64.57		-64.57
	dBm/47.88 MHz	3		-60.59		-60.59
Propagation Condition		1, 2, 3	AWGN			
<p>Note 1: The resources for uplink transmission are assigned to the UE prior to the start of time period T2.</p> <p>Note 2: Interference from other cells and noise sources not specified in the test is assumed to be constant over subcarriers and time and shall be modelled as AWGN of appropriate power for N_{oc} to be fulfilled.</p> <p>Note 3: PRS-RSRP levels have been derived from other parameters for information purposes. They are not settable parameters themselves.</p>						

The UE Rx-Tx time difference measurement period fulfils the requirements specified in clause 15.2.1.3.

FFS

15.2.8 UE Rx-Tx time difference measurement reporting delay test case for single positioning frequency layer with reduced number of samples in FR2 SA

Editor's Note: This test case has been completed for the following configurations:

- Test frequency $f \leq 40.8$ GHz
- UE PC3

This test case is incomplete for UE power classes other than PC3

This test case is incomplete for test frequencies > 40.8 GHz

15.2.8.1 Test purpose

The purpose of the test is to verify that the UE Rx-Tx measurement meets the requirements specified in TS 38.133 [50] clause 9.9.4.5 with $N_{\text{sample}} = 1$ in AWGN propagation condition in FR2 in standalone scenario when single positioning frequency layer is configured

15.2.8.2 Test applicability

This test applies to all types of NR UE release 17 onwards that supports Multi-RTT positioning and supportedDL-PRS-ProcessingSamples-RRC-CONNECTED.

15.2.8.3 Minimum conformance requirements

When physical layer receives last of *NR-Multi-RTT-ProvideAssistanceData* message and *NR-Multi-RTT-RequestLocationInformation* message from LMF via LPP [34], UE shall be able to measure multiple (up to the UE capability specified in clause 9.9.4.3) UE Rx-Tx time difference measurements as defined in TS 38.215 [4] in configured positioning frequency layers within the measurement period $T_{\text{UERxTx,Total}}$ ms.

$$T_{\text{UERxTx,Total}} = \sum_{i=1}^L T_{\text{UERxTx},i} + (L - 1) * \max(T_{\text{effect},i}).$$

where i is the index of positioning frequency layer,

$T_{\text{UERxTx},i}$ is the measurement period for UE Rx-Tx time difference measurements in positioning frequency layer i as further defined in this clause,

L is total number of positioning frequency layers, and

$T_{\text{effect},i}$ is the periodicity of the UE Rx-Tx time difference measurement in positioning frequency layer i as defined further in this clause.

$$T_{\text{UERxTx},i} = \left(k_{\text{multiTEG},i} * \text{CSSF}_i * \text{ceil}(K_{\text{p,PRS},i}) * N_{\text{RxBEAM},i} * \left\lceil \frac{N_{\text{PRS},i}^{\text{slot}}}{N'} \right\rceil \left\lceil \frac{L_{\text{available_PRS},i}}{N} \right\rceil * N_{\text{sample}} - 1 \right) * T_{\text{effect},i} + T_{\text{last},i}$$

Where

CSSF_i is the carrier-specific scaling factor for NR PRS-based measurement in the positioning frequency layer i as defined in clause 9.1.5.2,

$k_{\text{multiTEG},i}$ is the scaling factor for measurement of same PRS resource with multiple Rx TEGs.

$k_{\text{multiTEG},i} = 1$ if UE is not requested by LMF to measure a PRS resource with multiple Rx TEGs via *measureSameDL-PRS-ResourceWithDifferentRxTEGs-r17* or *measureSameDL-PRS-ResourceWithDifferentRxTxTEGs-r17* [34] in *NR-Multi-RTT-RequestLocationInformation*;

otherwise,

$k_{\text{multiTEG}} = N_{\text{TEG},i}$, if UE is not capable of receiving same DL PRS resource simultaneously from multiple Rx TEGs, and

$k_{\text{multiTEG}} = \left\lceil \frac{N_{\text{TEG},i}}{k_{\text{TEG,Simu},i}} \right\rceil$ if UE is capable of receiving the same DL PRS resource simultaneously from multiple Rx TEGs.

where

$N_{\text{TEG},i}$ is the number of Rx TEGs or RxTx TEGs with which UE is requested to measure a PRS resource indicated via *measureSameDL-PRS-ResourceWithDifferentRxTEGs-r17* or *measureSameDL-PRS-ResourceWithDifferentRxTxTEGs-r17* [34] in *NR-Multi-RTT-RequestLocationInformation*, and in case 'n0' is

indicated, $N_{TEG,i}$ is the maximum number of Rx TEGs with which UE can support to measure the same PRS resource as reported in *NR-UE-TEG-Capability*, and

$k_{TEG,simul,i}$ is the number of Rx TEGs UE can measure simultaneously which is reported via *measureSameDL-PRS-ResourceWithDifferentRxTEGsSimul*.

$K_{p,PRS,i}$ is a scaling factor for a positioning frequency layer to be measured within the associated measurement gap pattern, which is defined as $K_{p,PRS,i} = N_{total} / N_{available}$ for UE configured with concurrent measurement gap, and $K_{p,PRS,i} = 1$ for UE not configured with concurrent measurement gap.

For a window W of duration $\max(T_{PRS,i}, MGRP_max)$, where $MGRP_max$ is the maximum MGRP across all configured per-UE MG and per-FR MG within the same FR as the positioning frequency layer, and starting at the beginning of any associated gap occasions covering the PRS occasion:

N_{total} is the total number of associated gap occasions covering PRS occasions within the window, including both dropped and non-dropped instances of the associated measurement gap within the window, and

$N_{available}$ is the number of non-dropped associated gap occasions covering PRS occasions within the window W , after further accounting for MG collisions by applying the selected gap collision rule.

Requirements do not apply if $N_{available} = 0$.

$N_{RxBeam,i}$ is the scaling factor for Rx beam sweeping, and $N_{RxBeam,i} = 1$ if positioning frequency layer i is in FR1 and if positioning frequency layer i is in FR2, $N_{RxBeam,i}$ is equal to the value reported by the UE in *supportedLowerRxBeamSweepingFactor-FR2* if the UE supports the capability for the band containing positioning frequency layer i , and the LMF indicates *lowerRxBeamSweepingFactor-FR2* in *NR-TDOA-RequestLocationInformation*. $N_{RxBeam,i}$ is equal to 8, otherwise.

$L_{available_PRS,i}$ is the time duration of available PRS resources in the positioning frequency layer i , to be measured during $T_{available_PRS,i}$, and is calculated in the same way as PRS duration K defined in clause 5.1.6.5 of TS 38.214 [26]. For calculation of $L_{available_PRS,i}$, only the PRS resources unmuted and fully or partially overlapped with MG are considered.

$N_{PRS,i}^{slot}$ is the maximum number of DL PRS resources of positioning frequency layer i configured in a slot,

$\{N, T\}$ is UE capability combination per band where N is a duration of DL PRS symbols in ms corresponding to *durationOfPRS-ProcessingSymbols* in TS 37.355 [34] processed every T ms corresponding to *durationOfPRS-ProcessingSymbolsInEveryTms* in TS 37.355 [34] for a given maximum bandwidth supported by UE corresponding to *supportedBandwidthPRS* in clause 4.2.7.2 of TS 37.355 [34],

N' is UE capability for number of DL PRS resources that it can process in a slot corresponding to *maxNumOfDL-PRS-ResProcessedPerSlot* as specified in clause 6.4.3 of TS 37.355 [34],

N_{sample} is the number of UE Rx-Tx time difference measurement samples:

- $N_{sample} = 4$ if the UE is not capable of *supportedDL-PRS-ProcessingSamples* defined in [34].
- $N_{sample} = 1$ if the UE is capable of *supportedDL-PRS-ProcessingSamples* defined in [34] and LMF requests the UE to perform positioning measurements with reduced number of samples by *requestedDL-PRS-ProcessingSamples* [34] and the following conditions are met:
 - PRS bandwidth is within the active BWP and
 - Magnitude of difference between the serving cell's SS-RSRP and the neighbour cell's PRS-RSRP is within 6 dB.
- $N_{sample} = 2$ if the UE is capable of *supportedDL-PRS-ProcessingSamples* defined in [34] and the LMF requests the UE to perform positioning measurements with reduced number of samples by *requestedDL-PRS-ProcessingSamples* [34] but the following conditions are not met:
 - PRS bandwidth is within the active BWP and

- Magnitude of difference between the serving cell's SS-RSRP and the neighbour cell's PRS-RSRP is within 6 dB.
- $N_{sample} = 4$ otherwise.

$T_{last,i}$ is the measurement duration for the last UE Rx-Tx time difference measurement sample in the positioning layer i , including the sampling time and processing time, $T_{last,i} = T_i + T_{available_PRS,i}$,

$T_{effect,i}$ is periodicity of UE Rx-Tx time difference measurement in positioning frequency layer i :

$$T_{effect,i} = \left\lceil \frac{T_i}{T_{available_PRS,i}} \right\rceil * T_{available_PRS,i}$$

where

T_i corresponds to *durationOfPRS-ProcessingSymbolsInEveryTms* in TS 37.355 [34],

$T_{available_PRS,i} = LCM(T_{PRS,i}, MGRP_i)$, the least common multiple between $T_{PRS,i}$ and $MGRP_i$

$MGRP_i$ is the measurement gap repetition periodicity in positioning frequency layer i .

$T_{PRS,i}$ is the PRS resource periodicity in positioning frequency layer i . If the positioning frequency layer i has more than one DL PRS resource sets with different PRS periodicities with muting, $T_{per}^{PRS\ with\ muting} = N_{muting} * T_{per}^{PRS}$, the least common multiple of $T_{per}^{PRS\ with\ muting}$ among DL PRS resource sets is used to derive $T_{PRS,i}$, where

T_{per}^{PRS} is the periodicity of PRS resource sets given by the higher-layer parameter *DL-PRS-Periodicity*.

N_{muting} is the scaling factor considering PRS resource muting. $N_{muting} = T_{muting}^{PRS} * L_{muting}$, where T_{muting}^{PRS} is the muting repetition factor given by the higher-layer parameter *DL-PRS-MutingBitRepetitionFactor*, and L_{muting} is the size of the bitmap $\{b^1\}$

15.2.8.4 Test description

15.2.8.4.1 Initial conditions

The supported test configuration is listed in Table 15.2.8.4-1.

Table 15.2.8.4-1: Test Configuration

Test Configuration	Description
1	120 kHz SSB and PRS SCS, 200 MHz bandwidth, TDD duplex mode

Test Environment: Normal, as defined in TS 38.508-1 [45] clause 4.1.

Frequencies to be tested: Mid Range, as defined in TS 38.508-1 [45] clause 4.3.1.

Channel bandwidth to be tested: are specified in Table 15.2.8.4-1.

1. Connect the SS and AWGN noise sources to the UE antenna connector or antenna connectors as shown in Annex A, Figure A.14.
2. The general test parameter settings are set up according to Table 15.2.8.5-1 and Table 15.2.8.5-2.
3. Propagation conditions are set according to clause 4.14.2.
4. Message contents are defined in clause 15.2.8.4.3.
5. In the test there are two cells in the test: PCell (Cell 1) and a neighbour cell (Cell 2). All cells are on the same RF channel in FR2.

15.2.8.4.2 Test procedure

The test consists of two consecutive time intervals, with duration of T1 and T2. Cell 1 and Cell 2 mute PRS transmission during T1 and transmit PRS during T2. The beginning of the time interval T2 shall be aligned with the beginning of the first MG instance containing the PRS resources. The UE is configured to transmit SRS during T2.

The UE is configured with measurement gap pattern ID # 24 or #13 before T2.

2. Ensure the UE is in State RRC_CONNECTED with generic procedure parameters Connectivity NR, Connected without release On, according to TS 38.508-1 [45] clause 4.5. Note that in the remainder of the test the timing advance command $T_A = 31$ which indicates a timing advance adjustment value $N_{TA} = 0 T_c$.
2. The SS shall send a RESET UE POSITIONING STORED INFORMATION message.
3. The SS adjusts the downlink timing for Cell 1 to a delay of $+512 T_c$, compared to the current value.
4. Wait for 1.6 s to allow for the possibility that the UE makes autonomous timing adjustments.
5. T1 starts.
6. The SS shall transmit an RRCReconfiguration message with the SRS configuration.
7. The UE shall transmit RRCReconfigurationComplete message.
8. The SS shall transmit an LPP REQUEST CAPABILITIES message.
9. The UE shall transmit an LPP PROVIDE CAPABILITIES message indicating the UE supports *supportedDL-PRS-ProcessingSamples-RRC-CONNECTED* in the *NR-DL-PRS-ProcessingCapability* IE and the Multi-RTT capabilities supported by the UE in the *NR-Multi-RTT-ProvideCapabilities* IE.
10. The SS shall send a LPP PROVIDE ASSISTANCE DATA message, including the *NR-Multi-RTT-ProvideAssistanceData* IE. The position of neighbour Cell 2 is described in 3GPP TS 37.571-5 [20]. If the UE message at step 9 includes the *ackRequested* IE set to TRUE, then the SS shall send an acknowledgment in the LPP PROVIDE ASSISTANCE DATA message.
11. The SS shall send a LPP REQUEST LOCATION INFORMATION message, including the *reducedDL-PRS-ProcessingSamples-r17* in the *NR-Multi-RTT-RequestLocationInformation* IE such that the UE receives the message ΔT ms before the start of T2, where $\Delta T = 50$ ms.
12. When T1 expires, the SS shall switch the power setting from T1 to T2 as specified in Table 15.2.8.5-2.
13. The UE shall transmit a LPP PROVIDE LOCATION INFORMATION message including the *NR-Multi-RTT-ProvideLocationInformation* IE within the response time (see clause 15.2.8.4.3). The UE shall perform and report the UE rx-tx time difference measurements for Cell 1 and Cell 2. If the UE transmits an *NR-Multi-RTT-ProvideLocationInformation* IE including the *nr-UE-RxTxTimeDiff* field for Cell 1 and Cell 2 within the response time, then the number of successful tests is increased by one. If the UE fails to report the *NR-Multi-RTT-ProvideLocationInformation* IE with the *nr-UE-RxTxTimeDiff* field included within the response time then the number of failure tests is increased by one.
14. If the UE message at step 13 includes the *ackRequested* IE set to TRUE, the SS shall send a LPP acknowledgement message.
15. Repeat steps 1-14 until the confidence level according to Annex D is achieved.

NOTE: To avoid a large divergence between the sent TA and the set downlink timing, the SS may reset the downlink timing for Cell 1 to its initial value after a certain amount of loops. The loop during the reset does not count for the result statistics.

15.2.8.4.3 Message contents

Table 15.2.8.4.3-1: RESET UE POSITIONING STORED INFORMATION

Derivation Path: 38.509 [44] clause 6.6			
Information Element	Value/remark	Comment	Condition
UE Positioning Technology	0 0 0 0 1 1 0	Multi-RTT	

Table 15.2.8.4.3-2: RRCReconfiguration

Derivation Path: TS 38.508-1 [45], table 4.6.1-13			
Information Element	Value/remark	Comment	Condition
RRCReconfiguration ::= SEQUENCE {			
criticalExtensions CHOICE {			
rrcReconfiguration SEQUENCE {			
radioBearerConfig			
nonCriticalExtension SEQUENCE {			
masterCellGroup SEQUENCE {	CellGroupConfig		
spCellConfig SEQUENCE {			
spCellConfigDedicated SEQUENCE {			
uplinkConfig SEQUENCE {			
initialUplinkBWP SEQUENCE {			
srs-Config CHOICE {			
setup	As defined in Table 15.2.8.4.3-3		
}			
}			
}			
}			
}			
}			
}			
}			
}			
}			

Table 15.2.8.4.3-3: SRS-Config (Table 15.2.8.4.3-2)

Derivation Path: TS 38.508-1 [45], Table 4.6.3-182			
Information Element	Value/remark	Comment	Condition
SRS-Config ::= SEQUENCE {			
srs-ResourceSetToReleaseList	Not present		
srs-ResourceSetToAddModList	Not present		
srs-ResourceToReleaseList	Not present		
srs-ResourceToAddModList	Not present		
tpc-Accumulation	Not present		
srs-RequestDCI-1-2-r16	Not present		
srs-RequestDCI-0-2-r16	Not present		
srs-ResourceSetToAddModListDCI-0-2-r16	Not present		
srs-ResourceSetToReleaseListDCI-0-2-r16	Not present		
srs-PosResourceSetToReleaseList-r16	Not present		
srs-PosResourceSetToAddModList-r16 SEQUENCE (SIZE(1..maxNrofSRS-PosResourceSets-r16)) OF SRS-PosResourceSet-r16 {	1 entry		
SRS-PosResourceSet-r16[1] SEQUENCE {		entry 1	
srs-PosResourceSetId-r16	0		
srs-PosResourceCidList-r16 SEQUENCE (SIZE(1..maxNrofSRS-ResourcesPerSet)) OF SRS-PosResourceCid-r16 {	1 entry		
SRS-PosResourceCid-r16	0	1 entry	
}			
resourceType CHOICE {			
periodic SEQUENCE {			
}			
}			
alpha-r16	alpha0		
p0-r16	0		
pathlossReferenceRS-Pos-r16	Not present		
}			
srs-PosResourceToReleaseList-r16	Not present		

srs-PosResourceToAddModList-r16 SEQUENCE (SIZE(1..maxNrofSRS-PosResources-r16)) OF SRS-PosResource-r16 {	1 entry		
SRS-PosResource-r16[1] SEQUENCE {		entry 1	
srs-PosResource-r16	0		
transmissionComb-r16 CHOICE {			
n4-r16 SEQUENCE {			
combOffset-n4-r16	0		
cyclicShift-n4-r16	0		
}			
}			
resourceMapping-r16 SEQUENCE {			
startPosition-r16	0		
nrofSymbols-r16	n4		
}			
freqDomainShift-r16	0		
freqHopping-r16 SEQUENCE {			
c-SRS-r16	Matches N _{RB,c} Table 15.2.8.5-1		
}			
groupOrSequenceHopping-r16	neither		
resourceType-r16 CHOICE {			
periodic-r16 SEQUENCE {			
periodicityAndOffset-p-r16 CHOICE {			
sl1280	160		
}			
}			
}			
sequenceId-r16	0		
spatialRelationInfoPos-r16	Not present		
}			
}			
}			
}			

Table 15.2.8.4.3-4: LPP Request Capabilities

Information Element	Value/remark
nr-Multi-RTT-RequestCapabilities-r16	TRUE

Table 15.2.8.4.3-5: LPP RequestLocationInformation

Derivation Path: TS 37.355 [49] clause 6.2			
Information Element	Value/remark	Comment	Condition
LPP-Message ::= SEQUENCE {			
transactionID SEQUENCE {			
initiator	locationServer		
transactionNumber	1		
}			
endTransaction	FALSE		
sequenceNumber	Not present		
acknowledgement	Not present		
lpp-MessageBody CHOICE {			
c1 CHOICE {			
requestLocationInformation SEQUENCE {			
criticalExtensions CHOICE {			
c1 CHOICE {			
requestLocationInformation-r9 SEQUENCE {			
commonEsRequestLocationInformation SEQUENCE {			
locationInformationType	locationMeasurementsPreferred		
triggeredReporting	Not present		
periodicalReporting	Not present		

additionalInformation	onlyReturnInformationRequested		
qos SEQUENCE {			
horizontalAccuracy	Not present		
verticalCoordinateRequest	FALSE		
verticalAccuracy	Not present		
responseTime SEQUENCE {			
time	See 15.2.8.5	Result of the response time calculation rounded up to the next second if response time <= 128s. Result of the response time calculation rounded up to the next multiple of ten seconds if response time > 128s	
responseTimeEarlyFix-r12	Not present		Rel-12 onwards
unit-r15	Not present ten-seconds		Calculated response time >128s
}			
velocityRequest	FALSE		
}			
environment	Not present		
locationCoordinateTypes	Not present		
velocityTypes	Not present		
}			
a-gnss-RequestLocationInformation	Not present		
otdoa-RequestLocationInformation	Not present		
ecid-RequestLocationInformation	Not present		
epdu-RequestLocationInformation	Not Present		
sensor-RequestLocationInformation-r13	Not present		
tbs-RequestLocationInformation-r13	Not present		
wlan-RequestLocationInformation-r13	Not present		
bt-RequestLocationInformation-r13	Not present		
nr-ECID-RequestLocationInformation-r16	Not present		
nr-Multi-RTT-RequestLocationInformation-r16			
SEQUENCE {			
nr-UE-RxTxTimeDiffMeasurementInfoRequest-r16	Not present		
nr-RequestedMeasurements-r16	bit 0 = 1 (prsrsrpReq)		
nr-AssistanceAvailability-r16	FALSE		
nr-Multi-RTT-ReportConfig-r16 SEQUENCE {			
maxDL-PRS-RxTxTimeDiffMeasPerTRP-r16	Not present		
timingReportingGranularityFactor-r16	Not present		
}			
additionalPaths-r16	Not present		
nr-UE-RxTxTEG-Request-r17			
measureSameDL-PRS-ResourceWithDifferentRxTxTEGs-r17	Not present		
measureSameDL-PRS-ResourceWithDifferentRxTEGs-r17	Not present		
reducedDL-PRS-ProcessingSamples-r17	requested		
nr-los-nlos-IndicatorRequest-r17	Not present		
additionalPathsExt-r17	Not present		
additionalPathsDL-PRS-RSRP-Request-r17	Not present		
multiMeasInSameReport-r17	Not present		
lowerRxBeamSweepingFactor-FR2-r17	Not present		
}			

nr-DL-AoD-RequestLocationInformation-r16	Not present		
nr-DL-TDOA-RequestLocationInformation-r16	Not present		
}			
}			
}			
}			
}			
}			
}			

Table 15.2.8.4.3-6: LPP ProvideAssistanceData

Derivation Path: 37.355 clause 6.2			
Information Element	Value/remark	Comment	Condition
LPP-Message ::= SEQUENCE {			
transactionID SEQUENCE {			
initiator	locationServer		
transactionNumber	(0..255)		
}			
endTransaction	TRUE		
sequenceNumber	Not present		
acknowledgement	Not present		
lpp-MessageBody CHOICE {			
c1 CHOICE {			
provideAssistanceData SEQUENCE {			
criticalExtensions CHOICE {			
c1 CHOICE {			
provideAssistanceData-r9 SEQUENCE {			
commonEsProvideAssistanceData	Not present		
a-gnss-ProvideAssistanceData	Not present		
otdoa-ProvideAssistanceData	Not present		
epdu-Provide-AssistanceData	Not present		
sensor-ProvideAssistanceData-r15	Not present		
tbs-ProvideAssistanceData-r15	Not present		
wlan-ProvideAssistanceData-r15	Not present		
nr-Multi-RTT-ProvideAssistanceData-r16			
} SEQUENCE {			
nr-DL-PRS-AssistanceData	As defined in Table 15.2.8.4.3-7		
nr-SelectedDL-PRS-IndexList-r16	Not present		
nr-Multi-RTT-Error-r16	Not present		
nr-On-Demand-DL-PRS-Configurations-r17	Not present		
nr-On-Demand-DL-PRS-Configurations-Selected-IndexList-r17	Not present		
assistanceDataValidityArea-r17	Not present		
}			
nr-DL-AoD-ProvideAssistanceData-r16	Not present		
nr-DL-TDOA-ProvideAssistanceData-r16	Not present		
}			
}			
}			
}			

Table 15.2.8.4.3-7: NR-DL-PRS-AssistanceData

Derivation Path: 37.355 clause 6.4.3			
Information Element	Value/remark	Comment	Condition
NR-DL-PRS-AssistanceData-r16 ::= SEQUENCE {			
nr-DL-PRS-ReferenceInfo-r16 SEQUENCE {			
dl-PRS-ID-r16	0		
nr-DL-PRS-ResourceID-List-r16	Not present		

nr-DL-PRS-ResourceSetID-r16	Not present		
}			
nr-DL-PRS-AssistanceDataList-r16 SEQUENCE (SIZE (1..nrMaxFreqLayers-r16)) OF NR-DL-PRS-AssistanceDataPerFreq-r16 {	1 entry		
NR-DL-PRS-AssistanceDataPerFreq-r16[1] SEQUENCE {		entry 1	
nr-DL-PRS-PositioningFrequencyLayer-r16 SEQUENCE {			
dl-PRS-SubcarrierSpacing-r16	kHz120		
dl-PRS-ResourceBandwidth-r16	11	64 PRBs	
dl-PRS-StartPRB-r16	0		
dl-PRS-PointA-r16	absoluteFrequencyPointA as defined for the DL frequency of the Cell 1		
dl-PRS-CombSizeN-r16	n4		
dl-PRS-CyclicPrefix-r16	normal		
}			
nr-DL-PRS-AssistanceDataPerFreq-r16 SEQUENCE (SIZE (1..nrMaxTRPsPerFreq-r16)) OF NR-DL-PRS-AssistanceDataPerTRP-r16{	2 entries		
NR-DL-PRS-AssistanceDataPerTRP-r16[1] SEQUENCE {		entry 1	Cell 1
dl-PRS-ID-r16	0		
nr-PhysCellID-r16	Cell 1		
nr-CellGlobalID-r16	Cell 1		
nr-ARFCN-r16	Cell 1		
nr-DL-PRS-SFN0-Offset-r16 SEQUENCE {			
sfn-Offset-r16	0		
integerSubframeOffset-r16	0		
}			
nr-DL-PRS-ExpectedRSTD-r16	0		
nr-DL-PRS-ExpectedRSTD-Uncertainty-r16	0		
nr-DL-PRS-Info-r16	As specified in Table 15.2.8.4.3-8		
}			
NR-DL-PRS-AssistanceDataPerTRP-r16[2] SEQUENCE {		entry 2	Cell 2
dl-PRS-ID-r16	1		
nr-PhysCellID-r16	Cell 2		
nr-CellGlobalID-r16	Cell 2		
nr-ARFCN-r16	Cell 2		
nr-DL-PRS-SFN0-Offset-r16 SEQUENCE {			
sfn-Offset-r16	0		
integerSubframeOffset-r16	0		
}			
nr-DL-PRS-ExpectedRSTD-r16	23	About 3 μs	
nr-DL-PRS-ExpectedRSTD-Uncertainty-r16	154	About 5 μs	
nr-DL-PRS-Info-r16	As specified in Table 15.2.8.4.3-8		
}			
}			
}			
}			
}			

Table 15.2.8.4.3-8: NR-DL-PRS-Info

Derivation Path: 37.355 clause 6.4.3			
Information Element	Value/remark	Comment	Condition
NR-DL-PRS-Info-r16 ::= SEQUENCE {			
nr-DL-PRS-ResourceSetList-r16 SEQUENCE (SIZE (1..nrMaxSetsPerTrp-r16)) OF NR-DL-PRS-ResourceSet-r16 {	1 entry		
NR-DL-PRS-ResourceSet-r16[1] SEQUENCE {		entry 1	

nr-Multi-RTT- SignalMeasurementInformation-r16 SEQUENCE {			
nr-Multi-RTT-MeasList-r16 SEQUENCE (SIZE(1..nrMaxTRPs-r16)) OF NR-Multi-RTT- MeasElement-r16 {	2 entries		
NR-Multi-RTT-MeasElement-r16[1] SEQUENCE {		entry 1	
dl-PRS-ID-r16	INTEGER (0..255)		
nr-PhysCellID-r16			
nr-CellGlobalID-r16			
nr-ARFCN-r16			
nr-DL-PRS-ResourceID-r16			
nr-DL-PRS-ResourceSetID-r16			
nr-UE-RxTxTimeDiff-r16	Present. Any value acceptable.		
nr-AdditionalPathList-r16			
nr-TimeStamp-r16			
nr-TimingQuality-r16			
nr-DL-PRS-RSRP-Result-r16			
nr-Multi-RTT-AdditionalMeasurements- r16			
nr-UE-RxTx-TEG-Info-r17			
nr-DL-PRS-FirstPathRSRP-Result-r17			
nr-los-nlos-Indicator-r17			
nr-AdditionalPathListExt-r17			
nr-Multi-RTT- AdditionalMeasurementsExt-r17			
}			
NR-Multi-RTT-MeasElement-r16[2] SEQUENCE {		entry 2	
dl-PRS-ID-r16	INTEGER (0..255)		
nr-PhysCellID-r16			
nr-CellGlobalID-r16			
nr-ARFCN-r16			
nr-DL-PRS-ResourceID-r16			
nr-DL-PRS-ResourceSetID-r16			
nr-UE-RxTxTimeDiff-r16	Present. Any value acceptable.		
nr-AdditionalPathList-r16			
nr-TimeStamp-r16			
nr-TimingQuality-r16			
nr-DL-PRS-RSRP-Result-r16			
nr-Multi-RTT-AdditionalMeasurements- r16			
nr-UE-RxTx-TEG-Info-r17			
nr-DL-PRS-FirstPathRSRP-Result-r17			
nr-los-nlos-Indicator-r17			
nr-AdditionalPathListExt-r17			
nr-Multi-RTT- AdditionalMeasurementsExt-r17			
}			
nr-NTA-Offset-r16			
nr-SRS-TxTEG-Set-r17			
nr-UE-RxTEG-TimingErrorMargin-r17			
nr-UE-TxTEG-TimingErrorMargin-r17			
nr-UE-RxTxTEG-TimingErrorMargin-r17			
}			
nr-Multi-RTT-Error-r16			
nr-Multi-RTT- SignalMeasurementInstances-r17			
}			
nr-DL-AoD-ProvideLocationInformation-r16	Not present		
}			
}			

}			
}			
}			
}			
}			

15.2.8.5 Test requirement

Table 15.2.8.5-1 and Table 15.2.8.5-2 define the primary level settings including test tolerances for the test.

Table 15.2.8.5-1: General test parameters

Parameter	Unit	Test configuration	Value	Comment
Active cell		1	Cell 1	Cell 1 is the PCell in NR-Multi-RTT-ProvideAssistanceData [49].
Neighbour cell		1	Cell 2	Cell 2 is a neighbour cell in NR-Multi-RTT-ProvideAssistanceData [49].
RF Channel Number		1	1	For both Cell 1 and Cell 2
BW _{channel}	MHz	1	200: N _{RB,c} = 132	
SSB configuration		1	SSB.3 FR2	
SMTC configuration		1	SMTC.1	
Measurement gap		1	GP#24 or GP#13 ^{Note 1}	
CP length		1	Normal	
DRX		1	OFF	
Time offset between serving and neighbour cells	µs	1	3	Synchronous cells
T1	s	1	5	
T2	s	1	20	

NOTE 1: GP#24 is configured if UE supports MG#24, otherwise GP#13 is configured.

Table 15.2.8.5-2: Cell specific test parameters

Parameter	Unit	Test configuration	Cell 1		Cell 2	
			T1	T2	T1	T2
AoA setup		1	Setup 1 as specified in TS 38.133 [50] clause A.3.15			
Beam Assumption ^{Note 7}		1	Rough		Rough	
TDD configuration		1	TDDConf.3.1		TDDConf.3.1	
PDSCH RMC configuration		1	SR.3.1 TDD		N/A	
RMSI CORESET RMC configuration		1	CR.3.1 TDD		N/A	
Dedicated CORESET RMC configuration		1	CCR.3.1 TDD		N/A	
OCNG Patterns		1	OP.1		OP.1	
TRS Configuration		1	TRS.2.1 TDD		N/A	
Initial BWP configuration		1	DLBWP.0.1 ULBWP.0.1		N/A	
Active DL BWP configuration		1	DLBWP.1.1		N/A	
Active UL BWP configuration		1	ULBWP.1.1		N/A	
PRS configuration		1	PRS.1.1 FR2		PRS.1.1 FR2	
PRS BW			64 PRBs		64 PRBs	
PRS muting info		1	'10'		'01'	
SRS configuration		1	POS-SRS.3		N/A	
N _{oc} ^{Note 2}	dBm/SCS	1	-94			
N _{oc} ^{Note 2}	dBm/15 kHz	1	-103			

PRS \hat{E}_s/I_{ot}	dB	1	-Infinity	0.32	-Infinity	-5.64
PRS \hat{E}_s/N_{oc}	dB	1	-Infinity	3.56	-Infinity	-0.28
PRS-RSRP ^{Note 3}	dBm/SCS kHz	1	-Infinity	-90.4	-Infinity	-94.2
Io	dBm/190.08 MHz	1	N/A	-55.73	N/A	-55.73
Propagation Condition		1	AWGN			
Note 1:	The resources for uplink transmission are assigned to the UE prior to the start of time period T2.					
Note 2:	Interference from other cells and noise sources not specified in the test is assumed to be constant over subcarriers and time and shall be modelled as AWGN of appropriate power for N_{oc} to be fulfilled.					
Note 3:	SS-RSRP, PRS-RSRP and Io levels have been derived from other parameters for information purposes. They are not settable parameters themselves.					
Note 4:	PRS-RSRP minimum requirements are specified assuming independent interference and noise at each receiver antenna port.					
Note 5:	Equivalent power received by an antenna with 0 dBi gain at the centre of the quiet zone					
Note 6:	As observed with 0 dBi gain antenna at the centre of the quiet zone					
Note 7:	Information about types of UE beam is given TS 38.133 [50] in B.2.1.3, and does not limit UE implementation or test system implementation					
Note 8:	Calculation of Es/Iot includes the effect of UE internal noise up to the value assumed for the associated Refsens requirement in clause 7.3.2 of TS 38.101-2 [55], and an allowance of 1dB for UE multi-band relaxation factor ΔMBP from TS 38.101-2 [55] Table 6.2.1.3-4.					

The UE Rx-Tx time difference measurement period fulfils the requirements specified in clause 15.2.8.3.

The response time is equal to the LPP time IE value plus the test tolerance. The LPP time IE value is derived from the UE Rx-Tx time difference measurement period plus ΔT , where $\Delta T = 50\text{ms}$. The UE Rx-Tx time difference measurement period follows the equation:

$$T_{UE\text{RxTx},i} = \left(k_{multiTEG,i} * CSSF_i * \text{ceil}(K_{p,PRS,i}) * N_{RxBeam,i} * \left\lceil \frac{N_{PRS,i}^{slot}}{N'} \right\rceil \left\lceil \frac{L_{available_PRS,i}}{N} \right\rceil * N_{sample} - 1 \right) * T_{effect,i} + T_{last,i}$$

Where $CSSF_{PRS,i} = 1$, $K_{p,PRS,i} = 1$, $N_{RxBeam,i} = 8$, $CSSF_{PRS,i} = 1$, $N_{PRS,i}^{slot} = 2$, $L_{available_PRS,i} = 0.071$, $N_{sample} = 4$. N is the parameter durationOfPRS-ProcessingSysmbols from TS 37.355 [49], N' is the parameter maxNumOfDL-PRS-ResProcessedPerSlot from TS 37.355 [49], $T_{last,i} = T_i + T_{available_PRS,i}$ and $T_{effect,i} = \left\lceil \frac{T_i}{T_{available_PRS,i}} \right\rceil * T_{available_PRS,i}$

$T_{available_PRS,i} = LCM(T_{PRS,i}, MGRP_i)$; where $T_{prs} = 160$ ms, and MGRP is 80 (for GP#24) or 40 (for GP#13) depending on UE capabilities. Therefore, $T_{available_PRS,i} = 160$ ms.

T_i depends on the UE parameter durationOfPRS-ProcessingSymbolsInEveryTms from TS 37.355 [49]

Finally, it results in the following equation:

$$\left(8 * \left\lceil \frac{2}{N'} \right\rceil \left\lceil \frac{0.071}{N} \right\rceil * 4 - 1 \right) * T_{effect} + T_{last}$$

Where the remaining parameters depend on the UE capabilities. The LPP time IE ranges between 2.408s and 20.64s. The value of the LPP time IE is rounded up to the next second (if the value is >128s, it should be rounded up to the next multiple of ten seconds). The result is transmitted in the response time IE in the LPP-RequestLocationInformation in Table 15.2.8.4.3-5. The LPP time IE ranges between 3s and 21s.

The test tolerance for the response time is 300ms. Therefore, the response time ranges between 3.3s and 21.3s.

The values of N', N and Ti and the effect in the response time equation are defined in Table 15.2.8.5-3, Table 15.2.8.5-4 and Table 15.2.8.5-5 for reference.

Table 15.2.8.5-3: value of N' based on *maxNumOfDL-PRS-ResProcessedPerSlot*

<i>maxNumOfDL-PRS-ResProcessedPerSlot</i>	$\lceil \frac{2}{N'} \rceil$
n1	2
$\geq n2$	1

Table 15.2.8.5-4: value of N based on *durationOfPRS-ProcessingSymbols*

<i>durationOfPRS-ProcessingSymbols</i>	$\lceil \frac{0.071}{N} \rceil$
$\geq nDot125$	1

Table 15.2.8.5-5: value of T_{effect} and T_{last} based on *durationOfPRS-ProcessingSymbolsInEveryTms*

<i>durationOfPRS-ProcessingSymbolsInEveryTms</i>	T_{effect}	T_{last}
n8	160	168
n16	160	176
n20	160	180
n30	160	190
n40	160	200
n80	160	240
n160	160	320
n320	320	480
n640	640	800
n1280	1280	1440

The rate of successful tests during repeated tests shall be at least 90% with a confidence level of 95%.

15.2.9 UE Rx-Tx time difference measurement reporting delay test case for single positioning frequency layer without measurement gap in FR2 SA

Editor's Note: This test case has been completed for the following configurations:

- Test frequency $f \leq 40.8$ GHz
- UE PC3

This test case is incomplete for UE power classes other than PC3

This test case is incomplete for test frequencies > 40.8 GHz

15.2.9.1 Test purpose

The purpose of the test is to verify that the UE Rx-Tx measurement meets the requirements specified in TS 38.133 [50] clause 9.9.4.6 in AWGN propagation condition in FR2 in standalone scenario.

15.2.9.2 Test applicability

This test applies to all types of NR UE release 17 onwards that supports Multi-RTT positioning and prs Processing Window.

15.2.9.3 Minimum conformance requirements

When physical layer receives last of *NR-Multi-RTT-ProvideAssistanceData* message and *NR-Multi-RTT-RequestLocationInformation* message from LMF via LPP [34], UE shall be able to measure multiple (up to the UE

capability specified in clause 9.9.4.3) UE Rx-Tx time difference measurements as defined in TS 38.215 [4] in configured positioning frequency layers within the measurement period $T_{\text{UERxTx_wo_gap,Total}}$ ms.

$T_{\text{UERxTx_wo_gap,Total}} = \sum_{i=1}^L T_{\text{UERxTx_wo_gap},i} + (L - 1) * \max(T_{\text{effect},i})$, if any of the positioning frequency layers are in Case 1, or

$T_{\text{UERxTx_wo_gap,Total}} = \max(T_{\text{UERxTx_wo_gap},i} + T_{\text{uncertainty},i})$, if all the positioning frequency layers are in Case 2.

Where,

i is the index of positioning frequency layer, and

L is total number of positioning frequency layers, and

$T_{\text{effect},i}$ is the periodicity of the PRS RSTD measurement in positioning frequency layer i , and

$T_{\text{uncertainty},i}$ is the time from the start of the first PPW occasion for positioning frequency layer i to the start of measurement period $T_{\text{UERxTx_wo_gap,Total}}$.

A positioning frequency layer is in Case 1 if UE reports *ppw-durationOfPRS-Processing1-r17* for the band containing the positioning frequency layer, and a positioning frequency layer is in Case 2 if UE reports *ppw-durationOfPRS-Processing2-r17* for the band containing the positioning frequency layer.

$T_{\text{UERxTx_wo_gap},i}$ is the measurement period for UE Rx-Tx time difference measurement in positioning frequency layer i as specified below.

$$T_{\text{UERxTx_wo_gap},i} = \left(k_{\text{multiTEG},i} * N_{\text{RxBeam},i} * \left\lfloor \frac{N_{\text{PRS},i}^{\text{slot}}}{N'} \right\rfloor \left\lfloor \frac{L_{\text{available_PRS},i}}{N} \right\rfloor * N_{\text{sample}} - 1 \right) * T_{\text{effect},i} + T_{\text{last},i}$$

Where

$T_{\text{effect},i}$ is the periodicity of the UE Rx-Tx time difference measurement in positioning frequency layer i as defined further in this clause.

$k_{\text{multiTEG},i}$ is the scaling factor for measurement of same PRS resource with multiple Rx TEGs.

$k_{\text{multiTEG},i}=1$ if UE is not supported *measureSameDL-PRS-ResourceWithDifferentRxTEGs-r17* or not requested by LMF to measure a PRS resource with multiple Rx TEGs via *measureSameDL-PRS-ResourceWithDifferentRxTEGs-r17* or *measureSameDL-PRS-ResourceWithDifferentRxTxTEGs-r17* [34] in *NR-Multi-RTT-RequestLocationInformation*;

otherwise,

$k_{\text{multiTEG}}=N_{\text{TEG},i}$, if UE is not capable of receiving same DL PRS resource simultaneously from multiple Rx TEGs, and

$k_{\text{multiTEG}}=\left\lfloor \frac{N_{\text{TEG},i}}{k_{\text{TEG,simul},i}} \right\rfloor$ if UE is capable of receiving the same DL PRS resource simultaneously from multiple Rx TEGs.

where

$N_{\text{TEG},i}$ is the number of Rx TEGs or RxTx TEGs with which UE is requested to measure a PRS resource indicated via *measureSameDL-PRS-ResourceWithDifferentRxTEGs-r17* or *measureSameDL-PRS-ResourceWithDifferentRxTxTEGs-r17* [34] in *NR-Multi-RTT-RequestLocationInformation*, and in case 'n0' is indicated, $N_{\text{TEG},i}$ is the maximum number of Rx TEGs with which UE can support to measure the same PRS resource as reported in *NR-UE-TEG-Capability*, and

$k_{\text{TEG,simul},i}$ is the number of Rx TEGs UE can measure simultaneously which is reported via *measureSameDL-PRS-ResourceWithDifferentRxTEGsSimul*.

$N_{\text{RxBeam},i}$ is the scaling factor for Rx beam sweeping, and $N_{\text{RxBeam},i}=1$ if positioning frequency layer i is in FR1. If positioning frequency layer i is in FR2, $N_{\text{RxBeam},i}$ is equal to the value reported by the UE in *supportedLowerRxBeamSweepingFactor-FR2* if the UE supports the capability for the band containing

positioning frequency layer i , and the LMF indicates *lowerRxBeamSweepingFactor-FR2* in *NR-TDOA-RequestLocationInformation*. $N_{RxBeam,i}$ is equal to 8, otherwise.

$L_{available_PRS,i}$ is the time duration of available PRS resources in the positioning frequency layer i , to be measured during $T_{available_PRS,i}$, and is calculated in the same way as PRS duration K defined in clause 5.1.6.5 of TS 38.214 [26]. For calculation of $L_{available_PRS,i}$,

only the unmuted PRS resources that meet the applicability conditions and fully or partially overlapped with PRS processing window are considered, if positioning frequency layer i is in Case 1, or

only the PRS resources unmuted and fully or partially overlapped with the first (PPWL-T2) ms of PPW are considered, if positioning frequency layer i is in Case 2, where PPWL is the PPW length and T2 corresponds to *ppw-durationOfPRS-ProcessingSymbolsT2*.

$N_{PRS,i}^{slot}$ is the maximum number of DL PRS resources of positioning frequency layer i configured in a slot,

$\{N, T\}$ is UE capability combination per band where N is a duration of DL PRS symbols in ms corresponding to *ppw-durationOfPRS-ProcessingSymbolsN* in TS 37.355 [34] if positioning frequency layer i is in Case 1, or corresponding to *ppw-durationOfPRS-ProcessingSymbolsN2* in TS 37.355 [34] if positioning frequency layer i is in Case 2,

- N' is UE capability for number of DL PRS resources that it can process in a slot corresponding to *ppw-maxNumOfDL-PRS-ResProcessedPerSlot* as specified in clause 6.4.3 of TS 37.355 [34],
- N_{sample} is the number of UE Rx-Tx time difference measurement samples:
 - $N_{sample} = 4$ if the UE is not capable of *supportedDL-PRS-ProcessingSamples* defined in [34].
 - $N_{sample} = 1$ if the UE is capable of *supportedDL-PRS-ProcessingSamples* defined in [34] and LMF requests the UE to perform positioning measurements with reduced number of samples by *requestedDL-PRS-ProcessingSamples* [34] and the following conditions are met:
 - PRS bandwidth is within the active BWP and
 - Magnitude of difference between the serving cell's SS-RSRP and the neighbour cell's PRS-RSRP is within 6 dB.
 - $N_{sample} = 2$ if the UE is capable of *supportedDL-PRS-ProcessingSamples* defined in [34] and the LMF requests the UE to perform positioning measurements with reduced number of samples by *requestedDL-PRS-ProcessingSamples* [34] but the following conditions are not met:
 - PRS bandwidth is within the active BWP and
 - Magnitude of difference between the serving cell's SS-RSRP and the neighbour cell's PRS-RSRP is within 6 dB.
 - $N_{sample} = 4$ otherwise.
- $T_{last,i}$ is the measurement duration for the last UE Rx-Tx time difference measurement sample in the positioning layer i , including the sampling time and processing time.

If positioning frequency layer i is in Case 1 and all of the PRS resources to be measured are available in the same PPW occasion during $T_{available}$, then $T_{last,i} = T_i + PPWL$, else

if positioning frequency layer i is in Case 2 and all of the PRS resources to be measured are available in the same PPW occasion during $T_{available}$, then $T_{last,i} = PPWL$;

otherwise, $T_{last,i} = T_i + T_{available_PRS,i}$.

- $T_{effect,i}$ is periodicity of UE Rx-Tx time difference measurement in positioning frequency layer i :

$$T_{effect,i} = \left\lceil \frac{T_i}{T_{available_PRS,i}} \right\rceil * T_{available_PRS,i}$$

where

T_i corresponds to *ppw-durationOfPRS-ProcessingSymbolsT* in TS 37.355 [34] if positioning frequency layer i is in Case 1, or corresponds to the sum of *ppw-durationOfPRS-ProcessingSymbolsT2* and *ppw-durationOfPRS-ProcessingSymbolsN2* in TS 37.355 [34] if positioning frequency layer i is in Case 2,

$T_{available_PRS,i} = LCM(T_{PRS,i}, PPWRP_i)$, the least common multiple between $T_{PRS,i}$ and $PPWRP_i$

$PPWRP_i$ is the PRS processing window repetition periodicity in positioning frequency layer i .

$T_{PRS,i}$ is the PRS resource periodicity in positioning frequency layer i . If the positioning frequency layer i has more than one DL PRS resource sets with different PRS periodicities with muting, $T_{per}^{PRS\ with\ muting} = N_{muting} * T_{per}^{PRS}$, the least common multiple of $T_{per}^{PRS\ with\ muting}$ among DL PRS resource sets is used to derive $T_{PRS,i}$, where

T_{per}^{PRS} is the periodicity of PRS resource sets given by the higher-layer parameter *DL-PRS-Periodicity*.

N_{muting} is the scaling factor considering PRS resource muting. $N_{muting} = T_{muting}^{PRS} * L_{muting}$, where T_{muting}^{PRS} is the muting repetition factor given by the higher-layer parameter *DL-PRS-MutingBitRepetitionFactor*, and L_{muting} is the size of the bitmap $\{b^1\}$

15.2.9.4 Test description

15.2.9.4.1 Initial conditions

The supported test configuration is listed in Table 15.2.9.4-1.

Table 15.2.9.4-1: Test Configuration

Test Configuration	Description
1	120 kHz SSB and PRS SCS, 200 MHz bandwidth, TDD duplex mode

Test Environment: Normal, as defined in TS 38.508-1 [45] clause 4.1.

Frequencies to be tested: Mid Range, as defined in TS 38.508-1 [45] clause 4.3.1.

Channel bandwidth to be tested: are specified in Table 15.2.9.4-1.

1. Connect the SS and AWGN noise sources to the UE antenna connector or antenna connectors as shown in Annex A, Figure A.14.
2. The general test parameter settings are set up according to Table 15.2.9.5-1 and Table 15.2.9.5-2.
3. Propagation conditions are set according to clause 4.14.2.
4. Message contents are defined in clause 15.2.9.4.3.
5. In the test there are two cells in the test: PCell (Cell 1) and a neighbour cell (Cell 2). All cells are on the same RF channel in FR2.

15.2.9.4.2 Test procedure

The test consists of two sub-tests; Sub-test 1 is for $N_{sample} = 4$ and sub-test 2 is for $N_{sample} = 1$. Sub-test 2 is only conducted when UE also supporting supportedDL-PRS-ProcessingSamples-RRC-CONNECTED. The test consists of two consecutive time intervals, with duration of T1 and T2. Cell 1 and Cell 2 mute PRS transmission during T1 and transmit PRS during T2. The beginning of the time interval T2 shall be aligned with the beginning of the first MG instance containing the PRS resources. The UE is configured to transmit SRS during T2.

The UE is configured with measurement gap pattern ID # 24 or #13 before T2.

3. Ensure the UE is in State RRC_CONNECTED with generic procedure parameters Connectivity NR, Connected without release *On*, according to TS 38.508-1 [45] clause 4.5. Note that in the remainder of the test the timing advance command $T_A = 31$ which indicates a timing advance adjustment value $N_{TA} = 0 T_c$.

2. The SS shall send a RESET UE POSITIONING STORED INFORMATION message.
3. The SS adjusts the downlink timing for Cell 1 to a delay of +512 T_c, compared to the current value.
4. Wait for 1.6 s to allow for the possibility that the UE makes autonomous timing adjustments.
5. T1 starts.
6. The SS shall transmit an LPP REQUEST CAPABILITIES message.
7. The UE shall transmit an LPP PROVIDE CAPABILITIES message indicating the Multi-RTT capabilities supported by the UE in the *NR-Multi-RTT-ProvideCapabilities* IE.
8. The SS shall transmit an RRCReconfiguration message with SRS configuration and PPW configuration.
9. The UE shall transmit RRCReconfigurationComplete message.
10. The SS shall send a LPP PROVIDE ASSISTANCE DATA message, including the *NR-Multi-RTT-ProvideAssistanceData* IE. The position of neighbour Cell 2 is described in 3GPP TS 37.571-5 [20]. If the UE message at step 7 includes the *ackRequested* IE set to TRUE, then the SS shall send an acknowledgment in the LPP PROVIDE ASSISTANCE DATA message.
11. The SS shall send a LPP REQUEST LOCATION INFORMATION message, including the *NR-Multi-RTT-RequestLocationInformation* IE such that the UE receives the message ΔT ms before the start of T2, where ΔT = 50 ms.
12. When T1 expires, the SS shall switch the power setting from T1 to T2 as specified in Table 15.2.9.5-2.
13. The UE shall transmit a LPP PROVIDE LOCATION INFORMATION message including the *NR-Multi-RTT-ProvideLocationInformation* IE within the response time (see clause 15.2.9.4.3). The UE shall perform and report the UE rx-tx time difference measurements for Cell 1 and Cell 2. If the UE transmits an *NR-Multi-RTT-ProvideLocationInformation* IE including the *nr-UE-RxTxTimeDiff* field for Cell 1 and Cell 2 within the response time, then the number of successful tests is increased by one. If the UE fails to report the *NR-Multi-RTT-ProvideLocationInformation* IE with the *nr-UE-RxTxTimeDiff* field included within the response time then the number of failure tests is increased by one.
14. If the UE message at step 13 includes the *ackRequested* IE set to TRUE, the SS shall send a LPP acknowledgement message.
15. Repeat steps 1-14 until the confidence level according to Annex D is achieved.

If all (applicable) sub-tests pass, the whole test passes. If one (applicable) sub-test fails, the whole test fails.

NOTE: To avoid a large divergence between the sent TA and the set downlink timing, the SS may reset the downlink timing for Cell 1 to its initial value after a certain amount of loops. The loop during the reset does not count for the result statistics.

15.2.9.4.3 Message contents

Table 15.2.9.4.3-1: RESET UE POSITIONING STORED INFORMATION

Derivation Path: 38.509 [44] clause 6.6			
Information Element	Value/remark	Comment	Condition
UE Positioning Technology	0 0 0 0 1 1 0	Multi-RTT	

Table 15.2.9.4.3-2: RRCReconfiguration

Derivation Path: TS 38.508-1 [45],, table 4.6.1-13			
Information Element	Value/remark	Comment	Condition
RRCReconfiguration ::= SEQUENCE {			
criticalExtensions CHOICE {			
rrcReconfiguration SEQUENCE {			
radioBearerConfig			
nonCriticalExtension SEQUENCE {			

periodic SEQUENCE {			
}			
alpha-r16	alpha0		
p0-r16	0		
pathlossReferenceRS-Pos-r16	Not present		
}			
srs-PosResourceToReleaseList-r16	Not present		
srs-PosResourceToAddModList-r16 SEQUENCE (SIZE(1..maxNrofSRS-PosResources-r16)) OF SRS-PosResource-r16 {	1 entry		
SRS-PosResource-r16[1] SEQUENCE {		entry 1	
srs-PosResourceId-r16	0		
transmissionComb-r16 CHOICE {			
n4-r16 SEQUENCE {			
combOffset-n4-r16	0		
cyclicShift-n4-r16	0		
}			
}			
resourceMapping-r16 SEQUENCE {			
startPosition-r16	0		
nrofSymbols-r16	n4		
}			
freqDomainShift-r16	0		
freqHopping-r16 SEQUENCE {			
c-SRS-r16	Matches N _{RB,c} Table 15.2.9.5-1		
}			
groupOrSequenceHopping-r16	neither		
resourceType-r16 CHOICE {			
periodic-r16 SEQUENCE {			
periodicityAndOffset-p-r16 CHOICE {			
sl1280	160		
}			
}			
}			
sequenceId-r16	0		
spatialRelationInfoPos-r16	Not present		
}			
}			
}			

Table 15.2.9.4.3-4: LPP Request Capabilities

Information Element	Value/remark
nr-Multi-RTT-RequestCapabilities-r16	TRUE

Table 15.2.9.4.3-5: LPP RequestLocationInformation

Derivation Path: TS 37.355 [49] clause 6.2			
Information Element	Value/remark	Comment	Condition
LPP-Message ::= SEQUENCE {			
transactionID SEQUENCE {			
initiator	locationServer		
transactionNumber	1		
}			
endTransaction	FALSE		
sequenceNumber	Not present		
acknowledgement	Not present		
lpp-MessageBody CHOICE {			
c1 CHOICE {			
requestLocationInformation SEQUENCE {			
criticalExtensions CHOICE {			

c1 CHOICE {			
requestLocationInformation-r9 SEQUENCE {			
commonEsRequestLocationInformation SEQUENCE {			
locationInformationType	locationMeasurementsPreferred		
triggeredReporting	Not present		
periodicalReporting	Not present		
additionalInformation	onlyReturnInformationRequested		
qos SEQUENCE {			
horizontalAccuracy	Not present		
verticalCoordinateRequest	FALSE		
verticalAccuracy	Not present		
responseTime SEQUENCE {			
time	See 15.2.9.5	Result of the response time calculation rounded up to the next second if response time <= 128s. Result of the response time calculation rounded up to the next multiple of ten seconds if response time > 128s	
responseTimeEarlyFix-r12	Not present		Rel-12 onwards
unit-r15	Not present		
	ten-seconds		Calculated response time >128s
}			
velocityRequest	FALSE		
}			
environment	Not present		
locationCoordinateTypes	Not present		
velocityTypes	Not present		
}			
a-gnss-RequestLocationInformation	Not present		
otdoa-RequestLocationInformation	Not present		
ecid-RequestLocationInformation	Not present		
epdu-RequestLocationInformation	Not Present		
sensor-RequestLocationInformation-r13	Not present		
tbs-RequestLocationInformation-r13	Not present		
wlan-RequestLocationInformation-r13	Not present		
bt-RequestLocationInformation-r13	Not present		
nr-ECID-RequestLocationInformation-r16	Not present		
nr-Multi-RTT-RequestLocationInformation-r16 SEQUENCE {			
nr-UE-RxTxTimeDiffMeasurementInfoRequest-r16	Not present		
nr-RequestedMeasurements-r16	bit 0 = 1 (prsrsrpReq)		
nr-AssistanceAvailability-r16	FALSE		
nr-Multi-RTT-ReportConfig-r16 SEQUENCE {			
maxDL-PRS-RxTxTimeDiffMeasPerTRP-r16	Not present		
timingReportingGranularityFactor-r16	Not present		
}			
additionalPaths-r16	Not present		
nr-UE-RxTxTEG-Request-r17			
measureSameDL-PRS-ResourceWithDifferentRxTxTEGs-r17	Not present		

measureSameDL-PRS-ResourceWithDifferentRxTEGs-r17	Not present		
reducedDL-PRS-ProcessingSamples-r17	Not present		Sub-test 1
	requested		Sub-test 2
nr-los-nlos-IndicatorRequest-r17	Not present		
additionalPathsExt-r17	Not present		
additionalPathsDL-PRS-RSRP-Request-r17	Not present		
multiMeasInSameReport-r17	Not present		
lowerRxBeamSweepingFactor-FR2-r17	Not present		
}			
nr-DL-AoD-RequestLocationInformation-r16	Not present		
nr-DL-TDOA-RequestLocationInformation-r16	Not present		
}			
}			
}			
}			
}			
}			
}			
}			

Table 15.2.9.4.3-6: LPP ProvideAssistanceData

Derivation Path: 37.355 clause 6.2			
Information Element	Value/remark	Comment	Condition
LPP-Message ::= SEQUENCE {			
transactionID SEQUENCE {			
initiator	locationServer		
transactionNumber	(0..255)		
}			
endTransaction	TRUE		
sequenceNumber	Not present		
acknowledgement	Not present		
lpp-MessageBody CHOICE {			
c1 CHOICE {			
provideAssistanceData SEQUENCE {			
criticalExtensions CHOICE {			
c1 CHOICE {			
provideAssistanceData-r9 SEQUENCE {			
commonEsProvideAssistanceData	Not present		
a-gnss-ProvideAssistanceData	Not present		
otdoa-ProvideAssistanceData	Not present		
epdu-Provide-AssistanceData	Not present		
sensor-ProvideAssistanceData-r15	Not present		
tbs-ProvideAssistanceData-r15	Not present		
wlan-ProvideAssistanceData-r15	Not present		
nr-Multi-RTT-ProvideAssistanceData-r16			
}			
}			
nr-DL-PRS-AssistanceData	As defined in Table 15.2.9.4.3-7		
nr-SelectedDL-PRS-IndexList-r16	Not present		
nr-Multi-RTT-Error-r16	Not present		
nr-On-Demand-DL-PRS-Configurations-r17	Not present		
nr-On-Demand-DL-PRS-Configurations-Selected-IndexList-r17	Not present		
assistanceDataValidityArea-r17	Not present		
}			
nr-DL-AoD-ProvideAssistanceData-r16	Not present		
nr-DL-TDOA-ProvideAssistanceData-r16	Not present		
}			
}			
}			
}			
}			
}			
}			

Table 15.2.9.4.3-7: NR-DL-PRS-AssistanceData

Derivation Path: 37.355 clause 6.4.3			
Information Element	Value/remark	Comment	Condition
NR-DL-PRS-AssistanceData-r16 ::= SEQUENCE {			
nr-DL-PRS-ReferenceInfo-r16 SEQUENCE {			
dl-PRS-ID-r16	0		
nr-DL-PRS-ResourceID-List-r16	Not present		
nr-DL-PRS-ResourceSetID-r16	Not present		
}			
nr-DL-PRS-AssistanceDataList-r16 SEQUENCE (SIZE (1..nrMaxFreqLayers-r16)) OF NR-DL-PRS-AssistanceDataPerFreq-r16 {	1 entry		
NR-DL-PRS-AssistanceDataPerFreq-r16[1] SEQUENCE {		entry 1	
nr-DL-PRS-PositioningFrequencyLayer-r16 SEQUENCE {			
dl-PRS-SubcarrierSpacing-r16	kHz120		
dl-PRS-ResourceBandwidth-r16	11	64 PRBs	
dl-PRS-StartPRB-r16	0		
dl-PRS-PointA-r16	absoluteFrequencyPointA as defined for the DL frequency of the Cell 1		
dl-PRS-CombSizeN-r16	n4		
dl-PRS-CyclicPrefix-r16	normal		
}			
nr-DL-PRS-AssistanceDataPerFreq-r16 SEQUENCE (SIZE (1..nrMaxTRPsPerFreq-r16)) OF NR-DL-PRS-AssistanceDataPerTRP-r16{	2 entries		
NR-DL-PRS-AssistanceDataPerTRP-r16[1] SEQUENCE {		entry 1	Cell 1
dl-PRS-ID-r16	0		
nr-PhysCellID-r16	Cell 1		
nr-CellGlobalID-r16	Cell 1		
nr-ARFCN-r16	Cell 1		
nr-DL-PRS-SFN0-Offset-r16 SEQUENCE {			
sfn-Offset-r16	0		
integerSubframeOffset-r16	0		
}			
nr-DL-PRS-ExpectedRSTD-r16	0		
nr-DL-PRS-ExpectedRSTD-Uncertainty-r16	0		
nr-DL-PRS-Info-r16	As specified in Table 15.2.9.4.3-8		
}			
NR-DL-PRS-AssistanceDataPerTRP-r16[2] SEQUENCE {		entry 2	Cell 2
dl-PRS-ID-r16	1		
nr-PhysCellID-r16	Cell 2		
nr-CellGlobalID-r16	Cell 2		
nr-ARFCN-r16	Cell 2		
nr-DL-PRS-SFN0-Offset-r16 SEQUENCE {			
sfn-Offset-r16	0		
integerSubframeOffset-r16	0		
}			
nr-DL-PRS-ExpectedRSTD-r16	0	About 0 μ s	
nr-DL-PRS-ExpectedRSTD-Uncertainty-r16	17	About 0.58 μ s	
nr-DL-PRS-Info-r16	As specified in Table 15.2.9.4.3-8		
}			
}			
}			
}			
}			

Table 15.2.9.4.3-8: NR-DL-PRS-Info

Derivation Path: 37.355 clause 6.4.3			
Information Element	Value/remark	Comment	Condition
NR-DL-PRS-Info-r16 ::= SEQUENCE {			
nr-DL-PRS-ResourceSetList-r16 SEQUENCE (SIZE (1..nrMaxSetsPerTrp-r16)) OF NR-DL-PRS-ResourceSet-r16 {	1 entry		
NR-DL-PRS-ResourceSet-r16[1] SEQUENCE {		entry 1	
nr-DL-PRS-ResourceSetID-r16	0		
dl-PRS-Periodicity-and-ResourceSetSlotOffset-r16 CHOICE {			
scs120-r16 CHOICE {			
n160-r16	80		
}			
dl-PRS-ResourceRepetitionFactor-r16	Not present		
dl-PRS-ResourceTimeGap-r16	s1		
dl-PRS-NumSymbols-r16	n4		
dl-PRS-MutingOption1-r16 CHOICE {			
po2-r16	10		Cell 1
	01		Cell 2
}			
}			
dl-PRS-MutingOption2-r16	Not present		
dl-PRS-ResourcePower-r16	27		
dl-PRS-ResourceList-r16 SEQUENCE (SIZE (1..nrMaxResourcesPerSet-r16)) OF NR-DL-PRS-Resource-r16 {	1 entry		
NR-DL-PRS-Resource-r16[1] SEQUENCE {		entry 1	
nr-DL-PRS-ResourceID-r16	0		
dl-PRS-SequenceID-r16	0		
dl-PRS-CombSizeN-AndReOffset-r16 CHOICE {			
n4-r16	0		
}			
dl-PRS-ResourceSlotOffset-r16	4		
dl-PRS-ResourceSymbolOffset-r16	0		
dl-PRS-QCL-Info-r16	Not present		
}			
}			
}			
}			
}			
}			

Table 15.2.9.4.3-9: LPP ProvideLocation Information

Derivation Path: 37.355 clause 6.5.12			
Information Element	Value/remark	Comment	Condition
LPP-Message ::= SEQUENCE {			
transactionID SEQUENCE {			
initiator	locationServer		
transactionNumber	1		
}			
endTransaction	TRUE		
sequenceNumber	(0..255)		
acknowledgement			
lpp-MessageBody CHOICE {			
c1 CHOICE {			
provideLocationInformation SEQUENCE {			
criticalExtensions CHOICE {			
c1 CHOICE {			
provideLocationInformation-r9 SEQUENCE {			
commonIEsProvideLocationInformation	Not present.		
a-gnss-ProvideLocationInformation	Not present		
otdoa-ProvideLocationInformation	Not present		
ecid-ProvideLocationInformation	Not present		

epdu-ProvideLocationInformation	Not present		
sensor-ProvideLocationInformation-r13	Not present		
tbs-ProvideLocationInformation-r13	Not present		
wlan-ProvideLocationInformation-r13	Not present		
bt-ProvideLocationInformation-r13	Not present		
nr-ECID-ProvideLocationInformation-r16	Not present		
nr-Multi-RTT-ProvideLocationInformation-r16 SEQUENCE {			
nr-Multi-RTT-SignalMeasurementInformation-r16 SEQUENCE {			
nr-Multi-RTT-MeasList-r16 SEQUENCE (SIZE(1..nrMaxTRPs-r16)) OF NR-Multi-RTT-MeasElement-r16 {	2 entries		
NR-Multi-RTT-MeasElement-r16[1] SEQUENCE {		entry 1	
dl-PRS-ID-r16	INTEGER (0..255)		
nr-PhysCellID-r16			
nr-CellGlobalID-r16			
nr-ARFCN-r16			
nr-DL-PRS-ResourceID-r16			
nr-DL-PRS-ResourceSetID-r16			
nr-UE-RxTxTimeDiff-r16	Present. Any value acceptable.		
nr-AdditionalPathList-r16			
nr-TimeStamp-r16			
nr-TimingQuality-r16			
nr-DL-PRS-RSRP-Result-r16			
nr-Multi-RTT-AdditionalMeasurements-r16			
nr-UE-RxTx-TEG-Info-r17			
nr-DL-PRS-FirstPathRSRP-Result-r17			
nr-los-nlos-Indicator-r17			
nr-AdditionalPathListExt-r17			
nr-Multi-RTT-AdditionalMeasurementsExt-r17			
}			
NR-Multi-RTT-MeasElement-r16[2] SEQUENCE {		entry 2	
dl-PRS-ID-r16	INTEGER (0..255)		
nr-PhysCellID-r16			
nr-CellGlobalID-r16			
nr-ARFCN-r16			
nr-DL-PRS-ResourceID-r16			
nr-DL-PRS-ResourceSetID-r16			
nr-UE-RxTxTimeDiff-r16	Present. Any value acceptable.		
nr-AdditionalPathList-r16			
nr-TimeStamp-r16			
nr-TimingQuality-r16			
nr-DL-PRS-RSRP-Result-r16			
nr-Multi-RTT-AdditionalMeasurements-r16			
nr-UE-RxTx-TEG-Info-r17			
nr-DL-PRS-FirstPathRSRP-Result-r17			
nr-los-nlos-Indicator-r17			
nr-AdditionalPathListExt-r17			
nr-Multi-RTT-AdditionalMeasurementsExt-r17			
}			
}			
nr-NTA-Offset-r16			
nr-SRS-TxTEG-Set-r17			
nr-UE-RxTEG-TimingErrorMargin-r17			
nr-UE-TxTEG-TimingErrorMargin-r17			
nr-UE-RxTxTEG-TimingErrorMargin-r17			

}			
nr-Multi-RTT-Error-r16			
nr-Multi-RTT-SignalMeasurementInstances-r17			
}			
nr-DL-AoD-ProvideLocationInformation-r16	Not present		
}			
}			
}			
}			
}			
}			
}			

15.2.9.5 Test requirement

Table 15.2.9.5-1 and Table 15.2.9.5-2 define the primary level settings including test tolerances for the test. Table 15.2.9.5-1: General test parameters

Parameter	Unit	Test configuration	Value	Comment
Active cell		1	Cell 1	Cell 1 is the PCell in NR-Multi-RTT-ProvideAssistanceData [49].
Neighbour cell		1	Cell 2	Cell 2 is a neighbour cell in NR-Multi-RTT-ProvideAssistanceData [49].
RF Channel Number		1	1	For both Cell 1 and Cell 2
BW _{channel}	MHz	1	200: N _{RB,c} = 132	
SSB configuration		1	SSB.3 FR2	
SMTC configuration		1	SMTC.1	
PRS processing window		1	TS 38.133 [50] Table A.3.33-1: Reference PPW configuration	As defined in TS 38.133 [50] A.3.33
CP length		1	Normal	
DRX		1	OFF	
Time offset between serving and neighbour cells	µs	1	0.58, 2.25 or 3 ^{Note 1}	
Expected RSTD	µs	1	0	
Expected RSTD uncertainty	µs	1	Same as time offset between serving and neighbour cells	
T1	s	1	5	
T2	s	1	20	

NOTE 1: The value is up to the UE capability. The possible UE capability value: (1/4 symbol, 1/2 symbol, CP length, half of slot). When the UE reported value is > 3µs, the time offset between serving and neighbour cells is set to 3µs; when the UE reported value is < 3µs, the time offset between serving and neighbour cells is set to the UE reported value.

Table 15.2.9.5-2: Cell specific test parameters

Parameter	Unit	Test configuration	Cell 1		Cell 2	
			Sub-test 1	Sub-test 2	Sub-tests 1	Sub-test 2
AoA setup		1	Setup 1 as specified in TS 38.133 [50] clause A.3.15			
Beam Assumption ^{Note 7}		1	Rough		Rough	
TDD configuration		1	TDDConf.3.1		TDDConf.3.1	
PDSCH RMC configuration		1	SR.3.1 TDD		N/A	
RMSI CORESET RMC configuration		1	CR.3.1 TDD		N/A	
Dedicated CORESET RMC configuration		1	CCR.3.1 TDD		N/A	

OCNG Patterns		1	OP.1		OP.1	
TRS Configuration		1	TRS.2.1 TDD		N/A	
Initial BWP configuration		1	DLBWP.0.1 ULBWP.0.1		N/A	
Active DL BWP configuration		1	DLBWP.1.1		N/A	
Active UL BWP configuration		1	ULBWP.1.1		N/A	
PRS configuration		1	PRS.1.1 FR2		PRS.1.1 FR2	
PRS BW		1	64PRBs	64 PRBs	64 PRBs	64 PRBs
PRS muting info		1	'10'		'01'	
SRS configuration		1	POS-SRS.3		N/A	
N_{oc} Note 2	dBm/SCS	1	-94	-90.1	-94	-90.1
N_{oc} Note 2	dBm/15 kHz	1	-103	-99.1	-103	-99.1
PRS \hat{E}_s/I_{ot}	dB	1	0.32	-2.68	-5.64	-12.30
PRS \hat{E}_s/N_{oc}	dB	1	3.56	-2	-0.28	-10
PRS-RSRP Note 3	dBm/SCS kHz	1	-90.4	-92.1	-94.2	-100.1
Io	dBm/95.04 MHz	1	-55.73	-55.69	-55.73	-55.69
Propagation Condition		1	AWGN			
<p>Note 1: The resources for uplink transmission are assigned to the UE prior to the start of time period T2.</p> <p>Note 2: Interference from other cells and noise sources not specified in the test is assumed to be constant over subcarriers and time and shall be modelled as AWGN of appropriate power for N_{oc} to be fulfilled.</p> <p>Note 3: PRS-RSRP and Io levels have been derived from other parameters for information purposes. They are not settable parameters themselves.</p> <p>Note 4: PRS-RSRP minimum requirements are specified assuming independent interference and noise at each receiver antenna port.</p> <p>Note 5: Equivalent power received by an antenna with 0 dBi gain at the centre of the quiet zone</p> <p>Note 6: As observed with 0 dBi gain antenna at the centre of the quiet zone</p> <p>Note 7: Information about types of UE beam is given in TS 38.133 [50] B.2.1.3, and does not limit UE implementation or test system implementation</p> <p>Note 8: Calculation of E_s/I_{ot} includes the effect of UE internal noise up to the value assumed for the associated Refsens requirement in clause 7.3.2 of TS 38.101-2 [55], and an allowance of 1dB for UE multi-band relaxation factor ΔMB_P from TS 38.101-2 [55] Table 6.2.1.3-4.</p>						

The UE Rx-Tx time difference measurement period fulfils the requirements specified in clause 15.2.9.3.

The response time is equal to the LPP time IE value plus the test tolerance. The LPP time IE value is derived from the UE Rx-Tx time difference measurement period plus ΔT , where $\Delta T = 50\text{ms}$. The UE Rx-Tx time difference measurement period follows the equation:

$$T_{UERxTx,i} = \left(k_{multiTEG,i} * CSSF_i * \text{ceil}(K_{p,PRS,i}) * N_{RxBeam,i} * \left\lfloor \frac{N_{PRS,i}^{slot}}{N'} \right\rfloor \left\lceil \frac{L_{available_PRS,i}}{N} \right\rceil * N_{sample} - 1 \right) * T_{effect,i} + T_{last,i}$$

Where $CSSF_{PRS,i} = 1$, $K_{p,PRS,i} = 1$, $N_{RxBeam,i} = 8$, $CSSF_{PRS,i} = 1$, $N_{PRS,i}^{slot} = 2$, $L_{available_PRS,i} = 0.071$, $N_{sample} = 1$. N is the parameter durationOfPRS-ProcessingSymbols from TS 37.355 [49], N' is the parameter maxNumOfDL-PRS-ResProcessedPerSlot from TS 37.355 [49], $T_{last,i} = T_i + T_{available_PRS,i}$ and $T_{effect,i} = \left\lceil \frac{T_i}{T_{available_PRS,i}} \right\rceil * T_{available_PRS,i}$

$T_{available_PRS,i} = LCM(T_{PRS,i}, MGRP_i)$; where $T_{prs} = 160\text{ms}$, and $MGRP$ is 80 (for GP#24) or 40 (for GP#13) depending on UE capabilities. Therefore, $T_{available_PRS,i} = 160\text{ms}$.

T_i depends on the UE parameter durationOfPRS-ProcessingSymbolsInEveryTms from TS 37.355 [49]

Finally, it results in the following equation:

$$\left(1 * 1 * 1 * 8 * \left\lceil \frac{2}{N'} \right\rceil \left\lceil \frac{0.071}{N} \right\rceil * 4 - 1 \right) * T_{effect} + T_{last}$$

Where the remaining parameters depend on the UE capabilities. The LPP time IE ranges between 2.408s and 20.64s. The value of the LPP time IE is rounded up to the next second (if the value is >128s, it should be rounded up to the next multiple of ten seconds). The result is transmitted in the response time IE in the LPP-RequestLocationInformation in Table 15.2.9.4.3-5. The LPP time IE ranges between 3s and 21s.

The test tolerance for the response time is 300ms. Therefore, the response time ranges between 3.3s and 21.3s.

For sub-test 2, N_sample= 4. Finally, it results in the following equation:

$$\left(1 * 1 * 1 * 8 * \left\lceil \frac{2}{N'} \right\rceil \left\lceil \frac{0.071}{N} \right\rceil * 4 - 1 \right) * T_{effect} + T_{last}$$

Where the remaining parameters depend on the UE capabilities. The LPP time IE ranges between 5.128s and 82.08s. The value of the LPP time IE is rounded up to the next second (if the value is >128s, it should be rounded up to the next multiple of ten seconds). The result is transmitted in the response time IE in the LPP-RequestLocationInformation in Table 15.2.9.4.3-5. The LPP time IE ranges between 6.3s and 83.3s.

The values of N', N and Ti and the effect in the response time equation are defined in Table 15.2.9.5-3, Table 15.2.9.5-4 and Table 15.2.9.5-5 for reference.

Table 15.2.9.5-3: value of N' based on *maxNumOfDL-PRS-ResProcessedPerSlot*

<i>maxNumOfDL-PRS-ResProcessedPerSlot</i>	$\left\lceil \frac{2}{N'} \right\rceil$
n1	2
>=n2	1

Table 15.2.9.5-4: value of N based on *durationOfPRS-ProcessingSymbols*

<i>durationOfPRS-ProcessingSymbols</i>	$\left\lceil \frac{0.071}{N} \right\rceil$
>= nDot125	1

Table 15.2.9.5-5: value of T_{effect} and T_{last} based on *durationOfPRS-ProcessingSymbolsInEveryTms*

<i>durationOfPRS-ProcessingSymbolsInEveryTms</i>	T _{effect}	T _{last}
n8	160	168
n16	160	176
n20	160	180
n30	160	190
n40	160	200
n80	160	240
n160	160	320
n320	320	480
n640	640	800
n1280	1280	1440

The rate of successful tests during repeated tests shall be at least 90% with a confidence level of 95%.

15.2.10 UE Rx-Tx time difference measurement reporting delay test case for single positioning frequency layer with RxTx TEG in FR2 SA

Editor's Note: This test case has been completed for the following configurations:

- Test frequency $f \leq 40.8$ GHz
- UE PC3

This test case is incomplete for UE power classes other than PC3

This test case is incomplete for test frequencies > 40.8 GHz

15.2.10.1 Test purpose

The purpose of the test is to verify that the UE Rx-Tx measurement meets the requirements specified in TS 38.133 [50] clause 9.9.4.5 in AWGN propagation condition in FR2 in standalone scenario when single positioning frequency layer is configured, and when UE is requested to measure a PRS resource with RxTx TEG.

15.2.10.2 Test applicability

This test applies to all types of NR UE release 17 onwards that supports Multi-RTT positioning and nr-UE-RxTxTEG-ID-MaxSupport-r17.

15.2.10.3 Minimum conformance requirements

Same as defined in clause 15.2.8.3.

15.2.10.4 Test description

15.2.10.4.1 Initial conditions

The supported test configuration is listed in Table 15.2.10.4-1.

Table 15.2.10.4-1: Test Configuration

Test Configuration	Description
1	120 kHz SSB and PRS SCS, 200 MHz bandwidth, TDD duplex mode

Test Environment: Normal, as defined in TS 38.508-1 [45] clause 4.1.

Frequencies to be tested: Mid Range, as defined in TS 38.508-1 [45] clause 4.3.1.

Channel bandwidth to be tested: are specified in Table 15.2.10.4-1.

1. Connect the SS and AWGN noise sources to the UE antenna connector or antenna connectors as shown in Annex A, Figure A.14.
2. The general test parameter settings are set up according to Table 15.2.10.5-1 and Table 15.2.10.5-2.
3. Propagation conditions are set according to clause 4.14.2.
4. Message contents are defined in clause 15.2.10.4.3.
5. In the test there are two cells in the test: PCell (Cell 1) and a neighbour cell (Cell 2). All cells are on the same RF channel in FR2.

15.2.10.4.2 Test procedure

Same as defined in clause 15.2.8.4.2.

15.2.10.4.3 Message contents

Table 15.2.10.4.3-1: RESET UE POSITIONING STORED INFORMATION

Derivation Path: 38.509 [44] clause 6.6			
Information Element	Value/remark	Comment	Condition
UE Positioning Technology	0 0 0 0 1 1 0	Multi-RTT	

Table 15.2.10.4.3-2: RRCReconfiguration

Derivation Path: TS 38.508-1 [45], table 4.6.1-13			
Information Element	Value/remark	Comment	Condition
RRCReconfiguration ::= SEQUENCE {			
criticalExtensions CHOICE {			
rrcReconfiguration SEQUENCE {			
radioBearerConfig			
nonCriticalExtension SEQUENCE {			
masterCellGroup SEQUENCE {	CellGroupConfig		
spCellConfig SEQUENCE {			
spCellConfigDedicated SEQUENCE {			
uplinkConfig SEQUENCE {			
initialUplinkBWP SEQUENCE {			
srs-Config CHOICE {			
setup	As defined in Table 15.2.10.4.3-3		
}			
}			
}			
}			
}			
}			
}			
}			

Table 15.2.10.4.3-3: SRS-Config (Table 15.2.10.4.3-2)

Derivation Path: TS 38.508-1 [45], Table 4.6.3-182			
Information Element	Value/remark	Comment	Condition
SRS-Config ::= SEQUENCE {			
srs-ResourceSetToReleaseList	Not present		
srs-ResourceSetToAddModList	Not present		
srs-ResourceToReleaseList	Not present		
srs-ResourceToAddModList	Not present		
tpc-Accumulation	Not present		
srs-RequestDCI-1-2-r16	Not present		
srs-RequestDCI-0-2-r16	Not present		
srs-ResourceSetToAddModListDCI-0-2-r16	Not present		
srs-ResourceSetToReleaseListDCI-0-2-r16	Not present		
srs-PosResourceSetToReleaseList-r16	Not present		
srs-PosResourceSetToAddModList-r16 SEQUENCE (SIZE(1..maxNrofSRS-PosResourceSets-r16)) OF SRS-PosResourceSet-r16 {	1 entry		
SRS-PosResourceSet-r16[1] SEQUENCE {		entry 1	
srs-PosResourceSetId-r16	0		
srs-PosResourceCidList-r16 SEQUENCE (SIZE(1..maxNrofSRS-ResourcesPerSet)) OF SRS-PosResourceCid-r16 {	1 entry		
SRS-PosResourceCid-r16	0	1 entry	
}			
resourceType CHOICE {			
periodic SEQUENCE {			
}			
}			
alpha-r16	alpha0		
p0-r16	0		
pathlossReferenceRS-Pos-r16	Not present		
}			
srs-PosResourceToReleaseList-r16	Not present		
srs-PosResourceToAddModList-r16 SEQUENCE (SIZE(1..maxNrofSRS-PosResources-r16)) OF SRS-PosResource-r16 {	1 entry		

SRS-PosResource-r16[1] SEQUENCE {		entry 1	
srs-PosResourceId-r16	0		
transmissionComb-r16 CHOICE {			
n4-r16 SEQUENCE {			
combOffset-n4-r16	0		
cyclicShift-n4-r16	0		
}			
}			
resourceMapping-r16 SEQUENCE {			
startPosition-r16	0		
nrofSymbols-r16	n4		
}			
freqDomainShift-r16	0		
freqHopping-r16 SEQUENCE {			
c-SRS-r16	Matches N _{RB,c} Table 15.2.10.5-1		
}			
groupOrSequenceHopping-r16	neither		
resourceType-r16 CHOICE {			
periodic-r16 SEQUENCE {			
periodicityAndOffset-p-r16 CHOICE {			
sl1280	160		
}			
}			
}			
sequenceId-r16	0		
spatialRelationInfoPos-r16	Not present		
}			
}			
}			

Table 15.2.10.4.3-4: LPP Request Capabilities

Information Element	Value/remark
nr-Multi-RTT-RequestCapabilities-r16	TRUE

Table 15.2.10.4.3-5: LPP RequestLocationInformation

Derivation Path: TS 37.355 [49] clause 6.2			
Information Element	Value/remark	Comment	Condition
LPP-Message ::= SEQUENCE {			
transactionID SEQUENCE {			
initiator	locationServer		
transactionNumber	1		
}			
endTransaction	FALSE		
sequenceNumber	Not present		
acknowledgement	Not present		
lpp-MessageBody CHOICE {			
c1 CHOICE {			
requestLocationInformation SEQUENCE {			
criticalExtensions CHOICE {			
c1 CHOICE {			
requestLocationInformation-r9 SEQUENCE {			
commonEsRequestLocationInformation SEQUENCE {			
locationInformationType	locationMeasurementsPreferred		
triggeredReporting	Not present		
periodicalReporting	Not present		
additionalInformation	onlyReturnInformationRequested		
}			
}			
}			
}			
}			
}			
qos SEQUENCE {			

horizontalAccuracy	Not present		
verticalCoordinateRequest	FALSE		
verticalAccuracy	Not present		
responseTime SEQUENCE { time	See 15.2.10.5	Result of the response time calculation rounded up to the next second if response time <= 128s. Result of the response time calculation rounded up to the next multiple of ten seconds if response time > 128s	
responseTimeEarlyFix-r12	Not present		Rel-12 onwards
unit-r15	Not present		Calculated response time >128s
	ten-seconds		
}			
velocityRequest	FALSE		
}			
environment	Not present		
locationCoordinateTypes	Not present		
velocityTypes	Not present		
}			
a-gnss-RequestLocationInformation	Not present		
otdoa-RequestLocationInformation	Not present		
ecid-RequestLocationInformation	Not present		
epdu-RequestLocationInformation	Not Present		
sensor-RequestLocationInformation-r13	Not present		
tbs-RequestLocationInformation-r13	Not present		
wlan-RequestLocationInformation-r13	Not present		
bt-RequestLocationInformation-r13	Not present		
nr-ECID-RequestLocationInformation-r16	Not present		
nr-Multi-RTT-RequestLocationInformation-r16			
SEQUENCE {			
nr-UE- RxTxTimeDiffMeasurementInfoRequest-r16	Not present		
nr-RequestedMeasurements-r16	bit 0 = 1 (prsrsrpReq)		
nr-AssistanceAvailability-r16	FALSE		
nr-Multi-RTT-ReportConfig-r16 SEQUENCE {			
maxDL-PRS-RxTxTimeDiffMeasPerTRP-r16	Not present		
timingReportingGranularityFactor-r16	Not present		
}			
additionalPaths-r16	Not present		
nr-UE-RxTxTEG-Request-r17	case1		
measureSameDL-PRS- ResourceWithDifferentRxTxTEGs-r17	Not present		
measureSameDL-PRS- ResourceWithDifferentRxTEGs-r17	n0		
reducedDL-PRS-ProcessingSamples-r17	Not present		
nr-los-nlos-IndicatorRequest-r17	Not present		
additionalPathsExt-r17	Not present		
additionalPathsDL-PRS-RSRP-Request-r17	Not present		
multiMeasInSameReport-r17	Not present		
lowerRxBeamSweepingFactor-FR2-r17	Not present		
}			
nr-DL-AoD-RequestLocationInformation-r16	Not present		
nr-DL-TDOA-RequestLocationInformation-r16	Not present		
}			

}			
}			
}			
}			
}			
}			

Table 15.2.10.4.3-6: LPP ProvideAssistanceData

Derivation Path: 37.355 clause 6.2			
Information Element	Value/remark	Comment	Condition
LPP-Message ::= SEQUENCE {			
transactionID SEQUENCE {			
initiator	locationServer		
transactionNumber	(0..255)		
}			
endTransaction	TRUE		
sequenceNumber	Not present		
acknowledgement	Not present		
lpp-MessageBody CHOICE {			
c1 CHOICE {			
provideAssistanceData SEQUENCE {			
criticalExtensions CHOICE {			
c1 CHOICE {			
provideAssistanceData-r9 SEQUENCE {			
commonIEsProvideAssistanceData	Not present		
a-gnss-ProvideAssistanceData	Not present		
otdoa-ProvideAssistanceData	Not present		
epdu-Provide-AssistanceData	Not present		
sensor-ProvideAssistanceData-r15	Not present		
tbs-ProvideAssistanceData-r15	Not present		
wlan-ProvideAssistanceData-r15	Not present		
nr-Multi-RTT-ProvideAssistanceData-r16			
SEQUENCE {			
nr-DL-PRS-AssistanceData	As defined in Table 15.2.10.4.3-7		
nr-SelectedDL-PRS-IndexList-r16	Not present		
nr-Multi-RTT-Error-r16	Not present		
nr-On-Demand-DL-PRS-Configurations-r17	Not present		
nr-On-Demand-DL-PRS-Configurations-Selected-IndexList-r17	Not present		
assistanceDataValidityArea-r17	Not present		
}			
nr-DL-AoD-ProvideAssistanceData-r16	Not present		
nr-DL-TDOA-ProvideAssistanceData-r16	Not present		
}			
}			
}			
}			

Table 15.2.10.4.3-7: NR-DL-PRS-AssistanceData

Derivation Path: 37.355 clause 6.4.3			
Information Element	Value/remark	Comment	Condition
NR-DL-PRS-AssistanceData-r16 ::= SEQUENCE {			
nr-DL-PRS-ReferenceInfo-r16 SEQUENCE {			
dl-PRS-ID-r16	0		
nr-DL-PRS-ResourceID-List-r16	Not present		
nr-DL-PRS-ResourceSetID-r16	Not present		
}			

nr-DL-PRS-AssistanceDataList-r16 SEQUENCE (SIZE (1..nrMaxFreqLayers-r16)) OF NR-DL-PRS-AssistanceDataPerFreq-r16 {	1 entry		
NR-DL-PRS-AssistanceDataPerFreq-r16[1] SEQUENCE {		entry 1	
nr-DL-PRS-PositioningFrequencyLayer-r16 SEQUENCE {			
dl-PRS-SubcarrierSpacing-r16	kHz120		
dl-PRS-ResourceBandwidth-r16	3	32 PRBs	
dl-PRS-StartPRB-r16	0		
dl-PRS-PointA-r16	absoluteFrequencyPointA as defined for the DL frequency of the Cell 1		
dl-PRS-CombSizeN-r16	n2		
dl-PRS-CyclicPrefix-r16	normal		
}			
nr-DL-PRS-AssistanceDataPerFreq-r16 SEQUENCE (SIZE (1..nrMaxTRPsPerFreq-r16)) OF NR-DL-PRS-AssistanceDataPerTRP-r16{	2 entries		
NR-DL-PRS-AssistanceDataPerTRP-r16[1] SEQUENCE {		entry 1	Cell 1
dl-PRS-ID-r16	0		
nr-PhysCellID-r16	Cell 1		
nr-CellGlobalID-r16	Cell 1		
nr-ARFCN-r16	Cell 1		
nr-DL-PRS-SFN0-Offset-r16 SEQUENCE {			
sfn-Offset-r16	0		
integerSubframeOffset-r16	0		
}			
nr-DL-PRS-ExpectedRSTD-r16	0		
nr-DL-PRS-ExpectedRSTD-Uncertainty-r16	0		
nr-DL-PRS-Info-r16	As specified in Table 15.2.10.4.3-8		
}			
NR-DL-PRS-AssistanceDataPerTRP-r16[2] SEQUENCE {		entry 2	Cell 2
dl-PRS-ID-r16	1		
nr-PhysCellID-r16	Cell 2		
nr-CellGlobalID-r16	Cell 2		
nr-ARFCN-r16	Cell 2		
nr-DL-PRS-SFN0-Offset-r16 SEQUENCE {			
sfn-Offset-r16	0		
integerSubframeOffset-r16	0		
}			
nr-DL-PRS-ExpectedRSTD-r16	23	About 3 μs	
nr-DL-PRS-ExpectedRSTD-Uncertainty-r16	154	About 5 μs	
nr-DL-PRS-Info-r16	As specified in Table 15.2.10.4.3-8		
}			
}			
}			
}			
}			

Table 15.2.10.4.3-8: NR-DL-PRS-Info

Derivation Path: 37.355 clause 6.4.3			
Information Element	Value/remark	Comment	Condition
NR-DL-PRS-Info-r16 ::= SEQUENCE {			
nr-DL-PRS-ResourceSetList-r16 SEQUENCE (SIZE (1..nrMaxSetsPerTrp-r16)) OF NR-DL-PRS-ResourceSet-r16 {	1 entry		
NR-DL-PRS-ResourceSet-r16[1] SEQUENCE {		entry 1	
nr-DL-PRS-ResourceSetID-r16	0		

dl-PRS-Periodicity-and-ResourceSetSlotOffset-r16 CHOICE {			
scs120-r16 CHOICE {			
n160-r16	80		
}			
dl-PRS-ResourceRepetitionFactor-r16	n2		
dl-PRS-ResourceTimeGap-r16	s1		
dl-PRS-NumSymbols-r16	n4		
dl-PRS-MutingOption1-r16 CHOICE {			
po2-r16	10		Cell 1
	01		Cell 2
}			
}			
dl-PRS-MutingOption2-r16	Not present		
dl-PRS-ResourcePower-r16	27		
dl-PRS-ResourceList-r16 SEQUENCE (SIZE (1..nrMaxResourcesPerSet-r16)) OF NR-DL-PRS-Resource-r16 {	1 entry		
NR-DL-PRS-Resource-r16[1] SEQUENCE {		entry 1	
nr-DL-PRS-ResourceID-r16	0		
dl-PRS-SequenceID-r16	0		
dl-PRS-CombSizeN-AndReOffset-r16 CHOICE {			
n4-r16	0		
}			
dl-PRS-ResourceSlotOffset-r16	0		
dl-PRS-ResourceSymbolOffset-r16	0		
dl-PRS-QCL-Info-r16	Not present		
}			
}			
}			

Table 15.2.10.4.3-9: LPP ProvideLocation Information

Derivation Path: 37.355 clause 6.5.12			
Information Element	Value/remark	Comment	Condition
LPP-Message ::= SEQUENCE {			
transactionID SEQUENCE {			
initiator	locationServer		
transactionNumber	1		
}			
endTransaction	TRUE		
sequenceNumber	(0..255)		
acknowledgement			
lpp-MessageBody CHOICE {			
c1 CHOICE {			
provideLocationInformation SEQUENCE {			
criticalExtensions CHOICE {			
c1 CHOICE {			
provideLocationInformation-r9 SEQUENCE {			
commonIEsProvideLocationInformation	Not present.		
a-gnss-ProvideLocationInformation	Not present		
otdoa-ProvideLocationInformation	Not present		
ecid-ProvideLocationInformation	Not present		
epdu-ProvideLocationInformation	Not present		
sensor-ProvideLocationInformation-r13	Not present		
tbs-ProvideLocationInformation-r13	Not present		
wlan-ProvideLocationInformation-r13	Not present		
bt-ProvideLocationInformation-r13	Not present		
nr-ECID-ProvideLocationInformation-r16	Not present		
nr-Multi-RTT-ProvideLocationInformation-r16 SEQUENCE {			

nr-Multi-RTT- SignalMeasurementInformation-r16 SEQUENCE {			
nr-Multi-RTT-MeasList-r16 SEQUENCE (SIZE(1..nrMaxTRPs-r16)) OF NR-Multi-RTT- MeasElement-r16 {	2 entries		
NR-Multi-RTT-MeasElement-r16[1] SEQUENCE {		entry 1	
dl-PRS-ID-r16	INTEGER (0..255)		
nr-PhysCellID-r16			
nr-CellGlobalID-r16			
nr-ARFCN-r16			
nr-DL-PRS-ResourceID-r16			
nr-DL-PRS-ResourceSetID-r16			
nr-UE-RxTxTimeDiff-r16	Present. Any value acceptable.		
nr-AdditionalPathList-r16			
nr-TimeStamp-r16			
nr-TimingQuality-r16			
nr-DL-PRS-RSRP-Result-r16			
nr-Multi-RTT-AdditionalMeasurements- r16			
nr-UE-RxTx-TEG-Info-r17 CHOICE {			
case1-r17 SEQUENCE {			
nr-UE-RxTx-TEG-ID-r17	INTEGER (0..255)		
}			
}			
nr-DL-PRS-FirstPathRSRP-Result-r17			
nr-los-nlos-Indicator-r17			
nr-AdditionalPathListExt-r17			
nr-Multi-RTT- AdditionalMeasurementsExt-r17			
}			
NR-Multi-RTT-MeasElement-r16[2] SEQUENCE {		entry 2	
dl-PRS-ID-r16	INTEGER (0..255)		
nr-PhysCellID-r16			
nr-CellGlobalID-r16			
nr-ARFCN-r16			
nr-DL-PRS-ResourceID-r16			
nr-DL-PRS-ResourceSetID-r16			
nr-UE-RxTxTimeDiff-r16	Present. Any value acceptable.		
nr-AdditionalPathList-r16			
nr-TimeStamp-r16			
nr-TimingQuality-r16			
nr-DL-PRS-RSRP-Result-r16			
nr-Multi-RTT-AdditionalMeasurements- r16			
nr-UE-RxTx-TEG-Info-r17 CHOICE {			
case1-r17 SEQUENCE {			
nr-UE-RxTx-TEG-ID-r17	INTEGER (0..255)		
}			
}			
nr-DL-PRS-FirstPathRSRP-Result-r17			
nr-los-nlos-Indicator-r17			
nr-AdditionalPathListExt-r17			
nr-Multi-RTT- AdditionalMeasurementsExt-r17			
}			
}			
nr-NTA-Offset-r16			
nr-SRS-TxTEG-Set-r17			
nr-UE-RxTEG-TimingErrorMargin-r17			
nr-UE-TxTEG-TimingErrorMargin-r17			
nr-UE-RxTxTEG-TimingErrorMargin-r17			

}			
nr-Multi-RTT-Error-r16			
nr-Multi-RTT-SignalMeasurementInstances-r17			
}			
nr-DL-AoD-ProvideLocationInformation-r16	Not present		
}			
}			
}			
}			
}			
}			

15.2.10.5 Test requirement

Table 15.2.10.5-1 and Table 15.2.10.5-2 define the primary level settings including test tolerances for the test.

Table 15.2.10.5-1: General test parameters

Parameter	Unit	Test configuration	Value	Comment
Active cell		1	Cell 1	Cell 1 is the PCell in NR-Multi-RTT-ProvideAssistanceData [49].
Neighbour cell		1	Cell 2	Cell 2 is a neighbour cell in NR-Multi-RTT-ProvideAssistanceData [49].
RF Channel Number		1	1	For both Cell 1 and Cell 2
BW _{channel}	MHz	1	200: N _{RB,c} = 132	
SSB configuration		1	SSB.3 FR2	
SMTC configuration		1	SMTC.1	
Measurement gap		1	GP#24 or GP#13 ^{Note 1}	
CP length		1	Normal	
DRX		1	OFF	
Time offset between serving and neighbour cells	µs	1	3	Synchronous cells
T1	s	1	5	
T2	s	1	20	

NOTE 1: GP#24 is configured if UE supports MG#24, otherwise GP#13 is configured.

Table 15.2.10.5-2: Cell specific test parameters

Parameter	Unit	Test configuration	Cell 1		Cell 2	
			T1	T2	T1	T2
AoA setup		1	Setup 1 as specified in TS 38.133 [50] clause A.3.15			
Beam Assumption ^{Note 7}		1	Rough		Rough	
TDD configuration		1	TDDConf.3.1		TDDConf.3.1	
PDSCH RMC configuration		1	SR.3.1 TDD		N/A	
RMSI CORESET RMC configuration		1	CR.3.1 TDD		N/A	
Dedicated CORESET RMC configuration		1	CCR.3.1 TDD		N/A	
OCNG Patterns		1	OP.1		OP.1	
TRS Configuration		1	TRS.2.1 TDD		N/A	
Initial BWP configuration		1	DLBWP.0.1 ULBWP.0.1		N/A	
Active DL BWP configuration		1	DLBWP.1.1		N/A	
Active UL BWP configuration		1	ULBWP.1.1		N/A	

PRS configuration		1	PRS.1.1 FR2		PRS.1.1 FR2	
PRS muting info		1	'10'		'01'	
SRS configuration		1	POS-SRS.3		N/A	
N_{oc} Note 2	dBm/SCS	1	-90.1			
N_{oc} Note 2	dBm/15 kHz	1	-99.1			
PRS \hat{E}_s/I_{ot}	dB	1	-Infinity	-2.68	-Infinity	-12.30
PRS \hat{E}_s/N_{oc}	dB	1	-Infinity	-2	-Infinity	-10
PRS-RSRP Note 3	dBm/SCS kHz	1	-Infinity	-92.1	-Infinity	-100.1
I_o	dBm/190.08 MHz	1	N/A	-55.69	N/A	-55.69
Propagation Condition		1	AWGN			
Note 1:	The resources for uplink transmission are assigned to the UE prior to the start of time period T2.					
Note 2:	Interference from other cells and noise sources not specified in the test is assumed to be constant over subcarriers and time and shall be modelled as AWGN of appropriate power for N_{oc} to be fulfilled.					
Note 3:	PRS-RSRP and I_o levels have been derived from other parameters for information purposes. They are not settable parameters themselves.					
Note 4:	PRS-RSRP minimum requirements are specified assuming independent interference and noise at each receiver antenna port.					
Note 5:	Equivalent power received by an antenna with 0 dBi gain at the centre of the quiet zone					
Note 6:	As observed with 0 dBi gain antenna at the centre of the quiet zone					
Note 7:	Information about types of UE beam is given in TS 38.133 [50] B.2.1.3, and does not limit UE implementation or test system implementation					
Note 8:	Calculation of E_s/I_{ot} includes the effect of UE internal noise up to the value assumed for the associated Refsens requirement in clause 7.3.2 of TS 38.101-2 [55], and an allowance of 1dB for UE multi-band relaxation factor ΔMB_P from TS 38.101-2 [55] Table 6.2.1.3-4.					

The UE Rx-Tx time difference measurement period fulfils the requirements specified in clause 15.2.10.3.

The response time is equal to the LPP time IE value plus the test tolerance. The LPP time IE value is derived from the UE Rx-Tx time difference measurement period plus ΔT , where $\Delta T = 50$ ms. The UE Rx-Tx time difference measurement period follows the equation:

$$T_{UERxTx,i} = \left(k_{multiTEG,i} * CSSF_i * \text{ceil}(K_{p,PRS,i}) * N_{RxBeam,i} * \left\lceil \frac{N_{PRS,i}^{slot}}{N'} \right\rceil \left\lceil \frac{L_{available_PRS,i}}{N} \right\rceil * N_{sample} - 1 \right) * T_{effect,i} + T_{last,i}$$

Where $CSSF_{PRS,i} = 1$, $K_{p,PRS,i} = 2$, $N_{RxBeam,i} = 8$, $CSSF_{PRS,i} = 1$, $N_{PRS,i}^{slot} = 2$, $L_{available_PRS,i} = 0.071$, $N_{sample} = 4$. N is the parameter durationOfPRS-ProcessingSymbols from TS 37.355 [49], N' is the parameter maxNumOfDL-PRS-ResProcessedPerSlot from TS 37.355 [49], $T_{last,i} = T_i + T_{available_PRS,i}$ and $T_{effect,i} = \left\lceil \frac{T_i}{T_{available_PRS,i}} \right\rceil * T_{available_PRS,i}$

$T_{available_PRS,i} = LCM(T_{PRS,i}, MGRP_i)$; where $T_{prs} = 160$ ms, and $MGRP$ is 80 (for GP#24) or 40 (for GP#13) depending on UE capabilities. Therefore, $T_{available_PRS,i} = 160$ ms.

T_i depends on the UE parameter durationOfPRS-ProcessingSymbolsInEveryTms from TS 37.355 [49]

Finally, it results in the following equation:

$$\left(8 * \left\lceil \frac{2}{N'} \right\rceil \left\lceil \frac{0.071}{N} \right\rceil * 2 * 4 - 1 \right) * T_{effect} + T_{last}$$

Where the remaining parameters depend on the UE capabilities. The LPP time IE ranges between 10.248s and 164s. The value of the LPP time IE is rounded up to the next second (if the value is >128s, it should be rounded up to the next multiple of ten seconds). The result is transmitted in the response time IE in the LPP-RequestLocationInformation in Table 15.2.10.4.3-5. The LPP time IE ranges between 11s and 170s.

The test tolerance for the response time is 300ms. Therefore, the response time ranges between 11.3s and 170.3s.

Table 15.2.10.5-3: value of N' based on *maxNumOfDL-PRS-ResProcessedPerSlot*

<i>maxNumOfDL-PRS-ResProcessedPerSlot</i>	$\lceil \frac{2}{N'} \rceil$
n1	2
>=n2	1

Table 15.2.10.5-4: value of N based on *durationOfPRS-ProcessingSymbols*

<i>durationOfPRS-ProcessingSymbols</i>	$\lceil \frac{0.071}{N} \rceil$
>= nDot125	1

Table 15.2.10.5-5: value of T_{effect} and T_{last} based on *durationOfPRS-ProcessingSymbolsInEveryTms*

<i>durationOfPRS-ProcessingSymbolsInEveryTms</i>	T _{effect}	T _{last}
n8	160	168
n16	160	176
n20	160	180
n30	160	190
n40	160	200
n80	160	240
n160	160	320
n320	320	480
n640	640	800
n1280	1280	1440

The rate of successful tests during repeated tests shall be at least 90% with a confidence level of 95%.

15.3 UE Rx-Tx time difference measurement accuracy test cases in RRC_CONNECTED

15.3.1 UE Rx-Tx time difference measurement accuracy for single positioning frequency layer in FR1 SA

15.3.1.1 Test purpose

The purpose of the test is to verify that the UE Rx-Tx time difference measurement accuracy is within the specified limits. This test will verify the requirements in TS 38.133 [50] clause 10.1.25.2. The test is conducted in AWGN propagation condition in FR1 in standalone scenario when single positioning frequency layer is configured.

15.3.1.2 Test applicability

This test applies to all types of NR UE release 16 onwards that supports Multi-RTT positioning.

15.3.1.3 Minimum conformance requirements

The UE Rx-Tx time difference measurement accuracy requirements in this clause shall not apply, if:

N_{TA_offset} defined in Table 7.1.2-2 changes during the UE Rx-Tx measurement period or

if the uplink transmission timing changes during the UE Rx-Tx measurement period due to the network-configured Timing Advance.

The UE Rx-Tx time difference measurement accuracy requirements in this clause shall apply provided that:

- The UE transmits SRS within [-160, 160] msec of at least one DL PRS resource of each of the TRPs in the assistance data.

FFS: whether UE Rx-Tx time difference measurement accuracy requirements in this clause shall also apply if the uplink transmission timing changes during the UE Rx-Tx measurement period due to the autonomous timing adjustment defined in clause 7.1.2.

The UE shall continue and complete a UE Rx-Tx measurement while meeting UE Rx-Tx measurement accuracy requirements defined in this clause when a serving cell change occurs during the UE Rx-Tx measurement provided that the serving cell change does not impact the SRS configuration for the UE Rx-Tx measurement.

Note: The requirements for fading channel in this clause are derived based on TDL-A (30 ns delay spread, 5Hz) and TDL-C (60 ns delay spread, 300 Hz) channel models for FR1 and FR2 respectively.

The accuracy requirements in Table 10.1.25.2-1 for FR1 are valid under the following conditions:

Conditions defined in clause 7.3 of TS 38.101-1 [18] for reference sensitivity are fulfilled.

PRP_{dBm} according to Annex B.2.14 for a corresponding Band.

AWGN propagation condition.

Table 10.1.25.2-1: UE Rx-Tx time difference measurement accuracy in FR1 in AWGN

Accuracy	Conditions						
	PRS Es/lot	Minimum PRS bandwidth	PRS SCS	PRS resource repetition ($T_{rep}^{PRS} *$ L_{PRS}/K_{comb}^{PRS} Note 3)	NR operating band groups ^{Note 2}	Io ^{Note 4} range	
						Minimum Io ^{Note 1}	Maximum Io
Tc ^{Note 5}	dB	RB	kHz			dBm / SCS _{PRS}	dBm/BW
± 78+δ	-3	≥24	15	≥4	NR_FDD_FR1_A, NR_TDD_FR1_A, NR_SDL_FR1_A	-127	-50
					NR_FDD_FR1_B	-126.5	
					NR_TDD_FR1_C	-126	
					NR_FDD_FR1_D, NR_TDD_FR1_D	-125.5	
					NR_FDD_FR1_E, NR_TDD_FR1_E	-125	
					NR_FDD_FR1_F	-124.5	
					NR_FDD_FR1_G, NR_TDD_FR1_G	-124	
					NR_FDD_FR1_H	-123.5	
± 59+δ		≥52		≥1	Note 6	Note 6	Note 6
± 30+δ		>104		≥1	Note 6	Note 6	Note 6
± 57+δ		≥24	30	≥4	NR_FDD_FR1_A, NR_TDD_FR1_A, NR_SDL_FR1_A	-124	-50
					NR_FDD_FR1_B	-123.5	
					NR_TDD_FR1_C	-123	
					NR_FDD_FR1_D, NR_TDD_FR1_D	-122.5	
					NR_FDD_FR1_E, NR_TDD_FR1_E	-122	
					NR_FDD_FR1_F	-121.5	
					NR_FDD_FR1_G, NR_TDD_FR1_G	-121	
					NR_FDD_FR1_H	-120.5	
± 30+δ		≥48		≥1	NOTE 6	NOTE 6	NOTE 6
± 15+δ		≥132		≥1	NOTE 6	NOTE 6	NOTE 6
± 29+δ		≥24	60	≥4	NR_FDD_FR1_A, NR_TDD_FR1_A,	-121	-50

				NR_SDL_FR1_A		
				NR_FDD_FR1_B	-120.5	
				NR_TDD_FR1_C	-120	
				NR_FDD_FR1_D, NR_TDD_FR1_D	-119.5	
				NR_FDD_FR1_E, NR_TDD_FR1_E	-119	
				NR_FDD_FR1_F	-118.5	
				NR_FDD_FR1_G, NR_TDD_FR1_G	-118	
				NR_FDD_FR1_H	-117.5	
$\pm 15+\delta$	≥ 64		≥ 1	NOTE 6	NOTE 6	NOTE 6
$\pm 7+\delta$	≥ 132		≥ 1	NOTE 6	NOTE 6	NOTE 6
$\pm 101+\delta$	≥ 24	15	≥ 4	NOTE 6	NOTE 6	NOTE 6
$\pm 75+\delta$	≥ 52		≥ 1	NOTE 6	NOTE 6	NOTE 6
$\pm 37+\delta$	>104		≥ 1	NOTE 6	NOTE 6	NOTE 6
$\pm 58+\delta$	≥ 24	30	≥ 4	NOTE 6	NOTE 6	NOTE 6
$\pm 39+\delta$	≥ 48		≥ 1	NOTE 6	NOTE 6	NOTE 6
$\pm 16+\delta$	≥ 132		≥ 1	NOTE 6	NOTE 6	NOTE 6
$\pm 36+\delta$	≥ 24	60	≥ 4	NOTE 6	NOTE 6	NOTE 6
$\pm 16+\delta$	≥ 64		≥ 1	NOTE 6	NOTE 6	NOTE 6
$\pm 8+\delta$	≥ 132		≥ 1	NOTE 6	NOTE 6	NOTE 6

NOTE 1: This minimum lo condition is expressed as the average lo per RE over all REs in an OFDM symbol.
 NOTE 2: NR operating band groups are as defined in Section 3.5.
 NOTE 3: $T_{rep}^{PRS}, L_{PRS}, K_{comb}^{PRS}$ are configured by higher layer parameter *dl-PRS-ResourceRepetitionFactor, dl-PRS-NumSymbols and dl-PRS-CombSizeN* defined in TS 37.355 [34].
 NOTE 4: The lo is defined in PRS slots. The same lo range applies to PRS and non-PRS symbols. lo levels are different in PRS and non-PRS symbols within the same slot.
 NOTE 5: Tc is the basic timing unit defined in TS 38.211 [6].
 NOTE 6: The same bands and the same lo conditions for each band apply for this requirement as for the corresponding requirement with the PRS bandwidth of the smallest RB number for the corresponding SCS.
 NOTE 7: δ is the margin determined from Table 10.1.25.2-5.

...

...

Table 10.1.25.2-5: Margin for UE Rx-Tx time difference measurement accuracy in FR1

Min(PRS BW, SRS BW) (RB)			Margin (Tc ^{Note 1})
SCS = 15 kHz	SCS = 30 kHz	SCS = 60 kHz	
≥ 24	N/A	N/A	160
≥ 52	≥ 24	N/A	80
≥ 104	≥ 48	≥ 24	56
N/A	≥ 132	≥ 64	24
N/A	N/A	≥ 132	24

NOTE 1: Tc is the basic timing unit defined in TS 38.211 [6].
 NOTE 2: If SRS and PRS have different SCS, the margin corresponding to the smallest RS BW in MHz applies.

15.3.1.4 Test description

The test defines three possible test configurations; specified in Table 15.3.1.4-1. The UE is only required to be tested in one of the supported test configurations.

Table 15.3.1.4-1: Test Configurations

Test Configuration	Description
1	15 kHz SSB SCS, 20 MHz bandwidth, FDD duplex mode
2	15 kHz SSB SCS, 20 MHz bandwidth, TDD duplex mode

3	30 kHz SSB SCS, 50 MHz bandwidth, TDD duplex mode
Note:	The UE is only required to be tested in one of the supported test configurations.

15.3.1.4.1 Initial conditions

Test Environment: Normal, as defined in TS 38.508-1 [45] clause 4.1.

Frequencies to be tested: Mid Range, as defined in TS 38.508-1 [45] clause 4.3.1.

Channel bandwidth to be tested: are specified in Table 15.3.1.4-1.

1. Connect the SS and AWGN noise sources to the UE antenna connector or antenna connectors as shown in Annex A, Figure A.13.
2. The general test parameter settings are set up according to Table 15.3.1.5-1.
3. Propagation conditions are set according to clause 4.14.2.
4. Message contents are defined in clause 15.3.1.4.3.
5. There are two cells in the test: PCell (Cell 1) and a neighbour cell (Cell 2). All cells are on the same RF channel in FR1.

15.3.1.4.2 Test procedure

The test consists of a set-up period and a measurement period. Cell 1 and Cell 2 are both active during the complete test. The beginning of the measurement period shall be aligned with the first PRS positioning subframe of a positioning occasion in the reference cell. The NR-Multi-RTT-ProvideAssistanceData and NR-Multi-RTT-RequestLocationInformation as defined in clause 15.3.1.4.3 shall be provided to the UE during the set-up period. The last TTI containing the NR-Multi-RTT-RequestLocationInformation message shall be provided to the UE ΔT ms before the start of the measurement period, where $\Delta T = 50$ ms is the maximum processing time of the NR-Multi-RTT-RequestLocationInformation message and the Multi-RTT assistance data in the UE.

1. Ensure the UE is in State RRC_CONNECTED with generic procedure parameters Connectivity NR, Connected without release On, according to TS 38.508-1 [45] clause 4.5. Note that in the remainder of the test the timing advance command $T_A = 31$ which indicates a timing advance adjustment value $N_{TA} = 0 T_c$.
2. The SS shall send a RESET UE POSITIONING STORED INFORMATION message.
3. The SS adjusts the downlink timing for Cell 1 to a delay of $+512 T_c$, compared to the current value.
4. Wait for 1.6 s to allow for the possibility that the UE makes autonomous timing adjustments.
5. The SS shall transmit an RRCReconfiguration message with the SRS configuration.
6. The UE shall transmit RRCReconfigurationComplete message.
7. The SS shall transmit an LPP REQUEST CAPABILITIES message.
8. The UE shall transmit an LPP PROVIDE CAPABILITIES message indicating the Multi-RTT capabilities supported by the UE in the NR-Multi-RTT-ProvideCapabilities IE.
9. The SS shall send a LPP PROVIDE ASSISTANCE DATA message, including the NR-Multi-RTT-ProvideAssistanceData IE. If the UE message at step 8 includes the ackRequested IE set to TRUE, then the SS shall send an acknowledgment in the LPP PROVIDE ASSISTANCE DATA message.
10. The SS shall send a LPP REQUEST LOCATION INFORMATION message, including the NR-Multi-RTT-RequestLocationInformation IE such that the UE receives the message ΔT ms before the start of T2, where $\Delta T = 50$ ms.
11. The UE shall transmit a LPP PROVIDE LOCATION INFORMATION message including the NR-Multi-RTT-ProvideLocationInformation IE.

- 12. As soon as possible after step 11 the SS shall measure the transmit timing of the UE using the transmitted SRS, relative to the current downlink timing.
- 13. If the UE message at step 11 includes the *ackRequested* IE set to TRUE, the SS shall send a LPP acknowledgement message.
- 14. The SS shall check the reported value of *nr-UE-RxTxTimeDiff* in the *NR-Multi-RTT-SignalMeasurementInformation* IE provided by the UE in step 11 and compare it with the value measured in step 12. The SS shall check that the reported value is within the limits specified in table 15.3.1.5-2 compared to the measured value. If the reported value is within the limits the number of successful results is increased by one. If the reported value is not within the limits or the UE reports an error in the LPP PROVIDE LOCATION INFORMATION message in step 11, or does not respond at step 11 within the time given by the *time* IE in the *CommonIEsRequestLocationInformation* IE in step 10, then the number of unsuccessful results for is increased by one.
- 15. Repeat steps 1-14 until the confidence level according to Annex D is achieved.
- 16. Repeat step 1-15 for the other sub-test defined in Table 15.3.1.4-1 as appropriate.

If all (applicable) sub-tests pass, the whole test passes. If one (applicable) sub-test fails, the whole test fails.

NOTE: To avoid a large divergence between the sent TA and the set downlink timing, the SS may reset the downlink timing for Cell 1 to its initial value after a certain amount of loops. The loop during the reset does not count for the result statistics.

15.3.1.4.3 Message contents

Table 15.3.1.4.3-1: RESET UE POSITIONING STORED INFORMATION

Derivation Path: 38.509 [44] clause 6.6			
Information Element	Value/remark	Comment	Condition
UE Positioning Technology	0 0 0 0 1 1 0	Multi-RTT	

Table 15.3.1.4.3-2: RRCReconfiguration

Derivation Path: TS 38.508-1 [45], table 4.6.1-13			
Information Element	Value/remark	Comment	Condition
RRCReconfiguration ::= SEQUENCE {			
criticalExtensions CHOICE {			
rrcReconfiguration SEQUENCE {			
radioBearerConfig			
nonCriticalExtension SEQUENCE {			
masterCellGroup SEQUENCE {	CellGroupConfig		
spCellConfig SEQUENCE {			
spCellConfigDedicated SEQUENCE {			
uplinkConfig SEQUENCE {			
initialUplinkBWP SEQUENCE {			
srs-Config CHOICE {			
setup	As defined in Table 15.3.1.4.3-3		
}			
}			
}			
}			
}			
}			
}			
}			
}			
}			
}			

Table 15.3.1.4.3-3: SRS-Config (Table 15.3.1.4.3-2)

Derivation Path: TS 38.508-1 [45], Table 4.6.3-182			
Information Element	Value/remark	Comment	Condition
SRS-Config ::= SEQUENCE {			
srs-ResourceSetToReleaseList	Not present		
srs-ResourceSetToAddModList	Not present		
srs-ResourceToReleaseList	Not present		
srs-ResourceToAddModList	Not present		
tpc-Accumulation	Not present		
srs-RequestDCI-1-2-r16	Not present		
srs-RequestDCI-0-2-r16	Not present		
srs-ResourceSetToAddModListDCI-0-2-r16	Not present		
srs-ResourceSetToReleaseListDCI-0-2-r16	Not present		
srs-PosResourceSetToReleaseList-r16	Not present		
srs-PosResourceSetToAddModList-r16 SEQUENCE (SIZE(1..maxNrofSRS-PosResourceSets-r16)) OF SRS-PosResourceSet-r16 {	1 entry		
SRS-PosResourceSet-r16[1] SEQUENCE {		entry 1	
srs-PosResourceSetId-r16	0		
srs-PosResourceCidList-r16 SEQUENCE (SIZE(1..maxNrofSRS-ResourcesPerSet)) OF SRS-PosResourceCid-r16 {	1 entry		
SRS-PosResourceCid-r16	0	1 entry	
}			
resourceType CHOICE {			
periodic SEQUENCE {			
}			
}			
alpha-r16	alpha0		
p0-r16	0		
pathlossReferenceRS-Pos-r16	Not present		
}			
srs-PosResourceToReleaseList-r16	Not present		
srs-PosResourceToAddModList-r16 SEQUENCE (SIZE(1..maxNrofSRS-PosResources-r16)) OF SRS-PosResource-r16 {	1 entry		
SRS-PosResource-r16[1] SEQUENCE {		entry 1	
srs-PosResourceCid-r16	0		
transmissionComb-r16 CHOICE {			
n4-r16 SEQUENCE {			
combOffset-n4-r16	0		
cyclicShift-n4-r16	0		
}			
}			
resourceMapping-r16 SEQUENCE {			
startPosition-r16	0		
nrofSymbols-r16	n4		
}			
freqDomainShift-r16	0		
freqHopping-r16 SEQUENCE {			
c-SRS-r16	Matches N _{RB,c} Table 15.3.1.5-1		
}			
groupOrSequenceHopping-r16	neither		
resourceType-r16 CHOICE {			
periodic-r16 SEQUENCE {			
periodicityAndOffset-p-r16 CHOICE {			
sl160	20		Sub-test 1-1, Sub-test 1-2, Sub test 2-1 and Sub-test 2-2
sl320	40		Sub-test 3-1 and Sub-test 3-2

}			
}			
}			
sequenceId-r16	0		
spatialRelationInfoPos-r16	Not present		
}			
}			
}			

Table 15.3.1.4.3-4: LPP Request Capabilities

Information Element	Value/remark
nr-Multi-RTT-RequestCapabilities-r16	TRUE

Table 15.3.1.4.3-5: LPP RequestLocationInformation

Derivation Path: 37.355 clause 6.2			
Information Element	Value/remark	Comment	Condition
LPP-Message ::= SEQUENCE {			
transactionID SEQUENCE {			
initiator	locationServer		
transactionNumber	1		
}			
endTransaction	FALSE		
sequenceNumber	Not present		
acknowledgement	Not present		
lpp-MessageBody CHOICE {			
c1 CHOICE {			
requestLocationInformation SEQUENCE {			
criticalExtensions CHOICE {			
c1 CHOICE {			
requestLocationInformation-r9 SEQUENCE {			
commonIEsRequestLocationInformation SEQUENCE {			
locationInformationType	locationMeasurementsRequired		
triggeredReporting	Not present		
periodicalReporting	Not present		
additionalInformation	onlyReturnInformationRequested		
qos SEQUENCE {			
horizontalAccuracy	Not present		
verticalCoordinateRequest	FALSE		
verticalAccuracy	Not present		
responseTime SEQUENCE {			
time	11		
responseTimeEarlyFix-r12	Not present		Rel-12 onwards
}			
velocityRequest	FALSE		
}			
environment	Not present		
locationCoordinateTypes	Not present		
velocityTypes	Not present		
}			
a-gnss-RequestLocationInformation	Not present		
otdoa-RequestLocationInformation	Not present		
ecid-RequestLocationInformation	Not present		
epdu-RequestLocationInformation	Not present		
sensor-RequestLocationInformation-r13	Not present		
tbs-RequestLocationInformation-r13	Not present		
wlan-RequestLocationInformation-r13	Not present		
bt-RequestLocationInformation-r13	Not present		

nr-ECID-RequestLocationInformation-r16	Not present		
nr-Multi-RTT-RequestLocationInformation-r16			
SEQUENCE {			
nr-UE-	Not present		
RxTxTimeDiffMeasurementInfoRequest-r16			
nr-RequestedMeasurements-r16	bit 0 = 1 (prsrspReq)		
nr-AssistanceAvailability-r16	FALSE		
nr-Multi-RTT-ReportConfig-r16 SEQUENCE {			
maxDL-PRS-RxTxTimeDiffMeasPerTRP-r16	Not present		
timingReportingGranularityFactor-r16	Not present		
}			
additionalPaths-r16	Not present		
}			
nr-DL-AoD-RequestLocationInformation-r16	Not present		
nr-DL-TDOA-RequestLocationInformation-r16	Not present		
}			
}			
}			
}			
}			
}			

Table 15.3.1.4.3-6: LPP ProvideAssistanceData

Derivation Path: 37.355 clause 6.2			
Information Element	Value/remark	Comment	Condition
LPP-Message ::= SEQUENCE {			
transactionID SEQUENCE {			
initiator	locationServer		
transactionNumber	(0..255)		
}			
endTransaction	TRUE		
sequenceNumber	Not present		
acknowledgement	Not present		
lpp-MessageBody CHOICE {			
c1 CHOICE {			
provideAssistanceData SEQUENCE {			
criticalExtensions CHOICE {			
c1 CHOICE {			
provideAssistanceData-r9 SEQUENCE {			
commonEsProvideAssistanceData	Not present		
a-gnss-ProvideAssistanceData	Not present		
otdoa-ProvideAssistanceData	Not present		
epdu-Provide-AssistanceData	Not present		
sensor-ProvideAssistanceData-r15	Not present		
tbs-ProvideAssistanceData-r15	Not present		
wlan-ProvideAssistanceData-r15	Not present		
nr-Multi-RTT-ProvideAssistanceData-r16			
SEQUENCE {			
nr-DL-PRS-AssistanceData	As defined in Table 15.3.1.4.3-7		
nr-SelectedDL-PRS-IndexList-r16	Not present		
nr-Multi-RTT-Error-r16	Not present		
}			
nr-DL-AoD-ProvideAssistanceData-r16	Not present		
nr-DL-TDOA-ProvideAssistanceData-r16	Not present		
}			
}			
}			
}			
}			

Table 15.3.1.4.3-7: NR-DL-PRS-AssistanceData

Derivation Path: 37.355 clause 6.4.3			
Information Element	Value/remark	Comment	Condition
NR-DL-PRS-AssistanceData-r16 ::= SEQUENCE {			
nr-DL-PRS-ReferenceInfo-r16 SEQUENCE {			
dl-PRS-ID-r16	0		
nr-DL-PRS-ResourceID-List-r16	Not present		
nr-DL-PRS-ResourceSetID-r16	Not present		
}			
nr-DL-PRS-AssistanceDataList-r16 SEQUENCE (SIZE (1..nrMaxFreqLayers-r16)) OF NR-DL-PRS-AssistanceDataPerFreq-r16 {	1 entry		
NR-DL-PRS-AssistanceDataPerFreq-r16[1] SEQUENCE {		entry 1	
nr-DL-PRS-PositioningFrequencyLayer-r16 SEQUENCE {			
dl-PRS-SubcarrierSpacing-r16	kHz15		Sub-test 1-1, Sub-test 1-2, Sub-test 2-1 and Sub-test 2-2
	kHz30		Sub-test 3-1 and Sub-test 3-2
dl-PRS-ResourceBandwidth-r16	1	24 PRBs	Sub-test 1-1,, Sub test 2-1 and Sub-test 3-1
	21	104 PRBs	Sub-test 1-2 and Sub-test 2-2
	28	132 PRBs	Sub-test 3-2
dl-PRS-StartPRB-r16	0		
dl-PRS-PointA-r16	absoluteFrequencyPointA as defined for the DL frequency of the Cell 1		
dl-PRS-CombSizeN-r16	n2		Sub-test 1-1, Sub-test 2-1 and Sub-test 3-1
	n4		Sub-test 1-2, Sub-test 2-2 and Sub-test 3-2
dl-PRS-CyclicPrefix-r16	normal		
}			
nr-DL-PRS-AssistanceDataPerFreq-r16 SEQUENCE (SIZE (1..nrMaxTRPsPerFreq-r16)) OF NR-DL-PRS-AssistanceDataPerTRP-r16{	2 entries		
NR-DL-PRS-AssistanceDataPerTRP-r16[1] SEQUENCE {		entry 1	Cell 1
dl-PRS-ID-r16	0		
nr-PhysCellID-r16	Cell 1		
nr-CellGlobalID-r16	Cell 1		
nr-ARFCN-r16	Cell 1		
nr-DL-PRS-SFN0-Offset-r16 SEQUENCE {			
sfn-Offset-r16	0		
integerSubframeOffset-r16	0		
}			
nr-DL-PRS-ExpectedRSTD-r16	0		
nr-DL-PRS-ExpectedRSTD-Uncertainty-r16	0		

nr-DL-PRS-Info-r16	As specified in Table 15.3.1.4.3-8		
}			
NR-DL-PRS-AssistanceDataPerTRP-r16[2] SEQUENCE {		entry 2	Cell 2
dl-PRS-ID-r16	1		
nr-PhysCellID-r16	Cell 2		
nr-CellGlobalID-r16	Cell 2		
nr-ARFCN-r16	Cell 2		
nr-DL-PRS-SFN0-Offset-r16 SEQUENCE {			
sfn-Offset-r16	0		
integerSubframeOffset-r16	0		
}			
nr-DL-PRS-ExpectedRSTD-r16	23	About 3 μs	
nr-DL-PRS-ExpectedRSTD-Uncertainty-r16	39	About 5 μs	
nr-DL-PRS-Info-r16	As specified in Table 15.3.1.4.3-8		
}			
}			
}			
}			
}			

Table 15.3.1.4.3-8: NR-DL-PRS-Info

Derivation Path: 37.355 clause 6.4.3			
Information Element	Value/remark	Comment	Condition
NR-DL-PRS-Info-r16 ::= SEQUENCE {			
nr-DL-PRS-ResourceSetList-r16 SEQUENCE (SIZE (1..nrMaxSetsPerTrp-r16)) OF NR-DL-PRS-ResourceSet-r16 {	1 entry		
NR-DL-PRS-ResourceSet-r16[1] SEQUENCE {		entry 1	
nr-DL-PRS-ResourceSetID-r16	0		
dl-PRS-Periodicity-and-ResourceSetSlotOffset-r16 CHOICE {			
scs15-r16 CHOICE {			Sub-tests 1-1, Sub-test 1-2, Sub-test 2-1 and Sub-test 2-2
n160-r16	10		
}			
scs30-r16 CHOICE {			Sub-tests 3-1 and Sub-test 3-2
n320-r16-r16	20		
}			
dl-PRS-ResourceRepetitionFactor-r16	Not present		Sub-tests 1-2, Sub-test 2-2 and Sub-test 3-2
	n2		Sub-tests 1-1, Sub-test 2-1 and Sub-test 3-1
dl-PRS-ResourceTimeGap-r16	s1		
dl-PRS-NumSymbols-r16	n4		
dl-PRS-MutingOption1-r16	Not present		
dl-PRS-MutingOption2-r16	Not present		
dl-PRS-ResourcePower-r16	27		

dl-PRS-ResourceList-r16 SEQUENCE (SIZE (1..nrMaxResourcesPerSet-r16)) OF NR-DL-PRS-Resource-r16 {	1 entry		
NR-DL-PRS-Resource-r16[1] SEQUENCE {		entry 1	
nr-DL-PRS-ResourceID-r16	0		
dl-PRS-SequenceID-r16	0		
dl-PRS-CombSizeN-AndReOffset-r16 CHOICE {			
n2-r16	0		Sub-tests 1-1, Sub-test 2-1 and Sub-test 3-1
n4-r16	0		Sub-tests 1-2, Sub-test 2-2 and Sub-test 3-2
}			
dl-PRS-ResourceSlotOffset-r16	0		Sub-test 1-1 Cell 1, Sub-test 1-2 Cell 1, Sub-test 2-1 Cell 1, Sub-test 2-2 Cell 1, Sub-test 3-1 Cell 1, and Sub-test 3-2 Cell 1
	4		Sub-test 1-1 Cell 2, Sub-test 1-2 Cell 2, Sub-test 2-1 Cell 2, Sub-test 2-2 Cell 2, Sub-test 3-1 Cell 2, and Sub-test 3-2 Cell 2.
dl-PRS-ResourceSymbolOffset-r16	0		
dl-PRS-QCL-Info-r16	Not present		
}			
}			
}			
}			
}			

Table 15.3.1.4.3-9: LPP ProvideLocation Information

Derivation Path: 37.355 clause 6.5.12			
Information Element	Value/remark	Comment	Condition
LPP-Message ::= SEQUENCE {			
transactionID SEQUENCE {			
initiator	locationServer		
transactionNumber	1		
}			
endTransaction	TRUE		
sequenceNumber	(0..255)		
acknowledgement			
lpp-MessageBody CHOICE {			
c1 CHOICE {			
provideLocationInformation SEQUENCE {			

criticalExtensions CHOICE {			
c1 CHOICE {			
provideLocationInformation-r9 SEQUENCE {			
commonIEsProvideLocationInformation	Not present.		
a-gnss-ProvideLocationInformation	Not present		
otdoa-ProvideLocationInformation	Not present		
ecid-ProvideLocationInformation	Not present		
epdu-ProvideLocationInformation	Not present		
sensor-ProvideLocationInformation-r13	Not present		
tbs-ProvideLocationInformation-r13	Not present		
wlan-ProvideLocationInformation-r13	Not present		
bt-ProvideLocationInformation-r13	Not present		
nr-ECID-ProvideLocationInformation-r16	Not present		
nr-Multi-RTT-ProvideLocationInformation-r16 SEQUENCE {			
nr-Multi-RTT-SignalMeasurementInformation-r16 SEQUENCE {			
nr-Multi-RTT-MeasList-r16 SEQUENCE (SIZE(1..nrMaxTRPs-r16)) OF NR-Multi-RTT-MeasElement-r16 {	2 entries		
NR-Multi-RTT-MeasElement-r16[1] SEQUENCE {		entry 1	
dl-PRS-ID-r16	INTEGER (0..255)		
nr-PhysCellID-r16			
nr-CellGlobalID-r16			
nr-ARFCN-r16			
nr-DL-PRS-ResourceID-r16			
nr-DL-PRS-ResourceSetID-r16			
nr-UE-RxTxTimeDiff-r16	Present. Set according to specific test configuration.		
nr-AdditionalPathList-r16			
nr-TimeStamp-r16			
nr-TimingQuality-r16			
nr-DL-PRS-RSRP-Result-r16			
nr-Multi-RTT-AdditionalMeasurements-r16			
}			
NR-Multi-RTT-MeasElement-r16[2] SEQUENCE {		entry 2	
dl-PRS-ID-r16	INTEGER (0..255)		
nr-PhysCellID-r16			
nr-CellGlobalID-r16			
nr-ARFCN-r16			
nr-DL-PRS-ResourceID-r16			
nr-DL-PRS-ResourceSetID-r16			
nr-UE-RxTxTimeDiff-r16	Present. Set according to specific test configuration.		
nr-AdditionalPathList-r16			
nr-TimeStamp-r16			
nr-TimingQuality-r16			
nr-DL-PRS-RSRP-Result-r16			
nr-Multi-RTT-AdditionalMeasurements-r16			
}			
}			
nr-NTA-Offset-r16			
}			
nr-Multi-RTT-Error-r16			
}			
nr-DL-AoD-ProvideLocationInformation-r16	Not present		
}			
}			

}			
}			
}			
}			

15.3.1.5 Test requirement

Table 15.3.1.5-1 defines the primary level settings including the test tolerances for the test.

Table 15.3.1.5-1: UE Rx-Tx time difference measurement accuracy test parameters

Parameter	Unit	Test configuration	Test 1		Test 2							
			Cell 1	Cell 2	Cell 1	Cell 2						
RF Channel Number		1,2,3	1	1	1	1						
Measurement gap		1,2,3	GP#24 or GP#0 ^{Note 4}		GP#24 or GP#0 ^{Note 4}							
DRX		1,2,3	OFF		OFF							
Time offset with Cell 1	μs	1, 2, 3	N/A	3	N/A	3						
TDD configuration		1	N/A	N/A	N/A	N/A						
		2	TDDConf.1.1	TDDConf.1.1	TDDConf.1.1	TDDConf.1.1						
		3	TDDConf.2.1	TDDConf.2.1	TDDConf.2.1	TDDConf.2.1						
PDSCH RMC configuration		1	SR.1.1 FDD	N/A	SR.1.1 FDD	N/A						
		2	SR.1.1 TDD		SR.1.1 TDD							
		3	SR.2.1 TDD		SR.2.1 TDD							
RMSI CORESET RMC configuration		1	CR.1.1 FDD	N/A	CR.1.1 FDD	N/A						
		2	CR.1.1 TDD		CR.1.1 TDD							
		3	CR.2.1 TDD		CR.2.1 TDD							
Dedicated CORESET RMC configuration		1	CCR.1.1 FDD	N/A	CCR.1.1 FDD	N/A						
		2	CCR.1.1 TDD		CCR.1.1 TDD							
		3	CCR.2.1 TDD		CCR.2.1 TDD							
EPRE ratio of PSS to SSS	dB	1, 2, 3	0	0	0	0						
EPRE ratio of PBCH DMRS to SSS												
EPRE ratio of PBCH to PBCH DMRS												
EPRE ratio of PDCCH DMRS to SSS												
EPRE ratio of PDCCH to PDCCH DMRS												
EPRE ratio of PDSCH DMRS to SSS												
EPRE ratio of PDSCH to PDSCH DMRS												
EPRE ratio of OCNG DMRS to SSS ^{Note 1}												
EPRE ratio of OCNG to OCNG DMRS ^{Note 1}												
EPRE ratio of PRS to SSS												
OCNG Patterns								1, 2, 3	OP.1	OP.1	OP.1	OP.1
TRS Configuration								1	TRS.1.1 FDD	N/A	TRS.1.1 FDD	N/A
		2	TRS.1.1 TDD	TRS.1.1 TDD								
		3	TRS.1.2 TDD	TRS.1.2 TDD								

Initial BWP configuration		1, 2, 3	DLBWP.0.1 ULBWP.0.1	N/A	DLBWP.0.1 ULBWP.0.1	N/A
Active DL BWP configuration		1, 2, 3	DLBWP.1.1	N/A	DLBWP.1.1	N/A
Active UL BWP configuration		1, 2, 3	ULBWP.1.1	N/A	ULBWP.1.1	N/A
PRS configuration		1	PRS.1.1 FR1	PRS.1.1 FR1	PRS.1.2 FR1	PRS.1.2 FR1
		2	PRS.1.1 FR1	PRS.1.1 FR1	PRS.1.2 FR1	PRS.1.2 FR1
		3	PRS.2.1 FR1	PRS.2.1 FR1	PRS.2.2 FR1	PRS.2.2 FR1
PRS Resource slot offset	slot	1, 2, 3	0	4	0	4
SRS configuration		1	POS-SRS.1	N/A	POS-SRS.1	N/A
		2	POS-SRS.1	N/A	POS-SRS.1	N/A
		3	POS-SRS.2	N/A	POS-SRS.2	N/A
N_{oc} Note 2	dBm/SCS	1	-98		-98	
		2	-98		-98	
		3	-95		-95	
N_{oc} Note 2	dBm/15 kHz	1	-98		-98	
		2				
		3				
PRS \hat{E}_s/I_{ot}	dB	1	-2.31	-16.12	-2.31	-12.6
		2				
		3				
PRS \hat{E}_s/N_{oc}	dB	1	-1.9	-10	-1.9	-10
		2				
		3				
PRP Note 3	dBm/SCS kHz	1	-100	-108	-100	-108
		2	-100	-108	-100	-108
		3	-97	-105	-97	-105
l_o	dBm/9.36 MHz	1	-64.54	-64.54	-64.54	-64.54
		2	-64.54	-64.54	-64.54	-64.54
		3	-60.55	-60.55	-60.55	-60.55
Propagation Condition		1, 2, 3	AWGN		AWGN	
<p>Note 1: Void.</p> <p>Note 2: Interference from other cells and noise sources not specified in the test is assumed to be constant over subcarriers and time and shall be modelled as AWGN of appropriate power for N_{oc} to be fulfilled.</p> <p>Note 3: PP levels have been derived from other parameters for information purposes. They are not settable parameters themselves.</p> <p>Note 4: GP#24 is configured if UE supports MG#24, otherwise GP#0 is configured.</p>						

Table 15.3.1.5-2: UE Rx – Tx time difference measurement accuracy requirements

Test Configuration	Subtest	Lowest reported value	Highest reported value
1	Sub-test 1	(Measured value from step 12 - 270) T_c converted to UE Rx-Tx time difference measurement according to clause 4.14.6	(Measured value from step 12 + 270) T_c converted to UE Rx-Tx time difference measurement according to clause 4.14.6
	Sub-test 2	(Measured value from step 12 - 118) T_c converted to UE Rx-Tx time difference measurement according to clause 4.14.6	(Measured value from step 12 + 118) T_c converted to UE Rx-Tx time difference measurement according to clause 4.14.6
2	Sub-test 1	(Measured value from step 12 - 270) T_c converted to UE Rx-Tx time difference measurement according to clause 4.14.6	(Measured value from step 12 + 270) T_c converted to UE Rx-Tx time difference measurement according to clause 4.14.6
	Sub-test 2	(Measured value from step 12 - 118) T_c converted to UE Rx-Tx time difference measurement according to clause 4.14.6	(Measured value from step 12 + 118) T_c converted to UE Rx-Tx time difference measurement according to clause 4.14.6
3	Sub-test 1	(Measured value from step 12 - 169) T_c converted to UE Rx-Tx time difference measurement according to clause 4.14.6	(Measured value from step 12 + 169) T_c converted to UE Rx-Tx time difference measurement according to clause 4.14.6

	Sub-test 2	(Measured value from step 12 - 71) T_c converted to UE Rx-Tx time difference measurement according to clause 4.14.6	(Measured value from step 12 + 71) T_c converted to UE Rx-Tx time difference measurement according to clause 4.14.6
--	------------	---	---

For the overall test to pass, the ratio of successful reported values in each sub-test shall be more than 90% with a confidence level of 95%.

The UE Rx-Tx time difference measurement period fulfils the requirements specified in clause 15.3.1.3.

The test tolerances are defined in clauses C.1.6 and C.2.5.

15.3.2 UE Rx-Tx time difference measurement accuracy for single positioning frequency layer in FR2 SA

15.3.2.1 Test purpose

The purpose of the test is to verify that the UE Rx-Tx time difference measurement accuracy is within the specified limits. This test will verify the requirements in TS 38.133 [50] clause 10.1.25.2. The test is conducted in AWGN propagation condition in FR2 in standalone scenario when single positioning frequency layer is configured.

15.3.2.2 Test applicability

This test applies to all types of NR UE release 16 onwards that supports Multi-RTT positioning.

15.3.2.3 Minimum conformance requirements

Same as in clause 15.3.1.3.

15.3.2.4 Test description

The supported test configurations are listed in Table 15.3.2.4-1.

Table 15.3.2.4-1: Test Configurations

Test Configuration	Description
1	120 kHz SSB and PRS SCS, 100 MHz bandwidth, TDD duplex mode

15.3.2.4.1 Initial conditions

Test Environment: Normal, as defined in TS 38.508-1 [45] clause 4.1.

Frequencies to be tested: Mid Range, as defined in TS 38.508-1 [45] clause 4.3.1.

Channel bandwidth to be tested: are specified in Table 15.3.2.4-1.

1. Connect the SS and AWGN noise sources to the UE antenna connector or antenna connectors as shown in Annex A, Figure A.14.
2. The general test parameter settings are set up according to Table 15.3.2.5-1.
3. Propagation conditions are set according to clause 4.14.2.
4. Message contents are defined in clause 15.3.2.4.3.
5. There are two cells in the test: PCell (Cell 1) and a neighbour cell (Cell 2). All cells are on the same RF channel in FR2.

15.3.2.4.2 Test procedure

Same as in clause 15.3.1.4.2.

15.3.2.4.3 Message contents

Table 15.3.2.4.3-1: RESET UE POSITIONING STORED INFORMATION

Derivation Path: 38.509 [44] clause 6.6			
Information Element	Value/remark	Comment	Condition
UE Positioning Technology	0 0 0 0 1 1 0	Multi-RTT	

Table 15.3.2.4.3-2: RRCReconfiguration

Derivation Path: TS 38.508-1 [45], table 4.6.1-13			
Information Element	Value/remark	Comment	Condition
RRCReconfiguration ::= SEQUENCE {			
criticalExtensions CHOICE {			
rrcReconfiguration SEQUENCE {			
radioBearerConfig			
nonCriticalExtension SEQUENCE {			
masterCellGroup SEQUENCE {	CellGroupConfig		
spCellConfig SEQUENCE {			
spCellConfigDedicated SEQUENCE {			
uplinkConfig SEQUENCE {			
initialUplinkBWP SEQUENCE {			
srs-Config CHOICE {			
setup	As defined in Table 15.3.2.4.3-3		
}			
}			
}			
}			
}			
}			

Table 15.3.2.4.3-3: SRS-Config (Table 15.3.2.4.3-2)

Derivation Path: TS 38.508-1 [45], Table 4.6.3-182			
Information Element	Value/remark	Comment	Condition
SRS-Config ::= SEQUENCE {			
srs-ResourceSetToReleaseList	Not present		
srs-ResourceSetToAddModList	Not present		
srs-ResourceToReleaseList	Not present		
srs-ResourceToAddModList	Not present		
tpc-Accumulation	Not present		
srs-RequestDCI-1-2-r16	Not present		
srs-RequestDCI-0-2-r16	Not present		
srs-ResourceSetToAddModListDCI-0-2-r16	Not present		
srs-ResourceSetToReleaseListDCI-0-2-r16	Not present		
srs-PosResourceSetToReleaseList-r16	Not present		
srs-PosResourceSetToAddModList-r16 SEQUENCE (SIZE(1..maxNrofSRS-PosResourceSets-r16)) OF SRS-PosResourceSet-r16 {	1 entry		
SRS-PosResourceSet-r16[1] SEQUENCE {		entry 1	
srs-PosResourceSetId-r16	0		
srs-PosResourceCidList-r16 SEQUENCE (SIZE(1..maxNrofSRS-ResourcesPerSet)) OF SRS-PosResourceCid-r16 {	1 entry		
SRS-PosResourceCid-r16	0	1 entry	
}			
resourceType CHOICE {			
periodic SEQUENCE {			

}			
}			
alpha-r16	alpha0		
p0-r16	0		
pathlossReferenceRS-Pos-r16	Not present		
}			
srs-PosResourceToReleaseList-r16	Not present		
srs-PosResourceToAddModList-r16 SEQUENCE (SIZE(1..maxNrofSRS-PosResources-r16)) OF SRS-PosResource-r16 {	1 entry		
SRS-PosResource-r16[1] SEQUENCE {		entry 1	
srs-PosResourceId-r16	0		
transmissionComb-r16 CHOICE {			
n4-r16 SEQUENCE {			
combOffset-n4-r16	0		
cyclicShift-n4-r16	0		
}			
}			
resourceMapping-r16 SEQUENCE {			
startPosition-r16	0		
nrofSymbols-r16	n4		
}			
freqDomainShift-r16	0		
freqHopping-r16 SEQUENCE {			
c-SRS-r16	Matches $N_{RB,c}$ Table 15.3.2.5-1		
}			
groupOrSequenceHopping-r16	neither		
resourceType-r16 CHOICE {			
periodic-r16 SEQUENCE {			
periodicityAndOffset-p-r16 CHOICE {			
sl1280	160		
}			
}			
}			
sequenceId-r16	0		
spatialRelationInfoPos-r16	Not present		
}			
}			
}			

Table 15.3.2.4.3-4: LPP Request Capabilities

Information Element	Value/remark
nr-Multi-RTT-RequestCapabilities-r16	TRUE

Table 15.3.2.4.3-5: LPP RequestLocationInformation

Derivation Path: 37.355 clause 6.2			
Information Element	Value/remark	Comment	Condition
LPP-Message ::= SEQUENCE {			
transactionID SEQUENCE {			
initiator	locationServer		
transactionNumber	1		
}			
endTransaction	FALSE		
sequenceNumber	Not present		
acknowledgement	Not present		
lpp-MessageBody CHOICE {			
c1 CHOICE {			
requestLocationInformation SEQUENCE {			
criticalExtensions CHOICE {			
c1 CHOICE {			

requestLocationInformation-r9 SEQUENCE {			
commonIEsRequestLocationInformation SEQUENCE {			
locationInformationType	locationMeasurementsRequird		
triggeredReporting	Not present		
periodicalReporting	Not present		
additionalInformation	onlyReturnInformationRequested		
qos SEQUENCE {			
horizontalAccuracy	Not present		
verticalCoordinateRequest	FALSE		
verticalAccuracy	Not present		
responseTime SEQUENCE {			
time	42		
responseTimeEarlyFix-r12	Not present		Rel-12 onwards
}			
velocityRequest	FALSE		
}			
environment	Not present		
locationCoordinateTypes	Not present		
velocityTypes	Not present		
}			
a-gnss-RequestLocationInformation	Not present		
otdoa-RequestLocationInformation	Not present		
ecid-RequestLocationInformation	Not present		
epdu-RequestLocationInformation	Not present		
sensor-RequestLocationInformation-r13	Not present		
tbs-RequestLocationInformation-r13	Not present		
wlan-RequestLocationInformation-r13	Not present		
bt-RequestLocationInformation-r13	Not present		
nr-ECID-RequestLocationInformation-r16	Not present		
nr-Multi-RTT-RequestLocationInformation-r16 SEQUENCE {			
nr-UE-RxTxTimeDiffMeasurementInfoRequest-r16	Not present		
nr-RequestedMeasurements-r16	bit 0 = 1 (prsrsrpReq)		
nr-AssistanceAvailability-r16	FALSE		
nr-Multi-RTT-ReportConfig-r16 SEQUENCE {			
maxDL-PRS-RxTxTimeDiffMeasPerTRP-r16	Not present		
timingReportingGranularityFactor-r16	Not present		
}			
additionalPaths-r16	Not present		
}			
nr-DL-AoD-RequestLocationInformation-r16	Not present		
nr-DL-TDOA-RequestLocationInformation-r16	Not present		
}			
}			
}			
}			
}			
}			
}			
}			
}			

Table 15.3.2.4.3-6: LPP ProvideAssistanceData

Derivation Path: 37.355 clause 6.2			
Information Element	Value/remark	Comment	Condition
LPP-Message ::= SEQUENCE {			
transactionID SEQUENCE {			
initiator	locationServer		
transactionNumber	(0..255)		
}			
endTransaction	TRUE		

sequenceNumber	Not present		
acknowledgement	Not present		
lpp-MessageBody CHOICE {			
c1 CHOICE {			
provideAssistanceData SEQUENCE {			
criticalExtensions CHOICE {			
c1 CHOICE {			
provideAssistanceData-r9 SEQUENCE {			
commonEsProvideAssistanceData	Not present		
a-gnss-ProvideAssistanceData	Not present		
otdoa-ProvideAssistanceData	Not present		
epdu-Provide-AssistanceData	Not present		
sensor-ProvideAssistanceData-r15	Not present		
tbs-ProvideAssistanceData-r15	Not present		
wlan-ProvideAssistanceData-r15	Not present		
nr-Multi-RTT-ProvideAssistanceData-r16			
SEQUENCE {			
nr-DL-PRS-AssistanceData	As defined in Table 15.3.2.4.3-7		
nr-SelectedDL-PRS-IndexList-r16	Not present		
nr-Multi-RTT-Error-r16	Not present		
}			
nr-DL-AoD-ProvideAssistanceData-r16	Not present		
nr-DL-TDOA-ProvideAssistanceData-r16	Not present		
}			
}			
}			
}			

Table 15.3.2.4.3-7: NR-DL-PRS-AssistanceData

Derivation Path: 37.355 clause 6.4.3			
Information Element	Value/remark	Comment	Condition
NR-DL-PRS-AssistanceData-r16 ::= SEQUENCE {			
nr-DL-PRS-ReferenceInfo-r16 SEQUENCE {			
dl-PRS-ID-r16	0		
nr-DL-PRS-ResourceID-List-r16	Not present		
nr-DL-PRS-ResourceSetID-r16	Not present		
}			
nr-DL-PRS-AssistanceDataList-r16 SEQUENCE (SIZE (1..nrMaxFreqLayers-r16)) OF NR-DL-PRS-AssistanceDataPerFreq-r16 {	1 entry		
NR-DL-PRS-AssistanceDataPerFreq-r16[1] SEQUENCE {		entry 1	
nr-DL-PRS-PositioningFrequencyLayer-r16 SEQUENCE {			
dl-PRS-SubcarrierSpacing-r16	kHz120		
dl-PRS-ResourceBandwidth-r16	3	32 PRBs	Sub-test 1
	27	128 PRBs	Sub-test 2
dl-PRS-StartPRB-r16	0		
dl-PRS-PointA-r16	absoluteFrequencyPointA as defined for the DL frequency of the Cell 1		
dl-PRS-CombSizeN-r16	n2		
dl-PRS-CyclicPrefix-r16	normal		
}			
nr-DL-PRS-AssistanceDataPerFreq-r16 SEQUENCE (SIZE (1..nrMaxTRPsPerFreq-r16)) OF NR-DL-PRS-AssistanceDataPerTRP-r16{	2 entries		
NR-DL-PRS-AssistanceDataPerTRP-r16[1] SEQUENCE {		entry 1	Cell 1
dl-PRS-ID-r16	0		
nr-PhysCellID-r16	Cell 1		

nr-CellGlobalID-r16	Cell 1		
nr-ARFCN-r16	Cell 1		
nr-DL-PRS-SFN0-Offset-r16 SEQUENCE {			
sfn-Offset-r16	0		
integerSubframeOffset-r16	0		
}			
nr-DL-PRS-ExpectedRSTD-r16	0		
nr-DL-PRS-ExpectedRSTD-Uncertainty-r16	0		
nr-DL-PRS-Info-r16	As specified in Table 15.3.2.4.3-8		
}			
NR-DL-PRS-AssistanceDataPerTRP-r16[2] SEQUENCE {		entry 2	Cell 2
dl-PRS-ID-r16	1		
nr-PhysCellID-r16	Cell 2		
nr-CellGlobalID-r16	Cell 2		
nr-ARFCN-r16	Cell 2		
nr-DL-PRS-SFN0-Offset-r16 SEQUENCE {			
sfn-Offset-r16	0		
integerSubframeOffset-r16	0		
}			
nr-DL-PRS-ExpectedRSTD-r16	23	About 3 μs	
nr-DL-PRS-ExpectedRSTD-Uncertainty-r16	154	About 5 μs	
nr-DL-PRS-Info-r16	As specified in Table 15.3.2.4.3-8		
}			
}			
}			
}			
}			

Table 15.3.2.4.3-8: NR-DL-PRS-Info

Derivation Path: 37.355 clause 6.4.3			
Information Element	Value/remark	Comment	Condition
NR-DL-PRS-Info-r16 ::= SEQUENCE {			
nr-DL-PRS-ResourceSetList-r16 SEQUENCE (SIZE (1..nrMaxSetsPerTrp-r16)) OF NR-DL-PRS-ResourceSet-r16 {	1 entry		
NR-DL-PRS-ResourceSet-r16[1] SEQUENCE {		entry 1	
nr-DL-PRS-ResourceSetID-r16	0		
dl-PRS-Periodicity-and-ResourceSetSlotOffset-r16 CHOICE {			
scs120-r16 CHOICE {			
n160-r16	80		
}			
dl-PRS-ResourceRepetitionFactor-r16	Not present		Sub-test 2
	n2		Sub-test 1
dl-PRS-ResourceTimeGap-r16	s1		
dl-PRS-NumSymbols-r16	n4		
dl-PRS-MutingOption1-r16	Not present		
dl-PRS-MutingOption2-r16	Not present		
dl-PRS-ResourcePower-r16	27		
dl-PRS-ResourceList-r16 SEQUENCE (SIZE (1..nrMaxResourcesPerSet-r16)) OF NR-DL-PRS-Resource-r16 {	1 entry		
NR-DL-PRS-Resource-r16[1] SEQUENCE {		entry 1	
nr-DL-PRS-ResourceID-r16	0		
dl-PRS-SequenceID-r16	0		
dl-PRS-CombSizeN-AndReOffset-r16 CHOICE {			
n2-r16	0		Sub-test 1
n4-r16			Sub-test 2
}			
dl-PRS-ResourceSlotOffset-r16	0		Sub-test 1 Cell 1 and

			Sub-test 2 Cell 1
	4		Sub-test 1 Cell 2 and Sub-test 2 Cell 2
dl-PRS-ResourceSymbolOffset-r16	0		
dl-PRS-QCL-Info-r16	Not present		
}			
}			
}			
}			
}			

Table 15.3.2.4.3-9: LPP ProvideLocation Information

Derivation Path: 37.355 clause 6.5.12			
Information Element	Value/remark	Comment	Condition
LPP-Message ::= SEQUENCE {			
transactionID SEQUENCE {			
initiator	locationServer		
transactionNumber	1		
}			
endTransaction	TRUE		
sequenceNumber	(0..255)		
acknowledgement			
lpp-MessageBody CHOICE {			
c1 CHOICE {			
provideLocationInformation SEQUENCE {			
criticalExtensions CHOICE {			
c1 CHOICE {			
provideLocationInformation-r9 SEQUENCE {			
commonIEsProvideLocationInformation	Not present.		
a-gnss-ProvideLocationInformation	Not present		
otdoa-ProvideLocationInformation	Not present		
ecid-ProvideLocationInformation	Not present		
epdu-ProvideLocationInformation	Not present		
sensor-ProvideLocationInformation-r13	Not present		
tbs-ProvideLocationInformation-r13	Not present		
wlan-ProvideLocationInformation-r13	Not present		
bt-ProvideLocationInformation-r13	Not present		
nr-ECID-ProvideLocationInformation-r16	Not present		
nr-Multi-RTT-ProvideLocationInformation-r16 SEQUENCE {			
nr-Multi-RTT-SignalMeasurementInformation-r16 SEQUENCE {			
nr-Multi-RTT-MeasList-r16 SEQUENCE (SIZE(1..nrMaxTRPs-r16)) OF NR-Multi-RTT-MeasElement-r16 {	2 entries		
NR-Multi-RTT-MeasElement-r16[1] SEQUENCE {		entry 1	
dl-PRS-ID-r16	INTEGER (0..255)		
nr-PhysCellID-r16			
nr-CellGlobalID-r16			
nr-ARFCN-r16			
nr-DL-PRS-ResourceID-r16			
nr-DL-PRS-ResourceSetID-r16			
nr-UE-RxTxTimeDiff-r16	Present		
nr-AdditionalPathList-r16			
nr-TimeStamp-r16			
nr-TimingQuality-r16			
nr-DL-PRS-RSRP-Result-r16			
nr-Multi-RTT-AdditionalMeasurements-r16			
}			
}			
}			
}			
}			
}			

NR-Multi-RTT-MeasElement-r16[2]		entry 2	
SEQUENCE {			
dl-PRS-ID-r16	INTEGER (0..255)		
nr-PhysCellID-r16			
nr-CellGlobalID-r16			
nr-ARFCN-r16			
nr-DL-PRS-ResourceID-r16			
nr-DL-PRS-ResourceSetID-r16			
nr-UE-RxTxTimeDiff-r16	Present		
nr-AdditionalPathList-r16			
nr-TimeStamp-r16			
nr-TimingQuality-r16			
nr-DL-PRS-RSRP-Result-r16			
nr-Multi-RTT-AdditionalMeasurements-r16			
}			
nr-NTA-Offset-r16			
}			
nr-Multi-RTT-Error-r16			
}			
nr-DL-AoD-ProvideLocationInformation-r16	Not present		
}			
}			
}			
}			
}			
}			
}			
}			
}			

15.3.2.5 Test requirement

Table 15.3.2.5-1 defines the primary level settings including the test tolerances for the test.

Table 15.3.2.5-1: UE Rx-Tx time difference measurement accuracy test parameters

Parameter	Unit	Test configuration	Test 1		Test 2	
			Cell 1	Cell 2	Cell 1	Cell 2
AoA setup		1	Setup 1 as specified in TS 38.133 clause A.3.15		Setup 1 as specified in TS 38.133 clause A.3.15	
Beam Assumption ^{Note 7}		1	Rough	Rough	Rough	Rough
Measurement gap		1	GP#24 or GP#13 ^{Note 8}		GP#24 or GP#13 ^{Note 8}	
DRX		1	OFF		OFF	
Time offset with Cell 1	µs	1	N/A	3	N/A	3
TDD configuration		1	TDDConf.3.1	TDDConf.3.1	TDDConf.3.1	TDDConf.3.1
PDSCH RMC configuration		1	SR.3.1 TDD	N/A	SR.3.1 TDD	N/A
RMSI CORESET RMC configuration		1	CR.3.1 TDD	N/A	CR.3.1 TDD	N/A
Dedicated CORESET RMC configuration		1	CCR.3.1 TDD	N/A	CCR.3.1 TDD	N/A
OCNG Patterns		1	OP.1	OP.1	OP.1	OP.1

EPRE ratio of PSS to SSS	dB	1	0	0	0	0
EPRE ratio of PBCH DMRS to SSS						
EPRE ratio of PBCH to PBCH DMRS						
EPRE ratio of PDCCH DMRS to SSS						
EPRE ratio of PDCCH to PDCCH DMRS						
EPRE ratio of PDSCH DMRS to SSS						
EPRE ratio of PDSCH to PDSCH DMRS						
EPRE ratio of OCNG DMRS to SSS ^{Note 1}						
EPRE ratio of OCNG to OCNG DMRS ^{Note 1}						
EPRE ratio of PRS to SSS						
TRS Configuration		1	TRS.2.1 TDD	N/A	TRS.2.1 TDD	N/A
Initial BWP configuration		1	DLBWP.0.1 ULBWP.0.1	N/A	DLBWP.0.1 ULBWP.0.1	N/A
Active DL BWP configuration		1	DLBWP.1.1	N/A	DLBWP.1.1	N/A
Active UL BWP configuration		1	ULBWP.1.1	N/A	ULBWP.1.1	N/A
PRS configuration		1	PRS.1.1 FR2	PRS.1.1 FR2	PRS.1.2 FR2	PRS.1.2 FR2
PRS Resource slot offset	slot	1	0	4	0	4
SRS configuration		1	POS-SRS.3	N/A	POS-SRS.3	N/A
N_{oc} ^{Note 2}	dBm/SCS	1	-89		-89	
N_{oc} ^{Note 2}	dBm/15 kHz	1	-98		-98	
PRS \hat{E}_s/I_{ot}	dB	1	-2.62	-12.26	-2.62	-12.26
PRS \hat{E}_s/N_{oc}	dB	1	-2	-10	-2	-10
PRP ^{Note 3}	dBm/SCS kHz	1	-91	-99	-91	-99
I_o	dBm/190.08 MHz	1	-54.59	-54.59	-54.59	-54.59
Propagation Condition		1	AWGN		AWGN	

Note 1:	Void.
Note 2:	Interference from other cells and noise sources not specified in the test is assumed to be constant over subcarriers and time and shall be modelled as AWGN of appropriate power for N_{oc} to be fulfilled.
Note 3:	PRP and Io levels have been derived from other parameters for information purposes. They are not settable parameters themselves.
Note 4:	PRS-RSRP minimum requirements are specified assuming independent interference and noise at each receiver antenna port.
Note 5:	Equivalent power received by an antenna with 0 dBi gain at the centre of the quiet zone
Note 6:	As observed with 0 dBi gain antenna at the centre of the quiet zone
Note 7:	Information about types of UE beam is given in TS 38.133[B.2.1.3, and does not limit UE implementation or test system implementation
Note 8:	GP#24 is configured if UE supports MG#24, otherwise GP#13 is configured.

Table 15.3.2.5-2: UE Rx – Tx time difference measurement accuracy requirements

Test Configuration	Subtest	Lowest reported value	Highest reported value
1	Sub-test 1	(Measured value from step 12 - 76) T_c converted to UE Rx-Tx time difference measurement according to clause 4.14.6	(Measured value from step 12 + 76) T_c converted to UE Rx-Tx time difference measurement according to clause 4.14.6
	Sub-test 2	(Measured value from step 12 - 56) T_c converted to UE Rx-Tx time difference measurement according to clause 4.14.6	(Measured value from step 12 + 56) T_c converted to UE Rx-Tx time difference measurement according to clause 4.14.6

The UE Rx-Tx time difference measurement period fulfils the requirements specified in clause 15.3.2.3.

The test tolerances are defined in clauses C.1.6 and C.2.5.

The rate of successful tests during repeated tests shall be at least 90% with a confidence level of 95%.

15.3.3 UE Rx-Tx time difference measurement accuracy for single positioning frequency layer with reduced number of samples in FR1 SA

Editor's Note: This test case is incomplete. This test case has been completed for the following configurations:

- Test tolerance is missing
- Message contents require update

15.3.3.1 Test purpose

The purpose of the test is to verify that the UE Rx-Tx time difference measurement accuracy with reduced number of samples is within the specified limits. This test will verify the requirements in TS 38.133 [50] clause 10.1.25.2. The test is conducted in AWGN propagation condition in FR1 in standalone scenario when single positioning frequency layer is configured.

15.3.3.2 Test applicability

This test applies to all types of NR UE release 17 onwards that supports Multi-RTT positioning and supportedDL-PRS-ProcessingSamples-RRC-CONNECTED.

15.3.3.3 Minimum conformance requirements

The accuracy requirements in Table 10.1.25.2-1 for FR1 are valid under the following conditions:

Conditions defined in clause 7.3 of TS 38.101-2 [19] for reference sensitivity are fulfilled.

PRP_{dBm} according to Annex B.2.14 for a corresponding Band

Number of measurement samples is less than 4

AWGN propagation condition.

Table 10.1.25.2-3a: UE Rx-Tx time difference measurement accuracy in FR1 in AWGN with reduced measurement samples

Accuracy	Conditions							
	PRS Es/lot	Minimum PRS bandwidth	PRS SCS	PRS resource repetition ($T_{rep}^{PRS} *$ L_{PRS}/K_{comb}^{PRS} Note 3)	NR operating band groups ^{Note 2}	Io ^{Note 4} range		
						Minimum Io ^{Note 1}	Maximum Io	
Tc ^{Note 5}	dB	RB	kHz			dBm / SCS _{PRS}	dBm/BW	
± 59+δ	0	≥52	15	≥1	NR_FDD_FR1_A, NR_TDD_FR1_A, NR_SDL_FR1_A	-127	-50	
					NR_FDD_FR1_B	-126.5	-50	
					NR_TDD_FR1_C	-126	-50	
					NR_FDD_FR1_D, NR_TDD_FR1_D	-125.5	-50	
					NR_FDD_FR1_E, NR_TDD_FR1_E	-125	-50	
					NR_FDD_FR1_F	-124.5	-50	
					NR_FDD_FR1_G, NR_TDD_FR1_G	-124	-50	
NR_FDD_FR1_H	-123.5	-50						
± 30+δ6		>104		≥1	NOTE 6	NOTE 6	NOTE 6	
± 30+δ		≥48	30	≥1	NR_FDD_FR1_A, NR_TDD_FR1_A, NR_SDL_FR1_A	-124	-50	
					NR_FDD_FR1_B	-123.5	-50	
					NR_TDD_FR1_C	-123	-50	
					NR_FDD_FR1_D, NR_TDD_FR1_D	-122.5	-50	
					NR_FDD_FR1_E, NR_TDD_FR1_E	-122	-50	
					NR_FDD_FR1_F	-121.5	-50	
					NR_FDD_FR1_G, NR_TDD_FR1_G	-121	-50	
NR_FDD_FR1_H	-120.5	-50						
± 15+δ		≥132		≥1	NOTE 6	NOTE 6	NOTE 6	
± 15+δ		≥64	60	≥1	NR_FDD_FR1_A, NR_TDD_FR1_A, NR_SDL_FR1_A	-121	-50	
					NR_FDD_FR1_B	-120.5	-50	
					NR_TDD_FR1_C	-120	-50	
					NR_FDD_FR1_D, NR_TDD_FR1_D	-119.5	-50	
					NR_FDD_FR1_E, NR_TDD_FR1_E	-119	-50	
					NR_FDD_FR1_F	-118.5	-50	
					NR_FDD_FR1_G, NR_TDD_FR1_G	-118	-50	
NR_FDD_FR1_H	-117.5	-50						
± 7+δ		≥132		≥1	NOTE 6	NOTE 6	NOTE 6	
± 75+δ	-6	≥52	15	≥1	NOTE 6	NOTE 6	NOTE 6	
± 37+δ		>104		≥1	NOTE 6	NOTE 6	NOTE 6	
± 39+δ		≥48		30	≥1	NOTE 6	NOTE 6	NOTE 6
± 16+δ		≥132	≥1		NOTE 6	NOTE 6	NOTE 6	
± 16+δ		≥64	60		≥1	NOTE 6	NOTE 6	NOTE 6
± 8+δ		≥132			≥1	NOTE 6	NOTE 6	NOTE 6

NOTE 1: This minimum Io condition is expressed as the average Io per RE over all REs in an OFDM symbol.
 NOTE 2: NR operating band groups are as defined in Section 3.5.
 NOTE 3: T_{rep}^{PRS} , L_{PRS} , K_{comb}^{PRS} are configured by higher layer parameter *dl-PRS-ResourceRepetitionFactor*, *dl-PRS-NumSymbols* and *dl-PRS-CombSizeN* defined in TS 37.355 [34].

NOTE 4: The l_o is defined in PRS slots. The same l_o range applies to PRS and non-PRS symbols. l_o levels are different in PRS and non-PRS symbols within the same slot.

NOTE 5: T_c is the basic timing unit defined in TS 38.211 [6].

NOTE 6: The same bands and the same l_o conditions for each band apply for this requirement as for the corresponding requirement with the PRS bandwidth of the smallest RB number for the corresponding SCS.

NOTE 7: δ is the margin determined from Table 10.1.25.2-5.

...

Table 10.1.25.2-6: Margin for UE Rx-Tx time difference measurement accuracy in FR1

Min(PRS BW, SRS BW) (RB)			Margin (T_c ^{Note 1})
SCS = 15 kHz	SCS = 30 kHz	SCS = 60 kHz	
≥ 24	N/A	N/A	160
≥ 52	≥ 24	N/A	80
≥ 104	≥ 48	≥ 24	56
N/A	≥ 132	≥ 64	24
N/A	N/A	≥ 132	24

NOTE 1: T_c is the basic timing unit defined in TS 38.211 [6].

NOTE 2: If SRS and PRS have different SCS, the margin corresponding to the smallest RS BW in MHz applies.

15.3.3.4 Test description

15.3.3.4.1 Initial conditions

The supported test configuration is listed in Table 15.3.3.4-1.

Table 15.3.3.4-1: Test Configuration

Configuration	Description
1	15 kHz SSB SCS, 20 MHz bandwidth, FDD duplex mode
2	15 kHz SSB SCS, 20 MHz bandwidth, TDD duplex mode
3	30 kHz SSB SCS, 50 MHz bandwidth, TDD duplex mode

Note: The UE is only required to be tested in one of the supported test configurations.

Test Environment: Normal, as defined in TS 38.508-1 [45] clause 4.1.

Frequencies to be tested: Mid Range, as defined in TS 38.508-1 [45] clause 4.3.1.

Channel bandwidth to be tested: are specified in Table 15.3.3.4-1.

1. Connect the SS and AWGN noise sources to the UE antenna connector or antenna connectors as shown in Annex A, Figure A.13.
2. The general test parameter settings are set up according to Table 15.3.3.5-1.
3. Propagation conditions are set according to clause 4.14.2.
4. Message contents are defined in clause 15.3.3.4.3.
5. In the test there are two cells in the test: PCell (Cell 1) and a neighbour cell (Cell 2). All cells are on the same RF channel in FR1.

15.3.3.4.2 Test procedure

The test consists of a set-up period and a measurement period. Cell 1 and Cell 2 are both active during the complete test. The beginning of the measurement period shall be aligned with the first PRS positioning subframe of a positioning occasion in the reference cell. The *NR-Multi-RTT-ProvideAssistanceData* and *NR-Multi-RTT-RequestLocationInformation* shall be provided to the UE during the set-up period.

The UE is configured with measurement gap pattern ID # 24 or #13 before the test.

1. Ensure the UE is in State RRC_CONNECTED with generic procedure parameters Connectivity NR, Connected without release On, according to TS 38.508-1 [45] clause 4.5. Note that in the remainder of the test the timing advance command $T_A = 31$ which indicates a timing advance adjustment value $N_{TA} = 0 T_c$.
2. The SS shall send a RESET UE POSITIONING STORED INFORMATION message.
3. The SS adjusts the downlink timing for Cell 1 to a delay of $+512 T_c$, compared to the current value.
4. Wait for 1.6 s to allow for the possibility that the UE makes autonomous timing adjustments.
5. The SS shall transmit an RRCReconfiguration message with the SRS configuration.
6. The UE shall transmit RRCReconfigurationComplete message.
7. The SS shall transmit an LPP REQUEST CAPABILITIES message.
8. The UE shall transmit an LPP PROVIDE CAPABILITIES message indicating the UE supports *supportedDL-PRS-ProcessingSamples-RRC-CONNECTED* in the *NR-DL-PRS-ProcessingCapability* IE and the Multi-RTT capabilities supported by the UE in the *NR-Multi-RTT-ProvideCapabilities* IE.
9. The SS shall send a LPP PROVIDE ASSISTANCE DATA message, including the *NR-Multi-RTT-ProvideAssistanceData* IE. The position of neighbour Cell 2 is described in 3GPP TS 37.571-5 [20]. If the UE message at step 8 includes the *ackRequested* IE set to TRUE, then the SS shall send an acknowledgment in the LPP PROVIDE ASSISTANCE DATA message.
10. The SS shall send a LPP REQUEST LOCATION INFORMATION message, including the *reducedDL-PRS-ProcessingSamples-r17* in the *NR-Multi-RTT-RequestLocationInformation* IE such that the UE receives the message ΔT ms before the start of the measurement period, where $\Delta T = 50$ ms.
11. The UE shall transmit a LPP PROVIDE LOCATION INFORMATION message including the *NR-Multi-RTT-ProvideLocationInformation* IE within the response time (see clause 15.3.3.4.3).
12. If the UE message at step 11 includes the *ackRequested* IE set to TRUE, the SS shall send a LPP acknowledgement message.
13. The SS shall check *nr-UE-RxTxTimeDiff-r16* value for Cell 2 in the *NR-Multi-RTT-SignalMeasurementInformation* according to Table 15.3.3.5-3.
14. Repeat steps 1-13 until the confidence level according to Annex D is achieved.

NOTE: To avoid a large divergence between the sent TA and the set downlink timing, the SS may reset the downlink timing for Cell 1 to its initial value after a certain amount of loops. The loop during the reset does not count for the result statistics.

15.3.3.4.3 Message contents

Table 15.3.3.4.3-1: RESET UE POSITIONING STORED INFORMATION

Derivation Path: 38.509 [44] clause 6.6			
Information Element	Value/remark	Comment	Condition
UE Positioning Technology	0 0 0 0 1 1 0	Multi-RTT	

Table 15.3.3.4.3-2: RRCReconfiguration

Derivation Path: TS 38.508-1 [45],, table 4.6.1-13			
Information Element	Value/remark	Comment	Condition
RRCReconfiguration ::= SEQUENCE {			
criticalExtensions CHOICE {			
rrcReconfiguration SEQUENCE {			
radioBearerConfig			
nonCriticalExtension SEQUENCE {			
masterCellGroup SEQUENCE {	CellGroupConfig		

spCellConfig SEQUENCE {			
spCellConfigDedicated SEQUENCE {			
uplinkConfig SEQUENCE {			
initialUplinkBWP SEQUENCE {			
srs-Config CHOICE {			
setup	As defined in Table 15.3.3.4.3-3		
}			
}			
}			
}			

Table 15.3.3.4.3-3: SRS-Config

Derivation Path: TS 38.508-1 [45], Table 4.6.3-182			
Information Element	Value/remark	Comment	Condition
SRS-Config ::= SEQUENCE {			
srs-ResourceSetToReleaseList	Not present		
srs-ResourceSetToAddModList	Not present		
srs-ResourceToReleaseList	Not present		
srs-ResourceToAddModList	Not present		
tpc-Accumulation	Not present		
srs-RequestDCI-1-2-r16	Not present		
srs-RequestDCI-0-2-r16	Not present		
srs-ResourceSetToAddModListDCI-0-2-r16	Not present		
srs-ResourceSetToReleaseListDCI-0-2-r16	Not present		
srs-PosResourceSetToReleaseList-r16	Not present		
srs-PosResourceSetToAddModList-r16 SEQUENCE (SIZE(1..maxNrofSRS-PosResourceSets-r16)) OF SRS-PosResourceSet-r16 {	1 entry		
SRS-PosResourceSet-r16[1] SEQUENCE {		entry 1	
srs-PosResourceSetId-r16	0		
srs-PosResourceCidList-r16 SEQUENCE (SIZE(1..maxNrofSRS-ResourcesPerSet)) OF SRS-PosResourceCid-r16 {	1 entry		
SRS-PosResourceCid-r16	0	1 entry	
}			
resourceType CHOICE {			
periodic SEQUENCE {			
}			
}			
alpha-r16	alpha0		
p0-r16	0		
pathlossReferenceRS-Pos-r16	Not present		
}			
srs-PosResourceToReleaseList-r16	Not present		
srs-PosResourceToAddModList-r16 SEQUENCE (SIZE(1..maxNrofSRS-PosResources-r16)) OF SRS-PosResource-r16 {	1 entry		
SRS-PosResource-r16[1] SEQUENCE {		entry 1	
srs-PosResourceCid-r16	0		
transmissionComb-r16 CHOICE {			
n4-r16 SEQUENCE {			
combOffset-n4-r16	0		
cyclicShift-n4-r16	0		
}			
}			
}			
resourceMapping-r16 SEQUENCE {			
startPosition-r16	5		

nrofSymbols-r16	n4		
}			
freqDomainShift-r16	0		
freqHopping-r16 SEQUENCE {			
c-SRS-r16	Matches $N_{RB,c}$ Table 15.3.3.5-1		
}			
groupOrSequenceHopping-r16	neither		
resourceType-r16 CHOICE {			
periodic-r16 SEQUENCE {			
periodicityAndOffset-p-r16 CHOICE {			
sl160	20		Config 1 and config 2
sl320	40		Config 3
}			
}			
}			
}			
sequenceId-r16	0		
spatialRelationInfoPos-r16	Not present		
}			
}			
}			

Table 15.3.3.4.3-4: LPP Request Capabilities

Information Element	Value/remark
nr-Multi-RTT-RequestCapabilities-r16	TRUE

Table 15.3.3.4.3-5: LPP RequestLocationInformation

Derivation Path: TS 37.355 [49] clause 6.2			
Information Element	Value/remark	Comment	Condition
LPP-Message ::= SEQUENCE {			
transactionID SEQUENCE {			
initiator	locationServer		
transactionNumber	1		
}			
endTransaction	FALSE		
sequenceNumber	Not present		
acknowledgement	Not present		
lpp-MessageBody CHOICE {			
c1 CHOICE {			
requestLocationInformation SEQUENCE {			
criticalExtensions CHOICE {			
c1 CHOICE {			
requestLocationInformation-r9 SEQUENCE {			
commonEsRequestLocationInformation SEQUENCE {			
locationInformationType	locationMeasurementsPreferred		
triggeredReporting	Not present		
periodicalReporting	Not present		
additionalInformation	onlyReturnInformationRequested		
} SEQUENCE {			
horizontalAccuracy	Not present		
verticalCoordinateRequest	FALSE		
verticalAccuracy	Not present		
} SEQUENCE {			
time	See 15.3.3.5	Result of the response time calculation rounded	

		up to the next second.	
responseTimeEarlyFix-r12	Not present		Rel-12 onwards
unit-r15	Not present		
}			
velocityRequest	FALSE		
}			
environment	Not present		
locationCoordinateTypes	Not present		
velocityTypes	Not present		
}			
a-gnss-RequestLocationInformation	Not present		
otdoa-RequestLocationInformation	Not present		
ecid-RequestLocationInformation	Not present		
epdu-RequestLocationInformation	Not Present		
sensor-RequestLocationInformation-r13	Not present		
tbs-RequestLocationInformation-r13	Not present		
wlan-RequestLocationInformation-r13	Not present		
bt-RequestLocationInformation-r13	Not present		
nr-ECID-RequestLocationInformation-r16	Not present		
nr-Multi-RTT-RequestLocationInformation-r16			
SEQUENCE {			
nr-UE-	Not present		
RxTxTimeDiffMeasurementInfoRequest-r16			
nr-RequestedMeasurements-r16	bit 0 = 1 (prsrspReq)		
nr-AssistanceAvailability-r16	FALSE		
nr-Multi-RTT-ReportConfig-r16 SEQUENCE {			
maxDL-PRS-RxTxTimeDiffMeasPerTRP-r16	Not present		
timingReportingGranularityFactor-r16	Not present		
}			
additionalPaths-r16	Not present		
nr-UE-RxTxTEG-Request-r17			
measureSameDL-PRS-ResourceWithDifferentRxTxTEGs-r17	Not present		
measureSameDL-PRS-ResourceWithDifferentRxTEGs-r17	Not present		
reducedDL-PRS-ProcessingSamples-r17	requested		
nr-los-nlos-IndicatorRequest-r17	Not present		
additionalPathsExt-r17	Not present		
additionalPathsDL-PRS-RSRP-Request-r17	Not present		
multiMeasInSameReport-r17	Not present		
lowerRxBeamSweepingFactor-FR2-r17	Not present		
}			
nr-DL-AoD-RequestLocationInformation-r16	Not present		
nr-DL-TDOA-RequestLocationInformation-r16	Not present		
}			
}			
}			
}			
}			
}			
}			
}			

Table 15.3.3.4.3-6: LPP ProvideAssistanceData

Derivation Path: 37.355 clause 6.2			
Information Element	Value/remark	Comment	Condition
LPP-Message ::= SEQUENCE {			
transactionID SEQUENCE {			
initiator	locationServer		
transactionNumber	(0..255)		
}			
endTransaction	TRUE		

sequenceNumber	Not present		
acknowledgement	Not present		
lpp-MessageBody CHOICE {			
c1 CHOICE {			
provideAssistanceData SEQUENCE {			
criticalExtensions CHOICE {			
c1 CHOICE {			
provideAssistanceData-r9 SEQUENCE {			
commonEsProvideAssistanceData	Not present		
a-gnss-ProvideAssistanceData	Not present		
otdoa-ProvideAssistanceData	Not present		
epdu-Provide-AssistanceData	Not present		
sensor-ProvideAssistanceData-r15	Not present		
tbs-ProvideAssistanceData-r15	Not present		
wlan-ProvideAssistanceData-r15	Not present		
nr-Multi-RTT-ProvideAssistanceData-r16			
SEQUENCE {			
nr-DL-PRS-AssistanceData	As defined in Table 15.3.3.4.3-7		
nr-SelectedDL-PRS-IndexList-r16	Not present		
nr-Multi-RTT-Error-r16	Not present		
nr-On-Demand-DL-PRS-Configurations-r17	Not present		
nr-On-Demand-DL-PRS-Configurations-Selected-IndexList-r17	Not present		
assistanceDataValidityArea-r17	Not present		
}			
nr-DL-AoD-ProvideAssistanceData-r16	Not present		
nr-DL-TDOA-ProvideAssistanceData-r16	Not present		
}			
}			
}			
}			
}			
}			

Table 15.3.3.4.3-7: NR-DL-PRS-AssistanceData

Derivation Path: 37.355 clause 6.4.3			
Information Element	Value/remark	Comment	Condition
NR-DL-PRS-AssistanceData-r16 ::= SEQUENCE {			
nr-DL-PRS-ReferenceInfo-r16 SEQUENCE {			
dl-PRS-ID-r16	0		
nr-DL-PRS-ResourceID-List-r16	Not present		
nr-DL-PRS-ResourceSetID-r16	Not present		
}			
nr-DL-PRS-AssistanceDataList-r16 SEQUENCE (SIZE (1..nrMaxFreqLayers-r16)) OF NR-DL-PRS-AssistanceDataPerFreq-r16 {	1 entry		
NR-DL-PRS-AssistanceDataPerFreq-r16[1] SEQUENCE {		entry 1	
nr-DL-PRS-PositioningFrequencyLayer-r16 SEQUENCE {			
dl-PRS-SubcarrierSpacing-r16	kHz15 kHz30		Config 1&2 Config3
dl-PRS-ResourceBandwidth-r16	13 7	52 PRBs 48 PRBs	Config 1&2 Config3
dl-PRS-StartPRB-r16	0		
dl-PRS-PointA-r16	absoluteFrequencyPointA as defined for the DL frequency of the Cell 1		
dl-PRS-CombSizeN-r16	n2		
dl-PRS-CyclicPrefix-r16	normal		
}			

nr-DL-PRS-AssistanceDataPerFreq-r16 SEQUENCE (SIZE (1..nrMaxTRPsPerFreq-r16)) OF NR-DL-PRS-AssistanceDataPerTRP-r16{	2 entries		
NR-DL-PRS-AssistanceDataPerTRP-r16[1] SEQUENCE {		entry 1	Cell 1
dl-PRS-ID-r16	0		
nr-PhysCellID-r16	Cell 1		
nr-CellGlobalID-r16	Cell 1		
nr-ARFCN-r16	Cell 1		
nr-DL-PRS-SFN0-Offset-r16 SEQUENCE {			
sfn-Offset-r16	0		
integerSubframeOffset-r16	0		
}			
nr-DL-PRS-ExpectedRSTD-r16	0		
nr-DL-PRS-ExpectedRSTD-Uncertainty-r16	0		
nr-DL-PRS-Info-r16	As specified in Table 15.3.3.4.3-8		
}			
NR-DL-PRS-AssistanceDataPerTRP-r16[2] SEQUENCE {		entry 2	Cell 2
dl-PRS-ID-r16	1		
nr-PhysCellID-r16	Cell 2		
nr-CellGlobalID-r16	Cell 2		
nr-ARFCN-r16	Cell 2		
nr-DL-PRS-SFN0-Offset-r16 SEQUENCE {			
sfn-Offset-r16	0		
integerSubframeOffset-r16	0		
}			
nr-DL-PRS-ExpectedRSTD-r16	92	About 3 μs	
nr-DL-PRS-ExpectedRSTD-Uncertainty-r16	154	About 5 μs	
nr-DL-PRS-Info-r16	As specified in Table 15.3.3.4.3-8		
}			
}			
}			
}			
}			

Table 15.3.3.4.3-8: NR-DL-PRS-Info

Derivation Path: 37.355 clause 6.4.3			
Information Element	Value/remark	Comment	Condition
NR-DL-PRS-Info-r16 ::= SEQUENCE {			
nr-DL-PRS-ResourceSetList-r16 SEQUENCE (SIZE (1..nrMaxSetsPerTrp-r16)) OF NR-DL-PRS-ResourceSet-r16 {	1 entry		
NR-DL-PRS-ResourceSet-r16[1] SEQUENCE {		entry 1	
nr-DL-PRS-ResourceSetID-r16	0		
dl-PRS-Periodicity-and-ResourceSetSlotOffset-r16 CHOICE {			
scs120-r16 CHOICE {			
n160-r16	10		For config 1,2 &3
}			
dl-PRS-ResourceRepetitionFactor-r16	n2		
dl-PRS-ResourceTimeGap-r16	s1		
dl-PRS-NumSymbols-r16	n4		
dl-PRS-MutingOption1-r16	Not present		
dl-PRS-MutingOption2-r16	Not present		
dl-PRS-ResourcePower-r16	27		
dl-PRS-ResourceList-r16 SEQUENCE (SIZE (1..nrMaxResourcesPerSet-r16)) OF NR-DL-PRS-Resource-r16 {	1 entry		
NR-DL-PRS-Resource-r16[1] SEQUENCE {		entry 1	
nr-DL-PRS-ResourceID-r16	0		

dl-PRS-SequenceID-r16	0		
dl-PRS-CombSizeN-AndReOffset-r16 CHOICE {			
n2-r16	0		
}			
dl-PRS-ResourceSlotOffset-r16	0		
dl-PRS-ResourceSymbolOffset-r16	0		
dl-PRS-QCL-Info-r16	Not present		
}			
}			
}			
}			
}			

Table 15.3.3.4.3-9: LPP ProvideLocation Information

Derivation Path: 37.355 clause 6.5.12			
Information Element	Value/remark	Comment	Condition
LPP-Message ::= SEQUENCE {			
transactionID SEQUENCE {			
initiator	locationServer		
transactionNumber	1		
}			
endTransaction	TRUE		
sequenceNumber	(0..255)		
acknowledgement			
lpp-MessageBody CHOICE {			
c1 CHOICE {			
provideLocationInformation SEQUENCE {			
criticalExtensions CHOICE {			
c1 CHOICE {			
provideLocationInformation-r9 SEQUENCE {			
commonIEsProvideLocationInformation	Not present.		
a-gnss-ProvideLocationInformation	Not present		
otdoa-ProvideLocationInformation	Not present		
ecid-ProvideLocationInformation	Not present		
epdu-ProvideLocationInformation	Not present		
sensor-ProvideLocationInformation-r13	Not present		
tbs-ProvideLocationInformation-r13	Not present		
wlan-ProvideLocationInformation-r13	Not present		
bt-ProvideLocationInformation-r13	Not present		
nr-ECID-ProvideLocationInformation-r16	Not present		
nr-Multi-RTT-ProvideLocationInformation-			
r16 SEQUENCE {			
nr-Multi-RTT-			
SignalMeasurementInformation-r16 SEQUENCE {			
nr-Multi-RTT-MeasList-r16 SEQUENCE	2 entries		
(SIZE(1..nrMaxTRPs-r16)) OF NR-Multi-RTT-			
MeasElement-r16 {			
NR-Multi-RTT-MeasElement-r16[1]		entry 1	
} SEQUENCE {			
dl-PRS-ID-r16	INTEGER (0..255)		
nr-PhysCellID-r16			
nr-CellGlobalID-r16			
nr-ARFCN-r16			
nr-DL-PRS-ResourceID-r16			
nr-DL-PRS-ResourceSetID-r16			
nr-UE-RxTxTimeDiff-r16	Present. Any value acceptable.		
nr-AdditionalPathList-r16			
nr-TimeStamp-r16			
nr-TimingQuality-r16			
nr-DL-PRS-RSRP-Result-r16			
nr-Multi-RTT-AdditionalMeasurements-			
r16			
nr-UE-RxTx-TEG-Info-r17			

nr-DL-PRS-FirstPathRSRP-Result-r17			
nr-los-nlos-Indicator-r17			
nr-AdditionalPathListExt-r17			
nr-Multi-RTT-AdditionalMeasurementsExt-r17			
} NR-Multi-RTT-MeasElement-r16[2]		entry 2	
SEQUENCE { dl-PRS-ID-r16	INTEGER (0..255)		
nr-PhysCellID-r16			
nr-CellGlobalID-r16			
nr-ARFCN-r16			
nr-DL-PRS-ResourceID-r16			
nr-DL-PRS-ResourceSetID-r16			
nr-UE-RxTxTimeDiff-r16	Present. Any value acceptable.		
nr-AdditionalPathList-r16			
nr-TimeStamp-r16			
nr-TimingQuality-r16			
nr-DL-PRS-RSRP-Result-r16			
nr-Multi-RTT-AdditionalMeasurements-r16			
nr-UE-RxTx-TEG-Info-r17			
nr-DL-PRS-FirstPathRSRP-Result-r17			
nr-los-nlos-Indicator-r17			
nr-AdditionalPathListExt-r17			
nr-Multi-RTT-AdditionalMeasurementsExt-r17			
} }			
nr-NTA-Offset-r16			
nr-SRS-TxTEG-Set-r17			
nr-UE-RxTEG-TimingErrorMargin-r17			
nr-UE-TxTEG-TimingErrorMargin-r17			
nr-UE-RxTxTEG-TimingErrorMargin-r17			
} nr-Multi-RTT-Error-r16			
nr-Multi-RTT-SignalMeasurementInstances-r17			
} nr-DL-AoD-ProvideLocationInformation-r16	Not present		
} }			
} }			
} }			
} }			
} }			
} }			

15.3.3.5 Test requirement

Table 15.3.3.5-1 defines the primary level settings including test tolerances for the test.

Table 15.3.3.5-1: UE Rx-Tx time difference measurement accuracy test parameters

Parameter	Unit	Test configuration	Test 1	
			Cell 1	Cell 2
RF Channel Number		1,2,3	1	1
Measurement gap		1,2,3	GP#24 or GP#0 ^{Note 4}	
DRX		1,2,3	OFF	
Time offset with Cell 1	μs	1, 2, 3	N/A	3
		1	N/A	N/A

TDD configuration		2	TDDConf.1.1	TDDConf.1.1
		3	TDDConf.2.1	TDDConf.2.1
PDSCH RMC configuration		1	SR.1.1 FDD	N/A
		2	SR.1.1 TDD	
		3	SR.2.1 TDD	
RMSI CORESET RMC configuration		1	CR.1.1 FDD	N/A
		2	CR.1.1 TDD	
		3	CR.2.1 TDD	
Dedicated CORESET RMC configuration		1	CCR.1.1 FDD	N/A
		2	CCR.1.1 TDD	
		3	CCR.2.1 TDD	
OCNG Patterns		1, 2, 3	OP.1	OP.1
EPRE ratio of PSS to SSS	dB	1, 2, 3	0	0
EPRE ratio of PBCH DMRS to SSS				
EPRE ratio of PBCH to PBCH DMRS				
EPRE ratio of PDCCH DMRS to SSS				
EPRE ratio of PDCCH to PDCCH DMRS				
EPRE ratio of PDSCH DMRS to SSS				
EPRE ratio of PDSCH to PDSCH DMRS				
EPRE ratio of OCNG DMRS to SSS ^{Note 1}				
EPRE ratio of OCNG to OCNG DMRS ^{Note 1}				
EPRE ratio of PRS to SSS				
TRS Configuration		1	TRS.1.1 FDD	N/A
		2	TRS.1.1 TDD	
		3	TRS.1.2 TDD	
Initial BWP configuration		1, 2, 3	DLBWP.0.1 ULBWP.0.1	N/A
Active DL BWP configuration		1, 2, 3	DLBWP.1.1	N/A
Active UL BWP configuration		1, 2, 3	ULBWP.1.1	N/A
PRS configuration		1	PRS.1.1 FR1	PRS.1.1 FR1
		2	PRS.1.1 FR1	PRS.1.1 FR1
		3	PRS.2.1 FR1	PRS.2.1 FR1
PRS BW		1	52 PRBs	52 PRBs
		2	52 PRBs	52 PRBs
		3	48 PRBs	48 PRBs
PRS Resource slot offset	slot	1, 2, 3	0	4
SRS configuration		1	POS-SRS.1	N/A
		2	POS-SRS.1	N/A
		3	POS-SRS.2	N/A
N_{oc} ^{Note 2}	dBm/SCS	1	-98	
		2	-98	
		3	-95	
N_{oc} ^{Note 2}	dBm/15 kHz	1	-98	
		2		
		3		
PRS \hat{E}_s/I_{ot}	dB	1	0	-6
		2		
		3		
PRS \hat{E}_s/N_{oc}	dB	1	2.23	-1.73
		2		
		3		

PRP ^{Note 3}	dBm/SCS kHz	1	-95.77	-99.73
		2	-95.77	-99.73
		3	-92.77	-96.73
I _o	dBm/19.08 MHz	1	-61.71	-61.71
	dBm/19.08 MHz	2	-61.71	-61.71
	dBm/47.88 MHz	3	-57.73	-57.73
Propagation Condition		1, 2, 3	AWGN	
Note 1:	OCNG shall be used such that both cells are fully allocated and a constant total transmitted power spectral density is achieved for all OFDM symbols.			
Note 2:	Interference from other cells and noise sources not specified in the test is assumed to be constant over subcarriers and time and shall be modelled as AWGN of appropriate power for N_{oc} to be fulfilled.			
Note 3:	PRP levels have been derived from other parameters for information purposes. They are not settable parameters themselves.			
Note 4:	GP#24 is configured if UE supports MG#24, otherwise GP#0 is configured.			

Table 15.3.3.5-2: UE Rx – Tx time difference measurement accuracy requirements

Test Configuration	Subtest	Lowest reported value	Highest reported value
1	Sub-test 1	FFS	FFS
	Sub-test 2	FFS	FFS
2	Sub-test 1	FFS	FFS
	Sub-test 2	FFS	FFS
3	Sub-test 1	FFS	FFS
	Sub-test 2	FFS	FFS

For the overall test to pass, the ratio of successful reported values in each sub-test shall be more than 90% with a confidence level of 95%.

The UE Rx-Tx time difference measurement period fulfils the requirements specified in clause 15.3.3.3.

The test tolerances are defined in clauses C.1.6 and C.2.5.

15.3.4 UE Rx-Tx time difference measurement accuracy for single positioning frequency layer with RxTx TEG in FR1 SA

Editor's note: This test case is incomplete. The following aspect is either missing or TBD:

- Test tolerance is missing
- Message contents require update

15.3.4.1 Test purpose

The purpose of the test is to verify that the relative UE Rx-Tx time difference measurement accuracy when the two measurements are within the same RxTx TEG is within the specified limits. This test will verify the requirements in TS 38.133 [50] clause 10.1.25.2. The test is conducted in AWGN propagation condition in FR1 in standalone scenario when single positioning frequency layer is configured.

15.3.4.2 Test applicability

This test applies to all types of NR UE release 17 onwards that supports Multi-RTT positioning and nr-UE-RxTxTEG-ID-MaxSupport-r17.

15.3.4.3 Minimum conformance requirements

The relative accuracy requirements in Table 10.1.25.2-1 for FR1 are valid under the following conditions:

Conditions defined in clause 7.3 of TS 38.101-2 [19] for reference sensitivity are fulfilled.

$PRP|_{dBm}$ according to Annex B.2.14 for a corresponding Band

AWGN propagation condition.

the two UE Rx-Tx time difference measurements are associated with the same RxTx TEG

Table 10.1.25.2-3b: UE Rx-Tx time difference relative measurement accuracy in FR1 in AWGN with TEG reporting

Accuracy	Conditions							
	PRRS \hat{E}_s/lot	PRRS SCS	PRRS bandwidth Note 1	PRRS resource repetition ($T_{rep}^{PRRS} * L_{PRRS} / K_{comb}^{PRRS}$) Note 2	Io ^{Note 3} range			
					NR operating band groups Note 4	Minimum Io	Maximum Io	
Tc ^{Note 5}	dB	kHz	RB			dBm/SCS	dBm/BW _{Channel}	
132 + Δ ^{Note 7}	(PRRS \hat{E}_s/lot) _j \geq -6dB (PRRS \hat{E}_s/lot) _i \geq -13dB	15	\geq [24	\geq 4	NR_FDD_FR1_A, NR_TDD_FR1_A, NR_SDL_FR1_A	-127	-50	
					NR_FDD_FR1_B	-126.5	-50	
					NR_TDD_FR1_C	-126	-50	
					NR_FDD_FR1_D, NR_TDD_FR1_D	-125.5	-50	
					NR_FDD_FR1_E, NR_TDD_FR1_E	-125	-50	
					NR_FDD_FR1_F	-124.5	-50	
					NR_FDD_FR1_G, NR_TDD_FR1_G	-124	-50	
NR_FDD_FR1_H		-123.5	-50					
98 + Δ			\geq 52	\geq 1	Note 6	Note 6	Note 6	
42 + Δ			\geq 104	\geq 1	Note 6	Note 6	Note 6	
75 + Δ		(PRRS \hat{E}_s/lot) _j \geq -6dB (PRRS \hat{E}_s/lot) _i \geq -13dB	30	\geq 24	\geq 4	NR_FDD_FR1_A, NR_TDD_FR1_A, NR_SDL_FR1_A	-124	-50
						NR_FDD_FR1_B	-123.5	-50
						NR_TDD_FR1_C	-123	-50
						NR_FDD_FR1_D, NR_TDD_FR1_D	-122.5	-50
	NR_FDD_FR1_E, NR_TDD_FR1_E					-122	-50	
	NR_FDD_FR1_F					-121.5	-50	
	NR_FDD_FR1_G, NR_TDD_FR1_G					-121	-50	
NR_FDD_FR1_H	-120.5		-50					
48 + Δ			\geq 48	\geq 1	Note 6	Note 6	Note 6	
24 + Δ			\geq 132	\geq 1	Note 6	Note 6	Note 6	
50 + Δ	(PRRS \hat{E}_s/lot) _j \geq -6dB (PRRS \hat{E}_s/lot) _i \geq -13dB		60	\geq 24	\geq 4	NR_FDD_FR1_A, NR_TDD_FR1_A, NR_SDL_FR1_A	-121	-50
						NR_FDD_FR1_B	-120.5	-50
						NR_TDD_FR1_C	-120	-50
						NR_FDD_FR1_D, NR_TDD_FR1_D	-119.5	-50
		NR_FDD_FR1_E, NR_TDD_FR1_E				-119	-50	
		NR_FDD_FR1_F				-118.5	-50	
		NR_FDD_FR1_G, NR_TDD_FR1_G				-118	-50	
NR_FDD_FR1_H		-117.5	-50					
24 + Δ			\geq 64	\geq 1	Note 6	Note 6	Note 6	
10 + Δ			\geq 132	\geq 1	Note 6	Note 6	Note 6	

NOTE 1: Minimum PRRS bandwidth, which is minimum of the PRRS bandwidths of resource j and resource i.

NOTE 2: Minimum number of PRS resource repetitions among resource j and resource i . T_{rep}^{PRS} , L_{PRS} , K_{comb}^{PRS} are configured by higher layer parameter $dl-PRS-ResourceRepetitionFactor$, $dl-PRS-NumSymbols$ and $dl-PRS-CombSizeN$ defined in TS 37.355 [34], respectively.

NOTE 3: I_0 is assumed to have constant EPRE across the bandwidth.

NOTE 4: NR operating band groups in FR1 are as defined in clause 3.5.2.

NOTE 5: T_c is the basic timing unit defined in TS 38.211 [6].

NOTE 6: The same bands and the same I_0 conditions for each band apply for this requirement as for the corresponding requirement with the PRS bandwidth of the smallest RB number for the corresponding SCS.

NOTE 7: Δ is the value of the timing error margin for the RxTx TEG, reported via $nr-UE-RxTxTEG-TimingErrorMargin$. Δ cannot be larger than the sum of the margins in table 10.1.25.2-5 (dependent on PRS/SRS BW) for any pair of individual UE Rx-Tx time difference measurements associated with the RxTx TEG. .

...

Table 10.1.25.2-6: Margin for UE Rx-Tx time difference measurement accuracy in FR1

Min(PRS BW, SRS BW) (RB)			Margin (T_c ^{Note 1})
SCS = 15 kHz	SCS = 30 kHz	SCS = 60 kHz	
≥ 24	N/A	N/A	160
≥ 52	≥ 24	N/A	80
≥ 104	≥ 48	≥ 24	56
N/A	≥ 132	≥ 64	24
N/A	N/A	≥ 132	24

NOTE 1: T_c is the basic timing unit defined in TS 38.211 [6].
 NOTE 2: If SRS and PRS have different SCS, the margin corresponding to the smallest RS BW in MHz applies.

15.3.4.4 Test description

15.3.4.4.1 Initial conditions

The supported test configuration is listed in Table 15.3.4.4-1.

Table 15.3.4.4-1: Test Configuration

Test Configuration	Description
1	120 kHz SSB and PRS SCS, 100 MHz bandwidth, TDD duplex mode

Test Environment: Normal, as defined in TS 38.508-1 [45] clause 4.1.

Frequencies to be tested: Mid Range, as defined in TS 38.508-1 [45] clause 4.3.1.

Channel bandwidth to be tested: are specified in Table 15.3.4.4-1.

1. Connect the SS and AWGN noise sources to the UE antenna connector or antenna connectors as shown in Annex A, Figure A.13.
2. The general test parameter settings are set up according to Table 15.3.4.5-1.
3. Propagation conditions are set according to clause 4.14.2.
4. Message contents are defined in clause 15.3.4.4.3.
5. In the test there are two cells in the test: PCell (Cell 1) and a neighbour cell (Cell 2). All cells are on the same RF channel in FR1.

15.3.4.4.2 Test procedure

The test consists of two sub-tests; the difference between the sub-tests is the PRS configuration, PRS.1.1 FR1 and PRS.1.2 FR1. The test consists of a set-up period and a measurement period. Cell 1 and Cell 2 are both active during the complete test. The beginning of the measurement period shall be aligned with the first PRS positioning subframe of

a positioning occasion in the reference cell. The *NR-Multi-RTT-ProvideAssistanceData* and *NR-Multi-RTT-RequestLocationInformation* shall be provided to the UE during the set-up period.

The UE is configured with measurement gap pattern ID # 24 or #13 before T2.

1. Ensure the UE is in State RRC_CONNECTED with generic procedure parameters Connectivity NR, Connected without release On, according to TS 38.508-1 [45] clause 4.5. Note that in the remainder of the test the timing advance command $T_A = 31$ which indicates a timing advance adjustment value $N_{TA} = 0 T_c$.
2. The SS shall send a RESET UE POSITIONING STORED INFORMATION message.
3. The SS adjusts the downlink timing for Cell 1 to a delay of $+512 T_c$, compared to the current value.
4. Wait for 1.6 s to allow for the possibility that the UE makes autonomous timing adjustments.
5. The SS shall transmit an RRCReconfiguration message with the SRS configuration.
6. The UE shall transmit RRCReconfigurationComplete message.
7. The SS shall transmit an LPP REQUEST CAPABILITIES message.
8. The UE shall transmit an LPP PROVIDE CAPABILITIES message indicating the Multi-RTT capabilities supported by the UE in the *NR-Multi-RTT-ProvideCapabilities* IE.
9. The SS shall send a LPP PROVIDE ASSISTANCE DATA message, including the *NR-Multi-RTT-ProvideAssistanceData* IE. The position of neighbour Cell 2 is described in 3GPP TS 37.571-5 [20]. If the UE message at step 8 includes the ackRequested IE set to TRUE, then the SS shall send an acknowledgment in the LPP PROVIDE ASSISTANCE DATA message.
10. The SS shall send a LPP REQUEST LOCATION INFORMATION message, including the nr-UE-RxTxTEG-Request-r17 in the *NR-Multi-RTT-RequestLocationInformation* IE such that the UE receives the message ΔT ms before the start of the measurement period, where $\Delta T = 50$ ms.
11. The UE shall transmit a LPP PROVIDE LOCATION INFORMATION message including the *NR-Multi-RTT-ProvideLocationInformation* IE within the response time (see clause 15.3.4.4.3).
12. If the UE message at step 11 includes the *ackRequested* IE set to TRUE, the SS shall send a LPP acknowledgement message.
13. The SS shall check nr-UE-RxTxTimeDiff-r16 value for Cell 2 in the *NR-Multi-RTT-SignalMeasurementInformation* according to Table 15.3.4.5-3.
14. Repeat steps 1-13 until the confidence level according to Annex D is achieved.
15. Repeat step 1-14 for the other sub-test defined in Table 15.3.4.5-1 as appropriate.

If all (applicable) sub-tests pass, the whole test passes. If one (applicable) sub-test fails, the whole test fails.

NOTE: To avoid a large divergence between the sent TA and the set downlink timing, the SS may reset the downlink timing for Cell 1 to its initial value after a certain amount of loops. The loop during the reset does not count for the result statistics.

15.3.4.4.3 Message contents

Table 15.3.4.4.3-1: RESET UE POSITIONING STORED INFORMATION

Derivation Path: 38.509 [44] clause 6.6			
Information Element	Value/remark	Comment	Condition
UE Positioning Technology	0 0 0 0 1 1 0	Multi-RTT	

Table 15.3.4.4.3-2: RRCReconfiguration

Derivation Path: TS 38.508-1 [45],, table 4.6.1-13			
Information Element	Value/remark	Comment	Condition
RRCReconfiguration ::= SEQUENCE {			

criticalExtensions CHOICE {			
rrcReconfiguration SEQUENCE {			
radioBearerConfig			
nonCriticalExtension SEQUENCE {			
masterCellGroup SEQUENCE {	CellGroupConfig		
spCellConfig SEQUENCE {			
spCellConfigDedicated SEQUENCE {			
uplinkConfig SEQUENCE {			
initialUplinkBWP SEQUENCE {			
srs-Config CHOICE {			
setup	As defined in Table 15.3.4.4.3-3		
}			
}			
}			
}			
}			
}			
}			

Table 15.3.4.4.3-3: SRS-Config (Table 15.3.4.4.3-2)

Derivation Path: TS 38.508-1 [45], Table 4.6.3-182			
Information Element	Value/remark	Comment	Condition
SRS-Config ::= SEQUENCE {			
srs-ResourceSetToReleaseList	Not present		
srs-ResourceSetToAddModList	Not present		
srs-ResourceToReleaseList	Not present		
srs-ResourceToAddModList	Not present		
tpc-Accumulation	Not present		
srs-RequestDCI-1-2-r16	Not present		
srs-RequestDCI-0-2-r16	Not present		
srs-ResourceSetToAddModListDCI-0-2-r16	Not present		
srs-ResourceSetToReleaseListDCI-0-2-r16	Not present		
srs-PosResourceSetToReleaseList-r16	Not present		
srs-PosResourceSetToAddModList-r16 SEQUENCE (SIZE(1..maxNrofSRS-PosResourceSets-r16)) OF SRS-PosResourceSet-r16 {	1 entry		
SRS-PosResourceSet-r16[1] SEQUENCE {		entry 1	
srs-PosResourceSetId-r16	0		
srs-PosResourceCidList-r16 SEQUENCE (SIZE(1..maxNrofSRS-ResourcesPerSet)) OF SRS-PosResourceCid-r16 {	1 entry		
SRS-PosResourceCid-r16	0	1 entry	
}			
resourceType CHOICE {			
periodic SEQUENCE {			
}			
}			
alpha-r16	alpha0		
p0-r16	0		
pathlossReferenceRS-Pos-r16	Not present		
}			
srs-PosResourceToReleaseList-r16	Not present		
srs-PosResourceToAddModList-r16 SEQUENCE (SIZE(1..maxNrofSRS-PosResources-r16)) OF SRS-PosResource-r16 {	1 entry		
SRS-PosResource-r16[1] SEQUENCE {		entry 1	
srs-PosResourceCid-r16	0		
transmissionComb-r16 CHOICE {			
n4-r16 SEQUENCE {			
combOffset-n4-r16	0		

cyclicShift-n4-r16	0		
}			
}			
resourceMapping-r16 SEQUENCE {			
startPosition-r16	5		
nrofSymbols-r16	n4		
}			
freqDomainShift-r16	0		
freqHopping-r16 SEQUENCE {			
c-SRS-r16	Matches N _{RB,c} Table 15.3.4.5-1		
}			
groupOrSequenceHopping-r16	neither		
resourceType-r16 CHOICE {			
periodic-r16 SEQUENCE {			
periodicityAndOffset-p-r16 CHOICE {			
sl160	20		Config 1 and config 2
Sl320	40		Config 3
}			
}			
}			
sequenceId-r16	0		
spatialRelationInfoPos-r16	Not present		
}			
}			
}			

Table 15.3.4.4.3-4: LPP Request Capabilities

Information Element	Value/remark
nr-Multi-RTT-RequestCapabilities-r16	TRUE

Table 15.3.4.4.3-5: LPP RequestLocationInformation

Derivation Path: TS 37.355 [49] clause 6.2			
Information Element	Value/remark	Comment	Condition
LPP-Message ::= SEQUENCE {			
transactionID SEQUENCE {			
initiator	locationServer		
transactionNumber	1		
}			
endTransaction	FALSE		
sequenceNumber	Not present		
acknowledgement	Not present		
lpp-MessageBody CHOICE {			
c1 CHOICE {			
requestLocationInformation SEQUENCE {			
criticalExtensions CHOICE {			
c1 CHOICE {			
requestLocationInformation-r9 SEQUENCE {			
commonIEsRequestLocationInformation SEQUENCE {			
locationInformationType	locationMeasurementsPreferred		
triggeredReporting	Not present		
periodicalReporting	Not present		
additionalInformation	onlyReturnInformationRequested		
} SEQUENCE {			
horizontalAccuracy	Not present		
verticalCoordinateRequest	FALSE		
verticalAccuracy	Not present		

responseTime SEQUENCE { time	See 15.3.4.5	Result of the response time calculation rounded up to the next second if response time <= 128s. Result of the response time calculation rounded up to the next multiple of ten seconds if response time > 128s	
responseTimeEarlyFix-r12	Not present		Rel-12 onwards
unit-r15	Not present		Calculated response time >128s
	ten-seconds		
}			
velocityRequest	FALSE		
}			
environment	Not present		
locationCoordinateTypes	Not present		
velocityTypes	Not present		
}			
a-gnss-RequestLocationInformation	Not present		
otdoa-RequestLocationInformation	Not present		
ecid-RequestLocationInformation	Not present		
epdu-RequestLocationInformation	Not Present		
sensor-RequestLocationInformation-r13	Not present		
tbs-RequestLocationInformation-r13	Not present		
wlan-RequestLocationInformation-r13	Not present		
bt-RequestLocationInformation-r13	Not present		
nr-ECID-RequestLocationInformation-r16	Not present		
nr-Multi-RTT-RequestLocationInformation-r16			
SEQUENCE {			
nr-UE-RxTxTimeDiffMeasurementInfoRequest-r16	Not present		
nr-RequestedMeasurements-r16	bit 0 = 1 (prsrsrpReq)		
nr-AssistanceAvailability-r16	FALSE		
nr-Multi-RTT-ReportConfig-r16 SEQUENCE {			
maxDL-PRS-RxTxTimeDiffMeasPerTRP-r16	Not present		
timingReportingGranularityFactor-r16	Not present		
}			
additionalPaths-r16	Not present		
nr-UE-RxTxTEG-Request-r17	case1		
measureSameDL-PRS-ResourceWithDifferentRxTxTEGs-r17	Not present		
measureSameDL-PRS-ResourceWithDifferentRxTEGs-r17	n2		
reducedDL-PRS-ProcessingSamples-r17	Not present		
nr-los-nlos-IndicatorRequest-r17	Not present		
additionalPathsExt-r17	Not present		
additionalPathsDL-PRS-RSRP-Request-r17	Not present		
multiMeasInSameReport-r17	Not present		
lowerRxBeamSweepingFactor-FR2-r17	Not present		
}			
nr-DL-AoD-RequestLocationInformation-r16	Not present		
nr-DL-TDOA-RequestLocationInformation-r16	Not present		
}			
}			
}			
}			

}			
}			
}			

Table 15.3.4.4.3-6: LPP ProvideAssistanceData

Derivation Path: 37.355 clause 6.2			
Information Element	Value/remark	Comment	Condition
LPP-Message ::= SEQUENCE {			
transactionID SEQUENCE {			
initiator	locationServer		
transactionNumber	(0..255)		
}			
endTransaction	TRUE		
sequenceNumber	Not present		
acknowledgement	Not present		
lpp-MessageBody CHOICE {			
c1 CHOICE {			
provideAssistanceData SEQUENCE {			
criticalExtensions CHOICE {			
c1 CHOICE {			
provideAssistanceData-r9 SEQUENCE {			
commonIEsProvideAssistanceData	Not present		
a-gnss-ProvideAssistanceData	Not present		
otdoa-ProvideAssistanceData	Not present		
epdu-Provide-AssistanceData	Not present		
sensor-ProvideAssistanceData-r15	Not present		
tbs-ProvideAssistanceData-r15	Not present		
wlan-ProvideAssistanceData-r15	Not present		
nr-Multi-RTT-ProvideAssistanceData-r16			
} SEQUENCE {			
nr-DL-PRS-AssistanceData	As defined in Table 15.3.4.4.3-7		
nr-SelectedDL-PRS-IndexList-r16	Not present		
nr-Multi-RTT-Error-r16	Not present		
nr-On-Demand-DL-PRS-Configurations-r17	Not present		
nr-On-Demand-DL-PRS-Configurations-Selected-IndexList-r17	Not present		
assistanceDataValidityArea-r17	Not present		
}			
nr-DL-AoD-ProvideAssistanceData-r16	Not present		
nr-DL-TDOA-ProvideAssistanceData-r16	Not present		
}			
}			
}			
}			
}			
}			

Table 15.3.4.4.3-7: NR-DL-PRS-AssistanceData

Derivation Path: 37.355 clause 6.4.3			
Information Element	Value/remark	Comment	Condition
NR-DL-PRS-AssistanceData-r16 ::= SEQUENCE {			
nr-DL-PRS-ReferenceInfo-r16 SEQUENCE {			
dl-PRS-ID-r16	0		
nr-DL-PRS-ResourceID-List-r16	Not present		
nr-DL-PRS-ResourceSetID-r16	Not present		
}			
nr-DL-PRS-AssistanceDataList-r16 SEQUENCE (SIZE (1..nrMaxFreqLayers-r16)) OF NR-DL-PRS-AssistanceDataPerFreq-r16 {	1 entry		

NR-DL-PRS-AssistanceDataPerFreq-r16[1] SEQUENCE {		entry 1	
nr-DL-PRS-PositioningFrequencyLayer-r16 SEQUENCE {			
dl-PRS-SubcarrierSpacing-r16	kHz15 kHz30		Config 1&2 Config3
dl-PRS-ResourceBandwidth-r16	1 22 28	24 PRBs 128 PRBs 132 PRBs	Sub-test 1 Sub-test 2 Config 1 & config 2 Sub-test 2 Config 3
dl-PRS-StartPRB-r16	0		
dl-PRS-PointA-r16	absoluteFrequencyPointA as defined for the DL frequency of the Cell 1		
dl-PRS-CombSizeN-r16	n2 n4		Sub-test 1 Sub-test 2
dl-PRS-CyclicPrefix-r16	normal		
}			
nr-DL-PRS-AssistanceDataPerFreq-r16 SEQUENCE (SIZE (1..nrMaxTRPsPerFreq-r16)) OF NR-DL-PRS-AssistanceDataPerTRP-r16{	2 entries		
NR-DL-PRS-AssistanceDataPerTRP-r16[1] SEQUENCE {		entry 1	Cell 1
dl-PRS-ID-r16	0		
nr-PhysCellID-r16	Cell 1		
nr-CellGlobalID-r16	Cell 1		
nr-ARFCN-r16	Cell 1		
nr-DL-PRS-SFN0-Offset-r16 SEQUENCE {			
sfn-Offset-r16	0		
integerSubframeOffset-r16	0		
}			
nr-DL-PRS-ExpectedRSTD-r16	0		
nr-DL-PRS-ExpectedRSTD-Uncertainty-r16	0		
nr-DL-PRS-Info-r16	As specified in Table 15.3.4.4.3- 8		
}			
NR-DL-PRS-AssistanceDataPerTRP-r16[2] SEQUENCE {		entry 2	Cell 2
dl-PRS-ID-r16	1		
nr-PhysCellID-r16	Cell 2		
nr-CellGlobalID-r16	Cell 2		
nr-ARFCN-r16	Cell 2		
nr-DL-PRS-SFN0-Offset-r16 SEQUENCE {			
sfn-Offset-r16	0		
integerSubframeOffset-r16	0		
}			
nr-DL-PRS-ExpectedRSTD-r16	92	About 3 μs	
nr-DL-PRS-ExpectedRSTD-Uncertainty-r16	154	About 5 μs	
nr-DL-PRS-Info-r16	As specified in Table 15.3.4.4.3- 8		
}			
}			
}			
}			
}			

Table 15.3.4.4.3-8: NR-DL-PRS-Info

Derivation Path: 37.355 clause 6.4.3			
Information Element	Value/remark	Comment	Condition
NR-DL-PRS-Info-r16 ::= SEQUENCE {			

nr-DL-PRS-ResourceSetList-r16 SEQUENCE (SIZE (1..nrMaxSetsPerTrp-r16)) OF NR-DL-PRS-ResourceSet-r16 {	1 entry		
NR-DL-PRS-ResourceSet-r16[1] SEQUENCE {		entry 1	
nr-DL-PRS-ResourceSetID-r16	0		
dl-PRS-Periodicity-and-ResourceSetSlotOffset-r16 CHOICE {			
scs15-r16 CHOICE {			Config 1 & config2
n160-r16	10		
}			
scs30-r16 CHOICE {			Config 3
n320-r16	20		
}			
dl-PRS-ResourceRepetitionFactor-r16	n2		Sub-test 1
	n1		Sub-test 2
dl-PRS-ResourceTimeGap-r16	s1		
dl-PRS-NumSymbols-r16	n4		
dl-PRS-MutingOption1-r16	Not present		
dl-PRS-MutingOption2-r16	Not present		
dl-PRS-ResourcePower-r16	27		
dl-PRS-ResourceList-r16 SEQUENCE (SIZE (1..nrMaxResourcesPerSet-r16)) OF NR-DL-PRS-Resource-r16 {	1 entry		
NR-DL-PRS-Resource-r16[1] SEQUENCE {		entry 1	
nr-DL-PRS-ResourceID-r16	0		
dl-PRS-SequenceID-r16	0		
dl-PRS-CombSizeN-AndReOffset-r16 CHOICE {			
n2-r16	0		Sub-test 1
n4-r16	0		Sub-test 2
}			
dl-PRS-ResourceSlotOffset-r16	0		Sub-test 1
	4		Sub-test 2
dl-PRS-ResourceSymbolOffset-r16	0		
dl-PRS-QCL-Info-r16	Not present		
}			
}			
}			
}			
}			

Table 15.3.4.4.3-9: LPP ProvideLocation Information

Derivation Path: 37.355 clause 6.5.12			
Information Element	Value/remark	Comment	Condition
LPP-Message ::= SEQUENCE {			
transactionID SEQUENCE {			
initiator	locationServer		
transactionNumber	1		
}			
endTransaction	TRUE		
sequenceNumber	(0..255)		
acknowledgement			
lpp-MessageBody CHOICE {			
c1 CHOICE {			
provideLocationInformation SEQUENCE {			
criticalExtensions CHOICE {			
c1 CHOICE {			
provideLocationInformation-r9 SEQUENCE {			
commonIEsProvideLocationInformation	Not present.		
a-gnss-ProvideLocationInformation	Not present		
otdoa-ProvideLocationInformation	Not present		
ecid-ProvideLocationInformation	Not present		
epdu-ProvideLocationInformation	Not present		

sensor-ProvideLocationInformation-r13	Not present		
tbs-ProvideLocationInformation-r13	Not present		
wlan-ProvideLocationInformation-r13	Not present		
bt-ProvideLocationInformation-r13	Not present		
nr-ECID-ProvideLocationInformation-r16	Not present		
nr-Multi-RTT-ProvideLocationInformation-r16 SEQUENCE {			
nr-Multi-RTT-SignalMeasurementInformation-r16 SEQUENCE {			
nr-Multi-RTT-MeasList-r16 SEQUENCE (SIZE(1..nrMaxTRPs-r16)) OF NR-Multi-RTT-MeasElement-r16 {	2 entries		
NR-Multi-RTT-MeasElement-r16[1] SEQUENCE {		entry 1	
dl-PRS-ID-r16	INTEGER (0..255)		
nr-PhysCellID-r16			
nr-CellGlobalID-r16			
nr-ARFCN-r16			
nr-DL-PRS-ResourceID-r16			
nr-DL-PRS-ResourceSetID-r16			
nr-UE-RxTxTimeDiff-r16	Present. Any value acceptable.		
nr-AdditionalPathList-r16			
nr-TimeStamp-r16			
nr-TimingQuality-r16			
nr-DL-PRS-RSRP-Result-r16			
nr-Multi-RTT-AdditionalMeasurements-r16			
nr-UE-RxTx-TEG-Info-r17 CHOICE {			
case1-r17 SEQUENCE {			
nr-UE-RxTx-TEG-ID-r17	INTEGER (0..255)		
}			
nr-DL-PRS-FirstPathRSRP-Result-r17			
nr-los-nlos-Indicator-r17			
nr-AdditionalPathListExt-r17			
nr-Multi-RTT-AdditionalMeasurementsExt-r17			
}			
NR-Multi-RTT-MeasElement-r16[2] SEQUENCE {		entry 2	
dl-PRS-ID-r16	INTEGER (0..255)		
nr-PhysCellID-r16			
nr-CellGlobalID-r16			
nr-ARFCN-r16			
nr-DL-PRS-ResourceID-r16			
nr-DL-PRS-ResourceSetID-r16			
nr-UE-RxTxTimeDiff-r16	Present. Any value acceptable.		
nr-AdditionalPathList-r16			
nr-TimeStamp-r16			
nr-TimingQuality-r16			
nr-DL-PRS-RSRP-Result-r16			
nr-Multi-RTT-AdditionalMeasurements-r16			
nr-UE-RxTx-TEG-Info-r17 CHOICE {			
case1-r17 SEQUENCE {			
nr-UE-RxTx-TEG-ID-r17	INTEGER (0..255)		
}			
}			
nr-DL-PRS-FirstPathRSRP-Result-r17			
nr-los-nlos-Indicator-r17			
nr-AdditionalPathListExt-r17			
nr-Multi-RTT-AdditionalMeasurementsExt-r17			

}			
}			
nr-NTA-Offset-r16			
nr-SRS-TxTEG-Set-r17			
nr-UE-RxTEG-TimingErrorMargin-r17			
nr-UE-TxTEG-TimingErrorMargin-r17			
nr-UE-RxTxTEG-TimingErrorMargin-r17			
}			
nr-Multi-RTT-Error-r16			
nr-Multi-RTT-SignalMeasurementInstances-r17			
}			
nr-DL-AoD-ProvideLocationInformation-r16	Not present		
}			
}			
}			
}			
}			
}			
}			

15.3.4.5 Test requirement

Table 15.3.4.5-1 defines the primary level settings including test tolerances for the test.

Table 15.3.4.5-1: UE Rx-Tx time difference measurement accuracy test parameters

Parameter	Unit	Test configuration	Test 1		Test 2	
			Cell 1	Cell 2	Cell 1	Cell 2
RF Channel Number		1,2,3	1	1	1	1
Measurement gap		1,2,3	GP#24 or GP#0 ^{Note 4}		GP#24 or GP#0 ^{Note 4}	
DRX		1,2,3	OFF		OFF	
Time offset with Cell 1	μs	1, 2, 3	N/A	3	N/A	3
TDD configuration		1	N/A	N/A	N/A	N/A
		2	TDDConf.1.1	TDDConf.1.1	TDDConf.1.1	TDDConf.1.1
		3	TDDConf.2.1	TDDConf.2.1	TDDConf.2.1	TDDConf.2.1
PDSCH RMC configuration		1	SR.1.1 FDD	N/A	SR.1.1 FDD	N/A
		2	SR.1.1 TDD		SR.1.1 TDD	
		3	SR.2.1 TDD		SR.2.1 TDD	
RMSI CORESET RMC configuration		1	CR.1.1 FDD	N/A	CR.1.1 FDD	N/A
		2	CR.1.1 TDD		CR.1.1 TDD	
		3	CR.2.1 TDD		CR.2.1 TDD	
Dedicated CORESET RMC configuration		1	CCR.1.1 FDD	N/A	CCR.1.1 FDD	N/A
		2	CCR.1.1 TDD		CCR.1.1 TDD	
		3	CCR.2.1 TDD		CCR.2.1 TDD	
OCNG Patterns		1, 2, 3	OP.1	OP.1	OP.1	OP.1
EPRE ratio of PSS to SSS	dB	1, 2, 3	0	0	0	0
EPRE ratio of PBCH_DMRS to SSS						
EPRE ratio of PBCH to PBCH_DMRS						
EPRE ratio of PDCCH_DMRS to SSS						
EPRE ratio of PDCCH to PDCCH_DMRS						

EPRE ratio of PDSCH_DMRS to SSS						
EPRE ratio of PDSCH to PDSCH_DMRS						
EPRE ratio of OCNG DMRS to SSS ^{Note 1}						
EPRE ratio of OCNG to OCNG DMRS ^{Note 1}						
EPRE ratio of PRS to SSS						
TRS Configuration		1	TRS.1.1 FDD	N/A	TRS.1.1 FDD	N/A
		2	TRS.1.1 TDD		TRS.1.1 TDD	
		3	TRS.1.2 TDD		TRS.1.2 TDD	
Initial BWP configuration		1, 2, 3	DLBWP.0.1 ULBWP.0.1	N/A	DLBWP.0.1 ULBWP.0.1	N/A
Active DL BWP configuration		1, 2, 3	DLBWP.1.1	N/A	DLBWP.1.1	N/A
Active UL BWP configuration		1, 2, 3	ULBWP.1.1	N/A	ULBWP.1.1	N/A
PRS configuration		1	PRS.1.1 FR1	PRS.1.1 FR1	PRS.1.2 FR1	PRS.1.2 FR1
		2	PRS.1.1 FR1	PRS.1.1 FR1	PRS.1.2 FR1	PRS.1.2 FR1
		3	PRS.2.1 FR1	PRS.2.1 FR1	PRS.2.2 FR1	PRS.2.2 FR1
PRS Resource slot offset	slot	1, 2, 3	0	4	0	4
SRS configuration		1	POS-SRS.1	N/A	POS-SRS.1	N/A
		2	POS-SRS.1	N/A	POS-SRS.1	N/A
		3	POS-SRS.2	N/A	POS-SRS.2	N/A
N_{oc} ^{Note 2}	dBm/SCS	1	-98		-98	
		2	-98		-98	
		3	-95		-95	
N_{oc} ^{Note 2}	dBm/15 kHz	1	-98		-98	
		2				
		3				
PRS \hat{E}_s/I_{ot}	dB	1	-2.41	-12.12	-2.41	-12.12
		2				
		3				
PRS \hat{E}_s/N_{oc}	dB	1	-2	-10	-2	-10
		2				
		3				
PRP ^{Note 3}	dBm/SCS kHz	1	-100	-108	-100	-108
		2	-100	-108	-100	-108
		3	-97	-105	-97	-105
I _o	dBm/19.08 MHz	1	-64.57	-64.57	-64.57	-64.57
		2	-64.57	-64.57	-64.57	-64.57
		3	-60.59	-60.59	-60.59	-60.59
Propagation Condition		1, 2, 3	AWGN		AWGN	

Note 1: Void.

Note 2: Interference from other cells and noise sources not specified in the test is assumed to be constant over subcarriers and time and shall be modelled as AWGN of appropriate power for N_{oc} to be fulfilled.

Note 3: PRP levels have been derived from other parameters for information purposes. They are not settable parameters themselves.

Note 4: GP#24 is configured if UE supports MG#24, otherwise GP#0 is configured.

Table 15.3.4.5-2: UE Rx – Tx time difference measurement accuracy requirements

Test Configuration	Subtest	Lowest reported value	Highest reported value
1	Sub-test 1	FFS	FFS
	Sub-test 2	FFS	FFS
2	Sub-test 1	FFS	FFS
	Sub-test 2	FFS	FFS
3	Sub-test 1	FFS	FFS
	Sub-test 2	FFS	FFS

For the overall test to pass, the ratio of successful reported values in each sub-test shall be more than 90% with a confidence level of 95%.

The UE Rx-Tx time difference measurement period fulfils the requirements specified in clause 15.3.4.3.

The test tolerances are defined in clauses C.1.6 and C.2.5.

15.3.5 UE Rx-Tx time difference measurement accuracy for single positioning frequency layer with reduced number of samples in FR2 SA

Editor’s Note: This test case has been completed for the following configurations:

- Test frequency $f \leq 40.8$ GHz

- UE PC3

15.3.5.1 Test purpose

The purpose of the test is to verify that the UE Rx-Tx time difference measurement accuracy with reduced number of samples is within the specified limits. This test will verify the requirements in TS 38.133 [50] clause 10.1.25.2. The test is conducted in AWGN propagation condition in FR2 in standalone scenario when single positioning frequency layer is configured.

15.3.5.2 Test applicability

This test applies to all types of NR UE release 17 onwards that supports Multi-RTT positioning and supportedDL-PRS-ProcessingSamples-RRC-CONNECTED.

15.3.5.3 Minimum conformance requirements

The accuracy requirements in Table 10.1.25.2-3a for FR2 are valid under the following conditions:

Conditions defined in clause 7.3 of TS 38.101-2 [19] for reference sensitivity are fulfilled.

PRP_{dBm} according to Annex B.2.14 for a corresponding Band

Number of measurement samples is less than 4

AWGN propagation condition.

Table 10.1.25.2-3a: UE Rx-Tx time difference measurement accuracy in FR2 in AWGN with reduced measurement samples

Accuracy	Conditions					
	PRS Es/lot	Minimum PRS bandwidth	PRS SCS	PRS resource repetition ($T_{rep}^{PRS} * L_{PRS} / K_{comb}^{PRS}$ Note 3)	Io ^{Note 4} range	
					Minimum Io ^{Note 1}	Maximum Io

T_c ^{Note 5}	dB	RB	kHz		dBm / SCS _{PRS}	dBm/BW _{Channel}
$\pm 15+\delta$	0	≥ 64	60	≥ 1	Same value as PRP in Table B.2.14-2, according to UE Power class, operating band and angle of arrival	NOTE 6
$\pm 7+\delta$		≥ 132		≥ 1	NOTE 6	NOTE 6
$\pm 7+\delta$		≥ 64	120	≥ 1	Same value as PRP in Table B.2.14-2, according to UE Power class, operating band and angle of arrival	NOTE 6
$\pm 4+\delta$		≥ 128		≥ 1	NOTE 6	NOTE 6
$\pm 15+\delta$	-6	≥ 64	60	≥ 1	NOTE 6	NOTE 6
$\pm 7+\delta$		≥ 132		≥ 1	NOTE 6	NOTE 6
$\pm 9+\delta$		≥ 64	120	≥ 1	NOTE 6	NOTE 6
$\pm 4+\delta$		≥ 128		≥ 1	NOTE 6	NOTE 6

NOTE 1: This minimum l_0 condition is expressed as the average l_0 per RE over all REs in an OFDM symbol.
 NOTE 2: NR operating band groups are as defined in Section 3.5.
 NOTE 3: $T_{rep}^{PRS}, L_{PRS}, K_{comb}^{PRS}$ are configured by higher layer parameter dl-PRS-ResourceRepetitionFactor, dl-PRS-NumSymbols and dl-PRS-CombSizeN defined in TS 37.355 [34].
 NOTE 4: The l_0 is defined in PRS slots. The same l_0 range applies to PRS and non-PRS symbols. l_0 levels are different in PRS and non-PRS symbols within the same slot.
 NOTE 5: T_c is the basic timing unit defined in TS 38.211 [6].
 NOTE 6: The same bands and the same l_0 conditions for each band apply for this requirement as for the corresponding requirement with the PRS bandwidth of the smallest RB number for the corresponding SCS.
 NOTE 7: δ is the margin determined from Table 10.1.25.2-6.

...

Table 10.1.25.2-6: Margin for UE Rx-Tx time difference measurement accuracy in FR2

Min(PRS BW, SRS BW) (MHz)		Margin (T_c ^{Note 1})
SCS = 60 kHz	SCS = 120 kHz	
≥ 24	N/A	76
≥ 64	≥ 32	32
≥ 132	≥ 64	24
N/A	≥ 128	20

NOTE 1: T_c is the basic timing unit defined in TS 38.211 [6].
 NOTE 2: If SRS and PRS have different SCS, the margin corresponding to the smallest RS BW in MHz applies.

15.3.5.4 Test description

15.3.5.4.1 Initial conditions

The supported test configuration is listed in Table 15.3.5.4-1.

Table 15.3.5.4-1: Test Configuration

Test Configuration	Description
1	120 kHz SSB and PRS SCS, e200 MHz bandwidth, TDD duplex mode

Test Environment: Normal, as defined in TS 38.508-1 [45] clause 4.1.

Frequencies to be tested: Mid Range, as defined in TS 38.508-1 [45] clause 4.3.1.

Channel bandwidth to be tested: are specified in Table 15.3.5.4-1.

1. Connect the SS and AWGN noise sources to the UE antenna connector or antenna connectors as shown in Annex A, Figure A.14.
2. The general test parameter settings are set up according to Table 15.3.5.5-1.

3. Propagation conditions are set according to clause 4.14.2.
4. Message contents are defined in clause 15.3.5.4.3.
5. In the test there are two cells in the test: PCell (Cell 1) and a neighbour cell (Cell 2). All cells are on the same RF channel in FR2.

15.3.5.4.2 Test procedure

The test consists of a set-up period and a measurement period. Cell 1 and Cell 2 are both active during the complete test. The beginning of the measurement period shall be aligned with the first PRS positioning subframe of a positioning occasion in the reference cell. The *NR-Multi-RTT-ProvideAssistanceData* and *NR-Multi-RTT-RequestLocationInformation* shall be provided to the UE during the set-up period.

The UE is configured with measurement gap pattern ID # 24 or #13 before the test.

2. Ensure the UE is in State RRC_CONNECTED with generic procedure parameters Connectivity NR, Connected without release *On*, according to TS 38.508-1 [45] clause 4.5. Note that in the remainder of the test the timing advance command $T_A = 31$ which indicates a timing advance adjustment value $N_{TA} = 0 T_c$.
2. The SS shall send a RESET UE POSITIONING STORED INFORMATION message.
3. The SS adjusts the downlink timing for Cell 1 to a delay of $+512 T_c$, compared to the current value.
4. Wait for 1.6 s to allow for the possibility that the UE makes autonomous timing adjustments.
5. The SS shall transmit an RRCReconfiguration message with the SRS configuration.
6. The UE shall transmit RRCReconfigurationComplete message.
7. The SS shall transmit an LPP REQUEST CAPABILITIES message.
8. The UE shall transmit an LPP PROVIDE CAPABILITIES message indicating the UE supports *supportedDL-PRS-ProcessingSamples-RRC-CONNECTED* in the *NR-DL-PRS-ProcessingCapability* IE and the Multi-RTT capabilities supported by the UE in the *NR-Multi-RTT-ProvideCapabilities* IE.
9. The SS shall send a LPP PROVIDE ASSISTANCE DATA message, including the *NR-Multi-RTT-ProvideAssistanceData* IE. The position of neighbour Cell 2 is described in 3GPP TS 37.571-5 [20]. If the UE message at step 8 includes the *ackRequested* IE set to TRUE, then the SS shall send an acknowledgment in the LPP PROVIDE ASSISTANCE DATA message.
10. The SS shall send a LPP REQUEST LOCATION INFORMATION message, including the *reducedDL-PRS-ProcessingSamples-r17* in the *NR-Multi-RTT-RequestLocationInformation* IE such that the UE receives the message ΔT ms before the start of the measurement period, where $\Delta T = 50$ ms.
11. The UE shall transmit a LPP PROVIDE LOCATION INFORMATION message including the *NR-Multi-RTT-ProvideLocationInformation* IE within the response time (see clause 15.3.5.4.3).
12. If the UE message at step 11 includes the *ackRequested* IE set to TRUE, the SS shall send a LPP acknowledgement message.
13. The SS shall check *nr-UE-RxTxTimeDiff-r16* value for Cell 2 in the *NR-Multi-RTT-SignalMeasurementInformation* according to Table 15.3.5.5-3.
14. Repeat steps 1-13 until the confidence level according to Annex D is achieved.

NOTE: To avoid a large divergence between the sent TA and the set downlink timing, the SS may reset the downlink timing for Cell 1 to its initial value after a certain amount of loops. The loop during the reset does not count for the result statistics.

15.3.5.4.3 Message contents

Table 15.3.5.4.3-1: RESET UE POSITIONING STORED INFORMATION

Derivation Path: 38.509 [44] clause 6.6

Information Element	Value/remark	Comment	Condition
UE Positioning Technology	0 0 0 0 1 1 0	Multi-RTT	

Table 15.3.5.4.3-2: RRCReconfiguration

Derivation Path: TS 38.508-1 [45], table 4.6.1-13			
Information Element	Value/remark	Comment	Condition
RRCReconfiguration ::= SEQUENCE {			
criticalExtensions CHOICE {			
rrcReconfiguration SEQUENCE {			
radioBearerConfig			
nonCriticalExtension SEQUENCE {			
masterCellGroup SEQUENCE {	CellGroupConfig		
spCellConfig SEQUENCE {			
spCellConfigDedicated SEQUENCE {			
uplinkConfig SEQUENCE {			
initialUplinkBWP SEQUENCE {			
srs-Config CHOICE {			
setup	As defined in Table 15.3.5.4.3-3		
}			
}			
}			
}			
}			
}			

Table 15.3.5.4.3-3: SRS-Config (Table 15.3.5.4.3-2)

Derivation Path: TS 38.508-1 [45], Table 4.6.3-182			
Information Element	Value/remark	Comment	Condition
SRS-Config ::= SEQUENCE {			
srs-ResourceSetToReleaseList	Not present		
srs-ResourceSetToAddModList	Not present		
srs-ResourceToReleaseList	Not present		
srs-ResourceToAddModList	Not present		
tpc-Accumulation	Not present		
srs-RequestDCI-1-2-r16	Not present		
srs-RequestDCI-0-2-r16	Not present		
srs-ResourceSetToAddModListDCI-0-2-r16	Not present		
srs-ResourceSetToReleaseListDCI-0-2-r16	Not present		
srs-PosResourceSetToReleaseList-r16	Not present		
srs-PosResourceSetToAddModList-r16 SEQUENCE (SIZE(1..maxNrofSRS-PosResourceSets-r16)) OF SRS-PosResourceSet-r16 {	1 entry		
SRS-PosResourceSet-r16[1] SEQUENCE {		entry 1	
srs-PosResourceSetId-r16	0		
srs-PosResourceCidList-r16 SEQUENCE (SIZE(1..maxNrofSRS-ResourcesPerSet)) OF SRS-PosResourceCid-r16 {	1 entry		
SRS-PosResourceCid-r16	0	1 entry	
}			
resourceType CHOICE {			
periodic SEQUENCE {			
}			
}			
alpha-r16	alpha0		
p0-r16	0		
pathlossReferenceRS-Pos-r16	Not present		

}			
srs-PosResourceToReleaseList-r16	Not present		
srs-PosResourceToAddModList-r16 SEQUENCE (SIZE(1..maxNrofSRS-PosResources-r16)) OF SRS-PosResource-r16 {	1 entry		
SRS-PosResource-r16[1] SEQUENCE {		entry 1	
srs-PosResourceId-r16	0		
transmissionComb-r16 CHOICE {			
n4-r16 SEQUENCE {			
combOffset-n4-r16	0		
cyclicShift-n4-r16	0		
}			
}			
resourceMapping-r16 SEQUENCE {			
startPosition-r16	0		
nrofSymbols-r16	n4		
}			
freqDomainShift-r16	0		
freqHopping-r16 SEQUENCE {			
c-SRS-r16	Matches N _{RB,c} Table 15.3.5.5-1		
}			
groupOrSequenceHopping-r16	neither		
resourceType-r16 CHOICE {			
periodic-r16 SEQUENCE {			
periodicityAndOffset-p-r16 CHOICE {			
sl1280	160		
}			
}			
}			
sequenceId-r16	0		
spatialRelationInfoPos-r16	Not present		
}			
}			
}			

Table 15.3.5.4.3-4: LPP Request Capabilities

Information Element	Value/remark
nr-Multi-RTT-RequestCapabilities-r16	TRUE

Table 15.3.5.4.3-5: LPP RequestLocationInformation

Derivation Path: TS 37.355 [49] clause 6.2			
Information Element	Value/remark	Comment	Condition
LPP-Message ::= SEQUENCE {			
transactionID SEQUENCE {			
initiator	locationServer		
transactionNumber	1		
}			
endTransaction	FALSE		
sequenceNumber	Not present		
acknowledgement	Not present		
lpp-MessageBody CHOICE {			
c1 CHOICE {			
requestLocationInformation SEQUENCE {			
criticalExtensions CHOICE {			
c1 CHOICE {			
requestLocationInformation-r9 SEQUENCE {			
commonEsRequestLocationInformation SEQUENCE {			
locationInformationType	locationMeasurementsPreferred		

triggeredReporting	Not present		
periodicalReporting	Not present		
additionalInformation	onlyReturnInformationRequested		
qos SEQUENCE {			
horizontalAccuracy	Not present		
verticalCoordinateRequest	FALSE		
verticalAccuracy	Not present		
responseTime SEQUENCE {			
time	See 15.3.5.5	Result of the response time calculation rounded up to the next second.	
responseTimeEarlyFix-r12	Not present		Rel-12 onwards
unit-r15	Not present		
}			
velocityRequest	FALSE		
}			
environment	Not present		
locationCoordinateTypes	Not present		
velocityTypes	Not present		
}			
a-gnss-RequestLocationInformation	Not present		
otdoa-RequestLocationInformation	Not present		
ecid-RequestLocationInformation	Not present		
epdu-RequestLocationInformation	Not Present		
sensor-RequestLocationInformation-r13	Not present		
tbs-RequestLocationInformation-r13	Not present		
wlan-RequestLocationInformation-r13	Not present		
bt-RequestLocationInformation-r13	Not present		
nr-ECID-RequestLocationInformation-r16	Not present		
nr-Multi-RTT-RequestLocationInformation-r16			
SEQUENCE {			
nr-UE-	Not present		
RxTxTimeDiffMeasurementInfoRequest-r16			
nr-RequestedMeasurements-r16	bit 0 = 1 (prsrspReq)		
nr-AssistanceAvailability-r16	FALSE		
nr-Multi-RTT-ReportConfig-r16 SEQUENCE {			
maxDL-PRS-RxTxTimeDiffMeasPerTRP-r16	Not present		
timingReportingGranularityFactor-r16	Not present		
}			
additionalPaths-r16	Not present		
nr-UE-RxTxTEG-Request-r17			
measureSameDL-PRS-ResourceWithDifferentRxTxTEGs-r17	Not present		
measureSameDL-PRS-ResourceWithDifferentRxTEGs-r17	Not present		
reducedDL-PRS-ProcessingSamples-r17	requested		
nr-los-nlos-IndicatorRequest-r17	Not present		
additionalPathsExt-r17	Not present		
additionalPathsDL-PRS-RSRP-Request-r17	Not present		
multiMeasInSameReport-r17	Not present		
lowerRxBeamSweepingFactor-FR2-r17	Not present		
}			
nr-DL-AoD-RequestLocationInformation-r16	Not present		
nr-DL-TDOA-RequestLocationInformation-r16	Not present		
}			
}			
}			
}			
}			
}			
}			
}			

Table 15.3.5.4.3-6: LPP ProvideAssistanceData

Derivation Path: 37.355 clause 6.2			
Information Element	Value/remark	Comment	Condition
LPP-Message ::= SEQUENCE {			
transactionID SEQUENCE {			
initiator	locationServer		
transactionNumber	(0..255)		
}			
endTransaction	TRUE		
sequenceNumber	Not present		
acknowledgement	Not present		
lpp-MessageBody CHOICE {			
c1 CHOICE {			
provideAssistanceData SEQUENCE {			
criticalExtensions CHOICE {			
c1 CHOICE {			
provideAssistanceData-r9 SEQUENCE {			
commonEsProvideAssistanceData	Not present		
a-gnss-ProvideAssistanceData	Not present		
otdoa-ProvideAssistanceData	Not present		
epdu-Provide-AssistanceData	Not present		
sensor-ProvideAssistanceData-r15	Not present		
tbs-ProvideAssistanceData-r15	Not present		
wlan-ProvideAssistanceData-r15	Not present		
nr-Multi-RTT-ProvideAssistanceData-r16			
} SEQUENCE {			
nr-DL-PRS-AssistanceData	As defined in Table 15.3.5.4.3-7		
nr-SelectedDL-PRS-IndexList-r16	Not present		
nr-Multi-RTT-Error-r16	Not present		
nr-On-Demand-DL-PRS-Configurations-r17	Not present		
nr-On-Demand-DL-PRS-Configurations-Selected-IndexList-r17	Not present		
assistanceDataValidityArea-r17	Not present		
}			
nr-DL-AoD-ProvideAssistanceData-r16	Not present		
nr-DL-TDOA-ProvideAssistanceData-r16	Not present		
}			
}			
}			
}			
}			
}			

Table 15.3.5.4.3-7: NR-DL-PRS-AssistanceData

Derivation Path: 37.355 clause 6.4.3			
Information Element	Value/remark	Comment	Condition
NR-DL-PRS-AssistanceData-r16 ::= SEQUENCE {			
nr-DL-PRS-ReferenceInfo-r16 SEQUENCE {			
dl-PRS-ID-r16	0		
nr-DL-PRS-ResourceID-List-r16	Not present		
nr-DL-PRS-ResourceSetID-r16	Not present		
}			
nr-DL-PRS-AssistanceDataList-r16 SEQUENCE (SIZE (1..nrMaxFreqLayers-r16)) OF NR-DL-PRS-AssistanceDataPerFreq-r16 {	1 entry		
NR-DL-PRS-AssistanceDataPerFreq-r16[1] SEQUENCE {		entry 1	
nr-DL-PRS-PositioningFrequencyLayer-r16 SEQUENCE {			
dl-PRS-SubcarrierSpacing-r16	kHz120		
dl-PRS-ResourceBandwidth-r16	11	64 PRBs	
dl-PRS-StartPRB-r16	0		
}			
}			
}			
}			

dl-PRS-PointA-r16	absoluteFrequencyPointA as defined for the DL frequency of the Cell 1		
dl-PRS-CombSizeN-r16	n2		
dl-PRS-CyclicPrefix-r16	normal		
}			
nr-DL-PRS-AssistanceDataPerFreq-r16 SEQUENCE (SIZE (1..nrMaxTRPsPerFreq-r16)) OF NR-DL-PRS-AssistanceDataPerTRP-r16{	2 entries		
NR-DL-PRS-AssistanceDataPerTRP-r16[1] SEQUENCE {		entry 1	Cell 1
dl-PRS-ID-r16	0		
nr-PhysCellID-r16	Cell 1		
nr-CellGlobalID-r16	Cell 1		
nr-ARFCN-r16	Cell 1		
nr-DL-PRS-SFN0-Offset-r16 SEQUENCE {			
sfn-Offset-r16	0		
integerSubframeOffset-r16	0		
}			
nr-DL-PRS-ExpectedRSTD-r16	0		
nr-DL-PRS-ExpectedRSTD-Uncertainty-r16	0		
nr-DL-PRS-Info-r16	As specified in Table 15.3.5.4.3-8		
}			
NR-DL-PRS-AssistanceDataPerTRP-r16[2] SEQUENCE {		entry 2	Cell 2
dl-PRS-ID-r16	1		
nr-PhysCellID-r16	Cell 2		
nr-CellGlobalID-r16	Cell 2		
nr-ARFCN-r16	Cell 2		
nr-DL-PRS-SFN0-Offset-r16 SEQUENCE {			
sfn-Offset-r16	0		
integerSubframeOffset-r16	0		
}			
nr-DL-PRS-ExpectedRSTD-r16	23	About 3 μs	
nr-DL-PRS-ExpectedRSTD-Uncertainty-r16	154	About 5 μs	
nr-DL-PRS-Info-r16	As specified in Table 15.3.5.4.3-8		
}			
}			
}			
}			
}			
}			

Table 15.3.5.4.3-8: NR-DL-PRS-Info

Derivation Path: 37.355 clause 6.4.3			
Information Element	Value/remark	Comment	Condition
NR-DL-PRS-Info-r16 ::= SEQUENCE {			
nr-DL-PRS-ResourceSetList-r16 SEQUENCE (SIZE (1..nrMaxSetsPerTrp-r16)) OF NR-DL-PRS-ResourceSet-r16 {	1 entry		
NR-DL-PRS-ResourceSet-r16[1] SEQUENCE {		entry 1	
nr-DL-PRS-ResourceSetID-r16	0		
dl-PRS-Periodicity-and-ResourceSetSlotOffset-r16 CHOICE {			
scs120-r16 CHOICE {			
n160-r16	80		
}			
dl-PRS-ResourceRepetitionFactor-r16	n2		
dl-PRS-ResourceTimeGap-r16	s1		
dl-PRS-NumSymbols-r16	n4		
dl-PRS-MutingOption1-r16	Not present		
dl-PRS-MutingOption2-r16	Not present		
dl-PRS-ResourcePower-r16	27		

dl-PRS-ResourceList-r16 SEQUENCE (SIZE (1..nrMaxResourcesPerSet-r16)) OF NR-DL-PRS-Resource-r16 {	1 entry		
NR-DL-PRS-Resource-r16[1] SEQUENCE {		entry 1	
nr-DL-PRS-ResourceID-r16	0		
dl-PRS-SequenceID-r16	0		
dl-PRS-CombSizeN-AndReOffset-r16 CHOICE {			
n2-r16	0		
}			
dl-PRS-ResourceSlotOffset-r16	0		
dl-PRS-ResourceSymbolOffset-r16	0		
dl-PRS-QCL-Info-r16	Not present		
}			
}			
}			
}			
}			

Table 15.3.5.4.3-9: LPP ProvideLocation Information

Derivation Path: 37.355 clause 6.5.12			
Information Element	Value/remark	Comment	Condition
LPP-Message ::= SEQUENCE {			
transactionID SEQUENCE {			
initiator	locationServer		
transactionNumber	1		
}			
endTransaction	TRUE		
sequenceNumber	(0..255)		
acknowledgement			
lpp-MessageBody CHOICE {			
c1 CHOICE {			
provideLocationInformation SEQUENCE {			
criticalExtensions CHOICE {			
c1 CHOICE {			
provideLocationInformation-r9 SEQUENCE {			
commonIEsProvideLocationInformation	Not present.		
a-gnss-ProvideLocationInformation	Not present		
otdoa-ProvideLocationInformation	Not present		
ecid-ProvideLocationInformation	Not present		
epdu-ProvideLocationInformation	Not present		
sensor-ProvideLocationInformation-r13	Not present		
tbs-ProvideLocationInformation-r13	Not present		
wlan-ProvideLocationInformation-r13	Not present		
bt-ProvideLocationInformation-r13	Not present		
nr-ECID-ProvideLocationInformation-r16	Not present		
nr-Multi-RTT-ProvideLocationInformation-r16 SEQUENCE {			
nr-Multi-RTT-SignalMeasurementInformation-r16 SEQUENCE {			
nr-Multi-RTT-MeasList-r16 SEQUENCE (SIZE(1..nrMaxTRPs-r16)) OF NR-Multi-RTT-MeasElement-r16 {	2 entries		
NR-Multi-RTT-MeasElement-r16[1] SEQUENCE {		entry 1	
dl-PRS-ID-r16	INTEGER (0..255)		
nr-PhysCellID-r16			
nr-CellGlobalID-r16			
nr-ARFCN-r16			
nr-DL-PRS-ResourceID-r16			
nr-DL-PRS-ResourceSetID-r16			
nr-UE-RxTxTimeDiff-r16	Present. Any value acceptable.		
nr-AdditionalPathList-r16			
nr-TimeStamp-r16			

	nr-TimingQuality-r16			
	nr-DL-PRS-RSRP-Result-r16			
r16	nr-Multi-RTT-AdditionalMeasurements-			
	nr-UE-RxTx-TEG-Info-r17			
	nr-DL-PRS-FirstPathRSRP-Result-r17			
	nr-los-nlos-Indicator-r17			
	nr-AdditionalPathListExt-r17			
	nr-Multi-RTT-AdditionalMeasurementsExt-r17			
	}			
SEQUENCE {	NR-Multi-RTT-MeasElement-r16[2]		entry 2	
	dl-PRS-ID-r16	INTEGER (0..255)		
	nr-PhysCellID-r16			
	nr-CellGlobalID-r16			
	nr-ARFCN-r16			
	nr-DL-PRS-ResourceID-r16			
	nr-DL-PRS-ResourceSetID-r16			
	nr-UE-RxTxTimeDiff-r16	Present. Any value acceptable.		
	nr-AdditionalPathList-r16			
	nr-TimeStamp-r16			
	nr-TimingQuality-r16			
	nr-DL-PRS-RSRP-Result-r16			
	}			
r16	nr-Multi-RTT-AdditionalMeasurements-			
	nr-UE-RxTx-TEG-Info-r17			
	nr-DL-PRS-FirstPathRSRP-Result-r17			
	nr-los-nlos-Indicator-r17			
	nr-AdditionalPathListExt-r17			
	nr-Multi-RTT-AdditionalMeasurementsExt-r17			
	}			
	}			
	nr-NTA-Offset-r16			
	nr-SRS-TxTEG-Set-r17			
	nr-UE-RxTEG-TimingErrorMargin-r17			
	nr-UE-TxTEG-TimingErrorMargin-r17			
	nr-UE-RxTxTEG-TimingErrorMargin-r17			
	}			
	nr-Multi-RTT-Error-r16			
	nr-Multi-RTT-SignalMeasurementInstances-r17			
	}			
	nr-DL-AoD-ProvideLocationInformation-r16	Not present		
	}			
	}			
	}			
	}			
	}			
	}			
	}			

15.3.5.5 Test requirement

Table 15.3.5.5-1 defines the primary level settings including test tolerances for the test.

Table 15.3.5.5-1: UE Rx-Tx time difference measurement accuracy test parameters

Parameter	Unit	Test configuration	Test 1	
			Cell 1	Cell 2
AoA setup		1	Setup 1 as specified in clause A.3.15	

Beam Assumption ^{Note 7}		1	Rough	Rough
Measurement gap		1	GP#24 or GP#13 ^{Note 8}	
DRX		1	OFF	
Time offset with Cell 1	μs	1	N/A	3
TDD configuration		1	TDDConf.3.1	TDDConf.3.1
PDSCH RMC configuration		1	SR.3.1 TDD	N/A
RMSI CORESET RMC configuration		1	CR.3.1 TDD	N/A
Dedicated CORESET RMC configuration		1	CCR.3.1 TDD	N/A
OCNG Patterns		1	OP.1	OP.1
EPRE ratio of PSS to SSS	dB	1	0	0
EPRE ratio of PBCH DMRS to SSS				
EPRE ratio of PBCH to PBCH DMRS				
EPRE ratio of PDCCH DMRS to SSS				
EPRE ratio of PDCCH to PDCCH DMRS				
EPRE ratio of PDSCH DMRS to SSS				
EPRE ratio of PDSCH to PDSCH DMRS				
EPRE ratio of OCNG DMRS to SSS ^{Note 1}				
EPRE ratio of OCNG to OCNG DMRS ^{Note 1}				
EPRE ratio of PRS to SSS				
TRS Configuration		1	TRS.2.1 TDD	N/A
Initial BWP configuration		1	DLBWP.0.1 ULBWP.0.1	N/A
Active DL BWP configuration		1	DLBWP.1.1	N/A
Active UL BWP configuration		1	ULBWP.1.1	N/A
PRS configuration		1	PRS.1.1 FR2	PRS.1.1 FR2
PRS BW		1	64 PRBs	64 PRBs
PRS Resource slot offset	slot	1	0	4
SRS configuration		1	POS-SRS.3	N/A
N_{oc} ^{Note 2}	dBm/SCS	1	-94	
N_{oc} ^{Note 2}	dBm/15 kHz	1	-103	
PRS \hat{E}_s/I_{ot}	dB	1	0.32	-5.64
PRS \hat{E}_s/N_{oc}	dB	1	3.56	-0.28
PRP ^{Note 3}	dBm/SCS kHz	1	-90.4	-94.2
Io	dBm/190.08 MHz	1	-55.73	-55.73
Propagation Condition		1	AWGN	
<p>Note 1: Void.</p> <p>Note 2: Interference from other cells and noise sources not specified in the test is assumed to be constant over subcarriers and time and shall be modelled as AWGN of appropriate power for N_{oc} to be fulfilled.</p> <p>Note 3: PRP and Io levels have been derived from other parameters for information purposes. They are not settable parameters themselves.</p> <p>Note 4: PRP minimum requirements are specified assuming independent interference and noise at each receiver antenna port.</p> <p>Note 5: Equivalent power received by an antenna with 0 dBi gain at the centre of the quiet zone</p> <p>Note 6: As observed with 0 dBi gain antenna at the centre of the quiet zone</p> <p>Note 7: Information about types of UE beam is given in TS 38.133 [50] B.2.1.3, and does not limit UE implementation or test system implementation</p> <p>Note 8: GP#24 is configured if UE supports MG#24, otherwise GP#13 is configured.</p> <p>Note 9: Calculation of E_s/I_{ot} includes the effect of UE internal noise up to the value assumed for the associated Refsens requirement in clause 7.3.2 of TS 38.101-2 [55], and an allowance of 1dB for UE multi-band relaxation factor ΔMB_P from TS 38.101-2 [55] Table 6.2.1.3-4.</p>				

The UE Rx – Tx time difference measurement accuracy for Cell 2 shall fulfil the absolute requirement in clause 15.3.5.3.

The value of the LPP Time IE depends on the UE capabilities. The calculation is the same as in clause 15.2.8.5 Therefore, the value of the LPP Time IE is given by the following equation:

$$\left(1 * 1 * 1 * 8 * \left\lceil \frac{2}{N'} \right\rceil \left\lceil \frac{0.071}{N} \right\rceil * 1 - 1 \right)$$

Where the remaining parameters depend on the UE capabilities. The LPP time IE ranges between 12.88s and 21.92s.

Table 15.3.5.5-2: UE Rx – Tx time difference measurement accuracy requirements

Test Configuration	Lowest reported value	Highest reported value
test 1	(5898 – 65) T _c converted to UE Rx-Tx time difference measurement according to clause 4.14.6	(5898 + 65) T _c converted to UE Rx-Tx time difference measurement according to clause 4.14.6

The test tolerances are defined in clauses C.1.6 and C.2.5.

The rate of successful tests during repeated tests shall be at least 90% with a confidence level of 95%.

15.3.6 UE Rx-Tx time difference measurement accuracy for single positioning frequency layer with RxTx TEG in FR2 SA

Editor’s Note: This test case has been completed for the following configurations:

- Test frequency $f \leq 40.8$ GHz
- UE PC3

15.3.6.1 Test purpose

The purpose of the test is to verify that the relative UE Rx-Tx time difference measurement accuracy when the two measurements are within the same RxTx TEG is within the specified limits. This test will verify the requirements in TS 38.133 [50] clause 10.1.25.2. The test is conducted in AWGN propagation condition in FR2 in standalone scenario when single positioning frequency layer is configured.

15.3.6.2 Test applicability

This test applies to all types of NR UE release 17 onwards that supports Multi-RTT positioning and nr-UE-RxTxTEG-ID-MaxSupport-r17.

15.3.6.3 Minimum conformance requirements

The relative accuracy requirements in Table 10.1.25.2-3b for FR2 are valid under the following conditions:

Conditions defined in clause 7.3 of TS 38.101-2 [19] for reference sensitivity are fulfilled.

PRP_{dBm} according to Annex B.2.14 for a corresponding Band

AWGN propagation condition.

the two UE Rx-Tx time difference measurements are associated with the same RxTx TEG

Table 10.1.25.2-3b: UE Rx-Tx time difference relative measurement accuracy in FR2 in AWGN with TEG reporting

Accuracy	Conditions					
	PRS Ês/lot	PRS SCS	PRS bandwidth	PRS resource repetition	I _o ^{Note 3} range	
					Minimum I _o	Maximum I _o

T_c ^{Note 4}	dB	kHz	RB	Note 1 $(T_{rep}^{PRS} * L_{PRS} / K_{comb}^{PRS})$ Note 2	dBm/SCS	dBm/BW _{Channel}
$35 + \Delta$ ^{Note 6}	(PRS $\hat{E}_s/lot)_j \geq -6$ dB	60	≥ 24	≥ 4	Same value as PRS_RP in Table B.2.14-2, according to UE Power class, operating band and angle of arrival	-50
$24 + \Delta$			≥ 64	≥ 1	Note 5	Note 5
$11 + \Delta$			≥ 132	≥ 1	Note 5	Note 5
$24 + \Delta$	(PRS $\hat{E}_s/lot)_i \geq -13$ dB	120	≥ 32	≥ 4	Same value as PRS_RP in Table B.2.14-2, according to UE Power class, operating band and angle of arrival	-50
$13 + \Delta$			≥ 64	≥ 1	Note 5	Note 5
$6 + \Delta$			≥ 128	≥ 1	Note 5	Note 5

NOTE 1: Minimum PRS bandwidth, which is minimum of the PRS bandwidths of resource j and resource i.
 NOTE 2: Minimum number of PRS resource repetitions among resource j and resource i. $T_{rep}^{PRS}, L_{PRS}, K_{comb}^{PRS}$ are configured by higher layer parameter *dl-PRS-ResourceRepetitionFactor*, *dl-PRS-NumSymbols* and *dl-PRS-CombSizeN* defined in TS 37.355 [34], respectively.
 NOTE 3: l_o is assumed to have constant EPRE across the bandwidth.
 NOTE 4: T_c is the basic timing unit defined in TS 38.211 [6].
 NOTE 5: The same bands and the same l_o conditions for each band apply for this requirement as for the corresponding requirement with the PRS bandwidth of the smallest RB number for the corresponding SCS.
 NOTE 6: Δ is the value of the timing error margin for the RxTx TEG, reported via *nr-UE-RxTxTEG-TimingErrorMargin*. Δ cannot be larger than the sum of the margins in table 10.1.25.2-6 (dependent on PRS/SRS BW) for any pair of individual UE Rx-Tx time difference measurements associated with the RxTx TEG.

...

Table 10.1.25.2-6: Margin for UE Rx-Tx time difference measurement accuracy in FR2

Min(PRS BW, SRS BW) (MHz)		Margin (T_c ^{Note 1})
SCS = 60 kHz	SCS = 120 kHz	
≥ 24	N/A	76
≥ 64	≥ 32	32
≥ 132	≥ 64	24
N/A	≥ 128	20

NOTE 1: T_c is the basic timing unit defined in TS 38.211 [6].
 NOTE 2: If SRS and PRS have different SCS, the margin corresponding to the smallest RS BW in MHz applies.

15.3.6.4 Test description

15.3.6.4.1 Initial conditions

The supported test configuration is listed in Table 15.3.6.4-1.

Table 15.3.6.4-1: Test Configuration

Test Configuration	Description
1	120 kHz SSB and PRS SCS, 200 MHz bandwidth, TDD duplex mode

Test Environment: Normal, as defined in TS 38.508-1 [45] clause 4.1.

Frequencies to be tested: Mid Range, as defined in TS 38.508-1 [45] clause 4.3.1.

Channel bandwidth to be tested: are specified in Table 15.3.6.4-1.

1. Connect the SS and AWGN noise sources to the UE antenna connector or antenna connectors as shown in Annex A, Figure A.14.
2. The general test parameter settings are set up according to Table 15.3.6.5-1.
3. Propagation conditions are set according to clause 4.14.2.
4. Message contents are defined in clause 15.3.6.4.3.
5. In the test there are two cells in the test: PCell (Cell 1) and a neighbour cell (Cell 2). All cells are on the same RF channel in FR2.

15.3.6.4.2 Test procedure

The test consists of two sub-tests; the difference between the sub-tests is the PRS configuration, PRS.1.1 FR2 and PRS.1.2 FR2. The test consists of a set-up period and a measurement period. Cell 1 and Cell 2 are both active during the complete test. The beginning of the measurement period shall be aligned with the first PRS positioning subframe of a positioning occasion in the reference cell. The *NR-Multi-RTT-ProvideAssistanceData* and *NR-Multi-RTT-RequestLocationInformation* shall be provided to the UE during the set-up period.

The UE is configured with measurement gap pattern ID # 24 or #13 before T2.

2. Ensure the UE is in State RRC_CONNECTED with generic procedure parameters Connectivity NR, Connected without release On, according to TS 38.508-1 [45] clause 4.5. Note that in the remainder of the test the timing advance command $T_A = 31$ which indicates a timing advance adjustment value $N_{TA} = 0 T_c$.
2. The SS shall send a RESET UE POSITIONING STORED INFORMATION message.
3. The SS adjusts the downlink timing for Cell 1 to a delay of $+512 T_c$, compared to the current value.
4. Wait for 1.6 s to allow for the possibility that the UE makes autonomous timing adjustments.
5. The SS shall transmit an RRCReconfiguration message with the SRS configuration.
6. The UE shall transmit RRCReconfigurationComplete message.
7. The SS shall transmit an LPP REQUEST CAPABILITIES message.
8. The UE shall transmit an LPP PROVIDE CAPABILITIES message indicating the Multi-RTT capabilities supported by the UE in the *NR-Multi-RTT-ProvideCapabilities* IE.
9. The SS shall send a LPP PROVIDE ASSISTANCE DATA message, including the *NR-Multi-RTT-ProvideAssistanceData* IE. The position of neighbour Cell 2 is described in 3GPP TS 37.571-5 [20]. If the UE message at step 8 includes the *ackRequested* IE set to TRUE, then the SS shall send an acknowledgment in the LPP PROVIDE ASSISTANCE DATA message.
10. The SS shall send a LPP REQUEST LOCATION INFORMATION message, including the *nr-UE-RxTxTEG-Request-r17* in the *NR-Multi-RTT-RequestLocationInformation* IE such that the UE receives the message ΔT ms before the start of the measurement period, where $\Delta T = 50$ ms.
11. The UE shall transmit a LPP PROVIDE LOCATION INFORMATION message including the *NR-Multi-RTT-ProvideLocationInformation* IE within the response time (see clause 15.3.6.4.3).
12. If the UE message at step 11 includes the *ackRequested* IE set to TRUE, the SS shall send a LPP acknowledgement message.
13. The SS shall check *nr-UE-RxTxTimeDiff-r16* value for Cell 2 in the *NR-Multi-RTT-SignalMeasurementInformation* according to Table 15.3.6.5-3.
14. Repeat steps 1-13 until the confidence level according to Annex D is achieved.
15. Repeat step 1-14 for the other sub-test defined in Table 15.3.6.5-1 as appropriate.

If all (applicable) sub-tests pass, the whole test passes. If one (applicable) sub-test fails, the whole test fails.

NOTE: To avoid a large divergence between the sent TA and the set downlink timing, the SS may reset the downlink timing for Cell 1 to its initial value after a certain amount of loops. The loop during the reset does not count for the result statistics.

15.3.6.4.3 Message contents

Table 15.3.6.4.3-1: RESET UE POSITIONING STORED INFORMATION

Derivation Path: 38.509 [44] clause 6.6			
Information Element	Value/remark	Comment	Condition
UE Positioning Technology	0 0 0 0 1 1 0	Multi-RTT	

Table 15.3.6.4.3-2: RRCReconfiguration

Derivation Path: TS 38.508-1 [45], table 4.6.1-13			
Information Element	Value/remark	Comment	Condition
RRCReconfiguration ::= SEQUENCE {			
criticalExtensions CHOICE {			
rrcReconfiguration SEQUENCE {			
radioBearerConfig			
nonCriticalExtension SEQUENCE {			
masterCellGroup SEQUENCE {	CellGroupConfig		
spCellConfig SEQUENCE {			
spCellConfigDedicated SEQUENCE {			
uplinkConfig SEQUENCE {			
initialUplinkBWP SEQUENCE {			
srs-Config CHOICE {			
setup	As defined in Table 15.3.6.4.3-3		
}			
}			
}			
}			
}			
}			

Table 15.3.6.4.3-3: SRS-Config (Table 15.3.6.4.3-2)

Derivation Path: TS 38.508-1 [45], Table 4.6.3-182			
Information Element	Value/remark	Comment	Condition
SRS-Config ::= SEQUENCE {			
srs-ResourceSetToReleaseList	Not present		
srs-ResourceSetToAddModList	Not present		
srs-ResourceToReleaseList	Not present		
srs-ResourceToAddModList	Not present		
tpc-Accumulation	Not present		
srs-RequestDCI-1-2-r16	Not present		
srs-RequestDCI-0-2-r16	Not present		
srs-ResourceSetToAddModListDCI-0-2-r16	Not present		
srs-ResourceSetToReleaseListDCI-0-2-r16	Not present		
srs-PosResourceSetToReleaseList-r16	Not present		
srs-PosResourceSetToAddModList-r16 SEQUENCE (SIZE(1..maxNrofSRS-PosResourceSets-r16)) OF SRS-PosResourceSet-r16 {	1 entry		
SRS-PosResourceSet-r16[1] SEQUENCE {		entry 1	
srs-PosResourceSetId-r16	0		

srs-PosResourceIdList-r16 SEQUENCE (SIZE(1..maxNrofSRS-ResourcesPerSet)) OF SRS-PosResourceId-r16 {	1 entry		
SRS-PosResourceId-r16	0	1 entry	
}			
resourceType CHOICE {			
periodic SEQUENCE {			
}			
}			
alpha-r16	alpha0		
p0-r16	0		
pathlossReferenceRS-Pos-r16	Not present		
}			
srs-PosResourceToReleaseList-r16	Not present		
srs-PosResourceToAddModList-r16 SEQUENCE (SIZE(1..maxNrofSRS-PosResources-r16)) OF SRS-PosResource-r16 {	1 entry		
SRS-PosResource-r16[1] SEQUENCE {		entry 1	
srs-PosResourceId-r16	0		
transmissionComb-r16 CHOICE {			
n4-r16 SEQUENCE {			
combOffset-n4-r16	0		
cyclicShift-n4-r16	0		
}			
}			
resourceMapping-r16 SEQUENCE {			
startPosition-r16	0		
nrofSymbols-r16	n4		
}			
freqDomainShift-r16	0		
freqHopping-r16 SEQUENCE {			
c-SRS-r16	Matches N _{RB,c} Table 15.3.6.5-1		
}			
groupOrSequenceHopping-r16	neither		
resourceType-r16 CHOICE {			
periodic-r16 SEQUENCE {			
periodicityAndOffset-p-r16 CHOICE {			
sl1280	160		
}			
}			
}			
sequenceId-r16	0		
spatialRelationInfoPos-r16	Not present		
}			
}			
}			

Table 15.3.6.4.3-4: LPP Request Capabilities

Information Element	Value/remark
nr-Multi-RTT-RequestCapabilities-r16	TRUE

Table 15.3.6.4.3-5: LPP RequestLocationInformation

Derivation Path: TS 37.355 [49] clause 6.2			
Information Element	Value/remark	Comment	Condition
LPP-Message ::= SEQUENCE {			
transactionID SEQUENCE {			
initiator	locationServer		
transactionNumber	1		
}			
endTransaction	FALSE		

sequenceNumber	Not present		
acknowledgement	Not present		
lpp-MessageBody CHOICE {			
c1 CHOICE {			
requestLocationInformation SEQUENCE {			
criticalExtensions CHOICE {			
c1 CHOICE {			
requestLocationInformation-r9 SEQUENCE {			
commonEsRequestLocationInformation SEQUENCE {			
locationInformationType	locationMeasurementsPreferred		
triggeredReporting	Not present		
periodicalReporting	Not present		
additionalInformation	onlyReturnInformationRequested		
qos SEQUENCE {			
horizontalAccuracy	Not present		
verticalCoordinateRequest	FALSE		
verticalAccuracy	Not present		
responseTime SEQUENCE {			
time	See 15.3.6.5	Result of the response time calculation rounded up to the next second if response time <= 128s. Result of the response time calculation rounded up to the next multiple of ten seconds if response time > 128s	
responseTimeEarlyFix-r12	Not present		Rel-12 onwards
unit-r15	Not present ten-seconds		Calculated response time >128s
}			
velocityRequest	FALSE		
}			
environment	Not present		
locationCoordinateTypes	Not present		
velocityTypes	Not present		
}			
a-gnss-RequestLocationInformation	Not present		
otdoa-RequestLocationInformation	Not present		
ecid-RequestLocationInformation	Not present		
epdu-RequestLocationInformation	Not Present		
sensor-RequestLocationInformation-r13	Not present		
tbs-RequestLocationInformation-r13	Not present		
wlan-RequestLocationInformation-r13	Not present		
bt-RequestLocationInformation-r13	Not present		
nr-ECID-RequestLocationInformation-r16	Not present		
nr-Multi-RTT-RequestLocationInformation-r16 SEQUENCE {			
nr-UE-RxTxTimeDiffMeasurementInfoRequest-r16	Not present		
nr-RequestedMeasurements-r16	bit 0 = 1 (prsrsrpReq)		
nr-AssistanceAvailability-r16	FALSE		
nr-Multi-RTT-ReportConfig-r16 SEQUENCE {			
maxDL-PRS-RxTxTimeDiffMeasPerTRP-r16	Not present		
timingReportingGranularityFactor-r16	Not present		

}			
additionalPaths-r16	Not present		
nr-UE-RxTxTEG-Request-r17	case1		
measureSameDL-PRS-ResourceWithDifferentRxTxTEGs-r17	Not present		
measureSameDL-PRS-ResourceWithDifferentRxTEGs-r17	n2		
reducedDL-PRS-ProcessingSamples-r17	Not present		
nr-los-nlos-IndicatorRequest-r17	Not present		
additionalPathsExt-r17	Not present		
additionalPathsDL-PRS-RSRP-Request-r17	Not present		
multiMeasInSameReport-r17	Not present		
lowerRxBeamSweepingFactor-FR2-r17	Not present		
}			
nr-DL-AoD-RequestLocationInformation-r16	Not present		
nr-DL-TDOA-RequestLocationInformation-r16	Not present		
}			
}			
}			
}			
}			
}			
}			
}			

Table 15.3.6.4.3-6: LPP ProvideAssistanceData

Derivation Path: 37.355 clause 6.2			
Information Element	Value/remark	Comment	Condition
LPP-Message ::= SEQUENCE {			
transactionID SEQUENCE {			
initiator	locationServer		
transactionNumber	(0..255)		
}			
endTransaction	TRUE		
sequenceNumber	Not present		
acknowledgement	Not present		
lpp-MessageBody CHOICE {			
c1 CHOICE {			
provideAssistanceData SEQUENCE {			
criticalExtensions CHOICE {			
c1 CHOICE {			
provideAssistanceData-r9 SEQUENCE {			
commonIEsProvideAssistanceData	Not present		
a-gnss-ProvideAssistanceData	Not present		
otdoa-ProvideAssistanceData	Not present		
epdu-ProvideAssistanceData	Not present		
sensor-ProvideAssistanceData-r15	Not present		
tbs-ProvideAssistanceData-r15	Not present		
wlan-ProvideAssistanceData-r15	Not present		
nr-Multi-RTT-ProvideAssistanceData-r16			
} SEQUENCE {			
nr-DL-PRS-AssistanceData	As defined in Table 15.3.6.4.3-7		
nr-SelectedDL-PRS-IndexList-r16	Not present		
nr-Multi-RTT-Error-r16	Not present		
nr-On-Demand-DL-PRS-Configurations-r17	Not present		
nr-On-Demand-DL-PRS-Configurations-Selected-IndexList-r17	Not present		
assistanceDataValidityArea-r17	Not present		
}			
nr-DL-AoD-ProvideAssistanceData-r16	Not present		
nr-DL-TDOA-ProvideAssistanceData-r16	Not present		
}			
}			
}			
}			

}			
}			
}			
}			

Table 15.3.6.4.3-7: NR-DL-PRS-AssistanceData

Derivation Path: 37.355 clause 6.4.3			
Information Element	Value/remark	Comment	Condition
NR-DL-PRS-AssistanceData-r16 ::= SEQUENCE {			
nr-DL-PRS-ReferenceInfo-r16 SEQUENCE {			
dl-PRS-ID-r16	0		
nr-DL-PRS-ResourceID-List-r16	Not present		
nr-DL-PRS-ResourceSetID-r16	Not present		
}			
nr-DL-PRS-AssistanceDataList-r16 SEQUENCE (SIZE (1..nrMaxFreqLayers-r16)) OF NR-DL-PRS-AssistanceDataPerFreq-r16 {	1 entry		
NR-DL-PRS-AssistanceDataPerFreq-r16[1] SEQUENCE {		entry 1	
nr-DL-PRS-PositioningFrequencyLayer-r16 SEQUENCE {			
dl-PRS-SubcarrierSpacing-r16	kHz120		
dl-PRS-ResourceBandwidth-r16	3	32 PRBs	Sub-test 1
	27	128 PRBs	Sub-test 2
dl-PRS-StartPRB-r16	0		
dl-PRS-PointA-r16	absoluteFrequencyPointA as defined for the DL frequency of the Cell 1		
dl-PRS-CombSizeN-r16	n2		Sub-test 1
	n4		Sub-test 2
dl-PRS-CyclicPrefix-r16	normal		
}			
nr-DL-PRS-AssistanceDataPerFreq-r16 SEQUENCE (SIZE (1..nrMaxTRPsPerFreq-r16)) OF NR-DL-PRS-AssistanceDataPerTRP-r16{	2 entries		
NR-DL-PRS-AssistanceDataPerTRP-r16[1] SEQUENCE {		entry 1	Cell 1
dl-PRS-ID-r16	0		
nr-PhysCellID-r16	Cell 1		
nr-CellGlobalID-r16	Cell 1		
nr-ARFCN-r16	Cell 1		
nr-DL-PRS-SFN0-Offset-r16 SEQUENCE {			
sfn-Offset-r16	0		
integerSubframeOffset-r16	0		
}			
nr-DL-PRS-ExpectedRSTD-r16	0		
nr-DL-PRS-ExpectedRSTD-Uncertainty-r16	0		
nr-DL-PRS-Info-r16	As specified in Table 15.3.6.4.3-8		
}			
NR-DL-PRS-AssistanceDataPerTRP-r16[2] SEQUENCE {		entry 2	Cell 2
dl-PRS-ID-r16	1		
nr-PhysCellID-r16	Cell 2		
nr-CellGlobalID-r16	Cell 2		
nr-ARFCN-r16	Cell 2		
nr-DL-PRS-SFN0-Offset-r16 SEQUENCE {			
sfn-Offset-r16	0		
integerSubframeOffset-r16	0		
}			
nr-DL-PRS-ExpectedRSTD-r16	23	About 3 μs	
nr-DL-PRS-ExpectedRSTD-Uncertainty-r16	154	About 5 μs	
nr-DL-PRS-Info-r16	As specified in Table 15.3.6.4.3-8		

}			
}			
}			
}			
}			

Table 15.3.6.4.3-8: NR-DL-PRS-Info

Derivation Path: 37.355 clause 6.4.3			
Information Element	Value/remark	Comment	Condition
NR-DL-PRS-Info-r16 ::= SEQUENCE {			
nr-DL-PRS-ResourceSetList-r16 SEQUENCE (SIZE (1..nrMaxSetsPerTrp-r16)) OF NR-DL-PRS-ResourceSet-r16 {	1 entry		
NR-DL-PRS-ResourceSet-r16[1] SEQUENCE {		entry 1	
nr-DL-PRS-ResourceSetID-r16	0		
dl-PRS-Periodicity-and-ResourceSetSlotOffset-r16 CHOICE {			
scs120-r16 CHOICE {			
n160-r16	80		
}			
dl-PRS-ResourceRepetitionFactor-r16	n2		Sub-test 1
	Not present		Sub-test 2
dl-PRS-ResourceTimeGap-r16	s1		
dl-PRS-NumSymbols-r16	n4		
dl-PRS-MutingOption1-r16	Not present		
dl-PRS-MutingOption2-r16	Not present		
dl-PRS-ResourcePower-r16	27		
dl-PRS-ResourceList-r16 SEQUENCE (SIZE (1..nrMaxResourcesPerSet-r16)) OF NR-DL-PRS-Resource-r16 {	1 entry		
NR-DL-PRS-Resource-r16[1] SEQUENCE {		entry 1	
nr-DL-PRS-ResourceID-r16	0		
dl-PRS-SequenceID-r16	0		
dl-PRS-CombSizeN-AndReOffset-r16 CHOICE {			
n2-r16	0		Sub-test 1
n4-r16	0		Sub-test 2
}			
dl-PRS-ResourceSlotOffset-r16	0		Sub-test 1
	4		Sub-test 2
dl-PRS-ResourceSymbolOffset-r16	0		
dl-PRS-QCL-Info-r16	Not present		
}			
}			
}			
}			
}			

Table 15.3.6.4.3-9: LPP ProvideLocation Information

Derivation Path: 37.355 clause 6.5.12			
Information Element	Value/remark	Comment	Condition
LPP-Message ::= SEQUENCE {			
transactionID SEQUENCE {			
initiator	locationServer		
transactionNumber	1		
}			
endTransaction	TRUE		
sequenceNumber	(0..255)		
acknowledgement			
lpp-MessageBody CHOICE {			
c1 CHOICE {			
provideLocationInformation SEQUENCE {			

criticalExtensions CHOICE {			
c1 CHOICE {			
provideLocationInformation-r9 SEQUENCE {			
commonIEsProvideLocationInformation	Not present.		
a-gnss-ProvideLocationInformation	Not present		
otdoa-ProvideLocationInformation	Not present		
ecid-ProvideLocationInformation	Not present		
epdu-ProvideLocationInformation	Not present		
sensor-ProvideLocationInformation-r13	Not present		
tbs-ProvideLocationInformation-r13	Not present		
wlan-ProvideLocationInformation-r13	Not present		
bt-ProvideLocationInformation-r13	Not present		
nr-ECID-ProvideLocationInformation-r16	Not present		
nr-Multi-RTT-ProvideLocationInformation-r16 SEQUENCE {			
nr-Multi-RTT-SignalMeasurementInformation-r16 SEQUENCE {			
nr-Multi-RTT-MeasList-r16 SEQUENCE (SIZE(1..nrMaxTRPs-r16)) OF NR-Multi-RTT-MeasElement-r16 {	2 entries		
NR-Multi-RTT-MeasElement-r16[1] SEQUENCE {		entry 1	
dl-PRS-ID-r16	INTEGER (0..255)		
nr-PhysCellID-r16			
nr-CellGlobalID-r16			
nr-ARFCN-r16			
nr-DL-PRS-ResourceID-r16			
nr-DL-PRS-ResourceSetID-r16			
nr-UE-RxTxTimeDiff-r16	Present. Any value acceptable.		
nr-AdditionalPathList-r16			
nr-TimeStamp-r16			
nr-TimingQuality-r16			
nr-DL-PRS-RSRP-Result-r16			
nr-Multi-RTT-AdditionalMeasurements-r16			
nr-UE-RxTx-TEG-Info-r17 CHOICE {			
case1-r17 SEQUENCE {			
nr-UE-RxTx-TEG-ID-r17	INTEGER (0..255)		
}			
}			
nr-DL-PRS-FirstPathRSRP-Result-r17			
nr-los-nlos-Indicator-r17			
nr-AdditionalPathListExt-r17			
nr-Multi-RTT-AdditionalMeasurementsExt-r17			
}			
}		entry 2	
}			
}			
}			
}			
}			

nr-UE-RxTx-TEG-ID-r17	INTEGER (0..255)		
}			
}			
nr-DL-PRS-FirstPathRSRP-Result-r17			
nr-los-nlos-Indicator-r17			
nr-AdditionalPathListExt-r17			
nr-Multi-RTT-AdditionalMeasurementsExt-r17			
}			
}			
nr-NTA-Offset-r16			
nr-SRS-TxTEG-Set-r17			
nr-UE-RxTEG-TimingErrorMargin-r17			
nr-UE-TxTEG-TimingErrorMargin-r17			
nr-UE-RxTxTEG-TimingErrorMargin-r17			
}			
nr-Multi-RTT-Error-r16			
nr-Multi-RTT-SignalMeasurementInstances-r17			
}			
nr-DL-AoD-ProvideLocationInformation-r16	Not present		
}			
}			
}			
}			
}			
}			
}			

15.3.6.5 Test requirement

Table 15.3.6.5-1 defines the primary level settings including test tolerances for the test.

Table 15.3.6.5-1: UE Rx-Tx time difference measurement accuracy test parameters

Parameter	Unit	Test configuration	Test 1		Test 2	
			Cell 1	Cell 2	Cell 1	Cell 2
AoA setup		1	Setup 1 as specified in clause A.3.15		Setup 1 as specified in clause A.3.15	
Beam Assumption ^{Note 7}		1	Rough	Rough	Rough	Rough
Measurement gap		1	GP#24 or GP#13 ^{Note 8}		GP#24 or GP#13 ^{Note 8}	
DRX		1	OFF		OFF	
Time offset with Cell 1	µs	1	N/A	3	N/A	3
TDD configuration		1	TDDConf.3.1	TDDConf.3.1	TDDConf.3.1	TDDConf.3.1
PDSCH RMC configuration		1	SR.3.1 TDD	N/A	SR.3.1 TDD	N/A
RMSI CORESET RMC configuration		1	CR.3.1 TDD	N/A	CR.3.1 TDD	N/A
Dedicated CORESET RMC configuration		1	CCR.3.1 TDD	N/A	CCR.3.1 TDD	N/A
OCNG Patterns		1	OP.1	OP.1	OP.1	OP.1
EPRE ratio of PSS to SSS	dB	1	0	0	0	0

EPRE ratio of PBCH_DMRS to SSS						
EPRE ratio of PBCH to PBCH_DMRS						
EPRE ratio of PDCCH_DMRS to SSS						
EPRE ratio of PDCCH to PDCCH_DMRS						
EPRE ratio of PDSCH_DMRS to SSS						
EPRE ratio of PDSCH to PDSCH_DMRS						
EPRE ratio of OCNG DMRS to SSS ^{Note 1}						
EPRE ratio of OCNG to OCNG DMRS ^{Note 1}						
EPRE ratio of PRS to SSS						
TRS Configuration		1	TRS.2.1 TDD	N/A	TRS.2.1 TDD	N/A
Initial BWP configuration		1	DLBWP.0.1 ULBWP.0.1	N/A	DLBWP.0.1 ULBWP.0.1	N/A
Active DL BWP configuration		1	DLBWP.1.1	N/A	DLBWP.1.1	N/A
Active UL BWP configuration		1	ULBWP.1.1	N/A	ULBWP.1.1	N/A
PRS configuration		1	PRS.1.1 FR2	PRS.1.1 FR2	PRS.1.2 FR2	PRS.1.2 FR2
PRS Resource slot offset	slot	1	0	4	0	4
SRS configuration		1	POS-SRS.3	N/A	POS-SRS.3	N/A
N_{oc} ^{Note 2}	dBm/SCS	1	-89.1		-89.1	
N_{oc} ^{Note 2}	dBm/15 kHz	1	-98.1		-98.1	
PRS \hat{E}_s/I_{ot}	dB	1	-5.69	-12.69	-5.69	-12.69
PRS \hat{E}_s/N_{oc}	dB	1	-5.17	-11.36	-5.17	-11.36
PRP ^{Note 3}	dBm/SCS kHz	1	-94.2	-100.4	-94.2	-100.4
lo	dBm/190.08 MHz	1	-55.68	-55.68	-55.68	-55.68
Propagation Condition		1	AWGN		AWGN	

Note 1:	Void.
Note 2:	Interference from other cells and noise sources not specified in the test is assumed to be constant over subcarriers and time and shall be modelled as AWGN of appropriate power for N_{oc} to be fulfilled.
Note 3:	PRP and Io levels have been derived from other parameters for information purposes. They are not settable parameters themselves.
Note 4:	PRP minimum requirements are specified assuming independent interference and noise at each receiver antenna port.
Note 5:	Equivalent power received by an antenna with 0 dBi gain at the centre of the quiet zone
Note 6:	As observed with 0 dBi gain antenna at the centre of the quiet zone
Note 7:	Information about types of UE beam is given in TS 38.133 [50] B.2.1.3, and does not limit UE implementation or test system implementation
Note 8:	GP#24 is configured if UE supports MG#24, otherwise GP#13 is configured.
Note 9:	Calculation of Es/Iot includes the effect of UE internal noise up to the value assumed for the associated Refsens requirement in clause 7.3.2 of TS 38.101-2 [55], and an allowance of 1dB for UE multi-band relaxation factor ΔMB_P from TS 38.101-2 [55] Table 6.2.1.3-4.

The UE Rx-Tx time difference measurement accuracy for Cell 2 shall fulfil the absolute requirement in clause 15.3.6.3.

The value of the LPP Time IE depends on the UE capabilities. The calculation is the same as in clause 15.2.10.5 Therefore, the value of the LPP Time IE is given by the following equation:

$$\left(k_{multiTEG} * 8 * \left\lceil \frac{2}{N'} \right\rceil \left\lceil \frac{0.071}{N} \right\rceil * 4 - 1 \right)$$

Where the remaining parameters depend on the UE capabilities. The LPP time IE ranges between 10.248s and 164s.

Table 15.3.6.5-2: UE Rx – Tx time difference measurement accuracy requirements

Test Configuration	Lowest reported value	Highest reported value
Sub-test 1	(5898 – 88) T _c converted to UE Rx-Tx time difference measurement according to clause 4.14.6	(5898 + 88) T _c converted to UE Rx-Tx time difference measurement according to clause 4.14.6
Sub-test 2	(5898 – 58) T _c converted to UE Rx-Tx time difference measurement according to clause 4.14.6	(5898 + 58) T _c converted to UE Rx-Tx time difference measurement according to clause 4.14.6

The test tolerances are defined in clauses C.1.6 and C.2.5.

The rate of successful tests during repeated tests shall be at least 90% with a confidence level of 95%.

15.4 UE Rx-Tx time difference measurement period test cases in RRC_INACTIVE

15.4.1 UE Rx-Tx time difference measurement reporting delay test case for single positioning frequency layer in FR1 SA

Editor's note: This test case is incomplete. The following aspect is either missing or TBD:

- Test tolerance are not added in and analysis is missing

15.4.1.1 Test purpose

The purpose of the test is to verify that the UE Rx-Tx measurement in RRC_INACTIVE state meets the requirements specified in TS 38.133 [50] clause 5.6.4 in AWGN propagation condition in FR1 in standalone scenario when single positioning frequency layer is configured.

15.4.1.2 Test applicability

This test applies to all types of NR UE release 17 onwards that supports Multi-RTT positioning and supports DL-PRS measurement in RRC_INACTIVE state.

15.4.1.3 Minimum conformance requirements

When physical layer receives last of *NR-Multi-RTT-ProvideAssistanceData* message and *NR-Multi-RTT-RequestLocationInformation* message from LMF via LPP [34], UE shall be able to measure multiple (up to the UE capability specified in clause 5.6.4.3) UE Rx-Tx time difference measurements as defined in TS 38.215 [4] in configured positioning frequency layers within the measurement period $T_{\text{UERxTx,Total}}$ ms.

$$T_{\text{UERxTx, Total}} = \sum_{i=1}^L T_{\text{UERxTx},i} + (L - 1) * \max(T_{\text{effect},i})$$

Where:

- i is the index of positioning frequency layer,
- $T_{\text{UERxTx},i}$ is the measurement period for UE Rx-Tx time difference measurements in positioning frequency layer i as further defined in this clause,
- L is total number of positioning frequency layers,
- $T_{\text{effect},i}$ is the periodicity of the UE Rx-Tx time difference measurement in positioning frequency layer i as defined further in this clause.

$$T_{\text{UERxTx},i} = \left(K_{\text{carrier_PRS}} * N_{\text{RxTx,TEG},i} * N_{\text{RxBeam},i} * \left\lfloor \frac{N_{\text{PRS},i}^{\text{slot}}}{N'} \right\rfloor \left\lfloor \frac{L_{\text{available_PRS},i}}{N} \right\rfloor * N_{\text{sample}} - 1 \right) * T_{\text{effect},i} + T_{\text{last},i}$$

Where:

- $K_{\text{carrier_PRS}} = 1$ if the UE is capable of *parallelPRS-MeasRRC-Inactive-r17* defined in [34].
- $K_{\text{carrier_PRS}} = N_{\text{layer}} + 1$ if the UE is not capable of *parallelPRS-MeasRRC-Inactive-r17* defined in [34] and if $S_{\text{rxlev}} > S_{\text{nonIntraSearchP}}$ and $S_{\text{qual}} > S_{\text{nonIntraSearchQ}}$; where N_{layer} is defined in clause 4.2.2.7.
- $K_{\text{carrier_PRS}} = K_{\text{carrier}} + 1$ if the UE is not capable of *parallelPRS-MeasRRC-Inactive-r17* defined in [34] and if $S_{\text{rxlev}} \leq S_{\text{nonIntraSearchP}}$ or $S_{\text{qual}} \leq S_{\text{nonIntraSearchQ}}$; where K_{carrier} is defined in clause 4.2.2.4.
- $N_{\text{RxBeam},i}$ is the scaling factor for UE Rx beam sweeping:
 - $N_{\text{RxBeam},i} = 1$ if positioning frequency layer i is in FR1, and if positioning frequency layer i is in FR2.
 - $N_{\text{RxBeam},i}$ equals to the value as UE reported in *supportedLowerRxBeamSweepingFactor-FR2* if the capability is reported by the UE for the band containing positioning frequency layer i , and LMF indicates *lowerRxBeamSweepingFactor-FR2* in *NR-Multi-RTT-RequestLocationInformation*.
 - $N_{\text{RxBeam},i}$ equals to 8, otherwise.

$N_{\text{RxTx,TEG},i}$ is the Rx TEG specific scaling factor:

- $N_{\text{RxTx,TEG},i} = 1$ if UE is not configured by LMF with *measureSameDL-PRS-ResourceWithDifferentRxTxTEGs-r17* or *measureSameDL-PRS-ResourceWithDifferentRxTxTEGs-r17* [34].

Otherwise,

- $N_{\text{RxTx,TEG},i} = N_{\text{TEG},i}$, if UE is not capable of measuring same DL PRS resource simultaneously from multiple Rx TEGs, where $N_{\text{TEG},i}$ is the number of Rx TEGs or RxTx TEGs with which UE is requested to measure a PRS resource indicated via *measureSameDL-PRS-ResourceWithDifferentRxTxTEGs-r17* or *measureSameDL-PRS-ResourceWithDifferentRxTxTEGs-r17* [34], and in case 'n0' is indicated, $N_{\text{TEG},i}$ is the maximum number of Rx TEGs with which UE can support to measure the same PRS resource as reported in *NR-UE-TEG-Capability*.

- $N_{RxTx,TEG,i} = \left\lceil \frac{N_{TEG,i}}{k_{TEG,simul,i}} \right\rceil$, if UE is capable of measuring same DL PRS resource simultaneously from multiple Rx TEGs, where $k_{TEG,simul,i}$ is the number of Rx TEGs UE can measure simultaneously which is reported via *measureSameDL-PRS-ResourceWithDifferentRxTEGsSimul*.
- $L_{available_PRS,i}$ is the time duration of available PRS resources in the positioning frequency layer i , to be measured during $T_{PRS,i}$, and is calculated in the same way as PRS duration K defined in clause 5.1.6.5 of TS 38.214 [26]. For calculation of $L_{available_PRS,i}$, only unmuted PRS resources that are not fully overlapped with other higher-priority DL signals/channels are considered.
- $N_{PRS,i}^{slot}$ is the maximum number of DL PRS resources of positioning frequency layer i configured in a slot,
- $\{N, T\}$ is UE capability combination per band where N is a duration of DL PRS symbols in ms corresponding to *durationOfPRS-ProcessingSymbols-r17* in TS 37.355 [34] processed every T ms corresponding to *durationOfPRS-ProcessingSymbolsInEveryTms-r17* in TS 37.355 [34] for a given maximum bandwidth supported by UE corresponding to *supportedBandwidthPRS* in clause 4.2.7.2 of TS 37.355 [34],
- N' is UE capability for number of DL PRS resources that it can process in a slot corresponding to *maxNumOfDL-PRS-ResProcessedPerSlot-RRC-Inactive-r17* as specified in clause 6.4.3 of TS 37.355 [34],
- N_{sample} is the number of UE Rx-Tx time difference measurement samples:
 - $N_{sample} = 4$ if the UE is not capable of *supportedDL-PRS-ProcessingSamples-RRC-Inactive* defined in [34] or not configured to perform positioning measurements with reduced number of samples by *reducedDL-PRS-ProcessingSamples-r17* [34].
 - $N_{sample} = 1$ if the UE is capable of *supportedDL-PRS-ProcessingSamples-RRC-Inactive* defined in [34] and LMF requests the UE to perform positioning measurements with reduced number of samples by *reducedDL-PRS-ProcessingSamples-r17* [34] and the following conditions are met:
 - PRS bandwidth is within the initial BWP and
 - Magnitude of difference between the serving cell's SS-RSRP and the neighbour cell's PRS-RSRP is within 6 dB.
 - $N_{sample} = 2$ if the UE is capable of *supportedDL-PRS-ProcessingSamples-RRC-Inactive* defined in [34] and the LMF requests the UE to perform positioning measurements with reduced number of samples by *reducedDL-PRS-ProcessingSamples-r17* [34] but the following conditions are not met:
 - PRS bandwidth is within the initial BWP and
 - Magnitude of difference between the serving cell's SS-RSRP and the neighbour cell's PRS-RSRP is within 6 dB.
- $T_{last,i}$ is the measurement duration for the last UE Rx-Tx time difference measurement sample in the positioning layer i , including the sampling time and processing time, $T_{last,i} = T_i + T_{available_PRS,i}$,
- $T_{effect,i}$ is periodicity of UE Rx-Tx time difference measurement in positioning frequency layer i :

$$T_{effect,i} = \left\lceil \frac{T_i}{T_{available_PRS,i}} \right\rceil * T_{available_PRS,i}$$

Where:

- T_i corresponds to *durationOfPRS-ProcessingSymbolsInEveryTms-r17* in TS 37.355 [34],
- $T_{available_PRS,i} = LCM(T_{PRS,i}, T_{DRX})$, the least common multiple between $T_{PRS,i}$ and T_{DRX} .
- T_{DRX} is the DRX cycle of the UE in the serving cell.
- $T_{PRS,i}$ is the PRS resource periodicity in positioning frequency layer i . If the positioning frequency layer i has more than one DL PRS resource sets with different PRS periodicities with muting, $T_{per}^{PRS \text{ with muting}} = N_{muting} *$

T_{per}^{PRS} , the least common multiple of $T_{per}^{PRS \text{ with muting}}$ among DL PRS resource sets is used to derive $T_{PRS,i}$, where:

- T_{per}^{PRS} is the periodicity of PRS resource sets given by the higher-layer parameter *DL-PRS-Periodicity*.
- N_{muting} is the scaling factor considering PRS resource muting. $N_{muting} = T_{muting}^{PRS} * L_{muting}$, where T_{muting}^{PRS} is the muting repetition factor given by the higher-layer parameter *DL-PRS-MutingBitRepetitionFactor*, and L_{muting} is the size of the bitmap $\{b^1\}$

15.4.1.4 Test description

15.4.1.4.1 Initial conditions

The test defines three possible test configurations; specified in Table 15.4.1.4-1. The UE is only required to be tested in one of the supported test configurations.

Table 15.4.1.4-1: Test Configurations

Test Configuration	Description
1	15 kHz SSB SCS, 10 MHz bandwidth, FDD duplex mode
2	15 kHz SSB SCS, 10 MHz bandwidth, TDD duplex mode
3	30 kHz SSB SCS, 40 MHz bandwidth, TDD duplex mode
Note:	The UE is only required to be tested in one of the supported test configurations.

Test Environment: Normal, as defined in TS 38.508-1 [45] clause 4.1.

Frequencies to be tested: Mid Range, as defined in TS 38.508-1 [45] clause 4.3.1.

Channel bandwidth to be tested: are specified in Table 15.4.1.4-1.

1. Connect the SS and AWGN noise sources to the UE antenna connector or antenna connectors as shown in Annex A, Figure A.13.
2. The general test parameter settings are set up according to Table 15.4.1.5-1 and Table 15.4.1.5-2.
3. Propagation conditions are set according to clause 4.14.2.
4. Message contents are defined in clause 15.4.1.4.3.
5. There are two cells in the test: PCell (Cell 1) and a neighbour cell (Cell 2). All cells are on the same RF channel in FR1.

15.4.1.4.2 Test procedure

The test consists of two consecutive time intervals, with duration of T1 and T2. During time duration T1, the UE shall be in RRC_CONNECTED state and shall not have any timing information of Cell 2. During T2 UE shall be in RRC_INACTIVE state and all cells transmit PRS resources within initial DL BWP of the UE and with the same numerology as the initial DL BWP.

2. Configure the Cell for RA-SDT with SIB1 configured according to the message content Table 15.4.1.4.3-1.
3. Ensure the UE is in State RRC_CONNECTED with generic procedure parameters Connectivity NR, Connected without release On, according to TS 38.508-1 [45] clause 4.5. Note that in the remainder of the test the timing advance command $T_A = 31$ which indicates a timing advance adjustment value $N_{TA} = 0 T_c$.
4. The SS shall send a RESET UE POSITIONING STORED INFORMATION message.
5. The SS adjusts the downlink timing for Cell 1 to a delay of $+512 T_c$, compared to the current value.
6. Wait for 1.6 s to allow for the possibility that the UE makes autonomous timing adjustments.
6. Set the parameters for T1 according to Table 15.4.1.5-1 and Table 15.4.1.5-2.

7. T1 starts.
8. The SS shall transmit an RRCReconfiguration message with the DRX configuration.
9. The UE shall transmit RRCReconfigurationComplete message.
10. The SS shall transmit an LPP REQUEST CAPABILITIES message.
11. The UE shall transmit an LPP PROVIDE CAPABILITIES message indicating the Multi-RTT capabilities supported by the UE in the *NR-Multi-RTT-ProvideCapabilitie* IE.
12. The SS shall send a LPP PROVIDE ASSISTANCE DATA message, including the *NR-Multi-RTT-ProvideAssistanceData* IE. The position of neighbour Cell 2 is described in 3GPP TS 37.571-5 [20]. If the UE message at step 11 includes the *ackRequested* IE set to TRUE, then the SS shall send an acknowledgment in the LPP PROVIDE ASSISTANCE DATA message.
13. The SS shall transmit LCS Periodic-Triggered Invoke Request message with LPP REQUEST LOCATION INFORMATION embedded to start the periodic reporting procedure, including the *NR-Multi-RTT-RequestLocationInformation* IE such that the UE receives the message ΔT ms before the start of T2, where $\Delta T = 50$ ms.
14. The UE shall transmit an LCS Periodic-Triggered Invoke Return Result message.
15. When T1 expires, the SS shall transmit an RRCRelease message with the UL configuration and SDT configuration to transit the UE to RRC_INACTIVE state.
16. Switch the power setting from T1 to T2 as specified in Table 15.4.1.5-1 and Table 15.4.1.5-2.
17. Wait for the UE monitors for occurrence of the periodic event requested.
18. The UE shall transmit an *RRCResumeRequest* message. If the UE also supporting SDT feature, the UE shall include LPP PROVIDE LOCATION INFORMATION message in the *RRCResumeRequest* message and then go to step 21.
18. The SS transmits an *RRCResume* message.
19. The UE transmits an *RRCResumeComplete* message.
20. The UE shall transmit a LPP PROVIDE LOCATION INFORMATION message including the *NR-Multi-RTT-ProvideLocationInformation* IE within the response time (see clause 15.4.1.4.3) plus the maximum RRC processing time 10ms between *RRCResume* message and *RRCResumeComplete* message.
21. The UE shall perform and report the UE Rx-Tx time difference measurements for Cell 1 and Cell 2. If the UE transmits an *NR-Multi-RTT-ProvideLocationInformation* IE including the *nr-UE-RxTxTimeDiff* field for Cell 1 and Cell 2 within the response time, then the number of successful tests is increased by one. If the UE fails to report the *NR-Multi-RTT-ProvideLocationInformation* IE with the *nr-UE-RxTxTimeDiff* field included within the response time then the number of failure tests is increased by one.
22. If the UE message at step 20 includes the *ackRequested* IE set to TRUE, the SS shall send a LPP acknowledgement message.
23. UE shall be released and moved to RRC_IDLE.
24. Repeat steps 1-23 in Tables 15.4.1.4-1 until the confidence level according to Annex D is achieved.

NOTE: To avoid a large divergence between the sent TA and the set downlink timing, the SS may reset the downlink timing for Cell 1 to its initial value after a certain amount of loops. The loop during the reset does not count for the result statistics.

15.4.1.4.3 Message contents

Table 15.4.1.4.3-1: SIB1

Derivation Path: TS 38.508-1 [45], clause 4.6.1 with condition SDT
--

Table 15.4.1.4.3-2: RESET UE POSITIONING STORED INFORMATION

Derivation Path: 38.509 [44] clause 6.6			
Information Element	Value/remark	Comment	Condition
UE Positioning Technology	0 0 0 0 1 1 0	Multi-RTT	

Table 15.4.1.4.3-3: RRCReconfiguration

Derivation Path: TS 38.508-1 [45], table 4.6.1-13			
Information Element	Value/remark	Comment	Condition
RRCReconfiguration ::= SEQUENCE {			
criticalExtensions CHOICE {			
rrcReconfiguration SEQUENCE {			
nonCriticalExtension SEQUENCE {			
masterCellGroup	CellGroupConfig		
}			
}			
}			

Table 15.4.1.4.3-4: CellGroupConfig (Table 15.4.1.4.3-3)

Derivation Path: 38.508-1 [45], Table 4.6.3-19			
Information Element	Value/remark	Comment	Condition
CellGroupConfig ::= SEQUENCE {			
mac-CellGroupConfig SEQUENCE {			
drx-Config CHOICE {			
setup SEQUENCE {			
drx-onDurationTimer	ms6		
drx-InactivityTimer	ms1		
drx-HARQ-RTT-TimerDL	sl64		
drx-HARQ-RTT-TimerUL	sl64		
drx-RetransmissionTimerDL	sl1		
drx-RetransmissionTimerUL	sl1		
drx-LongCycleStartOffset CHOICE {			
ms1280	0		
}			
shortDRX	not present		
drx-SlotOffset	0		
}			
}			

Table 15.4.1.4.3-5: LPP Request Capabilities

Information Element	Value/remark
nr-Multi-RTT-RequestCapabilities-r16	TRUE

Table 15.4.1.4.3-6: LPP ProvideAssistanceData

Derivation Path: 37.355 clause 6.2			
Information Element	Value/remark	Comment	Condition
LPP-Message ::= SEQUENCE {			
transactionID SEQUENCE {			
initiator	locationServer		
transactionNumber	(0..255)		
}			
endTransaction	TRUE		
sequenceNumber	Not present		
acknowledgement	Not present		

lpp-MessageBody CHOICE {			
c1 CHOICE {			
provideAssistanceData SEQUENCE {			
criticalExtensions CHOICE {			
c1 CHOICE {			
provideAssistanceData-r9 SEQUENCE {			
commonEsProvideAssistanceData	Not present		
a-gnss-ProvideAssistanceData	Not present		
otdoa-ProvideAssistanceData	Not present		
epdu-Provide-AssistanceData	Not present		
sensor-ProvideAssistanceData-r15	Not present		
tbs-ProvideAssistanceData-r15	Not present		
wlan-ProvideAssistanceData-r15	Not present		
nr-Multi-RTT-ProvideAssistanceData-r16			
SEQUENCE {			
nr-DL-PRS-AssistanceData	As defined in Table 15.4.1.4.3-7		
nr-SelectedDL-PRS-IndexList-r16	Not present		
nr-Multi-RTT-Error-r16	Not present		
nr-On-Demand-DL-PRS-Configurations-r17	Not present		
nr-On-Demand-DL-PRS-Configurations-Selected-IndexList-r17	Not present		
assistanceDataValidityArea-r17	Not present		
}			
nr-DL-AoD-ProvideAssistanceData-r16	Not present		
nr-DL-TDOA-ProvideAssistanceData-r16	Not present		
}			
}			
}			
}			
}			

Table 15.4.1.4.3-7: NR-DL-PRS-AssistanceData

Derivation Path: 37.355 clause 6.4.3			
Information Element	Value/remark	Comment	Condition
NR-DL-PRS-AssistanceData-r16 ::= SEQUENCE {			
nr-DL-PRS-ReferenceInfo-r16 SEQUENCE {			
dl-PRS-ID-r16	0		
nr-DL-PRS-ResourceID-List-r16	Not present		
nr-DL-PRS-ResourceSetID-r16	Not present		
}			
nr-DL-PRS-AssistanceDataList-r16 SEQUENCE (SIZE (1..nrMaxFreqLayers-r16)) OF NR-DL-PRS-AssistanceDataPerFreq-r16 {	1 entry		
NR-DL-PRS-AssistanceDataPerFreq-r16[1] SEQUENCE {		entry 1	
nr-DL-PRS-PositioningFrequencyLayer-r16 SEQUENCE {			
dl-PRS-SubcarrierSpacing-r16	kHz15		Config 1 and Config 2
	kHz30		Config 3
dl-PRS-ResourceBandwidth-r16	21	104 PRBs	Config 1 and Config 2
	28	132 PRBs	Config 3
dl-PRS-StartPRB-r16	0		
dl-PRS-PointA-r16	absoluteFrequencyPointA as defined for the DL frequency of the Cell 1		
dl-PRS-CombSizeN-r16	n4		
dl-PRS-CyclicPrefix-r16	normal		
}			
}			
}			

nr-DL-PRS-AssistanceDataPerFreq-r16 SEQUENCE (SIZE (1..nrMaxTRPsPerFreq-r16)) OF NR-DL-PRS-AssistanceDataPerTRP-r16{	2 entries		
NR-DL-PRS-AssistanceDataPerTRP-r16[1] SEQUENCE {		entry 1	Cell 1
dl-PRS-ID-r16	0		
nr-PhysCellID-r16	Cell 1		
nr-CellGlobalID-r16	Cell 1		
nr-ARFCN-r16	Cell 1		
nr-DL-PRS-SFN0-Offset-r16 SEQUENCE {			
sfn-Offset-r16	0		
integerSubframeOffset-r16	0		
}			
nr-DL-PRS-ExpectedRSTD-r16	0		
nr-DL-PRS-ExpectedRSTD-Uncertainty-r16	0		
nr-DL-PRS-Info-r16	As specified in Table 15.4.1.4.3-8		
}			
NR-DL-PRS-AssistanceDataPerTRP-r16[2] SEQUENCE {		entry 2	Cell 2
dl-PRS-ID-r16	1		
nr-PhysCellID-r16	Cell 2		
nr-CellGlobalID-r16	Cell 2		
nr-ARFCN-r16	Cell 2		
nr-DL-PRS-SFN0-Offset-r16 SEQUENCE {			
sfn-Offset-r16	0		
integerSubframeOffset-r16	0		
}			
nr-DL-PRS-ExpectedRSTD-r16	23	About 3 μs	
nr-DL-PRS-ExpectedRSTD-Uncertainty-r16	154	About 5 μs	
nr-DL-PRS-Info-r16	As specified in Table 15.4.1.4.3-8		
}			
}			
}			
}			
}			

Table 15.4.1.4.3-8: NR-DL-PRS-Info

Derivation Path: 37.355 clause 6.4.3			
Information Element	Value/remark	Comment	Condition
NR-DL-PRS-Info-r16 ::= SEQUENCE {			
nr-DL-PRS-ResourceSetList-r16 SEQUENCE (SIZE (1..nrMaxSetsPerTrp-r16)) OF NR-DL-PRS-ResourceSet-r16 {	1 entry		
NR-DL-PRS-ResourceSet-r16[1] SEQUENCE {		entry 1	
nr-DL-PRS-ResourceSetID-r16	0		
dl-PRS-Periodicity-and-ResourceSetSlotOffset-r16 CHOICE {			
scs120-r16 CHOICE {			
n160-r16	80		
}			
dl-PRS-ResourceRepetitionFactor-r16	Not present		
dl-PRS-ResourceTimeGap-r16	s1		
dl-PRS-NumSymbols-r16	n4		
dl-PRS-MutingOption1-r16 CHOICE {			
po2-r16	10 01		Cell 1 Cell 2
}			
}			
dl-PRS-MutingOption2-r16	Not present		
dl-PRS-ResourcePower-r16	27		

dl-PRS-ResourceList-r16 SEQUENCE (SIZE (1..nrMaxResourcesPerSet-r16)) OF NR-DL-PRS-Resource-r16 {	1 entry		
NR-DL-PRS-Resource-r16[1] SEQUENCE {		entry 1	
nr-DL-PRS-ResourceID-r16	0		
dl-PRS-SequenceID-r16	0		
dl-PRS-CombSizeN-AndReOffset-r16 CHOICE {			
n4-r16	0		
}			
dl-PRS-ResourceSlotOffset-r16	4		
dl-PRS-ResourceSymbolOffset-r16	0		
dl-PRS-QCL-Info-r16	Not present		
}			
}			
}			
}			
}			

Table 15.4.1.4.3-9: lcs-PeriodicTriggeredInvoke

Derivation Path: 24.080 clause 4.4.2			
Information Element	Value/remark	Comment	Condition
LCS-PeriodicTriggeredInvokeArg ::= SEQUENCE {			
referenceNumber	LCS-ReferenceNumber		
h-gmlc-address	GSN-Address		
qoS	Not present		
reportingPLMNList	Not present		
periodicLocation SEQUENCE {			
periodicLDRInfo SEQUENCE {			
reportingAmount	5		
reportingInterval	1		
reportingOptionMilliseconds	Not present		
}			
}			
areaEventReporting	Not present		
motionEventReporting	Not present		
referenceNumberExt	LCS-ReferenceNumberExt		
h-gmlc-callBackUri	Not present		
supportedGADShapes	Not present		
deferredRoutingIdentifier	Not present		
reportingAccessTypes	00000001	NR	
multiplePositioningProtocolPDUs SIZE (1..maxNumLPPMsg) OF PositioningProtocolPDU {	1 entry		
PositioningProtocolPDU[1] SEQUENCE {		entry 1	
PositioningProtocolPDU	Contains a LPP RequestLocationInformation message defined in Table 15.4.1.4.3-12		
}			
}			
controlPlane-CIoT-5GS-Optimisation	Not present		
scheduledLocTime	Not present		
eventReportAllowedArea	Not present		
}			

Table 15.4.1.4.3-10: RRCRelease

Derivation Path: TS 38.508-1 [45], table 4.6.1-16 with condition NR_RRC_INACTIVE and SDT			
Information Element	Value/remark	Comment	Condition
RRCRelease ::= SEQUENCE {			
rrc-TransactionIdentifier	RRC-TransactionIdentifier		

criticalExtensions CHOICE {			
rrcRelease SEQUENCE {			
suspendConfig SEQUENCE {			
srs-PosRRC-Inactive-r17 CHOICE {			
setup SEQUENCE {			
SRS-PosRRC-Inactive-r17	OCTET STRING containing SRS- PosRRC-InactiveConfig- r17 as defined in Table 15.4.1.4.3-11		
}			
}			
}			
}			
}			

Table 15.4.1.4.3-11: SRS-PosRRC-InactiveConfig-r17

Derivation Path: TS 38.331 [52] clause 6.2.2			
Information Element	Value/remark	Comment	Condition
SRS-PosRRC-InactiveConfig-r17 ::= SEQUENCE {			
srs-PosConfigNUL-r17 SEQUENCE {			
srs-PosResourceSetToReleaseList-r17	Not present		
srs-PosResourceSetToAddModList-r17	1 entry		
SEQUENCE (SIZE(1..maxNrofSRS-PosResourceSets-r16)) OF {			
SRS-PosResourceSet-r16[1] SEQUENCE {		entry 1	
srs-PosResourceSetId-r16	0		
srs-PosResourceIdList-r16 SEQUENCE (SIZE(1..maxNrofSRS-ResourcesPerSet)) OF SRS-PosResourceId-r16 {	1 entry		
SRS-PosResourceId-r16	0	1 entry	
}			
resourceType CHOICE {			
periodic SEQUENCE {			
}			
}			
alpha-r16	alpha0		
p0-r16	0		
pathlossReferenceRS-Pos-r16	Not present		
}			
srs-PosResourceToReleaseList-r17	Not present		
srs-PosResourceToAddModList-r17 SEQUENCE (SIZE(1..maxNrofSRS-PosResources-r16)) OF SRS-PosResource-r16 {	1 entry		
SRS-PosResource-r16[1] SEQUENCE {		entry 1	
srs-PosResourceId-r16	0		
transmissionComb-r16 CHOICE {			
n4-r16 SEQUENCE {			
combOffset-n4-r16	0		
cyclicShift-n4-r16	0		
}			
}			
resourceMapping-r16 SEQUENCE {			
startPosition-r16	5		
nrofSymbols-r16	n4		
}			
freqDomainShift-r16	0		
freqHopping-r16 SEQUENCE {			
c-SRS-r16	Matches N _{RB,c} Table 15.4.1.5-1		
}			
groupOrSequenceHopping-r16	neither		

resourceType-r16 CHOICE {			
periodic-r16 SEQUENCE {			
periodicityAndOffset-p-r16 CHOICE {			
sl160	20		Config 1
sl320	40		Config 3
}			
}			
sequenceId-r16	0		
spatialRelationInfoPos-r16	Not present		
}			
}			
srs-PosConfigSUL-r17	Not present		
bwp-NUL-r17	Not present		
bwp-SUL-r17	Not present		
inactivePosSRS-TimeAlignmentTimer-r17	infinity		
inactivePosSRS-RSRP-ChangeThreshold-r17	Not present		
}			

Table 15.4.1.4.3-12: LPP RequestLocationInformation

Derivation Path: TS 37.355 [49] clause 6.2			
Information Element	Value/remark	Comment	Condition
LPP-Message ::= SEQUENCE {			
transactionID SEQUENCE {			
initiator	locationServer		
transactionNumber	1		
}			
endTransaction	FALSE		
sequenceNumber	Not present		
acknowledgement	Not present		
lpp-MessageBody CHOICE {			
c1 CHOICE {			
requestLocationInformation SEQUENCE {			
criticalExtensions CHOICE {			
c1 CHOICE {			
requestLocationInformation-r9 SEQUENCE {			
commonIEsRequestLocationInformation SEQUENCE {			
locationInformationType	locationMeasurementsPreferred		
triggeredReporting	Not present		
periodicalReporting	Not present		
additionalInformation	onlyReturnInformationRequested		
qos SEQUENCE {			
horizontalAccuracy	Not present		
verticalCoordinateRequest	FALSE		
verticalAccuracy	Not present		
responseTime SEQUENCE {			
time	See 15.4.1.5	Result of the response time calculation rounded up to the next second if response time <= 128s. Result of the response time calculation rounded up to the next multiple of ten seconds if response time > 128s	

responseTimeEarlyFix-r12	Not present		Rel-12 onwards
unit-r15	Not present		Calculated response time >128s
	ten-seconds		
}			
velocityRequest	FALSE		
}			
environment	Not present		
locationCoordinateTypes	Not present		
velocityTypes	Not present		
}			
a-gnss-RequestLocationInformation	Not present		
otdoa-RequestLocationInformation	Not present		
ecid-RequestLocationInformation	Not present		
epdu-RequestLocationInformation	Not Present		
sensor-RequestLocationInformation-r13	Not present		
tbs-RequestLocationInformation-r13	Not present		
wlan-RequestLocationInformation-r13	Not present		
bt-RequestLocationInformation-r13	Not present		
nr-ECID-RequestLocationInformation-r16	Not present		
nr-Multi-RTT-RequestLocationInformation-r16			
SEQUENCE {			
nr-UE-	Not present		
RxTxTimeDiffMeasurementInfoRequest-r16			
nr-RequestedMeasurements-r16	bit 0 = 1 (prsrsrpReq)		
nr-AssistanceAvailability-r16	FALSE		
nr-Multi-RTT-ReportConfig-r16 SEQUENCE {			
maxDL-PRS-RxTxTimeDiffMeasPerTRP-r16	Not present		
timingReportingGranularityFactor-r16	Not present		
}			
additionalPaths-r16	Not present		
nr-UE-RxTxTEG-Request-r17			
measureSameDL-PRS-ResourceWithDifferentRxTxTEGs-r17	Not present		
measureSameDL-PRS-ResourceWithDifferentRxTEGs-r17	Not present		
reducedDL-PRS-ProcessingSamples-r17	Not present		
nr-los-nlos-IndicatorRequest-r17	Not present		
additionalPathsExt-r17	Not present		
additionalPathsDL-PRS-RSRP-Request-r17	Not present		
multiMeasInSameReport-r17	Not present		
lowerRxBeamSweepingFactor-FR2-r17	Not present		
}			
nr-DL-AoD-RequestLocationInformation-r16	Not present		
nr-DL-TDOA-RequestLocationInformation-r16	Not present		
}			
}			
}			
}			
}			
}			
}			
}			

Table 15.4.1.4.3-13: LPP ProvideLocation Information

Derivation Path: 37.355 clause 6.5.12			
Information Element	Value/remark	Comment	Condition
LPP-Message ::= SEQUENCE {			
transactionID SEQUENCE {			
initiator	locationServer		
transactionNumber	1		
}			
endTransaction	TRUE		

sequenceNumber	(0..255)		
acknowledgement			
lpp-MessageBody CHOICE {			
c1 CHOICE {			
provideLocationInformation SEQUENCE {			
criticalExtensions CHOICE {			
c1 CHOICE {			
provideLocationInformation-r9 SEQUENCE {			
commonIEsProvideLocationInformation	Not present.		
a-gnss-ProvideLocationInformation	Not present		
otdoa-ProvideLocationInformation	Not present		
ecid-ProvideLocationInformation	Not present		
epdu-ProvideLocationInformation	Not present		
sensor-ProvideLocationInformation-r13	Not present		
tbs-ProvideLocationInformation-r13	Not present		
wlan-ProvideLocationInformation-r13	Not present		
bt-ProvideLocationInformation-r13	Not present		
nr-ECID-ProvideLocationInformation-r16	Not present		
nr-Multi-RTT-ProvideLocationInformation-r16 SEQUENCE {			
nr-Multi-RTT-SignalMeasurementInformation-r16 SEQUENCE {			
nr-Multi-RTT-MeasList-r16 SEQUENCE (SIZE(1..nrMaxTRPs-r16)) OF NR-Multi-RTT-MeasElement-r16 {	2 entries		
NR-Multi-RTT-MeasElement-r16[1] SEQUENCE {		entry 1	
dl-PRS-ID-r16	INTEGER (0..255)		
nr-PhysCellID-r16			
nr-CellGlobalID-r16			
nr-ARFCN-r16			
nr-DL-PRS-ResourceID-r16			
nr-DL-PRS-ResourceSetID-r16			
nr-UE-RxTxTimeDiff-r16	Present. Any value acceptable.		
nr-AdditionalPathList-r16			
nr-TimeStamp-r16			
nr-TimingQuality-r16			
nr-DL-PRS-RSRP-Result-r16			
nr-Multi-RTT-AdditionalMeasurements-r16			
nr-UE-RxTx-TEG-Info-r17			
nr-DL-PRS-FirstPathRSRP-Result-r17			
nr-los-nlos-Indicator-r17			
nr-AdditionalPathListExt-r17			
nr-Multi-RTT-AdditionalMeasurementsExt-r17			
}			
NR-Multi-RTT-MeasElement-r16[2] SEQUENCE {		entry 2	
dl-PRS-ID-r16	INTEGER (0..255)		
nr-PhysCellID-r16			
nr-CellGlobalID-r16			
nr-ARFCN-r16			
nr-DL-PRS-ResourceID-r16			
nr-DL-PRS-ResourceSetID-r16			
nr-UE-RxTxTimeDiff-r16	Present. Any value acceptable.		
nr-AdditionalPathList-r16			
nr-TimeStamp-r16			
nr-TimingQuality-r16			
nr-DL-PRS-RSRP-Result-r16			
nr-Multi-RTT-AdditionalMeasurements-r16			
nr-UE-RxTx-TEG-Info-r17			

nr-DL-PRS-FirstPathRSRP-Result-r17			
nr-los-nlos-Indicator-r17			
nr-AdditionalPathListExt-r17			
nr-Multi-RTT-AdditionalMeasurementsExt-r17			
}			
nr-NTA-Offset-r16			
nr-SRS-TxTEG-Set-r17			
nr-UE-RxTEG-TimingErrorMargin-r17			
nr-UE-TxTEG-TimingErrorMargin-r17			
nr-UE-RxTxTEG-TimingErrorMargin-r17			
}			
nr-Multi-RTT-Error-r16			
nr-Multi-RTT-SignalMeasurementInstances-r17			
}			
nr-DL-AoD-ProvideLocationInformation-r16	Not present		
}			
}			
}			
}			
}			
}			
}			

15.4.1.5 Test requirement

FFS

15.4.2 UE Rx-Tx time difference measurement reporting delay test case for single positioning frequency layer with reduced number of samples in FR1 SA

Editor's note: This test case is incomplete. The following aspect is either missing or TBD:

- Test tolerance are not added in and analysis is missing

15.4.2.1 Test purpose

The purpose of the test is to verify that the UE Rx-Tx measurement in RRC_INACTIVE state meets the requirements specified in TS 38.133 [50] clause 5.6.4 in AWGN propagation condition in FR1 in standalone scenario when single positioning frequency layer is configured.

15.4.2.2 Test applicability

This test applies to all types of NR UE release 17 onwards that supports Multi-RTT positioning, supports DL-PRS measurement in RRC_INACTIVE state and supportedDL-PRS-ProcessingSamples-RRC-Inactive.

15.4.2.3 Minimum conformance requirements

Same as clause 15.4.1.3.

15.4.2.4 Test description

15.4.2.4.1 Initial conditions

The test defines three possible test configurations; specified in Table 15.4.2.4-1. The UE is only required to be tested in one of the supported test configurations.

Table 15.4.2.4-1: Test Configurations

Test Configuration	Description
1	15 kHz SSB SCS, 10 MHz bandwidth, FDD duplex mode
2	15 kHz SSB SCS, 10 MHz bandwidth, TDD duplex mode
3	30 kHz SSB SCS, 40 MHz bandwidth, TDD duplex mode
Note:	The UE is only required to be tested in one of the supported test configurations.

Test Environment: Normal, as defined in TS 38.508-1 [45] clause 4.1.

Frequencies to be tested: Mid Range, as defined in TS 38.508-1 [45] clause 4.3.1.

Channel bandwidth to be tested: are specified in Table 15.4.2.4-1.

1. Connect the SS and AWGN noise sources to the UE antenna connector or antenna connectors as shown in Annex A, Figure A.13.
2. The general test parameter settings are set up according to Table 15.4.2.5-1 and Table 15.4.2.5-2.
3. Propagation conditions are set according to clause 4.14.2.
4. Message contents are defined in clause 15.4.2.4.3.
5. There are two cells in the test: PCell (Cell 1) and a neighbour cell (Cell 2). All cells are on the same RF channel in FR1.

15.4.2.4.2 Test procedure

Same as clause 15.4.1.4.2.

15.4.2.4.3 Message contents

As defined in clause 15.4.1.4.3, with the following exceptions:

Table 15.4.2.4.3-1 replaces Table 15.4.1.4.3-11.

Table 15.4.2.4.3-1: LPP RequestLocationInformation

Derivation Path: TS 37.355 [49] clause 6.2			
Information Element	Value/remark	Comment	Condition
LPP-Message ::= SEQUENCE {			
transactionID SEQUENCE {			
initiator	locationServer		
transactionNumber	1		
}			
endTransaction	FALSE		
sequenceNumber	Not present		
acknowledgement	Not present		
lpp-MessageBody CHOICE {			
c1 CHOICE {			
requestLocationInformation SEQUENCE {			
criticalExtensions CHOICE {			
c1 CHOICE {			
requestLocationInformation-r9 SEQUENCE {			
commonEsRequestLocationInformation SEQUENCE {			
locationInformationType	locationMeasurementsPreferred		
triggeredReporting	Not present		
periodicalReporting	Not present		
additionalInformation	onlyReturnInformationRequested		
} SEQUENCE {			
horizontalAccuracy	Not present		

verticalCoordinateRequest	FALSE		
verticalAccuracy	Not present		
responseTime SEQUENCE {			
time	See 15.4.2.5	Result of the response time calculation rounded up to the next second if response time <= 128s. Result of the response time calculation rounded up to the next multiple of ten seconds if response time > 128s	
responseTimeEarlyFix-r12	Not present		Rel-12 onwards
unit-r15	Not present		
	ten-seconds		Calculated response time >128s
}			
velocityRequest	FALSE		
}			
environment	Not present		
locationCoordinateTypes	Not present		
velocityTypes	Not present		
}			
a-gnss-RequestLocationInformation	Not present		
otdoa-RequestLocationInformation	Not present		
ecid-RequestLocationInformation	Not present		
epdu-RequestLocationInformation	Not Present		
sensor-RequestLocationInformation-r13	Not present		
tbs-RequestLocationInformation-r13	Not present		
wlan-RequestLocationInformation-r13	Not present		
bt-RequestLocationInformation-r13	Not present		
nr-ECID-RequestLocationInformation-r16	Not present		
nr-Multi-RTT-RequestLocationInformation-r16			
SEQUENCE {			
nr-UE-RxTxTimeDiffMeasurementInfoRequest-r16	Not present		
nr-RequestedMeasurements-r16	bit 0 = 1 (prsrsrpReq)		
nr-AssistanceAvailability-r16	FALSE		
nr-Multi-RTT-ReportConfig-r16 SEQUENCE {			
maxDL-PRS-RxTxTimeDiffMeasPerTRP-r16	Not present		
timingReportingGranularityFactor-r16	Not present		
}			
additionalPaths-r16	Not present		
nr-UE-RxTxTEG-Request-r17			
measureSameDL-PRS-ResourceWithDifferentRxTxTEGs-r17	Not present		
measureSameDL-PRS-ResourceWithDifferentRxTEGs-r17	Not present		
reducedDL-PRS-ProcessingSamples-r17	Not present		
nr-los-nlos-IndicatorRequest-r17	Not present		
additionalPathsExt-r17	Not present		
additionalPathsDL-PRS-RSRP-Request-r17	Not present		
multiMeasInSameReport-r17	Not present		
lowerRxBeamSweepingFactor-FR2-r17	Not present		
}			
nr-DL-AoD-RequestLocationInformation-r16	Not present		
nr-DL-TDOA-RequestLocationInformation-r16	Not present		
}			
}			

}			
}			
}			
}			
}			

15.4.2.5 Test requirement

FFS

15.4.3 UE Rx-Tx time difference measurement reporting delay test case for single positioning frequency layer in FR2 SA

Editor’s note: This test case is incomplete. The following aspect is either missing or TBD:

- Test tolerance are not added in and analysis is missing

15.4.3.1 Test purpose

The purpose of the test is to verify that the UE Rx-Tx measurement in RRC_INACTIVE state meets the requirements specified in TS 38.133 [50] clause 5.6.4 in AWGN propagation condition in FR2 in standalone scenario when single positioning frequency layer is configured.

15.4.3.2 Test applicability

This test applies to all types of NR UE release 17 onwards that supports Multi-RTT positioning and supports DL-PRS measurement in RRC_INACTIVE state.

15.4.3.3 Minimum conformance requirements

Same as clause 15.4.1.3.

15.4.3.4 Test description

15.4.3.4.1 Initial conditions

The supported test configurations in listed in Table 15.4.3.4.1-1

Table 15.4.3.4.1-1: Supported test configurations

Config	Description
1	120 kHz SSB and PRS SCS, 200 MHz bandwidth, TDD duplex mode

Test Environment: Normal, as defined in TS 38.508-1 [45] clause 4.1.

Frequencies to be tested: Mid Range, as defined in TS 38.508-1 [45] clause 4.3.1.

Channel bandwidth to be tested: are specified in Table 15.4.3.4.1-1.

1. Connect the SS and AWGN noise sources to the UE antenna connector or antenna connectors as shown in Annex A, Figure A.14.
2. The general test parameter settings are set up according to Table 15.4.3.5-1 and Table 15.4.3.5-2.
3. Propagation conditions are set according to clause 4.14.2.
4. Message contents are defined in clause 15.4.3.4.3.

5. In the test there are two cells in the test: PCell (Cell 1) and a neighbour cell (Cell 2). All cells are on the same RF channel in FR2.

15.4.3.4.2 Test procedure

Same as clause 15.4.1.4.2.

15.4.3.4.3 Message contents

As defined in clause 15.4.1.4.3, with the following exceptions:

Table 15.4.3.4.3-1 replaces Table 15.4.1.4.3-3, Table 15.4.3.4.3-2 replaces Table 15.4.1.4.3-6, Table 15.4.3.4.3-3 replaces Table 15.4.1.4.3-7 and Table 15.4.3.4.3-4 replaces Table 15.4.1.4.3-10.

Table 15.4.3.4.3-1: CellGroupConfig

Derivation Path: 38.508-1 [45], Table 4.6.3-19			
Information Element	Value/remark	Comment	Condition
CellGroupConfig ::= SEQUENCE {			
mac-CellGroupConfig SEQUENCE {			
drx-Config CHOICE {			
setup SEQUENCE {			
drx-onDurationTimer	ms6		
drx-InactivityTimer	ms1		
drx-HARQ-RTT-TimerDL	sl64		
drx-HARQ-RTT-TimerUL	sl64		
drx-RetransmissionTimerDL	sl1		
drx-RetransmissionTimerUL	sl1		
drx-LongCycleStartOffset CHOICE {			
ms640	0		
}			
shortDRX	not present		
drx-SlotOffset	0		
}			
}			

Table 15.4.3.4.3-2: NR-DL-PRS-AssistanceData

Derivation Path: 37.355 clause 6.4.3			
Information Element	Value/remark	Comment	Condition
NR-DL-PRS-AssistanceData-r16 ::= SEQUENCE {			
nr-DL-PRS-ReferenceInfo-r16 SEQUENCE {			
dl-PRS-ID-r16	0		
nr-DL-PRS-ResourceID-List-r16	Not present		
nr-DL-PRS-ResourceSetID-r16	Not present		
}			
nr-DL-PRS-AssistanceDataList-r16 SEQUENCE (SIZE (1..nrMaxFreqLayers-r16)) OF NR-DL-PRS-AssistanceDataPerFreq-r16 {	1 entry		
NR-DL-PRS-AssistanceDataPerFreq-r16[1] SEQUENCE {		entry 1	
nr-DL-PRS-PositioningFrequencyLayer-r16 SEQUENCE {			
dl-PRS-SubcarrierSpacing-r16	kHz120		
dl-PRS-ResourceBandwidth-r16	3	32 PRBs	
dl-PRS-StartPRB-r16	0		
dl-PRS-PointA-r16	absoluteFrequencyPointA as defined for the DL frequency of the Cell 1		
dl-PRS-CombSizeN-r16	n4		
dl-PRS-CyclicPrefix-r16	normal		
}			
}			

nr-DL-PRS-AssistanceDataPerFreq-r16 SEQUENCE (SIZE (1..nrMaxTRPsPerFreq-r16)) OF NR-DL-PRS-AssistanceDataPerTRP-r16{	2 entries		
NR-DL-PRS-AssistanceDataPerTRP-r16[1] SEQUENCE {		entry 1	Cell 1
dl-PRS-ID-r16	0		
nr-PhysCellID-r16	Cell 1		
nr-CellGlobalID-r16	Cell 1		
nr-ARFCN-r16	Cell 1		
nr-DL-PRS-SFN0-Offset-r16 SEQUENCE {			
sfn-Offset-r16	0		
integerSubframeOffset-r16	0		
}			
nr-DL-PRS-ExpectedRSTD-r16	0		
nr-DL-PRS-ExpectedRSTD-Uncertainty-r16	0		
nr-DL-PRS-Info-r16	As specified in Table 15.4.3.4.3-3		
}			
NR-DL-PRS-AssistanceDataPerTRP-r16[2] SEQUENCE {		entry 2	Cell 2
dl-PRS-ID-r16	1		
nr-PhysCellID-r16	Cell 2		
nr-CellGlobalID-r16	Cell 2		
nr-ARFCN-r16	Cell 2		
nr-DL-PRS-SFN0-Offset-r16 SEQUENCE {			
sfn-Offset-r16	0		
integerSubframeOffset-r16	0		
}			
nr-DL-PRS-ExpectedRSTD-r16	23	About 3 μs	
nr-DL-PRS-ExpectedRSTD-Uncertainty-r16	154	About 5 μs	
nr-DL-PRS-Info-r16	As specified in Table 15.4.3.4.3-3		
}			
}			
}			
}			
}			

Table 15.4.3.4.3-3: NR-DL-PRS-Info

Derivation Path: 37.355 clause 6.4.3			
Information Element	Value/remark	Comment	Condition
NR-DL-PRS-Info-r16 ::= SEQUENCE {			
nr-DL-PRS-ResourceSetList-r16 SEQUENCE (SIZE (1..nrMaxSetsPerTrp-r16)) OF NR-DL-PRS-ResourceSet-r16 {	1 entry		
NR-DL-PRS-ResourceSet-r16[1] SEQUENCE {		entry 1	
nr-DL-PRS-ResourceSetID-r16	0		
dl-PRS-Periodicity-and-ResourceSetSlotOffset-r16 CHOICE {			
scs120-r16 CHOICE {			
n1280-r16	80		
}			
dl-PRS-ResourceRepetitionFactor-r16	Not present		
dl-PRS-ResourceTimeGap-r16	s1		
dl-PRS-NumSymbols-r16	n4		
dl-PRS-MutingOption1-r16 CHOICE {			
po2-r16	10 01		Cell 1 Cell 2
}			
}			
dl-PRS-MutingOption2-r16	Not present		
dl-PRS-ResourcePower-r16	27		

dl-PRS-ResourceList-r16 SEQUENCE (SIZE (1..nrMaxResourcesPerSet-r16)) OF NR-DL-PRS-Resource-r16 {	1 entry		
NR-DL-PRS-Resource-r16[1] SEQUENCE {		entry 1	
nr-DL-PRS-ResourceID-r16	0		
dl-PRS-SequenceID-r16	0		
dl-PRS-CombSizeN-AndReOffset-r16 CHOICE {			
n4-r16	0		
}			
dl-PRS-ResourceSlotOffset-r16	4		
dl-PRS-ResourceSymbolOffset-r16	0		
dl-PRS-QCL-Info-r16	Not present		
}			
}			
}			
}			
}			

Table 15.4.3.4.3-4: SRS-PosRRC-InactiveConfig-r17

Derivation Path: TS 38.331 [52] clause 6.2.2			
Information Element	Value/remark	Comment	Condition
SRS-PosRRC-InactiveConfig-r17 ::= SEQUENCE {			
srs-PosConfigNUL-r17 SEQUENCE {			
srs-PosResourceSetToReleaseList-r17	Not present		
srs-PosResourceSetToAddModList-r17 SEQUENCE (SIZE(1..maxNrofSRS-PosResourceSets-r16)) OF {	1 entry		
SRS-PosResourceSet-r16[1] SEQUENCE {		entry 1	
srs-PosResourceSetId-r16	0		
srs-PosResourceIdList-r16 SEQUENCE (SIZE(1..maxNrofSRS-ResourcesPerSet)) OF SRS-PosResourceId-r16 {	1 entry		
SRS-PosResourceId-r16	0	1 entry	
}			
resourceType CHOICE {			
periodic SEQUENCE {			
}			
}			
alpha-r16	alpha0		
p0-r16	0		
pathlossReferenceRS-Pos-r16	Not present		
}			
}			
srs-PosResourceToReleaseList-r17	Not present		
srs-PosResourceToAddModList-r17 SEQUENCE (SIZE(1..maxNrofSRS-PosResources-r16)) OF SRS-PosResource-r16 {	1 entry		
SRS-PosResource-r16[1] SEQUENCE {		entry 1	
srs-PosResourceId-r16	0		
transmissionComb-r16 CHOICE {			
n4-r16 SEQUENCE {			
combOffset-n4-r16	0		
cyclicShift-n4-r16	0		
}			
}			
resourceMapping-r16 SEQUENCE {			
startPosition-r16	5		
nrofSymbols-r16	n4		
}			
freqDomainShift-r16	0		
freqHopping-r16 SEQUENCE {			
c-SRS-r16	Matches N _{RB,c} Table 15.4.3.5-1		
}			
}			

groupOrSequenceHopping-r16	neither		
resourceType-r16 CHOICE {			
periodic-r16 SEQUENCE {			
periodicityAndOffset-p-r16 CHOICE {			
s11280	160		
}			
}			
}			
sequenceId-r16	0		
spatialRelationInfoPos-r16	Not present		
}			
}			
}			
srs-PosConfigSUL-r17	Not present		
bwp-NUL-r17	Not present		
bwp-SUL-r17	Not present		
inactivePosSRS-TimeAlignmentTimer-r17	infinity		
inactivePosSRS-RSRP-ChangeThreshold-r17	Not present		
}			

15.4.3.5 Test requirement

FFS

15.4.4 UE Rx-Tx time difference measurement reporting delay test case for single positioning frequency layer with reduced number of samples in FR2 SA

Editor's note: This test case is incomplete. The following aspect is either missing or TBD:

- Test tolerance are not added in and analysis is missing

15.4.4.1 Test purpose

The purpose of the test is to verify that the UE Rx-Tx measurement in RRC_INACTIVE state meets the requirements specified in TS 38.133 [50] clause 5.6.4 in AWGN propagation condition in FR2 in standalone scenario when single positioning frequency layer is configured.

15.4.4.2 Test applicability

This test applies to all types of NR UE release 17 onwards that supports Multi-RTT positioning, supports DL-PRS measurement in RRC_INACTIVE state and supportedDL-PRS-ProcessingSamples-RRC-Inactive.

15.4.4.3 Minimum conformance requirements

Same as clause 15.4.1.3.

15.4.4.4 Test description

15.4.4.4.1 Initial conditions

The supported test configurations in listed in Table 15.4.4.4.1-1

Table 15.4.4.4.1-1: Supported test configurations

Config	Description
1	120 kHz SSB and PRS SCS, 200 MHz bandwidth, TDD duplex mode

Test Environment: Normal, as defined in TS 38.508-1 [45] clause 4.1.

Frequencies to be tested: Mid Range, as defined in TS 38.508-1 [45] clause 4.3.1.

Channel bandwidth to be tested: are specified in Table 15.4.4.4.1-1.

1. Connect the SS and AWGN noise sources to the UE antenna connector or antenna connectors as shown in Annex A, Figure A.14.
2. The general test parameter settings are set up according to Table 15.4.4.5-1 and Table 15.4.4.5-2.
3. Propagation conditions are set according to clause 4.14.2.
4. Message contents are defined in clause 15.4.4.4.3.
5. In the test there are two cells in the test: PCell (Cell 1) and a neighbour cell (Cell 2). All cells are on the same RF channel in FR2.

15.4.4.4.2 Test procedure

Same as clause 15.4.1.4.2.

15.4.4.4.3 Message contents

As defined in clause 15.4.1.4.3, with the following exceptions:

Table 15.4.4.4.3-1 replaces Table 15.4.1.4.3-3, Table 15.4.4.4.3-2 replaces Table 15.4.1.4.3-6, Table 15.4.4.4.3-3 replaces Table 15.4.1.4.3-7, Table 15.4.4.4.3-4 replaces Table 15.4.1.4.3-10, Table 15.4.4.4.3-4 replaces Table 15.4.1.4.3-10 and Table 15.4.4.4.3-5 replaces Table 15.4.1.4.3-11.

Table 15.4.4.4.3-1: CellGroupConfig

Derivation Path: 38.508-1 [45], Table 4.6.3-19			
Information Element	Value/remark	Comment	Condition
CellGroupConfig ::= SEQUENCE {			
mac-CellGroupConfig SEQUENCE {			
drx-Config CHOICE {			
setup SEQUENCE {			
drx-onDurationTimer	ms6		
drx-InactivityTimer	ms1		
drx-HARQ-RTT-TimerDL	sl64		
drx-HARQ-RTT-TimerUL	sl64		
drx-RetransmissionTimerDL	sl1		
drx-RetransmissionTimerUL	sl1		
drx-LongCycleStartOffset CHOICE {			
ms640	0		
}			
shortDRX	not present		
drx-SlotOffset	0		
}			
}			

Table 15.4.4.4.3-2: NR-DL-PRS-AssistanceData

Derivation Path: 37.355 clause 6.4.3			
Information Element	Value/remark	Comment	Condition
NR-DL-PRS-AssistanceData-r16 ::= SEQUENCE {			
nr-DL-PRS-ReferenceInfo-r16 SEQUENCE {			
dl-PRS-ID-r16	0		
nr-DL-PRS-ResourceID-List-r16	Not present		
nr-DL-PRS-ResourceSetID-r16	Not present		
}			

nr-DL-PRS-AssistanceDataList-r16 SEQUENCE (SIZE (1..nrMaxFreqLayers-r16)) OF NR-DL-PRS-AssistanceDataPerFreq-r16 {	1 entry		
NR-DL-PRS-AssistanceDataPerFreq-r16[1] SEQUENCE {		entry 1	
nr-DL-PRS-PositioningFrequencyLayer-r16 SEQUENCE {			
dl-PRS-SubcarrierSpacing-r16	kHz120		
dl-PRS-ResourceBandwidth-r16	3	32 PRBs	
dl-PRS-StartPRB-r16	0		
dl-PRS-PointA-r16	absoluteFrequencyPointA as defined for the DL frequency of the Cell 1		
dl-PRS-CombSizeN-r16	n4		
dl-PRS-CyclicPrefix-r16	normal		
}			
nr-DL-PRS-AssistanceDataPerFreq-r16 SEQUENCE (SIZE (1..nrMaxTRPsPerFreq-r16)) OF NR-DL-PRS-AssistanceDataPerTRP-r16{	2 entries		
NR-DL-PRS-AssistanceDataPerTRP-r16[1] SEQUENCE {		entry 1	Cell 1
dl-PRS-ID-r16	0		
nr-PhysCellID-r16	Cell 1		
nr-CellGlobalID-r16	Cell 1		
nr-ARFCN-r16	Cell 1		
nr-DL-PRS-SFN0-Offset-r16 SEQUENCE {			
sfn-Offset-r16	0		
integerSubframeOffset-r16	0		
}			
nr-DL-PRS-ExpectedRSTD-r16	0		
nr-DL-PRS-ExpectedRSTD-Uncertainty-r16	0		
nr-DL-PRS-Info-r16	As specified in Table 15.4.4.4.3-3		
}			
NR-DL-PRS-AssistanceDataPerTRP-r16[2] SEQUENCE {		entry 2	Cell 2
dl-PRS-ID-r16	1		
nr-PhysCellID-r16	Cell 2		
nr-CellGlobalID-r16	Cell 2		
nr-ARFCN-r16	Cell 2		
nr-DL-PRS-SFN0-Offset-r16 SEQUENCE {			
sfn-Offset-r16	0		
integerSubframeOffset-r16	0		
}			
nr-DL-PRS-ExpectedRSTD-r16	23	About 3 μs	
nr-DL-PRS-ExpectedRSTD-Uncertainty-r16	154	About 5 μs	
nr-DL-PRS-Info-r16	As specified in Table 15.4.4.4.3-3		
}			
}			
}			
}			
}			

Table 15.4.4.4.3-3: NR-DL-PRS-Info

Derivation Path: 37.355 clause 6.4.3			
Information Element	Value/remark	Comment	Condition
NR-DL-PRS-Info-r16 ::= SEQUENCE {			
nr-DL-PRS-ResourceSetList-r16 SEQUENCE (SIZE (1..nrMaxSetsPerTrp-r16)) OF NR-DL-PRS-ResourceSet-r16 {	1 entry		
NR-DL-PRS-ResourceSet-r16[1] SEQUENCE {		entry 1	
nr-DL-PRS-ResourceSetID-r16	0		

dl-PRS-Periodicity-and-ResourceSetSlotOffset-r16 CHOICE {			
scs120-r16 CHOICE {			
n160-r16	80		
}			
dl-PRS-ResourceRepetitionFactor-r16	Not present		
dl-PRS-ResourceTimeGap-r16	s1		
dl-PRS-NumSymbols-r16	n4		
dl-PRS-MutingOption1-r16 CHOICE {			
po2-r16	10		Cell 1
	01		Cell 2
}			
}			
dl-PRS-MutingOption2-r16	Not present		
dl-PRS-ResourcePower-r16	27		
dl-PRS-ResourceList-r16 SEQUENCE (SIZE (1..nrMaxResourcesPerSet-r16)) OF NR-DL-PRS-Resource-r16 {	1 entry		
NR-DL-PRS-Resource-r16[1] SEQUENCE {		entry 1	
nr-DL-PRS-ResourceID-r16	0		
dl-PRS-SequenceID-r16	0		
dl-PRS-CombSizeN-AndReOffset-r16 CHOICE {			
n4-r16	0		
}			
dl-PRS-ResourceSlotOffset-r16	4		
dl-PRS-ResourceSymbolOffset-r16	0		
dl-PRS-QCL-Info-r16	Not present		
}			
}			
}			
}			
}			
}			
}			
}			
}			
}			

Table 15.4.4.3-4: SRS-PosRRC-InactiveConfig-r17

Derivation Path: TS 38.331 [52] clause 6.2.2			
Information Element	Value/remark	Comment	Condition
SRS-PosRRC-InactiveConfig-r17 ::= SEQUENCE {			
srs-PosConfigNUL-r17 SEQUENCE {			
srs-PosResourceSetToReleaseList-r17	Not present		
srs-PosResourceSetToAddModList-r17 SEQUENCE (SIZE(1..maxNrofSRS-PosResourceSets-r16)) OF {	1 entry		
SRS-PosResourceSet-r16[1] SEQUENCE {		entry 1	
srs-PosResourceSetId-r16	0		
srs-PosResourceIdList-r16 SEQUENCE (SIZE(1..maxNrofSRS-ResourcesPerSet)) OF SRS-PosResourceId-r16 {	1 entry		
SRS-PosResourceId-r16	0	1 entry	
}			
resourceType CHOICE {			
periodic SEQUENCE {			
}			
}			
alpha-r16	alpha0		
p0-r16	0		
pathlossReferenceRS-Pos-r16	Not present		
}			
}			
srs-PosResourceToReleaseList-r17	Not present		
srs-PosResourceToAddModList-r17 SEQUENCE (SIZE(1..maxNrofSRS-PosResources-r16)) OF SRS-PosResource-r16 {	1 entry		
SRS-PosResource-r16[1] SEQUENCE {		entry 1	
srs-PosResourceId-r16	0		

transmissionComb-r16 CHOICE {			
n4-r16 SEQUENCE {			
combOffset-n4-r16	0		
cyclicShift-n4-r16	0		
}			
}			
resourceMapping-r16 SEQUENCE {			
startPosition-r16	5		
nrofSymbols-r16	n4		
}			
freqDomainShift-r16	0		
freqHopping-r16 SEQUENCE {			
c-SRS-r16	Matches N _{RB,c} Table 15.4.4.5-1		
}			
groupOrSequenceHopping-r16	neither		
resourceType-r16 CHOICE {			
periodic-r16 SEQUENCE {			
periodicityAndOffset-p-r16 CHOICE {			
sl1280	160		
}			
}			
}			
sequenceId-r16	0		
spatialRelationInfoPos-r16	Not present		
}			
}			
}			
srs-PosConfigSUL-r17	Not present		
bwp-NUL-r17	Not present		
bwp-SUL-r17	Not present		
inactivePosSRS-TimeAlignmentTimer-r17	infinity		
inactivePosSRS-RSRP-ChangeThreshold-r17	Not present		
}			

Table 15.4.4.3-5: LPP RequestLocationInformation

Derivation Path: TS 37.355 [49] clause 6.2			
Information Element	Value/remark	Comment	Condition
LPP-Message ::= SEQUENCE {			
transactionID SEQUENCE {			
initiator	locationServer		
transactionNumber	1		
}			
endTransaction	FALSE		
sequenceNumber	Not present		
acknowledgement	Not present		
lpp-MessageBody CHOICE {			
c1 CHOICE {			
requestLocationInformation SEQUENCE {			
criticalExtensions CHOICE {			
c1 CHOICE {			
requestLocationInformation-r9 SEQUENCE {			
commonEsRequestLocationInformation SEQUENCE {			
locationInformationType	locationMeasurementsPreferred		
triggeredReporting	Not present		
periodicalReporting	Not present		
additionalInformation	onlyReturnInformationRequested		
}			
}			
}			
}			
}			
}			
}			
qos SEQUENCE {			
horizontalAccuracy	Not present		
verticalCoordinateRequest	FALSE		

verticalAccuracy	Not present		
responseTime SEQUENCE { time	See 15.4.4.5	Result of the response time calculation rounded up to the next second if response time <= 128s. Result of the response time calculation rounded up to the next multiple of ten seconds if response time > 128s	
responseTimeEarlyFix-r12	Not present		Rel-12 onwards
unit-r15	Not present ten-seconds		Calculated response time >128s
}			
velocityRequest	FALSE		
}			
environment	Not present		
locationCoordinateTypes	Not present		
velocityTypes	Not present		
}			
a-gnss-RequestLocationInformation	Not present		
otdoa-RequestLocationInformation	Not present		
ecid-RequestLocationInformation	Not present		
epdu-RequestLocationInformation	Not Present		
sensor-RequestLocationInformation-r13	Not present		
tbs-RequestLocationInformation-r13	Not present		
wlan-RequestLocationInformation-r13	Not present		
bt-RequestLocationInformation-r13	Not present		
nr-ECID-RequestLocationInformation-r16	Not present		
nr-Multi-RTT-RequestLocationInformation-r16			
SEQUENCE {			
nr-UE-RxTxTimeDiffMeasurementInfoRequest-r16	Not present		
nr-RequestedMeasurements-r16	bit 0 = 1 (prsrsrpReq)		
nr-AssistanceAvailability-r16	FALSE		
nr-Multi-RTT-ReportConfig-r16 SEQUENCE {			
maxDL-PRS-RxTxTimeDiffMeasPerTRP-r16	Not present		
timingReportingGranularityFactor-r16	Not present		
}			
additionalPaths-r16	Not present		
nr-UE-RxTxTEG-Request-r17			
measureSameDL-PRS-ResourceWithDifferentRxTxTEGs-r17	Not present		
measureSameDL-PRS-ResourceWithDifferentRxTEGs-r17	Not present		
reducedDL-PRS-ProcessingSamples-r17	requested		
nr-los-nlos-IndicatorRequest-r17	Not present		
additionalPathsExt-r17	Not present		
additionalPathsDL-PRS-RSRP-Request-r17	Not present		
multiMeasInSameReport-r17	Not present		
lowerRxBeamSweepingFactor-FR2-r17	Not present		
}			
nr-DL-AoD-RequestLocationInformation-r16	Not present		
nr-DL-TDOA-RequestLocationInformation-r16	Not present		
}			
}			
}			

}			
}			
}			
}			

15.4.4.5 Test requirement

FFS

15.5 UE Rx-Tx time difference measurement accuracy test cases in RRC_INACTIVE

15.5.1

15.5.2

15.5.3 UE Rx-Tx time difference measurement accuracy for single positioning frequency layer in FR2 SA

Editor's Note: This test case is incomplete. The following aspect is either missing or TBD:

- Test tolerance analysis is missing
- The test procedure may require an update

15.5.3.1 Test purpose

The purpose of the test is to verify that the UE Rx-Tx time difference measurement accuracy is within the specified limits. This test will verify the requirements in TS 38.133 [50] clause 10.1.25.2. The test is conducted in AWGN propagation condition in FR2 in standalone scenario when single positioning frequency layer is configured.

15.5.3.2 Test applicability

This test applies to all types of NR UE release 17 onwards that supports Multi-RTT positioning and *supportedDL-PRS-ProcessingSamples-RRC-Inactive*. In addition, this test shall be verified with either SDT or non-SDT supporting UEs.

15.5.3.3 Minimum conformance requirements

The UE Rx-Tx time difference measurement accuracy requirements in this clause shall not apply, if:

N_{TA_offset} defined in Table 7.1.2-2 changes during the UE Rx-Tx measurement period or

if the uplink transmission timing changes during the UE Rx-Tx measurement period due to the network-configured Timing Advance.

The UE Rx-Tx time difference measurement accuracy requirements in this clause shall apply provided that:

- The UE transmits SRS within [-160, 160] msec of at least one DL PRS resource of each of the TRPs in the assistance data.

If the uplink transmission timing changes during the UE Rx-Tx measurement period due to the autonomous timing adjustment defined in clause 7.1.2 of TS38.133 [50] then:

- UE Rx-Tx measurement accuracy requirements shall apply for a cell, which is also the downlink reference cell (defined in section 7.1.1 of TS38.133 [50]) for SRS transmission even if the uplink transmission timing changes during the UE Rx-Tx measurement period due to autonomous adjustment.

- UE Rx-Tx measurement accuracy requirements shall not apply for a cell, which is not the downlink reference cell (defined in section 7.1.1 of TS38.133 [50]) for SRS transmission, if the uplink transmission timing changes during the UE Rx-Tx measurement period due to autonomous adjustment.

When a serving cell change occurs during the UE Rx-Tx measurement period, the UE Rx-Tx time difference measurement accuracy requirements in this clause shall apply provided that the serving cell change does not impact SRS configuration for the UE Rx-Tx measurement.

The relative accuracy of UE Rx-Tx measurement in this clause is defined as accuracy of the difference between two UE Rx-Tx measurements.

The accuracy requirements in Table 15.5.3.3-2 for FR2 are valid under the following conditions:

Conditions defined in clause 7.3 of TS 38.101-2 [55] for reference sensitivity are fulfilled.

PRP_{dBm} according to Annex B.2.14 of TS38.133 [50] for a corresponding Band.

AWGN propagation condition.

Table 15.5.3.3-1: UE Rx-Tx time difference measurement accuracy in FR2 in AWGN

Accuracy	Conditions					
	PRS Es/lot	Minimum PRS bandwidth	PRS SCS	PRS resource repetition ($T_{rep}^{PRS} * L_{PRS} / K_{comb}^{PRS}$ Note 3)	Io ^{Note 4} range	
					Minimum Io ^{Note 1}	Maximum Io
Tc ^{Note 5}	dB	RB	kHz		dBm / SCS _{PRS}	dBm/BW _{Channel}
± 22+δ	-3	≥24	60	≥4	Same value as PRP in Table B.2.14-2 of TS38.133[50], according to UE Power class, operating band and angle of arrival	-50
± 15+δ		≥64		≥1	NOTE 6	NOTE 6
± 7+δ		≥132		≥1	NOTE 6	NOTE 6
± 12+δ	-13	≥32	120	≥14	Same value as PRP in Table B.2.14-2 of TS38.133[50], according to UE Power class, operating band and angle of arrival	-50
± 7+δ		≥64		≥1	NOTE 6	NOTE 6
± 4+δ		≥128		≥1	NOTE 6	NOTE 6
± 35+δ		≥24	60	≥1	NOTE 6	NOTE 6
± 15+δ		≥64		≥1	NOTE 6	NOTE 6
± 7+δ		≥132		≥1	NOTE 6	NOTE 6
± 14+δ	120	≥32	≥4	NOTE 6	NOTE 6	
± 9+δ		≥64	≥1	NOTE 6	NOTE 6	
± 4+δ		≥128	≥1	NOTE 6	NOTE 6	

NOTE 1: This minimum Io condition is expressed as the average Io per RE over all REs in an OFDM symbol.
 NOTE 2: NR operating band groups are as defined in Section 3.5 of TS38.133[50].
 NOTE 3: T_{rep}^{PRS} , L_{PRS} , K_{comb}^{PRS} are configured by higher layer parameter *dl-PRS-ResourceRepetitionFactor*, *dl-PRS-NumSymbols* and *dl-PRS-CombSizeN* defined in TS 37.355 [49].
 NOTE 4: The Io is defined in PRS slots. The same Io range applies to PRS and non-PRS symbols. Io levels are different in PRS and non-PRS symbols within the same slot.
 NOTE 5: Tc is the basic timing unit defined in TS 38.211 [53].
 NOTE 6: The same bands and the same Io conditions for each band apply for this requirement as for the corresponding requirement with the PRS bandwidth of the smallest RB number for the corresponding SCS.
 NOTE 7: δ is the margin determined from Table 15.5.3.3-2.

Table 15.5.3.3-2: Margin for UE Rx-Tx time difference measurement accuracy in FR2

Min(PRS BW, SRS BW) (MHz)		Margin (Tc ^{Note 1})
SCS = 60 kHz	SCS = 120 kHz	
≥ 24	N/A	76

≥ 64	≥ 32	32
≥ 132	≥ 64	24
N/A	≥ 128	20
NOTE 1: T_c is the basic timing unit defined in TS 38.211 [53].		
NOTE 2: If SRS and PRS have different SCS, the margin corresponding to the smallest RS BW in MHz applies.		

15.5.3.4 Test description

15.5.3.4.1 Initial conditions

The supported test configuration is listed in Table 15.5.3.4.1-1.

Table 15.5.3.4.1-1: Supported test configurations

Config	Description
1	120 kHz SSB and PRS SCS, 200 MHz bandwidth, TDD duplex mode

Test Environment: Normal, as defined in TS 38.508-1 [45] clause 4.1.

Frequencies to be tested: Mid Range, as defined in TS 38.508-1 [45] clause 4.3.1.

Channel bandwidth to be tested: are specified in Table 15.5.3.4.1-1.

1. Connect the SS and AWGN noise sources to the UE antenna connector or antenna connectors as shown in Annex A, Figure A.14.
2. The general test parameter settings are set up according to Table 15.5.3.5-1.
3. Propagation conditions are set according to clause 4.14.2.
4. Message contents are defined in clause 15.5.3.4.3.
5. There are two cells in the test: PCell (Cell 1) and a neighbour cell (Cell 2). Both cells are on the same RF channel in FR2.

15.5.3.4.2 Test procedure

The test consists of a set-up period and a measurement period. The *NR-Multi-RTT-ProvideAssistanceData* and *NR-Multi-RTT-RequestLocationInformation* shall be provided to the UE during the set-up period. During the measurement period, UE shall be in RRC_INACTIVE state.

7. Configure the Cell for RA-SDT with SIB1 configured according to the message contents 15.5.3.4.3.
8. State RRC_CONNECTED with generic procedure parameters Connectivity *NR*, Connected without release *On*, according to TS 38.508-1 [45] clause 4.5. Note that in the remainder of the test the timing advance command $T_A = 31$ which indicates a timing advance adjustment value $N_{TA} = 0 T_c$.
9. The SS shall send a RESET UE POSITIONING STORED INFORMATION message.
10. The SS adjusts the downlink timing for Cell 1 to a delay of $+512 T_c$, compared to the current value.
11. Wait for 1.6 s to allow for the possibility that the UE makes autonomous timing adjustments.
12. The SS shall transmit an *RRCReconfiguration* message with DRX configuration.
13. The UE shall transmit *RRCReconfigurationComplete* message.
14. The SS shall transmit an LPP REQUEST CAPABILITIES message.
15. The UE shall transmit an LPP PROVIDE CAPABILITIES message indicating the UE supports *supportedDL-PRS-ProcessingSamples-RRC-Inactive* in the *NR-DL-PRS-ProcessingCapability* IE and the Multi-RTT capabilities supported by the UE in the *NR-Multi-RTT-ProvideCapabilities* IE.

16. The SS shall send a LPP PROVIDE ASSISTANCE DATA message, including the *NR-Multi-RTT-ProvideAssistanceData* IE. The position of neighbour Cell 2 is described in 3GPP TS 37.571-5 [20]. If the UE message at step 8 includes the *ackRequested* IE set to TRUE, then the SS shall send an acknowledgment in the LPP PROVIDE ASSISTANCE DATA message.
17. The SS shall send a LCS Periodic-Triggered Invoke Request message with LPP REQUEST LOCATION INFORMATION embedded to start the periodic reporting procedure, including the *NR-Multi-RTT-RequestLocationInformation* IE such that the UE receives the message ΔT ms before the start of the measurement period, where $\Delta T = 50$ ms.
18. The UE shall transmit an LCS Periodic-Triggered Invoke Return Result message.
19. The SS transmits an *RRCRelease* message including UL configuration and SDT configuration to transit the UE to RRC_INACTIVE state.
20. Wait for the UE as it monitors for occurrence of the periodic event requested.
21. The UE shall transmit an *RRCResumeRequest* message. If the UE supports SDT feature, the UE shall include LPP PROVIDE LOCATION INFORMATION message in the *RRCResumeRequest* message and then go to step 19.
22. The SS transmits an *RRCResume* message
23. The UE transmits an *RRCResumeComplete* message.
24. The UE shall transmit a LPP PROVIDE LOCATION INFORMATION message including the *NR-Multi-RTT-ProvideLocationInformation* IE within the response time (see clause 15.5.3.4.3) and *RRCResumeComplete* message.
25. If the UE message at step 15 or 18 includes the *ackRequested* IE set to TRUE, the SS shall send LPP acknowledgment message.
26. The SS shall check *nr-UE-RxTxTimeDiff-r16* value for Cell 2 in the *NR-Multi-RTT-SignalMeasurementInformation* according to Table 15.5.3.5-2.
27. UE shall be released and moved to RRC_IDLE.
28. Repeat steps 1-21 until the confidence level according to Annex D is achieved.

NOTE: To avoid a large divergence between the sent TA and the set downlink timing, the SS may reset the downlink timing for Cell 1 to its initial value after a certain amount of loops. The loop during the reset does not count for the result statistics.

15.5.3.4.3 Message contents

Message contents are the same as in 15.4.1.5.4.3 with the following exceptions:

Table 15.5.3.4.3-1: SRS-PosRRC-InactiveConfig-r17

Derivation Path: TS 38.331 [52] clause 6.2.2			
Information Element	Value/remark	Comment	Condition
SRS-PosRRC-InactiveConfig-r17 ::= SEQUENCE {			
srs-PosConfigNUL-r17 SEQUENCE {			
srs-PosResourceSetToReleaseList-r17	Not present		
srs-PosResourceSetToAddModList-r17	1 entry		
SEQUENCE (SIZE(1..maxNrofSRS-PosResourceSets-r16)) OF {			
SRS-PosResourceSet-r16[1] SEQUENCE {		entry 1	
srs-PosResourceSetId-r16	0		
srs-PosResourceIdList-r16 SEQUENCE (SIZE(1..maxNrofSRS-ResourcesPerSet)) OF SRS-PosResourceId-r16 {	1 entry		
SRS-PosResourceId-r16	0	1 entry	
}			
resourceType CHOICE {			

periodic SEQUENCE {			
}			
alpha-r16	alpha0		
p0-r16	0		
pathlossReferenceRS-Pos-r16	Not present		
}			
srs-PosResourceToReleaseList-r17	Not present		
srs-PosResourceToAddModList-r17 SEQUENCE (SIZE(1..maxNrofSRS-PosResources-r16)) OF SRS-PosResource-r16 {	1 entry		
SRS-PosResource-r16[1] SEQUENCE {		entry 1	
srs-PosResourceId-r16	0		
transmissionComb-r16 CHOICE {			
n4-r16 SEQUENCE {			
combOffset-n4-r16	0		
cyclicShift-n4-r16	0		
}			
resourceMapping-r16 SEQUENCE {			
startPosition-r16	5		
nrofSymbols-r16	n4		
}			
freqDomainShift-r16	0		
freqHopping-r16 SEQUENCE {			
c-SRS-r16	Matches N _{RB,c} Table 15.5.3.5-1		
}			
groupOrSequenceHopping-r16	neither		
resourceType-r16 CHOICE {			
periodic-r16 SEQUENCE {			
periodicityAndOffset-p-r16 CHOICE {			
SI1280	160		Config 1
}			
}			
sequenceId-r16	0		
spatialRelationInfoPos-r16	Not present		
}			
srs-PosConfigSUL-r17	Not present		
bwp-NUL-r17	Not present		
bwp-SUL-r17	Not present		
inactivePosSRS-TimeAlignmentTimer-r17	infinity		
inactivePosSRS-RSRP-ChangeThreshold-r17	Not present		

Table 15.5.3.4.3-2: CellGroupConfig

Derivation Path: 38.508-1 [45], Table 4.6.3-19			
Information Element	Value/remark	Comment	Condition
CellGroupConfig ::= SEQUENCE {			
mac-CellGroupConfig SEQUENCE {			
drx-Config CHOICE {			
setup SEQUENCE {			
drx-onDurationTimer	ms6		
drx-InactivityTimer	ms1		
drx-HARQ-RTT-TimerDL	sl64		
drx-HARQ-RTT-TimerUL	sl64		
drx-RetransmissionTimerDL	sl1		
drx-RetransmissionTimerUL	sl1		
drx-LongCycleStartOffset CHOICE {			
ms640	0		

}			
shortDRX	not present		
drx-SlotOffset	0		
}			
}			
}			
}			

Table 15.5.3.4.3-3: NR-DL-PRS-AssistanceData

Derivation Path: 37.355 clause 6.4.3			
Information Element	Value/remark	Comment	Condition
NR-DL-PRS-AssistanceData-r16 ::= SEQUENCE {			
nr-DL-PRS-ReferenceInfo-r16 SEQUENCE {			
dl-PRS-ID-r16	0		
nr-DL-PRS-ResourceID-List-r16	Not present		
nr-DL-PRS-ResourceSetID-r16	Not present		
}			
nr-DL-PRS-AssistanceDataList-r16 SEQUENCE (SIZE (1..nrMaxFreqLayers-r16)) OF NR-DL-PRS-AssistanceDataPerFreq-r16 {	1 entry		
NR-DL-PRS-AssistanceDataPerFreq-r16[1] SEQUENCE {		entry 1	
nr-DL-PRS-PositioningFrequencyLayer-r16 SEQUENCE {			
dl-PRS-SubcarrierSpacing-r16	kHz120		
dl-PRS-ResourceBandwidth-r16	11	32 PRBs	Sub-test 1
	27	128 PRBs	Sub-test 2
dl-PRS-StartPRB-r16	0		
dl-PRS-PointA-r16	absoluteFrequencyPointA as defined for the DL frequency of the Cell 1		
dl-PRS-CombSizeN-r16	n2		Sub-test 1
	n4		Sub-test 2
dl-PRS-CyclicPrefix-r16	normal		
}			
nr-DL-PRS-AssistanceDataPerFreq-r16 SEQUENCE (SIZE (1..nrMaxTRPsPerFreq-r16)) OF NR-DL-PRS-AssistanceDataPerTRP-r16{	2 entries		
NR-DL-PRS-AssistanceDataPerTRP-r16[1] SEQUENCE {		entry 1	Cell 1
dl-PRS-ID-r16	0		
nr-PhysCellID-r16	Cell 1		
nr-CellGlobalID-r16	Cell 1		
nr-ARFCN-r16	Cell 1		
nr-DL-PRS-SFN0-Offset-r16 SEQUENCE {			
sfn-Offset-r16	0		
integerSubframeOffset-r16	0		
}			
nr-DL-PRS-ExpectedRSTD-r16	0		
nr-DL-PRS-ExpectedRSTD-Uncertainty-r16	0		
nr-DL-PRS-Info-r16	As specified in Table 15.5.3.4.3-4		
}			
NR-DL-PRS-AssistanceDataPerTRP-r16[2] SEQUENCE {		entry 2	Cell 2
dl-PRS-ID-r16	1		
nr-PhysCellID-r16	Cell 2		
nr-CellGlobalID-r16	Cell 2		
nr-ARFCN-r16	Cell 2		
nr-DL-PRS-SFN0-Offset-r16 SEQUENCE {			

sfn-Offset-r16	0		
integerSubframeOffset-r16	0		
}			
nr-DL-PRS-ExpectedRSTD-r16	23	About 3 μs	
nr-DL-PRS-ExpectedRSTD-Uncertainty-r16	154	About 5 μs	
nr-DL-PRS-Info-r16	As specified in Table 15.5.3.4.3-4		
}			
}			
}			
}			
}			

Table 15.5.3.4.3-4: NR-DL-PRS-Info

Derivation Path: 37.355 clause 6.4.3			
Information Element	Value/remark	Comment	Condition
NR-DL-PRS-Info-r16 ::= SEQUENCE {			
nr-DL-PRS-ResourceSetList-r16 SEQUENCE (SIZE (1..nrMaxSetsPerTrp-r16)) OF NR-DL-PRS-ResourceSet-r16 {	1 entry		
NR-DL-PRS-ResourceSet-r16[1] SEQUENCE {		entry 1	
nr-DL-PRS-ResourceSetID-r16	0		
dl-PRS-Periodicity-and-ResourceSetSlotOffset-r16 CHOICE {			
scs120-r16 CHOICE {			
n1280-r16	80		
}			
dl-PRS-ResourceRepetitionFactor-r16	Not present		Sub-test 2
	n2		Sub-test 1
dl-PRS-ResourceTimeGap-r16	s1		
dl-PRS-NumSymbols-r16	n4		
dl-PRS-MutingOption1-r16 CHOICE {			
po2-r16	10		Cell 1
	01		Cell 2
}			
}			
dl-PRS-MutingOption2-r16	Not present		
dl-PRS-ResourcePower-r16	27		
dl-PRS-ResourceList-r16 SEQUENCE (SIZE (1..nrMaxResourcesPerSet-r16)) OF NR-DL-PRS-Resource-r16 {	1 entry		
NR-DL-PRS-Resource-r16[1] SEQUENCE {		entry 1	
nr-DL-PRS-ResourceID-r16	0		
dl-PRS-SequenceID-r16	0		
dl-PRS-CombSizeN-AndReOffset-r16 CHOICE {			
n2-r16	0		Sub-test 1
n4-r16	0		Sub-test 2
}			
dl-PRS-ResourceSlotOffset-r16	4		Cell 1
	0		Cell 2
dl-PRS-ResourceSymbolOffset-r16	0		
dl-PRS-QCL-Info-r16	Not present		
}			
}			
}			
}			
}			

15.5.3.5 Test requirement

The UE Rx-Tx time difference accuracy test parameters are given in Table 15.5.3.5-1.

Table 15.5.3.5-1: UE Rx-Tx time difference measurement accuracy test parameters

Parameter	Unit	Test configuration	Test 1		Test 2	
			Cell 1	Cell 2	Cell 1	Cell 2
AoA setup		1	Setup 1 as specified in clause A.3.15 of TS38.133 [50]		Setup 1 as specified in clause A.3.15 of TS38.133 [50]	
Beam Assumption ^{Note 7}		1	Rough	Rough	Rough	Rough
DRX	s	1	0.64		0.64	
Time offset with Cell 1	μs	1	N/A	3	N/A	3
TDD configuration		1	TDDConf.3.1	TDDConf.3.1	TDDConf.3.1	TDDConf.3.1
PDSCH RMC configuration		1	SR.3.1 TDD	N/A	SR.3.1 TDD	N/A
RMSI CORESET RMC configuration		1	CR.3.1 TDD	N/A	CR.3.1 TDD	N/A
Dedicated CORESET RMC configuration		1	CCR.3.1 TDD	N/A	CCR.3.1 TDD	N/A
OCNG Patterns		1	OP.1	OP.1	OP.1	OP.1
Initial BWP configuration		1	DLBWP.0.1 ULBWP.0.1	N/A	DLBWP.0.1 ULBWP.0.1	N/A
PRS configuration		1	PRS.1.1 FR2	PRS.1.2 FR2	PRS.1.1 FR2	PRS.1.2 FR2
PRS Resource slot offset	slot	1	0	4	0	4
SRS configuration		1	POS-SRS.3	N/A	POS-SRS.3	N/A
N_{oc} ^{Note 2}	dBm/SCS	1	-89+TT		-89+TT	
N_{oc} ^{Note 2}	dBm/15 kHz	1	-98+TT		-98+TT	
PRS \hat{E}_s/I_{ot}	dB	1	-2.41+TT	-12.12	-2.41+TT	-12.12+TT
PRS \hat{E}_s/N_{oc}	dB	1	-2+TT	-10+TT	-2+TT	-10+TT
PRS-RSRP ^{Note 3}	dBm/SCS kHz	1	-91+TT	-99+TT	-91+TT	-99+TT
I_o	dBm/190.08 MHz	1	-54.62+TT	-54.62+TT	-54.62+TT	-54.62+TT
Propagation Condition		1	AWGN		AWGN	

Note 1:	Void.
Note 2:	Interference from other cells and noise sources not specified in the test is assumed to be constant over subcarriers and time and shall be modelled as AWGN of appropriate power for N_{oc} to be fulfilled.
Note 3:	PRS-RSRP and I_0 levels have been derived from other parameters for information purposes. They are not settable parameters themselves.
Note 4:	PRS-RSRP minimum requirements are specified assuming independent interference and noise at each receiver antenna port.
Note 5:	Equivalent power received by an antenna with 0 dBi gain at the centre of the quiet zone
Note 6:	As observed with 0 dBi gain antenna at the centre of the quiet zone
Note 7:	Information about types of UE beam is given in B.2.1.3 of TS38.133[50], and does not limit UE implementation or test system implementation
Note 8:	Calculation of E_s/I_{otBB} includes the effect of UE internal noise up to the value assumed for the associated Refsens requirement in clause 7.3.2 of TS 36.101-2 [55], and an allowance of 1dB for UE multi-band relaxation factor ΔMB_P from TS 38.101-2 [55] Table 6.2.1.3-4.

Table 15.5.3.5-2: UE Rx – Tx time difference measurement accuracy requirements

Test Configuration	Subtest	Lowest reported value	Highest reported value
1	Sub-test 1	(Measured value from step 12 - 33) T_c converted to UE Rx-Tx time difference measurement according to clause 4.14.6	(Measured value from step 12 + 33) T_c converted to UE Rx-Tx time difference measurement according to clause 4.14.6
	Sub-test 2	(Measured value from step 12 - 33) T_c converted to UE Rx-Tx time difference measurement according to clause 4.14.6	(Measured value from step 12 +33) T_c converted to UE Rx-Tx time difference measurement according to clause 4.14.6

The UE Rx-Tx time difference measurement period fulfils the requirements specified in clause 15.5.3.3.

The test tolerances are defined in clauses C.1.6 and C.2.5.

For the overall test to pass, the ratio of successful reported values in each sub-test shall be more than 90% with a confidence level of 95%.

15.5.4 UE Rx-Tx time difference measurement accuracy with reduced number of samples in FR2 SA

Editor's note: This test case is incomplete. The following aspect is either missing or TBD:

- Test tolerance analysis is missing
- The test procedure may require an update

15.5.4.1 Test purpose

The purpose of the test is to verify that the UE Rx-Tx time difference measurement accuracy with reduced number of samples in RRC_INACTIVE state is within the specified limits. This test will verify the requirements in TS 38.133 [50] clause 10.1.25.2. The test is conducted in AWGN propagation condition in FR2 in standalone scenario when single positioning frequency layer is configured.

15.5.4.2 Test applicability

This test applies to all types of NR UE release 17 onwards that support Multi-RTT positioning and *supportedDL-PRS-ProcessingSamples-RRC-Inactive*. In addition, this test shall be verified with either SDT or non-SDT supporting UEs.

15.5.4.3 Minimum conformance requirements

The UE Rx-Tx time difference measurement accuracy requirements in this clause shall not apply, if:

N_{TA_offset} defined in Table 7.1.2-2 in TS38.133 [50] changes during the UE Rx-Tx measurement period or

if the uplink transmission timing changes during the UE Rx-Tx measurement period due to the network-configured Timing Advance.

The UE Rx-Tx time difference measurement accuracy requirements in this clause shall apply provided that:

- The UE transmits SRS within [-160, 160] msec of at least one DL PRS resource of each of the TRPs in the assistance data.

If the uplink transmission timing changes during the UE Rx-Tx measurement period due to the autonomous timing adjustment defined in clause 7.1.2 of TS38.133 [50] then:

- UE Rx-Tx measurement accuracy requirements shall apply for a cell, which is also the downlink reference cell (defined in section 7.1.1 of TS38.133 [50]) for SRS transmission even if the uplink transmission timing changes during the UE Rx-Tx measurement period due to autonomous adjustment.
- UE Rx-Tx measurement accuracy requirements shall not apply for a cell, which is not the downlink reference cell (defined in section 7.1.1 of TS38.133 [50]) for SRS transmission, if the uplink transmission timing changes during the UE Rx-Tx measurement period due to autonomous adjustment.

When a serving cell change occurs during the UE Rx-Tx measurement period, the UE Rx-Tx time difference measurement accuracy requirements in this clause shall apply provided that the serving cell change does not impact SRS configuration for the UE Rx-Tx measurement.

The relative accuracy of UE Rx-Tx measurement in this clause is defined as accuracy of the difference between two UE Rx-Tx measurements.

The accuracy requirements in Table 15.5.4.3-1 for FR2 are valid under the following conditions:

Conditions defined in clause 7.3 of TS 38.101-2 [55] for reference sensitivity are fulfilled.

$PRP|_{dBm}$ according to Annex B.2.14 of TS38.133 [50] for a corresponding Band

Number of measurement samples is less than 4.

AWGN propagation condition.

Table 15.5.4.3-1: UE Rx-Tx time difference measurement accuracy in FR2 in AWGN with reduced measurement samples

Accuracy	Conditions					
	PRS \hat{E}_s /lot	Minimum PRS bandwidth	PRS SCS	PRS resource repetition ($T_{rep}^{PRS} * L_{PRS} / K_{comb}^{PRS}$ Note 3)	I_o Note 4 range	
					Minimum I_o Note 1	Maximum I_o
T_c Note 5	dB	RB	kHz		dBm / SCS _{PRS}	dBm/BW _{Channel}
$\pm 15+\delta$	0	≥ 64	60	≥ 1	Same value as PRP in Table B.2.14-2 of TS38.133[50], according to UE Power class, operating band and angle of arrival	NOTE 6
$\pm 7+\delta$		≥ 132		≥ 1		
$\pm 7+\delta$		≥ 64	120	≥ 1	Same value as PRP in Table B.2.14-2 of TS38.133[50], according to UE Power class, operating band and angle of arrival	NOTE 6
$\pm 4+\delta$		≥ 128		≥ 1		
$\pm 15+\delta$	-6	≥ 64	60	≥ 1	NOTE 6	NOTE 6
$\pm 7+\delta$		≥ 132		≥ 1	NOTE 6	NOTE 6
$\pm 9+\delta$		≥ 64	120	≥ 1	NOTE 6	NOTE 6
$\pm 4+\delta$		≥ 128		≥ 1	NOTE 6	NOTE 6

NOTE 1: This minimum I_o condition is expressed as the average I_o per RE over all REs in an OFDM symbol.
 NOTE 2: NR operating band groups are as defined in Section 3.5 of TS38.133[50]
 NOTE 3: T_{rep}^{PRS} , L_{PRS} , K_{comb}^{PRS} are configured by higher layer parameter dl-PRS-ResourceRepetitionFactor, dl-PRS-NumSymbols and dl-PRS-CombSizeN defined in TS 37.355 [49].

NOTE 4: The l_o is defined in PRS slots. The same l_o range applies to PRS and non-PRS symbols. l_o levels are different in PRS and non-PRS symbols within the same slot.

NOTE 5: T_c is the basic timing unit defined in TS 38.211 [53].

NOTE 6: The same bands and the same l_o conditions for each band apply for this requirement as for the corresponding requirement with the PRS bandwidth of the smallest RB number for the corresponding SCS.

NOTE 7: δ is the margin determined from Table 15.5.4.3-2

Table 15.5.4.3-2: Margin for UE Rx-Tx time difference measurement accuracy in FR2

Min(PRS BW, SRS BW) (MHz)		Margin (T_c ^{Note 1})
SCS = 60 kHz	SCS = 120 kHz	
≥ 24	N/A	76
≥ 64	≥ 32	32
≥ 132	≥ 64	24
N/A	≥ 128	20
NOTE 1: T_c is the basic timing unit defined in TS 38.211 [53].		
NOTE 2: If SRS and PRS have different SCS, the margin corresponding to the smallest RS BW in MHz applies.		

15.5.4.4 Test description

15.5.4.4.1 Initial conditions

The supported test configuration is listed in Table 15.5.4.4.1-1.

Table 15.5.4.4.1-1: Supported test configurations

Config	Description
1	120 kHz SSB and PRS SCS, 200 MHz bandwidth, TDD duplex mode

Test Environment: Normal, as defined in TS 38.508-1 [45] clause 4.1.

Frequencies to be tested: Mid-Range, as defined in TS 38.508-1 [45] clause 4.3.1.

Channel bandwidth to be tested: are specified in Table 15.5.4.4.1-1.

1. Connect the SS and AWGN noise sources to the UE antenna connector or antenna connectors as shown in Annex A, Figure A.14.
2. The general test parameter settings are set up according to Table 15.5.4.4-2.
3. Propagation conditions are set according to clause 4.14.2.
4. Message contents are defined in clause 15.5.4.4.3.
5. In the test there are two cells in the test: PCell (Cell 1) and a neighbour cell (Cell 2). All cells are on the same RF channel in FR2.

15.5.4.4.2 Test procedure

The test consists of a set-up period and a measurement period. During the set-up period, the UE shall be in RRC_CONNECTED state and shall not have any timing information of Cell 2. During the measurement period UE shall be in RRC_INACTIVE state.

The beginning of the measurement period shall be aligned with the first DRX cycle containing a DL PRS resource(s). The *NR-Multi-RTT-ProvideAssistanceData* and *NR-Multi-RTT-RequestLocationInformation* shall be provided to the UE during the set-up period.

1. Configure the Cell for RA-SDT with SIB1 configured according to the message contents 15.5.4.4.3.

2. State RRC_CONNECTED with generic procedure parameters Connectivity NR, Connected without release On, according to TS 38.508-1 [45] clause 4.5. Note that in the remainder of the test the timing advance command $T_A = 31$ which indicates a timing advance adjustment value $N_{TA} = 0 T_c$.
3. The SS shall send a RESET UE POSITIONING STORED INFORMATION message.
4. The SS adjusts the downlink timing for Cell 1 to a delay of $+512 T_c$, compared to the current value.
5. Wait for 1.6 s to allow for the possibility that the UE makes autonomous timing adjustments.
6. The SS shall transmit an *RRCReconfiguration* message with DRX configuration.
7. The UE shall transmit *RRCReconfigurationComplete* message.
8. The SS shall transmit an LPP REQUEST CAPABILITIES message.
9. The UE shall transmit an LPP PROVIDE CAPABILITIES message indicating the UE supports *supportedDL-PRS-ProcessingSamples-RRC-Inactive* in the *NR-DL-PRS-ProcessingCapability* IE and the Multi-RTT capabilities supported by the UE in the *NR-Multi-RTT-ProvideCapabilities* IE.
10. The SS shall send a LPP PROVIDE ASSISTANCE DATA message, including the *NR-Multi-RTT-ProvideAssistanceData* IE. The position of neighbour Cell 2 is described in 3GPP TS 37.571-5 [20]. If the UE message at step 8 includes the *ackRequested* IE set to TRUE, then the SS shall send an acknowledgment in the LPP PROVIDE ASSISTANCE DATA message.
11. The SS shall send a LCS Periodic-Triggered Invoke Request message with LPP REQUEST LOCATION INFORMATION embedded to start the periodic reporting procedure, including the *reducedDL-PRS-ProcessingSamples-r17* in the *NR-Multi-RTT-RequestLocationInformation* IE such that the UE receives the message ΔT ms before the start of the measurement period, where $\Delta T = 50$ ms.
12. The UE shall transmit an LCS Periodic-Triggered Invoke Return Result message.
13. The SS transmits an *RRCRelease* message including the UL configuration and SDT configuration to transit the UE to RRC_INACTIVE state.
14. Wait for the UE as it monitors for occurrence of the periodic event requested.
15. The UE shall transmit an *RRCResumeRequest* message. If the UE also supporting SDT feature, the UE shall include LPP PROVIDE LOCATION INFORMATION message in the *RRCResumeRequest* message and then go to step 19.
16. The SS transmits an *RRCResume* message.
17. The UE transmits an *RRCResumeComplete* message.
18. The UE shall transmit a LPP PROVIDE LOCATION INFORMATION message including the *NR-Multi-RTT-ProvideLocationInformation* IE within the response time (see clause 15.5.4.4.3) and *RRCResumeComplete* message.
19. If the UE message at step 15 or 18 includes the *ackRequested* IE set to TRUE, the SS shall send LPP acknowledgment message.
20. The SS shall check *nr-UE-RxTxTimeDiff-r16* value for Cell 2 in the *NR-Multi-RTT-SignalMeasurementInformation* according to Table 15.5.4.5-2.
21. UE shall be released and moved to RRC_IDLE.
22. Repeat steps 1-21 until the confidence level according to Annex D is achieved.

NOTE: To avoid a large divergence between the sent TA and the set downlink timing, the SS may reset the downlink timing for Cell 1 to its initial value after a certain amount of loops. The loop during the reset does not count for the result statistics.

15.5.4.4.3 Message contents

Message contents are the same as 15.5.3.4.3 with following exceptions:

Table 15.5.4.4.3-1: NR-DL-PRS-AssistanceData

Derivation Path: 37.355 clause 6.4.3			
Information Element	Value/remark	Comment	Condition
NR-DL-PRS-AssistanceData-r16 ::= SEQUENCE {			
nr-DL-PRS-ReferenceInfo-r16 SEQUENCE {			
dl-PRS-ID-r16	0		
nr-DL-PRS-ResourceID-List-r16	Not present		
nr-DL-PRS-ResourceSetID-r16	Not present		
}			
nr-DL-PRS-AssistanceDataList-r16 SEQUENCE (SIZE (1..nrMaxFreqLayers-r16)) OF NR-DL-PRS-AssistanceDataPerFreq-r16 {	1 entry		
NR-DL-PRS-AssistanceDataPerFreq-r16[1] SEQUENCE {		entry 1	
nr-DL-PRS-PositioningFrequencyLayer-r16 SEQUENCE {			
dl-PRS-SubcarrierSpacing-r16	kHz120		
dl-PRS-ResourceBandwidth-r16	11	64 PRBs	
dl-PRS-StartPRB-r16	0		
dl-PRS-PointA-r16	absoluteFrequencyPointA as defined for the DL frequency of the Cell 1		
dl-PRS-CombSizeN-r16	n2		
dl-PRS-CyclicPrefix-r16	normal		
}			
nr-DL-PRS-AssistanceDataPerFreq-r16 SEQUENCE (SIZE (1..nrMaxTRPsPerFreq-r16)) OF NR-DL-PRS-AssistanceDataPerTRP-r16{	2 entries		
NR-DL-PRS-AssistanceDataPerTRP-r16[1] SEQUENCE {		entry 1	Cell 1
dl-PRS-ID-r16	0		
nr-PhysCellID-r16	Cell 1		
nr-CellGlobalID-r16	Cell 1		
nr-ARFCN-r16	Cell 1		
nr-DL-PRS-SFN0-Offset-r16 SEQUENCE {			
sfn-Offset-r16	0		
integerSubframeOffset-r16	0		
}			
nr-DL-PRS-ExpectedRSTD-r16	0		
nr-DL-PRS-ExpectedRSTD-Uncertainty-r16	0		
nr-DL-PRS-Info-r16	As specified in Table 15.5.4.4.3-2		
}			
NR-DL-PRS-AssistanceDataPerTRP-r16[2] SEQUENCE {		entry 2	Cell 2
dl-PRS-ID-r16	1		
nr-PhysCellID-r16	Cell 2		
nr-CellGlobalID-r16	Cell 2		
nr-ARFCN-r16	Cell 2		
nr-DL-PRS-SFN0-Offset-r16 SEQUENCE {			
sfn-Offset-r16	0		
integerSubframeOffset-r16	0		
}			
nr-DL-PRS-ExpectedRSTD-r16	23	About 3 μs	
nr-DL-PRS-ExpectedRSTD-Uncertainty-r16	154	About 5 μs	
nr-DL-PRS-Info-r16	As specified in Table 15.5.4.4.3-2		
}			
}			
}			
}			

}		
---	--	--

Table 15.5.4.4.3-2: NR-DL-PRS-Info

Derivation Path: 37.355 clause 6.4.3			
Information Element	Value/remark	Comment	Condition
NR-DL-PRS-Info-r16 ::= SEQUENCE {			
nr-DL-PRS-ResourceSetList-r16 SEQUENCE (SIZE (1..nrMaxSetsPerTrp-r16)) OF NR-DL-PRS-ResourceSet-r16 {	1 entry		
NR-DL-PRS-ResourceSet-r16[1] SEQUENCE {		entry 1	
nr-DL-PRS-ResourceSetID-r16	0		
dl-PRS-Periodicity-and-ResourceSetSlotOffset-r16 CHOICE {			
scs120-r16 CHOICE {			
n1280-r16	80		
}			
dl-PRS-ResourceRepetitionFactor-r16	Not present		
dl-PRS-ResourceTimeGap-r16	s1		
dl-PRS-NumSymbols-r16	n4		
dl-PRS-MutingOption1-r16 CHOICE {			
po2-r16	10		Cell 1
	01		Cell 2
}			
}			
dl-PRS-MutingOption2-r16	Not present		
dl-PRS-ResourcePower-r16	27		
dl-PRS-ResourceList-r16 SEQUENCE (SIZE (1..nrMaxResourcesPerSet-r16)) OF NR-DL-PRS-Resource-r16 {	1 entry		
NR-DL-PRS-Resource-r16[1] SEQUENCE {		entry 1	
nr-DL-PRS-ResourceID-r16	0		
dl-PRS-SequenceID-r16	0		
dl-PRS-CombSizeN-AndReOffset-r16 CHOICE {			
n4-r16	0		
}			
dl-PRS-ResourceSlotOffset-r16	4		Cell 1
	0		Cell 2
dl-PRS-ResourceSymbolOffset-r16	0		
dl-PRS-QCL-Info-r16	Not present		
}			
}			
}			
}			

Table 15.5.4.4.3-3: LPP RequestLocationInformation

Derivation Path: TS 37.355 [49] clause 6.2			
Information Element	Value/remark	Comment	Condition
LPP-Message ::= SEQUENCE {			
transactionID SEQUENCE {			
initiator	locationServer		
transactionNumber	1		
}			
endTransaction	FALSE		
sequenceNumber	Not present		
acknowledgement	Not present		
lpp-MessageBody CHOICE {			
c1 CHOICE {			
requestLocationInformation SEQUENCE {			

criticalExtensions CHOICE {			
c1 CHOICE {			
requestLocationInformation-r9 SEQUENCE {			
commonEsRequestLocationInformation SEQUENCE {			
locationInformationType	locationMeasurementsPreferred		
triggeredReporting	Not present		
periodicalReporting	Not present		
additionalInformation	onlyReturnInformationRequested		
qos SEQUENCE {			
horizontalAccuracy	Not present		
verticalCoordinateRequest	FALSE		
verticalAccuracy	Not present		
responseTime SEQUENCE {			
time	See 15.4.4.5	Result of the response time calculation rounded up to the next second if response time <= 128s. Result of the response time calculation rounded up to the next multiple of ten seconds if response time > 128s	
responseTimeEarlyFix-r12	Not present		Rel-12 onwards
unit-r15	Not present		
	ten-seconds		Calculated response time > 128s
}			
velocityRequest	FALSE		
}			
environment	Not present		
locationCoordinateTypes	Not present		
velocityTypes	Not present		
}			
a-gnss-RequestLocationInformation	Not present		
otdoa-RequestLocationInformation	Not present		
ecid-RequestLocationInformation	Not present		
epdu-RequestLocationInformation	Not Present		
sensor-RequestLocationInformation-r13	Not present		
tbs-RequestLocationInformation-r13	Not present		
wlan-RequestLocationInformation-r13	Not present		
bt-RequestLocationInformation-r13	Not present		
nr-ECID-RequestLocationInformation-r16	Not present		
nr-Multi-RTT-RequestLocationInformation-r16 SEQUENCE {			
nr-UE-RxTxTimeDiffMeasurementInfoRequest-r16	Not present		
nr-RequestedMeasurements-r16	bit 0 = 1 (prsrsrpReq)		
nr-AssistanceAvailability-r16	FALSE		
nr-Multi-RTT-ReportConfig-r16 SEQUENCE {			
maxDL-PRS-RxTxTimeDiffMeasPerTRP-r16	Not present		
timingReportingGranularityFactor-r16	Not present		
}			

additionalPaths-r16	Not present		
nr-UE-RxTxTEG-Request-r17			
measureSameDL-PRS-ResourceWithDifferentRxTxTEGs-r17	Not present		
measureSameDL-PRS-ResourceWithDifferentRxTEGs-r17	Not present		
reducedDL-PRS-ProcessingSamples-r17	requested		
nr-los-nlos-IndicatorRequest-r17	Not present		
additionalPathsExt-r17	Not present		
additionalPathsDL-PRS-RSRP-Request-r17	Not present		
multiMeasInSameReport-r17	Not present		
lowerRxBeamSweepingFactor-FR2-r17	Not present		
}			
nr-DL-AoD-RequestLocationInformation-r16	Not present		
nr-DL-TDOA-RequestLocationInformation-r16	Not present		
}			
}			
}			
}			
}			
}			
}			
}			

15.5.4.5 Test requirement

Table 15.5.4.5-1 defines the primary level settings including test tolerances for the test.

Table 15.5.4.5-1: UE Rx-Tx time difference measurement accuracy test parameters

Parameter	Unit	Test configuration	Test 1	
			Cell 1	Cell 2
AoA setup		1	Setup 1 as specified in clause A.3.15	
Beam Assumption ^{Note 7}		1	Rough	Rough
DRX cycle		1	0.64s	
Time offset with Cell 1	µs	1	N/A	3
TDD configuration		1	TDDConf.3.1	TDDConf.3.1
PDSCH RMC configuration		1	SR.3.1 TDD	N/A
RMSI CORESET RMC configuration		1	CR.3.1 TDD	N/A
Dedicated CORESET RMC configuration		1	CCR.3.1 TDD	N/A
OCNG Patterns		1	OP.1	OP.1
EPRE ratio of PSS to SSS	dB	1	0	0
EPRE ratio of PBCH DMRS to SSS				
EPRE ratio of PBCH to PBCH DMRS				
EPRE ratio of PDCCH DMRS to SSS				
EPRE ratio of PDCCH to PDCCH DMRS				
EPRE ratio of PDSCH DMRS to SSS				
EPRE ratio of PDSCH to PDSCH DMRS				
EPRE ratio of OCNG DMRS to SSS ^{Note 1}				

EPRE ratio of OCNG to OCNG DMRS ^{Note 1}				
EPRE ratio of PRS to SSS				
TRS Configuration		1	TRS.2.1 TDD	N/A
Initial BWP configuration		1	DLBWP.0.1 ULBWP.0.1	N/A
PRS configuration		1	PRS.1.1 FR2	PRS.1.1 FR2
PRS BW		1	64 PRBs	64 PRBs
PRS Resource slot offset	slot	1	0	4
SRS configuration		1	POS-SRS.3	N/A
N_{oc} ^{Note 2}	dBm/SCS	1	-89+TT	
N_{oc} ^{Note 2}	dBm/15 kHz	1	-98+TT	
PRS \hat{E}_s/I_{ot}	dB	1	0+TT	-6+TT
PRS \hat{E}_s/N_{oc}	dB	1	2.23+TT	-1.73+TT
PRP ^{Note 3}	dBm/SCS kHz	1	-86.77+TT	-90.73+TT
Io	dBm/190.08 MHz	1	-51.76+TT	-51.76+TT
Propagation Condition		1	AWGN	
Note 1:	Void.			
Note 2:	Interference from other cells and noise sources not specified in the test is assumed to be constant over subcarriers and time and shall be modelled as AWGN of appropriate power for N_{oc} to be fulfilled.			
Note 3:	PRP and Io levels have been derived from other parameters for information purposes. They are not settable parameters themselves.			
Note 4:	PRP minimum requirements are specified assuming independent interference and noise at each receiver antenna port.			
Note 5:	Equivalent power received by an antenna with 0 dBi gain at the centre of the quiet zone			
Note 6:	As observed with 0 dBi gain antenna at the centre of the quiet zone			
Note 7:	Information about types of UE beam is given in B.2.1.3, and does not limit UE implementation or test system implementation			
Note 8:	Calculation of $E_s/I_{ot_{BB}}$ includes the effect of UE internal noise up to the value assumed for the associated Refsens requirement in clause 7.3.2 of TS 38.101-2 [55], and an allowance of 1dB for UE multi-band relaxation factor ΔMB_P from TS 38.101-2 [55] Table 6.2.1.3-4.			

Table 15.5.4.5-2: UE Rx – Tx time difference measurement accuracy requirements

Test Configuration	Lowest reported value	Highest reported value
1	(5898 - 33) T _c converted to UE Rx-Tx time difference measurement according to clause 4.14.6	(5898 + 33) T _c converted to UE Rx-Tx time difference measurement according to clause 4.14.6

The UE Rx-Tx time difference measurement period fulfils the requirements specified in clause 15.5.4.3.

The test tolerances are defined in clauses C.1.6 and C.2.5.

The rate of successful tests during repeated tests shall be at least 90% with a confidence level of 95%.

16 NR PRS-RSRP measurement requirements

16.1 General

This clause defines the minimum performance requirements for NR UEs capable of PRS-RSRP measurements.

16.2 NR PRS-RSRP measurement period test cases in RRC_CONNECTED

16.2.1 PRS-RSRP measurement period test case for single positioning frequency layer in FR1 SA

16.2.1.1 Test purpose

The purpose of the test is to verify that the PRS-RSP measurement meets the requirements specified in TS 38.133 [50] Clause 9.9.2 in an environment with AWGN propagation conditions in FR1 in standalone scenario when single positioning frequency layer is configured.

16.2.1.2 Test applicability

This test applies to all types of NR UE release 16 onwards that supports DL-TDOA positioning and PRS-RSRP measurements in FR1.

16.2.1.3 Minimum conformance requirements

When the physical layer receives *NR-DL-AoD-ProvideAssistanceData* message and *NR-DL-AoD-RequestLocationInformation* message from LMF via LPP [34], the UE shall be able to measure multiple (up to the UE capability specified in Clause 9.9.3.3) PRS-RSRP measurements, defined in TS 38.215 [4], from configured PRS resources for configured TRPs on configured positioning frequency layers, within $T_{\text{PRS-RSRP, total}}$ ms.

$$T_{\text{PRS-RSRP, total}} = \sum_{i=1}^L T_{\text{PRS-RSRP, } i} + (L - 1) * \max(T_{\text{effect, } i})$$

where

i is the index of positioning frequency layer,

L is total number of positioning frequency layers,

$T_{\text{effect, } i}$ is the periodicity of the PRS-RSRP measurement in positioning frequency layer i .

$$T_{\text{PRS-RSRP, } i} = \left(\text{CSSF}_i * \text{ceil}(K_{\text{p,PRS, } i}) * N_{\text{RxBeam, } i} * \left\lfloor \frac{N_{\text{PRS, } i}^{\text{slot}}}{N'} \right\rfloor \left\lceil \frac{L_{\text{available_PRS, } i}}{N} \right\rceil * N_{\text{sample}} - 1 \right) * T_{\text{effect, } i} + T_{\text{last}}$$

where

CSSF_i is the carrier specific scaling factor for PRS-RSRP measurements specified in clause 9.1.5.2,

$K_{\text{p,PRS, } i}$ is a scaling factor for a positioning frequency layer to be measured within the associated measurement gap pattern, which is defined as $K_{\text{p,PRS, } i} = N_{\text{total}} / N_{\text{available}}$ for UE configured with concurrent measurement gap, and $K_{\text{p,PRS, } i} = 1$ for UE not configured with concurrent measurement gap.

For a window W of duration $\max(T_{\text{PRS, } i}, \text{MGRP_max})$, where MGRP_max is the maximum MGRP across all configured per-UE MG and per-FR MG within the same FR as the positioning frequency layer, and starting at the beginning of any associated gap occasions covering the PRS occasion:

N_{total} is the total number of associated gap occasions covering PRS occasions within the window, including those overlapped with other MG occasions within the window, and

$N_{\text{available}}$ is the number of non-dropped associated gap occasions covering PRS occasions within the window W , after further accounting for MG collisions by applying the selected gap collision rule

Requirements do not apply if $N_{\text{available}} = 0$.

$N_{RxBeam,i}$ is the scaling factor for Rx beam sweeping, and $N_{RxBeam,i}=1$ if positioning frequency layer i is in FR1 and if positioning frequency layer i is in FR2, $N_{RxBeam,i}$ is equal to the value reported by the UE in *supportedLowerRxBeamSweepingFactor-FR2* if the UE supports the capability for the band containing positioning frequency layer i , and the LMF indicates *lowerRxBeamSweepingFactor-FR2* in *NR-TDOA-RequestLocationInformation*. $N_{RxBeam,i}$ is equal to 8, otherwise.

$L_{available_PRS,i}$ is the time duration of available PRS to be measured in the positioning frequency layer i to be measured during $T_{available_PRS,i}$, and is calculated in the same way as PRS duration K defined in clause 5.1.6.5 of TS 38.214 [26]. For calculation of $L_{available_PRS,i}$, only the PRS resources unmuted and fully or partially overlapped with MG are considered.

$N_{PRS,i}^{slot}$ is the maximum number of DL PRS resources of positioning frequency layer i configured in a slot,

$\{N, T\}$ is UE capability combination per band where N is a duration of DL PRS symbols in ms corresponding to *durationOfPRS-ProcessingSymbols* in TS 37.355 [34] processed every T ms corresponding to *durationOfPRS-ProcessingSymbolsInEveryTms* in TS 37.355 [34] for a given maximum bandwidth supported by UE corresponding to *supportedBandwidthPRS* in TS 37.355 [34],

N' is UE capability for number of DL PRS resources that it can process in a slot as indicated by *maxNumOfDL-PRS-ResProcessedPerSlot* in clause 6.4.3 of TS 37.355 [34],

N_{sample} is the number of PRS RSRP measurement samples, where

- $N_{sample} = 1$ if the UE supports *supportedDL-PRS-ProcessingSamples* [34], and the LMF requests the UE to perform positioning measurements with reduced number of samples, and meets the following conditions:
 - PRS bandwidth is within the active BWP and
 - Magnitude of difference between the serving cell's SS-RSRP and the neighbour cell's PRS-RSRP is within [6] dB.
- $N_{sample} = [2]$ if the UE supports *supportedDL-PRS-ProcessingSamples* [34], and the LMF requests the UE to perform positioning measurements with reduced number of samples, and does not meet the following conditions:
 - PRS bandwidth is within the active BWP and
 - Magnitude of difference between the serving cell's SS-RSRP and the neighbour cell's PRS-RSRP is within [6] dB.
- $N_{sample} = 4$ otherwise.

$T_{last,i} = T_i + T_{available_PRS,i}$ is the measurement duration for the last PRS-RSRP sample, including the sampling time and processing time, if not all PRS resources to be measured are available in the same measurement gap occasion during $T_{available_PRS,i}$, otherwise $T_{last,i} = T_i + MGL$,

$T_{effect,i} = \left\lceil \frac{T_i}{T_{available_PRS,i}} \right\rceil * T_{available_PRS,i}$ is the periodicity of PRS-RSRP measurement in positioning frequency layer i ,

T_i corresponds to *durationOfPRS-ProcessingSymbolsInEveryTms* in TS 37.355 [34],

$T_{available_PRS,i} = LCM(T_{PRS,i}, MGRP_i)$ is the least common multiple between $T_{PRS,i}$ and $MGRP_i$,

$T_{PRS,i}$ is the maximum PRS resource periodicity among all PRS resources in positioning frequency layer i ,

$MGRP_i$ is the measurement gap repetition period in positioning frequency layer i .

If positioning frequency layer i has more than one DL PRS resource set with different PRS periodicities with muting, $T_{per}^{PRS\ with\ muting} = N_{muting} * T_{per}^{PRS}$, the least common multiple of $T_{per}^{PRS\ with\ muting}$ among the DL PRS resource sets is used to derive $T_{PRS,i}$, where:

T_{per}^{PRS} is the periodicity of PRS resource sets given by the higher-layer parameter *DL-PRS-Periodicity*.

N_{muting} is the scaling factor considering PRS resource muting. $N_{muting} = T_{muting}^{PRS} * L_{muting}$, where T_{muting}^{PRS} is the muting repetition factor given by the higher-layer parameter *DL-PRS-MutingBitRepetitionFactor*, and L_{muting} is the size of the bitmap $\{b^1\}$.

Note: For the purpose of calculating $T_{PRS,i}$, only the PRS resources fully or partially covered by the MG are considered.

When PRS-RSRP measurements are configured for DL-AoD, except for deferred MT-LR as defined in clause 4.1a.5 [TS 23.273], the time $T_{PRS-RSRP,total}$ starts from the first MG instance aligned with DL PRS resources in the assistance data after both the *NR-DL-AoD-RequestLocationInformation* message and *NR-DL-AoD-ProvideAssistanceData* message from LMF via LPP [34] are delivered to the physical layer of UE.

For deferred MT-LR with other event than “Periodic Location” as defined in clause 4.1a.5.1 [TS 23.273], the time $T_{PRS-RSRP,total}$ starts from the first MG instance aligned with a DL PRS resource(s) in the assistance data after the associated event(s) occurs.

For deferred MT-LR with event “Periodic Location” as defined in clause 4.1a.5.1 [TS 23.273], the UE shall perform the PRS-RSRP measurement in each reporting period and activate the location report at the time when the periodic timer expires.

Note: No per-positioning frequency layer requirement is applied in scenarios when multiple positioning frequency layers are configured.

When the PRS-RSRP measurement is configured together with RSTD measurement then the PRS-RSRP measurement shall meet the RSTD measurement requirements defined in clause 9.9.2.

When the PRS-RSRP measurement is configured together with UE Rx-Tx time difference measurement then the PRS-RSRP measurement shall meet the UE Rx-Tx time difference measurement requirements defined in clause 9.9.4.

If CSSF changes during the measurement period, the measurement period could be longer.

The measurement requirements do not apply for a PRS resource:

- if the PRS resource is across two sampling duration of N within duration $L_{available_PRS,i}$ or
- if time span of the PRS resource instance (including at least the minimum number of repetitions specified in the accuracy requirements) is greater than UE reported capability N.

If during the measurement period of one or more positioning frequency layers, the MG pattern is reconfigured either per UE request or not per UE request, the measurement period can be longer.

The requirements in this section apply, provided no PRS symbols are dropped during the measurement period $T_{PRS-RSRP,total}$ within measurement gaps due to collisions with other signals; otherwise, a longer measurement period may be used.

The requirements in clause 9.9.3 do not apply if the PRS configuration given by higher layer parameters *NR-DL-PRS-AssistanceData* exceeds any of the UE measurement capabilities given by *NR-DL-PRS-ResourcesCapability* in *NR-DL-AoD-ProvideCapabilities*, and it is up to UE implementation which PRS resources are measured, subject to UE measurement capabilities.

If handover occurs while PRS-RSRP measurements are being performed then the UE shall complete the ongoing PRS-RSRP measurements session. The PRS-RSRP measurement period can be longer. The UE shall meet the PRS-RSRP measurement accuracy requirements in clause 10.1.24.

16.2.1.4 Test description

16.2.1.4.1 Initial conditions

The test is defined with three possible Test Configurations. In the case that the UE supports more than one of these Test Configurations, then the UE is only required to be tested in one of the Test Configurations, chosen by the UE. The defined Test Configurations are specified in Table 16.2.1.4.1-1.

Table 16.2.1.4.1-1: Test Configurations

Configuration	Description
1	15 kHz SSB SCS, 10 MHz bandwidth, FDD duplex mode
2	15 kHz SSB SCS, 10 MHz bandwidth, TDD duplex mode
3	30 kHz SSB SCS, 40 MHz bandwidth, TDD duplex mode

Test Environment: Normal, as defined in TS 38.508-1 [45] clause 4.1.

Frequencies to be tested: Mid, as defined in TS 38.508-1 [45] clause 4.3.1.

Channel bandwidth to be tested: are specified in Table 16.2.1.4-1.

1. Connect the SS and AWGN noise sources to the UE antenna connector or antenna connectors as shown in Annex A, Figure A.12.
2. The general test parameter settings are set up according to Table 16.2.1.5-1 and Table 16.2.1.5-2.
3. Propagation conditions are set according to clause 4.15.2.
4. Message contents are defined in clause 16.2.1.4.3.
5. In the test there are two synchronous cells: Cell 1 and Cell 2. Cell 1 is the PCell. Cell 2 is the neighbour cell. The cells are on the same RF channel in FR1

16.2.1.4.2 Test procedure

The test consists of two consecutive time intervals, with duration of T1 and T2. Both cells transmit PRS during T2.

The *NR-DL-AoD-RequestLocationInformation* message and *NR-DL-AoD-ProvideAssistanceData* message as defined in TS 37.355 [49] shall be provided to the UE during T1. The last slot containing the two messages for the assistance data and location information request is denoted as #n.

The beginning of the time interval T2 shall be aligned with the beginning of the first MG instance containing the PRS resources that is ΔT after slot #n, where $\Delta T = 50$ ms is the maximum processing time of the assistance data and location information request.

1. Ensure the UE is in State RRC_CONNECTED with generic procedure parameters Connectivity NR, Connected without release On, according to TS 38.508-1 [45] clause 4.5.
2. The SS shall send a RESET UE POSITIONING STORED INFORMATION message.
3. Set the parameters according to Table 16.2.1.5-1 and Table 16.2.1.5-2 as appropriate. Propagation conditions are set according to clause 4.16.2.
4. T1 starts.
5. The SS shall send an LPP REQUEST CAPABILITIES message.
6. The UE shall transmit an LPP PROVIDE CAPABILITIES message indicating the DL-AoD capabilities supported by the UE in the NR-DL-AoD-ProvideCapabilities IE.
7. The SS shall send a LPP PROVIDE ASSISTANCE DATA message, including the nr-DL-AoD-ProvideAssistanceData-r16 IE. If the UE message at step 6 includes the ackRequested IE set to TRUE, then the SS shall send an acknowledgment in the LPP PROVIDE ASSISTANCE DATA message.
8. The SS shall send a LPP REQUEST LOCATION INFORMATION message, including the nr-DL-AoD-RequestLocationInformation-r16 such that the UE receives the message ΔT ms before the start of the measurement period, where $\Delta T = 50$ ms.
9. When T1 expires, the SS shall switch the power setting from T1 to T2 as specified in Table 16.2.1.5-2.
10. The UE shall transmit a LPP PROVIDE LOCATION INFORMATION message including the nr-DL-AoD-ProvideLocationInformation-r16 IE within the response time (see clause 4.16.3). The UE shall perform and report the PRS-RSRP measurements for both Cell 1 and Cell 2. If the UE transmits an nr-DL-AoD-

ProvideLocationInformation-r16 IE including the nr-DL-PRS-RSRP-Result-r16 field for Cell 1 and Cell 2 within the response time then the number of successful tests is increased by one. If the UE fails to report the nr-DL-AoD-ProvideLocationInformation-r16IE with the DL-PRS-RSRP-Result-r16 fields included within the response time then the number of failure tests is increased by one.

11. If the UE message at step 10 includes the *ackRequested* IE set to TRUE, the SS shall send a LPP acknowledgement message.

12. Repeat step 2-11 until the confidence level according to Annex D is achieved.

16.2.1.4.3 Message contents

Table 16.2.1.4.3-1: RESET UE POSITIONING STORED INFORMATION

Derivation Path: 38.509 [44] clause 6.6			
Information Element	Value/remark	Comment	Condition
UE Positioning Technology	0 0 0 1 0 0 0	DL-AoD	

Table 16.2.1.4.3-2: LPP Request Capabilities

Information Element	Value/remark
nr-DL-AoD-RequestCapabilities-r16	TRUE

Table 16.2.1.4.3-3: LPP RequestLocationInformation

Derivation Path: 37.355 clause 6.2			
Information Element	Value/remark	Comment	Condition
LPP-Message ::= SEQUENCE {			
transactionID SEQUENCE {			
initiator	locationServer		
transactionNumber	1		
}			
endTransaction	FALSE		
sequenceNumber	Not present		
acknowledgement	Not present		
lpp-MessageBody CHOICE {			
c1 CHOICE {			
requestLocationInformation SEQUENCE {			
criticalExtensions CHOICE {			
c1 CHOICE {			
requestLocationInformation-r9 SEQUENCE {			
commonEsRequestLocationInformation SEQUENCE {			
locationInformationType	locationMeasurementsRequired		
triggeredReporting	Not present		
periodicalReporting	Not present		
additionalInformation	onlyReturnInformationRequested		
qos SEQUENCE {			
horizontalAccuracy	Not present		
verticalCoordinateRequest	FALSE		
verticalAccuracy	Not present		
responseTime SEQUENCE {			
time	See 16.2.1.5	Result of the response time calculation rounded up to the next second if response time <= 128s. Result of the response time calculation rounded	

		up to the next multiple of ten seconds if response time > 128s.	
responseTimeEarlyFix-r12	Not present		Rel-12 onwards
unit-r15	Not present ten-seconds		Calculated response time >128s
}			
velocityRequest	FALSE		
}			
environment	Not present		
locationCoordinateTypes	Not present		
velocityTypes	Not present		
}			
a-gnss-RequestLocationInformation	Not present		
otdoa-RequestLocationInformation	Not present		
ecid-RequestLocationInformation	Not present		
epdu-RequestLocationInformation	Not Present		
sensor-RequestLocationInformation-r13	Not present		
tbs-RequestLocationInformation-r13	Not present		
wlan-RequestLocationInformation-r13	Not present		
bt-RequestLocationInformation-r13	Not present		
nr-ECID-RequestLocationInformation-r16	Not present		
nr-Multi-RTT-RequestLocationInformation-r16	Not present		
nr-DL-AoD-RequestLocationInformation-r16			
SEQUENCE {			
nr-AssistanceAvailability-r16	FALSE		
nr-DL-AoD-ReportConfig-r16 SEQUENCE {			
maxDL-PRS-RSRP-MeasurementsPerTRP-r16	Not present		
}			
}			
nr-DL-TDOA-RequestLocationInformation-r16	Not present		
}			
}			
}			
}			
}			
}			

Table 16.2.1.4.3-4: LPP ProvideAssistanceData

Derivation Path: 37.355 clause 6.2			
Information Element	Value/remark	Comment	Condition
LPP-Message ::= SEQUENCE {			
transactionID SEQUENCE {			
initiator	locationServer		
transactionNumber	(0..255)		
}			
endTransaction	TRUE		
sequenceNumber	Not present		
acknowledgement	Not present		
lpp-MessageBody CHOICE {			
c1 CHOICE {			
provideAssistanceData SEQUENCE {			
criticalExtensions CHOICE {			
c1 CHOICE {			
provideAssistanceData-r9 SEQUENCE {			
commonIESProvideAssistanceData	Not present		
a-gnss-ProvideAssistanceData	Not present		
otdoa-ProvideAssistanceData	Not present		

epdu-Provide-AssistanceData	Not present		
sensor-ProvideAssistanceData-r15	Not present		
tbs-ProvideAssistanceData-r15	Not present		
wlan-ProvideAssistanceData-r15	Not present		
nr-Multi-RTT-ProvideAssistanceData-r16	Not present		
nr-DL-AoD-ProvideAssistanceData-r16			
SEQUENCE {			
nr-DL-PRS-AssistanceData	As defined in Table 16.2.1.4.3-5		
nr-SelectedDL-PRS-IndexList-r16	Not present		
nr-PositionCalculationAssistance-r16			Depending on UE capabilities, i.e. support for UE-based DL-AoD
SEQUENCE {			
nr-TRP-LocationInfo-r16	As defined in TS 37.571-5 [20]		
nr-DL-PRS-BeamInfo-r16	Not present		
nr-RTD-Info-r16	Not present		
}			
nr-DL-AoD-Error-r16	Not present		
}			
nr-DL-TDOA-ProvideAssistanceData-r16	Not present		
}			
}			
}			
}			
}			
}			
}			

Table 16.2.1.4.3-5: NR-DL-PRS-AssistanceData

Derivation Path: 37.355 clause 6.4.3			
Information Element	Value/remark	Comment	Condition
NR-DL-PRS-AssistanceData-r16 ::= SEQUENCE {			
nr-DL-PRS-ReferenceInfo-r16 SEQUENCE {			
dl-PRS-ID-r16	0		
nr-DL-PRS-ResourceID-List-r16	Not present		
nr-DL-PRS-ResourceSetID-r16	Not present		
}			
nr-DL-PRS-AssistanceDataList-r16 SEQUENCE (SIZE (1..nrMaxFreqLayers-r16)) OF NR-DL-PRS-AssistanceDataPerFreq-r16 {	1 entry		
NR-DL-PRS-AssistanceDataPerFreq-r16[1]		entry 1	
SEQUENCE {			
nr-DL-PRS-PositioningFrequencyLayer-r16 SEQUENCE {			
dl-PRS-SubcarrierSpacing-r16	kHz15 kHz30		Test Configuration 3
dl-PRS-ResourceBandwidth-r16	1	24 PRBs	
dl-PRS-StartPRB-r16	0		
dl-PRS-PointA-r16	absoluteFrequencyPointA as defined for the DL frequency of the Cell 1		
dl-PRS-CombSizeN-r16	n2		
dl-PRS-CyclicPrefix-r16	normal		
}			
nr-DL-PRS-AssistanceDataPerFreq-r16 SEQUENCE (SIZE (1..nrMaxTRPsPerFreq-r16)) OF NR-DL-PRS-AssistanceDataPerTRP-r16{	2 entries		

NR-DL-PRS-AssistanceDataPerTRP-r16[1] SEQUENCE {		entry 1	Cell 1
dl-PRS-ID-r16	0		
nr-PhysCellID-r16	Cell 1		
nr-CellGlobalID-r16	Cell 1		
nr-ARFCN-r16	Cell 1		
nr-DL-PRS-SFN0-Offset-r16 SEQUENCE {			
sfn-Offset-r16	0		
integerSubframeOffset-r16	0		
}			
nr-DL-PRS-ExpectedRSTD-r16	0		
nr-DL-PRS-ExpectedRSTD-Uncertainty-r16	0		
nr-DL-PRS-Info-r16	As specified in Table 16.2.1.4.3-6		
}			
NR-DL-PRS-AssistanceDataPerTRP-r16[2] SEQUENCE {		entry 2	Cell 2
dl-PRS-ID-r16	1		
nr-PhysCellID-r16	Cell 2		
nr-CellGlobalID-r16	Cell 2		
nr-ARFCN-r16	Cell 2		
nr-DL-PRS-SFN0-Offset-r16 SEQUENCE {			
sfn-Offset-r16	0		
integerSubframeOffset-r16	0		
}			
nr-DL-PRS-ExpectedRSTD-r16	23	About 3 μs	
nr-DL-PRS-ExpectedRSTD-Uncertainty-r16	38	About 5 μs	
nr-DL-PRS-Info-r16	As specified in Table 16.2.1.4.3-6		
}			
}			
}			
}			
}			

Table 16.2.1.4.3-6: NR-DL-PRS-Info

Derivation Path: TS 37.355 [49] clause 6.4.3			
Information Element	Value/remark	Comment	Condition
NR-DL-PRS-Info-r16 ::= SEQUENCE {			
nr-DL-PRS-ResourceSetList-r16 SEQUENCE (SIZE (1..nrMaxSetsPerTrp-r16)) OF NR-DL-PRS-ResourceSet-r16 {	1 entry		
NR-DL-PRS-ResourceSet-r16[1] SEQUENCE {		entry 1	
nr-DL-PRS-ResourceSetID-r16	0		
dl-PRS-Periodicity-and-ResourceSetSlotOffset-r16 CHOICE {			
scs15-r16 CHOICE {			Config 1 and Config 2
n160-r16	10		
}			
scs30-r16 CHOICE {			Config 3
N320-r16	20		
}			
}			
dl-PRS-ResourceRepetitionFactor-r16	n2		
dl-PRS-ResourceTimeGap-r16	s1		
dl-PRS-NumSymbols-r16	n4		
dl-PRS-MutingOption1-r16 SEQUENCE {			
dl-prs-MutingBitRepetitionFactor-r16	Not present		
nr-option1-muting-r16 CHOICE {			
po2-r16	10		Cell 1
	01		Cell 2

}			
}			
dl-PRS-MutingOption2-r16	Not present		
dl-PRS-ResourcePower-r16	27		
dl-PRS-ResourceList-r16 SEQUENCE (SIZE (1..nrMaxResourcesPerSet-r16)) OF NR-DL-PRS-Resource-r16 {	1 entry		
NR-DL-PRS-Resource-r16[1] SEQUENCE {		entry 1	
nr-DL-PRS-ResourceID-r16	0		
dl-PRS-SequenceID-r16	0		
dl-PRS-CombSizeN-AndReOffset-r16 CHOICE {			
n2-r16	0		Cell 1
	1		Cell 2
}			
dl-PRS-ResourceSlotOffset-r16	0		
dl-PRS-ResourceSymbolOffset-r16	0		
dl-PRS-QCL-Info-r16	Not present		
}			
}			
}			
}			
}			

Table 16.2.1.4.3-7: LPP ProvideLocation Information

Derivation Path: 37.355 clause 6.5.12			
Information Element	Value/remark	Comment	Condition
LPP-Message ::= SEQUENCE {			
transactionID SEQUENCE {			
initiator	locationServer		
transactionNumber	1		
}			
endTransaction	TRUE		
sequenceNumber	(0..255)		
acknowledgement			
lpp-MessageBody CHOICE {			
c1 CHOICE {			
provideLocationInformation SEQUENCE {			
criticalExtensions CHOICE {			
c1 CHOICE {			
provideLocationInformation-r9 SEQUENCE {			
commonIEsProvideLocationInformation	Not present.		
a-gnss-ProvideLocationInformation	Not present		
otdoa-ProvideLocationInformation	Not present		
ecid-ProvideLocationInformation	Not present		
epdu-ProvideLocationInformation	Not present		
sensor-ProvideLocationInformation-r13	Not present		
tbs-ProvideLocationInformation-r13	Not present		
wlan-ProvideLocationInformation-r13	Not present		
bt-ProvideLocationInformation-r13	Not present		
nr-ECID-ProvideLocationInformation-r16	Not present		
nr-Multi-RTT-ProvideLocationInformation-r16	Not present		
nr-DL-AoD-ProvideLocationInformation-r16 SEQUENCE {			
nr-DL-AoD-SignalMeasurementInformation-r16 SEQUENCE {			
nr-DL-AoD-MeasList-r16 SEQUENCE (SIZE(1..nrMaxTRPs-r16)) OF NR-DL-AoD-MeasElement-r16 {			
NR-DL-AoD-MeasElement-r16[1] SEQUENCE {		entry 1	
dl-PRS-ID-r16	INTEGER (0..255)		
nr-PhysCellID-r16	Cell 1		

nr-CellGlobalID-r16			
nr-ARFCN-r16			
nr-DL-PRS-ResourceID-r16			
nr-DL-PRS-ResourceSetID-r16			
nr-TimeStamp-r16			
nr-DL-PRS-RSRP-Result-r16	Present. Any value acceptable.		
nr-DL-PRS-RxBeamIndex-r16			
nr-DL-AoD-AdditionalMeasurements-r16			
}			
NR-DL-AoD-MeasElement-r16[2]		entry 2	
SEQUENCE {			
dl-PRS-ID-r16	INTEGER (0..255)		
nr-PhysCellID-r16	Cell 2		
nr-CellGlobalID-r16			
nr-ARFCN-r16			
nr-DL-PRS-ResourceID-r16			
nr-DL-PRS-ResourceSetID-r16			
nr-TimeStamp-r16			
nr-DL-PRS-RSRP-Result-r16	Present. Any value acceptable.		
nr-DL-PRS-RxBeamIndex-r16			
nr-DL-AoD-AdditionalMeasurements-r16			
r16			
}			
}			
}			
nr-dl-AoD-LocationInformation-r16			
nr-DL-AoD-Error-r16	Not present		
}			
}			
}			
}			
}			
}			
}			
}			
}			
}			

16.2.1.5 Test requirement

Table 16.2.1.5-1 and Table 16.2.1.5-2 define the primary level settings including test tolerances for the test.

Table 16.2.1.5-1: General test parameters

Parameter	Unit	Test configuration	Value	Comment
Reference cell		1, 2, 3	Cell 1	Cell 1 is the PCell and the DL-AoD reference cell in the positioning assistance data.
Neighbour cell		1, 2, 3	Cell 2	Cell 2 is a neighbour cell in the positioning assistance data.
RF Channel Number		1, 2, 3	1: Cell 1 and Cell 2	
BW _{channel}	MHz	1	10: N _{RB,c} = 52	
		2	10: N _{RB,c} = 52	
		3	40: N _{RB,c} = 106	
SSB configuration		1	SSB.1 FR1	
		2	SSB.1 FR1	
		3	SSB.2 FR1	
SMTC configuration		1	SMTC.2	
		2	SMTC.1	
		3	SMTC.1	
Measurement gap		1, 2, 3	GP#24 or GP#0 ^{Note 1}	

CP length		1, 2, 3	Normal	
DRX		1, 2, 3	NA	OFF
Time offset between serving and neighbour cells	μs	1, 2, 3	3	Synchronous cells
Expected RSTD	μs	1, 2, 3	3	
Expected RSTD uncertainty	μs	1, 2, 3	5	
T1	s	1, 2, 3	2	
T2	s	1, 2, 3	[5]	
NOTE 1: GP#24 is configured if UE supports MG#24, otherwise GP#0 is configured.				

Table 16.2.1.5-2: Cell specific test parameters

Parameter	Unit	Test configuration	Cell 1		Cell 2	
			T1	T2	T1	T2
TDD configuration		1	N/A		N/A	
		2	TDDConf.1.1		TDDConf.1.1	
		3	TDDConf.2.1		TDDConf.2.1	
PDSCH RMC configuration		1	SR.1.1 FDD		N/A	
		2	SR.1.1 TDD			
		3	SR.2.1 TDD			
RMSI CORESET RMC configuration		1	CR.1.1 FDD		N/A	
		2	CR.1.1 TDD			
		3	CR.2.1 TDD			
Dedicated CORESET RMC configuration		1	CCR.1.1 FDD		N/A	
		2	CCR.1.1 TDD			
		3	CCR.2.1 TDD			
OCNG Patterns		1, 2, 3	OP.1		OP.1	
TRS Configuration		1	TRS.1.1 FDD		N/A	
		2	TRS.1.1 TDD			
		3	TRS.1.2 TDD			
Initial BWP configuration		1, 2, 3	DLBWP.0.1 ULBWP.0.1		N/A	
Active DL BWP configuration		1, 2, 3	DLBWP.1.1		N/A	
Active UL BWP configuration		1, 2, 3	ULBWP.1.1		N/A	
PRS configuration		1	PRS.1.4 FR1		PRS.1.4 FR1	
		2	PRS.1.4 FR1		PRS.1.4 FR1	
		3	PRS.2.4 FR1		PRS.2.4 FR1	
PRS muting info		1, 2, 3	'10'		'01'	
N_{oc} ^{Note 2}	dBm/SCS	1	-98			
		2	-98			
		3	-95			
N_{oc} ^{Note 2}	dBm/15 kHz	1	-98			
		2				
		3				
PRS \hat{E}_s / I_{ot}	dB	1	-Infinity	-3	-Infinity	-10
		2				
		3				
PRS \hat{E}_s / N_{oc}	dB	1	-Infinity	-3	-Infinity	-10
		2				
		3				
PRS-RSRP ^{Note 3}	dBm/SCS kHz	1	-Infinity	-101	-Infinity	-108
		2	-Infinity	-101	-Infinity	-108
		3	-Infinity	-98	-Infinity	-105
SS-RSRP ^{Note 3}	dBm/SCS kHz	1	-88	-88	-88	-88
		2	-88	-88	-88	-88
		3	-85	-85	-85	-85
I _o	dBm/9.36 MHz	1	N/A	-62.25	N/A	-62.25
	dBm/9.36 MHz	2		-62.25		-62.25
	dBm/38.16 MHz	3		-56.16		-56.16
Propagation Condition		1, 2, 3	AWGN			

Note 1:	The resources for uplink transmission are assigned to the UE prior to the start of time period T2.
Note 2:	Interference from other cells and noise sources not specified in the test is assumed to be constant over subcarriers and time and shall be modelled as AWGN of appropriate power for N_{oc} to be fulfilled.
Note 3:	SS-RSRP/PRS-RSRP levels have been derived from other parameters for information purposes. They are not settable parameters themselves.

The UE shall perform and report the PRS-RSRP measurements for Cell 1 and Cell 2, within the time limit specified in clause 16.2.1.3, starting from the beginning of time interval T2.

The response time is equal to the LPP time IE value plus the test tolerance. The LPP time IE value is derived from the PRS-RSRP measurement period plus ΔT, where ΔT = 50 ms. The RSTD measurement period follows the equation:

$$T_{PRS-RSRP,i} = \left(CSSF_{PRS,i} * N_{RxBeam,i} * \left\lceil \frac{N_{PRS,i}^{slot}}{N'} \right\rceil \left\lceil \frac{L_{available_PRS,i}}{N} \right\rceil * N_{sample} - 1 \right) * T_{effect,i} + T_{last,i}$$

Where $CSSF_{PRS,i} = 1$, $N_{RxBeam,i} = 1$, $N_{PRS,i}^{slot} = 16$, $L_{available_PRS,i} = 1$, $N_{sample} = 4$. N is the parameter *durationOfPRS-ProcessingSymsbols* from TS 37.355 [49], N' is the parameter *maxNumOfDL-PRS-ResProcessedPerSlot* from TS 37.355 [49], $T_{last,i} = T_i + T_{available_PRS,i}$ and $T_{effect,i} = \left\lceil \frac{T_i}{T_{available_PRS,i}} \right\rceil * T_{available_PRS,i}$

$T_{available_PRS,i} = LCM(T_{PRS,i}, MGRP_i)$; where $T_{prs} = 160$ ms, and MGRP is 80 (for GP#24) or 40 (for GP#0) depending on UE capabilities. Therefore, $T_{available_PRS,i} = 160$ ms.

T_i depends on the UE parameter *durationOfPRS-ProcessingSymsbolsInEveryTms* from TS 37.355 [49]

Finally, it results in the following equation:

$$\left(\left\lceil \frac{16}{N'} \right\rceil \left\lceil \frac{1}{N} \right\rceil * 4 - 1 \right) * T_{effect} + T_{last}$$

Where the remaining parameters depend on the UE capabilities. The LPP time IE ranges between 0.698s and 655.57s. The value of the LPP time IE is rounded up to the next second (if the value is >128s, it should be rounded up to the next multiple of ten seconds). The result is transmitted in the response time IE in the LPP-RequestLocationInformation in Table 16.2.1.4.3-3. The LPP time IE ranges between 1s and 660s.

The test tolerance for the response time is 300ms. Therefore, the response time ranges between 1.3s and 660.3s.

The values of N', N and Ti and the effect in the response time equation are defined in Table 16.2.1.5-4, Table 16.2.1.5-5 and Table 16.2.1.5-6 for reference.

Table 16.2.1.5-4: value of N' based on *maxNumOfDL-PRS-ResProcessedPerSlot*

<i>maxNumOfDL-PRS-ResProcessedPerSlot</i>	$\left\lceil \frac{16}{N'} \right\rceil$
n1	16
n2	8
n4	4
n8	2
>=n16	1

Table 16.2.1.5-5: value of N based on *durationOfPRS-ProcessingSymsbols*

<i>durationOfPRS-ProcessingSymsbols</i>	$\left\lceil \frac{1}{N} \right\rceil$
nDot125	8
nDot25	4
nDot5	2
>=n1	1

Table 16.2.1.5-6: value of T_{effect} and T_{last} based on *durationOfPRS-ProcessingSymbolsInEveryTms*

<i>durationOfPRS-ProcessingSymbolsInEveryTms</i>	T_{effect}	T_{last}
n8	160	168
n16	160	176
n20	160	180
n30	160	190
n40	160	200
n80	160	240
n160	160	320
n320	320	480
n640	640	800
n1280	1280	1440

The test tolerances are defined in clauses C.1.6, C 2.5 and C4.

The rate of successful tests during repeated tests shall be at least 90% with a confidence level of 95%.

16.2.2 PRS-RSRP measurement period test case for dual positioning frequency layer in FR1 SA

16.2.2.1 Test purpose

The purpose of the test is to verify that the PRS-RSP measurement meets the requirements specified in TS 38.133 [50] Clause 9.9.2 in an environment with AWGN propagation conditions in FR1 in standalone scenario when dual positioning frequency layer is configured.

16.2.2.2 Test applicability

This test applies to all types of NR UE release 16 onwards that supports DL-TDOA positioning and PRS-RSRP measurements in FR1.

16.2.2.3 Minimum conformance requirements

Same as in clause 16.2.1.3.

16.2.2.4 Test description

16.2.2.4.1 Initial conditions

The test is defined with three possible Test Configurations. In the case that the UE supports more than one of these Test Configurations, then the UE is only required to be tested in one of the Test Configurations, chosen by the UE. The defined Test Configurations are specified in Table 16.2.2.4.1-1.

Table 16.2.2.4.1-1: Test Configurations

Configuration	Description
1	15 kHz SSB SCS, 10 MHz bandwidth, FDD duplex mode
2	15 kHz SSB SCS, 10 MHz bandwidth, TDD duplex mode
3	30 kHz SSB SCS, 40 MHz bandwidth, TDD duplex mode

Test Environment: Normal, as defined in TS 38.508-1 [45] clause 4.1.

Frequencies to be tested: Low for RF channel #1 and High for RF channel #2, as defined in TS 38.508-1 [45] clause 4.3.1.

Channel bandwidth to be tested: are specified in Table 16.2.2.4-1.

1. Connect the SS and AWGN noise sources to the UE antenna connector or antenna connectors as shown in Annex A, Figure A.12.
2. The general test parameter settings are set up according to Table 16.2.2.5-1 and Table 16.2.2.5-2.
3. Propagation conditions are set according to clause 4.15.2.
4. Message contents are defined in clause 16.2.2.4.3.
5. In the test there are two synchronous cells: Cell 1 and Cell 2. Cell 1 is the RSTD reference as well as the PCell on NR RF channel #1 in FR1. Cell 2 is a neighbour cell on a different NR RF channel #2 in FR1.

16.2.2.4.2 Test procedure

Same as clause 16.2.1.4.2.

16.2.2.4.3 Message contents

Table 16.2.2.4.3-1: RESET UE POSITIONING STORED INFORMATION

Derivation Path: 38.509 [44] clause 6.6			
Information Element	Value/remark	Comment	Condition
UE Positioning Technology	0 0 0 1 0 0 0	DL-AoD	

Table 16.2.2.4.3-2: LPP Request Capabilities

Information Element	Value/remark
nr-DL-AoD-RequestCapabilities-r16	TRUE

Table 16.2.2.4.3-3: LPP RequestLocationInformation

Derivation Path: 37.355 clause 6.2			
Information Element	Value/remark	Comment	Condition
LPP-Message ::= SEQUENCE {			
transactionID SEQUENCE {			
initiator	locationServer		
transactionNumber	1		
}			
endTransaction	FALSE		
sequenceNumber	Not present		
acknowledgement	Not present		
lpp-MessageBody CHOICE {			
c1 CHOICE {			
requestLocationInformation SEQUENCE {			
criticalExtensions CHOICE {			
c1 CHOICE {			
requestLocationInformation-r9 SEQUENCE {			
commonEsRequestLocationInformation SEQUENCE {			
locationInformationType	locationMeasurementsRequired		
triggeredReporting	Not present		
periodicalReporting	Not present		
additionalInformation	onlyReturnInformationRequested		
qos SEQUENCE {			
horizontalAccuracy	Not present		
verticalCoordinateRequest	FALSE		
verticalAccuracy	Not present		
responseTime SEQUENCE {			
time	See 16.2.2.5	Result of the response time calculation rounded	

		up to the next second if response time <= 128s. Result of the response time calculation rounded up to the next multiple of ten seconds if response time > 128s	
responseTimeEarlyFix-r12	Not present		Rel-12 onwards
unit-r15	Not present		Calculated response time >128s
	ten-seconds		
}			
velocityRequest	FALSE		
}			
environment	Not present		
locationCoordinateTypes	Not present		
velocityTypes	Not present		
}			
a-gnss-RequestLocationInformation	Not present		
otdoa-RequestLocationInformation	Not present		
ecid-RequestLocationInformation	Not present		
epdu-RequestLocationInformation	Not Present		
sensor-RequestLocationInformation-r13	Not present		
tbs-RequestLocationInformation-r13	Not present		
wlan-RequestLocationInformation-r13	Not present		
bt-RequestLocationInformation-r13	Not present		
nr-ECID-RequestLocationInformation-r16	Not present		
nr-Multi-RTT-RequestLocationInformation-r16	Not present		
nr-DL-AoD-RequestLocationInformation-r16			
SEQUENCE {			
nr-AssistanceAvailability-r16	FALSE		
nr-DL-AoD-ReportConfig-r16 SEQUENCE {			
maxDL-PRS-RSRP-MeasurementsPerTRP-r16	Not present		
}			
}			
nr-DL-TDOA-RequestLocationInformation-r16	Not present		
}			
}			
}			
}			
}			
}			
}			

Table 16.2.2.4.3-4: LPP ProvideAssistanceData

Derivation Path: 37.355 clause 6.2			
Information Element	Value/remark	Comment	Condition
LPP-Message ::= SEQUENCE {			
transactionID SEQUENCE {			
initiator	locationServer		
transactionNumber	(0..255)		
}			
endTransaction	TRUE		
sequenceNumber	Not present		
acknowledgement	Not present		
lpp-MessageBody CHOICE {			
c1 CHOICE {			
provideAssistanceData SEQUENCE {			

criticalExtensions CHOICE {			
c1 CHOICE {			
provideAssistanceData-r9 SEQUENCE {			
commonEsProvideAssistanceData	Not present		
a-gnss-ProvideAssistanceData	Not present		
otdoa-ProvideAssistanceData	Not present		
epdu-ProvideAssistanceData	Not present		
sensor-ProvideAssistanceData-r15	Not present		
tbs-ProvideAssistanceData-r15	Not present		
wlan-ProvideAssistanceData-r15	Not present		
nr-Multi-RTT-ProvideAssistanceData-r16	Not present		
nr-DL-AoD-ProvideAssistanceData-r16			
SEQUENCE {			
nr-DL-PRS-AssistanceData	As defined in Table 16.2.2.4.3-5		
nr-SelectedDL-PRS-IndexList-r16	Not present		
nr-PositionCalculationAssistance-r16			Depending on UE capabilities, i.e. support for UE-based DL-AoD
SEQUENCE {			
nr-TRP-LocationInfo-r16	As defined in TS 37.571-5 [20]		
nr-DL-PRS-BeamInfo-r16	Not present		
nr-RTD-Info-r16	Not present		
}			
nr-DL-AoD-Error-r16	Not present		
}			
nr-DL-TDOA-ProvideAssistanceData-r16	Not present		
}			
}			
}			

Table 16.2.2.4.3-5: NR-DL-PRS-AssistanceData

Derivation Path: 37.355 clause 6.4.3			
Information Element	Value/remark	Comment	Condition
NR-DL-PRS-AssistanceData-r16 ::= SEQUENCE {			
nr-DL-PRS-ReferenceInfo-r16 SEQUENCE {			
dl-PRS-ID-r16	0		
nr-DL-PRS-ResourceID-List-r16	Not present		
nr-DL-PRS-ResourceSetID-r16	Not present		
}			
nr-DL-PRS-AssistanceDataList-r16 SEQUENCE (SIZE (1..nrMaxFreqLayers-r16)) OF NR-DL-PRS-AssistanceDataPerFreq-r16 {	2 entries		
NR-DL-PRS-AssistanceDataPerFreq-r16[1]		entry 1	
SEQUENCE {			
nr-DL-PRS-PositioningFrequencyLayer-r16			
SEQUENCE {			
dl-PRS-SubcarrierSpacing-r16	kHz15 kHz30		Test Configuration 3
dl-PRS-ResourceBandwidth-r16	1	24 PRBs	
dl-PRS-StartPRB-r16	0		
dl-PRS-PointA-r16	absoluteFrequencyPointA as defined for the DL frequency of the Cell 1		
dl-PRS-CombSizeN-r16	n2		

dl-PRS-CyclicPrefix-r16	normal		
}			
nr-DL-PRS-AssistanceDataPerFreq-r16 SEQUENCE (SIZE (1..nrMaxTRPsPerFreq-r16)) OF NR-DL-PRS-AssistanceDataPerTRP-r16{	1 entry		
NR-DL-PRS-AssistanceDataPerTRP-r16[1] SEQUENCE {		entry 1	Cell 1
dl-PRS-ID-r16	0		
nr-PhysCellID-r16	Cell 1		
nr-CellGlobalID-r16	Cell 1		
nr-ARFCN-r16	Cell 1		
nr-DL-PRS-SFN0-Offset-r16 SEQUENCE {			
sfn-Offset-r16	0		
integerSubframeOffset-r16	0		
}			
nr-DL-PRS-ExpectedRSTD-r16	0		
nr-DL-PRS-ExpectedRSTD-Uncertainty-r16	0		
nr-DL-PRS-Info-r16	As specified in Table 16.2.2.4.3-8		
}			
}			
NR-DL-PRS-AssistanceDataPerFreq-r16[2] SEQUENCE {		entry 2	
nr-DL-PRS-PositioningFrequencyLayer-r16 SEQUENCE {			
dl-PRS-SubcarrierSpacing-r16	kHz15		Config 1 and Config 2
	kHz30		Config 3
dl-PRS-ResourceBandwidth-r16	1	24 PRBs	
dl-PRS-StartPRB-r16	0		
dl-PRS-PointA-r16	absoluteFrequencyPointA as defined for the DL frequency of the Cell 2		
dl-PRS-CombSizeN-r16	n2		
dl-PRS-CyclicPrefix-r16	normal		
}			
nr-DL-PRS-AssistanceDataPerFreq-r16 SEQUENCE (SIZE (1..nrMaxTRPsPerFreq-r16)) OF NR-DL-PRS-AssistanceDataPerTRP-r16{	1 entry		
NR-DL-PRS-AssistanceDataPerTRP-r16[1] SEQUENCE {		entry 1	Cell 2
dl-PRS-ID-r16	1		
nr-PhysCellID-r16	Cell 2		
nr-CellGlobalID-r16	Cell 2		
nr-ARFCN-r16	Cell 2		
nr-DL-PRS-SFN0-Offset-r16 SEQUENCE {			
sfn-Offset-r16	0		
integerSubframeOffset-r16	0		
}			
nr-DL-PRS-ExpectedRSTD-r16	23	About 3 μ s	
nr-DL-PRS-ExpectedRSTD-Uncertainty-r16	154	About 5 μ s	
nr-DL-PRS-Info-r16	As specified in Table 16.2.2.4.3-8		
}			
}			
}			
}			
}			

Table 16.2.2.4.3-6: NR-DL-PRS-Info

Derivation Path: 37.355 clause 6.4.3			
Information Element	Value/remark	Comment	Condition

NR-DL-PRS-Info-r16 ::= SEQUENCE {			
nr-DL-PRS-ResourceSetList-r16 SEQUENCE (SIZE (1..nrMaxSetsPerTrp-r16)) OF NR-DL-PRS-ResourceSet-r16 {	1 entry		
NR-DL-PRS-ResourceSet-r16[1] SEQUENCE {		entry 1	
nr-DL-PRS-ResourceSetID-r16	0		
dl-PRS-Periodicity-and-ResourceSetSlotOffset-r16 CHOICE {			
scs15-r16 CHOICE {			Config 1 and Config 2
n160-r16	10		
}			
scs30-r16 CHOICE {			Config 3
n320-r16	20		
}			
dl-PRS-ResourceRepetitionFactor-r16	Not present n2		Config 2 Config 1 and Config 3
dl-PRS-ResourceTimeGap-r16	s1		
dl-PRS-NumSymbols-r16	n4		
dl-PRS-MutingOption1-r16 SEQUENCE {			
dl-prs-MutingBitRepetitionFactor-r16	Not present		
nr-option1-muting-r16 CHOICE {			
po2-r16	10 01		Cell 1 and Cell 3 Cell 2
}			
}			
dl-PRS-MutingOption2-r16	Not present		
dl-PRS-ResourcePower-r16	27		
dl-PRS-ResourceList-r16 SEQUENCE (SIZE (1..nrMaxResourcesPerSet-r16)) OF NR-DL-PRS-Resource-r16 {	1 entry		
NR-DL-PRS-Resource-r16[1] SEQUENCE {		entry 1	
nr-DL-PRS-ResourceID-r16	0		
dl-PRS-SequenceID-r16	0		
dl-PRS-CombSizeN-AndReOffset-r16 CHOICE {			
n2-r16	0 1		Cell 1 Cell 2
}			
dl-PRS-ResourceSlotOffset-r16	0 4		Config 1 and Config 3 Config 2
dl-PRS-ResourceSymbolOffset-r16	0		
dl-PRS-QCL-Info-r16	Not present		
}			
}			
}			
}			
}			

Table 16.2.2.4.3-7: LPP ProvideLocation Information

Derivation Path: 37.355 clause 6.5.12			
Information Element	Value/remark	Comment	Condition
LPP-Message ::= SEQUENCE {			
transactionID SEQUENCE {			
initiator	locationServer		
transactionNumber	1		
}			
endTransaction	TRUE		
sequenceNumber	(0..255)		

acknowledgement			
lpp-MessageBody CHOICE {			
c1 CHOICE {			
provideLocationInformation SEQUENCE {			
criticalExtensions CHOICE {			
c1 CHOICE {			
provideLocationInformation-r9 SEQUENCE {			
commonIEsProvideLocationInformation	Not present.		
a-gnss-ProvideLocationInformation	Not present		
otdoa-ProvideLocationInformation	Not present		
ecid-ProvideLocationInformation	Not present		
epdu-ProvideLocationInformation	Not present		
sensor-ProvideLocationInformation-r13	Not present		
tbs-ProvideLocationInformation-r13	Not present		
wlan-ProvideLocationInformation-r13	Not present		
bt-ProvideLocationInformation-r13	Not present		
nr-ECID-ProvideLocationInformation-r16	Not present		
nr-Multi-RTT-ProvideLocationInformation-	Not present		
r16			
nr-DL-AoD-ProvideLocationInformation-r16			
SEQUENCE {			
nr-DL-AoD-			
SignalMeasurementInformation-r16 SEQUENCE {			
nr-DL-AoD-MeasList-r16 SEQUENCE			
(SIZE(1..nrMaxTRPs-r16)) OF NR-DL-AoD-			
MeasElement-r16 {			
NR-DL-AoD-MeasElement-r16[1]		entry 1	
SEQUENCE {			
dl-PRS-ID-r16	INTEGER (0..255)		
nr-PhysCellID-r16	Cell 1		
nr-CellGlobalID-r16			
nr-ARFCN-r16			
nr-DL-PRS-ResourceID-r16			
nr-DL-PRS-ResourceSetID-r16			
nr-TimeStamp-r16			
nr-DL-PRS-RSRP-Result-r16	Present. Any value		
nr-DL-PRS-RxBeamIndex-r16	acceptable.		
nr-DL-AoD-AdditionalMeasurements-			
r16			
}			
NR-DL-AoD-MeasElement-r16[2]		entry 2	
SEQUENCE {			
dl-PRS-ID-r16	INTEGER (0..255)		
nr-PhysCellID-r16	Cell 2		
nr-CellGlobalID-r16			
nr-ARFCN-r16			
nr-DL-PRS-ResourceID-r16			
nr-DL-PRS-ResourceSetID-r16			
nr-TimeStamp-r16			
nr-DL-PRS-RSRP-Result-r16	Present. Any value		
nr-DL-PRS-RxBeamIndex-r16	acceptable.		
nr-DL-AoD-AdditionalMeasurements-			
r16			
}			
}			
}			
}			
nr-dl-AoD-LocationInformation-r16			
nr-DL-AoD-Error-r16	Not present		
}			
}			
}			

}		
}		

16.2.2.5 Test requirement

Table 16.2.2.5-1 and Table 16.2.2.5-2 define the primary level settings including test tolerances for the test.

Table 16.2.2.5-1: General test parameters

Parameter	Unit	Test configuration	Value	Comment
Reference cell		1, 2, 3	Cell 1	Cell 1 is the PCell and the DL-AoD reference cell in the positioning assistance data.
Neighbour cell		1, 2, 3	Cell 2	Cell 2 is a neighbour cell in the positioning assistance data.
RF Channel Number		1, 2, 3	1: Cell 1 2: Cell 2	Cell 1 and Cell 2 are on different positioning frequency layers
BW _{channel}	MHz	1	10: N _{RB,c} = 52	
		2	10: N _{RB,c} = 52	
		3	40: N _{RB,c} = 106	
SSB configuration		1	SSB.1 FR1	
		2	SSB.1 FR1	
		3	SSB.2 FR1	
SMTC configuration		1	SMTC.2	
		2	SMTC.1	
		3	SMTC.1	
Measurement gap		1, 2, 3	GP#24 or GP#0 ^{Note 1}	
CP length		1, 2, 3	Normal	
DRX		1, 2, 3	NA	OFF
Time offset between serving and neighbour cells	µs	1, 2, 3	3	Synchronous cells
Expected RSTD	µs	1, 2, 3	3	
Expected RSTD uncertainty	µs	1, 2, 3	5	
T1	s	1, 2, 3	2	
T2	s	1, 2, 3	[10]	

NOTE 1: GP#24 is configured if UE supports MG#24, otherwise GP#0 is configured.

Table 16.2.2.5-2: Cell specific test parameters

Parameter	Unit	Test configuration	Cell 1		Cell 2	
			T1	T2	T1	T2
TDD configuration		1	N/A		N/A	
		2	TDDConf.1.1		TDDConf.1.1	
		3	TDDConf.2.1		TDDConf.2.1	
PDSCH RMC configuration		1	SR.1.1 FDD		N/A	
		2	SR.1.1 TDD			
		3	SR.2.1 TDD			
RMSI CORESET RMC configuration		1	CR.1.1 FDD		N/A	
		2	CR.1.1 TDD			
		3	CR.2.1 TDD			
Dedicated CORESET RMC configuration		1	CCR.1.1 FDD		N/A	
		2	CCR.1.1 TDD			
		3	CCR.2.1 TDD			
OCNG Patterns		1, 2, 3	OP.1		OP.1	
TRS Configuration		1	TRS.1.1 FDD		N/A	
		2	TRS.1.1 TDD			
		3	TRS.1.2 TDD			
Initial BWP configuration		1, 2, 3	DLBWP.0.1 ULBWP.0.1		N/A	
Active DL BWP configuration		1, 2, 3	DLBWP.1.1		N/A	

Active UL BWP configuration		1, 2, 3	ULBWP.1.1		N/A	
PRS configuration		1	PRS.1.4 FR1		PRS.1.4 FR1	
		2	PRS.1.4 FR1		PRS.1.4 FR1	
		3	PRS.2.4 FR1		PRS.2.4 FR1	
PRS muting info		1, 2, 3	'10'		'01'	
N_{oc} <small>Note 2</small>	dBm/SCS	1	-98			
		2	-98			
		3	-95			
N_{oc} <small>Note 2</small>	dBm/15 kHz	1	-98			
		2				
		3				
PRS \hat{E}_s/I_{ot}	dB	1	-Infinity	-3	-Infinity	-10
		2				
		3				
PRS \hat{E}_s/N_{oc}	dB	1	-Infinity	-3	-Infinity	-10
		2				
		3				
PRS-RSRP <small>Note 3</small>	dBm/SCS kHz	1	-Infinity	-101	-Infinity	-108
		2	-Infinity	-101	-Infinity	-108
		3	-Infinity	-98	-Infinity	-105
SS-RSRP <small>Note 3</small>	dBm/SCS kHz	1	-88	-88	-88	-88
		2	-88	-88	-88	-88
		3	-85	-85	-85	-85
Io	dBm/9.36 MHz	1	N/A	-62.25	N/A	-62.25
		2		-62.25		-62.25
		3		-56.16		-56.16
Propagation Condition		1, 2, 3	AWGN			
<p>Note 1: The resources for uplink transmission are assigned to the UE prior to the start of time period T2.</p> <p>Note 2: Interference from other cells and noise sources not specified in the test is assumed to be constant over subcarriers and time and shall be modelled as AWGN of appropriate power for N_{oc} to be fulfilled.</p> <p>Note 3: SS-RSRP/PRS-RSRP levels have been derived from other parameters for information purposes. They are not settable parameters themselves.</p>						

The UE shall perform and report the PRS-RSRP measurements for Cell 1 and Cell 2, within the time limit specified in clause 16.2.2.3, starting from the beginning of time interval T2.

The response time is equal to the LPP time IE value plus the test tolerance. The LPP time IE value is derived from the PRS-RSRP measurement period plus ΔT , where $\Delta T = 50$ ms. The PRS-RSRP measurement period follows the equation:

$$T_{\text{PRS-RSRP,Total}} = T_{\text{PRS-RSRP,1}} + T_{\text{PRS-RSRP,2}} + \text{Max}(T_{\text{effect,i}})$$

Given that both PFLs have the same settings, it can be simplified:

$$T_{\text{PRS-RSRP,Total}} = 2 * T_{\text{PRS-RSRP,i}} + T_{\text{effect,i}}$$

$$T_{\text{PRS-RSRP,i}} = \left(\text{CSSF}_{\text{PRS,i}} * N_{\text{RxBeam,i}} * \left\lceil \frac{N_{\text{PRS,i}}^{\text{slot}}}{N'} \right\rceil \left\lceil \frac{L_{\text{available_PRS,i}}}{N} \right\rceil * N_{\text{sample}} - 1 \right) * T_{\text{effect,i}} + T_{\text{last,i}}$$

Where $\text{CSSF}_{\text{PRS,i}} = 1$, $N_{\text{RxBeam,i}} = 1$, $N_{\text{PRS,i}}^{\text{slot}} = 8$, $L_{\text{available_PRS,i}} = 1$, $N_{\text{sample}} = 4$. N is the parameter *durationOfPRS-ProcessingSymbols* from TS 37.355 [49], N' is the parameter *maxNumOfDL-PRS-ResProcessedPerSlot* from TS 37.355 [49], $T_{\text{last,i}} = T_i + T_{\text{available_PRS,i}}$ and $T_{\text{effect,i}} = \left\lceil \frac{T_i}{T_{\text{available_PRS,i}}} \right\rceil * T_{\text{available_PRS,i}}$

$T_{\text{available_PRS,i}} = \text{LCM}(T_{\text{PRS,i}}, \text{MGRP}_i)$; where $T_{\text{prs}} = 160$ ms, and MGRP is 80 (for GP#24) or 40 (for GP#0) depending on UE capabilities. Therefore, $T_{\text{available_PRS,i}} = 160$ ms.

T_i depends on the UE parameter *durationOfPRS-ProcessingSymbolsInEveryTms* from TS 37.355 [49]

Finally, it results in the following equation:

$$T_{PRS-RSRP,i} = \left(\left\lceil \frac{16}{N'} \right\rceil \left\lceil \frac{1}{N} \right\rceil * 4 - 1 \right) * T_{effect} + T_{last}$$

Where the remaining parameters depend on the UE capabilities. The LPP time IE ranges between 1.506s and 657.01s. The value of the LPP time IE is rounded up to the next second (if the value is >128s, it should be rounded up to the next multiple of ten seconds). The result is transmitted in the response time IE in the LPP-RequestLocationInformation in Table 16.2.2.4.3-3. The LPP time IE ranges between 2s and 660s.

The test tolerance for the response time is 300ms. Therefore, the response time ranges between 2.3s and 660.3s.

The values of N' , N and T_i and the effect in the response time equation are defined in Table 16.2.2.5-4, Table 16.2.2.5-5 and Table 16.2.2.5-6 for reference.

Table 16.2.2.5-4: value of N' based on *maxNumOfDL-PRS-ResProcessedPerSlot*

<i>maxNumOfDL-PRS-ResProcessedPerSlot</i>	$\left\lceil \frac{8}{N'} \right\rceil$
n1	8
n2	4
n4	2
>=n8	1

Table 16.2.2.5-5: value of N based on *durationOfPRS-ProcessingSymbols*

<i>durationOfPRS-ProcessingSymbols</i>	$\left\lceil \frac{1}{N} \right\rceil$
nDot125	8
nDot25	4
nDot5	2
>=n1	1

Table 16.2.2.5-6: value of T_{effect} and T_{last} based on *durationOfPRS-ProcessingSymbolsInEveryTms*

<i>durationOfPRS-ProcessingSymbolsInEveryTms</i>	T_{effect}	T_{last}
n8	160	168
n16	160	176
n20	160	180
n30	160	190
n40	160	200
n80	160	240
n160	160	320
n320	320	480
n640	640	800
n1280	1280	1440

The test tolerances are defined in clauses C.1.6, C 2.5 and C4.

The rate of successful tests during repeated tests shall be at least 90% with a confidence level of 95%.

16.2.3 PRS-RSRP measurement period test case for single positioning frequency layer in FR2 SA

16.2.3.1 Test purpose

The purpose of the test is to verify the PRS RSRP measurement requirements specified in TS 38.133 [50] Clause 9.9.3.5. The test is conducted in AWGN propagation condition in FR2 in standalone scenario when single positioning frequency layer is configured.

16.2.3.2 Test applicability

This test applies to all types of NR UE release 16 onwards that supports DL-AoD positioning and PRS-RSRP measurements in FR2.

16.2.3.3 Minimum conformance requirements

When the physical layer receives *NR-DL-AoD-ProvideAssistanceData* message and *NR-DL-AoD-RequestLocationInformation* message from LMF via LPP [49], the UE shall be able to measure multiple (up to the UE capability specified in TS 38.133 Clause 9.9.3.3) PRS-RSRP measurements, defined in TS 38.215 [57], from configured PRS resources for configured TRPs on configured positioning frequency layers, within $T_{\text{PRS-RSRP,total}}$ ms.

$$T_{\text{PRS-RSRP,total}} = \sum_{i=1}^L T_{\text{PRS-RSRP},i} + (L - 1) * \max(T_{\text{effect},i})$$

where

i is the index of positioning frequency layer,

L is total number of positioning frequency layers,

$T_{\text{effect},i}$ is the periodicity of the PRS-RSRP measurement in positioning frequency layer i .

$$T_{\text{PRS-RSRP},i} = \left(\text{CSSF}_i * N_{\text{RxBeam},i} * \left\lfloor \frac{N_{\text{PRS},i}^{\text{slot}}}{N'} \right\rfloor \left\lfloor \frac{L_{\text{available_PRS},i}}{N} \right\rfloor * N_{\text{sample}} - 1 \right) * T_{\text{effect},i} + T_{\text{last}}$$

where

CSSF_i is the carrier specific scaling factor for PRS-RSRP measurements specified in TS38.133 clause 9.1.5.2,

$N_{\text{RxBeam},i}$ is the scaling factor for Rx beam sweeping, and $N_{\text{RxBeam},i}=1$ if positioning frequency layer i is in FR1 and $N_{\text{RxBeam},i}=8$ if positioning frequency layer i is in FR2,

$L_{\text{available_PRS},i}$ is the time duration of available PRS to be measured in the positioning frequency layer i to be measured during $T_{\text{available_PRS},i}$, and is calculated in the same way as PRS duration K defined in clause 5.1.6.5 of TS 38.214 [56]. For calculation of $L_{\text{available_PRS},i}$, only the PRS resources unmuted and fully or partially overlapped with MG are considered.

$N_{\text{PRS},i}^{\text{slot}}$ is the maximum number of DL PRS resources of positioning frequency layer i configured in a slot,

$\{N, T\}$ is UE capability combination per band where N is a duration of DL PRS symbols in ms corresponding to *durationOfPRS-ProcessingSymsbols* in TS 37.355 [49] processed every T ms corresponding to *durationOfPRS-ProcessingSymsbolsInEveryTms* in TS 37.355 [49] for a given maximum bandwidth supported by UE corresponding to *supportedBandwidthPRS* in TS 37.355 [49],

N' is UE capability for number of DL PRS resources that it can process in a slot as indicated by *maxNumOfDL-PRS-ResProcessedPerSlot* in clause 6.4.3 of TS 37.355 [49],

N_{sample} is the number of PRS-RSRP measurement samples and $N_{\text{sample}} = 4$,

$T_{\text{last}} = T_i + T_{\text{available_PRS},i}$ is the measurement duration for the last PRS-RSRP sample, including the sampling time and processing time,

$T_{\text{effect},i} = \left\lceil \frac{T_i}{T_{\text{available_PRS},i}} \right\rceil * T_{\text{available_PRS},i}$ is the periodicity of PRS-RSRP measurement in positioning frequency layer i ,

T_i corresponds to *durationOfPRS-ProcessingSymsbolsInEveryTms* in TS 37.355 [49],

$T_{\text{available_PRS},i} = \text{LCM}(T_{\text{PRS},i}, \text{MGRP}_i)$ is the least common multiple between $T_{\text{PRS},i}$ and MGRP_i ,

$T_{\text{PRS},i}$ is the maximum PRS resource periodicity among all PRS resources in positioning frequency layer i ,

$MGRP_i$ is the measurement gap repetition period in positioning frequency layer i .

If positioning frequency layer i has more than one DL PRS resource set with different PRS periodicities with muting, $T_{per}^{PRS \text{ with muting}} = N_{muting} * T_{per}^{PRS}$, the least common multiple of $T_{per}^{PRS \text{ with muting}}$ among the DL PRS resource sets is used to derive $T_{PRS,i}$, where:

T_{per}^{PRS} is the periodicity of PRS resource sets given by the higher-layer parameter *DL-PRS-Periodicity*.

N_{muting} is the scaling factor considering PRS resource muting. $N_{muting} = T_{muting}^{PRS} * L_{muting}$, where T_{muting}^{PRS} is the muting repetition factor given by the higher-layer parameter *DL-PRS-MutingBitRepetitionFactor*, and L_{muting} is the size of the bitmap $\{b^1\}$.

16.2.3.4 Test description

The supported test configurations in listed in Table 16.2.3.4-1.

Table 16.2.3.4-1: Supported test configurations for PRS RSRP measurement for FR2

Config	Description
1	120 kHz SSB SCS, 200 MHz bandwidth, TDD duplex mode

16.2.3.4.1 Initial conditions

Test Environment: Normal, as defined in TS 38.508-1 [45] clause 4.1.

Frequencies to be tested: Mid Range, as defined in TS 38.508-1 [45] clause 4.3.1.

Channel bandwidth to be tested: are specified in Table 16.2.3.4-1.

1. Connect the SS and AWGN noise sources to the UE antenna connector or antenna connectors as shown in Annex A, Figure A.14.
2. The general test parameter settings are set up according to Table 16.2.3.5-1 and Table 16.2.3.5-2.
3. Propagation conditions are set according to clause 4.16.2.
4. Message contents are defined in clause 16.2.3.4.3.
5. There are two cells in the test: PCell (Cell 1) and a neighbour cell (Cell 2). All cells are on the same RF channel in FR2.

16.2.3.4.2 Test procedure

The test consists of two successive time periods, with time duration of T1 and T2 respectively. During time duration T1, the UE shall not have any timing information of Cell 2. Both cells transmit PRS during T2.

The NR-DL-AoD-RequestLocationInformation message and NR-DL-AoD-ProvideAssistanceData message as defined in TS 37.355 shall be provided to the UE during T1. The last slot containing the two messages for the assistance data and location information request is denoted as #n. The beginning of the time interval T2 shall be aligned with the beginning of the first MG instance containing the PRS resources that is ΔT after slot #n, where $\Delta T = 50$ ms is the maximum processing time of the assistance data and location information request.

1. Ensure the UE is in State RRC_CONNECTED with generic procedure parameters Connectivity NR, Connected without release On according to TS 38.508-1 [45] clause 4.5.
2. The SS shall send a RESET UE POSITIONING STORED INFORMATION message.
3. Set the parameters according to Table 16.2.3.5-1 and Table 16.2.3.5-2 as appropriate. Propagation conditions are set according to clause 4.16.2.
4. T1 starts.
5. The SS shall send an LPP REQUEST CAPABILITIES message.

6. The UE shall transmit an LPP PROVIDE CAPABILITIES message indicating the DL-AoD capabilities supported by the UE in the NR-DL-AoD-ProvideCapabilities IE.
7. The SS shall send a LPP PROVIDE ASSISTANCE DATA message, including the nr-DL-AoD-ProvideAssistanceData-r16 IE. If the UE message at step 6 includes the ackRequested IE set to TRUE, then the SS shall send an acknowledgment in the LPP PROVIDE ASSISTANCE DATA message.
8. The SS shall send a LPP REQUEST LOCATION INFORMATION message, including the nr-DL-AoD-RequestLocationInformation-r16 such that the UE receives the message ΔT ms before the start of the measurement period, where $\Delta T = 50$ ms.
9. When T1 expires, the SS shall switch the power setting from T1 to T2 as specified in Table 16.2.3.5-2.
10. The UE shall transmit a LPP PROVIDE LOCATION INFORMATION message including the nr-DL-AoD-ProvideLocationInformation-r16 IE within the response time (see clause 4.16.3). The UE shall perform and report the PRS-RSRP measurements for both Cell 1 and Cell 2. If the UE transmits an nr-DL-AoD-ProvideLocationInformation-r16 IE including the nr-DL-PRS-RSRP-Result-r16 field for Cell 1 and Cell 2 within the response time then the number of successful tests is increased by one. If the UE fails to report the nr-DL-AoD-ProvideLocationInformation-r16 IE with the DL-PRS-RSRP-Result-r16 fields included within the response time then the number of failure tests is increased by one.
11. If the UE message at step 10 includes the *ackRequested* IE set to TRUE, the SS shall send a LPP acknowledgement message.
12. Repeat step 2-11 until the confidence level according to Annex D is achieved.

16.2.3.4.3 Message contents

Table 16.2.3.4.3-1: RESET UE POSITIONING STORED INFORMATION

Derivation Path: 38.509 [44] clause 6.6			
Information Element	Value/remark	Comment	Condition
UE Positioning Technology	0 0 0 1 0 0 0	DL-AoD	

Table 16.2.3.4.3-2: LPP Request Capabilities

Information Element	Value/remark
nr-DL-AoD-RequestCapabilities-r16	TRUE

Table 16.2.3.4.3-3: LPP RequestLocationInformation

Derivation Path: 37.355 clause 6.2			
Information Element	Value/remark	Comment	Condition
LPP-Message ::= SEQUENCE {			
transactionID SEQUENCE {			
initiator	locationServer		
transactionNumber	1		
}			
endTransaction	FALSE		
sequenceNumber	Not present		
acknowledgement	Not present		
lpp-MessageBody CHOICE {			
c1 CHOICE {			
requestLocationInformation SEQUENCE {			
criticalExtensions CHOICE {			
c1 CHOICE {			
requestLocationInformation-r9 SEQUENCE {			
commonEsRequestLocationInformation SEQUENCE {			
locationInformationType	locationMeasurementsRequired		
triggeredReporting	Not present		

periodicalReporting	Not present		
additionalInformation	onlyReturnInformationRequested		
qos SEQUENCE {			
horizontalAccuracy	Not present		
verticalCoordinateRequest	FALSE		
verticalAccuracy	Not present		
responseTime SEQUENCE {			
time	See 16.2.3.5	Result of the response time calculation rounded up to the next second if response time <= 128s. Result of the response time calculation rounded up to the next multiple of ten seconds if response time > 128s.	
responseTimeEarlyFix-r12	Not present		Rel-12 onwards
unit-r15	Not present		
	ten-seconds		Calculated response time >128s
}			
velocityRequest	FALSE		
}			
environment	Not present		
locationCoordinateTypes	Not present		
velocityTypes	Not present		
}			
a-gnss-RequestLocationInformation	Not present		
otdoa-RequestLocationInformation	Not present		
ecid-RequestLocationInformation	Not present		
epdu-RequestLocationInformation	Not Present		
sensor-RequestLocationInformation-r13	Not present		
tbs-RequestLocationInformation-r13	Not present		
wlan-RequestLocationInformation-r13	Not present		
bt-RequestLocationInformation-r13	Not present		
nr-ECID-RequestLocationInformation-r16	Not present		
nr-Multi-RTT-RequestLocationInformation-r16	Not present		
nr-DL-AoD-RequestLocationInformation-r16			
SEQUENCE {			
nr-AssistanceAvailability-r16	FALSE		
nr-DL-AoD-ReportConfig-r16 SEQUENCE {			
maxDL-PRS-RSRP-MeasurementsPerTRP-r16	Not present		
}			
}			
nr-DL-TDOA-RequestLocationInformation-r16	Not present		
}			
}			
}			
}			
}			
}			

Table 16.2.3.4.3-4: LPP ProvideAssistanceData

Derivation Path: 37.355 clause 6.2			
Information Element	Value/remark	Comment	Condition

LPP-Message ::= SEQUENCE {			
transactionID SEQUENCE {			
initiator	locationServer		
transactionNumber	(0..255)		
}			
endTransaction	TRUE		
sequenceNumber	Not present		
acknowledgement	Not present		
lpp-MessageBody CHOICE {			
c1 CHOICE {			
provideAssistanceData SEQUENCE {			
criticalExtensions CHOICE {			
c1 CHOICE {			
provideAssistanceData-r9 SEQUENCE {			
commonEsProvideAssistanceData	Not present		
a-gnss-ProvideAssistanceData	Not present		
otdoa-ProvideAssistanceData	Not present		
epdu-Provide-AssistanceData	Not present		
sensor-ProvideAssistanceData-r15	Not present		
tbs-ProvideAssistanceData-r15	Not present		
wlan-ProvideAssistanceData-r15	Not present		
nr-Multi-RTT-ProvideAssistanceData-r16	Not present		
nr-DL-AoD-ProvideAssistanceData-r16			
SEQUENCE {			
nr-DL-PRS-AssistanceData	As defined in Table 16.2.3.4.3-5		
nr-SelectedDL-PRS-IndexList-r16	Not present		
nr-PositionCalculationAssistance-r16			Depending on UE capabilities, i.e. support for UE-based DL-AoD
SEQUENCE {			
nr-TRP-LocationInfo-r16	As defined in TS 37.571-5 [20]		
nr-DL-PRS-BeamInfo-r16	Not present		
nr-RTD-Info-r16	Not present		
}			
nr-DL-AoD-Error-r16	Not present		
}			
nr-DL-TDOA-ProvideAssistanceData-r16	Not present		
}			
}			
}			
}			
}			

Table 16.2.3.4.3-5: NR-DL-PRS-AssistanceData

Derivation Path: 37.355 clause 6.4.3			
Information Element	Value/remark	Comment	Condition
NR-DL-PRS-AssistanceData-r16 ::= SEQUENCE {			
nr-DL-PRS-ReferenceInfo-r16 SEQUENCE {			
dl-PRS-ID-r16	0		
nr-DL-PRS-ResourceID-List-r16	Not present		
nr-DL-PRS-ResourceSetID-r16	Not present		
}			
nr-DL-PRS-AssistanceDataList-r16 SEQUENCE (SIZE (1..nrMaxFreqLayers-r16)) OF NR-DL-PRS-AssistanceDataPerFreq-r16 {	1 entry		
NR-DL-PRS-AssistanceDataPerFreq-r16[1]		entry 1	
SEQUENCE {			

nr-DL-PRS-PositioningFrequencyLayer-r16 SEQUENCE {			
dl-PRS-SubcarrierSpacing-r16	kHz120		
dl-PRS-ResourceBandwidth-r16	3	32 PRBs	
dl-PRS-StartPRB-r16	0		
dl-PRS-PointA-r16	absoluteFrequencyPointA as defined for the DL frequency of the Cell 1		
dl-PRS-CombSizeN-r16	n2		
dl-PRS-CyclicPrefix-r16	normal		
}			
nr-DL-PRS-AssistanceDataPerFreq-r16 SEQUENCE (SIZE (1..nrMaxTRPsPerFreq-r16)) OF NR-DL-PRS-AssistanceDataPerTRP-r16{	2 entries		
NR-DL-PRS-AssistanceDataPerTRP-r16[1] SEQUENCE {		entry 1	Cell 1
dl-PRS-ID-r16	0		
nr-PhysCellID-r16	Cell 1		
nr-CellGlobalID-r16	Cell 1		
nr-ARFCN-r16	Cell 1		
nr-DL-PRS-SFN0-Offset-r16 SEQUENCE {			
sfn-Offset-r16	0		
integerSubframeOffset-r16	0		
}			
nr-DL-PRS-ExpectedRSTD-r16	0		
nr-DL-PRS-ExpectedRSTD-Uncertainty-r16	0		
nr-DL-PRS-Info-r16	As specified in Table 16.2.3.4.3-6		
}			
NR-DL-PRS-AssistanceDataPerTRP-r16[2] SEQUENCE {		entry 2	Cell 2
dl-PRS-ID-r16	1		
nr-PhysCellID-r16	Cell 2		
nr-CellGlobalID-r16	Cell 2		
nr-ARFCN-r16	Cell 2		
nr-DL-PRS-SFN0-Offset-r16 SEQUENCE {			
sfn-Offset-r16	0		
integerSubframeOffset-r16	0		
}			
nr-DL-PRS-ExpectedRSTD-r16	23	About 3 μs	
nr-DL-PRS-ExpectedRSTD-Uncertainty-r16	154	About 5 μs	
nr-DL-PRS-Info-r16	As specified in Table 16.2.3.4.3-6		
}			
}			
}			
}			
}			

Table 16.2.3.4.3-6: NR-DL-PRS-Info

Derivation Path: 37.355 clause 6.4.3			
Information Element	Value/remark	Comment	Condition
NR-DL-PRS-Info-r16 ::= SEQUENCE {			
nr-DL-PRS-ResourceSetList-r16 SEQUENCE (SIZE (1..nrMaxSetsPerTrp-r16)) OF NR-DL-PRS-ResourceSet-r16 {	1 entry		
NR-DL-PRS-ResourceSet-r16[1] SEQUENCE {		entry 1	
nr-DL-PRS-ResourceSetID-r16	0		
dl-PRS-Periodicity-and-ResourceSetSlotOffset-r16 CHOICE {			
scs120-r16 CHOICE {			
n1280-r16	80		
}			
dl-PRS-ResourceRepetitionFactor-r16	n2		

dl-PRS-ResourceTimeGap-r16	s1		
dl-PRS-NumSymbols-r16	n4		
dl-PRS-MutingOption1-r16 SEQUENCE {			
dl-prs-MutingBitRepetitionFactor-r16	Not present		
nr-option1-muting-r16 CHOICE {			
po2-r16	10		Cell 1
	01		Cell 2
}			
}			
dl-PRS-MutingOption2-r16	Not present		
dl-PRS-ResourcePower-r16	27		
dl-PRS-ResourceList-r16 SEQUENCE (SIZE (1..nrMaxResourcesPerSet-r16)) OF NR-DL-PRS-Resource-r16 {	1 entry		
NR-DL-PRS-Resource-r16[1] SEQUENCE {		entry 1	
nr-DL-PRS-ResourceID-r16	0		
dl-PRS-SequenceID-r16	0		
dl-PRS-CombSizeN-AndReOffset-r16 CHOICE {			
n2-r16	0		
}			
dl-PRS-ResourceSlotOffset-r16	0		
dl-PRS-ResourceSymbolOffset-r16	0		
dl-PRS-QCL-Info-r16	Not present		
}			
}			
}			
}			
}			

Table 16.2.3.4.3-7: LPP ProvideLocation Information

Derivation Path: 37.355 clause 6.5.12			
Information Element	Value/remark	Comment	Condition
LPP-Message ::= SEQUENCE {			
transactionID SEQUENCE {			
initiator	locationServer		
transactionNumber	1		
}			
endTransaction	TRUE		
sequenceNumber	(0..255)		
acknowledgement			
lpp-MessageBody CHOICE {			
c1 CHOICE {			
provideLocationInformation SEQUENCE {			
criticalExtensions CHOICE {			
c1 CHOICE {			
provideLocationInformation-r9 SEQUENCE {			
commonIEsProvideLocationInformation	Not present.		
a-gnss-ProvideLocationInformation	Not present		
otdoa-ProvideLocationInformation	Not present		
ecid-ProvideLocationInformation	Not present		
epdu-ProvideLocationInformation	Not present		
sensor-ProvideLocationInformation-r13	Not present		
tbs-ProvideLocationInformation-r13	Not present		
wlan-ProvideLocationInformation-r13	Not present		
bt-ProvideLocationInformation-r13	Not present		
nr-ECID-ProvideLocationInformation-r16	Not present		
nr-Multi-RTT-ProvideLocationInformation-r16	Not present		
nr-DL-AoD-ProvideLocationInformation-r16 SEQUENCE {			
nr-DL-AoD-SignalMeasurementInformation-r16 SEQUENCE {			

nr-DL-AoD-MeasList-r16 SEQUENCE (SIZE(1..nrMaxTRPs-r16)) OF NR-DL-AoD-MeasElement-r16 {			
NR-DL-AoD-MeasElement-r16[1] SEQUENCE {		entry 1	
dl-PRS-ID-r16	INTEGER (0..255)		
nr-PhysCellID-r16	Cell 1		
nr-CellGlobalID-r16			
nr-ARFCN-r16			
nr-DL-PRS-ResourceID-r16			
nr-DL-PRS-ResourceSetID-r16			
nr-TimeStamp-r16			
nr-DL-PRS-RSRP-Result-r16	Present. Any value acceptable.		
nr-DL-PRS-RxBeamIndex-r16			
nr-DL-AoD-AdditionalMeasurements-r16			
}			
NR-DL-AoD-MeasElement-r16[2] SEQUENCE {		entry 2	
dl-PRS-ID-r16	INTEGER (0..255)		
nr-PhysCellID-r16	Cell 2		
nr-CellGlobalID-r16			
nr-ARFCN-r16			
nr-DL-PRS-ResourceID-r16			
nr-DL-PRS-ResourceSetID-r16			
nr-TimeStamp-r16			
nr-DL-PRS-RSRP-Result-r16	Present. Any value acceptable.		
nr-DL-PRS-RxBeamIndex-r16			
nr-DL-AoD-AdditionalMeasurements-r16			
r16			
}			
}			
}			
nr-dl-AoD-LocationInformation-r16			
nr-DL-AoD-Error-r16	Not present		
}			
}			
}			
}			
}			
}			
}			
}			
}			

16.2.3.5 Test requirement

Table 16.2.3.5-1 and Table 16.2.3.5-2 define the primary level settings including the test tolerances for the test.

Table 16.2.3.5-1: General test parameters for PRS RSRP measurement reporting delay

Parameter	Unit	Test configuration	Value	Comment
NR RF Channel Number		Config 1	1: Cell 1 and Cell 2	One TDD carrier frequency is used for the NR cells.
Active cell		Config 1	NR cell 1 (Pcell)	Cell 1 is the PCell and the DL-AoD reference cell in the positioning assistance data.
Neighbour cell		Config 1	NR cell 2	Cell 2 is a neighbour cell in the positioning assistance data.

Gap Pattern Id		Config 1	GP#13 or GP#24 ^{Note1}	As specified in TS 38.133 [50] clause 9.1.2-1.
Measurement gap offset		Config 1	39	
SMTC parameters		Config 1	SMTC.1	As specified in TS 38.133 [50] clause A.3.11
SSB parameters		Config 1	SSB.3 FR2	As specified in TS 38.133 [50] clause A.3.10.2
A3-Offset	dB	Config 1	-6	
Hysteresis	dB	Config 1	0	
CP length		Config 1	Normal	
TimeToTrigger	s	Config 1	0	
Filter coefficient		Config 1	0	L3 filtering is not used
DRX		Config 1	OFF	DRX is not used
Time offset between serving and neighbour cells		Config 1	3µs	Synchronous cells.
Expected RSTD	µs	Config 1	3	
Expected RSTD uncertainty	µs	Config 1	5	
T1	s	Config 1	5	
T2	s	Config 1	7	
Note 1: GP#24 is configured if UE supports MG#24, otherwise GP#13 is configured.				

Table 16.2.3.5-2: Cell-specific test parameters for PRS RSRP measurement reporting delay

Parameter		Unit	Test configuration	Cell 1		Cell 2	
				T1	T2	T1	T2
AoA setup			Config 1	Setup 1 as specified in TS 38.133 [50] clause A.3.15			
Beam Assumption ^{Note 7}			Config 1	Rough		Rough	
TDD configuration			Config 1	TDDConf.3.1		TDDConf.3.1	
Duplex mode			Config 1	TDD		TDD	
BW _{channel}		MHz	Config 1	200: N _{RB,c} = 132		200: N _{RB,c} = 132	
BWP configuration	Initial DL BWP		Config 1	DLBWP.0.1		N/A	
	Initial UL BWP			ULBWP.0.1		N/A	
	Dedicated DL BWP			DLBWP.1.1		N/A	
	Dedicated UL BWP			ULBWP.1.1		N/A	
OCNG Patterns defined in A.3.2.1.1 (OP.1)			Config 1	OP.1		OP.1	
PDSCH Reference measurement channel			Config 1	SR.3.1 TDD		-	
CORESET Reference Channel			Config 1	CR.3.1 TDD		-	
Dedicated CORESET RMC configuration			Config 1	CCR.3.1 TDD		-	
TRS configuration			Config 1	TRS.2.1 TDD		-	
PDSCH/PDCCH subcarrier spacing		kHz	Config 1	120		120	
PRS configuration			Config 1	PRS.1.1 FR2		PRS.1.1 FR2	
PRS muting configuration			Config 1	'10'		'01'	
EPRE ratio of PSS to SSS							
EPRE ratio of PBCH DMRS to SSS							
EPRE ratio of PBCH to PBCH DMRS							
EPRE ratio of PDCCH DMRS to SSS							

EPRE ratio of PDCCH to PDCCH DMRS		Config 1	0		0	
EPRE ratio of PDSCH DMRS to SSS						
EPRE ratio of PDSCH to PDSCH						
EPRE ratio of OCNG DMRS to SSS(Note 1)						
EPRE ratio of OCNG to OCNG DMRS (Note 1)						
N_{oc} Note2	dBm/15 kHz Note5		-99.1		-99.1	
N_{oc} Note2	dBm/S CS Note4	Config 1	-90.1		-90.1	
SSB_RP>Note 3	dBm/S CS Note5	Config 1	-94.6	-94.6	-Infinity	-101.8
PRP Note 3	dBm/S CS Note5	Config 1	-Infinity	-92.1	-Infinity	-100.1
PRS \hat{E}_s/I_{ot}	dB	Config 1	-Infinity	-2.7	-Infinity	-11.2.3
PRS \hat{E}_s/N_{oc}	dB	Config 1	-Infinity	-2	-Infinity	-10
SSB \hat{E}_s/N_{oc}	dB	Config 1	-1.6	-1.6	-Infinity	-8.8
I_o Note3	dBm/95 .04 MHz Note5	Config 1	-58.07	-55.69	-58.07	-55.69
Propagation Condition		Config 1	AWGN			
<p>Note 1: OCNG shall be used such that both cells are fully allocated and a constant total transmitted power spectral density is achieved for all OFDM symbols.</p> <p>Note 2: Interference from other cells and noise sources not specified in the test is assumed to be constant over subcarriers and time and shall be modelled as AWGN of appropriate power for N_{oc} to be fulfilled.</p> <p>Note 3: SSB_RP/PRP and I_o levels have been derived from other parameters for information purposes. They are not settable parameters themselves.</p> <p>Note 4: PRS-RSRP minimum requirements are specified assuming independent interference and noise at each receiver antenna port.</p> <p>Note 5: Equivalent power received by an antenna with 0 dBi gain at the centre of the quiet zone.</p> <p>Note 6: As observed with 0 dBi gain antenna at the centre of the quiet zone.</p> <p>Note 7: Information about types of UE beam is given in TS 38.133 [50] B.2.1.3, and does not limit UE implementation or test system implementation</p>						

The PRS RSRP measurement time fulfils the requirements specified in TS 38.133 [50] Clause 9.9.3.5. The UE shall perform and report the PRS RSRP measurements for both Cell1 and Cell within the time duration specified in TS 38.133 [50] section 9.9.3.5 starting from the beginning of time interval T2.

The rate of the correct events for the neighbour cell observed during repeated tests shall be at least 90%, where the reported PRS RSRP measurement for each correct event shall be within the PRS RSRP reporting range specified in TS 38.133 [50] Clause 10.1.24.3, i.e., between PRS RSRP_0 and PRS RSRP_126.

The response time is equal to the LPP time IE value plus the test tolerance. The LPP time IE value is derived from the PRS-RSRP measurement period plus ΔT , where $\Delta T = 50ms$. The PRS-RSRP measurement period follows the equation:

$$T_{PRS-RSRP,i} = \left(CSSF_i * N_{RxBBeam,i} * \left\lceil \frac{N_{PRS,i}^{slot}}{N'} \right\rceil \left\lceil \frac{L_{available_PRS,i}}{N} \right\rceil * N_{sample} - 1 \right) * T_{effect,i} + T_{last}$$

Where $CSSF_{PRS,i} = 1$, $N_{RxBEAM,i} = 8$, $N_{PRS,i}^{slot} = 2$, $L_{available_PRS,i} = 0.142$, $N_{sample} = 4$. N is the parameter *durationOfPRS-ProcessingSymbols* from TS 37.355 [49], N' is the parameter *maxNumOfDL-PRS-ResProcessedPerSlot* from TS 37.355 [49], $T_{last,i} = T_i + T_{available_PRS,i}$ and $T_{effect,i} = \left\lceil \frac{T_i}{T_{available_PRS,i}} \right\rceil * T_{available_PRS,i}$.

$T_{available_PRS,i} = LCM(T_{PRS,i}, MGRP_i)$; where $T_{prs} = 160$ ms, and $MGRP$ is 80 (for GP#24) or 40 (for GP#13) depending on UE capabilities. Therefore, $T_{available_PRS,i} = 160$ ms.

T_i depends on the UE parameter *durationOfPRS-ProcessingSymbolsInEveryTms* from TS 37.355 [49]

Finally, it results in the following equation:

$$\left(1 * 8 * \left\lceil \frac{2}{N'} \right\rceil \left\lceil \frac{0.142}{N} \right\rceil * 4 - 1 \right) * T_{effect} + T_{last}$$

Where the remaining parameters depend on the UE capabilities. The LPP time IE ranges between 5.178s and 164.05s. The value of the LPP time IE is rounded up to the next second (if the value is >128s, it should be rounded up to the next multiple of ten seconds). The result is transmitted in the response time IE in the LPP-RequestLocationInformation in Table 16.2.3.4.3-3. The LPP time IE ranges between 6s and 170s.

The test tolerance for the response time is 300ms. Therefore, the response time ranges between 6.3s and 170.3s.

The values of N' , N and T_i and the effect in the response time equation are defined in Table 16.2.3.5-3, Table 16.2.3.5-4 and Table 16.2.3.5-5 for reference.

Table 16.2.3.5-3: value of N' based on *maxNumOfDL-PRS-ResProcessedPerSlot*

<i>maxNumOfDL-PRS-ResProcessedPerSlot</i>	$\left\lceil \frac{2}{N'} \right\rceil$
n1	2
>=n2	1

Table 16.2.3.5-4: value of N based on *durationOfPRS-ProcessingSymbols*

<i>durationOfPRS-ProcessingSymbols</i>	$\left\lceil \frac{0.142}{N} \right\rceil$
nDot125	2
>= nDot25	1

Table 16.2.3.5-5: value of T_{effect} and T_{last} based on *durationOfPRS-ProcessingSymbolsInEveryTms*

<i>durationOfPRS-ProcessingSymbolsInEveryTms</i>	T_{effect}	T_{last}
n8	160	168
n16	160	176
n20	160	180
n30	160	190
n40	160	200
n80	160	240
n160	160	320
n320	320	480
n640	640	800
n1280	1280	1440

The test tolerances are defined in clauses C.1.6 and C.2.5.

The rate of successful tests during repeated tests shall be at least 90% with a confidence level of 95%.

16.2.4 PRS-RSRP measurement period test case for dual positioning frequency layer in FR2 SA

16.2.4.1 Test purpose

The purpose of the test is to verify the PRS RSRP measurement requirements specified in TS 38.133 [50] Clause 9.9.3.5. The test is conducted in AWGN propagation condition in FR2 in standalone scenario when dual positioning frequency layers are configured.

16.2.4.2 Test applicability

This test applies to all types of NR UE release 16 onwards that supports DL-AoD positioning and PRS-RSRP measurements in FR2.

16.2.4.3 Minimum conformance requirements

Same as in clause 14.2.1.3.

16.2.4.4 Test description

The supported test configurations are listed in Table 16.2.4.4-1.

Table 16.2.4.4-1: Supported test configurations for PRS RSRP measurement for FR2

Config	Description
1	120 kHz SSB SCS, 200 MHz bandwidth, TDD duplex mode

16.2.4.4.1 Initial conditions

Test Environment: Normal, as defined in TS 38.508-1 [45] clause 4.1.

Frequencies to be tested: Low Range for Cell 1 and High Range for Cell 2, as defined in TS 38.508-1 [45] clause 4.3.1.

Channel bandwidth to be tested: are specified in Table 16.2.4.4-1.

1. Connect the SS and AWGN noise sources to the UE antenna connector or antenna connectors as shown in Annex A, Figure A.14.
2. The general test parameter settings are set up according to Table 16.2.4.5-1 and Table 16.2.4.5-2.
3. Propagation conditions are set according to clause 4.16.2.
4. Message contents are defined in clause 16.2.4.4.3.
5. There are two cells in the test: PCell (Cell 1) and a neighbour cell (Cell 2). All cells are on the different RF channel in FR2.

16.2.4.4.2 Test procedure

Same as defined in clause 16.2.3.4.2.

16.2.4.4.3 Message contents

Table 16.2.4.4.3-1: RESET UE POSITIONING STORED INFORMATION

Derivation Path: 38.509 [44] clause 6.6			
Information Element	Value/remark	Comment	Condition
UE Positioning Technology	0 0 0 1 0 0 0	DL-AoD	

Table 16.2.4.4.3-2: LPP Request Capabilities

Information Element	Value/remark
nr-DL-AoD-RequestCapabilities-r16	TRUE

Table 16.2.4.4.3-3: LPP RequestLocationInformation

Derivation Path: 37.355 clause 6.2			
Information Element	Value/remark	Comment	Condition
LPP-Message ::= SEQUENCE {			
transactionID SEQUENCE {			
initiator	locationServer		
transactionNumber	1		
}			
endTransaction	FALSE		
sequenceNumber	Not present		
acknowledgement	Not present		
lpp-MessageBody CHOICE {			
c1 CHOICE {			
requestLocationInformation SEQUENCE {			
criticalExtensions CHOICE {			
c1 CHOICE {			
requestLocationInformation-r9 SEQUENCE {			
commonEsRequestLocationInformation SEQUENCE {			
locationInformationType	locationMeasurementsRequired		
triggeredReporting	Not present		
periodicalReporting	Not present		
additionalInformation	onlyReturnInformationRequested		
qos SEQUENCE {			
horizontalAccuracy	Not present		
verticalCoordinateRequest	FALSE		
verticalAccuracy	Not present		
responseTime SEQUENCE {			
time	See 16.2.4.5	Result of the response time calculation rounded up to the next second if response time <= 128s. Result of the response time calculation rounded up to the next multiple of ten seconds if response time > 128s	
responseTimeEarlyFix-r12	Not present		Rel-12 onwards
unit-r15	Not present ten-seconds		Calculated response time >128s
}			
velocityRequest	FALSE		
}			
environment	Not present		
locationCoordinateTypes	Not present		
velocityTypes	Not present		
}			
a-gnss-RequestLocationInformation	Not present		
otdoa-RequestLocationInformation	Not present		

ecid-RequestLocationInformation	Not present		
epdu-RequestLocationInformation	Not Present		
sensor-RequestLocationInformation-r13	Not present		
tbs-RequestLocationInformation-r13	Not present		
wlan-RequestLocationInformation-r13	Not present		
bt-RequestLocationInformation-r13	Not present		
nr-ECID-RequestLocationInformation-r16	Not present		
nr-Multi-RTT-RequestLocationInformation-r16	Not present		
nr-DL-AoD-RequestLocationInformation-r16			
SEQUENCE {			
nr-AssistanceAvailability-r16	FALSE		
nr-DL-AoD-ReportConfig-r16 SEQUENCE {			
maxDL-PRS-RSRP-MeasurementsPerTRP-r16	Not present		
}			
}			
nr-DL-TDOA-RequestLocationInformation-r16	Not present		
}			
}			
}			
}			
}			
}			
}			
}			

Table 16.2.4.4.3-4: LPP ProvideAssistanceData

Derivation Path: 37.355 clause 6.2			
Information Element	Value/remark	Comment	Condition
LPP-Message ::= SEQUENCE {			
transactionID SEQUENCE {			
initiator	locationServer		
transactionNumber	(0..255)		
}			
endTransaction	TRUE		
sequenceNumber	Not present		
acknowledgement	Not present		
lpp-MessageBody CHOICE {			
c1 CHOICE {			
provideAssistanceData SEQUENCE {			
criticalExtensions CHOICE {			
c1 CHOICE {			
provideAssistanceData-r9 SEQUENCE {			
commonEsProvideAssistanceData	Not present		
a-gnss-ProvideAssistanceData	Not present		
otdoa-ProvideAssistanceData	Not present		
epdu-Provide-AssistanceData	Not present		
sensor-ProvideAssistanceData-r15	Not present		
tbs-ProvideAssistanceData-r15	Not present		
wlan-ProvideAssistanceData-r15	Not present		
nr-Multi-RTT-ProvideAssistanceData-r16	Not present		
nr-DL-AoD-ProvideAssistanceData-r16			
SEQUENCE {			
nr-DL-PRS-AssistanceData	As defined in Table 16.2.4.4.3-5		
nr-SelectedDL-PRS-IndexList-r16	Not present		
nr-PositionCalculationAssistance-r16			Depending on UE capabilities, i.e. support for UE-based DL-AoD
nr-TRP-LocationInfo-r16	As defined in TS 37.571-5 [20]		
nr-DL-PRS-BeamInfo-r16	Not present		

nr-RTD-Info-r16	Not present		
}			
nr-DL-AoD-Error-r16	Not present		
}			
nr-DL-TDOA-ProvideAssistanceData-r16	Not present		
}			
}			
}			
}			
}			
}			

Table 16.2.4.4.3-5: NR-DL-PRS-AssistanceData

Derivation Path: 37.355 clause 6.4.3			
Information Element	Value/remark	Comment	Condition
NR-DL-PRS-AssistanceData-r16 ::= SEQUENCE {			
nr-DL-PRS-ReferenceInfo-r16 SEQUENCE {			
dl-PRS-ID-r16	0		
nr-DL-PRS-ResourceID-List-r16	Not present		
nr-DL-PRS-ResourceSetID-r16	Not present		
}			
nr-DL-PRS-AssistanceDataList-r16 SEQUENCE (SIZE (1..nrMaxFreqLayers-r16)) OF NR-DL-PRS-AssistanceDataPerFreq-r16 {	2 entries		
NR-DL-PRS-AssistanceDataPerFreq-r16[1] SEQUENCE {		entry 1	
nr-DL-PRS-PositioningFrequencyLayer-r16 SEQUENCE {			
dl-PRS-SubcarrierSpacing-r16	kHz120		
dl-PRS-ResourceBandwidth-r16	3	32 PRBs	
dl-PRS-StartPRB-r16	0		
dl-PRS-PointA-r16	absoluteFrequencyPointA as defined for the DL frequency of the Cell 1		
dl-PRS-CombSizeN-r16	n2		
dl-PRS-CyclicPrefix-r16	normal		
}			
nr-DL-PRS-AssistanceDataPerFreq-r16 SEQUENCE (SIZE (1..nrMaxTRPsPerFreq-r16)) OF NR-DL-PRS-AssistanceDataPerTRP-r16{	1 entry		
NR-DL-PRS-AssistanceDataPerTRP-r16[1] SEQUENCE {		entry 1	Cell 1
dl-PRS-ID-r16	0		
nr-PhysCellID-r16	Cell 1		
nr-CellGlobalID-r16	Cell 1		
nr-ARFCN-r16	Cell 1		
nr-DL-PRS-SFN0-Offset-r16 SEQUENCE {			
sfn-Offset-r16	0		
integerSubframeOffset-r16	0		
}			
nr-DL-PRS-ExpectedRSTD-r16	0		
nr-DL-PRS-ExpectedRSTD-Uncertainty-r16	0		
nr-DL-PRS-Info-r16	As specified in Table 16.2.4.4.3-8		
}			
}			
NR-DL-PRS-AssistanceDataPerFreq-r16[2] SEQUENCE {		entry 2	
nr-DL-PRS-PositioningFrequencyLayer-r16 SEQUENCE {			
dl-PRS-SubcarrierSpacing-r16	kHz120		
dl-PRS-ResourceBandwidth-r16	3	32 PRBs	
dl-PRS-StartPRB-r16	0		

dl-PRS-PointA-r16	absoluteFrequencyPointA as defined for the DL frequency of the Cell 2		
dl-PRS-CombSizeN-r16	n2		
dl-PRS-CyclicPrefix-r16	normal		
}			
nr-DL-PRS-AssistanceDataPerFreq-r16 SEQUENCE (SIZE (1..nrMaxTRPsPerFreq-r16)) OF NR-DL-PRS-AssistanceDataPerTRP-r16{	1 entry		
NR-DL-PRS-AssistanceDataPerTRP-r16[1] SEQUENCE {		entry 1	Cell 2
dl-PRS-ID-r16	1		
nr-PhysCellID-r16	Cell 2		
nr-CellGlobalID-r16	Cell 2		
nr-ARFCN-r16	Cell 2		
nr-DL-PRS-SFN0-Offset-r16 SEQUENCE {			
sfn-Offset-r16	0		
integerSubframeOffset-r16	0		
}			
nr-DL-PRS-ExpectedRSTD-r16	23	About 3 μ s	
nr-DL-PRS-ExpectedRSTD-Uncertainty-r16	154	About 5 μ s	
nr-DL-PRS-Info-r16	As specified in Table 16.2.4.4.3-8		
}			
}			
}			
}			
}			

Table 16.2.4.4.3-6: NR-DL-PRS-Info

Derivation Path: 37.355 clause 6.4.3			
Information Element	Value/remark	Comment	Condition
NR-DL-PRS-Info-r16 ::= SEQUENCE {			
nr-DL-PRS-ResourceSetList-r16 SEQUENCE (SIZE (1..nrMaxSetsPerTrp-r16)) OF NR-DL-PRS-ResourceSet-r16 {	1 entry		
NR-DL-PRS-ResourceSet-r16[1] SEQUENCE {		entry 1	
nr-DL-PRS-ResourceSetID-r16	0		
dl-PRS-Periodicity-and-ResourceSetSlotOffset-r16 CHOICE {			
scs120-r16 CHOICE {			
n1280-r16	80		
}			
dl-PRS-ResourceRepetitionFactor-r16	n2		
dl-PRS-ResourceTimeGap-r16	s1		
dl-PRS-NumSymbols-r16	n4		
dl-PRS-MutingOption1-r16 SEQUENCE {			
dl-prs-MutingBitRepetitionFactor-r16	Not present		
nr-option1-muting-r16 CHOICE {			
po2-r16	10		Cell 1
	01		Cell 2
}			
dl-PRS-MutingOption2-r16	Not present		
dl-PRS-ResourcePower-r16	27		
dl-PRS-ResourceList-r16 SEQUENCE (SIZE (1..nrMaxResourcesPerSet-r16)) OF NR-DL-PRS-Resource-r16 {	1 entry		
NR-DL-PRS-Resource-r16[1] SEQUENCE {		entry 1	
nr-DL-PRS-ResourceID-r16	0		
dl-PRS-SequenceID-r16	0		
dl-PRS-CombSizeN-AndReOffset-r16 CHOICE {			
n2-r16	0		
}			

dl-PRS-ResourceSlotOffset-r16	0		
dl-PRS-ResourceSymbolOffset-r16	0		
dl-PRS-QCL-Info-r16	Not present		
}			
}			
}			
}			
}			

Table 16.2.4.4.3-7: LPP ProvideLocation Information

Derivation Path: 37.355 clause 6.5.12			
Information Element	Value/remark	Comment	Condition
LPP-Message ::= SEQUENCE {			
transactionID SEQUENCE {			
initiator	locationServer		
transactionNumber	1		
}			
endTransaction	TRUE		
sequenceNumber	(0..255)		
acknowledgement			
lpp-MessageBody CHOICE {			
c1 CHOICE {			
provideLocationInformation SEQUENCE {			
criticalExtensions CHOICE {			
c1 CHOICE {			
provideLocationInformation-r9 SEQUENCE {			
commonIEsProvideLocationInformation	Not present.		
a-gnss-ProvideLocationInformation	Not present		
otdoa-ProvideLocationInformation	Not present		
ecid-ProvideLocationInformation	Not present		
epdu-ProvideLocationInformation	Not present		
sensor-ProvideLocationInformation-r13	Not present		
tbs-ProvideLocationInformation-r13	Not present		
wlan-ProvideLocationInformation-r13	Not present		
bt-ProvideLocationInformation-r13	Not present		
nr-ECID-ProvideLocationInformation-r16	Not present		
nr-Multi-RTT-ProvideLocationInformation-r16	Not present		
nr-DL-AoD-ProvideLocationInformation-r16			
} SEQUENCE {			
nr-DL-AoD-SignalMeasurementInformation-r16 SEQUENCE {			
nr-DL-AoD-MeasList-r16 SEQUENCE (SIZE(1..nrMaxTRPs-r16)) OF NR-DL-AoD-MeasElement-r16 {			
NR-DL-AoD-MeasElement-r16[1] SEQUENCE {		entry 1	
dl-PRS-ID-r16	INTEGER (0..255)		
nr-PhysCellID-r16	Cell 1		
nr-CellGlobalID-r16			
nr-ARFCN-r16			
nr-DL-PRS-ResourceID-r16			
nr-DL-PRS-ResourceSetID-r16			
nr-TimeStamp-r16			
nr-DL-PRS-RSRP-Result-r16	Present. Any value acceptable.		
nr-DL-PRS-RxBeamIndex-r16			
nr-DL-AoD-AdditionalMeasurements-r16			
} SEQUENCE {			
NR-DL-AoD-MeasElement-r16[2] SEQUENCE {		entry 2	
dl-PRS-ID-r16	INTEGER (0..255)		
nr-PhysCellID-r16	Cell 2		

nr-CellGlobalID-r16			
nr-ARFCN-r16			
nr-DL-PRS-ResourceID-r16			
nr-DL-PRS-ResourceSetID-r16			
nr-TimeStamp-r16			
nr-DL-PRS-RSRP-Result-r16	Present. Any value acceptable.		
nr-DL-PRS-RxBeamIndex-r16			
nr-DL-AoD-AdditionalMeasurements-r16			
}			
}			
}			
nr-dl-AoD-LocationInformation-r16			
nr-DL-AoD-Error-r16	Not present		
}			
}			
}			
}			
}			
}			
}			
}			
}			

16.2.4.5 Test requirement

Table 16.2.4.5-1 and Table 16.2.4.5-2 define the primary level settings including the test tolerances for the test.

Table 16.2.4.5-1: General test parameters for PRS RSRP measurement reporting delay

Parameter	Unit	Test configuration	Value	Comment
Active cell		Config 1	NR cell 1 (Pcell)	Cell 1 is the PCell and the DL-AoD reference cell in the positioning assistance data.
Neighbour cell		Config 1	NR cell 2	Cell 2 is a neighbour cell in the positioning assistance data.
Gap Pattern Id		Config 1	GP#13 or GP#24 ^{Note1}	As specified in TS 38.133 [50] clause 9.1.2-1.
Measurement gap offset		Config 1	39	
SMTC parameters		Config 1	SMTC.1	As specified in TS 38.133 [50] clause A.3.11
SSB parameters		Config 1	SSB.3 FR2	As specified in TS 38.133 [50] clause A.3.10.2
A3-Offset	dB	Config 1	-6	
Hysteresis	dB	Config 1	0	
CP length		Config 1	Normal	
TimeToTrigger	s	Config 1	0	
Filter coefficient		Config 1	0	L3 filtering is not used
DRX		Config 1	OFF	DRX is not used
Time offset between serving and neighbour cells		Config 1	3µs	Synchronous cells.
Expected RSTD	µs	Config 1	3	
Expected RSTD uncertainty	µs	Config 1	5	
T1	s	Config 1	5	
T2	s	Config 1	7	

Note 1: GP#24 is configured if UE supports MG#24, otherwise GP#13 is configured.

Table 16.2.4.5-2: Cell-specific test parameters for PRS RSRP measurement reporting delay

Parameter		Unit	Test configuration	Cell 1		Cell 2	
				T1	T2	T1	T2
AoA setup			Config 1	Setup 1 as specified in TS 38.133 [50] clause A.3.15			
Beam Assumption ^{Note 7}			Config 1	Rough		Rough	
NR RF Channel Number			Config 1	1		2	
TDD configuration			Config 1	TDDConf.3.1		TDDConf.3.1	
Duplex mode			Config 1	TDD		TDD	
BW _{channel}		MHz	Config 1	200: N _{RB,c} = 132		200: N _{RB,c} = 132	
BWP configuration	Initial DL BWP		Config 1	DLBWP.0.1		N/A	
	Initial UL BWP			ULBWP.0.1		N/A	
	Dedicated DL BWP			DLBWP.1.1		N/A	
	Dedicated UL BWP			ULBWP.1.1		N/A	
OCNG Patterns defined in A.3.2.1.1 (OP.1)			Config 1	OP.1		OP.1	
PDSCH Reference measurement channel			Config 1	SR.3.1 TDD		-	
CORESET Reference Channel			Config 1	CR.3.1 TDD		-	
Dedicated CORESET RMC configuration			Config 1	CCR.3.1 TDD		-	
TRS configuration			Config 1	TRS.2.1 TDD		-	
PDSCH/PDCCH subcarrier spacing		kHz	Config 1	120		120	
PRS configuration			Config 1	PRS.1.1 FR2		PRS.1.1 FR2	
PRS muting configuration			Config 1	'10'		'01'	
EPRE ratio of PSS to SSS			Config 1	0		0	
EPRE ratio of PBCH DMRS to SSS							
EPRE ratio of PBCH to PBCH DMRS							
EPRE ratio of PDCCH DMRS to SSS							
EPRE ratio of PDCCH to PDCCH DMRS							
EPRE ratio of PDSCH DMRS to SSS							
EPRE ratio of PDSCH to PDSCH							
EPRE ratio of OCNG DMRS to SSS(Note 1)							
EPRE ratio of OCNG to OCNG DMRS (Note 1)							
N_{oc} ^{Note2}	dBm/15 kHz Note5		-98.7		-98		
N_{oc} ^{Note2}	dBm/S CS Note4	Config 1	-89.7		-89		
SSB _{RP} ^{Note 3}	dBm/S CS Note5	Config 1	-92.7	-92.7	-Infinity	-85.7	
PRP ^{Note 3}	dBm/S CS Note5	Config 1	-Infinity	-92.1	-Infinity	-101.4	
PRS \hat{E}_s/I_{ot}	dB	Config 1	-Infinity	-2.7	-Infinity	-12.7	
PRS \hat{E}_s/N_{oc}	dB	Config 1	-Infinity	-2.43	-Infinity	-12.47	
SSB \hat{E}_s/N_{oc}	dB	Config 1	-1.7	-1.7	-Infinity	-6	

I_0 ^{Note3}	dBm/19 0.08 MHz Note5	Config 1	-57.67	-55.71	-56.97	-56.73
Propagation Condition		Config 1	AWGN			
Note 1:	OCNG shall be used such that both cells are fully allocated and a constant total transmitted power spectral density is achieved for all OFDM symbols.					
Note 2:	Interference from other cells and noise sources not specified in the test is assumed to be constant over subcarriers and time and shall be modelled as AWGN of appropriate power for N_{oc} to be fulfilled.					
Note 3:	SSB_RPPRP and I_0 levels have been derived from other parameters for information purposes. They are not settable parameters themselves.					
Note 4:	PRS-RSRP minimum requirements are specified assuming independent interference and noise at each receiver antenna port.					
Note 5:	Equivalent power received by an antenna with 0 dBi gain at the centre of the quiet zone					
Note 6:	As observed with 0 dBi gain antenna at the centre of the quiet zone					
Note 7:	Information about types of UE beam is given in TS 38.133 [50] B.2.1.3, and does not limit UE implementation or test system implementation					

The PRS RSRP measurement time fulfils the requirements specified in TS 38.133 [50] Clause 9.9.3.5. The UE shall perform and report the PRS RSRP measurements for both Cell1 and Cell 2 within the time duration specified in TS 38.133 [50] section 9.9.3.5 starting from the beginning of time interval T2.

The rate of the correct events for the neighbour cell observed during repeated tests shall be at least 90%, where the reported PRS RSRP measurement for each correct event shall be within the PRS RSRP reporting range specified in TS 38.133 [50] Clause 10.1.24.3, i.e., between PRS RSRP_0 and PRS RSRP_126.

The response time is equal to the LPP time IE value plus the test tolerance. The LPP time IE value is derived from the PRS-RSRP measurement period plus ΔT , where $\Delta T = 50\text{ms}$. The PRS-RSRP measurement period follows the equation:

$$T_{\text{PRS-RSRP},i} = \left(\text{CSSF}_i * N_{\text{RxBeam},i} * \left\lceil \frac{N_{\text{PRS},i}^{\text{slot}}}{N'} \right\rceil \left\lceil \frac{L_{\text{available_PRS},i}}{N} \right\rceil * N_{\text{sample}} - 1 \right) * T_{\text{effect},i} + T_{\text{last}}$$

Where $\text{CSSF}_{\text{PRS},i} = 1$, $N_{\text{RxBeam},i} = 8$, $N_{\text{PRS},i}^{\text{slot}} = 1$, $L_{\text{available_PRS},i} = 0.071$, $N_{\text{sample}} = 4$. N is the parameter durationOfPRS-ProcessingSymbols from TS 37.355 [49], N' is the parameter maxNumOfDL-PRS-ResProcessedPerSlot from TS 37.355 [49], $T_{\text{last},i} = T_i + T_{\text{available_PRS},i}$ and $T_{\text{effect},i} = \left\lceil \frac{T_i}{T_{\text{available_PRS},i}} \right\rceil * T_{\text{available_PRS},i}$.

$T_{\text{available_PRS},i} = \text{LCM}(T_{\text{PRS},i}, \text{MGRP}_i)$; where $T_{\text{prs}} = 160\text{ms}$, and MGRP is 80 (for GP#24) or 40 (for GP#13) depending on UE capabilities. Therefore, $T_{\text{available_PRS},i} = 160\text{ms}$.

T_i depends on the UE parameter durationOfPRS-ProcessingSymbolsInEveryTms from TS 37.355 [49]

Finally, it results in the following equation:

$$\left(1 * 8 * \left\lceil \frac{1}{N'} \right\rceil \left\lceil \frac{0.071}{N} \right\rceil * 4 - 1 \right) * T_{\text{effect}} + T_{\text{last}}$$

Where the remaining parameters depend on the UE capabilities. The LPP time IE ranges between 10.466s and 83.57s. The value of the LPP time IE is rounded up to the next second (if the value is >128s, it should be rounded up to the next multiple of ten seconds). The result is transmitted in the response time IE in the LPP-RequestLocationInformation in Table 16.2.4.4.3-3. The LPP time IE ranges between 11s and 84s.

The test tolerance for the response time is 300ms. Therefore, the response time ranges between 11.3s and 84.3s.

The values of N' , N and T_i and the effect in the response time equation are defined in Table 16.2.4.5-3, Table 16.2.4.5-4 and Table 16.2.4.5-5 for reference.

Table 16.2.4.5-3: value of N' based on *maxNumOfDL-PRS-ResProcessedPerSlot*

<i>maxNumOfDL-PRS-ResProcessedPerSlot</i>	$\left\lceil \frac{1}{N'} \right\rceil$
$\geq n1$	1

Table 16.2.4.5-4: value of N based on *durationOfPRS-ProcessingSymbols*

<i>durationOfPRS-ProcessingSymbols</i>	$\lceil 0.071 \rceil$
	N
$\geq nDot25$	1

Table 16.2.4.5-5: value of T_{effect} and T_{last} based on *durationOfPRS-ProcessingSymbolsInEveryTms*

<i>durationOfPRS-ProcessingSymbolsInEveryTms</i>	T_{effect}	T_{last}
n8	160	168
n16	160	176
n20	160	180
n30	160	190
n40	160	200
n80	160	240
n160	160	320
n320	320	480
n640	640	800
n1280	1280	1440

The test tolerances are defined in clauses C.1.6 and C.2.5.

The rate of successful tests during repeated tests shall be at least 90% with a confidence level of 95%.

16.2.5 PRS-RSRP measurement reporting delay test case for single positioning frequency with reduced number of samples in FR1 SA

Editor's Note: This test case has been completed for the following configurations:

- Test tolerance is missing
- Message contents require update

16.2.5.1 Test purpose

The purpose of the test is to verify the PRS RSRP measurement requirements for reduced number of samples specified in TS 38.133 [50] Clause 9.9.3.5 for single positioning frequency layer under AWGN propagation conditions in FR1 in standalone scenario.

16.2.5.2 Test applicability

This test applies to all types of NR UE release 17 onwards that supports DL-AoD positioning and supportedDL-PRS-ProcessingSamples-RRC-CONNECTED.

16.2.5.3 Minimum conformance requirements

When the physical layer receives *NR-DL-AoD-ProvideAssistanceData* message and *NR-DL-AoD-RequestLocationInformation* message from LMF via LPP [34], the UE shall be able to measure multiple (up to the UE capability specified in Clause 9.9.3.3) PRS-RSRP measurements, defined in TS 38.215 [4], from configured PRS resources for configured TRPs on configured positioning frequency layers, within $T_{PRS-RSRP, total}$ ms.

$$T_{PRS-RSRP, total} = \sum_{i=1}^L T_{PRS-RSRP, i} + (L - 1) * \max(T_{effect, i})$$

where

i is the index of positioning frequency layer,

L is total number of positioning frequency layers,

$T_{\text{effect},i}$ is the periodicity of the PRS-RSRP measurement in positioning frequency layer i .

$$T_{\text{PRS-RSRP},i} = \left(\text{CSSF}_i * \text{ceil}(K_{p,\text{PRS},i}) * N_{\text{RxBeam},i} * \left\lceil \frac{N_{\text{PRS},i}^{\text{slot}}}{N'} \right\rceil \left\lceil \frac{L_{\text{available_PRS},i}}{N} \right\rceil * N_{\text{sample}} - 1 \right) * T_{\text{effect},i} + T_{\text{last}}$$

where

CSSF_i is the carrier specific scaling factor for PRS-RSRP measurements specified in clause 9.1.5.2,

$K_{p,\text{PRS},i}$ is a scaling factor for a positioning frequency layer to be measured within the associated measurement gap pattern, which is defined as $K_{p,\text{PRS},i} = N_{\text{total}} / N_{\text{available}}$ for UE configured with concurrent measurement gap, and $K_{p,\text{PRS},i} = 1$ for UE not configured with concurrent measurement gap.

For a window W of duration $\max(T_{\text{PRS},i}, \text{MGRP_max})$, where MGRP max is the maximum MGRP across all configured per-UE MG and per-FR MG within the same FR as the positioning frequency layer, and starting at the beginning of any associated gap occasions covering the PRS occasion:

N_{total} is the total number of associated gap occasions covering PRS occasions within the window, including both dropped and non-dropped instances of the associated measurement gap within the window, and

$N_{\text{available}}$ is the number of non-dropped associated gap occasions covering PRS occasions within the window W, after further accounting for MG collisions by applying the selected gap collision rule

Requirements do not apply if $N_{\text{available}} = 0$.

$N_{\text{RxBeam},i}$ is the scaling factor for Rx beam sweeping, and $N_{\text{RxBeam},i} = 1$ if positioning frequency layer i is in FR1 and if positioning frequency layer i is in FR2, $N_{\text{RxBeam},i}$ is equal to the value reported by the UE in *supportedLowerRxBeamSweepingFactor-FR2* if the UE supports the capability for the band containing positioning frequency layer i , and the LMF indicates *lowerRxBeamSweepingFactor-FR2* in *NR-DL-TDOA-RequestLocationInformation*. $N_{\text{RxBeam},i}$ is equal to 8, otherwise.

$L_{\text{available_PRS},i}$ is the time duration of available PRS to be measured in the positioning frequency layer i to be measured during $T_{\text{available_PRS},i}$, and is calculated in the same way as PRS duration K defined in clause 5.1.6.5 of TS 38.214 [26]. For calculation of $L_{\text{available_PRS},i}$, only the PRS resources unmuted and fully or partially overlapped with MG are considered.

$N_{\text{PRS},i}^{\text{slot}}$ is the maximum number of DL PRS resources of positioning frequency layer i configured in a slot,

{N, T} is UE capability combination per band where N is a duration of DL PRS symbols in ms corresponding to *durationOfPRS-ProcessingSysmbols* in TS 37.355 [34] processed every T ms corresponding to *durationOfPRS-ProcessingSysmbolsInEveryTms* in TS 37.355 [34] for a given maximum bandwidth supported by UE corresponding to *supportedBandwidthPRS* in TS 37.355 [34],

N' is UE capability for number of DL PRS resources that it can process in a slot as indicated by *maxNumOfDL-PRS-ResProcessedPerSlot* in clause 6.4.3 of TS 37.355 [34],

N_{sample} is the number of PRS RSRP measurement samples, where

- $N_{\text{sample}} = 1$ if the UE supports *supportedDL-PRS-ProcessingSamples-RRC-CONNECTED* [34], and the LMF requests the UE to perform positioning measurements with reduced number of samples, and meets the following conditions:
 - PRS bandwidth is within the active BWP and
 - Magnitude of difference between the serving cell's SS-RSRP and the neighbour cell's PRS-RSRP is within 6 dB.
- $N_{\text{sample}} = 2$ if the UE supports *supportedDL-PRS-ProcessingSamples-RRC-CONNECTED* [34], and the LMF requests the UE to perform positioning measurements with reduced number of samples, and does not meet the following conditions:

- PRS bandwidth is within the active BWP and
- Magnitude of difference between the serving cell's SS-RSRP and the neighbour cell's PRS-RSRP is within 6 dB.
- $N_{sample} = 4$ otherwise.

$T_{last,i} = T_i + T_{available_PRS,i}$ is the measurement duration for the last PRS-RSRP sample, including the sampling time and processing time, if not all PRS resources to be measured are available in the same measurement gap occasion during $T_{available_PRS,i}$, otherwise $T_{last,i} = T_i + MGL$,

$T_{effect,i} = \left\lceil \frac{T_i}{T_{available_PRS,i}} \right\rceil * T_{available_PRS,i}$ is the periodicity of PRS-RSRP measurement in positioning frequency layer i ,

T_i corresponds to durationOfPRS-ProcessingSymbolsInEveryTms in TS 37.355 [34],

$T_{available_PRS,i} = LCM(T_{PRS,i}, MGRP_i)$ is the least common multiple between $T_{PRS,i}$ and $MGRP_i$,

$T_{PRS,i}$ is the maximum PRS resource periodicity among all PRS resources in positioning frequency layer i ,

$MGRP_i$ is the measurement gap repetition period in positioning frequency layer i .

If positioning frequency layer i has more than one DL PRS resource set with different PRS periodicities with muting, $T_{per}^{PRS\ with\ muting} = N_{muting} * T_{per}^{PRS}$, the least common multiple of $T_{per}^{PRS\ with\ muting}$ among the DL PRS resource sets is used to derive $T_{PRS,i}$, where:

T_{per}^{PRS} is the periodicity of PRS resource sets given by the higher-layer parameter *DL-PRS-Periodicity*.

N_{muting} is the scaling factor considering PRS resource muting. $N_{muting} = T_{muting}^{PRS} * L_{muting}$, where T_{muting}^{PRS} is the muting repetition factor given by the higher-layer parameter *DL-PRS-MutingBitRepetitionFactor*, and L_{muting} is the size of the bitmap $\{b^1\}$.

16.2.5.4 Test description

16.2.5.4.1 Initial conditions

The supported test configurations in listed in Table 16.2.5.4-1.

Table 16.2.5.4-1: Test Configurations

Configuration	Description
1	15 kHz SSB SCS, 20 MHz bandwidth, FDD duplex mode
2	15 kHz SSB SCS, 20 MHz bandwidth, TDD duplex mode
3	30 kHz SSB SCS, 50 MHz bandwidth, TDD duplex mode
Note:	The UE is only required to be tested in one of the supported test configurations.

Test Environment: Normal, as defined in TS 38.508-1 [45] clause 4.1.

Frequencies to be tested: Mid Range, as defined in TS 38.508-1 [45] clause 4.3.1.

Channel bandwidth to be tested: are specified in Table 16.2.5.4-1.

1. Connect the SS and AWGN noise sources to the UE antenna connector or antenna connectors as shown in Annex A, Figure A.13.
2. The general test parameter settings are set up according to Table 16.2.5.5-1 and Table 16.2.5.5-2.
3. Propagation conditions are set according to clause 4.16.2.
4. Message contents are defined in clause 16.2.5.4.3.

5. In the test there are two synchronous cells: Cell 1 and Cell 2. Cell 1 is the reference as well as the PCell. Cell 2 is the neighbour cell. All cells are on the same RF channel distributed in single positioning frequency layer.

16.2.5.4.2 Test procedure

The test consists of two consecutive time intervals, with duration of T1 and T2. During time duration T1, the UE shall not have any timing information of Cell 2. All two cells transmit PRS during T2. The beginning of the time interval T2 shall be aligned with the beginning of the first MG instance containing the PRS resources.

The *NR-DL-AoD-ProvideAssistanceData* and *NR-DL-AoD-RequestLocationInformation* as defined in TS 37.355 [49] clause 6.5.11 shall be provided to the UE during T1. The last TTI containing the two messages shall be provided to the UE ΔT ms before the start of T2, where $\Delta T = 50$ ms is the maximum processing time of the *DL-AoD assistance* data and location information request.

1. Ensure the UE is in State RRC_CONNECTED with generic procedure parameters Connectivity NR, Connected without release On, according to TS 38.508-1 [45] clause 4.5.
2. The SS shall send a RESET UE POSITIONING STORED INFORMATION message.
3. Set the parameters according to Table 16.2.5.5-1 and Table 16.2.5.5-2. Propagation conditions are set according to clause 4.16.2.
4. T1 starts.
5. The SS shall transmit an LPP REQUEST CAPABILITIES message.
6. The UE shall transmit an LPP PROVIDE CAPABILITIES message indicating the DL-AoD capabilities supported by the UE in the *NR-DL-AoD-ProvideCapabilities* IE.
7. The SS shall send a LPP PROVIDE ASSISTANCE DATA message, including the *NR-DL-AoD-ProvideAssistanceData* IE. The position of neighbour Cell 2 is described in 3GPP TS 37.571-5 [20]. If the UE message at step 6 includes the *ackRequested* IE set to TRUE, then the SS shall send an acknowledgment in the LPP PROVIDE ASSISTANCE DATA message.
8. The SS shall send a LPP REQUEST LOCATION INFORMATION message, including the *NR-DL-AoD-RequestLocationInformation* IE such that the UE receives the message ΔT ms before the start of T2, where $\Delta T = 50$ ms.
9. When T1 expires, the SS shall switch the power setting from T1 to T2 as specified in Table 16.2.5.5-2.
10. The UE shall transmit a LPP PROVIDE LOCATION INFORMATION message including the *NR-DL-AoD-ProvideLocationInformation* IE within the response time (see clause 4.16.3). The UE shall perform and report the PRS-RSRP measurements for Cell 2 with respect to the reference cell in the DL-TDOA assistance data, Cell 1. If the UE transmits an *NR-DL-AoD-ProvideLocationInformation* IE including the *nr-DL-PRS-RSRP-Result-r16* field for Cell 2 within the response time then the number of successful tests is increased by one. If the UE fails to report the *NR-DL-AoD-ProvideLocationInformation* IE with both the *nr-DL-PRS-RSRP-Result-r16* fields included within the response time then the number of failure tests is increased by one.
11. If the UE message at step 10 includes the *ackRequested* IE set to TRUE, the SS shall send a LPP acknowledgement message.
12. Repeat steps 2-11 in Table 16.2.5.4-1 until the confidence level according to Annex D is achieved.

16.2.5.4.3 Message contents

Table 16.2.5.4.3-1: RESET UE POSITIONING STORED INFORMATION

Derivation Path: 38.509 [44] clause 6.6			
Information Element	Value/remark	Comment	Condition
UE Positioning Technology	0 0 0 1 0 0 0	DL-AoD	

Table 16.2.5.4.3-2: LPP Request Capabilities

Information Element	Value/remark
nr-DL-AoD-RequestCapabilities-r16	TRUE

Table 16.2.5.4.3-3: LPP ProvideAssistanceData

Derivation Path: 37.355 clause 6.2			
Information Element	Value/remark	Comment	Condition
LPP-Message ::= SEQUENCE {			
transactionID SEQUENCE {			
initiator	locationServer		
transactionNumber	(0..255)		
}			
endTransaction	TRUE		
sequenceNumber	Not present		
acknowledgement	Not present		
lpp-MessageBody CHOICE {			
c1 CHOICE {			
provideAssistanceData SEQUENCE {			
criticalExtensions CHOICE {			
c1 CHOICE {			
provideAssistanceData-r9 SEQUENCE {			
commonEsProvideAssistanceData	Not present		
a-gnss-ProvideAssistanceData	Not present		
otdoa-ProvideAssistanceData	Not present		
epdu-Provide-AssistanceData	Not present		
sensor-ProvideAssistanceData-r15	Not present		
tbs-ProvideAssistanceData-r15	Not present		
wlan-ProvideAssistanceData-r15	Not present		
nr-Multi-RTT-ProvideAssistanceData-r16	Not present		
nr-DL-AoD-ProvideAssistanceData-r16			
SEQUENCE {			
nr-DL-PRS-AssistanceData-r16	As defined in Table 16.2.5.4.3-4		
nr-SelectedDL-PRS-IndexList-r16	Not present		
nr-PositionCalculationAssistance-r16			Depending on UE capabilities, i.e. support for UE-based DL-AoD
SEQUENCE {			
nr-TRP-LocationInfo-r16	As defined in TS 37.571-5 [20]		
nr-DL-PRS-BeamInfo-r16	Not present		
nr-RTD-Info-r16	Not present		
nr-TRP-BeamAntennaInfo-r17	Not present		
nr-DL-PRS-Expected-LOS-NLOS-Assistance-r17	Not present		
nr-DL-PRS-TRP-TEG-Info-r17	Not present		
}			
nr-DL-AoD-Error-r16	Not present		
nr-DL-PRS-BeamInfo-r17	Not present		
nr-On-Demand-DL-PRS-Configurations-r17	Not present		
}			
nr-DL-TDOA-ProvideAssistanceData-r16	Not present		
}			
}			
}			
}			

Table 16.2.5.4.3-4: NR-DL-PRS-AssistanceData

Derivation Path: 37.355 clause 6.4.3			
Information Element	Value/remark	Comment	Condition
NR-DL-PRS-AssistanceData-r16 ::= SEQUENCE {			
nr-DL-PRS-ReferenceInfo-r16 SEQUENCE {			
dl-PRS-ID-r16	0		
nr-DL-PRS-ResourceID-List-r16	Not present		
nr-DL-PRS-ResourceSetID-r16	Not present		
}			
nr-DL-PRS-AssistanceDataList-r16 SEQUENCE (SIZE (1..nrMaxFreqLayers-r16)) OF NR-DL-PRS-AssistanceDataPerFreq-r16 {	1 entry		
NR-DL-PRS-AssistanceDataPerFreq-r16[1] SEQUENCE {		entry 1	
nr-DL-PRS-PositioningFrequencyLayer-r16 SEQUENCE {			
dl-PRS-SubcarrierSpacing-r16	kHz15		Config 1 and Config 2
	kHz30		Config 3
dl-PRS-ResourceBandwidth-r16	21	104 PRBs	Config 1 and Config 2
	28	132 PRBs	Config 3
dl-PRS-StartPRB-r16	0		
dl-PRS-PointA-r16	absoluteFrequencyPointA as defined for the DL frequency of the Cell 1		
dl-PRS-CombSizeN-r16	N4		
dl-PRS-CyclicPrefix-r16	normal		
}			
nr-DL-PRS-AssistanceDataPerFreq-r16 SEQUENCE (SIZE (1..nrMaxTRPsPerFreq-r16)) OF NR-DL-PRS-AssistanceDataPerTRP-r16{	2 entries		
NR-DL-PRS-AssistanceDataPerTRP-r16[1] SEQUENCE {		entry 1	Cell 1
dl-PRS-ID-r16	0		
nr-PhysCellID-r16	Cell 1		
nr-CellGlobalID-r16	Cell 1		
nr-ARFCN-r16	Cell 1		
nr-DL-PRS-SFN0-Offset-r16 SEQUENCE {			
sfn-Offset-r16	0		
integerSubframeOffset-r16	0		
}			
nr-DL-PRS-ExpectedRSTD-r16	0		
nr-DL-PRS-ExpectedRSTD-Uncertainty-r16	0		
nr-DL-PRS-Info-r16	As specified in Table 16.2.5.4.3-5		
}			
NR-DL-PRS-AssistanceDataPerTRP-r16[2] SEQUENCE {		entry 2	Cell 2
dl-PRS-ID-r16	1		
nr-PhysCellID-r16	Cell 2		
nr-CellGlobalID-r16	Cell 2		
nr-ARFCN-r16	Cell 2		
nr-DL-PRS-SFN0-Offset-r16 SEQUENCE {			
sfn-Offset-r16	0		
integerSubframeOffset-r16	0		
}			
nr-DL-PRS-ExpectedRSTD-r16	As specified in Table 16.2.5.5-1		
nr-DL-PRS-ExpectedRSTD-Uncertainty-r16	As specified in Table 16.2.5.5-1		
nr-DL-PRS-Info-r16	As specified in Table 16.2.5.4.3-5		

}			
}			
}			
}			
}			

Table 16.2.5.4.3-5: NR-DL-PRS-Info

Derivation Path: 37.355 clause 6.4.3			
Information Element	Value/remark	Comment	Condition
NR-DL-PRS-Info-r16 ::= SEQUENCE {			
nr-DL-PRS-ResourceSetList-r16 SEQUENCE (SIZE (1..nrMaxSetsPerTrp-r16)) OF NR-DL-PRS-ResourceSet-r16 {	1 entry		
NR-DL-PRS-ResourceSet-r16[1] SEQUENCE {		entry 1	
nr-DL-PRS-ResourceSetID-r16	0		
dl-PRS-Periodicity-and-ResourceSetSlotOffset-r16 CHOICE {			
scs15-r16 CHOICE {			Config 1 &2
n160-r16	10		
}			
scs30-r16 CHOICE {			Config 3
n320-r16	20		
}			
dl-PRS-ResourceRepetitionFactor-r16	n1		
dl-PRS-ResourceTimeGap-r16	s1		
dl-PRS-NumSymbols-r16	n4		
dl-PRS-MutingOption1-r16 SEQUENCE {			
dl-prs-MutingBitRepetitionFactor-r16	Not present		
nr-option1-muting-r16 CHOICE {			
po2-r16	10		Cell 1
	01		Cell 2
}			
}			
dl-PRS-MutingOption2-r16	Not present		
dl-PRS-ResourcePower-r16	27		
dl-PRS-ResourceList-r16 SEQUENCE (SIZE (1..nrMaxResourcesPerSet-r16)) OF NR-DL-PRS-Resource-r16 {	1 entry		
NR-DL-PRS-Resource-r16[1] SEQUENCE {		entry 1	
nr-DL-PRS-ResourceID-r16	0		
dl-PRS-SequenceID-r16	0		
dl-PRS-CombSizeN-AndReOffset-r16 CHOICE {			
N4-r16	0		Cell 1
	1		Cell 2
}			
dl-PRS-ResourceSlotOffset-r16	4		
dl-PRS-ResourceSymbolOffset-r16	0		
dl-PRS-QCL-Info-r16	Not present		
}			
}			
}			
}			
}			

Table 16.2.5.4.3-6: LPP RequestLocationInformation

Derivation Path: 37.355 clause 6.2			
Information Element	Value/remark	Comment	Condition
LPP-Message ::= SEQUENCE {			
transactionID SEQUENCE {			
initiator	locationServer		

transactionNumber	1		
}			
endTransaction	FALSE		
sequenceNumber	Not present		
acknowledgement	Not present		
lpp-MessageBody CHOICE {			
c1 CHOICE {			
requestLocationInformation SEQUENCE {			
criticalExtensions CHOICE {			
c1 CHOICE {			
requestLocationInformation-r9 SEQUENCE {			
commonIEsRequestLocationInformation SEQUENCE {			
locationInformationType	locationMeasurementsRequired		
triggeredReporting	Not present		
periodicalReporting	Not present		
additionalInformation	onlyReturnInformationRequested		
qos SEQUENCE {			
horizontalAccuracy	Not present		
verticalCoordinateRequest	FALSE		
verticalAccuracy	Not present		
responseTime SEQUENCE {			
time	See 16.2.5.5	Result of the response time calculation rounded up to the next second if response time <= 128s. Result of the response time calculation rounded up to the next multiple of ten seconds if response time > 128s.	
responseTimeEarlyFix-r12	Not present		Rel-12 onwards
unit-r15	Not present		
ten-seconds			Calculated response time >128s
}			
velocityRequest	FALSE		
}			
environment	Not present		
locationCoordinateTypes	Not present		
velocityTypes	Not present		
}			
a-gnss-RequestLocationInformation	Not present		
otdoa-RequestLocationInformation	Not present		
ecid-RequestLocationInformation	Not present		
epdu-RequestLocationInformation	Not Present		
sensor-RequestLocationInformation-r13	Not present		
tbs-RequestLocationInformation-r13	Not present		
wlan-RequestLocationInformation-r13	Not present		
bt-RequestLocationInformation-r13	Not present		
nr-ECID-RequestLocationInformation-r16	Not present		
nr-Multi-RTT-RequestLocationInformation-r16	Not present		
nr-DL-AoD-RequestLocationInformation-r16 SEQUENCE {			
nr-AssistanceAvailability-r16	FALSE		
nr-DL-AoD-ReportConfig-r16 SEQUENCE {			

r16	maxDL-PRS-RSRP-MeasurementsPerTRP-	Not present		
r17	maxDL-PRS-RSRP-MeasurementsPerTRP-	Not present		
	MeasurementsPerTRP-r17	Not present		
	nr-los-nlos-IndicatorRequest-r17	Not present		
	reducedDL-PRS-ProcessingSamples-r17	requested		
	lowerRxBeamSweepingFactor-FR2-r17	Not present		
	}			
	multiMeasInSameReport-r17			
	}			
	nr-DL-TDOA-RequestLocationInformation-r16	Not present		
	}			
	}			
	}			
	}			
	}			
	}			

Table 16.2.5.4.3-7: LPP ProvideLocation Information

Derivation Path: 37.355 clause 6.5.12			
Information Element	Value/remark	Comment	Condition
LPP-Message ::= SEQUENCE {			
transactionID SEQUENCE {			
initiator	locationServer		
transactionNumber	1		
}			
endTransaction	TRUE		
sequenceNumber	(0..255)		
acknowledgement			
lpp-MessageBody CHOICE {			
c1 CHOICE {			
provideLocationInformation SEQUENCE {			
criticalExtensions CHOICE {			
c1 CHOICE {			
provideLocationInformation-r9 SEQUENCE {			
commonIEsProvideLocationInformation	Not present.		
a-gnss-ProvideLocationInformation	Not present		
otdoa-ProvideLocationInformation	Not present		
ecid-ProvideLocationInformation	Not present		
epdu-ProvideLocationInformation	Not present		
sensor-ProvideLocationInformation-r13	Not present		
tbs-ProvideLocationInformation-r13	Not present		
wlan-ProvideLocationInformation-r13	Not present		
bt-ProvideLocationInformation-r13	Not present		
nr-ECID-ProvideLocationInformation-r16	Not present		
nr-Multi-RTT-ProvideLocationInformation-	Not present		
r16			
nr-DL-AoD-ProvideLocationInformation-r16			
SEQUENCE {			
nr-DL-AoD-			
SignalMeasurementInformation-r16 SEQUENCE {			
nr-DL-AoD-MeasList-r16 SEQUENCE			
(SIZE(1..nrMaxTRPs-r16)) OF NR-DL-AoD-			
MeasElement-r16 {			
NR-DL-AoD-MeasElement-r16[1]		entry 1	
SEQUENCE {			
dl-PRS-ID-r16	INTEGER (0..255)		
nr-PhysCellID-r16	Cell 1		
nr-CellGlobalID-r16			
nr-ARFCN-r16			
nr-DL-PRS-ResourceID-r16			
nr-DL-PRS-ResourceSetID-r16			

	nr-TimeStamp-r16			
	nr-DL-PRS-RSRP-Result-r16	Present. Any value acceptable.		
	nr-DL-PRS-RxBeamIndex-r16			
r16	nr-DL-AoD-AdditionalMeasurements-			
	nr-DL-PRS-FirstPathRSRP-Result-r17			
	nr-los-nlos-Indicator-r17			
	nr-DL-AoD-AdditionalMeasurementsExt-r17			
	} NR-DL-AoD-MeasElement-r16[2]		entry 2	
SEQUENCE {				
	dl-PRS-ID-r16	INTEGER (0..255)		
	nr-PhysCellID-r16	Cell 2		
	nr-CellGlobalID-r16			
	nr-ARFCN-r16			
	nr-DL-PRS-ResourceID-r16			
	nr-DL-PRS-ResourceSetID-r16			
	nr-TimeStamp-r16			
	nr-DL-PRS-RSRP-Result-r16	Present. Any value acceptable.		
	nr-DL-PRS-RxBeamIndex-r16			
r16	nr-DL-AoD-AdditionalMeasurements-			
	nr-DL-PRS-FirstPathRSRP-Result-r17			
	nr-los-nlos-Indicator-r17			
	nr-DL-AoD-AdditionalMeasurementsExt-r17			
	}			
	}			
	}			
	nr-dl-AoD-LocationInformation-r16			
	nr-DL-AoD-Error-r16	Not present		
r17	nr-DL-AoD-SignalMeasurementInstances-	Not present		
r17	nr-DL-AoD-LocationInformationInstances-	Not present		
	}			
	}			
	}			
	}			
	}			
	}			
	}			
	}			

16.2.5.5 Test requirement

Table 16.2.5.5-1 and Table 16.2.5.5-2 define the primary level settings including test tolerances for the test.

Table 16.2.5.5-1: General test parameters

Parameter	Unit	Test configuration	Value	Comment
Reference cell		1, 2, 3	Cell 1	Cell 1 is the PCell and the DL-AoD reference cell in the positioning assistance data.
Neighbour cell		1, 2, 3	Cell 2	Cell 2 is a neighbour cell in the positioning assistance data.
RF Channel Number		1, 2, 3	1: Cell 1 and Cell 2	
BW _{channel}	MHz	1	20: N _{RB,c} = 106	
		2	20: N _{RB,c} = 106	

		3	50: N _{RB,c} = 133	
SSB configuration		1	SSB.1 FR1	
		2	SSB.1 FR1	
		3	SSB.2 FR1	
SMTC configuration		1	SMTC.2	
		2	SMTC.1	
		3	SMTC.1	
Measurement gap		1, 2, 3	GP#24 or GP#0 ^{Note 1}	
CP length		1, 2, 3	Normal	
DRX		1, 2, 3	NA	OFF
Time offset between serving and neighbour cells	μs	1, 2, 3	3	Synchronous cells
Expected RSTD	μs	1, 2, 3	3	
Expected RSTD uncertainty	μs	1, 2, 3	5	
T1	s	1, 2, 3	2	
T2	s	1, 2, 3	5	
NOTE 1: GP#24 is configured if UE supports MG#24, otherwise GP#0 is configured.				

Table 16.2.5.5-2: Cell-specific test parameters for PRS RSRP measurement reporting delay

Parameter	Unit	Test configuration	Cell 1		Cell 2	
			T1	T2	T1	T2
TDD configuration		1	N/A		N/A	
		2	TDDConf.1.1		TDDConf.1.1	
		3	TDDConf.2.1		TDDConf.2.1	
PDSCH RMC configuration		1	SR.1.1 FDD		N/A	
		2	SR.1.1 TDD			
		3	SR.2.1 TDD			
RMSI CORESET RMC configuration		1	CR.1.1 FDD		N/A	
		2	CR.1.1 TDD			
		3	CR.2.1 TDD			
Dedicated CORESET RMC configuration		1	CCR.1.1 FDD		N/A	
		2	CCR.1.1 TDD			
		3	CCR.2.1 TDD			
OCNG Patterns		1, 2, 3	OP.1		OP.1	
EPRE ratio of PSS to SSS	dB	1, 2, 3	0		0	
EPRE ratio of PBCH DMRS to SSS						
EPRE ratio of PBCH to PBCH DMRS						
EPRE ratio of PDCCH DMRS to SSS						
EPRE ratio of PDCCH to PDCCH DMRS						
EPRE ratio of PDSCH DMRS to SSS						
EPRE ratio of PDSCH to PDSCH DMRS						
EPRE ratio of OCNG DMRS to SSS ^{Note 1}						
EPRE ratio of OCNG to OCNG DMRS ^{Note 1}						
EPRE ratio of PRS to SSS						
TRS Configuration						
		2	TRS.1.1 TDD			
		3	TRS.1.2 TDD			
Initial BWP configuration		1, 2, 3	DLBWP.0.1 ULBWP.0.1		N/A	
Active DL BWP configuration		1, 2, 3	DLBWP.1.1		N/A	

Active UL BWP configuration		1, 2, 3	ULBWP.1.1		N/A	
PRS configuration		1	PRS.1.4 FR1		PRS.1.4 FR1	
		2	PRS.1.4 FR1		PRS.1.4 FR1	
		3	PRS.2.4 FR1		PRS.2.4 FR1	
PRS muting info		1, 2, 3	'10'		'01'	
N_{oc} <small>Note 2</small>	dBm/SCS	1	-98			
		2	-98			
		3	-95			
N_{oc} <small>Note 2</small>	dBm/15 kHz	1	-98			
		2				
		3				
PRS \hat{E}_s/I_{ot}	dB	1	-Infinity	0	-Infinity	-6
		2				
		3				
PRS \hat{E}_s/N_{oc}	dB	1	-Infinity	2.23	-Infinity	-1.73
		2				
		3				
PRP <small>Note 3</small>	dBm/SCS kHz	1	-Infinity	-95.77	-Infinity	-99.73
		2	-Infinity	-95.77	-Infinity	-99.73
		3	-Infinity	-92.77	-Infinity	-96.73
I _o	dBm/19.08 MHz	1	N/A	-61.71	N/A	-61.71
		2		-61.71		-61.71
		3		-57.73		-57.73
	dBm/19.08 MHz					
	dBm/47.88 MHz					
Propagation Condition		1, 2, 3	AWGN			
<p>Note 1: OCNG shall be used such that both cells are fully allocated and a constant total transmitted power spectral density is achieved for all OFDM symbols.</p> <p>Note 2: Interference from other cells and noise sources not specified in the test is assumed to be constant over subcarriers and time and shall be modelled as AWGN of appropriate power for N_{oc} to be fulfilled.</p> <p>Note 3: PRP levels have been derived from other parameters for information purposes. They are not settable parameters themselves.</p> <p>Note 4: The resources for uplink transmission are assigned to the UE prior to the start of time period T2.</p>						

16.2.6 PRS-RSRP measurement reporting delay test case for single positioning frequency layer without measurement gap in FR1 SA

Editor’s Note: This test case has been completed for the following configurations:

- Test tolerance is missing
- Message contents require update

16.2.6.1 Test purpose

The purpose of the test is to verify the PRS RSRP measurement outside MG requirements specified in TS 38.133 [50] Clause 9.9.3.6 for single positioning frequency layer under AWGN propagation conditions in FR1 in standalone scenario.

16.2.6.2 Test applicability

This test applies to all types of NR UE release 17 onwards that supports DL-AoD positioning and prs-Processing Window.

16.2.6.3 Minimum conformance requirements

When the physical layer receives *NR-DL-AoD-ProvideAssistanceData* message and *NR-DL-AoD-RequestLocationInformation* message from LMF via LPP [34], the UE shall be able to measure multiple (up to the UE capability specified in Clause 9.9.3.3) PRS-RSRP measurements as defined in TS 38.215 [4] without measurement gap, on configured positioning frequency layer i , within $T_{\text{PRS-RSRP, total}}$ ms.

$T_{\text{PRS-RSRP, total}} = \sum_{i=1}^L T_{\text{PRS-RSRP, } i} + (L - 1) * \max(T_{\text{effect, } i})$ if any of the positioning frequency layers are in Case 1, or

$T_{\text{PRS-RSRP, total}} = \max(T_{\text{PRS-RSRP, } i} + T_{\text{uncertainty, } i})$, if all the positioning frequency layers are in Case 2,

Where,

i is the index of positioning frequency layer, and

L is total number of positioning frequency layers, and

$T_{\text{effect, } i}$ is the periodicity of the PRS RSTD measurement in positioning frequency layer i , and

$T_{\text{uncertainty, } i}$ is the time from the start of the first PPW occasion for positioning frequency layer i to the start of measurement period $T_{\text{PRS-RSRP, total}}$.

A positioning frequency layer is in Case 1 if UE reports *ppw-durationOfPRS-Processing1-r17* for the band containing the positioning frequency layer, and a positioning frequency layer is in Case 2 if UE reports *ppw-durationOfPRS-Processing2-r17* for the band containing the positioning frequency layer.

$T_{\text{PRS-RSRP, } i}$ is the measurement period for PRS-RSRP measurement in positioning frequency layer i as specified below.

$$T_{\text{PRS-RSRP, } i} = \left(N_{\text{RxBeam, } i} * \left\lfloor \frac{N_{\text{PRS, } i}^{\text{slot}}}{N'} \right\rfloor \left\lfloor \frac{L_{\text{available_PRS, } i}}{N} \right\rfloor * N_{\text{sample}} - 1 \right) * T_{\text{effect, } i} + T_{\text{last}}$$

where

$T_{\text{effect, } i}$ is the periodicity of the PRS-RSRP measurement in positioning frequency layer i .

$N_{\text{RxBeam, } i}$ is the scaling factor for Rx beam sweeping, and $N_{\text{RxBeam, } i}=1$ if positioning frequency layer i is in FR1. If positioning frequency layer i is in FR2, $N_{\text{RxBeam, } i}$ is equal to the value reported by the UE in *supportedLowerRxBeamSweepingFactor-FR2* if the UE supports the capability for the band containing positioning frequency layer i , and the LMF indicates *lowerRxBeamSweepingFactor-FR2* in *NR-DL-TDOA-RequestLocationInformation*. $N_{\text{RxBeam, } i}$ is equal to 8, otherwise.

$L_{\text{available_PRS, } i}$ is the time duration of available PRS to be measured in the positioning frequency layer i to be measured during $T_{\text{available_PRS, } i}$, and is calculated in the same way as PRS duration K defined in clause 5.1.6.5 of TS 38.214 [26]. For calculation of $L_{\text{available_PRS, } i}$,

only unmuted PRS resource instances that meet the applicability conditions and fully or partially overlapped with PRS processing window are considered, if positioning frequency layer i is in Case 1, or

only the PRS resources unmuted and fully or partially overlapped with the first (PPWL-T2) ms of PPW are considered, if positioning frequency layer i is in Case 2, where PPWL is the PPW length and T2 corresponds to *ppw-durationOfPRS-ProcessingSymbolsT2*.

$N_{\text{PRS, } i}^{\text{slot}}$ is the maximum number of DL PRS resources of positioning frequency layer i configured in a slot,

{N, T} is UE capability combination per band where N is a duration of DL PRS symbols in ms corresponding to *ppw-durationOfPRS-ProcessingSymbolsN* in TS 37.355 [34] if positioning frequency layer i is in Case 1, or corresponding to *ppw-durationOfPRS-ProcessingSymbolsN2* in TS 37.355 [34] if positioning frequency layer i is in Case 2,

N' is UE capability for number of DL PRS resources that it can process in a slot as indicated by $ppw\text{-}maxNumOfDL\text{-}PRS\text{-}ResProcessedPerSlot$ in clause 6.4.3 of TS 37.355 [34],

N_{sample} is the number of PRS RSRP measurement samples, where

- $N_{sample} = 1$ if the UE supports *supportedDL-PRS-ProcessingSamples-RRC-CONNECTED* [34], and the LMF requests the UE to perform positioning measurements with reduced number of samples, and meets the following conditions:
 - PRS bandwidth is within the active BWP and
 - Magnitude of difference between the serving cell's SS-RSRP and the neighbour cell's PRS-RSRP is within 6 dB.
- $N_{sample} = 2$ if the UE supports *supportedDL-PRS-ProcessingSamples-RRC-CONNECTED* [34], and the LMF requests the UE to perform positioning measurements with reduced number of samples, and does not meet the following conditions:
 - PRS bandwidth is within the active BWP and
 - Magnitude of difference between the serving cell's SS-RSRP and the neighbour cell's PRS-RSRP is within 6 dB.
- $N_{sample} = 4$ otherwise.

T_{last} is the measurement duration for the last PRS-RSRP sample, including the sampling time and processing time.

If positioning frequency layer i is in Case 1 and all of the PRS resources to be measured are available in the same PPW occasion during $T_{available}$, then $T_{last,i} = T_i + PPWL$, else

if positioning frequency layer i is in Case 2 and all of the PRS resources to be measured are available in the same PPW occasion during $T_{available}$, then $T_{last,i} = PPWL$;

otherwise, $T_{last,i} = T_i + T_{available_PRS,i}$.

$T_{effect,i} = \left\lceil \frac{T_i}{T_{available_PRS,i}} \right\rceil * T_{available_PRS,i}$ is the periodicity of PRS-RSRP measurement in positioning frequency layer i ,

T_i corresponds to $ppw\text{-}durationOfPRS\text{-}ProcessingSymbolsT$ in TS 37.355 [34] if positioning frequency layer i is in Case 1, or corresponds to the sum of $ppw\text{-}durationOfPRS\text{-}ProcessingSymbolsT2$ and $ppw\text{-}durationOfPRS\text{-}ProcessingSymbolsN2$ in TS 37.355 [34] if positioning frequency layer i is in Case 2

$T_{available_PRS,i} = LCM(T_{PRS,i}, PPWRP_i)$ is the least common multiple between $T_{PRS,i}$ and $PPWRP_i$,

$T_{PRS,i}$ is the maximum PRS resource periodicity among all PRS resources in positioning frequency layer i ,

$PPWRP_i$ is the PRS processing window repetition period in positioning frequency layer i .

If positioning frequency layer i has more than one DL PRS resource set with different PRS periodicities with muting, $T_{per}^{PRS\text{ with muting}} = N_{muting} * T_{per}^{PRS}$, the least common multiple of $T_{per}^{PRS\text{ with muting}}$ among the DL PRS resource sets is used to derive $T_{PRS,i}$, where:

T_{per}^{PRS} is the periodicity of PRS resource sets given by the higher-layer parameter *DL-PRS-Periodicity*.

N_{muting} is the scaling factor considering PRS resource muting. If bitmap $\{b^1\}$ for higher-layer parameter *DL-PRS-MutingBitRepetitionFactor*, $N_{muting} = T_{muting}^{PRS} * L_{muting}$, where T_{muting}^{PRS} is the muting repetition factor given by the higher-layer parameter *DL-PRS-MutingBitRepetitionFactor*, and L_{muting} is the size of the bitmap $\{b^1\}$.

16.2.6.4 Test description

16.2.6.4.1 Initial conditions

The supported test configurations in listed in Table 16.2.6.4-1.

Table 16.2.6.4-1: Test Configurations

Configuration	Description
1	15 kHz SSB SCS, 20 MHz bandwidth, FDD duplex mode
2	15 kHz SSB SCS, 20 MHz bandwidth, TDD duplex mode
3	30 kHz SSB SCS, 50 MHz bandwidth, TDD duplex mode
Note:	The UE is only required to be tested in one of the supported test configurations.

Test Environment: Normal, as defined in TS 38.508-1 [45] clause 4.1.

Frequencies to be tested: Mid Range, as defined in TS 38.508-1 [45] clause 4.3.1.

Channel bandwidth to be tested: are specified in Table 16.2.6.4-1.

1. Connect the SS and AWGN noise sources to the UE antenna connector or antenna connectors as shown in Annex A, Figure A.13.
2. The general test parameter settings are set up according to Table 16.2.6.5-1, Table 16.2.6.5-2 and Table 16.2.6.5-3.
3. Propagation conditions are set according to clause 4.16.2.
4. Message contents are defined in clause 16.2.6.4.3.
5. In the test there are two synchronous cells: Cell 1 and Cell 2. Cell 1 is the reference as well as the PCell. Cell 2 is the neighbour cell. All cells are on the same RF channel distributed in single positioning frequency layer.

16.2.6.4.2 Test procedure

The test consists of two sub-tests; Sub-test 1 is for $N_{\text{sample}} = 1$ and sub-test 2 is for $N_{\text{sample}} = 4$. Sub-test 2 is only conducted when UE also supporting supportedDL-PRS-ProcessingSamples-RRC-CONNECTED. The test consists of two consecutive time intervals, with duration of T1 and T2. During time duration T1, the UE shall not have any timing information of Cell 2. All two cells transmit PRS during T2. The beginning of the time interval T2 shall be aligned with the beginning of the first PRS processing window instance containing the PRS resources.

The *NR-DL-AoD-ProvideAssistanceData* and *NR-DL-AoD-RequestLocationInformation* as defined in TS 37.355 [49] clause 6.5.11 shall be provided to the UE during T1. The last TTI containing the two messages shall be provided to the UE ΔT ms before the start of T2, where $\Delta T = 50$ ms is the maximum processing time of the *DL-AoD assistance* data and location information request.

1. Ensure the UE is in State RRC_CONNECTED with generic procedure parameters Connectivity NR, Connected without release On, according to TS 38.508-1 [45] clause 4.5.
2. The SS shall send a RESET UE POSITIONING STORED INFORMATION message.
3. Set the parameters according to Table 16.2.6.5-1, Table 16.2.6.5-2 and Table 16.2.6.5-3. Propagation conditions are set according to clause 4.16.2.
4. T1 starts.
5. The SS shall transmit an LPP REQUEST CAPABILITIES message.
6. The UE shall transmit an LPP PROVIDE CAPABILITIES message indicating the DL-AoD capabilities supported by the UE in the *NR-DL-AoD-ProvideCapabilities* IE.
7. The SS shall transmit an RRCReconfiguration message with the PPW configuration.
8. The UE shall transmit RRCReconfigurationComplete message.

9. The SS shall send a LPP PROVIDE ASSISTANCE DATA message, including the *NR-DL-AoD-ProvideAssistanceData* IE. The position of neighbour Cell 2 is described in 3GPP TS 37.571-5 [20]. If the UE message at step 6 includes the *ackRequested* IE set to TRUE, then the SS shall send an acknowledgment in the LPP PROVIDE ASSISTANCE DATA message.
10. The SS shall send a LPP REQUEST LOCATION INFORMATION message, including the *NR-DL-AoD-RequestLocationInformation* IE such that the UE receives the message ΔT ms before the start of T2, where $\Delta T = 50$ ms.
11. The SS sends a Positioning Measurement Gap Activation command containing an ID to activate the associated measurement gap
12. When T1 expires, the SS shall switch the power setting from T1 to T2 as specified in Table 16.2.6.5-3.
13. The UE shall transmit a LPP PROVIDE LOCATION INFORMATION message including the *NR-DL-AoD-ProvideLocationInformation* IE within the response time (see clause 4.16.3). The UE shall perform and report the PRS-RSRP measurements for Cell 2 with respect to the reference cell in the DL-TDOA assistance data, Cell 1. If the UE transmits an *NR-DL-AoD-ProvideLocationInformation* IE including the *nr-DL-PRS-RSRP-Result-r16* field for Cell 2 within the response time then the number of successful tests is increased by one. If the UE fails to report the *NR-DL-AoD-ProvideLocationInformation* IE with both the *nr-DL-PRS-RSRP-Result-r16* fields included within the response time then the number of failure tests is increased by one.
14. If the UE message at step 13 includes the *ackRequested* IE set to TRUE, the SS shall send a LPP acknowledgement message.
15. Repeat steps 2-14 in Table 16.2.6.4-1 until the confidence level according to Annex D is achieved.

16.2.6.4.3 Message contents

Table 16.2.6.4.3-1: RESET UE POSITIONING STORED INFORMATION

Derivation Path: 38.509 [44] clause 6.6			
Information Element	Value/remark	Comment	Condition
UE Positioning Technology	0 0 0 1 0 0 0	DL-AoD	

Table 16.2.6.4.3-2: LPP Request Capabilities

Information Element	Value/remark
<i>nr-DL-AoD-RequestCapabilities-r16</i>	TRUE

Table 16.2.6.4.3-3: RRCReconfiguration

Derivation Path: TS 38.508-1 [45], table 4.6.1-13			
Information Element	Value/remark	Comment	Condition
RRCReconfiguration ::= SEQUENCE {			
rrc-TransactionIdentifier	RRC-TransactionIdentifier		
criticalExtensions CHOICE {			
rrcReconfiguration SEQUENCE {			
nonCriticalExtension SEQUENCE {			
masterCellGroup	OCTET STRING (CONTAINING CellGroupConfig)		
}			
}			
}			
}			

Table 16.2.6.4.3-4: CellGroupConfig

Derivation Path: 38.508-1 [45], Table 4.6.3-19
--

Information Element	Value/remark	Comment	Condition
CellGroupConfig ::= SEQUENCE {			
spCellConfig SEQUENCE {			
spCellConfigDedicated SEQUENCE {			
initialDownlinkBWP SEQUENCE {			
dl-PPW-PreConfigToAddModList-r17 SEQUENCE (SIZE (1..maxNrofPPW-Config-r17)) OF DL-PPW-PreConfig-r17 {	1 entry		
DL-PPW-PreConfig-r17[1] SEQUENCE {		entry 1	
dl-PPW-ID-r17	0		
dl-PPW-PeriodicityAndStartSlot-r17 CHOICE {	The periodicity is 160ms and the starting slot offset is 11 ms for any SCS configuration		
scs15-r16 CHOICE {			Config 1 and Config 2
n160-r16	10		
}			
scs30-r16 CHOICE {			Config 3
n320-r16	20		
}			
}			
length-r17	80		
type-r17	type1A		
priority-r17	st1		
}			
}			
}			
}			
}			
}			

Table 16.2.6.4.3-5: LPP ProvideAssistanceData

Derivation Path: 37.355 clause 6.2			
Information Element	Value/remark	Comment	Condition
LPP-Message ::= SEQUENCE {			
transactionID SEQUENCE {			
initiator	locationServer		
transactionNumber	(0..255)		
}			
endTransaction	TRUE		
sequenceNumber	Not present		
acknowledgement	Not present		
lpp-MessageBody CHOICE {			
c1 CHOICE {			
provideAssistanceData SEQUENCE {			
criticalExtensions CHOICE {			
c1 CHOICE {			
provideAssistanceData-r9 SEQUENCE {			
commonEsProvideAssistanceData	Not present		
a-gnss-ProvideAssistanceData	Not present		
otdoa-ProvideAssistanceData	Not present		
epdu-Provide-AssistanceData	Not present		
sensor-ProvideAssistanceData-r15	Not present		
tbs-ProvideAssistanceData-r15	Not present		
wlan-ProvideAssistanceData-r15	Not present		
nr-Multi-RTT-ProvideAssistanceData-r16	Not present		
nr-DL-AoD-ProvideAssistanceData-r16			
}			
}			
}			
}			
nr-DL-PRS-AssistanceData-r16	As defined in Table 16.2.6.4.3-6		
nr-SelectedDL-PRS-IndexList-r16	Not present		
}			

nr-PositionCalculationAssistance-r16 SEQUENCE {			Depending on UE capabilities, i.e. support for UE-based DL-AoD
nr-TRP-LocationInfo-r16	As defined in TS 37.571-5 [20]		
nr-DL-PRS-BeamInfo-r16	Not present		
nr-RTD-Info-r16	Not present		
nr-TRP-BeamAntennaInfo-r17	Not present		
nr-DL-PRS-Expected-LOS-NLOS-Assistance-r17	Not present		
nr-DL-PRS-TRP-TEG-Info-r17	Not present		
}			
nr-DL-AoD-Error-r16	Not present		
nr-DL-PRS-BeamInfo-r17	Not present		
nr-On-Demand-DL-PRS-Configurations-r17	Not present		
}			
nr-DL-TDOA-ProvideAssistanceData-r16	Not present		
}			
}			
}			
}			
}			
}			

Table 16.2.6.4.3-6: NR-DL-PRS-AssistanceData

Derivation Path: 37.355 clause 6.4.3			
Information Element	Value/remark	Comment	Condition
NR-DL-PRS-AssistanceData-r16 ::= SEQUENCE {			
nr-DL-PRS-ReferenceInfo-r16 SEQUENCE {			
dl-PRS-ID-r16	0		
nr-DL-PRS-ResourceID-List-r16	Not present		
nr-DL-PRS-ResourceSetID-r16	Not present		
}			
nr-DL-PRS-AssistanceDataList-r16 SEQUENCE (SIZE (1..nrMaxFreqLayers-r16)) OF NR-DL-PRS-AssistanceDataPerFreq-r16 {	1 entry		
NR-DL-PRS-AssistanceDataPerFreq-r16[1] SEQUENCE {		entry 1	
nr-DL-PRS-PositioningFrequencyLayer-r16 SEQUENCE {			
dl-PRS-SubcarrierSpacing-r16	kHz15		Config 1 and Config 2
	kHz30		Config 3
dl-PRS-ResourceBandwidth-r16	21	104 PRBs	Config 1 and Config 2
	28	132 PRBs	Config 3
dl-PRS-StartPRB-r16	0		
dl-PRS-PointA-r16	absoluteFrequencyPointA as defined for the DL frequency of the Cell 1		
dl-PRS-CombSizeN-r16	n4		
dl-PRS-CyclicPrefix-r16	normal		
}			
nr-DL-PRS-AssistanceDataPerFreq-r16 SEQUENCE (SIZE (1..nrMaxTRPsPerFreq-r16)) OF NR-DL-PRS-AssistanceDataPerTRP-r16{	2 entries		
NR-DL-PRS-AssistanceDataPerTRP-r16[1] SEQUENCE {		entry 1	Cell 1

dl-PRS-ID-r16	0		
nr-PhysCellID-r16	Cell 1		
nr-CellGlobalID-r16	Cell 1		
nr-ARFCN-r16	Cell 1		
nr-DL-PRS-SFN0-Offset-r16 SEQUENCE {			
sfn-Offset-r16	0		
integerSubframeOffset-r16	0		
}			
nr-DL-PRS-ExpectedRSTD-r16	0		
nr-DL-PRS-ExpectedRSTD-Uncertainty-r16	0		
nr-DL-PRS-Info-r16	As specified in Table 16.2.6.4.3-7		
}			
NR-DL-PRS-AssistanceDataPerTRP-r16[2] SEQUENCE {		entry 2	Cell 2
dl-PRS-ID-r16	1		
nr-PhysCellID-r16	Cell 2		
nr-CellGlobalID-r16	Cell 2		
nr-ARFCN-r16	Cell 2		
nr-DL-PRS-SFN0-Offset-r16 SEQUENCE {			
sfn-Offset-r16	0		
integerSubframeOffset-r16	0		
}			
nr-DL-PRS-ExpectedRSTD-r16	As specified in Table 16.2.6.5-1		
nr-DL-PRS-ExpectedRSTD-Uncertainty-r16	As specified in Table 16.2.6.5-1		
nr-DL-PRS-Info-r16	As specified in Table 16.2.6.4.3-7		
}			
}			
}			
}			
}			
}			

Table 16.2.6.4.3-7: NR-DL-PRS-Info

Derivation Path: 37.355 clause 6.4.3			
Information Element	Value/remark	Comment	Condition
NR-DL-PRS-Info-r16 ::= SEQUENCE {			
nr-DL-PRS-ResourceSetList-r16 SEQUENCE (SIZE (1..nrMaxSetsPerTrp-r16)) OF NR-DL-PRS-ResourceSet-r16 {	1 entry		
NR-DL-PRS-ResourceSet-r16[1] SEQUENCE {		entry 1	
nr-DL-PRS-ResourceSetID-r16	0		
dl-PRS-Periodicity-and-ResourceSetSlotOffset-r16 CHOICE {			
scs15-r16 CHOICE {			Config 1 &2
n160-r16	80		
}			
scs30-r16 CHOICE {			Config 3
n320-r16	20		
}			
dl-PRS-ResourceRepetitionFactor-r16	n1		
dl-PRS-ResourceTimeGap-r16	s1		
dl-PRS-NumSymbols-r16	n4		
dl-PRS-MutingOption1-r16 SEQUENCE {			
dl-prs-MutingBitRepetitionFactor-r16	Not present		
nr-option1-muting-r16 CHOICE {			
po2-r16	10		Cell 1
	01		Cell 2
}			
}			
}			
}			
dl-PRS-MutingOption2-r16	Not present		
dl-PRS-ResourcePower-r16	27		

dl-PRS-ResourceList-r16 SEQUENCE (SIZE (1..nrMaxResourcesPerSet-r16)) OF NR-DL-PRS-Resource-r16 {	1 entry		
NR-DL-PRS-Resource-r16[1] SEQUENCE {		entry 1	
nr-DL-PRS-ResourceID-r16	0		
dl-PRS-SequenceID-r16	0		
dl-PRS-CombSizeN-AndReOffset-r16 CHOICE {			
N4-r16	0		Cell 1
	1		Cell 2
}			
dl-PRS-ResourceSlotOffset-r16	4		
dl-PRS-ResourceSymbolOffset-r16	0		
dl-PRS-QCL-Info-r16	Not present		
}			
}			
}			
}			
}			

Table 16.2.6.4.3-8: LPP RequestLocationInformation

Derivation Path: 37.355 clause 6.2			
Information Element	Value/remark	Comment	Condition
LPP-Message ::= SEQUENCE {			
transactionID SEQUENCE {			
initiator	locationServer		
transactionNumber	1		
}			
endTransaction	FALSE		
sequenceNumber	Not present		
acknowledgement	Not present		
lpp-MessageBody CHOICE {			
c1 CHOICE {			
requestLocationInformation SEQUENCE {			
criticalExtensions CHOICE {			
c1 CHOICE {			
requestLocationInformation-r9 SEQUENCE {			
commonIEsRequestLocationInformation SEQUENCE {			
locationInformationType	locationMeasurementsRequired		
triggeredReporting	Not present		
periodicalReporting	Not present		
additionalInformation	onlyReturnInformationRequested		
qos SEQUENCE {			
horizontalAccuracy	Not present		
verticalCoordinateRequest	FALSE		
verticalAccuracy	Not present		
responseTime SEQUENCE {			
time	See 16.2.6.5	Result of the response time calculation rounded up to the next second if response time <= 128s. Result of the response time calculation rounded up to the next multiple of ten seconds if response time > 128s.	

responseTimeEarlyFix-r12	Not present		Rel-12 onwards
unit-r15	Not present		Calculated response time >128s
	ten-seconds		
}			
velocityRequest	FALSE		
}			
environment	Not present		
locationCoordinateTypes	Not present		
velocityTypes	Not present		
}			
a-gnss-RequestLocationInformation	Not present		
otdoa-RequestLocationInformation	Not present		
ecid-RequestLocationInformation	Not present		
epdu-RequestLocationInformation	Not Present		
sensor-RequestLocationInformation-r13	Not present		
tbs-RequestLocationInformation-r13	Not present		
wlan-RequestLocationInformation-r13	Not present		
bt-RequestLocationInformation-r13	Not present		
nr-ECID-RequestLocationInformation-r16	Not present		
nr-Multi-RTT-RequestLocationInformation-r16	Not present		
nr-DL-AoD-RequestLocationInformation-r16			
SEQUENCE {			
nr-AssistanceAvailability-r16	FALSE		
nr-DL-AoD-ReportConfig-r16 SEQUENCE {			
maxDL-PRS-RSRP-MeasurementsPerTRP-r16	Not present		
maxDL-PRS-RSRP-MeasurementsPerTRP-r17	Not present		
maxDL-PRS-RSRPP-MeasurementsPerTRP-r17	Not present		
nr-los-nlos-IndicatorRequest-r17	Not present		
reducedDL-PRS-ProcessingSamples-r17	requested		Sub-test 1
	Not present		Sub-test 2
lowerRxBeamSweepingFactor-FR2-r17	Not present		
}			
multiMeasInSameReport-r17			
}			
nr-DL-TDOA-RequestLocationInformation-r16	Not present		
}			
}			
}			
}			
}			
}			

Table 16.2.6.4.3-9: LPP ProvideLocation Information

Derivation Path: 37.355 clause 6.5.12			
Information Element	Value/remark	Comment	Condition
LPP-Message ::= SEQUENCE {			
transactionID SEQUENCE {			
initiator	locationServer		
transactionNumber	1		
}			
endTransaction	TRUE		
sequenceNumber	(0..255)		
acknowledgement			
lpp-MessageBody CHOICE {			
c1 CHOICE {			
provideLocationInformation SEQUENCE {			
criticalExtensions CHOICE {			
c1 CHOICE {			

	provideLocationInformation-r9 SEQUENCE {		
	commonIEsProvideLocationInformation	Not present.	
	a-gnss-ProvideLocationInformation	Not present	
	otdoa-ProvideLocationInformation	Not present	
	ecid-ProvideLocationInformation	Not present	
	epdu-ProvideLocationInformation	Not present	
	sensor-ProvideLocationInformation-r13	Not present	
	tbs-ProvideLocationInformation-r13	Not present	
	wlan-ProvideLocationInformation-r13	Not present	
	bt-ProvideLocationInformation-r13	Not present	
	nr-ECID-ProvideLocationInformation-r16	Not present	
r16	nr-Multi-RTT-ProvideLocationInformation-	Not present	
	nr-DL-AoD-ProvideLocationInformation-r16 SEQUENCE {		
	nr-DL-AoD-SignalMeasurementInformation-r16 SEQUENCE {		
	nr-DL-AoD-MeasList-r16 SEQUENCE (SIZE(1..nrMaxTRPs-r16)) OF NR-DL-AoD-MeasElement-r16 {		
	NR-DL-AoD-MeasElement-r16[1] SEQUENCE {		entry 1
	dl-PRS-ID-r16	INTEGER (0..255)	
	nr-PhysCellID-r16	Cell 1	
	nr-CellGlobalID-r16		
	nr-ARFCN-r16		
	nr-DL-PRS-ResourceID-r16		
	nr-DL-PRS-ResourceSetID-r16		
	nr-TimeStamp-r16		
	nr-DL-PRS-RSRP-Result-r16	Present. Any value acceptable.	
	nr-DL-PRS-RxBeamIndex-r16		
r16	nr-DL-AoD-AdditionalMeasurements-		
	nr-DL-PRS-FirstPathRSRP-Result-r17		
	nr-los-nlos-Indicator-r17		
	nr-DL-AoD-AdditionalMeasurementsExt-r17		
	} NR-DL-AoD-MeasElement-r16[2] SEQUENCE {		entry 2
	dl-PRS-ID-r16	INTEGER (0..255)	
	nr-PhysCellID-r16	Cell 2	
	nr-CellGlobalID-r16		
	nr-ARFCN-r16		
	nr-DL-PRS-ResourceID-r16		
	nr-DL-PRS-ResourceSetID-r16		
	nr-TimeStamp-r16		
	nr-DL-PRS-RSRP-Result-r16	Present. Any value acceptable.	
	nr-DL-PRS-RxBeamIndex-r16		
r16	nr-DL-AoD-AdditionalMeasurements-		
	nr-DL-PRS-FirstPathRSRP-Result-r17		
	nr-los-nlos-Indicator-r17		
	nr-DL-AoD-AdditionalMeasurementsExt-r17		
	} }		
	} }		
	nr-dl-AoD-LocationInformation-r16		
	nr-DL-AoD-Error-r16	Not present	
r17	nr-DL-AoD-SignalMeasurementInstances-	Not present	
r17	nr-DL-AoD-LocationInformationInstances-	Not present	

}			
}			
}			
}			
}			
}			
}			
}			

16.2.6.5 Test requirement

Table 16.2.6.5-1 and Table 16.2.6.5-2 define the primary level settings including test tolerances for the test.

Table 16.2.6.5-1: General test parameters for PRS RSRP measurement reporting delay

Parameter	Unit	Test configuration	Value	Comment
Reference cell		1, 2, 3	Cell 1	Cell 1 is the PCell and the DL-AoD reference cell in the positioning assistance data.
Neighbour cell		1, 2, 3	Cell 2	Cell 2 is a neighbour cell in the positioning assistance data.
RF Channel Number		1, 2, 3	1: Cell 1 and Cell 2	
BW _{channel}	MHz	1	20: N _{RB,c} = 106	
		2	20: N _{RB,c} = 106	
		3	50: N _{RB,c} = 133	
SSB configuration		1	SSB.1 FR1	
		2	SSB.1 FR1	
		3	SSB.2 FR1	
SMTC configuration		1	SMTC.2	
		2	SMTC.1	
		3	SMTC.1	
PPW configuration		1	PPW.1	As defined in A.3.33
		2	PPW.1	As defined in A.3.33
		3	PPW.1	As defined in A.3.33
CP length		1, 2, 3	Normal	
DRX		1, 2, 3	NA	OFF
Time offset between serving and neighbour cells	µs	1	3	
		2	3	
		3	3 or 2.34 ^{Note 1}	
Expected RSTD	µs	1, 2, 3	0	
Expected RSTD uncertainty	µs	1, 2, 3	Same as time offset between serving and neighbour cells	
T1	s	1, 2, 3	2	
T2	s	1, 2, 3	5	
NOTE 1: If UE indicates support of CP length for the receive time difference threshold, the time offset is set to 2.34µs, otherwise 3µs.				

Table 16.2.6.5-2: Cell-specific test parameters during T2 for PRS RSRP measurement reporting delay

Parameter	Unit	Test configuration	Cell 1		Cell 2	
			Sub-test 1	Sub-test 2	Sub-test 1	Sub-test 2
TDD configuration		1	N/A		N/A	
		2	TDDConf.1.1	TDDConf.1.1		
		3	TDDConf.2.1	TDDConf.2.1		
PDSCH RMC configuration		1	SR.1.1 FDD	N/A		
		2	SR.1.1 TDD			
		3	SR.2.1 TDD			
		1	CR.1.1 FDD	N/A		

RMSI CORESET RMC configuration		2	CR.1.1 TDD			
		3	CR.2.1 TDD			
Dedicated CORESET RMC configuration		1	CCR.1.1 FDD			
		2	CCR.1.1 TDD			
		3	CCR.2.1 TDD			
OCNG Patterns		1, 2, 3	OP.1			OP.1
TRS Configuration		1	TRS.1.1 FDD			
		2	TRS.1.1 TDD			
		3	TRS.1.2 TDD			
Initial BWP configuration		1, 2, 3	DLBWP.0.1 ULBWP.0.1		N/A	
Active DL BWP configuration		1, 2, 3	DLBWP.1.1		N/A	
Active UL BWP configuration		1, 2, 3	ULBWP.1.1		N/A	
PRS configuration		1	PRS.1.4 FR1		PRS.1.4 FR1	
		2	PRS.1.4 FR1		PRS.1.4 FR1	
		3	PRS.2.4 FR1		PRS.2.4 FR1	
PRS muting info		1, 2, 3	'10'		'01'	
N_{oc} <small>Note 2</small>	dBm/SCS	1	-98			
		2	-98			
		3	-95			
N_{oc} <small>Note 2</small>	dBm/15 kHz	1	-98			
		2				
		3				
PRS \hat{E}_s/I_{ot}	dB	1	0	-2.41	-6	-12.12
		2				
		3				
PRS \hat{E}_s/N_{oc}	dB	1	2.23	-2	-1.73	-10
		2				
		3				
PRS-RSRP <small>Note 3</small>	dBm/SCS kHz	1	-95.77	-100	-99.73	-108
		2	-95.77	-100	-99.73	-108
		3	-92.77	-97	-96.73	-105
SS-RSRP <small>Note 3</small>	dBm/SCS kHz	1	-101	-101	-104	-108
		2	-101	-101	-104	-108
		3	-98	-98	-101	-105
I _o	dBm/19.08 MHz	1	-61.71	-64.57	-61.71	-64.57
	dBm/19.08 MHz	2	-61.71	-64.57	-61.71	-64.57
	dBm/47.88 MHz	3	-57.73	-60.59	-57.73	-60.59
Propagation Condition		1, 2, 3	AWGN			
<p>Note 1: The resources for uplink transmission are assigned to the UE prior to the start of time period T2.</p> <p>Note 2: Interference from other cells and noise sources not specified in the test is assumed to be constant over subcarriers and time and shall be modelled as AWGN of appropriate power for N_{oc} to be fulfilled.</p> <p>Note 3: SS-RSRP/PRS-RSRP levels have been derived from other parameters for information purposes. They are not settable parameters themselves.</p>						

e16.2.7 PRS-RSRP measurement reporting delay test case for single positioning frequency with reduced number of samples in FR2 SA

Editor’s Note: This test case has been completed for the following configurations:

- Test frequency $f \leq 40.8$ GHz
- UE PC3

16.2.7.1 Test purpose

The purpose of the test is to verify the PRS RSRP measurement requirements for reduced number of samples specified in TS 38.133 [50] Clause 9.9.3.5 for single positioning frequency layer under AWGN propagation conditions in FR2 in standalone scenario.

16.2.7.2 Test applicability

This test applies to all types of NR UE release 17 onwards that supports DL-AoD positioning and supportedDL-PRS-ProcessingSamples-RRC-CONNECTED.

16.2.7.3 Minimum conformance requirements

When the physical layer receives *NR-DL-AoD-ProvideAssistanceData* message and *NR-DL-AoD-RequestLocationInformation* message from LMF via LPP [34], the UE shall be able to measure multiple (up to the UE capability specified in Clause 9.9.3.3) PRS-RSRP measurements, defined in TS 38.215 [4], from configured PRS resources for configured TRPs on configured positioning frequency layers, within $T_{\text{PRS-RSRP,total}}$ ms.

$$T_{\text{PRS-RSRP,total}} = \sum_{i=1}^L T_{\text{PRS-RSRP},i} + (L - 1) * \max(T_{\text{effect},i})$$

where

i is the index of positioning frequency layer,

L is total number of positioning frequency layers,

$T_{\text{effect},i}$ is the periodicity of the PRS-RSRP measurement in positioning frequency layer i .

$$T_{\text{PRS-RSRP},i} = \left(\text{CSSF}_i * \text{ceil}(K_{\text{p,PRS},i}) * N_{\text{RxBeam},i} * \left\lceil \frac{N_{\text{PRS},i}^{\text{slot}}}{N'} \right\rceil \left\lfloor \frac{L_{\text{available_PRS},i}}{N} \right\rfloor * N_{\text{sample}} - 1 \right) * T_{\text{effect},i} + T_{\text{last}}$$

where

CSSF_i is the carrier specific scaling factor for PRS-RSRP measurements specified in clause 9.1.5.2,

$K_{\text{p,PRS},i}$ is a scaling factor for a positioning frequency layer to be measured within the associated measurement gap pattern, which is defined as $K_{\text{p,PRS},i} = N_{\text{total}} / N_{\text{available}}$ for UE configured with concurrent measurement gap, and $K_{\text{p,PRS},i} = 1$ for UE not configured with concurrent measurement gap.

For a window W of duration $\max(T_{\text{PRS},i}, \text{MGRP_max})$, where MGRP_max is the maximum MGRP across all configured per-UE MG and per-FR MG within the same FR as the positioning frequency layer, and starting at the beginning of any associated gap occasions covering the PRS occasion:

N_{total} is the total number of associated gap occasions covering PRS occasions within the window, including both dropped and non-dropped instances of the associated measurement gap within the window, and

$N_{\text{available}}$ is the number of non-dropped associated gap occasions covering PRS occasions within the window W , after further accounting for MG collisions by applying the selected gap collision rule

Requirements do not apply if $N_{\text{available}} = 0$.

$N_{\text{RxBeam},i}$ is the scaling factor for Rx beam sweeping, and $N_{\text{RxBeam},i} = 1$ if positioning frequency layer i is in FR1 and if positioning frequency layer i is in FR2, $N_{\text{RxBeam},i}$ is equal to the value reported by the UE in *supportedLowerRxBeamSweepingFactor-FR2* if the UE supports the capability for the band containing positioning frequency layer i , and the LMF indicates *lowerRxBeamSweepingFactor-FR2* in *NR-TDOA-RequestLocationInformation*. $N_{\text{RxBeam},i}$ is equal to 8, otherwise.

$L_{\text{available_PRS},i}$ is the time duration of available PRS to be measured in the positioning frequency layer i to be measured during $T_{\text{available_PRS},i}$, and is calculated in the same way as PRS duration K defined in clause 5.1.6.5

of TS 38.214 [26]. For calculation of $L_{available_PRS,i}$, only the PRS resources unmuted and fully or partially overlapped with MG are considered.

$N_{PRS,i}^{slot}$ is the maximum number of DL PRS resources of positioning frequency layer i configured in a slot,

$\{N, T\}$ is UE capability combination per band where N is a duration of DL PRS symbols in ms corresponding to *durationOfPRS-ProcessingSymbols* in TS 37.355 [34] processed every T ms corresponding to *durationOfPRS-ProcessingSymbolsInEveryTms* in TS 37.355 [34] for a given maximum bandwidth supported by UE corresponding to *supportedBandwidthPRS* in TS 37.355 [34],

N' is UE capability for number of DL PRS resources that it can process in a slot as indicated by *maxNumOfDL-PRS-ResProcessedPerSlot* in clause 6.4.3 of TS 37.355 [34],

N_{sample} is the number of PRS RSRP measurement samples, where

- $N_{sample} = 1$ if the UE supports *supportedDL-PRS-ProcessingSamples* [34], and the LMF requests the UE to perform positioning measurements with reduced number of samples, and meets the following conditions:
 - PRS bandwidth is within the active BWP and
 - Magnitude of difference between the serving cell's SS-RSRP and the neighbour cell's PRS-RSRP is within 6 dB.
- $N_{sample} = 2$ if the UE supports *supportedDL-PRS-ProcessingSamples* [34], and the LMF requests the UE to perform positioning measurements with reduced number of samples, and does not meet the following conditions:
 - PRS bandwidth is within the active BWP and
 - Magnitude of difference between the serving cell's SS-RSRP and the neighbour cell's PRS-RSRP is within 6 dB.
- $N_{sample} = 4$ otherwise.

$T_{last,i} = T_i + T_{available_PRS,i}$ is the measurement duration for the last PRS-RSRP sample, including the sampling time and processing time, if not all PRS resources to be measured are available in the same measurement gap occasion during $T_{available_PRS,i}$, otherwise $T_{last,i} = T_i + MGL$,

$T_{effect,i} = \left\lceil \frac{T_i}{T_{available_PRS,i}} \right\rceil * T_{available_PRS,i}$ is the periodicity of PRS-RSRP measurement in positioning frequency layer i ,

T_i corresponds to *durationOfPRS-ProcessingSymbolsInEveryTms* in TS 37.355 [34],

$T_{available_PRS,i} = LCM(T_{PRS,i}, MGRP_i)$ is the least common multiple between $T_{PRS,i}$ and $MGRP_i$,

$T_{PRS,i}$ is the maximum PRS resource periodicity among all PRS resources in positioning frequency layer i ,

$MGRP_i$ is the measurement gap repetition period in positioning frequency layer i .

If positioning frequency layer i has more than one DL PRS resource set with different PRS periodicities with muting, $T_{per}^{PRS \text{ with muting}} = N_{muting} * T_{per}^{PRS}$, the least common multiple of $T_{per}^{PRS \text{ with muting}}$ among the DL PRS resource sets is used to derive $T_{PRS,i}$, where:

T_{per}^{PRS} is the periodicity of PRS resource sets given by the higher-layer parameter *DL-PRS-Periodicity*.

N_{muting} is the scaling factor considering PRS resource muting. $N_{muting} = T_{muting}^{PRS} * L_{muting}$, where T_{muting}^{PRS} is the muting repetition factor given by the higher-layer parameter *DL-PRS-MutingBitRepetitionFactor*, and L_{muting} is the size of the bitmap $\{b^1\}$.

16.2.7.4 Test description

16.2.7.4.1 Initial conditions

The supported test configurations in listed in Table 16.2.7.4-1.

Table 16.2.7.4-1: Test Configurations

Test Configuration	Description
1	120 kHz SSB and PRS SCS, 200 MHz bandwidth, TDD duplex mode

Test Environment: Normal, as defined in TS 38.508-1 [45] clause 4.1.

Frequencies to be tested: Mid Range, as defined in TS 38.508-1 [45] clause 4.3.1.

Channel bandwidth to be tested: are specified in Table 16.2.7.4-1.

1. Connect the SS and AWGN noise sources to the UE antenna connector or antenna connectors as shown in Annex A, Figure A.14.
2. The general test parameter settings are set up according to Table 16.2.7.5-1 and Table 16.2.7.5-2.
3. Propagation conditions are set according to clause 4.16.2.
4. Message contents are defined in clause 16.2.7.4.3.
5. In the test there are two synchronous cells: Cell 1 and Cell 2. Cell 1 is the reference as well as the PCell. Cell 2 is the neighbour cell. All cells are on the same RF channel distributed in single positioning frequency layer.

16.2.7.4.2 Test procedure

The test consists of two consecutive time intervals, with duration of T1 and T2. During time duration T1, the UE shall not have any timing information of Cell 2. All two cells transmit PRS during T2. The beginning of the time interval T2 shall be aligned with the beginning of the first MG instance containing the PRS resources.

The *NR-DL-AoD-ProvideAssistanceData* and *NR-DL-AoD-RequestLocationInformation* as defined in TS 37.355 [49] clause 6.5.11 shall be provided to the UE during T1. The last TTI containing the two messages shall be provided to the UE ΔT ms before the start of T2, where $\Delta T = 50$ ms is the maximum processing time of the *DL-AoD assistance* data and location information request.

2. Ensure the UE is in State RRC_CONNECTED with generic procedure parameters Connectivity *NR*, Connected without release *On*, according to TS 38.508-1 [45] clause 4.5.
2. The SS shall send a RESET UE POSITIONING STORED INFORMATION message.
3. Set the parameters according to Table 16.2.7.5-1 and Table 16.2.7.5-2. Propagation conditions are set according to clause 4.16.2.
4. T1 starts.
5. The SS shall transmit an LPP REQUEST CAPABILITIES message.
6. The UE shall transmit an LPP PROVIDE CAPABILITIES message indicating the DL-AoD capabilities supported by the UE in the *NR-DL-AoD-ProvideCapabilities* IE.
7. The SS shall send a LPP PROVIDE ASSISTANCE DATA message, including the *NR-DL-AoD-ProvideAssistanceData* IE. The position of neighbour Cell 2 is described in 3GPP TS 37.571-5 [20]. If the UE message at step 6 includes the *ackRequested* IE set to TRUE, then the SS shall send an acknowledgment in the LPP PROVIDE ASSISTANCE DATA message.
8. The SS shall send a LPP REQUEST LOCATION INFORMATION message, including the *NR-DL-AoD-RequestLocationInformation* IE such that the UE receives the message ΔT ms before the start of T2, where $\Delta T = 50$ ms.

9. When T1 expires, the SS shall switch the power setting from T1 to T2 as specified in Table 16.2.7.5-2.
10. The UE shall transmit a LPP PROVIDE LOCATION INFORMATION message including the *NR-DL-AoD-ProvideLocationInformation* IE within the response time (see clause 4.16.3). The UE shall perform and report the PRS-RSRP measurements for Cell 2 with respect to the reference cell in the DL-TDOA assistance data, Cell 1. If the UE transmits an *NR-DL-AoD-ProvideLocationInformation* IE including the nr-DL-PRS-RSRP-Result-r16 field for Cell 2 within the response time then the number of successful tests is increased by one. If the UE fails to report the *NR-DL-AoD-ProvideLocationInformation* IE with both the nr-DL-PRS-RSRP-Result-r16 fields included within the response time then the number of failure tests is increased by one.
11. If the UE message at step 10 includes the *ackRequested* IE set to TRUE, the SS shall send a LPP acknowledgement message.
12. Repeat steps 2-11 in Table 16.2.7.4-1 until the confidence level according to Annex D is achieved.

16.2.7.4.3 Message contents

Table 16.2.7.4.3-1: RESET UE POSITIONING STORED INFORMATION

Derivation Path: 38.509 [44] clause 6.6			
Information Element	Value/remark	Comment	Condition
UE Positioning Technology	0 0 0 1 0 0 0	DL-AoD	

Table 16.2.7.4.3-2: LPP Request Capabilities

Information Element	Value/remark
nr-DL-AoD-RequestCapabilities-r16	TRUE

Table 16.2.7.4.3-3: LPP ProvideAssistanceData

Derivation Path: 37.355 clause 6.2			
Information Element	Value/remark	Comment	Condition
LPP-Message ::= SEQUENCE {			
transactionID SEQUENCE {			
initiator	locationServer		
transactionNumber	(0..255)		
}			
endTransaction	TRUE		
sequenceNumber	Not present		
acknowledgement	Not present		
lpp-MessageBody CHOICE {			
c1 CHOICE {			
provideAssistanceData SEQUENCE {			
criticalExtensions CHOICE {			
c1 CHOICE {			
provideAssistanceData-r9 SEQUENCE {			
commonEsProvideAssistanceData	Not present		
a-gnss-ProvideAssistanceData	Not present		
otdoa-ProvideAssistanceData	Not present		
epdu-Provide-AssistanceData	Not present		
sensor-ProvideAssistanceData-r15	Not present		
tbs-ProvideAssistanceData-r15	Not present		
wlan-ProvideAssistanceData-r15	Not present		
nr-Multi-RTT-ProvideAssistanceData-r16	Not present		
nr-DL-AoD-ProvideAssistanceData-r16			
} SEQUENCE {			
nr-DL-PRS-AssistanceData-r16	As defined in Table 16.2.7.4.3-4		
nr-SelectedDL-PRS-IndexList-r16	Not present		
nr-PositionCalculationAssistance-r16			
} SEQUENCE {			Depending on UE capabilities, i.e. support

			for UE-based DL-AoD
nr-TRP-LocationInfo-r16	As defined in TS 37.571-5 [20]		
nr-DL-PRS-BeamInfo-r16	Not present		
nr-RTD-Info-r16	Not present		
nr-TRP-BeamAntennaInfo-r17	Not present		
nr-DL-PRS-Expected-LOS-NLOS-Assistance-r17	Not present		
nr-DL-PRS-TRP-TEG-Info-r17	Not present		
}			
nr-DL-AoD-Error-r16	Not present		
nr-DL-PRS-BeamInfo-r17	Not present		
nr-On-Demand-DL-PRS-Configurations-r17	Not present		
}			
nr-DL-TDOA-ProvideAssistanceData-r16	Not present		
}			
}			
}			
}			
}			
}			
}			

Table 16.2.7.4.3-4: NR-DL-PRS-AssistanceData

Derivation Path: 37.355 clause 6.4.3			
Information Element	Value/remark	Comment	Condition
NR-DL-PRS-AssistanceData-r16 ::= SEQUENCE {			
nr-DL-PRS-ReferenceInfo-r16 SEQUENCE {			
dl-PRS-ID-r16	0		
nr-DL-PRS-ResourceID-List-r16	Not present		
nr-DL-PRS-ResourceSetID-r16	Not present		
}			
nr-DL-PRS-AssistanceDataList-r16 SEQUENCE (SIZE (1..nrMaxFreqLayers-r16)) OF NR-DL-PRS-AssistanceDataPerFreq-r16 {	1 entry		
NR-DL-PRS-AssistanceDataPerFreq-r16[1] SEQUENCE {		entry 1	
nr-DL-PRS-PositioningFrequencyLayer-r16 SEQUENCE {			
dl-PRS-SubcarrierSpacing-r16	kHz120		
dl-PRS-ResourceBandwidth-r16	7	48 PRBs	
dl-PRS-StartPRB-r16	0		
dl-PRS-PointA-r16	absoluteFrequencyPointA as defined for the DL frequency of the Cell 1		
dl-PRS-CombSizeN-r16	n2		
dl-PRS-CyclicPrefix-r16	normal		
}			
nr-DL-PRS-AssistanceDataPerFreq-r16 SEQUENCE (SIZE (1..nrMaxTRPsPerFreq-r16)) OF NR-DL-PRS-AssistanceDataPerTRP-r16{	2 entries		
NR-DL-PRS-AssistanceDataPerTRP-r16[1] SEQUENCE {		entry 1	Cell 1
dl-PRS-ID-r16	0		
nr-PhysCellID-r16	Cell 1		
nr-CellGlobalID-r16	Cell 1		
nr-ARFCN-r16	Cell 1		
nr-DL-PRS-SFN0-Offset-r16 SEQUENCE {			
sfn-Offset-r16	0		
integerSubframeOffset-r16	0		
}			
nr-DL-PRS-ExpectedRSTD-r16	0		
nr-DL-PRS-ExpectedRSTD-Uncertainty-r16	0		

nr-DL-PRS-Info-r16	As specified in Table 16.2.7.4.3-5		
}			
NR-DL-PRS-AssistanceDataPerTRP-r16[2] SEQUENCE {		entry 2	Cell 2
dl-PRS-ID-r16	1		
nr-PhysCellID-r16	Cell 2		
nr-CellGlobalID-r16	Cell 2		
nr-ARFCN-r16	Cell 2		
nr-DL-PRS-SFN0-Offset-r16 SEQUENCE {			
sfn-Offset-r16	0		
integerSubframeOffset-r16	0		
}			
nr-DL-PRS-ExpectedRSTD-r16	23	About 3 μs	
nr-DL-PRS-ExpectedRSTD-Uncertainty-r16	154	About 5 μs	
nr-DL-PRS-Info-r16	As specified in Table 16.2.7.4.3-5		
}			
}			
}			
}			
}			

Table 16.2.7.4.3-5: NR-DL-PRS-Info

Derivation Path: 37.355 clause 6.4.3			
Information Element	Value/remark	Comment	Condition
NR-DL-PRS-Info-r16 ::= SEQUENCE {			
nr-DL-PRS-ResourceSetList-r16 SEQUENCE (SIZE (1..nrMaxSetsPerTrp-r16)) OF NR-DL-PRS-ResourceSet-r16 {	1 entry		
NR-DL-PRS-ResourceSet-r16[1] SEQUENCE {		entry 1	
nr-DL-PRS-ResourceSetID-r16	0		
dl-PRS-Periodicity-and-ResourceSetSlotOffset-r16 CHOICE {			
scs120-r16 CHOICE {			
n1280-r16	80		
}			
dl-PRS-ResourceRepetitionFactor-r16	n2		
dl-PRS-ResourceTimeGap-r16	s1		
dl-PRS-NumSymbols-r16	n4		
dl-PRS-MutingOption1-r16 SEQUENCE {			
dl-prs-MutingBitRepetitionFactor-r16	Not present		
nr-option1-muting-r16 CHOICE {			
po2-r16	10		Cell 1
	01		Cell 2
}			
}			
dl-PRS-MutingOption2-r16	Not present		
dl-PRS-ResourcePower-r16	27		
dl-PRS-ResourceList-r16 SEQUENCE (SIZE (1..nrMaxResourcesPerSet-r16)) OF NR-DL-PRS-Resource-r16 {	1 entry		
NR-DL-PRS-Resource-r16[1] SEQUENCE {		entry 1	
nr-DL-PRS-ResourceID-r16	0		
dl-PRS-SequenceID-r16	0		
dl-PRS-CombSizeN-AndReOffset-r16 CHOICE {			
n2-r16	0		
}			
dl-PRS-ResourceSlotOffset-r16	0		
dl-PRS-ResourceSymbolOffset-r16	0		
dl-PRS-QCL-Info-r16	Not present		
}			
}			
}			

}			
}			
}			

Table 16.2.7.4.3-6: LPP RequestLocationInformation

Derivation Path: 37.355 clause 6.2			
Information Element	Value/remark	Comment	Condition
LPP-Message ::= SEQUENCE {			
transactionID SEQUENCE {			
initiator	locationServer		
transactionNumber	1		
}			
endTransaction	FALSE		
sequenceNumber	Not present		
acknowledgement	Not present		
lpp-MessageBody CHOICE {			
c1 CHOICE {			
requestLocationInformation SEQUENCE {			
criticalExtensions CHOICE {			
c1 CHOICE {			
requestLocationInformation-r9 SEQUENCE {			
commonEsRequestLocationInformation SEQUENCE {			
locationInformationType	locationMeasurementsRequired		
triggeredReporting	Not present		
periodicalReporting	Not present		
additionalInformation	onlyReturnInformationRequested		
qos SEQUENCE {			
horizontalAccuracy	Not present		
verticalCoordinateRequest	FALSE		
verticalAccuracy	Not present		
responseTime SEQUENCE {			
time	See 16.2.7.5	Result of the response time calculation rounded up to the next second if response time <= 128s. Result of the response time calculation rounded up to the next multiple of ten seconds if response time > 128s.	
responseTimeEarlyFix-r12	Not present		Rel-12 onwards
unit-r15	Not present		
ten-seconds			Calculated response time >128s
}			
}			
velocityRequest	FALSE		
}			
environment	Not present		
locationCoordinateTypes	Not present		
velocityTypes	Not present		
}			
a-gnss-RequestLocationInformation	Not present		
otdoa-RequestLocationInformation	Not present		
ecid-RequestLocationInformation	Not present		

epdu-RequestLocationInformation	Not Present		
sensor-RequestLocationInformation-r13	Not present		
tbs-RequestLocationInformation-r13	Not present		
wlan-RequestLocationInformation-r13	Not present		
bt-RequestLocationInformation-r13	Not present		
nr-ECID-RequestLocationInformation-r16	Not present		
nr-Multi-RTT-RequestLocationInformation-r16	Not present		
nr-DL-AoD-RequestLocationInformation-r16			
SEQUENCE {			
nr-AssistanceAvailability-r16	FALSE		
nr-DL-AoD-ReportConfig-r16 SEQUENCE {			
maxDL-PRS-RSRP-MeasurementsPerTRP-r16	Not present		
maxDL-PRS-RSRP-MeasurementsPerTRP-r17	Not present		
maxDL-PRS-RSRPP-MeasurementsPerTRP-r17	Not present		
nr-los-nlos-IndicatorRequest-r17	Not present		
reducedDL-PRS-ProcessingSamples-r17	requested		
lowerRxBeamSweepingFactor-FR2-r17	Not present		
}			
multiMeasInSameReport-r17			
}			
nr-DL-TDOA-RequestLocationInformation-r16	Not present		
}			
}			
}			
}			
}			
}			

Table 16.2.7.4.3-7: LPP ProvideLocation Information

Derivation Path: 37.355 clause 6.5.12			
Information Element	Value/remark	Comment	Condition
LPP-Message ::= SEQUENCE {			
transactionID SEQUENCE {			
initiator	locationServer		
transactionNumber	1		
}			
endTransaction	TRUE		
sequenceNumber	(0..255)		
acknowledgement			
lpp-MessageBody CHOICE {			
c1 CHOICE {			
provideLocationInformation SEQUENCE {			
criticalExtensions CHOICE {			
c1 CHOICE {			
provideLocationInformation-r9 SEQUENCE {			
commonIEsProvideLocationInformation	Not present.		
a-gnss-ProvideLocationInformation	Not present		
otdoa-ProvideLocationInformation	Not present		
ecid-ProvideLocationInformation	Not present		
epdu-ProvideLocationInformation	Not present		
sensor-ProvideLocationInformation-r13	Not present		
tbs-ProvideLocationInformation-r13	Not present		
wlan-ProvideLocationInformation-r13	Not present		
bt-ProvideLocationInformation-r13	Not present		
nr-ECID-ProvideLocationInformation-r16	Not present		
nr-Multi-RTT-ProvideLocationInformation-r16	Not present		
nr-DL-AoD-ProvideLocationInformation-r16			
SEQUENCE {			
nr-DL-AoD-SignalMeasurementInformation-r16 SEQUENCE {			

nr-DL-AoD-MeasList-r16 SEQUENCE (SIZE(1..nrMaxTRPs-r16)) OF NR-DL-AoD-MeasElement-r16 {			
NR-DL-AoD-MeasElement-r16[1] SEQUENCE {		entry 1	
dl-PRS-ID-r16	INTEGER (0..255)		
nr-PhysCellID-r16	Cell 1		
nr-CellGlobalID-r16			
nr-ARFCN-r16			
nr-DL-PRS-ResourceID-r16			
nr-DL-PRS-ResourceSetID-r16			
nr-TimeStamp-r16			
nr-DL-PRS-RSRP-Result-r16	Present. Any value acceptable.		
nr-DL-PRS-RxBeamIndex-r16			
r16 nr-DL-AoD-AdditionalMeasurements-			
nr-DL-PRS-FirstPathRSRP-Result-r17			
nr-los-nlos-Indicator-r17			
nr-DL-AoD-AdditionalMeasurementsExt-r17			
}			
NR-DL-AoD-MeasElement-r16[2] SEQUENCE {		entry 2	
dl-PRS-ID-r16	INTEGER (0..255)		
nr-PhysCellID-r16	Cell 2		
nr-CellGlobalID-r16			
nr-ARFCN-r16			
nr-DL-PRS-ResourceID-r16			
nr-DL-PRS-ResourceSetID-r16			
nr-TimeStamp-r16			
nr-DL-PRS-RSRP-Result-r16	Present. Any value acceptable.		
nr-DL-PRS-RxBeamIndex-r16			
r16 nr-DL-AoD-AdditionalMeasurements-			
nr-DL-PRS-FirstPathRSRP-Result-r17			
nr-los-nlos-Indicator-r17			
nr-DL-AoD-AdditionalMeasurementsExt-r17			
}			
}			
}			
nr-dl-AoD-LocationInformation-r16			
nr-DL-AoD-Error-r16	Not present		
r17 nr-DL-AoD-SignalMeasurementInstances-	Not present		
r17 nr-DL-AoD-LocationInformationInstances-	Not present		
}			
}			
}			
}			
}			
}			
}			
}			

16.2.7.5 Test requirement

Table 16.2.7.5-1 and Table 16.2.7.5-2 define the primary level settings including test tolerances for the test.

Table 16.2.7.5-1: General test parameters for PRS RSRP measurement reporting delay

Parameter	Unit	Test configuration	Value	Comment
NR RF Channel Number		Config 1	1: Cell 1 and Cell 2	One TDD carrier frequency is used for the NR cells.
Active cell		Config 1	NR cell 1 (Pcell)	Cell 1 is the PCell and the DL-AoD reference cell in the positioning assistance data.
Neighbour cell		Config 1	NR cell 2	Cell 2 is a neighbour cell in the positioning assistance data.
Gap Pattern Id		Config 1	GP#13 or GP#24 ^{Note1}	As specified in TS 38.133 [50] clause 9.1.2-1.
Measurement gap offset		Config 1	39	
SMTC parameters		Config 1	SMTC.1	As specified in TS 38.133 [50] clause A.3.11
SSB parameters		Config 1	SSB.3 FR2	As specified in TS 38.133 [50] clause A.3.10.2
A3-Offset	dB	Config 1	-6	
Hysteresis	dB	Config 1	0	
CP length		Config 1	Normal	
TimeToTrigger	s	Config 1	0	
Filter coefficient		Config 1	0	L3 filtering is not used
DRX		Config 1	OFF	DRX is not used
Time offset between serving and neighbour cells		Config 1	3μs	Synchronous cells.
Expected RSTD	μs	Config 1	3	
Expected RSTD uncertainty	μs	Config 1	5	
T1	s	Config 1	5	
T2	s	Config 1	7	

Note 1: GP#24 is configured if UE supports MG#24, otherwise GP#13 is configured.

Table 16.2.7.5-2: Cell-specific test parameters for PRS RSRP measurement reporting delay

Parameter		Unit	Test configuration	Cell 1		Cell 2	
				T1	T2	T1	T2
AoA setup			Config 1	Setup 1 as specified in TS 38.133 [50] clause A.3.15			
Beam Assumption ^{Note 7}			Config 1	Rough		Rough	
TDD configuration			Config 1	TDDConf.3.1		TDDConf.3.1	
Duplex mode			Config 1	TDD		TDD	
BW _{channel}		MHz	Config 1	200: N _{RB,c} = 132		200: N _{RB,c} = 132	
BWP BW		MHz	Config 1	200: N _{RB,c} = 132		200: N _{RB,c} = 132	
BWP configuration	Initial DL BWP		Config 1	DLBWP.0.1		N/A	
	Initial UL BWP			ULBWP.0.1		N/A	
	Dedicated DL BWP			DLBWP.1.1		N/A	
	Dedicated UL BWP			ULBWP.1.1		N/A	
OCNG Patterns defined in A.3.2.1.1			Config 1	OP.1		OP.1	

PDSCH Reference measurement channel		Config 1	SR.3.1 TDD	-		
CORESET Reference Channel		Config 1	CR.3.1 TDD	-		
Dedicated CORESET RMC configuration		Config 1	CCR.3.1 TDD	-		
TRS configuration		Config 1	TRS.2.1 TDD	-		
PDSCH/PDCCH subcarrier spacing	kHz	Config 1	120	120		
PRS configuration		Config 1	PRS.1.1 FR2	PRS.1.1 FR2		
PRS BW		Config 1	48 PRBs	48 PRBs		
PRS muting configuration		Config 1	'10'	'01'		
EPRE ratio of PSS to SSS	dB	Config 1	0	0		
EPRE ratio of PBCH DMRS to SSS						
EPRE ratio of PBCH to PBCH DMRS						
EPRE ratio of PDCCH DMRS to SSS						
EPRE ratio of PDCCH to PDCCH DMRS						
EPRE ratio of PDSCH DMRS to SSS						
EPRE ratio of PDSCH to PDSCH						
EPRE ratio of OCNG DMRS to SSS(Note 1)						
EPRE ratio of OCNG to OCNG DMRS (Note 1)						
EPRE ratio of PRS to SSS						
N_{oc} Note2	dBm/15 kHz Note5		-103	-103		
N_{oc} Note2	dBm/S CS Note4	Config 1	-94	-94		
PRS-RSRP Note 3	dBm/S CS Note5	Config 1	-Infinity	-90.4	-Infinity	-94.2
PRS \hat{E}_s/I_{ot}	dB	Config 1	-Infinity	0.3	-Infinity	-5.6
PRS \hat{E}_s/N_{oc}	dB	Config 1	-Infinity	3.56	-Infinity	-0.28
I_0 Note3	dBm/19 0.08 MHz Note5	Config 1	-55.73	-55.73		
Propagation Condition		Config 1	AWGN			

Note 1:	OCNG shall be used such that both cells are fully allocated and a constant total transmitted power spectral density is achieved for all OFDM symbols.
Note 2:	Interference from other cells and noise sources not specified in the test is assumed to be constant over subcarriers and time and shall be modelled as AWGN of appropriate power for N_{oc} to be fulfilled.
Note 3:	PRP and Io levels have been derived from other parameters for information purposes. They are not settable parameters themselves.
Note 4:	PRP minimum requirements are specified assuming independent interference and noise at each receiver antenna port.
Note 5:	Equivalent power received by an antenna with 0 dBi gain at the centre of the quiet zone
Note 6:	As observed with 0 dBi gain antenna at the centre of the quiet zone
Note 7:	Information about types of UE beam is given in TS 38.133 [50] B.2.1.3, and does not limit UE implementation or test system implementation
Note 8:	Calculation of Es/Iot includes the effect of UE internal noise up to the value assumed for the associated Refsens requirement in clause 7.3.2 of TS 38.101-2 [55], and an allowance of 1dB for UE multi-band relaxation factor ΔMB_P from TS 38.101-2 [55] Table 6.2.1.3-4.

The PRS RSRP measurement time fulfils the requirements specified in clause 16.2.7.3.

The UE shall perform and report the PRS RSRP measurements for Cell 2 with respect to the reference cell in the DL-AoD assistance data, Cell 1, within the time duration specified starting from the beginning of time interval T2.

The rate of the correct events for the neighbour cell observed during repeated tests shall be at least 90%, where the reported PRS RSRP measurement for each correct event shall be within the PRS RSRP reporting range specified in Clause 10.1.24.3, i.e., between PRS RSRP_0 and PRS RSRP_126.

The response time is equal to the LPP time IE value plus the test tolerance. The LPP time IE value is derived from the RSTD measurement period plus ΔT , where $\Delta T = 50\text{ms}$. The PRS RSRP measurement period follows the equation:

$$T_{\text{PRS-RSRP},i} = \left(\text{CSSF}_i * \text{ceil}(K_{p,\text{PRS},i}) * N_{\text{RxBeam},i} * \left\lceil \frac{N_{\text{PRS},i}^{\text{slot}}}{N'} \right\rceil \left\lfloor \frac{L_{\text{available_PRS},i}}{N} \right\rfloor * N_{\text{sample}} - 1 \right) * T_{\text{effect},i} + T_{\text{last}}$$

Where $\text{CSSF}_{\text{PRS},i} = 1$, $N_{\text{RxBeam},i} = 8$, $N_{\text{PRS},i}^{\text{slot}} = 2$, $L_{\text{available_PRS},i} = 0.071 \text{ ms}$, $N_{\text{sample}} = 1$. N is the parameter *durationOfPRS-ProcessingSymbols* from TS 37.355 [49], N' is the parameter *maxNumOfDL-PRS-ResProcessedPerSlot* from TS 37.355 [49], $T_{\text{last},i} = T_i + T_{\text{available_PRS},i}$ and $T_{\text{effect},i} = \left\lfloor \frac{T_i}{T_{\text{available_PRS},i}} \right\rfloor * T_{\text{available_PRS},i}$

$T_{\text{available_PRS},i} = \text{LCM}(T_{\text{PRS},i}, \text{MGRP}_i)$; where $T_{\text{prs}} = 160 \text{ ms}$, and MGRP is 80 (for GP#24) or 40 (for GP#13) depending on UE capabilities. Therefore, $T_{\text{available_PRS},i} = 160 \text{ ms}$.

T_i depends on the UE parameter *durationOfPRS-ProcessingSymbolsInEveryTms* from TS 37.355 [49]

Finally, it results in the following equation:

$$\left(1 * 1 * 8 * \left\lceil \frac{2}{N'} \right\rceil \left\lfloor \frac{0.071}{N} \right\rfloor * 1 - 1 \right)$$

Where the remaining parameters depend on the UE capabilities. The LPP time IE ranges between 1.288s and 20.64s. The value of the LPP time IE is rounded up to the next second (if the value is >128s, it should be rounded up to the next multiple of ten seconds). The result is transmitted in the response time IE in the LPP-RequestLocationInformation in Table 16.2.7.4.3-3. The LPP time IE ranges between 2s and 21s.

The test tolerance for the response time is 300ms. Therefore, the response time ranges between 2.3s and 21.3s.

The values of N' , N and T_i and the effect in the response time equation are defined in Table 16.2.7.5-3, Table 16.2.7.5-4 and Table 16.2.7.5-5 for reference.

Table 16.2.7.5-3: value of N' based on *maxNumOfDL-PRS-ResProcessedPerSlot*

<i>maxNumOfDL-PRS-ResProcessedPerSlot</i>	$\left\lceil \frac{2}{N'} \right\rceil$
n1	2
>=n2	1

Table 16.2.7.5-4: value of N based on *durationOfPRS-ProcessingSymbols*

<i>durationOfPRS-ProcessingSymbols</i>	$\lceil 0.071 \rceil$
	N
$\geq nDot125$	1

Table 16.2.7.5-5: value of T_{effect} and T_{last} based on *durationOfPRS-ProcessingSymbolsInEveryTms*

<i>durationOfPRS-ProcessingSymbolsInEveryTms</i>	T_{effect}	T_{last}
n8	160	168
n16	160	176
n20	160	180
n30	160	190
n40	160	200
n80	160	240
n160	160	320
n320	320	480
n640	640	800
n1280	1280	1440

The test tolerances are defined in clauses C.1.6 and C.2.5.

The rate of successful tests during repeated tests shall be at least 90% with a confidence level of 95%.

16.2.8 PRS-RSRP measurement reporting delay test case for single positioning frequency layer without measurement gap in FR2 SA

Editor's Note: This test case has been completed for the following configurations:

- Test frequency $f \leq 40.8$ GHz
- UE PC3

16.2.8.1 Test purpose

The purpose of the test is to verify the PRS RSRP measurement outside MG requirements specified in TS 38.133 [50] Clause 9.9.3.6 for single positioning frequency layer under AWGN propagation conditions in FR2 in standalone scenario.

16.2.8.2 Test applicability

This test applies to all types of NR UE release 17 onwards that supports DL-AoD positioning and prs-Processing Window.

16.2.8.3 Minimum conformance requirements

When the physical layer receives *NR-DL-AoD-ProvideAssistanceData* message and *NR-DL-AoD-RequestLocationInformation* message from LMF via LPP [34], the UE shall be able to measure multiple (up to the UE capability specified in Clause 9.9.3.3) PRS-RSRP measurements as defined in TS 38.215 [4] without measurement gap, on configured positioning frequency layer i , within $T_{PRS-RSRP,total}$ ms.

$T_{PRS-RSRP,total} = \sum_{i=1}^L T_{PRS-RSRP,i} + (L - 1) * \max(T_{effect,i})$ if any of the positioning frequency layers are in Case 1, or

$T_{PRS-RSRP,total} = \max(T_{PRS-RSRP,i} + T_{uncertainty,i})$, if all the positioning frequency layers are in Case 2,

Where,

i is the index of positioning frequency layer, and

L is total number of positioning frequency layers, and

$T_{\text{effect},i}$ is the periodicity of the PRS RSTD measurement in positioning frequency layer i , and

$T_{\text{uncertainty},i}$ is the time from the start of the first PPW occasion for positioning frequency layer i to the start of measurement period $T_{\text{PRS-RSRP, total}}$.

A positioning frequency layer is in Case 1 if UE reports *ppw-durationOfPRS-Processing1-r17* for the band containing the positioning frequency layer, and a positioning frequency layer is in Case 2 if UE reports *ppw-durationOfPRS-Processing2-r17* for the band containing the positioning frequency layer.

$T_{\text{PRS-RSRP},i}$ is the measurement period for PRS-RSRP measurement in positioning frequency layer i as specified below.

$$T_{\text{PRS-RSRP},i} = \left(N_{\text{RxBeam},i} * \left\lceil \frac{N_{\text{PRS},i}^{\text{slot}}}{N'} \right\rceil \left\lfloor \frac{L_{\text{available_PRS},i}}{N} \right\rfloor * N_{\text{sample}} - 1 \right) * T_{\text{effect},i} + T_{\text{last}}$$

where

$T_{\text{effect},i}$ is the periodicity of the PRS-RSRP measurement in positioning frequency layer i .

$N_{\text{RxBeam},i}$ is the scaling factor for Rx beam sweeping, and $N_{\text{RxBeam},i}=1$ if positioning frequency layer i is in FR1. If positioning frequency layer i is in FR2, $N_{\text{RxBeam},i}$ is equal to the value reported by the UE in *supportedLowerRxBeamSweepingFactor-FR2* if the UE supports the capability for the band containing positioning frequency layer i , and the LMF indicates *lowerRxBeamSweepingFactor-FR2* in *NR-TDOA-RequestLocationInformation*. $N_{\text{RxBeam},i}$ is equal to 8, otherwise.

$L_{\text{available_PRS},i}$ is the time duration of available PRS to be measured in the positioning frequency layer i to be measured during $T_{\text{available_PRS},i}$, and is calculated in the same way as PRS duration K defined in clause 5.1.6.5 of TS 38.214 [26]. For calculation of $L_{\text{available_PRS},i}$,

only unmuted PRS resource instances that meet the applicability conditions and fully or partially overlapped with PRS processing window are considered, if positioning frequency layer i is in Case 1, or

only the PRS resources unmuted and fully or partially overlapped with the first (PPWL-T2) ms of PPW are considered, if positioning frequency layer i is in Case 2, where PPWL is the PPW length and T2 corresponds to *ppw-durationOfPRS-ProcessingSymbolsT2*.

$N_{\text{PRS},i}^{\text{slot}}$ is the maximum number of DL PRS resources of positioning frequency layer i configured in a slot,

$\{N, T\}$ is UE capability combination per band where N is a duration of DL PRS symbols in ms corresponding to *ppw-durationOfPRS-ProcessingSymbolsN* in TS 37.355 [34] if positioning frequency layer i is in Case 1, or corresponding to *ppw-durationOfPRS-ProcessingSymbolsN2* in TS 37.355 [34] if positioning frequency layer i is in Case 2,

N' is UE capability for number of DL PRS resources that it can process in a slot as indicated by *ppw-maxNumOfDL-PRS-ResProcessedPerSlot* in clause 6.4.3 of TS 37.355 [34],

N_{sample} is the number of PRS RSRP measurement samples, where

- $N_{\text{sample}} = 1$ if the UE supports *supportedDL-PRS-ProcessingSamples* [34], and the LMF requests the UE to perform positioning measurements with reduced number of samples, and meets the following conditions:
 - PRS bandwidth is within the active BWP and
 - Magnitude of difference between the serving cell's SS-RSRP and the neighbour cell's PRS-RSRP is within 6 dB.
- $N_{\text{sample}} = 2$ if the UE supports *supportedDL-PRS-ProcessingSamples* [34], and the LMF requests the UE to perform positioning measurements with reduced number of samples, and does not meet the following conditions:
 - PRS bandwidth is within the active BWP and

- Magnitude of difference between the serving cell's SS-RSRP and the neighbour cell's PRS-RSRP is within 6 dB.
- $N_{sample} = 4$ otherwise.

T_{last} is the measurement duration for the last PRS-RSRP sample, including the sampling time and processing time.

If positioning frequency layer i is in Case 1 and all of the PRS resources to be measured are available in the same PPW occasion during $T_{available}$, then $T_{last,i} = T_i + PPWL$, else

if positioning frequency layer i is in Case 2 and all of the PRS resources to be measured are available in the same PPW occasion during $T_{available}$, then $T_{last,i} = PPWL$;

otherwise, $T_{last,i} = T_i + T_{available_PRS,i}$.

$T_{effect,i} = \left\lceil \frac{T_i}{T_{available_PRS,i}} \right\rceil * T_{available_PRS,i}$ is the periodicity of PRS-RSRP measurement in positioning frequency layer i ,

T_i corresponds to *ppw-durationOfPRS-ProcessingSymbolsT* in TS 37.355 [34] if positioning frequency layer i is in Case 1, or corresponds to the sum of *ppw-durationOfPRS-ProcessingSymbolsT2* and *ppw-durationOfPRS-ProcessingSymbolsN2* in TS 37.355 [34] if positioning frequency layer i is in Case 2

$T_{available_PRS,i} = LCM(T_{PRS,i}, PPWRP_i)$ is the least common multiple between $T_{PRS,i}$ and $PPWRP_i$,

$T_{PRS,i}$ is the maximum PRS resource periodicity among all PRS resources in positioning frequency layer i ,

$PPWRP_i$ is the PRS processing window repetition period in positioning frequency layer i .

If positioning frequency layer i has more than one DL PRS resource set with different PRS periodicities with muting, $T_{per}^{PRS\ with\ muting} = N_{muting} * T_{per}^{PRS}$, the least common multiple of $T_{per}^{PRS\ with\ muting}$ among the DL PRS resource sets is used to derive $T_{PRS,i}$, where:

T_{per}^{PRS} is the periodicity of PRS resource sets given by the higher-layer parameter *DL-PRS-Periodicity*.

N_{muting} is the scaling factor considering PRS resource muting. If bitmap $\{b^1\}$ for higher-layer parameter *DL- N_{muting}* is the scaling factor considering PRS resource muting. $N_{muting} = T_{muting}^{PRS} * L_{muting}$, where T_{muting}^{PRS} is the muting repetition factor given by the higher-layer parameter *DL-PRS-MutingBitRepetitionFactor*, and L_{muting} is the size of the bitmap $\{b^1\}$.

16.2.8.4 Test description

16.2.8.4.1 Initial conditions

The supported test configurations in listed in Table 16.2.8.4-1.

Table 16.2.8.4-1: Test Configurations

Test Configuration	Description
1	120 kHz SSB and PRS SCS, 200 MHz bandwidth, TDD duplex mode

Test Environment: Normal, as defined in TS 38.508-1 [45] clause 4.1.

Frequencies to be tested: Mid Range, as defined in TS 38.508-1 [45] clause 4.3.1.

Channel bandwidth to be tested: are specified in Table 16.2.8.4-1.

1. Connect the SS and AWGN noise sources to the UE antenna connector or antenna connectors as shown in Annex A, Figure A.14.

2. The general test parameter settings are set up according to Table 16.2.8.5-1, Table 16.2.8.5-2 and Table 16.2.8.5-3.
3. Propagation conditions are set according to clause 4.16.2.
4. Message contents are defined in clause 16.2.8.4.3.
5. In the test there are two synchronous cells: Cell 1 and Cell 2. Cell 1 is the reference as well as the PCell. Cell 2 is the neighbour cell. All cells are on the same RF channel distributed in single positioning frequency layer.

16.2.8.4.2 Test procedure

The test consists of two sub-tests; Sub-test 1 is for $N_{\text{sample}} = 1$ and sub-test 2 is for $N_{\text{sample}} = 4$. Sub-test 2 is only conducted when UE also supporting supportedDL-PRS-ProcessingSamples-RRC-CONNECTED. The test consists of two consecutive time intervals, with duration of T1 and T2. During time duration T1, the UE shall not have any timing information of Cell 2. All two cells transmit PRS during T2. The beginning of the time interval T2 shall be aligned with the beginning of the first PRS processing window instance containing the PRS resources.

The *NR-DL-AoD-ProvideAssistanceData* and *NR-DL-AoD-RequestLocationInformation* as defined in TS 37.355 [49] clause 6.5.11 shall be provided to the UE during T1. The last TTI containing the two messages shall be provided to the UE ΔT ms before the start of T2, where $\Delta T = 50$ ms is the maximum processing time of the *DL-AoD assistance* data and location information request.

2. Ensure the UE is in State RRC_CONNECTED with generic procedure parameters Connectivity NR, Connected without release On, according to TS 38.508-1 [45] clause 4.5.
2. The SS shall send a RESET UE POSITIONING STORED INFORMATION message.
3. Set the parameters according to Table 16.2.8.5-1, Table 16.2.8.5-2 and Table 16.2.8.5-3. Propagation conditions are set according to clause 4.16.2.
4. T1 starts.
5. The SS shall transmit an LPP REQUEST CAPABILITIES message.
6. The UE shall transmit an LPP PROVIDE CAPABILITIES message indicating the DL-AoD capabilities supported by the UE in the *NR-DL-AoD-ProvideCapabilities* IE.
7. The SS shall transmit an RRCReconfiguration message with the PPW configuration.
8. The UE shall transmit RRCReconfigurationComplete message.
9. The SS shall send a LPP PROVIDE ASSISTANCE DATA message, including the *NR-DL-AoD-ProvideAssistanceData* IE. The position of neighbour Cell 2 is described in 3GPP TS 37.571-5 [20]. If the UE message at step 6 includes the ackRequested IE set to TRUE, then the SS shall send an acknowledgment in the LPP PROVIDE ASSISTANCE DATA message.
10. The SS shall send a LPP REQUEST LOCATION INFORMATION message, including the *NR-DL-AoD-RequestLocationInformation* IE such that the UE receives the message ΔT ms before the start of T2, where $\Delta T = 50$ ms.
11. The SS sends a Positioning Measurement Gap Activation command containing an ID to activate the associated measurement gap
12. When T1 expires, the SS shall switch the power setting from T1 to T2 as specified in Table 16.2.8.5-3.
13. The UE shall transmit a LPP PROVIDE LOCATION INFORMATION message including the *NR-DL-AoD-ProvideLocationInformation* IE within the response time (see clause 4.16.3). The UE shall perform and report the PRS-RSRP measurements for Cell 2 with respect to the reference cell in the DL-TDOA assistance data, Cell 1. If the UE transmits an *NR-DL-AoD-ProvideLocationInformation* IE including the nr-DL-PRS-RSRP-Result-r16 field for Cell 2 within the response time then the number of successful tests is increased by one. If the UE fails to report the *NR-DL-AoD-ProvideLocationInformation* IE with both the nr-DL-PRS-RSRP-Result-r16 fields included within the response time then the number of failure tests is increased by one.

14. If the UE message at step 13 includes the *ackRequested* IE set to TRUE, the SS shall send a LPP acknowledgement message.

15. Repeat steps 2-14 in Table 16.2.8.4-1 until the confidence level according to Annex D is achieved.

16.2.8.4.3 Message contents

Table 16.2.8.4.3-1: RESET UE POSITIONING STORED INFORMATION

Derivation Path: 38.509 [44] clause 6.6			
Information Element	Value/remark	Comment	Condition
UE Positioning Technology	0 0 0 1 0 0 0	DL-AoD	

Table 16.2.8.4.3-2: LPP Request Capabilities

Information Element	Value/remark
nr-DL-AoD-RequestCapabilities-r16	TRUE

Table 16.2.8.4.3-3: RRCReconfiguration

Derivation Path: TS 38.508-1 [45], table 4.6.1-13			
Information Element	Value/remark	Comment	Condition
RRCReconfiguration ::= SEQUENCE {			
rrc-TransactionIdentifier	RRC-TransactionIdentifier		
criticalExtensions CHOICE {			
rrcReconfiguration SEQUENCE {			
nonCriticalExtension SEQUENCE {			
masterCellGroup	OCTET STRING (CONTAINING CellGroupConfig)		
}			
}			
}			
}			

Table 16.2.8.4.3-4: CellGroupConfig (RRCReconfiguration, Table 16.2.8.4.3-3)

Derivation Path: 38.508-1 [45], Table 4.6.3-19			
Information Element	Value/remark	Comment	Condition
CellGroupConfig ::= SEQUENCE {			
spCellConfig SEQUENCE {			
spCellConfigDedicated SEQUENCE {			
initialDownlinkBWP SEQUENCE {			
dl-PPW-PreConfigToAddModList-r17 SEQUENCE (SIZE (1..maxNrofPPW-Config-r17)) OF DL-PPW-PreConfig-r17 {	1 entry		
DL-PPW-PreConfig-r17[1] SEQUENCE {		entry 1	
dl-PPW-ID-r17	0		
dl-PPW-PeriodicityAndStartSlot-r17 CHOICE {	The periodicity is 160ms and the starting slot offset is 11 ms for any SCS configuration		
scs120 CHOICE {			
n1280	4		
}			
}			
length-r17	80		
type-r17	type1A		
priority-r17	st1		
}			
}			
}			
}			

}			
}			
}			
}			
}			

Table 16.2.8.4.3-5: LPP ProvideAssistanceData

Derivation Path: 37.355 clause 6.2			
Information Element	Value/remark	Comment	Condition
LPP-Message ::= SEQUENCE {			
transactionID SEQUENCE {			
initiator	locationServer		
transactionNumber	(0..255)		
}			
endTransaction	TRUE		
sequenceNumber	Not present		
acknowledgement	Not present		
lpp-MessageBody CHOICE {			
c1 CHOICE {			
provideAssistanceData SEQUENCE {			
criticalExtensions CHOICE {			
c1 CHOICE {			
provideAssistanceData-r9 SEQUENCE {			
commonEsProvideAssistanceData	Not present		
a-gnss-ProvideAssistanceData	Not present		
otdoa-ProvideAssistanceData	Not present		
epdu-Provide-AssistanceData	Not present		
sensor-ProvideAssistanceData-r15	Not present		
tbs-ProvideAssistanceData-r15	Not present		
wlan-ProvideAssistanceData-r15	Not present		
nr-Multi-RTT-ProvideAssistanceData-r16	Not present		
nr-DL-AoD-ProvideAssistanceData-r16			
SEQUENCE {			
nr-DL-PRS-AssistanceData-r16	As defined in Table 16.2.8.4.3-6		
nr-SelectedDL-PRS-IndexList-r16	Not present		
nr-PositionCalculationAssistance-r16			Depending on UE capabilities, i.e. support for UE-based DL-AoD
SEQUENCE {			
nr-TRP-LocationInfo-r16	As defined in TS 37.571-5 [20]		
nr-DL-PRS-BeamInfo-r16	Not present		
nr-RTD-Info-r16	Not present		
nr-TRP-BeamAntennaInfo-r17	Not present		
nr-DL-PRS-Expected-LOS-NLOS-Assistance-r17	Not present		
nr-DL-PRS-TRP-TEG-Info-r17	Not present		
}			
nr-DL-AoD-Error-r16	Not present		
nr-DL-PRS-BeamInfo-r17	Not present		
nr-On-Demand-DL-PRS-Configurations-r17	Not present		
}			
nr-DL-TDOA-ProvideAssistanceData-r16	Not present		
}			
}			
}			

Table 16.2.8.4.3-6: NR-DL-PRS-AssistanceData

Derivation Path: 37.355 clause 6.4.3			
Information Element	Value/remark	Comment	Condition
NR-DL-PRS-AssistanceData-r16 ::= SEQUENCE {			
nr-DL-PRS-ReferenceInfo-r16 SEQUENCE {			
dl-PRS-ID-r16	0		
nr-DL-PRS-ResourceID-List-r16	Not present		
nr-DL-PRS-ResourceSetID-r16	Not present		
}			
nr-DL-PRS-AssistanceDataList-r16 SEQUENCE (SIZE (1..nrMaxFreqLayers-r16)) OF NR-DL-PRS-AssistanceDataPerFreq-r16 {	1 entry		
NR-DL-PRS-AssistanceDataPerFreq-r16[1] SEQUENCE {		entry 1	
nr-DL-PRS-PositioningFrequencyLayer-r16 SEQUENCE {			
dl-PRS-SubcarrierSpacing-r16	kHz120		
dl-PRS-ResourceBandwidth-r16	3	32 PRBs	
dl-PRS-StartPRB-r16	0		
dl-PRS-PointA-r16	absoluteFrequencyPointA as defined for the DL frequency of the Cell 1		
dl-PRS-CombSizeN-r16	n2		
dl-PRS-CyclicPrefix-r16	normal		
}			
nr-DL-PRS-AssistanceDataPerFreq-r16 SEQUENCE (SIZE (1..nrMaxTRPsPerFreq-r16)) OF NR-DL-PRS-AssistanceDataPerTRP-r16{	2 entries		
NR-DL-PRS-AssistanceDataPerTRP-r16[1] SEQUENCE {		entry 1	Cell 1
dl-PRS-ID-r16	0		
nr-PhysCellID-r16	Cell 1		
nr-CellGlobalID-r16	Cell 1		
nr-ARFCN-r16	Cell 1		
nr-DL-PRS-SFN0-Offset-r16 SEQUENCE {			
sfn-Offset-r16	0		
integerSubframeOffset-r16	0		
}			
nr-DL-PRS-ExpectedRSTD-r16	0		
nr-DL-PRS-ExpectedRSTD-Uncertainty-r16	0		
nr-DL-PRS-Info-r16	As specified in Table 16.2.8.4.3-7		
}			
NR-DL-PRS-AssistanceDataPerTRP-r16[2] SEQUENCE {		entry 2	Cell 2
dl-PRS-ID-r16	1		
nr-PhysCellID-r16	Cell 2		
nr-CellGlobalID-r16	Cell 2		
nr-ARFCN-r16	Cell 2		
nr-DL-PRS-SFN0-Offset-r16 SEQUENCE {			
sfn-Offset-r16	0		
integerSubframeOffset-r16	0		
}			
nr-DL-PRS-ExpectedRSTD-r16	0	About 0 μ s	
nr-DL-PRS-ExpectedRSTD-Uncertainty-r16	17	About 0.58 μ s	
nr-DL-PRS-Info-r16	As specified in Table 16.2.8.4.3-7		
}			
}			
}			
}			
}			

Table 16.2.8.4.3-7: NR-DL-PRS-Info

Derivation Path: 37.355 clause 6.4.3			
Information Element	Value/remark	Comment	Condition
NR-DL-PRS-Info-r16 ::= SEQUENCE {			
nr-DL-PRS-ResourceSetList-r16 SEQUENCE (SIZE (1..nrMaxSetsPerTrp-r16)) OF NR-DL-PRS-ResourceSet-r16 {	1 entry		
NR-DL-PRS-ResourceSet-r16[1] SEQUENCE {		entry 1	
nr-DL-PRS-ResourceSetID-r16	0		
dl-PRS-Periodicity-and-ResourceSetSlotOffset-r16 CHOICE {			
scs120-r16 CHOICE {			
n1280-r16	80		
}			
dl-PRS-ResourceRepetitionFactor-r16	n2		
dl-PRS-ResourceTimeGap-r16	s1		
dl-PRS-NumSymbols-r16	n4		
dl-PRS-MutingOption1-r16 SEQUENCE {			
dl-prs-MutingBitRepetitionFactor-r16	Not present		
nr-option1-muting-r16 CHOICE {			
po2-r16	10		Cell 1
	01		Cell 2
}			
dl-PRS-MutingOption2-r16	Not present		
dl-PRS-ResourcePower-r16	27		
dl-PRS-ResourceList-r16 SEQUENCE (SIZE (1..nrMaxResourcesPerSet-r16)) OF NR-DL-PRS-Resource-r16 {	1 entry		
NR-DL-PRS-Resource-r16[1] SEQUENCE {		entry 1	
nr-DL-PRS-ResourceID-r16	0		
dl-PRS-SequenceID-r16	0		
dl-PRS-CombSizeN-AndReOffset-r16 CHOICE {			
n2-r16	0		
}			
dl-PRS-ResourceSlotOffset-r16	0		
dl-PRS-ResourceSymbolOffset-r16	0		
dl-PRS-QCL-Info-r16	Not present		
}			
}			
}			
}			
}			

Table 16.2.8.4.3-8: LPP RequestLocationInformation

Derivation Path: 37.355 clause 6.2			
Information Element	Value/remark	Comment	Condition
LPP-Message ::= SEQUENCE {			
transactionID SEQUENCE {			
initiator	locationServer		
transactionNumber	1		
}			
endTransaction	FALSE		
sequenceNumber	Not present		
acknowledgement	Not present		
lpp-MessageBody CHOICE {			
c1 CHOICE {			
requestLocationInformation SEQUENCE {			
criticalExtensions CHOICE {			
c1 CHOICE {			
requestLocationInformation-r9 SEQUENCE {			
commonEsRequestLocationInformation SEQUENCE {			

locationInformationType	locationMeasurementsRequired		
triggeredReporting	Not present		
periodicalReporting	Not present		
additionalInformation	onlyReturnInformationRequested		
qos SEQUENCE {			
horizontalAccuracy	Not present		
verticalCoordinateRequest	FALSE		
verticalAccuracy	Not present		
responseTime SEQUENCE {			
time	See 16.2.8.5	Result of the response time calculation rounded up to the next second if response time <= 128s. Result of the response time calculation rounded up to the next multiple of ten seconds if response time > 128s.	
responseTimeEarlyFix-r12	Not present		Rel-12 onwards
unit-r15	Not present ten-seconds		Calculated response time >128s
}			
velocityRequest	FALSE		
}			
environment	Not present		
locationCoordinateTypes	Not present		
velocityTypes	Not present		
}			
a-gnss-RequestLocationInformation	Not present		
otdoa-RequestLocationInformation	Not present		
ecid-RequestLocationInformation	Not present		
epdu-RequestLocationInformation	Not Present		
sensor-RequestLocationInformation-r13	Not present		
tbs-RequestLocationInformation-r13	Not present		
wlan-RequestLocationInformation-r13	Not present		
bt-RequestLocationInformation-r13	Not present		
nr-ECID-RequestLocationInformation-r16	Not present		
nr-Multi-RTT-RequestLocationInformation-r16	Not present		
nr-DL-AoD-RequestLocationInformation-r16			
SEQUENCE {			
nr-AssistanceAvailability-r16	FALSE		
nr-DL-AoD-ReportConfig-r16 SEQUENCE {			
maxDL-PRS-RSRP-MeasurementsPerTRP-r16	Not present		
maxDL-PRS-RSRP-MeasurementsPerTRP-r17	Not present		
maxDL-PRS-RSRPP-MeasurementsPerTRP-r17	Not present		
nr-los-nlos-IndicatorRequest-r17	Not present		
reducedDL-PRS-ProcessingSamples-r17	requested Not present		Sub-test 1 Sub-test 2
lowerRxBeamSweepingFactor-FR2-r17	Not present		
}			
multiMeasInSameReport-r17			
}			
nr-DL-TDOA-RequestLocationInformation-r16	Not present		

}			
}			
}			
}			
}			
}			

Table 16.2.8.4.3-9: LPP ProvideLocation Information

Derivation Path: 37.355 clause 6.5.12			
Information Element	Value/remark	Comment	Condition
LPP-Message ::= SEQUENCE {			
transactionID SEQUENCE {			
initiator	locationServer		
transactionNumber	1		
}			
endTransaction	TRUE		
sequenceNumber	(0..255)		
acknowledgement			
lpp-MessageBody CHOICE {			
c1 CHOICE {			
provideLocationInformation SEQUENCE {			
criticalExtensions CHOICE {			
c1 CHOICE {			
provideLocationInformation-r9 SEQUENCE {			
commonIEsProvideLocationInformation	Not present.		
a-gnss-ProvideLocationInformation	Not present		
otdoa-ProvideLocationInformation	Not present		
ecid-ProvideLocationInformation	Not present		
epdu-ProvideLocationInformation	Not present		
sensor-ProvideLocationInformation-r13	Not present		
tbs-ProvideLocationInformation-r13	Not present		
wlan-ProvideLocationInformation-r13	Not present		
bt-ProvideLocationInformation-r13	Not present		
nr-ECID-ProvideLocationInformation-r16	Not present		
nr-Multi-RTT-ProvideLocationInformation-r16	Not present		
nr-DL-AoD-ProvideLocationInformation-r16			
SEQUENCE {			
nr-DL-AoD-SignalMeasurementInformation-r16 SEQUENCE {			
nr-DL-AoD-MeasList-r16 SEQUENCE (SIZE(1..nrMaxTRPs-r16)) OF NR-DL-AoD-MeasElement-r16 {			
NR-DL-AoD-MeasElement-r16[1]		entry 1	
SEQUENCE {			
dl-PRS-ID-r16	INTEGER (0..255)		
nr-PhysCellID-r16	Cell 1		
nr-CellGlobalID-r16			
nr-ARFCN-r16			
nr-DL-PRS-ResourceID-r16			
nr-DL-PRS-ResourceSetID-r16			
nr-TimeStamp-r16			
nr-DL-PRS-RSRP-Result-r16	Present. Any value acceptable.		
nr-DL-PRS-RxBeamIndex-r16			
nr-DL-AoD-AdditionalMeasurements-r16			
nr-DL-PRS-FirstPathRSRP-Result-r17			
nr-los-nlos-Indicator-r17			
nr-DL-AoD-AdditionalMeasurementsExt-r17			
}			
NR-DL-AoD-MeasElement-r16[2]		entry 2	
SEQUENCE {			

	dl-PRS-ID-r16	INTEGER (0..255)		
	nr-PhysCellID-r16	Cell 2		
	nr-CellGlobalID-r16			
	nr-ARFCN-r16			
	nr-DL-PRS-ResourceID-r16			
	nr-DL-PRS-ResourceSetID-r16			
	nr-TimeStamp-r16			
	nr-DL-PRS-RSRP-Result-r16	Present. Any value acceptable.		
	nr-DL-PRS-RxBeamIndex-r16			
r16	nr-DL-AoD-AdditionalMeasurements-			
	nr-DL-PRS-FirstPathRSRP-Result-r17			
	nr-los-nlos-Indicator-r17			
	nr-DL-AoD-AdditionalMeasurementsExt-r17			
	}			
	}			
	}			
	nr-dl-AoD-LocationInformation-r16			
	nr-DL-AoD-Error-r16	Not present		
r17	nr-DL-AoD-SignalMeasurementInstances-	Not present		
r17	nr-DL-AoD-LocationInformationInstances-	Not present		
	}			
	}			
	}			
	}			
	}			
	}			
	}			
	}			
	}			

16.2.8.5 Test requirement

Table 16.2.8.5-1 and Table 16.2.8.5-2 define the primary level settings including test tolerances for the test.

Table 16.2.8.5-1: General test parameters for PRS RSRP measurement reporting delay

Parameter	Unit	Test configuration	Value	Comment
NR RF Channel Number		Config 1	1: Cell 1 and Cell 2	One TDD carrier frequency is used for the NR cells.
Active cell		Config 1	NR cell 1 (Pcell)	Cell 1 is the PCell and the DL-AoD reference cell in the positioning assistance data.
Neighbour cell		Config 1	NR cell 2	Cell 2 is a neighbour cell in the positioning assistance data.
PPW configuration		Config 1	PPW.1	As specified in clause A.3.33
SMTc parameters		Config 1	SMTc.1	As specified in TS 38.133 [50] clause A.3.11
SSB parameters		Config 1	SSB.3 FR2	As specified in TS 38.133 [50] clause A.3.10.2
CP length		Config 1	Normal	
DRX		Config 1	OFF	DRX is not used
Time offset between serving and neighbour cells	µs	Config 1	0.58, 2.0 or 3 ^{Note 1}	

Expected RSTD	μs	Config 1	0	
Expected RSTD uncertainty	μs	Config 1	Same as time offset between serving and neighbour cells	
T1	s	Config 1	5	
T2	s	Config 1	7	
NOTE 1: If UE indicates support of CP length for the receive time difference threshold, the time offset is set to 0.58μs; If UE indicates support of 1/4 symbol length for the receive time difference threshold, the time offset is set to 2.0μs, otherwise 3μs.				

Table 16.2.8.5-2: Cell-specific test parameters during T2 for PRS RSRP measurement reporting delay

Parameter		Unit	Test configuration	Cell 1		Cell 2	
				Sub-test 1	Sub-test 2	Sub-test 1	Sub-test 2
AoA setup			Config 1	Setup 1 as specified in TS 38.133 [50] clause A.3.15			
Beam Assumption ^{Note 7}			Config 1	Rough		Rough	
TDD configuration			Config 1	TDDConf.3.1		TDDConf.3.1	
Duplex mode			Config 1	TDD		TDD	
BW _{channel}		MHz	Config 1	200: N _{RB,c} = 132		200: N _{RB,c} = 132	
BWP BW		MHz	Config 1	200: N _{RB,c} = 132		200: N _{RB,c} = 132	
BWP configuration	Initial DL BWP		Config 1	DLBWP.0.1		N/A	
	Initial UL BWP			ULBWP.0.1		N/A	
	Dedicated DL BWP			DLBWP.1.1		N/A	
	Dedicated UL BWP			ULBWP.1.1		N/A	
OCNG Patterns defined in A.3.2.1.1 (OP.1)			Config 1	OP.1		OP.1	
PDSCH Reference measurement channel			Config 1	SR.3.1 TDD		-	
CORESET Reference Channel			Config 1	CR.3.1 TDD		-	
Dedicated CORESET RMC configuration			Config 1	CCR.3.1 TDD		-	
TRS configuration			Config 1	TRS.2.1 TDD		-	
PDSCH/PDCCH subcarrier spacing		kHz	Config 1	120		120	
PRS configuration			Config 1	PRS.1.4 FR2		PRS.1.4 FR2	
PRS muting configuration			Config 1	'10'		'01'	
EPRE ratio of PSS to SSS			Config 1	0		0	
EPRE ratio of PBCH DMRS to SSS							
EPRE ratio of PBCH to PBCH DMRS							
EPRE ratio of PDCCH DMRS to SSS							
EPRE ratio of PDCCH to PDCCH DMRS							
EPRE ratio of PDSCH DMRS to SSS							
EPRE ratio of PDSCH to PDSCH							
EPRE ratio of OCNG DMRS to SSS(Note 1)							
EPRE ratio of OCNG to OCNG DMRS (Note 1)							
N_{oc} ^{Note2}	dBm/15 kHz Note5			-103	-99.1	-103	-99.1

N_{oc} ^{Note2}	dBm/S CS ^{Note4}	Config 1	-94	-90.1	-94	-90.1
SS-RSRP ^{Note 3}	dBm/S CS ^{Note5}	Config 1	-96	-96	-99	-103
PRS-RSRP ^{Note 3}	dBm/S CS ^{Note5}	Config 1	-90.4	-92.1	-94.2	-100.1
PRS \hat{E}_s/I_{ot}	dB	Config 1	0.3	-2.7	-5.6	-12.3
PRS \hat{E}_s/N_{oc}	dB	Config 1	3.56	-2	-0.28	-10
I_o ^{Note3}	dBm/95 .04 MHz ^{Note5}	Config 1	-55.73	-55.69	-55.73	-55.69
Propagation Condition		Config 1	AWGN			
Note 1:	OCNG shall be used such that both cells are fully allocated and a constant total transmitted power spectral density is achieved for all OFDM symbols.					
Note 2:	Interference from other cells and noise sources not specified in the test is assumed to be constant over subcarriers and time and shall be modelled as AWGN of appropriate power for N_{oc} to be fulfilled.					
Note 3:	SS-RSRP/PRS-RSRP and I_o levels have been derived from other parameters for information purposes. They are not settable parameters themselves.					
Note 4:	PRS-RSRP minimum requirements are specified assuming independent interference and noise at each receiver antenna port.					
Note 5:	Equivalent power received by an antenna with 0 dBi gain at the centre of the quiet zone					
Note 6:	As observed with 0 dBi gain antenna at the centre of the quiet zone					
Note 7:	Information about types of UE beam is given in TS 38.133 [50] B.2.1.3, and does not limit UE implementation or test system implementation					
Note 8:	Calculation of E_s/I_{ot} includes the effect of UE internal noise up to the value assumed for the associated Refsens requirement in clause 7.3.2 of TS 38.101-2 [55], and an allowance of 1dB for UE multi-band relaxation factor ΔMB_P from TS 38.101-2 [55] Table 6.2.1.3-4.					

The PRS RSRP measurement time fulfils the requirements specified in Clause 16.2.8.3, with $N_{sample}=1$ for sub-test 1 and $N_{sample}=4$ for sub-test 2. The UE shall perform and report the PRS RSRP measurements for Cell 2 with respect to the reference cell in the DL-AoD assistance data, Cell 1, within the time duration starting from the beginning of time interval T2.

The rate of the correct events for the neighbour cell observed during repeated tests shall be at least 90%, where the reported PRS RSRP measurement for each correct event shall be within the PRS RSRP reporting range specified in Clause 10.1.24.3, i.e., between PRS RSRP_0 and PRS RSRP_126.

The response time is equal to the LPP time IE value plus the test tolerance. The LPP time IE value is derived from the RSTD measurement period plus ΔT , where $\Delta T = 50$ ms. The LPP response time calculation procedure could be divided into two situations based on whether the UE support $ppw\text{-}durationOfPRS\text{-}Processing1\text{-}r17$ or $ppw\text{-}durationOfPRS\text{-}Processing2\text{-}r17$. The PRS-RSRP measurement period follows the equation:

$$T_{PRS-RSRP, total} = \sum_{i=1}^L T_{PRS-RSRP,i} + (L - 1) * \max(T_{effect,i}) \text{ if any of the positioning frequency layers are in Case 1, or}$$

$$T_{PRS-RSRP, total} = \max(T_{PRS-RSRP,i} + T_{uncertainty,i}), \text{ if all the positioning frequency layers are in Case 2,}$$

Where $N_{RxBeam,i} = 8$, $N_{PRS,i}^{slot} = 2$, $L_{available_PRS,i} = 0.071$, $N_{sample} = 1$ for sub-test 1, $N_{sample} = 4$ for sub-test 2, $T_{uncertainty,i} = 0$. N is the parameter $ppw\text{-}durationOfPRS\text{-}ProcessingSymbolsN$ from TS 37.355 [49], N' is the parameter

$$ppw\text{-}maxNumOfDL\text{-}PRS\text{-}ResProcessedPerSlot \text{ from TS 37.355 [49], } T_{last,i} = T_i + PPWL \text{ and } T_{effect,i} = \left\lceil \frac{T_i}{T_{available_PRS,i}} \right\rceil * T_{available_PRS,i}$$

$$T_{available_PRS,i} = LCM(T_{PRS,i}, PPWRP_i); \text{ where } T_{prs} = 160 \text{ ms, and the repetition periodicity } PPWRP_i = 160 \text{ms.}$$

$$\text{Therefore, } T_{available_PRS,i} = 160$$

T_i depends on the UE parameter $ppw\text{-}durationOfPRS\text{-}ProcessingSymbolsT$ from TS 37.355 [49]

Finally, it results in the following equation:

$$\left(8 * \left\lceil \frac{2}{N'} \right\rceil \left\lceil \frac{0.071}{N} \right\rceil * N_{sample} - 1 \right) * T_{effect} + T_{last}$$

Where the remaining parameters depend on the UE capabilities. The LPP time IE ranges between 2s and 21s for sub-test 1. The LPP time IE ranges between 6s and 80s for sub-test 2. The value of the LPP time IE is rounded up to the next second. The result is transmitted in the response time IE in the LPP-RequestLocationInformation in Table 16.2.8.4.3-8.

The test tolerance for the response time is 300ms. Therefore, the response time ranges for sub-test 1 is between 2.3s and 21.3s. The response time ranges for sub-test 2 is between 6.3s and 80.3s.

The test tolerances are defined in clauses C.1.6 and C.2.5.

The rate of successful tests during repeated tests shall be at least 90% with a confidence level of 95%.

16.3 NR PRS-RSRP measurement accuracy test case in RRC_CONNECTED

16.3.1 PRS-RSRP measurement accuracy with PRS in FR1

16.3.1.1 Test purpose

The purpose of the test is to verify that the PRS-RSRP measurement meets the accuracy requirements specified in TS 38.133 [50] clause 10.1.23.2 in an environment with AWGN propagation conditions.

16.3.1.2 Test applicability

This test applies to all types of NR UE release 16 onwards that supports DL-TDOA positioning and PRS-RSRP measurements in FR1.

16.3.1.3 Minimum conformance requirements

The absolute accuracy requirements for PRS-RSRP measurement for FR1 defined in Table 16.3.1.3-1 are valid under the following conditions:

- Conditions defined in 38.101-1 Clause 7.3 for reference sensitivity are fulfilled.
- PRP 1,2_{dBm} according to Annex B.2.14 for a corresponding Band
- UE does not support positioning measurements with reduced number of samples, or LMF does not indicate UE to perform positioning measurements with reduced number of samples

The absolute accuracy requirements for PRS-RSRP measurement for FR2 defined in Table 16.3.1.3-2 are valid under the following conditions:

- Conditions defined in 38.101-2 Clause 7.3 for reference sensitivity are fulfilled.
- PRP 1,2_{dBm} according to Annex B.2.14 for a corresponding Band
- UE does not support positioning measurements with reduced number of samples, or LMF does not indicate UE to perform positioning measurements with reduced number of samples

Table 16.3.1.3-1: PRS-RSRP absolute accuracy for FR1

Accuracy	Conditions	
	PRS BW	Io ^{Note 7} range

Normal condition	Extreme condition	PRS \hat{E}_s/lot	PRB	Repetition factor ($T_{\text{rep}}^{\text{PRS}} * L_{\text{PRS}} / K_{\text{comb}}^{\text{PRS}}$)	NR operating band groups Note 8	Minimum I_o Note 1 dBm / SCS _{PRS}			Maximum I_o
						dBm / SCS _{PRS}			
dB	dB	dB	PRB	-		dBm / SCS _{PRS}			dBm/BW _{Channel}
						dBm/15kHz Note 6	dBm/30kHz Note 6	dBm/60kHz Note 6	
±3.5	±8	≥-3dB	≥24	All	NR_FDD_FR1_A, NR_TDD_FR1_A, NR_SDL_FR1_A	-127	-124	-121	-50
					NR_FDD_FR1_B, NR_TDD_FR1_C	-126.5	-123.5	-120.5	-50
					NR_FDD_FR1_D, NR_TDD_FR1_D	-126	-123	-120	-50
					NR_FDD_FR1_E, NR_TDD_FR1_E	-125.5	-122.5	-119.5	-50
					NR_FDD_FR1_F, NR_TDD_FR1_F	-125	-122	-119	-50
					NR_FDD_FR1_G, NR_TDD_FR1_G	-124.5	-121.5	-118.5	-50
					NR_FDD_FR1_H, NR_TDD_FR1_H	-124	-121	-118	-50
					NR_FDD_FR1_I, NR_TDD_FR1_I	-123.5	-120.5	-117.5	-50
					Note 4			Note 4	
±8.5	±13	≥-13dB	24 ≤ BW ≤ 52	All	Note 4				
±6	±10.5		52 < BW ≤ 104	All	Note 4				
±4.5	±9		BW > 104	All	Note 4				

NOTE 1: This minimum I_o condition is expressed as the average I_o per RE over all REs in an OFDM symbol.
 NOTE 2: Void.
 NOTE 3: PRS bandwidth is as indicated in *prs-Bandwidth* in the OTDOA or DL-AoD assistance data defined in [34].
 NOTE 4: The same bands and the same I_o conditions for each band apply for this requirement as for the corresponding requirement with the PRS bandwidth ≥ 24 RB.
 NOTE 5: The serving cell, the reference cell, and the measured neighbour cell i are on the same carrier frequency.
 NOTE 6: The condition level is increased by $\Delta > 0$, when applicable, as described in Sections B.3.2 and B.3.3.
 NOTE 7: The I_o is defined in PRS positioning subframes. The same I_o range applies to PRS and non-PRS symbols. I_o levels are different in PRS and non-PRS symbols within the same subframe.
 NOTE 8: NR operating band groups are as defined in Section 3.5.2.

Table 16.3.1.3-2: PRS-RSRP absolute accuracy for FR2

Accuracy		Conditions					
Normal condition	Extreme condition	PRS \hat{E}_s/lot	PRS BW	Repetition factor ($T_{\text{rep}}^{\text{PRS}} * L_{\text{PRS}} / K_{\text{comb}}^{\text{PRS}}$)	I_o Note 7 range		Maximum I_o
					Minimum I_o Note 1 dBm / SCS _{PRS}		
dB	dB	dB	PRB	-	dBm / SCS _{PRS}		dBm/BW _{Channel} nel
					dBm/120kHz z Note 6	dBm/60kHz Note 6	

± 5	± 8	$\geq -3\text{dB}$	≥ 24	All	Same value as PRP in Table B.2.14-2, according to UE Power class, operating band and angle of arrival	-50
Note 4						
Note 4						
± 8.5	± 11.5	$\geq -13\text{dB}$	$24 \leq \text{BW} \leq 64$	All	Note 4	
± 6	± 9		$\text{BW} > 64$	All	Note 4	
NOTE 1: This minimum l_0 condition is expressed as the average l_0 per RE over all REs in an OFDM symbol.						
NOTE 2: Void.						
NOTE 3: PRS bandwidth is as indicated in <i>prs-Bandwidth</i> in the OTDOA or DL-AoD assistance data defined in [34].						
NOTE 4: The same bands and the same l_0 conditions for each band apply for this requirement as for the corresponding requirement with the PRS bandwidth ≥ 24 RB.						
NOTE 5: The serving cell, the reference cell, and the measured neighbour cell i are on the same carrier frequency.						
NOTE 6: The condition level is increased by $\Delta > 0$, when applicable, as described in Sections B.3.2 and B.3.3.						
NOTE 7: The l_0 is defined in PRS positioning subframes. The same l_0 range applies to PRS and non-PRS symbols. l_0 levels are different in PRS and non-PRS symbols within the same subframe.						
NOTE 8: NR operating band groups are as defined in Section 3.5.2.						

16.3.1.4 Test description

16.3.1.4.1 Initial conditions

The test is defined with three possible Test Configurations. In the case that the UE supports more than one of these Test Configurations, then the UE is only required to be tested in one of the Test Configurations, chosen by the UE. The defined Test Configurations are specified in Table 16.3.1.4.1-1.

Table 16.3.1.4.1-1: Test Configurations

Configuration	Description
1	15 kHz SSB SCS, 10 MHz bandwidth, FDD duplex mode
2	15 kHz SSB SCS, 10 MHz bandwidth, TDD duplex mode
3	30 kHz SSB SCS, 40 MHz bandwidth, TDD duplex mode

Test Environment: Normal, as defined in TS 38.508-1 [45] clause 4.1.

Frequencies to be tested: Mid, as defined in TS 38.508-1 [45] clause 4.3.1.

Channel bandwidth to be tested: are specified in Table 16.3.1.4-1.

1. Connect the SS and AWGN noise sources to the UE antenna connector or antenna connectors as shown in Annex A, Figure A.13.
2. The general test parameter settings are set up according to Table 16.3.1.5-1.
3. Propagation conditions are set according to clause 4.15.2.
4. Message contents are defined in clause 16.3.1.4.3.
5. In the test there are three synchronous cells: Cell 1 and Cell 2. Cell 1 is the PCell. Cell 2 is the neighbour cell. The cells are on the same RF channel in FR1

16.3.1.4.2 Test procedure

The test consists of a set-up period and a measurement period. Cell 1 and Cell 2 are both active during the complete test. The beginning of the measurement period shall be aligned with the first PRS positioning subframe of a positioning occasion in the reference cell.

The NR-DL-AoD-RequestLocationInformation message and NR-DL-AoD-ProvideAssistanceData message as defined in TS 37.355 shall be provided to the UE during T1. The last slot containing the two messages for the assistance data and location information request is denoted as #n. The beginning of the time interval T2 shall be aligned with the beginning of the first MG instance containing the PRS resources that is ΔT after slot #n, where ΔT = 50 ms is the maximum processing time of the assistance data and location information request

1. Ensure the UE is in State RRC_CONNECTED with generic procedure parameters Connectivity NR, Connected without release On, according to TS 38.508-1 [45] clause 4.5.
2. The SS shall send a RESET UE POSITIONING STORED INFORMATION message.
3. Set the parameters according to Table 16.3.1.5-1 as appropriate. Propagation conditions are set according to clause 4.15.2.
4. The SS shall send an LPP REQUEST CAPABILITIES message.
5. The UE shall transmit an LPP PROVIDE CAPABILITIES message indicating the DL-AoD capabilities supported by the UE in the NR-DL-AoD-ProvideCapabilities IE.
6. The SS shall send a LPP PROVIDE ASSISTANCE DATA message, including the nr-DL-AoD-ProvideAssistanceData-r16 IE. If the UE message at step 6 includes the ackRequested IE set to TRUE, then the SS shall send an acknowledgment in the LPP PROVIDE ASSISTANCE DATA message.
7. The SS shall send a LPP REQUEST LOCATION INFORMATION message, including the nr-DL-AoD-RequestLocationInformation-r16 such that the UE receives the message ΔT ms before the start of the measurement period, where ΔT = 50 ms.
8. The UE shall transmit a LPP PROVIDE LOCATION INFORMATION message, including the nr-DL-AoD-ProvideLocationInformation-r16 IE.
9. If the UE message at step 8 includes the ackRequested IE set to TRUE, the SS shall send a LPP acknowledgement message.
10. The SS shall check the nr-PRS-RSRP-r16 value for Cell 2 in the nr-DL-AoD-SignalMeasurementInformation-r16 according to Table 16.3.1.5-2.
11. Repeat step 2-10 until the confidence level according to Annex D is achieved.
12. Repeat step 1-11 for the other sub-test defined in Table 16.3.1.4-1 as appropriate.

If all (applicable) sub-tests pass, the whole test passes. If one (applicable) sub-test fails, the whole test fails.

16.3.1.4.3 Message contents

Table 16.3.1.4.3-1: RESET UE POSITIONING STORED INFORMATION

Derivation Path: 38.509 [44] clause 6.6			
Information Element	Value/remark	Comment	Condition
UE Positioning Technology	0 0 0 0 1 0 0 0	DL-AoD	

Table 16.3.1.4.3-2: LPP Request Capabilities

Information Element	Value/remark
nr-DL-AoD-RequestCapabilities-r16	TRUE

Table 16.3.1.4.3-3: LPP RequestLocationInformation

Derivation Path: TS 37.355 [49] clause 6.2			
Information Element	Value/remark	Comment	Condition
LPP-Message ::= SEQUENCE {			
transactionID SEQUENCE {			
initiator	locationServer		
transactionNumber	1		

}			
endTransaction	FALSE		
sequenceNumber	Not present		
acknowledgement	Not present		
lpp-MessageBody CHOICE {			
c1 CHOICE {			
requestLocationInformation SEQUENCE {			
criticalExtensions CHOICE {			
c1 CHOICE {			
requestLocationInformation-r9 SEQUENCE {			
commonEsRequestLocationInformation SEQUENCE {			
locationInformationType	locationMeasurementsPreferred		
triggeredReporting	Not present		
periodicalReporting	Not present		
additionalInformation	onlyReturnInformationRequested		
qos SEQUENCE {			
horizontalAccuracy	Not present		
verticalCoordinateRequest	FALSE		
verticalAccuracy	Not present		
responseTime SEQUENCE {			
time	See 16.3.1.5	Result of the response time calculation rounded up to the next second	
responseTimeEarlyFix-r12	Not present		Rel-12 onwards
}			
}			
velocityRequest	FALSE		
}			
environment	Not present		
locationCoordinateTypes	Not present		
velocityTypes	Not present		
}			
a-gnss-RequestLocationInformation	Not present		
otdoa-RequestLocationInformation	Not present		
ecid-RequestLocationInformation	Not present		
epdu-RequestLocationInformation	Not present		
sensor-RequestLocationInformation-r13	Not present		
tbs-RequestLocationInformation-r13	Not present		
wlan-RequestLocationInformation-r13	Not present		
bt-RequestLocationInformation-r13	Not present		
nr-ECID-RequestLocationInformation-r16	Not present		
nr-Multi-RTT-RequestLocationInformation-r16	Not present		
nr-DL-AoD-RequestLocationInformation-r16			
SEQUENCE {			
nr-AssistanceAvailability-r16	FALSE		
nr-DL-AoD-ReportConfig-r16 SEQUENCE {			
maxDL-PRS-RSRP-MeasurementsPerTRP-r16	Not present		
}			
}			
nr-DL-TDOA-RequestLocationInformation-r16	Not present		
}			
}			
}			
}			
}			
}			
}			
}			

Table 16.3.1.4.3-4: LPP ProvideAssistanceData

Derivation Path: 37.355 clause 6.2			
Information Element	Value/remark	Comment	Condition
LPP-Message ::= SEQUENCE {			
transactionID SEQUENCE {			
initiator	locationServer		
transactionNumber	(0..255)		
}			
endTransaction	TRUE		
sequenceNumber	Not present		
acknowledgement	Not present		
lpp-MessageBody CHOICE {			
c1 CHOICE {			
provideAssistanceData SEQUENCE {			
criticalExtensions CHOICE {			
c1 CHOICE {			
provideAssistanceData-r9 SEQUENCE {			
commonEsProvideAssistanceData	Not present		
a-gnss-ProvideAssistanceData	Not present		
otdoa-ProvideAssistanceData	Not present		
epdu-Provide-AssistanceData	Not present		
sensor-ProvideAssistanceData-r15	Not present		
tbs-ProvideAssistanceData-r15	Not present		
wlan-ProvideAssistanceData-r15	Not present		
nr-Multi-RTT-ProvideAssistanceData-r16	Not present		
nr-DL-AoD-ProvideAssistanceData-r16			
SEQUENCE {			
nr-DL-PRS-AssistanceData	As defined in Table 16.3.1.4.3-5		
nr-SelectedDL-PRS-IndexList-r16	Not present		
nr-PositionCalculationAssistance-r16			Depending on UE capabilities, i.e. support for UE-based DL-AoD
SEQUENCE {			
nr-TRP-LocationInfo-r16	As defined in TS 37.571-5 [20]		
nr-DL-PRS-BeamInfo-r16	Not present		
nr-RTD-Info-r16	Not present		
}			
nr-DL-AoD-Error-r16	Not present		
}			
nr-DL-TDOA-ProvideAssistanceData-r16	Not present		
}			
}			
}			
}			
}			

Table 16.3.1.4.3-5: NR-DL-PRS-AssistanceData

Derivation Path: TS 37.355 [49] clause 6.4.3			
Information Element	Value/remark	Comment	Condition
NR-DL-PRS-AssistanceData-r16 ::= SEQUENCE {			
nr-DL-PRS-ReferenceInfo-r16 SEQUENCE {			
dl-PRS-ID-r16	0		
nr-DL-PRS-ResourceID-List-r16	Not present		
nr-DL-PRS-ResourceSetID-r16	Not present		
}			

nr-DL-PRS-AssistanceDataList-r16 SEQUENCE (SIZE (1..nrMaxFreqLayers-r16)) OF NR-DL-PRS-AssistanceDataPerFreq-r16 {	1 entry		
NR-DL-PRS-AssistanceDataPerFreq-r16[1] SEQUENCE {		entry 1	
nr-DL-PRS-PositioningFrequencyLayer-r16 SEQUENCE {			
dl-PRS-SubcarrierSpacing-r16	kHz15		Sub-test 1-1, Sub-test 1-2, Sub-test 2-1 and Sub-test 2-2
	kHz30		Sub-test 3-1 and Sub-test 3-2
dl-PRS-ResourceBandwidth-r16	1	24 PRBs	Sub-test 1-1, Sub-test 2-1 and Sub-test 3-1
	21	104 PRBs	Sub-test 1-2 and Sub-test 2-2
	28	132 PRBs	Sub-test 3-2
dl-PRS-StartPRB-r16	0		
dl-PRS-PointA-r16	absoluteFrequencyPointA as defined for the DL frequency of the Cell 1		
dl-PRS-CombSizeN-r16	n2		Sub-test 1-1, Sub-test 2-1 and Sub-test 3-1
	n4		Sub-test 1-2, Sub-test 2-2 and Sub-test 3-2
dl-PRS-CyclicPrefix-r16	normal		
}			
nr-DL-PRS-AssistanceDataPerFreq-r16 SEQUENCE (SIZE (1..nrMaxTRPsPerFreq-r16)) OF NR-DL-PRS-AssistanceDataPerTRP-r16{	2 entries		
NR-DL-PRS-AssistanceDataPerTRP-r16[1] SEQUENCE {		entry 1	Cell 1
dl-PRS-ID-r16	0		
nr-PhysCellID-r16	Cell 1		
nr-CellGlobalID-r16	Cell 1		
nr-ARFCN-r16	Cell 1		
nr-DL-PRS-SFN0-Offset-r16 SEQUENCE {			
sfn-Offset-r16	0		
integerSubframeOffset-r16	0		
}			
nr-DL-PRS-ExpectedRSTD-r16	0		
nr-DL-PRS-ExpectedRSTD-Uncertainty-r16	0		
nr-DL-PRS-Info-r16	As specified in Table 16.3.1.4.3-6		
}			
NR-DL-PRS-AssistanceDataPerTRP-r16[2] SEQUENCE {		entry 2	Cell 2
dl-PRS-ID-r16	1		
nr-PhysCellID-r16	Cell 2		
nr-CellGlobalID-r16	Cell 2		
nr-ARFCN-r16	Cell 2		
nr-DL-PRS-SFN0-Offset-r16 SEQUENCE {			

sfn-Offset-r16	0		
integerSubframeOffset-r16	0		
}			
nr-DL-PRS-ExpectedRSTD-r16	23	About 3 μs	
nr-DL-PRS-ExpectedRSTD-Uncertainty-r16	39	About 5 μs	
nr-DL-PRS-Info-r16	As specified in Table 16.3.1.4.3-6		
}			
}			
}			
}			
}			

Table 16.3.1.4.3-6: NR-DL-PRS-Info

Derivation Path: TS 37.355 [49] clause 6.4.3			
Information Element	Value/remark	Comment	Condition
NR-DL-PRS-Info-r16 ::= SEQUENCE {			
nr-DL-PRS-ResourceSetList-r16 SEQUENCE (SIZE (1..nrMaxSetsPerTrp-r16)) OF NR-DL-PRS-ResourceSet-r16 {	1 entry		
NR-DL-PRS-ResourceSet-r16[1] SEQUENCE {		entry 1	
nr-DL-PRS-ResourceSetID-r16	0		
dl-PRS-Periodicity-and-ResourceSetSlotOffset-r16 CHOICE {			
scs15-r16 CHOICE {			Sub-tests 1-1, Sub-test 1-2, Sub-test 2-1 and Sub-test 2-2
n160-r16	10		
}			
scs30-r16 CHOICE {			Sub-tests 3-1 and Sub-test 3-2
N320-r16	20		
}			
dl-PRS-ResourceRepetitionFactor-r16	Not present		Sub-tests 1-2, Sub-test 2-2 and Sub-test 3-2
	n2		Sub-tests 1-1, Sub-test 2-1 and Sub-test 3-1
dl-PRS-ResourceTimeGap-r16	s1		
dl-PRS-NumSymbols-r16	n4		
dl-PRS-MutingOption1-r16	Not present		
dl-PRS-MutingOption2-r16	Not present		
dl-PRS-ResourcePower-r16	27		
dl-PRS-ResourceList-r16 SEQUENCE (SIZE (1..nrMaxResourcesPerSet-r16)) OF NR-DL-PRS-Resource-r16 {	1 entry		
NR-DL-PRS-Resource-r16[1] SEQUENCE {		entry 1	
nr-DL-PRS-ResourceID-r16	0		
dl-PRS-SequenceID-r16	0		
dl-PRS-CombSizeN-AndReOffset-r16 CHOICE {			
n2-r16	0		Sub-tests 1-1, Sub-test 2-1 and

			Sub-test 3-1
n4-r16	0		Sub-tests 1-2, Sub-test 2-2 and Sub-test 3-2
}			
dl-PRS-ResourceSlotOffset-r16	0		Sub-test 1-1 Cell 1, Sub-test 1-2 Cell 1, Sub-test 2-1 Cell 1, Sub-test 2-2 Cell 1, Sub-test 3-1 Cell 1, and Sub-test 3-2 Cell 1
	4		Sub-test 1-1 Cell 2, Sub-test 1-2 Cell 2, Sub-test 2-1 Cell 2, Sub-test 2-2 Cell 2, Sub-test 3-1 Cell 2, and Sub-test 3-2 Cell 2.
dl-PRS-ResourceSymbolOffset-r16	0		
dl-PRS-QCL-Info-r16	Not present		
}			
}			
}			
}			
}			

Table 16.3.1.4.3-7: LPP ProvideLocation Information

Derivation Path: 37.355 clause 6.5.12			
Information Element	Value/remark	Comment	Condition
LPP-Message ::= SEQUENCE {			
transactionID SEQUENCE {			
initiator	locationServer		
transactionNumber	1		
}			
endTransaction	TRUE		
sequenceNumber	(0..255)		
acknowledgement			
lpp-MessageBody CHOICE {			
c1 CHOICE {			
provideLocationInformation SEQUENCE {			
criticalExtensions CHOICE {			
c1 CHOICE {			
provideLocationInformation-r9 SEQUENCE {			
commonIEsProvideLocationInformation	Not present.		
a-gnss-ProvideLocationInformation	Not present		
otdoa-ProvideLocationInformation	Not present		
ecid-ProvideLocationInformation	Not present		
epdu-ProvideLocationInformation	Not present		
sensor-ProvideLocationInformation-r13	Not present		
tbs-ProvideLocationInformation-r13	Not present		

wlan-ProvideLocationInformation-r13	Not present		
bt-ProvideLocationInformation-r13	Not present		
nr-ECID-ProvideLocationInformation-r16	Not present		
nr-Multi-RTT-ProvideLocationInformation-r16	Not present		
nr-DL-AoD-ProvideLocationInformation-r16 SEQUENCE {			
nr-DL-AoD-SignalMeasurementInformation-r16 SEQUENCE {			
nr-DL-AoD-MeasList-r16 SEQUENCE (SIZE(1..nrMaxTRPs-r16)) OF NR-DL-AoD-MeasElement-r16 {			
NR-DL-AoD-MeasElement-r16[1] SEQUENCE {		entry 1	
dl-PRS-ID-r16	INTEGER (0..255)		
nr-PhysCellID-r16	Cell 1		
nr-CellGlobalID-r16			
nr-ARFCN-r16			
nr-DL-PRS-ResourceID-r16			
nr-DL-PRS-ResourceSetID-r16			
nr-TimeStamp-r16			
nr-DL-PRS-RSRP-Result-r16	Present. Any value acceptable.		
nr-DL-PRS-RxBeamIndex-r16			
nr-DL-AoD-AdditionalMeasurements-r16			
}			
NR-DL-AoD-MeasElement-r16[2] SEQUENCE {		entry 2	
dl-PRS-ID-r16	INTEGER (0..255)		
nr-PhysCellID-r16	Cell 2		
nr-CellGlobalID-r16			
nr-ARFCN-r16			
nr-DL-PRS-ResourceID-r16			
nr-DL-PRS-ResourceSetID-r16			
nr-TimeStamp-r16			
nr-DL-PRS-RSRP-Result-r16	Present. Any value acceptable.		
nr-DL-PRS-RxBeamIndex-r16			
nr-DL-AoD-AdditionalMeasurements-r16			
}			
}			
}			
nr-dl-AoD-LocationInformation-r16			
nr-DL-AoD-Error-r16	Not present		
}			
}			
}			
}			
}			
}			
}			
}			
}			

16.3.1.5 Test requirement

Table 16.3.1.5-1 defines the primary level settings including test tolerances for the test.

Table 16.3.1.5-1: General test parameters

Parameter	Unit	Test 1		Test 2	
		Cell 1	Cell 2	Cell 1	Cell 2
Cell ID		489	0	489	0

SSB ARFCN			freq1		freq1	
Duplex mode	Config 1		FDD			
	Config 2,3		TDD			
TDD configuration	Config 1		Not Applicable			
	Config 2		TDDConf.1.1			
	Config 3		TDDConf.2.1			
BW _{channel}	Config 1	MHz	10: N _{RB,c} = 52			
	Config 2		10: N _{RB,c} = 52			
	Config 3		40: N _{RB,c} = 106			
BWP BW	Config 1		10: N _{RB,c} = 52			
	Config 2		10: N _{RB,c} = 52			
	Config 3		40: N _{RB,c} = 106			
Downlink initial BWP configuration			DLBWP.0.1			
Downlink dedicated BWP configuration			DLBWP.1.1			
Uplink initial BWP configuration			ULBWP.0.1			
Uplink dedicated BWP configuration			ULBWP.1.1			
TRS configuration	Config 1		TRS.1.1 FDD	NA	TRS.1.1 FDD	NA
	Config 2		TRS.1.1 TDD	NA	TRS.1.1 TDD	NA
	Config 3		TRS.1.2 TDD	NA	TRS.1.2 TDD	NA
DRX Cycle		ms	Not Applicable			
Measurement gap			GP#24 or GP#0 ^{Note 7}			
PDSCH Reference measurement channel	Config 1		SR.1.1 FDD	-	SR.1.1 FDD	-
	Config 2		SR.1.1 TDD		SR.1.1 TDD	
	Config 3		SR2.1 TDD		SR2.1 TDD	
RMSI CORESET Reference Channel	Config 1		CR.1.1 FDD	-	CR.1.1 FDD	-
	Config 2		CR.1.1 TDD		CR.1.1 TDD	
	Config 3		CR2.1 TDD		CR2.1 TDD	
Control channel RMC	Config 1		CCR.1.1 FDD	-	CCR.1.1 FDD	-
	Config 2		CCR.1.1 TDD		CCR.1.1 TDD	
	Config 3		CCR2.1 TDD		CCR2.1 TDD	
PRS configuration	Config 1		PRS.1.3 FR1	PRS.1.3 FR1	PRS.1.4 FR1	PRS.1.4 FR1
	Config 2		PRS.1.3 FR1	PRS.1.3 FR1	PRS.1.4 FR1	PRS.1.4 FR1
	Config 3		PRS.2.3 FR1	PRS.2.3 FR1	PRS.2.4 FR1	PRS.2.4 FR1
PRS Resource slot offset (slot)	Config 1,2,3	slot	0	4	0	4
SSB configuration	Config 1		SSB.1 FR1	SSB.1 FR1	SSB.1 FR1	SSB.1 FR1
	Config 2		SSB.1 FR1	SSB.1 FR1	SSB.1 FR1	SSB.1 FR1
	Config 3		SSB.2 FR1	SSB.2 FR1	SSB.2 FR1	SSB.2 FR1
Time offset with Cell 1	Config 1	μs	-	3	-	3
	Config 2,3		-	3	-	3
Expected RSTD	Config 1,2,3	μs	3			

Expected RSTD uncertainty	Config 1,2,3	μ s	5			
SMTC configuration	Config 1		SMTC.2			
	Config 2,3		SMTC.1			
OCNG Patterns			OCNG pattern 1			
PDSCH/PDCCH subcarrier spacing	Config 1,2	kHz	15 kHz			
	Config 3		30 kHz			
EPRE ratio of PSS to SSS		dB	0	0	0	0
EPRE ratio of PBCH DMRS to SSS						
EPRE ratio of PBCH to PBCH DMRS						
EPRE ratio of PDCCH DMRS to SSS						
EPRE ratio of PDCCH to PDCCH DMRS						
EPRE ratio of PDSCH DMRS to SSS						
EPRE ratio of PDSCH to PDSCH						
EPRE ratio of OCNG DMRS to SSS(Note 1)						
EPRE ratio of OCNG to OCNG DMRS (Note 1)						
EPRE ratio of PRS to SSS			0	0	0	0
N_{oc} Note2	Config 1,2	dBm/15KhZ	-98		-98	
	Config 3		-98		-98	
N_{oc} Note2	Config 1,2	dBm/SCS	-98		-98	
	Config 3		-95		-95	
\hat{E}_s/I_{ot}	PRS	dB	-2.41	-12.12	-2.41	-12.12
\hat{E}_s/N_{oc}	PRS	dB	-2	-10	-2	-10
PRP Note3	Config 1, 2	dBm/SCS	-100	-108	-100	-108
	Config 3		-97	-105	-97	-105
I_o Note3	Config 1,2	dBm/9.36MHz	-67.67		-67.67	
	Config 3	dBm/38.16MHz	-61.57		-61.57	
Propagation condition			AWGN			
Antenna configuration			1x2			
<p>Note 1: OCNG shall be used such that both cells are fully allocated and a constant total transmitted power spectral density is achieved for all OFDM symbols.</p> <p>Note 2: Interference from other cells and noise sources not specified in the test is assumed to be constant over subcarriers and time and shall be modelled as AWGN of appropriate power for N_{oc} to be fulfilled.</p> <p>Note 3: PRP and I_o levels have been derived from other parameters for information purposes. They are not settable parameters themselves.</p> <p>Note 4: PRP minimum requirements are specified assuming independent interference and noise at each receiver antenna port.</p> <p>Note 5: Void.</p> <p>Note 6: The test configuration excludes support for band n51 and it is not required to run this test on band n51 in this release of the specification</p> <p>Note 7: GP#24 is configured if UE supports MG#24, otherwise GP#0 is configured.</p>						

The value of the LPP Time IE depends on the UE capabilities. The calculation is the same as in clause 16.2.1.5.

Table 16.3.1.5-2: PRS-RSRP accuracy requirements for the reported values

Test Configuration	Subtest	Cell 1		Cell 2	
		Lowest reported value	Highest reported value	Lowest reported value	Highest reported value

1	Sub-test 1	51	62	38	59
	Sub-test 2	51	62	41	56
2	Sub-test 1	51	62	38	59
	Sub-test 2	51	62	41	56
3	Sub-test 1	51	62	38	59
	Sub-test 2	51	62	41	56

For the overall test to pass, the ratio of successful reported values in each sub-test shall be more than 90% with a confidence level of 95%.

16.3.2 PRS-RSRP measurement accuracy with PRS in FR2

16.3.2.1 Test purpose

The purpose of this test is to verify that the PRS-RSRP measurement accuracy is within the specified limits. This test will verify the requirements in TS 38.133 [50] clauses 10.1.24.2.1 and 10.1.24.2.2.

16.3.2.2 Test applicability

This test applies to all types of NR UE release 16 onwards that supports DL-AoD positioning and PRS-RSRP measurements in FR2.

16.3.2.3 Minimum conformance requirements

The absolute accuracy requirements for PRS-RSRP measurement for FR2 defined in Table 16.3.2.3-1 are valid under the following conditions:

Conditions defined in 38.101-2 Clause 7.3 for reference sensitivity are fulfilled.

PRP $1,2_{dBm}$ according to TS 38.133 [50] Annex B.2.14 for a corresponding Band

Table 16.3.2.3-1: PRS-RSRP absolute accuracy for FR2

Accuracy		Conditions				
Normal condition	Extreme condition	PRS \hat{E}_s /lot	PRS BW	Repetition factor ($T_{rep}^{PRS} * L_{PRS} / K_{comb}^{PRS}$)	Io ^{Note 7} range	
					Minimum Io ^{Note 1} dBm / SCS _{PRS}	Maximum Io
dB	dB	dB	PRB	-	dBm / SCS _{PRS}	
					dBm/120kHz ^{Note 6}	dBm/60kHz ^{Note 6}
±5	±8	≥-3dB	≥24	All	Same value as PRP in TS 38.133 [50] Table B.2.14 -2, according to UE Power class, operating band and angle of arrival	
					Note 4	
					Note 4	
±8.5	±11.5	≥-13dB	24 ≤ BW ≤ 64	All	Note 4	
±6	±9		BW >64	All	Note 4	

NOTE 1: This minimum Io condition is expressed as the average Io per RE over all REs in an OFDM symbol.
 NOTE 2: Void.
 NOTE 3: PRS bandwidth is as indicated in *prs-Bandwidth* in the OTDOA or DL-AoD assistance data defined in TS 37.355 [49].
 NOTE 4: The same bands and the same Io conditions for each band apply for this requirement as for the corresponding requirement with the PRS bandwidth ≥ 24 RB.
 NOTE 5: The serving cell, the reference cell, and the measured neighbour cell i are on the same carrier frequency.

NOTE 6: The condition level is increased by $\Delta > 0$, when applicable, as described in TS 38.133 [50] Sections B.3.2 and B.3.3.
NOTE 7: The l_o is defined in PRS positioning subframes. The same l_o range applies to PRS and non-PRS symbols. l_o levels are different in PRS and non-PRS symbols within the same subframe.
NOTE 8: NR operating band groups are as defined in TS 38.133 [50] Section 3.5.2.

The accuracy requirements for PRS-RSRP measurement for FR2 defined in Table 116.3.2.3-2 are valid under the following conditions:

Conditions defined in 38.101-2 Clause 7.3 for reference sensitivity are fulfilled.

PRP $1,2_{dBm}$ according to TS 38.133 [50] Annex B.2.14 for a corresponding Band

Table 16.3.2.3-2: PRS-RSRP relative accuracy for FR2

Accuracy		Conditions					
Normal condition	Extreme condition	PRS \hat{E}_s/l_o	PRS BW	Repetition factor ($T_{rep}^{PRS} * L_{PRS} / K_{comb}^{PRS}$)	l_o ^{Note 7} range		
					Minimum l_o ^{Note 1} dBm / SCS _{PRS}	Maximum l_o	
dB	dB	dB	PRB	-	dBm / SCS _{PRS}		dBm/BW _{Channel}
					dBm/120kHz <small>Note 6</small>	dBm/60kHz <small>Note 6</small>	
±5.0	±8.0	≥-3dB	≥24	All	Same value as PRP in TS 38.133 [50] Table B.2.14-2, according to UE Power class, operating band and angle of arrival		-50
					Note 4		
±10 ±7.5	±13	≥-13dB	24 ≤ BW ≤ 64	All	Note 4		-
	±10.5		BW >64	All	Note 4		

NOTE 1: This minimum l_o condition is expressed as the average l_o per RE over all REs in an OFDM symbol.
 NOTE 2: Void.
 NOTE 3: PRS bandwidth is as indicated in *prs-Bandwidth* in the OTDOA or DL-AoD assistance data defined in TS 37.355 [49].
 NOTE 4: The same bands and the same l_o conditions for each band apply for this requirement as for the corresponding requirement with the PRS bandwidth ≥ 24 RB.
 NOTE 5: The serving cell, the reference cell, and the measured neighbour cell i are on the same carrier frequency.
 NOTE 6: The condition level is increased by $\Delta > 0$, when applicable, as described in TS 38.133 [50] Sections B.3.2 and B.3.3.
 NOTE 7: The l_o is defined in PRS positioning subframes. The same l_o range applies to PRS and non-PRS symbols. l_o levels are different in PRS and non-PRS symbols within the same subframe.
 NOTE 8: NR operating band groups are as defined in TS 38.133 [50] Section 3.5.2.

16.3.2.4 Test description

The supported test configurations in listed in Table 16.3.2.4-1.

Table 16.3.2.4-1: Supported test configurations for PRS RSRP measurement for FR2

Config	Description
1	120 kHz SSB SCS, 200 MHz bandwidth, TDD duplex mode

16.3.2.4.1 Initial conditions

Test Environment: Normal, as defined in TS 38.508-1 [45] clause 4.1.

Frequencies to be tested: Mid Range, as defined in TS 38.508-1 [45] clause 4.3.1.

Channel bandwidth to be tested: are specified in Table 16.3.2.4-1.

1. Connect the SS and AWGN noise sources to the UE antenna connector or antenna connectors as shown in Annex A, Figure A.14.
2. The general test parameter settings are set up according to Table 16.3.2.5-1 and Table 16.3.2.5-2.
3. Propagation conditions are set according to clause 4.16.2.
4. Message contents are defined in clause 16.3.2.4.3.
5. There are two cells in the test: PCell (Cell 1) and a neighbour cell (Cell 2). All cells are on the same RF channel in FR2.

16.3.2.4.2 Test procedure

The test consists of two sub-tests; the difference between the sub-tests is the PRS configuration, PRS.1.3 FR2 and PRS.1.4 FR2. The test consists of a set-up period and a measurement period. Cell 1 and Cell 2 are both active during the complete test. The beginning of the measurement period shall be aligned with the first PRS positioning subframe of a positioning occasion in the reference cell. The NR-DL-AoD-RequestLocationInformation message and the DL-AoD assistance data as defined in clause 16.3.2.4.3 shall be provided to the UE during the set-up period. The last TTI containing the NR-DL-AoD-RequestLocationInformation message shall be provided to the UE ΔT ms before the start of the measurement period, where $\Delta T = 50$ ms is the maximum processing time of the NR-DL-AoD-RequestLocationInformation message and the DL-AoD assistance data in the UE.

1. Ensure the UE is in State RRC_CONNECTED with generic procedure parameters Connectivity NR, Connected without release *On*, according to TS 38.508-1 [45] clause 4.5.
2. The SS shall send a RESET UE POSITIONING STORED INFORMATION message.
3. Set the parameters according to Table 16.3.2.5-1 and Table 16.3.2.5-2 as appropriate. Propagation conditions are set according to clause 4.16.2.
4. The SS shall send an LPP REQUEST CAPABILITIES message.
5. The UE shall transmit an LPP PROVIDE CAPABILITIES message indicating the DL-AoD capabilities supported by the UE in the NR-DL-AoD-ProvideCapabilities IE.
6. The SS shall send a LPP PROVIDE ASSISTANCE DATA message, including the nr-DL-AoD-ProvideAssistanceData-r16 IE. If the UE message at step 5 includes the *ackRequested* IE set to TRUE, then the SS shall send an acknowledgment in the LPP PROVIDE ASSISTANCE DATA message.
7. The SS shall send a LPP REQUEST LOCATION INFORMATION message, including the nr-DL-AoD-RequestLocationInformation-r16 IE such that the UE receives the message ΔT ms before the start of the measurement period, where $\Delta T = 50$ ms.
8. The UE shall transmit a LPP PROVIDE LOCATION INFORMATION message including the nr-DL-AoD-ProvideLocationInformation-r16 IE within the response time (see clause 4.16.3). The UE shall perform and report the PRS-RSRP measurements for both Cell 1 and Cell 2.
9. If the UE message at step 8 includes the *ackRequested* IE set to TRUE, the SS shall send a LPP acknowledgement message.
10. The SS shall check the nr-DL-PRS-RSRP-Result-r16 and nr-DL-PRS-RSRP-ResultDiff-r16 value for Cell 1 and Cell 2 in the nr-DL-AoD-SignalMeasurementInformation-r16 according to Table 16.3.2.5-3.
11. Repeat step 2-10 until the confidence level according to Annex D is achieved.
12. Repeat step 1-11 for the other sub-test defined in Table 16.3.2.5-1 as appropriate.

If all (applicable) sub-tests pass, the whole test passes. If one (applicable) sub-test fails, the whole test fails.

16.3.2.4.3 Message contents

Table 16.3.2.4.3-1: RESET UE POSITIONING STORED INFORMATION

Derivation Path: 38.509 [44] clause 6.6			
Information Element	Value/remark	Comment	Condition
UE Positioning Technology	0 0 0 1 0 0 0	DL-AoD	

Table 16.3.2.4.3-2: LPP Request Capabilities

Information Element	Value/remark
nr-DL-AoD-RequestCapabilities-r16	TRUE

Table 16.3.2.4.3-3: LPP RequestLocationInformation

Derivation Path: 37.355 clause 6.2			
Information Element	Value/remark	Comment	Condition
LPP-Message ::= SEQUENCE {			
transactionID SEQUENCE {			
initiator	locationServer		
transactionNumber	1		
}			
endTransaction	FALSE		
sequenceNumber	Not present		
acknowledgement	Not present		
lpp-MessageBody CHOICE {			
c1 CHOICE {			
requestLocationInformation SEQUENCE {			
criticalExtensions CHOICE {			
c1 CHOICE {			
requestLocationInformation-r9 SEQUENCE {			
commonEsRequestLocationInformation SEQUENCE {			
locationInformationType	locationMeasurementsRequired		
triggeredReporting	Not present		
periodicalReporting	Not present		
additionalInformation	onlyReturnInformationRequested		
qos SEQUENCE {			
horizontalAccuracy	Not present		
verticalCoordinateRequest	FALSE		
verticalAccuracy	Not present		
responseTime SEQUENCE {			
time	See 16.3.2.5 42+TT	Result of the response time calculation rounded up to the next second	
responseTimeEarlyFix-r12	Not present		Rel-12 onwards
}			
velocityRequest	FALSE		
}			
environment	Not present		
locationCoordinateTypes	Not present		
velocityTypes	Not present		
}			
a-gnss-RequestLocationInformation	Not present		
otdoa-RequestLocationInformation	Not present		
ecid-RequestLocationInformation	Not present		
epdu-RequestLocationInformation	Not Present		
sensor-RequestLocationInformation-r13	Not present		

tbs-RequestLocationInformation-r13	Not present		
wlan-RequestLocationInformation-r13	Not present		
bt-RequestLocationInformation-r13	Not present		
nr-ECID-RequestLocationInformation-r16	Not present		
nr-Multi-RTT-RequestLocationInformation-r16	Not present		
nr-DL-AoD-RequestLocationInformation-r16			
SEQUENCE {			
nr-AssistanceAvailability-r16	FALSE		
nr-DL-AoD-ReportConfig-r16 SEQUENCE {			
maxDL-PRS-RSRP-MeasurementsPerTRP-r16	2		
}			
}			
nr-DL-TDOA-RequestLocationInformation-r16	Not present		
}			
}			
}			
}			
}			
}			
}			

Table 16.3.2.4.3-4: LPP ProvideAssistanceData

Derivation Path: 37.355 clause 6.2			
Information Element	Value/remark	Comment	Condition
LPP-Message ::= SEQUENCE {			
transactionID SEQUENCE {			
initiator	locationServer		
transactionNumber	(0..255)		
}			
endTransaction	TRUE		
sequenceNumber	Not present		
acknowledgement	Not present		
lpp-MessageBody CHOICE {			
c1 CHOICE {			
provideAssistanceData SEQUENCE {			
criticalExtensions CHOICE {			
c1 CHOICE {			
provideAssistanceData-r9 SEQUENCE {			
commonEsProvideAssistanceData	Not present		
a-gnss-ProvideAssistanceData	Not present		
otdoa-ProvideAssistanceData	Not present		
epdu-Provide-AssistanceData	Not present		
sensor-ProvideAssistanceData-r15	Not present		
tbs-ProvideAssistanceData-r15	Not present		
wlan-ProvideAssistanceData-r15	Not present		
nr-Multi-RTT-ProvideAssistanceData-r16	Not present		
nr-DL-AoD-ProvideAssistanceData-r16			
SEQUENCE {			
nr-DL-PRS-AssistanceData	As defined in Table 16.3.2.4.3-5		
nr-SelectedDL-PRS-IndexList-r16	Not present		
nr-PositionCalculationAssistance-r16			Depending on UE capabilities, i.e. support for UE-based DL-AoD
SEQUENCE {			
nr-TRP-LocationInfo-r16	As defined in TS 37.571-5 [20]		
nr-DL-PRS-BeamInfo-r16	Not present		
nr-RTD-Info-r16	Not present		
}			
nr-DL-AoD-Error-r16	Not present		

}			
nr-DL-TDOA-ProvideAssistanceData-r16	Not present		
}			
}			
}			
}			
}			
}			

Table 16.3.2.4.3-5: NR-DL-PRS-AssistanceData

Derivation Path: 37.355 clause 6.4.3			
Information Element	Value/remark	Comment	Condition
NR-DL-PRS-AssistanceData-r16 ::= SEQUENCE {			
nr-DL-PRS-ReferenceInfo-r16 SEQUENCE {			
dl-PRS-ID-r16	0		
nr-DL-PRS-ResourceID-List-r16	Not present		
nr-DL-PRS-ResourceSetID-r16	Not present		
}			
nr-DL-PRS-AssistanceDataList-r16 SEQUENCE (SIZE (1..nrMaxFreqLayers-r16)) OF NR-DL-PRS-AssistanceDataPerFreq-r16 {	1 entry		
NR-DL-PRS-AssistanceDataPerFreq-r16[1] SEQUENCE {		entry 1	
nr-DL-PRS-PositioningFrequencyLayer-r16 SEQUENCE {			
dl-PRS-SubcarrierSpacing-r16	kHz120		
dl-PRS-ResourceBandwidth-r16	3	32 PRBs	Sub-test 1
	27	128 PRBs	Sub-test 2
dl-PRS-StartPRB-r16	0		
dl-PRS-PointA-r16	absoluteFrequencyPointA as defined for the DL frequency of the Cell 1		
dl-PRS-CombSizeN-r16	n2		Sub-test 1
	n4		Sub-test 2
dl-PRS-CyclicPrefix-r16	normal		
}			
nr-DL-PRS-AssistanceDataPerFreq-r16 SEQUENCE (SIZE (1..nrMaxTRPsPerFreq-r16)) OF NR-DL-PRS-AssistanceDataPerTRP-r16{	2 entries		
NR-DL-PRS-AssistanceDataPerTRP-r16[1] SEQUENCE {		entry 1	Cell 1
dl-PRS-ID-r16	0		
nr-PhysCellID-r16	Cell 1		
nr-CellGlobalID-r16	Cell 1		
nr-ARFCN-r16	Cell 1		
nr-DL-PRS-SFN0-Offset-r16 SEQUENCE {			
sfn-Offset-r16	0		
integerSubframeOffset-r16	0		
}			
nr-DL-PRS-ExpectedRSTD-r16	0		
nr-DL-PRS-ExpectedRSTD-Uncertainty-r16	0		
nr-DL-PRS-Info-r16	As specified in Table 16.3.2.4.3-6		
}			
NR-DL-PRS-AssistanceDataPerTRP-r16[2] SEQUENCE {		entry 2	Cell 2
dl-PRS-ID-r16	1		
nr-PhysCellID-r16	Cell 2		
nr-CellGlobalID-r16	Cell 2		
nr-ARFCN-r16	Cell 2		
nr-DL-PRS-SFN0-Offset-r16 SEQUENCE {			
sfn-Offset-r16	0		
integerSubframeOffset-r16	0		
}			

nr-DL-PRS-ExpectedRSTD-r16	23	About 3 μ s	
nr-DL-PRS-ExpectedRSTD-Uncertainty-r16	154	About 5 μ s	
nr-DL-PRS-Info-r16	As specified in Table 16.3.2.4.3-6		
}			
}			
}			
}			
}			

Table 16.3.2.4.3-6: NR-DL-PRS-Info

Derivation Path: 37.355 clause 6.4.3			
Information Element	Value/remark	Comment	Condition
NR-DL-PRS-Info-r16 ::= SEQUENCE {			
nr-DL-PRS-ResourceSetList-r16 SEQUENCE (SIZE (1..nrMaxSetsPerTrp-r16)) OF NR-DL-PRS-ResourceSet-r16 {	1 entry		
NR-DL-PRS-ResourceSet-r16[1] SEQUENCE {		entry 1	
nr-DL-PRS-ResourceSetID-r16	0		
dl-PRS-Periodicity-and-ResourceSetSlotOffset-r16 CHOICE {			
scs120-r16 CHOICE {			
n1280-r16	80		
}			
dl-PRS-ResourceRepetitionFactor-r16	n2		Sub-test 1
	Not present		Sub-test 2
dl-PRS-ResourceTimeGap-r16	s1		
dl-PRS-NumSymbols-r16	n4		
dl-PRS-MutingOption1-r16	Not present		
dl-PRS-MutingOption2-r16	Not present		
dl-PRS-ResourcePower-r16	27		
dl-PRS-ResourceList-r16 SEQUENCE (SIZE (1..nrMaxResourcesPerSet-r16)) OF NR-DL-PRS-Resource-r16 {	2 entries		
NR-DL-PRS-Resource-r16[1] SEQUENCE {		entry 1	
nr-DL-PRS-ResourceID-r16	0		
dl-PRS-SequenceID-r16	0		
dl-PRS-CombSizeN-AndReOffset-r16 CHOICE {			
n2-r16	0		Sub-test 1
n4-r16	0		Sub-test 2
}			
dl-PRS-ResourceSlotOffset-r16	0		Sub-test 1 Cell 1 and Sub-test 2 Cell 1
	4		Sub-test 1 Cell 2 and Sub-test 2 Cell 2
dl-PRS-ResourceSymbolOffset-r16	0		
dl-PRS-QCL-Info-r16	Not present		
}			
NR-DL-PRS-Resource-r16[2] SEQUENCE {		entry 2	
nr-DL-PRS-ResourceID-r16	1		
dl-PRS-SequenceID-r16	0		
dl-PRS-CombSizeN-AndReOffset-r16 CHOICE {			
n2-r16	1		Sub-test 1
n4-r16	1		Sub-test 2
}			
dl-PRS-ResourceSlotOffset-r16	0		Sub-test 1 Cell 1 and Sub-test 2 Cell 1

	4		Sub-test 1 Cell 2 and Sub-test 2 Cell 2
dl-PRS-ResourceSymbolOffset-r16	0		
dl-PRS-QCL-Info-r16	Not present		
}			
}			
}			
}			
}			

Table 16.3.2.4.3-7: LPP ProvideLocation Information

Derivation Path: 37.355 clause 6.5.12			
Information Element	Value/remark	Comment	Condition
LPP-Message ::= SEQUENCE {			
transactionID SEQUENCE {			
initiator	locationServer		
transactionNumber	1		
}			
endTransaction	TRUE		
sequenceNumber	(0..255)		
acknowledgement			
lpp-MessageBody CHOICE {			
c1 CHOICE {			
provideLocationInformation SEQUENCE {			
criticalExtensions CHOICE {			
c1 CHOICE {			
provideLocationInformation-r9 SEQUENCE {			
commonIEsProvideLocationInformation	Not present.		
a-gnss-ProvideLocationInformation	Not present		
otdoa-ProvideLocationInformation	Not present		
ecid-ProvideLocationInformation	Not present		
epdu-ProvideLocationInformation	Not present		
sensor-ProvideLocationInformation-r13	Not present		
tbs-ProvideLocationInformation-r13	Not present		
wlan-ProvideLocationInformation-r13	Not present		
bt-ProvideLocationInformation-r13	Not present		
nr-ECID-ProvideLocationInformation-r16	Not present		
nr-Multi-RTT-ProvideLocationInformation-r16	Not present		
nr-DL-AoD-ProvideLocationInformation-r16 SEQUENCE {			
nr-DL-AoD-SignalMeasurementInformation-r16 SEQUENCE {			
nr-DL-AoD-MeasList-r16 SEQUENCE (SIZE(1..nrMaxTRPs-r16)) OF NR-DL-AoD-MeasElement-r16 {	2 entries		
NR-DL-AoD-MeasElement-r16[1] SEQUENCE {		entry 1	
dl-PRS-ID-r16	INTEGER (0..255)		
nr-PhysCellID-r16	Cell 1		
nr-CellGlobalID-r16			
nr-ARFCN-r16			
nr-DL-PRS-ResourceID-r16	0		
nr-DL-PRS-ResourceSetID-r16	0		
nr-TimeStamp-r16			
nr-DL-PRS-RSRP-Result-r16	Present. Any value acceptable.		
nr-DL-PRS-RxBeamIndex-r16			
nr-DL-AoD-AdditionalMeasurements-r16 SEQUENCE (SIZE (1..7)) OF NR-DL-AoD-AdditionalMeasurementElement-r16 {	1 entry		

NR-DL-AoD-AdditionalMeasurementElement-r16[1] SEQUENCE {		entry 1	
nr-DL-PRS-ResourceID-r16	1		
nr-DL-PRS-ResourceSetID-r16	0		
nr-TimeStamp-r16			
nr-DL-PRS-RSRP-ResultDiff-r16	Present. Any value acceptable.		
nr-DL-PRS-RxBeamIndex-r16			
}			
}			
NR-DL-AoD-MeasElement-r16[2] SEQUENCE {		entry 2	
dl-PRS-ID-r16	INTEGER (0..255)		
nr-PhysCellID-r16	Cell 2		
nr-CellGlobalID-r16			
nr-ARFCN-r16			
nr-DL-PRS-ResourceID-r16			
nr-DL-PRS-ResourceSetID-r16			
nr-TimeStamp-r16			
nr-DL-PRS-RSRP-Result-r16	Present. Any value acceptable.		
nr-DL-PRS-RxBeamIndex-r16			
nr-DL-AoD-AdditionalMeasurements-r16 SEQUENCE (SIZE (1..7)) OF NR-DL-AoD-AdditionalMeasurementElement-r16 {	1 entry		
NR-DL-AoD-AdditionalMeasurementElement-r16[1] SEQUENCE {		entry 1	
nr-DL-PRS-ResourceID-r16	1		
nr-DL-PRS-ResourceSetID-r16	0		
nr-TimeStamp-r16			
nr-DL-PRS-RSRP-ResultDiff-r16	Present. Any value acceptable.		
nr-DL-PRS-RxBeamIndex-r16			
}			
}			
}			
}			
nr-dl-AoD-LocationInformation-r16			
nr-DL-AoD-Error-r16	Not present		
}			
}			
}			
}			
}			
}			
}			
}			

16.3.2.5 Test requirement

Table 16.3.2.5-1 and Table 16.3.2.5-2 define the primary level settings including the test tolerances for the test.

Table 16.3.2.5-1: PRS-RSRP general test parameters

Parameter	Unit	Test 1		Test 2	
		Cell 1	Cell 2	Cell 1	Cell 2
Cell ID		489	0	489	0
SSB ARFCN		freq1		freq1	
Duplex mode		TDD		TDD	
TDD configuration		TDDConf.3.1		TDDConf.3.1	
BW _{channel}	MHz	200: N _{RB,c} = 132		200: N _{RB,c} = 132	
Downlink initial BWP configuration		DLBWP.0.1	-	DLBWP.0.1	-

Downlink dedicated BWP configuration		DLBWP.1.1	-	DLBWP.1.1	-
Uplink initial BWP configuration		ULBWP.0.1	-	ULBWP.0.1	-
Uplink dedicated BWP configuration		ULBWP.1.1	-	ULBWP.1.1	-
DRX cycle configuration		Not applicable	-	Not applicable	-
Measurement gap		GP#13 or GP#24 ^{Note2}			
TRS configuration		TRS.2.1 TDD	-	TRS.2.1 TDD	-
TCI state		TCI.State.0	-	TCI.State.0	-
PDSCH Reference measurement channel		SR.3.1 TDD	-	SR.3.1 TDD	-
RMSI CORESET Reference Channel		CR.3.1 TDD	-	CR.3.1 TDD	-
Control channel RMC		CCR.3.1 TDD	-	CCR.3.1 TDD	-
OCNG Patterns		OP.1	OP.1	OP.1	OP.1
SSB configuration		SSB.3 FR2	SSB.3 FR2	SSB.3 FR2	SSB.3 FR2
SMTC configuration		SMTC.1	SMTC.1	SMTC.1	SMTC.1
Time offset with Cell 1	μs	-	3	-	3
Expected RSTD	μs	3			
Expected RSTD uncertainty	μs	5			
PRS configuration		PRS.1.3 FR2	PRS.1.3 FR2	PRS.1.4 FR2	PRS.1.4 FR2
PRS Resource slot offset	slot	0	4	0	4
PDSCH/PDCCH subcarrier spacing	kHz	120	120	120	120
EPRE ratio of PSS to SSS	dB	0	0	0	0
EPRE ratio of PBCH_DMRS to SSS					
EPRE ratio of PBCH to PBCH_DMRS					
EPRE ratio of PDCCH_DMRS to SSS					
EPRE ratio of PDCCH to PDCCH_DMRS					
EPRE ratio of PDSCH_DMRS to SSS					
EPRE ratio of PDSCH to PDSCH_DMRS					
EPRE ratio of OCNG DMRS to SSS ^{Note 1}					
EPRE ratio of OCNG to OCNG DMRS ^{Note 1}					
EPRE ratio of PRS to SSS	dB	0	0	0	0
Propagation conditions		AWGN	AWGN	AWGN	AWGN
Antenna configuration		1x2	1x2	1x2	1x2
<p>Note 1: OCNG shall be used such that both cells are fully allocated and a constant total transmitted power spectral density is achieved for all OFDM symbols.</p> <p>Note 2: GP#24 is configured if UE supports MG#24, otherwise GP#13 is configured.</p>					

Table 16.3.2.5-2: PRS-RSRP OTA related test parameters

Parameter	Unit	Test 1		Test 2	
		Cell 1	Cell 2	Cell 1	Cell 2
Angle of arrival configuration		Setup 1 according to TS 38.133 [50] clause A.3.15.1			
Assumption for UE beams ^{Note 7}		Rough		Rough	
N_{oc} ^{Note1}	dBm/15kHz ^{Note4}	-99.1		-99.1	
N_{oc} ^{Note1}	dBm/SCS ^{Note4}	-90.1		-90.1	

PRS \hat{E}_s / N_{oc}	dB	-2	-10	-2	-10
PRP ^{Note2}	dBm/SCS	-92.1	-100.1	-92.1	-100.1
PRS \hat{E}_s / I_{ot} \hat{E}_s / I_{ot} BB ^{Note6}	dB	-2.55	-12.22	-2.55	-12.22
Io ^{Note2}	dBm/190.08 MHz ^{Note4}	-55.69		-55.69	
<p>Note 1: Where used, interference from other cells and noise sources not specified in the test is assumed to be constant over subcarriers and time and shall be modelled as AWGN of appropriate power for N_{oc} to be fulfilled.</p> <p>Note 2: PPRP, Es/Iot and Io levels have been derived from other parameters for information purposes. They are not settable parameters themselves.</p> <p>Note 3: Void</p> <p>Note 4: Equivalent power received by an antenna with 0 dBi gain at the centre of the quiet zone</p> <p>Note 5: Void</p> <p>Note 6: Calculation of Es/Iot includes the effect of UE internal noise up to the value assumed for the associated Refsens requirement in clause 7.3.2 of TS 38.101-2 [55], and an allowance of 1dB for UE multi-band relaxation factor ΔMB_P from TS 38.101-2 [55] Table 6.2.1.3-4.</p> <p>Note 7: Information about types of UE beam is given in TS 38.133 [50] B.2.1.3, and does not limit UE implementation or test system implementation</p>					

The value of the LPP Time IE depends on the UE capabilities. The calculation is the same as in clause 16.2.3.5 Therefore, the value of the LPP Time IE is given by the following equation:

$$\left(1 * 8 * \left\lfloor \frac{2}{N'} \right\rfloor \left\lceil \frac{0.142}{N} \right\rceil * 4 - 1 \right) * T_{effect} + T_{last}$$

The resulting value shall be rounded up to the next integer and transmitted in the LPP-RequestLocationInformation (see Table 16.3.2.4.3-3).

Table 16.3.2.5-3: PRS RSRP accuracy requirements for the reported values

Test Configuration	Report Mapping	Lowest reported value	Highest reported value
Sub-test 1	Absolute PRS RSRP accuracy for Cell 1	54	85
	Relative PRS RSRP accuracy for Cell 1	22	30
	Absolute PRS RSRP accuracy for Cell 2	46	77
	Relative PRS RSRP accuracy for Cell 2	20	30
Sub-test 2	Absolute PRS RSRP accuracy for Cell 1	54	85
	Relative PRS RSRP accuracy for Cell 1	24	30
	Absolute PRS RSRP accuracy for Cell 2	46	77

Relative PRS RSRP accuracy for Cell 2	23	30
---------------------------------------	----	----

The PRS RSRP measurement period fulfils the requirements specified in clause 4.16.3.

The test tolerances are defined in clauses C.1.6 and C.2.5.

The rate of successful tests during repeated tests shall be at least 90% with a confidence level of 95%.

16.3.3 PRS-RSRP measurement accuracy with PRS in FR1 with reduced sample number

Editor’s Note: This test case has been completed for the following configurations:

- Test tolerance is missing
- Message contents require update

16.3.3.1 Test purpose

The purpose of this test is to verify that the accuracy of PRS-RSRP measurement with reduced sample number is within the specified limits. This test will verify the requirements in TS 38.133 [50] clauses 10.1.24.2.1 and 10.1.24.2.2.

16.3.3.2 Test applicability

This test applies to all types of NR UE release 17 onwards that supports DL-AoD positioning and supportedDL-PRS-ProcessingSamples-RRC-CONNECTED.

16.3.3.3 Minimum conformance requirements

The absolute accuracy requirements for PRS-RSRP measurement for FR1 defined in Table in TS 38.133 [50] clause 10.1.24.2.1-3 are valid under the following conditions:

- Conditions defined in 38.101-2 Clause 7.3 for reference sensitivity are fulfilled.
- PRP 1,2_{dBm} according to Annex B.2.14 for a corresponding Band
- UE supports positioning measurements with reduced number of samples, and LMF indicates UE to perform positioning measurements with reduced number of samples
- AWGN channel

Table 16.3.3.3-1: PRS-RSRP absolute accuracy for FR1 with reduced sample number

Accuracy		Conditions							
Normal condition	Extreme condition	PRS $\hat{\epsilon}$ /lot	PRS BW	Repetition factor ($T_{rep}^{PRS} * L_{PRS} / K_{comb}^{PRS}$)	I_o ^{Note 6} range				
					NR operating band groups ^{Note 7}	Minimum I_o ^{Note 1} dBm / SCS _{PRS}			Maximum I_o
dB	dB	dB	PRB	-		dBm / SCS _{PRS}			dBm/BW _{Channel}
						dBm/15k Hz ^{Note 5}	dBm/30k Hz ^{Note 5}	dBm/60kHz ^{Note 5}	
±3.5	±8	≥0	≥48	All	NR_FDD_FR1_A, NR_TDD_FR1_A, NR_SDL_FR1_A	-127	-124	-121	-50
					NR_FDD_FR1_B	-126.5	-123.5	-120.5	-50
					NR_TDD_FR1_C	-126	-123	-120	-50

					NR_FDD_FR1_D, NR_TDD_FR1_D	-125.5	-122.5	-119.5	-50
					NR_FDD_FR1_E, NR_TDD_FR1_E	-125	-122	-119	-50
					NR_FDD_FR1_F	-124.5	-121.5	-118.5	-50
					NR_FDD_FR1_G, NR_TDD_FR1_G	-124	-121	-118	-50
					NR_FDD_FR1_H	-123.5	-120.5	-117.5	-50
±8.5	±13	≥-6	48 ≤ BW ≤ 52	All	Note 3				
±6	±10.5		52 < BW ≤ 104	All	Note 3				
±4.5	±9		BW > 104	All	Note 3				

NOTE 1: This minimum I_{o} condition is expressed as the average I_{o} per RE over all REs in an OFDM symbol.
 NOTE 2: PRS bandwidth is as indicated in *prs-Bandwidth* in the OTDOA or DL-AoD assistance data defined in [34].
 NOTE 3: The same bands and the same I_{o} conditions for each band apply for this requirement as for the corresponding requirement with the PRS bandwidth ≥ 48 RB.
 NOTE 4: The serving cell, the reference cell, and the measured neighbour cell i are on the same carrier frequency.
 NOTE 5: The condition level is increased by $\Delta > 0$, when applicable, as described in Sections B.3.2 and B.3.3.
 NOTE 6: The I_{o} is defined in PRS positioning subframes. The same I_{o} range applies to PRS and non-PRS symbols. I_{o} levels are different in PRS and non-PRS symbols within the same subframe.
 NOTE 7: NR operating band groups are as defined in Section 3.5.2.

Table 16.3.3.3-2: PRS-RSRP relative accuracy for FR1 with reduced sample number

Accuracy		Conditions							
Normal condition	Extreme condition	PRS \hat{E}_s/lot	PRS BW	Repetition factor ($T_{\text{rep}}^{\text{PRS}} * L_{\text{PRS}}/K_{\text{comb}}^{\text{PRS}}$)	NR operating band groups Note 7	I_{o} Note 6 range			Maximum I_{o}
						Minimum I_{o} Note 1 dBm / SCS _{PRS}			
dB	dB	dB	PRB	-		dBm / SCS _{PRS}			dBm/BW _{Channel}
						dBm/15k Hz Note 5	dBm/30kHz z Note 5	dBm/60k Hz Note 5	
[±3.5]	±5.0	≥0	≥48	All	NR_FDD_FR1_A, NR_TDD_FR1_A, NR_SDL_FR1_A	-127	-124	-121	-50
					NR_FDD_FR1_B	-126.5	-123.5	-120.5	-50
					NR_TDD_FR1_C	-126	-123	-120	-50
					NR_FDD_FR1_D, NR_TDD_FR1_D	-125.5	-122.5	-119.5	-50
					NR_FDD_FR1_E, NR_TDD_FR1_E	-125	-122	-119	-50
					NR_FDD_FR1_F	-124.5	-121.5	-118.5	-50
					NR_FDD_FR1_G, NR_TDD_FR1_G	-124	-121	-118	-50
					NR_FDD_FR1_H	-123.5	-120.5	-117.5	-50
±9.5	±11.0	≥-6	48 ≤ BW ≤ 52	All	Note 3				
±6.5	±8.0		52 < BW ≤ 104	All	Note 3				
±5.0	±6.5		BW > 104	All	Note 3				

NOTE 1: This minimum I_{o} condition is expressed as the average I_{o} per RE over all REs in an OFDM symbol.
 NOTE 2: PRS bandwidth is as indicated in *prs-Bandwidth* in the OTDOA or DL-AoD assistance data defined in [34].
 NOTE 3: The same bands and the same I_{o} conditions for each band apply for this requirement as for the corresponding requirement with the PRS bandwidth ≥ 48 RB.
 NOTE 4: The serving cell, the reference cell, and the measured neighbour cell i are on the same carrier frequency.
 NOTE 5: The condition level is increased by $\Delta > 0$, when applicable, as described in Sections B.3.2 and B.3.3.
 NOTE 6: The I_{o} is defined in PRS positioning subframes. The same I_{o} range applies to PRS and non-PRS symbols. I_{o} levels are different in PRS and non-PRS symbols within the same subframe.
 NOTE 7: NR operating band groups are as defined in Section 3.5.2.

16.3.3.4 Test description

16.3.3.4.1 Initial conditions

The supported test configurations in listed in Table 16.3.3.4-1.

Table 16.3.3.4-1: Test Configurations

Config	Description
1	NR 15 kHz SSB SCS, 20 MHz bandwidth, FDD duplex mode
2	NR 15 kHz SSB SCS, 20 MHz bandwidth, TDD duplex mode
3	NR 30 kHz SSB SCS, 50 MHz bandwidth, TDD duplex mode
Note:	The UE is only required to be tested in one of the supported test configurations in each supported band

Test Environment: Normal, as defined in TS 38.508-1 [45] clause 4.1.

Frequencies to be tested: Mid Range, as defined in TS 38.508-1 [45] clause 4.3.1.

Channel bandwidth to be tested: are specified in Table 16.3.3.4-1.

1. Connect the SS and AWGN noise sources to the UE antenna connector or antenna connectors as shown in Annex A, Figure A.13.
2. The general test parameter settings are set up according to Table 16.3.3.5-1.
3. Propagation conditions are set according to clause 4.16.2.
4. Message contents are defined in clause 16.3.3.4.3.
5. In the test there are two synchronous cells: Cell 1 and Cell 2. Cell 1 is the reference as well as the PCell. Cell 2 is the neighbour cell. All cells are on the same RF channel distributed in single positioning frequency layer.

16.3.3.4.2 Test procedure

The test consists of a set-up period and a measurement period. Cell 1 and Cell 2 are both active during the complete test. The beginning of the measurement period shall be aligned with the first PRS positioning subframe of a positioning occasion in the reference cell. The NR-DL-AoD-ProvideAssistanceData and NR-DL-AoD-RequestLocationInformation as defined in TS 37.355 [49] shall be provided to the UE during the set-up period.

1. Ensure the UE is in State RRC_CONNECTED with generic procedure parameters Connectivity NR, Connected without release On, according to TS 38.508-1 [45] clause 4.5.
2. The SS shall send a RESET UE POSITIONING STORED INFORMATION message.
3. Set the parameters according to Table 16.3.3.5-1. Propagation conditions are set according to clause 4.16.2.
5. The SS shall transmit an LPP REQUEST CAPABILITIES message.
6. The UE shall transmit an LPP PROVIDE CAPABILITIES message indicating the DL-AoD capabilities supported by the UE in the NR-DL-AoD-ProvideCapabilities IE.
7. The SS shall send a LPP PROVIDE ASSISTANCE DATA message, including the NR-DL-AoD-ProvideAssistanceData IE. The position of neighbour Cell 2 is described in 3GPP TS 37.571-5 [20]. If the UE message at step 6 includes the ackRequested IE set to TRUE, then the SS shall send an acknowledgment in the LPP PROVIDE ASSISTANCE DATA message.
8. The SS shall send a LPP REQUEST LOCATION INFORMATION message, including the reducedDL-PRS-ProcessingSamples-r17 in the NR-DL-AoD-RequestLocationInformation IE such that the UE receives the message T ms before the start of the measurement period, where T = 50 ms.
9. The UE shall transmit a LPP PROVIDE LOCATION INFORMATION message including the NR-DL-AoD-ProvideLocationInformation IE within the response time (see clause 4.16.3). The UE shall perform and report the PRS-RSRP measurements for Cell 2 with respect to the reference cell in the DL-TDOA assistance data, Cell 1. If the UE transmits an NR-DL-AoD-ProvideLocationInformation IE including the nr-DL-PRS-RSRP-Result-

r16 field for Cell 2 within the response time then the number of successful tests is increased by one. If the UE fails to report the *NR-DL-AoD-ProvideLocationInformation* IE with both the *nr-DL-PRS-RSRP-Result-r16* fields included within the response time then the number of failure tests is increased by one.

10. If the UE message at step 10 includes the *ackRequested* IE set to TRUE, the SS shall send a LPP acknowledgement message.

11. Repeat steps 2-10 in Table 16.3.3.4-1 until the confidence level according to Annex D is achieved.

16.3.3.4.3 Message contents

Table 16.3.3.4.3-1: RESET UE POSITIONING STORED INFORMATION

Derivation Path: 38.509 [44] clause 6.6			
Information Element	Value/remark	Comment	Condition
UE Positioning Technology	0 0 0 1 0 0 0	DL-AoD	

Table 16.3.3.4.3-2: LPP Request Capabilities

Information Element	Value/remark
nr-DL-AoD-RequestCapabilities-r16	TRUE

Table 16.3.3.4.3-3: LPP ProvideAssistanceData

Derivation Path: 37.355 clause 6.2			
Information Element	Value/remark	Comment	Condition
LPP-Message ::= SEQUENCE {			
transactionID SEQUENCE {			
initiator	locationServer		
transactionNumber	(0..255)		
}			
endTransaction	TRUE		
sequenceNumber	Not present		
acknowledgement	Not present		
lpp-MessageBody CHOICE {			
c1 CHOICE {			
provideAssistanceData SEQUENCE {			
criticalExtensions CHOICE {			
c1 CHOICE {			
provideAssistanceData-r9 SEQUENCE {			
commonIEsProvideAssistanceData	Not present		
a-gnss-ProvideAssistanceData	Not present		
otdoa-ProvideAssistanceData	Not present		
epdu-Provide-AssistanceData	Not present		
sensor-ProvideAssistanceData-r15	Not present		
tbs-ProvideAssistanceData-r15	Not present		
wlan-ProvideAssistanceData-r15	Not present		
nr-Multi-RTT-ProvideAssistanceData-r16	Not present		
nr-DL-AoD-ProvideAssistanceData-r16			
SEQUENCE {			
nr-DL-PRS-AssistanceData-r16	As defined in Table 16.3.3.4.3-4		
nr-SelectedDL-PRS-IndexList-r16	Not present		
nr-PositionCalculationAssistance-r16			Depending on UE capabilities, i.e. support for UE-based DL-AoD
SEQUENCE {			
nr-TRP-LocationInfo-r16	As defined in TS 37.571-5 [20]		
nr-DL-PRS-BeamInfo-r16	Not present		

nr-RTD-Info-r16	Not present		
nr-TRP-BeamAntennaInfo-r17	Not present		
nr-DL-PRS-Expected-LOS-NLOS-Assistance-r17	Not present		
nr-DL-PRS-TRP-TEG-Info-r17	Not present		
}			
nr-DL-AoD-Error-r16	Not present		
nr-DL-PRS-BeamInfo-r17	Not present		
nr-On-Demand-DL-PRS-Configurations-r17	Not present		
}			
nr-DL-TDOA-ProvideAssistanceData-r16	Not present		
}			
}			
}			
}			
}			
}			
}			

Table 16.3.3.4.3-4: NR-DL-PRS-AssistanceData

Derivation Path: 37.355 clause 6.4.3			
Information Element	Value/remark	Comment	Condition
NR-DL-PRS-AssistanceData-r16 ::= SEQUENCE {			
nr-DL-PRS-ReferenceInfo-r16 SEQUENCE {			
dl-PRS-ID-r16	0		
nr-DL-PRS-ResourceID-List-r16	Not present		
nr-DL-PRS-ResourceSetID-r16	Not present		
}			
nr-DL-PRS-AssistanceDataList-r16 SEQUENCE (SIZE (1..nrMaxFreqLayers-r16)) OF NR-DL-PRS-AssistanceDataPerFreq-r16 {	1 entry		
NR-DL-PRS-AssistanceDataPerFreq-r16[1] SEQUENCE {		entry 1	
nr-DL-PRS-PositioningFrequencyLayer-r16 SEQUENCE {			
dl-PRS-SubcarrierSpacing-r16	kHz15		Config 1 and Config 2
	kHz30		Config 3
dl-PRS-ResourceBandwidth-r16	21	104 PRBs	Config 1 and Config 2
	28	132 PRBs	Config 3
dl-PRS-StartPRB-r16	0		
dl-PRS-PointA-r16	absoluteFrequencyPointA as defined for the DL frequency of the Cell 1		
dl-PRS-CombSizeN-r16	N4		
dl-PRS-CyclicPrefix-r16	normal		
}			
nr-DL-PRS-AssistanceDataPerFreq-r16 SEQUENCE (SIZE (1..nrMaxTRPsPerFreq-r16)) OF NR-DL-PRS-AssistanceDataPerTRP-r16{	2 entries		
NR-DL-PRS-AssistanceDataPerTRP-r16[1] SEQUENCE {		entry 1	Cell 1
dl-PRS-ID-r16	0		
nr-PhysCellID-r16	Cell 1		
nr-CellGlobalID-r16	Cell 1		
nr-ARFCN-r16	Cell 1		
nr-DL-PRS-SFN0-Offset-r16 SEQUENCE {			
sfn-Offset-r16	0		
integerSubframeOffset-r16	0		
}			
nr-DL-PRS-ExpectedRSTD-r16	0		
nr-DL-PRS-ExpectedRSTD-Uncertainty-r16	0		

nr-DL-PRS-Info-r16	As specified in Table 16.3.3.4.3-5		
}			
NR-DL-PRS-AssistanceDataPerTRP-r16[2] SEQUENCE {		entry 2	Cell 2
dl-PRS-ID-r16	1		
nr-PhysCellID-r16	Cell 2		
nr-CellGlobalID-r16	Cell 2		
nr-ARFCN-r16	Cell 2		
nr-DL-PRS-SFN0-Offset-r16 SEQUENCE {			
sfn-Offset-r16	0		
integerSubframeOffset-r16	0		
}			
nr-DL-PRS-ExpectedRSTD-r16	92	About 3 μs	
nr-DL-PRS-ExpectedRSTD-Uncertainty-r16	154	About 5 μs	
nr-DL-PRS-Info-r16	As specified in Table 16.3.3.4.3-5		
}			
}			
}			
}			
}			

Table 16.3.3.4.3-5: NR-DL-PRS-Info

Derivation Path: 37.355 clause 6.4.3			
Information Element	Value/remark	Comment	Condition
NR-DL-PRS-Info-r16 ::= SEQUENCE {			
nr-DL-PRS-ResourceSetList-r16 SEQUENCE (SIZE (1..nrMaxSetsPerTrp-r16)) OF NR-DL-PRS-ResourceSet-r16 {	1 entry		
NR-DL-PRS-ResourceSet-r16[1] SEQUENCE {		entry 1	
nr-DL-PRS-ResourceSetID-r16	0		
dl-PRS-Periodicity-and-ResourceSetSlotOffset-r16 CHOICE {			
scs15-r16 CHOICE {			Config 1 & 2
n160-r16	10		
}			
scs30-r16 CHOICE {			Config 3
n320-r16	20		
}			
dl-PRS-ResourceRepetitionFactor-r16	n1		
dl-PRS-ResourceTimeGap-r16	s1		
dl-PRS-NumSymbols-r16	n4		
dl-PRS-MutingOption1-r16 SEQUENCE {			
dl-prs-MutingBitRepetitionFactor-r16	Not present		
nr-option1-muting-r16 CHOICE {			
po2-r16	10 01		Cell 1 Cell 2
}			
}			
dl-PRS-MutingOption2-r16	Not present		
dl-PRS-ResourcePower-r16	27		
dl-PRS-ResourceList-r16 SEQUENCE (SIZE (1..nrMaxResourcesPerSet-r16)) OF NR-DL-PRS-Resource-r16 {	1 entry		
NR-DL-PRS-Resource-r16[1] SEQUENCE {		entry 1	
nr-DL-PRS-ResourceID-r16	0		
dl-PRS-SequenceID-r16	0		
dl-PRS-CombSizeN-AndReOffset-r16 CHOICE {			
N4-r16	0 1		Cell 1 Cell 2
}			
}			
dl-PRS-ResourceSlotOffset-r16	0		Cell1

	4		Cell2
dl-PRS-ResourceSymbolOffset-r16	0		
dl-PRS-QCL-Info-r16	Not present		
}			
}			
}			
}			
}			

Table 16.3.3.4.3-6: LPP RequestLocationInformation

Derivation Path: 37.355 clause 6.2			
Information Element	Value/remark	Comment	Condition
LPP-Message ::= SEQUENCE {			
transactionID SEQUENCE {			
initiator	locationServer		
transactionNumber	1		
}			
endTransaction	FALSE		
sequenceNumber	Not present		
acknowledgement	Not present		
lpp-MessageBody CHOICE {			
c1 CHOICE {			
requestLocationInformation SEQUENCE {			
criticalExtensions CHOICE {			
c1 CHOICE {			
requestLocationInformation-r9 SEQUENCE {			
commonEsRequestLocationInformation SEQUENCE {			
locationInformationType	locationMeasurementsRequired		
triggeredReporting	Not present		
periodicalReporting	Not present		
additionalInformation	onlyReturnInformationRequested		
qos SEQUENCE {			
horizontalAccuracy	Not present		
verticalCoordinateRequest	FALSE		
verticalAccuracy	Not present		
responseTime SEQUENCE {			
time	See 16.3.3.5	Result of the response time calculation rounded up to the next second if response time <= 128s. Result of the response time calculation rounded up to the next multiple of ten seconds if response time > 128s.	
responseTimeEarlyFix-r12	Not present		Rel-12 onwards
unit-r15	Not present ten-seconds		Calculated response time >128s
}			
velocityRequest	FALSE		
}			
environment	Not present		
locationCoordinateTypes	Not present		

velocityTypes	Not present		
}			
a-gnss-RequestLocationInformation	Not present		
otdoa-RequestLocationInformation	Not present		
ecid-RequestLocationInformation	Not present		
epdu-RequestLocationInformation	Not Present		
sensor-RequestLocationInformation-r13	Not present		
tbs-RequestLocationInformation-r13	Not present		
wlan-RequestLocationInformation-r13	Not present		
bt-RequestLocationInformation-r13	Not present		
nr-ECID-RequestLocationInformation-r16	Not present		
nr-Multi-RTT-RequestLocationInformation-r16	Not present		
nr-DL-AoD-RequestLocationInformation-r16			
SEQUENCE {			
nr-AssistanceAvailability-r16	FALSE		
nr-DL-AoD-ReportConfig-r16 SEQUENCE {			
r16 maxDL-PRS-RSRP-MeasurementsPerTRP-	Not present		
r17 maxDL-PRS-RSRP-MeasurementsPerTRP-	Not present		
maxDL-PRS-RSRPP-MeasurementsPerTRP-r17	Not present		
nr-los-nlos-IndicatorRequest-r17	Not present		
reducedDL-PRS-ProcessingSamples-r17	requested		
lowerRxBeamSweepingFactor-FR2-r17	Not present		
}			
multiMeasInSameReport-r17			
}			
nr-DL-TDOA-RequestLocationInformation-r16	Not present		
}			
}			
}			
}			
}			
}			

Table 16.3.3.4.3-7: LPP ProvideLocation Information

Derivation Path: 37.355 clause 6.5.12			
Information Element	Value/remark	Comment	Condition
LPP-Message ::= SEQUENCE {			
transactionID SEQUENCE {			
initiator	locationServer		
transactionNumber	1		
}			
endTransaction	TRUE		
sequenceNumber	(0..255)		
acknowledgement			
lpp-MessageBody CHOICE {			
c1 CHOICE {			
provideLocationInformation SEQUENCE {			
criticalExtensions CHOICE {			
c1 CHOICE {			
provideLocationInformation-r9 SEQUENCE {			
commonIEsProvideLocationInformation	Not present.		
a-gnss-ProvideLocationInformation	Not present		
otdoa-ProvideLocationInformation	Not present		
ecid-ProvideLocationInformation	Not present		
epdu-ProvideLocationInformation	Not present		
sensor-ProvideLocationInformation-r13	Not present		
tbs-ProvideLocationInformation-r13	Not present		
wlan-ProvideLocationInformation-r13	Not present		
bt-ProvideLocationInformation-r13	Not present		
nr-ECID-ProvideLocationInformation-r16	Not present		

nr-Multi-RTT-ProvideLocationInformation-r16	Not present		
nr-DL-AoD-ProvideLocationInformation-r16 SEQUENCE {			
nr-DL-AoD-SignalMeasurementInformation-r16 SEQUENCE {			
nr-DL-AoD-MeasList-r16 SEQUENCE (SIZE(1..nrMaxTRPs-r16)) OF NR-DL-AoD-MeasElement-r16 {			
NR-DL-AoD-MeasElement-r16[1] SEQUENCE {		entry 1	
dl-PRS-ID-r16	INTEGER (0..255)		
nr-PhysCellID-r16	Cell 1		
nr-CellGlobalID-r16			
nr-ARFCN-r16			
nr-DL-PRS-ResourceID-r16			
nr-DL-PRS-ResourceSetID-r16			
nr-TimeStamp-r16			
nr-DL-PRS-RSRP-Result-r16	Present. Any value acceptable.		
nr-DL-PRS-RxBeamIndex-r16			
nr-DL-AoD-AdditionalMeasurements-r16			
nr-DL-PRS-FirstPathRSRP-Result-r17			
nr-los-nlos-Indicator-r17			
nr-DL-AoD-AdditionalMeasurementsExt-r17			
}			
NR-DL-AoD-MeasElement-r16[2] SEQUENCE {		entry 2	
dl-PRS-ID-r16	INTEGER (0..255)		
nr-PhysCellID-r16	Cell 2		
nr-CellGlobalID-r16			
nr-ARFCN-r16			
nr-DL-PRS-ResourceID-r16			
nr-DL-PRS-ResourceSetID-r16			
nr-TimeStamp-r16			
nr-DL-PRS-RSRP-Result-r16	Present. Any value acceptable.		
nr-DL-PRS-RxBeamIndex-r16			
nr-DL-AoD-AdditionalMeasurements-r16			
nr-DL-PRS-FirstPathRSRP-Result-r17			
nr-los-nlos-Indicator-r17			
nr-DL-AoD-AdditionalMeasurementsExt-r17			
}			
}			
}			
nr-dl-AoD-LocationInformation-r16			
nr-DL-AoD-Error-r16	Not present		
nr-DL-AoD-SignalMeasurementInstances-r17	Not present		
nr-DL-AoD-LocationInformationInstances-r17	Not present		
}			
}			
}			
}			
}			
}			
}			
}			

16.3.3.5 Test requirement

Table 16.3.3.5-1 define the primary level settings including test tolerances for the test.

Table 16.3.3.5-1: PRS-RSRP general test parameters

Parameter		Unit	Test 1	
			Cell 1	Cell 2
Cell ID			489	0
SSB ARFCN			freq1	
Duplex mode	Config 1		FDD	
	Config 2,3		TDD	
TDD configuration	Config 1		Not Applicable	
	Config 2		TDDConf.1.1	
	Config 3		TDDConf.2.1	
BW _{channel}	Config 1	MHz	20: N _{RB,c} = 106	
	Config 2		20: N _{RB,c} = 106	
	Config 3		50: N _{RB,c} = 133	
BWP BW	Config 1		20: N _{RB,c} = 106	
	Config 2		20: N _{RB,c} = 106	
	Config 3		50: N _{RB,c} = 133	
Downlink initial BWP configuration			DLBWP.0.1	
Downlink dedicated BWP configuration			DLBWP.1.1	
Uplink initial BWP configuration			ULBWP.0.1	
Uplink dedicated BWP configuration			ULBWP.1.1	
TRS configuration	Config 1		TRS.1.1 FDD	NA
	Config 2		TRS.1.1 TDD	NA
	Config 3		TRS.1.2 TDD	NA
DRX Cycle		ms	Not Applicable	
Measurement gap			GP#24 or GP#0 ^{Note 7}	
PDSCH Reference measurement channel	Config 1		SR.1.1 FDD	-
	Config 2		SR.1.1 TDD	
	Config 3		SR2.1 TDD	
RMSI CORESET Reference Channel	Config 1		CR.1.1 FDD	-
	Config 2		CR.1.1 TDD	
	Config 3		CR2.1 TDD	
Control channel RMC	Config 1		CCR.1.1 FDD	-
	Config 2		CCR.1.1 TDD	
	Config 3		CCR2.1 TDD	
PRS configuration	Config 1		PRS.1.4 FR1	PRS.1.4 FR1
	Config 2		PRS.1.4 FR1	PRS.1.4 FR1
	Config 3		PRS.2.4 FR1	PRS.2.4 FR1
PRS Resource slot offset (slot)	Config 1,2,3	slot	0	4
SSB configuration	Config 1		SSB.1 FR1	SSB.1 FR1
	Config 2		SSB.1 FR1	SSB.1 FR1
	Config 3		SSB.2 FR1	SSB.2 FR1
Time offset with Cell 1	Config 1	ms	-	3
	Config 2,3	µs	-	3
SMTC configuration	Config 1		SMTC.2	
	Config 2,3		SMTC.1	
OCNG Patterns			OCNG pattern 1	
PDSCH/PDCCH subcarrier spacing	Config 1,2	kHz	15 kHz	
	Config 3		30 kHz	
EPRE ratio of PSS to SSS		dB	0	0
EPRE ratio of PBCH DMRS to SSS				
EPRE ratio of PBCH to PBCH DMRS				
EPRE ratio of PDCCH DMRS to SSS				

EPRE ratio of PDCCH to PDCCH DMRS				
EPRE ratio of PDSCH DMRS to SSS				
EPRE ratio of PDSCH to PDSCH				
EPRE ratio of OCNG DMRS to SSS(Note 1)				
EPRE ratio of OCNG to OCNG DMRS (Note 1)				
N_{oc} ^{Note2}	Config 1,2		dBm/15KhZ	-98
	Config 3			-98
N_{oc} ^{Note2}	Config 1,2		dBm/SCS	-98
	Config 3			-95
\hat{E}_s/I_{ot}			dB	0 -6
\hat{E}_s/N_{oc}			dB	2.23 -1.73
SS-RSRP			dB	Same as PRS-RSRP
PRS-RSRP ^{Note3}	Config 1, 2		dBm/SCS	-95.77 -99.73
	Config 3			-92.77 -96.73
I_o ^{Note3}	Config 1,2		dBm/19.08MHz	-61.71
	Config 3			-57.73
Propagation condition				AWGN
Antenna configuration				1x2
<p>Note 1: OCNG shall be used such that both cells are fully allocated and a constant total transmitted power spectral density is achieved for all OFDM symbols.</p> <p>Note 2: Interference from other cells and noise sources not specified in the test is assumed to be constant over subcarriers and time and shall be modelled as AWGN of appropriate power for N_{oc} to be fulfilled.</p> <p>Note 3: SS-RSRP and PRS-RSRP and I_o levels have been derived from other parameters for information purposes. They are not settable parameters themselves.</p>				

Note 4:	PRS-RSRP minimum requirements are specified assuming independent interference and noise at each receiver antenna port.
Note 5:	Void.
Note 6:	Void.
Note 7:	GP#24 is configured if UE supports MG#24, otherwise GP#0 is configured.

The value of the LPP Time IE depends on the UE capabilities. The calculation is the same as in clause 16.2.5.5. Therefore, the value of the LPP Time IE is given by the following equation:

$$\left(\left\lceil \frac{16}{N'} \right\rceil \left\lceil \frac{1}{N} \right\rceil * 4 - 1 \right) * T_{effect} + T_{last}$$

The resulting value shall be rounded up to the next integer and transmitted in the LPP-RequestLocationInformation (see Table 16.3.3.4.3-3).

Table 16.3.3.5-2: PRS-RSRP accuracy requirements for the reported values for Config 1 & 2

Test Configuration	SReport Mapping	Cell 1		Cell 2	
		Lowest reported value	Highest reported value	Lowest reported value	Highest reported value
1 & 2	Absolute Accuracy	FFS	FFS	FFS	FFS
3	Absolute Accuracy	FFS	FFS	FFS	FFS
1 & 2	Relative Accuracy	FFS	FFS	FFS	FFS
3	Relative Accuracy	FFS	FFS	FFS	FFS

The PRS RSRP measurement period fulfils the requirements specified in clause 4.16.3.

The test tolerances are defined in clauses C.1.6 and C.2.5.

The rate of successful tests during repeated tests shall be at least 90% with a confidence level of 95%.

16.3.4 PRS-RSRP measurement accuracy with PRS in FR2 with reduced sample number

Editor's Note: This test case has been completed for the following configurations:

- Test frequency $f \leq 40.8$ GHz

- UE PC3

16.3.4.1 Test purpose

The purpose of this test is to verify that the accuracy of PRS-RSRP measurement with reduced sample number is within the specified limits. This test will verify the requirements in TS 38.133 [50] clauses 10.1.24.2.1 and 10.1.24.2.2.

16.3.4.2 Test applicability

This test applies to all types of NR UE release 17 onwards that supports DL-AoD positioning and supportedDL-PRS-ProcessingSamples-RRC-CONNECTED.

16.3.4.3 Minimum conformance requirements

The absolute accuracy requirements for PRS-RSRP measurement for FR2 defined in Table 10.1.24.2.1-4 are valid under the following conditions:

- Conditions defined in 38.101-2 Clause 7.3 for reference sensitivity are fulfilled.
- PRP $1,2|_{dBm}$ according to Annex B.2.14 for a corresponding Band
- UE supports positioning measurements with reduced number of samples, and LMF indicates UE to perform positioning measurements with reduced number of samples
- AWGN channel

...

Table 10.1.24.2.1-4: PRS-RSRP absolute accuracy for FR2 with reduced sample number

Accuracy		Conditions					
Normal condition	Extreme condition	PRS \hat{E}_s/lot	PRS BW	Repetition factor ($T_{rep}^{PRS} * L_{PRS}/K_{comb}^{PRS}$)	Io ^{Note 6} range		
					Minimum Io ^{Note 1} dBm / SCS _{PRS}		Maximum Io
dB	dB	dB	PRB	-	dBm / SCS _{PRS}		dBm/BW _{Channel}
					dBm/120kHz z ^{Note 5}	dBm/60kHz ^{Note 5}	
±5	±8	≥0	≥48	All	Same value as PRP in Table B.2.14-2, according to UE Power class, operating band and angle of arrival		-50
±8.5	±11.5	≥-6	48 ≤ BW ≤ 64	All	Note 3		
±6	±9		BW >64	All	Note 3		
<p>NOTE 1: This minimum Io condition is expressed as the average Io per RE over all REs in an OFDM symbol.</p> <p>NOTE 2: PRS bandwidth is as indicated in <i>prs-Bandwidth</i> in the OTDOA or DL-AoD assistance data defined in [34].</p> <p>NOTE 3: The same bands and the same Io conditions for each band apply for this requirement as for the corresponding requirement with the PRS bandwidth ≥ 48 RB.</p> <p>NOTE 4: The serving cell, the reference cell, and the measured neighbour cell i are on the same carrier frequency.</p> <p>NOTE 5: The condition level is increased by Δ>0, when applicable, as described in Sections B.3.2 and B.3.3.</p> <p>NOTE 6: The Io is defined in PRS positioning subframes. The same Io range applies to PRS and non-PRS symbols. Io levels are different in PRS and non-PRS symbols within the same subframe.</p> <p>NOTE 7: NR operating band groups are as defined in Section 3.5.2.</p>							

16.3.4.4 Test description

16.3.4.4.1 Initial conditions

The supported test configurations in listed in Table 16.3.4.4-1.

Table 16.3.4.4-1: Test Configurations

Test Configuration	Description
1	120 kHz SSB and PRS SCS, 200 MHz bandwidth, TDD duplex mode

Test Environment: Normal, as defined in TS 38.508-1 [45] clause 4.1.

Frequencies to be tested: Mid Range, as defined in TS 38.508-1 [45] clause 4.3.1.

Channel bandwidth to be tested: are specified in Table 16.3.4.4-1.

1. Connect the SS and AWGN noise sources to the UE antenna connector or antenna connectors as shown in Annex A, Figure A.14.
2. The general test parameter settings are set up according to Table 16.3.4.5-1 and Table 16.3.4.5-2.
3. Propagation conditions are set according to clause 4.16.2.
4. Message contents are defined in clause 16.3.4.4.3.

- In the test there are two synchronous cells: Cell 1 and Cell 2. Cell 1 is the reference as well as the PCell. Cell 2 is the neighbour cell. All cells are on the same RF channel distributed in single positioning frequency layer.

16.3.4.4.2 Test procedure

The test consists of a set-up period and a measurement period. Cell 1 and Cell 2 are both active during the complete test. The beginning of the measurement period shall be aligned with the first PRS positioning subframe of a positioning occasion in the reference cell. The NR-DL-AoD-ProvideAssistanceData and NR-DL-AoD-RequestLocationInformation as defined in TS 37.355 [49] shall be provided to the UE during the set-up period.

- Ensure the UE is in State RRC_CONNECTED with generic procedure parameters Connectivity NR, Connected without release On, according to TS 38.508-1 [45] clause 4.5.
- The SS shall send a RESET UE POSITIONING STORED INFORMATION message.
- Set the parameters according to Table 16.3.4.5-1 and Table 16.3.4.5-2. Propagation conditions are set according to clause 4.16.2.
- The SS shall transmit an LPP REQUEST CAPABILITIES message.
- The UE shall transmit an LPP PROVIDE CAPABILITIES message indicating the DL-AoD capabilities supported by the UE in the NR-DL-AoD-ProvideCapabilities IE.
- The SS shall send a LPP PROVIDE ASSISTANCE DATA message, including the NR-DL-AoD-ProvideAssistanceData IE. The position of neighbour Cell 2 is described in 3GPP TS 37.571-5 [20]. If the UE message at step 6 includes the ackRequested IE set to TRUE, then the SS shall send an acknowledgment in the LPP PROVIDE ASSISTANCE DATA message.
- The SS shall send a LPP REQUEST LOCATION INFORMATION message, including the reducedDL-PRS-ProcessingSamples-r17 in the NR-DL-AoD-RequestLocationInformation IE such that the UE receives the message T ms before the start of the measurement period, where T = 50 ms.
- The UE shall transmit a LPP PROVIDE LOCATION INFORMATION message including the NR-DL-AoD-ProvideLocationInformation IE within the response time (see clause 4.16.3). The UE shall perform and report the PRS-RSRP measurements for Cell 2 with respect to the reference cell in the DL-TDOA assistance data, Cell 1. If the UE transmits an NR-DL-AoD-ProvideLocationInformation IE including the nr-DL-PRS-RSRP-Result-r16 field for Cell 2 within the response time then the number of successful tests is increased by one. If the UE fails to report the NR-DL-AoD-ProvideLocationInformation IE with both the nr-DL-PRS-RSRP-Result-r16 fields included within the response time then the number of failure tests is increased by one.
- If the UE message at step 10 includes the ackRequested IE set to TRUE, the SS shall send a LPP acknowledgement message.
- Repeat steps 2-10 in Table 16.3.4.4-1 until the confidence level according to Annex D is achieved.

16.3.4.4.3 Message contents

Table 16.3.4.4.3-1: RESET UE POSITIONING STORED INFORMATION

Derivation Path: 38.509 [44] clause 6.6			
Information Element	Value/remark	Comment	Condition
UE Positioning Technology	0 0 0 1 0 0 0	DL-AoD	

Table 16.3.4.4.3-2: LPP Request Capabilities

Information Element	Value/remark
nr-DL-AoD-RequestCapabilities-r16	TRUE

Table 16.3.4.4.3-3: LPP ProvideAssistanceData

Derivation Path: 37.355 clause 6.2			
Information Element	Value/remark	Comment	Condition

LPP-Message ::= SEQUENCE {			
transactionID SEQUENCE {			
initiator	locationServer		
transactionNumber	(0..255)		
}			
endTransaction	TRUE		
sequenceNumber	Not present		
acknowledgement	Not present		
lpp-MessageBody CHOICE {			
c1 CHOICE {			
provideAssistanceData SEQUENCE {			
criticalExtensions CHOICE {			
c1 CHOICE {			
provideAssistanceData-r9 SEQUENCE {			
commonEsProvideAssistanceData	Not present		
a-gnss-ProvideAssistanceData	Not present		
otdoa-ProvideAssistanceData	Not present		
epdu-Provide-AssistanceData	Not present		
sensor-ProvideAssistanceData-r15	Not present		
tbs-ProvideAssistanceData-r15	Not present		
wlan-ProvideAssistanceData-r15	Not present		
nr-Multi-RTT-ProvideAssistanceData-r16	Not present		
nr-DL-AoD-ProvideAssistanceData-r16			
SEQUENCE {			
nr-DL-PRS-AssistanceData-r16	As defined in Table 16.3.4.4.3-4		
nr-SelectedDL-PRS-IndexList-r16	Not present		
nr-PositionCalculationAssistance-r16			Depending on UE capabilities, i.e. support for UE-based DL-AoD
SEQUENCE {			
nr-TRP-LocationInfo-r16	As defined in TS 37.571-5 [20]		
nr-DL-PRS-BeamInfo-r16	Not present		
nr-RTD-Info-r16	Not present		
nr-TRP-BeamAntennaInfo-r17	Not present		
nr-DL-PRS-Expected-LOS-NLOS-Assistance-r17	Not present		
nr-DL-PRS-TRP-TEG-Info-r17	Not present		
}			
nr-DL-AoD-Error-r16	Not present		
nr-DL-PRS-BeamInfo-r17	Not present		
nr-On-Demand-DL-PRS-Configurations-r17	Not present		
}			
nr-DL-TDOA-ProvideAssistanceData-r16	Not present		
}			
}			
}			
}			
}			
}			

Table 16.3.4.4.3-4: NR-DL-PRS-AssistanceData

Derivation Path: 37.355 clause 6.4.3			
Information Element	Value/remark	Comment	Condition
NR-DL-PRS-AssistanceData-r16 ::= SEQUENCE {			
nr-DL-PRS-ReferenceInfo-r16 SEQUENCE {			
dl-PRS-ID-r16	0		
nr-DL-PRS-ResourceID-List-r16	Not present		
nr-DL-PRS-ResourceSetID-r16	Not present		

}			
nr-DL-PRS-AssistanceDataList-r16 SEQUENCE (SIZE (1..nrMaxFreqLayers-r16)) OF NR-DL-PRS-AssistanceDataPerFreq-r16 {	1 entry		
NR-DL-PRS-AssistanceDataPerFreq-r16[1] SEQUENCE {		entry 1	
nr-DL-PRS-PositioningFrequencyLayer-r16 SEQUENCE {			
dl-PRS-SubcarrierSpacing-r16	kHz120		
dl-PRS-ResourceBandwidth-r16	11	64 PRBs	
dl-PRS-StartPRB-r16	0		
dl-PRS-PointA-r16	absoluteFrequencyPointA as defined for the DL frequency of the Cell 1		
dl-PRS-CombSizeN-r16	n2		
dl-PRS-CyclicPrefix-r16	normal		
}			
nr-DL-PRS-AssistanceDataPerFreq-r16 SEQUENCE (SIZE (1..nrMaxTRPsPerFreq-r16)) OF NR-DL-PRS-AssistanceDataPerTRP-r16{	2 entries		
NR-DL-PRS-AssistanceDataPerTRP-r16[1] SEQUENCE {		entry 1	Cell 1
dl-PRS-ID-r16	0		
nr-PhysCellID-r16	Cell 1		
nr-CellGlobalID-r16	Cell 1		
nr-ARFCN-r16	Cell 1		
nr-DL-PRS-SFN0-Offset-r16 SEQUENCE {			
sfn-Offset-r16	0		
integerSubframeOffset-r16	0		
}			
nr-DL-PRS-ExpectedRSTD-r16	0		
nr-DL-PRS-ExpectedRSTD-Uncertainty-r16	0		
nr-DL-PRS-Info-r16	As specified in Table 16.3.4.4.3-5		
}			
NR-DL-PRS-AssistanceDataPerTRP-r16[2] SEQUENCE {		entry 2	Cell 2
dl-PRS-ID-r16	1		
nr-PhysCellID-r16	Cell 2		
nr-CellGlobalID-r16	Cell 2		
nr-ARFCN-r16	Cell 2		
nr-DL-PRS-SFN0-Offset-r16 SEQUENCE {			
sfn-Offset-r16	0		
integerSubframeOffset-r16	0		
}			
nr-DL-PRS-ExpectedRSTD-r16	23	About 3 μs	
nr-DL-PRS-ExpectedRSTD-Uncertainty-r16	154	About 5 μs	
nr-DL-PRS-Info-r16	As specified in Table 16.3.4.4.3-5		
}			
}			
}			
}			
}			

Table 16.3.4.4.3-5: NR-DL-PRS-Info

Derivation Path: 37.355 clause 6.4.3			
Information Element	Value/remark	Comment	Condition
NR-DL-PRS-Info-r16 ::= SEQUENCE {			
nr-DL-PRS-ResourceSetList-r16 SEQUENCE (SIZE (1..nrMaxSetsPerTrp-r16)) OF NR-DL-PRS-ResourceSet-r16 {	1 entry		
NR-DL-PRS-ResourceSet-r16[1] SEQUENCE {		entry 1	
nr-DL-PRS-ResourceSetID-r16	0		

dl-PRS-Periodicity-and-ResourceSetSlotOffset-r16 CHOICE {			
scs120-r16 CHOICE {			
n1280-r16	80		
}			
dl-PRS-ResourceRepetitionFactor-r16	n2		
dl-PRS-ResourceTimeGap-r16	s1		
dl-PRS-NumSymbols-r16	n4		
dl-PRS-MutingOption1-r16 SEQUENCE {			
dl-prs-MutingBitRepetitionFactor-r16	Not present		
nr-option1-muting-r16 CHOICE {			
po2-r16	10		Cell 1
	01		Cell 2
}			
}			
dl-PRS-MutingOption2-r16	Not present		
dl-PRS-ResourcePower-r16	27		
dl-PRS-ResourceList-r16 SEQUENCE (SIZE (1..nrMaxResourcesPerSet-r16)) OF NR-DL-PRS-Resource-r16 {	1 entry		
NR-DL-PRS-Resource-r16[1] SEQUENCE {		entry 1	
nr-DL-PRS-ResourceID-r16	0		
dl-PRS-SequenceID-r16	0		
dl-PRS-CombSizeN-AndReOffset-r16 CHOICE {			
n2-r16	0		
}			
dl-PRS-ResourceSlotOffset-r16	0		
dl-PRS-ResourceSymbolOffset-r16	0		
dl-PRS-QCL-Info-r16	Not present		
}			
}			
}			
}			
}			
}			

Table 16.3.4.4.3-6: LPP RequestLocationInformation

Derivation Path: 37.355 clause 6.2			
Information Element	Value/remark	Comment	Condition
LPP-Message ::= SEQUENCE {			
transactionID SEQUENCE {			
initiator	locationServer		
transactionNumber	1		
}			
endTransaction	FALSE		
sequenceNumber	Not present		
acknowledgement	Not present		
lpp-MessageBody CHOICE {			
c1 CHOICE {			
requestLocationInformation SEQUENCE {			
criticalExtensions CHOICE {			
c1 CHOICE {			
requestLocationInformation-r9 SEQUENCE {			
commonEsRequestLocationInformation SEQUENCE {			
locationInformationType	locationMeasurementsRequired		
triggeredReporting	Not present		
periodicalReporting	Not present		
additionalInformation	onlyReturnInformationRequested		
qos SEQUENCE {			
horizontalAccuracy	Not present		
verticalCoordinateRequest	FALSE		

verticalAccuracy	Not present		
responseTime SEQUENCE { time	See 16.3.4.5	Result of the response time calculation rounded up to the next second if response time <= 128s. Result of the response time calculation rounded up to the next multiple of ten seconds if response time > 128s.	
responseTimeEarlyFix-r12	Not present		Rel-12 onwards
unit-r15	Not present ten-seconds		Calculated response time >128s
}			
velocityRequest	FALSE		
}			
environment	Not present		
locationCoordinateTypes	Not present		
velocityTypes	Not present		
}			
a-gnss-RequestLocationInformation	Not present		
otdoa-RequestLocationInformation	Not present		
ecid-RequestLocationInformation	Not present		
epdu-RequestLocationInformation	Not Present		
sensor-RequestLocationInformation-r13	Not present		
tbs-RequestLocationInformation-r13	Not present		
wlan-RequestLocationInformation-r13	Not present		
bt-RequestLocationInformation-r13	Not present		
nr-ECID-RequestLocationInformation-r16	Not present		
nr-Multi-RTT-RequestLocationInformation-r16	Not present		
nr-DL-AoD-RequestLocationInformation-r16			
SEQUENCE {			
nr-AssistanceAvailability-r16	FALSE		
nr-DL-AoD-ReportConfig-r16 SEQUENCE {			
maxDL-PRS-RSRP-MeasurementsPerTRP-r16	Not present		
maxDL-PRS-RSRP-MeasurementsPerTRP-r17	Not present		
maxDL-PRS-RSRPP-MeasurementsPerTRP-r17	Not present		
nr-los-nlos-IndicatorRequest-r17	Not present		
reducedDL-PRS-ProcessingSamples-r17	requested		
lowerRxBeamSweepingFactor-FR2-r17	Not present		
}			
multiMeasInSameReport-r17			
}			
nr-DL-TDOA-RequestLocationInformation-r16	Not present		
}			
}			
}			
}			
}			
}			

Table 16.3.4.4.3-7: LPP ProvideLocation Information

Derivation Path: 37.355 clause 6.5.12			
Information Element	Value/remark	Comment	Condition
LPP-Message ::= SEQUENCE {			
transactionID SEQUENCE {			
initiator	locationServer		
transactionNumber	1		
}			
endTransaction	TRUE		
sequenceNumber	(0..255)		
acknowledgement			
lpp-MessageBody CHOICE {			
c1 CHOICE {			
provideLocationInformation SEQUENCE {			
criticalExtensions CHOICE {			
c1 CHOICE {			
provideLocationInformation-r9 SEQUENCE {			
commonIEsProvideLocationInformation	Not present.		
a-gnss-ProvideLocationInformation	Not present		
otdoa-ProvideLocationInformation	Not present		
ecid-ProvideLocationInformation	Not present		
epdu-ProvideLocationInformation	Not present		
sensor-ProvideLocationInformation-r13	Not present		
tbs-ProvideLocationInformation-r13	Not present		
wlan-ProvideLocationInformation-r13	Not present		
bt-ProvideLocationInformation-r13	Not present		
nr-ECID-ProvideLocationInformation-r16	Not present		
nr-Multi-RTT-ProvideLocationInformation-r16	Not present		
nr-DL-AoD-ProvideLocationInformation-r16 SEQUENCE {			
nr-DL-AoD-SignalMeasurementInformation-r16 SEQUENCE {			
nr-DL-AoD-MeasList-r16 SEQUENCE (SIZE(1..nrMaxTRPs-r16)) OF NR-DL-AoD-MeasElement-r16 {			
NR-DL-AoD-MeasElement-r16[1] SEQUENCE {		entry 1	
dl-PRS-ID-r16	INTEGER (0..255)		
nr-PhysCellID-r16	Cell 1		
nr-CellGlobalID-r16			
nr-ARFCN-r16			
nr-DL-PRS-ResourceID-r16			
nr-DL-PRS-ResourceSetID-r16			
nr-TimeStamp-r16			
nr-DL-PRS-RSRP-Result-r16	Present. Any value acceptable.		
nr-DL-PRS-RxBeamIndex-r16			
nr-DL-AoD-AdditionalMeasurements-r16			
nr-DL-PRS-FirstPathRSRP-Result-r17			
nr-los-nlos-Indicator-r17			
nr-DL-AoD-AdditionalMeasurementsExt-r17			
}			
}		entry 2	
}			
}			
}			

	nr-DL-PRS-RSRP-Result-r16	Present. Any value acceptable.		
	nr-DL-PRS-RxBeamIndex-r16			
r16	nr-DL-AoD-AdditionalMeasurements-			
	nr-DL-PRS-FirstPathRSRP-Result-r17			
	nr-los-nlos-Indicator-r17			
	nr-DL-AoD-AdditionalMeasurementsExt-r17			
	}			
	}			
	}			
	nr-dl-AoD-LocationInformation-r16			
	nr-DL-AoD-Error-r16	Not present		
r17	nr-DL-AoD-SignalMeasurementInstances-	Not present		
r17	nr-DL-AoD-LocationInformationInstances-	Not present		
	}			
	}			
	}			
	}			
	}			
	}			
	}			
	}			

16.3.4.5 Test requirement

Table 16.3.4.5-1 and Table 16.3.4.5-2 define the primary level settings including test tolerances for the test.

Table 16.3.4.5-1: PRS-RSRP general test parameters

Parameter	Unit	Test 1	
		Cell 1	Cell 2
Cell ID		489	0
SSB ARFCN		freq1	
Duplex mode		TDD	
TDD configuration		TDDConf.3.1	
BW _{channel}	MHz	200: N _{RB,c} = 132	
Downlink initial BWP configuration		DLBWP.0.1	-
Downlink dedicated BWP configuration		DLBWP.1.1	-
Uplink initial BWP configuration		ULBWP.0.1	-
Uplink dedicated BWP configuration		ULBWP.1.1	-
DRX cycle configuration		Not applicable	-
Measurement gap		GP#13 or GP#24 ^{Note2}	
TRS configuration		TRS.2.1 TDD	-
TCI state		TCI.State.0	-
PDSCH Reference measurement channel		SR.3.1 TDD	-
RMSI CORESET Reference Channel		CR.3.1 TDD	-
Control channel RMC		CCR.3.1 TDD	-
OCNG Patterns		OP.3	OP.3
SSB configuration		SSB.3 FR2	SSB.3 FR2
SMTC configuration		SMTC.1	SMTC.1
Time offset with Cell 1	µs	-	3
PRS configuration		PRS.1.4 FR2	PRS.1.4 FR2
PRS BW	RB	64	64
PRS Resource slot offset	slot	0	4
PDSCH/PDCCH subcarrier spacing	kHz	120	120
EPRE ratio of PSS to SSS	dB	0	0
EPRE ratio of PBCH_DMRS to SSS			
EPRE ratio of PBCH to PBCH_DMRS			
EPRE ratio of PDCCH_DMRS to SSS			
EPRE ratio of PDCCH to PDCCH_DMRS			

EPRE ratio of PDSCH_DMRS to SSS			
EPRE ratio of PDSCH to PDSCH_DMRS			
EPRE ratio of OCNG DMRS to SSS ^{Note 1}			
EPRE ratio of OCNG to OCNG DMRS ^{Note 1}			
Propagation conditions		AWGN	AWGN
Antenna configuration		1x2	1x2
<p>Note 1: OCNG shall be used such that both cells are fully allocated and a constant total transmitted power spectral density is achieved for all OFDM symbols.</p> <p>Note 2: GP#24 is configured if UE supports MG#24, otherwise GP#13 is configured.</p>			

Table 16.3.4.5-2: PRS-RSRP OTA related test parameters

Parameter	Unit	Test 1	
		Cell 1	Cell 2
Angle of arrival configuration		Setup 1 according to TS 38.133 [50] clause A.3.15.1	
Assumption for UE beams ^{Note 7}		Rough	
N_{oc} ^{Note1}	dBm/15kHz ^{Note4}	-103	
N_{oc} ^{Note1}	dBm/SCS ^{Note4}	-94	
PRS \hat{E}_s / N_{oc}	dB	3.56	-0.28
E_s	dBm/SCS ^{Note4}	-	-
PRS_RP ^{Note2}	dBm/SCS	-090.4	-94.2
SSB_RP ^{Note2}	dBm/SCS	-86.77	-90.73
$\hat{E}_s / I_{ot_{BB}}$ ^{Note6}	dB	0.32	-5.64
I_o ^{Note2}	dBm/190.08 MHz ^{Note4}	-55.73	
<p>Note 1: Where used, interference from other cells and noise sources not specified in the test is assumed to be constant over subcarriers and time and shall be modelled as AWGN of appropriate power for N_{oc} to be fulfilled.</p> <p>Note 2: SSB_RP, PRS_RP, E_s/I_{ot} and I_o levels have been derived from other parameters for information purposes. They are not settable parameters themselves.</p> <p>Note 3: Void</p> <p>Note 4: Equivalent power received by an antenna with 0 dBi gain at the centre of the quiet zone</p> <p>Note 5: Void</p> <p>Note 6: Calculation of $E_s/I_{ot_{BB}}$ includes the effect of UE internal noise up to the value assumed for the associated Refsens requirement in clause 7.3.2 of TS 38.101-2 [55], and an allowance of 1dB for UE multi-band relaxation factor ΔMB_P from TS 38.101-2 [55] Table 6.2.1.3-4.</p> <p>Note 7: Information about types of UE beam is given in B.2.1.3, and does not limit UE implementation or test system implementation</p>			

The value of the LPP Time IE depends on the UE capabilities. The calculation is the same as in clause 16.2.7.5 Therefore, the value of the LPP Time IE is given by the following equation:

$$\left(1 * 1 * 8 * \left\lceil \frac{2}{N'} \right\rceil \left\lceil \frac{0.071}{N} \right\rceil * 1 - 1 \right)$$

The resulting value shall be rounded up to the next integer and transmitted in the LPP-RequestLocationInformation (see Table 16.3.4.4.3-3).

Table 16.3.4.5-3: PRS RSRP accuracy requirements for the reported values

Test Configuration	Report Mapping	Lowest reported value	Highest reported value
Test 1	Absolute PRS RSRP accuracy for Cell 1	66	76
	Relative PRS RSRP accuracy for Cell 1	25	30
	Absolute PRS RSRP accuracy for Cell 2	61	73

	Relative PRS RSRP accuracy for Cell 2	23	30
--	---------------------------------------	----	----

The PRS RSRP measurement period fulfils the requirements specified in clause 4.16.3.

The test tolerances are defined in clauses C.1.6 and C.2.5.

The rate of successful tests during repeated tests shall be at least 90% with a confidence level of 95%.

16.4 NR PRS-RSRP measurement period test cases in RRC_INACTIVE

16.4.1 PRS-RSRP measurement reporting delay test case for single positioning frequency layer in FR1 SA

Editor's note: This test case is incomplete. The following aspect is either missing or TBD:

- Test tolerance is missing
- Message contents require update

16.4.1.1 Test purpose

The purpose of the test is to verify the PRS RSRP measurement requirements specified in TS 38.133 [50] Clause 5.6.3.5 for single positioning frequency layer under AWGN propagation conditions in RRC_INACTIVE in FR1 standalone scenario.

16.4.1.2 Test applicability

This test applies to all types of NR UE release 17 onwards that supports DL-AoD positioning and supports DL-PRS measurement in RRC_INACTIVE state.

16.4.1.3 Minimum conformance requirements

When the physical layer receives *NR-DL-AoD-ProvideAssistanceData* message and *NR-DL-AoD-RequestLocationInformation* message from LMF via LPP [34], the UE shall be able to measure multiple (up to the UE capability specified in Clause 5.6.3.3) PRS-RSRP measurements, defined in TS 38.215 [4], from configured PRS resources for configured TRPs on configured positioning frequency layers, within $T_{\text{PRS-RSRP, total}}$ ms.

$$T_{\text{PRS-RSRP, total}} = \sum_{i=1}^L T_{\text{PRS-RSRP, }i} + (L - 1) * \max(T_{\text{effect, }i})$$

Where:

- i is the index of positioning frequency layer,
- L is total number of positioning frequency layers,
- $T_{\text{effect, }i}$ is the periodicity of the PRS-RSRP measurement in positioning frequency layer i .

$$T_{\text{PRS-RSRP, }i} = \left(K_{\text{carrier_PRS}} * N_{\text{RxBeam, }i} * \left\lceil \frac{N_{\text{PRS, }i}^{\text{slot}}}{N'} \right\rceil \left\lfloor \frac{L_{\text{available_PRS, }i}}{N} \right\rfloor * N_{\text{sample}} - 1 \right) * T_{\text{effect, }i} + T_{\text{last, }i} \text{ Where:}$$

- $K_{\text{carrier_PRS}}$ is a scaling factor for PRS-based NR positioning measurements in RRC_INACTIVE. If the UE supports *parallelPRS-MeasRRC-Inactive-r17*, $K_{\text{carrier_PRS}} = 1$. Otherwise,
- If $S_{\text{rxlev}} \leq S_{\text{nonIntraSearchP}}$ or $S_{\text{qual}} \leq S_{\text{nonIntraSearchQ}}$, $K_{\text{carrier_PRS}}$ equals to the sum of K_{carrier} in 4.2.2.4 and one positioning layer.
- If $S_{\text{rxlev}} > S_{\text{nonIntraSearchP}}$ and $S_{\text{qual}} > S_{\text{nonIntraSearchQ}}$, $K_{\text{carrier_PRS}}$ equals to the sum of N_{layer} in 4.2.2.7 and one positioning layer.

- $N_{RxBeam,i}$ is the scaling factor for Rx beam sweeping:
 - $N_{RxBeam,i}=1$ if positioning frequency layer i is in FR1, and if positioning frequency layer i is in FR2
 - $N_{RxBeam,i}$ equals to the value as UE reported in *supportedLowerRxBeamSweepingFactor-FR2* if the capability is reported by the UE for the band containing positioning frequency layer i , and LMF indicates *lowerRxBeamSweepingFactor-FR2* in *NR-DL-AoD-RequestLocationInformation*.
 - $N_{RxBeam,i}$ equals to 8, otherwise.
- $L_{available_PRS,i}$ is the time duration of available PRS to be measured in the positioning frequency layer i to be measured during $T_{PRS,i}$, and is calculated in the same way as PRS duration K defined in clause 5.1.6.5 of TS 38.214 [26]. For calculation of $L_{available_PRS,i}$, only unmuted PRS resources that are not fully overlapped with other higher-priority DL signals/channels are considered.
- $N_{PRS,i}^{slot}$ is the maximum number of DL PRS resources of positioning frequency layer i configured in a slot,
- $\{N, T\}$ is UE capability combination per band where N is a duration of DL PRS symbols in ms corresponding to *durationOfPRS-ProcessingSymbols-r17* in TS 37.355 [34] processed every T ms corresponding to *durationOfPRS-ProcessingSymbolsInEveryTms-r17* in TS 37.355 [34] for a given maximum bandwidth supported by UE corresponding to *supportedBandwidthPRS* in TS 37.355 [34],
- N' is UE capability for number of DL PRS resources that it can process in a slot as indicated by *maxNumOfDL-PRS-ResProcessedPerSlot-RRC-Inactive-r17* in clause 6.4.3 of TS 37.355 [34],
- N_{sample} is the number of PRS-RSRP measurement samples and
 - $N_{sample} = 1$, if UE supports *supportedDL-PRS-ProcessingSamples-RRC-Inactive* [34], and the LMF indicates the UE to perform positioning measurements with reduced number of samples by *reducedDL-PRS-ProcessingSamples* [34], and the following conditions are met:
 - PRS bandwidth is within the initial BWP and
 - Magnitude of difference between the serving cell's SS-RSRP and the neighbour cell's PRS-RSRP is within 6 dB.
 - $N_{sample} = 2$, if UE supports *supportedDL-PRS-ProcessingSamples-RRC-Inactive* [34], and the LMF indicates the UE to perform positioning measurements with reduced number of samples by *reducedDL-PRS-ProcessingSamples* [34], and the following conditions are not met:
 - PRS bandwidth is within the initial BWP and
 - Magnitude of difference between the serving cell's SS-RSRP and the neighbour cell's PRS-RSRP is within 6 dB.
 - $N_{sample} = 4$ otherwise
- $T_{last,i} = T_i + T_{available_PRS,i}$ is the measurement duration for the last PRS-RSRP sample, including the sampling time and processing time,
 - $T_{effect,i} = \left\lceil \frac{T_i}{T_{available_PRS,i}} \right\rceil * T_{available_PRS,i}$ is the periodicity of PRS-RSRP measurement in positioning frequency layer i ,
 - T_i corresponds to *durationOfPRS-ProcessingSymbolsInEveryTms-r17* in TS 37.355 [34],
 - $T_{available_PRS,i} = LCM(T_{PRS,i}, T_{DRX})$ is the least common multiple between $T_{PRS,i}$ and T_{DRX} ,
 - $T_{PRS,i}$ is the maximum PRS resource periodicity among all PRS resources in positioning frequency layer i ,
 - T_{DRX} is the DRX cycle length.

If positioning frequency layer i has more than one DL PRS resource set with different PRS periodicities with muting, $T_{per}^{PRS \text{ with muting}} = N_{muting} * T_{per}^{PRS}$, the least common multiple of $T_{per}^{PRS \text{ with muting}}$ among the DL PRS resource sets is used to derive $T_{PRS,i}$, where:

- T_{per}^{PRS} is the periodicity of PRS resource sets given by the higher-layer parameter *DL-PRS-Periodicity*.
- N_{muting} is the scaling factor considering PRS resource muting. $N_{muting} = T_{muting}^{PRS} * L_{muting}$, where T_{muting}^{PRS} is the muting repetition factor given by the higher-layer parameter *DL-PRS-MutingBitRepetitionFactor*, and L_{muting} is the size of the bitmap $\{b^1\}$.

16.4.1.4 Test description

16.4.1.4.1 Initial conditions

The supported test configurations in listed in Table 16.4.1.4-1.

Table 16.4.1.4-1: Test Configurations

Configuration	Description
1	15 kHz SSB SCS, 20 MHz bandwidth, FDD duplex mode
2	15 kHz SSB SCS, 20 MHz bandwidth, TDD duplex mode
3	30 kHz SSB SCS, 50 MHz bandwidth, TDD duplex mode
Note:	The UE is only required to be tested in one of the supported test configurations.

Test Environment: Normal, as defined in TS 38.508-1 [45] clause 4.1.

Frequencies to be tested: Mid Range, as defined in TS 38.508-1 [45] clause 4.3.1.

Channel bandwidth to be tested: are specified in Table 16.4.1.4-1.

1. Connect the SS and AWGN noise sources to the UE antenna connector or antenna connectors as shown in Annex A, Figure A.13.
2. The general test parameter settings are set up according to Table 16.4.1.5-1 and Table 16.4.1.5-2.
3. Propagation conditions are set according to clause 4.16.2.
4. Message contents are defined in clause 16.4.1.4.3.
5. In the test there are two synchronous cells: Cell 1 and Cell 2. Cell 1 is the reference as well as the PCell. Cell 2 is the neighbour cell. All cells are on the same RF channel distributed in single positioning frequency layer.

16.4.1.4.2 Test procedure

The test consists of two consecutive time intervals, with duration of T1 and T2. During time duration T1, the UE shall be in RRC_CONNECTED state and shall not have any timing information of Cell 2. During T2 UE shall be in RRC_INACTIVE state and all cells transmit PRS resources within initial DL BWP of the UE and with the same numerology as the initial DL BWP.

The *NR-DL-AoD-ProvideAssistanceData* and *NR-DL-AoD-RequestLocationInformation* as defined in TS 37.355 [49] clause 6.5.11 shall be provided to the UE during T1. The last TTI containing the two messages shall be provided to the UE ΔT ms before the start of T2, where $\Delta T = 50$ ms is the maximum processing time of the *DL-AoD assistance* data and location information request.

The beginning of the time interval T2 shall be aligned with the first DRX cycle containing a DL PRS resource(s).

2. Configure the Cell for RA-SDT with SIB1 configured according to TS 38.508-1 [45], clause 4.6.1 with condition SDT
3. Ensure the UE is in State RRC_CONNECTED with generic procedure parameters Connectivity NR, Connected without release On, according to TS 38.508-1 [45] clause 4.5.
2. The SS shall send a RESET UE POSITIONING STORED INFORMATION message.

3. Set the parameters according to Table 16.4.1.5-1 and Table 16.4.1.5-2. Propagation conditions are set according to clause 4.16.2.
4. T1 starts.
5. The SS shall transmit an RRCReconfiguration message with the DRX configuration.
6. The UE shall transmit RRCReconfigurationComplete message.
7. The SS shall transmit an LPP REQUEST CAPABILITIES message.
8. The UE shall transmit an LPP PROVIDE CAPABILITIES message indicating the DL-AoD capabilities supported by the UE in the *NR-DL-AoD-ProvideCapabilities* IE.
9. The SS shall send a LPP PROVIDE ASSISTANCE DATA message, including the *NR-DL-AoD-ProvideAssistanceData* IE. The position of neighbour Cell 2 is described in 3GPP TS 37.571-5 [20]. If the UE message at step 8 includes the *ackRequested* IE set to TRUE, then the SS shall send an acknowledgment in the LPP PROVIDE ASSISTANCE DATA message.
10. The SS shall transmit LCS Periodic-Triggered Invoke Request message with LPP REQUEST LOCATION INFORMATION embedded to start the periodic reporting procedure, including the *NR-DL-AoD-RequestLocationInformation* IE such that the UE receives the message ΔT ms before the start of T2, where $\Delta T = 50$ ms.
11. The UE shall transmit an LCS Periodic-Triggered Invoke Return Result message.
12. When T1 expires, the SS shall transmit an RRCRelease message with SDT configuration to transit the UE to RRC_INACTIVE state and switch the power setting from T1 to T2 as specified in Table 16.4.1.5-1 and Table 16.4.1.5-2.
13. Wait for the UE monitors for occurrence of the periodic event requested.
14. The UE shall transmit the UE transmit an *RRCResumeRequest* message. If the UE also supporting SDT feature, the UE shall include LPP PROVIDE LOCATION INFORMATION message in the *RRCResumeRequest* message and then go to step 18.
15. The SS transmits an *RRCResume* message.
16. The UE transmits an *RRCResumeComplete* message. The time between the start of T2 and the UE send the *RRCResumeRequest* message should meet the requirements specified in TS 38.133 [50] Clause 5.6.3.5.
17. The UE shall transmit a LPP PROVIDE LOCATION INFORMATION message including the *NR-DL-AoD-ProvideLocationInformation* IE within the response time (see clause 4.16.3) plus the maximum RRC processing time 10ms between *RRCResume* message and *RRCResumeComplete* message.
18. The UE shall perform and report the RSTD measurements for Cell 2 with respect to the reference cell in the DL-AoD assistance data, Cell 1. If the UE transmits an *NR-DL-AoD-ProvideLocationInformation* IE including the *nr-DL-PRS-RSRP-Result-r16* field for Cell 2 within the response time then the number of successful tests is increased by one. If the UE fails to report the *NR-DL-AoD-ProvideLocationInformation* IE with both the *nr-DL-PRS-RSRP-Result-r16* fields included within the response time then the number of failure tests is increased by one.
19. If the UE message at step 17 includes the *ackRequested* IE set to TRUE, the SS shall send a LPP acknowledgement message.
20. Repeat steps 2-18 in Tables 16.4.1.4-1 until the confidence level according to Annex D is achieved.

16.4.1.4.3 Message contents

Table 16.4.1.4.3-1: RESET UE POSITIONING STORED INFORMATION

Derivation Path: 38.509 [44] clause 6.6			
Information Element	Value/remark	Comment	Condition
UE Positioning Technology	0 0 0 1 0 0 0	DL-AoD	

Table 16.4.1.4.3-2: RRCReconfiguration

Derivation Path: TS 38.508-1 [45], table 4.6.1-13			
Information Element	Value/remark	Comment	Condition
RRCReconfiguration ::= SEQUENCE {			
criticalExtensions CHOICE {			
rrcReconfiguration SEQUENCE {			
nonCriticalExtension SEQUENCE {			
masterCellGroup	CellGroupConfig		
}			
}			
}			
}			

Table 16.4.1.4.3-3: CellGroupConfig (Table 16.4.1.4.3-2)

Derivation Path: 38.508-1 [45], Table 4.6.3-19			
Information Element	Value/remark	Comment	Condition
CellGroupConfig ::= SEQUENCE {			
mac-CellGroupConfig SEQUENCE {			
drx-Config CHOICE {			
setup SEQUENCE {			
drx-onDurationTimer	ms6		
drx-InactivityTimer	ms1		
drx-HARQ-RTT-TimerDL	sl64		
drx-HARQ-RTT-TimerUL	sl64		
drx-RetransmissionTimerDL	sl1		
drx-RetransmissionTimerUL	sl1		
drx-LongCycleStartOffset CHOICE {			
ms1280	0		
}			
shortDRX	not present		
drx-SlotOffset	0		
}			
}			
}			

Table 16.4.1.4.3-4: LPP Request Capabilities

Information Element	Value/remark
nr-DL-AoD-RequestCapabilities-r16	TRUE

Table 16.4.1.4.3-5: LPP ProvideAssistanceData

Derivation Path: 37.355 clause 6.2			
Information Element	Value/remark	Comment	Condition
LPP-Message ::= SEQUENCE {			
transactionID SEQUENCE {			
initiator	locationServer		
transactionNumber	(0..255)		
}			
endTransaction	TRUE		
sequenceNumber	Not present		
acknowledgement	Not present		
lpp-MessageBody CHOICE {			
c1 CHOICE {			
provideAssistanceData SEQUENCE {			
criticalExtensions CHOICE {			
c1 CHOICE {			
provideAssistanceData-r9 SEQUENCE {			
commonIEsProvideAssistanceData	Not present		

a-gnss-ProvideAssistanceData	Not present		
otdoa-ProvideAssistanceData	Not present		
epdu-ProvideAssistanceData	Not present		
sensor-ProvideAssistanceData-r15	Not present		
tbs-ProvideAssistanceData-r15	Not present		
wlan-ProvideAssistanceData-r15	Not present		
nr-Multi-RTT-ProvideAssistanceData-r16	Not present		
nr-DL-AoD-ProvideAssistanceData-r16			
SEQUENCE {			
nr-DL-PRS-AssistanceData-r16	As defined in Table 16.4.1.4.3-6		
nr-SelectedDL-PRS-IndexList-r16	Not present		
nr-PositionCalculationAssistance-r16			Depending on UE capabilities, i.e. support for UE-based DL-AoD
SEQUENCE {			
nr-TRP-LocationInfo-r16	As defined in TS 37.571-5 [20]		
nr-DL-PRS-BeamInfo-r16	Not present		
nr-RTD-Info-r16	Not present		
nr-TRP-BeamAntennaInfo-r17	Not present		
nr-DL-PRS-Expected-LOS-NLOS-Assistance-r17	Not present		
nr-DL-PRS-TRP-TEG-Info-r17	Not present		
}			
nr-DL-AoD-Error-r16	Not present		
nr-DL-PRS-BeamInfo-r17	Not present		
nr-On-Demand-DL-PRS-Configurations-r17	Not present		
}			
nr-DL-TDOA-ProvideAssistanceData-r16	Not present		
}			
}			
}			
}			
}			
}			
}			

Table 16.4.1.4.3-6: NR-DL-PRS-AssistanceData

Derivation Path: 37.355 clause 6.4.3			
Information Element	Value/remark	Comment	Condition
NR-DL-PRS-AssistanceData-r16 ::= SEQUENCE {			
nr-DL-PRS-ReferenceInfo-r16 SEQUENCE {			
dl-PRS-ID-r16	0		
nr-DL-PRS-ResourceID-List-r16	Not present		
nr-DL-PRS-ResourceSetID-r16	Not present		
}			
nr-DL-PRS-AssistanceDataList-r16 SEQUENCE (SIZE (1..nrMaxFreqLayers-r16)) OF NR-DL-PRS-AssistanceDataPerFreq-r16 {	1 entry		
NR-DL-PRS-AssistanceDataPerFreq-r16[1]		entry 1	
SEQUENCE {			
nr-DL-PRS-PositioningFrequencyLayer-r16			
SEQUENCE {			
dl-PRS-SubcarrierSpacing-r16	kHz15		Config 1 and Config 2
	kHz30		Config 3
dl-PRS-ResourceBandwidth-r16	21	104 PRBs	Config 1 and Config 2
	28	132 PRBs	Config 3

dl-PRS-StartPRB-r16	0		
dl-PRS-PointA-r16	absoluteFrequencyPointA as defined for the DL frequency of the Cell 1		
dl-PRS-CombSizeN-r16	n4		
dl-PRS-CyclicPrefix-r16	normal		
}			
nr-DL-PRS-AssistanceDataPerFreq-r16 SEQUENCE (SIZE (1..nrMaxTRPsPerFreq-r16)) OF NR-DL-PRS-AssistanceDataPerTRP-r16{	2 entries		
NR-DL-PRS-AssistanceDataPerTRP-r16[1] SEQUENCE {		entry 1	Cell 1
dl-PRS-ID-r16	0		
nr-PhysCellID-r16	Cell 1		
nr-CellGlobalID-r16	Cell 1		
nr-ARFCN-r16	Cell 1		
nr-DL-PRS-SFN0-Offset-r16 SEQUENCE {			
sfm-Offset-r16	0		
integerSubframeOffset-r16	0		
}			
nr-DL-PRS-ExpectedRSTD-r16	0		
nr-DL-PRS-ExpectedRSTD-Uncertainty-r16	0		
nr-DL-PRS-Info-r16	As specified in Table 16.4.1.4.3-7		
}			
NR-DL-PRS-AssistanceDataPerTRP-r16[2] SEQUENCE {		entry 2	Cell 2
dl-PRS-ID-r16	1		
nr-PhysCellID-r16	Cell 2		
nr-CellGlobalID-r16	Cell 2		
nr-ARFCN-r16	Cell 2		
nr-DL-PRS-SFN0-Offset-r16 SEQUENCE {			
sfm-Offset-r16	0		
integerSubframeOffset-r16	0		
}			
nr-DL-PRS-ExpectedRSTD-r16	92	About 3 μs	
nr-DL-PRS-ExpectedRSTD-Uncertainty-r16	154	About 5 μs	
nr-DL-PRS-Info-r16	As specified in Table 16.4.1.4.3-7		
}			
}			
}			
}			
}			

Table 16.4.1.4.3-7: NR-DL-PRS-Info

Derivation Path: 37.355 clause 6.4.3			
Information Element	Value/remark	Comment	Condition
NR-DL-PRS-Info-r16 ::= SEQUENCE {			
nr-DL-PRS-ResourceSetList-r16 SEQUENCE (SIZE (1..nrMaxSetsPerTrp-r16)) OF NR-DL-PRS-ResourceSet-r16 {	1 entry		
NR-DL-PRS-ResourceSet-r16[1] SEQUENCE {		entry 1	
nr-DL-PRS-ResourceSetID-r16	0		
dl-PRS-Periodicity-and-ResourceSetSlotOffset-r16 CHOICE {			
scs15-r16 CHOICE {			Config 1 & 2
n160-r16	10		
}			
scs30-r16 CHOICE {			Config 3
n320-r16	20		
}			
dl-PRS-ResourceRepetitionFactor-r16	n1		
dl-PRS-ResourceTimeGap-r16	s1		

dl-PRS-NumSymbols-r16	n4		
dl-PRS-MutingOption1-r16 SEQUENCE {			
dl-prs-MutingBitRepetitionFactor-r16	Not present		
nr-option1-muting-r16 CHOICE {			
po2-r16	10		Cell 1
	01		Cell 2
}			
}			
dl-PRS-MutingOption2-r16	Not present		
dl-PRS-ResourcePower-r16	27		
dl-PRS-ResourceList-r16 SEQUENCE (SIZE (1..nrMaxResourcesPerSet-r16)) OF NR-DL-PRS-Resource-r16 {	1 entry		
NR-DL-PRS-Resource-r16[1] SEQUENCE {		entry 1	
nr-DL-PRS-ResourceID-r16	0		
dl-PRS-SequenceID-r16	0		
dl-PRS-CombSizeN-AndReOffset-r16 CHOICE {			
n4-r16	0		Cell 1
	1		Cell 2
}			
}			
dl-PRS-ResourceSlotOffset-r16	4		
dl-PRS-ResourceSymbolOffset-r16	0		
dl-PRS-QCL-Info-r16	Not present		
}			
}			
}			
}			
}			

Table 16.4.1.4.3-8: Ics-PeriodicTriggeredInvoke

Derivation Path: 24.080 clause 4.4.2			
Information Element	Value/remark	Comment	Condition
LCS-PeriodicTriggeredInvokeArg ::= SEQUENCE {			
referenceNumber	LCS-ReferenceNumber		
h-gmlc-address	GSN-Address		
qoS	Not present		
reportingPLMNList	Not present		
periodicLocation SEQUENCE {			
periodicLDRInfo SEQUENCE {			
reportingAmount	5		
reportingInterval	1		
reportingOptionMilliseconds	Not present		
}			
}			
areaEventReporting	Not present		
motionEventReporting	Not present		
referenceNumberExt	LCS-ReferenceNumberExt		
h-gmlc-callBackUri	Not present		
supportedGADShapes	Not present		
deferredRoutingIdentifier	Not present		
reportingAccessTypes	00000001	NR	
multiplePositioningProtocolPDUs SIZE (1..maxNumLPPMsg) OF PositioningProtocolPDU {	1 entry		
PositioningProtocolPDU[1] SEQUENCE {		entry 1	
PositioningProtocolPDU	Contains a LPP RequestLocationInformation message defined in Table 16.4.1.4.3-9		
}			
}			
}			
controlPlane-CIoT-5GS-Optimisation	Not present		
scheduledLocTime	Not present		
eventReportAllowedArea	Not present		

--	--	--

Table 16.4.1.4.3-9: LPP RequestLocationInformation

Derivation Path: 37.355 clause 6.2			
Information Element	Value/remark	Comment	Condition
LPP-Message ::= SEQUENCE {			
transactionID SEQUENCE {			
initiator	locationServer		
transactionNumber	1		
}			
endTransaction	FALSE		
sequenceNumber	Not present		
acknowledgement	Not present		
lpp-MessageBody CHOICE {			
c1 CHOICE {			
requestLocationInformation SEQUENCE {			
criticalExtensions CHOICE {			
c1 CHOICE {			
requestLocationInformation-r9 SEQUENCE {			
commonEsRequestLocationInformation SEQUENCE {			
locationInformationType	locationMeasurementsRequired		
triggeredReporting	Not present		
periodicalReporting	Not present		
additionalInformation	onlyReturnInformationRequested		
qos SEQUENCE {			
horizontalAccuracy	Not present		
verticalCoordinateRequest	FALSE		
verticalAccuracy	Not present		
responseTime SEQUENCE {			
time	See 16.4.1.5	Result of the response time calculation rounded up to the next second if response time <= 128s. Result of the response time calculation rounded up to the next multiple of ten seconds if response time > 128s.	
responseTimeEarlyFix-r12	Not present		Rel-12 onwards
unit-r15	Not present		
ten-seconds			Calculated response time >128s
}			
velocityRequest	FALSE		
}			
environment	Not present		
locationCoordinateTypes	Not present		
velocityTypes	Not present		
}			
a-gnss-RequestLocationInformation	Not present		
otdoa-RequestLocationInformation	Not present		
ecid-RequestLocationInformation	Not present		
epdu-RequestLocationInformation	Not Present		
sensor-RequestLocationInformation-r13	Not present		

tbs-RequestLocationInformation-r13	Not present		
wlan-RequestLocationInformation-r13	Not present		
bt-RequestLocationInformation-r13	Not present		
nr-ECID-RequestLocationInformation-r16	Not present		
nr-Multi-RTT-RequestLocationInformation-r16	Not present		
nr-DL-AoD-RequestLocationInformation-r16			
SEQUENCE {			
nr-AssistanceAvailability-r16	FALSE		
nr-DL-AoD-ReportConfig-r16 SEQUENCE {			
maxDL-PRS-RSRP-MeasurementsPerTRP-r16	Not present		
maxDL-PRS-RSRP-MeasurementsPerTRP-r17	Not present		
maxDL-PRS-RSRPP-MeasurementsPerTRP-r17	Not present		
nr-los-nlos-IndicatorRequest-r17	Not present		
reducedDL-PRS-ProcessingSamples-r17	Not present		
lowerRxBeamSweepingFactor-FR2-r17	Not present		
}			
multiMeasInSameReport-r17			
}			
nr-DL-TDOA-RequestLocationInformation-r16	Not present		
}			
}			
}			
}			
}			
}			
}			

Table 16.4.1.4.3-10: RRCRelease

Derivation Path: TS 38.508-1 [45], Table 4.6.1-16 with condition NR_RRC_INACTIVE and SDT

Table 16.4.1.4.3-11: LPP ProvideLocation Information

Derivation Path: 37.355 clause 6.5.12			
Information Element	Value/remark	Comment	Condition
LPP-Message ::= SEQUENCE {			
transactionID SEQUENCE {			
initiator	locationServer		
transactionNumber	1		
}			
endTransaction	TRUE		
sequenceNumber	(0..255)		
acknowledgement			
lpp-MessageBody CHOICE {			
c1 CHOICE {			
provideLocationInformation SEQUENCE {			
criticalExtensions CHOICE {			
c1 CHOICE {			
provideLocationInformation-r9 SEQUENCE {			
commonIEsProvideLocationInformation	Not present.		
a-gnss-ProvideLocationInformation	Not present		
otdoa-ProvideLocationInformation	Not present		
ecid-ProvideLocationInformation	Not present		
epdu-ProvideLocationInformation	Not present		
sensor-ProvideLocationInformation-r13	Not present		
tbs-ProvideLocationInformation-r13	Not present		
wlan-ProvideLocationInformation-r13	Not present		
bt-ProvideLocationInformation-r13	Not present		
nr-ECID-ProvideLocationInformation-r16	Not present		
nr-Multi-RTT-ProvideLocationInformation-r16	Not present		
}			
}			
}			
}			
}			
}			

nr-DL-AoD-ProvideLocationInformation-r16			
SEQUENCE {			
nr-DL-AoD-SignalMeasurementInformation-r16 SEQUENCE {			
nr-DL-AoD-MeasList-r16 SEQUENCE (SIZE(1..nrMaxTRPs-r16)) OF NR-DL-AoD-MeasElement-r16 {			
NR-DL-AoD-MeasElement-r16[1]		entry 1	
SEQUENCE {			
dl-PRS-ID-r16	INTEGER (0..255)		
nr-PhysCellID-r16	Cell 1		
nr-CellGlobalID-r16			
nr-ARFCN-r16			
nr-DL-PRS-ResourceID-r16			
nr-DL-PRS-ResourceSetID-r16			
nr-TimeStamp-r16			
nr-DL-PRS-RSRP-Result-r16	Present. Any value acceptable.		
nr-DL-PRS-RxBeamIndex-r16			
nr-DL-AoD-AdditionalMeasurements-r16			
nr-DL-PRS-FirstPathRSRP-Result-r17			
nr-los-nlos-Indicator-r17			
nr-DL-AoD-AdditionalMeasurementsExt-r17			
}			
NR-DL-AoD-MeasElement-r16[2]		entry 2	
SEQUENCE {			
dl-PRS-ID-r16	INTEGER (0..255)		
nr-PhysCellID-r16	Cell 2		
nr-CellGlobalID-r16			
nr-ARFCN-r16			
nr-DL-PRS-ResourceID-r16			
nr-DL-PRS-ResourceSetID-r16			
nr-TimeStamp-r16			
nr-DL-PRS-RSRP-Result-r16	Present. Any value acceptable.		
nr-DL-PRS-RxBeamIndex-r16			
nr-DL-AoD-AdditionalMeasurements-r16			
nr-DL-PRS-FirstPathRSRP-Result-r17			
nr-los-nlos-Indicator-r17			
nr-DL-AoD-AdditionalMeasurementsExt-r17			
}			
}			
}			
nr-dl-AoD-LocationInformation-r16			
nr-DL-AoD-Error-r16	Not present		
nr-DL-AoD-SignalMeasurementInstances-r17	Not present		
nr-DL-AoD-LocationInformationInstances-r17	Not present		
}			
}			
}			
}			
}			
}			
}			
}			

16.4.1.5 Test requirement

Table 16.4.1.5-1 define the primary level settings including test tolerances for the test

Table 16.4.1.5-1: General test parameters

Parameter	Unit	Test configuration	Value	Comment
Reference cell		1, 2, 3	Cell 1	Cell 1 is the PCell and the DL-AoD reference cell in the positioning assistance data.
Neighbour cell		1, 2, 3	Cell 2	Cell 2 is a neighbour cell in the positioning assistance data.
RF Channel Number		1, 2, 3	1: Cell 1 and Cell 2	
BW _{channel}	MHz	1	20: N _{RB,c} = 106	
		2	20: N _{RB,c} = 106	
		3	50: N _{RB,c} = 133	
SSB configuration		1	SSB.1 FR1	
		2	SSB.1 FR1	
		3	SSB.2 FR1	
SMTC configuration		1	SMTC.2	
		2	SMTC.1	
		3	SMTC.1	
CP length		1, 2, 3	Normal	
DRX		1, 2, 3	1.28s	
Time offset between serving and neighbour cells	µs	1, 2, 3	3	Synchronous cells
Expected RSTD	µs	1, 2, 3	3	
Expected RSTD uncertainty	µs	1, 2, 3	5	
T1	s	1, 2, 3	2	
T2	s	1, 2, 3	6	

Table 16.4.1.5-2: Cell specific test parameters

Parameter	Unit	Test configuration	Cell 1		Cell 2	
			T1	T2	T1	T2
TDD configuration		1	N/A		N/A	
		2	TDDConf.1.1		TDDConf.1.1	
		3	TDDConf.2.1		TDDConf.2.1	
PDSCH RMC configuration		1	SR.1.1 FDD		N/A	
		2	SR.1.1 TDD			
		3	SR.2.1 TDD			
RMSI CORESET RMC configuration		1	CR.1.1 FDD		N/A	
		2	CR.1.1 TDD			
		3	CR.2.1 TDD			
Dedicated CORESET RMC configuration		1	CCR.1.1 FDD		N/A	
		2	CCR.1.1 TDD			
		3	CCR.2.1 TDD			
OCNG Patterns		1, 2, 3	OP.1		OP.1	
Initial BWP configuration		1, 2, 3	DLBWP.0.1 ULBWP.0.1		N/A	
PRS configuration		1	PRS.1.4 FR1		PRS.1.4 FR1	
		2	PRS.1.4 FR1		PRS.1.4 FR1	
		3	PRS.2.4 FR1		PRS.2.4 FR1	
PRS muting info		1, 2, 3	'10'		'01'	
N _{oc} ^{Note 2}	dBm/SCS	1			-98	
		2			-98	
		3			-95	
N _{oc} ^{Note 2}	dBm/15 kHz	1			-98	
		2				

		3				
PRS \hat{E}_s/I_{ot}	dB	1	-Infinity	-2.41	-Infinity	-12.12
		2				
		3				
PRS \hat{E}_s/N_{oc}	dB	1	-Infinity	-2	-Infinity	-10
		2				
		3				
PRS-RSRP ^{Note 3}	dBm/SCS kHz	1	-Infinity	-100	-Infinity	-108
		2	-Infinity	-100	-Infinity	-108
		3	-Infinity	-97	-Infinity	-105
SS-RSRP ^{Note 3}	dBm/SCS kHz	1	-88	-88	-Infinity	-88
		2	-88	-88	-Infinity	-88
		3	-85	-85	-Infinity	-85
I _o	dBm/19.08 MHz	1	N/A	-64.57	N/A	-64.57
	dBm/19.08 MHz	2		-64.57		-64.57
	dBm/47.88 MHz	3		-60.59		-60.59
Propagation Condition		1, 2, 3	AWGN			
<p>Note 1: The resources for uplink transmission are assigned to the UE prior to the start of time period T2.</p> <p>Note 2: Interference from other cells and noise sources not specified in the test is assumed to be constant over subcarriers and time and shall be modelled as AWGN of appropriate power for N_{oc} to be fulfilled.</p> <p>Note 3: SS-RSRP/PRS-RSRP levels have been derived from other parameters for information purposes. They are not settable parameters themselves.</p>						

16.4.2 PRS-RSRP measurement reporting delay test case for single positioning frequency layer with reduced number of samples in FR1 SA

Editor’s note: This test case is incomplete. The following aspect is either missing or TBD:

- Test tolerance is missing
- Message contents require update

16.4.2.1 Test purpose

The purpose of the test is to verify the PRS RSRP measurement requirements specified in TS 38.133 [50] Clause 5.6.3.5 for single positioning frequency layer under AWGN propagation conditions in RRC_INACTIVE in FR1 standalone scenario.

16.4.2.2 Test applicability

This test applies to all types of NR UE release 17 onwards that supports DL-AoD positioning, supports DL-PRS measurement in RRC_INACTIVE state and reduced number of samples for PRS measurement in RRC_INACTIVE state.

16.4.2.3 Minimum conformance requirements

Same as in clause 16.4.1.3.

16.4.2.4 Test description

16.4.2.4.1 Initial conditions

The supported test configurations in listed in Table 16.4.2.4-1.

Table 16.4.2.4-1: Test Configurations

Configuration	Description
1	15 kHz SSB SCS, 20 MHz bandwidth, FDD duplex mode
2	15 kHz SSB SCS, 20 MHz bandwidth, TDD duplex mode
3	30 kHz SSB SCS, 50 MHz bandwidth, TDD duplex mode
Note:	The UE is only required to be tested in one of the supported test configurations.

Test Environment: Normal, as defined in TS 38.508-1 [45] clause 4.1.

Frequencies to be tested: Mid Range, as defined in TS 38.508-1 [45] clause 4.3.1.

Channel bandwidth to be tested: are specified in Table 16.4.2.4-1.

1. Connect the SS and AWGN noise sources to the UE antenna connector or antenna connectors as shown in Annex A, Figure A.13.
2. The general test parameter settings are set up according to Table 16.4.2.5-1 and Table 16.4.2.5-2.
3. Propagation conditions are set according to clause 4.16.2.
4. Message contents are defined in clause 16.4.2.4.3.
5. In the test there are two synchronous cells: Cell 1 and Cell 2. Cell 1 is the reference as well as the PCell. Cell 2 is the neighbour cell. All cells are on the same RF channel distributed in single positioning frequency layer.

16.4.2.4.2 Test procedure

Same as in clause 16.4.3.4.2.

16.4.2.4.3 Message contents

As defined in clause 16.4.1.4.3, with the following exceptions:

Table 16.4.1.4.3-1 replaces Table 16.4.2.4.3-6, Table 16.4.2.4.3-2 replaces Table 16.4.1.4.3-7 and Table 16.4.1.4.3-3 replaces Table 16.4.2.4.3-9.

Table 16.4.2.4.3-1: NR-DL-PRS-AssistanceData

Derivation Path: 37.355 clause 6.4.3			
Information Element	Value/remark	Comment	Condition
NR-DL-PRS-AssistanceData-r16 ::= SEQUENCE {			
nr-DL-PRS-ReferenceInfo-r16 SEQUENCE {			
dl-PRS-ID-r16	0		
nr-DL-PRS-ResourceID-List-r16	Not present		
nr-DL-PRS-ResourceSetID-r16	Not present		
}			
nr-DL-PRS-AssistanceDataList-r16 SEQUENCE (SIZE (1..nrMaxFreqLayers-r16)) OF NR-DL-PRS-AssistanceDataPerFreq-r16 {	1 entry		
NR-DL-PRS-AssistanceDataPerFreq-r16[1] SEQUENCE {		entry 1	
nr-DL-PRS-PositioningFrequencyLayer-r16 SEQUENCE {			
dl-PRS-SubcarrierSpacing-r16	kHz15		Config 1 and Config 2
	kHz30		Config 3
dl-PRS-ResourceBandwidth-r16	21	104 PRBs	Config 1 and Config 2
	28	132 PRBs	Config 3
dl-PRS-StartPRB-r16	0		

dl-PRS-PointA-r16	absoluteFrequencyPointA as defined for the DL frequency of the Cell 1		
dl-PRS-CombSizeN-r16	n4		
dl-PRS-CyclicPrefix-r16	normal		
}			
nr-DL-PRS-AssistanceDataPerFreq-r16 SEQUENCE (SIZE (1..nrMaxTRPsPerFreq-r16)) OF NR-DL-PRS-AssistanceDataPerTRP-r16{	2 entries		
NR-DL-PRS-AssistanceDataPerTRP-r16[1] SEQUENCE {		entry 1	Cell 1
dl-PRS-ID-r16	0		
nr-PhysCellID-r16	Cell 1		
nr-CellGlobalID-r16	Cell 1		
nr-ARFCN-r16	Cell 1		
nr-DL-PRS-SFN0-Offset-r16 SEQUENCE {			
sfn-Offset-r16	0		
integerSubframeOffset-r16	0		
}			
nr-DL-PRS-ExpectedRSTD-r16	0		
nr-DL-PRS-ExpectedRSTD-Uncertainty-r16	0		
nr-DL-PRS-Info-r16	As specified in Table 16.4.3.4.3-7		
}			
NR-DL-PRS-AssistanceDataPerTRP-r16[2] SEQUENCE {		entry 2	Cell 2
dl-PRS-ID-r16	1		
nr-PhysCellID-r16	Cell 2		
nr-CellGlobalID-r16	Cell 2		
nr-ARFCN-r16	Cell 2		
nr-DL-PRS-SFN0-Offset-r16 SEQUENCE {			
sfn-Offset-r16	0		
integerSubframeOffset-r16	0		
}			
nr-DL-PRS-ExpectedRSTD-r16	92	About 3 μs	
nr-DL-PRS-ExpectedRSTD-Uncertainty-r16	153	About 5 μs	
nr-DL-PRS-Info-r16	As specified in Table 16.4.3.4.3-7		
}			
}			
}			
}			
}			
}			

Table 16.4.2.4.3-2: NR-DL-PRS-Info

Derivation Path: 37.355 clause 6.4.3			
Information Element	Value/remark	Comment	Condition
NR-DL-PRS-Info-r16 ::= SEQUENCE {			
nr-DL-PRS-ResourceSetList-r16 SEQUENCE (SIZE (1..nrMaxSetsPerTrp-r16)) OF NR-DL-PRS-ResourceSet-r16 {	1 entry		
NR-DL-PRS-ResourceSet-r16[1] SEQUENCE {		entry 1	
nr-DL-PRS-ResourceSetID-r16	0		
dl-PRS-Periodicity-and-ResourceSetSlotOffset-r16 CHOICE {			
scs15-r16 CHOICE {			Config 1 & 2
n160-r16	10		
}			
scs30-r16 CHOICE {			Config 3
n320-r16	20		
}			
dl-PRS-ResourceRepetitionFactor-r16	n1		
dl-PRS-ResourceTimeGap-r16	s1		
dl-PRS-NumSymbols-r16	n4		

dl-PRS-MutingOption1-r16 SEQUENCE {			
dl-prs-MutingBitRepetitionFactor-r16	Not present		
nr-option1-muting-r16 CHOICE {			
po2-r16	10		Cell 1
	01		Cell 2
}			
dl-PRS-MutingOption2-r16	Not present		
dl-PRS-ResourcePower-r16	27		
dl-PRS-ResourceList-r16 SEQUENCE (SIZE (1..nrMaxResourcesPerSet-r16)) OF NR-DL-PRS-Resource-r16 {	1 entry		
NR-DL-PRS-Resource-r16[1] SEQUENCE {		entry 1	
nr-DL-PRS-ResourceID-r16	0		
dl-PRS-SequenceID-r16	0		
dl-PRS-CombSizeN-AndReOffset-r16 CHOICE {			
n4-r16	0		TBD
}			
dl-PRS-ResourceSlotOffset-r16	0		
dl-PRS-ResourceSymbolOffset-r16	0		
dl-PRS-QCL-Info-r16	Not present		
}			
}			
}			
}			
}			

Table 16.4.2.4.3-3: LPP RequestLocationInformation

Derivation Path: 37.355 clause 6.2			
Information Element	Value/remark	Comment	Condition
LPP-Message ::= SEQUENCE {			
transactionID SEQUENCE {			
initiator	locationServer		
transactionNumber	1		
}			
endTransaction	FALSE		
sequenceNumber	Not present		
acknowledgement	Not present		
lpp-MessageBody CHOICE {			
c1 CHOICE {			
requestLocationInformation SEQUENCE {			
criticalExtensions CHOICE {			
c1 CHOICE {			
requestLocationInformation-r9 SEQUENCE {			
commonEsRequestLocationInformation SEQUENCE {			
locationInformationType	locationMeasurementsRequired		
triggeredReporting	Not present		
periodicalReporting	Not present		
additionalInformation	onlyReturnInformationRequested		
qos SEQUENCE {			
horizontalAccuracy	Not present		
verticalCoordinateRequest	FALSE		
verticalAccuracy	Not present		
responseTime SEQUENCE {			
time	See 16.4.2.5	Result of the response time calculation rounded up to the next second if response time <= 128s. Result of the	

		response time calculation rounded up to the next multiple of ten seconds if response time > 128s.	
responseTimeEarlyFix-r12	Not present		Rel-12 onwards
unit-r15	Not present		Calculated response time >128s
	ten-seconds		
}			
velocityRequest	FALSE		
}			
environment	Not present		
locationCoordinateTypes	Not present		
velocityTypes	Not present		
}			
a-gnss-RequestLocationInformation	Not present		
otdoa-RequestLocationInformation	Not present		
ecid-RequestLocationInformation	Not present		
epdu-RequestLocationInformation	Not Present		
sensor-RequestLocationInformation-r13	Not present		
tbs-RequestLocationInformation-r13	Not present		
wlan-RequestLocationInformation-r13	Not present		
bt-RequestLocationInformation-r13	Not present		
nr-ECID-RequestLocationInformation-r16	Not present		
nr-Multi-RTT-RequestLocationInformation-r16	Not present		
nr-DL-AoD-RequestLocationInformation-r16			
SEQUENCE {			
nr-AssistanceAvailability-r16	FALSE		
nr-DL-AoD-ReportConfig-r16 SEQUENCE {			
maxDL-PRS-RSRP-MeasurementsPerTRP-r16	Not present		
maxDL-PRS-RSRP-MeasurementsPerTRP-r17	Not present		
maxDL-PRS-RSRPP-MeasurementsPerTRP-r17	Not present		
nr-los-nlos-IndicatorRequest-r17	Not present		
reducedDL-PRS-ProcessingSamples-r17	requested		
lowerRxBeamSweepingFactor-FR2-r17	Not present		
}			
multiMeasInSameReport-r17			
}			
nr-DL-TDOA-RequestLocationInformation-r16	Not present		
}			
}			
}			
}			
}			
}			

16.4.2.5 Test requirement

Table 16.4.2.5-1 and Table 16.4.2.5-2 define the primary level settings including test tolerances for the test

Table 16.4.2.5-1: General test parameters

Parameter	Unit	Test configuration	Value	Comment
-----------	------	--------------------	-------	---------

Reference cell		1, 2, 3	Cell 1	Cell 1 is the PCell and the DL-AoD reference cell in the positioning assistance data.
Neighbour cell		1, 2, 3	Cell 2	Cell 2 is a neighbour cell in the positioning assistance data.
RF Channel Number		1, 2, 3	1: Cell 1 and Cell 2	
BW _{channel}	MHz	1	20: N _{RB,c} = 106	
		2	20: N _{RB,c} = 106	
		3	50: N _{RB,c} = 133	
SSB configuration		1	SSB.1 FR1	
		2	SSB.1 FR1	
		3	SSB.2 FR1	
SMTC configuration		1	SMTC.2	
		2	SMTC.1	
		3	SMTC.1	
CP length		1, 2, 3	Normal	
DRX cycle length	s	1, 2, 3	1.28	
Time offset between serving and neighbour cells	μs	1, 2, 3	3	Synchronous cells
Expected RSTD	μs	1, 2, 3	3	
Expected RSTD uncertainty	μs	1, 2, 3	5	
T1	s	1, 2, 3	3	
T2	s	1, 2, 3	5	

Table 16.4.2.5-2: Cell specific test parameters

		configuration	T1	T2	T1	T2
3GPP TS 37.571-1 version 17.5.0 Release 17	TDD configuration	1	N/A		N/A	
		2	TDDConf.1.1		TDDConf.1.1	
		3	TDDConf.2.1		TDDConf.2.1	
PDSCH RMC configuration	1	SR.1.1 FDD		N/A		
	2	SR.1.1 TDD				
	3	SR.2.1 TDD				
RMSI CORESET RMC configuration	1	CR.1.1 FDD		N/A		
	2	CR.1.1 TDD				
	3	CR.2.1 TDD				
Dedicated CORESET RMC configuration	1	CCR.1.1 FDD		N/A		
	2	CCR.1.1 TDD				
	3	CCR.2.1 TDD				
OCNG Patterns		1, 2, 3	OP.1		OP.1	
TRS Configuration	1	TRS.1.1 FDD		N/A		
	2	TRS.1.1 TDD				
	3	TRS.1.2 TDD				
Initial BWP configuration		1, 2, 3	DLBWP.0.1 ULBWP.0.1		N/A	
PRS configuration Note 5	1	PRS.1.2 FR1		PRS.1.2 FR1		
	2	PRS.1.2 FR1		PRS.1.2 FR1		
	3	PRS.2.2 FR1		PRS.2.2 FR1		
PRS Resource slot offset	slots	1, 2, 3	0		0	
PRS muting info		1, 2, 3	'10'		'01'	
N_{oc} Note 2	dBm/SCS	1			-98	
		2			-98	
		3			-95	
N_{oc} Note 2	dBm/15 kHz	1			-98	
		2				
		3				
PRS \hat{E}_s/I_{ot}	dB	1	-Infinity	0	-Infinity	-6
		2				
		3				
PRS \hat{E}_s/N_{oc}	dB	1	-Infinity	2.23	-Infinity	-1.73
		2				
		3				
PRS-RSRP Note 3	dBm/SCS kHz	1	-Infinity	-95.77	-Infinity	-99.73
		2	-Infinity	-95.77	-Infinity	-99.73
		3	-Infinity	-92.77	-Infinity	-96.73
SS-RSRP Note 3	dBm/SCS kHz	1	-98	-98	-Infinity	-98
		2	-98	-98	-Infinity	-98
		3	-95	-95	-Infinity	-95
I_o Note 3	dBm/19.08 MHz	1	N/A	-61.71	N/A	-61.71
	dBm/19.08 MHz	2		-61.71		-61.71
	dBm/47.88 MHz	3		-57.73		-57.73
Propagation Condition		1, 2, 3	AWGN			
<p>Note 1: The resources for uplink transmission are assigned to the UE prior to the start of time period T2.</p> <p>Note 2: Interference from other cells and noise sources not specified in the test is assumed to be constant over subcarriers and time and shall be modelled as AWGN of appropriate power for N_{oc} to be fulfilled.</p> <p>Note 3: SS-RSRP/PRS-RSRP and I_o levels have been derived from other parameters for information purposes. They are not settable parameters themselves. I_o levels apply only for symbols where PRS is transmitted.</p> <p>Note 4: OCNG shall be used such that all active cells are fully allocated and a constant total transmitted power spectral density is achieved for all OFDM symbols, except for slots where PRS is transmitted by any of the cells.</p> <p>Note 5: Void.</p>						

16.4.3 PRS-RSRP measurement reporting delay test case for single positioning frequency layer in FR2 SA

Editor's note: This test case is incomplete. The following aspect is either missing or TBD:

- Test tolerance are not added in and analysis is missing

16.4.3.1 Test purpose

The purpose of the test is to verify the PRS RSRP measurement requirements specified in TS 38.133 [50] Clause 5.6.3.5 for single positioning frequency layer under AWGN propagation conditions in RRC_INACTIVE in FR2 standalone scenario.

16.4.3.2 Test applicability

This test applies to all types of NR UE release 17 onwards that supports DL-AoD positioning and supports DL-PRS measurement in RRC_INACTIVE state.

16.4.3.3 Minimum conformance requirements

When the physical layer receives *NR-DL-AoD-ProvideAssistanceData* message and *NR-DL-AoD-RequestLocationInformation* message from LMF via LPP [34], the UE shall be able to measure multiple (up to the UE capability specified in Clause 5.6.3.3) PRS-RSRP measurements, defined in TS 38.215 [4], from configured PRS resources for configured TRPs on configured positioning frequency layers, within $T_{\text{PRS-RSRP, total}}$ ms.

$$T_{\text{PRS-RSRP, total}} = \sum_{i=1}^L T_{\text{PRS-RSRP, }i} + (L - 1) * \max(T_{\text{effect, }i})$$

Where:

- i is the index of positioning frequency layer,
- L is total number of positioning frequency layers,
- $T_{\text{effect, }i}$ is the periodicity of the PRS-RSRP measurement in positioning frequency layer i .

$$T_{\text{PRS-RSRP, }i} = \left(K_{\text{carrier_PRS }i} * N_{\text{RxBeam, }i} * \left\lceil \frac{N_{\text{PRS, }i}^{\text{slot}}}{N'} \right\rceil \left\lfloor \frac{L_{\text{available_PRS, }i}}{N} \right\rfloor * N_{\text{sample}} - 1 \right) * T_{\text{effect, }i} + T_{\text{last, }i}$$

- $K_{\text{carrier_PRS}}$ is a scaling factor for PRS-based NR positioning measurements in RRC_INACTIVE. If the UE supports *parallelPRS-MeasRRC-Inactive-r17*, $K_{\text{carrier_PRS}} = 1$. Otherwise,
- If $S_{\text{rxlev}} \leq S_{\text{nonIntraSearchP}}$ or $S_{\text{qual}} \leq S_{\text{nonIntraSearchQ}}$, $K_{\text{carrier_PRS}}$ equals to the sum of K_{carrier} in 4.2.2.4 and one positioning layer.
- If $S_{\text{rxlev}} > S_{\text{nonIntraSearchP}}$ and $S_{\text{qual}} > S_{\text{nonIntraSearchQ}}$, $K_{\text{carrier_PRS}}$ equals to the sum of N_{layer} in 4.2.2.7 and one positioning layer.
- $N_{\text{RxBeam, }i}$ is the scaling factor for Rx beam sweeping:
 - $N_{\text{RxBeam, }i} = 1$ if positioning frequency layer i is in FR1, and if positioning frequency layer i is in FR2
 - $N_{\text{RxBeam, }i}$ equals to the value as UE reported in *supportedLowerRxBeamSweepingFactor-FR2* if the capability is reported by the UE for the band containing positioning frequency layer i , and LMF indicates *lowerRxBeamSweepingFactor-FR2* in *NR-DL-AoD-RequestLocationInformation*.
 - $N_{\text{RxBeam, }i}$ equals to 8, otherwise.
- $L_{\text{available_PRS, }i}$ is the time duration of available PRS to be measured in the positioning frequency layer i to be measured during $T_{\text{PRS, }i}$, and is calculated in the same way as PRS duration K defined in clause 5.1.6.5 of TS 38.214 [26]. For calculation of $L_{\text{available_PRS, }i}$, only unmuted PRS resources that are not fully overlapped with other higher-priority DL signals/channels are considered.
- $N_{\text{PRS, }i}^{\text{slot}}$ is the maximum number of DL PRS resources of positioning frequency layer i configured in a slot,
- $\{N, T\}$ is UE capability combination per band where N is a duration of DL PRS symbols in ms corresponding to *durationOfPRS-ProcessingSymbols-r17* in TS 37.355 [34] processed every T ms corresponding to *durationOfPRS-ProcessingSymbolsInEveryTms-r17* in TS 37.355 [34] for a given maximum bandwidth supported by UE corresponding to *supportedBandwidthPRS* in TS 37.355 [34],

- N' is UE capability for number of DL PRS resources that it can process in a slot as indicated by *maxNumOfDL-PRS-ResProcessedPerSlot-RRC-Inactive-r17* in clause 6.4.3 of TS 37.355 [34],
- N_{sample} is the number of PRS-RSRP measurement samples and
 - $N_{sample} = 1$, if UE supports *supportedDL-PRS-ProcessingSamples-RRC-Inactive* [34], and the LMF indicates the UE to perform positioning measurements with reduced number of samples by *reducedDL-PRS-ProcessingSamplesRequestedDL-PRS-ProcessingSamples* [34], and the following conditions are met:
 - PRS bandwidth is within the initial BWP and
 - Magnitude of difference between the serving cell's SS-RSRP and the neighbour cell's PRS-RSRP is within 6 dB.
 - $N_{sample} = 2$, if UE supports *supportedDL-PRS-ProcessingSamples-RRC-Inactive* [34], and the LMF indicates the UE to perform positioning measurements with reduced number of samples by *reducedDL-PRS-ProcessingSamples* [34], and the following conditions are not met:
 - PRS bandwidth is within the initial BWP and
 - Magnitude of difference between the serving cell's SS-RSRP and the neighbour cell's PRS-RSRP is within 6 dB.
 - $N_{sample} = 4$ otherwise
- $T_{last,i} = T_i + T_{available_PRS,i}$ is the measurement duration for the last PRS-RSRP sample, including the sampling time and processing time,
 - $T_{effect,i} = \left\lceil \frac{T_i}{T_{available_PRS,i}} \right\rceil * T_{available_PRS,i}$ is the periodicity of PRS-RSRP measurement in positioning frequency layer i ,
 - T_i corresponds to *durationOfPRS-ProcessingSymbolsInEveryTms-r17* in TS 37.355 [34],
 - $T_{available_PRS,i} = LCM(T_{PRS,i}, T_{DRX})$ is the least common multiple between $T_{PRS,i}$ and T_{DRX} ,
 - $T_{PRS,i}$ is the maximum PRS resource periodicity among all PRS resources in positioning frequency layer i ,
 - T_{DRX} is the DRX cycle length.

If positioning frequency layer i has more than one DL PRS resource set with different PRS periodicities with muting, $T_{per}^{PRS\ with\ muting} = N_{muting} * T_{per}^{PRS}$, the least common multiple of $T_{per}^{PRS\ with\ muting}$ among the DL PRS resource sets is used to derive $T_{PRS,i}$, where:

- T_{per}^{PRS} is the periodicity of PRS resource sets given by the higher-layer parameter *DL-PRS-Periodicity*.
- N_{muting} is the scaling factor considering PRS resource muting. $N_{muting} = T_{muting}^{PRS} * L_{muting}$, where T_{muting}^{PRS} is the muting repetition factor given by the higher-layer parameter *DL-PRS-MutingBitRepetitionFactor*, and L_{muting} is the size of the bitmap $\{b^1\}$.

16.4.3.4 Test description

16.4.3.4.1 Initial conditions

The supported test configurations are listed in Table 16.4.3.4-1.

Table 16.4.3.4-1: Test Configurations

Test Configuration	Description
1	120 kHz SSB and PRS SCS, 100 MHz bandwidth, TDD duplex mode

Test Environment: Normal, as defined in TS 38.508-1 [45] clause 4.1.

Frequencies to be tested: Mid Range, as defined in TS 38.508-1 [45] clause 4.3.1.

Channel bandwidth to be tested: are specified in Table 16.4.3.4-1.

1. Connect the SS and AWGN noise sources to the UE antenna connector or antenna connectors as shown in Annex A, Figure A.14.
2. The general test parameter settings are set up according to Table 16.4.3.5-1 and Table 16.4.3.5-2.
3. Propagation conditions are set according to clause 4.16.2.
4. Message contents are defined in clause 16.4.3.4.3.
5. In the test there are two synchronous cells: Cell 1 and Cell 2. Cell 1 is the reference as well as the PCell. Cell 2 is the neighbour cell. All cells are on the same RF channel distributed in single positioning frequency layer.

16.4.3.4.2 Test procedure

The test consists of two consecutive time intervals, with duration of T1 and T2. During time duration T1, the UE shall be in RRC_CONNECTED state and shall not have any timing information of Cell 2. During T2 UE shall be in RRC_INACTIVE state and all cells transmit PRS resources within initial DL BWP of the UE and with the same numerology as the initial DL BWP.

The *NR-DL-AoD-ProvideAssistanceData* and *NR-DL-AoD-RequestLocationInformation* as defined in TS 37.355 [49] clause 6.5.11 shall be provided to the UE during T1. The last TTI containing the two messages shall be provided to the UE ΔT ms before the start of T2, where $\Delta T = 50$ ms is the maximum processing time of the *DL-AoD assistance* data and location information request.

The beginning of the time interval T2 shall be aligned with the first DRX cycle containing a DL PRS resource(s).

4. Ensure the UE is in State RRC_CONNECTED with generic procedure parameters Connectivity NR, Connected without release On, according to TS 38.508-1 [45] clause 4.5.
2. The SS shall send a RESET UE POSITIONING STORED INFORMATION message.
3. Set the parameters according to Table 16.4.3.5-1 and Table 16.4.3.5-2. Propagation conditions are set according to clause 4.16.2.
4. T1 starts.
5. The SS shall transmit an RRCReconfiguration message with the DRX configuration.
6. The UE shall transmit RRCReconfigurationComplete message.
7. The SS shall transmit an LPP REQUEST CAPABILITIES message.
8. The UE shall transmit an LPP PROVIDE CAPABILITIES message indicating the DL-AoD capabilities supported by the UE in the *NR-DL-AoD-ProvideCapabilities* IE.
9. The SS shall send a LPP PROVIDE ASSISTANCE DATA message, including the *NR-DL-AoD-ProvideAssistanceData* IE. The position of neighbour Cell 2 is described in 3GPP TS 37.571-5 [20]. If the UE message at step 8 includes the ackRequested IE set to TRUE, then the SS shall send an acknowledgment in the LPP PROVIDE ASSISTANCE DATA message.
10. The SS shall transmit LCS Periodic-Triggered Invoke Request message with LPP REQUEST LOCATION INFORMATION embedded to start the periodic reporting procedure, including the *NR-DL-AoD-RequestLocationInformation* IE such that the UE receives the message ΔT ms before the start of T2, where $\Delta T = 50$ ms.
11. The UE shall transmit an LCS Periodic-Triggered Invoke Return Result message.
12. When T1 expires, the SS shall transmit an RRCRelease message to transit the UE to RRC_INACTIVE state and switch the power setting from T1 to T2 as specified in Table 16.4.3.5-1 and Table 16.4.3.5-2.
13. Wait for the UE monitors for occurrence of the periodic event requested.

- 14. The UE shall transmit the UE transmit an *RRCResumeRequest* message.
- 15. The SS transmits an *RRCResume* message.
- 16. The UE transmits an *RRCResumeComplete* message. The time between the start of T2 and the UE send the *RRCResumeRequest* message should meet the requirements specified in TS 38.133 [50] Clause 5.6.3.5.
- 17. The UE shall transmit a LPP PROVIDE LOCATION INFORMATION message including the NR-DL-AoD-ProvideLocationInformation IE within the response time (see clause 4.16.3) plus the maximum RRC processing time 10ms between *RRCResume* message and *RRCResumeComplete* message. The UE shall perform and report the RSTD measurements for Cell 2 with respect to the reference cell in the DL-AoD assistance data, Cell 1. If the UE transmits an NR-DL-AoD-ProvideLocationInformation IE including the nr-DL-PRS-RSRP-Result-r16 field for Cell 2 within the response time then the number of successful tests is increased by one. If the UE fails to report the NR-DL-AoD-ProvideLocationInformation IE with both the nr-DL-PRS-RSRP-Result-r16 fields included within the response time then the number of failure tests is increased by one.
- 18. If the UE message at step 17 includes the *ackRequested* IE set to TRUE, the SS shall send a LPP acknowledgement message.
- 19. Repeat steps 2-18 in Tables 16.4.3.4-1 until the confidence level according to Annex D is achieved.

16.4.3.4.3 Message contents

Table 16.4.3.4.3-1: RESET UE POSITIONING STORED INFORMATION

Derivation Path: 38.509 [44] clause 6.6			
Information Element	Value/remark	Comment	Condition
UE Positioning Technology	0 0 0 1 0 0 0	DL-AoD	

Table 16.4.3.4.3-2: RRCReconfiguration

Derivation Path: TS 38.508-1 [45], table 4.6.1-13			
Information Element	Value/remark	Comment	Condition
RRCReconfiguration ::= SEQUENCE {			
criticalExtensions CHOICE {			
rrcReconfiguration SEQUENCE {			
nonCriticalExtension SEQUENCE {			
masterCellGroup	CellGroupConfig		
}			
}			
}			
}			

Table 16.4.3.4.3-3: CellGroupConfig (Table 16.4.3.4.3-2)

Derivation Path: 38.508-1 [45], Table 4.6.3-19			
Information Element	Value/remark	Comment	Condition
CellGroupConfig ::= SEQUENCE {			
mac-CellGroupConfig SEQUENCE {			
drx-Config CHOICE {			
setup SEQUENCE {			
drx-onDurationTimer	ms6		
drx-InactivityTimer	ms1		
drx-HARQ-RTT-TimerDL	sl64		
drx-HARQ-RTT-TimerUL	sl64		
drx-RetransmissionTimerDL	sl1		
drx-RetransmissionTimerUL	sl1		
drx-LongCycleStartOffset CHOICE {			
ms640	0		
}			
shortDRX	not present		
drx-SlotOffset	0		
}			

}			
}			
}			

Table 16.4.3.4.3-4: LPP Request Capabilities

Information Element	Value/remark
nr-DL-AoD-RequestCapabilities-r16	TRUE

Table 16.4.3.4.3-5: LPP ProvideAssistanceData

Derivation Path: 37.355 clause 6.2			
Information Element	Value/remark	Comment	Condition
LPP-Message ::= SEQUENCE {			
transactionID SEQUENCE {			
initiator	locationServer		
transactionNumber	(0..255)		
}			
endTransaction	TRUE		
sequenceNumber	Not present		
acknowledgement	Not present		
lpp-MessageBody CHOICE {			
c1 CHOICE {			
provideAssistanceData SEQUENCE {			
criticalExtensions CHOICE {			
c1 CHOICE {			
provideAssistanceData-r9 SEQUENCE {			
commonEsProvideAssistanceData	Not present		
a-gnss-ProvideAssistanceData	Not present		
otdoa-ProvideAssistanceData	Not present		
epdu-Provide-AssistanceData	Not present		
sensor-ProvideAssistanceData-r15	Not present		
tbs-ProvideAssistanceData-r15	Not present		
wlan-ProvideAssistanceData-r15	Not present		
nr-Multi-RTT-ProvideAssistanceData-r16	Not present		
nr-DL-AoD-ProvideAssistanceData-r16			
SEQUENCE {			
nr-DL-PRS-AssistanceData-r16	As defined in Table 16.4.3.4.3-6		
nr-SelectedDL-PRS-IndexList-r16	Not present		
nr-PositionCalculationAssistance-r16			Depending on UE capabilities, i.e. support for UE-based DL-AoD
SEQUENCE {			
nr-TRP-LocationInfo-r16	As defined in TS 37.571-5 [20]		
nr-DL-PRS-BeamInfo-r16	Not present		
nr-RTD-Info-r16	Not present		
nr-TRP-BeamAntennaInfo-r17	Not present		
nr-DL-PRS-Expected-LOS-NLOS-Assistance-r17	Not present		
nr-DL-PRS-TRP-TEG-Info-r17	Not present		
}			
nr-DL-AoD-Error-r16	Not present		
nr-DL-PRS-BeamInfo-r17	Not present		
nr-On-Demand-DL-PRS-Configurations-r17	Not present		
}			
nr-DL-TDOA-ProvideAssistanceData-r16	Not present		
}			
}			
}			
}			

}			
}			
}			

Table 16.4.3.4.3-6: NR-DL-PRS-AssistanceData

Derivation Path: 37.355 clause 6.4.3			
Information Element	Value/remark	Comment	Condition
NR-DL-PRS-AssistanceData-r16 ::= SEQUENCE {			
nr-DL-PRS-ReferenceInfo-r16 SEQUENCE {			
dl-PRS-ID-r16	0		
nr-DL-PRS-ResourceID-List-r16	Not present		
nr-DL-PRS-ResourceSetID-r16	Not present		
}			
nr-DL-PRS-AssistanceDataList-r16 SEQUENCE (SIZE (1..nrMaxFreqLayers-r16)) OF NR-DL-PRS-AssistanceDataPerFreq-r16 {	1 entry		
NR-DL-PRS-AssistanceDataPerFreq-r16[1] SEQUENCE {		entry 1	
nr-DL-PRS-PositioningFrequencyLayer-r16 SEQUENCE {			
dl-PRS-SubcarrierSpacing-r16	kHz120		
dl-PRS-ResourceBandwidth-r16	27	128 PRBs	
dl-PRS-StartPRB-r16	0		
dl-PRS-PointA-r16	absoluteFrequencyPointA as defined for the DL frequency of the Cell 1		
dl-PRS-CombSizeN-r16	n4		
dl-PRS-CyclicPrefix-r16	normal		
}			
nr-DL-PRS-AssistanceDataPerFreq-r16 SEQUENCE (SIZE (1..nrMaxTRPsPerFreq-r16)) OF NR-DL-PRS-AssistanceDataPerTRP-r16{	2 entries		
NR-DL-PRS-AssistanceDataPerTRP-r16[1] SEQUENCE {		entry 1	Cell 1
dl-PRS-ID-r16	0		
nr-PhysCellID-r16	Cell 1		
nr-CellGlobalID-r16	Cell 1		
nr-ARFCN-r16	Cell 1		
nr-DL-PRS-SFN0-Offset-r16 SEQUENCE {			
sfn-Offset-r16	0		
integerSubframeOffset-r16	0		
}			
nr-DL-PRS-ExpectedRSTD-r16	0		
nr-DL-PRS-ExpectedRSTD-Uncertainty-r16	0		
nr-DL-PRS-Info-r16	As specified in Table 16.4.3.4.3-7		
}			
NR-DL-PRS-AssistanceDataPerTRP-r16[2] SEQUENCE {		entry 2	Cell 2
dl-PRS-ID-r16	1		
nr-PhysCellID-r16	Cell 2		
nr-CellGlobalID-r16	Cell 2		
nr-ARFCN-r16	Cell 2		
nr-DL-PRS-SFN0-Offset-r16 SEQUENCE {			
sfn-Offset-r16	0		
integerSubframeOffset-r16	0		
}			
nr-DL-PRS-ExpectedRSTD-r16	23	About 3 μs	
nr-DL-PRS-ExpectedRSTD-Uncertainty-r16	154	About 5 μs	
nr-DL-PRS-Info-r16	As specified in Table 16.4.3.4.3-7		
}			
}			

}			
}			
}			

Table 16.4.3.4.3-7: NR-DL-PRS-Info

Derivation Path: 37.355 clause 6.4.3			
Information Element	Value/remark	Comment	Condition
NR-DL-PRS-Info-r16 ::= SEQUENCE {			
nr-DL-PRS-ResourceSetList-r16 SEQUENCE (SIZE (1..nrMaxSetsPerTrp-r16)) OF NR-DL-PRS-ResourceSet-r16 {	1 entry		
NR-DL-PRS-ResourceSet-r16[1] SEQUENCE {		entry 1	
nr-DL-PRS-ResourceSetID-r16	0		
dl-PRS-Periodicity-and-ResourceSetSlotOffset-r16 CHOICE {			
scs120-r16 CHOICE {			
n1280-r16	80		
}			
dl-PRS-ResourceRepetitionFactor-r16	Not present		
dl-PRS-ResourceTimeGap-r16	s1		
dl-PRS-NumSymbols-r16	n4		
dl-PRS-MutingOption1-r16 SEQUENCE {			
dl-prs-MutingBitRepetitionFactor-r16	Not present		
nr-option1-muting-r16 CHOICE {			
po2-r16	10 01		Cell 1 Cell 2
}			
}			
dl-PRS-MutingOption2-r16	Not present		
dl-PRS-ResourcePower-r16	27		
dl-PRS-ResourceList-r16 SEQUENCE (SIZE (1..nrMaxResourcesPerSet-r16)) OF NR-DL-PRS-Resource-r16 {	1 entry		
NR-DL-PRS-Resource-r16[1] SEQUENCE {		entry 1	
nr-DL-PRS-ResourceID-r16	0		
dl-PRS-SequenceID-r16	0		
dl-PRS-CombSizeN-AndReOffset-r16 CHOICE {			
n4-r16	0		
}			
dl-PRS-ResourceSlotOffset-r16	4		
dl-PRS-ResourceSymbolOffset-r16	0		
dl-PRS-QCL-Info-r16	Not present		
}			
}			
}			
}			

Table 16.4.3.4.3-8: lcs-PeriodicTriggeredInvoke

Derivation Path: 24.080 clause 4.4.2			
Information Element	Value/remark	Comment	Condition
LCS-PeriodicTriggeredInvokeArg ::= SEQUENCE {			
referenceNumber	LCS-ReferenceNumber		
h-gmlc-address	GSN-Address		
qoS	Not present		
reportingPLMNList	Not present		
periodicLocation SEQUENCE {			
periodicLDRInfo SEQUENCE {			
reportingAmount	5		
reportingInterval	1		
reportingOptionMilliseconds	Not present		

}			
}			
areaEventReporting	Not present		
motionEventReporting	Not present		
referenceNumberExt	LCS-ReferenceNumberExt		
h-gmlc-callBackUri	Not present		
supportedGADShapes	Not present		
deferredRoutingIdentifier	Not present		
reportingAccessTypes	00000001	NR	
multiplePositioningProtocolPDUs SIZE (1..maxNumLPPMsg) OF PositioningProtocolPDU {	1 entry		
PositioningProtocolPDU[1] SEQUENCE {		entry 1	
PositioningProtocolPDU	Contains a LPP RequestLocationInformation message defined in Table 16.4.3.4.3-9		
}			
}			
controlPlane-CIoT-5GS-Optimisation	Not present		
scheduledLocTime	Not present		
eventReportAllowedArea	Not present		
}			

Table 16.4.3.4.3-9: LPP RequestLocationInformation

Derivation Path: 37.355 clause 6.2			
Information Element	Value/remark	Comment	Condition
LPP-Message ::= SEQUENCE {			
transactionID SEQUENCE {			
initiator	locationServer		
transactionNumber	1		
}			
endTransaction	FALSE		
sequenceNumber	Not present		
acknowledgement	Not present		
lpp-MessageBody CHOICE {			
c1 CHOICE {			
requestLocationInformation SEQUENCE {			
criticalExtensions CHOICE {			
c1 CHOICE {			
requestLocationInformation-r9 SEQUENCE {			
commonEsRequestLocationInformation SEQUENCE {			
locationInformationType	locationMeasurementsRequired		
triggeredReporting	Not present		
periodicalReporting	Not present		
additionalInformation	onlyReturnInformationRequested		
qos SEQUENCE {			
horizontalAccuracy	Not present		
verticalCoordinateRequest	FALSE		
verticalAccuracy	Not present		
responseTime SEQUENCE {			
time	See 16.4.3.5	Result of the response time calculation rounded up to the next second if response time <= 128s. Result of the response time calculation rounded up to the next	

		multiple of ten seconds if response time > 128s.	
responseTimeEarlyFix-r12	Not present		Rel-12 onwards
unit-r15	Not present		Calculated response time >128s
	ten-seconds		
}			
velocityRequest	FALSE		
}			
environment	Not present		
locationCoordinateTypes	Not present		
velocityTypes	Not present		
}			
a-gnss-RequestLocationInformation	Not present		
otdoa-RequestLocationInformation	Not present		
ecid-RequestLocationInformation	Not present		
epdu-RequestLocationInformation	Not Present		
sensor-RequestLocationInformation-r13	Not present		
tbs-RequestLocationInformation-r13	Not present		
wlan-RequestLocationInformation-r13	Not present		
bt-RequestLocationInformation-r13	Not present		
nr-ECID-RequestLocationInformation-r16	Not present		
nr-Multi-RTT-RequestLocationInformation-r16	Not present		
nr-DL-AoD-RequestLocationInformation-r16			
SEQUENCE {			
nr-AssistanceAvailability-r16	FALSE		
nr-DL-AoD-ReportConfig-r16 SEQUENCE {			
maxDL-PRS-RSRP-MeasurementsPerTRP-r16	Not present		
maxDL-PRS-RSRP-MeasurementsPerTRP-r17	Not present		
maxDL-PRS-RSRPP-MeasurementsPerTRP-r17	Not present		
nr-los-nlos-IndicatorRequest-r17	Not present		
reducedDL-PRS-ProcessingSamples-r17	Not present		
lowerRxBeamSweepingFactor-FR2-r17	Not present		
}			
multiMeasInSameReport-r17			
}			
nr-DL-TDOA-RequestLocationInformation-r16	Not present		
}			
}			
}			
}			
}			
}			

Table 16.4.3.4.3-10: RRCRelease

Derivation Path: TS 38.508-1 [45], Table 4.6.1-16 with condition NR_RRC_INACTIVE

Table 16.4.3.4.3-11: LPP ProvideLocation Information

Derivation Path: 37.355 clause 6.5.12			
Information Element	Value/remark	Comment	Condition
LPP-Message ::= SEQUENCE {			
transactionID SEQUENCE {			
initiator	locationServer		
transactionNumber	1		
}			

endTransaction	TRUE		
sequenceNumber	(0..255)		
acknowledgement			
lpp-MessageBody CHOICE {			
c1 CHOICE {			
provideLocationInformation SEQUENCE {			
criticalExtensions CHOICE {			
c1 CHOICE {			
provideLocationInformation-r9 SEQUENCE {			
commonIEsProvideLocationInformation	Not present.		
a-gnss-ProvideLocationInformation	Not present		
otdoa-ProvideLocationInformation	Not present		
ecid-ProvideLocationInformation	Not present		
epdu-ProvideLocationInformation	Not present		
sensor-ProvideLocationInformation-r13	Not present		
tbs-ProvideLocationInformation-r13	Not present		
wlan-ProvideLocationInformation-r13	Not present		
bt-ProvideLocationInformation-r13	Not present		
nr-ECID-ProvideLocationInformation-r16	Not present		
nr-Multi-RTT-ProvideLocationInformation-	Not present		
r16			
nr-DL-AoD-ProvideLocationInformation-r16			
SEQUENCE {			
nr-DL-AoD-			
SignalMeasurementInformation-r16 SEQUENCE {			
nr-DL-AoD-MeasList-r16 SEQUENCE			
(SIZE(1..nrMaxTRPs-r16)) OF NR-DL-AoD-			
MeasElement-r16 {			
NR-DL-AoD-MeasElement-r16[1]		entry 1	
SEQUENCE {			
dl-PRS-ID-r16	INTEGER (0..255)		
nr-PhysCellID-r16	Cell 1		
nr-CellGlobalID-r16			
nr-ARFCN-r16			
nr-DL-PRS-ResourceID-r16			
nr-DL-PRS-ResourceSetID-r16			
nr-TimeStamp-r16			
nr-DL-PRS-RSRP-Result-r16	Present. Any value acceptable.		
nr-DL-PRS-RxBeamIndex-r16			
nr-DL-AoD-AdditionalMeasurements-			
r16			
nr-DL-PRS-FirstPathRSRP-Result-r17			
nr-los-nlos-Indicator-r17			
nr-DL-AoD-			
AdditionalMeasurementsExt-r17			
}			
NR-DL-AoD-MeasElement-r16[2]		entry 2	
SEQUENCE {			
dl-PRS-ID-r16	INTEGER (0..255)		
nr-PhysCellID-r16	Cell 2		
nr-CellGlobalID-r16			
nr-ARFCN-r16			
nr-DL-PRS-ResourceID-r16			
nr-DL-PRS-ResourceSetID-r16			
nr-TimeStamp-r16			
nr-DL-PRS-RSRP-Result-r16	Present. Any value acceptable.		
nr-DL-PRS-RxBeamIndex-r16			
nr-DL-AoD-AdditionalMeasurements-			
r16			
nr-DL-PRS-FirstPathRSRP-Result-r17			
nr-los-nlos-Indicator-r17			
nr-DL-AoD-			
AdditionalMeasurementsExt-r17			
}			

	}		
	}		
	nr-dl-AoD-LocationInformation-r16		
	nr-DL-AoD-Error-r16	Not present	
r17	nr-DL-AoD-SignalMeasurementInstances-	Not present	
r17	nr-DL-AoD-LocationInformationInstances-	Not present	
	}		
	}		
	}		
	}		
	}		
	}		
	}		
	}		
	}		
	}		

16.4.3.5 Test requirement

FFS

16.4.4 PRS-RSRP measurement reporting delay test case for single positioning frequency layer with reduced number of samples in FR2 SA

Editor’s note: This test case is incomplete. The following aspect is either missing or TBD:

- Test tolerance are not added in and analysis is missing

16.4.4.1 Test purpose

The purpose of the test is to verify the PRS RSRP measurement requirements specified in TS 38.133 [50] Clause 5.6.3.5 for single positioning frequency layer under AWGN propagation conditions in RRC_INACTIVE in FR2 standalone scenario.

16.4.4.2 Test applicability

This test applies to all types of NR UE release 17 onwards that supports DL-AoD positioning, supports DL-PRS measurement in RRC_INACTIVE state and reduced number of samples for PRS measurement in RRC_INACTIVE state.

16.4.4.3 Minimum conformance requirements

Same as in clause 16.4.3.3.

16.4.4.4 Test description

16.4.4.4.1 Initial conditions

The supported test configurations in listed in Table 16.4.4.4-1.

Table 16.4.4.4-1: Test Configurations

Test Configuration	Description
1	120 kHz SSB and PRS SCS, 100 MHz bandwidth, TDD duplex mode

Test Environment: Normal, as defined in TS 38.508-1 [45] clause 4.1.

Frequencies to be tested: Mid Range, as defined in TS 38.508-1 [45] clause 4.3.1.

Channel bandwidth to be tested: are specified in Table 16.4.4.4-1.

1. Connect the SS and AWGN noise sources to the UE antenna connector or antenna connectors as shown in Annex A, Figure A.14.
2. The general test parameter settings are set up according to Table 16.4.4.5-1 and Table 16.4.4.5-2.
3. Propagation conditions are set according to clause 4.16.2.
4. Message contents are defined in clause 16.4.4.4.3.
5. In the test there are two synchronous cells: Cell 1 and Cell 2. Cell 1 is the reference as well as the PCell. Cell 2 is the neighbour cell. All cells are on the same RF channel distributed in single positioning frequency layer.

16.4.4.4.2 Test procedure

Same as in clause 16.4.3.4.2.

16.4.4.4.3 Message contents

As defined in clause 16.4.3.4.3, with the following exceptions:

Table 16.4.4.4.3-1 replaces Table 16.4.3.4.3-6 and Table 16.4.4.4.3-2 replaces Table 16.4.3.4.3-9.

Table 16.4.4.4.3-1: NR-DL-PRS-AssistanceData

Derivation Path: 37.355 clause 6.4.3			
Information Element	Value/remark	Comment	Condition
NR-DL-PRS-AssistanceData-r16 ::= SEQUENCE {			
nr-DL-PRS-ReferenceInfo-r16 SEQUENCE {			
dl-PRS-ID-r16	0		
nr-DL-PRS-ResourceID-List-r16	Not present		
nr-DL-PRS-ResourceSetID-r16	Not present		
}			
nr-DL-PRS-AssistanceDataList-r16 SEQUENCE (SIZE (1..nrMaxFreqLayers-r16)) OF NR-DL-PRS-AssistanceDataPerFreq-r16 {	1 entry		
NR-DL-PRS-AssistanceDataPerFreq-r16[1] SEQUENCE {		entry 1	
nr-DL-PRS-PositioningFrequencyLayer-r16 SEQUENCE {			
dl-PRS-SubcarrierSpacing-r16	kHz120		
dl-PRS-ResourceBandwidth-r16	11	64 PRBs	
dl-PRS-StartPRB-r16	0		
dl-PRS-PointA-r16	absoluteFrequencyPointA as defined for the DL frequency of the Cell 1		
dl-PRS-CombSizeN-r16	n4		
dl-PRS-CyclicPrefix-r16	normal		
}			
nr-DL-PRS-AssistanceDataPerFreq-r16 SEQUENCE (SIZE (1..nrMaxTRPsPerFreq-r16)) OF NR-DL-PRS-AssistanceDataPerTRP-r16{	2 entries		
NR-DL-PRS-AssistanceDataPerTRP-r16[1] SEQUENCE {		entry 1	Cell 1
dl-PRS-ID-r16	0		
nr-PhysCellID-r16	Cell 1		
nr-CellGlobalID-r16	Cell 1		
nr-ARFCN-r16	Cell 1		
nr-DL-PRS-SFN0-Offset-r16 SEQUENCE {			
sfn-Offset-r16	0		
integerSubframeOffset-r16	0		
}			

nr-DL-PRS-ExpectedRSTD-r16	0		
nr-DL-PRS-ExpectedRSTD-Uncertainty-r16	0		
nr-DL-PRS-Info-r16	As specified in Table 16.4.3.4.3-7		
}			
NR-DL-PRS-AssistanceDataPerTRP-r16[2]		entry 2	Cell 2
SEQUENCE {			
dl-PRS-ID-r16	1		
nr-PhysCellID-r16	Cell 2		
nr-CellGlobalID-r16	Cell 2		
nr-ARFCN-r16	Cell 2		
nr-DL-PRS-SFN0-Offset-r16 SEQUENCE {			
sfn-Offset-r16	0		
integerSubframeOffset-r16	0		
}			
nr-DL-PRS-ExpectedRSTD-r16	23	About 3 μ s	
nr-DL-PRS-ExpectedRSTD-Uncertainty-r16	154	About 5 μ s	
nr-DL-PRS-Info-r16	As specified in Table 16.4.3.4.3-7		
}			
}			
}			
}			
}			

Table 16.4.4.3-2: LPP RequestLocationInformation

Derivation Path: 37.355 clause 6.2			
Information Element	Value/remark	Comment	Condition
LPP-Message ::= SEQUENCE {			
transactionID SEQUENCE {			
initiator	locationServer		
transactionNumber	1		
}			
endTransaction	FALSE		
sequenceNumber	Not present		
acknowledgement	Not present		
lpp-MessageBody CHOICE {			
c1 CHOICE {			
requestLocationInformation SEQUENCE {			
criticalExtensions CHOICE {			
c1 CHOICE {			
requestLocationInformation-r9 SEQUENCE {			
commonEsRequestLocationInformation SEQUENCE {			
locationInformationType	locationMeasurementsRequired		
triggeredReporting	Not present		
periodicalReporting	Not present		
additionalInformation	onlyReturnInformationRequested		
qos SEQUENCE {			
horizontalAccuracy	Not present		
verticalCoordinateRequest	FALSE		
verticalAccuracy	Not present		
responseTime SEQUENCE {			
time	See 16.4.4.5	Result of the response time calculation rounded up to the next second if response time <= 128s. Result of the response time calculation rounded	

		up to the next multiple of ten seconds if response time > 128s.	
responseTimeEarlyFix-r12	Not present		Rel-12 onwards
unit-r15	Not present		Calculated response time >128s
	ten-seconds		
}			
velocityRequest	FALSE		
}			
environment	Not present		
locationCoordinateTypes	Not present		
velocityTypes	Not present		
}			
a-gnss-RequestLocationInformation	Not present		
otdoa-RequestLocationInformation	Not present		
ecid-RequestLocationInformation	Not present		
epdu-RequestLocationInformation	Not Present		
sensor-RequestLocationInformation-r13	Not present		
tbs-RequestLocationInformation-r13	Not present		
wlan-RequestLocationInformation-r13	Not present		
bt-RequestLocationInformation-r13	Not present		
nr-ECID-RequestLocationInformation-r16	Not present		
nr-Multi-RTT-RequestLocationInformation-r16	Not present		
nr-DL-AoD-RequestLocationInformation-r16			
SEQUENCE {			
nr-AssistanceAvailability-r16	FALSE		
nr-DL-AoD-ReportConfig-r16 SEQUENCE {			
r16 maxDL-PRS-RSRP-MeasurementsPerTRP-	Not present		
r17 maxDL-PRS-RSRP-MeasurementsPerTRP-	Not present		
MeasurementsPerTRP-r17	Not present		
nr-los-nlos-IndicatorRequest-r17	Not present		
reducedDL-PRS-ProcessingSamples-r17	requested		
lowerRxBeamSweepingFactor-FR2-r17	Not present		
}			
multiMeasInSameReport-r17			
}			
nr-DL-TDOA-RequestLocationInformation-r16	Not present		
}			
}			
}			
}			
}			
}			

16.4.4.5 Test requirement

FFS

16.5 NR PRS-RSRP measurement accuracy test case in RRC_INACTIVE

16.5.1 PRS-RSRP measurement accuracy test case for single positioning frequency layer with PRS in FR1 SA

Editor’s note: This test case is incomplete. The following aspect is either missing or TBD:

- Test tolerance is missing
- Message contents require update

16.5.1.1 Test purpose

The purpose of the test is to verify the PRS RSRP measurement accuracy requirements specified in TS 38.133 [50] Clause 10.1.24.2 for single positioning frequency layer under AWGN propagation conditions in RRC_INACTIVE in FR1 standalone scenario.

16.5.1.2 Test applicability

This test applies to all types of NR UE release 17 onwards that supports DL-AoD positioning and supports DL-PRS measurement in RRC_INACTIVE state.

16.5.1.3 Minimum conformance requirements

The absolute accuracy requirements for PRS-RSRP measurement for FR1 defined in Table 16.5.1.3-1 are valid under the following conditions:

- Conditions defined in 38.101-1 Clause 7.3 for reference sensitivity are fulfilled.
- PRP $1,2_{dBm}$ according to Annex B.2.14 for a corresponding Band
- UE does not support positioning measurements with reduced number of samples, or LMF does not indicate UE to perform positioning measurements with reduced number of samples

Table 16.5.1.3-1: PRS-RSRP absolute accuracy for FR1

Accuracy		Conditions							
Normal condition	Extreme condition	PRS \hat{E}_s/lot	PRS BW	Repetition factor $(T_{rep}^{PRS} * L_{PRS} / K_{comb}^{PRS})$	NR operating band groups <small>Note 8</small>	I_o <small>Note 7</small> range			Maximum I_o
						Minimum I_o <small>Note 1</small> dBm / SCS_{PRS}			
dB	dB	dB	PRB	-		dBm / SCS_{PRS}			dBm/BW _{Channel}
						dBm/15k Hz <small>Note 6</small>	dBm/30k Hz <small>Note 6</small>	dBm/60kHz <small>Note 6</small>	
±3.5	±8	≥-3dB	≥24	All	NR_FDD_FR1_A, NR_TDD_FR1_A, NR_SDL_FR1_A	-127	-124	-121	-50
					NR_FDD_FR1_B	-126.5	-123.5	-120.5	
					NR_TDD_FR1_C	-126	-123	-120	
					NR_FDD_FR1_D, NR_TDD_FR1_D	-125.5	-122.5	-119.5	

					NR_FDD_FR1_E, NR_TDD_FR1_E	-125	-122	-119	-50
					NR_FDD_FR1_F	-124.5	-121.5	-118.5	-50
					NR_FDD_FR1_G, NR_TDD_FR1_G	-124	-121	-118	-50
					NR_FDD_FR1_H	-123.5	-120.5	-117.5	-50
Note 4									
Note 4									
±8.5	±13	≥-13dB	24 ≤ BW ≤ 52	All	Note 4				
±6	±10.5		52 < BW ≤ 104	All	Note 4				
±4.5	±9		BW > 104	All	Note 4				
<p>NOTE 1: This minimum I_0 condition is expressed as the average I_0 per RE over all REs in an OFDM symbol.</p> <p>NOTE 2: Void.</p> <p>NOTE 3: PRS bandwidth is as indicated in <i>prs-Bandwidth</i> in the OTDOA or DL-AoD assistance data defined in [34].</p> <p>NOTE 4: The same bands and the same I_0 conditions for each band apply for this requirement as for the corresponding requirement with the PRS bandwidth ≥ 24 RB.</p> <p>NOTE 5: The serving cell, the reference cell, and the measured neighbour cell i are on the same carrier frequency.</p> <p>NOTE 6: The condition level is increased by $\Delta > 0$, when applicable, as described in Sections B.3.2 and B.3.3.</p> <p>NOTE 7: The I_0 is defined in PRS positioning subframes. The same I_0 range applies to PRS and non-PRS symbols. I_0 levels are different in PRS and non-PRS symbols within the same subframe.</p> <p>NOTE 8: NR operating band groups are as defined in Section 3.5.2.</p>									

The accuracy requirements for PRS-RSRP measurement for FR1 defined in Table 16.5.1.3-2 are valid under the following conditions:

- Conditions defined in 38.101-1 Clause 7.3 for reference sensitivity are fulfilled.
- PRP $1,2_{dBm}$ according to Annex B.2.14 for a corresponding Band
- UE does not support positioning measurements with reduced number of samples, or LMF does not indicate UE to perform positioning measurements with reduced number of samples

Table 16.5.1.3-2: PRS-RSRP relative accuracy for FR1

Accuracy		Conditions							
Normal condition	Extreme condition	PRS \hat{E}_s/lot	PRS BW	Repetition factor $(T_{rep}^{PRS} * L_{PRS}/K_{comb})$	I_0 ^{Note 7} range				Maximum I_0
					NR operating band groups ^{Note 8}	Minimum I_0 ^{Note 1} dBm / SCS _{PRS}			
dB	dB	dB	PRB	-		dBm/15k Hz ^{Note 6}	dBm/30k Hz ^{Note 6}	dBm/60kHz ^{Note 6}	
[±3.5]	±5.0	≥-3dB	≥24	All	NR_FDD_FR1_A, NR_TDD_FR1_A, NR_SDL_FR1_A	-127	-124	-121	-50
					NR_FDD_FR1_B	-126.5	-123.5	-120.5	-50
					NR_TDD_FR1_C	-126	-123	-120	-50
					NR_FDD_FR1_D,	-125.5	-122.5	-119.5	-50

					NR_TDD_FR1_D				
					NR_FDD_FR1_E, NR_TDD_FR1_E	-125	-122	-119	-50
					NR_FDD_FR1_F	-124.5	-121.5	-118.5	-50
					NR_FDD_FR1_G, NR_TDD_FR1_G	-124	-121	-118	-50
					NR_FDD_FR1_H	-123.5	-120.5	-117.5	-50
					Note 4				
					Note 4				
±9.5	±11.0	≥-13dB	24 ≤ BW ≤ 52	All	Note 4				
±6.5	±8.0		52 < BW ≤ 104	All	Note 4				
±5.0	±6.5		BW > 104	All	Note 4				
<p>NOTE 1: This minimum lo condition is expressed as the average lo per RE over all REs in an OFDM symbol.</p> <p>NOTE 2: Void.</p> <p>NOTE 3: PRS bandwidth is as indicated in <i>prs-Bandwidth</i> in the OTDOA or DL-AoD assistance data defined in [34].</p> <p>NOTE 4: The same bands and the same lo conditions for each band apply for this requirement as for the corresponding requirement with the PRS bandwidth ≥ 24 RB.</p> <p>NOTE 5: The serving cell, the reference cell, and the measured neighbour cell i are on the same carrier frequency.</p> <p>NOTE 6: The condition level is increased by Δ>0, when applicable, as described in Sections B.3.2 and B.3.3.</p> <p>NOTE 7: The lo is defined in PRS positioning subframes. The same lo range applies to PRS and non-PRS symbols. lo levels are different in PRS and non-PRS symbols within the same subframe.</p> <p>NOTE 8: NR operating band groups are as defined in Section 3.5.2.</p>									

16.5.1.4 Test description

16.5.1.4.1 Initial conditions

The supported test configurations in listed in Table 16.5.1.4-1.

Table 16.5.1.4-1: Test Configurations

Config	Description
1	NR 15 kHz SSB SCS, 20 MHz bandwidth, FDD duplex mode
2	NR 15 kHz SSB SCS, 20 MHz bandwidth, TDD duplex mode
3	NR 30 kHz SSB SCS, 50 MHz bandwidth, TDD duplex mode
Note:	The UE is only required to be tested in one of the supported test configurations in each supported band

Test Environment: Normal, as defined in TS 38.508-1 [45] clause 4.1.

Frequencies to be tested: Mid Range, as defined in TS 38.508-1 [45] clause 4.3.1.

Channel bandwidth to be tested: are specified in Table 16.5.1.4-1.

1. Connect the SS and AWGN noise sources to the UE antenna connector or antenna connectors as shown in Annex A, Figure A.13.
2. The general test parameter settings are set up according to Table 16.5.1.5-1.
3. Propagation conditions are set according to clause 4.15.2.
4. Message contents are defined in clause 16.5.1.4.3.
5. In the test there are two synchronous cells: Cell 1 and Cell 2. Cell 1 is the reference as well as the PCell. Cell 2 is the neighbour cell. All cells are on the same RF channel distributed in single positioning frequency layer.

16.5.1.4.2 Test procedure

The test consists of two sub-tests; the difference between the sub-tests is the PRS configuration. The test consists of a set-up period and a measurement period. During the set-up period, the UE shall be in RRC_CONNECTED state and shall not have any timing information of Cell 2. During the measurement period UE shall be in RRC_INACTIVE state and all cells start to transmit PRS resources within initial DL BWP of the UE and with the same numerology as the initial DL BWP.

The NR-DL-AoD-RequestLocationInformation message and the DL-AoD assistance data as defined in clause 16.5.1.4.3 shall be provided to the UE during the set-up period. The beginning of the measurement period shall be aligned with the first DRX cycle containing a DL PRS resource(s).

1. Configure the Cell for RA-SDT with SIB1 configured according to TS 38.508-1 [45], clause 4.6.1 with condition SDT
2. Ensure the UE is in State RRC_CONNECTED with generic procedure parameters Connectivity NR, Connected without release *On*, according to TS 38.508-1 [45] clause 4.5.
2. The SS shall send a RESET UE POSITIONING STORED INFORMATION message.
3. Set parameters other than PRSconfiguration according to the Table 16.5.1.5-1. Propagation conditions are set according to clause 4.15.2.
4. Set-up period starts.
5. The SS shall transmit an RRCReconfiguration message with the DRX configuration.
6. The UE shall transmit RRCReconfigurationComplete message.
7. The SS shall transmit an LPP REQUEST CAPABILITIES message.
8. The UE shall transmit an LPP PROVIDE CAPABILITIES message indicating the DL-AoD capabilities supported by the UE in the *NR-DL-AoD-ProvideCapabilities* IE.
9. The SS shall send a LPP PROVIDE ASSISTANCE DATA message, including the *NR-DL-AoD-ProvideAssistanceData* IE. The position of neighbour Cell 2 is described in 3GPP TS 37.571-5 [20]. If the UE message at step 8 includes the *ackRequested* IE set to TRUE, then the SS shall send an acknowledgment in the LPP PROVIDE ASSISTANCE DATA message.
10. The SS shall transmit LCS Periodic-Triggered Invoke Request message with LPP REQUEST LOCATION INFORMATION embedded to start the periodic reporting procedure, including the *NR-DL-AoD-RequestLocationInformation* IE such that the UE receives the message ΔT ms before the start of measurement period, where $\Delta T = 50$ ms.
11. The UE shall transmit an LCS Periodic-Triggered Invoke Return Result message.
12. When set-up period ends, the SS shall transmit an RRCRelease message with SDT configuration to transit the UE to RRC_INACTIVE state and set the PRS parameters as specified in Table 16.5.1.5-1.
13. Wait for the UE monitors for occurrence of the periodic event requested.
14. The UE shall transmit the UE transmit an *RRCResumeRequest* message. If the UE also supporting SDT feature, the UE shall include LPP PROVIDE LOCATION INFORMATION message in the *RRCResumeRequest* message and then go to step 17.
15. The SS transmits an *RRCResume* message.
16. The UE transmits an *RRCResumeComplete* message.
17. The UE shall transmit a LPP PROVIDE LOCATION INFORMATION message including the *NR-DL-AoD-ProvideLocationInformation* IE within the response time (see clause 4.15.3).
18. If the UE message at step 17 includes the *ackRequested* IE set to TRUE, the SS shall send a LPP acknowledgement message.

- 19. The SS shall check the nr-DL-PRS-RSRP-Result-r16 value for Cell 2 in the *NR-DL-AoD-SignalMeasurementInformation* according to Table 16.5.1.5-3.
 - 20. Repeat steps 2-19 in Table 16.5.1.4-1 until the confidence level according to Annex D is achieved.
 - 21. Repeat step 2-20 for the other sub-test defined in Table 16.5.1.5-1 as appropriate.
- If all (applicable) sub-tests pass, the whole test passes. If one (applicable) sub-test fails, the whole test fails.

16.5.1.4.3 Message contents

As defined in clause 16.4.1.4.3, with the following exceptions:

Table 16.5.1.4.3-1 replaces Table 16.4.1.4.3-6 and Table 16.5.1.4.3-2 replaces Table 16.4.1.4.3-7.

Table 16.5.1.4.3-1: NR-DL-PRS-AssistanceData

Derivation Path: 37.355 clause 6.4.3			
Information Element	Value/remark	Comment	Condition
NR-DL-PRS-AssistanceData-r16 ::= SEQUENCE {			
nr-DL-PRS-ReferenceInfo-r16 SEQUENCE {			
dl-PRS-ID-r16	0		
nr-DL-PRS-ResourceID-List-r16	Not present		
nr-DL-PRS-ResourceSetID-r16	Not present		
}			
nr-DL-PRS-AssistanceDataList-r16 SEQUENCE (SIZE (1..nrMaxFreqLayers-r16)) OF NR-DL-PRS-AssistanceDataPerFreq-r16 {	1 entry		
NR-DL-PRS-AssistanceDataPerFreq-r16[1] SEQUENCE {		entry 1	
nr-DL-PRS-PositioningFrequencyLayer-r16 SEQUENCE {			
dl-PRS-SubcarrierSpacing-r16	kHz120		
dl-PRS-ResourceBandwidth-r16	3	32 PRBs	Sub-test 1
	27	128 PRBs	Sub-test 2
dl-PRS-StartPRB-r16	0		
dl-PRS-PointA-r16	absoluteFrequencyPointA as defined for the DL frequency of the Cell 1		
dl-PRS-CombSizeN-r16	n2		Sub-test 1
	n4		Sub-test 2
dl-PRS-CyclicPrefix-r16	normal		
}			
nr-DL-PRS-AssistanceDataPerFreq-r16 SEQUENCE (SIZE (1..nrMaxTRPsPerFreq-r16)) OF NR-DL-PRS-AssistanceDataPerTRP-r16{	2 entries		
NR-DL-PRS-AssistanceDataPerTRP-r16[1] SEQUENCE {		entry 1	Cell 1
dl-PRS-ID-r16	0		
nr-PhysCellID-r16	Cell 1		
nr-CellGlobalID-r16	Cell 1		
nr-ARFCN-r16	Cell 1		
nr-DL-PRS-SFN0-Offset-r16 SEQUENCE {			
sfn-Offset-r16	0		
integerSubframeOffset-r16	0		
}			
nr-DL-PRS-ExpectedRSTD-r16	0		
nr-DL-PRS-ExpectedRSTD-Uncertainty-r16	0		
nr-DL-PRS-Info-r16	As specified in Table 16.5.1.4.3-2		
}			
NR-DL-PRS-AssistanceDataPerTRP-r16[2] SEQUENCE {		entry 2	Cell 2
dl-PRS-ID-r16	1		
nr-PhysCellID-r16	Cell 2		
nr-CellGlobalID-r16	Cell 2		

nr-ARFCN-r16	Cell 2		
nr-DL-PRS-SFN0-Offset-r16 SEQUENCE {			
sfn-Offset-r16	0		
integerSubframeOffset-r16	0		
}			
nr-DL-PRS-ExpectedRSTD-r16	23	About 3 μ s	
nr-DL-PRS-ExpectedRSTD-Uncertainty-r16	154	About 5 μ s	
nr-DL-PRS-Info-r16	As specified in Table 16.5.1.4.3-2		
}			
}			
}			
}			
}			

Table 16.5.1.4.3-2: NR-DL-PRS-Info

Derivation Path: 37.355 clause 6.4.3			
Information Element	Value/remark	Comment	Condition
NR-DL-PRS-Info-r16 ::= SEQUENCE {			
nr-DL-PRS-ResourceSetList-r16 SEQUENCE (SIZE (1..nrMaxSetsPerTrp-r16)) OF NR-DL-PRS-ResourceSet-r16 {	1 entry		
NR-DL-PRS-ResourceSet-r16[1] SEQUENCE {		entry 1	
nr-DL-PRS-ResourceSetID-r16	0		
dl-PRS-Periodicity-and-ResourceSetSlotOffset-r16 CHOICE {			
scs120-r16 CHOICE {			
n1280-r16	80		
}			
dl-PRS-ResourceRepetitionFactor-r16	n2		Sub-test 1
	Not present		Sub-test 2
dl-PRS-ResourceTimeGap-r16	s1		
dl-PRS-NumSymbols-r16	n4		
dl-PRS-MutingOption1-r16	Not present		
dl-PRS-MutingOption2-r16	Not present		
dl-PRS-ResourcePower-r16	27		
dl-PRS-ResourceList-r16 SEQUENCE (SIZE (1..nrMaxResourcesPerSet-r16)) OF NR-DL-PRS-Resource-r16 {	2 entries		
NR-DL-PRS-Resource-r16[1] SEQUENCE {		entry 1	
nr-DL-PRS-ResourceID-r16	0		
dl-PRS-SequenceID-r16	0		
dl-PRS-CombSizeN-AndReOffset-r16 CHOICE {			
n2-r16	0		Sub-test 1
n4-r16	0		Sub-test 2
}			
dl-PRS-ResourceSlotOffset-r16	0		Sub-test 1 Cell 1 and Sub-test 2 Cell 1
	4		Sub-test 1 Cell 2 and Sub-test 2 Cell 2
dl-PRS-ResourceSymbolOffset-r16	0		
dl-PRS-QCL-Info-r16	Not present		
}			
NR-DL-PRS-Resource-r16[2] SEQUENCE {		entry 2	
nr-DL-PRS-ResourceID-r16	1		
dl-PRS-SequenceID-r16	0		
dl-PRS-CombSizeN-AndReOffset-r16 CHOICE {			
n2-r16	1		Sub-test 1
n4-r16	1		Sub-test 2
}			

dl-PRS-ResourceSlotOffset-r16	0		Sub-test 1 Cell 1 and Sub-test 2 Cell 1
	4		Sub-test 1 Cell 2 and Sub-test 2 Cell 2
dl-PRS-ResourceSymbolOffset-r16	0		
dl-PRS-QCL-Info-r16	Not present		
}			
}			
}			
}			
}			

16.5.1.5 Test requirement

Table 16.5.1.5-1 defines the primary level settings including test tolerances for the test.

Table 16.5.1.5-1: PRS-RSRP test parameters

Parameter		Unit	Test 1		Test 2	
			Cell 1	Cell 2	Cell 1	Cell 2
Cell ID			489	0	489	0
SSB ARFCN			freq1		freq1	
Duplex mode	Config 1		FDD			
	Config 2,3		TDD			
TDD configuration	Config 1		Not Applicable			
	Config 2		TDDConf.1.1			
	Config 3		TDDConf.2.1			
BW _{channel}	Config 1	MHz	20: N _{RB,c} = 106			
	Config 2		20: N _{RB,c} = 106			
	Config 3		50: N _{RB,c} = 133			
BWP BW	Config 1		20: N _{RB,c} = 106			
	Config 2		20: N _{RB,c} = 106			
	Config 3		50: N _{RB,c} = 133			
Downlink initial BWP configuration			DLBWP.0.1			
Uplink initial BWP configuration			ULBWP.0.1			
DRX Cycle		ms	1280			
PDSCH Reference measurement channel	Config 1		SR.1.1 FDD	-	SR.1.1 FDD	-
	Config 2		SR.1.1 TDD		SR.1.1 TDD	
	Config 3		SR2.1 TDD		SR2.1 TDD	
RMSI CORESET Reference Channel	Config 1		CR.1.1 FDD	-	CR.1.1 FDD	-
	Config 2		CR.1.1 TDD		CR.1.1 TDD	
	Config 3		CR2.1 TDD		CR2.1 TDD	
Control channel RMC	Config 1		CCR.1.1 FDD	-	CCR.1.1 FDD	-
	Config 2		CCR.1.1 TDD		CCR.1.1 TDD	
	Config 3		CCR2.1 TDD		CCR2.1 TDD	
PRS configuration	Config 1		PRS.1.3 FR1	PRS.1.3 FR1	PRS.1.4 FR1	PRS.1.4 FR1
	Config 2		PRS.1.3 FR1	PRS.1.3 FR1	PRS.1.4 FR1	PRS.1.4 FR1
	Config 3		PRS.2.3 FR1	PRS.2.3 FR1	PRS.2.4 FR1	PRS.2.4 FR1

PRS Resource slot offset (slot)	Config 1,2,3	slot	0	4	0	4
SSB configuration	Config 1		SSB.1 FR1	SSB.1 FR1	SSB.1 FR1	SSB.1 FR1
	Config 2		SSB.1 FR1	SSB.1 FR1	SSB.1 FR1	SSB.1 FR1
	Config 3		SSB.2 FR1	SSB.2 FR1	SSB.2 FR1	SSB.2 FR1
Time offset with Cell 1	Config 1	ms	-	3	-	3
	Config 2,3	µs	-	3	-	3
SMTC configuration	Config 1		SMTC.2			
	Config 2,3		SMTC.1			
OCNG Patterns			OCNG pattern 1			
PDSCH/PDCCH subcarrier spacing	Config 1,2	kHz	15 kHz			
	Config 3		30 kHz			
EPRE ratio of PSS to SSS		dB	0	0	0	0
EPRE ratio of PBCH DMRS to SSS						
EPRE ratio of PBCH to PBCH DMRS						
EPRE ratio of PDCCH DMRS to SSS						
EPRE ratio of PDCCH to PDCCH DMRS						
EPRE ratio of PDSCH DMRS to SSS						
EPRE ratio of PDSCH to PDSCH						
EPRE ratio of OCNG DMRS to SSS(Note 1)						
EPRE ratio of OCNG to OCNG DMRS (Note 1)						
N_{oc} ^{Note2}	Config 1,2	dBm/15KhZ	-98		-98	
	Config 3		-98		-98	
N_{oc} ^{Note2}	Config 1,2	dBm/SCS	-98		-98	
	Config 3		-95		-95	
\hat{E}_s/I_{ot}		dB	-2.41	-12.12	-2.41	-12.12
\hat{E}_s/N_{oc}		dB	-2	-10	-2	-10
PRS-RSRP ^{Note3}	Config 1, 2	dBm/SCS	-100+TT	-108+TT	-100+TT	-108+TT
	Config 3		-97+TT	-105+TT	-97+TT	-105+TT
I_o ^{Note3}	Config 1,2	dBm/19.08MH z	-64.57+TT		-64.57+TT	
	Config 3		-60.59+TT		-60.59+TT	
Propagation condition			AWGN			
Antenna configuration			1x2			
<p>Note 1: OCNG shall be used such that both cells are fully allocated and a constant total transmitted power spectral density is achieved for all OFDM symbols.</p> <p>Note 2: Interference from other cells and noise sources not specified in the test is assumed to be constant over subcarriers and time and shall be modelled as AWGN of appropriate power for N_{oc} to be fulfilled.</p> <p>Note 3: PRS-RSRP and I_o levels have been derived from other parameters for information purposes. They are not settable parameters themselves.</p> <p>Note 4: PRS-RSRP minimum requirements are specified assuming independent interference and noise at each receiver antenna port.</p> <p>Note 5: Void.</p> <p>Note 6: Void</p>						

The value of the LPP Time IE depends on the UE capabilities. The calculation is FFS

Table 16.5.1.5-2: PRS-RSRP accuracy requirements for the reported values

Test Configuration	Subtest	Cell 1		Cell 2	
		Lowest reported value	Highest reported value	Lowest reported value	Highest reported value
1	Sub-test 1	FFS	FFS	FFS	FFS
	Sub-test 2	FFS	FFS	FFS	FFS
2	Sub-test 1	FFS	FFS	FFS	FFS
	Sub-test 2	FFS	FFS	FFS	FFS
3	Sub-test 1	FFS	FFS	FFS	FFS
	Sub-test 2	FFS	FFS	FFS	FFS

For the overall test to pass, the ratio of successful reported values in each sub-test shall be more than 90% with a confidence level of 95%.

16.5.2 PRS-RSRP measurement accuracy test case for single positioning frequency layer with PRS in FR1 SA

Editor's note: This test case is incomplete. The following aspect is either missing or TBD:

- Test tolerance is missing
- Message contents require update

16.5.2.1 Test purpose

The purpose of the test is to verify the PRS RSRP measurement accuracy requirements specified in TS 38.133 [50] Clause 10.1.24.2 for single positioning frequency layer under AWGN propagation conditions in RRC_INACTIVE in FR1 standalone scenario.

16.5.2.2 Test applicability

This test applies to all types of NR UE release 17 onwards that supports DL-AoD positioning and supports DL-PRS measurement in RRC_INACTIVE state.

16.5.2.3 Minimum conformance requirements

The absolute accuracy requirements for PRS-RSRP measurement for FR1 defined in Table 16.5.2.3-2 are valid under the following conditions:

- Conditions defined in 38.101-1 Clause 7.3 for reference sensitivity are fulfilled.
- PRP $1,2_{\text{dBm}}$ according to Annex B.2.14 for a corresponding Band
- UE supports positioning measurements with reduced number of samples, and LMF indicates UE to perform positioning measurements with reduced number of samples
- AWGN channel

Table 16.5.2.3-1: PRS-RSRP absolute accuracy for FR1 with reduced sample number

Accuracy		Conditions							
Normal condition	Extreme condition	PRS \hat{E}_s/lot	PRS BW	Repetition factor $(T_{\text{rep}}^{\text{PRS}} * L_{\text{PRS}} / K_{\text{comb}}^{\text{PRS}})$	NR operating band groups Note 7	I_0 Note 6 range			Maximum I_0
						Minimum I_0 Note 1 dBm / SCS _{PRS}			
dB	dB	dB	PRB	-		dBm / SCS _{PRS}			dBm/BW _{Channel}
						dBm/15k Hz Note 5	dBm/30k Hz Note 5	dBm/60kHz Note 5	

±3.5	±8	≥0	≥48	All	NR_FDD_FR1_A, NR_TDD_FR1_A, NR_SDL_FR1_A	-127	-124	-121	-50
					NR_FDD_FR1_B	-126.5	-123.5	-120.5	-50
					NR_TDD_FR1_C	-126	-123	-120	-50
					NR_FDD_FR1_D, NR_TDD_FR1_D	-125.5	-122.5	-119.5	-50
					NR_FDD_FR1_E, NR_TDD_FR1_E	-125	-122	-119	-50
					NR_FDD_FR1_F	-124.5	-121.5	-118.5	-50
					NR_FDD_FR1_G, NR_TDD_FR1_G	-124	-121	-118	-50
					NR_FDD_FR1_H	-123.5	-120.5	-117.5	-50
±8.5	±13	≥-6	48 ≤ BW ≤ 52	All	Note 3				
±6	±10.5		52 < BW ≤ 104	All	Note 3				
±4.5	±9		BW > 104	All	Note 3				
<p>NOTE 1: This minimum lo condition is expressed as the average lo per RE over all REs in an OFDM symbol.</p> <p>NOTE 2: PRS bandwidth is as indicated in <i>prs-Bandwidth</i> in the OTDOA or DL-AoD assistance data defined in [34].</p> <p>NOTE 3: The same bands and the same lo conditions for each band apply for this requirement as for the corresponding requirement with the PRS bandwidth ≥ 48 RB.</p> <p>NOTE 4: The serving cell, the reference cell, and the measured neighbour cell i are on the same carrier frequency.</p> <p>NOTE 5: The condition level is increased by Δ>0, when applicable, as described in Sections B.3.2 and B.3.3.</p> <p>NOTE 6: The lo is defined in PRS positioning subframes. The same lo range applies to PRS and non-PRS symbols. lo levels are different in PRS and non-PRS symbols within the same subframe.</p> <p>NOTE 7: NR operating band groups are as defined in Section 3.5.2.</p>									

The relative accuracy of PRS-RSRP is defined as accuracy of the difference between two PRS-RSRP measurements.

The relative PRS-RSRP accuracy requirements apply for the cases when PRS-RSRP is measured from PRS resources in the same PRS resource set in FR1.

The accuracy requirements for PRS-RSRP measurement for FR1 defined in Table 16.5.2.3-2 are valid under the following conditions:

- Conditions defined in 38.101-1 Clause 7.3 for reference sensitivity are fulfilled.
- PRP 1,2_{dBm} according to Annex B.2.14 for a corresponding Band
- UE supports positioning measurements with reduced number of samples, and LMF indicates UE to perform positioning measurements with reduced number of samples
- AWGN channel

Table 16.5.2.3-2: PRS-RSRP relative accuracy for FR1 with reduced sample number

Accuracy		Conditions							
Normal condition	Extreme condition	PRS Ês/lot	PRS BW	Repetition factor (T _{rep} ^{PRS} * L _{PRS} /K _{comb} ^{PRS})	NR operating band groups Note 7	lo ^{Note 6} range			Maximum lo
						dBm / SCS _{PRS}			
dB	dB	dB	PRB	-		dBm / SCS _{PRS}			dBm/BW _{channel}
						dBm/15k Hz ^{Note 5}	dBm/30kHz ^{Note 5}	dBm/60k Hz ^{Note 5}	
[±3.5]	±5.0	≥0	≥48	All	NR_FDD_FR1_A, NR_TDD_FR1_A, NR_SDL_FR1_A	-127	-124	-121	-50
					NR_FDD_FR1_B	-126.5	-123.5	-120.5	-50
					NR_TDD_FR1_C	-126	-123	-120	-50
					NR_FDD_FR1_D, NR_TDD_FR1_D	-125.5	-122.5	-119.5	-50
					NR_FDD_FR1_E, NR_TDD_FR1_E	-125	-122	-119	-50
					NR_FDD_FR1_F	-124.5	-121.5	-118.5	-50

					NR_FDD_FR1_G, NR_TDD_FR1_G	-124	-121	-118	-50
					NR_FDD_FR1_H	-123.5	-120.5	-117.5	-50
±9.5	±11.0	≥-6	48 ≤ BW ≤ 52	All	Note 3				
±6.5	±8.0		52 < BW ≤ 104	All	Note 3				
±5.0	±6.5		BW >104	All	Note 3				
<p>NOTE 1: This minimum l_0 condition is expressed as the average l_0 per RE over all REs in an OFDM symbol.</p> <p>NOTE 2: PRS bandwidth is as indicated in <i>prs-Bandwidth</i> in the OTDOA or DL-AoD assistance data defined in [34].</p> <p>NOTE 3: The same bands and the same l_0 conditions for each band apply for this requirement as for the corresponding requirement with the PRS bandwidth ≥ 48 RB.</p> <p>NOTE 4: The serving cell, the reference cell, and the measured neighbour cell i are on the same carrier frequency.</p> <p>NOTE 5: The condition level is increased by $\Delta > 0$, when applicable, as described in Sections B.3.2 and B.3.3.</p> <p>NOTE 6: The l_0 is defined in PRS positioning subframes. The same l_0 range applies to PRS and non-PRS symbols. l_0 levels are different in PRS and non-PRS symbols within the same subframe.</p> <p>NOTE 7: NR operating band groups are as defined in Section 3.5.2.</p>									

16.5.2.4 Test description

16.5.2.4.1 Initial conditions

The supported test configurations in listed in Table 16.5.2.4-1.

Table 16.5.2.4-1: Test Configurations

Config	Description
1	NR 15 kHz SSB SCS, 20 MHz bandwidth, FDD duplex mode
2	NR 15 kHz SSB SCS, 20 MHz bandwidth, TDD duplex mode
3	NR 30 kHz SSB SCS, 50 MHz bandwidth, TDD duplex mode
Note:	The UE is only required to be tested in one of the supported test configurations in each supported band

Test Environment: Normal, as defined in TS 38.508-1 [45] clause 4.1.

Frequencies to be tested: Mid Range, as defined in TS 38.508-1 [45] clause 4.3.1.

Channel bandwidth to be tested: are specified in Table 16.5.2.4-1.

1. Connect the SS and AWGN noise sources to the UE antenna connector or antenna connectors as shown in Annex A, Figure A.13.
2. The general test parameter settings are set up according to Table 16.5.2.5-1 and Table 16.5.2.5-2.
3. Propagation conditions are set according to clause 4.16.2.
4. Message contents are defined in clause 16.5.2.4.3.
5. In the test there are two synchronous cells: Cell 1 and Cell 2. Cell 1 is the reference as well as the PCell. Cell 2 is the neighbour cell. All cells are on the same RF channel distributed in single positioning frequency layer.

16.5.2.4.2 Test procedure

Same as in clause 16.5.1.4.2.

16.5.2.4.3 Message contents

As defined in clause 16.4.2.4.3, with the following exceptions:

Table 16.5.2.4.3-1 replaces Table 16.4.2.4.3-6 and Table 16.5.2.4.3-2 replaces Table 16.4.2.4.3-7.

Table 16.5.2.4.3-1: NR-DL-PRS-AssistanceData

Derivation Path: 37.355 clause 6.4.3

Information Element	Value/remark	Comment	Condition
NR-DL-PRS-AssistanceData-r16 ::= SEQUENCE {			
nr-DL-PRS-ReferenceInfo-r16 SEQUENCE {			
dl-PRS-ID-r16	0		
nr-DL-PRS-ResourceID-List-r16	Not present		
nr-DL-PRS-ResourceSetID-r16	Not present		
}			
nr-DL-PRS-AssistanceDataList-r16 SEQUENCE (SIZE (1..nrMaxFreqLayers-r16)) OF NR-DL-PRS-AssistanceDataPerFreq-r16 {	1 entry		
NR-DL-PRS-AssistanceDataPerFreq-r16[1] SEQUENCE {		entry 1	
nr-DL-PRS-PositioningFrequencyLayer-r16 SEQUENCE {			
dl-PRS-SubcarrierSpacing-r16	kHz120		
dl-PRS-ResourceBandwidth-r16	3	32 PRBs	Sub-test 1
	27	128 PRBs	Sub-test 2
dl-PRS-StartPRB-r16	0		
dl-PRS-PointA-r16	absoluteFrequencyPointA as defined for the DL frequency of the Cell 1		
dl-PRS-CombSizeN-r16	n2		Sub-test 1
	n4		Sub-test 2
dl-PRS-CyclicPrefix-r16	normal		
}			
nr-DL-PRS-AssistanceDataPerFreq-r16 SEQUENCE (SIZE (1..nrMaxTRPsPerFreq-r16)) OF NR-DL-PRS-AssistanceDataPerTRP-r16{	2 entries		
NR-DL-PRS-AssistanceDataPerTRP-r16[1] SEQUENCE {		entry 1	Cell 1
dl-PRS-ID-r16	0		
nr-PhysCellID-r16	Cell 1		
nr-CellGlobalID-r16	Cell 1		
nr-ARFCN-r16	Cell 1		
nr-DL-PRS-SFN0-Offset-r16 SEQUENCE {			
sfn-Offset-r16	0		
integerSubframeOffset-r16	0		
}			
nr-DL-PRS-ExpectedRSTD-r16	0		
nr-DL-PRS-ExpectedRSTD-Uncertainty-r16	0		
nr-DL-PRS-Info-r16	As specified in Table 16.5.2.4.3-2		
}			
NR-DL-PRS-AssistanceDataPerTRP-r16[2] SEQUENCE {		entry 2	Cell 2
dl-PRS-ID-r16	1		
nr-PhysCellID-r16	Cell 2		
nr-CellGlobalID-r16	Cell 2		
nr-ARFCN-r16	Cell 2		
nr-DL-PRS-SFN0-Offset-r16 SEQUENCE {			
sfn-Offset-r16	0		
integerSubframeOffset-r16	0		
}			
nr-DL-PRS-ExpectedRSTD-r16	23	About 3 μ s	
nr-DL-PRS-ExpectedRSTD-Uncertainty-r16	154	About 5 μ s	
nr-DL-PRS-Info-r16	As specified in Table 16.5.2.4.3-2		
}			
}			
}			
}			
}			

Table 16.5.2.4.3-2: NR-DL-PRS-Info

Derivation Path: 37.355 clause 6.4.3			
Information Element	Value/remark	Comment	Condition
NR-DL-PRS-Info-r16 ::= SEQUENCE {			
nr-DL-PRS-ResourceSetList-r16 SEQUENCE (SIZE (1..nrMaxSetsPerTrp-r16)) OF NR-DL-PRS-ResourceSet-r16 {	1 entry		
NR-DL-PRS-ResourceSet-r16[1] SEQUENCE {		entry 1	
nr-DL-PRS-ResourceSetID-r16	0		
dl-PRS-Periodicity-and-ResourceSetSlotOffset-r16 CHOICE {			
scs120-r16 CHOICE {			
n1280-r16	80		
}			
dl-PRS-ResourceRepetitionFactor-r16	n2		Sub-test 1
	Not present		Sub-test 2
dl-PRS-ResourceTimeGap-r16	s1		
dl-PRS-NumSymbols-r16	n4		
dl-PRS-MutingOption1-r16	Not present		
dl-PRS-MutingOption2-r16	Not present		
dl-PRS-ResourcePower-r16	27		
dl-PRS-ResourceList-r16 SEQUENCE (SIZE (1..nrMaxResourcesPerSet-r16)) OF NR-DL-PRS-Resource-r16 {	2 entries		
NR-DL-PRS-Resource-r16[1] SEQUENCE {		entry 1	
nr-DL-PRS-ResourceID-r16	0		
dl-PRS-SequenceID-r16	0		
dl-PRS-CombSizeN-AndReOffset-r16 CHOICE {			
n2-r16	0		Sub-test 1
n4-r16	0		Sub-test 2
}			
dl-PRS-ResourceSlotOffset-r16	0		Sub-test 1 Cell 1 and Sub-test 2 Cell 1
	4		Sub-test 1 Cell 2 and Sub-test 2 Cell 2
dl-PRS-ResourceSymbolOffset-r16	0		
dl-PRS-QCL-Info-r16	Not present		
}			
NR-DL-PRS-Resource-r16[2] SEQUENCE {		entry 2	
nr-DL-PRS-ResourceID-r16	1		
dl-PRS-SequenceID-r16	0		
dl-PRS-CombSizeN-AndReOffset-r16 CHOICE {			
n2-r16	1		Sub-test 1
n4-r16	1		Sub-test 2
}			
dl-PRS-ResourceSlotOffset-r16	0		Sub-test 1 Cell 1 and Sub-test 2 Cell 1
	4		Sub-test 1 Cell 2 and Sub-test 2 Cell 2
dl-PRS-ResourceSymbolOffset-r16	0		
dl-PRS-QCL-Info-r16	Not present		
}			
}			
}			
}			
}			

16.5.2.5 Test requirement

Table 16.5.2.5-1: PRS-RSRP test parameters

Parameter		Unit	Test 1		Test 2	
			Cell 1	Cell 2	Cell 1	Cell 2
Cell ID			489	0	489	0
SSB ARFCN			freq1		freq1	
Duplex mode	Config 1		FDD			
	Config 2,3		TDD			
TDD configuration	Config 1		Not Applicable			
	Config 2		TDDConf.1.1			
	Config 3		TDDConf.2.1			
BW _{channel}	Config 1	MHz	20: N _{RB,c} = 106			
	Config 2		20: N _{RB,c} = 106			
	Config 3		50: N _{RB,c} = 133			
BWP BW	Config 1		20: N _{RB,c} = 106			
	Config 2		20: N _{RB,c} = 106			
	Config 3		50: N _{RB,c} = 133			
Downlink initial BWP configuration			DLBWP.0.1			
Uplink initial BWP configuration			ULBWP.0.1			
DRX Cycle		s	1.28			
PDSCH Reference measurement channel	Config 1		SR.1.1 FDD	-	SR.1.1 FDD	-
	Config 2		SR.1.1 TDD		SR.1.1 TDD	
	Config 3		SR2.1 TDD		SR2.1 TDD	
RMSI CORESET Reference Channel	Config 1		CR.1.1 FDD	-	CR.1.1 FDD	-
	Config 2		CR.1.1 TDD		CR.1.1 TDD	
	Config 3		CR2.1 TDD		CR2.1 TDD	
Control channel RMC	Config 1		CCR.1.1 FDD	-	CCR.1.1 FDD	-
	Config 2		CCR.1.1 TDD		CCR.1.1 TDD	
	Config 3		CCR2.1 TDD		CCR2.1 TDD	
PRS configuration	Config 1		PRS.1.3 FR1	PRS.1.3 FR1	PRS.1.4 FR1	PRS.1.4 FR1
	Config 2		PRS.1.3 FR1	PRS.1.3 FR1	PRS.1.4 FR1	PRS.1.4 FR1
	Config 3		PRS.2.3 FR1	PRS.2.3 FR1	PRS.2.4 FR1	PRS.2.4 FR1
PRS BW	Config 1		52 PRBs	52 PRBs		
	Config 2		52 PRBs	52 PRBs		
	Config 3		48 PRBs	48 PRBs		
PRS Resource slot offset (slot)	Config 1,2,3	slot	0	4	0	4
SSB configuration	Config 1		SSB.1 FR1	SSB.1 FR1	SSB.1 FR1	SSB.1 FR1
	Config 2		SSB.1 FR1	SSB.1 FR1	SSB.1 FR1	SSB.1 FR1
	Config 3		SSB.2 FR1	SSB.2 FR1	SSB.2 FR1	SSB.2 FR1
Time offset with Cell 1	Config 1	ms	-	3	-	3
	Config 2,3	µs	-	3	-	3
SMTC configuration	Config 1		SMTC.2			
	Config 2,3		SMTC.1			
OCNG Patterns			OCNG pattern 1			
PDSCH/PDCCH subcarrier spacing	Config 1,2	kHz	15 kHz			
	Config 3		30 kHz			
EPRE ratio of PSS to SSS		dB	0	0	0	0
EPRE ratio of PBCH DMRS to SSS						
EPRE ratio of PBCH to PBCH DMRS						
EPRE ratio of PDCCH DMRS to SSS						

EPRE ratio of PDCCH to PDCCH DMRS						
EPRE ratio of PDSCH DMRS to SSS						
EPRE ratio of PDSCH to PDSCH						
EPRE ratio of OCNG DMRS to SSS(Note 1)						
EPRE ratio of OCNG to OCNG DMRS (Note 1)						
EPRE ratio of PRS to SSS						
N_{oc} ^{Note2}	Config 1,2	dBm/15Khz	-98		-98	
	Config 3					
N_{oc} ^{Note2}	Config 1,2	dBm/SCS	-98		-98	
	Config 3		-95		-95	
\hat{E}_s/I_{ot}		dB	0	-6	0	-6
\hat{E}_s/N_{oc}		dB	2.23	-1.73	2.23	-1.73
PRS-RSRP ^{Note3}	Config 1, 2	dBm/SCS	-95.77+TT	-99.73+TT	-95.77+TT	-99.73+TT
	Config 3		-92.77+TT	-96.73+TT	-92.77+TT	-96.73+TT
I_o ^{Note3}	Config 1,2	dBm/19.08MHz	-61.71+TT		-61.71+TT	
	Config 3	dBm/47.88MHz	-57.73+TT		-57.73+TT	
Propagation condition			AWGN			
Antenna configuration			1x2			
<p>Note 1: OCNG shall be used such that both cells are fully allocated and a constant total transmitted power spectral density is achieved for all OFDM symbols.</p> <p>Note 2: Interference from other cells and noise sources not specified in the test is assumed to be constant over subcarriers and time and shall be modelled as AWGN of appropriate power for N_{oc} to be fulfilled.</p> <p>Note 3: PRS-RSRP and I_o levels have been derived from other parameters for information purposes. They are not settable parameters themselves.</p> <p>Note 4: PRS-RSRP minimum requirements are specified assuming independent interference and noise at each receiver antenna port.</p>						

The value of the LPP Time IE depends on the UE capabilities. The calculation is FFS

Table 16.5.2.5-2: PRS-RSRP accuracy requirements for the reported values

Test Configuration	Subtest	Cell 1		Cell 2	
		Lowest reported value	Highest reported value	Lowest reported value	Highest reported value
1	Sub-test 1	FFS	FFS	FFS	FFS
	Sub-test 2	FFS	FFS	FFS	FFS
2	Sub-test 1	FFS	FFS	FFS	FFS
	Sub-test 2	FFS	FFS	FFS	FFS
3	Sub-test 1	FFS	FFS	FFS	FFS
	Sub-test 2	FFS	FFS	FFS	FFS

For the overall test to pass, the ratio of successful reported values in each sub-test shall be more than 90% with a confidence level of 95%.

16.5.3 PRS-RSRP measurement accuracy test case for single positioning frequency layer with PRS in FR2 SA

Editor's note: This test case is incomplete. The following aspect is either missing or TBD:

- Test tolerance are not added in and analysis is missing

16.5.3.1 Test purpose

The purpose of the test is to verify the PRS RSRP measurement accuracy requirements specified in TS 38.133 [50] Clause 10.1.24.2 for single positioning frequency layer under AWGN propagation conditions in RRC_INACTIVE in FR2 standalone scenario.

16.5.3.2 Test applicability

This test applies to all types of NR UE release 17 onwards that supports DL-AoD positioning and supports DL-PRS measurement in RRC_INACTIVE state.

16.5.3.3 Minimum conformance requirements

Same as in clause 16.3.2.3.

16.5.3.4 Test description

16.5.3.4.1 Initial conditions

The supported test configurations in listed in Table 16.5.3.4-1.

Table 16.5.3.4-1: Test Configurations

Test Configuration	Description
1	120 kHz SSB and PRS SCS, 100 MHz bandwidth, TDD duplex mode

Test Environment: Normal, as defined in TS 38.508-1 [45] clause 4.1.

Frequencies to be tested: Mid Range, as defined in TS 38.508-1 [45] clause 4.3.1.

Channel bandwidth to be tested: are specified in Table 16.5.3.4-1.

1. Connect the SS and AWGN noise sources to the UE antenna connector or antenna connectors as shown in Annex A, Figure A.14.
2. The general test parameter settings are set up according to Table 16.5.3.5-1 and Table 16.5.3.5-2.
3. Propagation conditions are set according to clause 4.16.2.
4. Message contents are defined in clause 16.5.3.4.3.
5. In the test there are two synchronous cells: Cell 1 and Cell 2. Cell 1 is the reference as well as the PCell. Cell 2 is the neighbour cell. All cells are on the same RF channel distributed in single positioning frequency layer.

16.5.3.4.2 Test procedure

The test consists of two sub-tests; the difference between the sub-tests is the PRS configuration, PRS.1.3 FR2 and PRS.1.4 FR2. The test consists of a set-up period and a measurement period. During the set-up period, the UE shall be in RRC_CONNECTED state and shall not have any timing information of Cell 2. During the measurement period UE shall be in RRC_INACTIVE state and all cells start to transmit PRS resources within initial DL BWP of the UE and with the same numerology as the initial DL BWP.

The NR-DL-AoD-RequestLocationInformation message and the DL-AoD assistance data as defined in clause 16.5.3.4.3 shall be provided to the UE during the set-up period. The beginning of the measurement period shall be aligned with the first DRX cycle containing a DL PRS resource(s).

1. Ensure the UE is in State RRC_CONNECTED with generic procedure parameters Connectivity NR, Connected without release On, according to TS 38.508-1 [45] clause 4.5.
2. The SS shall send a RESET UE POSITIONING STORED INFORMATION message.
3. Set parameters other than PRSconfiguration according to the Table 16.5.3.5-1 and Table 16.5.3.5-2. Propagation conditions are set according to clause 4.16.2.
4. Set-up period starts.
5. The SS shall transmit an RRCReconfiguration message with the DRX configuration.
6. The UE shall transmit RRCReconfigurationComplete message.
7. The SS shall transmit an LPP REQUEST CAPABILITIES message.
8. The UE shall transmit an LPP PROVIDE CAPABILITIES message indicating the DL-AoD capabilities supported by the UE in the NR-DL-AoD-ProvideCapabilities IE.
9. The SS shall send a LPP PROVIDE ASSISTANCE DATA message, including the NR-DL-AoD-ProvideAssistanceData IE. The position of neighbour Cell 2 is described in 3GPP TS 37.571-5 [20]. If the UE message at step 8 includes the ackRequested IE set to TRUE, then the SS shall send an acknowledgment in the LPP PROVIDE ASSISTANCE DATA message.
10. The SS shall transmit LCS Periodic-Triggered Invoke Request message with LPP REQUEST LOCATION INFORMATION embedded to start the periodic reporting procedure, including the NR-DL-AoD-RequestLocationInformation IE such that the UE receives the message ΔT ms before the start of measurement period, where $\Delta T = 50$ ms.
11. The UE shall transmit an LCS Periodic-Triggered Invoke Return Result message.
12. When set-up period ends, the SS shall transmit an RRCRelease message to transit the UE to RRC_INACTIVE state and set the PRS parameters as specified in Table 16.5.3.5-1 and Table 16.5.3.5-2.
13. Wait for the UE monitors for occurrence of the periodic event requested.
14. The UE shall transmit the UE transmit an RRCResumeRequest message.
15. The SS transmits an RRCResume message.
16. The UE transmits an RRCResumeComplete message.
17. The UE shall transmit a LPP PROVIDE LOCATION INFORMATION message including the NR-DL-AoD-ProvideLocationInformation IE within the response time (see clause 4.16.3).
18. If the UE message at step 17 includes the ackRequested IE set to TRUE, the SS shall send a LPP acknowledgement message.
19. The SS shall check the nr-DL-PRS-RSRP-Result-r16 value for Cell 2 in the NR-DL-AoD-SignalMeasurementInformation according to Table 16.5.3.5-3.
20. Repeat steps 2-19 in Table 16.5.3.4-1 until the confidence level according to Annex D is achieved.
21. Repeat step 2-20 for the other sub-test defined in Table 16.5.3.5-1 as appropriate.

If all (applicable) sub-tests pass, the whole test passes. If one (applicable) sub-test fails, the whole test fails.

16.5.3.4.3 Message contents

As defined in clause 16.4.3.4.3, with the following exceptions:

Table 16.5.3.4.3-1 replaces Table 16.4.3.4.3-6 and Table 16.5.3.4.3-2 replaces Table 16.4.3.4.3-7.

Table 16.5.3.4.3-1: NR-DL-PRS-AssistanceData

Derivation Path: 37.355 clause 6.4.3			
Information Element	Value/remark	Comment	Condition
NR-DL-PRS-AssistanceData-r16 ::= SEQUENCE {			
nr-DL-PRS-ReferenceInfo-r16 SEQUENCE {			
dl-PRS-ID-r16	0		
nr-DL-PRS-ResourceID-List-r16	Not present		
nr-DL-PRS-ResourceSetID-r16	Not present		
}			
nr-DL-PRS-AssistanceDataList-r16 SEQUENCE (SIZE (1..nrMaxFreqLayers-r16)) OF NR-DL-PRS-AssistanceDataPerFreq-r16 {	1 entry		
NR-DL-PRS-AssistanceDataPerFreq-r16[1] SEQUENCE {		entry 1	
nr-DL-PRS-PositioningFrequencyLayer-r16 SEQUENCE {			
dl-PRS-SubcarrierSpacing-r16	kHz120		
dl-PRS-ResourceBandwidth-r16	3	32 PRBs	Sub-test 1
	27	128 PRBs	Sub-test 2
dl-PRS-StartPRB-r16	0		
dl-PRS-PointA-r16	absoluteFrequencyPointA as defined for the DL frequency of the Cell 1		
dl-PRS-CombSizeN-r16	n2		Sub-test 1
	n4		Sub-test 2
dl-PRS-CyclicPrefix-r16	normal		
}			
nr-DL-PRS-AssistanceDataPerFreq-r16 SEQUENCE (SIZE (1..nrMaxTRPsPerFreq-r16)) OF NR-DL-PRS-AssistanceDataPerTRP-r16{	2 entries		
NR-DL-PRS-AssistanceDataPerTRP-r16[1] SEQUENCE {		entry 1	Cell 1
dl-PRS-ID-r16	0		
nr-PhysCellID-r16	Cell 1		
nr-CellGlobalID-r16	Cell 1		
nr-ARFCN-r16	Cell 1		
nr-DL-PRS-SFN0-Offset-r16 SEQUENCE {			
sfn-Offset-r16	0		
integerSubframeOffset-r16	0		
}			
nr-DL-PRS-ExpectedRSTD-r16	0		
nr-DL-PRS-ExpectedRSTD-Uncertainty-r16	0		
nr-DL-PRS-Info-r16	As specified in Table 16.5.3.4.3-2		
}			
NR-DL-PRS-AssistanceDataPerTRP-r16[2] SEQUENCE {		entry 2	Cell 2
dl-PRS-ID-r16	1		
nr-PhysCellID-r16	Cell 2		
nr-CellGlobalID-r16	Cell 2		
nr-ARFCN-r16	Cell 2		
nr-DL-PRS-SFN0-Offset-r16 SEQUENCE {			
sfn-Offset-r16	0		
integerSubframeOffset-r16	0		
}			
nr-DL-PRS-ExpectedRSTD-r16	23	About 3 μ s	
nr-DL-PRS-ExpectedRSTD-Uncertainty-r16	154	About 5 μ s	
nr-DL-PRS-Info-r16	As specified in Table 16.5.3.4.3-2		
}			
}			
}			
}			
}			

Table 16.5.3.4.3-2: NR-DL-PRS-Info

Derivation Path: 37.355 clause 6.4.3			
Information Element	Value/remark	Comment	Condition
NR-DL-PRS-Info-r16 ::= SEQUENCE {			
nr-DL-PRS-ResourceSetList-r16 SEQUENCE (SIZE (1..nrMaxSetsPerTrp-r16)) OF NR-DL-PRS-ResourceSet-r16 {	1 entry		
NR-DL-PRS-ResourceSet-r16[1] SEQUENCE {		entry 1	
nr-DL-PRS-ResourceSetID-r16	0		
dl-PRS-Periodicity-and-ResourceSetSlotOffset-r16 CHOICE {			
scs120-r16 CHOICE {			
n1280-r16	80		
}			
dl-PRS-ResourceRepetitionFactor-r16	n2		Sub-test 1
	Not present		Sub-test 2
dl-PRS-ResourceTimeGap-r16	s1		
dl-PRS-NumSymbols-r16	n4		
dl-PRS-MutingOption1-r16	Not present		
dl-PRS-MutingOption2-r16	Not present		
dl-PRS-ResourcePower-r16	27		
dl-PRS-ResourceList-r16 SEQUENCE (SIZE (1..nrMaxResourcesPerSet-r16)) OF NR-DL-PRS-Resource-r16 {	2 entries		
NR-DL-PRS-Resource-r16[1] SEQUENCE {		entry 1	
nr-DL-PRS-ResourceID-r16	0		
dl-PRS-SequenceID-r16	0		
dl-PRS-CombSizeN-AndReOffset-r16 CHOICE {			
n2-r16	0		Sub-test 1
n4-r16	0		Sub-test 2
}			
dl-PRS-ResourceSlotOffset-r16	0		Sub-test 1 Cell 1 and Sub-test 2 Cell 1
	4		Sub-test 1 Cell 2 and Sub-test 2 Cell 2
dl-PRS-ResourceSymbolOffset-r16	0		
dl-PRS-QCL-Info-r16	Not present		
}			
NR-DL-PRS-Resource-r16[2] SEQUENCE {		entry 2	
nr-DL-PRS-ResourceID-r16	1		
dl-PRS-SequenceID-r16	0		
dl-PRS-CombSizeN-AndReOffset-r16 CHOICE {			
n2-r16	1		Sub-test 1
n4-r16	1		Sub-test 2
}			
dl-PRS-ResourceSlotOffset-r16	0		Sub-test 1 Cell 1 and Sub-test 2 Cell 1
	4		Sub-test 1 Cell 2 and Sub-test 2 Cell 2
dl-PRS-ResourceSymbolOffset-r16	0		
dl-PRS-QCL-Info-r16	Not present		
}			
}			
}			
}			
}			

16.5.3.5 Test requirement

FFS

16.5.4 PRS-RSRP measurement accuracy test case for single positioning frequency layer with PRS in FR2 with reduced sample number

Editor's note: This test case is incomplete. The following aspect is either missing or TBD:

- Test tolerance are not added in and analysis is missing

16.5.4.1 Test purpose

The purpose of the test is to verify the PRS RSRP measurement accuracy requirements specified in TS 38.133 [50] Clause 10.1.24.2 for single positioning frequency layer with reduced sample number under AWGN propagation conditions in RRC_INACTIVE in FR2 standalone scenario.

16.5.4.2 Test applicability

This test applies to all types of NR UE release 17 onwards that supports DL-AoD positioning, supports DL-PRS measurement in RRC_INACTIVE state and reduced number of samples for PRS measurement in RRC_INACTIVE state.

16.5.4.3 Minimum conformance requirements

Same as in clause 16.3.4.3.

16.5.4.4 Test description

16.5.4.4.1 Initial conditions

The supported test configurations in listed in Table 16.5.4.4-1.

Table 16.5.4.4-1: Test Configurations

Test Configuration	Description
1	120 kHz SSB and PRS SCS, 100 MHz bandwidth, TDD duplex mode

Test Environment: Normal, as defined in TS 38.508-1 [45] clause 4.1.

Frequencies to be tested: Mid Range, as defined in TS 38.508-1 [45] clause 4.3.1.

Channel bandwidth to be tested: are specified in Table 16.5.4.4-1.

1. Connect the SS and AWGN noise sources to the UE antenna connector or antenna connectors as shown in Annex A, Figure A.14.
2. The general test parameter settings are set up according to Table 16.5.4.5-1 and Table 16.5.4.5-2.
3. Propagation conditions are set according to clause 4.16.2.
4. Message contents are defined in clause 16.5.4.4.3.
5. In the test there are two synchronous cells: Cell 1 and Cell 2. Cell 1 is the reference as well as the PCell. Cell 2 is the neighbour cell. All cells are on the same RF channel distributed in single positioning frequency layer.

16.5.4.4.2 Test procedure

Same as in clause 16.5.3.4.2.

16.5.4.4.3 Message contents

As defined in clause 16.5.3.4.3, with the following exceptions:

Table 16.5.4.4.3-1 replaces Table 16.4.3.4.3-6, Table 16.5.4.4.3-2 replaces Table 16.4.3.4.3-7 and Table 16.5.4.4.3-3 replaces Table 16.4.3.4.3-9.

Table 16.5.4.4.3-1: NR-DL-PRS-AssistanceData

Derivation Path: 37.355 clause 6.4.3			
Information Element	Value/remark	Comment	Condition
NR-DL-PRS-AssistanceData-r16 ::= SEQUENCE {			
nr-DL-PRS-ReferenceInfo-r16 SEQUENCE {			
dl-PRS-ID-r16	0		
nr-DL-PRS-ResourceID-List-r16	Not present		
nr-DL-PRS-ResourceSetID-r16	Not present		
}			
nr-DL-PRS-AssistanceDataList-r16 SEQUENCE (SIZE (1..nrMaxFreqLayers-r16)) OF NR-DL-PRS-AssistanceDataPerFreq-r16 {	1 entry		
NR-DL-PRS-AssistanceDataPerFreq-r16[1] SEQUENCE {		entry 1	
nr-DL-PRS-PositioningFrequencyLayer-r16 SEQUENCE {			
dl-PRS-SubcarrierSpacing-r16	kHz120		
dl-PRS-ResourceBandwidth-r16	3	32 PRBs	Sub-test 1
	27	128 PRBs	Sub-test 2
dl-PRS-StartPRB-r16	0		
dl-PRS-PointA-r16	absoluteFrequencyPointA as defined for the DL frequency of the Cell 1		
dl-PRS-CombSizeN-r16	n2		Sub-test 1
	n4		Sub-test 2
dl-PRS-CyclicPrefix-r16	normal		
}			
nr-DL-PRS-AssistanceDataPerFreq-r16 SEQUENCE (SIZE (1..nrMaxTRPsPerFreq-r16)) OF NR-DL-PRS-AssistanceDataPerTRP-r16{	2 entries		
NR-DL-PRS-AssistanceDataPerTRP-r16[1] SEQUENCE {		entry 1	Cell 1
dl-PRS-ID-r16	0		
nr-PhysCellID-r16	Cell 1		
nr-CellGlobalID-r16	Cell 1		
nr-ARFCN-r16	Cell 1		
nr-DL-PRS-SFN0-Offset-r16 SEQUENCE {			
sfn-Offset-r16	0		
integerSubframeOffset-r16	0		
}			
nr-DL-PRS-ExpectedRSTD-r16	0		
nr-DL-PRS-ExpectedRSTD-Uncertainty-r16	0		
nr-DL-PRS-Info-r16	As specified in Table 16.5.4.4.3-2		
}			
NR-DL-PRS-AssistanceDataPerTRP-r16[2] SEQUENCE {		entry 2	Cell 2
dl-PRS-ID-r16	1		
nr-PhysCellID-r16	Cell 2		
nr-CellGlobalID-r16	Cell 2		
nr-ARFCN-r16	Cell 2		
nr-DL-PRS-SFN0-Offset-r16 SEQUENCE {			
sfn-Offset-r16	0		
integerSubframeOffset-r16	0		
}			
nr-DL-PRS-ExpectedRSTD-r16	23	About 3 μ s	
nr-DL-PRS-ExpectedRSTD-Uncertainty-r16	154	About 5 μ s	

nr-DL-PRS-Info-r16	As specified in Table 16.5.4.4.3-2		
}			
}			
}			
}			
}			

Table 16.5.4.4.3-2: NR-DL-PRS-Info

Derivation Path: 37.355 clause 6.4.3			
Information Element	Value/remark	Comment	Condition
NR-DL-PRS-Info-r16 ::= SEQUENCE {			
nr-DL-PRS-ResourceSetList-r16 SEQUENCE (SIZE (1..nrMaxSetsPerTrp-r16)) OF NR-DL-PRS-ResourceSet-r16 {	1 entry		
NR-DL-PRS-ResourceSet-r16[1] SEQUENCE {		entry 1	
nr-DL-PRS-ResourceSetID-r16	0		
dl-PRS-Periodicity-and-ResourceSetSlotOffset-r16 CHOICE {			
scs120-r16 CHOICE {			
n1280-r16	80		
}			
dl-PRS-ResourceRepetitionFactor-r16	n2		Sub-test 1
	Not present		Sub-test 2
dl-PRS-ResourceTimeGap-r16	s1		
dl-PRS-NumSymbols-r16	n4		
dl-PRS-MutingOption1-r16	Not present		
dl-PRS-MutingOption2-r16	Not present		
dl-PRS-ResourcePower-r16	27		
dl-PRS-ResourceList-r16 SEQUENCE (SIZE (1..nrMaxResourcesPerSet-r16)) OF NR-DL-PRS-Resource-r16 {	2 entries		
NR-DL-PRS-Resource-r16[1] SEQUENCE {		entry 1	
nr-DL-PRS-ResourceID-r16	0		
dl-PRS-SequenceID-r16	0		
dl-PRS-CombSizeN-AndReOffset-r16 CHOICE {			
n2-r16	0		Sub-test 1
n4-r16	0		Sub-test 2
}			
dl-PRS-ResourceSlotOffset-r16	0		Sub-test 1 Cell 1 and Sub-test 2 Cell 1
	4		Sub-test 1 Cell 2 and Sub-test 2 Cell 2
dl-PRS-ResourceSymbolOffset-r16	0		
dl-PRS-QCL-Info-r16	Not present		
}			
NR-DL-PRS-Resource-r16[2] SEQUENCE {		entry 2	
nr-DL-PRS-ResourceID-r16	1		
dl-PRS-SequenceID-r16	0		
dl-PRS-CombSizeN-AndReOffset-r16 CHOICE {			
n2-r16	1		Sub-test 1
n4-r16	1		Sub-test 2
}			
dl-PRS-ResourceSlotOffset-r16	0		Sub-test 1 Cell 1 and Sub-test 2 Cell 1
	4		Sub-test 1 Cell 2 and

			Sub-test 2 Cell 2
dl-PRS-ResourceSymbolOffset-r16	0		
dl-PRS-QCL-Info-r16	Not present		
}			
}			
}			
}			

Table 16.5.4.4.3-3: LPP RequestLocationInformation

Derivation Path: 37.355 clause 6.2			
Information Element	Value/remark	Comment	Condition
LPP-Message ::= SEQUENCE {			
transactionID SEQUENCE {			
initiator	locationServer		
transactionNumber	1		
}			
endTransaction	FALSE		
sequenceNumber	Not present		
acknowledgement	Not present		
lpp-MessageBody CHOICE {			
c1 CHOICE {			
requestLocationInformation SEQUENCE {			
criticalExtensions CHOICE {			
c1 CHOICE {			
requestLocationInformation-r9 SEQUENCE {			
commonEsRequestLocationInformation SEQUENCE {			
locationInformationType	locationMeasurementsRequired		
triggeredReporting	Not present		
periodicalReporting	Not present		
additionalInformation	onlyReturnInformationRequested		
qos SEQUENCE {			
horizontalAccuracy	Not present		
verticalCoordinateRequest	FALSE		
verticalAccuracy	Not present		
responseTime SEQUENCE {			
time	See 16.5.4.5	Result of the response time calculation rounded up to the next second if response time <= 128s. Result of the response time calculation rounded up to the next multiple of ten seconds if response time > 128s.	
responseTimeEarlyFix-r12	Not present		Rel-12 onwards
unit-r15	Not present ten-seconds		Calculated response time >128s
}			
velocityRequest	FALSE		
}			
environment	Not present		

locationCoordinateTypes	Not present		
velocityTypes	Not present		
}			
a-gnss-RequestLocationInformation	Not present		
otdoa-RequestLocationInformation	Not present		
ecid-RequestLocationInformation	Not present		
epdu-RequestLocationInformation	Not Present		
sensor-RequestLocationInformation-r13	Not present		
tbs-RequestLocationInformation-r13	Not present		
wlan-RequestLocationInformation-r13	Not present		
bt-RequestLocationInformation-r13	Not present		
nr-ECID-RequestLocationInformation-r16	Not present		
nr-Multi-RTT-RequestLocationInformation-r16	Not present		
nr-DL-AoD-RequestLocationInformation-r16			
SEQUENCE {			
nr-AssistanceAvailability-r16	FALSE		
nr-DL-AoD-ReportConfig-r16 SEQUENCE {			
maxDL-PRS-RSRP-MeasurementsPerTRP-	Not present		
r16			
maxDL-PRS-RSRP-MeasurementsPerTRP-	Not present		
r17			
maxDL-PRS-RSRPP-	Not present		
MeasurementsPerTRP-r17			
nr-los-nlos-IndicatorRequest-r17	Not present		
reducedDL-PRS-ProcessingSamples-r17	requested		
lowerRxBeamSweepingFactor-FR2-r17	Not present		
}			
multiMeasInSameReport-r17			
}			
nr-DL-TDOA-RequestLocationInformation-r16	Not present		
}			
}			
}			
}			
}			
}			
}			
}			

16.5.4.5 Test requirement

FFS

17 NR PRS-RSRPP measurement requirements

17.1 General

This clause defines the minimum performance requirements for NR UEs capable of PRS-RSRPP measurements.

17.2 NR PRS-RSRPP measurement period test cases in RRC_CONNECTED

17.2.1 PRS-RSRPP measurement reporting delay test case for single positioning frequency layer in FR1 SA

Editor's note: This test case is incomplete. The following aspect is either missing or TBD:

- Test tolerance are not added in and analysis is missing

17.2.1.1 Test purpose

The purpose of the test is to verify the PRS RSRPP measurement requirements specified in TS 38.133 [50] Clause 9.9.6.5 for single positioning frequency layer under AWGN propagation conditions in standalone scenario.

17.2.1.2 Test applicability

This test applies to all types of NR UE release 17 onwards that supports DL-AoD positioning and maxDL-PRS-FirstPathRSRP-MeasPerTRP.

17.2.1.3 Minimum conformance requirements

When the physical layer receives *NR-DL-AoD-ProvideAssistanceData* message and *NR-DL-AoD-RequestLocationInformation* message from LMF via LPP [34], the UE shall be able to measure multiple (up to the UE capability specified in Clause 9.9.3.3) PRS-RSRP measurements, defined in TS 38.215 [4], from configured PRS resources for configured TRPs on configured positioning frequency layers, within $T_{\text{PRS-RSRP,total}}$ ms.

$$T_{\text{PRS-RSRP,total}} = \sum_{i=1}^L T_{\text{PRS-RSRP},i} + (L - 1) * \max(T_{\text{effect},i})$$

where

i is the index of positioning frequency layer,

L is total number of positioning frequency layers,

$T_{\text{effect},i}$ is the periodicity of the PRS-RSRP measurement in positioning frequency layer i .

$$T_{\text{PRS-RSRP},i} = \left(\text{CSSF}_i * \text{ceil}(K_{\text{p,PRS},i}) * N_{\text{RxBeam},i} * \left\lceil \frac{N_{\text{PRS},i}^{\text{slot}}}{N'} \right\rceil \left\lfloor \frac{L_{\text{available_PRS},i}}{N} \right\rfloor * N_{\text{sample}} - 1 \right) * T_{\text{effect},i} + T_{\text{last}}$$

where

CSSF_i is the carrier specific scaling factor for PRS-RSRP measurements specified in clause 9.1.5.2,

$K_{\text{p,PRS},i}$ is a scaling factor for a positioning frequency layer to be measured within the associated measurement gap pattern, which is defined as $K_{\text{p,PRS},i} = N_{\text{total}} / N_{\text{available}}$ for UE configured with concurrent measurement gap, and $K_{\text{p,PRS},i} = 1$ for UE not configured with concurrent measurement gap.

For a window W of duration $\max(T_{\text{PRS},i}, \text{MGRP_max})$, where MGRP_max is the maximum MGRP across all configured per-UE MG and per-FR MG within the same FR as the positioning frequency layer, and starting at the beginning of any associated gap occasions covering the PRS occasion:

N_{total} is the total number of associated gap occasions covering PRS occasions within the window, including both dropped and non-dropped instances of the associated measurement gap within the window, and

$N_{\text{available}}$ is the number of non-dropped associated gap occasions covering PRS occasions within the window W , after further accounting for MG collisions by applying the selected gap collision rule

Requirements do not apply if $N_{\text{available}} = 0$.

$N_{\text{RxBeam},i}$ is the scaling factor for Rx beam sweeping, and $N_{\text{RxBeam},i} = 1$ if positioning frequency layer i is in FR1 and if positioning frequency layer i is in FR2, $N_{\text{RxBeam},i}$ is equal to the value reported by the UE in *supportedLowerRxBeamSweepingFactor-FR2* if the UE supports the capability for the band containing positioning frequency layer i , and the LMF indicates *lowerRxBeamSweepingFactor-FR2* in *NR-TDOA-RequestLocationInformation*. $N_{\text{RxBeam},i}$ is equal to 8, otherwise.

$L_{\text{available_PRS},i}$ is the time duration of available PRS to be measured in the positioning frequency layer i to be measured during $T_{\text{available_PRS},i}$, and is calculated in the same way as PRS duration K defined in clause 5.1.6.5

of TS 38.214 [26]. For calculation of $L_{available_PRS,i}$, only the PRS resources unmuted and fully or partially overlapped with MG are considered.

$N_{PRS,i}^{slot}$ is the maximum number of DL PRS resources of positioning frequency layer i configured in a slot,

$\{N, T\}$ is UE capability combination per band where N is a duration of DL PRS symbols in ms corresponding to *durationOfPRS-ProcessingSymbols* in TS 37.355 [34] processed every T ms corresponding to *durationOfPRS-ProcessingSymbolsInEveryTms* in TS 37.355 [34] for a given maximum bandwidth supported by UE corresponding to *supportedBandwidthPRS* in TS 37.355 [34],

N' is UE capability for number of DL PRS resources that it can process in a slot as indicated by *maxNumOfDL-PRS-ResProcessedPerSlot* in clause 6.4.3 of TS 37.355 [34],

N_{sample} is the number of PRS RSRP measurement samples, where

- $N_{sample} = 1$ if the UE supports *supportedDL-PRS-ProcessingSamples* [34], and the LMF requests the UE to perform positioning measurements with reduced number of samples, and meets the following conditions:
 - PRS bandwidth is within the active BWP and
 - Magnitude of difference between the serving cell's SS-RSRP and the neighbour cell's PRS-RSRP is within 6 dB.
- $N_{sample} = 2$ if the UE supports *supportedDL-PRS-ProcessingSamples* [34], and the LMF requests the UE to perform positioning measurements with reduced number of samples, and does not meet the following conditions:
 - PRS bandwidth is within the active BWP and
 - Magnitude of difference between the serving cell's SS-RSRP and the neighbour cell's PRS-RSRP is within 6 dB.
- $N_{sample} = 4$ otherwise.

$T_{last,i} = T_i + T_{available_PRS,i}$ is the measurement duration for the last PRS-RSRP sample, including the sampling time and processing time, if not all PRS resources to be measured are available in the same measurement gap occasion during $T_{available_PRS,i}$, otherwise $T_{last,i} = T_i + MGL$,

$T_{effect,i} = \left\lceil \frac{T_i}{T_{available_PRS,i}} \right\rceil * T_{available_PRS,i}$ is the periodicity of PRS-RSRP measurement in positioning frequency layer i ,

T_i corresponds to *durationOfPRS-ProcessingSymbolsInEveryTms* in TS 37.355 [34],

$T_{available_PRS,i} = LCM(T_{PRS,i}, MGRP_i)$ is the least common multiple between $T_{PRS,i}$ and $MGRP_i$,

$T_{PRS,i}$ is the maximum PRS resource periodicity among all PRS resources in positioning frequency layer i ,

$MGRP_i$ is the measurement gap repetition period in positioning frequency layer i .

If positioning frequency layer i has more than one DL PRS resource set with different PRS periodicities with muting, $T_{per}^{PRS\ with\ muting} = N_{muting} * T_{per}^{PRS}$, the least common multiple of $T_{per}^{PRS\ with\ muting}$ among the DL PRS resource sets is used to derive $T_{PRS,i}$, where:

T_{per}^{PRS} is the periodicity of PRS resource sets given by the higher-layer parameter *DL-PRS-Periodicity*.

N_{muting} is the scaling factor considering PRS resource muting. $N_{muting} = T_{muting}^{PRS} * L_{muting}$, where T_{muting}^{PRS} is the muting repetition factor given by the higher-layer parameter *DL-PRS-MutingBitRepetitionFactor*, and L_{muting} is the size of the bitmap $\{b^1\}$.

17.2.1.4 Test description

17.2.1.4.1 Initial conditions

The supported test configurations are listed in Table 17.2.1.4-1.

Table 17.2.1.4-1: Test Configurations

Configuration	Description
1	15 kHz SSB SCS, 10 MHz bandwidth, FDD duplex mode
2	15 kHz SSB SCS, 10 MHz bandwidth, TDD duplex mode
3	30 kHz SSB SCS, 40 MHz bandwidth, TDD duplex mode
Note:	The UE is only required to be tested in one of the supported test configurations.

Test Environment: Normal, as defined in TS 38.508-1 [45] clause 4.1.

Frequencies to be tested: Mid Range, as defined in TS 38.508-1 [45] clause 4.3.1.

Channel bandwidth to be tested: are specified in Table 17.2.1.4-1.

1. Connect the SS and AWGN noise sources to the UE antenna connector or antenna connectors as shown in Annex A, Figure A.13.
2. The general test parameter settings are set up according to Table 17.2.1.5-1 and Table 17.2.1.5-2.
3. Propagation conditions are set according to clause 4.16.2.
4. Message contents are defined in clause 17.2.1.4.3.
5. In the test there are two synchronous cells: Cell 1 and Cell 2. Cell 1 is the reference as well as the PCell. Cell 2 is the neighbour cell. All cells are on the same RF channel distributed in single positioning frequency layer.

17.2.1.4.2 Test procedure

The test consists of two consecutive time intervals, with duration of T1 and T2. Both cells transmit PRS during T2. The *NR-DL-AoD-RequestLocationInformation* message and *NR-DL-AoD-ProvideAssistanceData* message as defined in TS 37.355 [49] shall be provided to the UE during T1. The last slot containing the two messages for the assistance data and location information request is denoted as #n.

The beginning of the time interval T2 shall be aligned with the beginning of the first MG instance containing the PRS resources that is ΔT after slot #n, where $\Delta T = 50$ ms is the maximum processing time of the assistance data and location information request.

1. Ensure the UE is in State RRC_CONNECTED with generic procedure parameters Connectivity NR, Connected without release On, according to TS 38.508-1 [45] clause 4.5.
2. The SS shall send a RESET UE POSITIONING STORED INFORMATION message.
3. Set the parameters according to Table 17.2.1.5-1 and Table 17.2.1.5-2 as appropriate. Propagation conditions are set according to clause 4.16.2.
4. T1 starts.
5. The SS shall send an LPP REQUEST CAPABILITIES message.
6. The UE shall transmit an LPP PROVIDE CAPABILITIES message indicating the DL-AoD capabilities supported by the UE in the NR-DL-AoD-ProvideCapabilities IE.
7. The SS shall send a LPP PROVIDE ASSISTANCE DATA message, including the nr-DL-AoD-ProvideAssistanceData-r16 IE. If the UE message at step 6 includes the ackRequested IE set to TRUE, then the SS shall send an acknowledgment in the LPP PROVIDE ASSISTANCE DATA message.

8. The SS shall send a LPP REQUEST LOCATION INFORMATION message, including the nr-DL-AoD-RequestLocationInformation-r16 such that the UE receives the message ΔT ms before the start of the measurement period, where $\Delta T = 50$ ms.
9. When T1 expires, the SS shall switch the power setting from T1 to T2 as specified in Table 17.2.1.5-2.
10. The UE shall transmit a LPP PROVIDE LOCATION INFORMATION message including the nr-DL-AoD-ProvideLocationInformation-r16 IE within the response time (see clause 4.16.3). The UE shall perform and report the PRS-RSRPP measurements for both Cell 1 and Cell 2. If the UE transmits an nr-DL-AoD-ProvideLocationInformation-r16 IE including the nr-DL-PRS-FirstPathRSRP-ResultDiff-r17 field for Cell 1 and Cell 2 within the response time then the number of successful tests is increased by one. If the UE fails to report the nr-DL-AoD-ProvideLocationInformation-r16IE with the nr-DL-PRS-FirstPathRSRP-ResultDiff-r17 fields included within the response time then the number of failure tests is increased by one.
11. If the UE message at step 10 includes the *ackRequested* IE set to TRUE, the SS shall send a LPP acknowledgement message.
12. Repeat step 2-11 until the confidence level according to Annex D is achieved.

17.2.1.4.3 Message contents

Table 17.2.1.4.3-1: RESET UE POSITIONING STORED INFORMATION

Derivation Path: 38.509 [44] clause 6.6			
Information Element	Value/remark	Comment	Condition
UE Positioning Technology	0 0 0 1 0 0 0	DL-AoD	

Table 17.2.1.4.3-2: LPP Request Capabilities

Information Element	Value/remark
nr-DL-AoD-RequestCapabilities-r16	TRUE

Table 17.2.1.4.3-3: LPP ProvideAssistanceData

Derivation Path: 37.355 clause 6.2			
Information Element	Value/remark	Comment	Condition
LPP-Message ::= SEQUENCE {			
transactionID SEQUENCE {			
initiator	locationServer		
transactionNumber	(0..255)		
}			
endTransaction	TRUE		
sequenceNumber	Not present		
acknowledgement	Not present		
lpp-MessageBody CHOICE {			
c1 CHOICE {			
provideAssistanceData SEQUENCE {			
criticalExtensions CHOICE {			
c1 CHOICE {			
provideAssistanceData-r9 SEQUENCE {			
commonEsProvideAssistanceData	Not present		
a-gnss-ProvideAssistanceData	Not present		
otdoa-ProvideAssistanceData	Not present		
epdu-Provide-AssistanceData	Not present		
sensor-ProvideAssistanceData-r15	Not present		
tbs-ProvideAssistanceData-r15	Not present		
wlan-ProvideAssistanceData-r15	Not present		
nr-Multi-RTT-ProvideAssistanceData-r16	Not present		
nr-DL-AoD-ProvideAssistanceData-r16			
} SEQUENCE {			
nr-DL-PRS-AssistanceData-r16	As defined in Table 17.2.1.4.3-4		

nr-SelectedDL-PRS-IndexList-r16	Not present		
nr-PositionCalculationAssistance-r16 SEQUENCE {			Depending on UE capabilities, i.e. support for UE-based DL-AoD
nr-TRP-LocationInfo-r16	As defined in TS 37.571-5 [20]		
nr-DL-PRS-BeamInfo-r16	Not present		
nr-RTD-Info-r16	Not present		
nr-TRP-BeamAntennaInfo-r17	Not present		
nr-DL-PRS-Expected-LOS-NLOS-Assistance-r17	Not present		
nr-DL-PRS-TRP-TEG-Info-r17	Not present		
}			
nr-DL-AoD-Error-r16	Not present		
nr-DL-PRS-BeamInfo-r17	Not present		
nr-On-Demand-DL-PRS-Configurations-r17	Not present		
}			
nr-DL-TDOA-ProvideAssistanceData-r16	Not present		
}			
}			
}			
}			
}			
}			

Table 17.2.1.4.3-4: NR-DL-PRS-AssistanceData

Derivation Path: 37.355 clause 6.4.3			
Information Element	Value/remark	Comment	Condition
NR-DL-PRS-AssistanceData-r16 ::= SEQUENCE {			
nr-DL-PRS-ReferenceInfo-r16 SEQUENCE {			
dl-PRS-ID-r16	0		
nr-DL-PRS-ResourceID-List-r16	Not present		
nr-DL-PRS-ResourceSetID-r16	Not present		
}			
nr-DL-PRS-AssistanceDataList-r16 SEQUENCE (SIZE (1..nrMaxFreqLayers-r16)) OF NR-DL-PRS-AssistanceDataPerFreq-r16 {	1 entry		
NR-DL-PRS-AssistanceDataPerFreq-r16[1] SEQUENCE {		entry 1	
nr-DL-PRS-PositioningFrequencyLayer-r16 SEQUENCE {			
dl-PRS-SubcarrierSpacing-r16	kHz15 kHz30		Config 3
dl-PRS-ResourceBandwidth-r16	21 28	104 PRBs 132 PRBs	Config 1 and Config 2 Config 3
dl-PRS-StartPRB-r16	0		
dl-PRS-PointA-r16	absoluteFrequencyPointA as defined for the DL frequency of the Cell 1		
dl-PRS-CombSizeN-r16	n2		
dl-PRS-CyclicPrefix-r16	normal		
}			
nr-DL-PRS-AssistanceDataPerFreq-r16 SEQUENCE (SIZE (1..nrMaxTRPsPerFreq-r16)) OF NR-DL-PRS-AssistanceDataPerTRP-r16{	2 entries		
NR-DL-PRS-AssistanceDataPerTRP-r16[1] SEQUENCE {		entry 1	Cell 1
dl-PRS-ID-r16	0		

nr-PhysCellID-r16	Cell 1		
nr-CellGlobalID-r16	Cell 1		
nr-ARFCN-r16	Cell 1		
nr-DL-PRS-SFN0-Offset-r16 SEQUENCE {			
sfn-Offset-r16	0		
integerSubframeOffset-r16	0		
}			
nr-DL-PRS-ExpectedRSTD-r16	0		
nr-DL-PRS-ExpectedRSTD-Uncertainty-r16	0		
nr-DL-PRS-Info-r16	As specified in Table 17.2.1.4.3-5		
}			
NR-DL-PRS-AssistanceDataPerTRP-r16[2] SEQUENCE {		entry 2	Cell 2
dl-PRS-ID-r16	1		
nr-PhysCellID-r16	Cell 2		
nr-CellGlobalID-r16	Cell 2		
nr-ARFCN-r16	Cell 2		
nr-DL-PRS-SFN0-Offset-r16 SEQUENCE {			
sfn-Offset-r16	0		
integerSubframeOffset-r16	0		
}			
nr-DL-PRS-ExpectedRSTD-r16	23	About 3 μs	
nr-DL-PRS-ExpectedRSTD-Uncertainty-r16	38	About 5 μs	
nr-DL-PRS-Info-r16	As specified in Table 17.2.1.4.3-5		
}			
}			
}			
}			
}			

Table 17.2.1.4.3-5: NR-DL-PRS-Info

Derivation Path: TS 37.355 [49] clause 6.4.3			
Information Element	Value/remark	Comment	Condition
NR-DL-PRS-Info-r16 ::= SEQUENCE {			
nr-DL-PRS-ResourceSetList-r16 SEQUENCE (SIZE (1..nrMaxSetsPerTrp-r16)) OF NR-DL-PRS-ResourceSet-r16 {	1 entry		
NR-DL-PRS-ResourceSet-r16[1] SEQUENCE {		entry 1	
nr-DL-PRS-ResourceSetID-r16	0		
dl-PRS-Periodicity-and-ResourceSetSlotOffset-r16 CHOICE {			
scs15-r16 CHOICE {			Config 1 and Config 2
n160-r16	10		
}			
scs30-r16 CHOICE {			Config 3
n320-r16	20		
}			
dl-PRS-ResourceRepetitionFactor-r16	Not present		
dl-PRS-ResourceTimeGap-r16	s1		
dl-PRS-NumSymbols-r16	n4		
dl-PRS-MutingOption1-r16 SEQUENCE {			
dl-prs-MutingBitRepetitionFactor-r16	Not present		
nr-option1-muting-r16 CHOICE {			
po2-r16	10		Cell 1
	01		Cell 2
}			
}			
}			
}			
dl-PRS-MutingOption2-r16	Not present		
dl-PRS-ResourcePower-r16	27		

dl-PRS-ResourceList-r16 SEQUENCE (SIZE (1..nrMaxResourcesPerSet-r16)) OF NR-DL-PRS-Resource-r16 {	2 entries		
NR-DL-PRS-Resource-r16[1] SEQUENCE {		entry 1	
nr-DL-PRS-ResourceID-r16	0		
dl-PRS-SequenceID-r16	0		
dl-PRS-CombSizeN-AndReOffset-r16 CHOICE {			
n4-r16	0		
}			
dl-PRS-ResourceSlotOffset-r16	4		
dl-PRS-ResourceSymbolOffset-r16	0		
dl-PRS-QCL-Info-r16	Not present		
}			
NR-DL-PRS-Resource-r16[2] SEQUENCE {		entry 2	
nr-DL-PRS-ResourceID-r16	1		
dl-PRS-SequenceID-r16	0		
dl-PRS-CombSizeN-AndReOffset-r16 CHOICE {			
n4-r16	0		
dl-PRS-ResourceSlotOffset-r16	4		
dl-PRS-ResourceSymbolOffset-r16	0		
dl-PRS-QCL-Info-r16	Not present		
}			
}			
}			
}			
}			

Table 17.2.1.4.3-6: LPP RequestLocationInformation

Derivation Path: 37.355 clause 6.2			
Information Element	Value/remark	Comment	Condition
LPP-Message ::= SEQUENCE {			
transactionID SEQUENCE {			
initiator	locationServer		
transactionNumber	1		
}			
endTransaction	FALSE		
sequenceNumber	Not present		
acknowledgement	Not present		
lpp-MessageBody CHOICE {			
c1 CHOICE {			
requestLocationInformation SEQUENCE {			
criticalExtensions CHOICE {			
c1 CHOICE {			
requestLocationInformation-r9 SEQUENCE {			
commonEsRequestLocationInformation SEQUENCE {			
locationInformationType	locationMeasurementsRequired		
triggeredReporting	Not present		
periodicalReporting	Not present		
additionalInformation	onlyReturnInformationRequested		
qos SEQUENCE {			
horizontalAccuracy	Not present		
verticalCoordinateRequest	FALSE		
verticalAccuracy	Not present		
responseTime SEQUENCE {			
time	See 17.2.1.5	Result of the response time calculation rounded up to the next second if response time <= 128s. Result of the	

		response time calculation rounded up to the next multiple of ten seconds if response time > 128s.	
responseTimeEarlyFix-r12	Not present		Rel-12 onwards
unit-r15	Not present ten-seconds		Calculated response time >128s
}			
velocityRequest	FALSE		
}			
environment	Not present		
locationCoordinateTypes	Not present		
velocityTypes	Not present		
}			
a-gnss-RequestLocationInformation	Not present		
otdoa-RequestLocationInformation	Not present		
ecid-RequestLocationInformation	Not present		
epdu-RequestLocationInformation	Not Present		
sensor-RequestLocationInformation-r13	Not present		
tbs-RequestLocationInformation-r13	Not present		
wlan-RequestLocationInformation-r13	Not present		
bt-RequestLocationInformation-r13	Not present		
nr-ECID-RequestLocationInformation-r16	Not present		
nr-Multi-RTT-RequestLocationInformation-r16	Not present		
nr-DL-AoD-RequestLocationInformation-r16			
SEQUENCE {			
nr-AssistanceAvailability-r16	FALSE		
nr-DL-AoD-ReportConfig-r16 SEQUENCE {			
maxDL-PRS-RSRP-MeasurementsPerTRP-r16	Not present		
maxDL-PRS-RSRP-MeasurementsPerTRP-r17	Not present		
maxDL-PRS-RSRPP-MeasurementsPerTRP-r17	Present. Set depending on UE capabilities.		
nr-los-nlos-IndicatorRequest-r17	Not present		
reducedDL-PRS-ProcessingSamples-r17	Not present		
lowerRxBeamSweepingFactor-FR2-r17	Not present		
}			
multiMeasInSameReport-r17			
}			
nr-DL-TDOA-RequestLocationInformation-r16	Not present		
}			
}			
}			
}			
}			
}			

Table 17.2.1.4.3-7: LPP ProvideLocation Information

Derivation Path: 37.355 clause 6.5.12			
Information Element	Value/remark	Comment	Condition
LPP-Message ::= SEQUENCE {			
transactionID SEQUENCE {			
initiator	locationServer		
transactionNumber	1		
}			
endTransaction	TRUE		
sequenceNumber	(0..255)		

acknowledgement			
lpp-MessageBody CHOICE {			
c1 CHOICE {			
provideLocationInformation SEQUENCE {			
criticalExtensions CHOICE {			
c1 CHOICE {			
provideLocationInformation-r9 SEQUENCE {			
commonIEsProvideLocationInformation	Not present.		
a-gnss-ProvideLocationInformation	Not present		
otdoa-ProvideLocationInformation	Not present		
ecid-ProvideLocationInformation	Not present		
epdu-ProvideLocationInformation	Not present		
sensor-ProvideLocationInformation-r13	Not present		
tbs-ProvideLocationInformation-r13	Not present		
wlan-ProvideLocationInformation-r13	Not present		
bt-ProvideLocationInformation-r13	Not present		
nr-ECID-ProvideLocationInformation-r16	Not present		
nr-Multi-RTT-ProvideLocationInformation-	Not present		
r16			
nr-DL-AoD-ProvideLocationInformation-r16			
SEQUENCE {			
nr-DL-AoD-			
SignalMeasurementInformation-r16 SEQUENCE {			
nr-DL-AoD-MeasList-r16 SEQUENCE			
(SIZE(1..nrMaxTRPs-r16)) OF NR-DL-AoD-			
MeasElement-r16 {			
NR-DL-AoD-MeasElement-r16[1]		entry 1	
SEQUENCE {			
dl-PRS-ID-r16	INTEGER (0..255)		
nr-PhysCellID-r16	Cell 1		
nr-CellGlobalID-r16			
nr-ARFCN-r16			
nr-DL-PRS-ResourceID-r16			
nr-DL-PRS-ResourceSetID-r16			
nr-TimeStamp-r16			
nr-DL-PRS-RSRP-Result-r16	Present. Any value acceptable.		
nr-DL-PRS-RxBeamIndex-r16			
nr-DL-AoD-AdditionalMeasurements-			
r16			
nr-DL-PRS-FirstPathRSRP-Result-r17	Present. Any value acceptable.		
nr-los-nlos-Indicator-r17			
nr-DL-AoD-			
AdditionalMeasurementsExt-r17			
}			
NR-DL-AoD-MeasElement-r16[2]		entry 2	
SEQUENCE {			
dl-PRS-ID-r16	INTEGER (0..255)		
nr-PhysCellID-r16	Cell 2		
nr-CellGlobalID-r16			
nr-ARFCN-r16			
nr-DL-PRS-ResourceID-r16			
nr-DL-PRS-ResourceSetID-r16			
nr-TimeStamp-r16			
nr-DL-PRS-RSRP-Result-r16	Present. Any value acceptable.		
nr-DL-PRS-RxBeamIndex-r16			
nr-DL-AoD-AdditionalMeasurements-			
r16			
nr-DL-PRS-FirstPathRSRP-Result-r17	Present. Any value acceptable.		
nr-los-nlos-Indicator-r17			
nr-DL-AoD-			
AdditionalMeasurementsExt-r17			
}			

}			
}			
nr-dl-AoD-LocationInformation-r16			
nr-DL-AoD-Error-r16	Not present		
r17 nr-DL-AoD-SignalMeasurementInstances-	Not present		
r17 nr-DL-AoD-LocationInformationInstances-	Not present		
}			
}			
}			
}			
}			
}			
}			
}			
}			

17.2.1.5 Test requirement

FFS

17.2.2 PRS-RSRPP measurement reporting delay test case for single positioning frequency layer with reduced number of samples in FR1 SA

Editor’s note: This test case is incomplete. The following aspect is either missing or TBD:

- Test tolerance are not added in and analysis is missing

17.2.2.1 Test purpose

The purpose of the test is to verify that the PRS-RSRPP measurement meets the reduced sample measurement delay requirements specified in TS 38.133 [50] clause 9.9.6.5 in an environment with AWGN propagation conditions for reduced number of samples.

17.2.2.2 Test applicability

This test applies to all types of NR UE release 17 onwards that supports DL-AoD positioning, maxDL-PRS-FirstPathRSRP-MeasPerTRP and supportedDL-PRS-ProcessingSamples.

17.2.2.3 Minimum conformance requirements

Same as clause 17.2.1.3.

17.2.2.4 Test description

17.2.2.4.1 Initial conditions

The supported test configurations are listed in Table 17.2.2.4-1.

Table 17.2.2.4-1: Test Configurations

Configuration	Description
1	15 kHz SSB SCS, 10 MHz bandwidth, FDD duplex mode
2	15 kHz SSB SCS, 10 MHz bandwidth, TDD duplex mode
3	30 kHz SSB SCS, 40 MHz bandwidth, TDD duplex mode
Note:	The UE is only required to be tested in one of the supported test configurations.

Test Environment: Normal, as defined in TS 38.508-1 [45] clause 4.1.

Frequencies to be tested: Mid Range, as defined in TS 38.508-1 [45] clause 4.3.1.

Channel bandwidth to be tested: are specified in Table 17.2.2.4-1.

1. Connect the SS and AWGN noise sources to the UE antenna connector or antenna connectors as shown in Annex A, Figure A.13.
2. The general test parameter settings are set up according to Table 17.2.2.5-1 and Table 17.2.2.5-2.
3. Propagation conditions are set according to clause 4.16.2.
4. Message contents are defined in clause 17.2.2.4.3.
5. In the test there are two synchronous cells: Cell 1 and Cell 2. Cell 1 is the reference as well as the PCell. Cell 2 is the neighbour cell. All cells are on the same RF channel distributed in single positioning frequency layer.

17.2.2.4.2 Test procedure

Same as clause 17.2.1.4.2.

17.2.2.4.3 Message contents

Table 17.2.2.4.3-1: RESET UE POSITIONING STORED INFORMATION

Derivation Path: 38.509 [44] clause 6.6			
Information Element	Value/remark	Comment	Condition
UE Positioning Technology	0 0 0 1 0 0 0	DL-AoD	

Table 17.2.2.4.3-2: LPP Request Capabilities

Information Element	Value/remark
nr-DL-AoD-RequestCapabilities-r16	TRUE

Table 17.2.2.4.3-3: LPP ProvideAssistanceData

Derivation Path: 37.355 clause 6.2			
Information Element	Value/remark	Comment	Condition
LPP-Message ::= SEQUENCE {			
transactionID SEQUENCE {			
initiator	locationServer		
transactionNumber	(0..255)		
}			
endTransaction	TRUE		
sequenceNumber	Not present		
acknowledgement	Not present		
lpp-MessageBody CHOICE {			
c1 CHOICE {			
provideAssistanceData SEQUENCE {			
criticalExtensions CHOICE {			
c1 CHOICE {			
provideAssistanceData-r9 SEQUENCE {			
commonEsProvideAssistanceData	Not present		
a-gnss-ProvideAssistanceData	Not present		
otdoa-ProvideAssistanceData	Not present		
epdu-Provide-AssistanceData	Not present		
sensor-ProvideAssistanceData-r15	Not present		
tbs-ProvideAssistanceData-r15	Not present		
wlan-ProvideAssistanceData-r15	Not present		
nr-Multi-RTT-ProvideAssistanceData-r16	Not present		
nr-DL-AoD-ProvideAssistanceData-r16			
}			
}			
}			
}			

nr-DL-PRS-AssistanceData-r16	As defined in Table 17.2.2.4.3-4		
nr-SelectedDL-PRS-IndexList-r16	Not present		
nr-PositionCalculationAssistance-r16			Depending on UE capabilities, i.e. support for UE-based DL-AoD
SEQUENCE {			
nr-TRP-LocationInfo-r16	As defined in TS 37.571-5 [20]		
nr-DL-PRS-BeamInfo-r16	Not present		
nr-RTD-Info-r16	Not present		
nr-TRP-BeamAntennaInfo-r17	Not present		
nr-DL-PRS-Expected-LOS-NLOS-Assistance-r17	Not present		
nr-DL-PRS-TRP-TEG-Info-r17	Not present		
}			
nr-DL-AoD-Error-r16	Not present		
nr-DL-PRS-BeamInfo-r17	Not present		
nr-On-Demand-DL-PRS-Configurations-r17	Not present		
}			
nr-DL-TDOA-ProvideAssistanceData-r16	Not present		
}			
}			
}			
}			
}			
}			

Table 17.2.2.4.3-4: NR-DL-PRS-AssistanceData

Derivation Path: 37.355 clause 6.4.3			
Information Element	Value/remark	Comment	Condition
NR-DL-PRS-AssistanceData-r16 ::= SEQUENCE {			
nr-DL-PRS-ReferenceInfo-r16 SEQUENCE {			
dl-PRS-ID-r16	0		
nr-DL-PRS-ResourceID-List-r16	Not present		
nr-DL-PRS-ResourceSetID-r16	Not present		
}			
nr-DL-PRS-AssistanceDataList-r16 SEQUENCE (SIZE (1..nrMaxFreqLayers-r16)) OF NR-DL-PRS-AssistanceDataPerFreq-r16 {	1 entry		
NR-DL-PRS-AssistanceDataPerFreq-r16[1]		entry 1	
SEQUENCE {			
nr-DL-PRS-PositioningFrequencyLayer-r16 SEQUENCE {			
dl-PRS-SubcarrierSpacing-r16	kHz15 kHz30		Config 3
dl-PRS-ResourceBandwidth-r16	7	48 PRBs	
dl-PRS-StartPRB-r16	0		
dl-PRS-PointA-r16	absoluteFrequencyPointA as defined for the DL frequency of the Cell 1		
dl-PRS-CombSizeN-r16	n4		
dl-PRS-CyclicPrefix-r16	normal		
}			
nr-DL-PRS-AssistanceDataPerFreq-r16 SEQUENCE (SIZE (1..nrMaxTRPsPerFreq-r16)) OF NR-DL-PRS-AssistanceDataPerTRP-r16{	2 entries		
NR-DL-PRS-AssistanceDataPerTRP-r16[1]		entry 1	Cell 1
SEQUENCE {			
dl-PRS-ID-r16	0		
nr-PhysCellID-r16	Cell 1		

nr-CellGlobalID-r16	Cell 1		
nr-ARFCN-r16	Cell 1		
nr-DL-PRS-SFN0-Offset-r16 SEQUENCE {			
sfn-Offset-r16	0		
integerSubframeOffset-r16	0		
}			
nr-DL-PRS-ExpectedRSTD-r16	0		
nr-DL-PRS-ExpectedRSTD-Uncertainty-r16	0		
nr-DL-PRS-Info-r16	As specified in Table 17.2.2.4.3-5		
}			
NR-DL-PRS-AssistanceDataPerTRP-r16[2] SEQUENCE {		entry 2	Cell 2
dl-PRS-ID-r16	1		
nr-PhysCellID-r16	Cell 2		
nr-CellGlobalID-r16	Cell 2		
nr-ARFCN-r16	Cell 2		
nr-DL-PRS-SFN0-Offset-r16 SEQUENCE {			
sfn-Offset-r16	0		
integerSubframeOffset-r16	0		
}			
nr-DL-PRS-ExpectedRSTD-r16	23	About 3 μs	
nr-DL-PRS-ExpectedRSTD-Uncertainty-r16	38	About 5 μs	
nr-DL-PRS-Info-r16	As specified in Table 17.2.1.4.3-5		
}			
}			
}			
}			
}			

Table 17.2.2.4.3-5: NR-DL-PRS-Info

Derivation Path: TS 37.355 [49] clause 6.4.3			
Information Element	Value/remark	Comment	Condition
NR-DL-PRS-Info-r16 ::= SEQUENCE {			
nr-DL-PRS-ResourceSetList-r16 SEQUENCE (SIZE (1..nrMaxSetsPerTrp-r16)) OF NR-DL-PRS-ResourceSet-r16 {	1 entry		
NR-DL-PRS-ResourceSet-r16[1] SEQUENCE {		entry 1	
nr-DL-PRS-ResourceSetID-r16	0		
dl-PRS-Periodicity-and-ResourceSetSlotOffset-r16 CHOICE {			
scs15-r16 CHOICE {			Config 1 and Config 2
n160-r16	10		
}			
scs30-r16 CHOICE {			Config 3
n320-r16	20		
}			
dl-PRS-ResourceRepetitionFactor-r16	Not present		
dl-PRS-ResourceTimeGap-r16	s1		
dl-PRS-NumSymbols-r16	n4		
dl-PRS-MutingOption1-r16 SEQUENCE {			
dl-prs-MutingBitRepetitionFactor-r16	Not present		
nr-option1-muting-r16 CHOICE {			
po2-r16	10 01		Cell 1 Cell 2
}			
}			
}			
}			
dl-PRS-MutingOption2-r16	Not present		
dl-PRS-ResourcePower-r16	27		

dl-PRS-ResourceList-r16 SEQUENCE (SIZE (1..nrMaxResourcesPerSet-r16)) OF NR-DL-PRS-Resource-r16 {	2 entries		
NR-DL-PRS-Resource-r16[1] SEQUENCE {		entry 1	
nr-DL-PRS-ResourceID-r16	0		
dl-PRS-SequenceID-r16	0		
dl-PRS-CombSizeN-AndReOffset-r16 CHOICE {			
n4-r16	0		
}			
dl-PRS-ResourceSlotOffset-r16	4		
dl-PRS-ResourceSymbolOffset-r16	0		
dl-PRS-QCL-Info-r16	Not present		
}			
NR-DL-PRS-Resource-r16[2] SEQUENCE {		entry 2	
nr-DL-PRS-ResourceID-r16	1		
dl-PRS-SequenceID-r16	0		
dl-PRS-CombSizeN-AndReOffset-r16 CHOICE {			
n4-r16	0		
dl-PRS-ResourceSlotOffset-r16	4		
dl-PRS-ResourceSymbolOffset-r16	0		
dl-PRS-QCL-Info-r16	Not present		
}			
}			
}			
}			
}			

Table 17.2.2.4.3-6: LPP RequestLocationInformation

Derivation Path: 37.355 clause 6.2			
Information Element	Value/remark	Comment	Condition
LPP-Message ::= SEQUENCE {			
transactionID SEQUENCE {			
initiator	locationServer		
transactionNumber	1		
}			
endTransaction	FALSE		
sequenceNumber	Not present		
acknowledgement	Not present		
lpp-MessageBody CHOICE {			
c1 CHOICE {			
requestLocationInformation SEQUENCE {			
criticalExtensions CHOICE {			
c1 CHOICE {			
requestLocationInformation-r9 SEQUENCE {			
commonEsRequestLocationInformation SEQUENCE {			
locationInformationType	locationMeasurementsRequired		
triggeredReporting	Not present		
periodicalReporting	Not present		
additionalInformation	onlyReturnInformationRequested		
qos SEQUENCE {			
horizontalAccuracy	Not present		
verticalCoordinateRequest	FALSE		
verticalAccuracy	Not present		
responseTime SEQUENCE {			
time	See 17.2.2.5	Result of the response time calculation rounded up to the next second if response time <= 128s. Result of the	

		response time calculation rounded up to the next multiple of ten seconds if response time > 128s.	
responseTimeEarlyFix-r12	Not present		Rel-12 onwards
unit-r15	Not present ten-seconds		Calculated response time >128s
}			
velocityRequest	FALSE		
}			
environment	Not present		
locationCoordinateTypes	Not present		
velocityTypes	Not present		
}			
a-gnss-RequestLocationInformation	Not present		
otdoa-RequestLocationInformation	Not present		
ecid-RequestLocationInformation	Not present		
epdu-RequestLocationInformation	Not Present		
sensor-RequestLocationInformation-r13	Not present		
tbs-RequestLocationInformation-r13	Not present		
wlan-RequestLocationInformation-r13	Not present		
bt-RequestLocationInformation-r13	Not present		
nr-ECID-RequestLocationInformation-r16	Not present		
nr-Multi-RTT-RequestLocationInformation-r16	Not present		
nr-DL-AoD-RequestLocationInformation-r16			
SEQUENCE {			
nr-AssistanceAvailability-r16	FALSE		
nr-DL-AoD-ReportConfig-r16 SEQUENCE {			
maxDL-PRS-RSRP-MeasurementsPerTRP-r16	Not present		
maxDL-PRS-RSRP-MeasurementsPerTRP-r17	Not present		
maxDL-PRS-RSRPP-MeasurementsPerTRP-r17	Present. Set depending on UE capabilities.		
nr-los-nlos-IndicatorRequest-r17	Not present		
reducedDL-PRS-ProcessingSamples-r17	requested		
lowerRxBeamSweepingFactor-FR2-r17	Not present		
}			
multiMeasInSameReport-r17			
}			
nr-DL-TDOA-RequestLocationInformation-r16	Not present		
}			
}			
}			
}			
}			
}			

Table 17.2.2.4.3-7: LPP ProvideLocation Information

Derivation Path: 37.355 clause 6.5.12			
Information Element	Value/remark	Comment	Condition
LPP-Message ::= SEQUENCE {			
transactionID SEQUENCE {			
initiator	locationServer		
transactionNumber	1		
}			
endTransaction	TRUE		
sequenceNumber	(0..255)		

acknowledgement			
lpp-MessageBody CHOICE {			
c1 CHOICE {			
provideLocationInformation SEQUENCE {			
criticalExtensions CHOICE {			
c1 CHOICE {			
provideLocationInformation-r9 SEQUENCE {			
commonIEsProvideLocationInformation	Not present.		
a-gnss-ProvideLocationInformation	Not present		
otdoa-ProvideLocationInformation	Not present		
ecid-ProvideLocationInformation	Not present		
epdu-ProvideLocationInformation	Not present		
sensor-ProvideLocationInformation-r13	Not present		
tbs-ProvideLocationInformation-r13	Not present		
wlan-ProvideLocationInformation-r13	Not present		
bt-ProvideLocationInformation-r13	Not present		
nr-ECID-ProvideLocationInformation-r16	Not present		
nr-Multi-RTT-ProvideLocationInformation-	Not present		
r16			
nr-DL-AoD-ProvideLocationInformation-r16			
SEQUENCE {			
nr-DL-AoD-			
SignalMeasurementInformation-r16 SEQUENCE {			
nr-DL-AoD-MeasList-r16 SEQUENCE			
(SIZE(1..nrMaxTRPs-r16)) OF NR-DL-AoD-			
MeasElement-r16 {			
NR-DL-AoD-MeasElement-r16[1]		entry 1	
SEQUENCE {			
dl-PRS-ID-r16	INTEGER (0..255)		
nr-PhysCellID-r16	Cell 1		
nr-CellGlobalID-r16			
nr-ARFCN-r16			
nr-DL-PRS-ResourceID-r16			
nr-DL-PRS-ResourceSetID-r16			
nr-TimeStamp-r16			
nr-DL-PRS-RSRP-Result-r16	Present. Any value acceptable.		
nr-DL-PRS-RxBeamIndex-r16			
nr-DL-AoD-AdditionalMeasurements-			
r16			
nr-DL-PRS-FirstPathRSRP-Result-r17	Present. Any value acceptable.		
nr-los-nlos-Indicator-r17			
nr-DL-AoD-			
AdditionalMeasurementsExt-r17			
}			
NR-DL-AoD-MeasElement-r16[2]		entry 2	
SEQUENCE {			
dl-PRS-ID-r16	INTEGER (0..255)		
nr-PhysCellID-r16	Cell 2		
nr-CellGlobalID-r16			
nr-ARFCN-r16			
nr-DL-PRS-ResourceID-r16			
nr-DL-PRS-ResourceSetID-r16			
nr-TimeStamp-r16			
nr-DL-PRS-RSRP-Result-r16	Present. Any value acceptable.		
nr-DL-PRS-RxBeamIndex-r16			
nr-DL-AoD-AdditionalMeasurements-			
r16			
nr-DL-PRS-FirstPathRSRP-Result-r17	Present. Any value acceptable.		
nr-los-nlos-Indicator-r17			
nr-DL-AoD-			
AdditionalMeasurementsExt-r17			
}			

}			
}			
nr-dl-AoD-LocationInformation-r16			
nr-DL-AoD-Error-r16	Not present		
r17 nr-DL-AoD-SignalMeasurementInstances-	Not present		
r17 nr-DL-AoD-LocationInformationInstances-	Not present		
}			
}			
}			
}			
}			
}			
}			
}			
}			

17.2.2.5 Test requirement

FFS

17.2.3 PRS-RSRPP measurement reporting delay test case for single positioning frequency layer without measurement gap in FR1 SA

Editor’s note: This test case is incomplete. The following aspect is either missing or TBD:

- Test tolerance are not added in and analysis is missing

17.2.3.1 Test purpose

The purpose of the test is to verify that the PRS-RSRPP measurement meets the reporting delay requirements without measurement gaps specified in TS 38.133 [50] clause 9.9.6.6 in an environment with AWGN propagation conditions.

17.2.3.2 Test applicability

This test applies to all types of NR UE release 17 onwards that supports DL-AoD positioning, maxDL-PRS-FirstPathRSRP-MeasPerTRP, supportedDL-PRS-ProcessingSamples and prs-Processing Window.

17.2.3.3 Minimum conformance requirements

Same as clause 17.2.1.3.

17.2.3.4 Test description

17.2.3.4.1 Initial conditions

The supported test configurations are listed in Table 17.2.3.4-1.

Table 17.2.3.4-1: Test Configurations

Configuration	Description
1	15 kHz SSB SCS, 10 MHz bandwidth, FDD duplex mode
2	15 kHz SSB SCS, 10 MHz bandwidth, TDD duplex mode
3	30 kHz SSB SCS, 40 MHz bandwidth, TDD duplex mode
Note: The UE is only required to be tested in one of the supported test configurations.	

Test Environment: Normal, as defined in TS 38.508-1 [45] clause 4.1.

Frequencies to be tested: Mid Range, as defined in TS 38.508-1 [45] clause 4.3.1.

Channel bandwidth to be tested: are specified in Table 17.2.3.4-1.

1. Connect the SS and AWGN noise sources to the UE antenna connector or antenna connectors as shown in Annex A, Figure A.13.
2. The general test parameter settings are set up according to Table 17.2.3.5-1 and Table 17.2.3.5-2.
3. Propagation conditions are set according to clause 4.16.2.
4. Message contents are defined in clause 17.2.3.4.3.
5. In the test there are two synchronous cells: Cell 1 and Cell 2. Cell 1 is the reference as well as the PCell. Cell 2 is the neighbour cell. All cells are on the same RF channel distributed in single positioning frequency layer.

17.2.3.4.2 Test procedure

The test consists of two sub-tests; Sub-test 1 is for $N_{\text{sample}} = 4$ and sub-test 2 is for $N_{\text{sample}} = 1$. Sub-test 2 is only conducted when UE also supporting supportedDL-PRS-ProcessingSamples-RRC-CONNECTED. The test consists of two consecutive time intervals, with duration of T1 and T2. During time duration T1, the UE shall not have any timing information of Cell 2. All two cells transmit PRS during T2. The beginning of the time interval T2 shall be aligned with the beginning of the first PRS processing window instance containing the PRS resources.

The *NR-DL-AoD-ProvideAssistanceData* and *NR-DL-AoD-RequestLocationInformation* as defined in TS 37.355 [49] clause 6.5.11 shall be provided to the UE during T1. The last TTI containing the two messages shall be provided to the UE ΔT ms before the start of T2, where $\Delta T = 50$ ms is the maximum processing time of the *DL-AoD assistance* data and location information request.

3. Ensure the UE is in State RRC_CONNECTED with generic procedure parameters Connectivity NR, Connected without release *On*, according to TS 38.508-1 [45] clause 4.5.
2. The SS shall send a RESET UE POSITIONING STORED INFORMATION message.
3. Set the parameters according to Table 17.2.3.5-1 and Table 17.2.3.5-2. Propagation conditions are set according to clause 4.16.2.
4. T1 starts.
5. The SS shall transmit an LPP REQUEST CAPABILITIES message.
6. The UE shall transmit an LPP PROVIDE CAPABILITIES message indicating the DL-AoD capabilities supported by the UE in the *NR-DL-AoD-ProvideCapabilities* IE.
7. The SS shall transmit an RRCReconfiguration message with the PPW configuration.
8. The UE shall transmit RRCReconfigurationComplete message.
9. The SS shall send a LPP PROVIDE ASSISTANCE DATA message, including the *NR-DL-AoD-ProvideAssistanceData* IE. The position of neighbour Cell 2 is described in 3GPP TS 37.571-5 [20]. If the UE message at step 6 includes the *ackRequested* IE set to TRUE, then the SS shall send an acknowledgment in the LPP PROVIDE ASSISTANCE DATA message.
10. The SS shall send a LPP REQUEST LOCATION INFORMATION message, including the *NR-DL-AoD-RequestLocationInformation* IE such that the UE receives the message ΔT ms before the start of T2, where $\Delta T = 50$ ms.
11. The SS sends a Positioning Measurement Gap Activation command containing an ID to activate the associated measurement gap
12. When T1 expires, the SS shall switch the power setting from T1 to T2 as specified in Table 17.2.3.5-2.
13. The UE shall transmit a LPP PROVIDE LOCATION INFORMATION message including the *NR-DL-AoD-ProvideLocationInformation* IE within the response time (see clause 4.16.3). The UE shall perform and report the PRS-RSRPP measurements for Cell 2 with respect to the reference cell in the DL-TDOA assistance data, Cell 1. If the UE transmits an *NR-DL-AoD-ProvideLocationInformation* IE including the *nr-DL-PRS-FirstPathRSRP-Result-r17* field for Cell 2 within the response time then the number of successful tests is

increased by one. If the UE fails to report the *NR-DL-AoD-ProvideLocationInformation* IE with both the *nr-DL-PRS-RSRP-Result-r16* fields included within the response time then the number of failure tests is increased by one.

14. If the UE message at step 13 includes the *ackRequested* IE set to TRUE, the SS shall send a LPP acknowledgement message.

15. Repeat steps 2-14 in Table 17.2.3.4-1 until the confidence level according to Annex D is achieved.

If all (applicable) sub-tests pass, the whole test passes. If one (applicable) sub-test fails, the whole test fails.

17.2.3.4.3 Message contents

Table 17.2.3.4.3-1: RESET UE POSITIONING STORED INFORMATION

Derivation Path: 38.509 [44] clause 6.6			
Information Element	Value/remark	Comment	Condition
UE Positioning Technology	0 0 0 1 0 0 0	DL-AoD	

Table 17.2.3.4.3-2: LPP Request Capabilities

Information Element	Value/remark
nr-DL-AoD-RequestCapabilities-r16	TRUE

Table 17.2.3.4.3-3: RRCReconfiguration

Derivation Path: TS 38.508-1 [45], table 4.6.1-13			
Information Element	Value/remark	Comment	Condition
RRCReconfiguration ::= SEQUENCE {			
rrc-TransactionIdentifier	RRC-TransactionIdentifier		
criticalExtensions CHOICE {			
rrcReconfiguration SEQUENCE {			
nonCriticalExtension SEQUENCE {			
masterCellGroup	OCTET STRING (CONTAINING CellGroupConfig)		
}			
}			
}			
}			

Table 17.2.3.4.3-4: CellGroupConfig (RRCReconfiguration, Table 17.2.3.4.3-3)

Derivation Path: 38.508-1 [45], Table 4.6.3-19			
Information Element	Value/remark	Comment	Condition
CellGroupConfig ::= SEQUENCE {			
spCellConfig SEQUENCE {			
spCellConfigDedicated SEQUENCE {			
initialDownlinkBWP SEQUENCE {			
dl-PPW-PreConfigToAddModList-r17 SEQUENCE (SIZE (1..maxNrofPPW-Config-r17)) OF DL-PPW-PreConfig-r17 {	1 entry		
DL-PPW-PreConfig-r17[1] SEQUENCE {		entry 1	
dl-PPW-ID-r17	0		
dl-PPW-PeriodicityAndStartSlot-r17 CHOICE {	The periodicity is 160ms and the starting slot offset is 11 ms for any SCS configuration		
scs120 CHOICE {			
n1280	4		

}			
}			
length-r17	80		
type-r17	type1A		
priority-r17	st1		
}			
}			
}			
}			
}			
}			

Table 17.2.3.4.3-5: LPP ProvideAssistanceData

Derivation Path: 37.355 clause 6.2			
Information Element	Value/remark	Comment	Condition
LPP-Message ::= SEQUENCE {			
transactionID SEQUENCE {			
initiator	locationServer		
transactionNumber	(0..255)		
}			
endTransaction	TRUE		
sequenceNumber	Not present		
acknowledgement	Not present		
lpp-MessageBody CHOICE {			
c1 CHOICE {			
provideAssistanceData SEQUENCE {			
criticalExtensions CHOICE {			
c1 CHOICE {			
provideAssistanceData-r9 SEQUENCE {			
commonEsProvideAssistanceData	Not present		
a-gnss-ProvideAssistanceData	Not present		
otdoa-ProvideAssistanceData	Not present		
epdu-Provide-AssistanceData	Not present		
sensor-ProvideAssistanceData-r15	Not present		
tbs-ProvideAssistanceData-r15	Not present		
wlan-ProvideAssistanceData-r15	Not present		
nr-Multi-RTT-ProvideAssistanceData-r16	Not present		
nr-DL-AoD-ProvideAssistanceData-r16			
SEQUENCE {			
nr-DL-PRS-AssistanceData-r16	As defined in Table 17.2.3.4.3-6		
nr-SelectedDL-PRS-IndexList-r16	Not present		
nr-PositionCalculationAssistance-r16			Depending on UE capabilities, i.e. support for UE-based DL-AoD
nr-TRP-LocationInfo-r16	As defined in TS 37.571-5 [20]		
nr-DL-PRS-BeamInfo-r16	Not present		
nr-RTD-Info-r16	Not present		
nr-TRP-BeamAntennaInfo-r17	Not present		
nr-DL-PRS-Expected-LOS-NLOS-Assistance-r17	Not present		
nr-DL-PRS-TRP-TEG-Info-r17	Not present		
}			
nr-DL-AoD-Error-r16	Not present		
nr-DL-PRS-BeamInfo-r17	Not present		
nr-On-Demand-DL-PRS-Configurations-r17	Not present		
}			
nr-DL-TDOA-ProvideAssistanceData-r16	Not present		
}			
}			
}			

}			
}			
}			
}			
}			

Table 17.2.3.4.3-6: NR-DL-PRS-AssistanceData

Derivation Path: 37.355 clause 6.4.3			
Information Element	Value/remark	Comment	Condition
NR-DL-PRS-AssistanceData-r16 ::= SEQUENCE {			
nr-DL-PRS-ReferenceInfo-r16 SEQUENCE {			
dl-PRS-ID-r16	0		
nr-DL-PRS-ResourceID-List-r16	Not present		
nr-DL-PRS-ResourceSetID-r16	Not present		
}			
nr-DL-PRS-AssistanceDataList-r16 SEQUENCE (SIZE (1..nrMaxFreqLayers-r16)) OF NR-DL-PRS-AssistanceDataPerFreq-r16 {	1 entry		
NR-DL-PRS-AssistanceDataPerFreq-r16[1] SEQUENCE {		entry 1	
nr-DL-PRS-PositioningFrequencyLayer-r16 SEQUENCE {			
dl-PRS-SubcarrierSpacing-r16	kHz15 kHz30		Test Configuration 3
dl-PRS-ResourceBandwidth-r16	21	104 PRBs	Sub-test 1 Config 1 and Config 2
	28	132 PRBs	Sub-test 1 Config 3
	7	48 PRBs	Sub-test 2
dl-PRS-StartPRB-r16	0		
dl-PRS-PointA-r16	absoluteFrequencyPointA as defined for the DL frequency of the Cell 1		
dl-PRS-CombSizeN-r16	n4		
dl-PRS-CyclicPrefix-r16	normal		
}			
nr-DL-PRS-AssistanceDataPerFreq-r16 SEQUENCE (SIZE (1..nrMaxTRPsPerFreq-r16)) OF NR-DL-PRS-AssistanceDataPerTRP-r16{	2 entries		
NR-DL-PRS-AssistanceDataPerTRP-r16[1] SEQUENCE {		entry 1	Cell 1
dl-PRS-ID-r16	0		
nr-PhysCellID-r16	Cell 1		
nr-CellGlobalID-r16	Cell 1		
nr-ARFCN-r16	Cell 1		
nr-DL-PRS-SFN0-Offset-r16 SEQUENCE {			
sfn-Offset-r16	0		
integerSubframeOffset-r16	0		
}			
nr-DL-PRS-ExpectedRSTD-r16	0		
nr-DL-PRS-ExpectedRSTD-Uncertainty-r16	0		
nr-DL-PRS-Info-r16	As specified in Table 17.2.3.4.3-7		
}			
NR-DL-PRS-AssistanceDataPerTRP-r16[2] SEQUENCE {		entry 2	Cell 2
dl-PRS-ID-r16	1		
nr-PhysCellID-r16	Cell 2		
nr-CellGlobalID-r16	Cell 2		
nr-ARFCN-r16	Cell 2		

nr-DL-PRS-SFN0-Offset-r16 SEQUENCE {			
sfn-Offset-r16	0		
integerSubframeOffset-r16	0		
}			
nr-DL-PRS-ExpectedRSTD-r16	0	About 0 μs	
nr-DL-PRS-ExpectedRSTD-Uncertainty-r16	17	About 0.58 μs	
nr-DL-PRS-Info-r16	As specified in Table 17.2.3.4.3-7		
}			
}			
}			
}			
}			

Table 17.2.3.4.3-7: NR-DL-PRS-Info

Derivation Path: TS 37.355 [49] clause 6.4.3			
Information Element	Value/remark	Comment	Condition
NR-DL-PRS-Info-r16 ::= SEQUENCE {			
nr-DL-PRS-ResourceSetList-r16 SEQUENCE (SIZE (1..nrMaxSetsPerTrp-r16)) OF NR-DL-PRS-ResourceSet-r16 {	1 entry		
NR-DL-PRS-ResourceSet-r16[1] SEQUENCE {		entry 1	
nr-DL-PRS-ResourceSetID-r16	0		
dl-PRS-Periodicity-and-ResourceSetSlotOffset-r16 CHOICE {			
scs15-r16 CHOICE {			Config 1 and Config 2
n160-r16	10		
}			
scs30-r16 CHOICE {			Config 3
n320-r16	20		
}			
dl-PRS-ResourceRepetitionFactor-r16	Not present		
dl-PRS-ResourceTimeGap-r16	s1		
dl-PRS-NumSymbols-r16	n4		
dl-PRS-MutingOption1-r16 SEQUENCE {			
dl-prs-MutingBitRepetitionFactor-r16	Not present		
nr-option1-muting-r16 CHOICE {			
po2-r16	10 01		Cell 1 Cell 2
}			
}			
}			
dl-PRS-MutingOption2-r16	Not present		
dl-PRS-ResourcePower-r16	27		
dl-PRS-ResourceList-r16 SEQUENCE (SIZE (1..nrMaxResourcesPerSet-r16)) OF NR-DL-PRS-Resource-r16 {	2 entries		
NR-DL-PRS-Resource-r16[1] SEQUENCE {		entry 1	
nr-DL-PRS-ResourceID-r16	0		
dl-PRS-SequenceID-r16	0		
dl-PRS-CombSizeN-AndReOffset-r16 CHOICE {			
n4-r16	0		
}			
dl-PRS-ResourceSlotOffset-r16	4		
dl-PRS-ResourceSymbolOffset-r16	0		
dl-PRS-QCL-Info-r16	Not present		
}			
NR-DL-PRS-Resource-r16[2] SEQUENCE {		entry 2	
nr-DL-PRS-ResourceID-r16	1		
dl-PRS-SequenceID-r16	0		
dl-PRS-CombSizeN-AndReOffset-r16 CHOICE {			
n4-r16	0		
}			

dl-PRS-ResourceSlotOffset-r16	4		
dl-PRS-ResourceSymbolOffset-r16	0		
dl-PRS-QCL-Info-r16	Not present		
}			
}			
}			
}			
}			

Table 17.2.3.4.3-8: LPP RequestLocationInformation

Derivation Path: 37.355 clause 6.2			
Information Element	Value/remark	Comment	Condition
LPP-Message ::= SEQUENCE {			
transactionID SEQUENCE {			
initiator	locationServer		
transactionNumber	1		
}			
endTransaction	FALSE		
sequenceNumber	Not present		
acknowledgement	Not present		
lpp-MessageBody CHOICE {			
c1 CHOICE {			
requestLocationInformation SEQUENCE {			
criticalExtensions CHOICE {			
c1 CHOICE {			
requestLocationInformation-r9 SEQUENCE {			
commonEsRequestLocationInformation SEQUENCE {			
locationInformationType	locationMeasurementsRequired		
triggeredReporting	Not present		
periodicalReporting	Not present		
additionalInformation	onlyReturnInformationRequested		
qos SEQUENCE {			
horizontalAccuracy	Not present		
verticalCoordinateRequest	FALSE		
verticalAccuracy	Not present		
responseTime SEQUENCE {			
time	See 17.2.3.5	Result of the response time calculation rounded up to the next second if response time <= 128s. Result of the response time calculation rounded up to the next multiple of ten seconds if response time > 128s.	
responseTimeEarlyFix-r12	Not present		Rel-12 onwards
unit-r15	Not present ten-seconds		Calculated response time >128s
}			
velocityRequest	FALSE		
}			
environment	Not present		
locationCoordinateTypes	Not present		

velocityTypes	Not present		
}			
a-gnss-RequestLocationInformation	Not present		
otdoa-RequestLocationInformation	Not present		
ecid-RequestLocationInformation	Not present		
epdu-RequestLocationInformation	Not Present		
sensor-RequestLocationInformation-r13	Not present		
tbs-RequestLocationInformation-r13	Not present		
wlan-RequestLocationInformation-r13	Not present		
bt-RequestLocationInformation-r13	Not present		
nr-ECID-RequestLocationInformation-r16	Not present		
nr-Multi-RTT-RequestLocationInformation-r16	Not present		
nr-DL-AoD-RequestLocationInformation-r16			
SEQUENCE {			
nr-AssistanceAvailability-r16	FALSE		
nr-DL-AoD-ReportConfig-r16 SEQUENCE {			
r16 maxDL-PRS-RSRP-MeasurementsPerTRP-	Not present		
r17 maxDL-PRS-RSRP-MeasurementsPerTRP-	Not present		
maxDL-PRS-RSRPP-MeasurementsPerTRP-r17	Present. Set depending on UE capabilities.		
nr-los-nlos-IndicatorRequest-r17	Not present		
reducedDL-PRS-ProcessingSamples-r17	requested		Sub-test 1
	Not present		Sub-test 2
lowerRxBearingSweepingFactor-FR2-r17	Not present		
}			
multiMeasInSameReport-r17			
}			
nr-DL-TDOA-RequestLocationInformation-r16	Not present		
}			
}			
}			
}			
}			
}			
}			

Table 17.2.3.4.3-9: LPP ProvideLocation Information

Derivation Path: 37.355 clause 6.5.12			
Information Element	Value/remark	Comment	Condition
LPP-Message ::= SEQUENCE {			
transactionID SEQUENCE {			
initiator	locationServer		
transactionNumber	1		
}			
endTransaction	TRUE		
sequenceNumber	(0..255)		
acknowledgement			
lpp-MessageBody CHOICE {			
c1 CHOICE {			
provideLocationInformation SEQUENCE {			
criticalExtensions CHOICE {			
c1 CHOICE {			
provideLocationInformation-r9 SEQUENCE {			
commonIEsProvideLocationInformation	Not present.		
a-gnss-ProvideLocationInformation	Not present		
otdoa-ProvideLocationInformation	Not present		
ecid-ProvideLocationInformation	Not present		
epdu-ProvideLocationInformation	Not present		
sensor-ProvideLocationInformation-r13	Not present		
tbs-ProvideLocationInformation-r13	Not present		
wlan-ProvideLocationInformation-r13	Not present		
bt-ProvideLocationInformation-r13	Not present		

	nr-ECID-ProvideLocationInformation-r16	Not present		
r16	nr-Multi-RTT-ProvideLocationInformation-	Not present		
	nr-DL-AoD-ProvideLocationInformation-r16			
	SEQUENCE {			
	nr-DL-AoD-			
	SignalMeasurementInformation-r16 SEQUENCE {			
	nr-DL-AoD-MeasList-r16 SEQUENCE			
	(SIZE(1..nrMaxTRPs-r16)) OF NR-DL-AoD-			
	MeasElement-r16 {			
	NR-DL-AoD-MeasElement-r16[1]		entry 1	
	SEQUENCE {			
	dl-PRS-ID-r16	INTEGER (0..255)		
	nr-PhysCellID-r16	Cell 1		
	nr-CellGlobalID-r16			
	nr-ARFCN-r16			
	nr-DL-PRS-ResourceID-r16			
	nr-DL-PRS-ResourceSetID-r16			
	nr-TimeStamp-r16			
	nr-DL-PRS-RSRP-Result-r16	Present. Any value acceptable.		
	nr-DL-PRS-RxBeamIndex-r16			
r16	nr-DL-AoD-AdditionalMeasurements-			
	nr-DL-PRS-FirstPathRSRP-Result-r17	Present. Any value acceptable.		
	nr-los-nlos-Indicator-r17			
	nr-DL-AoD-			
	AdditionalMeasurementsExt-r17			
	}			
	NR-DL-AoD-MeasElement-r16[2]		entry 2	
	SEQUENCE {			
	dl-PRS-ID-r16	INTEGER (0..255)		
	nr-PhysCellID-r16	Cell 2		
	nr-CellGlobalID-r16			
	nr-ARFCN-r16			
	nr-DL-PRS-ResourceID-r16			
	nr-DL-PRS-ResourceSetID-r16			
	nr-TimeStamp-r16			
	nr-DL-PRS-RSRP-Result-r16	Present. Any value acceptable.		
	nr-DL-PRS-RxBeamIndex-r16			
r16	nr-DL-AoD-AdditionalMeasurements-			
	nr-DL-PRS-FirstPathRSRP-Result-r17	Present. Any value acceptable.		
	nr-los-nlos-Indicator-r17			
	nr-DL-AoD-			
	AdditionalMeasurementsExt-r17			
	}			
	}			
	}			
	nr-dl-AoD-LocationInformation-r16			
	nr-DL-AoD-Error-r16	Not present		
r17	nr-DL-AoD-SignalMeasurementInstances-	Not present		
r17	nr-DL-AoD-LocationInformationInstances-	Not present		
	}			
	}			
	}			
	}			
	}			
	}			
	}			
	}			

17.2.3.5 Test requirement

FFS

17.2.4 PRS-RSRPP measurement reporting delay test case for single positioning frequency layer in FR2 SA

Editor's note: This test case is incomplete. The following aspect is either missing or TBD:

- Test tolerance are not added in and analysis is missing

17.2.4.1 Test purpose

The purpose of the test is to verify the PRS RSRPP measurement requirements specified in TS 38.133 [50] Clause 9.9.6.5 for single positioning frequency layer in FR2 SA under AWGN propagation conditions in standalone scenario.

17.2.4.2 Test applicability

This test applies to all types of NR UE release 17 onwards that supports DL-AoD positioning, maxDL-PRS-FirstPathRSRP-MeasPerTRP and supportedDL-PRS-ProcessingSamples.

17.2.4.3 Minimum conformance requirements

Same as clause 17.2.1.3.

17.2.4.4 Test description

17.2.4.4.1 Initial conditions

The supported test configuration is listed in Table 17.2.4.4-1.

Table 17.2.4.4-1: Test Configurations

Config	Description
1	120 kHz SSB SCS, 100 MHz bandwidth, TDD duplex mode

Test Environment: Normal, as defined in TS 38.508-1 [45] clause 4.1.

Frequencies to be tested: Mid Range, as defined in TS 38.508-1 [45] clause 4.3.1.

Channel bandwidth to be tested: are specified in Table 17.2.4.4-1.

1. Connect the SS and AWGN noise sources to the UE antenna connector or antenna connectors as shown in Annex A, Figure A.14.
2. The general test parameter settings are set up according to Table 17.2.4.5-1 and Table 17.2.4.5-2.
3. Propagation conditions are set according to clause 4.16.2.
4. Message contents are defined in clause 17.2.4.4.3.
5. In the test there are two synchronous cells: Cell 1 and Cell 2. Cell 1 is the reference as well as the PCell. Cell 2 is the neighbour cell. All cells are on the same RF channel distributed in single positioning frequency layer.

17.2.4.4.2 Test procedure

Same as clause 17.2.1.4.2.

17.2.4.4.3 Message contents

Table 17.2.4.4.3-1: RESET UE POSITIONING STORED INFORMATION

Derivation Path: 38.509 [44] clause 6.6			
Information Element	Value/remark	Comment	Condition
UE Positioning Technology	0 0 0 1 0 0 0	DL-AoD	

Table 17.2.4.4.3-2: LPP Request Capabilities

Information Element	Value/remark
nr-DL-AoD-RequestCapabilities-r16	TRUE

Table 17.2.4.4.3-3: LPP ProvideAssistanceData

Derivation Path: 37.355 clause 6.2			
Information Element	Value/remark	Comment	Condition
LPP-Message ::= SEQUENCE {			
transactionID SEQUENCE {			
initiator	locationServer		
transactionNumber	(0..255)		
}			
endTransaction	TRUE		
sequenceNumber	Not present		
acknowledgement	Not present		
lpp-MessageBody CHOICE {			
c1 CHOICE {			
provideAssistanceData SEQUENCE {			
criticalExtensions CHOICE {			
c1 CHOICE {			
provideAssistanceData-r9 SEQUENCE {			
commonEsProvideAssistanceData	Not present		
a-gnss-ProvideAssistanceData	Not present		
otdoa-ProvideAssistanceData	Not present		
epdu-Provide-AssistanceData	Not present		
sensor-ProvideAssistanceData-r15	Not present		
tbs-ProvideAssistanceData-r15	Not present		
wlan-ProvideAssistanceData-r15	Not present		
nr-Multi-RTT-ProvideAssistanceData-r16	Not present		
nr-DL-AoD-ProvideAssistanceData-r16			
SEQUENCE {			
nr-DL-PRS-AssistanceData-r16	As defined in Table 17.2.4.4.3-4		
nr-SelectedDL-PRS-IndexList-r16	Not present		
nr-PositionCalculationAssistance-r16			Depending on UE capabilities, i.e. support for UE-based DL-AoD
nr-TRP-LocationInfo-r16	As defined in TS 37.571-5 [20]		
nr-DL-PRS-BeamInfo-r16	Not present		
nr-RTD-Info-r16	Not present		
nr-TRP-BeamAntennaInfo-r17	Not present		
nr-DL-PRS-Expected-LOS-NLOS-Assistance-r17	Not present		
nr-DL-PRS-TRP-TEG-Info-r17	Not present		
}			
nr-DL-AoD-Error-r16	Not present		
nr-DL-PRS-BeamInfo-r17	Not present		
nr-On-Demand-DL-PRS-Configurations-r17	Not present		

}			
nr-DL-TDOA-ProvideAssistanceData-r16	Not present		
}			
}			
}			
}			
}			
}			

Table 17.2.4.4.3-4: NR-DL-PRS-AssistanceData

Derivation Path: 37.355 clause 6.4.3			
Information Element	Value/remark	Comment	Condition
NR-DL-PRS-AssistanceData-r16 ::= SEQUENCE {			
nr-DL-PRS-ReferenceInfo-r16 SEQUENCE {			
dl-PRS-ID-r16	0		
nr-DL-PRS-ResourceID-List-r16	Not present		
nr-DL-PRS-ResourceSetID-r16	Not present		
}			
nr-DL-PRS-AssistanceDataList-r16 SEQUENCE (SIZE (1..nrMaxFreqLayers-r16)) OF NR-DL-PRS-AssistanceDataPerFreq-r16 {	1 entry		
NR-DL-PRS-AssistanceDataPerFreq-r16[1] SEQUENCE {		entry 1	
nr-DL-PRS-PositioningFrequencyLayer-r16 SEQUENCE {			
dl-PRS-SubcarrierSpacing-r16	kHz120		
dl-PRS-ResourceBandwidth-r16	27	128 PRBs	
dl-PRS-StartPRB-r16	0		
dl-PRS-PointA-r16	absoluteFrequencyPointA as defined for the DL frequency of the Cell 1		
dl-PRS-CombSizeN-r16	n4		
dl-PRS-CyclicPrefix-r16	normal		
}			
nr-DL-PRS-AssistanceDataPerFreq-r16 SEQUENCE (SIZE (1..nrMaxTRPsPerFreq-r16)) OF NR-DL-PRS-AssistanceDataPerTRP-r16{	2 entries		
NR-DL-PRS-AssistanceDataPerTRP-r16[1] SEQUENCE {		entry 1	Cell 1
dl-PRS-ID-r16	0		
nr-PhysCellID-r16	Cell 1		
nr-CellGlobalID-r16	Cell 1		
nr-ARFCN-r16	Cell 1		
nr-DL-PRS-SFN0-Offset-r16 SEQUENCE {			
sfn-Offset-r16	0		
integerSubframeOffset-r16	0		
}			
nr-DL-PRS-ExpectedRSTD-r16	0		
nr-DL-PRS-ExpectedRSTD-Uncertainty-r16	0		
nr-DL-PRS-Info-r16	As specified in Table 17.2.4.4.3-5		
}			
NR-DL-PRS-AssistanceDataPerTRP-r16[2] SEQUENCE {		entry 2	Cell 2
dl-PRS-ID-r16	1		
nr-PhysCellID-r16	Cell 2		
nr-CellGlobalID-r16	Cell 2		
nr-ARFCN-r16	Cell 2		
nr-DL-PRS-SFN0-Offset-r16 SEQUENCE {			
sfn-Offset-r16	0		
integerSubframeOffset-r16	0		
}			
nr-DL-PRS-ExpectedRSTD-r16	23	About 3 μs	

nr-DL-PRS-ExpectedRSTD-Uncertainty-r16	154	About 5 μ s	
nr-DL-PRS-Info-r16	As specified in Table 17.2.4.4.3-5		
}			
}			
}			
}			
}			

Table 17.2.4.4.3-5: NR-DL-PRS-Info

Derivation Path: 37.355 clause 6.4.3			
Information Element	Value/remark	Comment	Condition
NR-DL-PRS-Info-r16 ::= SEQUENCE {			
nr-DL-PRS-ResourceSetList-r16 SEQUENCE (SIZE (1..nrMaxSetsPerTrp-r16)) OF NR-DL-PRS-ResourceSet-r16 {	1 entry		
NR-DL-PRS-ResourceSet-r16[1] SEQUENCE {		entry 1	
nr-DL-PRS-ResourceSetID-r16	0		
dl-PRS-Periodicity-and-ResourceSetSlotOffset-r16 CHOICE {			
scs120-r16 CHOICE {			
n1280-r16	80		
}			
dl-PRS-ResourceRepetitionFactor-r16	n2		
dl-PRS-ResourceTimeGap-r16	s1		
dl-PRS-NumSymbols-r16	n4		
dl-PRS-MutingOption1-r16 SEQUENCE {			
dl-prs-MutingBitRepetitionFactor-r16	Not present		
nr-option1-muting-r16 CHOICE {			
po2-r16	10		Cell 1
	01		Cell 2
}			
}			
dl-PRS-MutingOption2-r16	Not present		
dl-PRS-ResourcePower-r16	27		
dl-PRS-ResourceList-r16 SEQUENCE (SIZE (1..nrMaxResourcesPerSet-r16)) OF NR-DL-PRS-Resource-r16 {	2 entries		
NR-DL-PRS-Resource-r16[1] SEQUENCE {		entry 1	
nr-DL-PRS-ResourceID-r16	0		
dl-PRS-SequenceID-r16	0		
dl-PRS-CombSizeN-AndReOffset-r16 CHOICE {			
n4-r16	0		
}			
dl-PRS-ResourceSlotOffset-r16	4		
dl-PRS-ResourceSymbolOffset-r16	0		
dl-PRS-QCL-Info-r16	Not present		
}			
NR-DL-PRS-Resource-r16[2] SEQUENCE {		entry 2	
nr-DL-PRS-ResourceID-r16	2		
dl-PRS-SequenceID-r16	0		
dl-PRS-CombSizeN-AndReOffset-r16 CHOICE {			
n4-r16	1		
}			
dl-PRS-ResourceSlotOffset-r16	0		
dl-PRS-ResourceSymbolOffset-r16	0		
dl-PRS-QCL-Info-r16	Not present		
}			
}			
}			
}			
}			

Table 17.2.4.4.3-6: LPP RequestLocationInformation

Derivation Path: 37.355 clause 6.2			
Information Element	Value/remark	Comment	Condition
LPP-Message ::= SEQUENCE {			
transactionID SEQUENCE {			
initiator	locationServer		
transactionNumber	1		
}			
endTransaction	FALSE		
sequenceNumber	Not present		
acknowledgement	Not present		
lpp-MessageBody CHOICE {			
c1 CHOICE {			
requestLocationInformation SEQUENCE {			
criticalExtensions CHOICE {			
c1 CHOICE {			
requestLocationInformation-r9 SEQUENCE {			
commonEsRequestLocationInformation SEQUENCE {			
locationInformationType	locationMeasurementsRequired		
triggeredReporting	Not present		
periodicalReporting	Not present		
additionalInformation	onlyReturnInformationRequested		
qos SEQUENCE {			
horizontalAccuracy	Not present		
verticalCoordinateRequest	FALSE		
verticalAccuracy	Not present		
responseTime SEQUENCE {			
time	See 17.2.4.5	Result of the response time calculation rounded up to the next second if response time <= 128s. Result of the response time calculation rounded up to the next multiple of ten seconds if response time > 128s.	
responseTimeEarlyFix-r12	Not present		Rel-12 onwards
unit-r15	Not present ten-seconds		Calculated response time >128s
}			
velocityRequest	FALSE		
}			
environment	Not present		
locationCoordinateTypes	Not present		
velocityTypes	Not present		
}			
a-gnss-RequestLocationInformation	Not present		
otdoa-RequestLocationInformation	Not present		
ecid-RequestLocationInformation	Not present		
epdu-RequestLocationInformation	Not Present		
sensor-RequestLocationInformation-r13	Not present		
tbs-RequestLocationInformation-r13	Not present		
wlan-RequestLocationInformation-r13	Not present		
bt-RequestLocationInformation-r13	Not present		

nr-ECID-RequestLocationInformation-r16	Not present		
nr-Multi-RTT-RequestLocationInformation-r16	Not present		
nr-DL-AoD-RequestLocationInformation-r16 SEQUENCE {			
nr-AssistanceAvailability-r16	FALSE		
nr-DL-AoD-ReportConfig-r16 SEQUENCE {			
r16 maxDL-PRS-RSRP-MeasurementsPerTRP-	Not present		
r17 maxDL-PRS-RSRP-MeasurementsPerTRP-	Not present		
maxDL-PRS-RSRPP-MeasurementsPerTRP-r17	Present. Set depending on UE capabilities.		
nr-los-nlos-IndicatorRequest-r17	Not present		
reducedDL-PRS-ProcessingSamples-r17	Not present		
lowerRxBeamSweepingFactor-FR2-r17	Not present		
}			
multiMeasInSameReport-r17			
}			
nr-DL-TDOA-RequestLocationInformation-r16	Not present		
}			
}			
}			
}			
}			
}			
}			

Table 17.2.4.4.3-7: LPP ProvideLocation Information

Derivation Path: 37.355 clause 6.5.12			
Information Element	Value/remark	Comment	Condition
LPP-Message ::= SEQUENCE {			
transactionID SEQUENCE {			
initiator	locationServer		
transactionNumber	1		
}			
endTransaction	TRUE		
sequenceNumber	(0..255)		
acknowledgement			
lpp-MessageBody CHOICE {			
c1 CHOICE {			
provideLocationInformation SEQUENCE {			
criticalExtensions CHOICE {			
c1 CHOICE {			
provideLocationInformation-r9 SEQUENCE {			
commonIEsProvideLocationInformation	Not present.		
a-gnss-ProvideLocationInformation	Not present		
otdoa-ProvideLocationInformation	Not present		
ecid-ProvideLocationInformation	Not present		
epdu-ProvideLocationInformation	Not present		
sensor-ProvideLocationInformation-r13	Not present		
tbs-ProvideLocationInformation-r13	Not present		
wlan-ProvideLocationInformation-r13	Not present		
bt-ProvideLocationInformation-r13	Not present		
nr-ECID-ProvideLocationInformation-r16	Not present		
nr-Multi-RTT-ProvideLocationInformation-	Not present		
r16 nr-DL-AoD-ProvideLocationInformation-r16			
SEQUENCE {			
nr-DL-AoD-			
SignalMeasurementInformation-r16 SEQUENCE {			
nr-DL-AoD-MeasList-r16 SEQUENCE			
(SIZE(1..nrMaxTRPs-r16)) OF NR-DL-AoD-			
MeasElement-r16 {			
NR-DL-AoD-MeasElement-r16[1]		entry 1	
SEQUENCE {			

	dl-PRS-ID-r16	INTEGER (0..255)		
	nr-PhysCellID-r16	Cell 1		
	nr-CellGlobalID-r16			
	nr-ARFCN-r16			
	nr-DL-PRS-ResourceID-r16			
	nr-DL-PRS-ResourceSetID-r16			
	nr-TimeStamp-r16			
	nr-DL-PRS-RSRP-Result-r16	Present. Any value acceptable.		
	nr-DL-PRS-RxBeamIndex-r16			
r16	nr-DL-AoD-AdditionalMeasurements-			
	nr-DL-PRS-FirstPathRSRP-Result-r17	Present. Any value acceptable.		
	nr-los-nlos-Indicator-r17			
	nr-DL-AoD-AdditionalMeasurementsExt-r17			
	NR-DL-AoD-MeasElement-r16[2]		entry 2	
SEQUENCE {				
	dl-PRS-ID-r16	INTEGER (0..255)		
	nr-PhysCellID-r16	Cell 2		
	nr-CellGlobalID-r16			
	nr-ARFCN-r16			
	nr-DL-PRS-ResourceID-r16			
	nr-DL-PRS-ResourceSetID-r16			
	nr-TimeStamp-r16			
	nr-DL-PRS-RSRP-Result-r16	Present. Any value acceptable.		
	nr-DL-PRS-RxBeamIndex-r16			
r16	nr-DL-AoD-AdditionalMeasurements-			
	nr-DL-PRS-FirstPathRSRP-Result-r17	Present. Any value acceptable.		
	nr-los-nlos-Indicator-r17			
	nr-DL-AoD-AdditionalMeasurementsExt-r17			
	}			
	}			
	}			
	nr-dl-AoD-LocationInformation-r16			
	nr-DL-AoD-Error-r16	Not present		
r17	nr-DL-AoD-SignalMeasurementInstances-	Not present		
r17	nr-DL-AoD-LocationInformationInstances-	Not present		
	}			
	}			
	}			
	}			
	}			
	}			
	}			
	}			

17.2.4.5 Test requirement

FFS

17.2.5 PRS-RSRPP measurement reporting delay test case for single positioning frequency layer with reduced number of samples in FR2 SA

Editor's note: This test case is incomplete. The following aspect is either missing or TBD:

- Test tolerance are not added in and analysis is missing

17.2.5.1 Test purpose

The purpose of the test is to verify the PRS RSRPP measurement requirements for reduced number of samples specified in TS 38.133 [50] Clause 9.9.6.5 for single positioning frequency layer under AWGN propagation conditions in standalone scenario.

17.2.5.2 Test applicability

This test applies to all types of NR UE release 17 onwards that supports DL-AoD positioning, maxDL-PRS-FirstPathRSRP-MeasPerTRP and supportedDL-PRS-ProcessingSamples-RRC-CONNECTED.

17.2.5.3 Minimum conformance requirements

Same as clause 17.2.2.3.

17.2.5.4 Test description

17.2.5.4.1 Initial conditions

The supported test configuration is listed in Table 17.2.5.4-1.

Table 17.2.5.4-1: Test Configurations

Config	Description
1	120 kHz SSB SCS, 100 MHz bandwidth, TDD duplex mode

Test Environment: Normal, as defined in TS 38.508-1 [45] clause 4.1.

Frequencies to be tested: Mid Range, as defined in TS 38.508-1 [45] clause 4.3.1.

Channel bandwidth to be tested: are specified in Table 17.2.5.4-1.

1. Connect the SS and AWGN noise sources to the UE antenna connector or antenna connectors as shown in Annex A, Figure A.14.
2. The general test parameter settings are set up according to Table 17.2.5.5-1 and Table 17.2.5.5-2.
3. Propagation conditions are set according to clause 4.16.2.
4. Message contents are defined in clause 17.2.5.4.3.
5. In the test there are two synchronous cells: Cell 1 and Cell 2. Cell 1 is the reference as well as the PCell. Cell 2 is the neighbour cell. All cells are on the same RF channel distributed in single positioning frequency layer.

17.2.5.4.2 Test procedure

Same as clause 17.2.2.4.2.

17.2.5.4.3 Message contents

Table 17.2.5.4.3-1: RESET UE POSITIONING STORED INFORMATION

Derivation Path: 38.509 [44] clause 6.6			
Information Element	Value/remark	Comment	Condition
UE Positioning Technology	0 0 0 1 0 0 0	DL-AoD	

Table 17.2.5.4.3-2: LPP Request Capabilities

Information Element	Value/remark
nr-DL-AoD-RequestCapabilities-r16	TRUE

Table 17.2.5.4.3-3: LPP ProvideAssistanceData

Derivation Path: 37.355 clause 6.2			
Information Element	Value/remark	Comment	Condition
LPP-Message ::= SEQUENCE {			
transactionID SEQUENCE {			
initiator	locationServer		
transactionNumber	(0..255)		
}			
endTransaction	TRUE		
sequenceNumber	Not present		
acknowledgement	Not present		
lpp-MessageBody CHOICE {			
c1 CHOICE {			
provideAssistanceData SEQUENCE {			
criticalExtensions CHOICE {			
c1 CHOICE {			
provideAssistanceData-r9 SEQUENCE {			
commonEsProvideAssistanceData	Not present		
a-gnss-ProvideAssistanceData	Not present		
otdoa-ProvideAssistanceData	Not present		
epdu-Provide-AssistanceData	Not present		
sensor-ProvideAssistanceData-r15	Not present		
tbs-ProvideAssistanceData-r15	Not present		
wlan-ProvideAssistanceData-r15	Not present		
nr-Multi-RTT-ProvideAssistanceData-r16	Not present		
nr-DL-AoD-ProvideAssistanceData-r16			
SEQUENCE {			
nr-DL-PRS-AssistanceData-r16	As defined in Table 17.2.5.4.3-4		
nr-SelectedDL-PRS-IndexList-r16	Not present		
nr-PositionCalculationAssistance-r16			Depending on UE capabilities, i.e. support for UE-based DL-AoD
nr-TRP-LocationInfo-r16	As defined in TS 37.571-5 [20]		
nr-DL-PRS-BeamInfo-r16	Not present		
nr-RTD-Info-r16	Not present		
nr-TRP-BeamAntennaInfo-r17	Not present		
nr-DL-PRS-Expected-LOS-NLOS-Assistance-r17	Not present		
nr-DL-PRS-TRP-TEG-Info-r17	Not present		
}			
nr-DL-AoD-Error-r16	Not present		
nr-DL-PRS-BeamInfo-r17	Not present		
nr-On-Demand-DL-PRS-Configurations-r17	Not present		

}			
nr-DL-TDOA-ProvideAssistanceData-r16	Not present		
}			
}			
}			
}			
}			

Table 17.2.5.4.3-4: NR-DL-PRS-AssistanceData

Derivation Path: 37.355 clause 6.4.3			
Information Element	Value/remark	Comment	Condition
NR-DL-PRS-AssistanceData-r16 ::= SEQUENCE {			
nr-DL-PRS-ReferenceInfo-r16 SEQUENCE {			
dl-PRS-ID-r16	0		
nr-DL-PRS-ResourceID-List-r16	Not present		
nr-DL-PRS-ResourceSetID-r16	Not present		
}			
nr-DL-PRS-AssistanceDataList-r16 SEQUENCE (SIZE (1..nrMaxFreqLayers-r16)) OF NR-DL-PRS-AssistanceDataPerFreq-r16 {	1 entry		
NR-DL-PRS-AssistanceDataPerFreq-r16[1] SEQUENCE {		entry 1	
nr-DL-PRS-PositioningFrequencyLayer-r16 SEQUENCE {			
dl-PRS-SubcarrierSpacing-r16	kHz120		
dl-PRS-ResourceBandwidth-r16	27	128 PRBs	
dl-PRS-StartPRB-r16	0		
dl-PRS-PointA-r16	absoluteFrequencyPointA as defined for the DL frequency of the Cell 1		
dl-PRS-CombSizeN-r16	n4		
dl-PRS-CyclicPrefix-r16	normal		
}			
nr-DL-PRS-AssistanceDataPerFreq-r16 SEQUENCE (SIZE (1..nrMaxTRPsPerFreq-r16)) OF NR-DL-PRS-AssistanceDataPerTRP-r16{	2 entries		
NR-DL-PRS-AssistanceDataPerTRP-r16[1] SEQUENCE {		entry 1	Cell 1
dl-PRS-ID-r16	0		
nr-PhysCellID-r16	Cell 1		
nr-CellGlobalID-r16	Cell 1		
nr-ARFCN-r16	Cell 1		
nr-DL-PRS-SFN0-Offset-r16 SEQUENCE {			
sfn-Offset-r16	0		
integerSubframeOffset-r16	0		
}			
nr-DL-PRS-ExpectedRSTD-r16	0		
nr-DL-PRS-ExpectedRSTD-Uncertainty-r16	0		
nr-DL-PRS-Info-r16	As specified in Table 17.2.5.4.3-5		
}			
NR-DL-PRS-AssistanceDataPerTRP-r16[2] SEQUENCE {		entry 2	Cell 2
dl-PRS-ID-r16	1		
nr-PhysCellID-r16	Cell 2		
nr-CellGlobalID-r16	Cell 2		
nr-ARFCN-r16	Cell 2		
nr-DL-PRS-SFN0-Offset-r16 SEQUENCE {			
sfn-Offset-r16	0		
integerSubframeOffset-r16	0		
}			
nr-DL-PRS-ExpectedRSTD-r16	23	About 3 μs	

nr-DL-PRS-ExpectedRSTD-Uncertainty-r16	154	About 5 μ s	
nr-DL-PRS-Info-r16	As specified in Table 17.2.5.4.3-5		
}			
}			
}			
}			
}			

Table 17.2.5.4.3-5: NR-DL-PRS-Info

Derivation Path: 37.355 clause 6.4.3			
Information Element	Value/remark	Comment	Condition
NR-DL-PRS-Info-r16 ::= SEQUENCE {			
nr-DL-PRS-ResourceSetList-r16 SEQUENCE (SIZE (1..nrMaxSetsPerTrp-r16)) OF NR-DL-PRS-ResourceSet-r16 {	1 entry		
NR-DL-PRS-ResourceSet-r16[1] SEQUENCE {		entry 1	
nr-DL-PRS-ResourceSetID-r16	0		
dl-PRS-Periodicity-and-ResourceSetSlotOffset-r16 CHOICE {			
scs120-r16 CHOICE {			
n1280-r16	80		
}			
dl-PRS-ResourceRepetitionFactor-r16	n2		
dl-PRS-ResourceTimeGap-r16	s1		
dl-PRS-NumSymbols-r16	n4		
dl-PRS-MutingOption1-r16 SEQUENCE {			
dl-prs-MutingBitRepetitionFactor-r16	Not present		
nr-option1-muting-r16 CHOICE {			
po2-r16	10		Cell 1
	01		Cell 2
}			
}			
dl-PRS-MutingOption2-r16	Not present		
dl-PRS-ResourcePower-r16	27		
dl-PRS-ResourceList-r16 SEQUENCE (SIZE (1..nrMaxResourcesPerSet-r16)) OF NR-DL-PRS-Resource-r16 {	2 entries		
NR-DL-PRS-Resource-r16[1] SEQUENCE {		entry 1	
nr-DL-PRS-ResourceID-r16	0		
dl-PRS-SequenceID-r16	0		
dl-PRS-CombSizeN-AndReOffset-r16 CHOICE {			
n4-r16	0		
}			
dl-PRS-ResourceSlotOffset-r16	4		
dl-PRS-ResourceSymbolOffset-r16	0		
dl-PRS-QCL-Info-r16	Not present		
}			
NR-DL-PRS-Resource-r16[2] SEQUENCE {		entry 2	
nr-DL-PRS-ResourceID-r16	2		
dl-PRS-SequenceID-r16	0		
dl-PRS-CombSizeN-AndReOffset-r16 CHOICE {			
n4-r16	1		
}			
dl-PRS-ResourceSlotOffset-r16	0		
dl-PRS-ResourceSymbolOffset-r16	0		
dl-PRS-QCL-Info-r16	Not present		
}			
}			
}			
}			
}			

Table 17.2.5.4.3-6: LPP RequestLocationInformation

Derivation Path: 37.355 clause 6.2			
Information Element	Value/remark	Comment	Condition
LPP-Message ::= SEQUENCE {			
transactionID SEQUENCE {			
initiator	locationServer		
transactionNumber	1		
}			
endTransaction	FALSE		
sequenceNumber	Not present		
acknowledgement	Not present		
lpp-MessageBody CHOICE {			
c1 CHOICE {			
requestLocationInformation SEQUENCE {			
criticalExtensions CHOICE {			
c1 CHOICE {			
requestLocationInformation-r9 SEQUENCE {			
commonEsRequestLocationInformation SEQUENCE {			
locationInformationType	locationMeasurementsRequired		
triggeredReporting	Not present		
periodicalReporting	Not present		
additionalInformation	onlyReturnInformationRequested		
qos SEQUENCE {			
horizontalAccuracy	Not present		
verticalCoordinateRequest	FALSE		
verticalAccuracy	Not present		
responseTime SEQUENCE {			
time	See 17.2.5.5	Result of the response time calculation rounded up to the next second if response time <= 128s. Result of the response time calculation rounded up to the next multiple of ten seconds if response time > 128s.	
responseTimeEarlyFix-r12	Not present		Rel-12 onwards
unit-r15	Not present ten-seconds		Calculated response time >128s
}			
velocityRequest	FALSE		
}			
environment	Not present		
locationCoordinateTypes	Not present		
velocityTypes	Not present		
}			
a-gnss-RequestLocationInformation	Not present		
otdoa-RequestLocationInformation	Not present		
ecid-RequestLocationInformation	Not present		
epdu-RequestLocationInformation	Not Present		
sensor-RequestLocationInformation-r13	Not present		
tbs-RequestLocationInformation-r13	Not present		
wlan-RequestLocationInformation-r13	Not present		
bt-RequestLocationInformation-r13	Not present		

nr-ECID-RequestLocationInformation-r16	Not present		
nr-Multi-RTT-RequestLocationInformation-r16	Not present		
nr-DL-AoD-RequestLocationInformation-r16 SEQUENCE {			
nr-AssistanceAvailability-r16	FALSE		
nr-DL-AoD-ReportConfig-r16 SEQUENCE {			
r16 maxDL-PRS-RSRP-MeasurementsPerTRP-	Not present		
r17 maxDL-PRS-RSRP-MeasurementsPerTRP-	Not present		
maxDL-PRS-RSRPP-MeasurementsPerTRP-r17	Present. Set depending on UE capabilities.		
nr-los-nlos-IndicatorRequest-r17	Not present		
reducedDL-PRS-ProcessingSamples-r17	requested		
lowerRxBeamSweepingFactor-FR2-r17	Not present		
}			
multiMeasInSameReport-r17			
}			
nr-DL-TDOA-RequestLocationInformation-r16	Not present		
}			
}			
}			
}			
}			
}			

Table 17.2.5.4.3-7: LPP ProvideLocation Information

Derivation Path: 37.355 clause 6.5.12			
Information Element	Value/remark	Comment	Condition
LPP-Message ::= SEQUENCE {			
transactionID SEQUENCE {			
initiator	locationServer		
transactionNumber	1		
}			
endTransaction	TRUE		
sequenceNumber	(0..255)		
acknowledgement			
lpp-MessageBody CHOICE {			
c1 CHOICE {			
provideLocationInformation SEQUENCE {			
criticalExtensions CHOICE {			
c1 CHOICE {			
provideLocationInformation-r9 SEQUENCE {			
commonIEsProvideLocationInformation	Not present.		
a-gnss-ProvideLocationInformation	Not present		
otdoa-ProvideLocationInformation	Not present		
ecid-ProvideLocationInformation	Not present		
epdu-ProvideLocationInformation	Not present		
sensor-ProvideLocationInformation-r13	Not present		
tbs-ProvideLocationInformation-r13	Not present		
wlan-ProvideLocationInformation-r13	Not present		
bt-ProvideLocationInformation-r13	Not present		
nr-ECID-ProvideLocationInformation-r16	Not present		
nr-Multi-RTT-ProvideLocationInformation-	Not present		
r16 nr-DL-AoD-ProvideLocationInformation-r16			
SEQUENCE {			
nr-DL-AoD-			
SignalMeasurementInformation-r16 SEQUENCE {			
nr-DL-AoD-MeasList-r16 SEQUENCE			
(SIZE(1..nrMaxTRPs-r16)) OF NR-DL-AoD-			
MeasElement-r16 {			
NR-DL-AoD-MeasElement-r16[1]		entry 1	
SEQUENCE {			

	dl-PRS-ID-r16	INTEGER (0..255)		
	nr-PhysCellID-r16	Cell 1		
	nr-CellGlobalID-r16			
	nr-ARFCN-r16			
	nr-DL-PRS-ResourceID-r16			
	nr-DL-PRS-ResourceSetID-r16			
	nr-TimeStamp-r16			
	nr-DL-PRS-RSRP-Result-r16	Present. Any value acceptable.		
	nr-DL-PRS-RxBeamIndex-r16			
r16	nr-DL-AoD-AdditionalMeasurements-			
	nr-DL-PRS-FirstPathRSRP-Result-r17	Present. Any value acceptable.		
	nr-los-nlos-Indicator-r17			
	nr-DL-AoD-AdditionalMeasurementsExt-r17			
	} NR-DL-AoD-MeasElement-r16[2]		entry 2	
SEQUENCE {				
	dl-PRS-ID-r16	INTEGER (0..255)		
	nr-PhysCellID-r16	Cell 2		
	nr-CellGlobalID-r16			
	nr-ARFCN-r16			
	nr-DL-PRS-ResourceID-r16			
	nr-DL-PRS-ResourceSetID-r16			
	nr-TimeStamp-r16			
	nr-DL-PRS-RSRP-Result-r16	Present. Any value acceptable.		
	nr-DL-PRS-RxBeamIndex-r16			
r16	nr-DL-AoD-AdditionalMeasurements-			
	nr-DL-PRS-FirstPathRSRP-Result-r17	Present. Any value acceptable.		
	nr-los-nlos-Indicator-r17			
	nr-DL-AoD-AdditionalMeasurementsExt-r17			
	}			
	}			
	}			
	nr-dl-AoD-LocationInformation-r16			
	nr-DL-AoD-Error-r16	Not present		
r17	nr-DL-AoD-SignalMeasurementInstances-	Not present		
r17	nr-DL-AoD-LocationInformationInstances-	Not present		
	}			
	}			
	}			
	}			
	}			
	}			
	}			
	}			

17.2.5.5 Test requirement

FFS

17.2.6 PRS-RSRPP measurement reporting delay test case for single positioning frequency layer without measurement gap in FR2 SA

Editor’s note: This test case is incomplete. The following aspect is either missing or TBD:

- Test tolerance are not added in and analysis is missing

17.2.6.1 Test purpose

The purpose of the test is to verify the PRS RSRPP measurement outside MG requirements specified in TS 38.133 [50] Clause 9.9.6.6 for single positioning frequency layer under AWGN propagation conditions in FR2 in standalone scenario.

17.2.6.2 Test applicability

This test applies to all types of NR UE release 17 onwards that supports DL-AoD positioning, maxDL-PRS-FirstPathRSRP-MeasPerTRP and prs-Processing Window..

17.2.6.3 Minimum conformance requirements

Same as clause 17.2.3.3.

17.2.6.4 Test description

17.2.6.4.1 Initial conditions

The supported test configuration is listed in Table 17.2.6.4-1.

Table 17.2.6.4-1: Test Configurations

Config	Description
1	120 kHz SSB SCS, 100 MHz bandwidth, TDD duplex mode

Test Environment: Normal, as defined in TS 38.508-1 [45] clause 4.1.

Frequencies to be tested: Mid Range, as defined in TS 38.508-1 [45] clause 4.3.1.

Channel bandwidth to be tested: are specified in Table 17.2.6.4-1.

1. Connect the SS and AWGN noise sources to the UE antenna connector or antenna connectors as shown in Annex A, Figure A.14.
2. The general test parameter settings are set up according to Table 17.2.6.5-1 and Table 17.2.6.5-2.
3. Propagation conditions are set according to clause 4.16.2.
4. Message contents are defined in clause 17.2.6.4.3.
5. In the test there are two synchronous cells: Cell 1 and Cell 2. Cell 1 is the reference as well as the PCell. Cell 2 is the neighbour cell. All cells are on the same RF channel distributed in single positioning frequency layer.

17.2.6.4.2 Test procedure

Same as clause 17.2.3.4.2.

17.2.6.4.3 Message contents

Table 17.2.6.4.3-1: RESET UE POSITIONING STORED INFORMATION

Derivation Path: 38.509 [44] clause 6.6			
Information Element	Value/remark	Comment	Condition
UE Positioning Technology	0 0 0 1 0 0 0	DL-AoD	

Table 17.2.6.4.3-2: LPP Request Capabilities

Information Element	Value/remark
nr-DL-AoD-RequestCapabilities-r16	TRUE

Table 17.2.6.4.3-3: LPP ProvideAssistanceData

Derivation Path: 37.355 clause 6.2			
Information Element	Value/remark	Comment	Condition
LPP-Message ::= SEQUENCE {			
transactionID SEQUENCE {			
initiator	locationServer		
transactionNumber	(0..255)		
}			
endTransaction	TRUE		
sequenceNumber	Not present		
acknowledgement	Not present		
lpp-MessageBody CHOICE {			
c1 CHOICE {			
provideAssistanceData SEQUENCE {			
criticalExtensions CHOICE {			
c1 CHOICE {			
provideAssistanceData-r9 SEQUENCE {			
commonEsProvideAssistanceData	Not present		
a-gnss-ProvideAssistanceData	Not present		
otdoa-ProvideAssistanceData	Not present		
epdu-Provide-AssistanceData	Not present		
sensor-ProvideAssistanceData-r15	Not present		
tbs-ProvideAssistanceData-r15	Not present		
wlan-ProvideAssistanceData-r15	Not present		
nr-Multi-RTT-ProvideAssistanceData-r16	Not present		
nr-DL-AoD-ProvideAssistanceData-r16			
SEQUENCE {			
nr-DL-PRS-AssistanceData-r16	As defined in Table 17.2.6.4.3-4		
nr-SelectedDL-PRS-IndexList-r16	Not present		
nr-PositionCalculationAssistance-r16			Depending on UE capabilities, i.e. support for UE-based DL-AoD
SEQUENCE {			
nr-TRP-LocationInfo-r16	As defined in TS 37.571-5 [20]		
nr-DL-PRS-BeamInfo-r16	Not present		
nr-RTD-Info-r16	Not present		
nr-TRP-BeamAntennaInfo-r17	Not present		
nr-DL-PRS-Expected-LOS-NLOS-Assistance-r17	Not present		
nr-DL-PRS-TRP-TEG-Info-r17	Not present		
}			
nr-DL-AoD-Error-r16	Not present		
nr-DL-PRS-BeamInfo-r17	Not present		
nr-On-Demand-DL-PRS-Configurations-r17	Not present		
}			
nr-DL-TDOA-ProvideAssistanceData-r16	Not present		
}			
}			
}			
}			

Table 17.2.6.4.3-4: NR-DL-PRS-AssistanceData

Derivation Path: 37.355 clause 6.4.3			
Information Element	Value/remark	Comment	Condition
NR-DL-PRS-AssistanceData-r16 ::= SEQUENCE {			
nr-DL-PRS-ReferenceInfo-r16 SEQUENCE {			
dl-PRS-ID-r16	0		
nr-DL-PRS-ResourceID-List-r16	Not present		
nr-DL-PRS-ResourceSetID-r16	Not present		
}			
nr-DL-PRS-AssistanceDataList-r16 SEQUENCE (SIZE (1..nrMaxFreqLayers-r16)) OF NR-DL-PRS-AssistanceDataPerFreq-r16 {	1 entry		
NR-DL-PRS-AssistanceDataPerFreq-r16[1] SEQUENCE {		entry 1	
nr-DL-PRS-PositioningFrequencyLayer-r16 SEQUENCE {			
dl-PRS-SubcarrierSpacing-r16	kHz120		
dl-PRS-ResourceBandwidth-r16	27	128 PRBs	Sub-test 1
	7	48 PRBs	Sub-test 2
dl-PRS-StartPRB-r16	0		
dl-PRS-PointA-r16	absoluteFrequencyPointA as defined for the DL frequency of the Cell 1		
dl-PRS-CombSizeN-r16	n4		
dl-PRS-CyclicPrefix-r16	normal		
}			
nr-DL-PRS-AssistanceDataPerFreq-r16 SEQUENCE (SIZE (1..nrMaxTRPsPerFreq-r16)) OF NR-DL-PRS-AssistanceDataPerTRP-r16{	2 entries		
NR-DL-PRS-AssistanceDataPerTRP-r16[1] SEQUENCE {		entry 1	Cell 1
dl-PRS-ID-r16	0		
nr-PhysCellID-r16	Cell 1		
nr-CellGlobalID-r16	Cell 1		
nr-ARFCN-r16	Cell 1		
nr-DL-PRS-SFN0-Offset-r16 SEQUENCE {			
sfn-Offset-r16	0		
integerSubframeOffset-r16	0		
}			
nr-DL-PRS-ExpectedRSTD-r16	0		
nr-DL-PRS-ExpectedRSTD-Uncertainty-r16	0		
nr-DL-PRS-Info-r16	As specified in Table 17.2.6.4.3-5		
}			
NR-DL-PRS-AssistanceDataPerTRP-r16[2] SEQUENCE {		entry 2	Cell 2
dl-PRS-ID-r16	1		
nr-PhysCellID-r16	Cell 2		
nr-CellGlobalID-r16	Cell 2		
nr-ARFCN-r16	Cell 2		
nr-DL-PRS-SFN0-Offset-r16 SEQUENCE {			
sfn-Offset-r16	0		
integerSubframeOffset-r16	0		
}			
nr-DL-PRS-ExpectedRSTD-r16	0	About 0 μs	
nr-DL-PRS-ExpectedRSTD-Uncertainty-r16	17	About 0.58 μs	
nr-DL-PRS-Info-r16	As specified in Table 17.2.6.4.3-5		
}			
}			
}			
}			
}			

Table 17.2.6.4.3-5: NR-DL-PRS-Info

Derivation Path: 37.355 clause 6.4.3			
Information Element	Value/remark	Comment	Condition
NR-DL-PRS-Info-r16 ::= SEQUENCE {			
nr-DL-PRS-ResourceSetList-r16 SEQUENCE (SIZE (1..nrMaxSetsPerTrp-r16)) OF NR-DL-PRS-ResourceSet-r16 {	1 entry		
NR-DL-PRS-ResourceSet-r16[1] SEQUENCE {		entry 1	
nr-DL-PRS-ResourceSetID-r16	0		
dl-PRS-Periodicity-and-ResourceSetSlotOffset-r16 CHOICE {			
scs120-r16 CHOICE {			
n1280-r16	80		
}			
dl-PRS-ResourceRepetitionFactor-r16	n2		
dl-PRS-ResourceTimeGap-r16	s1		
dl-PRS-NumSymbols-r16	n4		
dl-PRS-MutingOption1-r16 SEQUENCE {			
dl-prs-MutingBitRepetitionFactor-r16	Not present		
nr-option1-muting-r16 CHOICE {			
po2-r16	10		Cell 1
	01		Cell 2
}			
dl-PRS-MutingOption2-r16	Not present		
dl-PRS-ResourcePower-r16	27		
dl-PRS-ResourceList-r16 SEQUENCE (SIZE (1..nrMaxResourcesPerSet-r16)) OF NR-DL-PRS-Resource-r16 {	2 entries		
NR-DL-PRS-Resource-r16[1] SEQUENCE {		entry 1	
nr-DL-PRS-ResourceID-r16	0		
dl-PRS-SequenceID-r16	0		
dl-PRS-CombSizeN-AndReOffset-r16 CHOICE {			
n4-r16	0		
}			
dl-PRS-ResourceSlotOffset-r16	4		
dl-PRS-ResourceSymbolOffset-r16	0		
dl-PRS-QCL-Info-r16	Not present		
}			
NR-DL-PRS-Resource-r16[2] SEQUENCE {		entry 2	
nr-DL-PRS-ResourceID-r16	2		
dl-PRS-SequenceID-r16	0		
dl-PRS-CombSizeN-AndReOffset-r16 CHOICE {			
n4-r16	1		
}			
dl-PRS-ResourceSlotOffset-r16	0		
dl-PRS-ResourceSymbolOffset-r16	0		
dl-PRS-QCL-Info-r16	Not present		
}			
}			
}			
}			
}			

Table 17.2.6.4.3-6: LPP RequestLocationInformation

Derivation Path: 37.355 clause 6.2			
Information Element	Value/remark	Comment	Condition
LPP-Message ::= SEQUENCE {			
transactionID SEQUENCE {			
initiator	locationServer		
transactionNumber	1		
}			
endTransaction	FALSE		

sequenceNumber	Not present		
acknowledgement	Not present		
lpp-MessageBody CHOICE {			
c1 CHOICE {			
requestLocationInformation SEQUENCE {			
criticalExtensions CHOICE {			
c1 CHOICE {			
requestLocationInformation-r9 SEQUENCE {			
commonEsRequestLocationInformation SEQUENCE {			
locationInformationType	locationMeasurementsRequired		
triggeredReporting	Not present		
periodicalReporting	Not present		
additionalInformation	onlyReturnInformationRequested		
qos SEQUENCE {			
horizontalAccuracy	Not present		
verticalCoordinateRequest	FALSE		
verticalAccuracy	Not present		
responseTime SEQUENCE {			
time	See 17.2.6.5	Result of the response time calculation rounded up to the next second if response time <= 128s. Result of the response time calculation rounded up to the next multiple of ten seconds if response time > 128s.	
responseTimeEarlyFix-r12	Not present		Rel-12 onwards
unit-r15	Not present ten-seconds		Calculated response time >128s
}			
velocityRequest	FALSE		
}			
environment	Not present		
locationCoordinateTypes	Not present		
velocityTypes	Not present		
}			
a-gnss-RequestLocationInformation	Not present		
otdoa-RequestLocationInformation	Not present		
ecid-RequestLocationInformation	Not present		
epdu-RequestLocationInformation	Not Present		
sensor-RequestLocationInformation-r13	Not present		
tbs-RequestLocationInformation-r13	Not present		
wlan-RequestLocationInformation-r13	Not present		
bt-RequestLocationInformation-r13	Not present		
nr-ECID-RequestLocationInformation-r16	Not present		
nr-Multi-RTT-RequestLocationInformation-r16	Not present		
nr-DL-AoD-RequestLocationInformation-r16			
SEQUENCE {			
nr-AssistanceAvailability-r16	FALSE		
nr-DL-AoD-ReportConfig-r16 SEQUENCE {			
maxDL-PRS-RSRP-MeasurementsPerTRP-r16	Not present		
maxDL-PRS-RSRP-MeasurementsPerTRP-r17	Not present		

maxDL-PRS-RSRPP-MeasurementsPerTRP-r17	Present. Set depending on UE capabilities.		
nr-los-nlos-IndicatorRequest-r17	Not present		
reducedDL-PRS-ProcessingSamples-r17	Not present requested		Sub-test 1 Sub-test 2
lowerRxBearingSweepingFactor-FR2-r17	Not present		
}			
multiMeasInSameReport-r17			
}			
nr-DL-TDOA-RequestLocationInformation-r16	Not present		
}			
}			
}			
}			
}			
}			

Table 17.2.6.4.3-7: LPP ProvideLocation Information

Derivation Path: 37.355 clause 6.5.12			
Information Element	Value/remark	Comment	Condition
LPP-Message ::= SEQUENCE {			
transactionID SEQUENCE {			
initiator	locationServer		
transactionNumber	1		
}			
endTransaction	TRUE		
sequenceNumber	(0..255)		
acknowledgement			
lpp-MessageBody CHOICE {			
c1 CHOICE {			
provideLocationInformation SEQUENCE {			
criticalExtensions CHOICE {			
c1 CHOICE {			
provideLocationInformation-r9 SEQUENCE {			
commonIEsProvideLocationInformation	Not present.		
a-gnss-ProvideLocationInformation	Not present		
otdoa-ProvideLocationInformation	Not present		
ecid-ProvideLocationInformation	Not present		
epdu-ProvideLocationInformation	Not present		
sensor-ProvideLocationInformation-r13	Not present		
tbs-ProvideLocationInformation-r13	Not present		
wlan-ProvideLocationInformation-r13	Not present		
bt-ProvideLocationInformation-r13	Not present		
nr-ECID-ProvideLocationInformation-r16	Not present		
nr-Multi-RTT-ProvideLocationInformation-r16	Not present		
nr-DL-AoD-ProvideLocationInformation-r16 SEQUENCE {			
nr-DL-AoD-SignalMeasurementInformation-r16 SEQUENCE {			
nr-DL-AoD-MeasList-r16 SEQUENCE (SIZE(1..nrMaxTRPs-r16)) OF NR-DL-AoD-MeasElement-r16 {			
NR-DL-AoD-MeasElement-r16[1] SEQUENCE {		entry 1	
dl-PRS-ID-r16	INTEGER (0..255)		
nr-PhysCellID-r16	Cell 1		
nr-CellGlobalID-r16			
nr-ARFCN-r16			
nr-DL-PRS-ResourceID-r16			
nr-DL-PRS-ResourceSetID-r16			
nr-TimeStamp-r16			
nr-DL-PRS-RSRP-Result-r16	Present. Any value acceptable.		

	nr-DL-PRS-RxBeamIndex-r16			
r16	nr-DL-AoD-AdditionalMeasurements-			
	nr-DL-PRS-FirstPathRSRP-Result-r17	Present. Any value acceptable.		
	nr-los-nlos-Indicator-r17			
	nr-DL-AoD-AdditionalMeasurementsExt-r17			
	} NR-DL-AoD-MeasElement-r16[2]		entry 2	
SEQUENCE {				
	dl-PRS-ID-r16	INTEGER (0..255)		
	nr-PhysCellID-r16	Cell 2		
	nr-CellGlobalID-r16			
	nr-ARFCN-r16			
	nr-DL-PRS-ResourceID-r16			
	nr-DL-PRS-ResourceSetID-r16			
	nr-TimeStamp-r16			
	nr-DL-PRS-RSRP-Result-r16	Present. Any value acceptable.		
	nr-DL-PRS-RxBeamIndex-r16			
r16	nr-DL-AoD-AdditionalMeasurements-			
	nr-DL-PRS-FirstPathRSRP-Result-r17	Present. Any value acceptable.		
	nr-los-nlos-Indicator-r17			
	nr-DL-AoD-AdditionalMeasurementsExt-r17			
	}			
	}			
	}			
	nr-dl-AoD-LocationInformation-r16			
	nr-DL-AoD-Error-r16	Not present		
r17	nr-DL-AoD-SignalMeasurementInstances-	Not present		
r17	nr-DL-AoD-LocationInformationInstances-	Not present		
	}			
	}			
	}			
	}			
	}			
	}			
	}			
	}			

17.2.6.5 Test requirement

FFS

17.3 NR PRS-RSRPP measurement accuracy test case in RRC_CONNECTED

17.3.1 PRS-RSRPP measurement accuracy test case for single positioning frequency layer in FR1 SA

Editor’s note: This test case is incomplete. The following aspect is either missing or TBD:

- Test tolerance are not added in and analysis is missing
- Some values are in square brackets

17.3.1.1 Test purpose

The purpose of the test is to verify that the PRS-RSRPP measurement meets the accuracy requirements specified in TS 38.133 [50] clause 10.1.38.2 in an environment with two-tap channel conditions.

17.3.1.2 Test applicability

This test applies to all types of NR UE release 17 onwards that supports DL-AoD positioning and maxDL-PRS-FirstPathRSRP-MeasPerTRP.

17.3.1.3 Minimum conformance requirements

The absolute accuracy requirements for PRS-RSRPP measurement for FR1 defined in Table 10.1.38.2.1-1 and Table 10.1.38.2.1-3 are valid under the following conditions:

- Conditions defined in 38.101-1 Clause 7.3 for reference sensitivity are fulfilled.
- PRP 1,2_{dBm} according to Annex B.2.14 for a corresponding Band

...

Table 10.1.38.2.1-1: PRS-RSRPP absolute accuracy for FR1

Accuracy		Conditions							
Normal condition	Extreme condition	PRS \bar{E}_s/lot	PRS BW	Repetition factor ($T_{\text{rep}}^{\text{PRS}} * L_{\text{PRS}} / K_{\text{comb}}^{\text{PRS}}$)	NR operating band groups Note 8	I_o Note 7 range			Maximum I_o
						Minimum I_o Note 1 dBm / SCS _{PRS}			
dB	dB	dB	PRB	-		dBm / SCS _{PRS}			dBm/BW _{Channel}
						dBm/15k Hz Note 6	dBm/30k Hz Note 6	dBm/60kHz Note 6	
±[4.1]	±[8.6]	≥-3	≥24	All	NR_FDD_FR1_A, NR_TDD_FR1_A, NR_SDL_FR1_A	-127	-124	-121	-50
					NR_FDD_FR1_B, NR_TDD_FR1_C	-126.5	-123.5	-120.5	-50
					NR_FDD_FR1_D, NR_TDD_FR1_D	-126	-123	-120	-50
					NR_FDD_FR1_E, NR_TDD_FR1_E	-125.5	-122.5	-119.5	-50
					NR_FDD_FR1_F, NR_TDD_FR1_F	-125	-122	-119	-50
					NR_FDD_FR1_G, NR_TDD_FR1_G	-124.5	-121.5	-118.5	-50
					NR_FDD_FR1_H, NR_TDD_FR1_H	-124	-121	-118	-50
					NR_FDD_FR1_H, NR_TDD_FR1_H	-123.5	-120.5	-117.5	-50
					Note 4				
Note 4									
±[5.8]	±[10.3]	≥-13	24 ≤ BW ≤ 52	All	Note 4				
±[4.9]	±[9.4]		BW > 52	All	Note 4				

NOTE 1: This minimum I_o condition is expressed as the average I_o per RE over all REs in an OFDM symbol.
NOTE 2: Void.

NOTE 3:	PRS bandwidth is as indicated in <i>prs-Bandwidth</i> in the DL-TDOA or DL-AoD assistance data defined in [34].
NOTE 4:	The same bands and the same <i>lo</i> conditions for each band apply for this requirement as for the corresponding requirement with the PRS bandwidth ≥ 24 RB.
NOTE 5:	The serving cell, the reference cell, and the measured neighbour cell <i>i</i> are on the same carrier frequency.
NOTE 6:	The condition level is increased by $\Delta > 0$, when applicable, as described in Sections B.3.2 and B.3.3.
NOTE 7:	The <i>lo</i> is defined in PRS positioning subframes. The same <i>lo</i> range applies to PRS and non-PRS symbols. <i>lo</i> levels are different in PRS and non-PRS symbols within the same subframe.
NOTE 8:	NR operating band groups are as defined in Section 3.5.2.

17.3.1.4 Test description

17.3.1.4.1 Initial conditions

The test is defined with three possible Test Configurations. In the case that the UE supports more than one of these Test Configurations, then the UE is only required to be tested in one of the Test Configurations, chosen by the UE. The defined Test Configurations are specified in Table 17.3.1.4.1-1.

Table 17.3.1.4.1-1: Test Configurations

Configuration	Description
1	15 kHz SSB SCS, 10 MHz bandwidth, FDD duplex mode
2	15 kHz SSB SCS, 10 MHz bandwidth, TDD duplex mode
3	30 kHz SSB SCS, 40 MHz bandwidth, TDD duplex mode

Test Environment: Normal, as defined in TS 38.508-1 [45] clause 4.1.

Frequencies to be tested: Mid Range, as defined in TS 38.508-1 [45] clause 4.3.1.

Channel bandwidth to be tested: are specified in Table 17.3.1.4-1.

1. Connect the SS and AWGN noise sources to the UE antenna connector or antenna connectors as shown in Annex A, Figure A.13.
2. The general test parameter settings are set up according to Table 17.3.1.5-1 and Table 17.3.1.5-2.
3. Propagation conditions are set according to clause 4.16.2.
4. Message contents are defined in clause 17.3.1.4.3.
5. In the test there are two synchronous cells: Cell 1 and Cell 2. Cell 1 is the reference as well as the PCell. Cell 2 is the neighbour cell. All cells are on the same RF channel distributed in single positioning frequency layer.

17.3.1.4.2 Test procedure

The test consists of a set-up period and a measurement period. Cell 1 and Cell 2 are both active during the complete test. The beginning of the measurement period shall be aligned with the first PRS positioning subframe of a positioning occasion in the reference cell. The test consists of two sub-tests; the difference between the sub-tests is the PRS configuration.

The NR-DL-AoD-RequestLocationInformation message and NR-DL-AoD-ProvideAssistanceData message as defined in TS 37.355 shall be provided to the UE during T1. The last slot containing the two messages for the assistance data and location information request is denoted as #n. The beginning of the time interval T2 shall be aligned with the beginning of the first MG instance containing the PRS resources that is ΔT after slot #n, where $\Delta T = 50$ ms is the maximum processing time of the assistance data and location information request

1. Ensure the UE is in State RRC_CONNECTED with generic procedure parameters Connectivity NR, Connected without release On, according to TS 38.508-1 [45] clause 4.5.
2. The SS shall send a RESET UE POSITIONING STORED INFORMATION message.
3. Set the parameters according to Table 17.3.1.5-1 as appropriate. Propagation conditions are set according to clause 4.16.2.

4. The SS shall send an LPP REQUEST CAPABILITIES message.
5. The UE shall transmit an LPP PROVIDE CAPABILITIES message indicating the DL-AoD capabilities supported by the UE in the NR-DL-AoD-ProvideCapabilities IE.
6. The SS shall send a LPP PROVIDE ASSISTANCE DATA message, including the nr-DL-AoD-ProvideAssistanceData-r16 IE. If the UE message at step 6 includes the ackRequested IE set to TRUE, then the SS shall send an acknowledgment in the LPP PROVIDE ASSISTANCE DATA message.
7. The SS shall send a LPP REQUEST LOCATION INFORMATION message, including the nr-DL-AoD-RequestLocationInformation-r16 such that the UE receives the message ΔT ms before the start of the measurement period, where $\Delta T = 50$ ms.
8. The UE shall transmit a LPP PROVIDE LOCATION INFORMATION message, including the nr-DL-AoD-ProvideLocationInformation-r16 IE.
9. If the UE message at step 8 includes the *ackRequested* IE set to TRUE, the SS shall send a LPP acknowledgement message.
10. The SS shall check the nr-DL-PRS-FirstPathRSRP-ResultDiff-r17 field for Cell 2 in the nr-DL-AoD-SignalMeasurementInformation-r16 according to Table 17.3.1.5-2.
11. Repeat step 2-10 until the confidence level according to Annex D is achieved.
12. Repeat step 1-11 for the other sub-test defined in Table 17.3.1.4-1 as appropriate.

If all (applicable) sub-tests pass, the whole test passes. If one (applicable) sub-test fails, the whole test fails.

17.3.1.4.3 Message contents

Table 17.3.1.4.3-1: RESET UE POSITIONING STORED INFORMATION

Derivation Path: 38.509 [44] clause 6.6			
Information Element	Value/remark	Comment	Condition
UE Positioning Technology	0 0 0 1 0 0 0	DL-AoD	

Table 17.3.1.4.3-2: LPP Request Capabilities

Information Element	Value/remark
nr-DL-AoD-RequestCapabilities-r16	TRUE

Table 17.3.1.4.3-3: LPP ProvideAssistanceData

Derivation Path: 37.355 clause 6.2			
Information Element	Value/remark	Comment	Condition
LPP-Message ::= SEQUENCE {			
transactionID SEQUENCE {			
initiator	locationServer		
transactionNumber	(0..255)		
}			
endTransaction	TRUE		
sequenceNumber	Not present		
acknowledgement	Not present		
lpp-MessageBody CHOICE {			
c1 CHOICE {			
provideAssistanceData SEQUENCE {			
criticalExtensions CHOICE {			
c1 CHOICE {			
provideAssistanceData-r9 SEQUENCE {			
commonEsProvideAssistanceData	Not present		
a-gnss-ProvideAssistanceData	Not present		
otdoa-ProvideAssistanceData	Not present		
epdu-Provide-AssistanceData	Not present		

sensor-ProvideAssistanceData-r15	Not present		
tbs-ProvideAssistanceData-r15	Not present		
wlan-ProvideAssistanceData-r15	Not present		
nr-Multi-RTT-ProvideAssistanceData-r16	Not present		
nr-DL-AoD-ProvideAssistanceData-r16			
SEQUENCE {			
nr-DL-PRS-AssistanceData-r16	As defined in Table 17.3.1.4.3-4		
nr-SelectedDL-PRS-IndexList-r16	Not present		
nr-PositionCalculationAssistance-r16			Depending on UE capabilities, i.e. support for UE-based DL-AoD
SEQUENCE {			
nr-TRP-LocationInfo-r16	As defined in TS 37.571-5 [20]		
nr-DL-PRS-BeamInfo-r16	Not present		
nr-RTD-Info-r16	Not present		
nr-TRP-BeamAntennaInfo-r17	Not present		
nr-DL-PRS-Expected-LOS-NLOS-Assistance-r17	Not present		
nr-DL-PRS-TRP-TEG-Info-r17	Not present		
}			
nr-DL-AoD-Error-r16	Not present		
nr-DL-PRS-BeamInfo-r17	Not present		
nr-On-Demand-DL-PRS-Configurations-r17	Not present		
}			
nr-DL-TDOA-ProvideAssistanceData-r16	Not present		
}			
}			
}			
}			
}			
}			
}			

Table 17.3.1.4.3-4: NR-DL-PRS-AssistanceData

Derivation Path: TS 37.355 [49] clause 6.4.3			
Information Element	Value/remark	Comment	Condition
NR-DL-PRS-AssistanceData-r16 ::= SEQUENCE {			
nr-DL-PRS-ReferenceInfo-r16 SEQUENCE {			
dl-PRS-ID-r16	0		
nr-DL-PRS-ResourceID-List-r16	Not present		
nr-DL-PRS-ResourceSetID-r16	Not present		
}			
nr-DL-PRS-AssistanceDataList-r16 SEQUENCE (SIZE (1..nrMaxFreqLayers-r16)) OF NR-DL-PRS-AssistanceDataPerFreq-r16 {	1 entry		
NR-DL-PRS-AssistanceDataPerFreq-r16[1] SEQUENCE {		entry 1	
nr-DL-PRS-PositioningFrequencyLayer-r16 SEQUENCE {			
dl-PRS-SubcarrierSpacing-r16	kHz15		Config 1 and Config 2
	kHz30		Config 3
dl-PRS-ResourceBandwidth-r16	8	24 PRBs	Sub-test 1-1, Sub-test 2-1 and Sub-test 3-1

	21	104 PRBs	Sub-test 1-2 and Sub-test 2-2
	28	132 PRBs	Sub-test 3-2
dl-PRS-StartPRB-r16	0		
dl-PRS-PointA-r16	absoluteFrequencyPointA as defined for the DL frequency of the Cell 1		
dl-PRS-CombSizeN-r16	n2		Sub-test 1
	n4		Sub-test 2
dl-PRS-CyclicPrefix-r16	normal		
nr-DL-PRS-AssistanceDataPerFreq-r16 SEQUENCE (SIZE (1..nrMaxTRPsPerFreq-r16)) OF NR-DL-PRS-AssistanceDataPerTRP-r16{	2 entries		
NR-DL-PRS-AssistanceDataPerTRP-r16[1] SEQUENCE {		entry 1	Cell 1
dl-PRS-ID-r16	0		
nr-PhysCellID-r16	Cell 1		
nr-CellGlobalID-r16	Cell 1		
nr-ARFCN-r16	Cell 1		
nr-DL-PRS-SFN0-Offset-r16 SEQUENCE {			
sfn-Offset-r16	0		
integerSubframeOffset-r16	0		
}			
nr-DL-PRS-ExpectedRSTD-r16	0		
nr-DL-PRS-ExpectedRSTD-Uncertainty-r16	0		
nr-DL-PRS-Info-r16	As specified in Table 17.3.1.4.3-5		
}			
NR-DL-PRS-AssistanceDataPerTRP-r16[2] SEQUENCE {		entry 2	Cell 2
dl-PRS-ID-r16	1		
nr-PhysCellID-r16	Cell 2		
nr-CellGlobalID-r16	Cell 2		
nr-ARFCN-r16	Cell 2		
nr-DL-PRS-SFN0-Offset-r16 SEQUENCE {			
sfn-Offset-r16	0		
integerSubframeOffset-r16	0		
}			
nr-DL-PRS-ExpectedRSTD-r16	23	About 3 μs	
nr-DL-PRS-ExpectedRSTD-Uncertainty-r16	39	About 5 μs	
nr-DL-PRS-Info-r16	As specified in Table 17.3.1.4.3-5		
}			
}			
}			
}			
}			

Table 17.3.1.4.3-5: NR-DL-PRS-Info

Derivation Path: TS 37.355 [49] clause 6.4.3			
Information Element	Value/remark	Comment	Condition
NR-DL-PRS-Info-r16 ::= SEQUENCE {			
nr-DL-PRS-ResourceSetList-r16 SEQUENCE (SIZE (1..nrMaxSetsPerTrp-r16)) OF NR-DL-PRS-ResourceSet-r16 {	1 entry		
NR-DL-PRS-ResourceSet-r16[1] SEQUENCE {		entry 1	
nr-DL-PRS-ResourceSetID-r16	0		
dl-PRS-Periodicity-and-ResourceSetSlotOffset-r16 CHOICE {			

scs15-r16 CHOICE {			Config 1 and Config 2
n160-r16	10		
}			
scs30-r16 CHOICE {			Config 3
n320-r16	20		
}			
dl-PRS-ResourceRepetitionFactor-r16	Not present		Sub-test 2
	n2		Sub-test 1
dl-PRS-ResourceTimeGap-r16	s1		
dl-PRS-NumSymbols-r16	n4		
dl-PRS-MutingOption1-r16	Not present		
dl-PRS-MutingOption2-r16	Not present		
dl-PRS-ResourcePower-r16	27		
dl-PRS-ResourceList-r16 SEQUENCE (SIZE (1..nrMaxResourcesPerSet-r16)) OF NR-DL-PRS-Resource-r16 {	2 entries		
NR-DL-PRS-Resource-r16[1] SEQUENCE {		entry 1	
nr-DL-PRS-ResourceID-r16	0		
dl-PRS-SequenceID-r16	0		
dl-PRS-CombSizeN-AndReOffset-r16 CHOICE {			
n2-r16	0		Sub-test 1
n4-r16	0		Sub-test 2
}			
dl-PRS-ResourceSlotOffset-r16	0		Cell 1
	4		Cell 2
dl-PRS-ResourceSymbolOffset-r16	0		
dl-PRS-QCL-Info-r16	Not present		
}			
NR-DL-PRS-Resource-r16[2] SEQUENCE {		entry 2	
nr-DL-PRS-ResourceID-r16	1		
dl-PRS-SequenceID-r16	1		
dl-PRS-CombSizeN-AndReOffset-r16 CHOICE {			
n2-r16	0		Sub-test 1
n4-r16	0		Sub-test 2
}			
dl-PRS-ResourceSlotOffset-r16	0		Cell 1
	4		Cell 2
dl-PRS-ResourceSymbolOffset-r16	0		
dl-PRS-QCL-Info-r16	Not present		
}			
}			
}			
}			
}			

Table 17.3.1.4.3-6: LPP RequestLocationInformation

Derivation Path: 37.355 clause 6.2			
Information Element	Value/remark	Comment	Condition
LPP-Message ::= SEQUENCE {			
transactionID SEQUENCE {			
initiator	locationServer		
transactionNumber	1		
}			
endTransaction	FALSE		
sequenceNumber	Not present		
acknowledgement	Not present		
lpp-MessageBody CHOICE {			
c1 CHOICE {			
requestLocationInformation SEQUENCE {			
criticalExtensions CHOICE {			
c1 CHOICE {			

requestLocationInformation-r9 SEQUENCE {			
commonEsRequestLocationInformation SEQUENCE {			
locationInformationType	locationMeasurementsRequired		
triggeredReporting	Not present		
periodicalReporting	Not present		
additionalInformation	onlyReturnInformationRequested		
qos SEQUENCE {			
horizontalAccuracy	Not present		
verticalCoordinateRequest	FALSE		
verticalAccuracy	Not present		
responseTime SEQUENCE {			
time	See 17.3.1.5	Result of the response time calculation rounded up to the next second if response time <= 128s. Result of the response time calculation rounded up to the next multiple of ten seconds if response time > 128s.	
responseTimeEarlyFix-r12	Not present		Rel-12 onwards
unit-r15	Not present		
	ten-seconds		Calculated response time >128s
}			
velocityRequest	FALSE		
}			
environment	Not present		
locationCoordinateTypes	Not present		
velocityTypes	Not present		
}			
a-gnss-RequestLocationInformation	Not present		
otdoa-RequestLocationInformation	Not present		
ecid-RequestLocationInformation	Not present		
epdu-RequestLocationInformation	Not Present		
sensor-RequestLocationInformation-r13	Not present		
tbs-RequestLocationInformation-r13	Not present		
wlan-RequestLocationInformation-r13	Not present		
bt-RequestLocationInformation-r13	Not present		
nr-ECID-RequestLocationInformation-r16	Not present		
nr-Multi-RTT-RequestLocationInformation-r16	Not present		
nr-DL-AoD-RequestLocationInformation-r16 SEQUENCE {			
nr-AssistanceAvailability-r16	FALSE		
nr-DL-AoD-ReportConfig-r16 SEQUENCE {			
maxDL-PRS-RSRP-MeasurementsPerTRP-r16	Not present		
maxDL-PRS-RSRP-MeasurementsPerTRP-r17	Not present		
maxDL-PRS-RSRPP-MeasurementsPerTRP-r17	Present. Set depending on UE capabilities.		
nr-los-nlos-IndicatorRequest-r17	Not present		
reducedDL-PRS-ProcessingSamples-r17	Not present		
lowerRxBeamSweepingFactor-FR2-r17	Not present		
}			
multiMeasInSameReport-r17			

}			
nr-DL-TDOA-RequestLocationInformation-r16	Not present		
}			
}			
}			
}			
}			
}			

Table 17.3.1.4.3-7: LPP ProvideLocation Information

Derivation Path: 37.355 clause 6.5.12			
Information Element	Value/remark	Comment	Condition
LPP-Message ::= SEQUENCE {			
transactionID SEQUENCE {			
initiator	locationServer		
transactionNumber	1		
}			
endTransaction	TRUE		
sequenceNumber	(0..255)		
acknowledgement			
lpp-MessageBody CHOICE {			
c1 CHOICE {			
provideLocationInformation SEQUENCE {			
criticalExtensions CHOICE {			
c1 CHOICE {			
provideLocationInformation-r9 SEQUENCE {			
commonIESProvideLocationInformation	Not present.		
a-gnss-ProvideLocationInformation	Not present		
otdoa-ProvideLocationInformation	Not present		
ecid-ProvideLocationInformation	Not present		
epdu-ProvideLocationInformation	Not present		
sensor-ProvideLocationInformation-r13	Not present		
tbs-ProvideLocationInformation-r13	Not present		
wlan-ProvideLocationInformation-r13	Not present		
bt-ProvideLocationInformation-r13	Not present		
nr-ECID-ProvideLocationInformation-r16	Not present		
nr-Multi-RTT-ProvideLocationInformation-r16	Not present		
nr-DL-AoD-ProvideLocationInformation-r16 SEQUENCE {			
nr-DL-AoD-SignalMeasurementInformation-r16 SEQUENCE {			
nr-DL-AoD-MeasList-r16 SEQUENCE (SIZE(1..nrMaxTRPs-r16)) OF NR-DL-AoD-MeasElement-r16 {			
NR-DL-AoD-MeasElement-r16[1] SEQUENCE {		entry 1	
dl-PRS-ID-r16	INTEGER (0..255)		
nr-PhysCellID-r16	Cell 1		
nr-CellGlobalID-r16			
nr-ARFCN-r16			
nr-DL-PRS-ResourceID-r16			
nr-DL-PRS-ResourceSetID-r16			
nr-TimeStamp-r16			
nr-DL-PRS-RSRP-Result-r16	Present. Any value acceptable.		
nr-DL-PRS-RxBeamIndex-r16			
nr-DL-AoD-AdditionalMeasurements-r16			
nr-DL-PRS-FirstPathRSRP-Result-r17	Present. Any value acceptable.		
nr-los-nlos-Indicator-r17			
nr-DL-AoD-AdditionalMeasurementsExt-r17			

	}		
SEQUENCE {	NR-DL-AoD-MeasElement-r16[2]		entry 2
	dl-PRS-ID-r16	INTEGER (0..255)	
	nr-PhysCellID-r16	Cell 2	
	nr-CellGlobalID-r16		
	nr-ARFCN-r16		
	nr-DL-PRS-ResourceID-r16		
	nr-DL-PRS-ResourceSetID-r16		
	nr-TimeStamp-r16		
	nr-DL-PRS-RSRP-Result-r16	Present. Any value acceptable.	
	nr-DL-PRS-RxBeamIndex-r16		
r16	nr-DL-AoD-AdditionalMeasurements-		
	nr-DL-PRS-FirstPathRSRP-Result-r17	Present. Any value acceptable.	
	nr-los-nlos-Indicator-r17		
	nr-DL-AoD-AdditionalMeasurementsExt-r17		
	}		
	}		
	}		
	nr-dl-AoD-LocationInformation-r16		
	nr-DL-AoD-Error-r16	Not present	
r17	nr-DL-AoD-SignalMeasurementInstances-	Not present	
r17	nr-DL-AoD-LocationInformationInstances-	Not present	
	}		
	}		
	}		
	}		
	}		
	}		
	}		
	}		

17.3.1.5 Test requirement

FFS

17.3.2 PRS-RSRPP measurement accuracy test case for single positioning frequency layer with reduced number of samples in FR1 SA

Editor’s note: This test case is incomplete. The following aspect is either missing or TBD:

- Test tolerance are not added in and analysis is missing
- Some values are in square brackets

17.3.2.1 Test purpose

The purpose of the test is to verify that the PRS-RSRPP measurement with reduce number of samples meets the accuracy requirements specified in TS 38.133 [50] clause 10.1.38.2 in an environment with two-tap channel conditions.

17.3.2.2 Test applicability

This test applies to all types of NR UE release 17 onwards that supports DL-AoD positioning and maxDL-PRS-FirstPathRSRP-MeasPerTRP and supportedDL-PRS-ProcessingSamples-RRC-CONNECTED.

17.3.2.3 Minimum conformance requirements

The absolute accuracy requirements for PRS-RSRPP measurement for FR1 defined in Table 10.1.38.2.1-1 and Table 10.1.38.2.1-3 are valid under the following conditions:

- Conditions defined in 38.101-1 Clause 7.3 for reference sensitivity are fulfilled.
- PRP 1,2_{dBm} according to Annex B.2.14 for a corresponding Band

...

Table 10.1.38.2.1-3: PRS-RSRPP absolute accuracy for FR1 for reduced number of samples

Accuracy		Conditions							
Normal condition	Extreme condition	PRS \hat{E}_s/lot	PRS BW	Repetition factor ($T_{\text{rep}}^{\text{PRS}} * L_{\text{PRS}} / K_{\text{comb}}^{\text{PRS}}$)	NR operating band groups Note 8	I_o Note 7 range			Maximum I_o
						Minimum I_o Note 1 dBm / SCS _{PRS}			
dB	dB	dB	PRB	-		dBm / SCS _{PRS}			dBm/BW _{Channel}
						dBm/15k Hz Note 6	dBm/30k Hz Note 6	dBm/60kHz Note 6	
±[3.9]	±[8.4]	≥0	≥48	All	NR_FDD_FR1_A, NR_TDD_FR1_A, NR_SDL_FR1_A	-127	-124	-121	-50
					NR_FDD_FR1_B	-126.5	-123.5	-120.5	-50
					NR_TDD_FR1_C	-126	-123	-120	-50
					NR_FDD_FR1_D, NR_TDD_FR1_D	-125.5	-122.5	-119.5	-50
					NR_FDD_FR1_E, NR_TDD_FR1_E	-125	-122	-119	-50
					NR_FDD_FR1_F	-124.5	-121.5	-118.5	-50
					NR_FDD_FR1_G	-124	-121	-118	-50
					NR_FDD_FR1_H	-123.5	-120.5	-117.5	-50
					Note 4			Note 4	
±[4.2]	±[8.7]	≥-6	48 ≤ BW ≤ 52	All	Note 4				
±TBD	±TBD		52 < BW ≤ 104	All	Note 4				
±[4.1]	±[8.6]		BW > 52	All	Note 4				

NOTE 1: This minimum I_o condition is expressed as the average I_o per RE over all REs in an OFDM symbol.
 NOTE 2: Void.
 NOTE 3: PRS bandwidth is as indicated in *prs-Bandwidth* in the DL-TDOA or DL-AoD assistance data defined in [34].
 NOTE 4: The same bands and the same I_o conditions for each band apply for this requirement as for the corresponding requirement with the PRS bandwidth ≥ 48 RB.
 NOTE 5: The serving cell, the reference cell, and the measured neighbour cell i are on the same carrier frequency.
 NOTE 6: The condition level is increased by $\Delta > 0$, when applicable, as described in Sections B.3.2 and B.3.3.
 NOTE 7: The I_o is defined in PRS positioning subframes. The same I_o range applies to PRS and non-PRS symbols. I_o levels are different in PRS and non-PRS symbols within the same subframe.
 NOTE 8: NR operating band groups are as defined in Section 3.5.2.

17.3.2.4 Test description

17.3.2.4.1 Initial conditions

The test is defined with three possible Test Configurations. In the case that the UE supports more than one of these Test Configurations, then the UE is only required to be tested in one of the Test Configurations, chosen by the UE. The defined Test Configurations are specified in Table 17.3.2.4.1-1.

Table 17.3.2.4.1-1: Test Configurations

Configuration	Description
1	15 kHz SSB SCS, 10 MHz bandwidth, FDD duplex mode
2	15 kHz SSB SCS, 10 MHz bandwidth, TDD duplex mode
3	30 kHz SSB SCS, 40 MHz bandwidth, TDD duplex mode

Test Environment: Normal, as defined in TS 38.508-1 [45] clause 4.1.

Frequencies to be tested: Mid Range, as defined in TS 38.508-1 [45] clause 4.3.1.

Channel bandwidth to be tested: are specified in Table 17.3.2.4-1.

1. Connect the SS and AWGN noise sources to the UE antenna connector or antenna connectors as shown in Annex A, Figure A.13.
2. The general test parameter settings are set up according to Table 17.3.2.5-1 and Table 17.3.2.5-2.
3. Propagation conditions are set according to clause 4.16.2.
4. Message contents are defined in clause 17.3.2.4.3.
5. In the test there are two synchronous cells: Cell 1 and Cell 2. Cell 1 is the reference as well as the PCell. Cell 2 is the neighbour cell. All cells are on the same RF channel distributed in single positioning frequency layer.

17.3.2.4.2 Test procedure

Same as defined in clause 17.3.1.4.2.

17.3.2.4.3 Message contents

As defined in clause 17.3.1.4.3, with the following exceptions:

Table 17.3.2.4.3-1 replaces Table 17.3.1.4.3-4, Table 17.3.2.4.3-2 replaces Table 17.3.1.4.3-5 and Table 17.3.2.4.3-3 replaces Table 17.3.1.4.3-6.

Table 17.3.2.4.3-1: NR-DL-PRS-AssistanceData

Derivation Path: TS 37.355 [49] clause 6.4.3			
Information Element	Value/remark	Comment	Condition
NR-DL-PRS-AssistanceData-r16 ::= SEQUENCE {			
nr-DL-PRS-ReferenceInfo-r16 SEQUENCE {			
dl-PRS-ID-r16	0		
nr-DL-PRS-ResourceID-List-r16	Not present		
nr-DL-PRS-ResourceSetID-r16	Not present		
}			
nr-DL-PRS-AssistanceDataList-r16 SEQUENCE (SIZE (1..nrMaxFreqLayers-r16)) OF NR-DL-PRS-AssistanceDataPerFreq-r16 {	1 entry		
NR-DL-PRS-AssistanceDataPerFreq-r16[1] SEQUENCE {		entry 1	
nr-DL-PRS-PositioningFrequencyLayer-r16 SEQUENCE {			
dl-PRS-SubcarrierSpacing-r16	kHz15		Config 1 and Config 2

	kHz30		Config 3
dl-PRS-ResourceBandwidth-r16	7	48 PRBs	
dl-PRS-StartPRB-r16	0		
dl-PRS-PointA-r16	absoluteFrequencyPointA as defined for the DL frequency of the Cell 1		
dl-PRS-CombSizeN-r16	n4		
dl-PRS-CyclicPrefix-r16	normal		
}			
nr-DL-PRS-AssistanceDataPerFreq-r16 SEQUENCE (SIZE (1..nrMaxTRPsPerFreq-r16)) OF NR-DL-PRS-AssistanceDataPerTRP-r16{	2 entries		
NR-DL-PRS-AssistanceDataPerTRP-r16[1] SEQUENCE {		entry 1	Cell 1
dl-PRS-ID-r16	0		
nr-PhysCellID-r16	Cell 1		
nr-CellGlobalID-r16	Cell 1		
nr-ARFCN-r16	Cell 1		
nr-DL-PRS-SFN0-Offset-r16 SEQUENCE {			
sfn-Offset-r16	0		
integerSubframeOffset-r16	0		
}			
nr-DL-PRS-ExpectedRSTD-r16	0		
nr-DL-PRS-ExpectedRSTD-Uncertainty-r16	0		
nr-DL-PRS-Info-r16	As specified in Table 17.3.2.4.3-2		
}			
NR-DL-PRS-AssistanceDataPerTRP-r16[2] SEQUENCE {		entry 2	Cell 2
dl-PRS-ID-r16	1		
nr-PhysCellID-r16	Cell 2		
nr-CellGlobalID-r16	Cell 2		
nr-ARFCN-r16	Cell 2		
nr-DL-PRS-SFN0-Offset-r16 SEQUENCE {			
sfn-Offset-r16	0		
integerSubframeOffset-r16	0		
}			
nr-DL-PRS-ExpectedRSTD-r16	23	About 3 μs	
nr-DL-PRS-ExpectedRSTD-Uncertainty-r16	39	About 5 μs	
nr-DL-PRS-Info-r16	As specified in Table 17.3.2.4.3-2		
}			
}			
}			
}			
}			

Table 17.3.2.4.3-2: NR-DL-PRS-Info

Derivation Path: TS 37.355 [49] clause 6.4.3			
Information Element	Value/remark	Comment	Condition
NR-DL-PRS-Info-r16 ::= SEQUENCE {			
nr-DL-PRS-ResourceSetList-r16 SEQUENCE (SIZE (1..nrMaxSetsPerTrp-r16)) OF NR-DL-PRS-ResourceSet-r16 {	1 entry		
NR-DL-PRS-ResourceSet-r16[1] SEQUENCE {		entry 1	
nr-DL-PRS-ResourceSetID-r16	0		
dl-PRS-Periodicity-and-ResourceSetSlotOffset-r16 CHOICE {			
scs15-r16 CHOICE {			Config 1 and Config 2
n160-r16	10		
}			
scs30-r16 CHOICE {			Config 3

n320-r16	20		
}			
dl-PRS-ResourceRepetitionFactor-r16	Not present		
dl-PRS-ResourceTimeGap-r16	s1		
dl-PRS-NumSymbols-r16	n4		
dl-PRS-MutingOption1-r16	Not present		
dl-PRS-MutingOption2-r16	Not present		
dl-PRS-ResourcePower-r16	27		
dl-PRS-ResourceList-r16 SEQUENCE (SIZE (1..nrMaxResourcesPerSet-r16)) OF NR-DL-PRS-Resource-r16 {	2 entries		
NR-DL-PRS-Resource-r16[1] SEQUENCE {		entry 1	
nr-DL-PRS-ResourceID-r16	0		
dl-PRS-SequenceID-r16	0		
dl-PRS-CombSizeN-AndReOffset-r16 CHOICE {			
n4-r16	0		
}			
dl-PRS-ResourceSlotOffset-r16	0		Cell 1
	4		Cell 2
dl-PRS-ResourceSymbolOffset-r16	0		
dl-PRS-QCL-Info-r16	Not present		
}			
NR-DL-PRS-Resource-r16[2] SEQUENCE {		entry 2	
nr-DL-PRS-ResourceID-r16	1		
dl-PRS-SequenceID-r16	1		
dl-PRS-CombSizeN-AndReOffset-r16 CHOICE {			
n4-r16	1		
}			
dl-PRS-ResourceSlotOffset-r16	0		Cell 1
	4		Cell 2
dl-PRS-ResourceSymbolOffset-r16	0		
dl-PRS-QCL-Info-r16	Not present		
}			
}			
}			
}			
}			

Table 17.3.2.4.3-3: LPP RequestLocationInformation

Derivation Path: 37.355 clause 6.2			
Information Element	Value/remark	Comment	Condition
LPP-Message ::= SEQUENCE {			
transactionID SEQUENCE {			
initiator	locationServer		
transactionNumber	1		
}			
endTransaction	FALSE		
sequenceNumber	Not present		
acknowledgement	Not present		
lpp-MessageBody CHOICE {			
c1 CHOICE {			
requestLocationInformation SEQUENCE {			
criticalExtensions CHOICE {			
c1 CHOICE {			
requestLocationInformation-r9 SEQUENCE {			
commonEsRequestLocationInformation SEQUENCE {			
locationInformationType	locationMeasurementsRequired		
triggeredReporting	Not present		
periodicalReporting	Not present		
additionalInformation	onlyReturnInformationRequested		

qos SEQUENCE {			
horizontalAccuracy	Not present		
verticalCoordinateRequest	FALSE		
verticalAccuracy	Not present		
responseTime SEQUENCE {			
time	See 17.3.2.5	Result of the response time calculation rounded up to the next second if response time <= 128s. Result of the response time calculation rounded up to the next multiple of ten seconds if response time > 128s.	
responseTimeEarlyFix-r12	Not present		Rel-12 onwards
unit-r15	Not present		
	ten-seconds		Calculated response time >128s
}			
velocityRequest	FALSE		
}			
environment	Not present		
locationCoordinateTypes	Not present		
velocityTypes	Not present		
}			
a-gnss-RequestLocationInformation	Not present		
otdoa-RequestLocationInformation	Not present		
ecid-RequestLocationInformation	Not present		
epdu-RequestLocationInformation	Not Present		
sensor-RequestLocationInformation-r13	Not present		
tbs-RequestLocationInformation-r13	Not present		
wlan-RequestLocationInformation-r13	Not present		
bt-RequestLocationInformation-r13	Not present		
nr-ECID-RequestLocationInformation-r16	Not present		
nr-Multi-RTT-RequestLocationInformation-r16	Not present		
nr-DL-AoD-RequestLocationInformation-r16			
SEQUENCE {			
nr-AssistanceAvailability-r16	FALSE		
nr-DL-AoD-ReportConfig-r16 SEQUENCE {			
r16 maxDL-PRS-RSRP-MeasurementsPerTRP-	Not present		
r17 maxDL-PRS-RSRP-MeasurementsPerTRP-	Not present		
r17 maxDL-PRS-RSRPP-MeasurementsPerTRP-r17	Present. Set depending on UE capabilities.		
nr-los-nlos-IndicatorRequest-r17	Not present		
reducedDL-PRS-ProcessingSamples-r17	requested		
lowerRxBeamSweepingFactor-FR2-r17	Not present		
}			
multiMeasInSameReport-r17			
}			
nr-DL-TDOA-RequestLocationInformation-r16	Not present		
}			
}			
}			
}			
}			
}			

17.3.2.5 Test requirement

FFS

17.3.3 PRS-RSRPP measurement accuracy test case for single positioning frequency layer in FR2 SA

Editor’s note: This test case is incomplete. The following aspect is either missing or TBD:

- Test tolerance are not added in and analysis is missing
- Some values are in square brackets

17.3.3.1 Test purpose

The purpose of the test is to verify that the PRS-RSRPP measurement meets the accuracy requirements specified in TS 38.133 [50] clause 10.1.38.2 in an environment with two-tap channel conditions.

17.3.3.2 Test applicability

This test applies to all types of NR UE release 17 onwards that supports DL-AoD positioning and maxDL-PRS-FirstPathRSRP-MeasPerTRP.

17.3.3.3 Minimum conformance requirements

The absolute accuracy requirements for PRS-RSRPP measurement for FR2 defined in Table 10.1.38.2.1-2 and Table 10.1.38.2.1-4 are valid under the following conditions:

- Conditions defined in 38.101-2 Clause 7.3 for reference sensitivity are fulfilled.
- PRP $1,2_{dBm}$ according to Annex B.2.14 for a corresponding Band

...

Table 10.1.38.2.1-2: PRS-RSRPP absolute accuracy for FR2

Accuracy		Conditions					
Normal condition	Extreme condition	PRS \hat{E}_s /lot	PRS BW	Repetition factor ($T_{rep}^{PRS} * L_{PRS} / K_{comb}^{PRS}$)	I_o ^{Note 7} range		
					Minimum I_o ^{Note 1} dBm / SCS _{PRS}		Maximum I_o
dB	dB	dB	PRB	-	dBm / SCS _{PRS}		dBm/BW _{Channel}
					dBm/120kHz _z ^{Note 6}	dBm/60kHz _z ^{Note 6}	
±[6.0]	±[9.0]	≥-3	≥24	All	Same value as PRP in Table B.2.14-2, according to UE Power class, operating band and angle of arrival		-50
					Note 4		
					Note 4		
±[7.3]	±[10.3]	≥-13	24 ≤ BW ≤ 64	All	Note 4		
±[6.2]	±[9.2]		BW >64	All	Note 4		

NOTE 1: This minimum I_o condition is expressed as the average I_o per RE over all REs in an OFDM symbol.
 NOTE 2: Void.
 NOTE 3: PRS bandwidth is as indicated in *prs-Bandwidth* in the DL-TDOA or DL-AoD assistance data defined in [34].
 NOTE 4: The same bands and the same I_o conditions for each band apply for this requirement as for the corresponding requirement with the PRS bandwidth ≥ 24 RB.
 NOTE 5: The serving cell, the reference cell, and the measured neighbour cell *i* are on the same carrier frequency.

NOTE 6: The condition level is increased by $\Delta > 0$, when applicable, as described in Sections B.3.2 and B.3.3.
 NOTE 7: The l_0 is defined in PRS positioning subframes. The same l_0 range applies to PRS and non-PRS symbols. l_0 levels are different in PRS and non-PRS symbols within the same subframe.
 NOTE 8: NR operating band groups are as defined in Section 3.5.2.

17.3.3.4 Test description

17.3.3.4.1 Initial conditions

The supported test configurations in listed in Table 17.3.3.4.1-1.

Table 17.3.3.4.1-1: Test Configurations

Configuration	Description
1	120 kHz SSB SCS, 100 MHz bandwidth, TDD duplex mode

Test Environment: Normal, as defined in TS 38.508-1 [45] clause 4.1.

Frequencies to be tested: Mid Range, as defined in TS 38.508-1 [45] clause 4.3.1.

Channel bandwidth to be tested: are specified in Table 17.3.3.4-1.

1. Connect the SS and AWGN noise sources to the UE antenna connector or antenna connectors as shown in Annex A, Figure A.14.
2. The general test parameter settings are set up according to Table 17.3.3.5-1 and Table 17.3.3.5-2.
3. Propagation conditions are set according to clause 4.16.2.
4. Message contents are defined in clause 17.3.3.4.3.
5. In the test there are two synchronous cells: Cell 1 and Cell 2. Cell 1 is the reference as well as the PCell. Cell 2 is the neighbour cell. All cells are on the same RF channel distributed in single positioning frequency layer.

17.3.3.4.2 Test procedure

Same as defined in clause 17.3.1.4.2.

17.3.3.4.3 Message contents

As defined in clause 17.3.1.4.3, with the following exceptions:

Table 17.3.3.4.3-1 replaces Table 17.3.1.4.3-4 and Table 17.3.3.4.3-2 replaces Table 17.3.1.4.3-5.

Table 17.3.3.4.3-1: NR-DL-PRS-AssistanceData

Derivation Path: 37.355 clause 6.4.3			
Information Element	Value/remark	Comment	Condition
NR-DL-PRS-AssistanceData-r16 ::= SEQUENCE {			
nr-DL-PRS-ReferenceInfo-r16 SEQUENCE {			
dl-PRS-ID-r16	0		
nr-DL-PRS-ResourceID-List-r16	Not present		
nr-DL-PRS-ResourceSetID-r16	Not present		
}			
nr-DL-PRS-AssistanceDataList-r16 SEQUENCE (SIZE (1..nrMaxFreqLayers-r16)) OF NR-DL-PRS-AssistanceDataPerFreq-r16 {	1 entry		
NR-DL-PRS-AssistanceDataPerFreq-r16[1] SEQUENCE {		entry 1	
nr-DL-PRS-PositioningFrequencyLayer-r16 SEQUENCE {			
dl-PRS-SubcarrierSpacing-r16	kHz120		

dl-PRS-ResourceBandwidth-r16	3	32 PRBs	Sub-test 1
	27	128 PRBs	Sub-test 2
dl-PRS-StartPRB-r16	0		
dl-PRS-PointA-r16	absoluteFrequencyPointA as defined for the DL frequency of the Cell 1		
dl-PRS-CombSizeN-r16	n2		Sub-test 1
	n4		Sub-test 2
dl-PRS-CyclicPrefix-r16	normal		
}			
nr-DL-PRS-AssistanceDataPerFreq-r16 SEQUENCE (SIZE (1..nrMaxTRPsPerFreq-r16)) OF NR-DL-PRS-AssistanceDataPerTRP-r16{	2 entries		
NR-DL-PRS-AssistanceDataPerTRP-r16[1] SEQUENCE {		entry 1	Cell 1
dl-PRS-ID-r16	0		
nr-PhysCellID-r16	Cell 1		
nr-CellGlobalID-r16	Cell 1		
nr-ARFCN-r16	Cell 1		
nr-DL-PRS-SFN0-Offset-r16 SEQUENCE {			
sfn-Offset-r16	0		
integerSubframeOffset-r16	0		
}			
nr-DL-PRS-ExpectedRSTD-r16	0		
nr-DL-PRS-ExpectedRSTD-Uncertainty-r16	0		
nr-DL-PRS-Info-r16	As specified in Table 17.3.3.4.3-2		
}			
NR-DL-PRS-AssistanceDataPerTRP-r16[2] SEQUENCE {		entry 2	Cell 2
dl-PRS-ID-r16	1		
nr-PhysCellID-r16	Cell 2		
nr-CellGlobalID-r16	Cell 2		
nr-ARFCN-r16	Cell 2		
nr-DL-PRS-SFN0-Offset-r16 SEQUENCE {			
sfn-Offset-r16	0		
integerSubframeOffset-r16	0		
}			
nr-DL-PRS-ExpectedRSTD-r16	23	About 3 μs	
nr-DL-PRS-ExpectedRSTD-Uncertainty-r16	154	About 5 μs	
nr-DL-PRS-Info-r16	As specified in Table 17.3.3.4.3-2		
}			
}			
}			
}			
}			

Table 17.3.3.4.3-2: NR-DL-PRS-Info

Derivation Path: 37.355 clause 6.4.3			
Information Element	Value/remark	Comment	Condition
NR-DL-PRS-Info-r16 ::= SEQUENCE {			
nr-DL-PRS-ResourceSetList-r16 SEQUENCE (SIZE (1..nrMaxSetsPerTrp-r16)) OF NR-DL-PRS-ResourceSet-r16 {	1 entry		
NR-DL-PRS-ResourceSet-r16[1] SEQUENCE {		entry 1	
nr-DL-PRS-ResourceSetID-r16	0		
dl-PRS-Periodicity-and-ResourceSetSlotOffset-r16 CHOICE {			
scs120-r16 CHOICE {			
n1280-r16	80		
}			
dl-PRS-ResourceRepetitionFactor-r16	n2		Sub-test 1
	Not present		Sub-test 2

dl-PRS-ResourceTimeGap-r16	s1		
dl-PRS-NumSymbols-r16	n4		
dl-PRS-MutingOption1-r16	Not present		
dl-PRS-MutingOption2-r16	Not present		
dl-PRS-ResourcePower-r16	27		
dl-PRS-ResourceList-r16 SEQUENCE (SIZE (1..nrMaxResourcesPerSet-r16)) OF NR-DL-PRS-Resource-r16 {	2 entries		
NR-DL-PRS-Resource-r16[1] SEQUENCE {		entry 1	
nr-DL-PRS-ResourceID-r16	0		
dl-PRS-SequenceID-r16	0		
dl-PRS-CombSizeN-AndReOffset-r16 CHOICE {			
n2-r16	0		Sub-test 1
n4-r16	0		Sub-test 2
}			
dl-PRS-ResourceSlotOffset-r16	0		Cell 1
	4		Cell 2
dl-PRS-ResourceSymbolOffset-r16	0		
dl-PRS-QCL-Info-r16	Not present		
}			
NR-DL-PRS-Resource-r16[2] SEQUENCE {		entry 2	
nr-DL-PRS-ResourceID-r16	1		
dl-PRS-SequenceID-r16	1		
dl-PRS-CombSizeN-AndReOffset-r16 CHOICE {			
n2-r16	1		Sub-test 1
n4-r16	1		Sub-test 2
}			
dl-PRS-ResourceSlotOffset-r16	0		Cell 1
	4		Cell 2
dl-PRS-ResourceSymbolOffset-r16	0		
dl-PRS-QCL-Info-r16	Not present		
}			
}			
}			
}			
}			

17.3.3.5 Test requirement

FFS

17.3.4 PRS-RSRPP measurement accuracy test case for single positioning frequency layer with reduced number of samples in FR2 SA

Editor's note: This test case is incomplete. The following aspect is either missing or TBD:

- Test tolerance are not added in and analysis is missing
- Some values are in square brackets

17.3.4.1 Test purpose

The purpose of the test is to verify that the PRS-RSRPP measurement with reduce number of samples meets the accuracy requirements specified in TS 38.133 [50] clause 10.1.38.2 in an environment with two-tap channel conditions.

17.3.4.2 Test applicability

This test applies to all types of NR UE release 17 onwards that supports DL-AoD positioning and maxDL-PRS-FirstPathRSRP-MeasPerTRP and supportedDL-PRS-ProcessingSamples-RRC-CONNECTED.

17.3.4.3 Minimum conformance requirements

The absolute accuracy requirements for PRS-RSRPP measurement for FR2 defined in Table 10.1.38.2.1-2 and Table 10.1.38.2.1-4 are valid under the following conditions:

- Conditions defined in 38.101-2 Clause 7.3 for reference sensitivity are fulfilled.
- PRP $1,2|_{dBm}$ according to Annex B.2.14 for a corresponding Band

...

Table 10.1.38.2.1-4: PRS-RSRPP absolute accuracy for FR2 for reduced number of samples

Accuracy		Conditions					
Normal condition	Extreme condition	PRS \hat{E}_s/lot	PRS BW	Repetition factor ($T_{\text{rep}}^{\text{PRS}} * L_{\text{PRS}} / K_{\text{comb}}^{\text{PRS}}$)	I_o ^{Note 7} range		
					Minimum I_o ^{Note 1} dBm / SCS _{PRS}	Maximum I_o	
dB	dB	dB	PRB	-	dBm / SCS _{PRS}		dBm/BW _{Channel}
					dBm/120kHz _z ^{Note 6}	dBm/60kHz _z ^{Note 6}	
$\pm[5.9]$	$\pm[8.9]$	≥ 0	≥ 48	All	Same value as PRP in Table B.2.14-2, according to UE Power class, operating band and angle of arrival		-50
					Note 4		
					Note 4		
$\pm[5.6]$	$\pm[8.6]$	≥ 6	$48 \leq \text{BW} \leq 64$	All	Note 4		
$\pm[5.4]$	$\pm[8.4]$		$\text{BW} > 64$	All	Note 4		

NOTE 1: This minimum I_o condition is expressed as the average I_o per RE over all REs in an OFDM symbol.
 NOTE 2: Void.
 NOTE 3: PRS bandwidth is as indicated in *prs-Bandwidth* in the DL-TDOA or DL-AoD assistance data defined in [34].
 NOTE 4: The same bands and the same I_o conditions for each band apply for this requirement as for the corresponding requirement with the PRS bandwidth ≥ 48 RB.
 NOTE 5: The serving cell, the reference cell, and the measured neighbour cell i are on the same carrier frequency.
 NOTE 6: The condition level is increased by $\Delta > 0$, when applicable, as described in Sections B.3.2 and B.3.3.
 NOTE 7: The I_o is defined in PRS positioning subframes. The same I_o range applies to PRS and non-PRS symbols. I_o levels are different in PRS and non-PRS symbols within the same subframe.
 NOTE 8: NR operating band groups are as defined in Section 3.5.2.

17.3.4.4 Test description

17.3.4.4.1 Initial conditions

The supported test configurations in listed in Table 17.3.4.4.1-1.

Table 17.3.4.4.1-1: Test Configurations

Configuration	Description
1	120 kHz SSB SCS, 100 MHz bandwidth, TDD duplex mode

Test Environment: Normal, as defined in TS 38.508-1 [45] clause 4.1.

Frequencies to be tested: Mid Range, as defined in TS 38.508-1 [45] clause 4.3.1.

Channel bandwidth to be tested: are specified in Table 17.3.4.4-1.

1. Connect the SS and AWGN noise sources to the UE antenna connector or antenna connectors as shown in Annex A, Figure A.14.
2. The general test parameter settings are set up according to Table 17.3.4.5-1 and Table 17.3.4.5-2.
3. Propagation conditions are set according to clause 4.16.2.
4. Message contents are defined in clause 17.3.4.4.3.
5. In the test there are two synchronous cells: Cell 1 and Cell 2. Cell 1 is the reference as well as the PCell. Cell 2 is the neighbour cell. All cells are on the same RF channel distributed in single positioning frequency layer.

17.3.4.4.2 Test procedure

Same as defined in clause 17.3.1.4.2.

17.3.4.4.3 Message contents

As defined in clause 17.3.1.4.3, with the following exceptions:

Table 17.3.4.4.3-1 replaces Table 17.3.1.4.3-4, Table 17.3.4.4.3-2 replaces Table 17.3.1.4.3-5 and Table 17.3.4.4.3-3 replaces Table 17.3.1.4.3-6.

Table 17.3.4.4.3-1: NR-DL-PRS-AssistanceData

Derivation Path: 37.355 clause 6.4.3			
Information Element	Value/remark	Comment	Condition
NR-DL-PRS-AssistanceData-r16 ::= SEQUENCE {			
nr-DL-PRS-ReferenceInfo-r16 SEQUENCE {			
dl-PRS-ID-r16	0		
nr-DL-PRS-ResourceID-List-r16	Not present		
nr-DL-PRS-ResourceSetID-r16	Not present		
}			
nr-DL-PRS-AssistanceDataList-r16 SEQUENCE (SIZE (1..nrMaxFreqLayers-r16)) OF NR-DL-PRS-AssistanceDataPerFreq-r16 {	1 entry		
NR-DL-PRS-AssistanceDataPerFreq-r16[1] SEQUENCE {		entry 1	
nr-DL-PRS-PositioningFrequencyLayer-r16 SEQUENCE {			
dl-PRS-SubcarrierSpacing-r16	kHz120		
dl-PRS-ResourceBandwidth-r16	7	48 PRBs	
dl-PRS-StartPRB-r16	0		
dl-PRS-PointA-r16	absoluteFrequencyPointA as defined for the DL frequency of the Cell 1		
dl-PRS-CombSizeN-r16	n2		
dl-PRS-CyclicPrefix-r16	normal		
}			
nr-DL-PRS-AssistanceDataPerFreq-r16 SEQUENCE (SIZE (1..nrMaxTRPsPerFreq-r16)) OF NR-DL-PRS-AssistanceDataPerTRP-r16{	2 entries		
NR-DL-PRS-AssistanceDataPerTRP-r16[1] SEQUENCE {		entry 1	Cell 1
dl-PRS-ID-r16	0		
nr-PhysCellID-r16	Cell 1		
nr-CellGlobalID-r16	Cell 1		
nr-ARFCN-r16	Cell 1		
nr-DL-PRS-SFN0-Offset-r16 SEQUENCE {			
sfn-Offset-r16	0		
integerSubframeOffset-r16	0		
}			
nr-DL-PRS-ExpectedRSTD-r16	0		
nr-DL-PRS-ExpectedRSTD-Uncertainty-r16	0		

nr-DL-PRS-Info-r16	As specified in Table 17.3.4.4.3-2		
}			
NR-DL-PRS-AssistanceDataPerTRP-r16[2] SEQUENCE {		entry 2	Cell 2
dl-PRS-ID-r16	1		
nr-PhysCellID-r16	Cell 2		
nr-CellGlobalID-r16	Cell 2		
nr-ARFCN-r16	Cell 2		
nr-DL-PRS-SFN0-Offset-r16 SEQUENCE {			
sfn-Offset-r16	0		
integerSubframeOffset-r16	0		
}			
nr-DL-PRS-ExpectedRSTD-r16	23	About 3 μs	
nr-DL-PRS-ExpectedRSTD-Uncertainty-r16	154	About 5 μs	
nr-DL-PRS-Info-r16	As specified in Table 17.3.4.4.3-2		
}			
}			
}			
}			
}			

Table 17.3.4.4.3-2: NR-DL-PRS-Info

Derivation Path: 37.355 clause 6.4.3			
Information Element	Value/remark	Comment	Condition
NR-DL-PRS-Info-r16 ::= SEQUENCE {			
nr-DL-PRS-ResourceSetList-r16 SEQUENCE (SIZE (1..nrMaxSetsPerTrp-r16)) OF NR-DL-PRS-ResourceSet-r16 {	1 entry		
NR-DL-PRS-ResourceSet-r16[1] SEQUENCE {		entry 1	
nr-DL-PRS-ResourceSetID-r16	0		
dl-PRS-Periodicity-and-ResourceSetSlotOffset-r16 CHOICE {			
scs120-r16 CHOICE {			
n1280-r16	80		
}			
dl-PRS-ResourceRepetitionFactor-r16	n2		
dl-PRS-ResourceTimeGap-r16	s1		
dl-PRS-NumSymbols-r16	n4		
dl-PRS-MutingOption1-r16 SEQUENCE {			
dl-prs-MutingBitRepetitionFactor-r16	Not present		
nr-option1-muting-r16 CHOICE {			
po2-r16	10		Cell 1
	01		Cell 2
}			
}			
dl-PRS-MutingOption2-r16	Not present		
dl-PRS-ResourcePower-r16	27		
dl-PRS-ResourceList-r16 SEQUENCE (SIZE (1..nrMaxResourcesPerSet-r16)) OF NR-DL-PRS-Resource-r16 {	2 entries		
NR-DL-PRS-Resource-r16[1] SEQUENCE {		entry 1	
nr-DL-PRS-ResourceID-r16	0		
dl-PRS-SequenceID-r16	0		
dl-PRS-CombSizeN-AndReOffset-r16 CHOICE {			
n4-r16	0		
}			
dl-PRS-ResourceSlotOffset-r16	0		Cell 1
	4		Cell 2
dl-PRS-ResourceSymbolOffset-r16	0		
dl-PRS-QCL-Info-r16	Not present		
}			

	ten-seconds		Calculated response time >128s
}			
velocityRequest	FALSE		
}			
environment	Not present		
locationCoordinateTypes	Not present		
velocityTypes	Not present		
}			
a-gnss-RequestLocationInformation	Not present		
otdoa-RequestLocationInformation	Not present		
ecid-RequestLocationInformation	Not present		
epdu-RequestLocationInformation	Not Present		
sensor-RequestLocationInformation-r13	Not present		
tbs-RequestLocationInformation-r13	Not present		
wlan-RequestLocationInformation-r13	Not present		
bt-RequestLocationInformation-r13	Not present		
nr-ECID-RequestLocationInformation-r16	Not present		
nr-Multi-RTT-RequestLocationInformation-r16	Not present		
nr-DL-AoD-RequestLocationInformation-r16			
SEQUENCE {			
nr-AssistanceAvailability-r16	FALSE		
nr-DL-AoD-ReportConfig-r16 SEQUENCE {			
r16 maxDL-PRS-RSRP-MeasurementsPerTRP-	Not present		
r17 maxDL-PRS-RSRP-MeasurementsPerTRP-	Not present		
MeasurementsPerTRP-r17	Present. Set depending on UE capabilities.		
nr-los-nlos-IndicatorRequest-r17	Not present		
reducedDL-PRS-ProcessingSamples-r17	requested		
lowerRxBeamSweepingFactor-FR2-r17	Not present		
}			
multiMeasInSameReport-r17			
}			
nr-DL-TDOA-RequestLocationInformation-r16	Not present		
}			
}			
}			
}			
}			
}			

17.3.4.5 Test requirement

FFS

17.4 NR PRS-RSRPP measurement period test cases in RRC_INACTIVE

17.4.1 PRS-RSRPP measurement reporting delay test case for single positioning frequency layer in FR1 SA

Editor’s note: This test case is incomplete. The following aspect is either missing or TBD:

- Test tolerance are not added in and analysis is missing

17.4.1.1 Test purpose

The purpose of the test is to verify that the PRS-RSRPP measurement in RRC_INACTIVE state meets the requirements specified in TS 38.133 [50] clause 5.6.5.5 in FR1 in standalone scenario when single positioning frequency layer is configured.

17.4.1.2 Test applicability

This test applies to all types of NR UE release 17 onwards that supports DL-AoD positioning, maxDL-PRS-FirstPathRSRP-MeasPerTRP and DL-PRS measurement in RRC_INACTIVE state.

17.4.1.3 Minimum conformance requirements

Same as defined in clause 16.4.3.3.

17.4.1.4 Test description

17.4.1.4.1 Initial conditions

The test defines three possible test configurations; specified in Table 17.4.1.4-1. The UE is only required to be tested in one of the supported test configurations.

Table 17.4.1.4-1: Test Configurations

Test Configuration	Description
1	15 kHz SSB SCS, 10 MHz bandwidth, FDD duplex mode
2	15 kHz SSB SCS, 10 MHz bandwidth, TDD duplex mode
3	30 kHz SSB SCS, 40 MHz bandwidth, TDD duplex mode
Note: The UE is only required to be tested in one of the supported test configurations.	

Test Environment: Normal, as defined in TS 38.508-1 [45] clause 4.1.

Frequencies to be tested: Mid Range, as defined in TS 38.508-1 [45] clause 4.3.1.

Channel bandwidth to be tested: are specified in Table 17.4.1.4-1.

1. Connect the SS and AWGN noise sources to the UE antenna connector or antenna connectors as shown in Annex A, Figure A.13.
2. The general test parameter settings are set up according to Table 17.4.1.5-1 and Table 17.4.1.5-2.
3. Propagation conditions are set according to clause 4.16.2.
4. Message contents are defined in clause 17.4.1.4.3.
5. There are two cells in the test: PCell (Cell 1) and a neighbour cell (Cell 2). All cells are on the same RF channel in FR1.

17.4.1.4.2 Test procedure

The test consists of two consecutive time intervals, with duration of T1 and T2. During time duration T1, the UE shall be in RRC_CONNECTED state and shall not have any timing information of Cell 2. During T2 UE shall be in RRC_INACTIVE state and all cells transmit PRS resources within initial DL BWP of the UE and with the same numerology as the initial DL BWP.

The *NR-DL-AoD-ProvideAssistanceData* and *NR-DL-AoD-RequestLocationInformation* as defined in TS 37.355 [49] clause 6.5.11 shall be provided to the UE during T1. The last TTI containing the two messages shall be provided to the UE ΔT ms before the start of T2, where $\Delta T = 50$ ms is the maximum processing time of the *DL-AoD assistance* data and location information request.

The beginning of the time interval T2 shall be aligned with the first DRX cycle containing a DL PRS resource(s).

5. Configure the Cell for RA-SDT with SIB1 configured according to the message content Table 17.4.1.4.3-1.
6. Ensure the UE is in State RRC_CONNECTED with generic procedure parameters Connectivity *NR*, Connected without release *On*, according to TS 38.508-1 [45] clause 4.5.
3. The SS shall send a RESET UE POSITIONING STORED INFORMATION message.
4. Set the parameters according to Table 17.4.1.5-1 and Table 17.4.1.5-2. Propagation conditions are set according to clause 4.16.2.
5. T1 starts.
6. The SS shall transmit an RRCReconfiguration message with the DRX configuration.
7. The UE shall transmit RRCReconfigurationComplete message.
8. The SS shall transmit an LPP REQUEST CAPABILITIES message.
9. The UE shall transmit an LPP PROVIDE CAPABILITIES message indicating the DL-AoD capabilities supported by the UE in the *NR-DL-AoD-ProvideCapabilities* IE.
10. The SS shall send a LPP PROVIDE ASSISTANCE DATA message, including the *NR-DL-AoD-ProvideAssistanceData* IE. The position of neighbour Cell 2 is described in 3GPP TS 37.571-5 [20]. If the UE message at step 9 includes the *ackRequested* IE set to TRUE, then the SS shall send an acknowledgment in the LPP PROVIDE ASSISTANCE DATA message.
11. The SS shall transmit LCS Periodic-Triggered Invoke Request message with LPP REQUEST LOCATION INFORMATION embedded to start the periodic reporting procedure, including the *NR-DL-AoD-RequestLocationInformation* IE such that the UE receives the message ΔT ms before the start of T2, where $\Delta T = 50$ ms.
12. The UE shall transmit an LCS Periodic-Triggered Invoke Return Result message.
13. When T1 expires, the SS shall transmit an RRCRelease message including SDT configuration to transit the UE to RRC_INACTIVE state and switch the power setting from T1 to T2 as specified in Table 17.4.1.5-1 and Table 17.4.1.5-2.
14. Wait for the UE monitors for occurrence of the periodic event requested.
15. The UE shall transmit an *RRCResumeRequest* message. If the UE also supporting SDT feature, the UE shall include LPP PROVIDE LOCATION INFORMATION message in the *RRCResumeRequest* message and then go to step 19.
16. The SS transmits an *RRCResume* message.
17. The UE transmits an *RRCResumeComplete* message. The time between the start of T2 and the UE send the *RRCResumeRequest* message should meet the requirements specified in TS 38.133 [50] Clause 5.6.3.5.
18. The UE shall transmit a LPP PROVIDE LOCATION INFORMATION message including the *NR-DL-AoD-ProvideLocationInformation* IE within the response time (see clause 4.16.3) plus the maximum RRC processing time 10ms between *RRCResume* message and *RRCResumeComplete* message.
19. The UE shall perform and report the PRS-RSRPP measurements for Cell 2 with respect to the reference cell in the DL-AoD assistance data, Cell 1. If the UE transmits an *NR-DL-AoD-ProvideLocationInformation* IE including the *nr-DL-PRS-FirstPathRSRP-ResultDiff-r17* field for Cell 2 field within the response time then the number of successful tests is increased by one. If the UE fails to report the *NR-DL-AoD-ProvideLocationInformation* IE with the *nr-DL-PRS-FirstPathRSRP-ResultDiff-r17* field included within the response time then the number of failure tests is increased by one.
20. If the UE message at step 19 includes the *ackRequested* IE set to TRUE, the SS shall send a LPP acknowledgement message.
21. UE shall be released and moved to RRC_IDLE.
22. Repeat steps 2-21 in Tables 17.4.1.4-1 until the confidence level according to Annex D is achieved.

17.4.1.4.3 Message contents

Table 17.4.1.4.3-1: SIB1

Derivation Path: TS 38.508-1 [45], clause 4.6.1 with condition SDT

Table 17.4.1.4.3-2: RESET UE POSITIONING STORED INFORMATION

Derivation Path: 38.509 [44] clause 6.6			
Information Element	Value/remark	Comment	Condition
UE Positioning Technology	0 0 0 1 0 0 0	DL-AoD	

Table 17.4.1.4.3-3: RRCReconfiguration

Derivation Path: TS 38.508-1 [45], table 4.6.1-13			
Information Element	Value/remark	Comment	Condition
RRCReconfiguration ::= SEQUENCE {			
criticalExtensions CHOICE {			
rrcReconfiguration SEQUENCE {			
nonCriticalExtension SEQUENCE {			
masterCellGroup	CellGroupConfig		
}			
}			
}			
}			

Table 17.4.1.4.3-4: CellGroupConfig (Table 17.4.1.4.3-3)

Derivation Path: 38.508-1 [45], Table 4.6.3-19			
Information Element	Value/remark	Comment	Condition
CellGroupConfig ::= SEQUENCE {			
mac-CellGroupConfig SEQUENCE {			
drx-Config CHOICE {			
setup SEQUENCE {			
drx-onDurationTimer	ms6		
drx-InactivityTimer	ms1		
drx-HARQ-RTT-TimerDL	sl64		
drx-HARQ-RTT-TimerUL	sl64		
drx-RetransmissionTimerDL	sl1		
drx-RetransmissionTimerUL	sl1		
drx-LongCycleStartOffset CHOICE {			
ms1280	0		
}			
shortDRX	not present		
drx-SlotOffset	0		
}			
}			
}			

Table 17.4.1.4.3-5: LPP Request Capabilities

Information Element	Value/remark
nr-DL-AoD-RequestCapabilities-r16	TRUE

Table 17.4.1.4.3-6: LPP ProvideAssistanceData

Derivation Path: 37.355 clause 6.2			
Information Element	Value/remark	Comment	Condition
LPP-Message ::= SEQUENCE {			

transactionID SEQUENCE {			
initiator	locationServer		
transactionNumber	(0..255)		
}			
endTransaction	TRUE		
sequenceNumber	Not present		
acknowledgement	Not present		
lpp-MessageBody CHOICE {			
c1 CHOICE {			
provideAssistanceData SEQUENCE {			
criticalExtensions CHOICE {			
c1 CHOICE {			
provideAssistanceData-r9 SEQUENCE {			
commonEsProvideAssistanceData	Not present		
a-gnss-ProvideAssistanceData	Not present		
otdoa-ProvideAssistanceData	Not present		
epdu-Provide-AssistanceData	Not present		
sensor-ProvideAssistanceData-r15	Not present		
tbs-ProvideAssistanceData-r15	Not present		
wlan-ProvideAssistanceData-r15	Not present		
nr-Multi-RTT-ProvideAssistanceData-r16	Not present		
nr-DL-AoD-ProvideAssistanceData-r16			
SEQUENCE {			
nr-DL-PRS-AssistanceData-r16	As defined in Table 17.4.1.4.3-7		
nr-SelectedDL-PRS-IndexList-r16	Not present		
nr-PositionCalculationAssistance-r16			Depending on UE capabilities, i.e. support for UE-based DL-AoD
SEQUENCE {			
nr-TRP-LocationInfo-r16	As defined in TS 37.571-5 [20]		
nr-DL-PRS-BeamInfo-r16	Not present		
nr-RTD-Info-r16	Not present		
nr-TRP-BeamAntennaInfo-r17	Not present		
nr-DL-PRS-Expected-LOS-NLOS-Assistance-r17	Not present		
nr-DL-PRS-TRP-TEG-Info-r17	Not present		
}			
nr-DL-AoD-Error-r16	Not present		
nr-DL-PRS-BeamInfo-r17	Not present		
nr-On-Demand-DL-PRS-Configurations-r17	Not present		
}			
nr-DL-TDOA-ProvideAssistanceData-r16	Not present		
}			
}			
}			
}			
}			
}			

Table 17.4.1.4.3-7: NR-DL-PRS-AssistanceData

Derivation Path: 37.355 clause 6.4.3			
Information Element	Value/remark	Comment	Condition
NR-DL-PRS-AssistanceData-r16 ::= SEQUENCE {			
nr-DL-PRS-ReferenceInfo-r16 SEQUENCE {			
dl-PRS-ID-r16	0		
nr-DL-PRS-ResourceID-List-r16	Not present		
nr-DL-PRS-ResourceSetID-r16	Not present		
}			

nr-DL-PRS-AssistanceDataList-r16 SEQUENCE (SIZE (1..nrMaxFreqLayers-r16)) OF NR-DL-PRS-AssistanceDataPerFreq-r16 {	1 entry		
NR-DL-PRS-AssistanceDataPerFreq-r16[1] SEQUENCE {		entry 1	
nr-DL-PRS-PositioningFrequencyLayer-r16 SEQUENCE {			
dl-PRS-SubcarrierSpacing-r16	kHz15		Config 1 and Config 2
	kHz30		Config 3
dl-PRS-ResourceBandwidth-r16	21	104 PRBs	Config 1 and Config 2
	28	132 PRBs	Config 3
dl-PRS-StartPRB-r16	0		
dl-PRS-PointA-r16	absoluteFrequencyPointA as defined for the DL frequency of the Cell 1		
dl-PRS-CombSizeN-r16	n4		
dl-PRS-CyclicPrefix-r16	normal		
}			
nr-DL-PRS-AssistanceDataPerFreq-r16 SEQUENCE (SIZE (1..nrMaxTRPsPerFreq-r16)) OF NR-DL-PRS-AssistanceDataPerTRP-r16{	2 entries		
NR-DL-PRS-AssistanceDataPerTRP-r16[1] SEQUENCE {		entry 1	Cell 1
dl-PRS-ID-r16	0		
nr-PhysCellID-r16	Cell 1		
nr-CellGlobalID-r16	Cell 1		
nr-ARFCN-r16	Cell 1		
nr-DL-PRS-SFN0-Offset-r16 SEQUENCE {			
sfn-Offset-r16	0		
integerSubframeOffset-r16	0		
}			
nr-DL-PRS-ExpectedRSTD-r16	0		
nr-DL-PRS-ExpectedRSTD-Uncertainty-r16	0		
nr-DL-PRS-Info-r16	As specified in Table 17.4.1.4.3-8		
}			
NR-DL-PRS-AssistanceDataPerTRP-r16[2] SEQUENCE {		entry 2	Cell 2
dl-PRS-ID-r16	1		
nr-PhysCellID-r16	Cell 2		
nr-CellGlobalID-r16	Cell 2		
nr-ARFCN-r16	Cell 2		
nr-DL-PRS-SFN0-Offset-r16 SEQUENCE {			
sfn-Offset-r16	0		
integerSubframeOffset-r16	0		
}			
nr-DL-PRS-ExpectedRSTD-r16	23	About 3 μ s	
nr-DL-PRS-ExpectedRSTD-Uncertainty-r16	154	About 5 μ s	
nr-DL-PRS-Info-r16	As specified in Table 17.4.1.4.3-8		
}			
}			
}			
}			
}			

Table 17.4.1.4.3-8: NR-DL-PRS-Info

Derivation Path: 37.355 clause 6.4.3			
Information Element	Value/remark	Comment	Condition
NR-DL-PRS-Info-r16 ::= SEQUENCE {			

nr-DL-PRS-ResourceSetList-r16 SEQUENCE (SIZE (1..nrMaxSetsPerTrp-r16)) OF NR-DL-PRS-ResourceSet-r16 {	1 entry		
NR-DL-PRS-ResourceSet-r16[1] SEQUENCE {		entry 1	
nr-DL-PRS-ResourceSetID-r16	0		
dl-PRS-Periodicity-and-ResourceSetSlotOffset-r16 CHOICE {			
scs15-r16 CHOICE {			Config 1 and Config 2
n160-r16	10		
}			
scs30-r16 CHOICE {			Config 3
n320-r16	20		
}			
dl-PRS-ResourceRepetitionFactor-r16	Not present		
dl-PRS-ResourceTimeGap-r16	s1		
dl-PRS-NumSymbols-r16	n4		
dl-PRS-MutingOption1-r16 SEQUENCE {			
dl-prs-MutingBitRepetitionFactor-r16	Not present		
nr-option1-muting-r16 CHOICE {			
po2-r16	10		Cell 1
	01		Cell 2
}			
dl-PRS-MutingOption2-r16	Not present		
dl-PRS-ResourcePower-r16	27		
dl-PRS-ResourceList-r16 SEQUENCE (SIZE (1..nrMaxResourcesPerSet-r16)) OF NR-DL-PRS-Resource-r16 {	2 entries		
NR-DL-PRS-Resource-r16[1] SEQUENCE {		entry 1	
nr-DL-PRS-ResourceID-r16	0		
dl-PRS-SequenceID-r16	0		
dl-PRS-CombSizeN-AndReOffset-r16 CHOICE {			
n4-r16	0		
}			
dl-PRS-ResourceSlotOffset-r16	4		
dl-PRS-ResourceSymbolOffset-r16	0		
dl-PRS-QCL-Info-r16	Not present		
}			
NR-DL-PRS-Resource-r16[2] SEQUENCE {		entry 2	
nr-DL-PRS-ResourceID-r16	1		
dl-PRS-SequenceID-r16	1		
dl-PRS-CombSizeN-AndReOffset-r16 CHOICE {			
n4-r16	1		
}			
dl-PRS-ResourceSlotOffset-r16	4		
dl-PRS-ResourceSymbolOffset-r16	0		
dl-PRS-QCL-Info-r16	Not present		
}			
}			
}			
}			
}			

Table 17.4.1.4.3-9: lcs-PeriodicTriggeredInvoke

Derivation Path: 24.080 clause 4.4.2			
Information Element	Value/remark	Comment	Condition
LCS-PeriodicTriggeredInvokeArg::= SEQUENCE {			
referenceNumber	LCS-ReferenceNumber		
h-gmlc-address	GSN-Address		
qoS	Not present		
reportingPLMNList	Not present		
periodicLocation SEQUENCE {			

periodicLDRInfo SEQUENCE {			
reportingAmount	5		
reportingInterval	1		
reportingOptionMilliseconds	Not present		
}			
areaEventReporting	Not present		
motionEventReporting	Not present		
referenceNumberExt	LCS-ReferenceNumberExt		
h-gmlc-callBackUri	Not present		
supportedGADShapes	Not present		
deferredRoutingIdentifier	Not present		
reportingAccessTypes	00000001	NR	
multiplePositioningProtocolPDUs SIZE (1..maxNumLPPMsg) OF PositioningProtocolPDU {	1 entry		
PositioningProtocolPDU[1] SEQUENCE {		entry 1	
PositioningProtocolPDU	Contains a LPP RequestLocationInformation message defined in Table 17.4.1.4.3-10		
}			
}			
controlPlane-CIoT-5GS-Optimisation	Not present		
scheduledLocTime	Not present		
eventReportAllowedArea	Not present		
}			

Table 17.4.1.4.3-10: LPP RequestLocationInformation

Derivation Path: 37.355 clause 6.2			
Information Element	Value/remark	Comment	Condition
LPP-Message ::= SEQUENCE {			
transactionID SEQUENCE {			
initiator	locationServer		
transactionNumber	1		
}			
endTransaction	FALSE		
sequenceNumber	Not present		
acknowledgement	Not present		
lpp-MessageBody CHOICE {			
c1 CHOICE {			
requestLocationInformation SEQUENCE {			
criticalExtensions CHOICE {			
c1 CHOICE {			
requestLocationInformation-r9 SEQUENCE {			
commonEsRequestLocationInformation SEQUENCE {			
locationInformationType	locationMeasurementsRequired		
triggeredReporting	Not present		
periodicalReporting	Not present		
additionalInformation	onlyReturnInformationRequested		
qos SEQUENCE {			
horizontalAccuracy	Not present		
verticalCoordinateRequest	FALSE		
verticalAccuracy	Not present		
responseTime SEQUENCE {			
time	See 17.4.1.5	Result of the response time calculation rounded up to the next second if response time <= 128s.	

		Result of the response time calculation rounded up to the next multiple of ten seconds if response time > 128s.	
responseTimeEarlyFix-r12	Not present		Rel-12 onwards
unit-r15	Not present ten-seconds		Calculated response time >128s
}			
velocityRequest	FALSE		
}			
environment	Not present		
locationCoordinateTypes	Not present		
velocityTypes	Not present		
}			
a-gnss-RequestLocationInformation	Not present		
otdoa-RequestLocationInformation	Not present		
ecid-RequestLocationInformation	Not present		
epdu-RequestLocationInformation	Not Present		
sensor-RequestLocationInformation-r13	Not present		
tbs-RequestLocationInformation-r13	Not present		
wlan-RequestLocationInformation-r13	Not present		
bt-RequestLocationInformation-r13	Not present		
nr-ECID-RequestLocationInformation-r16	Not present		
nr-Multi-RTT-RequestLocationInformation-r16	Not present		
nr-DL-AoD-RequestLocationInformation-r16			
SEQUENCE {			
nr-AssistanceAvailability-r16	FALSE		
nr-DL-AoD-ReportConfig-r16 SEQUENCE {			
maxDL-PRS-RSRP-MeasurementsPerTRP-r16	Not present		
maxDL-PRS-RSRP-MeasurementsPerTRP-r17	Not present		
maxDL-PRS-RSRP-MeasurementsPerTRP-r17	Present. Set depending on UE capabilities.		
nr-los-nlos-IndicatorRequest-r17	Not present		
reducedDL-PRS-ProcessingSamples-r17	Not present		
lowerRxBeamSweepingFactor-FR2-r17	Not present		
}			
multiMeasInSameReport-r17			
}			
nr-DL-TDOA-RequestLocationInformation-r16	Not present		
}			
}			
}			
}			
}			
}			

Table 17.4.1.4.3-11: RRCRelease

Derivation Path: TS 38.508-1 [45], Table 4.6.1-16 with condition NR_RRC_INACTIVE and SDT

Table 17.4.1.4.3-12: LPP ProvideLocation Information

Derivation Path: 37.355 clause 6.5.12			
Information Element	Value/remark	Comment	Condition
LPP-Message ::= SEQUENCE {			

transactionID SEQUENCE {			
initiator	locationServer		
transactionNumber	1		
}			
endTransaction	TRUE		
sequenceNumber	(0..255)		
acknowledgement			
lpp-MessageBody CHOICE {			
c1 CHOICE {			
provideLocationInformation SEQUENCE {			
criticalExtensions CHOICE {			
c1 CHOICE {			
provideLocationInformation-r9 SEQUENCE {			
commonIEsProvideLocationInformation	Not present.		
a-gnss-ProvideLocationInformation	Not present		
otdoa-ProvideLocationInformation	Not present		
ecid-ProvideLocationInformation	Not present		
epdu-ProvideLocationInformation	Not present		
sensor-ProvideLocationInformation-r13	Not present		
tbs-ProvideLocationInformation-r13	Not present		
wlan-ProvideLocationInformation-r13	Not present		
bt-ProvideLocationInformation-r13	Not present		
nr-ECID-ProvideLocationInformation-r16	Not present		
nr-Multi-RTT-ProvideLocationInformation-	Not present		
r16			
nr-DL-AoD-ProvideLocationInformation-r16			
SEQUENCE {			
nr-DL-AoD-			
SignalMeasurementInformation-r16 SEQUENCE {			
nr-DL-AoD-MeasList-r16 SEQUENCE			
(SIZE(1..nrMaxTRPs-r16)) OF NR-DL-AoD-			
MeasElement-r16 {			
NR-DL-AoD-MeasElement-r16[1]		entry 1	
SEQUENCE {			
dl-PRS-ID-r16	INTEGER (0..255)		
nr-PhysCellID-r16	Cell 1		
nr-CellGlobalID-r16			
nr-ARFCN-r16			
nr-DL-PRS-ResourceID-r16			
nr-DL-PRS-ResourceSetID-r16			
nr-TimeStamp-r16			
nr-DL-PRS-RSRP-Result-r16	Present. Any value acceptable.		
nr-DL-PRS-RxBeamIndex-r16			
r16			
nr-DL-AoD-AdditionalMeasurements-			
nr-DL-PRS-FirstPathRSRP-Result-r17	Present. Any value acceptable.		
nr-los-nlos-Indicator-r17			
nr-DL-AoD-			
AdditionalMeasurementsExt-r17			
}			
NR-DL-AoD-MeasElement-r16[2]		entry 2	
SEQUENCE {			
dl-PRS-ID-r16	INTEGER (0..255)		
nr-PhysCellID-r16	Cell 2		
nr-CellGlobalID-r16			
nr-ARFCN-r16			
nr-DL-PRS-ResourceID-r16			
nr-DL-PRS-ResourceSetID-r16			
nr-TimeStamp-r16			
nr-DL-PRS-RSRP-Result-r16	Present. Any value acceptable.		
nr-DL-PRS-RxBeamIndex-r16			
r16			
nr-DL-AoD-AdditionalMeasurements-			

nr-DL-PRS-FirstPathRSRP-Result-r17	Present. Any value acceptable.		
nr-los-nlos-Indicator-r17			
nr-DL-AoD-AdditionalMeasurementsExt-r17			
}			
}			
}			
nr-dl-AoD-LocationInformation-r16			
nr-DL-AoD-Error-r16	Not present		
nr-DL-AoD-SignalMeasurementInstances-r17	Not present		
nr-DL-AoD-LocationInformationInstances-r17	Not present		
}			
}			
}			
}			
}			
}			
}			
}			
}			

17.4.1.5 Test requirement

FFS

17.4.2 PRS-RSRPP measurement reporting delay test case for single positioning frequency layer with reduced number of samples in FR1 SA

Editor’s note: This test case is incomplete. The following aspect is either missing or TBD:

- Test tolerance are not added in and analysis is missing

17.4.2.1 Test purpose

The purpose of the test is to verify that the PRS-RSRPP measurement in RRC_INACTIVE state meets the requirements specified in TS 38.133 [50] clause 5.6.5.5 in FR1 in standalone scenario when single positioning frequency layer is configured and reduce sample measurements are requested by the LMF.

17.4.2.2 Test applicability

This test applies to all types of NR UE release 17 onwards that supports DL-AoD positioning, maxDL-PRS-FirstPathRSRP-MeasPerTRP and supportedDL-PRS-ProcessingSamples-RRC-Inactive.

17.4.2.3 Minimum conformance requirements

Same as defined in clause 16.4.3.3.

17.4.2.4 Test description

17.4.2.4.1 Initial conditions

The test defines three possible test configurations; specified in Table 17.4.2.4-1. The UE is only required to be tested in one of the supported test configurations.

Table 17.4.2.4-1: Test Configurations

Test Configuration	Description
1	15 kHz SSB SCS, 10 MHz bandwidth, FDD duplex mode
2	15 kHz SSB SCS, 10 MHz bandwidth, TDD duplex mode
3	30 kHz SSB SCS, 40 MHz bandwidth, TDD duplex mode
Note:	The UE is only required to be tested in one of the supported test configurations.

Test Environment: Normal, as defined in TS 38.508-1 [45] clause 4.1.

Frequencies to be tested: Mid Range, as defined in TS 38.508-1 [45] clause 4.3.1.

Channel bandwidth to be tested: are specified in Table 17.4.2.4-1.

1. Connect the SS and AWGN noise sources to the UE antenna connector or antenna connectors as shown in Annex A, Figure A.13.
2. The general test parameter settings are set up according to Table 17.4.2.5-1 and Table 17.4.2.5-2.
3. Propagation conditions are set according to clause 4.16.2.
4. Message contents are defined in clause 17.4.2.4.3.
5. There are two cells in the test: PCell (Cell 1) and a neighbour cell (Cell 2). All cells are on the same RF channel in FR1.

17.4.2.4.2 Test procedure

Same as defined in clause 17.4.1.4.2.

17.4.2.4.3 Message contents

As defined in clause 17.4.1.4.3, with the following exceptions:

Table 17.4.2.4.3-1 replaces Table 17.4.1.4.3-6 and Table 17.4.2.4.3-2 replaces Table 17.4.1.4.3-9.

Table 17.4.2.4.3-1: NR-DL-PRS-AssistanceData

Derivation Path: 37.355 clause 6.4.3			
Information Element	Value/remark	Comment	Condition
NR-DL-PRS-AssistanceData-r16 ::= SEQUENCE {			
nr-DL-PRS-ReferenceInfo-r16 SEQUENCE {			
dl-PRS-ID-r16	0		
nr-DL-PRS-ResourceID-List-r16	Not present		
nr-DL-PRS-ResourceSetID-r16	Not present		
}			
nr-DL-PRS-AssistanceDataList-r16 SEQUENCE (SIZE (1..nrMaxFreqLayers-r16)) OF NR-DL-PRS-AssistanceDataPerFreq-r16 {	1 entry		
NR-DL-PRS-AssistanceDataPerFreq-r16[1] SEQUENCE {		entry 1	
nr-DL-PRS-PositioningFrequencyLayer-r16 SEQUENCE {			
dl-PRS-SubcarrierSpacing-r16	kHz15		Config 1 and Config 2
	kHz30		Config 3
dl-PRS-ResourceBandwidth-r16	7	48 PRBs	
dl-PRS-StartPRB-r16	0		
dl-PRS-PointA-r16	absoluteFrequencyPointA as defined for the DL frequency of the Cell 1		
dl-PRS-CombSizeN-r16	n4		
dl-PRS-CyclicPrefix-r16	normal		
}			

nr-DL-PRS-AssistanceDataPerFreq-r16 SEQUENCE (SIZE (1..nrMaxTRPsPerFreq-r16)) OF NR-DL-PRS-AssistanceDataPerTRP-r16{	2 entries		
NR-DL-PRS-AssistanceDataPerTRP-r16[1] SEQUENCE {		entry 1	Cell 1
dl-PRS-ID-r16	0		
nr-PhysCellID-r16	Cell 1		
nr-CellGlobalID-r16	Cell 1		
nr-ARFCN-r16	Cell 1		
nr-DL-PRS-SFN0-Offset-r16 SEQUENCE {			
sfn-Offset-r16	0		
integerSubframeOffset-r16	0		
}			
nr-DL-PRS-ExpectedRSTD-r16	0		
nr-DL-PRS-ExpectedRSTD-Uncertainty-r16	0		
nr-DL-PRS-Info-r16	As specified in Table 17.4.1.4.3-7		
}			
NR-DL-PRS-AssistanceDataPerTRP-r16[2] SEQUENCE {		entry 2	Cell 2
dl-PRS-ID-r16	1		
nr-PhysCellID-r16	Cell 2		
nr-CellGlobalID-r16	Cell 2		
nr-ARFCN-r16	Cell 2		
nr-DL-PRS-SFN0-Offset-r16 SEQUENCE {			
sfn-Offset-r16	0		
integerSubframeOffset-r16	0		
}			
nr-DL-PRS-ExpectedRSTD-r16	23	About 3 μs	
nr-DL-PRS-ExpectedRSTD-Uncertainty-r16	154	About 5 μs	
nr-DL-PRS-Info-r16	As specified in Table 17.4.1.4.3-7		
}			
}			
}			
}			
}			

Table 17.4.2.4.3-2: LPP RequestLocationInformation

Derivation Path: 37.355 clause 6.2			
Information Element	Value/remark	Comment	Condition
LPP-Message ::= SEQUENCE {			
transactionID SEQUENCE {			
initiator	locationServer		
transactionNumber	1		
}			
endTransaction	FALSE		
sequenceNumber	Not present		
acknowledgement	Not present		
lpp-MessageBody CHOICE {			
c1 CHOICE {			
requestLocationInformation SEQUENCE {			
criticalExtensions CHOICE {			
c1 CHOICE {			
requestLocationInformation-r9 SEQUENCE {			
commonEsRequestLocationInformation SEQUENCE {			
locationInformationType	locationMeasurementsRequired		
triggeredReporting	Not present		
periodicalReporting	Not present		
additionalInformation	onlyReturnInformationRequested		
qos SEQUENCE {			

horizontalAccuracy	Not present		
verticalCoordinateRequest	FALSE		
verticalAccuracy	Not present		
responseTime SEQUENCE { time	See 17.4.2.5	Result of the response time calculation rounded up to the next second if response time <= 128s. Result of the response time calculation rounded up to the next multiple of ten seconds if response time > 128s.	
responseTimeEarlyFix-r12	Not present		Rel-12 onwards
unit-r15	Not present		Calculated response time >128s
	ten-seconds		
}			
velocityRequest	FALSE		
}			
environment	Not present		
locationCoordinateTypes	Not present		
velocityTypes	Not present		
}			
a-gnss-RequestLocationInformation	Not present		
otdoa-RequestLocationInformation	Not present		
ecid-RequestLocationInformation	Not present		
epdu-RequestLocationInformation	Not Present		
sensor-RequestLocationInformation-r13	Not present		
tbs-RequestLocationInformation-r13	Not present		
wlan-RequestLocationInformation-r13	Not present		
bt-RequestLocationInformation-r13	Not present		
nr-ECID-RequestLocationInformation-r16	Not present		
nr-Multi-RTT-RequestLocationInformation-r16	Not present		
nr-DL-AoD-RequestLocationInformation-r16			
SEQUENCE {			
nr-AssistanceAvailability-r16	FALSE		
nr-DL-AoD-ReportConfig-r16 SEQUENCE {			
maxDL-PRS-RSRP-MeasurementsPerTRP-r16	Not present		
maxDL-PRS-RSRP-MeasurementsPerTRP-r17	Not present		
maxDL-PRS-RSRPP-MeasurementsPerTRP-r17	Present. Set depending on UE capabilities.		
nr-los-nlos-IndicatorRequest-r17	Not present		
reducedDL-PRS-ProcessingSamples-r17	requested		
lowerRxBeamSweepingFactor-FR2-r17	Not present		
}			
multiMeasInSameReport-r17			
}			
nr-DL-TDOA-RequestLocationInformation-r16	Not present		
}			
}			
}			
}			
}			

17.4.2.5 Test requirement

FFS

17.4.3 PRS-RSRPP measurement reporting delay test case for single positioning frequency layer in FR2 SA

Editor's note: This test case is incomplete. The following aspect is either missing or TBD:

- Test tolerance are not added in and analysis is missing

17.4.3.1 Test purpose

The purpose of the test is to verify that the PRS-RSRPP measurement in RRC_INACTIVE state meets the requirements specified in TS 38.133 [50] clause 5.6.3.5 in FR2 in standalone scenario when single positioning frequency layer is configured.

17.4.3.2 Test applicability

This test applies to all types of NR UE release 17 onwards that supports DL-AoD positioning, maxDL-PRS-FirstPathRSRP-MeasPerTRP and DL-PRS measurement in RRC_INACTIVE state.

17.4.3.3 Minimum conformance requirements

Same as defined in clause 16.4.3.3.

17.4.3.4 Test description

17.4.3.4.1 Initial conditions

The supported test configurations in listed in Table 17.4.3.4.1-1

Table 17.4.3.4.1-1: Supported test configurations

Config	Description
1	120 kHz SSB and PRS SCS, 200 MHz bandwidth, TDD duplex mode

Test Environment: Normal, as defined in TS 38.508-1 [45] clause 4.1.

Frequencies to be tested: Mid Range, as defined in TS 38.508-1 [45] clause 4.3.1.

Channel bandwidth to be tested: are specified in Table 17.4.3.4.1-1.

1. Connect the SS and AWGN noise sources to the UE antenna connector or antenna connectors as shown in Annex A, Figure A.14.
2. The general test parameter settings are set up according to Table 17.4.3.5-1 and Table 17.4.3.5-2.
3. Propagation conditions are set according to clause 4.16.2.
4. Message contents are defined in clause 17.4.3.4.3.
5. There are two cells in the test: PCell (Cell 1) and a neighbour cell (Cell 2). All cells are on the same RF channel in FR2.

17.4.3.4.2 Test procedure

Same as defined in clause 17.4.1.4.2.

17.4.3.4.3 Message contents

As defined in clause 17.4.1.4.3, with the following exceptions:

Table 17.4.3.4.3-1 replaces Table 17.4.1.4.3-3, Table 17.4.3.4.3-2 replaces Table 17.4.1.4.3-6 and Table 17.4.3.4.3-3 replaces Table 17.4.1.4.3-7.

Table 17.4.3.4.3-1: CellGroupConfig

Derivation Path: 38.508-1 [45], Table 4.6.3-19			
Information Element	Value/remark	Comment	Condition
CellGroupConfig ::= SEQUENCE {			
mac-CellGroupConfig SEQUENCE {			
drx-Config CHOICE {			
setup SEQUENCE {			
drx-onDurationTimer	ms6		
drx-InactivityTimer	ms1		
drx-HARQ-RTT-TimerDL	sl64		
drx-HARQ-RTT-TimerUL	sl64		
drx-RetransmissionTimerDL	sl1		
drx-RetransmissionTimerUL	sl1		
drx-LongCycleStartOffset CHOICE {			
ms640	0		
}			
shortDRX	not present		
drx-SlotOffset	0		
}			
}			

Table 17.4.3.4.3-2: NR-DL-PRS-AssistanceData

Derivation Path: 37.355 clause 6.4.3			
Information Element	Value/remark	Comment	Condition
NR-DL-PRS-AssistanceData-r16 ::= SEQUENCE {			
nr-DL-PRS-ReferenceInfo-r16 SEQUENCE {			
dl-PRS-ID-r16	0		
nr-DL-PRS-ResourceID-List-r16	Not present		
nr-DL-PRS-ResourceSetID-r16	Not present		
}			
nr-DL-PRS-AssistanceDataList-r16 SEQUENCE (SIZE (1..nrMaxFreqLayers-r16)) OF NR-DL-PRS-AssistanceDataPerFreq-r16 {	1 entry		
NR-DL-PRS-AssistanceDataPerFreq-r16[1] SEQUENCE {		entry 1	
nr-DL-PRS-PositioningFrequencyLayer-r16 SEQUENCE {			
dl-PRS-SubcarrierSpacing-r16	kHz120		
dl-PRS-ResourceBandwidth-r16	27	128 PRBs	
dl-PRS-StartPRB-r16	0		
dl-PRS-PointA-r16	absoluteFrequencyPointA as defined for the DL frequency of the Cell 1		
dl-PRS-CombSizeN-r16	n4		
dl-PRS-CyclicPrefix-r16	normal		
}			
nr-DL-PRS-AssistanceDataPerFreq-r16 SEQUENCE (SIZE (1..nrMaxTRPsPerFreq-r16)) OF NR-DL-PRS-AssistanceDataPerTRP-r16{	2 entries		
NR-DL-PRS-AssistanceDataPerTRP-r16[1] SEQUENCE {		entry 1	Cell 1
dl-PRS-ID-r16	0		
nr-PhysCellID-r16	Cell 1		
nr-CellGlobalID-r16	Cell 1		
}			
}			

nr-ARFCN-r16	Cell 1		
nr-DL-PRS-SFN0-Offset-r16 SEQUENCE {			
sfn-Offset-r16	0		
integerSubframeOffset-r16	0		
}			
nr-DL-PRS-ExpectedRSTD-r16	0		
nr-DL-PRS-ExpectedRSTD-Uncertainty-r16	0		
nr-DL-PRS-Info-r16	As specified in Table 17.4.3.4.3-3		
}			
NR-DL-PRS-AssistanceDataPerTRP-r16[2] SEQUENCE {		entry 2	Cell 2
dl-PRS-ID-r16	1		
nr-PhysCellID-r16	Cell 2		
nr-CellGlobalID-r16	Cell 2		
nr-ARFCN-r16	Cell 2		
nr-DL-PRS-SFN0-Offset-r16 SEQUENCE {			
sfn-Offset-r16	0		
integerSubframeOffset-r16	0		
}			
nr-DL-PRS-ExpectedRSTD-r16	23	About 3 μs	
nr-DL-PRS-ExpectedRSTD-Uncertainty-r16	154	About 5 μs	
nr-DL-PRS-Info-r16	As specified in Table 17.4.3.4.3-3		
}			
}			
}			
}			
}			

Table 17.4.3.4.3-3: NR-DL-PRS-Info

Derivation Path: 37.355 clause 6.4.3			
Information Element	Value/remark	Comment	Condition
NR-DL-PRS-Info-r16 ::= SEQUENCE {			
nr-DL-PRS-ResourceSetList-r16 SEQUENCE (SIZE (1..nrMaxSetsPerTrp-r16)) OF NR-DL-PRS-ResourceSet-r16 {	1 entry		
NR-DL-PRS-ResourceSet-r16[1] SEQUENCE {		entry 1	
nr-DL-PRS-ResourceSetID-r16	0		
dl-PRS-Periodicity-and-ResourceSetSlotOffset-r16 CHOICE {			
scs120-r16 CHOICE {			
n1280-r16	80		
}			
dl-PRS-ResourceRepetitionFactor-r16	Not present		
dl-PRS-ResourceTimeGap-r16	s1		
dl-PRS-NumSymbols-r16	n4		
dl-PRS-MutingOption1-r16 SEQUENCE {			
dl-prs-MutingBitRepetitionFactor-r16	Not present		
nr-option1-muting-r16 CHOICE {			
po2-r16	10		Cell 1
	01		Cell 2
}			
}			
}			
dl-PRS-MutingOption2-r16	Not present		
dl-PRS-ResourcePower-r16	27		
dl-PRS-ResourceList-r16 SEQUENCE (SIZE (1..nrMaxResourcesPerSet-r16)) OF NR-DL-PRS-Resource-r16 {	2 entries		
NR-DL-PRS-Resource-r16[1] SEQUENCE {		entry 1	
nr-DL-PRS-ResourceID-r16	0		
dl-PRS-SequenceID-r16	0		
dl-PRS-CombSizeN-AndReOffset-r16 CHOICE {			

n4-r16	0		
}			
dl-PRS-ResourceSlotOffset-r16	4		
dl-PRS-ResourceSymbolOffset-r16	0		
dl-PRS-QCL-Info-r16	Not present		
}			
NR-DL-PRS-Resource-r16[2] SEQUENCE {		entry 2	
nr-DL-PRS-ResourceID-r16	1		
dl-PRS-SequenceID-r16	1		
dl-PRS-CombSizeN-AndReOffset-r16 CHOICE {			
n4-r16	1		
}			
dl-PRS-ResourceSlotOffset-r16	4		
dl-PRS-ResourceSymbolOffset-r16	0		
dl-PRS-QCL-Info-r16	Not present		
}			
}			
}			
}			
}			

17.4.3.5 Test requirement

FFS

17.4.4 PRS-RSRPP measurement reporting delay test case for single positioning frequency layer with reduced number of samples in FR2 SA

Editor’s note: This test case is incomplete. The following aspect is either missing or TBD:

- Test tolerance are not added in and analysis is missing

17.4.4.1 Test purpose

The purpose of the test is to verify the PRS RSRPP measurement requirements specified in TS 38.133 [50] clause 5.6.5.5 for single positioning frequency layer under AWGN propagation conditions in FR2 standalone scenario for reduced number of samples

17.4.4.2 Test applicability

This test applies to all types of NR UE release 17 onwards that supports DL-AoD positioning, maxDL-PRS-FirstPathRSRP-MeasPerTRP and supportedDL-PRS-ProcessingSamples-RRC-Inactive.

17.4.4.3 Minimum conformance requirements

Same as defined in clause 16.4.3.3.

17.4.4.4 Test description

17.4.4.4.1 Initial conditions

The supported test configurations in listed in Table 17.4.4.4.1-1

Table 17.4.4.4.1-1: Supported test configurations

Config	Description
1	120 kHz SSB and PRS SCS, 200 MHz bandwidth, TDD duplex mode

Test Environment: Normal, as defined in TS 38.508-1 [45] clause 4.1.

Frequencies to be tested: Mid Range, as defined in TS 38.508-1 [45] clause 4.3.1.

Channel bandwidth to be tested: are specified in Table 17.4.4.4.1-1.

1. Connect the SS and AWGN noise sources to the UE antenna connector or antenna connectors as shown in Annex A, Figure A.14.
2. The general test parameter settings are set up according to Table 17.4.4.5-1 and Table 17.4.4.5-2.
3. Propagation conditions are set according to clause 4.16.2.
4. Message contents are defined in clause 17.4.4.4.3.
5. There are two cells in the test: PCell (Cell 1) and a neighbour cell (Cell 2). All cells are on the same RF channel in FR2.

17.4.4.4.2 Test procedure

Same as defined in clause 17.4.1.4.2.

17.4.4.4.3 Message contents

As defined in clause 17.4.1.4.3, with the following exceptions:

Table 17.4.4.4.3-1 replaces Table 17.4.1.4.3-3, Table 17.4.4.4.3-2 replaces Table 17.4.1.4.3-6, Table 17.4.4.4.3-3 replaces Table 17.4.1.4.3-7 and Table 17.4.4.4.3-4 replaces Table 17.4.1.4.3-9.

Table 17.4.4.4.3-1: CellGroupConfig

Derivation Path: 38.508-1 [45], Table 4.6.3-19			
Information Element	Value/remark	Comment	Condition
CellGroupConfig ::= SEQUENCE {			
mac-CellGroupConfig SEQUENCE {			
drx-Config CHOICE {			
setup SEQUENCE {			
drx-onDurationTimer	ms6		
drx-InactivityTimer	ms1		
drx-HARQ-RTT-TimerDL	sl64		
drx-HARQ-RTT-TimerUL	sl64		
drx-RetransmissionTimerDL	sl1		
drx-RetransmissionTimerUL	sl1		
drx-LongCycleStartOffset CHOICE {			
ms640	0		
}			
shortDRX	not present		
drx-SlotOffset	0		
}			
}			

Table 17.4.4.4.3-2: NR-DL-PRS-AssistanceData

Derivation Path: 37.355 clause 6.4.3			
Information Element	Value/remark	Comment	Condition
NR-DL-PRS-AssistanceData-r16 ::= SEQUENCE {			
nr-DL-PRS-ReferenceInfo-r16 SEQUENCE {			
dl-PRS-ID-r16	0		
nr-DL-PRS-ResourceID-List-r16	Not present		
nr-DL-PRS-ResourceSetID-r16	Not present		
}			

nr-DL-PRS-AssistanceDataList-r16 SEQUENCE (SIZE (1..nrMaxFreqLayers-r16)) OF NR-DL-PRS-AssistanceDataPerFreq-r16 {	1 entry		
NR-DL-PRS-AssistanceDataPerFreq-r16[1] SEQUENCE {		entry 1	
nr-DL-PRS-PositioningFrequencyLayer-r16 SEQUENCE {			
dl-PRS-SubcarrierSpacing-r16	kHz120		
dl-PRS-ResourceBandwidth-r16	7	48 PRBs	
dl-PRS-StartPRB-r16	0		
dl-PRS-PointA-r16	absoluteFrequencyPointA as defined for the DL frequency of the Cell 1		
dl-PRS-CombSizeN-r16	n4		
dl-PRS-CyclicPrefix-r16	normal		
}			
nr-DL-PRS-AssistanceDataPerFreq-r16 SEQUENCE (SIZE (1..nrMaxTRPsPerFreq-r16)) OF NR-DL-PRS-AssistanceDataPerTRP-r16{	2 entries		
NR-DL-PRS-AssistanceDataPerTRP-r16[1] SEQUENCE {		entry 1	Cell 1
dl-PRS-ID-r16	0		
nr-PhysCellID-r16	Cell 1		
nr-CellGlobalID-r16	Cell 1		
nr-ARFCN-r16	Cell 1		
nr-DL-PRS-SFN0-Offset-r16 SEQUENCE {			
sfn-Offset-r16	0		
integerSubframeOffset-r16	0		
}			
nr-DL-PRS-ExpectedRSTD-r16	0		
nr-DL-PRS-ExpectedRSTD-Uncertainty-r16	0		
nr-DL-PRS-Info-r16	As specified in Table 17.4.4.4.3-3		
}			
NR-DL-PRS-AssistanceDataPerTRP-r16[2] SEQUENCE {		entry 2	Cell 2
dl-PRS-ID-r16	1		
nr-PhysCellID-r16	Cell 2		
nr-CellGlobalID-r16	Cell 2		
nr-ARFCN-r16	Cell 2		
nr-DL-PRS-SFN0-Offset-r16 SEQUENCE {			
sfn-Offset-r16	0		
integerSubframeOffset-r16	0		
}			
nr-DL-PRS-ExpectedRSTD-r16	23	About 3 μs	
nr-DL-PRS-ExpectedRSTD-Uncertainty-r16	154	About 5 μs	
nr-DL-PRS-Info-r16	As specified in Table 17.4.4.4.3-3		
}			
}			
}			
}			
}			

Table 17.4.4.4.3-3: NR-DL-PRS-Info

Derivation Path: 37.355 clause 6.4.3			
Information Element	Value/remark	Comment	Condition
NR-DL-PRS-Info-r16 ::= SEQUENCE {			
nr-DL-PRS-ResourceSetList-r16 SEQUENCE (SIZE (1..nrMaxSetsPerTrp-r16)) OF NR-DL-PRS-ResourceSet-r16 {	1 entry		
NR-DL-PRS-ResourceSet-r16[1] SEQUENCE {		entry 1	
nr-DL-PRS-ResourceSetID-r16	0		

SEQUENCE {			
locationInformationType	locationMeasurementsRequired		
triggeredReporting	Not present		
periodicalReporting	Not present		
additionalInformation	onlyReturnInformationRequested		
qos SEQUENCE {			
horizontalAccuracy	Not present		
verticalCoordinateRequest	FALSE		
verticalAccuracy	Not present		
responseTime SEQUENCE {			
time	See 17.4.4.5	Result of the response time calculation rounded up to the next second if response time <= 128s. Result of the response time calculation rounded up to the next multiple of ten seconds if response time > 128s.	
responseTimeEarlyFix-r12	Not present		Rel-12 onwards
unit-r15	Not present		
	ten-seconds		Calculated response time >128s
}			
velocityRequest	FALSE		
}			
environment	Not present		
locationCoordinateTypes	Not present		
velocityTypes	Not present		
}			
a-gnss-RequestLocationInformation	Not present		
otdoa-RequestLocationInformation	Not present		
ecid-RequestLocationInformation	Not present		
epdu-RequestLocationInformation	Not Present		
sensor-RequestLocationInformation-r13	Not present		
tbs-RequestLocationInformation-r13	Not present		
wlan-RequestLocationInformation-r13	Not present		
bt-RequestLocationInformation-r13	Not present		
nr-ECID-RequestLocationInformation-r16	Not present		
nr-Multi-RTT-RequestLocationInformation-r16	Not present		
nr-DL-AoD-RequestLocationInformation-r16			
SEQUENCE {			
nr-AssistanceAvailability-r16	FALSE		
nr-DL-AoD-ReportConfig-r16 SEQUENCE {			
r16 maxDL-PRS-RSRP-MeasurementsPerTRP-	Not present		
r17 maxDL-PRS-RSRP-MeasurementsPerTRP-	Not present		
MeasurementsPerTRP-r17	Present. Set depending on UE capabilities.		
nr-los-nlos-IndicatorRequest-r17	Not present		
reducedDL-PRS-ProcessingSamples-r17	requested		
lowerRxBeamSweepingFactor-FR2-r17	Not present		
}			
multiMeasInSameReport-r17			
}			
nr-DL-TDOA-RequestLocationInformation-r16	Not present		

}			
}			
}			
}			
}			
}			

17.4.4.5 Test requirement

FFS

17.5 NR PRS-RSRPP measurement accuracy test case in RRC_INACTIVE

17.5.1 PRS-RSRPP measurement accuracy test case for single positioning frequency layer in FR1 SA

Editor’s note: This test case is incomplete. The following aspect is either missing or TBD:

- Test tolerance are not added in and analysis is missing

17.5.1.1 Test purpose

The purpose of the test is to verify that the PRS-RSRPP measurement in RRC_INACTIVE state meets the requirements specified in TS 38.133 [50] clause 10.1.38.2 in FR1 in standalone scenario when single positioning frequency layer is configured.

17.5.1.2 Test applicability

This test applies to all types of NR UE release 17 onwards that supports DL-AoD positioning, maxDL-PRS-FirstPathRSRP-MeasPerTRP and DL-PRS measurement in RRC_INACTIVE state.

17.5.1.3 Minimum conformance requirements

Same as defined in clause 17.3.1.3.

17.5.1.4 Test description

17.5.1.4.1 Initial conditions

The test defines three possible test configurations; specified in Table 17.5.1.4-1. The UE is only required to be tested in one of the supported test configurations.

Table 17.5.1.4-1: Test Configurations

Test Configuration	Description
1	15 kHz SSB SCS, 10 MHz bandwidth, FDD duplex mode
2	15 kHz SSB SCS, 10 MHz bandwidth, TDD duplex mode
3	30 kHz SSB SCS, 40 MHz bandwidth, TDD duplex mode
Note:	The UE is only required to be tested in one of the supported test configurations.

Test Environment: Normal, as defined in TS 38.508-1 [45] clause 4.1.

Frequencies to be tested: Mid Range, as defined in TS 38.508-1 [45] clause 4.3.1.

Channel bandwidth to be tested: are specified in Table 17.5.1.4-1.

1. Connect the SS and AWGN noise sources to the UE antenna connector or antenna connectors as shown in Annex A, Figure A.13.
2. The general test parameter settings are set up according to Table 17.5.1.5-1.
3. Propagation conditions are set according to clause 4.16.2.
4. Message contents are defined in clause 17.5.1.4.3.
5. There are two cells in the test: PCell (Cell 1) and a neighbour cell (Cell 2). All cells are on the same RF channel in FR1.

17.5.1.4.2 Test procedure

The test consists of a set-up period and a measurement period. During the set-up period, the UE shall be in RRC_CONNECTED state and shall not have any timing information of Cell 2. During measurement period, the UE shall be in RRC_INACTIVE state and all cells transmit PRS resources within initial DL BWP of the UE and with the same numerology as the initial DL BWP. The test consists of two sub-tests; the difference between the sub-tests is the PRS configuration.

The *NR-DL-AoD-ProvideAssistanceData* and *NR-DL-AoD-RequestLocationInformation* as defined in TS 37.355 [49] clause 6.5.11 shall be provided to the UE during set-up period. The beginning of the measurement period shall be aligned with the first DRX cycle containing a DL PRS resource(s).

7. Configure the Cell for RA-SDT with SIB1 configured according to the message content Table 17.4.1.4.3-1.
8. Ensure the UE is in State RRC_CONNECTED with generic procedure parameters Connectivity *NR*, Connected without release *On*, according to TS 38.508-1 [45] clause 4.5.
3. The SS shall send a RESET UE POSITIONING STORED INFORMATION message.
4. Set the parameters according to Table 17.5.1.5-1. Propagation conditions are set according to clause 4.16.2.
5. The SS shall transmit an RRCReconfiguration message with the DRX configuration.
6. The UE shall transmit RRCReconfigurationComplete message.
7. The SS shall transmit an LPP REQUEST CAPABILITIES message.
8. The UE shall transmit an LPP PROVIDE CAPABILITIES message indicating the DL-AoD capabilities supported by the UE in the *NR-DL-AoD-ProvideCapabilities* IE.
9. The SS shall send a LPP PROVIDE ASSISTANCE DATA message, including the *NR-DL-AoD-ProvideAssistanceData* IE. The position of neighbour Cell 2 is described in 3GPP TS 37.571-5 [20]. If the UE message at step 8 includes the *ackRequested* IE set to TRUE, then the SS shall send an acknowledgment in the LPP PROVIDE ASSISTANCE DATA message.
10. The SS shall transmit LCS Periodic-Triggered Invoke Request message with LPP REQUEST LOCATION INFORMATION embedded to start the periodic reporting procedure, including the *NR-DL-AoD-RequestLocationInformation* IE such that the UE receives the message ΔT ms before the start of measurement period, where $\Delta T = 50$ ms.
11. The UE shall transmit an LCS Periodic-Triggered Invoke Return Result message.
12. When set-up period ends, the SS shall transmit an RRCRelease message including SDT configuration to transit the UE to RRC_INACTIVE state.
13. Wait for the UE monitors for occurrence of the periodic event requested.
14. The UE shall transmit an *RRCResumeRequest* message. If the UE also supporting SDT feature, the UE shall include LPP PROVIDE LOCATION INFORMATION message in the *RRCResumeRequest* message and then go to step 19.
15. The SS transmits an *RRCResume* message.
16. The UE transmits an *RRCResumeComplete* message.

17. The UE shall transmit a LPP PROVIDE LOCATION INFORMATION message, including the nr-DL-AoD-ProvideLocationInformation-r16 IE.
 18. If the UE message at step 17 includes the *ackRequested* IE set to TRUE, the SS shall send a LPP acknowledgement message.
 19. The SS shall check the nr-DL-PRS-FirstPathRSRP-ResultDiff-r17 field for Cell 2 in the nr-DL-AoD-SignalMeasurementInformation-r16 according to Table 17.5.1.5-2
 20. UE shall be released and moved to RRC_IDLE.
 21. Repeat steps 2-20 in Tables 17.5.1.4-1 until the confidence level according to Annex D is achieved.
 22. Repeat step 1-21 for the other sub-test defined in Table 17.5.1.4-1 as appropriate.
- If all (applicable) sub-tests pass, the whole test passes. If one (applicable) sub-test fails, the whole test fails.

17.5.1.4.3 Message contents

As defined in clause 17.4.1.4.3, with the following exceptions:

Table 17.5.1.4.3-1 replaces Table 17.4.1.4.3-6 and Table 17.5.1.4.3-2 replaces Table 17.4.1.4.3-7.

Table 17.5.1.4.3-1: NR-DL-PRS-AssistanceData

Derivation Path: 37.355 clause 6.4.3			
Information Element	Value/remark	Comment	Condition
NR-DL-PRS-AssistanceData-r16 ::= SEQUENCE {			
nr-DL-PRS-ReferenceInfo-r16 SEQUENCE {			
dl-PRS-ID-r16	0		
nr-DL-PRS-ResourceID-List-r16	Not present		
nr-DL-PRS-ResourceSetID-r16	Not present		
}			
nr-DL-PRS-AssistanceDataList-r16 SEQUENCE (SIZE (1..nrMaxFreqLayers-r16)) OF NR-DL-PRS-AssistanceDataPerFreq-r16 {	1 entry		
NR-DL-PRS-AssistanceDataPerFreq-r16[1] SEQUENCE {		entry 1	
nr-DL-PRS-PositioningFrequencyLayer-r16 SEQUENCE {			
dl-PRS-SubcarrierSpacing-r16	kHz15		Config 1 and Config 2
	kHz30		Config 3
dl-PRS-ResourceBandwidth-r16	8	24 PRBs	Sub-test 1-1, Sub-test 2-1 and Sub-test 3-1
	21	104 PRBs	Sub-test 1-2 and Sub-test 2-2
	28	132 PRBs	Sub-test 3-2
dl-PRS-StartPRB-r16	0		
dl-PRS-PointA-r16	absoluteFrequencyPointA as defined for the DL frequency of the Cell 1		
dl-PRS-CombSizeN-r16	n2		Sub-test 1
	n4		Sub-test 2
dl-PRS-CyclicPrefix-r16	normal		
}			
nr-DL-PRS-AssistanceDataPerFreq-r16 SEQUENCE (SIZE (1..nrMaxTRPsPerFreq-r16)) OF NR-DL-PRS-AssistanceDataPerTRP-r16{	2 entries		

NR-DL-PRS-AssistanceDataPerTRP-r16[1] SEQUENCE {		entry 1	Cell 1
dl-PRS-ID-r16	0		
nr-PhysCellID-r16	Cell 1		
nr-CellGlobalID-r16	Cell 1		
nr-ARFCN-r16	Cell 1		
nr-DL-PRS-SFN0-Offset-r16 SEQUENCE {			
sfn-Offset-r16	0		
integerSubframeOffset-r16	0		
}			
nr-DL-PRS-ExpectedRSTD-r16	0		
nr-DL-PRS-ExpectedRSTD-Uncertainty-r16	0		
nr-DL-PRS-Info-r16	As specified in Table 17.5.1.4.3-2		
}			
NR-DL-PRS-AssistanceDataPerTRP-r16[2] SEQUENCE {		entry 2	Cell 2
dl-PRS-ID-r16	1		
nr-PhysCellID-r16	Cell 2		
nr-CellGlobalID-r16	Cell 2		
nr-ARFCN-r16	Cell 2		
nr-DL-PRS-SFN0-Offset-r16 SEQUENCE {			
sfn-Offset-r16	0		
integerSubframeOffset-r16	0		
}			
nr-DL-PRS-ExpectedRSTD-r16	23	About 3 μs	
nr-DL-PRS-ExpectedRSTD-Uncertainty-r16	154	About 5 μs	
nr-DL-PRS-Info-r16	As specified in Table 17.5.1.4.3-2		
}			
}			
}			
}			
}			
}			

Table 17.5.1.4.3-2: NR-DL-PRS-Info

Derivation Path: TS 37.355 [49] clause 6.4.3			
Information Element	Value/remark	Comment	Condition
NR-DL-PRS-Info-r16 ::= SEQUENCE {			
nr-DL-PRS-ResourceSetList-r16 SEQUENCE (SIZE (1..nrMaxSetsPerTrp-r16)) OF NR-DL-PRS-ResourceSet-r16 {	1 entry		
NR-DL-PRS-ResourceSet-r16[1] SEQUENCE {		entry 1	
nr-DL-PRS-ResourceSetID-r16	0		
dl-PRS-Periodicity-and-ResourceSetSlotOffset-r16 CHOICE {			
scs15-r16 CHOICE {			Config 1 and Config 2
n160-r16	10		
}			
scs30-r16 CHOICE {			Config 3
n320-r16	20		
}			
dl-PRS-ResourceRepetitionFactor-r16	Not present		Sub-test 2
dl-PRS-ResourceTimeGap-r16	n2		Sub-test 1
dl-PRS-ResourceTimeGap-r16	s1		
dl-PRS-NumSymbols-r16	n4		
dl-PRS-MutingOption1-r16	Not present		
dl-PRS-MutingOption2-r16	Not present		
dl-PRS-ResourcePower-r16	27		
dl-PRS-ResourceList-r16 SEQUENCE (SIZE (1..nrMaxResourcesPerSet-r16)) OF NR-DL-PRS-Resource-r16 {	2 entries		

NR-DL-PRS-Resource-r16[1] SEQUENCE {		entry 1	
nr-DL-PRS-ResourceID-r16	0		
dl-PRS-SequenceID-r16	0		
dl-PRS-CombSizeN-AndReOffset-r16 CHOICE {			
n2-r16	0		Sub-test 1
n4-r16	0		Sub-test 2
}			
dl-PRS-ResourceSlotOffset-r16	0		Cell 1
	4		Cell 2
dl-PRS-ResourceSymbolOffset-r16	0		
dl-PRS-QCL-Info-r16	Not present		
}			
NR-DL-PRS-Resource-r16[2] SEQUENCE {		entry 2	
nr-DL-PRS-ResourceID-r16	1		
dl-PRS-SequenceID-r16	1		
dl-PRS-CombSizeN-AndReOffset-r16 CHOICE {			
n2-r16	0		Sub-test 1
n4-r16	0		Sub-test 2
}			
dl-PRS-ResourceSlotOffset-r16	0		Cell 1
	4		Cell 2
dl-PRS-ResourceSymbolOffset-r16	0		
dl-PRS-QCL-Info-r16	Not present		
}			
}			
}			
}			
}			

17.5.1.5 Test requirement

FFS

17.5.2 PRS-RSRPP measurement accuracy test case for single positioning frequency layer with reduced number of samples in FR1 SA

Editor’s note: This test case is incomplete. The following aspect is either missing or TBD:

- Test tolerance are not added in and analysis is missing

17.5.2.1 Test purpose

The purpose of the test is to verify that the PRS-RSRPP measurement in RRC_INACTIVE state with reduce number of samples meets the accuracy requirements specified in TS 38.133 [50] clause 10.1.38.2 in FR1 in standalone scenario when single positioning frequency layer is configured.

17.5.2.2 Test applicability

This test applies to all types of NR UE release 17 onwards that supports DL-AoD positioning, maxDL-PRS-FirstPathRSRP-MeasPerTRP and supportedDL-PRS-ProcessingSamples-RRC-Inactive.

17.5.2.3 Minimum conformance requirements

Same as defined in clause 17.3.2.3.

17.5.2.4 Test description

17.5.2.4.1 Initial conditions

The test defines three possible test configurations; specified in Table 17.5.2.4-1. The UE is only required to be tested in one of the supported test configurations.

Table 17.5.2.4-1: Test Configurations

Test Configuration	Description
1	15 kHz SSB SCS, 10 MHz bandwidth, FDD duplex mode
2	15 kHz SSB SCS, 10 MHz bandwidth, TDD duplex mode
3	30 kHz SSB SCS, 40 MHz bandwidth, TDD duplex mode
Note: The UE is only required to be tested in one of the supported test configurations.	

Test Environment: Normal, as defined in TS 38.508-1 [45] clause 4.1.

Frequencies to be tested: Mid Range, as defined in TS 38.508-1 [45] clause 4.3.1.

Channel bandwidth to be tested: are specified in Table 17.5.2.4-1.

1. Connect the SS and AWGN noise sources to the UE antenna connector or antenna connectors as shown in Annex A, Figure A.13.
2. The general test parameter settings are set up according to Table 17.5.2.5-1.
3. Propagation conditions are set according to clause 4.16.2.
4. Message contents are defined in clause 17.5.2.4.3.
5. There are two cells in the test: PCell (Cell 1) and a neighbour cell (Cell 2). All cells are on the same RF channel in FR1.

17.5.2.4.2 Test procedure

Same as defined in clause 17.5.1.4.2.

17.5.2.4.3 Message contents

As defined in clause 17.4.1.4.3, with the following exceptions:

Table 17.5.2.4.3-1 replaces Table 17.4.1.4.3-6, Table 17.5.2.4.3-2 replaces Table 17.4.1.4.3-7 and Table 17.5.2.4.3-3 replaces Table 17.4.1.4.3-9.

Table 17.5.2.4.3-1: NR-DL-PRS-AssistanceData

Derivation Path: 37.355 clause 6.4.3			
Information Element	Value/remark	Comment	Condition
NR-DL-PRS-AssistanceData-r16 ::= SEQUENCE {			
nr-DL-PRS-ReferenceInfo-r16 SEQUENCE {			
dl-PRS-ID-r16	0		
nr-DL-PRS-ResourceID-List-r16	Not present		
nr-DL-PRS-ResourceSetID-r16	Not present		
}			
nr-DL-PRS-AssistanceDataList-r16 SEQUENCE (SIZE (1..nrMaxFreqLayers-r16)) OF NR-DL-PRS-AssistanceDataPerFreq-r16 {	1 entry		
NR-DL-PRS-AssistanceDataPerFreq-r16[1] SEQUENCE {		entry 1	
nr-DL-PRS-PositioningFrequencyLayer-r16 SEQUENCE {			
dl-PRS-SubcarrierSpacing-r16	kHz15		Config 1 and Config 2

	kHz30		Config 3
dl-PRS-ResourceBandwidth-r16	8	52 PRBs	
dl-PRS-StartPRB-r16	0		
dl-PRS-PointA-r16	absoluteFrequencyPointA as defined for the DL frequency of the Cell 1		
dl-PRS-CombSizeN-r16	n4		
dl-PRS-CyclicPrefix-r16	normal		
}			
nr-DL-PRS-AssistanceDataPerFreq-r16 SEQUENCE (SIZE (1..nrMaxTRPsPerFreq-r16)) OF NR-DL-PRS-AssistanceDataPerTRP-r16{	2 entries		
NR-DL-PRS-AssistanceDataPerTRP-r16[1] SEQUENCE {		entry 1	Cell 1
dl-PRS-ID-r16	0		
nr-PhysCellID-r16	Cell 1		
nr-CellGlobalID-r16	Cell 1		
nr-ARFCN-r16	Cell 1		
nr-DL-PRS-SFN0-Offset-r16 SEQUENCE {			
sfn-Offset-r16	0		
integerSubframeOffset-r16	0		
}			
nr-DL-PRS-ExpectedRSTD-r16	0		
nr-DL-PRS-ExpectedRSTD-Uncertainty-r16	0		
nr-DL-PRS-Info-r16	As specified in Table 17.5.2.4.3-2		
}			
NR-DL-PRS-AssistanceDataPerTRP-r16[2] SEQUENCE {		entry 2	Cell 2
dl-PRS-ID-r16	1		
nr-PhysCellID-r16	Cell 2		
nr-CellGlobalID-r16	Cell 2		
nr-ARFCN-r16	Cell 2		
nr-DL-PRS-SFN0-Offset-r16 SEQUENCE {			
sfn-Offset-r16	0		
integerSubframeOffset-r16	0		
}			
nr-DL-PRS-ExpectedRSTD-r16	23	About 3 μs	
nr-DL-PRS-ExpectedRSTD-Uncertainty-r16	154	About 5 μs	
nr-DL-PRS-Info-r16	As specified in Table 17.5.2.4.3-2		
}			
}			
}			
}			
}			

Table 17.5.2.4.3-2: NR-DL-PRS-Info

Derivation Path: TS 37.355 [49] clause 6.4.3			
Information Element	Value/remark	Comment	Condition
NR-DL-PRS-Info-r16 ::= SEQUENCE {			
nr-DL-PRS-ResourceSetList-r16 SEQUENCE (SIZE (1..nrMaxSetsPerTrp-r16)) OF NR-DL-PRS-ResourceSet-r16 {	1 entry		
NR-DL-PRS-ResourceSet-r16[1] SEQUENCE {		entry 1	
nr-DL-PRS-ResourceSetID-r16	0		
dl-PRS-Periodicity-and-ResourceSetSlotOffset-r16 CHOICE {			
scs15-r16 CHOICE {			Config 1 and Config 2
n160-r16	10		
}			
scs30-r16 CHOICE {			Config 3

n320-r16	20		
}			
dl-PRS-ResourceRepetitionFactor-r16	Not present		
dl-PRS-ResourceTimeGap-r16	s1		
dl-PRS-NumSymbols-r16	n4		
dl-PRS-MutingOption1-r16	Not present		
dl-PRS-MutingOption2-r16	Not present		
dl-PRS-ResourcePower-r16	27		
dl-PRS-ResourceList-r16 SEQUENCE (SIZE (1..nrMaxResourcesPerSet-r16)) OF NR-DL-PRS-Resource-r16 {	2 entries		
NR-DL-PRS-Resource-r16[1] SEQUENCE {		entry 1	
nr-DL-PRS-ResourceID-r16	0		
dl-PRS-SequenceID-r16	0		
dl-PRS-CombSizeN-AndReOffset-r16 CHOICE {			
n4-r16	0		
}			
dl-PRS-ResourceSlotOffset-r16	0		Cell 1
	4		Cell 2
dl-PRS-ResourceSymbolOffset-r16	0		
dl-PRS-QCL-Info-r16	Not present		
}			
NR-DL-PRS-Resource-r16[2] SEQUENCE {		entry 2	
nr-DL-PRS-ResourceID-r16	1		
dl-PRS-SequenceID-r16	1		
dl-PRS-CombSizeN-AndReOffset-r16 CHOICE {			
n4-r16	0		
}			
dl-PRS-ResourceSlotOffset-r16	0		Cell 1
	4		Cell 2
dl-PRS-ResourceSymbolOffset-r16	0		
dl-PRS-QCL-Info-r16	Not present		
}			
}			
}			
}			
}			

Table 17.5.2.4.3-3: LPP RequestLocationInformation

Derivation Path: 37.355 clause 6.2			
Information Element	Value/remark	Comment	Condition
LPP-Message ::= SEQUENCE {			
transactionID SEQUENCE {			
initiator	locationServer		
transactionNumber	1		
}			
endTransaction	FALSE		
sequenceNumber	Not present		
acknowledgement	Not present		
lpp-MessageBody CHOICE {			
c1 CHOICE {			
requestLocationInformation SEQUENCE {			
criticalExtensions CHOICE {			
c1 CHOICE {			
requestLocationInformation-r9 SEQUENCE {			
commonEsRequestLocationInformation SEQUENCE {			
locationInformationType	locationMeasurementsRequired		
triggeredReporting	Not present		
periodicalReporting	Not present		
additionalInformation	onlyReturnInformationRequested		

qos SEQUENCE {			
horizontalAccuracy	Not present		
verticalCoordinateRequest	FALSE		
verticalAccuracy	Not present		
responseTime SEQUENCE {			
time	See 17.5.2.5	Result of the response time calculation rounded up to the next second if response time <= 128s. Result of the response time calculation rounded up to the next multiple of ten seconds if response time > 128s.	
responseTimeEarlyFix-r12	Not present		Rel-12 onwards
unit-r15	Not present		
	ten-seconds		Calculated response time >128s
}			
velocityRequest	FALSE		
}			
environment	Not present		
locationCoordinateTypes	Not present		
velocityTypes	Not present		
}			
a-gnss-RequestLocationInformation	Not present		
otdoa-RequestLocationInformation	Not present		
ecid-RequestLocationInformation	Not present		
epdu-RequestLocationInformation	Not Present		
sensor-RequestLocationInformation-r13	Not present		
tbs-RequestLocationInformation-r13	Not present		
wlan-RequestLocationInformation-r13	Not present		
bt-RequestLocationInformation-r13	Not present		
nr-ECID-RequestLocationInformation-r16	Not present		
nr-Multi-RTT-RequestLocationInformation-r16	Not present		
nr-DL-AoD-RequestLocationInformation-r16			
SEQUENCE {			
nr-AssistanceAvailability-r16	FALSE		
nr-DL-AoD-ReportConfig-r16 SEQUENCE {			
r16 maxDL-PRS-RSRP-MeasurementsPerTRP-	Not present		
r17 maxDL-PRS-RSRP-MeasurementsPerTRP-	Not present		
r17 maxDL-PRS-RSRPP-MeasurementsPerTRP-r17	Present. Set depending on UE capabilities.		
nr-los-nlos-IndicatorRequest-r17	Not present		
reducedDL-PRS-ProcessingSamples-r17	requested		
lowerRxBeamSweepingFactor-FR2-r17	Not present		
}			
multiMeasInSameReport-r17			
}			
nr-DL-TDOA-RequestLocationInformation-r16	Not present		
}			
}			
}			
}			
}			
}			

17.5.2.5 Test requirement

FFS

17.5.3 PRS-RSRPP measurement accuracy test case for single positioning frequency layer in FR2 SA

Editor's note: This test case is incomplete. The following aspect is either missing or TBD:

- Test tolerance are not added in and analysis is missing

17.5.3.1 Test purpose

The purpose of the test is to verify that the PRS-RSRPP measurement in RRC_INACTIVE state meets the requirements specified in TS 38.133 [50] clause 10.1.38.2 in FR2 in standalone scenario when single positioning frequency layer is configured.

17.5.3.2 Test applicability

This test applies to all types of NR UE release 17 onwards that supports DL-AoD positioning, maxDL-PRS-FirstPathRSRP-MeasPerTRP and DL-PRS measurement in RRC_INACTIVE state.

17.5.3.3 Minimum conformance requirements

Same as defined in clause 17.3.3.3.

17.5.3.4 Test description

17.5.3.4.1 Initial conditions

The supported test configurations in listed in Table 17.5.3.4.1-1

Table 17.5.3.4.1-1: Supported test configurations

Config	Description
1	120 kHz SSB and PRS SCS, 200 MHz bandwidth, TDD duplex mode

Test Environment: Normal, as defined in TS 38.508-1 [45] clause 4.1.

Frequencies to be tested: Mid Range, as defined in TS 38.508-1 [45] clause 4.3.1.

Channel bandwidth to be tested: are specified in Table 17.5.3.4.1-1.

1. Connect the SS and AWGN noise sources to the UE antenna connector or antenna connectors as shown in Annex A, Figure A.14.
2. The general test parameter settings are set up according to Table 17.5.3.5-1 and Table 17.5.3.5-2.
3. Propagation conditions are set according to clause 4.16.2.
4. Message contents are defined in clause 17.5.3.4.3.
5. There are two cells in the test: PCell (Cell 1) and a neighbour cell (Cell 2). All cells are on the same RF channel in FR2.

17.5.3.4.2 Test procedure

Same as defined in clause 17.5.1.4.2.

17.5.3.4.3 Message contents

As defined in clause 17.4.1.4.3, with the following exceptions:

Table 17.5.3.4.3-1 replaces Table 17.4.1.4.3-3, Table 17.5.3.4.3-2 replaces Table 17.4.1.4.3-6 and Table 17.5.3.4.3-3 replaces Table 17.4.1.4.3-7.

Table 17.5.3.4.3-1: CellGroupConfig

Derivation Path: 38.508-1 [45], Table 4.6.3-19			
Information Element	Value/remark	Comment	Condition
CellGroupConfig ::= SEQUENCE {			
mac-CellGroupConfig SEQUENCE {			
drx-Config CHOICE {			
setup SEQUENCE {			
drx-onDurationTimer	ms6		
drx-InactivityTimer	ms1		
drx-HARQ-RTT-TimerDL	sl64		
drx-HARQ-RTT-TimerUL	sl64		
drx-RetransmissionTimerDL	sl1		
drx-RetransmissionTimerUL	sl1		
drx-LongCycleStartOffset CHOICE {			
ms640	0		
}			
shortDRX	not present		
drx-SlotOffset	0		
}			
}			

Table 17.5.3.4.3-2: NR-DL-PRS-AssistanceData

Derivation Path: 37.355 clause 6.4.3			
Information Element	Value/remark	Comment	Condition
NR-DL-PRS-AssistanceData-r16 ::= SEQUENCE {			
nr-DL-PRS-ReferenceInfo-r16 SEQUENCE {			
dl-PRS-ID-r16	0		
nr-DL-PRS-ResourceID-List-r16	Not present		
nr-DL-PRS-ResourceSetID-r16	Not present		
}			
nr-DL-PRS-AssistanceDataList-r16 SEQUENCE (SIZE (1..nrMaxFreqLayers-r16)) OF NR-DL-PRS-AssistanceDataPerFreq-r16 {	1 entry		
NR-DL-PRS-AssistanceDataPerFreq-r16[1] SEQUENCE {		entry 1	
nr-DL-PRS-PositioningFrequencyLayer-r16 SEQUENCE {			
dl-PRS-SubcarrierSpacing-r16	kHz120		
dl-PRS-ResourceBandwidth-r16	3	32 PRBs	Sub-test 1
	27	128 PRBs	Sub-test 2
dl-PRS-StartPRB-r16	0		
dl-PRS-PointA-r16	absoluteFrequencyPointA as defined for the DL frequency of the Cell 1		
dl-PRS-CombSizeN-r16	n2		Sub-test 1
	n4		Sub-test 2
dl-PRS-CyclicPrefix-r16	normal		
}			
nr-DL-PRS-AssistanceDataPerFreq-r16 SEQUENCE (SIZE (1..nrMaxTRPsPerFreq-r16)) OF NR-DL-PRS-AssistanceDataPerTRP-r16{	2 entries		
NR-DL-PRS-AssistanceDataPerTRP-r16[1] SEQUENCE {		entry 1	Cell 1
dl-PRS-ID-r16	0		

nr-PhysCellID-r16	Cell 1		
nr-CellGlobalID-r16	Cell 1		
nr-ARFCN-r16	Cell 1		
nr-DL-PRS-SFN0-Offset-r16 SEQUENCE {			
sfn-Offset-r16	0		
integerSubframeOffset-r16	0		
}			
nr-DL-PRS-ExpectedRSTD-r16	0		
nr-DL-PRS-ExpectedRSTD-Uncertainty-r16	0		
nr-DL-PRS-Info-r16	As specified in Table 17.5.3.4.3-3		
}			
NR-DL-PRS-AssistanceDataPerTRP-r16[2] SEQUENCE {		entry 2	Cell 2
dl-PRS-ID-r16	1		
nr-PhysCellID-r16	Cell 2		
nr-CellGlobalID-r16	Cell 2		
nr-ARFCN-r16	Cell 2		
nr-DL-PRS-SFN0-Offset-r16 SEQUENCE {			
sfn-Offset-r16	0		
integerSubframeOffset-r16	0		
}			
nr-DL-PRS-ExpectedRSTD-r16	23	About 3 μs	
nr-DL-PRS-ExpectedRSTD-Uncertainty-r16	154	About 5 μs	
nr-DL-PRS-Info-r16	As specified in Table 17.5.3.4.3-3		
}			
}			
}			
}			
}			

Table 17.5.3.4.3-3: NR-DL-PRS-Info

Derivation Path: 37.355 clause 6.4.3			
Information Element	Value/remark	Comment	Condition
NR-DL-PRS-Info-r16 ::= SEQUENCE {			
nr-DL-PRS-ResourceSetList-r16 SEQUENCE (SIZE (1..nrMaxSetsPerTrp-r16)) OF NR-DL-PRS-ResourceSet-r16 {	1 entry		
NR-DL-PRS-ResourceSet-r16[1] SEQUENCE {		entry 1	
nr-DL-PRS-ResourceSetID-r16	0		
dl-PRS-Periodicity-and-ResourceSetSlotOffset-r16 CHOICE {			
scs120-r16 CHOICE {			
n1280-r16	80		
}			
dl-PRS-ResourceRepetitionFactor-r16	n2		Sub-test 1
	Not present		Sub-test 2
dl-PRS-ResourceTimeGap-r16	s1		
dl-PRS-NumSymbols-r16	n4		
dl-PRS-MutingOption1-r16	Not present		
dl-PRS-MutingOption2-r16	Not present		
dl-PRS-ResourcePower-r16	27		
dl-PRS-ResourceList-r16 SEQUENCE (SIZE (1..nrMaxResourcesPerSet-r16)) OF NR-DL-PRS-Resource-r16 {	2 entries		
NR-DL-PRS-Resource-r16[1] SEQUENCE {		entry 1	
nr-DL-PRS-ResourceID-r16	0		
dl-PRS-SequenceID-r16	0		
dl-PRS-CombSizeN-AndReOffset-r16 CHOICE {			
n2-r16	0		Sub-test 1
n4-r16	0		Sub-test 2
}			
}			

dl-PRS-ResourceSlotOffset-r16	0		Cell 1
	4		Cell 2
dl-PRS-ResourceSymbolOffset-r16	0		
dl-PRS-QCL-Info-r16	Not present		
}			
NR-DL-PRS-Resource-r16[2] SEQUENCE {		entry 2	
nr-DL-PRS-ResourceID-r16	1		
dl-PRS-SequenceID-r16	1		
dl-PRS-CombSizeN-AndReOffset-r16 CHOICE {			
n2-r16	1		Sub-test 1
n4-r16	1		Sub-test 2
}			
dl-PRS-ResourceSlotOffset-r16	0		Cell 1
	4		Cell 2
dl-PRS-ResourceSymbolOffset-r16	0		
dl-PRS-QCL-Info-r16	Not present		
}			
}			
}			
}			
}			

17.5.3.5 Test requirement

FFS

17.5.4 PRS-RSRPP measurement accuracy test case for single positioning frequency layer with reduced number of samples in FR2 SA

Editor’s note: This test case is incomplete. The following aspect is either missing or TBD:

- Test tolerance are not added in and analysis is missing

17.5.4.1 Test purpose

The purpose of the test is to verify that the PRS-RSRPP measurement in RRC_INACTIVE state with reduce number of samples meets the accuracy requirements specified in TS 38.133 [50] clause 10.1.38.2 in FR2 in standalone scenario when single positioning frequency layer is configured.

17.5.4.2 Test applicability

This test applies to all types of NR UE release 17 onwards that supports DL-AoD positioning, maxDL-PRS-FirstPathRSRP-MeasPerTRP and supportedDL-PRS-ProcessingSamples-RRC-Inactive

17.5.4.3 Minimum conformance requirements

Same as defined in clause 17.3.4.3.

17.5.4.4 Test description

17.5.4.4.1 Initial conditions

The supported test configurations in listed in Table 17.5.4.4.1-1

Table 17.5.4.4.1-1: Supported test configurations

Config	Description
1	120 kHz SSB and PRS SCS, 200 MHz bandwidth, TDD duplex mode

Test Environment: Normal, as defined in TS 38.508-1 [45] clause 4.1.

Frequencies to be tested: Mid Range, as defined in TS 38.508-1 [45] clause 4.3.1.

Channel bandwidth to be tested: are specified in Table 17.5.4.4.1-1.

1. Connect the SS and AWGN noise sources to the UE antenna connector or antenna connectors as shown in Annex A, Figure A.14.
2. The general test parameter settings are set up according to Table 17.5.4.5-1 and Table 17.5.4.5-2.
3. Propagation conditions are set according to clause 4.16.2.
4. Message contents are defined in clause 17.5.4.4.3.
5. There are two cells in the test: PCell (Cell 1) and a neighbour cell (Cell 2). All cells are on the same RF channel in FR2.

17.5.4.4.2 Test procedure

Same as defined in clause 17.5.1.4.2.

17.5.4.4.3 Message contents

As defined in clause 17.4.1.4.3, with the following exceptions:

Table 17.5.4.4.3-1 replaces Table 17.4.1.4.3-3, Table 17.5.4.4.3-2 replaces Table 17.4.1.4.3-6, Table 17.5.4.4.3-3 replaces Table 17.4.1.4.3-7 and Table 17.5.4.4.3-4 replaces Table 17.4.1.4.3-9.

Table 17.5.4.4.3-1: CellGroupConfig

Derivation Path: 38.508-1 [45], Table 4.6.3-19			
Information Element	Value/remark	Comment	Condition
CellGroupConfig ::= SEQUENCE {			
mac-CellGroupConfig SEQUENCE {			
drx-Config CHOICE {			
setup SEQUENCE {			
drx-onDurationTimer	ms6		
drx-InactivityTimer	ms1		
drx-HARQ-RTT-TimerDL	sl64		
drx-HARQ-RTT-TimerUL	sl64		
drx-RetransmissionTimerDL	sl1		
drx-RetransmissionTimerUL	sl1		
drx-LongCycleStartOffset CHOICE {			
ms640	0		
}			
shortDRX	not present		
drx-SlotOffset	0		
}			
}			

Table 17.5.4.4.3-2: NR-DL-PRS-AssistanceData

Derivation Path: 37.355 clause 6.4.3			
Information Element	Value/remark	Comment	Condition
NR-DL-PRS-AssistanceData-r16 ::= SEQUENCE {			
nr-DL-PRS-ReferenceInfo-r16 SEQUENCE {			
dl-PRS-ID-r16	0		
nr-DL-PRS-ResourceID-List-r16	Not present		
nr-DL-PRS-ResourceSetID-r16	Not present		
}			

nr-DL-PRS-AssistanceDataList-r16 SEQUENCE (SIZE (1..nrMaxFreqLayers-r16)) OF NR-DL-PRS-AssistanceDataPerFreq-r16 {	1 entry		
NR-DL-PRS-AssistanceDataPerFreq-r16[1] SEQUENCE {		entry 1	
nr-DL-PRS-PositioningFrequencyLayer-r16 SEQUENCE {			
dl-PRS-SubcarrierSpacing-r16	kHz120		
dl-PRS-ResourceBandwidth-r16	11	64 PRBs	
dl-PRS-StartPRB-r16	0		
dl-PRS-PointA-r16	absoluteFrequencyPointA as defined for the DL frequency of the Cell 1		
dl-PRS-CombSizeN-r16	n4		
dl-PRS-CyclicPrefix-r16	normal		
}			
nr-DL-PRS-AssistanceDataPerFreq-r16 SEQUENCE (SIZE (1..nrMaxTRPsPerFreq-r16)) OF NR-DL-PRS-AssistanceDataPerTRP-r16{	2 entries		
NR-DL-PRS-AssistanceDataPerTRP-r16[1] SEQUENCE {		entry 1	Cell 1
dl-PRS-ID-r16	0		
nr-PhysCellID-r16	Cell 1		
nr-CellGlobalID-r16	Cell 1		
nr-ARFCN-r16	Cell 1		
nr-DL-PRS-SFN0-Offset-r16 SEQUENCE {			
sfn-Offset-r16	0		
integerSubframeOffset-r16	0		
}			
nr-DL-PRS-ExpectedRSTD-r16	0		
nr-DL-PRS-ExpectedRSTD-Uncertainty-r16	0		
nr-DL-PRS-Info-r16	As specified in Table 17.5.4.4.3-3		
}			
NR-DL-PRS-AssistanceDataPerTRP-r16[2] SEQUENCE {		entry 2	Cell 2
dl-PRS-ID-r16	1		
nr-PhysCellID-r16	Cell 2		
nr-CellGlobalID-r16	Cell 2		
nr-ARFCN-r16	Cell 2		
nr-DL-PRS-SFN0-Offset-r16 SEQUENCE {			
sfn-Offset-r16	0		
integerSubframeOffset-r16	0		
}			
nr-DL-PRS-ExpectedRSTD-r16	23	About 3 μs	
nr-DL-PRS-ExpectedRSTD-Uncertainty-r16	154	About 5 μs	
nr-DL-PRS-Info-r16	As specified in Table 17.5.4.4.3-3		
}			
}			
}			
}			
}			

Table 17.5.4.4.3-3: NR-DL-PRS-Info

Derivation Path: 37.355 clause 6.4.3			
Information Element	Value/remark	Comment	Condition
NR-DL-PRS-Info-r16 ::= SEQUENCE {			
nr-DL-PRS-ResourceSetList-r16 SEQUENCE (SIZE (1..nrMaxSetsPerTrp-r16)) OF NR-DL-PRS-ResourceSet-r16 {	1 entry		
NR-DL-PRS-ResourceSet-r16[1] SEQUENCE {		entry 1	
nr-DL-PRS-ResourceSetID-r16	0		

dl-PRS-Periodicity-and-ResourceSetSlotOffset-r16 CHOICE {			
scs120-r16 CHOICE {			
n1280-r16	80		
}			
dl-PRS-ResourceRepetitionFactor-r16	Not present		
dl-PRS-ResourceTimeGap-r16	s1		
dl-PRS-NumSymbols-r16	n4		
dl-PRS-MutingOption1-r16	Not present		
dl-PRS-MutingOption2-r16	Not present		
dl-PRS-ResourcePower-r16	27		
dl-PRS-ResourceList-r16 SEQUENCE (SIZE (1..nrMaxResourcesPerSet-r16)) OF NR-DL-PRS-Resource-r16 {	2 entries		
NR-DL-PRS-Resource-r16[1] SEQUENCE {		entry 1	
nr-DL-PRS-ResourceID-r16	0		
dl-PRS-SequenceID-r16	0		
dl-PRS-CombSizeN-AndReOffset-r16 CHOICE {			
n4-r16	0		
}			
dl-PRS-ResourceSlotOffset-r16	0		Cell 1
	4		Cell 2
dl-PRS-ResourceSymbolOffset-r16	0		
dl-PRS-QCL-Info-r16	Not present		
}			
NR-DL-PRS-Resource-r16[2] SEQUENCE {		entry 2	
nr-DL-PRS-ResourceID-r16	1		
dl-PRS-SequenceID-r16	1		
dl-PRS-CombSizeN-AndReOffset-r16 CHOICE {			
n4-r16	1		
}			
dl-PRS-ResourceSlotOffset-r16	0		Cell 1
	4		Cell 2
dl-PRS-ResourceSymbolOffset-r16	0		
dl-PRS-QCL-Info-r16	Not present		
}			
}			
}			

Table 17.5.4.4.3-4: LPP RequestLocationInformation

Derivation Path: 37.355 clause 6.2			
Information Element	Value/remark	Comment	Condition
LPP-Message ::= SEQUENCE {			
transactionID SEQUENCE {			
initiator	locationServer		
transactionNumber	1		
}			
endTransaction	FALSE		
sequenceNumber	Not present		
acknowledgement	Not present		
lpp-MessageBody CHOICE {			
c1 CHOICE {			
requestLocationInformation SEQUENCE {			
criticalExtensions CHOICE {			
c1 CHOICE {			
requestLocationInformation-r9 SEQUENCE {			
commonEsRequestLocationInformation SEQUENCE {			
locationInformationType	locationMeasurementsRequired		
triggeredReporting	Not present		

periodicalReporting	Not present		
additionalInformation	onlyReturnInformationRequested		
qos SEQUENCE {			
horizontalAccuracy	Not present		
verticalCoordinateRequest	FALSE		
verticalAccuracy	Not present		
responseTime SEQUENCE {			
time	See 17.5.4.5	Result of the response time calculation rounded up to the next second if response time <= 128s. Result of the response time calculation rounded up to the next multiple of ten seconds if response time > 128s.	
responseTimeEarlyFix-r12	Not present		Rel-12 onwards
unit-r15	Not present		
	ten-seconds		Calculated response time >128s
}			
velocityRequest	FALSE		
}			
environment	Not present		
locationCoordinateTypes	Not present		
velocityTypes	Not present		
}			
a-gnss-RequestLocationInformation	Not present		
otdoa-RequestLocationInformation	Not present		
ecid-RequestLocationInformation	Not present		
epdu-RequestLocationInformation	Not Present		
sensor-RequestLocationInformation-r13	Not present		
tbs-RequestLocationInformation-r13	Not present		
wlan-RequestLocationInformation-r13	Not present		
bt-RequestLocationInformation-r13	Not present		
nr-ECID-RequestLocationInformation-r16	Not present		
nr-Multi-RTT-RequestLocationInformation-r16	Not present		
nr-DL-AoD-RequestLocationInformation-r16			
SEQUENCE {			
nr-AssistanceAvailability-r16	FALSE		
nr-DL-AoD-ReportConfig-r16 SEQUENCE {			
r16 maxDL-PRS-RSRP-MeasurementsPerTRP-	Not present		
r17 maxDL-PRS-RSRP-MeasurementsPerTRP-	Not present		
maxDL-PRS-RSRPP-MeasurementsPerTRP-r17	Present. Set depending on UE capabilities.		
nr-los-nlos-IndicatorRequest-r17	Not present		
reducedDL-PRS-ProcessingSamples-r17	requested		
lowerRxBeamSweepingFactor-FR2-r17	Not present		
}			
multiMeasInSameReport-r17			
}			
nr-DL-TDOA-RequestLocationInformation-r16	Not present		
}			
}			
}			
}			

}			
}			

17.5.4.5 Test requirement

FFS

Annex A (informative): Connection Diagrams

Definition of Terms

GNSS: In this clause the term GNSS also includes the case where the only satellite system used is GPS.

System Simulator or SS: A device or system, that is capable of generating simulated Node B and/or eNode B signalling and analysing UE signalling responses on one RF channel, in order to create the required test environment for the UE under test. It will also include the following capabilities:

1. Control of the UE Tx output power through TPC commands
2. Measurement of signalling timing and delays.
3. Ability to simulate UTRAN and/or E-UTRAN and/or NR signalling.

GNSS System Simulator or GSS: A device or system, that is capable of generating simulated GNSS satellite transmissions in order to create the required test environment for the UE under test. It will also include the following capabilities:

1. Control of the output power of individual satellites and the simulation of atmospheric delays and multi-path.
2. Generation of appropriate assistance data to be transmitted to the UE via the SS.
3. Ability to synchronize with UTRAN and/or E-UTRAN and/or NR timing in the SS.

MBS System Simulator or MSS: A device or system, that is capable of generating simulated MBS transmissions in order to create the required test environment for the UE under test. It will also include the following capabilities:

1. Control of the output power of individual beacons and the simulation of delays and multi-path.
2. Generation of appropriate messaging to be transmitted to the UE via the SS.

WLAN System Simulator or WSS: A device or system, that is capable of generating simulated WLAN beacons in order to create the required test environment for the UE under test. It will also include the following capabilities:

1. Control of the output power of individual beacons and the simulation of delays and AWGN.

BLE System Simulator or BSS: A device or system, that is capable of generating simulated BLE advertising signals in order to create the required test environment for the UE under test. It will also include the following capabilities:

1. Control of the output power of individual BLE signals and the simulation of delays and AWGN.

Test System: A combination of devices brought together into a system for the purpose of making one or more measurements on a UE in accordance with the test case requirements. The following diagrams are all examples of Test Systems.

NOTE: The above terms are logical definitions to be used to describe the test methods used in the present document, in practice, real devices called "System Simulators" may also include additional measurement capabilities or may only support those features required for the test cases they are designed to perform.

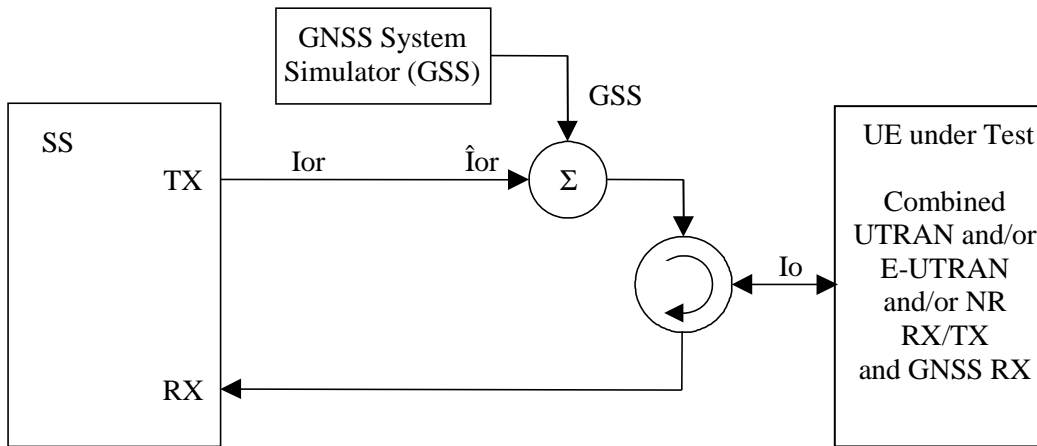

Figure A.1: Connection for A-GNSS Minimum Performance requirements tests for UE with combined UTRAN and/or E-UTRAN and/or NR and GNSS antenna

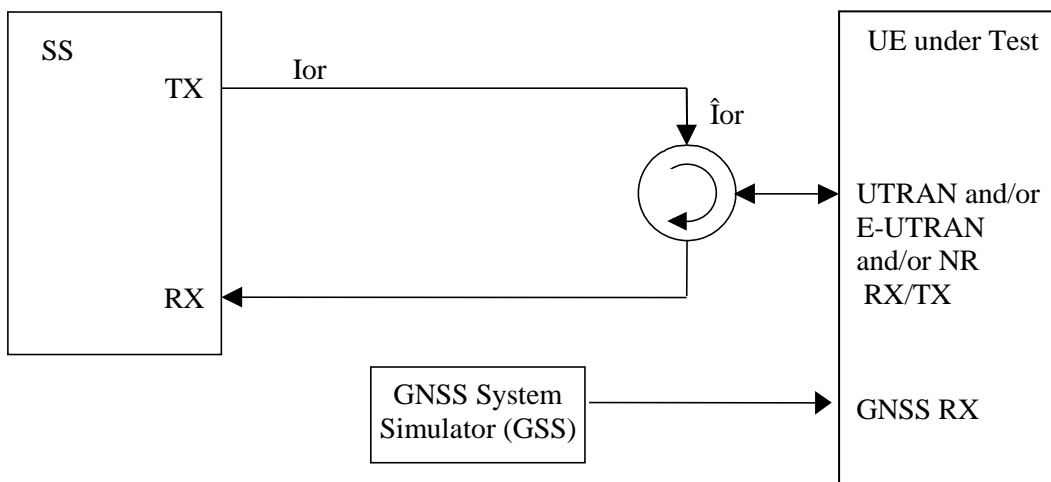

Figure A.2: Connection for A-GNSS Minimum Performance requirements tests for UE with separate UTRAN and/or E-UTRAN and/or NR and GNSS antennas

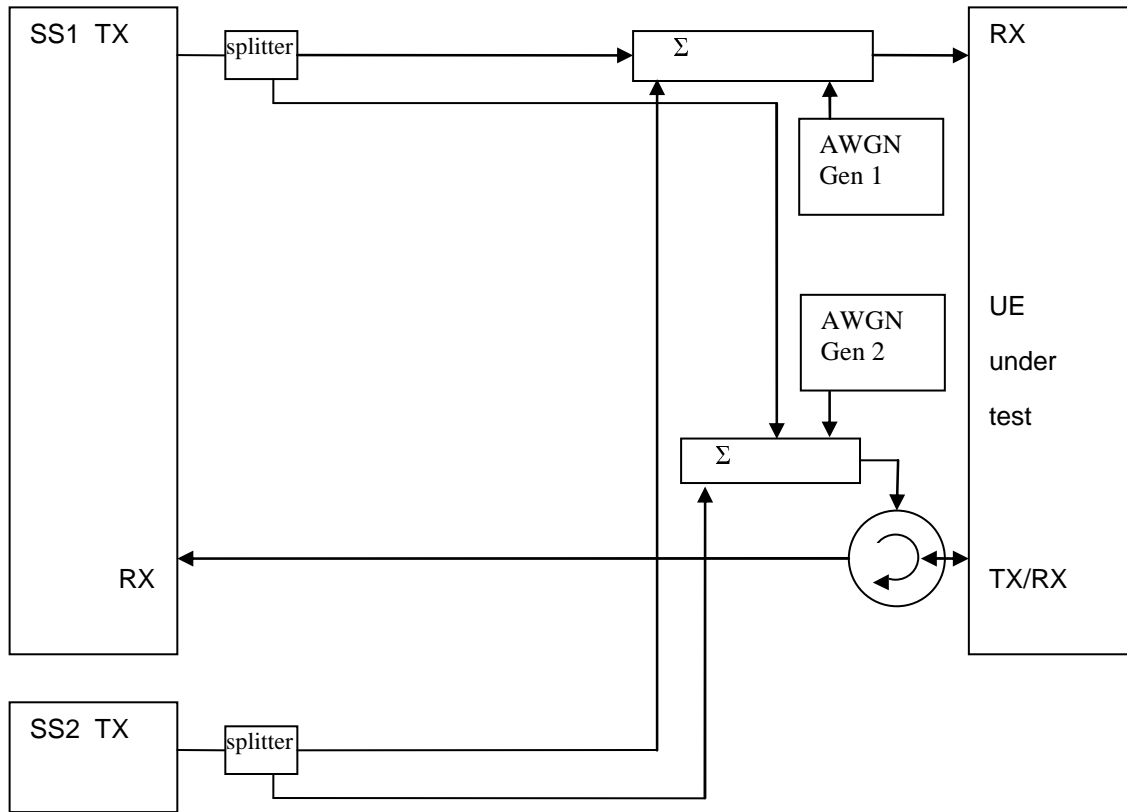

Figure A.3: Connection for 2 cells OTDOA tests with static propagation

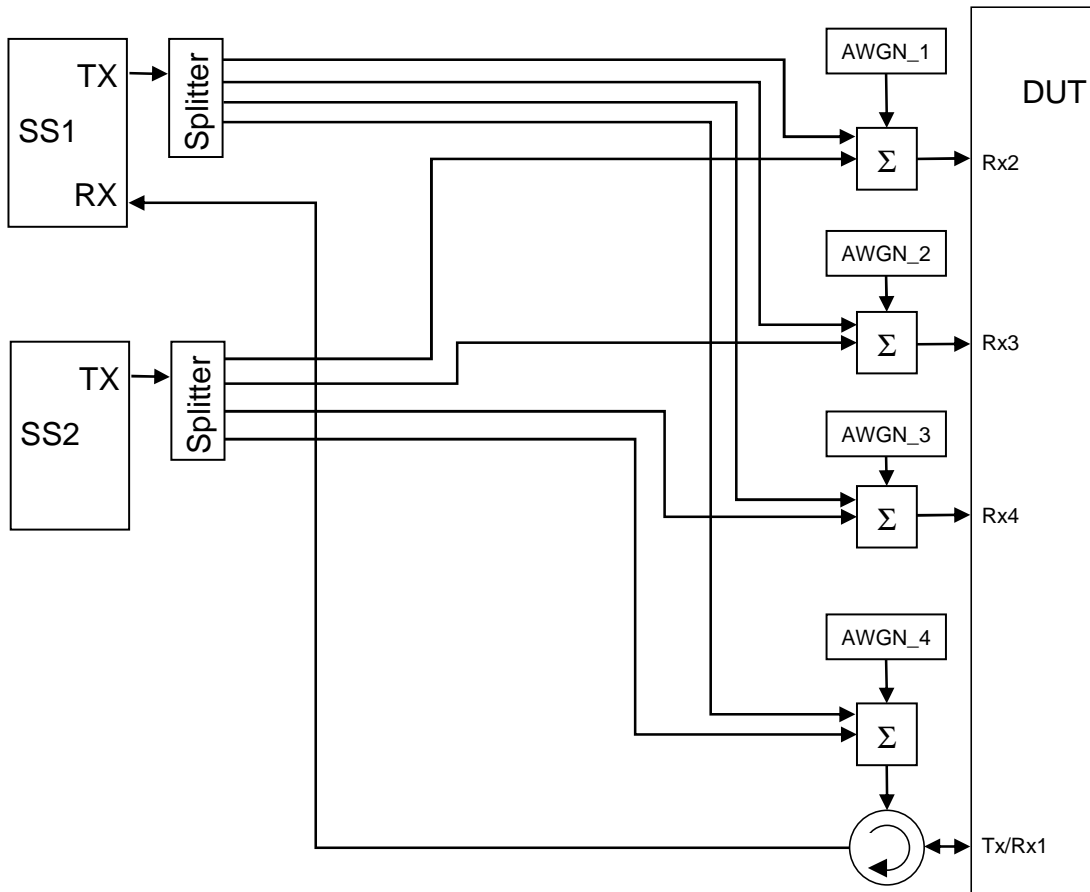

Figure A.3a: Connection for 2 cells OTDOA tests with static propagation for 4Rx capable UE

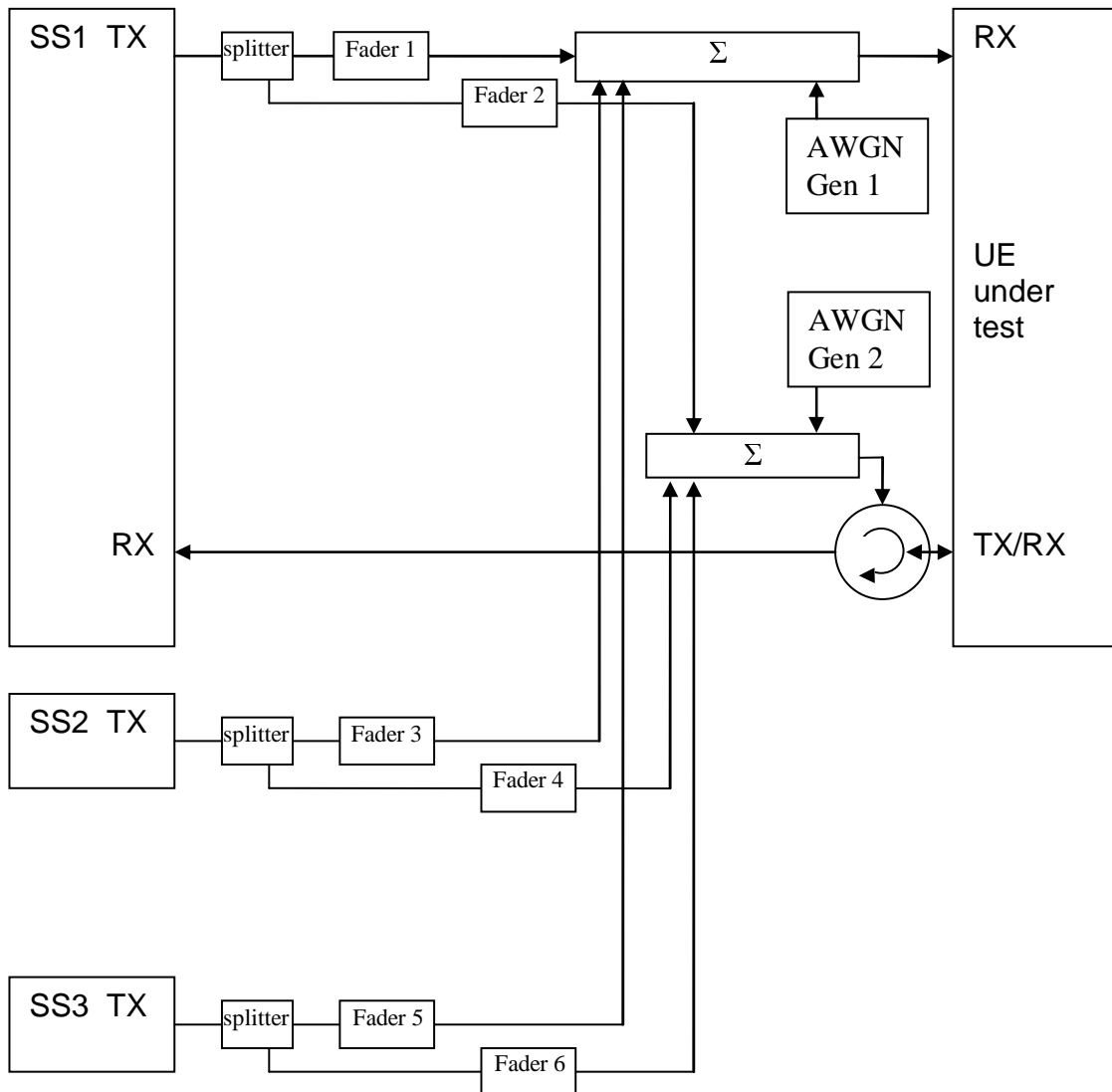

Figure A.4: Connection for 3 cells OTDOA tests with multipath fading propagation conditions

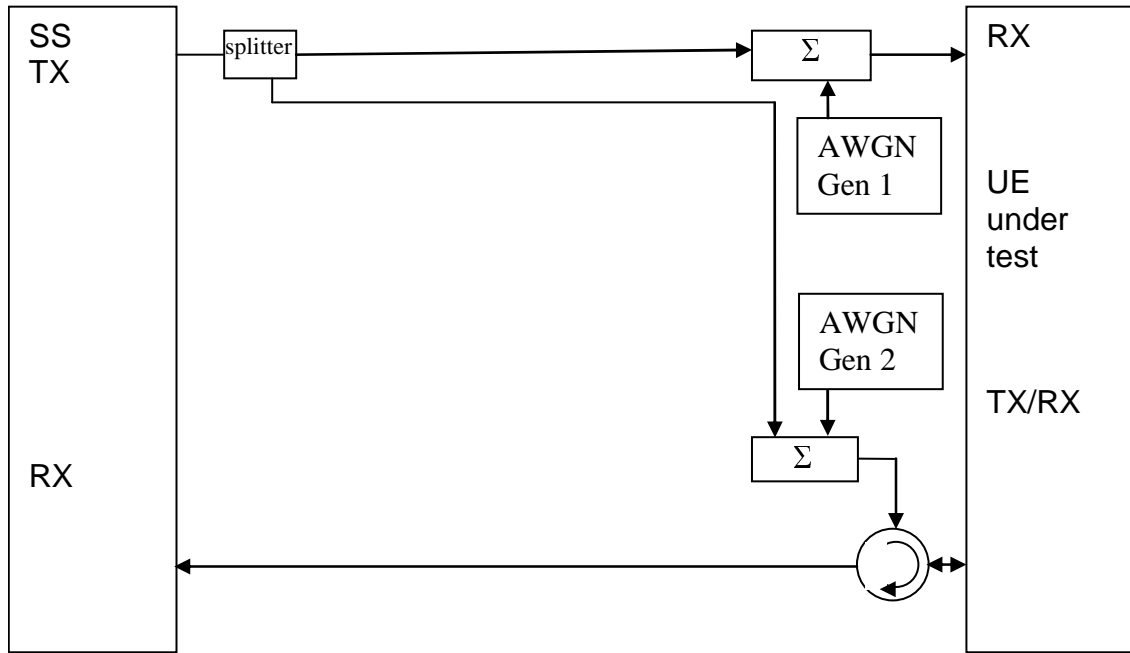

Figure A.5: Connection for 1 cell ECID tests with static propagation conditions

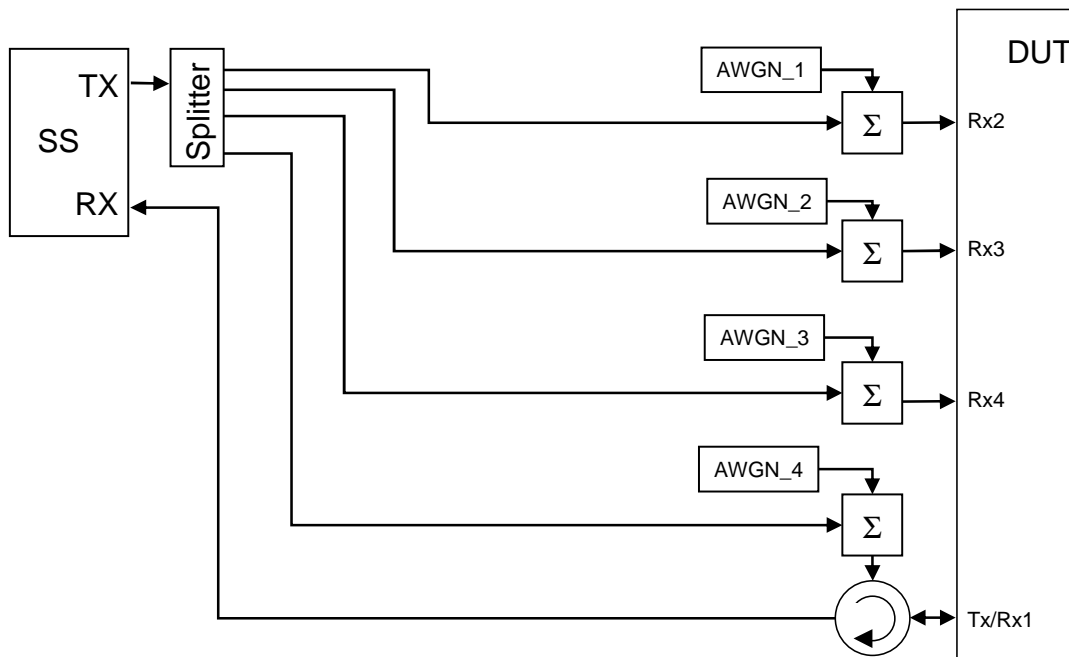

Figure A.5a: Connection 1 cell ECID tests with static propagation for 4Rx capable UE

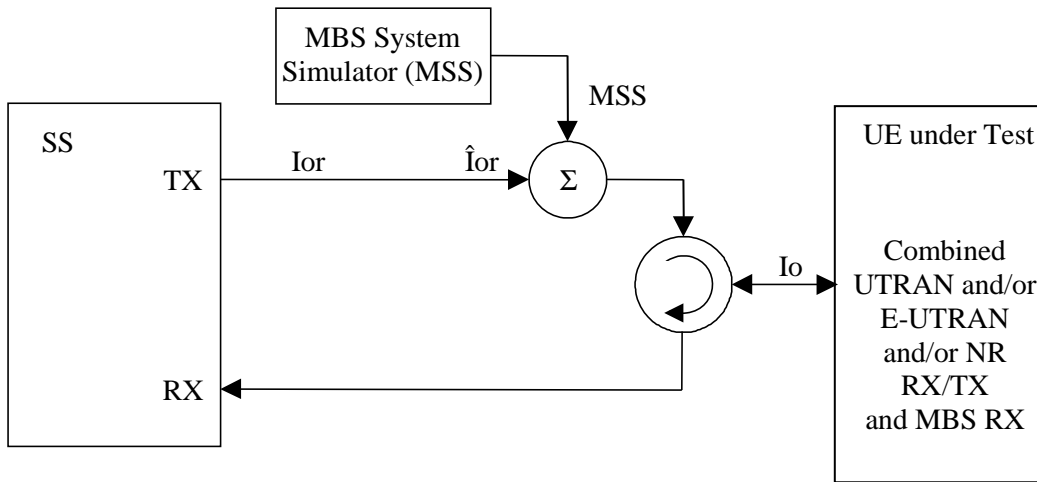

Figure A.6: Connection for MBS Minimum Performance requirements tests for UE with combined UTRAN and/or E-UTRAN and/or NR and MBS antenna

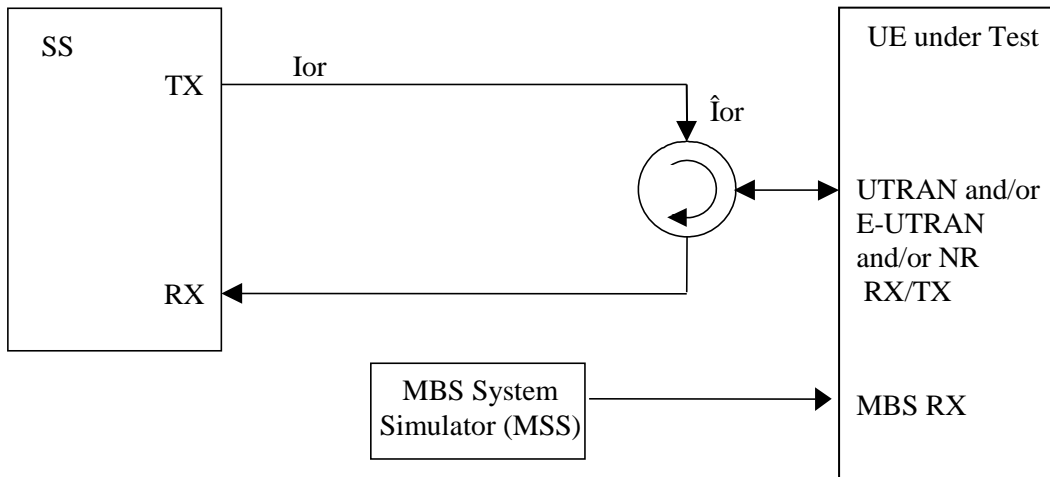

Figure A.7: Connection for MBS Minimum Performance requirements tests for UE with separate UTRAN and/or E-UTRAN and/or NR and MBS antennas

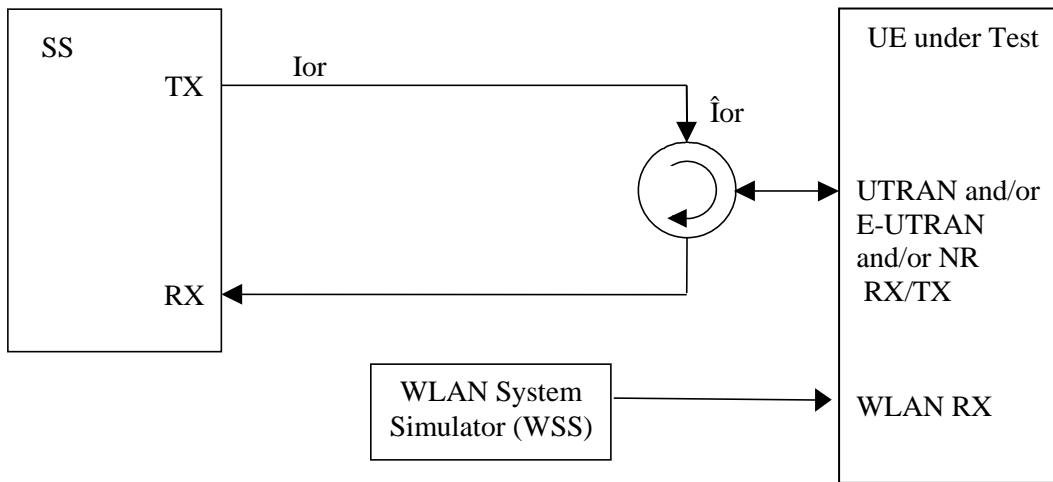

Figure A.8: Connection for WLAN tests for UE with separate UTRAN and/or E-UTRAN and/or NR and WLAN antennas

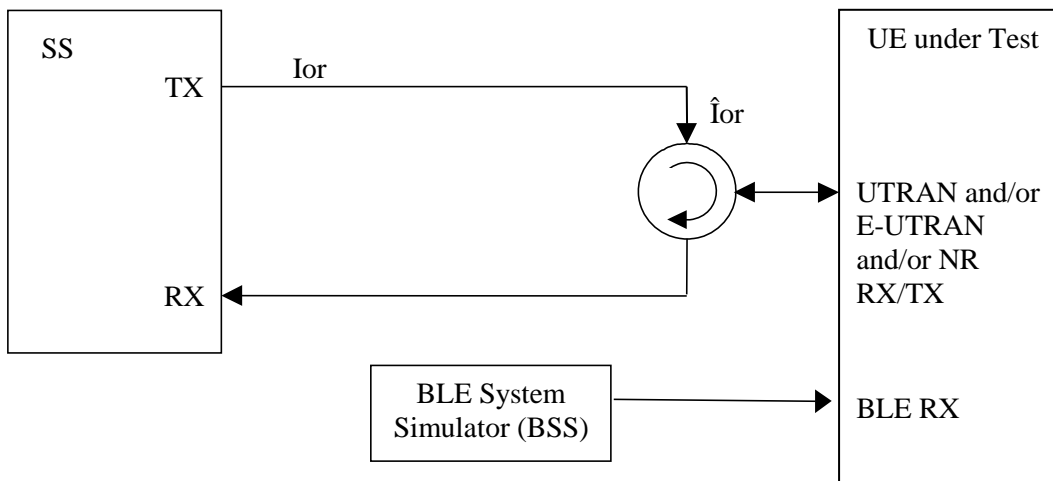

Figure A.9: Connection for BLE tests for UE with separate UTRAN and/or E-UTRAN and/or NR and BLE antennas

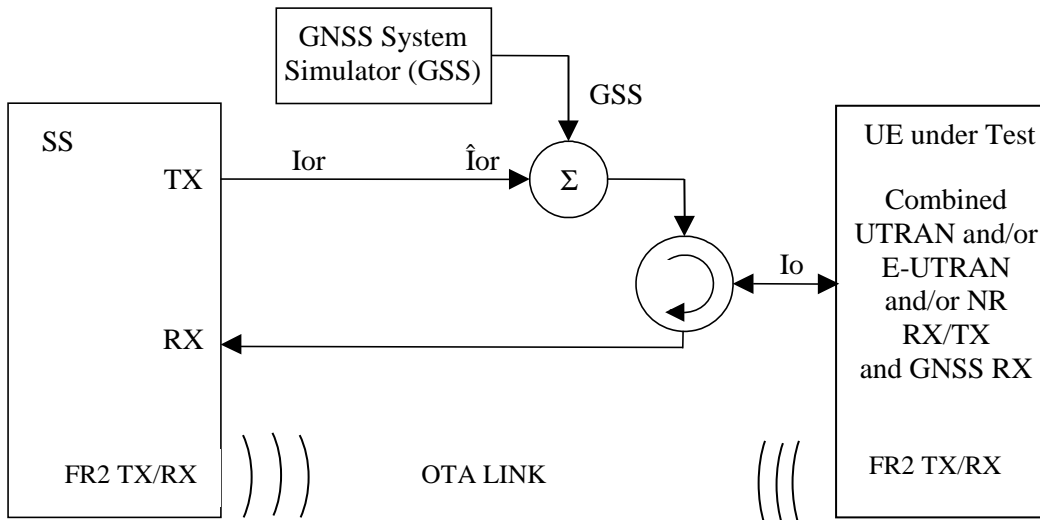

Figure A.10: Connection for A-GNSS Minimum Performance requirements tests for UE with combined and/or E-UTRAN and/or NR FR1 and GNSS antenna and separate NR FR2 OTA connection

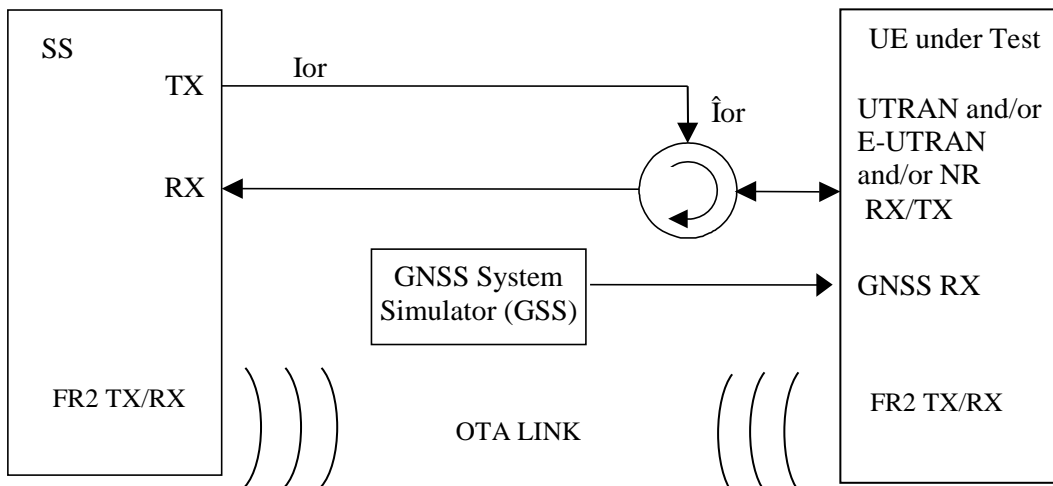

Figure A.11: Connection for A-GNSS Minimum Performance requirements tests for UE with separate and/or E-UTRAN and/or NR FR1 and GNSS antennas and separate NR FR2 OTA connection

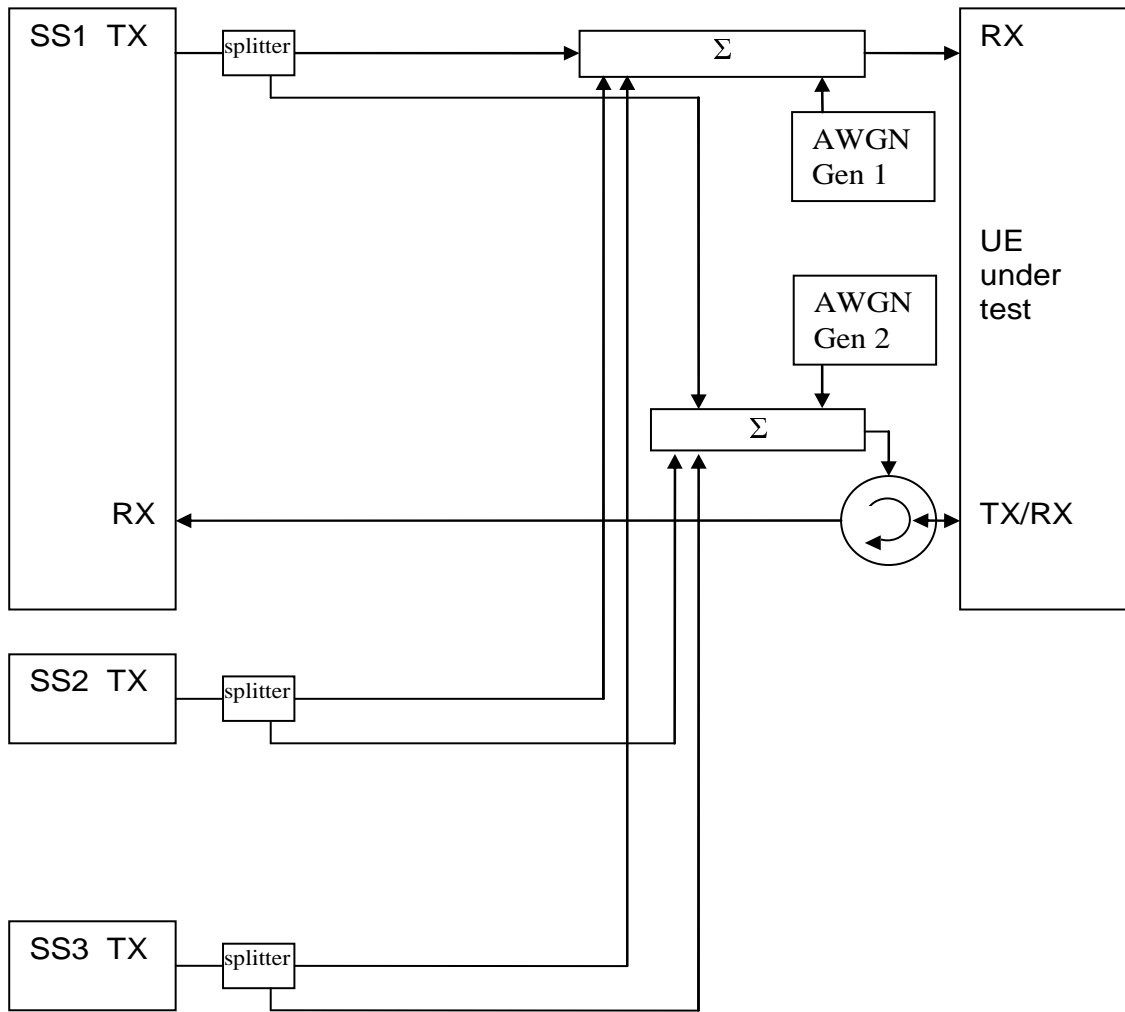

Figure A.12: Connection for 3 cells DL-TDOA tests with static propagation conditions in NR FR1

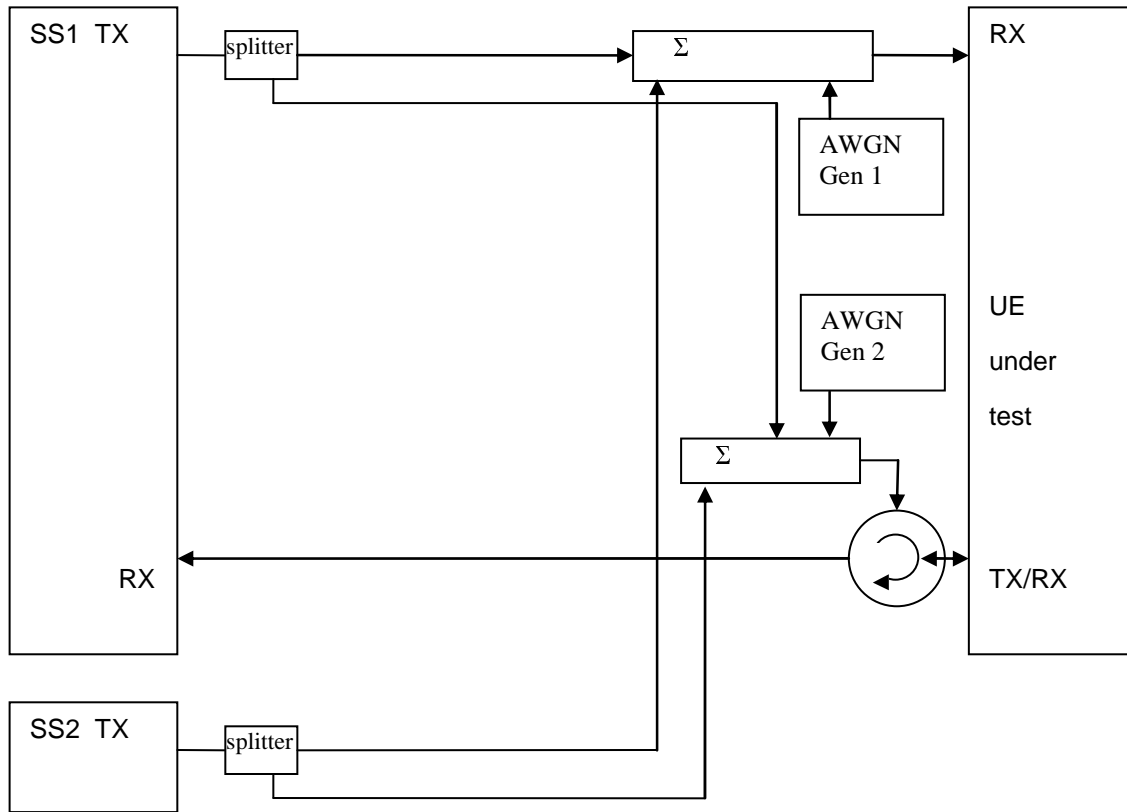

Figure A.13: Connection for 2 cells DL-TDOA and/or Multi-RTT and/or DL-AoD tests with static propagation conditions in NR FR1

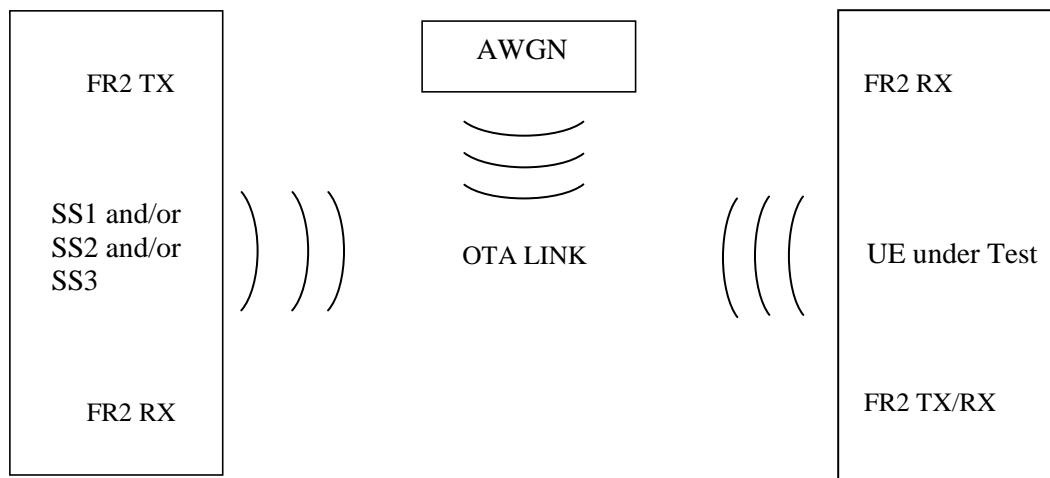

Figure A.14: Connection for DL-TDOA and/or Multi-RTT and/or DL-AoD tests with static propagation conditions in NR FR2

Annex B (normative): Converting A-GNSS UE-assisted measurement reports into position estimates

B.1 Introduction

In this clause the terms GNSS and A-GNSS also include the cases where the only satellite system used is GPS unless otherwise stated.

To convert the A-GNSS UE measurement reports in case of UE-assisted mode of A-GNSS into position errors, a transformation between the "measurement domain" (code-phases, etc.) into the "state" domain (position estimate) is necessary. Such a transformation procedure is outlined in the following clauses. The details can be found in [8-10] and [12-17].

B.2 UTRAN UE measurement reports for A-GPS L1 C/A only

In case of UTRAN UE-assisted A-GPS L1 C/A only, the measurement parameters are contained in the RRC UE POSITIONING GPS MEASURED RESULTS IE (clause 10.3.7.93 in 3GPP TS 25.331 [30]). The measurement parameters required for calculating the UE position are:

- 1) Reference Time: The UE has two choices for the Reference Time:
 - a) "UE GPS timing of cell frames";
 - b) "GPS TOW msec".
- 2) Measurement Parameters: 1 to <maxSat>:
 - a) "Satellite ID (SV PRN)";
 - b) "Whole GPS chips";
 - c) "Fractional GPS Chips";
 - d) "Pseudorange RMS Error".

Additional information required at the system simulator:

- 1) "UE positioning GPS reference UE position" (clause 10.3.8.4c in 3GPP TS 25.331 [30]):
Used for initial approximate receiver coordinates.
- 2) "UE positioning GPS navigation model" (clause 10.3.7.94 in 3GPP TS 25.331 [30]):
Contains the GPS ephemeris and clock correction parameters as specified in [8]; used for calculating the satellite positions and clock corrections.
- 3) "UE positioning GPS ionospheric model" (clause 10.3.7.92 in 3GPP TS 25.331 [30]):
Contains the ionospheric parameters which allow the single frequency user to utilize the ionospheric model as specified in [8] for computation of the ionospheric delay.

B.3 UTRAN UE measurement reports for A-GNSS

In case of UTRAN UE-assisted A-GNSS, the measurement parameters are contained in the RRC UE POSITIONING GANSS MEASURED RESULTS IE (clause 10.3.7.93a in 3GPP TS 25.331 [30]). In case the UE provides also measurements on the GPS L1 C/A signal, the measurement parameters are contained in the RRC UE POSITIONING GPS MEASURED RESULTS IE (clause 10.3.7.93 in 3GPP TS 25.331 [30]). The measurement parameters required for calculating the UE position are:

- 1) Reference Time: The UE has two choices for the Reference Time:

- a) "UE GANSS Timing of Cell Frames" and/or "UE GPS Timing of Cell Frames";
- b) "GANSS TOD msec" and/or "GPS TOW msec" if GPS L1 C/A signal measurements are also provided.

NOTE: It is not expected that an UE will ever report both a GANSS TOD and a GPS TOW. However if two time stamps are provided and they derive from different user times, be aware that no compensation is made for this difference and this could affect the location accuracy.

- 2) Measurement Parameters for each GANSS and GANSS Signal: 1 to <maxGANSSSat>:
 - a) "Satellite ID"; mapping according to table 10.3.7.88b in 3GPP TS 25.331 [30];
 - b) "GANSS Code Phase";
 - c) "GANSS Integer Code Phase";
 - d) "GANSS Integer Code Phase Extension";
 - e) "Code Phase RMS Error";
- 3) Additional Measurement Parameters in case of GPS L1 C/A signal measurements are also provided: 1 to <maxSat>:
 - a) "Satellite ID (SV PRN)";
 - b) "Whole GPS chips";
 - c) "Fractional GPS Chips";
 - d) "Pseudorange RMS Error".

Additional information required at the system simulator:

- 1) "UE Positioning GANSS Reference UE Position" or "UE Positioning GPS Reference UE Position" (clause 10.3.8.4c in 3GPP TS 25.331 [30]):
Used for initial approximate receiver coordinates.
- 2) "UE Positioning GANSS Navigation Model" and "UE Positioning GANSS Additional Navigation Models" (clauses 10.3.7.94a and 10.3.7.94b in 3GPP TS 25.331 [30]):
Contains the ephemeris and clock correction parameters as specified in the relevant ICD of each supported GANSS; used for calculating the satellite positions and clock corrections.
- 3) "UE Positioning GANSS Ionospheric Model" (clause 10.3.7.92a in 3GPP TS 25.331 [30]):
Contains the ionospheric parameters which allow the single frequency user to utilize the ionospheric model as specified in [15] for computation of the ionospheric delay.
- 4) "UE Positioning GANSS Additional Ionospheric Model" (clause 10.3.7.92b in 3GPP TS 25.331 [30]):
Contains the ionospheric parameters which allow the single frequency user to utilize the ionospheric model as specified in the relevant ICD of each supported GANSS [14], [37] for computation of the ionospheric delay.
- 5) "UE Positioning GANSS Time Model" (clause 10.3.7.97a in 3GPP TS 25.331 [30]):
Contains the GNSS-GNSS Time Offset for each supported GANSS. Note, that "UE Positioning GANSS Time Model" IE contains only the sub-ms part of the offset. Any potential integer seconds offset may be obtained from "UE Positioning GPS UTC Model" (clause 10.3.7.97 in 3GPP TS 25.331 [30]), "UE Positioning GANSS UTC Model" (clause 10.3.7.97c in 3GPP TS 25.331 [30]), or "UE Positioning GANSS Additional UTC Models" (clause 10.3.7.97d in 3GPP TS 25.331 [30]).
- 6) "UE Positioning GPS Navigation Model" (clause 10.3.7.94 in 3GPP TS 25.331 [30]):
Contains the GPS ephemeris and clock correction parameters as specified in [8]; used for calculating the GPS satellite positions and clock corrections in case of GPS L1 C/A signal measurements are the only GPS measurements provided in addition to GANSS measurements.
- 7) "UE Positioning GPS Ionospheric Model" (clause 10.3.7.92 in 3GPP TS 25.331 [30]):
Contains the ionospheric parameters which allow the single frequency user to utilize the ionospheric model as specified in [8] for computation of the ionospheric delay.

B.4 E-UTRAN and NR UE measurement reports

In case of E-UTRAN and NR UE-assisted A-GNSS, the measurement parameters are contained in the LPP GNSS-SignalMeasurementInformation IE (clause 6.5.2.6 in 3GPP TS 36.355 [4] and 3GPP TS 37.355 [49]). The measurement parameters required for calculating the UE position are:

- 1) Reference Time: The UE has two choices for the Reference Time:
 - a) "networkTime";
 - b) "gnss-TOD-msec".
- 2) Measurement Parameters for each GNSS and GNSS signal: 1 to 64:
 - a) "svID";
 - b) "codePhase";
 - c) "integerCodePhase";
 - d) "codePhaseRMSError".

Additional information required at the system simulator:

- 1) "GNSS-ReferenceLocation" (clause 6.5.2.2 in 3GPP TS 36.355 [4] and 3GPP TS 37.355 [49]):
Used for initial approximate receiver coordinates.
- 2) "GNSS-NavigationModel" (clause 6.5.2.2 in 3GPP TS 36.355 [4] and 3GPP TS 37.355 [49]):
Contains the GNSS ephemeris and clock correction parameters as specified in the relevant ICD of each supported GNSS; used for calculating the satellite positions and clock corrections.
- 3) "GNSS-IonosphericModel" (clause 6.5.2.2 in 3GPP TS 36.355 [4] and 3GPP TS 37.355 [49]):
Contains the ionospheric parameters which allow the single frequency user to utilize the ionospheric model as specified in the relevant ICD of each supported GNSS [8], [14], [15] and [37] for computation of the ionospheric delay.

B.5 WLS position solution

The WLS position solution problem is concerned with the task of solving for four unknowns; x_u , y_u , z_u the receiver coordinates in a suitable frame of reference (usually ECEF) and b_u the receiver clock bias. It typically requires the following steps:

Step 1: Formation of pseudo-ranges

The observation of code phase reported by the UE for each satellite SV_i is related to the pseudo-range/c modulo the "GNSS Code Phase Ambiguity" (UTRAN), or "gnss-CodePhaseAmbiguity" (E-UTRAN and NR), or modulo 1 ms (the length of the C/A code period) in case of GPS L1 C/A signal measurements. For the formation of pseudo-ranges, the integer number of milliseconds to be added to each code-phase measurement has to be determined first. Since 1 ms corresponds to a travelled distance of 300 km, the number of integer ms can be found with the help of reference location and satellite ephemeris. The distance between the reference location and each satellite SV_i is calculated and the integer number of milliseconds to be added to the UE code phase measurements is obtained.

Step 2: Correction of pseudo-ranges for the GNSS-GNSS time offsets

In the case that the UE reports measurements for more than a single GNSS, the pseudo-ranges are corrected for the time offsets between the GNSSs relative to the selected reference time using the GNSS-GNSS time offsets available at the system simulator:

$$\rho_{GNSS_m,i} \equiv \rho_{GNSS_m,i} - c \cdot (t_{GNSS_k} - t_{GNSS_m}),$$

where $\rho_{GNSS_m,i}$ is the measured pseudo-range of satellite i of GNSS_m. The system time t_{GNSS_k} of GNSS_k is the reference time frame, and Δt is the available GNSS-GNSS time offset, and c is the speed of light.

Step 3: Formation of weighting matrix

The UE reported "codePhaseRMSError" (E-UTRAN and NR) or "Code Phase RMS Error" and/or "Pseudorange RMS Error" (UTRAN) values are used to calculate the weighting matrix for the WLS algorithm [9]. According to 3GPP TS 25.331 [30] and 3GPP TS 36.355 [4] and 3GPP TS 37.355 [49], the encoding for this field is a 6 bit value that consists of a 3 bit mantissa, X_i and a 3 bit exponent, Y_i for each SV_i:

$$w_i = RMSError = 0.5 \times \left(1 + \frac{X_i}{8} \right) \times 2^{Y_i}$$

The weighting Matrix **W** is defined as a diagonal matrix containing the estimated variances calculated from the "codePhaseRMSError" (E-UTRAN and NR) or "Code Phase RMS Error" and/or "Pseudorange RMS Error" (UTRAN) values:

Step 4: WLS position solution

The WLS position solution is described in reference [9] and usually requires the following steps:

- 1) Computation of satellite locations at time of transmission using the ephemeris parameters and user algorithms defined in the relevant ICD of the particular GNSS. The satellite locations are transformed into WGS-84 reference frame, if needed.
- 2) Computation of clock correction parameters using the parameters and algorithms as defined in the relevant ICD of the particular GNSS.
- 3) Computation of atmospheric delay corrections using the parameters and algorithms defined in the relevant ICD of the particular GNSS for the ionospheric delay, and using the Gupta model in reference [10] p.121 equation (2) for the tropospheric delay. For GNSSs which do not natively provide ionospheric correction models (e.g., GLONASS), the ionospheric delay is determined using the available ionospheric model adapted to the particular GNSS frequency.
- 4) The WLS position solution starts with an initial estimate of the user state (position and clock offset). The Reference Location is used as initial position estimate. The following steps are required:
 - a) Calculate geometric range (corrected for Earth rotation) between initial location estimate and each satellite included in the UE measurement report.
 - b) Predict pseudo-ranges for each measurement including clock and atmospheric biases as calculated in 1) to 3) above and defined in the relevant ICD of the particular GNSS and [9].
 - c) Calculate difference between predicted and measured pseudo-ranges Δp
 - d) Calculate the "Geometry Matrix" **G** as defined in [9]:

$$\mathbf{G} \equiv \begin{bmatrix} -\hat{\mathbf{1}}_{GNSS_1,1}^T & 1 \\ -\hat{\mathbf{1}}_{GNSS_1,2}^T & 1 \\ \vdots & \vdots \\ -\hat{\mathbf{1}}_{GNSS_1,n}^T & 1 \\ \vdots & \vdots \\ -\hat{\mathbf{1}}_{GNSS_m,1}^T & 1 \\ -\hat{\mathbf{1}}_{GNSS_m,2}^T & 1 \\ \vdots & \vdots \\ -\hat{\mathbf{1}}_{GNSS_m,l}^T & 1 \end{bmatrix} \text{ with } \hat{\mathbf{1}}_{GNSS_m,i} \equiv \frac{\mathbf{r}_{s_{GNSS_m,i}} - \hat{\mathbf{r}}_u}{\left| \mathbf{r}_{s_{GNSS_m,i}} - \hat{\mathbf{r}}_u \right|} \text{ where } \mathbf{r}_{s_{GNSS_m,i}} \text{ is the satellite position vector for SV}_i \text{ of GNSS}_m$$

(calculated in 1) above), and $\hat{\mathbf{r}}_u$ is the estimate of the user location.

- e) Calculate the WLS solution according to [9]:

$$\Delta \hat{\mathbf{x}} = \left(\mathbf{G}^T \mathbf{W} \mathbf{G} \right)^{-1} \mathbf{G}^T \mathbf{W} \Delta \rho$$

- f) Adding the $\Delta \hat{\mathbf{x}}$ to the initial state estimate gives an improved estimate of the state vector:

$$\hat{\mathbf{x}} \rightarrow \hat{\mathbf{x}} + \Delta \hat{\mathbf{x}} .$$

- 5) This new state vector $\hat{\mathbf{x}}$ can be used as new initial estimate and the procedure is repeated until the change in $\hat{\mathbf{x}}$ is sufficiently small.

Step 5: Transformation from Cartesian coordinate system to Geodetic coordinate system

The state vector $\hat{\mathbf{x}}$ calculated in Step 4 contains the UE position in ECEF Cartesian coordinates together with the UE receiver clock bias relative to the selected GNSS system time. Only the user position is of further interest. It is usually desirable to convert from ECEF coordinates x_u, y_u, z_u to geodetic latitude φ , longitude λ and altitude h on the WGS84 reference ellipsoid.

Step 6: Calculation of "2-D Position Errors"

The latitude φ / longitude λ obtained after Step 5 is used to calculate the 2-D position error.

Annex C (normative): General test conditions and declarations

The requirements of this clause apply to all applicable tests in the present document.

In all the relevant clauses in this clause all 2D position error measurements shall be carried out according to the general rules for statistical testing in Annex D.

In this clause, the terms GNSS and A-GNSS also include the cases where the only satellite system used is GPS unless otherwise stated.

The test tolerances may not be valid for operating bands above 4200 MHz since some test system uncertainties are changed for frequencies above 4200 MHz. The test tolerances for bands above 4200 MHz are For Further Study [FFS].

C.1 Acceptable uncertainty of Test System

The maximum acceptable uncertainty of the Test System is specified below for each test, where appropriate. The Test System shall enable the stimulus signals in the test case to be adjusted to within the specified range, and the equipment under test to be measured with an uncertainty not exceeding the specified values. All ranges and uncertainties are absolute values, and are valid for a confidence level of 95 %, unless otherwise stated.

A confidence level of 95 % is the measurement uncertainty tolerance interval for a specific measurement that contains 95 % of the performance of a population of test equipment.

It should be noted that the uncertainties in clause C.1 apply to the Test System operating into a nominal 50 ohm load and do not include system effects due to mismatch between the DUT and the Test System.

C.1.1 Measurement of test environments

The measurement accuracy of the UE environmental test conditions, defined in Annex G or TS 36.508 [18] clause 4.1, shall be:

Pressure	± 5 kPa
Temperature	± 2 degrees
Relative Humidity	± 5 %
DC Voltage	± 1.0 %
AC Voltage	± 1.5 %
Vibration	10 %
Vibration frequency	0.1 Hz

The above values shall apply unless the test environment is otherwise controlled and the specification for the control of the test environment specifies the uncertainty for the parameter.

C.1.2 A-GNSS Minimum Performance requirements

Table C.1.1: Maximum Test System Uncertainty for A-GNSS Minimum Performance tests

Clause	Maximum Test System Uncertainty		Derivation of Test System Uncertainty
5.2.1, 6.2.1, 7.1.1, 13.2.1 Sensitivity Coarse Time Assistance	Coarse Time Assistance	± 200 ms	
	Absolute GNSS signal level	± 1 dB	
	Position error	± 0.05 m	Position error consists of ± 0.05 m system uncertainty. The effect of position reporting resolution of approximately ± 1.2 m (see note) is not included in the allowable test system uncertainty but is included in the Test Parameter Relaxations since this resolution limitation limits the reporting capability of the UE. For simplicity the combined Test Parameter Relaxation is given as ± 1.3 m

Clause	Maximum Test System Uncertainty	Derivation of Test System Uncertainty	
	Response time	± 300 ms	
5.2.2, 6.2.2, 7.1.2, 13.2.2 Sensitivity Fine Time Assistance	Coarse Time Assistance	±200 ms	
	Fine Time Assistance	±1 us	
	Absolute GNSS signal level	±1 dB	
	Position error	±0.05 m	Position error as above
	Response time	± 300 ms	
5.3, 6.3, 7.2, 13.3 Nominal Accuracy	Coarse Time Assistance	±200 ms	
	Absolute GNSS signal level	±1 dB	
	Position error	±0.05 m	Position error as above
	Response time	± 300 ms	
5.4, 6.4, 7.3, 13.4 Dynamic Range	Coarse Time Assistance	±200 ms	
	Absolute GNSS signal level	±1 dB	
	Relative GNSS signal level	±0.2 dB	
	Position error	±0.05 m	Position error as above
	Response time	± 300 ms	
5.5, 6.5, 7.4, 13.5 Multi-path scenario	Coarse Time Assistance	±200 ms	
	Absolute GNSS signal level	±1 dB	
	Relative GNSS signal level	±0.2 dB	
	Position error	±0.05 m	Position error as above
	Response time	± 300 ms	
5.6, 6.6, 7.5, 7.5A, 13.6, 13.7 Moving scenario and periodic update	Absolute GNSS signal level	±1 dB	
	Position error	±0.05 m	Position error as above
	Differential response time	± 100 ms	
	± 100 ms		

NOTE: For UE based mode the effect of position reporting resolution is given by:

$$\sqrt{\left(\frac{90 \times 2 \times \pi \times R}{2E23 \times 360}\right)^2 + \left(\frac{360 \times 2 \times \pi \times R \times \cos \phi}{2E24 \times 360}\right)^2}$$

meters, where R is the radius of the earth and φ is the latitude of the location. For the GNSS scenarios defined in TS 37.571-5 [20] this equates to approximately.

Editor’s note: this needs checking once the GNSS scenarios are agreed [TBD] m. For simplicity this is given as ±1.2 m.

For UE assisted mode it is assumed that the output from the WLS position solution calculation in Annex B is coded using the same position coding method as for UE based mode before being used to calculate position error. Therefore the effect of reporting resolution will be the same as for UE based mode.

C.1.3 ECID and OTDOA Measurement requirements

Table C.1.3-1: Maximum Test System Uncertainty for ECID and OTDOA Measurement Requirements

Clause	Maximum Test System Uncertainty	Derivation of Test System Uncertainty
8.1.1 E-UTRAN FDD UE Rx – Tx time difference case (Rel-9 to Rel-11)	<p>$N_{oc} \pm 1.0$ dB averaged over BW_{Config}</p> <p>$\hat{E}_s / N_{oc} \pm 0.3$ dB</p> <p>±3Ts Uplink signal transmit timing relative to downlink</p>	<p>Note:</p> <p>\hat{E}_s / N_{oc} is the ratio of cell 1 signal / AWGN</p> <p>$T_s = 1/(15000 \times 2048)$ seconds, the basic timing unit defined in TS 36.211 [26]</p>

8.1.1A E-UTRAN FDD UE Rx – Tx time difference case (Rel-12 onwards)	Same as 8.1.1	Same as 8.1.1
8.1.1B E-UTRAN FDD UE Rx – Tx time difference case for UE Category 1bis	Same as 8.1.1	Same as 8.1.1
8.1.2 E-UTRAN TDD UE Rx – Tx time difference case (Rel-9 to Rel-11)	Same as 8.1.1	Same as 8.1.1
8.1.2A E-UTRAN TDD UE Rx – Tx time difference case (Rel-12 onwards)	Same as 8.1.1	Same as 8.1.1
8.1.2B E-UTRAN TDD UE Rx – Tx time difference case for UE Category 1bis	Same as 8.1.1	Same as 8.1.1
8.1.3 E-UTRAN FDD UE Rx-Tx time difference under Time Domain Measurement Resource Restriction with Non-MBSFN ABS (eICIC)	$N_{oc} \pm 1.0$ dB averaged over BW_{Config} $\hat{E}_{S1} / N_{oc} \pm 0.3$ dB averaged over BW_{Config} $\hat{E}_{S2} / N_{oc} \pm 0.3$ dB averaged over BW_{Config} $\pm 3T_s$ Uplink signal transmit timing relative to downlink	Note: \hat{E}_{S1} / N_{oc} is the ratio of cell 1 signal / AWGN \hat{E}_{S2} / N_{oc} is the ratio of cell 2 signal / AWGN $T_s = 1/(15000 \times 2048)$ seconds, the basic timing unit defined in TS 36.211 [26]
8.1.4 E-UTRAN TDD UE Rx-Tx time difference under Time Domain Measurement Resource Restriction with Non-MBSFN ABS (eICIC)	Same as 8.1.3	Same as 8.1.3
8.1.5 E-UTRAN FDD UE Rx–Tx time difference under Time Domain Measurement Resource Restriction with CRS Assistance Information and Non-MBSFN ABS (feICIC)	$N_{oc} \pm 1.0$ dB averaged over BW_{Config} $\hat{E}_{S1} / N_{oc} \pm 0.3$ dB averaged over BW_{Config} $\hat{E}_{S2} / N_{oc} \pm 0.3$ dB averaged over BW_{Config} $\hat{E}_{S3} / N_{oc} \pm 0.3$ dB averaged over BW_{Config} $\pm 3T_s$ Uplink signal transmit timing relative to downlink	Note: \hat{E}_{S1} / N_{oc} is the ratio of cell 1 signal / AWGN \hat{E}_{S2} / N_{oc} is the ratio of cell 1 signal / AWGN \hat{E}_{S3} / N_{oc} is the ratio of cell 1 signal / AWGN $T_s = 1/(15000 \times 2048)$ seconds, the basic timing unit defined in TS 36.211 [26]
8.1.6 E-UTRAN TDD UE Rx–Tx time difference under Time Domain Measurement Resource Restriction with CRS Assistance Information and Non-MBSFN ABS (feICIC)	Same as 8.1.5	Same as 8.1.5
8.1.7 E-UTRAN FDD UE Rx-Tx time difference case for Category M1/M2 UE in CEModeA	Same as 8.1.1	Same as 8.1.1
8.1.8 E-UTRAN HD-FDD UE Rx-Tx time difference case for Category M1/M2 UE in CEModeA	Same as 8.1.1	Same as 8.1.1
8.1.9 E-UTRAN TDD UE Rx-Tx time difference case for Category M1/M2 UE in CEModeA	Same as 8.1.1	Same as 8.1.1

9.1.1 FDD RSTD Measurement Reporting Delay	$N_{oc} \pm 1.0$ dB averaged over BW_{Config} $PRS \hat{E}_{s1} / N_{oc} \pm 0.6$ dB averaged over BW_{Config} $\hat{E}_{s1} / N_{oc} \pm 0.6$ dB averaged over BW_{Config} $PRS \hat{E}_{s2} / N_{oc} \pm 0.6$ dB averaged over BW_{Config} $\hat{E}_{s2} / N_{oc} \pm 0.6$ dB averaged over BW_{Config} $PRS \hat{E}_{s3} / N_{oc} \pm 0.6$ dB averaged over BW_{Config} $\hat{E}_{s3} / N_{oc} \pm 0.6$ dB averaged over BW_{Config} Response Time = ± 300 ms	Note: $PRS \hat{E}_{s1} / N_{oc}$ and \hat{E}_{s1} / N_{oc} are the ratios of cell 1 signal / AWGN $PRS \hat{E}_{s2} / N_{oc}$ and \hat{E}_{s2} / N_{oc} are the ratios of cell 2 signal / AWGN $PRS \hat{E}_{s3} / N_{oc}$ and \hat{E}_{s3} / N_{oc} are the ratios of cell 3 signal / AWGN $PRS \hat{E}_s / N_{oc}$ and \hat{E}_s / N_{oc} uncertainty for fading condition comprises two quantities: 1. Signal-to-noise ratio uncertainty 2. Fading profile power uncertainty Items 1 and 2 are assumed to be uncorrelated so can be root sum squared: $PRS \hat{E}_s / N_{oc}$ and \hat{E}_s / N_{oc} uncertainty = $\text{SQRT}(\text{Signal-to-noise ratio uncertainty}^2 + \text{Fading profile power uncertainty}^2)$ Signal-to-noise ratio uncertainty ± 0.3 dB Fading profile power uncertainty ± 0.5 dB
9.1.1A FDD RSTD Measurement Reporting Delay for UE Category 1bis	Same as 9.1.1	
9.1.2 TDD RSTD Measurement Reporting Delay	Same as 9.1.1	
9.1.2A TDD RSTD Measurement Reporting Delay for UE Category 1bis	Same as 9.1.1	
9.1.3 FDD RSTD Measurement Accuracy	$N_{oc} \pm 1.0$ dB averaged over BW_{Config} $PRS \hat{E}_{s1} / N_{oc} \pm 0.3$ dB averaged over BW_{Config} $\hat{E}_{s1} / N_{oc} \pm 0.3$ dB averaged over BW_{Config} $PRS \hat{E}_{s2} / N_{oc} \pm 0.3$ dB averaged over BW_{Config} $\hat{E}_{s2} / N_{oc} \pm 0.3$ dB averaged over BW_{Config} Cell Timing Difference = $\pm 1 T_s$	Note: $PRS \hat{E}_{s1} / N_{oc}$ and \hat{E}_{s1} / N_{oc} are the ratios of cell 1 signal / AWGN $PRS \hat{E}_{s2} / N_{oc}$ and \hat{E}_{s2} / N_{oc} are the ratios of cell 2 signal / AWGN
9.1.3A FDD RSTD Measurement Accuracy for UE Category 1bis	Same as 9.1.3	
9.1.4 TDD RSTD Measurement Accuracy	Same as 9.1.3	
9.1.4A TDD RSTD Measurement Accuracy for UE Category 1bis	Same as 9.1.3	

<p>9.2.1 FDD-FDD inter-frequency RSTD measurement reporting delay</p>	<p>$N_{oc1} \pm 1.0$ dB averaged over BW_{Config} $N_{oc2} \pm 1.0$ dB averaged over BW_{Config} PRS $\hat{E}_{s1} / N_{oc1} \pm 0.6$ dB averaged over BW_{Config} $\hat{E}_{s1} / N_{oc1} \pm 0.6$ dB averaged over BW_{Config} PRS $\hat{E}_{s2} / N_{oc2} \pm 0.6$ dB averaged over BW_{Config} $\hat{E}_{s2} / N_{oc2} \pm 0.6$ dB averaged over BW_{Config} PRS $\hat{E}_{s3} / N_{oc2} \pm 0.6$ dB averaged over BW_{Config} $\hat{E}_{s3} / N_{oc2} \pm 0.6$ dB averaged over BW_{Config} Response Time = ± 300 ms</p>	<p>Note: PRS \hat{E}_{s1} / N_{oc1} and \hat{E}_{s1} / N_{oc1} are the ratios of cell 1 signal / AWGN for frequency 1 PRS \hat{E}_{s2} / N_{oc2} and \hat{E}_{s2} / N_{oc2} are the ratios of cell 2 signal / AWGN for frequency 2 PRS \hat{E}_{s3} / N_{oc2} and \hat{E}_{s3} / N_{oc2} are the ratios of cell 3 signal / AWGN for frequency 2 PRS \hat{E}_s / N_{oc} and \hat{E}_s / N_{oc} uncertainty for fading condition comprises two quantities: 1. Signal-to-noise ratio uncertainty 2. Fading profile power uncertainty Items 1 and 2 are assumed to be uncorrelated so can be root sum squared: PRS \hat{E}_s / N_{oc} and \hat{E}_s / N_{oc} uncertainty = SQRT (Signal-to-noise ratio uncertainty² + Fading profile power uncertainty²) Signal-to-noise ratio uncertainty ± 0.3 dB Fading profile power uncertainty ± 0.5 dB</p>
<p>9.2.1A FDD-FDD inter-frequency RSTD measurement reporting delay for UE Category 1bis</p>	<p>Same as 9.2.1</p>	
<p>9.2.2 TDD-TDD inter-frequency RSTD measurement reporting delay</p>	<p>Same as 9.2.1</p>	
<p>9.2.2A TDD-TDD inter-frequency RSTD measurement reporting delay for UE Category 1bis</p>	<p>Same as 9.2.1</p>	
<p>9.2.4 FDD-FDD inter frequency RSTD Accuracy</p>	<p>$N_{oc1} \pm 1.0$ dB averaged over BW_{Config} $N_{oc2} \pm 1.0$ dB averaged over BW_{Config} PRS $\hat{E}_{s1} / N_{oc1} \pm 0.3$ dB averaged over BW_{Config} $\hat{E}_{s1} / N_{oc1} \pm 0.3$ dB averaged over BW_{Config} PRS $\hat{E}_{s2} / N_{oc2} \pm 0.3$ dB averaged over BW_{Config} $\hat{E}_{s2} / N_{oc2} \pm 0.3$ dB averaged over BW_{Config} Cell Timing Difference = $\pm 2 T_s$</p>	<p>Note: PRS \hat{E}_{s1} / N_{oc1} and \hat{E}_{s1} / N_{oc1} are the ratios of cell 1 signal / AWGN for frequency 1 PRS \hat{E}_{s2} / N_{oc2} and \hat{E}_{s2} / N_{oc2} are the ratios of cell 2 signal / AWGN for frequency 2</p>
<p>9.2.4A FDD-FDD inter frequency RSTD Accuracy for UE Category 1bis</p>	<p>Same as 9.2.4</p>	
<p>9.2.5 TDD-TDD inter frequency RSTD Accuracy</p>	<p>Same as 9.2.4</p>	
<p>9.2.5A TDD-TDD inter frequency RSTD Accuracy for UE Category 1bis</p>	<p>Same as 9.2.4</p>	
<p>9.3.1.1 FDD intra-frequency RSTD Measurement Reporting Delay in CE Mode A for Category M1</p>	<p>Same as 9.1.1</p>	<p>Same as 9.1.1</p>
<p>9.3.1.2 FDD intra-frequency RSTD Measurement Reporting Delay in CE Mode A for Category M2</p>	<p>Same as 9.1.1</p>	<p>Same as 9.1.1</p>
<p>9.3.2.1 HD-FDD intra-frequency RSTD Measurement Reporting Delay in CE Mode A for Category M1</p>	<p>Same as 9.1.1</p>	<p>Same as 9.1.1</p>

9.3.2.2 HD-FDD intra-frequency RSTD Measurement Reporting Delay in CE Mode A for Category M2	Same as 9.1.1	Same as 9.1.1
9.3.3.1 TDD intra-frequency RSTD Measurement Reporting Delay in CE Mode A for Category M1	Same as 9.1.1	Same as 9.1.1
9.3.3.2 TDD intra-frequency RSTD Measurement Reporting Delay in CE Mode A for Category M2	Same as 9.1.1	Same as 9.1.1
9.3.4.1 FDD intra-frequency RSTD Measurement Reporting Delay in CE Mode B for Category M1	Same as 9.1.1	Same as 9.1.1
9.3.4.2 FDD intra-frequency RSTD Measurement Reporting Delay in CE Mode B for Category M2	Same as 9.1.1	Same as 9.1.1
9.3.5.1 HD-FDD intra-frequency RSTD Measurement Reporting Delay in CE Mode B for Category M1	Same as 9.1.1	Same as 9.1.1
9.3.5.2 HD-FDD intra-frequency RSTD Measurement Reporting Delay in CE Mode B for Category M2	Same as 9.1.1	Same as 9.1.1
9.3.6.1 TDD intra-frequency RSTD Measurement Reporting Delay in CE Mode B for Category M1	Same as 9.1.1	Same as 9.1.1
9.3.6.2 TDD intra-frequency RSTD Measurement Reporting Delay in CE Mode B for Category M2	Same as 9.1.1	Same as 9.1.1
9.3.7.1 FDD intra-frequency RSTD Measurement Accuracy in CE Mode A for Category M1	Same as 9.1.3	Same as 9.1.3
9.3.7.2 FDD intra-frequency RSTD Measurement Accuracy in CE Mode A for Category M2	Same as 9.1.3	Same as 9.1.3
9.3.8.1 HD-FDD intra-frequency RSTD Measurement Accuracy in CE Mode A for Category M1	Same as 9.1.3	Same as 9.1.3
9.3.8.2 HD-FDD intra-frequency RSTD Measurement Accuracy in CE Mode A for Category M2	Same as 9.1.3	Same as 9.1.3
9.3.9.1 TDD intra-frequency RSTD Measurement Accuracy in CE Mode A for Category M1	Same as 9.1.3	Same as 9.1.3
9.3.9.2 TDD intra-frequency RSTD Measurement Accuracy in CE Mode A for Category M2	Same as 9.1.3	Same as 9.1.3
9.3.10.1 FDD intra-frequency RSTD Measurement Accuracy in CE Mode B for Category M1	Same as 9.1.3	Same as 9.1.3
9.3.10.2 FDD intra-frequency RSTD Measurement Accuracy in CE Mode B for Category M2	Same as 9.1.3	Same as 9.1.3
9.3.11.1 HD-FDD intra-frequency RSTD Measurement Accuracy in CE Mode B for Category M1	Same as 9.1.3	Same as 9.1.3
9.3.11.2 HD-FDD intra-frequency RSTD Measurement Accuracy in CE Mode B for Category M2	Same as 9.1.3	Same as 9.1.3
9.3.12.1 TDD intra-frequency RSTD Measurement Accuracy in CE Mode B for Category M1	Same as 9.1.3	Same as 9.1.3
9.3.12.2 TDD intra-frequency RSTD Measurement Accuracy in CE Mode B for Category M2	Same as 9.1.3	Same as 9.1.3

9.3.13 E-UTRAN FDD intra-frequency RSTD measurement period test case in CE Mode A with longer PRS occasions	Same as 9.1.3	Same as 9.1.3
9.3.14 E-UTRAN HD-FDD intra-frequency RSTD measurement period test case in CE Mode A with longer PRS occasions	Same as 9.1.3	Same as 9.1.3
9.3.15 E-UTRAN TDD intra-frequency RSTD measurement period test case in CE Mode A with longer PRS occasions	Same as 9.1.3	Same as 9.1.3
9.3.16 E-UTRAN FDD intra-frequency RSTD measurement period test case in CE Mode B with longer PRS occasions	Same as 9.1.3	Same as 9.1.3
9.3.17 E-UTRAN HD-FDD intra-frequency RSTD measurement period test case in CE Mode B with longer PRS occasions	Same as 9.1.3	Same as 9.1.3
9.3.18 E-UTRAN TDD intra-frequency RSTD measurement period test case in CE Mode B with longer PRS occasions	Same as 9.1.3	Same as 9.1.3
9.4.1.1 FDD inter-frequency RSTD Measurement Reporting Delay in CE Mode A for Category M1	Same as 9.2.1	Same as 9.2.1
9.4.1.2 FDD inter-frequency RSTD Measurement Reporting Delay in CE Mode A for Category M2	Same as 9.2.1	Same as 9.2.1
9.4.2.1 HD-FDD inter-frequency RSTD Measurement Reporting Delay in CE Mode A for Category M1	Same as 9.2.1	Same as 9.2.1
9.4.2.2 HD-FDD inter-frequency RSTD Measurement Reporting Delay in CE Mode A for Category M2	Same as 9.2.1	Same as 9.2.1
9.4.3.1 TDD inter-frequency RSTD Measurement Reporting Delay in CE Mode A for Category M1	Same as 9.2.1	Same as 9.2.1
9.4.3.2 TDD inter-frequency RSTD Measurement Reporting Delay in CE Mode A for Category M2	Same as 9.2.1	Same as 9.2.1
9.4.4.1 FDD inter-frequency RSTD Measurement Reporting Delay in CE Mode B for Category M1	Same as 9.2.1	Same as 9.2.1
9.4.4.2 FDD inter-frequency RSTD Measurement Reporting Delay in CE Mode B for Category M2	Same as 9.2.1	Same as 9.2.1
9.4.5.1 HD-FDD inter-frequency RSTD Measurement Reporting Delay in CE Mode B for Category M1	Same as 9.2.1	Same as 9.2.1
9.4.5.2 HD-FDD inter-frequency RSTD Measurement Reporting Delay in CE Mode B for Category M2	Same as 9.2.1	Same as 9.2.1
9.4.6.1 TDD inter-frequency RSTD Measurement Reporting Delay in CE Mode B for Category M1	Same as 9.2.1	Same as 9.2.1
9.4.6.2 TDD inter-frequency RSTD Measurement Reporting Delay in CE Mode B for Category M2	Same as 9.2.1	Same as 9.2.1
9.4.7.1 FDD inter-frequency RSTD Measurement Accuracy in CE Mode A for Category M1	Same as 9.2.4	Same as 9.2.4

9.4.7.2 FDD inter-frequency RSTD Measurement Accuracy in CE Mode A for Category M2	Same as 9.2.4	Same as 9.2.4
9.4.8.1 HD-FDD inter-frequency RSTD Measurement Accuracy in CE Mode A for Category M1	Same as 9.2.4	Same as 9.2.4
9.4.8.2 HD-FDD inter-frequency RSTD Measurement Accuracy in CE Mode A for Category M2	Same as 9.2.4	Same as 9.2.4
9.4.9.1 TDD inter-frequency RSTD Measurement Accuracy in CE Mode A for Category M1	Same as 9.2.4	Same as 9.2.4
9.4.9.2 TDD inter-frequency RSTD Measurement Accuracy in CE Mode A for Category M2	Same as 9.2.4	Same as 9.2.4
9.4.10.1 FDD inter-frequency RSTD Measurement Accuracy in CE Mode B for Category M1	Same as 9.2.4	Same as 9.2.4
9.4.10.2 FDD inter-frequency RSTD Measurement Accuracy in CE Mode B for Category M2	Same as 9.2.4	Same as 9.2.4
9.4.11.1 HD-FDD inter-frequency RSTD Measurement Accuracy in CE Mode B for Category M1	Same as 9.2.4	Same as 9.2.4
9.4.11.2 HD-FDD inter-frequency RSTD Measurement Accuracy in CE Mode B for Category M2	Same as 9.2.4	Same as 9.2.4
9.4.12.1 TDD inter-frequency RSTD Measurement Accuracy in CE Mode B for Category M1	Same as 9.2.4	Same as 9.2.4
9.4.12.2 TDD inter-frequency RSTD Measurement Accuracy in CE Mode B for Category M2	Same as 9.2.4	Same as 9.2.4
9.4.13 E-UTRAN FDD inter-frequency RSTD measurement period test case in CE Mode A with longer PRS occasions	Same as 9.2.4	Same as 9.2.4
9.4.14 E-UTRAN HD-FDD inter-frequency RSTD measurement period test case in CE Mode A with longer PRS occasions	Same as 9.2.4	Same as 9.2.4
9.4.15 E-UTRAN TDD inter-frequency RSTD measurement period test case in CE Mode A with longer PRS occasions	Same as 9.2.4	Same as 9.2.4
9.4.16 E-UTRAN FDD inter-frequency RSTD measurement period test case in CE Mode B with longer PRS occasions	Same as 9.2.4	Same as 9.2.4
9.4.17 E-UTRAN HD-FDD inter-frequency RSTD measurement period test case in CE Mode B with longer PRS occasions	Same as 9.2.4	Same as 9.2.4
9.4.18 E-UTRAN TDD inter-frequency RSTD measurement period test case in CE Mode B with longer PRS occasions	Same as 9.2.4	Same as 9.2.4
9.5.1 HD-FDD Intra frequency RSTD Measurement Accuracy for NB-IOT Inband Mode in normal coverage	$N_{oc} \pm 1.0$ dB averaged over BW_{Config} NPRS $\hat{E}_{s1} / N_{oc} \pm 0.3$ dB averaged over BW_{Config} $\hat{E}_{s1} / N_{oc} \pm 0.3$ dB averaged over BW_{Config} NPRS $\hat{E}_{s2} / N_{oc} \pm 0.3$ dB averaged over BW_{Config} $\hat{E}_{s2} / N_{oc} \pm 0.3$ dB averaged over BW_{Config} Cell Timing Difference = ± 1 Ts	Note: NPRS \hat{E}_{s1} / N_{oc} and \hat{E}_{s1} / N_{oc} are the ratios of nCell 1 signal / AWGN NPRS \hat{E}_{s2} / N_{oc} and \hat{E}_{s2} / N_{oc} are the ratios of nCell 2 signal / AWGN

9.5.2 HD-FDD Intra frequency RSTD Measurement Accuracy for NB-IOT Inband Mode in enhanced coverage	Same as 9.5.1	Same as 9.5.1
9.5.3 HD-FDD Intra frequency RSTD Measurement Reporting Delay for NB-IOT Inband Mode in enhanced coverage	$N_{oc} \pm 1.0$ dB averaged over BW_{Config} NPRS $\hat{E}_{s1} / N_{oc} \pm 0.3$ dB averaged over BW_{Config} $\hat{E}_{s1} / N_{oc} \pm 0.3$ dB averaged over BW_{Config} NPRS $\hat{E}_{s2} / N_{oc} \pm 0.3$ dB averaged over BW_{Config} $\hat{E}_{s2} / N_{oc} \pm 0.3$ dB averaged over BW_{Config} NPRS $\hat{E}_{s3} / N_{oc} \pm 0.3$ dB averaged over BW_{Config} $\hat{E}_{s3} / N_{oc} \pm 0.3$ dB averaged over BW_{Config} Response Time = ± 300 ms	Note: NPRS \hat{E}_{s1} / N_{oc} and \hat{E}_{s1} / N_{oc} are the ratios of nCell 1 signal / AWGN NPRS \hat{E}_{s2} / N_{oc} and \hat{E}_{s2} / N_{oc} are the ratios of nCell 2 signal / AWGN
9.6.1 HD-FDD Inter-Frequency RSTD Measurement Accuracy for NB-IOT Inband Mode in normal coverage	$N_{oc1} \pm 1.0$ dB averaged over BW_{Config} $N_{oc2} \pm 1.0$ dB averaged over BW_{Config} NPRS $\hat{E}_{s1} / N_{oc1} \pm 0.3$ dB averaged over BW_{Config} $\hat{E}_{s1} / N_{oc1} \pm 0.3$ dB averaged over BW_{Config} NPRS $\hat{E}_{s2} / N_{oc2} \pm 0.3$ dB averaged over BW_{Config} $\hat{E}_{s2} / N_{oc2} \pm 0.3$ dB averaged over BW_{Config} Cell Timing Difference = $\pm 2 T_s$	Note: NPRS \hat{E}_{s1} / N_{oc1} and \hat{E}_{s1} / N_{oc1} are the ratios of nCell 1 signal / AWGN for frequency 1 NPRS \hat{E}_{s2} / N_{oc2} and \hat{E}_{s2} / N_{oc2} are the ratios of nCell 2 signal / AWGN for frequency 2
9.6.2 HD-FDD Inter-Frequency RSTD Measurement Accuracy for NB-IOT Inband Mode in enhanced coverage	Same as 9.6.1	Same as 9.6.1
9.6.3 HD-FDD Inter frequency RSTD Measurement Reporting Delay for NB-IOT Inband Mode in enhanced coverage	Same as 9.5.3	Same as 9.5.3
9.7.1 TDD Intra frequency RSTD Measurement Accuracy for NB-IOT Inband Mode in normal coverage	$N_{oc} \pm 1.0$ dB averaged over BW_{Config} NPRS $\hat{E}_{s1} / N_{oc} \pm 0.3$ dB averaged over BW_{Config} $\hat{E}_{s1} / N_{oc} \pm 0.3$ dB averaged over BW_{Config} NPRS $\hat{E}_{s2} / N_{oc} \pm 0.3$ dB averaged over BW_{Config} $\hat{E}_{s2} / N_{oc} \pm 0.3$ dB averaged over BW_{Config} Cell Timing Difference = $\pm 1 T_s$	Note: NPRS \hat{E}_{s1} / N_{oc} and \hat{E}_{s1} / N_{oc} are the ratios of nCell 1 signal / AWGN NPRS \hat{E}_{s2} / N_{oc} and \hat{E}_{s2} / N_{oc} are the ratios of nCell 2 signal / AWGN
9.7.2 TDD Intra frequency RSTD Measurement Accuracy for NB-IOT Inband Mode in enhanced coverage	Same as 9.7.1	Same as 9.7.1
9.7.3 TDD Intra frequency RSTD Measurement Reporting Delay for NB-IOT Inband Mode in enhanced coverage	$N_{oc} \pm 1.0$ dB averaged over BW_{Config} NPRS $\hat{E}_{s1} / N_{oc} \pm 0.3$ dB averaged over BW_{Config} $\hat{E}_{s1} / N_{oc} \pm 0.3$ dB averaged over BW_{Config} NPRS $\hat{E}_{s2} / N_{oc} \pm 0.3$ dB averaged over BW_{Config} $\hat{E}_{s2} / N_{oc} \pm 0.3$ dB averaged over BW_{Config} NPRS $\hat{E}_{s3} / N_{oc} \pm 0.3$ dB averaged over BW_{Config} $\hat{E}_{s3} / N_{oc} \pm 0.3$ dB averaged over BW_{Config} Response Time = ± 300 ms	Note: NPRS \hat{E}_{s1} / N_{oc} and \hat{E}_{s1} / N_{oc} are the ratios of nCell 1 signal / AWGN NPRS \hat{E}_{s2} / N_{oc} and \hat{E}_{s2} / N_{oc} are the ratios of nCell 2 signal / AWGN

9.8.1 TDD Inter-frequency RSTD Measurement Accuracy for NB-IOT Inband Mode in normal coverage	$N_{oc1} \pm 1.0$ dB averaged over BW_{Config} $N_{oc2} \pm 1.0$ dB averaged over BW_{Config} NPRS $\hat{E}_{s1} / N_{oc1} \pm 0.3$ dB averaged over BW_{Config} $\hat{E}_{s1} / N_{oc1} \pm 0.3$ dB averaged over BW_{Config} NPRS $\hat{E}_{s2} / N_{oc2} \pm 0.3$ dB averaged over BW_{Config} $\hat{E}_{s2} / N_{oc2} \pm 0.3$ dB averaged over BW_{Config} Cell Timing Difference = $\pm 2 T_s$	Note: NPRS \hat{E}_{s1} / N_{oc1} and \hat{E}_{s1} / N_{oc1} are the ratios of nCell 1 signal / AWGN for frequency 1 NPRS \hat{E}_{s2} / N_{oc2} and \hat{E}_{s2} / N_{oc2} are the ratios of nCell 2 signal / AWGN for frequency 2
9.8.2 TDD Inter-frequency RSTD Measurement Accuracy for NB-IOT Inband Mode in enhanced coverage	Same as 9.8.1	Same as 9.8.1
9.8.3 TDD Inter frequency RSTD Measurement Reporting Delay for NB-IOT Inband Mode in enhanced coverage	Same as 9.7.3	Same as 9.7.3
10.1 FDD RSTD Measurement Reporting Delay for Carrier Aggregation	$N_{oc1} \pm 1.0$ dB averaged over BW_{Config} $N_{oc2} \pm 1.0$ dB averaged over BW_{Config} PRS $\hat{E}_{s1} / N_{oc1} \pm 0.6$ dB averaged over BW_{Config} $\hat{E}_{s1} / N_{oc1} \pm 0.6$ dB averaged over BW_{Config} PRS $\hat{E}_{s2} / N_{oc2} \pm 0.6$ dB averaged over BW_{Config} $\hat{E}_{s2} / N_{oc2} \pm 0.6$ dB averaged over BW_{Config} PRS $\hat{E}_{s3} / N_{oc2} \pm 0.6$ dB averaged over BW_{Config} $\hat{E}_{s3} / N_{oc2} \pm 0.6$ dB averaged over BW_{Config} Response Time = ± 300 ms	Note: PRS \hat{E}_{s1} / N_{oc1} and \hat{E}_{s1} / N_{oc1} are the ratios of cell 1 signal / AWGN for frequency 1 PRS \hat{E}_{s2} / N_{oc2} and \hat{E}_{s2} / N_{oc2} are the ratios of cell 2 signal / AWGN for frequency 2 PRS \hat{E}_{s3} / N_{oc2} and \hat{E}_{s3} / N_{oc2} are the ratios of cell 3 signal / AWGN for frequency 2 PRS \hat{E}_s / N_{oc} and \hat{E}_s / N_{oc} uncertainty for fading condition comprises two quantities: 1. Signal-to-noise ratio uncertainty 2. Fading profile power uncertainty Items 1 and 2 are assumed to be uncorrelated so can be root sum squared: PRS \hat{E}_s / N_{oc} and \hat{E}_s / N_{oc} uncertainty = SQRT (Signal-to-noise ratio uncertainty ² + Fading profile power uncertainty ²) Signal-to-noise ratio uncertainty ± 0.3 dB Fading profile power uncertainty ± 0.5 dB
10.1A FDD RSTD Measurement Reporting Delay for Carrier Aggregation for 20 MHz	Same as 10.1	Same as 10.1
10.1B FDD RSTD Measurement Reporting Delay Carrier Aggregation for 5 MHz +5 MHz Bandwidth	Same as 10.1	Same as 10.1
10.1C FDD RSTD Measurement Reporting Delay for Carrier Aggregation for 10 MHz+5 MHz Bandwidth	Same as 10.1	Same as 10.1
10.2 TDD RSTD Measurement Reporting Delay for Carrier Aggregation	Same as 10.1	Same as 10.1
10.2A TDD RSTD Measurement Reporting Delay for Carrier Aggregation for 20 MHz	Same as 10.1	Same as 10.1
10.2B TDD RSTD Measurement Reporting Delay Carrier Aggregation for 5 MHz +5 MHz Bandwidth	Same as 10.1	Same as 10.1

10.2C TDD RSTD Measurement Reporting Delay for Carrier Aggregation for 10 MHz+5 MHz Bandwidth	Same as 10.1	Same as 10.1
10.2D TDD RSTD Measurement Reporting Delay for Carrier Aggregation for 20 MHz +10 MHz Bandwidth	Same as 10.1	Same as 10.1
10.3 FDD RSTD Measurement Accuracy for Carrier Aggregation	$N_{oc1} \pm 1.0$ dB averaged over BW_{Config} $N_{oc2} \pm 1.0$ dB averaged over BW_{Config} PRRS $\hat{E}_{s1} / N_{oc1} \pm 0.3$ dB averaged over BW_{Config} $\hat{E}_{s1} / N_{oc1} \pm 0.3$ dB averaged over BW_{Config} PRRS $\hat{E}_{s2} / N_{oc2} \pm 0.3$ dB averaged over BW_{Config} $\hat{E}_{s2} / N_{oc2} \pm 0.3$ dB averaged over BW_{Config} PRRS $\hat{E}_{s3} / N_{oc2} \pm 0.3$ dB averaged over BW_{Config} $\hat{E}_{s3} / N_{oc2} \pm 0.3$ dB averaged over BW_{Config} Cell Timing Difference = $\pm 1 T_s$	Note: PRRS \hat{E}_{s1} / N_{oc1} and \hat{E}_{s1} / N_{oc1} are the ratios of cell 1 signal / AWGN for frequency 1 PRRS \hat{E}_{s2} / N_{oc2} and \hat{E}_{s2} / N_{oc2} are the ratios of cell 2 signal / AWGN for frequency 2 PRRS \hat{E}_{s3} / N_{oc2} and \hat{E}_{s3} / N_{oc2} are the ratios of cell 3 signal / AWGN for frequency 2
10.3A FDD RSTD Measurement Accuracy for Carrier Aggregation for 20 MHz (Rel-10 and Rel-11)	Same as 10.3	
10.3A_1 FDD RSTD Measurement Accuracy for Carrier Aggregation for 20 MHz (Rel-12 onwards)	Same as 10.3	Same as 10.3
10.3B FDD RSTD Measurement Accuracy for Carrier Aggregation for 5 MHz+5 MHz Bandwidth	Same as 10.3	Same as 10.3
10.3C FDD RSTD Measurement Accuracy for Carrier Aggregation for 10 MHz+5 MHz Bandwidth	Same as 10.3	Same as 10.3
10.4 TDD RSTD Measurement Accuracy for Carrier Aggregation	Same as 10.3	
10.4A TDD RSTD Measurement Accuracy for Carrier Aggregation for 20 MHz (Rel-10 and Rel-11)	Same as 10.3	
10.4A_1 TDD RSTD Measurement Accuracy for Carrier Aggregation for 20 MHz (Rel-12 onwards)	Same as 10.3	Same as 10.3
10.4B TDD RSTD Measurement Accuracy for Carrier Aggregation for 5 MHz+5 MHz Bandwidth	Same as 10.3	Same as 10.3
10.4C TDD RSTD Measurement Accuracy for Carrier Aggregation for 10 MHz+5 MHz Bandwidth	Same as 10.3	Same as 10.3
10.4D TDD RSTD Measurement Accuracy for Carrier Aggregation for 20 MHz+10 MHz Bandwidth	Same as 10.3	Same as 10.3

10.5 FDD 3 DL CA RSTD Measurement Reporting Delay	$N_{oc1} \pm 1.0$ dB averaged over BW_{Config} $N_{oc2} \pm 1.0$ dB averaged over BW_{Config} $N_{oc3} \pm 1.0$ dB averaged over BW_{Config} PRRS $\hat{E}_{s1} / N_{oc1} \pm 0.6$ dB averaged over BW_{Config} $\hat{E}_{s1} / N_{oc1} \pm 0.6$ dB averaged over BW_{Config} PRRS $\hat{E}_{s2} / N_{oc2} \pm 0.6$ dB averaged over BW_{Config} $\hat{E}_{s2} / N_{oc2} \pm 0.6$ dB averaged over BW_{Config} PRRS $\hat{E}_{s3} / N_{oc3} \pm 0.6$ dB averaged over BW_{Config} $\hat{E}_{s3} / N_{oc3} \pm 0.6$ dB averaged over BW_{Config} PRRS $\hat{E}_{s4} / N_{oc3} \pm 0.6$ dB averaged over BW_{Config} $\hat{E}_{s4} / N_{oc3} \pm 0.6$ dB averaged over BW_{Config} Response Time = ± 300 ms	Note: PRRS \hat{E}_{s1} / N_{oc1} and \hat{E}_{s1} / N_{oc1} are the ratios of cell 1 signal / AWGN for frequency 1 PRRS \hat{E}_{s2} / N_{oc2} and \hat{E}_{s2} / N_{oc2} are the ratios of cell 2 signal / AWGN for frequency 2 PRRS \hat{E}_{s3} / N_{oc3} and \hat{E}_{s3} / N_{oc3} are the ratios of cell 3 signal / AWGN for frequency 3 PRRS \hat{E}_{s4} / N_{oc3} and \hat{E}_{s4} / N_{oc3} are the ratios of cell 4 signal / AWGN for frequency 3 PRRS \hat{E}_s / N_{oc} and \hat{E}_s / N_{oc} uncertainty for fading condition comprises two quantities: 1. Signal-to-noise ratio uncertainty 2. Fading profile power uncertainty Items 1 and 2 are assumed to be uncorrelated so can be root sum squared: PRRS \hat{E}_s / N_{oc} and \hat{E}_s / N_{oc} uncertainty = SQRT (Signal-to-noise ratio uncertainty ² + Fading profile power uncertainty ²) Signal-to-noise ratio uncertainty ± 0.3 dB Fading profile power uncertainty ± 0.5 dB
10.6 TDD 3 DL CA RSTD Measurement Reporting Delay	Same as 10.5	Same as 10.5
10.7 FDD RSTD Measurement Accuracy for 3DL Carrier Aggregation	$N_{oc1} \pm 1.0$ dB averaged over BW_{Config} $N_{oc2} \pm 1.0$ dB averaged over BW_{Config} $N_{oc3} \pm 1.0$ dB averaged over BW_{Config} PRRS $\hat{E}_{s1} / N_{oc1} \pm 0.3$ dB averaged over BW_{Config} $\hat{E}_{s1} / N_{oc1} \pm 0.3$ dB averaged over BW_{Config} PRRS $\hat{E}_{s2} / N_{oc2} \pm 0.3$ dB averaged over BW_{Config} $\hat{E}_{s2} / N_{oc2} \pm 0.3$ dB averaged over BW_{Config} PRRS $\hat{E}_{s3} / N_{oc3} \pm 0.3$ dB averaged over BW_{Config} $\hat{E}_{s3} / N_{oc3} \pm 0.3$ dB averaged over BW_{Config} PRRS $\hat{E}_{s4} / N_{oc3} \pm 0.3$ dB averaged over BW_{Config} $\hat{E}_{s4} / N_{oc3} \pm 0.3$ dB averaged over BW_{Config} Cell Timing Difference (Intra-freq) = $\pm 1 T_s$ Cell Timing Difference (Inter-freq) = $\pm 2 T_s$	Note: PRRS \hat{E}_{s1} / N_{oc1} and \hat{E}_{s1} / N_{oc1} are the ratios of cell 1 signal / AWGN for frequency 1 PRRS \hat{E}_{s2} / N_{oc2} and \hat{E}_{s2} / N_{oc2} are the ratios of cell 2 signal / AWGN for frequency 2 PRRS \hat{E}_{s3} / N_{oc3} and \hat{E}_{s3} / N_{oc3} are the ratios of cell 3 signal / AWGN for frequency 3 PRRS \hat{E}_{s4} / N_{oc3} and \hat{E}_{s4} / N_{oc3} are the ratios of cell 4 signal / AWGN for frequency 3
10.8 TDD RSTD Measurement Accuracy for 3DL Carrier Aggregation	Same as 10.7	Same as 10.7
In addition, the following Test System uncertainties and related constraints apply. Any additional constraints are defined in the specific tests.		
AWGN Bandwidth	≥ 1.08 MHz, 2.7 MHz, 4.5 MHz, 9 MHz, 13.5 MHz, 18 MHz; $N_{RB} \times 180$ kHz according to BW_{Config}	
AWGN absolute power uncertainty	Test-specific	
AWGN flatness and signal flatness, max deviation for any Resource Block, relative to average over BW_{Config}	± 2 dB	
AWGN peak to average ratio	≥ 10 dB @0.001%	

Signal-to noise ratio uncertainty	Test-specific
Fading profile power uncertainty	±0.5 dB
Fading profile delay uncertainty, relative to frame timing	±5 ns (excludes absolute errors related to baseband timing)

C.1.4 MBS Minimum Performance requirements

Table C.1.4-1: Maximum Test System Uncertainty for MBS Minimum Performance tests

Clause	Maximum Test System Uncertainty		Derivation of Test System Uncertainty
11.1, 11.1A MBS Measurement Reporting Delay	Beacon power level	±2 dB	
	Response time	±300 ms	
11.2, 11.2A MBS Sensitivity Measurement Accuracy	Beacon power level	±2 dB	
	Code phase delay difference	±5 ns	Code phase delay difference error value of +/- 5ns, being derived from 10% of the most stringent code phase delay measurement accuracy requirement
11.3, 11.3A MBS Nominal Measurement Accuracy	Beacon power level	±2 dB	
	Code phase delay	±5 ns	Code phase delay error as above
11.4, 11.4A MBS Dynamic Range Measurement Accuracy	Beacon power level	±2 dB	
	Code phase delay	±5 ns	Code phase delay error as above
11.5, 11.5A MBS Measurement Accuracy in Multipath	Beacon power level	±2 dB	
	Code phase delay	±5 ns	Code phase delay error as above
Note: Code phase delay is equal to the propagation delay from the (simulated) beacon transmitter to the UE receive antenna based on the propagation distance in the test case.			

C.1.5 WLAN and BLE measurement requirements

Table C.1.5-1: Maximum Test System Uncertainty for WLAN and BLE measurement tests

Clause	Maximum Test System Uncertainty		Derivation of Test System Uncertainty
12.1.1 WLAN AP Identification and reporting delay under nominal conditions	Response time	±300 ms	
12.1.2 WLAN AP Identification and reporting delay under dynamic range conditions	Response time	±300 ms	
	AP Power Level Difference	±1 dB	
12.2.1 Bluetooth identification	Response time	±300 ms	

Note: AP Power Level Difference is the difference between the WLAN Received Power Level from the high power WLAN AP with respect to the low power WLAN APs.

C.1.6 NR PRS-based measurement requirements

Table C.1.6-1: Maximum Test System Uncertainty for NR PRS-based Measurement Requirements

Clause	Maximum Test System Uncertainty	Derivation of Test System Uncertainty
--------	---------------------------------	---------------------------------------

14.2.1 NR RSTD measurement period test case for single positioning frequency layer in FR1 SA	$N_{oc} \pm 1.5$ dB averaged over BW_{Config} $PRS \hat{E}_{s1} / N_{oc} \pm 0.3$ dB averaged over BW_{Config} $\hat{E}_{s1} / N_{oc} \pm 0.3$ dB averaged over BW_{Config} $PRS \hat{E}_{s2} / N_{oc} \pm 0.3$ dB averaged over BW_{Config} $\hat{E}_{s2} / N_{oc} \pm 0.3$ dB averaged over BW_{Config} $PRS \hat{E}_{s3} / N_{oc} \pm 0.3$ dB averaged over BW_{Config} $\hat{E}_{s3} / N_{oc} \pm 0.3$ dB averaged over BW_{Config} Response Time = 300ms	Note: $PRS \hat{E}_{s1} / N_{oc}$ and \hat{E}_{s1} / N_{oc} are the ratios of cell 1 signal / AWGN $PRS \hat{E}_{s2} / N_{oc}$ and \hat{E}_{s2} / N_{oc} are the ratios of cell 2 signal / AWGN $PRS \hat{E}_{s3} / N_{oc}$ and \hat{E}_{s3} / N_{oc} are the ratios of cell 3 signal / AWGN Signal-to-noise ratio uncertainty ± 0.3 dB
14.2.2 NR RSTD measurement period test case for dual positioning frequency layers in FR1 SA	Same as 14.2.1	
14.2.3 NR RSTD measurement period test case for single positioning frequency layer in FR2 SA	$N_{oc} \pm 5.65$ dB averaged over BW_{Config} $PRS \hat{E}_{s1} / N_{oc} \pm 0.3$ dB averaged over BW_{Config} $\hat{E}_{s1} / N_{oc} \pm 0.3$ dB averaged over BW_{Config} $PRS \hat{E}_{s2} / N_{oc} \pm 0.3$ dB averaged over BW_{Config} $\hat{E}_{s2} / N_{oc} \pm 0.3$ dB averaged over BW_{Config} $PRS \hat{E}_{s3} / N_{oc} \pm 0.3$ dB averaged over BW_{Config} $\hat{E}_{s3} / N_{oc} \pm 0.3$ dB averaged over BW_{Config} Response Time = 300ms	Note: $PRS \hat{E}_{s1} / N_{oc}$ and \hat{E}_{s1} / N_{oc} are the ratios of cell 1 signal / AWGN $PRS \hat{E}_{s2} / N_{oc}$ and \hat{E}_{s2} / N_{oc} are the ratios of cell 2 signal / AWGN $PRS \hat{E}_{s3} / N_{oc}$ and \hat{E}_{s3} / N_{oc} are the ratios of cell 3 signal / AWGN Signal-to-noise ratio uncertainty ± 0.3 dB
14.2.4 NR RSTD measurement period test case for dual positioning frequency layers in FR2 SA	Same as 14.2.3	
14.2.8 NR RSTD measurement reporting delay test case for single positioning frequency layer with reduced number of samples in FR2 SA	Same as 14.2.3	
14.2.9 NR RSTD measurement reporting delay test case for single positioning frequency layer without measurement gap in FR2 SA	Same as 14.2.3	
14.2.10 NR RSTD measurement reporting delay test case for single positioning frequency layer with Rx TEG in FR2 SA	Same as 14.2.3	
14.3.1 NR RSTD measurement accuracy test case for single positioning frequency layer in FR1 SA	$N_{oc} \pm 1.5$ dB averaged over BW_{Config} $PRS \hat{E}_{s1} / N_{oc} \pm 0.3$ dB averaged over BW_{Config} $\hat{E}_{s1} / N_{oc} \pm 0.3$ dB averaged over BW_{Config} $PRS \hat{E}_{s2} / N_{oc} \pm 0.3$ dB averaged over BW_{Config} $\hat{E}_{s2} / N_{oc} \pm 0.3$ dB averaged over BW_{Config} Cell Timing Difference = $32 T_c$	Note: $PRS \hat{E}_{s1} / N_{oc}$ and \hat{E}_{s1} / N_{oc} are the ratios of cell 1 signal / AWGN $PRS \hat{E}_{s2} / N_{oc}$ and \hat{E}_{s2} / N_{oc} are the ratios of cell 2 signal / AWGN
14.3.2 NR RSTD measurement accuracy test case for dual positioning frequency layers in FR1 SA	$N_{oc} \pm 5.65$ dB averaged over BW_{Config} $PRS \hat{E}_{s1} / N_{oc} \pm 0.3$ dB averaged over BW_{Config} $\hat{E}_{s1} / N_{oc} \pm 0.3$ dB averaged over BW_{Config} $PRS \hat{E}_{s2} / N_{oc} \pm 0.3$ dB averaged over BW_{Config} $\hat{E}_{s2} / N_{oc} \pm 0.3$ dB averaged over BW_{Config} Cell Timing Difference = $32 T_c$	Note: $PRS \hat{E}_{s1} / N_{oc}$ and \hat{E}_{s1} / N_{oc} are the ratios of cell 1 signal / AWGN $PRS \hat{E}_{s2} / N_{oc}$ and \hat{E}_{s2} / N_{oc} are the ratios of cell 2 signal / AWGN

14.3.3 NR RSTD measurement accuracy test case for single positioning frequency layer in FR2 SA	Same as 14.3.1	
14.3.4 NR RSTD measurement accuracy test case for dual positioning frequency layer in FR2 SA	Same as 14.3.2	
14.3.7 NR RSTD measurement accuracy test case for single positioning frequency layer with reduced number of samples in FR2 SA	Same as 14.3.1	
14.3.8 NR RSTD measurement accuracy test case for single positioning frequency layer with Rx TEG in FR2 SA	Same as 14.3.1	
15.2.1 UE Rx-Tx time difference measurement period for single positioning frequency layer in FR1 SA	Noc ± 1.5 dB averaged over BWConfig PRS $\hat{E}s1 / Noc \pm 0.3$ dB averaged over BWConfig $\hat{E}s1 / Noc \pm 0.3$ dB averaged over BWConfig PRS $\hat{E}s2 / Noc \pm 0.3$ dB averaged over BWConfig $\hat{E}s2 / Noc \pm 0.3$ dB averaged over BWConfig Response Time = ± 300 ms	Note: PRS $\hat{E}s1 / Noc$ and $\hat{E}s1 / Noc$ are the ratios of cell 1 signal / AWGN PRS $\hat{E}s2 / Noc$ and $\hat{E}s2 / Noc$ are the ratios of cell 2 signal / AWGN $T_c = 1/(480000 \times 4096)$, the basic timing unit defined in TS 38.211 [53]
15.2.2 UE Rx-Tx time difference measurement period for dual positioning frequency layers in FR1 SA	Same as 15.2.1	Same as 15.2.1
15.2.3 UE Rx-Tx time difference measurement period for single positioning frequency layer in FR2 SA	Noc ± 5.65 dB averaged over BWConfig PRS $\hat{E}s1 / Noc \pm 0.3$ dB averaged over BWConfig $\hat{E}s1 / Noc \pm 0.3$ dB averaged over BWConfig PRS $\hat{E}s2 / Noc \pm 0.3$ dB averaged over BWConfig $\hat{E}s2 / Noc \pm 0.3$ dB averaged over BWConfig Response Time = ± 300 ms	PRS $\hat{E}s1 / Noc$ and $\hat{E}s1 / Noc$ are the ratios of cell 1 signal / AWGN PRS $\hat{E}s2 / Noc$ and $\hat{E}s2 / Noc$ are the ratios of cell 2 signal / AWGN $T_c = 1/(480000 \times 4096)$, the basic timing unit defined in TS 38.211 [53]
15.2.4 UE Rx-Tx time difference measurement period for dual positioning frequency layers in FR2 SA	Same as 15.2.3	Same as 15.2.3
15.2.8 UE Rx-Tx time difference measurement reporting delay test case for single positioning frequency layer with reduced number of samples in FR2 SA	Same as 15.2.3	Same as 15.2.3
15.2.9 UE Rx-Tx time difference measurement reporting delay test case for single positioning frequency layer without measurement gap in FR2 SA	Same as 15.2.3	Same as 15.2.3
15.2.10 UE Rx-Tx time difference measurement reporting delay test case for single positioning frequency layer with RxTx TEG in FR2 SA	Same as 15.2.3	Same as 15.2.3

15.3.1 UE Rx-Tx time difference measurement accuracy for single positioning frequency layer in FR1 SA	$N_{oc} \pm 1.5$ dB averaged over BW_{Config} $PRS \hat{E}_{s1} / N_{oc} \pm 0.3$ dB averaged over BW_{Config} $\hat{E}_{s1} / N_{oc} \pm 0.3$ dB averaged over BW_{Config} $PRS \hat{E}_{s2} / N_{oc} \pm 0.3$ dB averaged over BW_{Config} $\hat{E}_{s2} / N_{oc} \pm 0.3$ dB averaged over BW_{Config} Cell Timing Difference = $32 T_c$	Note: $PRS \hat{E}_{s1} / N_{oc}$ and \hat{E}_{s1} / N_{oc} are the ratios of cell 1 signal / AWGN $PRS \hat{E}_{s2} / N_{oc}$ and \hat{E}_{s2} / N_{oc} are the ratios of cell 2 signal / AWGN
15.3.2 UE Rx-Tx time difference measurement accuracy for single positioning frequency layer in FR2 SA	$N_{oc} \pm 5.65$ dB averaged over BW_{Config} $PRS \hat{E}_{s1} / N_{oc} \pm 0.3$ dB averaged over BW_{Config} $\hat{E}_{s1} / N_{oc} \pm 0.3$ dB averaged over BW_{Config} $PRS \hat{E}_{s2} / N_{oc} \pm 0.3$ dB averaged over BW_{Config} $\hat{E}_{s2} / N_{oc} \pm 0.3$ dB averaged over BW_{Config} Cell Timing Difference = $32 T_c$	Note: $PRS \hat{E}_{s1} / N_{oc}$ and \hat{E}_{s1} / N_{oc} are the ratios of cell 1 signal / AWGN $PRS \hat{E}_{s2} / N_{oc}$ and \hat{E}_{s2} / N_{oc} are the ratios of cell 2 signal / AWGN
15.3.5 UE Rx-Tx time difference measurement accuracy for single positioning frequency layer with reduced number of samples in FR2 SA	Same as 15.3.2	
15.3.6 UE Rx-Tx time difference measurement accuracy for single positioning frequency layer with RxTx TEG in FR2 SA	Same as 15.3.2	
16.2.1 PRS-RSRP measurement period test case for single positioning frequency layer in FR1 SA	$N_{oc} \pm 1.5$ dB averaged over BW_{Config} $PRS \hat{E}_{s1} / N_{oc} \pm 0.3$ dB averaged over BW_{Config} $\hat{E}_{s1} / N_{oc} \pm 0.3$ dB averaged over BW_{Config} $PRS \hat{E}_{s2} / N_{oc} \pm 0.3$ dB averaged over BW_{Config} $\hat{E}_{s2} / N_{oc} \pm 0.3$ dB averaged over BW_{Config}	Note: $PRS \hat{E}_{s1} / N_{oc}$ and \hat{E}_{s1} / N_{oc} are the ratios of cell 1 signal / AWGN $PRS \hat{E}_{s2} / N_{oc}$ and \hat{E}_{s2} / N_{oc} are the ratios of cell 2 signal / AWGN Signal-to-noise ratio uncertainty ± 0.3 dB
16.2.2 PRS-RSRP measurement period test case for dual positioning frequency layer in FR1 SA	$N_{oc} \pm 1.5$ dB averaged over BW_{Config} $PRS \hat{E}_{s1} / N_{oc} \pm 0.3$ dB averaged over BW_{Config} $\hat{E}_{s1} / N_{oc} \pm 0.3$ dB averaged over BW_{Config} $PRS \hat{E}_{s2} / N_{oc2} \pm 0.3$ dB averaged over BW_{Config} $\hat{E}_{s2} / N_{oc2} \pm 0.3$ dB averaged over BW_{Config}	Note: $PRS \hat{E}_{s1} / N_{oc}$ and \hat{E}_{s1} / N_{oc} are the ratios of cell 1 signal / AWGN $PRS \hat{E}_{s2} / N_{oc2}$ and \hat{E}_{s2} / N_{oc2} are the ratios of cell 2 signal / AWGN Signal-to-noise ratio uncertainty ± 0.3 dB
16.2.3 PRS-RSRP measurement period test case for single positioning frequency layer in FR2 SA	$N_{oc} \pm 5.65$ dB averaged over BW_{Config} $PRS \hat{E}_{s1} / N_{oc} \pm 0.3$ dB averaged over BW_{Config} $\hat{E}_{s1} / N_{oc} \pm 0.3$ dB averaged over BW_{Config} $PRS \hat{E}_{s2} / N_{oc} \pm 0.3$ dB averaged over BW_{Config} $\hat{E}_{s2} / N_{oc} \pm 0.3$ dB averaged over BW_{Config} Response Time = ± 300 ms	$PRS \hat{E}_{s1} / N_{oc}$ and \hat{E}_{s1} / N_{oc} are the ratios of cell 1 signal / AWGN $PRS \hat{E}_{s2} / N_{oc}$ and \hat{E}_{s2} / N_{oc} are the ratios of cell 2 signal / AWGN $T_c = 1/(480000 \times 4096)$, the basic timing unit defined in TS 38.211 [53]
16.2.4 PRS-RSRP measurement period test case for dual positioning frequency layer in FR2 SA	Same as 16.2.3	Same as 16.2.3
16.2.7 PRS-RSRP measurement reporting delay test case for single positioning frequency with reduced number of samples in FR2 SA	Same as 16.2.3	Same as 16.2.3

16.2.8 PRS-RSRP measurement reporting delay test case for single positioning frequency layer without measurement gap in FR2 SA	Same as 16.2.3	Same as 16.2.3
16.3.1 PRS-RSRP measurement accuracy with PRS in FR1	$N_{oc} \pm 1.5$ dB averaged over BW_{Config} PRS $\hat{E}_{s1} / N_{oc} \pm 0.3$ dB averaged over BW_{Config} $\hat{E}_{s1} / N_{oc} \pm 0.3$ dB averaged over BW_{Config} PRS $\hat{E}_{s2} / N_{oc} \pm 0.3$ dB averaged over BW_{Config} $\hat{E}_{s2} / N_{oc} \pm 0.3$ dB averaged over BW_{Config}	Note: PRS \hat{E}_{s1} / N_{oc} and \hat{E}_{s1} / N_{oc} are the ratios of cell 1 signal / AWGN PRS \hat{E}_{s2} / N_{oc} and \hat{E}_{s2} / N_{oc} are the ratios of cell 2 signal / AWGN Signal-to-noise ratio uncertainty ± 0.3 dB
16.3.2 PRS-RSRP measurement accuracy with PRS in FR2	$N_{oc} \pm 5.65$ dB averaged over BW_{Config} PRS $\hat{E}_{s1} / N_{oc} \pm 0.3$ dB averaged over BW_{Config} $\hat{E}_{s1} / N_{oc} \pm 0.3$ dB averaged over BW_{Config} PRS $\hat{E}_{s2} / N_{oc} \pm 0.3$ dB averaged over BW_{Config} $\hat{E}_{s2} / N_{oc} \pm 0.3$ dB averaged over BW_{Config}	Note: PRS \hat{E}_{s1} / N_{oc} and \hat{E}_{s1} / N_{oc} are the ratios of cell 1 signal / AWGN PRS \hat{E}_{s2} / N_{oc} and \hat{E}_{s2} / N_{oc} are the ratios of cell 2 signal / AWGN
16.3.4 PRS-RSRP measurement accuracy with PRS in FR2 with reduced sample number	Same as 16.3.2	Same as 16.3.2

C.2 Test Parameter Relaxations (This clause is informative)

The Test Parameter Relaxations defined in this clause have been used to relax the Conformance requirement to derive the Test Requirements.

The Test Parameter Relaxations are derived from Test System uncertainties, regulatory requirements and criticality to system performance. As a result, the Test Parameter Relaxations may sometimes be set to zero.

The Test Parameter Relaxations should not be modified for any reason e.g. to take account of commonly known test system errors (such as mismatch, cable loss, etc.).

C.2.1 A-GNSS Minimum Performance requirements

Table C.2.1: Test Parameter Relaxations for A-GNSS Minimum Performance tests

Clause	Test Parameter Relaxation	
5.2.1, 6.2.1, 7.1.1, 13.2.1 Sensitivity Coarse Time Assistance	Coarse Time Assistance	200 ms
	Absolute GNSS signal level	1 dB
	Position error	1.3 m
	Response time	300 ms
5.2.2, 6.2.2, 7.1.2, 13.2.2 Sensitivity Fine Time Assistance	Coarse Time Assistance	200 ms
	Fine Time Assistance	1 us
	Absolute GNSS signal level	1 dB
	Position error	1.3 m
5.3, 6.3, 7.2, 13.3 Nominal Accuracy	Coarse Time Assistance	200 ms
	Absolute GNSS signal level	0 dB
	Position error	1.3 m
	Response time	300 ms
5.4, 6.4, 7.3, 13.4 Dynamic Range	Coarse Time Assistance	200 ms
	Absolute GNSS signal level	1 dB
	Relative GNSS signal level	0.2 dB
	Position error	1.3 m
5.5, 6.5, 7.4, 13.5 Multi-path scenario	Coarse Time Assistance	200 ms
	Absolute GNSS signal level	0 dB
	Relative GNSS signal level	0.2 dB
	Response time	300 ms

	Position error	1.3 m
	Response time	300 ms
5.6, 6.6, 7.5, 7.5A, 13.6, 13.7 Moving scenario and periodic update	Absolute GNSS signal level	0 dB
	Position error	1.3 m
	Differential Response Time	100 ms

C.2.2 ECID and OTDOA Measurement requirements

Table C.2.2: Test Parameter Relaxations for ECID and OTDOA Measurement requirements

Clause	Test Parameter Relaxation	
8.1.1 E-UTRAN FDD UE Rx – Tx time difference case (Rel-9 to Rel-11)	Parameters N_{oc} : -98dBm/15kHz \hat{E}_s / N_{oc} : -3.00dB <u>RxTx time difference value:</u>	Test Tolerance 0dB +0.3dB $\pm 3T_s$
8.1.1A E-UTRAN FDD UE Rx – Tx time difference case (Rel-12 onwards)	Same as 8.1.1	Same as 8.1.1
8.1.1B E-UTRAN FDD UE Rx – Tx time difference case for UE Category 1bis	Same as 8.1.1	Same as 8.1.1
8.1.2 E-UTRAN TDD UE Rx – Tx time difference case (Rel-9 to Rel-11)	Same as 8.1.1	Same as 8.1.1
8.1.2A E-UTRAN TDD UE Rx – Tx time difference case (Rel-12 onwards)	Same as 8.1.1	Same as 8.1.1
8.1.2B E-UTRAN TDD UE Rx – Tx time difference case for UE Category 1bis	Same as 8.1.1	Same as 8.1.1
8.1.3 E-UTRAN FDD UE Rx-Tx time difference under Time Domain Measurement Resource Restriction with Non-MBSFN ABS (eICIC)	Parameters N_{oc} : -98dBm/15kHz \hat{E}_{S1} / N_{oc} : -3.00dB \hat{E}_{S2} / N_{oc} : +1.00dB	Test Tolerance 0dB +0.3dB 0dB
8.1.4 E-UTRAN TDD UE Rx-Tx time difference under Time Domain Measurement Resource Restriction with Non-MBSFN ABS (eICIC)	Same as 8.1.3	Same as 8.1.3
8.1.5 E-UTRAN FDD UE Rx-Tx time difference under Time Domain Measurement Resource Restriction with CRS Assistance Information and Non-MBSFN ABS (feICIC)	Parameters N_{oc} : -98dBm/15kHz \hat{E}_{S1} / N_{oc} : -3.00dB \hat{E}_{S2} / N_{oc} : +3.00dB \hat{E}_{S3} / N_{oc} : +1.00dB	Test Tolerance 0dB +0.4dB 0dB 0dB
8.1.6 E-UTRAN TDD UE Rx-Tx time difference under Time Domain Measurement Resource Restriction with CRS Assistance Information and Non-MBSFN ABS (feICIC)	Same as 8.1.5	Same as 8.1.5
8.1.7 E-UTRAN FDD UE Rx-Tx time difference case for Category M1/M2 UE in CEModeA	Same as 8.1.1	Same as 8.1.1
8.1.8 E-UTRAN HD-FDD UE Rx-Tx time difference case for Category M1/M2 UE in CEModeA	Same as 8.1.1	Same as 8.1.1
8.1.9 E-UTRAN TDD UE Rx-Tx time difference case for Category M1/M2 UE in CEModeA	Same as 8.1.1	Same as 8.1.1
9.1.1 FDD RSTD Measurement Reporting Delay	Response time	300 ms
9.1.1A FDD RSTD Measurement Reporting Delay for UE Category 1bis	Response time	300 ms
9.1.2 TDD RSTD Measurement Reporting Delay	Response time	300 ms

9.1.2A TDD RSTD Measurement Reporting Delay for UE Category 1bis	Response time	300 ms
9.1.3 FDD RSTD Measurement Accuracy	For Test 2 and Test 4: PRRS \hat{E}_{s1} / N_{oc} averaged over BW_{Config} PRRS \hat{E}_{s2} / N_{oc} averaged over BW_{Config}	+0.3 dB +0.3 dB
	For all tests: Cell Timing Difference	$\pm 1 T_s$
9.1.3A FDD RSTD Measurement Accuracy for UE Category 1bis	Same as 9.1.3	Same as 9.1.3
9.1.4 TDD RSTD Measurement Accuracy	Same as 9.1.3	Same as 9.1.3
9.1.4A TDD RSTD Measurement Accuracy for UE Category 1bis	Same as 9.1.3	Same as 9.1.3
9.2.1 FDD-FDD inter-frequency RSTD measurement reporting delay	Response time	300 ms
9.2.1A FDD-FDD inter-frequency RSTD measurement reporting delay for UE Category 1bis	Response time	300 ms
9.2.2 TDD-TDD inter-frequency RSTD measurement reporting delay	Response time	300 ms
9.2.2A TDD-TDD inter-frequency RSTD measurement reporting delay for UE Category 1bis	Response time	300 ms
9.2.4 FDD-FDD inter frequency RSTD Accuracy	PRRS \hat{E}_{s1} / N_{oc1} averaged over BW_{Config} PRRS \hat{E}_{s2} / N_{oc2} averaged over BW_{Config}	+0.3 dB +0.3 dB
	Cell Timing Difference	$\pm 2 T_s$
9.2.4A FDD-FDD inter frequency RSTD Accuracy for UE Category 1bis	Same as 9.2.4	Same as 9.2.4
9.2.5 TDD-TDD inter frequency RSTD Accuracy	Same as 9.2.4	Same as 9.2.4
9.2.5A TDD-TDD inter frequency RSTD Accuracy for UE Category 1bis	Same as 9.2.4	Same as 9.2.4
9.3.1.1 FDD intra-frequency RSTD Measurement Reporting Delay in CE Mode A for Category M1	Same as 9.1.1	Same as 9.1.1
9.3.1.2 FDD intra-frequency RSTD Measurement Reporting Delay in CE Mode A for Category M2	Same as 9.1.1	Same as 9.1.1
9.3.2.1 HD-FDD intra-frequency RSTD Measurement Reporting Delay in CE Mode A for Category M1	Same as 9.1.1	Same as 9.1.1
9.3.2.2 HD-FDD intra-frequency RSTD Measurement Reporting Delay in CE Mode A for Category M2	Same as 9.1.1	Same as 9.1.1
9.3.3.1 TDD intra-frequency RSTD Measurement Reporting Delay in CE Mode A for Category M1	Same as 9.1.1	Same as 9.1.1
9.3.3.2 TDD intra-frequency RSTD Measurement Reporting Delay in CE Mode A for Category M2	Same as 9.1.1	Same as 9.1.1
9.3.4.1 FDD intra-frequency RSTD Measurement Reporting Delay in CE Mode B for Category M1	Same as 9.1.1	Same as 9.1.1
9.3.4.2 FDD intra-frequency RSTD Measurement Reporting Delay in CE Mode B for Category M2	Same as 9.1.1	Same as 9.1.1

9.3.5.1 HD-FDD intra-frequency RSTD Measurement Reporting Delay in CE Mode B for Category M1	Same as 9.1.1	Same as 9.1.1
9.3.5.2 HD-FDD intra-frequency RSTD Measurement Reporting Delay in CE Mode B for Category M2	Same as 9.1.1	Same as 9.1.1
9.3.6.1 TDD intra-frequency RSTD Measurement Reporting Delay in CE Mode B for Category M1	Same as 9.1.1	Same as 9.1.1
9.3.6.2 TDD intra-frequency RSTD Measurement Reporting Delay in CE Mode B for Category M2	Same as 9.1.1	Same as 9.1.1
9.3.7.1 FDD intra-frequency RSTD Measurement Accuracy in CE Mode A for Category M1	Same as 9.1.3	Same as 9.1.3
9.3.7.2 FDD intra-frequency RSTD Measurement Accuracy in CE Mode A for Category M2	Same as 9.1.3	Same as 9.1.3
9.3.8.1 HD-FDD intra-frequency RSTD Measurement Accuracy in CE Mode A for Category M1	Same as 9.1.3	Same as 9.1.3
9.3.8.2 HD-FDD intra-frequency RSTD Measurement Accuracy in CE Mode A for Category M2	Same as 9.1.3	Same as 9.1.3
9.3.9.1 TDD intra-frequency RSTD Measurement Accuracy in CE Mode A for Category M1	Same as 9.1.3	Same as 9.1.3
9.3.9.2 TDD intra-frequency RSTD Measurement Accuracy in CE Mode A for Category M2	Same as 9.1.3	Same as 9.1.3
9.3.10.1 FDD intra-frequency RSTD Measurement Accuracy in CE Mode B for Category M1	Same as 9.1.3	Same as 9.1.3
9.3.10.2 FDD intra-frequency RSTD Measurement Accuracy in CE Mode B for Category M2	Same as 9.1.3	Same as 9.1.3
9.3.11.1 HD-FDD intra-frequency RSTD Measurement Accuracy in CE Mode B for Category M1	Same as 9.1.3	Same as 9.1.3
9.3.11.2 HD-FDD intra-frequency RSTD Measurement Accuracy in CE Mode B for Category M2	Same as 9.1.3	Same as 9.1.3
9.3.12.1 TDD intra-frequency RSTD Measurement Accuracy in CE Mode B for Category M1	Same as 9.1.3	Same as 9.1.3
9.3.12.2 TDD intra-frequency RSTD Measurement Accuracy in CE Mode B for Category M2	Same as 9.1.3	Same as 9.1.3
9.3.13 E-UTRAN FDD intra-frequency RSTD measurement period test case in CE Mode A with longer PRS occasions	Same as 9.1.3	Same as 9.1.3
9.3.14 E-UTRAN HD-FDD intra-frequency RSTD measurement period test case in CE Mode A with longer PRS occasions	Same as 9.1.3	Same as 9.1.3
9.3.15 E-UTRAN TDD intra-frequency RSTD measurement period test case in CE Mode A with longer PRS occasions	Same as 9.1.3	Same as 9.1.3
9.3.16 E-UTRAN FDD intra-frequency RSTD measurement period test case in CE Mode B with longer PRS occasions	Same as 9.1.3	Same as 9.1.3

9.3.17 E-UTRAN HD-FDD intra-frequency RSTD measurement period test case in CE Mode B with longer PRS occasions	Same as 9.1.3	Same as 9.1.3
9.3.18 E-UTRAN TDD intra-frequency RSTD measurement period test case in CE Mode B with longer PRS occasions	Same as 9.1.3	Same as 9.1.3
9.4.1.1 FDD inter-frequency RSTD Measurement Reporting Delay in CE Mode A for Category M1	Same as 9.2.1	Same as 9.2.1
9.4.1.2 FDD inter-frequency RSTD Measurement Reporting Delay in CE Mode A for Category M2	Same as 9.2.1	Same as 9.2.1
9.4.2.1 HD-FDD inter-frequency RSTD Measurement Reporting Delay in CE Mode A for Category M1	Same as 9.2.1	Same as 9.2.1
9.4.2.2 HD-FDD inter-frequency RSTD Measurement Reporting Delay in CE Mode A for Category M2	Same as 9.2.1	Same as 9.2.1
9.4.3.1 TDD inter-frequency RSTD Measurement Reporting Delay in CE Mode A for Category M1	Same as 9.2.1	Same as 9.2.1
9.4.3.2 TDD inter-frequency RSTD Measurement Reporting Delay in CE Mode A for Category M2	Same as 9.2.1	Same as 9.2.1
9.4.4.1 FDD inter-frequency RSTD Measurement Reporting Delay in CE Mode B for Category M1	Same as 9.2.1	Same as 9.2.1
9.4.4.2 FDD inter-frequency RSTD Measurement Reporting Delay in CE Mode B for Category M2	Same as 9.2.1	Same as 9.2.1
9.4.5.1 HD-FDD inter-frequency RSTD Measurement Reporting Delay in CE Mode B for Category M1	Same as 9.2.1	Same as 9.2.1
9.4.5.2 HD-FDD inter-frequency RSTD Measurement Reporting Delay in CE Mode B for Category M2	Same as 9.2.1	Same as 9.2.1
9.4.6.1 TDD inter-frequency RSTD Measurement Reporting Delay in CE Mode B for Category M1	Same as 9.2.1	Same as 9.2.1
9.4.6.2 TDD inter-frequency RSTD Measurement Reporting Delay in CE Mode B for Category M2	Same as 9.2.1	Same as 9.2.1
9.4.7.1 FDD inter-frequency RSTD Measurement Accuracy in CE Mode A for Category M1	Same as 9.2.4	Same as 9.2.4
9.4.7.2 FDD inter-frequency RSTD Measurement Accuracy in CE Mode A for Category M2	Same as 9.2.4	Same as 9.2.4
9.4.8.1 HD-FDD inter-frequency RSTD Measurement Accuracy in CE Mode A for Category M1	Same as 9.2.4	Same as 9.2.4
9.4.8.2 HD-FDD inter-frequency RSTD Measurement Accuracy in CE Mode A for Category M2	Same as 9.2.4	Same as 9.2.4
9.4.9.1 TDD inter-frequency RSTD Measurement Accuracy in CE Mode A for Category M1	Same as 9.2.4	Same as 9.2.4
9.4.9.2 TDD inter-frequency RSTD Measurement Accuracy in CE Mode A for Category M2	Same as 9.2.4	Same as 9.2.4

9.4.10.1 FDD inter-frequency RSTD Measurement Accuracy in CE Mode B for Category M1	Same as 9.2.4	Same as 9.2.4
9.4.10.2 FDD inter-frequency RSTD Measurement Accuracy in CE Mode B for Category M2	Same as 9.2.4	Same as 9.2.4
9.4.11.1 HD-FDD inter-frequency RSTD Measurement Accuracy in CE Mode B for Category M1	Same as 9.2.4	Same as 9.2.4
9.4.11.2 HD-FDD inter-frequency RSTD Measurement Accuracy in CE Mode B for Category M2	Same as 9.2.4	Same as 9.2.4
9.4.12.1 TDD inter-frequency RSTD Measurement Accuracy in CE Mode B for Category M1	Same as 9.2.4	Same as 9.2.4
9.4.12.2 TDD inter-frequency RSTD Measurement Accuracy in CE Mode B for Category M2	Same as 9.2.4	Same as 9.2.4
9.4.13 E-UTRAN FDD inter-frequency RSTD measurement period test case in CE Mode A with longer PRS occasions	Same as 9.2.4	Same as 9.2.4
9.4.14 E-UTRAN HD-FDD inter-frequency RSTD measurement period test case in CE Mode A with longer PRS occasions	Same as 9.2.4	Same as 9.2.4
9.4.15 E-UTRAN TDD inter-frequency RSTD measurement period test case in CE Mode A with longer PRS occasions	Same as 9.2.4	Same as 9.2.4
9.4.16 E-UTRAN FDD inter-frequency RSTD measurement period test case in CE Mode B with longer PRS occasions	Same as 9.2.4	Same as 9.2.4
9.4.17 E-UTRAN HD-FDD inter-frequency RSTD measurement period test case in CE Mode B with longer PRS occasions	Same as 9.2.4	Same as 9.2.4
9.4.18 E-UTRAN TDD inter-frequency RSTD measurement period test case in CE Mode B with longer PRS occasions	Same as 9.2.4	Same as 9.2.4
9.5.1 HD-FDD Intra frequency RSTD Measurement Accuracy for NB-IOT Inband Mode in normal coverage	$\text{PRS } \bar{\epsilon}_{s1} / N_{oc}$ averaged over BW_{Config} $\text{PRS } \bar{\epsilon}_{s2} / N_{oc}$ averaged over BW_{Config} Cell Timing Difference	+0.3 dB +0.3 dB $\pm 1 T_s$
9.5.2 HD-FDD Intra frequency RSTD Measurement Accuracy for NB-IOT Inband Mode in enhanced coverage	Same as 9.5.1	Same as 9.5.1
9.5.3 HD-FDD Intra frequency RSTD Measurement Reporting Delay for NB-IOT Inband Mode in enhanced coverage	Response time	300 ms
9.6.1 HD-FDD Inter-Frequency RSTD Measurement Accuracy for NB-IOT Inband Mode in normal coverage	$\text{PRS } \bar{\epsilon}_{s1} / N_{oc1}$ averaged over BW_{Config} $\text{PRS } \bar{\epsilon}_{s2} / N_{oc2}$ averaged over BW_{Config} Cell Timing Difference	+0.3 dB +0.3 dB $\pm 2 T_s$
9.6.2 HD-FDD Inter-Frequency RSTD Measurement Accuracy for NB-IOT Inband Mode in enhanced coverage	Same as 9.6.1	Same as 9.6.1
9.6.3 HD-FDD Inter frequency RSTD Measurement Reporting	Response time	300 ms

Delay for NB-IOT Inband Mode in enhanced coverage		
9.7.1 TDD Intra frequency RSTD Measurement Accuracy for NB-IOT Inband Mode in normal coverage	$\text{PRS } \hat{E}_{s1} / N_{oc}$ averaged over BW_{Config} $\text{PRS } \hat{E}_{s2} / N_{oc}$ averaged over BW_{Config} Cell Timing Difference	+0.3 dB +0.3 dB ± 1 Ts
9.7.2 TDD Intra frequency RSTD Measurement Accuracy for NB-IOT Inband Mode in enhanced coverage	Same as 9.7.1	Same as 9.7.1
9.7.3 TDD Intra frequency RSTD Measurement Reporting Delay for NB-IOT Inband Mode in enhanced coverage	Response time	300 ms
9.8.1 TDD Inter-frequency RSTD Measurement Accuracy for NB-IOT Inband Mode in normal coverage	$\text{PRS } \hat{E}_{s1} / N_{oc1}$ averaged over BW_{Config} $\text{PRS } \hat{E}_{s2} / N_{oc2}$ averaged over BW_{Config} Cell Timing Difference	+0.3 dB +0.3 dB ± 2 Ts
9.8.2 TDD Inter-frequency RSTD Measurement Accuracy for NB-IOT Inband Mode in enhanced coverage	Same as 9.8.1	Same as 9.8.1
9.8.3 TDD Inter frequency RSTD Measurement Reporting Delay for NB-IOT Inband Mode in enhanced coverage	Response time	300 ms
10.1 FDD RSTD Measurement Reporting Delay for Carrier Aggregation	Response time	300 ms
10.1A FDD RSTD Measurement Reporting Delay for Carrier Aggregation for 20 MHz	Response time	300 ms
10.1B FDD RSTD Measurement Reporting Delay Carrier Aggregation for 5 MHz +5 MHz Bandwidth	Response time	300 ms
10.1C FDD RSTD Measurement Reporting Delay for Carrier Aggregation for 10 MHz+5 MHz Bandwidth	Response time	300 ms
10.2 TDD RSTD Measurement Reporting Delay for Carrier Aggregation	Response time	300 ms
10.2A TDD RSTD Measurement Reporting Delay for Carrier Aggregation for 20 MHz	Response time	300 ms
10.2B TDD RSTD Measurement Reporting Delay Carrier Aggregation for 5 MHz +5 MHz Bandwidth	Response time	300 ms
10.2C TDD RSTD Measurement Reporting Delay for Carrier Aggregation for 10 MHz+5 MHz Bandwidth	Response time	300 ms
10.2D TDD RSTD Measurement Reporting Delay for Carrier Aggregation for 20 MHz +10 MHz Bandwidth	Response time	300 ms
10.3 FDD RSTD Measurement Accuracy for Carrier Aggregation	$\text{PRS } \hat{E}_{s2} / N_{oc2}$ averaged over BW_{Config} $\text{PRS } \hat{E}_{s3} / N_{oc2}$ averaged over BW_{Config} Cell Timing Difference	+0.3 dB +0.3 dB ± 1 Ts

10.3A FDD RSTD Measurement Accuracy for Carrier Aggregation for 20 MHz (Rel-10 and Rel-11)	Same as 10.3	Same as 10.3
10.3A_1 FDD RSTD Measurement Accuracy for Carrier Aggregation for 20 MHz (Rel-12 onwards)	Same as 10.3	Same as 10.3
10.3B FDD RSTD Measurement Accuracy for Carrier Aggregation for 5MHz+5MHz Bandwidth	Same as 10.3	Same as 10.3
10.3C FDD RSTD Measurement Accuracy for Carrier Aggregation for 10MHz+5MHz Bandwidth	Same as 10.3	Same as 10.3
10.4 TDD RSTD Measurement Accuracy for Carrier Aggregation	Same as 10.3	Same as 10.3
10.4A TDD RSTD Measurement Accuracy for Carrier Aggregation for 20 MHz (Rel-10 and Rel-11)	Same as 10.3	Same as 10.3
10.4A_1 TDD RSTD Measurement Accuracy for Carrier Aggregation for 20 MHz (Rel-12 onwards)	Same as 10.3	Same as 10.3
10.4B TDD RSTD Measurement Accuracy for Carrier Aggregation for 5MHz+5MHz Bandwidth	Same as 10.3	Same as 10.3
10.4C TDD RSTD Measurement Accuracy for Carrier Aggregation for 10MHz+5MHz Bandwidth	Same as 10.3	Same as 10.3
10.4D TDD RSTD Measurement Accuracy for Carrier Aggregation for 20 MHz+10 MHz Bandwidth	Same as 10.3	Same as 10.3
10.5 FDD 3 DL CA RSTD Measurement Reporting Delay	Response time	300 ms
10.6 TDD 3 DL CA RSTD Measurement Reporting Delay	Response time	300 ms
10.7 FDD RSTD Measurement Accuracy for 3DL Carrier Aggregation	$PRS \hat{E}s_3 / N_{oc3}$ averaged over BW_{Config}	+0.3 dB
	$PRS \hat{E}s_4 / N_{oc3}$ averaged over BW_{Config}	+0.3 dB
	Cell Timing Difference (Intra-band)	$\pm 1 T_s$
	Cell Timing Difference (Inter-band)	$\pm 2 T_s$
10.8 TDD RSTD Measurement Accuracy for 3DL Carrier Aggregation	Same as 10.7	Same as 10.7

C.2.3 MBS Minimum Performance requirements

Table C.2.3-1: Test Parameter Relaxations for MBS Minimum Performance tests

Clause	Test Parameter Relaxation	
11.1,11.1A MBS Measurement Reporting Delay	Beacon power level	0 dB (no relaxation)
	Response time	300 ms
11.2,11.2A MBS Sensitivity Measurement Accuracy	Beacon power level	2 dB
	Code phase difference	5 ns
11.3,11.3A MBS Nominal Measurement Accuracy	Beacon power level	0 dB (no relaxation)
	Code phase difference	5 ns
11.4,11.4A MBS Dynamic Range Measurement Accuracy	Beacon power level	2 dB
	Code phase difference	5 ns
11.5,11.5A MBS Measurement Accuracy in Multipath	Beacon power level	0 dB (no relaxation)
	Code phase difference	5 ns

C.2.4 WLAN and BLE measurement requirements

Table C.2.4-1: Test Parameter Relaxations for WLAN and BLE measurement tests

Clause	Test Parameter Relaxation	
12.1.1 WLAN AP Identification and reporting delay under nominal conditions	Response time	300 ms
12.1.2 WLAN AP Identification and reporting delay under dynamic range conditions	Response time	300 ms
	Low Power WLAN APs Received Power Level	1 dB
12.2.1 Bluetooth identification	Response time	300 ms

C.2.5 NR PRS-based Measurement requirements

Table C.2.5-1: Test Parameter Relaxations for NR PRS-based Measurement requirements

Clause	Test Parameter Relaxation	
14.2.1 NR RSTD measurement period test case for single positioning frequency layer in FR1 SA	Response time	300ms
14.2.2 NR RSTD measurement period test case for dual positioning frequency layers in FR1 SA	Response time	300ms
14.2.3 NR RSTD measurement period test case for single positioning frequency layer in FR2 SA	Response time	300ms
14.2.4 NR RSTD measurement period test case for dual positioning frequency layers in FR2 SA	Response time	300ms
14.2.8 NR RSTD measurement reporting delay test case for single positioning frequency layer with reduced number of samples in FR2 SA	Response time	300ms
14.2.9 NR RSTD measurement reporting delay test case for single positioning frequency layer without measurement gap in FR2 SA	Response time	300ms
14.2.10 NR RSTD measurement reporting delay test case for single positioning frequency layer with Rx TEG in FR2 SA	Response time	300ms
14.3.1 NR RSTD measurement accuracy test case for single positioning frequency layer in FR1 SA	Cell Timing Difference	32 Tc
14.3.2 NR RSTD measurement accuracy test case for dual positioning frequency layers in FR1 SA	Cell Timing Difference	32 Tc
14.3.3 NR RSTD measurement accuracy test case for single positioning frequency layer in FR2 SA	Same as 14.3.1	Same as 14.3.1
14.3.4 NR RSTD measurement accuracy test case for dual positioning frequency layer in FR2 SA	Same as 14.3.2	Same as 14.3.2
14.3.7 NR RSTD measurement accuracy test case for single positioning frequency layer with	Cell Timing Difference	32 Tc

reduced number of samples in FR2 SA		
14.3.8 NR RSTD measurement accuracy test case for single positioning frequency layer with Rx TEG in FR2 SA	Cell Timing Difference	32 Tc
15.2.1 UE Rx-Tx time difference measurement period for single positioning frequency layer in FR1 SA	Response time	300ms
15.2.2 UE Rx-Tx time difference measurement period for dual positioning frequency layer in FR1 SA	Response time	300ms
15.2.3 UE Rx-Tx time difference measurement period for single positioning frequency layer in FR2 SA	Response time	300ms
15.2.4 UE Rx-Tx time difference measurement period for dual positioning frequency layer in FR2 SA	Response time	300ms
15.3.1 UE Rx-Tx time difference measurement accuracy for single positioning frequency layer in FR1 SA	Cell Timing Difference	32 Tc
15.3.2 UE Rx-Tx time difference measurement accuracy for single positioning frequency layer in FR2 SA	Cell Timing Difference	32 Tc
15.3.5 UE Rx-Tx time difference measurement accuracy for single positioning frequency layer with reduced number of samples in FR2 SA	Cell Timing Difference	32 Tc
15.3.6 UE Rx-Tx time difference measurement accuracy for single positioning frequency layer with RxTx TEG in FR2 SA	Cell Timing Difference	32 Tc
16.2.1 PRS-RSRP measurement period test case for single positioning frequency layer in FR1 SA	Response time	300ms
16.2.2 PRS-RSRP measurement period test case for dual positioning frequency layer in FR1 SA	Response time	300ms
16.2.3 PRS-RSRP measurement period test case for single positioning frequency layer in FR2 SA	Response time	300ms
16.2.4 PRS-RSRP measurement period test case for dual positioning frequency layer in FR2 SA	Response time	300ms
16.3.1 PRS-RSRP measurement accuracy with PRS in FR1	Response time	300ms
16.3.2 PRS-RSRP measurement accuracy with PRS in FR2	<p>Test 1: Reported absolute PRP values Reported relative PRP values</p> <p>Test 2: Reported absolute PRP values Reported relative PRP values</p>	<p>Test 1: <u>Reported absolute PRP values:</u> ±8.5 <u>Reported relative PRP values:</u> ±10</p> <p>Test 2: Reported absolute PRP values: ±6 Reported relative PRP values: ±7.5</p>

16.3.4 PRS-RSRP measurement accuracy with PRS in FR2 with reduced sample number	Test 1: Reported absolute PRP values Reported relative PRP values Reported absolute PRP values Reported relative PRP values	Test 1: <u>Reported absolute PRP values: ±8.5</u> <u>Reported relative PRP values: ±10</u> Reported absolute PRP values: ±6 Reported relative PRP values: ±7.5
---	---	--

C.3 Interpretation of measurement results

The measurement results returned by the Test System are compared - without any modification - against the Test Requirements as defined by the shared risk principle.

The Shared Risk principle is defined in TR 102 273-1-2 [7], clause 6.5.

The actual measurement uncertainty of the Test System for the measurement of each parameter shall be included in the test report.

The recorded value for the Test System uncertainty shall be, for each measurement, equal to or lower than the appropriate figure in clause C.1.

If the Test System for a test is known to have a measurement uncertainty greater than that specified in clause C.1, it is still permitted to use this apparatus provided that an adjustment is made value as follows.

Any additional uncertainty in the Test System over and above that specified in clause C.1 shall be used to tighten the Test Requirement - making the test harder to pass. (This may require modification of stimulus signals). This procedure will ensure that a Test System not compliant with clause C.1 does not increase the chance of passing a device under test where that device would otherwise have failed the test if a Test System compliant with clause C.1 had been used.

C.4 Derivation of Test Requirements (This clause is informative)

The Test Requirements have been calculated by relaxing the Conformance requirement of the core specification using the Test Parameter Relaxations defined in clause C.2. When the Test Parameter Relaxation is zero, the Test Requirement will be the same as the Conformance requirement. When the Test Parameter Relaxation is non-zero, the Test Requirements will differ from the Conformance requirement, and the formula used for this relaxation is given in table C.4.1, C.4.2, C.4.3 and C.4.4.

Table C.4.1: Derivation of Test Requirements for A-GNSS Minimum Performance tests

Test	Conformance requirement in TS 25.171 [31] or TS 25.172 [19] or TS 36.171 [3] or 38.171 [43]		Test Parameter Relaxation (TPR)	Test Requirement
5.2.1, 6.2.1, 7.1.1, 13.2.1 Sensitivity Coarse Time Assistance	Coarse Time Assistance	±2 s	200 ms	Formulas: UL-TPR, LL+TPR: ±1.8 s
	Absolute GPS L1 C/A signal level (test 5.2.1, 7.1.1, 13.2.1, sub-test 1)	-142, -147 dBm	1 dB	Level + TPR: -141, -146 dBm
	Absolute GNSS signal level (Galileo)	-142, -147 dBm	1 dB	Level + TPR: -141, -146 dBm
	Absolute GNSS signal level (GPS) (test 6.2.1, 7.1.1, 13.2.1, sub-tests 4, 5, 8, and 10 to 13)	-142, -147 dBm	1 dB	Level + TPR: -141, -146 dBm
	Absolute GNSS signal level (GLONASS)	-142, -147 dBm	1 dB	Level + TPR: -141, -146 dBm
	Absolute GNSS signal level (BDS)	-136, -145 dBm	1 dB	Level + TPR: -135, -144 dBm
	Position error	100 m	1.3 m	Error +TPR: 101.3 m
	Response time	20 s	300 ms	Time + TPR: 20.3 s

Test	Conformance requirement in TS 25.171 [31] or TS 25.172 [19] or TS 36.171 [3] or 38.171 [43]		Test Parameter Relaxation (TPR)	Test Requirement
5.2.2, 6.2.2, 7.1.2, 13.2.2 Sensitivity Fine Time Assistance	Coarse Time Assistance	±2 s	200 ms	Formulas: UL-TPR, LL+TPR: ±1.8 s
	Fine Time Assistance	±10 us	1 us	UL-TPR, LL+TPR: ±9 us
	Absolute GPS L1 C/A signal level (test 5.2.2, 7.1.2, 13.2.2, sub-test 1)	-147 dBm	1 dB	Level + TPR: -146 dBm
	Absolute GNSS signal level (Galileo)	-147 dBm	1 dB	Level + TPR: -146 dBm
	Absolute GNSS signal level (GPS) (test 6.2.2, 7.1.2, 13.2.2, sub-tests 4, 5, 8 and 10 to 13)	-147 dBm	1 dB	Level + TPR: -146 dBm
	Absolute GNSS signal level (GLONASS)	-147 dBm	1 dB	Level + TPR: -146 dBm
	Absolute GNSS signal level (BDS)	-147 dBm	1 dB	Level + TPR: -146 dBm
	Position error	100 m	1.3 m	Error +TPR: 101.3 m
	Response time	20 s	300 ms	Time + TPR: 20.3 s
5.3, 6.3, 7.2, 13.3 Nominal Accuracy	Coarse Time Assistance	±2 s	200 ms	Formulas: UL-TPR, LL+TPR: ±1.8 s
	Absolute GPS L1 C/A signal level (test 5.3, 7.2, 13.3, sub-test 1)	-130 dBm	0 dB	Formulas: Level + TPR: -130 dBm
	Absolute GNSS signal level (Galileo)	-127 dBm	0 dB	Level + TPR: -127 dBm
	Absolute GNSS signal level (GPS) (test 6.3, 7.2, 13.3, sub-tests 4, 5, 8 and 10 to 13)	-128.5 dBm	0 dB	Level + TPR: -128.5 dBm
	Absolute GNSS signal level (GLONASS)	-131 dBm	0 dB	Level + TPR: -131 dBm
	Absolute GNSS signal level (QZSS)	-128.5 dBm	0 dB	Level + TPR: -128.5 dBm
	Absolute GNSS signal level (SBAS)	-131 dBm	0 dB	Level + TPR: -131 dBm
	Absolute GNSS signal level (BDS)	-133 dBm	0 dB	Level + TPR: -133 dBm
	Position error	30 m	1.3 m	Error +TPR: 31.3 m
	Response time	20 s	300 ms	Time + TPR: 20.3 s
5.4, 6.4, 7.3, 13.4 Dynamic Range	Coarse Time Assistance	±2 s	200 ms	Formulas: UL-TPR, LL+TPR: ±1.8 s
	Absolute GPS L1 C/A signal level (test 5.4, 7.3, 13.4, sub-test 1)	-129 to -147 dBm	1 dB	Level + TPR: each level +1 dBm
	Absolute GNSS signal level (Galileo)	-127.5 to -147 dBm	1 dB	Level + TPR: each level +1 dBm
	Absolute GNSS signal level (GPS) (test 6.4, 7.3, 13.4, sub-tests 4, 5, 8 and 10 to 13)	-129 to -147 dBm	1 dB	Level + TPR: each level +1 dBm
	Absolute GNSS signal level (GLONASS)	-131.5 to -147 dBm	1 dB	Level + TPR: each level +1 dBm
	Absolute GNSS signal level (BDS)	-133.5 to -145 dBm	1 dB	Level + TPR: each level +1 dBm
	Relative GPS L1 C/A signal level (test 5.4, 7.3, 13.4, sub-test 1)	18 dB	0.2 dB	Level - TPR: highest level -0.2 dB: -128.2 dBm
	Relative GNSS signal level (Galileo)	19.5 dB	0.2 dB	Level - TPR: highest level -0.2 dB: -126.7 dBm
Relative GNSS signal level (GPS) (test 6.4, 7.3, 13.4, sub-tests 4, 5, 8 and 10 to 13)	18 dB	0.2 dB	Level - TPR: highest level -0.2 dB: -128.2 dBm	

Test	Conformance requirement in TS 25.171 [31] or TS 25.172 [19] or TS 36.171 [3] or 38.171 [43]		Test Parameter Relaxation (TPR)	Test Requirement
	Relative GNSS signal level (GLONASS)	15.5 dB	0.2 dB	Level - TPR: highest level -0.2 dB: -130.7 dBm
	Relative GNSS signal level (BDS)	11.5 dB	0.2 dB	Level - TPR: highest level -0.2 dB: -132.7 dBm
	Position error	100 m	1.3 m	Error +TPR: 101.3 m
	Response time	20 s	300 ms	Time + TPR: 20.3 s
5.5, 6.5, 7.4, 13.5 Multi-path scenario	Coarse Time Assistance	±2 s	200 ms	Formulas: UL-TPR, LL+TPR: ±1.8 s
	Absolute GPS L1 C/A signal level (test 5.5, 7.4, 13.5, sub-test 1)	-130 dBm	0 dB	Formulas: Level + TPR: -130 dBm
	Absolute GNSS signal level (Galileo)	-127 dBm	0 dB	Level + TPR: -127 dBm
	Absolute GNSS signal level (GPS) (test 6.5, 7.4, 13.5, sub-tests 4, 5, 8 and 10 to 13)	-128.5 dBm	0 dB	Level + TPR: -128.5 dBm
	Absolute GNSS signal level (GLONASS)	-131 dBm	0 dB	Level + TPR: -131 dBm
	Absolute GNSS signal level (BDS)	-133 dBm	0 dB	Level + TPR: -133 dBm
	Relative GPS L1 C/A signal level (test 5.5, 7.4, 13.5, sub-test 1) -142, -147 dBm	6 dB	0.2 dB	Relative level + TPR: relative level + 0.2dB: 6.2 dB
	Relative GNSS signal level (all GNSSs) (test 6.5, 7.4, 13.5, sub-tests 4, 5, 8 and 10 to 13)	Y dB where “Y” is given in Table 4.2.2	0.2 dB	Relative level + TPR: relative level + 0.2dB: Y + 0.2 dB
	Position error	100 m	1.3 m	Error +TPR: 101.3 m
5.6, 6.6, 7.5, 7.5A., 13.6, 13.7 Moving scenario and periodic update	Response time	20 s	300 ms	Time + TPR: 20.3 s
	Absolute GPS L1 C/A Signal level (test 5.6, 7.5, 7.5A., 13.6, 13.7, sub-test 1)	-130 dBm	0 dB	Formulas: Level + TPR: -130 dBm
	Absolute GNSS signal level (Galileo)	-127 dBm	0 dB	Level + TPR: -127 dBm
	Absolute GNSS signal level (GPS) (test 6.6, 7.5, 7.5A., 13.6, 13.7, sub-tests 4, 5, 8 and 10 to 13)	-128.5 dBm	0 dB	Level + TPR: -128.5 dBm
	Absolute GNSS signal level (GLONASS)	-131 dBm	0 dB	Level + TPR: -131 dBm
	Absolute GNSS signal level (BDS)	-133 dBm	0 dB	Level + TPR: -133 dBm
	Position error	100 m	1.3 m	Error +TPR: 101.3 m
Differential response time	2s +/- 20 %	100 ms	Time +TPR: 1.5 s and 2.5 s	

Table C.4.2: Derivation of Test Requirements for ECID and OTDOA Measurement tests

Test	Minimum Requirement in TS 36.133	Test Parameter Relaxation (TPR)	Test Requirement in TS 36.571-1
8.1.1 E-UTRAN FDD UE Rx - Tx time difference case (Rel-9 to Rel-11)	<p><u>Test 1:</u> N_{oc}: -98dBm/15kHz \hat{E}_s / N_{oc}: -3.0dB Reported RxTx time difference value: Measured value converted to RX-TX_TIME_DIFFERENCE according to Table 4.6.3-1</p>	<p><u>Test 1:</u> 0dB 0.3dB Via mapping</p>	<p><u>Test 2:</u> N_{oc}: -98dBm/15kHz \hat{E}_s / N_{oc}: -2.7.0dB (Measured value from step 7 - 23) T_s converted to RX-TX_TIME_DIFFERENCE according to Table 4.6.3-1 T_o</p>

	<p><u>Test 2:</u> N_{oc}: -98dBm/15kHz \hat{E}_s / N_{oc}: -3.0dB <u>Reported RxTx time difference value:</u> Measured value converted to RX-TX_TIME_DIFFERENCE according to Table 4.6.3-1</p>	<p><u>Test 2:</u> 0dB 0.3dB Via mapping</p>	<p>(Measured value from step 7 +23) T_s converted to RX-TX_TIME_DIFFERENCE according to Table 4.6.3-1</p> <p><u>Test 2:</u> N_{oc}: -98dBm/15kHz \hat{E}_{s1} / N_{oc}: +6.0dB \hat{E}_{s2} / N_{oc}: +2.0dB Measured value from step 7 -13) T_s converted to RX-TX_TIME_DIFFERENCE according to Table 4.6.3-1</p> <p><u>To</u> (Measured value from step 7 +13) T_s converted to RX-TX_TIME_DIFFERENCE according to Table 4.6.3-1</p>
<p>8.1.1A E-UTRAN FDD UE Rx – Tx time difference case (Rel-12 onwards)</p>	<p>Same as 8.1.1</p>	<p>Same as 8.1.1</p>	<p><u>Test 1:</u> N_{oc}: -98dBm/15kHz \hat{E}_s / N_{oc}: -2.7.0dB (Measured value from step 7 - 23) T_s converted to RX-TX_TIME_DIFFERENCE according to Table 4.6.3-1</p> <p><u>To</u> (Measured value from step 7 +23) T_s converted to RX-TX_TIME_DIFFERENCE according to Table 4.6.3-1</p> <p><u>Test 2:</u> N_{oc}: -98dBm/15kHz \hat{E}_{s1} / N_{oc}: +6.0dB \hat{E}_{s2} / N_{oc}: +2.0dB Measured value from step 7 -10) T_s converted to RX-TX_TIME_DIFFERENCE according to Table 4.6.3-1</p> <p><u>To</u> (Measured value from step 7 +10) T_s converted to RX-TX_TIME_DIFFERENCE according to Table 4.6.3-1</p>
<p>8.1.1B E-UTRAN FDD UE Rx – Tx time difference case for UE Category 1bis</p>	<p>Same as 8.1.1</p>	<p>Same as 8.1.1</p>	<p>Same as 8.1.1A</p>
<p>8.1.2 E-UTRAN TDD UE Rx - Tx time difference case (Rel-9 to Rel-11)</p>	<p>Same as 8.1.1 except use Table 4.6.3-2</p>	<p>Same as 8.1.1</p>	<p>Same as 8.1.1 except use Table 4.6.3-2</p>
<p>8.1.2A E-UTRAN TDD UE Rx – Tx time difference case (Rel-12 onwards)</p>	<p>Same as 8.1.1 except use Table 4.6.3-2</p>	<p>Same as 8.1.1</p>	<p>Same as 8.1.1A except use Table 4.6.3-2</p>
<p>8.1.2B E-UTRAN TDD UE Rx – Tx time difference case for UE Category 1bis</p>	<p>Same as 8.1.1 except use Table 4.6.3-2</p>	<p>Same as 8.1.1</p>	<p>Same as 8.1.1A except use Table 4.6.3-2</p>
<p>8.1.3 E-UTRAN FDD UE Rx-Tx time difference under Time Domain Measurement Resource Restriction with Non-MBSFN ABS (eICIC)</p>	<p><u>Test 1:</u> N_{oc}: -98dBm/15kHz \hat{E}_{s1} / N_{oc}: -3.00dB \hat{E}_{s2} / N_{oc}: +1.00dB <u>Reported RxTx time difference value:</u> Measured value converted to RX-TX_TIME_DIFFERENCE according to Table 4.6.3-1</p>	<p><u>Test 1:</u> 0dB 0.3dB 0dB Via mapping</p>	<p><u>Test 2:</u> N_{oc}: -98dBm/15kHz \hat{E}_{s1} / N_{oc}: -2.70dB \hat{E}_{s2} / N_{oc}: +1.00dB Measured value from step 7 -13) T_s converted to RX-TX_TIME_DIFFERENCE according to Table 4.6.3-1</p> <p><u>To</u> (Measured value from step 7 +13) T_s converted to RX-</p>

	<p><u>Test 2:</u> N_{oc}: -98dBm/15kHz \hat{E}_{S1} / N_{oc}: -3.00dB \hat{E}_{S2} / N_{oc}: +1.00dB <u>Reported RxTx time difference value:</u> Measured value converted to RX-TX_TIME_DIFFERENCE according to Table 4.6.3-1</p>	<p><u>Test 2:</u> 0dB 0.3dB 0dB Via mapping</p>	<p>TX_TIME_DIFFERENCE according to Table 4.6.3-1</p> <p><u>Test 2:</u> N_{oc}: -98dBm/15kHz \hat{E}_{S1} / N_{oc}: -2.70dB \hat{E}_{S2} / N_{oc}: +1.00dB Measured value from step 7 -13) T_s converted to RX-TX_TIME_DIFFERENCE according to Table 4.6.3-1 T_o (Measured value from step 7 +13) T_s converted to RX-TX_TIME_DIFFERENCE according to Table 4.6.3-1</p>
8.1.4 E-UTRAN TDD UE Rx-Tx time difference under Time Domain Measurement Resource Restriction with Non-MBSFN ABS (eICIC)	Same as 8.1.3 except use Table 4.6.3-2	Same as 8.1.3	Same as 8.1.3 except use Table 4.6.3-2
8.1.5 E-UTRAN FDD UE Rx-Tx time difference under Time Domain Measurement Resource Restriction with CRS Assistance Information and Non-MBSFN ABS (feICIC)	<p><u>Test 1:</u> N_{oc}: -98dBm/15kHz \hat{E}_{S1} / N_{oc}: -3.00dB \hat{E}_{S2} / N_{oc}: +3.00dB \hat{E}_{S3} / N_{oc}: +1.00dB <u>Reported RxTx time difference value:</u> Measured value converted to RX-TX_TIME_DIFFERENCE according to Table 4.6.3-1</p> <p><u>Test 2:</u> N_{oc}: -98dBm/15kHz \hat{E}_{S1} / N_{oc}: -3.00dB \hat{E}_{S2} / N_{oc}: +3.00dB \hat{E}_{S3} / N_{oc}: +1.00dB <u>Reported RxTx time difference value:</u> Measured value converted to RX-TX_TIME_DIFFERENCE according to Table 4.6.3-1</p>	<p><u>Test 1:</u> 0dB 0.4dB 0dB 0dB Via mapping</p> <p><u>Test 2:</u> 0dB 0.4dB 0dB 0dB Via mapping</p>	<p><u>Test 1:</u> N_{oc}: -98dBm/15kHz \hat{E}_{S1} / N_{oc}: -2.60dB \hat{E}_{S2} / N_{oc}: +3.00dB \hat{E}_{S3} / N_{oc}: +1.00dB Measured value from step 7 -13) T_s converted to RX-TX_TIME_DIFFERENCE according to Table 4.6.3-1 T_o (Measured value from step 7 +13) T_s converted to RX-TX_TIME_DIFFERENCE according to Table 4.6.3-1</p> <p><u>Test 2:</u> N_{oc}: -98dBm/15kHz \hat{E}_{S1} / N_{oc}: -2.60dB \hat{E}_{S2} / N_{oc}: +3.00dB \hat{E}_{S3} / N_{oc}: +1.00dB Measured value from step 7 -13) T_s converted to RX-TX_TIME_DIFFERENCE according to Table 4.6.3-1 T_o (Measured value from step 7 +13) T_s converted to RX-TX_TIME_DIFFERENCE according to Table 4.6.3-1</p>
8.1.6 E-UTRAN TDD UE Rx-Tx time difference under Time Domain Measurement Resource Restriction with CRS Assistance Information and Non-MBSFN ABS (feICIC)	Same as 8.1.5 except use Table 4.6.3-2	Same as 8.1.5	Same as 8.1.5 except use Table 4.6.3-2

8.1.7 E-UTRAN FDD UE Rx-Tx time difference case for Category M1/M2 UE in CEModeA	N_{oc} : -98dBm/15kHz \hat{E}_s / N_{oc} : -3.0dB <u>Reported RxTx time difference value</u> : Measured value converted to RX-TX_TIME_DIFFERENCE according to Table 4.6.3-1	0dB 0.3dB Via mapping	N_{oc} : -98dBm/15kHz \hat{E}_s / N_{oc} : -2.7.0dB Category M1: (Measured value from step 7 - 23) T_s converted to RX-TX_TIME_DIFFERENCE according to Table 4.6.3-1 <u>To</u> (Measured value from step 7 +23) T_s converted to RX-TX_TIME_DIFFERENCE according to Table 4.6.3-1 Category M2: (Measured value from step 7 -13) T_s converted to RX-TX_TIME_DIFFERENCE according to Table 4.6.3-1 <u>To</u> (Measured value from step 7 +13) T_s converted to RX-TX_TIME_DIFFERENCE according to Table 4.6.3-1
8.1.8 E-UTRAN HD-FDD UE Rx-Tx time difference case for Category M1/M2 UE in CEModeA	Same as 8.1.7	Same as 8.1.7	Same as 8.1.7
8.1.9 E-UTRAN TDD UE Rx-Tx time difference case for Category M1/M2 UE in CEModeA	Same as 8.1.7 except use Table 4.6.3-2	Same as 8.1.7	Same as 8.1.7 except use Table 4.6.3-2
9.1.1 FDD RSTD Measurement Reporting Delay	Response Time = 3 s	300 ms	Time + TPR: 3.3 s
9.1.1A FDD RSTD Measurement Reporting Delay for UE Category 1bis	Response Time = 6 s	300 ms	Time + TPR: 6.3 s
9.1.2 TDD RSTD Measurement Reporting Delay	Response Time = 3 s	300 ms	Time + TPR: 3.3 s
9.1.2A TDD RSTD Measurement Reporting Delay for UE Category 1bis	Response Time = 6 s	300 ms	Time + TPR: 6.3 s
9.1.3 FDD RSTD Measurement Accuracy	For Test 2 and Test 4: PRS \hat{E}_{s1} / N_{oc} = -6dB PRS \hat{E}_{s2} / N_{oc} = -13dB Cell timing difference: Test 1 and 2 = $\pm 15 T_s$ Test 3 and 4 = $\pm 5 T_s$	+0.3 dB +0.3 dB $\pm 1 T_s$	Level + TPR, -5.7 dB Level + TPR, -12.7 dB Timing difference \pm TPR, $\pm 16 T_s$ $\pm 6 T_s$
9.1.3A FDD RSTD Measurement Accuracy for UE Category 1bis	Same as 9.1.3	Same as 9.1.3	Same as 9.1.3
9.1.4 TDD RSTD Measurement Accuracy	Same as 9.1.3	Same as 9.1.3	Same as 9.1.3
9.1.4A TDD RSTD Measurement Accuracy for UE Category 1bis	Same as 9.1.3	Same as 9.1.3	Same as 9.1.3
9.2.1 FDD-FDD inter-frequency RSTD measurement reporting delay	Response Time = 6 s	300 ms	Time + TPR: 6.3 s
9.2.1A FDD-FDD inter-frequency RSTD measurement reporting delay for UE Category 1bis	Response Time = 11 s	300 ms	Time + TPR: 11.3 s
9.2.2 TDD-TDD inter-frequency RSTD measurement reporting delay	Response Time = 6 s	300 ms	Time + TPR: 6.3 s

9.2.2A TDD-TDD inter-frequency RSTD measurement reporting delay for UE Category 1bis	Response Time = 11 s	300 ms	Time + TPR: 11.3 s
9.2.4 FDD-FDD inter frequency RSTD Accuracy	PRRS $\hat{E}_{s1} / N_{oc1} = -6\text{dB}$ PRRS $\hat{E}_{s2} / N_{oc2} = -13\text{dB}$ Cell timing difference: Test 1 = $\pm 21 T_s$ Test 2 = $\pm 9 T_s$	+0.3 dB +0.3 dB $\pm 2 T_s$	Level + TPR, -5.7 dB Level + TPR, -12.7 dB Timing difference \pm TPR, $\pm 23 T_s$ $\pm 11 T_s$
9.2.4A FDD-FDD inter frequency RSTD Accuracy for UE Category 1bis	Same as 9.2.4	Same as 9.2.4	Same as 9.2.4
9.2.5 TDD-TDD inter frequency RSTD Accuracy	Same as 9.2.4	Same as 9.2.4	Same as 9.2.4
9.2.5A TDD-TDD inter frequency RSTD Accuracy for UE Category 1bis	Same as 9.2.4	Same as 9.2.4	Same as 9.2.4
9.3.1.1 FDD intra-frequency RSTD Measurement Reporting Delay in CE Mode A for Category M1	Response Time = 6 s	300 ms	Time + TPR: 6.3 s
9.3.1.2 FDD intra-frequency RSTD Measurement Reporting Delay in CE Mode A for Category M2	Response Time = 6 s	300 ms	Time + TPR: 6.3 s
9.3.2.1 HD-FDD intra-frequency RSTD Measurement Reporting Delay in CE Mode A for Category M1	Response Time = 6 s	300 ms	Time + TPR: 6.3 s
9.3.2.2 HD-FDD intra-frequency RSTD Measurement Reporting Delay in CE Mode A for Category M2	Response Time = 6 s	300 ms	Time + TPR: 6.3 s
9.3.3.1 TDD intra-frequency RSTD Measurement Reporting Delay in CE Mode A for Category M1	Response Time = 6 s	300 ms	Time + TPR: 6.3 s
9.3.3.2 TDD intra-frequency RSTD Measurement Reporting Delay in CE Mode A for Category M2	Response Time = 6 s	300 ms	Time + TPR: 6.3 s
9.3.4.1 FDD intra-frequency RSTD Measurement Reporting Delay in CE Mode B for Category M1	Response Time = 13 s	300 ms	Time + TPR: 13.3 s
9.3.4.2 FDD intra-frequency RSTD Measurement Reporting Delay in CE Mode B for Category M2	Test 1: Response Time 13 s Test 2: Response Time 6 s	300 ms	Test 1: Time + TPR: 13.3 s Test 2: Time + TPR: 6.3 s
9.3.5.1 HD-FDD intra-frequency RSTD Measurement Reporting Delay in CE Mode B for Category M1	Response Time = 13 s	300 ms	Time + TPR: 13.3 s
9.3.5.2 HD-FDD intra-frequency RSTD Measurement Reporting Delay in CE Mode B for Category M2	Test 1: Response Time 13 s Test 2: Response Time 6 s	300 ms	Test 1: Time + TPR: 13.3 s Test 2: Time + TPR: 6.3 s
9.3.6.1 TDD intra-frequency RSTD Measurement Reporting Delay in CE Mode B for Category M1	Response Time = 13 s	300 ms	Time + TPR: 13.3 s

9.3.6.2 TDD intra-frequency RSTD Measurement Reporting Delay in CE Mode B for Category M2	Test 1: Response Time 13 s Test 2: Response Time 6 s	300 ms	Test 1: Time + TPR: 13.3 s Test 2: Time + TPR: 6.3 s
9.3.7.1 FDD intra-frequency RSTD Measurement Accuracy in CE Mode A for Category M1	PRRS $\hat{E}_{s1} / N_{oc1} = -6$ dB PRRS $\hat{E}_{s2} / N_{oc2} = -13$ dB Cell timing difference = ± 15 Ts	+0.3 dB +0.3 dB ± 1 Ts	Level + TPR, -5.7 dB Level + TPR, -12.7 dB Timing difference \pm TPR, ± 16 Ts
9.3.7.2 FDD intra-frequency RSTD Measurement Accuracy in CE Mode A for Category M2	PRRS $\hat{E}_{s1} / N_{oc1} = -6$ dB PRRS $\hat{E}_{s2} / N_{oc2} = -13$ dB Cell timing difference = ± 6 Ts	+0.3 dB +0.3 dB ± 1 Ts	Level + TPR, -5.7 dB Level + TPR, -12.7 dB Timing difference \pm TPR, ± 7 Ts
9.3.8.1 HD-FDD intra-frequency RSTD Measurement Accuracy in CE Mode A for Category M1	Same as 9.3.7.1	Same as 9.3.7.1	Same as 9.3.7.1
9.3.8.2 HD-FDD intra-frequency RSTD Measurement Accuracy in CE Mode A for Category M2	Same as 9.3.7.2	Same as 9.3.7.2	Same as 9.3.7.2
9.3.9.1 TDD intra-frequency RSTD Measurement Accuracy in CE Mode A for Category M1	Same as 9.3.7.1	Same as 9.3.7.1	Same as 9.3.7.1
9.3.9.2 TDD intra-frequency RSTD Measurement Accuracy in CE Mode A for Category M2	Same as 9.3.7.2	Same as 9.3.7.2	Same as 9.3.7.2
9.3.10.1 FDD intra-frequency RSTD Measurement Accuracy in CE Mode B for Category M1	PRRS $\hat{E}_{s1} / N_{oc1} = -15$ dB PRRS $\hat{E}_{s2} / N_{oc2} = -15$ dB Cell timing difference = ± 15 Ts	+0.3 dB +0.3 dB ± 1 Ts	Level + TPR, -14.7 dB Level + TPR, -14.7 dB Timing difference \pm TPR, ± 16 Ts
9.3.10.2 FDD intra-frequency RSTD Measurement Accuracy in CE Mode B for Category M2	PRRS $\hat{E}_{s1} / N_{oc1} = -15$ dB PRRS $\hat{E}_{s2} / N_{oc2} = -15$ dB Cell timing difference = ± 6 Ts	+0.3 dB +0.3 dB ± 1 Ts	Level + TPR, -14.7 dB Level + TPR, -14.7 dB Timing difference \pm TPR, ± 7 Ts
9.3.11.1 HD-FDD intra-frequency RSTD Measurement Accuracy in CE Mode B for Category M1	Same as 9.3.10.1	Same as 9.3.10.1	Same as 9.3.10.1
9.3.11.2 HD-FDD intra-frequency RSTD Measurement Accuracy in CE Mode B for Category M2	Same as 9.3.10.2	Same as 9.3.10.2	Same as 9.3.10.2
9.3.12.1 TDD intra-frequency RSTD Measurement Accuracy in CE Mode B for Category M1	Same as 9.3.10.1	Same as 9.3.10.1	Same as 9.3.10.1
9.3.12.2 TDD intra-frequency RSTD Measurement Accuracy in CE Mode B for Category M2	Same as 9.3.10.2	Same as 9.3.10.2	Same as 9.3.10.2
9.3.13 E-UTRAN FDD intra-frequency RSTD measurement period test case in CE Mode A with longer PRS occasions	Response Time = 3 s	300 ms	Time + TPR: 3.3 s
9.3.14 E-UTRAN HD-FDD intra-frequency RSTD measurement period test case in CE Mode A with longer PRS occasions	Response Time = 3 s	300 ms	Time + TPR: 3.3 s
9.3.15 E-UTRAN TDD intra-frequency RSTD measurement period test case in CE Mode A with longer PRS occasions	Response Time = 3 s	300 ms	Time + TPR: 3.3 s

9.3.16 E-UTRAN FDD intra-frequency RSTD measurement period test case in CE Mode B with longer PRS occasions	Response Time = 3 s	300 ms	Time + TPR: 3.3 s
9.3.17 E-UTRAN HD-FDD intra-frequency RSTD measurement period test case in CE Mode B with longer PRS occasions	Response Time = 3 s	300 ms	Time + TPR: 3.3 s
9.3.18 E-UTRAN TDD intra-frequency RSTD measurement period test case in CE Mode B with longer PRS occasions	Response Time = 6 s	300 ms	Time + TPR: 6.3 s
9.4.1.1 FDD inter-frequency RSTD Measurement Reporting Delay in CE Mode A for Category M1	Response Time = 16 s	300 ms	Time + TPR: 16.3 s
9.4.1.2 FDD inter-frequency RSTD Measurement Reporting Delay in CE Mode A for Category M2	Test 1: Response Time 16 s Test 2: Response Time 11 s	300 ms	Test 1: Time + TPR: 16.3 s Test 2: Time + TPR: 11.3 s
9.4.2.1 HD-FDD inter-frequency RSTD Measurement Reporting Delay in CE Mode A for Category M1	Response Time = 16 s	300 ms	Time + TPR: 16.3 s
9.4.2.2 HD-FDD inter-frequency RSTD Measurement Reporting Delay in CE Mode A for Category M2	Test 1: Response Time 16 s Test 2: Response Time 11 s	300 ms	Test 1: Time + TPR: 16.3 s Test 2: Time + TPR: 11.3 s
9.4.3.1 TDD inter-frequency RSTD Measurement Reporting Delay in CE Mode A for Category M1	Response Time = 16 s	300 ms	Time + TPR: 16.3 s
9.4.3.2 TDD inter-frequency RSTD Measurement Reporting Delay in CE Mode A for Category M2	Test 1: Response Time 16 s Test 2: Response Time 11 s	300 ms	Test 1: Time + TPR: 16.3 s Test 2: Time + TPR: 11.3 s
9.4.4.1 FDD inter-frequency RSTD Measurement Reporting Delay in CE Mode B for Category M1	Response Time = 42 s	300 ms	Time + TPR: 42.3 s
9.4.4.2 FDD inter-frequency RSTD Measurement Reporting Delay in CE Mode B for Category M2	Test 1: Response Time 42 s Test 2: Response Time 11 s	300 ms	Test 1: Time + TPR: 42.3 s Test 2: Time + TPR: 11.3 s
9.4.5.1 HD-FDD inter-frequency RSTD Measurement Reporting Delay in CE Mode B for Category M1	Response Time = 42 s	300 ms	Time + TPR: 42.3 s
9.4.5.2 HD-FDD inter-frequency RSTD Measurement Reporting Delay in CE Mode B for Category M2	Test 1: Response Time 42 s Test 2: Response Time 11 s	300 ms	Test 1: Time + TPR: 42.3 s Test 2: Time + TPR: 11.3 s
9.4.6.1 TDD inter-frequency RSTD Measurement Reporting Delay in CE Mode B for Category M1	Response Time = 42 s	300 ms	Time + TPR: 42.3 s
9.4.6.2 TDD inter-frequency RSTD Measurement Reporting Delay in CE Mode B for Category M2	Test 1: Response Time 42 s Test 2: Response Time 11 s	300 ms	Test 1: Time + TPR: 42.3 s Test 2: Time + TPR: 11.3 s

9.4.7.1 FDD inter-frequency RSTD Measurement Accuracy in CE Mode A for Category M1	PRRS $\hat{E}_{s1} / N_{oc1} = -6$ dB PRRS $\hat{E}_{s2} / N_{oc2} = -13$ dB Cell timing difference = $\pm 21 T_s$	+0.3 dB +0.3 dB $\pm 2 T_s$	Level + TPR, -5.7 dB Level + TPR, -12.7 dB Timing difference \pm TPR, $\pm 23 T_s$
9.4.7.2 FDD inter-frequency RSTD Measurement Accuracy in CE Mode A for Category M2	PRRS $\hat{E}_{s1} / N_{oc1} = -6$ dB PRRS $\hat{E}_{s2} / N_{oc2} = -13$ dB Cell timing difference = $\pm 10 T_s$	+0.3 dB +0.3 dB $\pm 2 T_s$	Level + TPR, -5.7 dB Level + TPR, -12.7 dB Timing difference \pm TPR, $\pm 12 T_s$
9.4.8.1 HD-FDD inter-frequency RSTD Measurement Accuracy in CE Mode A for Category M1	Same as 9.4.7.1	Same as 9.4.7.1	Same as 9.4.7.1
9.4.8.2 HD-FDD inter-frequency RSTD Measurement Accuracy in CE Mode A for Category M2	Same as 9.4.7.2	Same as 9.4.7.2	Same as 9.4.7.2
9.4.9.1 TDD inter-frequency RSTD Measurement Accuracy in CE Mode A for Category M1	Same as 9.4.7.1	Same as 9.4.7.1	Same as 9.4.7.1
9.4.9.2 TDD inter-frequency RSTD Measurement Accuracy in CE Mode A for Category M2	Same as 9.4.7.2	Same as 9.4.7.2	Same as 9.4.7.2
9.4.10.1 FDD inter-frequency RSTD Measurement Accuracy in CE Mode B for Category M1	PRRS $\hat{E}_{s1} / N_{oc1} = -15$ dB PRRS $\hat{E}_{s2} / N_{oc2} = -15$ dB Cell timing difference = $\pm 21 T_s$	+0.3 dB +0.3 dB $\pm 2 T_s$	Level + TPR, -14.7 dB Level + TPR, -14.7 dB Timing difference \pm TPR, $\pm 23 T_s$
9.4.10.2 FDD inter-frequency RSTD Measurement Accuracy in CE Mode B for Category M2	PRRS $\hat{E}_{s1} / N_{oc1} = -15$ dB PRRS $\hat{E}_{s2} / N_{oc2} = -[13]$ dB Cell timing difference = $\pm 10 T_s$	+0.3 dB +0.3 dB $\pm 2 T_s$	Level + TPR, -14.7 dB Level + TPR, -[12.7] dB Timing difference \pm TPR, $\pm 12 T_s$
9.4.11.1 HD-FDD inter-frequency RSTD Measurement Accuracy in CE Mode B for Category M1	Same as 9.4.10.1	Same as 9.4.10.1	Same as 9.4.10.1
9.4.11.2 HD-FDD inter-frequency RSTD Measurement Accuracy in CE Mode B for Category M2	Same as 9.4.10.2	Same as 9.4.10.2	Same as 9.4.10.2
9.4.12.1 TDD inter-frequency RSTD Measurement Accuracy in CE Mode B for Category M1	Same as 9.4.10.1	Same as 9.4.10.1	Same as 9.4.10.1
9.4.12.2 TDD inter-frequency RSTD Measurement Accuracy in CE Mode B for Category M2	Same as 9.4.10.2	Same as 9.4.10.2	Same as 9.4.10.2
9.4.13 E-UTRAN FDD inter-frequency RSTD measurement period test case in CE Mode A with longer PRS occasions	Response Time = 6 s	300 ms	Time + TPR: 6.3 s
9.4.14 E-UTRAN HD-FDD inter-frequency RSTD measurement period test case in CE Mode A with longer PRS occasions	Response Time = 6 s	300 ms	Time + TPR: 6.3 s
9.4.15 E-UTRAN TDD inter-frequency RSTD measurement period test case in CE Mode A with longer PRS occasions	Response Time = 6 s	300 ms	Time + TPR: 6.3 s
9.4.16 E-UTRAN FDD inter-frequency RSTD measurement period test case in CE Mode B with longer PRS occasions	Response Time = 6 s	300 ms	Time + TPR: 6.3 s

9.4.17 E-UTRAN HD-FDD inter-frequency RSTD measurement period test case in CE Mode B with longer PRS occasions	Response Time = 6 s	300 ms	Time + TPR: 6.3 s
9.4.18 E-UTRAN TDD inter-frequency RSTD measurement period test case in CE Mode B with longer PRS occasions	Response Time = 11 s	300 ms	Time + TPR: 11.3 s
9.5.1 HD-FDD Intra frequency RSTD Measurement Accuracy for NB-IOT Inband Mode in normal coverage	NPRS $\hat{E}_{S1} / N_{oc} = -6\text{dB}$ NPRS $\hat{E}_{S2} / N_{oc} = -13\text{dB}$ Cell timing difference= $\pm 20 T_s$	+0.3 dB +0.3 dB $\pm 1 T_s$	Level + TPR, -5.7 dB Level + TPR, -12.7 dB Timing difference \pm TPR, $\pm 21 T_s$
9.5.2 HD-FDD Intra frequency RSTD Measurement Accuracy for NB-IOT Inband Mode in enhanced coverage	NPRS $\hat{E}_{S1} / N_{oc} = -15\text{dB}$ NPRS $\hat{E}_{S2} / N_{oc} = -15\text{dB}$ Cell timing difference= $\pm 32 T_s$	+0.3 dB +0.3 dB $\pm 1 T_s$	Level + TPR, -14.7 dB Level + TPR, -14.7 dB Timing difference \pm TPR, $\pm 33 T_s$
9.5.3 HD-FDD Intra frequency RSTD Measurement Reporting Delay for NB-IOT Inband Mode in enhanced coverage	Response Time = 78 s	300 ms	Time + TPR: 78.3 s
9.6.1 HD-FDD Inter-Frequency RSTD Measurement Accuracy for NB-IOT Inband Mode in normal coverage	NPRS $\hat{E}_{S1} / N_{oc1} = -6\text{dB}$ NPRS $\hat{E}_{S2} / N_{oc2} = -13\text{dB}$ Cell timing difference= $\pm 28 T_s$	+0.3 dB +0.3 dB $\pm 2 T_s$	Level + TPR, -5.7 dB Level + TPR, -12.7 dB Timing difference \pm TPR, $\pm 30 T_s$
9.6.2 HD-FDD Inter-Frequency RSTD Measurement Accuracy for NB-IOT Inband Mode in enhanced coverage	NPRS $\hat{E}_{S1} / N_{oc1} = -15\text{dB}$ NPRS $\hat{E}_{S2} / N_{oc2} = -15\text{dB}$ Cell timing difference= $\pm 40 T_s$	+0.3 dB +0.3 dB $\pm 2 T_s$	Level + TPR, -14.7 dB Level + TPR, -14.7 dB Timing difference \pm TPR, $\pm 42 T_s$
9.6.3 HD-FDD Inter frequency RSTD Measurement Reporting Delay for NB-IOT Inband Mode in enhanced coverage	Same as 9.5.3	Same as 9.5.3	Same as 9.5.3
9.7.1 TDD Intra frequency RSTD Measurement Accuracy for NB-IOT Inband Mode in normal coverage	NPRS $\hat{E}_{S1} / N_{oc} = -6\text{dB}$ NPRS $\hat{E}_{S2} / N_{oc} = -13\text{dB}$ Cell timing difference= $\pm 20 T_s$	+0.3 dB +0.3 dB $\pm 1 T_s$	Level + TPR, -5.7 dB Level + TPR, -12.7 dB Timing difference \pm TPR, $\pm 21 T_s$
9.7.2 TDD Intra frequency RSTD Measurement Accuracy for NB-IOT Inband Mode in enhanced coverage	NPRS $\hat{E}_{S1} / N_{oc} = -15\text{dB}$ NPRS $\hat{E}_{S2} / N_{oc} = -15\text{dB}$ Cell timing difference= $\pm 32 T_s$	+0.3 dB +0.3 dB $\pm 1 T_s$	Level + TPR, -14.7 dB Level + TPR, -14.7 dB Timing difference \pm TPR, $\pm 33 T_s$
9.7.3 TDD Intra frequency RSTD Measurement Reporting Delay for NB-IOT Inband Mode in enhanced coverage	Response Time = 79 s	300 ms	Time + TPR: 79.3 s
9.8.1 TDD Inter-frequency RSTD Measurement Accuracy for NB-IOT Inband Mode in normal coverage	NPRS $\hat{E}_{S1} / N_{oc1} = -6\text{dB}$ NPRS $\hat{E}_{S2} / N_{oc2} = -13\text{dB}$ Cell timing difference= $\pm 28 T_s$	+0.3 dB +0.3 dB $\pm 2 T_s$	Level + TPR, -5.7 dB Level + TPR, -12.7 dB Timing difference \pm TPR, $\pm 30 T_s$
9.8.2 TDD Inter-frequency RSTD Measurement Accuracy for NB-IOT Inband Mode in enhanced coverage	NPRS $\hat{E}_{S1} / N_{oc1} = -15\text{dB}$ NPRS $\hat{E}_{S2} / N_{oc2} = -15\text{dB}$ Cell timing difference= $\pm 40 T_s$	+0.3 dB +0.3 dB $\pm 2 T_s$	Level + TPR, -14.7 dB Level + TPR, -14.7 dB Timing difference \pm TPR, $\pm 42 T_s$
9.8.3 TDD Inter frequency RSTD Measurement Reporting Delay for NB-IOT Inband Mode in enhanced coverage	Response Time = 90 s	300 ms	Time + TPR: 90.3 s

10.1 FDD RSTD Measurement Reporting Delay for Carrier Aggregation	Test 1: Response Time = 3 s Test 2: Response Time = 6 s	300 ms 300 ms	Time + TPR: 3.3 s Time + TPR: 6.3 s
10.1A FDD RSTD Measurement Reporting Delay for Carrier Aggregation for 20 MHz	Same as 10.1	Same as 10.1	Same as 10.1
10.1B FDD RSTD Measurement Reporting Delay Carrier Aggregation for 5 MHz +5 MHz Bandwidth	Same as 10.1	Same as 10.1	Same as 10.1
10.1C FDD RSTD Measurement Reporting Delay for Carrier Aggregation for 10 MHz+5 MHz Bandwidth	Same as 10.1	Same as 10.1	Same as 10.1
10.2 TDD RSTD Measurement Reporting Delay for Carrier Aggregation	Same as 10.1	Same as 10.1	Same as 10.1
10.2A TDD RSTD Measurement Reporting Delay for Carrier Aggregation for 20 MHz	Same as 10.1	Same as 10.1	Same as 10.1
10.2B TDD RSTD Measurement Reporting Delay Carrier Aggregation for 5 MHz +5 MHz Bandwidth	Same as 10.1	Same as 10.1	Same as 10.1
10.2C TDD RSTD Measurement Reporting Delay for Carrier Aggregation for 10 MHz+5 MHz Bandwidth	Same as 10.1	Same as 10.1	Same as 10.1
10.2D TDD RSTD Measurement Reporting Delay for Carrier Aggregation for 20 MHz +10 MHz Bandwidth	Same as 10.1	Same as 10.1	Same as 10.1
10.3 FDD RSTD Measurement Accuracy for Carrier Aggregation	$PRS \hat{E}_{s2} / N_{oc2} = -6dB$ $PRS \hat{E}_{s3} / N_{oc2} = -13dB$ Cell timing difference= $\pm 5 T_s$	+0.3 dB +0.3 dB $\pm 1 T_s$	Level + TPR, -5.7 dB Level + TPR, -12.7 dB Timing difference \pm TPR, $\pm 6 T_s$
10.3A FDD RSTD Measurement Accuracy for Carrier Aggregation for 20 MHz (Rel-10 and Rel-11)	Same as 10.3	Same as 10.3	Same as 10.3
10.3A_1 FDD RSTD Measurement Accuracy for Carrier Aggregation for 20 MHz (Rel-12 onwards)	$PRS \hat{E}_{s2} / N_{oc2} = -6dB$ $PRS \hat{E}_{s3} / N_{oc2} = -13dB$ Cell timing difference= $\pm 4 T_s$	+0.3 dB +0.3 dB $\pm 1 T_s$	Level + TPR, -5.7 dB Level + TPR, -12.7 dB Timing difference \pm TPR, $\pm 5 T_s$
10.3B FDD RSTD Measurement Accuracy for Carrier Aggregation for 5 MHz+5 MHz Bandwidth	$PRS \hat{E}_{s2} / N_{oc2} = -6dB$ $PRS \hat{E}_{s3} / N_{oc2} = -13dB$ Cell timing difference= $\pm 6 T_s$	+0.3 dB +0.3 dB $\pm 1 T_s$	Level + TPR, -5.7 dB Level + TPR, -12.7 dB Timing difference \pm TPR, $\pm 7 T_s$
10.3C FDD RSTD Measurement Accuracy for Carrier Aggregation for 10 MHz+5 MHz Bandwidth	Same as 10.3B	Same as 10.3B	Same as 10.3B
10.4 TDD RSTD Measurement Accuracy for Carrier Aggregation	Same as 10.3	Same as 10.3	Same as 10.3

10.4A TDD RSTD Measurement Accuracy for Carrier Aggregation for 20 MHz (Rel-10 and Rel-11)	Same as 10.3	Same as 10.3	Same as 10.4
10.4A_1 TDD RSTD Measurement Accuracy for Carrier Aggregation for 20 MHz (Rel-12 onwards)	PRS $\hat{E}_{s2} / N_{oc2} = -6\text{dB}$ PRS $\hat{E}_{s3} / N_{oc2} = -13\text{dB}$ Cell timing difference= $\pm 4 T_s$	+0.3 dB +0.3 dB $\pm 1 T_s$	Level + TPR, -5.7 dB Level + TPR, -12.7 dB Timing difference \pm TPR, $\pm 5 T_s$
10.4B TDD RSTD Measurement Accuracy for Carrier Aggregation for 5 MHz+5 MHz Bandwidth	Same as 10.3B	Same as 10.3B	Same as 10.3B
10.4C TDD RSTD Measurement Accuracy for Carrier Aggregation for 10 MHz+5 MHz Bandwidth	Same as 10.3B	Same as 10.3B	Same as 10.3B
10.4D TDD RSTD Measurement Accuracy for Carrier Aggregation for 20 MHz+10 MHz Bandwidth	Same as 10.3	Same as 10.3	Same as 10.3
10.5 FDD 3 DL CA RSTD Measurement Reporting Delay	Same as 10.1	Same as 10.1	Same as 10.1
10.6 TDD 3 DL CA RSTD Measurement Reporting Delay	Same as 10.1	Same as 10.1	Same as 10.1
10.7 FDD RSTD Measurement Accuracy for 3DL Carrier Aggregation	PRS $\hat{E}_{s3} / N_{oc3} = -6\text{dB}$ PRS $\hat{E}_{s4} / N_{oc3} = -13\text{dB}$ Cell timing difference= Cell 1: $\pm 10 T_s, \pm 9 T_s, \pm 8 T_s$ Cell 2: $\pm 10 T_s, \pm 9 T_s, \pm 8 T_s$ Cell 4: $\pm 6 T_s, \pm 5 T_s, \pm 4 T_s$	+0.3 dB +0.3 dB $\pm 2 T_s$ $\pm 2 T_s$ $\pm 1 T_s$	Level + TPR, -5.7 dB Level + TPR, -12.7 dB Timing difference \pm TPR, Cell 1: $\pm 12 T_s, \pm 11 T_s, \pm 10 T_s$ Cell 2: $\pm 12 T_s, \pm 11 T_s, \pm 10 T_s$ Cell 4: $\pm 7 T_s, \pm 6 T_s, \pm 5 T_s$
10.8 TDD RSTD Measurement Accuracy for 3DL Carrier Aggregation	Same as 10.7	Same as 10.7	Same as 10.7

Table C.4.3: Derivation of Test Requirements for MBS Minimum Performance tests

Test	Conformance requirements in 11.1.3, 11.2.3, 11.3.3, 11.4.3 and 11.5.3		Test Parameter Relaxation (TPR)	Test Requirement
11.1, 11.1A MBS Measurement Reporting Delay	Beacon power level	-30 dBm	0 dB	Level+TPR: -30 dBm
	Response time	12 seconds	300 ms	Time+TPR: 12.3 s
11.2 MBS Sensitivity Measurement Accuracy	Beacon power level	-130 dBm	2 dB	Level+TPR: -128 dBm
	Code phase difference	2.35×10^{-4} ms	5 ns	Error+TPR: 2.40×10^{-4} ms
	Code phase difference	9.3×10^{-5} ms	5 ns	Error+TPR: 9.8×10^{-5} ms
11.2A MBS Sensitivity Measurement Accuracy	Beacon power level	-130 dBm	2 dB	Level+TPR: -128 dBm
	Code phase difference	2.35×10^{-4} ms	5 ns	Error+TPR: 2.40×10^{-4} ms
	Code phase difference	9.3×10^{-5} ms	5 ns	Error+TPR: 9.8×10^{-5} ms
11.3 MBS Nominal Measurement Accuracy	Beacon power level	-30 dBm	0 dB	Level+TPR: -30 dBm
	Code phase difference	7.1×10^{-5} ms	5 ns	Error+TPR: 7.6×10^{-5} ms
11.3A MBS Nominal Measurement Accuracy	Beacon power level	-30 dBm	0 dB	Level+TPR: -30 dBm
	TB1 Code phase difference	7.1×10^{-5} ms	5 ns	Error+TPR: 7.6×10^{-5} ms
	TB2 Code phase difference	2.8×10^{-5} ms	5 ns	Error+TPR: 3.3×10^{-5} ms
11.4 MBS Dynamic Range Measurement Accuracy	High Power Beacon power level	-30 dBm	0 dB	Level+TPR: -30 dBm
	Code phase difference	7.1×10^{-5} ms	5 ns	Error+TPR: 7.6×10^{-5} ms
	Low Power Beacon power level	-130 dBm	2 dB	Level+TPR: -128 dBm
	Code phase difference	2.35×10^{-4} ms	5 ns	Error+TPR: 2.40×10^{-4} ms
	High Power Beacon power level	-30 dBm	0 dB	Level+TPR: -30 dBm

11.4A MBS Dynamic Range Measurement Accuracy	TB1 High Power code phase difference	7.1×10^{-5} ms	5 ns	Error+TPR: 7.6×10^{-5} ms
	TB2 High Power code phase difference	2.8×10^{-5} ms	5 ns	Error+TPR: 3.3×10^{-5} ms
	Low Power Beacon power level	-130 dBm	2 dB	Level+TPR: -128 dBm
	TB1 Low Power code phase difference	2.35×10^{-4} ms	5 ns	Error+TPR: 2.40×10^{-4} ms
	TB2 Low Power code phase difference	9.3×10^{-5} ms	5 ns	Error+TPR: 9.8×10^{-5} ms
11.5, 11.5A MBS Measurement Accuracy in Multipath	Beacon power level	-30 dBm	0 dB	Level+TPR: -30 dBm
	Code phase difference	2.35×10^{-4} ms	5 ns	Error+TPR: 2.40×10^{-4} ms

Table C.4.4: Derivation of Test Requirements for WLAN and BLE measurement tests

Test	Conformance requirements in 12.1.1, 12.1.2 and 12.2.1		Test Parameter Relaxation (TPR)	Test Requirement
12.1.1 WLAN AP Identification and reporting delay under nominal conditions	Response time	20.85 seconds	300 ms	Time+TPR: 21.15 s
12.1.2 WLAN AP Identification and reporting delay under dynamic range conditions	Response time	20.85 seconds	300 ms	Time+TPR: 21.15 s
	Low Power WLAN APs Received Power Level	WLAN 2.4 GHz band: -74 dBm WLAN 5 GHz band: -79 dBm	1 dB	Power+TPR: WLAN 2.4 GHz band: -73 dBm WLAN 5 GHz band: -78 dBm
12.2.1 Bluetooth identification	Response time	10.85 seconds	300 ms	Time+TPR: 11.15 s

Table C.4.5: Derivation of Test Requirements for NR RSTD Measurement tests

Test	Minimum Requirement in TS 38.133	Test Parameter Relaxation (TPR)	Test Requirement in TS 37.571-1
14.2.1 NR RSTD measurement period test case for single positioning frequency layer in FR1 SA	Response Time between 1 s and 660 s depending on UE capabilities	300 ms	Time + TPR: between 1.3 s and 660.3 s depending on UE capabilities
14.2.2 NR RSTD measurement period test case for dual positioning frequency layers in FR1 SA	Response Time between 2 s and 660 s depending on UE capabilities	300 ms	Time + TPR: between 2.3 s and 660.3 s depending on UE capabilities
14.2.3 NR RSTD measurement period test case for single positioning frequency layer in FR2 SA	Response Time between 6 s and 250 s depending on UE capabilities	300 ms	Time + TPR: between 6.3 s and 250.3 s depending on UE capabilities
14.2.4 NR RSTD measurement period test case for dual positioning frequency layers in FR2 SA	Response Time between 11 s and 210 s depending on UE capabilities	300 ms	Time + TPR: between 11.3 s and 210.3 s depending on UE capabilities
14.2.8 NR RSTD measurement reporting delay test case for single positioning frequency layer with reduced number of samples in FR2 SA	Response Time between 2 s and 31 s depending on UE capabilities	300 ms	Time + TPR: between 2.3 s and 31.3 s depending on UE capabilities
14.2.9 NR RSTD measurement reporting delay test case for single positioning frequency layer	Response Time between 5 s and 25 s depending on UE capabilities	300 ms	Time + TPR: between 5.3 s and 25.3 s depending on UE capabilities

without measurement gap in FR2 SA			
14.2.10 NR RSTD measurement reporting delay test case for single positioning frequency layer with Rx TEG in FR2 SA	Response Time between 11 s and 500 s depending on UE capabilities	300 ms	Time + TPR: between 11.3 s and 500.3 s depending on UE capabilities
14.3.1 NR RSTD measurement accuracy test case for single positioning frequency layer in FR1 SA	Cell Timing Difference = $3\mu\text{s}$	32 Tc	Time + TPR: $3\mu\text{s} \pm 32 Tc$
14.3.2 NR RSTD measurement accuracy test case for dual positioning frequency layers in FR1 SA	Cell Timing Difference = $3\mu\text{s}$	32 Tc	Time + TPR: $3\mu\text{s} \pm 32 Tc$
14.3.3 NR RSTD measurement accuracy test case for single positioning frequency layer in FR2 SA	Test 1: Cell Timing Difference = $3\mu\text{s} \pm 88 Tc$ Test 2: Cell Timing Difference = $3\mu\text{s} \pm 50 Tc$	32 Tc	Test 1: Time + TPR: $3\mu\text{s} \pm 120 Tc$ Test 2: Time + TPR: $3\mu\text{s} \pm 82 Tc$
14.3.4 NR RSTD measurement accuracy test case for dual positioning frequency layer in FR2 SA	Test 1: Cell Timing Difference = $3\mu\text{s} \pm 328 Tc$ Test 2: Cell Timing Difference = $3\mu\text{s} \pm 278 Tc$	32 Tc	Test 1: Time + TPR: $3\mu\text{s} \pm 360 Tc$ Test 2: Time + TPR: $3\mu\text{s} \pm 310 Tc$
14.3.7 NR RSTD measurement accuracy test case for single positioning frequency layer with reduced number of samples in FR2 SA	Test 1: Cell Timing Difference = $3\mu\text{s} \pm 61 Tc$ Test 2: Cell Timing Difference = $3\mu\text{s} \pm 50 Tc$	32 Tc	Test 1: Time + TPR: $3\mu\text{s} \pm 93 Tc$ Test 2: Time + TPR: $3\mu\text{s} \pm 82 Tc$
14.3.8 NR RSTD measurement accuracy test case for single positioning frequency layer with Rx TEG in FR2 SA	Test 1: Cell Timing Difference = $3\mu\text{s} \pm 88 Tc$ Test 2: Cell Timing Difference = $3\mu\text{s} \pm 50 Tc$	32 Tc	Test 1: Time + TPR: $3\mu\text{s} \pm 120 Tc$ Test 2: Time + TPR: $3\mu\text{s} \pm 82 Tc$

Table C.4.6: Derivation of Test Requirements for UE Rx–Tx time difference Measurement tests

Test	Minimum Requirement in TS 38.133	Test Parameter Relaxation (TPR)	Test Requirement in TS 37.571-1
15.2.1 UE Rx-Tx time difference measurement period for single positioning frequency layer in FR1 SA	Response Time between 1 s and 103 s depending on UE capabilities	300ms	Time + TPR: between 1.3 s and 103.3 s depending on UE capabilities
15.2.2 UE Rx-Tx time difference measurement period for dual positioning frequency layers in FR1 SA	Response Time between 2.3 s and 53.3 s depending on UE capabilities	300ms	Time + TPR: between 2.3 s and 53.3 s depending on UE capabilities
15.2.3 UE Rx-Tx time difference measurement period for single positioning frequency layer in FR2 SA	Response Time between 6 s and 170 s depending on UE capabilities	300ms	Time + TPR: between 6.3 s and 170.3 s depending on UE capabilities
15.2.4 UE Rx-Tx time difference measurement period for dual positioning frequency layers in FR2 SA	Response Time between 11 s and 84 s depending on UE capabilities	300ms	Time + TPR: between 11.3 s and 84.3 s depending on UE capabilities
15.2.8 UE Rx-Tx time difference measurement reporting delay test case for single positioning frequency	Response Time between 2 s and 21 s depending on UE capabilities	300ms	Time + TPR: between 2.3 s and 21.3 s depending on UE capabilities

layer with reduced number of samples in FR2 SA			
15.2.9 UE Rx-Tx time difference measurement reporting delay test case for single positioning frequency layer without measurement gap in FR2 SA	Response Time Sub-test 1: between 3 s and 21 s depending on UE capabilities Sub-test 2: between 6 s and 83 s depending on UE capabilities	300ms	Sub-test 1: Time + TPR: between 3.3 s and 21.3 s depending on UE capabilities Sub-test 2: Time + TPR: between 6.3 s and 83.3 s depending on UE capabilities
15.2.10 UE Rx-Tx time difference measurement reporting delay test case for single positioning frequency layer with RxTx TEG in FR2 SA	Response Time between 11 s and 170 s depending on UE capabilities	300ms	Time + TPR: between 11.3 s and 170.3 s depending on UE capabilities
15.3.1 UE Rx-Tx time difference measurement accuracy for single positioning frequency layer in FR1 SA	Config 1 and Config 2: Sub-test 1: Cell Timing Difference = $3\mu\text{s} \pm 238 T_c$ Sub-test 2: Cell Timing Difference = $3\mu\text{s} \pm 86 T_c$ Config 3: Sub-test 1: Cell Timing Difference = $3\mu\text{s} \pm 137 T_c$ Sub-test 2: Cell Timing Difference = $3\mu\text{s} \pm 39 T_c$	32 Tc	Config 1 and Config 2: Sub-test 1: Cell Timing Difference = $3\mu\text{s} \pm 270 T_c$ Sub-test 2: Cell Timing Difference = $3\mu\text{s} \pm 118 T_c$ Config 3: Sub-test 1: Cell Timing Difference = $3\mu\text{s} \pm 169 T_c$ Sub-test 2: Cell Timing Difference = $3\mu\text{s} \pm 71 T_c$
15.3.2 UE Rx-Tx time difference measurement accuracy for single positioning frequency layer in FR2 SA	Sub-test 1: Cell Timing Difference = $3\mu\text{s} \pm 44 T_c$ Sub-test 2: Cell Timing Difference = $3\mu\text{s} \pm 24 T_c$	32 Tc	Sub-test 1: Cell Timing Difference = $3\mu\text{s} \pm 76 T_c$ Sub-test 2: Cell Timing Difference = $3\mu\text{s} \pm 56 T_c$
15.3.5 UE Rx-Tx time difference measurement accuracy for single positioning frequency layer with reduced number of samples in FR2 SA	Cell Timing Difference = $3\mu\text{s} \pm 33 T_c$	32 Tc	Time + TPR: $3\mu\text{s} \pm 65 T_c$
15.3.6 UE Rx-Tx time difference measurement accuracy for single positioning frequency layer with RxTx TEG in FR2 SA	Sub-test 1: Cell Timing Difference = $3\mu\text{s} \pm 56 T_c$ Sub-test 2: Cell Timing Difference = $3\mu\text{s} \pm 26 T_c$	32 Tc	Sub-test 1: Cell Timing Difference = $3\mu\text{s} \pm 88 T_c$ Sub-test 2: Cell Timing Difference = $3\mu\text{s} \pm 58 T_c$

Table C.4.7: Derivation of Test Requirements for PRS-RSRP Measurement tests

Test	Minimum Requirement in TS 38.133	Test Parameter Relaxation (TPR)	Test Requirement in TS 37.571-1
16.2.1 PRS-RSRP measurement period test case for single positioning frequency layer in FR1 SA	Response Time between 1 s and 660 s depending on UE capabilities	300 ms	Time + TPR: between 1.3 s and 660.3 s depending on UE capabilities
16.2.2 PRS-RSRP measurement period test case for dual positioning frequency layer in FR1 SA	Response Time between 2 s and 660 s depending on UE capabilities	300 ms	Time + TPR: between 2.3 s and 660.3 s depending on UE capabilities
16.2.3 PRS-RSRP measurement period test case for single positioning frequency layer in FR2 SA	Response Time between 6 s and 170 s depending on UE capabilities	300ms	Time + TPR: between 6.3 s and 170.3 s depending on UE capabilities
16.2.4 PRS-RSRP measurement period test case for dual positioning frequency layer in FR2 SA	Response Time between 11 s and 84 s depending on UE capabilities	300ms	Time + TPR: between 11.3 s and 84.3 s depending on UE capabilities
16.2.7 PRS-RSRP measurement reporting delay test case for single positioning frequency with	Response Time between 2 s and 21 s depending on UE capabilities	300ms	Time + TPR: between 2.3 s and 21.3 s depending on UE capabilities

reduced number of samples in FR2 SA			
16.2.8 PRS-RSRP measurement reporting delay test case for single positioning frequency layer without measurement gap in FR2 SA	Response Time Sub-test 1: between 2 s and 21 s depending on UE capabilities Sub-test 2: between 6 s and 83 s depending on UE capabilities	300ms	Sub-test 1: Time + TPR: between 2.3 s and 21.3 s depending on UE capabilities Sub-test 2: Time + TPR: between 6.3 s and 83.3 s depending on UE capabilities
16.3.1 PRS-RSRP measurement accuracy with PRS in FR1	Absolute power, log: -98 dBm/15Hz PRS Es/Noc Cell#1: -2 PRS Es/Noc Cell#2: -10 Reported PRS-RSRP Cell#1: ± 5 dB Reported PRS-RSRP Cell#2 Test 1: ± 10 dB Reported PRS-RSRP Cell#2 Test 2: ± 7.5 dB	0 0 0 Via mapping	Absolute power, log: -98 dBm/15Hz PRS Es/Noc Cell#1: -2 PRS Es/Noc Cell#2: -10 Cell#1 PRS-RSRP_51 to RSRP_62 Cell#2 Test 1 PRS-RSRP_38 to RSRP_59 Cell#2 Test 2 PRS-RSRP_41 to RSRP_56
16.3.2 PRS-RSRP measurement accuracy with PRS in FR2	Test 1 : Reported absolute PRP1 values: ± 8.5 Reported relative PRP1 values: ± 10 Reported absolute PRP2 values: ± 8.5 Reported relative PRP2 values: ± 10 Test 2 : Reported absolute PRP1 values: ± 6 Reported relative PRP1 values: ± 7.5 Reported absolute PRP2 values: ± 6 Reported relative PRP2 values: ± 7.5	Via mapping	Test 1 : Reported absolute PRP1 : PRS_RSRP_54 to PRS_RSRP_85 Reported relative PRP1 : DIFFRSRP_22 to DIFFRSRP_30 Reported absolute PRP2 : PRS_RSRP_46 to PRS_RSRP_77 Reported relative PRP2 : DIFFRSRP_20 to DIFFRSRP_30 Test 2 : Reported absolute PRP1 : PRS_RSRP_54 to PRS_RSRP_85 Reported relative PRP1 : DIFFRSRP_24 to DIFFRSRP_30 Reported absolute PRP2 : PRS_RSRP_46 to PRS_RSRP_77 Reported relative PRP2 : DIFFRSRP_23 to DIFFRSRP_30
16.3.4 PRS-RSRP measurement accuracy with PRS in FR2 with reduced sample number	Reported absolute PRP1 values: ± 5 Reported relative PRP1 values: ± 5 Reported absolute PRP2 values: ± 8.5 Reported relative PRP2 values: ± 10	Via mapping	Reported absolute PRP1 : PRS_RSRP_66 to PRS_RSRP_76 Reported relative PRP1 : DIFFRSRP_25 to DIFFRSRP_30 Reported absolute PRP2 : PRS_RSRP_61 to PRS_RSRP_73 Reported relative PRP2 : DIFFRSRP_23 to DIFFRSRP_30

Annex D (normative): Rules for statistical testing

D.1 Test Method

In this clause the terms GNSS and A-GNSS also include the cases where the only satellite system used is GPS unless otherwise stated.

Each test is performed in the following manner:

- a) Setup the required test conditions.
- b) Start each repetition after having applied the message 'RESET UE POSITIONING STORED INFORMATION'. This ensures that each result is independent from the previous one.
- c) Make the required measurement a repeated number of times. The results, measured, are simplified to:

good result, if the measured result is \leq limit.

bad result, if the measured result is $>$ limit

For the relevant A-GNSS test cases measure the 2D position and Time to First Fix (TTFF) a repeated number of times. Measure the 2D position and Time to First Fix (if applicable) repeated times. Start each repetition after having applied the message 'RESET UE POSITIONING STORED INFORMATION'. This ensures that each result is independent from the previous one. The results, measured, are simplified to:

good result, if the 2D position and TTFF are \leq limit.

bad result, if the 2D position or TTFF or both are $>$ limit

- d) Record the number of results (ns) and the number of bad results (ne)
- e) Stop the test at a pass or a fail event.
- f) Once the test is stopped, decide according to the pass fail decision rules (D.4.2)

D.2 Error Ratio (ER)

The Error Ratio (ER) is defined as the ratio of bad results (ne) to all results (ns).

(1-ER is the success ratio)

D.3 Test Design

A statistical test is characterised by:

Test-time, Selectivity and Confidence level

D.3.1 Confidence level

The outcome of a statistical test is a decision. This decision may be correct or in-correct. The Confidence Level CL describes the probability that the decision is a correct one. The complement is the wrong decision probability (risk) $D = 1 - CL$

D.3.2 Introduction: Supplier Risk versus Customer Risk

There are two targets of decision:

- a) A measurement on the pass-limit shows, that the DUT has the specified quality or is better with probability CL (CL e.g.95%) This shall lead to a “pass decision”

The pass-limit is on the good side of the specified DUT-quality. A more stringent CL (CL e.g.99%) shifts the pass-limit further into the good direction. Given that the quality of the DUTs is distributed, a greater CL passes less and better DUTs.

A measurement on the bad side of the pass-limit is simply “not pass” (undecided)

- aa) Complementary:

A measurement on the fail-limit shows, that the DUT is worse than the specified quality with probability CL.

The fail-limit is on the bad side of the specified DUT-quality. A more stringent CL shifts the fail-limit further into the bad direction. Given that the quality of the DUTs is distributed, a greater CL fails less and worse DUTs.

A measurement on the good side of the fail-limit is simply “not fail”.

- b) A DUT, known to have the specified quality, shall be measured and decided pass with probability CL. This leads to the pass limit.

For CL e.g. 95%, the pass limit is on the bad side of the specified DUT-quality. CL e.g.99% shifts the pass-limit further into the bad direction. Given that the DUT-quality is distributed, a greater CL passes more and worse DUTs.

- bb) A DUT, known to be an ($\epsilon \rightarrow 0$) beyond the specified quality, shall be measured and decided fail with probability CL.

For CL e.g.95%, the fail limit is on the good side of the specified DUT-quality.

Note the different sense for CL in (a), (aa) versus (b), (bb).

NOTE: For constant CL in all 4 bullets, (a) is equivalent to (bb) and (aa) is equivalent to (b).

D.3.3 Supplier Risk versus Customer Risk

The table below summarizes the different targets of decision.

Table D.3.3: Equivalent statements

	Equivalent statements, using different cause-to-effect-directions, and assuming CL = constant >0.5	
cause-to-effect-directions	Known measurement result → estimation of the DUT's quality	Known DUT's quality → estimation of the measurement's outcome
Supplier Risk	A measurement on the pass-limit shows, that the DUT has the specified quality or is better (a)	A DUT, known to have an ($\epsilon \rightarrow 0$) beyond the specified DUT-quality, shall be measured and decided fail (bb)
Customer Risk	A measurement on the fail-limit shall shows, that the DUT is worse than the specified quality (aa)	A DUT, known to have the specified quality, shall be measured and decided pass (b)

NOTE: The bold text shows the obvious interpretation of Supplier Risk and Customer Risk. The same statements can be based on other DUT-quality-definitions.

D.3.4 Introduction: Standard test versus early decision concept

In standard statistical tests, a certain number of results (ns) is predefined in advance of the test. After ns results the number of bad results (ne) is counted and the error ratio (ER) is calculated as ne/ns.

Applying statistical theory, a decision limit can be designed, against which the calculated ER is compared to derive the decision. Such a limit is one decision point and is characterised by:

- D: the wrong decision probability (a predefined parameter)
- ns: the number of results (a fixed predefined parameter)
- ne: the number of bad results (the limit based on just ns)

In the formula for the limit, D and ns are parameters and ne is the variable. In the standard test ns and D are constant. The property of such a test is: It discriminates between two states only, depending on the test design:

- pass (with CL) / undecided (undecided in the sense: finally undecided)
- fail (with CL) / undecided (undecided in the sense: finally undecided)
- pass (with CL) / fail (with CL) (however against two limits).

In contrast to the standard statistical tests, the early decision concept predefines a set of (ne, ns) co-ordinates, representing the limit-curve for decision. After each result a preliminary ER is calculated and compared against the limit-curve. After each result one may make the decision or not (undecided for later decision). The parameters and variables in the limit-curve for the early decision concept have a similar but not equal meaning:

- D: the wrong decision probability (a predefined parameter)
- ns: the number of results (a variable parameter)
- ne: the number of bad results (the limit. It varies together with ns)

To avoid a “final undecided” in the standard test, a second limit must be introduced and the single decision co-ordinate (ne, ns) needs a high ne, leading to a fixed (high) test time. In the early decision concept, having the same selectivity and the same confidence level an “undecided” does not need to be avoided, as it can be decided later. A perfect DUT will hit the decision coordinate (ne, ns) with ne=0. This test time is short.

D.3.5 Standard test versus early decision concept

For Supplier Risk:

The wrong decision probability D in the standard test is the probability, to decide a DUT in-correctly in the single decision point. In the early decision concept there is a probability of in-correct decisions d at each point of the limit-curve. The sum of all those wrong decision probabilities accumulate to D. Hence $d < D$

For Customer Risk:

The correct decision probability CL in the standard test is the probability, to decide a DUT correctly in the single decision point. In the early decision concept there is a probability of correct decisions cl at each point of the limit-curve. The sum of all those correct decision probabilities accumulate to CL. Hence $cl < CL$ or $d > D$

D.3.6 Selectivity

There is no statistical test which can discriminate between a limit-DUT-quality and a DUT-quality which is an ($\epsilon \rightarrow 0$) apart from the limit in finite time and confidence level $CL > 1/2$. Either the test discriminates against one limit with the results pass (with CL)/undecided or fail (with CL)/undecided, or the test ends in a result pass (with CL)/fail (with CL) but this requires a second limit.

For $CL > 0.5$, a (measurement-result = specified-DUT-quality), generates undecided in test “supplier risk against pass limit” (a in clause D.3.2) and also in the equivalent test against the fail limit (aa in clause D.3.2)

For $CL > 0.5$, a DUT, known to be on the limit, will be decided pass for the test “customer risk against pass limit” (b in clause D.3.2) and also in the equivalent test against fail limit (bb in clause D.3.2).

This overlap or undecided area is not a fault or a contradiction, however it can be avoided by introducing a Bad or a Good DUT quality according to:

- Bad DUT quality: specified DUT-quality * M ($M > 1$)
- Good DUT quality: specified DUT-quality * m ($m < 1$)

Using e.g. $M > 1$ and $CL = 95\%$ the test for different DUT qualities yield different pass probabilities:

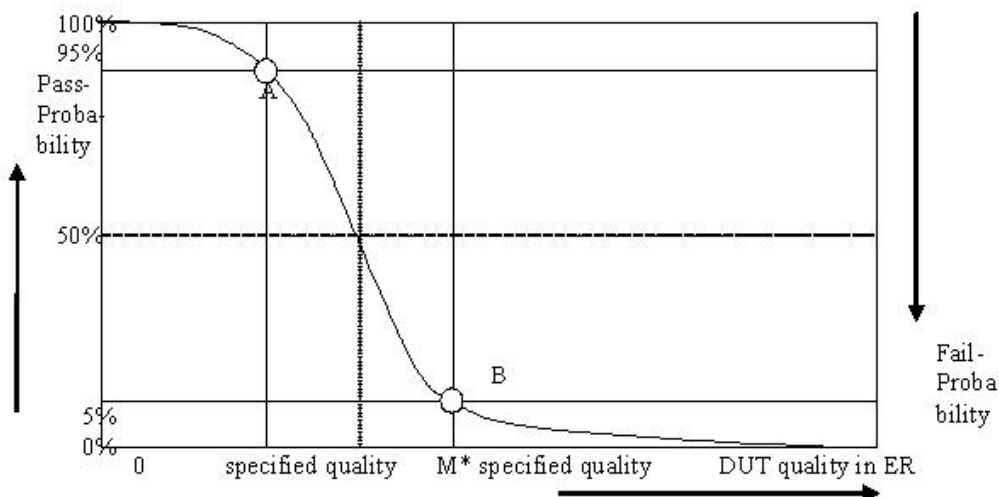

Figure D.3.6: Pass probability versus DUT quality

D.3.7 Design of the test

The test is defined according to the following design principles:

1. The early decision concept is applied.
2. A second limit is introduced: Bad DUT factor $M > 1$
3. To decide the test pass:

Supplier risk is applied based on the Bad DUT quality

To decide the test fail

Customer Risk is applied based on the specified DUT quality

The A-GNSS test cases are defined using the following parameters:

1. Specified DUT quality: $ER = 0.05$
2. Bad DUT quality: $M = 1.5$ (selectivity)
3. Confidence level $CL = 95\%$ (for specified DUT and Bad DUT-quality)

The ECID and OTDOA test cases are defined using the following parameters:

1. Specified DUT quality: $ER = 0.1$
2. Bad DUT quality: $M = 1.5$ (selectivity)
3. Confidence level $CL = 95\%$ (for specified DUT and Bad DUT-quality)

This has the following consequences:

- a) A measurement on the fail limit is connected with 2 equivalent statements:

A measurement on the fail-limit shows, that the DUT is worse than the specified DUT-quality	A DUT, known to have the specified quality, shall be measured and decided pass
---	--

A measurement on the pass limit is connected with the complementary statements:

A measurement on the pass limit shows, that the DUT is better than the Bad DUT-quality.	A DUT, known to have the Bad DUT quality, shall be measured and decided fail
---	--

The left column is used to decide the measurement.

The right column is used to verify the design of the test by simulation.

The simulation is based on the two fulcrums A and B only in Figure D.3.6. There is freedom to shape the remainder of the function.

b) Test time

1. The minimum and maximum test time is fixed.
2. The average test time is a function of the DUT’s quality.
3. The individual test time is not predictable (except ideal DUT).

c) The number of decision co-ordinates (ne, ns) in the early decision concept is responsible for the selectivity of the test and the maximum test time. Having fixed the number of decision co-ordinates there is still freedom to select the individual decision co-ordinates in many combinations, all leading to the same confidence level.

D.4 Pass fail decisions

D.4.1 Numerical definition of the pass fail limits for A-GNSS test cases

Table D.4.1: Pass/fail limits for A-GNSS test cases

ne	ns _p	ns _f	ne	ns _p	ns _f	ne	ns _p	ns _f	ne	ns _p	ns _f
0	77	NA	43	855	576	86	1525	1297	129	2173	2050
1	106	NA	44	871	592	87	1540	1314	130	2188	2067
2	131	NA	45	887	608	88	1556	1331	131	2203	2085
3	154	NA	46	903	625	89	1571	1349	132	2218	2103
4	176	NA	47	919	641	90	1586	1366	133	2233	2121
5	197	NA	48	935	657	91	1601	1383	134	2248	2139
6	218	42	49	951	674	92	1617	1401	135	2263	2156
7	238	52	50	967	690	93	1632	1418	136	2277	2174
8	257	64	51	982	706	94	1647	1435	137	2292	2192
9	277	75	52	998	723	95	1662	1453	138	2307	2210
10	295	87	53	1014	739	96	1677	1470	139	2322	2227
11	314	100	54	1030	756	97	1692	1487	140	2337	2245
12	333	112	55	1046	772	98	1708	1505	141	2352	2263
13	351	125	56	1061	789	99	1723	1522	142	2367	2281
14	369	139	57	1077	805	100	1738	1540	143	2381	2299
15	387	152	58	1093	822	101	1753	1557	144	2396	2317
16	405	166	59	1108	839	102	1768	1574	145	2411	2335
17	422	180	60	1124	855	103	1783	1592	146	2426	2352
18	440	194	61	1140	872	104	1798	1609	147	2441	2370
19	457	208	62	1155	889	105	1813	1627	148	2456	2388
20	474	222	63	1171	906	106	1828	1644	149	2470	2406
21	492	237	64	1186	922	107	1844	1662	150	2485	2424
22	509	251	65	1202	939	108	1859	1679	151	2500	2442
23	526	266	66	1217	956	109	1874	1697	152	2515	2460
24	543	281	67	1233	973	110	1889	1714	153	2530	2478
25	560	295	68	1248	990	111	1904	1732	154	2544	2496
26	577	310	69	1264	1007	112	1919	1750	155	2559	2513
27	593	325	70	1279	1024	113	1934	1767	156	2574	2531
28	610	341	71	1295	1040	114	1949	1785	157	2589	2549
29	627	356	72	1310	1057	115	1964	1802	158	2603	2567
30	643	371	73	1326	1074	116	1979	1820	159	2618	2585
31	660	387	74	1341	1091	117	1994	1838	160	2633	2603

32	676	402	75	1357	1108	118	2009	1855	161	2648	2621
33	693	418	76	1372	1126	119	2024	1873	162	2662	2639
34	709	433	77	1387	1143	120	2039	1890	163	2677	2657
35	725	449	78	1403	1160	121	2054	1908	164	2692	2675
36	742	465	79	1418	1177	122	2069	1926	165	2707	2693
37	758	480	80	1433	1194	123	2084	1943	166	2721	2711
38	774	496	81	1449	1211	124	2099	1961	167	2736	2729
39	790	512	82	1464	1228	125	2114	1979	168	2751	2747
40	807	528	83	1479	1245	126	2128	1997	169	2765	NA
41	823	544	84	1495	1263	127	2143	2014			
42	839	560	85	1510	1280	128	2158	2032			

NOTE: The first column is the number of bad results (ne)
 The second column is the number of results for the pass limit (ns_p)
 The third column is the number of results for the fail limit (ns_f)

D.4.2 Pass fail decision rules for A-GNSS test cases

Having observed 0 bad results, pass the test at ≥ 77 results, otherwise continue

Having observed 1 bad result, pass the test at ≥ 106 results, otherwise continue

Having observed 2 bad results, pass the test at ≥ 131 results, otherwise continue

etc. until

Having observed 6 bad results, pass the test at ≥ 218 results, fail the test at ≤ 42 results, otherwise continue

Having observed 7 bad results, pass the test at ≥ 238 results, fail the test at ≤ 52 results, otherwise continue

etc. until

Having observed 168 bad results, pass the test at ≥ 2751 results, fail the test at ≤ 2747 results, otherwise continue

Having observed 169 bad results, pass the test at ≥ 2765 results, otherwise fail

NOTE: an ideal DUT passes after 77 results. The maximum test time is 2765 results.

D.4.3 Numerical definition of the pass fail limits for ECID, OTDOA, MBS, WLAN and BLE test cases

Table D.4.3: Pass/fail limits for ECID, OTDOA, MBS, WLAN and BLE test cases

ne	ns _p	ns _f	ne	ns _p	ns _f	ne	ns _p	ns _f	ne	ns _p	ns _f
0	33	NA	43	408	283	86	737	644	129	1056	1021
1	46	NA	44	416	291	87	745	653	130	1064	1030
2	58	2	45	424	299	88	752	661	131	1071	1039
3	69	5	46	432	307	89	760	670	132	1078	1048
4	79	8	47	440	315	90	767	679	133	1086	1057
5	89	12	48	447	324	91	775	687	134	1093	1066
6	99	17	49	455	332	92	782	696	135	1100	1074
7	109	22	50	463	340	93	790	705	136	1108	1083
8	118	27	51	471	348	94	797	713	137	1115	1092
9	127	33	52	478	356	95	804	722	138	1122	1101
10	136	39	53	486	365	96	812	731	139	1130	1110
11	145	45	54	494	373	97	819	739	140	1137	1119
12	154	51	55	502	381	98	827	748	141	1144	1128
13	163	58	56	509	389	99	834	757	142	1152	1137
14	172	64	57	517	398	100	842	766	143	1159	1147
15	180	71	58	525	406	101	849	774	144	1166	1155
16	189	78	59	532	414	102	857	783	145	1174	1164
17	197	85	60	540	423	103	864	792	146	1181	1173
18	206	92	61	548	431	104	871	801	147	NA	1182

19	214	99	62	555	440	105	879	809	148		
20	223	106	63	563	448	106	886	818	149		
21	231	113	64	571	456	107	894	827	150		
22	239	120	65	578	465	108	901	836	151		
23	248	128	66	586	473	109	909	844	152		
24	256	135	67	594	482	110	916	853	153		
25	264	142	68	601	490	111	923	862	154		
26	272	150	69	609	499	112	931	871	155		
27	281	157	70	616	507	113	938	880	156		
28	289	165	71	624	516	114	946	888	157		
29	297	173	72	632	524	115	953	897	158		
30	305	180	73	639	533	116	960	906	159		
31	313	188	74	647	541	117	968	915	160		
32	321	196	75	654	550	118	975	924	161		
33	329	204	76	662	558	119	983	933	162		
34	337	211	77	669	567	120	990	941	163		
35	345	219	78	677	575	121	997	950	164		
36	353	227	79	684	584	122	1005	959	165		
37	361	235	80	692	592	123	1012	968	166		
38	369	243	81	700	601	124	1019	977	167		
39	377	251	82	707	610	125	1027	986	168		
40	385	259	83	715	618	126	1034	994	169		
41	393	267	84	722	627	127	1042	1003			
42	400	275	85	730	635	128	1049	1012			

The first column is the number of errors (n_e = number of exceeded delays or number of wrong reports)

The second column is the number of samples for the pass limit (n_{sp} , n_s =Number of samples= number of successes + number of exceedings or number of reports)

The third column is the number of samples for the fail limit (n_{sf})

D.4.4 Pass fail decision rules for ECID, OTDOA, MBS, WLAN and BLE test cases

Having observed 0 errors, pass the test at 33+ samples, otherwise continue

Having observed 1 error, pass the test at 46+ samples, otherwise continue

Having observed 2 errors, pass the test at 58+ samples, fail the test at 2 samples, otherwise continue

Having observed 146 errors, pass the test at 1181+ samples, fail the test at 1173- samples, otherwise continue

Having observed 147 errors, fail the test at 1182- samples,

Where $x+$ means: x or more, $x-$ means x or less

NOTE: an ideal DUT passes after 33 samples. The maximum test time is 1181 samples.

D.4.5 Background information to the pass fail limits

There is freedom to design the decision co-ordinates (n_e , n_s).

The binomial distribution and its inverse is used to design the pass and fail limits. Note that this method is not unique and that other methods exist.

$$\text{fail}(ne, d_f) := \frac{ne}{(ne + \text{qnbinom}(d_f, ne, ER))}$$

$$\text{pass}(ne, cl_p, M) := \frac{ne}{(ne + \text{qnbinom}(cl_p, ne, ER \cdot M))}$$

Where

fail(..) is the error ratio for the fail limit

pass(..) is the error ratio for the pass limit

ER is the specified error ratio e.g. 0.05

ne is the number of bad results. This is the variable in both equations

M is the Bad DUT factor M=1.5

d_f is the wrong decision probability of a single (ne, ns) co-ordinate for the fail limit.
It is found by simulation to be $d_f = 0.004$

cl_p is the confidence level of a single (ne, ns) co-ordinate for the pass limit.
It is found by simulation to be $cl_p = 0.9975$

qnbinom(..): The inverse cumulative function of the negative binomial distribution

The simulation works as follows:

A large population of limit DUTs with true ER = 0.05 is decided against the pass and fail limits.

cl_p and d_f are tuned such that CL (95%) of the population passes and D (5%) of the population fails.

A population of Bad DUTs with true ER = M*0.05 is decided against the same pass and fail limits.

cl_p and d_f are tuned such that CL (95%) of the population fails and D (5%) of the population passes.

This procedure and the relationship to the measurement is justified in clause D.3.7. The number of DUTs decreases during the simulation, as the decided DUTs leave the population. That number decreases with an approximately exponential characteristics. After 169 bad results all DUTs of the population are decided.

NOTE: The exponential decrease of the population is an optimal design goal for the decision co-ordinates (ne, ns), which can be achieved with other formulas or methods as well.

Annex E (normative): Conditions for ECID and OTDOA requirements

E.1 Conditions for E-CID UE Rx – Tx time difference Measurements

This clause defines the E-UTRAN RSRP applicable for ECID UE Rx-Tx time difference Measurements for a corresponding operating band

The conditions for E-UTRAN ECID UE Rx-Tx time difference measurements are as defined in Table E.1-1.

Table E.1-1: Conditions for ECID UE Rx-Tx time difference measurements

Parameter	E-UTRA operating band groups ^{Note 3}	Minimum RSRP ^{Note 1}
		dBm/15kHz
Conditions	FDD_A, TDD_A	-127
	FDD_B	-126.5
	FDD_C, TDD_C	-126
	FDD_D	-125.5
	FDD_E, TDD_E	-125
	FDD_F	-124.5 ^{Note 2}
	FDD_G	-124
	FDD_H	-123.5
	FDD_N	-120.5
NOTE 1: This condition level is increased by $\Delta > 0$, when applicable, as described in Sections B.4.2 and B.4.3 of TS 36.133 [23].		
NOTE 2: The condition is -125 dBm/15kHz when the carrier frequency of the assigned E-UTRA channel bandwidth is within 865-894 MHz.		
NOTE 3: E-UTRA operating band groups are as defined in clause 4.4.2.		

E.1.1 Conditions for E-CID UE Rx – Tx time difference by UE Category M1/M2

This clause defines the E-UTRAN RSRP applicable for ECID UE Rx-Tx time difference Measurements for a corresponding operating band for UE Category M1 and M2.

The conditions for CE mode A intra-frequency E-UTRAN FDD, HD-FDD and TDD measurements are defined in Table E.1.1-1.

Table B.2.14-1: E-UTRAN ECID UE Rx-Tx time difference measurements for FDD, HD-FDD and TDD for CE mode A

Parameter	E-UTRA operating band groups ^{Note 3}	Minimum RSRP ^{Note 1}
		dBm/15kHz
Conditions	FDD-M1_A, TDD-M1_A	-127
	FDD-M1_D	-125.5
	FDD-M1_E, TDD-M1_E	-125
	FDD-M1_F	-124.5 ^{Note 2}
	FDD-M1_G	-124
	FDD-M1_N	-120.5
NOTE 1: This condition level is increased by $\Delta > 0$, when applicable, as described in Sections B.4.2 and B.4.3 of TS 36.133 [23].		
NOTE 2: The condition is -125 dBm/15kHz when the carrier frequency of the assigned E-UTRA channel bandwidth is within 865-894 MHz.		
NOTE 3: E-UTRA operating band groups are as defined in clause 4.4.2.		

E.2 Conditions for OTDOA intra-frequency RSTD Measurements

This clause defines the E-UTRAN intra-frequency PRP_{1,2} applicable for OTDOA intra-frequency RSTD measurements for a corresponding operating band.

The conditions for E-UTRAN OTDOA intra-frequency RSTD measurements are as defined in Table E.2-1

Table E.2-1: Conditions for OTDOA intra-frequency RSTD measurements

Parameter	E-UTRA operating band group s ^{Note 3}	Minimum PRP _{1,2} Note 1
		dBm/15kHz
Conditions	FDD_A, TDD_A	-127
	FDD_B	-126.5
	FDD_C, TDD_C	-126
	FDD_D	-125.5
	FDD_E, TDD_E	-125
	FDD_F	-124.5 ^{Note 2}
	FDD_G	-124
	FDD_H	-123.5
	FDD_N	-120.5
NOTE 1: This condition level is increased by $\Delta > 0$, when applicable, as described in Sections B.4.2 and B.4.3 of TS 36.133[23].		
NOTE 2: The condition is -125 dBm/15kHz when the carrier frequency of the assigned E-UTRA channel bandwidth is within 865-894 MHz.		
NOTE 3: E-UTRA operating band groups are as defined in clause 4.4.2.		

E.2.1 Conditions for OTDOA intra-frequency RSTD Measurements by UE Category M1 and M2

This clause defines the E-UTRAN intra-frequency PRP_{1,2} applicable for a corresponding operating band.

The conditions for CE mode A intra-frequency E-UTRAN HD-FDD, FDD and TDD measurements are defined in Table E.2.1-1.

The conditions for CE mode B for intra-frequency E-UTRAN HD-FDD, FDD and TDD measurements are defined in Table E.2.1-2.

Table E.2.1-1: E-UTRAN intra-frequency measurements for HD-FDD, FDD and TDD for CE mode A

Parameter	E-UTRA operating band groups ^{Note 2}	Minimum PRP _{1,2}
		dBm/15kHz
Conditions	FDD_A, TDD_A	-127
	FDD_D	-125.5
	FDD_E, TDD_E	-125
	FDD_F	-124.5 ^{Note 1}
	FDD_G	-124
	FDD_N	-120.5
NOTE 1: The condition is -125 dBm/15kHz when the carrier frequency of the assigned E-UTRA channel bandwidth is within 865-894 MHz.		
NOTE 2: E-UTRA operating band groups are as defined in Section 4.4.2.		

Table E.2.1-2: E-UTRAN intra-frequency measurements for HD-FDD, FDD and TDD for CE mode B

Parameter	E-UTRA operating band groups ^{Note 2}	Minimum PRP _{1,2}
		dBm/15kHz
Conditions	FDD_A, TDD_A	-136
	FDD_D	-134.5
	FDD_E, TDD_E	-134
	FDD_F	-133.5 ^{Note 1}

	FDD_G	-133
	FDD_N	-129.5
NOTE 1: The condition is -125 dBm/15kHz when the carrier frequency of the assigned E-UTRA channel bandwidth is within 865-894 MHz.		
NOTE 2: E-UTRA operating band groups are as defined in Section 4.4.2.		

E.3 Conditions for OTDOA inter-frequency RSTD Measurements

This clause defines the E-UTRAN inter-frequency PRP_{1,2} applicable for OTDOA Inter-frequency RSTD measurements for a corresponding operating band.

The conditions for E-UTRAN OTDOA inter-frequency RSTD measurements are as defined in Table E.2-1.

E.3.1 Conditions for OTDOA inter-frequency RSTD Measurements by UE Category M1 and M2

This clause defines the E-UTRAN inter-frequency PRP_{1,2} applicable for a corresponding operating band.

The conditions for CE mode A inter-frequency E-UTRAN HD-FDD, FDD and TDD measurements are defined in Table E.3.1-1.

The conditions for CE mode B for inter-frequency E-UTRAN HD-FDD, FDD and TDD measurements are defined in Table E.3.1-2.

Table E.3.1-1: E-UTRAN inter-frequency measurements for HD-FDD, FDD and TDD for CE mode A

Parameter	E-UTRA operating band groups ^{Note 2}	Minimum PRP _{1,2} dBm/15kHz
Conditions	FDD_A, TDD_A	-127
	FDD_D	-125.5
	FDD_E, TDD_E	-125
	FDD_F	-124.5 ^{Note 1}
	FDD_G	-124
	FDD_N	-120.5
NOTE 1: The condition is -125 dBm/15kHz when the carrier frequency of the assigned E-UTRA channel bandwidth is within 865-894 MHz.		
NOTE 2: E-UTRA operating band groups are as defined in Section 4.4.2.		

Table E.3.1-2: E-UTRAN inter-frequency measurements for HD-FDD, FDD and TDD for CE mode B

Parameter	E-UTRA operating band groups ^{Note 2}	Minimum PRP _{1,2} dBm/15kHz
Conditions	FDD_A, TDD_A	-136
	FDD_D	-134.5
	FDD_E, TDD_E	-134
	FDD_F	-133.5 ^{Note 1}
	FDD_G	-133
	FDD_N	-129.5
NOTE 1: The condition is -125 dBm/15kHz when the carrier frequency of the assigned E-UTRA channel bandwidth is within 865-894 MHz.		
NOTE 2: E-UTRA operating band groups are as defined in Section 4.4.2.		

E.4 Conditions for UE Rx-Tx Time Difference Measurement under Time Domain Measurement Resource Restriction with CRS Assistance Information

This clause defines the E-UTRAN RSRP applicable for UE Rx-Tx Time Difference Measurement under Time Domain Measurement Resource Restriction with CRS Assistance Information for a corresponding operating band.

The conditions for UE Rx-Tx time difference measurements, when time domain measurement resource restriction pattern and CRS assistance information are provided, are as defined in Table E.1-1.

E.5 Conditions for NB-IOT OTDOA intra-frequency RSTD Measurements

This clause defines the NB-IoT intra-frequency PRP1,2 applicable for a corresponding operating band.

The conditions for intra-frequency RSTD measurements in normal coverage are defined in Table E.5-1.

The conditions for intra-frequency RSTD measurements in enhanced coverage are defined in Table E.5-2.

Table E.5-1: NB-IoT intra-frequency RSTD measurements for HD-FDD in normal coverage

Parameter	E-UTRA operating band groups ^{Note 1}	Minimum PRP1,2 ^{Note 1}
Conditions	NFDD_G	-129
NOTE 1: E-UTRA operating band groups for NB-IoT are as defined in Section 4.11.1		

Table E.5-2: NB-IoT intra-frequency RSTD measurements for HD-FDD in enhanced coverage

Parameter	E-UTRA operating band groups ^{Note 1}	Minimum PRP1,2 ^{Note 1}
Conditions	NFDD_G	-135
NOTE 1: E-UTRA operating band groups for NB-IoT are as defined in Section 4.11.1		

E.6 Conditions for NB-IOT OTDOA inter-frequency RSTD Measurements

This clause defines the NB-IoT intra-frequency PRP1,2 applicable for a corresponding operating band.

The conditions for inter-frequency RSTD measurements in normal coverage are defined in Table E.5-1.

The conditions for inter-frequency RSTD measurements in enhanced coverage are defined in Table E.5-2.

Annex F (normative): UTRAN Generic procedures

F.1 General

This normative annex specifies the set up and release procedure that shall be used for each UTRAN test case.

In this clause the terms GNSS and A-GNSS also include the cases where the only satellite system used is GPS unless otherwise stated.

F.2 UTRAN connection set up

F.2.1 Initial conditions

System Simulator:

- 1 cell, default parameters. The default system information, as specified in clause 6.1 of TS 34.108 [28], is broadcast with the exceptions of SIB15, SIB15.1, SIB15.2 and SIB15.3 which are not broadcast.

User Equipment:

- The UE shall be operated in Normal Propagation Conditions as specified in clause 5.2.1 of TS 34.108 [28].
- The UE is in state "MM idle" state with valid TMSI and CKSN.
- The UE is in state "PMM idle" with valid P-TMSI.

F.2.2 Procedures

CS Domain

Step	Direction		Message	Comments
	UE	SS		
1	<--		SYSTEM INFORMATION (BCCH)	Broadcast
2	<--		PAGING TYPE1 (PCCH)	Paging (CS domain, TMSI)
3	-->		RRC CONNECTION REQUEST (CCCH)	RRC
4	<--		RRC CONNECTION SETUP (CCCH)	RRC
5	-->		RRC CONNECTION SETUP COMPLETE (DCCH)	RRC
6	-->		PAGING RESPONSE	RR
7	<--		AUTHENTICATION REQUEST	MM
8	-->		AUTHENTICATION RESPONSE	MM
9	<--		SECURITY MODE COMMAND	RRC
10	-->		SECURITY MODE COMPLETE	RRC

PS Domain

Step	Direction		Message	Comments
	UE	SS		
1	<--		PAGING TYPE1 (PCCH)	Paging (PS domain, PMSI or IMSI)
2	-->		RRC CONNECTION REQUEST (CCCH)	RRC
3	<--		RRC CONNECTION SETUP (CCCH)	RRC
4	-->		RRC CONNECTION SETUP COMPLETE (DCCH)	RRC (Transport Channel: DCH or FACH)
5	-->		SERVICE REQUEST	GMM
6	<--		AUTHENTICATION REQUEST	GMM
7	-->		AUTHENTICATION RESPONSE	GMM
8	<--		SECURITY MODE COMMAND	RRC

9	-->	SECURITY MODE COMPLETE	RRC
---	-----	------------------------	-----

F.2.3 Specific message contents

The default message contents specified in clause 9.1 of TS 34.108 [28] will be used for the Moving Scenario and Periodic Update test. For all Minimum Performance TTFB Tests the default message contents specified in clause 9.1 of TS 34.108 [28] will be used with the following exception.

Contents of PAGING TYPE1:

Information Element	Value/remark
Paging Cause	Terminating High Priority Signalling

Contents of RRC CONNECTION SETUP:

For A-GNSS performance testing in CELL_DCH state: The RRC Connection Setup is defined in clause 9.1.1 of TS 34.108 [28] "Contents of RRC CONNECTION SETUP message: UM (Transition to CELL_DCH)".

For A-GNSS performance testing in CELL_FACH state: The RRC Connection Setup is defined in clause 9.1.1 of TS 34.108 [28] "Contents of RRC CONNECTION SETUP message: UM (Transition to CELL_FACH)".

Contents of RRC CONNECTION SETUP COMPLETE:

Information Element	Value/remark
UE radio access capability - UE positioning capability	Defines the A-GNSS mode the UE supports (UE-based, UE-assisted, or both). UE shall be tested for all modes it supports.

F.3 UTRAN connection release

F.3.1 Procedure

Table F.3.1: UTRAN connection release procedure

Step	Direction		Message	Comments
	UE	SS		
1	<--		RRC CONNECTION RELEASE	RRC
2		-->	RRC CONNECTION RELEASE COMPLETE	RRC

F.3.2 Specific message contents

The default message contents specified in clause 9.1 of TS 34.108 [28] are used.

Annex G (normative): Environmental conditions

G.1 General

This normative annex specifies the environmental requirements of the UE. Within these limits the requirements of the present documents shall be fulfilled.

G.2 Environmental requirements

The requirements in this clause apply to all types of UE(s).

G.2.1 Temperature

The UE shall fulfil all the requirements in the full temperature range of:

Table G.2.1.1

+15°C to +35°C	for normal conditions (with relative humidity up to 75 %)
----------------	---

G.2.2 Voltage

The UE shall fulfil all the requirements in the full voltage range, i.e. the voltage range between the extreme voltages.

The manufacturer shall declare the lower and higher extreme voltages and the approximate shutdown voltage. For the equipment that can be operated from one or more of the power sources listed below, the lower extreme voltage shall not be higher, and the higher extreme voltage shall not be lower than that specified below.

Table G.2.2.1

Power source	Normal conditions voltage
AC mains	nominal
Regulated lead acid battery	1.1 × nominal
Non regulated batteries:	
- Leclanché / lithium	Nominal
- Mercury/nickel and cadmium	Nominal

Annex H (informative): MBS Beacon parameters

H.1 General

This informative annex consolidates a description of the MBS beacon parameters that are specified in the MBS ICD [38]. They are provided here for reference.

H.2 Beacon parameters

This is a summary of the MBS beacon parameters to be used for MBS testing:

Beacon PN Code: 1023 chip length for TB1. Actual PN codes are listed in the MBS ICD [38]

MBS Beacon Configuration: TB1 (2.046 MHz, contains data) [38]

MBS Packet Type: Type 2 [38]

MBS Transmitter ID (TxID): Field used to signal a unique ID that identifies each transmitter within one major deployment area, such as within North America. Range: $[0, 2^{15}-1]$ [38]

Slot Index: This is the physical time slot within a MBS transmission period, in which a transmitter is transmitting. Each slot is 100 ms in duration and a MBS transmission period is 1 sec long. [38]

All other fields: Set to the min value (bit value equal to 0) for testing [38]

Annex I (normative): Conditions for NR PRS-based measurements

I.1 General

This clause defines the following conditions for NR PRS-based measurements and corresponding procedures performed based on PRS: PRP and PRS \hat{E} s/lot, applicable for a corresponding operating band.

I.2 General

The conditions are defined in Table I.2-1 for FR1 NR cells.

The conditions are defined in Table I.2-2 for FR2 NR cells.

Editor's notes for Table I.2-1 and Table I.2-2:

- The Table is not complete, FFS for PRS-RSRP and UE Rx-Tx.

Table I.2-1: Conditions for NR PRS-based measurements in FR1

Parameter	NR operating band groups ^{Note 1}	Minimum PRP _{1,2}			PRS \hat{E} s/lot for RSTD measurement reference cell PRS resource
		dBm / SCS _{PRS}			dB
		SCS _{PRS} = 15 kHz	SCS _{PRS} = 30 kHz	SCS _{PRS} = 60 kHz	
Conditions	NR_FDD_FR1_A, NR_TDD_FR1_A, NR_SDL_FR1_A	-127	-124	-121	≥ -6 ≥ -13
	NR_FDD_FR1_B	-126.5	-123.5	-120.5	
	NR_TDD_FR1_C	-126	-123	-120	
	NR_FDD_FR1_D, NR_TDD_FR1_D	-125.5	-122.5	-119.5	
	NR_FDD_FR1_E, NR_TDD_FR1_E	-125	-122	-119	
	NR_FDD_FR1_F	-124.5	-121.5	-118.5	
	NR_FDD_FR1_G	-124	-121	-118	
	NR_FDD_FR1_H	-123.5	-120.5	-117.5	

NOTE 1: NR operating band groups are defined in TS 38.101-1 [54] clause 3.5.2.

Table I.2-2: Conditions for NR PRS-based measurements in FR2

Parameter	Angle of arrival	NR operating bands	Minimum PRP _{1,2} ^{Note 2, Note 3}				PRS \hat{E} s/lot for RSTD measurement reference cell PRS resource
			dBm / SCS _{PRS}				dB
			SCS _{PRS} = 120 kHz			SCS _{PRS} = 60 kHz	
			UE power class			UE power class	
			1	2	3	4	
Conditions	Rx Beam Peak	n257	- 128.3+Y ₁	-113.8	-112.1	- 127.8+Y ₄	(Value for SCS _{PRS} = 120 kHz) - 3dB ≥ -6 ≥ -13
		n258	- 128.3+Y ₁	-113.8	-112.1	- 127.8+Y ₄	
		n259			-108.5		

		n260	$\bar{-}$ 125.3+Y ₁		-109.5	$\bar{-}$ 125.8+Y ₄		
		n261	$\bar{-}$ 128.3+Y ₁	-113.8	-112.1	$\bar{-}$ 127.8+Y ₄		
	Spherical coverage Note 1	n257	$\bar{-}$ 120.3+Z ₁	-102.8	-101.2	$\bar{-}$ 118.8+Z ₄	(Value for SCS _{PRS} = 120 kHz) - 3dB	≥ -6 ≥ -13
		n258	$\bar{-}$ 120.3+Z ₁	-102.8	-101.2	$\bar{-}$ 118.8+Z ₄		
		n259			-95.7			
		n260	$\bar{-}$ 117.3+Z ₁		-96.9	$\bar{-}$ 113.8+Z ₄		
		n261	$\bar{-}$ 120.3+Z ₁	-102.8	-101.2	$\bar{-}$ 118.8+Z ₄		
<p>NOTE 1: Values based on EIS spherical coverage as defined in clause 7.3.4 of TS 38.101-2 [55]. Side condition applies for directions in which EIS spherical coverage requirement is met.</p> <p>NOTE 2: Values specified at the Reference point to give minimum PRS \bar{E}s/lot, with no applied noise.</p> <p>NOTE 3: For UEs that support multiple FR2 bands, Rx Beam Peak values are increased by $\Delta MB_{P,n}$ and spherical coverage values are increased by $\Delta MB_{S,n}$, the UE multi-band relaxation factor in dB specified in clause 6.2.1 of TS 38.101-2 [55].</p>								

Annex J (informative): Change history

Change history							
Date	TSG #	TSG Doc.	CR	Rev	Subject/Comment TS 36.571-1	Old	New
2010-08	RAN#48	R5-104316			Initial draft TS 36.571-1 created		0.0.0
2010-11	RAN#49	R5-106613			V1.0.0 created for presentation to RAN Plenary	0.0.0	1.0.0
2011-02	RAN#50	R5-110124			Various values and corrections added	1.0.0	1.1.0
2011-08	RAN#52	R5-113133			Text changes from R5-112139, R5-112386, R5-112837, R5-112838, R5-112839 added	1.1.0	1.2.0
2011-08	RAN#53				Text changes from R5-113135, R5-113150, R5-114066, R5-113587 added	1.2.0	-
2011-11	RAN#53	R5-115206			Initial draft TS 37.571-1 created from TS 36.571-1, TS 34.171 and TS 34.172	-	1.0.0
2011-11	RAN#53	R5-115207			V2.0.0 created for presentation to RAN Plenary with additions from R5-115246, R5-115247, R5-115248, R5-115809	1.0.0	2.0.0
2011-12	RAN#54	-	-	-	Moved to Rel-9 with editorial changes only	2.0.0	9.0.0
2012-03	RAN#55	R5-120087	0001	-	Modify OTDOA connection diagrams	9.0.0	9.1.0
2012-03	RAN#55	R5-120089	0002	-	OTDOA parameter corrections	9.0.0	9.1.0
2012-03	RAN#55	R5-120414	0003	-	Adding ECID test cases to Annexes in TS 37.571-1	9.0.0	9.1.0
2012-03	RAN#55	R5-120822	0004	-	Correct A-GNSS signalling	9.0.0	9.1.0
2012-03	RAN#55	R5-120823	0005	-	ECID procedure modifications	9.0.0	9.1.0
2012-03	RAN#55	R5-120893	0006	-	OTDOA procedure updates	9.0.0	9.1.0
2012-06	RAN#56	R5-121126	0007	-	Update to Figure 9.1.1.3-1	9.1.0	9.2.0
2012-06	RAN#56	R5-121127	0008	-	Clarification to notes in tests 9.1.3 & 9.1.4	9.1.0	9.2.0
2012-06	RAN#56	R5-121128	0009	-	Clarifications to frequencies and bandwidths to be used	9.1.0	9.2.0
2012-06	RAN#56	R5-121129	0010	-	Setting responseTime in ECID test cases	9.1.0	9.2.0
2012-06	RAN#56	R5-121130	0011	-	Modifications to signalling used in OTDOA test cases	9.1.0	9.2.0
2012-06	RAN#56	R5-121908	0012	-	Adding operating band 26 to TS 37.571-1	9.1.0	9.2.0
2012-06	RAN#56	-	-	-	Added missing contents from R5-121126, R5-121127, R5-121128	9.2.0	9.2.1
2012-06	RAN#56	-	-	-	Upgraded to v10.0.0 with no change.	9.2.1	10.0.0
2012-09	RAN#57	R5-123066	0013	-	Correction to RSTD Measurement Accuracy Tests 9.1.3 and 9.1.4	10.0.0	10.1.0
2012-09	RAN#57	R5-123913	0014	-	Addition of RRM Test Case 9.8.4 TDD inter-frequency RSTD Accuracy	10.0.0	10.1.0
2012-12	RAN#58	R5-125136	0015	-	Corrections to references	10.1.0	10.2.0
2012-12	RAN#58	R5-125188	0016	-	Correction to LPP Message Content for GNSS Moving Scenario Test	10.1.0	10.2.0
2012-12	RAN#58	R5-125806	0018	-	New test case 10.1 FDD RSTD Measurement Reporting Delay for Carrier Aggregation	10.1.0	10.2.0
2012-12	RAN#58	R5-125807	0019	-	New test case 10.2 TDD RSTD Measurement Reporting Delay for Carrier Aggregation	10.1.0	10.2.0
2012-12	RAN#58	R5-125808	0020	-	New test case 10.3 FDD RSTD Measurement Accuracy for Carrier Aggregation	10.1.0	10.2.0
2012-12	RAN#58	R5-125809	0021	-	New test case 10.4 TDD RSTD Measurement Accuracy for Carrier Aggregation	10.1.0	10.2.0
2012-12	RAN#58	R5-125831	0022	-	Adding bands 28 and 44 to TS 37.571-1	10.1.0	10.2.0
2012-12	RAN#58	R5-125847	0023	-	Corrections to procedures for RSTD tests	10.1.0	10.2.0
2012-12	RAN#58	R5-125848	0024	-	Correction of OCNG Patterns for UE Rx - Tx Time Difference Test Cases	10.1.0	10.2.0
2012-12	RAN#58	R5-125916	0025	-	Add editor's note for value of lprs for test case 9.1.4	10.1.0	10.2.0
2012-12	RAN#58	R5-124120	0026	-	New common text for test cases 10.1 - 10.4 for RSTD for Carrier Aggregation	10.1.0	10.2.0
2013-03	RAN#59	R5-130959	0027	-	LBS Perf: Corrections to TCs 8.1.1 and 8.1.2	10.2.0	10.3.0
2013-06	RAN#60	R5-131097	0028	-	Removal of Note 1 from OTDOA parameter tables	10.3.0	10.4.0
2013-06	RAN#60	R5-131176	0029	-	Clarification to RSTD Delay Test procedures	10.3.0	10.4.0
2013-06	RAN#60	R5-131943	0030	-	New Test Case for FDD-FDD inter-frequency RSTD Accuracy	10.3.0	10.4.0
2013-06	RAN#60	R5-131944	0031	-	New Test Case for FDD-FDD inter-frequency RSTD measurement reporting delay	10.3.0	10.4.0
2013-06	RAN#60	R5-131945	0032	-	OTDOA test case alignment with RAN 4	10.3.0	10.4.0
2013-06	RAN#60	R5-131946	0033	-	Corrections to ECID and OTDOA tests Note: same contents as R5-131945 was submitted by accident.	10.3.0	10.4.0
2013-06	RAN#60	R5-131947	0034	-	RSTD test parameter updates	10.3.0	10.4.0
2013-06	RAN#60	R5-131993	0035	-	Test Description for TDD inter-frequency accuracy test case	10.3.0	10.4.0
2013-06	RAN#60	R5-131994	0036	-	New test case for TDD inter-frequency RSTD reporting delay 9.2.2	10.3.0	10.4.0
2013-09	RAN#61	R5-133173	0037	-	Tidy up of Table 9.2.1.4.1-1	10.4.0	10.5.0
2013-09	RAN#61	R5-133174	0038	-	Corrections to ECID and OTDOA tests	10.4.0	10.5.0

Change history							
Date	TSG #	TSG Doc.	CR	Rev	Subject/Comment TS 36.571-1	Old	New
2013-09	RAN#61	R5-133375	0039	-	Uncertainties and Test Tolerances for RSTD test cases 9.1.1 and 9.1.2	10.4.0	10.5.0
2013-09	RAN#61	R5-133378	0040	-	Uncertainties and Test Tolerances for RSTD test cases 9.1.3 and 9.1.4	10.4.0	10.5.0
2013-09	RAN#61	R5-133848	0041	-	LBS Perf: Uncertainties and test tolerances for TCs 8.1.1 and 8.1.2	10.4.0	10.5.0
2013-09	RAN#61	R5-133885	0042	-	LBS Perf: Revision of test procedure for TC-s 8.1.1-2	10.4.0	10.5.0
2013-12	RAN#62	R5-134200	0043	-	Updates to ECID and RSTD tests following RAN 4 updates	10.5.0	10.6.0
2013-12	RAN#62	R5-134202	0044	-	Addition of Capability exchange in ECID and RSTD tests	10.5.0	10.6.0
2013-12	RAN#62	R5-134205	0045	-	Addition of Applicabilities for 9.2.1 - 9.2.5	10.5.0	10.6.0
2013-12	RAN#62	R5-134849	0046	-	Addition of missing acknowledgements in ECID tests	10.5.0	10.6.0
2013-12	RAN#62	R5-134850	0047	-	Corrections to references for OCNG and RMC	10.5.0	10.6.0
2013-12	RAN#62	R5-134899	0048	-	Introduction 8.1.3 E-UTRAN FDD UE Rx-Tx time difference (felCIC)	10.5.0	10.6.0
2013-12	RAN#62	R5-134970	0049	-	Introduction 8.1.4 E-UTRAN TDD UE Rx-Tx time difference (felCIC)	10.5.0	10.6.0
2013-12	RAN#62	R5-134979	0050	-	Addition of new tests 10.1a, 10.2a, 10.3a and 10.4a for 20MHz CA	10.5.0	10.6.0
2013-12	RAN#62	R5-134980	0051	-	LBS Perf: Corrections to RSTD reporting tests	10.5.0	10.6.0
2013-12	RAN#62	R5-135016	0052	-	Uncertainties and Test Tolerances for RSTD test cases 9.2.1 and 9.2.2	10.5.0	10.6.0
2013-12	RAN#62	R5-135018	0053	-	Uncertainties and Test Tolerances for RSTD test cases 9.2.4 and 9.2.5	10.5.0	10.6.0
2014-03	RAN#63	R5-140107	0054	-	Corrections to PRS_RA in RSTD tests	10.6.0	10.7.0
2014-03	RAN#63	R5-140278	0055	-	Addition of E-UTRA band groups	10.6.0	10.7.0
2014-03	RAN#63	R5-140308	0056	-	LBS RF: Aperiodic CQI configuration for 1.4 MHz bandwidth subtests	10.6.0	10.7.0
2014-03	RAN#63	R5-141033	0057	-	RSTD test case updates	10.6.0	10.7.0
2014-03	RAN#63	R5-140875	0058	-	Additions to TC 8.1.6 E-UTRAN TDD UE Rx-Tx time difference (felCIC)	10.7.0	11.0.0
2014-03	RAN#63	R5-141010	0059	-	Additions to TC 8.1.5 E-UTRAN FDD UE Rx-Tx time difference (felCIC)	10.7.0	11.0.0
2014-06	RAN#64	R5-142098	0060	-	Corrections for OCNG patterns defined in RSTD Tables	11.0.0	11.1.0
2014-06	RAN#64	R5-142211	0061	-	Additions to felCIC UE Rx-Tx test cases in Annex C	11.0.0	11.1.0
2014-06	RAN#64	R5-142302	0062	-	LBS RF: Aperiodic CQI configuration for 1.4 MHz bandwidth tests	11.0.0	11.1.0
2014-06	RAN#64	R5-143109	0063	-	Additions to TC 8.1.6 E-UTRAN TDD UE Rx-Tx time difference (felCIC)	11.0.0	11.1.0
2014-06	RAN#64	R5-143111	0064	-	Additions to FDD interruption requirements for SCell	11.0.0	11.1.0
2014-06	RAN#64	R5-143180	0065	-	Additions to TC 8.1.5 E-UTRAN FDD UE Rx-Tx time difference (felCIC)	11.0.0	11.1.0
2014-06	RAN#64	R5-143211	0066	-	LBS RF: Update of RSTD tests	11.0.0	11.1.0
2014-09	RAN#65	R5-144080	0068	-	Corrections to RSTD Measurement Reporting Delay for Carrier Aggregation tests	11.1.0	11.2.0
2014-09	RAN#65	R5-144125	0069	-	Corrections to Physical Cell Id (PCI) Configuration Conditions in UE Rx-Tx time difference felCIC	11.1.0	11.2.0
2014-09	RAN#65	R5-144193	0072	-	Cell-specific test parameters for E-UTRAN	11.1.0	11.2.0
2014-09	RAN#65	R5-144215	0081	-	Clarification to RSTD Reporting Delay tests	11.1.0	11.2.0
2014-09	RAN#65	R5-144409	0083	-	Update to initial conditions and measurement procedure in for UTRA A-GPS and A-GNSS tests	11.1.0	11.2.0
2014-09	RAN#65	R5-144553	0084	-	Removal of editors note in TC 9.1.4	11.1.0	11.2.0
2014-09	RAN#65	R5-144620	0085	-	Updates OTDOA Neighbour Cell Info List	11.1.0	11.2.0
2014-09	RAN#65	R5-144763	0086	-	Correction for RSTD Measurement Accuracy in CA requirements in RRM	11.1.0	11.2.0
2014-09	RAN#65	R5-144789	0070	-	Uncertainties and Test Tolerances for RSTD test cases 10.1, 10.1A, 10.2 and 10.2A	11.1.0	11.2.0
2014-09	RAN#65	R5-144790	0071	-	Uncertainties and Test Tolerances for RSTD test cases 10.3, 10.3A, 10.4 and 10.4A	11.1.0	11.2.0
2014-09	RAN#65	R5-144791	0082	-	Updates to Annex E of TS 37.571-1	11.1.0	11.2.0
2014-09	RAN#65	R5-144792	0087	-	RSTD tests RAN 4 alignment	11.1.0	11.2.0
2014-09	RAN#65	R5-144865	0088	-	Editor's note to PRS levels with fading	11.1.0	11.2.0
2014-09	RAN#65	R5-144870	0089	-	Corrections to Note 3 for RSTD CA tests	11.1.0	11.2.0
2014-09	RAN#65	R5-144914	0090	-	Corrections to TDD RSTD Measurement Reporting Delay for Carrier Aggregation	11.1.0	11.2.0
2014-09	RAN#65	R5-144915	0091	-	RSTD CA Measurement Accuracy connection diagrams	11.1.0	11.2.0
2014-09	RAN#65	R5-144203	0073	-	Addition of new TC 10.1B FDD RSTD Measurement Reporting Delay CA for 5+5MHz	11.2.0	12.0.0
2014-09	RAN#65	R5-144204	0074	-	Addition of new TC 10.1C FDD RSTD Measurement Reporting Delay CA for 10+5MHz	11.2.0	12.0.0

Change history							
Date	TSG #	TSG Doc.	CR	Rev	Subject/Comment TS 36.571-1	Old	New
2014-09	RAN#65	R5-144205	0075	-	Addition of new TC 10.2B TDD RSTD Measurement Reporting Delay CA for 5+5MHz	11.2.0	12.0.0
2014-09	RAN#65	R5-144206	0076	-	Addition of new TC 10.2C TDD RSTD Measurement Reporting Delay CA for 10+5MHz	11.2.0	12.0.0
2014-09	RAN#65	R5-144207	0077	-	Addition of new TC 10.3B FDD RSTD Measurement Accuracy CA for 5+5MHz	11.2.0	12.0.0
2014-09	RAN#65	R5-144208	0078	-	Addition of new TC 10.3C FDD RSTD Measurement Accuracy CA for 10+5MHz	11.2.0	12.0.0
2014-09	RAN#65	R5-144209	0079	-	Addition of new TC 10.4B TDD RSTD Measurement Accuracy CA for 5+5MHz	11.2.0	12.0.0
2014-09	RAN#65	R5-144210	0080	-	Addition of new TC 10.4C TDD RSTD Measurement Accuracy CA for 10+5MHz	11.2.0	12.0.0
2014-12	RAN#66	R5-145133	0092	-	Update Galileo ICD reference	12.0.0	12.1.0
2014-12	RAN#66	R5-145211	0093	-	lo value incorrectly calculated	12.0.0	12.1.0
2014-12	RAN#66	R5-145212	0094	-	Editorial Note clarification	12.0.0	12.1.0
2014-12	RAN#66	R5-145213	0095	-	Alignment of Es/Nos value	12.0.0	12.1.0
2014-12	RAN#66	R5-145214	0096	-	Duplicated lo values listed in RSTD tables	12.0.0	12.1.0
2014-12	RAN#66	R5-145215	0097	-	Correction to References in Specification	12.0.0	12.1.0
2014-12	RAN#66	R5-145254	0098	-	LBS Perf: Corrections to measurement gap configuration	12.0.0	12.1.0
2014-12	RAN#66	R5-145490	0099	-	Test Tolerances for TC 8.1.5 E-UTRAN FDD UE Rx-Tx time difference (feICIC)	12.0.0	12.1.0
2014-12	RAN#66	R5-145491	0100	-	Test Tolerances for TC 8.1.6 E-UTRAN TDD UE Rx-Tx time difference (feICIC)	12.0.0	12.1.0
2014-12	RAN#66	R5-145492	0101	-	Uncertainties and Test Tolerances to Annex C for feICIC UE Rx-Tx test cases	12.0.0	12.1.0
2014-12	RAN#66	R5-145502	0102	-	Correction to periodicity of ABS pattern in UE RX-TX time difference for feICIC	12.0.0	12.1.0
2014-12	RAN#66	R5-145503	0103	-	Introduction of BDS testing in Annex C of 37.571	12.0.0	12.1.0
2014-12	RAN#66	R5-145510	0104	-	Correction to Annex E notes and tables	12.0.0	12.1.0
2014-12	RAN#66	R5-145836	0105	-	Changes to RSTD tests to align with RAN 4	12.0.0	12.1.0
2014-12	RAN#66	R5-145843	0106	-	Introduction of feICIC applicability statement for UE Rx-TX Time Difference test cases	12.0.0	12.1.0
2014-12	RAN#66	R5-145864	0107	-	Introduction of content for BDS and UTRA TDD UE in section 1-3 of TS 37.571-1	12.0.0	12.1.0
2014-12	RAN#66	R5-145865	0108	-	Introduction of content for BDS in section 4 in TS 37.571-1	12.0.0	12.1.0
2014-12	RAN#66	R5-145870	0109	-	Corrections to measurement procedures for UTRA A-GPS and A-GNSS tests	12.0.0	12.1.0
2014-12	RAN#66	R5-145871	0110	-	Correction to UE Rx-Tx Time difference tests	12.0.0	12.1.0
2014-12	RAN#66	R5-145920	0111	-	Introduction of test cases for BDS and UTRA TDD UE in section 6 of TS 37.571-1	12.0.0	12.1.0
2014-12	RAN#66	R5-145930	0112	-	Introduction of test cases for BDS in section 7 of TS 37.571-1	12.0.0	12.1.0
2015-03	RAN#67	R5-150051	0113	-	Updates to RSTD values and terminology following changes in RAN 4	12.1.0	12.2.0
2015-03	RAN#67	R5-150074	0114	-	Remove incorrect note from CA RSTD accuracy tests	12.1.0	12.2.0
2015-03	RAN#67	R5-150082	0115	-	Uncertainties and Test Tolerances for RSTD test cases 10.1, 10.1A, 10.1B, 10.1C, 10.2, 10.2A, 10.2B, and 10.2C	12.1.0	12.2.0
2015-03	RAN#67	R5-150085	0116	-	Uncertainties and Test Tolerances for RSTD test cases 10.3B, 10.3C, 10.4B, and 10.4C	12.1.0	12.2.0
2015-03	RAN#67	R5-150107	0117	-	Corrections to table headings in CA RSTD tests	12.1.0	12.2.0
2015-03	RAN#67	R5-150378	0118	-	Very minor corrections to references for feICIC test cases, 8.1.5 and 8.1.6	12.1.0	12.2.0
2015-03	RAN#67	R5-150609	0119	-	Abbreviation Corrections for BDS in 37.571-1	12.1.0	12.2.0
2015-03	RAN#67	R5-150833	0120	-	Addition of BDS ICD reference	12.1.0	12.2.0
2015-03	RAN#67	R5-150834	0121	-	Corrections to BDS Test Requirements for Minimum Performance tests	12.1.0	12.2.0
2015-03	RAN#67	R5-150835	0122	-	The lo Unit Parameter is Incorrect	12.1.0	12.2.0
2015-03	RAN#67	R5-150836	0123	-	Inconsistent Text Referenced	12.1.0	12.2.0
2015-03	RAN#67	R5-150837	0124	-	Missing Abbreviations in Specification	12.1.0	12.2.0
2015-03	RAN#67	R5-150888	0125	-	New TC: TDD RSTD Measurement Accuracy for Carrier Aggregation for 20MHz+10MHz bandwidth	12.1.0	12.2.0
2015-03	RAN#67	R5-150911	0126	-	New TC: TDD RSTD Measurement Reporting Delay for Carrier Aggregation for 20MHz +10MHz Bandwidth	12.1.0	12.2.0
2015-06	RAN#68	R5-151070	0128	-	Delete "FFS" from ECID test conditions	12.2.0	12.3.0
2015-06	RAN#68	R5-151083	0129	-	Uncertainties and Test Tolerances for RSTD test case 10.2D	12.2.0	12.3.0
2015-06	RAN#68	R5-151085	0130	-	Uncertainties and Test Tolerances for RSTD test case 10.4D	12.2.0	12.3.0
2015-06	RAN#68	R5-151086	0131	-	RSTD accuracy changes for Rel-12	12.2.0	12.3.0
2015-06	RAN#68	R5-151088	0132	-	Formatting error in Parameter Sensitivity Coarse Tables	12.2.0	12.3.0
2015-06	RAN#68	R5-151089	0133	-	Incorrect Expected RSTD value in Table 9.2.5.4.1-1	12.2.0	12.3.0
2015-06	RAN#68	R5-151162	0135	-	Correction of the TPR of Absolute GNSS signal level for Dynamic Range	12.2.0	12.3.0

Change history							
Date	TSG #	TSG Doc.	CR	Rev	Subject/Comment TS 36.571-1	Old	New
2015-06	RAN#68	R5-151331	0136	-	Addition of band 32 to 37.571-1	12.2.0	12.3.0
2015-06	RAN#68	R5-151335	0137	-	Corrections to message contents for felCIC TCs in 37.571-1	12.2.0	12.3.0
2015-06	RAN#68	R5-151912	0134	1	LPP responseTime update and correction	12.2.0	12.3.0
2015-06	RAN#68	R5-151913	0138	1	Introduction of new test case 8.1.3 to 37.571-1	12.2.0	12.3.0
2015-06	RAN#68	R5-151914	0139	1	Introduction of new test case 8.1.4 to 37.571-1	12.2.0	12.3.0
2015-06	RAN#68	R5-152014	0127	1	Add TDD to A-GNSS testing	12.2.0	12.3.0
2015-09	RAN#69	R5-153253	0140	-	CA LBS: Clarification of PHICH configuration	12.3.0	12.4.0
2015-09	RAN#69	R5-153661	0144	-	Update of Galileo OS SIS ICD reference	12.3.0	12.4.0
2015-09	RAN#69	R5-153863	0143	1	Update of felCIC Test cases 8.1.5 and 8.1.6	12.3.0	12.4.0
2015-09	RAN#69	R5-153864	0141	1	Update of eICIC Test case 8.1.3	12.3.0	12.4.0
2015-09	RAN#69	R5-153865	0142	1	Update of eICIC Test case 8.1.4	12.3.0	12.4.0
2015-09	RAN#69	-	-	-	update of the "non-specific references" in section 2 according to the approved R5-153582 and an action point on ETSI MCC	12.3.0	12.4.0
2015-12	RAN#70	R5-155018	0145	-	Uncertainties and Test Tolerances for RSTD Test Cases 10.3A_1 and 10.4A_1	12.4.0	12.5.0
2015-12	RAN#70	R5-155035	0146	-	Incorrect Table Note referenced in LPP Request Table	12.4.0	12.5.0
2015-12	RAN#70	R5-155063	0149	-	Incorrect references in TDD test cases	12.4.0	12.5.0
2015-12	RAN#70	R5-155064	0150	-	Reference [2] has no explanation	12.4.0	12.5.0
2015-12	RAN#70	R5-155065	0151	-	Remove square brackets from RSTD tests	12.4.0	12.5.0
2015-12	RAN#70	R5-155066	0152	-	Incorrect Section number referenced	12.4.0	12.5.0
2015-12	RAN#70	R5-155081	0153	-	Editorial changes to correct Section and Table references	12.4.0	12.5.0
2015-12	RAN#70	R5-155875	0154	1	Two new 3 DL CA RSTD Measurement Reporting Delay test cases	12.4.0	12.5.0
2015-12	RAN#70	R5-156111	0155	1	Two new 3 DL CA RSTD Measurement Accuracy test cases	12.4.0	12.5.0
2016-03	RAN#71	R5-160041	0156	-	Correction to Cells in OTDOA 3DL RSTD Measurement	12.5.0	12.6.0
2016-03	RAN#71	R5-160900	0164	-	Add Cell values in RSTD Table for 3DL RSTD	12.5.0	12.6.0
2016-03	RAN#71	R5-160909	0157	1	Correction of Cell Time offset in RSTD CA	12.5.0	12.6.0
2016-03	RAN#71	R5-161016	0161	1	Add Cell values in OTDOA table for 3DL RSTD Measurement Reporting Delay	12.5.0	12.6.0
2016-03	RAN#71	R5-161053	0158	1	Correction to Trstd values in 3DL RSTD Measurement Accuracy test cases	12.5.0	12.6.0
2016-03	RAN#71	R5-161054	0160	1	Addition of antenna diagram Figure for 3DL CA test cases	12.5.0	12.6.0
2016-06	RAN#72	R5-162114	0165	-	Uncertainties and Test Tolerances for RSTD Test Cases 10.5 and 10.6	12.6.0	12.7.0
2016-06	RAN#72	R5-162116	0166	-	Uncertainties and Test Tolerances for RSTD Test Cases 10.7 and 10.8	12.6.0	12.7.0
2016-06	RAN#72	R5-163116	0167	1	Uncertainties and Test tolerances for TS 37.571-1 Test cases 8.1.3 and 8.1.4	12.6.0	12.7.0
2016-06	RAN#72	R5-162970	0168	1	Add missing LTE FDD TDD bands to E-UTRA Band Groups	12.7.0	13.0.0
2016-06	RAN#72	R5-162971	0169	1	Add missing LTE FDD band to Annex E	12.7.0	13.0.0
2016-09	RAN#73	R5-165350	0179	-	Incorrect FDD Band reference noted for Band 32	13.0.0	13.1.0
2016-09	RAN#73	R5-165360	0181	-	Correct editorial changes in Annex C of 37.571-1	13.0.0	13.1.0
2016-09	RAN#73	R5-166125	0173	1	Updates to the UE Rx – Tx Time Difference tests for Rel-12 onwards	13.0.0	13.1.0
2016-09	RAN#73	R5-166126	0178	1	Add missing references to GPS and Galileo and A-GPS and A-Galileo	13.0.0	13.1.0

Change history							
Date	TSG #	TSG Doc.	CR	Rev	Subject/Comment TS 36.571-1	Old	New
2016-09	RAN#73	R5-166127	0180	1	Add Derivation of Test Requirements for test cases 8.1.5 and 8.1.6	13.0.0	13.1.0
2016-09	RAN#73	R5-166168	0182	1	Addition of performance test specification for Indoor Positioning Enhancements (MBS)	13.0.0	13.1.0
2016-09	RAN#73	R5-166179	0171	1	Addition of editor's notes for TDD UE Rx-TX tests	13.0.0	13.1.0
2016-09	RAN#73	R5-166181	0174	1	Unification of Channel BW testing requirements for OTDOA 3 DL CA test cases	13.0.0	13.1.0
2016-09	RAN#73	R5-166283	0183	-	Change of Reference Channel for 1.4 MHz RSTD tests	13.0.0	13.1.0
2016-12	RAN#74	R5-168060	0185	-	Change references to Reference Channel for RSTD tests	13.1.0	13.2.0
2016-12	RAN#74	R5-168063	0186	-	Change of applicability of UE Rx-Tx tests for TDD	13.1.0	13.2.0
2016-12	RAN#74	R5-168147	0187	-	Corrections for errors in 37.571-1	13.1.0	13.2.0
2016-12	RAN#74	R5-169602	0184	1	Addition of test tolerances to the performance test specification for Indoor Positioning Enhancements (MBS)	13.1.0	13.2.0
2016-12	RAN#74	R5-169611	0190	1	Clarification of MBS beacon code phase delay	13.1.0	13.2.0
2016-12	RAN#74	R5-169663	0188	1	Editorial correction on OTDOA TC10.6	13.1.0	13.2.0
2016-12	RAN#74	R5-168396	0189	-	Band 70 addition to band groups in 37.571-1	13.2.0	14.0.0
2017-01	RAN#74	-	-	-	correction of floating point of R5-169602 in Table 11.4.5-3	14.0.0	14.0.1
2017-03	RAN#75	R5-171304	0195	-	Removal of square brackets in the performance test specification for Indoor Positioning Enhancements (MBS)	14.0.1	14.1.0
2017-03	RAN#75	R5-171902	0191	1	Update TS 37.571-1 with Addition of LTE Band 48	14.0.1	14.1.0
2017-03	RAN#75	R5-171904	0192	1	Clarification on DRX for Single Mode OTDOA Measurement Reporting Delay Test Cases	14.0.1	14.1.0
2017-03	RAN#75	R5-171905	0193	1	Clarification on DRX for 2CC OTDOA Measurement Reporting Delay Test Cases	14.0.1	14.1.0
2017-03	RAN#75	R5-171906	0194	1	Clarification on DRX for 3CC OTDOA Measurement Reporting Delay Test Cases	14.0.1	14.1.0
2017-06	RAN#76	R5-172179	0197	-	Add Minimum Performance Sub-tests for 3 GNSS	14.1.0	14.2.0
2017-06	RAN#76	R5-172623	0198	-	Introduction of periodical reporting capability for GNSS	14.1.0	14.2.0
2017-06	RAN#76	R5-173364	0200	1	Introduction of MBS Assistance Data Measurement Test Cases	14.1.0	14.2.0
2017-06	RAN#76	R5-173414	0201	1	Addition of ACKs in step 5 of test procedures	14.1.0	14.2.0
2017-09	RAN#77	R5-173569	0202	-	Correction of PRS Subframe Offset for TC 10.5 and 10.6	14.2.0	14.3.0
2017-09	RAN#77	R5-173570	0203	-	Correction of SRS-Bandwidth for ECID TC 8.1.3 and 8.1.4	14.2.0	14.3.0
2017-09	RAN#77	R5-173571	0204	-	Correction of SRS-Bandwidth for ECID TC 8.1.5 and 8.1.6	14.2.0	14.3.0
2017-09	RAN#77	R5-173572	0205	-	Correction of message contents for ECID (Editorial Change)	14.2.0	14.3.0
2017-09	RAN#77	R5-173576	0209	-	WLAN and BLE Annex D updates (Editorial Change)	14.2.0	14.3.0
2017-09	RAN#77	R5-173863	0214	-	Editorial change to clarify the MBS test cases applicability	14.2.0	14.3.0
2017-09	RAN#77	R5-174053	0215	-	Update Statement Concerning Test System Uncertainties for Operating Bands Above 3 GHz	14.2.0	14.3.0
2017-09	RAN#77	R5-175116	0206	1	New Abbreviations and References for WLAN and BLE (Editorial Change)	14.2.0	14.3.0
2017-09	RAN#77	R5-175117	0207	1	WLAN test conditions	14.2.0	14.3.0

Change history							
Date	TSG #	TSG Doc.	CR	Rev	Subject/Comment TS 36.571-1	Old	New
2017-09	RAN#77	R5-175118	0208	1	WLAN and BLE Connection Diagrams	14.2.0	14.3.0
2017-09	RAN#77	R5-175119	0212	1	BLE test conditions	14.2.0	14.3.0
2017-09	RAN#77	R5-175186	0210	1	New WLAN AP Identification in Nominal Accuracy Test	14.2.0	14.3.0
2017-09	RAN#77	R5-175187	0211	1	New WLAN AP Identification in Dynamic Range Test	14.2.0	14.3.0
2017-09	RAN#77	R5-175188	0213	1	New BLE Reporting Test	14.2.0	14.3.0
2017-12	RAN#78	R5-176110	0219	-	Add 4Rx support for OTDOA/ECID tests – Tests	14.3.0	14.4.0
2017-12	RAN#78	R5-176111	0220	-	Add 4Rx support for OTDOA/ECID tests – Connection Diagrams	14.3.0	14.4.0
2017-12	RAN#78	R5-177118	0222	1	Adapt LTE A-GNSS test cases for BL/CE devices	14.3.0	14.4.0
2017-12	RAN#78	R5-177411	0216	1	Complete WLAN and BLE test cases	14.3.0	14.4.0
2017-12	RAN#78	R5-177413	0217	1	Editorial - Alignment of 2CC 5MHz OTDOA Nprs with core spec	14.3.0	14.4.0
2017-12	RAN#78	R5-177414	0218	1	Add 4Rx support for OTDOA/ECID tests – Common Sections	14.3.0	14.4.0
2017-12	RAN#78	R5-177415	0221	1	Add release information for sub-tests of test case 7.5.	14.3.0	14.4.0
2017-12	RAN#78	R5-176791	0223	-	Band 72 addition to band groups in 37.571-1	14.4.0	15.0.0
2017-12	RAN#78	R5-176816	0224	-	Band 71 addition to band groups in 37.571-1	14.4.0	15.0.0
2018-03	RAN#79	R5-180295	0228	-	New OTDOA Cat1bis TC 9.1.3A and 9.1.4A	15.0.0	15.1.0
2018-03	RAN#79	R5-180296	0229	-	New OTDOA Cat1bis TC 9.2.4A and 9.2.5A	15.0.0	15.1.0
2018-03	RAN#79	R5-180297	0230	-	Annex C OTDOA Cat1bis tests	15.0.0	15.1.0
2018-03	RAN#79	R5-180298	0231	-	UE Category M1/M2 General Sections for OTDOA	15.0.0	15.1.0
2018-03	RAN#79	R5-180299	0232	-	New OTDOA Cat M1/M2 reporting delay normal mode tests	15.0.0	15.1.0
2018-03	RAN#79	R5-180300	0233	-	New OTDOA Cat M1/M2 reporting delay enhanced mode tests	15.0.0	15.1.0
2018-03	RAN#79	R5-180301	0234	-	New OTDOA Cat M1/M2 reporting accuracy normal mode tests	15.0.0	15.1.0
2018-03	RAN#79	R5-180303	0236	-	New OTDOA Cat M1/M2 inter-freq reporting delay normal mode tests	15.0.0	15.1.0
2018-03	RAN#79	R5-180304	0237	-	New OTDOA Cat M1/M2 inter-freq reporting delay enhanced mode tests	15.0.0	15.1.0
2018-03	RAN#79	R5-180307	0240	-	New ECID Cat M1/M2 tests	15.0.0	15.1.0
2018-03	RAN#79	R5-180308	0241	-	Annex C OTDOA and ECID Cat M1/M2	15.0.0	15.1.0
2018-03	RAN#79	R5-180311	0244	-	NB-IOT Annex E	15.0.0	15.1.0
2018-03	RAN#79	R5-180325	0245	-	Band 68 addition to band groups in 37.571-1	15.0.0	15.1.0
2018-03	RAN#79	R5-180352	0246	-	[Editorial] Correct normative reference for minimum conformance requirements	15.0.0	15.1.0
2018-03	RAN#79	R5-180583	0247	-	feMTC Annex E	15.0.0	15.1.0
2018-03	RAN#79	R5-180584	0248	-	4Rx support for OTDOA 2CC	15.0.0	15.1.0
2018-03	RAN#79	R5-180585	0249	-	4Rx support for OTDOA 3CC	15.0.0	15.1.0
2018-03	RAN#79	R5-181360	0250	2	WLAN core specification updates	15.0.0	15.1.0
2018-03	RAN#79	R5-181584	0235	1	New OTDOA Cat M1/M2 reporting accuracy enhanced mode tests	15.0.0	15.1.0

Change history							
Date	TSG #	TSG Doc.	CR	Rev	Subject/Comment TS 36.571-1	Old	New
2018-03	RAN#79	R5-181585	0238	1	New OTDOA Cat M1/M2 inter-freq reporting accuracy normal mode tests	15.0.0	15.1.0
2018-03	RAN#79	R5-181586	0239	1	New OTDOA Cat M1/M2 inter-freq reporting accuracy enhanced mode tests	15.0.0	15.1.0
2018-03	RAN#79	R5-181599	0226	1	New OTDOA Cat1bis TC 9.1.1A and 9.1.2A	15.0.0	15.1.0
2018-03	RAN#79	R5-181600	0227	1	New OTDOA Cat1bis TC 9.2.1A and 9.2.2A	15.0.0	15.1.0
2018-03	RAN#79	R5-181605	0242	1	NB-IOT General Sections	15.0.0	15.1.0
2018-03	RAN#79	R5-181606	0243	1	NB-IOT OTDOA Test Cases	15.0.0	15.1.0
2018-03	RAN#79	R5-181613	0251	1	Addition of the Band 74 information into TS 37.571-1	15.0.0	15.1.0
2018-06	RAN#80	R5-182218	0256	-	Common clauses updates for new NB-IOT OTDOA tests	15.1.0	15.2.0
2018-06	RAN#80	R5-182219	0257	-	Annex C updates for NB-IOT OTDOA	15.1.0	15.2.0
2018-06	RAN#80	R5-182279	0258	-	New ECID Cat1bis tests	15.1.0	15.2.0
2018-06	RAN#80	R5-182280	0259	-	New ECID Cat1bis tests - Annexes	15.1.0	15.2.0
2018-06	RAN#80	R5-182382	0261	-	Corrections to WLAN dynamic range test case	15.1.0	15.2.0
2018-06	RAN#80	R5-182384	0263	-	Corrections to maximum response time for WLAN test cases	15.1.0	15.2.0
2018-06	RAN#80	R5-183252	0252	1	Completion of OTDOA NB-IOT TC 9.5.1 and 9.5.2	15.1.0	15.2.0
2018-06	RAN#80	R5-183253	0253	1	Completion of OTDOA NB-IOT TC 9.6.1 and 9.6.2	15.1.0	15.2.0
2018-06	RAN#80	R5-183261	0264	1	Clarifications for RSSI reporting in WLAN and BLE test cases	15.1.0	15.2.0
2018-06	RAN#80	R5-183844	0254	1	New OTDOA NB-IOT TC 9.5.3	15.1.0	15.2.0
2018-06	RAN#80	R5-183845	0255	1	New OTDOA NB-IOT TC 9.6.3	15.1.0	15.2.0
2018-06	RAN#80	R5-183847	0260	1	Removing editor note from A-GNSS min perf test cases for Cat M1	15.1.0	15.2.0
2018-06	RAN#80	R5-183848	0262	1	Clarifications and additions to EUTRAN, WLAN and BLE test frequencies and bandwidths	15.1.0	15.2.0
2018-06	RAN#80	R5-183849	0265	1	Corrections to WLAN and BLE applicabilities	15.1.0	15.2.0
2018-09	RAN#81	R5-184041	0266	-	Clarifications and corrections to Bluetooth identification test	15.2.0	15.3.0
2018-09	RAN#81	R5-184189	0271	-	Band groups added to specification	15.2.0	15.3.0
2018-09	RAN#81	R5-185416	0268	1	Correction to nrs-CRS-PowerOffset-r13 for NB-IOT OTDOA tests	15.2.0	15.3.0
2018-09	RAN#81	R5-185417	0269	1	NB-IOT OTDOA reporting delay test cases not testable	15.2.0	15.3.0
2018-09	RAN#81	R5-185419	0270	1	Changes to eMTC OTDOA tests	15.2.0	15.3.0
2018-09	RAN#81	R5-185552	0267	1	Applicability of tests for types and Categories of UE	15.2.0	15.3.0
2018-12	RAN#82	R5-186489	0272	-	Resubmission of CR 0269	15.3.0	15.4.0
2018-12	RAN#82	R5-186615	0274	-	Clarification of the meaning of A-GPS	15.3.0	15.4.0
2018-12	RAN#82	R5-186616	0275	-	Addition of two missing triple-GNSS test cases	15.3.0	15.4.0
2018-12	RAN#82	R5-186617	0276	-	Updates to Table 4B.2-1	15.3.0	15.4.0
2018-12	RAN#82	R5-187983	0277	1	Editorial Changes for TS 37.571-1	15.3.0	15.4.0
2019-03	RAN#83	R5-191607	0281	-	Editorial Changes for TS 37.571-1	15.4.0	15.5.0

Change history							
Date	TSG #	TSG Doc.	CR	Rev	Subject/Comment TS 36.571-1	Old	New
2019-03	RAN#83	R5-192506	0278	1	Addition of general NR information	15.4.0	15.5.0
2019-03	RAN#83	R5-192646	0282	1	Editorial updates for RSTD NB-IOT tests	15.4.0	15.5.0
2019-03	RAN#83	R5-192851	0279	1	Corrections to RSTD reporting accuracy NB-IOT tests	15.4.0	15.5.0
2019-03	RAN#83	R5-192642	0280	1	Band 53 introduction in TS 37-571-1	15.5.0	16.0.0
2019-06	RAN#84	R5-194099	0283	-	Addition of A-GNSS tests for NR	16.0.0	16.1.0
2019-06	RAN#84	R5-194100	0284	-	Updates to Table 4B.2-1 for WLAN and BLE for NR	16.0.0	16.1.0
2019-06	RAN#84	R5-194260	0285	-	38.509 reference update	16.0.0	16.1.0
2019-06	RAN#84	R5-195009	0286	1	MBS Tests for NR	16.0.0	16.1.0
2019-06	RAN#84	R5-195450	0287	2	Alignment 9.5.3 and 9.6.3 with core spec	16.0.0	16.1.0
2019-09	RAN#85	R5-196604	0292	-	Alignment of 9.5.3 and 9.6.3 to core spec	16.1.0	16.2.0
2019-09	RAN#85	R5-197356	0294	-	Missing Bands in Tables	16.1.0	16.2.0
2019-09	RAN#85	R5-197357	0295	-	Corrections to GNSS Multi-path Tests	16.1.0	16.2.0
2019-09	RAN#85	R5-197358	0296	-	Correct RSTD Test Parameter Values	16.1.0	16.2.0
2019-09	RAN#85	R5-197381	0288	1	Corrections to RSTD tests for NB-IoT	16.1.0	16.2.0
2019-09	RAN#85	R5-197471	0289	1	Alignment of NR terminology	16.1.0	16.2.0
2019-09	RAN#85	R5-197473	0290	2	Add default conditions for FR2 positioning tests for performance	16.1.0	16.2.0
2019-09	RAN#85	R5-197477	0291	1	Clarify LPP transport for min perf positioning	16.1.0	16.2.0
2019-09	RAN#85	R5-197478	0293	1	Correct MBS Applicability Table and Editorial Updates	16.1.0	16.2.0
2019-12	RAN#86	R5-198063	0297	-	Addition of User Plane testing of A-GNSS to clause 7 for LTE	16.2.0	16.3.0
2019-12	RAN#86	R5-198817	0302	-	Editorial Correction to Multi-Path Scenario Test Parameter Table	16.2.0	16.3.0
2019-12	RAN#86	R5-198821	0303	-	Add Reference to RRM Specifications for Frequency Band Groups	16.2.0	16.3.0
2019-12	RAN#86	R5-198822	0304	-	Editorial Corrections for RSTD Test Cases	16.2.0	16.3.0
2019-12	RAN#86	R5-199090	0300	1	Update to min perf positioning tests	16.2.0	16.3.0
2020-03	RAN#87	R5-201013	0305	1	Editorial changes to TS 37.571-X titles to remove references to individual RATs	16.3.0	16.4.0
2020-06	RAN#88	R5-202803	0308	1	Update of the Note 1 in the Power level and satellite allocation tables for the Sensitivity Coarse time assistance requirements and tests for E-UTRA and NR.	16.4.0	16.5.0
2020-09	RAN#89	R5-204979	0309	1	Clarification on frequency band test conditions for A-GNSS	16.5.0	16.6.0
2020-12	RAN#90	R5-206774	0311	1	Addition of BDS B1C Signal test contents in TS 37.571-1	16.6.0	16.7.0
2020-12	RAN#90	R5-206783	0310	1	Definition of A-GNSS Sensitivity testing conditions for EN-DC	16.6.0	16.7.0
2021-03	RAN#91	R5-210757	0318	-	Update to Annex C for TDD NB-IOT RSTD measurement test cases	16.7.0	16.8.0
2021-03	RAN#91	R5-211796	0312	1	Addition of TDD NB-IOT RSTD measurement test case 9.7.1	16.7.0	16.8.0
2021-03	RAN#91	R5-211797	0313	1	Addition of TDD NB-IOT RSTD measurement test case 9.7.2	16.7.0	16.8.0
2021-03	RAN#91	R5-211798	0314	1	Addition of TDD NB-IOT RSTD measurement test case 9.7.3	16.7.0	16.8.0
2021-03	RAN#91	R5-211799	0315	1	Addition of TDD NB-IOT RSTD measurement test case 9.8.1	16.7.0	16.8.0

Change history							
Date	TSG #	TSG Doc.	CR	Rev	Subject/Comment TS 36.571-1	Old	New
2021-03	RAN#91	R5-211800	0316	1	Addition of TDD NB-IOT RSTD measurement test case 9.8.2	16.7.0	16.8.0
2021-03	RAN#91	R5-211801	0317	1	Addition of TDD NB-IOT RSTD measurement test case 9.8.3	16.7.0	16.8.0
2021-06	RAN#92	R5-212200	0320	-	Addition of Derivation of Test Requirements for NB-IOT and CA RSTD tests	16.8.0	16.9.0
2021-06	RAN#92	R5-212201	0321	-	Corrections to RSTD accuracy requirements values for UE Category M1 and M2 test cases	16.8.0	16.9.0
2021-06	RAN#92	R5-212202	0322	-	Corrections to RSTD accuracy requirements values for NB-IOT test cases	16.8.0	16.9.0
2021-06	RAN#92	R5-212234	0323	-	Addition of Derivation of Test Requirements for RSTD and Category M1 and M2 RSTD tests	16.8.0	16.9.0
2021-06	RAN#92	R5-212235	0324	-	Correction to Derivation of Test Requirements for UE Rx-Tx tests for Category M1 and M2 UEs	16.8.0	16.9.0
2021-06	RAN#92	R5-212237	0325	-	Updates to Correction to Derivation of Test Requirements for UE Rx-Tx tests for Category M1 and M2 UEs	16.8.0	16.9.0
2021-06	RAN#92	R5-212238	0326	-	Addition of Test Parameter Relaxations for UE Rx - Tx time difference cases	16.8.0	16.9.0
2021-06	RAN#92	R5-212242	0327	-	Clarifications to FDD NB-IoT RSTD test case applicabilities and other corrections	16.8.0	16.9.0
2021-06	RAN#92	R5-212244	0328	-	Corrections to RSTD test cases for Category M1 and M2 UEs	16.8.0	16.9.0
2021-06	RAN#92	R5-212247	0329	-	Updates to requirements for RSTD test cases for Category M1 and M2 UEs	16.8.0	16.9.0
2021-06	RAN#92	R5-212397	0330	-	Update Release 15 and onwards references for TS 36.355 to TS 37.355	16.8.0	16.9.0
2021-06	RAN#92	R5-213134	0332	-	Add OTDOA feMTC test case 9.3.14	16.8.0	16.9.0
2021-06	RAN#92	R5-213135	0333	-	Add OTDOA feMTC test case 9.3.15	16.8.0	16.9.0
2021-06	RAN#92	R5-213138	0336	-	Add OTDOA feMTC test case 9.3.18	16.8.0	16.9.0
2021-06	RAN#92	R5-213139	0337	-	OTDOA feMTC test cases - Annexes	16.8.0	16.9.0
2021-06	RAN#92	R5-213992	0331	1	Add OTDOA feMTC test case 9.3.13	16.8.0	16.9.0
2021-06	RAN#92	R5-213993	0334	1	Add OTDOA feMTC test case 9.3.16	16.8.0	16.9.0
2021-06	RAN#92	R5-213994	0335	1	Add OTDOA feMTC test case 9.3.17	16.8.0	16.9.0
2021-09	RAN#93	R5-215973	0338	1	Addition of Multi-RTT, DI-AoD and DL-TDOA positioning method test conditions	16.9.0	16.10.0
2021-09	RAN#93	R5-215974	0340	1	Addition of conditions for NR PRS-based measurements and connection diagrams	16.9.0	16.10.0
2021-12	RAN#94	R5-217133	0346	-	Update number of satellites for multi-GNSS for LTE tests	16.10.0	16.11.0
2021-12	RAN#94	R5-217134	0347	-	Update number of satellites for multi-GNSS for NR tests	16.10.0	16.11.0
2021-12	RAN#94	R5-217183	0355	-	EN-DC frequency bands for testing of A-GNSS sensitivity requirements	16.10.0	16.11.0
2021-12	RAN#94	R5-218283	0348	1	Add OTDOA feMTC test case 9.4.13	16.10.0	16.11.0
2021-12	RAN#94	R5-218284	0349	1	Add OTDOA feMTC test case 9.4.14	16.10.0	16.11.0
2021-12	RAN#94	R5-218285	0350	1	Add OTDOA feMTC test case 9.4.15	16.10.0	16.11.0
2021-12	RAN#94	R5-218286	0351	1	Add OTDOA feMTC test case 9.4.16	16.10.0	16.11.0

Change history							
Date	TSG #	TSG Doc.	CR	Re v	Subject/Comment TS 36.571-1	Old	New
2021-12	RAN#94	R5-218287	0352	1	Add OTDOA feMTC test case 9.4.17	16.10.0	16.11.0
2021-12	RAN#94	R5-218288	0353	1	Add OTDOA feMTC test case 9.4.18	16.10.0	16.11.0
2021-12	RAN#94	R5-218289	0354	1	OTDOA feMTC test cases - Annexes	16.10.0	16.11.0
2022-03	RAN#95	R5-220518	0356	-	Addition of test cases for UE Rx-Tx time difference measurement period	16.11.0	16.12.0
2022-03	RAN#95	R5-220534	0358	-	Update test applicability to allow for support of limited GNSS combinations for 5G tests	16.11.0	16.12.0
2022-03	RAN#95	R5-220535	0359	-	Update test applicability to allow for support of limited GNSS combinations	16.11.0	16.12.0
2022-03	RAN#95	R5-221201	0360	-	Update for the signal conditions for FR2 test cases	16.11.0	16.12.0
2022-03	RAN#95	R5-221202	0361	-	New NR RSTD test case 14.2.1	16.11.0	16.12.0
2022-03	RAN#95	R5-221203	0362	-	New NR RSTD test case 14.2.2	16.11.0	16.12.0
2022-03	RAN#95	R5-221204	0363	-	New NR RSTD test case 14.3.1	16.11.0	16.12.0
2022-03	RAN#95	R5-221205	0364	-	New NR RSTD test case 14.3.2	16.11.0	16.12.0
2022-03	RAN#95	R5-221206	0365	-	New NR PRS-RSRP test case 16.2.1	16.11.0	16.12.0
2022-03	RAN#95	R5-221207	0366	-	New NR PRS-RSRP test case 16.2.2	16.11.0	16.12.0
2022-03	RAN#95	R5-221208	0367	-	New NR PRS-RSRP test case 16.3.1	16.11.0	16.12.0
2022-03	RAN#95	R5-221887	0357	1	Addition of UE Rx-Tx time difference measurement test uncertainties and test parameter relaxations	16.11.0	16.12.0
2022-06	RAN#96	R5-222596	0368	-	Addition of measurement period requirements in Multi-RTT test conditions, DL-TDOA test conditions and DL-AoD test conditions	16.12.0	16.13.0
2022-06	RAN#96	R5-222597	0369	-	Correction of NR RSTD test cases 14.2.1, 14.2.2, 14.3.1 and 14.3.2	16.12.0	16.13.0
2022-06	RAN#96	R5-222598	0370	-	Addition of SRS configuration in UE Rx-Tx time difference measurement period test cases	16.12.0	16.13.0
2022-06	RAN#96	R5-222599	0371	-	Addition of new RSTD accuracy test case 14.2.3	16.12.0	16.13.0
2022-06	RAN#96	R5-222600	0372	-	Addition of new RSTD accuracy test case 14.2.4	16.12.0	16.13.0
2022-06	RAN#96	R5-222601	0373	-	Addition of new RSTD accuracy test case 14.3.3	16.12.0	16.13.0
2022-06	RAN#96	R5-222603	0375	-	Addition of new UE Rx-TX time difference accuracy test case 15.3.1	16.12.0	16.13.0
2022-06	RAN#96	R5-222604	0376	-	Addition of new UE Rx-TX time difference accuracy test case 15.3.2	16.12.0	16.13.0
2022-06	RAN#96	R5-223748	0374	1	Addition of new RSTD accuracy test case 14.3.4	16.12.0	16.13.0
2022-09	RAN#97	R5-223972	0379	-	Annexes for TC 14.2.1 and 14.3.1	16.13.0	16.14.0
2022-09	RAN#97	R5-224401	0381	-	Correction of UE Rx-Tx time difference accuracy test cases	16.13.0	16.14.0
2022-09	RAN#97	R5-224403	0383	-	Addition of new PRS RSRP measurement period test case 16.2.3	16.13.0	16.14.0
2022-09	RAN#97	R5-224404	0384	-	Addition of new PRS RSRP measurement period test case 16.2.4	16.13.0	16.14.0
2022-09	RAN#97	R5-224478	0386	-	Core spec alignment 9.6.3	16.13.0	16.14.0
2022-09	RAN#97	R5-225698	0380	1	Correction to UE Rx-TX time difference measurement period test cases 15.2.1 and 15.2.2	16.13.0	16.14.0
2022-09	RAN#97	R5-225740	0382	1	Correction of NR RSTD test cases	16.13.0	16.14.0
2022-09	RAN#97	R5-225741	0385	1	Addition of new PRS RSRP measurement accuracy test case 16.3.2	16.13.0	16.14.0
2022-09	RAN#97	R5-225877	0377	1	Complete TC 14.2.1 including TT analysis results	16.13.0	16.14.0
2022-09	RAN#97	R5-225878	0378	1	Complete TC 14.3.1 including TT analysis results	16.13.0	16.14.0

Change history							
Date	TSG #	TSG Doc.	CR	Rev	Subject/Comment TS 36.571-1	Old	New
2022-12	RAN#98	R5-225944	0388		Addition of NR PRS-based measurement requirements for Multi-RTT test cases	16.14.0	16.15.0
2022-12	RAN#98	R5-226460	0389		Addition of accuracy requirements for RSTD and PRS-RSRP	16.14.0	16.15.0
2022-12	RAN#98	R5-226489	0394		Update on Annexes for RSTD TT results	16.14.0	16.15.0
2022-12	RAN#98	R5-227843	0387	1	Correction to UE Rx-Tx time difference test cases 15.2.3, 15.2.4, 15.3.1 and 15.3.2	16.14.0	16.15.0
2022-12	RAN#98	R5-228005	0390	1	Complete TC 14.2.1 with TT analysis results	16.14.0	16.15.0
2022-12	RAN#98	R5-228006	0391	1	Complete TC 14.3.1 with TT analysis results	16.14.0	16.15.0
2022-12	RAN#98	R5-228007	0392	1	Update TC 14.2.2 with TT analysis results	16.14.0	16.15.0
2022-12	RAN#98	R5-228008	0393	1	Update TC 14.3.2 with TT analysis results	16.14.0	16.15.0
2023-03	RAN#99	R5-230337	0404	-	Addition of accuracy requirements for UE Rx-Tx time difference	16.15.0	16.16.0
2023-03	RAN#99	R5-230927	0405	-	Update TC 14.3.2 with TT analysis results	16.15.0	16.16.0
2023-03	RAN#99	R5-231749	0395	1	Correction to RSTD test case 14.2.3	16.15.0	16.16.0
2023-03	RAN#99	R5-231750	0396	1	Correction to RSTD test case 14.2.4	16.15.0	16.16.0
2023-03	RAN#99	R5-231751	0397	1	Correction to RSTD test case 14.3.3	16.15.0	16.16.0
2023-03	RAN#99	R5-231752	0398	1	Correction to RSTD test case 14.3.4	16.15.0	16.16.0
2023-03	RAN#99	R5-231753	0399	1	Correction to PRS-RSRP test case 16.2.3	16.15.0	16.16.0
2023-03	RAN#99	R5-231754	0400	1	Correction to PRS-RSRP test case 16.2.4	16.15.0	16.16.0
2023-03	RAN#99	R5-231755	0402	1	Addition of NR PRS-based measurement requirements for NR RSTD and PRS-RSRP test cases	16.15.0	16.16.0
2023-03	RAN#99	R5-231798	0406	1	Update minimum conformance requirements for dual PFL for TC 14.3.2	16.15.0	16.16.0
2023-03	RAN#99	R5-231799	0403	1	Introduction of BDS B2a and B3I signal test contents in TS 37.571-1	16.16.0	17.0.0
2023-06	RAN#100	R5-232079	0407	-	Correction to PRS-RSRP test cases 16.3.2	17.0.0	17.1.0
2023-06	RAN#100	R5-232080	0408	-	Addition of NR PRS-based measurement requirements for PRS-RSRP accuracy test case	17.0.0	17.1.0
2023-06	RAN#100	R5-232438	0416	-	Annex C updated for PRS-RSRP TT results	17.0.0	17.1.0
2023-06	RAN#100	R5-232710	0417	-	Completion 16.3.1 with TT analysis results	17.0.0	17.1.0
2023-06	RAN#100	R5-233651	0410	1	Completion 16.2.1 with TT analysis results	17.0.0	17.1.0
2023-06	RAN#100	R5-233652	0411	1	Completion 16.2.2 with TT analysis results	17.0.0	17.1.0
2023-06	RAN#100	R5-233680	0413	1	Corrections to A-GNSS minimum performance test scenarios	17.0.0	17.1.0
2023-06	RAN#100	R5-233681	0414	1	Corrections to A-GNSS minimum performance test scenarios chapter 13	17.0.0	17.1.0
2023-09	RAN#101	R5-234205	0418	-	Addition of new NR RSTD reporting delay test case 14.2.8	17.1.0	17.2.0
2023-09	RAN#101	R5-234206	0419	-	Addition of new NR RSTD reporting delay test case 14.2.9	17.1.0	17.2.0
2023-09	RAN#101	R5-234207	0420	-	Addition of new NR RSTD reporting delay test case 14.2.10	17.1.0	17.2.0
2023-09	RAN#101	R5-234208	0421	-	Addition of new NR RSTD measurement accuracy test case 14.3.7	17.1.0	17.2.0
2023-09	RAN#101	R5-234209	0422	-	Addition of new NR RSTD measurement accuracy test case 14.3.8	17.1.0	17.2.0
2023-09	RAN#101	R5-234210	0423	-	Addition of new NR UE Rx-Tx time difference reporting delay test case 15.2.8	17.1.0	17.2.0
2023-09	RAN#101	R5-234211	0424	-	Addition of new NR UE Rx-Tx time difference reporting delay test case 15.2.9	17.1.0	17.2.0
2023-09	RAN#101	R5-234212	0425	-	Addition of new NR UE Rx-Tx time difference reporting delay test case 15.2.10	17.1.0	17.2.0
2023-09	RAN#101	R5-234213	0426	-	Addition of new NR UE Rx-Tx time difference measurement accuracy test case 15.3.5	17.1.0	17.2.0
2023-09	RAN#101	R5-234214	0427	-	Addition of new NR UE Rx-Tx time difference measurement accuracy test case 15.3.6	17.1.0	17.2.0
2023-09	RAN#101	R5-235786	0428	1	Addition of missed TT analysis results for 16.3.1 in Annex C.4.7	17.1.0	17.2.0
2023-12	RAN#102	R5-236010	0430		Update TC 14.2.8 with TT analysis results	17.2.0	17.3.0
2023-12	RAN#102	R5-236011	0431		Update TC 14.2.9 with TT analysis results	17.2.0	17.3.0
2023-12	RAN#102	R5-236012	0432		Update TC 14.2.10 with TT analysis results	17.2.0	17.3.0
2023-12	RAN#102	R5-236014	0434		Update TC 14.3.8 with TT analysis results	17.2.0	17.3.0
2023-12	RAN#102	R5-236015	0435		Update TC 15.3.5 with TT analysis results	17.2.0	17.3.0
2023-12	RAN#102	R5-236017	0437		Addition of NR PRS-based measurement requirements in annex C to include TT analysis results	17.2.0	17.3.0
2023-12	RAN#102	R5-236111	0438		Addition of new NR PRS-RSRP reporting delay test case 16.2.7	17.2.0	17.3.0
2023-12	RAN#102	R5-236112	0439		Addition of new NR PRS-RSRP reporting delay test case 16.2.8	17.2.0	17.3.0
2023-12	RAN#102	R5-236113	0440		Addition of new NR PRS-RSRP accuracy test case 16.3.4	17.2.0	17.3.0
2023-12	RAN#102	R5-236114	0441		Addition of new NR PRS-RSRPP reporting delay test case 17.2.1	17.2.0	17.3.0
2023-12	RAN#102	R5-236115	0442		Addition of new NR PRS-RSRPP reporting delay test case 17.2.2	17.2.0	17.3.0
2023-12	RAN#102	R5-236116	0443		Addition of new NR PRS-RSRPP reporting delay test case 17.2.3	17.2.0	17.3.0
2023-12	RAN#102	R5-236117	0444		Addition of new NR PRS-RSRPP reporting delay test case 17.2.4	17.2.0	17.3.0

Change history							
Date	TSG #	TSG Doc.	CR	Rev	Subject/Comment TS 36.571-1	Old	New
2023-12	RAN#102	R5-236118	0445		Addition of new NR PRS-RSRPP reporting delay test case 17.2.5	17.2.0	17.3.0
2023-12	RAN#102	R5-236119	0446		Addition of new NR PRS-RSRPP reporting delay test case 17.2.6	17.2.0	17.3.0
2023-12	RAN#102	R5-236259	0447		Update positioning test condition to include Rel-17 NR performance requirements	17.2.0	17.3.0
2023-12	RAN#102	R5-237794	0433	1	Update TC 14.3.7 with TT analysis results	17.2.0	17.3.0
2023-12	RAN#102	R5-237795	0436	1	Update TC 15.3.6 with TT analysis results	17.2.0	17.3.0
2023-12	RAN#102	R5-237794, R5-237795	-	-	implementation of missing R5-237794, R5-237795	17.3.0	17.3.1
2024-03	RAN#103	R5-240103	0450	-	Update TC 15.2.10 with TT analysis results	17.3.1	17.4.0
2024-03	RAN#103	R5-240104	0451	-	Update TC 16.2.7 with TT analysis results	17.3.1	17.4.0
2024-03	RAN#103	R5-240105	0452	-	Update TC 16.2.8 with TT analysis results	17.3.1	17.4.0
2024-03	RAN#103	R5-240107	0454	-	Addition of NR PRS-based measurement requirements in annex C to include TT analysis results	17.3.1	17.4.0
2024-03	RAN#103	R5-240108	0455	-	Addition of new RRC_INACTIVE NR RSTD reporting delay test case 14.4.3	17.3.1	17.4.0
2024-03	RAN#103	R5-240109	0456	-	Addition of new NR RSTD reporting delay test case 14.4.4 in RRC_INACTIVE state	17.3.1	17.4.0
2024-03	RAN#103	R5-240110	0457	-	Addition of new NR RSTD accuracy test case 14.5.3 in RRC_INACTIVE state	17.3.1	17.4.0
2024-03	RAN#103	R5-240112	0459	-	Addition of new NR PRS-RSRP reporting delay test case 16.4.3 in RRC_INACTIVE state	17.3.1	17.4.0
2024-03	RAN#103	R5-240113	0460	-	Addition of new NR PRS-RSRP reporting delay test case 16.4.4 in RRC_INACTIVE state	17.3.1	17.4.0
2024-03	RAN#103	R5-240114	0461	-	Addition of new NR PRS-RSRP accuracy test case 16.5.3 in RRC_INACTIVE state	17.3.1	17.4.0
2024-03	RAN#103	R5-240115	0462	-	Addition of new NR PRS-RSRP accuracy test case 16.5.4 in RRC_INACTIVE state	17.3.1	17.4.0
2024-03	RAN#103	R5-240116	0463	-	Addition of new NR PRS-RSRPP measurement accuracy test case 17.3.1	17.3.1	17.4.0
2024-03	RAN#103	R5-240117	0464	-	Addition of new NR PRS-RSRPP measurement accuracy test case 17.3.2	17.3.1	17.4.0
2024-03	RAN#103	R5-240118	0465	-	Addition of new NR PRS-RSRPP measurement accuracy test case 17.3.3	17.3.1	17.4.0
2024-03	RAN#103	R5-240119	0466	-	Addition of new NR PRS-RSRPP measurement accuracy test case 17.3.4	17.3.1	17.4.0
2024-03	RAN#103	R5-240120	0467	-	Addition of measurement period requirements in RRC_INACTIVE state for NR positioning methods	17.3.1	17.4.0
2024-03	RAN#103	R5-241897	0448	1	Update TC 15.2.8 with TT analysis results	17.3.1	17.4.0
2024-03	RAN#103	R5-241898	0449	1	Update TC 15.2.9 with TT analysis results	17.3.1	17.4.0
2024-03	RAN#103	R5-241899	0453	1	Update TC 16.3.4 with TT analysis results	17.3.1	17.4.0
2024-03	RAN#103	R5-241911	0458	1	Addition of new NR RSTD accuracy test case 14.5.4 in RRC_INACTIVE state	17.3.1	17.4.0
2024-03	RAN#103	R5-241912	0468	1	Correction to PRS-RSRPP positioning test cases	17.3.1	17.4.0
2024-03	RAN#103	R5-241913	0469	1	Correction to PRS-RSRP positioning test cases	17.3.1	17.4.0
2024-03	RAN#103	R5-241914	0470	1	Correction to NR RSTD positioning test cases	17.3.1	17.4.0
2024-03	RAN#103	R5-241915	0471	1	Correction to NR UE Rx-Tx time difference positioning test cases	17.3.1	17.4.0
2024-06	RAN#104	R5-242201	0483	-	Update TC 15.2.2 with TT analysis results	17.4.0	17.5.0
2024-06	RAN#104	R5-242208	0490	-	Update TC 15.3.2 with TT analysis results	17.4.0	17.5.0
2024-06	RAN#104	R5-242209	0491	-	Update TC 15.3.5 with TT analysis results	17.4.0	17.5.0
2024-06	RAN#104	R5-242210	0492	-	Update TC 15.3.6 with TT analysis results	17.4.0	17.5.0
2024-06	RAN#104	R5-242211	0493	-	Update TC 16.2.3 with TT analysis results	17.4.0	17.5.0
2024-06	RAN#104	R5-242212	0494	-	Update TC 16.2.4 with TT analysis results	17.4.0	17.5.0
2024-06	RAN#104	R5-242213	0495	-	Update TC 16.2.7 with TT analysis results	17.4.0	17.5.0
2024-06	RAN#104	R5-242214	0496	-	Update TC 16.2.8 with TT analysis results	17.4.0	17.5.0
2024-06	RAN#104	R5-242215	0497	-	Update TC 16.3.2 with TT analysis results	17.4.0	17.5.0
2024-06	RAN#104	R5-242216	0498	-	Update TC 16.3.4 with TT analysis results	17.4.0	17.5.0
2024-06	RAN#104	R5-242471	0500	-	Addition of new UE Rx-Tx time difference reporting delay test case 15.4.1 in RRC_INACTIVE state	17.4.0	17.5.0
2024-06	RAN#104	R5-242472	0501	-	Addition of new UE Rx-Tx time difference reporting delay test case 15.4.2 in RRC_INACTIVE state	17.4.0	17.5.0
2024-06	RAN#104	R5-242473	0502	-	Addition of new UE Rx-Tx time difference reporting delay test case 15.4.3 in RRC_INACTIVE state	17.4.0	17.5.0
2024-06	RAN#104	R5-242474	0503	-	Addition of new UE Rx-Tx time difference reporting delay test case 15.4.4 in RRC_INACTIVE state	17.4.0	17.5.0
2024-06	RAN#104	R5-242475	0504	-	Addition of new NR PRS-RSRPP measurement period test case 17.4.1 in RRC_INACTIVE	17.4.0	17.5.0
2024-06	RAN#104	R5-242476	0505	-	Addition of new NR PRS-RSRPP measurement period test case 17.4.2 in RRC_INACTIVE	17.4.0	17.5.0

Change history							
Date	TSG #	TSG Doc.	CR	Rev	Subject/Comment TS 36.571-1	Old	New
2024-06	RAN#104	R5-242477	0506	-	Addition of new NR PRS-RSRPP measurement period test case 17.4.3 in RRC_INACTIVE	17.4.0	17.5.0
2024-06	RAN#104	R5-242478	0507	-	Addition of new NR PRS-RSRPP measurement period test case 17.4.4 in RRC_INACTIVE	17.4.0	17.5.0
2024-06	RAN#104	R5-242479	0508	-	Addition of new NR PRS-RSRPP measurement accuracy test case 17.5.1 in RRC_INACTIVE	17.4.0	17.5.0
2024-06	RAN#104	R5-242480	0509	-	Addition of new NR PRS-RSRPP measurement accuracy test case 17.5.2 in RRC_INACTIVE	17.4.0	17.5.0
2024-06	RAN#104	R5-242481	0510	-	Addition of new NR PRS-RSRPP measurement accuracy test case 17.5.3 in RRC_INACTIVE	17.4.0	17.5.0
2024-06	RAN#104	R5-242482	0511	-	Addition of new NR PRS-RSRPP measurement accuracy test case 17.5.4 in RRC_INACTIVE	17.4.0	17.5.0
2024-06	RAN#104	R5-243760	0475	1	Update TC 14.2.8 with TT analysis results	17.4.0	17.5.0
2024-06	RAN#104	R5-243761	0476	1	Update TC 14.2.9 with TT analysis results	17.4.0	17.5.0
2024-06	RAN#104	R5-243762	0477	1	Update TC 14.2.10 with TT analysis results	17.4.0	17.5.0
2024-06	RAN#104	R5-243763	0480	1	Update TC 14.3.7 with TT analysis results	17.4.0	17.5.0
2024-06	RAN#104	R5-243764	0481	1	Update TC 14.3.8 with TT analysis results	17.4.0	17.5.0
2024-06	RAN#104	R5-243765	0486	1	Update TC 15.2.8 with TT analysis results	17.4.0	17.5.0
2024-06	RAN#104	R5-243766	0487	1	Update TC 15.2.9 with TT analysis results	17.4.0	17.5.0
2024-06	RAN#104	R5-243767	0488	1	Update TC 15.2.10 with TT analysis results	17.4.0	17.5.0
2024-06	RAN#104	R5-243768	0499	1	Update NR PRS-based measurement requirements in annex based on the updated TT analysis results	17.4.0	17.5.0
2024-06	RAN#104	R5-243784	0473	1	Update TC 14.2.3 with TT analysis results	17.4.0	17.5.0
2024-06	RAN#104	R5-243785	0474	1	Update TC 14.2.4 with TT analysis results	17.4.0	17.5.0
2024-06	RAN#104	R5-243786	0478	1	Update TC 14.3.3 with TT analysis results	17.4.0	17.5.0
2024-06	RAN#104	R5-243787	0479	1	Update TC 14.3.4 with TT analysis results	17.4.0	17.5.0
2024-06	RAN#104	R5-243788	0482	1	Update TC 15.2.1 with TT analysis results	17.4.0	17.5.0
2024-06	RAN#104	R5-243789	0484	1	Update TC 15.2.3 with TT analysis results	17.4.0	17.5.0
2024-06	RAN#104	R5-243790	0485	1	Update TC 15.2.4 with TT analysis results	17.4.0	17.5.0
2024-06	RAN#104	R5-243791	0489	1	Update TC 15.3.1 with TT analysis results	17.4.0	17.5.0
2024-06	RAN#104	R5-243803	0472	1	Addition of Test Case 14.2.6	17.4.0	17.5.0
2024-06	RAN#104	R5-243804	0512	1	Addition of Test Case: UE Rx-Tx time difference measurement accuracy with reduced number of samples in FR2 SA	17.4.0	17.5.0
2024-06	RAN#104	R5-243805	0513	1	Addition of UE Rx-Tx time difference measurements in RRC_INACTIVE test case	17.4.0	17.5.0
2024-06	RAN#104	R5-243857	0514	1	Addition of Test Case 14.2.5	17.4.0	17.5.0
2024-06	RAN#104	R5-243858	0515	1	Addition of Test Case 14.2.7	17.4.0	17.5.0
2024-06	RAN#104	R5-243859	0516	1	Addition of Test Case 14.3.5	17.4.0	17.5.0
2024-06	RAN#104	R5-243860	0517	1	Addition of Test Case 14.3.6	17.4.0	17.5.0
2024-06	RAN#104	R5-243861	0518	1	Addition of Test Case 14.4.1	17.4.0	17.5.0
2024-06	RAN#104	R5-243862	0519	1	Addition of Test Case 14.4.2	17.4.0	17.5.0
2024-06	RAN#104	R5-243863	0520	1	Addition of Test Case 14.5.1	17.4.0	17.5.0
2024-06	RAN#104	R5-243864	0521	1	Addition of Test Case 14.5.2	17.4.0	17.5.0
2024-06	RAN#104	R5-243865	0522	1	Addition of Test Case 15.2.5	17.4.0	17.5.0
2024-06	RAN#104	R5-243866	0523	1	Addition of Test Case 15.2.6	17.4.0	17.5.0
2024-06	RAN#104	R5-243867	0524	1	Addition of Test Case 15.2.7	17.4.0	17.5.0
2024-06	RAN#104	R5-243868	0525	1	Addition of Test Case 15.3.3	17.4.0	17.5.0
2024-06	RAN#104	R5-243869	0526	1	Addition of Test Case 15.3.4	17.4.0	17.5.0
2024-06	RAN#104	R5-243870	0527	1	Addition of Test Case 16.2.5	17.4.0	17.5.0
2024-06	RAN#104	R5-243871	0528	1	Addition of Test Case 16.2.6	17.4.0	17.5.0
2024-06	RAN#104	R5-243872	0529	1	Addition of Test Case 16.3.3	17.4.0	17.5.0
2024-06	RAN#104	R5-243873	0530	1	Addition of Test Case 16.4.1	17.4.0	17.5.0
2024-06	RAN#104	R5-243874	0531	1	Addition of Test Case 16.4.2	17.4.0	17.5.0
2024-06	RAN#104	R5-243875	0532	1	Addition of Test Case 16.5.1	17.4.0	17.5.0
2024-06	RAN#104	R5-243876	0533	1	Addition of Test Case 16.5.2	17.4.0	17.5.0

History

Document history		
V17.0.0	May 2023	Publication
V17.1.0	July 2023	Publication
V17.2.0	October 2023	Publication
V17.3.1	February 2024	Publication
V17.4.0	June 2024	Publication
V17.5.0	August 2024	Publication