

# ETSI TS 138 101-1 V18.7.0 (2024-11)



**5G;  
NR;  
User Equipment (UE) radio transmission and reception;  
Part 1: Range 1 Standalone  
(3GPP TS 38.101-1 version 18.7.0 Release 18)**



---

**Reference**

RTS/TSGR-0438101-1vi70

---

**Keywords**

5G

**ETSI**

650 Route des Lucioles  
F-06921 Sophia Antipolis Cedex - FRANCE

Tel.: +33 4 92 94 42 00 Fax: +33 4 93 65 47 16

Siret N° 348 623 562 00017 - APE 7112B  
Association à but non lucratif enregistrée à la  
Sous-Préfecture de Grasse (06) N° w061004871

---

**Important notice**

The present document can be downloaded from the  
[ETSI Search & Browse Standards](#) application.

The present document may be made available in electronic versions and/or in print. The content of any electronic and/or print versions of the present document shall not be modified without the prior written authorization of ETSI. In case of any existing or perceived difference in contents between such versions and/or in print, the prevailing version of an ETSI deliverable is the one made publicly available in PDF format on [ETSI deliver](#) repository.

Users should be aware that the present document may be revised or have its status changed,  
this information is available in the [Milestones listing](#).

If you find errors in the present document, please send your comments to  
the relevant service listed under [Committee Support Staff](#).

If you find a security vulnerability in the present document, please report it through our  
[Coordinated Vulnerability Disclosure \(CVD\)](#) program.

---

**Notice of disclaimer & limitation of liability**

The information provided in the present deliverable is directed solely to professionals who have the appropriate degree of experience to understand and interpret its content in accordance with generally accepted engineering or other professional standard and applicable regulations.

No recommendation as to products and services or vendors is made or should be implied.

No representation or warranty is made that this deliverable is technically accurate or sufficient or conforms to any law and/or governmental rule and/or regulation and further, no representation or warranty is made of merchantability or fitness for any particular purpose or against infringement of intellectual property rights.

In no event shall ETSI be held liable for loss of profits or any other incidental or consequential damages.

Any software contained in this deliverable is provided "AS IS" with no warranties, express or implied, including but not limited to, the warranties of merchantability, fitness for a particular purpose and non-infringement of intellectual property rights and ETSI shall not be held liable in any event for any damages whatsoever (including, without limitation, damages for loss of profits, business interruption, loss of information, or any other pecuniary loss) arising out of or related to the use of or inability to use the software.

---

**Copyright Notification**

No part may be reproduced or utilized in any form or by any means, electronic or mechanical, including photocopying and microfilm except as authorized by written permission of ETSI.

The content of the PDF version shall not be modified without the written authorization of ETSI.

The copyright and the foregoing restriction extend to reproduction in all media.

© ETSI 2024.  
All rights reserved.

---

## Intellectual Property Rights

### Essential patents

IPRs essential or potentially essential to normative deliverables may have been declared to ETSI. The declarations pertaining to these essential IPRs, if any, are publicly available for **ETSI members and non-members**, and can be found in ETSI SR 000 314: "*Intellectual Property Rights (IPRs); Essential, or potentially Essential, IPRs notified to ETSI in respect of ETSI standards*", which is available from the ETSI Secretariat. Latest updates are available on the [ETSI IPR online database](#).

Pursuant to the ETSI Directives including the ETSI IPR Policy, no investigation regarding the essentiality of IPRs, including IPR searches, has been carried out by ETSI. No guarantee can be given as to the existence of other IPRs not referenced in ETSI SR 000 314 (or the updates on the ETSI Web server) which are, or may be, or may become, essential to the present document.

### Trademarks

The present document may include trademarks and/or tradenames which are asserted and/or registered by their owners. ETSI claims no ownership of these except for any which are indicated as being the property of ETSI, and conveys no right to use or reproduce any trademark and/or tradename. Mention of those trademarks in the present document does not constitute an endorsement by ETSI of products, services or organizations associated with those trademarks.

**DECT™**, **PLUGTESTS™**, **UMTS™** and the ETSI logo are trademarks of ETSI registered for the benefit of its Members. **3GPP™**, **LTE™** and **5G™** logo are trademarks of ETSI registered for the benefit of its Members and of the 3GPP Organizational Partners. **oneM2M™** logo is a trademark of ETSI registered for the benefit of its Members and of the oneM2M Partners. **GSM®** and the GSM logo are trademarks registered and owned by the GSM Association.

---

## Legal Notice

This Technical Specification (TS) has been produced by the ETSI 3rd Generation Partnership Project (3GPP).

The present document may refer to technical specifications or reports using their 3GPP identities. These shall be interpreted as being references to the corresponding ETSI deliverables.

The cross reference between 3GPP and ETSI identities can be found at [3GPP to ETSI numbering cross-referencing](#).

---

## Modal verbs terminology

In the present document "**shall**", "**shall not**", "**should**", "**should not**", "**may**", "**need not**", "**will**", "**will not**", "**can**" and "**cannot**" are to be interpreted as described in clause 3.2 of the [ETSI Drafting Rules](#) (Verbal forms for the expression of provisions).

"**must**" and "**must not**" are **NOT** allowed in ETSI deliverables except when used in direct citation.

# Contents

Intellectual Property Rights .....	2
Legal Notice .....	2
Modal verbs terminology.....	2
Foreword.....	24
1 Scope .....	26
2 References .....	26
3 Definitions, symbols and abbreviations .....	27
3.1 Definitions .....	27
3.2 Symbols.....	28
3.3 Abbreviations .....	31
4 General .....	32
4.1 Relationship between minimum requirements and test requirements .....	32
4.2 Applicability of minimum requirements .....	32
4.3 Specification suffix information.....	33
5 Operating bands and channel arrangement.....	34
5.1 General .....	34
5.2 Operating bands.....	34
5.2A Operating bands for CA .....	36
5.2A.0 General.....	36
5.2A.1 Intra-band CA .....	37
5.2A.2 Inter-band CA .....	38
5.2A.2.1 Inter-band CA (two bands).....	38
5.2A.2.2 Inter-band CA (three bands).....	42
5.2A.2.3 Inter-band CA (four bands).....	48
5.2A.2.4 Inter-band CA (five bands) .....	50
5.2A.2.5 Inter-band CA (six bands).....	51
5.2B Operating bands for DC .....	51
5.2C Operating band combination for SUL .....	51
5.2D Operating bands for UL MIMO .....	54
5.2E Operating band for V2X.....	54
5.2E.1 V2X operating bands .....	54
5.2E.1A Sidelink CA operating bands .....	55
5.2E.1F Operating bands for Sidelink Unlicensed .....	55
5.2E.2 V2X operating bands for concurrent operation.....	55
5.2E.2F Operating bands for SL-U concurrent operation.....	56
5.2J Operating band for ATG .....	56
5.2K Operating bands for Aerial UE.....	56
5.3 UE channel bandwidth .....	56
5.3.1 General.....	56
5.3.2 Maximum transmission bandwidth configuration .....	58
5.3.3 Minimum guardband and transmission bandwidth configuration.....	58
5.3.4 RB alignment.....	60
5.3.5 UE channel bandwidth per operating band.....	60
5.3.6 Asymmetric channel bandwidths .....	64
5.3A UE channel bandwidth for CA .....	65
5.3A.1 General.....	65
5.3A.2 Maximum transmission bandwidth configuration for CA .....	65
5.3A.3 Minimum guardband and transmission bandwidth configuration for CA .....	66
5.3A.4 Void .....	67
5.3A.5 UE channel bandwidth per operating band for CA.....	67
5.3E Channel bandwidth for V2X .....	68
5.3E.1 General.....	68
5.3E.1A Channel bandwidth for Sidelink CA.....	69

5.3E.1F	Channel bandwidth for Sidelink Unlicensed .....	69
5.3E.2	Channel bandwidth for V2X concurrent operation .....	70
5.3E.2F	Channel bandwidth for SL-U concurrent operation .....	71
5.3I	Channel bandwidth for RedCap .....	72
5.4	Channel arrangement .....	72
5.4.1	Channel spacing .....	72
5.4.1.1	Channel spacing for adjacent NR carriers .....	72
5.4.2	Channel raster .....	72
5.4.2.1	NR-ARFCN and channel raster .....	72
5.4.2.2	Channel raster to resource element mapping .....	73
5.4.2.3	Channel raster entries for each operating band .....	73
5.4.3	Synchronization raster .....	77
5.4.3.1	Synchronization raster and numbering .....	77
5.4.3.3	Synchronization raster entries for each operating band .....	78
5.4.4	TX–RX frequency separation .....	80
5.4A	Channel arrangement for CA .....	81
5.4A.1	Channel spacing for CA .....	81
5.4A.2	Channel raster for CA .....	82
5.4A.3	Synchronization raster for CA .....	82
5.4A.4	Tx-Rx frequency separation for CA .....	82
5.4B	Reserved .....	82
5.4C	Reserved .....	82
5.4D	Reserved .....	82
5.4E	Channel arrangement for V2X .....	82
5.4E.1	Channel spacing .....	82
5.4E.1A	Channel spacing for Sidelink CA .....	82
5.4E.1F	Channel spacing for Sidelink Unlicensed .....	82
5.4E.2	Channel raster .....	82
5.4E.2.1	NR-ARFCN and channel raster .....	82
5.4E.2.1A	Void .....	83
5.4E.2.1F	Void .....	83
5.4E.2.2	Channel raster to resource element mapping .....	83
5.4E.2.2A	Void .....	83
5.4E.2.2F	Void .....	83
5.4E.2.3	Channel raster entries for each operating band .....	83
5.4E.2.3A	Void .....	83
5.4E.2.3F	Void .....	83
5.4E.3	Synchronization raster for V2X .....	84
5.4E.3A	Synchronization raster for Sidelink CA .....	84
5.4E.3F	Synchronization raster for Sidelink Unlicensed .....	84
5.4I	Channel arrangement for RedCap .....	84
5.4I.1	Channel spacing for RedCap .....	84
5.4I.2	Channel raster for RedCap .....	84
5.4I.2.1	NR-ARFCN and channel raster .....	84
5.4I.2.2	Channel raster to resource element mapping .....	84
5.4I.2.3	Channel raster entries for each operating band .....	84
5.4I.3	Synchronization raster for RedCap .....	85
5.4I.4	Tx-Rx frequency separation for RedCap .....	85
5.5	Void .....	86
5.5A	Configurations for CA .....	86
5.5A.0	General .....	86
5.5A.1	Configurations for intra-band contiguous CA .....	87
5.5A.2	Configurations for intra-band non-contiguous CA .....	90
5.5A.3	Configurations for inter-band CA .....	95
5.5A.3.0	General .....	95
5.5A.3.1	Configurations for inter-band CA (two bands) .....	95
Table 5.5A.3.1-1a ~ Table 5.5A.3.1-1e	.....	95
Table 5.5A.3.1-1f ~ Table 5.5A.3.1-1j	.....	111
Table 5.5A.3.1-1k ~ Table 5.5A.3.1-1n	.....	129
5.5A.3.2	Configurations for inter-band CA (three bands) .....	143
Table 5.5A.3.2-1a	143	
Table 5.5A.3.2-1b	198	

Table 5.5A.3.2-1c	244	
5.5A.3.3	Configurations for inter-band CA (four bands)	264
Table 5.5A.3.3-1a	264	
Table 5.5A.3.3-1b	311	
5.5A.3.4	Configurations for inter-band CA (five bands)	351
5.5A.3.5	Configurations for inter-band CA (six bands)	373
5.5B	Configurations for DC	375
5.5C	Configurations for SUL	388
5.5D	Reserved	399
5.5E	Void	399
5.5E.1A	Configurations for Sidelink CA	399
5.5E.1A.1	Configurations for Sidelink intra-band contiguous CA	399
6	Transmitter characteristics	400
6.1	General	400
6.1A	General	400
6.1F	General	400
6.1G	(Reserved)	400
6.1H	(Reserved)	400
6.1I	(Reserved)	400
6.1J	General	400
6.1K	(Reserved)	401
6.1L	(Reserved)	401
6.2	Transmitter power	401
6.2.1	UE maximum output power	401
6.2.1I	Void	403
6.2.2	UE maximum output power reduction	403
6.2.3	UE additional maximum output power reduction	406
6.2.3.1	General	406
6.2.3.2	A-MPR for NS_04	410
6.2.3.3	A-MPR for NS_10	413
6.2.3.4	A-MPR for NS_05 and NS_05U	413
6.2.3.5	A-MPR for NS_40	417
6.2.3.6	A-MPR for NS_43 and NS_43U	417
6.2.3.7	A-MPR for NS_03 and NS_03U	420
6.2.3.8	A-MPR for NS_37	421
6.2.3.9	A-MPR for NS_38	421
6.2.3.10	A-MPR for NS_39	422
6.2.3.11	A-MPR for NS_41	422
6.2.3.12	A-MPR for NS_42	422
6.2.3.13	A-MPR for NS_18	423
6.2.3.14	A-MPR for NS_21	424
6.2.3.15	A-MPR for NS_24	425
6.2.3.16	A-MPR for NS_27	425
6.2.3.17	A-MPR for NS_46	427
6.2.3.18	A-MPR for NS_47	430
6.2.3.19	A-MPR for NS_50	431
6.2.3.20	A-MPR for NS_44	435
6.2.3.21	A-MPR for NS_12	435
6.2.3.22	A-MPR for NS_13	436
6.2.3.23	A-MPR for NS_14	436
6.2.3.24	A-MPR for NS_15	437
6.2.3.25	A-MPR for NS_45	438
6.2.3.26	A-MPR for NS_48	438
6.2.3.27	A-MPR for NS_49	440
6.2.3.28	A-MPR for NS_51	442
6.2.3.29	A-MPR for NS_07	443
6.2.3.30	A-MPR for NS_56	444
6.2.3.31	A-MPR for NS_35	445
6.2.3.32	A-MPR for NS_06	445
6.2.4	Configured transmitted power	446
6.2A	Transmitter power for CA	450

6.2A.1	UE maximum output power for CA.....	450
6.2A.1.1	UE maximum output power for Intra-band contiguous CA.....	450
6.2A.1.2	UE maximum output power for Intra-band non-contiguous CA.....	451
6.2A.1.3	UE maximum output power for Inter-band CA.....	452
6.2A.1.4	Void.....	457
6.2A.1.5	Void.....	457
6.2A.2	UE maximum output power reduction for CA.....	457
6.2A.2.1	UE maximum output power reduction for Intra-band contiguous CA.....	457
6.2A.2.2	UE maximum output power reduction for Intra-band non-contiguous CA.....	460
6.2A.2.2.0	General.....	460
6.2A.2.2.1	MPR to meet -30dBm/MHz.....	462
6.2A.2.2.1.1	PC3 with indicating dualPA-Architecture supported.....	462
6.2A.2.2.1.2	PC2 with indicating dualPA-Architecture supported.....	462
6.2A.2.2.1.3	PC3 without indicating dualPA-Architecture supported.....	462
6.2A.2.2.1.4	PC2 without indicating dualPA-Architecture supported.....	463
6.2A.2.2.2	MPR to meet -13dBm/MHz.....	463
6.2A.2.2.2.1	PC3 with indicating dualPA-Architecture supported.....	463
6.2A.2.2.2.2	PC2 with indicating dualPA-Architecture supported.....	464
6.2A.2.2.2.3	PC3 without indicating dualPA-Architecture supported.....	464
6.2A.2.2.2.4	PC2 without indicating dualPA-Architecture supported.....	464
6.2A.2.3	UE maximum output power reduction for Inter-band CA.....	465
6.2A.2.4	Void.....	465
6.2A.3	UE additional maximum output power reduction for CA.....	465
6.2A.3.1	UE additional maximum output power reduction for Intra-band CA.....	465
6.2A.3.1.1	UE additional maximum output power reduction for Intra-band contiguous CA.....	465
6.2A.3.1.1.1	A-MPR for CA_NS_04.....	466
6.2A.3.1.1.1.1	Contiguous allocations.....	466
6.2A.3.1.1.1.2	Non-contiguous allocations.....	467
6.2A.3.1.2	UE additional maximum output power reduction for Intra-band non-contiguous CA.....	473
6.2A.3.1.3	UE additional maximum output power reduction for Inter-band CA.....	476
6.2A.4	Configured output power for CA.....	478
6.2A.4.1	Configured transmitted power level.....	478
6.2A.4.1.1	Configured transmitted power for Intra-band contiguous CA.....	478
6.2A.4.1.2	Configured transmitted power for Intra-band non-contiguous CA.....	481
6.2A.4.1.3	Configured transmitted power for Inter-band CA.....	484
6.2A.4.1.4	Void.....	488
6.2A.4.2	$\Delta T_{IB,c}$ for CA.....	488
6.2A.4.2.1	Void.....	488
6.2A.4.2.2	Void.....	488
6.2A.4.2.3	$\Delta T_{IB,c}$ for Inter-band CA (two bands).....	488
6.2A.4.2.4	$\Delta T_{IB,c}$ for Inter-band CA (three bands).....	492
6.2A.4.2.5	$\Delta T_{IB,c}$ for Inter-band CA (four bands).....	498
6.2A.4.2.6	$\Delta T_{IB,c}$ for Inter-band CA (five bands).....	501
6.2A.4.2.7	$\Delta T_{IB,c}$ for Inter-band CA (six bands).....	502
6.2B	Transmitter power for NR-DC.....	502
6.2B.0	General.....	502
6.2B.1	UE maximum output power for NR-DC.....	502
6.2B.2	UE maximum output power reduction for NR-DC.....	504
6.2B.3	UE additional maximum output power reduction for NR-DC.....	504
6.2B.4.1	Configured transmitted power level for NR-DC.....	504
6.2B.4.2	$\Delta T_{IB,c}$ for NR-DC.....	509
6.2C	Transmitter power for SUL.....	509
6.2C.1	Configured transmitted power for SUL.....	509
6.2C.2	$\Delta T_{IB,c}$ .....	509
6.2D	Transmitter power for UL MIMO.....	511
6.2D.1	UE maximum output power for UL MIMO.....	511
6.2D.2	UE maximum output power reduction for UL MIMO.....	513
6.2D.3	UE additional maximum output power reduction for UL MIMO.....	516
6.2D.4	Configured transmitted power for UL MIMO.....	516
6.2E	Transmitter power for V2X.....	517
6.2E.1	UE maximum output power for V2X.....	517
6.2E.1.1	General.....	517

6.2E.1.1A	Void.....	518
6.2E.1.2	UE maximum output power for V2X concurrent operation.....	518
6.2E.1A	UE maximum output power for Sidelink CA .....	519
6.2E.1F	UE maximum output power for Sidelink Unlicensed .....	519
6.2E.1F.1	General .....	519
6.2E.1.2F	Void.....	521
6.2E.1F.2	UE Maximum output power for SL-U concurrent operation .....	521
6.2E.2	UE maximum output power reduction for V2X .....	521
6.2E.2.1	General .....	521
6.2E.2.1A	MPR for sidelink CA .....	521
6.2E.2.2	MPR for Power class 2 and Power class 3 V2X UE .....	522
6.2E.2.3	MPR for Power class 2 and Power class 3 V2X concurrent operation .....	524
6.2E.2.4	MPR for Power class 1 UE in Band n14.....	527
6.2E.2F	UE maximum output power reduction for Sidelink Unlicensed .....	527
6.2E.2F.1	General .....	527
6.2E.2F.2	MPR for NR SL-U UE.....	528
6.2E.2F.3	MPR for SL-U concurrent operation.....	529
6.2E.3	UE additional maximum output power reduction for V2X.....	530
6.2E.3.1	General .....	530
6.2E.3.2	A-MPR for V2X UE by NS_33 .....	531
6.2E.3.3	A-MPR for Power class 3 V2X UE by NS_52 .....	534
6.2E.3.4	A-MPR for V2X concurrent operation.....	535
6.2E.3F	UE additional maximum output power reduction for Sidelink Unlicensed .....	535
6.2E.3F.1	General .....	535
6.2E.3F.2	A-MPR for NS_31 .....	536
6.2E.3F.3	Void.....	538
6.2E.3F.4	Void.....	538
6.2E.3F.5	Void.....	538
6.2E.3F.6	A-MPR for NS_61 .....	538
6.2E.3F.7	A-MPR for SL-U concurrent operation.....	539
6.2E.3F.8	A-MPR for NS_28 .....	539
6.2E.3F.9	A-MPR for NS_29 .....	540
6.2E.3F.10	A-MPR for NS_30 .....	541
6.2E.3F.11	A-MPR for NS_54 .....	543
6.2E.3F.12	A-MPR for NS_64 .....	544
6.2E.3F.13	A-MPR for NS_65 .....	545
6.2E.3F.14	A-MPR for NS_66 .....	546
6.2E.3F.15	A-MPR for NS_67 or NS_71 .....	547
6.2E.3F.16	A-MPR for NS_68 .....	548
6.2E.3F.17	A-MPR for NS_69 .....	549
6.2E.4	Configured transmitted power for V2X .....	550
6.2E.4.1	General .....	550
6.2E.4.2	Configured transmitted power for inter-band V2X concurrent operation .....	551
6.2E.4.3	Configured transmitted power for intra-band V2X concurrent operation .....	552
6.2E.4A	Configured transmitted power for Sidelink CA .....	554
6.2E.4F	Configured transmitted power for Sidelink Unlicensed.....	555
6.2E.4F.1	General .....	555
6.2E.4F.2	Configured transmitted power for inter-band concurrent operation.....	556
6.2F	Transmitter power for shared spectrum channel access .....	557
6.2F.1	UE maximum output power .....	557
6.2F.1A	UE maximum output power for CA.....	558
6.2F.1A.1	UE maximum output power for inter-band CA.....	558
6.2F.1A.2	UE maximum output power for intra-band contiguous CA .....	559
6.2F.1A.2.1	Additional requirements for transmit power density for intra-band contiguous CA for CA_NS_53 .....	559
6.2F.1A.2.2	Additional requirements for transmit power density for intra-band contiguous CA for CA_NS_54 .....	559
6.2F.1B	UE maximum output power for NR-DC.....	560
6.2F.1D	UE maximum output power for UL MIMO.....	560
6.2F.2	UE maximum output power reduction.....	560
6.2F.2A	UE maximum output power reduction for CA.....	562
6.2F.2A.1	UE maximum output power reduction for inter-band CA.....	562



6.2F.2A.2	UE maximum output power reduction for intra-band contiguous CA .....	563
6.2F.2D	UE maximum output power reduction for UL MIMO.....	565
6.2F.3	UE additional maximum output power reduction .....	565
6.2F.3.1	General .....	565
6.2F.3.2	A-MPR for NS_28 .....	566
6.2F.3.3	A-MPR for NS_29 .....	567
6.2F.3.4	A-MPR for NS_30 .....	567
6.2F.3.5	A-MPR for NS_31 .....	568
6.2F.3.6	A-MPR for NS_53 .....	569
6.2F.3.7	A-MPR for NS_54 .....	570
6.2F.3.8	A-MPR for NS_58 .....	571
6.2F.3.9	A-MPR for NS_59 .....	572
6.2F.3.10	A-MPR for NS_60 .....	573
6.2F.3.11	A-MPR for NS_61 .....	575
6.2F.3.12	A-MPR for NS_63 .....	575
6.2F.3.13	A-MPR for NS_64 .....	576
6.2F.3.14	A-MPR for NS_65 .....	576
6.2F.3.15	A-MPR for NS_66 .....	577
6.2F.3.16	A-MPR for "NS_67" or "NS_71" .....	577
6.2F.3.17	A-MPR for NS_68 .....	578
6.2F.3.18	A-MPR for NS_69 .....	578
6.2F.3A	UE additional maximum output power reduction for CA.....	579
6.2F.3A.1	UE additional maximum output power reduction for inter-band CA.....	579
6.2F.3A.2	UE additional maximum output power reduction for intra-band CA.....	579
6.2F.3A.2.1	UE additional maximum output power reduction for intra-band contiguous CA.....	579
6.2F.3A.2.2	A-MPR for CA_NS_53 .....	581
6.2F.3A.2.3	A-MPR for CA_NS_54 .....	583
6.2F.3D	UE additional maximum output power reduction for UL MIMO.....	583
6.2F.4	Configured transmitted power .....	583
6.2F.4D	Configured transmitted power UL MIMO.....	583
6.2G	Transmitter power for Tx Diversity.....	584
6.2G.1	UE maximum output power for Tx Diversity .....	584
6.2G.2	UE maximum output power reduction for Tx Diversity .....	584
6.2G.3	UE additional maximum output power reduction for Tx Diversity .....	584
6.2G.4	Configured transmitted power for Tx Diversity.....	585
6.2H	Transmitter power for CA with UL MIMO.....	585
6.2H.1	Transmitter power for intra-band UL contiguous CA with UL MIMO .....	585
6.2H.1.1	UE maximum output power for intra-band UL contiguous CA with UL MIMO .....	585
6.2H.1.2	UE maximum output power reduction for intra-band UL contiguous CA with UL MIMO .....	586
6.2H.1.3	UE additional maximum output power reduction for intra-band UL contiguous CA with UL MIMO .....	586
6.2H.1.4	Configured transmitted power for intra-band UL contiguous CA with UL MIMO.....	586
6.2H.2	Void .....	587
6.2H.3	Transmitter power for inter-band UL CA with UL MIMO .....	587
6.2H.3.1	UE maximum output power for inter-band UL CA with UL MIMO.....	587
6.2H.3.2	UE maximum output power reduction for inter-band UL CA with UL MIMO .....	589
6.2H.3.3	UE additional maximum output power reduction for inter-band UL CA with UL MIMO .....	589
6.2H.3.4	Configured transmitted power for inter-band UL CA with UL MIMO .....	589
6.2I	Transmitter power for RedCap.....	589
6.2I.1	Maximum output power for RedCap .....	589
6.2J	Transmitter power for ATG.....	590
6.2J.1	UE maximum output power for ATG.....	590
6.2J.2	Configured transmitted power for ATG.....	590
6.2K	Transmitter power for Aerial UE .....	591
6.2K.1	Maximum output power for Aerial UE.....	591
6.2K.2	Maximum output power reduction for Aerial UE.....	591
6.2K.3	Additional maximum output power reduction for Aerial UE .....	591
6.2K.3.1	General .....	591
6.2K.3.2	A-MPR for NS_UAV_44.....	592
6.2K.3.3	A-MPR for NS_UAV_70.....	592
6.2K.4	Configured transmitted power for Aerial UE.....	594
6.2L	Transmitter power for CA with Tx Diversity .....	594

6.2L.1	Void .....	594
6.2L.2	Void .....	594
6.2L.3	Transmitter power for inter-band UL CA with Tx Diversity .....	594
6.2L.3.1	UE maximum output power for inter-band UL CA with Tx Diversity .....	594
6.2L.3.2	UE maximum output power reduction for inter-band UL CA with Tx Diversity .....	596
6.2L.3.3	UE additional maximum output power reduction for inter-band UL CA with Tx Diversity .....	596
6.2L.3.4	Configured transmitted power for inter-band UL CA with Tx Diversity .....	596
6.3	Output power dynamics.....	597
6.3.1	Minimum output power .....	597
6.3.2	Transmit OFF power.....	597
6.3.3	Transmit ON/OFF time mask .....	597
6.3.3.1	General .....	597
6.3.3.2	General ON/OFF time mask .....	598
6.3.3.3	Transmit power time mask for slot and short or long subslot boundaries.....	598
6.3.3.4	PRACH time mask.....	599
6.3.3.5	Void.....	600
6.3.3.6	SRS time mask .....	600
6.3.3.7	PUSCH-PUCCH and PUSCH-SRS time masks .....	601
6.3.3.8	Transmit power time mask for consecutive slot or long subslot transmission and short subslot transmission boundaries .....	603
6.3.3.9	Transmit power time mask for consecutive short subslot transmissions boundaries .....	603
6.3.4	Power control.....	604
6.3.4.1	General .....	604
6.3.4.2	Absolute power tolerance.....	604
6.3.4.3	Relative power tolerance .....	604
6.3.4.4	Aggregate power tolerance.....	605
6.3A	Output power dynamics for CA .....	605
6.3A.1	Minimum output power for CA .....	605
6.3A.1.1	Minimum output power for intra-band contiguous CA.....	605
6.3A.1.2	Minimum output power for intra-band non-contiguous CA .....	605
6.3A.1.3	Minimum output power for inter-band CA .....	605
6.3A.1.4	Void.....	606
6.3A.2	Transmit OFF power for CA.....	606
6.3A.2.1	Transmit OFF power for intra-band contiguous CA .....	606
6.3A.2.2	Transmit OFF power for intra-band non-contiguous CA.....	606
6.3A.2.3	Transmit OFF power for inter-band CA.....	606
6.3A.2.4	Void.....	606
6.3A.3	Transmit ON/OFF time mask for CA .....	606
6.3A.3.1	Transmit ON/OFF time mask for intra-band contiguous CA.....	606
6.3A.3.2	Transmit ON/OFF time mask for intra-band non-contiguous CA .....	606
6.3A.3.3	Transmit ON/OFF time mask for inter-band CA .....	607
6.3A.3.3.1	General .....	607
6.3A.3.3.2	Time mask for switching between two uplink carriers .....	607
6.3A.3.3.3	Time mask for switching between two uplink carriers with two transmit antenna connectors .....	608
6.3A.3.3.4	Time mask for switching between one uplink band with one transmit antenna connector and one uplink band with two transmit antenna connectors.....	609
6.3A.3.3.5	Time mask for switching between two uplink bands with two transmit antenna connectors .....	611
6.3A.3.3.6	Time mask for switching across up to four uplink bands .....	612
6.3A.3.3.6a	Additional requirements for three-band switching with dual TAG .....	616
6.3A.3.4	Void.....	616
6.3A.4	Power control for CA.....	616
6.3A.4.1	Power control for intra-band contiguous CA .....	616
6.3A.4.1.1	Absolute power tolerance .....	616
6.3A.4.1.2	Relative power tolerance .....	616
6.3A.4.1.3	Aggregate power control tolerance.....	617
6.3A.4.2	Power control for intra-band non-contiguous CA .....	617
6.3A.4.2.1	Absolute power tolerance.....	617
6.3A.4.2.1.1	Minimum requirements .....	617
6.3A.4.2.2	Relative power tolerance .....	617
6.3A.4.2.2.1	Minimum requirements .....	617
6.3A.4.2.3	Aggregate power control tolerance .....	617
6.3A.4.3	Power control for inter-band CA.....	617

6.3A.4.4	Void.....	617
6.3B	Output power dynamics for NR-DC.....	617
6.3C	Output power dynamics for SUL .....	618
6.3C.1	Void.....	618
6.3C.2	Void.....	618
6.3C.3	Transmit ON/OFF time mask for SUL .....	618
6.3C.3.0	General .....	618
6.3C.3.1	Time mask for switching between two uplink carriers.....	618
6.3C.3.2	Time mask for switching between two uplink carriers with two transmit antenna connectors .....	619
6.3C.3.3	Time mask for switching between one uplink band with one transmit antenna connector and one uplink band with two transmit antenna connectors .....	620
6.3C.3.4	Time mask for switching between two uplink bands with two transmit antenna connectors.....	621
6.3C.3.5	Time mask for switching across up to four uplink bands.....	623
6.3C.3.5a	Additional requirements for three-band switching with dual TAG.....	626
6.3D	Output power dynamics for UL MIMO .....	627
6.3D.1	Minimum output power for UL MIMO .....	627
6.3D.2	Transmit OFF power for UL MIMO.....	627
6.3D.3	Transmit ON/OFF time mask for UL MIMO .....	627
6.3D.4	Power control for UL MIMO.....	627
6.3E	Output power dynamics for V2X .....	628
6.3E.1	Minimum output power for V2X.....	628
6.3E.1.1	General .....	628
6.3E.1.1A	Minimum output power for sidelink CA.....	628
6.3E.1.2	Minimum output power for V2X concurrent operation .....	628
6.3E.1F	Minimum output power for Sidelink Unlicensed.....	628
6.3E.1F.1	Minimum output power for SL-U concurrent operation .....	629
6.3E.2	Transmit OFF power for V2X .....	629
6.3E.2.1	General .....	629
6.3E.2.1A	Transmit OFF power for sidelink CA .....	629
6.3E.2.2	Transmit OFF power for V2X concurrent operation.....	629
6.3E.2F	Transmit OFF power for Sidelink Unlicensed.....	629
6.3E.2F.1	Transmit OFF power for SL-U concurrent operation.....	630
6.3E.3	Transmit ON/OFF time mask for V2X.....	630
6.3E.3.1	General .....	630
6.3E.3.1A	Transmit ON/OFF time mask for sidelink CA.....	630
6.3E.3.2	General time mask.....	630
6.3E.3.3	S-SSB time mask .....	630
6.3E.3.4	Transmit ON/OFF time mask for V2X concurrent operation .....	631
6.3E.3F	Transmit ON/OFF time mask for Sidelink Unlicensed.....	632
6.3E.3F.1	General .....	632
6.3E.3F.2	General ON/OFF time mask .....	632
6.3E.3F.3	S-SSB time mask .....	633
6.3E.3F.4	Transmit ON/OFF time mask for NR SL-U concurrent operation.....	633
6.3E.4	Power control for V2X .....	633
6.3E.4.1	General .....	633
6.3E.4.1A	Power control for sidelink CA .....	633
6.3E.4.2	Absolute power tolerance.....	633
6.3E.4.3	Power control for V2X concurrent operation.....	634
6.3E.4F	Power control for Sidelink Unlicensed .....	634
6.3E.4F.1	General .....	634
6.3E.4F.2	Absolute power tolerance.....	634
6.3E.4F.3	Power control for SL-U concurrent operation.....	634
6.3F	Output power dynamics for shared spectrum channel access.....	634
6.3F.1	Minimum output power .....	634
6.3F.2	Transmit OFF power.....	634
6.3F.3	Transmit ON/OFF time mask .....	634
6.3F.3.1	General .....	634
6.3F.3.2	General ON/OFF time mask .....	634
6.3F.3A	General ON/OFF mask for CA.....	635
6.3F.3A.1	General ON/OFF mask for inter-band CA .....	635
6.3F.4	Power control.....	635
6.3F.4.1	General .....	635

6.3F.4.2	Absolute power tolerance.....	635
6.3F.4.3	Relative power tolerance.....	635
6.3F.4.4	Aggregate power tolerance.....	635
6.3F.4A	Power control for inter-band CA .....	635
6.3G	Output power dynamics for Tx Diversity.....	636
6.3G.1	Minimum output power for Tx Diversity .....	636
6.3G.2	Transmit OFF power for Tx Diversity.....	636
6.3G.3	Transmit ON/OFF time mask for Tx Diversity .....	636
6.3G.4	Power control for Tx Diversity .....	636
6.3H	Output power dynamics for CA with UL MIMO .....	636
6.3H.1	Output power dynamics for intra-band UL contiguous CA with UL MIMO .....	636
6.3H.1.1	Minimum output power for intra-band UL contiguous CA with UL MIMO.....	636
6.3H.1.2	Transmit OFF power for intra-band UL contiguous CA with UL MIMO .....	636
6.3H.1.3	Transmit ON/OFF time mask for intra-band UL contiguous CA with UL MIMO.....	636
6.3H.1.4	Power control for intra-band UL contiguous CA with UL MIMO .....	637
6.3H.3	Output power dynamics for inter-band UL CA with UL MIMO.....	637
6.3H.3.1	Minimum output power for inter-band UL CA with UL MIMO .....	637
6.3H.3.2	Transmit OFF power for inter-band UL CA with UL MIMO.....	637
6.3H.3.3	Transmit ON/OFF time mask for inter-band UL CA with UL MIMO .....	637
6.3H.3.4	Power control for inter-band UL CA with UL MIMO.....	637
6.3I	(Reserved) .....	637
6.3J	Output power dynamics for ATG.....	637
6.3J.1	Minimum output power for ATG .....	637
6.3J.2	Transmit OFF power for ATG.....	638
6.3J.3	Transmit ON/OFF time mask for ATG.....	638
6.3J.4	Power control for ATG .....	638
6.3K	(Reserved) .....	639
6.3L	Output power dynamics for CA with Tx Diversity .....	639
6.3L.1	Void .....	639
6.3L.2	Void .....	639
6.3L.3	Output power dynamics for inter-band UL CA with Tx Diversity .....	639
6.3L.3.1	Minimum output power for inter-band UL CA with Tx Diversity.....	639
6.3L.3.2	Transmit OFF power for inter-band UL CA with Tx Diversity .....	639
6.3L.3.3	Transmit ON/OFF time mask for inter-band UL CA with Tx Diversity.....	639
6.3L.3.4	Power control for inter-band UL CA with Tx Diversity .....	639
6.4	Transmit signal quality .....	639
6.4.1	Frequency error.....	639
6.4.2	Transmit modulation quality.....	639
6.4.2.0	General .....	639
6.4.2.1	Error Vector Magnitude .....	640
6.4.2.1a	Error Vector Magnitude including symbols with transient period .....	640
6.4.2.2	Carrier leakage .....	641
6.4.2.3	In-band emissions .....	642
6.4.2.4	EVM equalizer spectrum flatness .....	642
6.4.2.4.1	Requirements for Pi/2 BPSK modulation with <i>powerBoosting-pi2BPSK</i> capability .....	644
6.4.2.4.2	Requirements for Pi/2 BPSK and QPSK modulation with <i>powerBoosting-pi2BPSK-QPSK-Modified-r18</i> capability .....	644
6.4.2.5	Phase continuity requirements for DMRS bundling .....	645
6.4A	Transmit signal quality for CA.....	646
6.4A.1	Frequency error for CA.....	646
6.4A.1.1	Frequency error for intra-band contiguous CA .....	646
6.4A.1.2	Frequency error for intra-band non-contiguous CA.....	646
6.4A.1.3	Frequency error for inter-band CA.....	646
6.4A.1.4	Void.....	647
6.4A.2	Transmit modulation quality for CA.....	647
6.4A.2.1	Transmit modulation quality for intra-band contiguous CA .....	647
6.4A.2.1.0	General .....	647
6.4A.2.1.1	Error Vector Magnitude.....	647
6.4A.2.1.2	In-band emissions .....	647
6.4A.2.1.3	Carrier leakage.....	649
6.4A.2.2	Transmit modulation quality for intra-band non-contiguous CA .....	650
6.4A.2.2.0	General .....	650

6.4A.2.2.1	Error Vector Magnitude.....	650
6.4A.2.2.2	In-band emissions.....	651
6.4A.2.2.3	Carrier leakage.....	651
6.4A.2.3	Transmit modulation quality for inter-band CA.....	651
6.4A.2.4	Void.....	652
6.4B	Transmit signal quality for NR-DC.....	652
6.4C	Transmit signal quality for SUL.....	652
6.4D	Transmit signal quality for UL MIMO.....	652
6.4D.0	General.....	652
6.4D.1	Frequency error for UL MIMO.....	652
6.4D.2	Transmit modulation quality for UL MIMO.....	653
6.4D.2.0	General.....	653
6.4D.2.1	Error Vector Magnitude.....	653
6.4D.2.2	Carrier leakage.....	653
6.4D.2.3	In-band emissions.....	653
6.4D.2.4	EVM equalizer spectrum flatness for UL MIMO.....	653
6.4D.3	Time alignment error for UL MIMO.....	653
6.4D.4	Requirements for coherent UL MIMO.....	654
6.4E	Transmit signal quality for V2X.....	654
6.4E.1	Frequency error for V2X.....	654
6.4E.1.1	General.....	654
6.4E.1.1A	Frequency error for sidelink CA.....	655
6.4E.1.2	Frequency error for V2X concurrent operation.....	655
6.4E.1F	Frequency error for Sidelink Unlicensed.....	655
6.4E.1F.1	Frequency error for SL-U concurrent operation.....	655
6.4E.2	Transmit modulation quality for V2X.....	655
6.4E.2.1	General.....	655
6.4E.2.2	Error Vector Magnitude for V2X.....	655
6.4E.2.2A	Error Vector Magnitude for sidelink CA.....	655
6.4E.2.3	Carrier leakage for V2X.....	655
6.4E.2.3A	Carrier leakage for sidelink CA.....	656
6.4E.2.4	In-band emissions for V2X.....	656
6.4E.2.4A	In-band emissions for sidelink CA.....	656
6.4E.2.5	EVM equalizer spectrum flatness for V2X.....	656
6.4E.2.6	Transmit modulation quality for V2X concurrent operation.....	656
6.4E.2F	Transmit modulation quality for Sidelink Unlicensed.....	656
6.4E.2F.0	General.....	656
6.4E.2F.1	Error Vector Magnitude.....	656
6.4E.2F.2	Carrier leakage.....	657
6.4E.2F.3	In-band emissions.....	657
6.4E.2F.4	EVM equalizer spectrum flatness.....	657
6.4E.2F.5	Transmit modulation quality for SL-U concurrent operation.....	657
6.4F	Transmit signal quality for shared spectrum channel access.....	657
6.4F.1	Frequency error.....	657
6.4F.2	Transmit modulation quality.....	657
6.4F.2.0	General.....	657
6.4F.2.1	Error Vector Magnitude.....	657
6.4F.2.2	Carrier leakage.....	657
6.4F.2.3	In-band emissions.....	658
6.4F.2.4	EVM equalizer spectrum flatness.....	658
6.4F.2A	Transmit modulation quality for CA.....	659
6.4F.2A.1	Transmit modulation quality for inter-band CA.....	659
6.4G	Transmit signal quality for Tx Diversity.....	659
6.4G.1	Frequency error for Tx Diversity.....	659
6.4G.2	Transmit modulation quality for Tx Diversity.....	659
6.4G.2.0	General.....	659
6.4H	Transmit signal quality for CA with UL MIMO.....	660
6.4H.1	Transmit signal quality for intra-band UL contiguous CA with UL MIMO.....	660
6.4H.1.1	Frequency error for intra-band UL contiguous CA with UL MIMO.....	660
6.4H.1.2	Transmit modulation quality for intra-band UL contiguous CA with UL MIMO.....	660
6.4H.1.2.0	General.....	660
6.4H.1.2.1	Error Vector Magnitude.....	661

6.4H.1.2.2	Carrier leakage.....	661
6.4H.1.2.3	In-band emissions.....	661
6.4H.1.3	Time alignment error for intra-band UL contiguous CA with UL MIMO.....	661
6.4H.1.4	Coherent UL MIMO requirement for intra-band UL contiguous CA with UL MIMO.....	661
6.4H.2	Void.....	661
6.4H.3	Transmit signal quality for inter-band UL CA with UL MIMO.....	661
6.4H.3.1	Frequency error for inter-band UL CA with UL MIMO.....	661
6.4H.3.2	Transmit modulation quality for inter-band UL CA with UL MIMO.....	661
6.4I	(Reserved).....	661
6.4J	Transmit signal quality for ATG.....	661
6.4J.1	Frequency error for ATG.....	661
6.4J.2	Transmit modulation quality for ATG.....	662
6.4K	(Reserved).....	662
6.4L	Transmit signal quality for CA with Tx Diversity.....	662
6.4L.1	Void.....	662
6.4L.2	Void.....	662
6.4L.3	Transmit signal quality for inter-band UL CA with Tx Diversity.....	662
6.4L.3.1	Frequency error for inter-band UL CA with Tx Diversity.....	662
6.4L.3.2	Transmit modulation quality for inter-band UL CA with Tx Diversity.....	662
6.5	Output RF spectrum emissions.....	662
6.5.1	Occupied bandwidth.....	662
6.5.2	Out of band emission.....	663
6.5.2.1	General.....	663
6.5.2.2	Spectrum emission mask.....	663
6.5.2.3	Additional spectrum emission mask.....	663
6.5.2.3.1	Requirements for network signalling value "NS_35".....	663
6.5.2.3.2	Requirements for network signalling value "NS_04".....	664
6.5.2.3.3	Requirements for network signalling values "NS_03" and "NS_03U".....	665
6.5.2.3.4	Requirements for network signalling value "NS_06" or "NS_07".....	665
6.5.2.3.5	Void.....	666
6.5.2.3.6	Void.....	666
6.5.2.3.7	Void.....	666
6.5.2.3.8	Requirements for network signalling value "NS_27".....	666
6.5.2.3.9	Requirements for network signalling value "NS_21".....	666
6.5.2.4	Adjacent channel leakage ratio.....	667
6.5.2.4.1	NR ACLR.....	667
6.5.2.4.2	UTRA ACLR.....	667
6.5.3	Spurious emissions.....	668
6.5.3.0	General.....	668
6.5.3.1	General spurious emissions.....	668
6.5.3.2	Spurious emissions for UE co-existence.....	669
6.5.3.3	Additional spurious emissions.....	677
6.5.3.3.1	Requirement for network signalling value "NS_04".....	677
6.5.3.3.2	Requirement for network signalling value "NS_17".....	677
6.5.3.3.3	Requirement for network signalling value "NS_18".....	678
6.5.3.3.4	Requirement for network signalling values "NS_05" and "NS_05U".....	678
6.5.3.3.5	Requirement for network signalling values "NS_43" and "NS_43U".....	678
6.5.3.3.6	Requirement for network signalling value "NS_37".....	678
6.5.3.3.7	Requirement for network signalling value "NS_38".....	679
6.5.3.3.8	Requirement for network signalling value "NS_39".....	679
6.5.3.3.9	Requirement for network signalling value "NS_40".....	679
6.5.3.3.10	Requirement for network signalling value "NS_41".....	679
6.5.3.3.11	Requirement for network signalling value "NS_42".....	680
6.5.3.3.12	Requirement for network signalling value "NS_21".....	680
6.5.3.3.13	Requirement for network signalling value "NS_24".....	680
6.5.3.3.14	Requirement for network signalling value "NS_27".....	681
6.5.3.3.15	Requirement for network signalling value "NS_47".....	681
6.5.3.3.16	Requirement for network signalling value "NS_50".....	681
6.5.3.3.17	Requirement for network signalling value "NS_12".....	681
6.5.3.3.18	Requirement for network signalling value "NS_13".....	682
6.5.3.3.19	Requirement for network signalling value "NS_14".....	682
6.5.3.3.20	Requirement for network signalling value "NS_15".....	682

6.5.3.3.21	Requirement for network signalling value "NS_45" .....	683
6.5.3.3.22	Requirement for network signalling values "NS_48" and "NS_51" .....	683
6.5.3.3.23	Requirement for network signalling value "NS_49" .....	683
6.5.3.3.24	Requirement for network signalling value "NS_44" .....	684
6.5.3.3.25	Requirement for network signalling value "NS_46" .....	684
6.5.3.3.26	Requirement for network signalling value "NS_07" .....	684
6.5.3.3.27	Requirement for network signalling value "NS_56" .....	684
6.5.3.3.28	Requirement for network signalling value "NS_62" .....	685
6.5.4	Transmit intermodulation .....	685
6.5A	Output RF spectrum emissions for CA.....	686
6.5A.0	General.....	686
6.5A.1	Occupied bandwidth for CA .....	686
6.5A.1.1	Void.....	686
6.5A.1.1a	Occupied bandwidth for Intra-band contiguous CA .....	686
6.5A.1.2	Occupied bandwidth for Intra-band non-contiguous CA .....	686
6.5A.1.3	Occupied bandwidth for Inter-band CA.....	686
6.5A.2	Out of band emission for CA.....	686
6.5A.2.1	General .....	686
6.5A.2.2	Spectrum emission mask.....	686
6.5A.2.2.1	Spectrum emission mask for intra-band contiguous CA .....	686
6.5A.2.2.2	Spectrum emission mask for intra-band non-contiguous CA .....	687
6.5A.2.2.3	Spectrum emission mask for Inter-band CA.....	687
6.5A.2.2.4	Void.....	688
6.5A.2.3	Additional spectrum emission mask for CA .....	688
6.5A.2.3.1	Additional spectrum emission mask for intra-band contiguous CA .....	688
6.5A.2.3.2	Additional spectrum emission mask for Intra-band non-contiguous CA.....	688
6.5A.2.3.3	Additional spectrum emission mask for Inter-band CA .....	689
6.5A.2.4	Adjacent channel leakage ratio .....	689
6.5A.2.4.1	NR ACLR.....	689
6.5A.2.4.2	UTRA ACLR .....	690
6.5A.3	Spurious emission for CA.....	691
6.5A.3.1	General spurious emissions.....	691
6.5A.3.2	Spurious emissions for UE co-existence .....	692
6.5A.3.2.0	General .....	692
6.5A.3.2.1	Spurious emissions for UE co-existence for intra-band contiguous CA.....	692
6.5A.3.2.2	Spurious emissions for UE co-existence for intra-band non-contiguous CA .....	694
6.5A.3.2.3	Spurious emissions for UE co-existence for Inter-band CA.....	695
6.5A.3.2.4	Void.....	700
6.5A.3.2.5	Void.....	700
6.5A.3.2.6	Void.....	700
6.5A.3.3	Additional spurious emissions for CA .....	700
6.5A.3.3.1	Additional spurious emissions for intra-band contiguous CA.....	700
6.5A.3.3.2	Additional spurious emissions for intra-band non-contiguous CA.....	701
6.5A.4	Transmit intermodulation for CA .....	702
6.5A.4.2.1	Transmit intermodulation for intra-band contiguous CA .....	702
6.5A.4.2.2	Void.....	702
6.5B	Output RF spectrum emissions for NR-DC.....	702
6.5D	Output RF spectrum emissions for UL MIMO.....	702
6.5D.1	Occupied bandwidth for UL MIMO .....	702
6.5D.2	Out of band emission for UL MIMO .....	703
6.5D.3	Spurious emission for UL MIMO.....	703
6.5D.4	Transmit intermodulation for UL MIMO .....	703
6.5E	Output RF spectrum emissions for V2X .....	704
6.5E.1	Occupied bandwidth for V2X.....	704
6.5E.1.1	General .....	704
6.5E.1.1A	Occupied bandwidth for sidelink CA.....	704
6.5E.1.2	Occupied bandwidth for V2X concurrent operation .....	704
6.5E.1F	Occupied bandwidth for Sidelink Unlicensed.....	704
6.5E.1F.1	Occupied bandwidth for SL-U concurrent operation .....	704
6.5E.2	Out of band emission for V2X.....	704
6.5E.2.1	General .....	704
6.5E.2.2	Spectrum emission mask.....	705

6.5E.2.2.1	General .....	705
6.5E.2.2.1A	Spectrum emission mask for sidelink CA .....	705
6.5E.2.2.2	Spectrum emission mask for V2X concurrent operation .....	705
6.5E.2.3	Additional Spectrum emission mask .....	705
6.5E.2.3.1	Requirements for network signalling value "NS_33" .....	705
6.5E.2.3.2	Requirements for network signalling value "NS_52" .....	706
6.5E.2.3.3	Requirements for network signalling value "NS_06" .....	706
6.5E.2.4	Adjacent channel leakage ratio .....	706
6.5E.2.4.1	General .....	706
6.5E.2.4.1A	ACLR for sidelink CA .....	706
6.5E.2.4.2	ACLR for V2X concurrent operation .....	707
6.5E.2F	Out of band emission for Sidelink Unlicensed .....	707
6.5E.2F.1	General .....	707
6.5E.2F.2	Spectrum emission mask for operation with shared spectrum channel access .....	707
6.5E.2F.2.1	Spectrum emission mask for SL-U concurrent operation .....	707
6.5E.2F.3	Additional spectrum emission mask .....	707
6.5E.2F.4	Adjacent channel leakage ratio .....	707
6.5E.2F.4.1	Adjacent channel leakage ratio for SL-U concurrent operation .....	707
6.5E.3	Spurious emissions for V2X .....	707
6.5E.3.1	General spurious emissions .....	707
6.5E.3.1A	Spurious emissions for sidelink CA .....	708
6.5E.3.2	Spurious emissions for UE co-existence .....	708
6.5E.3.2A	Spurious emissions band UE co-existence for sidelink CA .....	708
6.5E.3.3	Spurious emissions for UE co-existence for V2X concurrent operation .....	708
6.5E.3.4	Additional spurious emissions requirements for V2X .....	709
6.5E.3.4.1	General .....	709
6.5E.3.4.2	Requirements for network signalling value "NS_33" .....	709
6.5E.3.4.3	Void .....	710
6.5E.3F	Spurious emissions for Sidelink Unlicensed .....	710
6.5E.3F.0	General .....	710
6.5E.3F.1	General spurious emissions .....	710
6.5E.3F.2	Spurious emissions for UE co-existence .....	710
6.5E.3F.2.1	Spurious emissions for UE co-existence for SL-U concurrent operation .....	710
6.5E.3F.3	Additional spurious emissions .....	710
6.5E.3F.3.0	General .....	710
6.5E.4	Transmit intermodulation .....	711
6.5E.4.1	General .....	711
6.5E.4.1A	Transmit intermodulation for sidelink CA .....	711
6.5E.4.2	Transmit intermodulation for V2X concurrent operation .....	711
6.5F	Output RF spectrum emissions for shared spectrum channel access .....	711
6.5F.1	Occupied bandwidth .....	711
6.5F.2	Out of band emission .....	711
6.5F.2.1	General .....	711
6.5F.2.2	Spectrum emission mask for operation with shared spectrum channel access .....	712
6.5F.2.2.0	General .....	712
6.5F.2.2.1	Spectrum emission mask for non-transmitted channels .....	712
6.5F.2.3	Additional spectrum emission mask .....	712
6.5F.2.4	Adjacent channel leakage ratio .....	713
6.5F.2.4.0	General .....	713
6.5F.2.4.1	Shared spectrum channel access ACLR .....	713
6.5F.2.4.2	Additional requirement for network signalled value "NS_29" .....	713
6.5F.2A	Out of band emission for CA .....	713
6.5F.2A.1	Spectrum emission mask for CA .....	713
6.5F.2A.1.1	Spectrum emission mask for Inter-band CA .....	713
6.5F.2A.1.2	Spectrum emission mask for Intra-band contiguous CA .....	714
6.5F.2A.1.2.1	General .....	714
6.5F.2A.1.2.2	Intra-band contiguous CA spectrum emission mask for non-transmitted channels .....	714
6.5F.2A.2	Adjacent channel leakage ratio for CA .....	714
6.5F.2A.2.1	Adjacent channel leakage ratio for inter-band CA .....	714
6.5F.2A.2.2	Adjacent channel leakage ratio for intra-band contiguous CA .....	715
6.5F.3	Spurious emissions .....	715
6.5F.3.0	General .....	715



6.5F.3.1	General spurious emissions .....	715
6.5F.3.2	Spurious emissions for UE co-existence .....	715
6.5F.3.3	Additional spurious emissions .....	716
6.5F.3.3.0	General .....	716
6.5F.3.3.1	Requirement for network signalling value "NS_28" .....	716
6.5F.3.3.2	Requirement for network signalling value "NS_29" .....	716
6.5F.3.3.3	Requirement for network signalling value "NS_30" .....	718
6.5F.3.3.4	Requirement for network signalling value "NS_31" .....	718
6.5F.3.3.5	Requirements for network signalling value "NS_53" or "NS_54" or "NS_60" or "NS_66" or "NS_67" or "NS_71" .....	719
6.5F.3.3.6	Requirements for network signalling value "NS_58" .....	719
6.5F.3.3.7	Requirements for network signalling value "NS_61" .....	720
6.5F.3.3.8	Requirements for network signalling value "NS_63" or "NS_69" .....	720
6.5F.3.3.9	Requirements for network signalling value "NS_64" .....	720
6.5F.3A	Spurious emissions for CA .....	721
6.5F.3A.0	General .....	721
6.5F.3A.1	General spurious emissions .....	721
6.5F.3A.2	Spurious emissions for UE co-existence .....	721
6.5F.3A.3	Additional spurious emissions .....	721
6.5F.3A.3.0	General .....	721
6.5F.3A.3.1	Requirements for network signalling value "CA_NS_53" or "CA_NS_54" .....	721
6.5F.4	Transmit intermodulation .....	722
6.5G	Output RF spectrum emissions for Tx Diversity .....	722
6.5G.1	Occupied bandwidth for Tx Diversity .....	722
6.5G.2	Out of band emission for Tx Diversity .....	722
6.5G.3	Spurious emission for Tx Diversity .....	722
6.5G.4	Transmit intermodulation for Tx Diversity .....	722
6.5H	Output RF spectrum emissions for CA with UL MIMO .....	723
6.5H.1	Output RF spectrum emissions for intra-band UL contiguous CA with UL MIMO .....	723
6.5H.1.1	Occupied bandwidth for intra-band UL contiguous CA with UL MIMO .....	723
6.5H.1.2	Out of band emission for intra-band UL contiguous CA with UL MIMO .....	723
6.5H.1.3	Spurious emission for intra-band UL contiguous CA with UL MIMO .....	723
6.5H.1.4	Transmit intermodulation for intra-band UL contiguous CA with UL MIMO .....	723
6.5H.2	Void .....	724
6.5H.3	Output RF spectrum emissions for inter-band UL CA with UL MIMO .....	724
6.5H.3.1	Occupied bandwidth for inter-band UL CA with UL MIMO .....	724
6.5H.3.2	Out of band emission for inter-band UL CA with UL MIMO .....	724
6.5H.3.3	Spurious emission for inter-band UL CA with UL MIMO .....	724
6.5H.3.4	Transmit intermodulation for inter-band UL CA with UL MIMO .....	724
6.5I	(Reserved) .....	724
6.5J	Output RF spectrum emissions for ATG .....	724
6.5J.1	Occupied bandwidth for ATG .....	724
6.5J.2	Out of band emission for ATG .....	724
6.5J.2.1	General .....	724
6.5J.2.2	Spectrum emission mask .....	724
6.5J.2.3	Adjacent channel leakage ratio .....	725
6.5J.3	Spurious emissions for ATG .....	725
6.5K	Output RF spectrum emissions for Aerial UE .....	725
6.5K.1	Occupied bandwidth for Aerial UE .....	725
6.5K.2	Out of band emission for Aerial UE .....	725
6.5K.3	Spurious emissions for Aerial UE .....	725
6.5K.3.0	General .....	725
6.5K.3.1	General spurious emissions .....	725
6.5K.3.2	Spurious emissions for UE co-existence .....	726
6.5K.3.3	Additional spurious emissions .....	726
6.5K.3.3.1	Requirement for network signalling value "NS_UAV_44" .....	726
6.5K.3.3.2	Requirement for network signalling value "NS_UAV_46" .....	726
6.5K.3.3.3	Requirement for network signalling value "NS_UAV_70" .....	726
6.5L	Output RF spectrum emissions for CA with Tx Diversity .....	727
6.5L.1	Void .....	727
6.5L.2	Void .....	727
6.5L.3	Output RF spectrum emissions for inter-band UL CA with Tx Diversity .....	727

6.5L.3.1	Occupied bandwidth for inter-band UL CA with Tx Diversity .....	727
6.5L.3.2	Out of band emission for inter-band UL CA with Tx Diversity .....	727
6.5L.3.3	Spurious emission for inter-band UL CA with Tx Diversity .....	727
6.5L.3.4	Transmit intermodulation for inter-band UL CA with Tx Diversity .....	727
6.6	Void.....	727
6.6E	Time alignment error.....	727
7	Receiver characteristics .....	728
7.1	General .....	728
7.1A	General .....	729
7.1F	General .....	729
7.1G	(Reserved) .....	729
7.1H	(Reserved) .....	729
7.1I	General .....	729
7.1J	General for ATG .....	729
7.1K	(Reserved) .....	729
7.1L	(Reserved) .....	729
7.2	Diversity characteristics .....	729
7.2J	Diversity characteristics for ATG .....	730
7.3	Reference sensitivity .....	730
7.3.1	General.....	730
7.3.2	Reference sensitivity power level .....	730
7.3.3	$\Delta R_{IB,c}$ .....	740
7.3A	Reference sensitivity for CA .....	740
7.3A.1	General.....	740
7.3A.2	Reference sensitivity power level for CA .....	741
7.3A.2.1	Reference sensitivity power level for Intra-band contiguous CA .....	741
7.3A.2.2	Reference sensitivity power level for Intra-band non-contiguous CA .....	742
7.3A.2.3	Reference sensitivity power level for Inter-band CA .....	744
7.3A.2.4	Void.....	744
7.3A.3	$\Delta R_{IB,c}$ for CA .....	744
7.3A.3.1	General .....	744
7.3A.3.2	$\Delta R_{IB,c}$ for Inter-band CA.....	744
7.3A.3.2.1	$\Delta R_{IB,c}$ for two bands .....	744
7.3A.3.2.2	Void.....	747
7.3A.3.2.3	$\Delta R_{IB,c}$ for three bands .....	747
7.3A.3.2.4	$\Delta R_{IB,c}$ for four bands.....	751
7.3A.3.2.5	$\Delta R_{IB,c}$ for five bands .....	754
7.3A.3.2.6	$\Delta R_{IB,c}$ for six bands.....	755
7.3A.3.3	$\Delta R_{IB,c}$ for Intra-band CA.....	755
7.3A.4	Reference sensitivity exceptions due to harmonic interference for CA .....	755
7.3A.5	Reference sensitivity exceptions due to intermodulation interference due to 2UL CA .....	770
7.3A.6	Reference sensitivity exceptions due to cross band isolation for CA .....	813
7.3A.7	Lower-MSD requirements for inter-band CA .....	819
7.3B	Reference sensitivity for NR-DC .....	820
7.3C	Reference sensitivity for SUL .....	820
7.3C.1	General.....	820
7.3C.2	Reference sensitivity power level for SUL .....	821
7.3C.3	$\Delta R_{IB,c}$ for SUL .....	824
7.3C.3.1	General .....	824
7.3C.3.2	SUL band combination .....	824
7.3C.3.2.1	$\Delta R_{IB,c}$ for two bands .....	824
7.3C.3.2.2	$\Delta R_{IB,c}$ for three bands .....	825
7.3C.3.2.3	$\Delta R_{IB,c}$ for four bands.....	825
7.3D	Reference sensitivity for UL MIMO .....	826
7.3E	Reference sensitivity for V2X.....	826
7.3E.1	General.....	826
7.3E.2	Minimum requirements.....	826
7.3E.2A	Minimum requirements for Sidelink CA .....	827
7.3E.2A.1	Reference sensitivity power level for Sidelink CA.....	827
7.3E.2F	Minimum requirements for Sidelink Unlicensed.....	827
7.3E.2F.1	General .....	827

7.3E.2F.2	Reference sensitivity power level .....	827
7.3E.3	Reference sensitivity power level for V2X concurrent operation .....	828
7.3E.3.1	General .....	828
7.3E.3F	Minimum requirements for SL-U concurrent operation .....	829
7.3E.3F.1	Reference sensitivity power level for SL-U concurrent operation .....	829
7.3F	Reference sensitivity for shared spectrum channel access .....	830
7.3F.1	General.....	830
7.3F.2	Reference sensitivity power level .....	830
7.3F.3	Void .....	831
7.3F.4	Void .....	831
7.3F.4A	Shared spectrum channel access CA.....	831
7.3F.4A.1	Intra-band contiguous shared spectrum channel access CA.....	831
7.3F.5	Void .....	831
7.3F.5.1	Void.....	831
7.3F.5.2	Void.....	831
7.3F.5.3	Void.....	831
7.3G	Reference sensitivity for Tx Diversity.....	831
7.3G.5	Void .....	832
7.3G.5.0	Void.....	832
7.3H	(Reserved) .....	832
7.3I	Reference sensitivity for RedCap .....	832
7.3I.1	General.....	832
7.3I.2	Reference sensitivity power level .....	832
7.3I.3	Reference sensitivity power level for eRedCap .....	836
7.3J	Reference sensitivity for ATG.....	836
7.3J.1	General.....	836
7.3J.2	Reference sensitivity power level .....	837
7.3K	(Reserved) .....	837
7.3L	(Reserved) .....	837
7.4	Maximum input level .....	837
7.4A	Maximum input level for CA .....	837
7.4A.1	Maximum input level for Intra-band contiguous CA.....	837
7.4A.2	Maximum input level for Intra-band non-contiguous CA .....	838
7.4A.3	Maximum input level for Inter-band CA .....	838
7.4B	Maximum input level for NR-DC .....	838
7.4D	Maximum input level for UL MIMO .....	838
7.4E	Maximum input level for V2X .....	838
7.4E.1	General.....	838
7.4E.1A	Maximum input level for Sidelink CA .....	839
7.4E.1F	General requirement for Sidelink Unlicensed.....	839
7.4E.2	Maximum input level for V2X concurrent operation .....	839
7.4E.2F	Maximum input level for SL-U concurrent operation .....	839
7.4F	(Reserved) .....	840
7.4G	(Reserved) .....	840
7.4H	(Reserved) .....	840
7.4I	(Reserved) .....	840
7.4J	Maximum input level for ATG.....	840
7.4K	(Reserved) .....	840
7.4L	(Reserved) .....	840
7.5	Adjacent channel selectivity.....	840
7.5A	Adjacent channel selectivity for CA.....	842
7.5A.1	Adjacent channel selectivity for Intra-band contiguous CA .....	842
7.5A.2	Adjacent channel selectivity Intra-band non-contiguous CA .....	844
7.5A.3	Adjacent channel selectivity Inter-band CA .....	845
7.5B	Adjacent channel selectivity for NR-DC.....	845
7.5D	Adjacent channel selectivity for UL MIMO.....	845
7.5E	Adjacent channel selectivity for V2X .....	845
7.5E.1	General.....	845
7.5E.1A	Adjacent channel selectivity requirement for Sidelink CA.....	847
7.5E.1F	General requirement for Sidelink Unlicensed.....	847
7.5E.2	Adjacent channel selectivity for V2X concurrent operation.....	848
7.5E.2F	Adjacent channel selectivity for SL-U concurrent operation.....	848

7.5F	Adjacent channel selectivity for shared spectrum channel access.....	848
7.5F.1	General.....	848
7.5F.1A	Adjacent channel selectivity for shared spectrum channel access CA.....	849
7.5F.1A.1	Intra-band contiguous shared spectrum channel access CA.....	849
7.5F.2	Void.....	849
7.5G	(Reserved).....	849
7.5H	(Reserved).....	849
7.5I	(Reserved).....	849
7.5J	Adjacent channel selectivity for ATG.....	849
7.5K	(Reserved).....	852
7.5L	(Reserved).....	852
7.6	Blocking characteristics.....	852
7.6.1	General.....	852
7.6.2	In-band blocking.....	852
7.6.3	Out-of-band blocking.....	854
7.6.4	Narrow band blocking.....	857
7.6A	Blocking characteristics for CA.....	859
7.6A.1	General.....	859
7.6A.2	In-band blocking for CA.....	859
7.6A.2.1	In-band blocking for Intra-band contiguous CA.....	859
7.6A.2.2	In-band blocking for Intra-band non-contiguous CA.....	860
7.6A.2.3	In-band blocking for Inter-band CA.....	860
7.6A.3	Out-of-band blocking for CA.....	861
7.6A.3.1	Out-of-band blocking for Intra-band contiguous CA.....	861
7.6A.3.2	Out-of-band blocking for Intra-band non-contiguous CA.....	862
7.6A.3.3	Out-of-band blocking for Inter-band CA.....	862
7.6A.4	Narrow band blocking for CA.....	864
7.6A.4.1	Narrow band blocking for Intra-band contiguous CA.....	864
7.6A.4.2	Narrow band blocking for Intra-band non-contiguous CA.....	864
7.6A.4.3	Narrow band blocking for Inter-band CA.....	865
7.6B	Blocking characteristics for NR-DC.....	865
7.6C	Blocking characteristics for SUL.....	865
7.6C.1	General.....	865
7.6C.2	In-band blocking for SUL.....	865
7.6C.3	Out-of-band blocking for SUL.....	865
7.6C.4	Narrow band blocking for SUL.....	866
7.6D	Blocking characteristics for UL MIMO.....	866
7.6E	Blocking characteristics for V2X.....	866
7.6E.1	General.....	866
7.6E.2	In-band blocking.....	866
7.6E.2.1	General.....	866
7.6E.2.1A	In-band blocking for Sidelink CA.....	867
7.6E.2.2	In-band blocking for V2X concurrent operation.....	868
7.6E.2.2F	In-band blocking for SL-U concurrent operation.....	868
7.6E.3	Out-of-band blocking.....	868
7.6E.3.1	General.....	868
7.6E.3.1A	Out-of-band blocking for Sidelink CA.....	869
7.6E.3.2	Out-of-band blocking for V2X concurrent operation.....	869
7.6E.3.2F	Out-of-band blocking for SL-U concurrent operation.....	869
7.6E.3F	Out-of-band blocking for Sidelink Unlicensed.....	870
7.6F	Blocking characteristics for shared spectrum channel access.....	870
7.6F.1	General.....	870
7.6F.2	In-band blocking.....	870
7.6F.2.1	General.....	870
7.6F.2.2	Void.....	871
7.6F.2A	In-band blocking for shared spectrum CA.....	871
7.6F.2A.1	Intra-band contiguous shared spectrum channel access CA.....	871
7.6F.3	Out-of-band blocking.....	872
7.6F.3.1	General.....	872
7.6F.3.2	Void.....	873
7.6F.3A	Out-of-band blocking for shared spectrum CA.....	873
7.6F.3A.1	Intra-band contiguous shared spectrum channel access CA.....	873

7.6G	(Reserved) .....	873
7.6H	(Reserved) .....	873
7.6I	(Reserved) .....	873
7.6J	Blocking characteristics for ATG.....	873
7.6J.1	General.....	873
7.6J.2	In-band blocking for ATG .....	874
7.6J.3	Out-of-band blocking for ATG.....	874
7.6K	(Reserved) .....	874
7.6L	(Reserved) .....	874
7.7	Spurious response.....	874
7.7A	Spurious response for CA.....	875
7.7A.1	Spurious response for Intra-band contiguous CA .....	875
7.7A.2	Spurious response for Intra-band non-contiguous CA.....	875
7.7A.3	Spurious response for Inter-band CA.....	875
7.7B	Spurious response for NR-DC.....	876
7.7D	Spurious response for UL MIMO.....	876
7.7E	Spurious response for V2X .....	876
7.7E.1	General.....	876
7.7E.1A	Spurious response requirements for Sidelink CA .....	876
7.7E.1F	General requirement for Sidelink Unlicensed.....	877
7.7E.2	Spurious response for V2X concurrent operation.....	877
7.7E.2F	Spurious response for SL-U concurrent operation.....	877
7.7F	Spurious response for shared spectrum channel access.....	877
7.7F.1	General.....	877
7.7F.1A	Spurious response for shared spectrum channel access CA.....	878
7.7F.1A.1	Intra-band contiguous shared spectrum channel access CA.....	878
7.7F.2	Void .....	878
7.7G	(Reserved) .....	878
7.7H	(Reserved) .....	878
7.7I	(Reserved) .....	878
7.7J	Spurious response for ATG.....	878
7.7K	(Reserved) .....	879
7.7L	(Reserved) .....	879
7.8	Intermodulation characteristics .....	879
7.8.1	General.....	879
7.8.2	Wide band Intermodulation .....	879
7.8A	Intermodulation characteristics for CA .....	881
7.8A.1	General.....	881
7.8A.2	Wide band intermodulation for CA .....	881
7.8A.2.1	Wide band intermodulation for Intra-band contiguous CA.....	881
7.8A.2.2	Wide band intermodulation for Intra-band non-contiguous CA.....	882
7.8A.2.3	Wide band intermodulation for Inter-band CA .....	882
7.8B	Intermodulation characteristics for NR-DC .....	883
7.8D	Intermodulation characteristics for UL MIMO .....	883
7.8E	Intermodulation characteristics for V2X .....	883
7.8E.1	General.....	883
7.8E.2	Wide band Intermodulation .....	883
7.8E.2.1	General .....	883
7.8E.2.2	Wide band Intermodulation for V2X concurrent operation .....	884
7.8E.2.2A	Wide band intermodulation for Sidelink CA .....	884
7.8E.2.2F	Wide band Intermodulation for SL-U concurrent operation .....	884
7.8E.2F	Wide band Intermodulation for Sidelink Unlicensed.....	885
7.8F	Intermodulation characteristics for shared spectrum channel access .....	885
7.8F.1	General.....	885
7.8F.2	Wide band Intermodulation .....	885
7.8G	(Reserved) .....	886
7.8H	(Reserved) .....	886
7.8I	(Reserved) .....	886
7.8J	Intermodulation characteristics for ATG.....	886
7.8J.1	General.....	886
7.8J.2	Wide band intermodulation for ATG.....	886
7.8K	(Reserved) .....	886

7.8L	(Reserved) .....	886
7.9	Spurious emissions .....	886
7.9A	Spurious emissions for CA .....	887
7.9A.1	Void .....	887
7.9A.2	Void .....	887
7.9A.3	Spurious emissions for Inter-band CA .....	887
7.9B	Spurious emissions for NR-DC .....	887
7.9J	Spurious emissions for ATG .....	887
7.10	Power imbalance .....	887
7.10A	Power imbalance for CA .....	887
7.10A.1	General .....	887
7.10A.2	Minimum requirement .....	887
<b>Annex A (normative): Measurement channels .....</b>		<b>889</b>
A.1	General .....	889
A.2	UL reference measurement channels .....	889
A.2.1	General .....	889
A.2.2	Reference measurement channels .....	891
A.2.2.1	DFT-s-OFDM Pi/2-BPSK .....	891
A.2.2.2	DFT-s-OFDM QPSK .....	892
A.2.2.3	DFT-s-OFDM 16QAM .....	892
A.2.2.4	DFT-s-OFDM 64QAM .....	894
A.2.2.5	DFT-s-OFDM 256QAM .....	896
A.2.2.6	CP-OFDM QPSK .....	898
A.2.2.7	CP-OFDM 16QAM .....	900
A.2.2.8	CP-OFDM 64QAM .....	902
A.2.2.9	CP-OFDM 256QAM .....	904
A.2.3	Reference measurement channels for TDD .....	906
A.2.3.1	DFT-s-OFDM Pi/2-BPSK .....	906
A.2.3.2	DFT-s-OFDM QPSK .....	906
A.2.3.3	DFT-s-OFDM 16QAM .....	906
A.2.3.4	DFT-s-OFDM 64QAM .....	906
A.2.3.5	DFT-s-OFDM 256QAM .....	907
A.2.3.6	CP-OFDM QPSK .....	907
A.2.3.7	CP-OFDM 16QAM .....	907
A.2.3.8	CP-OFDM 64QAM .....	907
A.2.3.9	CP-OFDM 256QAM .....	908
A.3	DL reference measurement channels .....	909
A.3.1	General .....	909
A.3.2	DL reference measurement channels for FDD .....	911
A.3.2.1	General .....	911
A.3.2.2	FRC for receiver requirements for QPSK .....	911
A.3.2.3	FRC for maximum input level for 64QAM .....	914
A.3.2.4	FRC for maximum input level for 256 QAM .....	918
A.3.2.5	FRC for maximum input level for 1024 QAM .....	921
A.3.3	DL reference measurement channels for TDD .....	924
A.3.3.1	General .....	924
A.3.3.2	FRC for receiver requirements for QPSK .....	924
A.3.3.3	FRC for maximum input level for 64QAM .....	928
A.3.3.4	FRC for maximum input level for 256 QAM .....	931
A.3.3.5	FRC for maximum input level for 1024 QAM .....	935
A.4	CSI reference measurement channels .....	938
A.5	OFDMA Channel Noise Generator (OCNG) .....	938
A.5.1	OCNG Patterns for FDD .....	938
A.5.1.1	OCNG FDD pattern 1: Generic OCNG FDD Pattern for all unused REs .....	938
A.5.2	OCNG Patterns for TDD .....	938
A.5.2.1	OCNG TDD pattern 1: Generic OCNG TDD Pattern for all unused REs .....	938
A.6	Void .....	939

A.7	V2X reference measurement channels .....	939
A.7.1	General .....	939
A.7.2	FRC for V2X receiver requirements for QPSK.....	939
A.7.3	FRC for maximum input level for 64QAM.....	941
A.7.4	FRC for maximum input level for 256QAM.....	942
<b>Annex B (informative):</b>	<b>Void .....</b>	<b>944</b>
<b>Annex C (informative):</b>	<b>Downlink physical channels.....</b>	<b>945</b>
C.1	General .....	945
C.2	Setup.....	945
C.3	Connection .....	945
C.3.1	Measurement of Receiver Characteristics .....	945
<b>Annex D (normative):</b>	<b>Characteristics of the interfering signal .....</b>	<b>947</b>
D.1	General .....	947
D.2	Interference signals.....	947
<b>Annex E (normative):</b>	<b>Environmental conditions .....</b>	<b>949</b>
E.1	General .....	949
E.2	Environmental .....	949
E.2.1	Temperature .....	949
E.2.2	Voltage .....	949
E.2.3	Vibration.....	950
<b>Annex F (normative):</b>	<b>Transmit modulation.....</b>	<b>951</b>
F.0	General .....	951
F.1	Measurement Point.....	951
F.2	Basic Error Vector Magnitude measurement .....	951
F.3	Basic in-band emissions measurement.....	952
F.4	Modified signal under test.....	953
F.5	Window length .....	955
F.5.1	Timing offset.....	955
F.5.2	Window length .....	955
F.5.3	Window length for normal CP .....	955
F.5.4	Window length for Extended CP.....	956
F.5.5	Window length for PRACH .....	957
F.6	Averaged EVM .....	958
F.7	Spectrum Flatness .....	959
F.8	EVM measurement for multiple Tx .....	959
F.9	Phase offset measurement for DMRS bundling .....	959
F.9.1	Measurement point .....	959
F.9.2	Symbols used.....	959
F.9.3	Modified test signal .....	959
F.9.4	Phase offset measurement .....	960
F.10	EVM for UL MIMO.....	960
F10.1	General .....	960
F10.2	MIMO Equalization .....	962
F10.3	Layer processing .....	962
<b>Annex G (normative):</b>	<b>Difference of relative phase and power errors.....</b>	<b>964</b>

G.0	General .....	964
G.1	Measurement Point.....	964
G.2	Relative Phase Error Measurement .....	964
G.2.1	Symbols and subcarriers used .....	964
G.2.2	CFO (carrier frequency offset) correction.....	965
G.2.3	Steps of the measurement method.....	965
<b>Annex H (informative):</b>	<b>Void .....</b>	<b>966</b>
<b>Annex I (informative):</b>	<b>Void .....</b>	<b>967</b>
<b>Annex J (informative):</b>	<b>Void .....</b>	<b>968</b>
<b>Annex K (informative):</b>	<b>Void .....</b>	<b>969</b>
<b>Annex L (normative):</b>	<b>ModifiedMPR-Behavior .....</b>	<b>970</b>
L.1	Indication of modified MPR behavior.....	970
<b>Annex M (normative):</b>	<b>Declared Supported Post Antenna Gain for UE .....</b>	<b>973</b>
M.1	FRMCS operating bands .....	973
<b>Annex N (informative):</b>	<b>Change history .....</b>	<b>974</b>
History	.....	1004



---

# Foreword

This Technical Specification has been produced by the 3rd Generation Partnership Project (3GPP).

The contents of the present document are subject to continuing work within the TSG and may change following formal TSG approval. Should the TSG modify the contents of the present document, it will be re-released by the TSG with an identifying change of release date and an increase in version number as follows:

Version x.y.z

where:

- x the first digit:
  - 1 presented to TSG for information;
  - 2 presented to TSG for approval;
  - 3 or greater indicates TSG approved document under change control.
- y the second digit is incremented for all changes of substance, i.e. technical enhancements, corrections, updates, etc.
- z the third digit is incremented when editorial only changes have been incorporated in the document.

In the present document, modal verbs have the following meanings:

- shall** indicates a mandatory requirement to do something
- shall not** indicates an interdiction (prohibition) to do something

The constructions "shall" and "shall not" are confined to the context of normative provisions, and do not appear in Technical Reports.

The constructions "must" and "must not" are not used as substitutes for "shall" and "shall not". Their use is avoided insofar as possible, and they are not used in a normative context except in a direct citation from an external, referenced, non-3GPP document, or so as to maintain continuity of style when extending or modifying the provisions of such a referenced document.

- should** indicates a recommendation to do something
- should not** indicates a recommendation not to do something
- may** indicates permission to do something
- need not** indicates permission not to do something

The construction "may not" is ambiguous and is not used in normative elements. The unambiguous constructions "might not" or "shall not" are used instead, depending upon the meaning intended.

- can** indicates that something is possible
- cannot** indicates that something is impossible

The constructions "can" and "cannot" are not substitutes for "may" and "need not".

- will** indicates that something is certain or expected to happen as a result of action taken by an agency the behaviour of which is outside the scope of the present document
- will not** indicates that something is certain or expected not to happen as a result of action taken by an agency the behaviour of which is outside the scope of the present document
- might** indicates a likelihood that something will happen as a result of action taken by some agency the behaviour of which is outside the scope of the present document

**might not** indicates a likelihood that something will not happen as a result of action taken by some agency the behaviour of which is outside the scope of the present document

In addition:

**is** (or any other verb in the indicative mood) indicates a statement of fact

**is not** (or any other negative verb in the indicative mood) indicates a statement of fact

The constructions "is" and "is not" do not indicate requirements.

---

# 1 Scope

The present document establishes the minimum RF requirements for NR User Equipment (UE) operating on frequency Range 1.

---

# 2 References

The following documents contain provisions which, through reference in this text, constitute provisions of the present document.

References are either specific (identified by date of publication, edition number, version number, etc.) or non-specific.

For a specific reference, subsequent revisions do not apply.

For a non-specific reference, the latest version applies. In the case of a reference to a 3GPP document (including a GSM document), a non-specific reference implicitly refers to the latest version of that document in the same Release as the present document.

- [1] 3GPP TR 21.905: "Vocabulary for 3GPP Specifications".
- [2] 3GPP TS 38.101-2: "NR; User Equipment (UE) radio transmission and reception; Part 2: Range 2 Standalone".
- [3] 3GPP TS 38.101-3: "NR; User Equipment (UE) radio transmission and reception; Part 3: Range 1 and Range 2 Interworking operation with other radios".
- [4] 3GPP TS 38.521-1: "NR; User Equipment (UE) conformance specification; Radio transmission and reception; Part 1: Range 1 Standalone".
- [5] Recommendation ITU-R M.1545: "Measurement uncertainty as it applies to test limits for the terrestrial component of International Mobile Telecommunications-2000".
- [6] 3GPP TS 38.211: "NR; Physical channels and modulation".
- [7] 3GPP TS 38.331: "Radio Resource Control (RRC) protocol specification".
- [8] 3GPP TS 38.213: "NR; Physical layer procedures for control".
- [9] ITU-R Recommendation SM.329-10, "Unwanted emissions in the spurious domain".
- [10] 3GPP TS 38.214: "NR; Physical layer procedures for data".
- [11] 3GPP TS 36.101: Evolved Universal Terrestrial Radio Access (E-UTRA); User Equipment (UE) radio transmission and reception;
- [12] ETSI TS 102 792: "Intelligent Transport Systems (ITS); Mitigation techniques to avoid interference between European CEN Dedicated Short Range Communication (CEN DSRC) equipment and Intelligent Transport Systems (ITS) operating in the 5 GHz frequency range".
- [13] 3GPP TS 38.133: "NR; Requirements for support of radio resource management".
- [14] 3GPP TS 37.213: "Physical layer procedures for shared spectrum channel access".
- [15] 3GPP TS 38.306: "NR; User Equipment (UE) radio access capabilities".
- [16] 3GPP TS 38.104: "NR; Base Station (BS) radio transmission and reception".
- [17] 3GPP TS 23.256: "Support of Uncrewed Aerial Systems (UAS) connectivity, identification and tracking; Stage 2".

- [18] ECC Decision(22)07, “Harmonised technical conditions for the usage of aerial UE for communications based on LTE and 5G NR in the bands 703-733 MHz, 832-862 MHz, 880-915 MHz, 1710-1785 MHz, 1920-1980 MHz, 2500-2570 MHz and 2570-2620 MHz harmonised for MFCN”, 18 November 22.
- [19] ECC Decision(20)02: “Harmonised use of the paired frequency bands 874.4-880.0 MHz and 919.4-925.0 MHz and of the unpaired frequency band 1900-1910 MHz for Railway Mobile Radio (RMR)”

---

## 3 Definitions, symbols and abbreviations

### 3.1 Definitions

For the purposes of the present document, the terms and definitions given in 3GPP TR 21.905 [1] and the following apply. A term defined in the present document takes precedence over the definition of the same term, if any, in 3GPP TR 21.905 [1].

**Aerial UE:** A UE supporting UAS (Uncrewed Aircraft Systems) as indicated by the capability *aerialUE-Capability-r18* [15] and that has an aerial subscription as described in TS 23.256 [17]. The UE is considered to have access to UAS services after the UE has performed a successful authentication and authorization with the USS as described in TS 23.256 [17].

**Aggregated Allocation Bandwidth:** Total bandwidth of all allocated RBs in a transmission occasion. Can be calculated for two aggregated CCs as  $L_{CRB,1} * 12 * SCS_1 + L_{CRB,2} * 12 * SCS_2$ .

**Aggregated Channel Bandwidth:** The RF bandwidth in which a UE transmits and receives multiple contiguously aggregated carriers.

**ATG UE:** The terminals or user equipments which are mounted in aircraft and support ATG feature (i.e. UE capability *airToGroundNetwork-r18*) as defined in clause 4.2.2 from TS38.306[15].

**Carrier aggregation:** Aggregation of two or more component carriers in order to support wider transmission bandwidths.

**Carrier aggregation band:** A set of one or more operating bands across which multiple carriers are aggregated with a specific set of technical requirements.

**Carrier aggregation bandwidth class:** A class defined by the aggregated transmission bandwidth configuration and maximum number of component carriers supported by a UE.

**Carrier aggregation configuration:** A combination of CA operating band(s) and CA bandwidth class(es) supported by a UE.

**Concurrent operation:** The simultaneous transmission and reception of sidelink and Uu interfaces while operation is agnostic of the service used on each interface.

**Contiguous carriers:** A set of two or more carriers configured in a spectrum block where there are no RF requirements based on co-existence for un-coordinated operation within the spectrum block.

**Contiguous resource allocation:** A resource allocation of consecutive resource blocks within one carrier or across contiguously aggregated carriers. The gap between contiguously aggregated carriers due to the nominal channel spacing is allowed.

**Contiguous spectrum:** Spectrum consisting of a contiguous block of spectrum with no sub-block gap(s).

**Enhanced channel raster:** channel raster with a 10 kHz granularity in bands with a 100 kHz channel raster.

**Inter-band carrier aggregation:** Carrier aggregation of component carriers in different operating bands.

NOTE: Carriers aggregated in each band can be contiguous or non-contiguous.

**Inter-band concurrent operation:** Operation of NR Uu carrier and NR Sidelink carrier in different operating bands.

**Intra-band contiguous carrier aggregation:** Contiguous carriers aggregated in the same operating band.

**Intra-band non-contiguous carrier aggregation:** Non-contiguous carriers aggregated in the same operating band.

**Intra-band SL CA UE:** UE that supports NR SL CA operation in a single band

**NR SL CA:** Aggregation of two or more NR Sidelink component carriers in order to support wider transmission bandwidths

**NR SL inter-band concurrent operating Band :** Band combinations of NR Uu carrier and NR Sidelink carrier in different operating bands.

**NR SL-U UE:** UE that supports NR Sidelink operation in unlicensed bands (e.g. n46, n96, n102).

**Railway Mobile Radio:** railway operations encompassing GSM-R and its successor(s), including the Future Railway Mobile Communication System (FRMCS); in the context of this specification the Railway Mobile Radio is limited to NR operation in band n100, or n101.

**RedCap UE:** The UE with reduced capabilities as defined in clause 4.2.21.1 from TS38.306 [15].

**Sub-band:** For a UE that supports shared spectrum channel access in wideband operation, a sub-band is the set of RBs within an approximately 20 MHz segment of the channel where the wideband channel is uniformly divided into an integer number of 20 MHz sub-bands. Sub-bands may be separately allocated in uplink and downlink.

**Sub-block:** This is one contiguous allocated block of spectrum for transmission and reception by the same UE. There may be multiple instances of sub-blocks within an RF bandwidth.

**Sub-block bandwidth:** The bandwidth of one sub-block.

**Sub-block gap:** A frequency gap between two consecutive sub-blocks within an RF bandwidth, where the RF requirements in the gap are based on co-existence for un-coordinated operation.

**Two Rx antenna port XR UE:** A non-(e)RedCap XR UE that is equipped with only two Rx antenna ports in frequency band(s) where 4 Rx antenna ports are required. The UE is intended to be worn on human head. When in use, is intended to be supported only by/behind the ears and by a nose-bridge resulting in a constrained form factor with limited volume available for Rx chains.

**UE transmission bandwidth configuration:** Set of resource blocks located within the UE channel bandwidth which may be used for transmitting or receiving by the UE.

**Vehicular UE:** A UE embedded in a vehicle, permanently connected to an embedded antenna system that radiates externally for NR operating bands.

NOTE: Vehicular UE does not refer to other UE form factors placed inside the vehicle.

**Wideband operation:** For a UE that supports shared spectrum channel access, wideband operation refers to operation within a channel larger than 20 MHz in which intra-cell guard bands may be configured to distinguish individual RB-sets

## 3.2 Symbols

For the purposes of the present document, the following symbols apply:

$\Delta F_{\text{Global}}$	Granularity of the global frequency raster
$\Delta F_{\text{Raster}}$	Band dependent channel raster granularity
$\Delta f_{\text{OOB}}$	$\Delta$ Frequency of Out Of Band emission
$\Delta F_{\text{TX-RX}}$	Maximum deviation to the Tx-Rx carrier center frequency separation for asymmetric uplink/downlink channel bandwidth operation
$\Delta \text{MPR}_c$	Allowed Maximum Power Reduction relaxation for serving cell $c$
$\Delta P_{\text{PowerClass}}$	Adjustment to maximum output power for a given power class
$\Delta_{\text{RB}}$	The starting frequency offset between the allocated RB and the measured non-allocated RB

$\Delta R_{IB,c}$	Allowed reference sensitivity relaxation due to support for inter-band CA operation, for serving cell $c$
$\Delta R_{IBC}$	Allowed relaxation to the power class 3 reference sensitivity level due to support for intra-band contiguous CA operation
$\Delta R_{IBNC}$	Allowed relaxation to the power class 3 reference sensitivity level due to support for intra-band non-contiguous CA operation
$\Delta R_{IB,4R}$	Reference sensitivity adjustment due to support for 4 antenna ports
$\Delta R_{IB,8R}$	Reference sensitivity adjustment due to support for 8 antenna ports
$\Delta R_{1R}$	Reference sensitivity adjustment due to support for 1 antenna ports
$\Delta R_{XR,2R}$	Reference sensitivity adjustment for two antenna ports XR UEs on bands defined in Table 7.3.2-2b
$\Delta Shift$	Channel raster offset
$\Delta T_C$	Allowed operating band edge transmission power relaxation
$\Delta T_{C,c}$	Allowed operating band edge transmission power relaxation for serving cell $c$
$\Delta T_{IB,c}$	Allowed maximum configured output power relaxation due to support for inter-band CA operation, inter-band NR-DC operation and due to support for SUL operations, for serving cell $c$
$BW_{Channel}$	Channel bandwidth
$BW_{Channel,block}$	Sub-block bandwidth, expressed in MHz. $BW_{Channel,block} = F_{edge,block,high} - F_{edge,block,low}$
$BW_{Channel,CA}$	Aggregated channel bandwidth, expressed in MHz
$BW_{Channel,max}$	Maximum channel bandwidth supported among all bands in a release
$BW_{GB}$	$\max(GB_{Channel,low}, GB_{Channel,high})$
$BW_{DL}$	Channel bandwidth for DL
$BW_{UL}$	Channel bandwidth for UL
$BW_{interferer}$	Bandwidth of the interferer
$Ceil(x)$	Rounding upwards; $ceil(x)$ is the smallest integer such that $ceil(x) \geq x$
$Floor(x)$	Rounding downwards; $floor(x)$ is the greatest integer such that $floor(x) \leq x$
$F_C$	Center frequency of a carrier for a numerology defined by the <i>RF reference frequency</i> on the channel raster mapped to the carrier according to sub-clause 5.4.2.2 $F_{C,block,high}$ $F_C$ of the highest transmitted/received carrier in a <i>sub-block</i>
$F_{C,block,low}$	$F_C$ of the lowest transmitted/received carrier in a <i>sub-block</i>
$F_{C,low}$	The $F_C$ of the lowest carrier, expressed in MHz
$F_{C,high}$	The $F_C$ of the highest carrier, expressed in MHz
$F_{DL,low}$	The lowest frequency of the downlink <i>operating band</i>
$F_{DL,high}$	The highest frequency of the downlink <i>operating band</i>
$F_{UL,low}$	The lowest frequency of the uplink <i>operating band</i>
$F_{UL,high}$	The highest frequency of the uplink <i>operating band</i>
$F_{edge,block,low}$	The lower <i>sub-block</i> edge, where $F_{edge,block,low} = F_{C,block,low} - F_{offset,low}$ .
$F_{edge,block,high}$	The upper <i>sub-block</i> edge, where $F_{edge,block,high} = F_{C,block,high} + F_{offset,high}$ .
$F_{edge,low}$	The <i>lower edge</i> of aggregated channel bandwidth, expressed in MHz. $F_{edge,low} = F_{C,low} - F_{offset,low}$ .
$F_{edge,high}$	The <i>higher edge</i> of aggregated channel bandwidth, expressed in MHz. $F_{edge,high} = F_{C,high} + F_{offset,high}$ .
$F_{Interferer} (offset)$	Frequency offset of the interferer (between the center frequency of the interferer and the carrier frequency of the carrier measured). For intra-band contiguous CA, the $F_{Interferer} (offset)$ is the frequency separation of the center frequency of the carrier closest to the interferer and the center frequency of the interferer
$F_{Interferer}$	Frequency of the interferer
$F_{ioffset}$	Frequency offset of the interferer (between the center frequency of the interferer and the closest edge of the carrier measured)
$F_{offset}$	Frequency offset from $F_{C,high}$ to the <i>higher edge</i> or $F_{C,low}$ to the <i>lower edge</i> .
$F_{offset,high}$	Frequency offset from $F_{C,high}$ to the upper <i>UE RF Bandwidth edge</i> , or from $F_{C,block,high}$ to the upper sub-block edge
$F_{offset,low}$	Frequency offset from $F_{C,low}$ to the lower <i>UE RF Bandwidth edge</i> , or from $F_{C,block,low}$ to the lower sub-block edge
$F_{OOB}$	The boundary between the NR out of band emission and spurious emission domains
$F_{REF}$	RF reference frequency
$F_{REF-Offs}$	Offset used for calculating $F_{REF}$
$F_{REF,shift}$	RF reference frequency for Supplementary Uplink (SUL) bands, the uplink of all FDD bands, and TDD bands
$F_{uw} (offset)$	The frequency separation of the center frequency of the carrier closest to the interferer and the center frequency of the interferer
$G_{n100post connector}$	Declared value of the post chipset unit antenna connector gain for band n100, used for conversion of the radiated requirement into a conducted requirement (see principles described in annex M)

$G_{n101\text{post connector}}$	Declared value of the post chipset unit antenna connector gain for band n101, used for conversion of the radiated requirement into a conducted requirement (see principles described in annex M)
$GB_{\text{Channel}}$	Minimum guard band defined in clause 5.3.3, expressed in kHz
$GB_{\text{Channel}(i)}$	Minimum guard band defined in clause 5.3.3 of carrier $i$
$GB_{\text{Channel,low}}$	Minimum guard band defined in clause 5.3.3 for the lowest assigned component carrier in clause 5.3A.3
$GB_{\text{Channel,high}}$	Minimum guard band defined in clause 5.3.3 for the highest assigned component carrier in clause 5.3A.3
$L_{\text{CRB}}$	Transmission bandwidth which represents the length of a contiguous resource block allocation expressed in units of resource blocks
$\text{Max}()$	The largest of given numbers
$\text{Min}()$	The smallest of given numbers
$n_{\text{PRB}}$	Physical resource block number
$NR_{\text{ACLR}}$	NR ACLR
$N_{\text{RB}}$	Transmission bandwidth configuration, expressed in units of resource blocks
$N_{\text{RB\_agg}}$	The number of the aggregated RBs within the fully allocated aggregated channel bandwidth $N_{\text{RB\_agg}} = \sum_{i=1}^j N_{\text{RB}_i} * 2^{\mu_i}$ for carrier 1 to j, where $\mu$ is defined in TS 38.211 [6]
$N_{\text{RB},c}$	The transmission bandwidth configuration of component carrier c, expressed in units of resource blocks $N_{\text{RB},c_j} = N_{\text{RB}_j} * 2^{\mu_j}$ for carrier j, where $\mu$ is defined in TS 38.211 [6]
$N_{\text{RB,largest BW}}$	The largest transmission bandwidth configuration of the component carriers in the bandwidth combination, expressed in units of resource blocks
$N_{\text{RB,low}}$	The transmission bandwidth configurations according to Table 5.3.2-1 for the lowest assigned component carrier in clause 5.3A.1
$N_{\text{RB,high}}$	The transmission bandwidth configurations according to Table 5.3.2-1 for the highest assigned component carrier in clause 5.3A.1
$N_{\text{REF}}$	NR Absolute Radio Frequency Channel Number (NR-ARFCN)
$N_{\text{REF-Offs}}$	Offset used for calculating $N_{\text{REF}}$
$P_{\text{CMAX}}$	The configured maximum UE output power
$P_{\text{CMAX},c}$	The configured maximum UE output power for serving cell c
$P_{\text{CMAX},f,c}$	The configured maximum UE output power for carrier f of serving cell c in each slot
$P_{\text{EMAX}}$	Maximum allowed UE output power signalled by higher layers
$P_{\text{EMAX},c}$	Maximum allowed UE output power signalled by higher layers for serving cell c
$P_{\text{Interferer}}$	Modulated mean power of the interferer
$P_{\text{largest BW}}$	Power of the largest transmission bandwidth configuration of the component carriers in the bandwidth combination
$P_{\text{PowerClass}}$	The nominal UE power (i.e., no tolerance)
$P_{\text{max},c,AC}$	Maximum output power defined as the sum of measurement of all antenna connectors
$P_{\text{max},c,TABC}$	Maximum carrier output power defined as the sum of measurement of all TAB connectors
$P_{\text{rated},c,AC}$	Rated maximum output power defined as the sum of power over all antenna connectors
$P_{\text{rated},c,TABC}$	Rated maximum output power defined as the sum of power over all TAB connectors
$P\text{-MPR}_c$	Power Management Maximum Power Reduction for serving cell c
$P_{\text{RB}}$	The transmitted power per allocated RB, measured in dBm
$P_{\text{REFSENS\_SL}}$	The REFSENS power for Sidelink
$P_{\text{UMAX}}$	The measured configured maximum UE output power
$P_{\text{uw}}$	Power of an unwanted DL signal
$P_{\text{w}}$	Power of a wanted DL signal
$RB_{\text{start}}$	The lowest RB index of transmitted resource blocks
$RB_{\text{start\_CA}}$	The lowest RB index of transmitted resource blocks for intra-band contiguous CA
$SCS_c$	SCS for the component carrier c, expressed in kHz
$SCS_{\text{largest BW}}$	SCS for the largest transmission bandwidth configuration of the component carriers in the bandwidth combination, expressed in kHz
$SCS_{\text{low}}$	SCS for the lowest assigned component carrier in clause 5.3A.1, expressed in kHz
$SCS_{\text{high}}$	SCS for the highest assigned component carrier in clause 5.3A.1, expressed in kHz
$tp$	Transient Period value signalled by the UE
$tp_{\text{start}}$	Start position of transient period relative to the symbol boundary
$T(P_{\text{CMAX},f,c})$	Tolerance for applicable values of $P_{\text{CMAX},f,c}$ for configured maximum UE output power for carrier f of serving cell c

$T_{L,c}$	Absolute value of the lower tolerance for the applicable <i>operating band</i> as specified in clause 6.2.1
$SS_{REF}$	SS block reference frequency position
$UTRA_{ACLR}$	UTRA ACLR

### 3.3 Abbreviations

For the purposes of the present document, the abbreviations given in 3GPP TR 21.905 [1] and the following apply. An abbreviation defined in the present document takes precedence over the definition of the same abbreviation, if any, in 3GPP TR 21.905 [1].

ACLR	Adjacent Channel Leakage Ratio
ACS	Adjacent Channel Selectivity
A-MPR	Additional Maximum Power Reduction
ATG	Air-To-Ground
BS	Base Station
BW	Bandwidth
BWP	Bandwidth Part
CA	Carrier Aggregation
CA_nX-nY	Inter-band CA of component carrier(s) in one sub-block within Band nX and component carrier(s) in one sub-block within Band nY where nX and nY are the applicable NR <i>operating bands</i>
CC	Component Carriers
CG	Carrier Group
CP-OFDM	Cyclic Prefix-OFDM
CW	Continuous Wave
DC	Dual Connectivity
DFT-s-OFDM	Discrete Fourier Transform-spread-OFDM
DM-RS	Demodulation Reference Signal
DTX	Discontinuous Transmission
E-UTRA	Evolved UTRA
EIRP	Equivalent Isotropically Radiated Power
EVM	Error Vector Magnitude
FR	Frequency Range
FRC	Fixed Reference Channel
FRMCS	Future Railway Mobile Communication System
FWA	Fixed Wireless Access
GSCN	Global Synchronization Channel Number
HD	Half Duplex
IBB	In-band Blocking
IDFT	Inverse Discrete Fourier Transformation
ITS	Intelligent Transportation System
ITU-R	Radiocommunication Sector of the International Telecommunication Union
MBW	Measurement bandwidth defined for the protected band
MCG	Master Cell Group
MOP	Maximum Output Power
MPR	Allowed maximum power reduction
MSD	Maximum Sensitivity Degradation
NR	New Radio
NR-ARFCN	NR Absolute Radio Frequency Channel Number
NS	Network Signalling
OCNG	OFDMA Channel Noise Generator
OOB	Out-of-band
P-MPR	Power Management Maximum Power Reduction
PRB	Physical Resource Block
PS	Public Safety
PSBCH	Physical Sidelink Broadcast CHannel
PSCCH	Physical Sidelink Control CHannel
PSFCH	Physical Sidelink Feedback CHannel
PSSCH	Physical Sidelink Shared CHannel
QAM	Quadrature Amplitude Modulation
RE	Resource Element
REFSENS	Reference Sensitivity



RedCap	Reduced Capability
RF	Radio Frequency
RMR	Railway Mobile Radio
RMS	Root Mean Square (value)
RSRP	Reference Signal Receiving PowerRx Receiver
Rx	Receiver
SC	Single Carrier
SCG	Secondary Cell Group
SCS	Subcarrier spacing
SDL	Supplementary Downlink
SEM	Spectrum Emission Mask
SL	Sidelink
SL-MIMO	Sidelink-Multiple Antenna transmission
SL-U	Sidelink at unlicensed band
SNR	Signal-to-Noise Ratio
SRS	Sounding Reference Symbol
SS	Synchronization Symbol
S-SSB	Sidelink Synchronization Signal Block
SUL	Supplementary uplink
TAB	Transceiver Array Boundary
TAE	Time Alignment Error
TAG	Timing Advance Group
Tx	Transmitter
TxD	Tx Diversity
UAS	Uncrewed Aircraft Systems
UAV	Uncrewed Aerial Vehicle
UL MIMO	Uplink Multiple Antenna transmission
ULFPTx	Uplink Full Power Transmission
USS	UAS Service Supplier
V2X	Vehicle to Everything
XR	eXtended Reality

---

## 4 General

### 4.1 Relationship between minimum requirements and test requirements

The present document is a Single-RAT specification for NR UE, covering RF characteristics and minimum performance requirements. Conformance to the present specification is demonstrated by fulfilling the test requirements specified in the conformance specification 3GPP TS 38.521-1 [4].

The Minimum Requirements given in this specification make no allowance for measurement uncertainty. The test specification TS 38.521-1 [4] defines test tolerances. These test tolerances are individually calculated for each test. The test tolerances are used to relax the minimum requirements in this specification to create test requirements. For some requirements, including regulatory requirements, the test tolerance is set to zero.

The measurement results returned by the test system are compared - without any modification - against the test requirements as defined by the shared risk principle.

The shared risk principle is defined in Recommendation ITU-R M.1545 [5].

### 4.2 Applicability of minimum requirements

- a) In this specification the Minimum Requirements are specified as general requirements and additional requirements. Where the Requirement is specified as a general requirement, the requirement is mandated to be met in all scenarios
- b) For specific scenarios for which an additional requirement is specified, in addition to meeting the general requirement, the UE is mandated to meet the additional requirements.

- c) The spurious emissions power requirements are for the long-term average of the power. For the purpose of reducing measurement uncertainty it is acceptable to average the measured power over a period of time sufficient to reduce the uncertainty due to the statistical nature of the signal
- d) All the requirements for intra-band contiguous and non-contiguous CA apply under the assumption of the same slot format indicated by UL-DL-configuration-common in the PCell and SCells for NR SA.
- e) The requirements for Tx diversity are applied for UE which indicates Tx diversity capability by IE *txDiversity-r16*, *txDiversity2Tx-r18* or *txDiversity4Tx-r18*. 2Tx requirements for TxD should be applied to UE indicating *txDiversity-r16* or *txDiversity2Tx-r18*, and 4Tx requirements should be applied to UE indicating *txDiversity4Tx-r18*.
- f) All the requirements for intra-band contiguous SL CA apply under the assumption of the same subcarrier spacing for SL CA.

## 4.3 Specification suffix information

Unless stated otherwise, the suffixes shown in Table 4.3-1 are used for indicating at 2<sup>nd</sup> level clause. For shared spectrum channel access, suffixes A, B, and D are used for indicating at 3<sup>rd</sup> level clause. For V2X, suffixes A and F are used for indicating at 3<sup>rd</sup> level clause.

**Table 4.3-1: Definition of suffixes**

Clause suffix	Variant
None	Single Carrier
A	Carrier Aggregation (CA)
B	Dual-Connectivity (DC)
C	Supplementary Uplink (SUL)
D	UL MIMO
E	V2X
F	Shared spectrum channel access
G	Tx Diversity (TxD)
H	Carrier Aggregation (CA) with UL MIMO
I	RedCap
J	ATG
K	Aerial UE (UAV)
L	Carrier Aggregation (CA) with Tx Diversity

A terminal which supports the above features needs to meet both the general requirements and the additional requirement applicable to the additional clause (suffixes A to L) in clauses 5, 6 and 7. Where there is a difference in requirement between the general requirements and the additional clause requirements (suffixes A to L) in clauses 5, 6 and 7, the tighter requirements are applicable unless stated otherwise in the additional clause.

A terminal which supports advanced V2X services, public safety services and other commercial use cases related to NR sidelink operation shall meet all of the separate corresponding requirements in suffix E.

For a terminal that supports SUL for the band combination specified in Table 5.2C-1, the current version of the specification assumes the terminal is configured with active transmission either on UL carrier or SUL carrier at any time in one serving cell and the UE requirements for single carrier shall apply for the active UL or SUL carrier accordingly.

For a terminal that supports public safety service using sidelink, the minimum requirements are applicable when

- The UE is associated with a serving cell on PS carrier, or
- The UE is not associated with a serving cell on the PS carrier and is provisioned with the preconfigured radio parameters for PS that are associated with known Geographical Area, or
- The UE is associated with a serving cell on a carrier different than the PS carrier, and the radio parameters for PS that are provided by the serving cell, or

- The UE is associated with a serving cell on a carrier different than the PS carrier, and has a non-serving cell selected on the PS carrier with the preconfigured radio parameters.

When the advanced-V2X or PS UE is not associated with a serving cell on the V2X or PS carrier, and the UE does not have knowledge of its geographical area, or is provisioned with preconfigured radio parameters that are not associated with any Geographical Area, V2X or PS UE' transmissions are not allowed, and the requirements in Section 6.3E.2 apply.

For a terminal that supports operation in shared spectrum, the current version of this specification assumes in the uplink sub-bands within a wideband channel shall be contiguously allocated to the UE. The uplink requirements for one or more non-transmitted sub-bands between two transmitted sub-bands does not form a part of the current version of this specification.

Terminal that supports inter-band NR-DC configuration shall meet the minimum requirements for corresponding CA configuration (suffix A), unless otherwise specified.

For a terminal that supports inter-band Carrier Aggregation (CA) with UL MIMO or Tx diversity operation, the requirements are targeted for FWA form factor in current version of specification.

A terminal which supports intra-band contiguous UL CA with UL MIMO shall meet the corresponding requirements in suffix H with all UL CCs with UL MIMO.

A terminal which supports inter-band UL CA with UL MIMO shall meet the corresponding requirements in suffix H with all UL CCs with UL MIMO for the frequency band(s) said to be with UL MIMO.

## 5 Operating bands and channel arrangement

### 5.1 General

The channel arrangements presented in this clause are based on the operating bands and channel bandwidths defined in the present release of specifications.

NOTE: Other operating bands and channel bandwidths may be considered in future releases.

Requirements throughout the RF specifications are in many cases defined separately for different frequency ranges (FR). The frequency ranges in which NR can operate according to this version of the specification are identified as described in Table 5.1-1. Whenever the FR2 is referred, both FR2-1 and FR2-2 frequency sub-ranges shall be considered, unless otherwise stated.

**Table 5.1-1: Definition of frequency ranges**

Frequency range designation		Corresponding frequency range
FR1		410 MHz – 7125 MHz
FR2	FR2-1	24250 MHz – 52600 MHz
	FR2-2	52600 MHz – 71000 MHz

The present specification covers FR1 operating bands.

### 5.2 Operating bands

NR is designed to operate in the FR1 operating bands defined in Table 5.2-1.

**Table 5.2-1: NR operating bands in FR1**

NR operating	Uplink (UL) <i>operating band</i> BS receive / UE transmit	Downlink (DL) <i>operating band</i> BS transmit / UE receive	Duplex Mode
--------------	---	---	-------------

band	F <sub>UL_low</sub> – F <sub>UL_high</sub>	F <sub>DL_low</sub> – F <sub>DL_high</sub>	
n1	1920 MHz – 1980 MHz	2110 MHz – 2170 MHz	FDD
n2	1850 MHz – 1910 MHz	1930 MHz – 1990 MHz	FDD
n3	1710 MHz – 1785 MHz	1805 MHz – 1880 MHz	FDD
n5	824 MHz – 849 MHz	869 MHz – 894 MHz	FDD
n7	2500 MHz – 2570 MHz	2620 MHz – 2690 MHz	FDD
n8	880 MHz – 915 MHz	925 MHz – 960 MHz	FDD
n12	699 MHz – 716 MHz	729 MHz – 746 MHz	FDD
n13	777 MHz – 787 MHz	746 MHz – 756 MHz	FDD
n14	788 MHz – 798 MHz	758 MHz – 768 MHz	FDD
n18	815 MHz – 830 MHz	860 MHz – 875 MHz	FDD
n20	832 MHz – 862 MHz	791 MHz – 821 MHz	FDD
n24 <sup>16</sup>	1626.5 MHz – 1660.5 MHz	1525 MHz – 1559 MHz	FDD
n25	1850 MHz – 1915 MHz	1930 MHz – 1995 MHz	FDD
n26	814 MHz – 849 MHz	859 MHz – 894 MHz	FDD
n28	703 MHz – 748 MHz	758 MHz – 803 MHz	FDD
n29 <sup>19</sup>	N/A	717 MHz – 728 MHz	SDL
n30 <sup>3</sup>	2305 MHz – 2315 MHz	2350 MHz – 2360 MHz	FDD
n31	452.5 MHz – 457.5 MHz	462.5 MHz – 467.5 MHz	FDD
n34	2010 MHz – 2025 MHz	2010 MHz – 2025 MHz	TDD
n38 <sup>10</sup>	2570 MHz – 2620 MHz	2570 MHz – 2620 MHz	TDD
n39	1880 MHz – 1920 MHz	1880 MHz – 1920 MHz	TDD
n40	2300 MHz – 2400 MHz	2300 MHz – 2400 MHz	TDD
n41	2496 MHz – 2690 MHz	2496 MHz – 2690 MHz	TDD
n46 <sup>13</sup>	5150 MHz – 5925 MHz	5150 MHz – 5925 MHz	TDD
n47 <sup>11</sup>	5855 MHz – 5925 MHz	5855 MHz – 5925 MHz	TDD
n48	3550 MHz – 3700 MHz	3550 MHz – 3700 MHz	TDD
n50 <sup>1</sup>	1432 MHz – 1517 MHz	1432 MHz – 1517 MHz	TDD
n51	1427 MHz – 1432 MHz	1427 MHz – 1432 MHz	TDD
n53	2483.5 MHz – 2495 MHz	2483.5 MHz – 2495 MHz	TDD
n54	1670 MHz – 1675 MHz	1670 MHz – 1675 MHz	TDD
n65 <sup>4</sup>	1920 MHz – 2010 MHz	2110 MHz – 2200 MHz	FDD
n66 <sup>6,7</sup>	1710 MHz – 1780 MHz	2110 MHz – 2200 MHz	FDD
n67 <sup>19</sup>	N/A	738 MHz – 758 MHz	SDL
n70	1695 MHz – 1710 MHz	1995 MHz – 2020 MHz	FDD
n71	663 MHz – 698 MHz	617 MHz – 652 MHz	FDD
n72	451 MHz – 456 MHz	461 MHz – 466 MHz	FDD
n74	1427 MHz – 1470 MHz	1475 MHz – 1518 MHz	FDD
n75 <sup>2,19</sup>	N/A	1432 MHz – 1517 MHz	SDL
n76 <sup>19</sup>	N/A	1427 MHz – 1432 MHz	SDL
n77 <sup>12</sup>	3300 MHz – 4200 MHz	3300 MHz – 4200 MHz	TDD
n78	3300 MHz – 3800 MHz	3300 MHz – 3800 MHz	TDD
n79 <sup>17</sup>	4400 MHz – 5000 MHz	4400 MHz – 5000 MHz	TDD
n80	1710 MHz – 1785 MHz	N/A	SUL
n81	880 MHz – 915 MHz	N/A	SUL
n82	832 MHz – 862 MHz	N/A	SUL
n83	703 MHz – 748 MHz	N/A	SUL
n84	1920 MHz – 1980 MHz	N/A	SUL
n85	698 MHz – 716 MHz	728 MHz – 746 MHz	FDD
n86	1710 MHz – 1780 MHz	N/A	SUL
n89	824 MHz – 849 MHz	N/A	SUL
n90 <sup>5</sup>	2496 MHz – 2690 MHz	2496 MHz – 2690 MHz	TDD
n91 <sup>9</sup>	832 MHz – 862 MHz	1427 MHz – 1432 MHz	FDD
n92 <sup>9</sup>	832 MHz – 862 MHz	1432 MHz – 1517 MHz	FDD
n93 <sup>9</sup>	880 MHz – 915 MHz	1427 MHz – 1432 MHz	FDD
n94 <sup>9</sup>	880 MHz – 915 MHz	1432 MHz – 1517 MHz	FDD
n95 <sup>8</sup>	2010 MHz – 2025 MHz	N/A	SUL
n96 <sup>13,14</sup>	5925 MHz – 7125 MHz	5925 MHz – 7125 MHz	TDD
n97 <sup>15</sup>	2300 MHz – 2400 MHz	N/A	SUL
n98 <sup>15</sup>	1880 MHz – 1920 MHz	N/A	SUL
n99 <sup>22</sup>	1626.5 MHz – 1660.5 MHz	N/A	SUL
n100 <sup>21</sup>	874.4 MHz – 880 MHz	919.4 MHz – 925 MHz	FDD
n101 <sup>21</sup>	1900 MHz – 1910 MHz	1900 MHz – 1910 MHz	TDD
n102 <sup>13,14</sup>	5925 MHz – 6425 MHz	5925 MHz – 6425 MHz	TDD
n104 <sup>17,18</sup>	6425 MHz – 7125 MHz	6425 MHz – 7125 MHz	TDD

n105	663 MHz – 703 MHz	612 MHz – 652 MHz	FDD
n106	896 MHz – 901 MHz	935 MHz – 940 MHz	FDD
n109 <sup>9</sup>	703 MHz – 733 MHz	1432 MHz – 1517 MHz	FDD
NOTE 1: UE that complies with the NR Band n50 minimum requirements in this specification shall also comply with the NR Band n51 minimum requirements.			
NOTE 2: UE that complies with the NR Band n75 minimum requirements in this specification shall also comply with the NR Band n76 minimum requirements.			
NOTE 3: Uplink transmission is not allowed at this band for UE with external vehicle-mounted antennas.			
NOTE 4: A UE that complies with the NR Band n65 minimum requirements in this specification shall also comply with the NR Band n1 minimum requirements.			
NOTE 5: Unless otherwise stated, the applicability of requirements for Band n90 is in accordance with that for Band n41; a UE supporting Band n90 shall meet the requirements for Band n41. A UE supporting Band n90 shall also support band n41.			
NOTE 6: A UE that supports NR Band n66 shall receive in the entire DL operating band.			
NOTE 7: A UE that supports NR Band n66 and CA operation in any CA band shall also comply with the minimum requirements specified for the DL CA configurations CA_n66B and CA_n66(2A) in the current version of the specification.			
NOTE 8: This band is applicable in China only.			
NOTE 9: Variable duplex operation does not enable dynamic variable duplex configuration by the network, and is used such that DL and UL frequency ranges are supported independently in any valid frequency range for the band.			
NOTE 10: When this band is used for V2X SL service, the band is exclusively used for NR V2X in particular regions.			
NOTE 11: This band is unlicensed band used for V2X service. There is no expected network deployment in this band.			
NOTE 12: In the USA this band is restricted to 3450 – 3550 MHz and 3700 – 3980 MHz. In Canada this band is restricted to 3450 – 3650 MHz and 3650 – 3980 MHz.			
NOTE 13: This band is restricted to operation with shared spectrum channel access as defined in TS 37.213 [14].			
NOTE 14: This band is applicable only in countries/regions designating this band for shared-spectrum access use subject to country-specific conditions.			
NOTE 15: The requirements for this band are applicable only where no other NR or E-UTRA TDD operating band(s) are used within the frequency range of this band in the same geographical area. For scenarios where other NR or E-UTRA TDD operating band(s) are used within the frequency range of this band in the same geographical area, special co-existence requirements may apply that are not covered by the 3GPP specifications.			
NOTE 16: DL operation in this band is restricted to 1526 – 1536 MHz and UL operation is restricted to 1627.5 – 1637.5 MHz and 1646.5 – 1656.5 MHz.			
NOTE 17: For this band, CORESET#0 values from Table 13-5 or Table 13-6 in [8, TS 38.213] are applied regardless of the minimum channel bandwidth.			
NOTE 18: This band is applicable only in countries/regions designating this band for IMT licensed operation subject to country-specific conditions.			
NOTE 19: For SDL bands, downlink configuration for RRM performance testing is same as FDD.			
NOTE 20: Operating band n200 is a reserved value.			
NOTE 21: This band is applicable only in countries subject to ECC Decision (20)02 [16], for the FRMCS application.			
NOTE 22: UL operation in this band is restricted to 1627.5 – 1637.5 MHz and 1646.5 – 1656.5 MHz.			

## 5.2A Operating bands for CA

### 5.2A.0 General

CA operating bands including Band n90 are defined by the corresponding CA operating bands including Band n41 with Band n90 replacing Band n41. For brevity the said CA operating bands including Band n90 are not listed in the tables below but are covered by this specification.

## 5.2A.1 Intra-band CA

NR intra-band carrier aggregation is designed to operate in the operating bands defined in Table 5.2A.1-1 and Table 5.2A.1-2, where all operating bands are within FR1.

**Table 5.2A.1-1: Intra-band contiguous CA operating bands in FR1**

NR CA Band	NR Band (Table 5.2-1)
CA_n1	n1
CA_n2	n2
CA_n3	n3
CA_n5	n5
CA_n7	n7
CA_n25	n25
CA_n38	n38
CA_n40	n40
CA_n41	n41
CA_n46	n46
CA_n48	n48
CA_n66	n66
CA_n71	n71
CA_n77	n77
CA_n78	n78
CA_n79	n79
CA_n96	n96
CA_n102	n102
NOTE 1: The minimum requirements only apply for non simultaneous Tx/Rx between all carriers for TDD combinations.	

**Table 5.2A.1-2: Intra-band non-contiguous CA operating bands in FR1**

NR CA Band	NR Band (Table 5.2-1)
CA_n1(*)	n1
CA_n3(*)	n3
CA_n5(*)	n5
CA_n7(*)	n7
CA_n12(*)	n12
CA_n25(*)	n25
CA_n26(*)	n26
CA_n41(*)	n41
CA_n48(*)	n48
CA_n66(*)	n66
CA_n71(*)	n71
CA_n77(*)	n77
CA_n78(*)	n78
CA_n96(*)	n96
CA_n102(*)	n102
NOTE 1: The minimum requirements only apply for non simultaneous Tx/Rx between all carriers for TDD combinations.	
NOTE 2: The notation CA_nX(*) in this table indicates intra-band non-contiguous CA for band nX. The configurations for each band are in 5.5A.2.	

## 5.2A.2 Inter-band CA

NR inter-band carrier aggregation is designed to operate in the operating bands defined in Table 5.2A.2.1-1, Table 5.2A.2.2-1, Table 5.2A.2.3-1, Table 5.2A.2.4-1 and Table 5.2A.2.5-1, where all operating bands are within FR1.

If the mandatory simultaneous Rx/Tx capability applies for a lower order band combination, when the applicable lower order band combination is a band pair in a higher order band combination, the mandatory simultaneous Rx/Tx capability also applies for the band pair in the higher order band combination.

**Table 5.2A.2-1: Void**

**Table 5.2A.2-2: Void**

**Table 5.2A.2-3: Void**

### 5.2A.2.1 Inter-band CA (two bands)

**Table 5.2A.2.1-1: Inter-band CA operating bands involving FR1 (two bands)**

NR CA Band	NR Band (Table 5.2-1)	DL interruption allowed (Note 8)
CA_n1-n3	n1, n3	
CA_n1-n5	n1, n5	
CA_n1-n7	n1, n7	
CA_n1-n8	n1, n8	
CA_n1-n18	n1, n18	
CA_n1-n20	n1, n20	
CA_n1-n26	n1, n26	
CA_n1-n28	n1, n28	
CA_n1-n38	n1, n38	
CA_n1-n40	n1, n40	
CA_n1-n41 <sup>1</sup>	n1, n41	
CA_n1-n46	n1, n46	
CA_n1-n67	n1, n67	
CA_n1-n74	n1, n74	
CA_n1-n75	n1, n75	
CA_n1-n77 <sup>1</sup>	n1, n77	No
CA_n1-n78 <sup>1</sup>	n1, n78	No
CA_n1-n79 <sup>1</sup>	n1, n79	No
CA_n1-n102	n1, n102	
CA_n1-n105	n1, n105	
CA_n2-n5	n2, n5	
CA_n2-n7	n2, n7	
CA_n2-n12	n2, n12	
CA_n2-n14	n2, n14	
CA_n2-n29	n2, n29	
CA_n2-n30	n2, n30	
CA_n2-n41	n2, n41	
CA_n2-n48	n2, n48	
CA_n2-n66	n2, n66	
CA_n2-n71	n2, n71	
CA_n2-n77	n2, n77	
CA_n2-n78	n2, n78	
CA_n3-n5	n3, n5	
CA_n3-n7	n3, n7	
CA_n3-n8	n3, n8	
CA_n3-n18	n3, n18	
CA_n3-n20	n3, n20	
CA_n3-n26	n3, n26	
CA_n3-n28	n3, n28	

CA_n3-n34 <sup>1</sup>	n3, n34	
CA_n3-n38	n3, n38	
CA_n3-n39	n3, n39	
CA_n3-n40 <sup>1</sup>	n3, n40	No
CA_n3-n41 <sup>1</sup>	n3, n41	No
CA_n3-n67	n3, n67	
CA_n3-n74	n3, n74	
CA_n3-n75	n3, n75	
CA_n3-n77 <sup>1</sup>	n3, n77	No
CA_n3-n78 <sup>1</sup>	n3, n78	No
CA_n3-n79 <sup>1</sup>	n3, n79	No
CA_n3-n102	n3, n102	
CA_n3-n105	n3, n105	
CA_n5-n7	n5, n7	
CA_n5-n8	n5, n8	
CA_n5-n12	n5, n12	
CA_n5-n13	n5, n13	
CA_n5-n14	n5, n14	
CA_n5-n25	n5, n25	
CA_n5-n28	n5, n28	
CA_n5-n29	n5, n29	
CA_n5-n30	n5, n30	
CA_n5-n40	n5, n40	
CA_n5-n41	n5, n41	
CA_n5-n48	n5, n48	
CA_n5-n66	n5, n66	
CA_n5-n71	n5, n71	
CA_n5-n77 <sup>1</sup>	n5, n77	
CA_n5-n78 <sup>1</sup>	n5, n78	No
CA_n5-n79 <sup>1</sup>	n5, n79	No
CA_n5-n105	n5, n105	
CA_n7-n8	n7, n8	
CA_n7-n12	n7, n12	
CA_n7-n20	n7, n20	
CA_n7-n25	n7, n25	
CA_n7-n26	n7, n26	
CA_n7-n28	n7, n28	
CA_n7-n40	n7, n40	
CA_n7-n46 <sup>6</sup>	n7, n46	
CA_n7-n66	n7, n66	
CA_n7-n67	n7, n67	
CA_n7-n71	n7, n71	
CA_n7-n75	n7, n75	
CA_n7-n77	n7, n77	
CA_n7-n78 <sup>1</sup>	n7, n78	
CA_n7-n79	n7, n79	
CA_n7-n102	n7, n102	
CA_n7-n105	n7, n105	
CA_n8-n20	n8, n20	
CA_n8-n28	n8, n28	
CA_n8-n34 <sup>1</sup>	n8, n34	
CA_n8-n38	n8, n38	
CA_n8-n39 <sup>1</sup>	n8, n39	
CA_n8-n40 <sup>1</sup>	n8, n40	
CA_n8-n41 <sup>1</sup>	n8, n41	No
CA_n8-n75 <sup>1</sup>	n8, n75	
CA_n8-n77 <sup>1</sup>	n8, n77	
CA_n8-n78 <sup>1</sup>	n8, n78	No
CA_n8-n79 <sup>1</sup>	n8, n79	No
CA_n12-n25	n12, n25	
CA_n12-n30	n12, n30	
CA_n12-n41	n12, n41	
CA_n12-n48	n12, n48	
CA_n12-n66	n12, n66	
CA_n12-n71	n12, n71	



CA_n12-n77	n12, n77	
CA_n12-n78	n12, n78	
CA_n13-n25	n13, n25	
CA_n13-n66	n13, n66	
CA_n13-n77	n13, n77	
CA_n14-n30	n14, n30	
CA_n14-n66	n14, n66	
CA_n14-n77	n14, n77	
CA_n18-n28	n18, n28	
CA_n18-n40	n18, n40	
CA_n18-n41 <sup>1</sup>	n18, n41	
CA_n18-n74	n18, n74	
CA_n18-n77 <sup>10</sup>	n18, n77	
CA_n18-n78 <sup>11</sup>	n18, n78	
CA_n20-n28 <sup>2</sup>	n20, n28	
CA_n20-n40	n20, n40	
CA_n20-n67	n20, n67	
CA_n20-n75	n20, n75	
CA_n20-n78	n20, n78	
CA_n24-n41	n24, n41	
CA_n24-n48	n24, n48	
CA_n24-n77	n24, n77	
CA_n25-n29	n25, n29	
CA_n25-n38	n25, n38	
CA_n25-n41	n25, n41	
CA_n25-n46 <sup>6</sup>	n25, n46	
CA_n25-n48	n25, n48	
CA_n25-n66	n25, n66	
CA_n25-n71	n25, n71	
CA_n25-n77	n25, n77	
CA_n25-n78	n25, n78	
CA_n25-n85	n25, n85	
CA_n26-n28	n26, n28	
CA_n26-n29	n26, n29	
CA_n26-n48	n26, n48	
CA_n26-n66	n26, n66	
CA_n26-n70	n26, n70	
CA_n26-n71	n26, n71	
CA_n26-n77	n26, n77	
CA_n26-n78	n26, n78	
CA_n28-n34	n28, n34	
CA_n28-n38	n28, n38	
CA_n28-n39	n28, n39	
CA_n28-n40 <sup>1</sup>	n28, n40	
CA_n28-n41 <sup>1</sup>	n28, n41	
CA_n28-n46 <sup>6</sup>	n28, n46	
CA_n28-n50	n28, n50	
CA_n28-n71 <sup>12</sup>	n28, n71	
CA_n28-n74	n28, n74	
CA_n28-n75 <sup>2</sup>	n28, n75	
CA_n28-n77 <sup>1</sup>	n28, n77	No
CA_n28-n78 <sup>1</sup>	n28, n78	No
CA_n28-n79 <sup>1</sup>	n28, n79	
CA_n28-n94	n28, n94	
CA_n28-n102	n28, n102	
CA_n28-n105	n28, n105	
CA_n29-n30	n29, n30	
CA_n29-n48	n29, n48	
CA_n29-n66	n29, n66	
CA_n29-n70	n29, n70	
CA_n29-n71	n29, n71	
CA_n29-n77	n29, n77	
CA_n30-n66	n30, n66	
CA_n30-n77	n30, n77	
CA_n34-n39 <sup>9</sup>	n34, n39	

CA_n34-n40	n34, n40	
CA_n34-n41	n34, n41	
CA_n34-n79 <sup>1</sup>	n34, n79	
CA_n38-n40 <sup>9</sup>	n38, n40	
CA_n38-n66	n38, n66	
CA_n38-n71	n38, n71	
CA_n38-n78 <sup>1</sup>	n38, n78	
CA_n38-n79 <sup>1</sup>	n38, n79	
CA_n39-n40	n39, n40	
CA_n39-n41	n39, n41	No
CA_n39-n79 <sup>1</sup>	n39, n79	No
CA_n40-n41	n40, n41	
CA_n40-n77 <sup>1</sup>	n40, n77	
CA_n40-n78 <sup>1</sup>	n40, n78	
CA_n40-n79 <sup>1,4</sup>	n40, n79	No
CA_n40-n105	n40, n105	
CA_n41-n48 <sup>1</sup>	n41, n48	
CA_n41-n50 <sup>1</sup>	n41, n50	
CA_n41-n66	n41, n66	
CA_n41-n70	n41, n70	
CA_n41-n71 <sup>1</sup>	n41, n71	
CA_n41-n74	n41, n74	
CA_n41-n77 <sup>1</sup>	n41, n77	
CA_n41-n78 <sup>1</sup>	n41, n78	
CA_n41-n79 <sup>1,3</sup>	n41, n79	No
CA_n41-n85	n41, n85	
CA_n46-n48 <sup>1,6</sup>	n46, n48	
CA_n46-n66 <sup>6</sup>	n46, n66	
CA_n46-n77 <sup>1,6</sup>	n46, n77	
CA_n46-n78 <sup>1,6</sup>	n46, n78	
CA_n46-n96 <sup>9,16,17,18</sup>	n46, n96	
CA_n46-n102 <sup>9,16,18,20</sup>	n46, n102	
CA_n48-n53 <sup>9</sup>	n48, n53	
CA_n48-n66	n48, n66	
CA_n48-n70	n48, n70	
CA_n48-n71	n48, n71	
CA_n48-n77 <sup>9,14,18</sup>	n48, n77	
CA_n48-n96 <sup>1,6</sup>	n48, n96	
CA_n50-n78	n50, n78	
CA_n66-n70	n66, n70	
CA_n66-n71	n66, n71	
CA_n66-n77	n66, n77	
CA_n66-n78	n66, n78	
CA_n66-n85	n66, n85	
CA_n67-n78	n67, n78	
CA_n70-n71	n70, n71	
CA_n70-n77	n70, n77	
CA_n70-n78	n70, n78	
CA_n71-n77	n71, n77	
CA_n71-n78	n71, n78	
CA_n71-n85	n71, n85	
CA_n74-n77 <sup>1</sup>	n74, n77	
CA_n74-n78 <sup>1</sup>	n74, n78	
CA_n75-n78 <sup>1</sup>	n75, n78	
CA_n76-n78 <sup>1</sup>	n76, n78	
CA_n77-n78 <sup>7</sup>	n77, n78	
CA_n77-n79 <sup>7</sup>	n77, n79	
CA_n77-n85	n77, n85	
CA_n77-n102	n77, n102	
CA_n78-n79 <sup>5</sup>	n78, n79	
CA_n78-n92	n78, n92	
CA_n78-n94	n78, n94	
CA_n78-n102	n78, n102	
CA_n78-n104	n78, n104	
CA_n78-n105	n78, n105	

NOTE 1:	Applicable for UE supporting inter-band carrier aggregation with mandatory simultaneous Rx/Tx capability.
NOTE 2:	The frequency range in band n28 is restricted for this band combination to 703-733 MHz for the UL and 758-788 MHz for the DL.
NOTE 3:	The frequency range below 2506 MHz for Band n41 is not used in this combination.
NOTE 4:	Applicable for frequency range above 4800 MHz for Band n79 in this combination.
NOTE 5:	For UEs supporting band n77, the minimum requirements apply only when there is non-simultaneous Rx/Tx operation between n78-n79 NR carriers. This restriction applies also for these carriers when applicable NR CA configuration is part of a higher order configuration.
NOTE 6:	The PCell is allocated in the licensed band in this combination.
NOTE 7:	The minimum requirements apply only when there is non-simultaneous Rx/Tx operation between n77-n78 or n77-n79 NR carriers. This restriction applies also for these carriers when applicable NR CA configuration is part of a higher order configuration.
NOTE 8:	Applicable when dynamic Tx switching is conducted. The DL interruption requirement is specified in clause 8.2.2.2.10 of 38.133 [13].
NOTE 9:	Only applicable for UE supporting inter-band carrier aggregation without simultaneous Rx/Tx. Same restrictions are applied when applicable NR CA configuration is part of a higher order configurations.
NOTE 10:	The frequency range in band n77 is restricted for this band combination to 3520-3560 MHz, 3700-3800 MHz, 4000-4100 MHz.
NOTE 11:	The frequency range in band n78 is restricted for this band combination to 3520-3560 MHz and 3700-3800 MHz.
NOTE 12:	The implementation with 4 antennas is targeted for FWA form factor for this band combination.
NOTE 13:	Void
NOTE 14:	The band n48 and n77 will synchronize their uplink and downlink configurations and in commonly TDD network coordination
NOTE 15:	Void
NOTE 16:	The minimum requirements for intra-band non-contiguous CA/DC apply for CA_n46-n96 or CA_n46-n102 and related higher order CA/DC configurations.
NOTE 17:	The combination is not used alone as fall back mode of other band combinations in which UL in Band 48 is not used.
NOTE 18:	The minimum requirements for inter-band CA apply when the maximum power spectral density imbalance between downlink carriers is within 6 dB. The power spectral density imbalance condition also applies for these carriers when applicable CA configuration is a subset of a higher order CA configuration.
NOTE 19:	Void
NOTE 20:	The combination is not used alone as fall back mode of other band combinations in which UL in Band n78 is not used.

### 5.2A.2.2 Inter-band CA (three bands)

**Table 5.2A.2.2-1: Inter-band CA operating bands involving FR1 (three bands)**

NR CA Band	NR Band (Table 5.2-1)	DL interruption allowed (Note 4)
CA_n1-n3-n5	n1, n3, n5	
CA_n1-n3-n7	n1, n3, n7	
CA_n1-n3-n8	n1, n3, n8	
CA_n1-n3-n18	n1, n3, n18	
CA_n1-n3-n20	n1, n3, n20	
CA_n1-n3-n26	n1, n3, n26	
CA_n1-n3-n28	n1, n3, n28	
CA_n1-n3-n38	n1, n3, n38	
CA_n1-n3-n40	n1, n3, n40	
CA_n1-n3-n41 <sup>3</sup>	n1, n3, n41	
CA_n1-n3-n75	n1, n3, n75	
CA_n1-n3-n77	n1, n3, n77	
CA_n1-n3-n78 <sup>3</sup>	n1, n3, n78	No for CA_n1-n78, CA_n3-n78
CA_n1-n3-n79 <sup>3</sup>	n1, n3, n79	
CA_n1-n3-n105	n1, n3, n105	

CA_n1-n5-n7	n1, n5, n7	
CA_n1-n5-n28	n1, n5, n28	
CA_n1-n5-n40	n1, n5, n40	
CA_n1-n5-n78	n1, n5, n78	No for CA_n1-n78, CA_n5-n78
CA_n1-n5-n79	n1, n5, n79	
CA_n1-n5-n105	n1, n5, n105	
CA_n1-n7-n8	n1, n7, n8	
CA_n1-n7-n28	n1, n7, n28	
CA_n1-n7-n38	n1, n7, n38	
CA_n1-n7-n40	n1, n7, n40	
CA_n1-n7-n67	n1, n7, n67	
CA_n1-n7-n75	n1, n7, n75	
CA_n1-n7-n78 <sup>3</sup>	n1, n7, n78	
CA_n1-n7-n79	n1, n7, n79	
CA_n1-n7-n105	n1, n7, n105	
CA_n1-n8-n28	n1, n8, n28	
CA_n1-n8-n40	n1, n8, n40	
CA_n1-n8-n77	n1, n8, n77	
CA_n1-n8-n78 <sup>3</sup>	n1, n8, n78	
CA_n1-n8-n79	n1, n8, n79	
CA_n1-n18-n28	n1, n18, n28	
CA_n1-n18-n41	n1, n18, n41	
CA_n1-n18-n77	n1, n18, n77	
CA_n1-n20-n67	n1, n20, n67	
CA_n1-n20-n78	n1, n20, n78	
CA_n1-n26-n78	n1, n26, n78	
CA_n1-n28-n38	n1, n28, n38	
CA_n1-n28-n40	n1, n28, n40	
CA_n1-n28-n41 <sup>3</sup>	n1, n28, n41	
CA_n1-n28-n46	n1, n28, n46	
CA_n1-n28-n75	n1, n28, n75	
CA_n1-n28-n77 <sup>3</sup>	n1, n28, n77	
CA_n1-n28-n78 <sup>3</sup>	n1, n28, n78	
CA_n1-n28-n79 <sup>3</sup>	n1, n28, n79	
CA_n1-n28-n102	n1, n28, n102	
CA_n1-n38-n78	n1, n38, n78	
CA_n1-n40-n77	n1, n40, n77	
CA_n1-n40-n78	n1, n40, n78	
CA_n1-n40-n105	n1, n40, n105	
CA_n1-n41-n77 <sup>3</sup>	n1, n41, n77	
CA_n1-n41-n79	n1, n41, n79	
CA_n1-n46-n78	n1, n46, n78	
CA_n1-n67-n78	n1, n67, n78	
CA_n1-n75-n78	n1, n75, n78	
CA_n1-n77-n79	n1, n77, n79	
CA_n1-n78-n79	n1, n78, n79	
CA_n1-n78-n102	n1, n78, n102	
CA_n1-n78-n105	n1, n78, n105	
CA_n2-n5-n30	n2, n5, n30	
CA_n2-n5-n41	n2, n5, n41	
CA_n2-n5-n48	n2, n5, n48	
CA_n2-n5-n66	n2, n5, n66	
CA_n2-n5-n77	n2, n5, n77	
CA_n2-n7-n12	n2, n7, n12	
CA_n2-n7-n66	n2, n7, n66	
CA_n2-n7-n71	n2, n7, n71	
CA_n2-n7-n77	n2, n7, n77	
CA_n2-n12-n30	n2, n12, n30	
CA_n2-n12-n41	n2, n12, n41	
CA_n2-n12-n66	n2, n12, n66	
CA_n2-n12-n71	n2, n12, n71	
CA_n2-n12-n77	n2, n12, n77	

CA_n2-n14-n30	n2, n14, n30	
CA_n2-n14-n66	n2, n14, n66	
CA_n2-n14-n77	n2, n14, n77	
CA_n2-n29-n30	n2, n29, n30	
CA_n2-n29-n66	n2, n29, n66	
CA_n2-n29-n77	n2, n29, n77	
CA_n2-n30-n66	n2, n30, n66	
CA_n2-n30-n77	n2, n30, n77	
CA_n2-n41-n66	n2, n41, n66	
CA_n2-n41-n71	n2, n41, n71	
CA_n2-n48-n66	n2, n48, n66	
CA_n2-n48-n77	n2, n48, n77	
CA_n2-n66-n71	n2, n66, n71	
CA_n2-n66-n77	n2, n66, n77	
CA_n2-n66-n78	n2, n66, n78	
CA_n2-n71-n77	n2, n71, n77	
CA_n2-n71-n78	n2, n71, n78	
CA_n3-n5-n7	n3, n5, n7	
CA_n3-n5-n28	n3, n5, n28	
CA_n3-n5-n78	n3, n5, n78	No for CA_n3-n78, CA_n5-n78
CA_n3-n5-n79	n3, n5, n79	
CA_n3-n7-n8	n3, n7, n8	
CA_n3-n7-n20	n3, n7, n20	
CA_n3-n7-n26	n3, n7, n26	
CA_n3-n7-n28	n3, n7, n28	
CA_n3-n7-n38	n3, n7, n38	
CA_n3-n7-n67	n3, n7, n67	
CA_n3-n7-n75	n3, n7, n75	
CA_n3-n7-n78 <sup>3</sup>	n3, n7, n78	
CA_n3-n7-n79	n3, n7, n79	
CA_n3-n7-n105	n3, n7, n105	
CA_n3-n8-n28	n3, n8, n28	
CA_n3-n8-n39	n3, n8, n39	
CA_n3-n8-n40	n3, n8, n40	
CA_n3-n8-n41	n3, n8, n41	
CA_n3-n8-n77	n3, n8, n77	
CA_n3-n8-n78 <sup>3</sup>	n3, n8, n78	
CA_n3-n8-n79	n3, n8, n79	
CA_n3-n18-n28	n3, n18, n28	
CA_n3-n18-n41	n3, n18, n41	
CA_n3-n18-n77	n3, n18, n77	
CA_n3-n20-n28	n3, n20, n28	
CA_n3-n20-n67	n3, n20, n67	
CA_n3-n20-n78	n3, n20, n78	
CA_n3-n26-n78	n3, n26, n78	
CA_n3-n28-n38	n3, n28, n38	
CA_n3-n28-n40 <sup>3</sup>	n3, n28, n40	
CA_n3-n28-n41 <sup>3</sup>	n3, n28, n41	
CA_n3-n28-n77 <sup>3</sup>	n3, n28, n77	
CA_n3-n28-n78 <sup>3</sup>	n3, n28, n78	
CA_n3-n28-n79 <sup>3</sup>	n3, n28, n79	
CA_n3-n38-n40	n3, n38, n40	
CA_n3-n39-n41	n3, n39, n41	
CA_n3-n39-n79	n3, n39, n79	
CA_n3-n40-n41	n3, n40, n41	No for CA n3-n40, CA n3-n41
CA_n3-n40-n77	n3, n40, n77	
CA_n3-n40-n78	n3, n40, n78	
CA_n3-n40-n105	n3, n40, n105	
CA_n3-n41-n77 <sup>3</sup>	n3, n41, n77	
CA_n3-n41-n78 <sup>3</sup>	n3, n41, n78	
CA_n3-n41-n79 <sup>3</sup>	n3, n41, n79	No
CA_n3-n67-n78	n3, n67, n78	
CA_n3-n75-n78	n3, n75, n78	

CA_n3-n77-n79	n3, n77, n79	
CA_n3-n78-n79	n3, n78, n79	
CA_n3-n78-n105	n3, n78, n105	
CA_n5-n7-n25	n5, n7, n25	
CA_n5-n7-n28	n5, n7, n28	
CA_n5-n7-n40	n5, n7, n40	
CA_n5-n7-n66	n5, n7, n66	
CA_n5-n7-n77	n5, n7, n77	
CA_n5-n7-n78	n5, n7, n78	
CA_n5-n7-n105	n5, n7, n105	
CA_n5-n12-n77	n5, n12, n77	
CA_n5-n14-n77	n5, n14, n77	
CA_n5-n25-n29	n5, n25, n29	
CA_n5-n25-n41	n5, n25, n41	
CA_n5-n25-n66	n5, n25, n66	
CA_n5-n25-n77	n5, n25, n77	
CA_n5-n25-n78	n5, n25, n78	
CA_n5-n28-n78	n5, n28, n78	
CA_n5-n28-n79	n5, n28, n79	
CA_n5-n28-n105	n5, n28, n105	
CA_n5-n29-n66	n5, n29, n66	
CA_n5-n29-n77	n5, n29, n77	
CA_n5-n30-n66	n5, n30, n66	
CA_n5-n30-n77	n5, n30, n77	
CA_n5-n40-n78	n5, n40, n78	
CA_n5-n40-n105	n5, n40, n105	
CA_n5-n41-n66	n5, n41, n66	
CA_n5-n41-n77	n5, n41, n77	
CA_n5-n48-n66	n5, n48, n66	
CA_n5-n48-n77	n5, n48, n77	
CA_n5-n66-n77	n5, n66, n77	
CA_n5-n66-n78	n5, n66, n78	
CA_n5-n78-n79	n5, n78, n79	
CA_n5-n78-n105	n5, n78, n105	
CA_n7-n8-n28	n7, n8, n28	
CA_n7-n8-n40	n7, n8, n40	
CA_n7-n8-n78 <sup>3</sup>	n7, n8, n78	
CA_n7-n12-n25	n7, n12, n25	
CA_n7-n12-n66	n7, n12, n66	
CA_n7-n12-n71	n7, n12, n71	
CA_n7-n12-n77	n7, n12, n77	
CA_n7-n20-n67	n7, n20, n67	
CA_n7-n20-n78	n7, n20, n78	
CA_n7-n25-n66	n7, n25, n66	
CA_n7-n25-n71	n7, n25, n71	
CA_n7-n25-n77	n7, n25, n77	
CA_n7-n25-n78	n7, n25, n78	
CA_n7-n26-n78	n7, n26, n78	
CA_n7-n28-n38	n7, n28, n38	
CA_n7-n28-n40	n7, n28, n40	
CA_n7-n28-n78	n7, n28, n78	
CA_n7-n40-n105	n7, n40, n105	
CA_n7-n46-n78	n7, n46, n78	
CA_n7-n66-n71	n7, n66, n71	
CA_n7-n66-n77	n7, n66, n77	
CA_n7-n66-n78	n7, n66, n78	
CA_n7-n67-n78	n7, n67, n78	
CA_n7-n71-n77	n7, n71, n77	
CA_n7-n75-n78	n7, n75, n78	
CA_n7-n78-n102	n7, n78, n102	
CA_n7-n78-n105	n7, n78, n105	
CA_n8-n20-n28	n8, n20, n28	
CA_n8-n20-n75	n8, n20, n75	
CA_n8-n28-n40	n8, n28, n40	
CA_n8-n28-n75	n8, n28, n75	

CA_n8-n28-n77	n8, n28, n77	
CA_n8-n28-n78 <sup>3</sup>	n8, n28, n78	
CA_n8-n38-n40	n8, n38, n40	
CA_n8-n39-n40	n8, n39, n40	
CA_n8-n39-n41	n8, n39, n41	No for CA n8-n41, CA n39-n41
CA_n8-n39-n79	n8, n39, n79	
CA_n8-n40-n41	n8, n40, n41	
CA_n8-n40-n78	n8, n40, n78	
CA_n8-n40-n79	n8, n40, n79	
CA_n8-n41-n79 <sup>3</sup>	n8, n41, n79	No
CA_n8-n78-n79	n8, n78, n79	
CA_n12-n25-n41	n12, n25, n41	
CA_n12-n25-n66	n12, n25, n66	
CA_n12-n30-n66	n12, n30, n66	
CA_n12-n30-n77	n12, n30, n77	
CA_n12-n41-n66	n12, n41, n66	
CA_n12-n41-n77	n12, n41, n77	
CA_n12-n66-n77	n12, n66, n77	
CA_n12-n71-n77	n12, n71, n77	
CA_n13-n25-n66	n13, n25, n66	
CA_n13-n25-n77	n13, n25, n77	
CA_n13-n66-n77	n13, n66, n77	
CA_n14-n30-n66	n14, n30, n66	
CA_n14-n30-n77	n14, n30, n77	
CA_n14-n66-n77	n14, n66, n77	
CA_n18-n28-n41	n18, n28, n41	
CA_n18-n28-n77	n18, n28, n77	
CA_n18-n41-n77	n18, n41, n77	
CA_n20-n28-n75	n20, n28, n75	
CA_n20-n28-n78	n20, n28, n78	
CA_n20-n67-n78	n20, n67, n78	
CA_n24-n41-n48	n24, n41, n48	
CA_n24-n41-n77	n24, n41, n77	
CA_n24-n48-n77	n24, n48, n77	
CA_n25-n41-n77	n25, n41, n77	
CA_n25-n29-n66	n25, n29, n66	
CA_n25-n38-n78	n25, n38, n78	
CA_n25-n41-n66	n25, n41, n66	
CA_n25-n41-n71	n25, n41, n71	
CA_n25-n41-n77	n25, n41, n77	
CA_n25-n41-n78	n25, n41, n78	
CA_n25-n41-n85	n25, n41, n85	
CA_n25-n48-n66	n25, n48, n66	
CA_n25-n66-n71	n25, n66, n71	
CA_n25-n66-n77	n25, n66, n77	
CA_n25-n66-n78	n25, n66, n78	
CA_n25-n66-n85	n25, n66, n85	
CA_n25-n71-n77	n25, n71, n77	
CA_n25-n71-n78	n25, n71, n78	
CA_n25-n71-n85	n25, n71, n85	
CA_n25-n77-n85	n25, n77, n85	
CA_n26-n29-n66	n26, n29, n66	
CA_n26-n29-n70	n26, n29, n70	
CA_n26-n48-n66	n26, n48, n66	
CA_n26-n48-n70	n26, n48, n70	
CA_n26-n66-n70	n26, n66, n70	
CA_n26-n66-n71	n26, n66, n71	
CA_n26-n66-n77	n26, n66, n77	
CA_n26-n70-n71	n26, n70, n71	
CA_n26-n70-n77	n26, n70, n77	
CA_n28-n38-n78	n28, n38, n78	
CA_n28-n39-n40	n28, n39, n40	
CA_n28-n39-n41	n28, n39, n41	
CA_n28-n39-n79	n28, n39, n79	

CA_n28-n40-n41	n28, n40, n41	
CA_n28-n40-n77	n28, n40, n77	
CA_n28-n40-n78	n28, n40, n78	
CA_n28-n40-n79	n28, n40, n79	
CA_n28-n41-n77 <sup>3</sup>	n28, n41, n77	
CA_n28-n41-n78 <sup>3</sup>	n28, n41, n78	
CA_n28-n41-n79 <sup>3</sup>	n28, n41, n79	
CA_n28-n46-n78	n28, n46, n78	
CA_n28-n75-n78	n28, n75, n78	
CA_n28-n77-n79	n28, n77, n79	
CA_n28-n78-n79	n28, n78, n79	
CA_n28-n78-n102	n28, n78, n102	
CA_n29-n30-n66	n29, n30, n66	
CA_n29-n30-n77	n29, n30, n77	
CA_n29-n66-n70	n29, n66, n70	
CA_n29-n66-n71	n29, n66, n71	
CA_n29-n66-n77	n29, n66, n77	
CA_n29-n70-n71	n29, n70, n71	
CA_n30-n66-n77	n30, n66, n77	
CA_n34-n39-n40	n34, n39, n40	
CA_n34-n39-n41	n34, n39, n41	
CA_n34-n40-n41	n34, n40, n41	
CA_n34-n41-n79	n34, n41, n79	
CA_n38-n66-n78	n38, n66, n78	
CA_n39-n40-n41	n39, n40, n41	
CA_n39-n40-n79	n39, n40, n79	
CA_n39-n41-n79	n39, n41, n79	No
CA_n40-n41-n79 <sup>1,2</sup>	n40, n41, n79	No for CA n40-n79, CA n41-n79
CA_n40-n78-n105	n40, n78, n105	
CA_n41-n66-n71	n41, n66, n71	
CA_n41-n66-n77	n41, n66, n77	
CA_n41-n66-n78	n41, n66, n78	
CA_n41-n66-n85	n41, n66, n85	
CA_n41-n70-n78	n41, n70, n78	
CA_n41-n71-n77	n41, n71, n77	
CA_n41-n71-n78	n41, n71, n78	
CA_n41-n71-n85	n41, n71, n85	
CA_n41-n77-n79	n41, n77, n79	
CA_n41-n77-n85	n41, n77, n85	
CA_n46-n48-n96	n46, n48, n96	
CA_n46-n78-n102	n46, n78, n102	
CA_n48-n66-n70	n48, n66, n70	
CA_n48-n66-n71	n48, n66, n71	
CA_n48-n66-n77	n48, n66, n77	
CA_n48-n70-n71	n48, n70, n71	
CA_n48-n70-n77	n48, n70, n77	
CA_n48-n71-n77	n48, n71, n77	
CA_n66-n70-n71	n66, n70, n71	
CA_n66-n70-n77	n66, n70, n77	
CA_n66-n70-n78	n66, n70, n78	
CA_n66-n71-n77	n66, n71, n77	
CA_n66-n71-n78	n66, n71, n78	
CA_n66-n71-n85	n66, n71, n85	
CA_n66-n77-n85	n66, n77, n85	
CA_n70-n71-n77	n70, n71, n77	
NOTE 1: The frequency range below 2506 MHz for Band n41 is not used in this band combination.		
NOTE 2: Applicable for frequency range above 4800 MHz for Band n79 in this band combination.		
NOTE 3: Applicable for UE supporting inter-band carrier aggregation with mandatory simultaneous Rx/Tx capability		
NOTE 4: Applicable when dynamic Tx switching is conducted across 2 UL bands. The DL interruption requirement is specified in clause 8.2.2.2.10 of 38.133 [13].		
NOTE 5: Only applicable for UE supporting inter-band carrier aggregation without simultaneous Rx/Tx		



## 5.2A.2.3 Inter-band CA (four bands)

Table 5.2A.2.3-1: Inter-band CA operating bands involving FR1 (four bands)

NR CA Band	NR Band (Table 5.2-1)
CA_n1-n3-n5-n7	n1, n3, n5, n7
CA_n1-n3-n5-n28	n1, n3, n5, n28
CA_n1-n3-n5-n78	n1, n3, n5, n78
CA_n1-n3-n7-n8	n1, n3, n7, n8
CA_n1-n3-n7-n26	n1, n3, n7, n26
CA_n1-n3-n7-n28	n1, n3, n7, n28
CA_n1-n3-n7-n38	n1, n3, n7, n38
CA_n1-n3-n7-n67	n1, n3, n7, n67
CA_n1-n3-n7-n75	n1, n3, n7, n75
CA_n1-n3-n7-n79	n1, n3, n7, n79
CA_n1-n3-n7-n78 <sup>1</sup>	n1, n3, n7, n78
CA_n1-n3-n7-n105	n1, n3, n7, n105
CA_n1-n3-n8-n77	n1, n3, n8, n77
CA_n1-n3-n8-n78 <sup>1</sup>	n1, n3, n8, n78
CA_n1-n3-n18-n28	n1, n3, n18, n28
CA_n1-n3-n18-n41	n1, n3, n18, n41
CA_n1-n3-n18-n77	n1, n3, n18, n77
CA_n1-n3-n20-n67	n1, n3, n20, n67
CA_n1-n3-n26-n78	n1, n3, n26, n78
CA_n1-n3-n28-n38	n1, n3, n28, n38
CA_n1-n3-n28-n41	n1, n3, n28, n41
CA_n1-n3-n28-n77 <sup>1</sup>	n1, n3, n28, n77
CA_n1-n3-n28-n78	n1, n3, n28, n78
CA_n1-n3-n28-n79 <sup>1</sup>	n1, n3, n28, n79
CA_n1-n3-n40-n77	n1, n3, n40, n77
CA_n1-n3-n40-n105	n1, n3, n40, n105
CA_n1-n3-n41-n77	n1, n3, n41, n77
CA_n1-n3-n41-n79	n1, n3, n41, n79
CA_n1-n3-n67-n78	n1, n3, n67, n78
CA_n1-n3-n75-n78	n1, n3, n75, n78
CA_n1-n3-n77-n79	n1, n3, n77, n79
CA_n1-n5-n7-n40	n1, n5, n7, n40
CA_n1-n5-n7-n78	n1, n5, n7, n78
CA_n1-n5-n7-n105	n1, n5, n7, n105
CA_n1-n5-n28-n78	n1, n5, n28, n78
CA_n1-n5-n28-n79	n1, n5, n28, n79
CA_n1-n5-n40-n78	n1, n5, n40, n78
CA_n1-n5-n40-n105	n1, n5, n40, n105
CA_n1-n5-n78-n79	n1, n5, n78, n79
CA_n1-n5-n78-n105	n1, n5, n78, n105
CA_n1-n7-n8-n40	n1, n7, n8, n40
CA_n1-n7-n8-n78 <sup>1</sup>	n1, n7, n8, n78
CA_n1-n7-n26-n78	n1, n7, n26, n78
CA_n1-n7-n28-n38	n1, n7, n28, n38
CA_n1-n7-n28-n78	n1, n7, n28, n78
CA_n1-n7-n40-n78	n1, n7, n40, n78
CA_n1-n7-n40-n105	n1, n7, n40, n105
CA_n1-n7-n67-n78	n1, n7, n67, n78
CA_n1-n7-n75-n78	n1, n7, n75, n78
CA_n1-n7-n78-n105	n1, n7, n78, n105
CA_n1-n8-n40-n78	n1, n8, n40, n78
CA_n1-n8-n78-n79	n1, n8, n78, n79
CA_n1-n18-n28-n41	n1, n18, n28, n41
CA_n1-n18-n28-n77	n1, n18, n28, n77
CA_n1-n18-n41-n77	n1, n18, n41, n77
CA_n1-n28-n38-n78	n1, n28, n38, n78
CA_n1-n28-n40-n77	n1, n28, n40, n77

CA_n1-n28-n40-n78	n1, n28, n40, n78
CA_n1-n28-n41-n77	n1, n28, n41, n77
CA_n1-n28-n41-n79	n1, n28, n41, n79
CA_n1-n28-n75-n78	n1, n28, n75, n78
CA_n1-n28-n77-n79	n1, n28, n77, n79
CA_n1-n28-n78-n79	n1, n28, n78, n79
CA_n1-n41-n77-n79	n1, n41, n77, n79
CA_n2-n5-n30-n66	n2, n5, n30, n66
CA_n2-n5-n30-n77	n2, n5, n30, n77
CA_n2-n5-n48-n66	n2, n5, n48, n66
CA_n2-n5-n48-n77	n2, n5, n48, n77
CA_n2-n5-n66-n77	n2, n5, n66, n77
CA_n2-n12-n30-n66	n2, n12, n30, n66
CA_n2-n12-n30-n77	n2, n12, n30, n77
CA_n2-n12-n66-n77	n2, n12, n66, n77
CA_n2-n14-n30-n66	n2, n14, n30, n66
CA_n2-n14-n30-n77	n2, n14, n30, n77
CA_n2-n14-n66-n77	n2, n14, n66, n77
CA_n2-n29-n30-n66	n2, n29, n30, n66
CA_n2-n29-n30-n77	n2, n29, n30, n77
CA_n2-n29-n66-n77	n2, n29, n66, n77
CA_n2-n30-n66-n77	n2, n30, n66, n77
CA_n2-n41-n66-n71	n2, n41, n66, n71
CA_n2-n48-n66-n77	n2, n48, n66, n77
CA_n2-n66-n71-n77	n2, n66, n71, n77
CA_n2-n66-n71-n78	n2, n66, n71, n78
CA_n3-n5-n7-n78	n3, n5, n7, n78
CA_n3-n5-n28-n78	n3, n5, n28, n78
CA_n3-n5-n28-n79	n3, n5, n28, n79
CA_n3-n7-n8-n78 <sup>1</sup>	n3, n7, n8, n78
CA_n3-n7-n20-n67	n3, n7, n20, n67
CA_n3-n7-n20-n78	n3, n7, n20, n78
CA_n3-n7-n26-n78	n3, n7, n26, n78
CA_n3-n7-n28-n38	n3, n7, n28, n38
CA_n3-n7-n28-n78	n3, n7, n28, n78
CA_n3-n7-n40-n105	n3, n7, n40, n105
CA_n3-n7-n67-n78	n3, n7, n67, n78
CA_n3-n7-n75-n78	n3, n7, n75, n78
CA_n3-n7-n78-n105	n3, n7, n78, n105
CA_n3-n8-n41-n79	n3, n8, n41, n79
CA_n3-n18-n28-n41	n3, n18, n28, n41
CA_n3-n18-n28-n77	n3, n18, n28, n77
CA_n3-n20-n67-n78	n3, n20, n67, n78
CA_n3-n28-n40-n77	n3, n28, n40, n77
CA_n3-n18-n41-n77	n3, n18, n41, n77
CA_n3-n28-n41-n77	n3, n28, n41, n77
CA_n3-n28-n41-n79	n3, n28, n41, n79
CA_n3-n28-n77-n79	n3, n28, n77, n79
CA_n3-n28-n41-n78	n3, n28, n41, n78
CA_n3-n41-n77-n79	n3, n41, n77, n79
CA_n5-n7-n40-n78	n5, n7, n40, n78
CA_n5-n7-n40-n105	n5, n7, n40, n105
CA_n5-n7-n66-n77	n5, n7, n66, n77
CA_n5-n7-n78-n105	n5, n7, n78, n105
CA_n5-n25-n29-n66	n5, n25, n29, n66
CA_n5-n25-n66-n77	n5, n25, n66, n77
CA_n5-n25-n66-n78	n5, n25, n66, n78
CA_n5-n28-n78-n79	n5, n28, n78, n79
CA_n5-n30-n66-n77	n5, n30, n66, n77
CA_n5-n40-n78-n105	n5, n40, n78, n105
CA_n5-n48-n66-n77	n5, n48, n66, n77
CA_n7-n8-n40-n78	n7, n8, n40, n78
CA_n7-n12-n25-n66	n7, n12, n25, n66
CA_n7-n20-n67-n78	n7, n20, n67, n78
CA_n7-n25-n66-n71	n7, n25, n66, n71

CA_n7-n25-n66-n77	n7, n25, n66, n77
CA_n7-n25-n66-n78	n7, n25, n66, n78
CA_n7-n40-n78-n105	n7, n40, n78, n105
CA_n7-n66-n71-n77	n7, n66, n71, n77
CA_n8-n20-n28-n75	n8, n20, n28, n75
CA_n8-n39-n41-n79	n8, n39, n41, n79
CA_n12-n30-n66-n77	n12, n30, n66, n77
CA_n13-n25-n66-n77	n13, n25, n66, n77
CA_n14-n30-n66-n77	n14, n30, n66, n77
CA_n18-n28-n41-n77	n18, n28, n41, n77
CA_n25-n38-n66-n78	n25, n38, n66, n78
CA_n25-n41-n66-n71	n25, n41, n66, n71
CA_n25-n41-n66-n77	n25, n41, n66, n77
CA_n25-n41-n66-n78	n25, n41, n66, n78
CA_n25-n41-n66-n85	n25, n41, n66, n85
CA_n25-n41-n71-n77	n25, n41, n71, n77
CA_n25-n41-n71-n78	n25, n41, n71, n78
CA_n25-n41-n71-n85	n25, n41, n71, n85
CA_n25-n41-n77-n85	n25, n41, n77, n85
CA_n25-n66-n71-n77	n25, n66, n71, n77
CA_n25-n66-n71-n78	n25, n66, n71, n78
CA_n25-n66-n71-n85	n25, n66, n71, n85
CA_n25-n66-n77-n85	n25, n66, n77, n85
CA_n28-n41-n77-n79	n28, n41, n77, n79
CA_n29-n30-n66-n77	n29, n30, n66, n77
CA_n29-n66-n70-n71	n29, n66, n70, n71
CA_n41-n66-n70-n78	n41, n66, n70, n78
CA_n41-n66-n71-n77	n41, n66, n71, n77
CA_n41-n66-n71-n78	n41, n66, n71, n78
CA_n41-n66-n71-n85	n41, n66, n71, n85
CA_n41-n66-n77-n85	n41, n66, n77, n85
CA_n48-n66-n70-n71	n48, n66, n70, n71
CA_n48-n66-n70-n77	n48, n66, n70, n77
CA_n48-n66-n71-n77	n48, n66, n71, n77
CA_n48-n70-n71-n77	n48, n70, n71, n77
NOTE 1: Applicable for UE supporting inter-band carrier aggregation with mandatory simultaneous Rx/Tx capability.	

#### 5.2A.2.4 Inter-band CA (five bands)

**Table 5.2A.2.4-1: Inter-band CA operating bands involving FR1 (five bands)**

NR CA Band	NR Band (Table 5.2-1)
CA_n1-n3-n5-n7-n78	n1, n3, n5, n7, n78
CA_n1-n3-n5-n28-n78	n1, n3, n5, n28, n78
CA_n1-n3-n7-n8-n78 <sup>1</sup>	n1, n3, n7, n8, n78
CA_n1-n3-n7-n26-n78	n1, n3, n7, n26, n78
CA_n1-n3-n7-n28-n38	n1, n3, n7, n28, n38
CA_n1-n3-n7-n28-n78	n1, n3, n7, n28, n78
CA_n1-n3-n7-n40-n78	n1, n3, n7, n40, n78
CA_n1-n3-n7-n40-n105	n1, n3, n7, n40, n105
CA_n1-n3-n7-n67-n78	n1, n3, n7, n67, n78
CA_n1-n3-n7-n78-n105	n1, n3, n7, n78, n105
CA_n1-n3-n7-n75-n78	n1, n3, n7, n75, n78
CA_n1-n3-n28-n41-n77	n1, n3, n28, n41, n77
CA_n1-n3-n28-n41-n79	n1, n3, n28, n41, n79
CA_n1-n3-n28-n77-n79	n1, n3, n28, n77, n79
CA_n1-n3-n40-n78-n105	n1, n3, n40, n78, n105
CA_n1-n3-n41-n77-n79	n1, n3, n41, n77, n79
CA_n1-n5-n7-n40-n78	n1, n5, n7, n40, n78
CA_n1-n5-n7-n40-n105	n1, n5, n7, n40, n105
CA_n1-n5-n7-n78-n105	n1, n5, n7, n78, n105

CA_n1-n5-n28-n78-n79	n1, n5, n28, n78, n79
CA_n1-n5-n40-n78-n105	n1, n5, n40, n78, n105
CA_n1-n7-n40-n78-n105	n1, n7, n40, n78, n105
CA_n1-n28-n41-n77-n79	n1, n28, n41, n77, n79
CA_n2-n5-n30-n66-n77	n2, n5, n30, n66, n77
CA_n2-n5-n48-n66-n77	n2, n5, n48, n66, n77
CA_n2-n12-n30-n66-n77	n2, n12, n30, n66, n77
CA_n2-n14-n30-n66-n77	n2, n14, n30, n66, n77
CA_n2-n29-n30-n66-n77	n2, n29, n30, n66, n77
CA_n3-n7-n20-n67-n78	n3, n7, n20, n67, n78
CA_n3-n7-n40-n78-n105	n3, n7, n40, n78, n105
CA_n3-n28-n41-n77-n79	n3, n28, n41, n77, n79
CA_n5-n7-n40-n78-n105	n5, n7, n40, n78, n105
NOTE 1: Applicable for UE supporting inter-band carrier aggregation with mandatory simultaneous Rx/Tx capability.	

### 5.2A.2.5 Inter-band CA (six bands)

**Table 5.2A.2.5-1: Inter-band CA operating bands involving FR1 (six bands)**

NR CA Band	NR Band (Table 5.2-1)
CA_n1-n3-n7-n28-n38-n78	n1, n3, n7, n28, n38, n78
CA_n1-n3-n7-n40-n78-n105	n1, n3, n7, n40, n78, n105
CA_n1-n5-n7-n40-n78-n105	n1, n5, n7, n40, n78, n105

## 5.2B Operating bands for DC

The operating bands are specified in clause 5.5B for operation with NR dual connectivity configured, where all operating bands are within FR1.

If the mandatory simultaneous Rx/Tx capability applies for a band combination, the mandatory simultaneous Rx/Tx capability also applies for the band combination when the applicable band combination is a subset of a higher order band combination.

## 5.2C Operating band combination for SUL

NR operation is designed to operate in the operating band combination defined in Table 5.2C-1, Table 5.2C-2, Table 5.2C-3 and Table 5.2C-4, where all operating bands are within FR1.

If the mandatory simultaneous Rx/Tx capability applies for a band combination, when the applicable lower order band combination is a band pair in a higher order band combination, the mandatory simultaneous Rx/Tx capability also applies for the band pair in the higher order band combination.

**Table 5.2C-1: Operating band combination for SUL in FR1**

NR Band combination for SUL	NR Band (Table 5.2-1)
SUL_n1-n80 <sup>2</sup>	n1, n80
SUL_n1-n81 <sup>2</sup>	n1, n81
SUL_n1-n89 <sup>2</sup>	n1, n89
SUL_n3-n84 <sup>2</sup>	n3, n84
SUL_n5-n84 <sup>2</sup>	n5, n84
SUL_n8-n84 <sup>2</sup>	n8, n84
SUL_n24-n99 <sup>2</sup>	n24, n99

SUL_n41-n80 <sup>2</sup>	n41, n80
SUL_n41-n81 <sup>2</sup>	n41, n81
SUL_n41-n83 <sup>2</sup>	n41, n83
SUL_n41-n95 <sup>2</sup>	n41, n95
SUL_n41-n97 <sup>2</sup>	n41, n97
SUL_n41-n98 <sup>2</sup>	n41, n98
SUL_n41-n99 <sup>2</sup>	n41, n99
SUL_n48-n99 <sup>2</sup>	n48, n99
SUL_n77-n80 <sup>2</sup>	n77, n80
SUL_n77-n84 <sup>2</sup>	n77, n84
SUL_n77-n99 <sup>2</sup>	n77, n99
SUL_n78-n80 <sup>2</sup>	n78, n80
SUL_n78-n81 <sup>2</sup>	n78, n81
SUL_n78-n82 <sup>2</sup>	n78, n82
SUL_n78-n83 <sup>2</sup>	n78, n83
SUL_n78-n84 <sup>2</sup>	n78, n84
SUL_n78-n86 <sup>2</sup>	n78, n86
SUL_n78-n89 <sup>2</sup>	n78, n89
SUL_n79-n80 <sup>2</sup>	n79, n80
SUL_n79-n81 <sup>2</sup>	n79, n81
SUL_n79-n83 <sup>2</sup>	n79, n83
SUL_n79-n84 <sup>2</sup>	n79, n84
SUL_n79-n95 <sup>2</sup>	n79, n95
SUL_n79-n97 <sup>2</sup>	n79, n97
SUL_n79-n98 <sup>2</sup>	n79, n98
NOTE 1: If a UE is configured with both NR UL and NR SUL carriers in a cell, the switching time between NR UL carrier and NR SUL carrier is 0 us.	
NOTE 2: For UE supporting SUL band combination simultaneous Rx/Tx capability is mandatory.	

Table 5.2C-2: Operating SUL band combination with intra-band non-contiguous CA in FR1

NR Band combination for SUL	NR Band (Table 5.2-1)
CA_n41(*)-n99 <sup>2</sup>	n41, n99
CA_n48(*)-n99 <sup>2</sup>	n48, n99
CA_n77(*)-n99 <sup>2</sup>	n77, n99
CA_n78(*)-n86 <sup>2</sup>	n78, n86
NOTE 1: If a UE is configured with both NR UL and NR SUL carriers in a cell, the switching time between NR UL carrier and NR SUL carrier is 0 us.	
NOTE 2: For UE supporting SUL band combination simultaneous Rx/Tx capability is mandatory.	
NOTE 3: The notation CA_nX(*) in this table indicates intra-band non-contiguous CA for band nX. The configurations for each band are in table 5.5C-2.	

Table 5.2C-3: Operating SUL band combination with intra-band contiguous CA in FR1

NR Band combination for SUL	NR Band (Table 5.2-1)
CA_n41-n80	n41, n80
CA_n41-n83	n41, n83
CA_n41-n95	n41, n95
CA_n41-n98	n41, n98
CA_n78-n80	n78, n80
CA_n78-n81	n78, n81

CA_n78-n84	n78, n84
CA_n78-n89	n78, n89
CA_n79-n80	n79, n80
CA_n79-n83	n79, n83
CA_n79-n95	n79, n95
CA_n79-n98	n79, n98
NOTE 1: If a UE is configured with both NR UL and NR SUL carriers in a cell, the switching time between NR UL carrier and NR SUL carrier is 0 us.	
NOTE 2: For UE supporting SUL band combination simultaneous Rx/Tx capability is mandatory.	

Table 5.2C-4: Operating SUL band combination with inter-band CA in FR1

NR Band combination for SUL	NR Band (Table 5.2-1)
CA_n1_n78-n80	n1, n78, n80
CA_n1_n78-n81	n1, n78, n81
CA_n1_n78-n84	n1, n78, n84
CA_n1_n78-n89	n1, n78, n89
CA_n3_n41-n80	n3, n41, n80
CA_n3_n78-n80	n3, n78, n80
CA_n3_n78-n84	n3, n78, n84
CA_n3_n79-n80	n3, n79, n80
CA_n5_n78-n84	n5, n78, n84
CA_n8_n78-n81	n8, n78, n81
CA_n8_n78-n84	n8, n78, n84
CA_n28_n41-n83	n28, n41, n83
CA_n28_n79-n83	n28, n79, n83
CA_n41_n79-n80	n41, n79, n80
CA_n41_n79-n83	n41, n79, n83
CA_n41_n79-n95	n41, n79, n95
CA_n41_n79-n97	n41, n79, n97
CA_n41_n79-n98	n41, n79, n98
CA_n78_n1-n80	n1, n78, n80
CA_n78_n1-n81	n1, n78, n81
CA_n78_n1-n89	n1, n78, n89
CA_n78_n3-n84	n3, n78, n84
CA_n78_n5-n84	n5, n78, n84
CA_n78_n8-n84	n8, n78, n84
CA_n79_n41-n80	n41, n79, n80
CA_n79_n41-n83	n41, n79, n83
CA_n79_n41-n95	n41, n79, n95
CA_n79_n41-n97	n41, n79, n97
CA_n79_n41-n98	n41, n79, n98
CA_n28-n79_n41-n83	n28, n41, n79, n83
CA_n28-n41_n79-n83	n28, n41, n79, n83
CA_n41A-n95A_n79A-n98A	n41, n95, n79, n98
CA_n41A-n98A_n79A-n95A	n41, n98, n79, n95
CA_n41A-n83A_n79A-n98A	n41, n83, n79, n98
CA_n41A-n83A_n79A-n95A	n41, n83, n79, n95
CA_n78C_n80A-n84A	n78, n80, n84
CA_n78C_n81A-n84A	n78, n81, n84
CA_n78C_n84A-n89A	n78, n84, n89
NOTE 1: If a UE is configured with a single cell consisting of a NR UL carrier and a	

corresponding NR SUL carrier, the switching time between NR UL carrier and the corresponding NR SUL carrier is 0 us.  
 NOTE 2: For UE supporting SUL band combination simultaneous Rx/Tx capability is mandatory.

## 5.2D Operating bands for UL MIMO

NR is designed to support UL MIMO where all of the operating bands are in FR1 defined in Table 5.2D-1.

**Table 5.2D-1: NR operating bands for UL MIMO in FR1**

NR operating band
n1
n2
n3
n5
n7
n8
n13
n24
n25
n26
n28
n30 <sup>1</sup>
n34
n38
n39
n40
n41
n46
n48
n66
n70
n71
n77
n78
n79
n80
n81
n83
n84
n85
n86
n95
n96
n97
n98
n99
n102
n104
n105
NOTE 1: Uplink transmission is not allowed at this band for UE with external vehicle-mounted antennas. NOTE 2: Void.

## 5.2E Operating band for V2X

### 5.2E.1 V2X operating bands

NR V2X is designed to operate in the operating bands in FR1 defined in Table 5.2E.1-1.

**Table 5.2E.1-1 V2X operating bands in FR1**

V2X Operating Band	Sidelink (SL) Transmission operating band	Sidelink (SL) Reception operating band	Duplex Mode	Interface
	F <sub>UL_low</sub> – F <sub>UL_high</sub>	F <sub>DL_low</sub> – F <sub>DL_high</sub>		
n14 <sup>2</sup>	788 MHz – 798 MHz	788 MHz – 798 MHz	HD	PC5
n38 <sup>1</sup>	2570 MHz – 2620 MHz	2570 MHz – 2620 MHz	HD	PC5
n47	5855 MHz – 5925 MHz	5855 MHz – 5925 MHz	HD	PC5
n79	4400 MHz – 5000 MHz	4400 MHz – 5000 MHz	HD	PC5
Note 1:	When this band is used for V2X SL service, the band is exclusively used for NR V2X in particular region.			
Note 2:	When this band is used for public safety service, the NR band is operated with both in-coverage scenarios and out-of-coverage scenarios.			

### 5.2E.1A Sidelink CA operating bands

For NR sidelink intra-band CA operation is designed to operate in the operating bands in FR1 defined in Table 5.2E.1A-1.

**Table 5.2E.1A-1 Intra-band contiguous SL CA operating bands in FR1**

NR SL CA Band	NR Band	Interface
SL_n47	n47	PC5

### 5.2E.1F Operating bands for Sidelink Unlicensed

NR Sidelink is designed to operate in the unlicensed operating bands in FR1 defined in Table 5.2E.1F-1.

**Table 5.2E.1F-1. NR SL-U operating bands in FR1**

NR SL-U operating band	Sidelink (SL) Transmission operating band	Sidelink (SL) Reception operating band	Duplex Mode	Interface
	F <sub>UL_low</sub> – F <sub>UL_high</sub>	F <sub>DL_low</sub> – F <sub>DL_high</sub>		
n46 <sup>1</sup>	5150 MHz – 5925 MHz	5150 MHz – 5925 MHz	HD	PC5
n96 <sup>1</sup>	5925 MHz – 7125 MHz	5925 MHz – 7125 MHz	HD	PC5
n102 <sup>1</sup>	5925 MHz – 6425 MHz	5925 MHz – 6425 MHz	HD	PC5
NOTE 1:	Direct connection between client devices and between vehicular devices in the shared spectrum bands or portions of the shared spectrum bands is subject to country-specific conditions and can be prohibited per region-specific regulatory rules, e.g., in USA and Canada.			

### 5.2E.2 V2X operating bands for concurrent operation

NR V2X operation is designed to operate concurrent with NR uplink/downlink on the operating bands combinations listed in Table 5.2E.2-1 and Table 5.2E.2-2.

**Table 5.2E.2-1 Inter-band concurrent V2X operating bands**

V2X concurrent operating Band	NR or V2X Operating Band	Interface
V2X_n1-n47	n1	Uu



	n47	PC5
V2X_n3-n47	n3	Uu
	n47	PC5
V2X_n5-n47	n5	Uu
	n47	PC5
V2X_n8-n47	n8	Uu
	n47	PC5
V2X_n34-n47	n34	Uu
	n47	PC5
V2X_n39-n47	n39	Uu
	n47	PC5
V2X_n40-n47	n40	Uu
	n47	PC5
V2X_n41-n47	n41	Uu
	n47	PC5
V2X_n71-n47	n71	Uu
	n47	PC5
V2X_n78-n47	n78	Uu
	n47	PC5
V2X_n79-n47	n79	Uu
	n47	PC5

**Table 5.2E.2-2 Intra-band concurrent V2X operating bands**

V2X concurrent operating Band	NR or V2X Operating Band	Interface
V2X_n79-n79	n79	Uu
	n79	PC5

## 5.2E.2F Operating bands for SL-U concurrent operation

For NR SL-U inter-band concurrent operation, NR sidelink in the unlicensed operating band is designed to operate concurrently with NR uplink/downlink on the operating band combinations are listed in Table 5.2E.2F-1.

**Table 5.2E.2F-1 SL-U Inter-band concurrent operating bands**

NR SL inter-band concurrent operating Band	NR Operating Band	Interface
SL_n78-n46	n78	Uu
	n46	PC5

## 5.2J Operating band for ATG

NR operating bands n1, n3, n34, n39, n41, n78, n79, which are defined in Table 5.2-1, can be applied for ATG operation.

## 5.2K Operating bands for Aerial UE

Aerial UE is designed to operate in NR operating bands as defined in Table 5.2-1, following applicable spectrum regulations, e.g. ECC Decision (22)07 [17] for CEPT countries.

## 5.3 UE channel bandwidth

### 5.3.1 General

The UE channel bandwidth supports a single NR RF carrier in the uplink or downlink at the UE. From a BS perspective, different UE channel bandwidths may be supported within the same spectrum for transmitting to and receiving from UEs connected to the BS. Transmission of multiple carriers to the same UE (CA) or multiple carriers to different UEs within the BS channel bandwidth can be supported.

From a UE perspective, the UE is configured with one or more BWP / carriers, each with its own UE channel bandwidth. The UE does not need to be aware of the BS channel bandwidth or how the BS allocates bandwidth to different UEs.

The placement of the UE channel bandwidth for each UE carrier is flexible but can only be completely within the BS channel bandwidth.

The relationship between the channel bandwidth, the guardband and the maximum transmission bandwidth configuration is shown in Figure 5.3.1-1.

3MHz channel bandwidth is only applicable for single-carrier operation in the current release.

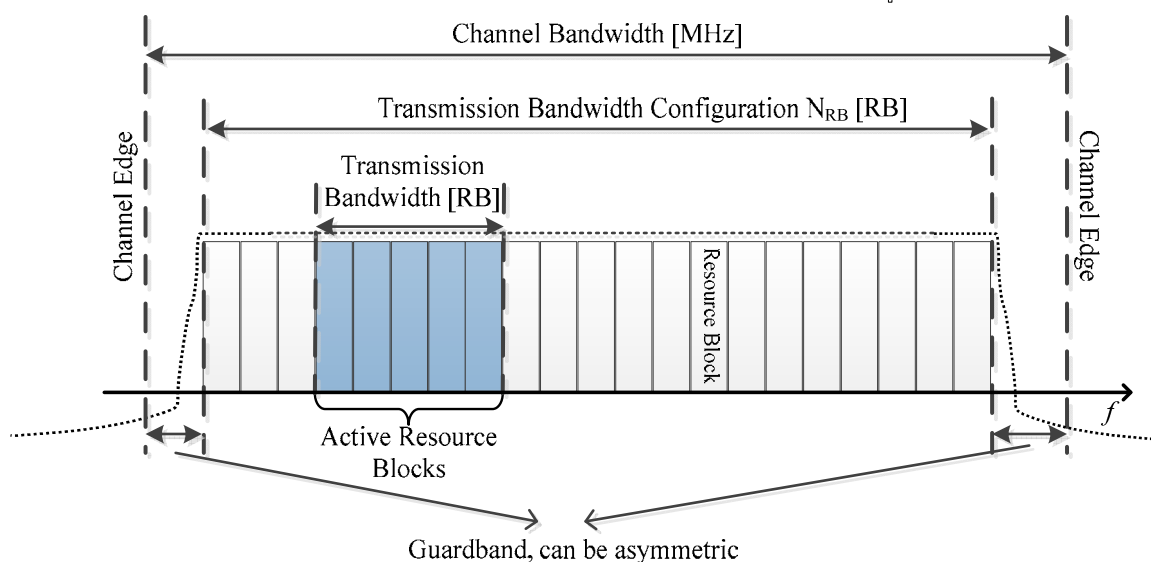

**Figure 5.3.1-1: Definition of the channel bandwidth and the maximum transmission bandwidth configuration for one NR channel**

### 5.3.2 Maximum transmission bandwidth configuration

The maximum transmission bandwidth configuration  $N_{RB}$  for each UE channel bandwidth and subcarrier spacing is specified in Table 5.3.2-1.

**Table 5.3.2-1: Maximum transmission bandwidth configuration  $N_{RB}$**

SCS (kHz)	3 MHz	5 MHz	10 MHz	15 MHz	20 MHz	25 MHz	30 MHz	35 MHz	40 MHz	45 MHz	50 MHz	60 MHz	70 MHz	80 MHz	90 MHz	100 MHz
	$N_{RB}$	$N_{RB}$	$N_{RB}$	$N_{RB}$	$N_{RB}$	$N_{RB}$	$N_{RB}$	$N_{RB}$	$N_{RB}$	$N_{RB}$	$N_{RB}$	$N_{RB}$	$N_{RB}$	$N_{RB}$	$N_{RB}$	$N_{RB}$
15	15	25	52	79	106	133	160	188	216	242	270	N/A	N/A	N/A	N/A	N/A
30	N/A	11	24	38	51	65	78	92	106	119	133	162	189	217	245	273
60	N/A	N/A	11	18	24	31	38	44	51	58	65	79	93	107	121	135

### 5.3.3 Minimum guardband and transmission bandwidth configuration

The minimum guardband for each UE channel bandwidth and SCS is specified in Table 5.3.3-1,

**Table 5.3.3-1: Minimum guardband for each UE channel bandwidth and SCS (kHz)**

SCS (kHz)	3 MHz	5 MHz	10 MHz	15 MHz	20 MHz	25 MHz	30 MHz	35 MHz	40 MHz	45 MHz	50 MHz	60 MHz	70 MHz	80 MHz	90 MHz	100 MHz
15	142.5	242.5	312.5	382.5	452.5	522.5	592.5	572.5	552.5	712.5	692.5	N/A	N/A	N/A	N/A	N/A
30	N/A	505	665	645	805	785	945	925	905	1065	1045	825	965	925	885	845
60	N/A	N/A	1010	990	1330	1310	1290	1630	1610	1590	1570	1530	1490	1450	1410	1370

NOTE: The minimum guardbands have been calculated using the following equation:  $GB_{Channel} = (BW_{Channel} \times 1000 \text{ (kHz)} - N_{RB} \times SCS \times 12) / 2 - SCS/2$ , where  $N_{RB}$  are from Table 5.3.2-1 and  $GB_{Channel}$  expressed in kHz.

**Figure 5.3.3-1: Void**

The number of RBs configured in any channel bandwidth shall ensure that the minimum guardband specified in this clause is met.

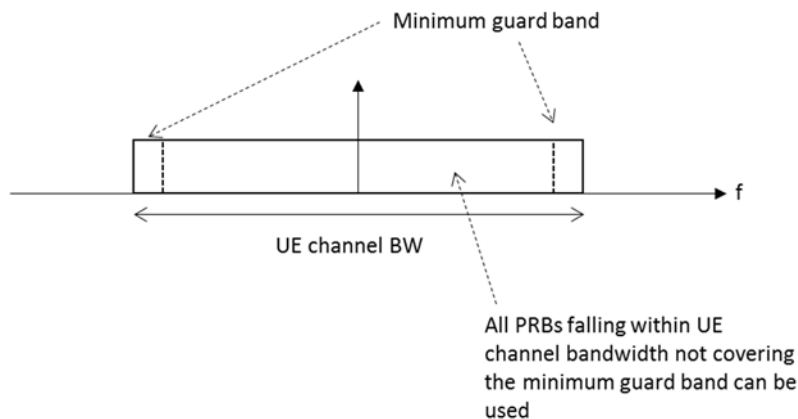

**Figure 5.3.3-2: UE PRB utilization**

In the case that multiple numerologies are multiplexed in the same symbol due to BS transmission of SSB, the minimum guardband on each side of the carrier is the guardband applied at the configured channel bandwidth for the numerology that is received immediately adjacent to the guard.

If multiple numerologies are multiplexed in the same symbol and the UE channel bandwidth is >50 MHz, the minimum guardband applied adjacent to 15 kHz SCS shall be the same as the minimum guardband defined for 30 kHz SCS for the same UE channel bandwidth.

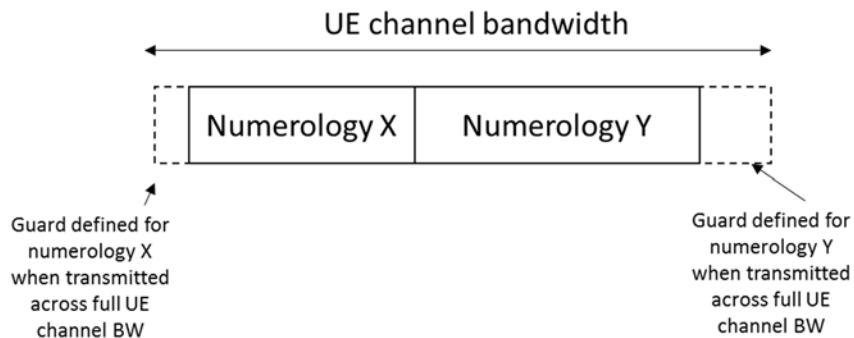

**Figure 5.3.3-3 Guard band definition when transmitting multiple numerologies**

NOTE: Figure 5.3.3-3 is not intended to imply the size of any guard between the two numerologies. Inter-numerology guard band within the carrier is implementation dependent.

For a UE supporting wideband operation, the nominal intra-cell guard bands and the corresponding sizes of the RB sets separated by the said guard bands are as specified in Table 5.3.3-2 for each UE channel bandwidth and sub-carrier spacing for the downlink, uplink and sidelink. The nominal intra-cell guard bands in Table 5.3.3-2 are applicable when the respective IE *intraCellGuardBandsUL-List*, *intraCellGuardBandsDL-List* [7] and *intraCellGuardBandsSL-List* for the uplink, downlink and sidelink are not provided, as specified in [10] clause 7.

**Table 5.3.3-2: Nominal intra-cell guard bands for wideband operation**

SCS (kHz)	40 MHz	60 MHz	80 MHz	100 MHz
15	105-6-105 (216)	N/A	N/A	N/A
30	50-6-50	50-6-50-6-50	50-6-50-5-50-6-50	50-6-50-6-49-6-50-6-50

	(106)	(162)	(217)	(273)
60	23-5-23 (51)	23-5-23-5-23 (79)	23-5-23-5-23-5-23 (107)	23-5-23-5-23-5-23-5-23 (135)
NOTE 1: The intra-cell guard band is denoted $TBW_0-GB_0-\dots-GB_{N\_RBset-2}-TBW_{N\_RBset-1}$ for $N\_RBset > 1$ number of RB-sets with $TBW_r$ the maximum transmission bandwidth (PRB) of RB-set $r$ and $GB_r$ the guard band (PRB) above the upper edge of RB-set $r$ . The RB-set 0 is starting at the first common resource block (CRB) of the carrier as indicated by <i>offsetToCarrier</i> . The total transmission bandwidth configuration (size of resource grid) including guard bands is given in between parentheses.				

For a UE that supports shared spectrum channel access, there are no uplink, downlink or sidelink intra-cell guard bands for operation with 10 MHz and 20 MHz channel bandwidths; the maximum transmission bandwidth configurations for these channel bandwidths are in accordance with clause 5.3.2.

For each UE channel bandwidth and sub-carrier spacing given by Table 5.3.3-2, the maximum transmission bandwidth configuration of the carrier including intra-cell guard bands, if configured for the uplink, downlink and sidelink by the respective IE *intraCellGuardBandsUL-List*, *intraCellGuardBandsDL-List* [7] and *intraCellGuardBandsSL-List*, and corresponding RB-set(s) shall be in accordance with clause 5.3.2 with a minimum inter-cell guard band of the UE channel bandwidth as specified in Table 5.3.3-1 for the uplink, downlink and sidelink. Minimum requirements specified for wideband operation in Clause 6 and Clause 7 also apply for intra-cell guard bands larger than the nominal sizes in Table 5.3.3-2 as listed in Table 5.3.3-3 for each sub-carrier spacing; each guard band in order of CRB index must be larger than or equal to the corresponding nominal guard band specified in Table 5.3.3-2 for each channel bandwidth.

**Table 5.3.3-3: Applicable intra-cell guard bands for wideband operation**

Parameter	Unit	SCS	
		15 kHz	30 kHz
Intra-cell guard band (size)	PRB	6,7	5,6,7
Transmission bandwidth (size) of RB-set	PRB	104,105	49,50,51

If the UE is configured with zero width intra-cell guard bands for the uplink, downlink and sidelink by the IE *intraCellGuardBandsUL-List*, *intraCellGuardBandsDL-List* [7] and *intraCellGuardBandsSL-List* on a carrier greater than 20 MHz, the maximum transmission bandwidth configuration for the uplink, downlink and sidelink shall be in accordance with clause 5.3.2 with a minimum inter-cell guard band of the UE channel bandwidth as specified in Table 5.3.3-1.

### 5.3.4 RB alignment

For each numerology, its common resource blocks are specified in Clause 4.4.4.3 in TS 38.211 [6], and the starting point of its transmission bandwidth configuration on the common resource block grid for a given channel bandwidth is indicated by an offset to "Reference point A" in the unit of the numerology. The *UE transmission bandwidth configuration* is indicated by the higher layer parameter *carrierBandwidth* [7] and will fulfil the minimum UE guardband requirement specified in Clause 5.3.3.

### 5.3.5 UE channel bandwidth per operating band

The requirements in this specification apply to the combination of channel bandwidths, SCS and operating bands shown in Table 5.3.5-1. The transmission bandwidth configuration in Table 5.3.2-1 shall be supported for each of the specified channel bandwidths. The channel bandwidths are specified for both the TX and RX path.

**Table 5.3.5-1 Channel bandwidths for each NR band**

NR Band	SCS (kHz)	UE Channel bandwidth (MHz)															
		3	5	10	15	20	25	30	35	40	45	50	60	70	80	90	100
n1	15		5	10	15	20	25	30		40	45	50					
	30			10	15	20	25	30		40	45	50					
	60			10	15	20	25	30		40	45	50					
n2	15		5	10	15	20	25	30	35	40							
	30			10	15	20	25	30	35	40							
	60			10	15	20	25	30	35	40							

NR Band	SCS (kHz)	UE Channel bandwidth (MHz)															
		3	5	10	15	20	25	30	35	40	45	50	60	70	80	90	100
n3	15		5	10	15	20	25	30	35	40	45	50					
	30			10	15	20	25	30	35	40	45	50					
	60			10	15	20	25	30	35	40	45	50					
n5	15		5	10	15	20	25 <sup>3</sup>										
	30			10	15	20	25 <sup>3</sup>										
	60																
n7	15		5	10	15	20	25	30	35	40		50					
	30			10	15	20	25	30	35	40		50					
	60			10	15	20	25	30	35	40		50					
n8	15		5	10	15	20	25 <sup>3</sup>	30 <sup>3</sup>	35 <sup>3</sup>								
	30			10	15	20	25 <sup>3</sup>	30 <sup>3</sup>	35 <sup>3</sup>								
	60																
n12	15		5	10	15												
	30			10	15												
	60																
n13	15		5	10													
	30			10													
	60																
n14 <sup>10</sup>	15		5	10													
	30			10													
	60																
n18	15		5	10	15												
	30			10	15												
	60																
n20	15		5	10	15	20											
	30			10	15	20											
	60																
n24	15		5	10													
	30			10													
	60			10													
n25	15		5	10	15	20	25	30	35	40	45 <sup>3</sup>						
	30			10	15	20	25	30	35	40	45 <sup>3</sup>						
	60			10	15	20	25	30	35	40	45 <sup>3</sup>						
n26	15	3 <sup>4</sup>	5	10	15	20	25 <sup>3</sup>	30 <sup>3</sup>									
	30			10	15	20	25 <sup>3</sup>	30 <sup>3</sup>									
	60																
n28	15	3 <sup>4</sup>	5	10	15	20 <sup>7</sup>	25 <sup>7</sup>	30 <sup>7</sup>									
	30			10	15	20 <sup>7</sup>	25 <sup>7</sup>	30 <sup>7</sup>									
	60																
n29	15		5	10													
	30			10													
	60																
n30	15		5	10													
	30			10													
	60																
n31	15	3 <sup>4</sup>	5														
	30																
	60																
n34	15		5	10	15												
	30			10	15												
	60			10	15												
n38 <sup>10</sup>	15		5	10	15	20	25	30		40							
	30			10	15	20	25	30		40							
	60			10	15	20	25	30		40							
n39	15		5	10	15	20	25	30	35	40							
	30			10	15	20	25	30	35	40							
	60			10	15	20	25	30	35	40							
n40	15		5 <sup>5</sup>	10	15	20	25	30		40		50					
	30			10	15	20	25	30		40		50	60	70	80	90	100
	60			10	15	20	25	30		40		50	60	70	80	90	100
n41	15		5 <sup>4,11</sup>	10	15	20	25	30	35	40	45	50					
	30			10	15	20	25	30	35	40	45	50	60	70	80	90	100
	60			10	15	20	25	30	35	40	45	50	60	70	80	90	100
n46	15			10 <sup>5</sup>		20				40							

NR Band	SCS (kHz)	UE Channel bandwidth (MHz)															
		3	5	10	15	20	25	30	35	40	45	50	60	70	80	90	100
n47 <sup>10</sup>	30			10 <sup>5</sup>		20				40			60		80		100 <sup>4</sup>
	60			10 <sup>5</sup>		20				40			60		80		100 <sup>4</sup>
	15			10		20		30		40							
	30			10		20		30		40							
n48	60			10		20		30		40							
	15		5 <sup>5</sup>	10	15	20		30		40		50 <sup>6</sup>					
	30			10	15	20		30		40		50 <sup>6</sup>	60 <sup>6</sup>	70 <sup>6</sup>	80 <sup>6</sup>	90 <sup>6</sup>	100 <sup>6</sup>
n50	60			10	15	20		30		40		50 <sup>6</sup>	60 <sup>6</sup>	70 <sup>6</sup>	80 <sup>6</sup>	90 <sup>6</sup>	100 <sup>6</sup>
	15		5 <sup>5</sup>	10	15	20		30		40		50					
	30			10	15	20		30		40		50	60		80 <sup>3</sup>		
n51	60			10	15	20		30		40		50	60		80 <sup>3</sup>		
	15		5														
	30																
n53	60																
	15		5	10													
	30			10													
n54	60			10													
	15		5														
	30																
n65	60																
	15		5	10	15	20						50					
	30			10	15	20						50					
n66	60			10	15	20						50					
	15		5	10	15	20	25	30	35	40	45						
	30			10	15	20	25	30	35	40	45						
n67	60			10	15	20	25	30	35	40	45						
	15		5	10	15	20											
	30			10	15	20											
n70	60																
	15		5	10	15	20 <sup>3</sup>	25 <sup>3</sup>										
	30			10	15	20 <sup>3</sup>	25 <sup>3</sup>										
n71	60			10	15	20 <sup>3</sup>	25 <sup>3</sup>										
	15		5	10	15	20	25 <sup>12</sup>	30 <sup>12</sup>	35 <sup>12</sup>								
	30			10	15	20	25 <sup>12</sup>	30 <sup>12</sup>	35 <sup>12</sup>								
n72	60																
	15	3 <sup>4</sup>	5														
	30																
n74	60																
	15		5	10	15	20											
	30			10	15	20											
n75	60			10	15	20											
	15		5	10	15	20	25	30		40		50					
	30			10	15	20	25	30		40		50					
n76	60			10	15	20	25	30		40		50					
	15		5														
	30																
n77	60																
	15			10	15	20	25	30		40		50					
	30			10	15	20	25	30		40		50	60	70	80	90	100
n78	60			10	15	20	25	30		40		50	60	70	80	90	100
	15			10	15	20	25	30		40		50					
	30			10	15	20	25	30		40		50	60	70	80	90	100
n79 <sup>10</sup>	60			10	15	20	25	30		40		50	60	70	80	90	100
	15			10		20		30		40		50					
	30			10		20		30		40		50	60	70 <sup>4</sup>	80	90	100
n80	60			10		20		30		40		50	60	70 <sup>4</sup>	80	90	100
	15		5	10	15	20	25	30		40							
	30			10	15	20	25	30		40							
n81	60			10	15	20	25	30		40							
	15		5	10	15	20											
	30			10	15	20											
n82	60																
	15		5	10	15	20											
	30			10	15	20											

NR Band	SCS (kHz)	UE Channel bandwidth (MHz)															
		3	5	10	15	20	25	30	35	40	45	50	60	70	80	90	100
n83	60																
	15		5	10	15	20 <sup>7</sup>	25 <sup>7</sup>	30 <sup>7</sup>									
	30			10	15	20 <sup>7</sup>	25 <sup>7</sup>	30 <sup>7</sup>									
n84	60																
	15		5	10	15	20	25	30		40		50					
	30			10	15	20	25	30		40		50					
n85	60			10	15	20	25	30		40		50					
	15	3 <sup>4</sup>	5	10	15												
	30			10	15												
n86	60																
	15		5	10	15	20				40							
	30			10	15	20				40							
n89	60			10	15	20				40							
	15		5	10	15	20											
	30			10	15	20											
n90	60																
	15		5 <sup>4</sup>	10	15	20	25	30	35	40	45	50					
	30			10	15	20	25	30	35	40	45	50	60	70	80	90	100
n91	60			10	15	20	25	30	35	40	45	50	60	70	80	90	100
	15		5	10 <sup>8</sup>													
	30																
n92	60																
	15		5	10	15	20											
	30			10	15	20											
n93	60																
	15		5	10 <sup>8</sup>													
	30																
n94	60																
	15		5	10	15	20											
	30			10	15	20											
n95	60																
	15		5	10	15												
	30			10	15												
n96	60																
	15					20				40							
	30					20				40		60		80		100 <sup>4</sup>	
n97	60					20				40		60		80		100 <sup>4</sup>	
	15		5	10	15	20	25	30		40		50					
	30			10	15	20	25	30		40		50	60	70	80	90	100
n98	60			10	15	20	25	30		40		50	60	70	80	90	100
	15		5	10	15	20	25	30	35	40							
	30			10	15	20	25	30	35	40							
n99	60			10	15	20	25	30	35	40							
	15		5	10													
	30			10													
n100	60																
	15	3 <sup>4</sup>	5														
	30																
n101	60																
	15		5	10													
	30			10													
n102	60																
	15					20				40							
	30					20				40		60		80		100 <sup>4</sup>	
n104	60					20				40		60		80		100 <sup>4</sup>	
	15					20		30		40		50					
	30					20		30		40		50	60	70	80	90	100
n105	60					20		30		40		50	60	70	80	90	100
	15		5	10	15	20	25 <sup>3</sup>	30 <sup>3</sup>	35 <sup>3</sup>								
	30			10	15	20	25 <sup>3</sup>	30 <sup>3</sup>	35 <sup>3</sup>								
n106	60																
	15	3															
	30																



NR Band	SCS (kHz)	UE Channel bandwidth (MHz)															
		3	5	10	15	20	25	30	35	40	45	50	60	70	80	90	100
n109	60																
	15		5	10	15	20	25	30		40 <sup>3</sup>		50 <sup>3</sup>					
	30			10	15	20	25	30		40 <sup>3</sup>		50 <sup>3</sup>					
	60																

NOTE 1: Void.

NOTE 2: Void.

NOTE 3: This UE channel bandwidth is applicable only to downlink.

NOTE 4: This UE channel bandwidth is optional in this release of the specification.

NOTE 5: For this bandwidth, the minimum requirements are restricted to operation when carrier is configured as an SCell part of DC or CA configuration.

NOTE 6: For this bandwidth, the minimum requirements are restricted to operation when carrier is configured as a downlink SCell part of CA configuration.

NOTE 7: For the 20 MHz bandwidth, the minimum requirements are specified for NR UL carrier frequencies confined to either 713-723 MHz or 728-738 MHz. For the 25 MHz bandwidth, the minimum requirements are specified for NR UL carrier frequencies confined to either 715.5-720.5 MHz or 730.5-735.5 MHz. For the 30MHz bandwidth, the minimum requirements are specified for NR UL transmission bandwidth configuration confined to either 703-733 or 718-748 MHz.

NOTE 8: This UE channel bandwidth is applicable only to uplink.

NOTE 9: Void.

NOTE 10: For this band, UE channel bandwidths which are applicable to sidelink operation are specified in Table 5.3E.1-1.

NOTE 11: Not all frequency positions of 5 MHz carriers are possible due limitations of the SSB position relative to the 5 MHz channels. 5 MHz channels with  $F_c$  such that  $2499+N*1.2 \leq F_c < 2499.3+N*1.2$  MHz for  $0 \leq N < 157$  are not compatible with SSB positions and cannot be used for 5 MHz n41.

NOTE 12: This UE channel Bandwidth is optional for uplink in this release of the specification.

### 5.3.6 Asymmetric channel bandwidths

The UE channel bandwidth can be asymmetric in downlink and uplink. In asymmetric channel bandwidth operation, the narrower carrier shall be confined within the frequency range of the wider channel bandwidth.

In FDD, the confinement is defined as a maximum deviation to the Tx-Rx carrier center frequency separation (defined in Table 5.4.4-1) as following:

$$\Delta F_{\text{TX-RX}} = |(\text{BW}_{\text{DL}} - \text{BW}_{\text{UL}})/2|$$

The operating bands and supported asymmetric channel bandwidth combinations are defined in Table 5.3.6-1.

**Table 5.3.6-1: FDD asymmetric UL and DL channel bandwidth combinations**

NR Band	Channel bandwidths for UL (MHz)	Channel bandwidths for DL (MHz)	Asymmetric channel bandwidth combination set
n5	20	25	0
n8	20	35	0
	10, 15, 20	25, 35	1
	10, 15, 20	25, 30, 35	2
n24	10	5	0
n25	40	45	0
n26	20	25, 30	0
n28 <sup>3</sup>	3	5	1
n66	5, 10	20, 40	0
	20	40	
	5, 10	20, 25, 30, 40	1
	20, 25, 30	40	
	5, 10, 15	20, 25, 30, 35, 40	2
	20, 25, 30	40	
n70	5, 10	15	0
	5, 10, 15	20, 25	
n71	5	10	0
	10	15	
	15	20	
	5	10	
	10	15	1

	15	20	
	20	35	
	20	25, 30, 35	2
n91 <sup>1</sup>	10	5	0
n92 <sup>1</sup>	5	10, 15, 20	0
	10	15, 20	
n93 <sup>1</sup>	10	5	0
n94 <sup>1</sup>	5	10, 15, 20	0
	10	15, 20	
n105	20	25, 30, 35	0
n109 <sup>1</sup>	5	10, 15, 20, 25, 30, 40, 50	0
	10	15, 20, 25, 30, 40, 50	
	15	20, 25, 30, 40, 50	
	20	25, 30, 40, 50	
	25	30, 40, 50	
	30	40, 50	

NOTE 1: The assignment of the paired UL and DL channels are subject to a TX-RX separation as specified in clause 5.4.4.

NOTE 2: As indicated for *asymmetricBandwidthCombinationSet* in TS 38.306 [15], it is mandatory for UEs to support asymmetric channel BCS0 if there is an asymmetric BCS0 defined for the band.

NOTE 3: This BCS1 is limited to uplink 715-718 MHz and downlink 768-773 MHz.

In TDD, the operating bands and supported asymmetric channel bandwidth combinations are defined in Table 5.3.6-2.

**Table 5.3.6-2: TDD asymmetric UL and DL channel bandwidth combinations**

NR Band	Channel bandwidths for UL (MHz)	Channel bandwidths for DL (MHz)	Asymmetric channel bandwidth combination set
n50	60	80	0

NOTE 1: Both centre frequency and BWP-ID shall match between DL and UL carriers as defined in TS 38.331 [7] cl. 6.3.2 and TS 38.213 [8] clause 12.

NOTE 2: In a case a UE is configured with a full width of BWP within both UL/ DL channels, the centre frequency of UL/ DL channels shall be same.

NOTE 3: A position of Point A is common between UL and DL carriers as defined in TS 38.331 [7] cl. 6.3.2.

## 5.3A UE channel bandwidth for CA

### 5.3A.1 General

**Figure 5.3A.1-1: Void**

**Figure 5.3A.1-2: Void**

### 5.3A.2 Maximum transmission bandwidth configuration for CA

For carrier aggregation, the maximum transmission bandwidth configuration is defined per component carrier and the requirement is specified in clause 5.3.2.

### 5.3A.3 Minimum guardband and transmission bandwidth configuration for CA

For intra-band contiguous carrier aggregation, *Aggregated Channel Bandwidth* and *Guard Bands* are defined as follows, see Figure 5.3A.3-1.

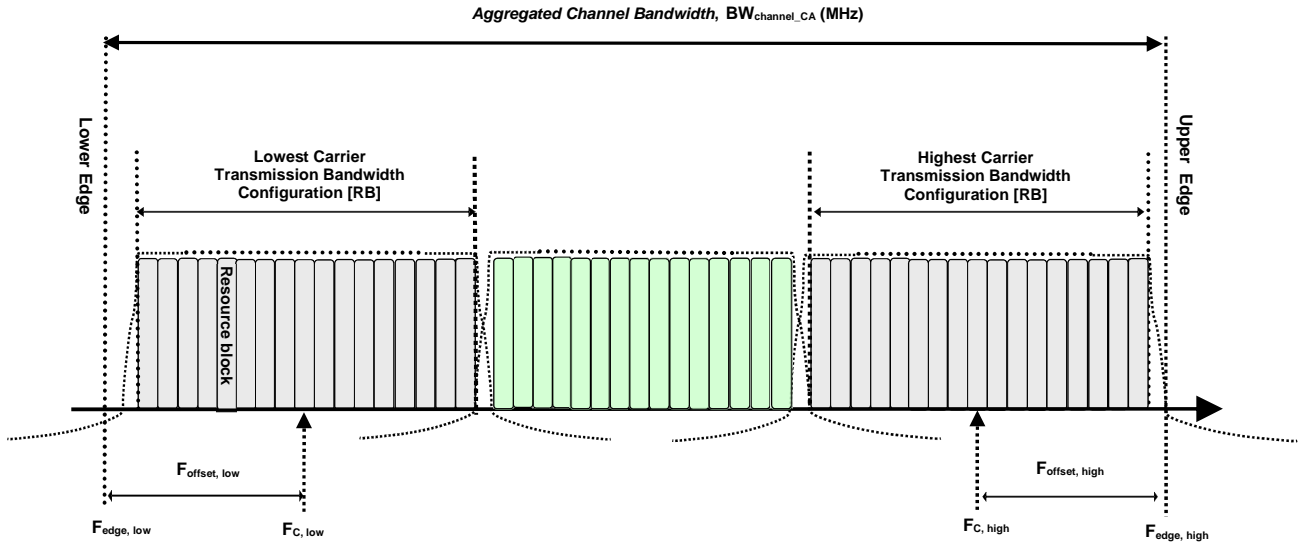

**Figure 5.3A.3-1: Definition of *Aggregated Channel Bandwidth* for intra-band carrier aggregation**

The *aggregated channel bandwidth*,  $BW_{\text{Channel\_CA}}$ , is defined as

$$BW_{\text{Channel\_CA}} = F_{\text{edge,high}} - F_{\text{edge,low}} \text{ (MHz)}$$

The lower bandwidth edge  $F_{\text{edge,low}}$  and the upper bandwidth edge  $F_{\text{edge,high}}$  of the aggregated channel bandwidth are used as frequency reference points for transmitter and receiver requirements and are defined by

$$F_{\text{edge,low}} = F_{C,\text{low}} - F_{\text{offset,low}}$$

$$F_{\text{edge,high}} = F_{C,\text{high}} + F_{\text{offset,high}}$$

The lower and upper frequency offsets depend on the transmission bandwidth configurations of the lowest and highest assigned edge component carrier and are defined as

$$F_{\text{offset,low}} = (N_{\text{RB,low}} * 12 + 1) * SCS_{\text{low}} / 2 + BW_{\text{GB}} \text{ (MHz)}$$

$$F_{\text{offset,high}} = (N_{\text{RB,high}} * 12 - 1) * SCS_{\text{high}} / 2 + BW_{\text{GB}} \text{ (MHz)}$$

$$BW_{\text{GB}} = \max(GB_{\text{Channel,low}}, GB_{\text{Channel,high}})$$

$N_{\text{RB,low}}$  and  $N_{\text{RB,high}}$  are the transmission bandwidth configurations according to Table 5.3.2-1 for the lowest and highest assigned component carrier,  $SCS_{\text{low}}$  and  $SCS_{\text{high}}$  are the sub-carrier spacing for the lowest and highest assigned component carrier respectively.  $SCS_{\text{low}}$ ,  $SCS_{\text{high}}$ ,  $N_{\text{RB,low}}$ ,  $N_{\text{RB,high}}$ ,  $GB_{\text{Channel,low}}$  and  $GB_{\text{Channel,high}}$  use the largest  $\mu$  value among the subcarrier spacing configurations supported in the operating band for both of the channel bandwidths according to Table 5.3.5-1.  $GB_{\text{Channel,low}}$  and  $GB_{\text{Channel,high}}$  are the minimum guard band for the lowest and highest assigned component carrier according to Table 5.3.3-1 for the said  $\mu$  value, respectively.

In case there is no common  $\mu$  value for both of the channel bandwidths,  $\mu=1$  is used for  $SCS_{\text{low}}$ ,  $SCS_{\text{high}}$ ,  $N_{\text{RB,low}}$ ,  $N_{\text{RB,high}}$ ,  $GB_{\text{Channel,low}}$  and  $GB_{\text{Channel,high}}$ .

For intra-band non-contiguous carrier aggregation *Sub-block Bandwidth* and *Sub-block edges* are defined as follows, see Figure 5.3A.3-2.

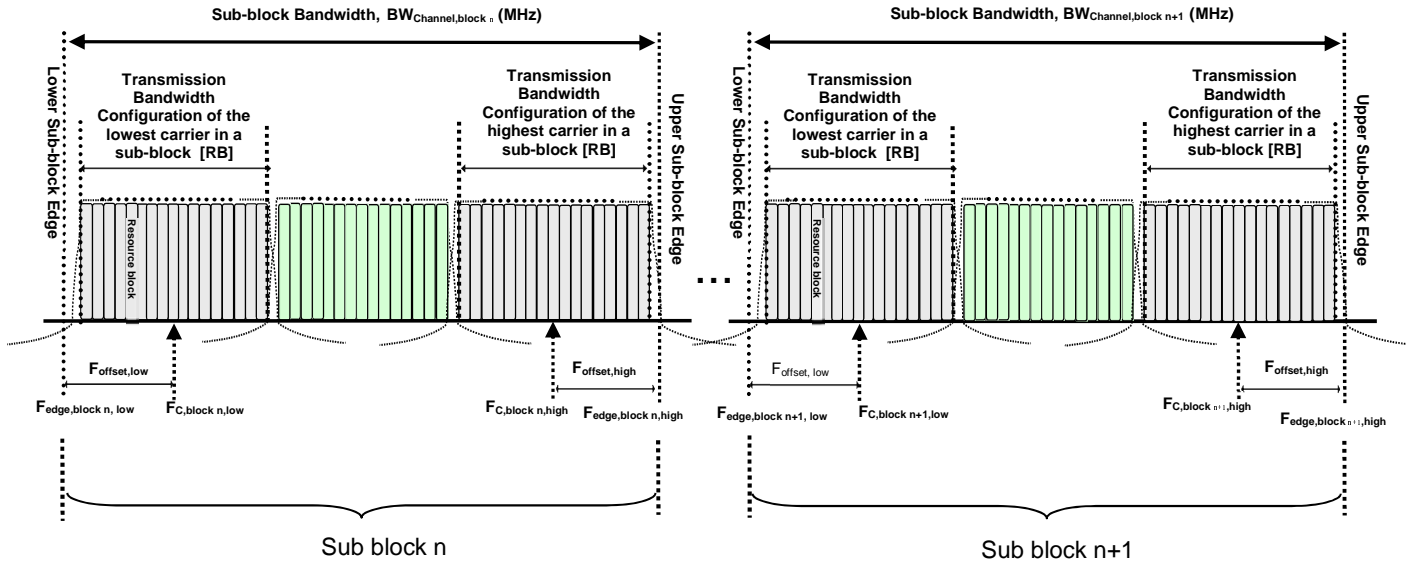

**Figure 5.3A.3-2: Definition of sub-block bandwidth for intra-band non-contiguous spectrum**

The lower sub-block edge of the Sub-block Bandwidth ( $BW_{Channel,block}$ ) is defined as

$$F_{edge,block,low} = F_{C,block,low} - F_{offset,low}$$

The upper sub-block edge of the Sub-block Bandwidth is defined as

$$F_{edge,block,high} = F_{C,block,high} + F_{offset,high}$$

The Sub-block Bandwidth,  $BW_{Channel,block}$ , is defined as follows:

$$BW_{Channel,block} = F_{edge,block,high} - F_{edge,block,low} \text{ (MHz)}$$

The lower and upper frequency offsets  $F_{offset,block,low}$  and  $F_{offset,block,high}$  depend on the transmission bandwidth configurations of the lowest and highest assigned edge component carriers within a sub-block and are defined as

$$F_{offset,block,low} = (N_{RB,low} * 12 + 1) * SCS_{low} / 2 + BW_{GB} \text{ (MHz)}$$

$$F_{offset,block,high} = (N_{RB,high} * 12 - 1) * SCS_{high} / 2 + BW_{GB} \text{ (MHz)}$$

$$BW_{GB} = \max(GB_{Channel,low}, GB_{Channel,high})$$

where  $N_{RB,low}$  and  $N_{RB,high}$  are the transmission bandwidth configurations according to Table 5.3.2-1 for the lowest and highest assigned component carrier within a sub-block, respectively.  $SCS_{low}$  and  $SCS_{high}$  are the sub-carrier spacing for the lowest and highest assigned component carrier within a sub-block, respectively.  $SCS_{low}$ ,  $SCS_{high}$ ,  $N_{RB,low}$ ,  $N_{RB,high}$ ,  $GB_{Channel,low}$  and  $GB_{Channel,high}$  use the largest  $\mu$  value among the subcarrier spacing configurations supported in the operating band for both of the channel bandwidths according to Table 5.3.5-1.  $GB_{Channel,low}$  and  $GB_{Channel,high}$  are the minimum guard band for the lowest and highest assigned component carrier according to Table 5.3.3-1 for the said  $\mu$  value, respectively. In case there is no common  $\mu$  value for both of the channel bandwidths,  $\mu=1$  is used for  $SCS_{low}$ ,  $SCS_{high}$ ,  $N_{RB,low}$ ,  $N_{RB,high}$ ,  $GB_{Channel,low}$  and  $GB_{Channel,high}$ .

The sub-block gap size between two consecutive sub-blocks  $W_{gap}$  is defined as

$$W_{gap} = F_{edge,block\ n+1,low} - F_{edge,block\ n,high} \text{ (MHz)}$$

### 5.3A.4 Void

### 5.3A.5 UE channel bandwidth per operating band for CA

The requirements for carrier aggregation in this specification are defined for carrier aggregation configurations.

For intra-band contiguous carrier aggregation, a carrier aggregation configuration is a single operating band supporting a carrier aggregation bandwidth class with associated bandwidth combination sets specified in clause 5.5A.1. For each carrier aggregation configuration, requirements are specified for all aggregated channel bandwidths contained in a bandwidth combination set, a UE can indicate support of several bandwidth combination sets per carrier aggregation configuration. For intra-band non-contiguous carrier aggregation, a carrier aggregation configuration is a single operating band supporting two or more sub-blocks, each supporting a carrier aggregation bandwidth class.

For intra-band non-contiguous uplink carrier aggregation, frequency separation class (Fs) specified in Table 5.3A.5-2 indicates the maximum frequency span between lower edge of lowest component carrier and upper edge of highest component carrier that UE can support per band combination in uplink in non-contiguous intra-band operation when the signalling is absent for dualPA-Architecture IE.

For inter-band carrier aggregation, a carrier aggregation configuration is a combination of operating bands, each supporting a carrier aggregation bandwidth class.

**Table 5.3A.5-1: NR CA bandwidth classes**

NR CA bandwidth class	Aggregated channel bandwidth	Number of contiguous CC	Fallback group
A	$BW_{\text{Channel}} \leq BW_{\text{Channel,max}}$	1	1, 2, 3 <sup>4</sup>
B	$20 \text{ MHz} \leq BW_{\text{Channel,CA}} \leq 100 \text{ MHz}$	2	2, 3 <sup>4</sup>
C	$100 \text{ MHz} < BW_{\text{Channel,CA}} \leq 2 \times BW_{\text{Channel,max}}$	2	1, 3 <sup>4</sup>
D	$200 \text{ MHz} < BW_{\text{Channel,CA}} \leq 3 \times BW_{\text{Channel,max}}$	3	
E	$300 \text{ MHz} < BW_{\text{Channel,CA}} \leq 4 \times BW_{\text{Channel,max}}$	4	
G	$100 \text{ MHz} < BW_{\text{Channel,CA}} \leq 150 \text{ MHz}$	3	
H	$150 \text{ MHz} < BW_{\text{Channel,CA}} \leq 200 \text{ MHz}$	4	2
I	$200 \text{ MHz} < BW_{\text{Channel,CA}} \leq 250 \text{ MHz}$	5	
J	$250 \text{ MHz} < BW_{\text{Channel,CA}} \leq 300 \text{ MHz}$	6	
K	$300 \text{ MHz} < BW_{\text{Channel,CA}} \leq 350 \text{ MHz}$	7	
L	$350 \text{ MHz} < BW_{\text{Channel,CA}} \leq 400 \text{ MHz}$	8	
M <sup>3</sup>	$50 \text{ MHz} \leq BW_{\text{Channel,CA}} \leq 200 \text{ MHz}$	3	
N <sup>3</sup>	$80 \text{ MHz} \leq BW_{\text{Channel,CA}} \leq 300 \text{ MHz}$	4	
O <sup>3</sup>	$100 \text{ MHz} \leq BW_{\text{Channel,CA}} \leq 400 \text{ MHz}$	5	

NOTE 1:  $BW_{\text{Channel,max}}$  is maximum channel bandwidth supported among all bands in a release  
NOTE 2: It is mandatory for a UE to be able to fallback to lower order NR CA bandwidth class configuration within a fallback group. It is not mandatory for a UE to be able to fallback to lower order NR CA bandwidth class configuration that belong to a different fallback group.  
NOTE 3: This bandwidth class is only applicable to bands identified for use with shared spectrum channel access in Table 5.2-1.  
NOTE 4: Fallback group 3 is only applicable to bands identified for use with shared spectrum channel access in Table 5.2-1.

**Table 5.3A.5-2: NR intra-band non-contiguous UL CA frequency separation classes**

NR NC UL CA frequency separation class	Maximum allowed frequency separation
I	100 MHz
II	200 MHz
III	[600MHz]

## 5.3E Channel bandwidth for V2X

### 5.3E.1 General

NR V2X operation channel bandwidths for each operating band are specified in Table 5.3E.1-1. The same (symmetrical) channel bandwidth is specified for both the transmission and reception path. The maximum channel bandwidth for SL operation in licensed band is 40MHz.

Table 5.3E.1-1 NR V2X operation channel bandwidths for each operating band

NR Band	NR band / SCS / UE Channel bandwidth (MHz)					
	SCS (kHz)	5	10	20	30	40
n14	15	5	10			
	30		10			
	60					
n38	15		10	20	30	40
	30		10	20	30	40
	60		10	20	30	40
n47	15		10	20	30	40
	30		10	20	30	40
	60		10	20	30	40
n79	15		10	20	30	40
	30		10	20	30	40
	60		10	20	30	40

### 5.3E.1A Channel bandwidth for Sidelink CA

For sidelink intra-band contiguous carrier aggregation, a carrier aggregation configuration is a single ITS operating band supporting a carrier aggregation bandwidth class with associated bandwidth combination sets specified in clause 5.5E.1A.1. The sidelink intra-band carrier aggregation bandwidth class follows Table 5.3A.5-1. For each carrier aggregation configuration, requirements are specified for all aggregated channel bandwidths contained in a bandwidth combination set.

### 5.3E.1F Channel bandwidth for Sidelink Unlicensed

NR SL-U Channel bandwidths for each band are specified in Table 5.3E.1F-1. The same (symmetrical) channel bandwidth is specified for both the transmission and reception path.

Table 5.3E.1F-1 NR SL-U channel bandwidth

NR SL-U Operating Band	SCS kHz	SL-U band /channel bandwidth								
		10 MHz	20 MHz	30 MHz	40 MHz	50 MHz	60 MHz	80 MHz	90 MHz	100 MHz
n46	15		20		40					
	30		20		40		60	80		100 <sup>1</sup>
	60		20		40		60	80		100 <sup>1</sup>
n96	15		20		40					
	30		20		40		60	80		100 <sup>1</sup>
	60		20		40		60	80		100 <sup>1</sup>
n102	15		20		40					
	30		20		40		60	80		100 <sup>1</sup>
	60		20		40		60	80		100 <sup>1</sup>

NOTE 1: This UE channel bandwidth is optional in this release of the specification.

## 5.3E.2 Channel bandwidth for V2X concurrent operation

For NR V2X inter-band concurrent operation in FR1, the NR V2X channel bandwidths for each operating band are specified in Table 5.3E.2-1.

**Table 5.3E.2-1: Inter-band concurrent operation configurations**

NR V2X inter-band concurrent operating configuration	NR Band	Interface	Channel bandwidth (MHz) (NOTE 1)	Bandwidth combination set
V2X_n1A-n47A	n1	Uu	5, 10, 15, 20, 25, 30, 40, 45, 50	0
	n47	PC5	10, 20, 30, 40	
V2X_n3A-n47A	n3	Uu	5, 10, 15, 20, 25, 30, 35, 40, 45, 50	0
	n47	PC5	10, 20, 30, 40	
V2X_n5A-n47A	n5	Uu	5, 10, 15, 20, 25	0
	n47	PC5	10, 20, 30, 40	
V2X_n8A-n47A	n8	Uu	5, 10, 15, 20, 35	0
	n47	PC5	10, 20, 30, 40	
V2X_n34A-n47A	n34	Uu	5, 10, 15	0
	n47	PC5	10, 20, 30, 40	
V2X_n39A-n47A	n39	Uu	5, 10, 15, 20, 25, 30, 40	0
	n47	PC5	10, 20, 30, 40	
V2X_n40A-n47A	n40	Uu	5, 10, 15, 20, 25, 30, 40, 50, 60, 80	0
	n47	PC5	10, 20, 30, 40	
V2X_n41A-n47A	n41	Uu	10, 15, 20, 25, 30, 40, 50, 60, 80, 90, 100	0
	n47	PC5	10, 20, 30, 40	
V2X_n71A-n47A	n71	Uu	5, 10, 15, 20	0
	n47	PC5	10, 20, 30, 40	
V2X_n78A-n47A	n78	Uu	10, 15, 20, 25, 30, 40, 50, 60, 70, 80, 90, 100	0
	n47	PC5	10, 20, 30, 40	

For NR V2X intra-band concurrent operation in FR1, the NR V2X channel bandwidths for each operating band are specified in Table 5.3E.2-2.

**Table 5.3E.2-2: Intra-band concurrent operation configurations**

NR V2X intra-band concurrent operating configuration	NR Band	Interface	Channel bandwidth (MHz) (NOTE 1)	Bandwidth combination set
V2X_n79B	n79	Uu	40, 50, 60, 80, 100	0
	n79	PC5	10, 20, 30, 40	
NOTE 1: The SCS of each channel bandwidth for NR band refers to Table 5.3.5-1.				

### 5.3E.2F Channel bandwidth for SL-U concurrent operation

For NR SL-U inter-band concurrent operation, the SL-U Channel bandwidths for each operating band are specified in Table 5.3E.2F-1.

**Table 5.3E.2F-1 NR SL-U inter-band concurrent operating configurations**

NR SL inter-band concurrent operating configuration	NR Band	Interface	Channel bandwidth (MHz) (NOTE 1)	Bandwidth combination set
SL_n78A-n46A	n78	Uu	10, 15, 20, 25, 30, 40, 50, 60, 70, 80, 90, 100	0
	n46	PC5	20, 40, 60, 80, 100	
NOTE 1: The SCS of each channel bandwidth for NR band refers to Table 5.3.5-1.				



## 5.3l Channel bandwidth for RedCap

The requirements in this specification apply to the combination of channel bandwidths, SCS and operating bands shown in Table 5.3.5-1 with maximum channel bandwidth of 20MHz. The transmission bandwidth configuration in Table 5.3.2-1 shall be supported for each of the specified channel bandwidths up to 20 MHz. When UE supports IE *supportOfERedCap-r18* and does not support IE *eRedCapNotReducedBB-BW-r18* the requirements in this specification apply with maximum transmission bandwidth of 25RBs for 15 kHz SCS and 12 RBs for 30 kHz SCS for PDSCH and PUSCH. The channel bandwidths are specified for both the TX and RX paths.

3MHz channel bandwidth is not applicable for RedCap UE in the current release.

## 5.4 Channel arrangement

### 5.4.1 Channel spacing

#### 5.4.1.1 Channel spacing for adjacent NR carriers

The spacing between carriers will depend on the deployment scenario, the size of the frequency block available and the channel bandwidths. The nominal channel spacing between two adjacent NR carriers is defined as following:

- For NR operating bands with 100 kHz or 10 kHz channel raster,

$$\text{Nominal Channel spacing} = (\text{BW}_{\text{Channel}(1)} + \text{BW}_{\text{Channel}(2)})/2$$

- For NR operating bands with 15 kHz channel raster,

$$\text{Nominal Channel spacing} = (\text{BW}_{\text{Channel}(1)} + \text{BW}_{\text{Channel}(2)})/2 + \{-5 \text{ kHz}, 0 \text{ kHz}, 5 \text{ kHz}\} \text{ for } \Delta F_{\text{Raster}} \text{ equals } 15 \text{ kHz}$$

$$\text{Nominal Channel spacing} = (\text{BW}_{\text{Channel}(1)} + \text{BW}_{\text{Channel}(2)})/2 + \{-10 \text{ kHz}, 0 \text{ kHz}, 10 \text{ kHz}\} \text{ for } \Delta F_{\text{Raster}} \text{ equals } 30 \text{ kHz}$$

where  $\text{BW}_{\text{Channel}(1)}$  and  $\text{BW}_{\text{Channel}(2)}$  are the channel bandwidths of the two respective NR carriers. The channel spacing can be adjusted depending on the channel raster to optimize performance in a particular deployment scenario.

For NR bands restricted to operation with shared-spectrum channel access, the maximum deviation from the nominal channel spacing is 40 kHz.

### 5.4.2 Channel raster

#### 5.4.2.1 NR-ARFCN and channel raster

The global frequency channel raster defines a set of RF reference frequencies  $F_{\text{REF}}$ . The RF reference frequency is used in signalling to identify the position of RF channels, SS blocks and other elements.

The global frequency raster is defined for all frequencies from 0 to 100 GHz. The granularity of the global frequency raster is  $\Delta F_{\text{Global}}$ .

RF reference frequencies are designated by an NR Absolute Radio Frequency Channel Number (NR-ARFCN) in the range (0...2016666) on the global frequency raster. The relation between the NR-ARFCN and the RF reference frequency  $F_{\text{REF}}$  in MHz is given by the following equation, where  $F_{\text{REF-Offs}}$  and  $N_{\text{REF-Offs}}$  are given in Table 5.4.2.1-1 and  $N_{\text{REF}}$  is the NR-ARFCN.

$$F_{\text{REF}} = F_{\text{REF-Offs}} + \Delta F_{\text{Global}} (N_{\text{REF}} - N_{\text{REF-Offs}})$$

**Table 5.4.2.1-1: NR-ARFCN parameters for the global frequency raster**

Frequency range (MHz)	$\Delta F_{\text{Global}}$ (kHz)	$F_{\text{REF-Offs}}$ (MHz)	$N_{\text{REF-Offs}}$	Range of $N_{\text{REF}}$
0 – 3000	5	0	0	0 – 599999
3000 – 24250	15	3000	600000	600000 – 2016666

The channel raster defines a subset of RF reference frequencies that can be used to identify the RF channel position in the uplink and downlink. The RF reference frequency for an RF channel maps to a resource element on the carrier. For each operating band, a subset of frequencies from the global frequency raster are applicable for that band and forms a channel raster with a granularity  $\Delta F_{\text{Raster}}$ , which may be equal to or larger than  $\Delta F_{\text{Global}}$ .

For SUL bands except n95, n97, n98 and for the uplink of all FDD bands defined in Table 5.2-1, and for TDD bands n34, n39, n48, n90, n38 and n40

$$F_{\text{REF, shift}} = F_{\text{REF}} + \Delta_{\text{shift}}, \Delta_{\text{shift}} = 0 \text{ kHz or } 7.5 \text{ kHz.}$$

where  $\Delta_{\text{shift}}$  is signalled by the network in higher layer parameter *frequencyShift7p5khz* [7]. For Band n34, n38, n39, n40, n48  $F_{\text{REF, shift}}$  is only applicable to uplink transmissions using a 15 kHz SCS.

The mapping between the channel raster and corresponding resource element is given in Clause 5.4.2.2. The applicable entries for each operating band are defined in Clause 5.4.2.3.

### 5.4.2.2 Channel raster to resource element mapping

The mapping between the RF reference frequency on the channel raster and the corresponding resource element is given in Table 5.4.2.2-1 and can be used to identify the RF channel position. The mapping depends on the total number of RBs that are allocated in the channel and applies to both UL and DL. The mapping must apply to at least one numerology supported by the UE.

**Table 5.4.2.2-1: Channel raster to resource element mapping**

	$N_{\text{RB}} \bmod 2 = 0$	$N_{\text{RB}} \bmod 2 = 1$
Resource element index $k$	0	6
Physical resource block index $n_{\text{PRB}}$	$n_{\text{PRB}} = \left\lfloor \frac{N_{\text{RB}}}{2} \right\rfloor$	$n_{\text{PRB}} = \left\lfloor \frac{N_{\text{RB}}}{2} \right\rfloor$

$N_{\text{RB}}$  is the maximum transmission bandwidth configuration specified in sub-clause 5.3.2,  $n_{\text{PRB}}$  is the PRB index within the  $N_{\text{RB}}$ , and  $k$  is the resource element index within this PRB.

### 5.4.2.3 Channel raster entries for each operating band

The RF channel positions on the channel raster in each NR operating band are given through the applicable NR-ARFCN in Table 5.4.2.3-1, using the channel raster to resource element mapping in clause 5.4.2.2.

For NR operating bands with 100 kHz channel raster,  $\Delta F_{\text{Raster}} = 20 \times \Delta F_{\text{Global}}$ . In this case every 20<sup>th</sup> NR-ARFCN within the operating band are applicable for the channel raster within the operating band and the step size for the channel raster in Table 5.4.2.3-1 is given as <20>.

For NR operating bands with 15 kHz channel raster below 3GHz,  $\Delta F_{\text{Raster}} = I \times \Delta F_{\text{Global}}$ , where  $I \in \{3,6\}$ . Every  $I^{\text{th}}$  NR-ARFCN within the operating band are applicable for the channel raster within the operating band and the step size for the channel raster in Table 5.4.2.3-1 is given as <I>.

For NR operating bands with 15 kHz channel raster above 3GHz,  $\Delta F_{\text{Raster}} = I \times \Delta F_{\text{Global}}$ , where  $I \in \{1,2\}$ . Every  $I^{\text{th}}$  NR-ARFCN within the operating band are applicable for the channel raster within the operating band and the step size for the channel raster in Table 5.4.2.3-1 is given as <I>.

In frequency bands with two or more  $\Delta F_{\text{Raster}}$ , the higher  $\Delta F_{\text{Raster}}$ : For 15 kHz and 30 kHz channel raster applies to channels using only the SCS that is equal to or larger than the higher  $\Delta F_{\text{Raster}}$  and SSB SCS is equal to the higher  $\Delta F_{\text{Raster}}$ .

**Table 5.4.2.3-1: Applicable NR-ARFCN per operating band**

NR operating band	$\Delta F_{\text{Raster}}$ (kHz)	Uplink Range of $N_{\text{REF}}$ (First – <Step size> – Last)	Downlink Range of $N_{\text{REF}}$ (First – <Step size> – Last)

n1	100	384000 – <20> – 396000	422000 – <20> – 434000
n2	100	370000 – <20> – 382000	386000 – <20> – 398000
n3	100	342000 – <20> – 357000	361000 – <20> – 376000
n5	100	164800 – <20> – 169800	173800 – <20> – 178800
n7	100	500000 – <20> – 514000	524000 – <20> – 538000
n8	100	176000 – <20> – 183000	185000 – <20> – 192000
n12	100	139800 – <20> – 143200	145800 – <20> – 149200
n13	100	155400 – <20> – 157400	149200 – <20> – 151200
n14	100	157600 – <20> – 159600	151600 – <20> – 153600
n18	100	163000 – <20> – 166000	172000 – <20> – 175000
n20	100	166400 – <20> – 172400	158200 – <20> – 164200
n24	100	325300 – <20> – 332100	305000 – <20> – 311800
n25	100	370000 – <20> – 383000	386000 – <20> – 399000
n26	100	162800 – <20> – 169800	171800 – <20> – 178800
n28	100	140600 – <20> – 149600	151600 – <20> – 160600
n29	100	N/A	143400 – <20> – 145600
n30	100	461000 – <20> – 463000	470000 – <20> – 472000
n31	100	90500 – <20> – 91500	92500 – <20> – 93500
n34	100	402000 – <20> – 405000	402000 – <20> – 405000
n38	100	514000 – <20> – 524000	514000 – <20> – 524000
n39	100	376000 – <20> – 384000	376000 – <20> – 384000
n40	100	460000 – <20> – 480000	460000 – <20> – 480000
n41	15	499200 – <3> – 537999	499200 – <3> – 537999
	30	499200 – <6> – 537996	499200 – <6> – 537996
n46 <sup>2</sup>	15	743334 – <1> – 795000	743334 – <1> – 795000
n47	15	790334 – <1> – 795000	790334 – <1> – 795000
n48	15	636667 – <1> – 646666	636667 – <1> – 646666
	30	636668 – <2> – 646666	636668 – <2> – 646666
n50	100	286400 – <20> – 303400	286400 – <20> – 303400
n51	100	285400 – <20> – 286400	285400 – <20> – 286400
n53	100	496700 – <20> – 499000	496700 – <20> – 499000
n54	100	334000 – <20> – 335000	334000 – <20> – 335000
n65	100	384000 – <20> – 402000	422000 – <20> – 440000
n66	100	342000 – <20> – 356000	422000 – <20> – 440000
n67	100	N/A	147600 – <20> – 151600
n70	100	339000 – <20> – 342000	399000 – <20> – 404000
n71	100	132600 – <20> – 139600	123400 – <20> – 130400
n72	100	90200 – <20> – 91200	92200 – <20> – 93200
n74	100	285400 – <20> – 294000	295000 – <20> – 303600
n75	100	N/A	286400 – <20> – 303400
n76	100	N/A	285400 – <20> – 286400
n77	15	620000 – <1> – 680000	620000 – <1> – 680000
	30	620000 – <2> – 680000	620000 – <2> – 680000
n78	15	620000 – <1> – 653333	620000 – <1> – 653333
	30	620000 – <2> – 653332	620000 – <2> – 653332
n79	15	693334 – <1> – 733333	693334 – <1> – 733333
	30	693334 – <2> – 733332	693334 – <2> – 733332
n80	100	342000 – <20> – 357000	N/A
n81	100	176000 – <20> – 183000	N/A
n82	100	166400 – <20> – 172400	N/A
n83	100	140600 – <20> – 149600	N/A
n84	100	384000 – <20> – 396000	N/A
n85	100	139600 – <20> – 143200	145600 – <20> – 149200
n86	100	342000 – <20> – 356000	N/A
n89	100	164800 – <20> – 169800	N/A
n90	15	499200 – <3> – 537999	499200 – <3> – 537999
	30	499200 – <6> – 537996	499200 – <6> – 537996
	100	499200 – <20> – 538000	499200 – <20> – 538000
n91	100	166400 – <20> – 172400	285400 – <20> – 286400
n92	100	166400 – <20> – 172400	286400 – <20> – 303400
n93	100	176000 – <20> – 183000	285400 – <20> – 286400
n94	100	176000 – <20> – 183000	286400 – <20> – 303400
n95	100	402000 – <20> – 405000	N/A
n96 <sup>3</sup>	15	795000 – <1> – 875000	795000 – <1> – 875000
n97	100	460000 – <20> – 480000	N/A

n98	100	376000 – <20> – 384000	N/A
n99	100	325300 – <20> – 332100	N/A
n100	100	174880 – <20> – 176000	183880 – <20> – 185000
n101	100	380000 – <20> – 382000	380000 – <20> – 382000
n102 <sup>4</sup>	15	795000 – <1> – 828333	795000 – <1> – 828333
n104	15	828334 – <1> – 875000	828334 – <1> – 875000
	30	828334 – <2> – 875000	828334 – <2> – 875000
n105	100	132600 – <20> – 140600	122400 – <20> – 130400
n106 <sup>5</sup>	100	179200 – <20> – 180200	187000 – <20> – 188000
n109	100	140600 – <20> – 146600	286400 – <20> – 303400

NOTE 1: The channel numbers that designate carrier frequencies so close to the operating band edges that the carrier extends beyond the operating band edge shall not be used.  
 NOTE 2: The following N<sub>REF</sub> are allowed for operation in Band n46: see Table 5.4.2.3-2.  
 NOTE 3: The following N<sub>REF</sub> are allowed for operation in Band n96: see Table 5.4.2.3-3.  
 NOTE 4: The following N<sub>REF</sub> are allowed for operation in Band n102: see Table 5.4.2.3-4.  
 NOTE 5: In the present version of the specification, only N<sub>REF</sub> 179800 and 187600 is applicable for 3 MHz channel bandwidth.

**Table 5.4.2.3-2: Allowed N<sub>REF</sub> (NR-ARFCN) for operation in Band n46**

Channel Bandwidth	Allowed N <sub>REF</sub>
10 MHz	782000, 788668
20 MHz	744000, 745332, 746668, 748000, 749332, 750668, 752000, 753332, 754668, 756000, 765332, 766668, 768000, 769332, 770668, 772000, 773332, 774668, 776000, 777332, 778668, 780000, 781332, 783000, 784332, 785668, 787000, 788332, 789668, 791000, 792332, 793668
40 MHz	744668, 746000, 748668, 751332, 754000, 755332, 766000, 767332, 770000, 772668, 775332, 778000, 780668, 783668, 786332, 787668, 790332, 793000
60 MHz	745332, 746668, 748000, 752000, 753332, 754668, 766668, 768000, 769332, 773332, 774668, 778668, 780000, 784332, 785668, 791000, 792332
80 MHz	746000, 747332, 752668, 754000, 767332, 768668, 774000, 779332, 785000, 791668
100 MHz	746668, 753332, 768000, 791000

NOTE: 10 MHz channel bandwidth shall only apply in certain regions where the absence of non 3GPP technologies can be guaranteed on a long-term basis in this version of specification.

**Table 5.4.2.3-3: Allowed N<sub>REF</sub> (NR-ARFCN) for operation in Band n96**

Channel Bandwidth	Allowed N <sub>REF</sub>
20 MHz	795668 <sup>1</sup> , 797000, 798332, 799668, 801000, 802332, 803668, 805000, 806332, 807668, 809000, 810332, 811668, 813000, 814332, 815668, 817000, 818332, 819668, 821000, 822332, 823668, 825000, 826332, 827668, 829000, 830332, 831668, 833000, 834332, 835668, 837000, 838332, 839668, 841000, 842332, 843668, 845000, 846332, 847668, 849000, 850332, 851668, 853000, 854332, 855668, 857000, 858332, 859668, 861000, 862332, 863668, 865000, 866332, 867668, 869000, 870332, 871668, 873000, 874332
40 MHz	797668, 800332, 803000, 805668, 808332, 811000, 813668, 816332, 819000, 821668, 824332, 827000, 829668, 832332, 835000, 837668, 840332, 843000, 845668, 848332, 851000, 853668, 856332, 859000, 861668, 864332, 867000, 869668, 872332
60 MHz	798332, 799668, 803668, 805000, 809000, 810332, 814332, 815668, 819668, 821000, 825000, 826332, 830332, 831668, 835668, 837000, 841000, 842332, 846332, 847668, 851668, 853000, 857000, 858332, 862332, 863668, 867668, 869000, 873000

80 MHz	799000, 804332, 809668, 815000, 820332, 825668, 831000, 836332, 841668, 847000, 852332, 857668, 863000, 868332
100 MHz	799668, 803668, 810332, 814332, 821000, 825000, 831668, 835668, 842332, 846332, 853000, 857000, 863668, 867668, 869000, 870332, 871668
Note 1: N <sub>REF</sub> is only applicable for DL only operation	

**Table 5.4.2.3-4: Allowed N<sub>REF</sub> (NR-ARFCN) for operation in Band n102**

Channel Bandwidth	Allowed N <sub>REF</sub>
20 MHz	795668 <sup>1</sup> , 797000, 798332, 799668, 801000, 802332, 803668, 805000, 806332, 807668, 809000, 810332, 811668, 813000, 814332, 815668, 817000, 818332, 819668, 821000, 822332, 823668, 825000, 826332, 827668
40 MHz	797668, 800332, 803000, 805668, 808332, 811000, 813668, 816332, 819000, 821668, 824332, 827000
60 MHz	798332, 799668, 803668, 805000, 809000, 810332, 814332, 815668, 819668, 821000, 825000, 826332
80 MHz	799000, 804332, 809668, 815000, 820332, 825668
100 MHz	799668, 803668, 810332, 814332, 821000, 825000
Note 1: N <sub>REF</sub> is only applicable for DL only operation	

For NR operating bands with 100 kHz channel raster, Enhanced channel raster is defined with  $\Delta F_{\text{Raster}} = 2 \times \Delta F_{\text{Global}}$ . In this case every 2<sup>th</sup> NR-ARFCN within the operating band are applicable for the channel raster within the operating band and the step size for the channel raster in Table 5.4.2.3-5 is given as <2>.

**Table 5.4.2.3-5: Applicable NR-ARFCN per operating band for enhanced channel raster**

NR operating band	$\Delta F_{\text{Raster}}$ (kHz)	Uplink Range of N <sub>REF</sub> (First – <Step size> – Last)	Downlink Range of N <sub>REF</sub> (First – <Step size> – Last)	Mandatory support
n1	10	384000 – <2> – 396000	422000 – <2> – 434000	Yes
n2	10	370000 – <2> – 382000	386000 – <2> – 398000	Yes
n3	10	342000 – <2> – 357000	361000 – <2> – 376000	Yes
n5	10	164800 – <2> – 169800	173800 – <2> – 178800	Yes
n7	10	500000 – <2> – 514000	524000 – <2> – 538000	
n8	10	176000 – <2> – 183000	185000 – <2> – 192000	
n12	10	139800 – <2> – 143200	145800 – <2> – 149200	
n13	10	155400 – <2> – 157400	149200 – <2> – 151200	
n14	10	157600 – <2> – 159600	151600 – <2> – 153600	
n18	10	163000 – <2> – 166000	172000 – <2> – 175000	
n20	10	166400 – <2> – 172400	158200 – <2> – 164200	
n24	10	325300 – <2> – 332100	305000 – <2> – 311800	
n25	10	370000 – <2> – 383000	386000 – <2> – 399000	Yes
n26	10	162800 – <2> – 169800	171800 – <2> – 178800	Yes
n28	10	140600 – <2> – 149600	151600 – <2> – 160600	Yes
n29	10	N/A	143400 – <2> – 145600	
n30	10	461000 – <2> – 463000	470000 – <2> – 472000	
n34	10	402000 – <2> – 405000	402000 – <2> – 405000	
n38	10	514000 – <2> – 524000	514000 – <2> – 524000	
n39	10	376000 – <2> – 384000	376000 – <2> – 384000	
n40	10	460000 – <2> – 480000	460000 – <2> – 480000	
n50	10	286400 – <2> – 303400	286400 – <2> – 303400	
n53	10	496700 – <2> – 499000	496700 – <2> – 499000	
n54	10	334000 – <2> – 335000	334000 – <2> – 335000	
n65	10	384000 – <2> – 402000	422000 – <2> – 440000	
n66	10	342000 – <2> – 356000	422000 – <2> – 440000	Yes
n67	10	N/A	147600 – <2> – 151600	
n70	10	339000 – <2> – 342000	399000 – <2> – 404000	
n71	10	132600 – <2> – 139600	123400 – <2> – 130400	Yes
n74	10	285400 – <2> – 294000	295000 – <2> – 303600	

n75	10	N/A	286400 – <2> – 303400	
n76	10	N/A	285400 – <2> – 286400	
n80	10	342000 – <2> – 357000	N/A	
n81	10	176000 – <2> – 183000	N/A	
n82	10	166400 – <2> – 172400	N/A	
n83	10	140600 – <2> – 149600	N/A	
n84	10	384000 – <2> – 396000	N/A	
n85	10	139600 – <2> – 143200	145600 – <2> – 149200	Yes
n86	10	342000 – <2> – 356000	N/A	
n89	10	164800 – <2> – 169800	N/A	
n90	10	499200 – <2> – 538000	499200 – <2> – 538000	
n91	10	166400 – <2> – 172400	285400 – <2> – 286400	
n92	10	166400 – <2> – 172400	286400 – <2> – 303400	
n93	10	176000 – <2> – 183000	285400 – <2> – 286400	
n94	10	176000 – <2> – 183000	286400 – <2> – 303400	
n95	10	402000 – <2> – 405000	N/A	
n97	10	460000 – <2> – 480000	N/A	
n98	10	376000 – <2> – 384000	N/A	
n99	10	325300 – <2> – 332100	N/A	
n100	10	174880 – <2> – 176000	183880 – <2> – 185000	
n101	10	380000 – <2> – 382000	380000 – <2> – 382000	
n105	10	132600 – <2> – 140600	122400 – <2> – 130400	

NOTE 1: The channel numbers that designate carrier frequencies so close to the operating band edges that the carrier extends beyond the operating band edge shall not be used. These channel numbers shall also be such that the minimum guard band for each channel bandwidth and SCS specified in Table 5.3.3-1 are met for carriers located at the upper or lower edge of an operating band.

## 5.4.3 Synchronization raster

### 5.4.3.1 Synchronization raster and numbering

The synchronization raster indicates the frequency positions of the synchronization block that can be used by the UE for system acquisition when explicit signalling of the synchronization block position is not present.

A global synchronization raster is defined for all frequencies. The frequency position of the SS block is defined as  $SS_{REF}$  with corresponding number GSCN. The parameters defining the  $SS_{REF}$  and GSCN for all the frequency ranges are in Table 5.4.3.1-1 for above 3 MHz channel bandwidth and in Table 5.4.3.1-2 for 3 MHz channel bandwidth.

For band n100, additional parameters defining the  $SS_{REF}$  and GSCN are specified in Table 5.4.3.1-3.

The resource element corresponding to the SS block reference frequency  $SS_{REF}$  is given in clause 5.4.3.2. The synchronization raster and the subcarrier spacing of the synchronization block is defined separately for each band.

The synchronization raster and the corresponding SS block do not cover all possible RF channel bandwidths and locations on Enhanced channel raster.

**Table 5.4.3.1-1: GSCN parameters for the global frequency raster for above 3 MHz channel bandwidth**

Frequency range	SS Block frequency position $SS_{REF}$	GSCN	Range of GSCN
0 – 3000 MHz	$N * 1200\text{kHz} + M * 50\text{ kHz}$ , $N=1:2499, M \in \{1,3,5\}$ <sup>1</sup>	$3N + (M-3)/2$	$2^2 - 7498$
3000 – 24250 MHz	$3000\text{ MHz} + N * 1.44\text{ MHz}$ $N = 0:14756$	$7499 + N$	$7499 - 22255$

NOTE 1: The default value for operating bands with which only support SCS spaced channel raster(s) is  $M=3$ .  
NOTE 2: GSCN=2 (corresponding to ARFCN-ValueNR = 250) is a reserved value paired with reserved operating band n200.

**Table 5.4.3.1-2: GSCN parameters for the global frequency for 3 MHz channel bandwidth**

Range of frequencies (MHz)	SS block frequency position $SS_{REF}$	GSCN	Range of GSCN
0 – 1000	$N * 600\text{ kHz} + M * 50\text{ kHz} + 300\text{ kHz}$ ,	$26638+3N + (M-3)/2$	$26640 - 31634$

N = 1:1665, M ∈ {1,3,5} (Note 1)
NOTE 1: Only applicable for 15 PRB transmission bandwidth configuration within 3 MHz channel bandwidth with punctured PBCH defined in TS 38.211 [6] clause 7.4.3.1.

**Table 5.4.3.1-3: Additional GSCN parameters for band n100**

SS Block frequency position SS <sub>REF</sub> (MHz)	GSCN	Note
920.73	41637	Only applicable for 12 PRB transmission bandwidth configuration within 3 MHz channel with punctured PBCH defined in TS 38.211 [6] clause 7.4.3.1.
921.45	41638	Only applicable for 20 PRB transmission bandwidth configuration within 5 MHz channel with unpunctured PBCH defined in TS 38.211 [6] clause 7.4.3.1.

### 5.4.3.2 Synchronization raster to synchronization block resource element mapping

The mapping between the synchronization raster and the corresponding resource element of the SS block is given in Table 5.4.3.2-1.

**Table 5.4.3.2-1: Synchronization raster to SS block resource element mapping**

Resource element index <i>k</i>	120
---------------------------------	-----

*k* is the subcarrier number of SS/PBCH block defined in TS 38.211 clause 7.4.3.1 [6].

### 5.4.3.3 Synchronization raster entries for each operating band

The synchronization raster for above 3 MHz channel bandwidth for each band is give in Table 5.4.3.3-1. The distance between applicable GSCN entries is given by the <Step size> indicated in Table 5.4.3.3-1.

**Table 5.4.3.3-1: Applicable SS raster entries per operating band for above 3 MHz channel bandwidth**

NR operating band	SS Block SCS	SS Block pattern <sup>1</sup>	Range of GSCN (First – <Step size> – Last)
n1	15 kHz	Case A	5279 – <1> – 5419
n2	15 kHz	Case A	4829 – <1> – 4969
n3	15 kHz	Case A	4517 – <1> – 4693
n5	15 kHz	Case A	2177 – <1> – 2230
	30 kHz	Case B	2183 – <1> – 2224
n7	15 kHz	Case A	6554 – <1> – 6718
n8	15 kHz	Case A	2318 – <1> – 2395
n12	15 kHz	Case A	1828 – <1> – 1858
n13	15 kHz	Case A	1871 – <1> – 1885
n14	15 kHz	Case A	1901 – <1> – 1915
n18	15 kHz	Case A	2156 – <1> – 2182
n20	15 kHz	Case A	1982 – <1> – 2047
n24	15 kHz	Case A	3818 – <1> – 3892
	30 kHz	Case B	3824 – <1> – 3886
n25	15 kHz	Case A	4829 – <1> – 4981
n26	15 kHz	Case A	2153 – <1> – 2230
n28	15 kHz	Case A	1901 – <1> – 2002
n29	15 kHz	Case A	1798 – <1> – 1813
n30	15 kHz	Case A	5879 – <1> – 5893
n31	15kHz	Case A	1161 – <1> – 1162
n34	15 kHz	Case A	NOTE 5
	30 kHz	Case C	5036 – <1> – 5050
n38	15 kHz	Case A	NOTE 2
	30 kHz	Case C	6437 – <1> – 6538

n39	15 kHz	Case A	NOTE 6
	30 kHz	Case C	4712 – <1> – 4789
n40	30 kHz	Case C	5762 – <1> – 5989
n41	15 kHz	Case A	6246 – <3> – 6717
	30 kHz	Case C	6252 – <3> – 6714
n46 <sup>3</sup>	30 kHz	Case C	8993 – <1> – 9530
n48	30 kHz	Case C	7884 – <1> – 7982
n50	30 kHz	Case C	3590 – <1> – 3781
n51	15 kHz	Case A	3572 – <1> – 3574
n53	15 kHz	Case A	6215 – <1> – 6232
	30 kHz	Case C	6221 – <1> – 6226
n54	15 kHz	Case A	4181 – <1> – 4182
n65	15 kHz	Case A	5279 – <1> – 5494
n66	15 kHz	Case A	5279 – <1> – 5494
	30 kHz	Case B	5285 – <1> – 5488
n67	15 kHz	Case A	1850 – <1> – 1888
n70	15 kHz	Case A	4993 – <1> – 5044
n71	15 kHz	Case A	1547 – <1> – 1624
n72	15 kHz	Case A	1157 – <1> – 1159
n74	15 kHz	Case A	3692 – <1> – 3790
n75	15 kHz	Case A	3584 – <1> – 3787
n76	15 kHz	Case A	3572 – <1> – 3574
n77	30 kHz	Case C	7711 – <1> – 8329
n78	30 kHz	Case C	7711 – <1> – 8051
n79	30 kHz	Case C	8480 – <16> – 8880 <sup>7</sup>
			8475 – <1> – 8884 <sup>8</sup>
n85	15 kHz	Case A	1826 – <1> – 1858
n90	15 kHz	Case A	6246 – <1> – 6717 <sup>10</sup>
			6245 – <1> – 6718 <sup>11</sup>
			6252 – <1> – 6714
n91	30 kHz	Case C	6252 – <1> – 6714
	15 kHz	Case A	3572 – <1> – 3574
n92	15 kHz	Case A	3584 – <1> – 3787
n93	15 kHz	Case A	3572 – <1> – 3574
n94	15 kHz	Case A	3584 – <1> – 3787
n96 <sup>4</sup>	30 kHz	Case C	9531 – <1> – 10363
n100	15 kHz	Case A	2303 – <1> – 2307, 41638 <sup>12</sup>
n101	15 kHz	Case A	4754 – <1> – 4768
	30 kHz	Case C	4760 – <1> – 4764
n102 <sup>9</sup>	30 kHz	Case C	9531 – <1> – 9877
n104	30 kHz	Case C	9882 – <7> – 10358
n105	15 kHz	Case A	1535 – <1> – 1624
n109	15 kHz	Case A	3584 – <1> – 3787

NOTE 1: SS Block pattern is defined in clause 4.1 in TS 38.213 [8].

NOTE 2: The applicable SS raster entries are GSCN = {6432, 6443, 6457, 6468, 6479, 6493, 6507, 6518, 6532, 6543}.

NOTE 3: The following GSCN are allowed for operation in band n46:

GSCN = {8996, 9010, 9024, 9038, 9051, 9065, 9079, 9093, 9107, 9121, 9218, 9232, 9246, 9260, 9274, 9288, 9301, 9315, 9329, 9343, 9357, 9371, 9385, 9402, 9416, 9430, 9444, 9458, 9472, 9485, 9499, 9513}.

NOTE 4: The following GSCN are allowed for operation in band n96:

GSCN = {9548, 9562, 9576, 9590, 9603, 9617, 9631, 9645, 9659, 9673, 9687, 9701, 9714, 9728, 9742, 9756, 9770, 9784, 9798, 9812, 9826, 9840, 9853, 9867, 9881, 9895, 9909, 9923, 9937, 9951, 9964, 9978, 9992, 10006, 10020, 10034, 10048, 10062, 10076, 10090, 10103, 10117, 10131, 10145, 10159, 10173, 10187, 10201, 10214, 10228, 10242, 10256, 10270, 10284, 10298, 10312, 10325, 10339, 10353}.

NOTE 5: The applicable SS raster entries are GSCN = {5032, 5043, 5054}

NOTE 6: The applicable SS raster entries are GSCN = {4707, 4715, 4718, 4729, 4732, 4743, 4747, 4754, 4761, 4768, 4772, 4782, 4786, 4793}

NOTE 7: The SS raster entries apply for channel bandwidths larger than or equal to 40 MHz

NOTE 8: The SS raster entries apply for channel bandwidths smaller than 40 MHz

NOTE 9: The following GSCN are allowed for operation in band n102:

GSCN = {9548, 9562, 9576, 9590, 9603, 9617, 9631, 9645, 9659, 9673, 9687, 9701, 9714, 9728, 9742, 9756, 9770, 9784, 9798, 9812, 9826, 9840, 9853, 9867}.

NOTE 10: The SS raster entries apply for channel bandwidths larger than or equal to 10 MHz.

NOTE 11: The SS raster entries apply for channel bandwidth equal to 5 MHz

NOTE 12: Only applicable for 20 PRB transmission bandwidth configuration within 5 MHz channel with unpunctured PBCH defined in TS 38.211 [6] clause 7.4.3.1.



The synchronization raster for channel bandwidth 3 MHz for each band is given in Table 5.4.3.3-2. The distance between applicable GSCN entries is given by the <Step size> indicated in Table 5.4.3.3-2.

**Table 5.4.3.3-2: Applicable SS raster entries per operating band for 3 MHz channel bandwidth**

NR operating band	SS Block SCS	SS Block pattern <sup>1</sup>	Range of GSCN (First – <Step size> – Last)
n26	15 kHz	Case A	30937 – <1> – 31100
n28	15 kHz	Case A	30432 – <1> – 30644
n31	15 kHz	Case A	28955 – <1> – 28967
n72	15 kHz	Case A	28947 – <1> – 28959
n85	15 kHz	Case A	30282 – <1> – 30359
n100	15 kHz	Case A	31240 – <1> – 31242, 31244 – <1> – 31253, 41637 <sup>2</sup>
n106	15 kHz	Case A	31317 – <1> – 31329

NOTE 1: SS Block pattern is defined in clause 4.1 in TS 38.213 [8].  
NOTE 2: Only applicable for 12 PRB transmission bandwidth configuration within 3 MHz channel with punctured PBCH defined in TS 38.211 [6] clause 7.4.3.1.

## 5.4.4 TX–RX frequency separation

The default TX channel (carrier centre frequency) to RX channel (carrier centre frequency) separation for operating bands is specified in Table 5.4.4-1.

**Table 5.4.4-1: UE TX-RX frequency separation**

NR Operating Band	TX – RX carrier centre frequency separation
n1	190 MHz
n2	80 MHz
n3	95 MHz
n5	45 MHz
n7	120 MHz
n8	45 MHz
n12	30 MHz
n13	-31 MHz
n14	-30 MHz
n18	45 MHz
n20	-41 MHz
n24	-101.5, -120.5 MHz
n25	80 MHz
n26	45 MHz
n28	55 MHz
n30	45 MHz
n31	10 MHz
n65	190 MHz
n66	400 MHz
n70	300 MHz
n71	-46 MHz
n72	10 MHz
n74	48 MHz
n85	30 MHz
n91	570 MHz – 595 MHz (NOTE 2)
n92	575 MHz – 680 MHz ( $\mu = 0$ ) 580 MHz – 675 MHz ( $\mu = 1$ ) (NOTE 2)
n93	517 MHz – 547 MHz (NOTE 2)
n94	522 MHz – 632 MHz ( $\mu = 0$ )

NR Operating Band	TX – RX carrier centre frequency separation
	527 MHz – 627 MHz ( $\mu = 1$ ) (NOTE 2)
n100	45 MHz
n105	-51 MHz
n106	39 MHz
n109	704 MHz - 809 MHz ( $\mu = 0$ ) 709 MHz - 804 MHz ( $\mu = 1$ ) (NOTE 2)
NOTE 1: Void NOTE 2: The range of TX-RX frequency separation given paired UL and DL channel bandwidths $BW_{UL}$ and $BW_{DL}$ is given by the respective lower and upper limit $F_{DL\_low} - F_{UL\_high} + 0.5(BW_{DL} + BW_{UL})$ and $F_{DL\_high} - F_{UL\_low} - 0.5(BW_{DL} + BW_{UL})$ . The UL and DL channel bandwidth combinations specified in Table 5.3.5-1 and 5.3.6-1 depend on the subcarrier spacing configuration $\mu$ [6].	

## 5.4A Channel arrangement for CA

### 5.4A.1 Channel spacing for CA

For intra-band contiguous carrier aggregation with two or more component carriers, the nominal channel spacing between two adjacent NR component carriers is defined as the following unless stated otherwise:

For NR operating bands with a 100 kHz or 10 kHz channel raster:

$$\text{Nominal channel spacing} = \left\lfloor \frac{BW_{Channel(1)} + BW_{Channel(2)} - 2|GB_{Channel(1)} - GB_{Channel(2)}|}{0.6} \right\rfloor 0.3 \text{ [MHz]}$$

while for NR operating bands without a 100 kHz channel raster:

$$\text{Nominal channel spacing} = \left\lfloor \frac{BW_{Channel(1)} + BW_{Channel(2)} - 2|GB_{Channel(1)} - GB_{Channel(2)}|}{0.015 * 2^{n+1}} \right\rfloor 0.015 * 2^n \text{ [MHz]}$$

with

$$n = \mu_0$$

where  $BW_{Channel(1)}$  and  $BW_{Channel(2)}$  are the channel bandwidths of the two respective NR component carriers according to Table 5.3.2-1 with values in MHz,  $\mu_0$  is the largest  $\mu$  value among the subcarrier spacing configurations supported in the operating band for both of the channel bandwidths according to Table 5.3.5-1 and  $GB_{Channel(i)}$  is the minimum guard band for channel bandwidth  $i$  according to Table 5.3.3-1 for the said  $\mu$  value with  $\mu$  as defined in TS 38.211. In case there is no common  $\mu$  value for both of the channel bandwidths,  $\mu_0=1$  is selected and  $GB_{Channel(i)}$  is the minimum guard band for channel bandwidth  $i$  according to Table 5.3.3-1 for  $\mu=1$  with  $\mu$  as defined in TS 38.211.

The channel spacing for intra-band contiguous carrier aggregation can be adjusted to any multiple of least common multiple of channel raster and sub-carrier spacing less than the nominal channel spacing to optimize performance in a particular deployment scenario.

For intra-band contiguous carrier aggregation in NR bands restricted to operation with shared-spectrum channel access, the maximum deviation from the nominal channel spacing is 300 kHz.

For intra-band non-contiguous carrier aggregation, the channel spacing between two NR component carriers in different sub-blocks shall be larger than the nominal channel spacing defined in this clause.

## 5.4A.2 Channel raster for CA

For inter-band and intra-band contiguous carrier aggregation, the channel raster requirements in clause 5.4.2 apply for each operating band.

## 5.4A.3 Synchronization raster for CA

For inter-band and intra-band contiguous carrier aggregation, the synchronization raster requirements in clause 5.4.3 apply for each operating band.

## 5.4A.4 Tx-Rx frequency separation for CA

For inter-band carrier aggregation, the Tx-Rx frequency separation requirements in clause 5.4.4 apply for each operating band.

For intra-band contiguous carrier aggregation, the same TX-RX frequency separation as specified in Table 5.4.4-1 is applied to PCC and SCC, respectively.

## 5.4B Reserved

## 5.4C Reserved

## 5.4D Reserved

## 5.4E Channel arrangement for V2X

### 5.4E.1 Channel spacing

For NR V2X, the channel spacing requirements in clause 5.4.1 apply for each operating band.

#### 5.4E.1A Channel spacing for Sidelink CA

For NR sidelink CA operation, the channel spacing requirements in clause 5.4A.1 apply.

#### 5.4E.1F Channel spacing for Sidelink Unlicensed

For NR SL-U operation, the channel spacing requirements in clause 5.4.1 apply for each operating band.

### 5.4E.2 Channel raster

#### 5.4E.2.1 NR-ARFCN and channel raster

For NR V2X, the NR-ARFCN and channel raster requirements in clause 5.4.2.1 apply for each operating band.

For NR V2X UE, the reference frequency can be shifted by configuration.

$$F_{\text{REF\_V2X}} = F_{\text{REF}} + \Delta_{\text{shift}} + N * 5 \text{ kHz}$$

where

$\Delta_{\text{shift}} = 0 \text{ kHz}$  or  $7.5 \text{ kHz}$  indicated in IE (*frequencyShift7p5khz*), and

N can be set as one of following values  $\{-1, 0, 1\}$ , which are signalled by the network in higher layer parameters or configured by pre-configuration parameters.

5.4E.2.1A Void

5.4E.2.1F Void

### 5.4E.2.2 Channel raster to resource element mapping

For NR V2X, the channel raster to resource element mapping requirements in clause 5.4.2.2 apply for each operating band.

5.4E.2.2A Void

5.4E.2.2F Void

### 5.4E.2.3 Channel raster entries for each operating band

For NR V2X, the channel raster entries requirements in clause 5.4.2.3 apply for each operating band.

The RF channel positions on the channel raster in each NR V2X operating band are given through the applicable NR-ARFCN in Table 5.4.2.3-1, using the channel raster to resource element mapping in clause 5.4.2.2.

For NR V2X operating band n47,  $\Delta F_{\text{Raster}} = I \times \Delta F_{\text{Global}}$ , where  $I \in \{1\}$ . Every  $I^{\text{th}}$  NR-ARFCN within the operating band are applicable for the channel raster within the operating band and the step size for the channel raster in Table 5.4.2.3-1 is given as  $\langle I \rangle$ .

5.4E.2.3A Void

5.4E.2.3F Void

## 5.4E.2A Channel raster for Sidelink CA

### 5.4E.2A.1 NR-ARFCN and channel raster for Sidelink CA

For NR SL intra-band contiguous CA operation, the NR-ARFCN and channel raster requirements in clause 5.4E.2.1 apply for each component carrier.

### 5.4E.2A.2 Channel raster to resource element mapping for Sidelink CA

For NR SL intra-band contiguous CA operation, the channel raster to resource element mapping requirements in clause 5.4.2.2 apply for each component carrier.

### 5.4E.2A.3 Channel raster entries for each operating band for Sidelink CA

For NR SL intra-band contiguous CA operation, the channel raster entries requirements in clause 5.4E.2.3 apply for each component carrier.

## 5.4E.2F Channel raster for Sidelink Unlicensed

### 5.4E.2F.1 NR-ARFCN and channel raster for Sidelink Unlicensed

For NR SL-U operation, the general requirements in clause 5.4.2 are applied.

NR-ARFCN and channel raster requirements in clause 5.4.2.1 are applied for NR SL-U with following exception:

- $N \times 5\text{kHz}/7.5\text{kHz}$  frequency raster shift, which can be used in NR V2X in band n47 is not defined for NR SL-U operation in bands n46, n96, n102.

- Channel raster entries for each operating band requirements in clause 5.4.2.3 are applied for NR SL-U with following exception: Channel raster points for 10MHz CBW in band n46 as defined in Table 5.4.2.3-2 are not applicable for NR SL-U.

#### 5.4E.2F.2 Channel raster to resource element mapping for Sidelink Unlicensed

The mapping between the RF reference frequency on the channel raster and the corresponding resource element is given in Table 5.4.2.2-1 and can be used to identify the RF channel position. The mapping depends on the total number of RBs that are allocated in the channel and applies to both Tx and Rx for SL. The mapping must apply to at least one numerology supported by the UE.

#### 5.4E.2F.3 Channel raster entries for Sidelink Unlicensed

For NR SL-U operation, the channel raster entries requirements in clause 5.4.2.3 apply for each operating band.

### 5.4E.3 Synchronization raster for V2X

There is no synchronization raster definition for NR V2X for both licensed bands and unlicensed bands.

#### 5.4E.3A Synchronization raster for Sidelink CA

There is no synchronization raster definition for NR SL CA operating bands.

#### 5.4E.3F Synchronization raster for Sidelink Unlicensed

There is no synchronization raster definition for NR SL-U operating bands n46, n96, n102.

## 5.4I Channel arrangement for RedCap

### 5.4I.1 Channel spacing for RedCap

For RedCap UEs, the channel spacing requirements in clause 5.4.1 apply for each operating band.

### 5.4I.2 Channel raster for RedCap

#### 5.4I.2.1 NR-ARFCN and channel raster

For RedCap UEs, the NR-ARFCN and channel raster requirements in clause 5.4.2.1 apply for each operating band.

#### 5.4I.2.2 Channel raster to resource element mapping

For RedCap UEs, the channel raster to resource element mapping requirements in clause 5.4.2.2 apply for each operating band.

#### 5.4I.2.3 Channel raster entries for each operating band

For RedCap UEs, the RF channel positions on the channel raster in each NR operating band are given through the applicable NR-ARFCN in Table 5.4.2.3-1 and additional intermediary NR-ARFCN with a step size of <2> for operating bands that are included in Table 5.4.2.3-1 with a step size of <20>, using the channel raster to resource element mapping in clause 5.4I.2.2.

For NR operating bands included in Table 5.4.2.3-1 with a step size of <20>, the channel raster for RedCap UEs is defined with  $\Delta F_{\text{Raster}} = 2 \times \Delta F_{\text{Global}}$ . In this case every 2<sup>nd</sup> NR-ARFCN within the operating band are applicable for the channel raster within the operating band and the step size for the channel raster is given as <2>, every 10<sup>th</sup> of these channel raster entries coincides with entries defined in Table 5.4.2.3-1 for this operating band.

### 5.4I.3 Synchronization raster for RedCap

For RedCap UEs, the synchronization raster requirements in clause 5.4.3 apply for each operating band. The synchronization raster and the corresponding SS block do not cover all possible RF channel bandwidths and locations on the channel raster defined in sub-clause 5.4I.2.

### 5.4I.4 Tx-Rx frequency separation for RedCap

For RedCap UEs, the Tx-Rx frequency separation requirements in clause 5.4.4 apply for each operating band.

## 5.5 Void

### 5.5A Configurations for CA

#### 5.5A.0 General

The configurations for CA operating band including Band n41 also apply for the corresponding CA operating bands with Band n90 replacing Band n41 but with otherwise identical parameters. For brevity the said configuration for CA operating bands with Band n90 are not listed in the tables below but are covered by this specification.

Non-contiguous resource allocation and almost contiguous allocation are not applicable for each NR carrier of intra-band contiguous and non-contiguous CA configurations.

For a CA configuration with one or more operating band supporting asymmetric channel bandwidths as specified in sub-clause 5.3.6, requirements are defined for an asymmetric UL and DL channel bandwidth combination of a supported asymmetric channel bandwidth combination set for an operating band of the CA configuration when the said UL and DL channel bandwidths are also contained in a supported bandwidth combination set of the CA configuration.

For a higher order band combination of which CA\_n20-n28 is a subset, the frequency range in band n28 is restricted for the higher order band combination to 703-733 MHz for the UL and 758-788 MHz for the DL.

The configuration tables for CA describe Bandwidth Combination Sets. Bandwidth Combination Set 4 and 5 contain all possible defined channel bandwidths for each band in the combination. The fact that BCS4 and BCS5 contain all channel bandwidths for each band does not alter if a bandwidth is mandatory or optional for a given band. Bandwidths that are identified as optional in Table 5.3.5-1 for a given release are still optional for UEs that support BCS4 or BCS5, where the bandwidths the UE supports for each band, the maximum bandwidth and/or minimum bandwidth for the band in the band combination are indicated in the UE capabilities. The minimum bandwidth per CC and maximum aggregated FDD, TDD and total bandwidth per band combination may be indicated only for BCS5 as described in 38.306 [15] and BCS5 shall not be indicated together with BCS4 for a CA configuration. For inter-band CA combinations including FR1 intra-band CA and with BCS4 or BCS5 in the following configuration tables, the Bandwidth Combination Sets for the FR1 intra-band CA are BCS4 or BCS5, respectively.

By default, unless otherwise noted/stated and except for NR band restricted to operation with share spectrum access channel, power class 3 applies to:

- all valid NR FR1 band single uplink configurations,
- all specified NR FR1 band intra-band uplink CA configurations,
- all specified inter-band CA configurations.

For NR bands with operation restricted to shared spectrum channel access, by default power class 5 applies to all valid single uplink configurations and to all specified intra-band uplink CA configuration. The applicability of higher power class(es) is described in the CA configuration tables in clauses 5.5A.1, 5.5A.2 and 5.5A.3. For inter-band CA combinations in clause 5.5A.3, the applicability of higher power class(es) for higher order band combinations is extended based on the following conditions:

- For a combination of intra-band and inter-band CA, the same higher power class(es) may be supported, which are specified for the inter-band UL CA configuration(s) in the combination composed of the same bands without intra-band CA.
- For a combination of intra-band and inter-band CA, the higher power class(es) may be supported for single-carrier UL when the same higher power class(es) are specified for all its fallback combinations.
- For a combination with 3 or more DL bands without intra-band CA, the higher power class(es) may be supported for single-carrier UL when the same higher power class(es) are specified for all its 2-band fallback combinations.
- For a combination with 4 or more DL bands without intra-band CA, the higher power class(es) may be supported for inter-band UL CA configuration(s) when the same higher power class(es) are specified for all its 3-band fallback combinations.

A UE supporting a given power class for a CA configuration shall meet the corresponding transmitter and receiver requirements in Clause 6 and Clause 7, respectively.

In the CA configuration tables of clause 5.5A.1 and clause 5.5A.2:

- Unless otherwise noted/stated, Uplink CA configuration entries with "-" mean single uplink carrier is valid for downlink intra-band CA,

In the CA configuration tables of clause 5.5A.3:

- Uplink CA configuration entries with "-" mean that any valid constituent band of the downlink inter-band CA combination can be configured as a single uplink carrier,
- Unless otherwise noted, all of the valid downlink constituent bands can be configured as a single uplink carrier,
- If an uplink CA configuration is supported, its fallback single uplink is also supported.

## 5.5A.1 Configurations for intra-band contiguous CA

**Table 5.5A.1-1: NR CA configurations and bandwidth combination sets defined for intra-band contiguous CA**

NR CA configuration / Bandwidth combination set								
NR CA configuration	Uplink CA configurations or single uplink carrier <sup>5</sup>	Channel bandwidths for carrier (MHz)	Channel bandwidths for carrier (MHz)	Channel bandwidths for carrier (MHz)	Channel bandwidths for carrier (MHz)	Channel bandwidths for carrier (MHz)	Maximum aggregated bandwidth (MHz)	Bandwidth combination set
CA_n1B	-	10	10,15				40	0
		15	15,20					
		20	20					
CA_n2B	-	5	15				20	0
		10	10					
CA_n3B	-	5	15, 20, 25, 30				60	0
		10	10, 15, 20, 25, 30					
		15, 20, 25, 30	5, 10, 15, 20, 25, 30					
	CA_n3B	5, 10, 15, 20	5, 10, 15, 20				40	1
		See n3 channel bandwidths in Table 5.3.5-1 for each carrier <sup>2</sup>					75	4 and 5
CA_n5B	CA_n5B	5, 10, 15	5, 10, 15				20	0
		5, 10, 15, 20	5, 10, 15, 20				25	1
CA_n7B	CA_n7B	10	10, 15, 20, 30, 40				50	0
		15	15, 20, 30					
		20	20, 30					
	-		See n7 channel bandwidths in Table 5.3.5-1 for each carrier <sup>2</sup>					70
CA_n25B	-	5	15				20	0
		10	10					
CA_n38B	-	5	15, 20, 25				50	0
		10	10, 15, 20, 25					



		15, 20, 25	5, 10, 15, 20, 25					
CA_n40B	-	20	80				100	0
		50	50					
	n40 <sup>3,4</sup> CA_n40B <sup>3</sup>	10,15, 20, 30, 40, 50, 60, 80	10, 15, 20, 30, 40, 50, 60, 80				100	1
		See n40 channel bandwidths in Table 5.3.5-1 for each carrier <sup>2</sup>					100	4 and 5
CA_n41B	n41 <sup>3</sup> CA_n41B	10, 20, 30, 40, 50	10, 20, 30, 40, 50				100	0
		See n41 channel bandwidths in Table 5.3.5-1 for each carrier <sup>2</sup>					100	4 and 5
CA_n41C	n41 <sup>3,4</sup> CA_n41C <sup>3</sup>	40	80, 100				180	0
		50, 60, 80	60, 80, 100					
		10	100				190	1
		15, 20	90, 100					
		40	80, 90, 100					
		50, 60, 80, 90	60, 80, 90, 100					
		10	100				190	2
		15, 20	90, 100					
		30, 40	80, 90, 100					
		50, 60, 80, 90	60, 80, 90, 100					
		See n41 channel bandwidths in Table 5.3.5-1 for each carrier <sup>2</sup>					190	4 and 5
CA_n46B	-	20, 40, 60	20, 40				100	0
CA_n46C	-	60, 80	60, 80				160	0
CA_n46D	-	60, 80	80	80			240	0
CA_n46M	-	20, 40, 60	20, 40	20, 40			140	0
CA_n46N	-	Void						0
		20, 40, 60	20, 40	20, 40	20, 40		180	1
CA_n46O	-	20, 60	20, 40	20, 40	20, 40	20, 40	220	0
CA_n48B	CA_n48B	5	15, 20				40	0
		10, 15, 20	10, 15, 20					
		15, 20	15, 20					
	-	10	50, 60, 80, 90				100	1
		15, 20	40, 50, 60, 80					
		40	40, 50, 60					
	-	10, 15, 20, 30, 40	10, 15, 20, 30, 40, 50, 60, 70, 80, 90				100	2
-	See n48 channel bandwidths in Table 5.3.5-1 for each carrier <sup>2</sup>					100	4 and 5	
CA_n48C	-	10	100				140	0
		15	90, 100					
		20	90, 100					
		40	80, 90, 100					
	-	10, 15, 20, 30, 40	70, 80, 90, 100				140	1
-	See n48 channel bandwidths in Table 5.3.5-1 for each carrier <sup>2</sup>					140	4 and 5	
CA_n66B	-	5	20, 40				50	0
		10	15, 20, 40					
		15	15, 20					
CA_n71B	n71 <sup>3</sup>	5	20				25	0

		10	15					
		10	20				35	1
		15	15, 20					
		5, 10, 15	15, 20				35	2
		See n71 channel bandwidths in Table 5.3.5-1 for each carrier <sup>2</sup>					35	4 and 5
CA_n77B	n77 <sup>3</sup>	20	25, 30, 40				60	0
		25	30					
		See n77 channel bandwidths in Table 5.3.5-1 for each carrier <sup>2</sup>					100	4 and 5
CA_n77C	n77 <sup>3,4</sup> CA_n77C <sup>3</sup>	50	60, 80, 100				200	0
		60	60, 80, 100					
		80	80, 100					
		100	100					
		10	100				200	1
		15, 20	90, 100					
		25, 30	80, 90, 100					
		40	70, 80, 90, 100					
		50, 60, 70, 80, 90, 100	60, 70, 80, 90, 100					
		See n77 channel bandwidths in Table 5.3.5-1 for each carrier <sup>2</sup>						200
CA_n77D	n77 <sup>3</sup>	100	100	100			300	0
		See n77 channel bandwidths in Table 5.3.5-1 for each carrier <sup>2</sup>						300
CA_n78B	n78 <sup>3</sup>	20	50				70	0
CA_n78C	n78 <sup>3,4</sup> CA_n78C <sup>3</sup>	50	60, 80, 100				200	0
		60	60, 80, 100					
		80	80, 100					
		100	100					
		10	100				200	1
		15, 20	90, 100					
		25, 30	80, 90, 100					
		40	70, 80, 90, 100					
		50, 60, 70, 80, 90, 100	60, 70, 80, 90, 100					
		See n78 channel bandwidths in Table 5.3.5-1 for each carrier <sup>2</sup>						200
CA_n78D	n78 <sup>3</sup>	100	100	100			300	0
		See n78 channel bandwidths in Table 5.3.5-1 for each carrier <sup>2</sup>						300
CA_n79C	CA_n79C <sup>3</sup>	50	60, 80, 100				200	0
		60	60, 80, 100					
		80	80, 100					
		100	100					
		See n79 channel bandwidths in Table 5.3.5-1 for each carrier <sup>2</sup>						200
CA_n79D	-	100	100	100			300	0
		See n79 channel bandwidths in Table 5.3.5-1 for each carrier <sup>2</sup>						300
CA_n96B	CA_n96B	20, 40	20, 40, 60, 80				100	0
CA_n96C	CA_n96C	80	40, 60, 80				160	0
CA_n96D		80	80	60, 80			240	0
CA_n96E		80	80	80	80		320	0

CA_n102B	CA_n102B	20, 40	20, 40, 60, 80				100	0
CA_n102C	CA_n102C	80	40, 60, 80				160	0
CA_n102D	-	80	80	60, 80			240	0
CA_n102E	-	80	80	80	80		320	0

NOTE 1: For each channel bandwidth of each component carrier, refer to Table 5.3.5-1 for the applicable SCSs. For a given band, not all UE channel bandwidths support the same SCSs.

NOTE 2: The aggregated bandwidth must be greater than or equal to the minimum for the bandwidth class defined in Table 5.3A.5-1, and smaller than or equal to the maximum aggregated bandwidth.

NOTE 3: Minimum requirements for Power Class 2 are applicable for this uplink combination or single uplink carrier in this downlink/uplink combination

NOTE 4: Minimum requirements for Power Class 1.5 are applicable for this uplink combination or single uplink carrier in this downlink/uplink combination

NOTE 5: Only single uplink carriers with power class other than PC3 are listed.

Table 5.5A.1-2: Void

## 5.5A.2 Configurations for intra-band non-contiguous CA

Table 5.5A.2-1: NR CA configurations and bandwidth combination sets defined for intra-band non-contiguous CA

NR CA Configuration	Uplink CA Configurations or single uplink carrier <sup>5</sup>	Channel bandwidths for carrier (MHz)	Channel bandwidths for carrier (MHz)	Channel bandwidths for carrier (MHz)	Channel bandwidths for carrier (MHz)	Maximum Aggregated bandwidth (MHz)	Bandwidth combination set
CA_n1(2A)	-	5, 10, 15, 20	5, 10, 15, 20			40	0
		See n1 channel bandwidths in Table 5.3.5-1 for each carrier				55	4 and 5
CA_n2(2A)	-	5, 10, 15, 20	5, 10, 15, 20			40	0
		See n2 channel bandwidths in Table 5.3.5-1 for each carrier				40	4 and 5
CA_n3(2A)	-	5, 10, 15, 20	5, 10, 15, 20			40	0
		5, 10, 15, 20, 25, 30	5, 10, 15, 20, 25, 30			60	1
		See n3 channel bandwidths in Table 5.3.5-1 for each carrier				70	4 and 5
CA_n5(2A)	-	5, 10, 15, 20	5, 10, 15, 20			25	0
CA_n7(2A)	-	5, 10, 15, 20	5, 10, 15, 20			40	0
		See n7 channel bandwidths in Table 5.3.5-1 for each carrier				65	4 and 5
CA_n12(2A)	-	5	5			10	0
CA_n25(2A)	n25 <sup>3</sup>	5, 10, 15, 20	5, 10, 15, 20			40	0
		5, 10, 15, 20, 25, 30, 40	5, 10, 15, 20, 25, 30, 40			60	1
		See n25 channel bandwidths in Table 5.3.5-1 for each carrier				60	4 and 5
CA_n25(3A)	-	5, 10, 15, 20, 25, 30, 40	5, 10, 15, 20, 25, 30, 40	5, 10, 15, 20, 25, 30, 40		55	0
		See n25 channel bandwidths in Table 5.3.5-1 for each carrier					55
CA_n26(2A)	CA_n26(2A) <sup>7</sup>	5, 10, 15	5, 10, 15			30	0
CA_n40(2A)	n40 <sup>3,4</sup> CA_n40(2A) <sup>3</sup>	See n40 channel bandwidths in Table 5.3.5-1 for each carrier				95	4 and 5
CA_n41(2A)	n41 <sup>3,4</sup> CA_n41(2A)	40, 50, 60, 80, 100	40, 50, 60, 80, 100			180	0

		10, 15, 20, 40, 50, 60, 80, 90, 100	10, 15, 20, 40, 50, 60, 80, 90, 100			190	1
		10, 15, 20, 30, 40, 50, 60, 80, 90	15, 20, 30, 40, 50, 60, 80, 90, 100			190	2
		10, 15, 20, 30, 40, 50, 60, 70, 80, 90, 100	10, 15, 20, 30, 40, 50, 60, 70, 80, 90, 100			190	3
		See n41 channel bandwidths in Table 5.3.5-1 for each carrier				190	4 and 5
CA_n41(3A)	n41 <sup>3,4</sup>	10, 15, 20, 30, 40, 50, 60, 70, 80, 90, 100	10, 15, 20, 30, 40, 50, 60, 70, 80, 90, 100	10, 15, 20, 30, 40, 50, 60, 70, 80, 90, 100		190	0
		See n41 channel bandwidths in Table 5.3.5-1 for each carrier				190	4 and 5
CA_n41(4A)	n41 <sup>3</sup>	10, 15, 20, 30, 40, 50, 60, 70, 80, 90, 100	10, 15, 20, 30, 40, 50, 60, 70, 80, 90, 100	10, 15, 20, 30, 40, 50, 60, 70, 80, 90, 100	10, 15, 20, 30, 40, 50, 60, 70, 80, 90, 100	190	0
		See n41 channel bandwidths in Table 5.3.5-1 for each carrier				190	4 and 5
CA_n46(2A)	-	10, 20, 40, 60, 80	10, 20, 40, 60, 80			160	0
CA_n48(2A)	-	10, 15, 20, 40, 50, 60, 80, 90, 100	10, 15, 20, 40, 50, 60, 80, 90, 100			140 <sup>2</sup>	0
		10, 15, 20, 30, 40, 50, 60, 70, 80, 90, 100	10, 15, 20, 30, 40, 50, 60, 70, 80, 90, 100			140 <sup>2</sup>	1
		See n48 channel bandwidths in Table 5.3.5-1 for each carrier				140 <sup>2</sup>	4 and 5
CA_n48(3A)	-	10, 15, 20, 40,50, 60, 80, 90, 100	10, 15, 20, 40,50, 60, 80, 90, 100	10, 15, 20, 40,50, 60, 80, 90, 100		140 <sup>2</sup>	0
		10, 15, 20, 30, 40, 50, 60, 70, 80, 90, 100	10, 15, 20, 30, 40, 50, 60, 70, 80, 90, 100	10, 15, 20, 30, 40, 50, 60, 70, 80, 90, 100		140 <sup>2</sup>	1
CA_n48(4A)	-	10, 15, 20, 40, 50, 60, 80, 90, 100	10, 15, 20, 40, 50, 60, 80, 90, 100	10, 15, 20, 40, 50, 60, 80, 90, 100	10, 15, 20, 40, 50, 60, 80, 90, 100	135 <sup>2</sup>	0
		10, 15, 20, 30, 40, 50, 60, 70, 80, 90, 100	10, 15, 20, 30, 40, 50, 60, 70, 80, 90, 100	10, 15, 20, 30, 40, 50, 60, 70, 80, 90, 100	10, 15, 20, 30, 40, 50, 60, 70, 80, 90, 100	135 <sup>2</sup>	1
CA_n66(2A)	n66 <sup>3</sup>	5, 10, 15, 20	5, 10, 15, 20, 40			60	0
		5, 10, 15, 20, 25, 30, 40	5, 10, 15, 20, 25, 30, 40			80	1
		5, 10, 15, 20, 40	5, 10, 15, 20, 40			80	2
		See n66 channel bandwidths in Table 5.3.5-1 for each carrier				85	4 and 5
CA_n66(3A)	-	5, 10, 15, 20, 40	5, 10, 15, 20, 40	5, 10, 15, 20, 40		80	0
CA_n71(2A)	n71 <sup>3</sup>	5, 10, 15, 20	5,10,15, 20			30	0
		See n71 channel bandwidths in Table 5.3.5-1				30	4 and 5

		for each carrier up to 25 MHz per carrier						
CA_n77(2A) <sup>6</sup>	n77 <sup>3,4</sup> CA_n77(2A) <sup>3</sup>	20, 40, 80, 100	20, 40, 80, 100			200	0	
		10, 15, 20, 25, 30, 40, 50, 60, 70, 80, 90, 100	10, 15, 20, 25, 30, 40, 50, 60, 70, 80, 90, 100			200	1	
		See n77 channel bandwidths in Table 5.3.5-1 for each carrier					200	4 and 5
CA_n77(3A)	n77 <sup>3,4</sup> CA_n77(2A) <sup>3</sup>	20, 40, 80, 100	20, 40, 80, 100	20, 40, 80, 100		300	0	
		10, 15, 20, 25, 30, 40, 50, 60, 70, 80, 90, 100	10, 15, 20, 25, 30, 40, 50, 60, 70, 80, 90, 100	10, 15, 20, 25, 30, 40, 50, 60, 70, 80, 90, 100		300	1	
		See n77 channel bandwidths in Table 5.3.5-1 for each carrier					300	4 and 5
CA_n78(2A) <sup>6</sup>	n78 <sup>3,4</sup> CA_n78(2A) <sup>3</sup>	10, 20, 40, 50, 60, 80, 90, 100	10, 20, 40, 50, 60, 80, 90, 100			200	0	
		10, 20, 25, 30, 40, 50, 60, 80, 90, 100	10, 20, 25, 30, 40, 50, 60, 80, 90, 100			200	1	
		10, 20, 25, 30, 40, 50, 60, 70, 80, 90, 100	10, 20, 25, 30, 40, 50, 60, 70, 80, 90, 100			200	2	
		See n78 channel bandwidths in Table 5.3.5-1 for each carrier					200	4 and 5
CA_n79(2A)	CA_n79(2A)	See n79 channel bandwidths in Table 5.3.5-1 for each carrier				200	4 and 5	
CA_n96(2A)	-	20, 40, 60, 80	20, 40, 60, 80			160	0	
CA_n96(3A)	-	20, 40, 60, 80	20, 40, 60, 80	20, 40, 60, 80		240	0	
CA_n96(4A)	-	20, 40, 60, 80	20, 40, 60, 80	20, 40, 60, 80	20, 40, 60, 80	320	0	
CA_n102(2A)	-	20, 40, 60, 80	20, 40, 60, 80			160	0	
CA_n102(3A)	-	20, 40, 60, 80	20, 40, 60, 80	20, 40, 60, 80		240	0	
CA_n102(4A)	-	20, 40, 60, 80	20, 40, 60, 80	20, 40, 60, 80	20, 40, 60, 80	320	0	

NOTE 1: Void.

NOTE 2: Parameter value accounts for both, the maximum frequency range of band n48 (150 MHz), and the minimum frequency gaps in between NR non-contiguous component carriers.

NOTE 3: Minimum requirements for Power Class 2 are applicable for this uplink combination or single uplink carrier in this downlink/uplink combination

NOTE 4: Minimum requirements for Power Class 1.5 are applicable for this uplink combination or single uplink carrier in this downlink/uplink combination

NOTE 5: Only single uplink carriers with power class other than PC3 are listed.

NOTE 6: If a UE does not indicate *intraBandNR-CA-non-collocated-r18*, the minimum requirements for intra-band non-contiguous CA apply when the maximum power spectral density imbalance between downlink carriers is within 6 dB. If a UE indicates *intraBandNR-CA-non-collocated-r18* and *nonCollocatedTypeNR-CA-r18* is not provided and UE is configured with *maxMIMO-Layers* with value less than or equal to 2, the power imbalance requirement defined in subclause 7.10A apply. If a UE indicates *intraBandNR-CA-non-collocated-r18* and *nonCollocatedTypeNR-CA-r18* is provided, the minimum requirements for intra-band non-contiguous CA apply when the maximum power spectral density imbalance between downlink carriers is within 6 dB. For these UEs, the power spectral density imbalance condition also applies for these carriers when applicable intra-band non-contiguous NR CA configuration is a subset of a higher order NR CA configuration.

NOTE 7: Unless otherwise stated, only RF requirements for dual PA architecture are applicable for UL CA\_n26(2A) and UE shall indicate the *dualPA-Architecture* for UL CA\_n26(2A).

NOTE 8: For each channel bandwidth of each component carrier, refer to Table 5.3.5-1 for the applicable SCSs. For a given band, not all UE channel bandwidths support the same SCSs.

**Table 5.5A.2-2: NR CA configurations and bandwidth combination sets defined for mixed intra-band contiguous and non-contiguous CA**

NR CA configuration	Uplink CA configuration or single uplink carrier <sup>4</sup>	NR Band	Channel bandwidth (MHz)	Bandwidth combination set
CA_n41(A-C)	n41 <sup>2,3</sup> CA_n41C <sup>2</sup>	n41	10, 15, 20, 30, 40, 50, 60, 70, 80, 90, 100	0
		n41	CA_n41C_BCS2	4 and 5
		n41	See n41 channel bandwidths in Table 5.3.5-1	
		n41	CA_n41C_BCS4 and 5	
CA_n41(2A-C)	n41 <sup>2,3</sup> CA_n41C	n41	CA_n41(2A)_BCS3	0
		n41	CA_n41C_BCS1	4 and 5
		n41	CA_n41(2A)_BCS4 and 5	
		n41	CA_n41C_BCS4 and 5	
CA_n48(A-B)	CA_n48B	n48	5, 10, 15, 20, 40, 50 <sup>1</sup> , 60 <sup>1</sup> , 80 <sup>1</sup> , 90 <sup>1</sup> , 100 <sup>1</sup>	0
		n48	CA_n48B_BCS0	1
		n48	5, 10, 15, 20, 30, 40, 50 <sup>1</sup> , 60 <sup>1</sup> , 70 <sup>1</sup> , 80 <sup>1</sup> , 90 <sup>1</sup> , 100 <sup>1</sup>	
		n48	CA_n48B_BCS2	
CA_n78(A-C)	-	n78	10, 15, 20, 25, 30, 40, 50, 60, 70, 80, 90, 100	0
		n78	CA_n78C_BCS0	1
		n78	10, 15, 20, 25, 30, 40, 50, 60, 70, 80, 90, 100	
		n78	CA_n78C_BCS1	

NOTE 1: This UE channel bandwidth is applicable only to downlink  
NOTE 2: Minimum requirements for Power Class 2 are applicable for this uplink combination or single uplink carrier in this downlink/uplink combination  
NOTE 3: Minimum requirements for Power Class 1.5 are applicable for this uplink combination or single uplink carrier in this downlink/uplink combination  
NOTE 4: Only single uplink carriers with power class other than PC3 are listed.  
NOTE 5: For each channel bandwidth of each component carrier, refer to Table 5.3.5-1 for the applicable SCSs. For a given band, not all UE channel bandwidths support the same SCSs.

## 5.5A.3 Configurations for inter-band CA

**Table 5.5A.3-1: Void**

**Table 5.5A.3-2: Void**

**Table 5.5A.3-3: Void**

### 5.5A.3.0 General

For the NR inter-band CA configurations in sub-clause 5.5A.3, when the capability [*BandCombination-UplinkTxSwitch-r18*] is present, three or four bands can be configured in the uplink with simultaneous uplink transmission on up to two bands, and the corresponding inter-band CA requirements with uplink assigned to one or two bands shall apply. For each uplink band pair in the NR inter-band CA configurations, according to the capability [*uplinkTxSwitchingOptionForBandPair*],

- if *switchedUL* is supported, uplink transmission on any one band of the band pair in the band combination shall be supported according to the scheduling commands, and the corresponding inter-band CA requirements with uplink assigned to one band on band X or band Y apply;
- if *dualUL* is supported, simultaneous uplink transmission on the two NR UL bands from the band pair for which *dualUL* is declared in the band combination shall be supported according to the scheduling commands, and the corresponding inter-band CA requirements with uplink CA between the two uplink bands apply. For a UE supporting [*BandOrdering1T1Tto1T1T*] for parallel uplink transmission switching for a band combination consisting with four different bands, the UE is allowed to report capability [*preferredBandPairs*] via band-ordering approach to indicate the UE's preferred switching band pairs for which it supports *dualUL* and perform the switching case configured by network.

### 5.5A.3.1 Configurations for inter-band CA (two bands)

Table 5.5A.3.1-1a ~ Table 5.5A.3.1-1e



**Table 5.5A.3.1-1a: NR CA configurations and bandwidth combinations sets defined for inter-band CA (two bands)**

NR CA configuration	Uplink CA configuration or single uplink carrier <sup>10</sup>	NR Band	Channel bandwidth (MHz) (NOTE 3)	Bandwidth combination set
CA_n1A-n3A	n3 <sup>8</sup> CA_n1A-n3A	n1	5, 10, 15, 20	0
		n3	5, 10, 15, 20, 25, 30	
		n1	5, 10, 15, 20, 25, 30, 40, 50	1
		n3	5, 10, 15, 20, 25, 30, 40	
		n1	5, 10, 15, 20	2
		n3	5, 10, 15, 20, 25, 30, 35, 40	
		n1	n1 channel bandwidths in Table 5.3.5-1	4 and 5
n3	n3 channel bandwidths in Table 5.3.5-1			
CA_n1A-n3B	CA_n1A-n3A	n1	5, 10, 15, 20	0
		n3	CA_n3B_BCS0	
CA_n1B-n3A	CA_n1A-n3A	n1	CA_n1B_BCS0	0
		n3	5, 10, 15, 20, 25, 30	
		n1	CA_n1B_BCS0	1
		n3	5, 10, 15, 20, 25, 30, 40	
CA_n1A-n3(2A)	CA_n1A-n3A	n1	5, 10, 15, 20	0
		n3	CA_n3(2A)_BCS0	
		n1	5, 10, 15, 20, 25, 30, 40, 50	1
		n3	CA_n3(2A)_BCS0	
		n1	5, 10, 15, 20	2
		n3	CA_n3(2A)_BCS1	
CA_n1(2A)-n3A	-	n1	CA_n1(2A)_BCS0	0
		n3	5, 10, 15, 20, 25, 30, 40	
CA_n1(2A)-n3(2A)	-	n1	CA_n1(2A)_BCS0	0
		n3	CA_n3(2A)_BCS1	
CA_n1(2A)-n3B	-	n1	CA_n1(2A)_BCS0	0
		n3	CA_n3B_BCS0	
CA_n1A-n5A	CA_n1A-n5A	n1	5, 10, 15, 20, 25, 30, 40, 50	0
		n5	5, 10, 15, 20	
		n1	n1 channel bandwidths in Table 5.3.5-1	4 and 5
		n5	n5 channel bandwidths in Table 5.3.5-1	
CA_n1(2A)-n5A	-	n1	CA_n1(2A)_BCS0	0
		n5	5, 10, 15, 20	
CA_n1A-n7A	n7 <sup>8</sup> CA_n1A-n7A	n1	5, 10, 15, 20	0
		n7	5, 10, 15, 20, 25, 30, 40, 50	
		n1	5, 10, 15, 20, 25, 30, 40, 50	1
		n7	5, 10, 15, 20, 25, 30, 40, 50	
		n1	n1 channel bandwidths in Table 5.3.5-1	4 and 5
		n7	n7 channel bandwidths in Table 5.3.5-1	
CA_n1A-n7B	CA_n1A-n7A CA_n7B	n1	5, 10, 15, 20	0
		n7	CA_n7B_BCS0	
CA_n1(2A)-n7A	-	n1	CA_n1(2A)_BCS0	0
		n7	5, 10, 15, 20, 25, 30, 40, 50	
CA_n1A-n8A	CA_n1A-n8A	n1	5, 10, 15, 20	0
		n8	5, 10, 15, 20	
		n1	5, 10, 15, 20, 25, 30, 40	1
		n8	5, 10, 15, 20	
CA_n1(2A)-n8A	-	n1	CA_n1(2A)_BCS0	0
		n8	5, 10, 15, 20	
CA_n1A-n18A	CA_n1A-n18A	n1	5, 10, 15, 20, 25, 30, 40, 50	0
		n18	5, 10, 15	
		n1	n1 channel bandwidths in Table 5.3.5-1	4 and 5
n20	n20 channel bandwidths in Table 5.3.5-1			
CA_n1A-n20A	CA_n1A-n20A	n1	5, 10, 15, 20, 25, 30, 40, 50	0
		n20	5, 10, 15, 20	
		n1	n1 channel bandwidths in Table 5.3.5-1	4 and 5
		n20	n20 channel bandwidths in Table 5.3.5-1	

CA_n1A-n26A	CA_n1A-n26A	n1	5, 10, 15, 20	0	
		n26	5, 10, 15, 20		
CA_n1A-n26(2A)	CA_n26(2A) CA_n1A-n26A	n1	5, 10, 15, 20, 25, 30, 40, 45, 50	0	
		n26	CA_n26(2A)_BCS0		
CA_n1A-n28A	CA_n1A-n28A	n1	5, 10, 15, 20	0	
		n28	5, 10, 15, 20		
		n1	5, 10, 15, 20, 25, 30, 40, 50		1
		n28	5, 10, 15, 20, 30		
CA_n1(2A)-n28A	-	n1	CA_n1(2A)_BCS0	0	
		n28	5, 10, 15, 20		
CA_n1A-n38A	-	n1	5, 10, 15, 20, 25, 30, 40, 50	0	
		n38	5, 10, 15, 20, 25, 30, 40		
CA_n1(2A)-n38A	-	n1	CA_n1(2A)_BCS0	0	
		n38	5, 10, 15, 20, 25, 30, 40		
CA_n1A-n40A	CA_n1A-n40A	n1	5, 10, 15, 20	0	
		n40	5, 10, 15, 20, 25, 30, 40, 50, 60, 80		
		n1	5, 10, 15, 20	1	
		n40	10, 15, 20, 25, 30, 40, 50, 60, 70, 80, 90, 100		
		n1	n1 channel bandwidths in Table 5.3.5-1	4 and 5	
		n40	n40 channel bandwidths in Table 5.3.5-1		
CA_n1A-n40B	-	n1	5, 10, 15, 20	0	
		n40	CA_n40B_BCS0		
		n1	n1 channel bandwidths in Table 5.3.5-1	4 and 5	
		n40	CA_n40B_BCS4 and 5		
CA_n1A-n41A	n41 <sup>8,9</sup> CA_n1A-n41A <sup>8</sup>	n1	5, 10, 15, 20	0	
		n41	10, 15, 20, 40, 50, 60, 80, 90, 100		
		n1	5, 10, 15, 20, 25, 30, 40, 50	1	
		n41	10, 15, 20, 30, 40, 50, 60, 80, 90, 100		
CA_n1A-n46A	CA_n1A-n46A	n1	5, 10, 15, 20, 25, 30, 40, 50	0	
		n46	10, 20, 40, 60, 80		
CA_n1A-n46C	CA_n1A-n46A	n1	5, 10, 15, 20, 25, 30, 40, 50	0	
		n46	CA_n46C_BCS0		
CA_n1A-n46D	CA_n1A-n46A	n1	5, 10, 15, 20, 25, 30, 40, 50	0	
		n46	CA_n46D_BCS0		
CA_n1A-n46(2A)	CA_n1A-n46A	n1	5, 10, 15, 20, 25, 30, 40, 50	0	
		n46	CA_n46(2A)_BCS0		
CA_n1A-n67A	-	n1	5, 10, 15, 20, 25, 30, 40, 50	0	
		n67	5, 10, 15, 20		
CA_n1A-n74A	CA_n1A-n74A	n1	5, 10, 15, 20, 25, 30, 40, 50	0	
		n74	5, 10, 15, 20		
CA_n1A-n75A	-	n1	5, 10, 15, 20, 25, 30, 40, 50	0	
		n75	5, 10, 15, 20, 25, 30, 40, 50		
		n1	n1 channel bandwidths in Table 5.3.5-1	4 and 5	
		n75	n75 channel bandwidths in Table 5.3.5-1		
CA_n1A-n77A	n77 <sup>8,9</sup> CA_n1A-n77A <sup>8</sup>	n1	5, 10, 15, 20	0	
		n77	10, 15, 20, 40, 50, 60, 80, 90, 100		
		n1	See n1 channel bandwidths in Table 5.3.5-1	4 and 5	
		n77	See n77 channel bandwidths in Table 5.3.5-1		
CA_n1A-n77(2A)	n77 <sup>8,9</sup> CA_n1A-n77A <sup>8</sup> CA_n77(2A) <sup>8</sup>	n1	5, 10, 15, 20	0	
		n77	CA_n77(2A)_BCS0		
	n77 <sup>8</sup> CA_n1A-n77A <sup>8</sup>	n1	See n1 channel bandwidths in Table 5.3.5-1	4 and 5	
n77	CA_n77(2A)_BCS4 and 5				
CA_n1A-n77(3A)	n77 <sup>8,9</sup> CA_n1A-n77A CA_n77(2A) <sup>8</sup>	n1	5, 10, 15, 20	0	
		n77	CA_n77(3A)_BCS1		
CA_n1A-n78A	n1 <sup>8</sup> n78 <sup>8,9</sup> CA_n1A-n78A <sup>8</sup>	n1	5, 10, 15, 20	0	
		n78	10, 15, 20, 40, 50, 60, 80, 90, 100		

		n1	5, 10, 15, 20, 25, 30, 40, 50	1
		n78	10, 15, 20, 25, 30, 40, 50, 60, 70, 80, 90, 100	
		n1	5, 10, 15, 20, 25, 30, 40	2
		n78	10, 15, 20, 40, 50, 60, 80, 90, 100	
		n1	5, 10, 15, 20	3
		n78	10, 15, 20, 25, 30, 40, 50, 60, 70, 80, 90, 100	
		n1	n1 channel bandwidths in Table 5.3.5-1	4 and 5
		n78	n78 channel bandwidths in Table 5.3.5-1	
CA_n1A-n78(2A)	n78 <sup>8,9</sup> CA_n1A-n78A <sup>8</sup>	n1	5, 10, 15, 20	0
		n78	CA_n78(2A)_BCS0	
		n1	5, 10, 15, 20, 25, 30, 40, 50	1
	n78 <sup>8,9</sup> CA_n78(2A) <sup>8</sup> CA_n1A-n78A <sup>8</sup>	n1	5, 10, 15, 20	2
		n78	CA_n78(2A)_BCS2	
		n1	See n1 channel bandwidths in Table 5.3.5-1	4 and 5
	n78	CA_n78(2A)_BCS4 and 5		
CA_n1A-n78C	CA_n78C CA_n1A-n78A	n1	5, 10, 15, 20	0
		n78	CA_n78C_BCS0	
		n1	5, 10, 15, 20, 25, 30, 40, 50	1
		n78	CA_n78C_BCS0	
		n1	5, 10, 15, 20, 25, 30, 40	2
		n78	CA_n78C_BCS0	
	CA_n78C CA_n1A-n78A CA_n1A-n78C	n1	5, 10, 15, 20, 25, 30, 40, 50	3
		n78	CA_n78C_BCS1	
		n1	See n1 channel bandwidths in Table 5.3.5-1	4 and 5
		n78	CA_n78C_BCS4 and 5	
CA_n1(2A)-n78A	-	n1	CA_n1(2A)_BCS0	0
		n78	10, 15, 20, 25, 30, 40, 50, 60, 70, 80, 90, 100	
		n1	CA_n1(2A)_BCS0	
CA_n1A-n79A	n79 <sup>8,9</sup> CA_n1A-n79A <sup>8</sup>	n1	5, 10, 15, 20	0
		n79	40, 50, 60, 80, 100	
		n1	See n1 channel bandwidths in Table 5.3.5-1	4 and 5
		n79	See n79 channel bandwidths in Table 5.3.5-1	
CA_n1A-n79C	CA_n1A-n79A	n1	5, 10, 15, 20	0
		n79	CA_n79C_BCS0	
		n1	See n1 channel bandwidths in Table 5.3.5-1	4 and 5
		n79	CA_n79C_BCS4 and 5	
CA_n1(2A)-n79A	-	n1	CA_n1(2A)_BCS0	0
		n79	40, 60, 80, 100	
		n1	CA_n1(2A)_BCS4 and 5	4 and 5
		n79	See n79 channel bandwidths in Table 5.3.5-1	
CA_n1(2A)-n79C	-	n1	CA_n1(2A)_BCS0	0
		n79	CA_n79C_BCS0	
		n1	CA_n1(2A)_BCS4 and 5	4 and 5
		n79	CA_n79C_BCS4 and 5	
CA_n1A-n102A	CA_n1A-n102A	n1	5, 10, 15, 20, 25, 30, 40, 50	0
		n102	20, 40, 60, 80, 100	
CA_n1A-n102(2A)	CA_n1A-n102A	n1	5, 10, 15, 20, 25, 30, 40, 50	0
		n102	CA_n102(2A)_BCS0	
CA_n1A-n102B	CA_n1A-n102A CA_n1A-n102B	n1	5, 10, 15, 20, 25, 30, 40, 50	0
		n102	CA_n102B_BCS0	
CA_n1A-n102C	CA_n1A-n102A CA_n1A-n102C	n1	5, 10, 15, 20, 25, 30, 40, 50	0
		n102	CA_n102C_BCS0	
CA_n1A-n102D	CA_n1A-n102A	n1	5, 10, 15, 20, 25, 30, 40, 50	0
		n102	CA_n102D_BCS0	
CA_n1A-n102E	CA_n1A-n102A	n1	5, 10, 15, 20, 25, 30, 40, 50	0
		n102	CA_n102E_BCS0	
CA_n1A-n105A	CA_n1A-n105A	n1	5, 10, 15, 20, 25, 30, 40, 50	0

	n105	5, 10, 15, 20, 25, 30, 35
--	------	---------------------------

**Table 5.5A.3.1-1b: NR CA configurations and bandwidth combinations sets defined for inter-band CA (two bands)**

NR CA configuration	Uplink CA configuration or single uplink carrier <sup>10</sup>	NR Band	Channel bandwidth (MHz) (NOTE 3)	Bandwidth combination set
CA_n2A-n5A	n2 <sup>8</sup> CA_n2A-n5A	n2	5, 10, 15, 20	0
		n5	5, 10, 15, 20	
CA_n2A-n5B	CA_n2A-n5A CA_n5B	n2	5, 10, 15, 20	0
		n5	CA_n5B_BCS0	
CA_n2(2A)-n5A	CA_n2A-n5A	n2	CA_n2(2A)_BCS0	0
		n5	5, 10, 15, 20	
CA_n2A-n7A	CA_n2A-n7A	n2	5, 10, 15, 20	0
		n7	5, 10, 15, 20, 25, 30, 40, 50	
CA_n2A-n7(2A)	CA_n2A-n7A	n2	5, 10, 15, 20	0
		n7	CA_n7(2A)_BCS0	
CA_n2(2A)-n7A	CA_n2A-n7A	n2	CA_n2(2A)_BCS0	0
		n7	5, 10, 15, 20, 25, 30, 40, 50	
CA_n2A-n12A	CA_n2A-n12A	n2	5, 10, 15, 20	0
		n12	5, 10, 15	
CA_n2(2A)-n12A	CA_n2A-n12A	n2	CA_n2(2A)_BCS0	0
		n12	5, 10, 15	
CA_n2A-n14A	CA_n2A-n14A	n2	5, 10, 15, 20	0
		n14	5, 10	
CA_n2(2A)-n14A	CA_n2A-n14A	n2	CA_n2(2A)_BCS0	0
		n14	5, 10	
CA_n2A-n29A	-	n2	5, 10, 15, 20	0
		n29	5, 10	
CA_n2(2A)-n29A	-	n2	CA_n2(2A)_BCS0	0
		n29	5, 10	
CA_n2A-n30A	CA_n2A-n30A	n2	5, 10, 15, 20	0
		n30	5, 10	
CA_n2(2A)-n30A	CA_n2A-n30A	n2	CA_n2(2A)_BCS0	0
		n30	5, 10	
CA_n2A-n38A	-	n2	5, 10, 15, 20	0
		n38	5, 10, 15, 20, 40	
CA_n2A-n41A	CA_n2A-n41A	n2	5, 10, 15, 20	0
		n41	10, 15, 20, 40, 50, 60, 80, 90, 100	
CA_n2(2A)-n41A	CA_n2A-n41A	n2	CA_n2(2A)_BCS0	0
		n41	10, 15, 20, 30, 40, 50, 60, 70, 80, 90, 100	
CA_n2A-n48A	CA_n2A-n48A	n2	5, 10, 15, 20	0
		n48	5, 10, 15, 20, 40, 50 <sup>6</sup> , 60 <sup>6</sup> , 80 <sup>6</sup> , 90 <sup>6</sup> , 100 <sup>6</sup>	
		n48	5, 10, 15, 20	1
CA_n2A-n48B	CA_n48B CA_n2A-n48A	n2	5, 10, 15, 20	0
		n48	CA_n48B_BCS0	
		n2	5, 10, 15, 20	
CA_n2A-n48C	CA_n2A-n48A	n48	CA_n48B_BCS2	0
		n2	5, 10, 15, 20	
CA_n2A-n48(2A)	CA_n2A-n48A	n48	CA_n48C_BCS0	0
		n2	5, 10, 15, 20	
CA_n2A-n48(2A)	CA_n2A-n48A	n48	CA_n48(2A)_BCS0	0
		n2	5, 10, 15, 20	
		n48	CA_n48(2A)_BCS1	
CA_n2A-n48(A-B)	CA_n2A-n48A	n2	5, 10, 15, 20	0
		n48	CA_n48(A-B)_BCS0	
		n2	5, 10, 15, 20	1

		n48	CA_n48(A-B)_BCS1		
CA_n2A-n66A	n2 <sup>8</sup> n66 <sup>8</sup>	n2	5, 10, 15, 20	0	
		n66	5, 10, 15, 20, 40		
CA_n2(2A)-n66A	n2 <sup>8</sup> n66 <sup>8</sup> CA_n2A-n66A	n2	5, 10, 15, 20	1	
		n66	5, 10, 15, 20, 25, 30, 40		
CA_n2(2A)-n66A	CA_n2A-n66A	n2	CA_n2(2A)_BCS0	0	
		n66	5, 10, 15, 20, 25, 30, 40		
CA_n2A-n66(2A)	CA_n2A-n66A	n2	5, 10, 15, 20	0	
		n66	CA_n66(2A)_BCS1		
CA_n2(2A)-n66(2A)	CA_n2A-n66A	n2	CA_n2(2A)_BCS0	0	
		n66	CA_n66(2A)_BCS1		
CA_n2(2A)-n66(3A)	CA_n2A-n66A	n2	CA_n2(2A)_BCS0	0	
		n66	CA_n66(3A)_BCS0		
CA_n2A-n66(3A)	CA_n2A-n66A	n2	5, 10, 15, 20	0	
		n66	CA_n66(3A)_BCS0		
CA_n2A-n66B	CA_n2A-n66A	n2	5, 10, 15, 20	0	
		n66	CA_n66B_BCS0		
CA_n2A-n71A	CA_n2A-n71A	n2	5, 10, 15, 20	0	
		n71	5, 10, 15, 20		
	-	n2	See n2 channel bandwidths in Table 5.3.5-1	4 and 5	
	n71	See n71 channel bandwidths in Table 5.3.5-1			
CA_n2(2A)-n71A	CA_n2A-n71A	n2	CA_n2(2A)_BCS0	0	
		n71	5, 10, 15, 20		
	-	n2	CA_n2(2A)_BCS 4 and 5	4 and 5	
	n71	See n71 channel bandwidths in Table 5.3.5-1			
CA_n2A-n77A	n77 <sup>8,9</sup> CA_n2A-n77A <sup>8</sup> 13,14	n2	5, 10, 15, 20	0	
		n77	10, 15, 20, 25, 30, 40, 50, 60, 70, 80, 90, 100		
		n2	n2 channel bandwidths in Table 5.3.5-1		4 and 5
		n77	n77 channel bandwidths in Table 5.3.5-1		
CA_n2A-n77(2A)	n77 <sup>8,9</sup> CA_n2A-n77A <sup>8</sup> CA_n77(2A) <sup>7</sup>	n2	5, 10, 15, 20	0	
		n77	CA_n77(2A)_BCS0		
		n2	5, 10, 15, 20		1
		n77	CA_n77(2A)_BCS1		
CA_n2A-n77B	CA_n2A-n77A	n2	5, 10, 15, 20	0	
		n77	CA_n77B_BCS0		
	-	n2	n2 channel bandwidths in Table 5.3.5-1	4 and 5	
	n77	CA_n77B_BCS 4 and 5			
CA_n2A-n77C	n77 <sup>8,9</sup> CA_n77C CA_n2A-n77A <sup>8</sup>	n2	5, 10, 15, 20	0	
		n77	CA_n77C_BCS0		
		n2	n2 channel bandwidths in Table 5.3.5-1		4 and 5
		n77	CA_n77C_BCS 4 and 5		
CA_n2(2A)-n77A	n77 <sup>8,9</sup> CA_n2A-n77A <sup>8</sup>	n2	CA_n2(2A)_BCS0	0	
		n77	10, 15, 20, 25, 30, 40, 50, 60, 70, 80, 90, 100		
		n2	CA_n2(2A)_BCS 4 and 5		4 and 5
		n77	n77 channel bandwidths in Table 5.3.5-1		
CA_n2(2A)-n77B	CA_n2A-n77A	n2	CA_n2(2A)_BCS0	0	
		n77	CA_n77B_BCS0		
	-	n2	CA_n2(2A)_BCS 4 and 5	4 and 5	
		n77	CA_n77B_BCS 4 and 5		
CA_n2(2A)-n77(2A)	n77 <sup>8,9</sup> CA_n2A-n77A <sup>8</sup> CA_n77(2A) <sup>7</sup>	n2	CA_n2(2A)_BCS0	0	
		n77	CA_n77(2A)_BCS1		
CA_n2A-n77(3A)	CA_n2A-n77A	n2	5, 10, 15, 20	0	
		n77	CA_n77(3A)_BCS0		
		n2	5, 10, 15, 20		1

		n77	CA_n77(3A)_BCS1	
CA_n2(2A)-n77C	n77 <sup>8,9</sup> CA_n77C CA_n2A-n77A <sup>8</sup>	n2	CA_n2(2A)_BCS0	0
		n77	CA_n77C_BCS1	
CA_n2A-n78A	CA_n2A-n78A	n2	5, 10, 15, 20	0
		n78	10, 15, 20, 25, 30, 40, 50, 60, 80, 90, 100	
		n2	5, 10, 15, 20	1
		n78	10, 15, 20, 25, 30, 40, 50, 60, 70, 80, 90, 100	
		n2	See n2 channel bandwidths in Table 5.3.5-1	
n78	See n78 channel bandwidths in Table 5.3.5-1	4 and 5		
CA_n2A-n78(2A)	CA_n2A-n78A	n2	5, 10, 15, 20	0
		n78	CA_n78(2A)_BCS1	
		n2	5, 10, 15, 20	1
		n78	CA_n78(2A)_BCS2	
		n2	See n2 channel bandwidths in Table 5.3.5-1	4 and 5
n78	CA_n78(2A)_BCS4 and 5			

**Table 5.5A.3.1-1c: NR CA configurations and bandwidth combinations sets defined for inter-band CA (two bands)**

NR CA configuration	Uplink CA configuration or single uplink carrier <sup>10</sup>	NR Band	Channel bandwidth (MHz) (NOTE 3)	Bandwidth combination set
CA_n3A-n5A	CA_n3A-n5A	n3	5, 10, 15, 20, 25, 30, 40, 50	0
		n5	5, 10, 15, 20	
CA_n3(2A)-n5A	-	n3	CA_n3(2A)_BCS0	0
		n5	5, 10, 15, 20	
CA_n3A-n7A	n3 <sup>8</sup> n7 <sup>8</sup> CA_n3A-n7A	n3	5, 10, 15, 20, 25, 30	0
		n7	5, 10, 15, 20, 25, 30, 40, 50	
		n3	5, 10, 15, 20, 25, 30, 40	1
		n7	5, 10, 15, 20, 25, 30, 40, 50	
		n3	n3 channel bandwidths in Table 5.3.5-1	
n7	n7 channel bandwidths in Table 5.3.5-1	4 and 5		
CA_n3A-n7B	CA_n3A-n7A CA_n7B	n3	5, 10, 15, 20, 25, 30	0
		n7	CA_n7B_BCS0	
		n3	5, 10, 15, 20, 25, 30, 40	1
		n7	CA_n7B_BCS0	
CA_n3A-n7(2A)	CA_n3A-n7A	n3	5, 10, 15, 20, 25, 30	0
CA_n3(2A)-n7A	CA_n3A-n7A	n3	CA_n3(2A)_BCS0	0
		n7	5, 10, 15, 20, 25, 30, 40, 50	
CA_n3(2A)-n7(2A)	CA_n3A-n7A	n3	CA_n3(2A)_BCS1	1
		n7	5, 10, 15, 20, 25, 30, 40, 50	
CA_n3(2A)-n7(2A)	CA_n3A-n7A	n3	CA_n3(2A)_BCS0	0
		n7	CA_n7(2A)_BCS0	
CA_n3B-n7A	CA_n3A-n7A	n3	CA_n3B_BCS0	0
		n7	5, 10, 15, 20, 25, 30, 40, 50	
CA_n3B-n7B	CA_n3A-n7A CA_n7B	n3	CA_n3B_BCS0	0
		n7	CA_n7B_BCS0	
		n3	CA_n3B_BCS 4 and 5	4 and 5
		n7	CA_n7B_BCS 4 and 5	
CA_n3A-n8A	CA_n3A-n8A	n3	5, 10, 15, 20, 25, 30	0
		n8	5, 10, 15, 20	
		n3	5, 10, 15, 20, 25, 30, 40, 50	1
		n8	5, 10, 15, 20	
		n3	See n3 channel bandwidths in Table 5.3.5-1	4 and 5
n8	See n8 channel bandwidths in Table 5.3.5-1			
CA_n3(2A)-n8A	CA_n3A-n8A	n3	CA_n3(2A)_BCS0	0

		n8	5, 10, 15, 20		
CA_n3A-n18A	CA_n3A-n18A	n3	5, 10, 15, 20, 25, 30, 40	0	
		n18	5, 10, 15		
CA_n3A-n20A	CA_n3A-n20A	n3	5, 10, 15, 20, 25, 30, 40	0	
		n20	5, 10, 15, 20		
		n3	n3 channel bandwidths in Table 5.3.5-1		4 and 5
n20	n20 channel bandwidths in Table 5.3.5-1				
CA_n3A-n26A	CA_n3A-n26A	n3	5, 10, 15, 20, 25, 30, 40	0	
		n26	5, 10, 15, 20		
CA_n3A-n26(2A)	CA_n26(2A) CA_n3A-n26A	n3	5, 10, 15, 20, 25, 30, 35, 40, 45, 50	0	
		n26	CA_n26(2A)_BCS0		
CA_n3B-n26A	CA_n3A-n26A	n3	CA_n3B_BCS0	0	
		n26	5, 10, 15, 20, 25, 30		
CA_n3B-n26(2A)	CA_n26(2A) CA_n3A-n26A	n3	CA_n3B_BCS0	0	
		n26	CA_n26(2A)_BCS0		
CA_n3A-n28A	n3 <sup>8</sup> CA_n3A-n28A	n3	5, 10, 15, 20, 25, 30	0	
		n28	5, 10, 15, 20		
		n3	5, 10, 15, 20, 25, 30, 40	1	
		n28	5, 10, 15, 20		
		n3	5, 10, 15, 20, 25, 30, 40, 50	2	
		n28	5, 10, 15, 20, 30		
		n3	5, 10, 15, 20, 25, 30, 35, 40	3	
		n28	5, 10, 15, 20, 25, 30		
n3	n3 channel bandwidths in Table 5.3.5-1	4 and 5			
n28	n28 channel bandwidths in Table 5.3.5-1				
CA_n3B-n28A	CA_n3A-n28A	n3	CA_n3B_BCS0	0	
		n28	5, 10, 15, 20		
CA_n3(2A)-n28A	-	n3	CA_n3(2A)_BCS0	0	
		n28	5, 10, 15, 20		
CA_n3A-n34A	CA_n3A-n34A	n3	5, 10, 15, 20, 25, 30	0	
		n34	5, 10, 15		
		n3	See n3 channel bandwidths in Table 5.3.5-1		4 and 5
		n34	See n34 channel bandwidths in Table 5.3.5-1		
CA_n3A-n38A	CA_n3A-n38A	n3	5, 10, 15, 20, 25, 30	0	
		n38	5, 10, 15, 20, 40		
CA_n3B-n38A	-	n3	CA_n3B_BCS0	0	
		n38	5, 10, 15, 20, 25, 30, 40		
CA_n3(2A)-n38A	-	n3	CA_n3(2A)_BCS1	0	
		n38	5, 10, 15, 20, 25, 30, 40		
CA_n3A-n39A	n3	n3	5, 10, 15, 20, 25, 30	0	
		n39	5, 10, 15, 20, 25, 30, 35, 40		
CA_n3A-n40A	n40 <sup>8,9</sup> CA_n3A-n40A <sup>8</sup>	n3	5, 10, 15, 20, 25, 30	0	
		n40	5, 10, 15, 20, 25, 30, 40, 50, 60, 80		
		n3	5, 10, 15, 20, 25, 30, 40, 50		1
		n40	5, 10, 15, 20, 25, 30, 40, 50, 60, 80		
		n3	5, 10, 15, 20, 25, 30, 35, 40		2
		n40	10, 15, 20, 25, 30, 40, 50, 60, 70, 80, 90, 100		
		n3	See n3 channel bandwidths in Table 5.3.5-1		4 and 5
n40	See n40 channel bandwidths in Table 5.3.5-1				
CA_n3A-n41A	n41 <sup>8,9</sup> CA_n3A-n41A <sup>8</sup>	n3	5, 10, 15, 20, 25, 30	0	
		n41	10, 15, 20, 40, 50, 60, 80, 90, 100		
		n3	5, 10, 15, 20, 25, 30		1
		n41	10, 15, 20, 40, 50, 60		
		n3	5, 10, 15, 20, 25, 30, 40		2
		n41	10, 15, 20, 30, 40, 50, 60, 80, 90, 100		
		n3	5, 10, 15, 20, 25, 30, 40, 50		3
		n41	10, 15, 20, 30, 40, 50, 60, 80, 90, 100		
n3	See n3 channel bandwidths in Table 5.3.5-1	4 and 5			
n41	See n41 channel bandwidths in Table 5.3.5-1				
CA_n3A-n41B	CA_n3A-n41A	n3	5, 10, 15, 20	0	
		n41	CA_n41B_BCS0		

CA_n3A-n41C	n41 <sup>8</sup> CA_n41C <sup>8</sup> CA_n3A-n41A <sup>8</sup> CA_n3A-n41C <sup>8</sup>	n3	5, 10, 15, 20, 25, 30	0
		n41	CA_n41C_BCS0	
		n3	See n3 channel bandwidths in Table 5.3.5-1	4 and 5
		n41	CA_n41C_BCS4 and 5	
CA_n3A-n41(2A)	CA_n3A-n41A	n3	5, 10, 15, 20, 25, 30	0
		n41	CA_n41(2A)_BCS0	
		n3	See n3 channel bandwidths in Table 5.3.5-1	4 and 5
		n41	CA_n41(2A)_BCS4 and 5	
CA_n3A-n67A	-	n3	5, 10, 15, 20, 25, 30, 40, 50	0
		n67	5, 10, 15, 20	
		n3	n3 channel bandwidths in Table 5.3.5-1	4 and 5
		n67	n67 channel bandwidths in Table 5.3.5-1	
CA_n3A-n74A	CA_n3A-n74A	n3	5, 10, 15, 20, 25, 30, 40	0
		n74	5, 10, 15, 20	
CA_n3A-n75A	-	n3	5, 10, 15, 20, 25, 30, 40	0
		n75	5, 10, 15, 20, 25, 30, 40, 50	
		n3	n3 channel bandwidths in Table 5.3.5-1	4 and 5
		n75	n75 channel bandwidths in Table 5.3.5-1	
CA_n3A-n77A	n77 <sup>8,9</sup> CA_n3A-n77A <sup>8</sup>	n3	5, 10, 15, 20, 25, 30	0
		n77	10, 15, 20, 40, 50, 60, 80, 90, 100	
		n3	5, 10, 15, 20, 25, 30, 35,40	1
		n77	10, 15, 20, 25, 30, 40, 50, 60, 70, 80, 90, 100	
		n3	See n3 channel bandwidths in Table 5.3.5-1	4 and 5
		n77	See n77 channel bandwidths in Table 5.3.5-1	
CA_n3A-n77(2A)	n77 <sup>8,9</sup> CA_n77(2A) <sup>8</sup> CA_n3A-n77A <sup>8</sup>	n3	5, 10, 15, 20, 25, 30	0
		n77	CA_n77(2A)_BCS0	
		n3	5, 10, 15, 20, 25, 30, 35,40	1
		n77	CA_n77(2A)_BCS1	
		n3	See n3 channel bandwidths in Table 5.3.5-1	4 and 5
		n77	CA_n77(2A)_BCS4 and 5	
CA_n3A-n77(3A)	n77 <sup>8,9</sup> CA_n77(2A) <sup>8</sup> CA_n3A-n77A <sup>8</sup>	n3	5, 10, 15, 20, 25, 30, 40	0
		n77	CA_n77(3A)_BCS0	
CA_n3A-n78A	n3 <sup>8</sup> n78 <sup>8,9</sup> CA_n3A-n78A <sup>8</sup>	n3	5, 10, 15, 20, 25, 30	0
		n78	10, 15, 20, 40, 50, 60, 80, 90, 100	
		n3	5, 10, 15, 20, 25, 30, 40,	1
		n78	10, 15, 20, 25, 30, 40, 50, 60, 70, 80, 90, 100	
		n3	n3 channel bandwidths in Table 5.3.5-1	4 and 5
		n78	n78 channel bandwidths in Table 5.3.5-1	
CA_n3A-n78C	CA_n78C CA_n3A-n78A	n3	5, 10, 15, 20, 25, 30	0
		n78	CA_n78C_BCS0	
	CA_n3A-n78A	n3	5, 10, 15, 20, 25, 30, 40	1
		n78	CA_n78C_BCS0	
		n3	5, 10, 15, 20, 25, 30, 40	2
	CA_n78C CA_n3A-n78A CA_n3A-n78C	n3	See n3 channel bandwidths in Table 5.3.5-1	4 and 5
		n78	CA_n78C_BCS4 and 5	
CA_n3A-n78(2A)	n3 <sup>8</sup> n78 <sup>8,9</sup> CA_n3A-n78A <sup>8</sup> CA_n78(2A) <sup>8</sup>	n3	5, 10, 15, 20, 25, 30	0
		n78	CA_n78(2A)_BCS0	
		n3	5, 10, 15, 20, 25, 30, 40	1
		n78	CA_n78(2A)_BCS2	



		n3	See n3 channel bandwidths in Table 5.3.5-1	4 and 5
		n78	CA_n78(2A)_BCS4 and 5	
CA_n3(2A)-n78A	CA_n3A-n78A	n3	CA_n3(2A)_BCS0	0
		n78	10, 15, 20, 25, 30, 40, 50, 60, 70, 80, 90, 100	
		n3	CA_n3(2A)_BCS1	1
		n78	10, 15, 20, 25, 30, 40, 50, 60, 70, 80, 90, 100	
CA_n3B-n78A	CA_n3A-n78A	n3	CA_n3B_BCS0	0
		n78	10, 15, 20, 25, 30, 40, 50, 60, 70, 80, 90, 100	
		n3	CA_n3B_BCS4 and 5	4 and 5
		n78	n78 channel bandwidths in Table 5.3.5-1	
CA_n3B-n78C	CA_n78C CA_n3A-n78A	n3	CA_n3B_BCS0	0
		n78	CA_n78C_BCS0	
CA_n3B-n78(2A)	CA_n3A-n78A	n3	CA_n3B_BCS0	0
		n78	CA_n78(2A)_BCS0	
		n3	CA_n3B_BCS4 and 5	4 and 5
		n78	CA_n78(2A)_BCS4 and 5	
CA_n3A-n79A	n3 <sup>8</sup> n79 <sup>8,9</sup> CA_n3A-n79A <sup>8</sup>	n3	5, 10, 15, 20, 25, 30	0
		n79	40, 50, 60, 80, 100	
		n3	5, 10, 15, 20, 25, 30, 40, 50	1
		n79	40, 50, 60, 80, 100	
		n3	See n3 channel bandwidths in Table 5.3.5-1	4 and 5
		n79	See n79 channel bandwidths in Table 5.3.5-1	
CA_n3(2A)-n79A	CA_n3A-n79A	n3	CA_n3(2A)_BCS1	0
		n79	40, 50, 60, 80, 100	
		n3	CA_n3(2A)_BCS4 and 5	4 and 5
		n79	See n79 channel bandwidths in Table 5.3.5-1	
CA_n3A-n79C	n3 <sup>8</sup> n79 <sup>8,9</sup> CA_n79C <sup>8</sup> CA_n3A-n79A <sup>8</sup>	n3	5, 10, 15, 20, 25, 30	0
		n79	CA_n79C_BCS0	
		n3	See n3 channel bandwidths in Table 5.3.5-1	4 and 5
		n79	CA_n79C_BCS4 and 5	
CA_n3(2A)-n79C	CA_n3A-n79A	n3	CA_n3(2A)_BCS1	0
		n79	CA_n79C_BCS0	
		n3	CA_n3(2A)_BCS4 and 5	4 and 5
		n79	CA_n79C_BCS4 and 5	
CA_n3B-n79A	-	n3	CA_n3B_BCS0	0
		n79	40, 50, 60, 80, 100	
		n3	CA_n3B_BCS4 and 5	4 and 5
		n79	See n79 channel bandwidths in Table 5.3.5-1	
CA_n3B-n79C	-	n3	CA_n3B_BCS0	0
		n79	CA_n79C_BCS0	
		n3	CA_n3B_BCS4 and 5	4 and 5
		n79	CA_n79C_BCS4 and 5	
CA_n3A-n102A	CA_n3A-n102A	n3	5, 10, 15, 20, 25, 30, 40, 45, 50	0
		n102	20, 40, 60, 80, 100	
CA_n3A-n102(2A)	CA_n3A-n102A	n3	5, 10, 15, 20, 25, 30, 40, 45, 50	0
		n102	CA_n102(2A)_BCS0	
CA_n3A-n102B	CA_n3A-n102A CA_n3A-n102B	n3	5, 10, 15, 20, 25, 30, 40, 45, 50	0
		n102	CA_n102B_BCS0	
CA_n3A-n102C	CA_n3A-n102A CA_n3A-n102C	n3	5, 10, 15, 20, 25, 30, 40, 45, 50	0
		n102	CA_n102C_BCS0	
CA_n3A-n102D	CA_n3A-n102A	n3	5, 10, 15, 20, 25, 30, 40, 45, 50	0
		n102	CA_n102D_BCS0	
CA_n3A-n102E	CA_n3A-n102A	n3	5, 10, 15, 20, 25, 30, 40, 45, 50	0
		n102	CA_n102E_BCS0	
CA_n3A-n105A	CA_n3A-n105A	n3	5, 10, 15, 20, 25, 30, 40, 50	0

	n105	5, 10, 15, 20, 25, 30, 35
--	------	---------------------------

**Table 5.5A.3.1-1d: NR CA configurations and bandwidth combinations sets defined for inter-band CA (two bands)**

NR CA configuration	Uplink CA configuration or single uplink carrier <sup>10</sup>	NR Band	Channel bandwidth (MHz) (NOTE 3)	Bandwidth combination set
CA_n5A-n7A	CA_n5A-n7A	n5	5, 10, 15, 20	0
		n7	5, 10, 15, 20, 25, 30, 40, 50	
		n5	n5 channel bandwidths in Table 5.3.5-1	4 and 5
		n7	n7 channel bandwidths in Table 5.3.5-1	
CA_n5A-n7B	CA_n5A-n7A CA_n7B	n5	5, 10, 15, 20	0
		n7	CA_n7B_BCS0	
CA_n5A-n8A <sup>15</sup>	-	n5	5, 10	0
		n8	5, 10	
CA_n5A-n12A	CA_n5A-n12A	n5	5, 10, 15, 20	0
		n12	5, 10, 15	
CA_n5B-n12A	CA_n5A-n12A CA_n5B	n5	CA_n5B_BCS0	0
		n12	5, 10, 15	
CA_n5A-n13A	CA_n5A-n13A	n5	5, 10, 15, 20	4 and 5
		n13	5, 10	
CA_n5B-n13A	CA_n5A-n13A	n5	CA_n5B_BCS0	0
		n13	5, 10	
CA_n5A-n14A	CA_n5A-n14A	n5	5, 10, 15, 20	0
		n14	5, 10	
CA_n5B-n14A	CA_n5A-n14A CA_n5B	n5	CA_n5B_BCS0	0
		n14	5, 10	
CA_n5A-n25A	CA_n5A-n25A	n5	5, 10, 15, 20	0
		n25	5, 10, 15, 20, 25, 30, 40	
		n5	n5 channel bandwidths in Table 5.3.5-1	4 and 5
		n25	n25 channel bandwidths in Table 5.3.5-1	
CA_n5A-n25(2A)	CA_n5A-n25A	n5	5, 10, 15, 20	0
		n25	CA_n25(2A)_BCS0	
CA_n5A-n28A	CA_n5A-n28A	n5	5, 10, 15, 20	0
		n28	5, 10, 15, 20, 30	
		n5	5, 10, 15, 20	1
		n28	5, 10, 15, 20, 25, 30	
CA_n5A-n29A	-	n5	5, 10, 15, 20	0
		n29	5, 10	
CA_n5B-n29A	CA_n5B	n5	CA_n5B_BCS0	0
		n29	5, 10	
CA_n5A-n30A	CA_n5A-n30A	n5	5, 10, 15, 20	0
		n30	5, 10	
CA_n5A-n40A	CA_n5A-n40A	n5	5, 10, 15, 20, 25 <sup>1</sup>	0
		n40	5 <sup>5</sup> , 10, 15, 20, 25, 30, 40, 50, 60, 70, 80, 90, 100	
CA_n5A-n41A	CA_n5A-n41A	n5	5, 10, 15, 20	0
		n41	10, 15, 20, 30, 40, 50, 60, 70, 80, 90, 100	
CA_n5A-n48A	CA_n5A-n48A	n5	5, 10, 15, 20	0
		n48	5, 10, 15, 20, 40, 50 <sup>6</sup> , 60 <sup>6</sup> , 80 <sup>6</sup> , 90 <sup>6</sup> , 100 <sup>6</sup>	
		n5	5, 10, 15, 20	1
		n48	5, 10, 15, 20, 30, 40, 50 <sup>6</sup> , 60 <sup>6</sup> , 70 <sup>6</sup> , 80 <sup>6</sup> , 90 <sup>6</sup> , 100 <sup>6</sup>	
CA_n5A-n48(2A)	CA_n5A-n48A	n5	5, 10, 15, 20	0
		n48	CA_n48(2A)_BCS0	
		n5	5, 10, 15, 20	1
		n48	CA_n48(2A)_BCS1	
CA_n5A-n48B	CA_n48B CA_n5A-n48A	n5	5, 10, 15, 20	0
		n48	CA_n48B_BCS0	

		n5	5, 10, 15, 20	1
		n48	CA_n48B_BCS2	
CA_n5A-n48C	CA_n5A-n48A	n5	5, 10, 15, 20	0
		n48	CA_n48C_BCS0	
CA_n5A-n48(A-B)	CA_n5A-n48A	n5	5, 10, 15, 20	0
		n48	CA_n48(A-B)_BCS0	
		n5	5, 10, 15, 20	1
		n48	CA_n48(A-B)_BCS1	
CA_n5A-n66A	n66 <sup>8</sup> CA_n5A-n66A	n5	5, 10, 15, 20	0
		n66	5, 10, 15, 20, 40	
		n5	5, 10, 15, 20	1
		n66	5, 10, 15, 20, 25, 30, 40	
		n5	n5 channel bandwidths in Table 5.3.5-1	4 and 5
		n66	n66 channel bandwidths in Table 5.3.5-1	
CA_n5A-n66B	CA_n5A-n66A	n5	5, 10, 15, 20	0
		n66	CA_n66B_BCS0	
CA_n5B-n66A	CA_n5A-n66A CA_n5B	n5	CA_n5B_BCS0	0
		n66	5, 10, 15, 20, 25, 30, 40	
CA_n5B-n66B	CA_n5A-n66A	n5	CA_n5B_BCS0	0
		n66	CA_n66B_BCS0	
CA_n5A-n66(2A)	CA_n5A-n66A	n5	5, 10, 15, 20	0
		n66	CA_n66(2A)_BCS0	
		n5	5, 10, 15, 20	1
		n66	CA_n66(2A)_BCS1	
CA_n5A-n66(3A)	CA_n5A-n66A	n5	5, 10, 15, 20	0
		n66	CA_n66(3A)_BCS0	
CA_n5B-n66(2A)	CA_n5A-n66A CA_n5B	n5	CA_n5B_BCS0	0
		n66	CA_n66(2A)_BCS1	
CA_n5A-n71A	-	n5	5, 10, 15, 20	0
		n71	5, 10, 15, 20	
		n5	n5 channel bandwidths in Table 5.3.5-1	4 and 5
		n71	n71 channel bandwidths in Table 5.3.5-1	
CA_n5A-n77A	n77 <sup>8,9</sup> CA_n5A- n77A <sup>8,13,14</sup>	n5	5, 10, 15, 20	0
		n77	10, 15, 20, 25, 30, 40, 50, 60, 70, 80, 90, 100	
		n5	n5 channel bandwidths in Table 5.3.5-1	4 and 5
		n77	n77 channel bandwidths in Table 5.3.5-1	
CA_n5A-n77B	CA_n5A-n77A n77 <sup>8,9</sup>	n5	n5 channel bandwidths in Table 5.3.5-1	4 and 5
		n77	CA_n77B_BCS 4 and 5	
CA_n5A-n77(2A)	n77 <sup>8,9</sup> CA_n5A-n77A <sup>8</sup> CA_n77(2A) <sup>8</sup>	n5	5, 10, 15, 20	0
		n77	CA_n77(2A)_BCS0	
		n5	5, 10, 15, 20	1
		n77	CA_n77(2A)_BCS1	
		n5	n5 channel bandwidths in Table 5.3.5-1	4 and 5
		n77	CA_n77(2A)_BCS4 and 5	
CA_n5A-n77(3A)	n77 <sup>8,9</sup> CA_n77(2A) <sup>8</sup> CA_n5A-n77A <sup>8</sup>	n5	5, 10, 15, 20	0
		n77	CA_n77(3A)_BCS0	
		n5	5, 10, 15, 20	1
		n77	CA_n77(3A)_BCS1	
		n5	n5 channel bandwidths in Table 5.3.5-1	4 and 5
		n77	CA_n77(3A)_BCS4 and 5	
CA_n5(2A)-n77A	n77 <sup>8,9</sup> CA_n5A-n77A <sup>8</sup>	n5	CA_n5(2A)_BCS0	0
		n77	10, 15, 20, 25, 30, 40, 50, 60, 70, 80, 90, 100	
CA_n5A-n77C	n77 <sup>8,9</sup> CA_n5A-n77A <sup>8</sup> CA_n77C	n5	5, 10, 15, 20	0

		n77	CA_n77C_BCS0	
		n5	5, 10, 15, 20	1
		n77	CA_n77C_BCS1	
CA_n5(2A)-n77C	n77 <sup>8,9</sup> CA_n77C CA_n5A-n77A <sup>8</sup>	n5	CA_n5(2A)_BCS0	0
		n77	CA_n77C_BCS0	
		n5	CA_n5(2A)_BCS0	1
		n77	CA_n77C_BCS1	
CA_n5B-n77A	n77 <sup>8,9</sup> CA_n5A-n77A <sup>8</sup> CA_n5B	n5	CA_n5B_BCS0	0
		n77	10, 15, 20, 25, 30, 40, 50, 60, 70, 80, 90, 100	
CA_n5B-n77C	n77 <sup>8,9</sup> CA_n5A-n77A <sup>8</sup> CA_n5B CA_n77C	n5	CA_n5B_BCS0	0
		n77	CA_n77C_BCS0	
		n5	CA_n5B_BCS0	1
		n77	CA_n77C_BCS1	
CA_n5A-n78A	n78 <sup>8,9</sup> CA_n5A-n78A <sup>8</sup>	n5	5, 10, 15, 20	0
		n78	10, 15, 20, 40, 50, 60, 80, 90, 100	
		n5	5, 10, 15, 20	1
		n78	10, 15, 20, 25, 30, 40, 50, 60, 70, 80, 90, 100	
		n5	See n5 channel bandwidths in Table 5.3.5-1	4 and 5
CA_n5A-n78(2A)	n78 <sup>8,9</sup> CA_n5A-n78A <sup>8</sup> CA_n78(2A) <sup>8</sup>	n5	5, 10, 15, 20	0
		n78	CA_n78(2A)_BCS2	
		n5	See n5 channel bandwidths in Table 5.3.5-1	4 and 5
		n78	CA_n78(2A)_BCS4 and 5	
CA_n5A-n78C	CA_n5A-n78A	n5	5, 10, 15, 20	0
		n78	CA_n78C_BCS0	
		n5	5, 10, 15, 20	1
		n78	CA_n78C_BCS1	
	CA_n78C CA_n5A-n78C	n5	See n5 channel bandwidths in Table 5.3.5-1	4 and 5
		n78	CA_n78C_BCS4 and 5	
CA_n5A-n79A	CA_n5A-n79A	n5	5, 10, 15, 20	0
		n79	40, 50, 60, 80, 100	
		n5	See n5 channel bandwidths in Table 5.3.5-1	4 and 5
		n79	See n79 channel bandwidths in Table 5.3.5-1	
CA_n5A-n79C	CA_n5A-n79A	n5	5, 10, 15, 20	0
		n79	CA_n79C_BCS0	
		n5	See n5 channel bandwidths in Table 5.3.5-1	4 and 5
		n79	CA_n79C_BCS4 and 5	
CA_n5A-n105A	CA_n5A-n105A	n5	5, 10, 15, 20	0
		n105	5, 10, 15, 20, 25, 30, 35	

**Table 5.5A.3.1-1e: NR CA configurations and bandwidth combinations sets defined for inter-band CA (two bands)**

NR CA configuration	Uplink CA configuration or single uplink carrier <sup>10</sup>	NR Band	Channel bandwidth (MHz) (NOTE 3)	Bandwidth combination set
CA_n7A-n8A	CA_n7A-n8A	n7	5, 10, 15, 20, 25, 30, 40, 50	0
		n8	5, 10, 15, 20	
CA_n7(2A)-n8A	CA_n7A-n8A	n7	CA_n7(2A)_BCS0	0
		n8	5, 10, 15, 20	
CA_n7A-n12A	-	n7	5, 10, 15, 20, 25, 30, 40, 50	0
		n12	5, 10, 15	

CA_n7A-n20A	CA_n7A-n20A	n7	See n7 channel bandwidths in Table 5.3.5-1	4 and 5
		n20	See n20 channel bandwidths in Table 5.3.5-1	
CA_n7A-n25A	CA_n7A-n25A	n7	5, 10, 15, 20, 25, 30, 40	0
		n25	5, 10, 15, 20, 25, 30, 40	
		n7	n7 channel bandwidths in Table 5.3.5-1	4 and 5
		n25	n25 channel bandwidths in Table 5.3.5-1	
CA_n7A-n25(2A)	CA_n7A-n25A	n7	5, 10, 15, 20, 25, 30, 40	0
		n25	CA_n25(2A)_BCS0	
CA_n7(2A)-n25A	CA_n7A-n25A	n7	CA_n7(2A)_BCS0	0
		n25	5, 10, 15, 20, 25, 30, 40	
CA_n7(2A)-n25(2A)	CA_n7A-n25A	n7	CA_n7(2A)_BCS0	0
		n25	CA_n25(2A)_BCS0	
CA_n7A-n26A	CA_n7A-n26A	n7	5, 10, 15, 20, 25, 30, 40, 50	0
		n26	5, 10, 15, 20	
CA_n7A-n26(2A)	CA_n26(2A) CA_n7A-n26A	n7	5, 10, 15, 20, 25, 30, 35, 40, 50	0
		n26	CA_n26(2A)_BCS0	
CA_n7B-n26A	CA_n7A-n26A CA_n7B	n7	CA_n7B_BCS0	0
		n26	5, 10, 15, 20	
CA_n7B-n26(2A)	CA_n7B CA_n26(2A) CA_n7A-n26A	n7	CA_n7B_BCS0	0
		n26	CA_n26(2A)_BCS0	
CA_n7A-n28A	n7 <sup>B</sup> CA_n7A-n28A	n7	5, 10, 15, 20, 25, 30, 40, 50	0
		n28	5, 10, 15, 20	
CA_n7B-n28A	CA_n7A-n28A CA_n7B	n7	CA_n7B_BCS0	0
		n28	5, 10, 15, 20	
CA_n7A-n40A	CA_n7A-n40A	n7	5, 10, 15, 20, 25, 30, 40, 50	0
		n40	5, 10, 15, 20, 25, 30, 40, 50, 60, 70, 80, 90, 100	
CA_n7A-n46A	CA_n7A-n46A	n7	5, 10, 15, 20, 25, 30, 40, 50	0
		n46	20, 40, 60, 80	
CA_n7A-n46C	CA_n7A-n46A	n7	5, 10, 15, 20, 25, 30, 40, 50	0
		n46	CA_n46C_BCS0	
CA_n7A-n46D	CA_n7A-n46A	n7	5, 10, 15, 20, 25, 30, 40, 50	0
		n46	CA_n46D_BCS0	
CA_n7A-n46(2A)	CA_n7A-n46A	n7	5, 10, 15, 20, 25, 30, 40, 50	0
		n46	CA_n46(2A)_BCS0	
CA_n7A-n66A	CA_n7A-n66A	n7	5, 10, 15, 20	0
		n66	10, 15, 20, 40	
		n7	5, 10, 15, 20, 25, 30, 40	1
		n66	5, 10, 15, 20, 25, 30, 40	
		n7	n7 channel bandwidths in Table 5.3.5-1	4 and 5
n66	n66 channel bandwidths in Table 5.3.5-1			
CA_n7A-n66(2A)	CA_n7A-n66A	n7	5, 10, 15, 20, 25, 30, 40	0
		n66	CA_n66(2A)_BCS1	
CA_n7(2A)-n66A	CA_n7A-n66A	n7	CA_n7(2A)_BCS0	0
		n66	5, 10, 15, 20, 25, 30, 40	
CA_n7(2A)-n66(2A)	CA_n7A-n66A	n7	CA_n7(2A)_BCS0	0
		n66	CA_n66(2A)_BCS1	
CA_n7A-n67A	-	n7	5, 10, 15, 20, 25, 30, 40, 50	0
		n67	5, 10, 15, 20	
		n7	n7 channel bandwidths in Table 5.3.5-1	4 and 5
		n67	n67 channel bandwidths in Table 5.3.5-1	
CA_n7A-n71A	-	n7	5, 10, 15, 20, 25, 30, 40, 50	0
		n71	5, 10, 15, 20	
		n7	See n7 channel bandwidths in Table 5.3.5-1	4 and 5
		n71	See n71 channel bandwidths in Table 5.3.5-1	
CA_n7A-n75A	-	n7	10, 15, 20	0
		n75	5, 10, 15, 20	
		n7	n7 channel bandwidths in Table 5.3.5-1	4 and 5
		n75	n75 channel bandwidths in Table 5.3.5-1	
CA_n7A-n77A	n77 <sup>B,9</sup>	n7	5, 10, 15, 20, 25, 30, 40, 50	0

	CA_n7A-n77A <sup>8,13,14</sup>	n77	10, 15, 20, 25, 30, 40, 50, 60, 70, 80, 90, 100	4 and 5
		n7	n7 channel bandwidths in Table 5.3.5-1	
		n77	n77 channel bandwidths in Table 5.3.5-1	
CA_n7(2A)-n77A	n77 <sup>8,9</sup> CA_n7A-n77A <sup>8</sup>	n7	CA_n7(2A)_BCS0	0
		n77	10, 15, 20, 25, 30, 40, 50, 60, 70, 80, 90, 100	
CA_n7A-n77(2A)	n77 <sup>8,9</sup> CA_n77(2A) <sup>8</sup> CA_n7A-n77A <sup>8</sup>	n7	5, 10, 15, 20, 25, 30, 40, 50	0
		n77	CA_n77(2A)_BCS1	
		n7	5, 10, 15, 20, 25, 30, 40, 50	1
		n77	CA_n77(2A)_BCS4 and 5	
		n7	n7 channel bandwidths in Table 5.3.5-1	4 and 5
n77	CA_n77(2A)_BCS4 and 5			
CA_n7(2A)-n77(2A)	n77 <sup>8,9</sup> CA_n77(2A) <sup>8</sup> CA_n7A-n77A <sup>8</sup>	n7	CA_n7(2A)_BCS0	0
		n77	CA_n77(2A)_BCS1	
CA_n7A-n77(3A)	n77 <sup>8,9</sup> CA_n77(2A) <sup>8</sup> CA_n7A-n77A <sup>8</sup>	n7	5, 10, 15, 20, 25, 30, 40, 50	0
		n77	CA_n77(3A)_BCS1	
		n7	n7 channel bandwidths in Table 5.3.5-1	4 and 5
		n77	CA_n77(3A)_BCS4 and 5	
CA_n7(2A)-n77(3A)	n77 <sup>8,9</sup> CA_n77(2A) <sup>8</sup> CA_n7A-n77A <sup>8</sup>	n7	CA_n7(2A)_BCS0	0
		n77	CA_n77(3A)_BCS1	
CA_n7A-n78A	n7 <sup>8</sup> n78 <sup>8,9</sup> CA_n7A-n78A <sup>8</sup>	n7	5, 10, 15, 20	0
		n78	10, 15, 20, 40, 50, 60, 80, 90, 100	
		n7	5, 10, 15, 20, 25, 30, 40, 50	1
		n78	10, 15, 20, 25, 30, 40, 50, 60, 70, 80, 90, 100	
		n7	n7 channel bandwidths in Table 5.3.5-1	4 and 5
n78	n78 channel bandwidths in Table 5.3.5-1			
CA_n7A-n78C	n78 <sup>8,9</sup> CA_n78C CA_n7A-n78A <sup>8</sup>	n7	5, 10, 15, 20, 25, 30, 40, 50	0
		n78	CA_n78C_BCS1	
CA_n7B-n78A	n78 <sup>8</sup> CA_n7A-n78A <sup>8</sup> CA_n7B	n7	CA_n7B_BCS0	0
		n78	10, 15, 20, 25, 30, 40, 50, 60, 70, 80, 90, 100	
		n7	CA_n7B_BCS4 and 5	4 and 5
		n78	n78 channel bandwidths in Table 5.3.5-1	
CA_n7B-n78(2A)	CA_n7A-n78A CA_n7B	n7	CA_n7B_BCS0	0
		n78	CA_n78(2A)_BCS0	
		n7	CA_n7B_BCS4 and 5	4 and 5
		n78	CA_n78(2A)_BCS4 and 5	
CA_n7B-n78C	CA_n7B CA_n78C CA_n7A-n78A	n7	CA_n7B_BCS0	0
		n78	CA_n78C_BCS0	
CA_n7A-n78(2A)	n7 <sup>8</sup> n78 <sup>8,9</sup> CA_n7A-n78A <sup>8</sup> CA_n78(2A) <sup>8</sup>	n7	5, 10, 15, 20, 25, 30, 40, 50	0
		n78	CA_n78(2A)_BCS0	
		n7	5, 10, 15, 20, 25, 30, 40, 50	1
		n78	CA_n78(2A)_BCS2	
		n7	See n7 channel bandwidths in Table 5.3.5-1	4 and 5
n78	CA_n78(2A)_BCS4 and 5			

CA_n7(2A)-n78A	n78 <sup>8,9</sup> CA_n7A-n78A <sup>8</sup>	n7	CA_n7(2A)_BCS0	0
		n78	10, 15, 20, 40, 50, 60, 80, 90, 100	
		n7	CA_n7(2A)_BCS0	1
		n78	10, 15, 20, 25, 30, 40, 50, 60, 70, 80, 90, 100	
		n7	CA_n7(2A)_BCS4 and 5	4 and 5
n78	See n78 channel bandwidths in Table 5.3.5-1			
CA_n7(2A)-n78(2A)	n78 <sup>8,9</sup> CA_n7A-n78A <sup>8</sup> CA_n78(2A)	n7	CA_n7(2A)_BCS0	0
		n78	CA_n78(2A)_BCS0	
		n7	CA_n7(2A)_BCS0	1
		n78	CA_n78(2A)_BCS2	
		n7	CA_n7(2A)_BCS4 and 5	4 and 5
n78	CA_n78(2A)_BCS4 and 5			
CA_n7A-n79A	-	n7	5, 10, 15, 20, 25, 30, 40, 50	0
		n79	40, 50, 60, 80, 100	
		n7	n7 channel bandwidths in Table 5.3.5-1	4 and 5
		n79	n79 channel bandwidths in Table 5.3.5-1	
CA_n7A-n79C	-	n7	5, 10, 15, 20, 25, 30, 40, 50	0
		n79	CA_n79C_BCS0	
		n7	n7 channel bandwidths in Table 5.3.5-1	4 and 5
		n79	CA_n79C_BCS4 and 5	
CA_n7A-n102A	CA_n7A-n102A	n7	5, 10, 15, 20, 25, 30, 40, 50	0
		n102	20, 40, 60, 80, 100	
CA_n7A-n102(2A)	CA_n7A-n102A	n7	5, 10, 15, 20, 25, 30, 40, 50	0
		n102	CA_n102(2A)_BCS0	
CA_n7A-n102B	CA_n7A-n102A CA_n7A-n102B	n7	5, 10, 15, 20, 25, 30, 40, 50	0
		n102	CA_n102B_BCS0	
CA_n7A-n102C	CA_n7A-n102A CA_n7A-n102C	n7	5, 10, 15, 20, 25, 30, 40, 50	0
		n102	CA_n102C_BCS0	
CA_n7A-n102D	CA_n7A-n102A	n7	5, 10, 15, 20, 25, 30, 40, 50	0
		n102	CA_n102D_BCS0	
CA_n7A-n102E	CA_n7A-n102A	n7	5, 10, 15, 20, 25, 30, 40, 50	0
		n102	CA_n102E_BCS0	
CA_n7A-n105A	CA_n7A-n105A	n7	5, 10, 15, 20, 25, 30, 40, 50	0
		n105	5, 10, 15, 20, 25, 30, 35	
CA_n8A-n20A	CA_n8A-n20A	n8	5, 10, 15, 20	0
		n20	5, 10, 15, 20	
CA_n8A-n28A	CA_n8A-n28A	n8	5, 10, 15, 20	0
		n28	5, 10, 15, 20, 30	
		n8	5, 10, 15, 20	1
		n28	5, 10, 15, 20, 25, 30	
CA_n8A-n34A	n8 <sup>8</sup> n34 <sup>8,9</sup> CA_n8A-n34A <sup>8</sup>	n8	5, 10, 15, 20	0
		n34	5, 10, 15	
CA_n8A-n38A	-	n8	5, 10, 15, 20	0
		n38	5, 10, 15, 20, 25, 30, 40	
CA_n8A-n39A	n8 <sup>8</sup> n39 <sup>8,9</sup> CA_n8A-n39A <sup>8</sup>	n8	5, 10, 15, 20	0
		n39	5, 10, 15, 20, 25, 30, 40	
		n8	See n8 channel bandwidths in Table 5.3.5-1	4 and 5
		n39	See n39 channel bandwidths in Table 5.3.5-1	
CA_n8A-n40A	n8 <sup>8</sup> n40 <sup>8,9</sup> CA_n8A-n40A <sup>8</sup>	n8	5, 10, 15, 20	0
		n40	5, 10, 15, 20, 25, 30, 40, 50, 60, 80	
		n8	See n8 channel bandwidths in Table 5.3.5-1	4 and 5
		n40	See n40 channel bandwidths in Table 5.3.5-1	
CA_n8A-n41A	n8 <sup>8</sup> CA_n8A-n41A	n8	5, 10, 15, 20	0
		n41	10, 15, 20, 40, 50, 60, 80, 90, 100	

		n8	5, 10, 15, 20	1
		n41	10, 15, 20, 40, 50, 60	
		n8	See n8 channel bandwidths in Table 5.3.5-1	4 and 5
		n41	See n41 channel bandwidths in Table 5.3.5-1	
CA_n8A-n41C	CA_n41C CA_n8A-n41A CA_n8A-n41C	n8	See n8 channel bandwidths in Table 5.3.5-1	4 and 5
		n41	CA_n41C_BCS4 and 5	
CA_n8A-n75A	-	n8	5, 10, 15, 20	0
		n75	5, 10, 15, 20	
		n8	5, 10, 15, 20	1
		n75	5, 10, 15, 20, 25, 30, 40, 50	
CA_n8A-n77A	n77 <sup>8,9</sup> CA_n8A-n77A <sup>8</sup>	n8	5, 10, 15, 20	0
		n77	10, 15, 20, 25, 30, 40, 50, 60, 70, 80, 90, 100	
CA_n8A-n77(2A)	-	n8	5, 10, 15, 20	0
		n77	CA_n77(2A)_BCS1	
CA_n8A-n78A	n78 <sup>8,9</sup> CA_n8A-n78A <sup>8,13</sup>	n8	5, 10, 15, 20	0
		n78	10, 15, 20, 40, 50, 60, 80, 90, 100	
		n8	5, 10, 15, 20	1
		n78	10, 15, 20, 25, 30, 40, 50, 60, 80, 90, 100	
		n8	See n8 channel bandwidths in Table 5.3.5-1	4 and 5
		n78	See n78 channel bandwidths in Table 5.3.5-1	
CA_n8A-n78C	CA_n8A-n78A	n8	5, 10, 15, 20	0
		n78	CA_n78C_BCS0	
	CA_n78C CA_n8A-n78A CA_n8A-n78C	n8	See n8 channel bandwidths in Table 5.3.5-1	4 and 5
		n78	CA_n78C_BCS4 and 5	
CA_n8A-n78(2A)	CA_n8A-n78A	n8	5, 10, 15, 20	0
		n78	CA_n78(2A)_BCS1	
		n8	See n8 channel bandwidths in Table 5.3.5-1	4 and 5
		n78	CA_n78(2A)_BCS4 and 5	
CA_n8A-n79A	n8 <sup>8</sup> n79 <sup>8,9</sup> CA_n8A-n79A <sup>8</sup> CA_n79C <sup>8</sup>	n8	5, 10, 15, 20	0
		n79	10, 20, 40, 50, 60, 80, 100	
		n8	See n8 channel bandwidths in Table 5.3.5-1	4 and 5
		n79	See n79 channel bandwidths in Table 5.3.5-1	
CA_n8A-n79C	CA_n79C CA_n8A-n79A	n8	5, 10, 15, 20	0
		n79	CA_n79C_BCS0	
	CA_n79C CA_n8A-n79A CA_n8A-n79C	n8	See n8 channel bandwidths in Table 5.3.5-1	4 and 5
		n79	CA_n79C_BCS0	

Table 5.5A.3.1-1f ~ Table 5.5A.3.1-1j

**Table 5.5A.3.1-1f: NR CA configurations and bandwidth combinations sets defined for inter-band CA (two bands)**

NR CA configuration	Uplink CA configuration or single uplink carrier <sup>10</sup>	NR Band	Channel bandwidth (MHz) (NOTE 3)	Bandwidth combination set
CA_n12A-n25A	CA_n12A-n25A	n12	5, 10, 15	0
		n25	5, 10, 15, 20, 25, 30, 40	
CA_n12A-n30A	CA_n12A-n30A	n12	5, 10, 15	0
		n30	5, 10	
CA_n12A-n41A	-	n12	5, 10, 15	0
		n41	10, 15, 20, 30, 40, 50, 60, 70, 80, 90, 100	



CA_n12A-n48A	-	n12	5, 10, 15	0
		n48	10, 15, 20, 30, 40	
CA_n12A-n66A	CA_n12A-n66A	n12	5, 10, 15	0
		n66	5, 10, 15, 20, 40	
CA_n12A-n66(2A)	CA_n12A-n66A	n12	5, 10, 15	0
		n66	CA_n66(2A)_BCS1	
CA_n12A-n66(3A)	CA_n12A-n66A	n12	5, 10, 15	0
		n66	CA_n66(3A)_BCS0	
CA_n12A-n71A	-	n12	5, 10, 15	0
		n71	5, 10, 15, 20	
CA_n12A-n77A	n77 <sup>8,9</sup> CA_n12A-n77A <sup>8</sup>	n12	5, 10, 15	0
		n77	10, 15, 20, 25, 30, 40, 50, 60, 70, 80, 90, 100	
		n12	n12 channel bandwidths in Table 5.3.5-1	
CA_n12A-n77B	CA_n12A-n77A	n77	n77 channel bandwidths in Table 5.3.5-1	4 and 5
		n12	n12 channel bandwidths in Table 5.3.5-1	
CA_n12A-n77C	CA_n12A-n77A	n77	CA_n77B_BCS 4 and 5	4 and 5
		n12	n12 channel bandwidths in Table 5.3.5-1	
CA_n12A-n77(2A)	n77 <sup>8,9</sup> CA_n12A-n77A <sup>8</sup>	n12	n12 channel bandwidths in Table 5.3.5-1	4 and 5
		n77	CA_n77C_BCS 4 and 5	
CA_n12A-n78A	CA_n12A-n78A	n12	5, 10, 15	0
		n78	10, 15, 20, 25, 30, 40, 50, 60, 70, 80, 90, 100	
CA_n12A-n78(2A)	CA_n12A-n78A	n12	5, 10, 15	0
		n78	CA_n78(2A)_BCS2	
CA_n13A-n25A	CA_n13A-n25A	n13	5, 10	0
		n25	5, 10, 15, 20, 25, 30, 40	
CA_n13A-n66A	CA_n13A-n66A	n13	5, 10	0
		n66	5, 10, 15, 20, 40	
		n13	5, 10,	
		n66	5, 10, 15, 20, 25, 30, 40	
CA_n13A-n66B	CA_n13A-n66A	n13	5, 10	0
		n66	CA_n66B_BCS0	
CA_n13A-n66(2A)	CA_n13A-n66A	n13	5, 10	0
		n66	CA_n66(2A)_BCS1	
CA_n13A-n77A	n77 <sup>8,9</sup> CA_n13A-n77A <sup>8</sup>	n13	5, 10	0
		n77	10, 15, 20, 25, 30, 40, 50, 60, 70, 80, 90, 100	
CA_n13A-n77(2A)	n77 <sup>8,9</sup> CA_n77(2A) <sup>8</sup> CA_n13A-n77A <sup>8</sup>	n13	5, 10	0
		n77	CA_n77(2A)_BCS1	
CA_n13A-n77C	n77 <sup>8,9</sup> CA_n77C CA_n13A-n77A <sup>8</sup>	n13	5, 10	0
		n77	CA_n77C_BCS1	
CA_n14A-n30A	CA_n14A-n30A	n14	5, 10	0
		n30	5, 10	
CA_n14A-n66A	CA_n14A-n66A	n14	5, 10	0
		n66	5, 10, 15, 20, 25, 30, 40	
CA_n14A-n66(2A)	CA_n14A-n66A	n14	5, 10	0
		n66	CA_n66(2A)_BCS1	
CA_n14A-n66(3A)	CA_n14A-n66A	n14	5, 10	0
		n66	CA_n66(3A)_BCS0	
CA_n14A-n77A	n77 <sup>8,9</sup> CA_n14A-n77A <sup>8</sup>	n14	5, 10	0
		n77	10, 15, 20, 25, 30, 40, 50, 60, 70, 80, 90, 100	
CA_n14A-n77(2A)	n77 <sup>8,9</sup> CA_n14A-n77A <sup>8</sup>	n14	5, 10	0
		n77	CA_n77(2A)_BCS1	
CA_n18A-n28A	CA_n18A-n28A	n18	5, 10, 15	0
		n28	5, 10	
CA_n18A-n40A	CA_n18A-n40A	n18	5, 10, 15	0
		n40	10, 15, 20, 30, 40	
CA_n18A-n41A	n41 <sup>8</sup>	n18	5, 10, 15	0

	CA_n18A-n41A <sup>8</sup>	n41	10, 15, 20, 30, 40, 50, 60, 80, 90, 100	
CA_n18A-n74A	CA_n18A-n74A	n18	5, 10, 15	0
		n74	5, 10, 15, 20	
CA_n18A-n77A	n77 <sup>8</sup> CA_n18A-n77A <sup>8</sup>	n18	5, 10, 15	0
		n77	10, 15, 20, 40, 50, 60, 80, 90, 100	
		n18	See n18 channel bandwidths in Table 5.3.5-1	4 and 5
		n77	See n77 channel bandwidths in Table 5.3.5-1	
CA_n18A-n77(2A)	n77 <sup>8</sup> CA_n18A-n77A <sup>8</sup>	n18	5, 10, 15	0
		n77	CA_n77(2A)_BCS0	
		n18	See n18 channel bandwidths in Table 5.3.5-1	4 and 5
		n77	CA_n77(2A)_BCS4 and 5	
CA_n18A-n77(3A)	CA_n18A-n77A	n18	5, 10, 15	0
		n77	CA_n77(3A)_BCS1	
CA_n18A-n78A	CA_n18A-n78A	n18	5, 10, 15	0
		n78	10, 15, 20, 40, 50, 60, 80, 90, 100	
		n18	See n18 channel bandwidths in Table 5.3.5-1	4 and 5
		n78	See n78 channel bandwidths in Table 5.3.5-1	
CA_n18A-n78(2A)	CA_n18A-n78A	n18	5, 10, 15	0
		n78	CA_n78(2A)_BCS2	
		n18	See n18 channel bandwidths in Table 5.3.5-1	4 and 5
		n78	CA_n78(2A)_BCS4 and 5	

**Table 5.5A.3.1-1g: NR CA configurations and bandwidth combinations sets defined for inter-band CA (two bands)**

NR CA configuration	Uplink CA configuration or single uplink carrier <sup>10</sup>	NR Band	Channel bandwidth (MHz) (NOTE 3)	Bandwidth combination set
CA_n20A-n28A	CA_n20A-n28A	n20	5, 10, 15, 20	0
		n28	5, 10, 15, 20	
		n20	5, 10, 15, 20	
		n28	5, 10, 15, 20, 30	1
		n20	5, 10, 15, 20	
		n28	5, 10, 15, 20, 25, 30	
CA_n20A-n40A	-	n20	5, 10, 15, 20	0
		n40	5, 10, 15, 20, 30, 40, 50, 60, 70, 80, 90, 100	
CA_n20A-n67A	-	n20	5, 10, 15, 20	0
		n67	5, 10, 15, 20	
		n20	n20 channel bandwidths in Table 5.3.5-1	4 and 5
		n67	n67 channel bandwidths in Table 5.3.5-1	
CA_n20A-n75A	-	n20	5, 10, 15, 20	0
		n75	5, 10, 15, 20	
		n20	5, 10, 15, 20	1
		n75	5, 10, 15, 20, 25, 30, 40, 50	
CA_n20A-n78A	CA_n20A-n78A	n20	5, 10, 15, 20	0
		n78	10, 15, 20, 40, 50, 60, 80, 90, 100	
		n20	See n20 channel bandwidths in Table 5.3.5-1	4 and 5
		n78	See n78 channel bandwidths in Table 5.3.5-1	
CA_n20A-n78C	-	n20	5, 10, 15, 20	0
		n78	CA_n78C_BCS1	
CA_n20A-n78(2A)	CA_n20A-n78A CA_n78(2A)	n20	See n20 channel bandwidths in Table 5.3.5-1	4 and 5
		n78	CA_n78(2A)_BCS4 and 5	
CA_n24A-n41A	CA_n24A-n41A	n24	5, 10	0
		n41	10, 15, 20, 30, 40, 50, 60, 80, 90, 100	
		n24	See n24 channel bandwidths in Table 5.3.5-1	4 and 5
		n41	See n41 channel bandwidths in Table 5.3.5-1	
CA_n24A-n41(2A)	CA_n24A-n41A	n24	5, 10	0
		n41	CA_n41(2A)_BCS1	
		n24	See n24 channel bandwidths in Table 5.3.5-1	4 and 5

		n41	CA_n41(2A)_BCS4 and 5	
CA_n24A-n48A	CA_n24A-n48A	n24	5, 10	0
		n48	5, 10, 15, 20, 40, 50 <sup>6</sup> , 60 <sup>6</sup> , 80 <sup>6</sup> , 90 <sup>6</sup> , 100 <sup>6</sup>	
CA_n24A-n48B	CA_n24A-n48A	n24	5, 10	0
		n48	CA_n48B_BCS1	
CA_n24A-n48(2A)	CA_n24A-n48A	n24	5, 10	0
		n48	CA_n48(2A)_BCS0	
CA_n24A-n48(3A)	CA_n24A-n48A	n24	5, 10	0
		n48	CA_n48(3A)_BCS0	
CA_n24A-n77A	CA_n24A-n77A	n24	5, 10	0
		n77	10, 15, 20, 25, 30, 40, 50, 60, 70, 80, 90, 100	
		n24	See n24 channel bandwidths in Table 5.3.5-1	4 and 5
		n77	See n77 channel bandwidths in Table 5.3.5-1	
CA_n24A-n77C	CA_n24A-n77A	n24	5, 10	0
		n77	CA_n77C_BCS1	
CA_n24A-n77(2A)	CA_n24A-n77A	n24	5, 10	0
		n77	CA_n77(2A)_BCS0	
		n24	See n25 channel bandwidths in Table 5.3.5-1	4 and 5
		n77	CA_n77(2A)_BCS4 and 5	
CA_n25A-n29A	-	n25	5, 10, 15, 20, 25, 30, 40	0
		n29	5, 10	
CA_n25A-n38A	CA_n25A-n38A	n25	5, 10, 15, 20, 25, 30, 40	0
		n38	5, 10, 15, 20, 25, 30, 40	
CA_n25(2A)-n38A	CA_n25A-n38A	n25	CA_n25(2A)_BCS0	0
		n38	5, 10, 15, 20, 25, 30, 40	
CA_n25A-n41A	n41 <sup>8,9</sup> n25A <sup>8</sup> CA_n25A-n41A <sup>8</sup> , 13,14	n25	5, 10, 15, 20	0
		n41	10, 15, 20, 40, 50, 60, 80, 90, 100	
		n25	5, 10, 15, 20, 25, 30, 40	1
		n41	10, 15, 20, 30, 40, 50, 60, 70, 80, 90, 100	
		n25	See n25 channel bandwidths in Table 5.3.5-1	4 and 5
		n41	See n41 channel bandwidths in Table 5.3.5-1	
CA_n25(2A)-n41A	n41 <sup>8,9</sup> CA_n25A-n41A <sup>8</sup>	n25	CA_n25(2A)_BCS0	0
		n41	10, 15, 20, 40, 50, 60, 80, 90, 100	
		n25	CA_n25(2A)_BCS1	1
		n41	10, 15, 20, 30, 40, 50, 60, 70, 80, 90, 100	
		n25	CA_n25(2A)_BCS 4 and 5	4 and 5
		n41	See n41 channel bandwidths in Table 5.3.5-1	
CA_n25(2A)-n41C	n41 <sup>8,9</sup> CA_n25A-n41A <sup>8</sup> CA_n25A-n41C CA_n41C <sup>8</sup>	n25	CA_n25(2A)_BCS1	0
		n41	CA_n41C_BCS2	
		n25	CA_n25(2A)_BCS 4 and 5	4 and 5
		n41	CA_n41C_BCS 4 and 5	
CA_n25(2A)-n41(2A)	n41 <sup>8,9</sup> CA_n25A-n41A <sup>8</sup>	n25	CA_n25(2A)_BCS1	0
		n41	CA_n41(2A)_BCS3	
		n25	CA_n25(2A)_BCS 4 and 5	4 and 5
		n41	CA_n41(2A)_BCS 4 and 5	
CA_n25A-n41C	n41 <sup>8,9</sup> CA_n25A-n41A <sup>8</sup> CA_n41C <sup>8</sup>	n25	5, 10, 15, 20	0
		n41	CA_n41C_BCS0	
		n25	5, 10, 15, 20, 25, 30, 40	1
		n41	CA_n41C_BCS1	
	n41 <sup>8,9</sup> CA_n25A-n41A <sup>8</sup> CA_n41C <sup>8</sup> CA_n25A-n41C	n25	n25 channel bandwidths in Table 5.3.5-1	4 and 5
		n41	CA_n41C_BCS 4 and 5	
CA_n25A-n41(2A)	n41 <sup>8,9</sup>	n25	5, 10, 15, 20	0

	CA_n25A-n41A <sup>8</sup>	n41	CA_n41(2A)_BCS1	1
		n25	5, 10, 15, 20, 25, 30, 40	
		n41	CA_n41(2A)_BCS3	
		n25	n25 channel bandwidths in Table 5.3.5-1	4 and 5
		n41	CA_n41(2A)_BCS 4 and 5	
CA_n25A-n41(3A)	n41 <sup>8,9</sup> CA_n25A-n41A <sup>8</sup>	n25	5, 10, 15, 20, 25, 30, 40	0
		n41	CA_n41(3A)_BCS0	4 and 5
		n25	n25 channel bandwidths in Table 5.3.5-1	
		n41	CA_n41(3A)_BCS 4 and 5	
CA_n25A-n41(A-C)	n41 <sup>8,9</sup> CA_n25A-n41A <sup>8</sup> CA_n25A-n41C CA_n41C <sup>8</sup>	n25	5, 10, 15, 20, 25, 30, 40	0
		n41	CA_n41(A-C)_BCS0	4 and 5
		n25	n25 channel bandwidths in Table 5.3.5-1	
		n41	CA_n41(A-C)_BCS 4 and 5	
CA_n25(2A)-n41(3A)	n41 <sup>8,9</sup> CA_n25A-n41A <sup>8</sup>	n25	CA_n25(2A)_BCS 4 and 5	4 and 5
		n41	CA_n41(3A)_BCS 4 and 5	
CA_n25(2A)-n41(A-C)	n41 <sup>8,9</sup> CA_n41C <sup>8</sup> CA_n25A-n41A <sup>8</sup>	n25	CA_n25(2A)_BCS 4 and 5	4 and 5
		n41	CA_n41(A-C)_BCS 4 and 5	
CA_n25A-n46A	-	n25	5, 10, 15, 20	0
		n46	20, 40, 60, 80	
CA_n25A-n48A	CA_n25A-n48A	n25	5, 10, 15, 20	0
		n48	5, 10, 15, 20, 40, 50 <sup>6</sup> , 60 <sup>6</sup> , 80 <sup>6</sup> , 90 <sup>6</sup> , 100 <sup>6</sup>	
		n25	5, 10, 15, 20, 25, 30, 40	1
		n48	5, 10, 15, 20, 40, 50 <sup>6</sup> , 60 <sup>6</sup> , 80 <sup>6</sup> , 90 <sup>6</sup> , 100 <sup>6</sup>	
CA_n25A-n48(2A)	CA_n25A-n48A	n25	5, 10, 15, 20	0
		n48	CA_n48(2A)_BCS0	
		n25	5, 10, 15, 20, 25, 30, 40	1
		n48	CA_n48(2A)_BCS0	
CA_n25A-n48C	CA_n25A-n48A	n25	5, 10, 15, 20	0
		n48	CA_n48C_BCS0	
		n25	5, 10, 15, 20, 25, 30, 40	1
		n48	CA_n48C_BCS0	
CA_n25A-n66A	n25A <sup>8</sup> n66A <sup>8</sup> CA_n25A-n66A	n25	5, 10, 15, 20, 25, 30, 40	0
		n66	5, 10, 15, 20, 30, 40	1
		n25	5, 10, 15, 20, 25, 30, 40	
		n66	5, 10, 15, 20, 25, 30, 40	
		n25	n25 channel bandwidths in Table 5.3.5-1	4 and 5
n66	n66 channel bandwidths in Table 5.3.5-1			
CA_n25A-n66(2A)	CA_n25A-n66A	n25	5, 10, 15, 20, 25, 30, 40	0
		n66	CA_n66(2A)_BCS0	
		n25	5, 10, 15, 20, 25, 30, 40	1
		n66	CA_n66(2A)_BCS1	
		n25	n25 channel bandwidths in Table 5.3.5-1	4 and 5
		n66	CA_n66(2A)_BCS 4 and 5	
CA_n25(2A)-n66A	CA_n25A-n66A	n25	CA_n25(2A)_BCS0	0
		n66	10, 15, 20, 30, 40	
		n25	CA_n25(2A)_BCS0	1
		n66	5, 10, 15, 20, 25, 30, 40	
		n25	CA_n25(2A)_BCS1	2
		n66	5, 10, 15, 20, 25, 30, 40	
		n25	CA_n25(2A)_BCS 4 and 5	4 and 5
n66	n66 channel bandwidths in Table 5.3.5-1			
CA_n25(2A)-n66(2A)	CA_n25A-n66A	n25	CA_n25(2A)_BCS0	0
		n66	CA_n66(2A)_BCS0	
		n25	CA_n25(2A)_BCS0	1
		n66	CA_n66(2A)_BCS1	
		n25	CA_n25(2A)_BCS1	2

		n66	CA_n66(2A)_BCS1	
		n25	CA_n25(2A)_BCS 4 and 5	4 and 5
		n66	CA_n66(2A)_BCS 4 and 5	
CA_n25(3A)-n66A	CA_n25A-n66A	n25	CA_n25(3A) BCS 4 and 5	4 and 5
		n66	n66 channel bandwidths in Table 5.3.5-1	
CA_n25A-n71A	n25 <sup>8</sup> n71 <sup>8</sup> CA_n25A-n71A	n25	5, 10, 15, 20	0
		n71	5, 10, 15, 20	
		n25	5, 10, 15, 20, 25, 30, 40	1
		n71	5, 10, 15, 20	
		n25	n25 channel bandwidths in Table 5.3.5-1	4 and 5
		n71	n71 channel bandwidths in Table 5.3.5-1	
CA_n25A-n71B	CA_n25A-n71A	n25	5, 10, 15, 20, 25, 30, 40	0
		n71	CA_n71B_BCS0	
		n25	5, 10, 15, 20, 25, 30, 40	1
		n71	CA_n71B_BCS2	
		n25	n25 channel bandwidths in Table 5.3.5-1	4 and 5
		n71	CA_n71B_BCS 4 and 5	
CA_n25A-n71(2A)	CA_n25A-n71A	n25	5, 10, 15, 20	0
		n71	CA_n71(2A)_BCS0	
		n25	5, 10, 15, 20, 25, 30, 40	1
		n71	CA_n71(2A)_BCS0	
		n25	n25 channel bandwidths in Table 5.3.5-1	4 and 5
		n71	CA_n71(2A)_BCS 4 and 5	
CA_n25(2A)-n71A	CA_n25A-n71A	n25	CA_n25(2A)_BCS1	0
		n71	5, 10, 15, 20	
		n25	CA_n25(2A)_BCS 4 and 5	4 and 5
		n71	n71 channel bandwidths in Table 5.3.5-1	
CA_n25(2A)-n71(2A)	CA_n25A-n71A	n25	CA_n25(2A)_BCS1	0
		n71	CA_n71(2A)_BCS0	
		n25	CA_n25(2A)_BCS 4 and 5	4 and 5
		n71	CA_n71(2A)_BCS 4 and 5	
CA_n25(2A)-n71B	CA_n25A-n71A	n25	CA_n25(2A)_BCS1	0
		n71	CA_n71B_BCS2	
		n25	CA_n25(2A)_BCS 4 and 5	4 and 5
		n71	CA_n71B_BCS 4 and 5	
CA_n25(3A)-n71A	CA_n25A-n71A	n25	CA_n25(3A) BCS 4 and 5	4 and 5
		n71	n71 channel bandwidths in Table 5.3.5-1	
CA_n25A-n77A	n25 <sup>8</sup> n77 <sup>8,9</sup> CA_n25A- n77A <sup>8,13,14</sup>	n25	5, 10, 15, 20	0
		n77	10, 15, 20, 25, 30, 40, 50, 60, 70, 80, 90, 100	
		n25	5, 10, 15, 20, 25, 30, 40	1
		n77	10, 15, 20, 25, 30, 40, 50, 60, 70, 80, 90, 100	
		n25	n25 channel bandwidths in Table 5.3.5-1	4 and 5
		n77	n77 channel bandwidths in Table 5.3.5-1	
CA_n25A-n77(2A)	n77 <sup>8,9</sup> CA_n77(2A) <sup>8</sup> CA_n25A-n77A <sup>8</sup>	n25	5, 10, 15, 20, 25, 30, 40	0
		n77	CA_n77(2A)_BCS1	
		n25	n25 channel bandwidths in Table 5.3.5-1	4 and 5
		n77	CA_n77(2A)_BCS 4 and 5	
CA_n25A-n77(3A)	n77 <sup>8,9</sup> CA_n77(2A) <sup>8</sup> CA_n25A-n77A <sup>8</sup>	n25	5, 10, 15, 20, 25, 30, 40	0
		n77	CA_n77(3A)_BCS1	
		n25	n25 channel bandwidths in Table 5.3.5-1	4 and 5
		n77	CA_n77(3A)_BCS4 and 5	
CA_n25(2A)-n77A	n77 <sup>8,9</sup> CA_n25A-n77A <sup>8</sup>	n25	CA_n25(2A)_BCS1	0
		n77	10, 15, 20, 25, 30, 40, 50, 60, 70, 80, 90, 100	
		n25	CA_n25(2A)_BCS0	1
		n77	10, 15, 20, 25, 30, 40, 50, 60, 70, 80, 90, 100	
		n25	CA_n25(2A)_BCS 4 and 5	4 and 5

		n77	n77 channel bandwidths in Table 5.3.5-1	
CA_n25(2A)-n77(2A)	n77 <sup>8,9</sup> CA_n77(2A) <sup>8</sup> CA_n25A-n77A <sup>8</sup>	n25	CA_n25(2A)_BCS1	0
		n77	CA_n77(2A)_BCS1	
		n25	CA_n25(2A)_BCS0	1
		n77	CA_n77(2A)_BCS1	
		n25	CA_n25(2A)_BCS 4 and 5	4 and 5
		n77	CA_n77(2A)_BCS 4 and 5	
CA_n25(2A)-n77(3A)	n77 <sup>8,9</sup> CA_n25(2A) CA_n77(2A) <sup>8</sup> CA_n25A-n77A <sup>8</sup>	n25	CA_n25(2A)_BCS0	0
		n77	CA_n77(3A)_BCS1	
CA_n25A-n78A	n78 <sup>8,9</sup> CA_n25A-n78A <sup>8</sup>	n25	5, 10, 15, 20, 25, 30, 40	0
		n78	10, 15, 20, 25, 30, 40, 50, 60, 80, 90, 100	
		n25	5, 10, 15, 20, 25, 30, 40	1
		n78	10, 15, 20, 25, 30, 40, 50, 60, 70, 80, 90, 100	
		n25	See n25 channel bandwidths in Table 5.3.5-1	4 and 5
		n78	See n78 channel bandwidths in Table 5.3.5-1	
CA_n25A-n78(2A)	n78 <sup>8,9</sup> CA_n25A-n78A <sup>8</sup>	n25	5, 10, 15, 20, 25, 30, 40	0
		n78	CA_n78(2A)_BCS0	
	CA_n78(2A) <sup>8</sup>	n25	5, 10, 15, 20, 25, 30, 40	1
		n78	CA_n78(2A)_BCS2	
		n25	See n25 channel bandwidths in Table 5.3.5-1	4 and 5
		n78	CA_n78(2A)_BCS4 and 5	
CA_n25(2A)-n78A	n78 <sup>8,9</sup> CA_n25A-n78A <sup>8</sup>	n25	CA_n25(2A)_BCS0	0
		n78	10, 15, 20, 25, 30, 40, 50, 60, 80, 90, 100	
		n25	CA_n25(2A)_BCS0	1
		n78	10, 15, 20, 25, 30, 40, 50, 60, 70, 80, 90, 100	
		n25	CA_n25(2A)_BCS4 and 5	4 and 5
		n78	See n78 channel bandwidths in Table 5.3.5-1	
CA_n25(2A)-n78(2A)	n78 <sup>8,9</sup> CA_n25A-n78A <sup>8</sup>	n25	CA_n25(2A)_BCS0	0
		n78	CA_n78(2A)_BCS1	
		n25	CA_n25(2A)_BCS0	1
		n78	CA_n78(2A)_BCS2	
		n25	CA_n25(2A)_BCS4 and 5	4 and 5
		n78	CA_n78(2A)_BCS4 and 5	
CA_n25A-n85A	n25 <sup>8</sup> CA_n25A-n85A	n25	See n25 channel bandwidths in Table 5.3.5-1	4 and 5
		n85	See n85 channel bandwidths in Table 5.3.5-1	
CA_n25(2A)-n85A	CA_n25A-n85A	n25	CA_n25(2A)_BCS 4 and 5	4 and 5
		n85	See n85 channel bandwidths in Table 5.3.5-1	
CA_n25(3A)-n85A	CA_n25A-n85A	n25	CA_n25(3A)_BCS 4 and 5	4 and 5
		n85	n85 channel bandwidths in Table 5.3.5-1	

**Table 5.5A.3.1-1h: NR CA configurations and bandwidth combinations sets defined for inter-band CA (two bands)**

NR CA configuration	Uplink CA configuration or single uplink carrier <sup>10</sup>	NR Band	Channel bandwidth (MHz) (NOTE 3)	Bandwidth combination set
CA_n26A-n28A	CA_n26A-n28A <sup>16</sup>	n26	5, 10, 15, 20	0
		n28	5, 10, 15, 20	
		n26	5, 10, 15, 20, 25, 30	1
		n28	5, 10, 15, 20, 25, 30	
CA_n26A-n29A	-	n26	5, 10, 15, 20, 25, 30	0
		n29	5, 10	
CA_n26A-n48A	CA_n26A-n48A	n26	5, 10, 15, 20, 25, 30	0

		n48	5, 10, 15, 20, 30, 40, 50 <sup>6</sup> , 60 <sup>6</sup> , 70 <sup>6</sup> , 80 <sup>6</sup> , 90 <sup>6</sup> , 100 <sup>6</sup>	
CA_n26A-n48(2A)	CA_n26A-n48A	n26	5, 10, 15, 20, 25, 30	0
		n48	CA_n48(2A)_BCS0	
CA_n26A-n66A	CA_n26A-n66A	n26	5, 10, 15, 20	0
		n66	5, 10, 15, 20, 25, 30, 40	
CA_n26A-n66(2A)	CA_n26A-n66A	n26	5, 10, 15, 20	0
		n66	CA_n66(2A)_BCS0	
CA_n26A-n66(3A)	-	n26	5, 10, 15, 20	0
		n66	CA_n66(3A)_BCS0	
CA_n26A-n70A	CA_n26A-n70A	n26	5, 10, 15, 20	0
		n70	5, 10, 15, 20 <sup>1</sup> , 25 <sup>1</sup>	
CA_n26A-n71A	-	n26	5, 10, 15, 20	0
		n71	5, 10, 15, 20	
CA_n26A-n77A	CA_n26A-n77A	n26	5, 10, 15, 20	0
		n77	10, 15, 20, 25, 30, 40, 50, 60, 70, 80, 90, 100	
CA_n26A-n78A	n78 <sup>8,9</sup> CA_n26A-n78A <sup>13</sup>	n26	5, 10, 15, 20	0
		n78	10, 15, 20, 25, 30, 40, 50, 60, 70, 80, 90, 100	
CA_n26A-n78C	CA_n78C CA_n26A-n78A	n26	5, 10, 15, 20	0
		n78	CA_n78C_BCS0	
CA_n26(2A)-n78A	CA_n26(2A) CA_n26A-n78A	n26	CA_n26(2A)_BCS0	0
		n78	10, 15, 20, 25, 30, 40, 50, 60, 70, 80, 90, 100	
CA_n26(2A)-n78C	CA_n78C CA_n26A-n78A CA_n26(2A)	n26	CA_n26(2A)_BCS0	0
		n78	CA_n78C_BCS0	
CA_n26A-n78(2A)	CA_n26A-n78A	n26	5, 10, 15, 20, 25, 30	0
		n78	CA_n78(2A)_BCS0	
CA_n26(2A)-n78(2A)	CA_n26(2A) CA_n26A-n78A	n26	CA_n26(2A)_BCS0	0
		n78	CA_n78(2A)_BCS0	
CA_n28A-n34A	n34 <sup>8,9</sup> CA_n28A-n34A <sup>8</sup>	n28	5, 10, 15, 20, 30	0
		n34	5, 10, 15	
CA_n28A-n38A	-	n28	5, 10, 15, 20, 30	0
		n38	5, 10, 15, 20, 25, 30, 40	
CA_n28A-n39A	n39 <sup>8</sup> CA_n28A-n39A <sup>8</sup>	n28	5, 10, 15, 20, 30	0
		n39	5, 10, 15, 20, 25, 30, 40	
		n28	See n28 channel bandwidths in Table 5.3.5-1	4 and 5
		n39	See n39 channel bandwidths in Table 5.3.5-1	
CA_n28A-n40A	n40 <sup>8,9</sup> CA_n28A-n40A <sup>8</sup>	n28	5, 10, 15, 20	0
		n40	5, 10, 15, 20, 25, 30, 40, 50, 60, 80	
		n28	5, 10, 15, 20, 25, 30	1
		n40	10, 15, 20, 25, 30, 40, 50, 60, 70, 80, 90, 100	
		n28	See n28 channel bandwidths in Table 5.3.5-1	4 and 5
		n40	See n40 channel bandwidths in Table 5.3.5-1	
CA_n28A-n40B	-	n28	5, 10, 15, 20	0
		n40	CA_n40B_BCS0	
		n28	See n28 channel bandwidths in Table 5.3.5-1	4 and 5
		n40	CA_n40B_BCS4 and 5	
CA_n28A-n41A	n41 <sup>8,9</sup> CA_n28A-n41A <sup>8,13</sup>	n28	5, 10, 15, 20	0
		n41	10, 15, 20, 40, 50, 60, 80, 90, 100	
		n28	5, 10, 15, 20, 30	1
		n41	10, 15, 20, 30, 40, 50, 60, 80, 90, 100	
		n28	See n28 channel bandwidths in Table 5.3.5-1	4 and 5
		n41	See n41 channel bandwidths in Table 5.3.5-1	
CA_n28A-n41B	CA_n28A-n41A	n28	5, 10	0
		n41	CA_n41B_BCS0	
CA_n28A-n41C	n41 <sup>8,9</sup>	n28	5, 10, 15, 20, 30	0

	CA_n41C <sup>8</sup> CA_n28A-n41A <sup>8</sup>	n41	CA_n41C_BCS1	
	CA_n41C CA_n28A-n41A CA_n28A-n41C	n28	See n28 channel bandwidths in Table 5.3.5-1	4 and 5
		n41	CA_n41C_BCS4 and 5	
CA_n28A-n46A	CA_n28A-n46A	n28	5, 10, 15, 20	0
		n46	20, 40, 60, 80	
CA_n28A-n46C	CA_n28A-n46A	n28	5, 10, 15, 20	0
		n46	CA_n46C_BCS0	
CA_n28A-n46D	CA_n28A-n46A	n28	5, 10, 15, 20	0
		n46	CA_n46D_BCS0	
CA_n28A-n46(2A)	CA_n28A-n46A	n28	5, 10, 15, 20	0
		n46	CA_n46(2A)_BCS0	
CA_n28A-n50A	CA_n28A-n50A	n28	5, 10, 15, 20	0
		n50	5, 10, 15, 20, 40, 50, 60, 80 <sup>1</sup>	
CA_n28A-n71A	-	n28	5, 10, 15, 20, 30	0
		n71	5, 10, 15, 20	
CA_n28A-n74A	CA_n28A-n74A	n28	5, 10, 15, 20, 30	0
		n74	5, 10, 15, 20	
CA_n28A-n75A	-	n28	5, 10, 15, 20	0
		n75	5, 10, 15, 20	
		n28	5, 10, 15, 20	1
		n75	5, 10, 15, 20, 25, 30, 40, 50	
		n28	5, 10, 15, 20, 25, 30	2
		n75	5, 10, 15, 20, 25, 30, 40, 50	
CA_n28A-n77A	n77 <sup>8,9</sup> CA_n28A-n77A <sup>8</sup>	n28	5, 10, 15, 20	0
		n77	10, 15, 20, 40, 50, 60, 80, 90, 100	
		n28	5, 10, 15, 20, 25, 30	1
		n77	10, 15, 20, 25, 30, 40, 50, 60, 70, 80, 90, 100	
		n28	See n28 channel bandwidths in Table 5.3.5-1	4 and 5
		n77	See n77 channel bandwidths in Table 5.3.5-1	
CA_n28A-n77C	CA_n28A-n77A	n28	5, 10, 15, 20	0
		n77	CA_n77C_BCS1	
CA_n28A-n77(2A)	n77 <sup>8,9</sup> CA_n77(2A) <sup>8</sup> CA_n28A-n77A <sup>8</sup>	n28	5, 10, 15, 20	0
		n77	CA_n77(2A)_BCS0	
		n28	5, 10, 15, 20, 25, 30	1
		n77	CA_n77(2A)_BCS1	
		n28	See n28 channel bandwidths in Table 5.3.5-1	4 and 5
		n77	CA_n77(2A)_BCS4 and 5	
CA_n28A-n77(3A)	n77 <sup>8,9</sup> CA_n77(2A) <sup>8</sup> CA_n28A-n77A <sup>8</sup>	n28	5, 10	0
		n77	CA_n77(3A)_BCS0	
		n28	See n28 channel bandwidths in Table 5.3.5-1	4 and 5
		n77	CA_n77(3A)_BCS4 and 5	
CA_n28A-n78A	n78 <sup>8,9</sup> CA_n28A-n78A <sup>8,13</sup>	n28	5, 10, 15, 20	0
		n78	10, 15, 20, 40, 50, 60, 80, 90, 100	
		n28	5, 10, 15, 20, 30	1
		n78	10, 15, 20, 25, 30, 40, 50, 60, 70, 80, 90, 100	
		n28	See n28 channel bandwidths in Table 5.3.5-1	4 and 5
		n78	See n78 channel bandwidths in Table 5.3.5-1	
CA_n28A-n78C	CA_n78C CA_n28A-n78A	n28	5, 10, 15, 20	0
		n78	CA_n78C_BCS1	
CA_n28A-n78(2A)	n78 <sup>8,9</sup> CA_n78(2A) <sup>8</sup> CA_n28A-n78A <sup>8</sup>	n28	5, 10, 15, 20	0
		n78	CA_n78(2A)_BCS0	
		n28	5, 10, 15, 20	1
		n78	CA_n78(2A)_BCS2	



		n28	See n28 channel bandwidths in Table 5.3.5-1	4 and 5
		n78	CA_n78(2A)_BCS4 and 5	
CA_n28A-n79A	n79 <sup>8,9</sup> CA_n28A-n79A <sup>8</sup>	n28	5, 10, 15, 20, 30	0
		n79	40, 50, 60, 80, 100	
		n28	See n28 channel bandwidths in Table 5.3.5-1	4 and 5
		n79	See n79 channel bandwidths in Table 5.3.5-1	
CA_n28A-n79C	n79 <sup>8,9</sup> CA_n79C <sup>8</sup>	n28	5, 10, 15, 20, 30	0
		n79	CA_n79C_BCS0	
	CA_n79C CA_n28A-n79A CA_n28A-n79C	n28	See n28 channel bandwidths in Table 5.3.5-1	4 and 5
		n79	CA_n79C_BCS4 and 5	
CA_n28A-n94A	-	n28	5, 10, 15, 20	0
		n94	5, 10, 15, 20	
CA_n28A-n102A	CA_n28A-n102A	n28	5, 10, 15, 20, 25, 30	0
		n102	20, 40, 60, 80, 100	
CA_n28A-n102(2A)	CA_n28A-n102A	n28	5, 10, 15, 20, 25, 30	0
		n102	CA_n102(2A)_BCS0	
CA_n28A-n102B	CA_n28A-n102A CA_n28A-n102B	n28	5, 10, 15, 20, 25, 30	0
		n102	CA_n102B_BCS0	
CA_n28A-n102C	CA_n28A-n102A CA_n28A-n102C	n28	5, 10, 15, 20, 25, 30	0
		n102	CA_n102C_BCS0	
CA_n28A-n102D	CA_n28A-n102A	n28	5, 10, 15, 20, 25, 30	0
		n102	CA_n102D_BCS0	
CA_n28A-n102E	CA_n28A-n102A	n28	5, 10, 15, 20, 25, 30	0
		n102	CA_n102E_BCS0	
CA_n28A-n105A	-	n28	5, 10, 15, 20, 25, 30	0
		n105	5, 10, 15, 20, 25, 30, 35	
CA_n29A-n30A	-	n29	5, 10	0
		n30	5, 10	
CA_n29A-n48A	-	n29	5, 10	0
		n48	5, 10, 15, 20, 30, 40, 50 <sup>6</sup> , 60 <sup>6</sup> , 70 <sup>6</sup> , 80 <sup>6</sup> , 90 <sup>6</sup> , 100 <sup>6</sup>	
CA_n29A-n66A	-	n29	5, 10	0
		n66	5, 10, 15, 20, 40	
		n29	5, 10	1
		n66	5, 10, 15, 20, 25, 30, 40	
CA_n29A-n66B	-	n29	5, 10	0
		n66	CA_n66B_BCS0	
CA_n29A-n66(2A)	-	n29	5, 10	0
		n66	CA_n66(2A)_BCS0	
		n29	5, 10	1
		n66	CA_n66(2A)_BCS1	
CA_n29A-n66(3A)	-	n29	5, 10	0
		n66	CA_n66(3A)_BCS0	
CA_n29A-n70A	-	n29	5, 10	0
		n70	5, 10, 15, 20 <sup>1</sup> , 25 <sup>1</sup>	
CA_n29A-n71A	-	n29	5, 10	0
		n71	5, 10, 15, 20	
CA_n29A-n77A	n77 <sup>8,9</sup>	n29	5, 10	0
		n77	10, 15, 20, 25, 30, 40, 50, 60, 70, 80, 90, 100	
CA_n29A-n77(2A)	n77 <sup>8,9</sup>	n29	5, 10	0
		n77	CA_n77(2A)_BCS1	

Table 5.5A.3.1-1i: NR CA configurations and bandwidth combinations sets defined for inter-band CA (two bands)

NR CA configuration	Uplink CA configuration or	NR Band	Channel bandwidth (MHz) (NOTE 3)	Bandwidth combination set
---------------------	----------------------------	---------	----------------------------------	---------------------------

	single uplink carrier <sup>10</sup>			
CA_n30A-n66A	CA_n30A-n66A	n30	5, 10	0
		n66	5, 10, 15, 20, 25, 30, 40	
CA_n30A-n66(2A)	CA_n30A-n66A	n30	5, 10	0
		n66	CA_n66(2A)_BCS1	
CA_n30A-n66(3A)	CA_n30A-n66A	n30	5, 10	0
		n66	CA_n66(3A)_BCS0	
CA_n30A-n77A	n77 <sup>8,9</sup> CA_n30A-n77A <sup>8</sup>	n30	5, 10	0
		n77	10, 15, 20, 25, 30, 40, 50, 60, 70, 80, 90, 100	
CA_n30A-n77(2A)	n77 <sup>8,9</sup> CA_n77(2A) CA_n30A-n77A <sup>8</sup>	n30	5, 10	0
		n77	CA_n77(2A)_BCS1	
CA_n34A-n39A	n34 <sup>8,9</sup> n39 <sup>8</sup> CA_n34A-n39A <sup>8</sup>	n34	See n34 channel bandwidths in Table 5.3.5-1	4 and 5
		n39	See n39 channel bandwidths in Table 5.3.5-1	
CA_n34A-n40A	n34 <sup>8,9</sup> n40 <sup>8,9</sup> CA_n34A-n40A <sup>8</sup>	n34	5, 10, 15	0
		n40	5, 10, 15, 20, 25, 30, 40, 50, 60, 80	4 and 5
		n34	See n34 channel bandwidths in Table 5.3.5-1	
		n40	See n40 channel bandwidths in Table 5.3.5-1	
CA_n34A-n41A	n34 <sup>8,9</sup> n41 <sup>8,9</sup> CA_n34A-n41A <sup>8</sup>	n34	5, 10, 15	0
		n41	10, 15, 20, 30, 40, 50, 60, 70, 80, 90, 100	4 and 5
		n34	See n34 channel bandwidths in Table 5.3.5-1	
		n41	See n41 channel bandwidths in Table 5.3.5-1	
CA_n34A-n41C	CA_n41C CA_n34A-n41A CA_n34A-n41C	n34	5, 10, 15	0
		n41	CA_n41C_BCS1	4 and 5
		n34	See n34 channel bandwidths in Table 5.3.5-1	
		n41	CA_n41C_BCS4 and 5	
CA_n34A-n79A	n34 <sup>8,9</sup> n79 <sup>8,9</sup> CA_n34A-n79A <sup>8</sup>	n34	5, 10, 15	0
		n79	40, 50, 60, 80, 100	4 and 5
		n34	See n34 channel bandwidths in Table 5.3.5-1	
		n79	See n79 channel bandwidths in Table 5.3.5-1	
CA_n34A-n79C	CA_n34A-n79A	n34	5, 10, 15	0
		n79	CA_n79C_BCS0	
	CA_n79C CA_n34A-n79C	n34	See n34 channel bandwidths in Table 5.3.5-1	4 and 5
		n79	CA_n79C_BCS4 and 5	
CA_n38A-n40A	-	n38	5, 10, 15, 20, 25, 30, 40	0
		n40	5, 10, 15, 20, 30, 40, 50, 60, 70, 80, 90, 100	
		n38	5, 10, 15, 20	
CA_n38A-n66A	CA_n38A-n66A	n66	5, 10, 15, 20, 30, 40	0
		n38	5, 10, 15, 20, 25, 30, 40	
		n66	5, 10, 15, 20, 25, 30, 40	
		n38	5, 10, 15, 20, 25, 30, 40	
CA_n38A-n66(2A)	CA_n38A-n66A	n38	5, 10, 15, 20	0
		n66	CA_n66(2A)_BCS1	
		n38	5, 10, 15, 20, 25, 30, 40	
		n66	CA_n66(2A)_BCS1	
CA_n38A-n71A	-	n38	5, 10, 15, 20	0
		n71	5, 10, 15, 20	
CA_n38A-n78A	CA_n38A-n78A	n38	5, 10, 15, 20	0
		n78	10, 15, 20, 25, 30, 40, 50, 60, 80, 90, 100	
		n38	5, 10, 15, 20, 25, 30, 40	
		n78	10, 15, 20, 25, 30, 40, 50, 60, 70, 80, 90, 100	
		n38	See n38 channel bandwidths in Table 5.3.5-1	
n78	See n78 channel bandwidths in Table 5.3.5-1			

CA_n38A-n78(2A)	CA_n38A-n78A	n38	5, 10, 15, 20	0
		n78	CA_n78(2A)_BCS0	
		n38	5, 10, 15, 20	1
		n78	CA_n78(2A)_BCS2	
		n38	See n38 channel bandwidths in Table 5.3.5-1	4 and 5
CA_n38A-n79A	-	n78	CA_n78(2A)_BCS4 and 5	
		n38	5, 10, 15, 20, 25, 30, 40	0
		n79	40, 50, 60, 80, 100	
		n38	See n38 channel bandwidths in Table 5.3.5-1	4 and 5
CA_n38A-n79C	-	n79	See n79 channel bandwidths in Table 5.3.5-1	
		n38	5, 10, 15, 20, 25, 30, 40	0
		n79	CA_n79C_BCS0	
		n38	See n38 channel bandwidths in Table 5.3.5-1	4 and 5
CA_n39A-n40A	n39 <sup>8</sup> n40 <sup>8,9</sup> CA_n39A-n40A <sup>8</sup>	n79	CA_n79C_BCS4 and 5	
		n39	5, 10, 15, 20, 25, 30, 40	0
		n40	5, 10, 15, 20, 25, 30, 40, 50, 60, 80	
		n39	See n39 channel bandwidths in Table 5.3.5-1	4 and 5
CA_n39A-n41A	n39 <sup>8</sup> n41 <sup>8,9</sup> CA_n39A-n41A <sup>8</sup>	n40	See n40 channel bandwidths in Table 5.3.5-1	
		n39	5, 10, 15, 20, 25, 30, 40	0
		n41	10, 15, 20, 40, 50, 60, 80, 90, 100	
		n39	See n39 channel bandwidths in Table 5.3.5-1	4 and 5
CA_n39A-n41C	n39 <sup>8</sup> n41 <sup>8,9</sup> CA_n41C <sup>8</sup> CA_n39A-n41A <sup>8</sup> CA_n39A-n41C <sup>8</sup>	n41	See n41 channel bandwidths in Table 5.3.5-1	
		n39	5, 10, 15, 20, 25, 30, 40	0
		n41	CA_n41C_BCS0	
		n39	See n39 channel bandwidths in Table 5.3.5-1	4 and 5
CA_n39A-n41(2A)	CA_n39A-n41A	n41	CA_n41C_BCS4 and 5	
		n39	5, 10, 15, 20, 25, 30, 40	0
		n41	CA_n41(2A)_BCS0	
		n39	See n39 channel bandwidths in Table 5.3.5-1	4 and 5
CA_n39A-n79A	n39 <sup>8</sup> n79 <sup>8,9</sup> CA_n39A-n79A <sup>8</sup>	n41	CA_n41(2A)_BCS4 and 5	
		n39	5, 10, 15, 20, 25, 30, 40	0
		n79	40, 50, 60, 80, 100	
		n39	See n39 channel bandwidths in Table 5.3.5-1	4 and 5
CA_n39A-n79C	CA_n79C CA_n39A-n79A CA_n39A-n79C A	n79	See n79 channel bandwidths in Table 5.3.5-1	
		n39	5, 10, 15, 20, 25, 30, 40	0
		n79	CA_n79C_BCS0	
		n39	See n39 channel bandwidths in Table 5.3.5-1	4 and 5
CA_n40A-n41A	n40 <sup>8,9</sup> n41 <sup>8,9</sup> CA_n40A-n41A <sup>8</sup>	n79	CA_n79C_BCS4 and 5	
		n40	5, 10, 15, 20, 25, 30, 40, 50, 60, 80	0
		n41	10, 15, 20, 40, 50, 60, 80, 90, 100	
		n40	5, 10, 15, 20, 25, 30, 40	1
		n41	10, 15, 20, 40, 50, 60	
		n40	See n40 channel bandwidths in Table 5.3.5-1	4 and 5
CA_n40A-n41C	CA_n41C CA_n40A-n41A CA_n40A-n41C	n41	See n41 channel bandwidths in Table 5.3.5-1	
		n40	5, 10, 15, 20, 25, 30, 40	0
		n41	CA_n41C_BCS0	
		n40	See n40 channel bandwidths in Table 5.3.5-1	4 and 5
CA_n40A-n77A	n40A <sup>8,9</sup> n77A <sup>8,9</sup>	n41	CA_n41C_BCS4 and 5	
		n40	10, 15, 20, 25, 30, 40, 50, 60, 80, 90, 100	0

	CA_n40A-n77A <sup>8</sup>	n77	10, 15, 20, 25, 30, 40, 50, 60, 70 <sup>4</sup> , 80, 90 <sup>4</sup> , 100	
CA_n40A-n77(2A)	CA_n40A-n77A	n40	10, 15, 20, 25, 30, 40, 50, 60, 80, 90, 100	0
		n77	CA_n77(2A)_BCS1	
CA_n40A-n77C	-	n40	10, 15, 20, 25, 30, 40, 50, 60, 80, 90, 100	0
		n77	CA_n77C_BCS1	
CA_n40B-n77A	n77 <sup>8</sup> CA_n40A-n77A	n40	CA_n40B_BCS1	0
		n77	10, 15, 20, 25, 30, 40, 50, 60, 70 <sup>4</sup> , 80, 90 <sup>4</sup> , 100	
CA_n40B-n77(2A)	CA_n40A-n77A	n40	CA_n40B_BCS1	0
		n77	CA_n77(2A)_BCS1	
CA_n40B-n77C	CA_n40A-n77A	n40	CA_n40B_BCS1	0
		n77	CA_n77C_BCS1	
CA_n40A-n78A	n40A <sup>8,9</sup> n78A <sup>8,9</sup> CA_n40A-n78A <sup>8</sup>	n40	5, 10, 15, 20, 25, 30, 40, 50, 60, 80	0
		n78	10, 15, 20, 40, 50, 60, 80, 90, 100	
		n40	5, 10, 15, 20, 25, 30, 40, 50, 60, 70, 80, 90, 100	1
		n78	10, 15, 20, 25, 30, 40, 50, 60, 70, 80, 90, 100	
		n40	See n40 channel bandwidths in Table 5.3.5-1	4 and 5
CA_n40A-n78(2A)	CA_n40A-n78A	n40	5, 10, 15, 20, 25, 30, 40, 50, 60, 80	0
		n78	CA_n78(2A)_BCS1	
		n40	See n40 channel bandwidths in Table 5.3.5-1	4 and 5
		n78	CA_n78(2A)_BCS4 and 5	
CA_n40A-n78C	CA_n40A-n78A	n40	10, 15, 20, 30, 40, 50, 60, 70, 80, 90, 100	0
		n78	CA_n78C_BCS1	
CA_n40B-n78A	-	n40	CA_n40B_BCS0	0
		n78	10, 15, 20, 40, 50, 60, 80, 90, 100	
	CA_n40A-n78A	n40	CA_n40B_BCS1	1
		n78	10, 15, 20, 25, 30, 40, 50, 60, 70, 80, 90, 100	
CA_n40B-n78(2A)	CA_n40A-n78A	n40	CA_n40B_BCS1	0
		n78	CA_n78(2A)_BCS2	
		n40	CA_n40B_BCS 4 and 5	4 and 5
		n78	CA_n78(2A)_BCS4 and 5	
CA_n40B-n78C	CA_n40A-n78A	n40	CA_n40B_BCS1	0
		n78	CA_n78C_BCS1	
CA_n40A-n79A	n40 <sup>8,9</sup> n79 <sup>8,9</sup> CA_n40A-n79A <sup>8</sup>	n40	5, 10, 15, 20, 25, 30, 40, 50, 60, 80	0
		n79	40, 50, 60, 80, 100	
		n40	5, 10, 15, 20, 25, 30, 40	1
		n79	40, 50, 60, 80, 100	
		n40	See n40 channel bandwidths in Table 5.3.5-1	4 and 5
		n79	See n79 channel bandwidths in Table 5.3.5-1	
CA_n40A-n79C	n40 <sup>8,9</sup> n79 <sup>8,9</sup> CA_n79C <sup>8</sup> CA_n40A-n79A <sup>8</sup>	n40	5, 10, 15, 20, 25, 30, 40, 50, 60, 80	0
		n79	CA_n79C_BCS0	
	CA_n79C CA_n40A-n79A CA_n40A-n79C	n40	See n40 channel bandwidths in Table 5.3.5-1	4 and 5
		n79	CA_n79C_BCS0	
CA_n40A-n105A	CA_n40A-n105A	n40	10, 15, 20, 25, 30, 40, 50, 60, 70, 80, 90, 100	0
		n105	5, 10, 15, 20, 25, 30, 35	

**Table 5.5A.3.1-1j: NR CA configurations and bandwidth combinations sets defined for inter-band CA (two bands)**

NR CA configuration	Uplink CA configuration or single uplink carrier <sup>10</sup>	NR Band	Channel bandwidth (MHz) (NOTE 3)	Bandwidth combination set
---------------------	--	---------	----------------------------------	---------------------------

CA_n41A-n48A	CA_n41A-n48A	n41	10, 15, 20, 30, 40, 50, 60, 70, 80, 90, 100	0
		n48	5, 10, 15, 20, 40, 50 <sup>6</sup> , 60 <sup>6</sup> , 80 <sup>6</sup> , 90 <sup>6</sup> , 100 <sup>6</sup>	
		n41	See n41 channel bandwidths in Table 5.3.5-1	4 and 5
		n48	See n48 channel bandwidths in Table 5.3.5-1	
CA_n41A-n48B	CA_n41A-n48A	n41	10, 15, 20, 30, 40, 50, 60, 70, 80, 90, 100	0
		n48	CA_n48B_BCS2	
CA_n41A-n48C	CA_n41A-n48A	n41	10, 15, 20, 30, 40, 50, 60, 70, 80, 90, 100	0
		n48	CA_n48C_BCS1	
CA_n41A-n48(2A)	CA_n41A-n48A	n41	10, 15, 20, 30, 40, 50, 60, 80, 90, 100	0
		n48	CA_n48(2A)_BCS0	
		n41	See n41 channel bandwidths in Table 5.3.5-1	4 and 5
		n48	CA_n48(2A)_BCS4 and 5	
CA_n41C-n48A	CA_n41A-n48A	n41	CA_n41C_BCS2	0
		n48	5, 10, 15, 20, 40, 50 <sup>6</sup> , 60 <sup>6</sup> , 80 <sup>6</sup> , 90 <sup>6</sup> , 100 <sup>6</sup>	
CA_n41C-n48B	CA_n41A-n48A	n41	CA_n41C_BCS2	0
		n48	CA_n48B_BCS2	
CA_n41C-n48C	CA_n41A-n48A	n41	CA_n41C_BCS2	0
		n48	CA_n48C_BCS1	
CA_n41(2A)-n48A	CA_n41A-n48A	n41	CA_n41(2A)_BCS3	0
		n48	5, 10, 15, 20, 40, 50 <sup>6</sup> , 60 <sup>6</sup> , 80 <sup>6</sup> , 90 <sup>6</sup> , 100 <sup>6</sup>	
		n41	CA_n41(2A)_BCS4 and 5	4 and 5
		n48	See n48 channel bandwidths in Table 5.3.5-1	
CA_n41(2A)-n48B	CA_n41A-n48A	n41	CA_n41(2A)_BCS3	0
		n48	CA_n48B_BCS2	
CA_n41(2A)-n48C	CA_n41A-n48A	n41	CA_n41(2A)_BCS3	0
		n48	CA_n48C_BCS1	
CA_n41(2A)-n48(2A)	CA_n41A-n48A	n41	CA_n41(2A)_BCS1	0
		n48	CA_n48(2A)_BCS0	
		n41	CA_n41(2A)_BCS4 and 5	4 and 5
		n48	CA_n48(2A)_BCS4 and 5	
CA_n41A-n50A	CA_n41A-n50A	n41	10, 15, 20, 40, 50, 60, 80, 90, 100	0
		n50	5, 10, 15, 20, 40, 50, 60, 80 <sup>1</sup>	
CA_n41A-n66A <sup>13,14</sup>	n41 <sup>8,9</sup> n66 <sup>8</sup> CA_n41A-n66A <sup>8</sup> <sup>13,14</sup>	n41	10, 15, 20, 40, 50, 60, 80, 90, 100	0
		n66	5, 10, 15, 20, 40	
		n41	10, 15, 20, 30, 40, 50, 60, 80, 90, 100	1
		n66	5, 10, 15, 20, 25, 30, 40	
		n41	n41 channel bandwidths in Table 5.3.5-1	4 and 5
		n66	n66 channel bandwidths in Table 5.3.5-1	
CA_n41(2A)-n66A	n41 <sup>8,9</sup> CA_n41A-n66A <sup>8</sup>	n41	CA_n41(2A)_BCS1	0
		n66	5, 10, 15, 20, 40	
		n41	CA_n41(2A)_BCS1	1
		n66	5, 10, 15, 20, 25, 30, 40	
		n41	CA_n41(2A)_BCS 4 and 5	4 and 5
n66	n66 channel bandwidths in Table 5.3.5-1			
CA_n41A-n66(2A)	n41 <sup>8,9</sup> CA_n41A-n66A <sup>8</sup>	n41	10, 15, 20, 30, 40, 50, 60, 70, 80, 90, 100	0
		n66	CA_n66(2A)_BCS1	
		n41	10, 15, 20, 30, 40, 50, 60, 80, 90, 100	1
		n66	CA_n66(2A)_BCS1	
		n41	n41 channel bandwidths in Table 5.3.5-1	4 and 5
		n66	CA_n66(2A)_BCS 4 and 5	
CA_n41C-n66A	n41 <sup>8,9</sup> CA_n41A-n66A <sup>8</sup> CA_n41C	n41	CA_n41C_BCS0	0
		n66	5, 10, 15, 20, 40	
		n41	CA_n41C_BCS1	1
		n66	5, 10, 15, 20, 25, 30, 40	
	CA_n41C-n66A	n41 <sup>8,9</sup> CA_n41A-n66A <sup>8</sup> CA_n41C <sup>8</sup> CA_n41C-n66A	n41	CA_n41C_BCS 4 and 5
n66			n66 channel bandwidths in Table 5.3.5-1	

CA_n41C-n66(2A)	n41 <sup>8,9</sup> CA_n41A-n66A <sup>8</sup> CA_n41C <sup>8</sup> CA_n41C-n66A	n41	CA_n41C_BCS2	0
		n66	CA_n66(2A)_BCS1	
		n41	CA_n41C_BCS 4 and 5	4 and 5
		n66	CA_n66(2A)_BCS 4 and 5	
CA_n41(2A)-n66(2A)	n41 <sup>8,9</sup> CA_n41A-n66A <sup>8</sup>	n41	CA_n41(2A)_BCS3	0
		n66	CA_n66(2A)_BCS1	
		n41	CA_n41(2A)_BCS 4 and 5	4 and 5
		n66	CA_n66(2A)_BCS 4 and 5	
CA_n41(3A)-n66A	n41 <sup>8,9</sup> CA_n41A-n66A <sup>8</sup>	n41	CA_n41(3A)_BCS0	0
		n66	5, 10, 15, 20, 25, 30, 40,	
		n41	CA_n41(3A)_BCS 4 and 5	4 and 5
		n66	n66 channel bandwidths in Table 5.3.5-1	
CA_n41(3A)-n66(2A)	n41 <sup>8,9</sup> CA_n41A-n66A <sup>8</sup>	n41	CA_n41(3A)_BCS 4 and 5	4 and 5
		n66	CA_n66(2A)_BCS 4 and 5	
CA_n41(A-C)-n66A	n41 <sup>8,9</sup> CA_n41C <sup>8</sup> CA_n41A-n66A <sup>8</sup> CA_n41C-n66A	n41	CA_n41(A-C)_BCS0	0
		n66	5, 10, 15, 20, 25, 30, 40	
		n41	CA_n41(A-C)_BCS 4 and 5	4 and 5
		n66	n66 channel bandwidths in Table 5.3.5-1	
CA_n41(A-C)-n66(2A)	n41 <sup>8,9</sup> CA_n41C <sup>8</sup> CA_n41A-n66A <sup>8</sup>	n41	CA_n41(A-C)_BCS 4 and 5	4 and 5
		n66	CA_n66(2A)_BCS 4 and 5	
CA_n41A-n70A	CA_n41A-n70A	n41	10, 15, 20, 30, 40, 50, 60, 70, 80, 90, 100	0
		n70	5, 10, 15, 20 <sup>1</sup> , 25 <sup>1</sup>	
CA_n41A-n71A	n41 <sup>8,9</sup> n71 <sup>8</sup> CA_n41A-n71A <sup>8</sup>	n41	10, 15, 20, 40, 50, 60, 80, 90, 100	0
		n71	5, 10, 15, 20	
		n41	10, 15, 20, 30, 40, 50, 60, 70, 80, 90, 100	1
		n71	5, 10, 15, 20	
		n41	n41 channel bandwidths in Table 5.3.5-1	4 and 5
		n71	n71 channel bandwidths in Table 5.3.5-1	
CA_n41A-n71B	n41 <sup>8,9</sup> CA_n41A-n71A <sup>8</sup>	n41	10, 15, 20, 30, 40, 50, 60, 80, 90, 100	0
		n71	CA_n71B_BCS0	
		n41	10, 15, 20, 30, 40, 50, 60, 70, 80, 90, 100	1
		n71	CA_n71B_BCS2	
		n41	n41 channel bandwidths in Table 5.3.5-1	4 and 5
		n71	CA_n71B_BCS 4 and 5	
CA_n41A-n71(2A)	n41 <sup>8,9</sup> CA_n41A-n71A <sup>8</sup>	n41	10, 15, 20, 40, 50, 60, 80, 90, 100	0
		n71	CA_n71(2A)_BCS0	
		n41	10, 15, 20, 30, 40, 50, 60, 70, 80, 90, 100	1
		n71	CA_n71(2A)_BCS0	
		n41	n41 channel bandwidths in Table 5.3.5-1	4 and 5
		n71	CA_n71(2A)_BCS 4 and 5	
CA_n41C-n71A	n41 <sup>8,9</sup> CA_n41A-n71A <sup>8</sup> CA_n41C <sup>8</sup>	n41	CA_n41C_BCS0	0
		n71	5, 10, 15, 20	
		n41	CA_n41C_BCS1	1
		n71	5, 10, 15, 20	
	n41	CA_n41C_BCS 4 and 5	4 and 5	

		n71	n71 channel bandwidths in Table 5.3.5-1	
CA_n41C-n71(2A)	n41 <sup>8,9</sup> CA_n41A-n71A <sup>8</sup> CA_n41C-n71A CA_n41C <sup>8</sup>	n41	CA_n41C_BCS1	0
		n71	CA_n71(2A)_BCS0	4 and 5
		n41	CA_n41C_BCS 4 and 5	
		n71	CA_n71(2A)_BCS 4 and 5	
CA_n41(2A)-n71A	n41 <sup>8,9</sup> CA_n41A-n71A <sup>8</sup>	n41	CA_n41(2A)_BCS1	0
		n71	5, 10, 15, 20	1
		n41	CA_n41(2A)_BCS3	
		n71	5, 10, 15, 20	
		n41	CA_n41(2A)_BCS 4 and 5	4 and 5
		n71	n71 channel bandwidths in Table 5.3.5-1	
CA_n41(2A)-n71(2A)	n41 <sup>8,9</sup> CA_n41A-n71A <sup>8</sup>	n41	CA_n41(2A)_BCS1	0
		n71	CA_n71(2A)_BCS0	4 and 5
		n41	CA_n41(2A)_BCS 4 and 5	
		n71	CA_n71(2A)_BCS 4 and 5	
CA_n41(2A)-n71B	n41 <sup>8,9</sup> CA_n41A-n71A <sup>8</sup>	n41	CA_n41(2A)_BCS1	0
		n71	CA_n71B_BCS0	1
		n41	CA_n41(2A)_BCS1	
		n71	CA_n71B_BCS2	
		n41	CA_n41(2A)_BCS 4 and 5	4 and 5
		n71	CA_n71B_BCS 4 and 5	
CA_n41(3A)-n71A	n41 <sup>8,9</sup> CA_n41A-n71A <sup>8</sup>	n41	CA_n41(3A)_BCS0	0
		n71	5, 10, 15, 20	4 and 5
		n41	CA_n41(3A)_BCS 4 and 5	
		n71	n71 channel bandwidths in Table 5.3.5-1	
CA_n41(3A)-n71B	n41 <sup>8,9</sup> CA_n41A-n71A <sup>8</sup>	n41	CA_n41(3A)_BCS4 and 5	4 and 5
		n71	CA_n71B_BCS4 and 5	
CA_n41(3A)-n71(2A)	n41 <sup>8,9</sup> CA_n41A-n71A <sup>8</sup>	n41	CA_n41(3A)_BCS4 and 5	4 and 5
		n71	CA_n71(2A)_BCS4 and 5	
CA_n41(A-C)-n71A	n41 <sup>8,9</sup> CA_n41A-n71A <sup>8</sup> CA_n41C <sup>8</sup> CA_n41C-n71A	n41	CA_n41(A-C)_BCS0	0
		n71	5, 10, 15, 20	4 and 5
		n41	CA_n41(A-C)_BCS 4 and 5	
		n71	n71 channel bandwidths in Table 5.3.5-1	
CA_n41(A-C)-n71B	n41 <sup>8,9</sup> CA_n41A-n71A <sup>8</sup> CA_n41C <sup>8</sup>	n41	CA_n41(A-C)_BCS 4 and 5	4 and 5
		n71	CA_n71B_BCS 4 and 5	
CA_n41(A-C)-n71(2A)	n41 <sup>8,9</sup> CA_n41A-n71A <sup>8</sup> CA_n41C <sup>8</sup>	n41	CA_n41(A-C)_BCS 4 and 5	4 and 5
		n71	CA_n71(2A)_BCS 4 and 5	
CA_n41C-n71B	n41 <sup>8,9</sup> CA_n41A-n71A <sup>8</sup> CA_n41C-n71A CA_n41C <sup>8</sup>	n41	CA_n41C_BCS0	0
		n71	CA_n71B_BCS0	1
		n41	CA_n41C_BCS1	
		n71	CA_n71B_BCS2	
		n41	CA_n41C_BCS 4 and 5	4 and 5
		n71	CA_n71B_BCS 4 and 5	
CA_n41A-n74A	CA_n41A-n74A	n41	10, 15, 20, 30, 40, 50, 60, 80, 90, 100	0
		n74	5, 10, 15, 20	
CA_n41A-n77A	n41 <sup>8,9</sup>	n41	10, 15, 20, 30, 40, 50, 60, 80, 90, 100	0

	n77 <sup>8,9</sup> CA_n41A-n77A <sup>8,13</sup>			
		n77	10, 15, 20, 25, 30, 40, 50, 60, 70, 80, 90, 100	1
		n41	10, 15, 20, 30, 40, 50, 60, 70, 80, 90, 100	
		n77	10, 15, 20, 25, 30, 40, 50, 60, 70, 80, 90, 100	4 and 5
		n41	n41 channel bandwidths in Table 5.3.5-1	
CA_n41B-n77A	CA_n41A-n77A	n77	n77 channel bandwidths in Table 5.3.5-1	
		n41	CA_n41B_BCS0	0
		n77	10, 15, 20, 25, 30, 40, 50, 60, 70, 80, 90, 100	
CA_n41(2A)-n77A	n41 <sup>8,9</sup> n77 <sup>8,9</sup> CA_n41A-n77A <sup>8</sup>	n41	CA_n41(2A)_BCS1	0
		n77	10, 15, 20, 25, 30, 40, 50, 60, 70, 80, 90, 100	4 and 5
		n41	CA_n41(2A)_BCS 4 and 5	
		n77	n77 channel bandwidths in Table 5.3.5-1	
CA_n41(3A)-n77A	n41 <sup>8,9</sup> n77 <sup>8,9</sup> CA_n41A-n77A <sup>8</sup>	n41	CA_n41(3A)_BCS0	0
		n77	10, 15, 20, 25, 30, 40, 50, 60, 70, 80, 90, 100	4 and 5
		n41	CA_n41(3A)_BCS 4 and 5	
		n77	n77 channel bandwidths in Table 5.3.5-1	
CA_n41(A-C)-n77A	n41 <sup>8,9</sup> n77 <sup>8,9</sup> CA_n41C <sup>8</sup> CA_n41A-n77A <sup>8</sup>	n41	CA_n41(A-C)_BCS0	0
		n77	10, 15, 20, 25, 30, 40, 50, 60, 70, 80, 90, 100	4 and 5
		n41	CA_n41(A-C)_BCS 4 and 5	
		n77	n77 channel bandwidths in Table 5.3.5-1	
CA_n41C-n77A	n41 <sup>8,9</sup> n77 <sup>8,9</sup> CA_n41A-n77A <sup>8</sup> CA_n41C <sup>8</sup>	n41	CA_n41C_BCS0	0
		n77	10, 15, 20, 25, 30, 40, 50, 60, 70, 80, 90, 100	
	n41 <sup>8,9</sup> n77 <sup>8,9</sup> CA_n41A-n77A <sup>8</sup> CA_n41C <sup>8</sup> CA_n41C-n77A	n41	CA_n41C_BCS 4 and 5	4 and 5
		n77	n77 channel bandwidths in Table 5.3.5-1	
CA_n41A-n77(2A)	n41 <sup>8,9</sup> n77 <sup>8,9</sup> CA_n77(2A) <sup>8</sup> CA_n41A-n77A <sup>8</sup>	n41	10, 15, 20, 30, 40, 50, 60, 70, 80, 90, 100	0
		n77	CA_n77(2A)_BCS1	
	n41 <sup>8,9</sup> n77 <sup>8,9</sup> CA_n41A-n77A <sup>8</sup>	n41	n41 channel bandwidths in Table 5.3.5-1	4 and 5
		n77	CA_n77(2A)_BCS 4 and 5	
CA_n41C-n77(2A)	n41 <sup>8,9</sup> n77 <sup>8,9</sup> CA_n41A-n77A <sup>8</sup> CA_n41C <sup>8</sup>	n41	CA_n41C_BCS0	0
		n77	CA_n77(2A)_BCS1	
		n41	CA_n41C_BCS 4 and 5	4 and 5
		n77	CA_n77(2A)_BCS 4 and 5	
CA_n41A-n77(3A)	n41 <sup>8,9</sup> n77 <sup>8,9</sup> CA_n41A-n77A <sup>8</sup>	n41	10, 15, 20, 30, 40, 50, 60, 80, 90, 100	0
		n77	CA_n77(3A)_BCS0	
		n41	See n41 channel bandwidths in Table 5.3.5-1	4 and 5
		n77	CA_n77(3A)_BCS 4 and 5	
CA_n41(2A)-n77(2A)	-	n41	CA_n41(2A)_BCS1	0
		n77	CA_n77(2A)_BCS1	
		n41 <sup>8,9</sup> n77 <sup>8,9</sup>	CA_n41(2A)_BCS 4 and 5	4 and 5



	CA_n41A-n77A <sup>8</sup>	n77	CA_n77(2A) BCS 4 and 5	
CA_n41A-n77C	CA_n41A-n77A	n41	10, 15, 20, 30, 40, 50, 60, 80, 90, 100	0
		n77	CA_n77C_BCS0	
		n41	See n41 channel bandwidths in Table 5.3.5-1	4 and 5
		n77	CA_n77C_BCS 4 and 5	
CA_n41A-n78A	CA_n41A-n78A	n41	10, 15, 20, 40, 50, 60, 80, 100	0
		n78	10, 15, 20, 40, 50, 60, 80, 90, 100	
		n41	10, 15, 20, 30, 40, 50, 60, 80, 90, 100	1
		n78	10, 15, 20, 25, 30, 40, 50, 60, 70, 80, 90, 100	
		n41	See n41 channel bandwidths in Table 5.3.5-1	4 and 5
		n78	See n78 channel bandwidths in Table 5.3.5-1	
CA_n41A-n78(2A)	CA_n41A-n78A	n41	10, 15, 20, 30, 40, 50, 60, 80, 90, 100	0
		n78	CA_n78(2A)_BCS2	
		n41	See n41 channel bandwidths in Table 5.3.5-1	4 and 5
		n78	CA_n78(2A)_BCS4 and 5	
CA_n41A-n78C	CA_n41A-n78A	n41	10, 15, 20, 30, 40, 50, 60, 80, 90, 100	0
		n78	CA_n78C_BCS0	
		n41	See n41 channel bandwidths in Table 5.3.5-1	4 and 5
		n78	CA_n78C_BCS4 and 5	
CA_n41A-n79A	n41 <sup>8,9</sup> n79 <sup>8,9</sup> CA_n41A-n79A <sup>8</sup>	n41	10, 15, 20, 40, 50, 60, 80, 90, 100	0
		n79	40, 50, 60, 80, 100	
		n41	10, 15, 20, 40, 50, 60	1
		n79	40, 50, 60, 80, 100	
		n41	10, 15, 20, 30, 40, 50, 60, 80, 90, 100	2
		n79	40, 50, 60, 80, 100	
		n41	See n41 channel bandwidths in Table 5.3.5-1	4 and 5
		n79	See n79 channel bandwidths in Table 5.3.5-1	
CA_n41A-n79C	n41 <sup>8,9</sup> n79 <sup>8,9</sup> CA_n41A-n79A <sup>8</sup> CA_n79C <sup>8</sup>	n41	10, 15, 20, 30, 40, 50, 60, 70, 80, 90, 100	0
		n79	CA_n79C_BCS0	
	CA_n79C CA_n41A-n79A CA_n41A-n79C	n41	See n41 channel bandwidths in Table 5.3.5-1	4 and 5
		n79	CA_n79C_BCS4 and 5	
CA_n41C-n79A	n41 <sup>8,9</sup> n79 <sup>8,9</sup> CA_n41A-n79A <sup>8</sup> CA_n41C <sup>8</sup>	n41	CA_n41C_BCS0	0
		n79	40, 50, 60, 80, 100	
		n41	CA_n41C_BCS4 and 5	4 and 5
		n79	See n79 channel bandwidths in Table 5.3.5-1	
CA_n41C-n79C	CA_n41C CA_n79C CA_n41A-n79A	n41	CA_n41C_BCS0	0
		n79	CA_n79C_BCS0	
		n41	CA_n41C_BCS4 and 5	4 and 5
		n79	CA_n79C_BCS4 and 5	
CA_n41A-n85A	n41 <sup>8,9</sup> CA_n41A-n85A <sup>8</sup>	n41	See n41 channel bandwidths in Table 5.3.5-1	4 and 5
		n85	See n85 channel bandwidths in Table 5.3.5-1	
CA_n41C-n85A	CA_n41A-n85A CA_n41C	n41	CA_n41C_BCS 4 and 5	4 and 5
		n85	See n85 channel bandwidths in Table 5.3.5-1	
CA_n41(2A)-n85A	CA_n41A-n85A	n41	CA_n41(2A)_BCS 4 and 5	4 and 5
		n85	See n85 channel bandwidths in Table 5.3.5-1	
CA_n41(3A)-n85A	CA_n41A-n85A	n41	CA_n41(3A)_BCS 4 and 5	4 and 5
		n85	See n85 channel bandwidths in Table 5.3.5-1	
CA_n41(A-C)-n85A	CA_n41A-n85A CA_n41C	n41	CA_n41(A-C)_BCS 4 and 5	4 and 5
		n85	See n85 channel bandwidths in Table 5.3.5-1	

Table 5.5A.3.1-1k ~ Table 5.5A.3.1-1n

**Table 5.5A.3.1-1k: NR CA configurations and bandwidth combinations sets defined for inter-band CA (two bands)**

NR CA configuration	Uplink CA configuration or single uplink carrier <sup>10</sup>	NR Band	Channel bandwidth (MHz) (NOTE 3)	Bandwidth combination set
CA_n46A-n48A	CA_n46A-n48A	n46	20, 40, 60, 80	0
		n48	20	
		n46	20, 40, 60, 80	1
		n48	5, 10, 15, 20, 40, 50 <sup>6</sup> , 60 <sup>6</sup> , 80 <sup>6</sup> , 90 <sup>6</sup> , 100 <sup>6</sup>	
CA_n46A-n48(2A)	CA_n46A-n48A	n46	10, 20, 40, 60, 80	0
		n48	CA_n48(2A)_BCS0	
CA_n46A-n48(3A)	CA_n46A-n48A	n46	10, 20, 40, 60, 80	0
		n48	CA_n48(3A)_BCS0	
CA_n46A-n48(4A)	CA_n46A-n48A	n46	10, 20, 40, 60, 80	0
		n48	CA_n48(4A)_BCS0	
CA_n46A-n48B	CA_n46A-n48A	n46	20, 40, 60, 80	0
		n48	CA_n48B_BCS0	
CA_n46A-n48C	CA_n46A-n48A CA_n46A-n48B	n46	20, 40, 60, 80	0
		n48	CA_n48C_BCS0	
CA_n46B-n48A	CA_n46A-n48A	n46	CA_n46B_BCS0	0
		n48	20	
		n46	CA_n46B_BCS0	1
		n48	5, 10, 15, 20, 40, 50 <sup>6</sup> , 60 <sup>6</sup> , 80 <sup>6</sup> , 90 <sup>6</sup> , 100 <sup>6</sup>	
CA_n46B-n48(2A)	CA_n46A-n48A	n46	CA_n46B_BCS0	0
		n48	CA_n48(2A)_BCS0	
CA_n46B-n48(3A)	CA_n46A-n48A	n46	CA_n46B_BCS0	0
		n48	CA_n48(3A)_BCS0	
CA_n46B-n48(4A)	CA_n46A-n48A	n46	CA_n46B_BCS0	0
		n48	CA_n48(4A)_BCS0	
CA_n46B-n48B	CA_n46A-n48A CA_n46A-n48B	n46	CA_n46B_BCS0	0
		n48	CA_n48B_BCS0	
CA_n46B-n48C	CA_n46A-n48A	n46	CA_n46B_BCS0	0
		n48	CA_n48C_BCS0	
CA_n46C-n48A	CA_n46A-n48A	n46	CA_n46C_BCS0	0
		n48	20	
		n46	CA_n46C_BCS0	1
		n48	5, 10, 15, 20, 40, 50 <sup>6</sup> , 60 <sup>6</sup> , 80 <sup>6</sup> , 90 <sup>6</sup> , 100 <sup>6</sup>	
CA_n46C-n48(2A)	CA_n46A-n48A	n46	CA_n46C_BCS0	0
		n48	CA_n48(2A)_BCS0	
CA_n46C-n48(3A)	CA_n46A-n48A	n46	CA_n46C_BCS0	0
		n48	CA_n48(3A)_BCS0	
CA_n46C-n48(4A)	CA_n46A-n48A	n46	CA_n46C_BCS0	0
		n48	CA_n48(4A)_BCS0	
CA_n46C-n48B	CA_n46A-n48A CA_n46A-n48B	n46	CA_n46C_BCS0	0
		n48	CA_n48B_BCS0	
CA_n46C-n48C	CA_n46A-n48A	n46	CA_n46C_BCS0	0
		n48	CA_n48C_BCS0	
CA_n46D-n48A	CA_n46A-n48A	n46	CA_n46D_BCS0	0
		n48	20	
		n46	CA_n46D_BCS0	1
		n48	5, 10, 15, 20, 40, 50 <sup>6</sup> , 60 <sup>6</sup> , 80 <sup>6</sup> , 90 <sup>6</sup> , 100 <sup>6</sup>	
CA_n46D-n48(2A)	CA_n46A-n48A	n46	CA_n46D_BCS0	0
		n48	CA_n48(2A)_BCS0	
CA_n46D-n48(3A)	CA_n46A-n48A	n46	CA_n46D_BCS0	0
		n48	CA_n48(3A)_BCS0	
CA_n46D-n48(4A)	CA_n46A-n48A	n46	CA_n46D_BCS0	0

		n48	CA_n48(4A)_BCS0	
CA_n46D-n48B	CA_n46A-n48A CA_n46A-n48B	n46	CA_n46D_BCS0	0
		n48	CA_n48B_BCS0	
CA_n46D-n48C	CA_n46A-n48A	n46	CA_n46D_BCS0	0
		n48	CA_n48C_BCS0	
CA_n46M-n48A	-	n46	CA_n46M_BCS0	0
		n48	20	
CA_n46M-n48(2A)	-	n46	CA_n46M_BCS0	0
		n48	CA_n48(2A)_BCS0	
CA_n46M-n48(3A)	-	n46	CA_n46M_BCS0	0
		n48	CA_n48(3A)_BCS0	
CA_n46M-n48(4A)	-	n46	CA_n46M_BCS0	0
		n48	CA_n48(4A)_BCS0	
CA_n46M-n48B	-	n46	CA_n46M_BCS0	0
		n48	CA_n48B_BCS0	
CA_n46M-n48C	-	n46	CA_n46M_BCS0	0
		n48	CA_n48C_BCS0	
CA_n46N-n48A	CA_n46A-n48A	n46	CA_n46N_BCS1	0
		n48	5, 10, 15, 20, 40, 50 <sup>6</sup> , 60 <sup>6</sup> , 80 <sup>6</sup> , 90 <sup>6</sup> , 100 <sup>6</sup>	
CA_n46N-n48(2A)	CA_n46A-n48A	n46	CA_n46N_BCS1	0
		n48	CA_n48(2A)_BCS0	
CA_n46N-n48(3A)	CA_n46A-n48A	n46	CA_n46N_BCS1	0
		n48	CA_n48(3A)_BCS0	
CA_n46N-n48(4A)	CA_n46A-n48A	n46	CA_n46N_BCS1	0
		n48	CA_n48(4A)_BCS0	
CA_n46N-n48B	CA_n46A-n48A CA_n46A-n48B	n46	CA_n46N_BCS1	0
		n48	CA_n48B_BCS0	
CA_n46N-n48C	CA_n46A-n48A	n46	CA_n46N_BCS1	0
		n48	CA_n48C_BCS0	
CA_n46A-n66A	-	n46	20, 40, 60, 80	0
		n66	5, 10, 15, 20, 25, 30, 40	
CA_n46A-n77A	CA_n46A-n77A	n46	10, 20, 40, 60, 80	0
		n77	10, 15, 20, 25, 30, 40, 50, 60, 70, 80, 90, 100	
CA_n46C-n77A	CA_n46A-n77A	n46	CA_n46C_BCS0	0
		n77	10, 15, 20, 25, 30, 40, 50, 60, 70, 80, 90, 100	
CA_n46D-n77A	CA_n46A-n77A	n46	CA_n46D_BCS0	0
		n77	10, 15, 20, 25, 30, 40, 50, 60, 70, 80, 90, 100	
CA_n46A-n77(2A)	CA_n77(2A) CA_n46A-n77A	n46	10, 20, 40, 60, 80	0
		n77	CA_n77(2A)_BCS4 and 5	
CA_n46C-n77(2A)	CA_n77(2A) CA_n46A-n77A	n46	CA_n46C_BCS0	0
		n77	CA_n77(2A)_BCS4 and 5	
CA_n46D-n77(2A)	CA_n77(2A) CA_n46A-n77A	n46	CA_n46D_BCS0	0
		n77	CA_n77(2A)_BCS4 and 5	
CA_n46(2A)-n77A	CA_n46A-n77A	n46	CA_n46(2A)_BCS0	0
		n77	10, 15, 20, 25, 30, 40, 50, 60, 70, 80, 90, 100	
CA_n46(2A)-n77(2A)	CA_n77(2A) CA_n46A-n77A	n46	CA_n46(2A)_BCS0	0
		n77	CA_n77(2A)_BCS4 and 5	
CA_n46A-n78A	CA_n46A-n78A	n46	20, 40, 60, 80	0
		n78	10, 15, 20, 25, 30, 40, 50, 60, 70, 80, 90, 100	
CA_n46C-n78A	CA_n46A-n78A	n46	CA_n46C_BCS0	0
		n78	10, 15, 20, 25, 30, 40, 50, 60, 70, 80, 90, 100	
CA_n46D-n78A	CA_n46A-n78A	n46	CA_n46D_BCS0	0
		n78	10, 15, 20, 25, 30, 40, 50, 60, 70, 80, 90, 100	
CA_n46A-n78(2A)	CA_n78(2A) CA_n46A-n78A	n46	10, 20, 40, 60, 80	0
		n78	CA_n78(2A)_BCS2	
CA_n46C-n78(2A)	CA_n78(2A) CA_n46A-n78A	n46	CA_n46C_BCS0	0
		n78	CA_n78(2A)_BCS2	
CA_n46D-n78(2A)	CA_n78(2A)	n46	CA_n46D_BCS0	0

	CA_n46A-n78A			
		n78	CA_n78(2A)_BCS2	
CA_n46(2A)-n78A	CA_n46A-n78A	n46	CA_n46(2A)_BCS0	0
		n78	10, 15, 20, 25, 30, 40, 50, 60, 70, 80, 90, 100	
CA_n46(2A)-n78(2A)	CA_n78(2A) CA_n46A-n78A	n46	CA_n46(2A)_BCS0	0
		n78	CA_n78(2A)_BCS2	
CA_n46A-n96A	-	n46	10, 20, 40, 60, 80	0
		n96	20, 40, 60, 80	
CA_n46B-n96A	-	n46	CA_n46B_BCS0	0
		n96	20, 40, 60, 80	
CA_n46C-n96A	-	n46	CA_n46C_BCS0	0
		n96	20, 40, 60, 80	
CA_n46D-n96A	-	n46	CA_n46D_BCS0	0
		n96	20, 40, 60, 80	
CA_n46M-n96A	-	n46	CA_n46M_BCS0	0
		n96	20, 40, 60, 80	
CA_n46N-n96A	-	n46	CA_n46N_BCS1	0
		n96	20, 40, 60, 80	
CA_n46A-n96B	-	n46	10, 20, 40, 60, 80	0
		n96	CA_n96B_BCS0	
CA_n46B-n96B	-	n46	CA_n46B_BCS0	0
		n96	CA_n96B_BCS0	
CA_n46C-n96B	-	n46	CA_n46C_BCS0	0
		n96	CA_n96B_BCS0	
CA_n46D-n96B	-	n46	CA_n46D_BCS0	0
		n96	CA_n96B_BCS0	
CA_n46M-n96B	-	n46	CA_n46M_BCS0	0
		n96	CA_n96B_BCS0	
CA_n46N-n96B	-	n46	CA_n46N_BCS1	0
		n96	CA_n96B_BCS0	
CA_n46A-n96C	-	n46	10, 20, 40, 60, 80	0
		n96	CA_n96C_BCS0	
CA_n46B-n96C	-	n46	CA_n46B_BCS0	0
		n96	CA_n96C_BCS0	
CA_n46C-n96C	-	n46	CA_n46C_BCS0	0
		n96	CA_n96C_BCS0	
CA_n46D-n96C	-	n46	CA_n46D_BCS0	0
		n96	CA_n96C_BCS0	
CA_n46M-n96C	-	n46	CA_n46M_BCS0	0
		n96	CA_n96C_BCS0	
CA_n46N-n96C	-	n46	CA_n46N_BCS1	0
		n96	CA_n96C_BCS0	
CA_n46A-n96D	-	n46	10, 20, 40, 60, 80	0
		n96	CA_n96D_BCS0	
CA_n46B-n96D	-	n46	CA_n46B_BCS0	0
		n96	CA_n96D_BCS0	
CA_n46C-n96D	-	n46	CA_n46C_BCS0	0
		n96	CA_n96D_BCS0	
CA_n46D-n96D	-	n46	CA_n46D_BCS0	0
		n96	CA_n96D_BCS0	
CA_n46M-n96D	-	n46	CA_n46M_BCS0	0
		n96	CA_n96D_BCS0	
CA_n46N-n96D	-	n46	CA_n46N_BCS1	0
		n96	CA_n96D_BCS0	
CA_n46A-n96E	-	n46	10, 20, 40, 60, 80	0
		n96	CA_n96E_BCS0	
CA_n46B-n96E	-	n46	CA_n46B_BCS0	0
		n96	CA_n96E_BCS0	
CA_n46C-n96E	-	n46	CA_n46C_BCS0	0
		n96	CA_n96E_BCS0	
CA_n46D-n96E	-	n46	CA_n46D_BCS0	0
		n96	CA_n96E_BCS0	
CA_n46M-n96E	-	n46	CA_n46M_BCS0	0
		n96	CA_n96E_BCS0	

CA_n46N-n96E	-	n46	CA_n46N_BCS1	0
		n96	CA_n96E_BCS0	
CA_n46A-n102A	-	n46	10, 20, 40, 60, 80, 100	0
		n102	20, 40, 60, 80, 100	
CA_n46A-n102(2A)	-	n46	10, 20, 40, 60, 80, 100	0
		n102	CA_n102(2A)_BCS0	
CA_n46A-n102B	CA_n102B	n46	10, 20, 40, 60, 80, 100	0
		n102	CA_n102B_BCS0	
CA_n46A-n102C	CA_n102C	n46	10, 20, 40, 60, 80, 100	0
		n102	CA_n102C_BCS0	
CA_n46A-n102D	-	n46	10, 20, 40, 60, 80, 100	0
		n102	CA_n102D_BCS0	
CA_n46A-n102E	-	n46	10, 20, 40, 60, 80, 100	0
		n102	CA_n102E_BCS0	
CA_n46(2A)-n102A	-	n46	CA_n46(2A)_BCS0	0
		n102	20, 40, 60, 80, 100	
CA_n46(2A)-n102(2A)	-	n46	CA_n46(2A)_BCS0	0
		n102	CA_n102(2A)_BCS0	
CA_n46(2A)-n102B	CA_n102B	n46	CA_n46(2A)_BCS0	0
		n102	CA_n102B_BCS0	
CA_n46(2A)-n102C	CA_n102C	n46	CA_n46(2A)_BCS0	0
		n102	CA_n102C_BCS0	
CA_n46(2A)-n102D	-	n46	CA_n46(2A)_BCS0	0
		n102	CA_n102D_BCS0	
CA_n46(2A)-n102E	-	n46	CA_n46(2A)_BCS0	0
		n102	CA_n102E_BCS0	
CA_n46C-n102A	-	n46	CA_n46C_BCS0	0
		n102	20, 40, 60, 80, 100	
CA_n46C-n102(2A)	-	n46	CA_n46C_BCS0	0
		n102	CA_n102(2A)_BCS0	
CA_n46C-n102B	CA_n102B	n46	CA_n46C_BCS0	0
		n102	CA_n102B_BCS0	
CA_n46C-n102C	CA_n102C	n46	CA_n46C_BCS0	0
		n102	CA_n102C_BCS0	
CA_n46C-n102D	-	n46	CA_n46C_BCS0	0
		n102	CA_n102D_BCS0	
CA_n46C-n102E	-	n46	CA_n46C_BCS0	0
		n102	CA_n102E_BCS0	
CA_n46D-n102A	-	n46	CA_n46D_BCS0	0
		n102	20, 40, 60, 80, 100	
CA_n46D-n102(2A)	-	n46	CA_n46D_BCS0	0
		n102	CA_n102(2A)_BCS0	
CA_n46D-n102B	CA_n102B	n46	CA_n46D_BCS0	0
		n102	CA_n102B_BCS0	
CA_n46D-n102C	CA_n102C	n46	CA_n46D_BCS0	0
		n102	CA_n102C_BCS0	
CA_n46D-n102D	-	n46	CA_n46D_BCS0	0
		n102	CA_n102D_BCS0	
CA_n46D-n102E	-	n46	CA_n46D_BCS0	0

		n102	CA_n102E_BCS0
--	--	------	---------------

**Table 5.5A.3.1-1I: NR CA configurations and bandwidth combinations sets defined for inter-band CA (two bands)**

NR CA configuration	Uplink CA configuration or single uplink carrier <sup>10</sup>	NR Band	Channel bandwidth (MHz) (NOTE 3)	Bandwidth combination set
CA_n48A-n53A	-	n48	5, 10, 15, 20, 40, 50, 60, 80, 90, 100	0
		n53	5, 10	
CA_n48(2A)-n53A	-	n48	CA_n48(2A)_BCS0	0
		n53	5, 10	
CA_n48A-n66A	CA_n48A-n66A	n48	5, 10, 15, 20, 40, 50 <sup>6</sup> , 60 <sup>6</sup> , 80 <sup>6</sup> , 90 <sup>6</sup> , 100 <sup>6</sup>	0
		n66	5, 10, 15, 20, 40	
		n48	5, 10, 15, 20, 40, 50 <sup>6</sup> , 60 <sup>6</sup> , 80 <sup>6</sup> , 90 <sup>6</sup> , 100 <sup>6</sup>	1
		n66	5, 10, 15, 20, 25, 30, 40	
CA_n48A-n66B	CA_n48A-n66A	n48	5, 10, 15, 20, 30, 40, 50 <sup>6</sup> , 60 <sup>6</sup> , 70 <sup>6</sup> , 80 <sup>6</sup> , 90 <sup>6</sup> , 100 <sup>6</sup>	0
		n66	CA_n66B_BCS0	
CA_n48A-n66(2A)	CA_n48A-n66A	n48	5, 10, 15, 20, 30, 40, 50 <sup>6</sup> , 60 <sup>6</sup> , 70 <sup>6</sup> , 80 <sup>6</sup> , 90 <sup>6</sup> , 100 <sup>6</sup>	0
		n66	CA_n66(2A)_BCS0	
CA_n48B-n66A	CA_n48B CA_n48A-n66A	n48	CA_n48B_BCS0	0
		n66	5, 10, 15, 20, 40	
		n48	CA_n48B_BCS1	1
		n66	5, 10, 15, 20, 25, 30, 40	
		n48	CA_n48B_BCS2	2
n66	5, 10, 15, 20, 25, 30, 40			
CA_n48B-n66B	CA_n48A-n66A	n48	CA_n48B_BCS0	0
		n66	CA_n66B_BCS0	
		n48	CA_n48B_BCS2	1
		n66	CA_n66B_BCS0	
CA_n48B-n66(2A)	CA_n48B CA_n48A-n66A	n48	CA_n48B_BCS2	0
		n66	CA_n66(2A)_BCS0	
		n48	CA_n48B_BCS2	1
		n66	CA_n66(2A)_BCS1	
		n48	CA_n48B_BCS2	2
n66	CA_n66(2A)_BCS2			
CA_n48C-n66A	CA_n48B CA_n48A-n66A	n48	CA_n48C_BCS0	0
		n66	5, 10, 15, 20, 40	
		n48	CA_n48C_BCS0	1
		n66	5, 10, 15, 20, 25, 30, 40	
CA_n48C-n66B	CA_n48A-n66A	n48	CA_n48C_BCS1	0
		n66	CA_n66B_BCS0	
CA_n48(2A)-n66A	CA_n48A-n66A	n48	CA_n48(2A)_BCS0	0
		n66	5, 10, 15, 20, 40	
		n48	CA_n48(2A)_BCS0	1
		n66	5, 10, 15, 20, 25, 30, 40	
		n48	CA_n48(2A)_BCS1	2
n66	5, 10, 15, 20, 25, 30, 40			
CA_n48(2A)-n66B	CA_n48A-n66A	n48	CA_n48(2A)_BCS1	0
		n66	CA_n66B_BCS0	
CA_n48(2A)-n66(2A)	CA_n48A-n66A	n48	CA_n48(2A)_BCS1	0
		n66	CA_n66(2A)_BCS0	

CA_n48(A-B)-n66A	CA_n48A-n66A	n48	CA_n48(A-B)_BCS0	0
		n66	5, 10, 15, 20, 25, 30, 40	
		n48	CA_n48(A-B)_BCS1	
		n66	5, 10, 15, 20, 25, 30, 40	
CA_n48A-n70A	CA_n48A-n70A	n48	5, 10, 15, 20, 30, 40, 50 <sup>6</sup> , 60 <sup>6</sup> , 70 <sup>6</sup> , 80 <sup>6</sup> , 90 <sup>6</sup> , 100 <sup>6</sup>	0
		n70	5, 10, 15, 20 <sup>1</sup> , 25 <sup>1</sup>	
		n48	CA_n48(2A)_BCS1	
		n70	5, 10, 15, 20, 25	
CA_n48B-n70A	CA_n48A-n70A	n48	CA_n48B_BCS2	0
		n70	5, 10, 15, 20 <sup>1</sup> , 25 <sup>1</sup>	
CA_n48A-n71A	CA_n48A-n71A	n48	5, 10, 15, 20, 30, 40, 50 <sup>6</sup> , 60 <sup>6</sup> , 70 <sup>6</sup> , 80 <sup>6</sup> , 90 <sup>6</sup> , 100 <sup>6</sup>	0
		n71	5, 10, 15, 20	
CA_n48A-n71(2A)	CA_n48A-n71A	n48	5, 10, 15, 20, 30, 40, 50 <sup>6</sup> , 60 <sup>6</sup> , 70 <sup>6</sup> , 80 <sup>6</sup> , 90 <sup>6</sup> , 100 <sup>6</sup>	0
		n71	CA_n71(2A)_BCS0	
CA_n48(2A)-n71A	CA_n48A-n71A	n48	CA_n48(2A)_BCS1	0
		n71	5, 10, 15, 20	
CA_n48(2A)-n71(2A)	CA_n48A-n71A	n48	CA_n48(2A)_BCS1	0
		n71	CA_n71(2A)_BCS0	
CA_n48(3A)-n71A	CA_n48A-n71A	n48	CA_n48(3A)_BCS0	0
		n71	5, 10, 15, 20	
CA_n48(4A)-n71A	CA_n48A-n71A	n48	CA_n48(4A)_BCS0	0
		n71	5, 10, 15, 20	
CA_n48B-n71A	CA_n48A-n71A	n48	CA_n48B_BCS2	0
		n71	5, 10, 15, 20	
CA_n48B-n71(2A)	CA_n48A-n71A	n48	CA_n48B_BCS2	0
		n71	CA_n71(2A)_BCS0	
CA_n48C-n71A	CA_n48A-n71A	n48	CA_n48C_BCS0	0
		n71	5, 10, 15, 20	
CA_n48A-n77A	n77 <sup>8,9</sup>	n48	5, 10, 15, 20, 30, 40, 50 <sup>6</sup> , 60 <sup>6</sup> , 70 <sup>6</sup> , 80 <sup>6</sup> , 90 <sup>6</sup> , 100 <sup>6</sup>	0
		n77	10, 15, 20, 25, 30, 40, 50, 60, 70, 80, 90, 100	
		n48	See n48 channel bandwidths in Table 5.3.5-1	
		n77	See n77 channel bandwidths in Table 5.3.5-1	
CA_n48A-n77C	n77 <sup>8,9</sup> CA_n77C	n48	5, 10, 15, 20, 30, 40, 50 <sup>6</sup> , 60 <sup>6</sup> , 70 <sup>6</sup> , 80 <sup>6</sup> , 90 <sup>6</sup> , 100 <sup>6</sup>	0
		n77	CA_n77C_BCS0	
		n48	5, 10, 15, 20, 30, 40, 50 <sup>6</sup> , 60 <sup>6</sup> , 70 <sup>6</sup> , 80 <sup>6</sup> , 90 <sup>6</sup> , 100 <sup>6</sup>	
		n77	CA_n77C_BCS1	
CA_n48A-n77(2A)	-	n48	5, 10, 15, 20, 30, 40, 50 <sup>6</sup> , 60 <sup>6</sup> , 70 <sup>6</sup> , 80 <sup>6</sup> , 90 <sup>6</sup> , 100 <sup>6</sup>	0
		n77	CA_n77(2A)_BCS0	
		n48	See n48 channel bandwidths in Table 5.3.5-1	
		n77	CA_n77(2A)_BCS4 and 5	
CA_n48(2A)-n77A	n77 <sup>8,9</sup>	n48	CA_n48(2A)_BCS0	0
		n77	10, 15, 20, 25, 30, 40, 50, 60, 70, 80, 90, 100	
		n48	CA_n48(2A)_BCS1	
		n77	10, 15, 20, 25, 30, 40, 50, 60, 70, 80, 90, 100	
		n48	CA_n48(2A)_BCS4 and 5	
		n77	See n77 channel bandwidths in Table 5.3.5-1	
CA_n48(2A)-n77C	n77 <sup>8,9</sup> CA_n77C	n48	CA_n48(2A)_BCS0	0
		n77	CA_n77C_BCS0	
		n48	CA_n48(2A)_BCS0	
		n77	CA_n77C_BCS1	
		n48	CA_n48(2A)_BCS1	
		n77	CA_n77C_BCS0	
		n48	CA_n48(2A)_BCS1	
n77	CA_n77C_BCS1			

CA_n48(2A)-n77(2A)	-	n48	CA_n48(2A)_BCS0	0
		n77	CA_n77(2A)_BCS0	
		n48	CA_n48(2A)_BCS4 and 5	4 and 5
		n77	CA_n77(2A)_BCS4 and 5	
CA_n48(3A)-n77A	-	n48	CA_n48(3A)_BCS0	0
		n77	10, 15, 20, 25, 30, 40, 50, 60, 70, 80, 90, 100	
CA_n48B-n77A	CA_n48B n77 <sup>8,9</sup>	n48	CA_n48B_BCS0	0
		n77	10, 15, 20, 25, 30, 40, 50, 60, 70, 80, 90, 100	
		n48	CA_n48B_BCS1	1
		n77	10, 15, 20, 25, 30, 40, 50, 60, 70, 80, 90, 100	
		n48	CA_n48B_BCS2	2
CA_n48B-n77C	CA_n48B n77 <sup>8,9</sup> CA_n77C	n48	CA_n48B_BCS0	0
		n77	CA_n77C_BCS0	
		n48	CA_n48B_BCS0	1
		n77	CA_n77C_BCS1	
		n48	CA_n48B_BCS2	2
		n77	CA_n77C_BCS0	
		n48	CA_n48B_BCS2	3
CA_n48(A-B)-n77A	n77 <sup>8,9</sup>	n48	CA_n48(A-B)_BCS0	0
		n77	10, 15, 20, 25, 30, 40, 50, 60, 70, 80, 90, 100	
		n48	CA_n48(A-B)_BCS1	1
		n77	10, 15, 20, 25, 30, 40, 50, 60, 70, 80, 90, 100	
CA_n48(A-B)-n77C	n77 <sup>8,9</sup> CA_n48B CA_n77C	n48	CA_n48(A-B)_BCS1	0
		n77	CA_n77C_BCS1	
CA_n48A-n96A	CA_n48A-n96A	n48	5, 10, 15, 20, 30, 40, 50 <sup>6</sup> , 60 <sup>6</sup> , 70 <sup>6</sup> , 80 <sup>6</sup> , 90 <sup>6</sup> , 100 <sup>6</sup>	0
		n96	20, 40, 60, 80	
CA_n48(2A)-n96A	CA_n48A-n96A	n48	CA_n48(2A)_BCS0	0
		n96	20, 40, 60, 80	
CA_n48(2A)-n96B	CA_n48A-n96B	n48	CA_n48(2A)_BCS0	0
		n96	CA_n96B_BCS0	
CA_n48(2A)-n96C	CA_n48A-n96A	n48	CA_n48(2A)_BCS0	0
		n96	CA_n96C_BCS0	
CA_n48(2A)-n96D	CA_n48A-n96A	n48	CA_n48(2A)_BCS0	0
		n96	CA_n96D_BCS0	
CA_n48(2A)-n96E	CA_n48A-n96A	n48	CA_n48(2A)_BCS0	0
		n96	CA_n96E_BCS0	
CA_n48(3A)-n96A	CA_n48A-n96A	n48	CA_n48(3A)_BCS0	0
		n96	20, 40, 60, 80	
CA_n48(3A)-n96B	CA_n48A-n96B	n48	CA_n48(3A)_BCS0	0
		n96	CA_n96B_BCS0	
CA_n48(3A)-n96C	CA_n48A-n96A	n48	CA_n48(3A)_BCS0	0
		n96	CA_n96C_BCS0	
CA_n48(3A)-n96D	CA_n48A-n96A	n48	CA_n48(3A)_BCS0	0
		n96	CA_n96D_BCS0	
CA_n48(3A)-n96E	CA_n48A-n96A	n48	CA_n48(3A)_BCS0	0
		n96	CA_n96E_BCS0	
CA_n48(4A)-n96A	CA_n48A-n96A	n48	CA_n48(4A)_BCS0	0
		n96	20, 40, 60, 80	
CA_n48(4A)-n96B	CA_n48A-n96A	n48	CA_n48(4A)_BCS0	0
		n96	CA_n96B_BCS0	
CA_n48(4A)-n96C	CA_n48A-n96A	n48	CA_n48(4A)_BCS0	0
		n96	CA_n96C_BCS0	
CA_n48(4A)-n96D	CA_n48A-n96A	n48	CA_n48(4A)_BCS0	0
		n96	CA_n96D_BCS0	
CA_n48(4A)-n96E	CA_n48A-n96A	n48	CA_n48(4A)_BCS0	0
		n96	CA_n96E_BCS0	
CA_n48A-n96B	CA_n48A-n96A	n48	5, 10, 15, 20, 30, 40, 50 <sup>6</sup> , 60 <sup>6</sup> , 70 <sup>6</sup> , 80 <sup>6</sup> , 90 <sup>6</sup> , 100 <sup>6</sup>	0



		n96	CA_n96B_BCS0	
CA_n48A-n96C	CA_n48A-n96A	n48	5, 10, 15, 20, 30, 40, 50 <sup>6</sup> , 60 <sup>6</sup> , 70 <sup>6</sup> , 80 <sup>6</sup> , 90 <sup>6</sup> , 100 <sup>6</sup>	0
		n96	CA_n96C_BCS0	
CA_n48A-n96D	CA_n48A-n96A	n48	5, 10, 15, 20, 30, 40, 50 <sup>6</sup> , 60 <sup>6</sup> , 70 <sup>6</sup> , 80 <sup>6</sup> , 90 <sup>6</sup> , 100 <sup>6</sup>	0
		n96	CA_n96D_BCS0	
CA_n48A-n96E	CA_n48A-n96A	n48	5, 10, 15, 20, 30, 40, 50 <sup>6</sup> , 60 <sup>6</sup> , 70 <sup>6</sup> , 80 <sup>6</sup> , 90 <sup>6</sup> , 100 <sup>6</sup>	0
		n96	CA_n96E_BCS0	
CA_n48B-n96A	CA_n48A-n96A CA_n48B-n96A	n48	CA_n48B_BCS0	0
		n96	20, 40, 60, 80	
CA_n48B-n96B	CA_n48A-n96A CA_n48B-n96A	n48	CA_n48B_BCS0	0
		n96	CA_n96B_BCS0	
CA_n48B-n96C	CA_n48A-n96A CA_n48B-n96A	n48	CA_n48B_BCS0	0
		n96	CA_n96C_BCS0	
CA_n48B-n96D	CA_n48A-n96A CA_n48B-n96A	n48	CA_n48B_BCS0	0
		n96	CA_n96D_BCS0	
CA_n48B-n96E	CA_n48A-n96A CA_n48B-n96A	n48	CA_n48B_BCS0	0
		n96	CA_n96E_BCS0	
CA_n48C-n96A	CA_n48A-n96A	n48	CA_n48C_BCS0	0
		n96	20, 40, 60, 80	
CA_n48C-n96B	CA_n48A-n96A	n48	CA_n48C_BCS0	0
		n96	CA_n96B_BCS0	
CA_n48C-n96C	CA_n48A-n96A	n48	CA_n48C_BCS0	0
		n96	CA_n96C_BCS0	
CA_n48C-n96D	CA_n48A-n96A	n48	CA_n48C_BCS0	0
		n96	CA_n96D_BCS0	
CA_n48C-n96E	CA_n48A-n96A	n48	CA_n48C_BCS0	0
		n96	CA_n96E_BCS0	
CA_n50A-n78A	CA_n50A-n78A	n50	5, 10, 15, 20, 30, 40, 50, 60, 80 <sup>1</sup>	0
		n78	10, 15, 20, 40, 50, 60, 80, 90, 100	

**Table 5.5A.3.1-1m: NR CA configurations and bandwidth combinations sets defined for inter-band CA (two bands)**

NR CA configuration	Uplink CA configuration or single uplink carrier <sup>10</sup>	NR Band	Channel bandwidth (MHz) (NOTE 3)	Bandwidth combination set	
CA_n66A-n70A	-	n66	5, 10, 15, 20, 40	0	
		n70	5, 10, 15, 20 <sup>1</sup> , 25 <sup>1</sup>		
CA_n66B-n70A	-	n66	CA_n66B_BCS0	0	
		n70	5, 10, 15, 20 <sup>1</sup> , 25 <sup>1</sup>		
CA_n66(2A)-n70A	-	n66	CA_n66(2A)_BCS0	0	
		n70	5, 10, 15, 20 <sup>1</sup> , 25 <sup>1</sup>		
CA_n66(3A)-n70A	-	n66	CA_n66(3A)_BCS0	0	
		n70	5, 10, 15, 20 <sup>1</sup> , 25 <sup>1</sup>		
CA_n66A-n71A	n66 <sup>8</sup> n71 <sup>8</sup> CA_n66A-n71A	n66	5, 10, 15, 20, 40	0	
		n71	5, 10, 15, 20		
		n66	5, 10, 15, 20, 25, 30, 40		1
		n71	5, 10, 15, 20		
		n66	n66 channel bandwidths in Table 5.3.5-1		4 and 5
n71	n71 channel bandwidths in Table 5.3.5-1				
CA_n66A-n71B	CA_n66A-n71A	n66	5, 10, 15, 20, 25, 30, 40	0	
		n71	CA_n71B_BCS0		
		n66	5, 10, 15, 20, 25, 30, 40		1

		n71	CA_n71B_BCS2	
		n66	n66 channel bandwidths in Table 5.3.5-1	4 and 5
		n71	CA_n71B_BCS 4 and 5	
CA_n66A-n71(2A)	CA_n66A-n71A	n66	5, 10, 15, 20, 40	0
		n71	CA_n71(2A)_BCS0	
		n66	5, 10, 15, 20, 25, 30, 40	1
		n71	CA_n71(2A)_BCS0	
		n66	n66 channel bandwidths in Table 5.3.5-1	4 and 5
		n71	CA_n71(2A)_BCS 4 and 5	
CA_n66(2A)-n71A	CA_n66A-n71A	n66	CA_n66(2A)_BCS0	0
		n71	5, 10, 15, 20	
		n66	CA_n66(2A)_BCS1	1
		n71	5, 10, 15, 20	
		n66	CA_n66(2A)_BCS 4 and 5	4 and 5
		n71	n71 channel bandwidths in Table 5.3.5-1	
CA_n66(2A)-n71B	CA_n66A-n71A	n66	CA_n66(2A)_BCS1	0
		n71	CA_n71B_BCS2	
		n66	CA_n66(2A)_BCS 4 and 5	4 and 5
		n71	CA_n71B_BCS 4 and 5	
CA_n66(2A)-n71(2A)	CA_n66A-n71A	n66	CA_n66(2A)_BCS1	0
		n71	CA_n71(2A)_BCS0	
		n66	CA_n66(2A)_BCS 4 and 5	4 and 5
		n71	CA_n71(2A)_BCS 4 and 5	
CA_n66(3A)-n71A	CA_n66A-n71A	n66	CA_n66(3A)_BCS0	0
		n71	5, 10, 15, 20	
CA_n66B-n71A	CA_n66A-n71A	n66	CA_n66B_BCS0	0
		n71	5, 10, 15, 20	
CA_n66A-n77A	n66 <sup>8</sup> n77 <sup>8,9</sup> CA_n66A- n77A <sup>8,13,14</sup>	n66	5, 10, 15, 20, 40	0
		n77	10, 15, 20, 25, 30, 40, 50, 60, 70, 80, 90, 100	
		n66	5, 10, 15, 20, 25, 30, 40	1
		n77	10, 15, 20, 25, 30, 40, 50, 60, 70, 80, 90, 100	
		n66	n66 channel bandwidths in Table 5.3.5-1	4 and 5
		n77	n77 channel bandwidths in Table 5.3.5-1	
CA_n66A-n77B	CA_n66A-n77A	n66	n66 channel bandwidths in Table 5.3.5-1	4 and 5
		n77	CA_n77B_BCS 4 and 5	
CA_n66(2A)-n77A	n77 <sup>8,9</sup> CA_n66A-n77A <sup>8</sup>	n66	CA_n66(2A)_BCS1	0
		n77	10, 15, 20, 25, 30, 40, 50, 60, 70, 80, 90, 100	
		n66	CA_n66(2A)_BCS1	1
		n77	10, 15, 20, 25, 30, 40, 50, 60, 70, 80, 90, 100	
		n66	CA_n66(2A)_BCS 4 and 5	4 and 5
		n77	n77 channel bandwidths in Table 5.3.5-1	
CA_n66(2A)-n77B	CA_n66A-n77A	n66	CA_n66(2A)_BCS 4 and 5	4 and 5
		n77	CA_n77B_BCS 4 and 5	
CA_n66A-n77(2A)	n77 <sup>8,9</sup> CA_n66A-n77A <sup>8</sup> CA_n77(2A) <sup>8</sup>	n66	5, 10, 15, 20, 40	0
		n77	CA_n77(2A)_BCS0	
		n66	5, 10, 15, 20, 25, 30, 40	1
		n77	CA_n77(2A)_BCS1	
		n66	n66 channel bandwidths in Table 5.3.5-1	4 and 5
		n77	CA_n77(2A)_BCS 4 and 5	
CA_n66(3A)-n77A	n77 <sup>8,9</sup> CA_n66A-n77A <sup>8</sup>	n66	CA_n66(3A)_BCS0	0
		n77	10, 15, 20, 25, 30, 40, 50, 60, 70, 80, 90, 100	
CA_n66(2A)-n77(2A)	n77 <sup>8,9</sup> CA_n66A-n77A <sup>8</sup> CA_n77(2A)	n66	CA_n66(2A)_BCS0	0
		n77	CA_n77(2A)_BCS0	
		n66	CA_n66(2A)_BCS1	1
		n77	CA_n77(2A)_BCS1	
		n66	CA_n66(2A)_BCS 4 and 5	4 and 5

		n77	CA_n77(2A)_BCS 4 and 5		
CA_n66(3A)-n77(2A)	n77 <sup>8,9</sup> CA_n66A-n77A <sup>8</sup>	n66	CA_n66(3A)_BCS0	0	
		n77	CA_n77(2A)_BCS1		
CA_n66A-n77C	n77 <sup>8,9</sup> CA_n77C CA_n66A-n77A <sup>8</sup>	n66	5, 10, 15, 20, 25, 30, 40	0	
		n77	CA_n77C_BCS1		
		n66	5, 10, 15, 20, 25, 30, 40	1	
		n77	CA_n77C_BCS1		
CA_n66A-n77(3A)	n77 <sup>8,9</sup> CA_n77(2A) <sup>8</sup> CA_n66A-n77A <sup>8</sup>	n66	5, 10, 15, 20, 40	0	
		n77	CA_n77(3A)_BCS0		
		n66	5, 10, 15, 20, 25, 30, 40	1	
		n77	CA_n77(3A)_BCS1		
		n66	n66 channel bandwidths in Table 5.3.5-1		4 and 5
n77	CA_n77(3A)_BCS4 and 5				
CA_n66(2A)-n77(3A)	CA_n77(2A) CA_n66A-n77A	n66	CA_n66(2A)_BCS0	0	
		n77	CA_n77(3A)_BCS1		
CA_n66(2A)-n77C	n77 <sup>8,9</sup> CA_n77C CA_n66A-n77A <sup>8</sup>	n66	CA_n66(2A)_BCS0	0	
		n77	CA_n77C_BCS1		
		n66	CA_n66(2A)_BCS1	1	
		n77	CA_n77C_BCS1		
CA_n66(3A)-n77C	n77 <sup>8,9</sup> CA_n77C CA_n66A-n77A <sup>8</sup>	n66	CA_n66(3A)_BCS0	0	
		n77	CA_n77C_BCS1		
CA_n66B-n77A	n77 <sup>8,9</sup> CA_n66A-n77A <sup>8</sup>	n66	CA_n66B_BCS0	0	
		n77	10, 15, 20, 25, 30, 40, 50, 60, 70, 80, 90, 100		
CA_n66B-n77C	n77 <sup>8,9</sup> CA_n77C CA_n66A-n77A <sup>8</sup>	n66	CA_n66B_BCS0	0	
		n77	CA_n77C_BCS0		
		n66	CA_n66B_BCS0	1	
		n77	CA_n77C_BCS1		
CA_n66A-n78A	n78 <sup>8,9</sup> CA_n66A-n78A <sup>8</sup>	n66	5, 10, 15, 20, 40	0	
		n78	10, 15, 20, 40, 50, 60, 80, 90, 100		
		n66	5, 10, 15, 20, 25, 30, 40	1	
		n78	10, 15, 20, 25, 30, 40, 50, 60, 70, 80, 90, 100		
		n66	See n66 channel bandwidths in Table 5.3.5-1		4 and 5
		n78	See n78 channel bandwidths in Table 5.3.5-1		
CA_n66A-n78(2A)	n78 <sup>8,9</sup> CA_n66A-n78A <sup>8</sup>	n66	5, 10, 15, 20, 30, 40	0	
		n78	CA_n78(2A)_BCS1		
	CA_n78(2A) <sup>8</sup>	n66	5, 10, 15, 20, 25, 30, 40	1	
		n78	CA_n78(2A)_BCS2		
		n66	See n66 channel bandwidths in Table 5.3.5-1	4 and 5	
n78	CA_n78(2A)_BCS4 and 5				
CA_n66(2A)-n78A	n78 <sup>8,9</sup> CA_n66A-n78A <sup>8</sup>	n66	CA_n66(2A)_BCS0	0	
		n78	10, 15, 20, 25, 30, 40, 50, 60, 80, 90, 100		
		n66	CA_n66(2A)_BCS1	1	
		n78	10, 15, 20, 25, 30, 40, 50, 60, 70, 80, 90, 100		
		n66	CA_n66(2A)_BCS4 and 5	4 and 5	
		n78	See n78 channel bandwidths in Table 5.3.5-1		
CA_n66(2A)-n78(2A)	n78 <sup>8,9</sup> CA_n66A-n78A <sup>8</sup>	n66	CA_n66(2A)_BCS0	0	
		n78	CA_n78(2A)_BCS1		
		n66	CA_n66(2A)_BCS1	1	

		n78	CA_n78(2A)_BCS2	
		n66	CA_n66(2A)_BCS4 and 5	4 and 5
		n78	CA_n78(2A)_BCS4 and 5	
CA_n66A-n85A	n66 <sup>8</sup> CA_n66A-n85A	n66	See n66 channel bandwidths in Table 5.3.5-1	4 and 5
		n85	See n85 channel bandwidths in Table 5.3.5-1	
CA_n66(2A)-n85A	CA_n66A-n85A	n66	CA_n66(2A)_BCS 4 and 5	4 and 5
		n85	See n85 channel bandwidths in Table 5.3.5-1	
CA_n67A-n78A	-	n67	5, 10, 15, 20	0
		n78	10, 15, 20, 25, 30, 40, 50, 60, 70, 80, 90, 100	
CA_n67A-n78(2A)	CA_n78(2A)	n67	5, 10, 15, 20	0
		n78	CA_n78(2A)_BCS2	

**Table 5.5A.3.1-1n: NR CA configurations and bandwidth combinations sets defined for inter-band CA (two bands)**

NR CA configuration	Uplink CA configuration or single uplink carrier <sup>10</sup>	NR Band	Channel bandwidth (MHz) (NOTE 3)	Bandwidth combination set
CA_n70A-n71A	CA_n70A-n71A	n70	5, 10, 15, 20 <sup>1</sup> , 25 <sup>1</sup>	0
		n71	5, 10, 15, 20	
CA_n70A-n71(2A)	CA_n70A-n71A	n70	5, 10, 15, 20 <sup>1</sup> , 25 <sup>1</sup>	0
		n71	CA_n71(2A)_BCS0	
CA_n70A-n77A	CA_n70A-n77A <sup>13,14</sup>	n70	5, 10, 15, 20 <sup>1</sup> , 25 <sup>1</sup>	0
		n77	10, 15, 20, 25, 30, 40, 50, 60, 70, 80, 90, 100	
CA_n70A-n78A	CA_n70A-n78A	n70	5, 10, 15, 20 <sup>1</sup> , 25 <sup>1</sup>	0
		n78	10, 15, 20, 25, 30, 40, 50, 60, 70, 80, 90, 100	
CA_n71A-n77A	n71 <sup>8</sup> n77 <sup>8,9</sup> CA_n71A-n77A <sup>8,13,14</sup>	n71	5, 10, 15, 20	0
		n77	10, 15, 20, 25, 30, 40, 50, 60, 70, 80, 90, 100	
		n71	n71 channel bandwidths in Table 5.3.5-1	4 and 5
		n77	n77 channel bandwidths in Table 5.3.5-1	
CA_n71A-n77(2A)	n77 <sup>8,9</sup> CA_n77(2A) <sup>8</sup> CA_n71A-n77A <sup>8</sup>	n71	5, 10, 15, 20	0
		n77	CA_n77(2A)_BCS1	
		n71	n71 channel bandwidths in Table 5.3.5-1	4 and 5
		n77	CA_n77(2A)_BCS 4 and 5	
CA_n71A-n77(3A)	n77 <sup>8,9</sup> CA_n77(2A) <sup>8</sup> CA_n71A-n77A <sup>8</sup>	n71	5, 10, 15, 20	0
		n77	CA_n77(3A)_BCS1	
		n71	n71 channel bandwidths in Table 5.3.5-1	4 and 5
		n77	CA_n77(3A)_BCS4 and 5	
CA_n71A-n77B	CA_n71A-n77A	n71	n71 channel bandwidths in Table 5.3.5-1	4 and 5
		n77	CA_n77B_BCS 4 and 5	
CA_n71A-n77C	CA_n71A-n77A	n71	n71 channel bandwidths in Table 5.3.5-1	4 and 5
		n77	CA_n77C_BCS 4 and 5	
CA_n71B-n77A	n77 <sup>8,9</sup> CA_n71A-n77A <sup>8</sup>	n71	CA_n71B_BCS2	0
		n77	10, 15, 20, 25, 30, 40, 50, 60, 70, 80, 90, 100	
		n71	CA_n71B_BCS 4 and 5	4 and 5
		n77	n77 channel bandwidths in Table 5.3.5-1	
CA_n71B-n77(2A)	n77 <sup>8,9</sup> CA_n71A-n77A <sup>8</sup>	n71	CA_n71B_BCS2	0
		n77	CA_n77(2A)_BCS1	
		n71	CA_n71B_BCS 4 and 5	4 and 5
		n77	CA_n77(2A)_BCS 4 and 5	
CA_n71(2A)-n77A	n77 <sup>8,9</sup> CA_n71A-n77A <sup>8</sup>	n71	CA_n71(2A)_BCS0	0
		n77	10, 15, 20, 25, 30, 40, 50, 60, 70, 80, 90, 100	

		n71	CA_n71(2A)_BCS 4 and 5	4 and 5
		n77	n77 channel bandwidths in Table 5.3.5-1	
CA_n71(2A)-n77(2A)	n77 <sup>8,9</sup> CA_n71A-n77A <sup>8</sup>	n71	CA_n71(2A)_BCS0	0
		n77	CA_n77(2A)_BCS1	
		n71	CA_n71(2A)_BCS 4 and 5	4 and 5
		n77	CA_n77(2A)_BCS 4 and 5	
CA_n71(2A)-n77B	CA_n71A-n77A	n71	CA_n71(2A)_BCS 4 and 5	4 and 5
		n77	CA_n77B_BCS 4 and 5	
CA_n71(2A)-n77C	CA_n71A-n77A	n71	CA_n71(2A)_BCS 4 and 5	4 and 5
		n77	CA_n77C_BCS 4 and 5	
CA_n71A-n78A	n78 <sup>8,9</sup> CA_n71A-n78A <sup>8</sup>	n71	5, 10, 15, 20	0
		n78	10, 15, 20, 25, 30, 40, 50, 60, 70, 80, 90, 100	
		n71	See n71 channel bandwidths in Table 5.3.5-1	4 and 5
		n78	See n78 channel bandwidths in Table 5.3.5-1	
CA_n71A-n78(2A)	n78 <sup>8,9</sup> CA_n71A-n78A <sup>8</sup>	n71	10, 15, 20	0
		n78	CA_n78(2A)_BCS2	
		n71	See n71 channel bandwidths in Table 5.3.5-1	4 and 5
		n78	CA_n78(2A)_BCS4 and 5	
CA_n71A-n85A	n71 <sup>8</sup>	n71	See n71 channel bandwidths in Table 5.3.5-1	4 and 5
		n85	See n85 channel bandwidths in Table 5.3.5-1	
CA_n71(2A)-n85A	-	n71	CA_n71(2A)_BCS 4 and 5	4 and 5
		n85	See n85 channel bandwidths in Table 5.3.5-1	
CA_n71B-n85A	-	n71	CA_n71B_BCS 4 and 5	4 and 5
		n85	See n85 channel bandwidths in Table 5.3.5-1	
CA_n74A-n77A	CA_n74A-n77A	n74	5, 10, 15, 20	0
		n77	10, 15, 20, 40, 50, 60, 80, 90, 100	
CA_n74A-n78A	CA_n74A-n78A	n74	5, 10, 15, 20	0
		n78	10, 15, 20, 40, 50, 60, 80, 90, 100	
CA_n75A-n78A	-	n75	5, 10, 15, 20	0
		n78	10, 15, 20, 40, 50, 60, 80, 90, 100	
		n75	n75 channel bandwidths in Table 5.3.5-1	4 and 5
		n78	n78 channel bandwidths in Table 5.3.5-1	
CA_n75A-n78(2A)	-	n75	5, 10, 15, 20	0
		n78	CA_n78(2A)_BCS1	
		n75	n75 channel bandwidths in Table 5.3.5-1	4 and 5
		n78	CA_n78(2A)_BCS4 and 5	
CA_n76A-n78A	-	n76	5	0
		n78	10, 15, 20, 40, 50, 60, 80, 90, 100	
CA_n77A-n78A <sup>2</sup>	-	n77	10, 15, 20, 40, 50, 60, 80, 90, 100	0
		n78	10, 15, 20, 40, 50, 60, 80, 90, 100	
		n77	See n77 channel bandwidths in Table 5.3.5-1	4 and 5
		n78	See n78 channel bandwidths in Table 5.3.5-1	
CA_n77A-n78C <sup>2</sup>	-	n77	10,15, 20, 25, 30, 40, 50, 60, 70, 80, 90, 100	0
		n78	CA_n78C_BCS1	
CA_n77A-n78(2A) <sup>2</sup>	-	n77	10,15, 20, 25, 30, 40, 50, 60, 70, 80, 90, 100	0
		n78	CA_n78(2A)_BCS2	
		n77	See n77 channel bandwidths in Table 5.3.5-1	4 and 5
		n78	CA_n78(2A)_BCS4 and 5	
CA_n77A-n79A	n77 <sup>8,9</sup> n79 <sup>8,9</sup> CA_n77A-n79A <sup>8</sup>	n77	10, 15, 20, 40, 50, 60, 80, 90, 100	0
		n79	40, 50, 60, 80, 100	
	CA_n77A-n79A	n77	See n77 channel bandwidths in Table 5.3.5-1	4 and 5
		n79	See n79 channel bandwidths in Table 5.3.5-1	
CA_n77(2A)-n79A	n77 <sup>8,9</sup> n79 <sup>8,9</sup> CA_n77(2A) <sup>8,12</sup> CA_n77A-n79A <sup>8</sup>	n77	CA_n77(2A)_BCS1	0
		n79	40, 50, 60, 80, 100	
	CA_n77A-n79A	n77	CA_n77(2A)_BCS 4 and 5	4 and 5
		n79	See n79 channel bandwidths in Table 5.3.5-1	
CA_n77(3A)-n79A	n77 <sup>8,9</sup> n79 <sup>8,9</sup>	n77	CA_n77(3A)_BCS1	0

	CA_n77(2A) <sup>8,12</sup> CA_n77A-n79A <sup>8</sup>	n79	40, 50, 60, 80, 100	
CA_n77A-n85A	n77 <sup>8,9</sup> CA_n77A-n85A <sup>8</sup>	n77	See n77 channel bandwidths in Table 5.3.5-1	4 and 5
		n85	See n85 channel bandwidths in Table 5.3.5-1	
CA_n77(2A)-n85A	CA_n77A-n85A	n77	CA_n77(2A)_BCS 4 and 5	4 and 5
		n85	See n85 channel bandwidths in Table 5.3.5-1	
CA_n77A-n102A	CA_n77A-n102A	n77	10, 15, 20, 25, 30, 40, 50, 60, 70, 80, 90, 100	0
		n102	20, 40, 60, 80, 100	
CA_n77A-n102(2A)	CA_n77A-n102A	n77	10, 15, 20, 25, 30, 40, 50, 60, 70, 80, 90, 100	0
		n102	CA_n102(2A)_BCS0	
CA_n77A-n102B	CA_n77A-n102A CA_n77A-n102B	n77	10, 15, 20, 25, 30, 40, 50, 60, 70, 80, 90, 100	0
		n102	CA_n102B_BCS0	
CA_n77A-n102C	CA_n77A-n102A CA_n77A-n102C	n77	10, 15, 20, 25, 30, 40, 50, 60, 70, 80, 90, 100	0
		n102	CA_n102C_BCS0	
CA_n77A-n102D	CA_n77A-n102A	n77	10, 15, 20, 25, 30, 40, 50, 60, 70, 80, 90, 100	0
		n102	CA_n102D_BCS0	
CA_n77A-n102E	CA_n77A-n102A	n77	10, 15, 20, 25, 30, 40, 50, 60, 70, 80, 90, 100	0
		n102	CA_n102E_BCS0	
CA_n77(2A)-n102A	CA_n77(2A) CA_n77A-n102A	n77	CA_n77(2A)_BCS4 and 5	0
		n102	20, 40, 60, 80, 100	
CA_n77(2A)-n102(2A)	CA_n77(2A) CA_n77A-n102A	n77	CA_n77(2A)_BCS4 and 5	0
		n102	CA_n102(2A)_BCS0	
CA_n77(2A)-n102B	CA_n77(2A) CA_n77A-n102A CA_n77A-n102B	n77	CA_n77(2A)_BCS4 and 5	0
		n102	CA_n102B_BCS0	
CA_n77(2A)-n102C	CA_n77(2A) CA_n77A-n102A CA_n77A-n102C	n77	CA_n77(2A)_BCS4 and 5	0
		n102	CA_n102C_BCS0	
CA_n77(2A)-n102D	CA_n77(2A) CA_n77A-n102A	n77	CA_n77(2A)_BCS4 and 5	0
		n102	CA_n102D_BCS0	
CA_n77(2A)-n102E	CA_n77(2A) CA_n77A-n102A	n77	CA_n77(2A)_BCS4 and 5	0
		n102	CA_n102E_BCS0	
CA_n78A-n79A	n78A <sup>8,9</sup> n79A <sup>8,9</sup> CA_n78A-n79A <sup>8</sup>	n78	10, 15, 20, 40, 50, 60, 80, 90, 100	0
		n79	40, 50, 60, 80, 100	
		n78	10, 15, 20, 25, 30, 40, 50, 60, 80, 90, 100	1
		n79	40, 50, 60, 80, 100	
		n78	See n78 channel bandwidths in Table 5.3.5-1	4 and 5
		n79	See n79 channel bandwidths in Table 5.3.5-1	
CA_n78A-n79C	-	n78	10, 15, 20, 25, 30, 40, 50, 60, 70, 80, 90, 100	0
		n79	CA_n79C_BCS0	
		n78	See n78 channel bandwidths in Table 5.3.5-1	4 and 5
		n79	CA_n79C_BCS4 and 5	
CA_n78(2A)-n79A	CA_n78A-n79A	n78	CA_n78(2A)_BCS1	0
		n79	40, 50, 60, 80, 100	
		n78	CA_n78(2A)_BCS4 and 5	4 and 5
		n79	See n79 channel bandwidths in Table 5.3.5-1	
CA_n78A-n92A	CA_n78A-n92A	n78	10, 15, 20, 40, 50, 60, 80, 90, 100	0
		n92	5, 10, 15, 20	
		n78	See n78 channel bandwidths in Table 5.3.5-1	4 and 5
		n92	See n92 channel bandwidths in Table 5.3.5-1	
CA_n78(2A)-n92A	CA_n78A-n92A	n78	CA_n78(2A)_BCS0	0
		n92	5, 10, 15, 20	
		n78	CA_n78(2A)_BCS4 and 5	4 and 5
		n92	See n92 channel bandwidths in Table 5.3.5-1	

CA_n78A-n94A	-	n78	10, 15, 20, 40, 50, 60, 80, 90, 100	0
		n94	5, 10, 15, 20	
CA_n78A-n102A	CA_n78A-n102A	n78	10, 15, 20, 25, 30, 40, 50, 60, 70, 80, 90, 100	0
		n102	20, 40, 60, 80, 100	
CA_n78A-n102(2A)	CA_n78A-n102A	n78	10, 15, 20, 25, 30, 40, 50, 60, 70, 80, 90, 100	0
		n102	CA_n102(2A)_BCS0	
CA_n78A-n102B	CA_n78A-n102A CA_n78A-n102B	n78	10, 15, 20, 25, 30, 40, 50, 60, 70, 80, 90, 100	0
		n102	CA_n102B_BCS0	
CA_n78A-n102C	CA_n78A-n102A CA_n78A-n102C	n78	10, 15, 20, 25, 30, 40, 50, 60, 70, 80, 90, 100	0
		n102	CA_n102C_BCS0	
CA_n78A-n102D	CA_n78A-n102A	n78	10, 15, 20, 25, 30, 40, 50, 60, 70, 80, 90, 100	0
		n102	CA_n102D_BCS0	
CA_n78A-n102E	CA_n78A-n102A	n78	10, 15, 20, 25, 30, 40, 50, 60, 70, 80, 90, 100	0
		n102	CA_n102E_BCS0	
CA_n78(2A)-n102A	CA_n78A-n102A CA_n78(2A)	n78	CA_n78(2A)_BCS2	0
		n102	20, 40, 60, 80, 100	
CA_n78(2A)-n102B	CA_n78A-n102A CA_n78(2A) CA_n78A-n102B	n78	CA_n78(2A)_BCS2	0
		n102	CA_n102B_BCS0	
CA_n78(2A)-n102C	CA_n78A-n102A CA_n78(2A) CA_n78A-n102C	n78	CA_n78(2A)_BCS2	0
		n102	CA_n102C_BCS0	
CA_n78(2A)-n102D	CA_n78A-n102A CA_n78(2A)	n78	CA_n78(2A)_BCS2	0
		n102	CA_n102D_BCS0	
CA_n78(2A)-n102E	CA_n78A-n102A CA_n78(2A)	n78	CA_n78(2A)_BCS2	0
		n102	CA_n102E_BCS0	
CA_n78(2A)- n102(2A)	CA_n78A-n102A CA_n78(2A)	n78	CA_n78(2A)_BCS2	0
		n102	CA_n102(2A)_BCS0	
CA_n78A-n104A	CA_n78A-n104A	n78	n78 channel bandwidths in Table 5.3.5-1	4 and 5
		n104	n104 channel bandwidths in Table 5.3.5-1	
CA_n78A-n105A	CA_n78A-n105A	n78	10, 15, 20, 25, 30, 40, 50, 60, 70, 80, 90, 100	0
		n105	5, 10, 15, 20, 25, 30, 35	

The following notes are applied to the above tables:

- NOTE 1: This UE channel bandwidth is applicable only to downlink.
- NOTE 2: The minimum requirements for intra-band contiguous or non-contiguous CA apply.
- NOTE 3: For each channel bandwidth of each component carrier, refer to Table 5.3.5-1 for the applicable SCSs. For a given band, not all UE channel bandwidths support the same SCSs.
- NOTE 4: This UE channel bandwidth is optional in this release of the specification.
- NOTE 5: For this bandwidth, the minimum requirements are restricted to operation when carrier is configured as an SCell part of DC or CA configuration.
- NOTE 6: For this bandwidth, the minimum requirements are restricted to operation when carrier is configured as an downlink SCell part of CA configuration
- NOTE 7: Limited to operation at 3450-3550 MHz and 3700–3980 MHz.
- NOTE 8: Minimum requirements for Power Class 2 are applicable for this uplink combination with 1Tx antenna connector in each band or single uplink carrier with up to 2Tx antenna connectors in this downlink/uplink combination
- NOTE 9: Minimum requirements for Power Class 1.5 are applicable for this single uplink carrier with up to 2Tx antenna connectors in this downlink/uplink combination
- NOTE 10: Only single uplink carriers with power class other than PC3 are listed.
- NOTE 11: The CA configurations are given in Table 5.5A.1-1 or Table 5.5A.2-1 in this specification
- NOTE 12: Void.
- NOTE 13: Minimum requirements for Power Class 2 are applicable for this uplink configuration with 1Tx antenna connector in one band and 2Tx antenna connectors in the other band.
- NOTE 14: Minimum requirements for Power Class 1.5 are applicable for this uplink configuration with 1Tx antenna connector in one band and 2Tx antenna connectors in the other band.
- NOTE 15: Uplink is only in n5 for CA\_n5-n8.
- NOTE 16: For UEs only supporting DL CA\_n26-n28, uplink support in band n26 is optional, if the UE supports CA\_n26-n28 UL configuration, it should also support UL in band n26 and n28.

5.5A.3.2 Configurations for inter-band CA (three bands)

Table 5.5A.3.2-1: Void

Table 5.5A.3.2-1a

Table 5.5A.3.2-1a: NR CA configurations and bandwidth combinations sets defined for inter-band CA (three bands)

NR CA configuration	Uplink CA configuration or single uplink carrier <sup>6</sup>	NR Band	Channel bandwidth (MHz) (NOTE 3)	Bandwidth combination set				
CA_n1A-n3A-n5A	CA_n1A-n3A CA_n1A-n5A CA_n3A-n5A	n1	5, 10, 15, 20, 25, 30, 40, 50	0				
		n3	5, 10, 15, 20, 25, 30, 40, 50					
		n5	5, 10, 15, 20					
CA_n1A-n3A-n7A	n3 <sup>7</sup> n7 <sup>7</sup> CA_n1A-n3A CA_n1A-n7A CA_n3A-n7A	n1	5, 10, 15, 20	0				
		n3	5, 10, 15, 20, 25, 30					
		n7	5, 10, 15, 20, 25, 30, 40, 50					
				n1	5, 10, 15, 20, 25, 30, 40, 50	1		
				n3	5, 10, 15, 20, 25, 30, 40			
				n7	5, 10, 15, 20, 25, 30, 40, 50			
						n1	5, 10, 15, 20	2
						n3	5, 10, 15, 20, 25, 30, 40	
						n7	5, 10, 15, 20, 25, 30, 40, 50	



	n3 <sup>7</sup> n7 <sup>7</sup>	n1	n1 channel bandwidths in Table 5.3.5-1	4 and 5
		n3	n3 channel bandwidths in Table 5.3.5-1	
		n7	n7 channel bandwidths in Table 5.3.5-1	
CA_n1A-n3A-n7B	-	n1	5, 10, 15, 20	0
		n3	5, 10, 15, 20, 25, 30	
		n7	CA_n7B_BCS0	
	CA_n1A-n3A CA_n1A-n7A CA_n3A-n7A CA_n7B	n1	5, 10, 15, 20, 25, 30, 40, 50	1
		n3	5, 10, 15, 20, 25, 30, 40, 50	
n7	CA_n7B_BCS0			
CA_n1A-n3A-n7(2A)	CA_n1A-n3A CA_n1A-n7A CA_n3A-n7A	n1	5, 10, 15, 20	0
		n3	5, 10, 15, 20, 25, 30	
		n7	CA_n7(2A)_BCS0	
CA_n1A-n3(2A)-n7A	CA_n1A-n3A CA_n1A-n7A CA_n3A-n7A	n1	5, 10, 15, 20, 25, 30, 40, 50	0
		n3	CA_n3(2A)_BCS1	
		n7	5, 10, 15, 20, 25, 30, 40, 50	
CA_n1A-n3(2A)-n7(2A)	CA_n1A-n3A CA_n1A-n7A CA_n3A-n7A	n1	5, 10, 15, 20	0
		n3	CA_n3(2A)_BCS0	
		n7	CA_n7(2A)_BCS0	
CA_n1(2A)-n3A-n7A	-	n1	CA_n1(2A)_BCS0	0
		n3	5, 10, 15, 20, 25, 30, 40, 50	
		n7	5, 10, 15, 20, 25, 30, 40, 50	
CA_n1A-n3B-n7A	CA_n1A-n3A CA_n1A-n7A CA_n3A-n7A	n1	5, 10, 15, 20, 25, 30, 40, 50	0
		n3	CA_n3B_BCS0	
		n7	5, 10, 15, 20, 25, 30, 40, 50	
CA_n1(2A)-n3B-n7A	-	n1	CA_n1(2A)_BCS0	0
		n3	CA_n3B_BCS0	
		n7	5, 10, 15, 20, 25, 30, 40, 50	
CA_n1(2A)-n3(2A)-n7A	-	n1	CA_n1(2A)_BCS0	0
		n3	CA_n3(2A)_BCS1	
		n7	5, 10, 15, 20, 25, 30, 40, 50	
CA_n1A-n3B-n7B	CA_n1A-n3A CA_n1A-n7A CA_n3A-n7A CA_n7B	n1	5, 10, 15, 20, 25, 30, 40, 45, 50	0
		n3	CA_n3B_BCS0	
		n7	CA_n7B_BCS0	
CA_n1A-n3A-n8A	CA_n1A-n3A CA_n1A-n8A CA_n3A-n8A	n1	5, 10, 15, 20	0
		n3	5, 10, 15, 20, 25, 30	
		n8	5, 10, 15, 20	
CA_n1A-n3(2A)-n8A	CA_n1A-n3A CA_n1A-n8A CA_n3A-n8A	n1	5, 10, 15, 20	0
		n3	CA_n3(2A)_BCS0	
		n8	5, 10, 15, 20	
CA_n1A-n3A-n18A	CA_n1A-n3A CA_n1A-n18A CA_n3A-n18A	n1	5, 10, 15, 20, 25, 30, 40, 50	0
		n3	5, 10, 15, 20, 25, 30, 40	
		n18	5, 10, 15	

CA_n1A-n3A-n20A	CA_n1A-n3A CA_n1A-n20A CA_n3A-n20A	n1	5, 10, 15, 20, 25, 30, 40, 50	0
		n3	5, 10, 15, 20, 25, 30, 40	
		n20	5, 10, 15, 20	
		n1	n1 channel bandwidths in Table 5.3.5-1	4 and 5
		n3	n3 channel bandwidths in Table 5.3.5-1	
		n20	n20 channel bandwidths in Table 5.3.5-1	
CA_n1A-n3A-n26A	CA_n1A-n3A CA_n1A-n26A CA_n3A-n26A	n1	5, 10, 15, 20	0
		n3	5, 10, 15, 20, 25, 30, 40	
		n26	5, 10, 15, 20	
CA_n1A-n3A-n26(2A)	CA_n26(2A) CA_n1A-n3A CA_n1A-n26A CA_n3A-n26A	n1	5, 10, 15, 20, 25, 30, 40, 45, 50	0
		n3	5, 10, 15, 20, 25, 30, 35, 40, 45, 50	
		n26	CA_n26(2A)_BCS0	
CA_n1A-n3B-n26A	CA_n1A-n3A CA_n1A-n26A CA_n3A-n26A	n1	5, 10, 15, 20, 25, 30, 40, 45, 50	0
		n3	CA_n3B_BCS0	
		n26	5, 10, 15, 20, 25, 30	
CA_n1A-n3B-n26(2A)	CA_n26(2A) CA_n1A-n3A CA_n1A-n26A CA_n3A-n26A	n1	5, 10, 15, 20, 25, 30, 40, 45, 50	0
		n3	CA_n3B_BCS0	
		n26	CA_n26(2A)_BCS0	
CA_n1A-n3A-n28A	n3 <sup>7</sup>	n1	5, 10, 15, 20	0
		n3	5, 10, 15, 20, 25, 30	
		n28	5, 10, 15, 20 <sup>2</sup>	
		n1	5, 10, 15, 20	
	n3	5, 10, 15, 20, 25, 30, 40		
	n28	5, 10, 15, 20		
	n1	5, 10, 15, 20, 25, 30, 40, 50	2	
	n3	5, 10, 15, 20, 25, 30, 40, 50		
	n28	5, 10, 15, 20 <sup>1</sup> , 30 <sup>1</sup>		
	CA_n1A-n3B-n28A	CA_n1A-n3A CA_n1A-n28A CA_n3A-n28A	n1	5, 10, 15, 20
n3			CA_n3B_BCS0	
n28			5, 10, 15, 20	
CA_n1A-n3A-n38A	-	n1	5, 10, 15, 20, 25, 30, 40, 50	0
		n3	5, 10, 15, 20, 25, 30, 40, 50	
		n38	5, 10, 15, 20, 25, 30, 40	
CA_n1A-n3B-n38A	-	n1	5, 10, 15, 20, 25, 30, 40, 50	0
		n3	CA_n3B_BCS0	
		n38	5, 10, 15, 20, 25, 30, 40	
CA_n1(2A)-n3A-n38A	-	n1	CA_n1(2A)_BCS0	0
		n3	5, 10, 15, 20, 25, 30, 40, 50	
		n38	5, 10, 15, 20, 25, 30, 40	
CA_n1(2A)-n3B-n38A	-	n1	CA_n1(2A)_BCS0	0
		n3	CA_n3B_BCS0	
		n38	5, 10, 15, 20, 25, 30, 40	
CA_n1A-n3(2A)-n38A	-	n1	5, 10, 15, 20, 25, 30, 40, 50	0
		n3	CA_n3(2A)_BCS1	
		n38	5, 10, 15, 20, 25, 30, 40	

CA_n1(2A)-n3(2A)-n38A	-	n1	CA_n1(2A)_BCS0	0
		n3	CA_n3(2A)_BCS1	
		n38	5, 10, 15, 20, 25, 30, 40	
CA_n1A-n3A-n40A	CA_n1A-n3A CA_n1A-n40A CA_n3A-n40A	n1	5, 10, 15, 20, 30, 40, 45, 50	0
		n3	5, 10, 15, 20, 30, 35, 40, 45, 50	
		n40	10, 15, 20, 25, 30, 40, 50, 60, 70, 80, 90, 100	
CA_n1A-n3A-n41A	n41 <sup>7,9</sup> CA_n1A-n3A CA_n1A-n41A <sup>7</sup> CA_n3A-n41A <sup>7</sup>	n1	5, 10, 15, 20	0
		n3	5, 10, 15, 20, 25, 30	
		n41	10, 15, 20, 30, 40, 50, 60, 80, 90, 100	
CA_n1A-n3A-n67A	CA_n1A-n3A	n1	5, 10, 15, 20, 25, 30, 40, 50	0
		n3	5, 10, 15, 20, 25, 30, 40	
		n67	5, 10, 15, 20	
CA_n1A-n3A-n75A	-	n1	n1 channel bandwidths in Table 5.3.5-1	4 and 5
		n3	n3 channel bandwidths in Table 5.3.5-1	
		n75	n75 channel bandwidths in Table 5.3.5-1	
CA_n1A-n3A-n77A	n77 <sup>7,9</sup> CA_n1A-n3A CA_n1A-n77A <sup>7</sup> CA_n3A-n77A <sup>7</sup>	n1	5, 10, 15, 20	0
		n3	5, 10, 15, 20, 25, 30	
		n77	10, 15, 20, 40, 50, 60, 80, 90, 100	
		1	n1	5, 10, 15, 20, 25, 30, 40, 50
			n3	5, 10, 15, 20, 25, 30, 40
			n77	10, 15, 20, 40, 50, 60, 80, 90, 100
		2	n1	5, 10, 15, 20
			n3	5, 10, 15, 20, 25, 30, 35, 40
			n77	10, 15, 20, 25, 30, 40, 50, 60, 70, 80, 90, 100
CA_n1A-n3A-n77(2A)	n77 <sup>7,9</sup> CA_n1A-n3A CA_n1A-n77A <sup>7</sup> CA_n3A-n77A <sup>7</sup>	n1	5, 10, 15, 20	0
		n3	5, 10, 15, 20, 25, 30	
		n77	CA_n77(2A)_BCS1	
	4 and 5	CA_n1A_n3A CA_n1A_n77A CA_n3A_n77A CA_n77(2A)	n1	n1 channel bandwidths in Table 5.3.5-1
			n3	n3 channel bandwidths in Table 5.3.5-1
			n77	CA_n77(2A)_BCS4 and 5
CA_n1A-n3A-n77(3A)	CA_n1A-n3A CA_n1A-n77A CA_n3A-n77A	n1	5, 10, 15, 20	0
		n3	5, 10, 15, 20, 25, 30	
		n77	CA_n77(3A)_BCS1	
CA_n1A-n3A-n78A	n3 <sup>7</sup> n78 <sup>7,9</sup> CA_n1A-n3A CA_n1A-n78A <sup>7</sup> CA_n3A-n78A <sup>7</sup>	n1	5, 10, 15, 20	0
		n3	5, 10, 15, 20, 25, 30	
		n78	10, 15, 20, 40, 50, 60, 80, 90, 100	
		1	n1	5, 10, 15, 20, 25, 30, 40, 50
			n3	5, 10, 15, 20, 25, 30, 40

		n78	10, 15, 20, 40, 50, 60, 70, 80, 90, 100	
		n1	5, 10, 15, 20	2
		n3	5, 10, 15, 20, 25, 30, 40	
		n78	10, 15, 20, 25, 30, 40, 50, 60, 70, 80, 90, 100	
		n1	n1 channel bandwidths in Table 5.3.5-1	4 and 5
		n3	n3 channel bandwidths in Table 5.3.5-1	
		n78	n78 channel bandwidths in Table 5.3.5-1	
CA_n1A-n3A-n78(2A)	n3 <sup>7</sup> n78 <sup>7,9</sup> CA_n78(2A) <sup>7</sup> CA_n1A-n3A CA_n1A-n78A <sup>7</sup> CA_n3A-n78A <sup>7</sup>	n1	5, 10, 15, 20	0
		n3	5, 10, 15, 20, 25, 30, 40	
		n78	CA_n78(2A)_BCS2	
CA_n1A-n3(2A)-n78A	CA_n1A-n3A CA_n1A-n78A CA_n3A-n78A	n1	5, 10, 15, 20	0
		n3	CA_n3(2A)_BCS0	
		n78	10, 15, 20, 25, 30, 40, 50, 60, 70, 80, 90, 100	
CA_n1A-n3A-n78C	CA_n78C CA_n1A-n3A CA_n1A-n78A CA_n3A-n78A	n1	5, 10, 15, 20, 25, 30, 40, 50	0
		n3	5, 10, 15, 20, 25, 30, 40	
		n78	CA_n78C_BCS1	
CA_n1A-n3B-n78A	CA_n1A-n3A CA_n1A-n78A CA_n3A-n78A	n1	5, 10, 15, 20, 25, 30, 40, 45, 50	0
		n3	CA_n3B_BCS0	
		n78	10, 15, 20, 25, 30, 40, 50, 60, 70, 80, 90, 100	
CA_n1A-n3B-n78(2A)	CA_n1A-n3A CA_n1A-n78A CA_n3A-n78A	n1	5, 10, 15, 20, 25, 30, 40, 45, 50	0
		n3	CA_n3B_BCS0	
		n78	CA_n78(2A)_BCS0	
CA_n1A-n3B-n78C	CA_n78C CA_n1A-n3A CA_n1A-n78A CA_n3A-n78A	n1	5, 10, 15, 20, 25, 30, 40, 45, 50	0
		n3	CA_n3B_BCS0	
		n78	CA_n78C_BCS0	
CA_n1A-n3A-n79A	n79 <sup>7</sup> CA_n1A-n3A CA_n1A-n79A <sup>7</sup> CA_n3A-n79A <sup>7</sup>	n1	5, 10, 15, 20	0
		n3	5, 10, 15, 20, 25, 30	
		n79	40, 50, 60, 80, 100	
		n1	5, 10, 15, 20, 25, 30, 40, 50	1
		n3	5, 10, 15, 20, 25, 30, 40, 50	
CA_n1(2A)-n3A-n79A	-	n1	CA_n1(2A)_BCS0	0
		n3	5, 10, 15, 20, 25, 30, 40, 50	
		n79	40, 50, 60, 80, 100	
CA_n1A-n3A-n79C	-	n1	5, 10, 15, 20, 25, 30, 40, 50	0
		n3	5, 10, 15, 20, 25, 30, 40, 50	
		n79	CA_n79C_BCS0	
CA_n1(2A)-n3A-n79C	-	n1	CA_n1(2A)_BCS0	0
		n3	5, 10, 15, 20, 25, 30, 40, 50	
		n79	CA_n79C_BCS0	

CA_n1A-n3B-n79A	-	n1	5, 10, 15, 20, 25, 30, 40, 50	0
		n3	CA_n3B_BCS0	
		n79	40, 50, 60, 80, 100	
CA_n1A-n3B-n79C	-	n1	5, 10, 15, 20, 25, 30, 40, 50	0
		n3	CA_n3B_BCS0	
		n79	CA_n79C_BCS0	
CA_n1(2A)-n3B-n79A	-	n1	CA_n1(2A)_BCS0	0
		n3	CA_n3B_BCS0	
		n79	40, 50, 60, 80, 100	
CA_n1(2A)-n3B-n79C	-	n1	CA_n1(2A)_BCS0	0
		n3	CA_n3B_BCS0	
		n79	CA_n79C_BCS0	
CA_n1A-n3(2A)-n79A	-	n1	5, 10, 15, 20, 25, 30, 40, 50	0
		n3	CA_n3(2A)_BCS1	
		n79	40, 50, 60, 80, 100	
CA_n1A-n3(2A)-n79C	-	n1	5, 10, 15, 20, 25, 30, 40, 50	0
		n3	CA_n3(2A)_BCS1	
		n79	CA_n79C_BCS0	
CA_n1(2A)-n3(2A)-n79A	-	n1	CA_n1(2A)_BCS0	0
		n3	CA_n3(2A)_BCS1	
		n79	40, 50, 60, 80, 100	
CA_n1(2A)-n3(2A)-n79C	-	n1	CA_n1(2A)_BCS0	0
		n3	CA_n3(2A)_BCS1	
		n79	CA_n79C_BCS0	
CA_n1A-n3A-n105A	CA_n1A-n3A CA_n1A-n105A CA_n3A-n105A	n1	5, 10, 15, 20, 25, 30, 40, 50	0
		n3	5, 10, 15, 20, 25, 30, 40, 50	
		n105	5, 10, 15, 20, 25, 30, 35	
CA_n1A-n5A-n7A	CA_n1A-n5A CA_n1A-n7A CA_n5A-n7A	n1	5, 10, 15, 20, 25, 30, 40, 50	0
		n5	5, 10, 15, 20	
		n7	5, 10, 15, 20, 25, 30, 40, 50	
CA_n1A-n5A-n7B	CA_n1A-n5A CA_n1A-n7A CA_n5A-n7A CA_n7B	n1	5, 10, 15, 20, 25, 30, 40, 50	0
		n5	5, 10, 15, 20	
		n7	CA_n7B_BCS0	
CA_n1A-n5A-n28A	-	n1	5, 10, 15, 20, 25, 30, 40, 50	0
		n5	5, 10, 15, 20	
		n28	5, 10, 15, 20, 30	
	CA_n1A-n5A CA_n1A-n28A CA_n5A-n28A	n1	See n1 channel bandwidths in Table 5.3.5-1	4 and 5
		n5	See n5 channel bandwidths in Table 5.3.5-1	
		n28	See n28 channel bandwidths in Table 5.3.5-1	
CA_n1A-n5A-n40A	CA_n1A-n5A CA_n1A-n40A CA_n5A-n40A	n1	5, 10, 15, 20	0
		n5	5, 10, 15, 20	
		n40	5, 10, 15, 20, 25, 30, 40, 50, 60, 70, 80, 90, 100	
		n1	5, 10, 15, 20, 25, 30, 40, 45, 50	1
		n5	5, 10, 15, 20, 25	
		n40	5, 10, 15, 20, 25, 30, 40, 50	
CA_n1A-n5A-n78A	CA_n1A-n5A CA_n1A-n78A CA_n5A-n78A	n1	5, 10, 15, 20, 25, 30, 40, 50	0
		n5	5, 10, 15, 20	
		n78	10, 15, 20, 25, 30, 40, 50, 60, 70 <sup>4</sup> , 80, 90, 100	

		n1	See n1 channel bandwidths in Table 5.3.5-1	4 and 5
		n5	See n5 channel bandwidths in Table 5.3.5-1	
		n78	See n78 channel bandwidths in Table 5.3.5-1	
CA_n1A-n5A-n78C	n78C CA_n1A-n5A CA_n1A-n78A CA_n5A-n78A	n1	See n1 channel bandwidths in Table 5.3.5-1	4 and 5
		n5	See n5 channel bandwidths in Table 5.3.5-1	
		n78	CA_n78C_BCS4 and 5	
CA_n1A-n5A-n79A	CA_n1A-n5A CA_n1A-n79A CA_n5A-n79A	n1	See n1 channel bandwidths in Table 5.3.5-1	4 and 5
		n5	See n5 channel bandwidths in Table 5.3.5-1	
		n79	See n79 channel bandwidths in Table 5.3.5-1	
CA_n1A-n5A-n105A	CA_n1A-n5A CA_n1A-n105A CA_n5A-n105A	n1	5, 10, 15, 20, 25, 30, 40, 45, 50	0
		n5	5, 10, 15, 20, 25	
		n105	5, 10, 15, 20, 25, 30, 35	
CA_n1A-n7A-n8A	CA_n1A-n7A CA_n1A-n8A CA_n7A-n8A	n1	5, 10, 15, 20, 25, 30, 40	0
		n7	5, 10, 15, 20, 25, 30, 40, 50	
		n8	5, 10, 15, 20	
CA_n1A-n7(2A)-n8A	CA_n1A-n7A CA_n1A-n8A CA_n7A-n8A	n1	5, 10, 15, 20	0
		n7	CA_n7(2A)_BCS0	
		n8	5, 10, 15, 20	
CA_n1A-n7A-n26A	CA_n1A-n26A CA_n1A-n7A CA_n7A-n26A	n1	5, 10, 15, 20	0
		n7	5, 10, 15, 20, 25, 30, 40, 50	
		n26	5, 10, 15, 20	
CA_n1A-n7A-n26(2A)	CA_n26(2A) CA_n1A-n26A CA_n1A-n7A CA_n7A-n26A	n1	5, 10, 15, 20, 25, 30, 40, 45, 50	0
		n7	5, 10, 15, 20, 25, 30, 35, 40, 50	
		n26	CA_n26(2A)_BCS0	
CA_n1A-n7B-n26A	CA_n1A-n26A CA_n1A-n7A CA_n7A-n26A CA_n7B	n1	5, 10, 15, 20	0
		n7	CA_n7B_BCS0	
		n26	5, 10, 15, 20	
CA_n1A-n7B-n26(2A)	CA_n1A-n26A CA_n1A-n7A CA_n7A-n26A CA_n7B CA_n26(2A)	n1	5, 10, 15, 20, 25, 30, 40, 45, 50	0
		n7	CA_n7B_BCS0	
		n26	CA_n26(2A)_BCS0	
CA_n1A-n7A-n28A	CA_n1A-n7A CA_n1A-n28A CA_n7A-n28A	n1	5, 10, 15, 20	0
		n7	5, 10, 15, 20, 25, 30, 40, 50	
		n28	5, 10, 15, 20	
CA_n1A-n7B-n28A	CA_n1A-n28A CA_n1A-n7A CA_n7A-n28A	n1	5, 10, 15, 20	0

	CA_n7B	n7	CA_n7B_BCS0	
		n28	5, 10, 15, 20	
CA_n1A-n7A-n38A <sup>10</sup>	-	n1	5, 10, 15, 20, 25, 30, 40, 50	0
		n7	5, 10, 15, 20, 25, 30, 40, 50	
		n38	5, 10, 15, 20, 25, 30, 40	
CA_n1(2A)-n7A-n38A <sup>10</sup>	-	n1	CA_n1(2A)_BCS0	0
		n7	5, 10, 15, 20, 25, 30, 40, 50	
		n38	5, 10, 15, 20, 25, 30, 40	
CA_n1A-n7A-n40A	CA_n1A-n7A CA_n1A-n40A CA_n7A-n40A	n1	5, 10, 15, 20, 25, 30, 40, 50	0
		n7	5, 10, 15, 20, 25, 30, 40, 50	
		n40	5, 10, 15, 20, 25, 30, 40, 50, 60, 80	
CA_n1A-n7A-n67A	CA_n1A-n7A	n1	5, 10, 15, 20, 30, 40, 45, 50	0
		n7	5, 10, 15, 20, 25, 30, 35, 40, 50	
		n67	5, 10, 15, 20	
CA_n1A-n7A-n75A	-	n1	n1 channel bandwidths in Table 5.3.5-1	4 and 5
		n7	n7 channel bandwidths in Table 5.3.5-1	
		n75	n75 channel bandwidths in Table 5.3.5-1	
CA_n1A-n7A-n78A	n78 <sup>7,9</sup> CA_n1A-n7A CA_n1A-n78A <sup>7</sup> CA_n7A-n78A <sup>7</sup>	n1	5, 10, 15, 20	0
		n7	5, 10, 15, 20, 25, 30, 40, 50	
		n78	10, 15, 20, 40, 50, 60, 80, 90 <sup>1</sup> , 100	
		n1	5, 10, 15, 20	1
		n7	5, 10, 15, 20, 25, 30, 40, 50	
		n78	10, 15, 20, 25, 30, 40, 50, 60, 70, 80, 90 <sup>1</sup> , 100	
	-	n1	n1 channel bandwidths in Table 5.3.5-1	4 and 5
		n7	n7 channel bandwidths in Table 5.3.5-1	
		n78	n78 channel bandwidths in Table 5.3.5-1	
CA_n1A-n7B-n78A	CA_n1A-n78A CA_n1A-n7A CA_n7A-n78A CA_n7B	n1	5, 10, 15, 20	0
		n7	CA_n7B_BCS0	
		n78	10, 15, 20, 25, 30, 40, 50, 60, 70 <sup>4</sup> , 80, 90, 100	
CA_n1A-n7B-n78(2A)	CA_n1A-n78A CA_n1A-n7A CA_n7A-n78A CA_n7B	n1	5, 10, 15, 20, 25, 30, 40, 45, 50	0
		n7	CA_n7B_BCS0	
		n78	CA_n78(2A)_BCS0	
CA_n1A-n7A-n78(2A)	n78 <sup>7,9</sup> CA_n1A-n7A CA_n1A-n78A <sup>7</sup> CA_n7A-n78A <sup>7</sup>	n1	5, 10, 15, 20	0
		n7	5, 10, 15, 20, 25, 30, 40, 50	
		n78	CA_n78(2A)_BCS0	
	n78 <sup>7,9</sup> CA_n78(2A) <sup>7</sup> CA_n1A-n7A CA_n1A-n78A <sup>7</sup> CA_n7A-n78A <sup>7</sup>	n1	5, 10, 15, 20	1
		n7	5, 10, 15, 20, 25, 30, 40, 50	
		n78	CA_n78(2A)_BCS2	

CA_n1A-n7A-n78C	CA_n78C CA_n1A-n7A CA_n1A-n78A CA_n7A-n78A	n1	5, 10, 15, 20, 25, 30, 40, 50	0	
		n7	5, 10, 15, 20, 25, 30, 40, 50		
		n78	CA_n78C_BCS1		
CA_n1A-n7B-n78C	CA_n7B CA_n1A-n7A CA_n1A-n78A CA_n7A-n78A CA_n78C	n1	5, 10, 15, 20, 25, 30, 40, 50	0	
		n7	CA_n7B_BCS0		
		n78	CA_n78C_BCS1		
CA_n1A-n7(2A)-n78A	CA_n1A-n7A CA_n1A-n78A CA_n7A-n78A	n1	5, 10, 15, 20	0	
		n7	CA_n7(2A)_BCS0		
		n78	10, 15, 20, 25, 30, 40, 50, 60, 70, 80, 90, 100		
CA_n1A-n7A-n79A	-	n1	5, 10, 15, 20, 25, 30, 40, 50	0	
		n7	5, 10, 15, 20, 25, 30, 40, 50		
		n79	40, 50, 60, 80, 100		
CA_n1A-n7A-n79C	-	n1	5, 10, 15, 20, 25, 30, 40, 50	0	
		n7	5, 10, 15, 20, 25, 30, 40, 50		
		n79	CA_n79C_BCS0		
CA_n1(2A)-n7A-n79A	-	n1	CA_n1(2A)_BCS0	0	
		n7	5, 10, 15, 20, 25, 30, 40, 50		
		n79	40, 50, 60, 80, 100		
CA_n1(2A)-n7A-n79C	-	n1	CA_n1(2A)_BCS0	0	
		n7	5, 10, 15, 20, 25, 30, 40, 50		
		n79	CA_n79C_BCS0		
CA_n1A-n7A-n105A	CA_n1A-n7A CA_n1A-n105A CA_n7A-n105A	n1	5, 10, 15, 20, 25, 30, 40, 50	0	
		n7	5, 10, 15, 20, 25, 30, 40, 50		
		n105	5, 10, 15, 20, 25, 30, 35		
CA_n1A-n8A-n28A	-	n1	5, 10, 15, 20, 25, 30, 40, 50	0	
		n8	5, 10, 15, 20		
		n28	10, 15, 20		
CA_n1A-n8A-n40A	CA_n1A-n8A CA_n1A-n40A CA_n8A-n40A	n1	5, 10, 15, 20, 25, 30, 40, 50	0	
		n8	5, 10, 15, 20		
		n40	5, 10, 15, 20, 25, 30, 40, 50, 60, 80		
		n1	n1 channel bandwidths in Table 5.3.5-1		4 and 5
		n8	n8 channel bandwidths in Table 5.3.5-1		
CA_n1A-n8A-n77A	-	n1	5, 10, 15, 20	0	
		n8	5, 10, 15, 20		
		n77	10, 15, 20, 40, 50, 60, 80, 90, 100		
CA_n1A-n8A-n77(2A)	-	n1	5, 10, 15, 20	0	
		n8	5, 10, 15, 20		
		n77	CA_n77(2A)_BCS1		
CA_n1A-n8A-n78A	CA_n1A-n8A CA_n1A-n78A CA_n8A-n78A	n1	5, 10, 15, 20	0	
		n8	5, 10, 15, 20		
		n78	10, 15, 20, 40, 50, 60, 80, 90, 100		
	-	n1	5, 10, 15, 20	1	
		n8	5, 10, 15, 20		
		n78	10, 15, 20, 25, 30, 40, 50, 60, 80, 90, 100		
CA_n1A-n8A CA_n1A-n78A	n1	See n1 channel bandwidths in Table 5.3.5-1	4 and 5		



	CA_n8A-n78A	n8	See n8 channel bandwidths in Table 5.3.5-1	
		n78	See n78 channel bandwidths in Table 5.3.5-1	
CA_n1A-n8A-n78C	CA_n1A-n8A CA_n1A-n78A CA_n8A-n78A	n1	See n1 channel bandwidths in Table 5.3.5-1	4 and 5
		n8	See n8 channel bandwidths in Table 5.3.5-1	
		n78	CA_n78C_BCS4 and 5	
CA_n1A-n8A-n78(2A)	-	n1	5, 10, 15, 20	0
		n8	5, 10, 15, 20	
		n78	CA_n78(2A)_BCS1	
CA_n1A-n8A-n79A	-	n1	5, 10, 15, 20	0
		n8	5, 10, 15, 20	
		n79	40, 50, 60, 80, 100	
CA_n1A-n18A-n28A	CA_n1A-n18A CA_n1A-n28A CA_n18A-n28A	n1	5, 10, 15, 20, 25, 30, 40, 50	0
		n18	5, 10, 15	
		n28	5, 10	
CA_n1A-n18A-n41A	CA_n1A-n18A CA_n1A-n41A CA_n18A-n41A	n1	5, 10, 15, 20, 25, 30, 40, 50	0
		n18	5, 10, 15	
		n41	10, 15, 20, 30, 40, 50, 60, 80, 90, 100	
CA_n1A-n18A-n77A	n77 <sup>7</sup> CA_n1A-n18A CA_n1A-n77A CA_n18A-n77A	n1	5, 10, 15, 20, 25, 30, 40, 50	0
		n18	5, 10, 15	
		n77	10, 15, 20, 40, 50, 60, 80, 90, 100	
CA_n1A-n18A-n77(2A)	CA_n1A-n18A CA_n1A-n77A CA_n18A-n77A	n1	5, 10, 15, 20	0
		n18	5, 10, 15	
		n77	CA_n77(2A)_BCS1	
CA_n1A-n20A-n67A	CA_n1A-n20A	n1	5, 10, 15, 20, 25, 30, 40, 50	0
		n20	5, 10, 15, 20	
		n67	5, 10, 15, 20	
CA_n1A-n20A-n78A	-	n1	5, 10, 15, 20, 25, 30, 40, 50	0
		n20	5, 10, 15, 20	
		n78	10, 15, 20, 25, 30, 40, 50, 60, 70, 80, 90, 100	
CA_n1A-n26A-n78A	CA_n1A-n26A CA_n1A-n78A CA_n26A-n78A	n1	5, 10, 15, 20	0
		n26	5, 10, 15, 20	
		n78	10, 15, 20, 25, 30, 40, 50, 60, 70, 80, 90, 100	
CA_n1A-n26A-n78C	CA_n78C CA_n1A-n26A CA_n1A-n78A CA_n26A-n78A	n1	5, 10, 15, 20	0
		n26	5, 10, 15, 20	
		n78	CA_n78C_BCS0	
CA_n1A-n26(2A)-n78A	CA_n1A-n26A CA_n1A-n78A CA_n26A-n78A CA_n26(2A)	n1	5, 10, 15, 20, 25, 30, 40, 45, 50	0
		n26	CA_n26(2A)_BCS0	
		n78	10, 15, 20, 25, 30, 40, 50, 60, 70, 80, 90, 100	
CA_n1A-n26A-n78(2A)	CA_n1A-n26A CA_n1A-n78A	n1	5, 10, 15, 20, 25, 30, 40, 45, 50	0

	CA_n26A-n78A	n26	5, 10, 15, 20, 25, 30	
		n78	CA_n78(2A)_BCS0	
CA_n1A-n26(2A)-n78(2A)	CA_n1A-n26A CA_n1A-n78A CA_n26A-n78A CA_n26(2A)	n1	5, 10, 15, 20, 25, 30, 40, 45, 50	0
		n26	CA_n26(2A)_BCS0	
		n78	CA_n78(2A)_BCS0	
CA_n1A-n26(2A)-n78C	CA_n26(2A) CA_n78C CA_n1A-n26A CA_n1A-n78A CA_n26A-n78A	n1	5, 10, 15, 20, 25, 30, 40, 45, 50	0
		n26	CA_n26(2A)_BCS0	
		n78	CA_n78C_BCS0	
CA_n1A-n28A-n38A	-	n1	5, 10, 15, 20, 25, 30, 40, 50	0
		n28	5, 10, 15, 20, 30	
		n38	5, 10, 15, 20, 25, 30, 40	
CA_n1A-n28A-n40A	-	n1	5, 10, 15, 20	0
		n28	5, 10, 15, 20	
		n40	5, 10, 15, 20, 25, 30, 40, 50, 60, 80	
		n1	5, 10, 15, 20	1
		n28	5, 10, 15, 20, 25, 30	
		n40	10, 15, 20, 25, 30, 40, 50, 60, 70, 80, 90, 100	
		n1	n1 channel bandwidths in Table 5.3.5-1	4 and 5
		n28	n28 channel bandwidths in Table 5.3.5-1	
		n40	n40 channel bandwidths in Table 5.3.5-1	
CA_n1A-n28A-n40B	-	n1	5, 10, 15, 20	0
		n28	5, 10, 15, 20	
		n40	CA_n40B_BCS0	
		n1	n1 channel bandwidths in Table 5.3.5-1	4 and 5
		n28	n28 channel bandwidths in Table 5.3.5-1	
		n40	CA_n40B_BCS4 and 5	
CA_n1A-n28A-n41A	n41 <sup>7,9</sup> CA_n1A-n28A CA_n1A-n41A <sup>7</sup> CA_n28A-n41A <sup>7</sup>	n1	5, 10, 15, 20	0
		n28	5, 10, 15, 20	
		n41	10, 15, 20, 30, 40, 50, 60, 80, 90, 100	
CA_n1A-n28A-n46A	CA_n1A-n28A CA_n1A-n46A CA_n28A-n46A	n1	5, 10, 15, 20, 25, 30, 40, 50	0
		n28	5, 10, 15, 20	
		n46	10, 20, 40, 60, 80	
CA_n1A-n28A-n46C	CA_n1A-n28A CA_n1A-n46A CA_n28A-n46A	n1	5, 10, 15, 20, 25, 30, 40, 50	0
		n28	5, 10, 15, 20	
		n46	CA_n46C_BCS0	
CA_n1A-n28A-n46D	CA_n1A-n28A CA_n1A-n46A CA_n28A-n46A	n1	5, 10, 15, 20, 25, 30, 40, 50	0
		n28	5, 10, 15, 20	
		n46	CA_n46D_BCS0	
CA_n1A-n28A-n46(2A)	CA_n1A-n28A CA_n1A-n46A CA_n28A-n46A	n1	5, 10, 15, 20, 25, 30, 40, 50	0
		n28	5, 10, 15, 20	

CA_n1A-n28A-n75A	-	n46	CA_n46(2A)_BCS0	0
		n1	5, 10, 15, 20	
		n28	5, 10, 15, 20	
		n75	5, 10, 15, 20, 25, 30, 40, 50	
CA_n1A-n28A-n77A	n77 <sup>7,9</sup> CA_n1A-n28A CA_n1A-n77A <sup>7</sup> CA_n28A-n77A <sup>7</sup>	n1	5, 10, 15, 20	0
		n28	5, 10, 15, 20	
		n77	10, 15, 20, 40, 50, 60, 80, 90, 100	
		n1	5, 10, 15, 20	1
		n28	5, 10, 15, 20, 25, 30	
		n77	10, 15, 20, 25, 30, 40, 50, 60, 70, 80, 90, 100	
CA_n1A-n28A-n77(2A)	n77 <sup>7,9</sup> CA_n1A-n28A CA_n1A-n77A <sup>7</sup> CA_n28A-n77A <sup>7</sup>	n1	5, 10, 15, 20	0
		n28	5, 10, 15, 20	
		n77	CA_n77(2A)_BCS0	
		n1	5, 10, 15, 20	1
		n28	5, 10	
	n77	CA_n77(2A)_BCS1	4 and 5	
	CA_n1A_n28A CA_n1A_n77A CA_n28A_n77A CA_n77(2A)	n1		n1 channel bandwidths in Table 5.3.5-1
	n28	n28 channel bandwidths in Table 5.3.5-1		
CA_n1A-n28A-n77(3A)	CA_n1A-n28A CA_n1A-n77A CA_n28A-n77A	n1	5, 10, 15, 20	0
		n28	5, 10, 15, 20	
		n77	CA_n77(3A)_BCS0	
CA_n1A-n28A-n78A	n78 <sup>7,9</sup> CA_n1A-n28A CA_n1A-n78A <sup>7</sup> CA_n28A-n78A <sup>7</sup>	n1	5, 10, 15, 20	0
		n28	5, 10, 15, 20 <sup>2</sup>	
		n78	10, 15, 20, 40, 50, 60, 80, 90, 100	
		n1	5, 10, 15, 20	1
		n28	5, 10, 15, 20	
		n78	10, 15, 20, 25, 30, 40, 50, 60, 70, 80, 90, 100	2
		n1	5, 10, 15, 20, 25, 30, 40, 50	
		n28	5, 10, 15, 20, 30	
n78	10, 15, 20, 25, 30, 40, 50, 60, 70, 80, 90, 100			
CA_n1A-n28A-n78(2A)	n78 <sup>7,9</sup> CA_n78(2A) <sup>7</sup> CA_n1A-n28A CA_n1A-n78A <sup>7</sup> CA_n28A-n78A <sup>7</sup>	n1	5, 10, 15, 20	0
		n28	5, 10, 15, 20	
		n78	CA_n78(2A)_BCS2	
CA_n1A-n28A-n78C	CA_n1A-n28A CA_n1A-n78A CA_n28A-n78A	n1	5, 10, 15, 20, 25, 30, 40, 50	0
		n28	5, 10, 15, 20	
		n78	CA_n78C_BCS1	
CA_n1A-n28A-n79A	n79 <sup>7,9</sup> CA_n1A-n28A CA_n1A-n79A <sup>7</sup> CA_n28A-n79A <sup>7</sup>	n1	5, 10, 15, 20	0
		n28	5, 10, 15, 20	

		n79	40, 50, 60, 80, 100	
CA_n1A-n28A-n102A	CA_n1A-n28A CA_n1A-n102A CA_n28A-n102A	n1	5, 10, 15, 20, 25, 30, 40, 50	0
		n28	5, 10, 15, 20, 30	
		n102	20, 40, 60, 80, 100	
CA_n1A-n28A-n102B	CA_n1A-n28A CA_n1A-n102A CA_n1A-n102B CA_n28A-n102A CA_n28A-n102B	n1	5, 10, 15, 20, 25, 30, 40, 50	0
		n28	5, 10, 15, 20, 30	
		n102	CA_n102B_BCS0	
CA_n1A-n28A-n102C	CA_n1A-n28A CA_n1A-n102A CA_n1A-n102C CA_n28A-n102A CA_n28A-n102C	n1	5, 10, 15, 20, 25, 30, 40, 50	0
		n28	5, 10, 15, 20, 30	
		n102	CA_n102C_BCS0	
CA_n1A-n28A-n102D	CA_n1A-n28A CA_n1A-n102A CA_n28A-n102A	n1	5, 10, 15, 20, 25, 30, 40, 50	0
		n28	5, 10, 15, 20, 30	
		n102	CA_n102D_BCS0	
CA_n1A-n28A-n102E	CA_n1A-n28A CA_n1A-n102A CA_n28A-n102A	n1	5, 10, 15, 20, 25, 30, 40, 50	0
		n28	5, 10, 15, 20, 30	
		n102	CA_n102E_BCS0	
CA_n1A-n28A-n102(2A)	CA_n1A-n28A CA_n1A-n102A CA_n28A-n102A	n1	5, 10, 15, 20, 25, 30, 40, 50	0
		n28	5, 10, 15, 20, 30	
		n102	CA_n102(2A)_BCS0	
CA_n1A-n38A-n78A	-	n1	5, 10, 15, 20, 25, 30, 40, 50	0
		n38	5, 10, 15, 20, 25, 30, 40	
		n78	10, 15, 20, 25, 30, 40, 50, 60, 70, 80, 90, 100	
CA_n1A-n40A-n77A	CA_n1A-n40A CA_n1A-n77A CA_n40A-n77A	n1	5, 10, 15, 20, 30, 40, 45, 50	0
		n40	10, 15, 20, 25, 30, 40, 50, 60, 70, 80, 90, 100	
		n77	10, 15, 20, 25, 30, 40, 50, 60, 70, 80, 90, 100	
CA_n1A-n40A-n77(2A)	CA_n1A-n40A CA_n1A-n77A CA_n40A-n77A	n1	5, 10, 15, 20, 30, 40, 45, 50	0
		n40	10, 15, 20, 25, 30, 40, 50, 60, 70, 80, 90, 100	
		n77	CA_n77(2A)_BCS1	
CA_n1A-n40A-n78A	CA_n1A-n40A CA_n1A-n78A CA_n40A-n78A	n1	5, 10, 15, 20	0
		n40	5, 10, 15, 20, 25, 30, 40, 50	
		n78	10, 15, 20, 40, 50, 60, 80, 90, 100	
		n1	5, 10, 15, 20	1
		n40	5, 10, 15, 20, 25, 30, 40, 50, 60, 80	
		n78	10, 15, 20, 40, 50, 60, 80, 90, 100	
		n1	5, 10, 15, 20	2
		n40	5, 10, 15, 20, 25, 30, 40, 50, 60, 70, 80, 90, 100	
		n78	10, 15, 20, 25, 30, 40, 50, 60, 70, 80, 90, 100	
n1	n1 channel bandwidths in Table 5.3.5-1	4 and 5		

		n40	n40 channel bandwidths in Table 5.3.5-1	
		n78	n78 channel bandwidths in Table 5.3.5-1	
CA_n1A-n40B-n78A	-	n1	5, 10, 15, 20	0
		n40	CA_n40B_BCS0	
		n78	10, 15, 20, 40, 50, 60, 80, 90, 100	
		n1	n1 channel bandwidths in Table 5.3.5-1	4 and 5
		n40	CA_n40B_BCS 4 and 5	
		n78	n78 channel bandwidths in Table 5.3.5-1	
CA_n1A-n40A-n105A	CA_n1A-n40A CA_n1A-n105A CA_n40A-n105A	n1	5, 10, 15, 20, 25, 30, 40, 50	0
		n40	10, 15, 20, 25, 30, 40, 50, 60, 70, 80, 90, 100	
		n105	5, 10, 15, 20, 25, 30, 35	
CA_n1A-n41A-n77A	n41 <sup>7,9</sup> n77 <sup>7,9</sup> CA_n1A-n41A <sup>7</sup> CA_n1A-n77A <sup>7</sup> CA_n41A-n77A <sup>7</sup>	n1	5, 10, 15, 20	0
		n41	10, 15, 20, 30, 40, 50, 60, 80, 90, 100	
		n77	10, 15, 20, 40, 50, 60, 80, 90, 100	
CA_n1A-n41A-n77(2A)	n41 <sup>7,9</sup> n77 <sup>7,9</sup> CA_n1A-n41A <sup>7</sup> CA_n1A-n77A <sup>7</sup> CA_n41A-n77A <sup>7</sup>	n1	5, 10, 15, 20	0
		n41	10, 15, 20, 30, 40, 50, 60, 80, 90, 100	
		n77	CA_n77(2A)_BCS1	
CA_n1A-n41A-n77(3A)	CA_n1A-n41A CA_n1A-n77A CA_n41A-n77A	n1	5, 10, 15, 20	0
		n41	10, 15, 20, 30, 40, 50, 60, 80, 90, 100	
		n77	CA_n77(3A)_BCS1	
CA_n1A-n41A-n79A	CA_n1A-n41A CA_n1A-n79A CA_n41A-n79A	n1	5, 10, 15, 20	0
		n41	10, 15, 20, 30, 40, 50, 60, 80, 90, 100	
		n79	40, 50, 60, 80, 100	
CA_n1A-n46A-n78A	CA_n1A-n46A CA_n1A-n78A CA_n46A-n78A	n1	5, 10, 15, 20, 25, 30, 40, 50	0
		n46	10, 20, 40, 60, 80	
		n78	10, 15, 20, 25, 30, 40, 50, 60, 70, 80, 90, 100	
CA_n1A-n46C-n78A	CA_n1A-n46A CA_n1A-n78A CA_n46A-n78A	n1	5, 10, 15, 20, 25, 30, 40, 50	0
		n46	CA_n46C_BCS0	
		n78	10, 15, 20, 25, 30, 40, 50, 60, 70, 80, 90, 100	
CA_n1A-n46D-n78A	CA_n1A-n46A CA_n1A-n78A CA_n46A-n78A	n1	5, 10, 15, 20, 25, 30, 40, 50	0
		n46	CA_n46D_BCS0	
		n78	10, 15, 20, 25, 30, 40, 50, 60, 70, 80, 90, 100	
CA_n1A-n46(2A)-n78A	CA_n1A-n46A CA_n1A-n78A CA_n46A-n78A	n1	5, 10, 15, 20, 25, 30, 40, 50	0

		n46	CA_n46(2A)_BCS0	
		n78	10, 15, 20, 25, 30, 40, 50, 60, 70, 80, 90, 100	
CA_n1A-n46A-n78(2A)	CA_n1A-n46A CA_n1A-n78A CA_n46A-n78A CA_n78(2A)	n1	5, 10, 15, 20, 25, 30, 40, 50	0
		n46	10, 20, 40, 60, 80	
		n78	CA_n78(2A)_BCS2	
CA_n1A-n46C-n78(2A)	CA_n1A-n46A CA_n1A-n78A CA_n46A-n78A CA_n78(2A)	n1	5, 10, 15, 20, 25, 30, 40, 50	0
		n46	CA_n46C_BCS0	
		n78	CA_n78(2A)_BCS2	
CA_n1A-n46D-n78(2A)	CA_n1A-n46A CA_n1A-n78A CA_n46A-n78A CA_n78(2A)	n1	5, 10, 15, 20, 25, 30, 40, 50	0
		n46	CA_n46D_BCS0	
		n78	CA_n78(2A)_BCS2	
CA_n1A-n46(2A)-n78(2A)	CA_n1A-n46A CA_n1A-n78A CA_n46A-n78A CA_n78(2A)	n1	5, 10, 15, 20, 25, 30, 40, 50	0
		n46	CA_n46(2A)_BCS0	
		n78	CA_n78(2A)_BCS2	
CA_n1A-n67A-n78A	CA_n1A-n78A	n1	5, 10, 15, 20, 30, 40, 45, 50	0
		n67	5, 10, 15, 20	
		n78	10, 15, 20, 25, 30, 40, 50, 60, 70, 80, 90, 100	
CA_n1A-n67A-n78(2A)	CA_n1A-n78A CA_n78(2A)	n1	5, 10, 15, 20, 30, 40, 45, 50	0
		n67	5, 10, 15, 20	
		n78	CA_n78(2A)_BCS2	
CA_n1A-n75A-n78A	-	n1	n1 channel bandwidths in Table 5.3.5-1	4 and 5
		n75	n75 channel bandwidths in Table 5.3.5-1	
		n78	n78 channel bandwidths in Table 5.3.5-1	
CA_n1A-n77A-n79A <sup>4</sup>	n77 <sup>7,9</sup> n79 <sup>7,9</sup> CA_n1A-n77A <sup>7</sup> CA_n1A-n79A <sup>7</sup> CA_n77A-n79A <sup>7</sup>	n1	5, 10, 15, 20	0
		n77	10, 15, 20, 40, 50, 60, 80, 90, 100	
		n79	40, 50, 60, 80, 100	
		n1	n1 channel bandwidths in Table 5.3.5-1	4 and 5
		n77	n77 channel bandwidths in Table 5.3.5-1	
CA_n1A-n77(2A)-n79A <sup>4</sup>	n77 <sup>7,9</sup> n79 <sup>7,9</sup> CA_n1A-n77A <sup>7</sup> CA_n1A-n79A <sup>7</sup> CA_n77A-n79A <sup>7</sup> CA_n77A(2A) <sup>7</sup>	n1	5, 10, 15, 20	0
		n77	CA_n77(2A)_BCS0	
		n79	40, 50, 60, 80, 100	
		n1	n1 channel bandwidths in Table 5.3.5-1	4 and 5
		n77	CA_n77(2A)_BCS4 and 5	
		n79	n79 channel bandwidths in Table 5.3.5-1	

CA_n1A-n77(3A)-n79A <sup>4</sup>	CA_n1A-n77A CA_n1A-n79A CA_n77A-n79A	n1	5, 10, 15, 20	0
		n77	CA_n77(3A)_BCS0	
		n79	40, 50, 60, 80, 100	
CA_n1A-n78A-n79A <sup>5</sup>	CA_n1A-n78A CA_n1A-n79A CA_n78A-n79A	n1	5, 10, 15, 20	0
		n78	10, 15, 20, 40, 50, 60, 80, 90, 100	
		n79	40, 50, 60, 80, 100	
		n1	5, 10, 15, 20	1
		n78	10, 15, 20, 25, 30, 40, 50, 60, 80, 90, 100	
n79	40, 50, 60, 80, 100			
		n1	n1 channel bandwidths in Table 5.3.5-1	4 and 5
		n78	n78 channel bandwidths in Table 5.3.5-1	
		n79	n79 channel bandwidths in Table 5.3.5-1	
CA_n1A-n78(2A)-n79A	-	n1	5, 10, 15, 20	0
		n78	CA_n78(2A)_BCS1	
		n79	40, 50, 60, 80, 100	
CA_n1A-n78A-n102A	CA_n1A-n78A CA_n1A-n102A CA_n78A-n102A	n1	5, 10, 15, 20, 25, 30, 40, 50	0
		n78	10, 15, 20, 25, 30, 40, 50, 60, 70, 80, 90, 100	
		n102	20, 40, 60, 80, 100	
CA_n1A-n78A-n102B	CA_n1A-n78A CA_n1A-n102A CA_n1A-n102B CA_n78A-n102A CA_n78A-n102B	n1	5, 10, 15, 20, 25, 30, 40, 50	0
		n78	10, 15, 20, 25, 30, 40, 50, 60, 70, 80, 90, 100	
		n102	CA_n102B_BCS0	
CA_n1A-n78A-n102C	CA_n1A-n78A CA_n1A-n102A CA_n1A-n102C CA_n78A-n102A CA_n78A-n102C	n1	5, 10, 15, 20, 25, 30, 40, 50	0
		n78	10, 15, 20, 25, 30, 40, 50, 60, 70, 80, 90, 100	
		n102	CA_n102C_BCS0	
CA_n1A-n78A-n102D	CA_n1A-n78A CA_n1A-n102A CA_n78A-n102A	n1	5, 10, 15, 20, 25, 30, 40, 50	0
		n78	10, 15, 20, 25, 30, 40, 50, 60, 70, 80, 90, 100	
		n102	CA_n102D_BCS0	
CA_n1A-n78A-n102E	CA_n1A-n78A CA_n1A-n102A CA_n78A-n102A	n1	5, 10, 15, 20, 25, 30, 40, 50	0
		n78	10, 15, 20, 25, 30, 40, 50, 60, 70, 80, 90, 100	
		n102	CA_n102E_BCS0	
CA_n1A-n78A-n102(2A)	CA_n1A-n78A CA_n1A-n102A CA_n78A-n102A	n1	5, 10, 15, 20, 25, 30, 40, 50	0
		n78	10, 15, 20, 25, 30, 40, 50, 60, 70, 80, 90, 100	
		n102	CA_n102(2A)_BCS0	
CA_n1A-n78(2A)-n102A	CA_n1A-n78A CA_n1A-n102A CA_n78A-n102A	n1	5, 10, 15, 20	0

	CA_n78(2A)			
		n78	CA_n78(2A)_BCS2	
		n102	20, 40, 60, 80, 100	
CA_n1A-n78(2A)-n102B	CA_n1A-n78A CA_n1A-n102A CA_n1A-n102B CA_n78A-n102A CA_n78A-n102B CA_n78(2A)	n1	5, 10, 15, 20	0
		n78	CA_n78(2A)_BCS2	
		n102	CA_n102B_BCS0	
CA_n1A-n78(2A)-n102C	CA_n1A-n78A CA_n1A-n102A CA_n1A-n102C CA_n78A-n102A CA_n78A-n102C CA_n78(2A)	n1	5, 10, 15, 20	0
		n78	CA_n78(2A)_BCS2	
		n102	CA_n102C_BCS0	
CA_n1A-n78(2A)-n102D	CA_n1A-n78A CA_n1A-n102A CA_n78A-n102A CA_n78(2A)	n1	5, 10, 15, 20	0
		n78	CA_n78(2A)_BCS2	
		n102	CA_n102D_BCS0	
CA_n1A-n78(2A)-n102E	CA_n1A-n78A CA_n1A-n102A CA_n78A-n102A CA_n78(2A)	n1	5, 10, 15, 20	0
		n78	CA_n78(2A)_BCS2	
		n102	CA_n102E_BCS0	
CA_n1A-n78(2A)-n102(2A)	CA_n1A-n78A CA_n1A-n102A CA_n78A-n102A CA_n78(2A)	n1	5, 10, 15, 20	0
		n78	CA_n78(2A)_BCS2	
		n102	CA_n102(2A)_BCS0	
CA_n1A-n78A-n105A	CA_n1A-n78A CA_n1A-n105A CA_n78A-n105A	n1	5, 10, 15, 20, 25, 30, 40, 50	0
		n78	10, 15, 20, 25, 30, 40, 50, 60, 70, 80, 90, 100	
		n105	5, 10, 15, 20, 25, 30, 35	
CA_n2A-n5A-n30A	CA_n2A-n5A CA_n2A-n30A CA_n5A-n30A	n2	5, 10, 15, 20	0
		n5	5, 10, 15, 20	
		n30	5, 10	
CA_n2A-n5A-n41A	CA_n2A-n5A CA_n2A-n41A CA_n5A-n41A	n2	5, 10, 15, 20, 25, 30, 35, 40	0
		n5	5, 10, 15, 20, 25	
		n41	10, 15, 20, 30, 40, 50, 60, 80, 90, 100	
CA_n2A-n5A-n48A	CA_n2A-n5A CA_n2A-n48A CA_n5A-n48A	n2	5, 10, 15, 20	0
		n5	5, 10, 15, 20	
		n48	5, 10, 15, 20, 30, 40, 50 <sup>12</sup> , 60 <sup>12</sup> , 70 <sup>12</sup> , 80 <sup>12</sup> , 90 <sup>12</sup> , 100 <sup>12</sup>	
CA_n2A-n5A-n48B	CA_n2A-n5A CA_n2A-n48A CA_n5A-n48A CA_n48B	n2	5, 10, 15, 20	0
		n5	5, 10, 15, 20	
		n48	CA_n48B_BCS0	
		n2	5, 10, 15, 20	1



		n5	5, 10, 15, 20	
		n48	CA_n48B_BCS1	
		n2	5, 10, 15, 20	2
		n5	5, 10, 15, 20	
		n48	CA_n48B_BCS2	
CA_n2A-n5A-n48(2A)	CA_n2A-n5A CA_n2A-n48A CA_n5A-n48A	n2	5, 10, 15, 20	0
		n5	5, 10, 15, 20	
		n48	CA_n48(2A)_BCS0	
		n2	5, 10, 15, 20	1
		n5	5, 10, 15, 20	
		n48	CA_n48(2A)_BCS1	
CA_n2A-n5A-n48(A-B)	CA_n2A-n5A CA_n2A-n48A CA_n5A-n48A	n2	5, 10, 15, 20, 25, 30, 40	0
		n5	5, 10, 15, 20, 25 <sup>1</sup>	
		n48	CA_n48(A-B)_BCS0	
		n2	5, 10, 15, 20, 25, 30, 40	1
		n5	5, 10, 15, 20, 25 <sup>1</sup>	
		n48	CA_n48(A-B)_BCS1	
CA_n2(2A)-n5A-n30A	CA_n2A-n5A CA_n2A-n30A CA_n5A-n30A	n2	CA_n2(2A)_BCS0	0
		n5	5, 10, 15, 20	
		n30	5, 10	
CA_n2A-n5A-n66A	CA_n2A-n5A CA_n2A-n66A CA_n5A-n66A	n2	5, 10, 15, 20	0
		n5	5, 10, 15, 20	
		n66	5, 10, 15, 20, 25, 30, 40	
CA_n2(2A)-n5A-n66A	CA_n2A-n5A CA_n2A-n66A CA_n5A-n66A	n2	CA_n2(2A)_BCS0	0
		n5	5, 10, 15, 20	
		n66	5, 10, 15, 20, 25, 30, 40	
CA_n2(2A)-n5A-n66(2A)	CA_n2A-n5A CA_n2A-n66A CA_n5A-n66A	n2	CA_n2(2A)_BCS0	0
		n5	5, 10, 15, 20	
		n66	CA_n66(2A)_BCS1	
CA_n2A-n5A-n66(2A)	CA_n2A-n5A CA_n2A-n66A CA_n5A-n66A	n2	5, 10, 15, 20	0
		n5	5, 10, 15, 20	
		n66	CA_n66(2A)_BCS0	
CA_n2A-n5A-n66(3A)	CA_n2A-n5A CA_n2A-n66A CA_n5A-n66A	n2	5, 10, 15, 20	0
		n5	5, 10, 15, 20	
		n66	CA_n66(3A)_BCS0	
CA_n2A-n5A-n77A	n77 <sup>7,9</sup> CA_n2A-n5A CA_n2A-n77A <sup>7</sup> CA_n5A-n77A <sup>7</sup>	n2	5, 10, 15, 20	0
		n5	5, 10, 15, 20	
		n77	10, 15, 20, 25, 30, 40, 50, 60, 70, 80, 90, 100	
CA_n2A-n5A-n77C	n77 <sup>7,9</sup> CA_n2A-n5A CA_n2A-n77A <sup>7</sup> CA_n5A-n77A <sup>7</sup> CA_n77C	n2	5, 10, 15, 20, 25, 30, 40	0
		n5	5, 10, 15, 20, 25 <sup>1</sup>	
		n77	CA_n77C_BCS0	
		n2	5, 10, 15, 20, 25, 30, 40	1

		n5	5, 10, 15, 20, 25 <sup>1</sup>	
		n77	CA_n77C_BCS1	
CA_n2A-n5A-n77(2A)	n77 <sup>7,9</sup> CA_n2A-n5A CA_n2A-n77A <sup>7</sup> CA_n5A-n77A <sup>7</sup>	n2	5, 10, 15, 20	0
		n5	5, 10, 15, 20	
		n77	CA_n77(2A)_BCS1	
CA_n2(2A)-n5A-n77A	n77 <sup>7,9</sup> CA_n2A-n5A CA_n2A-n77A <sup>7</sup> CA_n5A-n77A <sup>7</sup>	n2	CA_n2(2A)_BCS0	0
		n5	5, 10, 15, 20	
		n77	10, 15, 20, 25, 30, 40, 50, 60, 70, 80, 90, 100	
CA_n2(2A)-n5A-n77(2A)	n77 <sup>7,9</sup> CA_n2A-n5A CA_n2A-n77A <sup>7</sup> CA_n5A-n77A <sup>7</sup>	n2	CA_n2(2A)_BCS0	0
		n5	5, 10, 15, 20	
		n77	CA_n77(2A)_BCS1	
CA_n2A-n7A-n12A	-	n2	5, 10, 15, 20	0
		n7	5, 10, 15, 20, 25, 30, 40, 50	
		n12	5, 10, 15	
CA_n2A-n7A-n66A	-	n2	5, 10, 15, 20	0
		n7	5, 10, 15, 20, 25, 30, 40, 50	
		n66	5, 10, 15, 20, 40	
CA_n2A-n7A-n71A	-	n2	5, 10, 15, 20	0
		n7	5, 10, 15, 20, 25, 30, 40, 50	
		n71	5, 10, 15, 20	
CA_n2A-n7A-n77A	-	n2	5, 10, 15, 20	0
		n7	5, 10, 15, 20, 25, 30, 40, 50	
		n77	10, 15, 20, 25, 30, 40, 50, 60, 70, 80, 90, 100	
CA_n2A-n12A-n30A	CA_n2A-n12A CA_n2A-n30A CA_n12A-n30A	n2	5, 10, 15, 20	0
		n12	5, 10, 15	
		n30	5, 10	
CA_n2(2A)-n12A-n30A	CA_n2A-n12A CA_n2A-n30A CA_n12A-n30A	n2	CA_n2(2A)_BCS0	0
		n12	5, 10, 15	
		n30	5, 10	
CA_n2A-n12A-n41A	-	n2	5, 10, 15, 20	0
		n12	5, 10, 15	
		n41	10, 15, 20, 30, 40, 50, 60, 80, 90, 100	
CA_n2A-n12A-n66A	CA_n2A-n12A CA_n2A-n66A CA_n12A-n66A	n2	5, 10, 15, 20	0
		n12	5, 10, 15	
		n66	5, 10, 15, 20, 25, 30, 40	
CA_n2(2A)-n12A-n66A	CA_n2A-n12A CA_n2A-n66A CA_n12A-n66A	n2	CA_n2(2A)_BCS0	0
		n12	5, 10, 15	
		n66	5, 10, 15, 20, 25, 30, 40	
CA_n2A-n12A-n66(2A)	CA_n2A-n12A CA_n2A-n66A CA_n12A-n66A	n2	5, 10, 15, 20	0
		n12	5, 10, 15	
		n66	CA_n66(2A)_BCS1	
CA_n2(2A)-n12A-n66(2A)	CA_n2A-n12A CA_n2A-n66A CA_n12A-n66A	n2	CA_n2(2A)_BCS0	0

		n12	5, 10, 15	
		n66	CA_n66(2A)_BCS1	
CA_n2A-n12A-n66(3A)	CA_n2A-n12A CA_n2A-n66A CA_n12A-n66A	n2	5, 10, 15, 20	0
		n12	5, 10, 15	
		n66	CA_n66(3A)_BCS0	
CA_n2A-n12A-n71A	CA_n2A-n12A CA_n2A-n71A	n2	5, 10, 15, 20, 25, 30, 40	0
		n12	5, 10, 15	
		n71	5, 10, 15, 20	
CA_n2A-n12A-n77A	n77 <sup>7,9</sup> CA_n2A-n12A CA_n2A-n77A <sup>7</sup> CA_n12A-n77A <sup>7</sup>	n2	5, 10, 15, 20	0
		n12	5, 10, 15	
		n77	10, 15, 20, 25, 30, 40, 50, 60, 70, 80, 90, 100	
CA_n2(2A)-n12A-n77A	n77 <sup>7,9</sup> CA_n2A-n12A CA_n2A-n77A <sup>7</sup> CA_n12A-n77A <sup>7</sup>	n2	CA_n2(2A)_BCS0	0
		n12	5, 10, 15	
		n77	10, 15, 20, 25, 30, 40, 50, 60, 70, 80, 90, 100	
CA_n2A-n12A-n77(2A)	n77 <sup>7,9</sup> CA_n2A-n12A CA_n2A-n77A <sup>7</sup> CA_n12A-n77A <sup>7</sup>	n2	5, 10, 15, 20	0
		n12	5, 10, 15	
		n77	CA_n77(2A)_BCS1	
CA_n2(2A)-n12A-n77(2A)	n77 <sup>7,9</sup> CA_n2A-n12A CA_n2A-n77A <sup>7</sup> CA_n12A-n77A <sup>7</sup>	n2	CA_n2(2A)_BCS0	0
		n12	5, 10, 15	
		n77	CA_n77(2A)_BCS1	
CA_n2A-n14A-n30A	CA_n2A-n14A CA_n2A-n30A CA_n14A-n30A	n2	5, 10, 15, 20	0
		n14	5, 10	
		n30	5, 10	
CA_n2(2A)-n14A-n30A	CA_n2A-n14A CA_n2A-n30A CA_n14A-n30A	n2	CA_n2(2A)_BCS0	0
		n14	5, 10	
		n30	5, 10	
CA_n2A-n14A-n66A	CA_n2A-n14A CA_n2A-n66A CA_n14A-n66A	n2	5, 10, 15, 20	0
		n14	5, 10	
		n66	5, 10, 15, 20, 25, 30, 40	
CA_n2(2A)-n14A-n66A	CA_n2A-n14A CA_n2A-n66A CA_n14A-n66A	n2	CA_n2(2A)_BCS0	0
		n14	5, 10	
		n66	5, 10, 15, 20, 25, 30, 40	
CA_n2(2A)-n14A-n66(2A)	CA_n2A-n14A CA_n2A-n66A CA_n14A-n66A	n2	CA_n2(2A)_BCS0	0
		n14	5, 10	
		n66	CA_n66(2A)_BCS1	
CA_n2A-n14A-n66(2A)	CA_n2A-n14A CA_n2A-n66A CA_n14A-n66A	n2	5, 10, 15, 20	0
		n14	5, 10	
		n66	CA_n66(2A)_BCS1	

CA_n2A-n14A-n66(3A)	CA_n2A-n14A CA_n2A-n66A CA_n14A-n66A	n2	5, 10, 15, 20	0
		n14	5, 10	
		n66	CA_n66(3A)_BCS0	
CA_n2A-n14A-n77A	n77 <sup>7,9</sup> CA_n2A-n14A CA_n2A-n77A <sup>7</sup> CA_n14A-n77A <sup>7</sup>	n2	5, 10, 15, 20	0
		n14	5, 10	
		n77	10, 15, 20, 25, 30, 40, 50, 60, 70, 80, 90, 100	
CA_n2A-n14A-n77(2A)	n77 <sup>7,9</sup> CA_n2A-n14A CA_n2A-n77A <sup>7</sup> CA_n14A-n77A <sup>7</sup>	n2	5, 10, 15, 20	0
		n14	5, 10	
		n77	CA_n77(2A)_BCS1	
CA_n2(2A)-n14A-n77A	n77 <sup>7,9</sup> CA_n2A-n14A CA_n2A-n77A <sup>7</sup> CA_n14A-n77A <sup>7</sup>	n2	CA_n2(2A)_BCS0	0
		n14	5, 10	
		n77	10, 15, 20, 25, 30, 40, 50, 60, 70, 80, 90, 100	
CA_n2(2A)-n14A-n77(2A)	n77 <sup>7,9</sup> CA_n2A-n14A CA_n2A-n77A <sup>7</sup> CA_n14A-n77A <sup>7</sup>	n2	CA_n2(2A)_BCS0	0
		n14	5, 10	
		n77	CA_n77(2A)_BCS1	
CA_n2A-n29A-n30A	CA_n2A-n30A	n2	5, 10, 15, 20	0
		n29	5, 10	
		n30	5, 10	
CA_n2(2A)-n29A-n30A	CA_n2A-n30A	n2	CA_n2(2A)_BCS0	0
		n29	5, 10	
		n30	5, 10	
CA_n2A-n29A-n66A	CA_n2A-n66A	n2	5, 10, 15, 20	0
		n29	5, 10	
		n66	5, 10, 15, 20, 25, 30, 40	
CA_n2(2A)-n29A-n66A	CA_n2A-n66A	n2	CA_n2(2A)_BCS0	0
		n29	5, 10	
		n66	5, 10, 15, 20, 25, 30, 40	
CA_n2A-n29A-n66(2A)	CA_n2A-n66A	n2	5, 10, 15, 20	0
		n29	5, 10	
		n66	CA_n66(2A)_BCS1	
CA_n2(2A)-n29A-n66(2A)	CA_n2A-n66A	n2	CA_n2(2A)_BCS0	0
		n29	5, 10	
		n66	CA_n66(2A)_BCS1	
CA_n2A-n29A-n77A	n77 <sup>7,9</sup> CA_n2A-n77A <sup>7</sup>	n2	5, 10, 15, 20	0
		n29	5, 10	
		n77	10, 15, 20, 25, 30, 40, 50, 60, 70, 80, 90, 100	
CA_n2(2A)-n29A-n77A	n77 <sup>7,9</sup> CA_n2A-n77A <sup>7</sup>	n2	CA_n2(2A)_BCS0	0
		n29	5, 10	
		n77	10, 15, 20, 25, 30, 40, 50, 60, 70, 80, 90, 100	
CA_n2A-n29A-n77(2A)	77 <sup>7,9</sup> CA_n2A-n77A <sup>7</sup>	n2	5, 10, 15, 20	0
		n29	5, 10	

		n77	CA_n77(2A)_BCS1	
CA_n2(2A)-n29A-n77(2A)	n77 <sup>7,9</sup> CA_n2A-n77A <sup>7</sup>	n2	CA_n2(2A)_BCS0	0
		n29	5, 10	
		n77	CA_n77(2A)_BCS1	
CA_n2A-n30A-n66A	CA_n2A-n30A CA_n2A-n66A CA_n30A-n66A	n2	5, 10, 15, 20	0
		n30	5, 10	
		n66	5, 10, 15, 20, 40	
CA_n2(2A)-n30A-n66A	CA_n2A-n30A CA_n2A-n66A CA_n30A-n66A	n2	CA_n2(2A)_BCS0	0
		n30	5, 10	
		n66	5, 10, 15, 20, 40	
CA_n2(2A)-n30A-n66(2A)	CA_n2A-n30A CA_n2A-n66A CA_n30A-n66A	n2	CA_n2(2A)_BCS0	0
		n30	5, 10	
		n66	CA_n66(2A)_BCS1	
CA_n2A-n30A-n66(2A)	CA_n2A-n30A CA_n2A-n66A CA_n30A-n66A	n2	5, 10, 15, 20	0
		n30	5, 10	
		n66	CA_n66(2A)_BCS0	
CA_n2A-n30A-n66(3A)	CA_n2A-n30A CA_n2A-n66A CA_n30A-n66A	n2	5, 10, 15, 20	0
		n30	5, 10	
		n66	CA_n66(3A)_BCS0	
CA_n2A-n30A-n77A	n77 <sup>7,9</sup> CA_n2A-n30A CA_n2A-n77A <sup>7</sup> CA_n30A-n77A <sup>7</sup>	n2	5, 10, 15, 20	0
		n30	5, 10	
		n77	10, 15, 20, 25, 30, 40, 50, 60, 70, 80, 90, 100	
CA_n2A-n30A-n77(2A)	n77 <sup>7,9</sup> CA_n2A-n30A CA_n2A-n77A <sup>7</sup> CA_n30A-n77A <sup>7</sup>	n2	5, 10, 15, 20	0
		n30	5, 10	
		n77	CA_n77(2A)_BCS1	
CA_n2(2A)-n30A-n77A	n77 <sup>7,9</sup> CA_n2A-n30A CA_n2A-n77A <sup>7</sup> CA_n30A-n77A <sup>7</sup>	n2	CA_n2(2A)_BCS0	0
		n30	5, 10	
		n77	10, 15, 20, 25, 30, 40, 50, 60, 70, 80, 90, 100	
CA_n2(2A)-n30A-n77(2A)	n77 <sup>7,9</sup> CA_n2A-n30A CA_n2A-n77A <sup>7</sup> CA_n30A-n77A <sup>7</sup>	n2	CA_n2(2A)_BCS0	0
		n30	5, 10	
		n77	CA_n77(2A)_BCS1	
CA_n2A-n41A-n66A	-	n2	5, 10, 15, 20	0
		n41	10, 15, 20, 40, 50, 60, 80, 90, 100	
		n66	5, 10, 15, 20, 40	
CA_n2A-n41A-n71A	-	n2	5, 10, 15, 20	0
		n41	10, 15, 20, 40, 50, 60, 80, 90, 100	
		n71	5, 10, 15, 20	

CA_n2A-n48A-n66A	CA_n2A-n48A CA_n2A-n66A CA_n48A-n66A	n2	5, 10, 15, 20	0
		n48	5, 10, 15, 20, 30, 40, 50 <sup>12</sup> , 60 <sup>12</sup> , 70 <sup>12</sup> , 80 <sup>12</sup> , 90 <sup>12</sup> , 100 <sup>12</sup>	
		n66	5, 10, 15, 20, 25, 30, 40	
CA_n2A-n48(A-B)-n66A	CA_n2A-n48A CA_n2A-n66A CA_n48A-n66A	n2	5, 10, 15, 20, 25, 30, 40	0
		n48	CA_n48(A-B)_BCS0	
		n66	5, 10, 15, 20, 25, 30, 40	
		n2	5, 10, 15, 20, 25, 30, 40	1
		n48	CA_n48(A-B)_BCS1	
		n66	5, 10, 15, 20, 25, 30, 40	
CA_n2A-n48B-n66A	CA_n48B CA_n2A-n48A CA_n2A-n66A CA_n48A-n66A	n2	5, 10, 15, 20	0
		n48	CA_n48B_BCS0	
		n66	5, 10, 15, 20, 25, 30, 40	
		n2	5, 10, 15, 20	1
		n48	CA_n48B_BCS1	
		n66	5, 10, 15, 20, 25, 30, 40	
		n2	5, 10, 15, 20	2
		n48	CA_n48B_BCS2	
n66	5, 10, 15, 20, 25, 30, 40			
CA_n2A-n48(2A)-n66A	CA_n2A-n48A CA_n2A-n66A CA_n48A-n66A	n2	5, 10, 15, 20	0
		n48	CA_n48(2A)_BCS0	
		n66	5, 10, 15, 20, 25, 30, 40	
		n2	5, 10, 15, 20	1
		n48	CA_n48(2A)_BCS1	
		n66	5, 10, 15, 20, 25, 30, 40	
CA_n2A-n48A-n77A	n77 <sup>7,9</sup> CA_n2A-n48A CA_n2A-n77A <sup>7</sup>	n2	5, 10, 15, 20	0
		n48	5, 10, 15, 20, 30, 40, 50 <sup>12</sup> , 60 <sup>12</sup> , 70 <sup>12</sup> , 80 <sup>12</sup> , 90 <sup>12</sup> , 100 <sup>12</sup>	
		n77	10, 15, 20, 25, 30, 40, 50, 60, 70, 80, 90, 100	
CA_n2A-n48A-n77C	n77 <sup>7,9</sup> CA_n2A-n48A CA_n2A-n77A <sup>7</sup> CA_n77C	n2	5, 10, 15, 20, 25, 30, 40	0
		n48	5, 10, 15, 20, 30, 40, 50 <sup>12</sup> , 60 <sup>12</sup> , 70 <sup>12</sup> , 80 <sup>12</sup> , 90 <sup>12</sup> , 100 <sup>12</sup>	
		n77	CA_n77C_BCS0	
		n2	5, 10, 15, 20, 25, 30, 40	1
		n48	5, 10, 15, 20, 30, 40, 50 <sup>12</sup> , 60 <sup>12</sup> , 70 <sup>12</sup> , 80 <sup>12</sup> , 90 <sup>12</sup> , 100 <sup>12</sup>	
		n77	CA_n77C_BCS1	
CA_n2A-n48(2A)-n77C	n77 <sup>7,9</sup> CA_n2A-n48A CA_n2A-n77A <sup>7</sup>	n2	5, 10, 15, 20, 25, 30, 40	0
		n48	CA_n48(2A)_BCS1	
		n77	CA_n77C_BCS1	
CA_n2A-n48B-n77C	n77 <sup>7,9</sup> CA_n48B CA_n2A-n48A CA_n2A-n77A <sup>7</sup>	n2	5, 10, 15, 20, 25, 30, 40	0
		n48	CA_n48B_BCS2	
		n77	CA_n77C_BCS1	
CA_n2A-n48B-n77A	n77 <sup>7,9</sup> CA_n48B CA_n2A-n48A	n2	5, 10, 15, 20	0

	CA_n2A-n77A <sup>7</sup>	n48	CA_n48B_BCS0	1		
		n77	10, 15, 20, 25, 30, 40, 50, 60, 70, 80, 90, 100			
		n2	5, 10, 15, 20			
			CA_n2A-n77A <sup>7</sup>	n48	CA_n48B_BCS1	2
				n77	10, 15, 20, 25, 30, 40, 50, 60, 70, 80, 90, 100	
				n2	5, 10, 15, 20	
			CA_n2A-n77A <sup>7</sup>	n48	CA_n48B_BCS2	2
n77	10, 15, 20, 25, 30, 40, 50, 60, 70, 80, 90, 100					
n2	5, 10, 15, 20					
CA_n2A-n48(2A)-n77A	n77 <sup>7,9</sup> CA_n2A-n48A CA_n2A-n77A <sup>7</sup>	n2	5, 10, 15, 20	0		
		n48	CA_n48(2A)_BCS0			
		n77	10, 15, 20, 25, 30, 40, 50, 60, 70, 80, 90, 100			
			CA_n2A-n77A <sup>7</sup>	n2	5, 10, 15, 20	1
				n48	CA_n48(2A)_BCS1	
CA_n2A-n66A-n71A	-	n2	5, 10, 15, 20	0		
		n66	5, 10, 15, 20, 25, 30, 40			
		n71	5, 10, 15, 20			
CA_n2A-n66A-n77A	n77 <sup>7,9</sup> CA_n2A-n66A CA_n2A-n77A <sup>7</sup> CA_n66A-n77A <sup>7</sup>	n2	5, 10, 15, 20	0		
		n66	5, 10, 15, 20, 25, 30, 40			
		n77	10, 15, 20, 25, 30, 40, 50, 60, 70, 80, 90, 100			
CA_n2(2A)-n66A-n77A	n77 <sup>7,9</sup> CA_n2A-n66A CA_n2A-n77A <sup>7</sup> CA_n66A-n77A <sup>7</sup>	n2	CA_n2(2A)_BCS0	0		
		n66	5, 10, 15, 20, 25, 30, 40			
		n77	10, 15, 20, 25, 30, 40, 50, 60, 70, 80, 90, 100			
CA_n2A-n66(2A)-n77A	n77 <sup>7,9</sup> CA_n2A-n66A CA_n2A-n77A <sup>7</sup> CA_n66A-n77A <sup>7</sup>	n2	5, 10, 15, 20	0		
		n66	CA_n66(2A)_BCS1			
		n77	10, 15, 20, 25, 30, 40, 50, 60, 70, 80, 90, 100			
CA_n2A-n66A-n77C	n77 <sup>7,9</sup> CA_n2A-n66A CA_n2A-n77A <sup>7</sup> CA_n66A-n77A <sup>7</sup>	n2	5, 10, 15, 20, 25, 30, 40	0		
		n66	5, 10, 15, 20, 25, 30, 40			
		n77	CA_n77C_BCS0			
			CA_n77C_BCS1	n2	5, 10, 15, 20, 25, 30, 40	1
				n66	5, 10, 15, 20, 25, 30, 40	
CA_n2A-n66A-n77(2A)	n77 <sup>7,9</sup> CA_n2A-n66A CA_n2A-n77A <sup>7</sup> CA_n66A-n77A <sup>7</sup>	n2	5, 10, 15, 20	0		
		n66	5, 10, 15, 20, 25, 30, 40			
		n77	CA_n77(2A)_BCS1			

CA_n2(2A)-n66(2A)-n77A	n77 <sup>9</sup> CA_n2A-n66A CA_n66A-n77A <sup>7</sup> CA_n2A-n77A <sup>7</sup>	n2	CA_n2(2A)_BCS0	0
		n66	CA_n66(2A)_BCS1	
		n77	10, 15, 20, 25, 30, 40, 50, 60, 70, 80, 90, 100	
CA_n2(2A)-n66(2A)-n77(2A)	n77 <sup>7</sup> CA_n2A-n66A CA_n2A-n77A <sup>7</sup> CA_n66A-n77A <sup>7</sup>	n2	CA_n2(2A)_BCS0	0
		n66	CA_n66(2A)_BCS1	
		n77	CA_n77(2A)_BCS1	
CA_n2(2A)-n66A-n77(2A)	n77 <sup>9</sup> CA_n2A-n66A CA_n66A-n77A <sup>7</sup> CA_n2A-n77A <sup>7</sup>	n2	CA_n2(2A)_BCS0	0
		n66	5, 10, 15, 20, 25, 30, 40	
		n77	CA_n77(2A)_BCS1	
CA_n2A-n66(2A)-n77(2A)	n77 <sup>9</sup> CA_n2A-n66A CA_n66A-n77A <sup>7</sup> CA_n2A-n77A <sup>7</sup>	n2	5, 10, 15, 20	0
		n66	CA_n66(2A)_BCS1	
		n77	CA_n77(2A)_BCS1	
CA_n2A-n66(3A)-n77A	n77 <sup>9</sup> CA_n2A-n66A CA_n66A-n77A <sup>7</sup> CA_n2A-n77A <sup>7</sup>	n2	5, 10, 15, 20	0
		n66	CA_n66(3A)_BCS0	
		n77	10, 15, 20, 25, 30, 40, 50, 60, 70, 80, 90, 100	
CA_n2A-n66(3A)-n77(2A)	n77 <sup>7</sup> CA_n2A-n66A CA_n2A-n77A <sup>7</sup> CA_n66A-n77A <sup>7</sup>	n2	5, 10, 15, 20	0
		n66	CA_n66(3A)_BCS0	
		n77	CA_n77(2A)_BCS1	
CA_n2A-n66A-n78A	-	n2	5, 10, 15, 20	0
		n66	5, 10, 15, 20, 25, 30, 40	
		n78	10, 15, 20, 25, 30, 40, 50, 60, 70, 80, 90, 100	
CA_n2A-n66A-n78(2A)	-	n2	5, 10, 15, 20	0
		n66	5, 10, 15, 20, 25, 30, 40	
		n78	CA_n78(2A)_BCS2	
CA_n2A-n71A-n77A	CA_n2A-n71A CA_n2A-n77A CA_n71A-n77A	n2	5, 10, 15, 20, 25, 30, 35, 40	0
		n71	5, 10, 15, 20, 25, 30, 35	
		n77	10, 15, 20, 25, 30, 40, 50, 60, 70, 80, 90, 100	
CA_n2A-n71A-n77(2A)	CA_n2A-n71A CA_n2A-n77A CA_n71A-n77A	n2	5, 10, 15, 20, 25, 30, 35, 40	0
		n71	5, 10, 15, 20, 25, 30, 35	
		n77	CA_n77(2A)_BCS1	
CA_n2A-n71A-n78A	-	n2	5, 10, 15, 20	0
		n71	5, 10, 15, 20	
		n78	10, 15, 20, 25, 30, 40, 50, 60, 70, 80, 90, 100	
CA_n2A-n71A-n78(2A)	-	n2	5, 10, 15, 20	0
		n71	5, 10, 15, 20	
		n78	CA_n78(2A)_BCS2	
CA_n3A-n5A-n7A	-	n3	5, 10, 15, 20, 25, 30	0
		n5	5, 10, 15, 20	



		n7	5, 10, 15, 20, 25, 30, 40	
	CA_n3A-n5A CA_n3A-n7A CA_n5A-n7A	n3	5, 10, 15, 20, 25, 30, 40, 50	1
		n5	5, 10, 15, 20	
		n7	5, 10, 15, 20, 25, 30, 40, 50	
CA_n3A-n5A-n7B	-	n3	5, 10, 15, 20, 25, 30	0
		n5	5, 10, 15, 20	
		n7	CA_n7B_BCS0	
	CA_n3A-n5A CA_n3A-n7A CA_n5A-n7A CA_n7B	n3	5, 10, 15, 20, 25, 30, 40, 50	1
		n5	5, 10, 15, 20	
		n7	CA_n7B_BCS0	
CA_n3A-n5A-n28A	-	n3	5, 10, 15, 20, 25, 30, 40, 50	0
		n5	5, 10, 15, 20	
		n28	5, 10, 15, 20, 30	
	CA_n3A-n5A CA_n3A-n28A CA_n5A-n28A	n3	See n3 channel bandwidths in Table 5.3.5-1	4 and 5
		n5	See n5 channel bandwidths in Table 5.3.5-1	
		n28	See n28 channel bandwidths in Table 5.3.5-1	
CA_n3A-n5A-n78A	CA_n3A-n5A CA_n3A-n78A CA_n5A-n78A	n3	5, 10, 15, 20, 25, 30, 40, 50	0
		n5	5, 10, 15, 20	
		n78	10, 15, 20, 25, 30, 40, 50, 60, 70, 80, 90, 100	
CA_n3A-n5A-n79A	CA_n3A-n5A CA_n3A-n79A CA_n5A-n79A	n3	See n3 channel bandwidths in Table 5.3.5-1	4 and 5
		n5	See n5 channel bandwidths in Table 5.3.5-1	
		n79	See n79 channel bandwidths in Table 5.3.5-1	
CA_n3A-n7A-n8A	CA_n3A-n7A CA_n3A-n8A CA_n7A-n8A	n3	5, 10, 15, 20, 25, 30, 35, 40, 50	0
		n7	5, 10, 15, 20, 25, 30, 35, 40, 50	
		n8	5, 10, 15, 20, 35	
CA_n3A-n7(2A)-n8A	CA_n3A-n7A CA_n3A-n8A CA_n7A-n8A	n3	5, 10, 15, 20, 25, 30	0
		n7	CA_n7(2A)_BCS0	
		n8	5, 10, 15, 20	
CA_n3(2A)-n7A-n8A	CA_n3A-n7A CA_n3A-n8A CA_n7A-n8A	n3	CA_n3(2A)_BCS0	0
		n7	5, 10, 15, 20, 25, 30, 40, 50	
		n8	5, 10, 15, 20	
CA_n3(2A)-n7(2A)-n8A	CA_n3A-n7A CA_n3A-n8A CA_n7A-n8A	n3	CA_n3(2A)_BCS0	0
		n7	CA_n7(2A)_BCS0	
		n8	5, 10, 15, 20	
CA_n3A-n7A-n20A	CA_n3A-n7A CA_n3A-n20A CA_n7A-n20A	n3	See n3 channel bandwidths in Table 5.3.5-1	4 and 5
		n7	See n7 channel bandwidths in Table 5.3.5-1	
		n20	See n20 channel bandwidths in Table 5.3.5-1	
CA_n3A-n7A-n26A	CA_n3A-n26A CA_n3A-n7A	n3	5, 10, 15, 20, 25, 30, 40	0

	CA_n7A-n26A	n7	5, 10, 15, 20, 25, 30, 40, 50	
		n26	5, 10, 15, 20	
CA_n3A-n7A-n26(2A)	CA_n3A-n26A CA_n3A-n7A CA_n7A-n26A CA_n26(2A)	n3	5, 10, 15, 20, 25, 30, 35, 40, 45, 50	0
		n7	5, 10, 15, 20, 25, 30, 35, 40, 50	
		n26	CA_n26(2A)_BCS0	
CA_n3A-n7B-n26A	CA_n3A-n26A CA_n3A-n7A CA_n7A-n26A CA_n7B	n3	5, 10, 15, 20, 25, 30, 40	0
		n7	CA_n7B_BCS0	
		n26	5, 10, 15, 20	
CA_n3A-n7B-n26(2A)	CA_n3A-n26A CA_n3A-n7A CA_n7A-n26A CA_n7B CA_n26(2A)	n3	5, 10, 15, 20, 25, 30, 35, 40, 45, 50	0
		n7	CA_n7B_BCS0	
		n26	CA_n26(2A)_BCS0	
CA_n3B-n7A-n26A	CA_n3A-n7A CA_n3A-n26A CA_n7A-n26A	n3	CA_n3B_BCS0	0
		n7	5, 10, 15, 20, 25, 30, 35, 40, 50	
		n26	5, 10, 15, 20, 25, 30	
CA_n3B-n7A-n26(2A)	CA_n3A-n7A CA_n3A-n26A CA_n7A-n26A CA_n26(2A)	n3	CA_n3B_BCS0	0
		n7	5, 10, 15, 20, 25, 30, 35, 40, 50	
		n26	CA_n26(2A)_BCS0	
CA_n3B-n7B-n26A	CA_n3A-n7A CA_n3A-n26A CA_n7A-n26A CA_n7B	n3	CA_n3B_BCS0	0
		n7	CA_n7B_BCS0	
		n26	5, 10, 15, 20, 25, 30	
CA_n3B-n7B-n26(2A)	CA_n3A-n7A CA_n3A-n26A CA_n7A-n26A CA_n7B CA_n26(2A)	n3	CA_n3B_BCS0	0
		n7	CA_n7B_BCS0	
		n26	CA_n26(2A)_BCS0	
CA_n3A-n7A-n28A	n3 <sup>7</sup> n7 <sup>7</sup>	n3	5, 10, 15, 20, 25, 30	0
		n7	5, 10, 15, 20, 25, 30, 40, 50	
		n28	5, 10, 15, 20	
	n3 <sup>7</sup> n7 <sup>7</sup> CA_n3A-n7A CA_n3A-n28A CA_n7A-n28A	n3	5, 10, 15, 20, 25, 30, 40	1
		n7	5, 10, 15, 20, 25, 30, 40, 50	
		n28	5, 10, 15, 20	
		n3	5, 10, 15, 20, 25, 30, 40, 50	2
		n7	5, 10, 15, 20, 25, 30, 40, 50	
		n28	5, 10, 15, 20	
CA_n3A-n7B-n28A	-	n3	5, 10, 15, 20, 25, 30	0
		n7	CA_n7B_BCS0	
		n28	5, 10, 15, 20	
	CA_n3A-n7A CA_n3A-n28A CA_n7A-n28A CA_n7B	n3	5, 10, 15, 20, 25, 30, 40, 50	1

		n7	CA_n7B_BCS0	
		n28	5, 10, 15, 20	
CA_n3B-n7A-n28A	CA_n3A-n7A CA_n3A-n28A CA_n7A-n28A	n3	CA_n3B_BCS0	0
		n7	5, 10, 15, 20, 25, 30, 40, 50	
		n28	5, 10, 15, 20	
CA_n3B-n7B-n28A	CA_n7B CA_n3A-n7A CA_n3A-n28A CA_n7A-n28A	n3	CA_n3B_BCS0	0
		n7	CA_n7B_BCS0	
		n28	5, 10, 15, 20	
CA_n3A-n7A-n38A <sup>10</sup>	-	n3	5, 10, 15, 20, 25, 30, 40, 50	0
		n7	5, 10, 15, 20, 25, 30, 40, 50	
		n38	5, 10, 15, 20, 25, 30, 40	
CA_n3B-n7A-n38A <sup>10</sup>	-	n3	CA_n3B_BCS0	0
		n7	5, 10, 15, 20, 25, 30, 40, 50	
		n38	5, 10, 15, 20, 25, 30, 40	
CA_n3(2A)-n7A-n38A <sup>10</sup>	-	n3	CA_n3(2A)_BCS1	0
		n7	5, 10, 15, 20, 25, 30, 40, 50	
		n38	5, 10, 15, 20, 25, 30, 40	
CA_n3A-n7A-n40A	CA_n3A-n7A CA_n3A-n40A CA_n7A-n40A	n3	5, 10, 15, 20, 25, 30, 35, 40, 45, 50	0
		n7	5, 10, 15, 20, 25, 30, 40, 50	
		n40	5, 10, 15, 20, 25, 30, 40, 50, 60, 80	
CA_n3A-n7A-n67A	CA_n3A-n7A	n3	5, 10, 15, 20, 25, 30, 40	0
		n7	5, 10, 15, 20, 25, 30, 35, 40, 50	
		n67	5, 10, 15, 20	
		n3	n3 channel bandwidths in Table 5.3.5-1	4 and 5
		n7	n7 channel bandwidths in Table 5.3.5-1	
		n67	n67 channel bandwidths in Table 5.3.5-1	
CA_n3A-n7A-n75A	-	n3	n3 channel bandwidths in Table 5.3.5-1	4 and 5
		n7	n7 channel bandwidths in Table 5.3.5-1	
		n75	n75 channel bandwidths in Table 5.3.5-1	
CA_n3A-n7A-n78A	n3 <sup>7</sup> n7 <sup>7</sup> n78 <sup>7,9</sup> CA_n3A-n7A CA_n3A-n78A <sup>7</sup> CA_n7A-n78A <sup>7</sup>	n3	5, 10, 15, 20, 25, 30	0
		n7	5, 10, 15, 20, 25, 30, 40, 50	
		n78	10, 15, 20, 25, 30, 40, 50, 60, 80, 90, 100	
		n3	5, 10, 15, 20, 25, 30, 40	1
		n7	5, 10, 15, 20, 25, 30, 40, 50	
		n78	10, 15, 20, 25, 30, 40, 50, 60, 70 <sup>4</sup> , 80, 90, 100	
		n3	n3 channel bandwidths in Table 5.3.5-1	4 and 5
		n7	n7 channel bandwidths in Table 5.3.5-1	
		n78	n78 channel bandwidths in Table 5.3.5-1	
CA_n3A-n7A-n78C	CA_n78C CA_n3A-n7A CA_n3A-n78A CA_n7A-n78A	n3	5, 10, 15, 20, 25, 30, 40	0

		n7	5, 10, 15, 20, 25, 30, 40, 50	
		n78	CA_n78C_BCS1	
CA_n3A-n7B-n78A	-	n3	5, 10, 15, 20, 25, 30	0
		n7	CA_n7B_BCS0	
		n78	10, 15, 20, 25, 30, 40, 50, 60, 80, 90, 100	
		n3	5, 10, 15, 20, 25, 30, 40	
n7	CA_n7B_BCS0			
n78	10, 15, 20, 25, 30, 40, 50, 60, 70 <sup>4</sup> , 80, 90, 100			
CA_n3A-n7B-n78(2A)	CA_n3A-n7A CA_n3A-n78A CA_n7A-n78A CA_n7B	n3	5, 10, 15, 20, 25, 30, 35, 40, 45, 50	0
		n7	CA_n7B_BCS0	
		n78	CA_n78(2A)_BCS0	
CA_n3A-n7B-n78C	CA_n3A-n7A CA_n3A-n78A CA_n7A-n78A CA_n7B CA_n78C	n3	5, 10, 15, 20, 25, 30, 35, 40, 45, 50	0
		n7	CA_n7B_BCS0	
		n78	CA_n78C_BCS1	
CA_n3A-n7A-n78(2A)	n3 <sup>7</sup> n7 <sup>7</sup> n78 <sup>7,9</sup> CA_n78(2A) <sup>7</sup> CA_n3A-n7A CA_n3A-n78A <sup>7</sup> CA_n7A-n78A <sup>7</sup>	n3	5, 10, 15, 20, 25, 30, 40	0
		n7	5, 10, 15, 20, 25, 30, 40, 50	
		n78	CA_n78(2A)_BCS2	
CA_n3A-n7(2A)-n78A	CA_n3A-n7A CA_n3A-n78A CA_n7A-n78A	n3	5, 10, 15, 20, 25, 30	0
		n7	CA_n7(2A)_BCS0	
		n78	10, 15, 20, 25, 30, 40, 50, 60, 70, 80, 90, 100	
CA_n3B-n7A-n78A	CA_n3A-n7A CA_n3A-n78A CA_n7A-n78A	n3	CA_n3B_BCS0	0
		n7	5, 10, 15, 20, 25, 30, 35, 40, 50	
		n78	10, 15, 20, 25, 30, 40, 50, 60, 70, 80, 90, 100	
CA_n3B-n7A-n78(2A)	CA_n3A-n7A CA_n3A-n78A CA_n7A-n78A	n3	CA_n3B_BCS0	0
		n7	5, 10, 15, 20, 25, 30, 35, 40, 50	
		n78	CA_n78(2A)_BCS0	
CA_n3B-n7A-n78C	CA_n3A-n7A CA_n3A-n78A CA_n7A-n78A CA_n78C	n3	CA_n3B_BCS0	0
		n7	5, 10, 15, 20, 25, 30, 35, 40, 50	
		n78	CA_n78C_BCS1	
CA_n3B-n7B-n78A	CA_n3A-n7A CA_n3A-n78A CA_n7A-n78A CA_n7B	n3	CA_n3B_BCS0	0
		n7	CA_n7B_BCS0	
		n78	10, 15, 20, 25, 30, 40, 50, 60, 70, 80, 90, 100	
CA_n3B-n7B-n78(2A)	CA_n3A-n7A CA_n3A-n78A	n3	CA_n3B_BCS0	0

	CA_n7A-n78A CA_n7B	n7	CA_n7B_BCS0	
		n78	CA_n78(2A)_BCS0	
CA_n3B-n7B-n78C	CA_n3A-n7A CA_n3A-n78A CA_n7A-n78A CA_n7B CA_n78C	n3	CA_n3B_BCS0	0
		n7	CA_n7B_BCS0	
		n78	CA_n78C_BCS0	
CA_n3(2A)-n7A-n78A	CA_n3A-n7A CA_n3A-n78A CA_n7A-n78A	n3	CA_n3(2A)_BCS0	0
		n7	5, 10, 15, 20, 25, 30, 40, 50	
		n78	10, 15, 20, 25, 30, 40, 50, 60, 70, 80, 90, 100	
CA_n3(2A)-n7(2A)-n78A	CA_n3A-n7A CA_n3A-n78A CA_n7A-n78A	n3	CA_n3(2A)_BCS0	0
		n7	CA_n7(2A)_BCS0	
		n78	10, 15, 20, 25, 30, 40, 50, 60, 70, 80, 90, 100	
CA_n3A-n7A-n79A	-	n3	5, 10, 15, 20, 25, 30, 40	0
		n7	5, 10, 15, 20, 25, 30, 40, 50	
		n79	40, 50, 60, 70, 80, 90, 100	
CA_n3A-n7A-n79C	-	n3	5, 10, 15, 20, 25, 30	0
		n7	5, 10, 15, 20, 25, 30, 40, 50	
		n79	CA_n79C_BCS0	
CA_n3B-n7A-n79A	-	n3	CA_n3B_BCS0	0
		n7	5, 10, 15, 20, 25, 30, 40, 50	
		n79	40, 50, 60, 70, 80, 90, 100	
CA_n3(2A)-n7A-n79A	-	n3	CA_n3(2A)_BCS0	0
		n7	5, 10, 15, 20, 25, 30, 40, 50	
		n79	40, 50, 60, 70, 80, 90, 100	
CA_n3B-n7A-n79C	-	n3	CA_n3B_BCS0	0
		n7	5, 10, 15, 20, 25, 30, 40, 50	
		n79	CA_n79C_BCS0	
CA_n3(2A)-n7A-n79C	-	n3	CA_n3(2A)_BCS0	0
		n7	5, 10, 15, 20, 25, 30, 40, 50	
		n79	CA_n79C_BCS0	
CA_n3A-n7A-n105A	CA_n3A-n7A CA_n3A-n105A CA_n7A-n105A	n3	5, 10, 15, 20, 25, 30, 40, 50	0
		n7	5, 10, 15, 20, 25, 30, 40, 50	
		n105	5, 10, 15, 20, 25, 30, 35	
CA_n3A-n8A-n28A	-	n3	5, 10, 15, 20, 25, 30, 35, 40, 50	0
		n8	5, 10, 15, 20, 35	
		n28	5, 10, 15, 20, 30	
CA_n3A-n8A-n39A	-	n3	5, 10, 15, 20, 25, 30	0
		n8	5, 10, 15, 20	
		n39	5, 10, 15, 20, 25, 30, 35, 40	
CA_n3A-n8A-n40A	CA_n3A-n8A CA_n3A-n40A CA_n8A-n40A	n3	n3 channel bandwidths in Table 5.3.5-1	4 and 5
		n8	n8 channel bandwidths in Table 5.3.5-1	
		n40	n40 channel bandwidths in Table 5.3.5-1	
CA_n3A-n8A-n41A	CA_n3A-n8A CA_n3A-n41A CA_n8A-n41A	n3	5, 10, 15, 20, 25, 30	0
		n8	5, 10, 15, 20	
		n41	10, 15, 20, 30, 40, 50, 60, 80, 90, 100	
CA_n3A-n8A-n77A	-	n3	5, 10, 15, 20, 25, 30	0
		n8	5, 10, 15, 20	

CA_n3A-n8A-n77(2A)	-	n77	10, 15, 20, 40, 50, 60, 80, 90, 100	0
		n3	5, 10, 15, 20, 25, 30	
		n8	5, 10, 15, 20	
		n77	CA_n77(2A)_BCS1	
CA_n3A-n8A-n78A	CA_n3A-n8A CA_n3A-n78A CA_n8A-n78A	n3	5, 10, 15, 20, 25, 30	0
		n8	5, 10, 15, 20	
		n78	10, 15, 20, 40, 50, 60, 80, 90, 100	
CA_n3(2A)-n8A-n78A	CA_n3A-n8A CA_n3A-n78A CA_n8A-n78A	n3	CA_n3(2A)_BCS0	0
		n8	5, 10, 15, 20	
		n78	10, 15, 20, 25, 30, 40, 50, 60, 70, 80, 90, 100	
CA_n3A-n8A-n79A	CA_n3A-n8A CA_n3A-n79A CA_n8A-n79A	n3	5, 10, 15, 20, 25, 30	0
		n8	5, 10, 15, 20	
		n79	40, 50, 60, 80, 100	
CA_n3A-n18A-n28A	CA_n3A-n18A CA_n3A-n28A CA_n18A-n28A	n3	5, 10, 15, 20, 25, 30, 40	0
		n18	5, 10, 15	
		n28	5, 10	
CA_n3A-n18A-n41A	CA_n3A-n41A CA_n3A-n18A CA_n18A-n41A	n3	5, 10, 15, 20, 25, 30, 40	0
		n18	5, 10, 15	
		n41	10, 15, 20, 30, 40, 50, 60, 80, 90, 100	
CA_n3A-n18A-n77A	n77 <sup>7</sup> CA_n3A-n18A CA_n3A-n77A <sup>7</sup> CA_n18A-n77A <sup>7</sup>	n3	5, 10, 15, 20, 25, 30, 40	0
		n18	5, 10, 15	
		n77	10, 15, 20, 40, 50, 60, 80, 90, 100	
CA_n3A-n18A-n77(2A)	n77 <sup>7</sup> CA_n3A-n18A CA_n3A-n77A <sup>7</sup> CA_n18A-n77A <sup>7</sup>	n3	5, 10, 15, 20	0
		n18	5, 10, 15	
		n77	CA_n77(2A)_BCS1	
CA_n3A-n20A-n67A	CA_n3A-n20A	n3	5, 10, 15, 20, 25, 30, 40	0
		n20	5, 10, 15, 20	
		n67	5, 10, 15, 20	
		n3	n3 channel bandwidths in Table 5.3.5-1	4 and 5
		n20	n20 channel bandwidths in Table 5.3.5-1	
		n67	n67 channel bandwidths in Table 5.3.5-1	
CA_n3A-n20A-n28A	CA_n3A-n20A CA_n3A-n28A CA_n20A-n28A	n3	5, 10, 15, 20, 25, 30, 40	0
		n20	5, 10, 15, 20	
		n28	5, 10, 15, 20, 30	
CA_n3A-n20A-n78A	CA_n3A-n20A CA_n3A-n78A CA_n20A-n78A	n3	5, 10, 15, 20, 25, 30, 40	0
		n20	5, 10, 15, 20	
		n78	10, 15, 20, 25, 30, 40, 50, 60, 70, 80, 90, 100	
		n3	n3 channel bandwidths in Table 5.3.5-1	

		n20	n20 channel bandwidths in Table 5.3.5-1	
		n78	n78 channel bandwidths in Table 5.3.5-1	
CA_n3A-n20A-n78(2A)	CA_n3A-n20A CA_n3A-n78A CA_n20A-n78A CA_n78(2A)	n3	See n3 channel bandwidths in Table 5.3.5-1	4 and 5
		n20	See n20 channel bandwidths in Table 5.3.5-1	
		n78	CA_n78(2A)_BCS4 and 5	
CA_n3A-n26A-n78A	CA_n3A-n26A CA_n3A-n78A CA_n26A-n78A	n3	5, 10, 15, 20, 25, 30, 40	0
		n26	5, 10, 15, 20	
		n78	10, 15, 20, 25, 30, 40, 50, 60, 70, 80, 90, 100	
CA_n3A-n26A-n78(2A)	CA_n3A-n26A CA_n3A-n78A CA_n26A-n78A	n3	5, 10, 15, 20, 25, 30, 35, 40, 45, 50	0
		n26	5, 10, 15, 20, 25, 30	
		n78	CA_n78(2A)_BCS0	
CA_n3A-n26A-n78C	CA_n3A-n26A CA_n3A-n78A CA_n26A-n78A CA_n78C	n3	5, 10, 15, 20, 25, 30, 35, 40, 45, 50	0
		n26	5, 10, 15, 20, 25, 30	
		n78	CA_n78C_BCS0	
CA_n3A-n26(2A)-n78A	CA_n3A-n26A CA_n3A-n78A CA_n26A-n78A CA_n26(2A)	n3	5, 10, 15, 20, 25, 30, 35, 40, 45, 50	0
		n26	CA_n26(2A)_BCS0	
		n78	10, 15, 20, 25, 30, 40, 50, 60, 70, 80, 90, 100	
CA_n3A-n26(2A)-n78(2A)	CA_n3A-n26A CA_n3A-n78A CA_n26A-n78A CA_n26(2A)	n3	5, 10, 15, 20, 25, 30, 35, 40, 45, 50	0
		n26	CA_n26(2A)_BCS0	
		n78	CA_n78(2A)_BCS0	
CA_n3A-n26(2A)-n78C	CA_n3A-n26A CA_n3A-n78A CA_n26A-n78A CA_n26(2A) CA_n78C	n3	5, 10, 15, 20, 25, 30, 35, 40, 45, 50	0
		n26	CA_n26(2A)_BCS0	
		n78	CA_n78C_BCS0	
CA_n3B-n26A-n78A	CA_n3A-n26A CA_n3A-n78A CA_n26A-n78A	n3	CA_n3B_BCS0	0
		n26	5, 10, 15, 20, 25, 30	
		n78	10, 15, 20, 25, 30, 40, 50, 60, 70, 80, 90, 100	
CA_n3B-n26A-n78(2A)	CA_n3A-n26A CA_n3A-n78A CA_n26A-n78A	n3	CA_n3B_BCS0	0
		n26	5, 10, 15, 20, 25, 30	
		n78	CA_n78(2A)_BCS0	
CA_n3B-n26A-n78C	CA_n3A-n26A CA_n3A-n78A CA_n26A-n78A CA_n78C	n3	CA_n3B_BCS0	0
		n26	5, 10, 15, 20, 25, 30	
		n78	CA_n78C_BCS0	
CA_n3B-n26(2A)-n78A	CA_n3A-n26A CA_n3A-n78A	n3	CA_n3B_BCS0	0

	CA_n26A-n78A CA_n26(2A)			
		n26	CA_n26(2A)_BCS0	
		n78	10, 15, 20, 25, 30, 40, 50, 60, 70, 80, 90, 100	
CA_n3B-n26(2A)-n78(2A)	CA_n3A-n26A CA_n3A-n78A CA_n26A-n78A CA_n26(2A)	n3	CA_n3B_BCS0	0
		n26	CA_n26(2A)_BCS0	
		n78	CA_n78(2A)_BCS0	
CA_n3B-n26(2A)-n78C	CA_n3A-n26A CA_n3A-n78A CA_n26A-n78A CA_n26(2A) CA_n78C	n3	CA_n3B_BCS0	0
		n26	CA_n26(2A)_BCS0	
		n78	CA_n78C_BCS0	
CA_n3A-n28A-n38A	-	n3	5, 10, 15, 20, 30, 40, 50	0
		n28	5, 10, 15, 20	
		n38	5, 10, 15, 20, 30, 40	
CA_n3A-n28A-n40A	CA_n3A-n28A CA_n3A-n40A CA_n28A-n40A	n3	5, 10, 15, 20	0
		n28	5, 10	
		n40	20, 40	
		n3	5, 10, 15, 20, 25, 30, 35,40	1
		n28	5, 10, 15, 20, 25, 30	
		n40	10, 15, 20, 25, 30, 40, 50, 60, 70, 80, 90, 100	
CA_n3A-n28A-n41A	n41 <sup>7,9</sup> CA_n3A-n28A CA_n3A-n41A <sup>7</sup> CA_n28A-n41A <sup>7</sup>	n3	5, 10, 15, 20, 25, 30, 40	0
		n28	5, 10, 15, 20, 30	
		n41	10, 15, 20, 30, 40, 50, 60, 80, 90, 100	
CA_n3A-n28A-n41B	CA_n3A-n28A CA_n3A-n41A CA_n28A-n41A	n3	5, 10, 15, 20	0
		n28	5, 10	
		n41	CA_n41B_BCS0	
CA_n3A-n28A-n77A	n77 <sup>7,9</sup> CA_n3A-n28A CA_n3A-n77A <sup>7</sup> CA_n28A-n77A <sup>7</sup>	n3	5, 10, 15, 20, 25, 30	0
		n28	5, 10, 15, 20	
		n77	10, 15, 20, 40, 50, 60, 80, 90, 100	
		n3	5, 10, 15, 20, 25, 30, 40	1
		n28	5, 10, 15, 20, 30	
		n77	10, 15, 20, 40, 50, 60, 80, 90, 100	2
		n3	5, 10, 15, 20, 25, 30, 35,40	
		n28	5, 10, 15, 20, 25, 30	
		n77	10, 15, 20, 25, 30, 40, 50, 60, 70, 80, 90, 100	4 and 5
		n3	n3 channel bandwidths in Table 5.3.5-1	
n28	n28 channel bandwidths in Table 5.3.5-1			
n77	n77 channel bandwidths in Table 5.3.5-1			
CA_n3A-n28A-n77(2A)	n77 <sup>7,9</sup> CA_n3A-n28A CA_n3A-n77A <sup>7</sup> CA_n28A-n77A <sup>7</sup> CA_n77(2A) <sup>7</sup>	n3	5, 10, 15, 20, 25, 30	0
		n28	5, 10, 15, 20	



		n77	CA_n77(2A)_BCS0	1
		n3	5, 10, 15, 20, 25, 30, 40	
		n28	5, 10, 15, 20, 30	
		n77	CA_n77(2A)_BCS0	4 and 5
		n3	n3 channel bandwidths in Table 5.3.5-1	
		n28	n28 channel bandwidths in Table 5.3.5-1	
		n77	CA_n77(2A)_BCS4 and 5	
CA_n3A-n28A-n77(3A)	CA_n3A-n28A CA_n3A-n77A CA_n28A-n77A	n3	5, 10, 15, 20, 25, 30	0
		n28	5, 10, 15, 20	
		n77	CA_n77(3A)_BCS0	
CA_n3A-n28A-n78A	n3 <sup>7</sup> n78 <sup>7,9</sup> CA_n3A-n28A CA_n3A-n78A <sup>7</sup> CA_n28A-n78A <sup>7</sup>	n3	5, 10, 15, 20	0
		n28	5, 10, 15, 20 <sup>2</sup>	
		n78	10, 15, 20, 40, 50, 60, 80, 90, 100	
		n3	5, 10, 15, 20, 25, 30, 40	1
		n28	5, 10, 15, 20 <sup>2</sup>	
		n78	10, 15, 20, 25, 30, 40, 50, 60, 70, 80, 90, 100	2
		n3	5, 10, 15, 20, 25, 30, 40	
		n28	5, 10	
		n78	10, 15, 20, 40, 50, 60, 80, 90, 100	
CA_n3A-n28A-n78C	CA_n78C CA_n3A-n28A CA_n3A-n78A CA_n28A-n78A	n3	5, 10, 15, 20, 25, 30, 40	0
		n28	5, 10, 15, 20	
		n78	CA_n78C_BCS1	
CA_n3A-n28A-n78(2A)	n3 <sup>7</sup> n78 <sup>7,9</sup> CA_n3A-n28A CA_n3A-n78A <sup>7</sup> CA_n28A-n78A <sup>7</sup>	n3	5, 10, 15, 20	0
		n28	5, 10, 15, 20 <sup>2</sup>	
		n78	CA_n78(2A)_BCS0	
		n3	5, 10, 15, 20, 25, 30, 40	1
		n28	5, 10	
	n78	CA_n78(2A)_BCS2	2	
	n3	5, 10, 15, 20, 25, 30, 40		
	n28	5, 10, 15, 20		
	n78	CA_n78(2A)_BCS2		
CA_n3B-n28A-n78A	CA_n3A-n28A CA_n3A-n78A CA_n28A-n78A	n3	CA_n3B_BCS0	0
		n28	5, 10, 15, 20	
		n78	10, 15, 20, 25, 30, 40, 50, 60, 70, 80, 90, 100	
CA_n3B-n28A-n78(2A)	CA_n78(2A) CA_n3A-n28A CA_n3A-n78A CA_n28A-n78A	n3	CA_n3B_BCS0	0
		n28	5, 10, 15, 20	
		n78	CA_n78(2A)_BCS2	
CA_n3B-n28A-n78C	CA_n78C CA_n3A-n28A CA_n3A-n78A	n3	CA_n3B_BCS0	0

	CA_n28A-n78A	n28	5, 10, 15, 20	
		n78	CA_n78C_BCS0	
CA_n3A-n28A-n79A	n79 <sup>7,9</sup> CA_n3A-n28A CA_n3A-n79A <sup>7</sup> CA_n28A-n79A <sup>7</sup>	n3	5, 10, 15, 20, 25, 30	0
		n28	5, 10, 15, 20	
		n79	40, 50, 80, 100	
CA_n3A-n38A-n40A	-	n3	5, 10, 15, 20, 25, 30, 40, 50	0
		n38	5, 10, 15, 20, 25, 30, 40	
		n40	5, 10, 15, 20, 25, 30, 40, 50, 60, 70, 80, 90, 100	
CA_n3A-n38A-n78A	-	n3	5, 10, 15, 20, 25, 30, 40, 50	0
		n38	5, 10, 15, 20, 25, 30, 40	
		n78	10, 15, 20, 25, 30, 40, 50, 60, 70, 80, 90, 100	
CA_n3A-n39A-n41A	-	n3	5, 10, 15, 20, 25, 30	0
		n39	5, 10, 15, 20, 25, 30, 35, 40	
		n41	10, 15, 20, 25, 30, 40, 50, 60, 70, 80, 90, 100	
CA_n3A-n39A-n79A	-	n3	5, 10, 15, 20, 25, 30	0
		n39	5, 10, 15, 20, 25, 30, 35, 40	
		n79	10, 20, 30, 40, 50, 60, 70, 80, 90, 100	
CA_n3A-n40A-n78A	CA_n3A-n40A CA_n3A-n78A CA_n40A-n78A	n3	5, 10, 15, 20, 25, 30, 40, 50	0
		n40	10, 15, 20, 25, 30, 40, 50, 60, 70, 80, 90, 100	
		n78	10, 15, 20, 25, 30, 40, 50, 60, 70, 80, 90, 100	
CA_n3A-n40A-n105A	CA_n3A-n40A CA_n3A-n105A CA_n40A-n105A	n3	5, 10, 15, 20, 25, 30, 40, 50	0
		n40	10, 15, 20, 25, 30, 40, 50, 60, 70, 80, 90, 100	
		n105	5, 10, 15, 20, 25, 30, 35	
CA_n3A-n77A-n79A <sup>4</sup>	n77 <sup>7,9</sup> n79 <sup>7,9</sup> CA_n3A-n77A <sup>7</sup> CA_n3A-n79A <sup>7</sup> CA_n77A-n79A <sup>7</sup>	n3	5, 10, 15, 20, 25, 30	0
		n77	10, 15, 20, 40, 50, 60, 80, 90, 100	
		n79	40, 50, 60, 80, 100	
		n3	n3 channel bandwidths in Table 5.3.5-1	4 and 5
		n77	n77 channel bandwidths in Table 5.3.5-1	
		n79	n79 channel bandwidths in Table 5.3.5-1	
CA_n3A-n77(2A)-n79A <sup>4</sup>	n77 <sup>7,9</sup> n79 <sup>7,9</sup> CA_n3A-n77A <sup>7</sup> CA_n3A-n79A <sup>7</sup> CA_n77A-n79A <sup>7</sup>	n3	5, 10, 15, 20, 25, 30	0
		n77	CA_n77(2A)_BCS0	
		n79	40, 50, 60, 80, 100	
		n3	n3 channel bandwidths in Table 5.3.5-1	4 and 5
		n77	CA_n77(2A)_BCS4 and 5	
		n79	n79 channel bandwidths in Table 5.3.5-1	
CA_n3A-n77(3A)-n79A <sup>4</sup>	CA_n3A-n77A CA_n3A-n79A CA_n77A-n79A	n3	5, 10, 15, 20, 25, 30	0
		n77	CA_n77(3A)_BCS0	

		n79	40, 50, 60, 80, 100	
CA_n3A-n40A-n41A	CA_n3A-n40A CA_n3A-n41A CA_n40A-n41A	n3	5, 10, 15, 20, 25, 30	0
		n40	5, 10, 15, 20, 25, 30, 40, 50, 60, 80	
		n41	10, 15, 20, 40, 50, 60, 80, 90, 100	
		n3	See n3 channel bandwidths in Table 5.3.5-1	4 and 5
		n40	See n40 channel bandwidths in Table 5.3.5-1	
n41	See n41 channel bandwidths in Table 5.3.5-1			
CA_n3A-n40A-n41C	CA_n3A-n40A CA_n3A-n41A CA_n40A-n41A	n3	See n3 channel bandwidths in Table 5.3.5-1	4 and 5
		n40	See n40 channel bandwidths in Table 5.3.5-1	
		n41	CA_n41C_BCS4 and 5	
CA_n3A-n40A-n77A	CA_n3A-n40A CA_n3A-n77A CA_n40A-n77A	n3	5, 10, 15, 20, 30, 35, 40, 45, 50	0
		n40	10, 15, 20, 25, 30, 40, 50, 60, 70, 80, 90, 100	
		n77	10, 15, 20, 25, 30, 40, 50, 60, 70, 80, 90, 100	
CA_n3A-n40A-n77(2A)	CA_n3A-n40A CA_n3A-n77A CA_n40A-n77A	n3	5, 10, 15, 20, 30, 35, 40, 45, 50	0
		n40	10, 15, 20, 25, 30, 40, 50, 60, 70, 80, 90, 100	
		n77	CA_n77(2A)_BCS1	
CA_n3A-n41A-n77A	n41 <sup>7,9</sup> n77 <sup>7,9</sup> CA_n3A-n41A <sup>7</sup> CA_n3A-n77A <sup>7</sup>	n3	5, 10, 15, 20, 25, 30, 40	0
		n41	10, 15, 20, 30, 40, 50, 60, 80, 90, 100	
		n77	10, 15, 20, 25, 30, 40, 50, 60, 70, 80, 90, 100	
	CA_n41A-n77A <sup>7</sup>	n3	See n3 channel bandwidths in Table 5.3.5-1	4 and 5
		n41	See n41 channel bandwidths in Table 5.3.5-1	
		n77	See n77 channel bandwidths in Table 5.3.5-1	
CA_n3A-n41B-n77A	CA_n3A-n41A CA_n3A-n77A CA_n41A-n77A	n3	5, 10, 15, 20	0
		n41	CA_n41B_BCS0	
		n77	10, 15, 20, 25, 30, 40, 50, 60, 70, 80, 90, 100	
CA_n3A-n41A-n77(2A)	n41 <sup>7,9</sup> n77 <sup>7,9</sup> CA_n3A-n41A <sup>7</sup> CA_n3A-n77A CA_n41A-n77A <sup>7</sup>	n3	5, 10, 15, 20, 25, 30, 40	0
		n41	10, 15, 20, 30, 40, 50, 60, 80, 90, 100	
		n77	CA_n77(2A)_BCS0	
	CA_n77(2A) <sup>7</sup>	n3	See n3 channel bandwidths in Table 5.3.5-1	4 and 5
		n41	See n41 channel bandwidths in Table 5.3.5-1	
n77	CA_n77(2A)_BCS4 and 5			
CA_n3A-n41A-n77(3A)	CA_n3A-n41A CA_n3A-n77A CA_n41A-n77A	n3	5, 10, 15, 20	0

		n41	10, 15, 20, 30, 40, 50, 60, 80, 90, 100					
		n77	CA_n77(3A)_BCS1					
CA_n3A-n41A-n78A	-	n3	5, 10, 15, 20, 25, 30, 40	0				
		n41	10, 15, 20, 30, 40, 50, 60, 80, 90, 100					
		n78	10, 15, 20, 25, 30, 40, 50, 60, 70, 80, 90, 100					
		n3	5, 10, 15, 20, 25, 30, 40		1			
	n41	10, 15, 20, 30, 40, 50, 60, 80, 90, 100						
	n78	10, 15, 20, 40, 50, 60, 80, 90, 100						
CA_n3A-n41A-n78(2A)	CA_n3A-n41A CA_n3A-n78A CA_n41A-n78A	n3	5, 10, 15, 20, 25, 30, 40	0				
		n41	10, 15, 20, 30, 40, 50, 60, 80, 90, 100					
		n78	CA_n78(2A)_BCS2					
CA_n3A-n41A-n79A	CA_n3A-n41A CA_n3A-n79A CA_n41A-n79A	n3	5, 10, 15, 20, 25, 30	0				
		n41	10, 15, 20, 40, 50, 60, 80, 100					
		n79	40, 50, 60, 80, 100					
		n3	5, 10, 15, 20, 25, 30	1				
		n41	10, 15, 20, 40, 50, 60, 80					
		n79	40, 50, 60, 80, 100					
		n3	5, 10, 15, 20, 25, 30	2				
		n41	10, 15, 20, 30, 40, 50, 60, 80, 90, 100					
		n79	40, 50, 60, 80, 100					
		n3	See n3 channel bandwidths in Table 5.3.5-1			4 and 5		
							n41	See n41 channel bandwidths in Table 5.3.5-1
CA_n3A-n41A-n79C	CA_n3A-n41A CA_n3A-n79A CA_n41A-n79A	n3	See n3 channel bandwidths in Table 5.3.5-1	4 and 5				
		n41	See n41 channel bandwidths in Table 5.3.5-1					
		n79	CA_n79C_BCS4 and 5					
CA_n3A-n41C-n79A	CA_n41C CA_n3A-n41A CA_n3A-n79A CA_n41A-n79A	n3	See n3 channel bandwidths in Table 5.3.5-1	4 and 5				
		n41	CA_n41C_BCS4 and 5					
		n79	See n79 channel bandwidths in Table 5.3.5-1					
CA_n3A-n41C-n79C	CA_n3A-n41A CA_n3A-n79A CA_n41A-n79A	n3	See n3 channel bandwidths in Table 5.3.5-1	4 and 5				
		n41	CA_n41C_BCS4 and 5					
		n79	CA_n79C_BCS4 and 5					
CA_n3A-n67A-n78A	CA_n3A-n78A	n3	5, 10, 15, 20, 25, 30, 40	0				
		n67	5, 10, 15, 20					
		n78	10, 15, 20, 25, 30, 40, 50, 60, 70, 80, 90, 100					
CA_n3A-n67A-n78(2A)	CA_n78(2A) CA_n3A-n78A	n3	5, 10, 15, 20, 25, 30, 40	0				
		n67	5, 10, 15, 20					
		n78	CA_n78(2A)_BCS2					
CA_n3A-n75A-n78A	-	n3	n3 channel bandwidths in Table 5.3.5-1	4 and 5				

		n75	n75 channel bandwidths in Table 5.3.5-1	
		n78	n78 channel bandwidths in Table 5.3.5-1	
CA_n3A-n78A-n79A	n78 <sup>7,9</sup>	n3	5, 10, 15, 20, 25, 30, 40, 50	0
		n78	10, 15, 20, 25, 30, 40, 50, 60, 70, 80, 90, 100	
		n79	40, 50, 60, 80, 100	
CA_n3A-n78A-n79C	-	n3	5, 10, 15, 20, 25, 30, 40, 50	0
		n78	10, 15, 20, 25, 30, 40, 50, 60, 70, 80, 90, 100	
		n79	CA_n79C_BCS0	
CA_n3B-n78A-n79A	-	n3	CA_n3B_BCS0	0
		n78	10, 15, 20, 25, 30, 40, 50, 60, 70, 80, 90, 100	
		n79	40, 50, 60, 80, 100	
CA_n3B-n78A-n79C	-	n3	CA_n3B_BCS0	0
		n78	10, 15, 20, 25, 30, 40, 50, 60, 70, 80, 90, 100	
		n79	CA_n79C_BCS0	
CA_n3(2A)-n78A-n79A	-	n3	CA_n3(2A)_BCS1	0
		n78	10, 15, 20, 25, 30, 40, 50, 60, 70, 80, 90, 100	
		n79	40, 50, 60, 80, 100	
CA_n3(2A)-n78A-n79C	-	n3	CA_n3(2A)_BCS1	0
		n78	10, 15, 20, 25, 30, 40, 50, 60, 70, 80, 90, 100	
		n79	CA_n79C_BCS0	
CA_n3A-n78A-n105A	CA_n3A-n78A CA_n3A-n105A CA_n78A-n105A	n3	5, 10, 15, 20, 25, 30, 40, 50	0
		n78	10, 15, 20, 25, 30, 40, 50, 60, 70, 80, 90, 100	
		n105	5, 10, 15, 20, 25, 30, 35	
CA_n5A-n7A-n25A	CA_n5A-n7A CA_n5A-n25A CA_n7A-n25A	n5	5, 10, 15, 20, 25	0
		n7	5, 10, 15, 20, 25, 30, 35, 40, 50	
		n25	5, 10, 15, 20, 25, 30, 35, 40, 45	
CA_n5A-n7A-n25(2A)	CA_n5A-n7A CA_n5A-n25A CA_n7A-n25A	n5	5, 10, 15, 20, 25	0
		n7	5, 10, 15, 20, 25, 30, 35, 40, 50	
		n25	CA_n25(2A)	
CA_n5A-n7A-n28A	-	n5	5, 10, 15, 20	0
		n7	5, 10, 15, 25, 30, 40, 50	
		n28	5, 10, 15, 20, 30	
CA_n5A-n7A-n40A	CA_n5A-n7A CA_n5A-n40A CA_n7A-n40A	n5	5, 10, 15, 20, 25	0
		n7	5, 10, 15, 20, 25, 30, 35, 40, 50	
		n40	10, 15, 20, 25, 30, 40, 50, 60, 70, 80, 90, 100	
CA_n5A-n7A-n66A	CA_n5A-n7A CA_n5A-n66A CA_n7A-n66A	n5	5, 10, 15, 20, 25	0
		n7	5, 10, 15, 20, 25, 30, 35, 40, 50	
		n66	5, 10, 15, 20, 25, 30, 35, 40, 45	
		n5	n5 channel bandwidths in Table 5.3.5-1	4 and 5
		n7	n7 channel bandwidths in Table 5.3.5-1	
		n66	n66 channel bandwidths in Table 5.3.5-1	

CA_n5A-n7A-n77A	n77 <sup>7,9</sup> CA_n5A-n7A CA_n5A-n77A <sup>7</sup> CA_n7A-n77A <sup>7</sup>	n5	5, 10, 15, 20, 25	0
		n7	5, 10, 15, 20, 25, 30, 35, 40, 50	
		n77	10, 15, 20, 25, 30, 40, 50, 60, 70, 80, 90, 100	
		n5	See n5 channel bandwidths in Table 5.3.5-1	4 and 5
		n7	See n7 channel bandwidths in Table 5.3.5-1	
		n77	See n77 channel bandwidths in Table 5.3.5-1	
CA_n5A-n7A-n77(2A)	n77 <sup>7,9</sup> CA_n77(2A) <sup>7</sup> CA_n5A-n7A CA_n5A-n77A <sup>7</sup> CA_n7A-n77A <sup>7</sup>	n5	5, 10, 15, 20, 25	0
		n7	5, 10, 15, 20, 25, 30, 35, 40, 50	
		n77	CA_n77(2A)_BCS0	
		n5	See n5 channel bandwidths in Table 5.3.5-1	4 and 5
		n7	See n7 channel bandwidths in Table 5.3.5-1	
		n77	CA_n77(2A)_BCS4 and 5	
CA_n5A-n7A-n77(3A)	n77 <sup>7,9</sup> CA_n77(2A) <sup>7</sup> CA_n5A-n7A CA_n5A-n77A <sup>7</sup> CA_n7A-n77A <sup>7</sup>	n5	5, 10, 15, 20, 25	0
		n7	5, 10, 15, 20, 25, 30, 35, 40, 50	
		n77	CA_n77(3A)_BCS0	
CA_n5A-n7A-n78A	n78 <sup>8,9</sup> CA_n5A-n78A <sup>7</sup> CA_n7A-n78A <sup>7</sup>	n5	5, 10, 15, 20	0
		n7	5, 10, 15, 20, 25, 30, 40, 50	
		n78	10, 15, 20, 25, 30, 40, 50, 60, 70, 80, 90, 100	
	CA_n5A-n7A CA_n5A-n78A CA_n7A-n78A	n5	5, 10, 15, 20	1
		n7	5, 10, 15, 20, 25, 30, 40, 50	
		n78	10, 15, 20, 25, 30, 40, 50, 60, 70 <sup>4</sup> , 80, 90, 100	
CA_n5A-n7B-n78A	n78 <sup>8,9</sup> CA_n5A-n78A <sup>7</sup> CA_n7A-n78A <sup>7</sup>	n5	5, 10, 15, 20	0
		n7	CA_n7B_BCS0	
		n78	10, 15, 20, 25, 30, 40, 50, 60, 70, 80, 90, 100	
	CA_n5A-n7A CA_n5A-n78A CA_n7A-n78A CA_n7B	n5	5, 10, 15, 20	1
		n7	CA_n7B_BCS0	
		n78	10, 15, 20, 25, 30, 40, 50, 60, 70 <sup>4</sup> , 80, 90, 100	
CA_n5A-n7A-n105A	CA_n5A-n7A CA_n5A-n105A CA_n7A-n105A	n5	5, 10, 15, 20, 25	0
		n7	5, 10, 15, 20, 25, 30, 35, 40, 50	
		n105	5, 10, 15, 20, 25, 30, 35	
CA_n5A-n12A-n77A	n77 <sup>7</sup> CA_n5A-n12A CA_n5A-n77A <sup>7</sup> CA_n12A-n77A <sup>7</sup>	n5	5, 10, 15, 20	0
		n12	5, 10, 15	

		n77	10, 15, 20, 25, 30, 40, 50, 60, 70, 80, 90, 100	
CA_n5A-n12A-n77(2A)	n77 <sup>7</sup> CA_n5A-n12A CA_n5A-n77A <sup>7</sup> CA_n12A-n77A <sup>7</sup>	n5	5, 10, 15, 20	0
		n12	5, 10, 15	
		n77	CA_n77(2A)_BCS1	
CA_n5A-n14A-n77A	n77 <sup>7</sup> CA_n5A-n14A CA_n5A-n77A <sup>7</sup> CA_n14A-n77A <sup>7</sup>	n5	5, 10, 15, 20	0
		n14	5, 10	
		n77	10, 15, 20, 25, 30, 40, 50, 60, 70, 80, 90, 100	
CA_n5A-n14A-n77(2A)	n77 <sup>7</sup> CA_n5A-n14A CA_n5A-n77A <sup>7</sup> CA_n14A-n77A <sup>7</sup>	n5	5, 10, 15, 20	0
		n14	5, 10	
		n77	CA_n77(2A)_BCS1	
CA_n5A-n25A-n29A	CA_n5A-n25A	n5	5, 10, 15, 20	0
		n25	5, 10, 15, 20, 25, 30, 40	
		n29	5, 10	
CA_n5A-n25A-n41A	CA_n5A-n25A CA_n5A-n41A CA_n25A-n41A	n5	5, 10, 15, 20, 25	0
		n25	5, 10, 15, 20, 25, 30, 35, 40, 45	
		n41	5, 10, 15, 20, 25, 30, 35, 40, 45, 50	
CA_n5A-n25(2A)-n41A	CA_n5A-n25A CA_n5A-n41A CA_n25A-n41A	n5	5, 10, 15, 20, 25	0
		n25	CA_n25(2A)	
		n41	5, 10, 15, 20, 25, 30, 35, 40, 45, 50	
CA_n5A-n25A-n66A	CA_n5A-n25A CA_n5A-n66A CA_n25A-n66A	n5	5, 10, 15, 20	0
		n25	5, 10, 15, 20, 25, 30, 40	
		n66	5, 10, 15, 20, 25, 30, 40	
CA_n5A-n25(2A)-n66A	CA_n5A-n25A CA_n5A-n66A CA_n25A-n66A	n5	5, 10, 15, 20	0
		n25	CA_n25(2A)_BCS0	
		n66	5, 10, 15, 20, 25, 30, 40	
CA_n5A-n25A-n66(2A)	CA_n5A-n25A CA_n5A-n66A CA_n25A-n66A	n5	5, 10, 15, 20	0
		n25	5, 10, 15, 20, 25, 30, 40	
		n66	CA_n66(2A)_BCS1	
CA_n5A-n25(2A)-n66(2A)	CA_n5A-n25A CA_n5A-n66A CA_n25A-n66A	n5	5, 10, 15, 20	0
		n25	CA_n25(2A)_BCS0	
		n66	CA_n66(2A)_BCS1	
CA_n5A-n25A-n77A	n77 <sup>7,9</sup> CA_n5A-n25A CA_n5A-n77A <sup>7</sup> CA_n25A-n77A <sup>7</sup>	n5	5, 10, 15, 20	0
		n25	5, 10, 15, 20, 25, 30, 40	
		n77	10, 15, 20, 25, 30, 40, 50, 60, 70, 80, 90, 100	
CA_n5A-n25(2A)-n77A	n77 <sup>7,9</sup> CA_n5A-n25A CA_n5A-n77A <sup>7</sup> CA_n25A-n77A <sup>7</sup>	n5	5, 10, 15, 20	0
		n25	CA_n25(2A)_BCS0	
		n77	10, 15, 20, 25, 30, 40, 50, 60, 70, 80, 90, 100	

CA_n5A-n25A-n77(2A)	n77 <sup>7,9</sup> CA_n77(2A) <sup>7</sup> CA_n5A-n25A CA_n5A-n77A <sup>7</sup> CA_n25A-n77A <sup>7</sup>	n5	5, 10, 15, 20	0
		n25	5, 10, 15, 20, 25, 30, 40	
		n77	CA_n77(2A)_BCS1	
CA_n5A-n25A-n77(3A)	n77 <sup>7,9</sup> CA_n77(2A) <sup>7</sup> CA_n5A-n25A CA_n5A-n77A <sup>7</sup> CA_n25A-n77A <sup>7</sup>	n5	5, 10, 15, 20	0
		n25	5, 10, 15, 20, 25, 30, 40	
		n77	CA_n77(3A)_BCS1	
CA_n5A-n25(2A)-n77(2A)	n77 <sup>7,9</sup> CA_n5A-n25A CA_n5A-n77A <sup>7</sup> CA_n25A-n77A <sup>7</sup>	n5	5, 10, 15, 20	0
		n25	CA_n25(2A)_BCS0	
		n77	CA_n77(2A)_BCS1	
CA_n5A-n25A-n78A	n78 <sup>7,9</sup> CA_n5A-n25A CA_n5A-n78A <sup>7</sup> CA_n25A-n78A <sup>7</sup>	n5	5, 10, 15, 20	0
		n25	5, 10, 15, 20, 25, 30, 40	
		n78	10, 15, 20, 25, 30, 40, 50, 60, 70, 80, 90, 100	
CA_n5A-n25(2A)-n78A	n78 <sup>7,9</sup> CA_n5A-n25A CA_n5A-n78A <sup>7</sup> CA_n25A-n78A <sup>7</sup>	n5	5, 10, 15, 20	0
		n25	CA_n25(2A)_BCS0	
		n78	10, 15, 20, 25, 30, 40, 50, 60, 70, 80, 90, 100	
CA_n5A-n25A-n78(2A)	n78 <sup>7,9</sup> CA_n5A-n25A CA_n5A-n78A <sup>7</sup> CA_n25A-n78A <sup>7</sup>	n5	5, 10, 15, 20	0
		n25	5, 10, 15, 20, 25, 30, 40	
		n78	CA_n78(2A)_BCS2	
CA_n5A-n25(2A)-n78(2A)	n78 <sup>7,9</sup> CA_n5A-n25A CA_n5A-n78A <sup>7</sup> CA_n25A-n78A <sup>7</sup>	n5	5, 10, 15, 20	0
		n25	CA_n25(2A)_BCS0	
		n78	CA_n78(2A)_BCS2	
CA_n5A-n28A-n78A	CA_n5A-n28A CA_n5A-n78A CA_n28A-n78A	n5	See n5 channel bandwidths in Table 5.3.5-1	4 and 5
		n28	See n28 channel bandwidths in Table 5.3.5-1	
		n78	See n78 channel bandwidths in Table 5.3.5-1	
CA_n5A-n28A-n79A	CA_n5A-n28A CA_n5A-n79A CA_n28A-n79A	n5	See n5 channel bandwidths in Table 5.3.5-1	4 and 5
		n28	See n28 channel bandwidths in Table 5.3.5-1	
		n79	See n79 channel bandwidths in Table 5.3.5-1	
CA_n5A-n28A-n105A	CA_n5A-n28A CA_n5A-n105A	n5	5, 10, 15, 20	0
		n28	5, 10, 15, 20, 25, 30	
		n105	5, 10, 15, 20, 25, 30, 35	
CA_n5A-n29A-n66A	CA_n5A-n66A	n5	5, 10, 15, 20	0
		n29	5, 10	
		n66	5, 10, 15, 20, 25, 30, 40	



CA_n5A-n29A-n77A	n77 <sup>7</sup> CA_n5A-n77A <sup>7</sup>	n5	5, 10, 15, 20	0
		n29	5, 10	
		n77	10, 15, 20, 25, 30, 40, 50, 60, 70, 80, 90, 100	
CA_n5A-n29A-n77(2A)	n77 <sup>7</sup> CA_n5A-n77A <sup>7</sup>	n5	5, 10, 15, 20	0
		n29	5, 10	
		n77	CA_n77(2A)_BCS1	
CA_n5A-n30A-n66A	CA_n5A-n30A CA_n5A-n66A CA_n30A-n66A	n5	5, 10, 15, 20	0
		n30	5, 10	
		n66	5, 10, 15, 20, 40	
CA_n5A-n30A-n66(2A)	CA_n5A-n30A CA_n5A-n66A CA_n30A-n66A	n5	5, 10, 15, 20	0
		n30	5, 10	
		n66	CA_n66(2A)_BCS0	
CA_n5A-n30A-n66(3A)	CA_n5A-n30A CA_n5A-n66A CA_n30A-n66A	n5	5, 10, 15, 20	0
		n30	5, 10	
		n66	CA_n66(3A)_BCS0	
CA_n5A-n30A-n77A	n77 <sup>7,9</sup> CA_n5A-n30A CA_n5A-n77A <sup>7</sup> CA_n30A-n77A <sup>7</sup>	n5	5, 10, 15, 20	0
		n30	5, 10	
		n77	10, 15, 20, 25, 30, 40, 50, 60, 70, 80, 90, 100	
CA_n5A-n30A-n77(2A)	n77 <sup>7,9</sup> CA_n5A-n30A CA_n5A-n77A <sup>7</sup> CA_n30A-n77A <sup>7</sup>	n5	5, 10, 15, 20	0
		n30	5, 10	
		n77	CA_n77(2A)_BCS1	
CA_n5A-n40A-n78A	CA_n5A-n40A CA_n5A-n78A CA_n40A-n78A	n5	5, 10, 15, 20, 25 <sup>1</sup>	0
		n40	5 <sup>8</sup> , 10, 15, 20, 25, 30, 40, 50, 60, 70, 80, 90, 100	
		n78	10, 15, 20, 25, 30, 40, 50, 60, 70, 80, 90, 100	
CA_n5A-n40A-n105A	CA_n5A-n40A CA_n5A-n105A CA_n40A-n105A	n5	5, 10, 15, 20, 25	0
		n40	5, 10, 15, 20, 25, 30, 40, 50	
		n105	5, 10, 15, 20, 25, 30, 35	
CA_n5A-n41A-n66A	CA_n5A-n41A CA_n5A-n66A CA_n41A-n66A	n5	5, 10, 15, 20, 25	0
		n41	10, 15, 20, 30, 40, 50, 60, 80, 90, 100	
		n66	5, 10, 15, 20, 25, 30, 35, 40, 45	
CA_n5A-n41A-n77A	CA_n5A-n41A CA_n5A-n77A CA_n41A-n77A	n5	5, 10, 15, 20, 25	0
		n41	5, 10, 15, 20, 25, 30, 35, 40, 45, 50	
		n77	10, 15, 20, 25, 30, 40, 50, 60, 70, 80, 90, 100	
CA_n5A-n41A-n77(2A)	CA_n5A-n41A CA_n5A-n77A CA_n41A-n77A	n5	5, 10, 15, 20, 25	0

		n41	5, 10, 15, 20, 25, 30, 35, 40, 45, 50	
		n77	CA_n77(2A)	
CA_n5A-n48A-n66A	CA_n5A-n48A CA_n5A-n66A CA_n48A-n66A	n5	5, 10, 15, 20	0
		n48	5, 10, 15, 20, 30, 40, 50 <sup>12</sup> , 60 <sup>12</sup> , 70 <sup>12</sup> , 80 <sup>12</sup> , 90 <sup>12</sup> , 100 <sup>12</sup>	
		n66	5, 10, 15, 20, 25, 30, 40	
CA_n5A-n48(A-B)-n66A	CA_n5A-n48A CA_n5A-n66A CA_n48A-n66A	n5	5, 10, 15, 20, 25 <sup>1</sup>	0
		n48	CA_n48(A-B)_BCS0	
		n66	5, 10, 15, 20, 25, 30, 40	
		n5	5, 10, 15, 20, 25 <sup>1</sup>	1
		n48	CA_n48(A-B)_BCS1	
CA_n5A-n48B-n66A	CA_n48B CA_n5A-n48A CA_n5A-n66A CA_n48A-n66A	n5	5, 10, 15, 20	0
		n48	CA_n48B_BCS0	
		n66	5, 10, 15, 20, 25, 30, 40	
		n5	5, 10, 15, 20	1
		n48	CA_n48B_BCS1	
		n66	5, 10, 15, 20, 25, 30, 40	
		n5	5, 10, 15, 20	2
CA_n5A-n48(2A)-n66A	CA_n5A-n48A CA_n5A-n66A CA_n48A-n66A	n5	5, 10, 15, 20	0
		n48	CA_n48(2A)_BCS0	
		n66	5, 10, 15, 20, 25, 30, 40	
		n5	5, 10, 15, 20	1
		n48	CA_n48(2A)_BCS1	
CA_n5A-n48A-n77A	n77 <sup>7,9</sup> CA_n5A-n48A CA_n5A-n77A <sup>7</sup>	n5	5, 10, 15, 20	0
		n48	5, 10, 15, 20, 30, 40, 50 <sup>12</sup> , 60 <sup>12</sup> , 70 <sup>12</sup> , 80 <sup>12</sup> , 90 <sup>12</sup> , 100 <sup>12</sup>	
		n77	10, 15, 20, 25, 30, 40, 50, 60, 70, 80, 90, 100	
		n48	5, 10, 15, 20, 30, 40, 50 <sup>12</sup> , 60 <sup>12</sup> , 70 <sup>12</sup> , 80 <sup>12</sup> , 90 <sup>12</sup> , 100 <sup>12</sup>	
		n77	CA_n77C_BCS0	
CA_n5A-n48A-n77C	n77 <sup>7,9</sup> CA_n5A-n48A CA_n5A-n77A <sup>7</sup> CA_n77C	n5	5, 10, 15, 20, 25 <sup>1</sup>	0
		n48	5, 10, 15, 20, 30, 40, 50 <sup>12</sup> , 60 <sup>12</sup> , 70 <sup>12</sup> , 80 <sup>12</sup> , 90 <sup>12</sup> , 100 <sup>12</sup>	
		n77	CA_n77C_BCS0	
		n5	5, 10, 15, 20, 25 <sup>1</sup>	1
		n48	5, 10, 15, 20, 30, 40, 50 <sup>12</sup> , 60 <sup>12</sup> , 70 <sup>12</sup> , 80 <sup>12</sup> , 90 <sup>12</sup> , 100 <sup>12</sup>	
CA_n5A-n48B-n77A	n77 <sup>7,9</sup> CA_n5A-n48A CA_n5A-n77A <sup>7</sup>	n5	5, 10, 15, 20	0
		n48	CA_n48B_BCS0	
		n77	10, 15, 20, 25, 30, 40, 50, 60, 70, 80, 90, 100	
		n5	5, 10, 15, 20	1
		n48	CA_n48B_BCS1	
		n77	10, 15, 20, 25, 30, 40, 50, 60, 70, 80, 90, 100	
		n5	5, 10, 15, 20	2
n48	CA_n48B_BCS2			

		n77	10, 15, 20, 25, 30, 40, 50, 60, 70, 80, 90, 100	
CA_n5A-n48B-n77C	n77 <sup>7,9</sup> CA_n5A-n48A CA_n5A-n77A <sup>7</sup> CA_n77C	n5	5, 10, 15, 20	0
		n48	CA_n48B_BCS0	1
		n77	CA_n77C_BCS0	
		n5	5, 10, 15, 20	2
		n48	CA_n48B_BCS1	
		n77	CA_n77C_BCS1	3
		n5	5, 10, 15, 20	
		n48	CA_n48B_BCS1	
		n77	CA_n77C_BCS1	
		CA_n5A-n48(2A)-n77A	n77 <sup>7,9</sup> CA_n5A-n48A CA_n5A-n77A <sup>7</sup>	n5
n48	CA_n48(2A)_BCS0			1
n77	10, 15, 20, 25, 30, 40, 50, 60, 70, 80, 90, 100			
n5	5, 10, 15, 20			
n48	CA_n48(2A)_BCS1			
CA_n5A-n48(2A)-n77C	n77 <sup>7,9</sup> CA_n5A-n48A CA_n5A-n77A <sup>7</sup> CA_n77C	n5	5, 10, 15, 20	0
		n48	CA_n48(2A)_BCS0	1
		n77	CA_n77C_BCS0	
		n5	5, 10, 15, 20	2
		n48	CA_n48(2A)_BCS1	
		n77	CA_n77C_BCS1	3
		n5	5, 10, 15, 20	
		n48	CA_n48(2A)_BCS1	
		n77	CA_n77C_BCS1	
		CA_n5A-n66A-n77A	n77 <sup>7,9</sup> CA_n5A-n66A CA_n5A-n77A <sup>7</sup> CA_n66A-n77A <sup>7</sup>	n5
n66	5, 10, 15, 20, 25, 30, 40			4 and 5
n77	10, 15, 20, 25, 30, 40, 50, 60, 70, 80, 90, 100			
n5	n5 channel bandwidths in Table 5.3.5-1			
n66	n66 channel bandwidths in Table 5.3.5-1			
n77	n77 channel bandwidths in Table 5.3.5-1			
CA_n5A-n66(2A)-n77A	n77 <sup>7,9</sup> CA_n5A-n66A CA_n5A-n77A <sup>7</sup> CA_n66A-n77A <sup>7</sup>	n5	5, 10, 15, 20	0
		n66	CA_n66(2A)_BCS1	10, 15, 20, 25, 30, 40, 50, 60, 70, 80, 90, 100
		n77	10, 15, 20, 25, 30, 40, 50, 60, 70, 80, 90, 100	
CA_n5A-n66(2A)-n77(2A)	n77 <sup>7,9</sup> CA_n5A-n66A CA_n5A-n77A <sup>7</sup>	n5	5, 10, 15, 20	0

	CA_n66A-n77A <sup>7</sup>			
		n66	CA_n66(2A)_BCS1	
		n77	CA_n77(2A)_BCS1	
CA_n5A-n66(3A)-n77A	n77 <sup>7,9</sup> CA_n5A-n66A CA_n66A-n77A <sup>7</sup> CA_n5A-n77A <sup>7</sup>	n5	5, 10, 15, 20	0
		n66	CA_n66(3A)_BCS0	
		n77	10, 15, 20, 25, 30, 40, 50, 60, 70, 80, 90, 100	
CA_n5A-n66(3A)-n77(2A)	n77 <sup>7</sup> CA_n5A-n66A CA_n66A-n77A <sup>7</sup> CA_n5A-n77A <sup>7</sup>	n5	5, 10, 15, 20	0
		n66	CA_n66(3A)_BCS0	
		n77	CA_n77(2A)_BCS1	
CA_n5A-n66A-n77C	n77 <sup>7,9</sup> CA_n5A-n66A CA_n5A-n77A <sup>7</sup> CA_n66A-n77A <sup>7</sup> CA_n77C	n5	5, 10, 15, 20, 25 <sup>1</sup>	0
		n66	5, 10, 15, 20, 25, 30, 40	
		n77	CA_n77C_BCS0	
		n5	5, 10, 15, 20, 25 <sup>1</sup>	1
		n66	5, 10, 15, 20, 25, 30, 40	
		n77	CA_n77C_BCS1	
CA_n5A-n66A-n77(2A)	n77 <sup>7,9</sup> CA_n5A-n66A CA_n5A-n77A <sup>7</sup> CA_n66A-n77A <sup>7</sup> CA_n77(2A) <sup>7</sup>	n5	5, 10, 15, 20	0
		n66	5, 10, 15, 20, 25, 30, 40	
		n77	CA_n77(2A)_BCS1	
		n5	5, 10, 15, 20	1
		n66	5, 10, 15, 20, 30, 40	
		n77	CA_n77(2A)_BCS4 and 5	
		n5	n5 channel bandwidths in Table 5.3.5-1	4 and 5
		n66	n66 channel bandwidths in Table 5.3.5-1	
CA_n5A-n66A-n77(3A)	CA_n77(2A) CA_n5A-n66A CA_n5A-n77A <sup>7</sup> CA_n66A-n77A <sup>7</sup>	n5	5, 10, 15, 20	0
		n66	5, 10, 15, 20, 25, 30, 40	
		n77	CA_n77(3A)_BCS1	
		n5	n5 channel bandwidths in Table 5.3.5-1	4 and 5
		n66	n66 channel bandwidths in Table 5.3.5-1	
CA_n5A-n66A-n78A	CA_n5A-n66A CA_n5A-n78A CA_n66A-n78A	n5	5, 10, 15, 20	0
		n66	5, 10, 15, 20, 25, 30, 40	
		n78	10, 15, 20, 25, 30, 40, 50, 60, 80, 90, 100	
		n5	5, 10, 15, 20	1
		n66	5, 10, 15, 20, 25, 30, 40	
CA_n5A-n66(2A)-n78A	CA_n5A-n66A CA_n5A-n78A CA_n66A-n78A	n5	5, 10, 15, 20	0
		n66	CA_n66(2A)_BCS1	
		n78	10, 15, 20, 25, 30, 40, 50, 60, 70, 80, 90, 100	

		n78	10, 15, 20, 25, 30, 40, 50, 60, 70, 80, 90, 100	
CA_n5A-n66A-n78(2A)	CA_n5A-n66A CA_n5A-n78A CA_n66A-n78A	n5	5, 10, 15, 20	0
		n66	5, 10, 15, 20, 25, 30, 40	
		n78	CA_n78(2A)_BCS2	
CA_n5A-n66(2A)-n78(2A)	CA_n5A-n66A CA_n5A-n78A CA_n66A-n78A	n5	5, 10, 15, 20	0
		n66	CA_n66(2A)_BCS1	
		n78	CA_n78(2A)_BCS2	
CA_n5A-n78A-n79A	CA_n5A-n78A CA_n5A-n79A CA_n78A-n79A	n5	See n5 channel bandwidths in Table 5.3.5-1	4 and 5
		n78	See n78 channel bandwidths in Table 5.3.5-1	
		n79	See n79 channel bandwidths in Table 5.3.5-1	
CA_n5A-n78A-n105A	CA_n5A-n78A CA_n5A-n105A CA_n78A-n105A	n5	5, 10, 15, 20, 25	0
		n78	10, 15, 20, 25, 30, 40, 50, 60, 70, 80, 90, 100	
		n105	5, 10, 15, 20, 25, 30, 35	
CA_n7A-n8A-n28A	-	n7	5, 10, 15, 20, 25, 30, 40, 50	0
		n8	5, 10, 15, 20	
		n28	5, 10, 15, 20, 30	
CA_n7A-n8A-n40A	CA_n7A-n8A CA_n7A-n40A CA_n8A-n40A	n7	5, 10, 15, 20, 25, 30, 40, 50	0
		n8	5, 10, 15, 20	
		n40	5, 10, 15, 20, 25, 30, 40, 50, 60, 80	
CA_n7A-n8A-n78A	CA_n7A-n8A CA_n7A-n78A CA_n8A-n78A	n7	5, 10, 15, 20, 25, 30, 40, 50	0
		n8	5, 10, 15, 20	
		n78	10, 15, 20, 25, 30, 40, 50, 60, 70, 80, 90, 100	
CA_n7(2A)-n8A-n78A	CA_n7A-n8A CA_n7A-n78A CA_n8A-n78A	n7	CA_n7(2A)_BCS0	0
		n8	5, 10, 15, 20	
		n78	10, 15, 20, 25, 30, 40, 50, 60, 70, 80, 90, 100	
CA_n7A-n12A-n25A	-	n7	5, 10, 15, 20, 25, 30, 40, 50	0
		n12	5, 10, 15	
		n25	5, 10, 15, 20, 25, 30, 40	
CA_n7A-n12A-n66A	-	n7	5, 10, 15, 20, 25, 30, 35, 40, 50	0
		n12	5, 10, 15	
		n66	5, 10, 15, 20, 25, 30, 35, 40, 45	
CA_n7A-n12A-n71A	CA_n7A-n12A CA_n7A-n71A	n7	5, 10, 15, 20, 25, 30, 40, 50	0
		n12	5, 10, 15	
		n71	5, 10, 15, 20	
CA_n7A-n12A-n77A	-	n7	5, 10, 15, 20, 25, 30, 35, 40, 50	0
		n12	5, 10, 15	
		n77	10, 15, 20, 25, 30, 40, 50, 60, 70, 80, 90, 100	
CA_n7A-n20A-n67A	CA_n7A-n20A	n7	See n7 channel bandwidths in Table 5.3.5-1	4 and 5
		n20	See n20 channel bandwidths in Table 5.3.5-1	
		n67	See n67 channel bandwidths in Table 5.3.5-1	

CA_n7A-n20A-n78A	CA_n7A-n20A CA_n7A-n78A CA_n20A-n78A	n7	See n7 channel bandwidths in Table 5.3.5-1	4 and 5
		n20	See n20 channel bandwidths in Table 5.3.5-1	
		n78	See n78 channel bandwidths in Table 5.3.5-1	
CA_n7A-n20A-n78(2A)	CA_n7A-n20A CA_n7A-n78A CA_n20A-n78A CA_n78(2A)	n7	See n7 channel bandwidths in Table 5.3.5-1	4 and 5
		n20	See n20 channel bandwidths in Table 5.3.5-1	
		n78	CA_n78(2A)_BCS4 and 5	
CA_n7A-n25A-n66A	CA_n7A-n25A CA_n7A-n66A CA_n25A-n66A	n7	5, 10, 15, 20, 25, 30, 40, 50	0
		n25	5, 10, 15, 20, 25, 30, 40	
		n66	5, 10, 15, 20, 25, 30, 40	
CA_n7A-n25(2A)-n66A	CA_n7A-n25A CA_n7A-n66A CA_n25A-n66A	n7	5, 10, 15, 20, 25, 30, 40, 50	0
		n25	CA_n25(2A)_BCS0	
		n66	5, 10, 15, 20, 25, 30, 40	
CA_n7A-n25(2A)-n66(2A)	CA_n7A-n25A CA_n7A-n66A CA_n25A-n66A	n7	5, 10, 15, 20, 25, 30, 40, 50	0
		n25	CA_n25(2A)_BCS0	
		n66	CA_n66(2A)_BCS1	
CA_n7A-n25A-n66(2A)	CA_n7A-n25A CA_n7A-n66A CA_n25A-n66A	n7	5, 10, 15, 20, 25, 30, 40, 50	0
		n25	5, 10, 15, 20, 25, 30, 40	
		n66	CA_n66(2A)_BCS1	
CA_n7(2A)-n25A-n66A	CA_n7A-n25A CA_n7A-n66A CA_n25A-n66A	n7	CA_n7(2A)_BCS0	0
		n25	5, 10, 15, 20, 25, 30, 40	
		n66	5, 10, 15, 20, 25, 30, 40	
CA_n7(2A)-n25(2A)-n66A	CA_n7A-n25A CA_n7A-n66A CA_n25A-n66A	n7	CA_n7(2A)_BCS0	0
		n25	CA_n25(2A)_BCS0	
		n66	5, 10, 15, 20, 25, 30, 40	
CA_n7(2A)-n25A-n66(2A)	CA_n7A-n25A CA_n7A-n66A CA_n25A-n66A	n7	CA_n7(2A)_BCS0	0
		n25	5, 10, 15, 20, 25, 30, 40	
		n66	CA_n66(2A)_BCS1	
CA_n7(2A)-n25(2A)-n66(2A)	CA_n7A-n25A CA_n7A-n66A CA_n25A-n66A	n7	CA_n7(2A)_BCS0	0
		n25	CA_n25(2A)_BCS0	
		n66	CA_n66(2A)_BCS1	
CA_n7A-n25A-n71A	-	n7	5, 10, 15, 20, 25, 30, 40, 50	0
		n25	5, 10, 15, 20, 25, 30, 40	
		n71	5, 10, 15, 20	
CA_n7A-n25A-n77A	n77 <sup>7,9</sup> CA_n7A-n25A CA_n7A-n77A <sup>7</sup> CA_n25A-n77A <sup>7</sup>	n7	5, 10, 15, 20, 25, 30, 40, 50	0
		n25	5, 10, 15, 20, 25, 30, 40	
		n77	10, 15, 20, 25, 30, 40, 50, 60, 70, 80, 90, 100	
CA_n7A-n25(2A)-n77A	n77 <sup>7,9</sup> CA_n7A-n25A CA_n7A-n77A <sup>7</sup>	n7	5, 10, 15, 20, 25, 30, 40, 50	0

	CA_n25A-n77A <sup>7</sup>	n25	CA_n25(2A)_BCS0	
		n77	10, 15, 20, 25, 30, 40, 50, 60, 70, 80, 90, 100	
CA_n7A-n25A-n77(2A)	n77 <sup>7,9</sup> CA_n77(2A) <sup>7</sup> CA_n7A-n25A CA_n7A-n77A <sup>7</sup> CA_n25A-n77A <sup>7</sup>	n7	5, 10, 15, 20, 25, 30, 40, 50	0
		n25	5, 10, 15, 20, 25, 30, 40	
		n77	CA_n77(2A)_BCS1	
CA_n7A-n25A-n77(3A)	n77 <sup>7,9</sup> CA_n77(2A) <sup>7</sup> CA_n7A-n25A CA_n7A-n77A <sup>7</sup> CA_n25A-n77A <sup>7</sup>	n7	5, 10, 15, 20, 25, 30, 40, 50	0
		n25	5, 10, 15, 20, 25, 30, 40	
		n77	CA_n77(3A)_BCS1	
CA_n7A-n25(2A)-n77(2A)	n77 <sup>7,9</sup> CA_n7A-n25A CA_n7A-n77A <sup>7</sup> CA_n25A-n77A <sup>7</sup>	n7	5, 10, 15, 20, 25, 30, 40, 50	0
		n25	CA_n25(2A)_BCS0	
		n77	CA_n77(2A)_BCS1	
CA_n7(2A)-n25A-n77A	n77 <sup>7,9</sup> CA_n7A-n25A CA_n7A-n77A <sup>7</sup> CA_n25A-n77A <sup>7</sup>	n7	CA_n7(2A)_BCS0	0
		n25	5, 10, 15, 20, 25, 30, 40	
		n77	10, 15, 20, 25, 30, 40, 50, 60, 70, 80, 90, 100	
CA_n7(2A)-n25(2A)-n77A	n77 <sup>7,9</sup> CA_n7A-n25A CA_n7A-n77A <sup>7</sup> CA_n25A-n77A <sup>7</sup>	n7	CA_n7(2A)_BCS0	0
		n25	CA_n25(2A)_BCS0	
		n77	10, 15, 20, 25, 30, 40, 50, 60, 70, 80, 90, 100	
CA_n7(2A)-n25A-n77(2A)	n77 <sup>7,9</sup> CA_n7A-n25A CA_n7A-n77A <sup>7</sup> CA_n25A-n77A <sup>7</sup>	n7	CA_n7(2A)_BCS0	0
		n25	5, 10, 15, 20, 25, 30, 40	
		n77	CA_n77(2A)_BCS1	
CA_n7(2A)-n25(2A)-n77(2A)	n77 <sup>7,9</sup> CA_n7A-n25A CA_n7A-n77A <sup>7</sup> CA_n25A-n77A <sup>7</sup>	n7	CA_n7(2A)_BCS0	0
		n25	CA_n25(2A)_BCS0	
		n77	CA_n77(2A)_BCS1	
CA_n7A-n25A-n78A	CA_n7A-n25A CA_n7A-n78A CA_n25A-n78A	n7	5, 10, 15, 20, 25, 30, 40, 50	0
		n25	5, 10, 15, 20, 25, 30, 40	
		n78	10, 15, 20, 25, 30, 40, 50, 60, 70 <sup>4</sup> , 80, 90 <sup>4</sup> , 100	
CA_n7(2A)-n25A-n78A	-	n7	CA_n7(2A)_BCS0	0
		n25	5, 10, 15, 20, 25, 30, 40	
		n78	10, 15, 20, 25, 30, 40, 50, 60, 70 <sup>4</sup> , 80, 90 <sup>4</sup> , 100	
CA_n7A-n25(2A)-n78A	-	n7	5, 10, 15, 20, 25, 30, 40, 50	0
		n25	CA_n25(2A)_BCS0	
		n78	10, 15, 20, 25, 30, 40, 50, 60, 70 <sup>4</sup> , 80, 90 <sup>4</sup> , 100	

CA_n7(2A)-n25(2A)-n78A	-	n7	CA_n7(2A)_BCS0	0
		n25	CA_n25(2A)_BCS0	
		n78	10, 15, 20, 25, 30, 40, 50, 60, 70 <sup>4</sup> , 80, 90 <sup>4</sup> , 100	
CA_n7A-n25A-n78(2A)	CA_n7A-n25A CA_n7A-n78A CA_n25A-n78A	n7	5, 10, 15, 20, 25, 30, 40, 50	0
		n25	5, 10, 15, 20, 25, 30, 40	
		n78	CA_n78(2A)_BCS0	
		n7	5, 10, 15, 20, 25, 30, 40, 50	1
		n25	5, 10, 15, 20, 25, 30, 40	
n78	CA_n78(2A)_BCS2			
CA_n7(2A)-n25A-n78(2A)	-	n7	CA_n7(2A)_BCS0	0
		n25	5, 10, 15, 20, 25, 30, 40	
		n78	CA_n78(2A)_BCS0	
CA_n7A-n25(2A)-n78(2A)	-	n7	5, 10, 15, 20, 25, 30, 40, 50	0
		n25	CA_n25(2A)_BCS0	
		n78	CA_n78(2A)_BCS0	
CA_n7(2A)-n25(2A)-n78(2A)	-	n7	CA_n7(2A)_BCS0	0
		n25	CA_n25(2A)_BCS0	
		n78	CA_n78(2A)_BCS0	
CA_n7A-n26A-n78A	n78 <sup>8,9</sup> CA_n7A-n26A CA_n7A-n78A <sup>7</sup> CA_n26A-n78A <sup>7</sup>	n7	5, 10, 15, 20, 25, 30, 40, 50	0
		n26	5, 10, 15, 20	
		n78	10, 15, 20, 25, 30, 40, 50, 60, 70, 80, 90, 100	
CA_n7A-n26A-n78(2A)	CA_n7A-n26A CA_n7A-n78A CA_n26A-n78A	n7	5, 10, 15, 20, 25, 30, 35, 40, 50	0
		n26	5, 10, 15, 20, 25, 30	
		n78	CA_n78(2A)_BCS0	
CA_n7A-n26A-n78C	CA_n7A-n26A CA_n7A-n78A CA_n26A-n78A CA_n78C	n7	5, 10, 15, 20, 25, 30, 35, 40, 50	0
		n26	5, 10, 15, 20, 25, 30	
		n78	CA_n78C_BCS0	
CA_n7A-n26(2A)-n78A	CA_n7A-n26A CA_n7A-n78A CA_n26A-n78A CA_n26(2A)	n7	5, 10, 15, 20, 25, 30, 35, 40, 50	0
		n26	CA_n26(2A)_BCS0	
		n78	10, 15, 20, 25, 30, 40, 50, 60, 70, 80, 90, 100	
CA_n7A-n26(2A)-n78(2A)	CA_n7A-n26A CA_n7A-n78A CA_n26A-n78A CA_n26(2A)	n7	5, 10, 15, 20, 25, 30, 35, 40, 50	0
		n26	CA_n26(2A)_BCS0	
		n78	CA_n78(2A)_BCS0	
CA_n7A-n26(2A)-n78C	CA_n7A-n26A CA_n7A-n78A CA_n26A-n78A CA_n26(2A) CA_n78C	n7	5, 10, 15, 20, 25, 30, 35, 40, 50	0
		n26	CA_n26(2A)_BCS0	
		n78	CA_n78C_BCS0	
CA_n7B-n26A-n78A	n78 <sup>8,9</sup> CA_n7A-n26A CA_n7A-n78A <sup>7</sup> CA_n26A-n78A <sup>7</sup>	n7	CA_n7B_BCS0	0



	CA_n7B	n26	5, 10, 15, 20	
		n78	10, 15, 20, 25, 30, 40, 50, 60, 70, 80, 90, 100	
CA_n7B-n26A-n78(2A)	CA_n7A-n26A CA_n7A-n78A CA_n7B CA_n26A-n78A	n7	CA_n7B_BCS0	0
		n26	5, 10, 15, 20, 25, 30	
		n78	CA_n78(2A)_BCS0	
CA_n7B-n26A-n78C	CA_n7A-n26A CA_n7A-n78A CA_n7B CA_n26A-n78A CA_n78C	n7	CA_n7B_BCS0	0
		n26	5, 10, 15, 20, 25, 30	
		n78	CA_n78C_BCS0	
CA_n7B-n26(2A)-n78A	CA_n7A-n26A CA_n7A-n78A CA_n26A-n78A CA_n7B CA_n26(2A)	n7	CA_n7B_BCS0	0
		n26	CA_n26(2A)_BCS0	
		n78	10, 15, 20, 25, 30, 40, 50, 60, 70, 80, 90, 100	
CA_n7B-n26(2A)-n78(2A)	CA_n7A-n26A CA_n7A-n78A CA_n26A-n78A CA_n7B CA_n26(2A)	n7	CA_n7B_BCS0	0
		n26	CA_n26(2A)_BCS0	
		n78	CA_n78(2A)_BCS0	
CA_n7B-n26(2A)-n78C	CA_n7A-n26A CA_n7A-n78A CA_n26A-n78A CA_n7B CA_n26(2A) CA_n78C	n7	CA_n7B_BCS0	0
		n26	CA_n26(2A)_BCS0	
		n78	CA_n78C_BCS0	
CA_n7A-n28A-n38A <sup>11</sup>	-	n7	5, 10, 15, 20, 30, 40, 50	0
		n28	5, 10, 15, 20	
		n38	5, 10, 15, 20, 30, 40	
CA_n7A-n28A-n40A	CA_n7A-n28A CA_n7A-n40A CA_n28A-n40A	n7	5, 10, 15, 20, 25, 30, 35, 40, 50	0
		n28	3, 5, 10, 15, 20, 25, 30, 40	
		n40	10, 15, 20, 25, 30, 40, 50, 60, 70, 80, 90, 100	
CA_n7A-n28A-n78A	n78 <sup>7,9</sup> CA_n7A-n78A <sup>7</sup> CA_n28A-n78A <sup>7</sup>	n7	5, 10, 15, 20, 25, 30, 40, 50	0
		n28	5, 10, 15, 20	
		n78	10, 15, 20, 25, 30, 40, 50, 60, 80, 90, 100	
	n78 <sup>7,9</sup> CA_n7A-n28A CA_n7A-n78A <sup>7</sup> CA_n28A-n78A <sup>7</sup>	n7	5, 10, 15, 20, 25, 30, 40, 50	1
		n28	5, 10, 15, 20	
		n78	10, 15, 20, 25, 30, 40, 50, 60, 70 <sup>4</sup> , 80, 90, 100	
CA_n7A-n28A-n78(2A)	n78 <sup>7,9</sup> CA_n78(2A) <sup>7</sup> CA_n7A-n28A CA_n7A-n78A <sup>7</sup> CA_n28A-n78A <sup>7</sup>	n7	5, 10, 15, 20, 25, 30, 40, 50	0

		n28	5, 10, 15, 20	
		n78	CA_n78(2A)_BCS2	
CA_n7A-n28A-n78C	CA_n78C CA_n7A-n28A CA_n7A-n78A CA_n28A-n78A	n7	5, 10, 15, 20, 25, 30, 40, 50	0
		n28	5, 10, 15, 20	
		n78	CA_n78C_BCS1	
CA_n7B-n28A-n78A	n78 <sup>8,9</sup> CA_n7A-n78A <sup>7</sup> CA_n28A-n78A <sup>7</sup>	n7	CA_n7B_BCS0	0
		n28	5, 10, 15, 20	
		n78	10, 15, 20, 25, 30, 40, 50, 60, 80, 90, 100	
	CA_n7A-n28A CA_n7A-n78A CA_n28A-n78A CA_n7B	n7	CA_n7B_BCS0	1
		n28	5, 10, 15, 20	
		n78	10, 15, 20, 25, 30, 40, 50, 60, 70 <sup>4</sup> , 80, 90, 100	
CA_n7B-n28A-n78(2A)	CA_n7B CA_n78(2A) CA_n7A-n28A CA_n7A-n78A CA_n28A-n78A	n7	CA_n7B_BCS0	0
		n28	5, 10, 15, 20	
		n78	CA_n78(2A)_BCS2	
CA_n7B-n28A-n78C	CA_n7B CA_n78C CA_n7A-n28A CA_n7A-n78A CA_n28A-n78A	n7	CA_n7B_BCS0	0
		n28	5, 10, 15, 20	
		n78	CA_n78C_BCS1	
CA_n7A-n38A-n78A <sup>10</sup>	-	n7	5, 10, 15, 20, 25, 30, 40, 50	0
		n38	5, 10, 15, 20, 25, 30, 40	
		n78	10, 15, 20, 25, 30, 40, 50, 60, 70, 80, 90, 100	
CA_n7A-n40A-n78A	CA_n7A-n40A CA_n7A-n78A CA_n40A-n78A	n7	5, 10, 15, 20, 25, 30, 40, 50	0
		n40	5, 10, 15, 20, 30, 40, 50, 60, 80	
		n78	10, 15, 20, 25, 30, 40, 50, 60, 70, 80, 90, 100	
CA_n7A-n40A-n105A	CA_n7A-n40A CA_n7A-n105A CA_n40A-n105A	n7	5, 10, 15, 20, 25, 30, 40, 50	0
		n40	5, 10, 15, 20, 25, 30, 40, 50, 60, 70, 80, 90, 100	
		n105	5, 10, 15, 20, 25, 30, 35	
CA_n7A-n46A-n78A	CA_n7A-n46A CA_n7A-n78A CA_n46A-n78A	n7	5, 10, 15, 20, 25, 30, 40, 50	0
		n46	20, 40, 60, 80	
		n78	10, 15, 20, 25, 30, 40, 50, 60, 70, 80, 90, 100	
CA_n7A-n46C-n78A	CA_n7A-n46A CA_n7A-n78A CA_n46A-n78A	n7	5, 10, 15, 20, 25, 30, 40, 50	0
		n46	CA_n46C_BCS0	
		n78	10, 15, 20, 25, 30, 40, 50, 60, 70, 80, 90, 100	
CA_n7A-n46D-n78A	CA_n7A-n46A CA_n7A-n78A CA_n46A-n78A	n7	5, 10, 15, 20, 25, 30, 40, 50	0
		n46	CA_n46D_BCS0	

		n78	10, 15, 20, 25, 30, 40, 50, 60, 70, 80, 90, 100	
CA_n7A-n46(2A)-n78A	CA_n7A-n46A CA_n7A-n78A CA_n46A-n78A	n7	5, 10, 15, 20, 25, 30, 40, 50	0
		n46	CA_n46(2A)_BCS0	
		n78	10, 15, 20, 25, 30, 40, 50, 60, 70, 80, 90, 100	
CA_n7A-n46(2A)-n78(2A)	CA_n7A-n46A CA_n7A-n78A CA_n46A-n78A CA_n78(2A)	n7	5, 10, 15, 20, 25, 30, 40, 50	0
		n46	CA_n46(2A)_BCS0	
		n78	CA_n78(2A)_BCS2	
CA_n7A-n46A-n78(2A)	CA_n7A-n46A CA_n7A-n78A CA_n46A-n78A CA_n78(2A)	n7	5, 10, 15, 20, 25, 30, 40, 50	0
		n46	20, 40, 60, 80	
		n78	CA_n78(2A)_BCS2	
CA_n7A-n46C-n78(2A)	CA_n7A-n46A CA_n7A-n78A CA_n46A-n78A CA_n78(2A)	n7	5, 10, 15, 20, 25, 30, 40, 50	0
		n46	CA_n46C_BCS0	
		n78	CA_n78(2A)_BCS2	
CA_n7A-n46D-n78(2A)	CA_n7A-n46A CA_n7A-n78A CA_n46A-n78A CA_n78(2A)	n7	5, 10, 15, 20, 25, 30, 40, 50	0
		n46	CA_n46D_BCS0	
		n78	CA_n78(2A)_BCS2	
CA_n7A-n66A-n71A	CA_n7A-n66A CA_n7A-n71A CA_n66A-n71A	n7	5, 10, 15, 20, 25, 30, 40, 50	0
		n66	5, 10, 15, 20, 40	
		n71	5, 10, 15, 20	
		n7	n7 channel bandwidths in Table 5.3.5-1	4 and 5
		n66	n66 channel bandwidths in Table 5.3.5-1	
		n71	n71 channel bandwidths in Table 5.3.5-1	
CA_n7A-n66A-n77A	n77 <sup>7,9</sup> CA_n7A-n66A CA_n7A-n77A <sup>7</sup> CA_n66A-n77A <sup>7</sup>	n7	5, 10, 15, 20, 25, 30, 40, 50	0
		n66	5, 10, 15, 20, 25, 30, 40	
		n77	10, 15, 20, 25, 30, 40, 50, 60, 70, 80, 90, 100	
		n7	n7 channel bandwidths in Table 5.3.5-1	4 and 5
		n66	n66 channel bandwidths in Table 5.3.5-1	
		n77	n77 channel bandwidths in Table 5.3.5-1	
CA_n7A-n66(2A)-n77A	n77 <sup>7,9</sup> CA_n7A-n66A CA_n7A-n77A <sup>7</sup> CA_n66A-n77A <sup>7</sup>	n7	5, 10, 15, 20, 25, 30, 40, 50	0
		n66	CA_n66(2A)_BCS1	
		n77	10, 15, 20, 25, 30, 40, 50, 60, 70, 80, 90, 100	
CA_n7A-n66A-n77(2A)	n77 <sup>7,9</sup> CA_n77(2A)	n7	5, 10, 15, 20, 25, 30, 40, 50	0

	CA_n7A-n66A CA_n7A-n77A <sup>7</sup> CA_n66A-n77A <sup>7</sup>	n66	5, 10, 15, 20, 25, 30, 40	4 and 5
		n77	CA_n77(2A)_BCS1	
		n7	n7 channel bandwidths in Table 5.3.5-1	
		n66	n66 channel bandwidths in Table 5.3.5-1	
		n77	CA_n77(2A)_BCS4 and 5	
CA_n7A-n66A-n77(3A)	n77 <sup>7,9</sup> CA_n77(2A) <sup>7</sup> CA_n77(2A) <sup>7</sup> CA_n7A-n66A CA_n7A-n77A <sup>7</sup> CA_n66A-n77A <sup>7</sup>	n7	5, 10, 15, 20, 25, 30, 40, 50	0
		n66	5, 10, 15, 20, 25, 30, 40	
		n77	CA_n77(3A)_BCS1	
		n7	n7 channel bandwidths in Table 5.3.5-1	
		n66	n66 channel bandwidths in Table 5.3.5-1	
CA_n7A-n66(2A)-n77(2A)	n77 <sup>7,9</sup> CA_n7A-n66A CA_n7A-n77A <sup>7</sup> CA_n66A-n77A <sup>7</sup>	n7	5, 10, 15, 20, 25, 30, 40, 50	0
		n66	CA_n66(2A)_BCS1	
		n77	CA_n77(2A)_BCS1	
		n7	n7 channel bandwidths in Table 5.3.5-1	
		n66	n66 channel bandwidths in Table 5.3.5-1	
CA_n7(2A)-n66A-n77A	n77 <sup>7,9</sup> CA_n7A-n66A CA_n7A-n77A <sup>7</sup> CA_n66A-n77A <sup>7</sup>	n7	CA_n7(2A)_BCS0	0
		n66	5, 10, 15, 20, 25, 30, 40	
		n77	10, 15, 20, 25, 30, 40, 50, 60, 70, 80, 90, 100	
		n7	CA_n7(2A)_BCS0	
		n66	CA_n66(2A)_BCS1	
CA_n7(2A)-n66(2A)-n77A	n77 <sup>7,9</sup> CA_n7A-n66A CA_n7A-n77A <sup>7</sup> CA_n66A-n77A <sup>7</sup>	n7	CA_n7(2A)_BCS0	0
		n66	CA_n66(2A)_BCS1	
		n77	10, 15, 20, 25, 30, 40, 50, 60, 70, 80, 90, 100	
		n7	CA_n7(2A)_BCS0	
		n66	CA_n66(2A)_BCS1	
CA_n7(2A)-n66A-n77(2A)	n77 <sup>7,9</sup> CA_n7A-n66A CA_n7A-n77A <sup>7</sup> CA_n66A-n77A <sup>7</sup>	n7	CA_n7(2A)_BCS0	0
		n66	5, 10, 15, 20, 25, 30, 40	
		n77	CA_n77(2A)_BCS1	
		n7	CA_n7(2A)_BCS0	
		n66	CA_n66(2A)_BCS1	
CA_n7(2A)-n66(2A)-n77(2A)	n77 <sup>7,9</sup> CA_n7A-n66A CA_n7A-n77A <sup>7</sup> CA_n66A-n77A <sup>7</sup>	n7	CA_n7(2A)_BCS0	0
		n66	CA_n66(2A)_BCS1	
		n77	CA_n77(2A)_BCS1	
		n7	CA_n7(2A)_BCS0	
		n66	CA_n66(2A)_BCS1	
CA_n7A-n66A-n78A	n78 <sup>7,9</sup> CA_n7A-n66A CA_n7A-n78A <sup>7</sup> CA_n66A-n78A <sup>7</sup>	n7	5, 10, 15, 20, 25, 30, 40, 50	0
		n66	5, 10, 15, 20, 25, 30, 40	
		n78	10, 15, 20, 25, 30, 40, 50, 60, 80, 90, 100	
		n7	5, 10, 15, 20, 25, 30, 40, 50	
		n66	5, 10, 15, 20, 25, 30, 40	
		n78	10, 15, 20, 25, 30, 40, 50, 60, 70, 80, 90, 100	1

CA_n7A-n66A-n78(2A)	CA_n7A-n66A CA_n7A-n78A CA_n66A-n78A	n7	5, 10, 15, 20, 25, 30, 40, 50	0
		n66	5, 10, 15, 20, 25, 30, 40	
		n78	CA_n78(2A)_BCS1	
		n7	5, 10, 15, 20, 25, 30, 40, 50	1
		n66	5, 10, 15, 20, 25, 30, 40	
n78	CA_n78(2A)_BCS2			
CA_n7(2A)-n66A-n78A	CA_n7A-n66A CA_n7A-n78A CA_n66A-n78A	n7	CA_n7(2A)_BCS0	0
		n66	5, 10, 15, 20, 25, 30, 40	
		n78	10, 15, 20, 25, 30, 40, 50, 60, 70, 80, 90, 100	
CA_n7A-n66(2A)-n78A	CA_n7A-n66A CA_n7A-n78A CA_n66A-n78A	n7	5, 10, 15, 20, 25, 30, 40, 50	0
		n66	CA_n66(2A)_BCS1	
		n78	10, 15, 20, 25, 30, 40, 50, 60, 70, 80, 90, 100	
CA_n7(2A)-n66(2A)-n78A	CA_n7A-n66A CA_n7A-n78A CA_n66A-n78A	n7	CA_n7(2A)_BCS0	0
		n66	CA_n66(2A)_BCS1	
		n78	10, 15, 20, 25, 30, 40, 50, 60, 70, 80, 90, 100	
CA_n7A-n66(2A)-n78(2A)	-	n7	5, 10, 15, 20, 25, 30, 40, 50	0
		n66	CA_n66(2A)_BCS1	
		n78	CA_n78(2A)_BCS2	
CA_n7(2A)-n66A-n78(2A)	CA_n7A-n66A CA_n7A-n78A CA_n66A-n78A	n7	CA_n7(2A)_BCS0	0
		n66	5, 10, 15, 20, 25, 30, 40	
		n78	CA_n78(2A)_BCS2	
CA_n7(2A)-n66(2A)-n78(2A)	CA_n7A-n66A CA_n7A-n78A CA_n66A-n78A	n7	CA_n7(2A)_BCS0	0
		n66	CA_n66(2A)_BCS1	
		n78	CA_n78(2A)_BCS2	
CA_n7A-n67A-n78A	CA_n7A-n78A	n7	5, 10, 15, 20, 25, 30, 35, 40, 50	0
		n67	5, 10, 15, 20	
		n78	10, 15, 20, 25, 30, 40, 50, 60, 70, 80, 90, 100	
CA_n7A-n67A-n78(2A)	CA_n7A-n78A CA_n78(2A)	n7	5, 10, 15, 20, 25, 30, 35, 40, 50	0
		n67	5, 10, 15, 20	
		n78	CA_n78(2A)_BCS2	
CA_n7A-n71A-n77A	n77 <sup>7,9</sup> CA_n7A-n71A CA_n7A-n77A <sup>7</sup> CA_n71A-n77A <sup>7</sup>	n7	5, 10, 15, 20, 25, 30, 35, 40, 50	0
		n71	5, 10, 15, 20, 25, 30, 35	
		n77	10, 15, 20, 25, 30, 40, 50, 60, 70, 80, 90, 100	
		n7	See n7 channel bandwidths in Table 5.3.5-1	4 and 5
		n71	See n71 channel bandwidths in Table 5.3.5-1	
		n77	See n77 channel bandwidths in Table 5.3.5-1	
CA_n7A-n71A-n77(2A)	n77 <sup>7,9</sup> CA_n77(2A) <sup>7</sup> CA_n7A-n71A CA_n7A-n77A <sup>7</sup> CA_n71A-n77A <sup>7</sup>	n7	5, 10, 15, 20, 25, 30, 35, 40, 50	0
		n71	5, 10, 15, 20, 25, 30, 35	

		n77	CA_n77(2A)_BCS0	
		n7	See n7 channel bandwidths in Table 5.3.5-1	4 and 5
		n71	See n71 channel bandwidths in Table 5.3.5-1	
		n77	CA_n77(2A)_BCS4 and 5	
CA_n7A-n71A-n77(3A)	n77 <sup>7,9</sup> CA_n77(2A) <sup>7</sup> CA_n7A-n71A CA_n7A-n77A <sup>7</sup> CA_n71A-n77A <sup>7</sup>	n7	5, 10, 15, 20, 25, 30, 35, 40, 50	0
		n71	5, 10, 15, 20, 25, 30, 35	
		n77	CA_n77(3A)_BCS0	
CA_n7A-n75A-n78A	-	n7	n7 channel bandwidths in Table 5.3.5-1	4 and 5
		n75	n75 channel bandwidths in Table 5.3.5-1	
		n78	n78 channel bandwidths in Table 5.3.5-1	
CA_n7A-n78A-n102A	CA_n7A-n78A CA_n7A-n102A CA_n78A-n102A	n7	5, 10, 15, 20, 25, 30, 40, 50	0
		n78	10, 15, 20, 25, 30, 40, 50, 60, 70, 80, 90, 100	
		n102	20, 40, 60, 80, 100	
CA_n7A-n78A-n102B	CA_n7A-n78A CA_n7A-n102A CA_n7A-n102B CA_n78A-n102A CA_n78A-n102B	n7	5, 10, 15, 20, 25, 30, 40, 50	0
		n78	10, 15, 20, 25, 30, 40, 50, 60, 70, 80, 90, 100	
		n102	CA_n102B_BCS0	
CA_n7A-n78A-n102C	CA_n7A-n78A CA_n7A-n102A CA_n7A-n102C CA_n78A-n102A CA_n78A-n102C	n7	5, 10, 15, 20, 25, 30, 40, 50	0
		n78	10, 15, 20, 25, 30, 40, 50, 60, 70, 80, 90, 100	
		n102	CA_n102C_BCS0	
CA_n7A-n78A-n102D	CA_n7A-n78A CA_n7A-n102A CA_n78A-n102A	n7	5, 10, 15, 20, 25, 30, 40, 50	0
		n78	10, 15, 20, 25, 30, 40, 50, 60, 70, 80, 90, 100	
		n102	CA_n102D_BCS0	
CA_n7A-n78A-n102E	CA_n7A-n78A CA_n7A-n102A CA_n78A-n102A	n7	5, 10, 15, 20, 25, 30, 40, 50	0
		n78	10, 15, 20, 25, 30, 40, 50, 60, 70, 80, 90, 100	
		n102	CA_n102E_BCS0	
CA_n7A-n78A-n102(2A)	CA_n7A-n78A CA_n7A-n102A CA_n78A-n102A	n7	5, 10, 15, 20, 25, 30, 40, 50	0
		n78	10, 15, 20, 25, 30, 40, 50, 60, 70, 80, 90, 100	
		n102	CA_n102(2A)_BCS0	
CA_n7A-n78(2A)-n102A	CA_n7A-n78A CA_n7A-n102A CA_n78A-n102A CA_n78(2A)	n7	5, 10, 15, 20, 25, 30, 40, 50	0
		n78	CA_n78(2A)_BCS2	
		n102	20, 40, 60, 80, 100	
CA_n7A-n78(2A)-n102B	CA_n7A-n78A CA_n7A-n102A	n7	5, 10, 15, 20, 25, 30, 40, 50	0

	CA_n7A-n102B CA_n78A-n102A CA_n78A-n102B CA_n78(2A)	n78 n102	CA_n78(2A)_BCS2 CA_n102B_BCS0	
CA_n7A-n78(2A)-n102C	CA_n7A-n78A CA_n7A-n102A CA_n7A-n102C CA_n78A-n102A CA_n78A-n102C CA_n78(2A)	n7 n78 n102	5, 10, 15, 20, 25, 30, 40, 50 CA_n78(2A)_BCS2 CA_n102C_BCS0	0
CA_n7A-n78(2A)-n102D	CA_n7A-n78A CA_n7A-n102A CA_n78A-n102A CA_n78(2A)	n7 n78 n102	5, 10, 15, 20, 25, 30, 40, 50 CA_n78(2A)_BCS2 CA_n102D_BCS0	0
CA_n7A-n78(2A)-n102E	CA_n7A-n78A CA_n7A-n102A CA_n78A-n102A CA_n78(2A)	n7 n78 n102	5, 10, 15, 20, 25, 30, 40, 50 CA_n78(2A)_BCS2 CA_n102E_BCS0	0
CA_n7A-n78(2A)-n102(2A)	CA_n7A-n78A CA_n7A-n102A CA_n78A-n102A CA_n78(2A)	n7 n78 n102	5, 10, 15, 20, 25, 30, 40, 50 CA_n78(2A)_BCS2 CA_n102(2A)_BCS0	0
CA_n7A-n78A-n105A	CA_n7A-n78A CA_n7A-n105A CA_n78A-n105A	n7 n78 n105	5, 10, 15, 20, 25, 30, 40, 50 10, 15, 20, 25, 30, 40, 50, 60, 70, 80, 90, 100 5, 10, 15, 20, 25, 30, 35	0

Table 5.5A.3.2-1b

**Table 5.5A.3.2-1b: NR CA configurations and bandwidth combinations sets defined for inter-band CA (three bands)**

NR CA configuration	Uplink CA configuration or single uplink carrier <sup>6</sup>	NR Band	Channel bandwidth (MHz) (NOTE 3)	Bandwidth combination set
CA_n8A-n20A-n28A	CA_n8A-n20A CA_n8A-n28A CA_n20A-n28A	n8 n20 n28	5, 10, 15, 20 5, 10, 15, 20 5, 10, 15, 20, 25, 30	0
CA_n8A-n20A-n75A	-	n8 n20 n75	n8 channel bandwidths in Table 5.3.5-1 n20 channel bandwidths in Table 5.3.5-1 n75 channel bandwidths in Table 5.3.5-1	4 and 5
CA_n8A-n28A-n40A	CA_n8A-n28A CA_n8A-n40A CA_n28A-n40A	n8 n28 n40	n8 channel bandwidths in Table 5.3.5-1 n28 channel bandwidths in Table 5.3.5-1 n40 channel bandwidths in Table 5.3.5-1	4 and 5

CA_n8A-n28A-n75A	-	n8	n8 channel bandwidths in Table 5.3.5-1	4 and 5
		n28	n28 channel bandwidths in Table 5.3.5-1	
		n75	n75 channel bandwidths in Table 5.3.5-1	
CA_n8A-n28A-n77A	CA_n8A-n28A CA_n8A-n77A CA_n28A-n77A	n8	n8 channel bandwidths in Table 5.3.5-1	4 and 5
		n28	n28 channel bandwidths in Table 5.3.5-1	
		n77	n77 channel bandwidths in Table 5.3.5-1	
CA_n8A-n28A-n77(2A)	CA_n8A-n28A CA_n8A-n77A CA_n28A-n77A	n8	n8 channel bandwidths in Table 5.3.5-1	4 and 5
		n28	n28 channel bandwidths in Table 5.3.5-1	
		n77	CA_n77(2A)_BCS 4 and 5	
CA_n8A-n28A-n78A	-	n8	5, 10, 15, 20	0
		n28	5, 10, 15, 20	
		n78	10, 15, 20, 25, 30, 40, 50, 60, 70, 80, 90, 100	
CA_n8A-n38A-n40A	-	n8	5, 10, 15, 20	0
		n38	5, 10, 15, 20, 25, 30, 40	
		n40	5, 10, 15, 20, 25, 30, 40, 50, 60, 70, 80, 90, 100	
CA_n8A-n39A-n40A	CA_n8A-n39A CA_n8A-n40A CA_n39A-n40A	n8	See n8 channel bandwidths in Table 5.3.5-1	4 and 5
		n39	See n39 channel bandwidths in Table 5.3.5-1	
		n40	See n40 channel bandwidths in Table 5.3.5-1	
CA_n8A-n39A-n41A	CA_n8A-n39A CA_n8A-n41A CA_n39A-n41A	n8	5, 10, 15, 20	0
		n39	5, 10, 15, 20, 25, 30, 40	
		n41	10, 15, 20, 40, 50, 60, 80, 100	
	-	n8	5, 10, 15, 20	1
		n39	5, 10, 15, 20, 25, 30, 40	
		n41	10, 15, 20, 40, 50, 60	
	CA_n8A-n39A CA_n8A-n41A CA_n39A-n41A	n8	See n8 channel bandwidths in Table 5.3.5-1	4 and 5
		n39	See n39 channel bandwidths in Table 5.3.5-1	
		n41	See n41 channel bandwidths in Table 5.3.5-1	
CA_n8A-n39A-n41C	CA_n8A-n39A CA_n8A-n41A CA_n39A-n41A	n8	See n8 channel bandwidths in Table 5.3.5-1	4 and 5
		n39	See n39 channel bandwidths in Table 5.3.5-1	
		n41	CA_n41C_BCS 4 and 5	
CA_n8A-n39A-n79A	CA_n8A-n39A CA_n8A-n79A CA_n39A-n79A	n8	5, 10, 15, 20	0
		n39	5, 10, 15, 20, 25, 30, 40	
		n79	40, 50, 60, 80, 100	
		n8	See n8 channel bandwidths in Table 5.3.5-1	4 and 5
		n39	See n39 channel bandwidths in Table 5.3.5-1	
		n79	See n79 channel bandwidths in Table 5.3.5-1	
CA_n8A-n40A-n41A	CA_n8A-n40A	n8	5, 10, 15, 20	0



	CA_n8A-n41A CA_n40A-n41A	n40	5, 10, 15, 20, 25, 30, 40, 50, 60, 80	4 and 5
		n41	10, 15, 20, 40, 50, 60, 80, 90, 100	
		n8	See n8 channel bandwidths in Table 5.3.5-1	
		n40	See n40 channel bandwidths in Table 5.3.5-1	
		n41	See n41 channel bandwidths in Table 5.3.5-1	
		CA_n8A-n40A-n41C	CA_n41C CA_n8A-n40A CA_n8A-n41A CA_n40A-n41A	
		n40	See n40 channel bandwidths in Table 5.3.5-1	
		n41	CA_n41C_BCS4 and 5	
CA_n8A-n40A-n78A	CA_n8A-n40A CA_n8A-n78A CA_n40A-n78A	n8	5, 10, 15, 20	0
		n40	5, 10, 15, 20, 30, 40, 50, 60, 80	
		n78	10, 15, 20, 25, 30, 40, 50, 60, 70, 80, 90, 100	
CA_n8A-n40A-n77A	CA_n8A-n40A CA_n8A-n77A CA_n40A-n77A	n8	See n8 channel bandwidths in Table 5.3.5-1	4 and 5
		n40	See n40 channel bandwidths in Table 5.3.5-1	
		n77	See n77 channel bandwidths in Table 5.3.5-1	
CA_n8A-n40A-n77(2A)	CA_n8A-n40A CA_n8A-n77A CA_n40A-n77A	n8	See n8 channel bandwidths in Table 5.3.5-1	4 and 5
		n40	See n40 channel bandwidths in Table 5.3.5-1	
		n77	CA_n77(2A)_BCS 4 and 5	
CA_n8A-n40A-n79A	CA_n8A-n40A CA_n8A-n79A CA_n40A-n79A	n8	See n8 channel bandwidths in Table 5.3.5-1	4 and 5
		n40	See n40 channel bandwidths in Table 5.3.5-1	
		n79	See n79 channel bandwidths in Table 5.3.5-1	
CA_n8A-n41A-n79A	CA_n8A-n41A CA_n8A-n79A CA_n41A-n79A	n8	5, 10, 15, 20	0
		n41	10, 15, 20, 40, 50, 60, 80, 100	
		n79	40, 50, 60, 80, 100	
		n8	5, 10, 15, 20	
		n41	10, 15, 20, 40, 50, 60	1
		n79	40, 50, 60, 80, 100	
		n8	See n8 channel bandwidths in Table 5.3.5-1	
		n41	See n41 channel bandwidths in Table 5.3.5-1	
CA_n8A-n41A-n79A	CA_n41C CA_n8A-n41A CA_n8A-n79A CA_n41A-n79A	n8	See n8 channel bandwidths in Table 5.3.5-1	4 and 5
		n39	CA_n41C_BCS 4 and 5	
		n79	See n79 channel bandwidths in Table 5.3.5-1	
CA_n8A-n78A-n79A	-	n8	5, 10, 15, 20	0

		n78	10, 15, 20, 25, 30, 40, 50, 60, 80, 90, 100	
		n79	40, 50, 60, 80, 100	
CA_n8A-n78(2A)-n79A	-	n8	5, 10, 15, 20	0
		n78	CA_n78(2A)_BCS1	
		n79	40, 50, 60, 80, 100	
CA_n12A-n25A-n41A	-	n12	5, 10, 15	0
		n25	5, 10, 15, 20, 25, 30, 40	
		n41	10, 15, 20, 30, 40, 50, 60, 80, 90, 100	
CA_n12A-n25A-n66A	-	n12	5, 10, 15	0
		n25	5, 10, 15, 20, 25, 30, 40	
		n66	5, 10, 15, 20, 40	
CA_n12A-n30A-n66A	CA_n12A-n30A CA_n12A-n66A CA_n30A-n66A	n12	5, 10, 15	0
		n30	5, 10	
		n66	5, 10, 15, 20, 25, 30, 40	
CA_n12A-n30A-n66(2A)	CA_n12A-n30A CA_n12A-n66A CA_n30A-n66A	n12	5, 10, 15	0
		n30	5, 10	
		n66	CA_n66(2A)_BCS1	
CA_n12A-n30A-n66(3A)	CA_n12A-n30A CA_n12A-n66A CA_n30A-n66A	n12	5, 10, 15	0
		n30	5, 10	
		n66	CA_n66(3A)_BCS0	
CA_n12A-n30A-n77A	n77 <sup>7,9</sup> CA_n12A-n30A, CA_n12A-n77A <sup>7</sup> CA_n30A-n77A <sup>7</sup>	n12	5, 10	0
		n30	5, 10	
		n77	10, 15, 20, 25, 30, 40, 50, 60, 70, 80, 90, 100	
CA_n12A-n30A-n77(2A)	n77 <sup>7,9</sup> CA_n12A-n30A CA_n12A-n77A <sup>7</sup> CA_n30A-n77A <sup>7</sup>	n12	5, 10	0
		n30	5, 10	
		n77	CA_n77(2A)_BCS1	
CA_n12A-n41A-n66A	-	n12	5, 10, 15	0
		n41	10, 15, 20, 30, 40, 50, 60, 80, 90, 100	
		n66	5, 10, 15, 20, 40	
CA_n12A-n41A-n77A	-	n12	5, 10, 15	0
		n41	10, 15, 20, 30, 40, 50, 60, 80, 90, 100	
		n77	10, 15, 20, 25, 30, 40, 50, 60, 70, 80, 90, 100	
CA_n12A-n66A-n77A	n77 <sup>7,9</sup> CA_n12A-n66A CA_n12A-n77A <sup>7</sup> CA_n66A-n77A <sup>7</sup>	n12	5, 10, 15	0
		n66	5, 10, 15, 20, 25, 30, 40	
		n77	10, 15, 20, 25, 30, 40, 50, 60, 70, 80, 90, 100	
CA_n12A-n66(2A)-n77A	n77 <sup>7,9</sup> CA_n12A-n66A CA_n12A-n77A <sup>7</sup> CA_n66A-n77A <sup>7</sup>	n12	5, 10, 15	0
		n66	CA_n66(2A)_BCS1	
		n77	10, 15, 20, 25, 30, 40, 50, 60, 70, 80, 90, 100	
CA_n12A-n66A-n77(2A)	n77 <sup>7,9</sup> CA_n12A-n66A	n12	5, 10, 15	0

	CA_n12A-n77A <sup>7</sup> CA_n66A-n77A <sup>7</sup>	n66 n77	5, 10, 15, 20, 25, 30, 40 CA_n77(2A)_BCS1	
CA_n12A-n66(2A)-n77(2A)	n77 <sup>7,9</sup> CA_n12A-n66A CA_n12A-n77A <sup>7</sup> CA_n66A-n77A <sup>7</sup>	n12 n66 n77	5, 10, 15 CA_n66(2A)_BCS1 CA_n77(2A)_BCS1	0
CA_n12A-n66(3A)-n77A	n77 <sup>7,9</sup> CA_n12A-n66A CA_n12A-n77A <sup>7</sup> CA_n66A-n77A <sup>7</sup>	n12 n66 n77	5, 10, 15 CA_n66(3A)_BCS0 10, 15, 20, 25, 30, 40, 50, 60, 70, 80, 90, 100	0
CA_n12A-n66(3A)-n77(2A)	n77 <sup>7</sup> CA_n12A-n66A CA_n12A-n77A <sup>7</sup> CA_n66A-n77A <sup>7</sup>	n12 n66 n77	5, 10, 15 CA_n66(3A)_BCS0 CA_n77(2A)_BCS1	0
CA_n12A-n71A-n77A	CA_n12A-n77A CA_n71A-n77A	n12 n71 n77	5, 10, 15 5, 10, 15, 20 10, 15, 20, 25, 30, 40, 50, 60, 70, 80, 90, 100	0
CA_n13A-n25A-n66A	CA_n13A-n25A CA_n13A-n66A CA_n25A-n66A	n13 n25 n66	5, 10 5, 10, 15, 20, 25, 30, 40 5, 10, 15, 20, 25, 30, 40	0
CA_n13A-n25A-n77A	n77 <sup>7,9</sup> CA_n13A-n25A CA_n13A-n77A <sup>7</sup> CA_n25A-n77A <sup>7</sup>	n13 n25 n77	5, 10 5, 10, 15, 20, 25, 30, 40 10, 15, 20, 25, 30, 40, 50, 60, 70, 80, 90, 100	0
CA_n13A-n25A-n77(2A)	n77 <sup>7,9</sup> CA_n77(2A) <sup>7</sup> CA_n13A-n25A CA_n13A-n77A <sup>7</sup> CA_n25A-n77A <sup>7</sup>	n13 n25 n77	5, 10 5, 10, 15, 20, 25, 30, 40 CA_n77(2A)_BCS1	0
CA_n13A-n66A-n77A	n77 <sup>7,9</sup> CA_n13A-n66A CA_n13A-n77A <sup>7</sup> CA_n66A-n77A <sup>7</sup>	n13 n66 n77	5, 10 5, 10, 15, 20, 25, 30, 40 10, 15, 20, 25, 30, 40, 50, 60, 70, 80, 90, 100	0
CA_n13A-n66A-n77(2A)	n77 <sup>7,9</sup> CA_n77(2A) <sup>7</sup> CA_n13A-n66A CA_n13A-n77A <sup>7</sup> CA_n66A-n77A <sup>7</sup>	n13 n66 n77	5, 10 10, 15, 20, 25, 30, 40 CA_n77(2A)_BCS1	0
CA_n14A-n30A-n66A	CA_n14A-n30A CA_n14A-n66A CA_n30A-n66A	n14 n30 n66	5, 10 5, 10 5, 10, 15, 20, 25, 30, 40	0

CA_n14A-n30A-n66(2A)	CA_n14A-n30A CA_n14A-n66A CA_n30A-n66A	n14	5, 10	0
		n30	5, 10	
		n66	CA_n66(2A)_BCS1	
CA_n14A-n30A-n66(3A)	CA_n14A-n30A CA_n14A-n66A CA_n30A-n66A	n14	5, 10	0
		n30	5, 10	
		n66	CA_n66(3A)_BCS0	
CA_n14A-n30A-n77A	n77 <sup>7,9</sup> CA_n14A-n30A CA_n14A-n77A <sup>7</sup> CA_n30A-n77A <sup>7</sup>	n14	5, 10	0
		n30	5, 10	
		n77	10, 15, 20, 25, 30, 40, 50, 60, 70, 80, 90, 100	
CA_n14A-n30A-n77(2A)	n77 <sup>7,9</sup> CA_n14A-n30A CA_n14A-n77A <sup>7</sup> CA_n30A-n77A <sup>7</sup>	n14	5, 10	0
		n30	5, 10	
		n77	CA_n77(2A)_BCS1	
CA_n14A-n66A-n77A	n77 <sup>7,9</sup> CA_n14A-n66A CA_n14A-n77A <sup>7</sup> CA_n66A-n77A <sup>7</sup>	n14	5, 10	0
		n66	5, 10, 15, 20, 25, 30, 40	
		n77	10, 15, 20, 25, 30, 40, 50, 60, 70, 80, 90, 100	
CA_n14A-n66(2A)-n77A	n77 <sup>7,9</sup> CA_n14A-n66A CA_n14A-n77A <sup>7</sup> CA_n66A-n77A <sup>7</sup>	n14	5, 10	0
		n66	CA_n66(2A)_BCS1	
		n77	10, 15, 20, 25, 30, 40, 50, 60, 70, 80, 90, 100	
CA_n14A-n66A-n77(2A)	n77 <sup>7,9</sup> CA_n14A-n66A CA_n14A-n77A <sup>7</sup> CA_n66A-n77A <sup>7</sup>	n14	5, 10	0
		n66	5, 10, 15, 20, 25, 30, 40	
		n77	CA_n77(2A)_BCS1	
CA_n14A-n66(2A)-n77(2A)	n77 <sup>7,9</sup> CA_n14A-n66A CA_n14A-n77A <sup>7</sup> CA_n66A-n77A <sup>7</sup>	n14	5, 10	0
		n66	CA_n66(2A)_BCS1	
		n77	CA_n77(2A)_BCS1	
CA_n14A-n66(3A)-n77A	n77 <sup>7,9</sup> CA_n14A-n66A CA_n14A-n77A <sup>7</sup> CA_n66A-n77A <sup>7</sup>	n14	5, 10	0
		n66	CA_n66(3A)_BCS0	
		n77	10, 15, 20, 25, 30, 40, 50, 60, 70, 80, 90, 100	
CA_n14A-n66(3A)-n77(2A)	n77 <sup>7</sup> CA_n14A-n66A CA_n14A-n77A <sup>7</sup> CA_n66A-n77A <sup>7</sup>	n14	5, 10	0
		n66	CA_n66(3A)_BCS0	
		n77	CA_n77(2A)_BCS1	
CA_n18A-n28A-n41A	CA_n18A-n28A CA_n18A-n41A CA_n28A-n41A	n18	5, 10, 15	0
		n28	5, 10	

		n41	10, 15, 20, 30, 40, 50, 60, 80, 90, 100	
CA_n18A-n28A-n77A	n77 <sup>7</sup> CA_n18A-n28A CA_n18A-n77A <sup>7</sup> CA_n28A-n77A <sup>7</sup>	n18	5, 10, 15	0
		n28	5, 10	
		n77	10, 15, 20, 40, 50, 60, 80, 90, 100	
CA_n18A-n28A-n77(2A)	n77 <sup>7</sup> CA_n18A-n28A CA_n18A-n77A CA_n28A-n77A	n18	5, 10, 15	0
		n28	5, 10	
		n77	CA_n77(2A)_BCS1	
CA_n18A-n41A-n77A	n41 <sup>7</sup> n77 <sup>7</sup> CA_n18A-n41A <sup>7</sup> CA_n18A-n77A <sup>7</sup> CA_n41A-n77A <sup>7</sup>	n18	5, 10, 15	0
		n41	10, 15, 20, 30, 40, 50, 60, 80, 90, 100	
		n77	10, 15, 20, 40, 50, 60, 80, 90, 100	
CA_n18A-n41A-n77(2A)	n77 <sup>7</sup> CA_n18A-n41A <sup>7</sup> CA_n18A-n77A <sup>7</sup> CA_n41A-n77A <sup>7</sup>	n18	5, 10, 15	0
		n41	10, 15, 20, 30, 40, 50, 60, 80, 90, 100	
		n77	CA_n77(2A)_BCS1	
CA_n20A-n28A-n75A	-	n20	5, 10, 15, 20	0
		n28	5, 10, 15, 20	
		n75	5, 10, 15, 20	
CA_n20A-n28A-n78A	-	n20	5, 10, 15, 20	0
		n28	5, 10, 15, 20	
		n78	10, 15, 20, 30, 40, 50, 60, 80, 90, 100	
CA_n20A-n28A-n78C	-	n20	5, 10, 15, 20	0
		n28	5, 10, 15, 20	
		n78	CA_n78C_BCS1	
CA_n20A-n67A-n78A	CA_n20A-n78A	n20	See n20 channel bandwidths in Table 5.3.5-1	4 and 5
		n67	See n67 channel bandwidths in Table 5.3.5-1	
		n78	See n78 channel bandwidths in Table 5.3.5-1	
CA_n20A-n67A-n78(2A)	CA_n20A-n78A CA_n78(2A)	n20	See n20 channel bandwidths in Table 5.3.5-1	4 and 5
		n67	See n67 channel bandwidths in Table 5.3.5-1	
		n78	CA_n78(2A)_BCS4 and 5	
CA_n24A-n41A-n48A	CA_n24A-n41A CA_n24A-n48A CA_n41A-n48A	n24	5, 10	0
		n41	10, 15, 20, 30, 40, 50, 60, 80, 90, 100	
		n48	5, 10, 15, 20, 40, 50 <sup>12</sup> , 60 <sup>12</sup> , 70 <sup>12</sup> , 80 <sup>12</sup> , 90 <sup>12</sup> , 100 <sup>12</sup>	
CA_n24A-n41(2A)-n48A	CA_n24A-n41A CA_n24A-n48A CA_n41A-n48A	n24	5, 10	0
		n41	CA_n41(2A)_BCS1	
		n48	5, 10, 15, 20, 40, 50 <sup>12</sup> , 60 <sup>12</sup> , 70 <sup>12</sup> , 80 <sup>12</sup> , 90 <sup>12</sup> , 100 <sup>12</sup>	
CA_n24A-n41A-n48(2A)	CA_n24A-n41A CA_n24A-n48A	n24	5, 10	0

	CA_n41A-n48A			
		n41	10, 15, 20, 30, 40, 50, 60, 80, 90, 100	
		n48	CA_n48(2A) BCS0	
CA_n24A-n41(2A)-n48(2A)	CA_n24A-n41A CA_n24A-n48A CA_n41A-n48A	n24	5, 10	0
		n41	CA_n41(2A) BCS1	
		n48	CA_n48(2A) BCS0	
CA_n24A-n41A-n77A	CA_n24A-n41A CA_n24A-n77A CA_n41A-n77A	n24	5, 10	0
		n41	10, 15, 20, 30, 40, 50, 60, 80, 90, 100	
		n77	10, 15, 20, 25, 30, 40, 50, 60, 70, 80, 90, 100	
		n24	See n24 channel bandwidths in Table 5.3.5-1	4 and 5
		n41	See n41 channel bandwidths in Table 5.3.5-1	
		n77	See n77 channel bandwidths in Table 5.3.5-1	
CA_n24A-n41(2A)-n77A	CA_n24A-n41A CA_n24A-n77A CA_n41A-n77A	n24	5, 10	0
		n41	CA_n41(2A) BCS1	
		n77	10, 15, 20, 25, 30, 40, 50, 60, 70, 80, 90, 100	
		n24	5, 10	1
		n41	CA_n41(2A) BCS1	
		n77	10, 15, 20, 25, 30, 40, 50, 60, 70, 80, 90, 100	
		n24	See n24 channel bandwidths in Table 5.3.5-1	4 and 5
		n41	CA_n41(2A) BCS4 and 5	
n77	See n77 channel bandwidths in Table 5.3.5-1			
CA_n24A-n41A-n77(2A)	CA_n24A-n41A CA_n24A-n77A CA_n41A-n77A	n24	5, 10	0
		n41	10, 15, 20, 30, 40, 50, 60, 80, 90, 100	
		n77	CA_n77(2A) BCS0	
		n24	5, 10	1
		n41	10, 15, 20, 30, 40, 50, 60, 80, 90, 100	
		n77	CA_n77(2A) BCS0	
		n24	See n24 channel bandwidths in Table 5.3.5-1	4 and 5
		n41	See n41 channel bandwidths in Table 5.3.5-1	
n77	CA_n77(2A) BCS4 and 5			
CA_n24A-n41(2A)-n77(2A)	CA_n24A-n41A CA_n24A-n77A CA_n41A-n77A	n24	5, 10	0
		n41	CA_n41(2A) BCS1	
		n77	CA_n77(2A) BCS0	
		n24	5, 10	1
		n41	CA_n41(2A) BCS1	
		n77	CA_n77(2A) BCS0	
		n24	See n24 channel bandwidths in Table 5.3.5-1	4 and 5
n41	CA_n41(2A) BCS4 and 5			
n77	CA_n77(2A) BCS4 and 5			
CA_n24A-n48A-n77A	-	n24	5, 10	0
		n48	5, 10, 15, 20, 40, 50 <sup>12</sup> , 60 <sup>12</sup> , 80 <sup>12</sup> , 90 <sup>12</sup> , 100 <sup>12</sup>	

		n77	10, 15, 20, 25, 30, 40, 50, 60, 70, 80, 90, 100	
CA_n24A-n48(2A)-n77A	-	n24	5, 10	0
		n48	CA_n48(2A) BCS0	
		n77	10, 15, 20, 25, 30, 40, 50, 60, 70, 80, 90, 100	
CA_n24A-n48A-n77(2A)	-	n24	5, 10	0
		n48	5, 10, 15, 20, 40, 50 <sup>12</sup> , 60 <sup>12</sup> , 70 <sup>12</sup> , 80 <sup>12</sup> , 90 <sup>12</sup> , 100 <sup>12</sup>	
		n77	CA_n77(2A) BCS0	
CA_n24A-n48(2A)-n77(2A)	-	n24	5, 10	0
		n48	CA_n48(2A) BCS0	
		n77	CA_n77(2A) BCS0	
CA_n25A-n29A-n66A	CA_n25A-n66A	n25	5, 10, 15, 20, 25, 30, 40	0
		n29	5, 10	
		n66	5, 10, 15, 20, 25, 30, 40	
CA_n25A-n38A-n66A	CA_n25A-n38A CA_n25A-n66A CA_n38A-n66A	n25	5, 10, 15, 20, 25, 30, 40	0
		n38	5, 10, 15, 20, 25, 30, 40	
		n66	5, 10, 15, 20, 25, 30, 40	
CA_n25(2A)-n38A-n66A	CA_n25A-n38A CA_n25A-n66A CA_n38A-n66A	n25	CA_n25(2A)_BCS0	0
		n38	5, 10, 15, 20, 25, 30, 40	
		n66	5, 10, 15, 20, 25, 30, 40	
CA_n25(2A)-n38A-n66(2A)	CA_n25A-n38A CA_n25A-n66A CA_n38A-n66A	n25	CA_n25(2A)_BCS0	0
		n38	5, 10, 15, 20, 25, 30, 40	
		n66	CA_n66(2A)_BCS1	
CA_n25A-n38A-n66(2A)	CA_n25A-n38A CA_n25A-n66A CA_n38A-n66A	n25	5, 10, 15, 20, 25, 30, 40	0
		n38	5, 10, 15, 20	
		n66	CA_n66(2A)_BCS1	
CA_n25A-n38A-n78A	CA_n25A-n38A CA_n25A-n78A CA_n38A-n78A	n25	5, 10, 15, 20, 25, 30, 40	0
		n38	5, 10, 15, 20, 25, 30, 40	
		n78	10, 15, 20, 25, 30, 40, 50, 60, 70, 80, 90, 100	
CA_n25A-n38A-n78(2A)	CA_n25A-n38A CA_n25A-n78A CA_n38A-n78A	n25	5, 10, 15, 20, 25, 30, 40	0
		n38	5, 10, 15, 20, 25, 30, 40	
		n78	CA_n78(2A)_BCS2	
CA_n25(2A)-n38A-n78A	CA_n25A-n38A CA_n25A-n78A CA_n38A-n78A	n25	CA_n25(2A)_BCS0	0
		n38	5, 10, 15, 20, 25, 30, 40	
		n78	10, 15, 20, 25, 30, 40, 50, 60, 70, 80, 90, 100	
CA_n25(2A)-n38A-n78(2A)	CA_n25A-n38A CA_n25A-n78A CA_n38A-n78A	n25	CA_n25(2A)_BCS0	0
		n38	5, 10, 15, 20, 25, 30, 40	
		n78	CA_n78(2A)_BCS2	
CA_n25A-n41A-n66A	n41 <sup>7,9</sup> CA_n25A-n41A <sup>7</sup> CA_n25A-n66A CA_n41A-n66A <sup>7</sup>	n25	5, 10, 15, 20	0
		n41	10, 15, 20, 30, 40, 50, 60, 80, 90, 100	

		n66	5, 10, 15, 20, 40	
		n25	5, 10, 15, 20, 25, 30, 40	1
		n41	10, 15, 20, 30, 40, 50, 60, 70, 80, 90, 100	
		n66	5, 10, 15, 20, 25, 30, 40	
		n25	n25 channel bandwidths in Table 5.3.5-1	4 and 5
		n41	n41 channel bandwidths in Table 5.3.5-1	
		n66	n66 channel bandwidths in Table 5.3.5-1	
CA_n25A-n41A-n66(2A)	n41 <sup>7,9</sup> CA_n25A-n41A <sup>7</sup> CA_n25A-n66A CA_n41A-n66A <sup>7</sup>	n25	5, 10, 15, 20	0
		n41	10, 15, 20, 30, 40, 50, 60, 70, 80, 90, 100	
		n66	CA_n66(2A)_BCS1	
		n25	5, 10, 15, 20, 25, 30, 40	1
		n41	10, 15, 20, 30, 40, 50, 60, 70, 80, 90, 100	
		n66	CA_n66(2A)_BCS1	
		n25	n25 channel bandwidths in Table 5.3.5-1	4 and 5
		n41	n41 channel bandwidths in Table 5.3.5-1	
		n66	CA_n66(2A) BCS 4 and 5	
CA_n25A-n41C-n66A	n41 <sup>7,9</sup> CA_n25A-n41A <sup>7</sup> CA_n25A-n66A CA_n41A-n66A <sup>7</sup> CA_n41C <sup>7</sup> CA_n25A-n41C CA_n41C-n66A	n25	5, 10, 15, 20	0
		n41	CA_n41C_BCS0	
		n66	5, 10, 15, 20, 40	
		n25	5, 10, 15, 20, 25, 30, 40	1
		n41	CA_n41C_BCS1	
		n66	5, 10, 15, 20, 25, 30, 40	
		n25	n25 channel bandwidths in Table 5.3.5-1	4 and 5
		n41	CA_n41C BCS 4 and 5	
		n66	n66 channel bandwidths in Table 5.3.5-1	
CA_n25A-n41(2A)-n66A	n41 <sup>7,9</sup> CA_n25A-n41A <sup>7</sup> CA_n25A-n66A CA_n41A-n66A <sup>7</sup>	n25	5, 10, 15, 20	0
		n41	CA_n41(2A)_BCS1	
		n66	5, 10, 15, 20, 40	
		n25	5, 10, 15, 20, 25, 30, 40	1
		n41	CA_n41(2A)_BCS1	
		n66	5, 10, 15, 20, 25, 30, 40	
		n25	n25 channel bandwidths in Table 5.3.5-1	4 and 5
		n41	CA_n41(2A) BCS 4 and 5	
		n66	n66 channel bandwidths in Table 5.3.5-1	
CA_n25A-n41(2A)-n66(2A)	n41 <sup>7,9</sup> CA_n25A-n41A <sup>7</sup> CA_n25A-n66A CA_n41A-n66A <sup>7</sup>	n25	n25 channel bandwidths in Table 5.3.5-1	4 and 5
		n41	CA_n41(2A) BCS 4 and 5	
		n66	CA_n66(2A) BCS 4 and 5	
CA_n25A-n41(3A)-n66(2A)	CA_n25A-n41A CA_n25A-n66A CA_n41A-n66A	n25	n25 channel bandwidths in Table 5.3.5-1	4 and 5



		n41	CA_n41(3A) BCS 4 and 5	
		n66	CA_n66(2A) BCS 4 and 5	
CA_n25A-n41(3A)-n66A	n41 <sup>7,9</sup> CA_n25A-n41A <sup>7</sup> CA_n25A-n66A CA_n41A-n66A <sup>7</sup>	n25	n25 channel bandwidths in Table 5.3.5-1	4 and 5
		n41	CA_n41(3A) BCS 4 and 5	
		n66	n66 channel bandwidths in Table 5.3.5-1	
CA_n25A-n41C-n66(2A)	n41 <sup>7,9</sup> CA_n25A-n41A <sup>7</sup> CA_n25A-n66A CA_n41A-n66A <sup>7</sup> CA_n41C <sup>7</sup>	n25	n25 channel bandwidths in Table 5.3.5-1	4 and 5
		n41	CA_n41C BCS 4 and 5	
		n66	CA_n66(2A) BCS 4 and 5	
CA_n25A-n41(A-C)-n66A	n41 <sup>7,9</sup> CA_n25A-n41A <sup>7</sup> CA_n25A-n66A CA_n41A-n66A <sup>7</sup> CA_n41C <sup>7</sup>	n25	n25 channel bandwidths in Table 5.3.5-1	4 and 5
		n41	CA_n41(A-C) BCS 4 and 5	
		n66	n66 channel bandwidths in Table 5.3.5-1	
CA_n25A-n41(A-C)-n66(2A)	CA_n25A-n41A CA_n25A-n66A CA_n41A-n66A CA_n41C	n25	n25 channel bandwidths in Table 5.3.5-1	4 and 5
		n41	CA_n41(A-C) BCS 4 and 5	
		n66	CA_n66(2A) BCS 4 and 5	
CA_n25(2A)-n41A-n66A	n41 <sup>7,9</sup> CA_n25A-n41A <sup>7</sup> CA_n25A-n66A CA_n41A-n66A <sup>7</sup>	n25	CA_n25(2A)_BCS1	0
		n41	10, 15, 20, 30, 40, 50, 60, 70, 80, 90, 100	
		n66	5, 10, 15, 20, 40	
		n25	CA_n25(2A)_BCS1	1
		n41	10, 15, 20, 30, 40, 50, 60, 70, 80, 90, 100	
		n66	5, 10, 15, 20, 30, 40	
		n25	CA_n25(2A) BCS 4 and 5	4 and 5
		n41	n41 channel bandwidths in Table 5.3.5-1	
		n66	n66 channel bandwidths in Table 5.3.5-1	
CA_n25(2A)-n41A-n66(2A)	n41 <sup>7,9</sup> CA_n25A-n41A <sup>7</sup> CA_n25A-n66A CA_n41A-n66A <sup>7</sup>	n25	CA_n25(2A)_BCS 4 and 5	4 and 5
		n41	n41 channel bandwidths in Table 5.3.5-1	
		n66	CA_n66(2A)_BCS 4 and 5	
CA_n25(2A)-n41(2A)-n66A	n41 <sup>7,9</sup> CA_n25A-n41A <sup>7</sup> CA_n25A-n66A CA_n41A-n66A <sup>7</sup>	n25	CA_n25(2A) BCS 4 and 5	4 and 5
		n41	CA_n41(2A) BCS 4 and 5	
		n66	n66 channel bandwidths in Table 5.3.5-1	
CA_n25(2A)-n41(3A)-n66A	CA_n25A-n41A CA_n25A-n66A CA_n41A-n66A	n25	CA_n25(2A) BCS 4 and 5	4 and 5
		n41	CA_n41(3A) BCS 4 and 5	
		n66	n66 channel bandwidths in Table 5.3.5-1	

CA_n25(2A)-n41(2A)-n66(2A)	n41 <sup>7,9</sup> CA_n25A-n41A <sup>7</sup> CA_n25A-n66A CA_n41A-n66A <sup>7</sup>	n25	CA_n25(2A) BCS 4 and 5	4 and 5
		n41	CA_n41(2A) BCS 4 and 5	
		n66	CA_n66(2A) BCS 4 and 5	
CA_n25(2A)-n41C-n66A	n41 <sup>7,9</sup> CA_n25A-n41A <sup>7</sup> CA_n25A-n66A CA_n41A-n66A <sup>7</sup> CA_n41C <sup>7</sup>	n25	CA_n25(2A) BCS 4 and 5	4 and 5
		n41	CA_n41C BCS 4 and 5	
		n66	n66 channel bandwidths in Table 5.3.5-1	
CA_n25(2A)-n41C-n66(2A)	n41 <sup>7,9</sup> CA_n25A-n41A <sup>7</sup> CA_n25A-n66A CA_n41A-n66A <sup>7</sup> CA_n41C <sup>7</sup>	n25	CA_n25(2A) BCS 4 and 5	4 and 5
		n41	CA_n41C BCS 4 and 5	
		n66	CA_n66(2A) BCS 4 and 5	
CA_n25(2A)-n41(A-C)-n66A	CA_n25A-n41A CA_n25A-n66A CA_n41A-n66A CA_n41C	n25	CA_n25(2A)_BCS 4 and 5	4 and 5
		n41	CA_n41(A-C) BCS 4 and 5	
		n66	n66 channel bandwidths in Table 5.3.5-1	
CA_n25A-n41A-n71A	n41 <sup>7,9</sup> CA_n25A-n41A <sup>7</sup> CA_n25A-n71A CA_n41A-n71A <sup>7</sup>	n25	5, 10, 15, 20	0
		n41	10, 15, 20, 30, 40, 50, 60, 80, 90, 100	
		n71	5, 10, 15, 20	
		n25	5, 10, 15, 20, 25, 30, 40	1
		n41	10, 15, 20, 30, 40, 50, 60, 70, 80, 90, 100	
		n71	5, 10, 15, 20	
		n25	n25 channel bandwidths in Table 5.3.5-1	4 and 5
		n41	n41 channel bandwidths in Table 5.3.5-1	
		n71	n77 channel bandwidths in Table 5.3.5-1	
CA_n25A-n41A-n71B	n41 <sup>7,9</sup> CA_n25A-n41A <sup>7</sup> CA_n25A-n71A CA_n41A-n71A <sup>7</sup>	n25	5, 10, 15, 20	0
		n41	10, 15, 20, 30, 40, 50, 60, 80, 90, 100	
		n71	CA_n71B_BCS2	
		n25	5, 10, 15, 20, 30, 40	1
		n41	10, 15, 20, 30, 40, 50, 60, 80, 90, 100	
		n71	CA_n71B_BCS2	
		n25	n25 channel bandwidths in Table 5.3.5-1	4 and 5
		n41	n41 channel bandwidths in Table 5.3.5-1	
		n71	CA_n71B BCS 4 and 5	
CA_n25A-n41A-n71(2A)	n41 <sup>7,9</sup> CA_n25A-n41A <sup>7</sup> CA_n25A-n71A CA_n41A-n71A <sup>7</sup>	n25	5, 10, 15, 20	0
		n41	10, 15, 20, 30, 40, 50, 60, 80, 90, 100	

		n71	CA_n71(2A)_BCS0	
		n25	5, 10, 15, 20, 30, 40	1
		n41	10, 15, 20, 30, 40, 50, 60, 80, 90, 100	
		n71	CA_n71(2A)_BCS0	
		n25	n25 channel bandwidths in Table 5.3.5-1	4 and 5
		n41	n41 channel bandwidths in Table 5.3.5-1	
		n71	CA_n71(2A) BCS 4 and 5	
CA_n25A-n41(2A)-n71A	n41 <sup>7,9</sup> CA_n25A-n41A <sup>7</sup> CA_n25A-n71A CA_n41A-n71A <sup>7</sup>	n25	5, 10, 15, 20	0
		n41	CA_n41(2A)_BCS1	
		n71	5, 10, 15, 20	
		n25	5, 10, 15, 20, 25, 30, 40	1
		n41	CA_n41(2A)_BCS1	
		n71	5, 10, 15, 20	
		n25	n25 channel bandwidths in Table 5.3.5-1	4 and 5
		n41	CA_n41(2A) BCS 4 and 5	
CA_n25A-n41(2A)-n71B	n41 <sup>7,9</sup> CA_n25A-n41A <sup>7</sup> CA_n25A-n71A CA_n41A-n71A <sup>7</sup>	n25	n25 channel bandwidths in Table 5.3.5-1	4 and 5
		n41	CA_n41(2A) BCS 4 and 5	
		n71	CA_n71B BCS 4 and 5	
CA_n25A-n41(2A)-n71(2A)	n41 <sup>7,9</sup> CA_n25A-n41A <sup>7</sup> CA_n25A-n71A CA_n41A-n71A <sup>7</sup>	n25	n25 channel bandwidths in Table 5.3.5-1	4 and 5
		n41	CA_n41(2A) BCS 4 and 5	
		n71	CA_n71(2A) BCS 4 and 5	
CA_n25A-n41(3A)-n71A	n41 <sup>7,9</sup> CA_n25A-n41A <sup>7</sup> CA_n25A-n71A CA_n41A-n71A <sup>7</sup>	n25	n25 channel bandwidths in Table 5.3.5-1	4 and 5
		n41	CA_n41(3A) BCS 4 and 5	
		n71	n71 channel bandwidths in Table 5.3.5-1	
CA_n25A-n41(3A)-n71B	CA_n25A-n41A CA_n25A-n71A CA_n41A-n71A	n25	n25 channel bandwidths in Table 5.3.5-1	4 and 5
		n41	CA_n41(3A) BCS 4 and 5	
		n71	CA_n71B BCS 4 and 5	
CA_n25A-n41(3A)-n71(2A)	CA_n25A-n41A CA_n25A-n71A CA_n41A-n71A	n25	n25 channel bandwidths in Table 5.3.5-1	4 and 5
		n41	CA_n41(3A) BCS 4 and 5	
		n71	CA_n71(2A) BCS 4 and 5	
CA_n25A-n41C-n71A	n41 <sup>7,9</sup> CA_n25A-n41A <sup>7</sup> CA_n25A-n71A CA_n41A-n71A <sup>7</sup> CA_n41C <sup>7</sup> CA_n25A-n41C CA_n41C-n71A	n25	5, 10, 15, 20	0
		n41	CA_n41C_BCS0	
		n71	5, 10, 15, 20	
		n25	5, 10, 15, 20, 25, 30, 40	1
		n41	CA_n41C_BCS1	
		n71	5, 10, 15, 20	
		n25	n25 channel bandwidths in Table 5.3.5-1	4 and 5

		n41	CA_n41C BCS 4 and 5	
		n71	n71 channel bandwidths in Table 5.3.5-1	
CA_n25A-n41C-n71B	n41 <sup>7,9</sup> CA_n25A-n41A <sup>7</sup> CA_n25A-n71A CA_n41A-n71A <sup>7</sup> CA_n41C <sup>7</sup>	n25	n25 channel bandwidths in Table 5.3.5-1	4 and 5
		n41	CA_n41C BCS 4 and 5	
		n71	CA_n71B BCS 4 and 5	
CA_n25A-n41C-n71(2A)	n41 <sup>7,9</sup> CA_n25A-n41A <sup>7</sup> CA_n25A-n71A CA_n41A-n71A <sup>7</sup> CA_n41C <sup>7</sup>	n25	n25 channel bandwidths in Table 5.3.5-1	4 and 5
		n41	CA_n41C BCS 4 and 5	
		n71	CA_n71(2A) BCS 4 and 5	
CA_n25A-n41(A-C)-n71A	n41 <sup>7,9</sup> CA_n25A-n41A <sup>7</sup> CA_n25A-n71A CA_n41A-n71A <sup>7</sup> CA_n41C <sup>7</sup>	n25	n25 channel bandwidths in Table 5.3.5-1	4 and 5
		n41	CA_n41(A-C) BCS 4 and 5	
		n71	n71 channel bandwidths in Table 5.3.5-1	
CA_n25A-n41(A-C)-n71B	CA_n25A-n41A CA_n25A-n71A CA_n41A-n71A CA_n41C	n25	n25 channel bandwidths in Table 5.3.5-1	4 and 5
		n41	CA_n41(A-C) BCS 4 and 5	
		n71	CA_n71B BCS 4 and 5	
CA_n25A-n41(A-C)-n71(2A)	CA_n25A-n41A CA_n25A-n71A CA_n41A-n71A CA_n41C	n25	n25 channel bandwidths in Table 5.3.5-1	4 and 5
		n41	CA_n41(A-C) BCS 4 and 5	
		n71	CA_n71(2A) BCS 4 and 5	
CA_n25(2A)-n41A-n71A	n41 <sup>7,9</sup> CA_n25A-n41A <sup>7</sup> CA_n25A-n71A CA_n41A-n71A <sup>7</sup>	n25	CA_n25(2A)_BCS1	0
		n41	10, 15, 20, 30, 40, 50, 60, 80, 90, 100	
		n71	5, 10, 15, 20	1
		n25	CA_n25(2A)_BCS1	
		n41	10, 15, 20, 30, 40, 50, 60, 70, 80, 90, 100	4 and 5
		n71	5, 10, 15, 20	
		n25	CA_n25(2A) BCS 4 and 5	
		n41	n41 channel bandwidths in Table 5.3.5-1	
		n71	n71 channel bandwidths in Table 5.3.5-1	
CA_n25(2A)-n41A-n71B	n41 <sup>7,9</sup> CA_n25A-n41A <sup>7</sup> CA_n25A-n71A CA_n41A-n71A <sup>7</sup>	n25	CA_n25(2A)_BCS 4 and 5	4 and 5
		n41	n41 channel bandwidths in Table 5.3.5-1	
		n71	CA_n71B_BCS 4 and 5	
CA_n25(2A)-n41A-n71(2A)	n41 <sup>7,9</sup> CA_n25A-n41A <sup>7</sup> CA_n25A-n71A CA_n41A-n71A <sup>7</sup>	n25	CA_n25(2A)_BCS 4 and 5	4 and 5
		n41	n41 channel bandwidths in Table 5.3.5-1	
		n71	CA_n71(2A)_BCS 4 and 5	

CA_n25(2A)-n41(2A)-n71A	n41 <sup>7,9</sup> CA_n25A-n41A <sup>7</sup> CA_n25A-n71A CA_n41A-n71A <sup>7</sup>	n25	CA_n25(2A) BCS 4 and 5	4 and 5
		n41	CA_n41(2A) BCS 4 and 5	
		n71	n71 channel bandwidths in Table 5.3.5-1	
CA_n25(2A)-n41(2A)-n71(2A)	n41 <sup>7,9</sup> CA_n25A-n41A <sup>7</sup> CA_n25A-n71A CA_n41A-n71A <sup>7</sup>	n25	CA_n25(2A) BCS 4 and 5	4 and 5
		n41	CA_n41(2A) BCS 4 and 5	
		n71	CA_n71(2A) BCS 4 and 5	
CA_n25(2A)-n41(2A)-n71B	n41 <sup>7,9</sup> CA_n25A-n41A <sup>7</sup> CA_n25A-n71A CA_n41A-n71A <sup>7</sup>	n25	CA_n25(2A) BCS 4 and 5	4 and 5
		n41	CA_n41(2A) BCS 4 and 5	
		n71	CA_n71B_BCS 4 and 5	
CA_n25(2A)-n41(3A)-n71A	CA_n25A-n41A CA_n25A-n71A CA_n41A-n71A	n25	CA_n25(2A) BCS 4 and 5	4 and 5
		n41	CA_n41(3A) BCS 4 and 5	
		n71	n71 channel bandwidths in Table 5.3.5-1	
CA_n25(2A)-n41C-n71A	n41 <sup>7,9</sup> CA_n25A-n41A <sup>7</sup> CA_n25A-n71A CA_n41A-n71A <sup>7</sup> CA_n41C <sup>7</sup>	n25	CA_n25(2A) BCS 4 and 5	4 and 5
		n41	CA_n41C BCS 4 and 5	
		n71	n71 channel bandwidths in Table 5.3.5-1	
CA_n25(2A)-n41C-n71(2A)	n41 <sup>7,9</sup> CA_n25A-n41A <sup>7</sup> CA_n25A-n71A CA_n41A-n71A <sup>7</sup> CA_n41C <sup>7</sup>	n25	CA_n25(2A) BCS 4 and 5	4 and 5
		n41	CA_n41C BCS 4 and 5	
		n71	CA_n71(2A) BCS 4 and 5	
CA_n25(2A)-n41C-n71B	n41 <sup>7,9</sup> CA_n25A-n41A <sup>7</sup> CA_n25A-n71A CA_n41A-n71A <sup>7</sup> CA_n41C <sup>7</sup>	n25	CA_n25(2A) BCS 4 and 5	4 and 5
		n41	CA_n41C BCS 4 and 5	
		n71	CA_n71B_BCS 4 and 5	
CA_n25(2A)-n41(A-C)-n71A	CA_n25A-n41A CA_n25A-n71A CA_n41A-n71A CA_n41C	n25	CA_n25(2A) BCS 4 and 5	4 and 5
		n41	CA_n41(A-C) BCS 4 and 5	
		n71	n71 channel bandwidths in Table 5.3.5-1	
CA_n25A-n41A-n77A	n41 <sup>7,9</sup> n77 <sup>7,9</sup> CA_n25A-n41A <sup>7</sup> CA_n25A-n77A <sup>7</sup> CA_n41A-n77A <sup>7</sup>	n25	5, 10, 15, 20, 25, 30, 40	0
		n41	10, 15, 20, 30, 40, 50, 60, 80, 90, 100	
		n77	10, 15, 20, 25, 30, 40, 50, 60, 80, 90, 100	
		n25	5, 10, 15, 20, 25, 30, 40	
		n41	10, 15, 20, 30, 40, 50, 60, 80, 90, 100	1

		n77	10, 15, 20, 25, 30, 40, 50, 60, 70, 80, 90, 100	
		n25	n25 channel bandwidths in Table 5.3.5-1	4 and 5
		n41	n41 channel bandwidths in Table 5.3.5-1	
		n77	n77 channel bandwidths in Table 5.3.5-1	
CA_n25A-n41(2A)-n77A	n41 <sup>7,9</sup> n77 <sup>7,9</sup> CA_n25A-n41A <sup>7</sup> CA_n25A-n77A <sup>7</sup> CA_n41A-n77A <sup>7</sup>	n25	5, 10, 15, 20, 25, 30, 40	0
		n41	CA_n41(2A)_BCS1	
		n77	10, 15, 20, 25, 30, 40, 50, 60, 70, 80, 90, 100	
		n25	5, 10, 15, 20, 25, 30, 40	1
		n41	CA_n41(2A)_BCS1	
		n77	10, 15, 20, 25, 30, 40, 50, 60, 80, 90, 100	
		n25	n25 channel bandwidths in Table 5.3.5-1	4 and 5
		n41	CA_n41(2A) BCS 4 and 5	
		n77	n77 channel bandwidths in Table 5.3.5-1	
		CA_n25A-n41(3A)-n77A	n41 <sup>7,9</sup> n77 <sup>7,9</sup> CA_n25A-n41A <sup>7</sup> CA_n25A-n77A <sup>7</sup> CA_n41A-n77A <sup>7</sup>	n25
n41	CA_n41(3A) BCS 4 and 5			
n77	n77 channel bandwidths in Table 5.3.5-1			
CA_n25A-n41A-n77(2A)	n41 <sup>7,9</sup> n77 <sup>7,9</sup> CA_n25A-n41A <sup>7</sup> CA_n25A-n77A <sup>7</sup> CA_n41A-n77A <sup>7</sup>	n25	5, 10, 15, 20, 25, 30, 40	0
		n41	10, 15, 20, 30, 40, 50, 60, 80, 90, 100	
		n77	CA_n77(2A)_BCS1	
		n25	n25 channel bandwidths in Table 5.3.5-1	4 and 5
		n41	n41 channel bandwidths in Table 5.3.5-1	
		n77	CA_n77(2A) BCS 4 and 5	
CA_n25A-n41(2A)-n77(2A)	n41 <sup>7,9</sup> n77 <sup>7,9</sup> CA_n25A-n41A <sup>7</sup> CA_n25A-n77A <sup>7</sup> CA_n41A-n77A <sup>7</sup>	n25	n25 channel bandwidths in Table 5.3.5-1	4 and 5
		n41	CA_n41(2A) BCS 4 and 5	
		n77	CA_n77(2A) BCS 4 and 5	
CA_n25(2A)-n41A-n77A	n41 <sup>7,9</sup> n77 <sup>7,9</sup> CA_n25A-n41A <sup>7</sup> CA_n25A-n77A <sup>7</sup> CA_n41A-n77A <sup>7</sup>	n25	CA_n25(2A)_BCS1	0
		n41	10, 15, 20, 30, 40, 50, 60, 70, 80, 90, 100	
		n77	10, 15, 20, 25, 30, 40, 50, 60, 70, 80, 90, 100	
		n25	CA_n25(2A) BCS 4 and 5	4 and 5
		n41	n41 channel bandwidths in Table 5.3.5-1	
		n77	n77 channel bandwidths in Table 5.3.5-1	

CA_n25(2A)-n41A-n77(2A)	n41 <sup>7,9</sup> n77 <sup>7,9</sup> CA_n25A-n41A <sup>7</sup> CA_n25A-n77A <sup>7</sup> CA_n41A-n77A <sup>7</sup>	n25	CA_n25(2A) BCS 4 and 5	4 and 5
		n41	n41 channel bandwidths in Table 5.3.5-1	
		n77	CA_n77(2A) BCS 4 and 5	
CA_n25(2A)-n41C-n77A	n41 <sup>7,9</sup> n77 <sup>7,9</sup> CA_n25A-n41A <sup>7</sup> CA_n25A-n77A <sup>7</sup> CA_n41A-n77A <sup>7</sup> CA_n41C <sup>7</sup>	n25	CA_n25(2A) BCS 4 and 5	4 and 5
		n41	CA_n41C BCS 4 and 5	
		n77	n77 channel bandwidths in Table 5.3.5-1	
CA_n25(2A)-n41(2A)-n77A	n41 <sup>7,9</sup> n77 <sup>7,9</sup> CA_n25A-n41A <sup>7</sup> CA_n25A-n77A <sup>7</sup> CA_n41A-n77A <sup>7</sup>	n25	CA_n25(2A) BCS 4 and 5	4 and 5
		n41	CA_n41(2A) BCS 4 and 5	
		n77	n77 channel bandwidths in Table 5.3.5-1	
CA_n25A-n41C-n77A	n41 <sup>7,9</sup> n77 <sup>7,9</sup> CA_n25A-n41A <sup>7</sup> CA_n25A-n77A <sup>7</sup> CA_n41A-n77A <sup>7</sup> CA_n41C <sup>7</sup> CA_n25A-n41C CA_n41C-n77A	n25	5, 10, 15, 20, 25, 30, 40	0
		n41	CA_n41C_BCS0	
		n77	10, 15, 20, 25, 30, 40, 50, 60, 70, 80, 90, 100	1
		n25	5, 10, 15, 20, 25, 30, 40	
		n41	CA_n41C_BCS2	4 and 5
		n77	10, 15, 20, 25, 30, 40, 50, 60, 70, 80, 90, 100	
		n25	n25 channel bandwidths in Table 5.3.5-1	4 and 5
		n41	CA_n41C BCS 4 and 5	
		n77	n77 channel bandwidths in Table 5.3.5-1	
		CA_n25A-n41(A-C)-n77A	n41 <sup>7,9</sup> n77 <sup>7,9</sup> CA_n25A-n41A <sup>7</sup> CA_n25A-n77A <sup>7</sup> CA_n41A-n77A <sup>7</sup> CA_n41C <sup>7</sup>	n25
n41	CA_n41(A-C) BCS 4 and 5			
n77	n77 channel bandwidths in Table 5.3.5-1			
CA_n25A-n41C-n77(2A)	n41 <sup>7,9</sup> n77 <sup>7,9</sup> CA_n25A-n41A <sup>7</sup> CA_n25A-n77A <sup>7</sup> CA_n41A-n77A <sup>7</sup> CA_n41C <sup>7</sup>	n25	n25 channel bandwidths in Table 5.3.5-1	4 and 5
		n41	CA_n41C BCS 4 and 5	
		n77	CA_n77(2A) BCS 4 and 5	
CA_n25(2A)-n41C-n77(2A)	CA_n25A-n41A CA_n25A-n77A CA_n41A-n77A CA_n41C	n25	CA_n25(2A) BCS 4 and 5	4 and 5
		n41	CA_n41C BCS 4 and 5	

		n77	CA_n77(2A) BCS 4 and 5	
CA_n25(2A)-n41(2A)-n77(2A)	CA_n25A-n41A CA_n25A-n77A CA_n41A-n77A	n25	CA_n25(2A) BCS 4 and 5	4 and 5
		n41	CA_n41(2A) BCS 4 and 5	
		n77	CA_n77(2A) BCS 4 and 5	
CA_n25(2A)-n41(3A)-n77A	CA_n25A-n41A CA_n25A-n77A CA_n41A-n77A	n25	CA_n25(2A) BCS 4 and 5	4 and 5
		n41	CA_n41(3A) BCS 4 and 5	
		n77	n77 channel bandwidths in Table 5.3.5-1	
CA_n25(2A)-n41(A-C)-n77A	CA_n25A-n41A CA_n25A-n77A CA_n41A-n77A CA_n41C	n25	CA_n25(2A) BCS 4 and 5	4 and 5
		n41	CA_n41(A-C) BCS 4 and 5	
		n77	n77 channel bandwidths in Table 5.3.5-1	
CA_n25A-n41A-n78A	CA_n25A-n41A CA_n25A-n78A CA_n41A-n78A	n25	5, 10, 15, 20, 25, 30, 40	0
		n41	10, 15, 20, 30, 40, 50, 60, 70, 80, 90, 100	
		n78	10, 15, 20, 25, 30, 40, 50, 60, 70, 80, 90, 100	
CA_n25A-n41A-n78(2A)	CA_n25A-n41A CA_n25A-n78A CA_n41A-n78A	n25	5, 10, 15, 20, 25, 30, 40	0
		n41	10, 15, 20, 30, 40, 50, 60, 70, 80, 90, 100	
		n78	CA_n78(2A)_BCS2	
CA_n25A-n41A-n85A	CA_n25A-n41A CA_n25A-n85A CA_n41A-n85A	n25	n25 channel bandwidths in Table 5.3.5-1	4 and 5
		n41	n41 channel bandwidths in Table 5.3.5-1	
		n85	n85 channel bandwidths in Table 5.3.5-1	
CA_n25A-n41C-n85A	CA_n25A-n41A CA_n25A-n85A CA_n41A-n85A CA_n41C	n25	n25 channel bandwidths in Table 5.3.5-1	4 and 5
		n41	CA_n41C BCS 4 and 5	
		n85	n85 channel bandwidths in Table 5.3.5-1	
CA_n25A-n41(2A)-n85A	CA_n25A-n41A CA_n25A-n85A CA_n41A-n85A	n25	n25 channel bandwidths in Table 5.3.5-1	4 and 5
		n41	CA_n41(2A) BCS 4 and 5	
		n85	n85 channel bandwidths in Table 5.3.5-1	
CA_n25(2A)-n41A-n85A	CA_n25A-n41A CA_n25A-n85A CA_n41A-n85A	n25	CA_n25(2A) BCS 4 and 5	4 and 5
		n41	n41 channel bandwidths in Table 5.3.5-1	
		n85	n85 channel bandwidths in Table 5.3.5-1	
CA_n25A-n48A-n66A	CA_n25A-n48A CA_n25A-n66A CA_n48A-n66A	n25	5, 10, 15, 20	0
		n48	5, 10, 15, 20, 40, 50 <sup>12</sup>	
		n66	5, 10, 15, 20, 40	1
		n25	5, 10, 15, 20, 25, 30, 40	
		n48	5, 10, 15, 20, 40, 50 <sup>12</sup> , 60 <sup>12</sup> , 80 <sup>12</sup> , 90 <sup>12</sup> , 100 <sup>12</sup>	



CA_n25A-n48(2A)-n66A	CA_n25A-n48A CA_n25A-n66A CA_n48A-n66A	n66	5, 10, 15, 20, 25, 30, 40	0	
		n25	5, 10, 15, 20		
		n48	CA_n48(2A)_BCS0		
		n66	5, 10, 15, 20, 40		
		n25	5, 10, 15, 20, 25, 30, 40		1
		n48	CA_n48(2A)_BCS0		
CA_n25A-n48C-n66A	CA_n25A-n48A CA_n25A-n66A CA_n48A-n66A	n25	5, 10, 15, 20	0	
		n48	CA_n48C_BCS0		
		n66	5, 10, 15, 20, 40		
		n25	5, 10, 15, 20, 25, 30, 40		1
		n48	CA_n48C_BCS0		
		n66	5, 10, 15, 20, 25, 30, 40		
CA_n25A-n66A-n71A	-	n25	5, 10, 15, 20	0	
		n66	5, 10, 15, 20, 40		
		n71	5, 10, 15, 20		
	CA_n25A-n66A CA_n25A-n71A CA_n66A-n71A	-	n25	5, 10, 15, 20, 25, 30, 40	1
			n66	5, 10, 15, 20, 25, 30, 40	
			n71	5, 10, 15, 20	
	CA_n25A-n66A CA_n25A-n71A CA_n66A-n71A	-	n25	n25 channel bandwidths in Table 5.3.5-1	4 and 5
			n66	n66 channel bandwidths in Table 5.3.5-1	
			n71	n71 channel bandwidths in Table 5.3.5-1	
	CA_n25A-n66A-n71B	CA_n25A-n66A CA_n25A-n71A CA_n66A-n71A	n25	5, 10, 15, 20, 25, 30, 40	0
			n66	5, 10, 15, 20, 25, 30, 40	
			n71	CA_n71B_BCS2	
CA_n25A-n66A CA_n25A-n71A CA_n66A-n71A		-	n25	n25 channel bandwidths in Table 5.3.5-1	4 and 5
			n66	n66 channel bandwidths in Table 5.3.5-1	
			n71	CA_n71B BCS 4 and 5	
CA_n25A-n66A-n71(2A)	CA_n25A-n66A CA_n25A-n71A CA_n66A-n71A	n25	5, 10, 15, 20, 25, 30, 40	0	
		n66	5, 10, 15, 20, 25, 30, 40		
		n71	CA_n71(2A)_BCS0		
	CA_n25A-n66A CA_n25A-n71A CA_n66A-n71A	-	n25	n25 channel bandwidths in Table 5.3.5-1	4 and 5
			n66	n66 channel bandwidths in Table 5.3.5-1	
			n71	CA_n71(2A) BCS 4 and 5	
CA_n25A-n66(2A)-n71A	CA_n25A-n66A CA_n25A-n71A CA_n66A-n71A	n25	5, 10, 15, 20, 25, 30, 40	0	
		n66	CA_n66(2A)_BCS1		
		n71	5, 10, 15, 20		
	CA_n25A-n66A CA_n25A-n71A CA_n66A-n71A	-	n25	n25 channel bandwidths in Table 5.3.5-1	4 and 5
			n66	CA_n66(2A) BCS 4 and 5	
			n71	n71 channel bandwidths in Table 5.3.5-1	
CA_n25A-n66(2A)-n71B	CA_n25A-n66A CA_n25A-n71A	n25	n25 channel bandwidths in Table 5.3.5-1	4 and 5	

	CA_n66A-n71A	n66	CA_n66(2A)_BCS 4 and 5	
		n71	CA_n71B_BCS 4 and 5	
CA_n25A-n66(2A)-n71(2A)	CA_n25A-n66A CA_n25A-n71A CA_n66A-n71A	n25	n25 channel bandwidths in Table 5.3.5-1	4 and 5
		n66	CA_n66(2A)_BCS 4 and 5	
		n71	CA_n71(2A)_BCS 4 and 5	
CA_n25(2A)-n66A-n71A	CA_n25A-n66A CA_n25A-n71A CA_n66A-n71A	n25	CA_n25(2A)_BCS1	0
		n66	5, 10, 15, 20, 25, 30, 40	
		n71	5, 10, 15, 20	
	CA_n25A-n66A CA_n25A-n71A CA_n66A-n71A	n25	CA_n25(2A) BCS 4 and 5	4 and 5
		n66	n66 channel bandwidths in Table 5.3.5-1	
		n71	n71 channel bandwidths in Table 5.3.5-1	
CA_n25(2A)-n66(2A)-n71A	CA_n25A-n66A CA_n25A-n71A CA_n66A-n71A	n25	CA_n25(2A)_BCS 4 and 5	4 and 5
		n66	CA_n66(2A)_BCS 4 and 5	
		n71	n71 channel bandwidths in Table 5.3.5-1	
CA_n25(2A)-n66A-n71B	CA_n25A-n66A CA_n25A-n71A CA_n66A-n71A	n25	CA_n25(2A)_BCS 4 and 5	4 and 5
		n66	n66 channel bandwidths in Table 5.3.5-1	
		n71	CA_n71B_BCS 4 and 5	
CA_n25(2A)-n66(2A)-n71B	CA_n25A-n66A CA_n25A-n71A CA_n66A-n71A	n25	CA_n25(2A) BCS 4 and 5	4 and 5
		n66	CA_n66(2A) BCS 4 and 5	
		n71	CA_n71B BCS 4 and 5	
CA_n25(2A)-n66A-n71(2A)	CA_n25A-n66A CA_n25A-n71A CA_n66A-n71A	n25	CA_n25(2A)_BCS 4 and 5	4 and 5
		n66	n66 channel bandwidths in Table 5.3.5-1	
		n71	CA_n71(2A)_BCS 4 and 5	
CA_n25A-n66A-n77A	n77 <sup>7,9</sup> CA_n25A-n66A CA_n25A-n77A <sup>7</sup> CA_n66A-n77A <sup>7</sup>	n25	5, 10, 15, 20, 25, 30, 40	0
		n66	5, 10, 15, 20, 25, 30, 40	
		n77	10, 15, 20, 25, 30, 40, 50, 60, 70, 80, 90, 100	
		n25	n25 channel bandwidths in Table 5.3.5-1	4 and 5
		n66	n66 channel bandwidths in Table 5.3.5-1	
		n77	n77 channel bandwidths in Table 5.3.5-1	
CA_n25A-n66(2A)-n77A	n77 <sup>7,9</sup> CA_n25A-n66A CA_n25A-n77A <sup>7</sup> CA_n66A-n77A <sup>7</sup>	n25	5, 10, 15, 20, 25, 30, 40	0
		n66	CA_n66(2A)_BCS1	
		n77	10, 15, 20, 25, 30, 40, 50, 60, 70, 80, 90, 100	
		n25	n25 channel bandwidths in Table 5.3.5-1	4 and 5
		n66	CA_n66(2A) BCS 4 and 5	

		n77	n77 channel bandwidths in Table 5.3.5-1	
CA_n25A-n66A-n77(2A)	n77 <sup>7,9</sup> CA_n77(2A) <sup>7</sup> CA_n25A-n66A CA_n25A-n77A <sup>7</sup> CA_n66A-n77A <sup>7</sup>	n25	5, 10, 15, 20, 25, 30, 40	0
		n66	5, 10, 15, 20, 25, 30, 40	
		n77	CA_n77(2A)_BCS1	
		n25	n25 channel bandwidths in Table 5.3.5-1	4 and 5
		n66	n66 channel bandwidths in Table 5.3.5-1	
		n77	CA_n77(2A) BCS 4 and 5	
CA_n25A-n66A-n77(3A)	n77 <sup>7,9</sup> CA_n77(2A) <sup>7</sup> CA_n25A-n66A CA_n25A-n77A <sup>7</sup> CA_n66A-n77A <sup>7</sup>	n25	5, 10, 15, 20, 25, 30, 40	0
		n66	5, 10, 15, 20, 25, 30, 40	
		n77	CA_n77(3A)_BCS1	
		n25	n25 channel bandwidths in Table 5.3.5-1	4 and 5
		n66	n66 channel bandwidths in Table 5.3.5-1	
		n77	CA_n77(3A) BCS 4 and 5	
CA_n25A-n66(2A)-n77(2A)	n77 <sup>7,9</sup> CA_n25A-n66A CA_n25A-n77A <sup>7</sup> CA_n66A-n77A <sup>7</sup>	n25	5, 10, 15, 20, 25, 30, 40	0
		n66	CA_n66(2A)_BCS1	
		n77	CA_n77(2A)_BCS1	
		n25	5, 10, 15, 20, 25, 30, 40	4 and 5
		n66	CA_n66(2A) BCS 4 and 5	
		n77	CA_n77(2A) BCS 4 and 5	
CA_n25(2A)-n66A-n77A	n77 <sup>7,9</sup> CA_n25A-n66A CA_n25A-n77A <sup>7</sup> CA_n66A-n77A <sup>7</sup>	n25	CA_n25(2A)_BCS0	0
		n66	5, 10, 15, 20, 25, 30, 40	
		n77	10, 15, 20, 25, 30, 40, 50, 60, 70, 80, 90, 100	
		n25	CA_n25(2A) BCS 4 and 5	4 and 5
		n66	n66 channel bandwidths in Table 5.3.5-1	
		n77	n77 channel bandwidths in Table 5.3.5-1	
CA_n25(2A)-n66(2A)-n77A	n77 <sup>7,9</sup> CA_n25A-n66A CA_n25A-n77A <sup>7</sup> CA_n66A-n77A <sup>7</sup>	n25	CA_n25(2A)_BCS0	0
		n66	CA_n66(2A)_BCS1	
		n77	10, 15, 20, 25, 30, 40, 50, 60, 70, 80, 90, 100	
		n25	CA_n25(2A)_BCS 4 and 5	4 and 5
		n66	CA_n66(2A)_BCS 4 and 5	
		n77	n77 channel bandwidths in Table 5.3.5-1	
CA_n25(2A)-n66A-n77(2A)	n77 <sup>7,9</sup> CA_n25A-n66A CA_n25A-n77A <sup>7</sup> CA_n66A-n77A <sup>7</sup>	n25	CA_n25(2A)_BCS0	0
		n66	5, 10, 15, 20, 25, 30, 40	
		n77	CA_n77(2A)_BCS1	
		n25	CA_n25(2A)_BCS 4 and 5	4 and 5
		n66	n66 channel bandwidths in Table 5.3.5-1	
		n77	n77 channel bandwidths in Table 5.3.5-1	

		n77	CA_n77(2A) BCS 4 and 5	
CA_n25(2A)-n66(2A)-n77(2A)	n77 <sup>7,9</sup> CA_n25A-n66A CA_n25A-n77A <sup>7</sup> CA_n66A-n77A <sup>7</sup>	n25	CA_n25(2A)_BCS0	0
		n66	CA_n66(2A)_BCS1	
		n77	CA_n77(2A)_BCS1	
		n25	CA_n25(2A)_BCS 4 and 5	4 and 5
		n66	CA_n66(2A)_BCS 4 and 5	
		n77	CA_n77(2A)_BCS 4 and 5	
CA_n25A-n66A-n78A	n78 <sup>7,9</sup> CA_n25A-n66A CA_n25A-n78A <sup>7</sup> CA_n66A-n78A <sup>7</sup>	n25	5, 10, 15, 20, 25, 30, 40	0
		n66	5, 10, 15, 20, 25, 30, 40	
		n78	10, 15, 20, 25, 30, 40, 50, 60, 80, 90, 100	
		n25	5, 10, 15, 20, 25, 30, 40	1
		n66	5, 10, 15, 20, 25, 30, 40	
		n78	10, 15, 20, 25, 30, 40, 50, 60, 70, 80, 90, 100	
CA_n25(2A)-n66A-n78A	n78 <sup>7,9</sup> CA_n25A-n66A CA_n25A-n78A <sup>7</sup> CA_n66A-n78A <sup>7</sup>	n25	CA_n25(2A)_BCS0	0
		n66	5, 10, 15, 20, 25, 30, 40	
		n78	10, 15, 20, 25, 30, 40, 50, 60, 70, 80, 90, 100	
CA_n25A-n66(2A)-n78A	CA_n25A-n66A CA_n25A-n78A CA_n66A-n78A	n25	5, 10, 15, 20, 25, 30, 40	0
		n66	CA_n66(2A)_BCS1	
		n78	10, 15, 20, 25, 30, 40, 50, 60, 70, 80, 90, 100	
CA_n25A-n66A-n78(2A)	n78 <sup>7</sup> CA_n78(2A) <sup>7</sup> CA_n25A-n66A CA_n25A-n78A <sup>7</sup> CA_n66A-n78A <sup>7</sup>	n25	5, 10, 15, 20, 25, 30, 40	0
		n66	5, 10, 15, 20, 25, 30, 40	
		n78	CA_n78(2A)_BCS2	
CA_n25(2A)-n66(2A)-n78A	CA_n25A-n66A CA_n25A-n78A CA_n66A-n78A	n25	CA_n25(2A)_BCS0	0
		n66	CA_n66(2A)_BCS1	
		n78	10, 15, 20, 25, 30, 40, 50, 60, 70, 80, 90, 100	
CA_n25(2A)-n66A-n78(2A)	CA_n25A-n66A CA_n25A-n78A CA_n66A-n78A	n25	CA_n25(2A)_BCS0	0
		n66	5, 10, 15, 20, 25, 30, 40	
		n78	CA_n78(2A)_BCS2	
CA_n25A-n66(2A)-n78(2A)	CA_n25A-n66A CA_n25A-n78A CA_n66A-n78A	n25	5, 10, 15, 20, 25, 30, 40	0
		n66	CA_n66(2A)_BCS1	
		n78	CA_n78(2A)_BCS2	
CA_n25(2A)-n66(2A)-n78(2A)	CA_n25A-n66A CA_n25A-n78A CA_n66A-n78A	n25	CA_n25(2A)_BCS0	0
		n66	CA_n66(2A)_BCS1	
		n78	CA_n78(2A)_BCS2	
CA_n25A-n66A-n85A	CA_n25A-n66A CA_n25A-n85A CA_n66A-n85A	n25	n25 channel bandwidths in Table 5.3.5-1	4 and 5
		n66	n66 channel bandwidths in Table 5.3.5-1	

		n85	n85 channel bandwidths in Table 5.3.5-1	
CA_n25A-n66(2A)-n85A	CA_n25A-n66A CA_n25A-n85A CA_n66A-n85A	n25	n25 channel bandwidths in Table 5.3.5-1	4 and 5
		n66	CA_n66(2A) BCS 4 and 5	
		n85	n85 channel bandwidths in Table 5.3.5-1	
CA_n25(2A)-n66A-n85A	CA_n25A-n66A CA_n25A-n85A CA_n66A-n85A	n25	CA_n25(2A) BCS 4 and 5	4 and 5
		n66	n66 channel bandwidths in Table 5.3.5-1	
		n85	n85 channel bandwidths in Table 5.3.5-1	
CA_n25A-n71A-n77A	n77 <sup>7,9</sup> CA_n25A-n71A CA_n25A-n77A <sup>7</sup> CA_n71A-n77A <sup>7</sup>	n25	5, 10, 15, 20, 25, 30, 40	0
		n71	5, 10, 15, 20	
		n77	10, 15, 20, 25, 30, 40, 50, 60, 70, 80, 90, 100	
		n25	n25 channel bandwidths in Table 5.3.5-1	4 and 5
		n71	n71 channel bandwidths in Table 5.3.5-1	
		n77	n77 channel bandwidths in Table 5.3.5-1	
CA_n25A-n71A-n77(2A)	n77 <sup>7,9</sup> CA_n77(2A) <sup>7</sup> CA_n25A-n71A CA_n25A-n77A <sup>7</sup> CA_n71A-n77A <sup>7</sup>	n25	5, 10, 15, 20, 25, 30, 40	0
		n71	5, 10, 15, 20	
		n77	CA_n77(2A) BCS1	
		n25	n25 channel bandwidths in Table 5.3.5-1	4 and 5
		n71	n71 channel bandwidths in Table 5.3.5-1	
		n77	CA_n77(2A) BCS 4 and 5	
CA_n25A-n71A-n77(3A)	n77 <sup>7,9</sup> CA_n77(2A) <sup>7</sup> CA_n25A-n71A CA_n25A-n77A <sup>7</sup> CA_n71A-n77A <sup>7</sup>	n25	5, 10, 15, 20, 25, 30, 40	0
		n71	5, 10, 15, 20	
		n77	CA_n77(3A) BCS1	
CA_n25A-n71B-n77A	n77 <sup>7,9</sup> CA_n25A-n71A CA_n25A-n77A <sup>7</sup> CA_n71A-n77A <sup>7</sup>	n25	5, 10, 15, 20, 25, 30, 40	0
		n71	CA_n71B_BCS2	
		n77	10, 15, 20, 25, 30, 40, 50, 60, 70, 80, 90, 100	
		n25	n25 channel bandwidths in Table 5.3.5-1	4 and 5
		n71	CA_n71B BCS 4 and 5	
n77	n77 channel bandwidths in Table 5.3.5-1			
CA_n25A-n71B-n77(2A)	n77 <sup>7,9</sup> CA_n25A-n71A CA_n25A-n77A <sup>7</sup> CA_n71A-n77A <sup>7</sup>	n25	n25 channel bandwidths in Table 5.3.5-1	4 and 5
		n71	CA_n71B BCS 4 and 5	
		n77	CA_n77(2A) BCS 4 and 5	
CA_n25A-n71(2A)-n77A	n77 <sup>7,9</sup> CA_n25A-n71A	n25	5, 10, 15, 20, 25, 30, 40	0

	CA_n25A-n77A <sup>7</sup> CA_n71A-n77A <sup>7</sup>	n71	CA_n71(2A)_BCS0	4 and 5	
		n77	10, 15, 20, 25, 30, 40, 50, 60, 70, 80, 90, 100		
		n25	n25 channel bandwidths in Table 5.3.5-1		
		n71	CA_n71(2A) BCS 4 and 5		
		n77	n77 channel bandwidths in Table 5.3.5-1		
CA_n25A-n71(2A)-n77(2A)	n77 <sup>7,9</sup> CA_n25A-n71A CA_n25A-n77A <sup>7</sup> CA_n71A-n77A <sup>7</sup>	n25	n25 channel bandwidths in Table 5.3.5-1	4 and 5	
		n71	CA_n71(2A) BCS 4 and 5		
		n77	CA_n77(2A) BCS 4 and 5		
CA_n25(2A)-n71A-n77A	n77 <sup>7,9</sup> CA_n25A-n71A CA_n25A-n77A <sup>7</sup> CA_n71A-n77A <sup>7</sup>	n25	CA_n25(2A)_BCS1	0	
		n71	5, 10, 15, 20		
		n77	10, 15, 20, 25, 30, 40, 50, 60, 70, 80, 90, 100		
		n25	CA_n25(2A) BCS 4 and 5		4 and 5
		n71	n71 channel bandwidths in Table 5.3.5-1		
n77	n77 channel bandwidths in Table 5.3.5-1				
CA_n25(2A)-n71A-n77(2A)	n77 <sup>7,9</sup> CA_n25A-n71A CA_n25A-n77A <sup>7</sup> CA_n71A-n77A <sup>7</sup>	n25	CA_n25(2A) BCS 4 and 5	4 and 5	
		n71	n71 channel bandwidths in Table 5.3.5-1		
		n77	CA_n77(2A) BCS 4 and 5		
CA_n25(2A)-n71B-n77A	n77 <sup>7,9</sup> CA_n25A-n71A CA_n25A-n77A <sup>7</sup> CA_n71A-n77A <sup>7</sup>	n25	CA_n25(2A)_BCS 4 and 5	4 and 5	
		n71	CA_n71B_BCS 4 and 5		
		n77	n77 channel bandwidths in Table 5.3.5-1		
CA_n25(2A)-n71B-n77(2A)	n77 <sup>7,9</sup> CA_n25A-n71A CA_n25A-n77A <sup>7</sup> CA_n71A-n77A <sup>7</sup>	n25	CA_n25(2A)_BCS 4 and 5	4 and 5	
		n71	CA_n71B_BCS 4 and 5		
		n77	CA_n77(2A) BCS 4 and 5		
CA_n25(2A)-n71(2A)-n77A	n77 <sup>7,9</sup> CA_n25A-n71A CA_n25A-n77A <sup>7</sup> CA_n71A-n77A <sup>7</sup>	n25	CA_n25(2A)_BCS 4 and 5	4 and 5	
		n71	CA_n71(2A)_BCS 4 and 5		
		n77	n77 channel bandwidths in Table 5.3.5-1		
CA_n25(2A)-n71(2A)-n77(2A)	n77 <sup>7,9</sup> CA_n25A-n71A CA_n25A-n77A <sup>7</sup> CA_n71A-n77A <sup>7</sup>	n25	CA_n25(2A) BCS 4 and 5	4 and 5	
		n71	CA_n71(2A)_BCS 4 and 5		
		n77	CA_n77(2A) BCS 4 and 5		
CA_n25A-n71A-n78A	CA_n25A-n71A CA_n25A-n78A CA_n71A-n78A	n25	5, 10, 15, 20, 25, 30, 40	0	
		n71	5, 10, 15, 20		
		n78	10, 15, 20, 25, 30, 40, 50, 60, 70, 80, 90, 100		

CA_n25A-n71A-n78(2A)	CA_n25A-n71A CA_n25A-n78A CA_n71A-n78A	n25	5, 10, 15, 20, 25, 30, 40	0
		n71	5, 10, 15, 20	
		n78	CA_n78(2A)_BCS2	
CA_n25A-n71A-n85A	CA_n25A-n71A CA_n25A-n85A	n25	n25 channel bandwidths in Table 5.3.5-1	4 and 5
		n71	n71 channel bandwidths in Table 5.3.5-1	
		n85	n85 channel bandwidths in Table 5.3.5-1	
CA_n25A-n71B-n85A	CA_n25A-n71A CA_n25A-n85A	n25	n25 channel bandwidths in Table 5.3.5-1	4 and 5
		n71	CA_n71B BCS 4 and 5	
		n85	n85 channel bandwidths in Table 5.3.5-1	
CA_n25A-n71(2A)-n85A	CA_n25A-n71A CA_n25A-n85A	n25	n25 channel bandwidths in Table 5.3.5-1	4 and 5
		n71	CA_n71(2A) BCS 4 and 5	
		n85	n85 channel bandwidths in Table 5.3.5-1	
CA_n25(2A)-n71A-n85A	CA_n25A-n71A CA_n25A-n85A	n25	CA_n25(2A) BCS 4 and 5	4 and 5
		n71	n71 channel bandwidths in Table 5.3.5-1	
		n85	n85 channel bandwidths in Table 5.3.5-1	
CA_n25A-n77A-n85A	CA_n25A-n77A CA_n25A-n85A CA_n77A-n85A	n25	n25 channel bandwidths in Table 5.3.5-1	4 and 5
		n77	n77 channel bandwidths in Table 5.3.5-1	
		n85	n85 channel bandwidths in Table 5.3.5-1	
CA_n25A-n77(2A)-n85A	CA_n25A-n77A CA_n25A-n85A CA_n77A-n85A	n25	n25 channel bandwidths in Table 5.3.5-1	4 and 5
		n77	CA_n77(2A) BCS 4 and 5	
		n85	n85 channel bandwidths in Table 5.3.5-1	
CA_n25(2A)-n77A-n85A	CA_n25A-n77A CA_n25A-n85A CA_n77A-n85A	n25	CA_n25(2A) BCS 4 and 5	4 and 5
		n77	n77 channel bandwidths in Table 5.3.5-1	
		n85	n85 channel bandwidths in Table 5.3.5-1	
CA_n26A-n29A-n66A	CA_n26A-n66A	n26	5, 10, 15, 20	0
		n29	5, 10	
		n66	5, 10, 15, 20, 25, 30, 40	
CA_n26A-n29A-n66(2A)	CA_n26A-n66A	n26	5, 10, 15, 20	0
		n29	5, 10	
		n66	CA_n66(2A)_BCS1	
CA_n26A-n29A-n66(3A)	-	n26	5, 10, 15, 20	0
		n29	5, 10	
		n66	CA_n66(3A)_BCS0	
CA_n26A-n29A-n70A	CA_n26A-n70A	n26	5, 10, 15, 20	0
		n29	5, 10	
		n70	5, 10, 15, 20, 25	
CA_n26A-n48A-n66A	CA_n26A-n48A CA_n26A-n66A CA_n48A-n66A	n26	5, 10, 15, 20	0
		n48	5, 10, 15, 20, 40, 50 <sup>12</sup> , 60 <sup>12</sup> , 80 <sup>12</sup> , 90 <sup>12</sup> , 100 <sup>12</sup>	

		n66	5, 10, 15, 20, 25, 30, 40	
CA_n26A-n48(2A)-n66A	CA_n26A-n48A CA_n26A-n66A CA_n48A-n66A	n26	5, 10, 15, 20	0
		n48	CA_n48(2A)_BCS0	
		n66	5, 10, 15, 20, 25, 30, 40	
CA_n26A-n48A-n66(2A)	CA_n26A-n48A CA_n26A-n66A CA_n48A-n66A	n26	5, 10, 15, 20	0
		n48	5, 10, 15, 20, 40, 50 <sup>12</sup> , 60 <sup>12</sup> , 80 <sup>12</sup> , 90 <sup>12</sup> , 100 <sup>12</sup>	
		n66	CA_n66(2A)_BCS0	
CA_n26A-n48(2A)-n66(2A)	CA_n26A-n48A CA_n26A-n66A CA_n48A-n66A	n26	5, 10, 15, 20	0
		n48	CA_n48(2A)_BCS0	
		n66	CA_n66(2A)_BCS0	
CA_n26A-n48A-n70A	CA_n26A-n48A CA_n26A-n70A CA_n48A-n70A	n26	5, 10, 15, 20	0
		n48	5, 10, 15, 20, 40, 50 <sup>12</sup> , 60 <sup>12</sup> , 80 <sup>12</sup> , 90 <sup>12</sup> , 100 <sup>12</sup>	
		n70	5, 10, 15, 20, 25	
CA_n26A-n66A-n70A	CA_n26A-n66A CA_n26A-n70A	n26	5, 10, 15, 20	0
		n66	5, 10, 15, 20, 25, 30, 40	
		n70	5, 10, 15, 20 <sup>1</sup> , 25 <sup>1</sup>	
CA_n26A-n66(2A)-n70A	CA_n26A-n66A CA_n26A-n70A	n26	5, 10, 15, 20	0
		n66	CA_n66(2A)_BCS0	
		n70	5, 10, 15, 20 <sup>1</sup> , 25 <sup>1</sup>	
CA_n26A-n66(3A)-n70A	-	n26	5, 10, 15, 20	0
		n66	CA_n66(3A)_BCS0	
		n70	5, 10, 15, 20 <sup>1</sup> , 25 <sup>1</sup>	
CA_n26A-n66A-n71A	CA_n26A-n66A CA_n66A-n71A	n26	5, 10, 15, 20	0
		n66	5, 10, 15, 20, 25, 30, 40	
		n71	5, 10, 15, 20	
CA_n26A-n66(2A)-n71A	CA_n26A-n66A CA_n66A-n71A	n26	5, 10, 15, 20	0
		n66	CA_n66(2A)_BCS1	
		n71	5, 10, 15, 20	
CA_n26A-n66(3A)-n71A	CA_n66A-n71A	n26	5, 10, 15, 20	0
		n66	CA_n66(3A)_BCS0	
		n71	5, 10, 15, 20	
CA_n26A-n66A-n77A	CA_n26A-n66A CA_n26A-n77A CA_n66A-n77A	n26	5, 10, 15, 20	0
		n66	5, 10, 15, 20, 25, 30, 40	
		n77	10, 15, 20, 25, 30, 40	
CA_n26A-n70A-n71A	CA_n26A-n70A CA_n70A-n71A	n26	5, 10, 15, 20	0
		n70	5, 10, 15, 20, 25	
		n71	5, 10, 15, 20	
CA_n26A-n70A-n77A	CA_n26A-n70A CA_n26A-n77A CA_n70A-n77A	n26	5, 10, 15, 20	0
		n70	5, 10, 15, 20, 25	
		n77	10, 15, 20, 25, 30, 40	
CA_n28A-n38A-n78A	-	n28	5, 10, 15, 20, 30	0
		n38	5, 10, 15, 20, 25, 30, 40	
		n78	10, 15, 20, 25, 30, 40, 50, 60, 70, 80, 90, 100	
CA_n28A-n39A-n40A	CA_n28A-n39A	n28	5, 10, 15, 20, 30	0



	CA_n28A-n40A CA_n39A-n40A	n39	5, 10, 15, 20, 25, 30, 40		
		n40	5, 10, 15, 20, 25, 30, 40, 50, 60, 80, 100		
CA_n28A-n39A-n41A	CA_n28A-n39A CA_n28A-n41A CA_n39A-n41A	n28	5, 10, 15, 20, 30	0	
		n39	5, 10, 15, 20, 25, 30, 40		
		n41	10, 15, 20, 30, 40, 50, 60, 70, 80, 90, 100		
		n28	n28 channel bandwidths in Table 5.3.5-1	4 and 5	
		n39	n39 channel bandwidths in Table 5.3.5-1		
n41	n41 channel bandwidths in Table 5.3.5-1				
CA_n28A-n39A-n41C	CA_n28A-n39A CA_n28A-n41A CA_n39A-n41A	n28	5, 10, 15, 20, 30	0	
		n39	5, 10, 15, 20, 25, 30, 40		
		n41	CA_n41C_BCS1		
		n28	n28 channel bandwidths in Table 5.3.5-1	4 and 5	
		n39	n39 channel bandwidths in Table 5.3.5-1		
n41	CA_n41C_BCS 4 and 5				
CA_n28A-n39A-n79A	CA_n28A-n39A CA_n28A-n79A CA_n39A-n79A	n28	5, 10, 15, 20, 30	0	
		n39	5, 10, 15, 20, 25, 30, 40		
		n79	40, 50, 60, 80, 100		
CA_n28A-n40A-n41A	CA_n28A-n40A CA_n28A-n41A CA_n40A-n41A	n28	5, 10, 15, 20, 30	0	
		n40	5, 10, 15, 20, 25, 30, 40, 50, 60, 80, 90, 100		
		n41	10, 15, 20, 30, 40, 50, 60, 70, 80, 90, 100		
CA_n28A-n40A-n41C	CA_n28A-n40A CA_n28A-n41A CA_n40A-n41A	n28	5, 10, 15, 20, 30	0	
		n40	5, 10, 15, 20, 25, 30, 40, 50, 60, 80, 90, 100		
		n41	CA_n41C_BCS0		
CA_n28A-n40A-n78A	CA_n28A-n40A CA_n28A-n78A CA_n40A-n78A	n28	5, 10, 15, 20	0	
		n40	5, 10, 15, 20, 25, 30, 40, 50		
		n78	10, 15, 20, 40, 50, 60, 80, 90, 100		
	CA_n28A-n40A CA_n28A-n78A CA_n40A-n78A	CA_n28A-n40A CA_n28A-n78A CA_n40A-n78A	n28	5, 10, 15, 20	1
			n40	5, 10, 15, 20, 25, 30, 40, 50, 60, 80, 100	
			n78	10, 15, 20, 40, 50, 60, 80, 90, 100	
		n28	n28 channel bandwidths in Table 5.3.5-1	4 and 5	
		n40	n40 channel bandwidths in Table 5.3.5-1		
		n78	n78 channel bandwidths in Table 5.3.5-1		
CA_n28A-n40A-n77A	CA_n28A-n40A CA_n28A-n77A CA_n40A-n77A	n28	5, 10, 15, 20, 25, 30	0	

		n40	10, 15, 20, 25, 30, 40, 50, 60, 70, 80, 90, 100	
		n77	10, 15, 20, 25, 30, 40, 50, 60, 70, 80, 90, 100	
CA_n28A-n40A-n77(2A)	CA_n28A-n40A CA_n28A-n77A CA_n40A-n77A	n28	5, 10, 15, 20, 25, 30	0
		n40	10, 15, 20, 25, 30, 40, 50, 60, 70, 80, 90, 100	
		n77	CA_n77(2A)_BCS1	
CA_n28A-n40B-n78A	-	n28	5, 10, 15, 20	0
		n40	CA_n40B_BCS0	
		n78	10, 15, 20, 40, 50, 60, 80, 90, 100	
		n28	n28 channel bandwidths in Table 5.3.5-1	4 and 5
		n40	CA_n40B_BCS4 and 5	
		n78	n78 channel bandwidths in Table 5.3.5-1	
CA_n28A-n40A-n79A	CA_n28A-n40A CA_n28A-n79A CA_n40A-n79A	n28	5, 10, 15, 20, 30	0
		n40	10, 15, 20, 25, 30, 40, 50, 60, 80, 90, 100	
		n79	40, 50, 60, 80, 100	
CA_n28A-n41A-n77A	n41 <sup>7,9</sup> n77 <sup>7,9</sup> CA_n28A-n41A <sup>7</sup> CA_n28A-n77A CA_n41A-n77A	n28	5, 10, 15, 20, 30	0
		n41	10, 15, 20, 30, 40, 50, 60, 80, 90, 100	
		n77	10, 15, 20, 30, 40, 50, 60, 70, 80, 90, 100	
CA_n28A-n41B-n77A	CA_n28A-n41A CA_n28A-n77A CA_n41A-n77A	n28	5, 10	0
		n41	CA_n41B_BCS0	
		n77	10, 15, 20, 30, 40, 50, 60, 70, 80, 90, 100	
CA_n28A-n41A-n77(2A)	n41 <sup>7,9</sup> n77 <sup>7,9</sup> CA_n28A-n41A <sup>7</sup> CA_n28A-n77A <sup>7</sup> CA_n41A-n77A <sup>7</sup> CA_n77(2A) <sup>7</sup>	n28	5, 10, 15, 20, 30	0
		n41	10, 15, 20, 30, 40, 50, 60, 80, 90, 100	
		n77	CA_n77(2A)_BCS0	
CA_n28A-n41A-n77(3A)	CA_n28A-n41A CA_n28A-n77A CA_n41A-n77A	n28	5, 10	0
		n41	10, 15, 20, 30, 40, 50, 60, 80, 90, 100	
		n77	CA_n77(3A)_BCS1	
CA_n28A-n41A-n78A	CA_n28A-n41A CA_n41A-n78A CA_n28A-n78A	n28	5, 10, 15, 20	0
		n41	10, 15, 20, 30, 40, 50, 60, 90, 100	
		n78	10, 15, 20, 25, 30, 40, 50, 60, 80, 90, 100	
CA_n28A-n41A-n78(2A)	CA_n78(2A)	n28	5, 10, 15, 20, 30	0
		n41	10, 15, 20, 30, 40, 50, 60, 80, 90, 100	
		n78	CA_n78(2A)_BCS2	
CA_n28A-n41A-n79A	CA_n28A-n41A CA_n28A-n79A CA_n41A-n79A	n28	5, 10, 15, 20, 30	0

		n41	10, 15, 20, 30, 40, 50, 60, 70, 80, 90, 100	
		n79	40, 50, 60, 80, 100	
		n28	n28 channel bandwidths in Table 5.3.5-1	4 and 5
		n41	n41 channel bandwidths in Table 5.3.5-1	
		n79	n79 channel bandwidths in Table 5.3.5-1	
CA_n28A-n41A-n79C	-	n28	5, 10, 15, 20, 30	0
		n41	10, 15, 20, 30, 40, 50, 60, 70, 80, 90, 100	
		n79	CA_n79C_BCS0	
		n28	n28 channel bandwidths in Table 5.3.5-1	4 and 5
		n41	n41 channel bandwidths in Table 5.3.5-1	
		n79	CA_n79C_BCS 4 and 5	
CA_n28A-n41C-n79A	CA_n28A-n41A CA_n28A-n79A CA_n41A-n79A	n28	5, 10, 15, 20, 30	0
		n41	CA_n41C_BCS1	
		n79	40, 50, 60, 80, 100	
		n28	n28 channel bandwidths in Table 5.3.5-1	4 and 5
		n41	CA_n41C_BCS 4 and 5	
		n79	n79 channel bandwidths in Table 5.3.5-1	
CA_n28A-n41C-n79C	-	n28	5, 10, 15, 20, 30	0
		n41	CA_n41C_BCS1	
		n79	CA_n79C_BCS0	
		n28	n28 channel bandwidths in Table 5.3.5-1	4 and 5
		n41	CA_n41C_BCS 4 and 5	
		n79	CA_n79C_BCS 4 and 5	
CA_n28A-n46A-n78A	CA_n28A-n46A CA_n28A-n78A CA_n46A-n78A	n28	5, 10, 15, 20	0
		n46	20, 40, 60, 80	
		n78	10, 15, 20, 25, 30, 40, 50, 60, 70, 80, 90, 100	
CA_n28A-n46C-n78A	CA_n28A-n46A CA_n28A-n78A CA_n46A-n78A	n28	5, 10, 15, 20	0
		n46	CA_n46C_BCS0	
		n78	10, 15, 20, 25, 30, 40, 50, 60, 70, 80, 90, 100	
CA_n28A-n46D-n78A	CA_n28A-n46A CA_n28A-n78A CA_n46A-n78A	n28	5, 10, 15, 20	0
		n46	CA_n46D_BCS0	
		n78	10, 15, 20, 25, 30, 40, 50, 60, 70, 80, 90, 100	
CA_n28A-n46(2A)-n78A	CA_n28A-n46A CA_n28A-n78A CA_n46A-n78A	n28	5, 10, 15, 20	0
		n46	CA_n46(2A)_BCS0	
		n78	10, 15, 20, 25, 30, 40, 50, 60, 70, 80, 90, 100	
CA_n28A-n46(2A)-n78(2A)	CA_n28A-n46A CA_n28A-n78A CA_n46A-n78A CA_n78(2A)	n28	5, 10, 15, 20	0
		n46	CA_n46(2A)_BCS0	
		n78	CA_n78(2A)_BCS2	
CA_n28A-n46A-n78(2A)	CA_n28A-n46A CA_n28A-n78A	n28	5, 10, 15, 20	0

	CA_n46A-n78A CA_n78(2A)	n46 n78	20, 40, 60, 80 CA_n78(2A)_BCS2	
CA_n28A-n46C-n78(2A)	CA_n28A-n46A CA_n28A-n78A CA_n46A-n78A CA_n78(2A)	n28 n46 n78	5, 10, 15, 20 CA_n46C_BCS0 CA_n78(2A)_BCS2	0
CA_n28A-n46D-n78(2A)	CA_n28A-n46A CA_n28A-n78A CA_n46A-n78A CA_n78(2A)	n28 n46 n78	5, 10, 15, 20 CA_n46D_BCS0 CA_n78(2A)_BCS2	0
CA_n28A-n75A-n78A	-	n28 n75 n78	5, 10, 15, 20 5, 10, 15, 20 10, 15, 20, 40, 50, 60, 80, 90, 100	0
CA_n28A-n77A-n79A <sup>4</sup>	n77 <sup>7,9</sup> n79 <sup>7,9</sup> CA_n28A-n77A <sup>7</sup> CA_n28A-n79A <sup>7</sup> CA_n77A-n79A <sup>7</sup>	n28 n77 n79	5, 10, 15, 20 10, 15, 20, 40, 50, 60, 80, 90, 100 40, 50, 60, 80, 100	0
CA_n28A-n77(2A)-n79A <sup>4</sup>	n77 <sup>7,9</sup> n79 <sup>7,9</sup> CA_n28A-n77A <sup>7</sup> CA_n28A-n79A <sup>7</sup> CA_n77A-n79A <sup>7</sup>	n28 n77 n79	5, 10, 15, 20 CA_n77(2A)_BCS1 40, 50, 60, 80, 100	0
CA_n28A-n77(3A)-n79A <sup>4</sup>	CA_n28A-n77A CA_n28A-n79A CA_n77A-n79A	n28 n77 n79	5, 10, 15, 20 CA_n77(3A)_BCS0 40, 50, 60, 80, 100	0
CA_n28A-n78A-n79A	n78 <sup>7,9</sup> n79 <sup>7,9</sup> CA_n28A-n78A CA_n28A-n79A CA_n78A-n79A	n28 n78 n79	5, 10, 15, 20 10, 15, 20, 25, 30, 40, 50, 60, 80, 90, 100 40, 50, 60, 80, 100	0
CA_n28A-n78A-n102A	CA_n28A-n78A CA_n28A-n102A CA_n78A-n102A	n28 n78 n102	5, 10, 15, 20 10, 15, 20, 25, 30, 40, 50, 60, 70, 80, 90, 100 20, 40, 60, 80, 100	0
CA_n28A-n78A-n102B	CA_n28A-n78A CA_n28A-n102A CA_n28A-n102B CA_n78A-n102A CA_n78A-n102B	n28 n78 n102	5, 10, 15, 20 10, 15, 20, 25, 30, 40, 50, 60, 70, 80, 90, 100 CA_n102B_BCS0	0
CA_n28A-n78A-n102C	CA_n28A-n78A CA_n28A-n102A CA_n28A-n102C CA_n78A-n102A CA_n78A-n102C	n28	5, 10, 15, 20	0

		n78	10, 15, 20, 25, 30, 40, 50, 60, 70, 80, 90, 100	
		n102	CA_n102C_BCS0	
CA_n28A-n78A-n102D	CA_n28A-n78A CA_n28A-n102A CA_n78A-n102A	n28	5, 10, 15, 20	0
		n78	10, 15, 20, 25, 30, 40, 50, 60, 70, 80, 90, 100	
		n102	CA_n102D_BCS0	
		n28	5, 10, 15, 20	
CA_n28A-n78A-n102E	CA_n28A-n78A CA_n28A-n102A CA_n78A-n102A	n28	5, 10, 15, 20	0
		n78	10, 15, 20, 25, 30, 40, 50, 60, 70, 80, 90, 100	
		n102	CA_n102E_BCS0	
		n28	5, 10, 15, 20	
CA_n28A-n78A-n102(2A)	CA_n28A-n78A CA_n28A-n102A CA_n78A-n102A	n28	5, 10, 15, 20	0
		n78	10, 15, 20, 25, 30, 40, 50, 60, 70, 80, 90, 100	
		n102	CA_n102(2A)_BCS0	
		n28	5, 10, 15, 20	
CA_n28A-n78(2A)-n102A	CA_n28A-n78A CA_n28A-n102A CA_n78A-n102A CA_n78(2A)	n28	5, 10, 15, 20	0
		n78	CA_n78(2A)_BCS2	
		n102	20, 40, 60, 80, 100	
		n28	5, 10, 15, 20	
CA_n28A-n78(2A)-n102B	CA_n28A-n78A CA_n28A-n102A CA_n28A-n102B CA_n78A-n102A CA_n78A-n102B CA_n78(2A)	n28	5, 10, 15, 20	0
		n78	CA_n78(2A)_BCS2	
		n102	CA_n102B_BCS0	
		n28	5, 10, 15, 20	
CA_n28A-n78(2A)-n102C	CA_n28A-n78A CA_n28A-n102A CA_n28A-n102C CA_n78A-n102A CA_n78A-n102C CA_n78(2A)	n28	5, 10, 15, 20	0
		n78	CA_n78(2A)_BCS2	
		n102	CA_n102C_BCS0	
		n28	5, 10, 15, 20	
CA_n28A-n78(2A)-n102D	CA_n28A-n78A CA_n28A-n102A CA_n78A-n102A CA_n78(2A)	n28	5, 10, 15, 20	0
		n78	CA_n78(2A)_BCS2	
		n102	CA_n102D_BCS0	
		n28	5, 10, 15, 20	
CA_n28A-n78(2A)-n102E	CA_n28A-n78A CA_n28A-n102A CA_n78A-n102A CA_n78(2A)	n28	5, 10, 15, 20	0
		n78	CA_n78(2A)_BCS2	
		n102	CA_n102E_BCS0	
		n28	5, 10, 15, 20	
CA_n28A-n78(2A)-n102(2A)	CA_n28A-n78A CA_n28A-n102A CA_n78A-n102A CA_n78(2A)	n28	5, 10, 15, 20	0
		n78	CA_n78(2A)_BCS2	
		n102	CA_n102(2A)_BCS0	
		n29	5, 10	
CA_n29A-n30A-n66A	CA_n30A-n66A	n30	5, 10	0
		n66	5, 10, 15, 20, 25, 30, 40	
		n29	5, 10	
CA_n29A-n30A-n66(2A)	CA_n30A-n66A	n30	5, 10	0
		n30	5, 10	

CA_n29A-n30A-n77A	n77 <sup>7,9</sup> CA_n30A-n77A <sup>7</sup>	n66	CA_n66(2A)_BCS1	0
		n29	5, 10	
		n30	5, 10	
		n77	10, 15, 20, 25, 30, 40, 50, 60, 70, 80, 90, 100	
CA_n29A-n30A-n77(2A)	n77 <sup>7,9</sup> CA_n30A-n77A <sup>7</sup>	n29	5, 10	0
		n30	5, 10	
		n77	CA_n77(2A)_BCS1	
CA_n29A-n66A-n70A	-	n29	5, 10	0
		n66	5, 10, 15, 20, 40	
		n70	5, 10, 15, 20 <sup>1</sup> , 25 <sup>1</sup>	
		n77	CA_n77(2A)_BCS1	
CA_n29A-n66B-n70A	-	n29	5, 10	0
		n66	CA_n66B_BCS0	
		n70	5, 10, 15, 20 <sup>1</sup> , 25 <sup>1</sup>	
CA_n29A-n66(2A)-n70A	-	n29	5, 10	0
		n66	CA_n66(2A)_BCS0	
		n70	5, 10, 15, 20 <sup>1</sup> , 25 <sup>1</sup>	
CA_n29A-n66(3A)-n70A	-	n29	5, 10	0
		n66	CA_n66(3A)_BCS0	
		n70	5, 10, 15, 20 <sup>1</sup> , 25 <sup>1</sup>	
CA_n29A-n66A-n71A	CA_n66A-n71A	n29	5, 10	0
		n66	5, 10, 15, 20, 25, 30, 40	
		n71	5, 10, 15, 20	
CA_n29A-n66(2A)-n71A	CA_n66A-n71A	n29	5, 10	0
		n66	CA_n66(2A)_BCS1	
		n71	5, 10, 15, 20	
CA_n29A-n66(3A)-n71A	CA_n66A-n71A	n29	5, 10	0
		n66	CA_n66(3A)_BCS0	
		n71	5, 10, 15, 20	
CA_n29A-n66A-n77A	n77 <sup>7,9</sup> CA_n66A-n77A <sup>7</sup>	n29	5, 10	0
		n66	5, 10, 15, 20, 25, 30, 40	
		n77	10, 15, 20, 25, 30, 40, 50, 60, 70, 80, 90, 100	
CA_n29A-n66(2A)-n77A	n77 <sup>7,9</sup> CA_n66A-n77A <sup>7</sup>	n29	5, 10	0
		n66	CA_n66(2A)_BCS1	
		n77	10, 15, 20, 25, 30, 40, 50, 60, 70, 80, 90, 100	
CA_n29A-n66A-n77(2A)	n77 <sup>7,9</sup> CA_n66A-n77A <sup>7</sup>	n29	5, 10	0
		n66	5, 10, 15, 20, 25, 30, 40	
		n77	CA_n77(2A)_BCS1	
CA_n29A-n66(3A)-n77A	n77 <sup>7,9</sup> CA_n66A-n77A <sup>7</sup>	n29	5, 10	0
		n66	CA_n66(3A)_BCS0	
		n77	10, 15, 20, 25, 30, 40, 50, 60, 70, 80, 90, 100	
CA_n29A-n66(2A)-n77(2A)	n77 <sup>7,9</sup> CA_n66A-n77A <sup>7</sup>	n29	5, 10	0
		n66	CA_n66(2A)_BCS1	
		n77	CA_n77(2A)_BCS1	
CA_n29A-n66(3A)-n77(2A)	n77 <sup>7</sup> CA_n66A-n77A <sup>7</sup>	n29	5, 10	0
		n66	CA_n66(3A)_BCS0	
		n77	CA_n77(2A)_BCS1	
CA_n29A-n70A-n71A	CA_n70A-n71A	n29	5, 10	0
		n70	5, 10, 15, 20 <sup>1</sup> , 25 <sup>1</sup>	
		n71	5, 10, 15, 20	
CA_n30A-n66A-n77A	n77 <sup>7,9</sup>	n30	5, 10	0

	CA_n30A-n66A CA_n30A-n77A <sup>7</sup> CA_n66A-n77A <sup>7</sup>			
		n66	5, 10, 15, 20, 25, 30, 40	
		n77	10, 15, 20, 25, 30, 40, 50, 60, 70, 80, 90, 100	
CA_n30A-n66(2A)-n77A	n77 <sup>7,9</sup> CA_n30A-n66A CA_n30A-n77A <sup>7</sup> CA_n66A-n77A <sup>7</sup>	n30	5, 10	0
		n66	CA_n66(2A)_BCS1	
		n77	10, 15, 20, 25, 30, 40, 50, 60, 70, 80, 90, 100	
CA_n30A-n66A-n77(2A)	n77 <sup>7,9</sup> CA_n30A-n66A CA_n30A-n77A <sup>7</sup> CA_n66A-n77A <sup>7</sup>	n30	5, 10	0
		n66	5, 10, 15, 20, 25, 30, 40	
		n77	CA_n77(2A)_BCS1	
CA_n30A-n66(2A)-n77(2A)	n77 <sup>7,9</sup> CA_n30A-n66A CA_n30A-n77A <sup>7</sup> CA_n66A-n77A <sup>7</sup>	n30	5, 10	0
		n66	CA_n66(2A)_BCS1	
		n77	CA_n77(2A)_BCS1	
CA_n30A-n66(3A)-n77A	n77 <sup>7,9</sup> CA_n30A-n66A CA_n30A-n77A <sup>7</sup> CA_n66A-n77A <sup>7</sup>	n30	5, 10	0
		n66	CA_n66(3A)_BCS0	
		n77	10, 15, 20, 25, 30, 40, 50, 60, 70, 80, 90, 100	
CA_n30A-n66(3A)-n77(2A)	n77 <sup>7</sup> CA_n30A-n66A CA_n30A-n77A <sup>7</sup> CA_n66A-n77A <sup>7</sup>	n30	5, 10	0
		n66	CA_n66(3A)_BCS0	
		n77	CA_n77(2A)_BCS1	
CA_n34A-n39A-n40A	CA_n34A-n39A CA_n34A-n40A CA_n39A-n40A	n34	5, 10, 15	0
		n39	5, 10, 15, 20, 25, 30, 40	
		n40	5, 10, 15, 20, 25, 30, 40, 50, 60, 80, 100	
		n34	See n34 channel bandwidths in Table 5.3.5-1	4 and 5
		n39	See n39 channel bandwidths in Table 5.3.5-1	
		n40	See n40 channel bandwidths in Table 5.3.5-1	
CA_n34A-n39A-n41A	CA_n34A-n39A CA_n34A-n41A CA_n39A-n41A	n34	See n34 channel bandwidths in Table 5.3.5-1	4 and 5
		n39	See n39 channel bandwidths in Table 5.3.5-1	
		n41	See n41 channel bandwidths in Table 5.3.5-1	
CA_n34A-n39A-n41C	CA_n34A-n39A CA_n34A-n41A CA_n39A-n41A	n34	See n34 channel bandwidths in Table 5.3.5-1	4 and 5
		n39	See n39 channel bandwidths in Table 5.3.5-1	
		n41	CA_n41C_BCS 4 and 5	
CA_n34A-n40A-n41A	CA_n34A-n40A CA_n34A-n41A CA_n40A-n41A	n34	See n34 channel bandwidths in Table 5.3.5-1	4 and 5

		n40	See n40 channel bandwidths in Table 5.3.5-1	
		n41	See n41 channel bandwidths in Table 5.3.5-1	
CA_n34A-n40A-n41C	CA_n34A-n40A CA_n34A-n41A CA_n40A-n41A	n34	See n34 channel bandwidths in Table 5.3.5-1	4 and 5
		n40	See n40 channel bandwidths in Table 5.3.5-1	
		n41	CA_n41C_BCS 4 and 5	
CA_n34A-n41A-n79A	CA_n34A-n41A CA_n34A-n79A CA_n41A-n79A	n34	See n34 channel bandwidths in Table 5.3.5-1	4 and 5
		n41	See n41 channel bandwidths in Table 5.3.5-1	
		n79	See n79 channel bandwidths in Table 5.3.5-1	
CA_n34A-n41A-n79C	CA_n34A-n41A CA_n34A-n79A CA_n41A-n79A	n34	See n34 channel bandwidths in Table 5.3.5-1	4 and 5
		n41	See n41 channel bandwidths in Table 5.3.5-1	
		n79	CA_n79C_BCS 4 and 5	
CA_n34A-n41C-n79A	CA_n34A-n41A CA_n34A-n79A CA_n41A-n79A	n34	See n34 channel bandwidths in Table 5.3.5-1	4 and 5
		n41	CA_n41C_BCS 4 and 5	
		n79	See n79 channel bandwidths in Table 5.3.5-1	
CA_n34A-n41C-n79C	CA_n34A-n41A CA_n34A-n79A CA_n41A-n79A	n34	See n34 channel bandwidths in Table 5.3.5-1	4 and 5
		n41	CA_n41C_BCS 4 and 5	
		n79	CA_n79C_BCS 4 and 5	
CA_n38A-n66A-n78A	CA_n38A-n66A CA_n38A-n78A CA_n66A-n78A	n38	5, 10, 15, 20, 25, 30, 40	0
		n66	5, 10, 15, 20, 25, 30, 40	
		n78	10, 15, 20, 25, 30, 40, 50, 60, 70, 80, 90, 100	
CA_n38A-n66A-n78(2A)	CA_n38A-n66A CA_n38A-n78A CA_n66A-n78A	n38	5, 10, 15, 20, 25, 30, 40	0
		n66	5, 10, 15, 20, 25, 30, 40	
		n78	CA_n78(2A)_BCS2	
CA_n38A-n66(2A)-n78A	CA_n38A-n66A CA_n38A-n78A CA_n66A-n78A	n38	5, 10, 15, 20, 25, 30, 40	0
		n66	CA_n66(2A)_BCS1	
		n78	10, 15, 20, 25, 30, 40, 50, 60, 70, 80, 90, 100	
CA_n38A-n66(2A)-n78(2A)	CA_n38A-n66A CA_n38A-n78A CA_n66A-n78A	n38	5, 10, 15, 20, 25, 30, 40	0
		n66	CA_n66(2A)_BCS1	
		n78	CA_n78(2A)_BCS2	
CA_n39A-n40A-n41A	CA_n39A-n40A CA_n39A-n41A CA_n40A-n41A	n39	5, 10, 15, 20, 25, 30, 40	0
		n40	5, 10, 15, 20, 25, 30, 40, 50, 60, 80	
		n41	10, 15, 20, 40, 50, 60, 80, 90, 100	
		n39	See n39 channel bandwidths in Table 5.3.5-1	



		n40	See n40 channel bandwidths in Table 5.3.5-1	
		n41	See n41 channel bandwidths in Table 5.3.5-1	
CA_n39A-n40A-n41C	CA_n39A-n40A CA_n39A-n41A CA_n40A-n41A	n39	See n39 channel bandwidths in Table 5.3.5-1	4 and 5
		n40	See n40 channel bandwidths in Table 5.3.5-1	
		n41	CA_n41C_BCS 4 and 5	
CA_n39A-n40A-n79A	CA_n39A-n40A CA_n40A-n79A CA_n39A-n79A	n39	5, 10, 15, 20, 25, 30, 40	0
		n40	5, 10, 15, 20, 25, 30, 40, 50, 60, 80	
		n79	40, 50, 60, 80, 100	
		n39	See n39 channel bandwidths in Table 5.3.5-1	4 and 5
		n40	See n40 channel bandwidths in Table 5.3.5-1	
		n79	See n79 channel bandwidths in Table 5.3.5-1	
CA_n39A-n41A-n79C	CA_n39A-n41A CA_n39A-n79A CA_n41A-n79A	n39	See n39 channel bandwidths in Table 5.3.5-1	4 and 5
		n41	See n41 channel bandwidths in Table 5.3.5-1	
		n79	CA_n79C_BCS 4 and 5	
CA_n39A-n41A-n79A	CA_n39A-n41A CA_n39A-n79A CA_n41A-n79A	n39	5, 10, 15, 20, 25, 30, 40	0
		n41	10, 15, 20, 40, 50, 60, 80, 90, 100	
		n79	40, 50, 60, 80, 100	
		n39	5, 10, 15, 20, 25, 30, 40	1
		n41	10, 15, 20, 40, 50, 60	
		n79	40, 50, 60, 80, 100	
CA_n40A-n41A-n79A	CA_n40A-n41A CA_n40A-n79A CA_n41A-n79A	n40	5, 10, 15, 20, 25, 30, 40, 50, 60, 80	0
		n41	10, 15, 20, 40, 50, 60, 80, 100	
		n79	, 40, 50, 60, 80, 100	
		n40	5, 10, 15, 20, 25, 30, 40	1
		n41	10, 15, 20, 40, 50, 60	
		n79	, 40, 50, 60, 80, 100	
		n40	See n40 channel bandwidths in Table 5.3.5-1	4 and 5
		n41	See n41 channel bandwidths in Table 5.3.5-1	
n79	See n79 channel bandwidths in Table 5.3.5-1			
CA_n40A-n41C-n79A	CA_n41C CA_n41A-n79A CA_n40A-n41A CA_n40A-n79A	n40	See n40 channel bandwidths in Table 5.3.5-1	4 and 5
		n41	CA_n41C_BCS4 and 5	
		n79	See n79 channel bandwidths in Table 5.3.5-1	
CA_n40A-n78A-n105A	CA_n40A-n78A CA_n40A-n105A CA_n78A-n105A	n40	10, 15, 20, 25, 30, 40, 50, 60, 70, 80, 90, 100	0
		n78	10, 15, 20, 25, 30, 40, 50, 60, 70, 80, 90, 100	
		n105	5, 10, 15, 20, 25, 30, 35	
CA_n41A-n66A-n70A	CA_n41A-n66A CA_n41A-n70A	n41	10, 15, 20, 30, 40, 50, 60, 70, 80, 90, 100	0
		n66	10, 15, 20, 25, 30, 40	

		n70	5, 10, 15, 20 <sup>1</sup> , 25 <sup>1</sup>	
CA_n41A-n66A-n71A	n417,9 CA_n41A-n71A <sup>7</sup> CA_n41A-n66A <sup>7</sup> CA_n66A-n71A	n41	10, 15, 20, 30, 40, 50, 60, 80, 90, 100	0
		n66	5, 10, 15, 20, 40	
		n71	5, 10, 15, 20	
		n41	10, 15, 20, 30, 40, 50, 60, 70, 80, 90, 100	1
		n66	5, 10, 15, 20, 25, 30, 40	
		n71	5, 10, 15, 20	
		n41	n41 channel bandwidths in Table 5.3.5-1	4 and 5
		n66	n66 channel bandwidths in Table 5.3.5-1	
n71	n71 channel bandwidths in Table 5.3.5-1			
CA_n41A-n66A-n71B	n417,9 CA_n41A-n66A <sup>7</sup> CA_n41A-n71A <sup>7</sup> CA_n66A-n71A	n41	10, 15, 20, 30, 40, 50, 60, 70, 80, 90, 100	0
		n66	5, 10, 15, 20, 25, 30, 40	
		n71	CA_n71B_BCS2	
		n41	n41 channel bandwidths in Table 5.3.5-1	4 and 5
		n66	n66 channel bandwidths in Table 5.3.5-1	
n71	CA_n71B BCS 4 and 5			
CA_n41A-n66A-n71(2A)	n417,9 CA_n41A-n66A <sup>7</sup> CA_n41A-n71A <sup>7</sup> CA_n66A-n71A	n41	10, 15, 20, 30, 40, 50, 60, 70, 80, 90, 100	0
		n66	5, 10, 15, 20, 25, 30, 40	
		n71	CA_n71(2A)_BCS0	
		n41	n41 channel bandwidths in Table 5.3.5-1	4 and 5
		n66	n66 channel bandwidths in Table 5.3.5-1	
n71	CA_n71(2A) BCS 4 and 5			
CA_n41A-n66(2A)-n71A	n417,9 CA_n41A-n66A <sup>7</sup> CA_n66A-n71A CA_n41A-n71A <sup>7</sup>	n41	10, 15, 20, 30, 40, 50, 60, 70, 80, 90, 100	0
		n66	CA_n66(2A)_BCS1	
		n71	5, 10, 15, 20	
		n41	n41 channel bandwidths in Table 5.3.5-1	4 and 5
		n66	CA_n66(2A) BCS 4 and 5	
n71	n71 channel bandwidths in Table 5.3.5-1			
CA_n41A-n66(2A)-n71B	n417,9 CA_n41A-n66A <sup>7</sup> CA_n66A-n71A CA_n41A-n71A <sup>7</sup>	n41	n41 channel bandwidths in Table 5.3.5-1	4 and 5
		n66	CA_n66(2A)_BCS 4 and 5	
		n71	CA_n71B_BCS 4 and 5	
CA_n41A-n66(2A)-n71(2A)	n417,9 CA_n41A-n66A <sup>7</sup> CA_n66A-n71A CA_n41A-n71A <sup>7</sup>	n41	n41 channel bandwidths in Table 5.3.5-1	4 and 5
		n66	CA_n66(2A)_BCS 4 and 5	
		n71	CA_n71(2A)_BCS 4 and 5	
CA_n41(2A)-n66A-n71A	n417,9 CA_n41A-n71A <sup>7</sup> CA_n41A-n66A <sup>7</sup> CA_n66A-n71A	n41	CA_n41(2A)_BCS1	0
		n66	5, 10, 15, 20, 40	

		n71	5, 10, 15, 20	
		n41	CA_n41(2A)_BCS1	1
		n66	5, 10, 15, 20, 25, 30, 40	
		n71	5, 10, 15, 20	
		n41	CA_n41(2A) BCS 4 and 5	4 and 5
		n66	n66 channel bandwidths in Table 5.3.5-1	
		n71	n71 channel bandwidths in Table 5.3.5-1	
CA_n41(2A)-n66A-n71B	n41 <sup>7,9</sup> CA_n41A-n66A <sup>7</sup> CA_n41A-n71A <sup>7</sup> CA_n66A-n71A	n41	CA_n41(2A) BCS 4 and 5	4 and 5
		n66	n66 channel bandwidths in Table 5.3.5-1	
		n71	CA_n71B BCS 4 and 5	
CA_n41(2A)-n66A-n71(2A)	n41 <sup>7,9</sup> CA_n41A-n66A <sup>7</sup> CA_n41A-n71A <sup>7</sup> CA_n66A-n71A	n41	CA_n41(2A) BCS 4 and 5	4 and 5
		n66	n66 channel bandwidths in Table 5.3.5-1	
		n71	CA_n71(2A) BCS 4 and 5	
CA_n41(2A)-n66(2A)-n71A	n41 <sup>7,9</sup> CA_n41A-n71A <sup>7</sup> CA_n41A-n66A <sup>7</sup> CA_n66A-n71A	n41	CA_n41(2A) BCS 4 and 5	4 and 5
		n66	CA_n66(2A) BCS 4 and 5	
		n71	n71 channel bandwidths in Table 5.3.5-1	
CA_n41(2A)-n66(2A)-n71(2A)	n41 <sup>7,9</sup> CA_n41A-n71A <sup>7</sup> CA_n41A-n66A <sup>7</sup> CA_n66A-n71A	n41	CA_n41(2A) BCS 4 and 5	4 and 5
		n66	CA_n66(2A) BCS 4 and 5	
		n71	CA_n71(2A) BCS 4 and 5	
CA_n41(2A)-n66(2A)-n71B	n41 <sup>7,9</sup> CA_n41A-n71A <sup>7</sup> CA_n41A-n66A <sup>7</sup> CA_n66A-n71A	n41	CA_n41(2A) BCS 4 and 5	4 and 5
		n66	CA_n66(2A) BCS 4 and 5	
		n71	CA_n71B BCS 4 and 5	
CA_n41(3A)-n66A-n71A	n41 <sup>7,9</sup> CA_n41A-n71A <sup>7</sup> CA_n41A-n66A <sup>7</sup> CA_n66A-n71A	n41	CA_n41(3A) BCS 4 and 5	4 and 5
		n66	n66 channel bandwidths in Table 5.3.5-1	
		n71	n71 channel bandwidths in Table 5.3.5-1	
CA_n41(3A)-n66(2A)-n71A	CA_n41A-n71A CA_n41A-n66A CA_n66A-n71A	n41	CA_n41(3A) BCS 4 and 5	4 and 5
		n66	CA_n66(2A) BCS 4 and 5	
		n71	n71 channel bandwidths in Table 5.3.5-1	
CA_n41(3A)-n66A-n71B	CA_n41A-n71A CA_n41A-n66A CA_n66A-n71A	n41	CA_n41(3A) BCS 4 and 5	4 and 5
		n66	n66 channel bandwidths in Table 5.3.5-1	
		n71	CA_n71B BCS 4 and 5	
CA_n41(3A)-n66A-n71(2A)	CA_n41A-n71A CA_n41A-n66A CA_n66A-n71A	n41	CA_n41(3A) BCS 4 and 5	4 and 5
		n66	n66 channel bandwidths in Table 5.3.5-1	

		n71	CA_n71(2A) BCS 4 and 5	
CA_n41C-n66A-n71A	n417,9 CA_n41A-n71A <sup>7</sup> CA_n41A-n66A <sup>7</sup> CA_n41C <sup>7</sup> CA_n66A-n71A	n41	CA_n41C_BCS0	0
		n66	5, 10, 15, 20, 40	
		n71	5, 10, 15, 20	
		n41	CA_n41C_BCS1	1
		n66	5, 10, 15, 20, 25, 30, 40	
		n71	5, 10, 15, 20	
		n41	CA_n41C BCS 4 and 5	4 and 5
		n66	n66 channel bandwidths in Table 5.3.5-1	
n71	n71 channel bandwidths in Table 5.3.5-1			
CA_n41C-n66A-n71B	n417,9 CA_n41A-n66A <sup>7</sup> CA_n41A-n71A <sup>7</sup> CA_n41C <sup>7</sup> CA_n66A-n71A	n41	CA_n41C BCS 4 and 5	4 and 5
		n66	n66 channel bandwidths in Table 5.3.5-1	
		n71	CA_n71B BCS 4 and 5	
CA_n41C-n66A-n71(2A)	n417,9 CA_n41A-n66A <sup>7</sup> CA_n41A-n71A <sup>7</sup> CA_n41C <sup>7</sup> CA_n66A-n71A	n41	CA_n41C BCS 4 and 5	4 and 5
		n66	n66 channel bandwidths in Table 5.3.5-1	
		n71	CA_n71(2A) BCS 4 and 5	
CA_n41C-n66(2A)-n71A	n417,9 CA_n41A-n71A <sup>7</sup> CA_n41A-n66A <sup>7</sup> CA_n41C <sup>7</sup> CA_n66A-n71A	n41	CA_n41C BCS 4 and 5	4 and 5
		n66	CA_n66(2A) BCS 4 and 5	
		n71	n71 channel bandwidths in Table 5.3.5-1	
CA_n41C-n66(2A)-n71(2A)	n417,9 CA_n41A-n71A <sup>7</sup> CA_n41A-n66A <sup>7</sup> CA_n41C <sup>7</sup> CA_n66A-n71A	n41	CA_n41C BCS 4 and 5	4 and 5
		n66	CA_n66(2A) BCS 4 and 5	
		n71	CA_n71(2A) BCS 4 and 5	
CA_n41C-n66(2A)-n71B	n417,9 CA_n41A-n71A <sup>7</sup> CA_n41A-n66A <sup>7</sup> CA_n41C <sup>7</sup> CA_n66A-n71A	n41	CA_n41C BCS 4 and 5	4 and 5
		n66	CA_n66(2A) BCS 4 and 5	
		n71	CA_n71B BCS 4 and 5	
CA_n41(A-C)-n66A-n71A	n417,9 CA_n41C <sup>7</sup> CA_n41A-n71A <sup>7</sup> CA_n41A-n66A <sup>7</sup> CA_n66A-n71A	n41	CA_n41(A-C) BCS 4 and 5	4 and 5
		n66	n66 channel bandwidths in Table 5.3.5-1	
		n71	n71 channel bandwidths in Table 5.3.5-1	
CA_n41(A-C)-n66A-n71B	CA_n41A-n66A CA_n41A-n71A CA_n41C CA_n66A-n71A	n41	CA_n41(A-C) BCS 4 and 5	4 and 5

		n66	n66 channel bandwidths in Table 5.3.5-1	
		n71	CA_n71B BCS 4 and 5	
CA_n41(A-C)-n66A-n71(2A)	CA_n41A-n71A CA_n41A-n66A CA_n66A-n71A CA_n41C	n41	CA_n41(A-C) BCS 4 and 5	4 and 5
		n66	n66 channel bandwidths in Table 5.3.5-1	
		n71	CA_n71(2A) BCS 4 and 5	
CA_n41(A-C)-n66(2A)-n71A	CA_n41A-n71A CA_n41A-n66A CA_n66A-n71A CA_n41C	n41	CA_n41(A-C) BCS 4 and 5	4 and 5
		n66	CA_n66(2A) BCS 4 and 5	
		n71	n71 channel bandwidths in Table 5.3.5-1	
CA_n41A-n66A-n77A	n41 <sup>7,9</sup> n77 <sup>7,9</sup> CA_n41A-n66A <sup>7</sup> CA_n41A-n77A <sup>7</sup> CA_n66A-n77A <sup>7</sup>	n41	10, 15, 20, 30, 40, 50, 60, 80, 90, 100	0
		n66	5, 10, 15, 20, 25, 30, 40	
		n77	10, 15, 20, 25, 30, 40, 50, 60, 70, 80, 90, 100	
		n41	10, 15, 20, 30, 40, 50, 60, 70, 80, 90, 100	1
		n66	5, 10, 15, 20, 25, 30, 40	
		n77	10, 15, 20, 25, 30, 40, 50, 60, 70, 80, 90, 100	
		n41	n41 channel bandwidths in Table 5.3.5-1	4 and 5
		n66	n66 channel bandwidths in Table 5.3.5-1	
		n77	n77 channel bandwidths in Table 5.3.5-1	
CA_n41A-n66A-n77(2A)	n41 <sup>7,9</sup> n77 <sup>7,9</sup> CA_n41A-n77A <sup>7</sup> CA_n41A-n66A <sup>7</sup> CA_n66A-n77A <sup>7</sup>	n41	10, 15, 20, 30, 40, 50, 60, 80, 90, 100	0
		n66	5, 10, 15, 20, 25, 30, 40	
		n77	CA_n77(2A)_BCS1	
		n41	n41 channel bandwidths in Table 5.3.5-1	4 and 5
		n66	n66 channel bandwidths in Table 5.3.5-1	
CA_n41A-n66(2A)-n77A	n41 <sup>7,9</sup> n77 <sup>7,9</sup> CA_n41A-n66A <sup>7</sup> CA_n41A-n77A <sup>7</sup> CA_n66A-n77A <sup>7</sup>	n41	10, 15, 20, 30, 40, 50, 60, 70, 80, 90, 100	0
		n66	CA_n66(2A)_BCS1	
		n77	10, 15, 20, 25, 30, 40, 50, 60, 70, 80, 90, 100	
		n41	n41 channel bandwidths in Table 5.3.5-1	4 and 5
		n66	CA_n66(2A) BCS 4 and 5	
CA_n41A-n66(2A)-n77(2A)	n41 <sup>7,9</sup> n77 <sup>7,9</sup> CA_n41A-n66A <sup>7</sup> CA_n41A-n77A <sup>7</sup> CA_n66A-n77A <sup>7</sup>	n41	10, 15, 20, 30, 40, 50, 60, 70, 80, 90, 100	0
		n66	CA_n66(2A)_BCS1	

		n77	CA_n77(2A)_BCS1	
		n41	n41 channel bandwidths in Table 5.3.5-1	4 and 5
		n66	CA_n66(2A) BCS 4 and 5	
		n77	CA_n77(2A) BCS 4 and 5	
CA_n41(2A)-n66A-n77A	n41 <sup>7,9</sup> n77 <sup>7,9</sup> CA_n41A-n66A <sup>7</sup> CA_n41A-n77A <sup>7</sup> CA_n66A-n77A <sup>7</sup>	n41	CA_n41(2A)_BCS1	0
		n66	5, 10, 15, 20, 25, 30, 40	
		n77	10, 15, 20, 25, 30, 40, 50, 60, 70, 80, 90, 100	
		n41	CA_n41(2A) BCS 4 and 5	4 and 5
		n66	n66 channel bandwidths in Table 5.3.5-1	
		n77	n77 channel bandwidths in Table 5.3.5-1	
CA_n41(2A)-n66A-n77(2A)	n41 <sup>7,9</sup> n77 <sup>7,9</sup> CA_n41A-n66A <sup>7</sup> CA_n41A-n77A <sup>7</sup> CA_n66A-n77A <sup>7</sup>	n41	CA_n41(2A) BCS 4 and 5	4 and 5
		n66	n66 channel bandwidths in Table 5.3.5-1	
		n77	CA_n77(2A) BCS 4 and 5	
CA_n41(2A)-n66(2A)-n77A	n41 <sup>7,9</sup> n77 <sup>7,9</sup> CA_n41A-n66A <sup>7</sup> CA_n41A-n77A <sup>7</sup> CA_n66A-n77A <sup>7</sup>	n41	CA_n41(2A) BCS 4 and 5	4 and 5
		n66	CA_n66(2A) BCS 4 and 5	
		n77	n77 channel bandwidths in Table 5.3.5-1	
CA_n41(2A)-n66(2A)-n77(2A)	CA_n41A-n66A CA_n41A-n77A CA_n66A-n77A	n41	CA_n41(2A) BCS 4 and 5	4 and 5
		n66	CA_n66(2A) BCS 4 and 5	
		n77	CA_n77(2A) BCS 4 and 5	
CA_n41(3A)-n66A-n77A	n41 <sup>7,9</sup> n77 <sup>7,9</sup> CA_n41A-n66A <sup>7</sup> CA_n41A-n77A <sup>7</sup> CA_n66A-n77A <sup>7</sup>	n41	CA_n41(3A) BCS 4 and 5	4 and 5
		n66	n66 channel bandwidths in Table 5.3.5-1	
		n77	n77 channel bandwidths in Table 5.3.5-1	
CA_n41(3A)-n66(2A)-n77A	CA_n41A-n66A CA_n41A-n77A CA_n66A-n77A	n41	CA_n41(3A) BCS 4 and 5	4 and 5
		n66	CA_n66(2A) BCS 4 and 5	
		n77	n77 channel bandwidths in Table 5.3.5-1	
CA_n41C-n66A-n77A	n41 <sup>7,9</sup> n77 <sup>7,9</sup> CA_n41A-n66A <sup>7</sup> CA_n41A-n77A <sup>7</sup> CA_n41C <sup>7</sup> CA_n66A-n77A <sup>7</sup> CA_n41C-n66A CA_n41C-n77A	n41	CA_n41C_BCS0	0
		n66	5, 10, 15, 20, 25, 30, 40	
		n77	10, 15, 20, 25, 30, 40, 50, 60, 70, 80, 90, 100	
		n41	CA_n41C BCS 4 and 5	4 and 5

		n66	n66 channel bandwidths in Table 5.3.5-1	
		n77	n77 channel bandwidths in Table 5.3.5-1	
CA_n41C-n66A-n77(2A)	n41 <sup>7,9</sup> n77 <sup>7,9</sup> CA_n41A-n66A <sup>7</sup> CA_n41A-n77A <sup>7</sup> CA_n41C <sup>7</sup> CA_n66A-n77A <sup>7</sup>	n41	CA_n41C BCS 4 and 5	4 and 5
		n66	n66 channel bandwidths in Table 5.3.5-1	
		n77	CA_n77(2A) BCS 4 and 5	
CA_n41C-n66(2A)-n77A	n41 <sup>7,9</sup> n77 <sup>7,9</sup> CA_n41A-n66A <sup>7</sup> CA_n41A-n77A <sup>7</sup> CA_n41C <sup>7</sup> CA_n66A-n77A <sup>7</sup>	n41	CA_n41C BCS 4 and 5	4 and 5
		n66	CA_n66(2A) BCS 4 and 5	
		n77	n77 channel bandwidths in Table 5.3.5-1	
CA_n41C-n66(2A)-n77(2A)	CA_n41A-n66A CA_n41A-n77A CA_n41C CA_n66A-n77A	n41	CA_n41C BCS 4 and 5	4 and 5
		n66	CA_n66(2A) BCS 4 and 5	
		n77	CA_n77(2A) BCS 4 and 5	
CA_n41(A-C)-n66A-n77A	n41 <sup>7,9</sup> n77 <sup>7,9</sup> CA_n41A-n66A <sup>7</sup> CA_n41A-n77A <sup>7</sup> CA_n41C <sup>7</sup> CA_n66A-n77A <sup>7</sup>	n41	CA_n41(A-C) BCS 4 and 5	4 and 5
		n66	n66 channel bandwidths in Table 5.3.5-1	
		n77	n77 channel bandwidths in Table 5.3.5-1	
CA_n41(A-C)-n66(2A)-n77A	CA_n41A-n66A CA_n41A-n77A CA_n41C CA_n66A-n77A	n41	CA_n41(A-C) BCS 4 and 5	4 and 5
		n66	CA_n66(2A) BCS 4 and 5	
		n77	n77 channel bandwidths in Table 5.3.5-1	
CA_n41A-n66A-n78A	CA_n41A-n66A CA_n41A-n78A CA_n66A-n78A	n41	10, 15, 20, 30, 40, 50, 60, 70, 80, 90, 100	0
		n66	5, 10, 15, 20, 25, 30, 40	
		n78	10, 15, 20, 25, 30, 40, 50, 60, 70, 80, 90, 100	
CA_n41A-n66A-n78(2A)	CA_n41A-n66A CA_n41A-n78A CA_n66A-n78A	n41	10, 15, 20, 30, 40, 50, 60, 70, 80, 90, 100	0
		n66	5, 10, 15, 20, 25, 30, 40	
		n78	CA_n78(2A)_BCS2	
CA_n41A-n66(2A)-n78A	CA_n41A-n66A CA_n41A-n78A CA_n66A-n78A	n41	10, 15, 20, 30, 40, 50, 60, 70, 80, 90, 100	0
		n66	CA_n66(2A)_BCS1	
		n78	10, 15, 20, 25, 30, 40, 50, 60, 70, 80, 90, 100	
CA_n41A-n66(2A)-n78(2A)	CA_n41A-n66A CA_n41A-n78A CA_n66A-n78A	n41	10, 15, 20, 30, 40, 50, 60, 70, 80, 90, 100	0
		n66	CA_n66(2A)_BCS1	
		n78	CA_n78(2A)_BCS2	

CA_n41A-n66A-n85A	CA_n41A-n66A CA_n41A-n85A CA_n66A-n85A	n41	n41 channel bandwidths in Table 5.3.5-1	4 and 5
		n66	n66 channel bandwidths in Table 5.3.5-1	
		n85	n85 channel bandwidths in Table 5.3.5-1	
CA_n41A-n66(2A)-n85A	CA_n41A-n66A CA_n41A-n85A CA_n66A-n85A	n41	n41 channel bandwidths in Table 5.3.5-1	4 and 5
		n66	CA_n66(2A) BCS 4 and 5	
		n85	n85 channel bandwidths in Table 5.3.5-1	
CA_n41(2A)-n66A-n85A	CA_n41A-n66A CA_n41A-n85A CA_n66A-n85A	n41	CA_n41(2A) BCS 4 and 5	4 and 5
		n66	n66 channel bandwidths in Table 5.3.5-1	
		n85	n85 channel bandwidths in Table 5.3.5-1	
CA_n41C-n66A-n85A	CA_n41A-n66A CA_n41A-n85A CA_n41C CA_n66A-n85A	n41	CA_n41C BCS 4 and 5	4 and 5
		n66	n66 channel bandwidths in Table 5.3.5-1	
		n85	n85 channel bandwidths in Table 5.3.5-1	
CA_n41A-n70A-n78A	CA_n41A-n70A CA_n41A-n78A CA_n70A-n78A	n41	10, 15, 20, 30, 40, 50, 60, 70, 80, 90, 100	0
		n70	5, 10, 15, 20, 25	
		n78	10, 15, 20, 25, 30, 40, 50, 60, 70, 80, 90, 100	
CA_n41A-n71A-n77A	n41 <sup>7,9</sup> n77 <sup>7,9</sup> CA_n41A-n71A <sup>7</sup> CA_n41A-n77A <sup>7</sup> CA_n71A-n77A <sup>7</sup>	n41	10, 15, 20, 30, 40, 50, 60, 80, 90, 100	0
		n71	5, 10, 15, 20	
		n77	10, 15, 20, 25, 30, 40, 50, 60, 70, 80, 90, 100	
		n41	10, 15, 20, 30, 40, 50, 60, 70, 80, 90, 100	1
		n71	5, 10, 15, 20	
		n77	10, 15, 20, 25, 30, 40, 50, 60, 70, 80, 90, 100	
		n41	n41 channel bandwidths in Table 5.3.5-1	4 and 5
		n71	n71 channel bandwidths in Table 5.3.5-1	
		n77	n77 channel bandwidths in Table 5.3.5-1	
CA_n41A-n71B-n77A	n41 <sup>7,9</sup> n77 <sup>7,9</sup> CA_n41A-n71A <sup>7</sup> CA_n41A-n77A <sup>7</sup> CA_n71A-n77A <sup>7</sup>	n41	10, 15, 20, 30, 40, 50, 60, 70, 80, 90, 100	0
		n71	CA_n71B_BCS2	
		n77	10, 15, 20, 25, 30, 40, 50, 60, 70, 80, 90, 100	
		n41	n41 channel bandwidths in Table 5.3.5-1	4 and 5
		n71	CA_n71B BCS 4 and 5	
n77	n77 channel bandwidths in Table 5.3.5-1			



CA_n41A-n71B-n77(2A)	n41 <sup>7,9</sup> n77 <sup>7,9</sup> CA_n41A-n71A <sup>7</sup> CA_n41A-n77A <sup>7</sup> CA_n71A-n77A <sup>7</sup>	n41	n41 channel bandwidths in Table 5.3.5-1	4 and 5
		n71	CA_n71B_BCS 4 and 5	
		n77	CA_n77(2A)_BCS 4 and 5	
CA_n41A-n71(2A)-n77A	n41 <sup>7,9</sup> n77 <sup>7,9</sup> CA_n41A-n71A <sup>7</sup> CA_n41A-n77A <sup>7</sup> CA_n71A-n77A <sup>7</sup>	n41	10, 15, 20, 30, 40, 50, 60, 70, 80, 90, 100	0
		n71	CA_n71(2A)_BCS0	
		n77	10, 15, 20, 25, 30, 40, 50, 60, 70, 80, 90, 100	
		n41	n41 channel bandwidths in Table 5.3.5-1	4 and 5
		n71	CA_n71(2A) BCS 4 and 5	
		n77	n77 channel bandwidths in Table 5.3.5-1	
CA_n41A-n71A-n77(2A)	n41 <sup>7,9</sup> n77 <sup>7,9</sup> CA_n41A-n71A <sup>7</sup> CA_n41A-n77A <sup>7</sup> CA_n71A-n77A <sup>7</sup>	n41	10, 15, 20, 30, 40, 50, 60, 70, 80, 90, 100	0
		n71	5, 10, 15, 20	
		n77	CA_n77(2A)_BCS1	
		n41	n41 channel bandwidths in Table 5.3.5-1	4 and 5
		n71	n71 channel bandwidths in Table 5.3.5-1	
		n77	CA_n77(2A) BCS 4 and 5	
CA_n41(2A)-n71A-n77A	n41 <sup>7,9</sup> n77 <sup>7,9</sup> CA_n41A-n71A <sup>7</sup> CA_n41A-n77A <sup>7</sup> CA_n71A-n77A <sup>7</sup>	n41	CA_n41(2A)_BCS1	0
		n71	5, 10, 15, 20	
		n77	10, 15, 20, 25, 30, 40, 50, 60, 70, 80, 90, 100	
		n41	CA_n41(2A) BCS 4 and 5	4 and 5
		n71	n71 channel bandwidths in Table 5.3.5-1	
		n77	n77 channel bandwidths in Table 5.3.5-1	
CA_n41(2A)-n71B-n77A	n41 <sup>7,9</sup> n77 <sup>7,9</sup> CA_n41A-n71A <sup>7</sup> CA_n41A-n77A <sup>7</sup> CA_n71A-n77A <sup>7</sup>	n41	CA_n41(2A)_BCS 4 and 5	4 and 5
		n71	CA_n71B_BCS 4 and 5	
		n77	n77 channel bandwidths in Table 5.3.5-1	
CA_n41(2A)-n71(2A)-n77A	n41 <sup>7,9</sup> n77 <sup>7,9</sup> CA_n41A-n71A <sup>7</sup> CA_n41A-n77A <sup>7</sup> CA_n71A-n77A <sup>7</sup>	n41	CA_n41(2A)_BCS 4 and 5	4 and 5
		n71	CA_n71(2A)_BCS 4 and 5	
		n77	n77 channel bandwidths in Table 5.3.5-1	
CA_n41(2A)-n71A-n77(2A)	n41 <sup>7,9</sup> n77 <sup>7,9</sup> CA_n41A-n71A <sup>7</sup> CA_n41A-n77A <sup>7</sup> CA_n71A-n77A <sup>7</sup>	n41	CA_n41(2A) BCS 4 and 5	4 and 5

		n71	n71 channel bandwidths in Table 5.3.5-1	
		n77	CA_n77(2A) BCS 4 and 5	
CA_n41(3A)-n71A-n77A	n41 <sup>7,9</sup> n77 <sup>7,9</sup> CA_n41A-n71A <sup>7</sup> CA_n41A-n77A <sup>7</sup> CA_n71A-n77A <sup>7</sup>	n41	CA_n41(3A) BCS 4 and 5	4 and 5
		n71	n71 channel bandwidths in Table 5.3.5-1	
		n77	n77 channel bandwidths in Table 5.3.5-1	
CA_n41A-n71(2A)-n77(2A)	n41 <sup>7,9</sup> n77 <sup>7,9</sup> CA_n41A-n71A <sup>7</sup> CA_n41A-n77A <sup>7</sup> CA_n71A-n77A <sup>7</sup>	n41	n41 channel bandwidths in Table 5.3.5-1	4 and 5
		n71	CA_n71(2A)_BCS 4 and 5	
		n77	CA_n77(2A)_BCS 4 and 5	
CA_n41(2A)-n71B-n77(2A)	CA_n41A-n71A CA_n41A-n77A CA_n71A-n77A	n41	CA_n41(2A) BCS 4 and 5	4 and 5
		n71	CA_n71B BCS 4 and 5	
		n77	CA_n77(2A) BCS 4 and 5	
CA_n41(2A)-n71(2A)-n77(2A)	CA_n41A-n71A CA_n41A-n77A CA_n71A-n77A	n41	CA_n41(2A) BCS 4 and 5	4 and 5
		n71	CA_n71(2A) BCS 4 and 5	
		n77	CA_n77(2A) BCS 4 and 5	
CA_n41(3A)-n71B-n77A	CA_n41A-n71A CA_n41A-n77A CA_n71A-n77A	n41	CA_n41(3A) BCS 4 and 5	4 and 5
		n71	CA_n71B BCS 4 and 5	
		n77	n77 channel bandwidths in Table 5.3.5-1	
CA_n41(3A)-n71(2A)-n77A	CA_n41A-n71A CA_n41A-n77A CA_n71A-n77A	n41	CA_n41(3A) BCS 4 and 5	4 and 5
		n71	CA_n71(2A) BCS 4 and 5	
		n77	n77 channel bandwidths in Table 5.3.5-1	
CA_n41C-n71A-n77A	n41 <sup>7,9</sup> n77 <sup>7,9</sup> CA_n41A-n71A <sup>7</sup> CA_n41A-n77A <sup>7</sup> CA_n41C <sup>7</sup> CA_n71A-n77A <sup>7</sup> CA_n41C-n71A CA_n41C-n77A	n41	CA_n41C_BCS0	0
		n71	5, 10, 15, 20	
		n77	10, 15, 20, 25, 30, 40, 50, 60, 70, 80, 90, 100	
		n41	CA_n41C BCS 4 and 5	4 and 5
		n71	n71 channel bandwidths in Table 5.3.5-1	
		n77	n77 channel bandwidths in Table 5.3.5-1	
CA_n41C-n71B-n77A	n41 <sup>7,9</sup> n77 <sup>7,9</sup> CA_n41A-n71A <sup>7</sup> CA_n41A-n77A <sup>7</sup> CA_n41C <sup>7</sup> CA_n71A-n77A <sup>7</sup>	n41	CA_n41C_BCS 4 and 5	4 and 5
		n71	CA_n71B_BCS 4 and 5	
		n77	n77 channel bandwidths in Table 5.3.5-1	

CA_n41C-n71(2A)-n77A	n41 <sup>7,9</sup> n77 <sup>7,9</sup> CA_n41A-n71A <sup>7</sup> CA_n41A-n77A <sup>7</sup> CA_n41C <sup>7</sup> CA_n71A-n77A <sup>7</sup>	n41	CA_n41C_BCS 4 and 5	4 and 5
		n71	CA_n71(2A)_BCS 4 and 5	
		n77	n77 channel bandwidths in Table 5.3.5-1	
CA_n41C-n71A-n77(2A)	n41 <sup>7,9</sup> n77 <sup>7,9</sup> CA_n41A-n71A <sup>7</sup> CA_n41A-n77A <sup>7</sup> CA_n41C <sup>7</sup> CA_n71A-n77A <sup>7</sup>	n41	CA_n41C BCS 4 and 5	4 and 5
		n71	n71 channel bandwidths in Table 5.3.5-1	
		n77	CA_n77(2A) BCS 4 and 5	
CA_n41C-n71B-n77(2A)	CA_n41A-n71A CA_n41A-n77A CA_n41C CA_n71A-n77A	n41	CA_n41C BCS 4 and 5	4 and 5
		n71	CA_n71B BCS 4 and 5	
		n77	CA_n77(2A) BCS 4 and 5	
CA_n41C-n71(2A)-n77(2A)	CA_n41A-n71A CA_n41A-n77A CA_n41C CA_n71A-n77A	n41	CA_n41C BCS 4 and 5	4 and 5
		n71	CA_n71(2A) BCS 4 and 5	
		n77	CA_n77(2A) BCS 4 and 5	
CA_n41(A-C)-n71A-n77A	n41 <sup>7,9</sup> n77 <sup>7,9</sup> CA_n41A-n71A <sup>7</sup> CA_n41A-n77A <sup>7</sup> CA_n41C <sup>7</sup> CA_n71A-n77A <sup>7</sup>	n41	CA_n41(A-C) BCS 4 and 5	4 and 5
		n71	n71 channel bandwidths in Table 5.3.5-1	
		n77	n77 channel bandwidths in Table 5.3.5-1	
CA_n41(A-C)-n71B-n77A	CA_n41A-n71A CA_n41A-n77A CA_n41C CA_n71A-n77A	n41	CA_n41(A-C) BCS 4 and 5	4 and 5
		n71	CA_n71B BCS 4 and 5	
		n77	n77 channel bandwidths in Table 5.3.5-1	
CA_n41(A-C)-n71(2A)-n77A	CA_n41A-n71A CA_n41A-n77A CA_n41C CA_n71A-n77A	n41	CA_n41(A-C) BCS 4 and 5	4 and 5
		n71	CA_n71(2A) BCS 4 and 5	
		n77	n77 channel bandwidths in Table 5.3.5-1	
CA_n41A-n71A-n78A	CA_n41A-n71A CA_n41A-n78A CA_n71A-n78A	n41	10, 15, 20, 30, 40, 50, 60, 70, 80, 90, 100	0
		n71	5, 10, 15, 20	
		n78	10, 15, 20, 25, 30, 40, 50, 60, 70, 80, 90, 100	
CA_n41A-n71A-n78(2A)	CA_n41A-n71A CA_n41A-n78A CA_n71A-n78A	n41	10, 15, 20, 30, 40, 50, 60, 70, 80, 90, 100	0
		n71	5, 10, 15, 20	
		n78	CA_n78(2A)_BCS2	
CA_n41A-n71A-n85A	CA_n41A-n71A CA_n41A-n85A	n41	n41 channel bandwidths in Table 5.3.5-1	4 and 5

		n71	n71 channel bandwidths in Table 5.3.5-1	
		n85	n85 channel bandwidths in Table 5.3.5-1	
CA_n41A-n71B-n85A	CA_n41A-n71A CA_n41A-n85A	n41	n41 channel bandwidths in Table 5.3.5-1	4 and 5
		n71	CA_n71B BCS 4 and 5	
		n85	n85 channel bandwidths in Table 5.3.5-1	
CA_n41A-n71(2A)-n85A	CA_n41A-n71A CA_n41A-n85A	n41	n41 channel bandwidths in Table 5.3.5-1	4 and 5
		n71	CA_n71(2A) BCS 4 and 5	
		n85	n85 channel bandwidths in Table 5.3.5-1	
CA_n41A-n77A-n79A	CA_n41A-n77A CA_n41A-n79A CA_n77A-n79A	n41	10, 15, 20, 30, 40, 50, 60, 80, 90, 100	0
		n77	10, 15, 20, 40, 50, 60, 80, 90, 100	
		n79	40, 50, 60, 80, 100	
CA_n41A-n77(2A)-n79A	CA_n41A-n77A CA_n41A-n79A CA_n77A-n79A	n41	10, 15, 20, 30, 40, 50, 60, 80, 90, 100	0
		n77	CA_n77(2A)_BCS0	
		n79	40, 50, 60, 80, 100	
CA_n41A-n77(3A)-n79A	CA_n41A-n77A CA_n41A-n79A CA_n77A-n79A	n41	10, 15, 20, 30, 40, 50, 60, 80, 90, 100	0
		n77	CA_n77(3A)_BCS0	
		n79	40, 50, 60, 80, 100	
CA_n41A-n77A-n85A	CA_n41A-n77A CA_n41A-n85A CA_n77A-n85A	n41	n41 channel bandwidths in Table 5.3.5-1	4 and 5
		n77	n77 channel bandwidths in Table 5.3.5-1	
		n85	n85 channel bandwidths in Table 5.3.5-1	
CA_n41(2A)-n77A-n85A	CA_n41A-n77A CA_n41A-n85A CA_n77A-n85A	n41	CA_n41(2A) BCS 4 and 5	4 and 5
		n77	n77 channel bandwidths in Table 5.3.5-1	
		n85	n85 channel bandwidths in Table 5.3.5-1	
CA_n41A-n77(2A)-n85A	CA_n41A-n77A CA_n41A-n85A CA_n77A-n85A	n41	n41 channel bandwidths in Table 5.3.5-1	4 and 5
		n77	CA_n77(2A) BCS 4 and 5	
		n85	n85 channel bandwidths in Table 5.3.5-1	
CA_n41C-n77A-n85A	CA_n41A-n77A CA_n41A-n85A CA_n41C CA_n77A-n85A	n41	CA_n41C_BCS 4 and 5	4 and 5
		n77	n77 channel bandwidths in Table 5.3.5-1	
		n85	n85 channel bandwidths in Table 5.3.5-1	

Table 5.5A.3.2-1c

**Table 5.5A.3.2-1c: NR CA configurations and bandwidth combinations sets defined for inter-band CA (three bands)**

NR CA configuration	Uplink CA configuration or single uplink carrier <sup>6</sup>	NR Band	Channel bandwidth (MHz) (NOTE 3)	Bandwidth combination set
CA_n46A-n48A-n96A	CA_n46A-n48A CA_n48A-n96A	n46	10, 20, 40, 60, 80	0
		n48	5, 10, 15, 20, 30, 40, 50 <sup>12</sup> , 60 <sup>12</sup> , 70 <sup>12</sup> , 80 <sup>12</sup> , 90 <sup>12</sup> , 100 <sup>12</sup>	
		n96	20, 40, 60, 80	
CA_n46B-n48A-n96A	CA_n46A-n48A CA_n48A-n96A	n46	CA_n46B_BCS0	0
		n48	5, 10, 15, 20, 30, 40, 50 <sup>12</sup> , 60 <sup>12</sup> , 70 <sup>12</sup> , 80 <sup>12</sup> , 90 <sup>12</sup> , 100 <sup>12</sup>	
		n96	20, 40, 60, 80	
CA_n46C-n48A-n96A	CA_n46A-n48A CA_n48A-n96A	n46	CA_n46C_BCS0	0
		n48	5, 10, 15, 20, 30, 40, 50 <sup>12</sup> , 60 <sup>12</sup> , 70 <sup>12</sup> , 80 <sup>12</sup> , 90 <sup>12</sup> , 100 <sup>12</sup>	
		n96	20, 40, 60, 80	
CA_n46D-n48A-n96A	CA_n46A-n48A CA_n48A-n96A	n46	CA_n46D_BCS0	0
		n48	5, 10, 15, 20, 30, 40, 50 <sup>12</sup> , 60 <sup>12</sup> , 70 <sup>12</sup> , 80 <sup>12</sup> , 90 <sup>12</sup> , 100 <sup>12</sup>	
		n96	20, 40, 60, 80	
CA_n46M-n48A-n96A	-	n46	CA_n46M_BCS0	0
		n48	5, 10, 15, 20, 30, 40, 50 <sup>12</sup> , 60 <sup>12</sup> , 70 <sup>12</sup> , 80 <sup>12</sup> , 90 <sup>12</sup> , 100 <sup>12</sup>	
		n96	20, 40, 60, 80	
CA_n46N-n48A-n96A	CA_n46A-n48A CA_n48A-n96A	n46	CA_n46N_BCS1	0
		n48	5, 10, 15, 20, 30, 40, 50 <sup>12</sup> , 60 <sup>12</sup> , 70 <sup>12</sup> , 80 <sup>12</sup> , 90 <sup>12</sup> , 100 <sup>12</sup>	
		n96	20, 40, 60, 80	
CA_n46A-n48B-n96A	CA_n46A-n48A CA_n46A-n48B CA_n48A-n96A CA_n48B CA_n48B-n96A	n46	10, 20, 40, 60, 80	0
		n48	CA_n48B_BCS0	
		n96	20, 40, 60, 80	
CA_n46B-n48B-n96A	CA_n46A-n48A CA_n46A-n48B CA_n48A-n96A CA_n48B CA_n48B-n96A	n46	CA_n46B_BCS0	0
		n48	CA_n48B_BCS0	
		n96	20, 40, 60, 80	
CA_n46C-n48B-n96A	CA_n46A-n48A CA_n46A-n48B CA_n48A-n96A CA_n48B CA_n48B-n96A	n46	CA_n46C_BCS0	0
		n48	CA_n48B_BCS0	
		n96	20, 40, 60, 80	
CA_n46D-n48B-n96A	CA_n46A-n48A CA_n46A-n48B CA_n48A-n96A CA_n48B CA_n48B-n96A	n46	CA_n46D_BCS0	0
		n48	CA_n48B_BCS0	
		n96	20, 40, 60, 80	

CA_n46M-n48B-n96A	CA_n46A-n48A CA_n46A-n48B CA_n48A-n96A CA_n48B CA_n48B-n96A	n46	CA_n46M_BCS0	0
		n48	CA_n48B_BCS0	
		n96	20, 40, 60, 80	
CA_n46N-n48B-n96A	CA_n46A-n48A CA_n46A-n48B CA_n48A-n96A CA_n48B CA_n48B-n96A	n46	CA_n46N_BCS1	0
		n48	CA_n48B_BCS0	
		n96	20, 40, 60, 80	
CA_n46A-n48C-n96A	CA_n46A-n48A CA_n46A-n48B CA_n48A-n96A CA_n48B CA_n48B-n96A	n46	10, 20, 40, 60, 80	0
		n48	CA_n48C_BCS0	
		n96	20, 40, 60, 80	
CA_n46B-n48C-n96A	CA_n46A-n48A CA_n46A-n48B CA_n48A-n96A CA_n48B CA_n48B-n96A	n46	CA_n46B_BCS0	0
		n48	CA_n48C_BCS0	
		n96	20, 40, 60, 80	
CA_n46C-n48C-n96A	CA_n46A-n48A CA_n46A-n48B CA_n48A-n96A CA_n48B CA_n48B-n96A	n46	CA_n46C_BCS0	0
		n48	CA_n48C_BCS0	
		n96	20, 40, 60, 80	
CA_n46D-n48C-n96A	CA_n46A-n48A CA_n46A-n48B CA_n48A-n96A CA_n48B CA_n48B-n96A	n46	CA_n46D_BCS0	0
		n48	CA_n48C_BCS0	
		n96	20, 40, 60, 80	
CA_n46M-n48C-n96A	-	n46	CA_n46M_BCS0	0
		n48	CA_n48C_BCS0	
		n96	20, 40, 60, 80	
CA_n46N-n48C-n96A	CA_n46A-n48A CA_n46A-n48B CA_n48A-n96A CA_n48B CA_n48B-n96A	n46	CA_n46N_BCS1	0
		n48	CA_n48C_BCS0	
		n96	20, 40, 60, 80	
CA_n46A-n48A-n96B	CA_n46A-n48A CA_n48A-n96A	n46	10, 20, 40, 60, 80	0
		n48	5, 10, 15, 20, 30, 40, 50 <sup>12</sup> , 60 <sup>12</sup> , 70 <sup>12</sup> , 80 <sup>12</sup> , 90 <sup>12</sup> , 100 <sup>12</sup>	
		n96	CA_n96B_BCS0	
CA_n46B-n48A-n96B	CA_n46A-n48A CA_n48A-n96A	n46	CA_n46B_BCS0	0
		n48	5, 10, 15, 20, 30, 40, 50 <sup>12</sup> , 60 <sup>12</sup> , 70 <sup>12</sup> , 80 <sup>12</sup> , 90 <sup>12</sup> , 100 <sup>12</sup>	
		n96	CA_n96B_BCS0	
CA_n46C-n48A-n96B	CA_n46A-n48A CA_n48A-n96A	n46	CA_n46C_BCS0	0
		n48	5, 10, 15, 20, 30, 40, 50 <sup>12</sup> , 60 <sup>12</sup> , 70 <sup>12</sup> , 80 <sup>12</sup> , 90 <sup>12</sup> , 100 <sup>12</sup>	
		n96	CA_n96B_BCS0	

CA_n46D-n48A-n96B	CA_n46A-n48A CA_n48A-n96A	n46	CA_n46D_BCS0	0
		n48	5, 10, 15, 20, 30, 40, 50 <sup>12</sup> , 60 <sup>12</sup> , 70 <sup>12</sup> , 80 <sup>12</sup> , 90 <sup>12</sup> , 100 <sup>1</sup>	
		n96	CA_n96B_BCS0	
CA_n46M-n48A-n96B	-	n46	CA_n46M_BCS0	0
		n48	5, 10, 15, 20, 30, 40, 50 <sup>12</sup> , 60 <sup>12</sup> , 70 <sup>12</sup> , 80 <sup>12</sup> , 90 <sup>12</sup> , 100 <sup>12</sup>	
		n96	CA_n96B_BCS0	
CA_n46N-n48A-n96B	CA_n46A-n48A CA_n48A-n96A	n46	CA_n46N_BCS1	0
		n48	5, 10, 15, 20, 30, 40, 50 <sup>12</sup> , 60 <sup>12</sup> , 70 <sup>12</sup> , 80 <sup>12</sup> , 90 <sup>12</sup> , 100 <sup>12</sup>	
		n96	CA_n96B_BCS0	
CA_n46A-n48A-n96C	-	n46	10, 20, 40, 60, 80	0
		n48	5, 10, 15, 20, 30, 40, 50 <sup>12</sup> , 60 <sup>12</sup> , 70 <sup>12</sup> , 80 <sup>12</sup> , 90 <sup>12</sup> , 100 <sup>12</sup>	
		n96	CA_n96C_BCS0	
CA_n46B-n48A-n96C	-	n46	CA_n46B_BCS0	0
		n48	5, 10, 15, 20, 30, 40, 50 <sup>12</sup> , 60 <sup>12</sup> , 70 <sup>12</sup> , 80 <sup>12</sup> , 90 <sup>12</sup> , 100 <sup>12</sup>	
		n96	CA_n96C_BCS0	
CA_n46C-n48A-n96C	-	n46	CA_n46C_BCS0	0
		n48	5, 10, 15, 20, 30, 40, 50 <sup>12</sup> , 60 <sup>12</sup> , 70 <sup>12</sup> , 80 <sup>12</sup> , 90 <sup>12</sup> , 100 <sup>12</sup>	
		n96	CA_n96C_BCS0	
CA_n46D-n48A-n96C	-	n46	CA_n46D_BCS0	0
		n48	5, 10, 15, 20, 30, 40, 50 <sup>12</sup> , 60 <sup>12</sup> , 70 <sup>12</sup> , 80 <sup>12</sup> , 90 <sup>12</sup> , 100 <sup>12</sup>	
		n96	CA_n96C_BCS0	
CA_n46M-n48A-n96C	-	n46	CA_n46M_BCS0	0
		n48	5, 10, 15, 20, 30, 40, 50 <sup>12</sup> , 60 <sup>12</sup> , 70 <sup>12</sup> , 80 <sup>12</sup> , 90 <sup>12</sup> , 100 <sup>12</sup>	
		n96	CA_n96C_BCS0	
CA_n46N-n48A-n96C	-	n46	CA_n46N_BCS1	0
		n48	5, 10, 15, 20, 30, 40, 50 <sup>12</sup> , 60 <sup>12</sup> , 70 <sup>12</sup> , 80 <sup>12</sup> , 90 <sup>12</sup> , 100 <sup>12</sup>	
		n96	CA_n96C_BCS0	
CA_n46A-n48B-n96C	CA_n46A-n48A CA_n46A-n48B CA_n48A-n96A CA_n48B CA_n48B-n96A	n46	10, 20, 40, 60, 80	0
		n48	CA_n48B_BCS0	
		n96	CA_n96C_BCS0	
CA_n46B-n48B-n96C	CA_n46A-n48A CA_n46A-n48B CA_n48A-n96A CA_n48B CA_n48B-n96A	n46	CA_n46B_BCS0	0
		n48	CA_n48B_BCS0	
		n96	CA_n96C_BCS0	
CA_n46C-n48B-n96C	CA_n46A-n48A CA_n46A-n48B CA_n48A-n96A CA_n48B CA_n48B-n96A	n46	CA_n46C_BCS0	0
		n48	CA_n48B_BCS0	
		n96	CA_n96C_BCS0	
CA_n46D-n48B-n96C	CA_n46A-n48A CA_n46A-n48B CA_n48A-n96A CA_n48B CA_n48B-n96A	n46	CA_n46D_BCS0	0
		n48	CA_n48B_BCS0	
		n96	CA_n96C_BCS0	
CA_n46M-n48B-n96C	-	n46	CA_n46M_BCS0	0

		n48	CA_n48B_BCS0	
		n96	CA_n96C_BCS0	
CA_n46N-n48B-n96C	CA_n46A-n48A CA_n46A-n48B CA_n48A-n96A CA_n48B CA_n48B-n96A	n46	CA_n46N_BCS1	0
		n48	CA_n48B_BCS0	
		n96	CA_n96C_BCS0	
CA_n46A-n48C-n96C	-	n46	10, 20, 40, 60, 80	0
		n48	CA_n48C_BCS0	
		n96	CA_n96C_BCS0	
CA_n46B-n48C-n96C	-	n46	CA_n46B_BCS0	0
		n48	CA_n48C_BCS0	
		n96	CA_n96C_BCS0	
CA_n46C-n48C-n96C	-	n46	CA_n46C_BCS0	0
		n48	CA_n48C_BCS0	
		n96	CA_n96C_BCS0	
CA_n46D-n48C-n96C	-	n46	CA_n46D_BCS0	0
		n48	CA_n48C_BCS0	
		n96	CA_n96C_BCS0	
CA_n46M-n48C-n96C	-	n46	CA_n46M_BCS0	0
		n48	CA_n48C_BCS0	
		n96	CA_n96C_BCS0	
CA_n46N-n48C-n96C	-	n46	CA_n46N_BCS1	0
		n48	CA_n48C_BCS0	
		n96	CA_n96C_BCS0	
CA_n46A-n48A-n96D	-	n46	10, 20, 40, 60, 80	0
		n48	5, 10, 15, 20, 30, 40, 50 <sup>12</sup> , 60 <sup>12</sup> , 70 <sup>12</sup> , 80 <sup>12</sup> , 90 <sup>12</sup> , 100 <sup>12</sup>	
		n96	CA_n96D_BCS0	
CA_n46B-n48A-n96D	-	n46	CA_n46B_BCS0	0
		n48	5, 10, 15, 20, 30, 40, 50 <sup>12</sup> , 60 <sup>12</sup> , 70 <sup>12</sup> , 80 <sup>12</sup> , 90 <sup>12</sup> , 100 <sup>12</sup>	
		n96	CA_n96D_BCS0	
CA_n46C-n48A-n96D	-	n46	CA_n46C_BCS0	0
		n48	5, 10, 15, 20, 30, 40, 50 <sup>12</sup> , 60 <sup>12</sup> , 70 <sup>12</sup> , 80 <sup>12</sup> , 90 <sup>12</sup> , 100 <sup>12</sup>	
		n96	CA_n96D_BCS0	
CA_n46D-n48A-n96D	-	n46	CA_n46D_BCS0	0
		n48	5, 10, 15, 20, 30, 40, 50 <sup>12</sup> , 60 <sup>12</sup> , 70 <sup>12</sup> , 80 <sup>12</sup> , 90 <sup>12</sup> , 100 <sup>12</sup>	
		n96	CA_n96D_BCS0	
CA_n46M-n48A-n96D	-	n46	CA_n46M_BCS0	0
		n48	5, 10, 15, 20, 30, 40, 50 <sup>12</sup> , 60 <sup>12</sup> , 70 <sup>12</sup> , 80 <sup>12</sup> , 90 <sup>12</sup> , 100 <sup>12</sup>	
		n96	CA_n96D_BCS0	
CA_n46N-n48A-n96D	-	n46	CA_n46N_BCS1	0
		n48	5, 10, 15, 20, 30, 40, 50 <sup>12</sup> , 60 <sup>12</sup> , 70 <sup>12</sup> , 80 <sup>12</sup> , 90 <sup>12</sup> , 100 <sup>12</sup>	
		n96	CA_n96D_BCS0	
CA_n46A-n48C-n96D	CA_n46A-n48A CA_n46A-n48B CA_n48A-n96A CA_n48B CA_n48B-n96A	n46	10, 20, 40, 60, 80	0
		n48	CA_n48C_BCS0	
		n96	CA_n96D_BCS0	
CA_n46B-n48C-n96D	CA_n46A-n48A CA_n46A-n48B CA_n48A-n96A CA_n48B CA_n48B-n96A	n46	CA_n46B_BCS0	0
		n48	CA_n48C_BCS0	
		n96	CA_n96D_BCS0	
CA_n46C-n48C-n96D	CA_n46A-n48A	n46	CA_n46C_BCS0	0



	CA_n46A-n48B CA_n48A-n96A CA_n48B CA_n48B-n96A	n48	CA_n48C_BCS0	
		n96	CA_n96D_BCS0	
CA_n46D-n48C-n96D	CA_n46A-n48A CA_n46A-n48B CA_n48A-n96A CA_n48B CA_n48B-n96A	n46	CA_n46D_BCS0	0
		n48	CA_n48C_BCS0	
		n96	CA_n96D_BCS0	
CA_n46M-n48C-n96D	-	n46	CA_n46M_BCS0	0
		n48	CA_n48C_BCS0	
		n96	CA_n96D_BCS0	
CA_n46N-n48C-n96D	CA_n46A-n48A CA_n46A-n48B CA_n48A-n96A CA_n48B CA_n48B-n96A	n46	CA_n46N_BCS1	0
		n48	CA_n48C_BCS0	
		n96	CA_n96D_BCS0	
CA_n46A-n48A-n96E	-	n46	10, 20, 40, 60, 80	0
		n48	5, 10, 15, 20, 30, 40, 50 <sup>12</sup> , 60 <sup>12</sup> , 70 <sup>12</sup> , 80 <sup>12</sup> , 90 <sup>12</sup> , 100 <sup>12</sup>	
		n96	CA_n96E_BCS0	
CA_n46B-n48A-n96E	-	n46	CA_n46B_BCS0	0
		n48	5, 10, 15, 20, 30, 40, 50 <sup>12</sup> , 60 <sup>12</sup> , 70 <sup>12</sup> , 80 <sup>12</sup> , 90 <sup>12</sup> , 100 <sup>12</sup>	
		n96	CA_n96E_BCS0	
CA_n46C-n48A-n96E	-	n46	CA_n46C_BCS0	0
		n48	5, 10, 15, 20, 30, 40, 50 <sup>12</sup> , 60 <sup>12</sup> , 70 <sup>12</sup> , 80 <sup>12</sup> , 90 <sup>12</sup> , 100 <sup>12</sup>	
		n96	CA_n96E_BCS0	
CA_n46D-n48A-n96E	-	n46	CA_n46D_BCS0	0
		n48	5, 10, 15, 20, 30, 40, 50 <sup>12</sup> , 60 <sup>12</sup> , 70 <sup>12</sup> , 80 <sup>12</sup> , 90 <sup>12</sup> , 100 <sup>12</sup>	
		n96	CA_n96E_BCS0	
CA_n46M-n48A-n96E	-	n46	CA_n46M_BCS0	0
		n48	5, 10, 15, 20, 30, 40, 50 <sup>12</sup> , 60 <sup>12</sup> , 70 <sup>12</sup> , 80 <sup>12</sup> , 90 <sup>12</sup> , 100 <sup>12</sup>	
		n96	CA_n96E_BCS0	
CA_n46N-n48A-n96E	-	n46	CA_n46N_BCS1	0
		n48	5, 10, 15, 20, 30, 40, 50 <sup>12</sup> , 60 <sup>12</sup> , 70 <sup>12</sup> , 80 <sup>12</sup> , 90 <sup>12</sup> , 100 <sup>12</sup>	
		n96	CA_n96E_BCS0	
CA_n46A-n48C-n96E	CA_n46A-n48A CA_n46A-n48B CA_n48A-n96A CA_n48B CA_n48B-n96A	n46	10, 20, 40, 60, 80	0
		n48	CA_n48C_BCS0	
		n96	CA_n96E_BCS0	
CA_n46B-n48C-n96E	CA_n46A-n48A CA_n46A-n48B CA_n48A-n96A CA_n48B CA_n48B-n96A	n46	CA_n46B_BCS0	0
		n48	CA_n48C_BCS0	
		n96	CA_n96E_BCS0	
CA_n46C-n48C-n96E	CA_n46A-n48A CA_n46A-n48B CA_n48A-n96A CA_n48B CA_n48B-n96A	n46	CA_n46C_BCS0	0
		n48	CA_n48C_BCS0	
		n96	CA_n96E_BCS0	

		n48	CA_n48C_BCS0	
		n96	CA_n96E_BCS0	
CA_n46D-n48C-n96E	CA_n46A-n48A CA_n46A-n48B CA_n48A-n96A CA_n48B CA_n48B-n96A	n46	CA_n46D_BCS0	0
		n48	CA_n48C_BCS0	
		n96	CA_n96E_BCS0	
CA_n46M-n48C-n96E	-	n46	CA_n46M_BCS0	0
		n48	CA_n48C_BCS0	
		n96	CA_n96E_BCS0	
CA_n46N-n48C-n96E	CA_n46A-n48A CA_n46A-n48B CA_n48A-n96A CA_n48B CA_n48B-n96A	n46	CA_n46N_BCS1	0
		n48	CA_n48C_BCS0	
		n96	CA_n96E_BCS0	
CA_n46A-n48(2A)-n96A	CA_n46A-n48A CA_n48A-n96A	n46	10, 20, 40, 60, 80	0
		n48	CA_n48(2A)_BCS0	
		n96	20, 40, 60, 80	
CA_n46B-n48(2A)-n96A	CA_n46A-n48A CA_n48A-n96A	n46	CA_n46B_BCS0	0
		n48	CA_n48(2A)_BCS0	
		n96	20, 40, 60, 80	
CA_n46C-n48(2A)-n96A	CA_n46A-n48A CA_n48A-n96A	n46	CA_n46C_BCS0	0
		n48	CA_n48(2A)_BCS0	
		n96	20, 40, 60, 80	
CA_n46D-n48(2A)-n96A	CA_n46A-n48A CA_n48A-n96A	n46	CA_n46D_BCS0	0
		n48	CA_n48(2A)_BCS0	
		n96	20, 40, 60, 80	
CA_n46M-n48(2A)-n96A	-	n46	CA_n46M_BCS0	0
		n48	CA_n48(2A)_BCS0	
		n96	20, 40, 60, 80	
CA_n46N-n48(2A)-n96A	CA_n46A-n48A CA_n48A-n96A	n46	CA_n46N_BCS1	0
		n48	CA_n48(2A)_BCS0	
		n96	20, 40, 60, 80	
CA_n46A-n48(2A)-n96B	CA_n46A-n48A CA_n48A-n96A	n46	20, 40, 60, 80	0
		n48	CA_n48(2A)_BCS0	
		n96	CA_n96B_BCS0	
CA_n46B-n48(2A)-n96B	CA_n46A-n48A CA_n48A-n96A	n46	CA_n46B_BCS0	0
		n48	CA_n48(2A)_BCS0	
		n96	CA_n96B_BCS0	
CA_n46C-n48(2A)-n96B	CA_n46A-n48A CA_n48A-n96A	n46	CA_n46C_BCS0	0
		n48	CA_n48(2A)_BCS0	
		n96	CA_n96B_BCS0	
CA_n46D-n48(2A)-n96B	CA_n46A-n48A CA_n48A-n96A	n46	CA_n46D_BCS0	0
		n48	CA_n48(2A)_BCS0	
		n96	CA_n96B_BCS0	
CA_n46M-n48(2A)-n96B	-	n46	CA_n46M_BCS0	0
		n48	CA_n48(2A)_BCS0	
		n96	CA_n96B_BCS0	
CA_n46N-n48(2A)-n96B	CA_n46A-n48A CA_n48A-n96A	n46	CA_n46N_BCS1	0

		n48	CA_n48(2A)_BCS0	
		n96	CA_n96B_BCS0	
CA_n46A-n48(2A)-n96C	CA_n46A-n48A CA_n48A-n96A	n46	10, 20, 40, 60, 80	0
		n48	CA_n48(2A)_BCS0	
		n96	CA_n96C_BCS0	
CA_n46B-n48(2A)-n96C	CA_n46A-n48A CA_n48A-n96A	n46	CA_n46B_BCS0	0
		n48	CA_n48(2A)_BCS0	
		n96	CA_n96C_BCS0	
CA_n46C-n48(2A)-n96C	CA_n46A-n48A CA_n48A-n96A	n46	CA_n46C_BCS0	0
		n48	CA_n48(2A)_BCS0	
		n96	CA_n96C_BCS0	
CA_n46D-n48(2A)-n96C	CA_n46A-n48A CA_n48A-n96A	n46	CA_n46D_BCS0	0
		n48	CA_n48(2A)_BCS0	
		n96	CA_n96C_BCS0	
CA_n46M-n48(2A)-n96C	-	n46	CA_n46M_BCS0	0
		n48	CA_n48(2A)_BCS0	
		n96	CA_n96C_BCS0	
CA_n46N-n48(2A)-n96C	CA_n46A-n48A CA_n48A-n96A	n46	CA_n46N_BCS1	0
		n48	CA_n48(2A)_BCS0	
		n96	CA_n96C_BCS0	
CA_n46A-n48(2A)-n96D	CA_n46A-n48A CA_n48A-n96A	n46	10, 20, 40, 60, 80	0
		n48	CA_n48(2A)_BCS0	
		n96	CA_n96D_BCS0	
CA_n46B-n48(2A)-n96D	CA_n46A-n48A CA_n48A-n96A	n46	CA_n46B_BCS0	0
		n48	CA_n48(2A)_BCS0	
		n96	CA_n96D_BCS0	
CA_n46C-n48(2A)-n96D	CA_n46A-n48A CA_n48A-n96A	n46	CA_n46C_BCS0	0
		n48	CA_n48(2A)_BCS0	
		n96	CA_n96D_BCS0	
CA_n46D-n48(2A)-n96D	CA_n46A-n48A CA_n48A-n96A	n46	CA_n46D_BCS0	0
		n48	CA_n48(2A)_BCS0	
		n96	CA_n96D_BCS0	
CA_n46M-n48(2A)-n96D	-	n46	CA_n46M_BCS0	0
		n48	CA_n48(2A)_BCS0	
		n96	CA_n96D_BCS0	
CA_n46N-n48(2A)-n96D	CA_n46A-n48A CA_n48A-n96A	n46	CA_n46N_BCS1	0
		n48	CA_n48(2A)_BCS0	
		n96	CA_n96D_BCS0	
CA_n46A-n48(2A)-n96E	CA_n46A-n48A CA_n48A-n96A	n46	10, 20, 40, 60, 80	0
		n48	CA_n48(2A)_BCS0	
		n96	CA_n96E_BCS0	
CA_n46B-n48(2A)-n96E	CA_n46A-n48A CA_n48A-n96A	n46	CA_n46B_BCS0	0
		n48	CA_n48(2A)_BCS0	
		n96	CA_n96E_BCS0	
CA_n46C-n48(2A)-n96E	CA_n46A-n48A CA_n48A-n96A	n46	CA_n46C_BCS0	0
		n48	CA_n48(2A)_BCS0	
		n96	CA_n96E_BCS0	
CA_n46D-n48(2A)-n96E	CA_n46A-n48A CA_n48A-n96A	n46	CA_n46D_BCS0	0
		n48	CA_n48(2A)_BCS0	
		n96	CA_n96E_BCS0	

CA_n46M-n48(2A)-n96E	-	n46	CA_n46M_BCS0	0
		n48	CA_n48(2A)_BCS0	
		n96	CA_n96E_BCS0	
CA_n46N-n48(2A)-n96E	CA_n46A-n48A CA_n48A-n96A	n46	CA_n46N_BCS1	0
		n48	CA_n48(2A)_BCS0	
		n96	CA_n96E_BCS0	
CA_n46A-n48(3A)-n96A	CA_n46A-n48A CA_n48A-n96A	n46	10, 20, 40, 60, 80	0
		n48	CA_n48(3A)_BCS0	
		n96	20, 40, 60, 80	
CA_n46B-n48(3A)-n96A	CA_n46A-n48A CA_n48A-n96A	n46	CA_n46B_BCS0	0
		n48	CA_n48(3A)_BCS0	
		n96	20, 40, 60, 80	
CA_n46C-n48(3A)-n96A	CA_n46A-n48A CA_n48A-n96A	n46	CA_n46C_BCS0	0
		n48	CA_n48(3A)_BCS0	
		n96	20, 40, 60, 80	
CA_n46D-n48(3A)-n96A	CA_n46A-n48A CA_n48A-n96A	n46	CA_n46D_BCS0	0
		n48	CA_n48(3A)_BCS0	
		n96	20, 40, 60, 80	
CA_n46M-n48(3A)-n96A	-	n46	CA_n46M_BCS0	0
		n48	CA_n48(3A)_BCS0	
		n96	20, 40, 60, 80	
CA_n46N-n48(3A)-n96A	CA_n46A-n48A CA_n48A-n96A	n46	CA_n46N_BCS1	0
		n48	CA_n48(3A)_BCS0	
		n96	20, 40, 60, 80	
CA_n46A-n48(3A)-n96B	CA_n46A-n48A CA_n48A-n96A	n46	10, 20, 40, 60, 80	0
		n48	CA_n48(3A)_BCS0	
		n96	CA_n96B_BCS0	
CA_n46B-n48(3A)-n96B	CA_n46A-n48A CA_n48A-n96A	n46	CA_n46B_BCS0	0
		n48	CA_n48(3A)_BCS0	
		n96	CA_n96B_BCS0	
CA_n46C-n48(3A)-n96B	CA_n46A-n48A CA_n48A-n96A	n46	CA_n46C_BCS0	0
		n48	CA_n48(3A)_BCS0	
		n96	CA_n96B_BCS0	
CA_n46D-n48(3A)-n96B	CA_n46A-n48A CA_n48A-n96A	n46	CA_n46D_BCS0	0
		n48	CA_n48(3A)_BCS0	
		n96	CA_n96B_BCS0	
CA_n46M-n48(3A)-n96B	-	n46	CA_n46M_BCS0	0
		n48	CA_n48(3A)_BCS0	
		n96	CA_n96B_BCS0	
CA_n46N-n48(3A)-n96B	CA_n46A-n48A CA_n48A-n96A	n46	CA_n46N_BCS1	0
		n48	CA_n48(3A)_BCS0	
		n96	CA_n96B_BCS0	
CA_n46A-n48(3A)-n96C	CA_n46A-n48A CA_n48A-n96A	n46	10, 20, 40, 60, 80	0
		n48	CA_n48(3A)_BCS0	
		n96	CA_n96C_BCS0	
CA_n46B-n48(3A)-n96C	CA_n46A-n48A CA_n48A-n96A	n46	CA_n46B_BCS0	0
		n48	CA_n48(3A)_BCS0	
		n96	CA_n96C_BCS0	
CA_n46C-n48(3A)-n96C	CA_n46A-n48A CA_n48A-n96A	n46	CA_n46C_BCS0	0

		n48	CA_n48(3A)_BCS0	
		n96	CA_n96C_BCS0	
CA_n46D-n48(3A)-n96C	CA_n46A-n48A CA_n48A-n96A	n46	CA_n46D_BCS0	0
		n48	CA_n48(3A)_BCS0	
		n96	CA_n96C_BCS0	
CA_n46M-n48(3A)-n96C	-	n46	CA_n46M_BCS0	0
		n48	CA_n48(3A)_BCS0	
		n96	CA_n96C_BCS0	
CA_n46N-n48(3A)-n96C	CA_n46A-n48A CA_n48A-n96A	n46	CA_n46N_BCS1	0
		n48	CA_n48(3A)_BCS0	
		n96	CA_n96C_BCS0	
CA_n46A-n48(3A)-n96D	CA_n46A-n48A CA_n48A-n96A	n46	10, 20, 40, 60, 80	0
		n48	CA_n48(3A)_BCS0	
		n96	CA_n96D_BCS0	
CA_n46B-n48(3A)-n96D	CA_n46A-n48A CA_n48A-n96A	n46	CA_n46B_BCS0	0
		n48	CA_n48(3A)_BCS0	
		n96	CA_n96D_BCS0	
CA_n46C-n48(3A)-n96D	CA_n46A-n48A CA_n48A-n96A	n46	CA_n46C_BCS0	0
		n48	CA_n48(3A)_BCS0	
		n96	CA_n96D_BCS0	
CA_n46D-n48(3A)-n96D	CA_n46A-n48A CA_n48A-n96A	n46	CA_n46D_BCS0	0
		n48	CA_n48(3A)_BCS0	
		n96	CA_n96D_BCS0	
CA_n46M-n48(3A)-n96D	-	n46	CA_n46M_BCS0	0
		n48	CA_n48(3A)_BCS0	
		n96	CA_n96D_BCS0	
CA_n46N-n48(3A)-n96D	CA_n46A-n48A CA_n48A-n96A	n46	CA_n46N_BCS1	0
		n48	CA_n48(3A)_BCS0	
		n96	CA_n96D_BCS0	
CA_n46A-n48(3A)-n96E	CA_n46A-n48A CA_n48A-n96A	n46	10, 20, 40, 60, 80	0
		n48	CA_n48(3A)_BCS0	
		n96	CA_n96E_BCS0	
CA_n46B-n48(3A)-n96E	CA_n46A-n48A CA_n48A-n96A	n46	CA_n46B_BCS0	0
		n48	CA_n48(3A)_BCS0	
		n96	CA_n96E_BCS0	
CA_n46C-n48(3A)-n96E	CA_n46A-n48A CA_n48A-n96A	n46	CA_n46C_BCS0	0
		n48	CA_n48(3A)_BCS0	
		n96	CA_n96E_BCS0	
CA_n46D-n48(3A)-n96E	CA_n46A-n48A CA_n48A-n96A	n46	CA_n46D_BCS0	0
		n48	CA_n48(3A)_BCS0	
		n96	CA_n96E_BCS0	
CA_n46M-n48(3A)-n96E	-	n46	CA_n46M_BCS0	0
		n48	CA_n48(3A)_BCS0	
		n96	CA_n96E_BCS0	
CA_n46N-n48(3A)-n96E	CA_n46A-n48A CA_n48A-n96A	n46	CA_n46N_BCS1	0
		n48	CA_n48(3A)_BCS0	
		n96	CA_n96E_BCS0	
CA_n46A-n48(4A)-n96A	CA_n46A-n48A CA_n48A-n96A	n46	10, 20, 40, 60, 80	0
		n48	CA_n48(4A)_BCS0	
		n96	20, 40, 60, 80	

CA_n46B-n48(4A)-n96A	CA_n46A-n48A CA_n48A-n96A	n46	CA_n46B_BCS0	0
		n48	CA_n48(4A)_BCS0	
		n96	20, 40, 60, 80	
CA_n46C-n48(4A)-n96A	CA_n46A-n48A CA_n48A-n96A	n46	CA_n46C_BCS0	0
		n48	CA_n48(4A)_BCS0	
		n96	20, 40, 60, 80	
CA_n46D-n48(4A)-n96A	CA_n46A-n48A CA_n48A-n96A	n46	CA_n46D_BCS0	0
		n48	CA_n48(4A)_BCS0	
		n96	20, 40, 60, 80	
CA_n46M-n48(4A)-n96A	-	n46	CA_n46M_BCS0	0
		n48	CA_n48(4A)_BCS0	
		n96	20, 40, 60, 80	
CA_n46N-n48(4A)-n96A	CA_n46A-n48A CA_n48A-n96A	n46	CA_n46N_BCS1	0
		n48	CA_n48(4A)_BCS0	
		n96	20, 40, 60, 80	
CA_n46A-n48(4A)-n96B	CA_n46A-n48A CA_n48A-n96A	n46	10, 20, 40, 60, 80	0
		n48	CA_n48(4A)_BCS0	
		n96	CA_n96B_BCS0	
CA_n46B-n48(4A)-n96B	CA_n46A-n48A CA_n48A-n96A	n46	CA_n46B_BCS0	0
		n48	CA_n48(4A)_BCS0	
		n96	CA_n96B_BCS0	
CA_n46C-n48(4A)-n96B	CA_n46A-n48A CA_n48A-n96A	n46	CA_n46C_BCS0	0
		n48	CA_n48(4A)_BCS0	
		n96	CA_n96B_BCS0	
CA_n46D-n48(4A)-n96B	CA_n46A-n48A CA_n48A-n96A	n46	CA_n46D_BCS0	0
		n48	CA_n48(4A)_BCS0	
		n96	CA_n96B_BCS0	
CA_n46M-n48(4A)-n96B	-	n46	CA_n46M_BCS0	0
		n48	CA_n48(4A)_BCS0	
		n96	CA_n96B_BCS0	
CA_n46N-n48(4A)-n96B	CA_n46A-n48A CA_n48A-n96A	n46	CA_n46N_BCS1	0
		n48	CA_n48(4A)_BCS0	
		n96	CA_n96B_BCS0	
CA_n46A-n48(4A)-n96C	CA_n46A-n48A CA_n48A-n96A	n46	10, 20, 40, 60, 80	0
		n48	CA_n48(4A)_BCS0	
		n96	CA_n96C_BCS0	
CA_n46B-n48(4A)-n96C	CA_n46A-n48A CA_n48A-n96A	n46	CA_n46B_BCS0	0
		n48	CA_n48(4A)_BCS0	
		n96	CA_n96C_BCS0	
CA_n46C-n48(4A)-n96C	CA_n46A-n48A CA_n48A-n96A	n46	CA_n46C_BCS0	0
		n48	CA_n48(4A)_BCS0	
		n96	CA_n96C_BCS0	
CA_n46D-n48(4A)-n96C	CA_n46A-n48A CA_n48A-n96A	n46	CA_n46D_BCS0	0
		n48	CA_n48(4A)_BCS0	
		n96	CA_n96C_BCS0	
CA_n46M-n48(4A)-n96C	-	n46	CA_n46M_BCS0	0
		n48	CA_n48(4A)_BCS0	
		n96	CA_n96C_BCS0	
CA_n46N-n48(4A)-n96C	CA_n46A-n48A CA_n48A-n96A	n46	CA_n46N_BCS1	0

		n48	CA_n48(4A)_BCS0	
		n96	CA_n96C_BCS0	
CA_n46A-n48(4A)-n96D	CA_n46A-n48A CA_n48A-n96A	n46	10, 20, 40, 60, 80	0
		n48	CA_n48(4A)_BCS0	
		n96	CA_n96D_BCS0	
CA_n46B-n48(4A)-n96D	CA_n46A-n48A CA_n48A-n96A	n46	CA_n46B_BCS0	0
		n48	CA_n48(4A)_BCS0	
		n96	CA_n96D_BCS0	
CA_n46C-n48(4A)-n96D	CA_n46A-n48A CA_n48A-n96A	n46	CA_n46C_BCS0	0
		n48	CA_n48(4A)_BCS0	
		n96	CA_n96D_BCS0	
CA_n46D-n48(4A)-n96D	CA_n46A-n48A CA_n48A-n96A	n46	CA_n46D_BCS0	0
		n48	CA_n48(4A)_BCS0	
		n96	CA_n96D_BCS0	
CA_n46M-n48(4A)-n96D	CA_n46A-n48A CA_n48A-n96A	n46	CA_n46M_BCS0	0
		n48	CA_n48(4A)_BCS0	
		n96	CA_n96D_BCS0	
CA_n46N-n48(4A)-n96D	CA_n46A-n48A CA_n48A-n96A	n46	CA_n46N_BCS1	0
		n48	CA_n48(4A)_BCS0	
		n96	CA_n96D_BCS0	
CA_n46A-n48(4A)-n96E	CA_n46A-n48A CA_n48A-n96A	n46	10, 20, 40, 60, 80	0
		n48	CA_n48(4A)_BCS0	
		n96	CA_n96E_BCS0	
CA_n46B-n48(4A)-n96E	CA_n46A-n48A CA_n48A-n96A	n46	CA_n46B_BCS0	0
		n48	CA_n48(4A)_BCS0	
		n96	CA_n96E_BCS0	
CA_n46C-n48(4A)-n96E	CA_n46A-n48A CA_n48A-n96A	n46	CA_n46C_BCS0	0
		n48	CA_n48(4A)_BCS0	
		n96	CA_n96E_BCS0	
CA_n46D-n48(4A)-n96E	CA_n46A-n48A CA_n48A-n96A	n46	CA_n46D_BCS0	0
		n48	CA_n48(4A)_BCS0	
		n96	CA_n96E_BCS0	
CA_n46M-n48(4A)-n96E	-	n46	CA_n46M_BCS0	0
		n48	CA_n48(4A)_BCS0	
		n96	CA_n96E_BCS0	
CA_n46N-n48(4A)-n96E	CA_n46A-n48A CA_n48A-n96A	n46	CA_n46N_BCS1	0
		n48	CA_n48(4A)_BCS0	
		n96	CA_n96E_BCS0	
CA_n46A-n78A-n102A	CA_n46A-n78A CA_n78A-n102A	n46	10,20, 40, 60, 80, 100	0
		n78	10, 15, 20, 25, 30, 40, 50, 60, 70, 80, 90, 100	
		n102	20, 40, 60, 80, 100	
CA_n46A-n78A-n102B	CA_n46A-n78A CA_n78A-n102A CA_n78A-n102B	n46	10,20, 40, 60, 80, 100	0
		n78	10, 15, 20, 25, 30, 40, 50, 60, 70, 80, 90, 100	
		n102	CA_n102B_BCS0	
CA_n46A-n78A-n102C	CA_n46A-n78A CA_n78A-n102A CA_n78A-n102C	n46	10,20, 40, 60, 80, 100	0
		n78	10, 15, 20, 25, 30, 40, 50, 60, 70, 80, 90, 100	

CA_n46A-n78A-n102D	CA_n46A-n78A CA_n78A-n102A	n102	CA_n102C_BCS0	0
		n46	10,20, 40, 60, 80, 100	
		n78	10, 15, 20, 25, 30, 40, 50, 60, 70, 80, 90, 100	
CA_n46A-n78A-n102E	CA_n46A-n78A CA_n78A-n102A	n102	CA_n102D_BCS0	0
		n46	10,20, 40, 60, 80, 100	
		n78	10, 15, 20, 25, 30, 40, 50, 60, 70, 80, 90, 100	
CA_n46A-n78A-n102(2A)	CA_n46A-n78A CA_n78A-n102A	n102	CA_n102E_BCS0	0
		n46	10,20, 40, 60, 80, 100	
		n78	10, 15, 20, 25, 30, 40, 50, 60, 70, 80, 90, 100	
CA_n46(2A)-n78A-n102A	CA_n46A-n78A CA_n78A-n102A	n102	CA_n102(2A)_BCS0	0
		n46	CA_n46(2A)_BCS0	
		n78	10, 15, 20, 25, 30, 40, 50, 60, 70, 80, 90, 100	
CA_n46(2A)-n78A-n102B	CA_n46A-n78A CA_n78A-n102A CA_n78A-n102B	n102	20, 40, 60, 80, 100	0
		n46	CA_n46(2A)_BCS0	
		n78	10, 15, 20, 25, 30, 40, 50, 60, 70, 80, 90, 100	
CA_n46(2A)-n78A-n102C	CA_n46A-n78A CA_n78A-n102A CA_n78A-n102C	n102	CA_n102B_BCS0	0
		n46	CA_n46(2A)_BCS0	
		n78	10, 15, 20, 25, 30, 40, 50, 60, 70, 80, 90, 100	
CA_n46(2A)-n78A-n102D	CA_n46A-n78A CA_n78A-n102A	n102	CA_n102C_BCS0	0
		n46	CA_n46(2A)_BCS0	
		n78	10, 15, 20, 25, 30, 40, 50, 60, 70, 80, 90, 100	
CA_n46(2A)-n78A-n102E	CA_n46A-n78A CA_n78A-n102A	n102	CA_n102D_BCS0	0
		n46	CA_n46(2A)_BCS0	
		n78	10, 15, 20, 25, 30, 40, 50, 60, 70, 80, 90, 100	
CA_n46(2A)-n78A-n102(2A)	CA_n46A-n78A CA_n78A-n102A	n102	CA_n102E_BCS0	0
		n46	CA_n46(2A)_BCS0	
		n78	10, 15, 20, 25, 30, 40, 50, 60, 70, 80, 90, 100	
CA_n46C-n78A-n102A	CA_n46A-n78A CA_n78A-n102A	n102	CA_n102(2A)_BCS0	0
		n46	CA_n46C_BCS0	
		n78	10, 15, 20, 25, 30, 40, 50, 60, 70, 80, 90, 100	
CA_n46C-n78A-n102B	CA_n46A-n78A CA_n78A-n102A CA_n78A-n102B	n102	20, 40, 60, 80, 100	0
		n46	CA_n46C_BCS0	
		n78	10, 15, 20, 25, 30, 40, 50, 60, 70, 80, 90, 100	
CA_n46C-n78A-n102C	CA_n46A-n78A CA_n78A-n102A CA_n78A-n102C	n102	CA_n102B_BCS0	0
		n46	CA_n46C_BCS0	
		n78	10, 15, 20, 25, 30, 40, 50, 60, 70, 80, 90, 100	
CA_n46C-n78A-n102D	CA_n46A-n78A CA_n78A-n102A	n102	CA_n102C_BCS0	0
CA_n46C-n78A-n102D	CA_n46A-n78A CA_n78A-n102A	n46	CA_n46C_BCS0	0



		n78	10, 15, 20, 25, 30, 40, 50, 60, 70, 80, 90, 100	
		n102	CA_n102D_BCS0	
CA_n46C-n78A-n102E	CA_n46A-n78A CA_n78A-n102A	n46	CA_n46C_BCS0	0
		n78	10, 15, 20, 25, 30, 40, 50, 60, 70, 80, 90, 100	
		n102	CA_n102E_BCS0	
CA_n46C-n78A-n102(2A)	CA_n46A-n78A CA_n78A-n102A	n46	CA_n46C_BCS0	0
		n78	10, 15, 20, 25, 30, 40, 50, 60, 70, 80, 90, 100	
		n102	CA_n102(2A)_BCS0	
CA_n46D-n78A-n102A	CA_n46A-n78A CA_n78A-n102A	n46	CA_n46D_BCS0	0
		n78	10, 15, 20, 25, 30, 40, 50, 60, 70, 80, 90, 100	
		n102	20, 40, 60, 80, 100	
CA_n46D-n78A-n102B	CA_n46A-n78A CA_n78A-n102A CA_n78A-n102B	n46	CA_n46D_BCS0	0
		n78	10, 15, 20, 25, 30, 40, 50, 60, 70, 80, 90, 100	
		n102	CA_n102B_BCS0	
CA_n46D-n78A-n102C	CA_n46A-n78A CA_n78A-n102A CA_n78A-n102C	n46	CA_n46D_BCS0	0
		n78	10, 15, 20, 25, 30, 40, 50, 60, 70, 80, 90, 100	
		n102	CA_n102C_BCS0	
CA_n46D-n78A-n102D	CA_n46A-n78A CA_n78A-n102A	n46	CA_n46D_BCS0	0
		n78	10, 15, 20, 25, 30, 40, 50, 60, 70, 80, 90, 100	
		n102	CA_n102D_BCS0	
CA_n46D-n78A-n102E	CA_n46A-n78A CA_n78A-n102A	n46	CA_n46D_BCS0	0
		n78	10, 15, 20, 25, 30, 40, 50, 60, 70, 80, 90, 100	
		n102	CA_n102E_BCS0	
CA_n46D-n78A-n102(2A)	CA_n46A-n78A CA_n78A-n102A	n46	CA_n46D_BCS0	0
		n78	10, 15, 20, 25, 30, 40, 50, 60, 70, 80, 90, 100	
		n102	CA_n102(2A)_BCS0	
CA_n46A-n78(2A)-n102A	CA_n46A-n78A CA_n78A-n102A CA_n78(2A)	n46	10,20, 40, 60, 80, 100	0
		n78	CA_n78(2A)_BCS2	
		n102	20, 40, 60, 80, 100	
CA_n46A-n78(2A)-n102B	CA_n46A-n78A CA_n78A-n102A CA_n78A-n102B CA_n78(2A)	n46	10,20, 40, 60, 80, 100	0
		n78	CA_n78(2A)_BCS2	
		n102	CA_n102B_BCS0	
CA_n46A-n78(2A)-n102C	CA_n46A-n78A CA_n78A-n102A CA_n78A-n102C CA_n78(2A)	n46	10,20, 40, 60, 80, 100	0
		n78	CA_n78(2A)_BCS2	
		n102	CA_n102C_BCS0	
CA_n46A-n78(2A)-n102D	CA_n46A-n78A CA_n78A-n102A CA_n78(2A)	n46	10,20, 40, 60, 80, 100	0
		n78	CA_n78(2A)_BCS2	
		n102	CA_n102D_BCS0	

CA_n46A-n78(2A)-n102E	CA_n46A-n78A CA_n78A-n102A CA_n78(2A)	n46	10,20, 40, 60, 80, 100	0
		n78	CA_n78(2A)_BCS2	
		n102	CA_n102E_BCS0	
CA_n46A-n78(2A)-n102(2A)	CA_n46A-n78A CA_n78A-n102A CA_n78(2A)	n46	10,20, 40, 60, 80, 100	0
		n78	CA_n78(2A)_BCS2	
		n102	CA_n102(2A)_BCS0	
CA_n46(2A)-n78(2A)-n102A	CA_n46A-n78A CA_n78A-n102A CA_n78(2A)	n46	CA_n46(2A)_BCS0	0
		n78	CA_n78(2A)_BCS2	
		n102	20, 40, 60, 80, 100	
CA_n46(2A)-n78(2A)-n102B	CA_n46A-n78A CA_n78A-n102A CA_n78A-n102B CA_n78(2A)	n46	CA_n46(2A)_BCS0	0
		n78	CA_n78(2A)_BCS2	
		n102	CA_n102B_BCS0	
CA_n46(2A)-n78(2A)-n102C	CA_n46A-n78A CA_n78A-n102A CA_n78A-n102C CA_n78(2A)	n46	CA_n46(2A)_BCS0	0
		n78	CA_n78(2A)_BCS2	
		n102	CA_n102C_BCS0	
CA_n46(2A)-n78(2A)-n102D	CA_n46A-n78A CA_n78A-n102A CA_n78(2A)	n46	CA_n46(2A)_BCS0	0
		n78	CA_n78(2A)_BCS2	
		n102	CA_n102D_BCS0	
CA_n46(2A)-n78(2A)-n102E	CA_n46A-n78A CA_n78A-n102A CA_n78(2A)	n46	CA_n46(2A)_BCS0	0
		n78	CA_n78(2A)_BCS2	
		n102	CA_n102E_BCS0	
CA_n46(2A)-n78(2A)-n102(2A)	CA_n46A-n78A CA_n78A-n102A CA_n78(2A)	n46	CA_n46(2A)_BCS0	0
		n78	CA_n78(2A)_BCS2	
		n102	CA_n102(2A)_BCS0	
CA_n46C-n78(2A)-n102A	CA_n46A-n78A CA_n78A-n102A CA_n78(2A)	n46	CA_n46C_BCS0	0
		n78	CA_n78(2A)_BCS2	
		n102	20, 40, 60, 80, 100	
CA_n46C-n78(2A)-n102B	CA_n46A-n78A CA_n78A-n102A CA_n78A-n102B CA_n78(2A)	n46	CA_n46C_BCS0	0
		n78	CA_n78(2A)_BCS2	
		n102	CA_n102B_BCS0	
CA_n46C-n78(2A)-n102C	CA_n46A-n78A CA_n78A-n102A CA_n78A-n102C CA_n78(2A)	n46	CA_n46C_BCS0	0
		n78	CA_n78(2A)_BCS2	
		n102	CA_n102C_BCS0	
CA_n46C-n78(2A)-n102D	CA_n46A-n78A CA_n78A-n102A CA_n78(2A)	n46	CA_n46C_BCS0	0
		n78	CA_n78(2A)_BCS2	
		n102	CA_n102D_BCS0	
CA_n46C-n78(2A)-n102E	CA_n46A-n78A CA_n78A-n102A CA_n78(2A)	n46	CA_n46C_BCS0	0
		n78	CA_n78(2A)_BCS2	

		n102	CA_n102E_BCS0	
CA_n46C-n78(2A)-n102(2A)	CA_n46A-n78A CA_n78A-n102A CA_n78(2A)	n46	CA_n46C_BCS0	0
		n78	CA_n78(2A)_BCS2	
		n102	CA_n102(2A)_BCS0	
CA_n46D-n78(2A)-n102A	CA_n46A-n78A CA_n78A-n102A CA_n78(2A)	n46	CA_n46D_BCS0	0
		n78	CA_n78(2A)_BCS2	
		n102	20, 40, 60, 80, 100	
CA_n46D-n78(2A)-n102B	CA_n46A-n78A CA_n78A-n102A CA_n78A-n102B CA_n78(2A)	n46	CA_n46D_BCS0	0
		n78	CA_n78(2A)_BCS2	
		n102	CA_n102B_BCS0	
CA_n46D-n78(2A)-n102C	CA_n46A-n78A CA_n78A-n102A CA_n78A-n102C CA_n78(2A)	n46	CA_n46D_BCS0	0
		n78	CA_n78(2A)_BCS2	
		n102	CA_n102C_BCS0	
CA_n46D-n78(2A)-n102D	CA_n46A-n78A CA_n78A-n102A CA_n78(2A)	n46	CA_n46D_BCS0	0
		n78	CA_n78(2A)_BCS2	
		n102	CA_n102D_BCS0	
CA_n46D-n78(2A)-n102E	CA_n46A-n78A CA_n78A-n102A CA_n78(2A)	n46	CA_n46D_BCS0	0
		n78	CA_n78(2A)_BCS2	
		n102	CA_n102E_BCS0	
CA_n46D-n78(2A)-n102(2A)	CA_n46A-n78A CA_n78A-n102A CA_n78(2A)	n46	CA_n46D_BCS0	0
		n78	CA_n78(2A)_BCS2	
		n102	CA_n102(2A)_BCS0	
CA_n48A-n66A-n70A	CA_n48A-n66A CA_n48A-n70A	n48	5, 10, 15, 20, 30, 40, 50 <sup>12</sup> , 60 <sup>12</sup> , 70 <sup>12</sup> , 80 <sup>12</sup> , 90 <sup>12</sup> , 100 <sup>12</sup>	0
		n66	5, 10, 15, 20, 25, 30, 40	
		n70	5, 10, 15, 20 <sup>1</sup> , 25 <sup>1</sup>	
CA_n48A-n66(2A)-n70A	CA_n48A-n66A CA_n48A-n70A	n48	5, 10, 15, 20, 30, 40, 50 <sup>12</sup> , 60 <sup>12</sup> , 70 <sup>12</sup> , 80 <sup>12</sup> , 90 <sup>12</sup> , 100 <sup>12</sup>	0
		n66	CA_n66(2A)_BCS0	
		n70	5, 10, 15, 20 <sup>1</sup> , 25 <sup>1</sup>	
CA_n48(2A)-n66A-n70A	CA_n48A-n66A CA_n48A-n70A	n48	CA_n48(2A)_BCS1	0
		n66	5, 10, 15, 20, 25, 30, 40	
		n70	5, 10, 15, 20 <sup>1</sup> , 25 <sup>1</sup>	
CA_n48B-n66A-n70A	CA_n48A-n66A CA_n48A-n70A	n48	CA_n48B_BCS2	0
		n66	5, 10, 15, 20, 25, 30, 40	
		n70	5, 10, 15, 20 <sup>1</sup> , 25 <sup>1</sup>	
CA_n48A-n66A-n71A	CA_n48A-n66A CA_n48A-n71A CA_n66A-n71A	n48	5, 10, 15, 20, 30, 40, 50 <sup>12</sup> , 60 <sup>12</sup> , 70 <sup>12</sup> , 80 <sup>12</sup> , 90 <sup>12</sup> , 100 <sup>12</sup>	0
		n66	5, 10, 15, 20, 25, 30, 40	
		n71	5, 10, 15, 20	
CA_n48A-n66(2A)-n71A	CA_n48A-n66A CA_n48A-n71A CA_n66A-n71A	n48	5, 10, 15, 20, 30, 40, 50 <sup>12</sup> , 60 <sup>12</sup> , 70 <sup>12</sup> , 80 <sup>12</sup> , 90 <sup>12</sup> , 100 <sup>12</sup>	0
		n66	CA_n66(2A)_BCS0	
		n71	5, 10, 15, 20	
CA_n48(2A)-n66A-n71A	CA_n48A-n66A CA_n48A-n71A CA_n66A-n71A	n48	CA_n48(2A)_BCS1	0

		n66	5, 10, 15, 20, 25, 30, 40	
		n71	5, 10, 15, 20	
CA_n48B-n66A-n71A	CA_n48A-n66A CA_n48A-n71A CA_n66A-n71A	n48	CA_n48B_BCS2	0
		n66	5, 10, 15, 20, 25, 30, 40	
		n71	5, 10, 15, 20	
CA_n48A-n66A-n71(2A)	CA_n48A-n66A CA_n48A-n71A CA_n66A-n71A	n48	5, 10, 15, 20, 30, 40, 50 <sup>12</sup> , 60 <sup>12</sup> , 70 <sup>12</sup> , 80 <sup>12</sup> , 90 <sup>12</sup> , 100 <sup>12</sup>	0
		n66	5, 10, 15, 20, 25, 30, 40	
		n71	CA_n71(2A)_BCS0	
CA_n48A-n66A-n77A	n77 <sup>7,9</sup> CA_n48A-n66A CA_n66A-n77A <sup>7</sup>	n48	5, 10, 15, 20, 30, 40, 50 <sup>12</sup> , 60 <sup>12</sup> , 70 <sup>12</sup> , 80 <sup>12</sup> , 90 <sup>12</sup> , 100 <sup>12</sup>	0
		n66	5, 10, 15, 20, 25, 30, 40	
		n77	10, 15, 20, 25, 30, 40, 50, 60, 70, 80, 90, 100	
CA_n48A-n66(2A)-n77A	CA_n48A-n66A CA_n66A-n77A <sup>7</sup>	n48	5, 10, 15, 20, 30, 40, 50 <sup>12</sup> , 60 <sup>12</sup> , 70 <sup>12</sup> , 80 <sup>12</sup> , 90 <sup>12</sup> , 100 <sup>12</sup>	0
		n66	CA_n66(2A)_BCS0	
		n77	10, 15, 20, 25, 30, 40, 50, 60, 70, 80, 90, 100	
CA_n48A-n66A-n77C	n77 <sup>7,9</sup> CA_n48A-n66A CA_n66A-n77A <sup>7</sup> CA_n77C	n48	5, 10, 15, 20, 30, 40, 50 <sup>12</sup> , 60 <sup>12</sup> , 70 <sup>12</sup> , 80 <sup>12</sup> , 90 <sup>12</sup> , 100 <sup>12</sup>	0
		n66	5, 10, 15, 20, 25, 30, 40	
		n77	CA_n77C_BCS0	
		n48	5, 10, 15, 20, 30, 40, 50 <sup>12</sup> , 60 <sup>12</sup> , 70 <sup>12</sup> , 80 <sup>12</sup> , 90 <sup>12</sup> , 100 <sup>12</sup>	1
		n66	5, 10, 15, 20, 25, 30, 40	
		n77	CA_n77C_BCS1	
CA_n48B-n66A-n77C	n77 <sup>7,9</sup> CA_n48A-n66A CA_n66A-n77A <sup>7</sup> CA_n77C	n48	CA_n48B_BCS2	0
		n66	5, 10, 15, 20, 25, 30, 40	
		n77	CA_n77C_BCS1	
CA_n48B-n66A-n77A	n77 <sup>7,9</sup> CA_n48A-n66A CA_n66A-n77A <sup>7</sup>	n48	CA_n48B_BCS0	0
		n66	5, 10, 15, 20, 25, 30, 40	
		n77	10, 15, 20, 25, 30, 40, 50, 60, 70, 80, 90, 100	
		n48	CA_n48B_BCS1	1
		n66	5, 10, 15, 20, 25, 30, 40	
		n77	10, 15, 20, 25, 30, 40, 50, 60, 70, 80, 90, 100	
		n48	CA_n48B_BCS2	2
		n66	5, 10, 15, 20, 25, 30, 40	
		n77	10, 15, 20, 25, 30, 40, 50, 60, 70, 80, 90, 100	
CA_n48(2A)-n66A-n77A	n77 <sup>7,9</sup> CA_n48A-n66A CA_n66A-n77A <sup>7</sup>	n48	CA_n48(2A)_BCS0	0
		n66	5, 10, 15, 20, 25, 30, 40	
		n77	10, 15, 20, 25, 30, 40, 50, 60, 70, 80, 90, 100	
		n48	CA_n48(2A)_BCS1	1
		n66	5, 10, 15, 20, 25, 30, 40	
		n77	10, 15, 20, 25, 30, 40, 50, 60, 70, 80, 90, 100	
CA_n48(2A)-n66A-n77C	n77 <sup>7,9</sup> CA_n77C CA_n48A-n66A CA_n66A-n77A <sup>7</sup>	n48	CA_n48(2A)_BCS0	0

		n66	5, 10, 15, 20, 25, 30, 40	
		n77	CA_n77C_BCS0	
		n48	CA_n48(2A)_BCS0	1
		n66	5, 10, 15, 20, 25, 30, 40	
		n77	CA_n77C_BCS1	
		n48	CA_n48(2A)_BCS1	2
		n66	5, 10, 15, 20, 25, 30, 40	
		n77	CA_n77C_BCS0	
		n48	CA_n48(2A)_BCS1	3
		n66	5, 10, 15, 20, 25, 30, 40	
		n77	CA_n77C_BCS1	
CA_n48A-n70A-n71A	CA_n48A-n70A CA_n48A-n71A CA_n70A-n71A	n48	5, 10, 15, 20, 30, 40, 50 <sup>12</sup> , 60 <sup>12</sup> , 70 <sup>12</sup> , 80 <sup>12</sup> , 90 <sup>12</sup> , 100 <sup>12</sup>	0
		n70	5, 10, 15, 20 <sup>1</sup> , 25 <sup>1</sup>	
		n71	5, 10, 15, 20	
CA_n48(2A)-n70A-n71A	CA_n48A-n70A CA_n48A-n71A CA_n70A-n71A	n48	CA_n48(2A)_BCS1	0
		n70	5, 10, 15, 20 <sup>1</sup> , 25 <sup>1</sup>	
		n71	5, 10, 15, 20	
CA_n48B-n70A-n71A	CA_n48A-n70A CA_n48A-n71A CA_n70A-n71A	n48	CA_n48B_BCS2	0
		n70	5, 10, 15, 20 <sup>1</sup> , 25 <sup>1</sup>	
		n71	5, 10, 15, 20	
CA_n48A-n70A-n71(2A)	CA_n48A-n70A CA_n48A-n71A CA_n70A-n71A	n48	5, 10, 15, 20, 30, 40, 50 <sup>12</sup> , 60 <sup>12</sup> , 70 <sup>12</sup> , 80 <sup>12</sup> , 90 <sup>12</sup> , 100 <sup>12</sup>	0
		n70	5, 10, 15, 20 <sup>1</sup> , 25 <sup>1</sup>	
		n71	CA_n71(2A)_BCS0	
CA_n48A-n70A-n77A	CA_n48A-n70A CA_n70A-n77A	n48	5, 10, 15, 20, 30, 40, 50 <sup>12</sup> , 60 <sup>12</sup> , 70 <sup>12</sup> , 80 <sup>12</sup> , 90 <sup>12</sup> , 100 <sup>12</sup>	0
		n70	5, 10, 15, 20, 25	
		n77	10, 15, 20, 25, 30, 40, 50, 60, 70, 80, 90, 100	
CA_n48(2A)-n70A-n77A	CA_n48A-n70A CA_n70A-n77A	n48	CA_n48(2A)_BCS1	0
		n70	5, 10, 15, 20, 25	
		n77	10, 15, 20, 25, 30, 40, 50, 60, 70, 80, 90, 100	
CA_n48(2A)-n71A-n77A	CA_n48A-n71A CA_n71A-n77A	n48	CA_n48(2A)_BCS1	0
		n71	5, 10, 15, 20	
		n77	10, 15, 20, 25, 30, 40, 50, 60, 70, 80, 90, 100	
CA_n48A-n71A-n77A	CA_n48A-n71A CA_n71A-n77A	n48	5, 10, 15, 20, 30, 40, 50 <sup>12</sup> , 60 <sup>12</sup> , 70 <sup>12</sup> , 80 <sup>12</sup> , 90 <sup>12</sup> , 100 <sup>12</sup>	0
		n71	5, 10, 15, 20	
		n77	10, 15, 20, 25, 30, 40, 50, 60, 70, 80, 90, 100	
CA_n66A-n70A-n71A	CA_n66A-n71A CA_n70A-n71A	n66	5, 10, 15, 20, 40	0
		n70	5, 10, 15, 20 <sup>1</sup> , 25 <sup>1</sup>	
		n71	5, 10, 15, 20	
CA_n66A-n70A-n78A	CA_n66A-n78A CA_n70A-n78A	n66	10, 15, 20, 25, 30, 40	0
		n70	5, 10, 15, 20 <sup>1</sup> , 25 <sup>1</sup>	
		n78	10, 15, 20, 25, 30, 40, 50, 60, 70, 80, 90, 100	
CA_n66A-n70A-n71(2A)	CA_n66A-n71A CA_n70A-n71A	n66	5, 10, 15, 20, 25, 30, 40	0
		n70	5, 10, 15, 20 <sup>1</sup> , 25 <sup>1</sup>	
		n71	CA_n71(2A)_BCS0	
CA_n66B-n70A-n71A	CA_n66A-n71A CA_n70A-n71A	n66	CA_n66B_BCS0	0

		n70	5, 10, 15, 20 <sup>1</sup> , 25 <sup>1</sup>	
		n71	5, 10, 15, 20	
CA_n66(2A)-n70A-n71A	CA_n66A-n71A CA_n70A-n71A	n66	CA_n66(2A)_BCS0	0
		n70	5, 10, 15, 20 <sup>1</sup> , 25 <sup>1</sup>	
		n71	5, 10, 15, 20	
CA_n66(3A)-n70A-n71A	CA_n66A-n71A CA_n70A-n71A	n66	CA_n66(3A)_BCS0	0
		n70	5, 10, 15, 20 <sup>1</sup> , 25 <sup>1</sup>	
		n71	5, 10, 15, 20	
CA_n66A-n70A-n77A	CA_n66A-n77A CA_n70A-n77A	n66	5, 10, 15, 20, 25, 30, 35, 40	0
		n70	5, 10, 15, 20, 25	
		n77	10, 15, 20, 25, 30, 40, 50, 60, 70, 80, 90, 100	
CA_n66(2A)-n70A-n77A	CA_n66A-n77A CA_n70A-n77A	n66	CA_n66(2A)_BCS0	0
		n70	5, 10, 15, 20, 25	
		n77	10, 15, 20, 25, 30, 40, 50, 60, 70, 80, 90, 100	
CA_n66A-n71A-n77A	n77 <sup>7,9</sup> CA_n66A-n71A CA_n66A-n77A <sup>7</sup> CA_n71A-n77A <sup>7</sup>	n66	5, 10, 15, 20, 25, 30, 40	0
		n71	5, 10, 15, 20	
		n77	10, 15, 20, 25, 30, 40, 50, 60, 70, 80, 90, 100	
		n66	n66 channel bandwidths in Table 5.3.5-1	4 and 5
		n71	n71 channel bandwidths in Table 5.3.5-1	
n77	n77 channel bandwidths in Table 5.3.5-1			
CA_n66A-n71B-n77A	n77 <sup>7,9</sup> CA_n66A-n71A CA_n66A-n77A <sup>7</sup> CA_n71A-n77A <sup>7</sup>	n66	5, 10, 15, 20, 25, 30, 40	0
		n71	CA_n71B_BCS2	
		n77	10, 15, 20, 25, 30, 40, 50, 60, 70, 80, 90, 100	
		n66	n66 channel bandwidths in Table 5.3.5-1	4 and 5
		n71	CA_n71B BCS 4 and 5	
n77	n77 channel bandwidths in Table 5.3.5-1			
CA_n66A-n71B-n77(2A)	n77 <sup>7,9</sup> CA_n66A-n71A CA_n66A-n77A <sup>7</sup> CA_n71A-n77A <sup>7</sup>	n66	n66 channel bandwidths in Table 5.3.5-1	4 and 5
		n71	CA_n71B BCS 4 and 5	
		n77	CA_n77(2A) BCS 4 and 5	
CA_n66A-n71(2A)-n77A	n77 <sup>7,9</sup> CA_n66A-n71A CA_n66A-n77A <sup>7</sup> CA_n71A-n77A <sup>7</sup>	n66	5, 10, 15, 20, 25, 30, 40	0
		n71	CA_n71(2A)_BCS0	
		n77	10, 15, 20, 25, 30, 40, 50, 60, 70, 80, 90, 100	
		n66	n66 channel bandwidths in Table 5.3.5-1	4 and 5
		n71	CA_n71(2A) BCS 4 and 5	
n77	n77 channel bandwidths in Table 5.3.5-1			
CA_n66A-n71(2A)-n77(2A)	n77 <sup>7,9</sup> CA_n66A-n71A CA_n66A-n77A <sup>7</sup> CA_n71A-n77A <sup>7</sup>	n66	n66 channel bandwidths in Table 5.3.5-1	4 and 5

		n71	CA_n71(2A) BCS 4 and 5		
		n77	CA_n77(2A) BCS 4 and 5		
CA_n66(2A)-n71A-n77A	n77 <sup>7,9</sup> CA_n66A-n71A CA_n66A-n77A <sup>7</sup> CA_n71A-n77A <sup>7</sup>	n66	CA_n66(2A)_BCS1	0	
		n71	5, 10, 15, 20		
		n77	10, 15, 20, 25, 30, 40, 50, 60, 70, 80, 90, 100		
	CA_n66A-n71A CA_n66A-n77A CA_n71A-n77A	n66	CA_n66(2A) BCS 4 and 5	4 and 5	
		n71	n71 channel bandwidths in Table 5.3.5-1		
		n77	n77 channel bandwidths in Table 5.3.5-1		
CA_n66A-n71A-n77(2A)	n77 <sup>7,9</sup> CA_n77(2A) <sup>7</sup> CA_n66A-n71A CA_n66A-n77A <sup>7</sup> CA_n71A-n77A <sup>7</sup>	n66	5, 10, 15, 20, 25, 30, 40	0	
		n71	5, 10, 15, 20		
		n77	CA_n77(2A)_BCS1		
	CA_n66A-n71A-n77(3A)	n77 <sup>7,9</sup> CA_n77(2A) <sup>7</sup> CA_n66A-n71A CA_n66A-n77A <sup>7</sup> CA_n71A-n77A <sup>7</sup>	n66	n66 channel bandwidths in Table 5.3.5-1	4 and 5
			n71	n71 channel bandwidths in Table 5.3.5-1	
			n77	CA_n77(2A) BCS 4 and 5	
CA_n66A-n71A-n77(3A)	n77 <sup>7,9</sup> CA_n77(2A) <sup>7</sup> CA_n66A-n71A CA_n66A-n77A <sup>7</sup> CA_n71A-n77A <sup>7</sup>	n66	5, 10, 15, 20, 25, 30, 40	0	
		n71	5, 10, 15, 20		
		n77	CA_n77(3A)_BCS1		
CA_n66(2A)-n71B-n77A	n77 <sup>7,9</sup> CA_n66A-n71A CA_n66A-n77A <sup>7</sup> CA_n71A-n77A <sup>7</sup>	n66	CA_n66(2A)_BCS 4 and 5	4 and 5	
		n71	CA_n71B_BCS 4 and 5		
		n77	n77 channel bandwidths in Table 5.3.5-1		
CA_n66(2A)-n71B-n77(2A)	n77 <sup>7,9</sup> CA_n66A-n71A CA_n66A-n77A <sup>7</sup> CA_n71A-n77A <sup>7</sup>	n66	CA_n66(2A)_BCS 4 and 5	4 and 5	
		n71	CA_n71B_BCS 4 and 5		
		n77	CA_n77(2A) BCS 4 and 5		
CA_n66(2A)-n71(2A)-n77A	n77 <sup>7,9</sup> CA_n66A-n71A CA_n66A-n77A <sup>7</sup> CA_n71A-n77A <sup>7</sup>	n66	CA_n66(2A)_BCS 4 and 5	4 and 5	
		n71	CA_n71(2A)_BCS 4 and 5		
		n77	n77 channel bandwidths in Table 5.3.5-1		
CA_n66(2A)-n71A-n77(2A)	n77 <sup>7,9</sup> CA_n66A-n71A CA_n66A-n77A <sup>7</sup> CA_n71A-n77A <sup>7</sup>	n66	CA_n66(2A)_BCS1	0	
		n71	5, 10, 15, 20		
		n77	CA_n77(2A)_BCS1		
	CA_n66(2A)-n71(2A)-n77A	n77 <sup>7,9</sup> CA_n66A-n71A CA_n66A-n77A <sup>7</sup> CA_n71A-n77A <sup>7</sup>	n66	CA_n66(2A) BCS 4 and 5	4 and 5
			n71	n71 channel bandwidths in Table 5.3.5-1	
			n77	CA_n77(2A) BCS 4 and 5	
CA_n66(2A)-n71(2A)-n77(2A)	n77 <sup>7,9</sup> CA_n66A-n71A CA_n66A-n77A <sup>7</sup> CA_n71A-n77A <sup>7</sup>	n66	CA_n66(2A) BCS 4 and 5	4 and 5	

		n71	CA_n71(2A)_BCS 4 and 5	
		n77	CA_n77(2A) BCS 4 and 5	
CA_n66A-n71A-n78A	CA_n66A-n71A CA_n66A-n78A CA_n71A-n78A	n66	5, 10, 15, 20, 25, 30, 40	0
		n71	5, 10, 15, 20	
		n78	10, 15, 20, 25, 30, 40, 50, 60, 70, 80, 90, 100	
CA_n66A-n71A-n78(2A)	CA_n66A-n71A CA_n66A-n78A CA_n71A-n78A	n66	5, 10, 15, 20, 25, 30, 40	0
		n71	5, 10, 15, 20	
		n78	CA_n78(2A)_BCS2	
CA_n66(2A)-n71A-n78A	CA_n66A-n71A CA_n66A-n78A CA_n71A-n78A	n66	CA_n66(2A)_BCS1	0
		n71	5, 10, 15, 20	
		n78	10, 15, 20, 25, 30, 40, 50, 60, 70, 80, 90, 100	
CA_n66(2A)-n71A-n78(2A)	CA_n66A-n71A CA_n66A-n78A CA_n71A-n78A	n66	CA_n66(2A)_BCS1	0
		n71	5, 10, 15, 20	
		n78	CA_n78(2A)_BCS2	
CA_n66A-n71A-n85A	CA_n66A-n71A CA_n66A-n85A	n66	n66 channel bandwidths in Table 5.3.5-1	4 and 5
		n71	n71 channel bandwidths in Table 5.3.5-1	
		n85	n85 channel bandwidths in Table 5.3.5-1	
CA_n66A-n71B-n85A	CA_n66A-n71A CA_n66A-n85A	n66	n66 channel bandwidths in Table 5.3.5-1	4 and 5
		n71	CA_n71B BCS 4 and 5	
		n85	n85 channel bandwidths in Table 5.3.5-1	
CA_n66A-n71(2A)-n85A	CA_n66A-n71A CA_n66A-n85A	n66	n66 channel bandwidths in Table 5.3.5-1	4 and 5
		n71	CA_n71(2A) BCS 4 and 5	
		n85	n85 channel bandwidths in Table 5.3.5-1	
CA_n66(2A)-n71A-n85A	CA_n66A-n71A CA_n66A-n85A	n66	CA_n66(2A) BCS 4 and 5	4 and 5
		n71	n71 channel bandwidths in Table 5.3.5-1	
		n85	n85 channel bandwidths in Table 5.3.5-1	
CA_n66A-n77A-n85A	CA_n66A-n77A CA_n66A-n85A CA_n77A-n85A	n66	n66 channel bandwidths in Table 5.3.5-1	4 and 5
		n77	n77 channel bandwidths in Table 5.3.5-1	
		n85	n85 channel bandwidths in Table 5.3.5-1	
CA_n66A-n77(2A)-n85A	CA_n66A-n77A CA_n66A-n85A CA_n77A-n85A	n66	n66 channel bandwidths in Table 5.3.5-1	4 and 5
		n77	CA_n77(2A) BCS 4 and 5	
		n85	n85 channel bandwidths in Table 5.3.5-1	
CA_n66(2A)-n77A-n85A	CA_n66A-n77A CA_n66A-n85A CA_n77A-n85A	n66	CA_n66(2A) BCS 4 and 5	4 and 5
		n77	n77 channel bandwidths in Table 5.3.5-1	
		n85	n85 channel bandwidths in Table 5.3.5-1	



CA_n70A-n71A-n77A	CA_n70A-n71A CA_n70A-n77A CA_n71A-n77A	n70	5, 10, 15, 20, 25	0
		n71	5, 10, 15, 20	
		n77	10, 15, 20, 25, 30, 40, 50, 60, 70, 80, 90, 100	

The following notes are applied to the above tables.

- NOTE 1: This UE channel bandwidth is applicable only to downlink
- NOTE 2: For the 20 MHz bandwidth, the minimum requirements are specified for NR UL carrier frequencies confined to either 713-723 MHz or 728-738 MHz.
- NOTE 3: For each channel bandwidth of each component carrier, refer to Table 5.3.5-1 for the applicable SCSs. For a given band, not all UE channel bandwidths support the same SCSs.
- NOTE 4: The minimum requirements only apply for non-simultaneous Tx/Rx between all carriers for TDD combinations.
- NOTE 5: Simultaneous Rx/Tx capability for TDD combinations does not apply for UEs supporting band n78 with an n77 implementation.
- NOTE 6: Only single uplink carriers with power class other than PC3 are listed.
- NOTE 7: Minimum requirements for Power Class 2 are applicable for this uplink combination or single uplink carrier in this downlink/uplink combination
- NOTE 8: For this bandwidth, the minimum requirements are restricted to operation when carrier is configured as an SCell part of DC or CA configuration.
- NOTE 9: Minimum requirements for Power Class 1.5 are applicable for single uplink carrier in this downlink/uplink combination
- NOTE 10: For a band combination which include band n7 and n38 simultaneously, carriers in band n7 and n38 can only be configured as downlink carriers. Power imbalance between downlink carriers on Band n7 and Band n38 is assumed to be within 6dB.
- NOTE 11: UL carrier shall be supported in Band n28 only. Power imbalance between downlink carriers on Band 7 and Band 38 is assumed to be within 6dB.
- NOTE 12: For this bandwidth, the minimum requirements are restricted to operation when carrier is configured as a downlink SCell part of CA configuration

### 5.5A.3.3 Configurations for inter-band CA (four bands)

**Table 5.5A.3.3-1: Void**

Table 5.5A.3.3-1a

**Table 5.5A.3.3-1a: NR CA configurations and bandwidth combinations sets defined for inter-band CA (four bands)**

NR CA configuration	Uplink CA configuration or single uplink carrier <sup>4</sup>	NR Band	Channel bandwidth (MHz) (NOTE 3)	Bandwidth combination set
CA_n1A-n3A-n5A-n7A	CA_n1A-n3A CA_n1A-n5A CA_n1A-n7A CA_n3A-n5A CA_n3A-n7A CA_n5A-n7A	n1	5, 10, 15, 20	0
		n3	5, 10, 15, 20, 25, 30, 40, 50	
		n5	5, 10, 15, 20	
		n7	5, 10, 15, 20, 25, 30, 40, 50	
CA_n1A-n3A-n5A-n7B	CA_n1A-n3A CA_n1A-n5A CA_n1A-n7A CA_n3A-n5A CA_n3A-n7A	n1	5, 10, 15, 20	0

	CA_n5A-n7A CA_n7B	n3	5, 10, 15, 20, 25, 30, 40, 50	
		n5	5, 10, 15, 20	
		n7	CA_n7B_BCS0	
CA_n1A-n3A-n5A-n28A	CA_n1A-n3A CA_n1A-n5A CA_n1A-n28A CA_n3A-n5A CA_n3A-n28A CA_n5A-n28A	n1	n1 channel bandwidths in Table 5.3.5-1	4 and 5
		n3	n3 channel bandwidths in Table 5.3.5-1	
		n5	n5 channel bandwidths in Table 5.3.5-1	
		n28	n28 channel bandwidths in Table 5.3.5-1	
CA_n1A-n3A-n5A-n78A	CA_n1A-n3A CA_n1A-n5A CA_n1A-n78A CA_n3A-n5A CA_n3A-n78A CA_n5A-n78A	n1	5, 10, 15, 20, 25, 30, 40, 50	0
		n3	5, 10, 15, 20, 25, 30, 40, 50	
		n5	5, 10, 15, 20	
		n78	10, 15, 20, 25, 30, 40, 50, 60, 70, 80, 90, 100	
CA_n1A-n3A-n7A-n8A	CA_n1A-n3A CA_n1A-n7A CA_n1A-n8A CA_n3A-n7A CA_n3A-n8A CA_n7A-n8A	n1	5, 10, 15, 20	0
		n3	5, 10, 15, 20, 25, 30	
		n7	5, 10, 15, 20, 25, 30, 40, 50	
		n8	5, 10, 15, 20	
CA_n1A-n3(2A)-n7A-n8A	CA_n1A-n3A CA_n1A-n7A CA_n1A-n8A CA_n3A-n7A CA_n3A-n8A CA_n7A-n8A	n1	5, 10, 15, 20	0
		n3	CA_n3(2A)_BCS0	
		n7	5, 10, 15, 20, 25, 30, 40, 50	
		n8	5, 10, 15, 20	
CA_n1A-n3A-n7(2A)-n8A	CA_n1A-n3A CA_n1A-n7A CA_n1A-n8A CA_n3A-n7A CA_n3A-n8A CA_n7A-n8A	n1	5, 10, 15, 20	0
		n3	5, 10, 15, 20, 25, 30	
		n7	CA_n7(2A)_BCS0	
		n8	5, 10, 15, 20	
CA_n1A-n3(2A)-n7(2A)-n8A	CA_n1A-n3A CA_n1A-n7A CA_n1A-n8A CA_n3A-n7A CA_n3A-n8A CA_n7A-n8A	n1	5, 10, 15, 20	0
		n3	CA_n3(2A)_BCS0	
		n7	CA_n7(2A)_BCS0	
		n8	5, 10, 15, 20	
CA_n1A-n3A-n7A-n26A	CA_n1A-n3A CA_n1A-n7A CA_n1A-n26A CA_n3A-n7A	n1	5, 10, 15, 20	0

	CA_n3A-n26A CA_n7A-n26A	n3	5, 10, 15, 20, 25, 30, 40, 50	0
		n7	5, 10, 15, 20, 25, 30, 40, 50	
		n26	5, 10, 15, 20	
		n1	5, 10, 15, 20	
CA_n1A-n3B-n7A-n26A	CA_n3B CA_n1A-n3A CA_n1A-n7A CA_n1A-n26A CA_n3A-n7A CA_n3A-n26A CA_n7A-n26A	n3	CA_n3B_BCS0	0
		n7	5, 10, 15, 20, 25, 30, 40, 50	
		n26	5, 10, 15, 20	
		n1	5, 10, 15, 20	
CA_n1A-n3A-n7B-n26A	CA_n1A-n3A CA_n1A-n7A CA_n1A-n26A CA_n3A-n7A CA_n3A-n26A CA_n7A-n26A CA_n7B	n3	5, 10, 15, 20, 25, 30, 40, 50	0
		n7	CA_n7B_BCS0	
		n26	5, 10, 15, 20	
		n1	5, 10, 15, 20	
CA_n1A-n3B-n7B-n26A	CA_n7B CA_n1A-n3A CA_n1A-n7A CA_n1A-n26A CA_n3A-n7A CA_n3A-n26A CA_n7A-n26A	n3	CA_n3B_BCS0	0
		n7	CA_n7B_BCS0	
		n26	5, 10, 15, 20	
		n1	5, 10, 15, 20	
CA_n1A-n3A-n7A-n26(2A)	CA_n1A-n3A CA_n1A-n7A CA_n1A-n26A CA_n3A-n7A CA_n3A-n26A CA_n7A-n26A CA_n26(2A)	n3	5, 10, 15, 20, 25, 30, 40, 50	0
		n7	5, 10, 15, 20, 25, 30, 40, 50	
		n26	CA_n26(2A)_BCS0	
		n1	5, 10, 15, 20	
CA_n1A-n3B-n7A-n26(2A)	CA_n1A-n3A CA_n1A-n7A CA_n1A-n26A CA_n3A-n7A CA_n3A-n26A CA_n7A-n26A CA_n26(2A)	n3	CA_n3B_BCS0	0
		n7	5, 10, 15, 20, 25, 30, 40, 50	
		n26	CA_n26(2A)_BCS0	
		n1	5, 10, 15, 20	
CA_n1A-n3A-n7B-n26(2A)	CA_n7B CA_n26(2A) CA_n1A-n3A CA_n1A-n7A CA_n1A-n26A CA_n3A-n7A CA_n3A-n26A CA_n7A-n26A	n3	5, 10, 15, 20, 25, 30, 40, 50	0
		n7	CA_n7B_BCS0	
		n26	CA_n26(2A)_BCS0	
		n1	5, 10, 15, 20	
CA_n1A-n3B-n7B-n26(2A)	CA_n7B CA_n26(2A) CA_n1A-n3A	n3	5, 10, 15, 20	0
		n7	5, 10, 15, 20	
		n26	5, 10, 15, 20	
		n1	5, 10, 15, 20	

	CA_n1A-n7A CA_n1A-n26A CA_n3A-n7A CA_n3A-n26A CA_n7A-n26A	n3	CA_n3B_BCS0	
		n7	CA_n7B_BCS0	
		n26	CA_n26(2A)_BCS0	
CA_n1A-n3A-n7A-n28A	-	n1	5, 10, 15, 20	0
		n3	5, 10, 15, 20, 25, 30	
		n7	5, 10, 15, 20, 25, 30, 40, 50	
		n28	5, 10, 15, 20	
	CA_n1A-n3A CA_n1A-n7A CA_n1A-n28A CA_n3A-n7A CA_n3A-n28A CA_n7A-n28A	n1	5, 10, 15, 20	1
		n3	5, 10, 15, 20, 25, 30, 40	
		n7	5, 10, 15, 20, 25, 30, 40, 50	
		n28	5, 10, 15, 20 <sup>2</sup>	
CA_n1A-n3A-n7B-n28A	-	n1	5, 10, 15, 20	0
		n3	5, 10, 15, 20, 25, 30	
		n7	CA_n7B_BCS0	
		n28	5, 10, 15, 20	
	CA_n1A-n3A CA_n1A-n7A CA_n1A-n28A CA_n3A-n7A CA_n3A-n28A CA_n7A-n28A CA_n7B	n1	5, 10, 15, 20	1
		n3	5, 10, 15, 20, 25, 30, 40	
		n7	CA_n7B_BCS0	
		n28	5, 10, 15, 20	
CA_n1A-n3B-n7A-n28A	CA_n1A-n3A CA_n1A-n7A CA_n1A-n28A CA_n3A-n7A CA_n3A-n28A CA_n7A-n28A	n1	5, 10, 15, 20	0
		n3	CA_n3B_BCS0	
		n7	5, 10, 15, 20, 25, 30, 40, 50	
		n28	5, 10, 15, 20	
CA_n1A-n3B-n7B-n28A	CA_n7B CA_n1A-n3A CA_n1A-n7A CA_n1A-n28A CA_n3A-n7A CA_n3A-n28A CA_n7A-n28A	n1	5, 10, 15, 20, 25, 30, 40, 45, 50	0
		n3	CA_n3B_BCS0	
		n7	CA_n7B_BCS0	
		n28	5, 10, 15, 20	
CA_n1A-n3A-n7A-n38A <sup>7</sup>	-	n1	5, 10, 15, 20, 25, 30, 40, 45, 50	0
		n3	5, 10, 15, 20, 25, 30, 35, 40, 45, 50	
		n7	5, 10, 15, 20, 25, 30, 40, 50	
		n38	5, 10, 15, 20, 25, 30, 40	
CA_n1(2A)-n3A-n7A-n38A <sup>7</sup>	-	n1	CA_n1(2A)_BCS0	0
		n3	5, 10, 15, 20, 25, 30, 35, 40, 45, 50	
		n7	5, 10, 15, 20, 25, 30, 40, 50	

CA_n1A-n3B-n7A-n38A <sup>7</sup>	-	n38	5, 10, 15, 20, 25, 30, 40	0			
		n1	5, 10, 15, 20, 25, 30, 40, 45, 50				
		n3	CA_n3B_BCS0				
		n7	5, 10, 15, 20, 25, 30, 40, 50				
CA_n1(2A)-n3B-n7A-n38A <sup>7</sup>	-	n38	5, 10, 15, 20, 25, 30, 40	0			
		n1	CA_n1(2A)_BCS0				
		n3	CA_n3B_BCS0				
		n7	5, 10, 15, 20, 25, 30, 40, 50				
CA_n1A-n3(2A)-n7A-n38A <sup>7</sup>	-	n38	5, 10, 15, 20, 25, 30, 40	0			
		n1	5, 10, 15, 20, 25, 30, 40, 45, 50				
		n3	CA_n3(2A)_BCS1				
		n7	5, 10, 15, 20, 25, 30, 40, 50				
CA_n1(2A)-n3(2A)-n7A-n38A <sup>7</sup>	-	n38	5, 10, 15, 20, 25, 30, 40	0			
		n1	CA_n1(2A)_BCS0				
		n3	CA_n3(2A)_BCS1				
		n7	5, 10, 15, 20, 25, 30, 40, 50				
CA_n1A-n3A-n7A-n40A	CA_n1A-n3A CA_n1A-n7A CA_n1A-n40A CA_n3A-n7A CA_n3A-n40A CA_n7A-n40A	n38	5, 10, 15, 20, 25, 30, 40	0			
		n1	5, 10, 15, 20, 25, 30, 40, 45, 50				
		n3	5, 10, 15, 20, 25, 30, 40, 50				
		n7	5, 10, 15, 20, 25, 30, 40, 50				
CA_n1A-n3A-n7A-n67A	CA_n1A-n3A CA_n1A-n7A CA_n3A-n7A	n40	10, 15, 20, 25, 30, 40, 50, 60, 70, 80, 90, 100	0			
		n1	5, 10, 15, 20, 25, 30, 40, 50				
		n3	5, 10, 15, 20, 25, 30, 35, 40, 45, 50				
		n7	5, 10, 15, 20, 25, 30, 40, 50				
CA_n1A-n3A-n7A-n75A	-	n67	5, 10, 15, 20	4 and 5			
		n1	n1 channel bandwidths in Table 5.3.5-1				
		n3	n3 channel bandwidths in Table 5.3.5-1				
		n7	n7 channel bandwidths in Table 5.3.5-1				
CA_n1A-n3A-n7A-n78A	CA_n1A-n3A CA_n1A-n7A CA_n1A-n78A CA_n3A-n7A CA_n3A-n78A CA_n7A-n78A	n75	n75 channel bandwidths in Table 5.3.5-1	0			
		n1	5, 10, 15, 20				
		n3	5, 10, 15, 20, 25, 30				
		n7	5, 10, 15, 20, 25, 30, 40, 50				
		n78	10, 15, 20, 25, 30, 40, 50, 60, 70, 80, 90, 100				
		n1	5, 10, 15, 20		1		
		n3	5, 10, 15, 20, 25, 30, 40				
		n7	5, 10, 15, 20, 25, 30, 40, 50				
		CA_n1A-n3A-n7A-n78A	-		n78	10, 15, 20, 25, 30, 40, 50, 60, 70, 80, 90, 100	2
					n1	5, 10, 15, 20, 25, 30, 40, 50	
					n3	5, 10, 15, 20, 25, 30, 40, 50	
					n7	5, 10, 15, 20, 25, 30, 40, 50	
CA_n1A-n3A-n7A-n78A	-	n78	10, 15, 20, 25, 30, 40, 50, 60, 70, 80, 90, 100	0			
		n1	5, 10, 15, 20, 25, 30, 40, 50				
		n3	5, 10, 15, 20, 25, 30, 40, 50				
		n7	5, 10, 15, 20, 25, 30, 40, 50				

		n1	n1 channel bandwidths in Table 5.3.5-1	4 and 5
		n3	n3 channel bandwidths in Table 5.3.5-1	
		n7	n7 channel bandwidths in Table 5.3.5-1	
		n78	n78 channel bandwidths in Table 5.3.5-1	
CA_n1A-n3B-n7A-n78A	CA_n1A-n3A CA_n1A-n7A CA_n1A-n78A CA_n3A-n7A CA_n3A-n78A CA_n7A-n78A	n1	5, 10, 15, 20	0
		n3	CA_n3B_BCS0	
		n7	5, 10, 15, 20, 25, 30, 40, 50	
		n78	10, 15, 20, 25, 30, 40, 50, 60, 70, 80, 90, 100	
CA_n1A-n3B-n7B-n78A	CA_n7B CA_n1A-n3A CA_n1A-n7A CA_n1A-n78A CA_n3A-n7A CA_n3A-n78A CA_n7A-n78A	n1	5, 10, 15, 20	0
		n3	CA_n3B_BCS0	
		n7	CA_n7B_BCS0	
		n78	10, 15, 20, 25, 30, 40, 50, 60, 70, 80, 90, 100	
CA_n1A-n3A-n7A-n78(2A)	CA_n78(2A) CA_n1A-n3A CA_n1A-n7A CA_n1A-n78A CA_n3A-n7A CA_n3A-n78A CA_n7A-n78A	n1	5, 10, 15, 20	0
		n3	5, 10, 15, 20, 25, 30, 40	
		n7	5, 10, 15, 20, 25, 30, 40, 50	
		n78	CA_n78(2A)_BCS2	
CA_n1A-n3A-n7A-n78C	CA_n78C CA_n1A-n3A CA_n1A-n7A CA_n1A-n78A CA_n3A-n7A CA_n3A-n78A CA_n7A-n78A	n1	5, 10, 15, 20	0
		n3	5, 10, 15, 20, 25, 30, 40	
		n7	5, 10, 15, 20, 25, 30, 40, 50	
		n78	CA_n78C_BCS0	
CA_n1A-n3A-n7B-n78A	-	n1	5, 10, 15, 20	0
		n3	5, 10, 15, 20, 25, 30	
		n7	CA_n7B_BCS0	
		n78	10, 15, 20, 25, 30, 40, 50, 60, 70, 80, 90, 100	
	CA_n1A-n3A CA_n1A-n7A CA_n1A-n78A CA_n3A-n7A CA_n3A-n78A CA_n7A-n78A CA_n7B	n1	5, 10, 15, 20, 25, 30, 40, 50	1
		n3	5, 10, 15, 20, 25, 30, 40, 50	
		n7	CA_n7B_BCS0	
		n78	10, 15, 20, 25, 30, 40, 50, 60, 70, 80, 90, 100	
CA_n1A-n3B-n7A-	CA_n1A-n3A	n1	5, 10, 15, 20	0

n78(2A)	CA_n1A-n7A CA_n1A-n78A CA_n3A-n7A CA_n3A-n78A CA_n7A-n78A	n3	CA_n3B_BCS0	
		n7	5, 10, 15, 20, 25, 30, 40, 50	
		n78	CA_n78(2A)_BCS2	
CA_n1A-n3B-n7A-n78C	CA_n1A-n3A CA_n1A-n7A CA_n1A-n78A CA_n3A-n7A CA_n3A-n78A CA_n7A-n78A CA_n78C	n1	5, 10, 15, 20	0
		n3	CA_n3B_BCS0	
		n7	5, 10, 15, 20, 25, 30, 40, 50	
		n78	CA_n78C_BCS0	
CA_n1A-n3A-n7B-n78(2A)	CA_n1A-n3A CA_n1A-n7A CA_n1A-n78A CA_n3A-n7A CA_n3A-n78A CA_n7A-n78A CA_n7B	n1	5, 10, 15, 20	0
		n3	5, 10, 15, 20, 25, 30	
		n7	CA_n7B_BCS0	
		n78	CA_n78(2A)_BCS2	
CA_n1A-n3A-n7B-n78C	CA_n1A-n3A CA_n1A-n7A CA_n1A-n78A CA_n3A-n7A CA_n3A-n78A CA_n7A-n78A CA_n7B CA_n78C	n1	5, 10, 15, 20	0
		n3	5, 10, 15, 20, 25, 30	
		n7	CA_n7B_BCS0	
		n78	CA_n78C_BCS0	
CA_n1A-n3B-n7B-n78(2A)	CA_n1A-n3A CA_n1A-n7A CA_n1A-n78A CA_n3A-n7A CA_n3A-n78A CA_n7A-n78A CA_n7B	n1	5, 10, 15, 20	0
		n3	CA_n3B_BCS0	
		n7	CA_n7B_BCS0	
		n78	CA_n78(2A)_BCS0	
CA_n1A-n3B-n7B-n78C	CA_n1A-n3A CA_n1A-n7A CA_n1A-n78A CA_n3A-n7A CA_n3A-n78A CA_n7A-n78A CA_n7B CA_n78C	n1	5, 10, 15, 20	0
		n3	CA_n3B_BCS0	
		n7	CA_n7B_BCS0	
		n78	CA_n78C_BCS0	
CA_n1A-n3(2A)-n7A-n78A	CA_n1A-n3A CA_n1A-n7A CA_n1A-n78A CA_n3A-n7A CA_n3A-n78A CA_n7A-n78A	n1	5, 10, 15, 20	0
		n3	CA_n3(2A)_BCS0	

		n7	5, 10, 15, 20, 25, 30, 40, 50	
		n78	10, 15, 20, 25, 30, 40, 50, 60, 70, 80, 90, 100	
CA_n1A-n3A-n7(2A)-n78A	CA_n1A-n3A CA_n1A-n7A CA_n1A-n78A CA_n3A-n7A CA_n3A-n78A CA_n7A-n78A	n1	5, 10, 15, 20	0
		n3	5, 10, 15, 20, 25, 30	
		n7	CA_n7(2A)_BCS0	
		n78	10, 15, 20, 25, 30, 40, 50, 60, 70, 80, 90, 100	
CA_n1A-n3(2A)-n7(2A)-n78A	CA_n1A-n3A CA_n1A-n7A CA_n1A-n78A CA_n3A-n7A CA_n3A-n78A CA_n7A-n78A	n1	5, 10, 15, 20	0
		n3	CA_n3(2A)_BCS0	
		n7	CA_n7(2A)_BCS0	
		n78	10, 15, 20, 25, 30, 40, 50, 60, 70, 80, 90, 100	
CA_n1A-n3A-n7A-n79A	-	n1	5, 10, 15, 20, 25, 30, 40, 50	0
		n3	5, 10, 15, 20, 25, 30, 40, 50	
		n7	5, 10, 15, 20, 25, 30, 40, 50	
		n79	40, 50, 60, 80, 100	
CA_n1A-n3A-n7A-n79C	-	n1	5, 10, 15, 20, 25, 30, 40, 50	0
		n3	5, 10, 15, 20, 25, 30, 40, 50	
		n7	5, 10, 15, 20, 25, 30, 40, 50	
		n79	CA_n79C_BCS0	
CA_n1(2A)-n3A-n7A-n79A	-	n1	CA_n1(2A)_BCS0	0
		n3	5, 10, 15, 20, 25, 30, 40, 50	
		n7	5, 10, 15, 20, 25, 30, 40, 50	
		n79	40, 50, 60, 80, 100	
CA_n1(2A)-n3A-n7A-n79C	-	n1	CA_n1(2A)_BCS0	0
		n3	5, 10, 15, 20, 25, 30, 40, 50	
		n7	5, 10, 15, 20, 25, 30, 40, 50	
		n79	CA_n79C_BCS0	
CA_n1A-n3B-n7A-n79A	-	n1	5, 10, 15, 20, 25, 30, 40, 50	0
		n3	CA_n3B_BCS0	
		n7	5, 10, 15, 20, 25, 30, 40, 50	
		n79	40, 50, 60, 80, 100	
CA_n1A-n3B-n7A-n79C	-	n1	5, 10, 15, 20, 25, 30, 40, 50	0
		n3	CA_n3B_BCS0	
		n7	5, 10, 15, 20, 25, 30, 40, 50	
		n79	CA_n79C_BCS0	
CA_n1(2A)-n3B-n7A-n79A	-	n1	CA_n1(2A)_BCS0	0
		n3	CA_n3B_BCS0	
		n7	5, 10, 15, 20, 25, 30, 40, 50	
		n79	40, 50, 60, 80, 100	
CA_n1(2A)-n3B-n7A-n79C	-	n1	CA_n1(2A)_BCS0	0
		n3	CA_n3B_BCS0	
		n7	5, 10, 15, 20, 25, 30, 40, 50	
		n79	CA_n79C_BCS0	
CA_n1A-n3(2A)-n7A-n79A	-	n1	5, 10, 15, 20, 25, 30, 40, 50	0
		n3	CA_n3(2A)_BCS0	



		n7	5, 10, 15, 20, 25, 30, 40, 50	
		n79	40, 50, 60, 80, 100	
CA_n1A-n3(2A)-n7A-n79C	-	n1	5, 10, 15, 20, 25, 30, 40, 50	0
		n3	CA_n3(2A)_BCS0	
		n7	5, 10, 15, 20, 25, 30, 40, 50	
		n79	CA_n79C_BCS0	
CA_n1(2A)-n3(2A)-n7A-n79A	-	n1	CA_n1(2A)_BCS0	0
		n3	CA_n3(2A)_BCS0	
		n7	5, 10, 15, 20, 25, 30, 40, 50	
		n79	40, 50, 60, 80, 100	
CA_n1(2A)-n3(2A)-n7A-n79C	-	n1	CA_n1(2A)_BCS0	0
		n3	CA_n3(2A)_BCS0	
		n7	5, 10, 15, 20, 25, 30, 40, 50	
		n79	CA_n79C_BCS0	
CA_n1A-n3A-n7A-n105A	CA_n1A-n3A CA_n1A-n7A CA_n1A-n105A CA_n3A-n7A CA_n3A-n105A CA_n7A-n105A	n1	5, 10, 15, 20, 25, 30, 40, 50	0
		n3	5, 10, 15, 20, 25, 30, 40, 50	
		n7	5, 10, 15, 20, 25, 30, 40, 50	
		n105	5, 10, 15, 20, 25, 30, 35	
CA_n1A-n3A-n8A-n77A	-	n1	5, 10, 15, 20	0
		n3	5, 10, 15, 20, 25, 30	
		n8	5, 10, 15, 20	
		n77	10, 15, 20, 40, 50, 60, 80, 90, 100	
CA_n1A-n3A-n8A-n77(2A)	-	n1	5, 10, 15, 20	0
		n3	5, 10, 15, 20, 25, 30	
		n8	5, 10, 15, 20	
		n77	CA_n77(2A)_BCS1	
CA_n1A-n3A-n8A-n78A	CA_n1A-n3A CA_n1A-n8A CA_n1A-n78A CA_n3A-n8A CA_n3A-n78A CA_n8A-n78A	n1	5, 10, 15, 20	0
		n3	5, 10, 15, 20, 25, 30	
		n8	5, 10, 15, 20	
		n78	10, 15, 20, 40, 50, 60, 80, 90 <sup>1</sup> , 100	
CA_n1A-n3(2A)-n8A-n78A	CA_n1A-n3A CA_n1A-n8A CA_n1A-n78A CA_n3A-n8A CA_n3A-n78A CA_n8A-n78A	n1	5, 10, 15, 20	0
		n3	CA_n3(2A)_BCS0	
		n8	5, 10, 15, 20	
		n78	10, 15, 20, 25, 30, 40, 50, 60, 70, 80, 90, 100	
CA_n1A-n3A-n18A-n28A	CA_n1A-n3A CA_n1A-n18A CA_n1A-n28A CA_n3A-n18A CA_n3A-n28A	n1	5, 10, 15, 20	0
		n3	5, 10, 15, 20	
		n18	5, 10, 15	
		n28	5, 10	
CA_n1A-n3A-n18A-n41A	CA_n1A-n3A CA_n1A-n18A	n1	5, 10, 15, 20	0

	CA_n1A-n41A CA_n3A-n18A CA_n3A-n41A CA_n18A-n41A	n3	5, 10, 15, 20	
		n18	5, 10, 15	
		n41	10, 15, 20, 30, 40, 50, 60, 80, 90, 100	
CA_n1A-n3A-n18A-n77A	CA_n1A-n3A CA_n1A-n18A CA_n1A-n77A CA_n3A-n18A CA_n3A-n77A CA_n18A-n77A	n1	5, 10, 15, 20	0
		n3	5, 10, 15, 20	
		n18	5, 10, 15	
		n77	10, 15, 20, 25, 30, 40, 50, 60, 70, 80, 90, 100	
CA_n1A-n3A-n20A-n67A	CA_n1A-n3A CA_n1A-n20A CA_n3A-n20A	n1	n1 channel bandwidths in Table 5.3.5-1	4 and 5
		n3	n3 channel bandwidths in Table 5.3.5-1	
		n20	n20 channel bandwidths in Table 5.3.5-1	
		n67	n67 channel bandwidths in Table 5.3.5-1	
CA_n1A-n3A-n26A-n78A	CA_n1A-n3A CA_n1A-n26A CA_n1A-n78A CA_n3A-n26A CA_n3A-n78A CA_n26A-n78A	n1	5, 10, 15, 20	0
		n3	5, 10, 15, 20, 25, 30, 40, 50	
		n26	5, 10, 15, 20	
		n78	10, 15, 20, 25, 30, 40, 50, 60, 70, 80, 90, 100	
CA_n1A-n3A-n26(2A)-n78A	CA_n1A-n3A CA_n1A-n26A CA_n1A-n78A CA_n3A-n26A CA_n3A-n78A CA_n26A-n78A CA_n26(2A)	n1	5, 10, 15, 20, 25, 30, 40, 45, 50	0
		n3	5, 10, 15, 20, 25, 30, 35, 40, 45, 50	
		n26	CA_n26(2A)_BCS0	
		n78	10, 15, 20, 25, 30, 40, 50, 60, 70, 80, 90, 100	
CA_n1A-n3A-n26A-n78(2A)	CA_n1A-n3A CA_n1A-n26A CA_n1A-n78A CA_n3A-n26A CA_n3A-n78A CA_n26A-n78A	n1	5, 10, 15, 20, 25, 30, 40, 45, 50	0
		n3	5, 10, 15, 20, 25, 30, 35, 40, 45, 50	
		n26	5, 10, 15, 20, 25, 30	
		n78	CA_n78(2A) BCS0	
CA_n1A-n3A-n26A-n78C	CA_n1A-n3A CA_n1A-n26A CA_n1A-n78A CA_n3A-n26A CA_n3A-n78A CA_n26A-n78A CA_n78C	n1	5, 10, 15, 20, 25, 30, 40, 45, 50	0
		n3	5, 10, 15, 20, 25, 30, 35, 40, 45, 50	

		n26	5, 10, 15, 20, 25, 30	
		n78	CA_n78C_BCS0	
CA_n1A-n3A-n26(2A)-n78(2A)	CA_n1A-n3A CA_n1A-n26A CA_n1A-n78A CA_n3A-n26A CA_n3A-n78A CA_n26A-n78A	n1	5, 10, 15, 20, 25, 30, 40, 45, 50	0
		n3	5, 10, 15, 20, 25, 30, 35, 40, 45, 50	
		n26	CA_n26(2A)_BCS0	
		n78	CA_n78(2A)_BCS0	
CA_n1A-n3A-n26(2A)-n78C	CA_n1A-n3A CA_n1A-n26A CA_n1A-n78A CA_n3A-n26A CA_n3A-n78A CA_n26A-n78A CA_n26(2A) CA_n78C	n1	5, 10, 15, 20, 25, 30, 40, 45, 50	0
		n3	5, 10, 15, 20, 25, 30, 35, 40, 45, 50	
		n26	CA_n26(2A)_BCS0	
		n78	CA_n78C_BCS0	
CA_n1A-n3B-n26A-n78A	CA_n1A-n3A CA_n1A-n26A CA_n1A-n78A CA_n3A-n26A CA_n3A-n78A CA_n26A-n78A	n1	5, 10, 15, 20	0
		n3	CA_n3B_BCS0	
		n26	5, 10, 15, 20	
		n78	10, 15, 20, 25, 30, 40, 50, 60, 70, 80, 90, 100	
CA_n1A-n3B-n26(2A)-n78A	CA_n1A-n3A CA_n1A-n26A CA_n1A-n78A CA_n3A-n26A CA_n3A-n78A CA_n26A-n78A CA_n26(2A)	n1	5, 10, 15, 20, 25, 30, 40, 45, 50	0
		n3	CA_n3B_BCS0	
		n26	CA_n26(2A)_BCS0	
		n78	10, 15, 20, 25, 30, 40, 50, 60, 70, 80, 90, 100	
CA_n1A-n3B-n26A-n78(2A)	CA_n1A-n3A CA_n1A-n26A CA_n1A-n78A CA_n3A-n26A CA_n3A-n78A CA_n26A-n78A	n1	5, 10, 15, 20, 25, 30, 40, 45, 50	0
		n3	CA_n3B_BCS0	
		n26	5, 10, 15, 20	
		n78	CA_n78(2A)_BCS0	
CA_n1A-n3B-n26A-n78C	CA_n1A-n3A CA_n1A-n26A CA_n1A-n78A CA_n3A-n26A CA_n3A-n78A CA_n26A-n78A CA_n78C	n1	5, 10, 15, 20, 25, 30, 40, 45, 50	0
		n3	CA_n3B_BCS0	
		n26	5, 10, 15, 20	
		n78	CA_n78C_BCS0	
CA_n1A-n3B-n26(2A)-n78(2A)	CA_n1A-n3A CA_n1A-n26A CA_n1A-n78A CA_n3A-n26A	n1	5, 10, 15, 20, 25, 30, 40, 45, 50	0

	CA_n3A-n78A CA_n26A-n78A CA_n26(2A)	n3 n26 n78	CA_n3B_BCS0 CA_n26(2A)_BCS0 CA_n78(2A)_BCS0	
CA_n1A-n3B-n26(2A)-n78C	CA_n1A-n3A CA_n1A-n26A CA_n1A-n78A CA_n3A-n26A CA_n3A-n78A CA_n26A-n78A CA_n26(2A) CA_n78C	n1 n3 n26 n78	5, 10, 15, 20, 25, 30, 40, 45, 50 CA_n3B_BCS0 CA_n26(2A)_BCS0 CA_n78C_BCS0	0
CA_n1A-n3A-n28A-n38A	-	n1 n3 n28 n38	5, 10, 15, 20, 25, 30, 40, 45, 50 5, 10, 15, 20, 25, 30, 35, 40, 45, 50 5, 10, 15, 20, 25, 30 5, 10, 15, 20, 25, 30, 40	0
CA_n1A-n3A-n28A-n41A	n41 <sup>5,6</sup> CA_n1A-n3A CA_n1A-n28A CA_n1A-n41A <sup>5</sup> CA_n3A-n28A CA_n3A-n41A <sup>5</sup> CA_n28A-n41A <sup>5</sup>	n1 n3 n28 n41	5, 10, 15, 20 5, 10, 15, 20 5, 10 10, 15, 20, 30, 40, 50, 60, 80, 90, 100	0
CA_n1A-n3A-n28A-n77A	n77 <sup>5,6</sup> CA_n1A-n3A CA_n1A-n28A CA_n1A-n77A <sup>5</sup> CA_n3A-n28A CA_n3A-n77A <sup>5</sup> CA_n28A-n77A <sup>5</sup>	n1 n3 n28 n77	5, 10, 15, 20 5, 10, 15, 20, 25, 30 5, 10, 15, 20 10, 15, 20, 40, 50, 60, 80, 90, 100	0
	n77 <sup>5</sup> CA_n1A-n3A CA_n1A-n28A CA_n1A-n77A CA_n3A-n28A CA_n3A-n77A CA_n28A-n77A	n1 n3 n28 n77	5, 10, 15, 20 5, 10, 15, 20 5, 10 10, 15, 20, 25, 30, 40, 50, 60, 70, 80, 90, 100	1
CA_n1A-n3A-n28A-n77(2A)	n77 <sup>5</sup> CA_n1A-n3A CA_n1A-n28A CA_n1A-n77A CA_n3A-n28A CA_n3A-n77A CA_n28A-n77A	n1 n3 n28 n77	5, 10, 15, 20 5, 10, 15, 20, 25, 30 5, 10, 15, 20 CA_n77(2A)_BCS0	0
CA_n1A-n3A-n28A-n78A	-	n1	5, 10, 15, 20	0

		n3	5, 10, 15, 20, 25, 30	
		n28	5, 10, 15, 20 <sup>2</sup>	
		n78	10, 15, 20, 40, 50, 60, 80, 90 <sup>1</sup> , 100	
	CA_n1A-n3A CA_n1A-n28A CA_n1A-n78A CA_n3A-n28A CA_n3A-n78A CA_n28A-n78A	n1	5, 10, 15, 20	1
		n3	5, 10, 15, 20, 25, 30, 40	
		n28	5, 10, 15, 20 <sup>2</sup>	
		n78	10, 15, 20, 25, 30, 40, 50, 60, 70, 80, 90, 100	
		n1	5, 10, 15, 20, 25, 30, 40, 50	2
		n3	5, 10, 15, 20, 25, 30, 40, 50	
		n28	5, 10, 15, 20 <sup>2</sup> , 30 <sup>2</sup>	
		n78	10, 15, 20, 25, 30, 40, 50, 60, 70, 80, 90, 100	
CA_n1A-n3A-n28A-n78(2A)	CA_n78(2A) CA_n1A-n3A CA_n1A-n28A CA_n1A-n78A CA_n3A-n28A CA_n3A-n78A CA_n28A-n78A	n1	5, 10, 15, 20, 25, 30, 40, 50	0
		n3	5, 10, 15, 20, 25, 30, 40, 50	
		n28	5, 10, 15, 20 <sup>2</sup> , 30 <sup>2</sup>	
		n78	CA_n78(2A)_BCS2	
CA_n1A-n3A-n28A-n78C	CA_n78C CA_n1A-n3A CA_n1A-n28A CA_n1A-n78A CA_n3A-n28A CA_n3A-n78A CA_n28A-n78A	n1	5, 10, 15, 20, 25, 30, 40, 50	0
		n3	5, 10, 15, 20, 25, 30, 40, 50	
		n28	5, 10, 15, 20 <sup>2</sup> , 30 <sup>2</sup>	
		n78	CA_n78C_BCS1	
CA_n1A-n3B-n28A-n78A	CA_n1A-n3A CA_n1A-n28A CA_n1A-n78A CA_n3A-n28A CA_n3A-n78A CA_n28A-n78A	n1	5, 10, 15, 20	0
		n3	CA_n3B_BCS0	
		n28	5, 10, 15, 20	
		n78	10, 15, 20, 25, 30, 40, 50, 60, 70, 80, 90, 100	
CA_n1A-n3B-n28A-n78(2A)	CA_n78(2A) CA_n1A-n3A CA_n1A-n28A CA_n1A-n78A CA_n3A-n28A CA_n3A-n78A CA_n28A-n78A	n1	5, 10, 15, 20	0
		n3	CA_n3B_BCS0	
		n28	5, 10, 15, 20	
		n78	CA_n78(2A)_BCS2	
CA_n1A-n3B-n28A-n78C	CA_n1A-n3A CA_n1A-n28A CA_n1A-n78A CA_n3A-n28A CA_n3A-n78A CA_n28A-n78A CA_n78C	n1	5, 10, 15, 20	0
		n3	CA_n3B_BCS0	

		n28	5, 10, 15, 20	
		n78	CA_n78C_BCS0	
CA_n1A-n3A-n28A-n79A	CA_n1A-n3A CA_n1A-n28A CA_n1A-n79A CA_n3A-n28A CA_n3A-n79A CA_n28A-n79A	n1	5, 10, 15, 20	0
		n3	5, 10, 15, 20, 25,30	
		n28	5, 10, 15, 20	
		n79	40, 50, 60, 80, 100	
CA_n1A-n3A-n38A-n78A	-	n1	5, 10, 15, 20, 25, 30, 40, 45, 50	0
		n3	5, 10, 15, 20, 25, 30, 35, 40, 45, 50	
		n38	5, 10, 15, 20, 25, 30, 40	
		n78	10, 15, 20, 25, 30, 40, 50, 60, 70, 80, 90, 100	
CA_n1A-n3A-n40A-n77A	CA_n1A-n3A CA_n1A-n40A CA_n1A-n77A CA_n3A-n40A CA_n3A-n77A CA_n40A-n77A	n1	5, 10, 15, 20	0
		n3	5, 10, 15, 20	
		n40	10, 15, 20, 25, 30, 40, 50, 60, 80, 90, 100	
		n77	10, 15, 20, 25, 30, 40, 50, 60, 70, 80, 90, 100	
CA_n1A-n3A-n40A-n78A	CA_n1A-n3A CA_n1A-n40A CA_n1A-n78A CA_n3A-n40A CA_n3A-n78A CA_n40A-n78A	n1	5, 10, 15, 20, 25, 30, 40, 50	0
		n3	5, 10, 15, 20, 25, 30, 40, 50	
		n40	5, 10, 15, 20, 25, 30, 40, 50, 60, 80, 90, 100	
		n78	10, 15, 20, 25, 30, 40, 50, 60, 70, 80, 90, 100	
CA_n1A-n3A-n40A-n105A	CA_n1A-n3A CA_n1A-n40A CA_n1A-n105A CA_n3A-n40A CA_n3A-n105A CA_n40A-n105A	n1	5, 10, 15, 20	0
		n3	5, 10, 15, 20	
		n40	10, 15, 20, 25, 30, 40, 50, 60, 80, 90, 100	
		n105	5, 10, 15, 20, 25, 30, 35	
CA_n1A-n3A-n41A-n77A	n41 <sup>5,6</sup> n77 <sup>5,6</sup> CA_n1A-n3A CA_n1A-n41A CA_n1A-n77A CA_n3A-n41A CA_n3A-n77A CA_n41A-n77A	n1	5, 10, 15, 20	0
		n3	5, 10, 15, 20	
		n41	10, 15, 20, 30, 40, 50, 60, 80, 90, 100	
		n77	10, 15, 20, 25, 30, 40, 50, 60, 70, 80, 90, 100	
CA_n1A-n3A-n41A-n77(2A)	CA_n1A-n3A CA_n1A-n41A CA_n1A-n77A CA_n3A-n41A	n1	5, 10, 15, 20	0

	CA_n3A-n77A CA_n41A-n77A	n3 n41 n77	5, 10, 15, 20 10, 15, 20, 30, 40, 50, 60, 80, 90, 100 CA_n77(2A)_BCS0	
CA_n1A-n3A-n41A-n79A	CA_n1A-n3A CA_n1A-n41A CA_n1A-n79A CA_n3A-n41A CA_n3A-n79A CA_n41A-n79A	n1 n3 n41 n79	5, 10, 15, 20 5, 10, 15, 20, 25, 30 10, 15, 20, 30, 40, 50, 60, 80, 90, 100 40, 50, 60, 80, 100	0
CA_n1A-n3A-n67A-n78A	CA_n1A-n3A CA_n1A-n78A CA_n3A-n78A	n1 n3 n67 n78	5, 10, 15, 20, 25, 30, 40, 50 5, 10, 15, 20, 25, 30, 35, 40, 45, 50 5, 10, 15, 20 10, 20, 25, 30, 40, 50, 60, 70, 80, 90, 100	0
CA_n1A-n3A-n67A-n78(2A)	CA_n1A-n3A CA_n1A-n78A CA_n3A-n78A CA_n78(2A)	n1 n3 n67 n78	5, 10, 15, 20, 25, 30, 40, 50 5, 10, 15, 20, 25, 30, 35, 40, 45, 50 5, 10, 15, 20 CA_n78(2A)_BCS2	0
CA_n1A-n3A-n75A-n78A	-	n1 n3 n75 n78	n1 channel bandwidths in Table 5.3.5-1 n3 channel bandwidths in Table 5.3.5-1 n75 channel bandwidths in Table 5.3.5-1 n78 channel bandwidths in Table 5.3.5-1	4 and 5
CA_n1A-n3A-n77A-n79A	CA_n1A-n3A CA_n1A-n77A CA_n1A-n79A CA_n3A-n77A CA_n3A-n79A CA_n77A-n79A	n1 n3 n77 n79	5, 10, 15, 20 5, 10, 15, 20, 25,30 10, 15, 20, 40, 50, 60, 80, 90, 100 40, 50, 60, 80, 100	0
CA_n1A-n3A-n77(2A)-n79A	CA_n1A-n3A CA_n1A-n77A CA_n1A-n79A CA_n3A-n77A CA_n3A-n79A CA_n77A-n79A	n1 n3 n77 n79	5, 10, 15, 20 5, 10, 15, 20, 25,30 CA_n77(2A)_BCS1 40, 50, 60, 80, 100	0
CA_n1A-n3A-n78A-n105A	CA_n1A-n3A CA_n1A-n78A CA_n1A-n105A CA_n3A-n78A CA_n3A-n105A CA_n78A-n105A	n1 n3	5, 10, 15, 20 5, 10, 15, 20, 25,30, 40, 50	0

		n78	10, 15, 20, 25, 30, 40, 50, 60, 70, 80, 90, 100	
		n105	5, 10, 15, 20, 25, 30, 35	
CA_n1A-n5A-n7A-n40A	CA_n1A-n5A CA_n1A-n7A CA_n1A-n40A CA_n5A-n7A CA_n5A-n40A CA_n7A-n40A	n1	5, 10, 15, 20, 25, 30, 40, 45, 50	0
		n5	5, 10, 15, 20, 25	
		n7	5, 10, 15, 20, 25, 30, 40, 50	
		n40	5, 10, 15, 20, 25, 30, 40, 50, 60, 70, 80, 90, 100	
CA_n1A-n5A-n7A-n78A	CA_n1A-n5A CA_n1A-n7A CA_n1A-n78A CA_n5A-n7A CA_n5A-n78A	n1	5, 10, 15, 20, 25, 30, 40, 50	0
		n5	5, 10, 15, 20	
		n7	5, 10, 15, 20, 25, 30, 40, 50	
		n78	10, 15, 20, 25, 30, 40, 50, 60, 70, 80, 90, 100	
CA_n1A-n5A-n7B-n78A	CA_n1A-n5A CA_n1A-n7A CA_n1A-n78A CA_n5A-n7A CA_n5A-n78A CA_n7A-n78A CA_n7B	n1	5, 10, 15, 20, 25, 30, 40, 50	0
		n5	5, 10, 15, 20	
		n7	CA_n7B_BCS0	
		n78	10, 15, 20, 25, 30, 40, 50, 60, 70, 80, 90, 100	
CA_n1A-n5A-n7A-n105A	CA_n1A-n5A CA_n1A-n7A CA_n1A-n105A CA_n5A-n7A CA_n5A-n105A CA_n7A-n105A	n1	5, 10, 15, 20, 25, 30, 40, 45, 50	0
		n5	5, 10, 15, 20, 25	
		n7	5, 10, 15, 20, 25, 30, 40, 50	
		n105	5, 10, 15, 20, 25, 30, 35	
CA_n1A-n5A-n28A-n78A	CA_n1A-n5A CA_n1A-n28A CA_n1A-n78A CA_n5A-n28A CA_n5A-n78A CA_n28A-n78A	n1	n1 channel bandwidths in Table 5.3.5-1	4 and 5
		n5	n5 channel bandwidths in Table 5.3.5-1	
		n28	n28 channel bandwidths in Table 5.3.5-1	
		n78	n78 channel bandwidths in Table 5.3.5-1	
CA_n1A-n5A-n28A-n79A	CA_n1A-n5A CA_n1A-n28A CA_n1A-n79A CA_n5A-n28A CA_n5A-n79A CA_n28A-n79A	n1	n1 channel bandwidths in Table 5.3.5-1	4 and 5
		n5	n5 channel bandwidths in Table 5.3.5-1	
		n28	n28 channel bandwidths in Table 5.3.5-1	
		n79	n79 channel bandwidths in Table 5.3.5-1	
CA_n1A-n5A-n40A-	CA_n1A-n5A	n1	5, 10, 15, 20	0



n78A	CA_n1A-n40A CA_n1A-n78A CA_n5A-n40A CA_n5A-n78A CA_n40A-n78A	n5	5, 10, 15, 20	
		n40	5, 10, 15, 20, 25, 30, 40, 50, 60, 70, 80, 90, 100	
		n78	10, 15, 20, 25, 30, 40, 50, 60, 70, 80, 90, 100	
CA_n1A-n5A-n40A-n105A	CA_n1A-n5A CA_n1A-n40A CA_n1A-n105A CA_n5A-n40A CA_n5A-n105A CA_n40A-n105A	n1	5, 10, 15, 20, 25, 30, 40, 45, 50	0
		n5	5, 10, 15, 20, 25	
		n40	5, 10, 15, 20, 25, 30, 40, 50, 60, 70, 80, 90, 100	
		n105	5, 10, 15, 20, 25, 30, 35	
CA_n1A-n5A-n78A-n79A	CA_n1A-n5A CA_n1A-n78A CA_n1A-n79A CA_n5A-n78A CA_n5A-n79A CA_n78A-n79A	n1	n1 channel bandwidths in Table 5.3.5-1	4 and 5
		n5	n5 channel bandwidths in Table 5.3.5-1	
		n78	n78 channel bandwidths in Table 5.3.5-1	
		n79	n79 channel bandwidths in Table 5.3.5-1	
CA_n1A-n5A-n78A-n105A	CA_n1A-n5A CA_n1A-n78A CA_n1A-n105A CA_n5A-n78A CA_n5A-n105A CA_n78A-n105A	n1	5, 10, 15, 20, 25, 30, 40, 45, 50	0
		n5	5, 10, 15, 20, 25	
		n78	10, 15, 20, 25, 30, 40, 50	
		n105	5, 10, 15, 20, 25, 30, 35	
CA_n1A-n7A-n8A-n40A	CA_n1A-n7A CA_n1A-n8A CA_n1A-n40A CA_n7A-n8A CA_n7A-n40A CA_n8A-n40A	n1	5, 10, 15, 20, 25, 30, 40, 50	0
		n7	5, 10, 15, 20, 25, 30, 40, 50	
		n8	5, 10, 15, 20	
		n40	5, 10, 15, 20, 25, 30, 40, 50, 60, 80	
CA_n1A-n7A-n8A-n78A	CA_n1A-n7A CA_n1A-n8A CA_n1A-n78A CA_n7A-n8A CA_n7A-n78A CA_n8A-n78A	n1	5, 10, 15, 20, 25, 30, 40, 50	0
		n7	5, 10, 15, 20, 25, 30, 40, 50	
		n8	5, 10, 15, 20	
		n78	10, 15, 20, 25, 30, 40, 50, 60, 70, 80, 90, 100	
CA_n1A-n7(2A)-n8A-n78A	CA_n1A-n7A CA_n1A-n8A CA_n1A-n78A CA_n7A-n8A CA_n7A-n78A CA_n8A-n78A	n1	5, 10, 15, 20	0

		n7	CA_n7(2A)_BCS0	
		n8	5, 10, 15, 20	
		n78	10, 15, 20, 25, 30, 40, 50, 60, 70, 80, 90, 100	
CA_n1A-n7A-n26A-n78A	CA_n1A-n26A CA_n1A-n7A CA_n1A-n78A CA_n7A-n26A CA_n26A-n78A CA_n7A-n78A	n1	5, 10, 15, 20	0
		n7	5, 10, 15, 20, 25, 30, 40, 50	
		n26	5, 10, 15, 20	
		n78	10, 15, 20, 25, 30, 40, 50, 60, 70, 80, 90, 100	
CA_n1A-n7B-n26A-n78A	CA_n1A-n26A CA_n1A-n7A CA_n1A-n78A CA_n7A-n26A CA_n26A-n78A CA_n7A-n78A CA_n7B	n1	5, 10, 15, 20	0
		n7	CA_n7B_BCS0	
		n26	5, 10, 15, 20	
		n78	10, 15, 20, 25, 30, 40, 50, 60, 70, 80, 90, 100	
CA_n1A-n7A-n26(2A)-n78A	CA_n1A-n26A CA_n1A-n7A CA_n1A-n78A CA_n7A-n26A CA_n26A-n78A CA_n7A-n78A CA_n26(2A)	n1	5, 10, 15, 20	0
		n7	5, 10, 15, 20, 25, 30, 40, 50	
		n26	CA_n26(2A)_BCS0	
		n78	10, 15, 20, 25, 30, 40, 50, 60, 70, 80, 90, 100	
CA_n1A-n7A-n26A-n78(2A)	CA_n1A-n26A CA_n1A-n7A CA_n1A-n78A CA_n7A-n26A CA_n26A-n78A CA_n7A-n78A	n1	5, 10, 15, 20, 25, 30, 40, 45, 50	0
		n7	5, 10, 15, 20, 25, 30, 35, 40, 50	
		n26	5, 10, 15, 20, 25, 30	
		n78	CA_n78(2A)_BCS0	
CA_n1A-n7A-n26A-n78C	CA_n1A-n26A CA_n1A-n7A CA_n1A-n78A CA_n7A-n26A CA_n26A-n78A CA_n7A-n78A CA_n78C	n1	5, 10, 15, 20, 25, 30, 40, 45, 50	0
		n7	5, 10, 15, 20, 25, 30, 35, 40, 50	
		n26	5, 10, 15, 20, 25, 30	
		n78	CA_n78C_BCS0	
CA_n1A-n7A-n26(2A)-n78(2A)	CA_n1A-n26A CA_n1A-n7A CA_n1A-n78A CA_n7A-n26A CA_n26A-n78A CA_n7A-n78A CA_n26(2A)	n1	5, 10, 15, 20	0
		n7	5, 10, 15, 20, 25, 30, 40, 50	
		n26	CA_n26(2A)_BCS0	
		n78	CA_n78(2A)_BCS0	
CA_n1A-n7A-n26(2A)-n78C	CA_n1A-n26A CA_n1A-n7A CA_n1A-n78A CA_n7A-n26A	n1	5, 10, 15, 20	0

	CA_n26A-n78A CA_n7A-n78A CA_n26(2A) CA_n78C	n7 n26 n78	5, 10, 15, 20, 25, 30, 40, 50 CA_n26(2A)_BCS0 CA_n78C_BCS0	
CA_n1A-n7B-n26(2A)-n78A	CA_n1A-n26A CA_n1A-n7A CA_n1A-n78A CA_n7A-n26A CA_n26A-n78A CA_n7A-n78A CA_n7B CA_n26(2A)	n1 n7 n26 n78	5, 10, 15, 20 CA_n7B_BCS0 CA_n26(2A)_BCS0 10, 15, 20, 25, 30, 40, 50, 60, 70, 80, 90, 100	0
CA_n1A-n7B-n26A-n78(2A)	CA_n1A-n26A CA_n1A-n7A CA_n1A-n78A CA_n7A-n26A CA_n26A-n78A CA_n7A-n78A CA_n7B	n1 n7 n26 n78	5, 10, 15, 20, 25, 30, 40, 45, 50 CA_n7B_BCS0 5, 10, 15, 20, 25, 30 CA_n78(2A)_BCS0	0
CA_n1A-n7B-n26A-n78C	CA_n1A-n26A CA_n1A-n7A CA_n1A-n78A CA_n7A-n26A CA_n26A-n78A CA_n7A-n78A CA_n7B CA_n78C	n1 n7 n26 n78	5, 10, 15, 20, 25, 30, 40, 45, 50 CA_n7B_BCS0 5, 10, 15, 20, 25, 30 CA_n78C_BCS0	0
CA_n1A-n7B-n26(2A)-n78(2A)	CA_n1A-n26A CA_n1A-n7A CA_n1A-n78A CA_n7A-n26A CA_n26A-n78A CA_n7A-n78A CA_n7B CA_n26(2A)	n1 n7 n26 n78	5, 10, 15, 20 CA_n7B_BCS0 CA_n26(2A)_BCS0 CA_n78(2A)_BCS0	0
CA_n1A-n7B-n26(2A)-n78C	CA_n1A-n26A CA_n1A-n7A CA_n1A-n78A CA_n7A-n26A CA_n26A-n78A CA_n7A-n78A CA_n7B CA_n26(2A) CA_n78C	n1 n7 n26 n78	5, 10, 15, 20 CA_n7B_BCS0 CA_n26(2A)_BCS0 CA_n78C_BCS0	0
CA_n1A-n7A-n28A-n38A <sup>7</sup>	-	n1 n7 n28 n38	5, 10, 15, 20, 25, 30, 40, 45, 50 5, 10, 15, 20, 25, 30, 40, 50 5, 10, 15, 20, 25, 30 5, 10, 15, 20, 25, 30, 40	0
CA_n1A-n7A-n28A-	CA_n1A-n7A	n1	5, 10, 15, 20	0

n78A	CA_n1A-n28A CA_n1A-n78A CA_n7A-n28A CA_n7A-n78A CA_n28A-n78A	n7	5, 10, 15, 20, 25, 30, 40, 50	
		n28	5, 10, 15, 20	
		n78	10, 15, 20, 25, 30, 40, 50, 60, 70, 80, 90, 100	
CA_n1A-n7B-n28A-n78A	CA_n1A-n7A CA_n1A-n28A CA_n1A-n78A CA_n7A-n28A CA_n7A-n78A CA_n7B CA_n28A-n78A	n1	5, 10, 15, 20	0
		n7	CA_n7B_BCS0	
		n28	5, 10, 15, 20	
		n78	10, 15, 20, 25, 30, 40, 50, 60, 70, 80, 90, 100	
CA_n1A-n7B-n28A-n78(2A)	CA_n7B CA_n78(2A) CA_n1A-n7A CA_n1A-n28A CA_n1A-n78A CA_n7A-n28A CA_n7A-n78A CA_n28A-n78A	n1	5, 10, 15, 20	0
		n7	CA_n7B_BCS0	
		n28	5, 10, 15, 20	
		n78	CA_n78(2A)_BCS2	
CA_n1A-n7B-n28A-n78C	CA_n7B CA_n78C CA_n1A-n7A CA_n1A-n28A CA_n1A-n78A CA_n7A-n28A CA_n7A-n78A CA_n28A-n78A	n1	5, 10, 15, 20	0
		n7	CA_n7B_BCS0	
		n28	5, 10, 15, 20	
		n78	CA_n78C_BCS0	
CA_n1A-n7A-n28A-n78(2A)	CA_n78(2A) CA_n1A-n7A CA_n1A-n28A CA_n1A-n78A CA_n7A-n28A CA_n7A-n78A CA_n28A-n78A	n1	5, 10, 15, 20	0
		n7	5, 10, 15, 20, 25, 30, 40, 50	
		n28	5, 10, 15, 20 <sup>2</sup>	
		n78	CA_n78(2A)_BCS2	
CA_n1A-n7A-n28A-n78C	CA_n78C CA_n1A-n7A CA_n1A-n28A CA_n1A-n78A CA_n7A-n28A CA_n7A-n78A CA_n28A-n78A	n1	5, 10, 15, 20	0
		n7	5, 10, 15, 20, 25, 30, 40, 50	
		n28	5, 10, 15, 20 <sup>2</sup>	
		n78	CA_n78C_BCS0	
CA_n1A-n7A-n38A-n78A <sup>7</sup>	-	n1	5, 10, 15, 20, 25, 30, 40, 45, 50	0
		n7	5, 10, 15, 20, 25, 30, 40, 50	
		n38	5, 10, 15, 20, 25, 30, 40	
		n78	10, 15, 20, 25, 30, 40, 50, 60,	

			70, 80, 90, 100	
CA_n1A-n7A-n40A-n78A	CA_n1A-n7A CA_n1A-n40A CA_n1A-n78A CA_n7A-n40A CA_n7A-n78A CA_n40A-n78A	n1	5, 10, 15, 20, 25, 30, 40, 50	0
		n7	5, 10, 15, 20, 25, 30, 40, 50	
		n40	5, 10, 15, 20, 25, 30, 40, 50, 60, 80	
		n78	10, 15, 20, 25, 30, 40, 50, 60, 70, 80, 90, 100	
CA_n1A-n7A-n40A-n105A	CA_n1A-n7A CA_n1A-n40A CA_n1A-n105A CA_n7A-n40A CA_n7A-n105A CA_n40A-n105A	n1	5, 10, 15, 20, 25, 30, 40, 50	0
		n7	5, 10, 15, 20, 25, 30, 40, 50	
		n40	5, 10, 15, 20, 25, 30, 40, 50, 60, 80	
		n105	5, 10, 15, 20, 25, 30, 35	
CA_n1A-n7A-n67A-n78A	CA_n1A-n7A CA_n1A-n78A CA_n7A-n78A	n1	5, 10, 15, 20, 25, 30, 40, 50	0
		n7	5, 10, 15, 20, 25, 30, 40, 50	
		n67	5, 10, 15, 20	
		n78	10, 20, 25, 30, 40, 50, 60, 70, 80, 90, 100	
CA_n1A-n7A-n67A-n78(2A)	CA_n1A-n7A CA_n1A-n78A CA_n7A-n78A CA_n78(2A)	n1	5, 10, 15, 20, 25, 30, 40, 50	0
		n7	5, 10, 15, 20, 25, 30, 40, 50	
		n67	5, 10, 15, 20	
		n78	CA_n78(2A)_BCS2	
CA_n1A-n7A-n75A-n78A	-	n1	n1 channel bandwidths in Table 5.3.5-1	4 and 5
		n7	n7 channel bandwidths in Table 5.3.5-1	
		n75	n75 channel bandwidths in Table 5.3.5-1	
		n78	n78 channel bandwidths in Table 5.3.5-1	
CA_n1A-n7A-n78A-n105A	CA_n1A-n7A CA_n1A-n78A CA_n1A-n105A CA_n7A-n78A CA_n7A-n105A CA_n78A-n105A	n1	5, 10, 15, 20, 25, 30, 40, 50	0
		n7	5, 10, 15, 20, 25, 30, 40, 50	
		n78	10, 20, 25, 30, 40, 50, 60, 70, 80, 90, 100	
		n105	5, 10, 15, 20, 25, 30, 35	
CA_n1A-n8A-n40A-n78A	CA_n1A-n8A CA_n1A-n40A CA_n1A-n78A CA_n8A-n40A CA_n8A-n78A CA_n40A-n78A	n1	5, 10, 15, 20, 25, 30, 40, 50	0
		n8	5, 10, 15, 20	
		n40	5, 10, 15, 20, 25, 30, 40, 50, 60, 80	
		n78	10, 15, 20, 25, 30, 40, 50, 60, 70, 80, 90, 100	
CA_n1A-n8A-n78A-n79A	-	n1	5, 10, 15, 20	0

		n8	5, 10, 15, 20	
		n78	10, 15, 20, 25, 30, 40, 50, 60, 70, 80, 90, 100	
		n79	40, 50, 60, 80, 100	
CA_n1A-n8A-n78(2A)-n79A	-	n1	5, 10, 15, 20	0
		n8	5, 10, 15, 20	
		n78	CA_n78(2A)_BCS1	
		n79	40, 50, 60, 80, 100	
CA_n1A-n18A-n28A-n41A	CA_n1A-n18A CA_n1A-n28A CA_n1A-n41A CA_n18A-n28A CA_n18A-n41A CA_n28A-n41A	n1	5, 10, 15, 20	0
		n18	5, 10, 15	
		n28	5, 10	
		n41	10, 15, 20, 30, 40, 50, 60, 80, 90, 100	
CA_n1A-n18A-n28A-n77A	CA_n1A-n18A CA_n1A-n28A CA_n1A-n77A CA_n18A-n28A CA_n18A-n77A CA_n28A-n77A	n1	5, 10, 15, 20	0
		n18	5, 10, 15	
		n28	5, 10	
		n77	10, 15, 20, 25, 30, 40, 50, 60, 70, 80, 90, 100	
CA_n1A-n18A-n41A-n77A	CA_n1A-n18A CA_n1A-n41A CA_n1A-n77A CA_n18A-n41A CA_n18A-n77A CA_n41A-n77A	n1	5, 10, 15, 20	0
		n18	5, 10, 15	
		n41	10, 15, 20, 30, 40, 50, 60, 80, 90, 100	
		n77	10, 15, 20, 25, 30, 40, 50, 60, 70, 80, 90, 100	
CA_n1A-n28A-n38A-n78A	-	n1	5, 10, 15, 20, 25, 30, 40, 50	0
		n28	5, 10, 15, 20, 30	
		n38	5, 10, 15, 20, 25, 30, 40	
		n78	10, 15, 20, 25, 30, 40, 50, 60, 70, 80, 90, 100	
CA_n1A-n28A-n40A-n77A	CA_n1A-n28A CA_n1A-n40A CA_n1A-n77A CA_n28A-n40A CA_n28A-n77A CA_n40A-n77A	n1	5, 10, 15, 20	0
		n28	5, 10, 15, 20	
		n40	5, 10, 15, 20, 25, 30, 40, 50, 60, 80	
		n77	10, 15, 20, 25, 30, 40, 50, 60, 70, 80, 90, 100	
CA_n1A-n28A-n40A-n78A	CA_n1A-n28A CA_n1A-n40A CA_n1A-n78A CA_n28A-n40A CA_n28A-n78A CA_n40A-n78A	n1	5, 10, 15, 20	0
		n28	5, 10, 15, 20	
		n40	5, 10, 15, 20, 25, 30, 40, 50, 60, 80	
		n78	10, 15, 20, 25, 30, 40, 50, 60,	

CA_n1A-n28A-n40B-n78A	CA_n1A-n28A CA_n1A-n40A CA_n1A-n78A CA_n28A-n40A CA_n28A-n78A CA_n40A-n78A	n1	70, 80, 90, 100 5, 10, 15, 20	0
		n28	5, 10, 15, 20	
		n40	CA_n40B_BCS0	
		n78	10, 15, 20, 25, 30, 40, 50, 60, 70, 80, 90, 100	
CA_n1A-n28A-n41A-n77A	n41 <sup>5,6</sup> n77 <sup>5,6</sup> CA_n1A-n28A CA_n1A-n41A CA_n1A-n77A CA_n28A-n41A CA_n28A-n77A CA_n41A-n77A	n1	5, 10, 15, 20	0
		n28	5, 10	
		n41	10, 15, 20, 30, 40, 50, 60, 80, 90, 100	
		n77	10, 15, 20, 25, 30, 40, 50, 60, 70, 80, 90, 100	
CA_n1A-n28A-n41A-n77(2A)	CA_n1A-n28A CA_n1A-n41A CA_n1A-n77A CA_n28A-n41A CA_n28A-n77A CA_n41A-n77A	n1	5, 10, 15, 20	0
		n28	5, 10	
		n41	10, 15, 20, 30, 40, 50, 60, 80, 90, 100	
		n77	CA_n77(2A)_BCS0	
CA_n1A-n28A-n41A-n79A	CA_n1A-n28A CA_n1A-n41A CA_n1A-n79A CA_n28A-n41A CA_n28A-n79A CA_n41A-n79A	n1	5, 10, 15, 20	0
		n28	5, 10, 15, 20	
		n41	10, 15, 20, 30, 40, 50, 60, 80, 90, 100	
		n79	40, 50, 60, 80, 100	
CA_n1A-n28A-n75A-n78A	-	n1	5, 10, 15, 20	0
		n28	5, 10, 15, 20	
		n75	5, 10, 15, 20, 30, 40, 50	
		n78	10, 15, 20, 25, 30, 40, 50, 60, 70, 80, 90, 100	
CA_n1A-n28A-n77A-n79A	CA_n1A-n28A CA_n1A-n77A CA_n1A-n79A CA_n28A-n77A CA_n28A-n79A CA_n77A-n79A	n1	5, 10, 15, 20	0
		n28	5, 10, 15, 20	
		n77	10, 15, 20, 40, 50, 60, 80, 90, 100	
		n79	40, 50, 60, 80, 100	
CA_n1A-n28A-n78A-n79A	CA_n1A-n28A CA_n1A-n78A CA_n1A-n79A CA_n28A-n78A CA_n28A-n79A CA_n78A-n79A	n1	n1 channel bandwidths in Table 5.3.5-1	4 and 5
		n28	n28 channel bandwidths in	

		Table 5.3.5-1		
		n78	n78 channel bandwidths in Table 5.3.5-1	
		n79	n79 channel bandwidths in Table 5.3.5-1	
CA_n1A-n28A-n77(2A)-n79A	CA_n1A-n28A CA_n1A-n77A CA_n1A-n79A CA_n28A-n77A CA_n28A-n79A CA_n77A-n79A	n1	5, 10, 15, 20	0
		n28	5, 10, 15, 20	
		n77	CA_n77(2A)_BCS0	
		n79	40, 50, 60, 80, 100	
CA_n1A-n40A-n78A-n105A	CA_n1A-n40A CA_n1A-n78A CA_n1A-n105A CA_n40A-n78A CA_n40A-n105A CA_n78A-n105A	n1	5, 10, 15, 20	0
		n40	5, 10, 15, 20, 25, 30, 40, 50, 60, 80	
		n78	10, 15, 20, 25, 30, 40, 50, 60, 70, 80, 90, 100	
		n105	5, 10, 15, 20, 25, 30, 35	
CA_n1A-n41A-n77A-n79A	CA_n1A-n41A CA_n1A-n77A CA_n1A-n79A CA_n41A-n77A CA_n41A-n79A CA_n77A-n79A	n1	5, 10, 15, 20	0
		n41	10, 15, 20, 30, 40, 50, 60, 80, 90, 100	
		n77	10, 15, 20, 40, 50, 60, 80, 90, 100	
		n79	40, 50, 60, 80, 100	
CA_n1A-n41A-n77(2A)-n79A	CA_n1A-n41A CA_n1A-n77A CA_n1A-n79A CA_n41A-n77A CA_n41A-n79A CA_n77A-n79A	n1	5, 10, 15, 20	0
		n41	10, 15, 20, 30, 40, 50, 60, 80, 90, 100	
		n77	CA_n77(2A)_BCS0	
		n79	40, 50, 60, 80, 100	
CA_n2A-n5A-n30A-n66A	CA_n2A-n5A CA_n2A-n30A CA_n2A-n66A CA_n5A-n30A CA_n5A-n66A CA_n30A-n66A	n2	5, 10, 15, 20	0
		n5	5, 10, 15, 20	
		n30	5, 10	
		n66	10, 15, 20, 25, 30, 40	
CA_n2(2A)-n5A-n30A-n66A	CA_n2A-n5A CA_n2A-n30A CA_n2A-n66A CA_n5A-n30A CA_n5A-n66A CA_n30A-n66A	n2	CA_n2(2A)_BCS0	0
		n5	5, 10, 15, 20	
		n30	5, 10	
		n66	10, 15, 20, 25, 30, 40	
CA_n2A-n5A-n30A-n66(2A)	CA_n2A-n5A CA_n2A-n30A CA_n2A-n66A	n2	5, 10, 15, 20	0



	CA_n5A-n30A CA_n5A-n66A CA_n30A-n66A			
		n5	5, 10, 15, 20	
		n30	5, 10	
		n66	CA_n66(2A)_BCS1	
CA_n2A-n5A-n30A-n77A	n77 <sup>5,6</sup> CA_n2A-n5A CA_n2A-n30A CA_n2A-n77A <sup>5</sup> CA_n5A-n30A CA_n5A-n77A <sup>5</sup> CA_n30A-n77A <sup>5</sup>	n2	5, 10, 15, 20	0
		n5	5, 10, 15, 20	
		n30	5, 10	
		n77	10, 15, 20, 25, 30, 40, 50, 60, 70, 80, 90, 100	
CA_n2(2A)-n5A-n30A-n77A	n77 <sup>5,6</sup> CA_n2A-n5A CA_n2A-n30A CA_n2A-n77A <sup>5</sup> CA_n5A-n30A CA_n5A-n77A <sup>5</sup> CA_n30A-n77A <sup>5</sup>	n2	CA_n2(2A)_BCS0	0
		n5	5, 10, 15, 20	
		n30	5, 10	
		n77	10, 15, 20, 25, 30, 40, 50, 60, 70, 80, 90, 100	
CA_n2(2A)-n5A-n30A-n77(2A)	n77 <sup>5</sup> CA_n2A-n5A CA_n2A-n30A CA_n2A-n77A <sup>5</sup> CA_n5A-n30A CA_n5A-n77A <sup>5</sup> CA_n30A-n77A <sup>5</sup>	n2	CA_n2(2A)_BCS0	0
		n5	5, 10, 15, 20	
		n30	5, 10	
		n77	CA_n77(2A)_BCS1	
CA_n2A-n5A-n30A-n77(2A)	n77 <sup>5,6</sup> CA_n2A-n5A CA_n2A-n30A CA_n2A-n77A <sup>5</sup> CA_n5A-n30A CA_n5A-n77A <sup>5</sup> CA_n30A-n77A <sup>5</sup>	n2	5, 10, 15, 20	0
		n5	5, 10, 15, 20	
		n30	5, 10	
		n77	CA_n77(2A)_BCS1	
CA_n2A-n5A-n48A-n66A	-	n2	5, 10, 15, 20	0
		n5	5, 10, 15, 20	
		n48	5, 10, 15, 20, 30, 40, 50 <sup>8</sup> , 60 <sup>8</sup> , 70 <sup>8</sup> , 80 <sup>8</sup> , 90 <sup>8</sup> , 100 <sup>8</sup>	
		n66	10, 15, 20, 25, 30, 40	
	CA_n2A-n5A CA_n2A-n48A CA_n2A-n66A CA_n5A-n48A CA_n5A-n66A CA_n48A-n66A	n2	5, 10, 15, 20, 25, 30, 40	1
		n5	5, 10, 15, 20, 25	
		n48	5, 10, 15, 20, 30, 40, 50 <sup>8</sup> , 60 <sup>8</sup> , 70 <sup>8</sup> , 80 <sup>8</sup> , 90 <sup>8</sup> , 100 <sup>8</sup>	
		n66	5, 10, 15, 20, 25, 30, 40	
CA_n2A-n5A-n48B-n66A	-	n2	5, 10, 15, 20	0
		n5	5, 10, 15, 20	

	CA_n2A-n5A CA_n2A-n48A CA_n2A-n66A CA_n5A-n48A CA_n5A-n66A CA_n48A-n66A	n48	CA_n48B_BCS2	1		
		n66	10, 15, 20, 25, 30, 40			
		n2	5, 10, 15, 20, 25, 30, 40			
		n5	5, 10, 15, 20, 25			
		n48	CA_n48B_BCS0			
		n66	5, 10, 15, 20, 25, 30, 40			
		n2	5, 10, 15, 20, 25, 30, 40		2	
		n5	5, 10, 15, 20, 25			
		n48	CA_n48B_BCS1			
		n66	5, 10, 15, 20, 25, 30, 40		3	
		n2	5, 10, 15, 20, 25, 30, 40			
		n5	5, 10, 15, 20, 25			
		n48	CA_n48B_BCS2		0	
		n66	5, 10, 15, 20, 25, 30, 40			
CA_n2A-n5A-n48(2A)-n66A	-	n2	5, 10, 15, 20	0		
		n5	5, 10, 15, 20			
		n48	CA_n48(2A)_BCS1			
		n66	10, 15, 20, 25, 30, 40			
	CA_n2A-n5A CA_n2A-n48A CA_n2A-n66A CA_n5A-n48A CA_n5A-n66A CA_n48A-n66A		n2	5, 10, 15, 20, 25, 30, 40	1	
			n5	5, 10, 15, 20, 25		
			n48	CA_n48(2A)_BCS0		
			n66	5, 10, 15, 20, 25, 30, 40		
			n2	5, 10, 15, 20, 25, 30, 40		2
			n5	5, 10, 15, 20, 25		
			n48	CA_n48(2A)_BCS1		
			n66	5, 10, 15, 20, 25, 30, 40		
	CA_n2A-n5A-n48(A-B)-n66A	-	n2	5, 10, 15, 20	0	
			n5	5, 10, 15, 20		
n48			CA_n48(A-B)_BCS1			
n66			10, 15, 20, 25, 30, 40			
CA_n2A-n5A-n48A-n77A	n77 <sup>5,6</sup>	n2	5, 10, 15, 20	0		
		n5	5, 10, 15, 20			
		n48	5, 10, 15, 20, 30, 40, 50 <sup>8</sup> , 60 <sup>8</sup> , 70 <sup>8</sup> , 80 <sup>8</sup> , 90 <sup>8</sup> , 100 <sup>8</sup>			
		n77	10, 15, 20, 25, 30, 40, 50, 60, 70, 80, 90, 100			
	n77 <sup>5,6</sup> CA_n2A-n5A CA_n2A-n48A CA_n2A-n77A <sup>5</sup> CA_n5A-n48A CA_n5A-n77A <sup>5</sup>		n2	5, 10, 15, 20, 25, 30, 40	1	
			n5	5, 10, 15, 20, 25		
			n48	5, 10, 15, 20, 30, 40, 50 <sup>8</sup> , 60 <sup>8</sup> , 70 <sup>8</sup> , 80 <sup>8</sup> , 90 <sup>8</sup> , 100 <sup>8</sup>		
			n77	10, 15, 20, 25, 30, 40, 50, 60, 70, 80, 90, 100		
			n2	5, 10, 15, 20, 25, 30, 40		0
			n77	10, 15, 20, 25, 30, 40, 50, 60, 70, 80, 90, 100		
CA_n2A-n5A-n48A-n77C	n77 <sup>5,6</sup> CA_n77C CA_n2A-n5A CA_n2A-n48A CA_n2A-n77A <sup>5</sup> CA_n5A-n48A CA_n5A-n77A <sup>5</sup>	n2	5, 10, 15, 20, 25, 30, 40	0		
		n77	10, 15, 20, 25, 30, 40, 50, 60, 70, 80, 90, 100			

	n77 <sup>5,6</sup>	n5	5, 10, 15, 20, 25	1		
		n48	5, 10, 15, 20, 30, 40, 50 <sup>8</sup> , 60 <sup>8</sup> , 70 <sup>8</sup> , 80 <sup>8</sup> , 90 <sup>8</sup> , 100 <sup>8</sup>			
		n77	CA_n77C_BCS0			
		n2	5, 10, 15, 20, 25, 30, 40			
		n5	5, 10, 15, 20, 25			
		n48	5, 10, 15, 20, 30, 40, 50, 60, 70, 80, 90, 100			
CA_n2A-n5A-n48B-n77A	n77 <sup>5,6</sup>	n77	CA_n77C_BCS1	0		
		n2	5, 10, 15, 20			
		n5	5, 10, 15, 20			
		n48	CA_n48B_BCS2			
	n77 <sup>5,6</sup> CA_n2A-n5A CA_n2A-n48A CA_n2A-n77A <sup>5</sup> CA_n5A-n48A CA_n5A-n77A <sup>5</sup>	n77	10, 15, 20, 25, 30, 40, 50, 60, 70, 80, 90, 100	1		
		n2	5, 10, 15, 20, 25, 30, 40			
		n5	5, 10, 15, 20, 25			
		n48	CA_n48B_BCS0			
		n77	10, 15, 20, 25, 30, 40, 50, 60, 70, 80, 90, 100			
		n2	5, 10, 15, 20, 25, 30, 40		2	
		n5	5, 10, 15, 20, 25			
		n48	CA_n48B_BCS1			
		n77	10, 15, 20, 25, 30, 40, 50, 60, 70, 80, 90, 100			
		n77 <sup>5,6</sup> CA_n2A-n5A CA_n2A-n48A CA_n2A-n77A <sup>5</sup> CA_n5A-n48A CA_n5A-n77A <sup>5</sup>	n2		5, 10, 15, 20, 25, 30, 40	3
n5	5, 10, 15, 20, 25					
n48	CA_n48B_BCS2					
n77	10, 15, 20, 25, 30, 40, 50, 60, 70, 80, 90, 100					
CA_n2A-n5A-n48(2A)-n77A	n77 <sup>5,6</sup>		n2	5, 10, 15, 20	0	
			n5	5, 10, 15, 20		
			n48	CA_n48(2A)_BCS1		
			n77	10, 15, 20, 25, 30, 40, 50, 60, 70, 80, 90, 100		
CA_n2A-n5A-n48(2A)-n77A	n77 <sup>5,6</sup> CA_n2A-n5A CA_n2A-n48A CA_n2A-n77A <sup>5</sup> CA_n5A-n48A CA_n5A-n77A <sup>5</sup>	n2	5, 10, 15, 20, 25, 30, 40	1		
		n5	5, 10, 15, 20, 25			
		n48	CA_n48(2A)_BCS0			
		n77	10, 15, 20, 25, 30, 40, 50, 60, 70, 80, 90, 100			
	n77 <sup>5,6</sup> CA_n2A-n5A CA_n2A-n48A CA_n2A-n77A <sup>5</sup> CA_n5A-n48A CA_n5A-n77A <sup>5</sup>	n2	5, 10, 15, 20, 25, 30, 40	2		
		n5	5, 10, 15, 20, 25			
		n48	CA_n48(2A)_BCS1			
		n77	10, 15, 20, 25, 30, 40, 50, 60, 70, 80, 90, 100			
CA_n2A-n5A-n66A-n77A	n77 <sup>5,6</sup> CA_n2A-n5A CA_n2A-n66A CA_n2A-n77A <sup>5</sup> CA_n5A-n66A CA_n5A-n77A <sup>5</sup> CA_n66A-n77A <sup>5</sup>	n2	5, 10, 15, 20	0		
		n5	5, 10, 15, 20			
		n66	5, 10, 15, 20, 25, 30, 40			
		n77	10, 15, 20, 25, 30, 40, 50, 60, 70, 80, 90, 100			

CA_n2(2A)-n5A-n66A-n77A	n77 <sup>5,6</sup> CA_n2A-n5A CA_n2A-n66A CA_n2A-n77A <sup>5</sup> CA_n5A-n66A CA_n5A-n77A <sup>5</sup> CA_n66A-n77A <sup>5</sup>	n2	CA_n2(2A)_BCS0	0
		n5	5, 10, 15, 20	
		n66	5, 10, 15, 20, 25, 30,40	
		n77	10, 15, 20, 25, 30, 40, 50, 60, 70, 80, 90, 100	
CA_n2A-n5A-n66(2A)-n77A	n77 <sup>5,6</sup> CA_n2A-n5A CA_n2A-n66A CA_n2A-n77A <sup>5</sup> CA_n5A-n66A CA_n5A-n77A <sup>5</sup> CA_n66A-n77A <sup>5</sup>	n2	5, 10, 15, 20	0
		n5	5, 10, 15, 20	
		n66	CA_n66(2A)_BCS1	
		n77	10, 15, 20, 25, 30, 40, 50, 60, 70, 80, 90, 100	
CA_n2A-n5A-n66A-n77(2A)	n77 <sup>5,6</sup> CA_n2A-n5A CA_n2A-n66A CA_n2A-n77A <sup>5</sup> CA_n5A-n66A CA_n5A-n77A <sup>5</sup> CA_n66A-n77A <sup>5</sup>	n2	5, 10, 15, 20	0
		n5	5, 10, 15, 20	
		n66	5, 10, 15, 20, 25, 30, 40	
		n77	CA_n77(2A)_BCS1	
CA_n2A-n5A-n66(2A)-n77(2A)	n77 <sup>5</sup> CA_n2A-n5A CA_n2A-n66A CA_n2A-n77A <sup>5</sup> CA_n5A-n66A CA_n5A-n77A <sup>5</sup> CA_n66A-n77A <sup>5</sup>	n2	5, 10, 15, 20	0
		n5	5, 10, 15, 20	
		n66	CA_n66(2A)_BCS1	
		n77	CA_n77(2A)_BCS1	
CA_n2(2A)-n5A-n66A-n77(2A)	n77 <sup>5</sup> CA_n2A-n5A CA_n2A-n66A CA_n2A-n77A <sup>5</sup> CA_n5A-n66A CA_n5A-n77A <sup>5</sup> CA_n66A-n77A <sup>5</sup>	n2	CA_n2(2A)_BCS0	0
		n5	5, 10, 15, 20	
		n66	5, 10, 15, 20, 25, 30, 40	
		n77	CA_n77(2A)_BCS1	
CA_n2A-n5A-n66A-n77C	n77 <sup>5,6</sup> CA_n77C CA_n2A-n5A CA_n2A-n66A CA_n2A-n77A <sup>5</sup> CA_n5A-n77A <sup>5</sup> CA_n5A-n66A CA_n66A-n77A <sup>5</sup>	n2	5, 10, 15, 20	0
		n5	5, 10, 15, 20	
		n66	5, 10, 15, 20, 25, 30, 40	
		n77	CA_n77C_BCS1	
CA_n2A-n12A-n30A-n66A	CA_n2A-n12A CA_n2A-n30A CA_n2A-n66A CA_n12A-n30A	n2	5, 10, 15, 20	0

	CA_n12A-n66A CA_n30A-n66A	n12 n30 n66	5, 10, 15 5, 10 5, 10, 15, 20, 25, 30, 40	
CA_n2(2A)-n12A-n30A-n66A	CA_n2A-n12A CA_n2A-n30A CA_n2A-n66A CA_n12A-n30A CA_n12A-n66A CA_n30A-n66A	n2 n12 n30 n66	CA_n2(2A)_BCS0 5, 10, 15 5, 10 5, 10, 15, 20, 25, 30, 40	0
CA_n2A-n12A-n30A-n66(2A)	CA_n2A-n12A CA_n2A-n30A CA_n2A-n66A CA_n12A-n30A CA_n12A-n66A CA_n30A-n66A	n2 n12 n30 n66	5, 10, 15, 20 5, 10, 15 5, 10 CA_n66(2A)_BCS1	0
CA_n2A-n12A-n30A-n77A	n77 <sup>5,6</sup> CA_n2A-n12A CA_n2A-n30A CA_n2A-n77A <sup>5</sup> CA_n12A-n30A CA_n12A-n77A <sup>5</sup> CA_n30A-n77A <sup>5</sup>	n2 n12 n30 n77	5, 10, 15, 20 5, 10, 15 5, 10 10, 15, 20, 25, 30, 40, 50, 60, 70, 80, 90, 100	0
CA_n2(2A)-n12A-n30A-n77A	n77 <sup>5,6</sup> CA_n2A-n12A CA_n2A-n30A CA_n2A-n77A <sup>5</sup> CA_n12A-n30A CA_n12A-n77A <sup>5</sup> CA_n30A-n77A <sup>5</sup>	n2 n12 n30 n77	CA_n2(2A)_BCS0 5, 10, 15 5, 10 10, 15, 20, 25, 30, 40, 50, 60, 70, 80, 90, 100	0
CA_n2A-n12A-n30A-n77(2A)	n77 <sup>5,6</sup> CA_n2A-n12A CA_n2A-n30A CA_n2A-n77A <sup>5</sup> CA_n12A-n30A CA_n12A-n77A <sup>5</sup> CA_n30A-n77A <sup>5</sup>	n2 n12 n30 n77	5, 10, 15, 20 5, 10, 15 5, 10 CA_n77(2A)_BCS1	0
CA_n2(2A)-n12A-n30A-n77(2A)	n77 <sup>5</sup> CA_n2A-n12A CA_n2A-n30A CA_n2A-n77A <sup>5</sup> CA_n12A-n30A CA_n12A-n77A <sup>5</sup> CA_n30A-n77A <sup>5</sup>	n2 n12 n30 n77	CA_n2(2A)_BCS0 5, 10, 15 5, 10 CA_n77(2A)_BCS1	0
CA_n2A-n12A-n66A-n77A	n77 <sup>5,6</sup> CA_n2A-n12A	n2	5, 10, 15, 20	0

	CA_n2A-n66A CA_n2A-n77A <sup>5</sup> CA_n12A-n66A CA_n12A-n77A <sup>5</sup> CA_n66A-n77A <sup>5</sup>			
		n12	5, 10, 15	
		n66	5, 10, 15, 20, 25, 30, 40	
		n77	10, 15, 20, 30, 40, 50, 60, 70, 80, 90, 100	
CA_n2(2A)-n12A-n66A-n77A	n77 <sup>5,6</sup> CA_n2A-n12A CA_n2A-n66A CA_n2A-n77A <sup>5</sup> CA_n12A-n66A CA_n12A-n77A <sup>5</sup> CA_n66A-n77A <sup>5</sup>	n2	CA_n2(2A)_BCS0	0
		n12	5, 10, 15	
		n66	5, 10, 15, 20, 25, 30, 40	
		n77	10, 15, 20, 25, 30, 40, 50, 60, 70, 80, 90, 100	
CA_n2A-n12A-n66(2A)-n77A	n77 <sup>5,6</sup> CA_n2A-n12A CA_n2A-n66A CA_n2A-n77A <sup>5</sup> CA_n12A-n66A CA_n12A-n77A <sup>5</sup> CA_n66A-n77A <sup>5</sup>	n2	5, 10, 15, 20	0
		n12	5, 10, 15	
		n66	CA_n66(2A)_BCS1	
		n77	10, 15, 20, 25, 30, 40, 50, 60, 70, 80, 90, 100	
CA_n2A-n12A-n66A-n77(2A)	n77 <sup>5,6</sup> CA_n2A-n12A CA_n2A-n66A CA_n2A-n77A <sup>5</sup> CA_n12A-n66A CA_n12A-n77A <sup>5</sup> CA_n66A-n77A <sup>5</sup>	n2	5, 10, 15, 20	0
		n12	5, 10, 15	
		n66	5, 10, 15, 20, 25, 30, 40	
		n77	CA_n77(2A)_BCS1	
CA_n2A-n12A-n66(2A)-n77(2A)	n77 <sup>5</sup> CA_n2A-n12A CA_n2A-n66A CA_n2A-n77A <sup>5</sup> CA_n12A-n66A CA_n12A-n77A <sup>5</sup> CA_n66A-n77A <sup>5</sup>	n2	5, 10, 15, 20	0
		n12	5, 10, 15	
		n66	CA_n66(2A)_BCS1	
		n77	CA_n77(2A)_BCS1	
CA_n2(2A)-n12A-n66A-n77(2A)	n77 <sup>5</sup> CA_n2A-n12A CA_n2A-n66A CA_n2A-n77A <sup>5</sup> CA_n12A-n66A CA_n12A-n77A <sup>5</sup> CA_n66A-n77A <sup>5</sup>	n2	CA_n2(2A)_BCS0	0
		n12	5, 10, 15	
		n66	5, 10, 15, 20, 25, 30, 40	
		n77	CA_n77(2A)_BCS1	
CA_n2A-n14A-n30A-n66A	CA_n2A-n14A CA_n2A-n30A CA_n2A-n66A CA_n14A-n30A CA_n14A-n66A CA_n30A-n66A	n2	5, 10, 15, 20	0

		n14	5, 10	
		n30	5, 10	
		n66	5, 10, 15, 20, 25, 30, 40	
CA_n2(2A)-n14A-n30A-n66A	CA_n2A-n14A CA_n2A-n30A CA_n2A-n66A CA_n14A-n30A CA_n14A-n66A CA_n30A-n66A	n2	CA_n2(2A)_BCS0	0
		n14	5, 10	
		n30	5, 10	
		n66	5, 10, 15, 20, 25, 30, 40	
CA_n2A-n14A-n30A-n66(2A)	CA_n2A-n14A CA_n2A-n30A CA_n2A-n66A CA_n14A-n30A CA_n14A-n66A CA_n30A-n66A	n2	5, 10, 15, 20	0
		n14	5, 10	
		n30	5, 10	
		n66	CA_n66(2A)_BCS1	
CA_n2A-n14A-n30A-n77A	n77 <sup>5,6</sup> CA_n2A-n14A CA_n2A-n30A CA_n2A-n77A <sup>5</sup> CA_n14A-n30A CA_n14A-n77A <sup>5</sup> CA_n30A-n77A <sup>5</sup>	n2	5, 10, 15, 20	0
		n14	5, 10	
		n30	5, 10	
		n77	10, 15, 20, 25, 30, 40, 50, 60, 70, 80, 90, 100	
CA_n2(2A)-n14A-n30A-n77A	n77 <sup>5,6</sup> CA_n2A-n14A CA_n2A-n30A CA_n2A-n77A <sup>5</sup> CA_n14A-n30A CA_n14A-n77A <sup>5</sup> CA_n30A-n77A <sup>5</sup>	n2	CA_n2(2A)_BCS0	0
		n14	5, 10	
		n30	5, 10	
		n77	10, 15, 20, 25, 30, 40, 50, 60, 70, 80, 90, 100	
CA_n2A-n14A-n30A-n77(2A)	n77 <sup>5,6</sup> CA_n2A-n14A CA_n2A-n30A CA_n2A-n77A <sup>5</sup> CA_n14A-n30A CA_n14A-n77A <sup>5</sup> CA_n30A-n77A <sup>5</sup>	n2	5, 10, 15, 20	0
		n14	5, 10	
		n30	5, 10	
		n77	CA_n77(2A)_BCS1	
CA_n2(2A)-n14A-n30A-n77(2A)	n77 <sup>5</sup> CA_n2A-n14A CA_n2A-n30A CA_n2A-n77A <sup>5</sup> CA_n14A-n30A CA_n14A-n77A <sup>5</sup> CA_n30A-n77A <sup>5</sup>	n2	CA_n2(2A)_BCS0	0
		n14	5, 10	
		n30	5, 10	
		n77	CA_n77(2A)_BCS1	
CA_n2A-n14A-n66A-n77A	n77 <sup>5,6</sup> CA_n2A-n14A CA_n2A-n66A CA_n2A-n77A <sup>5</sup>	n2	5, 10, 15, 20	0

	CA_n14A-n66A CA_n14A-n77A <sup>5</sup> CA_n66A-n77A <sup>5</sup>	n14 n66 n77	5, 10 5, 10, 15, 20, 25, 30, 40 10, 15, 20, 25, 30, 40, 50, 60, 70, 80, 90, 100	
CA_n2(2A)-n14A-n66A-n77A	n77 <sup>5,6</sup> CA_n2A-n14A CA_n2A-n66A CA_n2A-n77A <sup>5</sup> CA_n14A-n66A CA_n14A-n77A <sup>5</sup> CA_n66A-n77A <sup>5</sup>	n2 n14 n66 n77	CA_n2(2A)_BCS0 5, 10 5, 10, 15, 20, 25, 30, 40 10, 15, 20, 25, 30, 40, 50, 60, 70, 80, 90, 100	0
CA_n2A-n14A-n66(2A)-n77A	n77 <sup>5,6</sup> CA_n2A-n14A CA_n2A-n66A CA_n2A-n77A <sup>5</sup> CA_n14A-n66A CA_n14A-n77A <sup>5</sup> CA_n66A-n77A <sup>5</sup>	n2 n14 n66 n77	5, 10, 15, 20 5, 10 CA_n66(2A)_BCS1 10, 15, 20, 25, 30, 40, 50, 60, 70, 80, 90, 100	0
CA_n2A-n14A-n66A-n77(2A)	n77 <sup>5,6</sup> CA_n2A-n14A CA_n2A-n66A CA_n2A-n77A <sup>5</sup> CA_n14A-n66A CA_n14A-n77A <sup>5</sup> CA_n66A-n77A <sup>5</sup>	n2 n14 n66 n77	5, 10, 15, 20 5, 10 5, 10, 15, 20, 25, 30, 40 CA_n77(2A)_BCS1	0
CA_n2A-n14A-n66(2A)-n77(2A)	n77 <sup>5</sup> CA_n2A-n14A CA_n2A-n66A CA_n2A-n77A <sup>5</sup> CA_n14A-n66A CA_n14A-n77A <sup>5</sup> CA_n66A-n77A <sup>5</sup>	n2 n14 n66 n77	5, 10, 15, 20 5, 10 CA_n66(2A)_BCS1 CA_n77(2A)_BCS1	0
CA_n2(2A)-n14A-n66A-n77(2A)	n77 <sup>5</sup> CA_n2A-n14A CA_n2A-n66A CA_n2A-n77A <sup>5</sup> CA_n14A-n66A CA_n14A-n77A <sup>5</sup> CA_n66A-n77A <sup>5</sup>	n2 n14 n66 n77	CA_n2(2A)_BCS0 5, 10 5, 10, 15, 20, 25, 30, 40 CA_n77(2A)_BCS1	0
CA_n2A-n29A-n30A-n66A	CA_n2A-n30A CA_n2A-n66A CA_n30A-n66A	n2 n29 n30 n66	5, 10, 15, 20 5, 10 5, 10 5, 10, 15, 20, 25, 30, 40	0
CA_n2(2A)-n29A-n30A-n66A	CA_n2A-n30A CA_n2A-n66A	n2	CA_n2(2A)_BCS0	0



	CA_n30A-n66A	n29	5, 10	
		n30	5, 10	
		n66	5, 10, 15, 20, 25, 30, 40	
CA_n2A-n29A-n30A-n66(2A)	CA_n2A-n30A CA_n2A-n66A CA_n30A-n66A	n2	5, 10, 15, 20	0
		n29	5, 10	
		n30	5, 10	
		n66	CA_n66(2A)_BCS1	
CA_n2A-n29A-n30A-n77A	n77 <sup>5,6</sup> CA_n2A-n30A CA_n2A-n77A <sup>5</sup> CA_n30A-n77A <sup>5</sup>	n2	5, 10, 15, 20	0
		n29	5, 10	
		n30	5, 10	
		n77	10, 15, 20, 30, 40, 50, 60, 70, 80, 90, 100	
CA_n2(2A)-n29A-n30A-n77A	n77 <sup>5,6</sup> CA_n2A-n30A CA_n2A-n77A <sup>5</sup> CA_n30A-n77A <sup>5</sup>	n2	CA_n2(2A)_BCS0	0
		n29	5, 10	
		n30	5, 10	
		n77	10, 15, 20, 25, 30, 40, 50, 60, 70, 80, 90, 100	
CA_n2A-n29A-n30A-n77(2A)	n77 <sup>5,6</sup> CA_n2A-n30A CA_n2A-n77A <sup>5</sup> CA_n30A-n77A <sup>5</sup>	n2	5, 10, 15, 20	0
		n29	5, 10	
		n30	5, 10	
		n77	CA_n77(2A)_BCS1	
CA_n2(2A)-n29A-n30A-n77(2A)	n77 <sup>5</sup> CA_n2A-n30A CA_n2A-n77A <sup>5</sup> CA_n30A-n77A <sup>5</sup>	n2	CA_n2(2A)_BCS0	0
		n29	5, 10	
		n30	5, 10	
		n77	CA_n77(2A)_BCS1	
CA_n2A-n29A-n66A-n77A	n77 <sup>5,6</sup> CA_n2A-n66A CA_n2A-n77A <sup>5</sup> CA_n66A-n77A <sup>5</sup>	n2	5, 10, 15, 20	0
		n29	5, 10	
		n66	5, 10, 15, 20, 25, 30, 40	
		n77	10, 15, 20, 30, 40, 50, 60, 70, 80, 90, 100	
CA_n2(2A)-n29A-n66A-n77A	n77 <sup>5,6</sup> CA_n2A-n66A CA_n2A-n77A <sup>5</sup> CA_n66A-n77A <sup>5</sup>	n2	CA_n2(2A)_BCS0	0
		n29	5, 10	
		n66	5, 10, 15, 20, 25, 30, 40	
		n77	10, 15, 20, 25, 30, 40, 50, 60, 70, 80, 90, 100	
CA_n2A-n29A-n66(2A)-n77A	n77 <sup>5,6</sup> CA_n2A-n66A CA_n2A-n77A <sup>5</sup> CA_n66A-n77A <sup>5</sup>	n2	5, 10, 15, 20	0
		n29	5, 10	
		n66	CA_n66(2A)_BCS1	
		n77	10, 15, 20, 25, 30, 40, 50, 60, 70, 80, 90, 100	
CA_n2A-n29A-n66A-n77(2A)	n77 <sup>5,6</sup> CA_n2A-n66A CA_n2A-n77A <sup>5</sup>	n2	5, 10, 15, 20	0

	CA_n66A-n77A <sup>5</sup>	n29	5, 10	
		n66	5, 10, 15, 20, 25, 30, 40	
		n77	CA_n77(2A)_BCS1	
CA_n2(2A)-n29A-n66A-n77(2A)	n77 <sup>5</sup> CA_n2A-n66A CA_n2A-n77A <sup>5</sup> CA_n66A-n77A <sup>5</sup>	n2	CA_n2(2A)_BCS0	0
		n29	5, 10	
		n66	5, 10, 15, 20, 25, 30, 40	
		n77	CA_n77(2A)_BCS1	
CA_n2A-n29A-n66(2A)-n77(2A)	n77 <sup>5</sup> CA_n2A-n66A CA_n2A-n77A <sup>5</sup> CA_n66A-n77A <sup>5</sup>	n2	5, 10, 15, 20	0
		n29	5, 10	
		n66	CA_n66(2A)_BCS1	
		n77	CA_n77(2A)_BCS1	
CA_n2A-n30A-n66A-n77A	n77 <sup>5,6</sup> CA_n2A-n30A CA_n2A-n66A CA_n2A-n77A <sup>5</sup> CA_n30A-n66A CA_n30A-n77A <sup>5</sup> CA_n66A-n77A <sup>5</sup>	n2	5, 10, 15, 20	0
		n30	5, 10	
		n66	5, 10, 15, 20, 25, 30, 40	
		n77	10, 15, 20, 25, 30, 40, 50, 60, 70, 80, 90, 100	
CA_n2(2A)-n30A-n66A-n77A	n77 <sup>5,6</sup> CA_n2A-n30A CA_n2A-n66A CA_n2A-n77A <sup>5</sup> CA_n30A-n66A CA_n30A-n77A <sup>5</sup> CA_n66A-n77A <sup>5</sup>	n2	CA_n2(2A)_BCS0	0
		n30	5, 10	
		n66	5, 10, 15, 20, 25, 30, 40	
		n77	10, 15, 20, 25, 30, 40, 50, 60, 70, 80, 90, 100	
CA_n2A-n30A-n66(2A)-n77A	n77 <sup>5,6</sup> CA_n2A-n30A CA_n2A-n66A CA_n2A-n77A <sup>5</sup> CA_n30A-n66A CA_n30A-n77A <sup>5</sup> CA_n66A-n77A <sup>5</sup>	n2	5, 10, 15, 20	0
		n30	5, 10	
		n66	CA_n66(2A)_BCS1	
		n77	10, 15, 20, 25, 30, 40, 50, 60, 70, 80, 90, 100	
CA_n2A-n30A-n66A-n77(2A)	n77 <sup>5,6</sup> CA_n2A-n30A CA_n2A-n66A CA_n2A-n77A <sup>5</sup> CA_n30A-n66A CA_n30A-n77A <sup>5</sup> CA_n66A-n77A <sup>5</sup>	n2	5, 10, 15, 20	0
		n30	5, 10	
		n66	5, 10, 15, 20, 25, 30, 40	
		n77	CA_n77(2A)_BCS1	
CA_n2A-n30A-n66(2A)-n77(2A)	n77 <sup>5</sup> CA_n2A-n30A CA_n2A-n66A CA_n2A-n77A <sup>5</sup> CA_n30A-n66A CA_n30A-n77A <sup>5</sup>	n2	5, 10, 15, 20	0

	CA_n66A-n77A <sup>5</sup>	n30	5, 10		
		n66	CA_n66(2A)_BCS1		
		n77	CA_n77(2A)_BCS1		
		n2	CA_n2(2A)_BCS0		
CA_n2(2A)-n30A-n66A-n77(2A)	n77 <sup>5</sup> CA_n2A-n30A CA_n2A-n66A CA_n2A-n77A <sup>5</sup> CA_n30A-n66A CA_n30A-n77A <sup>5</sup> CA_n66A-n77A <sup>5</sup>	n30	5, 10	0	
		n66	5, 10, 15, 20, 25, 30, 40		
		n77	CA_n77(2A)_BCS1		
		n2	5, 10, 15, 20		
CA_n2A-n41A-n66A-n71A	-	n2	5, 10, 15, 20	0	
		n41	10, 15, 20, 40, 50, 60, 80, 90, 100		
		n66	5, 10, 15, 20, 40		
		n71	5, 10, 15, 20		
CA_n2A-n48A-n66A-n77A	n77 <sup>5,6</sup>	n2	5, 10, 15, 20	0	
		n48	5, 10, 15, 20, 30, 40, 50 <sup>8</sup> , 60 <sup>8</sup> , 70 <sup>8</sup> , 80 <sup>8</sup> , 90 <sup>8</sup> , 100 <sup>8</sup>		
		n66	5, 10, 15, 20, 25, 30, 40		
		n77	10, 15, 20, 25, 30, 40, 50, 60, 70, 80, 90, 100		
	n77 <sup>5,6</sup> CA_n2A-n48A CA_n2A-n66A CA_n2A-n77A <sup>5</sup> CA_n48A-n66A CA_n66A-n77A <sup>5</sup>	n2	5, 10, 15, 20, 25, 30, 40	1	
		n48	5, 10, 15, 20, 30, 40, 50 <sup>8</sup> , 60 <sup>8</sup> , 70 <sup>8</sup> , 80 <sup>8</sup> , 90 <sup>8</sup> , 100 <sup>8</sup>		
		n66	5, 10, 15, 20, 25, 30, 40		
		n77	10, 15, 20, 25, 30, 40, 50, 60, 70, 80, 90, 100		
CA_n2A-n48B-n66A-n77A	n77 <sup>5,6</sup>	n2	5, 10, 15, 20	0	
		n48	CA_n48B_BCS1		
		n66	5, 10, 15, 20, 25, 30, 40		
		n77	10, 15, 20, 25, 30, 40, 50, 60, 70, 80, 90, 100		
	n77 <sup>5,6</sup> CA_n2A-n48A CA_n2A-n66A CA_n2A-n77A <sup>5</sup> CA_n48A-n66A CA_n66A-n77A <sup>5</sup>	n2	5, 10, 15, 20, 25, 30, 40	1	
		n48	CA_n48B_BCS0		
		n66	5, 10, 15, 20, 25, 30, 40		
		n77	10, 15, 20, 25, 30, 40, 50, 60, 70, 80, 90, 100		
		n2	5, 10, 15, 20, 25, 30, 40		2
		n48	CA_n48B_BCS1		
		n66	5, 10, 15, 20, 25, 30, 40		
		n77	10, 15, 20, 25, 30, 40, 50, 60, 70, 80, 90, 100		
n2	5, 10, 15, 20, 25, 30, 40	3			
	n48		CA_n48B_BCS2		
	n66		5, 10, 15, 20, 25, 30, 40		
	n77		10, 15, 20, 25, 30, 40, 50, 60, 70, 80, 90, 100		
CA_n2A-n48(2A)-n66A-n77A	n77 <sup>5,6</sup>	n2	5, 10, 15, 20	0	
		n48	CA_n48(2A)_BCS1		

		n66	5, 10, 15, 20, 25, 30, 40	1	
		n77	10, 15, 20, 25, 30, 40, 50, 60, 70, 80, 90, 100		
		n2	5, 10, 15, 20, 25, 30, 40		
		n48	CA_n48(2A)_BCS0		
		n66	5, 10, 15, 20, 25, 30, 40		
		n77	10, 15, 20, 25, 30, 40, 50, 60, 70, 80, 90, 100		
		n2	5, 10, 15, 20, 25, 30, 40		2
		n48	CA_n48(2A)_BCS1		
		n66	5, 10, 15, 20, 25, 30, 40		
		n77	10, 15, 20, 25, 30, 40, 50, 60, 70, 80, 90, 100		
CA_n2A-n48A-n66A-n77C	n77 <sup>5,6</sup>	n2	5, 10, 15, 20	0	
		n48	5, 10, 15, 20, 30, 40, 50 <sup>8</sup> , 60 <sup>8</sup> , 70 <sup>8</sup> , 80 <sup>8</sup> , 90 <sup>8</sup> , 100 <sup>8</sup>		
		n66	5, 10, 15, 20, 25, 30, 40		
		n77	CA_n77C_BCS0		
	n77 <sup>5,6</sup> CA_n77C CA_n2A-n48A CA_n2A-n66A CA_n2A-n77A <sup>5</sup> CA_n48A-n66A CA_n66A-n77A <sup>5</sup>	n2	5, 10, 15, 20, 25, 30, 40	1	
		n48	5, 10, 15, 20, 30, 40, 50 <sup>8</sup> , 60 <sup>8</sup> , 70 <sup>8</sup> , 80 <sup>8</sup> , 90 <sup>8</sup> , 100 <sup>8</sup>		
		n66	5, 10, 15, 20, 25, 30, 40		
		n77	CA_n77C_BCS1		
		n2	5, 10, 15, 20, 25, 30, 40		2
		n48	5, 10, 15, 20, 30, 40, 50 <sup>8</sup> , 60 <sup>8</sup> , 70 <sup>8</sup> , 80 <sup>8</sup> , 90 <sup>8</sup> , 100 <sup>8</sup>		
CA_n2A-n66A-n71A-n77A	-	n2	5, 10, 15, 20	0	
		n66	10, 15, 20, 25, 30, 40		
		n71	5, 10, 15, 20		
		n77	10, 15, 20, 25, 30, 40, 50, 60, 70, 80, 90, 100		
CA_n2A-n66A-n71A-n77(2A)	-	n2	5, 10, 15, 20	0	
		n66	10, 15, 20, 25, 30, 40		
		n71	5, 10, 15, 20		
		n77	CA_n77(2A)_BCS1		
CA_n2A-n66A-n71A-n78A	-	n2	5, 10, 15, 20, 25, 30, 40	0	
		n66	10, 15, 20, 25, 30, 40		
		n71	5, 10, 15, 20		
		n78	10, 15, 20, 25, 30, 40, 50, 60, 70, 80, 90, 100		
CA_n2A-n66A-n71A-n78(2A)	-	n2	5, 10, 15, 20, 25, 30, 40	0	
		n66	10, 15, 20, 25, 30, 40		
		n71	5, 10, 15, 20		
		n78	CA_n78(2A)_BCS2		
CA_n3A-n5A-n7A-n78A	-	n3	5, 10, 15, 20, 25, 30, 40	0	
		n5	5, 10, 15, 20		
		n7	5, 10, 15, 20, 25, 30, 40, 50		

		n78	10, 15, 20, 25, 30, 40, 50, 60, 70, 80, 90, 100	
	CA_n3A-n5A CA_n3A-n7A CA_n3A-n78A CA_n5A-n7A CA_n5A-n78A CA_n7A-n78A	n3	5, 10, 15, 20, 25, 30, 40, 50	1
		n5	5, 10, 15, 20	
		n7	5, 10, 15, 20, 25, 30, 40, 50	
		n78	10, 15, 20, 25, 30, 40, 50, 60, 70, 80, 90, 100	
CA_n3A-n5A-n7B-n78A	-	n3	5, 10, 15, 20, 25, 30, 40	0
		n5	5, 10, 15, 20	
		n7	CA_n7B_BCS0	
		n78	10, 15, 20, 25, 30, 40, 50, 60, 70, 80, 90, 100	
	CA_n3A-n5A CA_n3A-n7A CA_n3A-n78A CA_n5A-n7A CA_n5A-n78A CA_n7A-n78A CA_n7B	n3	5, 10, 15, 20, 25, 30, 40, 50	1
		n5	5, 10, 15, 20	
		n7	CA_n7B_BCS0	
		n78	10, 15, 20, 25, 30, 40, 50, 60, 70, 80, 90, 100	
CA_n3A-n5A-n28A-n78A	CA_n3A-n5A CA_n3A-n28A CA_n3A-n79A CA_n5A-n28A CA_n5A-n79A CA_n28A-n79A	n3	n3 channel bandwidths in Table 5.3.5-1	4 and 5
		n5	n5 channel bandwidths in Table 5.3.5-1	
		n28	n28 channel bandwidths in Table 5.3.5-1	
		n78	n78 channel bandwidths in Table 5.3.5-1	
CA_n3A-n5A-n28A-n79A	CA_n3A-n5A CA_n3A-n28A CA_n3A-n79A CA_n5A-n28A CA_n5A-n79A CA_n28A-n79A	n3	n3 channel bandwidths in Table 5.3.5-1	4 and 5
		n5	n5 channel bandwidths in Table 5.3.5-1	
		n28	n28 channel bandwidths in Table 5.3.5-1	
		n79	n79 channel bandwidths in Table 5.3.5-1	
CA_n3A-n7A-n8A-n78A	CA_n3A-n7A CA_n3A-n8A CA_n3A-n78A CA_n7A-n8A CA_n7A-n78A CA_n8A-n78A	n3	5, 10, 15, 20, 25, 30	0
		n7	5, 10, 15, 20, 25, 30, 40, 50	
		n8	5, 10, 15, 20	
		n78	10, 15, 20, 40, 50, 60, 80, 90, 100	
CA_n3(2A)-n7A-n8A-n78A	CA_n3A-n7A CA_n3A-n8A CA_n3A-n78A CA_n7A-n8A	n3	CA_n3(2A)_BCS0	0

	CA_n7A-n78A CA_n8A-n78A	n7	5, 10, 15, 20, 25, 30, 40, 50	
		n8	5, 10, 15, 20	
		n78	10, 15, 20, 25, 30, 40, 50, 60, 70, 80, 90, 100	
CA_n3A-n7(2A)-n8A-n78A	CA_n3A-n7A CA_n3A-n8A CA_n3A-n78A CA_n7A-n8A CA_n7A-n78A CA_n8A-n78A	n3	5, 10, 15, 20, 25, 30	0
		n7	CA_n7(2A)_BCS0	
		n8	5, 10, 15, 20	
		n78	10, 15, 20, 25, 30, 40, 50, 60, 70, 80, 90, 100	
CA_n3(2A)-n7(2A)-n8A-n78A	CA_n3A-n7A CA_n3A-n8A CA_n3A-n78A CA_n7A-n8A CA_n7A-n78A CA_n8A-n78A	n3	CA_n3(2A)_BCS0	0
		n7	CA_n7(2A)_BCS0	
		n8	5, 10, 15, 20	
		n78	10, 15, 20, 25, 30, 40, 50, 60, 70, 80, 90, 100	
CA_n3A-n7A-n20A-n67A	CA_n3A-n7A CA_n3A-n20A CA_n7A-n20A	n3	n3 channel bandwidths in Table 5.3.5-1	4 and 5
		n7	n7 channel bandwidths in Table 5.3.5-1	
		n20	n20 channel bandwidths in Table 5.3.5-1	
		n67	n67 channel bandwidths in Table 5.3.5-1	
CA_n3A-n7A-n20A-n78A	CA_n3A-n7A CA_n3A-n20A CA_n3A-n78A CA_n7A-n20A CA_n7A-n78A CA_n20A-n78A	n3	n3 channel bandwidths in Table 5.3.5-1	4 and 5
		n7	n7 channel bandwidths in Table 5.3.5-1	
		n20	n20 channel bandwidths in Table 5.3.5-1	
		n78	n78 channel bandwidths in Table 5.3.5-1	
CA_n3A-n7A-n20A-n78(2A)	CA_n3A-n7A CA_n3A-n20A CA_n3A-n78A CA_n7A-n20A CA_n7A-n78A CA_n20A-n78A CA_n78(2A)	n3	n3 channel bandwidths in Table 5.3.5-1	4 and 5
		n7	n7 channel bandwidths in Table 5.3.5-1	
		n20	n20 channel bandwidths in Table 5.3.5-1	
		n78	CA_n78(2A)_BCS 4 and 5	
CA_n3A-n7A-n26A-n78A	CA_n3A-n7A CA_n3A-n26A CA_n3A-n78A CA_n7A-n26A CA_n7A-n78A CA_n26A-n78A	n3	5, 10, 15, 20, 25, 30, 40, 50	0
		n7	5, 10, 15, 20, 25, 30, 40, 50	
		n26	5, 10, 15, 20	

		n78	10, 15, 20, 25, 30, 40, 50, 60, 70, 80, 90, 100	
CA_n3A-n7B-n26A-n78A	CA_n3A-n7A CA_n3A-n26A CA_n3A-n78A CA_n7A-n26A CA_n7A-n78A CA_n26A-n78A CA_n7B	n3	5, 10, 15, 20, 25, 30, 40, 50	0
		n7	CA_n7B_BCS0	
		n26	5, 10, 15, 20	
		n78	10, 15, 20, 25, 30, 40, 50, 60, 70, 80, 90, 100	
CA_n3A-n7A-n26(2A)-n78A	CA_n3A-n26A CA_n3A-n7A CA_n3A-n78A CA_n7A-n26A CA_n26A-n78A CA_n7A-n78A CA_n26(2A)	n3	5, 10, 15, 20, 25, 30, 35, 40, 45, 50	0
		n7	5, 10, 15, 20, 25, 30, 35, 40, 50	
		n26	CA_n26(2A)_BCS0	
		n78	10, 15, 20, 25, 30, 40, 50, 60, 70, 80, 90, 100	
CA_n3A-n7A-n26A-n78(2A)	CA_n3A-n26A CA_n3A-n7A CA_n3A-n78A CA_n7A-n26A CA_n26A-n78A CA_n7A-n78A	n3	5, 10, 15, 20, 25, 30, 35, 40, 45, 50	0
		n7	5, 10, 15, 20, 25, 30, 35, 40, 50	
		n26	5, 10, 15, 20, 25, 30	
		n78	CA_n78(2A)_BCS0	
CA_n3A-n7A-n26A-n78C	CA_n3A-n26A CA_n3A-n7A CA_n3A-n78A CA_n7A-n26A CA_n26A-n78A CA_n7A-n78A CA_n78C	n3	5, 10, 15, 20, 25, 30, 35, 40, 45, 50	0
		n7	5, 10, 15, 20, 25, 30, 35, 40, 50	
		n26	5, 10, 15, 20, 25, 30	
		n78	CA_n78C_BCS0	
CA_n3A-n7A-n26(2A)-n78(2A)	CA_n3A-n26A CA_n3A-n7A CA_n3A-n78A CA_n7A-n26A CA_n26A-n78A CA_n7A-n78A CA_n26(2A)	n3	5, 10, 15, 20, 25, 30, 35, 40, 45, 50	0
		n7	5, 10, 15, 20, 25, 30, 35, 40, 50	
		n26	CA_n26(2A)_BCS0	
		n78	CA_n78(2A)_BCS0	
CA_n3A-n7A-n26(2A)-n78C	CA_n3A-n26A CA_n3A-n7A CA_n3A-n78A CA_n7A-n26A CA_n26A-n78A CA_n7A-n78A CA_n26(2A) CA_n78C	n3	5, 10, 15, 20, 25, 30, 35, 40, 45, 50	0
		n7	5, 10, 15, 20, 25, 30, 35, 40, 50	
		n26	CA_n26(2A)_BCS0	
		n78	CA_n78C_BCS0	
CA_n3A-n7B-n26(2A)-n78A	CA_n3A-n26A CA_n3A-n7A CA_n3A-n78A CA_n7A-n26A CA_n26A-n78A	n3	5, 10, 15, 20, 25, 30, 35, 40, 45, 50	0

	CA_n7A-n78A CA_n7B CA_n26(2A)	n7	CA_n7B_BCS0	0
		n26	CA_n26(2A)_BCS0	
		n78	10, 15, 20, 25, 30, 40, 50, 60, 70, 80, 90, 100	
CA_n3A-n7B-n26A-n78(2A)	CA_n3A-n26A CA_n3A-n7A CA_n3A-n78A CA_n7A-n26A CA_n26A-n78A CA_n7A-n78A CA_n7B	n3	5, 10, 15, 20, 25, 30, 35, 40, 45, 50	0
		n7	CA_n7B_BCS0	
		n26	5, 10, 15, 20, 25, 30	
		n78	CA_n78(2A)_BCS0	
CA_n3A-n7B-n26A-n78C	CA_n3A-n26A CA_n3A-n7A CA_n3A-n78A CA_n7A-n26A CA_n26A-n78A CA_n7A-n78A CA_n7B CA_n78C	n3	5, 10, 15, 20, 25, 30, 35, 40, 45, 50	0
		n7	CA_n7B_BCS0	
		n26	5, 10, 15, 20, 25, 30	
		n78	CA_n78C_BCS0	
CA_n3A-n7B-n26(2A)-n78(2A)	CA_n3A-n26A CA_n3A-n7A CA_n3A-n78A CA_n7A-n26A CA_n26A-n78A CA_n7A-n78A CA_n7B CA_n26(2A)	n3	5, 10, 15, 20, 25, 30, 35, 40, 45, 50	0
		n7	CA_n7B_BCS0	
		n26	CA_n26(2A)_BCS0	
		n78	CA_n78(2A)_BCS0	
CA_n3A-n7B-n26(2A)-n78C	CA_n3A-n26A CA_n3A-n7A CA_n3A-n78A CA_n7A-n26A CA_n26A-n78A CA_n7A-n78A CA_n7B CA_n26(2A) CA_n78C	n3	5, 10, 15, 20, 25, 30, 35, 40, 45, 50	0
		n7	CA_n7B_BCS0	
		n26	CA_n26(2A)_BCS0	
		n78	CA_n78C_BCS0	
CA_n3B-n7A-n26A-n78A	CA_n3A-n7A CA_n3A-n26A CA_n3A-n78A CA_n7A-n26A CA_n7A-n78A CA_n26A-n78A	n3	CA_n3B_BCS0	0
		n7	5, 10, 15, 20, 25, 30, 35, 40, 50	
		n26	5, 10, 15, 20	
		n78	10, 15, 20, 25, 30, 40, 50, 60, 70, 80, 90, 100	
CA_n3B-n7A-n26(2A)-n78A	CA_n3A-n26A CA_n3A-n7A CA_n3A-n78A CA_n7A-n26A CA_n26A-n78A CA_n7A-n78A CA_n26(2A)	n3	CA_n3B_BCS0	0
		n7	5, 10, 15, 20, 25, 30, 35, 40, 50	
		n26	CA_n26(2A)_BCS0	



		n78	10, 15, 20, 25, 30, 40, 50, 60, 70, 80, 90, 100	
CA_n3B-n7A-n26A-n78(2A)	CA_n3A-n26A CA_n3A-n7A CA_n3A-n78A CA_n7A-n26A CA_n26A-n78A CA_n7A-n78A	n3	CA_n3B_BCS0	0
		n7	5, 10, 15, 20, 25, 30, 35, 40, 50	
		n26	5, 10, 15, 20, 25, 30	
		n78	CA_n78(2A)_BCS0	
CA_n3B-n7A-n26A-n78C	CA_n3A-n26A CA_n3A-n7A CA_n3A-n78A CA_n7A-n26A CA_n26A-n78A CA_n7A-n78A CA_n78C	n3	CA_n3B_BCS0	0
		n7	5, 10, 15, 20, 25, 30, 35, 40, 50	
		n26	5, 10, 15, 20, 25, 30	
		n78	CA_n78C_BCS0	
CA_n3B-n7A-n26(2A)-n78(2A)	CA_n3A-n26A CA_n3A-n7A CA_n3A-n78A CA_n7A-n26A CA_n26A-n78A CA_n7A-n78A CA_n26(2A)	n3	CA_n3B_BCS0	0
		n7	5, 10, 15, 20, 25, 30, 35, 40, 50	
		n26	CA_n26(2A)_BCS0	
		n78	CA_n78(2A)_BCS0	
CA_n3B-n7A-n26(2A)-n78C	CA_n3A-n26A CA_n3A-n7A CA_n3A-n78A CA_n7A-n26A CA_n26A-n78A CA_n7A-n78A CA_n26(2A) CA_n78C	n3	CA_n3B_BCS0	0
		n7	5, 10, 15, 20, 25, 30, 35, 40, 50	
		n26	CA_n26(2A)_BCS0	
		n78	CA_n78C_BCS0	
CA_n3B-n7B-n26A-n78A	CA_n3A-n7A CA_n3A-n26A CA_n3A-n78A CA_n7A-n26A CA_n7A-n78A CA_n26A-n78A CA_n7B	n3	CA_n3B_BCS0	0
		n7	CA_n7B_BCS0	
		n26	5, 10, 15, 20	
		n78	10, 15, 20, 25, 30, 40, 50, 60, 70, 80, 90, 100	
CA_n3B-n7B-n26(2A)-n78A	CA_n3A-n26A CA_n3A-n7A CA_n3A-n78A CA_n7A-n26A CA_n26A-n78A CA_n7A-n78A CA_n7B CA_n26(2A)	n3	CA_n3B_BCS0	0
		n7	CA_n7B_BCS0	
		n26	CA_n26(2A)_BCS0	
		n78	10, 15, 20, 25, 30, 40, 50, 60, 70, 80, 90, 100	
CA_n3B-n7B-n26A-n78(2A)	CA_n3A-n26A CA_n3A-n7A CA_n3A-n78A CA_n7A-n26A	n3	CA_n3B_BCS0	0

	CA_n26A-n78A CA_n7A-n78A CA_n7B			
		n7	CA_n7B_BCS0	
		n26	5, 10, 15, 20, 25, 30	
		n78	CA_n78(2A)_BCS0	
CA_n3B-n7B-n26A-n78C	CA_n3A-n26A CA_n3A-n7A CA_n3A-n78A CA_n7A-n26A CA_n26A-n78A CA_n7A-n78A CA_n7B CA_n78C	n3	CA_n3B_BCS0	0
		n7	CA_n7B_BCS0	
		n26	5, 10, 15, 20, 25, 30	
		n78	CA_n78C_BCS0	
CA_n3B-n7B-n26(2A)-n78(2A)	CA_n3A-n26A CA_n3A-n7A CA_n3A-n78A CA_n7A-n26A CA_n26A-n78A CA_n7A-n78A CA_n7B CA_n26(2A)	n3	CA_n3B_BCS0	0
		n7	CA_n7B_BCS0	
		n26	CA_n26(2A)_BCS0	
		n78	CA_n78(2A)_BCS0	
CA_n3B-n7B-n26(2A)-n78C	CA_n3A-n26A CA_n3A-n7A CA_n3A-n78A CA_n7A-n26A CA_n26A-n78A CA_n7A-n78A CA_n7B CA_n26(2A) CA_n78C	n3	CA_n3B_BCS0	0
		n7	CA_n7B_BCS0	
		n26	CA_n26(2A)_BCS0	
		n78	CA_n78C_BCS0	
CA_n3A-n7A-n28A-n38A <sup>7</sup>	-	n3	5, 10, 15, 20, 25, 30, 35, 40, 45, 50	0
		n7	5, 10, 15, 20, 25, 30, 40, 50	
		n28	5, 10, 15, 20, 25, 30	
		n38	5, 10, 15, 20, 25, 30, 40	
CA_n3A-n7A-n28A-n78A	-	n3	5, 10, 15, 20, 25, 30	0
		n7	5, 10, 15, 20, 25, 30, 40, 50	
		n28	5, 10, 15, 20	
		n78	10, 15, 20, 25, 30, 40, 50, 60, 70, 80, 90, 100	
	CA_n3A-n7A CA_n3A-n28A CA_n3A-n78A CA_n7A-n28A CA_n7A-n78A CA_n28A-n78A	n3	5, 10, 15, 20, 25, 30, 40	1
		n7	5, 10, 15, 20, 25, 30, 40, 50	
		n28	5, 10, 15, 20 <sup>2</sup>	
		n78	10, 15, 20, 25, 30, 40, 50, 60, 70, 80, 90, 100	
CA_n3A-n7A-n28A-n78(2A)	CA_n78(2A) CA_n3A-n7A CA_n3A-n28A CA_n3A-n78A CA_n7A-n28A CA_n7A-n78A CA_n28A-n78A	n3	5, 10, 15, 20, 25, 30, 40	0

		n7	5, 10, 15, 20, 25, 30, 40, 50	
		n28	5, 10, 15, 20 <sup>2</sup>	
		n78	CA_n78(2A)_BCS2	
CA_n3A-n7A-n28A-n78C	CA_n78C CA_n3A-n7A CA_n3A-n28A CA_n3A-n78A CA_n7A-n28A CA_n7A-n78A CA_n28A-n78A	n3	5, 10, 15, 20, 25, 30, 40	0
		n7	5, 10, 15, 20, 25, 30, 40, 50	
		n28	5, 10, 15, 20 <sup>2</sup>	
		n78	CA_n78C_BCS0	
CA_n3A-n7B-n28A-n78A	-	n3	5, 10, 15, 20, 25, 30	0
		n7	CA_n7B_BCS0	
		n28	5, 10, 15, 20	
		n78	10, 15, 20, 25, 30, 40, 50, 60, 70, 80, 90, 100	
	CA_n3A-n7A CA_n3A-n28A CA_n3A-n78A CA_n7A-n28A CA_n7A-n78A CA_n7B CA_n28A-n78A	n3	5, 10, 15, 20, 25, 30, 40	1
		n7	CA_n7B_BCS0	
		n28	5, 10, 15, 20	
		n78	10, 15, 20, 25, 30, 40, 50, 60, 70, 80, 90, 100	
CA_n3A-n7B-n28A-n78(2A)	CA_n7B CA_n78(2A) CA_n3A-n7A CA_n3A-n28A CA_n3A-n78A CA_n7A-n28A CA_n7A-n78A CA_n28A-n78A	n3	5, 10, 15, 20, 25, 30, 40	0
		n7	CA_n7B_BCS0	
		n28	5, 10, 15, 20	
		n78	CA_n78(2A)_BCS2	
CA_n3A-n7B-n28A-n78C	CA_n7B CA_n78C CA_n3A-n7A CA_n3A-n28A CA_n3A-n78A CA_n7A-n28A CA_n7A-n78A CA_n28A-n78A	n3	5, 10, 15, 20, 25, 30, 40	0
		n7	CA_n7B_BCS0	
		n28	5, 10, 15, 20	
		n78	CA_n78C_BCS0	
CA_n3B-n7A-n28A-n78A	CA_n3A-n7A CA_n3A-n28A CA_n3A-n78A CA_n7A-n28A CA_n7A-n78A CA_n28A-n78A	n3	CA_n3B_BCS0	0
		n7	5, 10, 15, 20, 25, 30, 40, 50	
		n28	5, 10, 15, 20	
		n78	10, 15, 20, 25, 30, 40, 50, 60, 70, 80, 90, 100	
CA_n3B-n7A-n28A-n78(2A)	CA_n78(2A) CA_n3A-n7A CA_n3A-n28A CA_n3A-n78A CA_n7A-n28A	n3	CA_n3B_BCS0	0

	CA_n7A-n78A CA_n28A-n78A	n7	5, 10, 15, 20, 25, 30, 40, 50	
		n28	5, 10, 15, 20	
		n78	CA_n78(2A)_BCS2	
CA_n3B-n7B-n28A-n78A	CA_n7B CA_n3A-n7A CA_n3A-n28A CA_n3A-n78A CA_n7A-n28A CA_n7A-n78A CA_n28A-n78A	n3	CA_n3B_BCS0	0
		n7	CA_n7B_BCS0	
		n28	5, 10, 15, 20	
		n78	10, 15, 20, 25, 30, 40, 50, 60, 70, 80, 90, 100	
CA_n3B-n7B-n28A-n78(2A)	CA_n7B CA_n78(2A) CA_n3A-n7A CA_n3A-n28A CA_n3A-n78A CA_n7A-n28A CA_n7A-n78A CA_n28A-n78A	n3	CA_n3B_BCS0	0
		n7	CA_n7B_BCS0	
		n28	5, 10, 15, 20	
		n78	CA_n78(2A)_BCS2	
CA_n3B-n7A-n28A-n78C	CA_n78C CA_n3A-n7A CA_n3A-n28A CA_n3A-n78A CA_n7A-n28A CA_n7A-n78A CA_n28A-n78A	n3	CA_n3B_BCS0	0
		n7	5, 10, 15, 20, 25, 30, 40, 50	
		n28	5, 10, 15, 20	
		n78	CA_n78C_BCS0	
CA_n3A-n7A-n38A-n78A <sup>7</sup>	-	n3	5, 10, 15, 20, 25, 30, 35, 40, 45, 50	0
		n7	5, 10, 15, 20, 25, 30, 40, 50	
		n38	5, 10, 15, 20, 25, 30, 40	
		n78	10, 15, 20, 25, 30, 40, 50, 60, 70, 80, 90, 100	
CA_n3A-n7A-n40A-n78A	CA_n3A-n7A CA_n3A-n40A CA_n3A-n78A CA_n7A-n40A CA_n7A-n78A CA_n40A-n78A	n3	5, 10, 15, 20, 25, 30, 40, 50	0
		n7	5, 10, 15, 20, 25, 30, 40, 50	
		n40	5, 10, 15, 20, 25, 30, 40, 50, 60, 80, 90, 100	
		n78	10, 15, 20, 25, 30, 40, 50, 60, 70, 80, 90, 100	
CA_n3A-n7A-n40A-n105A	CA_n3A-n7A CA_n3A-n40A CA_n3A-n105A CA_n7A-n40A CA_n7A-n105A CA_n40A-n105A	n3	5, 10, 15, 20, 25, 30, 35, 40, 45, 50	0
		n7	5, 10, 15, 20, 25, 30, 40, 50	
		n40	5, 10, 15, 20, 25, 30, 40, 50, 60, 80	
		n105	5, 10, 15, 20, 25, 30, 35	
CA_n3A-n7A-n67A-n78A	CA_n3A-n7A CA_n3A-n78A CA_n7A-n78A	n3	5, 10, 15, 20, 25, 30, 35, 40, 45, 50	0

		n7	5, 10, 15, 20, 25, 30, 40, 50	
		n67	5, 10, 15, 20	
		n78	10, 20, 25, 30, 40, 50, 60, 70, 80, 90, 100	
CA_n3A-n7A-n67A-n78(2A)	CA_n3A-n7A CA_n3A-n78A CA_n7A-n78A CA_n78(2A)	n3	5, 10, 15, 20, 25, 30, 35, 40, 45, 50	0
		n7	5, 10, 15, 20, 25, 30, 40, 50	
		n67	5, 10, 15, 20	
		n78	CA_n78(2A)_BCS2	
CA_n3A-n7A-n75A-n78A	-	n3	n3 channel bandwidths in Table 5.3.5-1	4 and 5
		n7	n7 channel bandwidths in Table 5.3.5-1	
		n75	n75 channel bandwidths in Table 5.3.5-1	
		n78	n78 channel bandwidths in Table 5.3.5-1	
CA_n3A-n7A-n78A-n105A	CA_n3A-n7A CA_n3A-n78A CA_n3A-n105A CA_n7A-n78A CA_n7A-n105A CA_n78A-n105A	n3	5, 10, 15, 20, 25, 30, 35, 40, 45, 50	0
		n7	5, 10, 15, 20, 25, 30, 40, 50	
		n78	10, 20, 25, 30, 40, 50, 60, 70, 80, 90, 100	
		n105	5, 10, 15, 20, 25, 30, 35	
CA_n3A-n8A-n41A-n79A	-	n3	5, 10, 15, 20, 25, 30	0
		n8	5, 10, 15, 20	
		n41	10, 15, 20, 30, 40, 50, 60, 80, 90, 100	
		n79	40, 50, 60, 80, 100	
CA_n3A-n18A-n28A-n41A	CA_n3A-n18A CA_n3A-n28A CA_n3A-n41A CA_n18A-n28A CA_n18A-n41A CA_n28A-n41A	n3	5, 10, 15, 20	0
		n18	5, 10, 15	
		n28	5, 10	
		n41	10, 15, 20, 30, 40, 50, 60, 80, 90, 100	
CA_n3A-n18A-n28A-n77A	n77A <sup>5</sup> CA_n3A-n18A CA_n3A-n28A CA_n3A-n77A CA_n18A-n28A CA_n18A-n77A CA_n28A-n77A	n3	5, 10, 15, 20	0
		n18	5, 10, 15	
		n28	5, 10	
		n77	10, 15, 20, 25, 30, 40, 50, 60, 70, 80, 90, 100	
CA_n3A-n18A-n41A-n77A	CA_n3A-n18A CA_n3A-n41A CA_n3A-n77A CA_n18A-n41A CA_n18A-n77A CA_n41A-n77A	n3	5, 10, 15, 20	0
		n18	5, 10, 15	
		n41	10, 15, 20, 30, 40, 50, 60, 80, 90, 100	
		n77	10, 15, 20, 25, 30, 40, 50, 60, 70, 80, 90, 100	

CA_n3A-n20A-n67A-n78A	CA_n3A-n20A CA_n3A-n78A CA_n20A-n78A	n3	n3 channel bandwidths in Table 5.3.5-1	4 and 5
		n20	n20 channel bandwidths in Table 5.3.5-1	
		n67	n67 channel bandwidths in Table 5.3.5-1	
		n78	n78 channel bandwidths in Table 5.3.5-1	
CA_n3A-n20A-n67A-n78(2A)	CA_n3A-n20A CA_n3A-n78A CA_n20A-n78A CA_n78(2A)	n3	n3 channel bandwidths in Table 5.3.5-1	4 and 5
		n20	n20 channel bandwidths in Table 5.3.5-1	
		n67	n67 channel bandwidths in Table 5.3.5-1	
		n78	CA_n78(2A)_BCS 4 and 5	
CA_n3A-n28A-n38A-n78A	-	n3	5, 10, 15, 20, 25, 30, 35, 40, 45, 50	0
		n28	5, 10, 15, 20, 25, 30	
		n38	5, 10, 15, 20, 25, 30, 40	
		n78	10, 15, 20, 25, 30, 40, 50, 60, 70, 80, 90, 100	
CA_n3A-n28A-n40A-n77A	CA_n3A-n28A CA_n3A-n40A CA_n3A-n77A CA_n28A-n40A CA_n28A-n77A CA_n40A-n77A	n3	5, 10, 15, 20, 25, 30, 40	0
		n28	5, 10, 15, 20, 30	
		n40	10, 15, 20, 30, 40, 50, 60, 80, 90, 100	
		n77	10, 15, 20, 25, 30, 40, 50, 60, 70, 80, 90, 100	
CA_n3A-n28A-n41A-n77A	n77 <sup>5,6</sup> CA_n3A-n28A CA_n3A-n41A <sup>5</sup> CA_n3A-n77A <sup>5</sup> CA_n28A-n41A CA_n28A-n77A CA_n41A-n77A <sup>5</sup>	n3	5, 10, 15, 20, 25, 30, 40	0
		n28	5, 10, 15, 20, 30	
		n41	10, 15, 20, 30, 40, 50, 60, 80, 90, 100	
		n77	10, 15, 20, 25, 30, 40, 50, 60, 70, 80, 90, 100	
CA_n3A-n28A-n41A-n77(2A)	CA_n3A-n28A CA_n3A-n41A CA_n3A-n77A CA_n28A-n41A CA_n28A-n77A CA_n41A-n77A	n3	5, 10, 15, 20, 25, 30, 40	0
		n28	5, 10	
		n41	10, 15, 20, 30, 40, 50, 60, 80, 90, 100	
		n77	CA_n77(2A)_BCS0	
	CA_n3A-n28A CA_n3A-n41A <sup>5</sup> CA_n3A-n77A <sup>5</sup> CA_n28A-n41A <sup>5</sup> CA_n28A-n77A <sup>5</sup> CA_n41A-n77A <sup>5</sup>	n3	5, 10, 15, 20	1
		n28	5, 10	
		n41	10, 15, 20, 30, 40, 50, 60, 80, 90, 100	
		n77	CA_n77(2A)_BCS1	

CA_n3A-n28A-n41A-n78A	CA_n3A-n28A CA_n3A-n41A CA_n3A-n78A CA_n28A-n41A CA_n28A-n78A CA_n41A-n78A	n3	5, 10, 15, 20, 25, 30, 40	0
		n28	5, 10, 15, 20	
		n41	10, 15, 20, 30, 40, 50, 60, 80, 90, 100	
		n78	10, 15, 20, 25, 30, 40, 50, 60, 70, 80, 90, 100	
CA_n3A-n28A-n41A-n78(2A)	CA_n3A-n28A CA_n3A-n41A CA_n3A-n78A CA_n28A-n41A CA_n28A-n78A CA_n41A-n78A	n3	5, 10, 15, 20, 25, 30, 40	0
		n28	5, 10	
		n41	10, 15, 20, 30, 40, 50, 60, 80, 90, 100	
		n78	CA_n78(2A)_BCS2	
CA_n3A-n28A-n41A-n79A	CA_n3A-n28A CA_n3A-n41A CA_n3A-n79A CA_n28A-n41A CA_n28A-n79A CA_n41A-n79A	n3	5, 10, 15, 20, 25, 30	0
		n28	5, 10, 15, 20	
		n41	10, 15, 20, 30, 40, 50, 60, 80, 90, 100	
		n79	40, 50, 60, 80, 100	
CA_n3A-n28A-n77A-n79A	n77 <sup>5,6</sup> n79 <sup>5,6</sup> CA_n3A-n28A CA_n3A-n77A <sup>5</sup> CA_n3A-n79A <sup>5</sup> CA_n28A-n77A <sup>5</sup> CA_n28A-n79A <sup>5</sup> CA_n77A-n79A <sup>5</sup>	n3	5, 10, 15, 20, 25, 30	0
		n28	5, 10, 15, 20	
		n77	10, 15, 20, 40, 50, 60, 80, 90, 100	
		n79	40, 50, 80, 100	
CA_n3A-n28A-n77(2A)-n79A	CA_n3A-n28A CA_n3A-n77A CA_n3A-n79A CA_n28A-n77A CA_n28A-n79A CA_n77A-n79A	n3	5, 10, 15, 20, 25, 30	0
		n28	5, 10, 15, 20	
		n77	CA_n77(2A)_BCS0	
		n79	40, 50, 80, 100	
CA_n3A-n40A-n78A-n105A	CA_n3A-n40A CA_n3A-n78A CA_n3A-n105A CA_n40A-n78A CA_n40A-n105A CA_n78A-n105A	n3	5, 10, 15, 20, 25, 30, 40, 50	0
		n40	5, 10, 15, 20, 25, 30, 40, 50, 60, 80	
		n78	10, 15, 20, 25, 30, 40, 50, 60, 70, 80, 90, 100	
		n105	5, 10, 15, 20, 25, 30, 35	
CA_n3A-n41A-n77A-n79A	CA_n3A-n41A CA_n3A-n77A CA_n3A-n79A CA_n41A-n77A	n3	5, 10, 15, 20, 25, 30	0

	CA_n41A-n79A CA_n77A-n79A	n41	10, 15, 20, 30, 40, 50, 60, 80, 90, 100	
		n77	10, 15, 20, 40, 50, 60, 80, 90, 100	
		n79	40, 50, 60, 80, 100	
CA_n3A-n41A-n77(2A)-n79A	CA_n3A-n41A CA_n3A-n77A CA_n3A-n79A CA_n41A-n77A CA_n41A-n79A CA_n77A-n79A	n3	5, 10, 15, 20, 25, 30	0
		n41	10, 15, 20, 30, 40, 50, 60, 80, 90, 100	
		n77	CA_n77(2A)_BCS0	
		n79	40, 50, 60, 80, 100	

Table 5.5A.3.3-1b

**Table 5.5A.3.3-1b: NR CA configurations and bandwidth combinations sets defined for inter-band CA (four bands)**

NR CA configuration	Uplink CA configuration or single uplink carrier <sup>4</sup>	NR Band	Channel bandwidth (MHz) (NOTE 3)	Bandwidth combination set
CA_n5A-n7A-n40A-n78A	CA_n5A-n7A CA_n5A-n40A CA_n5A-n78A CA_n7A-n40A CA_n7A-n78A CA_n40A-n78A	n5	5, 10, 15, 20, 25	0
		n7	5, 10, 15, 20, 25, 30, 35, 40, 50	
		n40	5, 10, 15, 20, 25, 30, 40, 50, 60, 70, 80, 90, 100	
		n78	10, 15, 20, 25, 30, 40, 50, 60, 70, 80, 90, 100	
CA_n5A-n7A-n40A-n105A	CA_n5A-n7A CA_n5A-n40A CA_n5A-n105A CA_n7A-n40A CA_n7A-n105A CA_n40A-n105A	n5	5, 10, 15, 20, 25	0
		n7	5, 10, 15, 20, 25, 30, 35, 40, 50	
		n40	5, 10, 15, 20, 25, 30, 40, 50, 60, 70, 80, 90, 100	
		n105	5, 10, 15, 20, 25, 30, 35	
CA_n5A-n7A-n66A-n77A	CA_n5A-n7A CA_n5A-n66A CA_n5A-n77A CA_n7A-n66A CA_n7A-n77A CA_n66A-n77A	n5	n5 channel bandwidths in Table 5.3.5-1	4 and 5
		n7	n7 channel bandwidths in Table 5.3.5-1	
		n66	n66 channel bandwidths in Table 5.3.5-1	
		n77	n77 channel bandwidths in Table 5.3.5-1	
CA_n5A-n7A-n66A-n77(2A)	CA_n77(2A) CA_n5A-n7A CA_n5A-n66A CA_n5A-n77A CA_n7A-n66A	n5	n5 channel bandwidths in Table 5.3.5-1	4 and 5



	CA_n7A-n77A CA_n66A-n77A	n7	n7 channel bandwidths in Table 5.3.5-1	
		n66	n66 channel bandwidths in Table 5.3.5-1	
		n77	CA_n77(2A)_BCS4 and 5	
CA_n5A-n7A-n66A-n77(3A)	CA_n5A-n7A CA_n5A-n66A CA_n5A-n77A CA_n7A-n66A CA_n7A-n77A CA_n66A-n77A	n5	5, 10, 15, 20	0
		n7	5, 10, 15, 20, 25, 30, 40, 50	
		n66	5, 10, 15, 20, 30, 40	
		n77	CA_n77(3A)_BCS1	4 and 5
		n5	n5 channel bandwidths in Table 5.3.5-1	
		n7	n7 channel bandwidths in Table 5.3.5-1	
		n66	n66 channel bandwidths in Table 5.3.5-1	
n77	CA_n77(3A)_BCS4 and 5			
CA_n5A-n7A-n78A-n105A	CA_n5A-n7A CA_n5A-n78A CA_n5A-n105A CA_n7A-n78A CA_n7A-n105A CA_n78A-n105A	n5	5, 10, 15, 20, 25	0
		n7	5, 10, 15, 20, 25, 30, 35, 40, 50	
		n78	10, 15, 20, 25, 30, 40, 50, 60, 70, 80, 90, 100	
		n105	5, 10, 15, 20, 25, 30, 35	
CA_n5A-n25A-n29A-n66A	CA_n5A-n25A CA_n5A-n66A CA_n25A-n66A	n5	5, 10, 15, 20	0
		n25	5, 10, 15, 20, 25, 30, 40	
		n29	5, 10	
		n66	5, 10, 15, 20, 30, 40	
CA_n5A-n25A-n66A-n77A	n77 <sup>5,6</sup> CA_n5A-n25A CA_n5A-n66A CA_n5A-n77A <sup>5</sup> CA_n25A-n66A CA_n25A-n77A <sup>5</sup> CA_n66A-n77A <sup>5</sup>	n5	5, 10, 15, 20	0
		n25	5, 10, 15, 20, 25, 30, 40	
		n66	5, 10, 15, 20, 25, 30, 40	
		n77	10, 15, 20, 25, 30, 40, 50, 60, 70, 80, 90, 100	
CA_n5A-n25(2A)-n66A-n77A	n77 <sup>5,6</sup> CA_n5A-n25A CA_n5A-n66A CA_n5A-n77A <sup>5</sup> CA_n25A-n66A CA_n25A-n77A <sup>5</sup> CA_n66A-n77A <sup>5</sup>	n5	5, 10, 15, 20	0
		n25	CA_n25(2A)_BCS0	
		n66	5, 10, 15, 20, 25, 30, 40	
		n77	10, 15, 20, 25, 30, 40, 50, 60, 70, 80, 90, 100	
CA_n5A-n25A-n66(2A)-n77A	n77 <sup>5,6</sup> CA_n5A-n25A CA_n5A-n66A CA_n5A-n77A <sup>5</sup>	n5	5, 10, 15, 20	0

	CA_n25A-n66A CA_n25A-n77A <sup>5</sup> CA_n66A-n77A <sup>5</sup>			
		n25	5, 10, 15, 20, 25, 30, 40	
		n66	CA_n66(2A)_BCS1	
		n77	10, 15, 20, 25, 30, 40, 50, 60, 70, 80, 90, 100	
CA_n5A-n25A-n66A-n77(2A)	n77 <sup>5,6</sup> CA_n5A-n25A CA_n5A-n66A CA_n5A-n77A <sup>5</sup> CA_n25A-n66A CA_n25A-n77A <sup>5</sup> CA_n66A-n77A <sup>5</sup>	n5	5, 10, 15, 20	0
		n25	5, 10, 15, 20, 25, 30, 40	
		n66	5, 10, 15, 20, 25, 30, 40	
		n77	CA_n77(2A)_BCS1	
CA_n5A-n25A-n66A-n77(3A)	CA_n5A-n25A CA_n5A-n66A CA_n5A-n77A CA_n25A-n66A CA_n25A-n77A CA_n66A-n77A	n5	5, 10, 15, 20	0
		n25	5, 10, 15, 20, 25, 30, 40	
		n66	5, 10, 15, 20, 30, 40	
		n77	CA_n77(3A)_BCS1	
		n5	n5 channel bandwidths in Table 5.3.5-1	4 and 5
		n25	n25 channel bandwidths in Table 5.3.5-1	
		n66	n66 channel bandwidths in Table 5.3.5-1	
CA_n5A-n25(2A)-n66(2A)-n77A	n77 <sup>5,6</sup> CA_n5A-n25A CA_n5A-n66A CA_n5A-n77A <sup>5</sup> CA_n25A-n66A CA_n25A-n77A <sup>5</sup> CA_n66A-n77A <sup>5</sup>	n5	5, 10, 15, 20	0
		n25	CA_n25(2A)_BCS0	
		n66	CA_n66(2A)_BCS1	
		n77	10, 15, 20, 25, 30, 40, 50, 60, 70, 80, 90, 100	
CA_n5A-n25(2A)-n66A-n77(2A)	n77 <sup>5,6</sup> CA_n5A-n25A CA_n5A-n66A CA_n5A-n77A <sup>5</sup> CA_n25A-n66A CA_n25A-n77A <sup>5</sup> CA_n66A-n77A <sup>5</sup>	n5	5, 10, 15, 20	0
		n25	CA_n25(2A)_BCS0	
		n66	5, 10, 15, 20, 25, 30, 40	
		n77	CA_n77(2A)_BCS1	
CA_n5A-n25A-n66(2A)-n77(2A)	n77 <sup>5,6</sup> CA_n5A-n25A CA_n5A-n66A CA_n5A-n77A <sup>5</sup> CA_n25A-n66A CA_n25A-n77A <sup>5</sup> CA_n66A-n77A <sup>5</sup>	n5	5, 10, 15, 20	0
		n25	5, 10, 15, 20, 25, 30, 40	
		n66	CA_n66(2A)_BCS1	
		n77	CA_n77(2A)_BCS1	
CA_n5A-n25(2A)-n66(2A)-n77(2A)	n77 <sup>5,6</sup> CA_n5A-n25A CA_n5A-n66A	n5	5, 10, 15, 20	0

	CA_n5A-n77A <sup>5</sup> CA_n25A-n66A CA_n25A-n77A <sup>5</sup> CA_n66A-n77A <sup>5</sup>			
		n25	CA_n25(2A)_BCS0	
		n66	CA_n66(2A)_BCS1	
		n77	CA_n77(2A)_BCS1	
CA_n5A-n25A-n66A-n78A	n78 <sup>5</sup> CA_n5A-n25A CA_n5A-n66A CA_n5A-n78A <sup>5</sup> CA_n25A-n66A CA_n25A-n78A <sup>5</sup> CA_n66A-n78A <sup>5</sup>	n5	5, 10, 15, 20	0
		n25	5, 10, 15, 20, 25, 30, 40	
		n66	5, 10, 15, 20, 25, 30, 40	
		n78	10, 15, 20, 25, 30, 40, 50, 60, 70, 80, 90, 100	
CA_n5A-n25(2A)-n66A-n78A	CA_n5A-n25A CA_n5A-n66A CA_n5A-n78A CA_n25A-n66A CA_n25A-n78A CA_n66A-n78A	n5	5, 10, 15, 20	0
		n25	CA_n25(2A)_BCS0	
		n66	5, 10, 15, 20, 25, 30, 40	
		n78	10, 15, 20, 25, 30, 40, 50, 60, 70, 80, 90, 100	
CA_n5A-n25A-n66(2A)-n78A	CA_n5A-n25A CA_n5A-n66A CA_n5A-n78A CA_n25A-n66A CA_n25A-n78A CA_n66A-n78A	n5	5, 10, 15, 20	0
		n25	5, 10, 15, 20, 25, 30, 40	
		n66	CA_n66(2A)_BCS1	
		n78	10, 15, 20, 25, 30, 40, 50, 60, 70, 80, 90, 100	
CA_n5A-n25A-n66A-n78(2A)	n78 <sup>5</sup> CA_n5A-n25A CA_n5A-n66A CA_n5A-n78A <sup>5</sup> CA_n25A-n66A CA_n25A-n78A <sup>5</sup> CA_n66A-n78A <sup>5</sup>	n5	5, 10, 15, 20	0
		n25	5, 10, 15, 20, 25, 30, 40	
		n66	5, 10, 15, 20, 25, 30, 40	
		n78	CA_n78(2A)_BCS2	
CA_n5A-n25(2A)-n66(2A)-n78A	CA_n5A-n25A CA_n5A-n66A CA_n5A-n78A CA_n25A-n66A CA_n25A-n78A CA_n66A-n78A	n5	5, 10, 15, 20	0
		n25	CA_n25(2A)_BCS0	
		n66	CA_n66(2A)_BCS1	
		n78	10, 15, 20, 25, 30, 40, 50, 60, 70, 80, 90, 100	
CA_n5A-n25(2A)-n66A-n78(2A)	CA_n5A-n25A CA_n5A-n66A CA_n5A-n78A CA_n25A-n66A CA_n25A-n78A CA_n66A-n78A	n5	5, 10, 15, 20	0
		n25	CA_n25(2A)_BCS0	
		n66	5, 10, 15, 20, 25, 30, 40	
		n78	CA_n78(2A)_BCS2	

CA_n5A-n25A-n66(2A)-n78(2A)	CA_n5A-n25A CA_n5A-n66A CA_n5A-n78A CA_n25A-n66A CA_n25A-n78A CA_n66A-n78A	n5	5, 10, 15, 20	0
		n25	5, 10, 15, 20, 25, 30, 40	
		n66	CA_n66(2A)_BCS1	
		n78	CA_n78(2A)_BCS2	
CA_n5A-n25(2A)-n66(2A)-n78(2A)	CA_n5A-n25A CA_n5A-n66A CA_n5A-n78A CA_n25A-n66A CA_n25A-n78A CA_n66A-n78A	n5	5, 10, 15, 20	0
		n25	CA_n25(2A)_BCS0	
		n66	CA_n66(2A)_BCS1	
		n78	CA_n78(2A)_BCS2	
CA_n5A-n28A-n78A-n79A	CA_n5A-n28A CA_n5A-n78A CA_n5A-n79A CA_n28A-n78A CA_n28A-n79A CA_n78A-n79A	n5	n5 channel bandwidths in Table 5.3.5-1	4 and 5
		n28	n28 channel bandwidths in Table 5.3.5-1	
		n78	n78 channel bandwidths in Table 5.3.5-1	
		n79	n79 channel bandwidths in Table 5.3.5-1	
CA_n5A-n30A-n66A-n77A	n77 <sup>5,6</sup> CA_n5A-n30A CA_n5A-n66A CA_n5A-n77A <sup>5</sup> CA_n30A-n66A CA_n30A-n77A <sup>5</sup> CA_n66A-n77A <sup>5</sup>	n5	5, 10, 15, 20	0
		n30	5, 10	
		n66	5, 10, 15, 20, 25, 30, 40	
		n77	10, 15, 20, 25, 30, 40, 50, 60, 70, 80, 90, 100	
CA_n5A-n30A-n66(2A)-n77A	n77 <sup>5,6</sup> CA_n5A-n30A CA_n5A-n66A CA_n5A-n77A <sup>5</sup> CA_n30A-n66A CA_n30A-n77A <sup>5</sup> CA_n66A-n77A <sup>5</sup>	n5	5, 10, 15, 20	0
		n30	5, 10	
		n66	CA_n66(2A)_BCS1	
		n77	10, 15, 20, 25, 30, 40, 50, 60, 70, 80, 90, 100	
CA_n5A-n30A-n66(2A)-n77(2A)	n77 <sup>5,6</sup> CA_n5A-n30A CA_n5A-n66A CA_n5A-n77A <sup>5</sup> CA_n30A-n66A CA_n30A-n77A <sup>5</sup> CA_n66A-n77A <sup>5</sup>	n5	5, 10, 15, 20	0
		n30	5, 10	
		n66	CA_n66(2A) BCS1	
		n77	CA_n77(2A) BCS1	
CA_n5A-n30A-n66A-n77(2A)	n77 <sup>5,6</sup> CA_n5A-n30A CA_n5A-n66A CA_n5A-n77A <sup>5</sup> CA_n30A-n66A CA_n30A-n77A <sup>5</sup>	n5	5, 10, 15, 20	0

	CA_n66A-n77A <sup>5</sup>	n30	5, 10	0
		n66	5, 10, 15, 20, 25, 30, 40	
		n77	CA_n77(2A)_BCS1	
		n5	5, 10, 15, 20, 25	
CA_n5A-n40A-n78A-n105A	CA_n5A-n40A CA_n5A-n78A CA_n5A-n105A CA_n40A-n78A CA_n40A-n105A CA_n78A-n105A	n40	5, 10, 15, 20, 25, 30, 40, 50, 60, 70, 80, 90, 100	0
		n78	10, 15, 20, 25, 30, 40, 50, 60, 70, 80, 90, 100	
		n105	5, 10, 15, 20, 25, 30, 35	
		n5	5, 10, 15, 20	
CA_n5A-n48A-n66A-n77A	n77 <sup>5,6</sup>	n48	5, 10, 15, 20, 30, 40, 50 <sup>8</sup> , 60 <sup>8</sup> , 70 <sup>8</sup> , 80 <sup>8</sup> , 90 <sup>8</sup> , 100 <sup>8</sup>	0
		n66	5, 10, 15, 20, 25, 30, 40	
		n77	10, 15, 20, 25, 30, 40, 50, 60, 70, 80, 90, 100	
		n5	5, 10, 15, 20, 25	
	n77 <sup>5,6</sup> CA_n5A-n48A CA_n5A-n66A CA_n5A-n77A <sup>5</sup> CA_n48A-n66A CA_n66A-n77A <sup>5</sup>	n48	5, 10, 15, 20, 30, 40, 50 <sup>8</sup> , 60 <sup>8</sup> , 70 <sup>8</sup> , 80 <sup>8</sup> , 90 <sup>8</sup> , 100 <sup>8</sup>	1
		n66	5, 10, 15, 20, 25, 30, 40	
		n77	10, 15, 20, 25, 30, 40, 50, 60, 70, 80, 90, 100	
		n5	5, 10, 15, 20	
CA_n5A-n48A-n66A-n77C	n77 <sup>5,6</sup> CA_n5A-n48A CA_n5A-n66A CA_n5A-n77A <sup>5</sup> CA_n48A-n66A CA_n66A-n77A <sup>5</sup>	n48	5, 10, 15, 20, 30, 40, 50 <sup>8</sup> , 60 <sup>8</sup> , 70 <sup>8</sup> , 80 <sup>8</sup> , 90 <sup>8</sup> , 100 <sup>8</sup>	0
		n66	5, 10, 15, 20, 25, 30, 40	
		n77	CA_n77C_BCS1	
		n5	5, 10, 15, 20	
CA_n5A-n48B-n66A-n77A	n77 <sup>5,6</sup>	n48	CA_n48B_BCS1	0
		n66	5, 10, 15, 20, 25, 30, 40	
		n77	10, 15, 20, 25, 30, 40, 50, 60, 70, 80, 90, 100	
		n5	5, 10, 15, 20, 25	
	n77 <sup>5,6</sup> CA_n5A-n48A CA_n5A-n66A CA_n5A-n77A <sup>5</sup> CA_n48A-n66A CA_n66A-n77A <sup>5</sup>	n48	CA_n48B_BCS0	1
		n66	5, 10, 15, 20, 25, 30, 40	
		n77	10, 15, 20, 25, 30, 40, 50, 60, 70, 80, 90, 100	
		n5	5, 10, 15, 20, 25	
		n48	CA_n48B_BCS1	
		n66	5, 10, 15, 20, 25, 30, 40	
		n77	10, 15, 20, 25, 30, 40, 50, 60, 70, 80, 90, 100	
		n5	5, 10, 15, 20, 25	
n77 <sup>5,6</sup> CA_n5A-n48A CA_n5A-n66A CA_n5A-n77A <sup>5</sup> CA_n48A-n66A CA_n66A-n77A <sup>5</sup>	n48	CA_n48B_BCS2	2	
	n66	5, 10, 15, 20, 25, 30, 40		
	n5	5, 10, 15, 20, 25		
n77 <sup>5,6</sup> CA_n5A-n48A CA_n5A-n66A CA_n5A-n77A <sup>5</sup> CA_n48A-n66A CA_n66A-n77A <sup>5</sup>	n48	CA_n48B_BCS1	3	
	n66	5, 10, 15, 20, 25, 30, 40		
	n5	5, 10, 15, 20, 25		

		n77	10, 15, 20, 25, 30, 40, 50, 60, 70, 80, 90, 100		
CA_n5A-n48(2A)-n66A-n77A	n77 <sup>5,6</sup>	n5	5, 10, 15, 20	0	
		n48	CA_n48(2A)_BCS1		
		n66	5, 10, 15, 20, 25, 30, 40		
		n77	10, 15, 20, 25, 30, 40, 50, 60, 70, 80, 90, 100		
	n77 <sup>5,6</sup> CA_n5A-n48A CA_n5A-n66A CA_n5A-n77A <sup>5</sup> CA_n48A-n66A CA_n66A-n77A <sup>5</sup>	n5	5, 10, 15, 20, 25	1	
		n48	CA_n48(2A)_BCS0		
		n66	5, 10, 15, 20, 25, 30, 40		
		n77	10, 15, 20, 25, 30, 40, 50, 60, 70, 80, 90, 100		
		n5	5, 10, 15, 20, 25		2
		n48	CA_n48(2A)_BCS1		
CA_n7A-n8A-n40A-n78A	CA_n7A-n8A CA_n7A-n40A CA_n7A-n78A CA_n8A-n40A CA_n8A-n78A CA_n40A-n78A	n7	5, 10, 15, 20, 25, 30, 40, 50	0	
		n8	5, 10, 15, 20		
		n40	5, 10, 15, 20, 25, 30, 40, 50, 60, 80		
		n78	10, 15, 20, 25, 30, 40, 50, 60, 70, 80, 90, 100		
CA_n7A-n12A-n25A-n66A	-	n7	5, 10, 15, 20, 25, 30, 40, 50	0	
		n12	5, 10, 15		
		n25	5, 10, 15, 20, 25, 30, 40		
		n66	5, 10, 15, 20, 25, 30, 40		
CA_n7A-n20A-n67A-n78A	CA_n7A-n20A CA_n7A-n78A CA_n20A-n78A	n7	n7 channel bandwidths in Table 5.3.5-1	4 and 5	
		n20	n20 channel bandwidths in Table 5.3.5-1		
		n67	n67 channel bandwidths in Table 5.3.5-1		
		n78	n78 channel bandwidths in Table 5.3.5-1		
CA_n7A-n20A-n67A-n78(2A)	CA_n7A-n20A CA_n7A-n78A CA_n20A-n78A CA_n78(2A)	n7	n7 channel bandwidths in Table 5.3.5-1	4 and 5	
		n20	n20 channel bandwidths in Table 5.3.5-1		
		n67	n67 channel bandwidths in Table 5.3.5-1		
		n78	CA_n78(2A)_BCS 4 and 5		
CA_n7A-n25A-n66A-n71A	-	n7	5, 10, 15, 20, 25, 30, 40, 50	0	
		n25	5, 10, 15, 20, 25, 30, 40		
		n66	5, 10, 15, 20, 25, 30, 40		
		n71	5, 10, 15, 20		
CA_n7A-n25A-n66A-n77A	n77 <sup>5,6</sup> CA_n7A-n25A CA_n7A-n66A CA_n7A-n77A <sup>5</sup> CA_n25A-n66A	n7	5, 10, 15, 20, 25, 30, 40, 50	0	

	CA_n25A-n77A <sup>5</sup> CA_n66A-n77A <sup>5</sup>			
		n25	5, 10, 15, 20, 25, 30, 40	
		n66	5, 10, 15, 20, 25, 30, 40	
		n77	10, 15, 20, 25, 30, 40, 50, 60, 70, 80, 90, 100	
CA_n7(2A)-n25A-n66A-n77A	n77 <sup>5,6</sup> CA_n7A-n25A CA_n7A-n66A CA_n7A-n77A <sup>5</sup> CA_n25A-n66A CA_n25A-n77A <sup>5</sup> CA_n66A-n77A <sup>5</sup>	n7	CA_n7(2A)_BCS0	0
		n25	5, 10, 15, 20, 25, 30, 40	
		n66	5, 10, 15, 20, 25, 30, 40	
		n77	10, 15, 20, 25, 30, 40, 50, 60, 70, 80, 90, 100	
CA_n7A-n25(2A)-n66A-n77A	n77 <sup>5,6</sup> CA_n7A-n25A CA_n7A-n66A CA_n7A-n77A <sup>5</sup> CA_n25A-n66A CA_n25A-n77A <sup>5</sup> CA_n66A-n77A <sup>5</sup>	n7	5, 10, 15, 20, 25, 30, 40, 50	0
		n25	CA_n25(2A)_BCS0	
		n66	5, 10, 15, 20, 25, 30, 40	
		n77	10, 15, 20, 25, 30, 40, 50, 60, 70, 80, 90, 100	
CA_n7A-n25A-n66(2A)-n77A	n77 <sup>5,6</sup> CA_n7A-n25A CA_n7A-n66A CA_n7A-n77A <sup>5</sup> CA_n25A-n66A CA_n25A-n77A <sup>5</sup> CA_n66A-n77A <sup>5</sup>	n7	5, 10, 15, 20, 25, 30, 40, 50	0
		n25	5, 10, 15, 20, 25, 30, 40	
		n66	CA_n66(2A)_BCS1	
		n77	10, 15, 20, 25, 30, 40, 50, 60, 70, 80, 90, 100	
CA_n7A-n25A-n66A-n77(2A)	n77 <sup>5,6</sup> CA_n77(2A) <sup>5</sup> CA_n7A-n25A CA_n7A-n66A CA_n7A-n77A <sup>5</sup> CA_n25A-n66A CA_n25A-n77A <sup>5</sup> CA_n66A-n77A <sup>5</sup>	n7	5, 10, 15, 20, 25, 30, 40, 50	0
		n25	5, 10, 15, 20, 25, 30, 40	
		n66	5, 10, 15, 20, 25, 30, 40	
		n77	CA_n77(2A)_BCS1	
CA_n7A-n25A-n66A-n77(3A)	CA_n7A-n25A CA_n7A-n66A CA_n7A-n77A CA_n25A-n66A CA_n25A-n77A CA_n66A-n77A	n7	5, 10, 15, 20, 25, 30, 40, 50	0
		n25	5, 10, 15, 20, 25, 30, 40	
		n66	5, 10, 15, 20, 30, 40	
		n77	CA_n77(3A)_BCS1	
		n7	n7 channel bandwidths in Table 5.3.5-1	4 and 5
		n25	n25 channel bandwidths in Table 5.3.5-1	
		n66	n66 channel bandwidths in Table 5.3.5-1	
		n77	CA_n77(3A)_BCS4 and 5	

CA_n7(2A)-n25(2A)-n66A-n77A	n77 <sup>5,6</sup> CA_n7A-n25A CA_n7A-n66A CA_n7A-n77A <sup>5</sup> CA_n25A-n66A CA_n25A-n77A <sup>5</sup> CA_n66A-n77A <sup>5</sup>	n7	CA_n7(2A)_BCS0	0
		n25	CA_n25(2A)_BCS0	
		n66	5, 10, 15, 20, 25, 30, 40	
		n77	10, 15, 20, 25, 30, 40, 50, 60, 70, 80, 90, 100	
CA_n7(2A)-n25A-n66(2A)-n77A	n77 <sup>5,6</sup> CA_n7A-n25A CA_n7A-n66A CA_n7A-n77A <sup>5</sup> CA_n25A-n66A CA_n25A-n77A <sup>5</sup> CA_n66A-n77A <sup>5</sup>	n7	CA_n7(2A)_BCS0	0
		n25	5, 10, 15, 20, 25, 30, 40	
		n66	CA_n66(2A)_BCS1	
		n77	10, 15, 20, 25, 30, 40, 50, 60, 70, 80, 90, 100	
CA_n7(2A)-n25A-n66A-n77(2A)	n77 <sup>5,6</sup> CA_n7A-n25A CA_n7A-n66A CA_n7A-n77A <sup>5</sup> CA_n25A-n66A CA_n25A-n77A <sup>5</sup> CA_n66A-n77A <sup>5</sup>	n7	CA_n7(2A)_BCS0	0
		n25	5, 10, 15, 20, 25, 30, 40	
		n66	5, 10, 15, 20, 25, 30, 40	
		n77	CA_n77(2A)_BCS1	
CA_n7A-n25(2A)-n66(2A)-n77A	n77 <sup>5,6</sup> CA_n7A-n25A CA_n7A-n66A CA_n7A-n77A <sup>5</sup> CA_n25A-n66A CA_n25A-n77A <sup>5</sup> CA_n66A-n77A <sup>5</sup>	n7	5, 10, 15, 20, 25, 30, 40, 50	0
		n25	CA_n25(2A)_BCS0	
		n66	CA_n66(2A)_BCS1	
		n77	10, 15, 20, 25, 30, 40, 50, 60, 70, 80, 90, 100	
CA_n7A-n25(2A)-n66A-n77(2A)	n77 <sup>5,6</sup> CA_n7A-n25A CA_n7A-n66A CA_n7A-n77A <sup>5</sup> CA_n25A-n66A CA_n25A-n77A <sup>5</sup> CA_n66A-n77A <sup>5</sup>	n7	5, 10, 15, 20, 25, 30, 40, 50	0
		n25	CA_n25(2A)_BCS0	
		n66	5, 10, 15, 20, 25, 30, 40	
		n77	CA_n77(2A)_BCS1	
CA_n7A-n25A-n66(2A)-n77(2A)	n77 <sup>5,6</sup> CA_n7A-n25A CA_n7A-n66A CA_n7A-n77A <sup>5</sup> CA_n25A-n66A CA_n25A-n77A <sup>5</sup> CA_n66A-n77A <sup>5</sup>	n7	5, 10, 15, 20, 25, 30, 40, 50	0
		n25	5, 10, 15, 20, 25, 30, 40	
		n66	CA_n66(2A)_BCS1	
		n77	CA_n77(2A)_BCS1	
CA_n7(2A)-n25(2A)-n66(2A)-n77A	n77 <sup>5,6</sup> CA_n7A-n25A CA_n7A-n66A CA_n7A-n77A <sup>5</sup>	n7	CA_n7(2A)_BCS0	0



	CA_n25A-n66A CA_n25A-n77A <sup>5</sup> CA_n66A-n77A <sup>5</sup>			
		n25	CA_n25(2A)_BCS0	
		n66	CA_n66(2A)_BCS1	
		n77	10, 15, 20, 25, 30, 40, 50, 60, 70, 80, 90, 100	
CA_n7(2A)-n25A-n66(2A)-n77(2A)	n77 <sup>5,6</sup> CA_n7A-n25A CA_n7A-n66A CA_n7A-n77A <sup>5</sup> CA_n25A-n66A CA_n25A-n77A <sup>5</sup> CA_n66A-n77A <sup>5</sup>	n7	CA_n7(2A)_BCS0	0
		n25	5, 10, 15, 20, 25, 30, 40	
		n66	CA_n66(2A)_BCS1	
		n77	CA_n77(2A)_BCS1	
CA_n7(2A)-n25(2A)-n66A-n77(2A)	n77 <sup>5,6</sup> CA_n7A-n25A CA_n7A-n66A CA_n7A-n77A <sup>5</sup> CA_n25A-n66A CA_n25A-n77A <sup>5</sup> CA_n66A-n77A <sup>5</sup>	n7	CA_n7(2A)_BCS0	0
		n25	CA_n25(2A)_BCS0	
		n66	5, 10, 15, 20, 25, 30, 40	
		n77	CA_n77(2A)_BCS1	
CA_n7A-n25(2A)-n66(2A)-n77(2A)	n77 <sup>5,6</sup> CA_n7A-n25A CA_n7A-n66A CA_n7A-n77A <sup>5</sup> CA_n25A-n66A CA_n25A-n77A <sup>5</sup> CA_n66A-n77A <sup>5</sup>	n7	5, 10, 15, 20, 25, 30, 40, 50	0
		n25	CA_n25(2A)_BCS0	
		n66	CA_n66(2A)_BCS1	
		n77	CA_n77(2A)_BCS1	
CA_n7(2A)-n25(2A)-n66(2A)-n77(2A)	n77 <sup>5,6</sup> CA_n7A-n25A CA_n7A-n66A CA_n7A-n77A <sup>5</sup> CA_n25A-n66A CA_n25A-n77A <sup>5</sup> CA_n66A-n77A <sup>5</sup>	n7	CA_n7(2A)_BCS0	0
		n25	CA_n25(2A)_BCS0	
		n66	CA_n66(2A)_BCS1	
		n77	CA_n77(2A)_BCS1	
CA_n7A-n25A-n66A-n78A	CA_n7A-n25A CA_n7A-n66A CA_n7A-n78A CA_n25A-n66A CA_n25A-n78A CA_n66A-n78A	n7	5, 10, 15, 20, 25, 30, 40, 50	0
		n25	5, 10, 15, 20, 25, 30, 40	
		n66	5, 10, 15, 20, 25, 30, 40	
		n78	10, 15, 20, 25, 30, 40, 50, 60, 70, 80, 90, 100	
CA_n7A-n25(2A)-n66A-n78A	CA_n7A-n25A CA_n7A-n66A CA_n7A-n78A CA_n25A-n66A CA_n25A-n78A CA_n66A-n78A	n7	5, 10, 15, 20, 25, 30, 40, 50	0
		n25	CA_n25(2A)_BCS0	
		n66	5, 10, 15, 20, 25, 30, 40	
		n78	10, 15, 20, 25, 30, 40, 50, 60, 70, 80, 90, 100	

CA_n7A-n25A-n66(2A)-n78A	CA_n7A-n25A CA_n7A-n66A CA_n7A-n78A CA_n25A-n66A CA_n25A-n78A CA_n66A-n78A	n7	5, 10, 15, 20, 25, 30, 40, 50	0
		n25	5, 10, 15, 20, 25, 30, 40	
		n66	CA_n66(2A)_BCS1	
		n78	10, 15, 20, 25, 30, 40, 50, 60, 70, 80, 90, 100	
CA_n7A-n25A-n66A-n78(2A)	CA_n7A-n25A CA_n7A-n66A CA_n7A-n78A CA_n25A-n66A CA_n25A-n78A CA_n66A-n78A	n7	5, 10, 15, 20, 25, 30, 40, 50	0
		n25	5, 10, 15, 20, 25, 30, 40	
		n66	5, 10, 15, 20, 25, 30, 40	
		n78	CA_n78(2A)_BCS2	
CA_n7(2A)-n25A-n66A-n78A	CA_n7A-n25A CA_n7A-n66A CA_n7A-n78A CA_n25A-n66A CA_n25A-n78A CA_n66A-n78A	n7	CA_n7(2A)_BCS0	0
		n25	5, 10, 15, 20, 25, 30, 40	
		n66	5, 10, 15, 20, 25, 30, 40	
		n78	10, 15, 20, 25, 30, 40, 50, 60, 70, 80, 90, 100	
CA_n7A-n25(2A)-n66A-n78(2A)	CA_n7A-n25A CA_n7A-n66A CA_n7A-n78A CA_n25A-n66A CA_n25A-n78A CA_n66A-n78A	n7	5, 10, 15, 20, 25, 30, 40, 50	0
		n25	CA_n25(2A)_BCS0	
		n66	5, 10, 15, 20, 25, 30, 40	
		n78	CA_n78(2A)_BCS2	
CA_n7A-n25(2A)-n66(2A)-n78A	CA_n7A-n25A CA_n7A-n66A CA_n7A-n78A CA_n25A-n66A CA_n25A-n78A CA_n66A-n78A	n7	5, 10, 15, 20, 25, 30, 40, 50	0
		n25	CA_n25(2A)_BCS0	
		n66	CA_n66(2A)_BCS1	
		n78	10, 15, 20, 25, 30, 40, 50, 60, 70, 80, 90, 100	
CA_n7A-n25A-n66(2A)-n78(2A)	CA_n7A-n25A CA_n7A-n66A CA_n7A-n78A CA_n25A-n66A CA_n25A-n78A CA_n66A-n78A	n7	5, 10, 15, 20, 25, 30, 40, 50	0
		n25	5, 10, 15, 20, 25, 30, 40	
		n66	CA_n66(2A)_BCS1	
		n78	CA_n78(2A)_BCS2	
CA_n7(2A)-n25(2A)-n66A-n78A	CA_n7A-n25A CA_n7A-n66A CA_n7A-n78A CA_n25A-n66A CA_n25A-n78A CA_n66A-n78A	n7	CA_n7(2A)_BCS0	0
		n25	CA_n25(2A)_BCS0	
		n66	5, 10, 15, 20, 25, 30, 40	
		n78	10, 15, 20, 25, 30, 40, 50, 60, 70, 80, 90, 100	

CA_n7(2A)-n25A-n66(2A)-n78A	CA_n7A-n25A CA_n7A-n66A CA_n7A-n78A CA_n25A-n66A CA_n25A-n78A CA_n66A-n78A	n7	CA_n7(2A)_BCS0	0
		n25	5, 10, 15, 20, 25, 30, 40	
		n66	CA_n66(2A)_BCS1	
		n78	10, 15, 20, 25, 30, 40, 50, 60, 70, 80, 90, 100	
CA_n7(2A)-n25A-n66A-n78(2A)	CA_n7A-n25A CA_n7A-n66A CA_n7A-n78A CA_n25A-n66A CA_n25A-n78A CA_n66A-n78A	n7	CA_n7(2A)_BCS0	0
		n25	5, 10, 15, 20, 25, 30, 40	
		n66	5, 10, 15, 20, 25, 30, 40	
		n78	CA_n78(2A)_BCS2	
CA_n7A-n25(2A)-n66(2A)-n78(2A)	CA_n7A-n25A CA_n7A-n66A CA_n7A-n78A CA_n25A-n66A CA_n25A-n78A CA_n66A-n78A	n7	5, 10, 15, 20, 25, 30, 40, 50	0
		n25	CA_n25(2A)_BCS0	
		n66	CA_n66(2A)_BCS1	
		n78	CA_n78(2A)_BCS2	
CA_n7(2A)-n25(2A)-n66A-n78(2A)	CA_n7A-n25A CA_n7A-n66A CA_n7A-n78A CA_n25A-n66A CA_n25A-n78A CA_n66A-n78A	n7	CA_n7(2A)_BCS0	0
		n25	CA_n25(2A)_BCS0	
		n66	5, 10, 15, 20, 25, 30, 40	
		n78	CA_n78(2A)_BCS2	
CA_n7(2A)-n25(2A)-n66(2A)-n78A	CA_n7A-n25A CA_n7A-n66A CA_n7A-n78A CA_n25A-n66A CA_n25A-n78A CA_n66A-n78A	n7	CA_n7(2A)_BCS0	0
		n25	CA_n25(2A)_BCS0	
		n66	CA_n66(2A)_BCS1	
		n78	10, 15, 20, 25, 30, 40, 50, 60, 70, 80, 90, 100	
CA_n7(2A)-n25A-n66(2A)-n78(2A)	CA_n7A-n25A CA_n7A-n66A CA_n7A-n78A CA_n25A-n66A CA_n25A-n78A CA_n66A-n78A	n7	CA_n7(2A)_BCS0	0
		n25	5, 10, 15, 20, 25, 30, 40	
		n66	CA_n66(2A)_BCS1	
		n78	CA_n78(2A)_BCS2	
CA_n7(2A)-n25(2A)-n66(2A)-n78(2A)	CA_n7A-n25A CA_n7A-n66A CA_n7A-n78A CA_n25A-n66A CA_n25A-n78A CA_n66A-n78A	n7	CA_n7(2A)_BCS0	0
		n25	CA_n25(2A)_BCS0	
		n66	CA_n66(2A)_BCS1	
		n78	CA_n78(2A)_BCS2	
CA_n7A-n28A-n38A-n78A <sup>7</sup>	-	n7	5, 10, 15, 20, 25, 30, 40, 50	0

		n28	5, 10, 15, 20, 25, 30	
		n38	5, 10, 15, 20, 25, 30, 40	
		n78	10, 15, 20, 25, 30, 40, 50, 60, 70, 80, 90, 100	
CA_n7A-n40A-n78A-n105A	CA_n7A-n40A CA_n7A-n78A CA_n7A-n105A CA_n40A-n78A CA_n40A-n105A CA_n78A-n105A	n7	5, 10, 15, 20, 25, 30, 40, 50	0
		n40	5, 10, 15, 20, 25, 30, 40, 50, 60, 80	
		n78	10, 20, 25, 30, 40, 50, 60, 70, 80, 90, 100	
		n105	5, 10, 15, 20, 25, 30, 35	
CA_n7A-n66A-n71A-n77A	CA_n7A-n66A CA_n7A-n71A CA_n7A-n77A CA_n66A-n71A CA_n66A-n77A CA_n71A-n77A	n7	n7 channel bandwidths in Table 5.3.5-1	4 and 5
		n66	n66 channel bandwidths in Table 5.3.5-1	
		n71	n71 channel bandwidths in Table 5.3.5-1	
		n77	n77 channel bandwidths in Table 5.3.5-1	
CA_n7A-n66A-n71A-n77(2A)	CA_n7A-n66A CA_n7A-n71A CA_n7A-n77A CA_n66A-n71A CA_n66A-n77A CA_n71A-n77A	n7	n7 channel bandwidths in Table 5.3.5-1	4 and 5
		n66	n66 channel bandwidths in Table 5.3.5-1	
		n71	n71 channel bandwidths in Table 5.3.5-1	
		n77	CA_n77(2A)_BCS4 and 5	
CA_n7A-n66A-n71A-n77(3A)	CA_n7A-n66A CA_n7A-n71A CA_n7A-n77A CA_n66A-n71A CA_n66A-n77A CA_n71A-n77A	n7	5, 10, 15, 20, 25, 30, 40, 50	0
		n66	5, 10, 15, 20, 30, 40	
		n71	5, 10, 15, 20, 25, 30, 35	
		n77	CA_n77(3A)_BCS1	4 and 5
		n7	n7 channel bandwidths in Table 5.3.5-1	
		n66	n66 channel bandwidths in Table 5.3.5-1	
		n71	n71 channel bandwidths in Table 5.3.5-1	
n77	CA_n77(3A)_BCS4 and 5			
CA_n8A-n20A-n28A-n75A	-	n8	5, 10, 15, 20	0
		n20	5, 10, 15, 20	
		n28	5, 10, 15, 20	
		n75	5, 10, 15, 20, 25, 30, 40, 50	
CA_n8A-n39A-n41A-n79A	-	n8	5, 10, 15, 20	0
		n39	5, 10, 15, 20, 25, 30, 40	
		n41	10, 15, 20, 40, 50, 60, 80, 100	
		n79	40, 50, 60, 80, 100	
CA_n12A-n30A-n66A-n77A	n77 <sup>5,6</sup> CA_n12A-n30A CA_n12A-n66A	n12	5, 10, 15	0

	CA_n12A-n77A <sup>5</sup> CA_n30A-n66A CA_n30A-n77A <sup>5</sup> CA_n66A-n77A <sup>5</sup>	n30	5, 10	0
		n66	5, 10, 15, 20, 25, 30, 40	
		n77	10, 15, 20, 30, 40, 50, 60, 70, 80, 90, 100	
		n12	5, 10, 15	
CA_n12A-n30A-n66(2A)-n77A	n77 <sup>5,6</sup> CA_n12A-n30A CA_n12A-n66A CA_n12A-n77A <sup>5</sup> CA_n30A-n66A CA_n30A-n77A <sup>5</sup> CA_n66A-n77A <sup>5</sup>	n30	5, 10	0
		n66	CA_n66(2A)_BCS1	
		n77	10, 15, 20, 25, 30, 40, 50, 60, 70, 80, 90, 100	
		n12	5, 10, 15	
CA_n12A-n30A-n66A-n77(2A)	n77 <sup>5,6</sup> CA_n12A-n30A CA_n12A-n66A CA_n12A-n77A <sup>5</sup> CA_n30A-n66A CA_n30A-n77A <sup>5</sup> CA_n66A-n77A <sup>5</sup>	n30	5, 10	0
		n66	5, 10, 15, 20, 25, 30, 40	
		n77	CA_n77(2A)_BCS1	
		n12	5, 10, 15	
CA_n12A-n30A-n66(2A)-n77(2A)	n77 <sup>5,6</sup> CA_n12A-n30A CA_n12A-n66A CA_n12A-n77A <sup>5</sup> CA_n30A-n66A CA_n30A-n77A <sup>5</sup> CA_n66A-n77A <sup>5</sup>	n30	5, 10	0
		n66	CA_n66(2A)_BCS1	
		n77	CA_n77(2A)_BCS1	
		n12	5, 10, 15	
CA_n13A-n25A-n66A-n77A	n77 <sup>5,6</sup> CA_n13A-n25A CA_n13A-n66A CA_n13A-n77A <sup>5</sup> CA_n25A-n66A CA_n25A-n77A <sup>5</sup> CA_n66A-n77A <sup>5</sup>	n25	5, 10, 15, 20, 25, 30, 40	0
		n66	5, 10, 15, 20, 25, 30, 40	
		n77	10, 15, 20, 25, 30, 40, 50, 60, 70, 80, 90, 100	
		n13	5, 10	
CA_n13A-n25A-n66A-n77(2A)	n77 <sup>5,6</sup> CA_n77(2A) CA_n13A-n25A CA_n13A-n66A CA_n13A-n77A <sup>5</sup> CA_n25A-n66A CA_n25A-n77A <sup>5</sup> CA_n66A-n77A <sup>5</sup>	n25	5, 10, 15, 20, 25, 30, 40	0
		n66	10, 15, 20, 25, 30, 40	
		n77	CA_n77(2A)_BCS1	
		n13	5, 10	
CA_n14A-n30A-n66A-n77A	n77 <sup>5,6</sup> CA_n14A-n30A CA_n14A-n66A CA_n14A-n77A <sup>5</sup> CA_n30A-n66A CA_n30A-n77A <sup>5</sup>	n14	5, 10	0
		n14	5, 10	

	CA_n66A-n77A <sup>5</sup>	n30	5, 10	
		n66	5, 10, 15, 20, 25, 30, 40	
		n77	10, 15, 20, 25, 30, 40, 50, 60, 70, 80, 90, 100	
CA_n14A-n30A-n66(2A)-n77A	n77 <sup>5,6</sup> CA_n14A-n30A CA_n14A-n66A CA_n14A-n77A <sup>5</sup> CA_n30A-n66A CA_n30A-n77A <sup>5</sup> CA_n66A-n77A <sup>5</sup>	n14	5, 10	0
		n30	5, 10	
		n66	CA_n66(2A)_BCS1	
		n77	10, 15, 20, 25, 30, 40, 50, 60, 70, 80, 90, 100	
CA_n14A-n30A-n66A-n77(2A)	n77 <sup>5,6</sup> CA_n14A-n30A CA_n14A-n66A CA_n14A-n77A <sup>5</sup> CA_n30A-n66A CA_n30A-n77A <sup>5</sup> CA_n66A-n77A <sup>5</sup>	n14	5, 10	0
		n30	5, 10	
		n66	5, 10, 15, 20, 25, 30, 40	
		n77	CA_n77(2A)_BCS1	
CA_n14A-n30A-n66(2A)-n77(2A)	n77 <sup>5,6</sup> CA_n14A-n30A CA_n14A-n66A CA_n14A-n77A <sup>5</sup> CA_n30A-n66A CA_n30A-n77A <sup>5</sup> CA_n66A-n77A <sup>5</sup>	n14	5, 10	0
		n30	5, 10	
		n66	CA_n66(2A)_BCS1	
		n77	CA_n77(2A)_BCS1	
CA_n18A-n28A-n41A-n77A	n77 CA_n18A-n28A CA_n18A-n41A CA_n18A-n77A <sup>5</sup> CA_n28A-n41A CA_n28A-n77A <sup>5</sup> CA_n41A-n77A <sup>5</sup>	n18	5, 10, 15	0
		n28	5, 10	
		n41	10, 15, 20, 30, 40, 50, 60, 80, 90, 100	
		n77	10, 15, 20, 25, 30, 40, 50, 60, 70, 80, 90, 100	
CA_n25A-n38A-n66A-n78A	CA_n25A-n38A CA_n25A-n66A CA_n25A-n78A CA_n38A-n66A CA_n38A-n78A CA_n66A-n78A	n25	5, 10, 15, 20, 25, 30, 40	0
		n38	5, 10, 15, 20, 25, 30, 40	
		n66	5, 10, 15, 20, 25, 30, 40	
		n78	10, 15, 20, 25, 30, 40, 50, 60, 70, 80, 90, 100	
CA_n25(2A)-n38A-n66A-n78A	CA_n25A-n38A CA_n25A-n66A CA_n25A-n78A CA_n38A-n66A CA_n38A-n78A CA_n66A-n78A	n25	CA_n25(2A)_BCS0	0
		n38	5, 10, 15, 20, 25, 30, 40	
		n66	5, 10, 15, 20, 25, 30, 40	

		n78	10, 15, 20, 25, 30, 40, 50, 60, 70, 80, 90, 100	
CA_n25A-n38A-n66(2A)-n78A	CA_n25A-n38A CA_n25A-n66A CA_n25A-n78A CA_n38A-n66A CA_n38A-n78A CA_n66A-n78A	n25	5, 10, 15, 20, 25, 30, 40	0
		n38	5, 10, 15, 20, 25, 30, 40	
		n66	CA_n66(2A)_BCS1	
		n78	10, 15, 20, 25, 30, 40, 50, 60, 70, 80, 90, 100	
CA_n25A-n38A-n66A-n78(2A)	CA_n25A-n38A CA_n25A-n66A CA_n25A-n78A CA_n38A-n66A CA_n38A-n78A CA_n66A-n78A	n25	5, 10, 15, 20, 25, 30, 40	0
		n38	5, 10, 15, 20, 25, 30, 40	
		n66	5, 10, 15, 20, 25, 30, 40	
		n78	CA_n78(2A)_BCS2	
CA_n25(2A)-n38A-n66(2A)-n78A	CA_n25A-n38A CA_n25A-n66A CA_n25A-n78A CA_n38A-n66A CA_n38A-n78A CA_n66A-n78A	n25	CA_n25(2A)_BCS0	0
		n38	5, 10, 15, 20, 25, 30, 40	
		n66	CA_n66(2A)_BCS1	
		n78	10, 15, 20, 25, 30, 40, 50, 60, 70, 80, 90, 100	
CA_n25(2A)-n38A-n66A-n78(2A)	CA_n25A-n38A CA_n25A-n66A CA_n25A-n78A CA_n38A-n66A CA_n38A-n78A CA_n66A-n78A	n25	CA_n25(2A)_BCS0	0
		n38	5, 10, 15, 20, 25, 30, 40	
		n66	5, 10, 15, 20, 25, 30, 40	
		n78	CA_n78(2A)_BCS2	
CA_n25A-n38A-n66(2A)-n78(2A)	CA_n25A-n38A CA_n25A-n66A CA_n25A-n78A CA_n38A-n66A CA_n38A-n78A CA_n66A-n78A	n25	5, 10, 15, 20, 25, 30, 40	0
		n38	5, 10, 15, 20, 25, 30, 40	
		n66	CA_n66(2A)_BCS1	
		n78	CA_n78(2A)_BCS2	
CA_n25(2A)-n38A-n66(2A)-n78(2A)	CA_n25A-n38A CA_n25A-n66A CA_n25A-n78A CA_n38A-n66A CA_n38A-n78A CA_n66A-n78A	n25	CA_n25(2A)_BCS0	0
		n38	5, 10, 15, 20, 25, 30, 40	
		n66	CA_n66(2A)_BCS1	
		n78	CA_n78(2A)_BCS2	
CA_n25A-n41A-n66A-n71A	-	n25	5, 10, 15, 20	0
		n41	10, 15, 20, 30, 40, 50, 60, 80, 90, 100	
		n66	5, 10, 15, 20, 40	
		n71	5, 10, 15, 20	
	n41 <sup>5,6</sup> CA_n25A-n41A CA_n25A-n66A <sup>5</sup>	n25	5, 10, 15, 20, 25, 30, 40	1

	CA_n25A-n71A CA_n41A-n66A <sup>5</sup> CA_n41A-n71A <sup>5</sup> CA_n66A-n71A	n41	10, 15, 20, 30, 40, 50, 60, 70, 80, 90, 100	4 and 5
		n66	5, 10, 15, 20, 25, 30, 40	
		n71	5, 10, 15, 20	
		n25	n25 channel bandwidths in Table 5.3.5-1	
		n41	n41 channel bandwidths in Table 5.3.5-1	
		n66	n66 channel bandwidths in Table 5.3.5-1	
		n71	n71 channel bandwidths in Table 5.3.5-1	
CA_n25A-n41(A-C)-n66A-n71A	CA_n25A-n41A CA_n25A-n66A CA_n25A-n71A CA_n41A-n66A CA_n41A-n71A CA_n41C CA_n66A-n71A	n25	n25 channel bandwidths in Table 5.3.5-1	4 and 5
		n41	CA_n41(A-C)_BCS 4 and 5	
		n66	n66 channel bandwidths in Table 5.3.5-1	
		n71	n71 channel bandwidths in Table 5.3.5-1	
CA_n25A-n41A-n66(2A)-n71A	n41 <sup>5,6</sup> CA_n25A-n41A <sup>5</sup> CA_n25A-n66A CA_n25A-n71A CA_n41A-n66A <sup>5</sup> CA_n41A-n71A <sup>5</sup> CA_n66A-n71A	n25	n25 channel bandwidths in Table 5.3.5-1	4 and 5
		n41	n41 channel bandwidths in Table 5.3.5-1	
		n66	CA_n66(2A)_BCS 4 and 5	
		n71	n71 channel bandwidths in Table 5.3.5-1	
CA_n25A-n41A-n66(2A)-n71(2A)	CA_n25A-n41A CA_n25A-n66A CA_n25A-n71A CA_n41A-n66A CA_n41A-n71A CA_n66A-n71A	n25	n25 channel bandwidths in Table 5.3.5-1	4 and 5
		n41	n41 channel bandwidths in Table 5.3.5-1	
		n66	CA_n66(2A) BCS 4 and 5	
		n71	CA_n71(2A) BCS 4 and 5	
CA_n25A-n41A-n66(2A)-n71B	CA_n25A-n41A CA_n25A-n66A CA_n25A-n71A CA_n41A-n66A CA_n41A-n71A CA_n66A-n71A	n25	n25 channel bandwidths in Table 5.3.5-1	4 and 5
		n41	n41 channel bandwidths in Table 5.3.5-1	
		n66	CA_n66(2A) BCS 4 and 5	
		n71	CA_n71B BCS 4 and 5	
CA_n25A-n41A-n66A-n71(2A)	n41 <sup>5,6</sup> CA_n25A-n41A <sup>5</sup> CA_n25A-n66A CA_n25A-n71A CA_n41A-n66A <sup>5</sup> CA_n41A-n71A <sup>5</sup> CA_n66A-n71A	n25	n25 channel bandwidths in Table 5.3.5-1	4 and 5



		n41	n41 channel bandwidths in Table 5.3.5-1	
		n66	n66 channel bandwidths in Table 5.3.5-1	
		n71	CA_n71(2A)_BCS 4 and 5	
CA_n25A-n41A-n66A-n71B	n41 <sup>5,6</sup> CA_n25A-n41A <sup>5</sup> CA_n25A-n66A CA_n25A-n71A CA_n41A-n66A <sup>5</sup> CA_n41A-n71A <sup>5</sup> CA_n66A-n71A	n25	n25 channel bandwidths in Table 5.3.5-1	4 and 5
		n41	n41 channel bandwidths in Table 5.3.5-1	
		n66	n66 channel bandwidths in Table 5.3.5-1	
		n71	CA_n71B_BCS 4 and 5	
CA_n25A-n41(2A)-n66A-n71A	-	n25	5, 10, 15, 20	0
		n41	CA_n41(2A)_BCS0	
		n66	5, 10, 15, 20	
		n71	5, 10, 15, 20	
	n41 <sup>5,6</sup> CA_n25A-n41A <sup>5</sup> CA_n25A-n66A CA_n25A-n71A CA_n41A-n66A <sup>5</sup> CA_n41A-n71A <sup>5</sup> CA_n66A-n71A	n25	5, 10, 15, 20, 25, 30, 40	1
		n41	CA_n41(2A)_BCS1	
		n66	5, 10, 15, 20, 25, 30, 40	
		n71	5, 10, 15, 20	
		n25	n25 channel bandwidths in Table 5.3.5-1	4 and 5
		n41	CA_n41(2A)_BCS 4 and 5	
		n66	n66 channel bandwidths in Table 5.3.5-1	
		n71	n71 channel bandwidths in Table 5.3.5-1	
CA_n25A-n41(2A)-n66A-n71(2A)	n41 <sup>5,6</sup> CA_n25A-n41A <sup>5</sup> CA_n25A-n66A CA_n25A-n71A CA_n41A-n66A <sup>5</sup> CA_n41A-n71A <sup>5</sup> CA_n66A-n71A	n25	n25 channel bandwidths in Table 5.3.5-1	4 and 5
		n41	CA_n41(2A)_BCS 4 and 5	
		n66	n66 channel bandwidths in Table 5.3.5-1	
		n71	CA_n71(2A)_BCS 4 and 5	
CA_n25A-n41(2A)-n66A-n71B	n41 <sup>5,6</sup> CA_n25A-n41A <sup>5</sup> CA_n25A-n66A CA_n25A-n71A CA_n41A-n66A <sup>5</sup> CA_n41A-n71A <sup>5</sup> CA_n66A-n71A	n25	n25 channel bandwidths in Table 5.3.5-1	4 and 5
		n41	CA_n41(2A)_BCS 4 and 5	
		n66	n66 channel bandwidths in Table 5.3.5-1	
		n71	CA_n71B_BCS 4 and 5	
CA_n25A-n41(2A)-n66(2A)-n71A	n41 <sup>5,6</sup> CA_n25A-n41A <sup>5</sup> CA_n25A-n66A CA_n25A-n71A	n25	n25 channel bandwidths in Table 5.3.5-1	4 and 5

	CA_n41A-n66A <sup>5</sup> CA_n41A-n71A <sup>5</sup> CA_n66A-n71A	n41	CA_n41(2A)_BCS 4 and 5	
		n66	CA_n66(2A)_BCS 4 and 5	
		n71	n71 channel bandwidths in Table 5.3.5-1	
CA_n25A-n41C-n66A-n71A	-	n25	5, 10, 15, 20	0
		n41	CA_n41C_BCS0	
		n66	5, 10, 15, 20, 40	
		n71	5, 10, 15, 20	
	n41 <sup>5,6</sup> CA_n25A-n41A <sup>5</sup> CA_n25A-n66A CA_n25A-n71A CA_n41A-n66A <sup>5</sup> CA_n41A-n71A <sup>5</sup> CA_n41C <sup>5</sup> CA_n66A-n71A	n25	5, 10, 15, 20, 25, 30, 40	1
		n41	CA_n41C_BCS1	
		n66	5, 10, 15, 20, 25, 30, 40	
		n71	5, 10, 15, 20	
		n25	n25 channel bandwidths in Table 5.3.5-1	
		n41	CA_n41C_BCS 4 and 5	
		n66	n66 channel bandwidths in Table 5.3.5-1	4 and 5
		n71	n71 channel bandwidths in Table 5.3.5-1	
		n25	n25 channel bandwidths in Table 5.3.5-1	
		n41	CA_n41C_BCS 4 and 5	
CA_n25A-n41C-n66A-n71(2A)	n41 <sup>5,6</sup> CA_n25A-n41A <sup>5</sup> CA_n25A-n66A CA_n25A-n71A CA_n41A-n66A <sup>5</sup> CA_n41A-n71A <sup>5</sup> CA_n41C <sup>5</sup> CA_n66A-n71A	n25	n25 channel bandwidths in Table 5.3.5-1	4 and 5
		n41	CA_n41C_BCS 4 and 5	
		n66	n66 channel bandwidths in Table 5.3.5-1	
		n71	CA_n71(2A)_BCS 4 and 5	
CA_n25A-n41C-n66A-n71B	n41 <sup>5,6</sup> CA_n25A-n41A <sup>5</sup> CA_n25A-n66A CA_n25A-n71A CA_n41A-n66A <sup>5</sup> CA_n41A-n71A <sup>5</sup> CA_n41C <sup>5</sup> CA_n66A-n71A	n25	n25 channel bandwidths in Table 5.3.5-1	4 and 5
		n41	CA_n41C_BCS 4 and 5	
		n66	n66 channel bandwidths in Table 5.3.5-1	
		n71	CA_n71B_BCS 4 and 5	
CA_n25A-n41C-n66(2A)-n71A	n41 <sup>5,6</sup> CA_n25A-n41A <sup>5</sup> CA_n25A-n66A CA_n25A-n71A CA_n41A-n66A <sup>5</sup> CA_n41A-n71A <sup>5</sup> CA_n41C <sup>5</sup> CA_n66A-n71A	n25	n25 channel bandwidths in Table 5.3.5-1	4 and 5
		n41	CA_n41C_BCS 4 and 5	
		n66	CA_n66(2A)_BCS 4 and 5	
		n71	n71 channel bandwidths in Table 5.3.5-1	

CA_n25(2A)-n41A-n66A-n71A	n41 <sup>5,6</sup> CA_n25A-n41A <sup>5</sup> CA_n25A-n66A CA_n25A-n71A CA_n41A-n66A <sup>5</sup> CA_n41A-n71A <sup>5</sup> CA_n66A-n71A	n25	CA_n25(2A)_BCS 4 and 5	4 and 5
		n41	n41 channel bandwidths in Table 5.3.5-1	
		n66	n66 channel bandwidths in Table 5.3.5-1	
		n71	n71 channel bandwidths in Table 5.3.5-1	
CA_n25(2A)-n41A-n66A-n71(2A)	CA_n25A-n41A CA_n25A-n66A CA_n25A-n71A CA_n41A-n66A CA_n41A-n71A CA_n66A-n71A	n25	CA_n25(2A) BCS 4 and 5	4 and 5
		n41	n41 channel bandwidths in Table 5.3.5-1	
		n66	n66 channel bandwidths in Table 5.3.5-1	
		n71	CA_n71(2A) BCS 4 and 5	
CA_n25(2A)-n41A-n66A-n71B	CA_n25A-n41A CA_n25A-n66A CA_n25A-n71A CA_n41A-n66A CA_n41A-n71A CA_n66A-n71A	n25	CA_n25(2A) BCS 4 and 5	4 and 5
		n41	n41 channel bandwidths in Table 5.3.5-1	
		n66	n66 channel bandwidths in Table 5.3.5-1	
		n71	CA_n71B BCS 4 and 5	
CA_n25(2A)-n41A-n66(2A)-n71A	CA_n25A-n41A CA_n25A-n66A CA_n25A-n71A CA_n41A-n66A CA_n41A-n71A CA_n66A-n71A	n25	CA_n25(2A) BCS 4 and 5	4 and 5
		n41	n41 channel bandwidths in Table 5.3.5-1	
		n66	CA_n66(2A) BCS 4 and 5	
		n71	n71 channel bandwidths in Table 5.3.5-1	
CA_n25(2A)-n41(2A)-n66A-n71A	n41 <sup>5,6</sup> CA_n25A-n41A <sup>5</sup> CA_n25A-n66A CA_n25A-n71A CA_n41A-n66A <sup>5</sup> CA_n41A-n71A <sup>5</sup> CA_n66A-n71A	n25	CA_n25(2A)_BCS 4 and 5	4 and 5
		n41	CA_n41(2A)_BCS 4 and 5	
		n66	n66 channel bandwidths in Table 5.3.5-1	
		n71	n71 channel bandwidths in Table 5.3.5-1	
CA_n25(2A)-n41C-n66A-n71A	n41 <sup>5,6</sup> CA_n25A-n41A <sup>5</sup> CA_n25A-n66A CA_n25A-n71A CA_n41A-n66A <sup>5</sup> CA_n41A-n71A <sup>5</sup> CA_n41C <sup>5</sup> CA_n66A-n71A	n25	CA_n25(2A)_BCS 4 and 5	4 and 5
		n41	CA_n41C_BCS 4 and 5	

		n66	n66 channel bandwidths in Table 5.3.5-1			
		n71	n71 channel bandwidths in Table 5.3.5-1			
CA_n25A-n41(3A)-n66A-n71A	CA_n25A-n41A CA_n25A-n66A CA_n25A-n71A CA_n41A-n66A CA_n41A-n71A CA_n66A-n71A	n25	n25 channel bandwidths in Table 5.3.5-1	4 and 5		
		n41	CA_n41(3A)_BCS 4 and 5			
		n66	n66 channel bandwidths in Table 5.3.5-1			
		n71	n71 channel bandwidths in Table 5.3.5-1			
CA_n25A-n41A-n66A-n77A	n41 <sup>5,6</sup> n77 <sup>5,6</sup> CA_n25A-n41A <sup>5</sup> CA_n25A-n66A CA_n25A-n77A <sup>5</sup> CA_n41A-n66A <sup>5</sup> CA_n41A-n77A <sup>5</sup> CA_n66A-n77A <sup>5</sup>	n25	5, 10, 15, 20, 25, 30, 40	0		
		n41	10, 15, 20, 30, 40, 50, 60, 70, 80, 90, 100			
		n66	5, 10, 15, 20, 25, 30, 40			
		n77	10, 15, 20, 25, 30, 40, 50, 60, 70, 80, 90, 100			
				n25	n25 channel bandwidths in Table 5.3.5-1	4 and 5
				n41	n41 channel bandwidths in Table 5.3.5-1	
				n66	n66 channel bandwidths in Table 5.3.5-1	
				n77	n77 channel bandwidths in Table 5.3.5-1	
CA_n25A-n41(A-C)-n66A-n77A	CA_n25A-n41A CA_n25A-n66A CA_n25A-n77A CA_n41C CA_n41A-n66A CA_n41A-n77A CA_n66A-n77A	n25	n25 channel bandwidths in Table 5.3.5-1	4 and 5		
		n41	CA_n41(A-C)_BCS 4 and 5			
		n66	n66 channel bandwidths in Table 5.3.5-1			
		n77	n77 channel bandwidths in Table 5.3.5-1			
CA_n25A-n41C-n66A-n77A	n41 <sup>5,6</sup> n77 <sup>5,6</sup> CA_n25A-n41A <sup>5</sup> CA_n25A-n66A CA_n25A-n77A <sup>5</sup> CA_n41A-n66A <sup>5</sup> CA_n41A-n77A <sup>5</sup> CA_n41C <sup>5</sup> CA_n66A-n77A <sup>5</sup>	n25	5, 10, 15, 20, 25, 30, 40	0		
		n41	CA_n41C_BCS1			
		n66	5, 10, 15, 20, 25, 30, 40			
				n77	10, 15, 20, 25, 30, 40, 50, 60, 70, 80, 90, 100	4 and 5
				n25	n25 channel bandwidths in Table 5.3.5-1	
				n41	CA_n41C_BCS 4 and 5	
				n66	n66 channel bandwidths in Table 5.3.5-1	

		n77	n77 channel bandwidths in Table 5.3.5-1			
CA_n25A-n41C-n66A-n77(2A)	CA_n25A-n41A CA_n25A-n66A CA_n25A-n77A CA_n41C CA_n41A-n66A CA_n41A-n77A CA_n66A-n77A	n25	n25 channel bandwidths in Table 5.3.5-1	4 and 5		
		n41	CA_n41C_BCS 4 and 5			
		n66	n66 channel bandwidths in Table 5.3.5-1			
		n77	CA_n77(2A)_BCS 4 and 5			
CA_n25A-n41C-n66(2A)-n77A	CA_n25A-n41A CA_n25A-n66A CA_n25A-n77A CA_n41A-n66A CA_n41A-n77A CA_n41C CA_n66A-n77A	n25	n25 channel bandwidths in Table 5.3.5-1	4 and 5		
		n41	CA_n41C_BCS 4 and 5			
		n66	CA_n66(2A)_BCS 4 and 5			
		n77	n77 channel bandwidths in Table 5.3.5-1			
CA_n25A-n41(2A)-n66A-n77A	n41 <sup>5,6</sup> n77 <sup>5,6</sup> CA_n25A-n41A <sup>5</sup> CA_n25A-n66A CA_n25A-n77A <sup>5</sup> CA_n41A-n66A <sup>5</sup> CA_n41A-n77A <sup>5</sup> CA_n66A-n77A <sup>5</sup>	n25	5, 10, 15, 20, 25, 30, 40	0		
		n41	CA_n41(2A)_BCS1			
		n66	5, 10, 15, 20, 25, 30, 40			
		n77	10, 15, 20, 25, 30, 40, 50, 60, 70, 80, 90, 100			
				n25	n25 channel bandwidths in Table 5.3.5-1	4 and 5
				n41	CA_n41(2A)_BCS 4 and 5	
				n66	n66 channel bandwidths in Table 5.3.5-1	
				n77	n77 channel bandwidths in Table 5.3.5-1	
CA_n25A-n41(2A)-n66A-n77(2A)	CA_n25A-n41A CA_n25A-n66A CA_n25A-n77A CA_n41A-n66A CA_n41A-n77A CA_n66A-n77A	n25	n25 channel bandwidths in Table 5.3.5-1	4 and 5		
		n41	CA_n41(2A)_BCS 4 and 5			
		n66	n66 channel bandwidths in Table 5.3.5-1			
		n77	CA_n77(2A)_BCS 4 and 5			
CA_n25A-n41(3A)-n66A-n77A	CA_n25A-n41A CA_n25A-n66A CA_n25A-n77A CA_n41A-n66A CA_n41A-n77A CA_n66A-n77A	n25	n25 channel bandwidths in Table 5.3.5-1	4 and 5		
		n41	CA_n41(3A)_BCS 4 and 5			
		n66	n66 channel bandwidths in Table 5.3.5-1			
		n77	n77 channel bandwidths in Table 5.3.5-1			
CA_n25A-n41A-n66(2A)-n77A	n41 <sup>5,6</sup> n77 <sup>5,6</sup> CA_n25A-n41A <sup>5</sup>	n25	n25 channel bandwidths in Table 5.3.5-1	4 and 5		

	CA_n25A-n66A CA_n25A-n77A <sup>5</sup> CA_n41A-n66A <sup>5</sup> CA_n41A-n77A <sup>5</sup> CA_n66A-n77A <sup>5</sup>	n41	n41 channel bandwidths in Table 5.3.5-1			
		n66	CA_n66(2A)_BCS 4 and 5			
		n77	n77 channel bandwidths in Table 5.3.5-1			
CA_n25A-n41A-n66A-n77(2A)	n41 <sup>5,6</sup> n77 <sup>5,6</sup> CA_n25A-n41A <sup>5</sup> CA_n25A-n66A CA_n25A-n77A <sup>5</sup> CA_n41A-n66A <sup>5</sup> CA_n41A-n77A <sup>5</sup> CA_n66A-n77A <sup>5</sup>	n25	5, 10, 15, 20, 25, 30, 40	0		
		n41	10, 15, 20, 30, 40, 50, 60, 70, 80, 90, 100			
		n66	5, 10, 15, 20, 25, 30, 40			
		n77	CA_n77(2A)_BCS1			
				n25	n25 channel bandwidths in Table 5.3.5-1	4 and 5
				n41	n41 channel bandwidths in Table 5.3.5-1	
				n66	n66 channel bandwidths in Table 5.3.5-1	
				n77	CA_n77(2A)_BCS 4 and 5	
CA_n25A-n41A-n66(2A)-n77(2A)	CA_n25A-n41A CA_n25A-n66A CA_n25A-n77A CA_n41A-n66A CA_n41A-n77A CA_n66A-n77A	n25	n25 channel bandwidths in Table 5.3.5-1	4 and 5		
		n41	n41 channel bandwidths in Table 5.3.5-1			
		n66	CA_n66(2A)_BCS 4 and 5			
		n77	CA_n77(2A)_BCS 4 and 5			
CA_n25A-n41(2A)-n66(2A)-n77A	CA_n25A-n41A CA_n25A-n66A CA_n25A-n77A CA_n41A-n66A CA_n41A-n77A CA_n66A-n77A	n25	n25 channel bandwidths in Table 5.3.5-1	4 and 5		
		n41	CA_n41(2A)_BCS 4 and 5			
		n66	CA_n66(2A)_BCS 4 and 5			
		n77	n77 channel bandwidths in Table 5.3.5-1			
CA_n25(2A)-n41A-n66A-n77A	n41 <sup>5,6</sup> n77 <sup>5,6</sup> CA_n25A-n41A <sup>5</sup> CA_n25A-n66A CA_n25A-n77A <sup>5</sup> CA_n41A-n66A <sup>5</sup> CA_n41A-n77A <sup>5</sup> CA_n66A-n77A <sup>5</sup>	n25	CA_n25(2A)_BCS 4 and 5	4 and 5		
		n41	n41 channel bandwidths in Table 5.3.5-1			
		n66	n66 channel bandwidths in Table 5.3.5-1			
		n77	n77 channel bandwidths in Table 5.3.5-1			
CA_n25(2A)-n41A-n66A-n77(2A)	CA_n25A-n41A CA_n25A-n66A CA_n25A-n77A CA_n41A-n66A	n25	CA_n25(2A)_BCS 4 and 5	4 and 5		

	CA_n41A-n77A CA_n66A-n77A	n41	n41 channel bandwidths in Table 5.3.5-1	
		n66	n66 channel bandwidths in Table 5.3.5-1	
		n77	CA_n77(2A)_BCS 4 and 5	
CA_n25(2A)-n41A-n66(2A)-n77A	n41 <sup>5,6</sup> n77 <sup>5,6</sup> CA_n25A-n41A <sup>5</sup> CA_n25A-n66A CA_n25A-n77A <sup>5</sup> CA_n41A-n66A <sup>5</sup> CA_n41A-n77A <sup>5</sup> CA_n66A-n77A <sup>5</sup>	n25	CA_n25(2A)_BCS 4 and 5	4 and 5
		n41	n41 channel bandwidths in Table 5.3.5-1	
		n66	CA_n66(2A)_BCS 4 and 5	
		n77	n77 channel bandwidths in Table 5.3.5-1	
CA_n25(2A)-n41C-n66A-n77A	CA_n25A-n41A CA_n25A-n66A CA_n25A-n77A CA_n41A-n66A CA_n41A-n77A CA_n66A-n77A	n25	CA_n25(2A)_BCS 4 and 5	4 and 5
		n41	CA_n41C_BCS 4 and 5	
		n66	n66 channel bandwidths in Table 5.3.5-1	
		n77	n77 channel bandwidths in Table 5.3.5-1	
CA_n25(2A)-n41(2A)-n66A-n77A	CA_n25A-n41A CA_n25A-n66A CA_n25A-n77A CA_n41A-n66A CA_n41A-n77A CA_n66A-n77A	n25	CA_n25(2A)_BCS 4 and 5	4 and 5
		n41	CA_n41(2A)_BCS 4 and 5	
		n66	n66 channel bandwidths in Table 5.3.5-1	
		n77	n77 channel bandwidths in Table 5.3.5-1	
CA_n25A-n41A-n66A-n78A	CA_n25A-n41A CA_n25A-n66A CA_n25A-n78A CA_n41A-n66A CA_n41A-n78A CA_n66A-n78A	n25	5, 10, 15, 20, 25, 30, 40	0
		n41	10, 15, 20, 30, 40, 50, 60, 70, 80, 90, 100	
		n66	5, 10, 15, 20, 25, 30, 40	
		n78	10, 15, 20, 25, 30, 40, 50, 60, 70, 80, 90, 100	
CA_n25A-n41A-n66A-n78(2A)	CA_n25A-n41A CA_n25A-n66A CA_n25A-n78A CA_n41A-n66A CA_n41A-n78A CA_n66A-n78A	n25	5, 10, 15, 20, 25, 30, 40	0
		n41	10, 15, 20, 30, 40, 50, 60, 70, 80, 90, 100	
		n66	5, 10, 15, 20, 25, 30, 40	
		n78	CA_n78(2A)_BCS2	
CA_n25A-n41A-n66A-n85A	CA_n25A-n41A CA_n25A-n66A CA_n25A-n85A CA_n41A-n66A	n25	n25 channel bandwidths in Table 5.3.5-1	4 and 5

	CA_n41A-n85A CA_n66A-n85A			
		n41	n41 channel bandwidths in Table 5.3.5-1	
		n66	n66 channel bandwidths in Table 5.3.5-1	
		n85	n85 channel bandwidths in Table 5.3.5-1	
CA_n25A-n41A-n71A-n77A	n41 <sup>5,6</sup> n77 <sup>5,6</sup> CA_n25A-n41A <sup>5</sup> CA_n25A-n71A CA_n25A-n77A <sup>5</sup> CA_n41A-n71A <sup>5</sup> CA_n41A-n77A <sup>5</sup> CA_n71A-n77A <sup>5</sup>	n25	5, 10, 15, 20, 25, 30, 40	0
		n41	10, 15, 20, 30, 40, 50, 60, 70, 80, 90, 100	
		n71	5, 10, 15, 20	
		n77	10, 15, 20, 25, 30, 40, 50, 60, 70, 80, 90, 100	
		n25	n25 channel bandwidths in Table 5.3.5-1	4 and 5
		n41	n41 channel bandwidths in Table 5.3.5-1	
		n71	n71 channel bandwidths in Table 5.3.5-1	
		n77	n77 channel bandwidths in Table 5.3.5-1	
CA_n25A-n41A-n71A-n77(2A)	n41 <sup>5,6</sup> n77 <sup>5,6</sup> CA_n25A-n41A <sup>5</sup> CA_n25A-n71A CA_n25A-n77A <sup>5</sup> CA_n41A-n71A <sup>5</sup> CA_n41A-n77A <sup>5</sup> CA_n71A-n77A <sup>5</sup>	n25	n25 channel bandwidths in Table 5.3.5-1	4 and 5
		n41	n41 channel bandwidths in Table 5.3.5-1	
		n71	n71 channel bandwidths in Table 5.3.5-1	
		n77	CA_n77(2A)_BCS 4 and 5	
CA_n25A-n41A-n71B-n77A	n41 <sup>5,6</sup> n77 <sup>5,6</sup> CA_n25A-n41A <sup>5</sup> CA_n25A-n71A CA_n25A-n77A <sup>5</sup> CA_n41A-n71A <sup>5</sup> CA_n41A-n77A <sup>5</sup> CA_n71A-n77A <sup>5</sup>	n25	n25 channel bandwidths in Table 5.3.5-1	4 and 5
		n41	n41 channel bandwidths in Table 5.3.5-1	
		n71	CA_n71B_BCS 4 and 5	
		n77	n77 channel bandwidths in Table 5.3.5-1	
CA_n25A-n41A-n71B-n77(2A)	CA_n25A-n41A CA_n25A-n71A CA_n25A-n77A CA_n41A-n71A CA_n41A-n77A CA_n71A-n77A	n25	n25 channel bandwidths in Table 5.3.5-1	4 and 5
		n41	n41 channel bandwidths in Table 5.3.5-1	
		n71	CA_n71B_BCS 4 and 5	
		n77	CA_n77(2A)_BCS 4 and 5	
CA_n25A-n41A-n71(2A)-n77A	n41 <sup>5,6</sup> n77 <sup>5,6</sup>	n25	n25 channel bandwidths in Table 5.3.5-1	4 and 5



	CA_n25A-n41A <sup>5</sup> CA_n25A-n71A CA_n25A-n77A <sup>5</sup> CA_n41A-n71A <sup>5</sup> CA_n41A-n77A <sup>5</sup> CA_n71A-n77A <sup>5</sup>					
		n41	n41 channel bandwidths in Table 5.3.5-1			
		n71	CA_n71(2A)_BCS 4 and 5			
		n77	n77 channel bandwidths in Table 5.3.5-1			
CA_n25A-n41A-n71(2A)-n77(2A)	CA_n25A-n41A CA_n25A-n71A CA_n25A-n77A CA_n41A-n71A CA_n41A-n77A CA_n71A-n77A	n25	n25 channel bandwidths in Table 5.3.5-1	4 and 5		
		n41	n41 channel bandwidths in Table 5.3.5-1			
		n71	CA_n71(2A)_BCS 4 and 5			
		n77	CA_n77(2A)_BCS 4 and 5			
CA_n25A-n41(A-C)-n71A-n77A	CA_n25A-n41A CA_n25A-n71A CA_n25A-n77A CA_n41C CA_n41A-n71A CA_n41A-n77A CA_n71A-n77A	n25	n25 channel bandwidths in Table 5.3.5-1	4 and 5		
		n41	CA_n41(A-C)_BCS 4 and 5			
		n71	n71 channel bandwidths in Table 5.3.5-1			
		n77	n77 channel bandwidths in Table 5.3.5-1			
CA_n25A-n41C-n71A-n77A	n41 <sup>5,6</sup> n77 <sup>5,6</sup> CA_n25A-n41A <sup>5</sup> CA_n25A-n71A CA_n25A-n77A <sup>5</sup> CA_n41A-n71A <sup>5</sup> CA_n41A-n77A <sup>5</sup> CA_n41C <sup>5</sup> CA_n71A-n77A <sup>5</sup>	n25	5, 10, 15, 20, 25, 30, 40	0		
		n41	CA_n41C_BCS1			
		n71	5, 10, 15, 20			
		n77	10, 15, 20, 25, 30, 40, 50, 60, 70, 80, 90, 100			
				n25	n25 channel bandwidths in Table 5.3.5-1	4 and 5
				n41	CA_n41C_BCS 4 and 5	
				n71	n71 channel bandwidths in Table 5.3.5-1	
				n77	n77 channel bandwidths in Table 5.3.5-1	
CA_n25A-n41C-n71A-n77(2A)	CA_n25A-n41A CA_n25A-n71A CA_n25A-n77A CA_n41C CA_n41A-n71A CA_n41A-n77A CA_n71A-n77A	n25	n25 channel bandwidths in Table 5.3.5-1	4 and 5		
		n41	CA_n41C_BCS 4 and 5			
		n71	n71 channel bandwidths in Table 5.3.5-1			
		n77	CA_n77(2A)_BCS 4 and 5			
CA_n25A-n41C-n71B-n77A	CA_n25A-n41A CA_n25A-n71A CA_n25A-n77A	n25	n25 channel bandwidths in Table 5.3.5-1	4 and 5		

	CA_n41A-n71A CA_n41A-n77A CA_n41C CA_n71A-n77A	n41	CA_n41C_BCS 4 and 5	4 and 5
		n71	CA_n71B_BCS 4 and 5	
		n77	n77 channel bandwidths in Table 5.3.5-1	
		n25	n25 channel bandwidths in Table 5.3.5-1	
CA_n25A-n41C-n71(2A)-n77A	CA_n25A-n41A CA_n25A-n71A CA_n25A-n77A CA_n41A-n71A CA_n41A-n77A CA_n41C CA_n71A-n77A	n41	CA_n41C_BCS 4 and 5	4 and 5
		n71	CA_n71(2A)_BCS 4 and 5	
		n77	n77 channel bandwidths in Table 5.3.5-1	
		n25	n25 channel bandwidths in Table 5.3.5-1	
CA_n25A-n41(2A)-n71A-n77A	n41 <sup>5,6</sup> n77 <sup>5,6</sup> CA_n25A-n41A <sup>5</sup> CA_n25A-n71A CA_n25A-n77A <sup>5</sup> CA_n41A-n71A <sup>5</sup> CA_n41A-n77A <sup>5</sup> CA_n71A-n77A <sup>5</sup>	n25	5, 10, 15, 20, 25, 30, 40	0
		n41	CA_n41(2A)_BCS1	4 and 5
		n71	5, 10, 15, 20	
		n77	10, 15, 20, 25, 30, 40, 50, 60, 70, 80, 90, 100	
		n25	n25 channel bandwidths in Table 5.3.5-1	
		n41	CA_n41(2A)_BCS 4 and 5	
		n71	n71 channel bandwidths in Table 5.3.5-1	
n77	n77 channel bandwidths in Table 5.3.5-1			
CA_n25A-n41(2A)-n71A-n77(2A)	CA_n25A-n41A CA_n25A-n71A CA_n25A-n77A CA_n41A-n71A CA_n41A-n77A CA_n71A-n77A	n25	n25 channel bandwidths in Table 5.3.5-1	4 and 5
		n41	CA_n41(2A)_BCS 4 and 5	
		n71	n71 channel bandwidths in Table 5.3.5-1	
		n77	CA_n77(2A)_BCS 4 and 5	
CA_n25A-n41(3A)-n71A-n77A	CA_n25A-n41A CA_n25A-n71A CA_n25A-n77A CA_n41A-n71A CA_n41A-n77A CA_n71A-n77A	n25	n25 channel bandwidths in Table 5.3.5-1	4 and 5
		n41	CA_n41(3A)_BCS 4 and 5	
		n71	n71 channel bandwidths in Table 5.3.5-1	
		n77	n77 channel bandwidths in Table 5.3.5-1	
CA_n25A-n41(2A)-n71B-n77A	CA_n25A-n41A CA_n25A-n71A CA_n25A-n77A CA_n41A-n71A CA_n41A-n77A CA_n71A-n77A	n25	n25 channel bandwidths in Table 5.3.5-1	4 and 5
		n41	CA_n41(2A)_BCS 4 and 5	
		n71	CA_n71B_BCS 4 and 5	

		n77	n77 channel bandwidths in Table 5.3.5-1	
CA_n25A-n41(2A)-n71(2A)-n77A	CA_n25A-n41A CA_n25A-n71A CA_n25A-n77A CA_n41A-n71A CA_n41A-n77A CA_n71A-n77A	n25	n25 channel bandwidths in Table 5.3.5-1	4 and 5
		n41	CA_n41(2A)_BCS 4 and 5	
		n71	CA_n71(2A)_BCS 4 and 5	
		n77	n77 channel bandwidths in Table 5.3.5-1	
CA_n25(2A)-n41A-n71A-n77A	n41 <sup>5,6</sup> n77 <sup>5,6</sup> CA_n25A-n41A <sup>5</sup> CA_n25A-n71A CA_n25A-n77A <sup>5</sup> CA_n41A-n71A <sup>5</sup> CA_n41A-n77A <sup>5</sup> CA_n71A-n77A <sup>5</sup>	n25	CA_n25(2A)_BCS 4 and 5	4 and 5
		n41	n41 channel bandwidths in Table 5.3.5-1	
		n71	n71 channel bandwidths in Table 5.3.5-1	
		n77	n77 channel bandwidths in Table 5.3.5-1	
CA_n25(2A)-n41A-n71(2A)-n77A	n41 <sup>5,6</sup> n77 <sup>5,6</sup> CA_n25A-n41A <sup>5</sup> CA_n25A-n71A CA_n25A-n77A <sup>5</sup> CA_n41A-n71A <sup>5</sup> CA_n41A-n77A <sup>5</sup> CA_n71A-n77A <sup>5</sup>	n25	CA_n25(2A)_BCS 4 and 5	4 and 5
		n41	n41 channel bandwidths in Table 5.3.5-1	
		n71	CA_n71(2A)_BCS 4 and 5	
		n77	n77 channel bandwidths in Table 5.3.5-1	
CA_n25(2A)-n41A-n71B-n77A	n41 <sup>5,6</sup> n77 <sup>5,6</sup> CA_n25A-n41A <sup>5</sup> CA_n25A-n71A CA_n25A-n77A <sup>5</sup> CA_n41A-n71A <sup>5</sup> CA_n41A-n77A <sup>5</sup> CA_n71A-n77A <sup>5</sup>	n25	CA_n25(2A)_BCS 4 and 5	4 and 5
		n41	n41 channel bandwidths in Table 5.3.5-1	
		n71	CA_n71B_BCS 4 and 5	
		n77	n77 channel bandwidths in Table 5.3.5-1	
CA_n25(2A)-n41A-n71A-n77(2A)	CA_n25A-n41A CA_n25A-n71A CA_n25A-n77A CA_n41A-n71A CA_n41A-n77A CA_n71A-n77A	n25	CA_n25(2A)_BCS 4 and 5	4 and 5
		n41	n41 channel bandwidths in Table 5.3.5-1	
		n71	n71 channel bandwidths in Table 5.3.5-1	
		n77	CA_n77(2A)_BCS 4 and 5	
CA_n25(2A)-n41C-n71A-n77A	CA_n25A-n41A CA_n25A-n71A CA_n25A-n77A CA_n41A-n71A	n25	CA_n25(2A)_BCS 4 and 5	4 and 5

	CA_n41A-n77A CA_n71A-n77A	n41	CA_n41C_BCS 4 and 5	4 and 5
		n71	n71 channel bandwidths in Table 5.3.5-1	
		n77	n77 channel bandwidths in Table 5.3.5-1	
CA_n25(2A)-n41(2A)-n71A-n77A	CA_n25A-n41A CA_n25A-n71A CA_n25A-n77A CA_n41A-n71A CA_n41A-n77A CA_n71A-n77A	n25	CA_n25(2A)_BCS 4 and 5	4 and 5
		n41	CA_n41(2A)_BCS 4 and 5	
		n71	n71 channel bandwidths in Table 5.3.5-1	
		n77	n77 channel bandwidths in Table 5.3.5-1	
CA_n25A-n41A-n71A-n78A	CA_n25A-n41A CA_n25A-n71A CA_n25A-n78A CA_n41A-n71A CA_n41A-n78A CA_n71A-n78A	n25	5, 10, 15, 20, 25, 30, 40	0
		n41	10, 15, 20, 30, 40, 50, 60, 70, 80, 90, 100	
		n71	5, 10, 15, 20	
		n78	10, 15, 20, 25, 30, 40, 50, 60, 70, 80, 90, 100	
CA_n25A-n41A-n71A-n85A	CA_n25A-n41A CA_n25A-n71A CA_n25A-n85A CA_n41A-n71A CA_n41A-n85A	n25	n25 channel bandwidths in Table 5.3.5-1	4 and 5
		n41	n41 channel bandwidths in Table 5.3.5-1	
		n71	n71 channel bandwidths in Table 5.3.5-1	
		n85	n85 channel bandwidths in Table 5.3.5-1	
CA_n25A-n41A-n77A-n85A	CA_n25A-n41A CA_n25A-n77A CA_n25A-n85A CA_n41A-n77A CA_n41A-n85A CA_n77A-n85A	n25	n25 channel bandwidths in Table 5.3.5-1	4 and 5
		n41	n41 channel bandwidths in Table 5.3.5-1	
		n77	n77 channel bandwidths in Table 5.3.5-1	
		n85	n85 channel bandwidths in Table 5.3.5-1	
CA_n25A-n66A-n71A-n77A	n77 <sup>5,6</sup> CA_n25A-n66A CA_n25A-n71A CA_n25A-n77A <sup>5</sup> CA_n66A-n71A CA_n66A-n77A <sup>5</sup> CA_n71A-n77A <sup>5</sup>	n25	5, 10, 15, 20, 25, 30, 40	0
		n66	5, 10, 15, 20, 25, 30, 40	
		n71	5, 10, 15, 20	
		n77	10, 15, 20, 25, 30, 40, 50, 60, 70, 80, 90, 100	4 and 5
		n25	n25 channel bandwidths in Table 5.3.5-1	
		n66	n66 channel bandwidths in Table 5.3.5-1	

		n71	n71 channel bandwidths in Table 5.3.5-1	
		n77	n77 channel bandwidths in Table 5.3.5-1	
CA_n25A-n66(2A)-n71A-n77A	n77 <sup>5,6</sup> CA_n25A-n66A CA_n25A-n71A CA_n25A-n77A <sup>5</sup> CA_n66A-n71A CA_n66A-n77A <sup>5</sup> CA_n71A-n77A <sup>5</sup>	n25	n25 channel bandwidths in Table 5.3.5-1	4 and 5
		n66	CA_n66(2A)_BCS 4 and 5	
		n71	n71 channel bandwidths in Table 5.3.5-1	
		n77	n77 channel bandwidths in Table 5.3.5-1	
CA_n25A-n66(2A)-n71A-n77(2A)	n77 <sup>5,6</sup> CA_n25A-n66A CA_n25A-n71A CA_n25A-n77A <sup>5</sup> CA_n66A-n71A CA_n66A-n77A <sup>5</sup> CA_n71A-n77A <sup>5</sup>	n25	n25 channel bandwidths in Table 5.3.5-1	4 and 5
		n66	CA_n66(2A)_BCS 4 and 5	
		n71	n71 channel bandwidths in Table 5.3.5-1	
		n77	CA_n77(2A)_BCS 4 and 5	
CA_n25A-n66A-n71B-n77A	n77 <sup>5,6</sup> CA_n25A-n66A CA_n25A-n71A CA_n25A-n77A <sup>5</sup> CA_n66A-n71A CA_n66A-n77A <sup>5</sup> CA_n71A-n77A <sup>5</sup>	n25	n25 channel bandwidths in Table 5.3.5-1	4 and 5
		n66	n66 channel bandwidths in Table 5.3.5-1	
		n71	CA_n71B_BCS 4 and 5	
		n77	n77 channel bandwidths in Table 5.3.5-1	
CA_n25A-n66A-n71(2A)-n77A	n77 <sup>5,6</sup> CA_n25A-n66A CA_n25A-n71A CA_n25A-n77A <sup>5</sup> CA_n66A-n71A CA_n66A-n77A <sup>5</sup> CA_n71A-n77A <sup>5</sup>	n25	n25 channel bandwidths in Table 5.3.5-1	4 and 5
		n66	n66 channel bandwidths in Table 5.3.5-1	
		n71	CA_n71(2A)_BCS 4 and 5	
		n77	n77 channel bandwidths in Table 5.3.5-1	
CA_n25A-n66A-n71A-n77(2A)	n77 <sup>5,6</sup> CA_n25A-n66A CA_n25A-n71A CA_n25A-n77A <sup>5</sup> CA_n66A-n71A CA_n66A-n77A <sup>5</sup> CA_n71A-n77A <sup>5</sup>	n25	n25 channel bandwidths in Table 5.3.5-1	4 and 5
		n66	n66 channel bandwidths in Table 5.3.5-1	
		n71	n71 channel bandwidths in Table 5.3.5-1	
		n77	CA_n77(2A)_BCS 4 and 5	
CA_n25A-n66A-n71A-n77(3A)	CA_n25A-n66A CA_n25A-n71A CA_n25A-n77A CA_n66A-n71A	n25	5, 10, 15, 20, 25, 30, 40	0

	CA_n66A-n77A CA_n71A-n77A	n66	5, 10, 15, 20, 30, 40	4 and 5
		n71	5, 10, 15, 20, 25, 30, 35	
		n77	CA_n77(3A)_BCS1	
		n25	n25 channel bandwidths in Table 5.3.5-1	
		n66	n66 channel bandwidths in Table 5.3.5-1	
		n71	n71 channel bandwidths in Table 5.3.5-1	
		n77	CA_n77(3A)_BCS 4 and 5	
CA_n25A-n66A-n71(2A)-n77(2A)	n77 <sup>5,6</sup> CA_n25A-n66A CA_n25A-n71A CA_n25A-n77A <sup>5</sup> CA_n66A-n71A CA_n66A-n77A <sup>5</sup> CA_n71A-n77A <sup>5</sup>	n25	n25 channel bandwidths in Table 5.3.5-1	4 and 5
		n66	n66 channel bandwidths in Table 5.3.5-1	
		n71	CA_n71(2A)_BCS 4 and 5	
		n77	CA_n77(2A)_BCS 4 and 5	
CA_n25A-n66A-n71B-n77(2A)	n77 <sup>5,6</sup> CA_n25A-n66A CA_n25A-n71A CA_n25A-n77A <sup>5</sup> CA_n66A-n71A CA_n66A-n77A <sup>5</sup> CA_n71A-n77A <sup>5</sup>	n25	n25 channel bandwidths in Table 5.3.5-1	4 and 5
		n66	n66 channel bandwidths in Table 5.3.5-1	
		n71	CA_n71B_BCS 4 and 5	
		n77	CA_n77(2A)_BCS 4 and 5	
CA_n25A-n66(2A)-n71(2A)-n77A	CA_n25A-n66A CA_n25A-n71A CA_n25A-n77A CA_n66A-n71A CA_n66A-n77A CA_n71A-n77A	n25	n25 channel bandwidths in Table 5.3.5-1	4 and 5
		n66	CA_n66(2A) BCS 4 and 5	
		n71	CA_n71(2A) BCS 4 and 5	
		n77	n77 channel bandwidths in Table 5.3.5-1	
CA_n25A-n66(2A)-n71B-n77A	CA_n25A-n66A CA_n25A-n71A CA_n25A-n77A CA_n66A-n71A CA_n66A-n77A CA_n71A-n77A	n25	n25 channel bandwidths in Table 5.3.5-1	4 and 5
		n66	CA_n66(2A) BCS 4 and 5	
		n71	CA_n71B BCS 4 and 5	
		n77	n77 channel bandwidths in Table 5.3.5-1	
CA_n25(2A)-n66A-n71A-n77A	n77 <sup>5,6</sup> CA_n25A-n66A CA_n25A-n71A CA_n25A-n77A <sup>5</sup> CA_n66A-n71A CA_n66A-n77A <sup>5</sup> CA_n71A-n77A <sup>5</sup>	n25	CA_n25(2A)_BCS 4 and 5	4 and 5
		n66	n66 channel bandwidths in Table 5.3.5-1	
		n71	n71 channel bandwidths in Table 5.3.5-1	
		n77	n77 channel bandwidths in Table 5.3.5-1	

CA_n25(2A)-n66A-n71A-n77(2A)	n77 <sup>5,6</sup> CA_n25A-n66A CA_n25A-n71A CA_n25A-n77A <sup>5</sup> CA_n66A-n71A CA_n66A-n77A <sup>5</sup> CA_n71A-n77A <sup>5</sup>	n25	CA_n25(2A)_BCS 4 and 5	4 and 5
		n66	n66 channel bandwidths in Table 5.3.5-1	
		n71	n71 channel bandwidths in Table 5.3.5-1	
		n77	CA_n77(2A)_BCS 4 and 5	
CA_n25(2A)-n66A-n71(2A)-n77A	CA_n25A-n66A CA_n25A-n71A CA_n25A-n77A CA_n66A-n71A CA_n66A-n77A CA_n71A-n77A	n25	CA_n25(2A) BCS 4 and 5	4 and 5
		n66	n66 channel bandwidths in Table 5.3.5-1	
		n71	CA_n71(2A) BCS 4 and 5	
		n77	n77 channel bandwidths in Table 5.3.5-1	
CA_n25(2A)-n66A-n71B-n77A	CA_n25A-n66A CA_n25A-n71A CA_n25A-n77A CA_n66A-n71A CA_n66A-n77A CA_n71A-n77A	n25	CA_n25(2A) BCS 4 and 5	4 and 5
		n66	n66 channel bandwidths in Table 5.3.5-1	
		n71	CA_n71B BCS 4 and 5	
		n77	n77 channel bandwidths in Table 5.3.5-1	
CA_n25(2A)-n66(2A)-n71A-n77A	CA_n25A-n66A CA_n25A-n71A CA_n25A-n77A CA_n66A-n71A CA_n66A-n77A CA_n71A-n77A	n25	CA_n25(2A) BCS 4 and 5	4 and 5
		n66	CA_n66(2A) BCS 4 and 5	
		n71	n71 channel bandwidths in Table 5.3.5-1	
		n77	n77 channel bandwidths in Table 5.3.5-1	
CA_n25A-n66A-n71A-n78A	CA_n25A-n66A CA_n25A-n71A CA_n25A-n78A CA_n66A-n71A CA_n66A-n78A CA_n71A-n78A	n25	5, 10, 15, 20, 25, 30, 40	0
		n66	5, 10, 15, 20, 25, 30, 40	
		n71	5, 10, 15, 20	
		n78	10, 15, 20, 25, 30, 40, 50, 60, 70, 80, 90, 100	
CA_n25A-n66(2A)-n71A-n78A	CA_n25A-n66A CA_n25A-n71A CA_n25A-n78A CA_n66A-n71A CA_n66A-n78A CA_n71A-n78A	n25	5, 10, 15, 20, 25, 30, 40	0
		n66	CA_n66(2A)_BCS1	
		n71	5, 10, 15, 20	
		n78	10, 15, 20, 25, 30, 40, 50, 60, 70, 80, 90, 100	
CA_n25A-n66A-n71A-n78(2A)	CA_n25A-n66A CA_n25A-n71A	n25	5, 10, 15, 20, 25, 30, 40	0

	CA_n25A-n78A CA_n66A-n71A CA_n66A-n78A CA_n71A-n78A	n66	5, 10, 15, 20, 25, 30, 40	0
		n71	5, 10, 15, 20	
		n78	CA_n78(2A)_BCS2	
		CA_n25A-n66(2A)-n71A-n78(2A)	CA_n25A-n66A CA_n25A-n71A CA_n25A-n78A CA_n66A-n71A CA_n66A-n78A CA_n71A-n78A	
		n66	CA_n66(2A)_BCS1	
		n71	5, 10, 15, 20	
		n78	CA_n78(2A)_BCS2	
CA_n25A-n66A-n71A-n85A	CA_n25A-n66A CA_n25A-n71A CA_n25A-n85A CA_n66A-n71A CA_n66A-n85A	n25	n25 channel bandwidths in Table 5.3.5-1	4 and 5
		n66	n66 channel bandwidths in Table 5.3.5-1	
		n71	n71 channel bandwidths in Table 5.3.5-1	
		n85	n85 channel bandwidths in Table 5.3.5-1	
CA_n25A-n66A-n77A-n85A	CA_n25A-n66A CA_n25A-n77A CA_n25A-n85A CA_n66A-n77A CA_n66A-n85A CA_n77A-n85A	n25	n25 channel bandwidths in Table 5.3.5-1	4 and 5
		n66	n66 channel bandwidths in Table 5.3.5-1	
		n77	n77 channel bandwidths in Table 5.3.5-1	
		n85	n85 channel bandwidths in Table 5.3.5-1	
CA_n28A-n41A-n77A-n79A	CA_n28A-n41A CA_n28A-n77A CA_n28A-n79A CA_n41A-n77A CA_n41A-n79A CA_n77A-n79A	n28	5, 10, 15, 20	0
		n41	10, 15, 20, 30, 40, 50, 60, 80, 90, 100	
		n77	10, 15, 20, 40, 50, 60, 80, 90, 100	
		n79	40, 50, 60, 80, 100	
CA_n28A-n41A-n77(2A)-n79A	CA_n28A-n41A CA_n28A-n77A CA_n28A-n79A CA_n41A-n77A CA_n41A-n79A CA_n77A-n79A	n28	5, 10, 15, 20	0
		n41	10, 15, 20, 30, 40, 50, 60, 80, 90, 100	
		n77	CA_n77(2A)_BCS0	
		n79	40, 50, 60, 80, 100	
CA_n29A-n30A-n66A-n77A	n77 <sup>5,6</sup> CA_n30A-n66A CA_n30A-n77A <sup>5</sup> CA_n66A-n77A <sup>5</sup>	n29	5, 10	0
		n30	5, 10	
		n66	5, 10, 15, 20, 25, 30, 40	



		n77	10, 15, 20, 30, 40, 50, 60, 70, 80, 90, 100	
CA_n29A-n30A-n66(2A)-n77A	n77 <sup>5,6</sup> CA_n30A-n66A CA_n30A-n77A <sup>5</sup> CA_n66A-n77A <sup>5</sup>	n29	5, 10	0
		n30	5, 10	
		n66	CA_n66(2A)_BCS1	
		n77	10, 15, 20, 25, 30, 40, 50, 60, 70, 80, 90, 100	
CA_n29A-n30A-n66A-n77(2A)	n77 <sup>5,6</sup> CA_n30A-n66A CA_n30A-n77A <sup>5</sup> CA_n66A-n77A <sup>5</sup>	n29	5, 10	0
		n30	5, 10	
		n66	5, 10, 15, 20, 25, 30, 40	
		n77	CA_n77(2A)_BCS1	
CA_n29A-n30A-n66(2A)-n77(2A)	n77 <sup>5,6</sup> CA_n30A-n66A CA_n30A-n77A <sup>5</sup> CA_n66A-n77A <sup>5</sup>	n29	5, 10	0
		n30	5, 10	
		n66	CA_n66(2A)_BCS1	
		n77	CA_n77(2A)_BCS1	
CA_n29A-n66A-n70A-n71A	CA_n66A-n71A CA_n70A-n71A	n29	5, 10	0
		n66	5, 10, 15, 20, 40	
		n70	5, 10, 15, 20 <sup>1</sup> , 25 <sup>1</sup>	
		n71	5, 10, 15, 20	
CA_n29A-n66(2A)-n70A-n71A	CA_n66A-n71A CA_n70A-n71A	n29	5, 10	0
		n66	CA_n66(2A)_BCS0	
		n70	5, 10, 15, 20 <sup>1</sup> , 25 <sup>1</sup>	
		n71	5, 10, 15, 20	
CA_n41A-n66A-n70A-n78A	CA_n41A-n66A CA_n41A-n70A CA_n41A-n78A CA_n66A-n78A CA_n70A-n78A	n41	10, 15, 20, 30, 40, 50, 60, 70, 80, 90, 100	0
		n66	10, 15, 20, 25, 30, 40	
		n70	5, 10, 15, 20, 25	
		n78	10, 15, 20, 25, 30, 40, 50, 60, 70, 80, 90, 100	
CA_n41A-n66A-n71A-n77A	n41 <sup>5,6</sup> n77 <sup>5,6</sup> CA_n41A-n66A <sup>5</sup> CA_n41A-n71A <sup>5</sup> CA_n41A-n77A <sup>5</sup> CA_n66A-n71A CA_n66A-n77A <sup>5</sup> CA_n71A-n77A <sup>5</sup>	n41	10, 15, 20, 30, 40, 50, 60, 70, 80, 90, 100	0
		n66	5, 10, 15, 20, 25, 30, 40	
		n71	5, 10, 15, 20	
		n77	10, 15, 20, 25, 30, 40, 50, 60, 70, 80, 90, 100	
		n41	n41 channel bandwidths in Table 5.3.5-1	4 and 5
		n66	n66 channel bandwidths in Table 5.3.5-1	
		n71	n71 channel bandwidths in Table 5.3.5-1	
		n77	n77 channel bandwidths in Table 5.3.5-1	
CA_n41A-n66A-n71B-n77A	n41 <sup>5,6</sup> n77 <sup>5,6</sup> CA_n41A-n66A <sup>5</sup> CA_n41A-n71A <sup>5</sup>	n41	n41 channel bandwidths in Table 5.3.5-1	4 and 5

	CA_n41A-n77A <sup>5</sup> CA_n66A-n71A CA_n66A-n77A <sup>5</sup> CA_n71A-n77A <sup>5</sup>	n66 n71 n77	n66 channel bandwidths in Table 5.3.5-1 CA_n71B_BCS 4 and 5 n77 channel bandwidths in Table 5.3.5-1	
CA_n41A-n66A-n71B-n77(2A)	CA_n41A-n66A CA_n41A-n71A CA_n41A-n77A CA_n66A-n71A CA_n66A-n77A CA_n71A-n77A	n41 n66 n71 n77	n41 channel bandwidths in Table 5.3.5-1 n66 channel bandwidths in Table 5.3.5-1 CA_n71B_BCS 4 and 5 CA_n77(2A)_BCS 4 and 5	4 and 5
CA_n41A-n66A-n71(2A)-n77A	n41 <sup>5,6</sup> n77 <sup>5,6</sup> CA_n41A-n66A <sup>5</sup> CA_n41A-n71A <sup>5</sup> CA_n41A-n77A <sup>5</sup> CA_n66A-n71A CA_n66A-n77A <sup>5</sup> CA_n71A-n77A <sup>5</sup>	n41 n66 n71 n77	n41 channel bandwidths in Table 5.3.5-1 n66 channel bandwidths in Table 5.3.5-1 CA_n71(2A)_BCS 4 and 5 n77 channel bandwidths in Table 5.3.5-1	4 and 5
CA_n41A-n66A-n71(2A)-n77(2A)	CA_n41A-n66A CA_n41A-n71A CA_n41A-n77A CA_n66A-n71A CA_n66A-n77A CA_n71A-n77A	n41 n66 n71 n77	n41 channel bandwidths in Table 5.3.5-1 n66 channel bandwidths in Table 5.3.5-1 CA_n71(2A)_BCS 4 and 5 CA_n77(2A)_BCS 4 and 5	4 and 5
CA_n41A-n66(2A)-n71A-n77(2A)	n41 <sup>5,6</sup> n77 <sup>5,6</sup> CA_n41A-n66A <sup>5</sup> CA_n41A-n71A <sup>5</sup> CA_n41A-n77A <sup>5</sup> CA_n66A-n71A CA_n66A-n77A <sup>5</sup> CA_n71A-n77A <sup>5</sup>	n41 n66 n71 n77 n41 n66 n71 n77	10, 15, 20, 30, 40, 50, 60, 70, 80, 90, 100 CA_n66(2A)_BCS1 5, 10, 15, 20 CA_n77(2A)_BCS1 n41 channel bandwidths in Table 5.3.5-1 CA_n66(2A)_BCS 4 and 5 n71 channel bandwidths in Table 5.3.5-1 CA_n77(2A)_BCS 4 and 5	0 4 and 5
CA_n41(A-C)-n66A-n71A-n77A	CA_n41C CA_n41A-n66A CA_n41A-n71A CA_n41A-n77A CA_n66A-n71A CA_n66A-n77A CA_n71A-n77A	n41	CA_n41(A-C)_BCS 4 and 5	4 and 5

		n66	n66 channel bandwidths in Table 5.3.5-1	
		n71	n71 channel bandwidths in Table 5.3.5-1	
		n77	n77 channel bandwidths in Table 5.3.5-1	
CA_n41C-n66A-n71A-n77A	n41 <sup>5,6</sup> n77 <sup>5,6</sup> CA_n41A-n66A <sup>5</sup> CA_n41A-n71A <sup>5</sup> CA_n41A-n77A <sup>5</sup> CA_n41C <sup>5</sup> CA_n66A-n71A CA_n66A-n77A <sup>5</sup> CA_n71A-n77A <sup>5</sup>	n41	CA_n41C_BCS1	0
		n66	5, 10, 15, 20, 25, 30, 40	
		n71	5, 10, 15, 20	
		n77	10, 15, 20, 25, 30, 40, 50, 60, 70, 80, 90, 100	
		n41	CA_n41C_BCS 4 and 5	4 and 5
		n66	n66 channel bandwidths in Table 5.3.5-1	
		n71	n71 channel bandwidths in Table 5.3.5-1	
CA_n41C-n66A-n71A-n77(2A)	CA_n41C CA_n41A-n66A CA_n41A-n71A CA_n41A-n77A CA_n66A-n71A CA_n66A-n77A CA_n71A-n77A	n41	CA_n41C_BCS 4 and 5	4 and 5
		n66	n66 channel bandwidths in Table 5.3.5-1	
		n71	n71 channel bandwidths in Table 5.3.5-1	
		n77	CA_n77(2A)_BCS 4 and 5	
CA_n41C-n66A-n71B-n77A	CA_n41C CA_n41A-n66A CA_n41A-n71A CA_n41A-n77A CA_n66A-n71A CA_n66A-n77A CA_n71A-n77A	n41	CA_n41C_BCS 4 and 5	4 and 5
		n66	n66 channel bandwidths in Table 5.3.5-1	
		n71	CA_n71B_BCS 4 and 5	
		n77	n77 channel bandwidths in Table 5.3.5-1	
CA_n41C-n66A-n71(2A)-n77A	CA_n41C CA_n41A-n66A CA_n41A-n71A CA_n41A-n77A CA_n66A-n71A CA_n66A-n77A CA_n71A-n77A	n41	CA_n41C_BCS 4 and 5	4 and 5
		n66	n66 channel bandwidths in Table 5.3.5-1	
		n71	CA_n71(2A)_BCS 4 and 5	
		n77	n77 channel bandwidths in Table 5.3.5-1	
CA_n41C-n66(2A)-n71A-n77A	CA_n41C CA_n41A-n66A CA_n41A-n71A CA_n41A-n77A CA_n66A-n71A	n41	CA_n41C_BCS 4 and 5	4 and 5

	CA_n66A-n77A CA_n71A-n77A			
		n66	CA_n66(2A)_BCS 4 and 5	
		n71	n71 channel bandwidths in Table 5.3.5-1	
		n77	n77 channel bandwidths in Table 5.3.5-1	
CA_n41(2A)-n66A-n71A-n77(2A)	CA_n41A-n66A CA_n41A-n71A CA_n41A-n77A CA_n66A-n71A CA_n66A-n77A CA_n71A-n77A	n41	CA_n41(2A)_BCS 4 and 5	4 and 5
		n66	n66 channel bandwidths in Table 5.3.5-1	
		n71	n71 channel bandwidths in Table 5.3.5-1	
		n77	CA_n77(2A)_BCS 4 and 5	
CA_n41(3A)-n66A-n71A-n77A	CA_n41A-n66A CA_n41A-n71A CA_n41A-n77A CA_n66A-n71A CA_n66A-n77A CA_n71A-n77A	n41	CA_n41(3A)_BCS 4 and 5	4 and 5
		n66	n66 channel bandwidths in Table 5.3.5-1	
		n71	n71 channel bandwidths in Table 5.3.5-1	
		n77	n77 channel bandwidths in Table 5.3.5-1	
CA_n41(2A)-n66A-n71A-n77A	n41 <sup>5,6</sup> n77 <sup>5,6</sup> CA_n41A-n66A <sup>5</sup> CA_n41A-n71A <sup>5</sup> CA_n41A-n77A <sup>5</sup> CA_n66A-n71A CA_n66A-n77A <sup>5</sup> CA_n71A-n77A <sup>5</sup>	n41	CA_n41(2A)_BCS1	0
		n66	5, 10, 15, 20, 25, 30, 40	
		n71	5, 10, 15, 20	
		n77	10, 15, 20, 25, 30, 40, 50, 60, 70, 80, 90, 100	
		n41	CA_n41(2A)_BCS 4 and 5	4 and 5
		n66	n66 channel bandwidths in Table 5.3.5-1	
		n71	n71 channel bandwidths in Table 5.3.5-1	
		n77	n77 channel bandwidths in Table 5.3.5-1	
CA_n41(2A)-n66A-n71B-n77A	CA_n41A-n66A CA_n41A-n71A CA_n41A-n77A CA_n66A-n71A CA_n66A-n77A CA_n71A-n77A	n41	CA_n41(2A)_BCS 4 and 5	4 and 5
		n66	n66 channel bandwidths in Table 5.3.5-1	
		n71	CA_n71B_BCS 4 and 5	
		n77	n77 channel bandwidths in Table 5.3.5-1	
CA_n41(2A)-n66A-n71(2A)-n77A	CA_n41A-n66A CA_n41A-n71A CA_n41A-n77A CA_n66A-n71A CA_n66A-n77A CA_n71A-n77A	n41	CA_n41(2A)_BCS 4 and 5	4 and 5

		n66	n66 channel bandwidths in Table 5.3.5-1	
		n71	CA_n71(2A)_BCS 4 and 5	
		n77	n77 channel bandwidths in Table 5.3.5-1	
CA_n41(2A)-n66(2A)-n71A-n77A	CA_n41A-n66A CA_n41A-n71A CA_n41A-n77A CA_n66A-n71A CA_n66A-n77A CA_n71A-n77A	n41	CA_n41(2A)_BCS 4 and 5	4 and 5
		n66	CA_n66(2A)_BCS 4 and 5	
		n71	n71 channel bandwidths in Table 5.3.5-1	
		n77	n77 channel bandwidths in Table 5.3.5-1	
CA_n41A-n66(2A)-n71A-n77A	n41 <sup>5,6</sup> n77 <sup>5,6</sup> CA_n41A-n66A <sup>5</sup> CA_n41A-n71A <sup>5</sup> CA_n41A-n77A <sup>5</sup> CA_n66A-n71A CA_n66A-n77A <sup>5</sup> CA_n71A-n77A <sup>5</sup>	n41	10, 15, 20, 30, 40, 50, 60, 70, 80, 90, 100	0
		n66	CA_n66(2A)_BCS1	
		n71	5, 10, 15, 20	
		n77	10, 15, 20, 25, 30, 40, 50, 60, 70, 80, 90, 100	
		n41	n41 channel bandwidths in Table 5.3.5-1	4 and 5
		n66	CA_n66(2A)_BCS 4 and 5	
		n71	n71 channel bandwidths in Table 5.3.5-1	
		n77	n77 channel bandwidths in Table 5.3.5-1	
CA_n41A-n66(2A)-n71(2A)-n77A	n41 <sup>5,6</sup> n77 <sup>5,6</sup> CA_n41A-n66A <sup>5</sup> CA_n41A-n71A <sup>5</sup> CA_n41A-n77A <sup>5</sup> CA_n66A-n71A CA_n66A-n77A <sup>5</sup> CA_n71A-n77A <sup>5</sup>	n41	n41 channel bandwidths in Table 5.3.5-1	4 and 5
		n66	CA_n66(2A)_BCS 4 and 5	
		n71	CA_n71(2A)_BCS 4 and 5	
		n77	n77 channel bandwidths in Table 5.3.5-1	
CA_n41A-n66(2A)-n71B-n77A	n41 <sup>5,6</sup> n77 <sup>5,6</sup> CA_n41A-n66A <sup>5</sup> CA_n41A-n71A <sup>5</sup> CA_n41A-n77A <sup>5</sup> CA_n66A-n71A CA_n66A-n77A <sup>5</sup> CA_n71A-n77A <sup>5</sup>	n41	n41 channel bandwidths in Table 5.3.5-1	4 and 5
		n66	CA_n66(2A)_BCS 4 and 5	
		n71	CA_n71B_BCS 4 and 5	
		n77	n77 channel bandwidths in Table 5.3.5-1	
CA_n41A-n66A-n71A-n77(2A)	n41 <sup>5,6</sup> n77 <sup>5,6</sup> CA_n41A-n66A <sup>5</sup> CA_n41A-n77A <sup>5</sup> CA_n41A-n71A <sup>5</sup> CA_n66A-n71A CA_n66A-n77A <sup>5</sup> CA_n71A-n77A <sup>5</sup>	n41	10, 15, 20, 30, 40, 50, 60, 70, 80, 90, 100	0

		n66	5, 10, 15, 20, 25, 30, 40	
		n71	5, 10, 15, 20	
		n77	CA_n77(2A)_BCS1	
		n41	n41 channel bandwidths in Table 5.3.5-1	4 and 5
		n66	n66 channel bandwidths in Table 5.3.5-1	
		n71	n71 channel bandwidths in Table 5.3.5-1	
		n77	CA_n77(2A)_BCS 4 and 5	
CA_n41A-n66A-n71A-n78A	CA_n41A-n66A CA_n41A-n71A CA_n41A-n78A CA_n66A-n71A CA_n66A-n78A CA_n71A-n78A	n41	10, 15, 20, 30, 40, 50, 60, 70, 80, 90, 100	0
		n66	5, 10, 15, 20, 25, 30, 40	
		n71	5, 10, 15, 20	
		n78	10, 15, 20, 25, 30, 40, 50, 60, 70, 80, 90, 100	
CA_n41A-n66(2A)-n71A-n78A	CA_n41A-n66A CA_n41A-n71A CA_n41A-n78A CA_n66A-n71A CA_n66A-n78A CA_n71A-n78A	n41	10, 15, 20, 30, 40, 50, 60, 70, 80, 90, 100	0
		n66	CA_n66(2A)_BCS1	
		n71	5, 10, 15, 20	
		n78	10, 15, 20, 25, 30, 40, 50, 60, 70, 80, 90, 100	
CA_n41A-n66A-n71A-n78(2A)	CA_n41A-n66A CA_n41A-n71A CA_n41A-n78A CA_n66A-n71A CA_n66A-n78A CA_n71A-n78A	n41	10, 15, 20, 30, 40, 50, 60, 70, 80, 90, 100	0
		n66	5, 10, 15, 20, 25, 30, 40	
		n71	5, 10, 15, 20	
		n78	CA_n78(2A)_BCS2	
CA_n41A-n66(2A)-n71A-n78(2A)	CA_n41A-n66A CA_n41A-n71A CA_n41A-n78A CA_n66A-n71A CA_n66A-n78A CA_n71A-n78A	n41	10, 15, 20, 30, 40, 50, 60, 70, 80, 90, 100	0
		n66	CA_n66(2A)_BCS1	
		n71	5, 10, 15, 20	
		n78	CA_n78(2A)_BCS2	
CA_n41A-n66A-n71A-n85A	CA_n41A-n66A CA_n41A-n71A CA_n41A-n85A CA_n66A-n71A CA_n66A-n85A	n41	n41 channel bandwidths in Table 5.3.5-1	4 and 5
		n66	n66 channel bandwidths in Table 5.3.5-1	
		n71	n71 channel bandwidths in Table 5.3.5-1	
		n85	n85 channel bandwidths in Table 5.3.5-1	
CA_n41A-n66A-n77A-n85A	CA_n41A-n66A CA_n41A-n77A CA_n41A-n85A CA_n66A-n77A CA_n66A-n85A CA_n77A-n85A	n41	n41 channel bandwidths in Table 5.3.5-1	4 and 5
		n66	n66 channel bandwidths in Table 5.3.5-1	

		n77	n77 channel bandwidths in Table 5.3.5-1	
		n85	n85 channel bandwidths in Table 5.3.5-1	
CA_n48A-n66A-n70A-n71A	CA_n48A-n66A CA_n48A-n70A CA_n48A-n71A CA_n66A-n71A CA_n70A-n71A	n48	5, 10, 15, 20, 30, 40, 50 <sup>8</sup> , 60 <sup>8</sup> , 70 <sup>8</sup> , 80 <sup>8</sup> , 90 <sup>8</sup> , 100 <sup>8</sup>	0
		n66	5, 10, 15, 20, 25, 30, 35, 40	
		n70	5, 10, 15, 20, 25	
		n71	5, 10, 15, 20	
CA_n48A-n66A-n70A-n77A	CA_n48A-n66A CA_n48A-n70A CA_n66A-n77A CA_n70A-n77A	n48	5, 10, 15, 20, 30, 40, 50 <sup>8</sup> , 60 <sup>8</sup> , 70 <sup>8</sup> , 80 <sup>8</sup> , 90 <sup>8</sup> , 100 <sup>8</sup>	0
		n66	5, 10, 15, 20, 25, 30, 35, 40	
		n70	5, 10, 15, 20, 25	
		n77	10, 15, 20, 25, 30, 40, 50, 60, 70, 80, 90, 100	
CA_n48A-n66(2A)-n70A-n77A	CA_n48A-n66A CA_n66A-n77A	n48	5, 10, 15, 20, 30, 40, 50, 60, 70, 80, 90, 100	0
		n66	CA_n66(2A)_BCS0	
		n70	5, 10, 15, 20, 25	
		n77	10, 15, 20, 25, 30, 40, 50, 60, 70, 80, 90, 100	
CA_n48(2A)-n66A-n70A-n77A	CA_n48A-n66A CA_n48A-n70A CA_n66A-n77A CA_n70A-n77A	n48	CA_n48(2A)_BCS0	0
		n66	5, 10, 15, 20, 25, 30, 35, 40	
		n70	5, 10, 15, 20, 25	
		n77	10, 15, 20, 25, 30, 40, 50, 60, 70, 80, 90, 100	
CA_n48A-n66A-n71A-n77A	CA_n48A-n66A CA_n48A-n71A CA_n66A-n71A CA_n66A-n77A CA_n71A-n77A	n48	5, 10, 15, 20, 30, 40, 50 <sup>8</sup> , 60 <sup>8</sup> , 70 <sup>8</sup> , 80 <sup>8</sup> , 90 <sup>8</sup> , 100 <sup>8</sup>	0
		n66	5, 10, 15, 20, 25, 30, 35, 40	
		n71	5, 10, 15, 20	
		n77	10, 15, 20, 25, 30, 40, 50, 60, 70, 80, 90, 100	
CA_n48A-n66(2A)-n71A-n77A	CA_n48A-n66A CA_n48A-n71A CA_n66A-n71A CA_n66A-n77A CA_n71A-n77A	n48	5, 10, 15, 20, 30, 40, 50 <sup>8</sup> , 60 <sup>8</sup> , 70 <sup>8</sup> , 80 <sup>8</sup> , 90 <sup>8</sup> , 100 <sup>8</sup>	0
		n66	CA_n66(2A)_BCS0	
		n71	5, 10, 15, 20	
		n77	10, 15, 20, 25, 30, 40, 50, 60, 70, 80, 90, 100	
		n48	5, 10, 15, 20, 30, 40, 50 <sup>8</sup> , 60 <sup>8</sup> , 70 <sup>8</sup> , 80 <sup>8</sup> , 90 <sup>8</sup> , 100 <sup>8</sup>	1
		n66	CA_n66(2A)_BCS1	
		n71	5, 10, 15, 20	
		n77	10, 15, 20, 25, 30, 40, 50, 60, 70, 80, 90, 100	
CA_n48A-n70A-n71A-n77A	CA_n48A-n70A CA_n48A-n71A CA_n70A-n71A CA_n70A-n77A CA_n71A-n77A	n48	5, 10, 15, 20, 30, 40, 50 <sup>8</sup> , 60 <sup>8</sup> , 70 <sup>8</sup> , 80 <sup>8</sup> , 90 <sup>8</sup> , 100 <sup>8</sup>	0
		n70	5, 10, 15, 20, 25	
		n71	5, 10, 15, 20	
		n77	10, 15, 20, 25, 30, 40, 50, 60, 70, 80, 90, 100	

CA_n66A-n70A-n71A-n77A	CA_n66A-n71A CA_n66A-n77A CA_n70A-n71A CA_n70A-n77A CA_n71A-n77A	n66	5, 10, 15, 20, 25, 30, 35, 40	0
		n70	5, 10, 15, 20, 25	
		n71	5, 10, 15, 20	
		n77	10, 15, 20, 25, 30, 40, 50, 60, 70, 80, 90, 100	

The following notes are applied to the above tables.

- NOTE 1: This UE channel bandwidth is optional in this release of the specification.
- NOTE 2: For the 20 MHz bandwidth, the minimum requirements are specified for NR UL carrier frequencies confined to either 713-723 MHz or 728-738 MHz. For the 30MHz bandwidth, the minimum requirements are specified for NR UL transmission bandwidth configuration confined to either 703-733 or 718-748 MHz.
- NOTE 3: For each channel bandwidth of each component carrier, refer to Table 5.3.5-1 for the applicable SCSs. For a given band, not all UE channel bandwidths support the same SCSs.
- NOTE 4: Only single uplink carriers with power class other than PC3 are listed.
- NOTE 5: Minimum requirements for Power Class 2 are applicable for this uplink combination or single uplink carrier in this downlink/uplink combination.
- NOTE 6: Minimum requirements for Power Class 1.5 are applicable for this uplink combination or single uplink carrier in this downlink/uplink combination.
- NOTE 7: For a band combination which includes band n7 and n38 simultaneously, carriers in band n7 and n38 can only be configured as downlink carriers. Power imbalance between downlink carriers on Band n7 and Band n38 is assumed to be within 6dB.
- NOTE 8: For this bandwidth, the minimum requirements are restricted to operation when carrier is configured as a downlink SCell part of CA configuration

### 5.5A.3.4 Configurations for inter-band CA (five bands)

**Table 5.5A.3.4-1: NR CA configurations and bandwidth combinations sets defined for inter-band CA (five bands)**

NR CA configuration	Uplink configuration or single uplink carrier <sup>2</sup>	NR Band	Channel bandwidth (MHz) (NOTE 1)	Bandwidth combination set
CA_n1A-n3A-n5A-n7A-n78A	CA_n1A-n3A CA_n1A-n5A CA_n1A-n7A CA_n1A-n78A CA_n3A-n5A CA_n3A-n7A CA_n3A-n78A CA_n5A-n7A CA_n5A-n78A CA_n7A-n78A	n1	5, 10, 15, 20	0
		n3	5, 10, 15, 20, 25, 30, 40	
		n5	5, 10, 15, 20	
		n7	5, 10, 15, 20, 25, 30, 40, 50	
		n78	10, 15, 20, 25, 30, 40, 50, 60, 70, 80, 90, 100	
CA_n1A-n3A-n5A-n7B-n78A	CA_n1A-n3A CA_n1A-n5A CA_n1A-n7A CA_n1A-n78A CA_n3A-n5A CA_n3A-n7A CA_n3A-n78A CA_n5A-n7A CA_n5A-n78A CA_n7A-n78A CA_n7B	n1	5, 10, 15, 20	0
		n3	5, 10, 15, 20, 25, 30, 40	



NR CA configuration	Uplink configuration or single uplink carrier <sup>2</sup>	NR Band	Channel bandwidth (MHz) (NOTE 1)	Bandwidth combination set
		n5	5, 10, 15, 20	
		n7	CA_n7B_BCS0	
		n78	10, 15, 20, 25, 30, 40, 50, 60, 70, 80, 90, 100	
CA_n1A-n3A-n5A-n28A-n78A	CA_n1A-n3A CA_n1A-n5A CA_n1A-n28A CA_n1A-n79A CA_n3A-n5A CA_n3A-n28A CA_n3A-n79A CA_n5A-n28A CA_n5A-n79A CA_n28A-n79A	n1	n1 channel bandwidths in Table 5.3.5-1	4 and 5
		n3	n3 channel bandwidths in Table 5.3.5-1	
		n5	n5 channel bandwidths in Table 5.3.5-1	
		n28	n28 channel bandwidths in Table 5.3.5-1	
		n78	n78 channel bandwidths in Table 5.3.5-1	
CA_n1A-n3A-n7A-n8A-n78A	CA_n1A-n3A CA_n1A-n7A CA_n1A-n8A CA_n1A-n78A CA_n3A-n7A CA_n3A-n8A CA_n3A-n78A CA_n7A-n8A CA_n7A-n78A CA_n8A-n78A	n1	5, 10, 15, 20	0
		n3	5, 10, 15, 20, 25, 30	
		n7	5, 10, 15, 20, 25, 30, 40, 50	
		n8	5, 10, 15, 20	
		n78	10, 15, 20, 40, 50, 60, 80, 90, 100	
CA_n1A-n3(2A)-n7A-n8A-n78A	CA_n1A-n3A CA_n1A-n7A CA_n1A-n8A CA_n1A-n78A CA_n3A-n7A CA_n3A-n8A CA_n3A-n78A CA_n7A-n8A CA_n7A-n78A CA_n8A-n78A	n1	5, 10, 15, 20	0
		n3	CA_n3(2A)_BCS0	
		n7	5, 10, 15, 20, 25, 30, 40, 50	
		n8	5, 10, 15, 20	
		n78	10, 15, 20, 25, 30, 40, 50, 60, 70, 80, 90, 100	
CA_n1A-n3A-n7(2A)-n8A-n78A	CA_n1A-n3A CA_n1A-n7A CA_n1A-n8A CA_n1A-n78A CA_n3A-n7A CA_n3A-n8A CA_n3A-n78A CA_n7A-n8A CA_n7A-n78A CA_n8A-n78A	n1	5, 10, 15, 20	0
		n3	5, 10, 15, 20, 25, 30	
		n7	CA_n7(2A)_BCS0	

NR CA configuration	Uplink configuration or single uplink carrier <sup>2</sup>	NR Band	Channel bandwidth (MHz) (NOTE 1)	Bandwidth combination set
		n8	5, 10, 15, 20	
		n78	10, 15, 20, 25, 30, 40, 50, 60, 70, 80, 90, 100	
CA_n1A-n3(2A)-n7(2A)-n8A-n78A	CA_n1A-n3A CA_n1A-n7A CA_n1A-n8A CA_n1A-n78A CA_n3A-n7A CA_n3A-n8A CA_n3A-n78A CA_n7A-n8A CA_n7A-n78A CA_n8A-n78A	n1	5, 10, 15, 20	0
		n3	CA_n3(2A)_BCS0	
		n7	CA_n7(2A)_BCS0	
		n8	5, 10, 15, 20	
		n78	10, 15, 20, 25, 30, 40, 50, 60, 70, 80, 90, 100	
CA_n1A-n3A-n7A-n26A-n78A	CA_n1A-n3A CA_n1A-n26A CA_n1A-n7A CA_n1A-n78A CA_n3A-n26A CA_n3A-n7A CA_n3A-n78A CA_n7A-n26A CA_n26A-n78A CA_n7A-n78A	n1	5, 10, 15, 20, 25, 30, 40, 45, 50	0
		n3	5, 10, 15, 20, 25, 30, 40, 45, 50	
		n7	5, 10, 15, 20, 25, 30, 40, 50	
		n26	5, 10, 15, 20, 25, 30	
		n78	10, 15, 20, 25, 30, 40, 50, 60, 70, 80, 90, 100	
CA_n1A-n3A-n7A-n26(2A)-n78A	CA_n1A-n3A CA_n1A-n26A CA_n1A-n7A CA_n1A-n78A CA_n3A-n26A CA_n3A-n7A CA_n3A-n78A CA_n7A-n26A CA_n26A-n78A CA_n7A-n78A CA_n26(2A)	n1	5, 10, 15, 20, 25, 30, 40, 45, 50	0
		n3	5, 10, 15, 20, 25, 30, 40, 45, 50	
		n7	5, 10, 15, 20, 25, 30, 40, 50	
		n26	CA_n26(2A)_BCS0	
		n78	10, 15, 20, 25, 30, 40, 50, 60, 70, 80, 90, 100	
CA_n1A-n3A-n7A-n26A-n78(2A)	CA_n1A-n3A CA_n1A-n26A CA_n1A-n7A CA_n1A-n78A CA_n3A-n26A CA_n3A-n7A CA_n3A-n78A CA_n7A-n26A CA_n26A-n78A CA_n7A-n78A	n1	5, 10, 15, 20, 25, 30, 40, 45, 50	0
		n3	5, 10, 15, 20, 25, 30, 40, 45, 50	
		n7	5, 10, 15, 20, 25, 30, 40, 50	
		n26	5, 10, 15, 20, 25, 30	
		n78	CA_n78(2A)_BCS0	
CA_n1A-n3A-n7A-n26A-n78C	CA_n78C CA_n1A-n3A	n1	5, 10, 15, 20, 25, 30, 40, 45, 50	0

NR CA configuration	Uplink configuration or single uplink carrier <sup>2</sup>	NR Band	Channel bandwidth (MHz) (NOTE 1)	Bandwidth combination set
	CA_n1A-n26A CA_n1A-n7A CA_n1A-n78A CA_n3A-n26A CA_n3A-n7A CA_n3A-n78A CA_n7A-n26A CA_n26A-n78A CA_n7A-n78A	n3	5, 10, 15, 20, 25, 30, 40, 45, 50	
		n7	5, 10, 15, 20, 25, 30, 40, 50	
		n26	5, 10, 15, 20, 25, 30	
		n78	CA_n78C_BCS0	
CA_n1A-n3A-n7A-n26(2A)-n78(2A)	CA_n1A-n3A CA_n1A-n26A CA_n1A-n7A CA_n1A-n78A CA_n3A-n26A CA_n3A-n7A CA_n3A-n78A CA_n7A-n26A CA_n26A-n78A CA_n7A-n78A CA_n26(2A)	n1	5, 10, 15, 20, 25, 30, 40, 45, 50	0
		n3	5, 10, 15, 20, 25, 30, 40, 45, 50	
		n7	5, 10, 15, 20, 25, 30, 40, 50	
		n26	CA_n26(2A)_BCS0	
CA_n1A-n3A-n7A-n26(2A)-n78C	CA_n26(2A) CA_n78C CA_n1A-n3A CA_n1A-n26A CA_n1A-n7A CA_n1A-n78A CA_n3A-n26A CA_n3A-n7A CA_n3A-n78A CA_n7A-n26A CA_n26A-n78A CA_n7A-n78A	n1	5, 10, 15, 20, 25, 30, 40, 45, 50	0
		n3	5, 10, 15, 20, 25, 30, 40, 45, 50	
		n7	5, 10, 15, 20, 25, 30, 40, 50	
		n26	CA_n26(2A)_BCS0	
CA_n1A-n3B-n7A-n26A-n78A	CA_n1A-n3A CA_n1A-n26A CA_n1A-n7A CA_n1A-n78A CA_n3A-n26A CA_n3A-n7A CA_n3A-n78A CA_n7A-n26A CA_n26A-n78A CA_n7A-n78A	n1	5, 10, 15, 20, 25, 30, 40, 45, 50	0
		n3	CA_n3B_BCS0	
		n7	5, 10, 15, 20, 25, 30, 40, 50	
		n26	5, 10, 15, 20, 25, 30	
CA_n1A-n3B-n7A-n26(2A)-n78A	CA_n1A-n3A CA_n1A-n26A CA_n1A-n7A CA_n1A-n78A CA_n3A-n26A CA_n3A-n7A	n1	5, 10, 15, 20, 25, 30, 40, 45, 50	0
		n3	CA_n3B_BCS0	
		n7	5, 10, 15, 20, 25, 30, 40, 50	
		n26	5, 10, 15, 20, 25, 30	
	CA_n1A-n3A CA_n1A-n26A CA_n1A-n7A CA_n1A-n78A CA_n3A-n26A CA_n3A-n7A	n1	5, 10, 15, 20, 25, 30, 40, 45, 50	0
		n3	CA_n3B_BCS0	
		n7	5, 10, 15, 20, 25, 30, 40, 50	
		n26	5, 10, 15, 20, 25, 30	
	CA_n1A-n3A CA_n1A-n26A CA_n1A-n7A CA_n1A-n78A CA_n3A-n26A CA_n3A-n7A	n1	5, 10, 15, 20, 25, 30, 40, 45, 50	0
		n3	CA_n3B_BCS0	
		n7	5, 10, 15, 20, 25, 30, 40, 50	
		n26	5, 10, 15, 20, 25, 30	

NR CA configuration	Uplink configuration or single uplink carrier <sup>2</sup>	NR Band	Channel bandwidth (MHz) (NOTE 1)	Bandwidth combination set
	CA_n3A-n78A CA_n7A-n26A CA_n26A-n78A CA_n7A-n78A CA_n26(2A)	n3	CA_n3B_BCS0	
		n7	5, 10, 15, 20, 25, 30, 40, 50	
		n26	CA_n26(2A)_BCS0	
		n78	10, 15, 20, 25, 30, 40, 50, 60, 70, 80, 90, 100	
CA_n1A-n3B-n7A-n26A-n78(2A)	CA_n1A-n3A CA_n1A-n26A CA_n1A-n7A CA_n1A-n78A CA_n3A-n26A CA_n3A-n7A CA_n3A-n78A CA_n7A-n26A CA_n26A-n78A CA_n7A-n78A	n1	5, 10, 15, 20, 25, 30, 40, 45, 50	0
		n3	CA_n3B_BCS0	
		n7	5, 10, 15, 20, 25, 30, 40, 50	
		n26	5, 10, 15, 20, 25, 30	
CA_n1A-n3B-n7A-n26A-n78C	CA_n1A-n3A CA_n1A-n26A CA_n1A-n7A CA_n1A-n78A CA_n3A-n26A CA_n3A-n7A CA_n3A-n78A CA_n7A-n26A CA_n26A-n78A CA_n7A-n78A CA_n78C	n1	5, 10, 15, 20, 25, 30, 40, 45, 50	0
		n3	CA_n3B_BCS0	
		n7	5, 10, 15, 20, 25, 30, 40, 50	
		n26	5, 10, 15, 20, 25, 30	
CA_n1A-n3B-n7A-n26(2A)-n78(2A)	CA_n1A-n3A CA_n1A-n26A CA_n1A-n7A CA_n1A-n78A CA_n3A-n26A CA_n3A-n7A CA_n3A-n78A CA_n7A-n26A CA_n26A-n78A CA_n7A-n78A CA_n26(2A)	n1	5, 10, 15, 20, 25, 30, 40, 45, 50	0
		n3	CA_n3B_BCS0	
		n7	5, 10, 15, 20, 25, 30, 40, 50	
		n26	CA_n26(2A)_BCS0	
CA_n1A-n3B-n7A-n26(2A)-n78C	CA_n1A-n3A CA_n1A-n26A CA_n1A-n7A CA_n1A-n78A CA_n3A-n26A CA_n3A-n7A CA_n3A-n78A CA_n7A-n26A CA_n26A-n78A CA_n7A-n78A CA_n26(2A) CA_n78C	n1	5, 10, 15, 20, 25, 30, 40, 45, 50	0
		n3	CA_n3B_BCS0	
		n7	5, 10, 15, 20, 25, 30, 40, 50	
		n26	CA_n26(2A)_BCS0	
CA_n1A-n3B-n7A-n26(2A)-n78C	CA_n1A-n3A CA_n1A-n26A CA_n1A-n7A CA_n1A-n78A CA_n3A-n26A CA_n3A-n7A CA_n3A-n78A CA_n7A-n26A CA_n26A-n78A CA_n7A-n78A CA_n26(2A) CA_n78C	n1	5, 10, 15, 20, 25, 30, 40, 45, 50	0
		n3	CA_n3B_BCS0	
		n7	5, 10, 15, 20, 25, 30, 40, 50	
		n26	CA_n26(2A)_BCS0	

NR CA configuration	Uplink configuration or single uplink carrier <sup>2</sup>	NR Band	Channel bandwidth (MHz) (NOTE 1)	Bandwidth combination set
		n3	CA_n3B_BCS0	
		n7	5, 10, 15, 20, 25, 30, 40, 50	
		n26	CA_n26(2A)_BCS0	
		n78	CA_n78C_BCS0	
CA_n1A-n3B-n7B-n26A-n78A	CA_n1A-n3A CA_n1A-n26A CA_n1A-n7A CA_n1A-n78A CA_n3A-n26A CA_n3A-n7A CA_n3A-n78A CA_n7A-n26A CA_n26A-n78A CA_n7A-n78A CA_n7B	n1	5, 10, 15, 20, 25, 30, 40, 45, 50	0
		n3	CA_n3B_BCS0	
		n7	CA_n7B_BCS0	
		n26	5, 10, 15, 20, 25, 30	
		n78	10, 15, 20, 25, 30, 40, 50, 60, 70, 80, 90, 100	
CA_n1A-n3B-n7B-n26(2A)-n78A	CA_n1A-n3A CA_n1A-n26A CA_n1A-n7A CA_n1A-n78A CA_n3A-n26A CA_n3A-n7A CA_n3A-n78A CA_n7A-n26A CA_n26A-n78A CA_n7A-n78A CA_n7B CA_n26(2A)	n1	5, 10, 15, 20, 25, 30, 40, 45, 50	0
		n3	CA_n3B_BCS0	
		n7	CA_n7B_BCS0	
		n26	CA_n26(2A)_BCS0	
		n78	10, 15, 20, 25, 30, 40, 50, 60, 70, 80, 90, 100	
CA_n1A-n3B-n7B-n26A-n78(2A)	CA_n1A-n3A CA_n1A-n26A CA_n1A-n7A CA_n1A-n78A CA_n3A-n26A CA_n3A-n7A CA_n3A-n78A CA_n7A-n26A CA_n26A-n78A CA_n7A-n78A CA_n7B	n1	5, 10, 15, 20, 25, 30, 40, 45, 50	0
		n3	CA_n3B_BCS0	
		n7	CA_n7B_BCS0	
		n26	5, 10, 15, 20, 25, 30	
		n78	CA_n78(2A)_BCS0	
CA_n1A-n3B-n7B-n26A-n78C	CA_n1A-n3A CA_n1A-n26A CA_n1A-n7A CA_n1A-n78A CA_n3A-n26A CA_n3A-n7A CA_n3A-n78A CA_n7A-n26A CA_n26A-n78A CA_n7A-n78A CA_n7B CA_n78C	n1	5, 10, 15, 20, 25, 30, 40, 45, 50	0
		n3	CA_n3B_BCS0	
		n7	CA_n7B_BCS0	
		n26	5, 10, 15, 20, 25, 30	

NR CA configuration	Uplink configuration or single uplink carrier <sup>2</sup>	NR Band	Channel bandwidth (MHz) (NOTE 1)	Bandwidth combination set
		n78	CA_n78C_BCS0	
CA_n1A-n3B-n7B-n26(2A)-n78(2A)	CA_n1A-n3A CA_n1A-n26A CA_n1A-n7A CA_n1A-n78A CA_n3A-n26A CA_n3A-n7A CA_n3A-n78A CA_n7A-n26A CA_n26A-n78A CA_n7A-n78A CA_n7B CA_n26(2A)	n1	5, 10, 15, 20, 25, 30, 40, 45, 50	0
		n3	CA_n3B_BCS0	
		n7	CA_n7B_BCS0	
		n26	CA_n26(2A)_BCS0	
		n78	CA_n78(2A)_BCS0	
CA_n1A-n3B-n7B-n26(2A)-n78C	CA_n1A-n3A CA_n1A-n26A CA_n1A-n7A CA_n1A-n78A CA_n3A-n26A CA_n3A-n7A CA_n3A-n78A CA_n7A-n26A CA_n26A-n78A CA_n7A-n78A CA_n7B CA_n26(2A) CA_n78C	n1	5, 10, 15, 20, 25, 30, 40, 45, 50	0
		n3	CA_n3B_BCS0	
		n7	CA_n7B_BCS0	
		n26	CA_n26(2A)_BCS0	
		n78	CA_n78C_BCS0	
CA_n1A-n3A-n7B-n26A-n78A	CA_n1A-n3A CA_n1A-n26A CA_n1A-n7A CA_n1A-n78A CA_n3A-n26A CA_n3A-n7A CA_n3A-n78A CA_n7A-n26A CA_n26A-n78A CA_n7A-n78A CA_n7B	n1	5, 10, 15, 20, 25, 30, 40, 45, 50	0
		n3	5, 10, 15, 20, 25, 30, 40, 45, 50	
		n7	CA_n7B_BCS0	
		n26	5, 10, 15, 20, 25, 30	
		n78	10, 15, 20, 25, 30, 40, 50, 60, 70, 80, 90, 100	
CA_n1A-n3A-n7B-n26(2A)-n78A	CA_n1A-n3A CA_n1A-n26A CA_n1A-n7A CA_n1A-n78A CA_n3A-n26A CA_n3A-n7A CA_n3A-n78A CA_n7A-n26A CA_n26A-n78A CA_n7A-n78A CA_n7B CA_n26(2A)	n1	5, 10, 15, 20, 25, 30, 40, 45, 50	0
		n3	5, 10, 15, 20, 25, 30, 40, 45, 50	
		n7	CA_n7B_BCS0	
		n26	CA_n26(2A)_BCS0	

NR CA configuration	Uplink configuration or single uplink carrier <sup>2</sup>	NR Band	Channel bandwidth (MHz) (NOTE 1)	Bandwidth combination set
		n78	10, 15, 20, 25, 30, 40, 50, 60, 70, 80, 90, 100	
CA_n1A-n3A-n7B-n26A-n78(2A)	CA_n1A-n3A CA_n1A-n26A CA_n1A-n7A CA_n1A-n78A CA_n3A-n26A CA_n3A-n7A CA_n3A-n78A CA_n7A-n26A CA_n26A-n78A CA_n7A-n78A CA_n7B	n1	5, 10, 15, 20, 25, 30, 40, 45, 50	0
		n3	5, 10, 15, 20, 25, 30, 40, 45, 50	
		n7	CA_n7B_BCS0	
		n26	5, 10, 15, 20, 25, 30	
		n78	CA_n78(2A)_BCS0	
CA_n1A-n3A-n7B-n26A-n78C	CA_n1A-n3A CA_n1A-n26A CA_n1A-n7A CA_n1A-n78A CA_n3A-n26A CA_n3A-n7A CA_n3A-n78A CA_n7A-n26A CA_n26A-n78A CA_n7A-n78A CA_n7B CA_n78C	n1	5, 10, 15, 20, 25, 30, 40, 45, 50	0
		n3	5, 10, 15, 20, 25, 30, 40, 45, 50	
		n7	CA_n7B_BCS0	
		n26	5, 10, 15, 20, 25, 30	
		n78	CA_n78C_BCS0	
CA_n1A-n3A-n7B-n26(2A)-n78(2A)	CA_n1A-n3A CA_n1A-n26A CA_n1A-n7A CA_n1A-n78A CA_n3A-n26A CA_n3A-n7A CA_n3A-n78A CA_n7A-n26A CA_n26A-n78A CA_n7A-n78A CA_n7B CA_n26(2A)	n1	5, 10, 15, 20, 25, 30, 40, 45, 50	0
		n3	5, 10, 15, 20, 25, 30, 40, 45, 50	
		n7	CA_n7B_BCS0	
		n26	CA_n26(2A)_BCS0	
		n78	CA_n78(2A)_BCS0	
CA_n1A-n3A-n7B-n26(2A)-n78C	CA_n1A-n3A CA_n1A-n26A CA_n1A-n7A CA_n1A-n78A CA_n3A-n26A CA_n3A-n7A CA_n3A-n78A CA_n7A-n26A CA_n26A-n78A CA_n7A-n78A CA_n7B CA_n26(2A) CA_n78C	n1	5, 10, 15, 20, 25, 30, 40, 45, 50	0
		n3	5, 10, 15, 20, 25, 30, 40, 45, 50	
		n7	CA_n7B_BCS0	
		n26	CA_n26(2A)_BCS0	
		n78	CA_n78(2A)_BCS0	

NR CA configuration	Uplink configuration or single uplink carrier <sup>2</sup>	NR Band	Channel bandwidth (MHz) (NOTE 1)	Bandwidth combination set	
		n78	CA_n78C_BCS0		
CA_n1A-n3A-n7A-n28A-n38A <sup>4</sup>	-	n1	5, 10, 15, 20, 25, 30, 40, 45, 50	0	
		n3	5, 10, 15, 20, 25, 30, 35, 40, 45, 50		
		n7	5, 10, 15, 20, 25, 30, 40, 50		
		n28	5, 10, 15, 20, 25, 30		
		n38	5, 10, 15, 20, 25, 30, 40		
CA_n1A-n3A-n7A-n28A-n78A	-	n1	5, 10, 15, 20, 25, 30, 40, 50	0	
		n3	5, 10, 15, 20, 25, 30, 40		
		n7	5, 10, 15, 20, 25, 30, 40, 50		
		n28	5, 10, 15, 20, 30		
		n78	10, 15, 20, 25, 30, 40, 50, 60, 70, 80, 90, 100		
	CA_n1A-n3A CA_n1A-n7A CA_n1A-n28A CA_n1A-n78A CA_n3A-n7A CA_n3A-n28A CA_n3A-n78A CA_n7A-n28A CA_n7A-n78A CA_n28A-n78A		n1	5, 10, 15, 20	1
			n3	5, 10, 15, 20, 25, 30, 40	
			n7	5, 10, 15, 20, 25, 30, 40, 50	
			n28	5, 10, 15, 20	
			n78	10, 15, 20, 25, 30, 40, 50, 60, 70, 80, 90, 100	
CA_n1A-n3A-n7B-n28A-n78A	CA_n1A-n3A CA_n1A-n7A CA_n1A-n28A CA_n1A-n78A CA_n3A-n7A CA_n3A-n28A CA_n3A-n78A CA_n7A-n28A CA_n7A-n78A CA_n7B CA_n28A-n78A	n1	5, 10, 15, 20, 25, 30, 40, 50	0	
		n3	5, 10, 15, 20, 25, 30, 40		
		n7	CA_n7B_BCS0		
		n28	5, 10, 15, 20, 30		
		n78	10, 15, 20, 25, 30, 40, 50, 60, 70, 80, 90, 100		
CA_n1A-n3A-n7A-n28A-n78(2A)	CA_n78(2A) CA_n1A-n3A CA_n1A-n7A CA_n1A-n28A CA_n1A-n78A CA_n3A-n7A CA_n3A-n28A CA_n3A-n78A CA_n7A-n28A CA_n7A-n78A CA_n28A-n78A	n1	5, 10, 15, 20, 25, 30, 40, 50	0	
		n3	5, 10, 15, 20, 25, 30, 40, 50		
		n7	5, 10, 15, 20, 25, 30, 40, 50		
		n28	5, 10, 15, 20, 30		
		n78	CA_n78(2A)_BCS2		
CA_n1A-n3A-n7A-n28A-n78C	CA_n78C CA_n1A-n3A CA_n1A-n7A	n1	5, 10, 15, 20, 25, 30, 40, 50	0	



NR CA configuration	Uplink configuration or single uplink carrier <sup>2</sup>	NR Band	Channel bandwidth (MHz) (NOTE 1)	Bandwidth combination set
	CA_n1A-n28A CA_n1A-n78A CA_n3A-n7A CA_n3A-n28A CA_n3A-n78A CA_n7A-n28A CA_n7A-n78A CA_n28A-n78A	n3	5, 10, 15, 20, 25, 30, 40, 50	
		n7	5, 10, 15, 20, 25, 30, 40, 50	
		n28	5, 10, 15, 20, 30	
		n78	CA_n78C_BCS0	
CA_n1A-n3A-n7B-n28A-n78(2A)	CA_n7B CA_n78(2A) CA_n1A-n3A CA_n1A-n7A CA_n1A-n28A CA_n1A-n78A CA_n3A-n7A CA_n3A-n28A CA_n3A-n78A CA_n7A-n28A CA_n7A-n78A CA_n28A-n78A	n1	5, 10, 15, 20	0
		n3	5, 10, 15, 20, 25, 30, 40	
		n7	CA_n7B_BCS0	
		n28	5, 10, 15, 20	
CA_n1A-n3A-n7B-n28A-n78C	CA_n7B CA_n78C CA_n1A-n3A CA_n1A-n7A CA_n1A-n28A CA_n1A-n78A CA_n3A-n7A CA_n3A-n28A CA_n3A-n78A CA_n7A-n28A CA_n7A-n78A CA_n28A-n78A	n1	5, 10, 15, 20	0
		n3	5, 10, 15, 20, 25, 30, 40	
		n7	CA_n7B_BCS0	
		n28	5, 10, 15, 20	
CA_n1A-n3B-n7A-n28A-n78A	CA_n1A-n3A CA_n1A-n7A CA_n1A-n28A CA_n1A-n78A CA_n3A-n7A CA_n3A-n28A CA_n3A-n78A CA_n7A-n28A CA_n7A-n78A CA_n28A-n78A	n1	5, 10, 15, 20	0
		n3	CA_n3B_BCS0	
		n7	5, 10, 15, 20, 25, 30, 40, 50	
		n28	5, 10, 15, 20	
CA_n1A-n3B-n7A-n28A-n78(2A)	CA_n78(2A) CA_n1A-n3A CA_n1A-n7A CA_n1A-n28A CA_n1A-n78A	n1	5, 10, 15, 20	0
		n3	CA_n3B_BCS0	
		n7	5, 10, 15, 20, 25, 30, 40, 50	
		n28	5, 10, 15, 20	
	CA_n78(2A) CA_n1A-n3A CA_n1A-n7A CA_n1A-n28A CA_n1A-n78A	n1	5, 10, 15, 20	0
		n3	CA_n3B_BCS0	
		n7	5, 10, 15, 20, 25, 30, 40, 50	
		n28	5, 10, 15, 20	

NR CA configuration	Uplink configuration or single uplink carrier <sup>2</sup>	NR Band	Channel bandwidth (MHz) (NOTE 1)	Bandwidth combination set
	CA_n3A-n7A CA_n3A-n28A CA_n3A-n78A CA_n7A-n28A CA_n7A-n78A CA_n28A-n78A	n3 n7 n28 n78	CA_n3B_BCS0 5, 10, 15, 20, 25, 30, 40, 50 5, 10, 15, 20 CA_n78(2A)_BCS2	
CA_n1A-n3B-n7A-n28A-n78C	CA_n78C CA_n1A-n3A CA_n1A-n7A CA_n1A-n28A CA_n1A-n78A CA_n3A-n7A CA_n3A-n28A CA_n3A-n78A CA_n7A-n28A CA_n7A-n78A CA_n28A-n78A	n1 n3 n7 n28 n78	5, 10, 15, 20 CA_n3B_BCS0 5, 10, 15, 20, 25, 30, 40, 50 5, 10, 15, 20 CA_n78C_BCS0	0
CA_n1A-n3B-n7B-n28A-n78A	CA_n7B CA_n1A-n3A CA_n1A-n7A CA_n1A-n28A CA_n1A-n78A CA_n3A-n7A CA_n3A-n28A CA_n3A-n78A CA_n7A-n28A CA_n7A-n78A CA_n28A-n78A	n1 n3 n7 n28 n78	5, 10, 15, 20 CA_n3B_BCS0 CA_n7B_BCS0 5, 10, 15, 20 10, 15, 20, 25, 30, 40, 50, 60, 70, 80, 90, 100	0
CA_n1A-n3B-n7B-n28A-n78(2A)	CA_n7B CA_n78(2A) CA_n1A-n3A CA_n1A-n7A CA_n1A-n28A CA_n1A-n78A CA_n3A-n7A CA_n3A-n28A CA_n3A-n78A CA_n7A-n28A CA_n7A-n78A CA_n28A-n78A	n1 n3 n7 n28 n78	5, 10, 15, 20 CA_n3B_BCS0 CA_n7B_BCS0 5, 10, 15, 20 CA_n78(2A)_BCS2	0
CA_n1A-n3B-n7B-n28A-n78C	CA_n7B CA_n78C CA_n1A-n3A CA_n1A-n7A CA_n1A-n28A CA_n1A-n78A CA_n3A-n7A	n1	5, 10, 15, 20	0

NR CA configuration	Uplink configuration or single uplink carrier <sup>2</sup>	NR Band	Channel bandwidth (MHz) (NOTE 1)	Bandwidth combination set
	CA_n3A-n28A CA_n3A-n78A CA_n7A-n28A CA_n7A-n78A CA_n28A-n78A	n3 n7 n28 n78	CA_n3B_BCS0 CA_n7B_BCS0 5, 10, 15, 20 CA_n78C_BCS0	
CA_n1A-n3A-n7A-n38A-n78A <sup>4</sup>	-	n1 n3 n7 n38 n78	5, 10, 15, 20, 25, 30, 40, 45, 50 5, 10, 15, 20, 25, 30, 40, 45, 50 5, 10, 15, 20, 25, 30, 40, 50 5, 10, 15, 20, 25, 30, 40 10, 15, 20, 25, 30, 40, 50, 60, 70, 80, 90, 100	0
CA_n1A-n3A-n7A-n40A-n78A	CA_n1A-n3A CA_n1A-n7A CA_n1A-n40A CA_n1A-n78A CA_n3A-n7A CA_n3A-n40A CA_n3A-n78A CA_n7A-n40A CA_n7A-n78A CA_n40A-n78A	n1 n3 n7 n40 n78	5, 10, 15, 20, 25, 30, 40, 50 5, 10, 15, 20, 25, 30, 40, 50 5, 10, 15, 20, 25, 30, 40, 50 10, 15, 20, 25, 30, 40, 50, 60, 70, 80, 90, 100 10, 15, 20, 25, 30, 40, 50, 60, 70, 80, 90, 100	0
CA_n1A-n3A-n7A-n40A-n105A	CA_n1A-n3A CA_n1A-n7A CA_n1A-n40A CA_n1A-n105A CA_n3A-n7A CA_n3A-n40A CA_n3A-n105A CA_n7A-n40A CA_n7A-n105A CA_n40A-n105A	n1 n3 n7 n40 n105	5, 10, 15, 20, 25, 30, 40, 50 5, 10, 15, 20, 25, 30, 40, 50 5, 10, 15, 20, 25, 30, 40, 50 10, 15, 20, 25, 30, 40, 50, 60, 70, 80, 90, 100 5, 10, 15, 20, 25, 30, 35	0
CA_n1A-n3A-n7A-n67A-n78A	CA_n1A-n3A CA_n1A-n7A CA_n1A-n78A CA_n3A-n7A CA_n3A-n78A CA_n7A-n78A	n1 n3 n7 n67 n78	5, 10, 15, 20, 25, 30, 40, 50 5, 10, 15, 20, 25, 30, 35, 40, 45, 50 5, 10, 15, 20, 25, 30, 40, 50 5, 10, 15, 20 10, 20, 25, 30, 40, 50, 60, 70, 80, 90, 100	0
CA_n1A-n3A-n7A-n67A-n78(2A)	CA_n1A-n3A CA_n1A-n7A CA_n1A-n78A CA_n3A-n7A CA_n3A-n78A	n1	5, 10, 15, 20, 25, 30, 40, 50	0

NR CA configuration	Uplink configuration or single uplink carrier <sup>2</sup>	NR Band	Channel bandwidth (MHz) (NOTE 1)	Bandwidth combination set
	CA_n7A-n78A CA_n78(2A)	n3	5, 10, 15, 20, 25, 30, 35, 40, 45, 50	
		n7	5, 10, 15, 20, 25, 30, 40, 50	
		n67	5, 10, 15, 20	
		n78	CA_n78(2A)_BCS2	
CA_n1A-n3A-n7A-n75A-n78A	-	n1	n1 channel bandwidths in Table 5.3.5-1	4 and 5
		n3	n3 channel bandwidths in Table 5.3.5-1	
		n7	n7 channel bandwidths in Table 5.3.5-1	
		n75	n75 channel bandwidths in Table 5.3.5-1	
		n78	n78 channel bandwidths in Table 5.3.5-1	
CA_n1A-n3A-n7A-n78A-n105A	CA_n1A-n3A CA_n1A-n7A CA_n1A-n78A CA_n1A-n105A CA_n3A-n7A CA_n3A-n78A CA_n3A-n105A CA_n7A-n78A CA_n7A-n105A CA_n78A-n105A	n1	5, 10,15, 20, 25, 30, 40, 50	0
		n3	5, 10,15, 20, 25, 30, 40, 50	
		n7	5, 10,15, 20, 25, 30, 40, 50	
		n78	10, 15, 20, 25, 30, 40, 50, 60, 70, 80, 90, 100	
		n105	5, 10,15, 20, 25, 30, 35	
CA_n1A-n3A-n28A-n38A-n78A	-	n1	5, 10, 15, 20, 25, 30, 40, 45, 50	0
		n3	5, 10, 15, 20, 25, 30, 40, 45, 50	
		n28	5, 10, 15, 20, 25, 30	
		n38	5, 10, 15, 20, 25, 30, 40	
		n78	10, 15, 20, 25, 30, 40, 50, 60, 70, 80, 90, 100	
CA_n1A-n3A-n28A-n41A-n77A	CA_n1A-n3A CA_n1A-n28A CA_n1A-n41A CA_n1A-n77A CA_n3A-n28A CA_n3A-n41A CA_n3A-n77A CA_n28A-n41A CA_n28A-n77A CA_n41A-n77A	n1	5, 10, 15, 20	0
		n3	5, 10, 15, 20	
		n28	5, 10	
		n41	10, 15, 20, 30, 40, 50, 60, 80, 90, 100	
		n77	10, 15, 20, 25, 30, 40, 50, 60, 70, 80, 90, 100	
CA_n1A-n3A-n28A-n41A-n79A	CA_n1A-n3A CA_n1A-n28A CA_n1A-n41A CA_n1A-n79A CA_n3A-n28A CA_n3A-n41A CA_n3A-n79A CA_n28A-n41A CA_n28A-n79A	n1	5, 10, 15, 20	0

NR CA configuration	Uplink configuration or single uplink carrier <sup>2</sup>	NR Band	Channel bandwidth (MHz) (NOTE 1)	Bandwidth combination set
	CA_n41A-n79A	n3	5, 10, 15, 20	
		n28	5, 10	
		n41	10, 15, 20, 30, 40, 50, 60, 80, 90, 100	
		n79	40, 50, 60, 80, 100	
CA_n1A-n3A-n28A-n77A-n79A	CA_n1A-n3A CA_n1A-n28A CA_n1A-n77A CA_n1A-n79A CA_n3A-n28A CA_n3A-n77A CA_n3A-n79A CA_n28A-n77A CA_n28A-n79A CA_n77A-n79A	n1	5, 10, 15, 20	0
		n3	5, 10, 15, 20	
		n28	5, 10	
		n77	10, 15, 20, 25, 30, 40, 50, 60, 70, 80, 90, 100	
CA_n1A-n3A-n40A-n78A-n105A	CA_n1A-n3A CA_n1A-n40A CA_n1A-n78A CA_n1A-n105A CA_n3A-n40A CA_n3A-n78A CA_n3A-n105A CA_n40A-n78A CA_n40A-n105A CA_n78A-n105A	n1	5, 10, 15, 20	0
		n3	5, 10, 15, 20	
		n40	10, 15, 20, 30, 40, 50, 60, 70, 80, 90, 100	
		n78	10, 15, 20, 25, 30, 40, 50, 60, 70, 80, 90, 100	
CA_n1A-n3A-n41A-n77A-n79A	CA_n1A-n3A CA_n1A-n41A CA_n1A-n77A CA_n1A-n79A CA_n3A-n41A CA_n3A-n77A CA_n3A-n79A CA_n41A-n77A CA_n41A-n79A CA_n77A-n79A	n1	5, 10, 15, 20	0
		n3	5, 10, 15, 20	
		n41	10, 15, 20, 30, 40, 50, 60, 80, 90, 100	
		n77	10, 15, 20, 30, 40, 50, 60, 70, 80, 90, 100	
CA_n1A-n5A-n7A-n40A-n78A	CA_n1A-n5A CA_n1A-n7A CA_n1A-n40A CA_n1A-n78A CA_n5A-n7A CA_n5A-n40A CA_n5A-n78A CA_n7A-n40A CA_n7A-n78A CA_n40A-n78A	n1	5, 10, 15, 20, 25, 30, 40, 45, 50	0
		n5	5, 10, 15, 20, 25	

NR CA configuration	Uplink configuration or single uplink carrier <sup>2</sup>	NR Band	Channel bandwidth (MHz) (NOTE 1)	Bandwidth combination set
		n7	5, 10,15, 20, 25, 30, 35, 40, 50	
		n40	5, 10, 15, 20, 25, 30, 40, 50, 60, 70, 80, 90, 100	
		n78	10, 15, 20, 25, 30, 40, 50, 60, 70, 80, 90, 100	
CA_n1A-n5A-n7A-n40A-n105A	CA_n1A-n5A CA_n1A-n7A CA_n1A-n40A CA_n1A-n105A CA_n5A-n7A CA_n5A-n40A CA_n5A-n105A CA_n7A-n40A CA_n7A-n105A CA_n40A-n105A	n1	5, 10, 15, 20, 25, 30, 40, 45, 50	0
		n5	5, 10, 15, 20, 25	
		n7	5, 10,15, 20, 25, 30, 35, 40, 50	
		n40	5, 10, 15, 20, 25, 30, 40, 50, 60, 70, 80, 90, 100	
		n105	5, 10, 15, 20, 25, 30, 35	
CA_n1A-n5A-n7A-n78A-n105A	CA_n1A-n5A CA_n1A-n7A CA_n1A-n78A CA_n1A-n105A CA_n5A-n7A CA_n5A-n78A CA_n5A-n105A CA_n7A-n78A CA_n7A-n105A CA_n78A-n105A	n1	5, 10, 15, 20, 25, 30, 40, 45, 50	0
		n5	5, 10, 15, 20, 25	
		n7	5, 10,15, 20, 25, 30, 35, 40, 50	
		n78	10, 15, 20, 25, 30, 40, 50, 60, 70, 80, 90, 100	
		n105	5, 10, 15, 20, 25, 30, 35	
CA_n1A-n5A-n28A-n78A-n79A	CA_n1A-n5A CA_n1A-n28A CA_n1A-n78A CA_n1A-n79A CA_n5A-n28A CA_n5A-n78A CA_n5A-n79A CA_n28A-n78A CA_n28A-n79A CA_n78A-n79A	n1	n1 channel bandwidths in Table 5.3.5-1	4 and 5
		n5	n5 channel bandwidths in Table 5.3.5-1	
		n28	n28 channel bandwidths in Table 5.3.5-1	
		n78	n78 channel bandwidths in Table 5.3.5-1	
		n79	n79 channel bandwidths in Table 5.3.5-1	
CA_n1A-n5A-n40A-n78A-n105A	CA_n1A-n5A CA_n1A-n40A CA_n1A-n78A CA_n1A-n105A CA_n5A-n40A CA_n5A-n78A CA_n5A-n105A CA_n40A-n78A CA_n40A-n105A CA_n78A-n105A	n1	5, 10, 15, 20, 25, 30, 40, 45, 50	0
		n5	5, 10, 15, 20, 25	

NR CA configuration	Uplink configuration or single uplink carrier <sup>2</sup>	NR Band	Channel bandwidth (MHz) (NOTE 1)	Bandwidth combination set
		n40	5, 10, 15, 20, 25, 30, 40, 50, 60, 70, 80, 90, 100	
		n78	10, 15, 20, 25, 30, 40, 50, 60, 70, 80, 90, 100	
		n105	5, 10, 15, 20, 25, 30, 35	
CA_n1A-n7A-n28A-n38A-n78A <sup>4</sup>	-	n1	5, 10, 15, 20, 25, 30, 40, 45, 50	0
		n7	5, 10, 15, 20, 25, 30, 40, 50	
		n28	5, 10, 15, 20, 25, 30	
		n38	5, 10, 15, 20, 25, 30, 40	
		n78	10, 15, 20, 25, 30, 40, 50, 60, 70, 80, 90, 100	
CA_n1A-n7A-n40A-n78A-n105A	CA_n1A-n7A CA_n1A-n40A CA_n1A-n78A CA_n1A-n105A CA_n7A-n40A CA_n7A-n78A CA_n7A-n105A CA_n40A-n78A CA_n40A-n105A CA_n78A-n105A	n1	5, 10, 15, 20	0
		n7	5, 10, 15, 20, 25, 30, 40, 50	
		n40	10, 15, 20, 30, 40, 50, 60, 70, 80, 90, 100	
		n78	10, 15, 20, 25, 30, 40, 50, 60, 70, 80, 90, 100	
		n105	5, 10, 15, 20, 25, 30, 35	
CA_n1A-n28A-n41A-n77A-n79A	CA_n1A-n28A CA_n1A-n41A CA_n1A-n77A CA_n1A-n79A CA_n28A-n41A CA_n28A-n77A CA_n28A-n79A CA_n41A-n77A CA_n41A-n79A CA_n77A-n79A	n1	5, 10, 15, 20	0
		n28	5, 10	
		n41	10, 15, 20, 30, 40, 50, 60, 80, 90, 100	
		n77	10, 15, 20, 30, 40, 50, 60, 70, 80, 90, 100	
		n79	40, 50, 60, 80, 100	
CA_n2A-n5A-n30A-n66A-n77A	n77 <sup>3,5</sup> CA_n2A-n5A CA_n2A-n30A CA_n2A-n66A CA_n2A-n77A <sup>3</sup> CA_n5A-n30A CA_n5A-n66A CA_n5A-n77A <sup>3</sup> CA_n30A-n66A CA_n30A-n77A <sup>3</sup> CA_n66A-n77A <sup>3</sup>	n2	5, 10, 15, 20	0
		n5	5, 10, 15, 20	
		n30	5, 10	
		n66	5, 10, 15, 20, 25, 30, 40	
		n77	10, 15, 20, 25, 30, 40, 50, 60, 70, 80, 90, 100	
CA_n2A-n5A-n30A-n66A-n77(2A)	n77 <sup>3</sup> CA_n2A-n5A CA_n2A-n30A CA_n2A-n66A	n2	5, 10, 15, 20	0

NR CA configuration	Uplink configuration or single uplink carrier <sup>2</sup>	NR Band	Channel bandwidth (MHz) (NOTE 1)	Bandwidth combination set
	CA_n2A-n77A <sup>3</sup> CA_n5A-n30A CA_n5A-n66A CA_n5A-n77A <sup>3</sup> CA_n30A-n66A CA_n30A-n77A <sup>3</sup> CA_n66A-n77A <sup>3</sup>	n5	5, 10, 15, 20	
		n30	5, 10	
		n66	5, 10, 15, 20, 25, 30, 40	
		n77	CA_n77(2A)_BCS1	
CA_n2A-n5A-n48A-n66A-n77A	n77 <sup>3,5</sup> CA_n2A-n5A CA_n2A-n48A CA_n2A-n66A CA_n2A-n77A <sup>3</sup> CA_n5A-n48A CA_n5A-n66A CA_n5A-n77A <sup>3</sup> CA_n48A-n66A CA_n66A-n77A <sup>3</sup>	n2	5, 10, 15, 20	0
		n5	5, 10, 15, 20	
		n48	5, 10, 15, 20, 40, 50 <sup>6</sup> , 60 <sup>6</sup> , 70 <sup>6</sup> , 80 <sup>6</sup> , 90 <sup>6</sup> , 100 <sup>6</sup>	
		n66	5, 10, 15, 20, 25, 30, 40	
CA_n2A-n5A-n48B-n66A-n77A	CA_n2A-n5A CA_n2A-n48A CA_n2A-n66A CA_n2A-n77A <sup>3</sup> CA_n5A-n48A CA_n5A-n66A CA_n5A-n77A <sup>3</sup> CA_n48A-n66A CA_n48B CA_n66A-n77A <sup>3</sup>	n2	5, 10, 15, 20	0
		n5	5, 10, 15, 20	
		n48	CA_n48B_BCS2	
		n66	5, 10, 15, 20, 25, 30, 40	
CA_n2A-n5A-n48A-n66A-n77C	n77 <sup>3,5</sup> CA_n2A-n5A CA_n2A-n48A CA_n2A-n66A CA_n2A-n77A <sup>3</sup> CA_n5A-n48A CA_n5A-n66A CA_n5A-n77A <sup>3</sup> CA_n48A-n66A CA_n66A-n77A <sup>3</sup> CA_n77C	n2	5, 10, 15, 20	0
		n5	5, 10, 15, 20	
		n48	5, 10, 15, 20, 40, 50 <sup>6</sup> , 60 <sup>6</sup> , 70 <sup>6</sup> , 80 <sup>6</sup> , 90 <sup>6</sup> , 100 <sup>6</sup>	
		n66	5, 10, 15, 20, 25, 30, 40	
CA_n2A-n12A-n30A-n66A-n77A	n77 <sup>3,5</sup> CA_n2A-n12A CA_n2A-n30A CA_n2A-n66A CA_n2A-n77A <sup>3</sup> CA_n12A-n30A	n2	5, 10, 15, 20	0
		n5	5, 10, 15, 20	
		n48	5, 10, 15, 20, 40, 50 <sup>6</sup> , 60 <sup>6</sup> , 70 <sup>6</sup> , 80 <sup>6</sup> , 90 <sup>6</sup> , 100 <sup>6</sup>	
		n66	5, 10, 15, 20, 25, 30, 40	
			CA_n77C_BCS1	



NR CA configuration	Uplink configuration or single uplink carrier <sup>2</sup>	NR Band	Channel bandwidth (MHz) (NOTE 1)	Bandwidth combination set
	CA_n12A-n66A CA_n12A-n77A <sup>3</sup> CA_n30A-n66A CA_n30A-n77A <sup>3</sup> CA_n66A-n77A <sup>3</sup>	n12	5, 10, 15	
		n30	5, 10	
		n66	5, 10, 15, 20, 25, 30, 40	
		n77	10, 15, 20, 25, 30, 40, 50, 60, 70, 80, 90, 100	
CA_n2A-n12A-n30A-n66A-n77(2A)	n77 <sup>3</sup> CA_n2A-n12A CA_n2A-n30A CA_n2A-n66A CA_n2A-n77A <sup>3</sup> CA_n12A-n30A CA_n12A-n66A CA_n12A-n77A <sup>3</sup> CA_n30A-n66A CA_n30A-n77A <sup>3</sup> CA_n66A-n77A <sup>3</sup>	n2	5, 10, 15, 20	0
		n12	5, 10, 15	
		n30	5, 10	
		n66	5, 10, 15, 20, 25, 30, 40	
CA_n2A-n14A-n30A-n66A-n77A	n77 <sup>3,5</sup> CA_n2A-n14A CA_n2A-n30A CA_n2A-n66A CA_n2A-n77A <sup>3</sup> CA_n14A-n30A CA_n14A-n66A CA_n14A-n77A <sup>3</sup> CA_n30A-n66A CA_n30A-n77A <sup>3</sup> CA_n66A-n77A <sup>3</sup>	n2	5, 10, 15, 20	0
		n14	5, 10	
		n30	5, 10	
		n66	5, 10, 15, 20, 25, 30, 40	
CA_n2A-n14A-n30A-n66A-n77(2A)	n77 <sup>3</sup> CA_n2A-n14A CA_n2A-n30A CA_n2A-n66A CA_n2A-n77A <sup>3</sup> CA_n14A-n30A CA_n14A-n66A CA_n14A-n77A <sup>3</sup> CA_n30A-n66A CA_n30A-n77A <sup>3</sup> CA_n66A-n77A <sup>3</sup>	n2	5, 10, 15, 20	0
		n14	5, 10	
		n30	5, 10	
		n66	5, 10, 15, 20, 25, 30, 40	
CA_n2A-n29A-n30A-n66A-n77A	n77 <sup>3,5</sup> CA_n2A-n30A CA_n2A-n66A CA_n2A-n77A <sup>3</sup> CA_n30A-n66A CA_n30A-n77A <sup>3</sup> CA_n66A-n77A <sup>3</sup>	n2	5, 10, 15, 20	0
		n29	5, 10	
		n30	5, 10	
		n66	5, 10, 15, 20, 25, 30, 40	
	CA_n77(2A)_BCS1	n77	CA_n77(2A)_BCS1	

NR CA configuration	Uplink configuration or single uplink carrier <sup>2</sup>	NR Band	Channel bandwidth (MHz) (NOTE 1)	Bandwidth combination set
		n30	5, 10	
		n66	5, 10, 15, 20, 25, 30, 40	
		n77	10, 15, 20, 25, 30, 40, 50, 60, 70, 80, 90, 100	
CA_n2A-n29A-n30A-n66A-n77(2A)	n77 <sup>3</sup> CA_n2A-n30A CA_n2A-n66A CA_n2A-n77A <sup>3</sup> CA_n30A-n66A CA_n30A-n77A <sup>3</sup> CA_n66A-n77A <sup>3</sup>	n2	5, 10, 15, 20	0
		n29	5, 10	
		n30	5, 10	
		n66	5, 10, 15, 20, 25, 30, 40	
		n77	CA_n77(2A)_BCS1	
CA_n3A-n7A-n20A-n67A-n78A	CA_n3A-n7A CA_n3A-n20A CA_n3A-n78A CA_n7A-n20A CA_n7A-n78A CA_n20A-n78A	n3	n3 channel bandwidths in Table 5.3.5-1	4 and 5
		n7	n7 channel bandwidths in Table 5.3.5-1	
		n20	n20 channel bandwidths in Table 5.3.5-1	
		n67	n67 channel bandwidths in Table 5.3.5-1	
		n78	n78 channel bandwidths in Table 5.3.5-1	
CA_n3A-n7A-n20A-n67A-n78(2A)	CA_n3A-n7A CA_n3A-n20A CA_n3A-n78A CA_n7A-n20A CA_n7A-n78A CA_n20A-n78A CA_n78(2A)	n3	n3 channel bandwidths in Table 5.3.5-1	4 and 5
		n7	n7 channel bandwidths in Table 5.3.5-1	
		n20	n20 channel bandwidths in Table 5.3.5-1	
		n67	n67 channel bandwidths in Table 5.3.5-1	
		n78	CA_n78(2A)_BCS 4 and 5	
CA_n3A-n7A-n28A-n38A-n78A <sup>4</sup>	-	n3	5, 10, 15, 20, 25, 30, 40, 45, 50	0
		n7	5, 10, 15, 20, 25, 30, 40, 50	
		n28	5, 10, 15, 20, 25, 30	
		n38	5, 10, 15, 20, 25, 30, 40	
		n78	10, 15, 20, 25, 30, 40, 50, 60, 70, 80, 90, 100	
CA_n3A-n7A-n40A-n78A-n105A	CA_n3A-n7A CA_n3A-n40A CA_n3A-n78A CA_n3A-n105A CA_n7A-n40A CA_n7A-n78A CA_n7A-n105A CA_n40A-n78A CA_n40A-n105A CA_n78A-n105A	n3	5, 10, 15, 20	0
		n7	5, 10, 15, 20, 25, 30, 40, 50	
		n40	10, 15, 20, 30, 40, 50, 60, 70, 80, 90, 100	

NR CA configuration	Uplink configuration or single uplink carrier <sup>2</sup>	NR Band	Channel bandwidth (MHz) (NOTE 1)	Bandwidth combination set
		n78	10, 15, 20, 25, 30, 40, 50, 60, 70, 80, 90, 100	
		n105	5, 10, 15, 20, 25, 30, 35	
CA_n3A-n28A-n41A-n77A-n79A	CA_n3A-n28A CA_n3A-n41A CA_n3A-n77A CA_n3A-n79A CA_n28A-n41A CA_n28A-n77A CA_n28A-n79A CA_n41A-n77A CA_n41A-n79A CA_n77A-n79A	n3	5, 10, 15, 20	0
		n28	5, 10	
		n41	10, 15, 20, 30, 40, 50, 60, 80, 90, 100	
		n77	10, 15, 20, 25, 30, 40, 50, 60, 70, 80, 90, 100	
		n79	40, 50, 60, 80, 100	
CA_n5A-n7A-n40A-n78A-n105A	CA_n5A-n7A CA_n5A-n40A CA_n5A-n78A CA_n5A-n105A CA_n7A-n40A CA_n7A-n78A CA_n7A-n105A CA_n40A-n78A CA_n40A-n105A CA_n78A-n105A	n5	5, 10, 15, 20, 25	0
		n7	5, 10, 15, 20, 25, 30, 35, 40, 50	
		n40	5, 10, 15, 20, 25, 30, 40, 50, 60, 70, 80, 90, 100	
		n78	10, 15, 20, 25, 30, 40, 50, 60, 70, 80, 90, 100	
		n105	5, 10, 15, 20, 25, 30, 35	
CA_n25A-n41A-n66A-n71A-n77A	n41 <sup>3,4</sup> n77 <sup>3,4</sup> CA_n25A-n41A <sup>3</sup> CA_n25A-n66A CA_n25A-n71A CA_n25A-n77A <sup>3</sup> CA_n41A-n66A <sup>3</sup> CA_n41A-n71A <sup>3</sup> CA_n41A-n77A <sup>3</sup> CA_n66A-n71A CA_n66A-n77A <sup>3</sup> CA_n71A-n77A <sup>3</sup>	n25	n25 channel bandwidths in Table 5.3.5-1	4 and 5
		n41	n41 channel bandwidths in Table 5.3.5-1	
		n66	n66 channel bandwidths in Table 5.3.5-1	
		n71	n71 channel bandwidths in Table 5.3.5-1	
		n77	n77 channel bandwidths in Table 5.3.5-1	
CA_n25A-n41A-n66A-n71A-n77(2A)	CA_n25A-n41A CA_n25A-n66A CA_n25A-n71A CA_n25A-n77A CA_n41A-n66A CA_n41A-n71A CA_n41A-n77A CA_n66A-n71A CA_n66A-n77A CA_n71A-n77A	n25	n25 channel bandwidths in Table 5.3.5-1	4 and 5

NR CA configuration	Uplink configuration or single uplink carrier <sup>2</sup>	NR Band	Channel bandwidth (MHz) (NOTE 1)	Bandwidth combination set
		n41	n41 channel bandwidths in Table 5.3.5-1	
		n66	n66 channel bandwidths in Table 5.3.5-1	
		n71	n71 channel bandwidths in Table 5.3.5-1	
		n77	CA_n77(2A)_BCS 4 and 5	
CA_n25A-n41A-n66(2A)-n71A-n77A	n41 <sup>3,4</sup> n77 <sup>3,4</sup> CA_n25A-n41A <sup>3</sup> CA_n25A-n66A CA_n25A-n71A CA_n25A-n77A <sup>3</sup> CA_n41A-n66A <sup>3</sup> CA_n41A-n71A <sup>3</sup> CA_n41A-n77A <sup>3</sup> CA_n66A-n71A CA_n66A-n77A <sup>3</sup> CA_n71A-n77A <sup>3</sup>	n25	n25 channel bandwidths in Table 5.3.5-1	4 and 5
		n41	n41 channel bandwidths in Table 5.3.5-1	
		n66	CA_n66(2A)_BCS 4 and 5	
		n71	n71 channel bandwidths in Table 5.3.5-1	
		n77	n77 channel bandwidths in Table 5.3.5-1	
CA_n25A-n41A-n66A-n71(2A)-n77A	n41 <sup>3,4</sup> n77 <sup>3,4</sup> CA_n25A-n41A <sup>3</sup> CA_n25A-n66A CA_n25A-n71A CA_n25A-n77A <sup>3</sup> CA_n41A-n66A <sup>3</sup> CA_n41A-n71A <sup>3</sup> CA_n41A-n77A <sup>3</sup> CA_n66A-n71A CA_n66A-n77A <sup>3</sup> CA_n71A-n77A <sup>3</sup>	n25	n25 channel bandwidths in Table 5.3.5-1	4 and 5
		n41	n41 channel bandwidths in Table 5.3.5-1	
		n66	n66 channel bandwidths in Table 5.3.5-1	
		n71	CA_n71(2A)_BCS 4 and 5	
		n77	n77 channel bandwidths in Table 5.3.5-1	
CA_n25A-n41A-n66A-n71B-n77A	n41 <sup>3,4</sup> n77 <sup>3,4</sup> CA_n25A-n41A <sup>3</sup> CA_n25A-n66A CA_n25A-n71A CA_n25A-n77A <sup>3</sup> CA_n41A-n66A <sup>3</sup> CA_n41A-n71A <sup>3</sup> CA_n41A-n77A <sup>3</sup> CA_n66A-n71A CA_n66A-n77A <sup>3</sup> CA_n71A-n77A <sup>3</sup>	n25	n25 channel bandwidths in Table 5.3.5-1	4 and 5
		n41	n41 channel bandwidths in Table 5.3.5-1	
		n66	n66 channel bandwidths in Table 5.3.5-1	
		n71	CA_n71B_BCS 4 and 5	
		n77	n77 channel bandwidths in Table 5.3.5-1	

NR CA configuration	Uplink configuration or single uplink carrier <sup>2</sup>	NR Band	Channel bandwidth (MHz) (NOTE 1)	Bandwidth combination set
CA_n25A-n41C-n66A-n71A-n77A	CA_n25A-n41A CA_n25A-n66A CA_n25A-n71A CA_n25A-n77A CA_n41A-n66A CA_n41A-n71A CA_n41A-n77A CA_n41C CA_n66A-n71A CA_n66A-n77A CA_n71A-n77A	n25	n25 channel bandwidths in Table 5.3.5-1	4 and 5
		n41	CA_n41C_BCS 4 and 5	
		n66	n66 channel bandwidths in Table 5.3.5-1	
		n71	n71 channel bandwidths in Table 5.3.5-1	
		n77	n77 channel bandwidths in Table 5.3.5-1	
CA_n25A-n41(2A)-n66A-n71A-n77A	CA_n25A-n41A CA_n25A-n66A CA_n25A-n71A CA_n25A-n77A CA_n41A-n66A CA_n41A-n71A CA_n41A-n77A CA_n66A-n71A CA_n66A-n77A CA_n71A-n77A	n25	n25 channel bandwidths in Table 5.3.5-1	4 and 5
		n41	CA_n41(2A)_BCS 4 and 5	
		n66	n66 channel bandwidths in Table 5.3.5-1	
		n71	n71 channel bandwidths in Table 5.3.5-1	
		n77	n77 channel bandwidths in Table 5.3.5-1	
CA_n25(2A)-n41A-n66A-n71A-n77A	n41 <sup>3,4</sup> n77 <sup>3,4</sup> CA_n25A-n41A <sup>3</sup> CA_n25A-n66A CA_n25A-n71A CA_n25A-n77A <sup>3</sup> CA_n41A-n66A <sup>3</sup> CA_n41A-n71A <sup>3</sup> CA_n41A-n77A <sup>3</sup> CA_n66A-n71A CA_n66A-n77A <sup>3</sup> CA_n71A-n77A <sup>3</sup>	n25	CA_n25(2A)_BCS 4 and 5	4 and 5
		n41	n41 channel bandwidths in Table 5.3.5-1	
		n66	n66 channel bandwidths in Table 5.3.5-1	
		n71	n71 channel bandwidths in Table 5.3.5-1	
		n77	n77 channel bandwidths in Table 5.3.5-1	
<p>NOTE 1: For each channel bandwidth of each component carrier, refer to Table 5.3.5-1 of TS 38.101-1 and TS 38.101-2 for the applicable SCSs for NR FR1 and NR FR2 bands respectively. For a given band, not all UE channel bandwidths support the same SCSs.</p> <p>NOTE 2: Only single uplink carriers with power class other than PC3 are listed.</p> <p>NOTE 3: Minimum requirements for Power Class 2 are applicable for this uplink combination or single uplink carrier in this downlink/uplink combination.</p> <p>NOTE 4: For a band combination which includes band n7 and n38 simultaneously, carriers in band n7 and n38 can only be configured as downlink carriers. Power imbalance between downlink carriers on Band n7 and Band n38 is assumed to be within 6dB.</p> <p>NOTE 5: Power Class 1.5 is allowed for this single uplink carrier in this downlink/uplink combination.</p>				

NR CA configuration	Uplink configuration or single uplink carrier <sup>2</sup>	NR Band	Channel bandwidth (MHz) (NOTE 1)	Bandwidth combination set
NOTE 6: For this bandwidth, the minimum requirements are restricted to operation when carrier is configured as a downlink SCell part of CA configuration				

5.5A.3.5 Configurations for inter-band CA (six bands)

Table 5.5A.3.5-1: NR CA configurations and bandwidth combinations sets defined for inter-band CA (six bands)

NR CA configuration	Uplink configuration	NR Band	Channel bandwidth (MHz) (NOTE 1)	Bandwidth combination set
CA_n1A-n3A-n7A-n28A-n38A-n78A <sup>2</sup>	-	n1	5, 10, 15, 20, 25, 30, 40, 45, 50	0
		n3	5, 10, 15, 20, 25, 30, 35, 40, 45, 50	
		n7	5, 10, 15, 20, 25, 30, 40, 50	
		n28	5, 10, 15, 20, 25, 30	
		n38	5, 10, 15, 20, 25, 30, 40	
		n78	10, 15, 20, 25, 30, 40, 50, 60, 70, 80, 90, 100	
CA_n1A-n3A-n7A-n40A-n78A-n105A	CA_n1A-n3A CA_n1A-n7A CA_n1A-n40A CA_n1A-n78A CA_n1A-n105A CA_n3A-n7A CA_n3A-n40A CA_n3A-n78A CA_n3A-n105A CA_n7A-n40A CA_n7A-n78A CA_n7A-n105A CA_n40A-n78A CA_n40A-n105A CA_n78A-n105A	n1	5, 10,15, 20, 25, 30, 40, 50	0
		n3	5, 10,15, 20, 25, 30, 40, 50	
		n7	5, 10,15, 20, 25, 30, 40, 50	
		n40	10, 15, 20, 25, 30, 40, 50, 60, 70, 80, 90, 100	
		n78	10, 15, 20, 25, 30, 40, 50, 60, 70, 80, 90, 100	
		n105	5, 10,15, 20, 25, 30, 35	
CA_n1A-n5A-n7A-n40A-n78A-n105A	CA_n1A-n5A CA_n1A-n7A CA_n1A-n40A CA_n1A-n78A CA_n1A-n105A CA_n5A-n7A CA_n5A-n40A CA_n5A-n78A CA_n5A-n105A CA_n7A-n40A CA_n7A-n78A CA_n7A-n105A CA_n40A-n78A CA_n40A-n105A CA_n78A-n105A	n1	5, 10, 15, 20, 25, 30, 40, 45, 50	0
		n5	5, 10, 15, 20, 25	
		n7	5, 10,15, 20, 25, 30, 35, 40, 50	
		n40	5, 10, 15, 20, 25, 30, 40, 50, 60, 70, 80, 90, 100	

NR CA configuration	Uplink configuration	NR Band	Channel bandwidth (MHz) (NOTE 1)	Bandwidth combination set
		n78	10, 15, 20, 25, 30, 40, 50, 60, 70, 80, 90, 100	
		n105	5, 10, 15, 20, 25, 30, 35	
<p>NOTE 1: For each channel bandwidth of each component carrier, refer to Table 5.3.5-1 of TS 38.101-1 and TS 38.101-2 for the applicable SCSs for NR FR1 and NR FR2 bands respectively. For a given band, not all UE channel bandwidths support the same SCSs.</p> <p>NOTE 2: For a band combination which includes band n7 and n38 simultaneously, carriers in band n7 and n38 can only be configured as downlink carriers. Power imbalance between downlink carriers on Band n7 and Band n38 is assumed to be within 6dB.</p>				

## 5.5B Configurations for DC

For an NR DC configuration specified in Table 5.5B-1, the bandwidth combination sets for the corresponding NR CA configuration in 5.5A.3, i.e., dual uplink inter-band carrier aggregation with uplink assigned to two NR bands, are applicable to Dual Connectivity.

**Table 5.5B-1: Inter-band NR DC configurations (two bands)**

NR DC configuration	Uplink NR DC configuration
DC_n1A-n3A	DC_n1A-n3A
DC_n1A-n7A	DC_n1A-n7A
DC_n1A-n20A	DC_n1A-n20A
DC_n1A-n28A	DC_n1A-n28A
DC_n1A-n41A	DC_n1A-n41A
DC_n1A-n46A DC_n1A-n46C DC_n1A-n46D	DC_n1A-n46A
DC_n1A-n46(2A)	DC_n1A-n46A
DC_n1A-n77A <sup>2</sup>	DC_n1A-n77A
DC_n1A-n78A	DC_n1A-n78A
DC_n1A-n78(2A)	DC_n1A-n78A
DC_n1A-n79A <sup>2</sup>	DC_n1A-n79A
DC_n1A-n102A DC_n1A-n102B DC_n1A-n102C DC_n1A-n102D DC_n1A-n102E	DC_n1A-n102A DC_n1A-n102B DC_n1A-n102C
DC_n1A-n102(2A)	DC_n1A-n102A
DC_n2A-n5A DC_n2A-n5B	DC_n2A-n5A
DC_n2A-n48A DC_n2A-n48B DC_n2A-n48C	DC_n2A-n48A
DC_n2A-n48(2A) DC_n2A-n48(A-B)	DC_n2A-n48A
DC_n2A-n66A DC_n2A-n66B	DC_n2A-n66A
DC_n2A-n77A DC_n2A-n77B DC_n2A-n77C	DC_n2A-n77A
DC_n2A-n77(2A) DC_n2A-n77(3A) DC_n2(2A)-n77A DC_n2(2A)-n77B DC_n2(2A)-n77(2A) DC_n2(2A)-n77C	DC_n2A-n77A
DC_n3A-n7A	DC_n3A-n7A
DC_n3A-n20A	DC_n3A-n20A
DC_n3A-n28A	DC_n3A-n28A
DC_n3A-n41A	DC_n3A-n41A
DC_n3A-n77A <sup>2</sup>	DC_n3A-n77A
DC_n3A-n77(2A) <sup>2</sup>	DC_n3A-n77A
DC_n3A-n78A <sup>2</sup>	DC_n3A-n78A
DC_n3A-n78(2A) <sup>2</sup>	DC_n3A-n78A
DC_n3A-n79A	DC_n3A-n79A
DC_n3A-n102A DC_n3A-n102B DC_n3A-n102C DC_n3A-n102D DC_n3A-n102E	DC_n3A-n102A DC_n3A-n102B DC_n3A-n102C
DC_n3A-n102(2A)	DC_n3A-n102A
DC_n5A-n13A	DC_n5A-n13A



NR DC configuration	Uplink NR DC configuration
DC_n5B-n13A	
DC_n5A-n48A DC_n5A-n48B DC_n5A-n48C	DC_n5A-n48A
DC_n5A-n48(2A)	DC_n5A-n48A
DC_n5A-n66A DC_n5A-n66B DC_n5B-n66A DC_n5B-n66B	DC_n5A-n66A
DC_n5A-n66(2A) DC_n5A-n66(3A) DC_n5B-n66(2A)	DC_n5A-n66A
DC_n5A-n77A DC_n5A-n77B DC_n5A-n77C DC_n5B-n77A DC_n5B-n77C	DC_n5A-n77A
DC_n5A-n77(2A) DC_n5A-n77(3A) DC_n5(2A)-n77A DC_n5(2A)-n77C	DC_n5A-n77A
DC_n7A-n20A	DC_n7A-n20A
DC_n7A-n28A	DC_n7A-n28A
DC_n7A-n46A DC_n7A-n46C DC_n7A-n46D	DC_n7A-n46A
DC_n7A-n46(2A)	DC_n7A-n46A
DC_n7A-n78A	DC_n7A-n78A
DC_n7A-n78(2A)	DC_n7A-n78A
DC_n7A-n102A DC_n7A-n102B DC_n7A-n102C DC_n7A-n102D DC_n7A-n102E	DC_n7A-n102A DC_n7A-n102B DC_n7A-n102C
DC_n7A-n102(2A)	DC_n7A-n102A
DC_n8A-n78A <sup>2</sup>	DC_n8A-n78A
DC_n12A-n77A	DC_n12A-n77A
DC_n12A-n77(2A)	DC_n12A-n77A
DC_n13A-n66A DC_n13A-n66B	DC_n13A-n66A
DC_n13A-n66(2A)	DC_n13A-n66A
DC_n13A-n77A DC_n13A-n77C	DC_n13A-n77A
DC_n20A-n78A	DC_n20A-n78A
DC_n20A-n78(2A)	DC_n20A-n78A
DC_n25A-n41A	DC_n25A-n41A
DC_n25A-n66A	DC_n25A-n66A
DC_n25A-n71A	DC_n25A-n71A
DC_n25A-n77A	DC_n25A-n77A
DC_n25A-n77(2A)	DC_n25A-n77A
DC_n28A-n41A	DC_n28A-n41A
DC_n28A-n46A DC_n28A-n46C DC_n28A-n46D	DC_n28A-n46A
DC_n28A-n46(2A)	DC_n28A-n46A
DC_n28A-n77A <sup>2</sup>	DC_n28A-n77A
DC_n28A-n77(2A)	DC_n28A-n77A
DC_n28A-n78A <sup>2</sup>	DC_n28A-n78A
DC_n28A-n78(2A) <sup>2</sup>	DC_n28A-n78A
DC_n28A-n79A	DC_n28A-n79A
DC_n28A-n102A DC_n28A-n102B DC_n28A-n102C DC_n28A-n102D	DC_n28A-n102A DC_n28A-n102B DC_n28A-n102C

NR DC configuration	Uplink NR DC configuration
DC_n28A-n102E	
DC_n28A-n102(2A)	DC_n28A-n102A
DC_n41A-n66A	DC_n41A-n66A
DC_n41A-n71A	DC_n41A-n71A
DC_n41A-n77A	DC_n41A-n77A
DC_n41A-n78A	DC_n41A-n78A
DC_n41A-n79A <sup>2,3</sup>	DC_n41A-n79A
DC_n46A-n48A	DC_n46A-n48A
DC_n46A-n48B	DC_n46A-n48B
DC_n46A-n48C	
DC_n46B-n48A	
DC_n46B-n48B	
DC_n46B-n48C	
DC_n46C-n48A	
DC_n46C-n48B	
DC_n46C-n48C	
DC_n46D-n48A	
DC_n46D-n48B	
DC_n46D-n48C	
DC_n46N-n48A	
DC_n46N-n48B	
DC_n46N-n48C	
DC_n46A-n77A	
DC_n46C-n77A	DC_n46A-n77A
DC_n46D-n77A	
DC_n46A-n77(2A)	
DC_n46C-n77(2A)	
DC_n46D-n77(2A)	DC_n46A-n77A
DC_n46(2A)-n77A	
DC_n46(2A)-n77(2A)	
DC_n46A-n78A	
DC_n46C-n78A	DC_n46A-n78A
DC_n46D-n78A	
DC_n46A-n78(2A)	
DC_n46C-n78(2A)	
DC_n46D-n78(2A)	DC_n46A-n78A
DC_n46(2A)-n78A	
DC_n46(2A)-n78(2A)	
DC_n48A-n66A	DC_n48A-n66A
DC_n48B-n66A	
DC_n48B-n66B	
DC_n48C-n66A	
DC_n48C-n66B	
DC_n48A-n66(2A)	
DC_n48B-n66(2A)	DC_n48A-n66A
DC_n48(2A)-n66A	
DC_n48(2A)-n66(2A)	
DC_n48A-n70A	DC_n48A-n70A
DC_n48B-n70A	
DC_n48(2A)-n70A	DC_n48A-n70A
DC_n48A-n71A	
DC_n48B-n71A	DC_n48A-n71A
DC_n48C-n71A	
DC_n48A-n71(2A)	
DC_n48(2A)-n71A	DC_n48A-n71A
DC_n48(2A)-n71(2A)	
DC_n48(3A)-n71A	
DC_n48(4A)-n71A	
DC_n48B-n71(2A)	
DC_n48A-n96A	
DC_n48B-n96A	DC_n48A-n96A
DC_n48C-n96A	DC_n48B-n96A
DC_n48A-n96B	
DC_n48B-n96B	

NR DC configuration	Uplink NR DC configuration
DC_n48C-n96B DC_n48A-n96C DC_n48B-n96C DC_n48C-n96C DC_n48A-n96D DC_n48B-n96D DC_n48C-n96D DC_n48A-n96E DC_n48B-n96E DC_n48C-n96E	
DC_n66A-n71A	DC_n66A-n71A
DC_n66A-n77A DC_n66A-n77B DC_n66A-n77C DC_n66B-n77A DC_n66B-n77C	DC_n66A-n77A
DC_n66A-n77(2A) DC_n66A-n77(3A) DC_n66(2A)-n77(2A) DC_n66(2A)-n77(3A) DC_n66(3A)-n77(2A) DC_n66(2A)-n77A DC_n66(2A)-n77B DC_n66(2A)-n77C DC_n66(3A)-n77A DC_n66(3A)-n77C	DC_n66A-n77A
DC_n71A-n77A	DC_n71A-n77A
DC_n71A-n77(2A)	DC_n71A-n77A
DC_n77A-n79A <sup>1</sup>	DC_n77A-n79A
DC_n77(2A)-n79A <sup>1</sup>	DC_n77A-n79A
DC_n78A-n79A DC_n78(2A)-n79A	DC_n78A-n79A
DC_n77A-n102A DC_n77A-n102B DC_n77A-n102C DC_n77A-n102D DC_n77A-n102E	DC_n77A-n102A DC_n77A-n102B DC_n77A-n102C
DC_n77A-n102(2A) DC_n77(2A)-n102A DC_n77(2A)-n102B DC_n77(2A)-n102C DC_n77(2A)-n102D DC_n77(2A)-n102E DC_n77(2A)-n102(2A)	DC_n77A-n102A DC_n77A-n102B DC_n77A-n102C
DC_n78A-n102A DC_n78A-n102B DC_n78A-n102C DC_n78A-n102D DC_n78A-n102E	DC_n78A-n102A DC_n78A-n102B DC_n78A-n102C
DC_n78A-n102(2A) DC_n78(2A)-n102A DC_n78(2A)-n102B DC_n78(2A)-n102C DC_n78(2A)-n102D DC_n78(2A)-n102E DC_n78(2A)-n102(2A)	DC_n78A-n102A DC_n78A-n102B DC_n78A-n102C
NOTE 1: The minimum requirements apply only when there is non-simultaneous Rx/Tx operation between n77-n79 NR carriers. This restriction applies also for these carriers when applicable NR DC configuration is part of a higher order configuration.	
NOTE 2: Applicable for UE supporting inter-band NR DC with mandatory simultaneous Rx/Tx capability.	
NOTE 3: The frequency range below 2506 MHz for Band n41 is not used in this combination.	

**Table 5.5B-2: Inter-band NR DC configurations (three bands)**

NR DC configuration	Uplink NR DC configuration
DC_n1A-n3A-n7A	DC_n1A-n3A DC_n1A-n7A DC_n3A-n7A
DC_n1A-n3A-n20A	DC_n1A-n3A DC_n1A-n20A DC_n3A-n20A
DC_n1A-n3A-n28A	DC_n1A-n3A DC_n1A-n28A DC_n3A-n28A
DC_n1A-n3A-n41A	DC_n1A-n3A DC_n1A-n41A DC_n3A-n41A
DC_n1A-n3A-n67A	DC_n1A-n3A
DC_n1A-n3A-n77A	DC_n1A-n3A DC_n3A-n77A DC_n1A-n77A
DC_n1A-n3A-n78A	DC_n1A-n3A DC_n3A-n78A DC_n1A-n78A
DC_n1A-n3A-n78(2A)	DC_n1A-n3A DC_n3A-n78A DC_n1A-n78A
DC_n1A-n3A-n79A	DC_n1A-n3A DC_n3A-n79A DC_n1A-n79A
DC_n1A-n7A-n28A	DC_n1A-n7A DC_n7A-n28A DC_n1A-n28A
DC_n1A-n7A-n67A	DC_n1A-n7A
DC_n1A-n7A-n78A	DC_n1A-n7A DC_n7A-n78A DC_n1A-n78A
DC_n1A-n7A-n78(2A)	DC_n1A-n7A DC_n7A-n78A DC_n1A-n78A
DC_n1A-n20A-n67A	DC_n1A-n20A
DC_n1A-n28A-n41A	DC_n1A-n28A DC_n1A-n41A DC_n28A-n41A
DC_n1A-n28A-n46A DC_n1A-n28A-n46C DC_n1A-n28A-n46D DC_n1A-n28A-n46(2A)	DC_n1A-n46A DC_n28A-n46A
DC_n1A-n28A-n77A	DC_n1A-n28A DC_n1A-n77A DC_n28A-n77A
DC_n1A-n28A-n78A	DC_n1A-n28A DC_n1A-n78A DC_n28A-n78A
DC_n1A-n28A-n78(2A)	DC_n1A-n28A DC_n1A-n78A DC_n28A-n78A
DC_n1A-n28A-n79A	DC_n1A-n28A DC_n1A-n79A DC_n28A-n79A
DC_n1A-n28A-n102A DC_n1A-n28A-n102B DC_n1A-n28A-n102C DC_n1A-n28A-n102D DC_n1A-n28A-n102E	DC_n1A-n102A DC_n1A-n102B DC_n1A-n102C DC_n28A-n102A DC_n28A-n102B DC_n28A-n102C
DC_n1A-n28A-n102(2A)	DC_n1A-n102A DC_n28A-n102A

NR DC configuration	Uplink NR DC configuration
DC_n1A-n41A-n77A	DC_n1A-n41A DC_n1A-n77A DC_n41A-n77A
DC_n1A-n41A-n79A	DC_n1A-n41A DC_n1A-n79A DC_n41A-n79A
DC_n1A-n46A-n78A DC_n1A-n46C-n78A DC_n1A-n46D-n78A DC_n1A-n46A-n78(2A) DC_n1A-n46C-n78(2A) DC_n1A-n46D-n78(2A) DC_n1A-n46(2A)-n78A DC_n1A-n46(2A)-n78(2A)	DC_n1A-n46A DC_n1A-n78A DC_n46A-n78A
DC_n1A-n67A-n78A	DC_n1A-n78A
DC_n1A-n67A-n78(2A)	DC_n1A-n78A
DC_n1A-n77A-n79A	DC_n1A-n77A DC_n1A-n79A DC_n77A-n79A
DC_n1A-n78A-n102A DC_n1A-n78A-n102B DC_n1A-n78A-n102C DC_n1A-n78A-n102D DC_n1A-n78A-n102E	DC_n1A-n78A DC_n1A-n102A DC_n1A-n102B DC_n1A-n102C DC_n78A-n102A DC_n78A-n102B DC_n78A-n102C
DC_n1A-n78(2A)-n102A DC_n1A-n78(2A)-n102B DC_n1A-n78(2A)-n102C DC_n1A-n78(2A)-n102D DC_n1A-n78(2A)-n102E DC_n1A-n78A-n102(2A) DC_n1A-n78(2A)-n102(2A)	DC_n1A-n78A DC_n1A-n102A DC_n1A-n102B DC_n1A-n102C DC_n78A-n102A DC_n78A-n102B DC_n78A-n102C
DC_n2A-n5A-n48A DC_n2A-n5A-n48B	DC_n2A-n5A DC_n2A-n48A DC_n5A-n48A
DC_n2A-n5A-n48(2A) DC_n2A-n5A-n48(A-B)	DC_n2A-n5A DC_n2A-n48A DC_n5A-n48A
DC_n2A-n5A-n66A	DC_n2A-n5A DC_n2A-n66A DC_n5A-n66A
DC_n2A-n5A-n66(2A) DC_n2A-n5A-n66(3A) DC_n2(2A)-n5A-n66A DC_n2(2A)-n5A-n66(2A)	DC_n2A-n5A DC_n2A-n66A DC_n5A-n66A
DC_n2A-n5A-n77A DC_n2A-n5A-n77C	DC_n2A-n5A DC_n2A-n77A DC_n5A-n77A
DC_n2A-n5A-n77(2A) DC_n2(2A)-n5A-n77A DC_n2(2A)-n5A-n77(2A)	DC_n2A-n5A DC_n2A-n77A DC_n5A-n77A
DC_n2A-n48A-n66A DC_n2A-n48B-n66A	DC_n2A-n48A DC_n2A-n66A DC_n48A-n66A
DC_n2A-n48(2A)-n66A DC_n2A-n48(A-B)-n66A	DC_n2A-n48A DC_n2A-n66A DC_n48A-n66A
DC_n2A-n48A-n77A DC_n2A-n48A-n77C DC_n2A-n48B-n77A DC_n2A-n48B-n77C	DC_n2A-n48A DC_n2A-n77A
DC_n2A-n48(2A)-n77A DC_n2A-n48(2A)-n77C	DC_n2A-n48A DC_n2A-n77A
DC_n2A-n66A-n77A DC_n2A-n66A-n77C	DA_n2A-n66A DA_n2A-n77A

NR DC configuration	Uplink NR DC configuration
	DA_n66A-n77A
DC_n2(2A)-n66A-n77A DC_n2A-n66(2A)-n77A DC_n2A-n66A-n77(2A) DC_n2(2A)-n66A-n77(2A) DC_n2A-n66(2A)-n77(2A) DC_n2(2A)-n66(2A)-n77A DC_n2(2A)-n66(2A)-n77(2A) DC_n2A-n66(3A)-n77A DC_n2A-n66(3A)-n77(2A)	DC_n2A-n66A DC_n2A-n77A DC_n66A-n77A
DC_n3A-n7A-n20A	DC_n3A-n7A DC_n3A-n20A DC_n7A-n20A
DC_n3A-n7A-n28A	DC_n3A-n7A DC_n3A-n28A DC_n7A-n28A
DC_n3A-n7A-n67A	DC_n3A-n7A
DC_n3A-n7A-n78A	DC_n3A-n7A DC_n3A-n78A DC_n7A-n78A
DC_n3A-n7A-n78(2A)	DC_n3A-n7A DC_n3A-n78A DC_n7A-n78A
DC_n3A-n20A-n67A	DC_n3A-n20A
DC_n3A-n20A-n78A	DC_n3A-n20A DC_n3A-n78A DC_n20A-n78A
DC_n3A-n20A-n78(2A)	DC_n3A-n20A DC_n3A-n78A DC_n20A-n78A
DC_n3A-n28A-n41A	DC_n3A-n28A DC_n3A-n41A DC_n28A-n41A
DC_n3A-n28A-n77A	DC_n3A-n28A DC_n3A-n77A DC_n28A-n77A
DC_n3A-n28A-n77(2A)	DC_n3A-n28A DC_n3A-n77A DC_n28A-n77A
DC_n3A-n28A-n78A	DC_n3A-n28A DC_n3A-n78A DC_n28A-n78A
DC_n3A-n28A-n78(2A)	DC_n3A-n28A DC_n3A-n78A DC_n28A-n78A
DC_n3A-n28A-n79A	DC_n3A-n28A DC_n3A-n79A DC_n28A-n79A
DC_n3A-n41A-n77A	DC_n3A-n41A DC_n3A-n77A DC_n41A-n77A
DC_n3A-n41A-n79A	DC_n3A-n41A DC_n3A-n79A DC_n41A-n79A
DC_n3A-n67A-n78A DC_n3A-n67A-n78(2A)	DC_n3A-n78A
DC_n3A-n77A-n79A	DC_n3A-n77A DC_n3A-n79A DC_n77A-n79A
DC_n3A-n77(2A)-n79A	DC_n3A-n77A DC_n3A-n79A DC_n77A-n79A
DC_n5A-n48A-n66A DC_n5A-n48B-n66A	DC_n5A-n48A DC_n5A-n66A DC_n48A-n66A

NR DC configuration	Uplink NR DC configuration
DC_n5A-n48(2A)-n66A DC_n5A-n48(A-B)-n66A	DC_n5A-n48A DC_n5A-n66A DC_n48A-n66A
DC_n5A-n48A-n77A DC_n5A-n48A-n77C DC_n5A-n48B-n77A DC_n5A-n48B-n77C	DC_n5A-n48A DC_n5A-n77A
DC_n5A-n48(2A)-n77A DC_n5A-n48(2A)-n77C	DC_n5A-n48A DC_n5A-n77A
DC_n5A-n66A-n77A DC_n5A-n66A-n77C	DC_n5A-n66A DC_n5A-n77A DC_n66A-n77A
DC_n5A-n66(2A)-n77A DC_n5A-n66A-n77(2A) DC_n5A-n66(2A)-n77(2A) DC_n5A-n66(3A)-n77A DC_n5A-n66(3A)-n77(2A) DC_n5A-n66A-n77(3A)	DC_n5A-n66A DC_n5A-n77A DC_n66A-n77A
DC_n7A-n20A-n67A	DC_n7A-n20A
DC_n7A-n20A-n78A	DC_n7A-n20A DC_n7A-n78A DC_n20A-n78A
DC_n7A-n20A-n78(2A)	DC_n7A-n20A DC_n7A-n78A DC_n20A-n78A
DC_n7A-n28A-n78A	DC_n7A-n28A DC_n7A-n78A DC_n28A-n78A
DC_n7A-n28A-n78(2A)	DC_n7A-n28A DC_n7A-n78A DC_n28A-n78A
DC_n7A-n46A-n78A	DC_n7A-n46A DC_n7A-n78A DC_n46A-n78A
DC_n7A-n46C-n78A	DC_n7A-n46A DC_n7A-n78A DC_n46A-n78A
DC_n7A-n46D-n78A	DC_n7A-n46A DC_n7A-n78A DC_n46A-n78A
DC_n7A-n46(2A)-n78A DC_n7A-n46(2A)-n78(2A) DC_n7A-n46A-n78(2A) DC_n7A-n46C-n78(2A) DC_n7A-n46D-n78(2A)	DC_n7A-n46A DC_n7A-n78A DC_n46A-n78A
DC_n7A-n67A-n78A	DC_n7A-n78A
DC_n7A-n67A-n78(2A)	DC_n7A-n78A
DC_n7A-n78A-n102A DC_n7A-n78A-n102B DC_n7A-n78A-n102C DC_n7A-n78A-n102D DC_n7A-n78A-n102E	DC_n7A-n78A DC_n7A-n102A DC_n7A-n102B DC_n7A-n102C DC_n78A-n102A DC_n78A-n102B DC_n78A-n102C
DC_n7A-n78(2A)-n102A DC_n7A-n78(2A)-n102B DC_n7A-n78(2A)-n102C DC_n7A-n78(2A)-n102D DC_n7A-n78(2A)-n102E DC_n7A-n78A-n102(2A) DC_n7A-n78(2A)-n102(2A)	DC_n7A-n78A DC_n7A-n102A DC_n7A-n102B DC_n7A-n102C DC_n78A-n102A DC_n78A-n102B DC_n78A-n102C
DC_n13A-n66A-n77A	DC_n13A-n66A DC_n13A-n77A DC_n66A-n77A
DC_n13A-n66A-n77(2A)	DC_n13A-n66A

NR DC configuration	Uplink NR DC configuration
	DC_n13A-n77A DC_n66A-n77A
DC_n20A-n67A-n78A	DC_n20A-n78A
DC_n20A-n67A-n78(2A)	DC_n20A-n78A
DC_n28A-n41A-n77A	DC_n28A-n41A DC_n28A-n77A DC_n41A-n77A
DC_n28A-n41A-n79A	DC_n28A-n41A DC_n28A-n79A DC_n41A-n79A
DC_n28A-n46A-n78A DC_n28A-n46C-n78A DC_n28A-n46D-n78A DC_n28A-n46(2A)-n78A DC_n28A-n46(2A)-n78(2A) DC_n28A-n46A-n78(2A) DC_n28A-n46C-n78(2A) DC_n28A-n46D-n78(2A)	DC_n28A-n46A DC_n28A-n78A DC_n46A-n78A
DC_n28A-n77A-n79A	DC_n28A-n77A DC_n28A-n79A DC_n77A-n79A
DC_n28A-n77(2A)-n79A	DC_n28A-n77A DC_n28A-n79A DC_n77A-n79A
DC_n28A-n78A-n102A DC_n28A-n78A-n102B DC_n28A-n78A-n102C DC_n28A-n78A-n102D DC_n28A-n78A-n102E	DC_n28A-n78A DC_n28A-n102A DC_n28A-n102B DC_n28A-n102C DC_n78A-n102A DC_n78A-n102B DC_n78A-n102C
DC_n28A-n78(2A)-n102A DC_n28A-n78(2A)-n102B DC_n28A-n78(2A)-n102C DC_n28A-n78(2A)-n102D DC_n28A-n78(2A)-n102E DC_n28A-n78A-n102(2A) DC_n28A-n78(2A)-n102(2A)	DC_n28A-n78A DC_n28A-n102A DC_n28A-n102B DC_n28A-n102C DC_n78A-n102A DC_n78A-n102B DC_n78A-n102C
DC_n41A-n77A-n79A	DC_n41A-n77A DC_n41A-n79A DC_n77A-n79A
DC_n46A-n48A-n96A DC_n46B-n48A-n96A DC_n46C-n48A-n96A DC_n46D-n48A-n96A DC_n46M-n48A-n96A DC_n46N-n48A-n96A DC_n46A-n48B-n96A DC_n46B-n48B-n96A DC_n46C-n48B-n96A DC_n46D-n48B-n96A DC_n46M-n48B-n96A DC_n46N-n48B-n96A DC_n46A-n48C-n96A DC_n46B-n48C-n96A DC_n46C-n48C-n96A DC_n46D-n48C-n96A DC_n46M-n48C-n96A DC_n46N-n48C-n96A DC_n46A-n48A-n96B DC_n46B-n48A-n96B DC_n46C-n48A-n96B DC_n46D-n48A-n96B DC_n46M-n48A-n96B DC_n46N-n48A-n96B	DC_n46A-n48A DC_n46A-n48B DC_n48A-n96A DC_n48B-n96A
DC_n48A-n66A-n77A	DC_n48A-n66A



NR DC configuration	Uplink NR DC configuration
DC_n48A-n66A-n77C DC_n48B-n66A-n77A DC_n48B-n66A-n77C	DC_n66A-n77A
DC_n48(2A)-n66A-n77A DC_n48(2A)-n66A-n77C DC_n48A-n66(2A)-n77A	DC_n48A-n66A DC_n66A-n77A

**Table 5.5B-3: Inter-band NR DC configurations (four bands)**

NR DC configuration	Uplink NR DC configuration
DC_n1A-n3A-n7A-n67A	DC_n1A-n3A DC_n1A-n7A DC_n3A-n7A
DC_n1A-n3A-n7A-n78A	DC_n1A-n3A DC_n1A-n7A DC_n1A-n78A DC_n3A-n7A DC_n3A-n78A DC_n7A-n78A
DC_n1A-n3A-n7A-n78(2A)	DC_n1A-n3A DC_n1A-n7A DC_n1A-n78A DC_n3A-n7A DC_n3A-n78A DC_n7A-n78A
DC_n1A-n3A-n20A-n67A	DC_n1A-n3A DC_n1A-n20A DC_n3A-n20A
DC_n1A-n3A-n28A-n41A	DC_n1A-n3A DC_n1A-n28A DC_n1A-n41A DC_n3A-n28A DC_n3A-n41A DC_n28A-n41A
DC_n1A-n3A-n28A-n77A	DC_n1A-n3A DC_n1A-n28A DC_n1A-n77A DC_n3A-n28A DC_n3A-n77A DC_n28A-n77A
DC_n1A-n3A-n28A-n79A	DC_n1A-n3A DC_n1A-n28A DC_n1A-n79A DC_n3A-n28A DC_n3A-n79A DC_n28A-n79A
DC_n1A-n3A-n41A-n77A	DC_n1A-n3A DC_n1A-n41A DC_n1A-n77A DC_n3A-n41A DC_n3A-n77A DC_n41A-n77A
DC_n1A-n3A-n41A-n79A	DC_n1A-n3A DC_n1A-n41A DC_n1A-n79A DC_n3A-n41A DC_n3A-n79A DC_n41A-n79A
DC_n1A-n3A-n67A-n78A	DC_n1A-n3A DC_n1A-n78A DC_n3A-n78A
DC_n1A-n3A-n67A-n78(2A)	DC_n1A-n3A DC_n1A-n78A

NR DC configuration	Uplink NR DC configuration
	DC_n3A-n78A
DC_n1A-n3A-n77A-n79A	DC_n1A-n3A DC_n1A-n77A DC_n1A-n79A DC_n3A-n77A DC_n3A-n79A DC_n77A-n79A
DC_n1A-n7A-n28A-n78A	DC_n1A-n7A DC_n1A-n28A DC_n1A-n78A DC_n7A-n28A DC_n7A-n78A DC_n28A-n78A
DC_n1A-n7A-n28A-n78(2A)	DC_n1A-n7A DC_n1A-n28A DC_n1A-n78A DC_n7A-n28A DC_n7A-n78A DC_n28A-n78A
DC_n1A-n7A-n67A-n78A	DC_n1A-n7A DC_n1A-n78A DC_n7A-n78A
DC_n1A-n7A-n67A-n78(2A)	DC_n1A-n7A DC_n1A-n78A DC_n7A-n78A
DC_n1A-n28A-n41A-n77A	DC_n1A-n28A DC_n1A-n41A DC_n1A-n77A DC_n28A-n41A DC_n28A-n77A DC_n41A-n77A
DC_n1A-n28A-n41A-n79A	DC_n1A-n28A DC_n1A-n41A DC_n1A-n79A DC_n28A-n41A DC_n28A-n79A DC_n41A-n79A
DC_n1A-n28A-n77A-n79A	DC_n1A-n28A DC_n1A-n77A DC_n1A-n79A DC_n28A-n77A DC_n28A-n79A DC_n77A-n79A
DC_n1A-n41A-n77A-n79A	DC_n1A-n41A DC_n1A-n77A DC_n1A-n79A DC_n41A-n77A DC_n41A-n79A DC_n77A-n79A
DC_n3A-n7A-n20A-n67A	DC_n3A-n7A DC_n3A-n20A DC_n7A-n20A
DC_n3A-n7A-n20A-n78A	DC_n3A-n7A DC_n3A-n20A DC_n3A-n78A DC_n7A-n20A DC_n7A-n78A DC_n20A-n78A
DC_n3A-n7A-n20A-n78(2A)	DC_n3A-n7A DC_n3A-n20A DC_n3A-n78A DC_n7A-n20A DC_n7A-n78A DC_n20A-n78A
DC_n3A-n7A-n28A-n78A	DC_n3A-n7A DC_n3A-n28A

NR DC configuration	Uplink NR DC configuration
	DC_n3A-n78A DC_n7A-n28A DC_n7A-n78A DC_n28A-n78A
DC_n3A-n7A-n28A-n78(2A)	DC_n3A-n7A DC_n3A-n28A DC_n3A-n78A DC_n7A-n28A DC_n7A-n78A DC_n28A-n78A
DC_n3A-n7A-n67A-n78A	DC_n3A-n7A DC_n3A-n78A DC_n7A-n78A
DC_n3A-n7A-n67A-n78(2A)	DC_n3A-n7A DC_n3A-n78A DC_n7A-n78A
DC_n3A-n20A-n67A-n78A	DC_n3A-n20A DC_n3A-n78A DC_n20A-n78A
DC_n3A-n20A-n67A-n78(2A)	DC_n3A-n20A DC_n3A-n78A DC_n20A-n78A
DC_n3A-n28A-n41A-n77A	DC_n3A-n28A DC_n3A-n41A DC_n3A-n77A DC_n28A-n41A DC_n28A-n77A DC_n41A-n77A
DC_n3A-n28A-n41A-n79A	DC_n3A-n28A DC_n3A-n41A DC_n3A-n79A DC_n28A-n41A DC_n28A-n79A DC_n41A-n79A
DC_n3A-n28A-n77A-n79A	DC_n3A-n28A DC_n3A-n77A DC_n3A-n79A DC_n28A-n77A DC_n28A-n79A DC_n77A-n79A
DC_n3A-n28A-n77(2A)-n79A	DC_n3A-n28A DC_n3A-n77A DC_n3A-n79A DC_n28A-n77A DC_n28A-n79A DC_n77A-n79A
DC_n3A-n41A-n77A-n79A	DC_n3A-n41A DC_n3A-n77A DC_n3A-n79A DC_n41A-n77A DC_n41A-n79A DC_n77A-n79A
DC_n7A-n20A-n67A-n78A	DC_n7A-n20A DC_n7A-n78A DC_n20A-n78A
DC_n7A-n20A-n67A-n78(2A)	DC_n7A-n20A DC_n7A-n78A DC_n20A-n78A
DC_n28A-n41A-n77A-n79A	DC_n28A-n41A DC_n28A-n77A DC_n28A-n79A DC_n41A-n77A DC_n41A-n79A DC_n77A-n79A

Table 5.5B-4: Inter-band NR DC configurations (five bands)

NR DC configuration	Uplink NR DC configuration
DC_n1A-n3A-n7A-n67A-n78A	DC_n1A-n3A DC_n1A-n7A DC_n1A-n78A DC_n3A-n7A DC_n3A-n78A DC_n7A-n78A
DC_n1A-n3A-n7A-n67A-n78(2A)	DC_n1A-n3A DC_n1A-n7A DC_n1A-n78A DC_n3A-n7A DC_n3A-n78A DC_n7A-n78A
DC_n1A-n3A-n28A-n41A-n77A	DC_n1A-n3A DC_n1A-n28A DC_n1A-n41A DC_n1A-n77A DC_n3A-n28A DC_n3A-n41A DC_n3A-n77A DC_n28A-n41A DC_n28A-n77A DC_n41A-n77A
DC_n1A-n3A-n28A-n41A-n79A	DC_n1A-n3A DC_n1A-n28A DC_n1A-n41A DC_n1A-n79A DC_n3A-n28A DC_n3A-n41A DC_n3A-n79A DC_n28A-n41A DC_n28A-n79A DC_n41A-n79A
DC_n1A-n3A-n28A-n77A-n79A	DC_n1A-n3A DC_n1A-n28A DC_n1A-n77A DC_n1A-n79A DC_n3A-n28A DC_n3A-n77A DC_n3A-n79A DC_n28A-n77A DC_n28A-n79A DC_n77A-n79A
DC_n1A-n3A-n41A-n77A-n79A	DC_n1A-n3A DC_n1A-n41A DC_n1A-n77A DC_n1A-n79A DC_n3A-n41A DC_n3A-n77A DC_n3A-n79A DC_n41A-n77A DC_n41A-n79A DC_n77A-n79A
DC_n1A-n28A-n41A-n77A-n79A	DC_n1A-n28A DC_n1A-n41A DC_n1A-n77A DC_n1A-n79A DC_n28A-n41A DC_n28A-n77A DC_n28A-n79A DC_n41A-n77A DC_n41A-n79A DC_n77A-n79A
DC_n3A-n7A-n20A-n67A-n78A	DC_n3A-n7A DC_n3A-n20A

NR DC configuration	Uplink NR DC configuration
	DC_n3A-n78A DC_n7A-n20A DC_n7A-n78A DC_n20A-n78A
DC_n3A-n7A-n20A-n67A-n78(2A)	DC_n3A-n7A DC_n3A-n20A DC_n3A-n78A DC_n7A-n20A DC_n7A-n78A DC_n20A-n78A
DC_n3A-n28A-n41A-n77A-n79A	DC_n3A-n28A DC_n3A-n41A DC_n3A-n77A DC_n3A-n79A DC_n28A-n41A DC_n28A-n77A DC_n28A-n79A DC_n41A-n77A DC_n41A-n79A DC_n77A-n79A

## 5.5C Configurations for SUL

The configuration tables for SUL describe Bandwidth Combination Sets. Bandwidth Combination Set 4 and 5 contains all possible defined channel bandwidths for each band in the combination. The fact that BCS4 and BCS5 contains all channel bandwidths for each band does not alter if a bandwidth is mandatory or optional for a given band. Bandwidths that are identified as optional in Table 5.3.5-1 for a given release are still optional for UEs that support BCS4 or BCS5, where the bandwidths the UE supports for each band, the maximum bandwidth and/or minimum bandwidth for the band in the band combination are indicated in the UE capabilities. The minimum bandwidth per CC and aggregated FDD, TDD and total bandwidth per band combination may be indicated only for BCS5 as described in 38.306 [15] and BCS5 shall not be indicated together with BCS4 for a SUL configuration. For SUL band combinations including FR1 intra-band CA and with BCS4 or BCS5, the Bandwidth Combination Sets for the FR1 intra-band CA are BCS4 or BCS5.

For the NR SUL band configurations with inter-band CA in sub-clause 5.5C, when the capability *supportedBandPairListNR-r18* is present, three or four bands can be configured in the uplink with simultaneous uplink transmission on up to two bands, and the corresponding requirements for SUL band configurations with inter-band CA and with uplink assigned to one or two bands shall apply. For each uplink band pair in the NR SUL band configurations with inter-band CA, according to the capability *uplinkTxSwitchingOptionForBandPair*,

- if *switchedUL* is supported, uplink transmission on any one band of the band pair in the band combination shall be supported according to the scheduling commands, and the corresponding requirements for SUL band configuration with inter-band CA and with uplink assigned to one band on band X or band Y apply;
- if *dualUL* is supported, simultaneous uplink transmission on the two NR UL bands from the band pair for which *dualUL* is declared in the band combination shall be supported according to the scheduling commands, and the corresponding requirements for SUL band configuration with inter-band CA and with uplink CA between the two uplink bands apply.

For SUL band configuration with inter-band CA, band pair(s) of two non-SUL bands with *switchedUL* or *dualUL* by the parameter *uplinkTxSwitchingOption* is supported, and any other band pair(s) including SUL with *switchedUL* is supported, in release 18.

**Table 5.5C-1: Supported channel bandwidths per SUL band combination**

SUL configuration	NR Band	Channel bandwidth (MHz) (NOTE 1)	Bandwidth combination set
SUL_n1A-n80A	n1	5, 10, 15, 20, 25, 30, 40, 50	0
	n80	5, 10, 15, 20, 25, 30	

SUL configuration	NR Band	Channel bandwidth (MHz) (NOTE 1)	Bandwidth combination set
SUL_n1A-n81A	n1	5, 10, 15, 20, 25, 30, 40, 50	0
	n81	5, 10, 15, 20	
SUL_n1A-n89A	n1	5, 10, 15, 20, 25, 30, 40, 50	0
	n89	5, 10, 15, 20	
SUL_n3A-n84A	n3	5, 10, 15, 20, 25, 30, 40	0
	n84	5, 10, 15, 20	
SUL_n5A-n84A	n5	5, 10, 15, 20	0
	n84	5, 10, 15, 20	
SUL_n8A-n84A	n8	5, 10, 15, 20	0
	n84	5, 10, 15, 20	
SUL_n24A-n99A	n24	5, 10	0
	n99	5, 10	
SUL_n41A-n80A	n41	10, 15, 20, 40, 50, 60, 80, 90, 100	0
	n80	5, 10, 15, 20, 25, 30	
	n41	10, 15, 20, 30, 40, 50, 60, 80, 90, 100	1
	n80	5, 10, 15, 20, 25, 30, 40	
SUL_n41A-n81A	n41	10, 15, 20, 40, 50, 60, 80, 90, 100	0
	n81	5, 10, 15, 20	
SUL_n41A-n83A	n41	10, 15, 20, 30, 40, 50, 60, 80, 90, 100	0
	n83	5, 10, 15, 20, 30	
SUL_n41A-n95A	n41	10, 15, 20, 30, 40, 50, 60, 80, 90, 100	0
	n95	5, 10, 15	
SUL_n41A-n97A	n41	10, 15, 20, 30, 40, 50, 60, 80, 90, 100	0
	n97	5, 10, 15, 20, 25, 30, 40, 50, 60, 80	
	n41	10, 15, 20, 30, 40, 50, 60, 70, 80, 90, 100	1
	n97	5, 10, 15, 20, 25, 30, 40, 50, 60, 70, 80, 90, 100	
SUL_n41A-n98A	n41	10, 15, 20, 30, 40, 50, 60, 80, 90, 100	0
	n98	5, 10, 15, 20, 25, 30, 40	
SUL_n41A-n99A	n41	10, 15, 20, 30, 40, 50, 60, 80, 90, 100	0
	n99	5, 10	
SUL_n48A-n99A	n48	5, 10, 15, 20, 40, 50, 60, 80, 90, 100	0
	n99	5, 10	
SUL_n77A-n80A	n77	10, 15, 20, 40, 50, 60, 80, 90, 100	0
	n80	5, 10, 15, 20, 25, 30	
SUL_n77A-n84A	n77	10, 15, 20, 40, 50, 60, 80, 90, 100	0
	n84	5, 10, 15, 20	
SUL_n77A-n99A	n77	10, 15, 20, 40, 50, 60, 80, 90, 100	0
	n99	5, 10	
SUL_n78A-n80A	n78	10, 15, 20, 40, 50, 60, 80, 90, 100	0
	n80	5, 10, 15, 20, 25, 30	
	n78	10, 15, 20, 25, 30, 40, 50, 60, 70, 80, 90, 100	1
	n80	5, 10, 15, 20, 25, 30, 40	
SUL_n78A-n81A	n78	10, 15, 20, 40, 50, 60, 80, 90, 100	0
	n81	5, 10, 15, 20	
	n78	10, 15, 20, 25, 30, 40, 50, 60, 70, 80, 90, 100	1
	n81	5, 10, 15, 20	
SUL_n78A-n82A	n78	10, 15, 20, 40, 50, 60, 80, 90, 100	0
	n82	5, 10, 15, 20	
SUL_n78A-n83A	n78	10, 15, 20, 40, 50, 60, 80, 90, 100	0
	n83	5, 10, 15, 20	
	n78	10, 15, 20, 25, 30, 40, 50, 60, 70, 80, 90, 100	1
	n83	5, 10, 15, 20, 30	
SUL_n78A-n84A	n78	10, 15, 20, 40, 50, 60, 80, 90, 100	0
	n84	5, 10, 15, 20	
	n78	10, 15, 20, 25, 30, 40, 50, 60, 70, 80, 90, 100	1
	n84	5, 10, 15, 20, 25, 30, 40, 50	
SUL_n78A-n86A	n78	10, 15, 20, 40, 50, 60, 70, 80, 90, 100	0

SUL configuration	NR Band	Channel bandwidth (MHz) (NOTE 1)	Bandwidth combination set
	n86	5, 10, 15, 20	
SUL_n78A-n89A	n78	10, 15, 20, 25, 30, 40, 50, 60, 70, 80, 90, 100	0
	n89	5, 10, 15, 20	
SUL_n79A-n80A	n79	40, 50, 60, 80, 100	0
	n80	5, 10, 15, 20, 25, 30	
	n79	40, 50, 60, 80, 100	1
	n80	5, 10, 15, 20, 25, 30, 40	
SUL_n79A-n81A	n79	40, 50, 60, 80, 100	0
	n81	5, 10, 15, 20	
SUL_n79A-n83A	n79	40, 50, 60, 80, 100	0
	n83	5, 10, 15, 20, 30	
	n79	See n79 channel bandwidths in Table 5.3.5-1 for each carrier	4 and 5
	n83	See n83 channel bandwidths in Table 5.3.5-1 for each carrier	
SUL_n79A-n84A	n79	40, 50, 60, 80, 100	0
	n84	5, 10, 15, 20	
SUL_n79A-n95A	n79	40, 50, 60, 80, 100	0
	n95	5, 10, 15	
SUL_n79A-n97A	n79	40, 50, 60, 80, 100	0
	n97	5, 10, 15, 20, 25, 30, 40, 50, 60, 80	
	n79	40, 50, 60, 80, 100	1
	n97	5, 10, 15, 20, 25, 30, 40, 50, 60, 70, 80, 90, 100	
	n79	See n79 channel bandwidths in Table 5.3.5-1 for each carrier	4 and 5
	n97	See n97 channel bandwidths in Table 5.3.5-1 for each carrier	
SUL_n79A-n98A	n79	40, 50, 60, 80, 100	0
	n98	5, 10, 15, 20, 25, 30, 40	

NOTE 1: The SCS of each channel bandwidth for NR band refers to Table 5.3.5-1.

**Table 5.5C-2: Supported channel bandwidths per SUL band combination with intra-band non-contiguous CA**

SUL band combination with intra-band non-contiguous CA	SUL configuration	NR Band	Channel bandwidth (MHz) (NOTE 1)	Bandwidth combination set
CA_n41(2A)-n99A	SUL_n41A-n99A	n41	CA_n41(2A)_BCS0	0
		n99	5, 10	
CA_n48(2A)-n99A	SUL_n48A-n99A	n48	CA_n48(2A)_BCS0	0
		n99	5, 10	
CA_n77(2A)-n99A	SUL_n77A-n99A	n77	CA_n77(2A)_BCS0	0
		n99	5, 10	
CA_n78(2A)-n86A	SUL_n78A-n86A	n78	CA_n78(2A)_BCS0	0
		n86	5, 10, 15, 20	

NOTE 1: The SCS of each channel bandwidth for NR band refers to Table 5.3.5-1.

**Table 5.5C-3: Supported channel bandwidths per SUL band combination with intra-band contiguous CA**

SUL band combination with CA	SUL configuration	NR Band	Channel bandwidth (MHz) (NOTE 1)	Bandwidth combination set
CA_n41C-n80A	SUL_n41A-n80A CA_n41C-n80A	n41	CA_n41C_BCS1	0
		n80	5, 10, 15, 20, 25, 30, 40	
CA_n41C-n83A	SUL_n41A-n83A CA_n41C-n83A	n41	CA_n41C_BCS1	0
		n83	5, 10, 15, 20, 30	
CA_n41C-n95A	SUL_n41A-n95A CA_n41C-n95A	n41	CA_n41C_BCS1	0
		n95	5, 10, 15	
CA_n41C-n98A	SUL_n41A-n98A CA_n41C-n98A	n41	CA_n41C_BCS1	0
		n98	5, 10, 15, 20, 25, 30, 40	
CA_n78C-n80A	SUL_n78A-n80A CA_n78C-n80A	n78	CA_n78C_BCS1	0
		n80	5, 10, 15, 20, 25, 30, 40	
CA_n78C-n81A	SUL_n78A-n81A CA_n78C-n81A	n78	CA_n78C_BCS1	0
		n81	5, 10, 15, 20	
CA_n78C-n84A	SUL_n78A-n84A CA_n78C-n84A	n78	CA_n78C_BCS1	0
		n84	5, 10, 15, 20, 25, 30, 40, 50	
CA_n78C-n89A	SUL_n78A-n89A CA_n78C-n89A	n78	CA_n78C_BCS1	0
		n89	5, 10, 15, 20	
CA_n79C-n80A	SUL_n79A-n80A CA_n79C-n80A	n79	CA_n79C_BCS0	0
		n80	5, 10, 15, 20, 25, 30, 40	
CA_n79C-n83A	SUL_n79A-n83A CA_n79C-n83A	n79	CA_n79C_BCS0	0
		n83	5, 10, 15, 20, 30	
CA_n79C-n95A	SUL_n79A-n95A CA_n79C-n95A	n79	CA_n79C_BCS0	0
		n95	5, 10, 15	
CA_n79C-n98A	SUL_n79A-n98A CA_n79C-n98A	n79	CA_n79C_BCS0	0
		n98	5, 10, 15, 20, 25, 30, 40	

NOTE 1: The SCS of each channel bandwidth for NR band refers to Table 5.3.5-1.

**Table 5.5C-4: Supported channel bandwidths per SUL band combination with inter-band CA**

SUL band combination with CA	UL configuration	NR Band	Channel bandwidth (MHz) (NOTE 1)	Bandwidth combination set
CA_n1A_n78A-n80A	SUL_n78A-n80A	n1	5, 10, 15, 20, 25, 30, 40, 50	0
		n78	10, 15, 20, 25, 30, 40, 50, 60, 70, 80, 90, 100	
		n80	5, 10, 15, 20, 25, 30, 40	
CA_n1A_n78C-n80A	SUL_n78A-n80A CA_n78C CA_n1A-n78A CA_n78C-n80A	n1	5, 10, 15, 20, 25, 30, 40, 50	0
		n78	CA_n78C_BCS1	
		n80	5, 10, 15, 20, 25, 30, 40	
CA_n1A_n78A-n81A	SUL_n78A-n81A	n1	5, 10, 15, 20, 25, 30, 40, 50	0
		n78	10, 15, 20, 25, 30, 40, 50, 60, 70, 80, 90, 100	
		n81	5, 10, 15, 20	
CA_n1A_n78C-n81A	SUL_n78A-n81A CA_n78C-n81A CA_n78C	n1	5, 10, 15, 20, 25, 30, 40, 50	0



SUL band combination with CA	UL configuration	NR Band	Channel bandwidth (MHz) (NOTE 1)	Bandwidth combination set
	CA_n1A-n78A	n78	CA_n78C_BCS1	
		n81	5, 10, 15, 20	
CA_n1A_n78A-n84A	SUL_n78A-n84A	n1	5, 10, 15, 20, 25, 30, 40, 50	0
		n78	10, 15, 20, 25, 30, 40, 50, 60, 70, 80, 90, 100	
		n84	5, 10, 15, 20, 25, 30, 40, 50	
CA_n1A_n78C-n84A	SUL_n78A-n84A CA_n78C-n84A	n1	5, 10, 15, 20, 25, 30, 40, 50	0
		n78	CA_n78C_BCS1	
		n84	5, 10, 15, 20, 25, 30, 40, 50	
CA_n1A_n78A-n89A	SUL_n78A-n89A CA_n1A-n78A	n1	5, 10, 15, 20, 25, 30, 40, 50	0
		n78	10, 15, 20, 25, 30, 40, 50, 60, 70, 80, 90, 100	
		n89	5, 10, 15, 20	
CA_n1A_n78C-n89A	SUL_n78A-n89A CA_n78C CA_n1A-n78A CA_n78C-n89A	n1	5, 10, 15, 20, 25, 30, 40, 50	0
		n78	See CA_n78C Bandwidth Combination Set 1 in Table 5.5A.1-1	
		n89	5, 10, 15, 20	
CA_n3A_n41A-n80A	SUL_n41A-n80A	n3	5, 10, 15, 20, 25, 30, 40	0
		n41	10, 15, 20, 30, 40, 50, 60, 80, 90, 100	
		n80	5, 10, 15, 20, 25, 30, 40	
CA_n3A_n41C-n80A	SUL_n41A-n80A CA_n41C-n80A	n3	5, 10, 15, 20, 25, 30, 40	0
		n41	CA_n41C_BCS1	
		n80	5, 10, 15, 20, 25, 30, 40	
CA_n3A_n78A-n80A	SUL_n78A-n80A	n3	5, 10, 15, 20, 25, 30, 40	0
		n78	10, 15, 20, 25, 30, 40, 50, 60, 70, 80, 90, 100	
		n80	5, 10, 15, 20, 25, 30, 40	
CA_n3A_n78C-n80A	SUL_n78A-n80A CA_n78C-n80A	n3	5, 10, 15, 20, 25, 30, 40	0
		n78	CA_n78C_BCS1	
		n80	5, 10, 15, 20, 25, 30, 40	
CA_n3A_n78A-n84A	SUL_n78A-n84A CA_n3A-n78A	n3	5, 10, 15, 20, 25, 30, 40	0
		n78	10, 15, 20, 25, 30, 40, 50, 60, 70, 80, 90, 100	
		n84	5, 10, 15, 20	
CA_n3A_n78C-n84A	SUL_n78A-n84A CA_n3A-n78A CA_n78C CA_n78C-n84A	n3	5, 10, 15, 20, 25, 30, 40	0
		n78	See CA_n78C Bandwidth Combination Set 1 in Table 5.5A.1-1	
		n84	5, 10, 15, 20	
CA_n3A_n79A-n80A	SUL_n79A-n80A	n3	5, 10, 15, 20, 25, 30, 40	0
		n79	40, 50, 60, 80, 100	
		n80	5, 10, 15, 20, 25, 30, 40	
CA_n3A_n79C-n80A	SUL_n79A-n80A CA_n79C-n80A	n3	5, 10, 15, 20, 25, 30, 40	0
		n79	CA_n79C_BCS0	
		n80	5, 10, 15, 20, 25, 30, 40	
CA_n5A_n78A-n84A	SUL_n78A-n84A CA_n5A-n78A	n5	5, 10, 15, 20	0
		n78	10, 15, 20, 25, 30, 40, 50, 60, 70, 80, 90, 100	

SUL band combination with CA	UL configuration	NR Band	Channel bandwidth (MHz) (NOTE 1)	Bandwidth combination set
		n84	5, 10, 15, 20	
CA_n5A_n78C-n84A	SUL_n78A-n84A CA_n5A-n78A CA_n78C CA_n78C-n84A	n5	5, 10, 15, 20	0
		n78	See CA_n78C Bandwidth Combination Set 1 in Table 5.5A.1-1	
		n84	5, 10, 15, 20	
CA_n8A_n78A-n81A	SUL_n78A-n81A	n8	5, 10, 15, 20	0
		n78	10, 15, 20, 25, 30, 40, 50, 60, 70, 80, 90, 100	
		n81	5, 10, 15, 20	
CA_n8A_n78A-n84A	SUL_n78A-n84A CA_n8A-n78A	n8	5, 10, 15, 20	0
		n78	10, 15, 20, 25, 30, 40, 50, 60, 70, 80, 90, 100	
		n84	5, 10, 15, 20	
CA_n8A_n78C-n84A	SUL_n78A-n84A CA_n78C CA_n8A-n78A CA_n78C-n84A	n8	5, 10, 15, 20	0
		n78	See CA_n78C Bandwidth Combination Set 1 in Table 5.5A.1-1	
		n84	5, 10, 15, 20	
CA_n28A_n41A-n83A	SUL_n41A-n83A	n28	5, 10, 15, 20, 30	0
		n41	10, 15, 20, 30, 40, 50, 60, 80, 90, 100	
		n83	5, 10, 15, 20, 30	
CA_n28A_n41C-n83A	SUL_n41A-n83A CA_n41C-n83A	n28	5, 10, 15, 20, 30	0
		n41	CA_n41C_BCS1	
		n83	5, 10, 15, 20, 30	
CA_n28A_n79A-n83A	SUL_n79A-n83A	n28	5, 10, 15, 20, 30	0
		n79	40, 50, 60, 80, 100	
		n83	5, 10, 15, 20, 30	
CA_n28A_n79C-n83A	SUL_n79A-n83A CA_n79C-n83A	n28	5, 10, 15, 20, 30	0
		n79	CA_n79C_BCS0	
		n83	5, 10, 15, 20, 30	
CA_n41A_n79A-n80A	SUL_n79A-n80A	n41	10, 15, 20, 30, 40, 50, 60, 80, 90, 100	0
		n79	40, 50, 60, 80, 100	
		n80	5, 10, 15, 20, 25, 30, 40	
CA_n41A_n79A-n83A	SUL_n79A-n83A	n41	10, 15, 20, 30, 40, 50, 60, 80, 90, 100	0
		n79	40, 50, 60, 80, 100	
		n83	5, 10, 15, 20, 30	
CA_n41A_n79C-n83A	SUL_n79A-n83A CA_n79C-n83A CA_n41A-n79A CA_n79C	n41	10, 15, 20, 30, 40, 50, 60, 80, 90, 100	0
		n79	CA_n79C_BCS0	
		n83	5, 10, 15, 20, 30	
CA_n41C_n79A-n83A	SUL_n79A-n83A CA_n41C CA_n41A-n79A	n41	CA_n41C_BCS1	0
		n79	40, 50, 60, 80, 100	
		n83	5, 10, 15, 20, 30	
CA_n41C_n79C-n83A	CA_n41C CA_n79C SUL_n79A-n83A CA_n79C-n83A CA_n41A-n79A	n41	CA_n41C_BCS1	0

SUL band combination with CA	UL configuration	NR Band	Channel bandwidth (MHz) (NOTE 1)	Bandwidth combination set
		n79	CA_n79C_BCS0	
		n83	5, 10, 15, 20, 30	
CA_n41A_n79A-n95A	SUL_n79A-n95A	n41	10, 15, 20, 25, 30, 40, 50, 60, 70, 80, 90, 100	0
		n79	10, 20, 30, 40, 50, 60, 70, 80, 90, 100	
		n95	5, 10, 15	
CA_n41A_n79C-n95A	SUL_n79A-n95A CA_n79C-n95A CA_n41A-n79A CA_n79C	n41	10, 15, 20, 25, 30, 40, 50, 60, 70, 80, 90, 100	0
		n79	CA_n79C_BCS0	
		n95	5, 10, 15	
CA_n41C_n79A-n95A	SUL_n79A-n95A CA_n41C CA_n41A-n79A	n41	CA_n41C_BCS1	0
		n79	10, 20, 30, 40, 50, 60, 70, 80, 90, 100	
		n95	5, 10, 15	
CA_n41C_n79C-n95A	CA_n41C CA_n79C SUL_n79A-n95A CA_n79C-n95A CA_n41A-n79A	n41	CA_n41C_BCS1	0
		n79	CA_n79C_BCS0	
		n98	5, 10, 15	
CA_n41A_n79A-n97A	SUL_n79A-n97A	n41	10, 15, 20, 30, 40, 50, 60, 80, 90, 100	0
		n79	40, 50, 60, 80, 100	
		n97	5, 10, 15, 20, 25, 30, 40, 50, 60, 70, 80, 90, 100	
CA_n41A_n79A-n98A	SUL_n79A-n98A	n41	10, 15, 20, 25, 30, 40, 50, 60, 70, 80, 90, 100	0
		n79	10, 20, 30, 40, 50, 60, 70, 80, 90, 100	
		n98	5, 10, 15, 20, 25, 30, 40	
CA_n41A_n79C-n98A	SUL_n79A-n98A CA_n79C-n98A CA_n41A-n79A CA_n79C	n41	10, 15, 20, 25, 30, 40, 50, 60, 70, 80, 90, 100	0
		n79	CA_n79C_BCS0	
		n98	5, 10, 15, 20, 25, 30, 40	
CA_n41C_n79A-n98A	SUL_n79A-n98A CA_n41C CA_n41A-n79A	n41	CA_n41C_BCS1	0
		n79	10, 20, 30, 40, 50, 60, 70, 80, 90, 100	
		n98	5, 10, 15, 20, 25, 30, 40	
CA_n41C_n79C-n98A	CA_n41C CA_n79C SUL_n79A-n98A CA_n79C-n98A CA_n41A-n79A	n41	CA_n41C_BCS1	0
		n79	CA_n79C_BCS0	
		n98	5, 10, 15, 20, 25, 30, 40	
CA_n78A_n1A-n80A	SUL_n1A-n80A	n1	5, 10, 15, 20, 25, 30, 40, 50	0
		n78	10, 15, 20, 25, 30, 40, 50, 60, 70, 80, 90, 100	
		n80	5, 10, 15, 20, 25, 30	
CA_n78C_n1A-n80A	SUL_n1A-n80A CA_n78C CA_n1A-n78A	n1	5, 10, 15, 20, 25, 30, 40, 50	0
		n78	CA_n78C_BCS1	
		n80	5, 10, 15, 20, 25, 30	
CA_n78A_n1A-n81A	SUL_n1A-n81A	n1	5, 10, 15, 20, 25, 30, 40, 50	0

SUL band combination with CA	UL configuration	NR Band	Channel bandwidth (MHz) (NOTE 1)	Bandwidth combination set
		n78	10, 15, 20, 25, 30, 40, 50, 60, 70, 80, 90, 100	
		n81	5, 10, 15, 20	
CA_n78C_n1A-n81A	SUL_n1A-n81A CA_n78C CA_n1-n78A	n1	5, 10, 15, 20, 25, 30, 40, 50	0
		n78	CA_n78C_BCS1	
		n81	5, 10, 15, 20	
CA_n78A_n1A-n89A	SUL_n1A-n89A	n1	5, 10, 15, 20, 25, 30, 40, 50	0
		n78	10, 15, 20, 25, 30, 40, 50, 60, 70, 80, 90, 100	
		n89	5, 10, 15, 20	
CA_n78C_n1A-n89A	SUL_n1A-n89A CA_n78C CA_n1A-n78A	n1	5, 10, 15, 20, 25, 30, 40, 50	0
		n78	CA_n78C_BCS1	
		n89	5, 10, 15, 20	
CA_n78A_n3A-n84A	SUL_n3A-n84A	n3	5, 10, 15, 20, 25, 30, 40	0
		n78	10, 15, 20, 25, 30, 40, 50, 60, 70, 80, 90, 100	
		n84	5, 10, 15, 20	
CA_n78C_n3A-n84A	SUL_n3A-n84A CA_n78C CA_n3A-n78A	n3	5, 10, 15, 20, 25, 30, 40	0
		n78	CA_n78C_BCS1	
		n84	5, 10, 15, 20	
CA_n78A_n5A-n84A	SUL_n5A-n84A CA_n5A-n78A	n5	5, 10, 15, 20	0
		n78	10, 15, 20, 25, 30, 40, 50, 60, 70, 80, 90, 100	
		n84	5, 10, 15, 20	
CA_n78C_n5A-n84A	SUL_n5A-n84A CA_n78C CA_n5A-n78A	n5	5, 10, 15, 20	0
		n78	See CA_n78C Bandwidth Combination Set 1 in Table 5.5A.1-1	
		n84	5, 10, 15, 20	
CA_n78A_n8A-n84A	SUL_n8A-n84A CA_n8A-n78A	n8	5, 10, 15, 20	0
		n78	10, 15, 20, 25, 30, 40, 50, 60, 70, 80, 90, 100	
		n84	5, 10, 15, 20	
CA_n78C_n8A-n84A	SUL_n8A-n84A CA_n78C CA_n8A-n78A	n8	5, 10, 15, 20	0
		n78	See CA_n78C Bandwidth Combination Set 1 in Table 5.5A.1-1	
		n84	5, 10, 15, 20	
CA_n79A_n41A-n80A	SUL_n41A-n80A	n41	10, 15, 20, 30, 40, 50, 60, 80, 90, 100	0
		n79	40, 50, 60, 80, 100	
		n80	5, 10, 15, 20, 25, 30, 40	
CA_n79A_n41A-n83A	SUL_n41A-n83A	n41	10, 15, 20, 30, 40, 50, 60, 80, 90, 100	0
		n79	40, 50, 60, 80, 100	
		n83	5, 10, 15, 20, 30	
CA_n79A_n41C-n83A	SUL_n41A-n83A CA_n41C-n83A CA_n41A-n79A CA_n41C	n41	CA_n41C_BCS1	0
		n79	40, 50, 60, 80, 100	
		n83	5, 10, 15, 20, 30	

SUL band combination with CA	UL configuration	NR Band	Channel bandwidth (MHz) (NOTE 1)	Bandwidth combination set
CA_n79C_n41A-n83A	SUL_n41A-n83A CA_n41A-n79A CA_n79C	n41	10, 15, 20, 30, 40, 50, 60, 80, 90, 100	0
		n79	CA_n79C_BCS0	
		n83	5, 10, 15, 20, 30	
CA_n79C_n41C-n83A	CA_n41C CA_n79C SUL_n41A-n83A CA_n41C-n83A CA_n41A-n79A	n41	CA_n41C_BCS1	0
		n79	CA_n79C_BCS0	
		n83	5, 10, 15, 20, 30	
CA_n79A_n41A-n95A	SUL_n41A-n95A	n41	10, 15, 20, 25, 30, 40, 50, 60, 70, 80, 90, 100	0
		n79	10, 20, 30, 40, 50, 60, 70, 80, 90, 100	
		n95	5, 10, 15	
CA_n79C_n41A-n95A	SUL_n41A-n95A CA_n41A-n79A CA_n79C	n41	10, 15, 20, 25, 30, 40, 50, 60, 70, 80, 90, 100	0
		n79	CA_n79C_BCS0	
		n95	5, 10, 15	
CA_n79A_n41C-n95A	SUL_n41A-n95A CA_n41C-n95A CA_n41A-n79A CA_n41C	n41	CA_n41C_BCS1	0
		n79	10, 20, 30, 40, 50, 60, 70, 80, 90, 100	
		n95	5, 10, 15	
CA_n79C_n41C-n95A	CA_n41C CA_n79C SUL_n41A-n95A CA_n41C-n95A CA_n41A-n79A	n41	CA_n41C_BCS1	0
		n79	CA_n79C_BCS0	
		n95	5, 10, 15	
CA_n79A_n41A-n97A	SUL_n41A-n97A	n41	10, 15, 20, 30, 40, 50, 60, 80, 90, 100	0
		n79	40, 50, 60, 80, 100	
		n97	5, 10, 15, 20, 25, 30, 40, 50, 60, 70, 80, 90, 100	
CA_n79A_n41A-n98A	SUL_n41A-n98A	n41	10, 15, 20, 25, 30, 40, 50, 60, 70, 80, 90, 100	0
		n79	10, 20, 30, 40, 50, 60, 70, 80, 90, 100	
		n98	5, 10, 15, 20, 25, 30, 40	
CA_n79C_n41A-n98A	SUL_n41A-n98A CA_n41A-n79A CA_n79C	n41	10, 15, 20, 25, 30, 40, 50, 60, 70, 80, 90, 100	0
		n79	CA_n79C_BCS0	
		n98	5, 10, 15, 20, 25, 30, 40	
CA_n79A_n41C-n98A	SUL_n41A-n98A CA_n41C-n98A CA_n41A-n79A CA_n41C	n41	CA_n41C_BCS1	0
		n79	10, 20, 30, 40, 50, 60, 70, 80, 90, 100	
		n98	5, 10, 15, 20, 25, 30, 40	
CA_n79C_n41C-n98A	CA_n41C CA_n79C SUL_n41A-n98A CA_n41C-n98A CA_n41A-n79A	n41	CA_n41C_BCS1	0
		n79	CA_n79C_BCS0	
		n98	5, 10, 15, 20, 25, 30, 40	

SUL band combination with CA	UL configuration	NR Band	Channel bandwidth (MHz) (NOTE 1)	Bandwidth combination set
CA_n28A-n79A_n41A-n83A	SUL_n41A-n83A	n28	5, 10, 15, 20, 30	0
		n41	10, 15, 20, 30, 40, 50, 60, 80, 90, 100	
		n79	40, 50, 60, 80, 100	
		n83	5, 10, 15, 20, 30	
CA_n28A-n41A_n79A-n83A	SUL_n79A-n83A	n28	5, 10, 15, 20, 30	0
		n41	10, 15, 20, 30, 40, 50, 60, 70, 80, 90, 100	
		n79	40, 50, 60, 80, 100	
		n83	5, 10, 15, 20, 30	

NOTE 1: The SCS of each channel bandwidth for NR band refers to Table 5.3.5-1.

**Table 5.5C-5: Supported channel bandwidths per SUL band combination with inter-band CA (two SUL cells)**

SUL band combination with CA	Uplink CA configuration or SUL configuration	NR Band	Channel bandwidth (MHz) (NOTE 1)	Bandwidth combination set
CA_n41A-n95A_n79A-n98A	SUL_n41A-n95A SUL_n79A-n98A CA_n41A-n79A	n41	10, 15, 20, 25, 30, 35, 40, 45, 50, 60, 70, 80, 90, 100	0
		n79	10, 20, 30,40, 50, 60, 70, 80, 90, 100	
		n95	5, 10, 15	
		n98	5, 10, 15, 20, 25, 30, 40	
CA_n41A-n98A_n79A-n95A	SUL_n41A-n98A SUL_n79A-n95A CA_n41A-n79A	n41	10, 15, 20, 25, 30, 35, 40, 45, 50, 60, 70, 80, 90, 100	0
		n79	10, 20, 30,40, 50, 60, 70, 80, 90, 100	
		n95	5, 10, 15	
		n98	5, 10, 15, 20, 25, 30, 40	
CA_n41A-n83A_n79A-n98A	SUL_n41A-n83A SUL_n79A-n98A CA_n41A-n79A	n41	10, 15, 20, 25, 30, 35, 40, 45, 50, 60, 70, 80, 90, 100	0
		n79	10, 20, 30,40, 50, 60, 70, 80, 90, 100	
		n83	5, 10, 15, 20,30	
		n98	5, 10, 15, 20, 25, 30, 40	
CA_n41A-n83A_n79A-n95A	SUL_n41A-n83A SUL_n79A-n95A CA_n41A-n79A	n41	10, 15, 20, 25, 30, 35, 40, 45, 50, 60, 70, 80, 90, 100	0
		n79	10, 20, 30,40, 50, 60, 70, 80, 90, 100	
		n83	5, 10, 15, 20,30	
		n95	5, 10, 15	
CA_n78C_n80A-n84A	SUL_n78A-n80A SUL_n78A-n84A CA_n78C <sup>2</sup>	n78	CA_n78C_BCS1	0
		n80	5, 10, 15, 20, 25, 30, 40	
		n84	5, 10, 15, 20, 25, 30, 40, 50	
CA_n78C_n81A-n84A	SUL_n78A-n81A SUL_n78A-n84A CA_n78C <sup>2</sup>	n78	10, 15, 20, 25, 30, 40, 50, 60, 70, 80, 90, 100 CA_n78C_BCS1	0
		n81	5, 10, 15, 20	
		n84	5, 10, 15, 20, 25, 30, 40, 50	
CA_n78C_n84A-n89A	SUL_n78A-n84A SUL_n78A-n89A CA_n78C	n78	CA_n78C_BCS1	0
		n84	5, 10, 15, 20, 25, 30, 40, 50	
		n89	5, 10, 15, 20	

NOTE 1: The SCS of each channel bandwidth for NR band refers to Table 5.3.5-1.

NOTE 2: Power Class 2 is allowed for this uplink combination or single uplink carrier in this downlink/uplink combination.

NOTE 3: Minimum requirements for Power Class 2 are applicable for this uplink combination with up to 2Tx antenna connectors in this downlink/uplink combination.

## 5.5D Reserved

## 5.5E Void

### 5.5E.1A Configurations for Sidelink CA

For NR SL CA operation, the SL CA channel bandwidths for intra-band contiguous are specified in clause 5.5E.1A.1. The same (symmetrical) channel bandwidth is specified for both the transmission and reception path.

#### 5.5E.1A.1 Configurations for Sidelink intra-band contiguous CA

**Table 5.5E.1A.1-1 NR SL CA configurations and bandwidth combination set for SL intra-band contiguous CA in FR1**

Sidelink CA configuration / Bandwidth combination set							
Sidelink CA configuration	Sidelink CA configuration for TX	Component carriers in order of increasing carrier frequency				Maximum aggregated bandwidth [MHz]	Bandwidth combination set
		Channel bandwidths for carrier [MHz]	Channel bandwidths for carrier [MHz]	Channel bandwidths for carrier [MHz]	Channel bandwidths for carrier [MHz]		
SL_n47B	SL_n47B	10	10, 20,30			70	0
		[20]	[20,30]				
		30	30,40				



---

## 6 Transmitter characteristics

### 6.1 General

Unless otherwise stated, the transmitter characteristics are specified at the antenna connector of the UE with a single or multiple transmit antenna(s). For UE with integral antenna only, a reference antenna with a gain of 0 dBi is assumed.

For UEs that do not indicate IE *dualPA-Architecture*, transmitter requirements for CA operation apply only when the DMRS initialization parameters (including the case when the UE applies cell ID as DMRS scrambling ID) are different across all CCs. The UE may use higher MPR values outside this limitation.

Transmitter requirements for UL MIMO operation apply when the UE transmits on 2 ports/4 ports on the same CDM group. The UE may use higher MPR values outside this limitation.

The applicability of transmitter requirements for Band n90 is in accordance with that for Band n41; a UE supporting Band n90 shall meet the minimum requirements for Band n41.

NOTE: For FRMCS (Future Railway Mobile Communication System) operation in bands n100 and n101, the EIRP requirements shall be converted to conducted requirements based on the post chipset unit antenna connector gain  $G_{n100\text{post connector}}$  or  $G_{n101\text{post connector}}$  declared for the UE following the principle described in annex M.

#### 6.1A General

The minimum requirements for band combinations including Band n41 also apply for the corresponding band combinations with Band n90 replacing Band n41 but with otherwise identical parameters. For brevity the said band combinations with Band n90 are not listed in the tables below but are covered by this specification.

UE supporting the IE *posSRS-BWA-IndependentCA-RRC-Connected-r18* for SRS bandwidth aggregation shall meet the minimum requirements for intra-band contiguous CA for SRS transmission only.

#### 6.1F General

For wideband operations, the minimum requirements for the transmitter characteristics are specified for transmissions on one scheduled RB set or  $\geq 1$  scheduled contiguous RB set(s) within the UE channel. The requirements apply with configured UL intra-cell guard bands of non-zero size according to Table 5.3.3-2, with the union of the scheduled RB sets and the intra-cell guard bands.

Unless stated otherwise, when a clause is not present for shared spectrum channel access, the general requirements and the additional clause requirements (suffices A,B,D) in clause 6 apply.

#### 6.1G (Reserved)

#### 6.1H (Reserved)

#### 6.1I (Reserved)

#### 6.1J General

Unless otherwise stated, the transmitter characteristics are specified at the antenna connector(s) of the ATG UE with one or multiple omni-directional antenna(s) or at the *transceiver array boundary* (TAB) connectors of the ATG UE with the antenna array. The definition about *transceiver array boundary* (TAB) is specified in clause 4.3.2 of TS 38.104 [16].

6.1K (Reserved)

6.1L (Reserved)

## 6.2 Transmitter power

## 6.2.1 UE maximum output power

The following UE Power Classes define the maximum output power for any transmission bandwidth within the channel bandwidth of NR carrier unless otherwise stated. The period of measurement shall be at least one sub frame (1ms).

Table 6.2.1-1: UE Power Class

NR band	Class 1 (dBm)	Tolerance (dB)	Class 1.5 (dBm)	Tolerance (dB)	Class 2 (dBm)	Tolerance (dB)	Class 3 (dBm)	Tolerance (dB)
n1					26	+2/-3	23	±2
n2					26	+2/-3 <sup>3</sup>	23	±2 <sup>3</sup>
n3					26	+2/-3 <sup>3</sup>	23	±2 <sup>3</sup>
n5							23	±2
n7	31 <sup>6</sup>	+2/-3			26	+2/-3 <sup>3</sup>	23	±2 <sup>3</sup>
n8					26	+2/-3 <sup>3</sup>	23	±2 <sup>3</sup>
n12							23	±2 <sup>3</sup>
n13					26	+2/-3	23	±2
n14	31 <sup>6,7</sup>	+2/-3			26	+2/-3	23	±2
n18							23	±2
n20							23	±2 <sup>3</sup>
n24							23	+2/-3 <sup>3</sup>
n25	31 <sup>6</sup>	+2/-3			26	+2/-3 <sup>3</sup>	23	±2 <sup>3</sup>
n26							23	±2 <sup>3</sup>
n28							23	+2/-2.5
n30							23	±2
n31	31 <sup>6</sup>	+2/-3					23	±2
n34			29 <sup>5</sup>	+2/-3	26	+2/-3	23	±2
n38							23	±2
n39			29 <sup>5</sup>	+2/-3	26	+2/-3	23	±2
n40	31 <sup>6</sup>	+2/-3	29 <sup>5</sup>	+2/-3	26	+2/-3	23	±2
n41	31 <sup>6</sup>	+2/-3	29 <sup>5</sup>	+2/-3 <sup>3</sup>	26	+2/-3 <sup>3</sup>	23	±2 <sup>3</sup>
n47							23	±2
n48							23	+2/-3
n50							23	±2
n51							23	±2
n53							23	±2
n54							23	±2
n65							23	±2
n66	31 <sup>6</sup>	+2/-3			26	+2/-3	23	±2
n70					26	+2/-3	23	±2
n71	31 <sup>6</sup>	+2/-3			26	+2/-3	23	+2/-2.5
n72	31 <sup>6</sup>	+2/-3					23	±2
n74							23	±2
n77	31 <sup>6</sup>	+2/-3	29 <sup>5</sup>	+2/-3	26	+2/-3	23	+2/-3
n78	31 <sup>6</sup>	+2/-3	29 <sup>5</sup>	+2/-3	26	+2/-3	23	+2/-3
n79			29 <sup>5</sup>	+2/-3	26	+2/-3	23	+2/-3
n80					26	+2/-3 <sup>3</sup>	23	±2 <sup>3</sup>
n81							23	±2
n82							23	±2
n83							23	+2/-2.5
n84					26	+2/-3	23	±2
n85	31 <sup>6</sup>	+2/-3			26	+2/-3 <sup>3</sup>	23	±2 <sup>3</sup>

n86						23	$\pm 2$
n89						23	$\pm 2$
n91						23	$\pm 2^{3,4}$
n92						23	$\pm 2^{3,4}$
n93						23	$\pm 2^{3,4}$
n94						23	$\pm 2^{3,4}$
n95				26	+2/-3	23	$\pm 2$
n97				26	+2/-3	23	$\pm 2$
n98				26	+2/-3	23	$\pm 2$
n99						23	$+2/-3^3$
n100	31 <sup>6,8</sup>	+2/-3				23	$\pm 2$
n101	31 <sup>6,8</sup>	+2/-3				23	$\pm 2$
n104				26	+2/-3	23	$+2/-3$
n105						23	$+2/-2.5$
n106						23	$\pm 2$
n109						23	$\pm 2^{3,4}$

NOTE 1: P<sub>PowerClass</sub> is the maximum UE power specified without taking into account the tolerance.  
NOTE 2: Power class 3 is default power class unless otherwise stated.  
NOTE 3: Refers to the transmission bandwidths confined within F<sub>UL,low</sub> and F<sub>UL,low</sub> + 4 MHz or F<sub>UL,high</sub> – 4 MHz and F<sub>UL,high</sub>, the maximum output power requirement is relaxed by reducing the lower tolerance limit by 1.5 dB.  
NOTE 4: The maximum output power requirement is relaxed by reducing the lower tolerance limit by 0.3 dB.  
NOTE 5: Achieved via dual Tx.  
NOTE 6: Generally, PC1 UE is not targeted for smartphone form factor.  
NOTE 7: The UE power class 1 requirements for Band n14 are applicable for public safety scenario only.  
NOTE 8: PC1 in Band n100 and n101 is allowed only for FRMCS cab-radio's, i.e. user equipments installed on trains with external antenna on top of the train roof at approximately 4m over ground.

If a UE supports a different power class than the default UE power class for the band and the supported power class enables the higher maximum output power than that of the default power class:

- if the field of UE capability *maxUplinkDutyCycle-PC2-FRI* is absent and the field of UE capability *maxUplinkDutyCycle-PC1dot5-MPE-FRI* is absent and the percentage of uplink symbols transmitted in a certain evaluation period is larger than 50% (The exact evaluation period is no less than one radio frame); or
- if the field of UE capability *maxUplinkDutyCycle-PC2-FRI* is not absent and the percentage of uplink symbols transmitted in a certain evaluation period is larger than *maxUplinkDutyCycle-PC2-FRI* as defined in TS 38.306 (The exact evaluation period is no less than one radio frame); or
- if the field of UE capability *maxUplinkDutyCycle-PC1dot5-MPE-FRI* is not absent and half the percentage of uplink symbols transmitted in a certain evaluation period is larger than *maxUplinkDutyCycle-PC1dot5-MPE-FRI* as defined in TS 38.306 (The exact evaluation period is no less than one radio frame); or
- if the IE P-Max as defined in TS 38.331 [7] is provided and set to the maximum output power of the default power class or lower;
- shall apply all requirements for the default power class to the supported power class and set the configured transmitted power as specified in clause 6.2.4;
- else if the UE does not support a power class with higher maximum output power than PC2; or
- if the field of UE capability *maxUplinkDutyCycle-PC2-FRI* is absent and the field of UE capability *maxUplinkDutyCycle-PC1dot5-MPE-FRI* is absent and the percentage of uplink symbols transmitted in a certain evaluation period is larger than 25% (The exact evaluation period is no less than one radio frame); or
- if the field of UE capability *maxUplinkDutyCycle-PC2-FRI* is not absent and the percentage of uplink symbols transmitted in a certain evaluation period is larger than  $0.5 * \text{maxUplinkDutyCycle-PC2-FRI}$  (The exact evaluation period is no less than one radio frame); or
- if the field of UE capability *maxUplinkDutyCycle-PC1dot5-MPE-FRI* is not absent and the percentage of uplink symbols transmitted in a certain evaluation period is larger than *maxUplinkDutyCycle-PC1dot5-MPE-FRI* as defined in TS 38.306 (The exact evaluation period is no less than one radio frame); or
- if the IE P-Max as defined in TS 38.331 [7] is provided and set to the maximum output power of the power class 2 or lower;

- shall apply all requirements for power class 2 to the supported power class and set the configured transmitted power as specified in clause 6.2.4;
- else shall apply all requirements for the supported power class and set the configured transmitted power as specified in clause 6.2.4.

## 6.2.11 Void

## 6.2.2 UE maximum output power reduction

UE is allowed to reduce the maximum output power due to higher order modulations and transmit bandwidth configurations. For UE power class 2 and 3 and UE power class 1, the allowed maximum power reduction (MPR) is defined in Table 6.2.2-2, Table 6.2.2-1, Table 6.2.2-4b and Table 6.2.2-5, respectively for channel bandwidths  $\leq 100$  MHz. For UE power class 1.5 with dual Tx, the allowed maximum power reduction (MPR) is defined in Table 6.2D.2-2 and Table 6.2D.2-3 in accordance with the indicated *modifiedMPR-Behavior* specified in Table L.1-1 for channel bandwidths  $\leq 100$  MHz. For UE power class 1.5 with 4 Tx, the allowed maximum power reduction is defined in Table 6.2D.2-4, 6.2D.2-5. When A UE that indicates PC1.5 for a given band is limited to PC2 by the rules in clause 6.2.1, the MPR requirements in Table 6.2.2-2 apply.

If the relative channel bandwidth  $\leq 4\%$  for TDD bands or  $\leq 3\%$  for FDD band, the  $\Delta$ MPR is set to zero.

If the relative channel bandwidth  $> 4\%$  for TDD bands or  $> 3\%$  for FDD bands, the  $\Delta$ MPR is defined in Table 6.2.2-3.

Where relative channel bandwidth =  $2 * BW_{\text{Channel}} / (F_{\text{UL\_low}} + F_{\text{UL\_high}})$

The allowed MPR for SRS, PUCCH formats 0, 1, 3 and 4, and PRACH shall be as specified for QPSK modulated DFT-s-OFDM of equivalent RB allocation. The allowed MPR for PUCCH format 2 shall be as specified for QPSK modulated CP-OFDM of equivalent RB allocation.

**Table 6.2.2-1 Maximum power reduction (MPR) for power class 3**

Modulation		MPR (dB)		
		Edge RB allocations	Outer RB allocations	Inner RB allocations
DFT-s-OFDM	Pi/2 BPSK	$\leq 3.5^1$	$\leq 1.2^1$	$\leq 0.2^1$
		$\leq 0.5^{2,3}$	$\leq 0.5^2$	$0^{2,4}$
	Pi/2 BPSK w Pi/2 BPSK DMRS	$\leq 0.5^{2,3}$	$0^2$	$0^{2,4}$
	QPSK	$\leq 1$		$0^5$
	16 QAM	$\leq 2$		$\leq 1$
	64 QAM	$\leq 2.5$		
CP-OFDM	256 QAM	$\leq 4.5$		
	QPSK	$\leq 3$		$\leq 1.5$
	16 QAM	$\leq 3$		$\leq 2$
	64 QAM	$\leq 3.5$		
	256 QAM	$\leq 6.5$		

NOTE 1: Applicable for UE operating in TDD mode with Pi/2 BPSK modulation and UE indicates support for UE capability *powerBoosting-pi2BPSK* and if the IE *powerBoostPi2BPSK* is set to 1 and 40 % or less slots in radio frame are used for UL transmission for bands n40, n41, n77, n78 and n79. The reference power of 0 dB MPR is 26 dBm.

NOTE 2: Applicable for conditions where note 1 does not apply.

NOTE 3: For 3 MHz channel bandwidth the Pi/2 BPSK edge allocation MPR is 1 dB

NOTE 4: For a UE indicating support for UE capability *powerBoosting-pi2BPSK-QPSK-r18* or *powerBoosting-pi2BPSK-QPSK-Modified-r18* and if the IE *powerBoostPi2BPSK-r18* is set to 1, the reference power is increased by  $[\Delta P_{\text{PowerBoost}} - \Delta P_{\text{PowerClass}}]$

NOTE 5: For a UE indicating support for UE capability *powerBoosting-pi2BPSK-QPSK-r18* or *powerBoosting-pi2BPSK-QPSK-Modified-r18* and if the IE *powerBoostQPSK-r18* is set to 1, the reference power is increased by  $[\Delta P_{\text{PowerBoost}} - \Delta P_{\text{PowerClass}}]$

**Table 6.2.2-2 Maximum power reduction (MPR) for power class 2**

Modulation		MPR (dB)		
		Edge RB allocations	Outer RB allocations	Inner RB allocations
DFT-s-OFDM	Pi/2 BPSK	≤ 3.5	≤ 0.5	0 <sup>1</sup>
	QPSK	≤ 3.5	≤ 1	0 <sup>2</sup>
	16 QAM	≤ 3.5	≤ 2	≤ 1
	64 QAM	≤ 3.5	≤ 2.5	
	256 QAM	≤ 4.5		
CP-OFDM	QPSK	≤ 3.5	≤ 3	≤ 1.5
	16 QAM	≤ 3.5	≤ 3	≤ 2
	64 QAM	≤ 3.5		
	256 QAM	≤ 6.5		

NOTE 1: Applicable for a UE indicating support for UE capability *powerBoosting-pi2BPSK-QPSK-r18* or *powerBoosting-pi2BPSK-QPSK-Modified-r18* and if the IE *powerBoostPi2BPSK-r18* is set to 1. The reference power is increased by  $[\Delta P_{PowerBoost} - \Delta P_{PowerClass}]$

NOTE 2: Applicable for a UE indicating support for UE capability *powerBoosting-pi2BPSK-QPSK-r18* or *powerBoosting-pi2BPSK-QPSK-Modified-r18* and if the IE *powerBoostQPSK-r18* is set to 1. The reference power is increased by  $[\Delta P_{PowerBoost} - \Delta P_{PowerClass}]$

**Table 6.2.2-3: ΔMPR**

NR Band	Power class	Channel bandwidth	ΔMPR (dB)
n28 and n83	Power class 3	30 MHz	0.5
n40 and n97	Power class 3 and power class 2	100 MHz	1
n71	Power class 3	25 MHz	0.5
	Power class 3	30 MHz	
	Power class 2	35 MHz	

**Table 6.2.2-4 Void**

**Table 6.2.2-4a Void**

**Table 6.2.2-4b: Maximum power reduction (MPR) for power class 1 for bands other than Band n14**

Modulation		MPR (dB)		
		Edge RB allocations	Outer RB allocations	Inner RB allocations
DFT-s-OFDM	Pi/2 BPSK	(NOTE 1)	≤ 0.5	0
	Pi/2 BPSK w Pi/2 BPSK DMRS	(NOTE 1)	0	0
	QPSK	(NOTE 1)	≤ 1	0
	16 QAM	(NOTE 1)	≤ 2	≤ 1
	64 QAM	(NOTE 1)	≤ 2.5	
	256 QAM	(NOTE 1)	≤ 4.5	
CP-OFDM	QPSK	(NOTE 1)	≤ 3	≤ 1.5
	16 QAM	(NOTE 1)	≤ 3	≤ 2
	64 QAM	(NOTE 1)	≤ 3.5	
	256 QAM	(NOTE 1)	≤ 6.5	

NOTE 1: MPR for all modulations for Edge RB allocation is defined as following for two distinguished channel bandwidths groups as:  
 Within the <50MHz channel bandwidth group:  

$$MPR = CEIL(7.2 \text{ dB} - 6 \text{ dB} \cdot \frac{CBW}{100 \text{ MHz}}, 0.5 \text{ dB})$$
  
 Within the ≥50MHz channel bandwidth group:  

$$MPR = CEIL\left(5.35 \text{ dB} + 3.15 \text{ dB} \cdot \frac{CBW}{100 \text{ MHz}}, 0.5 \text{ dB}\right)$$
  
 where CEIL(x,0.5 dB) means rounding x upwards to the closest multiple of 0.5 dB.

**Table 6.2.2-5 Maximum power reduction (MPR) for power class 1 for Band n14**

Modulation		MPR (dB)		
		Edge RB allocations	Outer RB allocations	Inner RB allocations
DFT-s-OFDM	Pi/2 BPSK	$\leq 0.5$	$\leq 0.5$	0
	Pi/2 BPSK w Pi/2 BPSK DMRS	$\leq 0.5$	0	0
	QPSK	$\leq 1$		0
	16 QAM	$\leq 2$		$\leq 1$
	64 QAM	$\leq 2.5$		
	256 QAM	$\leq 4.5$		
CP-OFDM	QPSK	$\leq 3$		$\leq 1.5$
	16 QAM	$\leq 3$		$\leq 2$
	64 QAM	$\leq 3.5$		
	256 QAM	$\leq 6.5$		

Where the following parameters are defined to specify valid RB allocation ranges for Outer and Inner RB allocations:

$N_{RB}$  is the maximum number of RBs for a given Channel bandwidth and sub-carrier spacing defined in Table 5.3.2-1.

$$RB_{Start,Low} = \max(1, \text{floor}(L_{CRB}/2))$$

where  $\max()$  indicates the largest value of all arguments and  $\text{floor}(x)$  is the greatest integer less than or equal to  $x$ .

$$RB_{Start,High} = N_{RB} - RB_{Start,Low} - L_{CRB}$$

The RB allocation is an Inner RB allocation if the following conditions are met

$$RB_{Start,Low} \leq RB_{Start} \leq RB_{Start,High}, \text{ and}$$

$$L_{CRB} \leq \text{ceil}(N_{RB}/2)$$

where  $\text{ceil}(x)$  is the smallest integer greater than or equal to  $x$ .

An Edge RB allocation is the one for which the RB(s) is (are) allocated at the lowermost or uppermost edge of the channel  $L_{CRB} \leq 2$  RBs, except for PC1 UE supporting other bands than n14.

And for PC1 UE supporting other bands than n14 RB allocation is an Edge RB allocation if

$$L_{CRB} \leq L_{CRB,edge} \text{ AND } ( RB_{start} \leq RB_{start,edge} \text{ OR } RB_{start} \geq N_{RB} - RB_{start,edge} - L_{CRB} ),$$

where

$$L_{CRB,edge} = \begin{cases} 6, & CBW < 50 \text{ MHz} \\ 12, & CBW \geq 50 \text{ MHz}. \end{cases}$$

For  $CBW \geq 70$  MHz with DFT-S-OFDM waveform and pi/2-BPSK, QPSK, or 16-QAM modulation,  $RB_{start,edge} = 1$ . Otherwise,  $RB_{start,edge} = 0$ .

The RB allocation is an Outer RB allocation for all other allocations which are not an Inner RB allocation or Edge RB allocation.

When  $\Delta P_{PowerBoost}$  is a positive value and the UE supports *powerBoosting-pi2BPSK-QPSK-r18*

- An enhanced power inner allocation region within the inner region is defined so any waveform it contains satisfies the following condition:

$$RB_{Start,Low} + P1 \leq RB_{Start} \leq RB_{Start,High} - P1$$

$$\text{Where } P1 = \text{MIN}\{12, \text{CEIL}(2+N_{RB}/25)\}$$

- When a UE that supports *powerBoosting-pi2BPSK-QPSK-r18* but does not support *powerBoosting-pi2BPSK-QPSK-Modified-r18* an RB allocation that belongs to the inner region but is outside the enhanced power inner region, the applicable MPR from Table 6.2.2-x is increased by the value of  $\Delta P_{\text{PowerBoost}}$ .

If CP-OFDM allocation satisfies following conditions, it is considered as almost contiguous allocation

$$N_{\text{RB\_gap}} / (N_{\text{RB\_alloc}} + N_{\text{RB\_gap}}) \leq 0.25$$

and  $N_{\text{RB\_alloc}} + N_{\text{RB\_gap}}$  is larger than 106, 51 or 24 RBs for 15 kHz, 30 kHz or 60 kHz respectively where  $N_{\text{RB\_gap}}$  is the total number of unallocated RBs between allocated RBs and  $N_{\text{RB\_alloc}}$  is the total number of allocated RBs. The size and location of allocated and unallocated RBs are restricted by RBG parameters specified in clause 6.1.2.2 of TS 38.214 [10]. For UE that indicates support for *almostContiguousCP-OFDM-UL*, the almost contiguous signals in power class 1.5, 2 and 3, the allowed maximum power reduction defined in Table 6.2.2-2, Table 6.2.2-1 and Tables 6.2D.2-1 to 6.2D.2-5 are increased by

$$\text{CEIL}\{ 10 \log_{10}(1 + N_{\text{RB\_gap}} / N_{\text{RB\_alloc}}), 0.5 \} \text{ dB},$$

where  $\text{CEIL}\{x, 0.5\}$  means  $x$  rounding upwards to closest 0.5dB. The parameter of  $L_{\text{CRB}}$  which is used to specify valid RB allocation ranges for Outer and Inner RB allocations is replaced by  $(N_{\text{RB\_alloc}} + N_{\text{RB\_gap}})$  for almost contiguous allocation cases

For the UE maximum output power modified by MPR, the power limits specified in clause 6.2.4 apply.

## 6.2.3 UE additional maximum output power reduction

### 6.2.3.1 General

Additional emission requirements can be signalled by the network. Each additional emission requirement is associated with a unique network signalling (NS) value indicated in RRC signalling by an NR frequency band number of the applicable operating band and an associated value in the field *additionalSpectrumEmission*. Throughout this specification, the notion of indication or signalling of an NS value refers to the corresponding indication of an NR frequency band number of the applicable operating band, the IE field *freqBandIndicatorNR* and an associated value of *additionalSpectrumEmission* in the relevant RRC information elements [7].

To meet the additional requirements, additional maximum power reduction (A-MPR) is allowed for the maximum output power as specified in Table 6.2.1-1. Unless stated otherwise, the total reduction to UE maximum output power is  $\max(\text{MPR} + \Delta\text{MPR}, \text{A-MPR})$  where MPR and  $\Delta\text{MPR}$  are defined in clause 6.2.2. Outer and inner allocation notation used in clause 6.2.3 is defined in clause 6.2.2. Unless stated otherwise, Edge RB allocations get the same AMPR as Outer RB allocations. In absence of modulation and waveform types the A-MPR applies to all modulation and waveform types.

Table 6.2.3.1-1 specifies the additional requirements with their associated network signalling values and the allowed A-MPR and applicable operating band(s) for each NS value. In case of a power class 3 UE, when IE *powerBoostPi2BPSK* is set to 1, power class 2 A-MPR values apply. When IE *powerBoostPi2BPSK-r18* or *powerBoostQPSK-r18* is enabled, A-MPR, if larger than zero, is increased by  $\Delta P_{\text{PowerBoost}}$ . The mapping of NR frequency band numbers and values of the *additionalSpectrumEmission* to network signalling labels is specified in Table 6.2.3.1-1A.

For almost contiguous allocations in CP-OFDM waveforms in power class 1.5, 2 and 3, the allowed A-MPR defined in clause 6.2.3 is increased by  $\text{CEIL}\{ 10 \log_{10}(1 + N_{\text{RB\_gap}} / N_{\text{RB\_alloc}}), 0.5 \} \text{ dB}$ , where  $\text{CEIL}\{x, 0.5\}$  means  $x$  rounding upwards to closest 0.5dB,  $N_{\text{RB\_gap}}$  is the total number of unallocated RBs between allocated RBs and  $N_{\text{RB\_alloc}}$  is the total number of allocated RBs, and the parameter  $L_{\text{CRB}}$  is replaced by  $N_{\text{RB\_alloc}} + N_{\text{RB\_gap}}$  in specifying the RB allocation regions.

Unless otherwise specified, pi/2 BPSK in following A-MPR tables refers to both variants of pi/2 BPSK referenced in clause 6.2.2 Table 6.2.2-1.

**Table 6.2.3.1-1: Additional maximum power reduction (A-MPR)**

Network signalling label	Requirements (clause)	NR Band	Channel bandwidth (MHz)	Resources blocks ( $N_{\text{RB}}$ )	A-MPR (dB)
--------------------------	-----------------------	---------	-------------------------	--------------------------------------	------------

NS_01		Table 5.2-1 (NOTE 8)	3, 5, 10, 15, 20, 25, 30, 35, 40, 45, 50, 60, 70, 80, 90, 100	Table 5.3.2-1	N/A
NS_03	6.5.2.3.3	n2, n25, n66, n70, n86			Clause 6.2.3.7
NS_03U	6.5.2.3.3, 6.5.2.4.2	n2, n25, n66, n86 (NOTE 1)			Clause 6.2.3.7
NS_04	6.5.2.3.2, 6.5.3.3.1	n41, n90	5, 10, 15, 20, 25, 30, 35, 40, 45, 50, 60, 70, 80, 90, 100		Clause 6.2.3.2
NS_05	6.5.3.3.4	n1, n65, n84 (NOTE 1)	5, 10, 15, 20 (NOTE 2)		Clause 6.2.3.4 (NOTE 7)
NS_05U	6.5.3.3.4, 6.5.2.4.2	n1, n65, n84	5, 10, 15, 20		Clause 6.2.3.4 (NOTE 7)
NS_06	6.5.2.3.4	n12	5, 10, 15		Clause 6.2.3.32
		n13, n14	5, 10		
		n85	3, 5, 10, 15		
NS_07	6.5.2.3.4 6.5.3.3.26	n13	5,10	Table 6.2.3.29-1, Table 6.2.3.29-3	Table 6.2.3.29-2. Table 6.2.3.29-4
NS_10		n20, n82	15, 20	Table 6.2.3.3-1	Table 6.2.3.3-1
NS_12	6.5.3.3.17	n26	3,5,10	Table 6.2.3.21-1	Table 6.2.3.21-2
NS_13	6.5.3.3.18	n26	3, 5	Table 6.2.3.22-1	Table 6.2.3.22-2
NS_14	6.5.3.3.19	n26	10,15,20	Table 6.2.3.23-1	Table 6.2.3.23-2
NS_15	6.5.3.3.20	n26	3,5,10,15,20	Table 6.2.3.24-1	Table 6.2.3.24-2
NS_17	6.5.3.3.2	n28, n83 <sup>13</sup>	3,5,10	Table 5.3.2-1	N/A
NS_18	6.5.3.3.3	n28, n83 <sup>13</sup> , n109	3, 5		Table 6.2.3.13-1, A1
			10, 15, 20		Table 6.2.3.13-1, A2
			25, 30		Table 6.2.3.13-1, A3, A4, A5
NS_21	6.5.2.3.9 6.5.3.3.12	n30	5, 10		Clause 6.2.3.14
NS_24	6.5.3.3.13	n65 (NOTE 4)	5, 10, 15, 20	Table 6.2.3.15-1	Clause 6.2.3.15
NS_27	6.5.2.3.8 6.5.3.3.14	n48	5, 10, 15, 20, 30, 40	Table 6.2.3.16-1	Table 6.2.3.16-2
NS_35	6.5.2.3.1	n71	5, 10, 15, 20, 25, 30, 35	Table 5.3.2-1	Clause 6.2.3.31 <sup>11</sup>
NS_37	6.5.3.3.6	n74 (NOTE 3)	10, 15	Table 6.2.3.8-1	Table 6.2.3.8-1
NS_38	6.5.3.3.7	n74	5, 10, 15, 20	Table 6.2.3.9-1	Table 6.2.3.9-1
NS_39	6.5.3.3.8	n74	10, 15, 20	Table 6.2.3.10-1	Table 6.2.3.10-1
NS_40	6.5.3.3.9	n51	5		Table 6.2.3.5-1
NS_41	6.5.3.3.10	n50	5, 10, 15, 20, 30, 40, 50, 60		Table 6.2.3.11-1
NS_42	6.5.3.3.11	n50	5, 10, 15, 20, 30, 40, 50, 60		Table 6.2.3.12-1
NS_43	6.5.3.3.5	n8, n81	5, 10, 15		Clause 6.2.3.6
NS_43U	6.5.3.3.5, 6.5.2.4.2	n8, n81 (NOTE 1)	5, 10, 15		Clause 6.2.3.6
NS_44	6.5.3.3.24	n38	25, 30, 40	Table 6.2.3.20-1	Table 6.2.3.20-1



NS_45	6.5.3.3.21	n53	5, 10		Clause 6.2.3.25
NS_46	6.5.3.3.25	n7	10, 15, 20, 25, 30, 35, 40, 50	Table 6.2.3.17-1 Table 6.2.3.17-3 <sup>11</sup> Table 6.2.3.17-5	Table 6.2.3.17-2 Table 6.2.3.17-4 <sup>11</sup> Table 6.2.3.17-6
NS_47	6.5.3.3.15	n41 (Note 5)	30 (Note 5)	Table 6.2.3.18-1 Table 6.2.3.18-3	Table 6.2.3.18-2 Table 6.2.3.18-4
NS_48	6.5.3.3.22	n1 and n84	10, 15, 20, 25, 30, 40, 45, 50	Table 6.2.3.26-1, Table 6.2.3.26-3	Table 6.2.3.26-2, Table 6.2.3.26-4 (NOTE 7)
NS_49	6.5.3.3.23	n1 and n84	10, 15, 20, 25, 30, 40, 45, 50	Table 6.2.3.27-1, Table 6.2.3.27-3	Table 6.2.3.27-2, Table 6.2.3.27-4 (NOTE 7)
NS_50	6.5.3.3.16	n39, n98	10, 15, 20, 25, 30, 35, 40		Clause 6.2.3.19
NS_51	6.5.3.3.22	n65	50	Table 6.2.3.28-1	Table 6.2.3.28-2
NS_55	NOTE 6	n77	10, 15, 20, 25, 30, 40, 50, 60, 70, 80, 90, 100		N/A
NS_56	6.5.3.3.27	n24, n99	5, 10		Clause 6.2.3.30
NS_57	NOTE 10	n77	10, 15, 20, 25, 30, 40, 50, 60, 70, 80, 90, 100		N/A
NS_62	6.5.3.3.28	n54	5		N/A
NS_100	6.5.2.4.2	n1, n2, n3, n5, n8, n18, n25, n26, n65, n66, n80, n81, n84, n86, n89 (NOTE 1)			Table 6.2.3.1-2

- NOTE 1: This NS can be signalled for NR bands that have UTRA services deployed.
- NOTE 2: No A-MPR is applied for 5 MHz  $BW_{Channel}$  where the upper channel edge is  $\geq 1930$  MHz, 10 MHz  $BW_{Channel}$  where the upper channel edge is  $\geq 1950$  MHz and 15 MHz  $BW_{Channel}$  where the upper channel edge is  $\geq 1955$  MHz and 20 MHz  $BW_{Channel}$  where the upper channel edge is  $\geq 1970$  MHz.
- NOTE 3: Applicable when the NR carrier is within 1447.9 – 1462.9 MHz.
- NOTE 4: Applicable when the upper edge of the channel bandwidth frequency is greater than 1980 MHz.
- NOTE 5: Applicable when the NR carrier is within 2545 – 2575 MHz. PC1 operation is not allowed.  $BW_{Channel}$  less than 30 MHz are addressed in Table 6.5.3.2-1.
- NOTE 6: This NS value is applicable for cells in the range 3450 – 3550 MHz for operations in the USA. This NS value does not indicate any additional spurious emission and maximum output power reduction requirements.
- NOTE 7: The 1Tx architecture is assumed. For power class 2 UE indicating *txDiversity-r16* or *txDiversity2Tx-r18* [TS 38.306], the additional relaxation of [2] dB is applicable.
- NOTE 8: The NS\_01 label with the field *additionalPmax* [7] absent is default for all NR bands.
- NOTE 9: Void
- NOTE 10: This NS value is applicable for cells below 3980 MHz that are partly or fully within the range 3650-3980 MHz for operations in Canada. This NS value does not indicate any additional spurious emission and maximum output power reduction requirements.
- NOTE 11: Void.
- NOTE 12: Void.
- NOTE 13: Void.
- NOTE 14: Void.

**Table 6.2.3.1-1A: Mapping of network signalling label**

NR band	Value of <i>additionalSpectrumEmission</i>							
	0	1	2	3	4	5	6	7

n1	NS_01	NS_100	NS_05	NS_05U	NS_48	NS_49		Reserved
n2	NS_01	NS_100	NS_03	NS_03U				Reserved
n3	NS_01	NS_100						Reserved
n5	NS_01	NS_100						Reserved
n7	NS_01	NS_46						Reserved
n8	NS_01	NS_100	NS_43	NS_43U				Reserved
n12	NS_01	NS_06						Reserved
n13	NS_01	NS_06	NS_07					Reserved
n14	NS_01	NS_06						Reserved
n18	NS_01	NS_100						Reserved
n20	NS_01	Void	NS_10					Reserved
n24	NS_01	NS_56						Reserved
n25	NS_01	NS_100	NS_03	NS_03U				Reserved
n26	NS_01	NS_100	NS_12	NS_13	NS_14	NS_15		Reserved
n28	NS_01	NS_17	NS_18					Reserved
n30	NS_01	NS_21						Reserved
n31	NS_01							Reserved
n34	NS_01							Reserved
n38	NS_01	NS_44						Reserved
n39	NS_01	NS_50						Reserved
n40	NS_01							Reserved
n41	NS_01	NS_04	NS_47					Reserved
n48	NS_01	NS_27						Reserved
n50	NS_01	NS_41	NS_42					Reserved
n51	NS_01	NS_40						Reserved
n53	NS_01	NS_45						Reserved
n54	NS_01	NS_62						Reserved
n65	NS_01	NS_24	NS_100	NS_05	NS_05U	NS_51		Reserved
n66	NS_01	NS_100	NS_03	NS_03U				Reserved
n70	NS_01	NS_03						Reserved
n71	NS_01	NS_35						Reserved
n72	NS_01							Reserved
n74	NS_01	NS_37	NS_38	NS_39				Reserved
n77	NS_01	NS_55	NS_57					Reserved
n78	NS_01							Reserved
n79	NS_01							Reserved
n80	NS_01	NS_100						Reserved
n81	NS_01	NS_100	NS_43	NS_43U				Reserved
n82	NS_01	Void	NS_10					Reserved
n83	NS_01	NS_17	NS_18					Reserved
n84	NS_01	NS_100	NS_05	NS_05U	NS_48	NS_49		Reserved
n85	NS_01	NS_06						Reserved
n86	NS_01	NS_100	NS_03	NS_03U				Reserved
n89	NS_01	NS_100						Reserved
n90	NS_01	NS_04						Reserved
n91	NS_01							Reserved
n92	NS_01							Reserved
n93	NS_01							Reserved
n94	NS_01							Reserved
n95	NS_01							Reserved
n97	NS_01							Reserved
n98	NS_01	NS_50						Reserved
n99	NS_01	NS_56						Reserved
n104 <sup>2</sup>	NS_01							Reserved
n105	NS_01							Reserved
n106	NS_01							Reserved
n109	NS_01	NS_18						Reserved

NOTE 1: *additionalSpectrumEmission* corresponds to an information element of the same name defined in clause 6.3.2 of TS 38.331 [7].

NOTE 2: Additional emission requirements and associated network signalling for Band n104 are not defined in this version of the specification but may be forthcoming in the future.

**Table 6.2.3.1-2: A-MPR for NS\_100 (UTRA protection) (Power Class 3 and Power Class 2)**

Modulation/Waveform		Outer (dB)
DFT-s-OFDM	Pi/2 BPSK	≤ 2
	QPSK	≤ 2
	16 QAM	≤ 2.5
	64 QAM	≤ 3
	256 QAM	≤ 4.5
CP-OFDM	QPSK	≤ 4
	16 QAM	≤ 4
	64 QAM	≤ 4
	256 QAM	≤ 6.5
NOTE 1: Void		
NOTE 2: Void		

### 6.2.3.2 A-MPR for NS\_04

For NS\_04, A-MPR is not added to MPR. Also, when NS\_04 is signalled, MPR shall be set to zero in the  $P_{C_{MAX}}$  equations to avoid double counting MPR.

For power Class 1.5, 2 and 3, allowed maximum power reduction is defined as A-MPR = max(MPR, A-MPR'),

Note that A-MPR' = 0 dB means only MPR is applied,

where A-MPR' is defined as

```

if  $R_{B_{start}} \leq f_{start,max,IMD3} / (12 \cdot SCS)$  and  $L_{CRB} \leq AW_{max,IMD3} / (12 \cdot SCS)$  and  $F_C - BW_{channel}/2 < F_{UL,low} + offset_{IMD3}$ ,
then
    the A-MPR' is defined according to Table 6.2.3.2-2 PC3_A2 relative to 23 dBm for power class 3,
    PC2_A4 relative to 26 dBm for power class 2, and PC1.5_A6 relative to 29 dBm for power class 1.5,
    else,
if  $R_{B_{start}} \leq L_{CRB}/2 + \Delta_{start} / (12 \cdot SCS)$  and  $L_{CRB} \leq AW_{max,regrowth} / (12 \cdot SCS)$  and  $F_C - BW_{channel}/2 < F_{UL,low} + offset_{regrowth}$ ,
then
    the A-MPR' is defined according to Table 6.2.3.2-2 PC3_A1 relative to 23 dBm for power class 3,
    PC2_A3 relative to 26 dBm for power class 2, , and PC1.5_A5 relative to 29 dBm for power class 1.5,
    else
    A-MPR' = 0 dB and apply MPR.

```

With the parameters defined in Table 6.2.3.2-1.

**Table 6.2.3.2-1: Parameters for region edges and frequency offsets (Power Class 1.5, 2 and 3)**

Parameter	Symbol	Value		Related condition
		CP-OFDM	DFT-s-OFDM	
Max allocation start in IMD3 region	$f_{start,max,IMD3}$	0.33 $BW_{channel}$		$R_{B_{start}} \leq f_{start,max,IMD3} / (12SCS)$
Max allocation BW in IMD3 region	$AW_{max,IMD3}$	4 MHz		$L_{CRB} \leq AW_{max,IMD3} / (12SCS)$
Freq. offset required to avoid A-MPR in IMD3 region	$offset_{IMD3}$	$BW_{channel} - 6$ MHz		$F_C - BW_{channel}/2 \geq F_{UL,low} + offset_{IMD3}$
Right edge of regrowth region	$\Delta_{start}$	0.08 $BW_{channel}$		$R_{B_{start}} \leq L_{CRB}/2 + \Delta_{start} / (12SCS)$
Max allocation BW in regrowth region	$AW_{max,regrowth}$	100 MHz		$L_{CRB} \leq \text{Min}(L_{CRB,Max}, AW_{max,regrowth} / (12SCS))$
Freq. offset required to avoid A-MPR in regrowth region	$offset_{regrowth}$	Max (10 MHz, 0.25* $BW_{channel}$ MHz)	Max (10 MHz, 0.45* $BW_{channel}$ MHz)	$F_C - BW_{channel}/2 \geq F_{UL,low} + offset_{regrowth}$

**Table 6.2.3.2-2: A-MPR' values Access (Power Class 1.5, 2 and 3)**

Modulation/Waveform		A-MPR' (dB)					
		PC3_A1	PC3_A2	PC2_A3	PC2_A4	PC1.5_A5 <sup>1</sup>	PC1.5_A6 <sup>1</sup>
DFT-s-OFDM	Pi/2-BPSK	≤ 3.5	≤ 3.5	≤ 3.5	≤ 5.5	≤ 5	≤ 7
	QPSK	≤ 4	≤ 4	≤ 4.5	≤ 6	≤ 6	≤ 7.5
	16 QAM	≤ 4	≤ 4	≤ 5	≤ 6	≤ 6.5	≤ 7.5
	64 QAM	≤ 4	≤ 4.5	≤ 5	≤ 6.5	≤ 6.5	≤ 8
	256 QAM	≤ 4.5	≤ 6	≤ 6.5	≤ 8	≤ 8	≤ 9.5
CP-OFDM	QPSK	≤ 5.5	≤ 5.5	≤ 6.5	≤ 7.5	≤ 8	≤ 9
	16 QAM	≤ 5.5	≤ 5.5	≤ 6.5	≤ 7.5	≤ 8	≤ 9
	64 QAM	≤ 5.5	≤ 5.5	≤ 6.5	≤ 7.5	≤ 8	≤ 9
	256 QAM	≤ 6.5	≤ 8	≤ 7.5	≤ 10	≤ 9	≤ 11.5

NOTE 1: PC1.5 assumes dual Tx.

For Power Class 1, NS\_04 A-MPR is defined as  
 $A-MPR = \max(MPR, A-MPR_{regrowth}, A-MPR_{IMD3}, A-MPR_{CIM3}, A-MPR_{edge})$ .

$A-MPR_{regrowth}$  is obtained from Table 6.2.3.2-3 in terms of *total guard bandwidth* (TGBW). The TGBW is defined as the frequency distance between the RB allocation and the additional spurious emission limit defined in Table 6.5.3.3.1-1, i.e.,

$$TGBW = f_{alloc,low} - 2496 \text{ MHz},$$

where

$$f_{alloc,low} = F_C - \frac{BW_{channel}}{2} + BW_{GB} + RB_{start} \cdot 12 \text{ SCS}$$

is the lower edge frequency of the RB allocation,  $F_C$  is the channel centre frequency,  $BW_{channel}$  is the channel bandwidth, and  $BW_{GB}$  is the minimum guard bandwidth defined in Table 5.3.3-1.

**Table 6.2.3.2-3: A-MPR<sub>regrowth</sub> for NS\_04 (Power Class 1)**

TGBW range	A-MPR <sub>regrowth</sub> *(dB)
$G_{0dB}(BW_{alloc}) \leq TGBW$	0
$G_{1dB}(BW_{alloc}) \leq TGBW < G_{0dB}(BW_{alloc})$	1
$G_{2dB}(BW_{alloc}) \leq TGBW < G_{1dB}(BW_{alloc})$	2
$G_{3dB}(BW_{alloc}) \leq TGBW < G_{2dB}(BW_{alloc})$	3
$G_{4dB}(BW_{alloc}) \leq TGBW < G_{3dB}(BW_{alloc})$	4
$G_{5dB}(BW_{alloc}) \leq TGBW < G_{4dB}(BW_{alloc})$	5
$TGBW < G_{5dB}(BW_{alloc})$	6

Each function  $G_A(BW_{alloc})$  defines the required minimum total guard bandwidth for A-MPR value  $A$  and is defined as

$$G_A(BW_{alloc}) = \max(0, C_2 \left(\frac{BW_{alloc}}{100\text{MHz}}\right)^2 + C_1 \frac{BW_{alloc}}{100\text{MHz}} + C_0),$$

where  $BW_{alloc} = L_{CRB} \cdot 12 \text{ SCS}$  is the allocation bandwidth, and  $C_2$ ,  $C_1$ , and  $C_0$  are obtained from Table 6.2.3.2-4 for each combination of waveform, modulation, and back-off value  $A$ .

**Table 6.2.3.2-4: Polynomial coefficients for determining the required total guard bandwidth for each value of A-MPR<sub>regrowth</sub> (Power Class 1)**

Waveform	Modulation	Back-off value A [dB] / Polynomial coefficients $C_2, C_1, C_0$ [MHz]						
		0	1	2	3	4	5	6

DFT-s-OFDM	Pi/2-BPSK	-3, 40, 10	-91, 98, 0	-248, 143, -9	-2148, 604, -40	0,0,0	N/A	N/A
	QPSK	-27, 71, 1	-49, 73, 0	-76, 76, -3	-108, 62, -3	0,0,0	N/A	N/A
	16-QAM	-34, 81, -1 (NOTE 1)	-57, 92, -5	-69, 82, -5	-119, 79, -5	0,0,0	N/A	N/A
	64-QAM	-23, 74, -1 (NOTE 1)	-61, 91, -4 (NOTE 1)	-84, 92, -5	-116, 80, -5	0,0,0	N/A	N/A
	256-QAM	0, 0, 0 (NOTE 2)	N/A	N/A	N/A	N/A	N/A	N/A
CP-OFDM	QPSK	-32, 81, -2 (NOTE 1)	-36, 77, -3	-40, 70, -3	-52, 67, -3	-67, 60, -3	-101, 56, -4	0,0,0
	16-QAM	-31, 80, -2 (NOTE 1)	-32, 72, -2 (NOTE 1)	-36, 66, -2	-48, 62, -2	-66, 58, -2	-108, 60, -4	0,0,0
	64-QAM	-28, 78, -2 (NOTE 1)	-33, 73, -2 (NOTE 1)	-36, 66, -2 (NOTE 1)	-48, 62, -2	-65, 58, -2	-124, 67, -5	0,0,0
	256-QAM	0, 0, 0 (NOTE 2)	N/A	N/A	N/A	N/A	N/A	N/A
NOTE 1: Back-off value $A$ is less than $\text{floor}(\text{MPR})$ , thus this polynomial is irrelevant.								
NOTE 2: For 256-QAM, always $A - \text{MPR}_{\text{regrowth}} = 0$ .								

For both OFDM and DFT-S-OFDM,  $A\text{-MPR}_{\text{IMD3}} = \max\left(0, \min\left(3, 4 - 2.77 \frac{BW_{\text{alloc}}}{1 \text{ MHz}}\right)\right) \text{ dB}$   
 if  $3f_{\text{alloc,low}} - 2F_C \leq 2490.5 \text{ MHz}$ ; otherwise,  $A\text{-MPR}_{\text{IMD3}} = 0 \text{ dB}$ .

For OFDM,  $A\text{-MPR}_{\text{CIM3}} = \max\left(0, \min\left(11, 12 - 2 \frac{BW_{\text{alloc}}}{1 \text{ MHz}}\right)\right) \text{ dB}$  if  $4F_C - 3f_{\text{alloc,high}} \leq 2490.5 \text{ MHz}$ ;  
 otherwise,  $A\text{-MPR}_{\text{CIM3}} = 0$ .

For DFT-S-OFDM,  $A\text{-MPR}_{\text{CIM3}} = 3 \text{ dB}$  if  $BW_{\text{alloc}} \leq 1.08 \text{ MHz}$  and  $4F_C - 3f_{\text{alloc,high}} \leq 2490.5 \text{ MHz}$ ;  
 otherwise,  $A\text{-MPR}_{\text{CIM3}} = 0$ .

Here,  $f_{\text{alloc,high}} = f_{\text{alloc,low}} + BW_{\text{alloc}}$  is the upper edge frequency of the RB allocation.

For both OFDM and DFT-S-OFDM, if  $RB_{\text{start}} = 0$ ,  $L_{\text{CRB}} = 1$ , and  $F_C - \frac{BW_{\text{channel}}}{2} - 2496 \text{ MHz} < 360 \text{ kHz}$ ,  $A\text{-MPR}_{\text{edge}}$  is defined in Table 6.2.3.2-5. Otherwise,  $A\text{-MPR}_{\text{edge}} = 0 \text{ dB}$ .

Table 6.2.3.2-5:  $A\text{-MPR}_{\text{edge}}$  for NS\_04 (Power Class 1)

Waveform	$BW_{\text{channel}}$ [MHz]	$BW_{\text{alloc}}$ [MHz]	A-MPR [dB]
DFT-s-OFDM	< 40	N/A	0
	40...90		3.5

	100	$\leq -9.8 \left( \frac{CBW}{100MHz} \right)^2 + 24.1 \frac{CBW}{100MHz} - 6.3$	11
OFDM	< 90	N/A	0
	90	$\leq 6.5$	3.5
	100	$\leq 8$	11

6.2.3.3 A-MPR for NS\_10

Table 6.2.3.3-1: A-MPR for NS\_10

Channel bandwidth (MHz)	Parameters	Region A
15	RB <sub>start</sub>	0 – 10
	L <sub>CRB</sub> (RBs)	1 – 20
	A (dB)	≤ 3
20	RB <sub>start</sub>	0 – 15
	L <sub>CRB</sub> (RBs)	1 – 20
	A (dB)	≤ 6

NOTE 1: RB<sub>start</sub> indicates the lowest RB index of transmitted resource blocks  
 NOTE 2: L<sub>CRB</sub> is the length of a contiguous resource block allocation  
 NOTE 3: For intra-subframe frequency hopping which intersects Region A, notes 1 and 2 apply on a per slot basis. For intra-slot or intra-subslot frequency hopping which intersects Region A, notes 1 and 2 apply on a T<sub>no\_hopping</sub> basis.  
 NOTE 4: For intra-subframe frequency hopping which intersect Region A, the larger A-MPR value may be applied for both slots in the subframe. For intra-slot frequency hopping which intersects Region A, the larger A-MPR value may be applied for the slot. For intra-subslot frequency hopping which intersects Region A, the larger A-MPR value may be applied for the subslot.  
 NOTE 5: The A-MPR for DFT-s-OFDM is the total backoff and is obtained by taking the maximum value of MPR + A-MPR specified in Table 6.2.3-1 and Table 6.2.4-1 in TS 36.101 and A value specified in Table 6.2.3.3-1.  
 NOTE 6: The A-MPR for CP-OFDM is the total backoff and is obtained by adding the A value in Table 6.2.3.3-1 to the corresponding MPR specified in Table 6.2.2-1.

6.2.3.4 A-MPR for NS\_05 and NS\_05U

Table 6.2.3.4-1: A-MPR regions for NS\_05 and NS\_05U (Power Class 3)

Channel Bandwidth (MHz)	Carrier Centre Frequency, $F_c$ (MHz)	Region A			Region B			Region C		
		$RB_{start}$	LCRB	A-MPR	$RB_{start}$	LCRB	A-MPR	$RB_{start}$	LCRB	A-MPR
5	$1922.5 \leq F_c < 1927.5$	$< 1.62 \text{ MHz}/12/\text{SCS}$	$> 2.52 \text{ MHz}/12/\text{SCS}$	A3						
10	$1925 \leq F_c < 1935$	$\leq 1.62 \text{ MHz}/12/\text{SCS}$	$> 0$	A1	$> 1.62 \text{ MHz}/12/\text{SCS}$ $\leq 3.60 \text{ MHz}/12/\text{SCS}$	$> 5.4 \text{ MHz}/12/\text{SCS}$	A7	$\geq 7.2 \text{ MHz}/12/\text{SCS}$	$\leq 1.08 \text{ MHz}/12/\text{SCS}$	A2
10	$1935 \leq F_c < 1945$		$> 4.5 \text{ MHz}/12/\text{SCS}$	A4						
15	$1927.5 \leq F_c < 1932.5$	$\leq 3.24 \text{ MHz}/12/\text{SCS}$	$> 0$	A1	$> 3.24 \text{ MHz}/12/\text{SCS}$ $\leq 5.40 \text{ MHz}/12/\text{SCS}$	$> 8.1 \text{ MHz}/12/\text{SCS}$	A7	$\geq 10.08 \text{ MHz}/12/\text{SCS}$	$\leq 1.08 \text{ MHz}/12/\text{SCS}$	A2
15	$1932.5 \leq F_c < 1942.5$	$< 1.62 \text{ MHz}/12/\text{SCS}$	$> 0$	A1				$\geq 12.24 \text{ MHz}/12/\text{SCS}$	$\leq 1.08 \text{ MHz}/12/\text{SCS}$	A2
15	$1942.5 \leq F_c < 1947.5$		$> 7.2 \text{ MHz}/12/\text{SCS}$	A5						
20	$1930 \leq F_c < 1950$	$\leq 4.86 \text{ MHz}/12/\text{SCS}$	$> 0$	A1	$> 4.86 \text{ MHz}/12/\text{SCS}$ $\leq 7.20 \text{ MHz}/12/\text{SCS}$	$> 9.0 \text{ MHz}/12/\text{SCS}$	A7	$\geq 13.68 \text{ MHz}/12/\text{SCS}$	$\leq 1.08 \text{ MHz}/12/\text{SCS}$	A2
20	$1950 \leq F_c < 1960$		$> 9.0 \text{ MHz}/12/\text{SCS}$	A6						

NOTE 1: The A-MPR values are specified in Table 6.2.3.4-2, 6.2.3.4-3 and 6.2.3.4-10.  
NOTE 2: Void

**Table 6.2.3.4-2: A-MPR for NS\_05 and NS\_05U (Power Class 3)**

Modulation/Waveform		A1 (dB)		A2 (dB)		A3 (dB)	
		Outer/Inner	Outer/Inner	Outer/Inner	Outer	Outer	Outer
DFT-s-OFDM	Pi/2 BPSK	≤ 10	≤ 5	≤ 4			
	QPSK	≤ 10	≤ 5	≤ 4.5			
	16 QAM	≤ 10	≤ 5	≤ 6			
	64 QAM	≤ 11	≤ 5	≤ 6			
	256 QAM	≤ 13	≤ 5	≤ 7			
CP-OFDM	QPSK	≤ 10	≤ 5	≤ 7.5			
	16 QAM	≤ 10	≤ 5	≤ 7.5			
	64 QAM	≤ 11	≤ 5	≤ 8			
	256 QAM	≤ 13		≤ 10			
NOTE 1: Void							
NOTE 2: Void							

**Table 6.2.3.4-3: A-MPR for NS\_05 (Power Class 3)**

Modulation/Waveform		A4 (dB)		A5 (dB)	A6 (dB)		A7 (dB)
		Outer	Inner	Outer	Outer	Inner	Outer/Inner
DFT-s-OFDM	Pi/2 BPSK	≤ 1	N/A	≤ 1	≤ 1	N/A	≤ 6
	QPSK			≤ 1.5	≤ 1.5		≤ 6
	16 QAM						≤ 6
	64 QAM						≤ 6
	256 QAM						≤ 6
CP-OFDM	QPSK	≤ 3.5		≤ 3.5	≤ 3.5		≤ 6
	16 QAM	≤ 3.5		≤ 3.5	≤ 3.5		≤ 6
	64 QAM						≤ 6
	256 QAM						≤ 6
NOTE 1: Void							
NOTE 2: Void							

**Table 6.2.3.4-4 - Table 6.2.3.4-9: Void**

**Table 6.2.3.4-10: A-MPR for modulation and waveform type for NS\_05U (Power Class 3)**

Modulation/Waveform		A4 (dB)		A5 (dB)	A6 (dB)		A7 (dB)
		Outer	Inner	Outer	Outer	Inner	Outer/Inner
DFT-s-OFDM	Pi/2 BPSK	≤ 2	N/A	≤ 2	≤ 2	N/A	≤ 6
	QPSK	≤ 2		≤ 2	≤ 2		≤ 6
	16 QAM	≤ 2.5		≤ 2.5	≤ 2.5		≤ 6
	64 QAM	≤ 3		≤ 3	≤ 3		≤ 6
	256 QAM	≤ 4.5		≤ 4.5	≤ 4.5		≤ 6
CP-OFDM	QPSK	≤ 4		≤ 4	≤ 4		≤ 6
	16 QAM	≤ 4		≤ 4	≤ 4		≤ 6
	64 QAM	≤ 4		≤ 4	≤ 4		≤ 6
	256 QAM	≤ 6.5		≤ 6.5	≤ 6.5		≤ 6.5
NOTE 1: Void							
NOTE 2: Void							



Table 6.2.3.4-11: A-MPR regions for NS\_05 and NS\_05U (Power Class 2)

Channel Bandwidth (MHz)	Carrier Centre Frequency, $F_c$ (MHz)	Region A			Region B			Region C		
		$RB_{start}$	LCRB	A-MPR	$RB_{start}$	LCRB	A-MPR	$RB_{start}$	LCRB	A-MPR
5	$1922.5 \leq F_c < 1927.5$	$< 1.98$ MHz/12/SCS	$> 1.44$ MHz/12/SCS	A3	$< 0.72$ MHz/12/SCS	$\leq 1.44$ MHz/12/SCS	A4			
10	$1925 \leq F_c < 1935$	$< 1.98$ MHz/12/SCS	$> 0$	A1	$\geq 1.98$ MHz/12/SCS	$> \max(0, RB_{start}-1.08$ MHz/12/SCS)	A7	$\geq 7.2$ MHz/12/SCS	$\leq 1.08$ MHz/12/SCS	A1
					$\geq 1.98, \leq 2.7$ MHz/12/SCS	$< 1.08$ MHz/12/SCS	A8			
10	$1935 \leq F_c < 1945$		$> 3.96$ MHz/12/SCS	A4						
15	$1927.5 \leq F_c < 1932.5$	$< 3.6$ MHz/12/SCS	$> 0$	A1	$\geq 3.6$ MHz/12/SCS	$> \max(0, RB_{start}-1.8$ MHz/12/SCS)	A7	$\geq 10.08$ MHz/1 2/SCS	$\leq 1.08$ MHz/12/SCS	A1
					$\geq 3.6, \leq 4.68$ MHz/12/SCS	$\leq 1.08$ MHz/12/SCS	A8			
15	$1932.5 \leq F_c < 1942.5$	$< 1.98$ MHz/12/SCS	$> 0$	A1	$\geq 1.98$ MHz/12/SCS	$> \max(0, RB_{start}+1.08$ MHz/12/SCS)	A7	$\geq 12.24$ MHz/12/SCS	$\leq 1.08$ MHz/12/SCS	A1
15	$1942.5 \leq F_c < 1947.5$		$> 5.04$ MHz/12/SCS	A5						
20	$1930 \leq F_c < 1950$	$< 5.04$ MHz/12/SCS	$> 0$	A1	$\geq 5.04$ MHz/12/SCS	$> \max(0, RB_{start}-3.6$ MHz/12/SCS)	A7	$\geq 13.68$ MHz/12/SCS	$\leq 1.08$ MHz/12/SCS	A1
					$\geq 5.04, \leq 6.66$ MHz/12/SCS	$\leq 1.08$ MHz/12/SCS	A8			
20	$1950 \leq F_c < 1960$		$> 9.0$ MHz/12/SCS	A6						

NOTE 1: The A-MPR values are specified in Table 6.2.3.4-12 and 6.2.3.4-13.  
NOTE 2: Void

**Table 6.2.3.4-12: A-MPR for NS\_05 and NS\_05U (Power Class 2)**

Modulation/Waveform		A1 (dB)		A2 (dB)		A3 (dB)	
		Outer/Inner	Outer/Inner	Outer	Inner	Outer	Inner
DFT-s-OFDM	Pi/2 BPSK	≤ [13]	≤ 6	≤ 6.5	≤ 2		
	QPSK	≤ [13]	≤ 6	≤ 7	≤ 2		
	16 QAM	≤ [13]	≤ 6	≤ 8.5	≤ 2		
	64 QAM	≤ [14]	≤ 6	≤ 9	≤ 2		
	256 QAM	≤ [15]	≤ 6	≤ 9.5			
CP-OFDM	QPSK	≤ [13]	≤ 6	≤ 10	≤ 4		
	16 QAM	≤ [13]	≤ 6	≤ 10	≤ 4		
	64 QAM	≤ [14]	≤ 6	≤ 10	≤ 4		
	256 QAM	≤ [16]		≤ 10			

NOTE 1: Void  
NOTE 2: Void

**Table 6.2.3.4-13: A-MPR for NS\_05 and NS\_05U (Power Class 2)**

Modulation/Waveform		A4 (dB)		A5 (dB)		A6 (dB)		A7 (dB)	A8 (dB)
		Outer	Inner	Outer	Inner	Outer	Inner	Outer/Inner	Outer/Inner
DFT-s-OFDM	Pi/2 BPSK	≤ 3	N/A	≤ 2		≤ 2	N/A	≤ 8	≤ 3.5
	QPSK	≤ 3		≤ 2		≤ 2		≤ 8	≤ 3.5
	16 QAM	≤ 3.5		≤ 2.5		≤ 2		≤ 8	≤ 3.5
	64 QAM	≤ 3.5		≤ 2.5				≤ 8	≤ 3.5
	256 QAM							≤ 8	
CP-OFDM	QPSK	≤ 4.5		≤ 4.5		≤ 4		≤ 8.5	≤ 3.5
	16 QAM	≤ 4.5		≤ 4.5		≤ 4		≤ 8.5	≤ 3.5
	64 QAM	≤ 5		≤ 5	≤ 5	≤ 4		≤ 8.5	
	256 QAM							≤ 8.5	

NOTE 1: Void  
NOTE 2: Void

6.2.3.5 A-MPR for NS\_40

**Table 6.2.3.5-1: A-MPR for NS\_40**

Modulation/ Waveform		A (dB)	
		Channel bandwidth: 5 MHz	
		Outer	Inner
DFT-s-OFDM	QPSK	≤ 15.5	≤ 12
	16 QAM	≤ 14.5	≤ 11
	64 QAM	≤ 14.5	≤ 10
	256 QAM	≤ 12.5	≤ 7.5
CP-OFDM	QPSK	≤ 14.5	≤ 10
	16 QAM	≤ 14.5	≤ 10
	64 QAM	≤ 14	≤ 8
	256 QAM	≤ 11	≤ 5.5

NOTE 1: The A-MPR for NS\_40 is the total backoff and is obtained by taking the maximum value of MPR + A-MPR specified in Table 6.2.3-1 and Table 6.2.4-30a in TS 36.101 and MPR + A specified in Table 6.2.2-1 and Table 6.2.3.5-1.

6.2.3.6 A-MPR for NS\_43 and NS\_43U

**Table 6.2.3.6-1: A-MPR regions for NS\_43 (Power class 3 and 2)**

	Region A	Region B
--	----------	----------

Channel Bandwidth (MHz)	Carrier Centre Frequency, $F_c$ (MHz)	$RB_{start}$	$L_{CRB}$	A-MPR	$RB_{start}$	$L_{CRB}$	A-MPR
5 MHz	$902.5 \leq F_c < 912.5$		$> 2.7$ MHz/12/SCS	A1			
10 MHz	$F_c = 910$		$> 7.2$ MHz/12/SCS	A2		$> 5.4$ MHz/12/SCS	A4
			$> 8.1$ MHz/12/SCS	A3		$> 7.2$ MHz/12/SCS	A5
15 MHz	$F_c = 907.5$	$\leq 1.8$ MHz /12/SCS	$> 0$	A6	$> 1.8$ MHz/12/SCS $< 6.12$ MHz/12/SCS	$\geq 7.2$ MHz/12/SCS	A6
		$\geq 12.24$ MHz/12/SCS	$> 0$	A6	$> 1.8$ MHz/12/SCS $< 6.12$ MHz/12/SCS	$< 7.2$ MHz/12/SCS	A7
					$\geq 6.12$ MHz/12/SCS $\leq 7.2$ MHz/12/SCS	$> 5.4$ MHz/12/SCS	A7

NOTE 1: The A-MPR values are specified in Table 6.2.3.6-2 and Table 6.2.3.6-2a.  
 NOTE 2: Void  
 NOTE 3: Void

Table 6.2.3.6-2: A-MPR for NS\_43 (Power class 3)

Modulation/Waveform		A1 (dB)		A2 (dB)		A3 (dB)		A4 (dB)		A5 (dB)		A6 (dB)
		Outer	Inner	Outer	Inner	Outer	Inner	Outer	Inner	Outer	Inner	Outer / Inner
DFT-s-OFDM	Pi/2 BPSK		N/A	$\leq 1.5$	N/A				N/A		N/A	$\leq 9$
	QPSK	$\leq 2$						$\leq 2.5$				$\leq 9$
	16 QAM									$\leq 2.5$		$\leq 9$
	64 QAM					$\leq 2.5$						$\leq 9$
CP-OFDM	256 QAM											$\leq 9$
	QPSK	$\leq 3.5$								$\leq 4$		$\leq 9$
	16 QAM	$\leq 3.5$								$\leq 4$		$\leq 9$
	64 QAM					$\leq 4$						$\leq 9$
	256 QAM											$\leq 9$

Table 6.2.3.6-2a: A-MPR for NS\_43 (Power Class 2)

Modulation/Waveform		A1 (dB)		A2 (dB)		A3 (dB)		A4 (dB)		A5 (dB)		A6 (dB)		A7 (dB)	
		Outer	Inner	Outer	Inner	Outer	Inner	Outer	Inner	Outer	Inner	Outer / Inner	Outer	Inner	
DFT-s-OFDM	Pi/2 BPSK	≤ 1	N/A	≤ 1.5	N/A				N/A		N/A	≤ 12	≤ 4	3	
	QPSK	≤ 3.5						≤ 3.5		≤ 5.5		≤ 12	≤ 4	3	
	16 QAM	≤ 3.5						≤ 3.5		≤ 5.5		≤ 12	≤ 5	4	
	64 QAM	≤ 3.5		≤ 4.5		≤ 5						≤ 12	≤ 5.5	5.5	
	256 QAM											≤ 12	≤ 6.5	5.5	
CP-OFDM	QPSK	≤ 4						≤ 4		≤ 6		≤ 12	≤ 6	4.5	
	16 QAM	≤ 4						≤ 4.5		≤ 6		≤ 12	≤ 6	5	
	64 QAM	≤ 4		≤ 5		≤ 6.5						≤ 12	≤ 6.5	6	
	256 QAM											≤ 12	≤ 7	7	

**Table 6.2.3.6-3: Void**

For power class 3 operation, when NS\_43U is signalled for 5 and 10 MHz channel bandwidths A-MPR is defined in Table 6.2.3.1-2 except for DFT-s-OFDM QPSK when  $L_{CRB} > 5.4 \text{ MHz}/12/\text{SCS}$  the A-MPR is 2.5 dB. For 15 MHz channel bandwidth Table 6.2.3.6-4 applies.

**Table 6.2.3.6-4: A-MPR for NS\_43U**

Modulation/Waveform		15 MHz
		Outer / Inner (dB)
DFT-s-OFDM	Pi/2 BPSK	$\leq 9$
	QPSK	$\leq 9$
	16 QAM	$\leq 9$
	64 QAM	$\leq 9$
	256 QAM	$\leq 9$
CP-OFDM	QPSK	$\leq 9$
	16 QAM	$\leq 9$
	64 QAM	$\leq 9$
	256 QAM	$\leq 9$

For power class 2 operation, when NS\_43U is signalled, the larger one between the PC2 A-MPR for NS\_100 defined in Table 6.2.3.1-2 and the PC2 A-MPR for NS\_43 defined in this clause applies.

### 6.2.3.7 A-MPR for NS\_03 and NS\_03U

**Table 6.2.3.7-1 A-MPR for NS\_03**

Modulation/Waveform		Outer (dB)	Inner (dB)
DFT-s-OFDM	PI/2 BPSK	$\leq 1.5$	N/A
	QPSK	$\leq 2$	
	16 QAM	$\leq 3$	
	64 QAM	$\leq 3.5$	
	256 QAM	$\leq 5.5$	
CP-OFDM	QPSK	$\leq 4$	
	16 QAM	$\leq 4$	
	64 QAM	$\leq 4.5$	
	256 QAM	$\leq 7.5$	
NOTE 1: Void			
NOTE 2: Void			

In case UE operates in a band where NS\_03U applies and it receives *additionalSpectrumEmission* value of 3 then A-MPR values specified in Table 6.2.3.7-1 apply with an exception that DFT-s-OFDM Pi/2 BPSK A-MPR is 2 dB.

When power class 2 UE receives network signalling NS\_03, A-MPR values specified in Table 6.2.3.7-1 apply.

6.2.3.8 A-MPR for NS\_37

Table 6.2.3.8-1: A-MPR regions for B11/B21 protection (NS\_37) (1447.9 - 1462.9 MHz)

Channel Bandwidth (MHz)	Carrier Centre Frequency, F <sub>c</sub> (MHz)	Region A (Outer/Inner)			Region B (Outer/Inner)			Region C (Outer/Inner)		
		RB <sub>start</sub>	LCRB	A-MPR	RB <sub>start</sub>	LCRB	A-MPR	RB <sub>start</sub>	LCRB	A-MPR
10	1452.9 < F <sub>c</sub> ≤ 1457.9	≥ 0	> 7.2 MHz/12/SCS	≤ A1	N/A	N/A	N/A	N/A	N/A	N/A
15	F <sub>c</sub> = 1455.4	≥ 0	> 9.9 MHz/12/SCS	≤ A1	< 0.54 MHz/12/S CS	< 1.08 MHz/12/S CS	≤ A2	> 13.86 MHz/12/S CS	< 1.08 MHz/12/S CS	≤ A2

NOTE 1: The A-MPR values are specified in Table 6.2.3.8-2  
 NOTE 2: Void  
 NOTE 3: Void  
 NOTE 4: No A-MPR for SCS = 60 kHz for region B and C only.

Table 6.2.3.8-2: A-MPR for NS\_37

Modulation/Waveform		A1 (dB)		A2 (dB)
		Outer	Inner	Outer/Inner
DFT-s-OFDM	Pi/2 BPSK	≤ 1	N/A	≤ 3
	QPSK	≤ 1.5		≤ 3
	16 QAM	≤ 2.5		≤ 3
	64 QAM	≤ 3		≤ 3
	256 QAM			
CP-OFDM	QPSK	≤ 3.5		≤ 3
	16 QAM	≤ 3.5		≤ 3
	64 QAM			
	256 QAM			

NOTE 1: Void  
 NOTE 2: Void

6.2.3.9 A-MPR for NS\_38

Table 6.2.3.9-1: A-MPR for EESS (NS\_38) Protection (1430 – 1470 MHz)

Channel Bandwidth (MHz)	Carrier Centre Frequency, F <sub>c</sub> (MHz)	Region A Outer/Inner			Region B Outer/Inner		
		RB <sub>start</sub>	LCRB	A-MPR (dB)	RB <sub>start</sub>	RB <sub>start</sub> +LCRB	A-MPR (dB)
5	1432.5 ≤ F <sub>c</sub> < 1437.5	≤ -3.6 MHz/12/SCS + LCRB	≥ 3.6 MHz/12/SCS	≤ 7	> -3.6 MHz/12/SCS + LCRB)	≤ 2.16 MHz/12/SCS	≤ 5.5
10	1435 ≤ F <sub>c</sub> < 1442	≤ -3.6 MHz/12/SCS + LCRB	≥ 3.6 MHz/12/SCS	≤ 12	> -3.6 MHz/12/SCS + LCRB)	≤ 2.16 MHz/12/SCS	≤ 9

15	$1437.5 \leq F_c < 1447.5$	$\leq -3.6$ MHz/12/SCS + LCRB	$\geq 3.6$ MHz/12/SCS	$\leq 13$	$> -3.6$ MHz/12/SCS + LCRB)	$\leq 3.6$ MHz/12/SCS	$\leq 10$
20	$1440 \leq F_c < 1450$	$\leq -3.6$ MHz/12/SCS + LCRB	$\geq 3.6$ MHz/12/SCS	$\leq 13$	$> -3.6$ MHz/12/SCS + LCRB)	$\leq 5.4$ MHz/12/SCS	$\leq 10$

NOTE 1 - 4: Void

6.2.3.10 A-MPR for NS\_39

Table 6.2.3.10-1: A-MPR for own RX (NS\_39) Protection (1440 – 1470 MHz)

Channel Bandwidth, MHz	Carrier Centre Frequency, F <sub>c</sub> , MHz	Region A (Outer/Inner)	
		RB <sub>start</sub> +LCRB	A-MPR (dB)
10	$1462 < F_c \leq 1465$	$> 7.9$ MHz/12/SCS	$\leq 6$
15	$1456.3 < F_c \leq 1462.5$	$> 11.2$ MHz/12/SCS	$\leq 6$
20	$1450.8 < F_c \leq 1460$	$> 12.6$ MHz/12/SCS	$\leq 6$

NOTE 1 - 4: Void

6.2.3.11 A-MPR for NS\_41

Table 6.2.3.11-1: A-MPR for NS\_41

Channel Bandwidth (MHz)	Carrier Centre Frequency, F <sub>c</sub> (MHz)	Region A Outer/Inner			Region B Outer/Inner	
		RB <sub>start</sub>	LCRB	A-MPR (dB)	RB <sub>start</sub> +LCRB	A-MPR (dB)
5	-	-	-	-	-	-
10	$1437 \leq F_c < 1442$	$\leq -4.5$ MHz/12/SCS + LCRB	$> 4.5$ MHz/12/SCS	$\leq 9$	$< 1.8$ MHz/12/SCS	$\leq 9$
15	$1439.5 \leq F_c < 1447.5$	$\leq -5.4$ MHz/12/SCS + LCRB	$> 5.4$ MHz/12/SCS	$\leq 11$	$< 3.42$ MHz/12/SCS	$\leq 9$
20	$1442 \leq F_c < 1450$	$\leq -5.4$ MHz/12/SCS + LCRB	$> 5.4$ MHz/12/SCS	$\leq 12$	$< 5.04$ MHz/12/SCS	$\leq 9$
30	$1452 \leq F_c < 1502$	$\leq -7.2$ MHz/12/SCS + LCRB	$> 7.2$ MHz/12/SCS	$\leq 13.5$	$< 11.7$ MHz/12/SCS	$\leq 13.5$
40	$1452 \leq F_c < 1497$	$\leq -7.2$ MHz/12/SCS + LCRB	$> 7.2$ MHz/12/SCS	$\leq 13.5$	$< 11.7$ MHz/12/SCS	$\leq 13.5$
50	$1457 \leq F_c < 1492$	$\leq -7.2$ MHz/12/SCS + LCRB	$> 7.2$ MHz/12/SCS	$\leq 13.5$	$< 15.12$ MHz/12/SCS	$\leq 13.5$
60	$1462 \leq F_c < 1487$	$\leq -7.2$ MHz/12/SCS + LCRB	$> 7.2$ MHz/12/SCS	$\leq 13.5$	$< 18.72$ MHz/12/SCS	$\leq 13.5$

NOTE 1 - 4: Void

6.2.3.12 A-MPR for NS\_42

Table 6.2.3.12-1: A-MPR for NS\_42

Channel Bandwidth (MHz)	Carrier Centre Frequency, F <sub>c</sub> (MHz)	Region A	Region B
-------------------------	--	----------	----------

		RB <sub>start</sub> +LCRB	A-MPR Outer/Inner (dB)	RB <sub>start</sub>	RB <sub>start</sub> +LCRB	A-MPR Inner (dB)	A-MPR Outer (dB)
5	1512 ≤ F <sub>C</sub> ≤ 1514.5	> 3.1 MHz / 12 / SCS	≤ 7	< 0.90 MHz / 12 / SCS	≤ 3.1 MHz / 12 / SCS	≤ 1.5	≤ 4
10	1497 ≤ F <sub>C</sub> ≤ 1512	> 6.2 MHz / 12 / SCS	≤ 8	< 0.90 MHz / 12 / SCS	≤ 6.2 MHz / 12 / SCS	≤ 1.5	≤ 5
15	1502 ≤ F <sub>C</sub> ≤ 1509.5	> 9.3 MHz / 12 / SCS	≤ 8	< 3.06 MHz / 12 / SCS	≤ 9.3 MHz / 12 / SCS	≤ 1.5	≤ 5
20	1497 ≤ F <sub>C</sub> ≤ 1507	> 12.4 MHz / 12 / SCS	≤ 8	< 4.50 MHz / 12 / SCS	≤ 12.4 MHz / 12 / SCS	≤ 1.5	≤ 5
30	1477 ≤ F <sub>C</sub> ≤ 1502	> 24.8 MHz / 12 / SCS	≤ 8	< 5.40 MHz / 12 / SCS	≤ 24.8 MHz / 12 / SCS	≤ 1.5	≤ 5
40	1477 ≤ F <sub>C</sub> ≤ 1497	> 24.8 MHz / 12 / SCS	≤ 8	< 5.40 MHz / 12 / SCS	≤ 24.8 MHz / 12 / SCS	≤ 1.5	≤ 5
50	1467 ≤ F <sub>C</sub> ≤ 1492	> 31 MHz / 12 / SCS	≤ 8	< 7.20 MHz / 12 / SCS	≤ 31 MHz / 12 / SCS	≤ 1.5	≤ 5
60	1462 ≤ F <sub>C</sub> ≤ 1487	> 37.2 MHz / 12 / SCS	≤ 8	< 7.20 MHz / 12 / SCS	≤ 37.2 MHz / 12 / SCS	≤ 1.5	≤ 5

NOTE 1 - 5: Void

6.2.3.13 A-MPR for NS<sub>18</sub>

Table 6.2.3.13-0: Band n28 and n83 30MHz A-MPR regions for NS<sub>18</sub>

Channel Bandwidth, MHz	Frequency range of UL transmission bandwidth configuration, MHz	Regions		A-MPR
		RB <sub>start</sub> *12*SCS MHz	LCRB*12*SCS MHz	
25	703~733	>(LCRB*12*SCS)/2+ 3.6	≥Max(0, 12*SCS*N <sub>RB</sub> - 1.8 - RBstart*12*SCS)	A3
		≤(LCRB*12*SCS)/2+ 3.6	≥5.4	A4
		≤6.3	<5.4	A5
30	703~733	>(LCRB*12*SCS)/2+ 5.22	≥Max(0, 12*SCS*N <sub>RB</sub> - 1.8 - RBstart*12*SCS)	A3
		≤(LCRB*12*SCS)/2+ 5.22	≥5.4	A4
		≤7.92	<5.4	A5

Table 6.2.3.13-1: A-MPR for NS<sub>18</sub>

Modulation/Waveform		A1 (dB)		A2 (dB)	A3 (dB)	A4 (dB)	A5 (dB)
		Outer	Inner	Inner/Outer	Outer/Inner	Outer/Inner	Outer/Inner
DFT-s-OFDM	Pi/2 BPSK	≤ 2	N/A	≤ 5	3	8	3
	QPSK	≤ 2		≤ 5	3	8	3
	16 QAM	≤ 3		≤ 6	3	8	3
	64 QAM	≤ 4		≤ 7	3	8	4.5
	256 QAM	≤ 6		≤ 9	3	8	5.5
CP-OFDM	QPSK	≤ 5		≤ 6.5	4.5	9.5	5
	16 QAM	≤ 5		≤ 7	4.5	9.5	5
	64 QAM	≤ 5.5		≤ 8.5	4.5	9.5	5.5



	256 QAM	≤ 8.5		≤ 11.5	4.5	9.5	7.5
NOTE 1: Void							
NOTE 2: Void							

6.2.3.14 A-MPR for NS<sub>21</sub>

Table 6.2.3.14-1: A-MPR for "NS<sub>21</sub>"

Channel Bandwidth (MHz)	Modulation/Waveform		Region A1a	Region A1b	Region A2	Region A3b	Region A3a
			RB <sub>start</sub> ≤ 1.44MHz/12/SCS LCRB ≤ 0.54 MHz/12/SCS	RB <sub>start</sub> ≤ 1.44MHz/12/SCS LCRB > 0.54 MHz/12/SCS LCRB ≤ 2.16MHz/12/SCS	LCRB > 5.4MHz/12/SCS	RB <sub>end</sub> ≥ 7.74MHz/12/SCS LCRB > 0.54 MHz/12/SCS LCRB ≤ 2.16MHz/12/SCS	RB <sub>end</sub> ≥ 7.74MHz/12/SCS LCRB ≤ 0.54 MHz/12/SCS
			Outer/Inner	Outer	Outer/Inner		
10	DFT-s-OFDM	PI/2 BPSK	6	3	4	3	6
		QPSK	6	3	4	3	6
		16 QAM	6	3	4	3	6
		64 QAM	6	3	4	3	6
		256 QAM	6	3	4	3	6
	CP-OFDM	QPSK	6	4	5.5	4	6
		16 QAM	6	4	5.5	4	6
		64 QAM	6	4	5.5	4	6
		256 QAM	6	4	5.5	4	6

Table 6.2.3.14-2: A-MPR for "NS<sub>21</sub>"

Channel Bandwidth (MHz)	Modulation/Waveform		Region A1a	Region A1b	Region A2	Region A3b	Region A3a
			RB <sub>start</sub> ≤ 0.36MHz/12/SCS LCRB ≤ 0.54 MHz/12/SCS	RB <sub>start</sub> ≤ 0.36MHz/12/SCS LCRB > 0.54 MHz/12/SCS LCRB ≤ 2.52MHz/12/SCS	LCRB > 2.52MHz/12/SCS	RB <sub>end</sub> ≥ 3.96MHz/12/SCS LCRB > 0.54 MHz/12/SCS LCRB ≤ 2.52MHz/12/SCS	RB <sub>end</sub> ≥ 3.96MHz/12/SCS LCRB ≤ 0.54 MHz/12/SCS
			Outer/Inner	Outer	Outer/Inner		
5	DFT-s-OFDM	PI/2 BPSK	≤ 4.0	≤ 2.0	≤ 1.5	2.0	4.0
		QPSK	≤ 4.5	≤ 2.5	≤ 2.0	≤ 2.5	≤ 4.5
		16 QAM	≤ 4.5	≤ 2.5	≤ 2.5	≤ 2.5	≤ 4.5
		64 QAM	≤ 4.5	≤ 2.5	≤ 2.5	≤ 2.5	≤ 4.5
		256 QAM	≤ 4.5	≤ 4.5	≤ 4.5	≤ 4.5	≤ 4.5
	CP-OFDM	QPSK	≤ 4.5	≤ 4.0	≤ 4.0	≤ 4.0	≤ 4.5
		16 QAM	≤ 4.5	≤ 4.0	≤ 4.0	≤ 4.0	≤ 4.5
		64 QAM	≤ 4.5	≤ 4.0	≤ 4.0	≤ 4.0	≤ 4.5
		256 QAM	≤ 6.5	≤ 6.5	≤ 6.5	≤ 6.5	≤ 6.5

6.2.3.15 A-MPR for NS\_24

Table 6.2.3.15-1: A-MPR for NS\_24

Channel Bandwidth, MHz	Carrier Centre Frequency, Fc, MHz	Region A			Region B			Region C		
		RB <sub>end</sub> *12* SCS MHz	LCRB*12* SCS MHz	A-MPR	RB <sub>end</sub> *12*S CS MHz	LCRB*12* SCS MHz	A-MPR	RB <sub>end</sub> *12*S CS MHz	LCRB*12* SCS MHz	A-MPR
5MHz	1987.5 < Fc ≤ 1992.5		>3.24	A7						
5MHz	1992.5 < Fc ≤ 1997.5		>3.24	A4						
5MHz	1997.5 < Fc ≤ 2002.5		>1.98	A1	>3.6	>1.08	A2	≤3.6	≤1.98	A3
						≤1.98				
10MHz	1975 < Fc ≤ 1985	>5.4		A4						
10MHz	1985 < Fc ≤ 1995		>4.32	A1	≥7.2	>1.08	A2	<7.2	≤4.32	A3
						≤4.32				
10MHz	1995 < Fc ≤ 2000	≥5.76		A5	<3.06		A5	≥3.06	<5.76	A6
15MHz	1972.5 < Fc ≤ 1987.5		>6.84	A1	≥10.8	>1.08	A2	<10.8	≤6.84	A3
						≤6.84				
15MHz	1987.5 < Fc ≤ 1997.5	≥8.64		A5	<3.78		A5	≥3.78	<8.64	A6
20MHz	1970 < Fc ≤ 1990	≥12.96		A5	<4.68		A5	≥4.68	<12.96	A6
20MHz	1990 < Fc ≤ 1995	≥11.52		A5	<5.58		A5	≥5.58	<11.52	A6

NOTE 1: The A-MPR values are listed in Table 6.2.3.15-2.  
 NOTE 2: For any undefined region, MPR applies

Table 6.2.3.15-2: A-MPR for modulation and waveform type

Modulation/Waveform	A1	A2	A3	A4	A5	A6	A7
	Outer/Inner	Outer/Inner	Outer/Inner	Outer	Outer/Inner	Outer/Inner	Outer
DFT-s-OFDM PI/2 BPSK	≤ 11	≤ 5	≤ 4	≤ 8.5	≤ 18	≤ 10	≤ 3.5
DFT-s-OFDM QPSK	≤ 11	≤ 5	≤ 4	≤ 8.5	≤ 18	≤ 10	≤ 3.5
DFT-s-OFDM 16 QAM	≤ 11	≤ 5	≤ 4	≤ 8.5	≤ 18	≤ 10	≤ 3.5
DFT-s-OFDM 64 QAM	≤ 11	≤ 5	≤ 4	≤ 8.5	≤ 19	≤ 10	≤ 3.5
DFT-s-OFDM 256 QAM	≤ 11	≤ 5		≤ 8.5	≤ 20	≤ 10	
CP-OFDM QPSK	≤ 13	≤ 6.5	≤ 4	≤ 8.5	≤ 19	≤ 12	≤ 5.5
CP-OFDM 16 QAM	≤ 13	≤ 6.5	≤ 4	≤ 8.5	≤ 19	≤ 12	≤ 5.5
CP-OFDM 64 QAM	≤ 13	≤ 6.5	≤ 4	≤ 8.5	≤ 19	≤ 12	≤ 5.5
CP-OFDM 256 QAM	≤ 13	≤ 6.5		≤ 8.5	≤ 20	≤ 12	

NOTE 1: The backoff applied is max(MPR, A-MPR) where MPR is defined in Table 6.2.2-1  
 NOTE 2: Outer and inner allocations are defined in clause 6.2.2

6.2.3.16 A-MPR for NS\_27

Table 6.2.3.16-1: A-MPR for NS\_27

Channel Bandwidth, MHz	Carrier Centre Frequency, Fc, MHz	Region A		Region B	

		RBstart*12* SCS	RBend*12*S CS	LCRB*12* SCS	A-MPR	LCRB*12* SCS	A-MPR	
15 MHz	$3557.5 \leq F_c < 3562.5$	<1.8 MHz			A3	$\geq 10.8$ MHz	A3	
	$3687.5 < F_c \leq 3692.5$	>11.52 MHz						
15 MHz	$3562.5 \leq F_c < 3567.5$	$\leq 1.08$ MHz		<1.44 MHz	A4	$\geq 11.52$ MHz	2	
	$3682.5 < F_c \leq 3687.5$		$\geq 13.22$ MHz					
20 MHz	$3560 \leq F_c < 3570$	<3.6 MHz			A5	$\geq 10.8$ MHz	A5	
	$3680 < F_c \leq 3690$	>12.96 MHz						
20 MHz	$3570 \leq F_c < 3580$	$\leq 2.16$ MHz		<1.44 MHz	A6	$\geq 14.4$ MHz	2	
	$3670 < F_c \leq 3680$		$\geq 16.92$					
30 MHz	$3565 \leq F_c < 3585$	< 7.38MHz			A7			
		$\geq 7.38$ MHz		$\geq 15.3$ MHz	A2			
		$\leq 24.48$ MHz		< 15.3 MHz	A1			
		$\geq 24.48$ MHz		< 2.7 MHz	A7			
	$3665 < F_c \leq 3685$		> 19.44 MHz			A7		
			$\leq 19.44$ MHz	$\geq 15.3$ MHz		A2		
			$\geq 3.24$ MHz	< 15.3 MHz		A1		
			<3.24 MHz	< 2.7MHz		A7		
	$3585 \leq F_c \leq 3665$	$\leq [3.96]$ MHz		<	A8	$\geq 19.44$ MHz	4	
			$\geq 24.48$ MHz	1.44MHz		A8		
40 MHz	$3570 \leq F_c < 3600$	<11.34 MHz			A7			
		$\geq 11.34$ MHz,		$\geq 18$ MHz	A2			
		$\leq 31.0$ MHz		<18 MHz	A1			
		>31.0 MHz		<3.6 MHz	A7			
	$3650 < F_c \leq 3680$		>24.48 MHz			A7		
			$\leq 24.48$ MHz	$\geq 18$ MHz		A2		
			$\geq 6.48$ MHz	<18 MHz		A1		
			<6.48 MHz	<3.6 MHz		A7		
40 MHz	$3600 \leq F_c \leq 3650$	$\leq 6.12$ MHz		<1.44 MHz	A8	>20 MHz	4.5	
			$\geq 32.76$					

NOTE 1: Void  
NOTE 2: Void

Table 6.2.3.16-2: A-MPR for modulation and waveform type

Modulation/Waveform		A1	A2	A3	A4	A5	A6	A7	A8
		Outer	Outer	Outer/Inner	Outer/Inner	Outer/Inner	Outer/Inner	Outer/Inner	Outer/Inner
DFT-s-OFDM	PI/2 BPSK	4.5	6	4	4	4	4	10.5	4
	QPSK	4.5	6	4	4	4	4	10.5	4
	16 QAM	4.5	6	5	4	5	4	11	4

	64 QAM	4.5	6	5	4	5	4	11	4
	256 QAM		6					11	
CP-OFDM	QPSK	5.5	7	6	4	6	4	11.5	4
	16 QAM	5.5	7	6	4	6	4	11.5	4
	64 QAM	5.5	7	6	4	6	4	11.5	4
	256 QAM		7					11.5	
NOTE 1: The backoff applied is max (MPR, A-MPR) where MPR is defined in Table 6.2.2-1									
NOTE 2: Outer and inner allocations are defined in clause 6.2.2									

6.2.3.17 A-MPR for NS\_46

Table 6.2.3.17-1: A-MPR regions for NS\_46 (Power class 3)

Channel Bandwidth, MHz	Carrier Center Frequency, $F_c$ , MHz	Regions		A-MPR
		$RB_{end} * 12 * SCS$ MHz	$LCRB * 12 * SCS$ MHz	
25 MHz	$2534.5 \leq F_c \leq 2557.5$		Note 1	A3
30 MHz	$2515 \leq F_c \leq 2555$	$\geq 0, < 1.44$	$> 0$	A4
		$\geq 1.44, < 13.5$	$> \max(0, 12 * SCS * RB_{end} - 1.8)$	A5
		$\geq 13.5, < 19.8$	$> 11.52$	A6
		$\geq 19.8, < 25.92$	$> 6.3$	A7
		$\geq 25.92$	$> 0$	A8
35 MHz	$2517.5 \leq F_c \leq 2552.5$	$\geq 0, < 3.42$	$> 0$	A4
		$\geq 3.42, < 15.84$	$> \max(0, 12 * SCS * RB_{end} - 3.06)$	A5
		$\geq 15.84, < 22.68$	$> 12.6$	A6
		$\geq 22.68, < 28.8$	$> 9.0$	A7
		$\geq 28.8$	$> 0$	A8
40 MHz	$2520 \leq F_c \leq 2550$	$\geq 0, < 4.14$	$> 0$	A4
		$\geq 4.14, < 18$	$> \max(0, 12 * SCS * RB_{end} - 4.5)$	A5
		$\geq 18, < 25.74$	$> 13.5$	A6
		$\geq 25.74, < 32.4$	$> 12.6$	A7
		$\geq 32.4$	$> 0$	A8
50 MHz	$2525 \leq F_c \leq 2545$	$\geq 0, < 9$	$> 0$	A4
		$\geq 9, < 21.6$	$> \max(0, 12 * SCS * RB_{end} - 7.2)$	A5
		$\geq 21.6, < 31.5$	$> 18$	A6
		$\geq 31.5, < 39.6$	$> 16.2$	A7
		$\geq 39.6$	$> 0$	A8
NOTE 1: $> 9.72$ MHz for DFT-s-OFDM, $> 16.02$ MHz for CP-OFDM.				

Table 6.2.3.17-2: A-MPR for NS\_46 (Power class 3)

Modulation/Waveform		A3	A4	A5	A6	A7	A8
		Outer	Outer/Inner	Outer/Inner	Outer/Inner	Outer/Inner	Outer/Inner
DFT-s-OFDM	PI/2 BPSK	4.5	5	2	3.5	6	10
	QPSK	4.5	5	2	3.5	6	10
	16 QAM	4.5	5	2	3.5	6	10
	64 QAM	4.5	5		3.5	6	10
	256 QAM					6	10
CP-OFDM	QPSK	6	5	3.5	5.5	7	11

16 QAM	6	5	3.5	5.5	7	11
64 QAM	6	5	3.5	5.5	7	11
256 QAM	6				7	11

Table 6.2.3.17-3: A-MPR regions for NS\_46 (Power class 1)

Channel Bandwidth, MHz	Carrier Center Frequency, $F_c$ , MHz	Regions		A-MPR
		$RB_{end} * 12 * SCS$ MHz	$L_{CRB} * 12 * SCS$ MHz	
15 MHz	$F_c > 2559.5$	$\geq 11.8$	$\geq -1.8 * 12 * SCS * RB_{end} + 32.5$	A1
		$\geq 13.3$	$\leq 1.62$	A2
20 MHz	$F_c > 2547.5$	$\geq 15.3$	$\geq -1.5 * 12 * SCS * RB_{end} + 36.5$	A1
		$\geq 15$	$\leq 5.7$	A2
25 MHz	$F_c > 2547.5$	$\geq 17$	$\geq -1.5 * 12 * SCS * RB_{end} + 43.5$	A3
		$\geq 18.5$	$\leq 6.7$	A2
	$2535.5 < F_c \leq 2547.5$	$\geq 21.6$	$\geq 21.6$	A5
		$\geq 20.5$	$\leq 5.6$	A2
30 MHz	$2523 < F_c \leq 2545$	$\geq 22.5$	$\geq -0.7 * 12 * SCS * RB_{end} + 41.0$	A5
		$\geq 23.4$	$\leq 7.2$	A2
	$F_c > 2545$	$\geq 20.0$	$\geq -1.5 * 12 * SCS * RB_{end} + 50.5$	A8
		$\geq 21.6$	$\leq 7.2$	A9
35 MHz	$F_c \leq 2532.5$	$\leq 9.6$	$\geq 1.1 * 12 * SCS * RB_{end} - 1.5$	A7
		$\geq 28$	$\leq 7.2$	A2
	$2532.5 < F_c \leq 2542.5$	$\geq 27.7$	$\geq -1.2 * 12 * SCS * RB_{end} + 59.4$	A4
		$\geq 24.5$	$\leq 7.2$	A2
	$F_c > 2542.5$	$\leq 18.4$	$\geq 1.15 * 12 * SCS * RB_{end} - 3.4$	A7
$\geq 21.6$		$\geq 9, \geq -1.2 * 12 * SCS * RB_{end} + 47$	A8	
40 MHz	$F_c > 2540$	$\geq 23$	$< 9$	A9
		$\leq 24$	$\geq 1.15 * 12 * SCS * RB_{end} - 6$	A7
		$> 24, < 35$	$\geq -0.75 * 12 * SCS * RB_{end} + 40.5$	A9
		$\geq 34$	$> 7.2$	A9
	$2530 < F_c \leq 2540$	$\geq 27$	$> 2.2, \leq 7.2$	A8
		$\geq 27$	$\leq 2.2$	A9
		$\leq 10.8$	$\geq 1.2 * 12 * SCS * RB_{end} - 2$	A7
		$\geq 29$	$\leq 7.2$	A9
$F_c \leq 2530$	$\geq 28$	$\geq -1 * 12 * SCS * RB_{end} + 56$	A10	
	$\geq 30$	$\leq 7.2$	A2	
50 MHz	$F_c > 2535$	$\leq 19$	$\geq 1.17 * 12 * SCS * RB_{end} - 10$	A7
		$> 19, \leq 29.5$	$\geq 1.17 * 12 * SCS * RB_{end} - 10$	A11
		$> 29.5$	$> 12.8, \geq -1.15 * 12 * SCS * RB_{end} + 60$	A9
		$> 41$	$> 7.2, \leq 12.8$	A12
		$\geq 33$	$> 2.2, \leq 7.2$	A8
		$\geq 33$	$\leq 2.2$	A9
	$2525 < F_c \leq 2535$	$\leq 14$	$\geq 1.17 * 12 * SCS * RB_{end} - 6$	A7
		$> 14, \leq 26$	$\geq 1.17 * 12 * SCS * RB_{end} - 6$	A11
		$\geq 34$	$> 22.5, \geq -1.25 * 12 * SCS * RB_{end} + 77.5$	A8
		$\geq 43$	$> 7.2, \leq 22.5$	A12
		$\geq 35$	$> 2.2, \leq 7.2$	A8
		$\geq 35$	$\leq 2.2$	A9
	$F_c = 2525$	$\geq 47$	$\geq -1 * 12 * SCS * RB_{end} + 94$	A13
$\leq 9$		$\geq 1.14 * 12 * SCS * RB_{end} - 2$	A7	
$\geq 37.4$		$> 2.2, \leq 7.6$	A8	
$\geq 37.4$		$\leq 2.2$	A9	

Table 6.2.3.17-4: A-MPR regions for NS\_46 (Power class 1)

Modulation /Waveform		A1	A2	A3	A4	A5	A6	A7	A8	A9	A10	A11	A12	A13
		Outer/Inner	Outer/Inner	Outer/Inner	Outer/Inner	Outer/Inner	Outer/Inner	Outer/Inner	Outer/Inner	Outer/Inner	Outer/Inner	Outer/Inner	Outer/Inner	Outer/Inner
DF T-s-OF DM	PI/2 BPSK	2		2	1	1	3	9.5	5	6	4		4	2.5
	QPSK	3	4	3	2	2	6	11	6	6	5		4	4
	16 QAM	3	6.5	3			6	12	6	6.5	5		4	4
	64 QAM	3	7	3			6	12.5	6	7	5		4	4
	256 QAM		7				6	12.5	6	7	5			
CP-OF DM	QPSK	4	12.5	6	4		6.5	15	9	12.5	5.5	10	5	4
	16 QAM	4	12.5	6	4		6.5	15	9	13	5.5	10	5	4
	64 QAM	4	13	6			6.5	15	9	13	5.5	10	5	4
	256 QAM		13					15	9	13		10		

Table 6.2.3.17-5: A-MPR regions for NS\_46 (power class 2)

Channel Bandwidth, MHz	Carrier Center Frequency, F <sub>c</sub> , MHz	Regions		A-MPR
		RB <sub>end</sub> *12*SCS MHz	L <sub>CRB</sub> *12*SCS MHz	
10 MHz	2563 ≤ F <sub>c</sub> ≤ 2565	≥ 7.92	≥ 5.4	A6
		≥ 7.92	< 2.16	A5
15 MHz	2560.5 ≤ F <sub>c</sub> ≤ 2562.5	≥ 11.16	≥ 7.2	A6
		≥ 11.16	< 7.2	A5
20 MHz	2552 ≤ F <sub>c</sub> ≤ 2560	≥12.6, < 15.3	> 10.8	A6
		≥ 15.3	> 8.64	A9
		≥ 14.4	≤ 8.64	A10
25 MHz	2534.5 ≤ F <sub>c</sub> ≤ 2557.5	< 14.4	>max (0, 12*SCS*RB <sub>end</sub> - 2.7)	A5
		≥ 14.4, <18.9	> 12.6	A6
		≥ 18.9	> 16.02	A9
		≥ 18.9	≤ 16.02, ≥ 9.72	A6
30 MHz	2515 ≤ F <sub>c</sub> ≤ 2555	≥ 17.64	< 9.72	A10
		≥ 0, < 1.44	> 0	A4
		≥ 1.44, < 13.5	>max (0, 12*SCS*RB <sub>end</sub> -1.8)	A5
		≥ 13.5, < 19.8	> 11.52	A6
		≥ 19.8, < 25.92	> 6.3	A7
35 MHz	2517.5 ≤ F <sub>c</sub> ≤ 2552.5	≥ 25.92	> 0	A8
		> 20.7, < 25.92	≤ 6.3	A10
		≥0, <3.42	> 0	A4
		≥3.42, <15.84	> max (0, 12*SCS*RB <sub>end</sub> - 3.06)	A5
		≥15.84, <22.68	> 12.6	A6
		≥22.68, <28.8	> 9.0	A7
40 MHz	2520 ≤ F <sub>c</sub> ≤ 2550	≥28.8	> 0	A8
		> 24.3, < 28.8	≤ 9.0	A10
		≥0, < 4.5	> 0	A4
		≥ 4.14, < 5.04	> max (0, 12*SCS*RB <sub>end</sub> - 4.5)	A11
		≥ 5.04, < 18	> max (0, 12*SCS*RB <sub>end</sub> - 4.5)	A5
		≥ 18, < 25.74	> 13.5	A6

50 MHz	$2525 \leq F_c \leq 2545$	$\geq 25.74, < 32.4$	$> 12.6$	A7
		$\geq 32.4$	$> 0$	A8
		$> 27.9, < 32.4$	$\leq 12.6$	A10
		$\geq 0, < 9$	$> 0$	A4
		$\geq 9, < 21.6$	$> \max(0, 12 \cdot \text{SCS} \cdot \text{RBend} - 7.2)$	A5
		$\geq 21.6, < 31.5$	$> 18$	A6
		$\geq 31.5, < 39.6$	$> 16.2$	A7
		$\geq 39.6$	$> 0$	A8
		$> 33.84, < 39.6$	$\leq 16.2$	A10

Table 6.2.3.17-6: A-MPR for NS\_46 (power class 2)

Modulation/Waveform		A4	A5	A6	A7	A8	A9	A10	A11
		Outer/Inner	Outer/Inner	Outer/Inner	Outer/Inner	Outer/Inner	Outer/Inner	Outer/Inner	Outer/Inner
DFT-s-OFDM	PI/2 BPSK	6.5	2.5	3.5	7	11	6.5	3.0	5.0
	QPSK	6.5	2.5	3.5	7	11	6.5	3.0	5.0
	16 QAM	6.5	2.5	3.5	7	11	6.5	3.5	5.0
	64 QAM	6.5	2.5	3.5	7	11	6.5	3.5	5.0
	256 QAM	6.5			7	11	6.5		5.0
CP-OFDM	QPSK	6.5	3.5	5.5	8	12	8	4.5	6.5
	16 QAM	6.5	3.5	5.5	8	12	8	4.5	6.5
	64 QAM	6.5	3.5	5.5	8	12	8	4.5	6.5
	256 QAM	6.5			8	12	8		

6.2.3.18 A-MPR for NS\_47

Table 6.2.3.18-1: A-MPR regions and types for NS\_47 (Power Class 2 and 3)

Channel Bandwidth, (MHz)	Carrier Centre Frequency, $F_c$ , (MHz)	RBstart*12*SCS (MHz)	LCRB*12*SCS (MHz)	A-MPR
30MHz	$F_c=2560-2560.020$	$\leq 5.04$	$\leq 1.44$	A1
		$> 5.04, \leq 9.6$	$\leq 1.44$	A2
		$> 24.48$	$\leq 1.44$	A3
		$\leq 9.6$	$> 21$	A2
			$> 14.4, < 21$	A4
		$\leq 6.12$	$> 10, \leq 14.4$	A4
$> 1.44, < 10$	A2			

NOTE: The A-MPR values are listed in Table 6.2.3.18-2.

Table 6.2.3.18-2: A-MPR for modulation and waveform type (Power Class 2 and 3)

Modulation/Waveform	A1(dB)		A2(dB)		A3(dB)		A4(dB)	
	PC3	PC2	PC3	PC2	PC3	PC2	PC3	PC2
	Outer/Inner	Outer/Inner	Outer/Inner	Outer/Inner	Outer/Inner	Outer/Inner	Outer/Inner	Outer/Inner
DFT-s-OFDM PI/2 BPSK	$\leq 7$	$\leq 10$	$\leq 5.5$	$\leq 8.5$	$\leq 2$	$\leq 5$	$\leq 3$	$\leq 6$
DFT-s-OFDM QPSK	$\leq 7$	$\leq 10$	$\leq 5.5$	$\leq 8.5$	$\leq 2$	$\leq 5$	$\leq 3$	$\leq 6$
DFT-s-OFDM 16 QAM	$\leq 7$	$\leq 10$	$\leq 5.5$	$\leq 8.5$		$\leq 5$	$\leq 3$	$\leq 6$
DFT-s-OFDM 64 QAM	$\leq 7$	$\leq 10$	$\leq 6$	$\leq 8.5$		$\leq 5$	$\leq 3$	$\leq 6$
DFT-s-OFDM 256 QAM	$\leq 7$	$\leq 10$	$\leq 6$	$\leq 8.5$		$\leq 5$		$\leq 6$
CP-OFDM QPSK	$\leq 7$	$\leq 10$	$\leq 7$	$\leq 10$		$\leq 5$	$\leq 4$	$\leq 7$

CP-OFDM 16 QAM	≤ 7	≤ 10	≤ 7	≤ 10		≤ 5	≤ 4	≤ 7
CP-OFDM 64 QAM	≤ 7	≤ 10	≤ 7	≤ 10		≤ 5		≤ 7
CP-OFDM 256 QAM	≤ 7	≤ 10	≤ 7	≤ 10				≤ 7

**Table 6.2.3.18-3: A-MPR regions and types for NS\_47 (Power Class 1.5)**

Channel Bandwidth, (MHz)	Carrier Centre Frequency, F <sub>c</sub> , (MHz)	RB <sub>start</sub> *12*SCS (MHz)	LCRB*12*SCS (MHz)	A-MPR
30MHz	F <sub>c</sub> =2560-2560.020	≤5.04	≤1.44	A1
		>5.04, ≤9.6	≤1.44	A2
		>24.48	≤1.44	A3
		≤9.6	>21	A2
			>14.4, <21	A4
		>6.12, ≤7.92	>10, ≤14.4	A5
		≤6.12	>10, ≤14.4	A4
>1.44, <10	A2			

NOTE: The A-MPR values are listed in Table 6.2.3.18-4.

**Table 6.2.3.18-4: A-MPR for NS\_47 (Power Class 1.5)**

Modulation/Waveform		A1(dB)	A2(dB)	A3(dB)	A4(dB)	A5(dB)
		Outer/Inner	Outer/Inner	Outer/Inner	Outer/Inner	Outer/Inner
DFT-s-OFDM	PI/2 BPSK	≤ 13	≤ 11	≤ 8	≤ 8.5	≤ 3
	QPSK	≤ 13	≤ 11	≤ 8	≤ 8.5	≤ 3
	16 QAM	≤ 13	≤ 11	≤ 8	≤ 8.5	≤ 3
	64 QAM	≤ 13	≤ 11	≤ 8	≤ 8.5	
CP-OFDM	256 QAM	≤ 13	≤ 11	≤ 8	≤ 8.5	
	QPSK	≤ 13	≤ 12.5	≤ 8	≤ 9.5	≤ 4
	16 QAM	≤ 13	≤ 12.5	≤ 8	≤ 9.5	≤ 4
	64 QAM	≤ 13	≤ 12.5	≤ 8	≤ 9.5	
	256 QAM	≤ 13	≤ 12.5	≤ 8	≤ 9.5	

NOTE 1: PC1.5 assumes dual Tx.

6.2.3.19 A-MPR for NS\_50

**Table 6.2.3.19-1: A-MPR regions for NS\_50 (Power Class 3)**

Channel Bandwidth (MHz)	RB <sub>start</sub> *12*SCS (MHz)	LCRB*12*SCS (MHz)	A-MPR
25 MHz	≤ L <sub>CRB</sub> *12*SCS - 5	> 5	A7
	≤ 6.48	≤ 1.44	A8
		≤ 3.6	A9
30 MHz	≤ L <sub>CRB</sub> *12*SCS - 5	> 5	A7
	≤ 8.64	≤ 1.44	A8
		≤ 3.6	A9
35 MHz	≤ 1.62	> 0	A1
	> 1.62, ≤ 9.36	≤ 9.0	A3
	> 1.62, ≤ 13.68	> 9.0	A2
	> 13.68, ≤ 30.6	> max (29.7 - RB <sub>start</sub> *12*SCS, 0)	A6
	> 30.6	> 0	A5
40 MHz	≤ 4.32	> 0	A1



> 4.32, ≤ 10.44	≤ 10.8	A3
> 4.32, ≤ 18	> 10.8	A2
> 18, ≤ 31.68	> max (31.68 – RB <sub>start</sub> *12*SCS, 0)	A6
> 31.68	> 0	A5

NOTE 1: The A-MPR values are specified in Table 6.2.3.19-2.

**Table 6.2.3.19-2: A-MPR for NS\_50 (Power Class 3)**

Modulation/Waveform		A1 (dB)	A2 (dB)	A3 (dB)	A5 (dB)	A6 (dB)	A7 (dB)	A8 (dB)	A9 (dB)
		Outer/Inner	Outer/Inner	Outer/Inner	Outer/Inner	Outer/Inner	Outer/Inner	Outer/Inner	Inner
DFT-s-OFDM	Pi/2 BPSK	≤ 11	≤ 7	≤ 3	≤ 5	≤ 2	≤ 4	≤ 2	
	QPSK	≤ 11	≤ 7	≤ 3	≤ 5	≤ 2	≤ 5	≤ 2	
	16 QAM	≤ 11	≤ 7	≤ 3	≤ 5	≤ 2	≤ 5	≤ 2.5	
	64 QAM	≤ 11	≤ 7	≤ 3	≤ 5		≤ 5		
	256 QAM	≤ 11	≤ 7		≤ 5		≤ 5		
CP-OFDM	QPSK	≤ 12	≤ 8	≤ 4.5	≤ 5	≤ 3.5	≤ 6.5		
	16 QAM	≤ 12	≤ 8	≤ 4.5	≤ 5	≤ 3.5	≤ 6.5		≤ 3.0
	64 QAM	≤ 12	≤ 8	≤ 4.5	≤ 5		≤ 6.5		≤ 3.0
	256 QAM	≤ 12	≤ 8				≤ 6.5		

**Table 6.2.3.19-3: A-MPR regions for NS\_50 (Power Class 2)**

Channel Bandwidth (MHz)	RB <sub>start</sub> *12*SCS (MHz)	L <sub>CRB</sub> *12*SCS (MHz)	A-MPR
10 MHz	≤ 1.44	< 1.44	A5
	≤ 1.8	≥ 2.7+2* RB <sub>start</sub> *12*SCS	A4
	>1.8	≥ 8.1- RB <sub>start</sub> *12*SCS	A4
15 MHz	≤ 2.88	< 2.7	A5
	≤ 3.24	≥ 2.7+2* RB <sub>start</sub> *12*SCS	A3
	>3.24	≥ 12.42- RB <sub>start</sub> *12*SCS	A4
20 MHz	≤ 4.32	< 3.6	A5
	≤ 4.5	≥ 3.6+2* RB <sub>start</sub> *12*SCS	A3
	>4.5	≥ 17.1- RB <sub>start</sub> *12*SCS	A4
25 MHz	≤ L <sub>CRB</sub> *12*SCS – 5	> 5	A2
	≤ 6.48	≤ 1.44	A5
	> 8.28	> max (21.6 – RB <sub>start</sub> *12*SCS, 0), <RB <sub>start</sub> *12*SCS+5	A4
	>1.8, ≤6.48	> 1.44, ≤ 3.6	A6
	> L <sub>CRB</sub> *12*SCS – 5, ≤ 1.8	> 1.44	A4
30 MHz	≤ L <sub>CRB</sub> *12*SCS – 5	>5	A2
	≤ 7.56	≤ 1.44	A5
	>1.8, ≤7.56	> 1.44, ≤ 3.6	A6
	≤ 1.8	>1.44, <RB <sub>start</sub> *12*SCS+5	A4
	> 10.8	> max (26.64 – RB <sub>start</sub> *12*SCS, 0), <RB <sub>start</sub> *12*SCS+5	A4

<b>35 MHz</b>	$\leq 1.62$	$> 0$	A1
	$> 1.62, \leq 9.36$	$\leq 9.0$	A3
	$> 1.62, \leq 13.68$	$> 9.0$	A8
	$> 13.68, \leq 30.6$	$> \max(29.7 - RB_{start} * 12 * SCS, 0)$	A4
	$> 30.6$	$> 0$	A9
<b>40 MHz</b>	$\leq 4.32$	$> 0$	A1
	$> 4.32$	$> RB_{start} * 12 * SCS + 11.88$	A8
	$> 4.32, \leq 12.96$	$\leq 10.8$	A3
	$> 4.32, \leq 18$	$> 10.8, \leq RB_{start} * 12 * SCS + 11.88$	A7
	$> 18, \leq 31.68$	$> \max(31.68 - RB_{start} * 12 * SCS, 0)$	A4
	$> 31.68$	$> 0$	A9
NOTE 1: The A-MPR values are specified in Table 6.2.3.19-4.			

**Table 6.2.3.19-4: A-MPR for NS\_50 (Power Class 2)**

Modulation/Waveform		A1 (dB)	A2 (dB)	A3 (dB)	A4 (dB)	A5 (dB)	A6 (dB)	A7 (dB)	A8 (dB)	A9 (dB)
		Outer/Inner	Outer/Inner	Outer/Inner	Outer/Inner	Outer/Inner	Outer/Inner	Outer/Inner	Outer/Inner	Outer/Inner
<b>DFT-s-OFDM</b>	Pi/2 BPSK	$\leq 11.5$	$\leq 4.5$	$\leq 4$	$\leq 2.5$	$\leq 4$	$\leq 1$	$\leq 3.5$	$\leq 10$	$\leq 8$
	QPSK	$\leq 11.5$	$\leq 5.5$	$\leq 4$	$\leq 2.5$	$\leq 4$	$\leq 1$	$\leq 3.5$	$\leq 10$	$\leq 8$
	16 QAM	$\leq 11.5$	$\leq 5.5$	$\leq 4$	$\leq 2.5$	$\leq 4$	$\leq 1.5$	$\leq 3.5$	$\leq 10$	$\leq 8$
	64 QAM	$\leq 11.5$	$\leq 5.5$	$\leq 4$		$\leq 4$			$\leq 10$	$\leq 8$
	256 QAM	$\leq 11.5$	$\leq 5.5$						$\leq 10$	$\leq 8$
<b>CP-OFDM</b>	QPSK	$\leq 12.5$	$\leq 7$	$\leq 5.5$	$\leq 4$	$\leq 4$	$\leq 2$	$\leq 5$	$\leq 11$	$\leq 8$
	16 QAM	$\leq 12.5$	$\leq 7$	$\leq 5.5$	$\leq 4$	$\leq 4$		$\leq 5$	$\leq 11$	$\leq 8$
	64 QAM	$\leq 12.5$	$\leq 7$	$\leq 5.5$	$\leq 4$	$\leq 4$		$\leq 5$	$\leq 11$	$\leq 8$
	256 QAM	$\leq 12.5$	$\leq 7$						$\leq 11$	$\leq 8$

**Table 6.2.3.19-5: A-MPR regions for NS\_50 (Power Class 1.5)**

Channel Bandwidth (MHz)	$RB_{start} * 12 * SCS$ (MHz)	$L_{CRB} * 12 * SCS$ (MHz)	A-MPR
<b>10 MHz</b>	$\leq 1.44$	$< 1.44$	A5
	$\leq 1.8$	$\geq 2.7 + 2 * RB_{start} * 12 * SCS$	A4
	$> 1.8$	$\geq 8.1 - RB_{start} * 12 * SCS$	A4
<b>15 MHz</b>	$\leq 2.88$	$< 2.7$	A5
	$\leq 3.24$	$\geq 2.7 + 2 * RB_{start} * 12 * SCS$	A3
	$> 3.24$	$\geq 12.42 - RB_{start} * 12 * SCS$	A4

	$< 12.42 \cdot L_{CRB} \cdot 12 \cdot SCS$	$\geq 2.7$ $< 2.7 + 2 \cdot RB_{start} \cdot 12 \cdot SCS$ $\geq 2 \cdot RB_{start} \cdot 12 \cdot SCS - 1.08$	A10
<b>20 MHz</b>	$\leq 4.32$	$< 3.6$	A5
	$\leq 4.5$	$\geq 3.6 + 2 \cdot RB_{start} \cdot 12 \cdot SCS$	A3
	$> 4.5$	$\geq 17.1 - RB_{start} \cdot 12 \cdot SCS$	A4
	$< 17.1 \cdot L_{CRB} \cdot 12 \cdot SCS$	$\geq 3.6$ $< 3.6 + 2 \cdot RB_{start} \cdot 12 \cdot SCS$ $\geq 2 \cdot RB_{start} \cdot 12 \cdot SCS - 3.6$	A10
<b>25 MHz</b>	$\leq L_{CRB} \cdot 12 \cdot SCS - 5$	$> 5$	A2
	$\leq 6.48$	$\leq 1.44$	A5
	$> 8.28$	$> \max(21.6 - RB_{start} \cdot 12 \cdot SCS, 0)$ , $< RB_{start} \cdot 12 \cdot SCS + 5$	A4
	$> 1.8, \leq 6.48$	$> 1.44, \leq 3.6$	A6
	$> L_{CRB} \cdot 12 \cdot SCS - 5, \leq 1.8$	$> 1.44$	A4
	$> 1.8, \leq 6.48$ $> L_{CRB} \cdot 12 \cdot SCS - 5$	$> 3.6$	A10
<b>30 MHz</b>	$\leq L_{CRB} \cdot 12 \cdot SCS - 5$	$> 5$	A2
	$\leq 7.56$	$\leq 1.44$	A5
	$> 1.8, \leq 7.56$	$> 1.44, \leq 3.6$	A6
	$\leq 1.8$	$> 1.44, < RB_{start} \cdot 12 \cdot SCS + 5$	A4
	$> 10.8$	$> \max(26.64 - RB_{start} \cdot 12 \cdot SCS, 0)$ , $< RB_{start} \cdot 12 \cdot SCS + 5$	A4
	$> 1.8, \leq 7.56$ $> L_{CRB} \cdot 12 \cdot SCS - 5$	$> 3.6$	A10
<b>35 MHz</b>	$\leq 1.62$	$> 0$	A1
	$> 1.62, \leq 9.36$	$\leq 9.0$	A3
	$> 1.62, \leq 13.68$	$> 9.0$	A8
	$> 13.68, \leq 30.6$	$> \max(29.7 - RB_{start} \cdot 12 \cdot SCS, 0)$	A4
	$> 30.6$	$> 0$	A9
<b>40 MHz</b>	$\leq 4.32$	$> 0$	A1
	$> 4.32$	$> RB_{start} \cdot 12 \cdot SCS + 11.88$	A8
	$> 4.32, \leq 12.96$	$\leq 10.8$	A3
	$> 4.32, \leq 18$	$> 10.8, \leq RB_{start} \cdot 12 \cdot SCS + 11.88$	A7
	$> 18, \leq 31.68$	$> \max(31.68 - RB_{start} \cdot 12 \cdot SCS, 0)$	A4
	$> 31.68$	$> 0$	A9
NOTE 1: The A-MPR values are specified in Table 6.2.3.19-4.			

**Table 6.2.3.19-6: A-MPR for NS\_50 (Power Class 1.5)**

Modulation/Waveform		A1 (dB)	A2 (dB)	A3 (dB)	A4 (dB)	A5 (dB)	A6 (dB)	A7 (dB)	A8 (dB)	A9 (dB)	A10 (dB)	
		Outer/ Inner	Outer/ Inner	Outer/ Inner	Outer/ Inner	Outer/ Inner	Outer/ Inner	Outer/ Inner	Outer/ Inner	Outer/ Inner	Outer/ Inner	Outer/ Inner
<b>DFT-s-OFDM</b>	Pi/2 BPSK	$\leq 14.5$	$\leq 7.5$	$\leq 6.5$	$\leq 5.0$	$\leq 6.0$	$\leq 3.5$	$\leq 5.5$	$\leq 12.5$	$\leq 10.5$	$\leq 3.5$	$\leq 3.0$
	QPSK	$\leq 14.5$	$\leq 8.5$	$\leq 6.5$	$\leq 5.0$	$\leq 6.0$	$\leq 3.5$	$\leq 5.5$	$\leq 12.5$	$\leq 10.5$	$\leq 3.5$	$\leq 3.0$

	16 QAM	≤ 14.5	≤ 8.5	≤ 6.5	≤ 5.0	≤ 6.0	≤ 4.0	≤ 5.5	≤ 12.5	≤ 10.5	≤ 4.0	≤ 4.0
	64 QAM	≤ 14.5	≤ 8.5	≤ 6.5	≤ 5.0	≤ 6.0	≤ 4.0	≤ 5.5	≤ 12.5	≤ 10.5	≤ 4.0	≤ 4.0
	256 QAM	≤ 14.5	≤ 8.5	≤ 6.5	≤ 5.0	≤ 6.0		≤ 5.5	≤ 12.5	≤ 10.5		
CP-OFDM	QPSK	≤ 15.5	≤ 10.0	≤ 8.5	≤ 7.0	≤ 6.5	≤ 5.0	≤ 7.0	≤ 13.5	≤ 10.5	≤ 5.0	≤ 4.5
	16 QAM	≤ 15.5	≤ 10.0	≤ 8.5	≤ 7.0	≤ 6.5	≤ 5.0	≤ 7.0	≤ 13.5	≤ 10.5	≤ 5.0	≤ 4.5
	64 QAM	≤ 15.5	≤ 10.0	≤ 8.5	≤ 7.0	≤ 6.5	≤ 5.0	≤ 7.0	≤ 13.5	≤ 10.5	≤ 5.0	≤ 4.5
	256 QAM	≤ 15.5	≤ 10.0	≤ 8.5	≤ 7.0			≤ 7.0	≤ 13.5	≤ 10.5		

6.2.3.20 A-MPR for NS\_44

Table 6.2.3.20-1: A-MPR regions for NS\_44

Channel Bandwidth, MHz	Carrier Center Frequency, F <sub>c</sub> , MHz	Regions		A-MPR
		RB <sub>end</sub> *12*SCS MHz	L <sub>CRB</sub> *12*SCS MHz	
25 MHz	2582.5 ≤ F <sub>c</sub> ≤ 2602.5	<18.0	>max(0, 12*SCS* RB <sub>end</sub> - 3.6)	A3
		≥18.0	<7.2	A3
		≥18.0	≥7.2	A6
30 MHz	2585 ≤ F <sub>c</sub> ≤ 2600	<21.6	>max(0, 12*SCS* RB <sub>end</sub> - 3.6)	A3
		≥21.6	<12.6	A3
		≥21.6	≥12.6	A6
40 MHz	2590 ≤ F <sub>c</sub> ≤ 2595	≥0, <2.88	>0	A1
		≥2.88, <14.4	>max (0, 12*SCS*RB <sub>end</sub> - 3.6)	A2
		≥14.4, <23.4	>10.8	A3
		≥23.4, <32.4	>16.2	A4
		≥32.4	>0	A5

Table 6.2.3.20-2: A-MPR for NS\_44

Modulation/Waveform		A1	A2	A3	A4	A5	A6
		Outer/Inner	Outer/Inner	Outer/Inner	Outer/Inner	Outer/Inner	Outer/Inner
DFT-s-OFDM	PI/2 BPSK	5	2	3	7	12	4
	QPSK	5	2	3	7	12	4
	16 QAM	5		3	7	12	4
	64 QAM	5		3	7	12	4
	256 QAM	5			7	12	
CP-OFDM	QPSK	5	4	5	8	12	6
	16 QAM	5	4	5	8	12	6
	64 QAM	5	4	5	8	12	6
	256 QAM				8	12	

6.2.3.21 A-MPR for NS\_12

Table 6.2.3.21-1: A-MPR regions for NS\_12

Channel BW	Carrier Frequency, F <sub>c</sub> , MHz	RB <sub>Start</sub> *12*SCS (MHz)	L <sub>CRB</sub> *12*SCS (MHz)	A-MPR
3MHz	815.5 ≤ F <sub>c</sub> < 817.5	≤0.9	>0	A2

5MHz		$\leq 1.8$	$> 0$	A1
10MHz		$\leq 3.6$	$> 0$	A1

Table 6.2.3.21-2: A-MPR for NS\_12

Modulation/Waveform	A1	A2
	Outer/Inner	Outer/Inner
DFT-s-OFDM PI/2 BPSK	$\leq 5$	$\leq 4$
DFT-s-OFDM QPSK	$\leq 5$	$\leq 4.5$
DFT-s-OFDM 16 QAM	$\leq 5.5$	$\leq 4.5$
DFT-s-OFDM 64 QAM	$\leq 5.5$	$\leq 5$
DFT-s-OFDM 256 QAM	$\leq 9.5$	$\leq 5$
CP-OFDM QPSK	$\leq 7$	$\leq 6$
CP-OFDM 16 QAM	$\leq 7$	$\leq 6$
CP-OFDM 64 QAM	$\leq 7$	$\leq 6$
CP-OFDM 256 QAM	$\leq 9.5$	

## 6.2.3.22 A-MPR for NS\_13

Table 6.2.3.22-1: A-MPR regions for NS\_13

Channel BW	Carrier Frequency, $F_c$ , MHz	$RB_{Start} * 12 * SCS$ (MHz)	$L_{CRB} * 12 * SCS$ (MHz)	A-MPR
3MHz	$818.5 \leq F_c < 820$	$\leq 0.54$	$> 0$	A4
5MHz	$819.5 \leq F_c < 821.5$	$\leq 1.44$	$< 1.08$	A1
		$\leq 1.44$	$\geq 1.08$	A2
5MHz	$F_c \geq 821.5$	$\leq 0.54$	$< 1.08$	A1
			$\geq 3.24$	A3

Table 6.2.3.22-2: A-MPR for NS\_13

Modulation/Waveform	A1	A2	A3	A4
	Outer/Inner	Outer/Inner	Outer	Outer/Inner
DFT-s-OFDM PI/2 BPSK	$\leq 3.5$	$\leq 4.5$	$\leq 3$	$\leq 3$
DFT-s-OFDM QPSK	$\leq 3.5$	$\leq 4.5$	$\leq 3$	$\leq 4$
DFT-s-OFDM 16 QAM	$\leq 3.5$	$\leq 5$	$\leq 3$	$\leq 4$
DFT-s-OFDM 64 QAM	$\leq 4.5$	$\leq 5$	$\leq 3$	$\leq 4$
DFT-s-OFDM 256 QAM	$\leq 8$	$\leq 6$		
CP-OFDM QPSK	$\leq 5$	$\leq 6.5$	$\leq 4.5$	$\leq 5.5$
CP-OFDM 16 QAM	$\leq 5$	$\leq 6.5$	$\leq 4.5$	$\leq 5.5$
CP-OFDM 64 QAM	$\leq 6$	$\leq 6.5$	$\leq 4.5$	$\leq 5.5$
CP-OFDM 256 QAM	$\leq 8$	$\leq 8$		

## 6.2.3.23 A-MPR for NS\_14

Table 6.2.3.23-1: A-MPR regions for NS\_14

Channel BW	$RB_{Start} * 12 * SCS$ (MHz)	$L_{CRB} * 12 * SCS$ (MHz)	A-MPR
10MHz	$\leq 0.18$	$< 1.08$	A1
	$\geq 0$	$\geq 9$	A2
15MHz	$\leq 1.8$	$< 1.8$	A1
	$\geq 0$	$\geq 9$	A2
20MHz	$\leq 3.42$	$< 1.8$	A3
	$\geq 0$	$\geq 9$	A2

Table 6.2.3.23-2: A-MPR for NS\_14

Modulation/Waveform	A1	A2	A3
	Outer/Inner	Outer	Outer/Inner
DFT-s-OFDM PI/2 BPSK	$\leq 3$	$\leq 2$	$\leq 3$
DFT-s-OFDM QPSK	$\leq 3$	$\leq 2$	$\leq 3$
DFT-s-OFDM 16 QAM	$\leq 3$	$\leq 2$	$\leq 3$
DFT-s-OFDM 64 QAM	$\leq 3$		$\leq 3$
DFT-s-OFDM 256 QAM			$\leq 8$
CP-OFDM QPSK	$\leq 5$	$\leq 4$	$\leq 5$
CP-OFDM 16 QAM	$\leq 5$	$\leq 4$	$\leq 5$
CP-OFDM 64 QAM	$\leq 6$		$\leq 6$
CP-OFDM 256 QAM	$\leq 8$		$\leq 8$

## 6.2.3.24 A-MPR for NS\_15

Table 6.2.3.24-1: A-MPR regions for NS\_15

Channel BW	Carrier Frequency, Fc, MHz	$RB_{end} * 12 * SCS$ (MHz)	$L_{CRB} * 12 * SCS$ (MHz)	A-MPR
3MHz	844.5 < Fc ≤ 847.5	$\geq 1.44$	$> 0$	A5
		$\leq 0.18$	$\leq 0.36$	A6
5MHz	840.5 < Fc ≤ 846.5	$\geq 3.24$	$> 0$	A1
		$< 3.24, \geq 2.52$	$\geq 1.44$	A2
		$< 0.9$	$\leq 0.36$	A3
10MHz	840 < Fc ≤ 844	$\geq 5.76$	$> 1.08$	A1
		$\geq 5.76$	$\leq 1.08$	A4
		$< 5.76, \geq 4.14$	$\geq 2.7$	A2
		$< 2.52$	$\leq 0.36$	A3
	835 < Fc ≤ 840	$\geq 7.2$	$> 0$	A1
		$< 7.2, \geq 5.22$	$\geq 4.32$	A2
15MHz	837.5 < Fc ≤ 841.5	$\geq 9.36$	$> 1.08$	A1
		$\geq 9.36$	$\leq 1.08$	A4
		$< 9.36, \geq 4.68$	$\geq 3.6$	A2
		$< 3.96$	$\leq 0.36$	A3
	831.5 < Fc ≤ 837.5	$\geq 10.8$	$> 1.08$	A1
		$\geq 10.8$	$\leq 1.08$	A4
		$< 10.8, \geq 6.48$	$\geq 3.6$	A2
		$< 2.7$	$\leq 0.36$	A3
	Fc ≤ 831.5	$\geq 13.14$	$> 0$	A1
		$< 13.14, \geq 7.92$	$\geq 3.6$	A2
		$< 0.72$	$\leq 0.36$	A3
20MHz	835 < Fc ≤ 839	$\geq 12.24$	$> 1.08$	A1
		$\geq 12.24$	$\leq 1.08$	A4
		$< 12.24, \geq 8.46$	$\geq 5.4$	A2
		$< 5.58$	$\leq 0.36$	A3
	Fc ≤ 835	$\geq 13.68$	$> 1.08$	A1
		$\geq 13.68$	$\leq 1.08$	A4
		$< 13.68, \geq 8.46$	$\geq 5.4$	A2
		$< 4.32$	$\leq 0.36$	A3

Table 6.2.3.24-2: A-MPR for NS\_15

Modulation/Waveform	A1	A2	A3	A4	A5	A6
	Outer/Inner	Outer/Inner	Outer/Inner	Outer/Inner	Outer/Inner	Edge/Inner
DFT-s-OFDM PI/2 BPSK	≤ 9	≤ 5	≤ 4	≤ 9	≤ 5	1
DFT-s-OFDM QPSK	≤ 9	≤ 5	≤ 4	≤ 9	≤ 5.5	1.5
DFT-s-OFDM 16 QAM	≤ 9	≤ 5	≤ 4	≤ 9	≤ 5.5	2
DFT-s-OFDM 64 QAM	≤ 9	≤ 5	≤ 4	≤ 9	≤ 5.5	
DFT-s-OFDM 256 QAM	≤ 9	≤ 5	≤ 9	≤ 13.5	≤ 6	
CP-OFDM QPSK	≤ 10.5	≤ 6.5	≤ 4	≤ 10.5	≤ 7	3
CP-OFDM 16 QAM	≤ 10.5	≤ 6.5	≤ 4	≤ 10.5	≤ 7	3
CP-OFDM 64 QAM	≤ 10.5	≤ 6.5	≤ 4	≤ 10.5	≤ 7	
CP-OFDM 256 QAM	≤ 10.5	≤ 6.5	≤ 9	≤ 13.5	≤ 7.5	

6.2.3.25 A-MPR for NS\_45

Table 6.2.3.25-1: A-MPR for NS\_45

Modulation/Waveform		Outer
DFT-s-OFDM	Pi/2 BPSK	≤ 1.5
	QPSK	≤ 2
	16 QAM	≤ 2.5
	64 QAM	≤ 3

6.2.3.26 A-MPR for NS\_48

Table 6.2.3.26-1: A-MPR regions for NS\_48 (Power Class 3)

Channel Bandwidth, MHz	Carrier Center Frequency, F <sub>c</sub> , MHz	Regions		A-MPR
		RB <sub>end</sub> *12*SCS MHz	L <sub>CRB</sub> *12*SCS MHz	
25 MHz	1932.5 ≤ F <sub>c</sub> ≤ 1967.5	≥ 0	≥ 9.72	A3
		≥ 18.72	< 1.08	A3
30 MHz	1935 ≤ F <sub>c</sub> ≤ 1965	≥ 0	≥ 13.5	A3
		≥ 21.6	< 1.08	A5
40 MHz	1940 ≤ F <sub>c</sub> ≤ 1960	≥ 0, < 2.88	≥ 0	A2
		≥ 2.88, < 17.1	≥ max (0, 12*SCS*RB <sub>end</sub> - 3.6)	A3
		≥ 17.1, < 27.36	≥ 13.5	A4
		≥ 27.36, < 34.56	≥ 13.5	A2
		≥ 27.36, < 34.56	< 1.08	A3
		≥ 34.56	≥ 0	A1
45 MHz	1942.5 ≤ F <sub>c</sub> ≤ 1957.5	≥ 0, < 4.86	> 0	A2
		≥ 4.86, < 19	≥ max (0, 12*SCS*RB <sub>end</sub> - 3.6)	A4
		≥ 19, < 37.44	≥ 15.4	A2
		≥ 30.96, < 37.44	< 1.08	A5
		≥ 37.44	> 0	A1
50 MHz	1945 ≤ F <sub>c</sub> ≤ 1955	≥ 0, < 6.12	> 0	A2
		≥ 6.12, < 20.7	≥ max (0, 12*SCS*RB <sub>end</sub> - 3.6)	A4
		≥ 20.7, < 41.04	≥ 17.1	A2
		≥ 33.84, < 41.04	< 1.08	A5
		≥ 41.04	> 0	A1

**Table 6.2.3.26-2: A-MPR for NS\_48 (Power Class 3)**

Modulation/Waveform		A1	A2	A3	A4	A5
		Outer/Inner	Outer/Inner	Outer/Inner	Outer/Inner	Outer/Inner
DFT-s-OFDM	PI/2 BPSK	≤10	≤6	≤3	≤4	≤5
	QPSK	≤10	≤6	≤3	≤4	≤5
	16 QAM	≤10	≤6	≤3	≤4	≤5
	64 QAM	≤10	≤6	≤3	≤4	≤5
	256 QAM	≤10	≤6	≤3	≤4	≤5
CP-OFDM	QPSK	≤11	≤7	≤4.5	≤5.5	≤5
	16 QAM	≤11	≤7	≤4.5	≤5.5	≤5
	64 QAM	≤11	≤7	≤4.5	≤5.5	≤5
	256 QAM	≤11	≤7	≤4.5	≤5.5	≤5

**Table 6.2.3.26-3: A-MPR regions for NS\_48 (Power Class 2)**

Channel Bandwidth, MHz	Carrier Center Frequency, F <sub>C</sub> , MHz	Regions		A-MPR
		RB <sub>end</sub> *12*SCS MHz	LCRB*12*SCS MHz	
10 MHz	1925 ≤ F <sub>C</sub> ≤ 1975	≥0	≥8.1	A6
		<1.8	≥0	A6
15 MHz	1927.5 ≤ F <sub>C</sub> ≤ 1972.5	≥0	≥9	A6
		≥0	≥max (0, 12*SCS* RB <sub>end</sub> - 2.88) <9	A6
20 MHz	1930 ≤ F <sub>C</sub> ≤ 1970	≥0	≥9.72	A4
		≥0	≥max (0, 12*SCS* RB <sub>end</sub> - 3.6) <9.72	A6
25 MHz	1932.5 ≤ F <sub>C</sub> ≤ 1967.5	≥0	≥9.72	A4
		≥18.72	<1.08	A3
		≥0	≥max (0, 12*SCS*RB <sub>end</sub> - 1.08) < 9.72	A4
30 MHz	1935 ≤ F <sub>C</sub> ≤ 1965	≥0	≥12.96	A4
		≥21.6	<1.08	A5
		≥0	≥max (0, 12*SCS*RB <sub>end</sub> - 3.6) < 12.96	A4
40 MHz	1940 ≤ F <sub>C</sub> ≤ 1960	≥0, <2.88	≥0	A1
		≥2.88, <17.1	≥max (0, 12*SCS*RB <sub>end</sub> - 4.68)	A3
		≥17.1, <27.36	≥12.96	A4
		≥27.36, <34.56	≥12.96	A2
		≥27.36, <34.56	<1.08	A3
45 MHz	1942.5 ≤ F <sub>C</sub> ≤ 1957.5	≥34.56	≥0	A1
		≥0, <5.22	>0	A1
		≥5.22, <19	≥max (0, 12*SCS*RB <sub>end</sub> - 5.4)	A4
		≥19, <37.44	≥14.04	A2
		≥30.96, <37.44	<1.08	A5
50 MHz	1945 ≤ F <sub>C</sub> ≤ 1955	≥37.44	>0	A1
		≥0, <7.2	>0	A1
		≥7.2, <20.7	≥max (0, 12*SCS*RB <sub>end</sub> - 5.4)	A4
		≥20.7, <41.04	≥15.12	A2
		≥33.84, <41.04	<1.08	A5
		≥41.04	>0	A1



Table 6.2.3.26-4: A-MPR for NS\_48 (Power Class 2)

Modulation/Waveform		A1	A2	A3	A4	A5	A6
		Outer/Inner	Outer/Inner	Outer/Inner	Outer/Inner	Outer/Inner	Outer/Inner
DFT-s-OFDM	PI/2 BPSK	≤[12]	≤8.0	≤4.0	≤4.5	≤6.0	≤3.0
	QPSK	≤[12]	≤8.0	≤4.0	≤4.5	≤6.0	≤3.0
	16 QAM	≤[12]	≤8.0	≤4.0	≤4.5	≤6.0	≤3.0
	64 QAM	≤[12]	≤8.0	≤4.0	≤4.5	≤6.0	≤3.0
	256 QAM	≤[12]	≤8.0	≤4.0	≤4.5	≤6.0	≤3.0
CP-OFDM	QPSK	≤[12.5]	≤9.0	≤5.5	≤6.0	≤6.0	≤4.5
	16 QAM	≤[12.5]	≤9.0	≤5.5	≤6.0	≤6.0	≤4.5
	64 QAM	≤[12.5]	≤9.0	≤5.5	≤6.0	≤6.0	≤4.5
	256 QAM	≤[12.5]	≤9.0	≤5.5	≤6.0	≤6.0	≤4.5

6.2.3.27 A-MPR for NS\_49

Table 6.2.3.27-1: A-MPR regions for NS\_49 (Power Class 3)

Channel Bandwidth, MHz	Carrier Center Frequency, F <sub>c</sub> , MHz	Regions		A-MPR
		RB <sub>end</sub> *12*SCS MHz	L <sub>CRB</sub> *12*SCS MHz	
25 MHz	1932.5 ≤ F <sub>c</sub> ≤ 1967.5	≥0	≥9.72	A3
		≥18.72	<1.08	A3
		≤3.96	<1.08	A3
30 MHz	1935 ≤ F <sub>c</sub> ≤ 1965	≥0, <3.6	≥0	A1
		≥3.6, <6.48	≥0	A5
		≥6.48, <14.4	≥max(0, 12*SCS*RB <sub>end</sub> - 3.6)	A3
		≥14.4, <21.6	≥10.8	A4
		≥21.6	≥10.8	A2
		≥21.6	<1.08	A5
40 MHz	1940 ≤ F <sub>c</sub> ≤ 1960	≥0, <7.2	≥0	A1
		≥7.2, <10.44	<1.08	A5
		≥7.2, <18	≥max(0, 12*SCS*RB <sub>end</sub> - 3.6)	A4
		≥18, <34.56	≥14.4, <28.8	A2
		≥27.36, <34.56	<1.08	A5
		<34.56	≥28.8	A1
45 MHz	1942.5 ≤ F <sub>c</sub> ≤ 1957.5	≥34.56	≥0	A1
		≥6.12, <12.42	< min [1.08, max(0, 12*SCS*RB <sub>end</sub> - 6.12)]	A5
		≥30.76, <36.72	<1.08	A5
		<36.72	≥16.2, <max(0, 12*SCS*RB <sub>end</sub> - 6.12)	A2
		<36.72	≥max(0, 12*SCS*RB <sub>end</sub> - 6.12)	A1
50 MHz	1945 ≤ F <sub>c</sub> ≤ 1955	≥36.72	>0	A1
		≥7.74, <14.4	< min [1.08, max(0, 12*SCS*RB <sub>end</sub> - 7.74)]	A5
		≥36, <39.6	<1.08	A5
		<39.6	≥18, <max(0, 12*SCS*RB <sub>end</sub> - 7.74)	A2
		<39.6	≥max(0, 12*SCS*RB <sub>end</sub> - 7.74)	A1

		$\geq 39.6$	$> 0$	A1
--	--	-------------	-------	----

**Table 6.2.3.27-2: A-MPR for NS\_49 (Power Class 3)**

Modulation/Waveform		A1	A2	A3	A4	A5
		Outer/Inner	Outer/Inner	Outer/Inner	Outer/Inner	Outer/Inner
DFT-s-OFDM	PI/2 BPSK	$\leq 10$	$\leq 6$	$\leq 3$	$\leq 4$	$\leq 5$
	QPSK	$\leq 10$	$\leq 6$	$\leq 3$	$\leq 4$	$\leq 5$
	16 QAM	$\leq 10$	$\leq 6$	$\leq 3$	$\leq 4$	$\leq 5$
	64 QAM	$\leq 10$	$\leq 6$	$\leq 3$	$\leq 4$	$\leq 5$
	256 QAM	$\leq 10$	$\leq 6$	$\leq 3$	$\leq 4$	$\leq 5$
CP-OFDM	QPSK	$\leq 11$	$\leq 7$	$\leq 4.5$	$\leq 5.5$	$\leq 5$
	16 QAM	$\leq 11$	$\leq 7$	$\leq 4.5$	$\leq 5.5$	$\leq 5$
	64 QAM	$\leq 11$	$\leq 7$	$\leq 4.5$	$\leq 5.5$	$\leq 5$
	256 QAM	$\leq 11$	$\leq 7$	$\leq 4.5$	$\leq 5.5$	$\leq 5$

**Table 6.2.3.27-3: A-MPR regions for NS\_49 (Power Class 2)**

Channel Bandwidth, MHz	Carrier Center Frequency, $F_c$ , MHz	Regions		A-MPR
		$RB_{end} * 12 * SCS$ MHz	$LCRB * 12 * SCS$ MHz	
10 MHz	$1925 \leq F_c \leq 1975$	$\geq 0$	$\geq 8.1$	A3
		$< 1.8$	$\geq 0$	A3
15 MHz	$1927.5 \leq F_c \leq 1972.5$	$\geq 0$	$\geq 9$	A3
		$\geq 0$	$\geq \max(0, 12 * SCS * RB_{end} - 2.88)$ $< 9$	A3
20 MHz	$1930 \leq F_c \leq 1970$	$\geq 0$	$\geq 9.72$	A4
		$\geq 0$	$\geq \max(0, 12 * SCS * RB_{end} - 3.6)$ $< 9.72$	A3
25 MHz	$1932.5 \leq F_c \leq 1967.5$	$\geq 0$	$\geq 7.92$	A4
		$\geq 18.72$	$< 1.08$	A3
		$\leq 6.48$	$< 3.6$	A3
30 MHz	$1935 \leq F_c \leq 1965$	$\geq 0, < 3.6$	$\geq 0$	A1
		$\geq 3.6, < 7.92$	$\geq 0$	A5
		$\geq 7.92, < 14.4$	$\geq \max(0, 12 * SCS * RB_{end} - 4.32)$	A3
		$\geq 14.4, < 21.6$	$\geq 10.44$	A4
		$\geq 21.6$	$\geq 10.44$	A2
		$\geq 21.6$	$< 1.8$	A1
40 MHz	$1940 \leq F_c \leq 1960$	$\geq 0, < 9$	$\geq 0$	A1
		$\geq 9, < 11.52$	$< 3.06$	A5
		$\geq 9, < 18$	$\geq \max(3.06, 12 * SCS * RB_{end} - 6.48)$	A4
		$\geq 18, < 34.56$	$\geq 11.16, < 27$	A2
		$\geq 27.36, < 34.56$	$< 1.08$	A5
		$< 34.56$	$\geq 27$	A1
45 MHz	$1942.5 \leq F_c \leq 1957.5$	$\geq 34.56$	$\geq 0$	A1
		$\geq 7.92, < 12.42$	$< \min[1.08, \max(0, 12 * SCS * RB_{end} - 7.92)]$	A5
		$\geq 30.76, < 36.72$	$< 1.08$	A5
		$< 36.72$	$\geq 12.24, < \max(0, 12 * SCS * RB_{end} - 7.92)$	A2
		$< 36.72$	$\geq \max(0, 12 * SCS * RB_{end} - 7.92)$	A1
50 MHz	$1945 \leq F_c \leq 1955$	$\geq 36.72$	$> 0$	A1
		$\geq 10.08, < 14.4$	$< \min[1.08, \max(0, 12 * SCS * RB_{end} - 10.08)]$	A5

		$\geq 36, < 39.6$	$< 1.08$	A5
		$< 39.6$	$\geq 13.68, < \max(0, 12 \cdot \text{SCS} \cdot \text{RB}_{\text{end}} - 10.08)$	A2
		$< 39.6$	$\geq \max(0, 12 \cdot \text{SCS} \cdot \text{RB}_{\text{end}} - 10.08)$	A1
		$\geq 39.6$	$> 0$	A1

Table 6.2.3.27-4: A-MPR for NS\_49 (Power Class 2)

Modulation/Waveform		A1	A2	A3	A4	A5
		Outer/Inner	Outer/Inner	Outer/Inner	Outer/Inner	Outer/Inner
DFT-s-OFDM	PI/2 BPSK	$\leq [12.5]$	$\leq 7$	$\leq 4$	$\leq 5.5$	$\leq 6$
	QPSK	$\leq [12.5]$	$\leq 7$	$\leq 4$	$\leq 5.5$	$\leq 6$
	16 QAM	$\leq [12.5]$	$\leq 7$	$\leq 4$	$\leq 5.5$	$\leq 6$
	64 QAM	$\leq [12.5]$	$\leq 7$	$\leq 4$	$\leq 5.5$	$\leq 6$
	256 QAM	$\leq [12.5]$	$\leq 7$	$\leq 4$	$\leq 5.5$	$\leq 6$
CP-OFDM	QPSK	$\leq [13.5]$	$\leq 8$	$\leq 5.5$	$\leq 7.5$	$\leq 6$
	16 QAM	$\leq [13.5]$	$\leq 8$	$\leq 5.5$	$\leq 7.5$	$\leq 6$
	64 QAM	$\leq [13.5]$	$\leq 8$	$\leq 5.5$	$\leq 7.5$	$\leq 6$
	256 QAM	$\leq [13.5]$	$\leq 8$	$\leq 5.5$	$\leq 7.5$	$\leq 6$

6.2.3.28 A-MPR for NS\_51

Table 6.2.3.28-1: A-MPR regions for NS\_51

Channel Bandwidth, MHz	Carrier Center Frequency, $F_c$ , MHz	Regions		A-MPR
		$\text{RB}_{\text{end}} \cdot 12 \cdot \text{SCS}$ MHz	$L_{\text{CRB}} \cdot 12 \cdot \text{SCS}$ MHz	
50 MHz	$F_c \leq 1945$	$\leq 4.5$	$> 0$	A7
		$> 4.5, < 32.4$	$\geq \max(0, 12 \cdot \text{SCS} \cdot \text{RB}_{\text{end}} - 14.4)$	A4
		$< 32.4$	$< \max(0, 12 \cdot \text{SCS} \cdot \text{RB}_{\text{end}} - 14.4)$	A5
		$\geq 32.4$	$> 0$	A6
50 MHz	$1945 < F_c \leq 1980$	$< 27$	$\geq \max(0, 12 \cdot \text{SCS} \cdot \text{RB}_{\text{end}} - 14.4)$	A1
		$< 27$	$< \max(0, 12 \cdot \text{SCS} \cdot \text{RB}_{\text{end}} - 14.4)$	A2
		$\geq 27$	$> 0$	A3

Table 6.2.3.28-2: A-MPR for NS\_51

Modulation/Waveform		A1	A2	A3	A4	A5	A6	A7
		Outer/Inner	Outer/Inner	Outer/Inner	Outer/Inner	Outer/Inner	Outer/Inner	Outer/Inner
DFT-s-OFDM	PI/2 BPSK	17	12.5	22	7	4.5	16	14
	QPSK	17	12.5	22	7	4.5	16	14
	16 QAM	17	12.5	22	7	4.5	16	14
	64 QAM	17	12.5	22	7	4.5	16	14
	256 QAM	17	12.5	22	7	4.5	16	14
CP-OFDM	QPSK	17	12.5	22	8.5	4.5	17	14
	16 QAM	17	12.5	22	8.5	4.5	17	14
	64 QAM	17	12.5	22	8.5	4.5	17	14
	256 QAM	17	12.5	22	8.5	4.5	17	14

6.2.3.29 A-MPR for NS\_07

Table 6.2.3.29-1: A-MPR regions for NS\_07 (Power class 3)

Channel Bandwidth, MHz	Carrier Frequency, MHz	Regions		A-MPR
		$RB_{start} * 12 * SCS$ MHz	$LCRB * 12 * SCS$ MHz	
5 MHz	$782 \leq F_c \leq 784.5$	$\geq 0$	$\geq 1.8$	A3
5 MHz	$779.5 \leq F_c < 782$	$\leq 0.9$	$\geq 0$	A1
		$> 0.9, \leq 1.26$	$\geq 1.26$	A2
		$> 1.26, \leq 3.42$	$\geq 1.8$	A3
		$> 3.42$	$\leq 0.36$	A4
10 MHz	$F_c = 782$	$\leq 2.34$	$\geq 0$	A1
		$> 2.34, \leq 3.24$	$\geq 1.44$	A2
		$> 3.24, \leq 6.48$	$\geq 3.24$	A3
		$> 6.48$	$\leq 0.36$	A4

Table 6.2.3.29-2: A-MPR for NS\_07 (Power class 3)

Modulation/Waveform	A1	A2	A3	A4
	Outer/Inner	Outer/Inner	Outer/Inner	Outer/Inner
DFT-s-OFDM PI/2 BPSK	12	9	6	3
DFT-s-OFDM QPSK	12	9	6	3
DFT-s-OFDM 16 QAM	12	9	6	3
DFT-s-OFDM 64 QAM	12	9	6	3
DFT-s-OFDM 256 QAM	12	9	6	3
CP-OFDM QPSK	14	10	7	3
CP-OFDM 16 QAM	14	10	7	3
CP-OFDM 64 QAM	14	10	7	3
CP-OFDM 256 QAM	14	10	7	3

Table 6.2.3.29-3: A-MPR regions for NS\_07 (Power class 2)

Channel Bandwidth, MHz	Carrier Frequency, MHz	Regions		A-MPR
		$RB_{start} * 12 * SCS$ MHz	$LCRB * 12 * SCS$ MHz	
5 MHz	$782 \leq F_c \leq 784.5$	$\geq 0$	$\geq 1.8$	A3
5 MHz	$779.5 \leq F_c < 782$	$\leq 0.9$	$\geq 0$	A1
		$> 0.9, \leq 1.26$	$\geq 1.26$	A2
		$> 1.26, \leq 3.42$	$\geq 1.8$	A3
		$> 3.42$	$\leq 0.36$	A4
		$> 1.26, \leq 2.16$	$\geq 1.26, < 1.8$	A5
		$> 3.06$	$> 0.36$	A5
10 MHz	$F_c = 782$	$\leq 2.34$	$\geq 0$	A1
		$> 2.34, \leq 3.24$	$\geq 1.44$	A2
		$> 3.24, \leq 6.48$	$\geq 3.24$	A3
		$> 6.48$	$\leq 0.36$	A4
		$> 3.24, \leq 6.48$	$\geq 1.8, < 3.24$	A5
		$> 6.48$	$> 0.36$	A5

Table 6.2.3.29-4: A-MPR for NS\_07 (Power class 2)

Modulation/Waveform	A1	A2	A3	A4	A5
	Outer/Inner	Outer/Inner	Outer/Inner	Outer/Inner	Outer/Inner
DFT-s-OFDM PI/2 BPSK	14.5	11	8.5	6	3
DFT-s-OFDM QPSK	14.5	11	8.5	6	3
DFT-s-OFDM 16 QAM	14.5	11	8.5	6	3
DFT-s-OFDM 64 QAM	14.5	11	8.5	6	3
DFT-s-OFDM 256 QAM	14.5	11	8.5	6	3
CP-OFDM QPSK	16.5	12	9.5	6	3
CP-OFDM 16 QAM	16.5	12	9.5	6	3
CP-OFDM 64 QAM	16.5	12	9.5	6	3
CP-OFDM 256 QAM	16.5	12	9.5	6	3

### 6.2.3.30 A-MPR for NS\_56

For 5 MHz channel centered on frequencies ( $F_C$ ) = 1630.0, 1630.3 MHz, A-MPR is defined as

```

if  $R_{B_{start}} \leq \text{ceil}\{3/SCS/15 \text{ kHz}\}$  and  $L_{CRB} \leq \text{ceil}\{17/SCS/15 \text{ kHz}\}$ ,
then
    the A-MPR = 14 dB for SCS = 15 kHz and AMPR = 8 dB for SCS  $\geq$  30 kHz,
else,
if  $R_{B_{start}} \leq \text{ceil}\{3/(SCS/15 \text{ kHz})\}$  and  $L_{CRB} > \text{ceil}\{17/(SCS/15 \text{ kHz})\}$ ,
then
    the A-MPR = 6 dB,
else,
if  $R_{B_{start}} \leq \text{ceil}\{8/(SCS/15 \text{ kHz})\}$ ,
then
    the A-MPR = 4 dB.

```

For 5 MHz channel centered on frequencies ( $F_C$ ) = 1635.0, 1649.0, 1654.0 MHz, no A-MPR is needed.

For Channel 10 MHz with center frequency of 1632.5 MHz, A-MPR is defined as

```

if  $R_{B_{start}} < \text{ceil}\{3/(SCS/15 \text{ kHz})\}$  and  $L_{CRB} \leq \text{ceil}\{8/(SCS/15 \text{ kHz})\}$ ,
then
    the A-MPR = 12 dB for SCS = 15 kHz and AMPR = 8 dB for SCS  $\geq$  30 kHz,
else,
if  $R_{B_{start}} < \text{ceil}\{9/(SCS/15 \text{ kHz})\}$ , and  $L_{CRB} > \text{ceil}\{8/(SCS/15 \text{ kHz})\}$ ,
then
    the A-MPR = 8 dB,
else,
if  $R_{B_{start}} \leq \text{ceil}\{18/(SCS/15 \text{ kHz})\}$ ,
then
    the A-MPR = 6 dB,
else,
if  $R_{B_{start}} \geq \text{floor}\{40/(SCS/15 \text{ kHz})\}$ , and  $L_{CRB} \leq \text{ceil}\{7/(SCS/15 \text{ kHz})\}$ ,
then
    the A-MPR = 5 dB,
else,
if  $R_{B_{start}} \geq \text{floor}\{40/(SCS/15 \text{ kHz})\}$  and  $L_{CRB} > \text{ceil}\{7/(SCS/15 \text{ kHz})\}$ ,
then
    the A-MPR = 3 dB,
else,
if  $R_{B_{start}} \geq \text{floor}\{35/(SCS/15 \text{ kHz})\}$  and  $L_{CRB} \leq \text{ceil}\{7/(SCS/15 \text{ kHz})\}$ ,
then
    the A-MPR = 4 dB,
else,
if  $R_{B_{start}} \geq \text{floor}\{35/(SCS/15 \text{ kHz})\}$  and  $L_{CRB} > \text{ceil}\{7/(SCS/15 \text{ kHz})\}$ ,

```

then  
the A-MPR = 2 dB.

For 10 MHz channel centered on frequency of 1651.5 MHz, no A-MPR is needed.

### 6.2.3.31 A-MPR for NS\_35

For power class 1 operation A-MPR = 8.5 dB if

$$(L_{CRB} \leq 0.20 \cdot N_{RB} \text{ and } (RB_{start} = 0 \text{ or } RB_{start} + L_{CRB} = N_{RB}))$$

or

$$(L_{CRB} = 1 \text{ and } 5 \cdot |RB_{start} + 0.5 - N_{RB} / 2| \cdot 12 \cdot SCS \geq 1.5 \cdot CBW + 5 \text{ MHz}).$$

[For power class 2 operation A-MPR = 3dB for DFT-s-OFDM and A-MPR = 4.5dB for and CP-OFDM if

$$(L_{CRB} \leq 0.20 \cdot N_{RB} \text{ and } (RB_{start} = 0 \text{ or } RB_{start} + L_{CRB} = N_{RB}))$$

or

$$(L_{CRB} = 1 \text{ and } 5 \cdot |RB_{start} + 0.5 - N_{RB} / 2| \cdot 12 \cdot SCS \geq 1.5 \cdot CBW + 5 \text{ MHz}).]$$

### 6.2.3.32 A-MPR for NS\_06

For power class 3 operation on bands n12, n13, n14 and n85, no A-MPR is applicable.

For power class 1 operation on band n14, no A-MPR is applicable.

For power class 1 operation on band n85 A-MPR = 8.5 dB if

$$(L_{CRB} \leq 0.20 \cdot N_{RB} \text{ and } (RB_{start} = 0 \text{ or } RB_{start} + L_{CRB} = N_{RB}))$$

or

$$(L_{CRB} = 1 \text{ and } 5 \cdot |RB_{start} + 0.5 - N_{RB} / 2| \cdot 12 \cdot SCS \geq 1.5 \cdot CBW + 5 \text{ MHz}).$$

For power class 2 operation on bands n13, n14 and n85, the PC2 A-MPR requirements for NS\_06 are defined below in Table 6.2.3.32-1.

**Table 6.2.3.32-1: A-MPR for NS\_06 (Power Class 2)**

Modulation/Waveform		Outer (dB)
DFT-s-OFDM	Pi/2 BPSK	≤ 1.0
	QPSK	≤ 1.5
	16 QAM	≤ 2.5
	64 QAM	≤ 3.0
	256 QAM	≤ 4.5
CP-OFDM	QPSK	≤ 3.5
	16 QAM	≤ 3.5
	64 QAM	≤ 4.0
	256 QAM	≤ 6.5

## 6.2.4 Configured transmitted power

The UE is allowed to set its configured maximum output power  $P_{\text{CMAX},f,c}$  for carrier  $f$  of serving cell  $c$  in each slot. The configured maximum output power  $P_{\text{CMAX},f,c}$  is set within the following bounds:

$$P_{\text{CMAX}_L,f,c} \leq P_{\text{CMAX},f,c} \leq P_{\text{CMAX}_H,f,c} \text{ with}$$

$$P_{\text{CMAX}_L,f,c} = \text{MIN} \{ P_{\text{EMAX},c} - \Delta T_{C,c}, (P_{\text{PowerClass}} - \Delta P_{\text{PowerClass}} + \Delta P_{\text{PowerBoost}}) - \text{MAX}(\text{MAX}(\text{MPR}_c + \Delta \text{MPR}_c, A - \text{MPR}_c) + \Delta T_{\text{IB},c} + \Delta T_{C,c} + \Delta T_{\text{RxsRS}}, P - \text{MPR}_c) \}$$

$$P_{\text{CMAX}_H,f,c} = \text{MIN} \{ P_{\text{EMAX},c}, P_{\text{PowerClass}} - \Delta P_{\text{PowerClass}} + \Delta P_{\text{PowerBoost}} \}$$

where

$P_{\text{EMAX},c}$  is the value given by either the *p-Max* IE or the field *additionalPmax* of the *NR-NS-PmaxList* IE, whichever is applicable according to TS 38.331[7];

$P_{\text{PowerClass}}$  is the maximum UE power specified in Table 6.2.1-1 and in Table 6.2F.1-1 for shared spectrum access operation, without taking into account the tolerance specified in the Table 6.2.1-1 and in Table 6.2F.1-1 for shared spectrum access operation;

When the IE *powerBoostPi2BPSK* is set to 1,  $P_{\text{EMAX},c}$  is increased by +3 dB for a power class 3 UE operating in TDD bands n40, n41, n77, n78, and n79 with Pi/2 BPSK modulation and UE indicates support for UE capability *powerBoosting-pi2BPSK* and 40% or less symbols in certain evaluation period are used for UL transmission when  $P_{\text{EMAX},c} \geq 20$  dBm (The exact evaluation period is no less than one radio frame).

When the IE *powerBoostPi2BPSK* is set to 1,  $\Delta P_{\text{PowerClass}} = -3$  dB for a power class 3 UE operating in TDD bands n40, n41, n77, n78, and n79 with Pi/2 BPSK modulation and UE indicates support for UE capability *powerBoosting-pi2BPSK* and 40% or less slots in radio frame are used for UL transmission.

$\Delta P_{\text{PowerClass}} =$

- 3 dB for a power class 2 UE or 6 dB for a power class 1.5 UE when P-max of 23 dBm or lower is indicated; or when the field of UE capability *maxUplinkDutyCycle-PC2-FRI* is absent and the field of UE capability *maxUplinkDutyCycle-PC1dot5-MPE-FRI* is absent and the percentage of uplink symbols transmitted in a certain evaluation period is larger than 50%; or when the field of UE capability *maxUplinkDutyCycle-PC2-FRI* is not absent and the percentage of uplink symbols transmitted in a certain evaluation period is larger than *maxUplinkDutyCycle-PC2-FRI* as defined in TS 38.306 (The exact evaluation period is no less than one radio frame); or when the field of UE capability *maxUplinkDutyCycle-PC1dot5-MPE-FRI* is not absent and half the percentage of uplink symbols transmitted in a certain evaluation period is larger than *maxUplinkDutyCycle-PC1dot5-MPE-FRI* as defined in TS 38.306 (The exact evaluation period is no less than one radio frame).
- 3 dB for a power class 1.5 UE when P-max of between 23 dBm and 26 dB is indicated; or when the field of UE capability *maxUplinkDutyCycle-PC2-FRI* is absent and the field of UE capability *maxUplinkDutyCycle-PC1dot5-MPE-FRI* is absent and the percentage of uplink symbols transmitted in a certain evaluation period is between 25% and 50%; or when the field of UE capability *maxUplinkDutyCycle-PC2-FRI* is not absent and the percentage of uplink symbols transmitted in a certain evaluation period is between *maxUplinkDutyCycle-PC2-FRI* and *maxUplinkDutyCycle-PC2-FRI/2* as defined in TS 38.306 (The exact evaluation period is no less than one radio frame); or when the field of UE capability *maxUplinkDutyCycle-PC1dot5-MPE-FRI* is not absent and the percentage of uplink symbols transmitted in a certain evaluation period is larger than *maxUplinkDutyCycle-PC1dot5-MPE-FRI* as defined in TS 38.306 (The exact evaluation period is no less than one radio frame).
- 3dB when the UE is configured with SUL configurations and the requirements of default power class are applied as specified in sub-clause 6.2C.1 on the band where UE indicates power class 2;

- 3dB is applied during SRS transmission occasions with usage in SRS-ResourceSet set as 'antennaSwitching' with configured SRS resources in each SRS resource set(s) consisting of one SRS port when PC2 UE with *txDiversity-r16* or *txDiversity2Tx-r18* capability or PC1.5 UE further indicates SRS-TxSwitch capability 't1r2' or 't1r4' or 't1r1-t1r2' or 't1r1-t1r2-t1r4' or further indicates *srs-AntennaSwitchingBeyond4RX-r17* as 't1r8';
- 0 dB otherwise;

NOTE: UE reports  $\Delta P_{\text{PowerClass}}$  when *deltaPowerClassReporting-r18* is present, *dpc-Reporting-FR1* [7] is configured and the reporting is triggered only by uplink duty cycle exceedance or by return to the *ue-PowerClass* after the duty cycle exceedance.

$\Delta T_{\text{IB},c}$  is the additional tolerance for serving cell *c* as specified in clause 6.2A.4.2 for NR CA, clause 6.2C.2 for SUL, or TS 38.101-3 clause 6.2B.4.2 for EN-DC;  $\Delta T_{\text{IB},c} = 0$  dB otherwise; In case the UE supports more than one of band combinations for V2X operating bands for concurrent operation, CA, SUL or DC, and an operating band belongs to more than one band combinations then

- a) When the operating band frequency range is  $\leq 1$  GHz, the applicable additional  $\Delta T_{\text{IB},c}$  shall be the average value for all band combinations defined in clause 6.2A.4.2, 6.2C.2 in this specification and 6.2B.4.2 in TS 38.101-3 [3], truncated to one decimal place that apply for that operating band among the supported band combinations. In case there is a harmonic relation between low band UL and high band DL, then the maximum  $\Delta T_{\text{IB},c}$  among the different supported band combinations involving such band shall be applied
- b) When the operating band frequency range is  $> 1$  GHz, the applicable additional  $\Delta T_{\text{IB},c}$  shall be the maximum value for all band combinations defined in clause 6.2A.4.2, 6.2C.2 in this specification and 6.2B.4.2 in TS 38.101-3 [3] for the applicable operating bands.

$\Delta P_{\text{PowerBoost}}$  is defined as 1dB for power class 3 and 0.5dB for power class 2, when all of the following conditions are met:

- If the UE indicates support for UE capability *powerBoosting-pi2BPSK-QPSK-r18* and/or *powerBoosting-pi2BPSK-QPSK-Modified-r18*, and if IE *powerBoostPi2BPSK-r18* and/or *powerBoostQPSK-r18* is set to 1 and  $P_{\text{EMAX},c}$ , if configured, is increased by at least  $\Delta P_{\text{PowerBoost}}$
- If UE indicates power class 2 in a TDD band or power class 3
- If  $\Delta P_{\text{PowerClass}}$  is 0dB
- If scheduled UL transmission is DFT-s-OFDM with either PI/2 BPSK modulation or QPSK modulation
- If the RB allocation belongs to the inner region defined in clause 6.2.2.
- If UE indicates power class 3, the percentage of uplink symbols transmitted in a certain evaluation period is less than 80%
- If UE indicates power class 2, when the field of UE capability *maxUplinkDutyCycle-PC2-FR1* is absent and the field of UE capability *maxUplinkDutyCycle-PC1dot5-MPE-FR1* is absent and the percentage of uplink symbols transmitted in a certain evaluation period is less than  $0.9 \cdot 50\%$ ; or when the field of UE capability *maxUplinkDutyCycle-PC2-FR1* is not absent and the percentage of uplink symbols transmitted in a certain evaluation period is less than  $0.9 \cdot \text{maxUplinkDutyCycle-PC2-FR1}$  as defined in TS 38.306 (The exact evaluation period is no less than one radio frame); or when the field of UE capability *maxUplinkDutyCycle-PC1dot5-MPE-FR1* is not absent and half the percentage of uplink symbols transmitted in a certain evaluation period is less than  $0.9 \cdot \text{maxUplinkDutyCycle-PC1dot5-MPE-FR1}$  as defined in TS 38.306 (The exact evaluation period is no less than one radio frame)
- 0 dB otherwise;

$\Delta T_{\text{C},c} = 1.5\text{dB}$  when NOTE 3 in Table 6.2.1-1 in 38.101-1 applies for a serving cell *c*, otherwise  $\Delta T_{\text{C},c} = 0$  dB ;



$MPR_c$  and  $A-MPR_c$  for serving cell  $c$  are specified in clause 6.2.2 and clause 6.2.3, respectively and in clause 6.2F.2 and clause 6.2F.3 respectively for shared spectrum access operation;

$\Delta MP R_c$  for serving cell  $c$  is specified in clause 6.2.2 and in clause 6.2F.2 for shared spectrum access operation.

$\Delta T_{RxSRS}$  is applied during SRS transmission occasions with *usage* in *SRS-ResourceSet* set as 'antennaSwitching' when

- a) UE transmits SRS on the second SRS resource in every configured SRS resource set when the *SRS-TxSwitch* capability is indicated as 't1r2' or 't1r1-t1r2'
- b) UE transmits SRS on the second, third and fourth SRS resources of the total 4 SRS resources from all configured SRS resource set(s) consisting of one SRS port when the *SRS-TxSwitch* capability is indicated as 't1r4' or, 't1r4-t2r4' or 't1r1-t1r2-t1r4' or, 't1r1-t1r2-t2r2-t1r4-t2r4'
- c) UE transmits SRS from the SRS port pair on the second SRS resource in every configured SRS resource set consisting of two SRS ports when the *SRS-TxSwitch* capability is indicated as 't2r4' or 't1r4-t2r4', or 't1r1-t1r2-t2r2-t2r4' or 't1r1-t1r2-t2r2-t1r4-t2r4', or
- d) UE transmits SRS to a DL-only carrier
- e) UE transmits SRS on the second, third, fourth, fifth, sixth, seventh and eighth SRS resources of the total 8 SRS resources from all configured SRS resource set(s) consisting of one SRS port when the *srs-AntennaSwitchingBeyond4RX-r17* capability is indicated as at least 't1r8', or
- f) UE transmits SRS from the SRS port pair on the second, third and fourth SRS resource in every configured SRS resource set consisting of two SRS ports when the *srs-AntennaSwitchingBeyond4RX-r17* capability is indicated as at least 't2r8', or
- g) UE transmits SRS from the set of SRS ports on the second SRS resource in every configured SRS resource set consisting of four SRS ports when the *srs-AntennaSwitchingBeyond4RX-r17* capability is indicated as at least 't4r8',

The following  $\Delta T_{RxSRS}$  applies according to the indicated *SRS-TxSwitch* or *srs-AntennaSwitchingBeyond4RX-r17* capabilities:

if 't1r8' and 't4r8' are indicated:

- The value of  $\Delta T_{RxSRS}$  is 7.3 dB for bands whose  $F_{UL\_high}$  is higher than the  $F_{UL\_low}$  of n79 and 5.8 dB for bands whose  $F_{UL\_high}$  is lower than the  $F_{UL\_low}$  of n79 when the device is power class 3 or power class 5 or power class 1.5 in the band, or when the device is power class 2 in the band and  $\Delta P_{PowerClass} = 3$  dB, or when UE indicating Tx diversity capability.
- The value of  $\Delta T_{RxSRS}$  is 10.3 dB for bands whose  $F_{UL\_high}$  is higher than the  $F_{UL\_low}$  of n79 and 8.8 dB for bands whose  $F_{UL\_high}$  is lower than the  $F_{UL\_low}$  of n79 during SRS transmission occasions with configured SRS resources consisting of one SRS port when the device is power class 2 in the band and  $\Delta P_{PowerClass} = 0$  dB and not indicating Tx diversity capability.

else, if 't1r8' and 't2r8' are indicated:

- The value of  $\Delta T_{RxSRS}$  is 6.0 dB for bands whose  $F_{UL\_high}$  is higher than the  $F_{UL\_low}$  of n79 and 4.5 dB for bands whose  $F_{UL\_high}$  is lower than the  $F_{UL\_low}$  of n79 when the device is power class 3 or power class 5 or power class 1.5 in the band, or when the device is power class 2 in the band and  $\Delta P_{PowerClass} = 3$  dB, or when UE indicating *txDiversity-r16*.
- The value of  $\Delta T_{RxSRS}$  is 9.0 dB for bands whose  $F_{UL\_high}$  is higher than the  $F_{UL\_low}$  of n79 and 7.5 dB for bands whose  $F_{UL\_high}$  is lower than the  $F_{UL\_low}$  of n79 during SRS transmission occasions with configured

SRS resources consisting of one SRS port when the device is power class 2 in the band and  $\Delta P_{\text{PowerClass}} = 0$  dB and not indicating Tx diversity capability.

else, if 't1r8' or 't2r8', but not both is indicated:

- The value of  $\Delta T_{\text{RxSRS}}$  is 5.5 dB for bands whose  $F_{\text{UL\_high}}$  is higher than the  $F_{\text{UL\_low}}$  of n79 and 4.0 dB for bands whose  $F_{\text{UL\_high}}$  is lower than the  $F_{\text{UL\_low}}$  of n79 when the device is power class 3 or power class 5 or power class 1.5 in the band, or when the device is power class 2 in the band and  $\Delta P_{\text{PowerClass}} = 3$  dB, or when UE indicating Tx diversity capability.
- The value of  $\Delta T_{\text{RxSRS}}$  is 8.5 dB for bands whose  $F_{\text{UL\_high}}$  is higher than the  $F_{\text{UL\_low}}$  of n79 and 7.0 dB for bands whose  $F_{\text{UL\_high}}$  is lower than the  $F_{\text{UL\_low}}$  of n79 during SRS transmission occasions with configured SRS resources consisting of one SRS port when the device is power class 2 in the band and  $\Delta P_{\text{PowerClass}} = 0$  dB and not indicating Tx diversity capability.

else, if 't1r2', 't1r1-t1r2', 't1r4', 't1r4-t2r4', 't1r1-t1r2-t1r4', 't2r4', 't1r1-t1r2-t2r2-t2r4', 't1r1-t1r2-t2r2-t1r4-t2r4' or 't4r8' is indicated:

- The value of  $\Delta T_{\text{RxSRS}}$  is 4.5dB for bands whose  $F_{\text{UL\_high}}$  is higher than the  $F_{\text{UL\_low}}$  of n79 and 3 dB for bands whose  $F_{\text{UL\_high}}$  is lower than the  $F_{\text{UL\_low}}$  of n79 when the device is power class 3 or power class 5 or power class 1.5 in the band, or when the device is power class 2 in the band and  $\Delta P_{\text{PowerClass}} = 3$  dB, or when UE indicating Tx diversity capability.
- The value of  $\Delta T_{\text{RxSRS}}$  is 7.5dB for bands whose  $F_{\text{UL\_high}}$  is higher than the  $F_{\text{UL\_low}}$  of n79 and 6 dB for bands whose  $F_{\text{UL\_high}}$  is lower than the  $F_{\text{UL\_low}}$  of n79 during SRS transmission occasions with configured SRS resources consisting of one SRS port when the device is power class 2 in the band and  $\Delta P_{\text{PowerClass}} = 0$  dB and not indicating Tx diversity capability.

For other SRS transmissions  $\Delta T_{\text{RxSRS}}$  is zero;

$P\text{-MPR}_c$  is the power management maximum power reduction for

- a) ensuring compliance with applicable electromagnetic energy absorption requirements and addressing unwanted emissions / self desense requirements in case of simultaneous transmissions on multiple RAT(s) for scenarios not in scope of 3GPP RAN specifications;
- b) ensuring compliance with applicable electromagnetic energy absorption requirements in case of proximity detection is used to address such requirements that require a lower maximum output power.

The UE shall apply  $P\text{-MPR}_c$  for serving cell c only for the above cases. For UE conducted conformance testing  $P\text{-MPR}_c$  shall be 0 dB

NOTE 1:  $P\text{-MPR}_c$  was introduced in the  $P_{\text{CMAX},f,c}$  equation such that the UE can report to the gNB the available maximum output transmit power. This information can be used by the gNB for scheduling decisions.

NOTE 2:  $P\text{-MPR}_c$  may impact the maximum uplink performance for the selected UL transmission path.

$T_{\text{REF}}$  and  $T_{\text{eval}}$  are specified in Table 6.2.4-1. For each  $T_{\text{REF}}$ , the  $P_{\text{CMAX},L,c}$  for serving cell c are evaluated per  $T_{\text{eval}}$  and given by the minimum value taken over the transmission(s) within the  $T_{\text{eval}}$ ; the minimum  $P_{\text{CMAX},L,f,c}$  over one or more  $T_{\text{eval}}$  is then applied for the entire  $T_{\text{REF}}$

**Table 6.2.4-1: Evaluation and reference periods for Pcm<sub>ax</sub>**

$T_{\text{REF}}$	$T_{\text{eval}}$	$T_{\text{eval}}$ with frequency hopping
Physical channel length	Physical channel length	$\text{Min}(T_{\text{no\_hopping}}, \text{Physical Channel Length})$

The measured configured maximum output power  $P_{UMAX,f,c}$  shall be within the following bounds:

$$P_{CMAX\_L,f,c} - \text{MAX}\{T_{L,c}, T(P_{CMAX\_L,f,c})\} \leq P_{UMAX,f,c} \leq P_{CMAX\_H,f,c} + T(P_{CMAX\_H,f,c}).$$

where the tolerance  $T(P_{CMAX,f,c})$  for applicable values of  $P_{CMAX,f,c}$  is specified in Table 6.2.4-1. The tolerance  $T_{L,c}$  is the absolute value of the lower tolerance for the applicable operating band as specified in Table 6.2.1-1 and in Table 6.2F.1-1 for shared spectrum access operation.

**Table 6.2.4-1:  $P_{CMAX}$  tolerance**

$P_{CMAX,f,c}$ (dBm)	Tolerance $T(P_{CMAX,f,c})$ (dB)
$23 < P_{CMAX,c} \leq 33$	2.0
$21 \leq P_{CMAX,c} \leq 23$	2.0
$20 \leq P_{CMAX,c} < 21$	2.5
$19 \leq P_{CMAX,c} < 20$	3.5
$18 \leq P_{CMAX,c} < 19$	4.0
$13 \leq P_{CMAX,c} < 18$	5.0
$8 \leq P_{CMAX,c} < 13$	6.0
$-40 \leq P_{CMAX,c} < 8$	7.0

## 6.2A Transmitter power for CA

### 6.2A.1 UE maximum output power for CA

#### 6.2A.1.1 UE maximum output power for Intra-band contiguous CA

For uplink intra-band contiguous carrier aggregation, the maximum output power is specified in Table 6.2A.1.1-1. For downlink intra-band contiguous carrier aggregation with a single uplink component carrier configured in the NR band, the maximum output power is specified in Table 6.2.1-1 for power class 3 and other power classes if indicated in clause 5.5A.1.

**Table 6.2A.1.1-1: UE Power Class for intra-band contiguous CA**

NR CA Configuration	Class 1 (dBm)	Tolerance (dB)	Class 2 (dBm)	Tolerance (dB)	Class 3 (dBm)	Tolerance (dB)	Class 5 (dBm)	Tolerance (dB)
CA_n3B					23	+2/-2		
CA_n5B					23	+2/-2		
CA_n7B					23	+2/-2		
CA_n40B			26	+2/-3	23	+2/-2		
CA_n41B					23	+2/-2		
CA_n41C			26	+2/-3	23	+2/-2		
CA_n48B					23	+2/-3		
CA_n77C			26	+2/-3	23	+2/-3		
CA_n78C			26	+2/-3	23	+2/-3		
CA_n79C			26	+2/-3	23	+2/-3		

NOTE 1: An uplink CA configuration in which the band has NOTE 3 in Table 6.2.1-1 is allowed to reduce the lower tolerance limit by 1.5 dB when the transmission bandwidths of the band are confined within  $F_{UL\_low}$  and  $F_{UL\_low} + 4$  MHz or  $F_{UL\_high} - 4$  MHz and  $F_{UL\_high}$ .

NOTE 2:  $P_{PowerClass}$  is the maximum UE power specified without taking into account the tolerance.

NOTE 3: For intra-band contiguous carrier aggregation the maximum power requirement shall apply to the total transmitted power over all component carriers (per UE).

NOTE 4: Power class 3 is the default power class unless otherwise stated.

If a UE supports a different power class than the default UE power class for the band combination listed in Table 6.2A.1.1-1 and the supported power class enables the higher maximum output power than that of the default power class:

- if the field of UE capability *maxUplinkDutyCycle-PC2-FRI* is absent and the percentage of total uplink symbols transmitted on all UL CCs in a certain evaluation period is larger than 50% (The exact evaluation period is no less than one radio frame); or
- if the field of UE capability *maxUplinkDutyCycle-PC2-FRI* is not absent and the percentage of total uplink symbols transmitted on all UL CCs in a certain evaluation period is larger than *maxUplinkDutyCycle-PC2-FRI* as defined in TS 38.306 (The exact evaluation period is no less than one radio frame); or
- if  $10 \log_{10} \sum P_{EMAX,c}$  or  $P_{EMAX,CA}$  which defined in clause 6.2A.4.1.1 is 23dBm or lower;
  - shall apply all requirements for the default power class to the supported power class and set the configured transmitted power as specified in clause 6.2A.4.1.1;
- else shall apply all requirements for the supported power class and set the configured transmitted power as specified in clause 6.2A.4.1.1.

### 6.2A.1.2 UE maximum output power for Intra-band non-contiguous CA

For intra-band non-contiguous carrier aggregation with one uplink carrier on the PCC, the requirements in clause 6.2.1 apply for power class 3 and other power classes if indicated in clause 5.5A.2. For intra-band non-contiguous carrier aggregation with two uplink carriers the maximum output power is specified in Table 6.2A.1.2-1.

**Table 6.2A.1.2-1: UE Power Class for intraband non-contiguous CA**

NR CA Configuration	Class 1 (dBm)	Tolerance (dB)	Class 2 (dBm)	Tolerance (dB)	Class 3 (dBm)	Tolerance (dB)	Class 5 (dBm)	Tolerance (dB)
CA_n26(2A)					23	+2/-3		
CA_n40(2A)			26	+2/-3	23	+2/-3		
CA_n41(2A)			26	+2/-3	23	+2/-3		
CA_n77(2A)			26	+2/-3	23	+2/-3		
CA_n78(2A)			26	+2/-3	23	+2/-3		
CA_n79(2A)					23	+2/-3		
NOTE 1: An uplink CA configuration in which the band has NOTE 3 in Table 6.2.1-1 is allowed to reduce the lower tolerance limit by 1.5 dB when the transmission bandwidths of the band are confined within $F_{UL,low}$ and $F_{UL,low} + 4$ MHz or $F_{UL,high} - 4$ MHz and $F_{UL,high}$ . NOTE 2: $P_{PowerClass}$ is the maximum UE power specified without taking into account the tolerance. NOTE 3: For intra-band non-contiguous carrier aggregation the maximum power requirement shall apply to the total transmitted power over all component carriers (per UE). NOTE 4: Power class 3 is the default power class unless otherwise stated.								

If a UE supports a different power class than the default UE power class for the band combination listed in Table 6.2A.1.1-2 and the supported power class enables the higher maximum output power than that of the default power class:

- if the field of UE capability *maxUplinkDutyCycle-PC2-FRI* is absent and the percentage of total uplink symbols transmitted on all UL CCs in a certain evaluation period is larger than 50% (The exact evaluation period is no less than one radio frame); or
- if the field of UE capability *maxUplinkDutyCycle-PC2-FRI* is not absent and the percentage of total uplink symbols transmitted on all UL CCs in a certain evaluation period is larger than *maxUplinkDutyCycle-PC2-FRI* as defined in TS 38.306 (The exact evaluation period is no less than one radio frame); or

- if  $10 \log_{10} \sum P_{EMAX,c}$  or  $P_{EMAX,CA}$  which defined in clause 6.2A.4.1.2 is 23dBm or lower;
- shall apply all requirements for the default power class to the supported power class and set the configured transmitted power as specified in clause 6.2A.4.1.2;
- else shall apply all requirements for the supported power class and set the configured transmitted power as specified in clause 6.2A.4.1.2.

### 6.2A.1.3 UE maximum output power for Inter-band CA

For inter-band downlink carrier aggregation with one uplink carrier assigned to one NR band, the transmitter power requirements in Table 6.2.1-1 apply for power class 3 and other power classes if indicated in clause 5.5A.3.

For inter-band carrier aggregation with two uplink contiguous carrier assigned to one NR band, the transmitter power requirements specified in subclause 6.2A.1.1 apply.

For inter-band carrier aggregation with two uplink non-contiguous carrier assigned to one NR band, the transmitter power requirements specified in subclause 6.2A.1.2 apply. For inter-band uplink carrier aggregation with uplink assigned to two NR bands, UE maximum output power shall be measured over all component carriers from different bands. If each band has separate antenna connectors, maximum output power is defined as the sum of maximum output power from each UE antenna connector. The period of measurement shall be at least one sub frame (1 ms). The maximum output power is specified in Table 6.2A.1.3-1.

**Table 6.2A.1.3-1: UE Power Class for uplink inter-band CA (two bands)**

Uplink CA Configuration	Class 1 (dBm)	Tolerance (dB)	Class 2 (dBm)	Tolerance (dB)	Class 3 (dBm)	Tolerance (dB)	Class 5 (dBm)	Tolerance (dB)
CA_n1A-n3A					23	+2/-3		
CA_n1A-n5A					23	+2/-3		
CA_n1A-n7A					23	+2/-3		
CA_n1A-n8A					23	+2/-3		
CA_n1A-n18A					23	+2/-3		
CA_n1A-n20A					23	+2/-3		
CA_n1A-n26A					23	+2/-3		
CA_n1A-n28A					23	+2/-3		
CA_n1A-n40A					23	+2/-3		
CA_n1A-n41A			26 <sup>6</sup>	+2/-3	23	+2/-3		
CA_n1A-n46A					23	+2/-3		
CA_n1A-n74A					23	+2/-3		
CA_n1A-n77A			26 <sup>6</sup>	+2/-3	23	+2/-3		
CA_n1A-n78A			26 <sup>6</sup>	+2/-3	23	+2/-3		
CA_n1A-n78C					23	+2/-3		
CA_n1A-n79A			26 <sup>6</sup>	+2/-3	23	+2/-3		
CA_n1A-n102A					23	+2/-3		
CA_n1A-n102B					23	+2/-3		
CA_n1A-n102C					23	+2/-3		
CA_n1A-n105A					23	+2/-3		
CA_n2A-n5A					23	+2/-3		
CA_n2A-n7A					23	+2/-3		
CA_n2A-n12A					23	+2/-3		
CA_n2A-n14A					23	+2/-3		
CA_n2A-n30A					23	+2/-3		
CA_n2A-n41A					23	+2/-3		
CA_n2A-n48A					23	+2/-3		
CA_n2A-n66A					23	+2/-3		

CA_n2A-n71A				23	+2/-3		
CA_n2A-n77A		26 <sup>6</sup>	+2/-3	23	+2/-3		
CA_n2A-n78A				23	+2/-3		
CA_n3A-n5A				23	+2/-3		
CA_n3A-n7A				23	+2/-3		
CA_n3A-n8A				23	+2/-3		
CA_n3A-n18A				23	+2/-3		
CA_n3A-n20A				23	+2/-3		
CA_n3A-n26A				23	+2/-3		
CA_n3A-n28A				23	+2/-3		
CA_n3A-n34A				23	+2/-3		
CA_n3A-n38A				23	+2/-3		
CA_n3A-n40A		26 <sup>6</sup>	+2/-3	23	+2/-3		
CA_n3A-n41A		26 <sup>6</sup>	+2/-3	23	+2/-3		
CA_n3A-n41C		26 <sup>6</sup>	+2/-3	23	+2/-3		
CA_n3A-n74A				23	+2/-3		
CA_n3A-n77A		26 <sup>6</sup>	+2/-3	23	+2/-3		
CA_n3A-n78A		26 <sup>6</sup>	+2/-3	23	+2/-3		
CA_n3A-n78C				23	+2/-3		
CA_n3A-n79A		26 <sup>6</sup>	+2/-3	23	+2/-3		
CA_n3A-n79C		26 <sup>6</sup>	+2/-3	23	+2/-3		
CA_n3A-n102A				23	+2/-3		
CA_n3A-n102B				23	+2/-3		
CA_n3A-n102C				23	+2/-3		
CA_n3A-n105A				23	+2/-3		
CA_n5A-n7A				23	+2/-3		
CA_n5A-n12A				23	+2/-3		
CA_n5A-n13A				23	+2/-3		
CA_n5A-n14A				23	+2/-3		
CA_n5A-n25A				23	+2/-3		
CA_n5A-n28A				23	+2/-3		
CA_n5A-n30A				23	+2/-3		
CA_n5A-n40A				23	+2/-3		
CA_n5A-n41A				23	+2/-3		
CA_n5A-n48A				23	+2/-3		
CA_n5A-n66A				23	+2/-3		
CA_n5A-n77A		26 <sup>6</sup>	+2/-3	23	+2/-3		
CA_n5A-n78A		26 <sup>6</sup>	+2/-3	23	+2/-3		
CA_n5A-n78C				23	+2/-3		
CA_n5A-n79A				23	+2/-3		
CA_n5A-n105A				23	+2/-3		
CA_n7A-n8A				23	+2/-3		
CA_n7A-n20A				23	+2/-3		
CA_n7A-n25A				23	+2/-3		
CA_n7A-n26A				23	+2/-3		
CA_n7A-n28A				23	+2/-3		
CA_n7A-n40A				23	+2/-3		
CA_n7A-n46A				23	+2/-3		
CA_n7A-n66A				23	+2/-3		
CA_n7A-n71A				23	+2/-3		
CA_n7A-n77A		26 <sup>6</sup>	+2/-3	23	+2/-3		
CA_n7A-n78A		26 <sup>6</sup>	+2/-3	23	+2/-3		
CA_n7A-n102A				23	+2/-3		
CA_n7A-n102B				23	+2/-3		
CA_n7A-n102C				23	+2/-3		
CA_n7A-n105A				23	+2/-3		
CA_n8A-n20A				23	+2/-3		
CA_n8A-n28A				23	+2/-3		
CA_n8A-n34A		26 <sup>6</sup>	+2/-3	23	+2/-3		

CA_n8A-n39A			26 <sup>6</sup>	+2/-3	23	+2/-3		
CA_n8A-n40A			26 <sup>6</sup>	+2/-3	23	+2/-3		
CA_n8A-n41A					23	+2/-3		
CA_n8A-n41C					23	+2/-3		
CA_n8A-n77A			26 <sup>6</sup>	+2/-3	23	+2/-3		
CA_n8A-n78A			26 <sup>6</sup>	+2/-3	23	+2/-3		
CA_n8A-n78C					23	+2/-3		
CA_n8A-n79A			26 <sup>6</sup>	+2/-3	23	+2/-3		
CA_n8A-n79C			26 <sup>6</sup>	+2/-3	23	+2/-3		
CA_n12A-n25A					23	+2/-3		
CA_n12A-n30A					23	+2/-3		
CA_n12A-n66A					23	+2/-3		
CA_n12A-n77A			26 <sup>6</sup>	+2/-3	23	+2/-3		
CA_n12A-n78A					23	+2/-3		
CA_n13A-n25A					23	+2/-3		
CA_n13A-n66A					23	+2/-3		
CA_n13A-n77A			26 <sup>6</sup>	+2/-3	23	+2/-3		
CA_n14A-n30A					23	+2/-3		
CA_n14A-n66A					23	+2/-3		
CA_n14A-n77A			26 <sup>6</sup>	+2/-3	23	+2/-3		
CA_n18A-n28A					23	+2/-3		
CA_n18A-n40A					23	+2/-3		
CA_n18A-n41A			26 <sup>6</sup>	+2/-3	23	+2/-3		
CA_n18A-n74A					23	+2/-3		
CA_n18A-n77A			26 <sup>6</sup>	+2/-3	23	+2/-3		
CA_n18A-n78A					23	+2/-3		
CA_n20A-n28A					23	+2/-3		
CA_n20A-n78A					23	+2/-3		
CA_n24A-n41A					23	+2/-3		
CA_n24A-n48A					23	+2/-3		
CA_n24A-n77A					23	+2/-3		
CA_n25A-n38A					23	+2/-3		
CA_n25A-n41A			26 <sup>6</sup>	+2/-3 <sup>2</sup>	23	+2/-3		
CA_25A-n48A					23	+2/-3		
CA_n25A-n66A					23	+2/-3		
CA_n25A-n71A					23	+2/-3		
CA_n25A-n77A			26 <sup>6</sup>	+2/-3	23	+2/-3		
CA_n25A-n78A			26 <sup>6</sup>	+2/-3	23	+2/-3		
CA_n25A-n85A					23	+2/-3		
CA_n26A-n28A					23	+2/-3		
CA_n26A-n48A					23	+2/-3		
CA_n26A-n66A					23	+2/-3		
CA_n26A-n70A					23	+2/-3		
CA_n26A-n77A					23	+2/-3		
CA_n26A-n78A			26 <sup>6</sup>	+2/-3 <sup>2</sup>	23	+2/-3		
CA_n28A-n34A			26 <sup>6</sup>	+2/-3 <sup>2</sup>	23	+2/-3		
CA_n28A-n39A			26 <sup>6</sup>	+2/-3 <sup>2</sup>	23	+2/-3		
CA_n28A-n40A			26 <sup>6</sup>	+2/-3 <sup>2</sup>	23	+2/-3		
CA_n28A-n41A			26 <sup>6</sup>	+2/-3	23	+2/-3		
CA_n28A-n41C			26 <sup>6</sup>	+2/-3	23	+2/-3		
CA_n28A-n46A					23	+2/-3		
CA_n28A-n50A					23	+2/-3		
CA_n28A-n74A					23	+2/-3		
CA_n28A-n77A			26 <sup>6</sup>	+2/-3	23	+2/-3		
CA_n28A-n78A			26 <sup>6</sup>	+2/-3	23	+2/-3		
CA_n28A-n79A			26 <sup>6</sup>	+2/-3	23	+2/-3		
CA_n28A-n79C			26 <sup>6</sup>	+2/-3	23	+2/-3		
CA_n28A-n102A					23	+2/-3		
CA_n28A-n102B					23	+2/-3		

CA_n28A-n102C				23	+2/-3		
CA_n34A-n79A				23	+2/-3		
CA_n30A-n66A				23	+2/-3		
CA_n30A-n77A		26 <sup>6</sup>	+2/-3	23	+2/-3		
CA_n34A-n39A		26 <sup>9</sup>	+2/-3	23	+2/-3		
CA_n34A-n40A		26 <sup>9</sup>	+2/-3	23	+2/-3		
CA_n34A-n41A		26 <sup>9</sup>	+2/-3	23	+2/-3		
CA_n34A-n41C				23	+2/-3		
CA_n34A-n79A		26 <sup>9</sup>	+2/-3	23	+2/-3		
CA_n34A-n79C				23	+2/-3		
CA_n38A-n66A				23	+2/-3		
CA_n38A-n78A				23	+2/-3		
CA_n39A-n40A		26 <sup>9</sup>	+2/-3	23	+2/-3		
CA_n39A-n41A		26 <sup>9</sup>	+2/-3	23	+2/-3		
CA_n39A-n41C		26 <sup>9</sup>	+2/-3	23	+2/-3		
CA_n39A-n79A		26 <sup>9</sup>	+2/-3	23	+2/-3		
CA_n39A-n79C				23	+2/-3		
CA_n40A-n41A		26 <sup>9</sup>	+2/-3	23	+2/-3		
CA_n40A-n77A		26 <sup>9</sup>	+2/-3	23	+2/-3		
CA_n40A-n78A		26 <sup>9</sup>	+2/-3	23	+2/-3		
CA_n40A-n79A		26 <sup>9</sup>	+2/-3	23	+2/-3		
CA_n40A-n79C		26 <sup>9</sup>	+2/-3	23	+2/-3		
CA_n40A-n105A				23	+2/-3		
CA_n41A-n48A				23	+2/-3		
CA_n41A-n50A				23	+2/-3		
CA_n41A-n66A		26 <sup>6</sup>	+2/-3	23	+2/-3		
CA_n41A-n70A				23	+2/-3		
CA_n41A-n71A		26 <sup>6</sup>	+2/-3	23	+2/-3		
CA_n41A-n74A				23	+2/-3		
CA_n41A-n77A		26 <sup>9</sup>	+2/-3	23	+2/-3		
CA_n41A-n78A				23	+2/-3		
CA_n41A-n79A		26 <sup>9</sup>	+2/-3	23	+2/-3		
CA_n41A-n79C		26 <sup>9</sup>	+2/-3	23	+2/-3		
CA_n41C-n79A		26 <sup>9</sup>	+2/-3	23	+2/-3		
CA_n41A-n85A				23	+2/-3		
CA_n46A-n48A				23	+2/-3		
CA_n46A-n48B				23	+2/-3		
CA_n46A-n77A				23	+2/-3		
CA_n46A-n78A				23	+2/-3		
CA_n48A-n66A				23	+2/-3		
CA_n48A-n70A				23	+2/-3		
CA_n48A-n71A				23	+2/-3		
CA_n48A-n96A				23	+2/-3		
CA_n48B-n96A				23	+2/-3		
CA_n48A-n96B				23	+2/-3		
CA_n50A-n78A				23	+2/-3		
CA_n66A-n71A				23	+2/-3		
CA_n66A-n77A		26 <sup>6</sup>	+2/-3	23	+2/-3		
CA_n66A-n78A		26 <sup>6</sup>	+2/-3	23	+2/-3		
CA_n66A-n85A				23	+2/-3		
CA_n70A-n71A				23	+2/-3		
CA_n70A-n77A				23	+2/-3		
CA_n70A-n78A				23	+2/-3		
CA_n71A-n77A		26 <sup>6</sup>	+2/-3	23	+2/-3		
CA_n71A-n78A		26 <sup>6</sup>	+2/-3	23	+2/-3		
CA_n74A-n77A				23	+2/-3		
CA_n74A-n78A				23	+2/-3		
CA_n77A-n79A		26 <sup>9</sup>	+2/-3	23	+2/-3		
CA_n77A-n85A		26 <sup>6</sup>	+2/-3	23	+2/-3		



CA_n77A-n102A					23	+2/-3		
CA_n77A-n102B					23	+2/-3		
CA_n77A-n102C					23	+2/-3		
CA_n78A-n79A		26 <sup>9</sup>	+2/-3		23	+2/-3		
CA_n78A-n92A					23	+2/-3		
CA_n78A-n102A					23	+2/-3		
CA_n78A-n102B					23	+2/-3		
CA_n78A-n102C					23	+2/-3		
CA_n78A-n104A					23	+2/-3		
CA_n78A-n105A					23	+2/-3		

NOTE 1: Void

NOTE 2: An uplink CA configuration in which at least one of the bands has NOTE 3 in Table 6.2.1-1 is allowed to reduce the lower tolerance limit by 1.5 dB when the transmission bandwidths of at least one of the bands is confined within  $F_{UL\_low}$  and  $F_{UL\_low} + 4$  MHz or  $F_{UL\_high} - 4$  MHz and  $F_{UL\_high}$ .

NOTE 3:  $P_{PowerClass}$  is the maximum UE power specified without taking into account the tolerance

NOTE 4: For inter-band carrier aggregation the maximum power requirement should apply to the total transmitted power over all component carriers (per UE).

NOTE 5: Power class 3 is the default power class unless otherwise stated.

NOTE 6: The UE supports PC3 within NR FDD band, and supports either PC3 or PC2 within NR TDD band.

NOTE 7: The UE that supports a PC2 uplink CA configuration with single carrier for each individual band and a composite of supporting PC3 within an NR TDD or FDD band and PC2 within a second NR TDD band may signal a *higherPowerLimit-r17* capability whereby the maximum output power indicated in the table may be exceeded in accordance with sub-clause 6.2A.4.1.3. The power classes referenced are according to the reported *ue-PowerClassPerBandPerBC-r17* if indicated or *ue-PowerClass* otherwise.

NOTE 8: The UE that supports a PC3 uplink CA configuration with a composite of supporting PC3 within an NR TDD or FDD band and PC5 within a second NR band listed in Table 6.2F.1-1 may signal a *higherPowerLimit-r17* capability whereby the maximum output power indicated in the table may be exceeded in accordance with sub-clause 6.2A.4.1.3. The power classes referenced are according to the reported *ue-PowerClassPerBandPerBC-r17* if indicated or *ue-PowerClass* otherwise.

NOTE 9: The UE supports either PC3 or PC2 within each NR TDD band.

If a UE supports a different power class than the default UE power class for the band combination listed in Table 6.2A.1.3-1 and the supported power class enables the higher maximum output power than that of the default power class:

- if the field of UE capability *maxUplinkDutyCycle-interBandCA-PC2* is not absent and the average percentage of uplink symbols transmitted in a certain evaluation period is larger than *maxUplinkDutyCycle-interBandCA-PC2* as defined in TS 38.331 (The exact evaluation period is no less than one radio frame); or
- if  $10 \log_{10} \sum P_{EMAX,c}$  or  $P_{EMAX,CA}$  which defined in clause 6.2A.4.1.3 is 23dBm or lower;
  - shall apply all requirements for the default power class to the supported power class and set the configured transmitted power as specified in clause 6.2A.4.1.3;
- else;
  - shall apply all requirements for the supported power class and set the configured transmitted power as specified in clause 6.2A.4.1.3 (regardless of the average percentage of uplink symbols if the field of UE capability *maxUplinkDutyCycle-interBandCA-PC2* is absent).

The average percentage of uplink symbols is defined as  $50\% \times (Duty_{NR,x} / \max Duty_{NR,x} + Duty_{NR,y} / \max Duty_{NR,y})$ .  $Duty_{NR,x}$ ,  $Duty_{NR,y}$  represent the actual percentage of uplink symbols transmitted in the same evaluation period (The exact evaluation period is no less than one radio frame) for NR Band x, NR Band y respectively;  $\max Duty_{NR,x}$ ,  $\max Duty_{NR,y}$  represent the field of UE capability *maxUplinkDutyCycle-PC2-FR1* per band as defined in TS 38.331. For NR Band x or NR Band y,

- if power class of one or both of the bands within the band combination is power class 2 and the corresponding UE capability *maxUplinkDutyCycle-PC2-FR1* is absent;

- the corresponding maxDutyNR,x or maxDutyNR,y is equal to 50%;
- else if the band is configured with power class 3;
- the corresponding maxDutyNR,x or maxDutyNR,y is equal to 100%.

**Table 6.2A.1.3-2 Void**

6.2A.1.4 Void

6.2A.1.5 Void

**6.2A.2 UE maximum output power reduction for CA****6.2A.2.1 UE maximum output power reduction for Intra-band contiguous CA**

For intra-band contiguous carrier aggregation the allowed Maximum Power Reduction (MPR) for the maximum output power in 6.2A.1.1-1 with contiguous RB allocation is specified in Table 6.2A.2.1-1 for UE power class 3 CA bandwidth classes B and C. The MPR with contiguous RB allocation is specified in Table 6.2A.2.1-1a for power class 2 CA bandwidth classes B and C when the signalling is absent for *dualPA-Architecture* IE, and for power class 2 CA bandwidth class C when the signalling is indicated for *dualPA-Architecture* IE. The MPR with contiguous RB allocation is specified in Table 6.2A.2.1-1b for power class 2 CA bandwidth classes B and C with TxD supported.

In case the modulation format or waveform type is different on different component carriers then the requirement is set by rules applied to the waveform type (DFT-s-OFDM or CP-OFDM) and modulation order used in the configuration with the largest MPR..

Unless otherwise specified, pi/2 BPSK in following MPR tables refers to both variants of pi/2 BPSK referenced in clause 6.2.2 Table 6.2.2-1.

**Table 6.2A.2.1-1: Contiguous RB allocation for Power Class 3**

Modulation		MPR for bandwidth class B(dB)		MPR for bandwidth class C(dB)	
		inner	outer	inner	outer
DFT-s-OFDM	Pi/2 BPSK	1.0	3.5	2.5	7
	QPSK	1.0	3.5	2.5	7
	16QAM	1.5	3.5	2.5	7
	64QAM	3.0	4.0	5	7
	256QAM	5.5	6.0	7	7.5
CP-OFDM	QPSK	2.0	4.0	3.5	8
	16QAM	2.5	4.0	3.5	8
	64QAM	3.5	4.0	5	8
	256QAM	6.5	6.5	7	8

**Table 6.2A.2.1-1a: Contiguous RB allocation for Power Class 2**

Modulation		MPR for bandwidth class B(dB)		MPR for bandwidth class C(dB)	
		inner	Outer <sup>1</sup>	inner	outer
DFT-s-OFDM	Pi/2 BPSK	2.0	4.0 <sup>1</sup>	2.5	7

	QPSK	2.0	4.0 <sup>1</sup>	2.5	7
	16QAM	2.5	4.0 <sup>1</sup>	2.5	7
	64QAM	3.0	4.5 <sup>1</sup>	5	7
	256QAM	5.5	6.0	7	7.5
CP-OFDM	QPSK	2.5	5.0 <sup>1</sup>	3.5	8
	16QAM	3.0	5.0 <sup>1</sup>	3.5	8
	64QAM	3.5	5.0 <sup>1</sup>	5	8
	256QAM	6.5	6.5	7	8

NOTE 1: When 1 RB or 2 RB are allocated at the lower edge of lowest CC or upper edge of upper CC, MPR for outer is 5.5 dB.

Table 6.2A.2.1-1b: Contiguous RB allocation for Power Class 2 with dual Tx<sup>2</sup>

Modulation		MPR for bandwidth class B(dB)		MPR for bandwidth class C(dB)	
		inner	Outer <sup>1</sup>	inner	outer
DFT-s-OFDM	Pi/2 BPSK	3.0	5.0 <sup>1</sup>	3.5	8
	QPSK	3.0	5.0 <sup>1</sup>	3.5	8
	16QAM	3.5	5.0 <sup>1</sup>	3.5	8
	64QAM	4.0	5.5 <sup>1</sup>	6	8
	256QAM	6.5	7.0	8	8.5
CP-OFDM	QPSK	3.0	5.5 <sup>1</sup>	4.0	8.5
	16QAM	3.5	5.5 <sup>1</sup>	4.0	8.5
	64QAM	4.0	5.5 <sup>1</sup>	5.5	8.5
	256QAM	7.0	7.0	7.5	8.5

NOTE 1: When 1 RB or 2 RB are allocated at the lower edge of lowest CC or upper edge of upper CC, MPR for outer is 5.5 dB.  
NOTE 2: UE indicating TxD supported

For CA bandwidth class B and bandwidth class C with contiguous RB allocation, the following parameters are defined to specify valid RB allocation ranges for Inner and Outer RB allocations:

An RB allocation is contiguous if  $L_{CRB1} = 0$  or  $L_{CRB2} = 0$  or ( $L_{CRB1} \neq 0$  and  $L_{CRB2} \neq 0$  and  $RB_{Start1} + L_{CRB1} = N_{RB1}$  and  $RB_{Start2} = 0$ ), where  $RB_{Start1}$ ,  $L_{CRB1}$ , and  $N_{RB1}$  are for CC1,  $RB_{Start2}$ ,  $L_{CRB2}$ , and  $N_{RB2}$  are for CC2, CC1 is the component carrier with lower frequency.

In contiguous CA, a contiguous allocation is an inner allocation if

$$RB_{Start,Low} \leq RB_{Start,CA} \leq RB_{Start,High}, \text{ and } N_{RB,alloc} \leq \text{ceil}(N_{RB,agg}/2),$$

where

$$RB_{Start,Low} = \max(1, \text{floor}(N_{RB,alloc}/2))$$

$$RB_{Start,High} = N_{RB,agg} - RB_{Start,Low} - N_{RB,alloc},$$

with

$$N_{RB,alloc} = L_{CRB1} \cdot 2^{\mu_1} + L_{CRB2} \cdot 2^{\mu_2},$$

$$N_{RB,agg} = N_{RB1} \cdot 2^{\mu_1} + N_{RB2} \cdot 2^{\mu_2}.$$

$$\text{If } L_{CRB1} = 0, RB_{Start,CA} = N_{RB1} \cdot 2^{\mu_1} + RB_{Start2} \cdot 2^{\mu_2},$$

$$\text{if } L_{CRB1} > 0, RB_{Start,CA} = RB_{Start1} \cdot 2^{\mu_1}.$$

A contiguous allocation that is not an Inner contiguous allocation is an Outer contiguous allocation.

For intra-band contiguous carrier aggregation the allowed Maximum Power Reduction (MPR) for the maximum output power in Table Table 6.2A.1.1-1 with non-contiguous RB allocation is specified in Table 6.2A.2.1-2 for UE power class 3 CA bandwidth classes B and C. The MPR with non-contiguous RB allocation is specified in Table 6.2A.2.1-3 for power class 2 CA bandwidth classes B and C when the signalling is absent for *dualPA-Architecture*

IE, and for power class 2 CA bandwidth class C when the signalling is indicated for *dualPA-Architecture* IE. The MPR with non-contiguous RB allocation is specified in Table 6.2A.2.1-4 for power class 2 CA bandwidth classes B and C with TxD supported.

**Table 6.2A.2.1-2: non-contiguous RB allocation for Power Class 3**

Modulation		MPR for bandwidth class B(dB)			MPR for bandwidth class C(dB)		
		inner	Outer1 <sup>1</sup>	Outer2 <sup>2</sup>	inner	Outer1 <sup>1</sup>	Outer2 <sup>2</sup>
DFT-s-OFDM	Pi/2 BPSK	2	5.5	11.5	2.5	6	13
	QPSK	2	5.5		2.5	6	
	16QAM	2.5	5.5		3	6	
	64QAM	4.5	6		5	6	
	256QAM	6	6.5		6.5	6.5	
CP-OFDM	QPSK	2.5	6.5	12	3.5	7	14
	16QAM	3	7		3.5	7	
	64QAM	5	7		5	7	
	256QAM	7.5	7.5		7.5	7.5	

NOTE 1: Outer 1 MPR for Pi/2 BPSK and QPSK is reduced by 2dB for aggregated allocation bandwidth > 10MHz  
NOTE 2: Outer 2 MPR is reduced by 4.5dB for aggregated allocation bandwidth > 10MHz

**Table 6.2A.2.1-3: non-contiguous RB allocation for Power Class 2**

Modulation		MPR for bandwidth class B(dB)			MPR for bandwidth class C(dB)		
		inner	Outer1 <sup>2</sup>	Outer2 <sup>3</sup>	Inner	Outer1 <sup>2</sup>	Outer2 <sup>3</sup>
DFT-s-OFDM	Pi/2 BPSK	3 <sup>1</sup>	6.5	13	3 <sup>1</sup>	7.5	13.5
	QPSK	3 <sup>1</sup>	6.5		3 <sup>1</sup>	7.5	
	16QAM	3 <sup>1</sup>	6.5		3 <sup>1</sup>	7.5	
	64QAM	5	6.5		5	7.5	
	256QAM	6.5	7		6.5	7.5	
CP-OFDM	QPSK	3.5 <sup>1</sup>	7	14	3.5 <sup>1</sup>	8	14.5
	16QAM	3.5 <sup>1</sup>	7		3.5 <sup>1</sup>	8	
	64QAM	5	7		5	8	
	256QAM	7.5	7.5		7.5	8	

NOTE 1: the allowed MPR is [4]dB for aggregated allocation bandwidth < [2MHz].  
NOTE 2: Outer 1 MPR for Pi/2 BPSK and QPSK is reduced by 2dB for aggregated allocation bandwidth > 10MHz  
NOTE 3: Outer 2 MPR is reduced by 4.5dB for aggregated allocation bandwidth > 10MHz

**Table 6.2A.2.1-4: non-contiguous RB allocation for Power Class 2 with dual Tx<sup>4</sup>**

Modulation		MPR for bandwidth class B(dB)			MPR for bandwidth class C(dB)		
		inner	Outer1 <sup>2</sup>	Outer2 <sup>3</sup>	Inner	Outer1 <sup>2</sup>	Outer2 <sup>3</sup>
DFT-s-OFDM	Pi/2 BPSK	4 <sup>1</sup>	7.5	14	4 <sup>1</sup>	8.5	14.5
	QPSK	4 <sup>1</sup>	7.5		4 <sup>1</sup>	8.5	
	16QAM	4 <sup>1</sup>	7.5		4 <sup>1</sup>	8.5	
	64QAM	6	7.5		6	8.5	
	256QAM	7.5	8		7.5	8.5	
CP-OFDM	QPSK	4.5 <sup>1</sup>	8	15	4.5 <sup>1</sup>	9	15.5
	16QAM	4.5 <sup>1</sup>	8		4.5 <sup>1</sup>	9	
	64QAM	6	8		6	9	
	256QAM	8.5	8.5		8.5	9	

NOTE 1: the allowed MPR is [4]dB for aggregated allocation bandwidth < [2MHz].

NOTE 2: Outer 1 MPR for Pi/2 BPSK and QPSK is reduced by 2dB for aggregated allocation bandwidth > 10MHz  
 NOTE 3: Outer 2 MPR is reduced by 4.5dB for aggregated allocation bandwidth > 10MHz  
 NOTE 4: UE indicating TxD supported

For CA bandwidth classes B and C with non-contiguous RB allocation, the following parameters are defined to specify valid RB allocation ranges for Inner, Outer1 and Outer2 RB allocations:

Non-Contiguous RB allocation is defined as  $RB_{Start1} + L_{CRB1} < N_{RB1}$ , or  $RB_{Start2} > 0$ , when both uplink CCs are activated and allocated with RB(s), where  $RB_{Start1}$ ,  $L_{CRB1}$ , and  $N_{RB1}$  are for CC1,  $RB_{Start2}$ ,  $L_{CRB2}$ , and  $N_{RB2}$  are for CC2, CC1 is the component carrier with lower frequency.

In contiguous CA, a non-contiguous RB allocation is a non-contiguous Inner RB allocation if the following conditions are met:

$$RB_{Start,Low} \leq RB_{Start,CA} \leq RB_{Start,High} \text{ and } N_{RB\_alloc} \leq \text{ceil}((BW_{Channel\_CA} / 3 - BW_{gap}) / 0.18\text{MHz}),$$

where

$$N_{RB\_alloc} = (N_{RB1} - RB_{Start1}) \cdot 2^{\mu_1} + (RB_{Start2} + L_{CRB2}) \cdot 2^{\mu_2},$$

$$RB_{Start,CA} = RB_{Start1} \cdot 2^{\mu_1}$$

$$RB_{Start,Low} = \max(1, \text{floor}(N_{RB\_alloc} + (BW_{gap} - BW_{GB,low}) / 0.18\text{MHz}))$$

$$RB_{Start,High} = \text{floor}((BW_{Channel\_CA} - 2 \cdot BW_{gap} - BW_{GB,low}) / 0.18\text{MHz} - 2 \cdot N_{RB\_alloc})$$

$$BW_{GB,low} = F_{offset,low} - (N_{RB1} \cdot 12 + 1) \cdot SCS_1 / 2$$

$BW_{gap}$  is the bandwidth of the gap between the upper edge of the Transmission Bandwidth Configuration  $N_{RB1}$  of CC1 and the lower edge of the Transmission Bandwidth Configuration  $N_{RB2}$  of CC2.

In contiguous CA, a non-contiguous RB allocation is a non-contiguous outer 1 RB allocation when it is not satisfying inner allocation conditions and when the following conditions are met:

$$RB_{Start,Low} \leq RB_{Start,CA} \leq RB_{Start,High} \text{ and } N_{RB\_alloc} \leq \text{ceil}((3 \cdot BW_{Channel\_CA} / 5 - BW_{gap}) / 0.18\text{MHz})$$

where

$$RB_{Start,Low} = \max(1, 2 \cdot N_{RB\_alloc} - \text{floor}((BW_{Channel\_CA} - 2 \cdot BW_{gap} + BW_{GB,low}) / 0.18\text{MHz})),$$

$$RB_{Start,High} = \text{floor}((2 \cdot BW_{Channel\_CA} - 3 \cdot BW_{gap} - BW_{GB,low}) / 0.18\text{MHz} - 3 \cdot N_{RB\_alloc})$$

$N_{RB\_alloc}$ ,  $RB_{Start,CA}$ ,  $BW_{gap}$  and  $BW_{GB,low}$  are as defined for the Inner region.

In contiguous CA, a non-contiguous allocation is an Outer 2 allocation if it is neither a non-contiguous Inner allocation nor an Outer 1 allocation.

## 6.2A.2.2 UE maximum output power reduction for Intra-band non-contiguous CA

### 6.2A.2.2.0 General

For intra-band non-contiguous CA, the allowed Maximum Power Reduction (MPR) for the maximum output power is specified into 2 types: MPR to meet -30dBm/MHz and -13dBm/MHz. The UE determines the MPR type as follows:

For UE indicating *dualPA-Architecture* supported

If OR ( $L_{CRB1} = 0$ ,  $L_{CRB2} = 0$ )

MPR defined in Table 6.2.2-1 and Table 6.2.2-2 for PC3 and PC2 UE respectively

Else If AND(  $F_{IM3,low\_block,low} > SEM_{-13,low}$  ,  $F_{IM3,high\_block,high} < SEM_{-13,high}$  )

MPR defined in Clause 6.2A.2.2.2.1 and Clause 6.2A.2.2.2.2 for PC3 and PC2 UE respectively.

Else

MPR defined in Clause 6.2A.2.2.1.1 and Clause 6.2A.2.2.1.2 for PC3 and PC2 UE respectively.

For UE without indicating *dualPA-Architecture* supported

If OR(  $L_{CRB1} = 0$  ,  $L_{CRB2} = 0$  )

For PC3 UE, MPR defined in Table 6.2.2-1, except for  $B < 9$  MHz where 5.5 dB MPR is used;

For PC2 UE without indicating *TxD*, MPR defined in Table 6.2.2-2 is used, except for  $B < 11.52$  MHz where 6.5 dB MPR is used;

For PC2 UE indicating *TxD*, MPR defined in Table 6.2D.2-1 is used, except for  $B < 11.52$  MHz where the maximum value between 6.5 dB and MPR defined in Table 6.2D.2-1 is used.

Else If AND(  $F_{IM3,low\_block,low} > SEM_{-13,low}$  ,  $F_{IM3,high\_block,high} < SEM_{-13,high}$  )

MPR defined in Clause 6.2A.2.2.2.3 and Clause 6.2A.2.2.2.4 for PC3 and PC2 UE respectively.

Else

MPR defined in Clause 6.2A.2.2.1.3 and Clause 6.2A.2.2.1.4 for PC3 and PC2 UE respectively.

where

- $L_{CRB1}$  is for CC1 which is the component carrier with lower frequency
- $L_{CRB2}$  is for CC2 which is the component carrier with higher frequency
- $B = (L_{CRB1} * 12 * SCS_1 + L_{CRB2} * 12 * SCS_2) / 1,000$  (MHz), where  $SCS_1$  and  $SCS_2$  are expressed in kHz.
- $F_{IM3,high\_block,high} = (2 * F_{high\_alloc,high\_edge}) - F_{low\_alloc,low\_edge}$
- $F_{IM3,low\_block,low} = (2 * F_{low\_alloc,low\_edge}) - F_{high\_alloc,high\_edge}$
- $F_{low\_alloc,low\_edge}$  is the lowermost frequency of the lower transmission bandwidth allocation.
- $F_{low\_alloc,high\_edge}$  is the uppermost frequency of the lower transmission bandwidth allocation.
- $F_{high\_alloc,low\_edge}$  is the lowermost frequency of the upper transmission bandwidth allocation.
- $F_{high\_alloc,high\_edge}$  is the uppermost frequency of the upper transmission bandwidth allocation.
- $SEM_{-13,low}$  = Threshold frequency where lower spectral emission mask below the lower channel drops from -13 dBm / MHz to -25 dBm / MHz, as specified in Clause 6.5A.2.2.2.
- $SEM_{-13,high}$  = Threshold frequency where upper spectral emission mask above the upper channel drops from -13 dBm / MHz to -25 dBm / MHz, as specified in Clause 6.5A.2.2.2.

MPRs in section 6.2A.2.2.1.3, 6.2A.2.2.1.4, 6.2A.2.2.2.3 and 6.2A.2.2.2.4 are applicable only when the Gap between the component carriers is  $\leq$  the overall channel bandwidth summed across all the component carriers and when UE declares *intraBandFreqSeparationUL-AggBW-GapBW-r16* value  $\leq 200$  MHz.

The definition of the gap is between the component carriers in a spectrum that is not part of any configured component carrier that is located in between the lowest edge of the component carrier with higher center frequency and the highest edge of the component carrier with center frequency that is located lower in frequency.

### 6.2A.2.2.1 MPR to meet -30dBm/MHz

#### 6.2A.2.2.1.1 PC3 with indicating dualPA-Architecture supported

MPR in this clause is for intra-band non-contiguous CA power class 3 for UEs indicating IE *dualPA-Architecture* supported. The allowed maximum output power reduction is defined as:

MPR= $M_A$  Where  $M_A$  is defined as follows

$M_A =$	15;	$0 \leq B < 1.08$
	14.5;	$1.08 \leq B < 2.16$
	13.5;	$2.16 \leq B < 3.24$
	12.5;	$3.24 \leq B < 5.04$
	11.5;	$5.04 \leq B < 10.08$
	10.5;	$10.08 \leq B < 16.38$
	10;	$16.38 \leq B < 21.78$
	9;	$21.78 \leq B$

#### 6.2A.2.2.1.2 PC2 with indicating dualPA-Architecture supported

MPR in this clause is for intra-band non-contiguous CA power class 2 for UEs indicating IE *dualPA-Architecture* supported. The allowed maximum output power reduction is defined as:

MPR= $M_A$  Where  $M_A$  is defined as follows

$M_A =$	15.5;	$0 \leq B < 1.44$
	15.0;	$1.44 \leq B < 2.88$
	14.0;	$2.88 \leq B < 5.76$
	12.0;	$5.76 \leq B < 10.8$
	10.5;	$10.8 \leq B < 23.04$
	9.0;	$23.04 \leq B$

#### 6.2A.2.2.1.3 PC3 without indicating dualPA-Architecture supported

MPR in this clause is for intra-band non-contiguous CA power class 3 for UEs without indicating IE *dualPA-Architecture* supported. The allowed maximum output power reduction is defined as:

$M_{PR}=M_A$  Where  $M_A$  is defined as follows

$M_A =$	17.5;	$0 \leq B < 1.08$
	17.0;	$1.08 \leq B < 2.16$
	16.5;	$2.16 \leq B < 3.24$
	16;	$3.24 \leq B < 5.04$
	15;	$5.04 \leq B < 10.08$
	14.5;	$10.08 \leq B < 36$
	10;	$36 \leq B < 56.88$
	9;	$56.88 \leq B$

#### 6.2A.2.2.1.4 PC2 without indicating dualPA-Architecture supported

$M_{PR}$  in this clause is for intra-band non-contiguous CA power class 2 for UEs without indicating IE *dualPA-Architecture* supported. The allowed maximum output power reduction is defined as:

$M_{PR}=M_A$  Where  $M_A$  is defined as follows

$M_A =$	19.5;	$0 \leq B < 1.08$
	19;	$1.08 \leq B < 2.16$
	18;	$2.16 \leq B < 5.04$
	16.5;	$5.04 \leq B < 10.08$
	16;	$10.08 \leq B < 36$
	12;	$36 \leq B < 56.88$
	10.5;	$56.88 \leq B$

#### 6.2A.2.2.2 MPR to meet -13dBm/MHz

##### 6.2A.2.2.2.1 PC3 with indicating dualPA-Architecture supported

$M_{PR}$  in this clause is for intra-band non-contiguous CA power class 3 for UEs indicating IE *dualPA-Architecture* supported. The allowed maximum output power reduction is defined as:

$$M_{PR}=M_A$$

Where  $M_A$  is defined as follows

$M_A =$	9 ;	$0 \leq B < 0.54$
	8 ;	$0.54 \leq B < 1.08$
	7 ;	$1.08 \leq B < 2.16$
	6.5 ;	$2.16 \leq B < 3.24$



$$5.5; \quad 3.24 \leq B < 5.4$$

$$4; \quad 5.4 \leq B$$

#### 6.2A.2.2.2.2 PC2 with indicating dualPA-Architecture supported

MPR in this clause is for intra-band non-contiguous CA power class 2 for UEs indicating IE *dualPA-Architecture* supported. The allowed maximum output power reduction is defined as:

$$\text{MPR} = M_A$$

Where  $M_A$  is defined as follows

$$M_A = 9; \quad 0 \leq B < 0.54$$

$$8; \quad 0.54 \leq B < 1.08$$

$$7; \quad 1.08 \leq B < 2.16$$

$$6.5; \quad 2.16 \leq B < 3.24$$

$$6; \quad 3.24 \leq B < 5.4$$

$$5.5; \quad 5.4 \leq B \leq 10.8$$

$$4; \quad 10.8 < B$$

#### 6.2A.2.2.2.3 PC3 without indicating dualPA-Architecture supported

MPR in this clause is for intra-band non-contiguous CA power class 3 for UEs without indicating IE *dualPA-Architecture* supported. The allowed maximum output power reduction is defined as:

MPR =  $M_A$  Where  $M_A$  is defined as follows

$$M_A = 11; \quad 0 \leq B < 1.08$$

$$10.5; \quad 1.08 \leq B < 2.16$$

$$10; \quad 2.16 \leq B < 3.24$$

$$9.5; \quad 3.24 \leq B < 5.04$$

$$8.5; \quad 5.04 \leq B < 10.08$$

$$7.5; \quad 10.08 \leq B < 36$$

$$7; \quad 36 \leq B$$

#### 6.2A.2.2.2.4 PC2 without indicating dualPA-Architecture supported

MPR in this clause is for intra-band non-contiguous CA power class 2 for UEs without indicating IE *dualPA-Architecture* supported. The allowed maximum output power reduction is defined as:

MPR =  $M_A$  Where  $M_A$  is defined as follows

$$M_A = 14; \quad 0 \leq B < 1.08$$

12;	$1.08 \leq B < 2.16$
11.5;	$2.16 \leq B < 3.24$
11;	$3.24 \leq B < 5.04$
9.5;	$5.04 \leq B < 10.08$
8.5;	$10.08 \leq B < 36$
6.5;	$36 \leq B$

### 6.2A.2.3 UE maximum output power reduction for Inter-band CA

For inter-band carrier aggregation with one uplink carrier assigned to one NR band, the requirements in subclause 6.2.2 apply.

For inter-band carrier aggregation with two uplink contiguous carrier assigned to one NR band, the maximum output power reduction requirements for intra-band contiguous carrier aggregation in subclause 6.2A.2.1 apply for that band.

For inter-band carrier aggregation with two uplink non-contiguous carrier assigned to one NR band, the maximum output power reduction requirements for intra-band non-contiguous carrier aggregation in subclause 6.2A.2.2 apply for that band.

For inter-band carrier aggregation with uplink assigned to two NR bands, the requirements in clause 6.2.2 apply for each uplink component carrier.

For combinations of intra-band and inter-band carrier aggregation with three uplink component carriers (up to two contiguously aggregated carriers per operating band), the maximum output power reduction requirements specified in subclause 6.2.2 apply for the NR band supporting one component carrier, and for the NR band supporting two contiguous component carriers the requirements specified in subclause 6.2A.2.1 apply.

### 6.2A.2.4 Void

## 6.2A.3 UE additional maximum output power reduction for CA

### 6.2A.3.1 UE additional maximum output power reduction for Intra-band CA

#### 6.2A.3.1.1 UE additional maximum output power reduction for Intra-band contiguous CA

Additional emission requirements can be signalled by the network. Each additional emission requirement is associated with a unique network signalling (NS) value indicated in RRC signalling by an NR frequency band number of the applicable operating band and an associated value in the field *additionalSpectrumEmission*. Throughout this specification, the notion of indication or signalling of an NS value refers to the corresponding indication of an NR frequency band number of the applicable operating band, the IE field *freqBandIndicatorNR* and an associated value of *additionalSpectrumEmission* in the relevant RRC information elements [7]. Relation between NR CA band and NR frequency band is specified in Table 5.2A.1-1.

To meet the additional requirements, additional maximum power reduction (A-MPR) is allowed for the maximum output power as specified in Table 6.2A.1.1-1. Unless stated otherwise, the total reduction to UE maximum output power is  $\max(\text{MPR}, \text{A-MPR})$  where MPR is defined in clause 6.2A.2.1. In absence of modulation and waveform types the A-MPR applies to all modulation and waveform types.

Table 6.2A.3.1.1-1 specifies the additional requirements with their associated network signalling values and the allowed A-MPR and applicable CA band(s) for each CA\_NS value. The CA\_NS\_xy value indicates the additional unwanted emissions requirements that apply for intra-band contiguous CA bands with NS\_xy indicated or configured in multiple uplink serving cells, except CA\_NS\_01 that indicates the general emission requirements for intra-band contiguous CA bands. The mapping of NR CA band numbers and values of the *additionalSpectrumEmission* to network signalling labels is specified in Table 6.2A.3.1.1-2. For any NR CA band not listed in Table 6.2A.3.1.1-2 the network signalling label CA\_NS\_01 applies.

**Table 6.2A.3.1.1-1: Additional maximum power reduction (A-MPR)**

Network signalling label	Requirements (clause)	NR CA Band	Aggregated channel bandwidth (MHz)	Resources blocks ( $N_{RB}$ )	A-MPR (dB)
CA_NS_01	6.5A.2.2.1 6.5A.3.2.1	Table 5.2A.1-1	All applicable NR CA bands	All applicable NR CA configurations	N/A
CA_NS_04	6.5A.2.3.1.1 6.5A.3.3.1.1	CA_n41	Table 5.5A.1-1	6.2A.3.1.1.1	6.2A.3.1.1.1
CA_NS_27	6.5A.2.3.1.2 6.5A.3.3.1.2	CA_n48	Table 5.5A.1-1	6.2A.3.1.1.2	6.2A.3.1.1.2
CA_NS_46	6.5A.3.3.1.3	CA_n7	Table 5.5A.1-1	6.2A.3.1.1.3	6.2A.3.1.1.3
CA_NS_55, CA_NS_57	See CA_NS_01	CA_n77	Table 5.5A.1-1	6.2A.2.1	See CA_NS_01

For UEs configured with intra-band contiguous CA in n77 and if NS\_01 is indicated for an uplink component carrier in the range 3450-3650 MHz and NS\_01 or NS\_57 for another uplink component carrier below 3980 MHz and partly or fully confined within the range 3650-3980 MHz, the allowed additional spurious emission and maximum output power reduction requirements are according to CA\_NS\_01.

**Table 6.2A.3.1.1-2: Mapping of network signaling label**

NR CA band	Value of additionalSpectrumEmission							
	0	1	2	3	4	5	6	7
CA_n41	CA_NS_01	CA_NS_04						
CA_n48	CA_NS_01	CA_NS_27						
CA_n7	CA_NS_01	CA_NS_46						
CA_n77	CA_NS_01	CA_NS_55	CA_NS_57					

NOTE: *additionalSpectrumEmission* corresponds to an information element of the same name defined in clause 6.3.2 of TS 38.331 [7].

6.2A.3.1.1.1 A-MPR for CA\_NS\_04

6.2A.3.1.1.1.1 Contiguous allocations

For all waveform type, modulations and scs when  $F_{edge, low} - BW_{Channel\_CA} \geq 2490.5$  MHz, A-MPR = MPR

For all modulations and SCS when  $F_{edge, low} - BW_{Channel\_CA} < 2490.5$  MHz

if the RB allocation is an inner allocation as defined in clause 6.2A.2.1, then A-MPR = MPR

Except for  $RB_{start} \leq 0.33 * BW_{channel\_CA} / 0.18 \text{ MHz}$ ,  $AMPR = \max(MPR, AMPR_{cc})$ .

if the RB allocation is an outer allocation as defined in clause 6.2A.2.1,

then A-MPR = MPR+1.5dB for BW Class B A-MPR = MPR for BW class C.

Where

- MPR is the MPR as defined in Table 6.2A.2.1-1, Table 6.2A.2.1-1a and Table 6.2A.2.1-1b for PC3 and PC2 respectively and the respective CA bandwidth class
- AMPR<sub>cc</sub> is defined as the PC3\_A2 or PC2\_A4 AMPR in Table 6.2.3.2-2 for PC3 and PC2 respectively.

#### 6.2A.3.1.1.1.2 Non-contiguous allocations

For intra-band contiguous CA<sub>n41B</sub> and CA<sub>n41C</sub> and it receives IE CA\_NS\_04, the UE determines the allowed Additional Maximum Power Reduction (AMPR) for the maximum output power as specified in this clause. The AMPR is specified by AMPR<sub>IM3</sub> to meet -25dBm/MHz when IM3 falls in -25dBm/MHz region of Table 6.5A.2.3.1.1-1 or Table 6.5A.3.3.1.1-1. And uses MPR for all other cases.

The UE determines the AMPR type as follows:

For all waveform types, modulations and SCS when  $F_{\text{edge, low}} - \text{BW}_{\text{Channel\_CA}} \geq 2490.5 \text{ MHz}$ ,

- if allocation is an inner or outer 1 allocation as defined in clause 6.2A.2.1 then A-MPR = MPR
- if allocation is an outer 2 allocation as defined in clause 6.2A.2.1 then A-MPR = MPR+1dB

For all waveform types, modulations and SCS when  $F_{\text{edge, low}} - \text{BW}_{\text{Channel\_CA}} < 2490.5 \text{ MHz}$

If  $\text{AND}(\text{MIN}(F_{\text{IM3,low\_block,high}}, \text{SEM}_{-13,\text{low}}) < F_{\text{filter,low}}, \text{MAX}(\text{SEM}_{-13,\text{high}}, F_{\text{IM3,high\_block,low}}) > F_{\text{filter,high}})$

- if RB allocation is an inner or outer 1 allocation as defined in clause 6.2A.2.1 then A-MPR = MPR
- if RB allocation is an outer 2 allocation as defined in clause 6.2A.2.1 then A-MPR = MPR+1dB

Else

A-MPR = A-MPR<sub>IM3</sub> defined in Clause 6.2A.3.1.1.1.3.

where

- MPR is the MPR as defined in Table 6.2A.2.1-2, Table 6.2A.2.1-3 and Table 6.2A.2.1-4 for PC3 and PC2 respectively and the respective CA bandwidth class

- $F_{\text{IM3,low\_block,high}} = (2 * F_{\text{low\_alloc,high\_edge}}) - F_{\text{high\_alloc,low\_edge}}$
- $F_{\text{IM3,high\_block,low}} = (2 * F_{\text{high\_alloc,low\_edge}}) - F_{\text{low\_alloc,high\_edge}}$
- $F_{\text{low\_alloc,low\_edge}}$  is the lowermost frequency of lower transmission bandwidth allocation.
- $F_{\text{low\_alloc,high\_edge}}$  is the uppermost frequency of lower transmission bandwidth allocation.
- $F_{\text{high\_alloc,low\_edge}}$  is the lowermost frequency of upper transmission bandwidth allocation.
- $F_{\text{high\_alloc,high\_edge}}$  is the uppermost frequency of upper transmission bandwidth allocation.
- $F_{\text{filter,low}} = 2480 \text{ MHz}$
- $F_{\text{filter,high}} = 2745 \text{ MHz}$
- $\text{SEM}_{-13,\text{high}}$  = Threshold frequency where upper spectral emission mask for upper channel drops from -13 dBm / 1MHz to -25 dBm / 1MHz, as specified in Clause 6.5A.2.3.1.1
- $\text{SEM}_{-13,\text{low}}$  = Threshold frequency where lower spectral emission mask below the lower channel drops from -13 dBm / MHz to -25 dBm / MHz, as specified in Clause 6.5A.2.3.1.1

6.2A.3.1.1.1.3  $AMPR_{IM3}$  to meet -25dBm/MHz

$AMPR$  in this clause is for intra-band contiguous CA\_n41B and CA\_n41C. The allowed maximum output power reduction is defined as:

$AMPR_{IM3}=M_A$ , Where  $M_A$  is defined as follows

$$M_A = \begin{array}{ll} 13; & 0 \leq B < 2.16 \\ 11.5; & 2.16 \leq B < 3.24 \\ 10.5; & 3.24 \leq B < 5.04 \\ 9.5; & 5.04 \leq B < 10.08 \\ 8; & 10.08 \leq B < 16.56 \\ 7; & 16.56 \leq B < 21.96 \\ 6; & 21.96 \leq B \end{array}$$

Where:

$$B=(L_{CRB1} * 12 * SCS_1 + L_{CRB2} * 12 * SCS_2)/1,000 \text{ (MHz)}, \text{ where } SCS_1 \text{ and } SCS_2 \text{ are expressed in kHz.}$$

and  $L_{CRB1}$ ,  $SCS_1$  are for CC1,  $L_{CRB2}$ ,  $SCS_2$  are for CC2, CC1 is the component carrier with lower frequency.

## 6.2A.3.1.1.2 A-MPR for CA\_NS\_27

## 6.2A.3.1.1.2.1 Contiguous allocations

For all modulations and scs when  $F_{edge, low} - BW_{Channel\_CA} \geq 3540 \text{ MHz}$  AND  $F_{edge, high} + BW_{Channel\_CA} \leq 3710 \text{ MHz}$  if allocation is inner 1 then A-MPR = 0 dB where inner 1 is defined as

$$RB_{Start,Low} = \max(1, \text{floor}(L_{CRB}/2))$$

where  $\max()$  indicates the largest value of all arguments and  $\text{floor}(x)$  is the greatest integer less than or equal to  $x$ .

$$RB_{Start,High} = N_{RB\_agg} - RB_{Start,Low} - L_{CRB}$$

with following conditions

$$RB_{Start,Low} \leq RB_{Start} \leq RB_{Start,High}, \text{ and}$$

$$L_{CRB} \leq \text{ceil}(N_{RB\_agg} / 2)$$

$AMPR = 5 \text{ dB}$  for some exceptions for inner 1 region. These exceptions are defined when  $L_{CRB} < 8$  any of the following conditions are met:

$$RB_{start} \leq 30 \text{ or } RB_{end} \geq 164 \text{ for } BW_{Channel\_CA} = 40\text{MHz or}$$

for the subset of frequencies that satisfy  $3540 \text{ MHz} + BW_{Channel\_CA} \leq F_{edge, low} < 3530 \text{ MHz} + 2 * BW_{Channel\_CA}$ , the following exception thresholds apply

for  $BW_{Channel\_CA} = 35\text{MHz}$  threshold of  $RB_{start} \leq 25$ , and

for  $BW_{Channel\_CA} = 30\text{MHz}$  threshold of  $RB_{start} \leq 19$ , and

for  $BW_{\text{Channel\_CA}} = 25\text{MHz}$  threshold of  $RB_{\text{start}} \leq 14$ , and

for  $BW_{\text{Channel\_CA}} = 20\text{MHz}$  threshold of  $RB_{\text{start}} \leq 9$ , and

for  $BW_{\text{Channel\_CA}} = 15\text{MHz}$  threshold of  $RB_{\text{start}} \leq 3$

or for the subset of frequencies that satisfy  $3720\text{ MHz} - 2 * BW_{\text{Channel\_CA}} < F_{\text{edge, high}} \leq 3710\text{ MHz} - BW_{\text{Channel\_CA}}$ , the following exception thresholds apply

for  $BW_{\text{Channel\_CA}} = 35\text{MHz}$  threshold of  $RB_{\text{end}} \geq 144$ , and

for  $BW_{\text{Channel\_CA}} = 30\text{MHz}$  threshold of  $RB_{\text{end}} \geq 124$ , and

for  $BW_{\text{Channel\_CA}} = 25\text{MHz}$  threshold of  $RB_{\text{end}} \geq 104$ , and

for  $BW_{\text{Channel\_CA}} = 20\text{MHz}$  threshold of  $RB_{\text{end}} \geq 80$ , and

for  $BW_{\text{Channel\_CA}} = 15\text{MHz}$  threshold of  $RB_{\text{end}} \geq 68$ ,

else for non-inner 1 allocations  $A\text{-MPR} = 5\text{ dB}$  when  $F_{\text{edge, low}} - BW_{\text{Channel\_CA}} \geq 3540\text{ MHz}$  AND  $F_{\text{edge, high}} + BW_{\text{Channel\_CA}} \leq 3710\text{ MHz}$

For all modulations and scs when  $3550\text{ MHz} \leq F_{\text{edge, low}} < 3540\text{ MHz} + BW_{\text{Channel\_CA}}$

if allocation is inner 3 then  $A\text{-MPR} = 0\text{ dB}$ , where inner 3 is defined as

$$N_{\text{RB\_agg}}/4 < RB_{\text{start}} < N_{\text{RB\_agg}} 3/4 - L_{\text{CRB}} \text{ AND } L_{\text{CRB}} < N_{\text{RB\_agg}}/4$$

Inner 3 region exceptions thresholds are

for  $BW_{\text{Channel\_CA}} = 40\text{MHz}$  threshold of  $RB_{\text{start}} \leq 63$ , and

for  $BW_{\text{Channel\_CA}} = 35\text{MHz}$  threshold of  $RB_{\text{start}} \leq 52$ , and

for  $BW_{\text{Channel\_CA}} = 30\text{MHz}$  threshold of  $RB_{\text{start}} \leq 42$ , and

For which  $A\text{MPR} = 11.5\text{dB}$

else for non-inner 3 allocations when  $BW_{\text{agg}} \leq 20\text{ MHz}$ ,  $A\text{-MPR} = 7\text{ dB}$  or when  $BW_{\text{agg}} > 20\text{ MHz}$ ,  $A\text{-MPR} = 11.5\text{dB}$  when  $3550\text{ MHz} \leq F_{\text{edge, low}} < 3540\text{ MHz} + BW_{\text{Channel\_CA}}$ .

For all modulations and scs when  $3710\text{ MHz} - BW_{\text{Channel\_CA}} < F_{\text{edge, high}} \leq 3700$

if allocation is inner 3 then  $A\text{-MPR} = 0\text{ dB}$ .

Inner 3 region exceptions thresholds are

for  $BW_{\text{Channel\_CA}} = 40\text{MHz}$  threshold of  $RB_{\text{end}} \geq 132$ , and

for  $BW_{\text{Channel\_CA}} = 35\text{MHz}$  threshold of  $RB_{\text{end}} \geq 121$ , and

for  $BW_{\text{Channel\_CA}} = 30\text{MHz}$  threshold of  $RB_{\text{end}} \geq 110$ , and

For which  $A\text{MPR} 11.5\text{dB}$

else for non-inner 3 allocation when  $BW_{agg} \leq 20$  MHz, A-MPR = 7 dB or when  $BW_{agg} > 20$  MHz, A-MPR = 11.5dB when  $3710 \text{ MHz} - BW_{Channel\_CA} < F_{edge, high} \leq 3700$ .

#### 6.2A.3.1.1.2.2 Non-contiguous allocations

For all modulations and scs when  $F_{edge, low} - BW_{Channel\_CA} \geq 3540$  MHz AND  $F_{edge, high} + BW_{Channel\_CA} \leq 3710$  MHz

A-MPR=

13;	$0 \leq B < 1.08$
12;	$1.08 \leq B < 2.16$
11;	$2.16 \leq B < 3.24$
10.5;	$3.24 \leq B < 5.04$
9.5;	$5.04 \leq B < 10.08$
8;	$10.08 \leq B < 16.56$
7;	$16.56 \leq B < 21.96$
6.5;	$21.96 \leq B$

For all modulations and scs when  $3550 \text{ MHz} \leq F_{edge, low} < 3540 \text{ MHz} + BW_{Channel\_CA}$  or  $3710 \text{ MHz} - BW_{Channel\_CA} < F_{edge, high} \leq 3700$

when  $BW_{Channel\_CA} \leq 20$  MHz

A-MPR=

13;	$0 \leq B < 1.08$
12;	$1.08 \leq B < 2.16$
11;	$2.16 \leq B < 3.24$
10.5;	$3.24 \leq B < 5.04$
9.5;	$5.04 \leq B < 10.08$
8;	$10.08 \leq B < 16.56$
7;	$16.56 \leq B < 21.96$
6.5;	$21.96 \leq B$

or when  $BW_{Channel\_CA} > 20$  MHz

A-MPR =

20;	$0 \leq B < 1.08$
19.5;	$1.08 \leq B < 2.16$
19;	$2.16 \leq B < 3.24$
18.5;	$3.24 \leq B < 5.04$

18;	$5.04 \leq B < 10.08$
17;	$10.08 \leq B < 16.56$
16;	$16.56 \leq B < 21.96$
13;	$21.96 \leq B$ .

Where:

$B = (L_{CRB1} * 12 * SCS_1 + L_{CRB2} * 12 * SCS_2) / 1,000$  (MHz), where  $SCS_1$  and  $SCS_2$  are expressed in kHz.  
and  $L_{CRB1}$ ,  $SCS_1$  are for CC1,  $L_{CRB2}$ ,  $SCS_2$  are for CC2, CC1 is the component carrier with lower frequency.

### 6.2A.3.1.1.3 A-MPR for CA\_NS\_46

#### 6.2A.3.1.1.3.1 Contiguous allocations

For all modulations and scs when  $BWChannel\_CA > 25$  MHz

IF  $RBend > NRB\_agg \ 5/6$  for all BW's except for  $BWChannel\_CA=50$ MHz where the threshold is  $RBend > NRB\_agg \ 3/4$  OR for all BW's  $RBend > 4/3 \ NRB\_agg - LCRB$

THEN A-MPR = 11dB

ELSE IF  $RBend < NRB\_agg / 6$  AND  $LCRB < 5$

THEN A-MPR = 5dB

ELSE IF  $LCRB \ 3/2 < RBend < NRB\_agg \ 3/4$  AND  $LCRB < NRB\_agg / 4$

THEN A-MPR = 0 dB,

OTHERWISE A-MPR = 7 dB.

For all modulations and scs when  $BWChannel\_CA \leq 25$  MHz and  $2595 \text{ MHz} - 2 * BWChannel\_CA < Fedge\_high \leq 2570$  MHz

IF  $RBend \geq 4/3 \ NRB\_agg - LCRB$

THEN A-MPR = 6 dB.

OTHERWISE A-MPR = 0 dB.

For all modulations and scs when  $BWChannel\_CA \leq 25$  MHz and  $Fedge\_high \leq 2595 \text{ MHz} - 2 * BWChannel\_CA$ ,

A-MPR = 0 dB.

#### 6.2A.3.1.1.3.2 Non-contiguous allocations

[For all modulations and scs when  $BWChannel\_CA > 25$  MHz and  $2595 \text{ MHz} - BWChannel\_CA \leq Fedge\_high \leq 2570$  MHz

$A-MPR_{CA\_IM3} =$

20;  $0 \leq B < 1.08$

19.5;  $1.08 \leq B < 2.16$



- 19;  $2.16 \leq B < 3.24$
- 18.5;  $3.24 \leq B < 5.04$
- 18;  $5.04 \leq B < 10.08$
- 17;  $10.08 \leq B < 16.56$
- 16;  $16.56 \leq B < 21.96$
- 13;  $21.96 \leq B$

For all modulations and scs when  $BWChannel\_CA > 25$  MHz and  $Fedge\_high < 2595$  MHz -  $BWChannel\_CA$

$A-MPR_{CA\_IM5} =$

- 13;  $0 \leq B < 1.08$
- 12;  $1.08 \leq B < 2.16$
- 11;  $2.16 \leq B < 3.24$
- 10.5;  $3.24 \leq B < 5.04$
- 9.5;  $5.04 \leq B < 10.08$
- 8;  $10.08 \leq B < 16.56$
- 7.5;  $16.56 \leq B < 21.96$
- 7;  $21.96 \leq B$

For all modulations and scs when  $BWChannel\_CA \leq 25$  MHz and  $2595$  MHz -  $2 * BWChannel\_CA \leq Fedge\_high \leq 2570$  MHz

$A-MPR_{CA\_IM5} =$

- 13;  $0 \leq B < 1.08$
- 12;  $1.08 \leq B < 2.16$
- 11;  $2.16 \leq B < 3.24$
- 10.5;  $3.24 \leq B < 5.04$
- 9.5;  $5.04 \leq B < 10.08$
- 8;  $10.08 \leq B < 16.56$
- 7.5;  $16.56 \leq B < 21.96$
- 7;  $21.96 \leq B$

Where:

$B = (L_{CRB1} * 12 * SCS_1 + L_{CRB2} * 12 * SCS_2) / 1,000$  (MHz), where  $SCS_1$  and  $SCS_2$  are expressed in kHz.  
and  $L_{CRB1}$ ,  $SCS_1$  are for CC1,  $L_{CRB2}$ ,  $SCS_2$  are for CC2, CC1 is the component carrier with lower frequency.]

### 6.2A.3.1.2 UE additional maximum output power reduction for Intra-band non-contiguous CA

#### 6.2A.3.1.2.0 General

Table 6.2A.3.1.2-1 specifies the additional requirements with their associated network signalling values and the allowed A-MPR and applicable CA band(s) for each CA\_NC\_NS value. The CA\_NC\_NS\_xy value indicates the additional unwanted emissions requirements that apply for intra-band non-contiguous CA bands with NS\_xy indicated or configured in multiple uplink serving cells, except CA\_NC\_NS\_01 that indicates the general emission requirements for intra-band non-contiguous CA bands. The mapping of NR CA band numbers and values of the *additionalSpectrumEmission* to network signalling labels is specified in Table 6.2A.3.1.2-2. For any NR CA band not listed in Table 6.2A.3.1.2-2 the network signalling label CA\_NC\_NS\_01 applies.

**Table 6.2A.3.1.2-1: Additional Maximum Power Reduction (A-MPR) for intra-band non-contiguous CA**

CA Network Signalling value	Requirements (clause)	Uplink CA Configuration	A-MPR for sub-blocks in order of increasing uplink carrier frequency
			A-MPR [dB] (clause)
CA_NC_NS_01	6.5A.2.2.2 6.5A.3.2.2	All applicable NR CA configurations	N/A
CA_NC_NS_04	6.5A.2.3.2.1 6.5A.3.3.2.1	CA_n41(2A)	6.2A.3.1.2.1
CA_NC_NS_12	6.5A.3.3.2.2	CA_n26(2A)	[20] dB
CA_NC_NS_13	6.5A.3.3.2.3	CA_n26(2A)	[20] dB
CA_NC_NS_14	6.5A.3.3.2.4	CA_n26(2A)	[20] dB
CA_NC_NS_15	6.5A.3.3.2.5	CA_n26(2A)	[20] dB
CA_NC_NS_55, CA_NC_NS_57	See CA_NC_NS_01	CA_n77(2A)	See CA_NC_NS_01
CA_NC_NS_100	6.5A.2.4.2.4	CA_n26(2A)	[20] dB

For UEs configured with intra-band non-contiguous CA in n77 and if NS\_01 is indicated for an uplink component carrier in the range 3700-3980 MHz and NS\_01 or NS\_55 for another uplink component carrier in the range 3450-3550 MHz, or if NS\_01 is indicated for an uplink component carrier in the range 3450-3650 MHz and NS\_01 or NS\_57 for another uplink component carrier below 3980 MHz and partly or fully confined within the range 3650-3980 MHz, the allowed additional spurious emission and maximum output power reduction requirements are according to CA\_NC\_NS\_01.

**Table 6.2A.3.1.2-2: Mapping of network signaling label**

NR CA band	Value of additionalSpectrumEmission							
	0	1	2	3	4	5	6	7
CA_n26	CA_NC_NS_01	CA_NC_NS_10 0	CA_NC_NS_12	CA_NC_NS_13	CA_NC_NS_14	CA_NC_NS_15		
CA_n41	CA_NC_NS_01	CA_NC_NS_04						
CA_n77	CA_NC_NS_01	CA_NC_NS_55	CA_NC_NS_57					

NOTE: *additionalSpectrumEmission* corresponds to an information element of the same name defined in clause 6.3.2 of TS 38.331 [7].

#### 6.2A.3.1.2.1 AMPR for CA\_NC\_NS\_04 (CA\_n41(2A))

For intra-band non-contiguous CA\_n41(2A) and it receives IE CA\_NC\_NS\_04 for UE indicating *dualPA-Architecture* supported for PC3 and PC2 operation, the UE determines the allowed Additional Maximum Power

Reduction (AMPR) for the maximum output power as specified in this clause. The AMPR is specified into 2 types: AMPR to meet -25dBm/MHz and -13dBm/MHz. The A-MPR defined in this clause is used instead of MPR defined in 6.2A.2.2, not additively, so CA MPR=0 when CA\_NC\_NS\_04 is signaled.

The UE determines the AMPR type as follows:

If AND( MIN( $F_{IM3,low\_block,high}$ ,  $SEM_{-13,low}$ ) <  $F_{filter,low}$ , MAX(  $SEM_{-13,high}$ ,  $F_{IM3,high\_block,low}$  ) >  $F_{filter,high}$  )

- A-MPR<sub>IM3</sub> defined in Clause 6.2A.3.1.2.1.2 for PC3 and 6.2A.3.1.2.1.4 for PC2

Else

- A-MPR<sub>IM3</sub> defined in Clause 6.2A.3.1.2.1.1 for PC3 and 6.2A.3.1.2.1.3 for PC2

where

- $L_{CRB1}$  is for CC1 which is the component carrier with lower frequency
- $L_{CRB2}$  is for CC2 which is the component carrier with higher frequency
- $B = (L_{CRB1} * 12 * SCS_1 + L_{CRB2} * 12 * SCS_2) / 1,000$  (MHz), where  $SCS_1$  and  $SCS_2$  are expressed in kHz.
- $F_{IM3,low\_block,high} = (2 * F_{low\_alloc,high\_edge}) - F_{high\_alloc,low\_edge}$
- $F_{IM3,high\_block,low} = (2 * F_{high\_alloc,low\_edge}) - F_{low\_alloc,high\_edge}$
- $F_{low\_alloc,low\_edge}$  is the lowermost frequency of lower transmission bandwidth allocation.
- $F_{low\_alloc,high\_edge}$  is the uppermost frequency of lower transmission bandwidth allocation.
- $F_{high\_alloc,low\_edge}$  is the lowermost frequency of upper transmission bandwidth allocation.
- $F_{high\_alloc,high\_edge}$  is the uppermost frequency of upper transmission bandwidth allocation.
- $F_{filter,low} = 2480$  MHz
- $F_{filter,high} = 2745$  MHz
- $SEM_{-13,high}$  = Threshold frequency where upper spectral emission mask for upper channel drops from -13 dBm / 1MHz to -25 dBm / 1MHz, as specified in Clause 6.5A.2.3.2.
- $SEM_{-13,low}$  = Threshold frequency where lower spectral emission mask below the lower channel drops from -13 dBm / MHz to -25 dBm / MHz, as specified in Clause 6.5A.2.3.2.

#### 6.2A.3.1.2.1.1 AMPR<sub>IM3</sub> to meet -25dBm/MHz for PC3

AMPR in this clause is for intra-band non-contiguous CA\_n41(2A) power class 3 for UEs indicating IE *dualPA-Architecture* supported. The allowed maximum output power reduction is defined as:

AMPR<sub>IM3</sub>=M<sub>A</sub> Where M<sub>A</sub> is defined as follows

$$M_A = \begin{array}{ll} 12; & 0 \leq B < 1.08 \\ & 1.08 \leq B < 2.16 \\ 11; & 2.16 \leq B < 3.24 \\ 10; & 3.24 \leq B < 5.04 \end{array}$$

- 9;  $5.04 \leq B < 10.08$
- 8;  $10.08 \leq B < 16.38$
- 7;  $16.38 \leq B < 21.78$
- 6;  $21.78 \leq B$

#### 6.2A.3.1.2.1.2 $AMPR_{IM3}$ to meet -13dBm/MHz for PC3

$AMPR$  in this clause is for intra-band non-contiguous CA\_n41(2A) power class 3 for UEs indicating IE *dualPA-Architecture* supported. The allowed maximum output power reduction is defined as:

$$AMPR_{IM3} = M_A$$

Where  $M_A$  is defined as follows

- $M_A = 9$  ;  $0 \leq B < 0.54$
- 8 ;  $0.54 \leq B < 1.08$
- 7 ;  $1.08 \leq B < 2.16$
- 6.5 ;  $2.16 \leq B < 3.24$
- 5.5 ;  $3.24 \leq B < 5.4$
- 4 ;  $5.4 \leq B$

#### 6.2A.3.1.2.1.3 $AMPR_{IM3}$ to meet -25dBm/MHz for PC2

$AMPR$  in this clause is for intra-band non-contiguous CA\_n41(2A) power class 2 for UEs indicating IE *dualPA-Architecture* supported. The allowed maximum output power reduction is defined as:

$AMPR_{IM3} = M_A$  Where  $M_A$  is defined as follows

- $M_A = 14.5$ ;  $0 \leq B < 1.44$
- 14.0;  $1.44 \leq B < 2.88$
- 13.0;  $2.88 \leq B < 5.76$
- 11.0;  $5.76 \leq B < 10.8$
- 9.5;  $10.8 \leq B < 23.04$
- 9.0;  $23.04 \leq B$

Where:

$$B = (L_{CRB\_alloc,1} * 12 * SCS_1 + L_{CRB\_alloc,2} * 12 * SCS_2) / 1,000 \text{ (MHz)}, \text{ where } SCS_1 \text{ and } SCS_2 \text{ are expressed in kHz.}$$

6.2A.3.1.2.1.4  $AMPR_{IM3}$  to meet -13dBm/MHz for PC2

$AMPR$  in this clause is for intra-band non-contiguous CA<sub>n41(2A)</sub> power class 2 for UEs indicating IE *dualPA-Architecture* supported. The allowed maximum output power reduction is defined as:

$$AMPR_{IM3} = M_A$$

Where  $M_A$  is defined as follows

$$M_A = \begin{array}{ll} 9 & ; \quad 0 \leq B < 0.54 \\ 8 & ; \quad 0.54 \leq B < 1.08 \\ 7 & ; \quad 1.08 \leq B < 2.16 \\ 6.5 & ; \quad 2.16 \leq B < 3.24 \\ 6 & ; \quad 3.24 \leq B < 5.4 \\ 5.5 & ; \quad 5.4 \leq B \leq 10.8 \\ 4 & ; \quad 10.8 < B \end{array}$$

Where:

$$B = (LCRB_{alloc,1} * 12 * SCS_1 + LCRB_{alloc,2} * 12 * SCS_2) / 1,000 \text{ (MHz)}, \text{ where } SCS_1 \text{ and } SCS_2 \text{ are expressed in kHz.}$$

## 6.2A.3.1.3 UE additional maximum output power reduction for Inter-band CA

Unless otherwise stated, for inter-band carrier aggregation with one uplink carrier assigned to one NR band, the requirements in subclause 6.2.3 apply.

Unless otherwise stated, for inter-band carrier aggregation with two uplink contiguous carrier assigned to one NR band, the additional maximum output power reduction requirements for intra-band contiguous carrier aggregation in subclause 6.2A.3.1.1 apply for that band, for inter-band carrier aggregation with two uplink non-contiguous carrier assigned to one NR band, the additional maximum output power reduction requirements for intra-band contiguous carrier aggregation in subclause 6.2A.3.1.2 apply for that band.

For combinations of intra-band and inter-band carrier aggregation with three uplink component carriers (up to two contiguously aggregated carriers per operating band), the additional maximum output power reduction requirements specified in subclause 6.2.3 apply for the NR band supporting one component carrier, and for the NR band supporting two contiguous component carriers the requirements specified in subclause 6.2A.3.1.1 apply.

Unless specified in Table 6.2A.3.1.3-1, for inter-band carrier aggregation with uplink assigned to two NR bands, the requirements in clause 6.2.3 apply only to the indicated carrier. The requirements in Table 6.2A.3.1.3-1 are specified in terms of an additional spectrum emission requirement with their associated network signalling values and the allowed A-MPR. Unless otherwise stated, the combined requirements and allowed A-MPR are applicable on both bands when both component carriers are active. Additional spurious emission requirements are signalled by the network to indicate that the UE shall meet the additional requirement for a specific deployment scenario as part of the cell handover/broadcast message.

To meet the additional requirements, additional maximum power reduction (A-MPR) is allowed for the maximum output power as specified in Table 6.2.1-1. Unless stated otherwise, the total reduction to UE maximum output power is  $\max(MPR + \Delta MPR, A-MPR)$  where  $MPR$  and  $\Delta MPR$  are defined in clause 6.2.2. In case of a power class 3 UE, when IE *powerBoostPi2BPSK* is set to 1, power class 2 A-MPR values apply.

For almost contiguous allocations in CP-OFDM waveforms in power class 1.5, 2 and 3, the allowed A-MPR defined in clause 6.2.3 is increased by  $\text{CEIL}\{10 \log_{10}(1 + NRB\_gap / NRB\_alloc), 0.5\}$  dB, where  $NRB\_gap$  is the total

number of unallocated RBs between allocated RBs and NRB\_alloc is the total number of allocated RBs, and the parameter LCRB is replaced by NRB\_alloc + NRB\_gap in specifying the RB allocation regions.

Unless otherwise specified, pi/2 BPSK in following A-MPR tables refers to both variants of pi/2 BPSK referenced in clause 6.2.2 Table 6.2.2-1.

The emission requirements specified in Table 6.2A.3.1.3-1 also apply for the frequency ranges that are less than  $F_{OOB}$  (MHz) in Table 6.5.3.1-1 from the edge of the channel bandwidth.

**Table 6.2A.3.1.3-1: Additional Requirements for uplink inter-band carrier aggregation (two-bands)**

NR CA combination	Band	Applied NS	Requirements (clause)	A-MPR (table/clause)	Note
CA_n1-n3	n1	05	6.5.3.3.4	Clause 6.2.3.4	1
		05U	6.5.3.3.4, 6.5.2.4.2	Clause 6.2.3.4	
	n3	100	6.5.2.4.2	Table 6.2.3.1-2	
CA_n1-n8	n1	05	6.5.3.3.4	Clause 6.2.3.4	1
		05U	6.5.3.3.4, 6.5.2.4.2	Clause 6.2.3.4	
	n8	43	6.5.3.3.5	Clause 6.2.3.6	
		43U	6.5.3.3.5, 6.5.2.4.2	Clause 6.2.3.6	
CA_n1-n18	n1	05	6.5.3.3.4	Clause 6.2.3.4	1
		05U	6.5.3.3.4, 6.5.2.4.2	Clause 6.2.3.4	
	n18	100	6.5.2.4.2	Table 6.2.3.1-2	
CA_n1-n28	n1	05	6.5.3.3.4	Clause 6.2.3.4	1,2
		05U	6.5.3.3.4, 6.5.2.4.2	Clause 6.2.3.4	
	n28	17	6.5.3.3.2	N/A	
CA_n1-n40	n1	05	6.5.3.3.4	Clause 6.2.3.4	1
		05U	6.5.3.3.4, 6.5.2.4.2	Clause 6.2.3.4	
CA_n1-n41	n1	05	6.5.3.3.4	Clause 6.2.3.4	1
		05U	6.5.3.3.4, 6.5.2.4.2	Clause 6.2.3.4	
	n41	47	6.5.3.3.15	Table 6.2.3.18-2	
CA_n1-n74	n1	05	6.5.3.3.4	Clause 6.2.3.4	1
		05U	6.5.3.3.4, 6.5.2.4.2	Clause 6.2.3.4	
	n74	37	6.5.3.3.6	Table 6.2.3.8-1	
CA_n1-n77	n1	05	6.5.3.3.4	Clause 6.2.3.4	1
		05U	6.5.3.3.4, 6.5.2.4.2	Clause 6.2.3.4	
CA_n1-n78	n1	05	6.5.3.3.4	Clause 6.2.3.4	1
		05U	6.5.3.3.4, 6.5.2.4.2	Clause 6.2.3.4	
CA_n1-n79	n1	05	6.5.3.3.4	Clause 6.2.3.4	1
		05U	6.5.3.3.4, 6.5.2.4.2	Clause 6.2.3.4	
CA_n3-n8	n3	100	6.5.2.4.2	Table 6.2.3.1-2	1
		43	6.5.3.3.5	Clause 6.2.3.6	
	n8	43U	6.5.3.3.5, 6.5.2.4.2	Clause 6.2.3.6	
CA_n3-n18	n3	100	6.5.2.4.2	Table 6.2.3.1-2	1
	n18	100	6.5.2.4.2	Table 6.2.3.1-2	
CA_n3-n28	n3	100	6.5.2.4.2	Table 6.2.3.1-2	1,2
	n28	17	6.5.3.3.2	N/A	
CA_n3-n40	n3	100	6.5.2.4.2	Table 6.2.3.1-2	1
CA_n3-n41	n3	100	6.5.2.4.2	Table 6.2.3.1-2	1
	n41	47	6.5.3.3.15	Table 6.2.3.18-2	
CA_n3-n74	n3	100	6.5.2.4.2	Table 6.2.3.1-2	1
	n74	37	6.5.3.3.6	Table 6.2.3.8-1	
CA_n3-n77	n3	100	6.5.2.4.2	Table 6.2.3.1-2	1
CA_n3-n78	n3	100	6.5.2.4.2	Table 6.2.3.1-2	1
CA_n3-n79	n3	100	6.5.2.4.2	Table 6.2.3.1-2	1
CA_n5-n28	n5	100	6.5.2.4.2	Table 6.2.3.1-2	1,2
	n28	17	6.5.3.3.2	N/A	

CA_n5-n77	n5	100	6.5.2.4.2	Table 6.2.3.1-2	1
CA_n5-n78	n5	100	6.5.2.4.2	Table 6.2.3.1-2	1
CA_n5-n79	n5	100	6.5.2.4.2	Table 6.2.3.1-2	1
CA_n8-n40	n8	43	6.5.3.3.5	Clause 6.2.3.6	1
		43U	6.5.3.3.5, 6.5.2.4.2	Clause 6.2.3.6	
CA_n8-n41	n8	43	6.5.3.3.5	Clause 6.2.3.6	1
		43U	6.5.3.3.5, 6.5.2.4.2	Clause 6.2.3.6	
	n41	47	6.5.3.3.15	Table 6.2.3.18-2	
CA_n8-n78	n8	43	6.5.3.3.5	Clause 6.2.3.6	1
		43U	6.5.3.3.5, 6.5.2.4.2	Clause 6.2.3.6	
CA_n8-n79	n8	43	6.5.3.3.5	Clause 6.2.3.6	1
		43U	6.5.3.3.5, 6.5.2.4.2	Clause 6.2.3.6	
CA_n18-n28	n18	100	6.5.2.4.2	Table 6.2.3.1-2	1, 2
	n28	17	6.5.3.3.2	N/A	
CA_n18-n41	n18	100	6.5.2.4.2	Table 6.2.3.1-2	1
CA_n18-n74	n18	100	6.5.2.4.2	Table 6.2.3.1-2	1
	n74	37	6.5.3.3.6	Table 6.2.3.8-1	
CA_n18-n77	n18	100	6.5.2.4.2	Table 6.2.3.1-2	1
CA_n18-n78	n18	100	6.5.2.4.2	Table 6.2.3.1-2	1
CA_n26-n28	n26	100	6.5.2.4.2	Table 6.2.3.1-2	1, 2
	n28	17	6.5.3.3.2	N/A	
CA_n28-n40	n28	17	6.5.3.3.2	N/A	2
CA_n28-n41	n28	17	6.5.3.3.2	N/A	2
	n41	47	6.5.3.3.15	Table 6.2.3.18-2	
CA_n28-n74	n28	17	6.5.3.3.2	N/A	2
	n74	37	6.5.3.3.6	Table 6.2.3.8-1	2
CA_n28-n77	n28	17	6.5.3.3.2	N/A	2
CA_n28-n78	n28	17	6.5.3.3.2	N/A	2
CA_n28-n79	n28	17	6.5.3.3.2	N/A	2
CA_n40-n41	n41	47	6.5.3.3.15	Table 6.2.3.18-2	
CA_n41-n74	n41	47	6.5.3.3.15	Table 6.2.3.18-2	
	n74	37	6.5.3.3.6	Table 6.2.3.8-1	
CA_n41-n77	n41	47	6.5.3.3.15	Table 6.2.3.18-2	
CA_n41-n78	n41	47	6.5.3.3.15	Table 6.2.3.18-2	
CA_n41-n79	n41	47	6.5.3.3.15	Table 6.2.3.18-2	
CA_n74-n77	n74	37	6.5.3.3.6	Table 6.2.3.8-1	
CA_n74-n78	n74	37	6.5.3.3.6	Table 6.2.3.8-1	

NOTE 1: NS\_05U, NS\_43U and NS\_100 can be signalled for NR bands that have UTRA services deployed and the requirements in clause 6.5.2.4.2 are only applicable to the signalling carrier.

NOTE 2: Applicable when the assigned NR carrier is confined within 718 MHz and 748 MHz and when the channel bandwidth used is 5 or 10 MHz.

## 6.2A.4 Configured output power for CA

### 6.2A.4.1 Configured transmitted power level

#### 6.2A.4.1.1 Configured transmitted power for Intra-band contiguous CA

For uplink carrier aggregation the UE is allowed to set its configured maximum output power  $P_{\text{CMAX},c}$  for serving cell  $c$  and its total configured maximum output power  $P_{\text{CMAX}}$ .

The configured maximum output power  $P_{\text{CMAX},c}$  on serving cell  $c$  shall be set as specified in clause 6.2.4, but with  $\text{MPR}_c = \text{MPR}$  and  $\text{A-MPR}_c = \text{A-MPR}$  with MPR and A-MPR as determined by subclause 6.2A.2 and 6.2A.3, respectively. For PH reporting the following exception applies: if the UE is configured with multiple uplink serving cells, the power  $P_{\text{CMAX},c}$  used for the purpose of PH reporting on first serving cell  $c = c_1$  does not consider for

computation of the PH report transmissions on a second serving cell  $c_2$  as exempted in subclause 7.7.1 in [8]. There is one power management term for the UE, denoted P-MPR, and  $P\text{-MPR}_c = P\text{-MPR}$ .

The total configured maximum output power  $P_{\text{CMAX}}$  shall be set within the following bounds:

$$P_{\text{CMAX\_L}} \leq P_{\text{CMAX}} \leq P_{\text{CMAX\_H}}$$

For uplink intra-band contiguous carrier aggregation when same slot pattern is used in all aggregated serving cells,

$$P_{\text{CMAX\_L}} = \text{MIN}\{10 \log_{10} \sum p_{\text{EMAX},c} - \Delta T_C, P_{\text{EMAX},CA}, (P_{\text{PowerClass},CA} - \Delta P_{\text{PowerClass},CA}) - \text{MAX}(\text{MAX}(\text{MPR}, \text{A-MPR}) + \Delta T_{\text{IB},c} + \Delta T_C + \Delta T_{\text{RxsRS}}, P\text{-MPR}_c) \}$$

$$P_{\text{CMAX\_H}} = \text{MIN}\{10 \log_{10} \sum p_{\text{EMAX},c}, P_{\text{EMAX},CA}, P_{\text{PowerClass},CA} - \Delta P_{\text{PowerClass},CA} \}$$

where

- $p_{\text{EMAX},c}$  is the linear value of  $P_{\text{EMAX},c}$  which is given by IE *P-Max* for serving cell  $c$  in [7];
- $P_{\text{PowerClass},CA}$  is the maximum UE power specified in Table 6.2A.1.1-1 without taking into account the tolerance;
- MPR and A-MPR are specified in clause 6.2A.2 and 6.2A.3, respectively;
- $\Delta P_{\text{PowerClass},CA} = 3$  dB for a power class 2 UE when the requirements of default power class are applied as specified in sub-clause 6.2.A.1.1; otherwise  $\Delta P_{\text{PowerClass},CA} = 0$  dB;

NOTE: UE reports  $\Delta P_{\text{PowerClass},CA}$  when *deltaPowerClassReporting-r18* is present, *dpc-Reporting-FR1* [7] is configured and the reporting is triggered only by uplink duty cycle exceedance or by return to the *powerClass* after the duty cycle exceedance.

- $\Delta T_{\text{IB},c}$  is the additional tolerance for serving cell  $c$  as specified in clause 6.2A.4.2 for NR CA, clause 6.2C.2 for SUL, or TS 38.101-3 clause 6.2B.4.2 for EN-DC; In case the UE supports more than one of band combinations for CA, SUL or DC, and an operating band belongs to more than one band combinations then
  - a) When the operating band frequency range is  $\leq 1$  GHz, the applicable additional  $\Delta T_{\text{IB},c}$  shall be the average value for all band combinations defined in clause 6.2A.4.2, 6.2C.2 in this specification and 6.2B.4.2 in TS 38.101-3 [3], truncated to one decimal place that apply for that operating band among the supported band combinations. In case there is a harmonic relation between low band UL and high band DL, then the maximum  $\Delta T_{\text{IB},c}$  among the different supported band combinations involving such band shall be applied
  - b) When the operating band frequency range is  $> 1$  GHz, the applicable additional  $\Delta T_{\text{IB},c}$  shall be the maximum value for all band combinations defined in clause 6.2A.4.2, 6.2C.2 in this specification and 6.2B.4.2 in TS 38.101-3 [3] for the applicable operating bands.
- P-MPR is the power management term for the UE;
- $\Delta T_C$  is the highest value  $\Delta T_{C,c}$  among all serving cells  $c$ ;
- $\Delta T_{\text{RxsRS}}$  is the highest value among all serving cells  $c$ ;
- $P_{\text{EMAX},CA}$  is the value indicated by *p-NR-FRI* or by *p-UE-FRI* whichever is the smallest if both are present.

For uplink intra-band contiguous carrier aggregation, when at least one different numerology/slot pattern is used in aggregated cells, the UE is allowed to set its configured maximum output power  $P_{\text{CMAX},c(i),i}$  for serving cell  $c(i)$  of slot numerology type  $i$ , and its total configured maximum output power  $P_{\text{CMAX}}$ .

The configured maximum output power  $P_{\text{CMAX},c(i),i}(p)$  in slot  $p$  of serving cell  $c(i)$  on slot numerology type  $i$  shall be set within the following bounds:

$$P_{\text{CMAX\_L},f,c(i),i}(p) \leq P_{\text{CMAX},f,c(i),i}(p) \leq P_{\text{CMAX\_H},f,c(i),i}(p)$$



where  $P_{\text{CMAX\_L},f,c(i),i}(p)$  and  $P_{\text{CMAX\_H},f,c(i),i}(p)$  are the limits for a serving cell  $c(i)$  of slot numerology type  $i$  as specified in clause 6.2.4.

The total UE configured maximum output power  $P_{\text{CMAX}}(p,q)$  in a slot  $p$  of slot numerology or symbol pattern  $i$ , and a slot  $q$  of slot numerology or symbol pattern  $j$  that overlap in time shall be set within the following bounds unless stated otherwise:

$$P_{\text{CMAX\_L}}(p,q) \leq P_{\text{CMAX}}(p,q) \leq P_{\text{CMAX\_H}}(p,q)$$

When slots  $p$  and  $q$  have different transmissions lengths and belong to different cells on different or same bands:

$$P_{\text{CMAX\_L}}(p,q) = \text{MIN} \{ 10 \log_{10} [p_{\text{CMAX\_L},f,c(i),i}(p) + p_{\text{CMAX\_L},f,c(i),j}(q)], P_{\text{PowerClass,CA}}, P_{\text{EMAX,CA}} \}$$

$$P_{\text{CMAX\_H}}(p,q) = \text{MIN} \{ 10 \log_{10} [p_{\text{CMAX\_H},f,c(i),i}(p) + p_{\text{CMAX\_H},f,c(i),j}(q)], P_{\text{PowerClass,CA}}, P_{\text{EMAX,CA}} \}$$

where  $p_{\text{CMAX\_L},f,c(i),i}$  and  $p_{\text{CMAX\_H},f,c(i),i}$  are the respective limits  $P_{\text{CMAX\_L},f,c(i),i}$  and  $P_{\text{CMAX\_H},f,c(i),i}$  expressed in linear scale.

$T_{\text{REF}}$  and  $T_{\text{eval}}$  are specified in Table 6.2A.4.1.1-0 when same and different slot patterns are used in aggregated carriers. For each  $T_{\text{REF}}$ , the  $P_{\text{CMAX\_L}}$  is evaluated per  $T_{\text{eval}}$  and given by the minimum value taken over the transmission(s) within the  $T_{\text{eval}}$ ; the minimum  $P_{\text{CMAX\_L}}$  over the one or more  $T_{\text{eval}}$  is then applied for the entire  $T_{\text{REF}}$ . The lesser of  $P_{\text{PowerClass,CA}}$  and  $P_{\text{EMAX,CA}}$  shall not be exceeded by the UE during any period of time.

**Table 6.2A.4.1.1-0:  $P_{\text{CMAX}}$  evaluation window for different slot and channel durations**

$T_{\text{REF}}$	$T_{\text{eval}}$	$T_{\text{eval}}$ with frequency hopping
$T_{\text{REF}}$ of largest slot duration over both UL CCs	Physical channel length	Min( $T_{\text{no\_hopping}}$ , Physical Channel Length)

If the UE is configured with multiple TAGs and transmissions of the UE on slot  $i$  for any serving cell in one TAG overlap some portion of the first symbol of the transmission on slot  $i+1$  for a different serving cell in another TAG, the UE minimum of  $P_{\text{CMAX\_L}}$  for slots  $i$  and  $i+1$  applies for any overlapping portion of slots  $i$  and  $i+1$ . The lesser of  $P_{\text{PowerClass,CA}}$  and  $P_{\text{EMAX,CA}}$  shall not be exceeded by the UE during any period of time.

The measured maximum output power  $P_{\text{UMAX}}$  over all serving cells with same slot pattern shall be within the following range:

$$P_{\text{CMAX\_L}} - \text{MAX}\{T_{\text{L}}, T_{\text{LOW}}(P_{\text{CMAX\_L}})\} \leq P_{\text{UMAX}} \leq P_{\text{CMAX\_H}} + T_{\text{HIGH}}(P_{\text{CMAX\_H}})$$

$$P_{\text{UMAX}} = 10 \log_{10} \sum p_{\text{UMAX},c}$$

where  $p_{\text{UMAX},c}$  denotes the measured maximum output power for serving cell  $c$  expressed in linear scale. The tolerances  $T_{\text{LOW}}(P_{\text{CMAX}})$  and  $T_{\text{HIGH}}(P_{\text{CMAX}})$  for applicable values of  $P_{\text{CMAX}}$  are specified in Table 6.2A.4.1.1-1. The tolerance  $T_{\text{L}}$  is the absolute value of the lower tolerance for applicable NR CA configuration as specified in Table 6.2A.1.1-1 for intra-band carrier aggregation.

The measured maximum output power  $P_{\text{UMAX}}$  over all serving cells, when at least one slot has a different transmission numerology or slot pattern, shall be within the following range:

$$P'_{\text{CMAX\_L}} - \text{MAX}\{T_{\text{L}}, T_{\text{LOW}}(P'_{\text{CMAX\_L}})\} \leq P'_{\text{UMAX}} \leq P'_{\text{CMAX\_H}} + T_{\text{HIGH}}(P'_{\text{CMAX\_H}})$$

$$P'_{\text{UMAX}} = 10 \log_{10} \sum p'_{\text{UMAX},c}$$

where  $p'_{\text{UMAX},c}$  denotes the average measured maximum output power for serving cell  $c$  expressed in linear scale over  $T_{\text{REF}}$ . The tolerances  $T_{\text{LOW}}(P'_{\text{CMAX}})$  and  $T_{\text{HIGH}}(P'_{\text{CMAX}})$  for applicable values of  $P'_{\text{CMAX}}$  are specified in Table 6.2A.4.1.1-1 for intra-band carrier aggregation. The tolerance  $T_{\text{L}}$  is the absolute value of the lower tolerance for applicable NR CA configuration as specified in Table 6.2A.1.1-1 for intra-band carrier aggregation.

where:

$$P'_{\text{CMAX}_L} = \text{MIN}\{ \text{MIN}\{ 10\log_{10}\sum(\text{p}_{\text{CMAX}_L,f,c(i),i}), P_{\text{PowerClass,CA}}\} \text{ over all overlapping slots in } T_{\text{REF}}\}$$

$$P'_{\text{CMAX}_H} = \text{MAX}\{ \text{MIN}\{ 10\log_{10}\sum \text{p}_{\text{EMAX},c}, P_{\text{PowerClass,CA}}\} \text{ over all overlapping slots in } T_{\text{REF}}\}$$

**Table 6.2A.4.1.1-1: P<sub>CMAX</sub> tolerance for uplink intra-band contiguous CA**

P <sub>CMAX</sub> (dBm)	Tolerance T <sub>LOW</sub> (P <sub>CMAX</sub> ) (dB)	Tolerance T <sub>HIGH</sub> (P <sub>CMAX</sub> ) (dB)
23 < P <sub>CMAX</sub> ≤ 26	3	2
21 ≤ P <sub>CMAX</sub> ≤ 23	2.0	
20 ≤ P <sub>CMAX</sub> < 21	2.5	
19 ≤ P <sub>CMAX</sub> < 20	3.5	
18 ≤ P <sub>CMAX</sub> < 19	4.0	
13 ≤ P <sub>CMAX</sub> < 18	5.0	
8 ≤ P <sub>CMAX</sub> < 13	6.0	
-40 ≤ P <sub>CMAX</sub> < 8	7.0	

#### 6.2A.4.1.2 Configured transmitted power for Intra-band non-contiguous CA

For uplink carrier aggregation the UE is allowed to set its configured maximum output power P<sub>CMAX,c</sub> for serving cell *c* and its total configured maximum output power P<sub>CMAX</sub>.

The configured maximum output power P<sub>CMAX,c</sub> on serving cell *c* shall be set as specified in subclause 6.2.4.

The configured maximum output power P<sub>CMAX,c</sub> on serving cell *c* shall be set as specified in subclause 6.2.4, but with MPR<sub>c</sub> = MPR and A-MPR<sub>c</sub> = A-MPR with MPR and A-MPR as determined by subclause 6.2A.2 and 6.2A.3, respectively. For PH reporting the following exception applies: if the UE is configured with multiple uplink serving cells, the power P<sub>CMAX,c</sub> used for the purpose of PH reporting on first serving cell *c* = *c*<sub>1</sub> does not consider for computation of the PH report transmissions on a second serving cell *c*<sub>2</sub> as exempted in subclause 7.7.1 in [8]. There is one power management term for the UE, denoted P-MPR, and P-MPR<sub>c</sub> = P-MPR.

The total configured maximum output power P<sub>CMAX</sub> shall be set within the following bounds:

$$P_{\text{CMAX}_L} \leq P_{\text{CMAX}} \leq P_{\text{CMAX}_H}$$

For uplink intra-band non-contiguous carrier aggregation when same slot pattern is used in all aggregated serving cells,

$$P_{\text{CMAX}_L} = \text{MIN}\{ 10\log_{10}\sum \text{p}_{\text{EMAX},c} - \Delta T_C, P_{\text{EMAX,CA}}(P_{\text{PowerClass,CA}} - \Delta P_{\text{PowerClass,CA}}) - \text{MAX}(\text{MAX}(\text{MPR}_c, \text{A-MPR}_c) + \Delta T_{\text{IB},c} + \Delta T_C + \Delta T_{\text{RxsRS}}, \text{P-MPR}) \}$$

$$P_{\text{CMAX}_H} = \text{MIN}\{ 10\log_{10}\sum \text{p}_{\text{EMAX},c}, P_{\text{EMAX,CA}}, P_{\text{PowerClass,CA}} - \Delta P_{\text{PowerClass,CA}} \}$$

where

- p<sub>EMAX,c</sub> is the linear value of P<sub>EMAX,c</sub> which is given by IE *P-Max* for serving cell *c* in [7];
- P<sub>PowerClass,CA</sub> is the maximum UE power specified in Table 6.2A.1.2-1 without taking into account the tolerance;
- MPR and A-MPR are specified in subclause 6.2A.2 and subclause 6.2A.3 respectively;
- ΔP<sub>PowerClass,CA</sub> = 3 dB for a power class 2 UE when the requirements of default power class are applied as specified in sub-clause 6.2.A.1.2; otherwise ΔP<sub>PowerClass,CA</sub> = 0 dB;

NOTE: UE reports  $\Delta P_{\text{PowerClass,CA}}$  when *deltaPowerClassReporting-r18* is present, *dpc-Reporting-FR1* [7] is configured and the reporting is triggered only by uplink duty cycle exceedance or by return to the *powerClass* after the duty cycle exceedance.

- $\Delta T_{\text{IB},c}$  is the additional tolerance for serving cell *c* as specified in clause 6.2A.4.2 for NR CA, clause 6.2C.2 for SUL, or TS 38.101-3 clause 6.2B.4.2 for EN-DC; In case the UE supports more than one of band combinations for CA, SUL or DC, and an operating band belongs to more than one band combinations then
  - a) When the operating band frequency range is  $\leq 1$  GHz, the applicable additional  $\Delta T_{\text{IB},c}$  shall be the average value for all band combinations defined in clause 6.2A.4.2, 6.2C.2 in this specification and 6.2B.4.2 in TS 38.101-3 [3], truncated to one decimal place that apply for that operating band among the supported band combinations. In case there is a harmonic relation between low band UL and high band DL, then the maximum  $\Delta T_{\text{IB},c}$  among the different supported band combinations involving such band shall be applied
  - b) When the operating band frequency range is  $> 1$  GHz, the applicable additional  $\Delta T_{\text{IB},c}$  shall be the maximum value for all band combinations defined in clause 6.2A.4.2, 6.2C.2 in this specification and 6.2B.4.2 in TS 38.101-3 [3] for the applicable operating bands.
- P-MPR is the power management term for the UE;
- $\Delta T_{\text{C}}$  is the highest value  $\Delta T_{\text{C},c}$  among all serving cells *c*;
- $\Delta T_{\text{RxsRS}}$  is the highest value among all serving cells *c*;
- $P_{\text{EMAX,CA}}$  is the value indicated by *p-NR-FRI* or by *p-UE-FRI* whichever is the smallest if both are present.

[For uplink intra-band non-contiguous carrier aggregation, when at least one different numerology/slot pattern is used in aggregated cells, the UE is allowed to set its configured maximum output power  $P_{\text{CMAX},c(i),i}$  for serving cell *c(i)* of slot numerology type *i*, and its total configured maximum output power  $P_{\text{CMAX}}$ .

The configured maximum output power  $P_{\text{CMAX},c(i),i}(p)$  in slot *p* of serving cell *c(i)* on slot numerology type *i* shall be set within the following bounds:

$$P_{\text{CMAX}_L,f,c(i),i}(p) \leq P_{\text{CMAX},f,c(i),i}(p) \leq P_{\text{CMAX}_H,f,c(i),i}(p)$$

where  $P_{\text{CMAX}_L,f,c(i),i}(p)$  and  $P_{\text{CMAX}_H,f,c(i),i}(p)$  are the limits for a serving cell *c(i)* of slot numerology type *i* as specified in subclause 6.2.4.

The total UE configured maximum output power  $P_{\text{CMAX}}(p,q)$  in a slot *p* of slot numerology or symbol pattern *i*, and a slot *q* of slot numerology or symbol pattern *j* that overlap in time shall be set within the following bounds unless stated otherwise:

$$P_{\text{CMAX}_L}(p,q) \leq P_{\text{CMAX}}(p,q) \leq P_{\text{CMAX}_H}(p,q)$$

When slots *p* and *q* have different transmissions lengths and belong to different cells on different or same bands:

$$P_{\text{CMAX}_L}(p,q) = \text{MIN} \{ 10 \log_{10} [p_{\text{CMAX}_L,f,c(i),i}(p) + p_{\text{CMAX}_L,f,c(i),j}(q)], P_{\text{PowerClass,CA}}, P_{\text{EMAX,CA}} \}$$

$$P_{\text{CMAX}_H}(p,q) = \text{MIN} \{ 10 \log_{10} [p_{\text{CMAX}_H,f,c(i),i}(p) + p_{\text{CMAX}_H,f,c(i),j}(q)], P_{\text{PowerClass,CA}}, P_{\text{EMAX,CA}} \}$$

where  $p_{\text{CMAX}_L,f,c(i),i}$  and  $p_{\text{CMAX}_H,f,c(i),i}$  are the respective limits  $P_{\text{CMAX}_L,f,c(i),i}$  and  $P_{\text{CMAX}_H,f,c(i),i}$  expressed in linear scale.]

$T_{\text{REF}}$  and  $T_{\text{eval}}$  are specified in Table 6.2A.4.1.2-1 when same and different slot patterns are used in aggregated carriers. For each  $T_{\text{REF}}$ , the  $P_{\text{CMAX}_L}$  is evaluated per  $T_{\text{eval}}$  and given by the minimum value taken over the transmission(s) within the  $T_{\text{eval}}$ ; the minimum  $P_{\text{CMAX}_L}$  over the one or more  $T_{\text{eval}}$  is then applied for the entire  $T_{\text{REF}}$ . The lesser of  $P_{\text{PowerClass,CA}}$  and  $P_{\text{EMAX,CA}}$  shall not be exceeded by the UE during any period of time.

**Table 6.2A.4.1.2-1: P<sub>CMAX</sub> evaluation window for different slot and channel durations**

T <sub>REF</sub>	T <sub>eval</sub>	T <sub>eval</sub> with frequency hopping
T <sub>REF</sub> of largest slot duration over both UL CCs	Physical channel length	Min(T <sub>no_hopping</sub> , Physical Channel Length)

If the UE is configured with multiple TAGs and transmissions of the UE on slot  $i$  for any serving cell in one TAG overlap some portion of the first symbol of the transmission on slot  $i + 1$  for a different serving cell in another TAG, the UE minimum of P<sub>CMAX,L</sub> for slots  $i$  and  $i + 1$  applies for any overlapping portion of slots  $i$  and  $i + 1$ . The lesser of P<sub>PowerClass,CA</sub> and P<sub>EMAX,CA</sub> shall not be exceeded by the UE during any period of time.

The measured maximum output power P<sub>UMAX</sub> over all serving cells with same slot pattern shall be within the following range:

$$P_{\text{CMAX}_L} - \text{MAX}\{T_L, T_{\text{LOW}}(P_{\text{CMAX}_L})\} \leq P_{\text{UMAX}} \leq P_{\text{CMAX}_H} + T_{\text{HIGH}}(P_{\text{CMAX}_H})$$

$$P_{\text{UMAX}} = 10 \log_{10} \sum p_{\text{UMAX},c}$$

where p<sub>UMAX,c</sub> denotes the measured maximum output power for serving cell  $c$  expressed in linear scale. The tolerances T<sub>LOW</sub>(P<sub>CMAX</sub>) and T<sub>HIGH</sub>(P<sub>CMAX</sub>) for applicable values of P<sub>CMAX</sub> are specified in Table 6.2A.4.1.2-2. The tolerance T<sub>L</sub> is the absolute value of the lower tolerance for applicable NR CA configuration as specified in Table 6.2A.1.2-1 for intra-band carrier aggregation.

The measured maximum output power P<sub>UMAX</sub> over all serving cells, when at least one slot has a different transmission numerology or slot pattern, shall be within the following range:

$$P'_{\text{CMAX}_L} - \text{MAX}\{T_L, T_{\text{LOW}}(P'_{\text{CMAX}_L})\} \leq P'_{\text{UMAX}} \leq P'_{\text{CMAX}_H} + T_{\text{HIGH}}(P'_{\text{CMAX}_H})$$

$$P'_{\text{UMAX}} = 10 \log_{10} \sum p'_{\text{UMAX},c}$$

where p'<sub>UMAX,c</sub> denotes the average measured maximum output power for serving cell  $c$  expressed in linear scale over T<sub>REF</sub>. The tolerances T<sub>LOW</sub>(P'<sub>CMAX</sub>) and T<sub>HIGH</sub>(P'<sub>CMAX</sub>) for applicable values of P'<sub>CMAX</sub> are specified in Table 6.2A.4.1.2-2 for intra-band carrier aggregation. The tolerance T<sub>L</sub> is the absolute value of the lower tolerance for applicable NR CA configuration as specified in Table 6.2A.1.2-1 for intra-band carrier aggregation.

where:

$$P'_{\text{CMAX}_L} = \text{MIN}\{ \text{MIN}\{10 \log_{10} \sum (p_{\text{CMAX}_L, f, c(i), i}), P_{\text{PowerClass}, \text{CA}}\} \text{ over all overlapping slots in } T_{\text{REF}}\}$$

$$P'_{\text{CMAX}_H} = \text{MAX}\{ \text{MIN}\{10 \log_{10} \sum p_{\text{EMAX}, c}, P_{\text{PowerClass}, \text{CA}}\} \text{ over all overlapping slots in } T_{\text{REF}}\}$$

**Table 6.2A.4.1.2-2: P<sub>CMAX</sub> tolerance for uplink intra-band non-contiguous CA**

P <sub>CMAX</sub> (dBm)	Tolerance T <sub>LOW</sub> (P <sub>CMAX</sub> ) (dB)	Tolerance T <sub>HIGH</sub> (P <sub>CMAX</sub> ) (dB)
21 ≤ P <sub>CMAX</sub> ≤ 26	3.0	2.0
20 ≤ P <sub>CMAX</sub> < 21		2.5
19 ≤ P <sub>CMAX</sub> < 20		3.5
18 ≤ P <sub>CMAX</sub> < 19		4.0
13 ≤ P <sub>CMAX</sub> < 18		5.0
8 ≤ P <sub>CMAX</sub> < 13		6.0
-40 ≤ P <sub>CMAX</sub> < 8		7.0

### 6.2A.4.1.3 Configured transmitted power for Inter-band CA

For uplink carrier aggregation the UE is allowed to set its configured maximum output power  $P_{\text{CMAX},c}$  for serving cell  $c$  and its total configured maximum output power  $P_{\text{CMAX}}$ .

The configured maximum output power  $P_{\text{CMAX},c}$  on serving cell  $c$  shall be set as specified in clause 6.2.4, except that the UE power class for serving cell  $c$  on the specific operating band shall be determined by the *ue-PowerClassPerBandPerBC-r17* IE [7] as indicated for the band combination if signalled.

For uplink inter-band carrier aggregation,  $\text{MPR}_c$  and  $\text{A-MPR}_c$  apply per serving cell  $c$  and are specified in clause 6.2.2 and clause 6.2.3, respectively.  $\text{P-MPR}_c$  accounts for power management for serving cell  $c$ .  $P_{\text{CMAX},c}$  is calculated under the assumption that the transmit power is increased independently on all component carriers.

The total configured maximum output power  $P_{\text{CMAX}}$  shall be set within the following bounds:

$$P_{\text{CMAX}_L} \leq P_{\text{CMAX}} \leq P_{\text{CMAX}_H}$$

For uplink inter-band carrier aggregation with one serving cell  $c$  per operating band when same slot symbol pattern is used in all aggregated serving cells,

$$P_{\text{CMAX}_L} = \text{MIN} \{ 10 \log_{10} \sum \text{MIN} [ p_{\text{EMAX},c} / (\Delta t_{C,c}), p_{\text{PowerClass},c} / (\text{MAX}(\text{mpr}_c \cdot \Delta \text{mpr}_c, \text{a-mpr}_c) \cdot \Delta t_{C,c} \cdot \Delta t_{\text{IB},c} \cdot \Delta t_{\text{RxsRS},c}), p_{\text{PowerClass},c} / \text{pmpr}_c ], P_{\text{EMAX},CA}, P_{\text{PowerClass},CA} - \Delta P_{\text{PowerClass},CA} \}$$

$$P_{\text{CMAX}_H} = \text{MIN} \{ 10 \log_{10} \sum p_{\text{EMAX},c}, P_{\text{EMAX},CA}, P_{\text{PowerClass},CA} - \Delta P_{\text{PowerClass},CA} \}$$

where

- $p_{\text{EMAX},c}$  is the linear value of  $P_{\text{EMAX},c}$  which is given by IE *P-Max* for serving cell  $c$  in [7];
- $P_{\text{PowerClass},CA}$  is the maximum UE power specified in Table 6.2A.1.3-1 without taking into account the tolerance specified in the Table 6.2A.1.3-1; If the UE indicates *higherPowerLimit-r17* for an eligible CA configuration as specified in Table 6.2A.1.3-1 and  $\Delta P_{\text{PowerClass},CA} = 0$ ,  $P_{\text{PowerClass},CA}$  is replaced by  $10 \log_{10} \sum P_{\text{PowerClass},c}$ .
- $p_{\text{PowerClass},c}$  is the linear value of the maximum UE power for serving cell  $c$  specified in Table 6.2.1-1 according to *ue-PowerClassPerBandPerBC-r17* if indicated or *ue-PowerClass* otherwise without taking into account the tolerance;
- $\Delta P_{\text{PowerClass},CA} = 3$  dB for a power class 2 UE when the requirements of default power class are applied as specified in sub-clause 6.2.A.1.3; otherwise  $\Delta P_{\text{PowerClass},CA} = 0$  dB;

NOTE: UE reports  $\Delta P_{\text{PowerClass},CA}$  when *deltaPowerClassReporting-r18* is present, *dpc-Reporting-FR1* [7] is configured and the reporting is triggered only by uplink duty cycle exceedance or by return to the *powerClass* after the duty cycle exceedance.

- $\text{mpr}_c$  and  $\text{a-mpr}_c$  are the linear values of  $\text{MPR}_c$  and  $\text{A-MPR}_c$  as specified in clause 6.2.2 and clause 6.2.3, respectively;
- $\Delta \text{mpr}_c$  is the linear value of  $\Delta \text{MPR}_c$  as specified in clause 6.2.2;
- $\text{pmpr}_c$  is the linear value of  $\text{P-MPR}_c$ ;
- $\Delta t_{\text{RxsRS},c}$  is the linear value of  $\Delta T_{\text{RxsRS},c}$ ;
- $\Delta t_{C,c}$  is the linear value of  $\Delta T_{C,c}$ .  $\Delta t_{C,c} = 1.41$  when NOTE 2 in Table 6.2A.1.3-1 applies for a serving cell  $c$ , otherwise  $\Delta t_{C,c} = 1$ ;
- $\Delta t_{\text{IB},c}$  is the linear value of the inter-band relaxation term  $\Delta T_{\text{IB},c}$  of the serving cell  $c$  as specified in clause 6.2A.4.2 for NR CA, clause 6.2C.2 for SUL, or TS 38.101-3 clause 6.2B.4.2 for EN-DC; otherwise

$\Delta T_{IB,c} = 1$ ; In case the UE supports more than one of band combinations for CA, SUL or DC, and an operating band belongs to more than one band combinations then

- a) When the operating band frequency range is  $\leq 1$  GHz, the applicable additional  $\Delta T_{IB,c}$  shall be the average value for all band combinations defined in clause 6.2A.4.2, 6.2C.2 in this specification and 6.2B.4.2 in TS 38.101-3 [3], truncated to one decimal place that apply for that operating band among the supported band combinations. In case there is a harmonic relation between low band UL and high band DL, then the maximum  $\Delta T_{IB,c}$  among the different supported band combinations involving such band shall be applied
  - b) When the operating band frequency range is  $> 1$  GHz, the applicable additional  $\Delta T_{IB,c}$  shall be the maximum value for all band combinations defined in clause 6.2A.4.2, 6.2C.2 in this specification and 6.2B.4.2 in TS 38.101-3 [3] for the applicable operating bands.
- $P_{EMAX,CA}$  is the value indicated by *p-NR-FRI* or by *p-UE-FRI* whichever is the smallest if both are present. For uplink inter-band carrier aggregation with one serving cell *c* per operating band when at least one different numerology/slot pattern is used in aggregated cells, the UE is allowed to set its configured maximum output power  $P_{CMAX,c(i),i}$  for serving cell *c(i)* of slot numerology type *i*, and its total configured maximum output power  $P_{CMAX}$ .

The configured maximum output power  $P_{CMAX,c(i),i}(p)$  in slot *p* of serving cell *c(i)* on slot numerology type *i* shall be set within the following bounds:

$$P_{CMAX\_L,f,c(i),i}(p) \leq P_{CMAX,f,c(i),i}(p) \leq P_{CMAX\_H,f,c(i),i}(p)$$

where  $P_{CMAX\_L,f,c(i),i}(p)$  and  $P_{CMAX\_H,f,c(i),i}(p)$  are the limits for a serving cell *c(i)* of slot numerology type *i* as specified in clause 6.2.4, except that the UE power class for the serving cell *c(i)* on the specific operating band shall be determined by the *ue-PowerClassPerBandPerBC-r17* IE [7] as indicated for the band combination if signalled.

The total UE configured maximum output power  $P_{CMAX}(p,q)$  in a slot *p* of slot numerology or symbol pattern *i*, and a slot *q* of slot numerology or symbol pattern *j* that overlap in time shall be set within the following bounds unless stated otherwise:

$$P_{CMAX\_L}(p,q) \leq P_{CMAX}(p,q) \leq P_{CMAX\_H}(p,q)$$

When slots *p* and *q* have different transmissions lengths and belong to different cells on different bands:

$$P_{CMAX\_L}(p,q) = \text{MIN} \{ 10 \log_{10} [p_{CMAX\_L,f,c(i),i}(p) + p_{CMAX\_L,f,c(i),j}(q)], P_{PowerClass,CA}, P_{EMAX,CA} \}$$

$$P_{CMAX\_H}(p,q) = \text{MIN} \{ 10 \log_{10} [p_{CMAX\_H,f,c(i),i}(p) + p_{CMAX\_H,f,c(i),j}(q)], P_{PowerClass,CA}, P_{EMAX,CA} \}$$

where  $p_{CMAX\_L,f,c(i),i}$  and  $p_{CMAX\_H,f,c(i),i}$  are the respective limits  $P_{CMAX\_L,f,c(i),i}$  and  $P_{CMAX\_H,f,c(i),i}$  expressed in linear scale and  $p_{PowerClass,c}$  is the linear value of the maximum UE power for serving cell *c* specified in Table 6.2.1-1 according to *ue-PowerClassPerBandPerBC-r17* if indicated or *ue-PowerClass* otherwise without taking into account the tolerance; If the UE indicates *higherPowerLimit-r17*,  $P_{PowerClass,CA}$  is replaced by  $10 \log_{10} \sum p_{PowerClass,c}$ .

For combinations of intra-band and inter-band carrier aggregation with UE configured for transmission on three serving cells (up to two contiguously aggregated carriers per operating band), the following apply:

The UE power class for the serving cell(s) on the operating band *B<sub>i</sub>* including intra-band carrier aggregation shall be determined by the *ue-PowerClassPerBandPerBC-r17* IE [7] as indicated for the band combination if signalled.

For the case when the UE indicates *higherPowerLimit-r17*,  $P_{PowerClass,CA}$  is replaced by  $10 \log_{10} (p_{PowerClass,A} + p_{PowerClass,CA,B})$ .

Where

- $p_{PowerClass,A}$  is the linear value of the maximum UE power for serving cell *c* on the operating band *A* specified in Table 6.2.1-1 according to *ue-PowerClassPerBandPerBC-r17* if indicated or *ue-PowerClass* otherwise without taking into account the tolerance;

- $P_{PowerClass,CA,B}$  is the linear value of the maximum UE power for serving cell(s) on the operating band B including intra-band carrier aggregation specified in Table 6.2F.1A.2-1 according to *ue-PowerClassPerBandPerBC-r17* if indicated or *ue-PowerClass*, otherwise without taking into account the tolerance.

For the case when p and q belong to the same band and k belongs to a different band, but p, q and k are of the same numerology and slot patterns.

$$P_{CMAX\_L} = \text{MIN} \{ 10 \log_{10} \sum (p_{CMAX\_L, Bi}), P_{EMAX,CA}, P_{PowerClass,CA} \}$$

$$P_{CMAX\_H} = \text{MIN} \{ 10 \log_{10} \sum p_{EMAX,c}, P_{EMAX,CA}, P_{PowerClass,CA} \}$$

Where

- $p_{CMAX\_L, Bi}$  is the linear values of  $P_{CMAX\_L}$  specified for the specific operating band  $B_i$ .
- The linear value of  $P_{CMAX\_L}$  specified for uplink intra-band contiguous carrier aggregation in subclause 6.2A.4.1.1 applies for operating band supporting two contiguous serving cells, designated by its band index  $B_i$ . The linear value of  $P_{CMAX\_L}$  specified for single carrier in subclause 6.2.4 applies for operating band  $B_j$  supporting one serving cell.

For the case when p and q belong to the same band and are of the same numerology  $i$  and slot patterns (p,q), while k belong to a different band and is of different numerology  $j$  and/or slot pattern on the 3<sup>rd</sup> cell then:

$$P_{CMAX\_L}(p,q,k) = \text{MIN} \{ 10 \log_{10} [p_{CMAX\_L, Bi}(p,q) + p_{CMAX\_L, c(3), Bj, j}(k)], P_{EMAX,CA}, P_{PowerClass,CA} \}$$

$$P_{CMAX\_H}(p,q,k) = \text{MIN} \{ 10 \log_{10} [p_{CMAX\_H, Bi, i}(p,q) + p_{CMAX\_H, c(3), Bj, j}(k)], P_{EMAX,CA}, P_{PowerClass,CA} \}$$

Where

- $p_{EMAX,c}$  is the linear value of  $P_{EMAX,c}$  which is given by IE *P-Max* for serving cell  $c$  in [7];
- $P_{EMAX,CA}$  is p-UE-FR1 value signalled by RRC and defined in [38.331];
- $P_{PowerClass,CA}$  is the maximum UE power specified in Table 6.2A.1.3-1 without taking into account the tolerance specified in the Table 6.2A.1.3-1 or Table 6.2F.1A.1-1 for shared spectrum bands;
- $p_{CMAX\_L, c(3), Bj, j}(k)$  and  $p_{CMAX\_H, c(3), Bj, j}(k)$  are the linear values of  $P_{CMAX\_L}$  and  $P_{CMAX\_H}$  respectively, specified for single carrier in subclause 6.2.4 and applies for operating band supporting one serving cell in the  $B_j$  band on numerology  $j$ , using slot pattern  $k$ ;
- $p_{CMAX\_L, Bi, i}(p,q)$  and  $p_{CMAX\_H, Bi, i}(p,q)$  are the linear values of  $P_{CMAX\_L}$  respectively  $P_{CMAX\_H}$  for uplink intra-band contiguous carrier aggregation specified in subclause 6.2A.4.1.1 which applies for operating band  $B_i$  on numerology  $i$ , supporting two contiguous serving cells, using the same slot pattern (p,q).

$T_{REF}$  and  $T_{eval}$  are specified in Table 6.2A.4.1.3-0 when same and different slot patterns are used in aggregated carriers. For each  $T_{REF}$ , the  $P_{CMAX\_L}$  is evaluated per  $T_{eval}$  and given by the minimum value taken over the transmission(s) within the  $T_{eval}$ ; the minimum  $P_{CMAX\_L}$  over the one or more  $T_{eval}$  is then applied for the entire  $T_{REF}$ . The lesser of  $P_{PowerClass,CA}$  and  $P_{EMAX,CA}$  shall not be exceeded by the UE during any period of time.

**Table 6.2A.4.1.3-0:  $P_{CMAX}$  evaluation window for different slot and channel durations**

$T_{REF}$	$T_{eval}$	$T_{eval}$ with frequency hopping
$T_{REF}$ of largest slot duration over both UL CCs	Physical channel length	Min( $T_{no\_hopping}$ , Physical Channel Length)

If the UE is configured with multiple TAGs and transmissions of the UE on slot  $i$  for any serving cell in one TAG overlap some portion of the first symbol of the transmission on slot  $i + 1$  for a different serving cell in another TAG, the UE minimum of  $P_{\text{CMAX}_L}$  for slots  $i$  and  $i + 1$  applies for any overlapping portion of slots  $i$  and  $i + 1$ . The lesser of  $P_{\text{PowerClass,CA}}$  and  $P_{\text{EMAX,CA}}$  shall not be exceeded by the UE during any period of time.

The measured maximum output power  $P_{\text{UMAX}}$  over all serving cells with same slot pattern shall be within the following range:

$$P_{\text{CMAX}_L} - \text{MAX}\{T_L, T_{\text{LOW}}(P_{\text{CMAX}_L})\} \leq P_{\text{UMAX}} \leq P_{\text{CMAX}_H} + T_{\text{HIGH}}(P_{\text{CMAX}_H})$$

$$P_{\text{UMAX}} = 10 \log_{10} \sum p_{\text{UMAX},c}$$

where  $p_{\text{UMAX},c}$  denotes the measured maximum output power for serving cell  $c$  expressed in linear scale. The tolerances  $T_{\text{LOW}}(P_{\text{CMAX}})$  and  $T_{\text{HIGH}}(P_{\text{CMAX}})$  for applicable values of  $P_{\text{CMAX}}$  are specified in Table 6.2A.4.1.3-1. The tolerance  $T_L$  is the absolute value of the lower tolerance for applicable NR CA configuration as specified in Table 6.2A.1.3-1 for inter-band carrier aggregation.

The measured maximum output power  $P_{\text{UMAX}}$  over all serving cells, when at least one slot has a different transmission numerology or symbol pattern, shall be within the following range:

$$P'_{\text{CMAX}_L} - \text{MAX}\{T_L, T_{\text{LOW}}(P'_{\text{CMAX}_L})\} \leq P'_{\text{UMAX}} \leq P'_{\text{CMAX}_H} + T_{\text{HIGH}}(P'_{\text{CMAX}_H})$$

$$P'_{\text{UMAX}} = 10 \log_{10} \sum p'_{\text{UMAX},c}$$

where  $p'_{\text{UMAX},c}$  denotes the average measured maximum output power for serving cell  $c$  expressed in linear scale over  $T_{\text{REF}}$ . The tolerances  $T_{\text{LOW}}(P'_{\text{CMAX}})$  and  $T_{\text{HIGH}}(P'_{\text{CMAX}})$  for applicable values of  $P'_{\text{CMAX}}$  are specified in Table 6.2A.4.1.3-1 for inter-band carrier aggregation. The tolerance  $T_L$  is the absolute value of the lower tolerance for applicable NR CA configuration as specified in Table 6.2A.1.3-1 for inter-band carrier aggregation.

where:

$$P'_{\text{CMAX}_L} = \text{MIN}\{ \text{MIN}\{10 \log_{10} \sum (p_{\text{CMAX}_L,f,c(i),i}), P_{\text{PowerClass,CA}}\} \text{ over all overlapping slots in } T_{\text{REF}}\}$$

$$P'_{\text{CMAX}_H} = \text{MAX}\{ \text{MIN}\{10 \log_{10} \sum p_{\text{EMAX},c}, P_{\text{PowerClass,CA}}\} \text{ over all overlapping slots in } T_{\text{REF}}\}$$

If the UE indicates *higherPowerLimit-r17*,  $P_{\text{PowerClass,CA}}$  is replaced by  $10 \log_{10} \sum p_{\text{PowerClass},c}$

**Table 6.2A.4.1.3-1:  $P_{\text{CMAX}}$  tolerance for uplink inter-band CA (two bands)**

$P_{\text{CMAX}}$ (dBm)	Tolerance $T_{\text{LOW}}(P_{\text{CMAX}})$ (dB)	Tolerance $T_{\text{HIGH}}(P_{\text{CMAX}})$ (dB)
$23 \leq P_{\text{CMAX}} \leq 29$	3.0	2.0
$22 \leq P_{\text{CMAX}} < 23$	5.0	2.0
$21 \leq P_{\text{CMAX}} < 22$	5.0	3.0
$20 \leq P_{\text{CMAX}} < 21$	5.0	4.0
$16 \leq P_{\text{CMAX}} < 20$	5.0	
$11 \leq P_{\text{CMAX}} < 16$	6.0	
$-40 \leq P_{\text{CMAX}} < 11$	7.0	



6.2A.4.1.4 Void

6.2A.4.2  $\Delta T_{IB,c}$  for CA

For the UE which supports inter-band NR CA configuration,  $\Delta T_{IB,c}$  in tables below applies. Unless otherwise stated,  $\Delta T_{IB,c}$  is set to zero.

6.2A.4.2.1 Void

6.2A.4.2.2 Void

6.2A.4.2.3  $\Delta T_{IB,c}$  for Inter-band CA (two bands)Table 6.2A.4.2.3-1:  $\Delta T_{IB,c}$  due to NR CA (two bands)

Inter-band CA combination	$\Delta T_{IB,c}$ for NR bands (dB) <sup>9</sup>	
	Component band in order of bands in configuration <sup>10</sup>	
CA_n1-n3	0.3	0.3
CA_n1-n5	0.3	0.3
CA_n1-n7	0.5	0.6
CA_n1-n8	0.3	0.3
CA_n1-n18	0.3	0.3
CA_n1-n20	0.3	0.3
CA_n1-n26	0.3	0.3
CA_n1-n28	0.3	0.6
CA_n1-n38	0.5	0.5
CA_n1-n40	0.5	0.5
CA_n1-n41	0.5	0.5
CA_n1-n67	0.3	N/A
CA_n1-n74	0.3	0.3
CA_n1-n75	0.3	N/A
CA_n1-n77	0.6	0.8
CA_n1-n78	0.3	0.8
CA_n1-n102	0.6	0.8
CA_n1-n105	0.3	0.6
CA_n2-n5	0.3	0.3
CA_n2-n7	0.5	0.5
CA_n2-n12	0.3	0.3
CA_n2-n14	0.3	0.3
CA_n2-n29	0.3	N/A
CA_n2-n30	0.5	0.3
CA_n2-n41	0.5	0.4 <sup>5</sup> /0.9 <sup>6</sup>
CA_n2-n48	0.6	0.8
CA_n2-n66	0.5	0.5
CA_n2-n71	0.3	0.6
CA_n2-n77	0.6	0.8
CA_n2-n78	0.6	0.8
CA_n3-n7	0.5	0.5
CA_n3-n8	0.3	0.3
CA_n3-n18	0.3	0.3
CA_n3-n20	0.3	0.3
CA_n3-n26	0.3	0.3
CA_n3-n28	0.3	0.3
CA_n3-n34	0.5	0.5
CA_n3-n38	0.5	0.5

CA_n3-n39	0.5	0.5
CA_n3-n40	0.5	0.5
CA_n3-n41	0.5	$0.3^4 / 0.8^5$
CA_n3-n74	0.8	0.9
CA_n3-n77	0.6	0.8
CA_n3-n78	0.6	0.8
CA_n3-n79	0.3	0.8
CA_n3-n102	0.3	0.8
CA_n3-n105	0.3	0.6
CA_n5-n7	0.3	0.3
CA_n5-n8	0.5	0.5
CA_n5-n12	0.8	0.4
CA_n5-n13	0.5	0.5
CA_n5-n14	0.5	0.5
CA_n5-n25	0.3	0.3
CA_n5-n28	0.7	0.7
CA_n5-n29	0.5	N/A
CA_n5-n30	0.3	0.3
CA_n5-n40	0.3	0.3
CA_n5-n41	0.6	0.3
CA_n5-n48	0.3	0.3
CA_n5-n66	0.3	0.3
CA_n5-n71	0.5	0.5
CA_n5-n77	0.6	0.8
CA_n5-n78	0.6	0.8
CA_n5-n105	0.5	0.5
CA_n7-n8	0.3	0.6
CA_n7-n12	0.3	0.3
CA_n7-n20	0.3	0.3
CA_n7-n25	0.5	0.5
CA_n7-n26	0.3	0.3
CA_n7-n28	0.3	0.3
CA_n7-n40	0.5	0.6
CA_n7-n46	0.3	-
CA_n7-n66	0.5	0.5
CA_n7-n67	0.3	N/A
CA_n7-n71	0.6	0.3
CA_n7-n75	0.7	N/A
CA_n7-n77	0.5	0.8
CA_n7-n78	0.5	0.8
CA_n7-n79	0.5	0.8
CA_n7-n102	0.5	0.8
CA_n7-n105	0.3	0.6
CA_n8-n20	0.4	0.4
CA_n8-n28	0.6	0.5
CA_n8-n34	0.3	0.3
CA_n8-n38	0.6	0.3
CA_n8-n39	0.3	0.3
CA_n8-n40	0.3	0.3
CA_n8-n41	0.6	0.3
CA_n8-n75	0.3	N/A
CA_n8-n77	0.6	0.8
CA_n8-n78	0.6	0.8
CA_n8-n79	0.3	0.8
CA_n12-n25	0.3	0.3
CA_n12-n30	0.3	0.3
CA_n12-n41	0.3	0.3
CA_n12-n48	0.3	0.3
CA_n12-n66	0.8	0.3

CA_n12-n71	1.0	1.0
CA_n12-n77	0.5	0.8
CA_n12-n78	0.5	0.8
CA_n13-n25	0.3	0.3
CA_n13-n66	0.3	0.3
CA_n13-n77	0.5	0.8
CA_n14-n30	0.3	0.3
CA_n14-n66	0.3	0.3
CA_n14-n77	0.5	0.8
CA_n18-n28	0.5	0.5
CA_n18-n40	0.3	0.3
CA_n18-n41	0.3	0.3
CA_n18-n74	0.3	0.3
CA_n18-n77	0.3	0.8
CA_n18-n78	0.3	0.8
CA_n20-n28	0.5	0.5
CA_n20-n40	0.3	0.3
CA_n20-n75	0.3	N/A
CA_n20-n78	0.6	0.8
CA_n20-n67	0.5	N/A
CA_n24-n41	0.3	0.4 <sup>6</sup> / 0.9 <sup>7</sup>
CA_n24-n48	0.6	0.8
CA_n24-n77	0.6	0.8
CA_n25-n29	0.3	N/A
CA_n25-n38	0.5	0.5
CA_n25-n41	0.5	0.4 <sup>6</sup> / 0.9 <sup>7</sup>
CA_n25-n48	0.6	0.8
CA_n25-n66	0.5	0.5
CA_n25-n71	0.3	0.6
CA_n25-n77	0.6	0.8
CA_n25-n85	0.3	0.6
CA_n26-n28	0.7	0.7
CA_n26-n29	0.5	N/A
CA_n26-n48	0.3	0.8
CA_n26-n66	0.3	0.3
CA_n26-n70	0.3	0.3
CA_n26-n71	0.5	0.5
CA_n26-n77	0.3	0.8
CA_n26-n78	0.3	0.8
CA_n28-n34	0.3	0.3
CA_n28-n38	0.3	0.3
CA_n28-n39	0.3	0.3
CA_n28-n40	0.3	0.3
CA_n28-n41	0.3	0.3
CA_n28-n50	0.3	0.4
CA_n28-n71	1.1	1.1
CA_n28-n74	0.6	0.4
CA_n28-n75	0.3	N/A
CA_n28-n77	0.5	0.8
CA_n28-n78	0.5	0.8
CA_n28-n79	0.5	0.8
CA_n28-n94	0.5	0.6
CA_n28-n102	0.5	0.8
CA_n28-n105	1.0	1.0
CA_n29-n30	N/A	0.3
CA_n29-n48	N/A	0.8
CA_n29-n66	N/A	0.3
CA_n29-n70	N/A	0.3
CA_n29-n71	N/A	0.5

CA_n29-n77	N/A	0.8
CA_n34-n79	0.3	0.8
CA_n30-n66	0.5	0.8
CA_n30-n77	0.3	0.8
CA_n34-n41	0.3	0.3
CA_n34-n79	0.3	0.8
CA_n38-n40	0.5 <sup>3</sup>	0.5 <sup>3</sup>
CA_n38-n66	0.5	0.5
CA_n38-n78	0.3	0.8
CA_n38-n79	0.3	0.8
CA_n39-n41	0 <sup>2</sup> / 0.5	0 <sup>2</sup> / 0.5
CA_n39-n79	0.3	0.8
CA_n40-n41	0.5	0.5
CA_n40-n77	N/A	0.5
CA_n40-n78	N/A	0.5
CA_n40-n79	0.3	0.8
CA_n40-n105	0.3	0.6
CA_n41-n48	0.3	0.8
CA_n41-n50	0.3	0.4
CA_n41-n66	0.8 <sup>6</sup> / 1.3 <sup>7</sup>	0.5
CA_n41-n70	0.5	0.5
CA_n41-n71	0.3	0.6
CA_n41-n74	0.3	0.3
CA_n41-n77 <sup>1</sup>	0.3	0.8
CA_n41-n78 <sup>1</sup>	0.3	0.8
CA_n41-n79	0.3	0.8
CA_n41-n85	0.3	0.6
CA_n46-n48	-	0.5
CA_n46-n77	-	0.8
CA_n46-n78	-	0.8
CA_n46-n96	-	0.5
CA_n46-n102	-	0.5
CA_n48-n53	0.5 <sup>3</sup>	0.3 <sup>3</sup>
CA_n48-n66	0.8	0.6
CA_n48-n70	0.8	0.6
CA_n48-n71	0.3	0.3
CA_n48-n96	0.5	0.5
CA_n50-n78	0 <sup>2</sup> / 0.5 <sup>3</sup>	0 <sup>2</sup> / 0.5 <sup>3</sup>
CA_n66-n70	0.5	0.5
CA_n66-n71	0.3	0.3
CA_n66-n77	0.6	0.8
CA_n66-n78	0.6	0.8
CA_n66-n85	0.3	0.3
CA_n67-n78	N/A	0.8
CA_n70-n71	0.3	0.6
CA_n70-n77	0.6	0.8
CA_n70-n78	0.6	0.8
CA_n71-n77	0.5	0.8
CA_n71-n78	0.5	0.8
CA_n71-n85	1	1
CA_n74-n77	0.4	0.8
CA_n74-n78	0.4	0.8
CA_n75-n78	-	0.8
CA_n76-n78	-	0.8
CA_n77-n79	0.5	0.5
CA_n77-n85	0.7	0.5
CA_n77-n102	1.5	1.5
CA_n78-n79	0.5 / 1.5 <sup>8</sup>	0.5 / 1.5 <sup>8</sup>
CA_n78-n92	0.8	0.6

CA_n78-n102	1.5	1.5
CA_n78-n104	0.9	1.0
CA_n78-n105	0.8	0.5
<p>NOTE 1: The requirements only apply when the sub-frame and Tx-Rx timings are synchronized between the component carriers. In the absence of synchronization, the requirements are not within scope of these specifications.</p> <p>NOTE 2: Only applicable for UE supporting inter-band carrier aggregation with uplink in one NR band and without simultaneous Rx/Tx.</p> <p>NOTE 3: Applicable for UE supporting inter-band carrier aggregation without simultaneous Rx/Tx.</p> <p>NOTE 4: The requirement is applied for UE transmitting on the frequency range of 2515-2690 MHz.</p> <p>NOTE 5: The requirement is applied for UE transmitting on the frequency range of 2496-2515 MHz.</p> <p>NOTE 6: The requirement is applied for UE transmitting on the frequency range of 2545-2690 MHz.</p> <p>NOTE 7: The requirement is applied for UE transmitting on the frequency range of 2496-2545 MHz.</p> <p>NOTE 8: The requirements only apply for UE supporting inter-band carrier aggregation with simultaneous Rx/Tx capability, and NR UL carrier frequencies are confined to 3700 MHz-3800MHz for n78 and 4400 MHz-4500MHz for n79. Simultaneous Rx/Tx capability does not apply for UEs supporting band n78 with a n77 implementation.</p> <p>NOTE 9: "-" denotes <math>\Delta T_{IB,c} = 0</math>.</p> <p>NOTE 10: The component band order in the configuration should be listed by the order of NR bands, such as for CA_n1-n3 the band order from left to right is n1 and n3.</p>		

Table 6.2A.4.2.3-2: Void

Table 6.2A.4.2.3-3: Void

6.2A.4.2.4  $\Delta T_{IB,c}$  for Inter-band CA (three bands)Table 6.2A.4.2.4-1:  $\Delta T_{IB,c}$  due to NR CA (three bands)

Inter-band CA combination	$\Delta T_{IB,c}$ for NR bands (dB) <sup>8</sup>		
	Component band in order of bands in configuration <sup>9</sup>		
CA_n1-n3-n5	0.3	0.3	0.3
CA_n1-n3-n7	0.6	0.6	0.6
CA_n1-n3-n8	0.3	0.3	0.3
CA_n1-n3-n18	0.3	0.3	0.3
CA_n1-n3-n20	0.3	0.3	0.3
CA_n1-n3-n26	0.3	0.3	0.3
CA_n1-n3-n28	0.3	0.3	0.6
CA_n1-n3-n38	0.5	0.5	0.3
CA_n1-n3-n40	0.5	0.5	0.5
CA_n1-n3-n41	0.5	0.5	0.3 <sup>5</sup> / 0.8 <sup>6</sup>
CA_n1-n3-n75	0.3	0.3	N/A
CA_n1-n3-n77	0.6	0.6	0.8
CA_n1-n3-n78	0.6	0.6	0.8
CA_n1-n3-n79	0.3	0.3	0.8
CA_n1-n3-n105	0.3	0.3	0.6
CA_n1-n5-n7	0.5	0.3	0.6
CA_n1-n5-n28	0.3	0.6	0.6
CA_n1-n5-n40	0.6	0.3	0.5
CA_n1-n5-n78	0.6	0.6	0.8
CA_n1-n5-n79	0.6	0.6	0.8
CA_n1-n5-n105	0.3	0.6	0.6
CA_n1-n7-n8	0.5	0.6	0.6
CA_n1-n7-n26	0.5	0.6	0.3
CA_n1-n7-n28	0.5	0.6	0.6
CA_n1-n7-n38	0.5	N/A	N/A
CA_n1-n7-n40	0.6	0.8	0.9
CA_n1-n7-n67	0.5	0.5	N/A

CA_n1-n7-n75	0.5	0.6	N/A
CA_n1-n7-n78	0.6	0.6	0.8
CA_n1-n7-n79	0.6	0.6	0.8
CA_n1-n7-n105	0.5	0.6	0.6
CA_n1-n8-n28	0.3	0.6	0.6
CA_n1-n8-n40	0.3	0.3	0.5
CA_n1-n8-n77	0.3	0.6	0.8
CA_n1-n8-n78	0.3	0.6	0.8
CA_n1-n8-n79	0.3	0.6	0.8
CA_n1-n18-n28	0.3	0.5	0.5
CA_n1-n18-n41	0.5	0.3	0.5
CA_n1-n18-n77	0.3	0.3	0.8
CA_n1-n20-n67	0.5	0.6	N/A
CA_n1-n20-n78	0.3	0.6	0.8
CA_n1-n26-n78	0.6	0.6	0.8
CA_n1-n28-n38	0.5	0.6	0.5
CA_n1-n28-n40	0.6	0.3	0.5
CA_n1-n28-n41	0.5	0.6	0.6
CA_n1-n28-n46	0.3	0.6	-
CA_n1-n28-n75	0.3	0.6	N/A
CA_n1-n28-n77	0.6	0.6	0.8
CA_n1-n28-n78	0.3	0.6	0.8
CA_n1-n28-n79	-	0.2	0.5
CA_n1-n28-n102	0.6	0.6	0.8
CA_n1-n38-n78	0.5	0.5	0.8
CA_n1-n40-n77	0.3	0.5	0.8
CA_n1-n40-n78	0.3	0.5	0.8
CA_n1-n40-n105	0.5	0.5	0.6
CA_n1-n41-n77	0.5	0.5	0.8
CA_n1-n41-n79	0.5	0.5	0.8
CA_n1-n46-n78	0.3	-	0.8
CA_n1-n67-n78	0.3	N/A	0.8
CA_n1-n75-n78	0.3	N/A	0.8
CA_n1-n77-n79	0.6	0.8	0.5
CA_n1-n78-n79	0.3	0.8 / 1.5 <sup>7</sup>	0.5 / 1.5 <sup>7</sup>
CA_n1-n78-n102	0.6	1.5	1.5
CA_n1-n78-n105	0.3	0.8	0.6
CA_n2-n5-n30	0.5	0.3	0.3
CA_n2-n5-n41	0.5	0.6	0.4 <sup>5</sup> / 0.9 <sup>6</sup>
CA_n2-n5-n48	0.6	0.3	0.8
CA_n2-n5-n66	0.5	0.3	0.5
CA_n2-n5-n77	0.6	0.8	0.8
CA_n2-n7-n12	0.5	0.5	0.3
CA_n2-n7-n71	0.5	0.5	0.6
CA_n2-n7-n66	0.5	0.5	0.5
CA_n2-n7-n77	0.6	0.5	0.8
CA_n2-n12-n30	0.5	0.3	0.3
CA_n2-n12-n41	0.5	0.3	0.4 <sup>5</sup> / 0.9 <sup>6</sup>
CA_n2-n12-n66	0.5	0.8	0.5
CA_n2-n12-n71	0.3	1	1
CA_n2-n12-n77	0.6	0.3	0.8
CA_n2-n14-n30	0.5	0.3	0.5
CA_n2-n14-n66	0.5	0.3	0.5
CA_n2-n14-n77	0.5	0.3	0.8
CA_n2-n29-n30	0.5	N/A	0.3
CA_n2-n29-n66	0.5	N/A	0.5
CA_n2-n29-n77	0.6	N/A	0.8
CA_n2-n30-n66	0.5	0.3	0.5
CA_n2-n30-n77	0.6	0.3	0.8

CA_n2-n41-n66	0.5	$0.8^6 / 1.3^7$	0.5
CA_n2-n41-n71	0.5	$0.4^5 / 0.9^6$	0.6
CA_n2-n48-n66	0.6	0.8	0.6
CA_n2-n48-n77	0.6	0.8	0.8
CA_n2-n66-n71	0.5	0.5	0.3
CA_n2-n66-n77	0.6	0.6	0.8
CA_n2-n66-n78	0.6	0.6	0.8
CA_n2-n71-n77	0.6	0.3	0.8
CA_n2-n71-n78	0.6	0.6	0.8
CA_n3-n5-n7	0.5	0.3	0.5
CA_n3-n5-n28	0.3	0.6	0.5
CA_n3-n5-n78	0.6	0.6	0.8
CA_n3-n5-n79	0.3	0.5	0.8
CA_n3-n7-n8	0.5	0.5	0.6
CA_n3-n7-n20	0.5	0.5	0.3
CA_n3-n7-n26	0.5	0.5	0.3
CA_n3-n7-n28	0.5	0.5	0.3
CA_n3-n7-n38	0.5	N/A	N/A
CA_n3-n7-n40	0.6	0.6	0.6
CA_n3-n7-n67	0.5	0.5	N/A
CA_n3-n7-n75	0.7	0.7	N/A
CA_n3-n7-n78	0.6	0.6	0.8
CA_n3-n7-n79	0.5	0.5	0.8
CA_n3-n7-n105	0.5	0.5	0.6
CA_n3-n8-n28	0.3	0.6	0.5
CA_n3-n8-n39	0.5	0.3	0.5
CA_n3-n8-n40	0.5	0.3	0.5
CA_n3-n8-n41	0.5	0.3	$0.3^1 / 0.8^2$
CA_n3-n8-n77	0.6	0.6	0.8
CA_n3-n8-n78	0.6	0.6	0.8
CA_n3-n8-n79	0.3	0.3	0.5
CA_n3-n18-n28	0.3	0.5	0.3
CA_n3-n18-n41	0.5	0.3	$0.3^1 / 0.8^2$
CA_n3-n18-n77	0.6	0.3	0.8
CA_n3-n20-n28	0.3	0.5	0.5
CA_n3-n20-n67	0.3	0.5	N/A
CA_n3-n20-n78	0.5	0.3	0.8
CA_n3-n26-n78	0.6	0.6	0.8
CA_n3-n28-n38	0.5	0.5	0.3
CA_n3-n28-n40	0.5	0.3	0.5
CA_n3-n28-n41	0.5	0.3	$0.3^1 / 0.8^2$
CA_n3-n28-n77	0.6	0.5	0.8
CA_n3-n28-n78	0.5	0.3	0.8
CA_n3-n28-n79	0.3	0.5	0.8
CA_n3-n38-n40	0.5	$0.5^{1.3}$	0.5
CA_n3-n39-n41	0.5	0.5	$0.5^4 / 1.0^5$
CA_n3-n39-n79	0.5	0.5	0.8
CA_n3-n40-n78	0.6	0.5	0.8
CA_n3-n40-n105	0.5	0.5	0.6
CA_n3-n67-n78	0.5	N/A	0.8
CA_n3-n75-n78	0.6	N/A	0.8
CA_n3-n77-n79	0.6	0.8	-
CA_n3-n78-n79	0.6	0.8	0.8
CA_n3-n78-n105	0.6	0.8	0.6
CA_n3-n40-n41	0.5	0.5	$0.5^1 / 0.8^{23}$
CA_n3-n40-n77	0.6	0.5	0.8
CA_n3-n41-n77	0.6	$0.3^1 / 0.8^2$	0.8
CA_n3-n41-n78	0.6	$0.3^1 / 0.8^2$	0.8
CA_n3-n41-n79	0.3	$0.3^1 / 0.8^2$	0.8

CA_n5-n7-n25	0.3	0.5	0.5
CA_n5-n7-n28	0.5	0.3	0.6
CA_n5-n7-n40	0.3	0.5	0.6
CA_n5-n7-n66	0.3	0.5	0.5
CA_n5-n7-n77	0.6	0.6	0.8
CA_n5-n7-n78	0.6	0.6	0.8
CA_n5-n7-n105	0.5	0.3	0.6
CA_n5-n12-n77	0.8	0.4	0.5
CA_n5-n14-n77	0.5	0.3	0.8
CA_n5-n25-n29	0.5	0.3	N/A
CA_n5-n25-n41	0.6	0.5	0.4 <sup>5</sup> / 0.9 <sup>6</sup>
CA_n5-n25-n66	0.3	0.5	0.5
CA_n5-n25-n77	0.6	0.6	0.8
CA_n5-n25-n78	0.6	0.6	0.8
CA_n5-n28-n105	0.7	1.0	1.0
CA_n5-n28-n78	0.7	0.7	0.8
CA_n5-n28-n79	0.7	0.7	0.8
CA_n5-n29-n66	0.5	N/A	0.3
CA_n5-n29-n77	0.8	N/A	0.5
CA_n5-n30-n66	0.3	0.3	0.5
CA_n5-n30-n77	0.6	0.3	0.8
CA_n5-n40-n78	0.6	0.5	0.8
CA_n5-n40-n105	0.6	0.9	0.6
CA_n5-n41-n66	0.6	0.8 <sup>5</sup> / 1.3 <sup>6</sup>	0.5
CA_n5-n41-n77	0.6	0.3	0.8
CA_n5-n48-n66	0.3	0.8	0.6
CA_n5-n48-n77	0.6	0.8	0.8
CA_n5-n66-n77	0.6	0.6	0.8
CA_n5-n66-n78	0.6	0.6	0.8
CA_n5-n78-n79	0.5	0.8 / 1.5 <sup>7</sup>	0.5 / 1.5 <sup>7</sup>
CA_n5-n78-n105	0.7	0.8	0.7
CA_n7-n8-n28	0.3	0.6	0.5
CA_n7-n8-n40	0.5	0.6	0.6
CA_n7-n8-n78	0.5	0.6	0.8
CA_n7-n12-n25	0.5	0.3	0.5
CA_n7-n12-n66	0.5	0.3	0.5
CA_n7-n12-n71	0.3	1	1
CA_n7-n12-n77	0.5	0.5	0.8
CA_n7-n20-n67	0.3	0.3	N/A
CA_n7-n20-n78	0.3	0.3	0.8
CA_n7-n25-n66	0.5	0.5	0.5
CA_n7-n25-n71	0.5	0.5	0.3
CA_n7-n25-n77	0.5	0.6	0.8
CA_n7-n25-n78	0.5	0.6	0.8
CA_n7-n26-n78	0.6	0.6	0.8
CA_n7-n28-n38	N/A	0.3	N/A
CA_n7-n28-n40	0.5	0.3	0.6
CA_n7-n28-n78	0.3	0.3	0.8
CA_n7-n40-n105	0.5	0.6	0.6
CA_n7-n46-n78	0.5	-	0.8
CA_n7-n66-n71	0.5	0.5	0.5
CA_n7-n66-n77	0.5	0.6	0.8
CA_n7-n66-n78	0.5	0.6	0.8
CA_n7-n67-n78	0.5	N/A	0.8
CA_n7-n71-n77	0.3	0.5	0.8
CA_n7-n75-n78	0.7	N/A	0.8
CA_n7-n78-n102	0.5	1.5	1.5
CA_n7-n78-n105	0.3	0.8	0.5
CA_n8-n20-n28	0.8	0.7	0.7



CA_n8-n20-n75	0.4	0.4	N/A
CA_n8-n28-n40	0.6	0.5	0.3
CA_n8-n28-n75	0.6	0.5	N/A
CA_n8-n28-n77	0.6	0.5	0.8
CA_n8-n28-n78	0.6	0.5	0.8
CA_n8-n38-n40	0.3	0.3	0.3
CA_n8-n39-n40	0.3	0.3	0.3
CA_n8-n39-n41	0.6	0.5	0.5
CA_n8-n39-n79	0.3	0.3	-
CA_n8-n40-n41	0.3	0.3	0.3
CA_n8-n40-n77	0.6	0.3	0.8
CA_n8-n40-n78	0.6	0.3	0.8
CA_n8-n40-n79	0.3	0.3	0.8
CA_n8-n41-n79	0.6	0.3	0.8
CA_n8-n78-n79	0.6	0.8	0.8
CA_n12-n25-n41	0.3	0.5	$0.4^5 / 0.9^6$
CA_n12-n25-n66	0.8	0.5	0.5
CA_n12-n30-n66	0.8	0.3	0.5
CA_n12-n30-n77	0.5	0.3	0.5
CA_n12-n41-n66	0.5	0.5	0.5
CA_n12-n41-n77	0.5	0.5	0.8
CA_n12-n66-n77	0.8	0.6	0.8
CA_n12-n71-n77	1	1	0.8
CA_n13-n25-n66	0.3	0.5	0.5
CA_n13-n25-n77	0.3	0.6	0.8
CA_n13-n66-n77	0.5	0.6	0.8
CA_n14-n30-n66	0.3	0.3	0.5
CA_n14-n30-n77	0.5	0.3	0.8
CA_n14-n66-n77	0.6	0.6	0.8
CA_n18-n28-n41	0.4	0.4	0.3
CA_n18-n28-n77	0.5	0.5	0.8
CA_n18-n41-n77	0.3	0.3	0.8
CA_n20-n28-n75	0.5	0.5	N/A
CA_n20-n28-n78	0.6	0.5	0.8
CA_n20-n67-n78	0.6	N/A	0.8
CA_n24-n41-n48	0.6	$0.4^1 / 0.9^2$	0.8
CA_n24-n41-n77	0.6	$0.4^5 / 0.9^6$	0.8
CA_n24-n48-n77	0.6	0.8	0.8
CA_n25-n29-n66	0.5	N/A	0.5
CA_n25-n38-n78	0.5	0.4	0.8
CA_n25-n41-n66	0.5	$0.8^5 / 1.3^6$	0.5
CA_n25-n41-n71	0.5	0.5	0.6
CA_n25-n41-n77	0.5	0.5	0.6
CA_n25-n41-n78	0.6	0.5	0.8
CA_n25-n41-n85	0.5	0.5	0.3
CA_n25-n48-n66	0.6	0.8	0.6
CA_n25-n66-n71	0.5	0.5	0.6
CA_n25-n66-n77	0.6	0.6	0.8
CA_n25-n66-n78	0.6	0.6	0.8
CA_n25-n66-n85	0.5	0.5	0.8
CA_n25-n71-n77	0.6	0.6	0.8
CA_n25-n71-n78	0.6	0.6	0.8
CA_n25-n71-n85	0.3	1	1
CA_n25-n77-n85	0.6	0.8	0.3
CA_n26-n29-n66	0.5	N/A	0.3
CA_n26-n29-n70	0.5	N/A	0.3
CA_n26-n48-n66	0.3	0.8	0.6
CA_n26-n48-n70	0.3	0.8	0.6
CA_n26-n66-n70	0.3	0.5	0.5

CA_n26-n66-n71	0.5	0.3	0.5
CA_n26-n66-n77	0.6	0.6	0.8
CA_n26-n70-n71	0.5	0.3	0.6
CA_n26-n70-n77	0.6	0.6	0.8
CA_n28-n38-n78	0.5	0.3	0.8
CA_n28-n39-n40	0.3	0.3	0.3
CA_n28-n39-n41	0.3	0.5	0.5
CA_n28-n39-n79	0.5	0.3	0.8
CA_n28-n40-n41	0.3	0.5	0.5
CA_n28-n40-n77	0.5	0.3	0.8
CA_n28-n40-n78	0.5	0.3	0.8
CA_n28-n40-n79	0.5	0.3	0.8
CA_n28-n41-n79	0.5	0.3	0.8
CA_n28-n41-n77	0.5	0.3	0.8
CA_n28-n41-n78	0.5	0.3	0.8
CA_n28-n46-n78	0.5	-	0.8
CA_n28-n75-n78	0.3	N/A	0.8
CA_n28-n77-n79	0.5	0.8	0.5
CA_n28-n78-n79	0.5	0.8 / 1.5 <sup>7</sup>	0.5 / 1.5 <sup>7</sup>
CA_n28-n78-n102	0.5	1.5	1.5
CA_n29-n30-n66	N/A	0.3	0.5
CA_n29-n30-n77	N/A	0.3	0.5
CA_n29-n66-n70	N/A	0.5	0.5
CA_n29-n66-n71	N/A	0.3	0.5
CA_n29-n66-n77	N/A	0.6	0.8
CA_n29-n70-n71	N/A	0.3	0.6
CA_n30-n66-n77	0.3	0.6	0.8
CA_n34-n39-n41	0.3	0.5	0.5
CA_n34-n40-n41	0.3	0.5	0.5
CA_n34-n41-n79	0.3	0.5	0.8
CA_n38-n66-n78	0.5	0.5	0.8
CA_n39-n40-n41	0.3	0.3 / 0.6 <sup>10</sup>	0.3 / 0.6 <sup>10</sup>
CA_n39-n40-n79	0.3	-	0.8
CA_n39-n41-n79	0.3	0.3	0.8
CA_n40-n41-n79	0.5	0.5	0.8
CA_n40-n78-n105	0.3	0.8	0.5
CA_n41-n66-n71	0.8 / 1.3 <sup>6</sup>	0.5	0.3
CA_n41-n66-n77	0.5	0.6	0.8
CA_n41-n66-n78	0.5	0.6	0.8
CA_n41-n66-n85	0.8 <sup>1</sup> / 1.3 <sup>2</sup>	0.5	0.6
CA_n41-n70-n78	0.6	0.6	0.8
CA_n41-n71-n77	0.3	0.5	0.8
CA_n41-n71-n78	0.3	0.5	0.8
CA_n41-n71-n85	0.3	1	1
CA_n41-n77-n79	0.3	0.8	0.8
CA_n41-n77-n85	0.6	0.8	0.8
CA_n46-n48-n96	0.5	0.8	0.6
CA_n46-n78-n102	-	1.5	1.5
CA_n48-n66-n70	0.8	0.6	0.6
CA_n48-n66-n71	0.5	0.5	0.3
CA_n48-n66-n77	0.8	0.6	0.8
CA_n48-n70-n71	0.5	0.5	0.3
CA_n48-n70-n77	0.8	0.6	0.8
CA_n48-n71-n77	0.8	0.6	0.8
CA_n66-n70-n71	0.5	0.5	0.6
CA_n66-n70-n77	0.6	0.6	0.8
CA_n66-n71-n77	0.6	0.6	0.8
CA_n66-n71-n78	0.6	0.5	0.8
CA_n66-n71-n85	0.8	1	1

CA_n66-n77-n85	0.6	0.8	0.8
CA_n70-n71-n77	0.6	0.3	0.8

NOTE 1: The requirement is applied for UE transmitting on the frequency range of 2515-2690 MHz.  
 NOTE 2: The requirement is applied for UE transmitting on the frequency range of 2496-2515 MHz.  
 NOTE 3: Void.  
 NOTE 4: Void.  
 NOTE 5: The requirement is applied for UE transmitting on the frequency range of 2545 - 2690 MHz.  
 NOTE 6: The requirement is applied for UE transmitting on the frequency range of 2496 - 2545 MHz.  
 NOTE 7: The requirements only apply for UE supporting inter-band carrier aggregation with simultaneous Rx/Tx capability, and NR UL carrier frequencies are confined to 3700 MHz-3800MHz for n78 and 4400 MHz-4500MHz for n79. Simultaneous Rx/Tx capability does not apply for UEs supporting band n78 with a n77 implementation.  
 NOTE 8: “-” denotes  $\Delta T_{IB,c} = 0$ .  
 NOTE 9: The component band order in the configuration should be listed by the order of NR bands, such as for CA\_n1-n3-n5 the band order from left to right is n1, n3 and n5.  
 NOTE 10: The requirements only apply for UE supporting inter-band carrier aggregation with simultaneous Rx/Tx capability.

6.2A.4.2.5  $\Delta T_{IB,c}$  for Inter-band CA (four bands)

Table 6.2A.4.2.5-1:  $\Delta T_{IB,c}$  due to NR CA (four bands)

Inter-band CA combination	$\Delta T_{IB,c}$ for NR bands (dB) <sup>5</sup>			
	Component band in order of bands in configuration <sup>6</sup>			
CA_n1-n3-n5-n7	0.6	0.6	0.3	-
CA_n1-n3-n5-n28	0.3	0.3	0.7	0.7
CA_n1-n3-n5-n78	0.6	0.6	0.3	0.8
CA_n1-n3-n7-n8	0.6	0.6	0.6	0.6
CA_n1-n3-n7-n26	0.6	0.6	0.6	0.6
CA_n1-n3-n7-n28	0.6	0.6	0.6	0.6
CA_n1-n3-n7-n38	0.6	0.6	N/A	N/A
CA_n1-n3-n7-n40	0.6	0.6	0.6	0.6
CA_n1-n3-n7-n67	0.6	0.6	0.6	N/A
CA_n1-n3-n7-n75	0.6	0.6	0.6	N/A
CA_n1-n3-n7-n78	0.7	0.7	0.7	0.8
CA_n1-n3-n7-n79	0.6	0.6	0.6	0.8
CA_n1-n3-n7-n105	0.6	0.6	0.6	0.6
CA_n1-n3-n8-n78	0.6	0.6	0.6	0.8
CA_n1-n3-n8-n77	0.6	0.6	0.6	0.8
CA_n1-n3-n18-n28	0.3	0.3	0.5	0.5
CA_n1-n3-n18-n41	0.5	0.5	0.3	0.3 <sup>3</sup> / 0.8 <sup>4</sup>
CA_n1-n3-n18-n77	0.6	0.6	0.3	0.8
CA_n1-n3-n20-n67	0.3	0.3	0.3	N/A
CA_n1-n3-n26-n78	0.6	0.6	0.6	0.8
CA_n1-n3-n28-n38	0.6	0.6	0.6	0.6
CA_n1-n3-n28-n41	0.5	0.5	0.5	0.3 <sup>3</sup> / 0.8 <sup>4</sup>
CA_n1-n3-n28-n77	0.6	0.6	0.6	0.8
CA_n1-n3-n28-n78	0.6	0.6	0.6	0.8
CA_n1-n3-n28-n79	0.3	0.3	0.6	0.8
CA_n1-n3-n40-n77	0.7	0.7	0.7	0.8
CA_n1-n3-n40-n78	0.6	0.6	0.6	0.8
CA_n1-n3-n40-n105	0.7	0.7	0.7	0.5
CA_n1-n3-n41-n77	0.6	0.6	0.3 <sup>3</sup> / 0.8 <sup>4</sup>	0.8
CA_n1-n3-n41-n79	0.5	0.5	0.5 <sup>3</sup> / 0.8 <sup>4</sup>	0.8
CA_n1-n3-n67-n78	0.6	0.6	N/A	0.8
CA_n1-n3-n75-n78	0.6	0.6	N/A	0.8

CA_n1-n3-n77-n79	0.6	0.6	0.8	0.8
CA_n1-n5-n7-n40	0.5	0.3	0.6	0.5
CA_n1-n5-n7-n78	0.6	0.6	0.6	0.8
CA_n1-n5-n7-n105	0.5	0.3	0.6	0.6
CA_n1-n5-n28-n78	0.3	0.7	0.7	0.8
CA_n1-n5-n28-n79	0.3	0.7	0.7	0.8
CA_n1-n5-n40-n78	0.6	0.6	0.5	0.8
CA_n1-n5-n40-n105	0.5	0.3	0.5	0.6
CA_n1-n5-n78-n79	0.6	0.6	0.8	0.5
CA_n1-n5-n78-n105	0.3	0.6	0.8	0.6
CA_n1-n7-n8-n40	0.6	0.8	0.6	0.9
CA_n1-n7-n8-n78	0.6	0.6	0.6	0.8
CA_n1-n7-n26-n78	0.6	0.6	0.6	0.8
CA_n1-n7-n28-n38	0.5	N/A	0.6	N/A
CA_n1-n7-n28-n78	0.6	0.6	0.6	0.8
CA_n1-n7-n40-n78	0.6	0.5	0.5	0.8
CA_n1-n7-n40-n105	0.6	0.5	0.5	0.5
CA_n1-n7-n67-n78	0.6	0.6	N/A	0.8
CA_n1-n7-n75-n78	0.6	0.6	N/A	0.8
CA_n1-n7-n78-n105	0.6	0.6	0.8	0.5
CA_n1-n8-n40-n78	0.5	0.3	0.5	0.8
CA_n1-n8-n78-n79	0.3	0.6	0.8	0.5
CA_n1-n18-n28-n41	0.6	0.5	0.6	0.5
CA_n1-n18-n28-n77	0.6	0.5	0.6	0.8
CA_n1-n18-n41-n77	0.5	0.5	0.5	0.8
CA_n1-n28-n38-n78	0.6	0.6	0.6	0.8
CA_n1-n28-n40-n77	0.3	0.6	0.5	0.8
CA_n1-n28-n40-n78	0.3	0.6	0.5	0.8
CA_n1-n28-n41-n77	0.6	0.6	0.6	0.8
CA_n1-n28-n41-n79	0.5	0.6	0.6	0.8
CA_n1-n28-n75-n78	0.5	0.6	N/A	0.8
CA_n1-n28-n77-n79	0.6	0.6	0.8	0.8
CA_n1-n28-n78-n79	0.6	0.6	0.8	0.8
CA_n1-n41-n77-n79	0.6	0.5	0.8	0.8
CA_n2-n5-n30-n66	0.5	0.3	0.3	0.5
CA_n2-n5-n30-n77	0.6	0.6	0.3	0.8
CA_n2-n5-n48-n66	0.6	0.3	0.8	0.6
CA_n2-n5-n48-n77	0.6	0.3	0.8	0.8
CA_n2-n5-n66-n77	0.5	0.3	0.5	0.8
CA_n2-n12-n30-n66	0.5	0.8	0.3	0.5
CA_n2-n12-n30-n77	0.6	0.5	0.3	0.8
CA_n2-n12-n66-n77	0.6	0.8	0.6	0.8
CA_n2-n14-n30-n66	0.5	0.3	0.3	0.5
CA_n2-n14-n30-n77	0.6	0.5	0.3	0.8
CA_n2-n14-n66-n77	0.6	0.6	0.6	0.8
CA_n2-n29-n30-n66	0.5	N/A	0.3	0.5
CA_n2-n29-n30-n77	0.6	N/A	0.3	0.8
CA_n2-n29-n66-n77	0.6	N/A	0.6	0.8
CA_n2-n30-n66-n77	0.6	0.3	0.6	0.8
CA_n2-n41-n66-n71	0.5	$0.8^3 / 1.3^4$	0.5	0.6
CA_n2-n48-n66-n77	0.6	0.8	0.6	0.8
CA_n2-n66-n71-n77	0.5	0.5	0.3	0.5
CA_n2-n66-n71-n78	0.5	0.5	0.3	0.5
CA_n3-n5-n7-n78	0.6	0.6	0.6	0.8
CA_n3-n5-n28-n78	0.6	0.7	0.7	0.8
CA_n3-n5-n28-n79	0.6	0.7	0.7	0.8
CA_n3-n7-n8-n78	0.6	0.6	0.6	0.8
CA_n3-n7-n20-n67	0.5	0.5	0.3	N/A
CA_n3-n7-n20-n78	0.6	0.6	0.6	0.8

CA_n3-n7-n26-n78	0.6	0.6	0.6	0.6
CA_n3-n7-n28-n38	0.5	N/A	0.3	N/A
CA_n3-n7-n28-n78	0.6	0.6	0.6	0.6
CA_n3-n7-n40-n78	0.6	0.6	0.6	0.8
CA_n3-n7-n40-n105	0.6	0.6	0.6	0.5
CA_n3-n7-n67-n78	0.6	0.6	N/A	0.6
CA_n3-n7-n75-n78	0.6	0.6	N/A	0.6
CA_n3-n7-n78-n105	0.6	0.6	0.8	0.5
CA_n3-n8-n41-n79	0.5	0.5	$0.3^1 / 0.8^2$	0.8
CA_n3-n18-n28-n41	0.5	0.4	0.4	$0.3^3 / 0.8^4$
CA_n3-n18-n28-n77	0.6	0.5	0.5	0.8
CA_n3-n18-n41-n77	0.6	0.4	$0.3^3 / 0.8^4$	0.8
CA_n3-n20-n67-n78	0.5	0.5	N/A	0.8
CA_n3-n28-n40-n77	0.6	0.6	0.6	0.8
CA_n3-n28-n41-n77	1	0.5	$0.3^1 / 0.8^2$	0.8
CA_n3-n28-n41-n78	1	0.5	$0.3^1 / 0.8^2$	0.8
CA_n3-n28-n41-n79	0.5	0.5	$0.3^1 / 0.8^2$	0.8
CA_n3-n28-n77-n79	0.6	0.5	0.8	0.8
CA_n3-n41-n77-n79	0.6	$0.3^1 / 0.8^2$	0.8	0.8
CA_n5-n7-n40-n78	0.6	0.6	0.5	0.8
CA_n5-n7-n40-n105	0.3	0.3	0.6	0.6
CA_n5-n7-n66-n77	0.6	0.6	0.6	0.8
CA_n5-n7-n78-n105	0.6	0.3	0.8	0.5
CA_n5-n25-n29-n66	0.5	0.5	N/A	0.5
CA_n5-n25-n66-n77	0.6	0.6	0.6	0.8
CA_n5-n25-n66-n78	0.6	0.6	0.6	0.8
CA_n5-n28-n78-n79	0.7	0.7	0.8	0.8
CA_n5-n30-n66-n77	0.6	0.3	0.6	0.8
CA_n5-n40-n78-n105	0.6	0.3	0.8	0.5
CA_n5-n48-n66-n77	0.6	0.8	0.6	0.8
CA_n7-n8-n40-n78	0.5	0.3	0.5	0.8
CA_n7-n12-n25-n66	0.5	0.3	0.5	0.5
CA_n7-n20-n67-n78	0.6	0.6	N/A	0.8
CA_n7-n25-n66-n71	0.5	0.5	0.5	0.6
CA_n7-n25-n66-n77	0.5	0.6	0.6	0.8
CA_n7-n25-n66-n78	0.5	0.6	0.6	0.8
CA_n7-n40-n78-n105	0.5	0.6	0.8	0.5
CA_n7-n66-n71-n77	0.5	0.6	0.6	0.8
CA_n8-n20-n28-n75	0.8	0.7	0.7	N/A
CA_n8-n39-n41-n79	0.5	0.5	$0.3^1 / 0.8^2$	0.8
CA_n12-n30-n66-n77	0.8	0.3	0.6	0.8
CA_n13-n25-n66-n77	0.5	0.6	0.6	0.8
CA_n14-n30-n66-n77	0.6	0.3	0.6	0.8
CA_n18-n28-n41-n77	0.5	0.5	$0.3^3 / 0.8^4$	0.8
CA_n25-n38-n66-n78	0.6	0.6	0.6	0.8
CA_n25-n41-n66-n71	0.5	0.5	0.5	0.3
CA_n25-n41-n66-n77	0.5	$0.8^3 / 1.3^4$	0.5	0.8
CA_n25-n41-n66-n78	0.5	$0.8^3 / 1.3^4$	0.5	0.8
CA_n25-n41-n66-n85	0.5	0.5	0.5	0.3
CA_n25-n41-n71-n77	0.5	0.5	0.6	0.8
CA_n25-n41-n71-n78	0.5	0.5	0.6	0.8
CA_n25-n41-n71-n85	0.5	0.5	0.5	0.5
CA_n25-n41-n77-n85	0.5	0.5	0.8	0.6
CA_n25-n66-n71-n77	0.5	0.5	0.6	0.8
CA_n25-n66-n71-n78	0.6	0.6	0.6	0.8
CA_n25-n66-n71-n85	0.5	0.5	1	1
CA_n25-n66-n77-n85	0.6	0.6	0.8	0.8
CA_n28-n41-n77-n79	0.5	0.3	0.8	0.8
CA_n29-n30-n66-n77	N/A	0.3	0.6	0.8

CA_n29-n66-n70-n71	N/A	0.5	0.5	0.6
CA_n41-n66-n70-n78	0.5	0.6	0.6	0.8
CA_n41-n66-n71-n77	$0.3^3 / 0.8^4$	1	0.5	0.8
CA_n41-n66-n71-n78	$0.3^3 / 0.8^4$	1	0.5	0.8
CA_n41-n66-n71-n85	0.5	0.5	0.5	0.5
CA_n41-n66-n77-n85	$0.3^3 / 0.8^4$	1	0.8	0.5
CA_n48-n66-n70-n77	0.8	0.6	0.6	0.8

NOTE 1: Applicable for the frequency range of 2515-2690 MHz.  
 NOTE 2: Applicable for the frequency range of 2496-2515 MHz.  
 NOTE 3: The requirement is applied for UE transmitting on the frequency range of 2545 - 2690 MHz.  
 NOTE 4: The requirement is applied for UE transmitting on the frequency range of 2496 - 2545 MHz.  
 NOTE 5: "-" denotes  $\Delta T_{IB,c} = 0$ .  
 NOTE 6: The component band order in the configuration should be listed by the order of NR bands, such as for CA\_n1-n3-n5-n78 the band order from left to right is n1, n3, n5 and n78.

6.2A.4.2.6  $\Delta T_{IB,c}$  for Inter-band CA (five bands)

Table 6.2A.4.2.6-1:  $\Delta T_{IB,c}$  due to NR CA (five bands)

Inter-band CA combination	$\Delta T_{IB,c}$ for NR bands (dB) <sup>1</sup>				
	Component band in order of bands in configuration <sup>2</sup>				
CA_n1-n3-n5-n7-n78	0.6	0.6	0.6	0.6	0.8
CA_n1-n3-n5-n28-n78	0.6	0.6	0.7	0.7	0.8
CA_n1-n3-n7-n8-n78	0.7	0.7	0.7	0.6	0.8
CA_n1-n3-n7-n26-n78	0.7	0.7	0.7	0.6	0.8
CA_n1-n3-n7-n28-n38	0.6	0.6	N/A	0.6	N/A
CA_n1-n3-n7-n28-n78	0.7	0.7	0.7	0.6	0.8
CA_n1-n3-n7-n40-n78	0.6	0.6	0.6	0.6	0.8
CA_n1-n3-n7-n40-n105	0.6	0.6	0.6	0.6	0.6
CA_n1-n3-n7-n67-n78	0.7	0.7	0.7	N/A	0.8
CA_n1-n3-n7-n75-n78	0.6	0.6	0.6	N/A	0.8
CA_n1-n3-n28-n41-n77	0.6	1	0.6	$0.6^3/0.8^4$	0.8
CA_n1-n3-n28-n41-n79	0.5	0.5	0.6	$0.6^3/0.8^4$	0.8
CA_n1-n3-n28-n77-n79	0.6	0.6	0.6	0.8	0.8
CA_n1-n3-n40-n78-n105	0.6	0.6	0.6	0.8	0.6
CA_n1-n3-n41-n77-n79	0.6	0.6	$0.5^3/0.8^4$	0.8	0.8
CA_n1-n5-n7-n40-n78	0.5	0.6	0.6	0.5	0.8
CA_n1-n5-n7-n40-n105	0.5	0.3	0.6	0.5	0.6
CA_n1-n5-n7-n78-n105	0.5	0.6	0.6	0.8	0.6
CA_n1-n5-n28-n78-n79	0.6	0.7	0.7	0.8	0.8
CA_n1-n5-n40-n78-n105	0.5	0.6	0.5	0.8	0.6
CA_n1-n7-n40-n78-n105	0.6	0.6	0.6	0.8	0.6
CA_n1-n28-n41-n77-n79	0.6	0.6	0.6	0.8	0.8
CA_n2-n5-n30-n66-n77	0.6	0.6	0.3	0.6	0.8
CA_n2-n5-n48-n66-n77	0.6	0.3	0.8	0.6	0.8
CA_n2-n12-n30-n66-n77	0.6	0.8	0.3	0.6	0.8
CA_n2-n14-n30-n66-n77	0.6	0.6	0.3	0.6	0.8
CA_n2-n29-n30-n66-n77	0.6	N/A	0.3	0.6	0.8
CA_n3-n7-n20-n67-n78	0.6	0.6	0.6	N/A	0.8
CA_n3-n7-n40-n78-n105	0.6	0.8	0.6	0.8	0.6
CA_n3-n28-n41-n77-n79	1	0.5	0.8	0.8	0.8
CA_n5-n7-n40-n78-n105	0.6	0.6	0.5	0.8	0.6

NOTE 1: "-" denotes  $\Delta T_{IB,c} = 0$ .  
 NOTE 2: The component band order in the configuration should be listed by the order of NR bands, such as for CA\_n1-n3-n5-n7-n78 the band order from left to right is n1, n3, n5, n7 and n78.  
 NOTE 3: The requirement is applied for UE transmitting on the frequency range of 2545 - 2690 MHz

NOTE 4: The requirement is applied for UE transmitting on the frequency range of 2496 - 2545 MHz

### 6.2A.4.2.7 $\Delta T_{IB,c}$ for Inter-band CA (six bands)

**Table 6.2A.4.2.7-1:  $\Delta T_{IB,c}$  due to NR CA (six bands)**

Inter-band CA combination	$\Delta T_{IB,c}$ for NR bands (dB) <sup>1</sup>					
	Component band in order of bands in configuration <sup>2</sup>					
CA_n1-n3-n7-n28-n38-n78	0.7	0.7	N/A	0.6	N/A	0.8
CA_n1-n3-n7-n40-n78-n105	0.6	0.6	0.6	0.6	0.8	0.6
CA_n1-n5-n7-n40-n78-n105	0.5	0.6	0.6	0.5	0.8	0.6

NOTE 1: “-” denotes  $\Delta T_{IB,c} = 0$ .  
NOTE 2: The component band order in the configuration should be listed by the order of NR bands, such as for CA\_n1-n3-n5-n7-n78 the band order from left to right is n1, n3, n5, n7 and n78.

## 6.2B Transmitter power for NR-DC

### 6.2B.0 General

The requirements apply for inter-band NR-DC with one uplink serving cell configured per CG.

### 6.2B.1 UE maximum output power for NR-DC

For inter-band NR-DC with one uplink carrier assigned per NR band, the transmitter power requirements in clause 6.2 apply per band.

For inter-band NR-DC with one uplink assigned per band, the UE maximum output power shall be measured over all component carriers from different bands. If each band has separate antenna connectors, the maximum output power is defined as the sum of maximum output power from each UE antenna connector. The period of measurement shall be at least one sub frame (1 ms). The maximum output power is specified in Table 6.2B.1.3-1.

**Table 6.2B.1.3-1 UE Power Class for inter-band NR-DC**

Uplink CA Configuration	Class 1 (dBm)	Tolerance (dB)	Class 2 (dBm)	Tolerance (dB)	Class 3 (dBm)	Tolerance (dB)	Class 5 (dBm)	Tolerance (dB)
DC_n1A-n3A					23	+2/-3		
DC_n1A-n7A					23	+2/-3		
DC_n1A-n20A					23	+2/-3		
DC_n1A-n28A					23	+2/-3		
DC_n1A-n41A					23	+2/-3		
DC_n1A-n46A					23	+2/-3		
DC_n1A-n77A					23	+2/-3		
DC_n1A-n78A					23	+2/-3		
DC_n1A-n79A					23	+2/-3		
DC_n1A-n102A					23	+2/-3		
DC_n1A-n102B					23	+2/-3		
DC_n1A-n102C					23	+2/-3		
DC_n2A-n5A					23	+2/-3		
DC_n2A-n48A					23	+2/-3		

DC_n2A-n66A					23	+2/-3		
DC_n2A-n77A					23	+2/-3		
DC_n3A-n7A					23	+2/-3		
DC_n3A-n20A					23	+2/-3		
DC_n3A-n28A					23	+2/-3		
DC_n3A-n41A					23	+2/-3		
DC_n3A-n77A					23	+2/-3		
DC_n3A-n78A					23	+2/-3		
DC_n3A-n79A					23	+2/-3		
DC_n3A-n102A					23	+2/-3		
DC_n5A-n13A					23	+2/-3		
DC_n5A-n48A					23	+2/-3		
DC_n5A-n66A					23	+2/-3		
DC_n5A-n77A					23	+2/-3		
DC_n7A-n20A					23	+2/-3		
DC_n7A-n28A					23	+2/-3		
DC_n7A-n46A					23	+2/-3		
DC_n7A-n78A					23	+2/-3		
DC_n7A-n102A					23	+2/-3		
DC_n7A-n102B					23	+2/-3		
DC_n7A-n102C					23	+2/-3		
DC_n8A-n78A					23	+2/-3		
DC_n12A-n77A					23	+2/-3		
DC_n13A-n66A					23	+2/-3		
DC_n13A-n77A					23	+2/-3		
DC_n20A-n78A					23	+2/-3		
DC_n25A-n41A					23	+2/-3		
DC_n25A-n66A					23	+2/-3		
DC_n25A-n71A					23	+2/-3		
DC_n25A-n77A					23	+2/-3		
DC_n28A-n41A					23	+2/-3		
DC_n28A-n46A					23	+2/-3		
DC_n28A-n77A					23	+2/-3		
DC_n28A-n78A					23	+2/-3		
DC_n28A-n79A					23	+2/-3		
DC_n28A-n102A					23	+2/-3		
DC_n28A-n102B					23	+2/-3		
DC_n28A-n102C					23	+2/-3		
DC_n41A-n66A					23	+2/-3		
DC_n41A-n71A					23	+2/-3		
DC_n41A-n77A					23	+2/-3		
DC_n41A-n78A					23	+2/-3		
DC_n41A-n79A					23	+2/-3		
DC_n46A-n48A					23	+2/-3		
DC_n46A-n48B					23	+2/-3		
DC_n46A-n77A					23	+2/-3		
DC_n46A-n78A					23	+2/-3		
DC_n48A-n66A					23	+2/-3		
DC_n48A-n70A					23	+2/-3		
DC_n48A-n71A					23	+2/-3		
DC_n48A-n96A					23	+2/-3		
DC_n48B-n96A					23	+2/-3		
DC_n66A-n71A					23	+2/-3		
DC_n66A-n77A					23	+2/-3		
DC_n71A-n77A					23	+2/-3		
DC_n77A-n79A					23	+2/-3		
DC_n77A-n102A					23	+2/-3		
DC_n77A-n102B					23	+2/-3		
DC_n77A-n102C					23	+2/-3		



DC_n78A-n79A					23	+2/-3		
DC_n78A-n102A					23	+2/-3		
DC_n78A-n102B					23	+2/-3		
DC_n78A-n102C					23	+2/-3		
<p>NOTE 1: An uplink DC configuration in which at least one of the bands has NOTE 3 in Table 6.2.1-1 is allowed to reduce the lower tolerance limit by 1.5 dB when the transmission bandwidths of at least one of the bands is confined within <math>F_{UL\_low}</math> and <math>F_{UL\_low} + 4</math> MHz or <math>F_{UL\_high} - 4</math> MHz and <math>F_{UL\_high}</math>.</p> <p>NOTE 2: <math>P_{PowerClass}</math> is the maximum UE power specified without account of the tolerance</p> <p>NOTE 3: The maximum power requirement applies to the total transmitted power over both the MCG and SCG.</p> <p>NOTE 4: Power class 3 is the default power class unless otherwise stated.</p>								

## 6.2B.2 UE maximum output power reduction for NR-DC

For inter-band NR-DC with one uplink assigned per band, the requirements in clause 6.2.2 or 6.2F.2 when the uplink belongs to a spectrum sharing defined band apply for each uplink component carrier.

When inter-band NR-DC is configured with intra-band contiguous carrier aggregation in one of the cell groups or both, the requirements in clause 6.2A.2 apply for each cell group configured with uplink contiguous carrier aggregation.

## 6.2B.3 UE additional maximum output power reduction for NR-DC

For inter-band NR-DC with one uplink assigned per band, the requirements in clause 6.2.3 apply for each uplink component carrier.

For inter-band NR-DC with one uplink assigned per band, the requirements in clause 6.2.3 or 6.2F.3 when the uplink belongs to a spectrum sharing defined band apply for each uplink component carrier.

For inter-band NR-DC where the corresponding inter-band CA configuration is specified in Table 6.2A.3.1.3-1, the combined requirements and allowed A-MPR are applicable on both bands when both component carriers are active.

When inter-band NR-DC is configured with intra-band contiguous carrier aggregation in one of the cell groups or both, the requirements in clause 6.2A.3 or 6.2F.3A for shared spectrum defined bands, are applicable for each cell group configured with uplink contiguous carrier aggregation.

## 6.2B.4 Configured output power for NR-DC

### 6.2B.4.1 Configured transmitted power level for NR-DC

The UE is allowed to set its configured maximum output power  $P_{CMAX,f,c,MCG}$  and  $P_{CMAX,f,c,SCG}$  for the respective MCG and SCG and its total configured maximum output power for NR-DC operation  $P_{Total}^{NR-DC} = 10 \log_{10}(\hat{P}_{Total}^{NR-DC})$  with  $\hat{P}_{Total}^{NR-DC}$  as specified in clause 7.6.2 of [8]. The UE is configured with an inter-CG power sharing mode by *NR-DC-PC-mode*. The requirements apply for one uplink serving cell configured per CG and for asynchronous and synchronous NR-DC if not otherwise stated.

Unless otherwise stated, the configured maximum output power  $P_{CMAX,f,c,MCG}(q)$  in physical-channel  $q$  for carrier  $f$  of serving cell  $c$  shall be set within the bounds if contained in the MCG,

$$P_{CMAX\_L,f,c,MCG}(q) \leq P_{CMAX,f,c,MCG}(q) \leq P_{CMAX\_H,f,c,MCG}(q)$$

and the corresponding  $P_{CMAX\_L,f,c,SCG}(q)$  for a serving cell contained in the SCG,

$$P_{CMAX\_L,f,c,SCG}(q) \leq P_{CMAX,f,c,SCG}(q) \leq P_{CMAX\_H,f,c,SCG}(q)$$

where  $P_{\text{CMAX\_L,f,c,MCG}}$ ,  $P_{\text{CMAX\_H,f,c,MCG}}$ ,  $P_{\text{CMAX\_L,f,c,SCG}}$  and  $P_{\text{CMAX\_H,f,c,SCG}}$  are the limits for a serving cell  $c$  as specified in clause 6.2.4 modified as follows:

$$P_{\text{CMAX\_L,f,c,MCG}} = \text{MIN}\{\text{MIN}(P_{\text{EMAX,c}}, P_{\text{EMAX,NR-DC}}, P_{\text{NR}}) - \Delta T_{\text{C,c}}, (P_{\text{PowerClass,NR-DC}} - \Delta P_{\text{PowerClass,NR-DC}}) - \text{MAX}(\text{MAX}(\text{MPR}_c + \Delta \text{MPR}_c, \text{A-MPR}_c) + \Delta T_{\text{IB,c}} + \Delta T_{\text{C,c}} + \Delta T_{\text{RxsRS}}, \text{P-MPR}_c)\}$$

$$P_{\text{CMAX\_H,f,c,MCG}} = \text{MIN}\{P_{\text{EMAX,c}}, P_{\text{EMAX,NR-DC}}, P_{\text{NR}}, P_{\text{PowerClass,NR-DC}} - \Delta P_{\text{PowerClass,NR-DC}}\}$$

for the MCG and

$$P_{\text{CMAX\_L,f,c,SCG}} = \text{MIN}\{\text{MIN}(P_{\text{EMAX,c}}, P_{\text{EMAX,NR-DC}}, P_{\text{NR}}) - \Delta T_{\text{C,c}}, (P_{\text{PowerClass,NR-DC}} - \Delta P_{\text{PowerClass,NR-DC}}) - \text{MAX}(\text{MAX}(\text{MPR}_c + \Delta \text{MPR}_c, \text{A-MPR}_c) + \Delta T_{\text{IB,c}} + \Delta T_{\text{C,c}} + \Delta T_{\text{RxsRS}}, \text{P-MPR}_c)\}$$

$$P_{\text{CMAX\_H,f,c,SCG}} = \text{MIN}\{P_{\text{EMAX,c}}, P_{\text{EMAX,NR-DC}}, P_{\text{NR}}, P_{\text{PowerClass,NR-DC}} - \Delta P_{\text{PowerClass,NR-DC}}\}$$

for the SCG, where

- $P_{\text{EMAX,NR-DC}}$  is the value given by the field *p-UE-FRI* of the *PhysicalCellGroupConfig* IE for the MCG as defined in [7];
- $P_{\text{NR}}$  is the value given by the field *p-NR-FRI* of the *PhysicalCellGroupConfig* IE as defined in [7];
- $P_{\text{PowerClass,NR-DC}}$  is the maximum UE power specified in Table 6.2B.1.3-1 without taking into account the tolerance specified in the Table 6.2B.1.3-1;
- $\Delta T_{\text{IB,c}}$  is the additional tolerance for serving cell  $c$  as specified in clause 6.2B.4.2 for NR-DC;  $\Delta T_{\text{IB,c}} = 0$  dB otherwise;
- $\Delta T_{\text{C,c}} = 1.5$  dB when NOTE 2 in Table 6.2B.1.3-1 applies for a serving cell  $c$ , otherwise  $\Delta T_{\text{C,c}} = 0$  dB ;
- $\Delta \text{MPR}_c$  for serving cell  $c$  is specified in clause 6.2.2.
- $\Delta P_{\text{PowerClass,NR-DC}} = 0$  dB for a power class 3 UE.

When MSG or SCG are configured with intra-band contiguous carrier aggregation, then intra-band carrier aggregation  $P_{\text{CMAX\_CA,MCG}}(q)$  and/or  $P_{\text{CMAX\_CA,SCG}}(q)$  in physical-channel  $q$  shall be set within the bounds:

$$P_{\text{CMAX\_L,CA,MCG}}(q) \leq P_{\text{CMAX\_CA,MCG}}(q) \leq P_{\text{CMAX\_H,CA,MCG}}(q)$$

for MSG, and/or

$$P_{\text{CMAX\_L,CA,SCG}}(q) \leq P_{\text{CMAX\_CA,SCG}}(q) \leq P_{\text{CMAX\_H,CA,SCG}}(q)$$

for SCG, where  $P_{\text{CMAX\_L,CA,MCG}}$ ,  $P_{\text{CMAX\_H,CA,MCG}}$ ,  $P_{\text{CMAX\_CA,SCG}}$  and  $P_{\text{CMAX\_H,CA,SCG}}$  are the limits for a carrier aggregation uplink as specified in clause 6.2A.4.1.1 modified as follows:

$$P_{\text{CMAX\_L,CA,MCG}} = \text{MIN}\{10 \log_{10} \sum p_{\text{EMAX,c}} - \Delta T_{\text{C}}, P_{\text{EMAX,CA}}, P_{\text{EMAX,NR-DC}}, P_{\text{NR,MCG}}, (P_{\text{PowerClass,NR-DC}} - \Delta P_{\text{PowerClass,NR-DC}}) - \text{MAX}(\text{MAX}(\text{MPR}, \text{A-MPR}) + \Delta T_{\text{IB,c}} + \Delta T_{\text{C}} + \Delta T_{\text{RxsRS}}, \text{P-MPR}_c)\}$$

$$P_{\text{CMAX\_H,CA,MCG}} = \text{MIN}\{10 \log_{10} \sum p_{\text{EMAX,c}}, P_{\text{EMAX,CA}}, P_{\text{EMAX,NR-DC}}, P_{\text{NR,MCG}}, P_{\text{PowerClass,NR-DC}} - \Delta P_{\text{PowerClass,NR-DC}}\}$$

for the MCG, and

$$P_{\text{CMAX\_L,CA,SCG}} = \text{MIN}\{10 \log_{10} \sum p_{\text{EMAX,c}} - \Delta T_{\text{C}}, P_{\text{EMAX,CA}}, P_{\text{EMAX,NR-DC}}, P_{\text{NR,SCG}}, (P_{\text{PowerClass,NR-DC}} - \Delta P_{\text{PowerClass,NR-DC}}) - \text{MAX}(\text{MAX}(\text{MPR}, \text{A-MPR}) + \Delta T_{\text{IB,c}} + \Delta T_{\text{C}} + \Delta T_{\text{RxsRS}}, \text{P-MPR}_c)\}$$

$$P_{\text{CMAX\_H,CA,SCG}} = \text{MIN}\{10 \log_{10} \sum p_{\text{EMAX,c}}, P_{\text{EMAX,CA}}, P_{\text{EMAX,NR-DC}}, P_{\text{NR,SCG}}, P_{\text{PowerClass,NR-DC}} - \Delta P_{\text{PowerClass,NR-DC}}\}$$

for SCG.

For a UE provided with *NR-DC-PC-mode = Semi-static-model*,

$$P_{Total}^{NR-DC} = \text{MIN}\{P_{EMAX, NR-DC}, P_{PowerClass, NR-DC}\} + 0.3 \text{ dB}$$

with  $P_{PowerClass, NR-DC}$  set to power class 3 in case the UE indicates a higher power class in any CG. The UE determines the maximum transmission power for the MCG and the SCG using the respective configured maximum power  $P_{CMAX, f, c, MCG}$  and  $P_{CMAX, f, c, SCG}$ .

If for synchronous NR-DC operation a UE is provided *NR-DC-PC-mode = Semi-static-mode2*, the  $P_{Total}^{NR-DC}$  is determined as above and

- if at least one symbol of slot  $i_1$  of the MCG/SCG is indicated as uplink or flexible to a UE by *tdd-UL-DL-ConfigurationCommon* and *tdd-UL-DL-ConfigurationDedicated*, if provided, overlaps with a symbol for any ongoing transmission overlapping with slot  $i_2$  of the SCG/MCG, the UE determines a maximum power for the transmission on the SCG/MCG overlapping with slot  $i_2$  using the configured maximum power  $P_{CMAX, f, c, SCG}$  or  $P_{CMAX, f, c, MCG}$  for the SCG or MCG, respectively,
- otherwise (i.e. an ongoing transmission overlapping with slot  $i_2$  of the SCG/MCG overlaps with only semi-static downlink symbols within slot  $i_1$  of the MCG/SCG), the UE determines a maximum power for the transmission on MCG or the SCG overlapping with slot  $i_2$  using the configured maximum power as specified in clause 6.2.4.

If a UE indicates a capability for dynamic power sharing between the MCG and the SCG and is provided with *NR-DC-PC-mode = Dynamic*,

$$P_{Total}^{NR-DC} = \text{MIN}\{P_{EMAX, NR-DC}, P_{PowerClass, NR-DC}\}$$

with  $P_{PowerClass, NR-DC}$  set to power class 3 in case the UE indicates a higher power class in any CG. The UE determines the maximum transmission power for the MCG and the SCG using the respective configured maximum power  $P_{CMAX, f, c, MCG}$  and  $P_{CMAX, f, c, SCG}$  except

- if UE transmission(s) in slot  $i_1$  of the MCG or in slot  $i_2$  of the SCG do not overlap in time with any UE transmission(s) on the SCG or the MCG, respectively, the UE determines a maximum transmission power in slot  $i_1$  of the MCG or in slot  $i_2$  of the SCG using the configured maximum power as specified in clause 6.2.4.

If a UE indicates a capability to determine a total transmission power on the SCG at a first symbol of a transmission occasion on the SCG by determining transmissions on the MCG as specified in clause 7.6.2 of [8], and is provided with *NR-DC-PC-mode = Dynamic*,

$$P_{Total}^{NR-DC} = \text{MIN}\{P_{EMAX, NR-DC}, P_{PowerClass, NR-DC}\}$$

with  $P_{PowerClass, NR-DC}$  set to power class 3 in case the UE indicates a higher power class in any CG. The UE determines the maximum transmission power for the MCG and the SCG using the respective configured maximum power  $P_{CMAX, f, c, MCG}$  and  $P_{CMAX, f, c, SCG}$ .

The measured total maximum output power  $P_{UMAX}$  over both CGs measured over the transmission reference time duration is

$$P_{UMAX} = 10 \log_{10} (p_{UMAX, c, MCG} + p_{UMAX, c, SCG}),$$

where  $p_{UMAX, c, MCG}$  and  $p_{UMAX, c, SCG}$  denote the measured output power of serving cells  $c$  contained in the respective MCG and SCG expressed in linear scale.

The measured total configured maximum output power  $P_{UMAX}$  shall be within the following bounds:

$$P_{CMAX\_L} - T_{LOW}(P_{CMAX\_L}) \leq P_{UMAX} \leq P_{CMAX\_H} + T_{HIGH}(P_{CMAX\_H})$$

with the tolerances  $T_{LOW}(P_{CMAX\_H})$  and  $T_{HIGH}(P_{CMAX\_H})$  for applicable values of  $P_{CMAX}$  specified in Table 6.2B.4.1.3-2.

When a subframe  $p$  on the MSG overlap with a physical-channel  $q$  on the SCG, then for  $P_{UMAX}$  evaluation, the subframe  $p$  on the MCG is taken as reference period  $T_{REF}$  and always considered as the reference measurement duration and the following rules are applicable.

$T_{REF}$  and  $T_{eval}$  are specified in Table 6.2B.4.1.3-1 when same or different subframe and physical-channel durations are used on the carriers. The  $P_{PowerClass}$  shall not be exceeded by the UE during any evaluation period of time.

**Table 6.2B.4.1.3-1:  $P_{CMAX}$  evaluation window**

Transmission duration	$T_{REF}$	$T_{eval}$
Different transmission duration in different CG carriers	MCG subframe	$\text{MIN}(T_{no\_hopping}, \text{Physical Channel Length})$

For each  $T_{REF}$ , the  $P_{CMAX\_H}$  is evaluated per  $T_{eval}$  and given by the maximum value over the transmission(s) within the  $T_{eval}$  as follows:

$$P_{CMAX\_H} = \text{MAX}\{P_{CMAX\_NR-DC\_H}(p,q), P_{CMAX\_NR-DC\_H}(p,q+I), \dots, P_{CMAX\_NR-DC\_H}(p,q+n)\}$$

where  $P_{CMAX\_NR-DC\_H}$  entries are the applicable upper limits for each overlapping scheduling unit pairs  $(p,q)$ ,  $(p,q+I)$ , up to  $(p,q+n)$  for each applicable  $T_{eval}$  duration, where  $q+n$  is the last physical-channel on the SCG overlapping with subframe  $p$  on the MCG, while  $P_{CMAX\_L}$  is computed as follows:

$$P_{CMAX\_L} = \text{MIN}\{P_{CMAX\_NR-DC\_L}(p,q), P_{CMAX\_NR-DC\_L}(p,q+I), \dots, P_{CMAX\_NR-DC\_L}(p,q+n)\}$$

where  $P_{CMAX\_NR-DC\_L}$  entries are the applicable lower limits for each overlapping scheduling unit pairs  $(p,q)$ ,  $(p,q+I)$  up to  $(p,q+n)$  for each applicable  $T_{eval}$  duration, where  $q+n$  is the last physical-channel on the SCG overlapping with subframe  $p$  on the MCG.

For a UE provided with  $NR-DC-PC-mode = Semi-static-mode1$  and configured with  $p_{NR,MCG} + p_{NR,SCG} \leq \hat{P}_{Total}^{NR-DC}$  with  $p_{NR,MCG}$  and  $p_{NR,SCG}$  the values of the  $P_{NR}$  for the respective MCG and SCG expressed in linear scale

$$P_{CMAX\_NR-DC\_L}(p,q) = 10 \log_{10} [p_{CMAX\_L, MCG}(p) + p_{CMAX\_L, SCG}(q)]$$

$$P_{CMAX\_NR-DC\_H}(p,q) = 10 \log_{10} [p_{CMAX\_H, MCG}(p) + p_{CMAX\_H, SCG}(q)]$$

where

$p_{CMAX\_L, MCG}$ ,  $p_{CMAX\_L, SCG}$ ,  $p_{CMAX\_H, MCG}$ ,  $p_{CMAX\_H, SCG}$  can be  $p_{CMAX\_L,f,c,MCG}$ ,  $p_{CMAX\_H,f,c,MCG}$ ,  $p_{CMAX\_L,f,c,SCG}$ , and  $p_{CMAX\_H,f,c,SCG}$  the values of the respective  $P_{CMAX\_L,f,c,MCG}$ ,  $P_{CMAX\_H,f,c,MCG}$ ,  $P_{CMAX\_L,f,c,SCG}$ , and  $P_{CMAX\_H,f,c,SCG}$  expressed in linear scale, or  $p_{CMAX\_L,CA,MCG}$ ,  $p_{CMAX\_H,CA,MCG}$ ,  $p_{CMAX\_L,CA,SCG}$ , and  $p_{CMAX\_H,CA,SCG}$  the values of the respective  $P_{CMAX\_L,CA,MCG}$ ,  $P_{CMAX\_H,CA,MCG}$ ,  $P_{CMAX\_L,CA,SCG}$ , and  $P_{CMAX\_H,CA,SCG}$  expressed in linear scale if the contiguous carrier aggregation is configured in MCG and/or SCG or a combinations of single cell and carrier aggregation while the measured configured maximum power  $P_{UMAX}$  for each CG shall meet the requirements as specified in clause 6.2.4 but with bounds for  $P_{CMAX,f,c,MCG}(p)$  and  $P_{CMAX,f,c,SCG}$  as specified in this clause or 6.2A.4.1.1 as modified in this clause for contiguous carrier aggregation configured cell group.

If for synchronized NR-DC a UE is provided with  $NR-DC-PC-mode = Semi-static-mode2$  and configured with  $p_{NR,MCG} + p_{NR,SCG} \leq \hat{P}_{Total}^{NR-DC}$  with  $p_{NR,MCG}$  and  $p_{NR,SCG}$  the linear-scale values of the  $P_{NR}$  for the respective MCG and SCG

$$P_{CMAX\_NR-DC\_L}(p,q) = 10 \log_{10} [p_{CMAX\_L, MCG}(p) + p_{CMAX\_L, SCG}(q)]$$

$$P_{CMAX\_NR-DC\_H}(p,q) = 10 \log_{10} [p_{CMAX\_H, MCG}(p) + p_{CMAX\_H, SCG}(q)]$$

while the measured configured maximum power  $P_{UMAX}$  for each CG shall meet the requirements specified in Table 6.2.4-2 but with bounds for  $P_{CMAX,f,c,MCG}(p)$  and  $P_{CMAX,f,c,SCG}(q)$  as specified in this clause or 6.2A.4.1.1-1 when

intra-band carrier aggregation contiguous is configured in the MCG and/or SCG with the bounds  $P_{\text{CMAX,CA,MCG}}(p)$  and  $P_{\text{CMAX,CA,SCG}}$  defined in this clause except

- if an ongoing transmission overlapping with physical channel  $q$  of the SCG or subframe  $p$  of the MCG overlaps with only semi-static downlink symbols within the respective subframe  $p$  of the MCG or physical channel  $q$  of the SCG as indicated to a UE by *tdd-UL-DL-ConfigurationCommon* and *tdd-UL-DL-ConfigurationDedicated*, if provided,

then the measured configured maximum power  $P_{\text{UMAX}}$  for the transmission subframe  $p$  on the MCG or physical channel  $q$  on the SCG shall meet the requirements as specified in clause 6.2.4 and with bounds for  $P_{\text{CMAX,f,c,MCG}}(p)$  or  $P_{\text{CMAX,f,c,SCG}}$  as specified in this clause or Table 6.2A.4.1.1-1 when intra-band carrier aggregation contiguous is configured in the MCG and/or SCG with bounds for  $P_{\text{CMAX,CA,MCG}}(p)$  and  $P_{\text{CMAX,CA,SCG}}$  defined in this clause For a UE provided with *NR-DC-PC-mode = Dynamic*,

$$P_{\text{CMAX\_NR-DC\_L}}(p,q) = \text{MIN}\{10 \log_{10} [p_{\text{CMAX\_L,MCG}}(p) + p_{\text{CMAX\_L,SCG}}(q)], P_{\text{Total}}^{\text{NR-DC}}\}$$

$$P_{\text{CMAX\_NR-DC\_H}}(p,q) = \text{MIN}\{10 \log_{10} [p_{\text{CMAX\_H,MCG}}(p) + p_{\text{CMAX\_H,SCG}}(q)], P_{\text{Total}}^{\text{NR-DC}}\}$$

while the measured configured maximum power  $P_{\text{UMAX}}$  on the MCG shall meet the requirements as specified in clause 6.2.4-2 but with bounds for  $P_{\text{CMAX,f,c,MCG}}(p)$  as specified in this clause, or as specified in Table 6.2A.4.1.1-1 when intra-band carrier aggregation contiguous is configured in the MCG with the bounds for  $P_{\text{CMAX,CA,MCG}}(p)$  as specified in this clause and the  $P_{\text{UMAX}}$  on the SCG shall be within

$$P_{\text{CMAX\_L}} - \text{MAX}\{T_{\text{L,c}}, T(P_{\text{CMAX\_L}})\} \leq P_{\text{UMAX}} \leq P_{\text{CMAX\_H}} + T(P_{\text{CMAX\_H,f,c}})$$

where for single uplink cell SCG

$$P_{\text{CMAX\_L}} = \text{MIN}\{P_{\text{CMAX\_L,f,c,SCG}}(p), 10 \log_{10} (\hat{P}_{\text{Total}}^{\text{NR-DC}} - p_{\text{NR,MSG}})\}$$

$$P_{\text{CMAX\_H}} = \text{MIN}\{P_{\text{CMAX\_H,f,c,SCG}}(p), 10 \log_{10} (\hat{P}_{\text{Total}}^{\text{NR-DC}} - p_{\text{NR,MSG}})\}$$

and for intra-band carrier aggregation configured SCG

$$P_{\text{CMAX\_L}} = \text{MIN}\{P_{\text{CMAX\_L,CA,SCG}}(p), 10 \log_{10} (\hat{P}_{\text{Total}}^{\text{NR-DC}} - p_{\text{NR,MSG}})\}$$

$$P_{\text{CMAX\_H}} = \text{MIN}\{P_{\text{CMAX\_H,CA,SCG}}(p), 10 \log_{10} (\hat{P}_{\text{Total}}^{\text{NR-DC}} - p_{\text{NR,MSG}})\}$$

where  $P_{\text{CMAX\_L,CA,SCG}}$  and  $P_{\text{CMAX\_H,CA,SCG}}$  bounds are defined in this clause,

with limits as specified in Table 6.2.4-2 or as specified in Table 6.2A.4.1.1-1 when intra-band carrier aggregation contiguous is configured in the MCG and  $p_{\text{NR,MCG}}$  the value of the  $P_{\text{NR}}$  for the MCG expressed in linear scale.

**Table 6.2B.4.1.3-2:  $P_{\text{CMAX}}$  tolerance for NR-DC**

$P_{\text{CMAX}}(\text{dBm})$	Tolerance $T_{\text{LOW}}(P_{\text{CMAX\_L}})$ (dB)	Tolerance $T_{\text{HIGH}}(P_{\text{CMAX\_H}})$ (dB)
$23 \leq P_{\text{CMAX}} \leq 33$	3.0	2.0
$22 \leq P_{\text{CMAX}} < 23$	5.0	2.0
$21 \leq P_{\text{CMAX}} < 22$	5.0	3.0
$20 \leq P_{\text{CMAX}} < 21$	5.0	4.0
$16 \leq P_{\text{CMAX}} < 20$	5.0	
$11 \leq P_{\text{CMAX}} < 16$	6.0	
$-40 \leq P_{\text{CMAX}} < 11$	7.0	
NOTE 1: For UEs provided with <i>NR-DC-PC-mode = Semi-static-mode1</i> or with <i>NR-DC-PC-mode = Semi-static-mode2</i> , the upper tolerance $T_{\text{high}}$ shall be reduced by 0.3 dB for $P \geq 20$ dBm.		

### 6.2B.4.2 $\Delta T_{IB,c}$ for NR-DC

For inter-band NR-DC with one uplink carrier assigned per NR band, the  $\Delta T_{IB,c}$  for the corresponding inter-band CA configuration as specified in clause 6.2A.4.2 applies.

## 6.2C Transmitter power for SUL

### 6.2C.1 Configured transmitted power for SUL

When a UE is configured with both NR UL and NR SUL carriers in a serving cell with active transmission either on the UL carrier(s) or SUL carrier, the configured transmit power requirements specified in clause 6.2.4 and 6.2A.4 are applicable for the UL carrier(s) and the SUL carrier, respectively.

If a UE supports a different power class than the default UE power class for NR UL band of SUL combination and the supported power class enables the higher maximum output power for SUL combination than that of the default power class:

- if the field of UE capability *maxUplinkDutyCycle-SULcombination-PC2* is not absent and the average percentage of uplink symbols transmitted in a certain evaluation period is larger than the maximum percentage of uplink symbols that the UE indicates by *maxUplinkDutyCycle-SULcombination-PC2* as defined in TS 38.331 (The exact evaluation period is no less than one radio frame); or
- if the IE P-Max as defined in TS 38.331 [7] is provided and set to the maximum output power of the default power class or lower;
  - shall apply all requirements for the default power class to the supported power class and set the configured transmitted power as specified in clause 6.2.4;
- else;
  - shall apply all requirements for the supported power class and set the configured transmitted power as specified in clause 6.2.4 (regardless of the average percentage of uplink symbols if the field of UE capability *maxUplinkDutyCycle-interBandCA-PC2* is absent).

The average percentage of uplink symbols is defined as  $50\% \times (\text{Duty}_{NR,x} / \text{maxDuty}_{NR,x} + \text{Duty}_{NR,y} / \text{maxDuty}_{NR,y})$ .  $\text{Duty}_{NR,x}$ ,  $\text{Duty}_{NR,y}$  represent the actual percentage of uplink symbols transmitted in the same evaluation period (The exact evaluation period is no less than one radio frame) for NR Band x, NR Band y respectively  $\text{maxDuty}_{NR,x}$ ,  $\text{maxDuty}_{NR,y}$  represent the field of UE capability *maxUplinkDutyCycle-PC2-FR1* per band as defined in TS 38.331. For NR Band x or NR Band y,

- if power class of one or both of the bands within the band combination is power class 2 and the corresponding UE capability *maxUplinkDutyCycle-PC2-FR1* is absent;
  - the corresponding  $\text{maxDuty}_{NR,x}$  or  $\text{maxDuty}_{NR,y}$  is equal to 50%;
- else if the band is configured with power class 3;
  - the corresponding  $\text{maxDuty}_{NR,x}$  or  $\text{maxDuty}_{NR,y}$  is equal to 100%.

### 6.2C.2 $\Delta T_{IB,c}$

For the UE which supports SUL band combination,  $\Delta T_{IB,c}$  in Tables below applies. Unless otherwise stated,  $\Delta T_{IB,c}$  is set to zero.

Table 6.2C.2-1:  $\Delta T_{IB,c}$  due to SUL

Band combination for SUL	$\Delta T_{IB,c}$ for NR bands (dB) <sup>3</sup>	
	Component band in order of bands in configuration <sup>4</sup>	
SUL_n1-n80	0.3	0.3
SUL_n1-n81	0.3	0.3
SUL_n1-n89	0.3	0.3
SUL_n3-n84	0.3	0.3
SUL_n5-n84	0.3	0.3
SUL_n8-n84	0.3	0.3
SUL_n41-n80	$0.3^1 / 0.8^2$	0.5
SUL_n41-n81	0.3	0.3
SUL_n41-n83	0.3	0.3
SUL_n41-n97	0.5	0.5
SUL_n41-n98	0.5	0.5
SUL_n41-n99	$0.4^1 / 0.9^2$	0.3
SUL_n48-n99	0.6	0.8
SUL_n77-n80	0.8	0.6
SUL_n77-n84	0.8	0.6
SUL_n77-n99	0.6	0.8
SUL_n78-n80	0.8	0.6
SUL_n78-n81	0.8	0.6
SUL_n78-n82	0.8	0.6
SUL_n78-n83	0.8	0.5
SUL_n78-n84	0.8	0.3
SUL_n78-n86	0.8	0.6
SUL_n78-n89	0.8	0.6
SUL_n79-n83	0.8	0.5
SUL_n79-n97	0.8	0.3
SUL_n79-n98	0.8	0.3

NOTE 1: The requirement is applied for UE transmitting on the frequency range of 2515 – 2690MHz.  
NOTE 2: The requirement is applied for UE transmitting on the frequency range of 2496 - 2515MHz.  
NOTE 3: “-” denotes  $\Delta T_{IB,c} = 0$ .  
NOTE 4: The component band order in the configuration should be listed by the order of NR bands such as for SUL\_n41-n81 the order of band is n41 and n81.

Table 6.2C.2-2:  $\Delta T_{IB,c}$  for SUL band combination (Three bands)

Band combination for SUL	$\Delta T_{IB,c}$ for NR bands (dB) <sup>3</sup>		
	Component band in order of bands in configuration <sup>4</sup>		
CA_n1_n78-n80	0.6	0.8	0.6
CA_n1_n78-n81	0.3	0.8	0.6
CA_n1_n78-n84	0.6	0.8	0.6
CA_n1_n78-n89	0.6	0.8	0.6
CA_n3_n41-n80	0.5	$0.3^1 / 0.8^2$	0.5
CA_n3_n78-n80	0.6	0.8	0.6
CA_n3_n78-n84	0.6	0.8	0.6
CA_n3_n79-n80	0.3	0.8	0.3
CA_n5_n78-n84	0.6	0.8	0.6
CA_n8_n78-n81	0.6	0.8	0.6
CA_n8_n78-n84	0.6	0.8	0.3
CA_n28_n41-n83	0.3	0.3	0.3
CA_n28_n79-n83	0.5	0.8	0.5
CA_n41_n79-n80	$0.3^1 / 0.8^2$	0.8	0.3
CA_n41_n79-n83	0.3	0.8	0.5
CA_n41_n79-n95	0.3	0.8	0.3
CA_n41_n79-n97	0.5	0.5	0.5
CA_n41_n79-n98	0.3	0.8	0.3

CA_n78_n1-n80	0.8	0.6	0.6
CA_n78_n1-n81	0.8	0.3	0.6
CA_n78_n1-n89	0.8	0.6	0.6
CA_n78_n3-n84	0.8	0.6	0.6
CA_n78_n5-n84	0.8	0.6	0.6
CA_n78_n8-n84	0.8	0.6	0.3
CA_n78_n80-n84	0.8	0.6	0.6
CA_n78_n81-n84	0.8	0.6	0.3
CA_n78_n84-n89	0.8	0.6	0.6
CA_n79_n41-n80	0.3 <sup>1</sup> / 0.8 <sup>2</sup>	0.8	0.3
CA_n79_n41-n83	0.3	0.8	0.5
CA_n79_n41-n95	0.3	0.8	0.3
CA_n79_n41-n97	0.5	0.5	0.5
CA_n79_n41-n98	0.3	0.8	0.3

NOTE 1: The requirement is applied for UE transmitting on the frequency range of 2515-2690MHz.  
NOTE 2: The requirement is applied for UE transmitting on the frequency range of 2496-2515MHz.  
NOTE 3: “-” denotes  $\Delta T_{B,c} = 0$ .  
NOTE 4: The component band order in the configuration should be listed by the order of NR bands, such as for CA\_n1\_n78-n80 the band order from left to right is n1, n78 and n80.

Table 6.2C.2-3:  $\Delta T_{B,c}$  for SUL band combination (Four bands)

Band combination for SUL	$\Delta T_{B,c}$ for NR bands (dB) <sup>1</sup>			
	Component band in order of bands in configuration <sup>2</sup>			
CA_n28-n79_n41-n83	0.3	0.3	0.5	0.3
CA_n28-n41_n79-n83	0.3	0.3	0.5	0.3
CA_n41A-n95A_n79A-n98A	0.3	0.8	-	0.3
CA_n41A-n98A_n79A-n95A	0.5	0.8	0.5	-
CA_n41A-n83A_n79A-n98A	0.3	0.8	0.3	0.3
CA_n41A-n83A_n79A-n95A	0.3	0.8	0.3	-

NOTE 1: “-” denotes  $\Delta T_{B,c} = 0$ .  
NOTE 2: The component band order in the configuration should be listed by the order of NR bands and SUL band, such as for CA\_n28-n79\_n41-n83 the band order from left to right is n28, n41, n79 and n83.

## 6.2D Transmitter power for UL MIMO

### 6.2D.1 UE maximum output power for UL MIMO

For UE with two or four transmit antenna connectors in closed-loop spatial multiplexing scheme, the maximum output power for any transmission bandwidth within the channel bandwidth is specified in Table 6.2D.1-1. The requirements shall be met with the UL MIMO configurations specified in Table 6.2D.1-2. For UE supporting UL MIMO, the maximum output power is defined as the sum of the maximum output power from all UE antenna connectors. The period of measurement shall be at least one sub frame (1 ms).

The requirements shall be met with the UL MIMO configurations of using 2-layer UL MIMO codebook-based transmission with precoding matrix of  $W = \frac{1}{\sqrt{2}} \begin{bmatrix} 1 & 0 \\ 0 & 1 \end{bmatrix}$ , or 4-layer UL MIMO transmission with codebook of



$$\frac{1}{2} \begin{bmatrix} 1 & 0 & 0 & 0 \\ 0 & 1 & 0 & 0 \\ 0 & 0 & 1 & 0 \\ 0 & 0 & 0 & 1 \end{bmatrix}$$
 . DCI Format for UE configured in PUSCH transmission mode for uplink single-user MIMO shall be used.

Table 6.2D.1-1: UE Power Class for UL MIMO in closed loop spatial multiplexing scheme

NR band	Class 1.5 (dBm)	Tolerance (dB)	Class 2 (dBm)	Tolerance (dB)	Class 3 (dBm)	Tolerance (dB)	Class 5 (dBm)	Tolerance (dB)
n1			26	+2/-3 <sup>1</sup>	23	+2/-3		
n2					23	+2/-3 <sup>1</sup>		
n3			26	+2/-3 <sup>1</sup>	23	+2/-3 <sup>1</sup>		
n5					23	+2/-3 <sup>1</sup>		
n7					23	+2/-3 <sup>1</sup>		
n8			26	+2/-3 <sup>1</sup>	23	+2/-3 <sup>1</sup>		
n13					23	+2/-3		
n24					23	+2/-4 <sup>1</sup>		
n25			26	+2/-3 <sup>1</sup>	23	+2/-3 <sup>1</sup>		
n26					23	+2/-3 <sup>1</sup>		
n28					23	+2/-3 <sup>1</sup>		
n30					23	+2/-3		
n34			26	+2/-3	23	+2/-3		
n38					23	+2/-3		
n39			26	+2/-3	23	+2/-3		
n40			26	+2/-3 <sup>1</sup>	23	+2/-3		
n41	29	+2/-3 <sup>1</sup>	26	+2/-3 <sup>1</sup>	23	+2/-3 <sup>1</sup>		
n48					23	+2/-3		
n66			26	+2/-3	23	+2/-3		
n70			26	+2/-3	23	+2/-3		
n71			26	+2/-3	23	+2/-3		
n77	29	+2/-3	26	+2/-3	23	+2/-3		
n78	29	+2/-3	26	+2/-3	23	+2/-3		
n79	29	+2/-3	26	+2/-3	23	+2/-3		
n80			26	+2/-3 <sup>1</sup>	23	+2/-3 <sup>1</sup>		
n81					23	+2/-3 <sup>1</sup>		
n83					23	+2/-3 <sup>1</sup>		
n84			26	+2/-3 <sup>1</sup>	23	+2/-3		
n85					23	+2/-3 <sup>1</sup>		
n86			26	+2/-3 <sup>1</sup>	23	+2/-3 <sup>1</sup>		
n95			26	+2/-3	23	+2/-3		
n97			26	+2/-3	23	+2/-3		
n98			26	+2/-3	23	+2/-3		
n99					23	+2/-4 <sup>1</sup>		
n104			26	+2/-3	23	+2/-3		
n105					23	+2/-3		

NOTE 1: The transmission bandwidths confined within  $F_{UL\_low}$  and  $F_{UL\_low} + 4$  MHz or  $F_{UL\_high} - 4$  MHz and  $F_{UL\_high}$ , the maximum output power requirement is relaxed by reducing the lower tolerance limit by 1.5 dB

NOTE 2: Power class 3 is the default power class unless otherwise stated

Table 6.2D.1-2: UL MIMO configuration in closed-loop spatial multiplexing scheme

Transmission scheme	DCI format	Number of layers	TPMI index
Codebook based uplink	DCI format 0_1	2	0
Codebook based uplink	DCI format 0_1	4	0 <sup>2</sup>

NOTE 1: The UE is configured with one SRS resource with the parameter *nrofSRS-Ports* set to 2.  
 NOTE 2: The UE is configured with one SRS resource with the parameter *nrofSRS-Ports* set to 4.

For UE support uplink full power transmission (ULFPTx) for UL MIMO, the maximum output power requirements specified in Table 6.2D.1-1 shall be met with the PUSCH configurations specified in Table 6.2D.1-3, based upon UE's support of uplink full power transmission mode. For UE supporting uplink full power transmission (ULFPTx) for UL MIMO, the maximum output power is defined as the sum of the maximum output power from all UE antenna connectors. The period of measurement shall be at least one sub frame (1 ms).

**Table 6.2D.1-3: PUSCH Configuration for uplink full power transmission (ULFPTx)**

ULFPTx Mode	Transmission scheme	DCI format	Modulation	Number of layers	Number of Tx Port	TPMI index
Mode-1	Codebook based uplink	DCI format 0_1	DFT-s-OFDM, CP-OFDM <sup>NOTE3</sup>	1	2 <sup>NOTE1</sup>	2
			CP-OFDM <sup>NOTE3</sup>	2	4 <sup>NOTE4</sup>	13
Mode-2	Codebook based uplink	DCI format 0_1	DFT-s-OFDM, CP-OFDM	1	2 <sup>NOTE1</sup>	0 or 1 <sup>NOTE2</sup>
			CP-OFDM	2	4 <sup>NOTE4</sup>	4, 5, 6, 7 or 4, 5, 6, 7, 8, 9, 10, 11 <sup>NOTE2</sup>
Mode-full power	Codebook based uplink	DCI format 0_1	DFT-s-OFDM, CP-OFDM	1	2 <sup>NOTE1</sup>	1 or 0, 1, 2, 3, 4, 5 <sup>NOTE2</sup>
NOTE 1: The UE is configured with one SRS resource with the parameter <i>nrofSRS-Ports</i> set to 2. NOTE 2: TPMI index selected shall be based upon the full power TPMI reported by the UE [8, TS 38.213]. NOTE 3: For PUSCH configured with <i>ul-FullPowerTransmission</i> set to <i>fullpowerMode1</i> , all the transmitter requirement for CP-OFDM based modulation does not need to be verified if the requirements for 2-layer or 4-layer UL MIMO according to Table 6.2D.1-2 has been verified. NOTE 4: The UE is configured with one SRS resource with the parameter <i>nrofSRS-Ports</i> set to 4.						

If the UE is scheduled for single antenna-port PUSCH transmission by DCI format 0\_0 or by DCI format 0\_1 for codebook based transmission with precoding matrix  $W=1$  [6.3.1.5 TS 38.211], the requirements in clause 6.2 apply for at least one antenna connector for the power class as indicated by the *ue-PowerClass* field in capability signalling with the following exception: for UEs indicating Tx diversity capability, the requirements in clause 6.2G for the power class indicated by the *ue-PowerClass*.

A UE with dual Tx indicating the feature *ul-FullPwrMode-r16* or *ul-FullPwrMode2-TPMIGroup-r16* for a band shall meet the requirement in clause 6.2 for at least one antenna connector when scheduled for single antenna-port transmission by DCI format 0\_0 or by DCI format 0\_1 for codebook-based transmission with precoding matrix  $W=1$  [6.3.1.5 TS 38.211].

## 6.2D.2 UE maximum output power reduction for UL MIMO

For UE with two or four transmit antenna connectors in closed-loop spatial multiplexing scheme, the allowed Maximum Power Reduction (MPR) for the maximum output power in Table 6.2D.1-1 is specified in Table 6.2.2-1 for PC3, Table 6.2D.2-1 for 2Tx PC2 when the UE does not indicate *ul-FullPwrMode-r16* or *ul-FullPwrMode2-TPMIGroup-r16* for the band and Table 6.2.2-2 for 2Tx PC2 when the UE indicates *ul-FullPwrMode-r16* or *ul-FullPwrMode2-TPMIGroup-r16* for the band, Table 6.2D.2-2 and Table 6.2D.2-3 for PC1.5 with dual Tx, Table 6.2D.2-4, 6.2D.2-5 for PC1.5 with 4 Tx respectively. For UE power class 1.5 with dual Tx, the allowed maximum power reduction (MPR) defined in Table 6.2D.2-3 is in accordance with the indicated *modifiedMPR-Behavior*

specified in Table L.1-1 for channel bandwidths  $\leq 100$  MHz. The requirements shall be met with UL MIMO configurations defined in Table 6.2D.1-2. For UE supporting UL MIMO, the maximum output power is defined as the sum of the maximum output power from both UE antenna connectors.

For UE support uplink full power transmission (ULFPTx) for UL MIMO except the feature *ul-FullPwrMode-r16* or *ul-FullPwrMode2-TPMIGroup-r16*, the allowed MPR for the maximum output power in Table 6.2D.1-1 is specified in Table 6.2.2-1 for PC3, Table 6.2D.2-1 when *TxD* is indicated and Table 6.2.2-2 when *TxD* is not indicated for PC2, Table 6.2D.2-2 and Table 6.2D.2-3 for PC1.5 with dual Tx, Table 6.2D.2-4, 6.2D.2-5 for PC1.5 with 4 Tx respectively, and the requirements shall be met with the PUSCH configurations specified in Table 6.2D.1-3, based upon UE's support of uplink full power transmission mode. A UE with dual Tx indicating the feature *ul-FullPwrMode-r16* or *ul-FullPwrMode2-TPMIGroup-r16* for a band shall meet the maximum output power requirement with MPR according to clause 6.2.2. When a UE that indicates PC1.5 for a given band is limited to PC2 by the rules in clause 6.2.1, the MPR requirements in Table 6.2.2-2 apply. For UE support uplink full power transmission (ULFPTx) for UL MIMO, the maximum output power is defined as the sum of the maximum output power from all UE antenna connectors.

The same MPR requirements shall be applicable to UE with 1-layer UL MIMO transmission (either with or without ULFPTx) as with the UL MIMO configurations of using 2-layer UL MIMO transmission with codebook of

$$\frac{1}{\sqrt{2}} \begin{bmatrix} 1 & 0 \\ 0 & 1 \end{bmatrix}.$$

For the UE maximum output power modified by MPR, the power limits specified in clause 6.2D.4 apply.

If UE is scheduled for single antenna-port PUSCH transmission by DCI format 0\_0 or by DCI format 0\_1 for single antenna port codebook based transmission, the corresponding requirements in clause 6.2D.1 apply for the power class as indicated by the *ue-PowerClass* field in capability signaling. A UE indicating the feature *ul-FullPwrMode-r16* or *ul-FullPwrMode2-TPMIGroup-r16* for a band shall meet the requirement in clause 6.2 with MPR according to clause 6.2.2 for at least one antenna connector when scheduled for single antenna-port transmission by DCI format 0\_0 or by DCI format 0\_1 for codebook-based transmission on a single antenna port with precoding matrix  $W=1$  [6.3.1.5 TS 38.211].

**Table 6.2D.2-1: Maximum power reduction (MPR) for power class 2 with dual Tx**

Modulation		MPR (dB)		
		Edge RB allocations	Outer RB allocations	Inner RB allocations
DFT-s-OFDM	Pi/2 BPSK	$\leq 3.5$	$\leq 1$	0 <sup>1</sup>
	QPSK	$\leq 3.5$	$\leq 2$	0.5 <sup>2</sup>
	16 QAM	$\leq 3.5$	$\leq 2.5$	$\leq 1.5$
	64 QAM	$\leq 3.5$	$\leq 3$	
	256 QAM	$\leq 5.5$		
CP-OFDM	QPSK	$\leq 4.0$	$\leq 3.5$	$\leq 2$
	16 QAM	$\leq 4.0$	$\leq 3.5$	$\leq 2.5$
	64 QAM	$\leq 4.5$		
	256 QAM	$\leq 8.0$		
NOTE 1: For a UE indicating support for UE capability <i>powerBoosting-pi2BPSK-QPSK-r18</i> or <i>powerBoosting-pi2BPSK-QPSK-Modified-r18</i> and if the IE <i>powerBoostPi2BPSK-r18</i> is set to 1, the reference power is increased by $\Delta$ PowerBoost.				
NOTE 2: For a UE indicating support for UE capability <i>powerBoosting-pi2BPSK-QPSK-r18</i> or <i>powerBoosting-pi2BPSK-QPSK-Modified-r18</i> and if the IE <i>powerBoostQPSK-r18</i> is set to 1, the reference power is increased by $\Delta$ PowerBoost.				

**Table 6.2D.2-2: Maximum power reduction (MPR) for power class 1.5 with dual Tx**

Modulation		MPR (dB)		
		Edge RB allocations	Outer RB allocations	Inner RB allocations
DFT-s-OFDM	Pi/2 BPSK	$\leq 6$	$\leq [2]$	$\leq 0.5$

CP-OFDM	QPSK	≤ 6.5	≤ [2.5]	≤ 0.5
	16 QAM	≤ 6.5	≤ [3.5]	≤ 1.5
	64 QAM	≤ 6.5	≤ [4]	≤ 3.5
	256 QAM	≤ 6.5	≤ 6.5	≤ [6.5]
	QPSK	≤ 6.5	≤ [4.5]	≤ 2
	16 QAM	≤ 6.5	≤ [4.5]	≤ 2.5
	64 QAM	≤ 6.5	≤ [5]	≤ 4.5
	256 QAM	≤ 8.5	≤ 8.5	≤ [8.5]

**Table 6.2D.2-3: Maximum power reduction (MPR) for power class 1.5 with dual Tx**

Modulation		MPR (dB)		
		Edge RB allocations	Outer RB allocations	Inner RB allocations
DFT-s-OFDM	Pi/2 BPSK	≤ 6	≤ 1.5	≤ 0
	QPSK	≤ 6.5	≤ 2	≤ 0
	16 QAM	≤ 6.5	≤ 3	≤ 1
	64 QAM	≤ 6.5	≤ 3.5	≤ 3
	256 QAM	≤ 6.5	≤ 5.5	≤ 5.5
CP-OFDM	QPSK	≤ 6.5	≤ 4	≤ 1.5
	16 QAM	≤ 6.5	≤ 4	≤ 2
	64 QAM	≤ 6.5	≤ 4.5	≤ 4
	256 QAM	≤ 7.5	≤ 7.5	≤ 7.5

NOTE 1: This table is targeted to large FWA form factor with 20 dB or above antenna isolation.

**Table 6.2D.2-4: Maximum power reduction (MPR) for power class 1.5 with 4 Tx**

Modulation		MPR (dB)		
		Edge RB allocations	Outer RB allocations	Inner RB allocations
DFT-s-OFDM	Pi/2 BPSK	≤ 8.0	≤ 3.0	≤ 2.0
	QPSK	≤ 8.5	≤ 3.5	≤ 2.0
	16 QAM	≤ 8.5	≤ 4.0	≤ 2.5
	64 QAM	≤ 8.5	≤ 4.7	≤ 4.5
	256 QAM	≤ 9.5	≤ 7.0	≤ 7.0
CP-OFDM	QPSK	≤ 9.5	≤ 5.0	≤ 3.5
	16 QAM	≤ 9.5	≤ 5.0	≤ 4.0
	64 QAM	≤ 9.5	≤ 7.0	≤ 7.0
	256 QAM	≤ 9.5	≤ 9.5	≤ 9.5

NOTE 1: This table is targeted to vehicular UE or other industrial device form factor with 10dB antenna isolation.

**Table 6.2D.2-5: Maximum power reduction (MPR) for power class 1.5 with 4 Tx**

Modulation		MPR (dB)		
		Edge RB allocations	Outer RB allocations	Inner RB allocations
DFT-s-OFDM	Pi/2 BPSK	≤ 7.5	≤ 2.0	≤ 0.5
	QPSK	≤ 8.0	≤ 2.5	≤ 0.5
	16 QAM	≤ 8.0	≤ 3.5	≤ 1.5
	64 QAM	≤ 8.0	≤ 4.0	≤ 3.5
	256 QAM	≤ 8.0	≤ 6.5	≤ 6.5
CP-OFDM	QPSK	≤ 8.0	≤ 4.5	≤ 2.0
	16 QAM	≤ 8.0	≤ 4.5	≤ 2.5
	64 QAM	≤ 8.0	≤ 5.0	≤ 5.0
	256 QAM	≤ 8.5	≤ 8.5	≤ 8.5

NOTE 1: This table is targeted to large FWA form factor with 20 dB or above antenna isolation.

Inner, outer and edge allocations are as defined in section 6.2.2 except for PC1.5 edge allocations which is for  $L_{CRB} \leq 4$  RBs instead of  $L_{CRB} \leq 2$  RBs for other power classes.

### 6.2D.3 UE additional maximum output power reduction for UL MIMO

For UE with two or four transmit antenna connectors in closed-loop spatial multiplexing scheme, the A-MPR values specified in clause 6.2.3 shall apply to the maximum output power specified in Table 6.2D.1-1. The requirements shall be met with the UL MIMO configurations specified in Table 6.2D.1-2. For UE supporting UL MIMO, the maximum output power is defined as the sum of the maximum output power from both UE antenna connector. Unless stated otherwise, an A-MPR of 0 dB shall be used.

For UE support uplink full power transmission (ULFPTx) for UL MIMO, the A-MPR values specified in clause 6.2.3 shall apply to the maximum output power specified in Table 6.2D.1-1. The requirements shall be met with the PUSCH configurations specified in Table 6.2D.1-3, based upon UE's support of uplink full power transmission mode. For UE support uplink full power transmission (ULFPTx) for UL MIMO, the maximum output power is defined as the sum of the maximum output power from both UE antenna connector.

For the UE maximum output power modified by A-MPR, the power limits specified in clause 6.2D.4 apply.

If the UE is scheduled for single antenna-port PUSCH transmission by DCI format 0\_0 or by DCI format 0\_1 for single antenna port codebook-based transmission, the corresponding requirements in clause 6.2D.1 apply for the power class as indicated by the *ue-PowerClass* field in capability signaling. A UE with dual Tx indicating the feature *ul-FullPwrMode-r16* or *ul-FullPwrMode2-TPMIGroup-r16* for a band shall meet the requirement in clause 6.2 for at least one connector with A-MPR according to clause 6.2.3 when scheduled for single antenna-port transmission by DCI format 0\_0 or by DCI format 0\_1 for codebook-based transmission on a single antenna port with precoding matrix  $W=1$  [6.3.1.5 TS 38.211].

### 6.2D.4 Configured transmitted power for UL MIMO

For UE supporting UL MIMO, the transmitted power is configured per each UE.

The definitions of configured maximum output power  $P_{CMAX,c}$ , the lower bound  $P_{CMAX\_L,c}$ , and the higher bound  $P_{CMAX\_H,c}$  specified in clause 6.2.4 shall apply to UE supporting UL MIMO, where

- $P_{PowerClass}$ ,  $\Delta P_{PowerClass}$ ,  $\Delta P_{PowerBoost}$  and  $\Delta T_{C,c}$  are specified in clause 6.2.4 unless otherwise stated;
- $MPR_c$  is specified in clause 6.2D.2;
- $A-MPR_c$  is specified in clause 6.2D.3.

The measured configured maximum output power  $P_{UMAX,c}$  for serving cell  $c$  shall be within the following bounds:

$$P_{CMAX\_L,c} - \text{MAX}\{T_L, T_{LOW}(P_{CMAX\_L,c})\} \leq P_{UMAX,c} \leq P_{CMAX\_H,c} + T_{HIGH}(P_{CMAX\_H,c})$$

where  $T_{LOW}(P_{CMAX\_L,c})$  and  $T_{HIGH}(P_{CMAX\_H,c})$  are defined as the tolerance and applies to  $P_{CMAX\_L,c}$  and  $P_{CMAX\_H,c}$  separately, while  $T_L$  is the absolute value of the lower tolerance in Table 6.2D.1-1 for the applicable operating band.

For UE with two transmit antenna connectors in closed-loop spatial multiplexing scheme, the tolerance is specified in Table 6.2D.4-1. For UE with four transmit antenna connectors in closed-loop spatial multiplexing scheme, the tolerance is specified in Table 6.2D.4-2. The requirements shall be met with UL MIMO configurations specified in Table 6.2D.1-2.

For UE support uplink full power transmission (ULFPT<sub>x</sub>) for UL MIMO, the tolerance is specified in Table 6.2D.4-1. The requirements shall be met with the PUSCH configurations specified in Table 6.2D.1-3, based upon UE's support of uplink full power transmission mode.

**Table 6.2D.4-1:  $P_{\text{CMAX},c}$  tolerance in closed-loop spatial multiplexing scheme**

$P_{\text{CMAX},c}$ (dBm)	Tolerance $T_{\text{LOW}}(P_{\text{CMAX}_L,c})$ (dB)	Tolerance $T_{\text{HIGH}}(P_{\text{CMAX}_H,c})$ (dB)
$23 \leq P_{\text{CMAX},c} \leq 29$	3.0	2.0
$22 \leq P_{\text{CMAX},c} < 23$	5.0	2.0
$21 \leq P_{\text{CMAX},c} < 22$	5.0	3.0
$20 \leq P_{\text{CMAX},c} < 21$	5.0	4.0
$16 \leq P_{\text{CMAX},c} < 20$	5.0	
$11 \leq P_{\text{CMAX},c} < 16$	6.0	
$-40 \leq P_{\text{CMAX},c} < 11$	7.0	

**Table 6.2D.4-2:  $P_{\text{CMAX},c}$  tolerance in closed-loop spatial multiplexing scheme for 4Tx**

$P_{\text{CMAX},c}$ (dBm)	Tolerance $T_{\text{LOW}}(P_{\text{CMAX}_L,c})$ (dB)	Tolerance $T_{\text{HIGH}}(P_{\text{CMAX}_H,c})$ (dB)
$24.5 \leq P_{\text{CMAX},c} \leq 29$	3.0	2.0
$23.5 \leq P_{\text{CMAX},c} < 24.5$	5.0	2.0
$22.5 \leq P_{\text{CMAX},c} < 23.5$	5.0	3.0
$21.5 \leq P_{\text{CMAX},c} < 22.5$	5.0	4.0
$18 \leq P_{\text{CMAX},c} < 21.5$	5.0	
$13 \leq P_{\text{CMAX},c} < 18$	6.0	
$-40 \leq P_{\text{CMAX},c} < 13$	7.0	

If the UE is scheduled for single antenna-port PUSCH transmission by DCI format 0\_0 or by DCI format 0\_1 for single antenna port codebook-based transmission, the corresponding requirements in clause 6.2D.1 apply for the power class as indicated by the *ue-PowerClass* field in capability signaling.

## 6.2E Transmitter power for V2X

### 6.2E.1 UE maximum output power for V2X

#### 6.2E.1.1 General

When NR V2X UE is configured for NR V2X sidelink transmissions non-concurrent with NR uplink transmissions for NR V2X operating bands specified in Table 5.2E.1-1, the allowed NR V2X UE maximum output power is specified in Table 6.2E.1.1-0.

**Table 6.2E.1.1-0: NR V2X UE Power Class**

NR band	Class 1 (dBm)	Tolerance (dB)	Class 2 (dBm)	Tolerance (dB)	Class 3 (dBm)	Tolerance (dB)
n14	31	+2/-3			23	±2
n38					23	±2
n47			26	+2/-3	23	±2
n79					23	+2/-3

When a UE is configured for NR V2X sidelink transmissions in NR Band n47, the V2X UE shall meet the following additional requirements for transmission within the frequency ranges 5855-5925 MHz:

- The maximum mean power spectral density shall be restricted to 23 dBm/MHz EIRP when the network signaling value NS\_33 is indicated.

where the network signaling values are specified in clause 6.2E.3.

NOTE: The PSD limit in EIRP shall be converted to conducted requirement depend on the supported post antenna connector gain  $G_{\text{post connector}}$  declared by the UE following the principle described in annex I in [11].

For NR V2X UE supporting SL MIMO or Tx diversity, the maximum output power requirements in Table 6.2E.1.1-1 is defined as the sum of the maximum output power from each UE antenna connector. The period of measurement shall be at least one sub frame (1 ms). For UE supporting SL MIMO, the requirements shall be met with the SL MIMO configurations specified in Table 6.2D.1-2.

**Table 6.2E.1.1-1: NR V2X UE Power Class for SL-MIMO**

NR band	Class 1 (dBm)	Tolerance (dB)	Class 2 (dBm)	Tolerance (dB)	Class 3 (dBm)	Tolerance (dB)	Class 5 (dBm)	Tolerance (dB)
n38					23	+2/-3		
n47			26	+2/-3	23	+2/-3		
n79					23	+2/-3		

If the UE transmits on one antenna connector at a time, the requirements in Table 6.2E.1.1-0 shall apply to the active antenna connector.

#### 6.2E.1.1A Void

#### 6.2E.1.2 UE maximum output power for V2X concurrent operation

For the inter-band NR V2X concurrent operation, the maximum output power is specified in Table 6.2E.1.2-1 for each operating band. The period of measurement shall be at least one sub frame (1ms).

**Table 6.2E.1.2-1: Power Class for NR V2X inter-band concurrent combination (two bands)**

NR V2X concurrent operating band Configuration	NR band	Class 1 (dBm)	Tolerance (dB)	Class 2 (dBm)	Tolerance (dB)	Class 3 (dBm)	Tolerance (dB)	Class 5 (dBm)	Tolerance (dB)
V2X_n1A-n47A	n1					23	±2		
	n47					23	+2/-3		
V2X_n5A-n47A	n5					23	±2		
	n47					23	+2/-3		
V2X_n8A-n47A	n8					23	±2		
	n47					23	+2/-3		
V2X_n39A-n47A	n39					23	+2/-3		
	n47					23	+2/-3		
V2X_n40A-n47A	n40					23	+2/-3		
	n47					23	+2/-3		
V2X_n41A-n47A	n41					23	+2/-3		
	n47					23	+2/-3		
V2X_n71A-n47A	n71					23	+2/-3 <sup>4</sup>		
	n47					23	+2/-3		
V2X_n78A-n47A	n78					23	+2/-3		
	n47					23	+2/-3		

V2X_n79A-n47A	n79					23	+2/-3		
	n47					23	+2/-3		

NOTE 1: For the concurrent band combinations, the simultaneous transmission and reception of sidelink and Uu interfaces can be supported while operation is agnostic of the service used on each interface.

NOTE 2:  $P_{\text{PowerClass}}$  is the maximum output power specified without taking into account the tolerance for each operating band.

NOTE 3: For inter-band concurrent operation, the aggregation power apply to the total transmitted power over all component carriers (per UE).

NOTE 4: <sup>4</sup> refers to the transmission bandwidths (Figure 5.6-1) confined within  $F_{\text{UL\_low}}$  and  $F_{\text{UL\_low}} + 4 \text{ MHz}$  or  $F_{\text{UL\_high}} - 4 \text{ MHz}$  and  $F_{\text{UL\_high}}$ , the maximum output power requirement is relaxed by reducing the lower tolerance limit by 1.5 dB

For the intra-band concurrent NR V2X operation, the maximum output power is specified in Table 6.2E.1.2-2. The period of measurement shall be at least one sub frame (1ms).

**Table 6.2E.1.2-2: NR V2X UE Power Class for intra-band concurrent combination**

NR V2X concurrent operating band Configuration	Class 1 (dBm)	Tolerance (dB)	Class 2 (dBm)	Tolerance (dB)	Class 3 (dBm)	Tolerance (dB)	Class 5 (dBm)	Tolerance (dB)
V2X_n79B			26	+2/-3 <sup>2</sup>	23	+2/-3 <sup>2</sup>		

NOTE 1: Void.

NOTE 2:  $P_{\text{PowerClass}}$  is the maximum UE power specified without taking into account the tolerance

NOTE 3: For intra-band concurrent aggregation the maximum power requirement apply to the total transmitted power over all component carriers (per UE).

NOTE 4: Power Class 3 is the default power class unless otherwise stated.

## 6.2E.1A UE maximum output power for Sidelink CA

For the intra-band SL CA operation, the following NR SL CA UE Power Classes define the maximum output power for any transmission bandwidth within the channel bandwidth. The period of measurement shall be at least one sub frame (1ms).

**Table 6.2E.1A-1: NR SL CA UE Power Class**

NR SL CA band Configuration	Class 1 (dBm)	Tolerance (dB)	Class 2 (dBm)	Tolerance (dB)	Class 3 (dBm)	Tolerance (dB)	Class 4 (dBm)	Tolerance (dB)
SL_n47B					23	+2/-3		

NOTE 1:  $P_{\text{PowerClass}}$  is the maximum UE power specified without taking into account the tolerance

NOTE 2: For intra-band SL CA UE, the maximum power requirement apply to the total transmitted power over all component carriers (per UE).

## 6.2E.1F UE maximum output power for Sidelink Unlicensed

### 6.2E.1F.1 General

The following UE Power Classes define the maximum output power for any transmission bandwidth within the channel bandwidth of shared spectrum channel access carrier unless otherwise stated. The period of measurement shall be at least one sub frame (1ms).



Table 6.2E.1F-1: UE Power Class

NR band	Class 1 (dBm)	Tolerance (dB)	Class 2 (dBm)	Tolerance (dB)	Class 3 (dBm)	Tolerance (dB)	Class 5 (dBm)	Tolerance (dB)
n46							20	+2/-3
n96							20	+2/-3
n102							20	+2/-3
NOTE 1: $P_{PowerClass}$ is the maximum UE power specified without taking into account the tolerance								
NOTE 2: Power class 5 is default power class unless otherwise stated								

The UE operating shall meet the following additional requirements for maximum mean transmission power density specified in Table 6.2E.1F-2 when NS is signaled and when transmission overlaps with any portion of the specified frequency range. In case transmission overlaps multiple frequency ranges, the lowest power density requirement applies.

Table 6.2E.1F-2: Additional requirements for transmit power density

NR Band	NS value	Channel bandwidth (MHz)	Frequency range (MHz)	Maximum mean power density (dBm/MHz)	
n46	NS_28	20, 40, 60, 80	5150 – 5350	10	
			5470 – 5725		
	NS_29	20	5170 – 5330	10	
			5490 – 5730		
			40	5170 – 5330	7
				5490 – 5730	
	60, 80	5170 – 5330	4		
		5490 – 5730			
	NS_30	20, 40, 60, 80	5150 – 5350	11	
			5470 – 5725		
	NS_31	20	5150 - 5230	10	
			5250 – 5350		
			5470 – 5725		
			5725 - 5850		
		40	5230 – 5250	4	
			5150 - 5230		7
5250 – 5350					
5470 – 5725					
60, 80		5725 - 5850	4		
		5230 – 5250			
		5150 - 5230		4	
		5250 – 5350			
60, 80	5470 – 5725	4			
	5725 - 5850				
	5230 – 5250				
	5150 - 5230				
n96	NS_54	20, 40, 60, 80	5925 – 6425	17	
			6525 – 6875		
	NS_61	20, 40, 60, 80	5925 - 6425	1	
	NS_66	20, 40, 60, 80, 100	5925 - 7125	-8	
	NS_67	20, 40, 60, 80, 100	5925 - 7125	-5	
NS_71	20, 40, 60, 80, 100	5925 – 6425MHz 6525 – 6875MHz	-5		
n102	NS_64	20, 40, 60, 80, 100	5945 – 6425	1	
	NS_65	20, 40, 60, 80, 100	5945 – 6425	11	
	NS_68	20, 40, 60, 80, 100	5945 – 6425	1	

## 6.2E.1.2F Void

## 6.2E.1F.2 UE Maximum output power for SL-U concurrent operation

For the inter-band NR SL-U concurrent operation, the maximum output power is specified in Table 6.2E.1F.2-1 for each operating band. The period of measurement shall be at least one sub frame (1ms).

**Table 6.2E.1F.2-1:NR UE Power Class for inter band SL-U concurrent combination**

NR SL concurrent operating band Configuration	NR band	Class 1 (dBm)	Tolerance (dB)	Class 2 (dBm)	Tolerance (dB)	Class 3 (dBm)	Tolerance (dB)	Class 4 (dBm)	Tolerance (dB)	Class 5 (dBm)	Tolerance (dB)
SL_n78A-n46A	n78					23	+2/-3				
	n46									20	+2/-3
NOTE 1: For the concurrent band combinations, the simultaneous transmission and reception of sidelink and Uu interfaces can be supported while operation is agnostic of the service used on each interface.											
NOTE 2: $P_{PowerClass}$ is the maximum output power specified without taking into account the tolerance for each operating band.											
NOTE 3: For inter-band concurrent operation, the aggregation power apply to the total transmitted power over all component carriers per UE.											

## 6.2E.2 UE maximum output power reduction for V2X

## 6.2E.2.1 General

When UE is configured for NR V2X sidelink transmissions non-concurrent with NR uplink transmissions for NR V2X operating bands specified in Table 5.2E.1-1, this clause specifies the allowed Maximum Power Reduction (MPR) power for V2X physical channels and signals due to PSCCH/PSSCH, PSFCH and S-SSB transmission.

## 6.2E.2.1A MPR for sidelink CA

For SL intra-band contiguous CA of PSCCH and PSSCH simultaneous transmission with contiguous RB allocation, the allowed MPR for the maximum output power are specified in Table 6.2E.2.1A-1.

**Table 6.2E.2.1A-1: MPR for power class 3 SL CA with contiguous RB allocation**

Modulation		MPR for bandwidth class B(dB)	
		inner	outer
CP-OFDM	QPSK	≤ 3.0	≤ 5.0
	16QAM	≤ 3.0	≤ 5.0
	64QAM	≤ 4.5	≤ 5.0
	256QAM	≤ 6.5	≤ 7.0

The contiguous allocation rule of inner and outer for SL intra-band contiguous CA refers to that for NR intra-band contiguous CA in 6.2A.2.1 in TS38.101-1.

For SL intra-band contiguous CA of PSCCH and PSSCH simultaneous transmission with non-contiguous RB allocation, the allowed MPR for the maximum output power are specified in Table 6.2E.2A-1a.

**Table 6.2E.2A-1a: MPR for power class 3 SL CA with non-contiguous RB allocation**

Modulation		MPR for bandwidth class B(dB)		
		Inner	Outer1	Outer2
CP-OFDM	QPSK	≤ 3.0	≤ 5.0	≤ 9.5
	16QAM	≤ 3.0	≤ 5.0	≤ 9.5
	64QAM	≤ 4.5	≤ 5.0	≤ 9.5
	256QAM	≤ 7.0	≤ 7.0	≤ 9.5

The non-contiguous allocation rule of inner, outer1, and outer2 for SL intra-band contiguous CA refers to that for NR intra-band contiguous CA in 6.2A.2.1 in TS38.101-1.

For SL intra-band CA of PSFCH with single RB transmission on each carrier, the required MPR are specified as Table 6.2E.2.1A-2.

**Table 6.2E.2.1A-2: PSFCH MPR for intra-band SL CA**

MPR <sub>PSFCH_SLCA</sub> (dB)	R (Ratio of gap bandwidth)
2.5;	0 < R ≤ 0.3
7.5;	0.3 < R ≤ 0.5
12;	0.5 < R ≤ 1

Where,

R is the ratio of the gap bandwidth between the two PSFCH transmitted on the two intra-band carrier by the total bandwidth of the two carrier.

When single S-SSB is transmitted on intra-band contiguous carriers, required MPR for single cell V2X in Table 6.2E.2.2-2 is reused. For two S-SSB transmissions on intra-band contiguous carriers, the required MPR are specified as Table 6.2E.2.1A-3.

**Table 6.2E.2.1A-3: MPR for two S-SSB transmissions on intra-band contiguous carriers for power class 3**

MPR for bandwidth class B(dB)		
Inner	Outer1	Outer2
3.5	9.0	13.0

## 6.2E.2.2 MPR for Power class 2 and Power class 3 V2X UE

For contiguous allocation of PSCCH and PSSCH simultaneous transmission, the allowed MPR for the maximum output power for NR V2X physical channels PSCCH and PSSCH shall be as specified in Table 6.2E.2.2-1 for Power class 3 NR V2X UE and Table 6.2E.2.2-2 for power class 2 NR V2X UE.

**Table 6.2E.2.2-1: Maximum Power Reduction (MPR) for power class 3 NR V2X**

Modulation		Channel bandwidth/MPR (dB)	
		Outer RB allocations	Inner RB allocations
CP-OFDM	QPSK	≤ 4.5	≤ 2.5
	16QAM	≤ 4.5	≤ 2.5
	64 QAM	≤ 4.5	

	256 QAM	$\leq 7.0$
--	---------	------------

**Table 6.2E.2.2-2: Maximum Power Reduction (MPR) for power class 2 NR V2X**

Modulation		Channel bandwidth/MPR (dB)	
		Outer RB allocations	Inner RB allocations
CP-OFDM	QPSK	$\leq 5.5$	$\leq 2.5$
	16QAM		
	64 QAM	$\leq 6$	$\leq 4.5$
	256 QAM	$\leq 7.0$	

For NR V2X UE supporting SL MIMO or Tx diversity, the allowed MPR for the maximum output power for NR V2X physical channels PSCCH and PSSCH are specified in Table 6.2E.2.2-3 for power class 2 UE.

**Table 6.2E.2.2-3: Maximum Power Reduction (MPR) for power class 2 NR V2X with dual Tx**

Modulation		Channel bandwidth/MPR (dB)	
		Outer RB allocations	Inner RB allocations
CP-OFDM	QPSK	$\leq 6.0$	$\leq 3.0$
	16QAM		
	64 QAM	$\leq 7.0$	$\leq 5.5$
	256 QAM	$\leq 9.0$	

Where the following parameters are defined to specify valid RB allocation ranges for Outer and Inner RB allocations:

$N_{RB}$  is the maximum number of RBs for a given Channel bandwidth and sub-carrier spacing defined in Table 5.3.2-1.

$$RB_{Start,Low} = \max(1, \text{floor}(L_{CRB}/2))$$

where  $\max()$  indicates the largest value of all arguments and  $\text{floor}(x)$  is the greatest integer less than or equal to  $x$ .

$$RB_{Start,High} = N_{RB} - RB_{Start,Low} - L_{CRB}$$

The RB allocation is an Inner RB allocation if the following conditions are met

$$RB_{Start,Low} \leq RB_{Start} \leq RB_{Start,High}, \text{ and}$$

$$L_{CRB} \leq \text{ceil}(N_{RB}/2)$$

where  $\text{ceil}(x)$  is the smallest integer greater than or equal to  $x$ .

The RB allocation is an Outer RB allocation for all other allocations which are not an Inner RB allocation.

For PSFCH with single RB transmission for PC3 NR V2X UE, the required MPR is defined as follow

$$MPR_{PSFCH} = 3.5 \text{ dB}$$

For contiguous and non-contiguous allocation for simultaneous PSFCH transmission for PC3 NR V2X UE, the required MPR are specified as follow

$$MPR_{PSFCH} = \text{CEIL} \{M_{A\_PSFCH}, 0.5\}$$

Where  $M_{A\_PSFCH}$  for power class 3 is defined as follows

$$\begin{aligned} M_{A\_PSFCH} &= 7.5 \quad ; 0.00 < N_{Gap}/N_{RB} \leq 0.55 \\ &= 12.0 \quad ; 0.55 < N_{Gap}/N_{RB} \leq 1.0 \end{aligned}$$

For PSFCH with single RB transmission for PC2 NR V2X UE, the required MPR is defined as follow

$$MPR_{PSFCH} = 4.5 \text{ dB}$$

For contiguous and non-contiguous allocation for simultaneous PSFCH transmission for PC2 NR V2X UE, the required MPR are specified as follow

$$MPR_{PSFCH} = \text{CEIL} \{M_{A\_PSFCH}, 0.5\}$$

Where  $M_A$  is defined as follows

Where  $M_{A\_PSFCH}$  for power class 2 is defined as follows

$$\begin{aligned} M_{A\_PSFCH} &= 8.5 \quad ; 0.00 \leq N_{Gap}/N_{RB} < 0.4 \\ &= 10.0 \quad ; 0.4 \leq N_{Gap}/N_{RB} < 0.55 \\ &= 14.0 \quad ; 0.55 \leq N_{Gap}/N_{RB} \leq 1.0 \end{aligned}$$

Where,

$N_{Gap}$  is the gap RB amount between  $RB_{start}$  and  $RB_{end}$  for contiguous and non-contiguous allocation simultaneous PSFCH transmission. ( $N_{Gap} = RB_{end} - RB_{start}$ )

$\text{CEIL}\{M_A, 0.5\}$  means rounding upwards to closest 0.5dB.

The allowed MPR for the maximum output power for NR V2X physical channels on S-SSB transmission shall be specified in Table 6.2E.2.2-2 for power class 3 and power class 2.

**Table 6.2E.2.2-2: Maximum Power Reduction (MPR) for S-SSB transmission for power class 3 and power class 2 NR V2X**

Channel	MPR <sub>S-SSB</sub> (dB)	
	Outer RB allocations	Inner RB allocations
S-SSB	≤ 6.0	≤ 2.5

For NR V2X UE with two transmit antenna connectors, the allowed Maximum Power Reduction (MPR) values specified in clause 6.2E.2 for PC3 and PC2 shall apply to the maximum output power specified in Table 6.2E.1.1-1. For UE supporting SL MIMO, the requirements shall be met with SL MIMO configurations defined in Table 6.2D.1-2. For UE supporting SL MIMO or Tx diversity, the maximum output power is defined as the sum of the maximum output power from each UE antenna connector.

For the UE maximum output power modified by MPR, the power limits specified in clause 6.2E.4 apply.

### 6.2E.2.3 MPR for Power class 2 and Power class 3 V2X concurrent operation

For the inter-band concurrent NR V2X operation, the allowed maximum power reduction (MPR) for the maximum output power shall be applied per each component carrier. The MPR requirements in clause 6.2.2 apply for NR Uu operation in licensed band, and the MPR requirements in clause 6.2E.2 apply for NR sidelink operation in licensed band or Band n47.

For the intra-band concurrent NR V2X operation with contiguous RB allocation, the allowed maximum power reduction (MPR) for NR V2X physical channels PSCCH and PSSCH shall be as specified in Table 6.2E.2.3-1 for Power class 3 V2X concurrent UE.

**Table 6.2E.2.3-1: MPR for contiguous RB allocation for power class 3 NR V2X concurrent UE**

Higher Modulation order between Sidelink and Uplink		MPR for bandwidth class B(dB)	
		Inner RB allocation	Outer RB allocation
CP-OFDM	QPSK	≤ 2.5	≤ 4.5
	16QAM	≤ 2.5	≤ 4.5
	64QAM	≤ 4.5	≤ 5.0
	256QAM	≤ 6.0	≤ 6.0

For bandwidth class B with contiguous RB allocation, the following parameters are defined to specify valid RB allocation ranges for Inner and Outer RB allocations:

An RB allocation is contiguous if  $L_{CRB1} = 0$  or  $L_{CRB2} = 0$  or ( $L_{CRB1} \neq 0$  and  $L_{CRB2} \neq 0$  and  $RB_{Start1} + L_{CRB1} = N_{RB1}$  and  $RB_{Start2} = 0$ ), where  $RB_{Start1}$ ,  $L_{CRB1}$ , and  $N_{RB1}$  are for SL CC1,  $RB_{Start2}$ ,  $L_{CRB2}$ , and  $N_{RB2}$  are for UL CC2. SL CC1 is the component carrier with lower frequency.

In contiguous NR V2X intra-band concurrent operation, a contiguous allocation is an inner allocation if

$$RB_{Start,Low} \leq RB_{Start,SL\&UL} \leq RB_{Start,High}, \text{ and } N_{RB,alloc} \leq \text{ceil}(N_{RB,agg}/2),$$

where

$$RB_{Start,Low} = \max(1, \text{floor}(N_{RB,alloc}/2))$$

$$RB_{Start,High} = N_{RB,agg} - RB_{Start,Low} - N_{RB,alloc},$$

with

$$N_{RB,alloc} = L_{CRB1} \cdot 2^{\mu_1} + L_{CRB2} \cdot 2^{\mu_2}$$

$$N_{RB,agg} = (N_{RB1} - RB_{Start1}) \cdot 2^{\mu_1} + (RB_{Start2} + L_{CRB2}) \cdot 2^{\mu_2},$$

$$N_{RB,agg} = N_{RB1} \cdot 2^{\mu_1} + N_{RB2} \cdot 2^{\mu_2}.$$

$$\text{If } L_{CRB1} = 0, RB_{Start,SL\&UL} = N_{RB1} \cdot 2^{\mu_1} + RB_{Start2} \cdot 2^{\mu_2},$$

$$\text{if } L_{CRB1} > 0, RB_{Start,SL\&UL} = RB_{Start1} \cdot 2^{\mu_1}.$$

Where,  $\mu_1$  and  $\mu_2$  is 0, 1 and 2 for SCS of 15kHz, 30kHz and 60kHz respectively.

A contiguous allocation that is not an Inner contiguous allocation is an Outer contiguous allocation.

For the intra-band concurrent NR V2X operation with non-contiguous RB allocation, the allowed maximum power reduction (MPR) for NR V2X physical channels PSCCH and PSSCH shall be as specified in Table 6.2E.2.3-2 for Power class 3 V2X concurrent UE.

**Table 6.2E.2.3-2: MPR for non-contiguous RB allocation for power class 3 NR V2X concurrent UE**

Higher Modulation order between Sidelink and Uplink		MPR for bandwidth class B(dB)		
		Inner RB allocation	Outer1 RB allocation	Outer2 RB allocation
CP-OFDM	QPSK	≤ 2.5	≤ 4.0	≤ 4.5
	16QAM	≤ 2.5	≤ 4.0	≤ 4.5
	64QAM	≤ 4.5	≤ 4.5	≤ 5.0

	256QAM	$\leq 6.0$	$\leq 6.0$	$\leq 6.0$
--	--------	------------	------------	------------

For bandwidth classes B with non-contiguous RB allocation, the following parameters are defined to specify valid RB allocation ranges for Inner, Outer1 and Outer2 RB allocations:

Non-Contiguous RB allocation is defined as  $RB_{Start1} + L_{CRB1} < N_{RB1}$ , or  $RB_{Start2} > 0$ , when both SL CC and UL CC are activated and allocated with RB(s), where  $RB_{Start1}$ ,  $L_{CRB1}$ , and  $N_{RB1}$  are for SL CC1,  $RB_{Start2}$ ,  $L_{CRB2}$ , and  $N_{RB2}$  are for UL CC2. SL CC1 is the component carrier with lower frequency.

In contiguous NR V2X intra-band concurrent operation, a non-contiguous RB allocation is a non-contiguous Inner RB allocation if the following conditions are met:

$$RB_{Start,Low} \leq RB_{Start,CA} \leq RB_{Start,High} \text{ and } N_{RB\_alloc} \leq \text{ceil}((BW_{Channel\_SL\&UL} / 3 - BW_{gap}) / 0.18\text{MHz}),$$

where

$$N_{RB\_alloc} = (N_{RB1} - RB_{Start1}) \cdot 2^{\mu_1} + (RB_{Start2} + L_{CRB2}) \cdot 2^{\mu_2}, RB_{Start\_SL\&UL} = RB_{Start1} \cdot 2^{\mu_1}$$

$$RB_{Start,Low} = \max(1, \text{floor}(N_{RB\_alloc} + (BW_{gap} - BW_{GB,low}) / 0.18\text{MHz}))$$

$$RB_{Start,High} = \text{floor}((BW_{Channel\_SL\&UL} - 2 \cdot BW_{gap} - BW_{GB,low}) / 0.18\text{MHz} - 2 \cdot N_{RB\_alloc})$$

$$BW_{GB,low} = F_{\text{offset,low}} - (N_{RB1} \cdot 12 + 1) \cdot SCS_1 / 2$$

$BW_{gap}$  is the bandwidth of the gap between  $N_{RB1}$  and  $N_{RB2}$  possible allocations of SL CC1 and UL CC2 respectively.

In contiguous NR V2X intra-band concurrent operation, a non-contiguous RB allocation is a non-contiguous outer 1 RB allocation if the following conditions are met:

$$RB_{Start,Low} \leq RB_{Start\_SL\&UL} \leq RB_{Start,High} \text{ and } N_{RB\_alloc} \leq \text{ceil}((3 \cdot BW_{Channel\_SL\&UL} / 5 - BW_{gap}) / 0.18\text{MHz})$$

where

$$RB_{Start,Low} = \max(1, 2 \cdot N_{RB\_alloc} - \text{floor}((BW_{Channel\_SL\&UL} - 2 \cdot BW_{gap} + BW_{GB,low}) / 0.18\text{MHz})),$$

$$RB_{Start,High} = \text{floor}((2 \cdot BW_{Channel\_SL\&UL} - 3 \cdot BW_{gap} - BW_{GB,low}) / 0.18\text{MHz} - 3 \cdot N_{RB\_alloc})$$

$N_{RB\_alloc}$ ,  $RB_{Start\_SL\&UL}$ ,  $BW_{gap}$  and  $BW_{GB,low}$  are as defined for the Inner region.

In contiguous NR V2X intra-band concurrent operation, a non-contiguous allocation is an Outer 2 allocation if it is neither a non-contiguous Inner allocation nor an Outer 1 allocation.

For PSFCH with single RB transmission for PC3 NR V2X intra-band concurrent UE, the required MPR is specified in clause 6.2E.2.2 shall be applied.

For the allowed MPR for S-SSB transmission for PC3 NR V2X intra-band concurrent UE, the required MPR is specified in clause 6.2E.2.2 shall be applied.

For the intra-band concurrent NR V2X operation with contiguous RB allocation in contiguous carrier, the allowed maximum power reduction (MPR) for NR V2X physical channels PSCCH and PSSCH shall be as specified in Table 6.2E.2.3-3 for Power class 2 V2X concurrent UE.

**Table 6.2E.2.3-3: MPR for contiguous RB allocation for power class 2 NR V2X concurrent UE**

Higher Modulation order between Sidelink and Uplink	MPR for bandwidth class B(dB)	
	Inner RB allocation	Outer RB allocation

CP-OFDM	QPSK	$\leq 3.0$	$\leq 5.5$
	16QAM	$\leq 4.0$	$\leq 5.5$
	64QAM	$\leq 5.5$	$\leq 6.0$
	256QAM	$\leq 7.5$	$\leq 7.5$

For the intra-band concurrent NR V2X operation with non-contiguous RB allocation in contiguous carrier, the allowed maximum power reduction (MPR) for NR V2X physical channels PSCCH and PSSCH shall be as specified in Table 6.2E.2.3-4 for Power class 2 V2X concurrent UE.

**Table 6.2E.2.3-4: MPR for non-contiguous RB allocation for power class 2 NR V2X concurrent UE**

Higher Modulation order between Sidelink and Uplink		MPR for bandwidth class B(dB)		
		Inner RB allocation	Outer1 RB allocation	Outer2 RB allocation
CP-OFDM	QPSK	$\leq 3.0$	$\leq 5.5$	$\leq 6.0$
	16QAM	$\leq 4.5$	$\leq 5.5$	$\leq 6.5$
	64QAM	$\leq 5.5$	$\leq 6.5$	$\leq 7.0$
	256QAM	$\leq 8.0$	$\leq 8.0$	$\leq 8.0$

The parameters in clause 6.2E.2.3 are considered to determine MPR values according to RB allocation.

For PSFCH with single RB transmission for PC2 NR V2X intra-band concurrent UE, the required MPR is specified in clause 6.2E.2.2 shall be applied.

For the allowed MPR for S-SSB transmission for PC2 NR V2X intra-band concurrent UE, the required MPR is specified in clause 6.2E.2.2 shall be applied.

#### 6.2E.2.4 MPR for Power class 1 UE in Band n14

For NR Public Safety (PS) UE with contiguous allocation of PSCCH and PSSCH simultaneous transmission, the allowed NR PS UE maximum output power reduction for power class 1 UE shall meet the NR V2X MPR values specified in Table 6.2E.2.2-1 of clause 6.2E.2.2.

For NR Public Safety (PS) UE of single or multiple PSFCH simultaneous transmission, the allowed NR PS UE maximum output power reduction for power class 1 UE shall meet the NR V2X MPR values for PC3 UE's PSFCH transmission in clause 6.2E.2.2.

For NR Public Safety (PS) UE of S-SSB transmission, the allowed NR PS UE maximum output power reduction for power class 1 UE shall meet the NR V2X MPR values specified in Table 6.2E.2.2-2 of clause 6.2E.2.2.

### 6.2E.2F UE maximum output power reduction for Sidelink Unlicensed

#### 6.2E.2F.1 General

When UE is configured for NR sidelink transmissions in the unlicensed operating bands in FR1 defined in Table 5.2E.1F-1, this clause specifies the allowed Maximum Power Reduction (MPR) power for NR sidelink physical channels and signals due to PSCCH/PSSCH, PSFCH and S-SSB transmission.

For wideband operation, only sub-bands which are contiguously transmitted are considered in Table 6.2E.2F-3 for PSCCH/PSSCH.



For wideband operation, sub-bands which are contiguously transmitted and sub-bands which are non-contiguously transmitted in Table 6.2E.2F-3 are considered for PSFCH and S-SSB.

### 6.2E.2F.2 MPR for NR SL-U UE

For contiguous allocation of PSCCH and PSSCH simultaneous transmission, the allowed MPR for the maximum output power is specified in Table 6.2E.2F-1 for power class 5 NR sidelink UE.

**Table 6.2E.2F-1 Maximum power reduction (MPR) for NR SL-U UE power class 5**

Pre-coding	Modulation	MPR for PSCCH and PSSCH simultaneous transmission (dB)/ RB Allocation				
		Outer RB set configuration <sup>5</sup>		Inner RB set configuration <sup>5</sup>		Exception for 100MHz Full <sup>4</sup>
		Full <sup>2</sup>	Partial <sup>3</sup>	Full <sup>2</sup>	Partial <sup>3</sup>	
CP-OFDM	QPSK	≤ 3.5	≤ 3.5	≤ 3.5	≤ 2.0	≤ 4.5
	16 QAM	≤ 4.0	≤ 4.0	≤ 4.0	≤ 3.0	≤ 4.5
	64 QAM	≤ 5.5	≤ 5.5	≤ 5.5	≤ 5.5	
	256 QAM	≤ 7.0	≤ 7.0	≤ 7.0	≤ 7.0	

NOTE 1: The MPR shall apply to all SCS in all active 20 MHz sub-bands contiguously allocated in the channel.  
NOTE 2: The MPR for Full RB allocation applies to all RB's in all transmitted 20 MHz or larger channels that are fully allocated or all RB's in all transmitted sub-bands for wideband operation that are fully allocated excluding the wideband configurations of Table 6.2E.2F-2.  
NOTE 3: The MPR for Partial RB allocation applies to interlaced allocations with uplink resource allocation type 2 as specified in TS 38.214 [10] or transmitted sub-bands for wideband operation are transmitted according to the wideband configurations of Table 6.2E.2F-2.  
NOTE 4: Exception for 100MHz Full RB allocation MPR applies when all RB's in all sub-bands for 100MHz wideband operation are fully allocated and sub-bands are transmitted according to the wideband configurations of Table 6.2E.2F-2.  
NOTE 5: Contiguous sub-band configuration in Table 6.2E.2F-3 applies.

**Table 6.2E.2F-2**

Wideband operation channel bandwidth (MHz)	Sub-band configuration exceptions
40	10, 01
60	None
80	1100, 0011, 0100, 0010
100	00111, 11100, 00011, 11000

NOTE 1: The sub-band configuration is represented as a bitmap where '1' indicates that a sub-band is transmitted and '0' indicates a sub-band is not transmitted. The bitmap is ordered with MSB mapped to the lowest frequency sub-band and LSB mapped to highest frequency sub-band within the wideband channel.  
NOTE 2: Void.

#### Exception MPR mapping for NR SL-U wideband operation

**Table 6.2E.2F-3 Outer/Inner sub-band configuration for NR SL-U wideband operation**

Wideband operation channel bandwidth (MHz)	Contiguous sub-band configuration <sup>2</sup>		Non-contiguous sub-band configuration <sup>2</sup>	
	Outer	Inner	Outer	Inner
40	11, 10, 01	N/A	N/A	N/A

60	111, 110, 011, 100, 001	010	101	N/A
80	1111, 1110, 0111, 1100, 0011, 1000, 0001	0110, 0100, 0010	1101, 1011, 1010, 0101, 1001	N/A
100	11111, 11110, 01111, 11100, 00111, 11000, 00011, 10000, 00001	01110, 01100, 00110, 01000, 00010, 00100	11011, 11010, 01011, 11001, 10011, 10101, 10110, 01101, 10100, 00101, 10010, 01001, 11101, 10111, 10001	01010
NOTE 1: The sub-band configuration is represented as a bitmap where '1' indicates that a sub-band is transmitted and '0' indicates a sub-band is not transmitted. The bitmap is ordered with MSB mapped to the lowest frequency sub-band and LSB mapped to highest frequency sub-band within the wideband channel.				
NOTE 2: Only contiguous sub-band configuration applies to PSCCH/PSSCH. Both contiguous and non-contiguous sub-band configuration apply to PSFCH and S-SSB.				

For PSFCH transmission with single RB set the allowed MPR for the maximum output power is 10dB for power class 5 NR sidelink UE.

For PSFCH transmission with multiple RB sets the allowed MPR for the maximum output power is specified in Table 6.2E.2F-4 for power class 5 NR sidelink UE.

**Table 6.2E.2F-4 Maximum power reduction (MPR) for PSFCH transmission for NR SL-U UE power class 5**

	MPR for PSFCH (dB) /RB Allocation	
	Outer RB set configuration <sup>2</sup>	Inner RB set configuration <sup>2</sup>
Contiguous/Non-contiguous sub-band RB sets	≤ 12.5	≤ 10.0
NOTE 1: The MPR shall apply to all SCS in all active 20 MHz sub-bands contiguously or non-contiguously allocated in the channel.		
NOTE 2: Outer sub-band configuration and inner sub-band configuration in Table 6.2E.2F-3 apply.		

For S-SSB transmission, the allowed MPR for the maximum output power is specified in Table 6.2E.2F-5 for power class 5 NR sidelink UE.

**Table 6.2E.2F-5 Maximum power reduction (MPR) for S-SSB transmission for NR SL-U UE power class 5**

	MPR for S-SSB (dB) /RB Allocation	
	Outer RB set configuration	Inner RB set configuration
Contiguous/Non-contiguous sub-band RB sets	≤ 12.5	≤ 9.5
NOTE 1: Outer sub-band configuration and inner sub-band configuration in Table 6.2E.2F-3 apply.		

### 6.2E.2F.3 MPR for SL-U concurrent operation

For NR SL-U inter-band concurrent operation, the allowed maximum power reduction (MPR) for the maximum output power shall be applied per each component carrier. The MPR requirements in clause 6.2.2 apply for NR Uu operation in licensed band, and the MPR requirements in clause 6.2E.2F apply for NR sidelink operation in unlicensed band.

## 6.2E.3 UE additional maximum output power reduction for V2X

### 6.2E.3.1 General

For the applied maximum output power reduction is obtained by taking the maximum value of MPR requirements specified in clause 6.2E.2 and A-MPR requirements specified in current clause.

Additional emission requirements can be indicated by the network or pre-configured radio parameters. Each additional emission requirement is associated with a unique network signalling (NS) value indicated in RRC signalling by an NR frequency band number of the applicable operating band and an associated value in the field [*additionalSpectrumEmission*]. Throughout this specification, the notion of indication or signalling of an NS value refers to the corresponding indication of an NR V2X frequency band number of the applicable operating band, the IE field [*freqBandIndicatorNR*] and an associated value of [*additionalSpectrumEmission*] in the relevant RRC information elements [7].

To meet the additional requirements, additional maximum power reduction (A-MPR) is allowed for the maximum output power as specified in Table 6.2.1-1. Outer and inner allocation notation used in clause 6.2E.3 is defined in clause 6.2E.2. In absence of modulation and waveform types the A-MPR applies to all modulation and waveform types.

**Table 6.2E.3.1-1: Additional Maximum Power Reduction (A-MPR) for PC3 NR V2X**

Network Signalling value	Requirements (clause)	NR Band	Channel bandwidth (MHz)	Resources Blocks ( $N_{RB}$ )	A-MPR (dB)
NS_01		Table 5.2E.1-1	10, 20, 30, 40	Table 5.3.2-1	N/A
NS_06	6.5.2.3.4 (A-SEM)	n14	5, 10	Table 5.3.2-1	N/A
NS_33	6.5E.2.3.1 (A-SEM) 6.5E.3.4 (A-SE)	n47	10	Clause 6.2E.3.2	
NS_52	6.5E.2.3.2 (A-SEM)	n47	40	Clause 6.2E.3.3	

**Table 6.2E.3.1-2: Mapping of network signaling label**

NR V2X operating bands	Value of <i>additionalSpectrumEmission</i>							
	0	1	2	3	4	5	6	7
n14 <sup>2</sup>	NS_01	NS_06						
n38	NS_01							
n47	NS_01	NS_33	NS_52					
NOTE 1: [ <i>additionalSpectrumEmission</i> ] corresponds to an information element of the same name defined in clause 6.3.2 of TS 38.331 [7].								
NOTE 2: For the NR PS UE in n14, same A-MPR shall be applied for PC1 PS UE since PC1 PS UE for Band n14 is not targeted for smartphone form factor.								

For UE with two transmit antenna connectors, the A-MPR values specified in clause 6.2E.3.2 and 6.2E.3.3 shall apply to the maximum output power specified in Table 6.2E.1.1-1. The requirements shall be met with the SL MIMO configurations specified in Table 6.2D.1-2. For UE supporting SL MIMO or Tx Diversity, the maximum output power is defined as the sum of the maximum output power from each UE antenna connector. Unless stated otherwise, an A-MPR of 0 dB shall be used.

For the UE maximum output power modified by A-MPR, the power limits specified in clause 6.2E.4 apply.

### 6.2E.3.2 A-MPR for V2X UE by NS\_33

When NS\_33 is indicated by the network or pre-configured radio parameters for NR V2X UE, the additional maximum output power reduction specified as

$$A\text{-MPR} = \text{CEIL} \{M_A, 0.5\}$$

Where  $M_A$  is defined as follows

$$M_A = A\text{-MPR}_{\text{Base}} + G_{\text{post connector}} * A\text{-MPR}_{\text{Step}}$$

CEIL $\{M_A, 0.5\}$  means rounding upwards to closest 0.5dB.

$A\text{-MPR}_{\text{Base}}$  and  $A\text{-MPR}_{\text{Step}}$  are specified in Tables 6.2E.3.2-1, 6.2E.3.2-2 is allowed when network signalling value is provided.  $A\text{-MPR}_{\text{Base}}$  is the default A-MPR value when no  $G_{\text{post connector}}$  is declared. The supported post antenna connector gain  $G_{\text{post connector}}$  is declared by the UE following the principle described in annex I in [11]. The  $A\text{-MPR}_{\text{Step}}$  is the increase in A-MPR allowance to allow UE to meet tighter conducted A-SE and A-SEM requirements with higher value of declared  $G_{\text{post connector}}$ .

For the contiguous PSSCH and PSCCH transmission when NS\_33 is indicated by the network or pre-configured radio parameters for NR V2X UE, the NR UE allow the follow A-MPR requirements specified in Table 6.2E.3.2-1 and 6.2E.3.2-2 for power class 3. And A-MPR requirements specified in Table 6.2E.3.2-2a and 6.2E.3.2-2b for power class 2 are allowed for NR V2X UE.

**Table 6.2E.3.2-1: PC3 A-MPR for PSSCH/PSCCH by NS\_33 (at Fc =5860MHz)**

Carrier frequency [MHz]	Resources Blocks ( $L_{\text{CRB}}$ )	Start Resource Block	A-MPR <sub>Base</sub> (dB)		
			QPSK/16QAM	64QAM	256QAM
5860	$\geq 10$ and $\leq 15$	0	$\leq 24$		
		$\geq 1$ and $\leq 3$	$\leq 19$		
	$\geq 10$ and $\leq 15$	$\geq 26$ and $\leq 38$	$\leq 6$		
	$\geq 10$ and $\leq 15$	$\geq 38$	$\leq 6$		
	$\geq 10$ and $\leq 20$	$\geq 12$ and $\leq 14$	$\leq 11$		
		$\geq 15$ and $\leq 19$	$\leq 9.5$		
		$\geq 20$ and $\leq 25$	$\leq 8.0$		
	$> 15$ and $< 25$	$\geq 25$	$\leq 8$		
	$\geq 10$ and $< 40$	$\geq 4$ and $\leq 7$	$\leq 16$		
		$\geq 8$ and $\leq 11$	$\leq 13.5$		
	$\geq 20$ and $< 40$	$\geq 0$ and $\leq 3$	$\leq 22$		
	$\geq 25$ and $< 40$	$\geq 16$ and $\leq 21$	$\leq 9.5$		
		$\geq 22$ and $\leq 27$	$\leq 8.0$		
	$\geq 24$ and $\leq 40$	$\geq 12$ and $\leq 15$	$\leq 12$		
	40 and 45	0 and 1	$\leq 19$		
		$\geq 2$ and $\leq 5$	$\leq 16$		
$\geq 6$ and $\leq 11$		$\leq 13.5$			
$> 45$	$\geq 0$	$\leq 16$			

NOTE 1:  $A\text{-MPR}_{\text{step}} = 1.2$  dB is applied for  $\text{RB}_{\text{start}}$  0 and 1 and  $A\text{-MPR}_{\text{step}} = 0.7$  dB is applied for all other  $\text{RB}_{\text{start}}$

NOTE 2: Applicable for Channel Bandwidth = 10 MHz

**Table 6.2E.3.2-2: PC3 A-MPR for PSSCH/PSCCH by NS\_33 (at other carrier frequency)**

Carrier frequency [MHz]	RB allocations	A-MPR <sub>Base</sub> (dB)				A-MPR <sub>step</sub> (dB)
		QPSK	16QAM	64QAM	256QAM	

5870, 5880, 5890, 5900, 5910, 5920	Inner	≤ 3.0	≤ 5.0	≤ 6.0	0.5
	Outer	≤ 4.5			
NOTE 1: Inner and Outer RB allocations are defined in clause 6.2E.2.2					
NOTE 2: Applicable for Channel Bandwidth = 10 MHz					

Table 6.2E.3.2-2a: PC2 A-MPR for PSCCH/PSSCH by NS\_33 (at Fc=5860MHz)

Carrier frequency [MHz]	Resource Block (LCRB)	Start Resource Block	A-MPR(dB)		
			QPSK/16QAM	64QAM	256QAM
5860	≥ 10 and ≤ 15	0 and 1	≤ 24		
		2 and 3	≤ 22		
		4	≤ 20		
	≥ 10 and ≤ 25	≥ 5 and ≤ 7	≤ 17.5		
	≥ 10 and ≤ 30	10	≤ 16		
	≥ 10	8 and 9	≤ 16		
		≥ 11 and ≤ 14	≤ 14.5		
		≥ 15 and ≤ 19	≤ 13		
		≥ 20 and ≤ 24	≤ 11.5		
		≥ 25 and ≤ 29	≤ 10		
	≥ 20 and ≤ 24	≥ 30	≤ 8.5		
	≥ 20 and ≤ 24	1	≤ 22		
		0	≤ 22		
		2 and 3	≤ 20		
	≥ 20 and ≤ 30	4	≤ 17.5		
		1	≤ 20		
		≥ 25 and ≤ 40	≤ 20		
	≥ 30	≥ 5 and ≤ 7	≤ 16		
	≥ 36	0	≤ 20		
		≥ 2 and ≤ 4	≤ 17.5		
10		≤ 14.5			
≥ 45	1	≤ 17.5			
NOTE 1: A-MPR <sub>step</sub> = 1.2 dB is applied for RB <sub>start</sub> 0 and 1 and A-MPR <sub>step</sub> = 0.7 dB is applied for all other RB <sub>start</sub>					
NOTE 2: Applicable for Channel Bandwidth = 10 MHz					

Table 6.2E.3.2-2b: PC2 A-MPR for PSSCH/PSCCH by NS\_33 (at other carrier frequency)

Carrier frequency [MHz]	RB allocations	A-MPR (dB)			
		QPSK	16QAM	64QAM	256QAM
5870,5910,5920	outer	≤ 8.5			≤ 8.5
	inner	≤ 6.0			
5880,5890,5900	outer	≤ 6.0			≤ 6.5
	inner	≤ 3.5	≤ 4.5		
NOTE 1: Inner and Outer RB allocations are defined in clause 6.2E.2.1					
NOTE 2: Applicable for Channel Bandwidth = 10 MHz					

For the simultaneous PSFCH transmission when NS\_33 is indicated by the network or pre-configured radio parameters for NR V2X UE, the NR UE allow the follow A-MPR requirements specified in Table 6.2E.3.2-3 for power class 3 and in Table 6.2E.3.2-3a for power class 2.

Table 6.2E.3.2-3: PC3 A-MPR for simultaneous PSFCH by NS\_33

Channel Bandwidth [MHz]	Center Frequency [MHz]	RB allocation	A-MPR <sub>Base</sub> (dB)		A-MPR <sub>step</sub> (dB)

			$0 \leq N_{Gap} / N_{RB} < 0.15$	$0.15 \leq N_{Gap} / N_{RB} < 0.3$	$0.3 \leq N_{Gap} / N_{RB} \leq 1$	
10	5860	$N_{RB}=1$	19.0			1.0
		$N_{RB} > 1$	22.0			
	5870, 5880, 5890, 5900, 5910, 5920	$N_{RB}=1$	5			0.8
		$N_{RB} > 1$	14	7	18.5	

Note 1:  $N_{Gap}$  is the gap RB amount between  $RB_{start}$  and  $RB_{end}$  for contiguous and non-contiguous allocation simultaneous PSFCH transmission. ( $N_{Gap} = RB_{end} - RB_{start}$ )

**Table 6.2E.3.2-3a: PC2 A-MPR for simultaneous PSFCH by NS\_33**

Channel Bandwidth [MHz]	Center Frequency [MHz]	RB allocation	A-MPR <sub>Base</sub> (dB)			A-MPR <sub>step</sub> (dB)
			$0 \leq N_{Gap} / N_{RB} < 0.2$	$0.2 \leq N_{Gap} / N_{RB} < 0.4$	$0.4 \leq N_{Gap} / N_{RB} \leq 1$	
10	5860	$N_{RB}=1$	25.0			1.0
		$N_{RB} > 1$	22.0			
	5870, 5880, 5890, 5900, 5910, 5920	$N_{RB}=1$	5			0.8
		$N_{RB} > 1$	16.5	12	20	

Note 1:  $N_{Gap}$  is the gap RB amount between  $RB_{start}$  and  $RB_{end}$  for contiguous and non-contiguous allocation simultaneous PSFCH transmission. ( $N_{Gap} = RB_{end} - RB_{start}$ )

For the S-SSB transmission when NS\_33 is indicated by the network or pre-configured radio parameters for NR V2X UE, the NR UE allow the follow A-MPR requirements specified in Table 6.2E.3.2-4 for power class 3 and in Table 6.2E.3.2-5 for power class 2.

**Table 6.2E.3.2-4: PC3 A-MPR for S-SSB transmission by NS\_33**

Carrier Frequency (MHz)	$RB_{start} * 12 * SCS$ [MHz]	A-MPR <sub>Base</sub> (dB)	AMPR <sub>Step</sub> (dB)
5860	$\leq 1.0$	$\leq 25$	0.6
	$> 1.0$ and $\leq 2.0$	$\leq 19$	
	$> 2.0$ and $\leq 3.24$	$\leq 12$	
	$> 3.24$ and $\leq 3.6$	$\leq 10$	
	$> 3.6$	$\leq 9$	
5870, 5880, 5890, 5900, 5910, 5920	$\leq 1.0$	$\leq 7.0$	0.85
	$> 1.0$ and $\leq 1.6$	$\leq 6.5$	
	$> 1.6$ and $\leq 2.6$	$\leq 5.8$	
	$> 2.6$ and $\leq 3.24$	$\leq 4.5$	
	$> 3.24$ and $\leq 4.32$	$\leq 5.5$	
	$> 4.32$	$\leq 6.5$	

**Table 6.2E.3.2-5: PC2 A-MPR for S-SSB transmission by NS\_33**

Carrier Frequency (MHz)	$RB_{start} * 12 * SCS$ [MHz]	A-MPR <sub>Base</sub> (dB)	AMPR <sub>Step</sub> (dB)
5860	$\leq 1.0$	$\leq 25$	0.6
	$> 1.0$ and $\leq 2.0$	$\leq 19$	
	$> 2.0$ and $\leq 3.24$	$\leq 12$	
	$> 3.24$ and $\leq 3.6$	$\leq 10$	
	$> 3.6$	$\leq 14$	

5870, 5880, 5890, 5900, 5910, 5920	$\leq 1.0$	$\leq 7.0$	0.85
	$>1.0$ and $\leq 1.6$	$\leq 6.5$	
	$>1.6$ and $\leq 2.6$	$\leq 5.8$	
	$>2.6$ and $\leq 3.24$	$\leq 4.5$	
	$>3.24$ and $\leq 4.32$	$\leq 5.5$	
	$>4.32$	$\leq 6.5$	

### 6.2E.3.3 A-MPR for Power class 3 V2X UE by NS\_52

When NS\_52 is indicated by the network or pre-configured radio parameters for NR V2X UE, the additional maximum output power reduction specified as

$$\text{A-MPR} = \text{CEIL} \{M_A, 0.5\}$$

Where  $M_A$  is defined as follows

$$M_A = \text{A-MPR}$$

$\text{CEIL}\{M_A, 0.5\}$  means rounding upwards to closest 0.5dB.

For the contiguous PSSCH and PSCCH transmission when NS\_52 is indicated by the network or pre-configured radio parameters for NR V2X UE, the NR UE allow the follow A-MPR requirements.

**Table 6.2E.3.3-1: A-MPR for PSSCH/PSCCH by NS\_52**

Carrier frequency(MHz)	Modulation	A-MPR(dB)		
		Region 1	Region 2	Region 3
5885	QPSK	$\leq 15$	$\leq 8.0$	$\leq 5.5$
	16QAM		$\leq 8.0$	$\leq 5.5$
	64QAM		$\leq 8.5$	$\leq 5.5$
	256QAM		$\leq 8.5$	$\leq 6.0$
Note1: Void.				

Where the following parameters are defined to specify valid RB allocation ranges for Region1, Region2 and Region3 according to RB allocations:

**Table 6.2E.3.3-1a: A-MPR Region definitions for PSSCH/PSCCH by NS\_52**

Channel Bandwidth, MHz	Carrier frequency (MHz)	A-MPR parameters for region definitions		A-MPR
		$\text{RB}_{\text{start}}$ or $\text{RB}_{\text{end}}$	$\text{LCRB}$	
40	5885	$\text{RB}_{\text{start}} \leq \text{floor}(\text{N}_{\text{RB}} \cdot 0.2)$ or $\text{RB}_{\text{end}} \geq \text{N}_{\text{RB}} - \text{floor}(\text{N}_{\text{RB}} \cdot 0.2)$	$\text{LCRB} \leq \text{floor}(\text{N}_{\text{RB}} \cdot 0.2)$	Region 1
		The RB allocation is in Region 2 allocation for all other allocations which are not a Region1 or Region3 allocation.		Region 2
		$\text{floor}(\text{N}_{\text{RB}} / 3.5) \leq \text{RB}_{\text{start}} \leq \text{N}_{\text{RB}} - \text{floor}(\text{N}_{\text{RB}} / 3.5) - \text{LCRB}$	$\text{LCRB} \leq \text{ceil}(\text{N}_{\text{RB}} / 3.5)$	Region 3

$\text{N}_{\text{RB}}$  is the maximum number of RBs for a given Channel bandwidth and sub-carrier spacing defined in Table 5.3.2-1 [3].

For the simultaneous PSFCH transmission when NS\_52 is indicated by the network or pre-configured radio parameters for NR V2X UE, the NR UE allow the follow A-MPR requirements

**Table 6.2E.3.3-2: A-MPR for simultaneous PSFCH by NS\_52**

Channel Bandwidth [MHz]	Carrier frequency [MHz]	A-MPR (dB)
40 MHz	5885	23.5

For the S-SSB transmission when NS\_52 is indicated by the network or pre-configured radio parameters for NR V2X UE, the NR UE allow the follow A-MPR requirements

**Table 6.2E.3.2-3: A-MPR for S-SSB transmission by NS\_52**

Carrier Frequency [MHz]	RB <sub>start</sub> * 12*SCS [MHz]	A-MPR (dB)
5885	≤ 7	≤ 16
	> 7 and ≤ 12	≤ 10.5
	> 12 and ≤ 19	≤ 4.0
	> 19 and ≤ 25	≤ 10.5
	> 25	≤ 16

#### 6.2E.3.4 A-MPR for V2X concurrent operation

For the inter-band concurrent NR V2X operation, the allowed additional maximum power reduction (A-MPR) for the maximum output power shall be applied per each component carrier. The A-MPR requirements in clause 6.2.3 apply for NR Uu operation in licensed band, and the A-MPR requirements in clause 6.2E.3.2 and 6.2E.3.3 apply for NR sidelink operation in Band n47.

For the intra-band concurrent NR V2X operation, the A-MPR requirements in [6.2E.3.4] apply for NR Uu and SL concurrent operation in the licensed band.

### 6.2E.3F UE additional maximum output power reduction for Sidelink Unlicensed

#### 6.2E.3F.1 General

Additional emission requirements can be signalled by the network or pre-configured radio parameters. Each additional emission requirement is associated with a unique network signalling (NS) value indicated in RRC signalling by an NR frequency band number of the applicable operating band and an associated value in the field *additionalSpectrumEmission*. Throughout this specification, the notion of indication or signalling of an NS value refers to the corresponding indication of an NR frequency band number of the applicable operating band, the IE field *freqBandIndicatorNR* and an associated value of *additionalSpectrumEmission* in the relevant RRC information elements [7].

To meet the additional requirements, additional maximum power reduction (A-MPR) is allowed for the maximum output power as specified in Table 6.2E.1F-1. Unless stated otherwise, the total reduction to UE maximum output power is max(MPR, A-MPR) where MPR is defined in clause 6.2E.2F.

Table 6.2E.3F.1-1 specifies the additional requirements with their associated network signalling values and the allowed A-MPR and applicable operating band(s) for each NS value. The mapping of NR frequency band numbers and values of the *additionalSpectrumEmission* to network signalling labels is specified in Table 6.2E.3F.1-1A.



Table 6.2E.3F.1-1: Additional maximum power reduction (A-MPR)

Network signalling label	Requirements (clause)	NR Band	Channel bandwidth (MHz)	Resources blocks ( $N_{RB}$ )	A-MPR (clause)
NS_01		n46, n96	20, 40, 60, 80		N/A
NS_28	6.5F.3.3.1, 6.2F.1	n46	20, 40, 60, 80		6.2E.3F.8
NS_29	6.5F.3.3.2, 6.2F.1	n46	20, 40, 60, 80		6.2E.3F.9
NS_30	6.5F.3.3.3, 6.2F.1	n46	20, 40, 60, 80		6.2E.3F.10
NS_31	6.5F.3.3.4, 6.2F.1	n46	20, 40, 60, 80		6.2E.3F.2
NS_54	6.5F.3.3.5, 6.2F.1	n96	20, 40, 60, 80		6.2E.3F.11
NS_61	6.5F.3.3.7, 6.2F.1	n96	20, 40, 60, 80, 100		6.2E.3F.6
NS_64	6.5F.3.3.9, 6.2F.1	n102	20, 40, 60, 80, 100		6.2E.3F.14
NS_65	6.2F.1	n102	20, 40, 60, 80, 100		6.2E.3F.15
NS_66	6.5F.3.3.5, 6.2F.1	n96	20, 40, 60, 80, 100		6.2E.3F.16
NS_67	6.5F.3.3.5, 6.2F.1	n96	20, 40, 60, 80, 100		6.2E.3F.17
NS_68	6.2F.1	n102	20, 40, 60, 80, 100		6.2E.3F.18
NS_69	6.5F.3.3.8	n102	20, 40, 80		6.2E.3F.19
NS_71	6.5F.3.3.5, 6.2F.1	n96	20, 40, 60, 80, 100		6.2E.3F.17

NOTE 1: The A-MPR shall apply to all active 20 MHz sub-bands contiguously allocated in the channel.

[The NS\_01 label with the field *additionalPmax* [7] absent is default for all NR bands.]

Table 6.2E.3F.1-1A: Mapping of network signaling label

NR band	Value of additionalSpectrumEmission							
	0	1	2	3	4	5	6	7
n46	NS_01	NS_28	NS_29	NS_30	NS_31			Reserved
n96	NS_01		NS_54			NS_61		Reserved
n102	NS_01							Reserved

NOTE: *additionalSpectrumEmission* corresponds to an information element of the same name defined in clause 6.3.2 of TS 38.331 [7].

Table 6.2E.3F.1-1B: Mapping of extended network signaling label

NR band	Value of extendedAdditionalSpectrumEmission							
	8	9	10	11	12	13	14	15
n96	NS_66	NS_67	NS_71					
n102	NS_64	NS_65	NS_68	NS_69				

NOTE: *extendedAdditionalSpectrumEmission* corresponds to an information element of the name [EXTENDED\_ *additionalSpectrumEmission*] defined in clause 6.3.2 of TS 38.331 [7].

## 6.2E.3F.2 A-MPR for NS\_31

When NS\_31 is indicated by the network or pre-configured radio parameters for NR sidelink UE, this clause specifies the allowed Maximum Power Reduction (MPR) power for NR sidelink physical channels and signals due to PSCCH/PSSCH, PSFCH and S-SSB transmission.

For contiguous allocation of PSCCH and PSSCH simultaneous transmission, the allowed A-MPR is specified in Table 6.2E.3F.2-1 for power class 5 NR sidelink UE.

Table 6.2E.3F.2-1: A-MPR for NS\_31 NR SL-U UE power class 5

Pre-coding	Modulation	RB Allocation (Note 4)				RB Allocation (Note 3)
		Outer RB set configuration <sup>5</sup>		Inner RB set configuration <sup>5</sup>		
		Full (dB)	Partial (dB)	Full (dB)	Partial (dB)	
						Full/Partial

CP-OFDM	QPSK	$\leq 5.5$	$\leq 6.5$	$\leq 4.5$	$\leq 6.5$	See Table 6.2E.2F-1
	16 QAM	$\leq 5.5$	$\leq 7.0$	$\leq 4.5$	$\leq 7.0$	
	64 QAM	$\leq 5.5$	$\leq 7.0$	$\leq 4.5$	$\leq 7.0$	
	256 QAM	$\leq 7.5$	$\leq 7.5$	$\leq 7.5$	$\leq 7.5$	

NOTE 1: The A-MPR shall apply to all SCS in all active 20 MHz sub-bands contiguously allocated in the channel.  
NOTE 2: Full allocation A-MPR applies when all RB's in a 20 MHz channel or all RB's in all sub-bands for wideband operation are fully allocated and all sub-bands are transmitted. Partial allocation A-MPR applies when one or more RB's in one or more sub-bands are not allocated or when not all transmitted sub-bands for wideband operation are transmitted.  
NOTE 3: Applicable for 20 MHz channels centered at the nearest NR-ARFCN corresponding to 5180, 5200, 5220, 5280, 5300, 5320, 5500, 5520, 5540, 5560, 5580, 5600, 5620, 5640, 5660, 5680, 5745, 5765, 5785, and 5805 MHz.  
NOTE 4: Applicable for all valid channels and bandwidths other than those enumerated in NOTE 3.  
NOTE 5: Contiguous sub-band configuration in Table 6.2E.2F-3 applies.

For PSFCH transmission with single RB set and multiple RB sets, the allowed A-MPR is specified in Table 6.2E.3F.2-2 for power class 5 NR sidelink UE.

**Table 6.2E.3F.2-2: A-MPR for NS\_31 for PSFCH transmission for NR SL-U UE power class 5**

	RB Allocation	
	Outer RB set configuration <sup>2</sup>	Inner RB set configuration <sup>2</sup>
Contiguous/Non-contiguous sub-band RB sets	$\leq 12.5$	$\leq 12.5$

NOTE 1: The MPR shall apply to all SCS in all active 20 MHz sub-bands contiguously or non-contiguously allocated in the channel.  
NOTE 2: Outer sub-band configuration and inner sub-band configuration in Table 6.2E.2F-3 apply.  
NOTE 3: Void  
NOTE 4: Void

For S-SSB transmission, the allowed A-MPR is specified in Table 6.2E.3F.2-3 for power class 5 NR sidelink UE.

**Table 6.2E.3F.2-3: A-MPR for NS\_31 for S-SSB transmission for NR SL-U UE power class 5**

	RB Allocation			
	Outer RB set configuration		Inner RB set configuration	
# of S-SSB repetition/RBset	> 2	2	> 2	2
Contiguous/Non-contiguous sub-band RB sets	$\leq 13.5$	$\leq 10.0$	$\leq 10.0$	$\leq 10.0$

NOTE 1: The A-MPR shall apply to all SCS in all active 20 MHz sub-bands contiguously or non-contiguously allocated in the channel.  
NOTE 2: Void  
NOTE 3: Void

6.2E.3F.3 Void

6.2E.3F.4 Void

6.2E.3F.5 Void

6.2E.3F.6 A-MPR for NS\_61

When NS\_61 is indicated by the network or pre-configured radio parameters for NR sidelink UE, this clause specifies the allowed Maximum Power Reduction (MPR) power for NR sidelink physical channels and signals due to PSCCH/PSSCH, PSFCH and S-SSB transmission.

For contiguous allocation of PSCCH and PSSCH simultaneous transmission, the allowed A-MPR is specified in Table 6.2E.3F.6-1 for power class 5 NR sidelink UE.

**Table 6.2E.3F.6-1: A-MPR for NS\_61 NR SL-U UE power class 5**

Pre-coding	Modulation	Channel bandwidth (Sub-band allocation) / RB Allocation									
		20MHz		40MHz		60MHz		80MHz		100MHz	
		Full (dB)	Partial (dB)	Full (dB)	Partial (dB)	Full (dB)	Partial (dB)	Full (dB)	Partial (dB)	Full (dB)	Partial (dB)
CP-OFDM	QPSK	≤ 7.5	≤ 10.0	≤ 6.5	≤ 6.5	≤ 6.0	≤ 6.0	≤ 6.0	≤ 6.0	≤ 6.0	≤ 6.0
	16 QAM	≤ 7.5	≤ 10.5	≤ 6.5	≤ 6.5	≤ 6.0	≤ 6.0	≤ 6.0	≤ 6.0	≤ 6.0	≤ 6.0
	64 QAM	≤ 7.5	≤ 10.5	≤ 6.5	≤ 6.5	≤ 6.0	≤ 6.0	≤ 6.0	≤ 6.0	≤ 6.0	≤ 6.0
	256 QAM	≤ 8.0	≤ 10.5	≤ 8.0	≤ 7.0	≤ 8.0	≤ 7.0	≤ 8.0	≤ 7.0	≤ 8.0	≤ 7.0
NOTE 1: The A-MPR shall apply to all SCS in all active 20 MHz sub-bands contiguously allocated in the channel.											
NOTE 2: Full allocation A-MPR applies when all RB's in a 20 MHz channel or all RB's in all sub-bands for wideband operation are fully allocated and all sub-bands are transmitted. Partial allocation A-MPR applies when one or more RB's in one or more sub-bands are not allocated but when all sub-bands within the channel are transmitted. When not all sub-bands within the channel are transmitted, the A-MPR associated with the channel bandwidth according to the bandwidth of the contiguously transmitted sub-bands and according to the allocation type applies											

For PSFCH transmission with single RB set and multiple RB sets, the allowed A-MPR is specified in Table 6.2E.3F.6-2 for power class 5 NR sidelink UE.

**Table 6.2E.3F.6-2: A-MPR for NS\_61 for PSFCH transmission for NR SL-U UE power class 5**

RB set configuration	Channel bandwidth (Sub-band allocation) / RB Allocation				
	20MHz	40MHz	60MHz	80MHz	100MHz
Contiguous/Non-contiguous	≤12.5	≤12.5	≤12.5	≤12.5	≤12.5
NOTE 1: The A-MPR shall apply to all SCS in all active 20 MHz sub-bands contiguously or non-contiguously allocated in the channel.					

For S-SSB transmission, the allowed A-MPR is specified in Table 6.2E.3F.6-3 for power class 5 NR sidelink UE.

**Table 6.2E.3F.6-3: A-MPR for NS\_61 for S-SSB transmission for NR SL-U UE power class 5**

RB set configuration	Channel bandwidth (Sub-band allocation) / RB Allocation									
	20MHz		40MHz		60MHz		80MHz		100MHz	
# of S-SSB repetition/RBset	> 2	2	> 2	2	> 2	2	> 2	2	> 2	2

Contiguous/Non-contiguous	≤13.5	≤15.5	≤13.5	≤15.5	≤13.5	≤13.5	≤13.5	≤13.5	≤13.5	≤13.5
NOTE 1: The A-MPR shall apply to all SCS in all active 20 MHz sub-bands contiguously or non-contiguously allocated in the channel.										

### 6.2E.3F.7 A-MPR for SL-U concurrent operation

For NR SL-U inter-band concurrent operation, the allowed additional maximum power reduction (A-MPR) for the maximum output power shall be applied per each component carrier. The A-MPR requirements in clause 6.2.3 apply for NR Uu operation in licensed band, and the A-MPR requirements in clause 6.2E.3F apply for NR sidelink operation in unlicensed band, n46, n96 and n102.

### 6.2E.3F.8 A-MPR for NS\_28

When NS\_28 is indicated by the network or pre-configured radio parameters for NR sidelink UE, this clause specifies the allowed Maximum Power Reduction (MPR) power for NR sidelink physical channels and signals due to PSCCH/PSSCH, PSFCH and S-SSB transmission.

For contiguous allocation of PSCCH and PSSCH simultaneous transmission, the allowed A-MPR is specified in Table 6.2F.3F.8-1 for power class 5 NR sidelink UE.

**Table 6.2E.3F.8-1: A-MPR for NS\_28 NR SL-U UE power class 5**

Pre-coding	Modulation	RB Allocation (Note 3)				RB Allocation (Note 4)
		Outer RB set configuration <sup>5</sup>		Inner RB set configuration <sup>5</sup>		
		Full (dB)	Partial (dB)	Full (dB)	Partial (dB)	Full/Partial
CP-OFDM	QPSK	≤ 6.0	≤ 7.0	≤ 4.0	≤ 5.0	Table 6.2E.2F-1
	16 QAM	≤ 6.0	≤ 7.5	≤ 4.0	≤ 5.0	
	64 QAM	≤ 6.5	≤ 7.5	≤ 4.5	≤ 5.5	
	256 QAM	≤ 8.0	≤ 8.5	≤ 7.5	≤ 7.5	
NOTE 1: The A-MPR shall apply to all SCS in all active 20 MHz sub-bands contiguously allocated in the channel.						
NOTE 2: Full allocation A-MPR applies when all RB's in a 20 MHz channel or all RB's in all sub-bands for wideband operation are fully allocated and all sub-bands are transmitted. Partial allocation A-MPR applies when one or more RB's in one or more sub-bands are not allocated or when not all transmitted sub-bands for wideband operation are transmitted.						
NOTE 3: Applicable for 20 MHz channels centered at the nearest NR-ARFCN corresponding to 5160, 5340, 5480, and 5700 MHz, 40 MHz channels centered at the nearest NR-ARFCN corresponding to 5170, 5190, 5310, 5330, 5490, and 5510 MHz, 60 MHz channels centered at the nearest NR-ARFCN corresponding to 5180, 5200, 5300, 5320, 5500, 5520, 5680 MHz, and 80 MHz channels centered at the nearest NR-ARFCN corresponding to 5190, 5210, 5290, 5310, 5510, and 5530 MHz.						
NOTE 4: Applicable for all valid channels other than those enumerated under NOTE 3.						
NOTE 5: Contiguous outer sub-band configuration and contiguous inner sub-band configuration in Table 6.2E.2F-3 apply.						
NOTE 6: In current release larger CBW than 80MHz are not applicable for this network signalling.						

For PSFCH transmission with single RB set and multiple RB sets, the allowed A-MPR is specified in Table 6.2E.3F.8-2 for power class 5 NR sidelink UE.

**Table 6.2E.3F.8-2: A-MPR for NS\_28 for PSFCH transmission for NR SL-U UE power class 5**

	RB Allocation <sup>2</sup>	RB Allocation <sup>3</sup>
--	----------------------------	----------------------------

	Outer RB set configuration	Inner RB set configuration	Outer/Inner RB sets
Contiguous/Non-contiguous sub-band RB sets	$\leq 15.0$	$\leq 12.5$	Table 6.2E.2F-4(TS38.101-1)
NOTE 1: The A-MPR shall apply to all SCS in all active 20 MHz sub-bands contiguously or non-contiguously allocated in the channel.			
NOTE 2: Applicable for 20 MHz channels centered at the nearest NR-ARFCN corresponding to 5160, 5340, and 5480 MHz, 40 MHz channels centered at the nearest NR-ARFCN corresponding to 5170, 5190, 5310, 5330, and 5490 MHz, 60 MHz hannels centered at the nearest NR-ARFCN corresponding to 5180, 5200, 5220, 5280, 5300, 5320, 5500, 5520, 5540, 5680 MHz, and 80 MHz channels centered at the nearest NR-ARFCN corresponding to 5190, 5210, 5290, 5310, 5510, 5530, and 5610 MHz.			
NOTE 3: Applicable for all valid channels other than those enumerated under NOTE 3.			
NOTE 4: Void			
NOTE 5: In current release larger CBW than 80MHz are not applicable for this network signalling.			

For S-SSB transmission, the allowed A-MPR is specified in Table 6.2E.3F.8-3 for power class 5 NR sidelink UE.

**Table 6.2E.3F.8-3: A-MPR for NS\_28 for S-SSB transmission for NR SL-U UE power class 5**

# of S-SSB repetition/RBset	RB Allocation <sup>2</sup>				RB Allocation <sup>3</sup> Outer/Inner RB sets
	Outer RB set configuration		Inner RB set configuration		
	> 2	2	> 2	2	
Contiguous/Non-contiguous sub-band RB sets	$\leq 13.5$	$\leq 10.0$	$\leq 10.0$	$\leq 8.5$	Table 6.2E.2F-5(TS38.101-1)
NOTE 1: The A-MPR shall apply to all SCS in all active 20 MHz sub-bands contiguously or non-contiguously allocated in the channel.					
NOTE 2: Applicable for 40 MHz channels centered at the nearest NR-ARFCN corresponding to 5965 MHz, 60 MHz channels centered at the nearest NR-ARFCN corresponding to 5975 MHz, and 80 MHz channels centered at the nearest NR-ARFCN corresponding to 5985 MHz.					
NOTE 3: Applicable for all valid channels and bandwidths other than those enumerated under NOTE 2.					
NOTE 4: Void					
NOTE 5: In current release larger CBW than 80MHz are not applicable for this network signalling.					

### 6.2E.3F.9 A-MPR for NS\_29

When NS\_29 is indicated by the network or pre-configured radio parameters for NR sidelink UE, this clause specifies the allowed Maximum Power Reduction (MPR) power for NR sidelink physical channels and signals due to PSCCH/PSSCH, PSFCH and S-SSB transmission.

For contiguous allocation of PSCCH and PSSCH simultaneous transmission, the allowed A-MPR is specified in Table 6.2E.3F.9-1 for power class 5 NR sidelink UE.

**Table 6.2E.3F.9-1: A-MPR for NS\_29 NR SL-U UE power class 5**

Pre-coding	Modulation	Channel bandwidth (Sub-band allocation) / RB Allocation							
		20MHz		40MHz		60MHz		80MHz	
		Full (dB)	Partial (dB)	Full (dB)	Partial (dB)	Full (dB)	Partial (dB)	Full (dB)	Partial (dB)
CP-OFDM	QPSK	$\leq 4.5$	$\leq 7.5$	$\leq 3.5$	$\leq 4.5$	$\leq 3.5$	$\leq 4.0$	$\leq 3.5$	$\leq 4.0$
	16 QAM	$\leq 5.0$	$\leq 7.5$	$\leq 4.0$	$\leq 4.5$	$\leq 4.0$	$\leq 4.0$	$\leq 4.0$	$\leq 4.0$

	64 QAM	≤ 5.5	≤ 7.5	≤ 5.5	≤ 5.5	≤ 5.5	≤ 5.0	≤ 5.5	≤ 5.0
	256 QAM	≤ 7.5	≤ 7.5	≤ 7.5	≤ 7.5	≤ 7.5	≤ 7.5	≤ 7.5	≤ 7.5
NOTE 1: The A-MPR shall apply to all SCS in all active 20 MHz sub-bands contiguously allocated in the channel.									
NOTE 2: Full allocation A-MPR applies when all RB's in a 20 MHz channel or all RB's in all sub-bands for wideband operation are fully allocated and all sub-bands are transmitted. Partial allocation A-MPR applies when one or more RB's in one or more sub-bands are not allocated but when all sub-bands within the channel are transmitted. When not all sub-bands within the channel are transmitted, the A-MPR associated with the channel bandwidth according to the bandwidth of the contiguously transmitted sub-bands and according to the allocation type applies.									
NOTE 3: In current release larger CBW than 80MHz are not applicable for this network signalling.									

For PSFCH transmission with single RB set and multiple RB sets, the allowed A-MPR is specified in Table 6.2E.3F.9-2 for power class 5 NR sidelink UE.

**Table 6.2E.3F.9-2: A-MPR for NS\_29 for PSFCH transmission for NR SL-U UE power class 5**

RB set configuration	Channel bandwidth (Sub-band allocation) / RB Allocation			
	20MHz (Full/Partial)	40MHz (Full/Partial)	60MHz (Full/Partial)	80MHz (Full/Partial)
Contiguous/Non-contiguous sub-band RB sets	≤ 11.0	≤12.5	≤13.5	≤15.5
NOTE 1: The A-MPR shall apply to all SCS in all active 20 MHz sub-bands contiguously or non-contiguously allocated in the channel.				
NOTE 2: Larger CBW than 80MHz are not applicable for this network signalling.				

For S-SSB transmission, the allowed A-MPR is specified in Table 6.2E.3F.9-3 for power class 5 NR sidelink UE.

**Table 6.2E.3F.9-3: A-MPR for NS\_29 for S-SSB transmission for NR SL-U UE power class 5**

RB set configuration	Channel bandwidth (Sub-band allocation) / RB Allocation							
	20MHz		40MHz		60MHz		80MHz	
# of S-SSB repetition/RBset	> 2	2	> 2	2	> 2	2	> 2	2
Contiguous/Non-contiguous	≤ 11.5	≤ 8.0	≤12.0	≤10.0	≤12.0	≤10.0	≤12.5	≤10.0
NOTE 1: The A-MPR shall apply to all SCS in all active 20 MHz sub-bands contiguously or non-contiguously allocated in the channel.								

### 6.2E.3F.10 A-MPR for NS\_30

When NS\_30 is indicated by the network or pre-configured radio parameters for NR sidelink UE, this clause specifies the allowed Maximum Power Reduction (MPR) power for NR sidelink physical channels and signals due to PSCCH/PSSCH, PSFCH and S-SSB transmission.

For contiguous allocation of PSCCH and PSSCH simultaneous transmission, the allowed A-MPR is specified in Table 6.2E.3F.10-1 for power class 5 NR sidelink UE.

**Table 6.2E.3F.10-1: A-MPR for NS\_30 NR SL-U UE power class 5**

Pre-coding	Modulation	RB Allocation <sup>3</sup>		RB Allocation <sup>4</sup>		RB Allocation (Note 5)
		Outer RB set configuration	Inner RB set configuration	Outer RB set configuration	Inner RB set configuration	

		Full	Partial	Full	Partial	Full	Partial	Full	Partial	Full/Partial
		(dB)	(dB)	(dB)	(dB)	(dB)	(dB)	(dB)	(dB)	
CP-OFDM	QPSK	≤ 10.0	≤ 12.0	≤ 7.0	≤ 7.5	≤ 6.0	≤ 7.0	≤ 3.0	≤ 2.0	Table 6.2E.2F-1
	16 QAM	≤ 10.0	≤ 12.5	≤ 7.0	≤ 7.5	≤ 6.0	≤ 7.0	≤ 3.0	≤ 2.0	
	64 QAM	≤ 10.0	≤ 13.0	≤ 7.0	≤ 7.5	≤ 6.0	≤ 7.0	≤ 4.0	≤ 3.0	
	256 QAM	≤ 10.5	≤ 13.5	≤ 7.5	≤ 8.0	≤ 7.5	≤ 7.5	≤ 7.5	≤ 7.5	

NOTE 1: The A-MPR shall apply to all SCS in all active 20 MHz sub-bands contiguously allocated in the channel.  
NOTE 2: Full allocation A-MPR applies when all RB's in a 20 MHz channel or all RB's in all sub-bands for wideband operation are fully allocated and all sub-bands are transmitted. Partial allocation A-MPR applies when one or more RB's in one or more sub-bands are not allocated or when not all transmitted sub-bands for wideband operation are transmitted.  
NOTE 3: Applicable for 20 MHz channels centered at the nearest NR-ARFCN corresponding to 5160, 5340, and 5480 MHz, 40 MHz channels centered at the nearest NR-ARFCN corresponding to 5170, 5190, 5310, 5330, and 5490 MHz, 60 MHz channels centered at the nearest NR-ARFCN corresponding to 5180, 5200, 5300, 5320, 5500, and 5520 MHz, and 80 MHz channels centered at the nearest NR-ARFCN corresponding to 5190, 5210, 5290, 5310, 5510, and 5530 MHz.  
NOTE 4: Applicable for 20 MHz channels centered at the nearest NR-ARFCN corresponding to 5180 and 5320 MHz, and 40 MHz channels centered at the nearest NR-ARFCN corresponding to 5510 MHz, and 60 MHz channels centered at the nearest NR-ARFCN corresponding to 5220, 5280, 5540, and 5680 MHz.  
NOTE 5: Applicable for all valid channels other than those enumerated under NOTE 3 and NOTE 4.  
NOTE 6: In current release larger CBW than 80MHz are not applicable for this network signalling.

For PSFCH transmission with single RB set and multiple RB sets, the allowed A-MPR is specified in Table 6.2E.3F.10-2 for power class 5 NR sidelink UE.

**Table 6.2E.3F.10-2: A-MPR for NS\_30 for PSFCH transmission for NR SL-U UE power class 5**

RB set configuration	RB Allocation /Centre frequency of CBW (MHz)			
	RB Allocation <sup>2</sup>		RB Allocation <sup>3</sup>	
	Outer RB set configuration	Inner RB set configuration	Outer RB set configuration	Inner RB set configuration
Contiguous/Non-contiguous sub-band RB sets	≤ 36.0	≤ 16.0	≤ 15.5	≤ 12.5

NOTE 1: The A-MPR shall apply to all SCS in all active 20 MHz sub-bands contiguously or non-contiguously allocated in the channel.  
NOTE 2: Applicable for 20 MHz channels centered at the nearest NR-ARFCN corresponding to 5160, 5340, and 5480 MHz, 40 MHz channels centered at the nearest NR-ARFCN corresponding to 5170, 5190, 5310, 5330, 5490, and 5510 MHz, 60 MHz channels centered at the nearest NR-ARFCN corresponding to 5180, 5200, 5300, 5320, 5500, and 5520 MHz, and 80 MHz channels centered at the nearest NR-ARFCN corresponding to 5190, 5210, 5290, 5310, 5510, and 5530 MHz.  
NOTE 3: Applicable for all valid channels other than those enumerated under NOTE 2.  
NOTE 4: In current release larger CBW than 80MHz are not applicable for this network signalling.

For S-SSB transmission, the allowed A-MPR is specified in Table 6.2E.3F.10-3 for power class 5 NR sidelink UE.

**Table 6.2E.3F.10-3: A-MPR for NS\_30 for S-SSB transmission for NR SL-U UE power class 5**

	RB Allocation <sup>2</sup>				RB Allocation <sup>3</sup>			
	Outer RB set configuration		Inner RB set configuration		Outer RB set configuration		Inner RB set configuration	
# of S-SSB repetition/RBset	> 2	2	> 2	2	> 2	2	> 2	2
Contiguous/ Non-contiguous sub-band RB sets	≤ 35.5	≤ 28.0	≤ 13.5	≤ 11.0	≤ 13.0	≤ 11.0	≤ 10.5	≤ 8.5

NOTE 1: The A-MPR shall apply to all SCS in all active 20 MHz sub-bands contiguously or non-contiguously allocated in the channel.

NOTE 2: Applicable for 20 MHz channels centered at the nearest NR-ARFCN corresponding to 5160, 5340, and 5480 MHz, 40 MHz channels centered at the nearest NR-ARFCN corresponding to 5170, 5190, 5310, 5330, and 5490 MHz, 60 MHz channels centered at the nearest NR-ARFCN corresponding to 5180, 5200, 5300, 5320, 5500, and 5520 MHz, and 80 MHz channels centered at the nearest NR-ARFCN corresponding to 5190, 5210, 5290, 5310, 5510, and 5530 MHz.

NOTE 3: Applicable for all valid channels other than those enumerated under NOTE 2.

NOTE 4: In current release larger CBW than 80MHz are not applicable for this network signalling.

### 6.2E.3F.11 A-MPR for NS\_54

When NS\_54 is indicated by the network or pre-configured radio parameters for NR sidelink UE, this clause specifies the allowed Maximum Power Reduction (MPR) power for NR sidelink physical channels and signals due to PSCCH/PSSCH, PSFCH and S-SSB transmission.

For contiguous allocation of PSCCH and PSSCH simultaneous transmission, the allowed A-MPR is specified in Table 6.2E.3F.11-1 for power class 5 NR sidelink UE.

**Table 6.2E.3F.11-1: A-MPR for NS\_54 NR SL-U UE power class 5**

Pre-coding	Modulation	RB Allocation (Note 3)				RB Allocation (Note 4)
		Outer RB set configuration <sup>5</sup>		Inner RB set configuration <sup>5</sup>		
		Full (dB)	Partial (dB)	Full (dB)	Partial (dB)	Full/Partial
CP-OFDM	QPSK	≤ 4.5	≤ 6.0	≤ 4.5	≤ 2.0	Table 6.2E.2F-1
	16 QAM	≤ 4.5	≤ 6.0	≤ 4.5	≤ 3.0	
	64 QAM	≤ 5.5	≤ 6.0	≤ 5.5	≤ 5.5	
	256 QAM	≤ 7.5	≤ 7.5	≤ 7.5	≤ 7.5	
NOTE 1: The A-MPR shall apply to all SCS in all active 20 MHz sub-bands contiguously allocated in the channel.						
NOTE 2: Full allocation A-MPR applies when all RB's in a 20 MHz channel or all RB's in all sub-bands for wideband operation are fully allocated and all sub-bands are transmitted. Partial allocation A-MPR applies when one or more RB's in one or more sub-bands are not allocated or when not all transmitted sub-bands for wideband operation are transmitted.						
NOTE 3: Applicable for 40 MHz channels centered at the nearest NR-ARFCN corresponding to 5965 MHz, 60 MHz channels centered at the nearest NR-ARFCN corresponding to 5975 MHz, and 80 MHz channels centered at the nearest NR-ARFCN corresponding to 5985 MHz.						
NOTE 4: Applicable for all valid channels other than those enumerated under NOTE 3.						
NOTE 5: Contiguous outer sub-band configuration and contiguous inner sub-band configuration in Table 6.2E.2F-3 apply.						
NOTE 6: In current release larger CBW than 80MHz are not applicable for this network signalling.						

For PSFCH transmission with single RB set and multiple RB sets, the allowed A-MPR is specified in Table 6.2E.3F.11-2 for power class 5 NR sidelink UE.

**Table 6.2E.3F.11-2: A-MPR for NS\_54 for PSFCH transmission for NR SL-U UE power class 5**

	RB Allocation <sup>2</sup>		RB Allocation <sup>3</sup>
	Outer RB set configuration	Inner RB set configuration	Outer/Inner RB sets
Contiguous/Non-contiguous sub-band RB sets	≤ 15.0	≤ 12.5	Table 6.2E.2F-4
NOTE 1: The A-MPR shall apply to all SCS in all active 20 MHz sub-bands contiguously or non-contiguously allocated in the channel.			
NOTE 2: Applicable for 40 MHz channels centered at the nearest NR-ARFCN corresponding to 5965 MHz, 60 MHz channels centered at the nearest NR-ARFCN corresponding to 5975 MHz, and 80 MHz channels centered at the nearest NR-ARFCN corresponding to 5985 MHz.			
NOTE 3: Applicable for all valid channels and bandwidths other than those enumerated under NOTE 2.			



NOTE 4: Void

NOTE 5: In current release larger CBW than 80MHz are not applicable for this network signalling.

For S-SSB transmission, the allowed A-MPR is specified in Table 6.2E.3F.11-3 for power class 5 NR sidelink UE.

**Table 6.2E.3F.11-3: A-MPR for NS\_54 for S-SSB transmission for NR SL-U UE power class 5**

# of S-SSB repetition/RBset	RB Allocation <sup>2</sup>				RB Allocation <sup>3</sup>
	Outer RB set configuration		Inner RB set configuration		Outer/Inner RB sets
	> 2	2	> 2	2	
Contiguous/Non-contiguous sub-band RB sets	≤ 13.5	≤ 10.0	≤ 10.0	≤ 8.5	Table 6.2E.2F-5
NOTE 1: The A-MPR shall apply to all SCS in all active 20 MHz sub-bands contiguously or non-contiguously allocated in the channel.					
NOTE 2: Applicable for 40 MHz channels centered at the nearest NR-ARFCN corresponding to 5965 MHz, 60 MHz channels centered at the nearest NR-ARFCN corresponding to 5975 MHz, and 80 MHz channels centered at the nearest NR-ARFCN corresponding to 5985 MHz.					
NOTE 3: Applicable for all valid channels and bandwidths other than those enumerated under NOTE 2.					
NOTE 4: Void					
NOTE 5: In current release larger CBW than 80MHz are not applicable for this network signalling.					

### 6.2E.3F.12 A-MPR for NS\_64

When NS\_64 is indicated by the network or pre-configured radio parameters for NR sidelink UE, this clause specifies the allowed Maximum Power Reduction (MPR) power for NR sidelink physical channels and signals due to PSCCH/PSSCH, PSFCH and S-SSB transmission.

For contiguous allocation of PSCCH and PSSCH simultaneous transmission, the allowed A-MPR is specified in Table 6.2E.3F.12-1 for power class 5 NR sidelink UE.

**Table 6.2E.3F.12-1: A-MPR for NS\_64 NR SL-U UE power class 5**

Pre-coding	Modulation	RB Allocation <sup>3</sup>				RB Allocation <sup>4</sup>			
		Outer RB set configuration		Inner RB set configuration		Outer RB set configuration		Inner RB set configuration	
		Full (dB)	Partial (dB)	Full (dB)	Partial (dB)	Full (dB)	Partial (dB)	Full (dB)	Partial (dB)
CP-OFDM	QPSK	≤ 14.0	≤ 15.0	≤ 9.0	≤ 11.5	≤ 9.0	≤ 11.5	≤ 8.5	≤ 11.5
	16 QAM	≤ 14.0	≤ 15.0	≤ 9.0	≤ 11.5	≤ 9.0	≤ 11.5	≤ 8.5	≤ 11.5
	64 QAM	≤ 14.0	≤ 15.0	≤ 9.0	≤ 11.5	≤ 9.0	≤ 11.5	≤ 8.5	≤ 11.5
	256 QAM	≤ 15.0	≤ 15.0	≤ 9.0	≤ 11.5	≤ 9.0	≤ 11.5	≤ 8.5	≤ 11.5
NOTE 1: The A-MPR shall apply to all SCS in all active 20 MHz sub-bands contiguously allocated in the channel.									
NOTE 2: Full allocation A-MPR applies when all RB's in a 20 MHz channel or all RB's in all sub-bands for wideband operation are fully allocated and all sub-bands are transmitted. Partial allocation A-MPR applies when one or more RB's in one or more sub-bands are not allocated or when not all transmitted sub-bands for wideband operation are transmitted.									
NOTE 3: Applicable for 20 MHz channels centered at the nearest NR-ARFCN corresponding to 5955 MHz, 40 MHz channels centered at the nearest NR-ARFCN corresponding to 5965 MHz, 60 MHz channels centered at the nearest NR-ARFCN corresponding to 5975 MHz, 80 MHz channels centered at the nearest NR-ARFCN corresponding to 5985 MHz, and 100 MHz channels centered at the nearest NR-ARFCN corresponding to 5995 MHz.									
NOTE 4: Applicable for all valid channels other than those enumerated under NOTE 3.									

For PSFCH transmission with single RB set and multiple RB sets, the allowed A-MPR is specified in Table 6.2E.3F.12-2 for power class 5 NR sidelink UE.

**Table 6.2E.3F.12-2: A-MPR for NS<sub>64</sub> for PSFCH transmission for NR SL-U UE power class 5**

	RB Allocation <sup>2</sup>		RB Allocation <sup>3</sup>	
	Outer RB set configuration	Inner RB set configuration	Outer RB set configuration	Inner RB set configuration
Contiguous/Non-contiguous sub-band RB sets	≤36.0	≤32.0	≤13.5	≤12.5
NOTE 1: The A-MPR shall apply to all SCS in all active 20 MHz sub-bands contiguously allocated in the channel.				
NOTE 2: Applicable for 20 MHz channels centered at the nearest NR-ARFCN corresponding to 5955 MHz, 40 MHz channels centered at the nearest NR-ARFCN corresponding to 5965 MHz, 60 MHz channels centered at the nearest NR-ARFCN corresponding to 5975 and 5995 MHz, 80 MHz channels centered at the nearest NR-ARFCN corresponding to 5985 MHz, and 100 MHz channels centered at the nearest NR-ARFCN corresponding to 5995 and 6055 MHz.				
NOTE 3: Applicable for all valid channels other than those enumerated under NOTE 2.				

For S-SSB transmission, the allowed A-MPR is specified in Table 6.2E.3F.12-3 for power class 5 NR sidelink UE.

**Table 6.2E.3F.12-3: A-MPR for NS<sub>64</sub> for S-SSB transmission for NR SL-U UE power class 5**

	RB Allocation <sup>2</sup>				RB Allocation <sup>3</sup>			
	Outer RB set configuration		Inner RB set configuration		Outer RB set configuration		Inner RB set configuration	
# of S-SSB repetition/RBset	> 2	2	> 2	2	> 2	2	> 2	2
Contiguous/ Non-contiguous sub-band RB sets	≤ 35.0	≤ 32.0	≤ 24.0	≤ 13.0	≤ 11.5	≤ 15.5	≤ 10.0	≤ 12.5
NOTE 1: The A-MPR shall apply to all SCS in all active 20 MHz sub-bands contiguously or non-contiguously allocated in the channel.								
NOTE 2: Applicable for 20 MHz channels centered at the nearest NR-ARFCN corresponding to 5955 MHz, 40 MHz channels centered at the nearest NR-ARFCN corresponding to 5965 MHz, 60 MHz channels centered at the nearest NR-ARFCN corresponding to 5975 and 5995 MHz, 80 MHz channels centered at the nearest NR-ARFCN corresponding to 5985 MHz and 100 MHz channels centered at the nearest NR-ARFCN corresponding to 5995 and 6055 MHz.								
NOTE 3: Applicable for all valid channels other than those enumerated under NOTE 2.								

### 6.2E.3F.13 A-MPR for NS<sub>65</sub>

When NS<sub>65</sub> is indicated by the network or pre-configured radio parameters for NR sidelink UE, this clause specifies the allowed Maximum Power Reduction (MPR) power for NR sidelink physical channels and signals due to PSCCH/PSSCH, PSFCH and S-SSB transmission.

For contiguous allocation of PSCCH and PSSCH simultaneous transmission, the allowed A-MPR is specified in Table 6.2E.3F.13-1 for power class 5 NR sidelink UE.

**Table 6.2E.3F.13-1: A-MPR for NS<sub>65</sub> NR SL-U UE power class 5**

Pre-coding	Modulation	RB Allocation			
		Outer RB set configuration <sup>3</sup>		Inner RB set configuration <sup>3</sup>	
		Full (dB)	Partial (dB)	Full (dB)	Partial (dB)
CP-OFDM	QPSK	≤ 6.0	≤ 6.0	≤ 6.0	≤ 6.0
	16 QAM	≤ 6.0	≤ 6.0	≤ 6.0	≤ 6.0

	64 QAM	≤ 6.0	≤ 6.0	≤ 6.0	≤ 6.0
	256 QAM	≤ 7.0	≤ 7.5	≤ 7.0	≤ 7.5
NOTE 1: The A-MPR shall apply to all SCS in all active 20 MHz sub-bands contiguously allocated in the channel.					
NOTE 2: Full allocation A-MPR applies when all RB's in a 20 MHz channel or all RB's in all sub-bands for wideband operation are fully allocated and all sub-bands are transmitted. Partial allocation A-MPR applies when one or more RB's in one or more sub-bands are not allocated or when not all transmitted sub-bands for wideband operation are transmitted.					
NOTE 3: Contiguous outer sub-band configuration and contiguous inner sub-band configuration in Table 6.2E.2F-3 apply.					

For PSFCH transmission with single RB set and multiple RB sets, the allowed A-MPR is specified in Table 6.2E.3F.13-2 for power class 5 NR sidelink UE.

**Table 6.2E.3F.13-2: A-MPR for NS<sub>65</sub> for PSFCH transmission for NR SL-U UE power class 5**

	<b>RB Allocation<sup>2</sup></b>	
	<b>Outer RB set configuration</b>	<b>Inner RB set configuration</b>
Contiguous/Non-contiguous sub-band RB sets	≤ 16.0	≤ 12.5
NOTE 1: The A-MPR shall apply to all SCS in all active 20 MHz sub-bands contiguously or non-contiguously allocated in the channel.		

For S-SSB transmission, the allowed A-MPR is specified in Table 6.2E.3F.13-3 for power class 5 NR sidelink UE.

**Table 6.2E.3F.13-3: A-MPR for NS<sub>65</sub> for S-SSB transmission for NR SL-U UE power class 5**

	<b>RB Allocation</b>			
	<b>Outer RB set configuration</b>		<b>Inner RB set configuration</b>	
<b># of S-SSB repetition/RBset</b>	<b>&gt; 2</b>	<b>2</b>	<b>&gt; 2</b>	<b>2</b>
Contiguous/Non-contiguous sub-band RB sets	≤ 13.5	≤ 10.0	≤ 10.0	≤ 8.5
NOTE 1: The A-MPR shall apply to all SCS in all active 20 MHz sub-bands contiguously or non-contiguously allocated in the channel.				

#### 6.2E.3F.14 A-MPR for NS<sub>66</sub>

When NS<sub>66</sub> is indicated by the network or pre-configured radio parameters for NR sidelink UE, this clause specifies the allowed Maximum Power Reduction (MPR) power for NR sidelink physical channels and signals due to PSCCH/PSSCH, PSFCH and S-SSB transmission.

For contiguous allocation of PSCCH and PSSCH simultaneous transmission, the allowed A-MPR is specified in Table 6.2E.3F.14-1 for power class 5 NR sidelink UE.

**Table 6.2E.3F.14-1: A-MPR for NS<sub>66</sub> NR SL-U UE power class 5**

Pre-coding	Modulation	Channel bandwidth (Sub-band allocation) / RB Allocation									
		20MHz		40MHz		60MHz		80MHz		100MHz	
		Full (dB)	Partial (dB)	Full (dB)	Partial (dB)	Full (dB)	Partial (dB)	Full (dB)	Partial (dB)	Full (dB)	Partial (dB)
CP-OFDM	QPSK	≤ 16.5	≤ 19.0	≤ 13.5	≤ 16.0	≤ 11.5	≤ 14.0	≤ 10.0	≤ 12.5	≤ 9.0	≤ 11.5
	16 QAM	≤ 16.5	≤ 19.0	≤ 13.5	≤ 16.0	≤ 11.5	≤ 14.0	≤ 10.0	≤ 12.5	≤ 9.0	≤ 11.5
	64 QAM	≤ 16.5	≤ 19.0	≤ 13.5	≤ 16.0	≤ 11.5	≤ 14.0	≤ 10.0	≤ 12.5	≤ 9.0	≤ 11.5
	256 QAM	≤ 16.5	≤ 19.0	≤ 13.5	≤ 16.0	≤ 11.5	≤ 14.0	≤ 10.0	≤ 12.5	≤ 9.0	≤ 11.5

NOTE 1: The A-MPR shall apply to all SCS in all active 20 MHz sub-bands contiguously allocated in the channel.  
 NOTE 2: Full allocation A-MPR applies when all RB's in a 20 MHz channel or all RB's in all sub-bands for wideband operation are fully allocated and all sub-bands are transmitted. Partial allocation A-MPR applies when one or more RB's in one or more sub-bands are not allocated but when all sub-bands within the channel are transmitted. When not all sub-bands within the channel are transmitted, the A-MPR associated with the channel bandwidth according to the bandwidth of the contiguously transmitted sub-bands and according to the allocation type applies.

For PSFCH transmission with single RB set and multiple RB sets, the allowed A-MPR is specified in Table 6.2E.3F.14-2 for power class 5 NR sidelink UE.

**Table 6.2E.3F.14-2: A-MPR for NS<sub>66</sub> for PSFCH transmission for NR SL-U UE power class 5**

RB set configuration	Channel bandwidth (Sub-band allocation) / RB Allocation				
	20MHz	40MHz	60MHz	80MHz	100MHz
Contiguous/Non-contiguous	≤ 20.5	≤17.5	≤15.5	≤14.5	≤14.0
NOTE 1: The A-MPR shall apply to all SCS in all active 20 MHz sub-bands contiguously or non-contiguously allocated in the channel.					

For S-SSB transmission, the allowed A-MPR is specified in Table 6.2E.3F.14-3 for power class 5 NR sidelink UE.

**Table 6.2E.3F.14-3: A-MPR for NS<sub>66</sub> for S-SSB transmission for NR SL-U UE power class 5**

RB set configuration	Channel bandwidth (Sub-band allocation) / RB Allocation									
	20MHz		40MHz		60MHz		80MHz		100MHz	
# of S-SSB repetition/RBset	> 2	2	> 2	2	> 2	2	> 2	2	> 2	2
Contiguous/Non-contiguous	≤ 21.0	≤ 24.5	≤ 21.0	≤24.5	≤19.0	≤21.5	≤19.0	≤21.5	≤19.0	≤21.5
NOTE 1: The A-MPR shall apply to all SCS in all active 20 MHz sub-bands contiguously or non-contiguously allocated in the channel.										

### 6.2E.3F.15 A-MPR for NS<sub>67</sub> or NS<sub>71</sub>

When NS<sub>67</sub> or NS<sub>71</sub> is indicated by the network or pre-configured radio parameters for NR sidelink UE, this clause specifies the allowed Maximum Power Reduction (MPR) power for NR sidelink physical channels and signals due to PSCCH/PSSCH, PSFCH and S-SSB transmission.

For contiguous allocation of PSCCH and PSSCH simultaneous transmission, the allowed A-MPR is specified in Table 6.2E.3F.15-1 for power class 5 NR sidelink UE.

**Table 6.2E.3F.15-1: A-MPR for NS<sub>67</sub> or NS<sub>71</sub> NR SL-U UE power class 5**

Pre-coding	Modulation	Channel bandwidth (Sub-band allocation) / RB Allocation									
		20MHz		40MHz		60MHz		80MHz		100MHz	
		Full (dB)	Partial (dB)	Full (dB)	Partial (dB)	Full (dB)	Partial (dB)	Full (dB)	Partial (dB)	Full (dB)	Partial (dB)
CP-OFDM	QPSK	≤ 13.5	≤ 16.0	≤ 10.5	≤ 13.5	≤ 8.5	≤ 11.5	≤ 7.0	≤ 10.0	≤ 6.5	≤ 9.0
	16 QAM	≤ 13.5	≤ 16.0	≤ 10.5	≤ 13.5	≤ 8.5	≤ 11.5	≤ 7.0	≤ 10.0	≤ 6.5	≤ 9.0
	64 QAM	≤ 13.5	≤ 16.0	≤ 10.5	≤ 13.5	≤ 8.5	≤ 11.5	≤ 7.0	≤ 10.0	≤ 6.5	≤ 9.0
	256 QAM	≤ 13.5	≤ 16.0	≤ 10.5	≤ 13.5	≤ 8.5	≤ 11.5	≤ 7.0	≤ 10.0	≤ 6.5	≤ 9.0
NOTE 1: The A-MPR shall apply to all SCS in all active 20 MHz sub-bands contiguously allocated in the channel.											
NOTE 2: Full allocation A-MPR applies when all RB's in a 20 MHz channel or all RB's in all sub-bands for wideband operation are fully allocated and all sub-bands are transmitted. Partial allocation A-MPR applies when one or more											

RB's in one or more sub-bands are not allocated but when all sub-bands within the channel are transmitted. When not all sub-bands within the channel are transmitted, the A-MPR associated with the channel bandwidth according to the bandwidth of the contiguously transmitted sub-bands and according to the allocation type applies.

For PSFCH transmission with single RB set and multiple RB sets, the allowed A-MPR is specified in Table 6.2E.3F.15-2 for power class 5 NR sidelink UE.

**Table 6.2E.3F.15-2: A-MPR for NS\_67 or NS\_71 for PSFCH transmission for NR SL-U UE power class 5**

RB set configuration	Channel bandwidth (Sub-band allocation) / RB Allocation				
	20MHz	40MHz	60MHz	80MHz	100MHz
Contiguous/Non-contiguous	≤17.5	≤14.5	≤14.0	≤14.0	≤14.0
NOTE 1: The A-MPR shall apply to all SCS in all active 20 MHz sub-bands contiguously or non-contiguously allocated in the channel.					

For S-SSB transmission, the allowed A-MPR is specified in Table 6.2E.3F.15-3 for power class 5 NR sidelink UE.

**Table 6.2E.3F.15-3: A-MPR for NS\_67 or NS\_71 for S-SSB transmission for NR SL-U UE power class 5**

RB set configuration	Channel bandwidth (Sub-band allocation) / RB Allocation									
	20MHz		40MHz		60MHz		80MHz		100MHz	
# of S-SSB repetition/RBset	> 2	2	> 2	2	> 2	2	> 2	2	> 2	2
Contiguous/Non-contiguous	≤ 18.5	≤ 21.5	≤18.0	≤21.5	≤16.0	≤18.5	≤16.0	≤18.5	≤16.0	≤18.5
NOTE 1: The A-MPR shall apply to all SCS in all active 20 MHz sub-bands contiguously or non-contiguously allocated in the channel.										

### 6.2E.3F.16 A-MPR for NS\_68

When NS\_68 is indicated by the network or pre-configured radio parameters for NR sidelink UE, this clause specifies the allowed Maximum Power Reduction (MPR) power for NR sidelink physical channels and signals due to PSCCH/PSSCH, PSFCH and S-SSB transmission.

For contiguous allocation of PSCCH and PSSCH simultaneous transmission, the allowed A-MPR is specified in Table 6.2E.3F.16-1 for power class 5 NR sidelink UE.

**Table 6.2E.3F.16-1: A-MPR for NS\_68 NR SL-U UE power class 5**

Pre-coding	Modulation	Channel bandwidth (Sub-band allocation) / RB Allocation									
		20MHz		40MHz		60MHz		80MHz		100MHz	
		Full (dB)	Partial (dB)	Full (dB)	Partial (dB)	Full (dB)	Partial (dB)	Full (dB)	Partial (dB)	Full (dB)	Partial (dB)
CP-OFDM	QPSK	≤ 7.5	≤ 10.0	≤ 6.0	≤ 7.0	≤ 6.0	≤ 6.0	≤ 6.0	≤ 6.0	≤ 6.0	≤ 6.0
	16 QAM	≤ 7.5	≤ 10.0	≤ 6.0	≤ 7.0	≤ 6.0	≤ 6.0	≤ 6.0	≤ 6.0	≤ 6.0	≤ 6.0
	64 QAM	≤ 7.5	≤ 10.0	≤ 6.0	≤ 7.0	≤ 6.0	≤ 6.0	≤ 6.0	≤ 6.0	≤ 6.0	≤ 6.0
	256 QAM	≤ 7.5	≤ 10.0	≤ 6.0	≤ 7.0	≤ 6.0	≤ 6.0	≤ 6.0	≤ 6.0	≤ 6.0	≤ 6.0
NOTE 1: The A-MPR shall apply to all SCS in all active 20 MHz sub-bands contiguously allocated in the channel.											
NOTE 2: Full allocation A-MPR applies when all RB's in a 20 MHz channel or all RB's in all sub-bands for wideband operation are fully allocated and all sub-bands are transmitted. Partial allocation A-MPR applies when one or more RB's in one or more sub-bands are not allocated but when all sub-bands within the channel are transmitted. When not all sub-bands within the channel are transmitted, the A-											

MPR associated with the channel bandwidth according to the bandwidth of the contiguously transmitted sub-bands and according to the allocation type applies.

For PSFCH transmission with single RB set and multiple RB sets, the allowed A-MPR is specified in Table 6.2E.3F.16-2 for power class 5 NR sidelink UE.

**Table 6.2E.3F.16-2: A-MPR for NS<sub>68</sub> for PSFCH transmission for NR SL-U UE power class 5**

RB set configuration	Channel bandwidth (Sub-band allocation) / RB Allocation				
	20MHz	40MHz	60MHz	80MHz	100MHz
Contiguous/Non-contiguous	≤ 13.5	≤ 13.5	≤ 13.5	≤ 13.5	≤ 13.0
NOTE 1: The A-MPR shall apply to all SCS in all active 20 MHz sub-bands contiguously or non-contiguously allocated in the channel.					

For S-SSB transmission, the allowed A-MPR is specified in Table 6.2E.3F.16-3 for power class 5 NR sidelink UE.

**Table 6.2E.3F.16-3: A-MPR for NS<sub>68</sub> for S-SSB transmission for NR SL-U UE power class 5**

RB set configuration	Channel bandwidth (Sub-band allocation) / RB Allocation									
	20MHz		40MHz		60MHz		80MHz		100MHz	
# of S-SSB repetition/RBset	> 2	2	> 2	2	> 2	2	> 2	2	> 2	2
Contiguous/Non-contiguous	≤ 13.5	≤ 15.5	≤ 13.5	≤ 15.5	≤ 12.0	≤ 12.5	≤ 12.0	≤ 12.5	≤ 12.0	≤ 12.5
NOTE 1: The A-MPR shall apply to all SCS in all active 20 MHz sub-bands contiguously or non-contiguously allocated in the channel.										

### 6.2E.3F.17 A-MPR for NS<sub>69</sub>

When NS<sub>69</sub> is indicated by the network or pre-configured radio parameters for NR sidelink UE, this clause specifies the allowed Maximum Power Reduction (MPR) power for NR sidelink physical channels and signals due to PSCCH/PSSCH, PSFCH and S-SSB transmission.

For contiguous allocation of PSCCH and PSSCH simultaneous transmission, the allowed A-MPR is specified in Table 6.2E.3F.17-1 for power class 5 NR sidelink UE.

**Table 6.2E.3F.17-1: A-MPR for NS<sub>69</sub> NR SL-U UE power class 5**

Pre-coding	Modulation	Channel bandwidth (Sub-band allocation) / RB Allocation					
		20MHz		40MHz		80MHz	
		Full (dB)	Partial (dB)	Full (dB)	Partial (dB)	Full (dB)	Partial (dB)
CP-OFDM	QPSK	≤ 6.0	≤ 6.0	≤ 6.0	≤ 8.0	≤ 6.5	≤ 8.5
	16 QAM	≤ 6.0	≤ 6.0	≤ 6.0	≤ 8.0	≤ 6.5	≤ 8.5
	64 QAM	≤ 6.0	≤ 6.0	≤ 6.0	≤ 8.0	≤ 6.5	≤ 8.5
	256 QAM	≤ 7.5	≤ 6.5	≤ 7.5	≤ 8.0	≤ 7.5	≤ 8.5
NOTE 1: The A-MPR shall apply to all SCS in all active 20 MHz sub-bands contiguously allocated in the channel.							
NOTE 2: Full allocation A-MPR applies when all RB's in a 20 MHz channel or all RB's in all sub-bands for wideband operation are fully allocated and all sub-bands are transmitted. Partial allocation A-MPR applies when one or more RB's in one or more sub-bands are not allocated but when all sub-bands within the channel are transmitted. When not all sub-bands within the channel are transmitted, the A-MPR associated with the channel bandwidth according to the bandwidth of the contiguously transmitted sub-bands and according to the allocation type applies.							
NOTE 3: Channel bandwidth sizes of 60MHz and 100MHz are not applicable for this network signalling.							

For PSFCH transmission with single RB set and multiple RB sets, the allowed A-MPR is specified in Table 6.2E.3F.17-2 for power class 5 NR sidelink UE.

**Table 6.2E.3F.17-2: A-MPR for NS<sub>69</sub> for PSFCH transmission for NR SL-U UE power class 5**

RB set configuration	Channel bandwidth (Sub-band allocation) / RB Allocation		
	20MHz	40MHz	80MHz
Contiguous/Non-contiguous sub-band RB sets	≤ 11.0	≤ 12.5	≤ 15.0
NOTE 1: The A-MPR shall apply to all SCS in all active 20 MHz sub-bands contiguously or non-contiguously allocated in the channel.			

For S-SSB transmission, the allowed A-MPR is specified in Table 6.2E.3F.17-3 for power class 5 NR sidelink UE.

**Table 6.2E.3F.17-3: A-MPR for NS<sub>69</sub> for S-SSB transmission for NR SL-U UE power class 5**

RB set configuration	Channel bandwidth (Sub-band allocation) / RB Allocation					
	20MHz		40MHz		80MHz	
# of S-SSB repetition/RBset	> 2	2	> 2	2	> 2	2
Contiguous/ Non-contiguous sub-band RB sets	≤ 11.5	≤ 8.0	≤ 11.5	≤ 8.0	≤ 12.5	≤ 10.0
NOTE 1: The A-MPR shall apply to all SCS in all active 20 MHz sub-bands contiguously or non-contiguously allocated in the channel.						

## 6.2E.4 Configured transmitted power for V2X

### 6.2E.4.1 General

The NR V2X UE is allowed to set its configured maximum output power  $P_{\text{CMAX},f,c}$  for carrier  $f$  of serving cell  $c$  in each slot. The configured maximum output power  $P_{\text{CMAX},f,c}$  is set within the following bounds:

$$P_{\text{CMAX},L,f,c} \leq P_{\text{CMAX},f,c} \leq P_{\text{CMAX},H,f,c} \text{ with}$$

$$P_{\text{CMAX},L,f,c} = \text{MIN} \{ P_{\text{EMAX},c}, P_{\text{PowerClass},V2X} - \text{MAX}(\text{MAX}(\text{MPR}_c, \text{A-MPR}_c) + \Delta T_{\text{IB},c}, \text{P-MPR}_c), P_{\text{Regulatory},c} \}$$

$$P_{\text{CMAX},H,f,c} = \text{MIN} \{ P_{\text{EMAX},c}, P_{\text{PowerClass},V2X}, P_{\text{Regulatory},c} \}$$

where

- $P_{\text{CMAX},f,c}$  is configured for PSSCH\PSCCH, S-SSB and PSFCH, respectively;
- For the total transmitted power  $P_{\text{CMAX},\text{PSSCH}/\text{PSCCH}}$ ,  $P_{\text{EMAX},c}$  is the value given by IE *sl-maxTransPower*, defined by TS 38.331
- For the total transmitted power  $P_{\text{CMAX},\text{S-SSB}}$ , the  $P_{\text{CMAX},L,f,c}$  and  $P_{\text{CMAX},H,f,c}$  are defined as follows:

$$P_{\text{CMAX},L,f,c} = \text{MIN} \{ P_{\text{PowerClass},V2X} - \text{MAX}(\text{MAX}(\text{MPR}_c, \text{A-MPR}_c) + \Delta T_{\text{IB},c}, \text{P-MPR}_c), P_{\text{Regulatory},c} \}$$

$$P_{\text{CMAX},H,f,c} = \text{MIN} \{ P_{\text{PowerClass},V2X}, P_{\text{Regulatory},c} \}$$

- For the total transmitted power  $P_{\text{CMAX},\text{PSFCH}}$ ,  $P_{\text{EMAX},c}$  is the value given by IE *sl-maxTransPower* when single resource pool configured is transmitted at a given time and sum of the IEs *sl-maxTransPower* when multiple resource pools configured are transmitted at a given time, defined by TS 38.331.

- $P_{\text{PowerClass,V2X}}$  is the maximum UE power specified in Table 6.2E.1.1-1 without taking into account the tolerance specified in the Table 6.2E.1.1-1;
- $\text{MPR}_c$  and  $\text{A-MPR}_c$  for serving cell  $c$  are specified in clause 6.2E.2 and clause 6.2E.3 for PSSCH\PSCCH, S-SSB and PSFCH, respectively;
- $\Delta T_{\text{IB},c}$ , and  $\text{P-MPR}_c$  are specified in clause 6.2.4
- $P_{\text{Regulatory},c} = 10 - G_{\text{post connector}}$  dBm the V2X UE is within the protected zone [12] of CEN DSRC tolling system and operating in Band n47;  $P_{\text{Regulatory},c} = 33 - G_{\text{post connector}}$  dBm otherwise.

The maximum output power  $P_{\text{CMAX,PSSCH}}$  and  $P_{\text{CMAX,PSCCH}}$  are derived from  $P_{\text{CMAX},c}$  based on 0dB PSD offset between PSSCH and PSCCH.

For the measured configured maximum output power  $P_{\text{UMAX},c}$  for NR V2X sidelink transmissions non-concurrent with NR uplink transmissions, the same requirement as in clause 6.2.4 shall be applied.

When NR V2X UE is configured to co-channel coexistence operation with LTE V2X and NR SCS is configured to 30kHz the evaluation period for  $P_{\text{UMAX},c}$  for NR V2X sidelink is the first slot of NR SL slots overlapping with an LTE SL subframe and the  $P_{\text{CMAX},f,c}$  tolerances in Table 6.2.4-1 are relaxed by 1dB i.e.  $T(P_{\text{CMAX},f,c}) = T(P_{\text{CMAX},f,c}) + 1$  (dB).

For NR V2X UE supporting SL MIMO or Tx Diversity, the transmitted power is configured per each UE.

For NR V2X UE with two transmit antenna connectors at the same time, the tolerance is specified in Table 6.2E.4.1-1. The requirements shall be met with SL MIMO configurations specified in Table 6.2D.1-2.

**Table 6.2E.4.1-1:  $P_{\text{CMAX},c}$  tolerance schemes for MIMO**

$P_{\text{CMAX},c}$ (dBm)	Tolerance $T_{\text{LOW}}(P_{\text{CMAX}_L,c})$ (dB)	Tolerance $T_{\text{HIGH}}(P_{\text{CMAX}_H,c})$ (dB)
$P_{\text{CMAX},c} = 26$	3.0	2.0
$23 \leq P_{\text{CMAX},c} < 26$	3.0	2.0
$22 \leq P_{\text{CMAX},c} < 23$	5.0	2.0
$21 \leq P_{\text{CMAX},c} < 22$	5.0	3.0
$20 \leq P_{\text{CMAX},c} < 21$	5.0	4.0
$16 \leq P_{\text{CMAX},c} < 20$	5.0	
$11 \leq P_{\text{CMAX},c} < 16$	6.0	
$-40 \leq P_{\text{CMAX},c} < 11$	7.0	

#### 6.2E.4.2 Configured transmitted power for inter-band V2X concurrent operation

When a UE is configured for simultaneous NR V2X sidelink and NR uplink transmissions for inter-band concurrent operation, the UE is allowed to set its configured maximum output power  $P_{\text{CMAX},c,NR}$  and  $P_{\text{CMAX},c,V2X}$  for the configured NR uplink carrier and the configured NR V2X carrier, respectively, and its total configured maximum output power  $P_{\text{CMAX},c}$ .

The configured maximum output power  $P_{\text{CMAX},c,NR}(p)$  in slot  $p$  for the configured NR uplink carrier shall be set within the bounds:

$$P_{\text{CMAX}_L,c,NR}(p) \leq P_{\text{CMAX},c,NR}(p) \leq P_{\text{CMAX}_H,c,NR}(p)$$

where  $P_{\text{CMAX}_L,c,NR}$  and  $P_{\text{CMAX}_H,c,NR}$  are the limit as specified in clause 6.2.4.1.

The configured maximum output power  $P_{\text{CMAX},c,V2X}(q)$  in slot  $q$  for the configured NR V2X carrier shall be set within the bounds:

$$P_{\text{CMAX},c,V2X}(q) \leq P_{\text{CMAX}_H,c,V2X}(q)$$



where  $P_{\text{CMAX\_H,c,V2X}}$  is the limit as specified in clause 6.2E.4.1.

The total UE configured maximum output power  $P_{\text{CMAX}}(p,q)$  in a slot  $p$  of NR uplink carrier and a slot  $q$  of NR V2X sidelink that overlap in time shall be set within the following bounds for synchronous and asynchronous operation unless stated otherwise:

$$P_{\text{CMAX\_L}}(p,q) \leq P_{\text{CMAX}}(p,q) \leq P_{\text{CMAX\_H}}(p,q)$$

with

$$P_{\text{CMAX\_L}}(p,q) = P_{\text{CMAX\_L,c,NR}}(p)$$

$$P_{\text{CMAX\_H}}(p,q) = 10 \log_{10} [p_{\text{CMAX\_H,c,NR}}(p) + p_{\text{CMAX\_H,c,V2X}}(q)]$$

where  $p_{\text{CMAX\_H,c,V2X}}$  and  $p_{\text{CMAX\_H,c,NR}}$  are the limits  $P_{\text{CMAX\_H,c,V2X}}(q)$  and  $P_{\text{CMAX\_H,c,NR}}(p)$  expressed in linear scale.

The measured total maximum output power  $P_{\text{UMAX}}$  over both the NR uplink and NR V2X carriers is

$$P_{\text{UMAX}} = 10 \log_{10} [p_{\text{UMAX,c,NR}} + p_{\text{UMAX,c,V2X}}],$$

where  $p_{\text{UMAX,c,NR}}$  denotes the measured output power of serving cell  $c$  for the configured NR uplink carrier, and  $p_{\text{UMAX,c,V2X}}$  denotes the measured output power for the configured NR V2X carrier expressed in linear scale.

When a UE is configured for synchronous V2X sidelink and uplink transmissions,

$$P_{\text{CMAX\_L}}(p,q) - T_{\text{LOW}}(P_{\text{CMAX\_L}}(p,q)) \leq P_{\text{UMAX}} \leq P_{\text{CMAX\_H}}(p,q) + T_{\text{HIGH}}(P_{\text{CMAX\_H}}(p,q))$$

where  $P_{\text{CMAX\_L}}(p,q)$  and  $P_{\text{CMAX\_H}}(p,q)$  are the limits for the pair  $(p,q)$  and with the tolerances  $T_{\text{LOW}}(P_{\text{CMAX}})$  and  $T_{\text{HIGH}}(P_{\text{CMAX}})$  for applicable values of  $P_{\text{CMAX}}$  specified in Table 6.2E.4.1-1..  $P_{\text{CMAX\_L}}$  may be modified for any overlapping portion of slots  $(p,q)$  and  $(p+1,q+1)$ .

### 6.2E.4.3 Configured transmitted power for intra-band V2X concurrent operation

For intra-band concurrent operation, if transmission of Uu and SL does not overlap in time, the configured output power  $P_{\text{CMAX,c}}$  specified in clause 6.2E.4.1 and 6.2.4 apply for SL and Uu transmission respectively; otherwise, if transmission of Uu and SL overlap in time, the configured maximum output power  $P_{\text{CMAX,c}}$  on serving cell  $c$  for SL and Uu shall be set as specified in clause 6.2E.4.1 and in clause 6.2.4, but with  $\text{MPR}_c = \text{MPR}$  and  $\text{A-MPR}_c = \text{A-MPR}$  with MPR and A-MPR as determined by subclause 6.2E.2.3 for both PC3 and PC2 and subclause 6.2E.3.4, respectively. There is one power management term for the UE, denoted P-MPR, and  $\text{P-MPR}_c = \text{P-MPR}$ .

The total configured maximum output power  $P_{\text{CMAX}}$  shall be set within the following bounds:

$$P_{\text{CMAX\_L}} \leq P_{\text{CMAX}} \leq P_{\text{CMAX\_H}}$$

For intra-band concurrent operation when same slot pattern is used in all aggregated serving cells,

$$P_{\text{CMAX\_L}} = \text{MIN}\{10 \log_{10} \sum p_{\text{EMAX,c}} - \Delta T_{\text{C}}, P_{\text{PowerClass,concurrent}} - \text{MAX}(\text{MAX}(\text{MPR}, \text{A-MPR}) + \Delta T_{\text{IB,c}} + \Delta T_{\text{C}}, \text{P-MPR})\}$$

$$P_{\text{CMAX\_H}} = \text{MIN}\{10 \log_{10} \sum p_{\text{EMAX,c}}, P_{\text{PowerClass,concurrent}}\}$$

where

- $p_{\text{EMAX,c}}$  is the linear value of  $P_{\text{EMAX,c}}$  which is given by IE *P-Max* for Uu serving cell  $c$  or by IE *sl-MaxTransPower* for SL defined in [7];
- $P_{\text{PowerClass,concurrent}}$  is the maximum UE power specified in Table 6.2E.1.2-2 without taking into account the tolerance;
- MPR and A-MPR are specified in clause 6.2E.2 and 6.2E.3, respectively;

- $\Delta T_{IB,c}$  is the additional tolerance for serving cell  $c$  as specified in clause 6.2E.4.3
- P-MPR is the power management term for the UE;
- $\Delta T_C$  is the highest value  $\Delta T_{C,c}$  among all serving cells  $c$ ;

For intra-band concurrent operation, when at least one different numerology/slot pattern is used in aggregated cells, the UE is allowed to set its configured maximum output power  $P_{CMAX,c(i),i}$  for serving cell  $c(i)$  of slot numerology type  $i$ , and its total configured maximum output power  $P_{CMAX}$ .

The configured maximum output power  $P_{CMAX,c(i),i}(p)$  in slot  $p$  of serving cell  $c(i)$  on slot numerology type  $i$  shall be set within the following bounds:

$$P_{CMAX\_L,f,c(i),i}(p) \leq P_{CMAX,f,c(i),i}(p) \leq P_{CMAX\_H,f,c(i),i}(p)$$

where  $P_{CMAX\_L,f,c(i),i}(p)$  and  $P_{CMAX\_H,f,c(i),i}(p)$  are the limits for a serving cell  $c(i)$  of slot numerology type  $i$  as specified in clause 6.2.4.

The total UE configured maximum output power  $P_{CMAX}(p,q)$  in a slot  $p$  of slot numerology or symbol pattern  $i$ , and a slot  $q$  of slot numerology or symbol pattern  $j$  that overlap in time shall be set within the following bounds unless stated otherwise:

$$P_{CMAX\_L}(p,q) \leq P_{CMAX}(p,q) \leq P_{CMAX\_H}(p,q)$$

When slots  $p$  and  $q$  have different transmissions lengths and belong to different cells on same band for intra-band operation:

$$P_{CMAX\_L}(p,q) = \text{MIN} \{ 10 \log_{10} [p_{CMAX\_L,f,c(i),Uu,i}(p) + p_{CMAX\_L,f,c(i),V2X,j}(q)], P_{PowerClass,concurrent} \}$$

$$P_{CMAX\_H}(p,q) = \text{MIN} \{ 10 \log_{10} [p_{CMAX\_H,f,c(i),Uu,i}(p) + p_{CMAX\_H,f,c(i),V2X,j}(q)], P_{PowerClass,concurrent} \}$$

where  $p_{CMAX\_L,f,c(i),Uu,i}$  and  $p_{CMAX\_H,f,c(i),Uu,i}$  are the respective limits  $P_{CMAX\_L,f,c(i),Uu,i}$  and  $P_{CMAX\_H,f,c(i),Uu,i}$  expressed in linear scale.

$T_{REF}$  and  $T_{eval}$  are specified in Table 6.2E.4.3-1 when same and different slot patterns are used in aggregated carriers. For each  $T_{REF}$ , the  $P_{CMAX\_L}$  is evaluated per  $T_{eval}$  and given by the minimum value taken over the transmission(s) within the  $T_{eval}$ ; the minimum  $P_{CMAX\_L}$  over the one or more  $T_{eval}$  is then applied for the entire  $T_{REF}$ .  $P_{PowerClass,Concurrent}$  shall not be exceeded by the UE during any period of time.

**Table 6.2E.4.3-1:  $P_{CMAX}$  evaluation window for different slot and channel durations**

$T_{REF}$	$T_{eval}$	$T_{eval}$ with frequency hopping
$T_{REF}$ of largest slot duration over both UL and SL CCs	Physical channel length	Min( $T_{no\_hopping}$ , Physical Channel Length)

The measured maximum output power  $P_{UMAX}$  over all serving cells with same slot pattern shall be within the following range:

$$P_{CMAX\_L} - \text{MAX}\{T_L, T_{LOW}(P_{CMAX\_L})\} \leq P_{UMAX} \leq P_{CMAX\_H} + T_{HIGH}(P_{CMAX\_H})$$

$$P_{UMAX} = 10 \log_{10} \sum p_{UMAX,c}$$

where  $p_{UMAX,c}$  denotes the measured maximum output power for serving cell  $c$  expressed in linear scale. The tolerances  $T_{LOW}(P_{CMAX})$  and  $T_{HIGH}(P_{CMAX})$  for applicable values of  $P_{CMAX}$  are specified in Table 6.2E.4.3-2. The tolerance  $T_L$  is the absolute value of the lower tolerance for applicable NR V2X concurrent operation configuration as specified in Table 6.2 E.1.2-2 for intra-band NR V2X concurrent operation.

The measured maximum output power  $P_{UMAX}$  over all serving cells, when at least one slot has a different transmission numerology or slot pattern, shall be within the following range:

$$P'_{\text{CMAX}_L} - \text{MAX}\{T_L, T_{\text{LOW}}(P'_{\text{CMAX}_L})\} \leq P'_{\text{UMAX}} \leq P'_{\text{CMAX}_H} + T_{\text{HIGH}}(P'_{\text{CMAX}_H})$$

$$P'_{\text{UMAX}} = 10 \log_{10} \sum p'_{\text{UMAX},c}$$

where  $p'_{\text{UMAX},c}$  denotes the average measured maximum output power for serving cell  $c$  expressed in linear scale over  $T_{\text{REF}}$ . The tolerances  $T_{\text{LOW}}(P'_{\text{CMAX}})$  and  $T_{\text{HIGH}}(P'_{\text{CMAX}})$  for applicable values of  $P'_{\text{CMAX}}$  are specified in Table 6.2E.4.3-2. The tolerance  $T_L$  is the absolute value of the lower tolerance for applicable NR V2X concurrent operation configuration as specified in Table 6.2E.1.2-2 for intra-band NR V2X concurrent operation.

where:

$$P'_{\text{CMAX}_L} = \text{MIN}\{ \text{MIN}\{ 10 \log_{10} \sum (P_{\text{CMAX}_L,f,c(i,i)}, P_{\text{PowerClass,concurrent}}) \text{ over all overlapping slots in } T_{\text{REF}} \}$$

$$P'_{\text{CMAX}_H} = \text{MAX}\{ \text{MIN}\{ 10 \log_{10} \sum P_{\text{EMAX},c}, P_{\text{PowerClass,concurrent}} \} \text{ over all overlapping slots in } T_{\text{REF}} \}$$

**Table 6.2E.4.3-2:  $P_{\text{CMAX}}$  tolerance for SL intra-band concurrent operation**

$P_{\text{CMAX}}$ (dBm)	Tolerance $T_{\text{LOW}}(P_{\text{CMAX}})$ (dB)	Tolerance $T_{\text{HIGH}}(P_{\text{CMAX}})$ (dB)
$26 \leq P_{\text{CMAX}} < 23$	3	2
$21 \leq P_{\text{CMAX}} \leq 23$		2.0
$20 \leq P_{\text{CMAX}} < 21$		2.5
$19 \leq P_{\text{CMAX}} < 20$		3.5
$18 \leq P_{\text{CMAX}} < 19$		4.0
$13 \leq P_{\text{CMAX}} < 18$		5.0
$8 \leq P_{\text{CMAX}} < 13$		6.0
$-40 \leq P_{\text{CMAX}} < 8$		7.0

A UE supporting sidelink operation can be configured by higher layers with one or more sidelink resource pools. A sidelink resource pool can be associated with either sidelink resource allocation mode 1 or sidelink resource allocation mode 2.

For sidelink resource allocation in either mode 1 or mode 2, if UE is in RRC\_CONNECTED state, and the preparation procedure time for transmission of sidelink physical channel is available before  $T_{\text{proc},2}$  of PUSCH preparation procedure time, for transmission of Uu and SL not overlap in time, the configured output power  $P_{\text{CMAX},c}$  specified in clause 6.2E.4.1 and in clause 6.2.4 apply for SL and Uu transmission respectively, otherwise, the configured maximum output power  $P_{\text{CMAX}}$  specified in this clause shall apply.

For sidelink resource allocation mode 2, if UE is in RRC\_IDLE state, sidelink transmission is based on pre-configured sidelink resource pool, the UE configured output power is determined by sidelink only, where the configured output power specified in clause 6.2E.4.1 apply.

For sidelink resource allocation mode 2, if UE is in RRC\_INACTIVE state, and Uu does not support SDT, the configured output power specified in clause 6.2E.4.1 apply, otherwise, the configured maximum output power  $P_{\text{CMAX}}$  in this clause shall apply.

## 6.2E.4A Configured transmitted power for Sidelink CA

For intra-band contiguous SL CA operation,  $\text{MPR}_c = \text{MPR}$  and  $\text{A-MPR}_c = \text{A-MPR}$  with MPR and A-MPR specified in subclause 6.2E.2 and subclause 6.2E.3 respectively. There is one power management term for the UE, denoted P-MPR, and  $\text{P-MPR}_c = \text{P-MPR}$ .  $P_{\text{CMAX},c}$  is calculated under the assumption that the transmit power is increased by the same amount in dB on all component carriers.

The total configured maximum output power  $P_{\text{CMAX}}$  shall be set within the following bounds:

$$P_{\text{CMAX}_L} \leq P_{\text{CMAX}} \leq P_{\text{CMAX}_H}$$

For SL transmission of intra-band contiguous CA when same slot pattern is used in all aggregated component carriers.

$$P_{\text{CMAX}_L} = \text{MIN}\{10 \log_{10} \sum p_{\text{EMAX},c} - \Delta T_C, P_{\text{EMAX},CA}, P_{\text{PowerClass}, SL\_CA} - \text{MAX}(\text{MAX}(\text{MPR}, \text{A-MPR}) + \Delta T_{\text{IB},c} + \Delta T_C, P\text{-MPR}), P_{\text{Regulatory}}\}$$

$$P_{\text{CMAX}_H} = \text{MIN}\{10 \log_{10} \sum p_{\text{EMAX},c}, P_{\text{EMAX},CA}, P_{\text{PowerClass}, SL\_CA}, P_{\text{Regulatory}}\}$$

where

- For the total transmitted power  $P_{\text{CMAX},\text{PSSCH}/\text{PSCCH}}$ ,  $p_{\text{EMAX},c}$  is the linear value of  $P_{\text{EMAX},c}$  given by the IE *sl-maxTransPower* for each component carrier and  $P_{\text{EMAX},CA}$  is the value given by the IE *sl-maxTransPower-CA* for maximum transmitted power of SL CA, defined by TS 38.331;
- For the total transmitted power  $P_{\text{CMAX},\text{S-SSB}}$ , the  $P_{\text{CMAX}_L}$  and  $P_{\text{CMAX}_H}$  are defined as follows:

$$P_{\text{CMAX}_L} = \text{MIN}\{P_{\text{PowerClass}, SL\_CA} - \text{MAX}(\text{MAX}(\text{MPR}, \text{A-MPR}) + \Delta T_{\text{IB},c}, P\text{-MPR}), P_{\text{EMAX},CA}, P_{\text{Regulatory}}\}$$

$$P_{\text{CMAX}_H} = \text{MIN}\{P_{\text{PowerClass}, SL\_CA}, P_{\text{EMAX},CA}, P_{\text{Regulatory}}\}$$

- For the total transmitted power  $P_{\text{CMAX},\text{PSFCH}}$ ,  $p_{\text{EMAX},c}$  is the linear value of  $P_{\text{EMAX},c}$  given by IE *sl-maxTransPower* when single resource pool configured is transmitted at a given time and sum of the IEs *sl-maxTransPower* when multiple resource pools configured are transmitted at a given time, defined by TS 38.331;
- $P_{\text{PowerClass}, SL\_CA}$  is the maximum UE power specified in Table 6.2E.1A-1 without taking into account the tolerance;
- MPR and A-MPR are specified in subclause 6.2E.2 and subclause 6.2E.3 respectively;
- $\Delta T_{\text{IB},c}$  and P-MPR are specified in clause 6.2.4 in TS38.101-1;
- $\Delta T_C$  is the highest value  $\Delta T_{C,c}$  among all component carriers  $c$  in the subframe over both timeslots.  $\Delta T_{C,c} = 1.5$  dB when NOTE 3 in Table 6.2.1-1 in TS38.101-1 applies, otherwise  $\Delta T_{C,c} = 0$  dB;
- $P_{\text{Regulatory}} = 10 - G_{\text{post connector}}$  dBm when V2X UE is within the protected zone in ETSI TS 102 792 of CEN DSRC tolling system and operating in Band n47;  $P_{\text{Regulatory}} = 33 - G_{\text{post connector}}$  dBm otherwise.

The maximum output power  $P_{\text{CMAX},\text{PSSCH}}$  and  $P_{\text{CMAX},\text{PSCCH}}$  are derived from  $P_{\text{CMAX},c}$  based on 0dB PSD offset between PSSCH and PSCCH.

For intra-band SL CA operation, when at least one different numerology/slot pattern is used in aggregated cells, the same requirement as specified in clause 6.2E.4.3 in TS38.101-1 shall be applied.

The measured configured maximum output power  $P_{\text{UMAX},c}$  for sidelink CA operation, when at least one slot has a different transmission numerology or slot pattern, the same requirement as specified in clause 6.2E.4.3 in TS38.101-1 shall be applied.

## 6.2E.4F Configured transmitted power for Sidelink Unlicensed

### 6.2E.4F.1 General

The NR SL-U UE is allowed to set its configured maximum output power  $P_{\text{CMAX},f,c}$  for carrier  $f$  of serving cell  $c$  in each slot. The configured maximum output power  $P_{\text{CMAX},f,c}$  is set within the following bounds:

$$P_{\text{CMAX\_L},f,c} \leq P_{\text{CMAX},f,c} \leq P_{\text{CMAX\_H},f,c} \text{ with}$$

$$P_{\text{CMAX\_L},f,c} = \text{MIN} \{ P_{\text{EMAX},c}, P_{\text{PowerClass,SL}} - \text{MAX}(\text{MAX}(\text{MPR}_c, \text{A-MPR}_c) + \Delta T_{\text{IB},c}, \text{P-MPR}_c), P_{\text{Regulatory},c} \}$$

$$P_{\text{CMAX\_H},f,c} = \text{MIN} \{ P_{\text{EMAX},c}, P_{\text{PowerClass,SL}}, P_{\text{Regulatory},c} \}$$

where

- $P_{\text{CMAX},f,c}$  is configured for PSSCH\PSCCH, S-SSB and PSFCH, respectively;
- For the total transmitted power  $P_{\text{CMAX,PSSCH/PSCCH}}$ ,  $P_{\text{EMAX},c}$  is the value given by IE *sl-maxTransPower*, defined by TS 38.331

- For the total transmitted power  $P_{\text{CMAX,S-SSB}}$ , the  $P_{\text{CMAX\_L},f,c}$  and  $P_{\text{CMAX\_H},f,c}$  are defined as follows:

$$P_{\text{CMAX\_L},f,c} = \text{MIN} \{ P_{\text{PowerClass,SL}} - \text{MAX}(\text{MAX}(\text{MPR}_c, \text{A-MPR}_c) + \Delta T_{\text{IB},c}, \text{P-MPR}_c), P_{\text{Regulatory},c} \}$$

$$P_{\text{CMAX\_H},f,c} = \text{MIN} \{ P_{\text{PowerClass,SL}}, P_{\text{Regulatory},c} \}$$

- For the total transmitted power  $P_{\text{CMAX,PSFCH}}$ ,  $P_{\text{EMAX},c}$  is the value given by IE *sl-maxTransPower* when single resource pool configured is transmitted at a given time and sum of the IEs *sl-maxTransPower* when multiple resource pools configured are transmitted at a given time, defined by TS 38.331.
- $P_{\text{PowerClass,SL}}$  is the maximum UE power specified in Table 6.2E.1F-1 without taking into account the tolerance specified in the Table 6.2E.1F-1;
- $\text{MPR}_c$  and  $\text{A-MPR}_c$  for serving cell  $c$  are specified in clause 6.2E.2F and clause 6.2E.3F for PSSCH\PSCCH, S-SSB and PSFCH, respectively;
- $\Delta T_{\text{IB},c}$  and  $\text{P-MPR}_c$  are specified in clause 6.2.4
- $P_{\text{Regulatory},c} = 10 - G_{\text{post connector}}$  dBm the V2X UE is within the protected zone [12] of CEN DSRC tolling system and operating in Band n47;  $P_{\text{Regulatory},c} = 33 - G_{\text{post connector}}$  dBm otherwise.

The maximum output power  $P_{\text{CMAX,PSSCH}}$  and  $P_{\text{CMAX,PSCCH}}$  are derived from  $P_{\text{CMAX},c}$  based on 0dB PSD offset between PSSCH and PSCCH.

For the measured configured maximum output power  $P_{\text{UMAX},c}$  for NR SL-U transmissions non-concurrent with NR uplink transmissions, the same requirement as in clause 6.2.4 shall be applied.

## 6.2E.4F.2 Configured transmitted power for inter-band concurrent operation

When a UE is configured for simultaneous NR sidelink and NR uplink transmissions for inter-band concurrent operation, the UE is allowed to set its configured maximum output power  $P_{\text{CMAX},c,\text{NR}}$  and  $P_{\text{CMAX},c,\text{SL}}$  for the configured NR uplink carrier and the configured NR SL carrier, respectively, and its total configured maximum output power  $P_{\text{CMAX},c}$ .

The configured maximum output power  $P_{\text{CMAX},c,\text{NR}}(p)$  in slot  $p$  for the configured NR uplink carrier shall be set within the bounds:

$$P_{\text{CMAX\_L},c,\text{NR}}(p) \leq P_{\text{CMAX},c,\text{NR}}(p) \leq P_{\text{CMAX\_H},c,\text{NR}}(p)$$

where  $P_{\text{CMAX\_L},c,\text{NR}}$  and  $P_{\text{CMAX\_H},c,\text{NR}}$  are the limit as specified in TS 38.101-1 clause 6.2.4.

The configured maximum output power  $P_{\text{CMAX},c,\text{SL}}(q)$  in slot  $q$  for the configured NR SL carrier shall be set within the bounds:

$$P_{\text{CMAX},c,\text{SL}}(q) \leq P_{\text{CMAX\_H},c,\text{SL}}(q)$$

where  $P_{\text{CMAX\_H,c,SL}}$  is the limit as specified in TS 38.101-1 clause 6.2E.4F.1.

The total UE configured maximum output power  $P_{\text{CMAX}}(p,q)$  in a slot  $p$  of NR uplink carrier and a slot  $q$  of NR sidelink that overlap in time shall be set within the following bounds for synchronous and asynchronous operation unless stated otherwise:

$$P_{\text{CMAX\_L}}(p,q) \leq P_{\text{CMAX}}(p,q) \leq P_{\text{CMAX\_H}}(p,q)$$

with

$$P_{\text{CMAX\_L}}(p,q) = P_{\text{CMAX\_L,c,NR}}(p)$$

$$P_{\text{CMAX\_H}}(p,q) = 10 \log_{10} [p_{\text{CMAX\_H,c,NR}}(p) + p_{\text{CMAX\_H,c,SL}}(q)]$$

where  $p_{\text{CMAX\_H,c,SL}}$  and  $p_{\text{CMAX\_H,c,NR}}$  are the limits  $P_{\text{CMAX\_H,c,SL}}(q)$  and  $P_{\text{CMAX\_H,c,NR}}(p)$  expressed in linear scale.

The measured total maximum output power  $P_{\text{UMAX}}$  over both the NR uplink and NR SL carriers is

$$P_{\text{UMAX}} = 10 \log_{10} [p_{\text{UMAX,c,NR}} + p_{\text{UMAX,c,SL}}],$$

where  $p_{\text{UMAX,c,NR}}$  denotes the measured output power of serving cell  $c$  for the configured NR uplink carrier, and  $p_{\text{UMAX,c,SL}}$  denotes the measured output power for the configured NR SL carrier expressed in linear scale.

When a UE is configured for synchronous NR sidelink and uplink transmissions,

$$P_{\text{CMAX\_L}}(p,q) - T_{\text{LOW}}(P_{\text{CMAX\_L}}(p,q)) \leq P_{\text{UMAX}} \leq P_{\text{CMAX\_H}}(p,q) + T_{\text{HIGH}}(P_{\text{CMAX\_H}}(p,q))$$

where  $P_{\text{CMAX\_L}}(p,q)$  and  $P_{\text{CMAX\_H}}(p,q)$  are the limits for the pair  $(p,q)$  and with the tolerances  $T_{\text{LOW}}(P_{\text{CMAX}})$  and  $T_{\text{HIGH}}(P_{\text{CMAX}})$  for applicable values of  $P_{\text{CMAX}}$  specified in Table 6.2E.4.1-1.  $P_{\text{CMAX\_L}}$  may be modified for any overlapping portion of slots  $(p,q)$  and  $(p+1,q+1)$ .

## 6.2F Transmitter power for shared spectrum channel access

### 6.2F.1 UE maximum output power

The following UE Power Classes define the maximum output power for any transmission bandwidth within the channel bandwidth of shared spectrum channel access carrier unless otherwise stated. The period of measurement shall be at least one sub frame (1ms).

**Table 6.2F.1-1: UE Power Class**

NR band	Class 1 (dBm)	Tolerance (dB)	Class 2 (dBm)	Tolerance (dB)	Class 3 (dBm)	Tolerance (dB)	Class 5 (dBm)	Tolerance (dB)
n46					23	+2/-3	20	+2/-3
n96					23	+2/-3	20	+2/-3
n102					23	+2/-3	20	+2/-3
NOTE 1: $P_{\text{PowerClass}}$ is the maximum UE power specified without taking into account the tolerance								
NOTE 2: Power class 5 is default power class unless otherwise stated.								

The UE operating shall meet the following additional requirements for maximum mean transmission power density specified in Table 6.2F.1-2 when NS is signaled and when transmission overlaps with any portion of the specified frequency range. In case transmission overlaps multiple frequency ranges, the lowest power density requirement applies.

Table 6.2F.1-2: Additional requirements for transmit power density

NR Band	NS value	Channel bandwidth (MHz)	Frequency range (MHz)	Maximum mean power density (dBm/MHz)	
n46	NS_28	20, 40, 60, 80	5150 – 5350	10	
			5470 – 5725		
	NS_29	20	5170 – 5330	10	
			5490 – 5730		
		40	5170 – 5330	7	
			5490 – 5730		
	60, 80	5170 – 5330	4		
		5490 – 5730			
	NS_30	20, 40, 60, 80	5150 – 5350	11	
			5470 – 5725		
	NS_31	20	5150 – 5230	10	
			5250 – 5350		
			5470 – 5725		
			5725 – 5850		
		40	5230 – 5250	4	
			5150 – 5230		7
			5250 – 5350		
			5470 – 5725		
60, 80		5725 – 5850	4		
		5230 – 5250		4	
		5150 – 5230			
		5250 – 5350			
n96	NS_53	20, 40, 60, 80, 100	5925 – 7125		-1
	NS_54	20, 40, 60, 80	5925 – 6425	17	
			6525 – 6875		
	NS_59	20, 40, 60, 80, 100	5925 – 7125	5	
	NS_60	20, 40, 60, 80, 100	5925 – 7125	2	
	NS_61	20, 40, 60, 80	5925 – 6425	1	
	NS_66	20, 40, 60, 80, 100	5925 – 7125	-8	
	NS_67	20, 40, 60, 80, 100	5925 – 7125	-5	
NS_71	20, 40, 60, 80, 100	5925 – 6425 6525 – 6875	-5		
n102	NS_58	20, 40, 60, 80, 100	5945 – 6425	10	
	NS_64	20, 40, 60, 80, 100	5945 – 6425	1	
	NS_65	20, 40, 60, 80, 100	5945 – 6425	11	
	NS_68	20, 40, 60, 80, 100	5945 – 6425	1	

## 6.2F.1A UE maximum output power for CA

### 6.2F.1A.1 UE maximum output power for inter-band CA

For inter-band carrier aggregation with one uplink carrier assigned to one NR band, the transmitter power requirements in clause 6.2 apply.

For inter-band carrier aggregation with uplink assigned to two bands and including one of the bands listed in Table 6.2F.1-1, the requirements in clause 6.2.2 apply for the NR uplink carrier and clause 6.2F.2 for the carrier operating with shared spectrum access.

For inter-band carrier aggregation with uplink assigned to two NR bands and including one of the bands listed in Table 6.2F.1-1, UE maximum output power shall be measured over all component carriers from different bands. If

each band has separate antenna connectors, maximum output power is defined as the sum of maximum output power from each UE antenna connector. The period of measurement shall be at least one sub frame (1 ms). The maximum output power is specified in Table 6.2A.1.3-1.

**Table 6.2F.1A.1-1 void**

### 6.2F.1A.2 UE maximum output power for intra-band contiguous CA

For uplink intra-band contiguous carrier aggregation, the maximum output power is specified in Table 6.2F.1A.2-1. For downlink intra-band contiguous carrier aggregation with a single uplink component carrier configured in the NR-U band, the maximum output power is specified in Table 6.2F.1-1 for power class 5.

**Table 6.2F.1A.2-1: UE Power Class for intra-band contiguous CA**

NR CA Configuration	Class 1 (dBm)	Tolerance (dB)	Class 2 (dBm)	Tolerance (dB)	Class 3 (dBm)	Tolerance (dB)	Class 5 (dBm)	Tolerance (dB)
CA_n96B							20	+2/-3
CA_n96C							20	+2/-3
CA_n102B							20	+2/-3
CA_n102C							20	+2/-3

NOTE 1:  $P_{PowerClass}$  is the maximum UE power specified without taking into account the tolerance.  
NOTE 2: Power class 5 is default power class unless otherwise stated.

#### 6.2F.1A.2.1 Additional requirements for transmit power density for intra-band contiguous CA for CA\_NS\_53

The UE operating shall meet the following additional requirements for maximum mean transmission power density specified in Table 6.2F.1A.2.1-1 when CA\_NS\_53 is signalled.

**Table 6.2F.1A.2.1-1: Additional requirements for transmit power density for CA\_NS\_53**

NR CA Band	NS value	Aggregated channel bandwidth (MHz)	Frequency range (MHz)	Maximum mean power density (dBm/MHz)
CA_n96	CA_NS_53	40, 60, 80, 100, 120, 140, 160	5925 – 7125	-1

#### 6.2F.1A.2.2 Additional requirements for transmit power density for intra-band contiguous CA for CA\_NS\_54

The UE operating shall meet the following additional requirements for maximum mean transmission power density specified in Table 6.2F.1A.2.2-1 when CA\_NS\_54 is signalled and when transmission overlaps with any portion of the specified frequency range. In case transmission overlaps multiple frequency ranges, the lowest power density requirement applies.

**Table 6.2F.1A.2.2-1: Additional requirements for transmit power density for CA\_NS\_54**

NR CA Band	NS value	Aggregated channel bandwidth (MHz)	Frequency range (MHz)	Maximum mean power density (dBm/MHz)
CA_n96	CA_NS_54	40, 60, 80, 100, 120, 140, 160	5925 – 6425	17
			6525 – 6875	



## 6.2F.1B UE maximum output power for NR-DC

For inter-band NR-DC with uplink assigned to two bands and including one of the bands listed in Table 6.2F.1-1, the requirements in clause 6.2.2 apply for the NR uplink carrier and clause 6.2F.2 for the carrier operating with shared spectrum access.

For inter-band NR-DC with uplink assigned to two bands and including one of the bands listed in Table 6.2F.1-1, the UE maximum output power shall be measured over all component carriers from different bands. If each band has separate antenna connectors, the maximum output power is defined as the sum of maximum output power from each UE antenna connector. The period of measurement shall be at least one sub frame (1 ms). The maximum output power is specified in Table 6.2B.1.3-1.

## 6.2F.1D UE maximum output power for UL MIMO

For UE with two transmit antenna connectors in closed-loop spatial multiplexing scheme, the maximum output power for any transmission bandwidth within the channel bandwidth is specified in Table 6.2F.1D-1. The requirements shall be met with the UL MIMO configurations specified in Table 6.2D.1-2. For UE supporting UL MIMO, the maximum output power is defined as the sum of the maximum output power from both UE antenna connectors. The period of measurement shall be at least one sub frame (1 ms).

The requirements shall be met with the UL MIMO configurations of using 2-layer UL MIMO transmission with codebook of  $\frac{1}{\sqrt{2}} \begin{bmatrix} 1 & 0 \\ 0 & 1 \end{bmatrix}$ . DCI Format for UE configured in PUSCH transmission mode for uplink single-user MIMO shall be used.

**Table 6.2F.1D-1 UE Power Class for UL MIMO in closed loop spatial multiplexing scheme**

NR band	Class 1 (dBm)	Tolerance (dB)	Class 2 (dBm)	Tolerance (dB)	Class 3 (dBm)	Tolerance (dB)	Class 5 (dBm)	Tolerance (dB)
n46					23	+2/-3	20	+2/-3
n96					23	+2/-3	20	+2/-3
n102					23	+2/-3	20	+2/-3

NOTE 1: Power class 5 is default power class unless otherwise stated.

For UE supporting uplink full power transmission (ULFPTx) for UL MIMO, the maximum output power requirements specified in Table 6.2F.1D-1 shall be met with the PUSCH configurations specified in Table 6.2D.1-3, based upon UE's support of uplink full power transmission mode.

## 6.2F.2 UE maximum output power reduction

For UE maximum output power reduction, the general requirements of clause 6.2.2 do not apply but instead the UE is allowed to reduce the maximum output power due to higher order modulations and transmit bandwidth configurations for power class 5 according to Table 6.2F.2-1 and Table 6.2F.2-2.

For wideband operation only sub-bands which are contiguously transmitted are considered in the current version of the specification as defined in clause 6.1F.

**Table 6.2F.2-1 Maximum power reduction (MPR) for shared spectrum access UE power class 5**

Pre-coding	Modulation	RB Allocation
------------	------------	---------------

		Full <sup>2</sup> (dB)	Partial <sup>3</sup> (dB)	Exception for 100MHz Full <sup>5</sup> (dB)
DFT-s-OFDM	Pi/2 BPSK <sup>4</sup>	≤ 1.5	≤ 2.5	
	QPSK	≤ 1.5	≤ 2.5	
	16 QAM	≤ 2.0	≤ 3.0	
	64 QAM	≤ 3.5	≤ 4.5	
	256 QAM	≤ 5.0	≤ 5.5	
CP-OFDM	QPSK	≤ 3.5	≤ 3.5	≤ 4.5
	16 QAM	≤ 4.0	≤ 4.0	≤ 4.5
	64 QAM	≤ 5.5	≤ 5.5	
	256 QAM	≤ 7.0	≤ 7.0	

NOTE 1: The MPR shall apply to all SCS in all active 20 MHz sub-bands contiguously allocated in the channel.

NOTE 2: The MPR for Full RB allocation applies to all RB's in all transmitted 20 MHz or larger channels that are fully allocated or all RB's in all transmitted sub-bands for wideband operation that are fully allocated excluding the wideband configurations of Table 6.2F.2-2.

NOTE 3: The MPR for Partial RB allocation applies to interlaced allocations with uplink resource allocation type 2 as specified in TS 38.214 [10] or transmitted sub-bands for wideband operation are transmitted according to the wideband configurations of Table 6.2F.2-2.

NOTE 4: Applicable to Pi/2-BPSK modulation when IE powerBoostPi2BPSK is set to 0.

NOTE 5: Exception for 100MHz Full RB allocation MPR applies when all RB's in all sub-bands for 100MHz wideband operation are fully allocated and sub-bands are transmitted according to the wideband configurations of Table 6.2F.2-2.

**Table 6.2F.2-2 Exception MPR mapping for wideband operation**

Wideband operation channel bandwidth (MHz)	Sub-band configuration exceptions
40	10, 01
60	None
80	1100, 0011, 0100, 0010
100	00111, 11100, 00011, 11000

NOTE 1: The sub-band configuration is represented as a bitmap where '1' indicates that a sub-band is transmitted and '0' indicates a sub-band is not transmitted. The bitmap is ordered with MSB mapped to the lowest frequency sub-band and LSB mapped to highest frequency sub-band within the wideband channel.

NOTE 2: Void.

**Table 6.2F.2-3 Maximum power reduction (MPR) for shared spectrum access UE power class 3**

Pre-coding	Modulation	RB Allocation		
		Full <sup>2</sup> (dB)	Partial <sup>3</sup> (dB)	Exception for 100MHz Full <sup>5</sup> (dB)
DFT-s-OFDM	Pi/2 BPSK <sup>4</sup>	≤ 1.0	≤ 1.5	
	QPSK	≤ 1.0	≤ 2.0	
	16 QAM	≤ 1.5	≤ 2.5	
	64 QAM	≤ 2.0	≤ 3.0	
	256 QAM	≤ 4.5	≤ 4.5	
CP-OFDM	QPSK	≤ 2.0	≤ 3.5	≤ [4.0]
	16 QAM	≤ 2.5	≤ 3.5	≤ [4.0]
	64 QAM	≤ 4.0	≤ 4.5	
	256 QAM	≤ 6.5	≤ 6.5	

NOTE 1: The MPR shall apply to all SCS in all active 20 MHz sub-bands contiguously allocated in the channel.

NOTE 2: The MPR for Full RB allocation applies to all RB's in all transmitted 20 MHz or larger channels that are fully allocated or all RB's in all transmitted sub-bands for wideband operation that are fully allocated excluding the wideband configurations of Table 6.2F.2-2.
NOTE 3: The MPR for Partial RB allocation applies to interlaced allocations with uplink resource allocation type 2 as specified in TS 38.214 [10] or transmitted sub-bands for wideband operation are transmitted according to the wideband configurations of Table 6.2F.2-2.
NOTE 4: Applicable to Pi/2-BPSK modulation when IE powerBoostPi2BPSK is set to 0.
NOTE 5: Exception for 100MHz Full RB allocation MPR applies when all RB's in all sub-bands for 100MHz wideband operation are fully allocated and sub-bands are transmitted according to the wideband configurations of Table 6.2F.2-2.

**Table 6.2F.2-4 Maximum power reduction (MPR)  
for shared spectrum access UE power class 3 with dual Tx**

Pre-coding	Modulation	RB Allocation		
		Full <sup>2</sup> (dB)	Partial <sup>3</sup> (dB)	Exception for 100MHz Full <sup>5</sup> (dB)
DFT-s-OFDM	Pi/2 BPSK <sup>4</sup>	≤ [2.0]	≤ [3.0]	
	QPSK	≤ [2.0]	≤ [3.0]	
	16 QAM	≤ [2.5]	≤ [3.0]	
	64 QAM	≤ [2.5]	≤ [3.5]	
	256 QAM	≤ [4.5]	≤ [4.5]	
CP-OFDM	QPSK	≤ [3.5]	≤ [4.0]	≤ [5.0]
	16 QAM	≤ [3.5]	≤ [4.0]	≤ [5.0]
	64 QAM	≤ [4.5]	≤ [4.5]	
	256 QAM	≤ [6.5]	≤ [6.5]	
NOTE 1: The MPR shall apply to all SCS in all active 20 MHz sub-bands contiguously allocated in the channel.				
NOTE 2: The MPR for Full RB allocation applies to all RB's in all transmitted 20 MHz or larger channels that are fully allocated or all RB's in all transmitted sub-bands for wideband operation that are fully allocated excluding the wideband configurations of Table 6.2F.2-2.				
NOTE 3: The MPR for Partial RB allocation applies to interlaced allocations with uplink resource allocation type 2 as specified in TS 38.214 [10] or transmitted sub-bands for wideband operation are transmitted according to the wideband configurations of Table 6.2F.2-2.				
NOTE 4: Applicable to Pi/2-BPSK modulation when IE powerBoostPi2BPSK is set to 0.				
NOTE 5: Exception for 100MHz Full RB allocation MPR applies when all RB's in all sub-bands for 100MHz wideband operation are fully allocated and sub-bands are transmitted according to the wideband configurations of Table 6.2F.2-2.				

For the UE maximum output power modified by MPR, the power limits specified in clause 6.2F.4 apply.

## 6.2F.2A UE maximum output power reduction for CA

### 6.2F.2A.1 UE maximum output power reduction for inter-band CA

For inter-band carrier aggregation with uplink assigned to two bands and including one of the bands listed in Table 6.2F.1-1, the requirements in clause 6.2.2 apply for the NR uplink carrier and clause 6.2F.2 for the carrier operating with shared spectrum access.

When inter-band carrier aggregation is configured with intra-band contiguous carrier aggregation in one of the bands, the requirements in clause 6.2A.2 apply for the NR uplink contiguous carrier aggregation and 6.2F.2A.2 apply for the shared spectrum band.

### 6.2F.2A.2 UE maximum output power reduction for intra-band contiguous CA

For intra-band contiguous carrier aggregation, the allowed Maximum Power Reduction (MPR) for the maximum output power in Table 6.2A.1.1-1 with contiguous RB allocation is specified in Table 6.2F.2A.2-1 and Table 6.2F.2A.2-2 for UE power class 5 CA bandwidth classes B and C. For UE maximum output power reduction, the general requirements of clause 6.2.2 do not apply but instead the UE is allowed to reduce the maximum output power due to higher order modulations and transmit bandwidth configurations for power class 5 according to Table 6.2F.2A.2-1 and Table 6.2F.2A.2-2.

For wideband operation only sub-bands which are contiguously transmitted are considered in the current version of the specification as defined in clause 6.1F.

**Table 6.2F.2A.2-1 Maximum power reduction (MPR) for power class 5 shared spectrum access intra-band contiguous CA for bandwidth class B and class C.**

Pre-coding	Modulation	RB Allocation		
		Full <sup>2</sup> (dB)	Partial <sup>3</sup> (dB)	Exception for Full <sup>5</sup> (dB)
DFT-s-OFDM	Pi/2 BPSK <sup>4</sup>	≤ [3.0]		≤ [4.0]
	QPSK	≤ [3.0]		≤ [4.0]
	16 QAM	≤ [3.5]		≤ [4.5]
	64 QAM	≤ [4.5]		≤ [5.0]
CP-OFDM	256 QAM	≤ [6.0]		≤ [6.0]
	QPSK	≤ [4.0]		≤ [5.5]
	16 QAM	≤ [4.5]		≤ [6.0]
	64 QAM	≤ [6.0]		≤ [6.5]
	256 QAM	≤ [7.0]		≤ [7.0]
NOTE 1: The MPR shall apply to all SCS in all active 20 MHz sub-bands contiguously allocated in the channel.				
NOTE 2: The MPR for Full RB allocation applies to all RB's in all transmitted 20 MHz or larger channels that are fully allocated or all RB's in all contiguously transmitted sub-bands for wideband operation that are fully allocated excluding the wideband configurations of Table 6.2F.2A.2-2.				
NOTE 3: The MPR for Partial RB allocation applies to interlaced allocations with uplink resource allocation type 2 as specified in TS 38.214 [10] excluding the wideband configurations of Table 6.2F.2A.2-2.				
NOTE 4: Applicable to Pi/2-BPSK modulation when IE powerBoostPi2BPSK is set to 0.				
NOTE 5: Exception for Full RB allocation MPR applies when all RB's in a 20 MHz channel or all RB's in all sub-bands for wideband operation are fully allocated and sub-bands are transmitted according to the wideband configurations of Table 6.2F.2A.2-2.				

**Table 6.2F.2A.2-2 Exception MPR mapping for intra-band CA wideband operation**

Wideband operation channel bandwidth (MHz)	Sub-band configuration exceptions	
20+20	1-1	1-0, 0-1
20+40	1-11, 1-10, 0-01, 0-10, 0-11, 1-00	None

20+60	1-111, 1-110, 0-111, 0-110, 1-000, 0-001	0-010, 0-100, 0-011, 1-100
20+80	1-1111, 1-1110, 0-1111, 0-1110, 0-1100, 0-0100, 0-0111, 1-1000, 0-0011, 0-1000, 0-0010, 1-0000, 0-0001	1-1100, 0-0111
40+20	11-1, 01-1, 11-0, 00-1, 01-0, 01-1, 10-0	None
40+40	11-11, 11-10, 01-11, 01-10, 10-00, 00-01	00-10, 01-00, 00-11, 11-00
40+60	11-111, 11-110, 01-111, 01-110, 01-100, 00-100, 00-111, 11-000, 00-011, 01-000, 00-010, 10-000, 00-001	11-100, 00-111
40+80	11-1111, 11-1110, 01-1111, 01-1110, 11-1100, 00-1111, 01-1100, 00-1110, 00-1100, 11-0000, 00-0011, 01-0000, 00-0010, 10-0000, 00-0001	11-1000, 00-0111, 01-1000, 00-0110, 00-1000, 00-0100
60+20	111-1, 111-0, 011-1, 011-0, 100-0, 000-1	001-0, 010-0, 001-1, 110-0
60+40	111-11, 111-10, 011-11, 011-10, 011-00, 001-00, 001-10, 001-11, 110-00, 000-11, 010-00, 000-10, 100-00, 000-01	111-00, 001-11
60+60	111-111, 111-110, 011-111, 011-110, 111-100, 001-111, 011-100, 001-110, 001-100, 110-000, 000-011, 010-000, 000-010, 100-000, 000-001	111-000, 000-111, 011-000, 000-110, 001-000, 000-100
60+80	111-1111, 111-1110, 111-1100, , 011-1111, 011-1110, 011-1100, 001-1111, 001-1110, 001-1100, 001-1000, 000-1100, 000-1000, 000-1000, 001-0000, 000-0100, 110-0000, 000-0011, 010-0000, 000-0010, 100-0000, 000-0001	111-1000, 000-1111, 011-1000, 000-1110, 111-0000, 000-0111, 011-0000, 000-0110
80+20	1111-1, 1111-0, 0111-1, 0111-0, 0110-0, 0010-0, 0011-1, 1100-0, 0001-1, 0100-0, 0001-0, 1000-0, 0000-1	1110-0, 0011-1
80+40	1111-11, 1111-10, 0111-11, 0111-10, 1111-00, 0011-11, 0111-00, 0011-10, 0011-00, 1100-00, 0000-11, 0100-00, 0000-10, 1000-00, 0000-01	1110-00, 0001-11, 0110-00, 0001-10, 0010-00, 0001-00
80+60	1111-111, 1111-110, 1111-100, 0111-111, 0111-110, 0111-100, 0011-111, 0011-110, 0011-100, 0011-000, 0001-100, 0001-000, 0001-000, 0010-000, 0000-100, 1100-000, 0000-011, 01000-00, 0000-010, 1000-000, 0000-001	1111-000, 0001-111, 0111-000, 0001-110, 1110-000, 0000-111, 0110-000, 0000-110
80+80	1111-1111, 1111-1110, 1111-1100, 0111-1111, 0111-1110, 0111-1100, 0011-1111, 0011-1110, 0011-1100, 0011-1000, 0001-1100, 0001-1000, 1110-0000, 0000-0111, 0110-0000, 0000-0110, 0010-0000, 0000-0100, 1100-0000, 0000-0011, 0100-0000, 0000-0010, 1000-0000, 0000-0001	1111-1000, 0001-1111, 0111-1000, 0001-1110, 1111-0000, 0000-1111, 0111-0000, 0000-1110, 0011-0000, 0000-1100, 0001-0000, 0000-1000

NOTE 1: The sub-band configuration is represented as a bitmap where '1' indicates that a sub-band is transmitted and '0' indicates a sub-band is not transmitted. The bitmap is ordered with MSB mapped to the lowest frequency sub-band and LSB mapped to highest frequency sub-band within the wideband channel.

## 6.2F.2D UE maximum output power reduction for UL MIMO

For UE with two transmit antenna connectors in closed-loop spatial multiplexing scheme, the allowed Maximum Power Reduction (MPR) for the maximum output power in Table 6.2F.1D-1 is specified in Table 6.2F.2-1 for power class 5, and in Table 6.2F.2-3 and Table 6.2F.2-4 for power class 3. The requirements shall be met with UL MIMO configurations defined in Table 6.2D.1-2. For UE supporting UL MIMO, the maximum output power is defined as the sum of the maximum output power from both UE antenna connectors.

For UE supporting uplink full power transmission (ULFPTx) for UL MIMO, the allowed MPR for the maximum output power in Table 6.2F.1D-1 is specified in Table 6.2F.2-1 for power class 5, and in Table 6.2F.2-3 and Table 6.2F.2-4 for power class 3, and the requirements shall be met with the PUSCH configurations specified in Table 6.2D.1-3, based upon UE's support of uplink full power transmission mode.

The same MPR requirements shall be applicable to UE with 1-layer UL MIMO transmission (either with or without ULFPTx) as with the UL MIMO configurations of using 2-layer UL MIMO transmission with codebook of

$$\frac{1}{\sqrt{2}} \begin{bmatrix} 1 & 0 \\ 0 & 1 \end{bmatrix}.$$

For the UE maximum output power modified by MPR, the power limits specified in clause 6.2D.4 apply.

If UE is scheduled for single antenna-port PUSCH transmission by DCI format 0\_0 or by DCI format 0\_1 for single antenna port codebook based transmission, the requirements in clause 6.2F.2 apply for the power class as indicated by the *ue-PowerClass* field in capability signaling.

## 6.2F.3 UE additional maximum output power reduction

### 6.2F.3.1 General

Additional emission requirements can be signalled by the network. Each additional emission requirement is associated with a unique network signalling (NS) value indicated in RRC signalling by an NR frequency band number of the applicable operating band and an associated value in the field *additionalSpectrumEmission*. Throughout this specification, the notion of indication or signalling of an NS value refers to the corresponding indication of an NR frequency band number of the applicable operating band, the IE field *freqBandIndicatorNR* and an associated value of *additionalSpectrumEmission* in the relevant RRC information elements [7].

To meet the additional requirements, additional maximum power reduction (A-MPR) is allowed for the maximum output power as specified in Table 6.2F.1-1. Unless stated otherwise, the total reduction to UE maximum output power is max(MPR, A-MPR) where MPR is defined in clause 6.2F.2.

Table 6.2F.3.1-1 specifies the additional requirements with their associated network signalling values and the allowed A-MPR and applicable operating band(s) for each NS value. The mapping of NR frequency band numbers and values of the *additionalSpectrumEmission* to network signalling labels is specified in Table 6.2F.3.1-1A and Table 6.2F.3.1-1B. The NS\_01 label with the field *additionalPmax* [7] absent is default for all NR bands.

**Table 6.2F.3.1-1: Additional maximum power reduction (A-MPR)**

Network signalling label	Requirements (clause)	NR Band	Channel bandwidth (MHz)	Resources blocks ( $N_{RB}$ )	A-MPR (clause)
NS_01		n46, n96, n102	20, 40, 60, 80		N/A
NS_28	6.5F.3.3.1, 6.2F.1	n46	20, 40, 60, 80		6.2F.3.2
NS_29	6.5F.3.3.2, 6.2F.1	n46	20, 40, 60, 80		6.2F.3.3
NS_30	6.5F.3.3.3, 6.2F.1	n46	20, 40, 60, 80		6.2F.3.4
NS_31	6.5F.3.3.4, 6.2F.1	n46	20, 40, 60, 80		6.2F.3.5

NS_53	6.5F.3.3.5, 6.2F.1	n96	20, 40, 60, 80, 100		6.2F.3.6
NS_54	6.5F.3.3.5, 6.2F.1	n96	20, 40, 60, 80		6.2F.3.7
NS_58	6.5F.3.3.6, 6.2F.1	n102	20, 40, 60, 80		6.2F.3.8
NS_59	6.2F.1	n96	20, 40, 60, 80, 100		6.2F.3.9
NS_60	6.5F.3.3.5, 6.2F.1	n96	20, 40, 60, 80, 100		6.2F.3.10
NS_61	6.5F.3.3.7, 6.2F.1	n96	20, 40, 60, 80		6.2F.3.11
NS_63	6.5F.3.3.8	n102	20, 40, 80		6.2F.3.12
NS_64	6.5F.3.3.9, 6.2F.1	n102	20, 40, 60, 80, 100		6.2F.3.13
NS_65	6.2F.1	n102	20, 40, 60, 80, 100		6.2F.3.14
NS_66	6.5F.3.3.5, 6.2F.1	n96	20, 40, 60, 80, 100		6.2F.3.15
NS_67	6.5F.3.3.5, 6.2F.1	n96	20, 40, 60, 80, 100		6.2F.3.16
NS_68	6.2F.1	n102	20, 40, 60, 80, 100		6.2F.3.17
NS_69	6.5F.3.3.8	n102	20, 40, 80		6.2F.3.18
NS_71	6.5F.3.3.5, 6.2F.1	n96	20, 40, 60, 80, 100		6.2F.3.19

NOTE 1: The A-MPR shall apply to all active 20 MHz sub-bands contiguously allocated in the channel.

Table 6.2F.3.1-1A: Mapping of network signaling label

NR band	Value of <i>additionalSpectrumEmission</i>							
	0	1	2	3	4	5	6	7
n46	NS_01	NS_28	NS_29	NS_30	NS_31			Reserved
n96	NS_01	NS_53	NS_54	NS_59	NS_60	NS_61		Reserved
n102	NS_01	NS_58	NS_63					Reserved

NOTE: *additionalSpectrumEmission* corresponds to an information element of the same name defined in clause 6.3.2 of TS 38.331 [7].

Table 6.2F.3.1-1B: Mapping of extended network signaling label

NR band	Value of <i>extendedAdditionalSpectrumEmission</i>							
	8	9	10	11	12	13	14	15
n96	NS_66	NS_67	NS_71					
n102	NS_64	NS_65	NS_68	NS_69				

NOTE: *extendedAdditionalSpectrumEmission* corresponds to an information element of the name [EXTENDED\_ *additionalSpectrumEmission*] defined in clause 6.3.2 of TS 38.331 [7].

### 6.2F.3.2 A-MPR for NS\_28

When "NS\_28" is indicated in the cell, the A-MPR is specified in Table 6.2F.3.2-1.

Table 6.2F.3.2-1: A-MPR for NS\_28 power class 5

Pre-coding	Modulation	RB Allocation (Note 2)		RB Allocation (Note 3)
		Full (dB)	Partial (dB)	Full/Partial
DFT-s-OFDM	PI/2 BPSK <sup>4</sup>	≤ 4.0	≤ 6.0	See Table 6.2F.2-1
	QPSK	≤ 4.0	≤ 6.0	
	16 QAM	≤ 4.5	≤ 6.0	
	64 QAM	≤ 4.5	≤ 6.5	
	256 QAM	≤ 5.5	≤ 6.5	
CP-OFDM	QPSK	≤ 6.0	≤ 7.0	
	16 QAM	≤ 6.0	≤ 7.5	
	64 QAM	≤ 6.5	≤ 7.5	
	256 QAM	≤ 7.0	≤ 7.5	

NOTE 1: Full allocation A-MPR applies when all RB's in a 20 MHz channel or all RB's in all sub-bands for wideband operation are fully allocated and all sub-bands are

transmitted. Partial allocation A-MPR applies when one or more RB's in one or more sub-bands are not allocated or when not all transmitted sub-bands for wideband operation are transmitted.

NOTE 2: Applicable for 20 MHz channels centered at the nearest NR-ARFCN corresponding to 5160, 5340, 5480, and 5700 MHz, 40 MHz channels centered at the nearest NR-ARFCN corresponding to 5170, 5190, 5310, 5330, 5490, and 5510 MHz, 60 MHz channels centered at the nearest NR-ARFCN corresponding to 5180, 5200, 5220, 5280, 5300, 5320, 5500, 5520, 5540, 5680 MHz, and 80 MHz channels centered at the nearest NR-ARFCN corresponding to 5190, 5210, 5290, 5310, 5510, and 5530 MHz.

NOTE 3: Applicable for all valid channels other than those enumerated under NOTE 2.

NOTE 4: Applicable to Pi/2-BPSK modulation when IE powerBoostPi2BPSK is set to 0.

NOTE 5: In current release larger CBW than 80MHz are not applicable for this network signalling.

### 6.2F.3.3 A-MPR for NS\_29

When "NS\_29" is indicated in the cell, the A-MPR is specified in Table 6.2F.3.3-1.

**Table 6.2F.3.3-1: A-MPR for NS\_29 power class 5**

Pre-coding	Modulation	Channel bandwidth (Sub-band allocation) / RB Allocation				
		20 MHz	40 MHz		60 MHz, 80 MHz	
			Full/Partial	Full (dB)	Partial (dB)	Full (dB)
DFT-s-OFDM	PI/2 BPSK <sup>2</sup>	See Table 6.2F.2-1	≤ 2.0	≤ 4.0	≤ 4.0	≤ 6.0
	QPSK		≤ 2.0	≤ 4.0	≤ 4.0	≤ 6.0
	16 QAM		≤ 2.5	≤ 4.0	≤ 4.0	≤ 6.0
	64 QAM		≤ 3.5	≤ 4.5	≤ 4.5	≤ 6.0
	256 QAM		≤ 5.0	≤ 5.5	≤ 5.5	≤ 6.0
CP-OFDM	QPSK		≤ 3.5	≤ 4.5	≤ 4.0	≤ 6.0
	16 QAM		≤ 4.0	≤ 4.5	≤ 4.0	≤ 6.0
	64 QAM		≤ 5.5	≤ 5.5	≤ 5.5	≤ 6.5
	256 QAM		≤ 7.0	≤ 7.0	≤ 7.0	≤ 7.0

NOTE 1: Full allocation A-MPR applies when all RB's in a 20 MHz channel or all RB's in all sub-bands for wideband operation are fully allocated and all sub-bands are transmitted. Partial allocation A-MPR applies when one or more RB's in one or more sub-bands are not allocated but when all sub-bands within the channel are transmitted. When not all sub-bands within the channel are transmitted, the A-MPR associated with the channel bandwidth according to the bandwidth of the contiguously transmitted sub-bands and according to the allocation type applies.

NOTE 2: Applicable to Pi/2-BPSK modulation when IE powerBoostPi2BPSK is set to 0.

NOTE 3: Larger CBW than 80MHz are not applicable for this network signalling.

### 6.2F.3.4 A-MPR for NS\_30

When "NS\_30" is indicated in the cell, the A-MPR is specified in Table 6.2F.3.4-1 for power class 5 and Table 6.2F.3.4-2 for power class 3.

**Table 6.2F.3.4-1: A-MPR for NS\_30 power class 5**

Pre-coding	Modulation	RB Allocation (Note 2)		RB Allocation (Note 3)		RB Allocation (Note 4)
		Full (dB)	Partial (dB)	Full (dB)	Partial (dB)	Full/Partial
DFT-s-OFDM	PI/2 BPSK <sup>5</sup>	≤ 9.0	≤ 15.0	≤ 2.5	≤ 5.0	



	QPSK	≤ 9.0	≤ 15.0	≤ 2.5	≤ 5.0	See Table 6.2F.2-1
	16 QAM	≤ 9.0	≤ 15.5	≤ 3.0	≤ 5.0	
	64 QAM	≤ 9.0	≤ 15.5	≤ 4.5	≤ 5.5	
	256 QAM	≤ 9.0	≤ 16.0	≤ 5.5	≤ 5.5	
CP-OFDM	QPSK	≤ 9.0	≤ 14.0	≤ 4.0	≤ 6.0	
	16 QAM	≤ 9.5	≤ 14.5	≤ 4.0	≤ 6.0	
	64 QAM	≤ 9.5	≤ 15.0	≤ 5.5	≤ 6.5	
	256 QAM	≤ 9.5	≤ 15.0	≤ 7.0	≤ 7.0	

NOTE 1: Full allocation A-MPR applies when all RB's in a 20 MHz channel or all RB's in all sub-bands for wideband operation are fully allocated and all sub-bands are transmitted. Partial allocation A-MPR applies when one or more RB's in one or more sub-bands are not allocated or when not all transmitted sub-bands for wideband operation are transmitted.

NOTE 2: Applicable for 20 MHz channels centered at the nearest NR-ARFCN corresponding to 5160, 5340, 5480, and 5700 MHz, 40 MHz channels centered at the nearest NR-ARFCN corresponding to 5170, 5190, 5310, 5330, 5490, and 5510 MHz, 60 MHz channels centered at the nearest NR-ARFCN corresponding to 5180, 5200, 5220, 5280, 5300, 5320, 5500, 5520, 5540, 5680 MHz, and 80 MHz channels centered at the nearest NR-ARFCN corresponding to 5190, 5210, 5290, 5310, 5510, and 5530 MHz.

NOTE 3: Applicable for 20 MHz channels centered at the nearest NR-ARFCN corresponding to 5180 and 5320 MHz, and 40 MHz channels centered at the nearest NR-ARFCN corresponding to 5230 and 5270 MHz.

NOTE 4: Applicable for all valid channels other than those enumerated under NOTE 2 and NOTE 3.

NOTE 5: Applicable to Pi/2-BPSK modulation when IE powerBoostPi2BPSK is set to 0.

NOTE 6: In current release larger CBW than 80MHz are not applicable for this network signalling.

**Table 6.2F.3.4-2: A-MPR for NS\_30 power class 3 with single Tx**

Pre-coding	Modulation	RB Allocation (Note 2)		RB Allocation (Note 3)		RB Allocation (Note 4)
		Full (dB)	Partial (dB)	Full (dB)	Partial (dB)	Full/Partial
DFT-s-OFDM	PI/2 BPSK <sup>5</sup>	≤ 12.0	≤ 15.5	≤ 3.5	≤ 5.5	See Table MPR table for PC3
	QPSK	≤ 12.5	≤ 16.0	≤ 4.0	≤ 6.5	
	16 QAM	≤ 12.5	≤ 16.0	≤ 4.5	≤ 7.0	
	64 QAM	≤ 13.0	≤ 16.0	≤ 4.5	≤ 7.0	
	256 QAM	≤ 13.0	≤ 16.0	≤ 4.5	≤ 7.0	
CP-OFDM	QPSK	≤ 14.0	≤ 16.5	≤ 6.0	≤ 7.5	
	16 QAM	≤ 14.0	≤ 16.5	≤ 6.0	≤ 7.5	
	64 QAM	≤ 14.0	≤ 16.5	≤ 6.0	≤ 7.5	
	256 QAM	≤ 14.0	≤ 16.5	≤ 6.5	≤ 7.5	

NOTE 1: Full allocation A-MPR applies when all RB's in a 20 MHz channel or all RB's in all sub-bands for wideband operation are fully allocated and all sub-bands are transmitted. Partial allocation A-MPR applies when one or more RB's in one or more sub-bands are not allocated or when not all transmitted sub-bands for wideband operation are transmitted.

NOTE 2: Applicable for 20 MHz channels centered at the nearest NR-ARFCN corresponding to 5160, 5340, 5480, and 5700 MHz, 40 MHz channels centered at the nearest NR-ARFCN corresponding to 5170, 5190, 5310, 5330, 5490, and 5510 MHz, 60 MHz channels centered at the nearest NR-ARFCN corresponding to 5180, 5200, 5220, 5280, 5300, 5320, 5500, 5520, 5540, 5680 MHz, and 80 MHz channels centered at the nearest NR-ARFCN corresponding to 5190, 5210, 5290, 5310, 5510, and 5530 MHz.

NOTE 3: Applicable for 20 MHz channels centered at the nearest NR-ARFCN corresponding to 5180 and 5320 MHz, and 40 MHz channels centered at the nearest NR-ARFCN corresponding to 5230 and 5270 MHz.

NOTE 4: Applicable for all valid channels other than those enumerated under NOTE 2 and NOTE 3.

NOTE 5: Applicable to Pi/2-BPSK modulation when IE powerBoostPi2BPSK is set to 0.

NOTE 6: In current release larger CBW than 80MHz are not applicable for this network signalling.

**6.2F.3.5 A-MPR for NS\_31**

When "NS\_31" is indicated in the cell, the A-MPR is specified in Table 6.2F.3.5-1.

Table 6.2F.3.5-1: A-MPR for NS\_31 power class 5

Pre-coding	Modulation	RB Allocation (Note 2)	RB Allocation (Note 3)	
		Full/Partial	Full (dB)	Partial (dB)
DFT-s-OFDM	PI/2 BPSK <sup>4</sup>	See Table 6.2F.2-1	≤ 4.0	≤ 6.5
	QPSK		≤ 4.0	≤ 6.5
	16 QAM		≤ 4.0	≤ 6.5
	64 QAM		≤ 4.0	≤ 6.5
	256 QAM		≤ 5.0	≤ 6.5
CP-OFDM	QPSK		≤ 5.5	≤ 6.5
	16 QAM		≤ 5.5	≤ 7.0
	64 QAM		≤ 5.5	≤ 7.0
	256 QAM		≤ 7.0	≤ 7.0
NOTE 1: Full allocation A-MPR applies when all RB's in a 20 MHz channel or all RB's in all sub-bands for wideband operation are fully allocated and all sub-bands are transmitted. Partial allocation A-MPR applies when one or more RB's in one or more sub-bands are not allocated or when not all transmitted sub-bands for wideband operation are transmitted.				
NOTE 2: Applicable for 20 MHz channels centered at the nearest NR-ARFCN corresponding to 5180, 5200, 5220, 5280, 5300, 5320, 5500, 5520, 5540, 5560, 5580, 5600, 5620, 5640, 5660, 5680, 5745, 5765, 5785, and 5805 MHz.				
NOTE 3: Applicable for all valid channels and bandwidths other than those enumerated in NOTE 2.				
NOTE 4: Applicable to Pi/2-BPSK modulation when IE powerBoostPi2BPSK is set to 0.				

## 6.2F.3.6 A-MPR for NS\_53

When "NS\_53" is indicated in the cell, the A-MPR is specified in Table 6.2F.3.6-1 for power class 5 and in Table 6.2F.3.6-2 for power class 3.

Table 6.2F.3.6-1: A-MPR for NS\_53 power class 5

Pre-coding	Modulation	Channel bandwidth (Sub-band allocation) / RB Allocation									
		20 MHz		40 MHz		60 MHz		80 MHz		100MHz	
		Full (dB)	Partial (dB)	Full (dB)	Partial (dB)	Full (dB)	Partial (dB)	Full (dB)	Partial (dB)	Full (dB)	Partial (dB)
DFT-s-OFDM	PI/2 BPSK <sup>2</sup>	≤ 9.0	≤ 12.0	≤ 6.5	≤ 8.5	≤ 4.5	≤ 6.5	≤ 3.0	≤ 5.5	≤ 1.5	≤ 4.0
	QPSK	≤ 9.0	≤ 12.0	≤ 6.5	≤ 8.5	≤ 4.5	≤ 6.5	≤ 3.0	≤ 5.5	≤ 1.5	≤ 4.0
	16 QAM	≤ 9.0	≤ 12.0	≤ 6.5	≤ 8.5	≤ 4.5	≤ 6.5	≤ 3.0	≤ 5.5	≤ 1.5	≤ 4.0
	64 QAM	≤ 9.0	≤ 12.0	≤ 6.5	≤ 8.5	≤ 4.5	≤ 6.5	≤ 4.0	≤ 5.5	≤ 2.0	≤ 4.0
	256 QAM	≤ 9.0	≤ 12.0	≤ 6.5	≤ 8.5	≤ 5.0	≤ 7.0	≤ 5.0	≤ 5.5	≤ 3.5	≤ 4.5
CP-OFDM	QPSK	≤ 9.0	≤ 12.0	≤ 6.5	≤ 8.5	≤ 4.5	≤ 6.5	≤ 4.0	≤ 5.5	≤ 4.0	≤ 4.5
	16 QAM	≤ 9.0	≤ 12.0	≤ 6.5	≤ 8.5	≤ 4.5	≤ 6.5	≤ 4.0	≤ 5.5	≤ 4.0	≤ 4.5
	64 QAM	≤ 9.0	≤ 12.0	≤ 6.5	≤ 8.5	≤ 5.5	≤ 6.5	≤ 5.5	≤ 5.5	≤ 5.5	≤ 5.5
	256 QAM	≤ 9.0	≤ 12.0	≤ 7.0	≤ 8.5	≤ 7.0	≤ 7.0	≤ 7.0	≤ 7.0	≤ 7.0	≤ 7.0
NOTE 1: Full allocation A-MPR applies when all RB's in a 20 MHz channel or all RB's in all sub-bands for wideband operation are fully allocated and all sub-bands are transmitted. Partial allocation A-MPR applies when one or more RB's in one or more sub-bands are not allocated but when all sub-bands within the channel are transmitted. When not all sub-bands within the channel are transmitted, the A-MPR associated with the channel bandwidth according to the bandwidth of the contiguously transmitted sub-bands and according to the allocation type applies.											
NOTE 2: Applicable to Pi/2-BPSK modulation when IE powerBoostPi2BPSK is set to 0.											

Table 6.2F.3.6-2: A-MPR for NS\_53 power class 3 with single Tx

Pre-coding	Modulation	Channel bandwidth (Sub-band allocation) / RB Allocation									
		20 MHz		40 MHz		60 MHz		80 MHz		100 MHz	
		Full (dB)	Partial (dB)	Full (dB)	Partial (dB)	Full (dB)	Partial (dB)	Full (dB)	Partial (dB)	Full (dB)	Partial (dB)
DFT-s-OFDM	PI/2 BPSK <sup>2</sup>	≤ 12.0	≤ 14.5	≤ 9.0	≤ 11.5	≤ 7.0	≤ 10.0	≤ 5.5	≤ 8.5	≤ 4.5	≤ 7.5
	QPSK	≤ 12.0	≤ 14.5	≤ 9.0	≤ 11.5	≤ 7.0	≤ 10.0	≤ 5.5	≤ 8.5	≤ 4.5	≤ 7.5
	16 QAM	≤ 12.0	≤ 14.5	≤ 9.0	≤ 11.5	≤ 7.0	≤ 10.0	≤ 5.5	≤ 8.5	≤ 4.5	≤ 7.5
	64 QAM	≤ 12.0	≤ 14.5	≤ 9.0	≤ 11.5	≤ 7.0	≤ 10.0	≤ 5.5	≤ 8.5	≤ 4.5	≤ 7.5
	256 QAM	≤ 12.0	≤ 14.5	≤ 9.0	≤ 11.5	≤ 7.0	≤ 10.0	≤ 5.5	≤ 8.5	≤ 4.5	≤ 7.5
CP-OFDM	QPSK	≤ 12.0	≤ 14.5	≤ 9.0	≤ 11.5	≤ 7.0	≤ 10.0	≤ 5.5	≤ 8.5	≤ 4.5	≤ 7.5
	16 QAM	≤ 12.0	≤ 14.5	≤ 9.0	≤ 11.5	≤ 7.0	≤ 10.0	≤ 5.5	≤ 8.5	≤ 4.5	≤ 7.5
	64 QAM	≤ 12.0	≤ 14.5	≤ 9.0	≤ 11.5	≤ 7.0	≤ 10.0	≤ 5.5	≤ 8.5	≤ 4.5	≤ 7.5
	256 QAM	≤ 12.0	≤ 14.5	≤ 9.0	≤ 11.5	≤ 7.0	≤ 10.0	≤ 6.5	≤ 8.5	≤ 6.5	≤ 7.5

NOTE 1: Full allocation A-MPR applies when all RB's in a 20 MHz channel or all RB's in all sub-bands for wideband operation are fully allocated and all sub-bands are transmitted. Partial allocation A-MPR applies when one or more RB's in one or more sub-bands are not allocated but when all sub-bands within the channel are transmitted. When not all sub-bands within the channel are transmitted, the A-MPR associated with the channel bandwidth according to the bandwidth of the contiguously transmitted sub-bands and according to the allocation type applies.

NOTE 2: Applicable to Pi/2-BPSK modulation when IE powerBoostPi2BPSK is set to 0.

## 6.2F.3.7 A-MPR for NS\_54

When "NS\_54" is indicated in the cell, the A-MPR is specified in Table 6.2F.3.7-1 for power class 5 and Table 6.2F.3.7-2 for power class 3.

Table 6.2F.3.7-1: A-MPR for NS\_54 power class 5

Pre-coding	Modulation	RB Allocation (Note 2)	RB Allocation (Note 3)	
		Full/Partial	Full (dB)	Partial (dB)
DFT-s-OFDM	PI/2 BPSK <sup>4</sup>	See Table 6.2F.2-1	≤ 2.5	≤ 5.0
	QPSK		≤ 2.5	≤ 5.0
	16 QAM		≤ 3.0	≤ 5.0
	64 QAM		≤ 3.5	≤ 5.0
	256 QAM		≤ 5.0	≤ 6.0
CP-OFDM	QPSK	≤ 4.5	≤ 6.0	
	16 QAM	≤ 4.5	≤ 6.0	
	64 QAM	≤ 5.5	≤ 6.0	
	256 QAM	≤ 7.0	≤ 7.0	

NOTE 1: Full allocation A-MPR applies when all RB's in a 20 MHz channel or all RB's in all sub-bands for wideband operation are fully allocated and all sub-bands are transmitted. Partial allocation A-MPR applies when one or more RB's in one or more sub-bands are not allocated or when not all transmitted sub-bands for wideband operation are transmitted.

NOTE 2: Applicable for all valid channels and bandwidths other than those enumerated in NOTE 3.

NOTE 3: Applicable for 40 MHz channels centered at the nearest NR-ARFCN corresponding to [5965 MHz], 60 MHz channels centered at the nearest NR-ARFCN corresponding to [5975 and 5995 MHz], and 80 MHz channels centered at the nearest NR-ARFCN corresponding to [5985 MHz].

NOTE 4: Applicable to Pi/2-BPSK modulation when IE powerBoostPi2BPSK is set to 0.

**Table 6.2F.3.7-2: A-MPR for NS\_54 power class 3 with single Tx**

Pre-coding	Modulation	RB Allocation (Note 2)	RB Allocation (Note 3)	
		Full/Partial	Full (dB)	Partial (dB)
DFT-s-OFDM	Pi/2 BPSK <sup>4</sup>	See Table PC3 MPR	≤ 2.0	≤ 4.5
	QPSK		≤ 3.0	≤ 5.0
	16 QAM		≤ 3.5	≤ 5.0
	64 QAM		≤ 3.5	≤ 5.0
	256 QAM		≤ 5.0	≤ 6.0
CP-OFDM	QPSK		≤ 4.5	≤ 6.0
	16 QAM		≤ 5.0	≤ 6.0
	64 QAM		≤ 5.0	≤ 6.0
	256 QAM		≤ 6.5	≤ 7.0

NOTE 1: Full allocation A-MPR applies when all RB's in a 20 MHz channel or all RB's in all sub-bands for wideband operation are fully allocated and all sub-bands are transmitted. Partial allocation A-MPR applies when one or more RB's in one or more sub-bands are not allocated or when not all transmitted sub-bands for wideband operation are transmitted.

NOTE 2: Applicable for all valid channels and bandwidths other than those enumerated in NOTE 3 and NOTE 5.

NOTE 3: Applicable for 40 MHz channels centered at the nearest NR-ARFCN corresponding to [5965 MHz], 60 MHz channels centered at the nearest NR-ARFCN corresponding to [5975 and 5995 MHz], and 80 MHz channels centered at the nearest NR-ARFCN corresponding to [5985 MHz].

NOTE 4: Applicable to Pi/2-BPSK modulation when IE powerBoostPi2BPSK is set to 0.

### 6.2F.3.8 A-MPR for NS\_58

When "NS\_58" is indicated in the cell, the A-MPR is specified in Table 6.2F.3.8-1 for power class 5. The Table 6.2F.3.8-2 is applicable for power class 3 with single Tx.

**Table 6.2F.3.8-1: A-MPR for NS\_58 power class 5**

Pre-coding	Modulation	RB Allocation	
		Full <sup>2</sup> (dB)	Partial <sup>3</sup> (dB)
DFT-s-OFDM	Pi/2 BPSK <sup>4</sup>	≤ 1.5	≤ 2.5
	QPSK	≤ 2.0	≤ 3.5
	16 QAM	≤ 2.5	≤ 4.0
	64 QAM	≤ 3.5	≤ 4.5
	256 QAM	≤ 5.0	≤ 5.5
CP-OFDM	QPSK	≤ 3.5	≤ 4.5
	16 QAM	≤ 4.0	≤ 4.5
	64 QAM	≤ 5.5	≤ 5.5
	256 QAM	≤ 7.0	≤ 7.0

NOTE 1: The A-MPR shall apply to all SCS in all active 20 MHz sub-bands contiguously allocated in the channel.

NOTE 2: The A-MPR for Full RB allocation applies to all RB's in all transmitted 20 MHz or larger channels that are fully allocated or all RB's in all transmitted sub-bands for wideband operation that are fully allocated excluding the wideband configurations of Table 6.2F.2-2.

NOTE 3: The A-MPR for Partial RB allocation applies to interlaced allocations with uplink resource allocation type 2 as specified

in TS 38.214 [10] or transmitted sub-bands for wideband operation are transmitted according to the wideband configurations of Table 6.2F.2-2.

NOTE 4: Applicable to Pi/2-BPSK modulation when IE powerBoostPi2BPSK is set to 0.

NOTE 5: The A-MPR applies instead of MPR for 20 MHz channel centered at the nearest NR-ARFCN corresponding to 5955 MHz, 40 MHz channel at the nearest NR-ARFCN corresponding to 5965 MHz, 60 MHz channel at the nearest NR-ARFCN corresponding to 5975 MHz, and 80 MHz channel at the nearest NR-ARFCN corresponding to 5985 MHz. For all other channels, A-MPR is zero and MPR as specified in Table 6.2F.2-1 applies.

**Table 6.2F.3.8-2: A-MPR for NS\_58 power class 3 with single Tx**

Pre-coding	Modulation	RB Allocation	
		Full <sup>2</sup> (dB)	Partial <sup>3</sup> (dB)
DFT-s-OFDM	Pi/2 BPSK4	≤ 1.5	≤ 4.5
	QPSK	≤ 2.0	≤ 4.5
	16 QAM	≤ 2.5	≤ 4.5
	64 QAM	≤ 3.0	≤ 4.5
	256 QAM	≤ 4.5	≤ 5.5
CP-OFDM	QPSK	≤ 3.5	≤ 5.0
	16 QAM	≤ 4.0	≤ 5.0
	64 QAM	≤ 4.5	≤ 5.5
	256 QAM	≤ 6.5	≤ 7.0

NOTE 1: The A-MPR shall apply to all SCS in all active 20 MHz sub-bands contiguously allocated in the channel.

NOTE 2: The A-MPR for Full RB allocation applies to all RB's in all transmitted 20 MHz or larger channels that are fully allocated or all RB's in all transmitted sub-bands for wideband operation that are fully allocated excluding the wideband configurations of Table 6.2F.2-2.

NOTE 3: The A-MPR for Partial RB allocation applies to interlaced allocations with uplink resource allocation type 2 as specified in TS 38.214 [10] or transmitted sub-bands for wideband operation are transmitted according to the wideband configurations of Table 6.2F.2-2.

NOTE 4: Applicable to Pi/2-BPSK modulation when IE powerBoostPi2BPSK is set to 0.

NOTE 5: The A-MPR applies instead of MPR for 20 MHz channel centered at the nearest NR-ARFCN corresponding to 5955 MHz, 40 MHz channel at the nearest NR-ARFCN corresponding to 5965 MHz, 60 MHz channel at the nearest NR-ARFCN corresponding to 5975 MHz, 80 MHz channel at the nearest NR-ARFCN corresponding to 5985 MHz. For all other channels, A-MPR is zero and MPR as specified in Table 6.2F.2-1 applies.

**6.2F.3.9 A-MPR for NS\_59**

When "NS\_59" is indicated in the cell, the A-MPR is specified in Table 6.2F.3.9-1.

**Table 6.2F.3.9-1: A-MPR for NS\_59 power class 5**

Pre-coding	Modulation	Channel bandwidth (Sub-band allocation) / RB Allocation
------------	------------	---

		Full (dB)	Partial (dB)
DFT-s-OFDM	Pi/2 BPSK <sup>2</sup>	≤ 3.0	≤ 5.5
	QPSK	≤ 3.0	≤ 5.5
	16 QAM	≤ 3.0	≤ 5.5
	64 QAM	≤ 3.5	≤ 5.5
	256 QAM	≤ 5.0	≤ 5.5
CP-OFDM	QPSK	≤ 3.5	≤ 5.5
	16 QAM	≤ 4.0	≤ 5.5
	64 QAM	≤ 5.5	≤ 5.5
	256 QAM	≤ 7.0	≤ 7.0

NOTE 1: Full allocation A-MPR applies when all RB's in a 20 MHz channel or all RB's in all sub-bands for wideband operation are fully allocated and all sub-bands are transmitted. Partial allocation A-MPR applies when one or more RB's in one or more sub-bands are not allocated but when all sub-bands within the channel are transmitted. When not all sub-bands within the channel are transmitted, the A-MPR associated with the channel bandwidth according to the bandwidth of the contiguously transmitted sub-bands and according to the allocation type applies.

NOTE 2: Applicable to Pi/2-BPSK modulation when IE powerBoostPi2BPSK is set to 0.

### 6.2F.3.10 A-MPR for NS\_60

When "NS\_60" is indicated in the cell, the A-MPR is specified in Table 6.2F.3.10-1 for power class 5. The Table 6.2F.3.10-2 is applicable for power class 3 with single Tx and Table 6.2F.3.10-2 is applicable for power class 3 with dual Tx.

**Table 6.2F.3.10-1: A-MPR for NS\_60 power class 5**

Pre-coding	Modulation	Channel bandwidth (Sub-band allocation) / RB Allocation							
		20 MHz		40 MHz		60 MHz		80 MHz	
		Full (dB)	Partial (dB)	Full (dB)	Partial (dB)	Full (dB)	Partial (dB)	Full (dB)	Partial (dB)
DFT-s-OFDM	Pi/2 BPSK <sup>2</sup>	≤ 6.0	≤ 8.5	≤ 4.0	≤ 5.5	≤ 3.5	≤ 4.5	≤ 3.0	≤ 4.5
	QPSK	≤ 6.0	≤ 8.5	≤ 4.0	≤ 5.5	≤ 3.5	≤ 4.5	≤ 3.0	≤ 4.5
	16 QAM	≤ 6.0	≤ 8.5	≤ 4.0	≤ 5.5	≤ 4.0	≤ 5.0	≤ 3.5	≤ 5.0
	64 QAM	≤ 6.0	≤ 8.5	≤ 4.0	≤ 5.5	≤ 4.0	≤ 5.0	≤ 3.5	≤ 5.0
	256 QAM	≤ 6.0	≤ 8.5	≤ 5.0	≤ 5.5	≤ 5.0	≤ 5.5	≤ 5.0	≤ 5.5
CP-OFDM	QPSK	≤ 6.0	≤ 8.5	≤ 5.5	≤ 5.5	≤ 5.0	≤ 5.5	≤ 4.5	≤ 5.5
	16 QAM	≤ 6.0	≤ 8.5	≤ 5.5	≤ 5.5	≤ 5.0	≤ 5.5	≤ 4.5	≤ 5.5
	64 QAM	≤ 6.0	≤ 8.5	≤ 5.5	≤ 5.5	≤ 5.5	≤ 5.5	≤ 5.5	≤ 5.5
	256 QAM	≤ 7.0	≤ 8.5	≤ 7.0	≤ 7.0	≤ 7.0	≤ 7.0	≤ 7.0	≤ 7.0

NOTE 1: Full allocation A-MPR applies when all RB's in a 20 MHz channel or all RB's in all sub-bands for wideband operation are fully allocated and all sub-bands are transmitted. Partial allocation A-MPR applies when one or more RB's in one or more sub-bands are not allocated but when all sub-bands within the channel are transmitted. When not all sub-bands within the channel are transmitted, the A-MPR associated with the channel bandwidth according to the bandwidth of the contiguously transmitted sub-bands and according to the allocation type applies.

NOTE 2: Applicable to Pi/2-BPSK modulation when IE powerBoostPi2BPSK is set to 0.

NOTE 3: For larger channels than 80MHz the A-MPR is zero and MPR as specified in Table 6.2F.2-1 applies.

**Table 6.2F.3.10-2: A-MPR for NS\_60 power class 3 with single Tx**

Pre-coding	Modulation	Channel bandwidth (Sub-band allocation) / RB Allocation									
		20 MHz		40 MHz		60 MHz		80 MHz		100 MHz	
		Full (dB)	Partial (dB)	Full (dB)	Partial (dB)	Full (dB)	Partial (dB)	Full (dB)	Partial (dB)	Full (dB)	Partial (dB)
DFT-s-OFDM	Pi/2 BPSK <sup>2</sup>	≤ 9.5	≤ 11.5	≤ 6.0	≤ 9.0	≤ 4.5	≤ 7.0	≤ 3.0	≤ 6.0	≤ 2.5	≤ 5.0
	QPSK	≤ 9.5	≤ 11.5	≤ 6.0	≤ 9.0	≤ 4.5	≤ 7.0	≤ 3.0	≤ 6.0	≤ 2.5	≤ 5.0
	16 QAM	≤ 9.5	≤ 11.5	≤ 6.0	≤ 9.0	≤ 4.5	≤ 7.0	≤ 3.0	≤ 6.0	≤ 2.5	≤ 5.0
	64 QAM	≤ 9.5	≤ 11.5	≤ 6.0	≤ 9.0	≤ 4.5	≤ 7.0	≤ 3.0	≤ 6.0	≤ 2.5	≤ 5.5
	256 QAM	≤ 9.5	≤ 11.5	≤ 6.0	≤ 9.0	≤ 4.5	≤ 7.0	≤ 4.5	≤ 6.0	≤ 4.5	≤ 5.5
CP-OFDM	QPSK	≤ 9.5	≤ 11.5	≤ 6.0	≤ 9.0	≤ 4.5	≤ 7.0	≤ 4.0	≤ 6.0	≤ 3.5	≤ 5.0
	16 QAM	≤ 9.5	≤ 11.5	≤ 6.0	≤ 9.0	≤ 4.5	≤ 7.0	≤ 4.0	≤ 6.0	≤ 3.5	≤ 5.0
	64 QAM	≤ 9.5	≤ 11.5	≤ 6.0	≤ 9.0	≤ 4.5	≤ 7.0	≤ 4.0	≤ 6.0	≤ 4.0	≤ 5.0
	256 QAM	≤ 9.5	≤ 11.5	≤ 6.0	≤ 9.0	≤ 4.5	≤ 7.0	≤ 5.5	≤ 6.5	≤ 5.5	≤ 6.0

NOTE 1: Full allocation A-MPR applies when all RB's in a 20 MHz channel or all RB's in all sub-bands for wideband operation are fully allocated and all sub-bands are transmitted. Partial allocation A-MPR applies when one or more RB's in one or more sub-bands are not allocated but when all sub-bands within the channel are transmitted. When not all sub-bands within the channel are transmitted, the A-MPR associated with the channel bandwidth according to the bandwidth of the contiguously transmitted sub-bands and according to the allocation type applies.

NOTE 2: Applicable to Pi/2-BPSK modulation when IE powerBoostPi2BPSK is set to 0.

**Table 6.2F.3.10-2: A-MPR for NS\_60 power class 3 with dual Tx**

Pre-coding	Modulation	Channel bandwidth (Sub-band allocation) / RB Allocation									
		20 MHz		40 MHz		60 MHz		80 MHz		100 MHz	
		Full (dB)	Partial (dB)	Full (dB)	Partial (dB)	Full (dB)	Partial (dB)	Full (dB)	Partial (dB)	Full (dB)	Partial (dB)
DFT-s-OFDM	Pi/2 BPSK <sup>2</sup>	≤ 9.5	≤ 11.5	≤ 6.0	≤ 9.0	≤ 4.5	≤ 7.0	≤ 3.0	≤ 6.0	≤ 3.0	≤ 5.5
	QPSK	≤ 9.5	≤ 11.5	≤ 6.0	≤ 9.0	≤ 4.5	≤ 7.0	≤ 3.0	≤ 6.0	≤ 3.0	≤ 5.5
	16 QAM	≤ 9.5	≤ 11.5	≤ 6.0	≤ 9.0	≤ 4.5	≤ 7.0	≤ 3.0	≤ 6.0	≤ 3.0	≤ 5.5
	64 QAM	≤ 9.5	≤ 11.5	≤ 6.0	≤ 9.0	≤ 4.5	≤ 7.0	≤ 3.0	≤ 6.0	≤ 3.0	≤ 5.5
	256 QAM	≤ 9.5	≤ 11.5	≤ 6.0	≤ 9.0	≤ 4.5	≤ 7.0	≤ 4.5	≤ 6.0	≤ 4.5	≤ 5.5
CP-OFDM	QPSK	≤ 9.5	≤ 11.5	≤ 6.0	≤ 9.0	≤ 5.0	≤ 7.0	≤ 4.5	≤ 6.0	≤ 4.5	≤ 5.5
	16 QAM	≤ 9.5	≤ 11.5	≤ 6.0	≤ 9.0	≤ 5.0	≤ 7.0	≤ 4.5	≤ 6.0	≤ 4.5	≤ 5.5
	64 QAM	≤ 9.5	≤ 11.5	≤ 6.0	≤ 9.0	≤ 5.0	≤ 7.0	≤ 4.5	≤ 6.0	≤ 4.5	≤ 5.5
	256 QAM	≤ 9.5	≤ 11.5	≤ 6.0	≤ 9.0	≤ 5.0	≤ 7.0	≤ 5.5	≤ 6.5	≤ 5.5	≤ 6.0

NOTE 1: Full allocation A-MPR applies when all RB's in a 20 MHz channel or all RB's in all sub-bands for wideband operation are fully allocated and all sub-bands are transmitted. Partial allocation A-MPR applies when one or more RB's in one or more sub-bands are not allocated but when all sub-bands within the channel are transmitted. When not all sub-bands within the channel are transmitted, the A-MPR associated with the channel bandwidth according to the bandwidth of the contiguously transmitted sub-bands and according to the allocation type applies.

NOTE 2: Applicable to Pi/2-BPSK modulation when IE powerBoostPi2BPSK is set to 0.

## 6.2F.3.11 A-MPR for NS\_61

When "NS\_61" is indicated in the cell, the A-MPR is specified in Table 6.2F.3.11-1.

Table 6.2F.3.11-1: A-MPR for NS\_61 power class 5

Pre-coding	Modulation	Channel bandwidth (Sub-band allocation) / RB Allocation							
		20 MHz		40 MHz		60 MHz		80 MHz	
		Full (dB)	Partial (dB)	Full (dB)	Partial (dB)	Full (dB)	Partial (dB)	Full (dB)	Partial (dB)
DFT-s-OFDM	PI/2 BPSK <sup>2</sup>	≤ 7.5	≤ 10.0	≤ 6.5	≤ 6.5	≤ 6.0	≤ 6.0	≤ 6.0	≤ 6.0
	QPSK	≤ 7.5	≤ 10.0	≤ 6.5	≤ 6.5	≤ 6.0	≤ 6.0	≤ 6.0	≤ 6.0
	16 QAM	≤ 7.5	≤ 10.5	≤ 6.5	≤ 6.5	≤ 6.0	≤ 6.0	≤ 6.0	≤ 6.0
	64 QAM	≤ 7.5	≤ 10.5	≤ 6.5	≤ 6.5	≤ 6.0	≤ 6.0	≤ 6.0	≤ 6.0
	256 QAM	≤ 7.5	≤ 10.5	≤ 6.5	≤ 6.5	≤ 6.0	≤ 6.0	≤ 6.0	≤ 6.0
CP-OFDM	QPSK	≤ 7.5	≤ 10.0	≤ 6.5	≤ 6.5	≤ 6.0	≤ 6.0	≤ 6.0	≤ 6.0
	16 QAM	≤ 7.5	≤ 10.5	≤ 6.5	≤ 6.5	≤ 6.0	≤ 6.0	≤ 6.0	≤ 6.0
	64 QAM	≤ 7.5	≤ 10.5	≤ 6.5	≤ 6.5	≤ 6.0	≤ 6.0	≤ 6.0	≤ 6.0
	256 QAM	≤ 7.5	≤ 10.5	≤ 7.0	≤ 7.0	≤ 7.0	≤ 7.0	≤ 7.0	≤ 7.0

NOTE 1: Full allocation A-MPR applies when all RB's in a 20 MHz channel or all RB's in all sub-bands for wideband operation are fully allocated and all sub-bands are transmitted. Partial allocation A-MPR applies when one or more RB's in one or more sub-bands are not allocated but when all sub-bands within the channel are transmitted. When not all sub-bands within the channel are transmitted, the A-MPR associated with the channel bandwidth according to the bandwidth of the contiguously transmitted sub-bands and according to the allocation type applies.

NOTE 2: Applicable to Pi/2-BPSK modulation when IE powerBoostPi2BPSK is set to 0.

## 6.2F.3.12 A-MPR for NS\_63

When "NS\_63" is indicated in the cell, the A-MPR is specified in Table 6.2F.3.12-1.

Table 6.2F.3.12-1: A-MPR for NS\_63 power class 5

Pre-coding	Modulation	RB Allocation (Note 2)	RB Allocation (Note 3, Note 4)	
		Full/Partial	Full (dB)	Partial (dB)
DFT-s-OFDM	PI/2 BPSK <sup>4</sup>	See Table PC5 MPR	≤ 2.0	≤ 3.0
	QPSK		≤ 2.5	≤ 3.5
	16 QAM		≤ 3.0	≤ 3.5
	64 QAM		≤ 3.5	≤ 4.5
	256 QAM		≤ 5.0	≤ 5.5
CP-OFDM	QPSK		≤ 4.5	≤ 5.0
	16 QAM		≤ 4.5	≤ 5.5
	64 QAM		≤ 5.5	≤ 5.5
	256 QAM		≤ 7.0	≤ 7.0

NOTE 1: Full allocation A-MPR applies when all RB's in a 20 MHz channel or all RB's in all sub-bands for wideband operation are fully allocated and all sub-bands are transmitted. Partial allocation A-MPR applies when one or more RB's in one or more sub-bands are not allocated or when not all transmitted sub-bands for wideband operation are transmitted.

NOTE 2: Applicable for all valid channels and bandwidths other than those enumerated in NOTE 3 and NOTE 4.

NOTE 3: Applicable for 40 MHz channels centered at the nearest NR-ARFCN corresponding to [5965 MHz], and 80 MHz channels centered at the nearest NR-ARFCN corresponding to [5985 MHz].



NOTE 4: Applicable for 20 MHz channels centered at the nearest NR-ARFCN corresponding to [6415 MHz], 40 MHz channels centered at the nearest NR-ARFCN corresponding to [6405 MHz] and 80 MHz channels centered at the nearest NR-ARFCN corresponding to [6385 MHz].
NOTE 5: Applicable to Pi/2-BPSK modulation when IE powerBoostPi2BPSK is set to 0.
NOTE 6: Channel bandwidth sizes of 60MHz and 100MHz are not applicable for this network signalling.

### 6.2F.3.13 A-MPR for NS\_64

When "NS\_64" is indicated in the cell, the A-MPR is specified in Table 6.2F.3.13-1.

**Table 6.2F.3.13-1: A-MPR for NS\_64 power class 5**

Pre-coding	Modulation	RB Allocation (Note 2)		RB Allocation (Note 3)	
		Full (dB)	Partial (dB)	Full (dB)	Partial (dB)
DFT-s-OFDM	Pi/2 BPSK <sup>4</sup>	≤ 12	≤ 14	≤ 8	≤ 10
	QPSK	≤ 12	≤ 14	≤ 8	≤ 10
	16 QAM	≤ 12	≤ 15	≤ 9	≤ 10
	64 QAM	≤ 12	≤ 15	≤ 11	≤ 11
	256 QAM	≤ 13	≤ 15	≤ 13	≤ 14
CP-OFDM	QPSK	≤ 13	≤ 15	≤ 10	≤ 10
	16 QAM	≤ 13	≤ 15	≤ 11	≤ 11
	64 QAM	≤ 13	≤ 15	≤ 13	≤ 13
	256 QAM	≤ 15	≤ 15	≤ 15	≤ 15

NOTE 1: Full allocation A-MPR applies when all RB's in a 20 MHz channel or all RB's in all sub-bands for wideband operation are fully allocated and all sub-bands are transmitted. Partial allocation A-MPR applies when one or more RB's in one or more sub-bands are not allocated or when not all transmitted sub-bands for wideband operation are transmitted.

NOTE 2: Applicable for 20 MHz channels centered at the nearest NR-ARFCN corresponding to 5955 MHz, 40 MHz channels centered at the nearest NR-ARFCN corresponding to 5965 MHz, 60 MHz channels centered at the nearest NR-ARFCN corresponding to 5975 and 5995 MHz, 80 MHz channels centered at the nearest NR-ARFCN corresponding to 5985 MHz, and 100 MHz channels centered at the nearest NR-ARFCN corresponding to 5995 MHz.

NOTE 3: Applicable for all valid channels other than those enumerated under NOTE 2.

NOTE 4: Applicable to Pi/2-BPSK modulation when IE powerBoostPi2BPSK is set to 0.

### 6.2F.3.14 A-MPR for NS\_65

When "NS\_65" is indicated in the cell, the A-MPR is specified in Table 6.2F.3.14-1.

**Table 6.2F.3.14-1: A-MPR for NS\_65 power class 5**

Pre-coding	Modulation	RB Allocation	
		Full <sup>2</sup> (dB)	Partial <sup>3</sup> (dB)
DFT-s-OFDM	Pi/2 BPSK <sup>4</sup>	≤ 6.0	≤ 6.0
	QPSK	≤ 6.0	≤ 6.0
	16 QAM	≤ 6.0	≤ 6.0
	64 QAM	≤ 6.0	≤ 6.0
	256 QAM	≤ 6.0	≤ 6.0
CP-OFDM	QPSK	≤ 6.0	≤ 6.0
	16 QAM	≤ 6.0	≤ 6.0
	64 QAM	≤ 6.0	≤ 6.0
	256 QAM	≤ 6.5	≤ 7.0

NOTE 1:	The A-MPR shall apply to all SCS in all active 20 MHz sub-bands contiguously allocated in the channel.
NOTE 2:	The A-MPR for Full RB allocation applies to all RB's in all transmitted 20 MHz or larger channels that are fully allocated or all RB's in all contiguously transmitted sub-bands for wideband operation that are fully allocated excluding the wideband configurations of Table 6.2F.2-2.
NOTE 3:	The A-MPR for Partial RB allocation applies to interlaced allocations with uplink resource allocation type 2 as specified in TS 38.214 [10] or transmitted sub-bands for wideband operation are transmitted according to the wideband configurations of Table 6.2F.2-2.
NOTE 4:	Applicable to Pi/2-BPSK modulation when IE powerBoostPi2BPSK is set to 0.

### 6.2F.3.15 A-MPR for NS\_66

When "NS\_66" is indicated in the cell, the A-MPR is specified in Table 6.2F.3.15-1.

**Table 6.2F.3.15-1: A-MPR for NS\_66 power class 5**

Pre-coding	Modulation	Channel bandwidth (Sub-band allocation) / RB Allocation									
		20 MHz		40 MHz		60 MHz		80 MHz		100 MHz	
		Full (dB)	Partial (dB)	Full (dB)	Partial (dB)	Full (dB)	Partial (dB)	Full (dB)	Partial (dB)	Full (dB)	Partial (dB)
DFT-s-OFDM	PI/2 BPSK <sup>2</sup>	≤ 16.0	≤ 18.5	≤ 12.5	≤ 15.5	≤ 11.0	≤ 14.0	≤ 9.5	≤ 12.5	≤ 8.5	≤ 11.5
	QPSK	≤ 16.0	≤ 18.5	≤ 12.5	≤ 15.5	≤ 11.0	≤ 14.0	≤ 9.5	≤ 12.5	≤ 8.5	≤ 11.5
	16 QAM	≤ 16.0	≤ 18.5	≤ 12.5	≤ 15.5	≤ 11.0	≤ 14.0	≤ 9.5	≤ 12.5	≤ 8.5	≤ 11.5
	64 QAM	≤ 16.0	≤ 18.5	≤ 12.5	≤ 15.5	≤ 11.0	≤ 14.0	≤ 9.5	≤ 12.5	≤ 8.5	≤ 11.5
	256 QAM	≤ 16.0	≤ 18.5	≤ 12.5	≤ 15.5	≤ 11.0	≤ 14.0	≤ 9.5	≤ 12.5	≤ 8.5	≤ 11.5
CP-OFDM	QPSK	≤ 16.0	≤ 18.5	≤ 12.5	≤ 15.5	≤ 11.0	≤ 14.0	≤ 9.5	≤ 12.5	≤ 8.5	≤ 11.5
	16 QAM	≤ 16.0	≤ 18.5	≤ 12.5	≤ 15.5	≤ 11.0	≤ 14.0	≤ 9.5	≤ 12.5	≤ 8.5	≤ 11.5
	64 QAM	≤ 16.0	≤ 18.5	≤ 12.5	≤ 15.5	≤ 11.0	≤ 14.0	≤ 9.5	≤ 12.5	≤ 8.5	≤ 11.5
	256 QAM	≤ 16.0	≤ 18.5	≤ 12.5	≤ 15.5	≤ 11.0	≤ 14.0	≤ 9.5	≤ 12.5	≤ 8.5	≤ 11.5
NOTE 1: Full allocation A-MPR applies when all RB's in a 20 MHz channel or all RB's in all sub-bands for wideband operation are fully allocated and all sub-bands are transmitted. Partial allocation A-MPR applies when one or more RB's in one or more sub-bands are not allocated but when all sub-bands within the channel are transmitted. When not all sub-bands within the channel are transmitted, the A-MPR associated with the channel bandwidth according to the bandwidth of the contiguously transmitted sub-bands and according to the allocation type applies.											
NOTE 2: Applicable to Pi/2-BPSK modulation when IE powerBoostPi2BPSK is set to 0.											

### 6.2F.3.16 A-MPR for "NS\_67" or "NS\_71"

When "NS\_67" or "NS\_71" is indicated in the cell, the A-MPR is specified in Table 6.2F.3.16-1.

**Table 6.2F.3.16-1: A-MPR for "NS\_67" and "NS\_71" power class 5**

Pre-coding	Modulation	Channel bandwidth (Sub-band allocation) / RB Allocation									
		20 MHz		40 MHz		60 MHz		80 MHz		100 MHz	
		Full (dB)	Partial (dB)	Full (dB)	Partial (dB)	Full (dB)	Partial (dB)	Full (dB)	Partial (dB)	Full (dB)	Partial (dB)
DFT-s-OFDM	PI/2 BPSK <sup>2</sup>	≤ 13.0	≤ 15.5	≤ 9.5	≤ 12.5	≤ 8.0	≤ 11.0	≤ 6.5	≤ 9.5	≤ 6.0	≤ 8.5
	QPSK	≤ 13.0	≤ 15.5	≤ 9.5	≤ 12.5	≤ 8.0	≤ 11.0	≤ 6.5	≤ 9.5	≤ 6.0	≤ 8.5
	16 QAM	≤ 13.0	≤ 15.5	≤ 9.5	≤ 12.5	≤ 8.0	≤ 11.0	≤ 6.5	≤ 9.5	≤ 6.0	≤ 8.5
	64 QAM	≤ 13.0	≤ 15.5	≤ 9.5	≤ 12.5	≤ 8.0	≤ 11.0	≤ 6.5	≤ 9.5	≤ 6.0	≤ 8.5
	256 QAM	≤ 13.0	≤ 15.5	≤ 9.5	≤ 12.5	≤ 8.0	≤ 11.0	≤ 6.5	≤ 9.5	≤ 6.0	≤ 8.5

CP-OFDM	QPSK	≤ 13.0	≤ 15.5	≤ 9.5	≤ 12.5	≤ 8.0	≤ 11.0	≤ 6.5	≤ 9.5	≤ 6.0	≤ 8.5
	16 QAM	≤ 13.0	≤ 15.5	≤ 9.5	≤ 12.5	≤ 8.0	≤ 11.0	≤ 6.5	≤ 9.5	≤ 6.0	≤ 8.5
	64 QAM	≤ 13.0	≤ 15.5	≤ 9.5	≤ 12.5	≤ 8.0	≤ 11.0	≤ 6.5	≤ 9.5	≤ 6.0	≤ 8.5
	256 QAM	≤ 13.0	≤ 15.5	≤ 9.5	≤ 12.5	≤ 8.0	≤ 11.0	≤ 6.5	≤ 9.5	≤ 6.0	≤ 8.5
NOTE 1: Full allocation A-MPR applies when all RB's in a 20 MHz channel or all RB's in all sub-bands for wideband operation are fully allocated and all sub-bands are transmitted. Partial allocation A-MPR applies when one or more RB's in one or more sub-bands are not allocated but when all sub-bands within the channel are transmitted. When not all sub-bands within the channel are transmitted, the A-MPR associated with the channel bandwidth according to the bandwidth of the contiguously transmitted sub-bands and according to the allocation type applies.											
NOTE 2: Applicable to Pi/2-BPSK modulation when IE powerBoostPi2BPSK is set to 0.											

### 6.2F.3.17 A-MPR for NS\_68

When "NS\_68" is indicated in the cell, the A-MPR is specified in Table 6.2F.3.17-1.

**Table 6.2F.3.17-1: A-MPR for NS\_68 power class 5**

Pre-coding	Modulation	Channel bandwidth (Sub-band allocation) / RB Allocation									
		20 MHz		40 MHz		60 MHz		80 MHz		100 MHz	
		Full (dB)	Partial (dB)	Full (dB)	Partial (dB)	Full (dB)	Partial (dB)	Full (dB)	Partial (dB)	Full (dB)	Partial (dB)
DFT-s-OFDM	PI/2 BPSK <sup>2</sup>	≤ 7.0	≤ 9.5	≤ 6.0	≤ 6.5	≤ 6.0	≤ 6.0	≤ 6.0	≤ 6.0	≤ 6.0	≤ 6.0
	QPSK	≤ 7.0	≤ 9.5	≤ 6.0	≤ 6.5	≤ 6.0	≤ 6.0	≤ 6.0	≤ 6.0	≤ 6.0	≤ 6.0
	16 QAM	≤ 7.0	≤ 9.5	≤ 6.0	≤ 6.5	≤ 6.0	≤ 6.0	≤ 6.0	≤ 6.0	≤ 6.0	≤ 6.0
	64 QAM	≤ 7.0	≤ 9.5	≤ 6.0	≤ 6.5	≤ 6.0	≤ 6.0	≤ 6.0	≤ 6.0	≤ 6.0	≤ 6.0
	256 QAM	≤ 7.0	≤ 9.5	≤ 6.0	≤ 6.5	≤ 6.0	≤ 6.0	≤ 6.0	≤ 6.0	≤ 6.0	≤ 6.0
CP-OFDM	QPSK	≤ 7.0	≤ 9.5	≤ 6.0	≤ 6.5	≤ 6.0	≤ 6.0	≤ 6.0	≤ 6.0	≤ 6.0	≤ 6.0
	16 QAM	≤ 7.0	≤ 9.5	≤ 6.0	≤ 6.5	≤ 6.0	≤ 6.0	≤ 6.0	≤ 6.0	≤ 6.0	≤ 6.0
	64 QAM	≤ 7.0	≤ 9.5	≤ 6.0	≤ 6.5	≤ 6.0	≤ 6.0	≤ 6.0	≤ 6.0	≤ 6.0	≤ 6.0
	256 QAM	≤ 7.0	≤ 9.5	≤ 6.0	≤ 6.5	≤ 6.0	≤ 6.0	≤ 6.0	≤ 6.0	≤ 6.0	≤ 6.0
NOTE 1: Full allocation A-MPR applies when all RB's in a 20 MHz channel or all RB's in all sub-bands for wideband operation are fully allocated and all sub-bands are transmitted. Partial allocation A-MPR applies when one or more RB's in one or more sub-bands are not allocated but when all sub-bands within the channel are transmitted. When not all sub-bands within the channel are transmitted, the A-MPR associated with the channel bandwidth according to the bandwidth of the contiguously transmitted sub-bands and according to the allocation type applies.											
NOTE 2: Applicable to Pi/2-BPSK modulation when IE powerBoostPi2BPSK is set to 0.											

### 6.2F.3.18 A-MPR for NS\_69

When "NS\_69" is indicated in the cell, the A-MPR is specified in Table 6.2F.3.18-1.

**Table 6.2F.3.18-1: A-MPR for NS\_69 power class 5**

Pre-coding	Modulation	Channel bandwidth (Sub-band allocation) / RB Allocation					
		20 MHz		40 MHz		80 MHz	
		Full (dB)	Partial (dB)	Full (dB)	Partial (dB)	Full (dB)	Partial (dB)
DFT-s-OFDM	PI/2 BPSK <sup>2</sup>	≤ 6.0	≤ 6.0	≤ 6.0	≤ 6.5	≤ 6.5	≤ 7.0
	QPSK	≤ 6.0	≤ 6.0	≤ 6.0	≤ 6.5	≤ 6.5	≤ 7.0
	16 QAM	≤ 6.0	≤ 6.0	≤ 6.0	≤ 6.5	≤ 6.5	≤ 7.0
	64 QAM	≤ 6.0	≤ 6.0	≤ 6.0	≤ 6.5	≤ 6.5	≤ 7.0
	256 QAM	≤ 6.0	≤ 6.0	≤ 6.0	≤ 6.5	≤ 6.5	≤ 7.0
CP-OFDM	QPSK	≤ 6.0	≤ 6.0	≤ 6.0	≤ 8.0	≤ 6.5	≤ 8.5
	16 QAM	≤ 6.0	≤ 6.0	≤ 6.0	≤ 8.0	≤ 6.5	≤ 8.5
	64 QAM	≤ 6.0	≤ 6.0	≤ 6.0	≤ 8.0	≤ 6.5	≤ 8.5

	256 QAM	≤ 7.0	≤ 6.0	≤ 6.0	≤ 8.0	≤ 7.0	≤ 8.5
NOTE 1:	Full allocation A-MPR applies when all RB's in a 20 MHz channel or all RB's in all sub-bands for wideband operation are fully allocated and all sub-bands are transmitted. Partial allocation A-MPR applies when one or more RB's in one or more sub-bands are not allocated but when all sub-bands within the channel are transmitted. When not all sub-bands within the channel are transmitted, the A-MPR associated with the channel bandwidth according to the bandwidth of the contiguously transmitted sub-bands and according to the allocation type applies.						
NOTE 2:	Applicable to Pi/2-BPSK modulation when IE powerBoostPi2BPSK is set to 0.						
NOTE 3:	Channel bandwidth sizes of 60MHz and 100MHz are not applicable for this network signalling.						

## 6.2F.3A UE additional maximum output power reduction for CA

### 6.2F.3A.1 UE additional maximum output power reduction for inter-band CA

For inter-band carrier aggregation with uplink assigned to two bands and including one of the bands listed in Table 6.2F.1-1, the requirements in clause 6.2.3 apply for the NR uplink carrier and clause 6.2F.3 for the carrier operating with shared spectrum access.

### 6.2F.3A.2 UE additional maximum output power reduction for intra-band CA

To meet the additional requirements, additional maximum power reduction (A-MPR) is allowed for the maximum output power as specified in Table 6.2F.1A.2-1. Unless stated otherwise, the total reduction to UE maximum output power is  $\max(\text{MPR}, \text{A-MPR})$  where MPR is defined in clause 6.2F.2A.2 for intra-band carrier aggregation.

#### 6.2F.3A.2.1 UE additional maximum output power reduction for intra-band contiguous CA

Additional emission requirements can be signalled by the network. Each additional emission requirement is associated with a unique network signalling (NS) value indicated in RRC signalling by an NR frequency band number of the applicable operating band and an associated value in the field *additionalSpectrumEmission*. Throughout this specification, the notion of indication or signalling of an NS value refers to the corresponding indication of an NR frequency band number of the applicable operating band, the IE field *freqBandIndicatorNR* and an associated value of *additionalSpectrumEmission* in the relevant RRC information elements [7]. Relation between NR CA band and NR frequency band is specified in Table 5.2A.1-1.

To meet the additional requirements, additional maximum power reduction (A-MPR) is allowed for the maximum output power as specified in Table 6.2F.1A.2-1. Unless stated otherwise, the total reduction to UE maximum output power is  $\max(\text{MPR}, \text{A-MPR})$  where MPR is defined in clause 6.2F.2A.2. In absence of modulation and waveform types the A-MPR applies to all modulation and waveform types.

Table 6.2F.3A.2.1-1 specifies the additional requirements with their associated network signalling values and the allowed A-MPR and applicable CA band(s) for each CA\_NS value. The CA\_NS\_xy value indicates the additional unwanted emissions requirements that apply for intra-band contiguous CA bands with NS\_xy indicated or configured in multiple uplinks serving cells, except CA\_NS\_01 that indicates the general emission requirements for intra-band contiguous CA bands. The mapping of NR CA band numbers and values of the *additionalSpectrumEmission* to network signalling labels is specified in Table 6.2F.3A.2.1-2. For any NR CA band not listed in Table 6.2F.3A.2.1-2 the network signalling label CA\_NS\_01 applies.

**Table 6.2F.3A.2.1-1: Additional maximum power reduction (A-MPR)**

Network signalling label	Requirements (clause)	NR CA Band	Aggregated channel bandwidth (MHz)	Resources blocks ( $N_{RB}$ )	A-MPR (dB)
--------------------------	-----------------------	------------	------------------------------------	-------------------------------	------------

CA_NS_53	6.5F.3A.3.1 6.2F.1A.2.1	CA_n96	40, 60, 80, 100, 120, 140, 160		6.2F.3A.2.2
CA_NS_54	6.5F.3A.3.1 6.2F.1A.2.2	CA_n96	40, 60, 80, 100, 120, 140, 160		6.2F.3A.2.3
NOTE 1: The A-MPR shall apply to all active 20 MHz sub-bands contiguously allocated in the channel.					

Table 6.2F.3A.2.1-2: Mapping of network signalling label

NR CA band	Value of additionalSpectrumEmission							
	0	1	2	3	4	5	6	7
CA_n96	CA_NS_01	CA_NS_53	CA_NS_54					
NOTE: <i>additionalSpectrumEmission</i> corresponds to an information element of the same name defined in clause 6.3.2 of TS 38.331 [7].								

#### 6.2F.3A.2.2 A-MPR for CA\_NS\_53

When "CA\_NS\_53" is indicated in the cell, the A-MPR is specified in Table 6.2F.3A.2.2-1.

Table 6.2F.3A.2.2-1: A-MPR for CA\_NS\_53 power class 5

Pre-coding	Modulation	Bandwidth of contiguously transmitted sub-bands / RB Allocation / A-MPR (dB)															
		20 MHz		40 MHz		60 MHz		80 MHz		100MHz		120MHz		140MHz		160MHz	
		Full	Partial	Full	Partial	Full	Partial	Full	Partial	Full	Partial	Full	Partial	Full	Partial	Full	Partial
DFT-s-OFDM	PI/2 BPSK <sup>2</sup>	≤ 9.0	≤ 11.5	≤ 5.5	≤ 8.5	≤ 4.0	≤ 6.5	≤ 3.5	≤ 5.5	≤ 3.5	≤ 5.0	≤ 3.5	≤ 4.0	≤ 3.5	≤ 4.0	≤ 3.5	≤ 4.0
	QPSK	≤ 9.0	≤ 11.5	≤ 5.5	≤ 8.5	≤ 4.0	≤ 6.5	≤ 3.5	≤ 5.5	≤ 3.5	≤ 5.0	≤ 3.5	≤ 4.0	≤ 3.5	≤ 4.0	≤ 3.5	≤ 4.0
	16 QAM	≤ 9.0	≤ 11.5	≤ 5.5	≤ 8.5	≤ 4.0	≤ 6.5	≤ 3.5	≤ 5.5	≤ 3.5	≤ 5.0	≤ 3.5	≤ 4.5	≤ 3.5	≤ 4.0	≤ 3.5	≤ 4.0
	64 QAM	≤ 9.0	≤ 11.5	≤ 5.5	≤ 8.5	≤ 4.5	≤ 6.5	≤ 4.5	≤ 5.5	≤ 4.5	≤ 5.0	≤ 4.5	≤ 4.5	≤ 4.5	≤ 4.5	≤ 4.5	≤ 4.5
	256 QAM	≤ 9.0	≤ 11.5	≤ 6.0	≤ 8.5	≤ 6.0	≤ 6.5	≤ 6.0	≤ 6.0	≤ 6.0	≤ 6.0	≤ 6.0	≤ 6.0	≤ 6.0	≤ 6.0	≤ 6.0	≤ 6.0
CP-OFDM	QPSK	≤ 9.0	≤ 11.0	≤ 5.5	≤ 8.5	≤ 5.0	≤ 6.5	≤ 5.0	≤ 5.5	≤ 5.0	≤ 5.0	≤ 4.5	≤ 5.0	≤ 4.5	≤ 5.0	≤ 4.5	≤ 5.0
	16 QAM	≤ 9.0	≤ 11.0	≤ 5.5	≤ 8.5	≤ 5.0	≤ 6.5	≤ 5.0	≤ 5.5	≤ 5.0	≤ 5.0	≤ 5.0	≤ 5.0	≤ 5.0	≤ 5.0	≤ 4.5	≤ 5.0
	64 QAM	≤ 9.0	≤ 11.0	≤ 6.0	≤ 8.5	≤ 6.0	≤ 6.5	≤ 6.0	≤ 6.0	≤ 6.0	≤ 6.0	≤ 6.0	≤ 6.0	≤ 6.0	≤ 6.0	≤ 6.0	≤ 6.0
	256 QAM	≤ 9.0	≤ 11.0	≤ 7.0	≤ 8.5	≤ 7.0	≤ 7.0	≤ 7.0	≤ 7.0	≤ 7.0	≤ 7.0	≤ 7.0	≤ 7.0	≤ 7.0	≤ 7.0	≤ 7.0	≤ 7.0

NOTE 1: Full allocation A-MPR applies when all RB's in a 20 MHz channel or all RB's in all sub-bands for wideband operation are fully allocated and all sub-bands are transmitted. Partial allocation A-MPR applies when one or more RB's in one or more sub-bands are not allocated but when all sub-bands within the channel are transmitted. When not all sub-bands within the channel are transmitted, the A-MPR associated with the channel bandwidth according to the bandwidth of the contiguously transmitted sub-bands and according to the allocation type applies.

NOTE 2: Applicable to Pi/2-BPSK modulation when IE powerBoostPi2BPSK is set to 0.

## 6.2F.3A.2.3 A-MPR for CA\_NS\_54

When “CA\_NS\_54” is indicated in the cell, the A-MPR is specified in Table 6.2F.3A.2.3-1.

**Table 6.2F.3A.2.3-1: A-MPR for CA\_NS\_54 power class 5**

Pre-coding	Modulation	Bandwidth of contiguously transmitted sub-bands / RB Allocation / A-MPR (dB)							
		RB Allocation (Note 4)		40MHz – 80MHz (Note 5)		100MHz – 120MHz (Note 5)		140MHz – 160MHz (Note 5)	
		Full <sup>2</sup>	Partial <sup>3</sup>	Full <sup>2</sup>	Partial <sup>3</sup>	Full <sup>2</sup>	Partial <sup>3</sup>	Full <sup>2</sup>	Partial <sup>3</sup>
DFT-s-OFDM	PI/2 BPSK <sup>7</sup>	≤ 3.0		≤ 3.5	≤ 4.5	≤ 3.0	≤ 4.0	≤ 3.0	≤ 3.5
	QPSK	≤ 3.0		≤ 3.5	≤ 4.5	≤ 3.0	≤ 4.0	≤ 3.0	≤ 3.5
	16 QAM	≤ 3.5		≤ 4.0	≤ 4.5	≤ 3.5	≤ 4.0	≤ 3.5	≤ 3.5
	64 QAM	≤ 4.5		≤ 4.5	≤ 4.5	≤ 4.5	≤ 4.5	≤ 4.5	≤ 4.5
	256 QAM	≤ 6.0		≤ 6.0	≤ 6.0	≤ 6.0	≤ 6.0	≤ 6.0	≤ 6.0
CP-OFDM	QPSK	≤ 4.0		≤ 4.5	≤ 5.0	≤ 4.0	≤ 4.5	≤ 4.0	≤ 4.0
	16 QAM	≤ 4.5		≤ 4.5	≤ 5.5	≤ 4.5	≤ 4.5	≤ 4.5	≤ 4.0
	64 QAM	≤ 6.0		≤ 5.5	≤ 6.0	≤ 6.0	≤ 6.0	≤ 6.0	≤ 6.0
	256 QAM	≤ 7.0		≤ 7.0	≤ 7.0	≤ 7.0	≤ 7.0	≤ 7.0	≤ 7.0
Z									

## 6.2F.3D UE additional maximum output power reduction for UL MIMO

For UE with two transmit antenna connectors in closed-loop spatial multiplexing scheme, the A-MPR values specified in clause 6.2F.3 shall apply to the maximum output power specified in Table 6.2F.1D-1. The requirements shall be met with the UL MIMO configurations specified in Table 6.2D.1-2. For UE supporting UL MIMO, the maximum output power is defined as the sum of the maximum output power from both UE antenna connector.

For UE supporting uplink full power transmission (ULFPTx) for UL MIMO, the A-MPR values specified in clause 6.2F.3 shall apply to the maximum output power specified in Table 6.2F.1D-1. The requirements shall be met with the PUSCH configurations specified in Table 6.2D.1-3, based upon UE’s support of uplink full power transmission mode.

For the UE maximum output power modified by A-MPR, the power limits specified in clause 6.2D.4 apply.

If UE is scheduled for single antenna-port PUSCH transmission by DCI format 0\_0 or by DCI format 0\_1 for single antenna port codebook based transmission, the requirements in clause 6.2.4 apply for the power class as indicated by the *ue-PowerClass* field in capability signaling.

## 6.2F.4 Configured transmitted power

The requirements for configured maximum output power in clause 6.2.4 apply.

## 6.2F.4D Configured transmitted power UL MIMO

For UE supporting UL MIMO, the transmitted power is configured per each UE.

The definitions of configured maximum output power  $P_{\text{CMAX},c}$ , the lower bound  $P_{\text{CMAX}_L,c}$ , and the higher bound  $P_{\text{CMAX}_H,c}$  specified in clause 6.2.4 shall apply to UE supporting UL MIMO, where

- $P_{\text{PowerClass}}$ ,  $\Delta P_{\text{PowerClass}}$  and  $\Delta T_{C,c}$  are specified in clause 6.2.4 unless otherwise stated;



- $MPR_c$  is specified in clause 6.2F.2D;
- A- $MPR_c$  is specified in clause 6.2F.3.

The measured configured maximum output power  $P_{UMAX,c}$  for serving cell  $c$  shall be within the following bounds:

$$P_{CMAX\_L,c} - \text{MAX}\{T_L, T_{LOW}(P_{CMAX\_L,c})\} \leq P_{UMAX,c} \leq P_{CMAX\_H,c} + T_{HIGH}(P_{CMAX\_H,c})$$

where  $T_{LOW}(P_{CMAX\_L,c})$  and  $T_{HIGH}(P_{CMAX\_H,c})$  are defined as the tolerance and applies to  $P_{CMAX\_L,c}$  and  $P_{CMAX\_H,c}$  separately, while  $T_L$  is the absolute value of the lower tolerance in Table 6.2F.1D-1 for the applicable operating band.

For UE with two transmit antenna connectors in closed-loop spatial multiplexing scheme, the tolerance is specified in Table 6.2F.4D-1. The requirements shall be met with UL MIMO configurations specified in Table 6.2D.1-2.

For UE supporting uplink full power transmission (ULFPTx) for UL MIMO, the tolerance is specified in Table 6.2F.4D-1. The requirements shall be met with the PUSCH configurations specified in Table 6.2D.1-3, based upon UE's support of uplink full power transmission mode.

**Table 6.2F.4D-1:  $P_{CMAX,c}$  tolerance in closed-loop spatial multiplexing scheme**

$P_{CMAX,c}$ (dBm)	Tolerance $T_{LOW}(P_{CMAX\_L,c})$ (dB)	Tolerance $T_{HIGH}(P_{CMAX\_H,c})$ (dB)
$P_{CMAX,c} = 23$	3.0	2.0
$20 \leq P_{CMAX,c} < 23$	3.0	2.0
$19 \leq P_{CMAX,c} < 20$	5.0	2.0
$18 \leq P_{CMAX,c} < 19$	5.0	3.0
$17 \leq P_{CMAX,c} < 18$	5.0	4.0
$13 \leq P_{CMAX,c} < 17$	5.0	
$8 \leq P_{CMAX,c} < 13$	6.0	
$-40 \leq P_{CMAX,c} < 8$	7.0	

## 6.2G Transmitter power for Tx Diversity

### 6.2G.1 UE maximum output power for Tx Diversity

For UE supporting Tx Diversity, the maximum output power as indicated by UE power class in Table 6.2.1-1 is defined as the sum of the maximum output power from all UE transmit antenna connectors. The period of measurement shall be at least one sub frame (1 ms).

When a UE indicates PC1.5 for a given band it achieves maximum power by means of Tx Diversity in the current version of the spec. Therefore, Tx Diversity is implied for PC1.5 even if the UE does not indicate Tx diversity capability.

### 6.2G.2 UE maximum output power reduction for Tx Diversity

For UE supporting Tx diversity, the allowed MPR for the maximum output power is specified in Table 6.2.2-1 for UE power class 3, in Table 6.2D.2-1 for UE power class 2, in Table 6.2D.2-2 and Table 6.2D.2-3 for UE power class 1.5 with dual TX, in Table 6.2D.2-4 and 6.2D.2-5 for UE power class 1.5 with 4 Tx. For UE power class 1.5 with dual Tx, the allowed maximum power reduction (MPR) defined in Table 6.2D.2-3 is in accordance with the indicated *modifiedMPR-Behavior* specified in Table L.1-1 for channel bandwidths  $\leq 100$  MHz. The maximum output power is defined as the sum of the maximum output power at each UE antenna connector. If a UE that supports PC1.5 has to apply the requirements of PC2 according to the rules in clause 6.2.1, the MPR requirements in Table 6.2.2-2 apply

### 6.2G.3 UE additional maximum output power reduction for Tx Diversity

For UE supporting Tx diversity, the A-MPR values specified in clause 6.2.3 shall apply to the maximum output power specified in Table 6.2.1-1, and the maximum output power is defined as the sum of the maximum output power at each UE antenna connector. Unless stated otherwise, an A-MPR of 0 dB shall be used.

## 6.2G.4 Configured transmitted power for Tx Diversity

For UE supporting Tx diversity, the transmitted power is configured per each UE.

The definitions of configured maximum output power  $P_{\text{CMAX},c}$ , the lower bound  $P_{\text{CMAX}_L,c}$ , and the higher bound  $P_{\text{CMAX}_H,c}$  specified in clause 6.2.4 shall apply to UE supporting Tx diversity, where

- $P_{\text{PowerClass}}$ ,  $\Delta P_{\text{PowerClass}}$  +  $\Delta P_{\text{PowerBoost}}$ , and  $\Delta T_{C,c}$  are specified in clause 6.2.4 unless otherwise stated;
- $\text{MPR}_c$  is specified in clause 6.2G.2;

The measured configured maximum output power  $P_{\text{UMAX},c}$  for serving cell  $c$  shall be within the following bounds:

$$P_{\text{CMAX}_L,c} - \text{MAX}\{T_L, T_{\text{LOW}}(P_{\text{CMAX}_L,c})\} \leq P_{\text{UMAX},c} \leq P_{\text{CMAX}_H,c} + T_{\text{HIGH}}(P_{\text{CMAX}_H,c})$$

where  $T_{\text{LOW}}(P_{\text{CMAX}_L,c})$  and  $T_{\text{HIGH}}(P_{\text{CMAX}_H,c})$  are defined as the tolerance and applies to  $P_{\text{CMAX}_L,c}$  and  $P_{\text{CMAX}_H,c}$  separately, while  $T_L$  is the absolute value of the lower tolerance in Table 6.2.1-1 for the applicable operating band.

For UE supporting Tx diversity, the tolerance is specified in Table 6.2G.4-1 and 6.2G.4-2.

**Table 6.2G.4-1:  $P_{\text{CMAX},c}$  tolerance for Tx Diversity with 2Tx**

$P_{\text{CMAX},c}$ (dBm)	Tolerance $T_{\text{LOW}}(P_{\text{CMAX}_L,c})$ (dB)	Tolerance $T_{\text{HIGH}}(P_{\text{CMAX}_H,c})$ (dB)
$23 \leq P_{\text{CMAX},c} \leq 29$	3.0	2.0
$22 \leq P_{\text{CMAX},c} < 23$	5.0	2.0
$21 \leq P_{\text{CMAX},c} < 22$	5.0	3.0
$20 \leq P_{\text{CMAX},c} < 21$	5.0	4.0
$16 \leq P_{\text{CMAX},c} < 20$	5.0	
$11 \leq P_{\text{CMAX},c} < 16$	6.0	
$-40 \leq P_{\text{CMAX},c} < 11$	7.0	

**Table 6.2G.4-2:  $P_{\text{CMAX},c}$  tolerance for Tx Diversity with 4Tx**

$P_{\text{CMAX},c}$ (dBm)	Tolerance $T_{\text{LOW}}(P_{\text{CMAX}_L,c})$ (dB)	Tolerance $T_{\text{HIGH}}(P_{\text{CMAX}_H,c})$ (dB)
$24.5 \leq P_{\text{CMAX},c} \leq 29$	3.0	2.0
$23.5 \leq P_{\text{CMAX},c} < 24.5$	5.0	2.0
$22.5 \leq P_{\text{CMAX},c} < 23.5$	5.0	3.0
$21.5 \leq P_{\text{CMAX},c} < 22.5$	5.0	4.0
$18 \leq P_{\text{CMAX},c} < 21.5$	5.0	
$13 \leq P_{\text{CMAX},c} < 18$	6.0	
$-40 \leq P_{\text{CMAX},c} < 13$	7.0	

## 6.2H Transmitter power for CA with UL MIMO

### 6.2H.1 Transmitter power for intra-band UL contiguous CA with UL MIMO

#### 6.2H.1.1 UE maximum output power for intra-band UL contiguous CA with UL MIMO

For intra-band UL contiguous CA and UE with two transmit antenna connectors in closed-loop spatial multiplexing scheme, the maximum output power is defined as the sum of the maximum output power from both UE antenna connectors and all UL CCs. The period of measurement shall be at least one sub frame (1 ms), as specified in Table 6.2H.1.1-1. The requirements shall be met with the UL MIMO configurations specified in Table 6.2D.1-2 for 2 layer configuration and the PUSCH configurations specified in Table 6.2D.1-3 for ULFPTx configuration.

**Table 6.2H.1.1-1: UE Power Class for intra-band UL contiguous CA with UL MIMO in closed loop spatial multiplexing scheme**

NR CA Configuration	Class 1 (dBm)	Tolerance (dB)	Class 2 (dBm)	Tolerance (dB)	Class 3 (dBm)	Tolerance (dB)	Class 5 (dBm)	Tolerance (dB)
CA_n41C			26	+2/-3	23	+2/-3		
CA_n78C			26	+2/-3	23	+2/-3		

NOTE 1: An uplink CA configuration in which the band has NOTE 3 in Table 6.2.1-1 is allowed to reduce the lower tolerance limit by 1.5 dB when the transmission bandwidths of the band are confined within  $F_{UL\_low}$  and  $F_{UL\_low} + 4$  MHz or  $F_{UL\_high} - 4$  MHz and  $F_{UL\_high}$ .

NOTE 2:  $P_{PowerClass}$  is the maximum UE power specified without taking into account the tolerance.

If UE is scheduled for single antenna-port PUSCH transmission by DCI format 0\_0 or by DCI format 0\_1 for single antenna port codebook based transmission with precoding matrix  $W=1$  [6.3.1.5 TS 38.211], the requirements in clause 6.2A.1.1 apply for at least one antenna connector for the power class as indicated by the *ue-PowerClass* field in capability signalling.

### 6.2H.1.2 UE maximum output power reduction for intra-band UL contiguous CA with UL MIMO

For intra-band UL contiguous CA and UE with two transmit antenna connectors in closed-loop spatial multiplexing scheme, the allowed Maximum Power Reduction (MPR) for the maximum output power in Table 6.2H.1.1-1 is specified in Table 6.2A.2.1-1, Table 6.2A.2.1-2 for power class 3 CA; Table 6.2A.2.1-1b, Table 6.2A.2.1-4 for power class 2 CA.

The requirements shall be met with UL MIMO configurations defined in Table 6.2D.1-2 for 2 layer configuration and the PUSCH configurations specified in Table 6.2D.1-3 for ULFPTx configuration. For the UE maximum output power modified by MPR, the power limits specified in clause 6.2H.1.4 apply.

If UE is scheduled for single antenna-port PUSCH transmission by DCI format 0\_0 or by DCI format 0\_1 for single antenna port codebook based transmission with precoding matrix  $W=1$  [6.3.1.5 TS 38.211], the requirements in clause 6.2A.2.1 apply for the power class as indicated by the *ue-PowerClass* field in capability signaling.

### 6.2H.1.3 UE additional maximum output power reduction for intra-band UL contiguous CA with UL MIMO

For intra-band UL contiguous CA and UE with two transmit antenna connectors in closed-loop spatial multiplexing scheme, the A-MPR values specified in clause 6.2A.3.1.1 shall apply to the maximum output power specified in Table 6.2H.1.1-1. The requirements shall be met with UL MIMO configurations defined in Table 6.2D.1-2 for 2 layer configuration and the PUSCH configurations specified in Table 6.2D.1-3 for ULFPTx configuration.

For the UE maximum output power modified by A-MPR, the power limits specified in clause 6.2H.1.4 apply.

If UE is scheduled for single antenna-port PUSCH transmission by DCI format 0\_0 or by DCI format 0\_1 for single antenna port codebook based transmission with precoding matrix  $W=1$  [6.3.1.5 TS 38.211], the requirements in clause 6.2A.3.1.1 apply for the power class as indicated by the *ue-PowerClass* field in capability signaling.

### 6.2H.1.4 Configured transmitted power for intra-band UL contiguous CA with UL MIMO

For UE supporting intra-band UL contiguous CA with UL MIMO, the transmitted power is configured per each UE.

The definitions of configured maximum output power  $P_{CMAX,c}$ , the lower bound  $P_{CMAX\_L,c}$ , and the higher bound  $P_{CMAX\_H,c}$  specified in clause 6.2A.4.1.1 shall apply to UE supporting intra-band UL contiguous CA with UL MIMO, where

- $\Delta P_{PowerClass,CA}$  and  $\Delta T_{C,c}$  are specified in clause 6.2A.4.1.1 unless otherwise stated;
- $P_{PowerClass,CA}$  is the maximum UE power specified in Table 6.2H.1.1-1 without taking into account the tolerance;
- MPR, AMPR is specified in clause 6.2H.1.2 and 6.2H.1.3;

The measured configured maximum output power  $P_{UMAX}$  over all serving cells shall be within the following bounds:

$$P_{CMAX\_L} - \text{MAX}\{T_L, T_{LOW}(P_{CMAX\_L})\} \leq P_{UMAX} \leq P_{CMAX\_H} + T_{HIGH}(P_{CMAX\_H})$$

where  $T_{LOW}(P_{CMAX\_L})$  and  $T_{HIGH}(P_{CMAX\_H})$  are defined as the tolerance and applies to  $P_{CMAX\_L}$  and  $P_{CMAX\_H}$  separately, while  $T_L$  is the absolute value of the lower tolerance in Table 6.2H.1.1-1 for the applicable operating band.

For UE supporting intra-band UL contiguous CA with UL MIMO, the tolerance is specified in Table 6.2H.1.4-1.

**Table 6.2H.1.4-1:  $P_{CMAX}$  tolerance for intra-band UL contiguous CA with UL MIMO**

$P_{CMAX}$ (dBm)	Tolerance $T_{LOW}(P_{CMAX\_L})$ (dB)	Tolerance $T_{HIGH}(P_{CMAX\_H})$ (dB)
$23 \leq P_{CMAX} \leq 26$	3.0	2.0
$22 \leq P_{CMAX} < 23$	5.0	2.0
$21 \leq P_{CMAX} < 22$	5.0	3.0
$20 \leq P_{CMAX} < 21$	5.0	4.0
$16 \leq P_{CMAX} < 20$	5.0	
$11 \leq P_{CMAX} < 16$	6.0	
$-40 \leq P_{CMAX} < 11$	7.0	

## 6.2H.2 Void

## 6.2H.3 Transmitter power for inter-band UL CA with UL MIMO

### 6.2H.3.1 UE maximum output power for inter-band UL CA with UL MIMO

For inter-band UL CA with UL MIMO in one of the two frequency bands, the maximum output power is defined as the sum of the maximum output power from all UE antenna connectors and all UL CCs, as specified in Table 6.2H.3.1-1. The period of measurement shall be at least one sub frame (1 ms). The requirements shall be met with the UL MIMO configurations specified in Table 6.2D.1-2 and 6.2D.1-3 for 2-layer configuration and ULFPTx configuration respectively for the component carrier configured with UL MIMO.

**Table 6.2H.3.1-1: UE Power Class for inter-band UL CA with UL MIMO in one frequency band**

NR UL CA Configuration	Class 1.5 (dBm)	Tolerance (dB)	Class 2 (dBm)	Tolerance (dB)	Class 3 (dBm)	Tolerance (dB)
CA_n2A-n77A	29 <sup>3</sup>	+2/-3	26 <sup>2</sup>	+2/-3	23	+2/-3
CA_n5A-n77A	29 <sup>3</sup>	+2/-3	26 <sup>2</sup>	+2/-3	23	+2/-3
CA_n7A-n77A	29 <sup>3</sup>	+2/-3	26 <sup>2</sup>	+2/-3	23	+2/-3
CA_n8A-n78A			26 <sup>2</sup>	+2/-3	23	+2/-3
CA_n25A-n41A	29 <sup>3</sup>	+2/-3	26 <sup>2</sup>	+2/-3	23	+2/-3
CA_n25A-n77A	29 <sup>3</sup>	+2/-3			23	+2/-3
CA_n26A-n78A			26 <sup>2</sup>	+2/-3	23	+2/-3
CA_n28A-n41A			26 <sup>2</sup>	+2/-3	23	+2/-3
CA_n28A-n78A			26 <sup>2</sup>	+2/-3	23	+2/-3
CA_n41A-n66A	29 <sup>3</sup>	+2/-3	26 <sup>2</sup>	+2/-3	23	+2/-3
CA_n41A-n71A	29 <sup>3</sup>	+2/-3	26 <sup>2</sup>	+2/-3	23	+2/-3
CA_n41A-n77A			26 <sup>4</sup>	+2/-3	23	+2/-3
CA_n66A-n77A	29 <sup>3</sup>	+2/-3	26 <sup>2</sup>	+2/-3	23	+2/-3
CA_n70A-n77A	29 <sup>3</sup>	+2/-3	26 <sup>2</sup>	+2/-3	23	+2/-3
CA_n71A-n77A	29 <sup>3</sup>	+2/-3	26 <sup>2</sup>	+2/-3	23	+2/-3

NOTE 1: An uplink CA configuration in which at least one of the bands has NOTE 3 in Table 6.2.1-1 is allowed to reduce the lower tolerance limit by 1.5 dB when the transmission bandwidths of at least one of the bands is confined within  $F_{UL\_low}$  and  $F_{UL\_low} + 4$  MHz or  $F_{UL\_high} - 4$  MHz and  $F_{UL\_high}$ .

NOTE 2: The UE supports PC3 in FDD band and PC3 or PC2 with UL MIMO in TDD band.

NOTE 3: The UE supports PC3 in FDD band and PC1.5 with UL MIMO in TDD band.

NOTE 4: The UE supports PC2 with UL MIMO in either one of the TDD bands and PC2 in the other TDD band.

NOTE 5: Power class 3 is default power class unless otherwise stated.

NOTE 6: FWA form factor is targeted unless otherwise stated.

If a UE supports power class 2 for the band combination listed in Table 6.2H.3.1-1:

- if the field of UE capability *maxUplinkDutyCycle-interBandCA-PC2* is present and the average percentage of uplink symbols transmitted in a certain evaluation period is larger than *maxUplinkDutyCycle-interBandCA-PC2* as defined in TS 38.331 (The exact evaluation period is no less than one radio frame); or
- if  $10\log_{10} \sum P_{EMAX,c}$  or  $P_{EMAX,CA}$  which defined in clause 6.2H.3.4 is 23dBm or lower;
  - shall apply all requirements for the default power class and set the configured transmitted power as specified in clause 6.2H.3.4;
- else;
  - shall apply all requirements for the power class 2 and set the configured transmitted power as specified in clause 6.2H.3.4 (regardless of the average percentage of uplink symbols if the field of UE capability *maxUplinkDutyCycle-interBandCA-PC2* is absent).

The average percentage of uplink symbols is defined as  $0.5 * (\text{Duty}_{NR,x} / \text{maxDuty}_{NR,x} + \text{Duty}_{NR,y} / \text{maxDuty}_{NR,y})$ .  $\text{Duty}_{NR,x}$ ,  $\text{Duty}_{NR,y}$  represent the actual percentage of uplink symbols transmitted in the same evaluation period (The exact evaluation period is no less than one radio frame) for NR Band x, NR Band y respectively;  $\text{maxDuty}_{NR,x}$ ,  $\text{maxDuty}_{NR,y}$  represent the field of UE capability *maxUplinkDutyCycle-PC2-FR1* per band as defined in TS 38.331. For NR Band x or NR Band y,

- if power class of one or both of the bands within the band combination is power class 2 and the corresponding UE capability *maxUplinkDutyCycle-PC2-FR1* is absent;
  - the corresponding  $\text{maxDuty}_{NR,x}$  or  $\text{maxDuty}_{NR,y}$  is equal to 50%;
- else if the band is configured with power class 3;
  - the corresponding  $\text{maxDuty}_{NR,x}$  or  $\text{maxDuty}_{NR,y}$  is equal to 100%.

If a UE supports power class 1.5 for the band combination listed in Table 6.2H.3.1-1:

- if the field of UE capability *maxUplinkDutyCycle-interBandCA-PC2* is present and the average percentage of uplink symbols transmitted in a certain evaluation period is larger than *maxUplinkDutyCycle-interBandCA-PC2* (The exact evaluation period is no less than one radio frame); or
- if  $10\log_{10} \sum P_{EMAX,c}$  or  $P_{EMAX,CA}$  which defined in clause 6.2H.3.4 is 23dBm or lower;
  - shall apply all requirements for the default power class and set the configured transmitted power as specified in clause 6.2H.3.4;
- if the field of UE capability *maxUplinkDutyCycle-interBandCA-PC2* is present and the average percentage of uplink symbols transmitted in a certain evaluation period is larger than  $0.5 \times \text{maxUplinkDutyCycle-interBandCA-PC2}$  but less than or equal to *maxUplinkDutyCycle-interBandCA-PC2*; or
- if  $10\log_{10} \sum P_{EMAX,c}$  or  $P_{EMAX,CA}$  which defined in clause 6.2H.3.4 is between 23dBm and 26dBm;
  - shall apply all requirements for the power class 2 and set the configured transmitted power as specified in clause 6.2H.3.4;
- else;
  - shall apply all requirements for the power class 1.5 and set the configured transmitted power as specified in clause 6.2H.3.4 (regardless of the average percentage of uplink symbols if the field of UE capability *maxUplinkDutyCycle-interBandCA-PC2* is absent).

The average percentage of uplink symbols is defined as  $0.5 * (\text{Duty}_{NR,x} / \text{maxDuty}_{NR,x} + \text{Duty}_{NR,y} / \text{maxDuty}_{NR,y})$ .  $\text{Duty}_{NR,x}$ ,  $\text{Duty}_{NR,y}$  represent the actual percentage of uplink symbols transmitted in the same evaluation period (The exact evaluation period is no less than one radio frame) for NR Band x, NR Band y respectively;  $\text{maxDuty}_{NR,x}$ ,  $\text{maxDuty}_{NR,y}$  represent the field of UE capability  $0.5 \times \text{maxUplinkDutyCycle-PC2-FR1}$  or *maxUplinkDutyCycle-PC1dot5-MPE-FR1* per band as defined in TS 38.331. For NR Band x or NR Band y,

- if power class of one band within the band combination is power class 1.5

- if the corresponding UE capability  $0.5 \cdot \text{maxUplinkDutyCycle-PC2-FRI}$  and  $\text{maxUplinkDutyCycle-PC1dot5-MPE-FRI}$  are both absent;
  - the corresponding  $\text{maxDutyNR,x}$  or  $\text{maxDutyNR,y}$  is equal to 25%;
- else if only one of the corresponding UE capability  $0.5 \cdot \text{maxUplinkDutyCycle-PC2-FRI}$  and  $\text{maxUplinkDutyCycle-PC1dot5-MPE-FRI}$  is reported;
  - the corresponding  $\text{maxDutyNR,x}$  or  $\text{maxDutyNR,y}$  is according to the reported capability;
- else
  - the corresponding  $\text{maxDutyNR,x}$  or  $\text{maxDutyNR,y}$  is the smaller of  $\text{maxUplinkDutyCycle-PC1dot5-MPE-FRI}$  and  $0.5 \cdot \text{maxUplinkDutyCycle-PC2-FRI}$ ;
- if the band is configured with power class 3;
  - the corresponding  $\text{maxDutyNR,x}$  or  $\text{maxDutyNR,y}$  is equal to 100%.

### 6.2H.3.2 UE maximum output power reduction for inter-band UL CA with UL MIMO

For inter-band UL CA with UL MIMO in one of the two frequency bands, the requirements in clause 6.2D.2 apply for the component carrier configured with UL MIMO and the requirements in clause 6.2.2 apply for the other component carrier.

### 6.2H.3.3 UE additional maximum output power reduction for inter-band UL CA with UL MIMO

For inter-band UL CA with UL MIMO in one of the two frequency bands, unless specified in Table 6.2A.3.1.3-1, the requirements in clause 6.2.3 apply only to the indicated carrier.

### 6.2H.3.4 Configured transmitted power for inter-band UL CA with UL MIMO

For inter-band UL CA with UL MIMO in one of the two frequency bands, the requirements in clause 6.2A.4.1.3 apply except that:

- $P_{\text{PowerClass,CA}}$  is the maximum UE power specified in Table 6.2H.3.1-1 without taking into account the tolerance;
- $\text{MPRc}$  and  $\text{A-MPRc}$  are specified in clause 6.2D.2 and clause 6.2D.3 respectively for the component carrier configured with UL MIMO.
- $\Delta P_{\text{PowerClass,CA}}$ :
  - For a power class 2 UE, it is 3dB when the requirements of default power class are applied as specified in sub-clause 6.2.H.3.1, otherwise  $\Delta P_{\text{PowerClass,CA}} = 0$  dB;
  - For a power class 1.5 UE, it is 6dB when the requirements of default power class are applied as specified in sub-clause 6.2.H.3.1; and it is 3dB when the requirements of power class 2 are applied as specified in sub-clause 6.2.H.3.1; otherwise  $\Delta P_{\text{PowerClass,CA}} = 0$  dB;

## 6.2I Transmitter power for RedCap

### 6.2I.1 Maximum output power for RedCap

For Redcap UE, the requirements for power class 3 specified in clause 6.2.1 apply.

## 6.2J Transmitter power for ATG

### 6.2J.1 UE maximum output power for ATG

For the ATG UE, the rated maximum output power is reported via UE capability *maxOutputPowerATG-r18* at maximum modulation order reported by ATG UE and full PRB configurations within the channel bandwidth of NR carrier unless otherwise stated. The period of measurement shall be at least one sub frame (1ms). UE capability *maxOutputPowerATG-r18* is an integer value in the range 23 to 40 dBm.

For ATG UE with multiple omni-directional antennas not indicating the capability *antennaArrayType-r18*, the measured maximum output power  $P_{\max,c,AC}$  shall remain within +2 dB and -2 dB of the rated maximum output power  $P_{\text{rated},c,AC}$  reported by the ATG UE.

For ATG UE with antenna array indicating the capability *antennaArrayType-r18*, the measured maximum output power  $P_{\max,c,TABC}$  shall remain within +2 dB and -2 dB of the rated maximum output power  $P_{\text{rated},c,TABC}$  reported by the ATG UE.

### 6.2J.2 Configured transmitted power for ATG

The UE is allowed to set its configured maximum output power  $P_{\text{CMAX},f,c}$  for carrier  $f$  of serving cell  $c$  in each slot. The configured maximum output power  $P_{\text{CMAX},f,c}$  is set within the following bounds:

$$P_{\text{CMAX},L,f,c} \leq P_{\text{CMAX},f,c} \leq P_{\text{CMAX},H,f,c} \text{ with}$$

$$P_{\text{CMAX},L,f,c} = \text{MIN} \{ P_{\text{EMAX},c}, P_{\text{rated},c,AC} \text{ Or } P_{\text{rated},c,TABC} \}$$

$$P_{\text{CMAX},H,f,c} = P_{\text{EMAX},c}$$

where

$P_{\text{EMAX},c}$  is the value given by ATG specific the *p-Max* IE or the field *additionalPmax* of the *NR-NS-PmaxList IE*, whichever is applicable according to TS 38.331 [7]; It's noted that the actual  $P_{\text{EMAX},c}$  value is (9 + field value) in ATG cell, according to *p-Max* IE definition in TS 38.331 [7];

$P_{\text{rated},c,AC}$  is the rated maximum output power at maximum modulation order and full PRB configurations which is indicated by ATG UE capability *maxOutputPowerATG-r18* for ATG UE with multiple omni-directional antennas not indicating the capability *antennaArrayType-r18*;

$P_{\text{rated},c,TABC}$  is the rated maximum output power at maximum modulation order and full PRB configurations which is indicated by ATG UE capability *maxOutputPowerATG-r18* for ATG UE with antenna array indicating the capability *antennaArrayType-r18*.

$T_{\text{REF}}$  and  $T_{\text{eval}}$  are specified in Table 6.2J.2-0. For each  $T_{\text{REF}}$ , the  $P_{\text{CMAX},L,c}$  for serving cell  $c$  are evaluated per  $T_{\text{eval}}$  and given by the minimum value taken over the transmission(s) within the  $T_{\text{eval}}$ ; the minimum  $P_{\text{CMAX},L,f,c}$  over one or more  $T_{\text{eval}}$  is then applied for the entire  $T_{\text{REF}}$

**Table 6.2J.2-0: Evaluation and reference periods for Pcmx**

$T_{\text{REF}}$	$T_{\text{eval}}$	$T_{\text{eval}}$ with frequency hopping
Physical channel length	Physical channel length	$\text{Min}(T_{\text{no\_hopping}}, \text{Physical Channel Length})$

The measured configured maximum output power  $P_{\text{UMAX},f,c}$  shall be within the following bounds:

$$P_{\text{CMAX},L,f,c} - T(P_{\text{CMAX},L,f,c}) \leq P_{\text{UMAX},f,c} \leq P_{\text{CMAX},H,f,c} + T(P_{\text{CMAX},H,f,c}).$$

where the tolerance  $T(P_{\text{CMAX},f,c})$  for applicable values of  $P_{\text{CMAX},f,c}$  is specified in Table 6.2J.2-1.

Table 6.2J.2-1: ATG  $P_{\text{CMAX}}$  tolerance

$P_{\text{CMAX},f,c}$ (dBm)	Tolerance $T(P_{\text{CMAX},f,c})$ (dB)
$23 < P_{\text{CMAX},c} \leq 40$	2.0
$21 \leq P_{\text{CMAX},c} \leq 23$	2.0
$20 \leq P_{\text{CMAX},c} < 21$	2.5
$19 \leq P_{\text{CMAX},c} < 20$	3.5
$18 \leq P_{\text{CMAX},c} < 19$	4.0
$13 \leq P_{\text{CMAX},c} < 18$	5.0
$8 \leq P_{\text{CMAX},c} < 13$	6.0
$-19 \leq P_{\text{CMAX},c} < 8$	7.0

## 6.2K Transmitter power for Aerial UE

### 6.2K.1 Maximum output power for Aerial UE

For Aerial UE, the requirements for power class 3 specified in clause 6.2.1 apply.

### 6.2K.2 Maximum output power reduction for Aerial UE

For Aerial UE, the requirements specified in clause 6.2.2 apply.

### 6.2K.3 Additional maximum output power reduction for Aerial UE

#### 6.2K.3.1 General

Additional emission requirements can be signalled by the network. Each additional emission requirement is associated with a unique network signalling (NS) value indicated in RRC signalling by an NR frequency band number of the applicable operating band and an associated value in the field *additionalSpectrumEmission* as described in Clause 5.2.2.4 of [7]. In this specification, NS\_UAV refers to a network signalling value applicable only for Aerial UEs [7]. The notion of indication or signalling of an NS\_UAV value refers to the corresponding indication of an NR frequency band number of the applicable operating band, the IE field *frequencyBandListAerial* and an associated value of *additionalSpectrumEmission* in the relevant RRC information elements [7].

To meet the additional requirements, additional maximum power reduction (A-MPR) is allowed for the maximum output power as specified in Table 6.2.1-1. Unless stated otherwise, the total reduction to UE maximum output power is  $\max(\text{MPR}, \text{A-MPR})$  where MPR is defined in clause 6.2.2. Outer and inner allocation notation used in clause 6.2K.3 are defined in clause 6.2.2. Unless stated otherwise, Edge RB allocations get the same AMPR as Outer RB allocations. In absence of modulation and waveform types the A-MPR applies to all modulation and waveform types.

Table 6.2K.3.1-1 specifies the additional requirements with their associated Network Signalling label and the allowed A-MPR and applicable operating band(s). The mapping of NR frequency band numbers and values of the *additionalSpectrumEmission* to network signalling labels is specified in Table 6.2.3.1-1A.

For almost contiguous allocations in CP-OFDM waveforms in power class 3, the allowed A-MPR defined in clause 6.2K.3 is increased by  $\text{CEIL}\{10 \log_{10}(1 + N_{\text{RB\_gap}}/N_{\text{RB\_alloc}}), 0.5\}$  dB, where  $\text{CEIL}\{x, 0.5\}$  means  $x$  rounding upwards to closest 0.5dB,  $N_{\text{RB\_gap}}$  is the total number of unallocated RBs between allocated RBs and  $N_{\text{RB\_alloc}}$  is the total number of allocated RBs, and the parameter  $L_{\text{CRB}}$  is replaced by  $N_{\text{RB\_alloc}} + N_{\text{RB\_gap}}$  in specifying the RB allocation regions.

Table 6.2K.3.1-1: Additional Maximum Power Reduction (A-MPR) for Uncrewed Aerial UE

Network signalling label	Requirements (clause)	NR Band	Channel bandwidth (MHz)	Resources blocks ( $N_{\text{RB}}$ )	A-MPR (dB)
NS_UAV_44	6.5K.3.3.1	38	25, 30, 40	Table 6.2K.3.2-1	Table 6.2K.3.2-2



NS_UAV_46	6.5K.3.3.2	7	5, 10, 15, 20, 25, 30, 35, 40, 50		N/A
NS_UAV_70	6.5K.3.3.3	3	5, 10, 15, 20, 25, 30, 35, 40, 45, 50	Table 6.2K.3.3-1	Table 6.2K.3.3-2

**Table 6.2K.3.1-1A: Mapping of network signalling label**

NR band	Value of additional Spectrum Emission							
	0	1	2	3	4	5	6	7
n3	NS_UAV_01	NS_UAV_70						Reserved
n7	NS_UAV_01	NS_UAV_46						Reserved
n38	NS_UAV_01	NS_UAV_44						Reserved

6.2K.3.2 A-MPR for NS\_UAV\_44

**Table 6.2K.3.2-1: A-MPR regions for NS\_UAV\_44**

Channel Bandwidth, MHz	Carrier Center Frequency, F <sub>c</sub> , MHz	Regions		A-MPR
		RB <sub>end</sub> *12*SCS MHz	L <sub>CRB</sub> *12*SCS MHz	
25 MHz	2582.5 ≤ F <sub>c</sub> ≤ 2602.5	<18.0	> 12*SCS* RB <sub>end</sub> - 3.6	A3
		≥18.0	<7.2	A3
		≥18.0	≥7.2	A6
30 MHz	2585 ≤ F <sub>c</sub> ≤ 2600	<21.6	> 12*SCS* RB <sub>end</sub> - 3.6	A3
		≥21.6	<12.6	A3
		≥21.6	≥12.6	A6
40 MHz	2590 ≤ F <sub>c</sub> ≤ 2595	≥0, <2.88	>0	A1
		≥2.88, <14.4	>, 12*SCS*RB <sub>end</sub> - 3.6	A2
		≥14.4, <23.4	>10.8	A3
		≥23.4, <32.4	>16.2	A4
		≥32.4	>0	A5

**Table 6.2K.3.2-2: A-MPR for NS\_UAV\_44**

Modulation/Waveform		A1	A2	A3	A4	A5	A6
		Outer/Inner	Outer/Inner	Outer/Inner	Outer/Inner	Outer/Inner	Outer/Inner
DFT-s-OFDM	PI/2 BPSK	5	2	3	7	12	4
	QPSK	5	2	3	7	12	
	16 QAM	5	2	3	7	12	4
	64 QAM	5		3	7	12	4
	256 QAM	5			7	12	
CP-OFDM	QPSK	5	4	5	8	12	
	16 QAM	5	4	5	8	12	
	64 QAM	5	4	5	8	12	
	256 QAM	5			8	12	

6.2K.3.3 A-MPR for NS\_UAV\_70

**Table 6.2K.3.3-1: A-MPR regions for NS\_UAV\_70 (Power Class 3)**

Channel	Carrier Center	Regions	A-MPR
---------	----------------	---------	-------

Bandwidth, [MHz]	Frequency, $F_c$ , [MHz]	$RB_{start} * 12 * SCS$ [MHz]	$LCRB * 12 * SCS$ [MHz]	
5 MHz	$F_c \leq 1722.5$	$\leq 0.18$	$\leq 2.34$	A1
			$> 2.34$	A3
		$> 0.18, \leq 0.36$	$\leq 0.36$	A2
			$> 0.36$	A3
		$> 0.36, \leq 0.72$	$< 1.8$	A4
			$\geq 1.8$	A3
$> 0.72$	$> 1.5 * RB_{start} * 12 * SCS - 2.5 * 12 * SCS$	A4		
	$\leq 1.5 * RB_{start} * 12 * SCS - 2.5 * 12 * SCS$	A5		
10 MHz	$F_c \leq 1735$	$\leq 0.72$	$\leq 1.26$	A1
			$> 1.26$	A2
		$> 0.72, \leq 3.78$	$> 1.5 * RB_{start} * 12 * SCS - 2.5 * 12 * SCS$	A4
			$\leq 1.5 * RB_{start} * 12 * SCS - 2.5 * 12 * SCS$	A5
		$> 3.78, \leq 5.04$	$> 2.7$	A5
			$\leq 2.7$	A6
$> 5.04$	$> 0$	A5		
15 MHz	$F_c \leq 1747.5$	$\leq 0.72$	$\leq 1.26$	A1
			$> 1.26$	A2
		$> 0.72, \leq 5.58$	$> 1.5 * RB_{start} * 12 * SCS - 2.5 * 12 * SCS$	A4
			$\leq 1.5 * RB_{start} * 12 * SCS - 2.5 * 12 * SCS$	A5
		$> 5.58, \leq 9.72$	$> 3.78$	A5
			$\leq 3.78$	A6
$> 9.72$	$> 0$	A5		
20 MHz	$F_c \leq 1760$	$\leq 0.72$	$\leq 8.1$	A1
			$> 8.1$	A4
		$> 0.72, \leq 7.2$	$> 1.5 * RB_{start} * 12 * SCS - 2.5 * 12 * SCS$	A4
			$\leq 1.5 * RB_{start} * 12 * SCS - 2.5 * 12 * SCS$	A5
		$> 7.2, \leq 12.96$	$> 5.58$	A5
			$\leq 5.58$	A6
$> 12.96$	$> 0$	A5		
25 MHz	$F_c \leq 1772.5$	$\leq 0.72$	$> 0$	A1
			$> 0.72, \leq 8.64$	$> 1.5 * RB_{start} * 12 * SCS - 2.5 * 12 * SCS$
		$> 8.64$	$\leq 1.5 * RB_{start} * 12 * SCS - 2.5 * 12 * SCS$	A5
			$> 6.12$	A5
		$> 8.64$	$\leq 6.12, > 0.72$	A6
			$\leq 0.72$	A5
30 MHz	$F_c \leq 1750$	$\leq 24.3$	$> 0$	A2
		$> 24.3$	$> 0$	A5
	$1750 < F_c < 1765$	$\leq 24.3$	$> 0$	A5
		$> 24.3$	$> 0$	A6
	$F_c \geq 1765$	$\geq 0$	$> 0$	A5
	35 MHz	$F_c \leq 1750$	$\leq 29.16$	$> 0$
$> 29.16$			$> 0$	A5
$1750 < F_c < 1765$		$\leq 29.16$	$> 0$	A5
		$> 29.16$	$> 0$	A6
$F_c \geq 1765$		$\geq 0$	$> 0$	A6
40 MHz		$F_c \leq 1740$	$\leq 32.4$	$> 0$
	$> 32.4$		$> 0$	A5
	$F_c > 1740$	$\leq 32.4$	$> 0$	A5
		$> 32.4$	$> 0$	A6
45 MHz	$F_c \leq 1740$	$\leq 35.64$	$> 0$	A2
		$> 35.64$	$> 0$	A5
	$F_c > 1740$	$\leq 35.64$	$> 0$	A5
		$> 35.64$	$> 0$	A6
50 MHz	$F_c \leq 1740$	$\leq 38.88$	$> 0$	A2
		$> 38.88$	$> 0$	A5
	$F_c > 1740$	$\leq 38.88$	$> 0$	A5
		$> 38.88$	$> 0$	A6

NOTE 1: The A-MPR values are listed in Table 6.2K.3.2-2.

NOTE 2: For any undefined region, MPR applies.

Table 6.2K.3.3-2: A-MPR for NS\_UAV\_70 (Power Class 3)

Modulation/Waveform		A1	A2	A3	A4	A5	A6
		Outer/Inner	Outer/Inner	Outer/Inner	Outer/Inner	Outer/Inner	Outer/Inner
DFT-s-OFDM	PI/2 BPSK	30	25	20	15	10	5
	QPSK	30	25	20	15	10	5
	16 QAM	30	25	20	15	10	5
	64 QAM	30	25	20	15	10	5
	256 QAM	30	25	20	15	10	
CP-OFDM	QPSK	30	25	20	15	10	5
	16 QAM	30	25	20	15	10	5
	64 QAM	30	25	20	15	10	5
	256 QAM	30	25	20	15	10	

NOTE 1: The backoff applied is max (MPR, A-MPR) where MPR is defined in Table 6.2.2-1

## 6.2K.4 Configured transmitted power for Aerial UE

For the Aerial UE, the requirements in clause 6.2.4 apply with the following modifications:

- only requirements related to Power Class 3 UEs are applicable for Aerial UEs. In the current Release Aerial UEs that are not PC3 are not considered; and
- when *NR-NS-PmaxValueAerial* is configured for the applicable operating band, the UE shall not consider the value of the *additionalPmax* of the *NR-NS-PmaxList IE*. In such case, the value of *additionalPmax* to be considered is the one related to *NR-NS-PmaxValueAerial*, when configured, according to TS 38.331[7]; and
- when determining the parameters in the formulas used to calculate the UE configured transmitted power, use clause 6.2K.3 for A-MPR determination instead of clause 6.2.3, whenever *frequencyBandListAerial* is configured for the operating band.

Note: When the aerial UE is not configured with *NR-NS-PmaxValueAerial* the determination of whether to use and which value to use for *additionalPmax* shall be performed as described in clause 6.2.4.

## 6.2L Transmitter power for CA with Tx Diversity

### 6.2L.1 Void

### 6.2L.2 Void

### 6.2L.3 Transmitter power for inter-band UL CA with Tx Diversity

#### 6.2L.3.1 UE maximum output power for inter-band UL CA with Tx Diversity

For inter-band UL CA with Tx Diversity in one of the two frequency bands, the maximum output power is defined as the sum of the maximum output power from all UE antenna connectors and all UL CCs, as specified in Table 6.2L.3.1-1. The period of measurement shall be at least one sub frame (1 ms).

Table 6.2L.3.1-1: UE Power Class for inter-band UL CA with Tx Diversity in one frequency band

NR UL CA Configuration	Class 1.5 (dBm)	Tolerance (dB)	Class 2 (dBm)	Tolerance (dB)	Class 3 (dBm)	Tolerance (dB)
CA_n2A-n77A	29 <sup>3</sup>	+2/-3	26 <sup>2</sup>	+2/-3	23	+2/-3
CA_n5A-n77A	29 <sup>3</sup>	+2/-3	26 <sup>2</sup>	+2/-3	23	+2/-3
CA_n7A-n77A	29 <sup>3</sup>	+2/-3	26 <sup>2</sup>	+2/-3	23	+2/-3
CA_n8A-n78A			26 <sup>2</sup>	+2/-3	23	+2/-3
CA_n25A-n41A	29 <sup>3</sup>	+2/-3	26 <sup>2</sup>	+2/-3	23	+2/-3

CA_n25A-n77A	29 <sup>3</sup>	+2/-3	26 <sup>2</sup>	+2/-3	23	+2/-3
CA_n26A-n78A			26 <sup>2</sup>	+2/-3	23	+2/-3
CA_n28A-n41A			26 <sup>2</sup>	+2/-3	23	+2/-3
CA_n28A-n78A			26 <sup>2</sup>	+2/-3	23	+2/-3
CA_n41A-n66A	29 <sup>3</sup>	+2/-3	26 <sup>2</sup>	+2/-3	23	+2/-3
CA_n41A-n71A	29 <sup>3</sup>	+2/-3	26 <sup>2</sup>	+2/-3	23	+2/-3
CA_n41A-n77A			26 <sup>2</sup>	+2/-3	23	+2/-3
CA_n66A-n77A	29 <sup>3</sup>	+2/-3	26 <sup>2</sup>	+2/-3	23	+2/-3
CA_n70A-n77A	29 <sup>3</sup>	+2/-3	26 <sup>2</sup>	+2/-3	23	+2/-3
CA_n71A-n77A	29 <sup>3</sup>	+2/-3	26 <sup>2</sup>	+2/-3	23	+2/-3
NOTE 1: An uplink CA configuration in which at least one of the bands has NOTE 3 in Table 6.2.1-1 is allowed to reduce the lower tolerance limit by 1.5 dB when the transmission bandwidths of at least one of the bands is confined within $F_{UL\_low}$ and $F_{UL\_low} + 4$ MHz or $F_{UL\_high} - 4$ MHz and $F_{UL\_high}$ .						
NOTE 2: The UE supports PC3 in FDD band and PC2 with Tx Diversity in TDD band.						
NOTE 3: The UE supports PC3 in FDD band and PC1.5 with Tx Diversity in TDD band.						
NOTE 4: Power class 3 is the default power class unless otherwise stated.						
NOTE 5: FWA form factor is targeted unless otherwise stated.						

If a UE supports power class 2 for the band combination listed in Table 6.2L.3.1-1:

- if the field of UE capability *maxUplinkDutyCycle-interBandCA-PC2* is present and the average percentage of uplink symbols transmitted in a certain evaluation period is larger than *maxUplinkDutyCycle-interBandCA-PC2* as defined in TS 38.331 (The exact evaluation period is no less than one radio frame); or
- if  $10\log_{10} \sum p_{EMAX,c}$  or  $P_{EMAX,CA}$  which defined in clause 6.2L.3.4 is 23dBm or lower;
  - shall apply all requirements for the default power class and set the configured transmitted power as specified in clause 6.2L.3.4;
- else;
  - shall apply all requirements for the power class 2 and set the configured transmitted power as specified in clause 6.2L.3.4 (regardless of the average percentage of uplink symbols if the field of UE capability *maxUplinkDutyCycle-interBandCA-PC2* is absent).

The average percentage of uplink symbols is defined as  $0.5 \cdot (\text{Duty}_{NR,x} / \text{maxDuty}_{NR,x} + \text{Duty}_{NR,y} / \text{maxDuty}_{NR,y})$ .  $\text{Duty}_{NR,x}$ ,  $\text{Duty}_{NR,y}$  represent the actual percentage of uplink symbols transmitted in the same evaluation period (The exact evaluation period is no less than one radio frame) for NR Band x, NR Band y respectively;  $\text{maxDuty}_{NR,x}$ ,  $\text{maxDuty}_{NR,y}$  represent the field of UE capability *maxUplinkDutyCycle-PC2-FR1* per band as defined in TS 38.331. For NR Band x or NR Band y,

- if power class of one or both of the bands within the band combination is power class 2 and the corresponding UE capability *maxUplinkDutyCycle-PC2-FR1* is absent;
  - the corresponding  $\text{maxDuty}_{NR,x}$  or  $\text{maxDuty}_{NR,y}$  is equal to 50%;
- else if the band is configured with power class 3;
  - the corresponding  $\text{maxDuty}_{NR,x}$  or  $\text{maxDuty}_{NR,y}$  is equal to 100%.

If a UE supports power class 1.5 for the band combination listed in Table 6.2L.3.1-1:

- if the field of UE capability *maxUplinkDutyCycle-interBandCA-PC2* is present and the average percentage of uplink symbols transmitted in a certain evaluation period is larger than *maxUplinkDutyCycle-interBandCA-PC2* (The exact evaluation period is no less than one radio frame); or
- if  $10\log_{10} \sum p_{EMAX,c}$  or  $P_{EMAX,CA}$  which defined in clause 6.2L.3.4 is 23dBm or lower;
  - shall apply all requirements for the default power class and set the configured transmitted power as specified in clause 6.2L.3.4;
- if the field of UE capability *maxUplinkDutyCycle-interBandCA-PC2* is present and the average percentage of uplink symbols transmitted in a certain evaluation period is larger than  $0.5 \cdot \text{maxUplinkDutyCycle-interBandCA-PC2}$  but less than or equal to *maxUplinkDutyCycle-interBandCA-PC2*; or

- if  $10\log_{10} \sum P_{EMAX,c}$  or  $P_{EMAX,CA}$  which defined in clause 6.2L.3.4 is between 23dBm and 26dBm;
  - shall apply all requirements for the power class 2 and set the configured transmitted power as specified in clause 6.2L.3.4;
- else;
  - shall apply all requirements for the power class 1.5 and set the configured transmitted power as specified in clause 6.2L.3.4 (regardless of the average percentage of uplink symbols if the field of UE capability *maxUplinkDutyCycle-interBandCA-PC2* is absent).

The average percentage of uplink symbols is defined as  $0.5 * (\text{Duty}_{NR,x} / \text{maxDuty}_{NR,x} + \text{Duty}_{NR,y} / \text{maxDuty}_{NR,y})$ .  $\text{Duty}_{NR,x}$ ,  $\text{Duty}_{NR,y}$  represent the actual percentage of uplink symbols transmitted in the same evaluation period (The exact evaluation period is no less than one radio frame) for NR Band x, NR Band y respectively;  $\text{maxDuty}_{NR,x}$ ,  $\text{maxDuty}_{NR,y}$  represent the field of UE capability *0.5\*maxUplinkDutyCycle-PC2-FR1* or *maxUplinkDutyCycle-PC1dot5-MPE-FR1* per band as defined in TS 38.331. For NR Band x or NR Band y,

- if power class of one band within the band combination is power class 1.5
  - if the corresponding UE capability *0.5\*maxUplinkDutyCycle-PC2-FR1* and *maxUplinkDutyCycle-PC1dot5-MPE-FR1* are both absent;
    - the corresponding  $\text{maxDuty}_{NR,x}$  or  $\text{maxDuty}_{NR,y}$  is equal to 25%;
  - else if only one of the corresponding UE capability *0.5\*maxUplinkDutyCycle-PC2-FR1* and *maxUplinkDutyCycle-PC1dot5-MPE-FR1* is reported;
    - the corresponding  $\text{maxDuty}_{NR,x}$  or  $\text{maxDuty}_{NR,y}$  is according to the reported capability;
  - else
    - the corresponding  $\text{maxDuty}_{NR,x}$  or  $\text{maxDuty}_{NR,y}$  is the smaller of *maxUplinkDutyCycle-PC1dot5-MPE-FR1* and *0.5\*maxUplinkDutyCycle-PC2-FR1*;
- if the band is configured with power class 3;
  - the corresponding  $\text{maxDuty}_{NR,x}$  or  $\text{maxDuty}_{NR,y}$  is equal to 100%.

### 6.2L.3.2 UE maximum output power reduction for inter-band UL CA with Tx Diversity

For inter-band UL CA with Tx Diversity in one of the two frequency bands, the requirements in clause 6.2G.2 apply for the component carrier configured with Tx Diversity and the requirements in clause 6.2.2 apply for the other component carrier.

### 6.2L.3.3 UE additional maximum output power reduction for inter-band UL CA with Tx Diversity

For inter-band UL CA with Tx Diversity in one of the two frequency bands, unless specified in Table 6.2A.3.1.3-1, the requirements in clause 6.2.3 apply only to the indicated carrier.

### 6.2L.3.4 Configured transmitted power for inter-band UL CA with Tx Diversity

For inter-band UL CA with Tx Diversity in one of the two frequency bands, the requirements in clause 6.2A.4.1.3 apply except that:

- $P_{\text{PowerClass,CA}}$  is the maximum UE power specified in Table 6.2L.3.1-1 without taking into account the tolerance;
- $MPR_c$  and  $A-MPR_c$  are specified in clause 6.2G.2 and clause 6.2G.3 respectively for the component carrier configured with Tx Diversity.
- $\Delta P_{\text{PowerClass,CA}}$ :

- For a power class 2 UE, it is 3dB when the requirements of default power class are applied as specified in sub-clause 6.2.J.3.1, otherwise  $\Delta P_{\text{PowerClass, CA}} = 0$  dB;
- For a power class 1.5 UE, it is 6dB when the requirements of default power class are applied as specified in sub-clause 6.2.J.3.1; and it is 3dB when the requirements of power class 2 are applied as specified in sub-clause 6.2.J.3.1; otherwise  $\Delta P_{\text{PowerClass, CA}} = 0$  dB;

## 6.3 Output power dynamics

### 6.3.1 Minimum output power

The minimum controlled output power of the UE is defined as the power in the channel bandwidth for all transmit bandwidth configurations (resource blocks), when the power is set to a minimum value.

The minimum output power is defined as the mean power in at least one sub-frame 1 ms. The minimum output power shall not exceed the values specified in Table 6.3.1-1.

**Table 6.3.1-1: Minimum output power**

Channel bandwidth	(MHz)	3,5,10,15,20	25,30,35,40,45,50	60,70,80,90,100
REF_SCS	(kHz)	15		30
Minimum output power	(dBm)	-40	$-40+10\log_{10}(BW_{\text{Channel}}/20)$	$-40+10\log_{10}(BW_{\text{Channel}}/20)$
Measurement bandwidth	(MHz)	$MBW=REF\_SCS*(12*N_{RB}+1)/1000$		
NOTE: The minimum output power value is rounded to the nearest number down to one decimal point.				

### 6.3.2 Transmit OFF power

Transmit OFF power is defined as the mean power in the channel bandwidth when the transmitter is OFF. The transmitter is considered OFF when the UE is not allowed to transmit on any of its ports..

The transmit OFF power is defined as the mean power in a duration of at least one sub-frame (1 ms) excluding any transient periods. The transmit OFF power shall not exceed the values specified in Table 6.3.2-1.

**Table 6.3.2-1: Transmit OFF power**

Channel bandwidth	(MHz)	3,5,10,15,20,25,30,35,40,45,50	60,70,80,90,100
REF_SCS	(kHz)	15	30
Transmit OFF power	(dBm)	-50	
Measurement bandwidth	(MHz)	$MBW=REF\_SCS*(12*N_{RB}+1)/1000$	
NOTE : “N <sub>RB</sub> ” in the formula is the maximum transmission bandwidth configuration as defined in Table 5.3.2-1.			

### 6.3.3 Transmit ON/OFF time mask

#### 6.3.3.1 General

The transmit power time mask defines the transient period(s) allowed

- between transmit OFF power as defined in clause 6.3.2 and transmit ON power symbols (transmit ON/OFF)

- between continuous ON-power transmissions with power change or RB hopping is applied. When a UE signals the transient period capability, the transient period value ( $tp$ ) can be 2, 4, or 7 $\mu$ s. If no capability is signalled, the default transient period value of 10 $\mu$ s applies.

In case of RB hopping, and in following figures where  $tp_{start}$  is specified, the transient period is shared symmetrically when the transient period is 10 $\mu$ s. If the UE signals a transient period ( $tp$ ) of 2, 4 or 7 $\mu$ s, the transient period start position is given by  $tp_{start}$  in Table 6.3.3.1-1.

**Table 6.3.3.1-1  $tp_{start}$  values**

$tp$ ( $\mu$ s)	$tp_{start}$ ( $\mu$ s)
2	-0.5
4	-1
7	-2.7

NOTE 1: Negative values mean that the transient period starts before the symbol boundary

Unless otherwise stated the requirements in clause 6.5 apply also in transient periods.

In the following clauses, following definitions apply:

- A slot or long subslot transmission is a transmission with more than 2 symbols.
- A short subslot transmission is a transmission with 1 or 2 symbols.

### 6.3.3.2 General ON/OFF time mask

The general ON/OFF time mask defines the observation period between transmit OFF and ON power and between transmit ON and OFF power for each SCS. ON/OFF scenarios include: contiguous, and non-contiguous transmission, etc

The OFF power measurement period is defined in a duration of at least one slot excluding any transient periods. The ON power is defined as the mean power over one slot excluding any transient period.



**Figure 6.3.3.2-1: General ON/OFF time mask for NR UL transmission in FR1**

### 6.3.3.3 Transmit power time mask for slot and short or long subslot boundaries

The transmit power time mask for slot and a long subslot transmission boundaries defines the transient periods allowed between slot and long subslot PUSCH transmissions. For PUSCH-PUCCH and PUSCH-SRS transitions and multiplexing the time masks in clause 6.3.3.7 apply.

The transmit power time mask for slot or long subslot and short subslot transmission boundaries defines the transient periods allowed between slot or long subslot and short subslot transmissions. The time masks in clause 6.3.3.8 apply.

The transmit power time mask for short subslot transmission boundaries defines the transient periods allowed between short subslot transmissions. The time masks in clause 6.3.3.9 apply.

### 6.3.3.4 PRACH time mask

The PRACH ON power is specified as the mean power over the PRACH measurement period excluding any transient periods as shown in Figure 6.3.3.4-1. The measurement period for different PRACH preamble format is specified in Table 6.3.3.4-1.

**Table 6.3.3.4-1: PRACH ON power measurement period**

PRACH preamble format	SCS (kHz)	Measurement period (ms)
0	1.25	0.903125
1	1.25	2.284375
2	1.25	3.352604
3	5	0.903125
A1	15	0.142708
	30	0.071354
A2	15	0.285417
	30	0.142708
A3	15	0.428125
	30	0.2140625
B1	15	0.140365
	30	0.070182
B4	15	0.83046875
	30	0.415234375
A1/B1	15	0.142708 ms for first six occasion 0.140365 ms for the last occasion
	30	0.071354 ms for first six occasion 0.070182 ms for the last occasion
A2/B2	15	0.285417 ms for first two occasion 0.278385 ms for the third occasion
	30	0.142708 ms for first two occasion 0.1391925 ms for the third occasion
A3/B3	15	0.428125 ms for the first occasion 0.41640625 ms for the second occasion
	30	0.2140625 ms for the first occasion 0.208203125 ms for the second occasion
C0	15	0.10703125
	30	0.053515625
C2	15	0.333333
	30	0.166667
NOTE: For PRACH on PRACH occasion start from the beginning of 0.5 ms or span the boundary of 0.5 ms of the subframe, the measurement period will plus 0.032552 $\mu$ s		



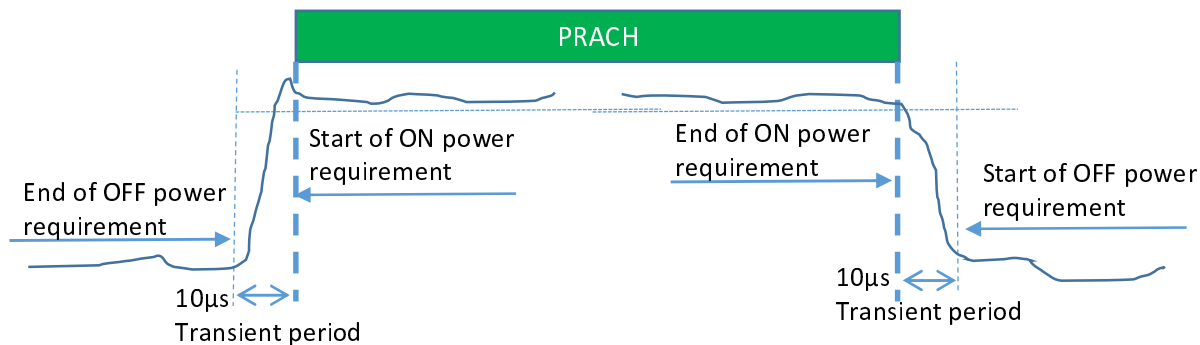

Figure 6.3.3.4-1: PRACH ON/OFF time mask

6.3.3.5 Void

6.3.3.6 SRS time mask

For SRS transmission mapped to one OFDM symbol, the ON power is defined as the mean power over the symbol duration excluding any transient period; See Figure 6.3.3.6-1

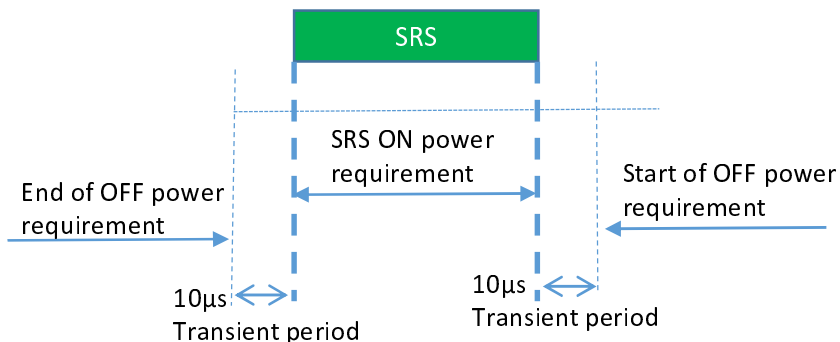

Figure 6.3.3.6-1: Single SRS time mask for NR UL transmission

For SRS transmission mapped to two or more OFDM symbols the ON power is defined as the mean power for each symbol duration excluding any transient period. For consecutive SRS transmissions without power change, Figure 6.3.3.6-2 applies.

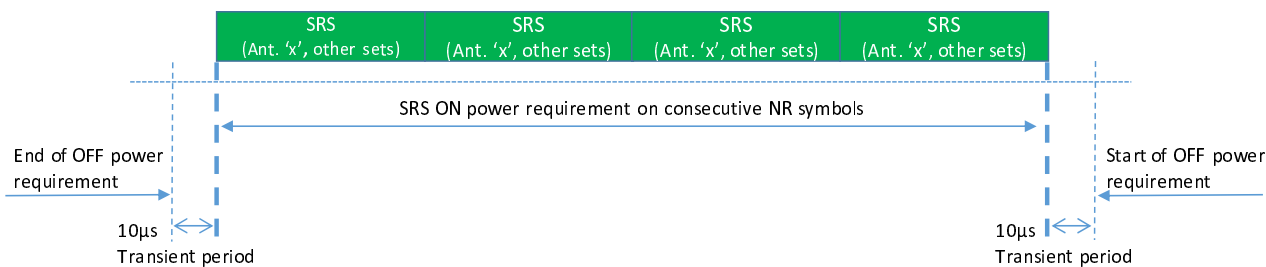
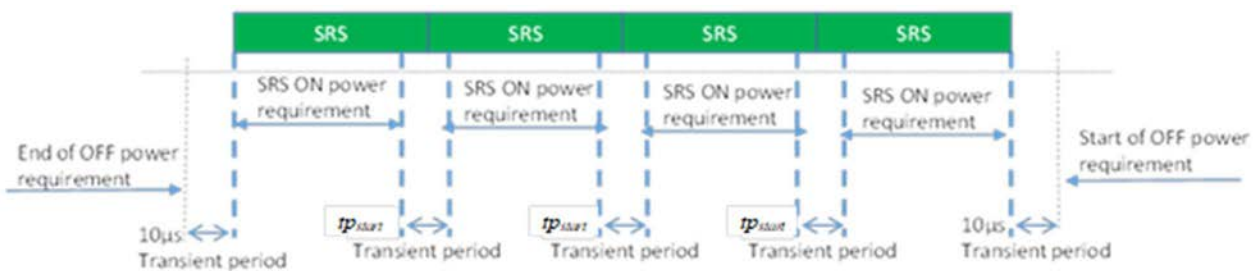
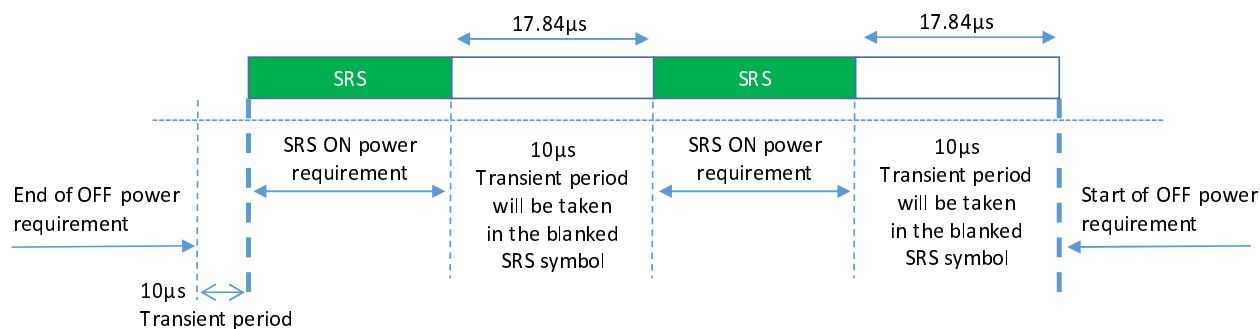

Figure 6.3.3.6-2: Consecutive SRS time mask for the case when no power change is required with SRS usage other than antenna switching.

When power change between consecutive SRS transmissions is required, then Figure 6.3.3.6-3 and Figure 6.3.3.6-4 apply.



**Figure 6.3.3.6-3: Consecutive SRS time mask for the case when power change is required and when 15 kHz and 30 kHz SCS is used in FR1 with SRS usage other than antenna switching.**



**Figure 6.3.3.6-4: Consecutive SRS time mask for the case when power change is required and when 60 kHz SCS is used in FR1, when the transient period is 10 µs**

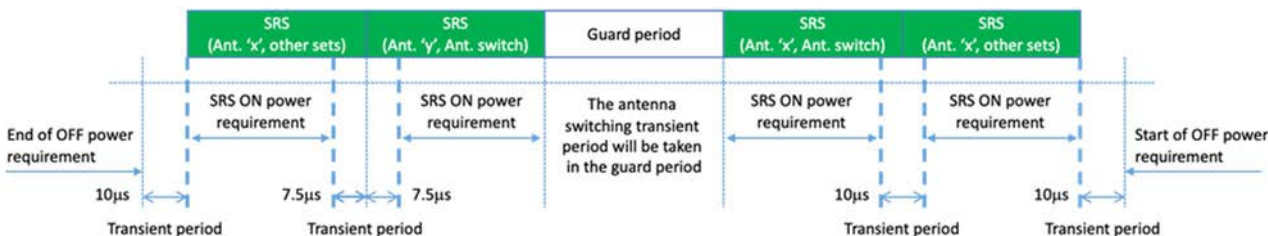

**Figure 6.3.3.6-5: FR1 Time mask for 15 kHz and 30 kHz SCS for the case when consecutive SRS switching usage is between antenna switching & other sets**

where "other sets" belongs to a "usage set" other than the set for antenna switching. The usage sets for SRS switching are defined in clause 6.2.1 of TS 38.214 [10].

NOTE: Guard period of one symbol is defined between two SRS resources of an SRS resource set for antenna switching for 15kHz, 30kHz and 60kHz SCS in Table 6.2.1.2-1 of TS 38.214 [10].

The above transient period applies to all the transmit CCs in CA with the CC sounding SRS. UE RF requirements do not apply during this transient period.

### 6.3.3.7 PUSCH-PUCCH and PUSCH-SRS time masks

The PUCCH/PUSCH/SRS time mask defines the observation period between sounding reference symbol (SRS) and an adjacent PUSCH/PUCCH symbol and subsequent UL transmissions. The time masks apply for all types of frame structures and their allowed PUCCH/PUSCH/SRS transmissions unless otherwise stated.

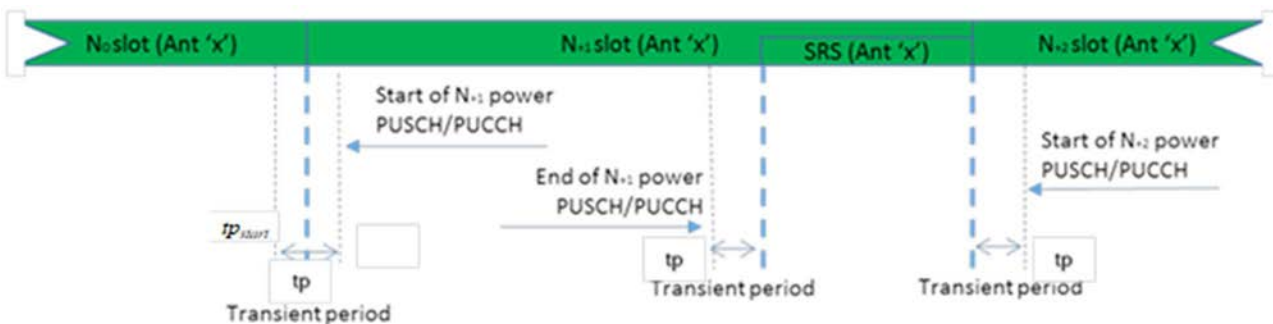

Figure 6.3.3.7-1: PUCCH/PUSCH/SRS time mask when there is a transmission before or after or both before and after SRS, when sounded on the same antenna (Ant 'x')

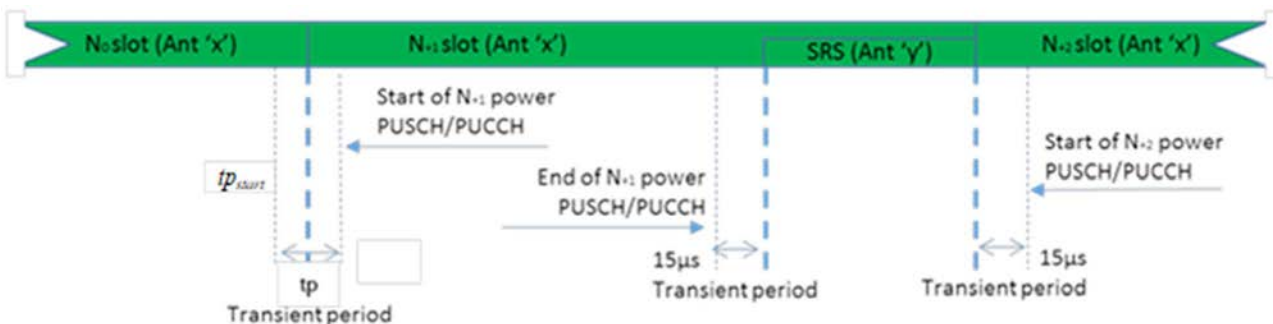

Figure 6.3.3.7-2: PUCCH/PUSCH/SRS time mask when there is a transmission before or after or both before and after SRS, when sounded on a different antenna (Ant 'x' and Ant 'y' are different antenna ports)

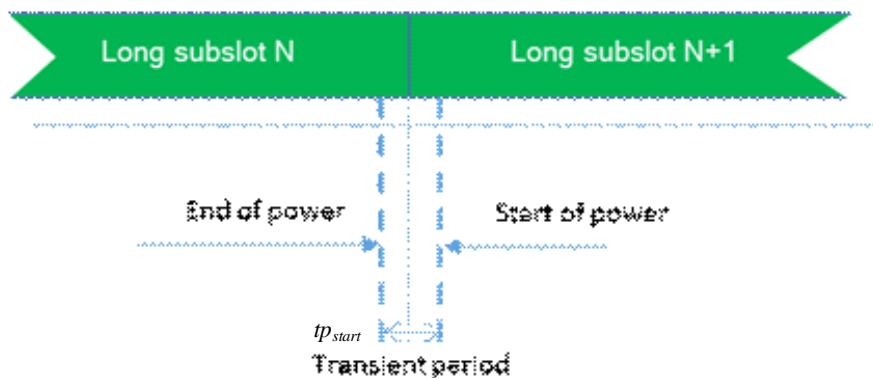

Figure 6.3.3.7-3: Consecutive long subslot transmission and long subslot transmission time mask

This transient period of  $15\mu s$  applies before and after SRS transmission to all the transmit CCs in CA with the CC sounding SRS. UE RF requirements do not apply during this transient period.

When there is no transmission preceding SRS transmission or succeeding SRS transmission, then the same time mask applies as shown in Figure 6.3.3.7-1.

6.3.3.8 Transmit power time mask for consecutive slot or long subslot transmission and short subslot transmission boundaries

The transmit power time mask for consecutive slot or long subslot transmission and short slot transmission boundaries defines the transient periods allowed between such transmissions.

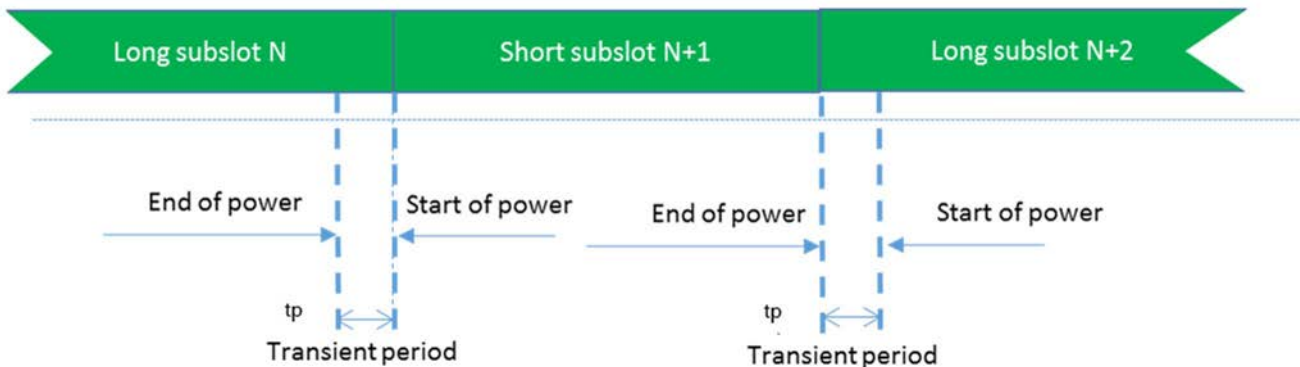

Figure 6.3.3.8-1: Consecutive slot or long subslot transmission and short subslot transmission time mask

6.3.3.9 Transmit power time mask for consecutive short subslot transmissions boundaries

The transmit power time mask for consecutive short subslot transmission boundaries defines the transient periods allowed between short subslot transmissions.

The transient period shall be equally shared as shown on Figure 6.3.3.9-2.

Figure 6.3.3.9-1: Void

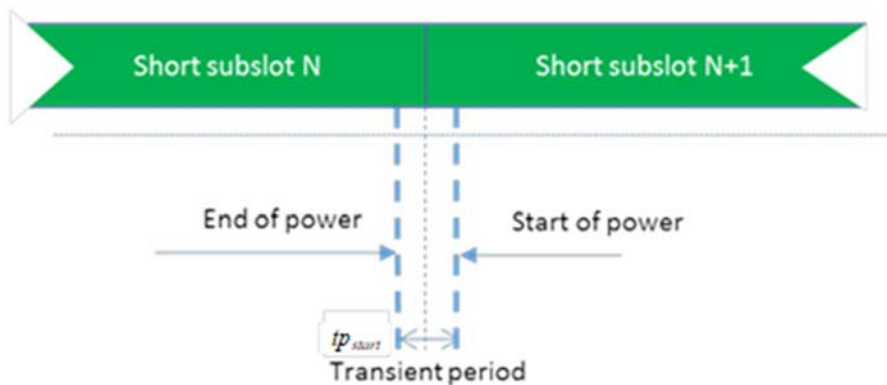
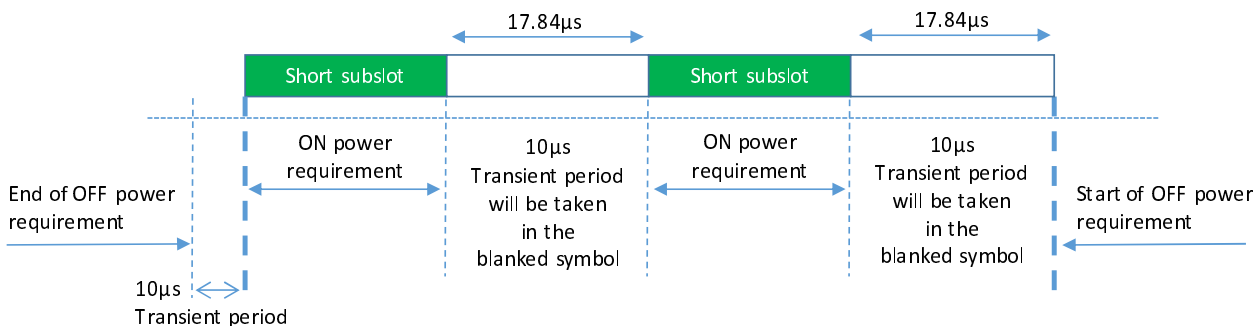

Figure 6.3.3.9-2: Consecutive short subslot transmissions time mask



**Figure 6.3.3.9-3: Consecutive short subslot (1 symbol gap) time mask for the case when transient period is required on both sides of the symbol and when 60 kHz SCS is used in FR1, where the transient period is 10 µs**

### 6.3.4 Power control

#### 6.3.4.1 General

The requirements on power control accuracy apply under normal conditions.

#### 6.3.4.2 Absolute power tolerance

The absolute power tolerance is the ability of the UE transmitter to set its initial output power to a specific value for the first sub-frame (1 ms) at the start of a contiguous transmission or non-contiguous transmission with a transmission gap larger than 20 ms. The tolerance includes the channel estimation error.

The minimum requirement specified in Table 6.3.4.2-1 apply in the power range bounded by the minimum output power as specified in clause 6.3.1 and the maximum output power as specified in clause 6.2.1.

**Table 6.3.4.2-1: Absolute power tolerance**

Conditions	Tolerance
Normal	± 9.0 dB

#### 6.3.4.3 Relative power tolerance

The relative power tolerance is the ability of the UE transmitter to set its output power in a target sub-frame (1 ms) relatively to the power of the most recently transmitted reference sub-frame (1 ms) if the transmission gap between these sub-frames is less than or equal to 20 ms.

The minimum requirements specified in Table 6.3.4.3-1 apply when the power of the target and reference sub-frames are within the power range bounded by the minimum output power as defined in clause 6.3.1 and the measured P<sub>UMAX</sub> as defined in clause 6.2.4.

To account for RF Power amplifier mode changes, 2 exceptions are allowed for each of two test patterns. The test patterns are a monotonically increasing power sweep and a monotonically decreasing power sweep over a range bounded by the requirements of minimum power and maximum power specified in clauses 6.3.1 and 6.2.1, respectively. For those exceptions, the power tolerance limit is a maximum of ± 6.0 dB in Table 6.3.4.3-1.

**Table 6.3.4.3-1: Relative power tolerance**

Power step ΔP (Up or down) (dB)	All combinations of PUSCH and PUCCH transitions (dB)	All combinations of PUSCH/PUCCH and SRS transitions between sub-frames (dB)	PRACH (dB)
ΔP < 2	± 2.0 (NOTE)	± 2.5	± 2.0

$2 \leq \Delta P < 3$	$\pm 2.5$	$\pm 3.5$	$\pm 2.5$
$3 \leq \Delta P < 4$	$\pm 3.0$	$\pm 4.5$	$\pm 3.0$
$4 \leq \Delta P < 10$	$\pm 3.5$	$\pm 5.5$	$\pm 3.5$
$10 \leq \Delta P < 15$	$\pm 4.0$	$\pm 7.0$	$\pm 4.0$
$15 \leq \Delta P$	$\pm 5.0$	$\pm 8.0$	$\pm 5.0$
NOTE: For PUSCH to PUSCH transitions with the allocated resource blocks fixed in frequency and no transmission gaps other than those generated by downlink subframes, DwPTS fields or Guard Periods: for a power step $\Delta P \leq 1$ dB, the relative power tolerance for transmission is $\pm 0.7$ dB.			

#### 6.3.4.4 Aggregate power tolerance

The aggregate power control tolerance is the ability of the UE transmitter to maintain its power in a sub-frame (1 ms) during non-contiguous transmissions within 21 ms in response to 0 dB commands with respect to the first UE transmission and all other power control parameters as specified in TS 38.213 [8] kept constant.

The minimum requirement specified in Table 6.3.4.4-1 apply in the power range bounded by the minimum output power as specified in clause 6.3.1 and the maximum output power as specified in clause 6.2.1.

**Table 6.3.4.4-1: Aggregate power tolerance**

TPC command	UL channel	Aggregate power tolerance within 21 ms
0 dB	PUCCH	$\pm 2.5$ dB
0 dB	PUSCH	$\pm 3.5$ dB

### 6.3A Output power dynamics for CA

#### 6.3A.1 Minimum output power for CA

##### 6.3A.1.1 Minimum output power for intra-band contiguous CA

For intra-band contiguous carrier aggregation, the minimum output power is defined per carrier and the requirement is specified in clause 6.3.1.

##### 6.3A.1.2 Minimum output power for intra-band non-contiguous CA

For intra-band non-contiguous carrier aggregation, the minimum output power is defined per carrier and the requirement is specified in clause 6.3.1.

##### 6.3A.1.3 Minimum output power for inter-band CA

For inter-band carrier aggregation with one uplink carrier assigned to one NR band, the minimum output power requirements in clause 6.3.1 apply.

For inter-band carrier aggregation with two uplink contiguous carrier assigned to one NR band, the minimum output power requirements in subclause 6.3A.1.1 apply for those carriers. For inter-band carrier aggregation with uplink assigned to two NR bands, the minimum output power is defined per carrier and the requirement is specified in clause 6.3.1.

For inter-band carrier aggregation with two uplink non-contiguous carrier assigned to one NR band, the minimum output power requirements in subclause 6.3A.1.2 apply for those carriers.

For inter-band carrier aggregation with uplink assigned to two NR bands, the minimum output power is defined per carrier and the requirement is specified in clause 6.3.1.

For combinations of intra-band and inter-band carrier aggregation with three uplink component carriers (up to two contiguously aggregated carriers per operating band), the minimum output power requirements specified in subclause 6.3.1 apply for the NR band supporting one component carrier, and for the NR band supporting two contiguous component carriers the requirements specified in subclause 6.3A.1.1 apply.

#### 6.3A.1.4 Void

### 6.3A.2 Transmit OFF power for CA

#### 6.3A.2.1 Transmit OFF power for intra-band contiguous CA

For intra-band contiguous carrier aggregation, the transmit OFF power specified in clause 6.3.2 is applicable for each component carrier when the transmitter is OFF on all component carriers. The transmitter is considered to be OFF when the UE is not allowed to transmit on any of its ports.

#### 6.3A.2.2 Transmit OFF power for intra-band non-contiguous CA

For intra-band non-contiguous carrier aggregation, the transmit OFF power specified in clause 6.3.2 is applicable for each component carrier when the transmitter is OFF on all component carriers. The transmitter is considered to be OFF when the UE is not allowed to transmit on any of its ports.

#### 6.3A.2.3 Transmit OFF power for inter-band CA

For inter-band carrier aggregation with one uplink carrier assigned to one NR band, the transmit OFF power requirements in subclause 6.3.2 apply.

For inter-band carrier aggregation with two contiguous carriers assigned to one NR band, the transmit OFF power requirements in subclause 6.3A.2.1 apply for those carriers.

For inter-band carrier aggregation with two uplink non-contiguous carrier assigned to one NR band, the transmit OFF power requirements in subclause 6.3A.2.2 apply for those carriers.

For inter-band carrier aggregation with uplink assigned to two NR bands, the transmit OFF power specified in clause 6.3.2 is applicable for each component carrier when the transmitter is OFF on all component carriers. The transmitter is considered to be OFF when the UE is not allowed to transmit on any of its ports.

For combinations of intra-band and inter-band carrier aggregation with three uplink component carriers (up to two continuously aggregated carriers per operating band), the transmit OFF power requirements specified in subclause 6.3.2 apply for the NR band supporting one component carrier, and for the NR band supporting two contiguous component carriers the requirements specified in subclause 6.3A.2.1 apply.

#### 6.3A.2.4 Void

### 6.3A.3 Transmit ON/OFF time mask for CA

#### 6.3A.3.1 Transmit ON/OFF time mask for intra-band contiguous CA

For intra-band contiguous carrier aggregation, the general output power ON/OFF time mask specified in clause 6.3.3.1 is applicable for each component carrier during the ON power period and the transient periods. The OFF period as specified in clause 6.3.3.1 shall only be applicable for each component carrier when all the component carriers are OFF.

#### 6.3A.3.2 Transmit ON/OFF time mask for intra-band non-contiguous CA

For intra-band non-contiguous carrier aggregation, the general output power ON/OFF time mask specified in clause 6.3.3.1 is applicable for each component carrier during the ON power period and the transient periods. The OFF period as specified in clause 6.3.3.1 shall only be applicable for each component carrier when all the component carriers are OFF.

### 6.3A.3.3 Transmit ON/OFF time mask for inter-band CA

#### 6.3A.3.3.1 General

For inter-band carrier aggregation with one uplink carrier assigned to one NR band, the transmit ON/OFF time mask requirements in subclause 6.3.3 apply.

For inter-band carrier aggregation with two contiguous carriers assigned to one NR band, the transmit ON/OFF time mask requirements in subclause 6.3A.3.1 apply for those carriers.

For inter-band carrier aggregation with two uplink non-contiguous carrier assigned to one NR band, the transmit ON/OFF time mask requirements in subclause 6.3A.3.2 apply for those carriers.

For inter-band carrier aggregation with uplink assigned to two NR bands, the general output power ON/OFF time mask specified in clause 6.3.3.1 is applicable for each component carrier during the ON power period and the transient periods. The OFF period as specified in clause 6.3.3.1 shall only be applicable for each component carrier when all the component carriers are OFF.

Time masks for Tx switching due to switching period are defined in clauses 6.3A.3.3.2-6.3A.3.3.5 for both single TAG and dual-TAG scenarios. When a UE is configured with dual-TAG with at least two cells corresponding to two TAGs involved in one switching event, the timing advance difference should be considered in the time masks in sub-clauses 6.3A.3.3.2-6.3A.3.3.5 for two uplink carriers or two uplink bands and in sub-clause 6.3A.3.3.6 for 3-4 uplink bands. The UE may omit uplink transmission on OFDM symbols that partially or fully overlap with the configured switching period for any timing advance difference.

When the location of the switching period by *uplinkTxSwitchingPeriodLocation* is ignored by the UE, the length and location of allowed transient periods for dual TAG are as specified in 6.3A.3.3.2 – 6.3A.3.3.5 and in 6.3A.3.3.6 for a switching band pair with the UE scheduled or configured with uplink transmissions that do not result in

- simultaneous transmission on two antenna ports on one uplink carrier on one band, and any transmission on another uplink carrier on another band
- transmission of any of the carriers for a duration of at least the uplink switching gap indicated by UE capability

for any timing difference between uplink carriers in different bands up to the MTTD specified for UL CA in clause 7.5.4 of [7] in case of dual TAG.

Carriers within the same band belong to the same TAG in all cases.

#### 6.3A.3.3.2 Time mask for switching between two uplink carriers

In addition to the requirements in 6.3A.3.3.1 and the maximum output power requirement specified in Table 6.2A.1.3-1 with uplink assigned to two NR bands, the switching time mask specified in this clause is applicable for an uplink band pair of a inter-band UL CA configuration when the capability *uplinkTxSwitchingPeriod* is present, and is only applicable for uplink switching mechanisms specified in clause 6.1.6 of TS 38.214 [10], where NR UL carrier 1 is capable of one transmit antenna connector and NR UL carrier 2 is capable of two transmit antenna connectors with 3dB boosting on the maximum output power for CA power class 3 when the capability *uplinkTxSwitching-PowerBoosting* is present and the IE *uplinkTxSwitchingPowerBoosting* is enabled, and the two uplink carriers are in different bands with different carrier frequencies. The UE shall support the switch between single layer transmission with one antenna port and two-layer transmission with two antenna ports on the two uplink carriers following the scheduling commands and rank adaptation, i.e., both single layer and two-layer transmission with 2 antenna ports, and single layer transmission with 1 antenna port shall be supported on NR UL carrier 2 as specified in [38.306].

The switching periods described in Figure 6.3A.3.3.2-1a and Figure 6.3A.3.3.2-1b are located in either NR carrier 1 or carrier 2 as indicated in RRC signalling *uplinkTxSwitchingPeriodLocation* [7], and the length of uplink switching period  $X$  is less than the value indicated by UE capability *uplinkTxSwitchingPeriod*.

When switching from one carrier to another, if there is no uplink transmission scheduled or configured on the switch-from carrier for at least the duration of the switching period ( $X \mu\text{s}$ ) before the point in time the UE is scheduled or configured to start the transmission on the switch-to carrier, the switching period is fully contained in the time period between the end of the transmission on the switch-from carrier and the start of the transmission on the switch-to carrier.



In addition, the RRC signalling *uplinkTxSwitchingPeriodLocation* is ignored by the UE and does not take effect in this case.

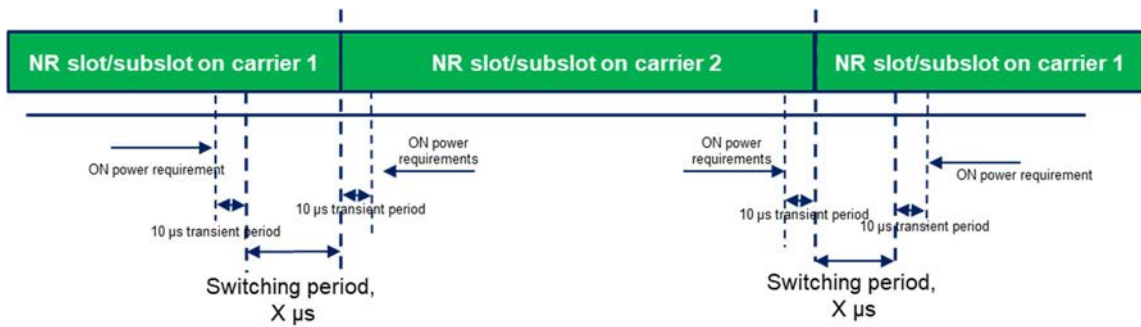

Figure 6.3A.3.3.2-1a: Time mask for switching between UL carrier 1 and UL Carrier 2, where the switching period is located in carrier 1

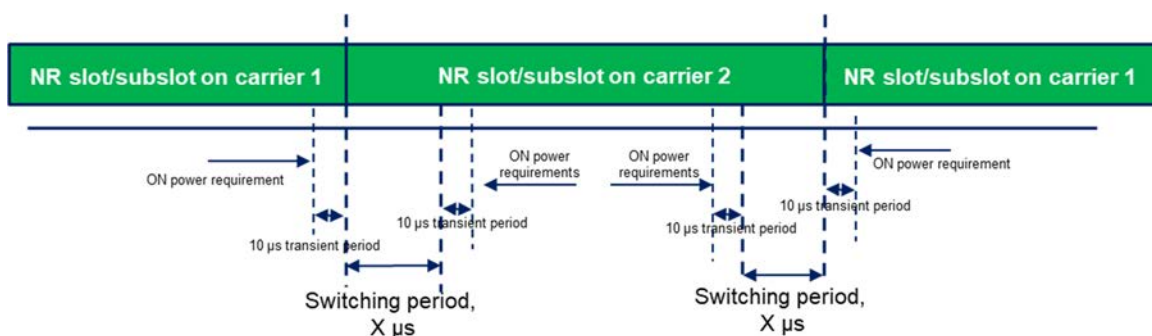

Figure 6.3A.3.3.2-1b: Time mask for switching between UL carrier 1 and UL Carrier 2, where the switching period is located in carrier 2

The following applies for the uplink switching cases specified in clause 6.1.6.2 of [10] with *uplinkTxSwitchingOption* set to either *switchedUL* or *dualUL* when the configuration of the location of the switching period by *uplinkTxSwitchingPeriodLocation* is ignored by the UE:

- if an uplink switching is triggered for an uplink transmission starting at  $T_0$  based on higher layer configuration(s) or DCI(s) received before  $T_0 - T_{offset}$  as specified in [10] and the UE is not configured or scheduled with uplink transmissions for a duration of at least the uplink switching gap indicated by *uplinkTxSwitchingPeriod* on any of the carriers before  $T_0$ , transient periods of  $10 \mu\text{s}$  are located at the end of the last symbol(s) configured or scheduled on the carriers before  $T_0$  and at the start of the first symbol(s) configured or scheduled at  $T_0$  on the switched-to carrier.

The requirements apply for the case of both non-co-located and co-located and synchronized network deployment for the two uplink carriers.

The time mask is applicable to uplink transmissions when configured with *switchedUL* or *dualUL*.

### 6.3A.3.3.3 Time mask for switching between two uplink carriers with two transmit antenna connectors

In addition to the requirements in 6.3A.3.3.1 and the maximum output power requirement specified in Table 6.2A.1.3-1 with uplink assigned to two NR bands, the switching time mask specified in this clause is applicable for an uplink band pair of a inter-band UL CA configuration when the capability *uplinkTxSwitchingPeriod2T2T* is present, and is only applicable for uplink switching mechanisms specified in clause 6.1.6 of TS 38.214 [10], where NR UL carrier 1 is capable of two transmit antenna connectors and NR UL carrier 2 is capable of two transmit antenna connectors, and the two uplink carriers are in different bands with different carrier frequencies. The UE shall support the switch between two-layer transmission with two antenna ports and two-layer transmission with two antenna ports on the two uplink carriers following the scheduling commands and rank adaptation, i.e., both single layer and two-layer transmission with 2 antenna ports, and single layer transmission with 1 antenna port shall be supported on NR UL carrier 1 and carrier 2.

The switching periods described in Figure 6.3A.3.3.3-1a and Figure 6.3A.3.3.3-1b are located in either NR carrier 1 or carrier 2 as indicated in RRC signalling *uplinkTxSwitchingPeriodLocation* [7], and the length of uplink switching period  $X$  is less than the value indicated by UE capability *uplinkTxSwitchingPeriod2T2T*.

When switching from one carrier to another, if there is no uplink transmission scheduled or configured on the switch-from carrier for at least the duration of the switching period ( $X \mu\text{s}$ ) before the point in time the UE is scheduled or configured to start the transmission on the switch-to carrier, the switching period is fully contained in the time period between the end of the transmission on the switch-from carrier and the start of the transmission on the switch-to carrier. In addition, the RRC signalling *uplinkTxSwitchingPeriodLocation* is ignored by the UE and does not take effect in this case.

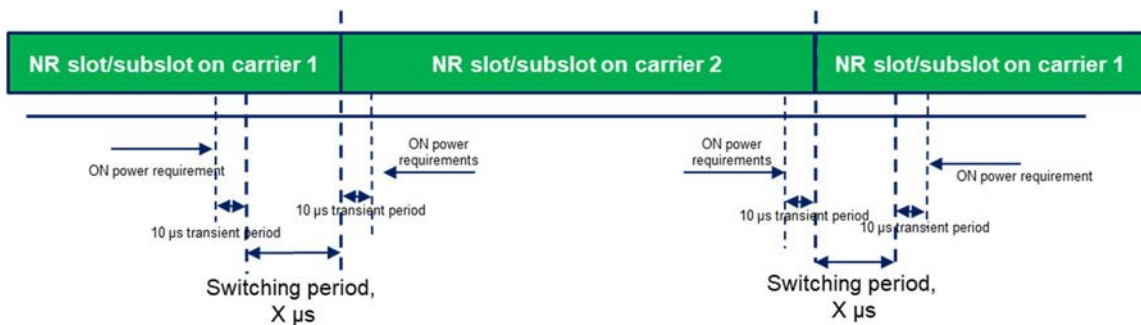

Figure 6.3A.3.3.3-1a: Time mask for switching between UL carrier 1 and UL Carrier 2, where the switching period is located in carrier 1

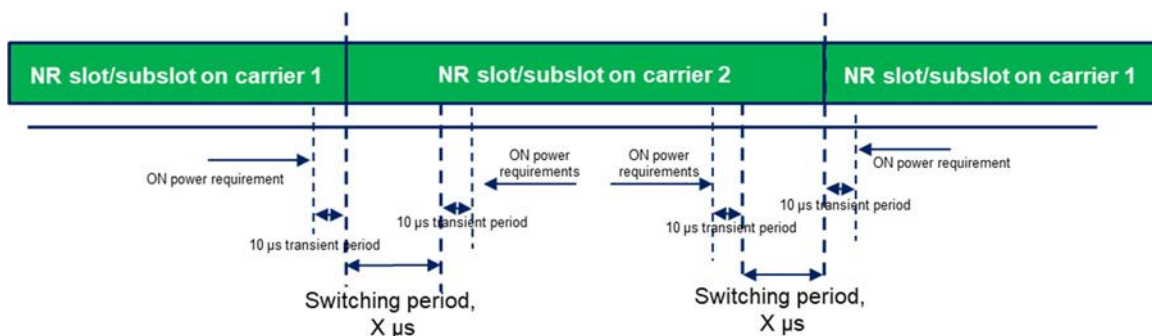

Figure 6.3A.3.3.3-1b: Time mask for switching between UL carrier 1 and UL Carrier 2, where the switching period is located in carrier 2

The following applies for the uplink switching cases specified in clause 6.1.6.2 of [10] with *uplinkTxSwitchingOption* set to either *switchedUL* or *dualUL* when the configuration of the location of the switching period by *uplinkTxSwitchingPeriodLocation* is ignored by the UE:

- if an uplink switching is triggered for an uplink transmission starting at  $T_0$  based on higher layer configuration(s) or DCI(s) received before  $T_0 - T_{\text{offset}}$  as specified in [10] and the UE is not configured or scheduled with uplink transmissions for a duration of at least the uplink switching gap indicated by *uplinkTxSwitchingPeriod2T2T* on any of the carriers before  $T_0$ , transient periods of  $10 \mu\text{s}$  are located at the end of the last symbol(s) configured or scheduled on the carriers before  $T_0$  and at the start of the first symbol(s) configured or scheduled at  $T_0$  on the switched-to carrier.

The requirements apply for the case of both non-co-located and co-located and synchronized network deployment for the two uplink carriers.

The time mask is applicable to uplink transmissions when configured with *switchedUL* or *dualUL*.

#### 6.3A.3.3.4 Time mask for switching between one uplink band with one transmit antenna connector and one uplink band with two transmit antenna connectors

In addition to the requirements in 6.3A.3.3.1 and the maximum output power requirement specified in Table 6.2A.1.3-1 with uplink assigned to two NR bands, the switching time mask specified in this clause is applicable for an uplink band

pair of a inter-band UL CA configuration when the capability *uplinkTxSwitchingPeriod* is present, and is only applicable for uplink switching mechanisms specified in clause 6.1.6 of TS 38.214 [10], where NR UL carrier 1 in band A is capable of one transmit antenna connector, NR UL carrier 2 and carrier 3 in band B are capable of two transmit antenna connectors. NR UL carrier 2 and carrier 3 are two contiguous aggregated carriers, and band A and band B are different bands with different carrier frequencies. The UE shall support the switch between single layer transmission with one antenna port and two-layer transmission with two antenna ports on the two uplink bands following the scheduling commands and rank adaptation, i.e., both single layer and two-layer transmission with 2 antenna ports, and single layer transmission with 1 antenna port shall be supported on NR UL carrier 2 and carrier 3 in band B.

The switching periods described in Figure 6.3A.3.3.4-1a and Figure 6.3A.3.3.4-1b are located in either NR band A or band B as indicated in RRC signalling *uplinkTxSwitchingPeriodLocation* [7], and the length of uplink switching period  $X$  is less than the value indicated by UE capability *uplinkTxSwitchingPeriod*.

When switching from one carrier to another, if there is no uplink transmission scheduled or configured on the switch-from carrier for at least the duration of the switching period ( $X \mu\text{s}$ ) before the point in time the UE is scheduled or configured to start the transmission on the switch-to carrier, the switching period is fully contained in the time period between the end of the transmission on the switch-from carrier and the start of the transmission on the switch-to carrier. In addition, the RRC signalling *uplinkTxSwitchingPeriodLocation* is ignored by the UE and does not take effect in this case.

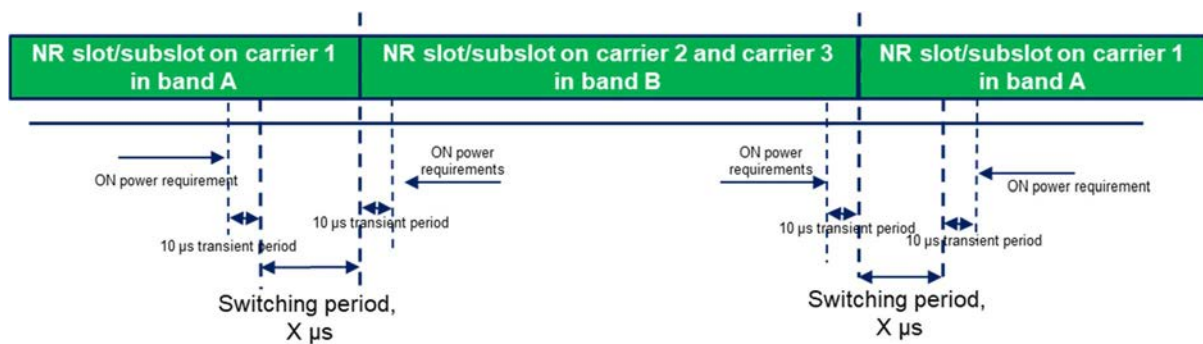

Figure 6.3A.3.3.4-1a: Time mask for switching between one carrier in band A and two contiguous carriers in band B, where the switching period is located in band A

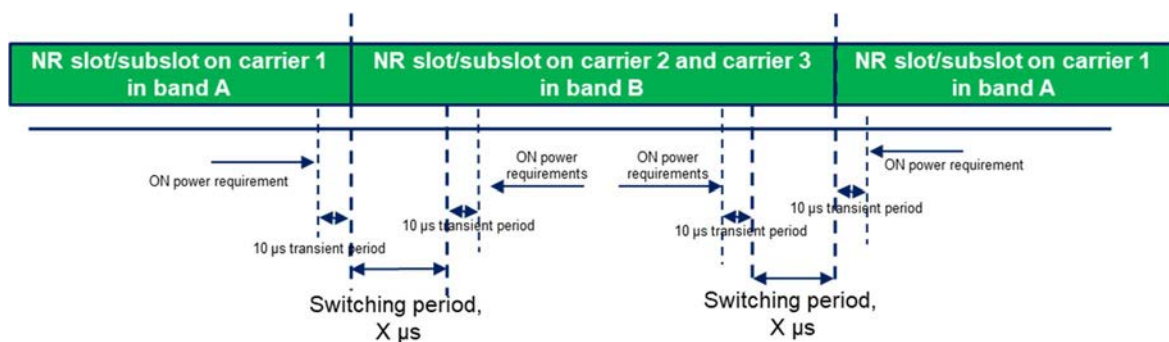

Figure 6.3A.3.3.4-1b: Time mask for switching between one carrier in band A and two contiguous carriers in band B, where the switching period is located in band B

The following applies for the uplink switching cases specified in clause 6.1.6.2 of [10] with *uplinkTxSwitchingOption* set to either *switchedUL* or *dualUL* when the configuration of the location of the switching period by *uplinkTxSwitchingPeriodLocation* is ignored by the UE:

- if an uplink switching is triggered for an uplink transmission starting at  $T_0$  based on higher layer configuration(s) or DCI(s) received before  $T_0 - T_{offset}$  as specified in [10] and the UE is not configured or scheduled with uplink transmissions for a duration of at least the uplink switching gap indicated by *uplinkTxSwitchingPeriod* on any of the carriers before  $T_0$ , transient periods of  $10 \mu\text{s}$  are located at the end of the last symbol(s) configured or scheduled on the carriers before  $T_0$  and at the start of the first symbol(s) configured or scheduled at  $T_0$  on the switched-to carrier.

The requirements apply for the case of both non-co-located and co-located and synchronized network deployment for the three uplink carriers.

The time mask is applicable to uplink transmissions when configured with *switchedUL* or *dualUL*.

### 6.3A.3.3.5 Time mask for switching between two uplink bands with two transmit antenna connectors

In addition to the requirements in 6.3A.3.3.1 and the maximum output power requirement specified in Table 6.2A.1.3-1 with uplink assigned to two NR bands, the switching time mask specified in this clause is applicable for an uplink band pair of a inter-band UL CA configuration when the capability *uplinkTxSwitchingPeriod2T2T* is present, and is only applicable for uplink switching mechanisms specified in clause 6.1.6 of TS 38.214 [10], where NR UL carriers in band A and B are capable of two transmit antenna connectors. NR UL carriers are two contiguous aggregated carriers in band B, and one or two contiguous aggregated carriers in band A. Band A and band B are different bands with different carrier frequencies. The UE shall support the switch between two-layer transmission with two antenna ports and two-layer transmission with two antenna ports on the two uplink bands following the scheduling commands and rank adaptation, i.e., both single layer and two-layer transmission with 2 antenna ports, and single layer transmission with 1 antenna port shall be supported on NR UL carriers in the two bands.

The switching periods described in Figure 6.3A.3.3.5-1a and Figure 6.3A.3.3.5-1b are located in either NR band A or band B as indicated in RRC signalling *uplinkTxSwitchingPeriodLocation* [7], and the length of uplink switching period *X* is less than the value indicated by UE capability *uplinkTxSwitchingPeriod2T2T*.

When switching from one carrier to another, if there is no uplink transmission scheduled or configured on the switch-from carrier for at least the duration of the switching period (*X* μs) before the point in time the UE is scheduled or configured to start the transmission on the switch-to carrier, the switching period is fully contained in the time period between the end of the transmission on the switch-from carrier and the start of the transmission on the switch-to carrier. In addition, the RRC signalling *uplinkTxSwitchingPeriodLocation* is ignored by the UE and does not take effect in this case.

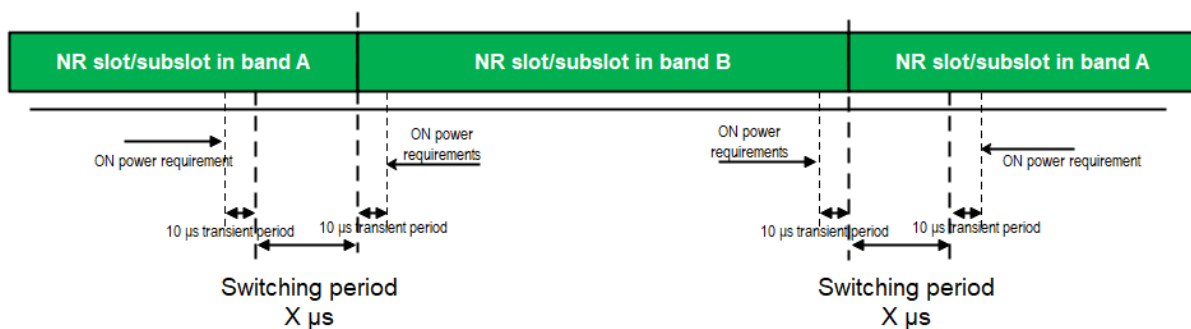

Figure 6.3A.3.3.5-1a: Time mask for switching between band A and band B, where the switching period is located in band A

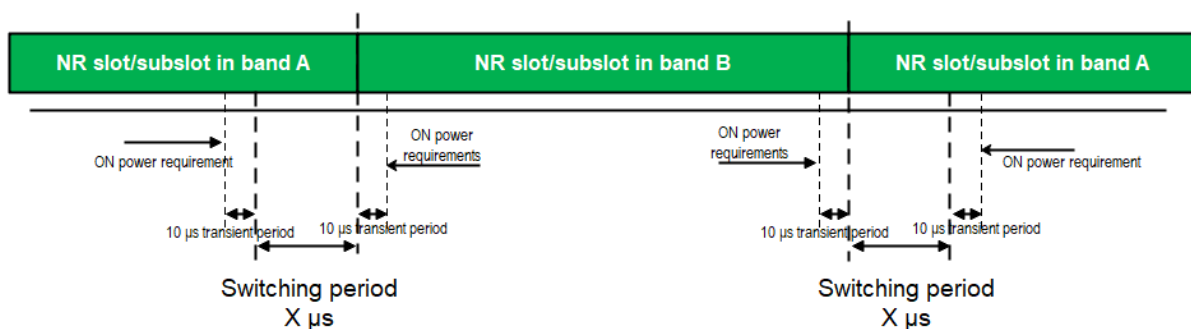

Figure 6.3A.3.3.5-1b: Time mask for switching between band A and band B, where the switching period is located in band B



The following applies for the uplink switching cases specified in clause 6.1.6.2 of [10] with *uplinkTxSwitchingOption* set to either *switchedUL* or *dualUL* when the configuration of the location of the switching period by *uplinkTxSwitchingPeriodLocation* is ignored by the UE:

- if an uplink switching is triggered for an uplink transmission starting at  $T_0$  based on higher layer configuration(s) or DCI(s) received before  $T_0 - T_{offset}$  as specified in [10] and the UE is not configured or scheduled with uplink transmissions for a duration of at least the uplink switching gap indicated by *uplinkTxSwitchingPeriod2T2T* on any of the carriers before  $T_0$ , transient periods of 10  $\mu$ s are located at the end of the last symbol(s) configured or scheduled on the carriers before  $T_0$  and at the start of the first symbol(s) configured or scheduled at  $T_0$  on the switched-to carrier.

The requirements apply for the case of both non-co-located and co-located and synchronized network deployment for the three uplink carriers.

The time mask is applicable to uplink transmissions when configured with *switchedUL* or *dualUL*.

### 6.3A.3.3.6 Time mask for switching across up to four uplink bands

The switching time mask requirements specified in this sub-clause are applicable for an NR inter-band CA configuration when the capability *supportedBandPairListNR-r18* is present, and are only applicable for uplink switching mechanisms specified in clause [6.1.6] of TS 38.214 [10].

In the NR inter-band CA configuration, the number of NR uplink bands is up to four. NR UL carrier(s) in each of the up to four uplink bands are capable of one or two transmit antenna connector(s), according to the UE capability *FeatureSetUplinkPerCC*.

The switching time masks in Figure 6.3A.3.3.6-1 and Figure 6.3A.3.3.6-2 are applicable to each of the uplink band pairs in the CA configuration, and are applicable to uplink transmissions when configured with *switchedUL* or *dualUL* by the parameter *switchingOptionConfigForBandPair*. To simplify the figures, the two bands in different band pairs are denoted as NR band X and band Y. The uplink transmission on either band X or band Y is with one or two transmit antenna connector(s),

- if NR UL carriers in both bands in one band pair are capable of one transmit antenna connector, 1Tx-1Tx switching is supported for the band pair;
- if NR UL carrier(s) in one band of one band pair is capable of one transmit antenna connector, and NR UL carrier(s) in the other band of the band pair is capable of two transmit antenna connectors, 1Tx-2Tx switching is supported for the band pair;
- if NR UL carriers in both bands of one band pair are capable of two transmit antenna connectors, 2Tx-2Tx switching is supported for the band pair.

For each band pair, the switching periods described in Figure 6.3A.3.3.6-1 and Figure 6.3A.3.3.6-2 are located in either NR band X or band Y as indicated in RRC signalling *uplinkTxSwitchingBandList* [7]. For each band pair, the length of uplink switching period X is indicated by RRC signalling *switchingPeriodConfigForBandPair*. UE shall be capable to transmit until the beginning of the switching period and after the end of switching period with the exception of transient periods.

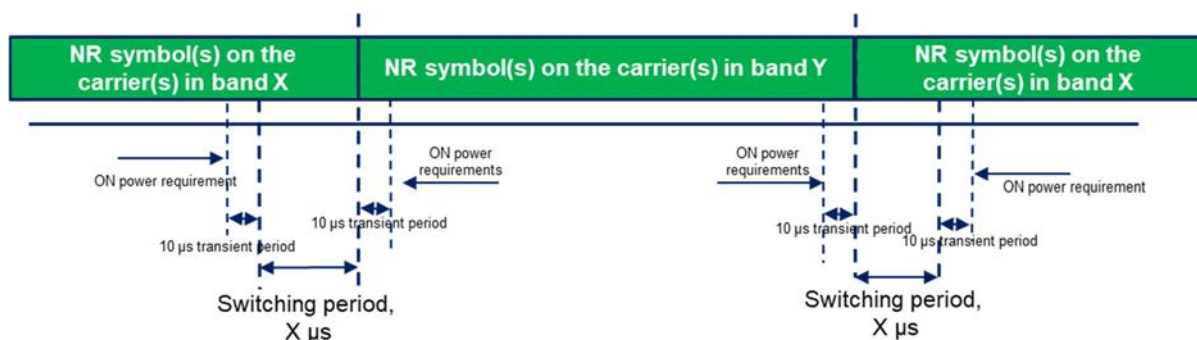
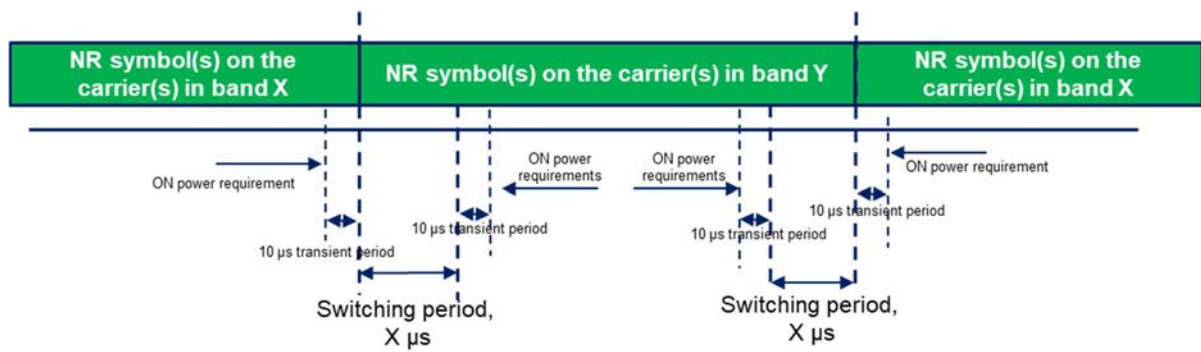

Figure 6.3A.3.3.6-1: Time mask for switching between band X and band Y, where the switching period is located in band X



**Figure 6.3A.3.3.6-2: Time mask for switching between band X and band Y, where the switching period is located in band Y**

The following applies for the uplink switching cases specified in Figure 6.3A.3.3.6-1 and 6.3A.3.3.6-2 in a band pair with *switchingOptionConfigForBandPair* set to either *switchedUL* or *dualUL*:

- if an uplink switching is triggered for an uplink transmission starting at  $T_0$  based on higher layer configuration(s) or DCI(s) received before  $T_0 - T_{offset}$  as specified in [10] and the UE is not configured or scheduled with uplink transmissions for a duration of at least the length of uplink switching period of  $X \mu\text{s}$  indicated by RRC signalling *switchingPeriodConfigForBandPair* on any of the carriers band X and band Y before  $T_0$ ,
- the configuration of the location of the switching period by *uplinkTxSwitchingBandList* is ignored by the UE;
- transient periods of  $10 \mu\text{s}$  are located at the end of the last symbol(s) configured or scheduled on the carrier(s) before  $T_0$  and at the start of the first symbol(s) configured or scheduled at  $T_0$  on the switch-to carrier(s).

In addition to the requirements in Figure 6.3A.3.3.6-1 and Figure 6.3A.3.3.6-2, the requirements in Figure 6.3A.3.3.6-3 to 6.3A.3.3.6-5 are applicable when *dualUL* are supported on certain band pair(s) in the CA configuration.

The switching time masks in Figure 6.3A.3.3.6-3 and Figure 6.3A.3.3.6-4 are applicable when *dualUL* is supported for at least two uplink band pairs in the CA configuration. The two band pairs supporting *dualUL* are denoted as band pairs of {band X and band Z} and {band Y and band Z}. When one transmitter is switched between band X and band Y,

- As baseline UE behaviour, the UE is not required to transmit on any of the three bands during time period T1 located on band X and band Z, where T1 is the length of switching period for the band pair of band X and band Y, as shown in Figure 6.3A.3.3.6-4.
- As optional UE behaviours, when the UE indicates band Z in the capability *bandIndexUnaffected*,
  - if the UE indicates *maintainedUL-Trans* for band pair of {band X and band Y}, UE shall be capable of uplink transmission on band Z during the switching period that is located on band X, and UE is not required to transmit on band X and Y during time period T1 located on band X, where T1 is the length of switching period for the band pair of band X and band Y, as shown in Figure 6.3A.3.3.6-3;
  - otherwise, the UE is not required to transmit on any of the three bands during the switching period indicated by UE capability *periodOnULBands* located on band X and band Z, as shown in Figure 6.3A.3.3.6-4.

In Figure 6.3A.3.3.6-3 and Figure 6.3A.3.3.6-4, the uplink transmission on band X, band Y and band Z are all with one transmit antenna connector and one antenna port.

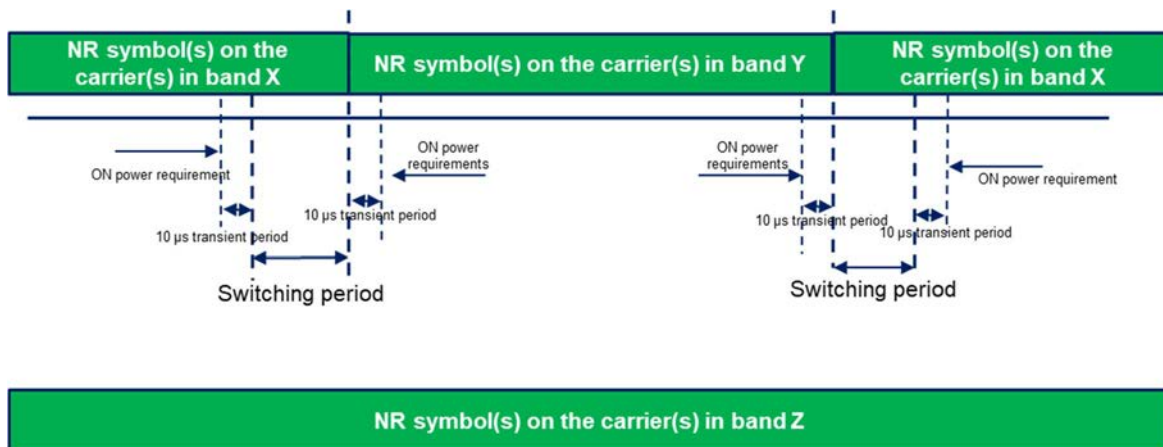

**Figure 6.3A.3.3.6-3: Time mask for one transmitter switching between band X and band Y, and UE is capable of uplink transmission on band Z during the switching period**

The following applies for the uplink switching cases specified in Figure 6.3A.3.3.6-3 in a band pair with *switchingOptionConfigForBandPair* set to *dualUL*:

- if an uplink switching is triggered for an uplink transmission starting at  $T_0$  based on higher layer configuration(s) or DCI(s) received before  $T_0 - T_{offset}$  as specified in [10] and the UE is not configured or scheduled with uplink transmissions for a duration of at least the length of uplink switching period X indicated by RRC signalling *switchingPeriodConfigForBandPair* on any of the carriers in band X and band Y before  $T_0$ ,
- the configuration of the location of the switching period by *uplinkTxSwitchingBandList* is ignored by the UE;
- transient periods of 10 μs are located at the end of the last symbol(s) configured or scheduled on the carrier(s) before  $T_0$  and at the start of the first symbol(s) configured or scheduled at  $T_0$  on the switch-to carrier(s).

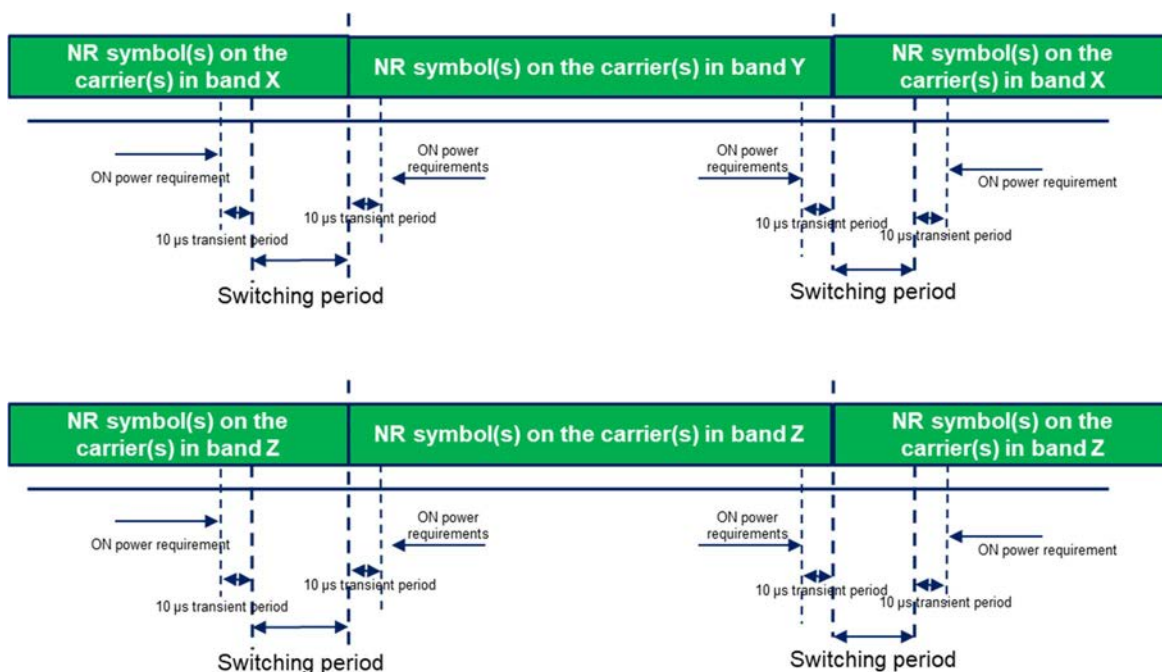

**Figure 6.3A.3.3.6-4: Time mask for one transmitter switching between band X and band Y, and UE is not capable of uplink transmission on band Z during the switching period**

The switching time mask in Figure 6.3A.3.3.6-5 is applicable when *dualUL* is supported for at least one uplink band pair including band X and band Y, and two transmit antenna connectors are supported on at least one uplink band of

band Z. When one transmitter is switched between band X and band Z, and across the same time, the other transmitter is switched between Y and band Z, the switching time mask in Figure 6.3A.3.3.6-5 is applicable.

- As baseline UE behaviour, UE is not required to transmit on any of the three bands during time period with the larger one of switching period T2 and T3, where T2 is the length of switching period for the band pair of band X and band Z, and T3 is the length of switching period for the band pair of band Y and band Z.
- As optional UE behaviour, when UE additionally reports band pair of {band X and band Y} and band Z in the capability *uplinkTxSwitchingAdditionalPeriodDualUL-List*, UE is not required to transmit on any of the three bands during time period indicated by UE capability *switchingAdditionalPeriodDualUL*.

In Figure 6.3A.3.3.6-5, the uplink transmission on band X and band Y is with one transmit antenna connector and one antenna port, and the uplink transmission on band Z is with two transmit antenna connectors and two antenna ports. The switching period location is configured according to [7], and band Z is with the highest priority according to the RRC configuration *uplinkTxSwitchingBandList*.

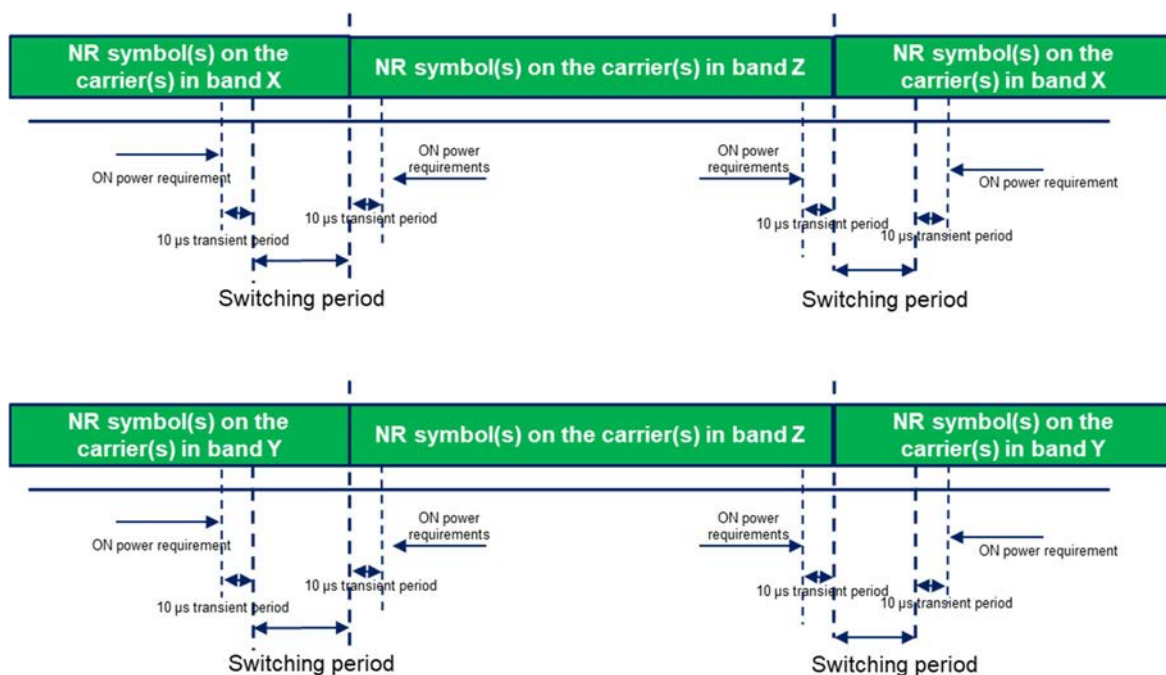

**Figure 6.3A.3.3.6-5: Time mask for one transmitter switching between band X and band Z, and one transmitter switching between band Y and band Z**

The following applies for the uplink switching case specified in Figure 6.3A.3.3.6-5 and with *uplinkTxSwitchingOptionForBandPair* set to *dualUL* for at least one band pair

- if uplink switching on a band pair is triggered for an uplink transmission starting at  $T_0$  based on higher layer configuration(s) or DCI(s) received before  $T_0 - T_{offset}$  as specified in [10] and the UE is not configured or scheduled with uplink transmissions for a duration of at least the maximum of the lengths of uplink switching periods indicated by RRC signalling *switchingPeriodConfigForBandPair* on any of the carriers in band X, band Y and band Z before  $T_0$  on any switched-to carrier
- the configuration of the location of the switching period and the priority of bands in the *uplinkTxSwitchingBandList* are ignored by the UE
- transient periods of 10 µs are located at the end of the last symbol(s) configured or scheduled on the switched-from carrier(s) before  $T_0$  on any switched-to carrier and at the start of the first symbol(s) configured or scheduled at  $T_0$  on the switch-to carrier(s)

The requirements in this sub-clause apply for the case of synchronized network deployment for the uplink bands.



### 6.3A.3.3.6a Additional requirements for three-band switching with dual TAG

The following applies for the uplink switching case specified in Figure 6.3A.3.3.6-5 with three bands involved in the switching and with *uplinkTxSwitchingOptionForBandPair-r18* set to *dualUL* for at least one band pair.

If the UE is configured with dual TAG and not configured or scheduled with uplink transmissions for a duration of at least the maximum of the lengths of uplink switching periods indicated by UE capability [*uplinkTxSwitchingPeriodForBandPair-r18*] on any of the carriers in band X, band Y and band Z including any timing difference between the uplink carriers before the first  $T_0$  on any switched-to carrier,

- the configuration of the location of the switching period and the priority of bands in the *uplinkTxSwitchingBandList* are ignored by the UE
- transient periods of 10  $\mu$ s are located at the end of the last symbol(s) configured or scheduled on the switched-from carrier(s) before the first  $T_0$  on any switched-to carrier and at the start of the first symbol(s) configured or scheduled at  $T_0$  on the switch-to carrier(s)

### 6.3A.3.4 Void

## 6.3A.4 Power control for CA

### 6.3A.4.1 Power control for intra-band contiguous CA

#### 6.3A.4.1.1 Absolute power tolerance

The absolute power tolerance is the ability of the UE transmitter to set its initial output power to a specific value for the first sub-frame at the start of a contiguous transmission or non-contiguous transmission with a transmission gap on each active component carriers larger than 20ms. The requirement can be tested by time aligning any transmission gaps on the component carriers.

##### 6.3A.4.1.1.1 Minimum requirements

For intra-band contiguous carrier aggregation the absolute power control tolerance per component carrier is given in Table 6.3.4.2-1.

#### 6.3A.4.1.2 Relative power tolerance

##### 6.3A.4.1.2.1 Minimum requirements

For intra-band contiguous carrier aggregation, the requirements apply when the power of the target and reference sub-frames on each component carrier exceed the minimum output power as defined in clause 6.3A.1 and the total power is limited by  $P_{UMAX}$  as defined in clause 6.2A.4. The UE shall meet the following requirements for transmission on both assigned component carriers when the average transmit power per PRB is aligned across both assigned carriers in the reference sub-frame:

- a) for all possible combinations of PUSCH and PUCCH transitions per component carrier, the corresponding requirements given in Table 6.3.4.3-1;
- b) for SRS transitions on each component carrier, the requirements for combinations of PUSCH/PUCCH and SRS transitions given in Table 6.3.4.2-1 with simultaneous SRS of constant SRS bandwidth allocated in the target and reference subframes;
- c) for RACH on the primary component carrier, the requirements given in Table 6.3.4.3-1 for PRACH.

For a) and b) above, the power step  $\Delta P$  between the reference and target subframes shall be set by a TPC command and/or an uplink scheduling grant transmitted by means of an appropriate DCI Format.

### 6.3A.4.1.3 Aggregate power control tolerance

For intra-band contiguous carrier aggregation, the aggregate power tolerance per component carrier is given in Table 6.3.4.4-1. The average power per PRB shall be aligned across both assigned carriers before the start of the test. The requirement can be tested with the transmission gaps time aligned between component carriers.

### 6.3A.4.2 Power control for intra-band non-contiguous CA

#### 6.3A.4.2.1 Absolute power tolerance

The absolute power tolerance is the ability of the UE transmitter to set its initial output power to a specific value for the first sub-frame at the start of a contiguous transmission or non-contiguous transmission with a transmission gap on each active component carriers larger than 20ms. The requirement can be tested by time aligning any transmission gaps on the component carriers.

##### 6.3A.4.2.1.1 Minimum requirements

For intra-band non-contiguous carrier aggregation the absolute power control tolerance per component carrier is given in Table 6.3.4.2-1.

#### 6.3A.4.2.2 Relative power tolerance

##### 6.3A.4.2.2.1 Minimum requirements

For intra-band non-contiguous carrier aggregation, the requirements apply when the power of the target and reference sub-frames on each component carrier exceed the minimum output power as defined in subclause 6.3A.1 and the total power is limited by  $P_{UMAX}$  as defined in subclause 6.2A.4. The UE shall meet the following requirements for transmission on both assigned component carriers when the average transmit power per PRB is aligned across both assigned carriers in the reference sub-frame:

- a) for all possible combinations of PUSCH and PUCCH transitions per component carrier, the corresponding requirements given in Table 6.3.4.3-1;
- b) for SRS transitions on each component carrier, the requirements for combinations of PUSCH/PUCCH and SRS transitions given in Table 6.3.4.3-1 with simultaneous SRS of constant SRS bandwidth allocated in the target and reference subframes;
- c) for RACH on the primary component carrier, the requirements given in Table 6.3.4.3-1 for PRACH.

For a) and b) above, the power step  $\Delta P$  between the reference and target subframes shall be set by a TPC command and/or an uplink scheduling grant transmitted by means of an appropriate DCI Format.

#### 6.3A.4.2.3 Aggregate power control tolerance

For intra-band non-contiguous carrier aggregation, the aggregate power tolerance per component carrier is given in Table 6.3.4.4-1. The average power per PRB shall be aligned across both assigned carriers before the start of the test. The requirement can be tested with the transmission gaps time aligned between component carriers.

### 6.3A.4.3 Power control for inter-band CA

No requirements unique to CA operation are defined.

### 6.3A.4.4 Void

## 6.3B Output power dynamics for NR-DC

For inter-band NR-DC with one uplink carrier assigned per NR band, the output power dynamics for the corresponding inter-band CA configuration as specified in clause 6.3A applies.

## 6.3C Output power dynamics for SUL

### 6.3C.1 Void

### 6.3C.2 Void

### 6.3C.3 Transmit ON/OFF time mask for SUL

#### 6.3C.3.0 General

Time masks for Tx switching due to switching period are defined in clause 6.3C.3.5 for both single TAG and dual-TAG scenarios. When a UE is configured with dual-TAG with at least two cells corresponding to two TAGs involved in one switching event, the timing advance difference is considered in the time masks in sub-clause 6.3C.3.5. The UE may omit uplink transmission on OFDM symbols that partially or fully overlap with the configured switching period for any timing advance difference.

#### 6.3C.3.1 Time mask for switching between two uplink carriers

The switching time mask specified in this clause is applicable for an uplink band pair of a SUL configuration when the capability *uplinkTxSwitchingPeriod* is present, is only applicable for uplink switching mechanisms specified in clause 6.16 of TS 38.214 [10], where NR SUL carrier 1 is capable of one transmit antenna connector and NR UL carrier 2 is capable of two transmit antenna connectors, and the two uplink carriers are in different bands with different carrier frequencies. The UE shall support the switch between single layer transmission with one antenna port and two-layer transmission with two antenna ports on the two uplink carriers following the scheduling commands and rank adaptation, i.e., both single layer and two-layer transmission with 2 antenna ports, and single layer transmission with 1 antenna port shall be supported on NR UL carrier 2 as specified in [38.306].

The switching periods described in Figure 6.3C.3.1-1a and Figure 6.3C.3.1-1b are located in either NR carrier 1 or carrier 2 as indicated in RRC signalling *uplinkTxSwitchingPeriodLocation* [7], and the length of uplink switching period  $X$  is less than the value indicated by UE capability *uplinkTxSwitchingPeriod*.

When switching from one carrier to another, if there is no uplink transmission scheduled or configured on the switch-from carrier for at least the duration of the switching period ( $X \mu\text{s}$ ) before the point in time the UE is scheduled or configured to start the transmission on the switch-to carrier, the switching period is fully contained in the time period between the end of the transmission on the switch-from carrier and the start of the transmission on the switch-to carrier. In addition, the RRC signalling *uplinkTxSwitchingPeriodLocation* is ignored by the UE and does not take effect in this case.

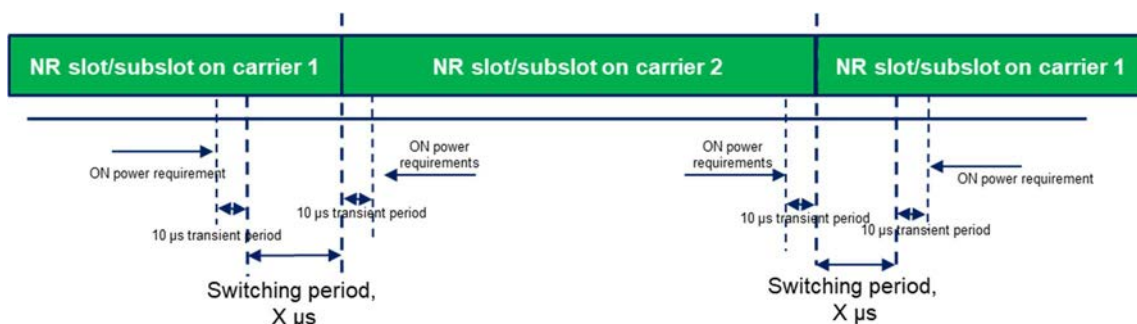
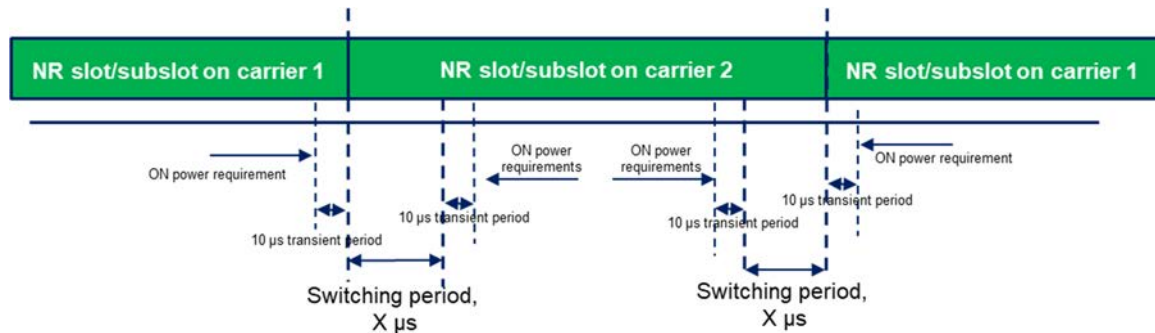

Figure 6.3C.3.1-1a: Time mask for switching between SUL carrier 1 and UL Carrier 2, where the switching period is located in carrier 1



**Figure 6.3C.3.1-1b: Time mask for switching between SUL carrier 1 and UL Carrier 2, where the switching period is located in carrier 2**

The following applies for the uplink switching case specified in clause 6.1.6.3 of [10] when the configuration of the location of the switching period by *uplinkTxSwitchingPeriodLocation* is ignored by the UE:

- if an uplink switching is triggered for an uplink transmission starting at  $T_0$  based on higher layer configuration(s) or DCI(s) received before  $T_0 - T_{offset}$  as specified in [10] and the UE is not configured or scheduled with uplink transmissions for a duration of at least the uplink switching gap indicated by *uplinkTxSwitchingPeriod* on any of the carriers before  $T_0$ , transient periods of  $10\ \mu\text{s}$  are located at the end of the last symbol(s) scheduled on the carriers before  $T_0$  and at the start of the first symbol(s) configured or scheduled at  $T_0$  on the switched-to carrier.

The requirements apply for the case of co-located and synchronized network deployment for the two uplink carriers.

The requirements apply for the case of single TAG for the two uplink carriers, i.e., the same uplink timing for the two carriers as described in clause 4.2 of TS 38.213 [8].

### 6.3C.3.2 Time mask for switching between two uplink carriers with two transmit antenna connectors

The switching time mask specified in this clause is applicable for an uplink band pair of a SUL configuration when the capability *uplinkTxSwitchingPeriod2T2T* is present, is only applicable for uplink switching mechanisms specified in clause 6.1.6 of TS 38.214 [10], where NR SUL carrier 1 is capable of two transmit antenna connectors and NR UL carrier 2 is capable of two transmit antenna connectors, and the two uplink carriers are in different bands with different carrier frequencies. The UE shall support the switch between two-layer transmission with two antenna ports and two-layer transmission with two antenna ports on the two uplink carriers following the scheduling commands and rank adaptation, i.e., both single layer and two-layer transmission with 2 antenna ports, and single layer transmission with 1 antenna port shall be supported on NR UL carrier 1 and carrier 2.

The switching periods described in Figure 6.3C.3.2-1a and Figure 6.3C.3.2-1b are located in either NR carrier 1 or carrier 2 as indicated in RRC signalling *uplinkTxSwitchingPeriodLocation* [7], and the length of uplink switching period  $X$  is less than the value indicated by UE capability *uplinkTxSwitchingPeriod2T2T*.

When switching from one carrier to another, if there is no uplink transmission scheduled or configured on the switch-from carrier for at least the duration of the switching period ( $X\ \mu\text{s}$ ) before the point in time the UE is scheduled or configured to start the transmission on the switch-to carrier, the switching period is fully contained in the time period between the end of the transmission on the switch-from carrier and the start of the transmission on the switch-to carrier. In addition, the RRC signalling *uplinkTxSwitchingPeriodLocation* is ignored by the UE and does not take effect in this case.

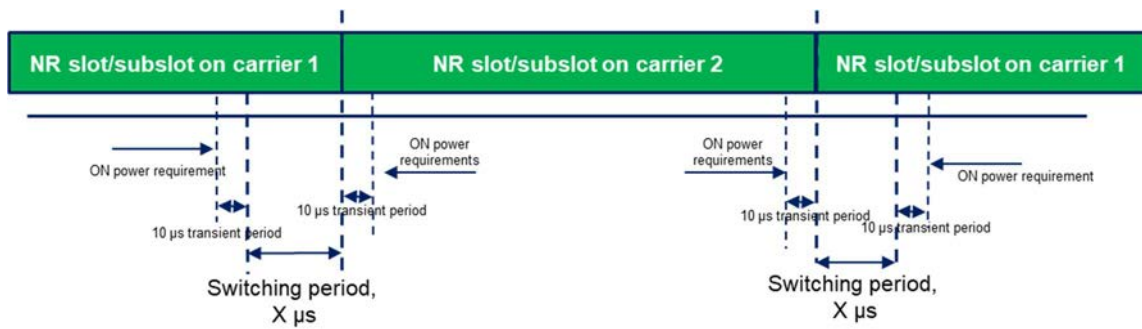

Figure 6.3C.3.2-1a: Time mask for switching between SUL carrier 1 and UL Carrier 2, where the switching period is located in carrier 1

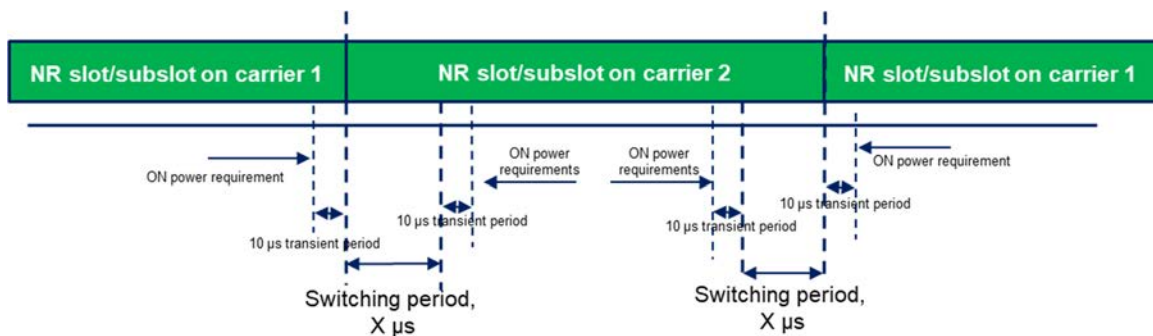

Figure 6.3C.3.2-1b: Time mask for switching between SUL carrier 1 and UL Carrier 2, where the switching period is located in carrier 2

The following applies for the uplink switching case specified in clause 6.1.6.3 of [10] when the configuration of the location of the switching period by *uplinkTxSwitchingPeriodLocation* is ignored by the UE:

- if an uplink switching is triggered for an uplink transmission starting at  $T_0$  based on higher layer configuration(s) or DCI(s) received before  $T_0 - T_{offset}$  as specified in [10] and the UE is not configured or scheduled with uplink transmissions for a duration of at least the uplink switching gap indicated by *uplinkTxSwitchingPeriod2T2T* on any of the carriers before  $T_0$ , transient periods of  $10 \mu\text{s}$  are located at the end of the last symbol(s) configured or scheduled on the carriers before  $T_0$  and at the start of the first symbol(s) configured or scheduled at  $T_0$  on the switched-to carrier.

The requirements apply for the case of co-located and synchronized network deployment for the two uplink carriers.

The requirements apply for the case of single TAG for the two uplink carriers, i.e., the same uplink timing for the two carriers as described in clause 4.2 of TS 38.213 [8].

### 6.3C.3.3 Time mask for switching between one uplink band with one transmit antenna connector and one uplink band with two transmit antenna connectors

The switching time mask specified in this clause is applicable for an uplink band pair of a SUL configuration when the capability *uplinkTxSwitchingPeriod* is present, is only applicable for uplink switching mechanisms specified in clause 6.1.6 of TS 38.214 [10], where NR SUL carrier 1 in band A is capable of one transmit antenna connector and NR UL carrier 2 and carrier 3 in band B are capable of two transmit antenna connectors. NR UL carrier 2 and carrier 3 are two contiguous aggregated carriers, and band A and band B are different bands with different carrier frequencies. The UE shall support the switch between single layer transmission with one antenna port and two-layer transmission with two antenna ports on the two uplink bands following the scheduling commands and rank adaptation, i.e., both single layer and two-layer transmission with 2 antenna ports, and single layer transmission with 1 antenna port shall be supported on NR UL carrier 2 and carrier 3 in band B.

The switching periods described in Figure 6.3C.3.3-1a and Figure 6.3C.3.3-1b are located in either NR band A or band B as indicated in RRC signalling *uplinkTxSwitchingPeriodLocation* [7], and the length of uplink switching period  $X$  is less than the value indicated by UE capability *uplinkTxSwitchingPeriod*.

When switching from one carrier to another, if there is no uplink transmission scheduled or configured on the switch-from carrier for at least the duration of the switching period ( $X \mu\text{s}$ ) before the point in time the UE is scheduled or configured to start the transmission on the switch-to carrier, the switching period is fully contained in the time period between the end of the transmission on the switch-from carrier and the start of the transmission on the switch-to carrier. In addition, the RRC signalling *uplinkTxSwitchingPeriodLocation* is ignored by the UE and does not take effect in this case.

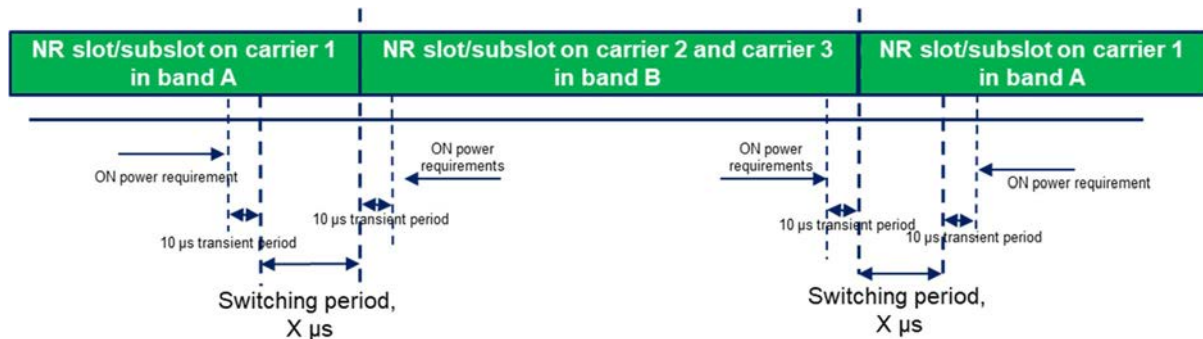

Figure 6.3C.3.3-1a: Time mask for switching between one carrier in band A and two contiguous carriers in band B, where the switching period is located in band A

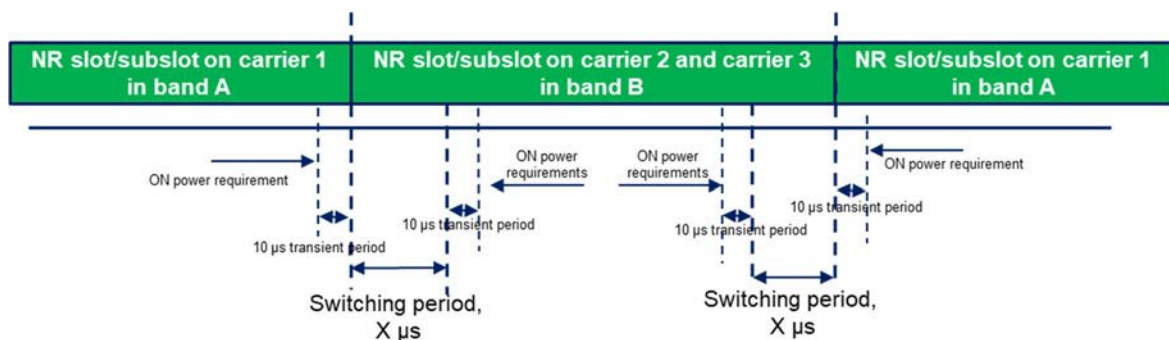

Figure 6.3C.3.3-1b: Time mask for switching between one carrier in band A and two contiguous carriers in band B, where the switching period is located in band B

The following applies for the uplink switching case specified in clause 6.1.6.3 of [10] when the configuration of the location of the switching period by *uplinkTxSwitchingPeriodLocation* is ignored by the UE:

- if an uplink switching is triggered for an uplink transmission starting at  $T_0$  based on higher layer configuration(s) or DCI(s) received before  $T_0 - T_{offset}$  as specified in [10] and the UE is not configured or scheduled with uplink transmissions for a duration of at least the uplink switching gap indicated by *uplinkTxSwitchingPeriod* on any of the carriers before  $T_0$ , transient periods of  $10 \mu\text{s}$  are located at the end of the last symbol(s) configured or scheduled on the carriers before  $T_0$  and at the start of the first symbol(s) configured or scheduled at  $T_0$  on the switched-to carrier.

The requirements apply for the case of co-located and synchronized network deployment for the three uplink carriers.

The requirements apply for the case of single TAG for the three uplink carriers, i.e., the same uplink timing for the three carriers as described in clause 4.2 of TS 38.213 [8].

#### 6.3C.3.4 Time mask for switching between two uplink bands with two transmit antenna connectors

The switching time mask specified in this clause is applicable for an uplink band pair of a SUL configuration when the capability *uplinkTxSwitchingPeriod2T2T* is present, is only applicable for uplink switching mechanisms specified in clause 6.1.6 of TS 38.214 [10], where NR SUL carrier 1 in band A is capable of two transmit antenna connectors and NR UL carrier 2 and carrier 3 in band B are capable of two transmit antenna connectors. NR UL carrier 2 and carrier 3 are two contiguous aggregated carriers, and band A and band B are different bands with different carrier frequencies. The UE shall support the switch between two-layer transmission with two antenna ports and two-layer



transmission with two antenna ports on the two uplink bands following the scheduling commands and rank adaptation, i.e., both single layer and two-layer transmission with 2 antenna ports, and single layer transmission with 1 antenna port shall be supported on NR UL carrier 1, carrier 2 and carrier 3 in the two bands.

The switching periods described in Figure 6.3C.3.4-1a and Figure 6.3C.3.4-1b are located in either NR band A or band B as indicated in RRC signalling *uplinkTxSwitchingPeriodLocation* [7], and the length of uplink switching period  $X$  is less than the value indicated by UE capability *uplinkTxSwitchingPeriod2T2T*.

When switching from one carrier to another, if there is no uplink transmission scheduled or configured on the switch-from carrier for at least the duration of the switching period ( $X \mu\text{s}$ ) before the point in time the UE is scheduled or configured to start the transmission on the switch-to carrier, the switching period is fully contained in the time period between the end of the transmission on the switch-from carrier and the start of the transmission on the switch-to carrier. In addition, the RRC signalling *uplinkTxSwitchingPeriodLocation* is ignored by the UE and does not take effect in this case.

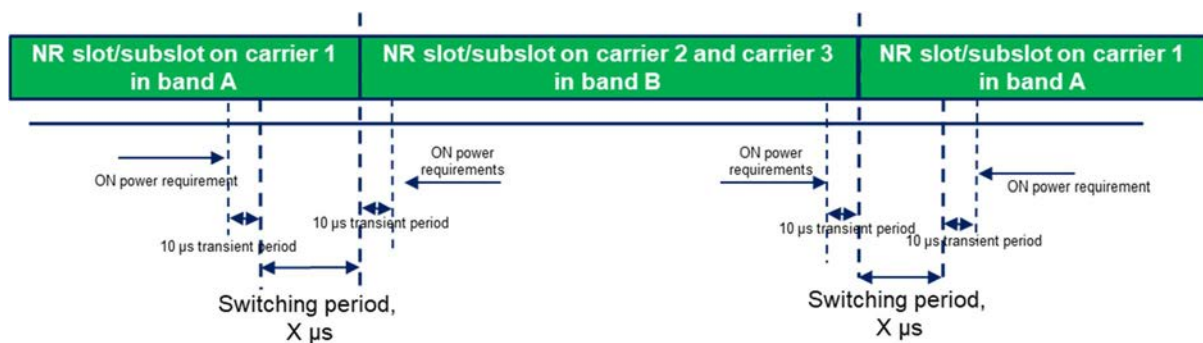

Figure 6.3C.3.4-1a: Time mask for switching between one carrier in band A and two contiguous carriers in band B, where the switching period is located in band A

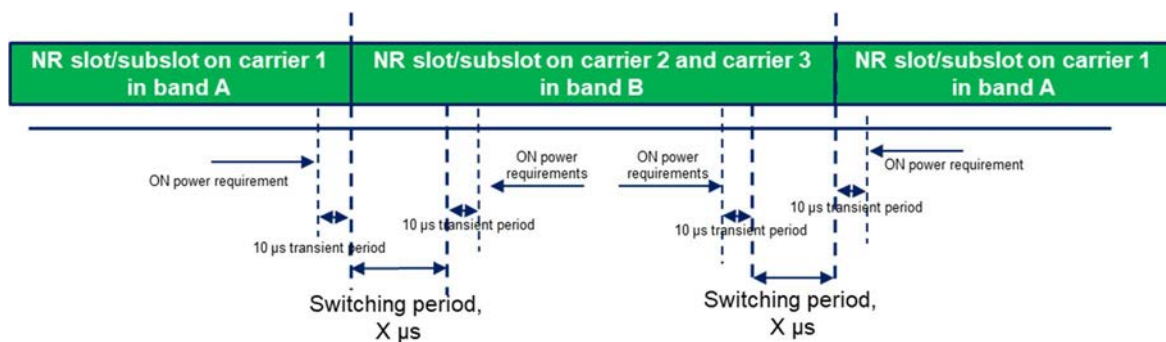

Figure 6.3C.3.4-1b: Time mask for switching between one carrier in band A and two contiguous carriers in band B, where the switching period is located in band B

The following applies for the uplink switching case specified in clause 6.1.6.3 of [10] when the configuration of the location of the switching period by *uplinkTxSwitchingPeriodLocation* is ignored by the UE:

- if an uplink switching is triggered for an uplink transmission starting at  $T_0$  based on higher layer configuration(s) or DCI(s) received before  $T_0 - T_{offset}$  as specified in [10] and the UE is not configured or scheduled with uplink transmissions for a duration of at least the uplink switching gap indicated by *uplinkTxSwitchingPeriod2T2T* on any of the carriers before  $T_0$ , transient periods of  $10 \mu\text{s}$  are located at the end of the last symbol(s) configured or scheduled on the carriers before  $T_0$  and at the start of the first symbol(s) configured or scheduled at  $T_0$  on the switched-to carrier.

The requirements apply for the case of co-located and synchronized network deployment for the three uplink carriers.

The requirements apply for the case of single TAG for the three uplink carriers, i.e., the same uplink timing for the three carriers as described in clause 4.2 of TS 38.213 [8].

### 6.3C.3.5 Time mask for switching across up to four uplink bands

The switching time mask requirements specified in this sub-clause are applicable for an NR SUL band configuration with inter-band CA when the capability *supportedBandPairListNR-r18* is present, and are only applicable for uplink switching mechanisms specified in clause [6.1.6] of TS 38.214 [10].

In the NR SUL band configuration with inter-band CA, the number of uplink bands with different carrier frequencies is up to four. NR UL carrier(s) in each of the up to four uplink bands are capable of one or two transmit antenna connector(s), according to the UE capability *FeatureSetUplinkPerCC*.

The switching time masks in Figure 6.3C.3.5-1 and Figure 6.3C.3.5-2 are applicable to each of the uplink band pairs in the SUL band configuration with inter-band CA, and are applicable to uplink transmissions when configured with *switchedUL* or *dualUL* by the parameter *switchingOptionConfigForBandPair*. To simplify the figures, the two bands in different band pairs are denoted as NR band X and band Y. The uplink transmission on either band X or band Y is with one or two transmit antenna connector(s),

- if NR UL carriers in both bands in one band pair are capable of one transmit antenna connector, 1Tx-1Tx switching is supported for the band pair;
- if NR UL carrier(s) in one band of one band pair is capable of one transmit antenna connector, and NR UL carrier(s) in the other band of the band pair is capable of two transmit antenna connectors, 1Tx-2Tx switching is supported for the band pair;
- if NR UL carriers in both bands of one band pair are capable of two transmit antenna connectors, 2Tx-2Tx switching is supported for the band pair.

For each band pair, the switching periods described in Figure 6.3C.3.5-1 and Figure 6.3C.3.5-2 are located in either NR band X or band Y as indicated in RRC signalling *uplinkTxSwitchingBandList* [7]. For each band pair, the length of uplink switching period *X* is indicated by RRC signalling *switchingPeriodConfigForBandPair* [7]. UE shall be capable to transmit until the beginning of the switching period and after the end of switching period with the exception of transient periods.

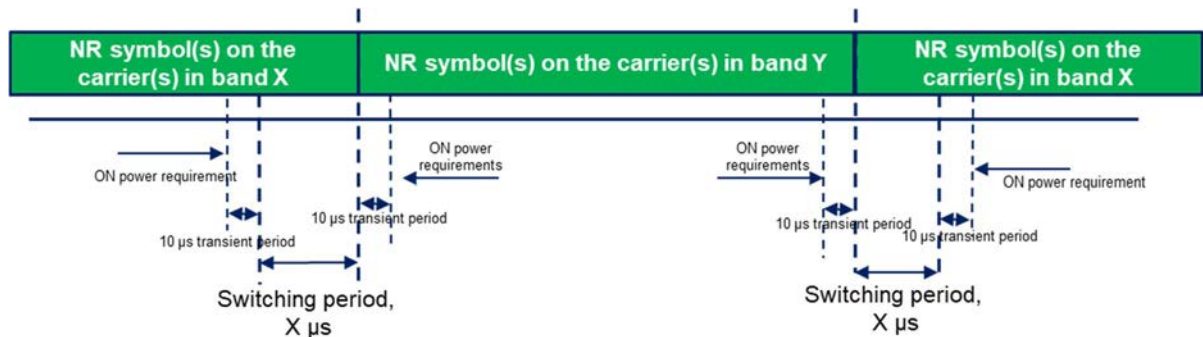

Figure 6.3C.3.5-1: Time mask for switching between band X and band Y, where the switching period is located in band X

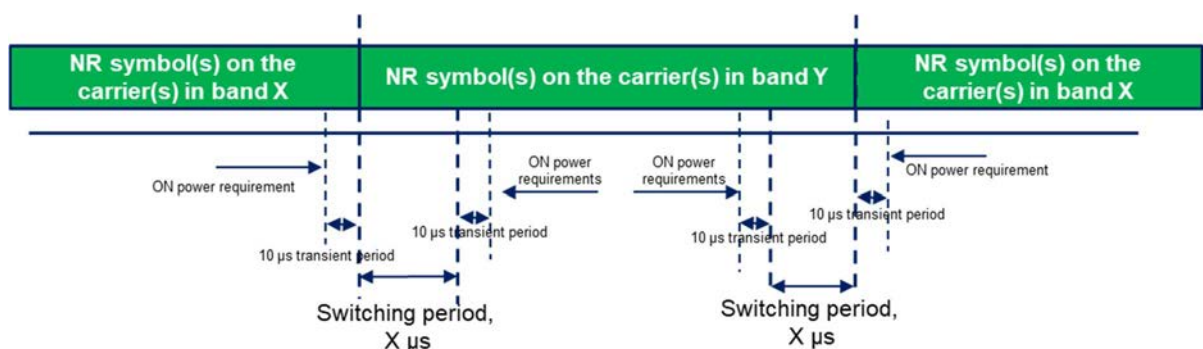

Figure 6.3C.3.5-2: Time mask for switching between band X and band Y, where the switching period is located in band Y



The following applies for the uplink switching cases specified in Figure 6.3C.3.5-1 and 6.3C.3.5-2 in a band pair with *switchingOptionConfigForBandPair* set to either *switchedUL* or *dualUL*:

- if an uplink switching is triggered for an uplink transmission starting at  $T_0$  based on higher layer configuration(s) or DCI(s) received before  $T_0 - T_{offset}$  as specified in [10] and the UE is not configured or scheduled with uplink transmissions for a duration of at least the length of uplink switching period of  $X \mu s$  indicated by RRC signalling *switchingPeriodConfigForBandPair* on any of the carriers band X and band Y before  $T_0$ ,
- the configuration of the location of the switching period by [*uplinkTxSwitchingBandList-r18*] is ignored by the UE;
- transient periods of  $10 \mu s$  are located at the end of the last symbol(s) configured or scheduled on the carrier(s) before  $T_0$  and at the start of the first symbol(s) configured or scheduled at  $T_0$  on the switch-to carrier(s).

In addition to the requirements in Figure 6.3C.3.5-1 and Figure 6.3C.3.5-2, the requirements in Figure 6.3C.3.5-3 to 6.3C.3.5-5 are applicable when *dualUL* are supported on certain band pair(s) in the SUL band configuration with inter-band CA.

The switching time masks in Figure 6.3C.3.5-3 and Figure 6.3C.3.5-4 are applicable when *dualUL* is supported for at least two uplink band pairs in the band configuration. The two band pairs supporting *dualUL* are denoted as band pairs of {band X and band Z} and {band Y and band Z}. When one transmitter is switched between band X and band Y,

- As baseline UE behaviour, the UE is not required to transmit on any of the three bands during time period T1 located on band X and band Z, where T1 is the length of switching period for the band pair of band X and band Y, as shown in Figure 6.3C.3.5-4.
- As optional UE behaviours, when the UE indicates band Z in the capability *bandIndexUnaffected*,
- if the UE indicates *maintainedUL-Trans* for band pair of {band X and band Y}, UE shall be capable of uplink transmission on band Z during the switching period that is located on band X, and UE is not required to transmit on band X and Y during time period T1 located on band X, where T1 is the length of switching period for the band pair of band X and band Y, as shown in Figure 6.3C.3.5-3;
- otherwise, the UE is not required to transmit on any of the three bands during the switching period indicated by UE capability *periodOnULBands* [located on band X and band Z, as shown in Figure 6.3C.3.5-4.

In Figure 6.3C.3.5-3 and Figure 6.3C.3.5-4, the uplink transmission on band X, band Y and band Z are all with one transmit antenna connector and one antenna port.

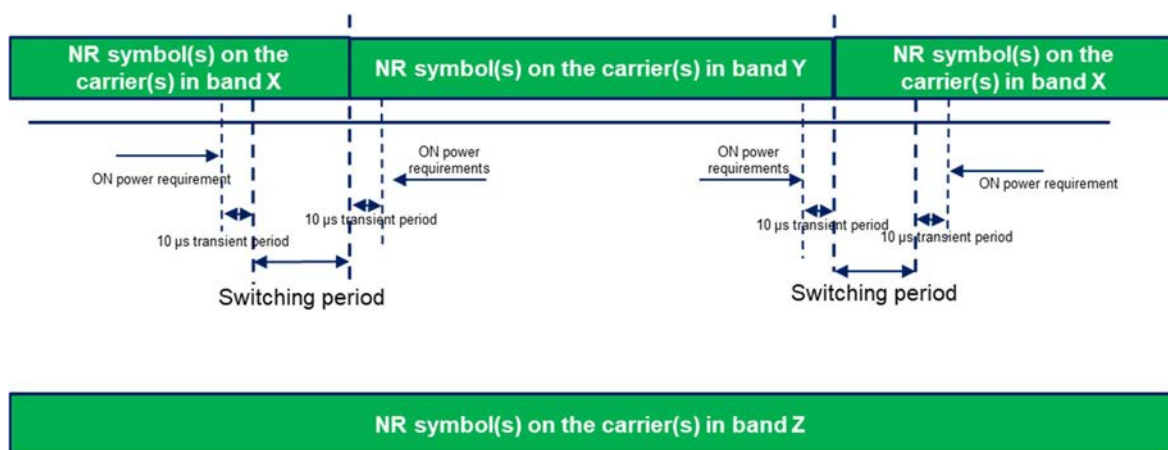

**Figure 6.3C.3.5-3: Time mask for one transmitter switching between band X and band Y, and UE is capable of uplink transmission on band Z during the switching period**

The following applies for the uplink switching cases specified in Figure 6.3C.3.5-3 in a band pair with *switchingOptionConfigForBandPair* set to *dualUL*:

- if an uplink switching is triggered for an uplink transmission starting at  $T_0$  based on higher layer configuration(s) or DCI(s) received before  $T_0 - T_{offset}$  as specified in [10] and the UE is not configured or scheduled with uplink

transmissions for a duration of at least the length of uplink switching periods indicated by RRC signalling *switchingPeriodConfigForBandPair* on any of the carriers in band X and band Y before  $T_0$ ,

- the configuration of the location of the switching period by *uplinkTxSwitchingBandList* is ignored by the UE;
- transient periods of 10  $\mu$ s are located at the end of the last symbol(s) configured or scheduled on the carrier(s) before  $T_0$  and at the start of the first symbol(s) configured or scheduled at  $T_0$  on the switch-to carrier(s).

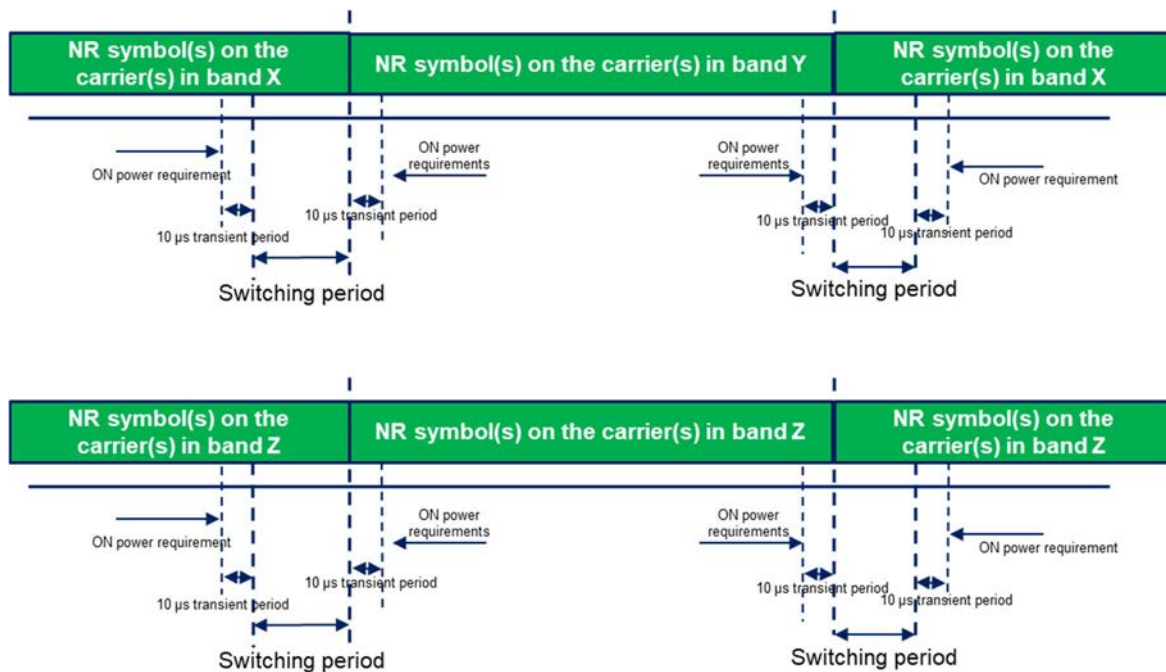
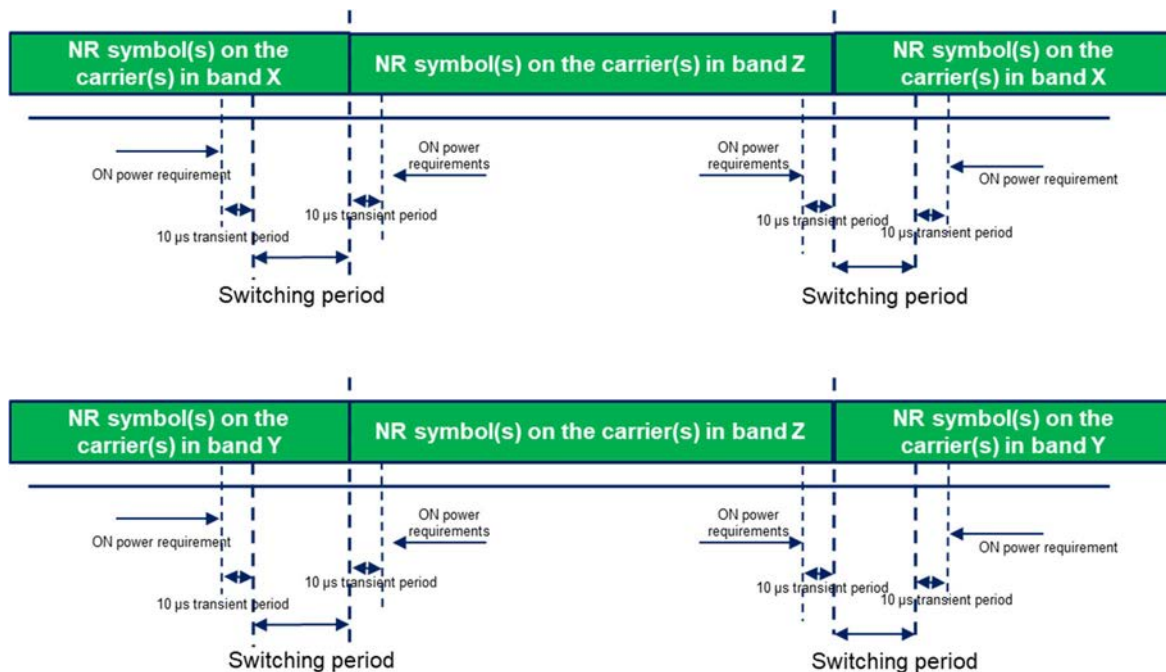

**Figure 6.3C.3.5-4: Time mask for one transmitter switching between band X and band Y, and UE is not capable of uplink transmission on band Z during the switching period**

The switching time mask in Figure 6.3C.3.5-5 is applicable when *dualUL* is supported for at least one uplink band pair including band X and band Y, and two transmit antenna connectors are supported on at least one uplink band of band Z. When one transmitter is switched between band X and band Z, and across the same time, the other transmitter is switched between Y and band Z, the switching time mask in Figure 6.3C.3.5-5 is applicable.

- As baseline UE behaviour, UE is not required to transmit on any of the three bands during time period with the larger one of switching period  $T_2$  and  $T_3$ , where  $T_2$  is the length of switching period for the band pair of band X and band Z, and  $T_3$  is the length of switching period for the band pair of band Y and band Z.
- As optional UE behaviour when UE additionally reports band pair of {band X and band Y} and band Z in the capability *uplinkTxSwitchingAdditionalPeriodDualUL-List*, UE is not required to transmit on any of the three bands during time period indicated by UE capability *switchingAdditionalPeriodDualUL*.

In Figure 6.3C.3.5-5, the uplink transmission on band X and band Y is with one transmit antenna connector and one antenna port, and the uplink transmission on band Z is with two transmit antenna connectors and two antenna ports. The switching period location is configured according to [7], and band Z is with the highest priority according to the RRC configuration *uplinkTxSwitchingBandList*.



**Figure 6.3C.3.5-5: Time mask for one transmitter switching between band X and band Z, and one transmitter switching between band Y and band Z**

The following applies for the uplink switching case specified in Figure 6.3C.3.5-5 and with *uplinkTxSwitchingOptionForBandPair* set to *dualUL* for at least one band pair

- if uplink switching on a band pair is triggered for an uplink transmission starting at  $T_0$  based on higher layer configuration(s) or DCI(s) received before  $T_0 - T_{offset}$  as specified in [10] and the UE is not configured or scheduled with uplink transmissions for a duration of at least the maximum of the lengths of uplink switching periods indicated by RRC signalling *switchingPeriodConfigForBandPair* on any of the carriers in band X, band Y and band Z before  $T_0$  on any switched-to carrier
- the configuration of the location of the switching period and the priority of bands in the *uplinkTxSwitchingBandList* are ignored by the UE
- transient periods of 10 μs are located at the end of the last symbol(s) configured or scheduled on the switched-from carrier(s) before  $T_0$  on any switched-to and at the start of the first symbol(s) configured or scheduled at  $T_0$  on the switch-to carrier(s)

The requirements in this sub-clause apply for the case of synchronized network deployment for the uplink bands.

### 6.3C.3.5a Additional requirements for three-band switching with dual TAG

The following applies for the uplink switching case specified in Figure 6.3C.3.5-5 with three bands involved in the switching and with *uplinkTxSwitchingOptionForBandPair-r18* set to *dualUL* for at least one band pair.

If the UE is configured with dual TAG and not configured or scheduled with uplink transmissions for a duration of at least the maximum of the lengths of uplink switching periods indicated by UE capability [*uplinkTxSwitchingPeriodForBandPair-r18*] on any of the carriers in band X, band Y and band Z including any timing difference between the uplink carriers before the first  $T_0$  on any switched-to carrier,

- the configuration of the location of the switching period and the priority of bands in the *uplinkTxSwitchingBandList* are ignored by the UE
- transient periods of 10 μs are located at the end of the last symbol(s) configured or scheduled on the switched-from carrier(s) before the first  $T_0$  on any switched-to carrier and at the start of the first symbol(s) configured or scheduled at  $T_0$  on the switch-to carrier(s)

## 6.3D Output power dynamics for UL MIMO

### 6.3D.1 Minimum output power for UL MIMO

For UE with two or four transmit antenna connectors in closed-loop spatial multiplexing scheme, the minimum output power is defined as the sum of the mean power from all transmit connectors in one sub-frame (1 ms). The minimum output power shall not exceed the values specified in Table 6.3.1-1.

If UE is scheduled for single antenna-port PUSCH transmission by DCI format 0\_0 or by DCI format 0\_1 for single antenna port codebook based transmission with precoding matrix  $W=1$  [6.3.1.5 TS 38.211], the requirements in clause 6.3.1 apply when  $TxD$  is not indicated, and the requirements in clause 6.3G.1 apply when  $TxD$  is indicated.

### 6.3D.2 Transmit OFF power for UL MIMO

The transmit OFF power is defined as the mean power at each transmit antenna connector in a duration of at least one sub-frame (1 ms) excluding any transient periods.

The transmit OFF power at each transmit antenna connector shall not exceed the values specified in Table 6.3.2-1.

### 6.3D.3 Transmit ON/OFF time mask for UL MIMO

For UE supporting UL MIMO, the ON/OFF time mask requirements in clause 6.3.3 apply at each transmit antenna connector.

For UE with two or four transmit antenna connectors in closed-loop spatial multiplexing scheme, the general ON/OFF time mask requirements specified in clause 6.3.3.1 apply to each transmit antenna connector. The requirements shall be met with the UL MIMO configurations described in clause 6.2D.1.

If UE is scheduled for single antenna-port PUSCH transmission by DCI format 0\_0 or by DCI format 0\_1 for single antenna port codebook based transmission with precoding matrix  $W=1$  [6.3.1.5 TS 38.211], the requirements in clause 6.3.3 apply when  $TxD$  is not indicated, and the requirements in clause 6.3G.3 apply when  $TxD$  is indicated.

### 6.3D.4 Power control for UL MIMO

For UE supporting UL MIMO, the power control tolerance applies to the sum of output powers from all transmit antenna connectors.

The power control requirements specified in clause 6.3.4 apply to UE with all transmit antenna connectors in closed-loop spatial multiplexing scheme. The requirements shall be met with UL MIMO configurations described in clause 6.2D.1.

If UE is scheduled for single antenna-port PUSCH transmission by DCI format 0\_0 or by DCI format 0\_1 for single antenna port codebook based transmission with precoding matrix  $W=1$  [6.3.1.5 TS 38.211], the requirements in clause 6.3.4 apply when  $TxD$  is not indicated, and the requirements in clause 6.3G.4 apply when  $TxD$  is indicated.

## 6.3E Output power dynamics for V2X

### 6.3E.1 Minimum output power for V2X

#### 6.3E.1.1 General

When UE is configured for NR V2X sidelink transmissions non-concurrent with NR uplink transmissions for NR V2X operating bands in Table 5.2E.1-1, the minimum output power is specified in Table 6.3E.1.1-1. The minimum output power is defined as the mean power in at least one sub-frame 1 ms.

**Table 6.3E.1.1-1: Minimum output power**

Channel bandwidth (MHz)	Minimum output power (dBm)	Measurement bandwidth (MHz)
5 <sup>1</sup>	-30	4.515
10	-30	9.375
20	-30	19.095
30	-28.2	28.815
40	-27	38.895
Note 1: The CBW is only applicable to PS UE in n14.		

For NR V2X UE with two transmit antenna connectors, the minimum output power is defined as the sum of the mean power at each transmit connector in one sub-frame (1 ms). The minimum output power shall not exceed the values specified for single carrier.

If the UE transmits on one antenna connector at a time, the requirements specified for single carrier shall apply to the active antenna connector.

#### 6.3E.1.1A Minimum output power for sidelink CA

For SL intra-band contiguous CA, the minimum output power requirement as specified in Table 6.3E.1.1A -1 shall be applied per component carrier.

**Table 6.3E.1.1A -1: Minimum output power**

Channel bandwidth (MHz)	Minimum output power (dBm)	Measurement bandwidth (MHz)
10	-30	$MBW = \frac{REF\_SCS * (12 * N_{RB} + 1)}{100}$ 0
20	-30	
30	-28.2	
40	-27	

#### 6.3E.1.2 Minimum output power for V2X concurrent operation

For the inter-band concurrent NR V2X operation, the requirements specified in clause 6.3.1 shall apply for the uplink in licensed band and the requirements specified in clause 6.3E.1.1 shall apply for the sidelink in licensed band or Band n47.

For intra-band concurrent NR V2X operation, the minimum output power is defined per carrier and the requirement for NR uplink is specified in clause 6.3.1 and the requirement for NR sidelink is specified in clause 6.3E.1, respectively.

#### 6.3E.1F Minimum output power for Sidelink Unlicensed

The requirements for minimum output power in clause 6.3.1 apply.

### 6.3E.1F.1 Minimum output power for SL-U concurrent operation

For NR SL-U inter-band concurrent operation, the requirements specified in clause 6.3.1 shall apply for NR Uu operation in licensed band and the requirements specified in clause 6.3E.1F shall apply for NR sidelink operation in unlicensed band.

## 6.3E.2 Transmit OFF power for V2X

### 6.3E.2.1 General

When UE is configured for NR V2X sidelink transmissions non-concurrent with NR uplink transmissions for NR V2X operating bands in Table 5.2E.1-1, the requirements specified in current clause apply.

**Table 6.3E.2.1-1: Transmit OFF power**

Channel bandwidth (MHz)	Transmit OFF power (dBm)	Measurement bandwidth (MHz)
5 <sup>1</sup>	-50	4.515
10	-50	9.375
20	-50	19.095
30	-50	28.815
40	-50	38.895

Note 1: The CBW is only applicable to PS UE in n14.

For NR V2X UE supporting SL MIMO or Tx Diversity, the transmit OFF power at each transmit antenna connector shall not exceed the values specified in Table 6.3E.2.1-1 for single carrier. Transmit off power is defined as the mean power in at least one sub-frame 1 ms.

### 6.3E.2.1A Transmit OFF power for sidelink CA

For SL intra-band contiguous CA, the transmit OFF power requirement as specified in Table 6.3E.2.1A -1 shall be applied per component carrier.

**Table 6.3E.2.1A -1: Transmit OFF power**

Channel bandwidth (MHz)	Transmit OFF power (dBm)	Measurement bandwidth (MHz)
10	-50	$MBW = \frac{REF\_SCS * (12 * N_{RB} + 1)}{100}$ 0
20	-50	
30	-50	
40	-50	

### 6.3E.2.2 Transmit OFF power for V2X concurrent operation

For the inter-band concurrent NR V2X operation, the requirements specified in clause 6.3.2 shall apply for the uplink in licensed band and the requirements specified in clause 6.3E.2.1 shall apply for the sidelink in licensed band or Band n47.

For intra-band concurrent NR V2X operation, the transmit OFF power requirement is defined per carrier and the requirement for NR uplink is specified in clause 6.3.2 and the requirement for NR sidelink is specified in clause 6.3E.2, respectively.

### 6.3E.2F Transmit OFF power for Sidelink Unlicensed

The requirements for Transmit OFF power in clause 6.3.2 apply for SL-U operation.

### 6.3E.2F.1 Transmit OFF power for SL-U concurrent operation

For NR SL-U inter-band concurrent operation, the requirements specified in TS 38.101-1 clause 6.3.2 shall apply for NR Uu operation in licensed band and the requirements specified in clause 6.3E.2F shall apply for NR sidelink operation in unlicensed band.

## 6.3E.3 Transmit ON/OFF time mask for V2X

### 6.3E.3.1 General

For NR V2X UE, additional requirements on ON/OFF time masks for V2X physical channels and signals are specified in this clause.

#### 6.3E.3.1A Transmit ON/OFF time mask for sidelink CA

For SL intra-band contiguous CA, the SL ON/OFF time masks specified in clause 6.3E.3.2, 6.3E.3.3 and 6.3E.3.4 are applicable to each component carrier during the ON power period and the transient periods. The OFF period shall only be applicable to each component carrier when all the component carriers are OFF.

### 6.3E.3.2 General time mask

The General ON/OFF time mask defines the observation period between the Transmit OFF and ON power and between Transmit ON and OFF power for PSCCH, and PSSCH transmissions in a slot wherein the last symbol is punctured to create a guard period.

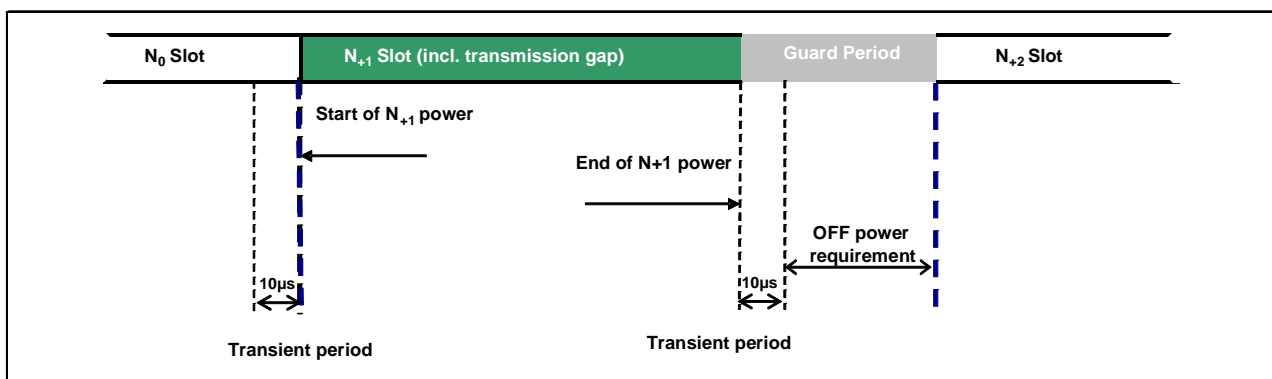

**Figure 6.3E.3.2-1: General PSCCH/PSSCH time mask for NR V2X UE**

For NR V2X UE supporting SL MIMO or Tx Diversity, the ON/OFF time mask requirements apply at each transmit antenna connector.

For UE with two transmit antenna connectors, the general ON/OFF time mask requirements specified in current subclause apply to each transmit antenna connector. The requirements shall be met with the SL MIMO configurations described in subclause 6.2D.1.

If the UE transmits on one antenna connector at a time, the general ON/OFF time mask requirements apply to the active antenna connector.

### 6.3E.3.3 S-SSB time mask

The S-PSS/S-SSS/PSBCH time mask for NR V2X UE defines the observation period between transmit OFF and ON S-PSS power and between transmit ON PSBCH and OFF power in a slot wherein the last symbol is punctured to create a guard period.



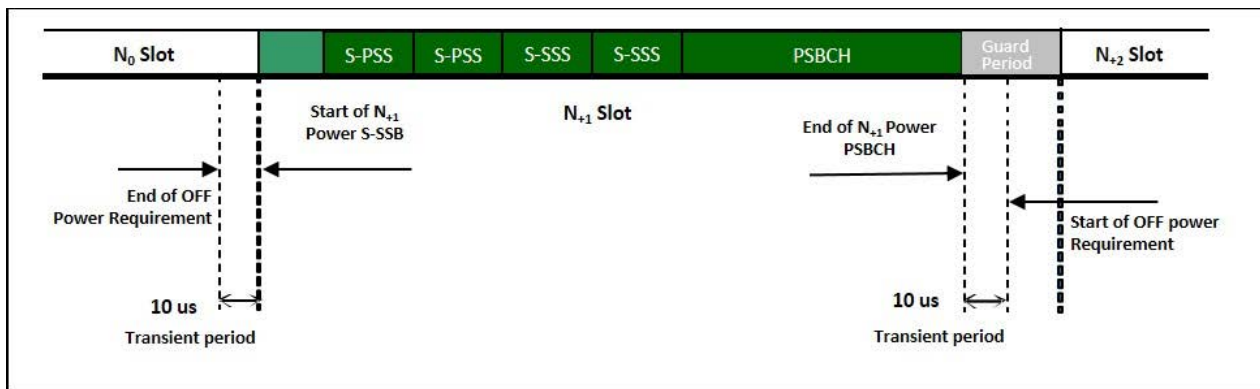

Figure 6.3E.3.3-1: S-SSB time mask for NR V2X UE

For NR V2X UE supporting SL MIMO or Tx Diversity, the ON/OFF time mask requirements apply at each transmit antenna connector.

For UE with two transmit antenna connectors, the S-SSB ON/OFF time mask requirements specified in current subclause apply to each transmit antenna connector. The requirements shall be met with the SL MIMO configurations described in subclause 6.2D.1.

If the UE transmits on one antenna connector at a time, the S-SSB ON/OFF time mask requirements apply to the active antenna connector.

### 6.3E.3.4 Transmit ON/OFF time mask for V2X concurrent operation

For the inter-band concurrent NR V2X operation, the requirements specified in clause 6.3.3 shall apply for the uplink in licensed band and the requirements specified in clause 6.3E.3.2 and 6.3E.3.3 shall apply for the sidelink in licensed band or Band n47.

For intra-band V2X concurrent operation band specified in subclause 5.2.E.2, the general output power ON/OFF time mask is defined per carrier during the ON power period and the transient periods. The ON/OFF time mask specified in clause 6.3.3.1 is applicable for NR uplink and the ON/OFF time mask in 6.3E.3.1 is applicable for NR sidelink. The OFF period as specified in clause 6.3.3.1 shall only be applicable for each component carrier when all the component carriers are OFF.

For the TDM operation in same carrier with same bandwidth, the switching time mask in Figure 6.3E.3.4-1 shall be applied.

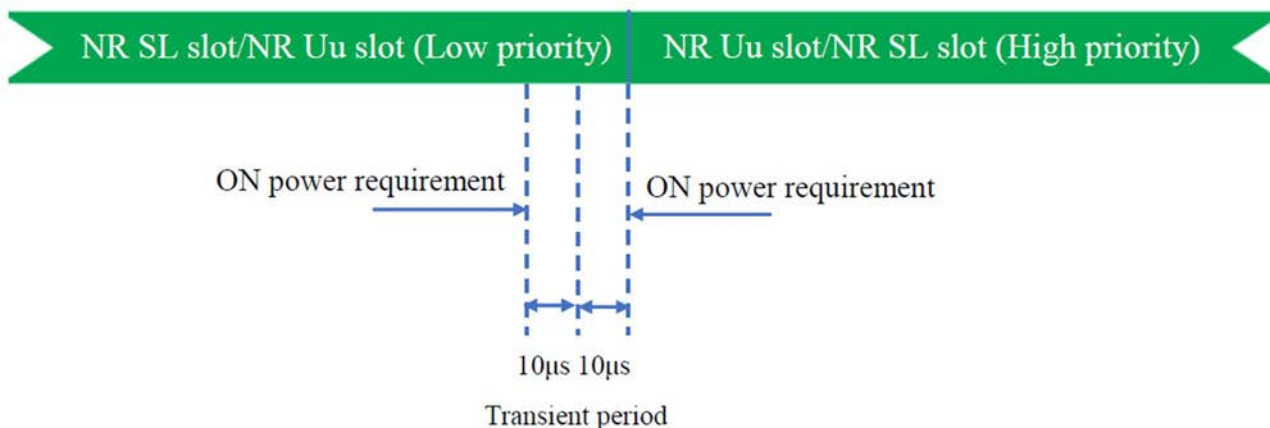

Figure 6.3E.3.4-1: Time mask for switching between Uu and SL for same carrier case with same bandwidth

For intra-band V2X concurrent operation band specified in subclause 5.3.E.2, the switching time mask in Figure 6.3E.3.4-2 shall apply for the different carrier case. The switching time shall be located on the RAT of low priority when NR Uu and NR SL have different priorities based on priority information specified in TS 38.321 and TS38.213. It



is up to UE implementation when NR Uu and NR SL have the same priority based on priority information specified in TS 38.213.

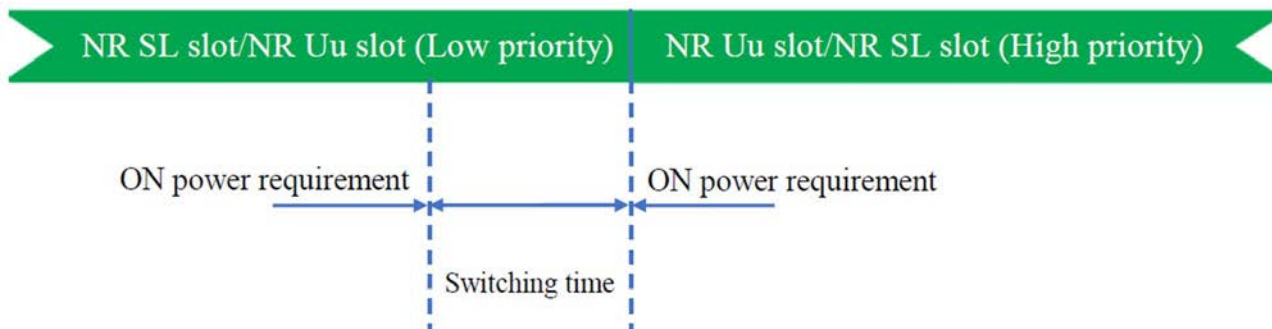

Figure 6.3E.3.4-2: Time mask for switching between Uu and SL for different carrier case

In the real field, there is a timing advance difference, i.e.  $N_{TA} \cdot T_c$  between NR Uu slot and NR SL slot due to different timing advance of NR Uu and NR SL. The switching time masks do not include timing advance difference but the timing advance difference should be considered with the switching time for same carrier case and different carrier case.

### 6.3E.3F Transmit ON/OFF time mask for Sidelink Unlicensed

#### 6.3E.3F.1 General

The transmit power time mask defines the transient period(s) allowed between transmit OFF power as defined in clause 6.3E.2F and transmit ON power symbols (transmit ON/OFF). The transmit power ON/OFF time mask specified in clause 6.3E.3F.2 supercedes the ON/OFF masks specified in clause 6.3.3; however, between continuous ON-power transmissions the requirements in clause 6.3.3 apply. Unless otherwise stated the requirements in clause 6.5F apply also in transient periods.

#### 6.3E.3F.2 General ON/OFF time mask

The general ON/OFF time mask defines the observation period between transmit OFF and ON power and between transmit ON and OFF power for each SCS as illustrated below in Figure 6.3E.3F.2-1. ON/OFF scenarios include: contiguous, and non-contiguous transmission, etc.

The OFF power measurement period is defined in a duration of at least one slot excluding any transient periods. The ON power is defined as the mean power over the duration of at least one slot excluding any transient period and non-transmitted symbols. The leading transient period starts 5us before the beginning of the first symbol of transmission and extends 10us into the transmission including the CP extension if applicable. The last symbol is punctured to create a guard period where the trailing transient period of 10us is located inside.

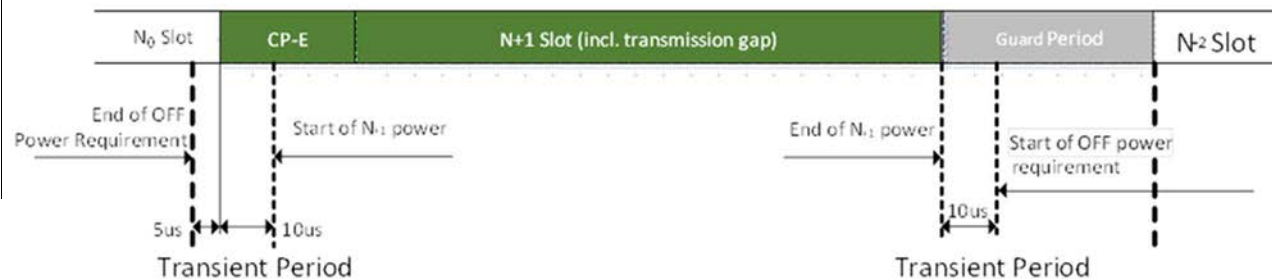

Figure 6.3E.3F-1 General ON/OFF time mask for SL-U PSSCH and PSCCH

### 6.3E.3F.3 S-SSB time mask

The S-PSS/S-SSS/PSBCH time mask for NR Sidelink Unlicensed UE defines the observation period between transmit OFF and ON S-PSS power and between transmit ON PSBCH and OFF power in a slot wherein the last symbol is punctured to create a guard period. The leading transient period starts 5 $\mu$ s before the beginning of the first symbol of transmission and extends 10 $\mu$ s into the transmission including the CP extension if applicable. The last symbol is punctured to create a guard period where the trailing transient period of 10 $\mu$ s is located inside.



Figure 6.3E.3F-2 ON/OFF time mask for SL-U S-SSB

### 6.3E.3F.4 Transmit ON/OFF time mask for NR SL-U concurrent operation

For NR SL-U inter-band concurrent operation, the requirements specified in clause 6.3.3 shall apply for the uplink in licensed band and the requirements specified in clause 6.3E.3F.2 and 6.3E.3F.3 shall apply for NR sidelink operation in unlicensed band.

## 6.3E.4 Power control for V2X

### 6.3E.4.1 General

When UE is configured for NR V2X sidelink transmissions non-concurrent with NR uplink transmissions for NR V2X operating bands in Table 5.2E.1-1, the following requirements are applied for NR V2X sidelink transmission.

For NR V2X UE supporting SL MIMO or Tx Diversity, the power control tolerance for single carrier shall apply to the sum of output power at each transmit antenna connector.

If the UE transmits on one antenna connector at a time, the requirements for single carrier shall apply to the active antenna connector.

The relative slot power tolerance for V2X UE supporting co-channel coexistence with LTE SL is the ability of the NR V2X UE operating with 30kHz SCS to control the output power of transmitted slots during PSCCH/PSSCH transmission consisting of two slots overlapping with an LTE SL subframe (500 $\mu$ s). The reference slot is the 1st slot overlapping with LTE SL subframe and target slot is the subsequent NR SL slot overlapping with the LTE SL subframe. The measurement period for reference and target slot is one NR SL slot with guard symbol omitted. The power of the target slot must be the same or lower than the power of the reference slot using the tolerance equal to relaxation given for Table 6.2.4-1 values in 6.2E.4.1.

### 6.3E.4.1A Power control for sidelink CA

For SL intra-band contiguous CA, the power control requirement as specified in clause 6.3E.4.2 shall be applied per component carrier.

### 6.3E.4.2 Absolute power tolerance

The requirements in clause 6.3.4.2 shall apply for NR V2X transmission.

### 6.3E.4.3 Power control for V2X concurrent operation

For the inter-band concurrent NR V2X operation, the requirements specified in clause 6.3.4 shall apply for the uplink in licensed band and the requirements specified in clause 6.3E.4.1 and 6.3E.4.2 shall apply for the sidelink in licensed band or Band n47.

For the intra-band concurrent NR V2X operation, the requirements specified in clause 6.3.4 shall apply for the uplink in licensed band and the requirements specified in clause 6.3E.4 shall apply for the sidelink in licensed band.

## 6.3E.4F Power control for Sidelink Unlicensed

### 6.3E.4F.1 General

The requirements on power control accuracy apply under normal conditions.

### 6.3E.4F.2 Absolute power tolerance

The absolute power tolerance requirements of clause 6.3.4.2 apply at the start of a contiguous transmission or non-contiguous transmission with a transmission gap larger than 40 ms.

### 6.3E.4F.3 Power control for SL-U concurrent operation

For NR SL-U inter-band concurrent operation, the requirements specified in clause 6.3.4 shall apply for NR Uu operation in licensed band and the requirements specified in clause 6.3E.4F.1 and 6.3E.4F.2 shall apply for NR sidelink operation in unlicensed band.

## 6.3F Output power dynamics for shared spectrum channel access

### 6.3F.1 Minimum output power

The requirements for minimum output power in clause 6.3.1 apply.

### 6.3F.2 Transmit OFF power

The requirements for Transmit OFF power in clause 6.3.2 apply.

### 6.3F.3 Transmit ON/OFF time mask

#### 6.3F.3.1 General

The transmit power time mask defines the transient period(s) allowed between transmit OFF power as defined in clause 6.3F.2 and transmit ON power symbols (transmit ON/OFF). The transmit power ON/OFF time mask specified in clause 6.3F.3.2 supercedes the ON/OFF masks specified in clause 6.3.3; however, between continuous ON-power transmissions the requirements in clause 6.3.3 apply. Unless otherwise stated the requirements in clause 6.5F apply also in transient periods.

#### 6.3F.3.2 General ON/OFF time mask

The general ON/OFF time mask defines the observation period between transmit OFF and ON power and between transmit ON and OFF power for each SCS as illustrated below in Figure 6.3F.3.2-1. ON/OFF scenarios include: contiguous, and non-contiguous transmission, etc.

The OFF power measurement period is defined in a duration of at least one slot excluding any transient periods. The ON power is defined as the mean power over the duration of at least one slot excluding any transient period and non-

transmitted symbols. The leading transient period starts 5 $\mu$ s before the beginning of the first symbol of transmission and extends 10 $\mu$ s into the transmission including the CP extension if applicable. The trailing transient period starts 5 $\mu$ s before the end of transmission and extends 5 $\mu$ s beyond the end of transmission.

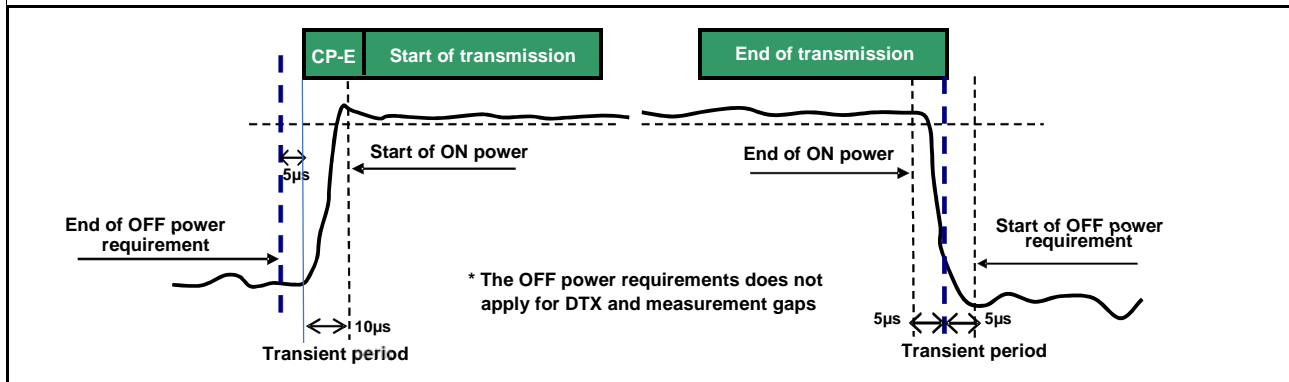

Figure 6.3F.3.2-1: General ON/OFF time mask for shared spectrum channel access

## 6.3F.3A General ON/OFF mask for CA

### 6.3F.3A.1 General ON/OFF mask for inter-band CA

For inter-band carrier aggregation with uplink assigned to two bands and including one of the bands listed in Table 6.2F.1-1, the general output power ON/OFF time mask specified in clause 6.3.3.1 is applicable for the NR uplink carrier while the general output power ON/OFF time mask specified in clause 6.3F.3 is applicable for the carrier operating with shared spectrum access. The OFF period as specified in clause 6.3.3.1 and clause 6.3F.3 shall only be applicable for each component carrier when all the component carriers are OFF.

## 6.3F.4 Power control

### 6.3F.4.1 General

The requirements on power control accuracy apply under normal conditions.

### 6.3F.4.2 Absolute power tolerance

The absolute power tolerance requirements of clause 6.3.4.2 apply at the start of a contiguous transmission or non-contiguous transmission with a transmission gap larger than 40 ms.

### 6.3F.4.3 Relative power tolerance

The relative power tolerance requirements of clause 6.3.4.3 apply if the transmission gap between the target sub-frame and the reference sub-frame is less than or equal to 40 ms.

### 6.3F.4.4 Aggregate power tolerance

The aggregate power tolerance requirements of clause 6.3.4.4 apply during non-contiguous transmissions within 41ms with respect to the first UE transmission.

## 6.3F.4A Power control for inter-band CA

No requirements unique to CA operation are defined.

## 6.3G Output power dynamics for Tx Diversity

### 6.3G.1 Minimum output power for Tx Diversity

For UE supporting Tx diversity, the minimum output power is defined as the sum of the mean power at each transmit connector in one sub-frame (1 ms). The minimum output power shall not exceed the values specified in Table 6.3.1-1.

### 6.3G.2 Transmit OFF power for Tx Diversity

For UE supporting Tx diversity, the transmit OFF power is defined as the mean power at each transmit antenna connector in a duration of at least one sub-frame (1 ms) excluding any transient periods.

The transmit OFF power at each transmit antenna connector shall not exceed the values specified in Table 6.3.2-1.

### 6.3G.3 Transmit ON/OFF time mask for Tx Diversity

For UE supporting Tx diversity, the ON/OFF time mask requirements in clause 6.3.3 apply at each transmit antenna connector.

### 6.3G.4 Power control for Tx Diversity

For UE supporting Tx diversity, the power control tolerance applies to the sum of output power at each transmit antenna connector.

The requirements specified in clause 6.3.4 apply.

## 6.3H Output power dynamics for CA with UL MIMO

### 6.3H.1 Output power dynamics for intra-band UL contiguous CA with UL MIMO

#### 6.3H.1.1 Minimum output power for intra-band UL contiguous CA with UL MIMO

For intra-band UL contiguous CA and UE with two transmit antenna connectors in closed-loop spatial multiplexing scheme, the minimum output power is defined as the sum of the mean power from both transmit connector in one sub-frame (1 ms) on each CC. The minimum output power shall not exceed the values specified in clause 6.3A.1.1.

If UE is scheduled for single antenna-port PUSCH transmission by DCI format 0\_0 or by DCI format 0\_1 for single antenna port codebook based transmission with precoding matrix  $W=1$  [6.3.1.5 TS 38.211], the requirements in clause 6.3A.1.1 apply.

#### 6.3H.1.2 Transmit OFF power for intra-band UL contiguous CA with UL MIMO

The transmit OFF power is defined as the mean power at each transmit antenna connector in a duration of at least one sub-frame (1 ms) excluding any transient periods.

The transmit OFF power at each transmit antenna connector on each CC shall not exceed the values specified in clause 6.3A.2.1.

#### 6.3H.1.3 Transmit ON/OFF time mask for intra-band UL contiguous CA with UL MIMO

For UE supporting intra-band UL contiguous CA and UL MIMO, the ON/OFF time mask requirements in clause 6.3A.3.1 apply at each transmit antenna connector on each CC. The requirements shall be met with the UL MIMO configurations described in Table 6.2D.1-2.

If UE is scheduled for single antenna-port PUSCH transmission by DCI format 0\_0 or by DCI format 0\_1 for single antenna port codebook based transmission with precoding matrix  $W=1$  [6.3.1.5 TS 38.211], the requirements in clause 6.3A.3.1 apply.

### 6.3H.1.4 Power control for intra-band UL contiguous CA with UL MIMO

For UE supporting intra-band UL contiguous CA and UL MIMO, the power control tolerance in clause 6.3A.4.1 applies to the sum of output powers from both transmit antenna connector on each CC. The requirements shall be met with UL MIMO configurations described in Table 6.2D.1-2.

If UE is scheduled for single antenna-port PUSCH transmission by DCI format 0\_0 or by DCI format 0\_1 for single antenna port codebook based transmission with precoding matrix  $W=1$  [6.3.1.5 TS 38.211], the requirements in clause 6.3A.4.1 apply.

## 6.3H.2 Void

### 6.3H.3 Output power dynamics for inter-band UL CA with UL MIMO

#### 6.3H.3.1 Minimum output power for inter-band UL CA with UL MIMO

For inter-band UL CA with UL MIMO in one of the two frequency bands, the minimum output power is defined per carrier. The requirement is specified in clause 6.3.1 for the carrier without UL MIMO and specified in clause 6.3D.1 for the carrier configured with UL MIMO.

#### 6.3H.3.2 Transmit OFF power for inter-band UL CA with UL MIMO

For inter-band UL CA with UL MIMO in one of the two frequency bands, the transmit OFF power specified in clause 6.3.2 is applicable for the carrier without UL MIMO and the transmit OFF power specified in clause 6.3D.2 is applicable for the carrier configured with UL MIMO when the transmitter is OFF on all component carriers. The transmitter is considered to be OFF when the UE is not allowed to transmit on any of its ports.

#### 6.3H.3.3 Transmit ON/OFF time mask for inter-band UL CA with UL MIMO

For inter-band UL CA with UL MIMO in one of the two frequency bands, the general output power ON/OFF time mask specified in clause 6.3.3.1 is applicable for the component carrier without UL MIMO during the ON power period and the transient periods, the ON/OFF time mask specified in clause 6.3D.3 is applicable for the component carrier configured with UL MIMO. The OFF period as specified in clause 6.3.3.1 shall only be applicable for each component carrier when all the component carriers are OFF.

#### 6.3H.3.4 Power control for inter-band UL CA with UL MIMO

No requirements unique to CA operation are defined.

## 6.3I (Reserved)

### 6.3J Output power dynamics for ATG

#### 6.3J.1 Minimum output power for ATG

The minimum controlled output power of the UE is defined as the power in the channel bandwidth for all transmit bandwidth configurations (resource blocks) when the power is set to a minimum value.

The minimum output power is defined as the sum of the mean power from all antenna connectors or all TAB connectors in at least one sub-frame (1 ms). The minimum output power shall not exceed the values specified in Table 6.3J.1-1 for ATG UE with omni-directional antenna and in Table 6.3J.1-2 for ATG UE with antenna array.

**Table 6.3J.1-1: Minimum output power for ATG UE with omni-directional antenna**

Channel bandwidth	(MHz)	5,10,15,20	25,30,35,40,45,50	60,70,80,90,100
REF_SCS	(kHz)	15		30
Minimum output power	(dBm)	-15	$-15+10\log_{10}(BW_{\text{Channel}}/20)$	$-15+10\log_{10}(BW_{\text{Channel}}/20)$
Measurement bandwidth	(MHz)	$MBW=REF\_SCS*(12*N_{RB}+1)/1000$		
NOTE: The minimum output power value is rounded to the nearest number down to one decimal point.				

**Table 6.3J.1-2: Minimum output power for ATG UE with antenna array**

Channel bandwidth	(MHz)	5,10,15,20	25,30,35,40,45,50	60,70,80,90,100
REF_SCS	(kHz)	15		30
Minimum output power	(dBm)	-19	$-19+10\log_{10}(BW_{\text{Channel}}/20)$	$-19+10\log_{10}(BW_{\text{Channel}}/20)$
Measurement bandwidth	(MHz)	$MBW=REF\_SCS*(12*N_{RB}+1)/1000$		
NOTE: The minimum output power value is rounded to the nearest number down to one decimal point.				

## 6.3J.2 Transmit OFF power for ATG

The transmit OFF power is defined as the mean power at each transmit antenna connector or each TAB connector in a duration of at least one sub-frame (1 ms) excluding any transient periods.

The transmit OFF power requirements as specified in clause 6.3.2 are applicable for ATG UE.

## 6.3J.3 Transmit ON/OFF time mask for ATG

The transmit ON/OFF time mask requirements as specified in clause 6.3.3 are applicable for ATG UE at each transmit antenna connector or each TAB connector.

## 6.3J.4 Power control for ATG

The power control requirements specified in clause 6.3.4 are applicable for ATG UE with all transmit antenna connectors or all TAB connectors.

## 6.3K (Reserved)

## 6.3L Output power dynamics for CA with Tx Diversity

### 6.3L.1 Void

### 6.3L.2 Void

### 6.3L.3 Output power dynamics for inter-band UL CA with Tx Diversity

#### 6.3L.3.1 Minimum output power for inter-band UL CA with Tx Diversity

For inter-band UL CA with Tx Diversity in one of the two frequency bands, the minimum output power is defined per carrier. The requirement is specified in clause 6.3.1 for the carrier without Tx Diversity and specified in clause 6.3G.1 for the carrier configured with Tx Diversity.

#### 6.3L.3.2 Transmit OFF power for inter-band UL CA with Tx Diversity

For inter-band UL CA with Tx Diversity in one of the two frequency bands, the transmit OFF power specified in clause 6.3.2 is applicable for the carrier without Tx Diversity and the transmit OFF power specified in clause 6.3G.2 is applicable for the carrier configured with Tx Diversity when the transmitter is OFF on all component carriers. The transmitter is considered to be OFF when the UE is not allowed to transmit on any of its ports.

#### 6.3L.3.3 Transmit ON/OFF time mask for inter-band UL CA with Tx Diversity

For inter-band UL CA with Tx Diversity in one of the two frequency bands, the general output power ON/OFF time mask specified in clause 6.3.3.1 is applicable for the component carrier without Tx Diversity during the ON power period and the transient periods, the ON/OFF time mask specified in clause 6.3G.3 is applicable for the component carrier configured with Tx Diversity. The OFF period as specified in clause 6.3.3.1 shall only be applicable for each component carrier when all the component carriers are OFF.

#### 6.3L.3.4 Power control for inter-band UL CA with Tx Diversity

No requirements unique to CA operation are defined.

## 6.4 Transmit signal quality

### 6.4.1 Frequency error

The UE basic measurement interval of modulated carrier frequency is 1 UL slot. The mean value of basic measurements of UE modulated carrier frequency shall be accurate to within  $\pm 0.1$  PPM observed over a period of 1 ms of cumulated measurement intervals compared to the carrier frequency received from the NR Node B.

### 6.4.2 Transmit modulation quality

#### 6.4.2.0 General

Transmit modulation quality defines the modulation quality for expected in-channel RF transmissions from the UE. The transmit modulation quality is specified in terms of:

- Error Vector Magnitude (EVM) for the allocated resource blocks (RBs)



- EVM equalizer spectrum flatness derived from the equalizer coefficients generated by the EVM measurement process
- Carrier leakage
- In-band emissions for the non-allocated RB

All the parameters defined in clause 6.4.2 are defined using the measurement methodology specified in Annex F.

In case the parameter 3300 or 3301 is reported from UE via the parameter *txDirectCurrentLocation* in *UplinkTxDirectCurrentList* IE (as defined in TS 38.331 [7]), carrier leakage measurement requirement in clause 6.4.2.2 and 6.4.2.3 shall be waived, and the RF correction with regard to the carrier leakage and IQ image shall be omitted during the calculation of transmit modulation quality.

### 6.4.2.1 Error Vector Magnitude

The Error Vector Magnitude is a measure of the difference between the reference waveform and the measured waveform. This difference is called the error vector. Before calculating the EVM the measured waveform is corrected by the sample timing offset and RF frequency offset. Then the carrier leakage shall be removed from the measured waveform before calculating the EVM.

The measured waveform is further equalised using the channel estimates subjected to the EVM equaliser spectrum flatness requirement specified in clause 6.4.2.4. For DFT-s-OFDM waveforms, the EVM result is defined after the front-end FFT and IDFT as the square root of the ratio of the mean error vector power to the mean reference power expressed as a %. For CP-OFDM waveforms, the EVM result is defined after the front-end FFT as the square root of the ratio of the mean error vector power to the mean reference power expressed as a %.

The basic EVM measurement interval in the time domain is one preamble sequence for the PRACH and one slot for PUCCH and PUSCH in the time domain. The EVM measurement interval is reduced by any symbols that contains an allowable power transient in the measurement interval, as defined in clause 6.3.3.

The RMS average of the basic EVM measurements over 10 subframes for the average EVM case, and over 60 subframes for the reference signal EVM case, for the different modulation schemes shall not exceed the values specified in Table 6.4.2.1-1 for the parameters defined in Table 6.4.2.1-2. For EVM evaluation purposes, all 13 PRACH preamble formats and all 5 PUCCH formats are considered to have the same EVM requirement as QPSK modulated..

**Table 6.4.2.1-1: Requirements for Error Vector Magnitude**

Parameter	Unit	Average EVM Level
Pi/2-BPSK	%	30
QPSK	%	17.5
16 QAM	%	12.5
64 QAM	%	8
256 QAM	%	3.5

**Table 6.4.2.1-2: Parameters for Error Vector Magnitude**

Parameter	Unit	Level
UE Output Power	dBm	≥ Table 6.3.1-1
UE Output Power for 256 QAM	dBm	≥ Table 6.3.1-1 + 10 dB
Operating conditions		Normal conditions

#### 6.4.2.1a Error Vector Magnitude including symbols with transient period

In 6.4.2.1, EVM has been defined by excluding the symbols which have a transient period. In this section, measurement interval is defined for the symbols with a transient period to include these symbols in the RMS average EVM computation when the UE reports a transient period capability other than the default. Before calculating the EVM, the measured waveform is corrected for sample timing offset and RF frequency offset. Then the carrier leakage shall be removed from the measured waveform before calculating the EVM. The symbols with transient period should not be used for equalization. Only CP-OFDM waveform is used for conformance testing.

In the case of PUSCH or PUCCH transmissions when the mean power, modulation or RB allocation across slot or subslot boundaries is expected to change the EVM result over the symbols where the transient occurs is calculated according to Table 6.4.2.1a-1.

**Table 6.4.2.1a-1: EVM definition for reported transient period**

Reported transient capability (us)	EVM definition	$tp_{start}$ (μs)	SCS <sup>4</sup>
2	$EVM_{after} = \max(\overline{EVM_{l,tp}}, \overline{EVM_h})$ $EVM_{before} = \max(\overline{EVM_l}, \overline{EVM_{h,tp}})$	-0.5	15kHz or 30kHz <sup>5</sup>
4	$EVM_{after} = \max(\overline{EVM_{l,tp}}, \overline{EVM_h})$ $EVM_{before} = \max(\overline{EVM_l}, \overline{EVM_{h,tp}})$	-1	15kHz
7	$EVM_{after} = \min(\overline{EVM_{l,tp}}, \overline{EVM_h})$ $EVM_{before} = \max(\overline{EVM_l}, \overline{EVM_{h,tp}})$	-2.7	15kHz

NOTE 1:  $\overline{EVM_l}$ ,  $\overline{EVM_h}$ ,  $\overline{EVM_{l,tp}}$ , and  $\overline{EVM_{h,tp}}$  are defined in Annex F  
NOTE 2:  $EVM_{after}$  is the EVM for a symbol right after a transition;  $EVM_{before}$  is the EVM for a symbol right before a transition  
NOTE 3:  $tp_{start}$  denotes the start position of the EVM exclusion window as shown in Annex F.4  
NOTE 4: SCS denotes the SCS that can be used in the conformance test  
NOTE 5: 30kHz shall be used in the conformance test unless the UE signals in *supportedSubCarrierSpacingUL* in *FeatureSetPerCC* that it only supports 15kHz in the corresponding band

The RMS average of the basic EVM measurements over 108 subframes calculated only on the symbols where the transient occurs for the different modulation schemes shall not exceed the values specified in Table 6.4.2.1a-2 for the parameters defined in Table 6.4.2.1a-3. This requirement can be verified with 64 QAM and 256 QAM modulation.

**Table 6.4.2.1a-2: Requirements for Error Vector Magnitude**

Parameter	Unit	Average EVM Level
64 QAM	%	10
256 QAM	%	8

**Table 6.4.2.1a-3: Parameters for Error Vector Magnitude**

Parameter	Unit	Level
UE Output Power	dBm	≥ Table 6.3.1-1
UE Output Power for 256 QAM	dBm	≥ Table 6.3.1-1 + 10 dB
Operating conditions		Normal conditions

## 6.4.2.2 Carrier leakage

Carrier leakage is an additive sinusoid waveform whose frequency is the same as the modulated waveform carrier frequency. The measurement interval is one slot in the time domain.

In the case that uplink sharing, the carrier leakage may have 7.5 kHz shift with the carrier frequency.

The relative carrier leakage power is a power ratio of the additive sinusoid waveform and the modulated waveform. The relative carrier leakage power shall not exceed the values specified in Table 6.4.2.2-1.

**Table 6.4.2.2-1: Requirements for Carrier Leakage**

Parameter	Relative Limit (dBc)
Output power > 10 dBm	-28
0 dBm ≤ Output power ≤ 10 dBm	-25
-30 dBm ≤ Output power < 0 dBm	-20
-40 dBm ≤ Output power < -30 dBm	-10

### 6.4.2.3 In-band emissions

The in-band emission is defined as the average emission across 12 sub-carriers and as a function of the RB offset from the edge of the allocated UL transmission bandwidth. The in-band emission is measured as the ratio of the UE output power in a non-allocated RB to the UE output power in an allocated RB.

The basic in-band emissions measurement interval is defined over one slot in the time domain; however, the minimum requirement applies when the in-band emission measurement is averaged over 10 sub-frames. When the PUSCH or PUCCH transmission slot is shortened due to multiplexing with SRS, the in-band emissions measurement interval is reduced by one or more symbols, accordingly.

The average of the basic in-band emission measurement over 10 sub-frames shall not exceed the values specified in Table 6.4.2.3-1.

**Table 6.4.2.3-1: Requirements for in-band emissions**

Parameter description	Unit	Limit (NOTE 1)		Applicable Frequencies
General	dB	$\max \left\{ -25 - 10 \cdot \log_{10} (N_{RB} / L_{CRB}), \right.$ $20 \cdot \log_{10} EVM - 3 - 5 \cdot ( \Delta_{RB}  - 1) / L_{CRB},$ $\left. -57 \text{ dBm} + 10 \log_{10} (SCS / 15 \text{ kHz}) - \overline{P_{RB}} \right\}$		Any non-allocated (NOTE 2)
IQ Image	dB	-28	Image frequencies when output power > 10 dBm	Image frequencies (NOTES 2, 3)
		-25	Image frequencies when output power ≤ 10 dBm	
Carrier leakage	dBc	-28	Output power > 10 dBm	Carrier leakage frequency (NOTES 4, 5)
		-25	0 dBm ≤ Output power ≤ 10 dBm	
		-20	-30 dBm ≤ Output power < 0 dBm	
		-10	-40 dBm ≤ Output power < -30 dBm	
<p>NOTE 1: An in-band emissions combined limit is evaluated in each non-allocated RB. For each such RB, the minimum requirement is calculated as the higher of <math>\overline{P_{RB}} - 30</math> dB and the power sum of all limit values (General, IQ Image or Carrier leakage) that apply. <math>\overline{P_{RB}}</math> is defined in NOTE 10.</p> <p>NOTE 2: The measurement bandwidth is 1 RB and the limit is expressed as a ratio of measured power in one non-allocated RB to the measured average power per allocated RB, where the averaging is done across all allocated RBs. For pi/2 BPSK with Spectrum Shaping, the limit is expressed as a ratio of measured power in one non-allocated RB to the measured power in the allocated RB with highest PSD.</p> <p>NOTE 3: The applicable frequencies for this limit are those that are enclosed in the reflection of the allocated bandwidth, based on symmetry with respect to the carrier leakage frequency, but excluding any allocated RBs.</p> <p>NOTE 4: The measurement bandwidth is 1 RB and the limit is expressed as a ratio of measured power in one non-allocated RB to the measured total power in all allocated RBs.</p> <p>NOTE 5: The applicable frequencies for this limit depend on the parameter <i>txDirectCurrentLocation</i> in <i>UplinkTxDirectCurrent</i> IE, and are those that are enclosed either in the RB containing the carrier leakage frequency, or in the two RBs immediately adjacent to the carrier leakage frequency but excluding any allocated RB.</p> <p>NOTE 6: <math>L_{CRB}</math> is the Transmission Bandwidth (see clause 5.3).</p> <p>NOTE 7: <math>N_{RB}</math> is the Transmission Bandwidth Configuration (see clause 5.3).</p> <p>NOTE 8: <math>EVM</math> is the limit specified in Table 6.4.2.1-1 for the modulation format used in the allocated RBs.</p> <p>NOTE 9: <math>\Delta_{RB}</math> is the starting frequency offset between the allocated RB and the measured non-allocated RB (e.g. <math>\Delta_{RB} = 1</math> or <math>\Delta_{RB} = -1</math> for the first adjacent RB outside of the allocated bandwidth).</p> <p>NOTE 10: <math>\overline{P_{RB}}</math> is an average of the transmitted power over 10 sub-frames normalized by the number of allocated RBs, measured in dBm.</p> <p>NOTE 11: For almost contiguous allocations defined in clause 6.2.2, <math>L_{CRB} = N_{RB\_alloc} + N_{RB\_gap}</math> with no in-gap emission requirement.</p>				

### 6.4.2.4 EVM equalizer spectrum flatness

The zero-forcing equalizer correction applied in the EVM measurement process (as described in Annex F) must meet a spectral flatness requirement for the EVM measurement to be valid. The EVM equalizer spectrum flatness is defined in

terms of the maximum peak-to-peak ripple of the equalizer coefficients (dB) across the allocated uplink block. The basic measurement interval is the same as for EVM.

The peak-to-peak variation of the EVM equalizer coefficients contained within the frequency range of the uplink allocation shall not exceed the maximum ripple specified in Table 6.4.2.4-1 for normal conditions. For uplink allocations contained within both Range 1 and Range 2, the coefficients evaluated within each of these frequency ranges shall meet the corresponding ripple requirement and the following additional requirement: the relative difference between the maximum coefficient in Range 1 and the minimum coefficient in Range 2 must not be larger than 5 dB, and the relative difference between the maximum coefficient in Range 2 and the minimum coefficient in Range 1 must not be larger than 7 dB (see Figure 6.4.2.4-1).

The EVM equalizer spectral flatness shall not exceed the values specified in Table 6.4.2.4-2 for extreme conditions. For uplink allocations contained within both Range 1 and Range 2, the coefficients evaluated within each of these frequency ranges shall meet the corresponding ripple requirement and the following additional requirement: the relative difference between the maximum coefficient in Range 1 and the minimum coefficient in Range 2 must not be larger than 6 dB, and the relative difference between the maximum coefficient in Range 2 and the minimum coefficient in Range 1 must not be larger than 10 dB (see Figure 6.4.2.4-1).

**Table 6.4.2.4-1: Requirements for EVM equalizer spectrum flatness (normal conditions)**

Frequency range	Maximum ripple (dB)
$F_{UL\_Meas} - F_{UL\_Low} \geq 3$ MHz and $F_{UL\_High} - F_{UL\_Meas} \geq 3$ MHz (Range 1)	4 (p-p)
$F_{UL\_Meas} - F_{UL\_Low} < 3$ MHz or $F_{UL\_High} - F_{UL\_Meas} < 3$ MHz (Range 2)	8 (p-p)
NOTE 1: $F_{UL\_Meas}$ refers to the sub-carrier frequency for which the equalizer coefficient is evaluated	
NOTE 2: $F_{UL\_Low}$ and $F_{UL\_High}$ refer to each NR frequency band specified in Table 5.2-1	

**Table 6.4.2.4-2: Minimum requirements for EVM equalizer spectrum flatness (extreme conditions)**

Frequency range	Maximum Ripple (dB)
$F_{UL\_Meas} - F_{UL\_Low} \geq 5$ MHz and $F_{UL\_High} - F_{UL\_Meas} \geq 5$ MHz (Range 1)	4 (p-p)
$F_{UL\_Meas} - F_{UL\_Low} < 5$ MHz or $F_{UL\_High} - F_{UL\_Meas} < 5$ MHz (Range 2)	12 (p-p)
NOTE 1: $F_{UL\_Meas}$ refers to the sub-carrier frequency for which the equalizer coefficient is evaluated	
NOTE 2: $F_{UL\_Low}$ and $F_{UL\_High}$ refer to each NR frequency band specified in Table 5.2-1	

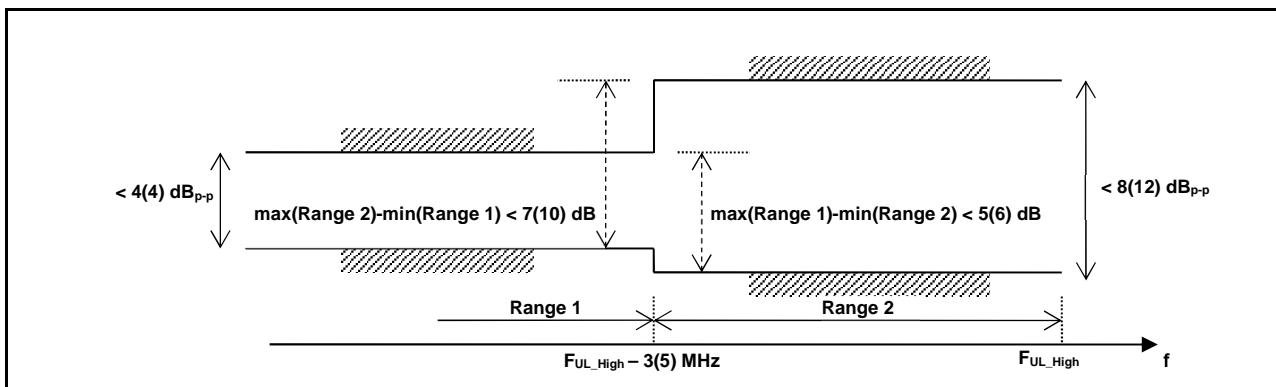

**Figure 6.4.2.4-1: The limits for EVM equalizer spectral flatness with the maximum allowed variation of the coefficients indicated (the ETC minimum requirement are within brackets).**

6.4.2.4.1 Requirements for Pi/2 BPSK modulation with *powerBoosting-pi2BPSK* capability

These requirements apply if the IE *powerBoostPi2BPSK* is set to 1 for power class 3 UE operating in TDD bands n40, n41, n77, n78 and n79 with Pi/2 BPSK modulation and UE indicates support for UE capability *powerBoosting-pi2BPSK* and 40 % or less slots in radio frame are used for UL transmission. These requirements also apply if the IE *dmrs-UplinkTransformPrecoding-r16* is configured and UE indicates support for UE capability *lowPAPR-DMRS-PUSCHwithPrecoding-r16*. Otherwise the requirements for EVM equalizer spectrum flatness defined in clause 6.4.2.4 apply

The EVM equalizer coefficients across the allocated uplink block shall be modified to fit inside the mask specified in Table 6.4.2.4.1-1 for normal conditions, prior to the calculation of EVM. The limiting mask shall be placed to minimize the change in equalizer coefficients in a sum of squares sense.

**Table 6.4.2.4.1-1: Mask for EVM equalizer coefficients for Pi/2 BPSK, normal conditions**

Frequency range	Parameter	Maximum ripple (dB)
$ F_{UL\_Meas} - F_{center}  \leq X$ MHz (Range 1)	X1	6 (p-p)
$ F_{UL\_Meas} - F_{center}  > X$ MHz (Range 2)	X2	14 (p-p)

NOTE 1:  $F_{UL\_Meas}$  refers to the sub-carrier frequency for which the equalizer coefficient is evaluated  
 NOTE 2:  $F_{center}$  refers to the center frequency of an allocated block of PRBs  
 NOTE 3: X, in MHz, is equal to 25% of the bandwidth of the PRB allocation  
 NOTE 4: See Figure 6.4.2.4.1-1 for description of X1, X2

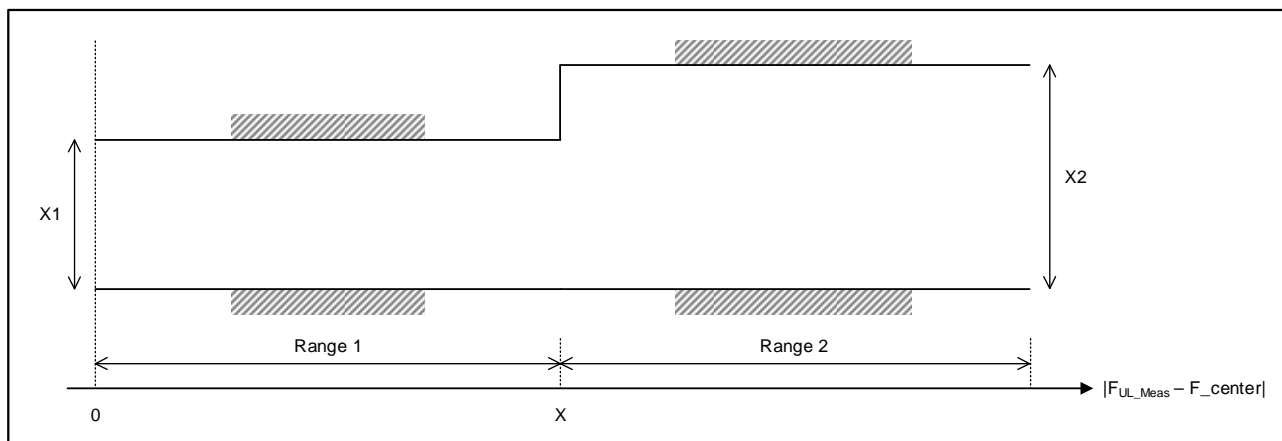

**Figure 6.4.2.4.1-1: The limits for EVM equalizer spectral flatness with the maximum allowed variation.**

For Pi/2 BPSK modulation the UE shall be allowed to employ spectral shaping and the shaping filter shall be restricted so that the impulse response of the shaping filter itself shall meet

$$|\tilde{a}_t(t,0)| \geq |\tilde{a}_t(t,\tau)| \quad \forall \tau \neq 0$$

$$20\log_{10} |\tilde{a}_t(t,\tau)| < -15 \text{ dB} \quad 1 < \tau < M - 1,$$

where  $|\tilde{a}_t(t,\tau)| = IDFT\{|\tilde{a}_t(t,f)| e^{j\varphi(t,f)}\}$ ,  $f$  is the frequency of the  $M$  allocated subcarriers,  $\tilde{a}_t(t,f)$  and  $\varphi(t,f)$  are the amplitude and phase response.

0 dB reference is defined as  $20\log_{10} |\tilde{a}_t(t,0)|$ .

6.4.2.4.2 Requirements for Pi/2 BPSK and QPSK modulation with *powerBoosting-pi2BPSK-QPSK-Modified-r18* capability

These requirements apply when the IE *powerBoostPi2BPSK-r18* or *powerBoostQPSK-r18* is set to 1 for a UE supporting the capability of *powerBoosting-pi2BPSK-QPSK-Modified-r18* and  $\Delta P_{PowerBoost}$  assumes a positive value. If the UE also indicates support for *powerBoosting-pi2BPSK-QPSK-r18*, and the allocation belongs to the enhanced

power inner region, as defined in clause 6.2.2, these requirements do not apply, requirements in clause 6.4.2.4 apply instead.

The EVM equalizer coefficients across the allocated uplink block shall be modified to fit inside the mask specified in Table 6.4.2.4.2-1 for normal conditions, prior to the calculation of EVM. The limiting mask shall be placed to minimize the change in equalizer coefficients in a sum of squares sense.

**Table 6.4.2.4.2-1: Mask for EVM equalizer coefficients for *powerBoosting-pi2BPSK-QPSK-Modified-r18* normal conditions**

Frequency range	Parameter	Maximum ripple (dB)
$ F_{UL\_Meas} - F_{center}  \leq X$ MHz (Range 1)	X1	6 (p-p)
$ F_{UL\_Meas} - F_{center}  > X$ MHz (Range 2)	X2	10 (p-p)

NOTE 1:  $F_{UL\_Meas}$  refers to the sub-carrier frequency for which the equalizer coefficient is evaluated  
 NOTE 2:  $F_{center}$  refers to the center frequency of an allocated block of PRBs  
 [NOTE 3: X, in MHz, is equal to [35%] of the bandwidth of the PRB allocation]  
 NOTE 4: See Figure 6.4.2.4.2-1 for description of X1, X2

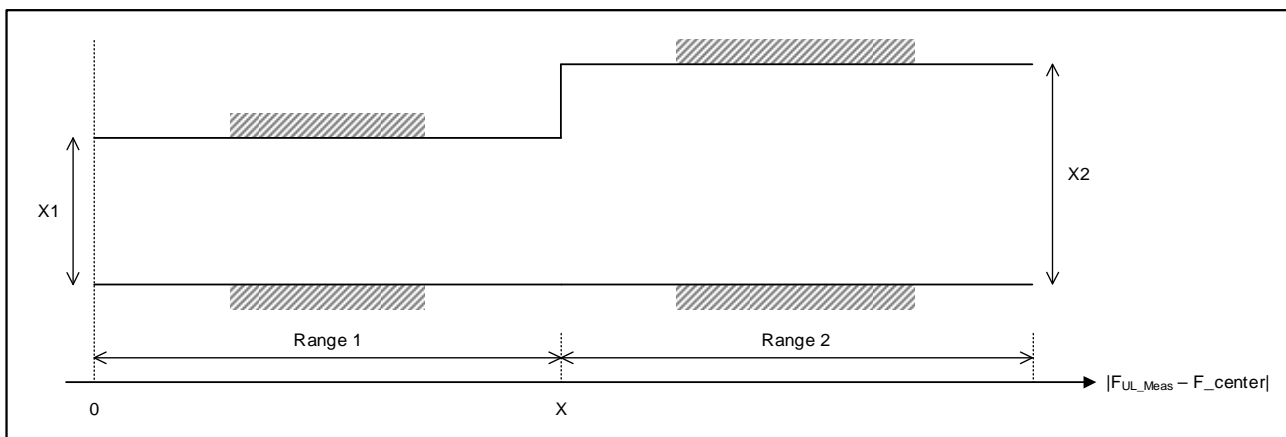

**Figure 6.4.2.4.2-1: The limits for EVM equalizer spectral flatness referenced in table 6.4.2.4.2-1.**

**6.4.2.5 Phase continuity requirements for DMRS bundling**

For bands that UE indicates the support of DMRS bundling, when the UE is configured with DMRS bundling, the maximum allowable difference between the measured phase value in any slot  $p-1$  and slot  $p$ , or slot 0 and any slot  $p$  for each antenna connector shall satisfy the requirements as listed in Table 6.4.2.5-1 for the measurement conditions defined in Table 6.4.2.5-2, within a measurement time window limited by the UE capability of maximum duration for DMRS bundling [ $maxDurationDMRS-Bundling-r17$ ], and defined for each frequency band separately. The phase value for each slot is measured as shown in Annex F.9. These requirements apply to PUCCH and PUSCH transmissions with DFT-s-OFDM and CP-OFDM waveforms.

**Table 6.4.2.5-1: Maximum allowable phase difference for DMRS bundling**

UL channel	Modulation order	Phase difference between any slot $p-1$ and slot $p$ (NOTE 2)	Phase difference between slot 0 and any slot $p$ (NOTE 3)
PUSCH	Pi/2 BPSK, QPSK	[25] degrees	[30] degrees
PUCCH	Pi/2 BPSK, BPSK, QPSK		

NOTE 1: The UE capability of the length of maximum duration refers to the maximum time duration during which UE is able to meet the phase continuity requirements, assuming no phase consistency violating events defined in TS 38.214 in between.  
 NOTE 2: This requirement applies for FDD and TDD bands, for supported DMRS bundling configurations  $\leq 8$  slots.  
 NOTE 3: This requirement applies only for FDD bands, for supported DMRS bundling configurations of 16 slots.

The above requirements are applicable when all the following conditions are met within the measurement time window:

- RB allocation in terms of length and frequency position does not change, and intra-slot and inter-slot frequency hopping is not activated.
- Modulation order does not change.
- No network commanded TA takes effect.
- The TPMI precoder does not change.
- There is no change in UE transmission power level, and no change in the level of P-MPR applied by the UE.
- UE is not scheduled with uplink transmission of other physical channel/signal in-between the PUSCH or PUCCH transmissions.
- For TDD, no downlink slot(s) or downlink symbol(s) or flexible symbol(s) with/without DL monitoring occasion configured in-between the PUSCH or PUCCH transmissions.

**Table 6.4.2.5-2: Measurement conditions for the maximum allowable phase difference**

Parameter	Unit	Level
UE Output Power	dBm	$P_{\text{CMAX},f,c}$ in clause 6.2.4, P-MPR = 0
UE downlink received power		Not change
Operating conditions		Normal conditions
Transmission bandwidth		Confined within $F_{\text{UL,low}} + [4]$ MHz and $F_{\text{UL,high}} - [4]$ MHz
DL signal frequency		Not change before and during the measurement window
DL signal timing		Maintained constant before and during the measurement window
UL slots for testing		Tested on consecutive UL slots
PUSCH waveform for testing		DFT-s-OFDM

## 6.4A Transmit signal quality for CA

### 6.4A.1 Frequency error for CA

#### 6.4A.1.1 Frequency error for intra-band contiguous CA

For intra-band contiguous carrier aggregation the UE modulated carrier frequencies per band shall be accurate to within  $\pm 0.1$  PPM observed over a period of 1 ms of cumulated measurement intervals compared to the carrier frequency of primary component carrier received in the corresponding band

#### 6.4A.1.2 Frequency error for intra-band non-contiguous CA

For intra-band non-contiguous carrier aggregation the requirements in Section 6.4.1 applies per component carrier.

#### 6.4A.1.3 Frequency error for inter-band CA

For inter-band carrier aggregation with one uplink carrier assigned to one NR band, the frequency error requirements in subclause 6.4.1 apply.

For inter-band carrier aggregation with two uplink non-contiguous carrier assigned to one NR band, the frequency error requirements in subclause 6.4A.1.2 apply for those carriers.

For inter-band carrier aggregation with uplink assigned to two NR bands, the frequency error requirements defined in clause 6.4.1 shall apply on each component carrier with all component carriers active.

For combinations of intra-band and inter-band carrier aggregation with three uplink component carriers (up to two contiguously aggregated carriers per operating band), the frequency error requirements specified in subclause 6.4.1 apply for the NR band supporting one component carrier, and for the NR band supporting two contiguous component carriers the requirements specified in subclause 6.4A.1.1 apply.

#### 6.4A.1.4 Void

### 6.4A.2 Transmit modulation quality for CA

#### 6.4A.2.1 Transmit modulation quality for intra-band contiguous CA

##### 6.4A.2.1.0 General

For intra-band contiguous carrier aggregation, the requirements in clauses 6.4A.2.1.1, 6.4A.2.1.2 and 6.4A.2.1.3 applies.

The requirements in this clause apply with PCC and SCC in the UL configured and activated: PCC with PRB allocation and SCC without PRB allocation and without CSI reporting and SRS configured.

The Carrier leakage frequency is optionally indicated by the UE via IE *UplinkTxDirectCurrentList*, IE *UplinkTxDirectCurrentTwoCarrierList-r16* for CA with two component carriers configured for uplink or IE *UplinkTxDirectCurrentMoreCarrierList-r17* for CA of any configuration.

If the UE does not indicate DC location parameters, the carrier leakage measurement requirement in clauses 6.4A.2.2 and 6.4A.2.3 shall be waived and the UE's UL signal left uncorrected for carrier leakage. Any requirement relaxation to accommodate the IQ image shall be omitted.

If the UE indicates carrier leakage frequency as 3300 or 3301 with IE *UplinkTxDirectCurrentList* or *UplinkTxDirectCurrentTwoCarrierList-r16*, or if the carrier leakage frequency is outside the activated UL component carriers, the carrier leakage measurement requirement in clauses 6.4A.2.2 and 6.4A.2.3 shall be waived and the UE's UL signal left uncorrected for carrier leakage. Any requirement relaxation to accommodate the IQ image shall be omitted.

##### 6.4A.2.1.1 Error Vector Magnitude

For the intra-band contiguous carrier aggregation, the Error Vector Magnitude requirement should be defined for each component carrier. Requirements only apply with PRB allocation in one of the component carriers. Similar transmitter impairment removal procedures are applied for CA waveform before EVM calculation as is specified for non-CA waveform in sub-clause 6.4.2.1.

When a single component carrier is configured Table 6.4.2.1-1 apply.

The EVM requirements are according to Table 6.4A.2.1.1-1 if CA is configured in uplink with the parameters defined in Table 6.4.2.1-2.

**Table 6.4A.2.1.1-1: Minimum requirements for Error Vector Magnitude**

Parameter	Unit	Average EVM Level per CC
Pi/2-BPSK	%	30
QPSK	%	17.5
16 QAM	%	12.5
64 QAM	%	8
256 QAM	%	3.5

##### 6.4A.2.1.2 In-band emissions

For intra-band contiguous carrier aggregation, the requirements in Table 6.4A.2.1.2-1 and 6.4A.2.1.2-2 apply within the aggregated transmission bandwidth configuration with both component carrier (s) active and one single contiguous PRB allocation of bandwidth  $L_{CRB}$  at the edge of the aggregated transmission bandwidth configuration.



The inband emission is defined as the interference falling into the non allocated resource blocks for all component carriers. The measurement method for the inband emissions in the component carrier with PRB allocation is specified in annex F.3. For a non allocated component carrier a spectral measurement is specified.

**Table 6.4A.2.1.2-1: Minimum requirements for in-band emissions (allocated component carrier)**

Parameter	Unit	Limit		Applicable Frequencies
General	dB	$\max \left\{ -25 - 10 \cdot \log_{10} (N_{RB} / L_{CRB}), \right.$ $20 \cdot \log_{10} EVM - 3 - 5 \cdot ( \Delta_{RB}  - 1) / L_{CRB},$ $\left. -57 \text{ dBm} + 10 \log_{10} (SCS / 15 \text{ kHz}) - \overline{P_{RB}} \right\}$		Any non-allocated (NOTE 2)
IQ Image	dB	-28	Output power > 10 dBm	Image frequencies (NOTE 3)
		-25	0 ≤ Output power ≤ 10 dBm	
Carrier leakage	dBc	-28	Output power > 10 dBm	Carrier leakage frequency (NOTE 4,5)
		-25	0 dBm ≤ Output power ≤ 10 dBm	
		-20	-30 dBm ≤ Output power ≤ 0 dBm	
		-10	-40 dBm ≤ Output power < -30 dBm	

NOTE 1: An in-band emissions combined limit is evaluated in each non-allocated RB. For each such RB, the minimum requirement is calculated as the higher of  $\overline{P_{RB}} - 30$  dB and the power sum of all limit values (General, IQ Image or Carrier leakage) that apply.  $\overline{P_{RB}}$  is defined in NOTE 10. The limit is evaluated in each non-allocated RB.

NOTE 2: The measurement bandwidth is 1 RB and the limit is expressed as a ratio of measured power in one non-allocated RB to the measured average power per allocated RB, where the averaging is done across all allocated RBs

NOTE 3: The applicable frequencies for this limit are those that are enclosed in the reflection of the allocated bandwidth, based on symmetry with respect to the carrier leakage frequency, but excluding any allocated RBs.

NOTE 4: Exceptions to the general limit are allowed for up to two contiguous non-allocated RBs. The measurement bandwidth is 1 RB and the limit is expressed as a ratio of measured power in the non-allocated RB to the measured total power in all allocated RBs.

NOTE 5: The applicable frequencies for this limit are those that are enclosed either in the RB containing the carrier leakage frequency, or in the two RBs immediately adjacent to the carrier leakage frequency but excluding any allocated RB. Carrier leakage frequency is indicated by the UE as described in clause 6.4A.2.1.0. When only one uplink carrier is activated, the applicable LO leakage frequency follow definition in clause 6.4.2.

NOTE 6:  $L_{CRB}$  is the Transmission Bandwidth (see clause 5.3) not exceeding  $\lfloor N_{RB}/2 - 1 \rfloor$ .

NOTE 7:  $N_{RB}$  is the Transmission Bandwidth Configuration (see clause 5.3) of the component carrier with RBs allocated.

NOTE 8:  $EVM$  is the limit specified in Table 6.4.2.1-1 for the modulation format used in the allocated RBs.

NOTE 9:  $\Delta_{RB}$  is the starting frequency offset between the allocated RB and the measured non-allocated RB (e.g.  $\Delta_{RB}=1$  or  $\Delta_{RB}=-1$  for the first adjacent RB outside of the allocated bandwidth).

NOTE 10:  $\overline{P_{RB}}$  is an average of the transmitted power over 10 sub-frames normalized by the number of allocated RBs, measured in dBm.

**Table 6.4A.2.1.2-2: Minimum requirements for in-band emissions (not allocated component carrier)**

Parameter	Unit	Meas BW NOTE 1	Limit	remark	Applicable Frequencies
General	dB	BW of 1 RB	$\max \left\{ -25 - 10 \cdot \log_{10} (N_{RB} / L_{CRB}), \right.$ $20 \cdot \log_{10} EVM - 3 - 5 \cdot ( \Delta_{RB}  - 1) / L_{CRB},$ $\left. -57 \text{ dBm} + 10 \log_{10} (SCS / 15 \text{ kHz}) - \overline{P_{RB}} \right\}$	The reference value is the average power per allocated RB in the allocated	Any RB in the non allocated component carrier. The frequency raster of the RBs is derived when this

				component carrier	component carrier is allocated with RBs	
IQ Image	dB	BW of 1 RB	NOTE 2		The reference value is the average power per allocated RB in the allocated component carrier	Image frequencies (NOTES 6,7) If UE does not indicate exact frequency for carrier leakage, this requirement does not apply.
			-28	Output power > 10 dBm		
			-25	0 ≤ Output power ≤ 10 dBm		
Carrier leakage	dBc	BW of 1 RB	NOTE 3		The reference value is the total power of the allocated RBs in the allocated component carrier	The frequencies of the up to 2 non-allocated RBs are indicated with IE <i>UplinkTxDirectCurrentMoreCarrierList-r17</i> . If UE does not indicate exact frequency for carrier leakage, this requirement does not apply.
			-28	Output power > 10 dBm		
			-25	0 dBm ≤ Output power ≤ 10 dBm		
			-20	-30 dBm ≤ Output power ≤ 0 dBm		
			-10	-40 dBm ≤ Output power < -30 dBm		
<p>NOTE 1: Resolution BWs smaller than the measurement BW may be integrated to achieve the measurement bandwidth.</p> <p>NOTE 2: Exceptions to the general limit is are allowed for up to <math>L_{CRB}+1</math> RBs within a contiguous width of <math>L_{CRB}+1</math> non-allocated RBs.</p> <p>NOTE 3: Two Exceptions to the general limit are allowed for up to two contiguous non-allocated RBs</p> <p>NOTE 4: NOTES 1, 5, 6, 7, 8, 9 from Table 6.4A.2.1.1-1 apply for Table 6.4A.2.1.2-2 as well.</p> <p>NOTE 5: <math>\Delta_{RB}</math> for measured non-allocated RB in the non allocated component carrier may take non-integer values when the carrier spacing between the CCs is not a multiple of RB.</p> <p>NOTE 6: The applicable frequencies for this limit are those that are enclosed in the reflection of the allocated bandwidth, based on symmetry with respect to the carrier leakage frequency, but excluding any allocated RBs</p> <p>NOTE 7: The measurement bandwidth is 1 RB and the limit is expressed as a ratio of measured power in one non-allocated RB to the measured average power per allocated RB, where the averaging is done across all allocated RBs.</p>						

### 6.4A.2.1.3 Carrier leakage

Carrier leakage is an additive sinusoid waveform that is confined within the aggregated transmission bandwidth configuration. When only one uplink carrier is activated, the applicable carrier leakage requirement follows definition in clause 6.4.2. The measurement interval is one slot in the time domain.

The relative carrier leakage power is a power ratio of the additive sinusoid waveform and the modulated waveform. For intra-band contiguous CA, the relative carrier leakage power shall not exceed the values specified in Table 6.4A.2.1.3-1. The requirement does not apply if the indicated location of carrier leakage is outside the activated UL carriers.

**Table 6.4A.2.1.3-1: Minimum requirements for Relative Carrier Leakage Power**

Parameters	Relative Limit (dBc)
Output power > 10 dBm	-28
0 dBm ≤ Output power ≤ 10 dBm	-25
-30 dBm ≤ Output power < 0 dBm	-20
-40 dBm ≤ Output power < -30 dBm	-10

## 6.4A.2.2 Transmit modulation quality for intra-band non-contiguous CA

### 6.4A.2.2.0 General

For intra-band non-contiguous carrier aggregation, the requirements in subclauses 6.4A.2.2.1, 6.4A.2.2.2 applies.

The requirements in this clause apply with PCC and SCC in the UL configured and activated: PCC with PRB allocation and SCC without PRB allocation and without CSI reporting and SRS configured.

Carrier leakage frequency is indicated by the UE with IE UplinkTxDirectCurrentMoreCarrierList-r17 or UplinkTxDirectCurrentTwoCarrierList-r16 or UplinkTxDirectCurrentList.

The carrier leakage measurement requirement in clause 6.4A.2.2.2 shall be waived and the UE's UL signal left uncorrected for carrier leakage when one of the following qualifying conditions apply:

1. UE reports the parameter 3300 or 3301
2. UE doesn't indicate the DC location parameters

Any requirement relaxation to accommodate the IQ image shall be omitted if the qualifying conditions above are present or if the IQ image frequency is outside the activated UL component carriers.

### 6.4A.2.2.1 Error Vector Magnitude

For the intra-band non-contiguous carrier aggregation, the Error Vector Magnitude requirement should be defined for each component carrier. Requirements only apply with PRB allocation in one of the component carriers. Similar transmitter impairment removal procedures are applied for CA waveform before EVM calculation as is specified for non-CA waveform in sub-section 6.4.2.1.

When a single component carrier is configured Table 6.4.2.1-1 apply.

The EVM requirements are according to Table 6.4A.2.2.1-1 if CA is configured in uplink with the parameters defined in Table 6.4.2.1-2.

**Table 6.4A.2.2.1-1: Minimum requirements for Error Vector Magnitude**

Parameter	Unit	Average EVM Level per CC
Pi/2-BPSK	%	30
QPSK	%	17.5
16 QAM	%	12.5
64 QAM	%	8
256 QAM	%	3.5

### 6.4A.2.2.2 In-band emissions

For intra-band non-contiguous carrier aggregation the requirements for in-band emissions are defined for each component carrier. Requirements defined in clause 6.4A.2.1.2 only apply with PRB allocation in one of the component carriers.

When signalling for dualPA-Architecture IE is absent, carrier leakage or I/Q image may land inside the gap spectrum between 2 UL CCs.

For intra-band non-contiguous CA, the IQ image requirement is defined with the applicable frequencies based on symmetry with respect to the carrier leakage frequency, but excluding any allocated RBs.

### 6.4A.2.2.3 Carrier leakage

The relative carrier leakage power is a power ratio of the additive sinusoid waveform and the modulated waveform. For intra-band non-contiguous CA, the relative carrier leakage power shall not exceed the values specified in Table 6.4A.2.4.3-1. The requirement does not apply if the indicated location of carrier leakage is outside the activated UL carriers.

### 6.4A.2.3 Transmit modulation quality for inter-band CA

For inter-band carrier aggregation with one uplink carrier assigned to one NR band, the transmit modulation quality requirements in subclause 6.4.2 apply.

For inter-band downlink carrier aggregation with a single uplink carrier assigned to one NR band, DMRS bundling requirements in subclause 6.4.2.5 apply to the uplink carrier when the UE indicates support of [*maxDurationDMRS-Bundling-r17*] for the NR band and is configured for DMRS bundling in the uplink carrier.

For inter-band carrier aggregation with two contiguous carriers assigned to one NR band, the transmit modulation quality requirements in subclause 6.4A.2.1 apply for those carriers.

For inter-band carrier aggregation with two uplink non-contiguous carrier assigned to one NR band, the transmit modulation quality requirements in subclause 6.4A.2.2 apply for those carriers.

For inter-band carrier aggregation with uplink assigned to two NR bands, the transmit modulation quality requirements shall apply on each component carrier as defined in clause 6.4.2 with all component carriers active: PCC with PRB allocation and SCC without PRB allocation and without CSI reporting and SRS configured. For DMRS bundling [*maxDurationDMRS-Bundling-r17*], requirements for phase continuity in clause 6.4.2.5 apply when all of the following additional conditions are met:

- During DMRS bundling time window, concurrent transmissions scheduled/configured over multiple carriers [including any channels and/or signals] are not expected by UE
- Only one band is configured with DMRS bundling at a time
- All carriers are on same TAG

When the capability *uplinkTxSwitchingPeriod* is present, the UE indicates support of [*dmrs-BundlingPUCCH-RepPerBC-r17*], and the UE is configured for uplink switching mechanisms specified in clause 6.1.6 of TS 38.214 [10], the phase continuity requirement in clause 6.4.2.5 for DMRS bundling is applicable under the following conditions:

- During the DMRS bundling time window, concurrent transmissions scheduled/configured over multiple carriers, including any channels and/or signals, are not expected by UE
- Only one carrier is configured with DMRS bundling at a time
- All carriers are on the same TAG
- DMRS bundling is not maintained across Tx switching period in the UL carrier configured with DMRS bundling

For combinations of intra-band and inter-band carrier aggregation with three uplink component carriers (up to two contiguously aggregated carriers per operating band): for the NR band supporting one component carrier the transmit modulation quality requirements specified in subclauses from 6.4.2.1 to 6.4.2.4 apply and for DMRS bundling

[*maxDurationDMRS-Bundling-r17*] the DMRS bundling requirements for inter-band carrier aggregation with uplink assigned to two NR bands apply. For the NR band supporting two contiguous component carriers the requirements specified in subclause 6.4A.2.1 apply.

#### 6.4A.2.4 Void

### 6.4B Transmit signal quality for NR-DC

For inter-band NR-DC with one uplink carrier assigned per NR band, the transmit signal quality for the corresponding inter-band CA configuration as specified in clause 6.4A applies with the exception of DMRS bundling [*maxDurationDMRS-Bundling-r17*] requirements.

### 6.4C Transmit signal quality for SUL

For the UE which is configured with both NR UL and NR SUL carriers in a serving cell with active transmission either on the UL carrier(s) or SUL carrier, the transmit signal quality requirements specified in clause 6.4.2 and 6.4A.2 are applicable for the UL carrier(s) and the SUL carrier, respectively.

If the UE indicates that it is capable of DMRS bundling *maxDurationDMRS-Bundling-r17* on the NR SUL band and UE is configured for DMRS bundling on SUL carrier or the UE indicates that it is capable of DMRS bundling *maxDurationDMRS-Bundling-r17* on the NR UL band and UE is configured for DMRS bundling on NR UL carrier, the requirements for phase continuity in clause 6.4.2.5 apply for the corresponding SUL carrier or NR UL carrier, respectively. Only one band can be configured with DMRS bundling at a time.

### 6.4D Transmit signal quality for UL MIMO

#### 6.4D.0 General

For a UE supporting UL MIMO, the requirements in this section are defined per layer or as the sum of emissions from all UE antennas to account for the UL MIMO scheme.

Alternatively, when applicable, requirements may be verified per antenna connector using 2-layer UL MIMO

transmission with codebook of  $\frac{1}{\sqrt{2}} \begin{bmatrix} 1 & 0 \\ 0 & 1 \end{bmatrix}$  or 4-layer UL MIMO transmission with codebook of  $\frac{1}{2} \begin{bmatrix} 1 & 0 & 0 & 0 \\ 0 & 1 & 0 & 0 \\ 0 & 0 & 1 & 0 \\ 0 & 0 & 0 & 1 \end{bmatrix}$ , and a

configuration defined in Table 6.4D.0-1.

**Table 6.4D.0-1: UL MIMO configuration for per connector measurements**

Transmission scheme	DCI format	Codebook Index
Codebook based uplink	DCI format 0_1	Codebook index 0

#### 6.4D.1 Frequency error for UL MIMO

For UE(s) supporting UL MIMO, the basic measurement interval of modulated carrier frequency is 1 UL slot. The mean value of basic measurements of UE modulated carrier frequency per layer shall be accurate to within  $\pm 0.1$  PPM observed over a period of 1 ms of cumulated measurement intervals compared to the carrier frequency received from the NR Node B.

## 6.4D.2 Transmit modulation quality for UL MIMO

### 6.4D.2.0 General

For UE supporting UL MIMO, the transmit modulation quality requirements are specified based on measurements made at each transmit antenna connector.

If UE is scheduled for single antenna-port PUSCH transmission by DCI format 0\_0 or by DCI format 0\_1 for single antenna port codebook based transmission with precoding matrix  $W=1$  [6.3.1.5 TS 38.211], the requirements in clause 6.4.2 apply when  $TxD$  is not indicated, and the requirements in clause 6.4G.2 apply when  $TxD$  is indicated.

The transmit modulation quality is specified in terms of:

- Error Vector Magnitude (EVM) for the allocated resource blocks (RBs)
- EVM equalizer spectrum flatness derived from the equalizer coefficients generated by the EVM measurement process
- Carrier leakage (caused by IQ offset)
- In-band emissions for the non-allocated RB

In case the parameter 3300 or 3301 is reported from UE via the parameter *txDirectCurrentLocation* in *UplinkTxDirectCurrentList* IE (as defined in TS 38.331 [7]), carrier leakage measurement requirement in clause 6.4D.2.2 and 6.4D.2.3 shall be waived, and the RF correction with regard to the carrier leakage and IQ image shall be omitted during the calculation of transmit modulation quality.

### 6.4D.2.1 Error Vector Magnitude

For UE with two or four transmit antenna connectors in closed-loop spatial multiplexing scheme, the Error Vector Magnitude requirements specified in clause 6.4.2.1 apply per layer. The requirements shall be met with the UL MIMO configurations specified in Table 6.2D.1-2.

### 6.4D.2.2 Carrier leakage

For UE with two or four transmit antenna connectors in closed-loop spatial multiplexing scheme, the Relative Carrier Leakage Power requirements specified in Table 6.4.2.2-1 which is defined in clause 6.4.2.2 apply per layer. The requirements shall be met with the UL MIMO configurations specified in Table 6.2D.1-2.

### 6.4D.2.3 In-band emissions

For UE with two or four transmit antenna connectors in closed-loop spatial multiplexing scheme, the In-band Emission requirements specified in Table 6.4.2.3-1 which is defined in clause 6.4.2.3 apply at each transmit antenna connector. The requirements shall be met with the uplink MIMO configurations specified in Table 6.2D.1-2

### 6.4D.2.4 EVM equalizer spectrum flatness for UL MIMO

For UE with two or four transmit antenna connectors in closed-loop spatial multiplexing scheme, the EVM Equalizer Spectrum Flatness requirements specified in clause 6.4.2.4 apply per layer. The requirements shall be met with the UL MIMO configurations specified in Table 6.2D.1-2

## 6.4D.3 Time alignment error for UL MIMO

For UE(s) with multiple transmit antenna connectors supporting UL MIMO, this requirement applies to frame timing differences between transmissions on multiple transmit antenna connectors in the closed-loop spatial multiplexing scheme.

The time alignment error (TAE) is defined as the average frame timing difference between any two transmissions on different transmit antenna connectors.

For UE(s) with multiple transmit antenna connectors, the Time Alignment Error (TAE) shall not exceed 130 ns.

## 6.4D.4 Requirements for coherent UL MIMO

For coherent UL MIMO, Table 6.4D.4-1 lists the maximum allowable difference between the measured relative power and phase errors between any two coherent ports out of the scheduled ports for UL transmission at their respective antenna connectors in any slot within the specified time window from the last transmitted SRS on the same antenna connectors, for the purpose of uplink transmission (codebook or non-codebook usage) and those measured at that last SRS. The requirements in Table 6.4D.4-1 apply when the UL transmission power at each antenna connector is larger than 0 dBm for SRS transmission and for the duration of time window.

**Table 6.4D.4-1: Maximum allowable difference of relative phase and power errors in a given slot compared to those measured at last SRS transmitted**

Difference of relative phase error	Difference of relative power error	Time window
40 degrees	4 dB	20 msec

The above requirements when all the following conditions are met within the specified time window:

- UE is not signaled with a change in number of SRS ports in SRS-config, or a change in PUSCH-config
- UE remains in DRX active time (UE does not enter DRX OFF time)
- No measurement gap occurs
- No instance of SRS transmission with the usage antenna switching occurs
- Active BWP remains the same
- EN-DC and CA configuration is not changed for the UE (UE is not configured or de-configured with PSCell or SCell(s))
- When UE is not configured with uplink switching; or when UE is configured with uplink switching, and ‘fullCoherent’ codebook subset is supported in the corresponding carrier according to the capability *uplinkTxSwitching-PUSCH-TransCoherence* and/or *uplinkTxSwitching2T2T-PUSCH-TransCoherence*; or when UE is configured with uplink switching, ‘nonCoherent’ codebook subset is supported in the corresponding carrier according to the capability *uplinkTxSwitching-PUSCH-TransCoherence* and/or *uplinkTxSwitching2T2T-PUSCH-TransCoherence*, and uplink switching is not triggered by the switching mechanisms specified in sub-clause 6.1.6 of TS 38.214 [10] between last transmitted SRS and scheduled transmission.

## 6.4E Transmit signal quality for V2X

### 6.4E.1 Frequency error for V2X

#### 6.4E.1.1 General

The UE modulated carrier frequency for NR V2X sidelink transmissions in Table 5.2E.1-1, shall be accurate to within  $\pm 0.1$  PPM observed over a period of 1 ms compared to the absolute frequency in case of using GNSS synchronization source. The same requirements applied over a period of 1 ms compared to the carrier frequency received from the gNB or V2X synchronization reference UE in case of using the gNB or V2X synchronization reference UE sidelink synchronization signals.

For NR V2X UE supporting SL MIMO or Tx Diversity, the UE modulated carrier frequency at each transmit antenna connector shall be accurate to within  $\pm 0.1$  PPM observed over a period of 1 ms in case of using GNSS synchronization source. The same requirements apply over a period of 1 ms compared to the relative frequency in case of using the NR gNode B or V2X synchronization reference UE sidelink synchronization signals.

If the UE transmits on one antenna connector at a time, the requirements for single carrier shall apply to the active antenna connector.

### 6.4E.1.1A Frequency error for sidelink CA

For SL intra-band contiguous CA,  $\pm 0.1$  PPM observed over a period of 1 ms will be applied per CC compared to the absolute frequency in case of using GNSS synchronization source. The same requirements will be applied to all SL synchronous reference sources (the gNB or V2X synchronization reference UE).

### 6.4E.1.2 Frequency error for V2X concurrent operation

For the inter-band concurrent NR V2X operation, the requirements specified in clause 6.4.1 shall apply for the uplink in licensed band and the requirements specified in clause 6.4E.1.1 shall apply for the sidelink in licensed band or Band n47.

For the intra-band concurrent NR V2X operation, the requirements specified in clause 6.4.1 shall apply for the uplink in licensed band and the requirements specified in clause 6.4E.1 shall apply for the sidelink in licensed band.

## 6.4E.1F Frequency error for Sidelink Unlicensed

The requirements for frequency error in 6.4E.1 apply for SL-U operation.

### 6.4E.1F.1 Frequency error for SL-U concurrent operation

For NR SL-U inter-band concurrent operation, the requirements specified in clause 6.4.1 shall apply for NR Uu operation in licensed band and the requirements specified in clause 6.4E.1 shall apply for NR sidelink operation in unlicensed band.

## 6.4E.2 Transmit modulation quality for V2X

### 6.4E.2.1 General

The transmit modulation quality requirements in this clause apply to V2X sidelink transmissions.

For NR V2X UE supporting SL MIMO or Tx Diversity, the transmit modulation quality requirements for single carrier shall apply to each transmit antenna connector.

If V2X UE transmits on one antenna connector at a time, the requirements specified for single carrier apply to the active antenna connector.

### 6.4E.2.2 Error Vector Magnitude for V2X

For V2X sidelink physical channels PSCCH and PSSCH, the Error Vector Magnitude requirements shall be as specified for PUSCH in Table 6.4.2.1-1 except pi/2-BPSK for NR V2X operating bands in Table 5.2E.1-1. When sidelink transmissions are shortened due to transmission gap of one symbol at the end of the slot, the EVM measurement interval is reduced by one symbol, accordingly.

### 6.4E.2.2A Error Vector Magnitude for sidelink CA

For SL intra-band contiguous CA, the EVM requirement as specified in clause 6.4E.2.2 shall be applied per component carrier.

### 6.4E.2.3 Carrier leakage for V2X

Carrier leakage of NR V2X sidelink transmission, the requirements for NR PUSCH in Table 6.4.2.2-1 shall be applied.



### 6.4E.2.3A Carrier leakage for sidelink CA

For SL intra-band contiguous CA, the carrier leakage requirement as specified in clause 6.4E.2.3 shall be applied per component carrier when only one SL transmission carrier is activated in a time.

### 6.4E.2.4 In-band emissions for V2X

For V2X sidelink physical channels PSCCH, PSSCH and PSBCH, the In-band emissions requirements shall be as specified for PUSCH in subclause 6.4.2.3 for the corresponding modulation and transmission bandwidth. When V2X transmissions are shortened due to transmission gap of one symbol at the end of the subframe, the In-band emissions measurement interval is reduced by one symbol, accordingly.

### 6.4E.2.4A In-band emissions for sidelink CA

For SL intra-band contiguous CA, the In-band emission requirement as specified in clause 6.4E.2.4 shall be applied to the SL aggregated transmission bandwidth. This is same as NR intra-band CA UE.

### 6.4E.2.5 EVM equalizer spectrum flatness for V2X

For V2X sidelink physical channels PSCCH, PSSCH and PSBCH, the EVM equalizer spectrum flatness requirements shall be as specified for PUSCH in clause 6.4.2.4 for the corresponding modulation and transmission bandwidth.

### 6.4E.2.6 Transmit modulation quality for V2X concurrent operation

For the inter-band concurrent NR V2X operation, the requirements specified in clause 6.4.2 shall apply for the uplink in licensed band and the requirements specified in clause 6.4E.2.1 through 6.4E.2.5 shall apply for the sidelink in licensed band or Band n47.

For the intra-band concurrent NR V2X operation, the requirements specified in clause 6.4.2 shall apply for the uplink in licensed band and the requirements specified in clause 6.4E.2 shall apply for the sidelink in licensed band.

## 6.4E.2F Transmit modulation quality for Sidelink Unlicensed

### 6.4E.2F.0 General

Transmit modulation quality defines the modulation quality for expected in-channel RF transmissions from the UE. The transmit modulation quality is specified in terms of:

- Error Vector Magnitude (EVM) for the allocated resource blocks (RBs)
- EVM equalizer spectrum flatness derived from the equalizer coefficients generated by the EVM measurement process
- Carrier leakage
- In-band emissions for the non-allocated RB

All the parameters defined in clause 6.4.2 are defined using the measurement methodology specified in Annex F.

In case the parameter 3300 or 3301 is reported from UE via *txDirectCurrentLocation* IE (as defined in TS 38.331 [7]), carrier leakage measurement requirement in clause 6.4E.2F.2 and 6.4E.2F.3 shall be waived, and the RF correction with regard to the carrier leakage and IQ image shall be omitted during the calculation of transmit modulation quality.

### 6.4E.2F.1 Error Vector Magnitude

The requirements for Error Vector Magnitude in clause 6.4E.2.2 apply for SL-U operation.

### 6.4E.2F.2 Carrier leakage

The requirements for carrier leakage in clause 6.4.2.2 apply for SL-U operation.

### 6.4E.2F.3 In-band emissions

The requirements for in-band emission in clause 6.4F.2.3 apply for SL-U operation.

### 6.4E.2F.4 EVM equalizer spectrum flatness

The requirements for EVM equalizer spectrum flatness in clause 6.4.2.4 apply for SL-U operation.

### 6.4E.2F.5 Transmit modulation quality for SL-U concurrent operation

For NR SL-U inter-band concurrent operation, the requirements specified in clause 6.4.2 shall apply for the uplink in licensed band and the requirements specified in clause 6.4E.2F.0 through 6.4E.2F.4 shall apply for NR sidelink operation in unlicensed band.

## 6.4F Transmit signal quality for shared spectrum channel access

### 6.4F.1 Frequency error

The requirements for frequency error in clause 6.4.1 apply.

### 6.4F.2 Transmit modulation quality

#### 6.4F.2.0 General

Transmit modulation quality defines the modulation quality for expected in-channel RF transmissions from the UE. The transmit modulation quality is specified in terms of:

- Error Vector Magnitude (EVM) for the allocated resource blocks (RBs)
- EVM equalizer spectrum flatness derived from the equalizer coefficients generated by the EVM measurement process
- Carrier leakage
- In-band emissions for the non-allocated RB

All the parameters defined in clause 6.4.2 are defined using the measurement methodology specified in Annex F.

In case the parameter 3300 or 3301 is reported from UE via *txDirectCurrentLocation* IE (as defined in TS 38.331 [7]), carrier leakage measurement requirement in clause 6.4F.2.2 and 6.4F.2.3 shall be waived, and the RF correction with regard to the carrier leakage and IQ image shall be omitted during the calculation of transmit modulation quality.

#### 6.4F.2.1 Error Vector Magnitude

The requirements for Error Vector Magnitude in clause 6.4.2.1 apply.

#### 6.4F.2.2 Carrier leakage

The requirements for carrier leakage in clause 6.4.2.2 apply.

### 6.4F.2.3 In-band emissions

The in-band emission is defined as the average emission across 12 sub-carriers and as a function of the RB offset from the edge of the allocated UL transmission bandwidth. The in-band emission is measured as the ratio of the UE output power in a non-allocated RB to the UE output power in an allocated RB.

The basic in-band emissions measurement interval is defined over one slot in the time domain; however, the minimum requirement applies when the in-band emission measurement is averaged over 10 sub-frames. When the PUSCH or PUCCH transmission slot is shortened, the in-band emissions measurement interval is reduced by one or more symbols, accordingly. The requirement applies for power class 5 UE for 20 MHz channel bandwidth and 15 kHz SCS,

Instead of the general requirement in clause 6.4.2.3, the average of the basic in-band emission measurement over 10 sub-frames shall not exceed the values specified in Table 6.4F.2.3-1.

**Table 6.4F.2.3-1: Minimum requirements for in-band emissions**

Parameter description	Unit	Limit (NOTE 1)		Applicable Frequencies
General	dB	$\max \left\{ \begin{array}{l} -10 - 6( \Delta_{RB}  - 1), \\ -57 \frac{dBm}{180 kHz} - P_{RB} \end{array} \right\}$		Any non-allocated (NOTE 2)
IQ Image	dB	-28	Image frequencies when output power > 10 dBm	Image frequencies (NOTES 2, 3)
		-25	Image frequencies when output power ≤ 10 dBm	
Carrier leakage	dBc	-28	Output power > 10 dBm	Carrier frequency (NOTES 4, 5)
		-25	0 dBm ≤ Output power ≤ 10 dBm	
		-20	-30 dBm ≤ Output power ≤ 0 dBm	
		-10	-40 dBm ≤ Output power < -30 dBm	
<p>NOTE 1: An in-band emissions combined limit is evaluated in each non-allocated RB. For each such RB, the minimum requirement is calculated as the higher of <math>P_{RB}</math>- 30 dB and the power sum of all limit values (General, IQ Image or Carrier leakage) that apply. <math>P_{RB}</math> is defined in NOTE 10.</p> <p>NOTE 2: The measurement bandwidth is 1 RB and the limit is expressed as a ratio of measured power in one non-allocated RB to the measured average power per allocated RB, where the averaging is done across all allocated RBs. The requirement applies with <math> \Delta_{RB}  \leq 5</math> for any non-allocated RB with <math>RIV=1</math> and <math>RIV=5</math> in the uplink scheduling grant where <math>RIV</math> is specified in [10].</p> <p>NOTE 3: [The applicable frequencies for this limit are those that are enclosed in the reflection of the allocated RBs, based on symmetry with respect to the reported carrier frequency location in <math>txDirectCurrentLocation</math> field of the <math>UplinkTxDirectCurrentBWP</math>, but excluding any allocated RBs. If <math>txDirectCurrentLocation</math> is not available or is reported with value 3300 or 3301, applicable frequencies shall be calculated with an assumed carrier frequency location at the center of the channel.]</p> <p>NOTE 4: [The measurement bandwidth is 1 RB and the limit is expressed as a ratio of measured power in one non-allocated RB to the measured total power in all allocated RBs with <math>RIV=1</math> and <math>RIV=5</math> in the uplink scheduling grant.]</p> <p>NOTE 5: [The applicable frequencies for this limit are those that are enclosed in the RBs containing the DC frequency if <math>N_{RB}</math> is odd, or in the two RBs immediately adjacent to the DC frequency if <math>N_{RB}</math> is even, but excluding any allocated RB. The location of the DC frequency is given by <math>txDirectCurrentLocation</math> field of the <math>UplinkTxDirectCurrentBWP</math>. If <math>txDirectCurrentLocation</math> is not available or is reported with value 3300 or 3301, applicable frequencies shall be those that are enclosed in the RB(s) in the center of the channel.]</p> <p>NOTE 6: <math>N_{RB}</math> is the Transmission Bandwidth Configuration (see Figure 5.6-1).</p> <p>NOTE 7: <math>\Delta_{RB}</math> is the starting frequency offset between the allocated RB and the measured non-allocated RB (e.g. <math>\Delta_{RB} = 1</math> or <math>\Delta_{RB} = -1</math> for the first adjacent RB outside of the allocated bandwidth).</p> <p>NOTE 10: <math>P_{RB}</math> is the transmitted power per <math>180 \cdot 2^u</math> kHz in allocated RBs, measured in dBm.</p>				

### 6.4F.2.4 EVM equalizer spectrum flatness

The requirements for EVM equalizer spectrum flatness in clause 6.4.2.4 apply.

## 6.4F.2A Transmit modulation quality for CA

### 6.4F.2A.1 Transmit modulation quality for inter-band CA

For inter-band carrier aggregation with uplink assigned to two bands and including one of the bands listed in Table 6.2F.1-1, the transmit modulation quality requirements shall apply on the NR carrier as defined in clause 6.4.2 and on the carrier operating with shared spectrum access as defined in clause 6.4F.2. The requirements apply with all component carrier active: PCC with PRB allocation and SCC without PRB allocation and without CSI reporting and SRS configured.

## 6.4G Transmit signal quality for Tx Diversity

### 6.4G.1 Frequency error for Tx Diversity

For UE(s) supporting Tx diversity, the basic measurement interval of modulated carrier frequency is 1 UL slot. The mean value of basic measurements of UE modulated carrier frequency at each transmit antenna connector shall be accurate to within  $\pm 0.1$  PPM observed over a period of 1 ms of cumulated measurement intervals compared to the carrier frequency received from the NR Node B.

### 6.4G.2 Transmit modulation quality for Tx Diversity

#### 6.4G.2.0 General

For UE supporting Tx diversity, the transmit modulation quality requirements are specified based on measurements made at each transmit antenna connector. The transmit modulation quality is specified in terms of:

- Error Vector Magnitude (EVM) for the allocated resource blocks (RBs)
- EVM equalizer spectrum flatness derived from the equalizer coefficients generated by the EVM measurement process
- Carrier leakage (caused by IQ offset)
- In-band emissions for the non-allocated RB

In case the parameter 3300 or 3301 is reported from UE via *txDirectCurrentLocation* IE (as defined in TS 38.331 [7]), carrier leakage measurement requirement in clause 6.4.2.2 and 6.4.2.3 shall be waived, and the RF correction with regard to the carrier leakage and IQ image shall be omitted during the calculation of transmit modulation quality.

#### 6.4G.2.1 Error Vector Magnitude

For UE supporting Tx diversity, the Error Vector Magnitude requirements specified in clause 6.4.2.1. The total EVM requirement is derived based on the measurement at each antenna connector according to Annex F.8.

#### 6.4G.2.2 Carrier leakage

For UE supporting Tx diversity, the Relative Carrier Leakage Power requirements specified in Table 6.4.2.2-1 which is defined in clause 6.4.2.2 apply at each transmit antenna connector.

#### 6.4G.2.3 In-band emissions

For UE supporting Tx diversity, the In-band Emission requirements specified in Table 6.4.2.3-1 which is defined in clause 6.4.2.3 apply at each transmit antenna connector.

## 6.4G.2.4 EVM equalizer spectrum flatness for Tx Diversity

For UE supporting Tx diversity, the EVM Equalizer Spectrum Flatness requirements specified in Table 6.4.2.4-1 and Table 6.4.2.4-2 which are defined in clause 6.4.2.4. The composite EVM equalizer  $EC(f)$  is defined as

$$EC(f) = \frac{P_1 \cdot |EC_1(f)| + P_2 \cdot |EC_2(f)|}{P_1 + P_2}$$

where

$EC_n(f)$  represents equalizer coefficient for each antenna connector,  $f \in F$ ,  $f$  is the allocated subcarriers within the transmission bandwidth ( $|F|=12 \cdot L_{CRBS}$ );

$P_1$  and  $P_2$  denote the linear power measured at each antenna connector respectively.

## 6.4H Transmit signal quality for CA with UL MIMO

### 6.4H.1 Transmit signal quality for intra-band UL contiguous CA with UL MIMO

#### 6.4H.1.1 Frequency error for intra-band UL contiguous CA with UL MIMO

For UE supporting intra-band UL contiguous CA and UL MIMO, the basic measurement interval of modulated carrier frequency is 1 UL slot. The mean value of basic measurements of UE modulated carrier frequency at each transmit antenna connector on each CC shall be accurate to within  $\pm 0.1$  PPM observed over a period of 1 ms of cumulated measurement intervals compared to the carrier frequency of primary component carrier received from the NR Node B.

#### 6.4H.1.2 Transmit modulation quality for intra-band UL contiguous CA with UL MIMO

##### 6.4H.1.2.0 General

For UE supporting intra-band UL contiguous CA and UL MIMO, the transmit modulation quality requirements are specified based on measurements made at each transmit antenna connector on each CC.

The requirements in this clause apply with PCC and SCC in the UL configured and activated: PCC with PRB allocation and SCC without PRB allocation and without CSI reporting and SRS configured.

If UE is scheduled for single antenna-port PUSCH transmission by DCI format 0\_0 or by DCI format 0\_1 for single antenna port codebook based transmission with precoding matrix  $W=1$  [6.3.1.5 TS 38.211], the requirements in clause 6.4A.2.1 apply.

The transmit modulation quality requirements listed below shall be met with UL MIMO configurations specified in Table 6.2D.1-2.

For all Transmit modulation quality requirements the Carrier leakage frequency is indicated by the UE with IE *UplinkTxDirectCurrentTwoCarrierList-r16* or *UplinkTxDirectCurrentMoreCarrierList-r17* or *UplinkTxDirectCurrentList*.

The carrier leakage measurement requirement in clauses 6.4H.1.2.2 and 6.4H.1.2.3 shall be waived and the UE's UL signal left uncorrected for carrier leakage when one of the following qualifying conditions apply:

1. UE reports the parameter 3300 or 3301
2. UE doesn't indicate the DC location parameters

Any requirement relaxation to accommodate the IQ image shall be omitted if the qualifying conditions above are present or if the IQ image frequency is outside the activated UL component carriers.

#### 6.4H.1.2.1 Error Vector Magnitude

For intra-band UL contiguous CA and UE with two transmit antenna connectors in closed-loop spatial multiplexing scheme, the Error Vector Magnitude requirements specified in clause 6.4A.2.1.1 apply per layer.

#### 6.4H.1.2.2 Carrier leakage

For UE supporting intra-band UL contiguous CA and UL MIMO, the relative carrier leakage power requirements specified in clause 6.4A.2.1.3 apply at each transmit antenna connector.

#### 6.4H.1.2.3 In-band emissions

For UE supporting intra-band UL contiguous CA and UL MIMO, the In-band emission requirements specified in clause 6.4A.2.1.2 apply at each transmit antenna connector.

#### 6.4H.1.3 Time alignment error for intra-band UL contiguous CA with UL MIMO

For intra-band UL contiguous CA and UE(s) with multiple transmit antenna connectors supporting UL MIMO, this requirement applies as specified in clause 6.4D.3: The time alignment error (TAE) is defined as the average frame timing difference between any two transmissions on different transmit antenna connectors for each CC. For UE(s) with multiple transmit antenna connectors, the Time Alignment Error (TAE) shall not exceed 130 ns.

#### 6.4H.1.4 Coherent UL MIMO requirement for intra-band UL contiguous CA with UL MIMO

For UE supporting intra-band UL contiguous CA and UL MIMO, the coherent UL MIMO requirement are specified on each CC as in clause 6.4D.4.

#### 6.4H.2 Void

#### 6.4H.3 Transmit signal quality for inter-band UL CA with UL MIMO

##### 6.4H.3.1 Frequency error for inter-band UL CA with UL MIMO

For inter-band UL CA with UL MIMO in one of the two frequency bands, the frequency error requirement defined in clause 6.4.1 shall apply on the component carrier without UL MIMO and the frequency error requirement defined in clause 6.4D.1 shall apply on the component carrier configured with UL MIMO with all component carriers active.

##### 6.4H.3.2 Transmit modulation quality for inter-band UL CA with UL MIMO

For inter-band UL CA with UL MIMO in one of the two frequency bands, the transmit modulation quality requirements defined in clause 6.4.2 shall apply on the component carrier without UL MIMO and the transmit modulation quality requirements defined in clause 6.4D.2 shall apply on the component carrier configured with UL MIMO with all component carriers active: PCC with PRB allocation and SCC without PRB allocation and without CSI reporting and SRS configured.

#### 6.4I (Reserved)

#### 6.4J Transmit signal quality for ATG

##### 6.4J.1 Frequency error for ATG

The ATG UE basic measurement interval of modulated carrier frequency is 1 UL slot. The ATG UE pre-compensates the uplink modulated carrier frequency by the estimated Doppler shift. The mean value of basic measurements of ATG UE modulated carrier frequency per layer shall be accurate to within  $\pm 0.1$  PPM observed

over a period of 1 ms of cumulated measurement intervals compared to ideally pre-compensated reference uplink carrier frequency.

UE [shall] rely on the ATG BS location broadcasted by the SIB22 in TS 38.331 [7].

NOTE 1: the ideally pre-compensated reference uplink carrier frequency consists of the UL carrier frequency signalled to the UE by ATG BS and UL precompensated doppler frequency shift.

## 6.4J.2 Transmit modulation quality for ATG

The requirements for transmit modulation quality defined in clause 6.4.2 shall apply for ATG UE except for the phase continuity requirements for DMRS bundling in 6.4.2.5. And the requirements for 256QAM modulation are only applicable to ATG UE indicating support of 256QAM.

## 6.4K (Reserved)

## 6.4L Transmit signal quality for CA with Tx Diversity

### 6.4L.1 Void

### 6.4L.2 Void

### 6.4L.3 Transmit signal quality for inter-band UL CA with Tx Diversity

#### 6.4L.3.1 Frequency error for inter-band UL CA with Tx Diversity

For inter-band UL CA with Tx Diversity in one of the two frequency bands, the frequency error requirement defined in clause 6.4.1 shall apply on the component carrier without Tx Diversity and the frequency error requirement defined in clause 6.4G.1 shall apply on the component carrier configured with Tx Diversity with all component carriers active.

#### 6.4L.3.2 Transmit modulation quality for inter-band UL CA with Tx Diversity

For inter-band UL CA with Tx Diversity in one of the two frequency bands, the transmit modulation quality requirements defined in clause 6.4.2 shall apply on the component carrier without Tx Diversity and the transmit modulation quality requirements defined in clause 6.4G.2 shall apply on the component carrier configured with Tx Diversity with all component carriers active: PCC with PRB allocation and SCC without PRB allocation and without CSI reporting and SRS configured.

## 6.5 Output RF spectrum emissions

### 6.5.1 Occupied bandwidth

Occupied bandwidth is defined as the bandwidth containing 99 % of the total integrated mean power of the transmitted spectrum on the assigned channel. The occupied bandwidth for all transmission bandwidth configurations (Resources Blocks) shall be less than the channel bandwidth specified in Table 6.5.1-1.

**Table 6.5.1-1: Occupied channel bandwidth**

	NR channel bandwidth (MHz)
	3, 5, 10, 15, 20, 25, 30, 35, 40, 45, 50, 60, 70, 80, 90, 100

<b>Occupied channel bandwidth (MHz)</b>	Same as NR channel bandwidth
---	------------------------------

## 6.5.2 Out of band emission

### 6.5.2.1 General

The Out of band emissions are unwanted emissions immediately outside the assigned channel bandwidth resulting from the modulation process and non-linearity in the transmitter but excluding spurious emissions. This out of band emission limit is specified in terms of a spectrum emission mask and an adjacent channel leakage power ratio.

To improve measurement accuracy, sensitivity and efficiency, the resolution bandwidth may be smaller than the measurement bandwidth. When the resolution bandwidth is smaller than the measurement bandwidth, the result should be integrated over the measurement bandwidth in order to obtain the equivalent noise bandwidth of the measurement bandwidth.

### 6.5.2.2 Spectrum emission mask

The spectrum emission mask of the UE applies to frequencies ( $\Delta f_{\text{OOB}}$ ) starting from the  $\pm$  edge of the assigned NR channel bandwidth. For frequencies offset greater than  $\Delta f_{\text{OOB}}$ , the spurious requirements in clause 6.5.3 are applicable.

**NOTE:** For measurement conditions at the edge of each frequency range, the lowest frequency of the measurement position in each frequency range should be set at the lowest boundary of the frequency range plus MBW/2. The highest frequency of the measurement position in each frequency range should be set at the highest boundary of the frequency range minus MBW/2. MBW denotes the measurement bandwidth defined for the protected band.

The power of any UE emission shall not exceed the levels specified in Table 6.5.2.2-1 for the specified channel bandwidth.

**Table 6.5.2.2-1: General NR spectrum emission mask**

$\Delta f_{\text{OOB}}$ (MHz)	Channel bandwidth (MHz) / Spectrum emission limit (dBm)				Measurement bandwidth
	3	5	10, 15, 20, 25, 30, 35, 40, 45	50, 60, 70, 80, 90, 100	
$\pm 0-1$	-13	-13	-13		1 % of channel BW
$\pm 0-1$				-24	30 kHz
$\pm 1-5$	-10	-10	-10		1 MHz
$\pm 5-6$	-25	-13			
$\pm 6-10$		-25			
$\pm 5-BW_{\text{Channel}}$			-13		
$\pm BW_{\text{Channel}}-(BW_{\text{Channel}}+5)$			-25		

### 6.5.2.3 Additional spectrum emission mask

#### 6.5.2.3.1 Requirements for network signalling value "NS\_35"

Additional spectrum emission requirements are signalled by the network to indicate that the UE shall meet an additional requirement for a specific deployment scenario as part of the cell handover/broadcast message.

When "NS\_35" is indicated in the cell, the power of any UE emission shall not exceed the levels specified in Table 6.5.2.3.1-1.

**Table 6.5.2.3.1-1: Additional requirements for "NS\_35"**

$\Delta f_{\text{OOB}}$ (MHz)	Channel bandwidth (MHz) / Spectrum emission limit (dBm)							Measurement bandwidth
	5	10	15	20	25	30	35	
$\pm 0-0.1$	-15	-18	-20	-21	-22	-23	-23.5	30 kHz
$\pm 0.1-6$	-13							100 kHz
$\pm 6-10$	-25							1 MHz



± 6-CBW		-13	100 kHz
± CBW-CBW+5		-25	1 MHz

NOTE: As a general rule, the resolution bandwidth of the measuring equipment should be equal to the measurement bandwidth. However, to improve measurement accuracy, sensitivity and efficiency, the resolution bandwidth may be smaller than the measurement bandwidth. When the resolution bandwidth is smaller than the measurement bandwidth, the result should be integrated over the measurement bandwidth in order to obtain the equivalent noise bandwidth of the measurement bandwidth.

6.5.2.3.2 Requirements for network signalling value "NS\_04"

Additional spectrum emission requirements are signalled by the network to indicate that the UE shall meet an additional requirement for a specific deployment scenario as part of the cell handover/broadcast message. The additional spectrum emission requirements in NS\_04 are based on FCC rule 47 CFR 27.53(m)(4).

The n41 SEM transition point from -13 dBm/MHz to -25 dBm/MHz is based on the emission bandwidth. The emission bandwidth is defined as the width of the signal between two points, one below the carrier center frequency and one above the carrier center frequency, outside of which all emissions are attenuated at least 26 dB below the transmitter power based on FCC rule 47 CFR 27.53(m)(6). Since the 26-dB emission bandwidth is implementation dependent, the maximum transmission bandwidth of the channel bandwidth in MHz (for CP-OFDM, this bandwidth equals  $N_{RB} * SCS * 12 / 1,000$ , and for DFT-S-OFDM, this bandwidth equals the maximum applicable  $L_{CRB} * SCS * 12 / 1,000$ ) contained within the 26 dB emission bandwidth is used for determining the applicable SEM indicated by NS\_04 as specified in Table 6.5.2.3.2-1 and Table 6.5.2.3.2-2.

Table 6.5.2.3.2-1: transmission bandwidth determining the NS\_04 SEM for CP-OFDM

SCS (kHz)	Channel bandwidth (MHz) / Maximum transmission bandwidth (MHz)														
	5	10	15	20	25	30	35	40	45	50	60	70	80	90	100
15	4.50	9.36	14.22	19.08	23.94	28.80	33.84	38.88	43.56	48.6	N/A	N/A	N/A	N/A	N/A
30	N/A	8.64	13.68	18.36	23.40	28.08	33.12	38.16	42.84	47.88	58.32	68.04	78.12	88.02	98.28
60	N/A	7.92	12.96	17.28	22.32	27.36	31.68	36.72	41.76	46.8	56.88	66.96	77.04	87.12	97.20

Table 6.5.2.3.2-2: transmission bandwidth determining the NS\_04 SEM for DFT-S-OFDM

SCS (kHz)	Channel bandwidth (MHz) / Maximum transmission bandwidth (MHz)														
	5	10	15	20	25	30	35	40	45	50	60	70	80	90	100
15	4.50	9.00	13.50	18.00	23.04	28.80	32.40	38.88	43.20	48.60	N/A	N/A	N/A	N/A	N/A
30	N/A	8.64	12.96	18.00	23.04	27.00	32.40	36.00	38.88	46.08	58.32	64.80	77.76	87.48	97.20
60	N/A	7.20	12.96	17.28	21.60	25.92	28.80	36.00	38.88	46.08	54.00	64.80	72.00	86.40	97.20

When "NS\_04" is indicated in the cell, the power of any UE emission shall not exceed the levels specified in Table 6.5.2.3.2-3.

Table 6.5.2.3.2-3: n41 and n90 SEM with "NS\_04"

$\Delta f_{OOB}$ MHz	Channel bandwidth (MHz) / Spectrum emission limit (dBm)															Measurement bandwidth
	5	10	15	20	25	30	35	40	45	50	60	70	80	90	100	
± 0 - 1	-10										-10					2 % channel bandwidth 1 MHz
± 1 - 5											-10					1 MHz
± 5 - X											-13					
± X - ( $BW_{Channel} + 5$ MHz)											-25					

NOTE 1: X= MAX(6, maximum transmission bandwidth), where maximum transmission bandwidth is defined in Table 6.5.2.3.2-1 for CP-OFDM and 6.5.2.3.2-2 for DFT-S-OFDM

6.5.2.3.3 Requirements for network signalling values "NS\_03" and "NS\_03U"

Additional spectrum emission requirements are signalled by the network to indicate that the UE shall meet an additional requirement for a specific deployment scenario as part of the cell handover/broadcast message.

When "NS\_03" or "NS\_03U" is indicated in the cell, the power of any UE emission shall not exceed the levels specified in Table 6.5.2.3.3-1.

**Table 6.5.2.3.3-1: Additional requirements for "NS\_03" and "NS\_03U"**

$\Delta f_{\text{OoB}}$ MHz	Channel bandwidth (MHz) / Spectrum emission limit (dBm)		Measurement bandwidth
	5	10, 15, 20, 25, 30, 35, 40, 45	
± 0-1	-13	-13	1 % of channel BW
± 1-6	-13		1 MHz
± 6-10	-25		
± 1-BWChannel		-13	
± BWChannel-(BWChannel+5)		-25	

NOTE: As a general rule, the resolution bandwidth of the measuring equipment should be equal to the measurement bandwidth. However, to improve measurement accuracy, sensitivity and efficiency, the resolution bandwidth may be smaller than the measurement bandwidth. When the resolution bandwidth is smaller than the measurement bandwidth, the result should be integrated over the measurement bandwidth in order to obtain the equivalent noise bandwidth of the measurement bandwidth.

**Table 6.5.2.3.3-2: Void**

6.5.2.3.4 Requirements for network signalling value "NS\_06" or "NS\_07"

Additional spectrum emission requirements are signalled by the network to indicate that the UE shall meet an additional requirement for a specific deployment scenario as part of the cell handover/broadcast message.

When "NS\_06" or "NS\_07" is indicated in the cell, the power of any UE emission shall not exceed the levels specified in Table 6.5.2.3.4-1.

**Table 6.5.2.3.4-1: Additional requirements for "NS\_06" or "NS\_07"**

$\Delta f_{\text{OoB}}$ (MHz)	Channel bandwidth (MHz) / Spectrum emission limit (dBm)				Measurement bandwidth
	3	5	10	15	
± 0 – 0.1	-13	-15	-18	-20	30 kHz
± 0.1 – 1	-13	-13	-13	-13	100 kHz
± 1 – 5	-13	-13	-13	-13	1 MHz
± 5 – 6	-25	-13	-13	-13	1 MHz
± 6 – 10		-25			
± 10 – 15			-25		
± 15 – 20				-25	

NOTE: As a general rule, the resolution bandwidth of the measuring equipment should be equal to the measurement bandwidth. However, to improve measurement accuracy, sensitivity and efficiency, the resolution bandwidth may be smaller than the measurement bandwidth. When the resolution bandwidth is smaller than the measurement bandwidth, the result should be integrated over the measurement bandwidth in order to obtain the equivalent noise bandwidth of the measurement bandwidth.

6.5.2.3.5 Void

6.5.2.3.6 Void

6.5.2.3.7 Void

6.5.2.3.8 Requirements for network signalling value "NS\_27"

Additional spectrum emission requirements are signalled by the network to indicate that the UE shall meet an additional requirement for a specific deployment scenario as part of the cell handover/broadcast message.

When "NS\_27" is indicated in the cell, the power of any UE emission shall not exceed the levels specified in Table 6.5.2.3.8-1.

**Table 6.5.2.3.8-1: Additional requirements for "NS\_27"**

$\Delta f_{\text{OOB}}$ MHz	Channel bandwidth (MHz) / Spectrum emission limit (dBm)						Measurement bandwidth
	5	10	15	20	30	40	
$\pm 0 - 1$	-13						1 % channel bandwidth
$\pm 1 - X$	-13						1 MHz
$< - X$ or $> X$	-25						
NOTE 1: X is occupied channel bandwidth as defined in Table 6.5.1-1. NOTE 2: The requirements apply only at the frequency range from 3540 MHz to 3710 MHz.							

NOTE: As a general rule, the resolution bandwidth of the measuring equipment should be equal to the measurement bandwidth. However, to improve measurement accuracy, sensitivity and efficiency, the resolution bandwidth may be smaller than the measurement bandwidth. When the resolution bandwidth is smaller than the measurement bandwidth, the result should be integrated over the measurement bandwidth in order to obtain the equivalent noise bandwidth of the measurement bandwidth.

6.5.2.3.9 Requirements for network signalling value "NS\_21"

Additional spectrum emission requirements are signalled by the network to indicate that the UE shall meet an additional requirement for a specific deployment scenario as part of the cell handover/broadcast message.

When "NS\_21" is indicated in the cell, the power of any UE emission shall not exceed the levels specified in Table 6.5.2.3.9-1.

**Table 6.5.2.3.9-1: Additional requirements for "NS\_21"**

$\Delta f_{\text{OOB}}$ MHz	Channel bandwidth (MHz) / Spectrum emission limit (dBm)		Measurement bandwidth
	5	10	
$\pm 0-1$	-13	-13	1 MHz
$\pm 1-6$	-13	-13	1 MHz
$\pm 6-10$	-25	-13	1 MHz
$\pm 10-15$		-25	1 MHz

NOTE 1: As a general rule, the resolution bandwidth of the measuring equipment should be equal to the measurement bandwidth. However, to improve measurement accuracy, sensitivity and efficiency, the resolution bandwidth may be smaller than the measurement bandwidth. When the resolution bandwidth is smaller than the measurement bandwidth, the result should be integrated over the measurement bandwidth in order to obtain the equivalent noise bandwidth of the measurement bandwidth.

NOTE 2: For  $\Delta f_{\text{OOB}} = \pm 0-1\text{MHz}$ , a resolution bandwidth of as close as possible to, without being less than 1% of the channel bandwidth, shall be employed provided that the measured power is integrated over the full required measurement bandwidth of 1 MHz.

## 6.5.2.4 Adjacent channel leakage ratio

Adjacent Channel Leakage power Ratio (ACLR) is the ratio of the filtered mean power centred on the assigned channel frequency to the filtered mean power centred on an adjacent channel frequency.

To improve measurement accuracy, sensitivity and efficiency, the resolution bandwidth may be smaller than the measurement bandwidth. When the resolution bandwidth is smaller than the measurement bandwidth, the result should be integrated over the measurement bandwidth in order to obtain the equivalent noise bandwidth of the measurement bandwidth.

### 6.5.2.4.1 NR ACLR

NR Adjacent Channel Leakage power Ratio ( $NR_{ACLR}$ ) is the ratio of the filtered mean power centred on the assigned NR channel frequency to the filtered mean power centred on an adjacent NR channel frequency at nominal channel spacing.

The assigned NR channel power and adjacent NR channel power are measured with rectangular filters with measurement bandwidths specified in Table 6.5.2.4.1-1.

If the measured adjacent channel power is greater than  $-50$  dBm then the  $NR_{ACLR}$  shall be higher than the value specified in Table 6.5.2.4.1-2.

When the IE *powerBoostPi2BPSK-r18* or *powerBoostQPSK-r18* is set to 1 for a UE supporting the capability of *powerBoosting-pi2BPSK-QPSK-r18* or capability of *powerBoosting-pi2BPSK-QPSK-Modified-r18*, for power class 2 UE, the ACLR requirement of PC2 applies. For power class 3 UE, the ACLR requirement of PC3 applies.

**Table 6.5.2.4.1-1: NR ACLR measurement bandwidth**

<b>Channel bandwidth</b>	(MHz)	3,5,10,15,20,25,30,35,40,45,50	60,70,80,90,100
<b>REF_SCS</b>	(kHz)	15	30
<b>NR ACLR measurement bandwidth</b>	(MHz)	$MBW=REF\_SCS*(12*N_{RB}+1)/1000$	
NOTE : "N <sub>RB</sub> " in the formula is the maximum transmission bandwidth configuration as defined in Table 5.3.2-1.			

**Table 6.5.2.4.1-2: NR ACLR requirement**

	<b>Power class 1</b>	<b>Power class 1.5</b>	<b>Power class 2</b>	<b>Power class 3</b>
<b>NR ACLR</b>	37 dB	31 dB	31 dB	30 dB
NOTE 1: Void				

### 6.5.2.4.2 UTRA ACLR

UTRA adjacent channel leakage power ratio ( $UTRA_{ACLR}$ ) is the ratio of the filtered mean power centred on the assigned NR channel frequency to the filtered mean power centred on an adjacent(s) UTRA channel frequency.

$UTRA_{ACLR}$  is specified for the first adjacent UTRA channel ( $UTRA_{ACLR1}$ ) which center frequency is  $\pm 2.5$  MHz from NR channel edge and for the 2<sup>nd</sup> adjacent UTRA channel ( $UTRA_{ACLR2}$ ) which center frequency is  $\pm 7.5$  MHz from NR channel edge.

The UTRA channel power is measured with a RRC filter with roll-off factor  $\alpha = 0.22$  and bandwidth of 3.84 MHz. The assigned NR channel power is measured with a rectangular filter with measurement bandwidth specified in Table 6.5.2.4.1-1.

If the measured adjacent channel power is greater than  $-50$  dBm then the  $UTRA_{ACLR1}$  and  $UTRA_{ACLR2}$  shall be higher than the value specified in Table 6.5.2.4.2-1.

**Table 6.5.2.4.2-1: UTRA ACLR requirement**

	Power class 2	Power class 3
$UTRA_{ACLR1}$	33 dB	33 dB
$UTRA_{ACLR2}$	36 dB	36 dB

UTRA ACLR requirement is applicable when the network signalling value NS\_03U, NS\_05U, NS\_43U or NS\_100 is signalled by the network in the field *additionalSpectrumEmission*.

## 6.5.3 Spurious emissions

### 6.5.3.0 General

Spurious emissions are emissions which are caused by unwanted transmitter effects such as harmonics emission, parasitic emissions, intermodulation products and frequency conversion products, but exclude out of band emissions unless otherwise stated. The spurious emission limits are specified in terms of general requirements in line with SM.329 [9] and NR operating band requirement to address UE co-existence.

To improve measurement accuracy, sensitivity and efficiency, the resolution bandwidth may be smaller than the measurement bandwidth. When the resolution bandwidth is smaller than the measurement bandwidth, the result should be integrated over the measurement bandwidth in order to obtain the equivalent noise bandwidth of the measurement bandwidth.

**NOTE:** For measurement conditions at the edge of each frequency range, the lowest frequency of the measurement position in each frequency range should be set at the lowest boundary of the frequency range plus  $MBW/2$ . The highest frequency of the measurement position in each frequency range should be set at the highest boundary of the frequency range minus  $MBW/2$ . MBW denotes the measurement bandwidth defined for the protected band.

### 6.5.3.1 General spurious emissions

Unless otherwise stated, the spurious emission limits apply for the frequency ranges that are more than  $F_{OoB}$  (MHz) in Table 6.5.3.1-1 from the edge of the channel bandwidth. The spurious emission limits in Table 6.5.3.1-2 apply for all transmitter band configurations ( $N_{RB}$ ) and channel bandwidths.

**Table 6.5.3.1-1: Boundary between NR out of band and general spurious emission domain**

Channel bandwidth	OoB boundary $F_{OoB}$ (MHz)
3	6
5, 10, 15, 20, 25, 30, 35, 40, 45, 50, 60, 70, 80, 90, 100	$BW_{Channel} + 5$

**Table 6.5.3.1-2: Requirement for general spurious emissions limits**

Frequency Range	Maximum Level	Measurement bandwidth	NOTE
$9 \text{ kHz} \leq f < 150 \text{ kHz}$	-36 dBm	1 kHz	
$150 \text{ kHz} \leq f < 30 \text{ MHz}$	-36 dBm	10 kHz	
$30 \text{ MHz} \leq f < 1000 \text{ MHz}$	-36 dBm	100 kHz	
$1 \text{ GHz} \leq f < 12.75 \text{ GHz}$	-30 dBm	1 MHz	4
	-25 dBm	1 MHz	3
$12.75 \text{ GHz} \leq f < 5^{\text{th}}$ harmonic of the upper frequency edge of the	-30 dBm	1 MHz	1

UL operating band in GHz			
12.75 GHz < f < 26 GHz	-30 dBm	1 MHz	2
NOTE 1: Applies for Band for which the upper frequency edge of the UL Band is greater than 2.55 GHz and less than or equal to 5.2 GHz			
NOTE 2: Applies for Band that the upper frequency edge of the UL Band more than 5.2 GHz			
NOTE 3: Applies for Band n41, CA configurations including Band n41, and EN-DC configurations that include n41 specified in clause 5.2B of TS 38.101-3 [3] when NS_04 is signalled.			
NOTE 4: Does not apply for Band n41, CA configurations including Band n41, and EN-DC configurations that include n41 specified in subclause 5.2B of TS 38.101-3 [3] when NS_04 is signalled.			

### 6.5.3.2 Spurious emissions for UE co-existence

This clause specifies the requirements for NR bands for coexistence with protected bands. Unless otherwise stated, the spurious emission for UE co-existence apply for the frequency ranges that are more than F<sub>OOB</sub> (MHz) in Table 6.5.3.1-1 from the edge of the channel bandwidth.

**Table 6.5.3.2-1: Requirements for spurious emissions for UE co-existence**

NR Band	Spurious emission for UE co-existence						
	Protected band	Frequency range (MHz)		Maximum Level (dBm)	MBW (MHz)	NOTE	
n1, n84	E-UTRA Band 1, 5, 7, 8, 11, 18, 19, 20, 21, 22, 26, 27, 28, 31, 32, 38, 40, 41, 42, 43, 44, 45, 50, 51, 52, 65, 67, 68, 69, 72, 73, 74, 75, 76 NR Band n78, n79, n100, n104, n105, n109	F <sub>DL_low</sub>	-	F <sub>DL_high</sub>	-50	1	
	NR Band n77	F <sub>DL_low</sub>	-	F <sub>DL_high</sub>	-50	1	2
	E-UTRA Band 3	F <sub>DL_low</sub>	-	F <sub>DL_high</sub>	-50	1	15
	E-UTRA Band 34	F <sub>DL_low</sub>	-	F <sub>DL_high</sub>	-50	1	15, 47
	Frequency range	1880	-	1895	-40	1	15, 27
	Frequency range	1895	-	1915	-15.5	5	15, 26, 27
	Frequency range	1915	-	1920	+1.6	5	15, 26, 27
n2	E-UTRA Band 4, 5, 7, 12, 13, 14, 17, 24, 26, 27, 28, 29, 30, 38, 41, 42, 50, 51, 53, 54, 66, 70, 71, 74, 85, 103, 106 NR Band n105	F <sub>DL_low</sub>	-	F <sub>DL_high</sub>	-50	1	
	E-UTRA Band 2, 25	F <sub>DL_low</sub>	-	F <sub>DL_high</sub>	-50	1	15
	E-UTRA Band 43, 48 NR Band n77, n78	F <sub>DL_low</sub>	-	F <sub>DL_high</sub>	-50	1	2
n3, n80	E-UTRA Band 1, 5, 7, 8, 20, 26, 27, 28, 31, 32, 33, 34, 38, 39, 40, 41, 43, 44, 45, 50, 51, 65, 67, 68, 69, 72, 73, 74, 75, 76 NR Band n79, n100, n101, n105	F <sub>DL_low</sub>	-	F <sub>DL_high</sub>	-50	1	
	E-UTRA Band 3	F <sub>DL_low</sub>	-	F <sub>DL_high</sub>	-50	1	15
	E-UTRA Band 11, 18, 19, 21	F <sub>DL_low</sub>	-	F <sub>DL_high</sub>	-50	1	
	E-UTRA Band 22, 42, 52 NR Band n77, n78, n104	F <sub>DL_low</sub>	-	F <sub>DL_high</sub>	-50	1	2
	Frequency range	1884.5	-	1915.7	-41	0.3	8
n5, n89	E-UTRA Band 1, 2, 3, 4, 5, 7, 8, 12, 13, 14, 17, 18, 19, 24, 25, 28, 29, 30, 31, 34, 38, 40, 42,	F <sub>DL_low</sub>	-	F <sub>DL_high</sub>	-50	1	

NR Band	Spurious emission for UE co-existence						
	Protected band	Frequency range (MHz)			Maximum Level (dBm)	MBW (MHz)	NOTE
	43, 45, 48, 50, 51, 65, 66, 70, 71, 73, 74, 85, 103, 106 NR Band n79, n105, n109						
	E-UTRA Band 41, 52, 53, 54 NR Band n77, n78	F <sub>DL_low</sub>	-	F <sub>DL_high</sub>	-50	1	2
	E-UTRA Band 11, 21	F <sub>DL_low</sub>	-	F <sub>DL_high</sub>	-50	1	
	E-UTRA Band 26	F <sub>DL_low</sub>	-	F <sub>DL_high</sub>	-50	1	15
	Frequency range	1884.5	-	1915.7	-41	0.3	8
n7	E-UTRA Band 1, 2, 3, 4, 5, 7, 8, 12, 13, 14, 17, 20, 22, 25, 26, 27, 28, 29, 30, 31, 32, 33, 34, 40, 42, 43, 50, 51, 52, 65, 66, 67, 68, 71, 72, 74, 75, 76, 85, 103, NR Band n77, n78, n100, n101, n105, n109	F <sub>DL_low</sub>	-	F <sub>DL_high</sub>	-50	1	
	NR Band n79	F <sub>DL_low</sub>	-	F <sub>DL_high</sub>	-50	1	2
	Frequency range	2570	-	2575	+1.6	5	15, 21, 26
	Frequency range	2575	-	2595	-15.5	5	15, 21, 26
	Frequency range	2595	-	2620	-40	1	15, 21
n8, n81, n93, n94	E-UTRA Band 1, 20, 28, 31, 32, 33, 34, 38, 39, 40, 45, 50, 51, 54, 65, 67, 68, 69, 72, 73, 74, 75, 76 NR Band n101, n104, n105, n109	F <sub>DL_low</sub>	-	F <sub>DL_high</sub>	-50	1	
	E-UTRA band 3, 7, 22, 41, 42, 43, 52 NR Band n77, n78, n79	F <sub>DL_low</sub>	-	F <sub>DL_high</sub>	-50	1	2
	E-UTRA 8	F <sub>DL_low</sub>	-	F <sub>DL_high</sub>	-50	1	15
	E-UTRA Band 11, 21	F <sub>DL_low</sub>	-	F <sub>DL_high</sub>	-50	1	
	Frequency range	1884.5	-	1915.7	-41	0.3	8
n12	E-UTRA Band 2, 5, 13, 14, 17, 24, 25, 26, 27, 30, 41, 53, 54, 70, 71, 74, 103, 106	F <sub>DL_low</sub>	-	F <sub>DL_high</sub>	-50	1	
	E-UTRA Band 4, 48, 50, 51, 66 NR Band n77	F <sub>DL_low</sub>	-	F <sub>DL_high</sub>	-50	1	2
	E-UTRA Band 12, 85	F <sub>DL_low</sub>	-	F <sub>DL_high</sub>	-50	1	15
n13	E-UTRA Band 2, 4, 5, 12, 13, 17, 25, 26, 27, 29, 41, 48, 50, 51, 53, 54, 66, 70, 71, 74, 85, 106	F <sub>DL_low</sub>	-	F <sub>DL_high</sub>	-50	1	
	E-UTRA Band 14, 103	F <sub>DL_low</sub>	-	F <sub>DL_high</sub>	-50	1	15
	E-UTRA Band 24, 30 NR Band n77	F <sub>DL_low</sub>	-	F <sub>DL_high</sub>	-50	1	2
	Frequency range	769	-	775	-35	0.00625	15
	Frequency range	799	-	805	-35	0.00625	11, 15
n14	E-UTRA Band 2, 4, 5, 12, 13, 14, 17, 23, 24, 25, 26, 27, 29, 30, 41, 48, 53, 54, 66, 70, 71, 85, 103, 106	F <sub>DL_low</sub>	-	F <sub>DL_high</sub>	-50	1	
	NR Band n77	F <sub>DL_low</sub>	-	F <sub>DL_high</sub>	-50	1	2
	Frequency range	769	-	775	-35	0.00625	12, 15
	Frequency range	799	-	805	-35	0.00625	11, 12, 15
n18	E-UTRA Band 1, 3, 11, 21, 34, 40, 42, 65 NR Band n79	F <sub>DL_low</sub>	-	F <sub>DL_high</sub>	-50	1	

NR Band	Spurious emission for UE co-existence						
	Protected band	Frequency range (MHz)			Maximum Level (dBm)	MBW (MHz)	NOTE
	NR Band n77, n78	F <sub>DL_low</sub>	-	F <sub>DL_high</sub>	-50	1	2
	Frequency range	758	-	799	-50	1	
	Frequency range	799	-	803	-40	1	
	Frequency range	860	-	890	-40	1	
	Frequency range	945	-	960	-50	1	
	Frequency range	1884.5	-	1915.7	-41	0.3	8
	Frequency range	2545	-	2575	-50	1	
	Frequency range	2595	-	2645	-50	1	
n20, n82, n91, n92	E-UTRA Band 1, 3, 7, 8, 22, 31, 32, 33, 34, 40, 43, 50, 51, 65, 67, 68, 72, 74, 75, 76 NR Band n100, n101, n104, n109	F <sub>DL_low</sub>	-	F <sub>DL_high</sub>	-50	1	
	E-UTRA Band 20	F <sub>DL_low</sub>	-	F <sub>DL_high</sub>	-50	1	15
	E-UTRA Band 38, 42, 52, 69 NR Band n77, n78	F <sub>DL_low</sub>	-	F <sub>DL_high</sub>	-50	1	2
	Frequency range	758	-	788	-50	1	
n24, n99	E-UTRA Band 2, 4, 5, 10, 12, 13, 14, 17, 24, 25, 26, 29, 30, 41, 48, 66, 70, 71, 85, 103, 106	F <sub>DL_low</sub>	-	F <sub>DL_high</sub>	-50	1	
	NR Band n77	F <sub>DL_low</sub>	-	F <sub>DL_high</sub>	-50	1	2
n25	E-UTRA Band 4, 5, 7, 12, 13, 14, 17, 24, 26, 27, 28, 29, 30, 38, 41, 42, 53, 54, 66, 70, 71, 85, 103, 106 NR Band n105	F <sub>DL_low</sub>	-	F <sub>DL_high</sub>	-50	1	
	E-UTRA Band 2	F <sub>DL_low</sub>	-	F <sub>DL_high</sub>	-50	1	15
	E-UTRA Band 25	F <sub>DL_low</sub>	-	F <sub>DL_high</sub>	-50	1	15
	E-UTRA Band 43, 48 NR Band n77, n78	F <sub>DL_low</sub>	-	F <sub>DL_high</sub>	-50	1	2
	Frequency range	703	-	799 <sup>48</sup>	-50	1	
n26	E-UTRA Band 1, 2, 3, 4, 5, 7, 11, 12, 13, 14, 17, 18, 19, 21, 24, 25, 29, 30, 31, 34, 39, 40, 42, 43, 48, 50, 51, 65, 66, 70, 71, 73, 74, 85, 103, 106	F <sub>DL_low</sub>	-	F <sub>DL_high</sub>	-50	1	
	E-UTRA Band 41, 53, 54 NR Band n77, n78, n79	F <sub>DL_low</sub>	-	F <sub>DL_high</sub>	-50	1	2
	E-UTRA Band 26	F <sub>DL_low</sub>	-	F <sub>DL_high</sub>	-50	1	15
	Frequency range	799 <sup>48</sup>	-	803	-40	1	15
	Frequency range	945	-	960	-50	1	
	Frequency range	1884.5	-	1915.7	-41	0.3	8
	Frequency range	773	-	803	-50	1	
n28, n83	E-UTRA Band 1, 4, 22, 32, 42, 43, 50, 51, 65, 66, 74, 75, 76 NR Band n77, n78, n100, n101, n109	F <sub>DL_low</sub>	-	F <sub>DL_high</sub>	-50	1	2
	E-UTRA Band 1	F <sub>DL_low</sub>	-	F <sub>DL_high</sub>	-50	1	19, 25
	E-UTRA Band 2, 3, 5, 7, 8, 18, 19, 20, 25, 26, 27, 31, 34, 38, 39, 40, 41, 52, 71, 72, 73 NR Band n79, n105	F <sub>DL_low</sub>	-	F <sub>DL_high</sub>	-50	1	
	E-UTRA Band 11, 21	F <sub>DL_low</sub>	-	F <sub>DL_high</sub>	-50	1	19, 24
	Frequency range	470	-	694	-42	8	15, 35
	Frequency range	470	-	710	-26.2	6	34
	Frequency range	662	-	694	-26.2	6	15
	Frequency range	758	-	773	-32	1	15
	Frequency range	773	-	803	-50	1	
	Frequency range	1884.5	-	1915.7	-41	0.3	8, 19



NR Band	Spurious emission for UE co-existence						
	Protected band	Frequency range (MHz)			Maximum Level (dBm)	MBW (MHz)	NOTE
n30	E-UTRA Band 2, 4, 5, 7, 12, 13, 14, 17, 24, 25, 26, 27, 29, 30, 38, 41, 48, 53, 54, 66, 70, 71, 85, 103, 106 NR Band n77	F <sub>DL_low</sub>	-	F <sub>DL_high</sub>	-50	1	
n31	E-UTRA Band 1, 5, 7, 8, 20, 22, 26, 27, 28, 31, 32, 33, 34, 38, 40, 42, 43, 50, 51, 52, 65, 67, 68, 69, 74, 75, 76, 87, 88 NR Band n100, n101	F <sub>DL_low</sub>	-	F <sub>DL_high</sub>	-50	1	
	E-UTRA Band 3	F <sub>DL_low</sub>	-	F <sub>DL_high</sub>	-50	1	2
	Frequency range	470	-	694	-42	8	
n34	E-UTRA Band 1, 3, 7, 8, 11, 18, 19, 20, 21, 22, 26, 28, 31, 32, 33, 38, 39, 40, 41, 42, 43, 44, 45, 50, 51, 52, 65, 67, 69, 72, 74, 75, 76 NR Band n78, n79, n100, n101, n105, n109	F <sub>DL_low</sub>	-	F <sub>DL_high</sub>	-50	1	5
	NR Band n77	F <sub>DL_low</sub>	-	F <sub>DL_high</sub>	-50	1	2
	Frequency range	1884.5	-	1915.7	-41	0.3	8
n38	E-UTRA Band 1, 2, 3, 4, 5, 8, 12, 13, 14, 17, 20, 22, 25, 27, 28, 29, 30, 31, 32, 33, 34, 40, 42, 43, 50, 51, 52, 65, 66, 67, 68, 71, 72, 74, 75, 76, 85, 103 NR Band n100, n101, n109	F <sub>DL_low</sub>	-	F <sub>DL_high</sub>	-50	1	
	NR Band n77, n78, n79	F <sub>DL_low</sub>	-	F <sub>DL_high</sub>	-50	1	
	Frequency range	2620	-	2645	-15.5	5	15, 22, 26
	Frequency range	2645	-	2690	-40	1	15, 22
n39, n98	E-UTRA Band 1, 8, 22, 26, 28, 34, 40, 41, 42, 44, 45, 50, 51, 52, 74 NR Band n79, n105	F <sub>DL_low</sub>	-	F <sub>DL_high</sub>	-50	1	
	NR Band n77, n78	F <sub>DL_low</sub>	-	F <sub>DL_high</sub>	-50	1	2
	Frequency range	1805	-	1855	-40	1	33
	Frequency range	1855	-	1880	-15.5	5	15, 26, 33
n40, n97	E-UTRA Band 1, 3, 5, 7, 8, 11, 18, 19, 20, 21, 22, 26, 27, 28, 31, 32, 33, 34, 38, 39, 41, 42, 43, 44, 45, 50, 51, 52, 65, 67, 68, 69, 72, 74, 75, 76 NR Band n77, n78, n100, n101, n105, n109	F <sub>DL_low</sub>	-	F <sub>DL_high</sub>	-50	1	44
	NR Band n79	F <sub>DL_low</sub>	-	F <sub>DL_high</sub>	-50	1	2
	Frequency range	1884.5	-	1915.7	-41	0.3	8
n41	E-UTRA Band 1, 2, 3, 4, 5, 8, 12, 13, 14, 17, 24, 25, 26, 27, 28, 29, 30, 34, 39, 42, 44, 45, 48, 50, 51, 52, 54, 65, 66, 70, 71, 73, 74, 85, 103, 106 NR Band n77, n78, n105	F <sub>DL_low</sub>	-	F <sub>DL_high</sub>	-50	1	
	E-UTRA Band 40	F <sub>DL_low</sub>	-	F <sub>DL_high</sub>	-40	1	
	NR Band n79	F <sub>DL_low</sub>	-	F <sub>DL_high</sub>	-50	1	2
	E-UTRA Band 11, 18, 19, 21	F <sub>DL_low</sub>	-	F <sub>DL_high</sub>	-50	1	
	Frequency range	1884.5	-	1915.7	-41	0.3	8
	Frequency range	2530	-	2535	-25	1	49
	Frequency range	2505	-	2530	-30	1	49

NR Band	Spurious emission for UE co-existence						
	Protected band	Frequency range (MHz)			Maximum Level (dBm)	MBW (MHz)	NOTE
n47	E-UTRA Band 1, 3, 5, 7, 8, 22, 26, 28, 34, 39, 40, 41, 42, 44, 45, 65, 68, 72, 73, 75, 76	F <sub>DL_low</sub>	-	F <sub>DL_high</sub>	-50	1	
	NR Band n71, n77, n78, n79, n105, n109	F <sub>DL_low</sub>	-	F <sub>DL_high</sub>	-50	1	
n48	E-UTRA Band 2, 4, 5, 12, 13, 14, 17, 24, 25, 26, 29, 30, 41, 50, 51, 53, 54, 66, 70, 71, 74, 85, 103, 106	F <sub>DL_low</sub>	-	F <sub>DL_high</sub>	-50	1	
n50	E-UTRA Band 1, 2, 3, 4, 5, 7, 8, 12, 13, 17, 20, 26, 28, 29, 31, 34, 38, 39, 40, 41, 42, 43, 48, 65, 66, 67, 68, 103 NR Band n100, n101, n105	F <sub>DL_low</sub>	-	F <sub>DL_high</sub>	-50	1	
n51	E-UTRA Band 1, 2, 3, 4, 5, 7, 8, 12, 13, 17, 20, 26, 28, 29, 31, 34, 38, 39, 40, 41, 42, 43, 48, 52, 65, 66, 67, 68, 85, 103 NR Band n100, n101, n105	F <sub>DL_low</sub>	-	F <sub>DL_high</sub>	-50	1	
n53	E-UTRA Band 2, 4, 5, 12, 13, 14, 17, 24, 25, 26, 29, 30, 48, 54, 66, 70, 71, 85, 103, 106 NR Band n77	F <sub>DL_low</sub>	-	F <sub>DL_high</sub>	-50	1	
n54	E-UTRA Band 2, 4, 5, 12, 13, 14, 17, 24, 25, 26, 29, 30, 48, 50, 51, 53, 66, 70, 71, 85, 103, 106 NR NTN Band n255, n256	F <sub>DL_low</sub>	-	F <sub>DL_high</sub>	-50	1	
	NR Band n77	F <sub>DL_low</sub>	-	F <sub>DL_high</sub>	-50	1	2
n65	E-UTRA Band 1, 3, 5, 7, 8, 11, 18, 19, 20, 21, 22, 26, 27, 28, 31, 32, 38, 40, 41, 42, 43, 50, 51, 65, 68, 69, 72, 74, 75, 76 NR Band n78, n79, n100, n105, n109	F <sub>DL_low</sub>	-	F <sub>DL_high</sub>	-50	1	
	NR Band n77	F <sub>DL_low</sub>	-	F <sub>DL_high</sub>	-50	1	2
	E-UTRA Band 34	F <sub>DL_low</sub>	-	F <sub>DL_high</sub>	-50	1	43
	Frequency range	1900	-	1915	-15.5	5	15, 26, 27
	Frequency range	1915	-	1920	+1.6	5	15, 26, 27
n66, n86	E-UTRA Band 2, 4, 5, 7, 12, 13, 14, 17, 25, 26, 27, 28, 29, 30, 38, 41, 43, 50, 51, 53, 66, 70, 71, 74, 85, 103, 106 NR Band n105	F <sub>DL_low</sub>	-	F <sub>DL_high</sub>	-50	1	
	E-UTRA Band 42, 48 NR Band n77	F <sub>DL_low</sub>	-	F <sub>DL_high</sub>	-50	1	2
n70	E-UTRA Band 2, 4, 5, 12, 13, 14, 17, 24, 25, 26, 29, 30, 41, 47, 48, 66, 70, 71, 85, 103, 106	F <sub>DL_low</sub>	-	F <sub>DL_high</sub>	-50	1	
	NR Band n77, n78	F <sub>DL_low</sub>	-	F <sub>DL_high</sub>	-50	1	2
n71	E-UTRA Band 4, 5, 12, 13, 14, 17, 24, 26, 28, 30, 38, 48, 53, 54, 66, 85, 103, 106	F <sub>DL_low</sub>	-	F <sub>DL_high</sub>	-50	1	
	E-UTRA Band 2, 7, 25, 41, 70 NR Band n77, n78	F <sub>DL_low</sub>	-	F <sub>DL_high</sub>	-50	1	2
	E-UTRA Band 29	F <sub>DL_low</sub>	-	F <sub>DL_high</sub>	-38	1	15
	E-UTRA Band 71	F <sub>DL_low</sub>	-	F <sub>DL_high</sub>	-50	1	15
n72	E-UTRA Band 1, 7, 20, 22, 28, 31, 32, 33, 34, 38, 42, 43, 47, 52, 65, 68, 72, 87, 88	F <sub>DL_low</sub>	-	F <sub>DL_high</sub>	-50	1	

NR Band	Spurious emission for UE co-existence						
	Protected band	Frequency range (MHz)			Maximum Level (dBm)	MBW (MHz)	NOTE
	NR Band n100, n101						
	E-UTRA Band 3, 8, 40	F <sub>DL_low</sub>	-	F <sub>DL_high</sub>	-50	1	2
	Frequency range	470	-	694	-42	8	
n74	E-UTRA Band 1, 2, 3, 4, 5, 7, 8, 12, 13, 17, 18, 19, 20, 26, 28, 29, 31, 34, 38, 39, 40, 41, 42, 43, 48, 52, 65, 66, 67, 68, 85 NR Band n77, n78, n100, n101, n103, n105	F <sub>DL_low</sub>	-	F <sub>DL_high</sub>	-50	1	
	NR Band n79	F <sub>DL_low</sub>	-	F <sub>DL_high</sub>	-50	1	2
	Frequency range	1884.5	-	1915.7	-41	0.3	8
	Frequency range	1400	-	1427	-32	27	15, 41
	Frequency range	1475	-	1488	-28	1	15, 42
	Frequency range	1475	-	1488	-50	1	15, 45
	Frequency range	1475.9	-	1510.9	-35	1	15, 46
	Frequency range	1488	-	1518	-50	1	15
n77	E-UTRA Band 1, 2, 3, 4, 5, 7, 8, 11, 12, 13, 14, 17, 18, 19, 20, 21, 24, 25, 26, 27, 28, 29, 30, 34, 39, 40, 41, 53, 54, 65, 66, 70, 71, 74, 85, 103 NR Band n100, n101, n105	F <sub>DL_low</sub>	-	F <sub>DL_high</sub>	-50	1	
	NR Band n104	F <sub>DL_low</sub>	-	F <sub>DL_high</sub>	-50	1	2
	Frequency range	1884.5	-	1915.7	-41	0.3	8
n78	E-UTRA Band 1, 2, 3, 5, 7, 8, 11, 18, 19, 20, 21, 25, 26, 28, 32, 34, 38, 39, 40, 41, 50, 65, 66, 67, 70, 71, 74, 75, 76 NR Band n100, n101, n105, n109	F <sub>DL_low</sub>	-	F <sub>DL_high</sub>	-50	1	
	NR Band n104	F <sub>DL_low</sub>	-	F <sub>DL_high</sub>	-50	1	2
	Frequency range	1884.5	-	1915.7	-41	0.3	8
n79	E-UTRA Band 1, 3, 5, 7, 8, 11, 18, 19, 21, 28, 34, 38, 39, 40, 41, 42, 65, 74 NR Band n105	F <sub>DL_low</sub>	-	F <sub>DL_high</sub>	-50	1	
	Frequency range	1884.5	-	1915.7	-41	0.3	8
n85	E-UTRA Band 2, 5, 13, 14, 17, 24, 25, 26, 27, 30, 41, 53, 54, 70, 71, 74, 103, 106	F <sub>DL_low</sub>	-	F <sub>DL_high</sub>	-50	1	
	E-UTRA Band 4, 48, 50, 51, 66 NR Band n77, n78	F <sub>DL_low</sub>	-	F <sub>DL_high</sub>	-50	1	2
	E-UTRA Band 12, 85	F <sub>DL_low</sub>	-	F <sub>DL_high</sub>	-50	1	15
n95	E-UTRA Band 1, 3, 5, 8, 28, 39, 40, 41 NR Band n78, n79	F <sub>DL_low</sub>	-	F <sub>DL_high</sub>	-50	1	5
	NR Band n77	F <sub>DL_low</sub>	-	F <sub>DL_high</sub>	-50	1	2
	Frequency range	1884.5	-	1915.7	-41	0.3	8
n100	E-UTRA Band 1, 3, 8, 20, 28, 31, 32, 33, 34, 38, 40, 43, 50, 51, 52, 65, 67, 68, 69, 72, 74, 75, 76 NR Band n101, n105, n109	F <sub>DL_low</sub>	-	F <sub>DL_high</sub>	-50	1	
	E-UTRA Band 7, 22, 42 NR Band n77, n78	F <sub>DL_low</sub>	-	F <sub>DL_high</sub>	-50	1	2
	Frequency range	758	-	788	-50	1	
n101	E-UTRA Band 1, 3, 8, 20, 22, 28, 31, 32, 38, 40, 50, 51, 52, 65, 67, 68, 69, 72, 74, 75, 76 NR Band n100, n109	F <sub>DL_low</sub>	-	F <sub>DL_high</sub>	-50	1	

NR Band	Spurious emission for UE co-existence						
	Protected band	Frequency range (MHz)			Maximum Level (dBm)	MBW (MHz)	NOTE
	E-UTRA Band 7, 42, 43 NR Band n77, n78	F <sub>DL_low</sub>	-	F <sub>DL_high</sub>	-50	1	2
	Frequency range	758	-	788	-50	1	
n104	E-UTRA Band 1, 3, 7, 8, 20	F <sub>DL_low</sub>	-	F <sub>DL_high</sub>	-50	1	
	NR Band n77, n78	F <sub>DL_low</sub>	-	F <sub>DL_high</sub>	-50	1	
n105	E-UTRA Band 1, 3, 4, 5, 8, 11, 18, 19, 20, 21, 26, 27, 28, 31, 32, 38, 39, 40, 43, 50, 51, 65, 66, 72, 73, 74, 75, 76 NR Band n79, n100, n109	F <sub>DL_low</sub>	-	F <sub>DL_high</sub>	-50	1	
	E-UTRA Band 2, 7, 22, 25, 34, 41, 42, 52 NR Band n77, n78	F <sub>DL_low</sub>	-	F <sub>DL_high</sub>	-50	1	2
	Frequency range	1884.5	-	1915.7	-41	0.3	8
n106	E-UTRA Band 2, 4, 12, 13, 14, 23, 24, 25, 30, 53, 54, 66, 70, 71, 85, 103, 106	F <sub>DL_low</sub>	-	F <sub>DL_high</sub>	-50	1	
	E-UTRA Band 41, 48, NR Band n77	F <sub>DL_low</sub>	-	F <sub>DL_high</sub>	-50	1	2
	E-UTRA Band 5, 26	F <sub>DL_low</sub>	-	F <sub>DL_high</sub>	-30	1	
n109	E-UTRA Band 22, 32, 42, 43, 65, 75, 76, NR Band n78, n100, n101	F <sub>DL_low</sub>	-	F <sub>DL_high</sub>	-50	1	2
	E-UTRA Band 1	F <sub>DL_low</sub>	-	F <sub>DL_high</sub>	-50	1	19, 25
	E-UTRA Band 3, 7, 8, 20, 38, 40	F <sub>DL_low</sub>	-	F <sub>DL_high</sub>	-50	1	
	Frequency range	662	-	694	-26.2	6	15
	Frequency range	758	-	773	-32	1	15
	Frequency range	773	-	803	-50	1	
NOTE 1: F <sub>DL_low</sub> and F <sub>DL_high</sub> refer to each frequency band specified in Table 5.2-1 in TS 38.101-1 or Table 5.5-1 in TS 36.101							
NOTE 2: As exceptions, measurements with a level up to the applicable requirements defined in Table 6.5.3.1-2 are permitted for each assigned NR carrier used in the measurement due to 2nd, 3rd, 4th or 5th harmonic spurious emissions. Due to spreading of the harmonic emission the exception is also allowed for the first 1 MHz frequency range immediately outside the harmonic emission on both sides of the harmonic emission. This results in an overall exception interval centred at the harmonic emission of (2 MHz + N x L <sub>CRB</sub> x RB <sub>size</sub> kHz), where N is 2, 3, 4, 5 for the 2nd, 3rd, 4th or 5th harmonic respectively. The exception is allowed if the measurement bandwidth (MBW) totally or partially overlaps the overall exception interval.							
NOTE 3: 15 kHz SCS is assumed when RB is mentioned in the note when channel bandwidth is less than or equal to 50 MHz, lowest SCS is assumed when channel bandwidth is larger than 50 MHz. The transmission bandwidth in terms of RB position and range is not limited to 15 kHz SCS and shall scale with SCS accordingly.							
NOTE 4: Void							
NOTE 5: For non-synchronised TDD operation to meet these requirements some restriction will be needed for either the operating band or protected band							
NOTE 6: N/A							
NOTE 7: Void							
NOTE 8: Applicable when co-existence with PHS system operating in 1884.5 - 1915.7 MHz.							
NOTE 9: Void							
NOTE 10: Void							
NOTE 11: Void							
NOTE 12: The emissions measurement shall be sufficiently power averaged to ensure a standard deviation < 0.5 dB							
NOTE 13: Void							
NOTE 14: Void							
NOTE 15: These requirements also apply for the frequency ranges that are less than F <sub>OOB</sub> (MHz) in Table 6.5.3.1-1 from the edge of the channel bandwidth.							
NOTE 16: Void							
NOTE 17: Void							
NOTE 18: Void							

NR Band	Spurious emission for UE co-existence				
	Protected band	Frequency range (MHz)	Maximum Level (dBm)	MBW (MHz)	NOTE
	NOTE 19: Applicable when the assigned NR carrier is confined within 718 MHz and 748 MHz and when the channel bandwidth used is 5 or 10 MHz. Applicable when the assigned NR carrier is confined within 715 MHz and 718 MHz and when the channel bandwidth used is 3 MHz.				
	NOTE 20: Void				
	NOTE 21: This requirement is applicable for any channel bandwidths up to 20MHz within the range 2500 - 2570 MHz with the following restriction: for carriers of 15 MHz bandwidth when carrier centre frequency is within the range 2560.5 - 2562.5 MHz and for carriers of 20 MHz bandwidth when carrier centre frequency is within the range 2552 - 2560 MHz the requirement is applicable only for an uplink transmission bandwidth less than or equal to 54 RB.				
	NOTE 22: This requirement is applicable for power class 3 UE for any channel bandwidths up to 20 MHz. For channel bandwidth within the range 2570 - 2615 MHz with the following restriction: for carriers of 15 MHz bandwidth when the carrier centre frequency is within the range 2605.5 - 2607.5 MHz and for carriers of 20 MHz bandwidth when the carrier centre frequency is within the range 2597 - 2605 MHz the requirement is applicable only for an uplink transmission bandwidth less than or equal to 54 RB. For carriers overlapping the frequency range 2615 - 2620 MHz the requirement applies with the maximum output power configured to +19 dBm in the IE P-Max.				
	NOTE 23: Void				
	NOTE 24: As exceptions, measurements with a level up to the applicable requirement of -38 dBm/MHz is permitted for each assigned NR carrier used in the measurement due to 2nd harmonic spurious emissions. An exception is allowed if there is at least one individual RB within the transmission bandwidth (see Figure 5.3.1-1) for which the 2nd harmonic totally or partially overlaps the measurement bandwidth (MBW).				
	NOTE 25: As exceptions, measurements with a level up to the applicable requirement of -36 dBm/MHz is permitted for each assigned NR carrier used in the measurement due to 3rd harmonic spurious emissions. An exception is allowed if there is at least one individual RB within the transmission bandwidth (see Figure 5.3.1-1) for which the 3rd harmonic totally or partially overlaps the measurement bandwidth (MBW).				
	NOTE 26: For these adjacent bands, the emission limit could imply risk of harmful interference to UE(s) operating in the protected operating band.				
	NOTE 27: This requirement is applicable for power class 3 and channel bandwidths up to 20 MHz within the range 1920 - 1980 MHz with the following restriction: for carriers of 15 MHz bandwidth when the carrier centre frequency is within the range 1927.5 - 1929.5 MHz and for carriers of 20 MHz bandwidth when the carrier centre frequency is within the range 1930 - 1938 MHz the requirement is applicable only for an uplink transmission bandwidth less than or equal to 54 RB.				
	NOTE 28: Void				
	NOTE 29: Void				
	NOTE 30: Void				
	NOTE 31: Void				
	NOTE 32: Void				
	NOTE 33: This requirement is only applicable for carriers with bandwidth up to 20MHz and confined within 1885-1920 MHz (requirement for carriers with at least 1RB confined within 1880 - 1885 MHz is not specified). This requirement applies for an uplink transmission bandwidth less than or equal to 54 RB for carriers of 15 MHz bandwidth when carrier center frequency is within the range 1892.5 - 1894.5 MHz and for carriers of 20 MHz bandwidth when carrier center frequency is within the range 1895 - 1903 MHz. The above restriction is applicable to only power class 3 UEs.				
	NOTE 34: This requirement is applicable for 5 and 10 MHz NR channel bandwidth allocated within 718-728 MHz. For carriers of 10 MHz bandwidth, this requirement applies for an uplink transmission bandwidth less than or equal to 30 RB with $RB_{start} > 1$ and $RB_{start} < 48$ . Applicable when the assigned NR carrier is confined within 715 MHz and 718 MHz and when the channel bandwidth used is 3 MHz.				
	NOTE 35: This requirement is applicable in the case of a 10 MHz NR carrier confined within 703 MHz and 733 MHz, otherwise the requirement of -25 dBm with a measurement bandwidth of 8 MHz applies.				
	NOTE 36: Void				
	NOTE 37: Void				
	NOTE 38: Void				
	NOTE 39: Void				
	NOTE 40: Void				
	NOTE 41: Applicable for cases and when the lower edge of the assigned NR UL channel bandwidth frequency is greater than or equal to 1427 MHz + the channel BW assigned for 5 and 10 MHz bandwidth, and when the lower edge of the assigned NR UL channel bandwidth frequency is greater than or equal to 1440 MHz for 15 and 20 MHz bandwidth. This requirement shall be verified with UE transmission power configured as high as possible but no higher than 15 dBm.				

NR Band	Spurious emission for UE co-existence			
	Protected band	Frequency range (MHz)	Maximum Level (dBm)	MBW (MHz)
NOTE 42: Applicable when upper edge of the assigned NR UL channel bandwidth frequency is more than 1460 MHz and less than or equal to 1470 MHz for 5 MHz bandwidth, and when the upper edge of the assigned NR UL channel bandwidth frequency is more than 1460 MHz and less than or equal to 1465 MHz for 10 MHz bandwidth. NOTE 43: This requirement is applicable for UE which is operating in power class 3 and NR channel bandwidths up to 20MHz within frequency range 1920-1980 MHz. NOTE 44: As exceptions, for 90 and 100 MHz channel bandwidth, -40 dBm/MHz is applicable in the frequency range of 2496 – 2505 MHz. NOTE 45: Applicable when upper edge of the assigned NR UL channel bandwidth frequency is equal to or less than 1460 MHz. NOTE 46: Applicable for 5 MHz bandwidth and when the NR carrier is within 1447.9 – 1462.9 MHz. NOTE 47: This requirement is applicable for power class 3 and channel bandwidths up to 20MHz. NOTE 48: For 20MHz channel bandwidth this value is changed to 794MHz. NOTE 49: Applicable when contained within 2545 – 2575 MHz in Japan. Channel bandwidth shall be confined so that there is at least $BW_{Channel}$ separation between 2535 MHz and lower $BW_{Channel}$ edge in the current release. With this $BW_{Channel}$ placement the requirement is covered by general SEM and the spurious emission limits.				

NOTE: To simplify Table 6.5.3.2-1, E-UTRA band numbers are listed for bands which are specified only for E-UTRA operation or both E-UTRA and NR operation. NR band numbers are listed for bands which are specified only for NR operation.

### 6.5.3.3 Additional spurious emissions

These requirements are specified in terms of an additional spectrum emission requirement. Additional spurious emission requirements are signalled by the network to indicate that the UE shall meet an additional requirement for a specific deployment scenario as part of the cell handover/broadcast message.

#### 6.5.3.3.1 Requirement for network signalling value "NS\_04"

When "NS\_04" is indicated in the cell, the power of any UE emission shall not exceed the levels specified in Table 6.5.3.3.1-1. This requirement also applies for the frequency ranges that are less than  $F_{OOB}$  (MHz) in Table 6.5.3.1-1 from the edge of the channel bandwidth.

**Table 6.5.3.3.1-1: Additional requirements for "NS\_04"**

Frequency range (MHz)	Channel bandwidth (MHz) / Spectrum emission limit (dBm)	Measurement bandwidth
	10, 15, 20, 30, 40, 50, 60, 80, 90, 100 MHz	
$2495 \leq f < 2496$	-13	1 % of Channel BW
$2490.5 \leq f < 2495$	-13	1 MHz
$0.009 < f < 2490.5$	-25	1 MHz

#### 6.5.3.3.2 Requirement for network signalling value "NS\_17"

When "NS\_17" is indicated in the cell, the power of any UE emission shall not exceed the levels specified in Table 6.5.3.3.2-1. This requirement also applies for the frequency ranges that are less than  $F_{OOB}$  (MHz) in Table 6.5.3.1-1 from the edge of the channel bandwidth.

**Table 6.5.3.3.2-1: Additional requirements for "NS\_17"**

Frequency range (MHz)	Channel bandwidth (MHz) / Spectrum emission limit (dBm)	Measurement bandwidth	NOTE
	3, 5, 10		
$470 \leq f \leq 710$	-26.2	6 MHz	1

NOTE 1: Applicable when the assigned NR carrier is confined within 718 MHz and 748 MHz and when the channel bandwidth used is 5 or 10 MHz. Applicable when the assigned NR carrier is confined within 715 MHz and 718 MHz and when the channel bandwidth used is 3 MHz.

#### 6.5.3.3.3 Requirement for network signalling value "NS\_18"

When "NS\_18" is indicated in the cell, the power of any UE emission shall not exceed the levels specified in Table 6.5.3.3.3-1. This requirement also applies for the frequency ranges that are less than  $F_{OOB}$  (MHz) in Table 6.5.3.1-1 from the edge of the channel bandwidth.

**Table 6.5.3.3.3-1: Additional requirements for "NS\_18"**

Frequency range (MHz)	Channel bandwidth (MHz) / Spectrum emission limit (dBm)	Measurement bandwidth	
	3, 5, 10, 15, 20, 25, 30		
692-698	-26.2	6 MHz	

#### 6.5.3.3.4 Requirement for network signalling values "NS\_05" and "NS\_05U"

When "NS\_05" or "NS\_05U" is indicated in the cell, the power of any UE emission shall not exceed the levels specified in Table 6.5.3.3.4-1. This requirement also applies for the frequency ranges that are less than  $F_{OOB}$  (MHz) in Table 6.5.3.1-1 from the edge of the channel bandwidth.

**Table 6.5.3.3.4-1: Additional requirements for "NS\_05" and "NS\_05U"**

Frequency range (MHz)	Channel bandwidth (MHz) / Spectrum emission limit (dBm)	Measurement bandwidth	
	5, 10, 15, 20		
$1884.5 \leq f \leq 1915.7$	-41	300 kHz	

#### 6.5.3.3.5 Requirement for network signalling values "NS\_43" and "NS\_43U"

When "NS\_43" or "NS\_43U" is indicated in the cell, the power of any UE emission shall not exceed the levels specified in Table 6.5.3.3.5-1. This requirement also applies for the frequency ranges that are less than  $F_{OOB}$  (MHz) in Table 6.5.3.1-1 from the edge of the channel bandwidth.

**Table 6.5.3.3.5-1: Additional requirements for "NS\_43" and "NS\_43U"**

Frequency range (MHz)	Channel bandwidth (MHz) / Spectrum emission limit (dBm)	Measurement bandwidth	
	5, 10, 15		
$860 \leq f \leq 890$	-40	1 MHz	
NOTE 1: Applicable for 5 MHz and 15 MHz channel BW confined between 900 MHz and 915 MHz and for 10 MHz channel BW confined between 905 MHz and 915 MHz			

#### 6.5.3.3.6 Requirement for network signalling value "NS\_37"

When "NS\_37" is indicated in the cell, the power of any UE emission shall not exceed the levels specified in Table 6.5.3.3.6-1. This requirement also applies for the frequency ranges that are less than  $F_{OOB}$  (MHz) in Table 6.5.3.1-1 from the edge of the channel bandwidth.

**Table 6.5.3.3.6-1: Additional requirement for "NS\_37"**

Frequency range (MHz)	Channel bandwidth (MHz) / Spectrum emission limit (dBm)	Measurement bandwidth
	5, 10, 15	

$1475.9 \leq f \leq 1510.9$	-35	1 MHz
-----------------------------	-----	-------

#### 6.5.3.3.7 Requirement for network signalling value "NS\_38"

When "NS\_38" is indicated in the cell, the power of any UE emission shall not exceed the levels specified in Table 6.5.3.3.7-1. This requirement also applies for the frequency ranges that are less than  $F_{OOB}$  (MHz) in Table 6.5.3.1-1 from the edge of the channel bandwidth.

**Table 6.5.3.3.7-1: Additional requirements for NR channels assigned within 1430-1452MHz for "NS\_38"**

Frequency range (MHz)	Channel bandwidth (MHz) / Spectrum emission limit (dBm)	Measurement bandwidth
	5, 10, 15	
$1400 \leq f \leq 1427$	-32	27 MHz
NOTE 1: This requirement shall be verified with UE transmission power configured as high as possible but no higher than 15 dBm.		

#### 6.5.3.3.8 Requirement for network signalling value "NS\_39"

When "NS\_39" is indicated in the cell, the power of any UE emission shall not exceed the levels specified in Table 6.5.3.3.8-1. This requirement also applies for the frequency ranges that are less than  $F_{OOB}$  (MHz) in Table 6.5.3.1-1 from the edge of the channel bandwidth.

**Table 6.5.3.3.8-1: Additional requirements for "NS\_39"**

Frequency range (MHz)	Channel bandwidth (MHz) / Spectrum emission limit (dBm)	Measurement bandwidth
	5, 10, 15, 20	
$1475 \leq f \leq 1488$	-28	1 MHz

#### 6.5.3.3.9 Requirement for network signalling value "NS\_40"

When "NS\_40" is indicated in the cell, the power of any UE emission shall not exceed the levels specified in Table 6.5.3.3.9-1. This requirement also applies for the frequency ranges that are less than  $F_{OOB}$  (MHz) in Table 6.5.3.1-1 from the edge of the channel bandwidth.

**Table 6.5.3.3.9-1: Additional requirements for NR channels assigned within 1427-1432MHz for "NS\_40"**

Frequency range (MHz)	Channel bandwidth (MHz) / Spectrum emission limit (dBm)	Measurement bandwidth
	5	
$1400 \leq f \leq 1427$	-32	27 MHz
NOTE 1: This requirement shall be verified with UE transmission power configured as high as possible but no higher than 15 dBm.		

#### 6.5.3.3.10 Requirement for network signalling value "NS\_41"

When "NS\_41" is indicated in the cell, the power of any UE emission shall not exceed the levels specified in Table 6.5.3.3.10-1. This requirement also applies for the frequency ranges that are less than  $F_{OOB}$  (MHz) in Table 6.5.3.1-1 from the edge of the channel bandwidth.



**Table 6.5.3.3.10-1: Additional requirements for NR channels assigned within 1432-1517 MHz for "NS\_41"**

Frequency range (MHz)	Channel bandwidth (MHz) / Spectrum emission limit (dBm)	Measurement bandwidth
	5, 10, 15, 20, 40, 50, 60	
$1400 \leq f \leq 1427$	-32	27 MHz
NOTE 1: This requirement shall be verified with UE transmission power configured as high as possible but no higher than 15 dBm.		

**6.5.3.3.11 Requirement for network signalling value "NS\_42"**

When "NS\_42" is indicated in the cell, the power of any UE emission shall not exceed the levels specified in Table 6.5.3.3.11-1. This requirement also applies for the frequency ranges that are less than  $F_{OoB}$  (MHz) in Table 6.5.3.1-1 from the edge of the channel bandwidth.

**Table 6.5.3.3.11-1: Additional requirements for NR channels assigned within 1432-1517 MHz for "NS\_42"**

Frequency range (MHz)	Channel bandwidth (MHz) / Spectrum emission limit (dBm)	Measurement bandwidth
	5, 10, 15, 20, 40, 50, 60 MHz	
$1518 \leq f \leq 1520$	-0.8	1 MHz
$1520 < f \leq 1559$	-30	1 MHz

**6.5.3.3.12 Requirement for network signalling value "NS\_21"**

When "NS\_21" is indicated in the cell, the power of any UE emission shall not exceed the levels specified in Table 6.5.3.3.12-1. These requirements also apply for the frequency ranges that are less than  $F_{OoB}$  (MHz) in Table 6.5.3.1-1 from the edge of the channel bandwidth.

**Table 6.5.3.3.12-1: Additional requirements for "NS\_21"**

Frequency range (MHz)	Channel bandwidth (MHz) / Spectrum emission limit (dBm)	Measurement bandwidth
	5, 10	
$2200 \leq f < 2288$	-40	1 MHz
$2288 \leq f < 2292$	-37	1 MHz
$2292 \leq f < 2296$	-31	1 MHz
$2296 \leq f < 2300$	-25	1 MHz
$2320 \leq f < 2324$	-25	1 MHz
$2324 \leq f < 2328$	-31	1 MHz
$2328 \leq f < 2332$	-37	1 MHz
$2332 \leq f \leq 2395$	-40	1 MHz

**6.5.3.3.13 Requirement for network signalling value "NS\_24"**

When "NS\_24" is indicated in the cell, the power of any UE emission shall not exceed the levels specified in Table 6.5.3.3.13-1. This requirement also applies for the frequency ranges that are less than  $F_{OoB}$  (MHz) in Table 6.5.3.1-1 from the edge of the channel bandwidth.

**Table 6.5.3.3.13-1: Additional requirements for "NS\_24"**

Frequency range (MHz)	Channel bandwidth (MHz) / Spectrum emission limit (dBm)	Measurement bandwidth
	5 MHz, 10 MHz, 15 MHz, 20 MHz	
$2010 \leq f \leq 2025$	-50	1 MHz

NOTE 1: This requirement applies at a frequency offset equal or larger than 5 MHz from the upper edge of the channel bandwidth, whenever these frequencies overlap with the specified frequency band.

#### 6.5.3.3.14 Requirement for network signalling value "NS\_27"

When "NS\_27" is indicated in the cell, the power of any UE emission shall not exceed the levels specified in Table 6.5.3.3.14-1. This requirement also applies for the frequency ranges that are less than  $F_{OOB}$  (MHz) in Table 6.5.3.1-1 from the edge of the channel bandwidth.

**Table 6.5.3.3.14-1: Additional requirements for "NS\_27"**

Frequency range (MHz)	Channel bandwidth (MHz) / Spectrum emission limit (dBm)	Measurement bandwidth
	5, 10, 15, 20, 30, 40	
9 kHz – 3530 MHz	-40	1 MHz
3530 MHz – 3540 MHz	-25	
3710 MHz – 3720 MHz	-25	
3720 MHz – 12.75 GHz	-40	

#### 6.5.3.3.15 Requirement for network signalling value "NS\_47"

When "NS\_47" is indicated in the cell, the power of any UE emission shall not exceed the levels specified in Table 6.5.3.3.15-1. This requirement also applies for the frequency ranges that are less than  $F_{OOB}$  (MHz) in Table 6.5.3.1-1 from the edge of the channel bandwidth.

**Table 6.5.3.3.15-1: Additional requirements for NR channels assigned within 2545 - 2575 MHz for "NS\_47"**

Frequency range (MHz)	Channel bandwidth (MHz) / Spectrum emission limit (dBm)	Measurement bandwidth
	30	
$2530 \leq f \leq 2535$	-25	1 MHz
$2505 \leq f \leq 2530$	-30	1 MHz

#### 6.5.3.3.16 Requirement for network signalling value "NS\_50"

When "NS\_50" is indicated in the cell, the power of any UE emission shall not exceed the levels specified in Table 6.5.3.3.16-1. This requirement also applies for the frequency ranges that are less than  $F_{OOB}$  (MHz) in Table 6.5.3.1-1 from the edge of the channel bandwidth.

**Table 6.5.3.3.16-1: Additional requirements for "NS\_50"**

Protected band	Frequency range (MHz)			Maximum Level (dBm)	MBW (MHz)	NOTE
Frequency range	1805	-	1855	-40	1	1
Frequency range	1855	-	1880	-15.5	5	1, 2, 3
NOTE 1: This requirement is applicable for carriers with aggregated channel bandwidths confined in 1885-1920 MHz for $\leq 35$ MHz channel BWs and confined in 1880-1920 MHz for 40 MHz channel BW.						
NOTE 2: The requirement also applies for the frequency ranges that are less than $F_{OOB}$ (MHz) in Table 6.5.3.1-1 and Table 6.5A.3.1-1 from the edge of the channel bandwidth.						
NOTE 3: For these adjacent bands, the emission limit could imply risk of harmful interference to UE(s) operating in the protected operating band.						

#### 6.5.3.3.17 Requirement for network signalling value "NS\_12"

When "NS\_12" is indicated in the cell, the power of any UE emission shall not exceed the levels specified in Table 6.5.3.3.17-1. This requirement also applies for the frequency ranges that are less than  $F_{OOB}$  (MHz) in Table 6.5.3.1-1 from the edge of the channel bandwidth.

**Table 6.5.3.3.17-1: Additional requirements "NS\_12"**

Frequency range (MHz)	Channel bandwidth / Spectrum emission limit (dBm)	Measurement bandwidth
	3 MHz, 5 MHz, 10 MHz	
$806 \leq f \leq 813.5$	-42	6.25 kHz
NOTE 1: The requirement applies for NR carriers with lower channel edge at or above 814 MHz.		
NOTE 2: The emissions measurement shall be sufficiently power averaged to ensure a standard deviation < 0.5 dB.		

**6.5.3.3.18 Requirement for network signalling value "NS\_13"**

When "NS\_13" is indicated in the cell, the power of any UE emission shall not exceed the levels specified in Table 6.5.3.3.18-1. This requirement also applies for the frequency ranges that are less than  $F_{OOB}$  (MHz) in Table 6.5.3.1-1 from the edge of the channel bandwidth.

**Table 6.5.3.3.18-1: Additional requirements "NS\_13"**

Frequency range (MHz)	Channel bandwidth / Spectrum emission limit (dBm)	Measurement bandwidth
	3 MHz, 5 MHz	
$806 \leq f \leq 816$	-42	6.25 kHz
NOTE 1: The requirement applies for NR carriers with lower channel edge at or above 817 MHz.		
NOTE 2: The emissions measurement shall be sufficiently power averaged to ensure a standard deviation < 0.5 dB.		

**6.5.3.3.19 Requirement for network signalling value "NS\_14"**

When "NS\_14" is indicated in the cell, the power of any UE emission shall not exceed the levels specified in Table 6.5.3.3.19-1. This requirement also applies for the frequency ranges that are less than  $F_{OOB}$  (MHz) in Table 6.5.3.1-1 from the edge of the channel bandwidth.

**Table 6.5.3.3.19-1: Additional requirements "NS\_14"**

Frequency range (MHz)	Channel bandwidth / Spectrum emission limit (dBm)	Measurement bandwidth
	10 MHz, 15 MHz, 20MHz	
$806 \leq f \leq 816$	-42	6.25 kHz
NOTE 1: The requirement applies for NR carriers with lower channel edge at or above 824 MHz		
NOTE 2: The emissions measurement shall be sufficiently power averaged to ensure a standard deviation < 0.5 dB.		

**6.5.3.3.20 Requirement for network signalling value "NS\_15"**

When "NS\_15" is indicated in the cell, the power of any UE emission shall not exceed the levels specified in Table 6.5.3.3.20-1. This requirement also applies for the frequency ranges that are less than  $F_{OOB}$  (MHz) in Table 6.5.3.1-1 from the edge of the channel bandwidth.

**Table 6.5.3.3.20-1: Additional requirements "NS\_15"**

Frequency range (MHz)	Channel bandwidth / Spectrum emission limit (dBm)	Measurement bandwidth
	3 MHz, 5 MHz, 10 MHz, 15 MHz, 20 MHz	
$851 \leq f \leq 859$	-53	6.25 kHz

NOTE 1: The emissions measurement shall be sufficiently power averaged to ensure a standard deviation < 0.5 dB.

#### 6.5.3.3.21 Requirement for network signalling value "NS\_45"

When "NS\_45" is indicated in the cell, the power of any UE emission shall not exceed the levels specified in Table 6.5.3.3.21-1. This requirement also applies for the frequency ranges that are less than  $F_{OOB}$  (MHz) in Table 6.5.3.1-1 from the edge of the channel bandwidth.

**Table 6.5.3.3.21-1: Additional requirements "NS\_45"**

Frequency range (MHz)	Channel bandwidth / Spectrum emission limit (dBm)		Measurement bandwidth
	5 MHz	10 MHz	
$0.009 < f \leq 2473.5$	-25	-25	1 MHz
$2473.5 < f \leq 2477.5$	-25	-13	1 MHz
$2477.5 < f \leq 2478.5$	-13	-13	1 MHz
$2478.5 < f \leq 2483.5$	-10	-10	1 MHz
$2495 \leq f < 2496$	-13	-13	1% of Channel Bandwidth
$2496 \leq f < 2501$	-13	-13	1 MHz
$2501 < f \leq 2505$	-25	-13	1 MHz
$2505 \leq f \leq 5^{\text{th}}$ harmonic of the upper frequency edge of the UL operating band	-25	-25	1 MHz

#### 6.5.3.3.22 Requirement for network signalling values "NS\_48" and "NS\_51"

When "NS\_48" or "NS\_51" is indicated in the cell, the power of any UE emission shall not exceed the levels specified in Table 6.5.3.3.22-1. This requirement also applies for the frequency ranges that are less than  $F_{OOB}$  (MHz) in Table 6.5.3.1-1 from the edge of the channel bandwidth.

**Table 6.5.3.3.22-1: Additional requirements for "NS\_48" and "NS\_51"**

Protected band	Frequency range (MHz)			Maximum Level (dBm)	MBW (MHz)	NOTE
E-UTRA band 34 – NR band n34	$F_{DL\_low}$	-	$F_{DL\_high}$	-50	1	
Frequency range	1900	-	1915	-15.5	5	1
Frequency range	1915	-	1920	+1.6	5	1
NOTE 1: For these adjacent bands, the emission limit could imply risk of harmful interference to UE(s) operating in the protected operating band.						

#### 6.5.3.3.23 Requirement for network signalling value "NS\_49"

When "NS\_49" is indicated in the cell, the power of any UE emission shall not exceed the levels specified in Table 6.5.3.3.23-1. This requirement also applies for the frequency ranges that are less than  $F_{OOB}$  (MHz) in Table 6.5.3.1-1 from the edge of the channel bandwidth.

**Table 6.5.3.3.23-1: Additional requirements for "NS\_49"**

Protected band	Frequency range (MHz)			Maximum Level (dBm)	MBW (MHz)	NOTE
E-UTRA band 34 - NR band n34	$F_{DL\_low}$	-	$F_{DL\_high}$	-50	1	
Frequency range	1880	-	1895	-40	1	
Frequency range	1895	-	1915	-15.5	5	1
Frequency range	1915	-	1920	1.6	5	1
NOTE 1: For these adjacent bands, the emission limit could imply risk of harmful interference to UE(s) operating in the protected operating band.						

### 6.5.3.3.24 Requirement for network signalling value "NS\_44"

When "NS\_44" is indicated in the cell, the power of any UE emission shall not exceed the levels specified in Table 6.5.3.3.24-1. This requirement also applies for the frequency ranges that are less than  $F_{OOB}$  (MHz) in Table 6.5.3.1-1 from the edge of the channel bandwidth.

**Table 6.5.3.3.24-1: Additional requirements for "NS\_44"**

Protected band	Frequency range (MHz)			Maximum Level (dBm)	MBW (MHz)	NOTE
Frequency range	2620	-	2645	-15.5	5	1, 2
Frequency range	2645	-	2690	-40	1	1
NOTE 1: This requirement is applicable for carriers confined in 2570-2615 MHz.						
NOTE 2: For these adjacent bands, the emission limit could imply risk of harmful interference to UE(s) operating in the protected operating band.						

### 6.5.3.3.25 Requirement for network signalling value "NS\_46"

When "NS\_46" is indicated in the cell, the power of any UE emission shall not exceed the levels specified in Table 6.5.3.3.25-1. This requirement also applies for the frequency ranges that are less than  $F_{OOB}$  (MHz) in Table 6.5.3.1-1 from the edge of the channel bandwidth.

**Table 6.5.3.3.25-1: Additional requirements for "NS\_46"**

Protected band	Frequency range (MHz)			Maximum Level (dBm)	MBW (MHz)	NOTE
Frequency range	2570	-	2575	+1.6	5	1, 2
Frequency range	2575	-	2595	-15.5	5	1, 2
Frequency range	2595	-	2620	-40	1	1
NOTE 1: This requirement is applicable for all carriers confined in 2500-2570 MHz. For power class 3 UE special restrictions apply for channel bandwidths up to 20MHz: For carriers of 15 MHz bandwidth when carrier centre frequency is within the range 2560.5 - 2562.5 MHz and for carriers of 20 MHz bandwidth when carrier centre frequency is within the range 2552 - 2560 MHz the requirement is applicable only for an uplink transmission bandwidth less than or equal to 54 RB with the minimum supported SCS of 15KHz.						
NOTE 2: For these adjacent bands, the emission limit could imply risk of harmful interference to UE(s) operating in the protected operating band.						

### 6.5.3.3.26 Requirement for network signalling value "NS\_07"

When "NS\_07" is indicated in the cell, the power of any UE emission shall not exceed the levels specified in Table 6.5.3.3.26-1. This requirement also applies for the frequency ranges that are less than  $F_{OOB}$  (MHz) in Table 6.5.3.1-1 from the edge of the channel bandwidth.

**Table 6.5.3.3.26-1: Additional requirements for "NS\_07"**

Frequency range (MHz)	Channel bandwidth / Spectrum emission limit (dBm)	Measurement bandwidth
	5 MHz, 10 MHz	
$769 \leq f \leq 775$	-57	6.25 kHz
NOTE: The emissions measurement shall be sufficiently power averaged to ensure standard standard deviation < 0.5 dB.		

### 6.5.3.3.27 Requirement for network signalling value "NS\_56"

When "NS\_56" is indicated in the cell, the power of any UE emission shall not exceed the levels specified in Table 6.5.3.3.27-1. This requirement also applies for the frequency ranges that are less than  $F_{OOB}$  (MHz) in Table 6.5.3.1-1 from the edge of the channel bandwidth.

**Table 6.5.3.3.27-1: Additional requirements for "NS\_56"**

Frequency range (MHz)	Channel bandwidth / Spectrum emission limit <sup>1</sup> (dBm)	Measurement bandwidth	NOTE
-----------------------	--	-----------------------	------

	5 MHz, 10MHz		
$1541 \leq f \leq 1559$	-102	2kHz	Averaged over any 2 millisecond active transmission interval
$1559 \leq f \leq 1608$	-85	700Hz	
$1608 \leq f \leq 1610$	$-85 + 5/2 (f-1608)$	700Hz	
$1610 \leq f \leq 1625$	$-80 + 66/15 (f-1610)$	700Hz	
$1541 \leq f \leq 1608$	-75	1MHz	Averaged over any 2 millisecond active transmission interval
$1608 \leq f \leq 1610$	$-75 + 5/2 (f-1608)$	1MHz	
$1610 \leq f \leq 1627.5$	$-70 + 57/17.5 (f-1610)$	1MHz	
1627.5	-37	4kHz	
$1638.5 \leq f \leq 1645.5$	-28	4kHz	
$1657.5 \leq f \leq 1660.5$	-28	4kHz	
NOTE 1: The EIRP requirement in regulation is converted to conducted requirement using a 0 dBi antenna.			

### 6.5.3.3.28 Requirement for network signalling value "NS\_62"

When "NS\_62" is indicated in the cell, the power of any UE emission shall not exceed the levels specified in Table 6.5.3.3.28-1. This requirement also applies for the frequency ranges that are less than  $F_{OOB}$  (MHz) in Table 6.5.3.1-1 from the edge of the channel bandwidth.

**Table 6.5.3.3.28-1: Additional requirements for "NS\_62"**

Frequency range (MHz)	Channel bandwidth / Spectrum emission limit (dBm)	Measurement bandwidth	NOTE
	5 MHz		
$1541 \leq f \leq 1559$	-102	2kHz	Averaged over any 2 millisecond active transmission interval
$1559 \leq f \leq 1608$	-85	700Hz	
$1608 \leq f \leq 1610$	$-85 + 5/2 (f-1608)$	700Hz	
$1610 \leq f \leq 1625$	$-80 + 66/15 (f-1610)$	700Hz	
$1541 \leq f \leq 1608$	-75	1MHz	Averaged over any 2 millisecond active transmission interval
$1608 \leq f \leq 1610$	$-75 + 5/2 (f-1608)$	1MHz	
$1610 \leq f \leq 1625$	$-70 + 66/15 (f-1610)$	1MHz	
NOTE 1: The EIRP requirement in regulation is converted to conducted requirement using 0 dBi antenna.			

## 6.5.4 Transmit intermodulation

The transmit intermodulation performance is a measure of the capability of the transmitter to inhibit the generation of signals in its non linear elements caused by presence of the wanted signal and an interfering signal reaching the transmitter via the antenna.

UE transmit intermodulation is defined by the ratio of the mean power of the wanted signal to the mean power of the intermodulation product when an interfering CW signal is added at a level below the wanted signal at each transmitter antenna port with the other antenna port(s) if any terminated. Both the wanted signal power and the intermodulation product power are measured through NR rectangular filter with measurement bandwidth shown in Table 6.5.4-1.

The requirement of transmit intermodulation is specified in Table 6.5.4-1.

**Table 6.5.4-1: Transmit Intermodulation**

Wanted signal channel bandwidth	$BW_{Channel}$	
Interference signal	$BW_{Channel}$	$2 * BW_{Channel}$

frequency offset from channel center		
Interference CW signal level	-40 dBc	
Intermodulation product	< -29 dBc	< -35 dBc
Measurement bandwidth	The maximum transmission bandwidth configuration among the different SCS's for the channel BW as defined in Table 6.5.2.4.1-1	
Measurement offset from channel center	$BW_{\text{Channel}}$ and $2 \cdot BW_{\text{Channel}}$	$2 \cdot BW_{\text{Channel}}$ and $4 \cdot BW_{\text{Channel}}$

## 6.5A Output RF spectrum emissions for CA

### 6.5A.0 General

For inter-band carrier aggregation with one uplink carrier assigned to one NR band, the output RF spectrum emissions requirements in clause 6.5 apply.

#### 6.5A.1 Occupied bandwidth for CA

##### 6.5A.1.1 Void

##### 6.5A.1.1a Occupied bandwidth for Intra-band contiguous CA

For intra-band contiguous carrier aggregation the occupied bandwidth is a measure of the bandwidth containing 99 % of the total integrated power of the transmitted spectrum. The occupied bandwidth shall be less than the aggregated channel bandwidth defined in clause 5.3A.3.

##### 6.5A.1.2 Occupied bandwidth for Intra-band non-contiguous CA

For intra-band non-contiguous carrier aggregation, the OBW requirement is met when the ratio of the transmitted power in all sub-blocks of the uplink CA configuration to the total integrated power of the transmitted spectrum is greater than 99%.

##### 6.5A.1.3 Occupied bandwidth for Inter-band CA

For inter-band carrier aggregation with two contiguous carriers assigned to one NR band, the occupied bandwidth requirements in subclause 6.5A.1.1a apply for that band.

For inter-band carrier aggregation with uplink assigned to two NR bands, the occupied bandwidth is defined per component carrier. Occupied bandwidth is the bandwidth containing 99 % of the total integrated mean power of the transmitted spectrum on assigned channel bandwidth on the component carrier. The occupied bandwidth shall be less than the channel bandwidth specified in Table 6.5.1-1.

### 6.5A.2 Out of band emission for CA

#### 6.5A.2.1 General

This clause contains requirements for out of band emissions for UE configured of carrier aggregation.

#### 6.5A.2.2 Spectrum emission mask

##### 6.5A.2.2.1 Spectrum emission mask for intra-band contiguous CA

For intra-band contiguous carrier aggregation the spectrum emission mask of the UE applies to frequencies ( $\Delta f_{\text{OOB}}$ ) starting from the  $\pm$  edge of the aggregated channel bandwidth. For intra-band contiguous carrier aggregation, the power of any UE emission shall not exceed the levels specified in Table 6.5A.2.2.1-1 for the specified channel bandwidth.

For power class 2 intra-band contiguous carrier aggregation, the spectrum emission mask is measured as the sum from both UE transmit antenna connectors when UE indicates support for *dualPA-Architecture* IE.

**Table 6.5A.2.2.1-1: General NR CA spectrum emission mask**

$\Delta f_{\text{OOB}}$ (MHz)	Spectrum emission limit(dBm)	MBW(MHz)
$\pm 0 - 1$	-13	$\text{Min}(0.01 * BW_{\text{channel\_CA}}, 0.4)$
$\pm 1 - 5$	-10	1MHz
$\pm 5 - BW_{\text{channel\_CA}}$	-13	1MHz
$\pm BW_{\text{channel\_CA}} -$ $BW_{\text{channel\_CA}} + 5$	-25	1MHz

### 6.5A.2.2.2 Spectrum emission mask for intra-band non-contiguous CA

For intra-band non-contiguous carrier aggregation the spectrum emission mask requirement is defined as a composite spectrum emissions mask. Composite spectrum emission mask applies to frequencies up to  $\Delta f_{\text{OOB}}$  starting from the edges of the sub-blocks. Composite spectrum emission mask is defined as follows

- Composite spectrum emission mask is a combination of individual sub-block spectrum emissions masks
- In case the sub-block consist of one component carrier the sub-lock general spectrum emission mask is defined in subclause 6.5.2.1
- If for some frequency sub-block spectrum emission masks overlap then spectrum emission mask allowing higher power spectral density applies for that frequency
- If for some frequency a sub-block spectrum emission mask overlaps with the sub-block bandwidth of another sub-block, then the emission mask does not apply for that frequency.

For intra-band non-contiguous carrier aggregation, the spectrum emission mask is measured as the sum from both UE transmit antenna connectors when UE indicates support for *dualPA-Architecture* IE.

### 6.5A.2.2.3 Spectrum emission mask for Inter-band CA

For inter-band carrier aggregation with two contiguous carriers assigned to one NR band, the spectrum emission mask requirements in subclause 6.5A.2.2.1 apply for that band.

For inter-band carrier aggregation with two uplink non-contiguous carrier assigned to one NR band, the spectrum emission mask requirements in subclause 6.5A.2.2.2 apply for that band.

For inter-band carrier aggregation with uplink assigned to two NR bands, the spectrum emission mask of the UE is defined per component carrier while both component carriers are active and the requirements are specified in clauses 6.5.2.1 and 6.5.2.2. If for some frequency spectrum emission masks of component carriers overlap then spectrum emission mask allowing higher power spectral density applies for that frequency. If for some frequency a component carrier spectrum emission mask overlaps with the channel bandwidth of another component carrier, then the emission mask does not apply for that frequency.

For combinations of intra-band and inter-band carrier aggregation with three uplink component carriers (up to two continuously aggregated carriers per operating band), the spectrum emission mask of the UE is defined per NR band while all component carriers are active. For the NR band supporting one component carrier the requirements in subclauses 6.5.2.1 and 6.5.2.2 apply. For the NR band supporting two contiguous component carriers the requirements specified in subclause 6.5A.2.2.1 apply. If for some frequency spectrum emission masks of single component carrier and two contiguous component carriers overlap then spectrum emission mask allowing higher power spectral density applies for that frequency. If for some frequency spectrum emission masks of single component carrier or two contiguous component carriers overlap then the emission mask does not apply for that frequency.



6.5.A.2.2.4 Void

### 6.5A.2.3 Additional spectrum emission mask for CA

#### 6.5A.2.3.1 Additional spectrum emission mask for intra-band contiguous CA

##### 6.5A.2.3.1.1 Requirements for network signalling value "CA\_NS\_04"

When "CA\_NS\_04" is indicated in the cell, the power of any UE emission shall not exceed the levels specified in Table 6.5A.2.3.1.1-1. For power class 2 intra-band contiguous carrier aggregation, the additional spectrum emission mask is measured as the sum from both UE transmit antenna connectors when UE indicates support for *dualPA-Architecture* IE.

**Table 6.5A.2.3.1.1-1: Additional requirements for "CA\_NS\_04"**

$\Delta f_{\text{OOB}}$ MHz	BWChannel_CA (MHz) / Spectrum emission limit (dBm)		Measurement bandwidth
	$\leq 50$	$> 50$	
$\pm 0 - 1$	-10	-10	2 % of BWChannel_CA
$\pm 1 - 5$	-10		1 MHz
$\pm 5 - X$	-13		1 MHz
$\pm X - (\text{BW}_{\text{Channel\_CA}} + 5 \text{ MHz})$	-25		

NOTE: X is aggregated bandwidth

##### 6.5A.2.3.1.2 Requirements for network signalling value "CA\_NS\_27"

When "CA\_NS\_27" is indicated in the cell, the power of any UE emission shall not exceed the levels specified in Table 6.2A.2.3.2.1-1.

**Table 6.2A.2.3.2.1-1: Additional requirements for "CA\_NS\_27"**

Spectrum emission limit (dBm) / measurement bandwidth for each aggregated channel bandwidth		
$\Delta f_{\text{OOB}}$ MHz	Aggregated channel bandwidth of max 40 MHz	Measurement bandwidth
$\pm 0 - 1$	-13	1 % of X
$\pm 1 - X$	-13	1 MHz
$< -X$ or $> X$	-25	

NOTE 1: X is the aggregated channel bandwidth  
NOTE 2: The requirements apply only at the frequency range from 3540 MHz to 3710 MHz.

NOTE: As a general rule, the resolution bandwidth of the measuring equipment should be equal to the measurement bandwidth. However, to improve measurement accuracy, sensitivity and efficiency, the resolution bandwidth may be smaller than the measurement bandwidth. When the resolution bandwidth is smaller than the measurement bandwidth, the result should be integrated over the measurement bandwidth in order to obtain the equivalent noise bandwidth of the measurement bandwidth.

#### 6.5A.2.3.2 Additional spectrum emission mask for Intra-band non-contiguous CA

##### 6.5A.2.3.2.1 Minimum requirement (network signalling value "CA\_NC\_NS\_04")

For intra-band non-cotiguous CA\_n41(2A), the additional SEM requirements in subclause 6.5.2.3.2 (indicated by NS\_04) applies in each uplink CC.

## 6.5A.2.3.3 Additional spectrum emission mask for Inter-band CA

## 6.5A.2.4 Adjacent channel leakage ratio

## 6.5A.2.4.1 NR ACLR

## 6.5A.2.4.1.1 NR ACLR for intra-band contiguous CA

For intra-band contiguous carrier aggregation the carrier aggregation the Adjacent Channel Leakage power Ratio is the ratio of the filtered mean power centred on the aggregated channel bandwidth to the filtered mean power centred on an adjacent aggregated channel bandwidth at nominal channel spacing. The assigned aggregated channel bandwidth power and adjacent aggregated channel bandwidth power are measured with rectangular filters with measurement bandwidths specified in Table 6.5A.2.4.1.1-1 for power class 3 and 6.5A.2.4.1.1-2 for power class 2. If the measured adjacent channel power is greater than  $-50\text{dBm}$  then the  $\text{NR}_{\text{ACLR}}$  shall be higher than the value specified in Table 6.5A.2.4.1.1-1 for power class 3 and 6.5A.2.4.1.1-2 for power class 2.

**Table 6.5A.2.4.1.1-1: General requirements for intra-band contiguous CA ACLR power class 3**

	ACLR / Measurement bandwidth
CA ACLR	30 dB
CA Measurement bandwidth (NOTE 1)	Nominal channel space + $\text{MBW}_{\text{ACLR,low}}/2 + \text{MBW}_{\text{ACLR,high}}/2$
Adjacent channel centre frequency offset (in MHz)	$+ \text{BW}_{\text{Channel\_CA}}$ / $- \text{BW}_{\text{Channel\_CA}}$
Difference between ACLR MBW center and $F_{\text{c,low}}$	$\text{MBW}_{\text{shift}} = (\text{MBW}_{\text{ACLR\_CA}} - \text{MBW}_{\text{ACLR,low}})/2$
NOTE 1: $\text{MBW}_{\text{ACLR,low}}$ and $\text{MBW}_{\text{ACLR,high}}$ are the single-channel ACLR measurement bandwidths specified for channel bandwidths $\text{BW}_{\text{channel(low)}}$ and $\text{BW}_{\text{channel(high)}}$ in 6.5.2.4.1, respectively.	

**Table 6.5A.2.4.1.1-2: General requirements for intra-band contiguous CA ACLR power class 2**

	ACLR / Measurement bandwidth
CA ACLR	31 dB
CA Measurement bandwidth (NOTE 1)	Nominal channel space + $\text{MBW}_{\text{ACLR,low}}/2 + \text{MBW}_{\text{ACLR,high}}/2$
Adjacent channel centre frequency offset (in MHz)	$+ \text{BW}_{\text{Channel\_CA}}$ / $- \text{BW}_{\text{Channel\_CA}}$
Difference between ACLR MBW center and $F_{\text{c,low}}$	$\text{MBW}_{\text{shift}} = (\text{MBW}_{\text{ACLR\_CA}} - \text{MBW}_{\text{ACLR,low}})/2$
NOTE 1: $\text{MBW}_{\text{ACLR,low}}$ and $\text{MBW}_{\text{ACLR,high}}$ are the single-channel ACLR measurement bandwidths specified for channel bandwidths $\text{BW}_{\text{channel(low)}}$ and $\text{BW}_{\text{channel(high)}}$ in 6.5.2.4.1, respectively.	

## 6.5A.2.4.1.2 NR ACLR for intra-band non-contiguous CA

For intra-band non-contiguous carrier aggregation, CA Adjacent Channel Leakage power Ratio ( $\text{CA}_{\text{ACLR}}$ ) is the ratio of the sum of the filtered mean power centred on each assigned channel frequency to the filtered mean power centred on an adjacent NR channel frequency at nominal channel spacing. In case the gap bandwidth  $W_{\text{gap}}$  between 2 uplink CCs is smaller than maximum of the 2 uplink channel bandwidths then no  $\text{CA}_{\text{ACLR}}$  requirement is set for the gap. Each assigned NR channel power and adjacent NR channel power are measured with rectangular filters with measurement bandwidths specified in Table 6.5A.2.4.1.2-1 for power class 3 and 6.5A.2.4.1.2-2 for power class 2. If the measured adjacent channel power is greater than  $-50\text{dBm}$  then the ACLR shall be higher than the value specified in Table 6.5A.2.4.1.2-1 for power class 3 and 6.5A.2.4.1.2-2 for power class 2.

**Table 6.5A.2.4.1.2-1: General requirements for intra-band non-contiguous CA ACLR power class 3**

	ACLR / Measurement bandwidth
CA ACLR	30 dB
CA Measurement bandwidth for each sub block (NOTE 1)	$MBW_{ACLR}$
Adjacent channel centre frequency offset (in MHz)	+ $BW_{Channel}$ / - $BW_{Channel}$
NOTE 1: $MBW_{ACLR}$ is the single-channel ACLR measurement bandwidths specified in 6.5.2.4.1.	

**Table 6.5A.2.4.1.2-2: General requirements for intra-band non-contiguous CA ACLR power class 2**

	ACLR / Measurement bandwidth
CA ACLR	31 dB
CA Measurement bandwidth for each sub block (NOTE 1)	$MBW_{ACLR}$
Adjacent channel centre frequency offset (in MHz)	+ $BW_{Channel}$ / - $BW_{Channel}$
NOTE 1: $MBW_{ACLR}$ is the single-channel ACLR measurement bandwidths specified in 6.5.2.4.1.	

#### 6.5A.2.4.1.3 NR ACLR for Inter-band CA

For inter-band carrier aggregation with two contiguous carriers assigned to one NR band, the NR Adjacent Channel Leakage power Ratio (NRACLR) requirements in subclause 6.5A.2.4.1.1 apply for that band. For inter-band carrier aggregation with two uplink non-contiguous carrier assigned to one NR band, the NR Adjacent Channel Leakage power Ratio (NRACLR) requirements in subclause 6.5A.2.4.1.2 apply for that band.

For inter-band carrier aggregation with uplink assigned to two NR bands, the NR Adjacent Channel Leakage power Ratio (NRACLR) is defined per component carrier while both component carriers are active and the requirement is specified in clause 6.5.2.4.1.

For combinations of intra-band and inter-band carrier aggregation with three uplink component carriers (up to two contiguously aggregated carriers per operating band), the NR ACLR is defined as follows. For the NR band supporting one component carrier, the NR ACLR is the ratio of the filtered mean power centred on the assigned channel bandwidth of the component carrier to the filtered mean power centred on an adjacent channel frequency and the requirements in subclause 6.5.2.4.1 apply. For the NR band supporting two contiguous component carriers the NR ACLR is the ratio of the filtered mean power centred on the aggregated channel bandwidth to the filtered mean power centred on an adjacent(s) aggregated channel bandwidth at nominal channel spacing and the requirements of CA ACLR specified in subclause 6.5A.2.4.1.1 apply.

6.5A.2.4.1.4 Void

#### 6.5A.2.4.2 UTRA ACLR

6.5A.2.4.2.1 Void

6.5A.2.4.2.2 Void

#### 6.5A.2.4.2.3 UTRA ACLR for Inter-band CA

For inter-band carrier aggregation with uplink assigned to two NR bands, the UTRA Adjacent Channel Leakage power Ratio (UTRAACLR) is defined per component carrier while both component carrier are active and the requirement is specified in clause 6.5.2.4.2.

#### 6.5A.2.4.2.4 UTRA ACLR for Intra-band non-contiguous CA

For intra-band non-contiguous carrier aggregation, UTRA adjacent channel leakage power ratio ( $UTRA_{ACLR}$ ) is the ratio of the sum of the filtered mean power centred on each assigned channel frequency to the filtered mean power centred on an adjacent(s) UTRA channel frequency. In case the gap bandwidth  $W_{gap}$  between 2 uplink CCs is smaller than 10MHz then no UTRA ACLR requirement is set for the gap. In case  $W_{gap}$  is greater than or equal to 10MHz but less than 20MHz, then only the first UTRA ACLR ( $UTRA_{ACLR1}$ ) requirement applies in the gap. In case  $W_{gap}$  is greater than or equal to 20MHz, then both the first and the second UTRA ACLR ( $UTRA_{ACLR1}$  and  $UTRA_{ACLR2}$ ) requirements apply in the gap. Each assigned NR channel power is measured with rectangular filters with measurement bandwidths specified in Table 6.5.2.4.1-1 and adjacent UTRA channel power is measured with a RRC filter with roll-off factor  $\alpha=0.22$  and bandwidth of 3.84 MHz. If the measured adjacent channel power is greater than  $-50\text{dBm}$  then the  $UTRA_{ACLR1}$  and  $UTRA_{ACLR2}$  shall be higher than the value specified in Table 6.5A.2.4.2.4-1.

**Table 6.5A.2.4.2.4-1: General requirements for intra-band non-contiguous CA ACLR**

	ACLR / Measurement bandwidth	UTRA ACLR requirement
CA Measurement bandwidth for each sub block (NOTE 1)	$MBW_{ACLR}$	
The first adjacent UTRA channel ( $UTRA_{ACLR1}$ ) center frequency from NR channel edge	$\pm 2.5$ MHz	33dB
The 2 <sup>nd</sup> adjacent UTRA channel ( $UTRA_{ACLR2}$ ) center frequency from NR channel edge	$\pm 7.5$ MHz	36dB
NOTE 1: $MBW_{ACLR}$ is the single-channel ACLR measurement bandwidths specified in 6.5.2.4.1.		

### 6.5A.3 Spurious emission for CA

#### 6.5A.3.1 General spurious emissions

For inter-band carrier aggregation with uplink assigned to two NR bands, the spurious emission requirement Table 6.5.3.1-2 apply for the frequency ranges that are more than  $F_{OOB}$  as defined in Table 6.5.3.1-1 away from edges of the assigned channel bandwidth on a component carrier. If for some frequency a spurious emission requirement of individual component carrier overlaps with the spectrum emission mask or channel bandwidth of another component carrier then it does not apply.

NOTE: For inter-band carrier aggregation with uplink assigned to two NR bands the requirements in Table 6.5.3.1-2 could be verified by measuring spurious emissions at the specific frequencies where second and third order intermodulation products generated by the two transmitted carriers can occur; in that case, the requirements for remaining applicable frequencies in Table 6.5.3.1-2 would be considered to be verified by the measurements verifying the one uplink inter-band CA spurious emission requirement.

For intra-band contiguous carrier aggregation the spurious emission limits apply for the frequency ranges that are more than  $FOOB$  (MHz) in Table 6.5A.3.1-1 from the edge of the aggregated channel bandwidth. For frequencies  $\Delta f_{OOB}$  greater than  $FOOB$  as specified in Table 6.5A.3.1-1 the spurious emission requirements in Table 6.5.3.1-2 are applicable. For power class 2 intra-band contiguous carrier aggregation, the spurious emissions is measured as the sum from both UE transmit antenna connectors when UE indicates support for *dualPA-Architecture* IE.

**Table 6.5A.3.1-1: Boundary between out of band and spurious emission domain for intra-band contiguous carrier aggregation**

Aggregated Channel bandwidth	OOB boundary $F_{OOB}$ (MHz)
$BW_{Channel\_CA}$	$BW_{Channel\_CA} + 5$

For intra-band non-contiguous carrier aggregation transmission the spurious emission requirement is defined as a composite spurious emission requirement. Composite spurious emission requirement applies to frequency ranges that are more than  $FOOB$  away from the edges of each carrier in the gap and out of the gap. Composite spurious emission requirement is defined as follows

- a) Composite spurious emission requirement is a combination of individual sub-block spurious emission requirements
- b) In case the sub-block consist of one component carrier the sub-block spurious emission requirement and FOOB are defined in subclause 6.5.3.1
- c) If for some frequency an individual sub-block spurious emission requirement overlaps with the general spectrum emission mask or the sub-block bandwidth of another sub-block then it does not apply

For intra-band non-contiguous carrier aggregation, the spurious emissions is measured as the sum from both UE transmit antenna connectors when UE indicates support for *dualPA-Architecture* IE.

For combinations of intra-band and inter-band carrier aggregation with three uplink component carriers (up to two contiguously aggregated carriers per operating band), the spurious emission requirement is defined as follows. For the NR band supporting one component carrier the requirements in Table 6.5.3.1-2 apply for frequency ranges that are more than FOOB (MHz) from the edges of assigned channel bandwidth as defined in Table 6.5.3.1-1. For the NR band supporting two contiguous component carriers the requirements in Table 6.5.3.1-2 apply for frequency ranges that are more than FOOB (MHz) from the edges of assigned aggregated channel bandwidth as defined in Table 6.5A.3.1-1. If for some frequency a spurious emission requirement of a single component carrier or two contiguous component carriers overlap with the spurious emission requirement or channel bandwidth of another component carrier or two contiguously aggregated carriers then it does not apply.

### 6.5A.3.2 Spurious emissions for UE co-existence

#### 6.5A.3.2.0 General

Unless otherwise stated, the spurious emission for UE co-existence apply for the frequency ranges that are more than FOOB (MHz) in Table 6.5.3.1-1 from the edge of the channel bandwidth configured on each component carrier.

#### 6.5A.3.2.1 Spurious emissions for UE co-existence for intra-band contiguous CA

This clause specifies the requirements for the specified intra-band contiguous carrier aggregation configurations for coexistence with protected bands, the requirements in Table 6.5A.3.2.1-1 apply. For power class 2 intra-band contiguous carrier aggregation, the spurious emissions is measured as the sum from both UE transmit antenna connectors when UE indicates support for *dualPA-Architecture* IE.

NOTE: For measurement conditions at the edge of each frequency range, the lowest frequency of the measurement position in each frequency range should be set at the lowest boundary of the frequency range plus MBW/2. The highest frequency of the measurement position in each frequency range should be set at the highest boundary of the frequency range minus MBW/2. MBW denotes the measurement bandwidth defined for the protected band.

**Table 6.5A.3.2.1-1: Requirements for uplink intra-band contiguous carrier aggregation**

NR CA combination	Spurious emission						
	Protected Band	Frequency range (MHz)			Maximum Level (dBm)	MBW (MHz)	NOTE
CA_n3	E-UTRA Band 1, 5, 7, 8, 11, 18, 19, 20, 21, 26, 27, 28, 31, 32, 33, 34, 38, 39, 40, 41, 43, 44, 45, 50, 51, 65, 67, 68, 69, 72, 73, 74, 75, 76, 87, 88 NR Band n79, n100, n101, n105	F <sub>DL_low</sub>	-	F <sub>DL_high</sub>	-50	1	
	E-UTRA Band 3	F <sub>DL_low</sub>	-	F <sub>DL_high</sub>	-50	1	8
	E-UTRA Band 22, 42, 52 NR Band n77, n78	F <sub>DL_low</sub>	-	F <sub>DL_high</sub>	-50	1	4
	Frequency range	1884.5	-	1915.7	-41	0.3	5
CA_n5	E-UTRA Band 1, 2, 3, 4, 5, 7, 8, 12, 13, 14, 17, 18, 19, 24, 25, 28, 29, 30, 31, 34, 38, 40,	F <sub>DL_low</sub>	-	F <sub>DL_high</sub>	-50	1	

	42, 43, 45, 48, 50, 51, 54, 65, 66, 70, 71, 73, 74, 85, 103 NR Band n79, n105						
	E-UTRA Band 41, 52, 53 NR Band n77, n78	F <sub>DL_low</sub>	-	F <sub>DL_high</sub>	-50	1	4
	E-UTRA Band 11, 21	F <sub>DL_low</sub>	-	F <sub>DL_high</sub>	-50	1	
	E-UTRA Band 26	F <sub>DL_low</sub>	-	F <sub>DL_high</sub>	-50	1	8
	Frequency range	1884.5	-	1915.7	-41	0.3	9
CA_n7	E-UTRA Band 1, 2, 3, 4, 5, 7, 8, 12, 13, 14, 17, 20, 22, 26, 27, 28, 29, 30, 31, 32, 33, 34, 40, 42, 43, 50, 51, 52, 65, 66, 67, 68, 72, 74, 75, 76, 85, 103 NR Band n77, n78, n100, n101	F <sub>DL_low</sub>	-	F <sub>DL_high</sub>	-50	1	
CA_n40	E-UTRA Band 1, 3, 5, 7, 8, 11, 18, 19, 20, 21, 22, 26, 27, 28, 31, 32, 33, 34, 38, 39, 41, 42, 43, 44, 45, 50, 51, 52, 65, 67, 68, 69, 72, 74, 75, 76, NR Band n77, n78, n100, n101	F <sub>DL_low</sub>	-	F <sub>DL_high</sub>	-50	1	7
	NR Band n79	F <sub>DL_low</sub>	-	F <sub>DL_high</sub>	-50	1	2, 4
	Frequency range	1884.5	-	1915.7	-41	0.3	5
CA_n41	E-UTRA Band 1, 2, 3, 4, 5, 8, 12, 13, 14, 17, 24, 25, 26, 27, 28, 29, 30, 34, 39, 42, 44, 45, 48, 50, 51, 52, 54, 65, 66, 70, 71, 73, 74, 85, 103 NR Band n77, n78, n100	F <sub>DL_low</sub>	-	F <sub>DL_high</sub>	-50	1	
	NR Band n79	F <sub>DL_low</sub>	-	F <sub>DL_high</sub>	-50	1	2, 4
	E-UTRA Band 9, 11, 18, 19, 21	F <sub>DL_low</sub>	-	F <sub>DL_high</sub>	-50	1	6
	E-UTRA Band 40	F <sub>DL_low</sub>	-	F <sub>DL_high</sub>	-40	1	
	Frequency range	1884.5	-	1915.7	-41	0.3	5, 6
CA_n48	E-UTRA Band 2, 4, 5, 12, 13, 14, 17, 24, 25, 26, 29, 30, 41, 50, 51, 54, 66, 70, 71, 74, 85, 103	F <sub>DL_low</sub>	-	F <sub>DL_high</sub>	-50	1	
CA_n77	E-UTRA Band 1, 3, 5, 7, 8, 11, 18, 19, 20, 21, 26, 28, 34, 39, 40, 41, 54, 65, n100, n101	F <sub>DL_low</sub>	-	F <sub>DL_high</sub>	-50	1	
	Frequency range	1884.5	-	1915.7	-41	0.3	5
CA_n78	E-UTRA Band 1, 3, 5, 7, 8, 11, 18, 19, 20, 21, 26, 28, 34, 39, 40, 41, 65, n100, n101	F <sub>DL_low</sub>	-	F <sub>DL_high</sub>	-50	1	
	Frequency range	1884.5	-	1915.7	-41	0.3	5
CA_n79	E-UTRA Band 1, 3, 5, 8, 11, 18, 19, 21, 28, 34, 39, 40, 41, 42, 65	F <sub>DL_low</sub>	-	F <sub>DL_high</sub>	-50	1	
	Frequency range	1884.5	-	1915.7	-41	0.3	5

NOTE 1: Void

NOTE 2: Void

NOTE 3: Void

NOTE 4: As exceptions, measurements with a level up to the applicable requirements defined in Table 6.5.3.1-2 are permitted for each assigned NR carrier used in the measurement due to 2nd, 3rd, 4th or 5th harmonic spurious emissions. Due to spreading of the harmonic emission the exception is also allowed for the first 1 MHz frequency range immediately outside the harmonic emission on both sides of the harmonic emission. This results in an overall exception interval centred at the harmonic emission of  $(2 \text{ MHz} + N \times L_{\text{CRB}} \times R_{\text{Bsize}} \text{ kHz})$ , where N is 2, 3, 4, 5 for the 2nd, 3rd, 4th or 5th harmonic respectively. The exception is allowed if the measurement bandwidth (MBW) totally or partially overlaps the overall exception interval.

NOTE 5: Applicable when co-existence with PHS system operating in 1884.5 - 1915.7 MHz.

NOTE 6: This requirement applies when the NR carrier is confined within 2545 – 2575 MHz or 2595 – 2645 MHz and the channel bandwidth is 10 or 20 MHz

NOTE 7: As exceptions, for 90 and 100 MHz aggregated bandwidth, -40 dBm/MHz is applicable in the frequency range of 2496 – 2505 MHz.

NOTE 8: These requirements also apply for the frequency ranges that are less than  $F_{OOB}$  (MHz) in Table 6.5.3.1-1 from the edge of the aggregated uplink channel bandwidth.  
 NOTE 9: Applicable when co-existence with PHS system operating in 1884.5 - 1915.7 MHz.

### 6.5A.3.2.2 Spurious emissions for UE co-existence for intra-band non-contiguous CA

This clause specifies the requirements for the specified intra-band non-contiguous carrier aggregation configurations for coexistence with protected bands, the requirements in Table 6.5A.3.2.2-1 apply. For intra-band non-contiguous carrier aggregation, the spurious emissions is measured as the sum from both UE transmit antenna connectors when UE indicates support for *dualPA-Architecture* IE.

NOTE: For measurement conditions at the edge of each frequency range, the lowest frequency of the measurement position in each frequency range should be set at the lowest boundary of the frequency range plus MBW/2. The highest frequency of the measurement position in each frequency range should be set at the highest boundary of the frequency range minus MBW/2. MBW denotes the measurement bandwidth defined for the protected band.

**Table 6.5A.3.2.2-1: Requirements for uplink intra-band non-contiguous carrier aggregation**

NR CA combination	Spurious emission						
	Protected Band	Frequency range (MHz)			Maximum Level (dBm)	MBW (MHz)	NOTE
CA_n26	E-UTRA Band 1, 2, 3, 4, 5, 7, 11, 12, 13, 14, 17, 18,19, 21, 24, 25, 29, 30, 31, 34, 39, 40, 42, 43, 48, 50, 51, 65, 66, 70, 71, 73,74, 85, 103	$F_{DL\_low}$	-	$F_{DL\_high}$	-50	1	
	E-UTRA Band 41, 53, 54 NR Band n77, n78, n79	$F_{DL\_low}$	-	$F_{DL\_high}$	-50	1	2
	E-UTRA Band 26	$F_{DL\_low}$	-	$F_{DL\_high}$	-50	1	[5]
	Frequency range	703	-	799 <sup>3</sup>	-50	1	
	Frequency range	799 <sup>3</sup>	-	803	-40	1	[5]
	Frequency range	945	-	960	-50	1	
CA_n41	Frequency range	1884.5	-	1915.7	-41	0.3	4
	E-UTRA Band 1, 2, 3, 4, 5, 8, 10, 12, 13, 14, 17, 24, 25, 26, 27, 28, 29, 30, 34, 39, 42, 44, 45, 48, 50, 51, 52, 54, 65, 66, 70, 71, 73, 74, 85, 103 NR Band n77, n78, n100	$F_{DL\_low}$	-	$F_{DL\_high}$	-50	1	
	NR Band n79	$F_{DL\_low}$	-	$F_{DL\_high}$	-50	1	1, 2
	E-UTRA Band 40	$F_{DL\_low}$	-	$F_{DL\_high}$	-40	1	
CA_n77	E-UTRA Band 9, 11, 18, 19, 21	$F_{DL\_low}$	-	$F_{DL\_high}$	-50	1	2
	E-UTRA Band 1, 3, 5, 7, 8, 11, 18, 19, 20, 21, 26, 28, 34, 39, 40, 41, 54, 65 NR Band n100, n101	$F_{DL\_low}$	-	$F_{DL\_high}$	-50	1	
CA_n78	E-UTRA Band 1, 3, 5, 7, 8, 11, 18, 19, 20, 21, 26, 28, 34, 39, 40, 41, 65, n101	$F_{DL\_low}$	-	$F_{DL\_high}$	-50	1	

NOTE 1: As exceptions, measurements with a level up to the applicable requirements defined in Table 6.5.3.1-2 are permitted for each assigned NR carrier used in the measurement due to 2nd, 3rd, 4th or 5th harmonic spurious emissions. Due to spreading of the harmonic emission the exception is also allowed for the first 1 MHz frequency range immediately outside the harmonic emission on both sides of the harmonic emission. This results in an overall exception interval centred at the harmonic emission of  $(2 \text{ MHz} + N \times L_{CRB} \times R_{Bsize} \text{ kHz})$ , where N is 2, 3, 4, 5 for the 2nd, 3rd, 4th or 5th harmonic respectively. The exception is allowed if the measurement bandwidth (MBW) totally or partially overlaps the overall exception interval.

NOTE 2: This requirement applies when the NR carrier is confined within 2545 – 2575 MHz or 2595 – 2645 MHz and the channel bandwidth is 10 or 20 MHz  
 NOTE 3: This value is changed to 794MHz if channel bandwidth of one UL carrier is 20 MHz.  
 NOTE 4: Applicable when co-existence with PHS system operating in 1884.5 - 1915.7 MHz.  
 [NOTE 5: These requirements also apply for the frequency ranges that are less than  $F_{OoB}$  (MHz) in Table 6.5.3.1-1 from the edge of the channel bandwidth.]

### 6.5A.3.2.3 Spurious emissions for UE co-existence for Inter-band CA

This clause specifies the additional requirements for inter-band uplink carrier aggregation configurations with the single CC uplink assigned to two NR bands for coexistence with protected bands for the specified uplink carrier aggregation configurations in Table 6.5A.3.2.3-1. The intersection of the requirements for the individual bands specified in clause 6.5.3.2 shall also apply for the specified uplink carrier aggregation configurations. Intersection of a requirement means that both UL constituent bands have the same protected band requirement specified and if one or both protected bands have note(s) associated those note(s) also apply.

For inter-band carrier aggregation with two contiguous carriers assigned to one NR band, the requirements in subclause 6.5A.3.2.1 apply for that band.

For inter-band carrier aggregation with two uplink non-contiguous carrier assigned to one NR band, the spurious emissions for UE co-existence requirements in subclause 6.5A.3.2.2 apply for that band.

For inter-band carrier aggregation with the uplink assigned to two NR bands, the requirements in Table 6.5A.3.2.3-1 apply on each component carrier with all component carriers are active.

NOTE: For inter-band carrier aggregation with uplink assigned to two NR bands the requirements in Table 6.5A.3.2.3-1 could be verified by measuring spurious emissions at the specific frequencies where second and third order intermodulation products generated by the two transmitted carriers can occur; in that case, the requirements for remaining applicable frequencies in Table 6.5A.3.2.3-1 and in clause 6.5.3.2 would be considered to be verified by the measurements verifying the one uplink inter-band CA UE to UE co-existence requirements.

**Table 6.5A.3.2.3-1: Requirements for uplink inter-band carrier aggregation (two bands)**

NR CA combination	Spurious emission						
	Protected Band	Frequency range (MHz)			Maximum Level (dBm)	MBW (MHz)	NOTE
CA_n1-n18	Frequency range	758	-	799	-50	1	
	Frequency range	799	-	803	-40	1	4
	Frequency range	860	-	890	-40	1	
	Frequency range	945	-	960	-50	1	
	Frequency range	2545	-	2575	-50	1	
	Frequency range	2595	-	2645	-50	1	
CA_n1-n20	Frequency range	758	-	788	-50	1	
CA_n1-n26	Frequency range	945	-	960	-50	1	
	Frequency range	703	-	799 <sup>24</sup>	-50	1	
	Frequency range	799 <sup>24</sup>	-	803	-40	1	4
CA_n1-n28	Frequency range	470	-	694	-42	8	4, 14
	Frequency range	470	-	710	-26.2	6	15
	Frequency range	758	-	773	-30	1	4
	Frequency range	773	-	803	-50	1	
	Frequency range	662	-	694	-26.2	6	4
CA_n1-n40	Frequency range	1884.5	-	1915.7	-41	0.3	3
CA_n1-n74	Frequency range	1884.5	-	1915.7	-41	0.3	3
	Frequency range	1400	-	1427	-32	27	4, 20
	Frequency range	1475	-	1488	-28	1	4, 21
	Frequency range	1475	-	1488	-50	1	4, 22
	Frequency range	1488	-	1510.9	-35	1	4, 23
	Frequency range	1488	-	1518	-50	1	4
CA_n2-n14	Frequency range	769	-	775	-35	0.00625	4
	Frequency range	799	-	805	-35	0.00625	4



CA_n3-n5	Frequency range	1884.5	-	1915.7	-41	0.3	3
CA_n3-n8	Frequency range	1884.5	-	1915.7	-41	0.3	3
CA_n3-n18	Frequency range	945	-	960	-50	1	
	Frequency range	1884.5	-	1915.7	-41	0.3	3
	Frequency range	2545	-	2575	-50	1	
	Frequency range	2595	-	2645	-50	1	
CA_n3-n20	Frequency range	758	-	788	-50	1	
CA_n3-n26	Frequency range	1884.5	-	1915.7	-41	0.3	3
	Frequency range	703	-	799 <sup>24</sup>	-50	1	
	Frequency range	799 <sup>24</sup>	-	803	-40	1	4
	Frequency range	945	-	960	-50	1	
CA_n3-n34	Frequency range	1884.5	-	1915.7	-41	0.3	3
CA_n3-n28	Frequency range	470	-	694	-42	8	4, 14
	Frequency range	470	-	710	-26.2	6	15
	Frequency range	758	-	773	-30	1	4
	Frequency range	773	-	803	-50	1	
	Frequency range	662	-	694	-26.2	6	4
	Frequency range	1839.9	-	1879.9	-50	1	4
	Frequency range	1884.5	-	1915.7	-41	0.3	3, 11
CA_n3-n40	Frequency range	1884.5	-	1915.7	-41	0.3	3
CA_n3-n41	Frequency range	1884.5	-	1915.7	-41	0.3	3
CA_n3-n74	Frequency range	1884.5	-	1915.7	-41	0.3	3
	Frequency range	1400	-	1427	-32	27	4, 20
	Frequency range	1475	-	1488	-28	1	4, 21
	Frequency range	1475	-	1488	-50	1	4, 22
	Frequency range	1488	-	1510.9	-35	1	4, 23
	Frequency range	1488	-	1518	-50	1	4
CA_n3-n77	Frequency range	1884.5	-	1915.7	-41	0.3	3
CA_n3-n78	Frequency range	1884.5	-	1915.7	-41	0.3	3
CA_n3-n79	Frequency range	1884.5	-	1915.7	-41	0.3	3
CA_n5-n7	Frequency range	859	-	869	-27	1	
CA_n5-n28	Frequency range	470	-	710	-26.2	6	13
	Frequency range	758	-	773	-32	1	4
	Frequency range	773	-	803	-50	1	
	Frequency range	1884.5	-	1915.7	-41	0.3	3
CA_n5-n40	Frequency range	1884.5	-	1915.7	-41	0.3	3
CA_n5-n48	Frequency range	1884.5	-	1915.7	-41	0.3	8
CA_n5-n66	Frequency range	1884.5	-	1915.7	-41	0.3	3
CA_n5-n77	Frequency range	1884.5	-	1915.7	-41	0.3	3
CA_n5-n78	Frequency range	945	-	960	-50	1	
	Frequency range	1884.5	-	1915.7	-41	0.3	3
	Frequency range	2545	-	2575	-50	1	2
	Frequency range	2595	-	2645	-50	1	
CA_n5-n79	Frequency range	1884.5	-	1915.7	-41	0.3	3
CA_n5-n105	Frequency range	1884.5	-	1915.7	-41	0.3	3
CA_n7-n26	Frequency range	703	-	799 <sup>24</sup>	-50	1	
	Frequency range	799 <sup>24</sup>	-	803	-40	1	4
	Frequency range	945	-	960	-50	1	
	Frequency range	1884.5	-	1915.7	-41	0.3	3
CA_n7-n28	Frequency range	758	-	773	-32	1	4
	Frequency range	773	-	803	-50	1	
CA_n8-n20	Frequency range	758	-	788	-50	1	
CA_n8-n28	Frequency range	470	-	694	-42	8	4, 14
	Frequency range	470	-	710	-26.2	6	13
	Frequency range	662	-	694	-26.2	6	4
	Frequency range	758	-	773	-32	1	4
	Frequency range	773	-	803	-50	1	
	Frequency range	1884.5	-	1915.7	-41	0.3	3, 11
CA_n8-n34	Frequency range	1884.5	-	1915.7	-41	0.3	3
CA_n8-n40	Frequency range	1884.5	-	1915.7	-41	0.3	3
CA_n8-n41	Frequency range	1884.5	-	1915.7	-41	0.3	3
CA_n8-n77	Frequency range	1884.5	-	1915.7	-41	0.3	3
CA_n8-n78	Frequency range	1884.5	-	1915.7	-41	0.3	3
CA_n8-n79	Frequency range	1884.5	-	1915.7	-41	0.3	3
CA_n12-n78	Frequency range	1884.5	-	1915.7	-41	0.3	3

CA_n13-n25	Frequency range	769	-	775	-35	0.00625	4
	Frequency range	799	-	805	-35	0.00625	4
CA_n13-n66	Frequency range	769	-	775	-35	0.00625	4
	Frequency range	799	-	805	-35	0.00625	4
CA_n13-n77	Frequency range	769	-	775	-35	0.00625	4
	Frequency range	799	-	805	-35	0.00625	4
CA_n14-n30	Frequency range	769	-	775	-35	0.00625	4
	Frequency range	799	-	805	-35	0.00625	4
CA_n14-n66	Frequency range	769	-	775	-35	0.00625	4
	Frequency range	799	-	805	-35	0.00625	4
CA_n14-n77	Frequency range	769	-	775	-35	0.00625	4, 20
	Frequency range	799	-	805	-35	0.00625	4, 20
CA_n18-n28	Frequency range	470	-	694	-42	8	4, 14
	Frequency range	470	-	710	-26.2	6	13
	Frequency range	662	-	694	-26.2	6	4
	Frequency range	758	-	799	-50	1	
	Frequency range	799	-	803	-40	1	4
	Frequency range	860	-	890	-40	1	
	Frequency range	945	-	960	-50	1	4
	Frequency range	1884.5	-	1915.7	-41	0.3	3
	Frequency range	2545	-	2575	-50	1	
CA_n18-n40	Frequency range	2595	-	2645	-50	1	
	Frequency range	758	-	799	-50	1	
	Frequency range	799	-	803	-40	1	
	Frequency range	860	-	890	-40	1	
	Frequency range	945	-	960	-50	1	
	Frequency range	1884.5	-	1915.7	-41	0.3	3
CA_n18-n41	Frequency range	2545	-	2575	-50	1	
	Frequency range	2595	-	2645	-50	1	
	Frequency range	758	-	799	-50	1	
	Frequency range	799	-	803	-40	1	
	Frequency range	860	-	890	-40	1	
CA_n18-n74	Frequency range	945	-	960	-50	1	
	Frequency range	1884.5	-	1915.7	-41	0.3	3
	Frequency range	758	-	799	-50	1	
	Frequency range	799	-	803	-40	1	
	Frequency range	860	-	890	-40	1	
	Frequency range	945	-	960	-50	1	
	Frequency range	1400	-	1427	-32	27	4, 20
	Frequency range	1475	-	1488	-28	1	4, 21
	Frequency range	1475	-	1488	-50	1	4, 22
	Frequency range	1488	-	1510.9	-35	1	4, 23
	Frequency range	1488	-	1518	-50	1	4
CA_n18-n77	Frequency range	1884.5	-	1915.7	-41	0.3	3
	Frequency range	2545	-	2575	-50	1	
	Frequency range	2595	-	2645	-50	1	
	Frequency range	758	-	799	-50	1	
	Frequency range	799	-	803	-40	1	
	Frequency range	860	-	890	-40	1	
	Frequency range	945	-	960	-50	1	
CA_n18-n78	Frequency range	1884.5	-	1915.7	-41	0.3	3
	Frequency range	2545	-	2575	-50	1	
	Frequency range	2595	-	2645	-50	1	
	Frequency range	758	-	799	-50	1	
	Frequency range	799	-	803	-40	1	
	Frequency range	860	-	890	-40	1	
CA_n20-n28	Frequency range	945	-	960	-50	1	
	Frequency range	1884.5	-	1915.7	-41	0.3	3
CA_n26-n28	Frequency range	2545	-	2575	-50	1	
	Frequency range	2595	-	2645	-50	1	
CA_n26-n28	Frequency range	758	-	773	-32	1	4
	Frequency range	773	-	803	-50	1	
	Frequency range	470	-	710	-26.2	6	13
CA_n26-n28	Frequency range	758	-	773	-32	1	4
	Frequency range	773	-	799 <sup>24</sup>	-50	1	

	Frequency range	799 <sup>24</sup>	-	803	-40	1	4
	Frequency range	1884.5	-	1915.7	-41	0.3	3
CA_n26-n48	Frequency range	703	-	799 <sup>24</sup>	-50	1	
	Frequency range	799 <sup>24</sup>	-	803	-40	1	4
	Frequency range	945	-	960	-50	1	
	Frequency range	1884.5	-	1915.7	-41	0.3	3
CA_n26-n66	Frequency range	1884.5	-	1915.7	-41	0.3	3
CA_n26-n70	Frequency range	1884.5	-	1915.7	-41	0.3	3
CA_n26-n77	Frequency range	1884.5	-	1915.7	-41	0.3	3
CA_n26-n78	Frequency range	703	-	799 <sup>x</sup>	-50	1	
	Frequency range	799 <sup>x</sup>	-	803	-40	1	4
	Frequency range	945	-	960	-50	1	
	Frequency range	1884.5	-	1915.7	-41	0.3	3
CA_n28-n34	Frequency range	470	-	694	-42	8	4, 14
	Frequency range	470	-	710	-26.2	6	13
	Frequency range	662	-	694	-26.2	6	4
	Frequency range	758	-	773	-32	1	4
	Frequency range	773	-	803	-50	1	
	Frequency range	1884.5	-	1915.7	-41	0.3	3
CA_n28-n39	Frequency range	470	-	694	-42	8	4, 14
	Frequency range	470	-	710	-26.2	6	13
	Frequency range	662	-	694	-26.2	6	4
	Frequency range	758	-	773	-32	1	4
	Frequency range	773	-	803	-50	1	
CA_n28-n40	Frequency range	758	-	773	-32	1	4
	Frequency range	773	-	803	-50	1	
	Frequency range	1884.5	-	1915.7	-41	0.3	3
CA_n28-n41	Frequency range	470	-	694	-42	8	4, 14
	Frequency range	470	-	710	-26.2	6	13
	Frequency range	662	-	694	-26.2	6	4
	Frequency range	758	-	773	-32	1	4
	Frequency range	773	-	803	-50	1	
	Frequency range	1884.5	-	1915.7	-41	0.3	3, 11
CA_n28-n46	Frequency range	470	-	694	-42	8	15
	Frequency range	470	-	710	-26.2	6	
	Frequency range	662	-	694	-26.2	6	15
	Frequency range	758	-	773	-32	1	15
	Frequency range	773	-	803	-50	1	
	Frequency range	1884.5	-	1915.7	-41	0.3	8, 19
CA_n28-n50	Frequency range	470	-	694	-42	8	4, 14
	Frequency range	470	-	710	-26.2	6	13
	Frequency range	662	-	694	-26.2	6	4
	Frequency range	758	-	773	-32	1	4
	Frequency range	773	-	803	-50	1	
	Frequency range	1884.5	-	1915.7	-41	0.3	3, 11
CA_n28-n77	Frequency range	758	-	773	-32	1	
	Frequency range	773	-	803	-50	1	
	Frequency range	1884.5	-	1915.7	-41	0.3	3, 11
CA_n28-n74	Frequency range	470	-	694	-42	8	4, 14
	Frequency range	470	-	710	-26.2	6	13
	Frequency range	662	-	694	-26.2	6	4
	Frequency range	758	-	773	-32	1	4
	Frequency range	773	-	803	-50	1	
	Frequency range	1884.5	-	1915.7	-41	0.3	3, 11
	Frequency range	1400	-	1427	-32	27	4, 20, 2
	Frequency range	1475	-	1488	-28	1	4, 21, 2
	Frequency range	1475	-	1488	-50	1	4, 22, 2
	Frequency range	1488	-	1510.9	-35	1	4, 23, 2
	Frequency range	1488	-	1518	-50	1	4, 2
CA_n28-n78	Frequency range	758	-	773	-32	1	
	Frequency range	773	-	803	-50	1	
	Frequency range	1884.5	-	1915.7	-41	0.3	3, 11
CA_n28-n79	Frequency range	470	-	694	-42	8	4, 14
	Frequency range	470	-	710	-26.2	6	13
	Frequency range	662	-	694	-26.2	6	4

	Frequency range	758	-	773	-32	1	4
	Frequency range	773	-	803	-50	1	
	Frequency range	1884.5	-	1915.7	-41	0.3	3, 11
CA_n34-n39	Frequency range	1884.5	-	1915.7	-41	0.3	3
CA_n34-n40	Frequency range	1884.5	-	1915.7	-41	0.3	8
CA_n34-n41	Frequency range	1884.5	-	1915.7	-41	0.3	3
CA_n34-n79	Frequency range	1884.5	-	1915.7	-41	0.3	8
CA_n40-n41	Frequency range	1884.5	-	1915.7	-41	0.3	3
CA_n40-n77	Frequency range	1884.5	-	1915.7	-41	0.3	3
CA_n40-n78	Frequency range	1884.5	-	1915.7	-41	0.3	3
CA_n40-n79	Frequency range	1884.5	-	1915.7	-41	0.3	3
CA_n41-n74	Frequency range	1884.5		1915.7	-41	0.3	3
	Frequency range	1400	-	1427	-32	27	4, 20
	Frequency range	1475	-	1488	-28	1	4, 21
	Frequency range	1475	-	1488	-50	1	4, 22
	Frequency range	1488	-	1510.9	-35	1	4, 23
CA_n41-n77	Frequency range	1884.5		1915.7	-41	0.3	3
CA_n41-n78	Frequency range	1884.5		1915.7	-41	0.3	3
CA_n41-n79	Frequency range	1884.5	-	1915.7	-41	0.3	3
CA_n46-n77	Frequency range	1884.5	-	1915.7	-41	0.3	8
CA_n46-n78	Frequency range	1884.5	-	1915.7	-41	0.3	8
CA_n70-n77	Frequency range	1884.5	-	1915.7	-41	0.3	3
CA_n71-n77	Frequency range	1884.5		1915.7	-41	0.3	3
CA_n74-n77	Frequency range	1884.5	-	1915.7	-41	0.3	3
	Frequency range	1400	-	1427	-32	27	4, 20
	Frequency range	1475	-	1488	-50	1	21
	Frequency range	1475	-	1488	-28	1	4, 21
	Frequency range	1475	-	1488	-50	1	4, 22
CA_n74-n78	Frequency range	1488	-	1510.9	-35	1	4, 23
	Frequency range	1884.5	-	1915.7	-41	0.3	3
	Frequency range	1400	-	1427	-32	27	4, 20
	Frequency range	1475	-	1488	-28	1	4, 21
	Frequency range	1475	-	1488	-50	1	4, 22
CA_n74-n79	Frequency range	1488	-	1510.9	-35	1	4, 23
	Frequency range	1488	-	1518	-50	1	4
	Frequency range	1884.5	-	1915.7	-41	0.3	3
CA_n77-n85	Frequency range	1884.5		1915.7	-41	0.3	3
CA_n78-n79	Frequency range	1884.5	-	1915.7	-41	0.3	3

NOTE 1: Void.

NOTE 2: As exceptions, measurements with a level up to the applicable requirements defined in Table 6.5.3.1-2 are permitted for each assigned NR carrier used in the measurement due to 2nd, 3rd, 4th or 5<sup>th</sup> harmonic spurious emissions. Due to spreading of the harmonic emission the exception is also allowed for the first 1 MHz frequency range immediately outside the harmonic emission on both sides of the harmonic emission. This results in an overall exception interval centred at the harmonic emission of  $(2 \text{ MHz} + N \times L_{\text{CRB}} \times 180\text{kHz})$ , where N is 2, 3, 4, 5 for the 2nd, 3rd, 4th or 5th harmonic respectively. The exception is allowed if the measurement bandwidth (MBW) totally or partially overlaps the overall exception interval.

NOTE 3: Applicable when co-existence with PHS system operating in 1884.5 -1915.7 MHz

NOTE 4: These requirements also apply for the frequency ranges that are less than  $F_{\text{OoB}}$  (MHz) in Table 6.5.3.1-1 from the edge of the channel bandwidth.

NOTE 5: Void.

NOTE 6: Void.

NOTE 7: Void.

NOTE 8: This requirement is only applicable for carriers with bandwidth confined within 1885-1920 MHz (requirement for carriers with at least 1RB confined within 1880 - 1885 MHz is not specified). This requirement applies for an uplink transmission bandwidth less than or equal to 54 RB for carriers of 15 MHz bandwidth when carrier center frequency is within the range 1892.5 - 1894.5 MHz and for carriers of 20 MHz bandwidth when carrier center frequency is within the range 1895 - 1903 MHz.

NOTE 9: Void.

NOTE 10: Void.

NOTE 11: Applicable when the assigned NR carrier is confined within 718 MHz and 748 MHz and when the channel bandwidth used is 5 or 10 MHz.

NOTE 12: Void.

NOTE 13: This requirement is applicable for 5 and 10 MHz NR channel bandwidth allocated within 718 - 728 MHz. For carriers of 10 MHz bandwidth, this requirement applies for an uplink transmission bandwidth less than or equal to 30 RB with  $\text{RB}_{\text{start}} > 1$  and  $\text{RB}_{\text{start}} < 48$ .

NOTE 14:	This requirement is applicable in the case of a 10 MHz NR carrier confined within 703 MHz and 733 MHz, otherwise the requirement of -25 dBm with a measurement bandwidth of 8 MHz applies.
NOTE 15:	As exceptions, measurements with a level up to the applicable requirement of -36 dBm/MHz is permitted for each assigned E-UTRA carrier used in the measurement due to 3rd harmonic spurious emissions. An exception is allowed if there is at least one individual RB within the transmission bandwidth (see Figure 5.6-1) for which the 3rd harmonic totally or partially overlaps the measurement bandwidth (MBW).
NOTE 17:	Void.
NOTE 18:	Void.
NOTE 19:	This requirement is applicable for power class 3 UE for any channel bandwidths within the range 2570 - 2615 MHz with the following restriction: for carriers of 15 MHz bandwidth when carrier centre frequency is within the range 2605.5 - 2607.5 MHz and for carriers of 20 MHz bandwidth when carrier centre frequency is within the range 2597 - 2605 MHz the requirement is applicable only for an uplink transmission bandwidth less than or equal to 54 RB. For power class 2 UE for any channel bandwidths within the range 2570 - 2615 MHz, NS_44 shall apply. For power class 2 or 3 UE for carriers with channel bandwidth overlapping the frequency range 2615 - 2620 MHz the requirement applies with the maximum output power configured to +19 dBm in the IE P-Max.
NOTE 20:	Applicable for cases and when the lower edge of the assigned NR UL channel bandwidth frequency is greater than or equal to 1427 MHz + the channel BW assigned for 5 and 10 MHz bandwidth, and when the lower edge of the assigned NR UL channel bandwidth frequency is greater than or equal to 1440 MHz for 15 and 20 MHz bandwidth.
NOTE 21:	Applicable for 5 MHz bandwidth, and when the upper edge of the assigned NR UL channel bandwidth frequency is less than or equal to 1467 MHz assigned for 10 MHz bandwidth, and when the upper edge of the assigned NR UL channel bandwidth frequency is less than or equal to 1463.8 MHz for 15 MHz bandwidth, and when the upper edge of the assigned NR UL channel bandwidth.
NOTE 22:	As exceptions, for 90 and 100 MHz channel bandwidth, -40 dBm/MHz is applicable in the frequency range of 2496 – 2505 MHz.
NOTE 23:	For these adjacent bands, the emission limit could imply risk of harmful interference to UE(s) operating in the protected operating band.if the measurement bandwidth (MBW) totally or partially overlaps the overall exception interval.
NOTE 24:	For 20MHz channel bandwidth in band n26 this value is changed to 794MHz.

6.5A.3.2.4 Void

6.5A.3.2.5 Void

6.5A.3.2.6 Void

### 6.5A.3.3 Additional spurious emissions for CA

#### 6.5A.3.3.1 Additional spurious emissions for intra-band contiguous CA

##### 6.5A.3.3.1.1 Requirement for network signalling value "CA\_NS\_04"

When "CA\_NS04" is indicated in the cell, the power of any UE emission shall not exceed the levels specified in Table 6.5A.3.3.1.1-1. This requirement also applies for the frequency ranges that are less than FOOB (MHz) in Table 6.5A.3.1-1 from the edge of the aggregated channel bandwidth. For power class 2 intra-band contiguous carrier aggregation, the additional spurious emissions is measured as the sum from both UE transmit antenna connectors when UE indicates support for *dualPA-Architecture* IE.

**Table 6.5A.3.3.1.1-1: Additional requirements for "CA\_NS\_04"**

Frequency range (MHz)	BWChannel_CA (MHz) / Spectrum emission limit (dBm)	Measurement bandwidth
	20 to 190 MHz	
$2495 \leq f < 2496$	-13	Max(1 % of BW <sub>Channel_CA</sub> , 1 MHz)
$2490.5 \leq f < 2495$	-13	1 MHz
$0.009 < f < 2490.5$	-25	1 MHz

### 6.5A.3.3.1.2 Requirement for network signalling value "CA\_NS\_27"

When "CA\_NS 27" is indicated in the cell, the power of any UE emission shall not exceed the levels specified in Table 6.5A.3.3.1.2-1. This requirement also applies for the frequency ranges that are less than  $F_{OOB}$  (MHz) in Table 6.5A.3.1-1 from the edge of the aggregated channel bandwidth.

**Table 6.5A.3.3.1.2-1: Additional requirements for "CA\_NS\_27"**

Frequency range (MHz)	Spectrum emission limit (dBm) for aggregated channel bandwidth of max 40 MHz	Measurement bandwidth
9 kHz – 3530 MHz	-40	1 MHz
3530 MHz – 3540 MHz	-25	
3710 MHz – 3720 MHz	-25	
3720 MHz – 12.75 GHz	-40	

### 6.5A.3.3.1.3 Requirement for network signalling value "CA\_NS\_46"

When "CA\_NS 46" is indicated in the cell, the power of any UE emission shall not exceed the levels specified in Table 6.5A.3.3.1.3-1. This requirement also applies for the frequency ranges that are less than  $F_{OOB}$  (MHz) in Table 6.5A.3.1-1 from the edge of the aggregated channel bandwidth.

**Table 6.5A.3.3.1.3-1: Additional requirements for "CA\_NS\_46"**

Protected band	Frequency range (MHz)			Maximum Level (dBm)	MBW (MHz)	NOTE
Frequency range	2570	-	2575	+1.6	5	1, 2
Frequency range	2575	-	2595	-15.5	5	1, 2
Frequency range	2595	-	2620	-40	1	1
NOTE 1: This requirement is applicable for carriers confined in 2500-2570 MHz.						
NOTE 2: For these adjacent bands, the emission limit could imply risk of harmful interference to UE(s) operating in the protected operating band.						

### 6.5A.3.3.2 Additional spurious emissions for intra-band non-contiguous CA

#### 6.5A.3.3.2.1 Requirement for network signalling value "CA\_NC\_NS\_04"

For intra-band non-contiguous CA<sub>n41</sub>(2A), the spurious emission requirements in subclause 6.5.3.3.1 (indicated by NS\_04) applies in each uplink CC.

#### 6.5A.3.3.2.2 Requirement for network signalling value "CA\_NC\_NS\_12"

For intra-band non-contiguous CA<sub>n26</sub>(2A), the spurious emission requirements in subclause 6.5.3.3.17 (indicated by NS\_12) applies in each uplink CC for 5MHz and 10MHz channel bandwidth.

#### 6.5A.3.3.2.3 Requirement for network signalling value "CA\_NC\_NS\_13"

For intra-band non-contiguous CA<sub>n26</sub>(2A), the spurious emission requirements in subclause 6.5.3.3.18 (indicated by NS\_13) applies in each uplink CC for 5MHz channel bandwidth.

#### 6.5A.3.3.2.4 Requirement for network signalling value "CA\_NC\_NS\_14"

For intra-band non-contiguous CA<sub>n26</sub>(2A), the spurious emission requirements in subclause 6.5.3.3.19 (indicated by NS\_14) applies in each uplink CC for 10MHz channel bandwidth.

#### 6.5A.3.3.2.5 Requirement for network signalling value "CA\_NC\_NS\_15"

For intra-band non-contiguous CA<sub>n26</sub>(2A), the spurious emission requirements in subclause 6.5.3.3.20 (indicated by NS\_15) applies in each uplink CC for 5MHz, 10MHz and 15MHz channel bandwidth.

## 6.5A.4 Transmit intermodulation for CA

### 6.5A.4.2.1 Transmit intermodulation for intra-band contiguous CA

For intra-band contiguous carrier aggregation the requirement of transmitting intermodulation is specified in Table 6.5A.4.2.1-1.

**Table 6.5A.4.2.1-1: Transmit Intermodulation**

CA bandwidth class(UL)	B and C	
Interference Signal Frequency Offset	$BW_{\text{Channel\_CA}}$	$2 \cdot BW_{\text{Channel\_CA}}$
Interference CW Signal Level	-40dBc	
Intermodulation Product	-29dBc	-35dBc
Measurement bandwidth (NOTE1)	Nominal channel space + $MBW_{\text{ACLR,low}}/2$ + $MBW_{\text{ACLR,high}}/2$	
Measurement offset from channel center	$BW_{\text{Channel\_CA}}$ and $2 \cdot BW_{\text{Channel\_CA}}$	$2 \cdot BW_{\text{Channel\_CA}}$ and $4 \cdot BW_{\text{Channel\_CA}}$
NOTE 1: $MBW_{\text{ACLR,low}}$ and $MBW_{\text{ACLR,high}}$ are the single-channel ACLR measurement bandwidths specified for channel bandwidths $BW_{\text{channel(low)}}$ and $BW_{\text{channel(high)}}$ in 6.5.2.4.1, respectively.		

### 6.5A.4.2.2 Void

### 6.5A.4.2.3 Transmit intermodulation for Inter-band CA

For inter-band carrier aggregation with two contiguous carriers assigned to one NR band, the transmit intermodulation requirements in subclause 6.5A.4.2.1 apply for that band.

For inter-band carrier aggregation with two uplink non-contiguous carrier assigned to one NR band, the transmit intermodulation requirements in subclause 6.5A.4.2.2 apply for that band.

For inter-band carrier aggregation with uplink assigned to two NR bands, the transmit intermodulation requirement is specified in Table 6.5.4-1 which shall apply on each component carrier with both component carriers active.

For combinations of intra-band and inter-band carrier aggregation with three uplink component carriers (up to two contiguously aggregated carriers per operating band) transmit intermodulation is defined as follows. For the NR band supporting one component carrier the requirement specified in Table 6.5.4-1 apply. For the NR band supporting two contiguous component carriers the requirements specified in Table 6.5A.4.2.1-1 apply.

## 6.5B Output RF spectrum emissions for NR-DC

For inter-band NR-DC with one uplink carrier assigned per NR band, the output RF spectrum emissions for the corresponding inter-band CA configuration as specified in clause 6.5A applies.

## 6.5D Output RF spectrum emissions for UL MIMO

### 6.5D.1 Occupied bandwidth for UL MIMO

For UE supporting UL MIMO, the requirements for occupied bandwidth apply to the sum of the powers from all UE transmit antenna connectors. The occupied bandwidth is defined as the bandwidth containing 99 % of the total integrated mean power of the transmitted spectrum on the assigned channel at each transmit antenna connector.

For UE with two or four transmit antenna connectors in closed-loop spatial multiplexing scheme, the occupied bandwidth shall be less than the channel bandwidth specified in Table 6.5.1-1. The requirements shall be met with UL MIMO configurations described in clause 6.2D.1.

If UE is scheduled for single antenna-port PUSCH transmission by DCI format 0\_0 or by DCI format 0\_1 for single antenna port codebook based transmission with precoding matrix  $W=1$  [6.3.1.5 TS 38.211], the requirements in clause 6.5.1 apply when  $TxD$  is not indicated, and the requirements in clause 6.5G.1 apply when  $TxD$  is indicated.

## 6.5D.2 Out of band emission for UL MIMO

For UE supporting UL MIMO or uplink full power transmission (ULFPTx) for UL MIMO, the requirements for Out of band emissions resulting from the modulation process and non-linearity in the transmitters is defined as the sum of the emissions from all UE transmit antenna connectors.

For UEs with two or four transmit antenna connectors in closed-loop spatial multiplexing scheme, the requirements in subclause 6.5.2 apply. The requirements shall be met with UL MIMO configurations described in clause 6.2D.1.

For UE support uplink full power transmission (ULFPTx) for UL MIMO, the requirements in clause 6.5.2 shall apply. The requirements shall be met with the PUSCH configurations specified in Table 6.2D.1-3, based upon UE's support of uplink full power transmission mode.

If UE is scheduled for single antenna-port PUSCH transmission by DCI format 0\_0 or by DCI format 0\_1 for single antenna port codebook based transmission with precoding matrix  $W=1$  [6.3.1.5 TS 38.211], the requirements in clause 6.5.2 apply when  $TxD$  is not indicated, and the requirements in clause 6.5G.2 apply when  $TxD$  is indicated.

## 6.5D.3 Spurious emission for UL MIMO

For UE supporting UL MIMO or uplink full power transmission (ULFPTx) for UL MIMO, the requirements for Spurious emissions which are caused by unwanted transmitter effects such as harmonics emission, parasitic emissions, intermodulation products and frequency conversion products is defined as the sum of the emissions from all UE transmit antenna connectors.

For UEs with two or four transmit antenna connectors in closed-loop spatial multiplexing scheme, the requirements specified in subclause 6.5.3 apply. The requirements shall be met with the UL MIMO configurations described in clause 6.2D.1.

For UE support uplink full power transmission (ULFPTx) for UL MIMO, the requirements in clause 6.5.3 shall apply. The requirements shall be met with the PUSCH configurations specified in Table 6.2D.1-3, based upon UE's support of uplink full power transmission mode.

If UE is scheduled for single antenna-port PUSCH transmission by DCI format 0\_0 or by DCI format 0\_1 for single antenna port codebook based transmission with precoding matrix  $W=1$  [6.3.1.5 TS 38.211], the requirements in clause 6.5.3 apply when  $TxD$  is not indicated, and the requirements in clause 6.5G.3 apply when  $TxD$  is indicated.

## 6.5D.4 Transmit intermodulation for UL MIMO

For UE supporting UL MIMO, the transmit intermodulation requirements are specified at each transmit antenna connector and the wanted signal is defined as the sum of output powers from all UE transmit antenna connectors.

For UEs with two or four transmit antenna connectors in closed-loop spatial multiplexing scheme, the requirements specified in clause 6.5.4 apply to each transmit antenna connector. The requirements shall be met with the UL MIMO configurations described in clause 6.2D.1.

If UE is scheduled for single antenna-port PUSCH transmission by DCI format 0\_0 or by DCI format 0\_1 for single antenna port codebook based transmission with precoding matrix  $W=1$  [6.3.1.5 TS 38.211], the requirements in clause 6.5.4 apply when  $TxD$  is not indicated, and the requirements in clause 6.5G.4 apply when  $TxD$  is indicated.



## 6.5E Output RF spectrum emissions for V2X

### 6.5E.1 Occupied bandwidth for V2X

#### 6.5E.1.1 General

When UE is configured for NR V2X sidelink transmissions non-concurrent with NR uplink transmissions for NR V2X operating bands specified in Table 5.2E.1-1, the requirements in clause 6.5.1 shall apply for NR V2X sidelink transmission.

For NR V2X UE with two transmit antenna connectors, the occupied bandwidth at each transmitter antenna shall be less than the channel bandwidth specified in Table 6.5.1-1. The requirements shall be met with SL MIMO configurations described in clause 6.2D.1.

If V2X UE transmits on one antenna connector at a time, the requirements specified for single carrier shall apply to the active antenna connector.

#### 6.5E.1.1A Occupied bandwidth for sidelink CA

For SL intra-band contiguous CA, the occupied bandwidth is a measure of the bandwidth containing 99 % of the total integrated power of the aggregated CBW. The occupied bandwidth shall be less than the aggregated channel bandwidth.

#### 6.5E.1.2 Occupied bandwidth for V2X concurrent operation

For the inter-band concurrent NR V2X operation, the requirements specified in clause 6.5.1 shall apply for the uplink in licensed band and the requirements specified in clause 6.5E.1.1 shall apply for the sidelink in licensed band or Band n47.

For the intra-band concurrent NR V2X operation, the requirements specified in clause 6.5.1 shall apply for the uplink in licensed band and the requirements specified in clause 6.5E.1 shall apply for the sidelink in licensed band.

### 6.5E.1F Occupied bandwidth for Sidelink Unlicensed

The requirements for occupied bandwidth in clause 6.5.1 apply for the specified SL-U channel bandwidths in Table 5.3E.1F-1.

#### 6.5E.1F.1 Occupied bandwidth for SL-U concurrent operation

For NR SL-U inter-band concurrent operation, the requirements specified in clause 6.5.1 shall apply for the uplink in licensed band and the requirements specified in clause 6.5E.1F shall apply for NR sidelink operation in unlicensed band.

### 6.5E.2 Out of band emission for V2X

#### 6.5E.2.1 General

When UE is configured for NR V2X sidelink transmissions non-concurrent with NR uplink transmissions for NR V2X operating bands specified in Table 5.2E.1-1, the requirements in clause 6.5E.2.2.1, 6.5E.2.3 and 6.5E.2.4.1 apply for NR V2X sidelink transmission.

For NR V2X UE with two transmit antenna connectors, the requirements specified for single carrier shall apply to each transmit antenna connector. The requirements shall be met with SL MIMO configurations described in clause 6.2D.1.

## 6.5E.2.2 Spectrum emission mask

### 6.5E.2.2.1 General

For NR V2X UE, the existing NR general spectrum emission mask in subclause 6.5.2.2 applies for all supporting NR V2X channel bandwidths. The spectrum emission mask of the UE applies to frequencies ( $\Delta f_{\text{OOB}}$ ) starting from the  $\pm$  edge of the assigned NR channel bandwidth. For frequencies greater than ( $\Delta f_{\text{OOB}}$ ), the power of any UE emission shall not exceed the levels specified in Table 6.5.2.2-1 for the specified channel bandwidth for NR V2X operating bands in Table 5.2E.1-1.

#### 6.5E.2.2.1A Spectrum emission mask for sidelink CA

For SL intra-band contiguous CA, the SEM requirement for NR intra-band contiguous CA as specified in clause 6.5A.2.2.1 shall be applied to the aggregated channel bandwidth with SL CA bandwidth class B.

### 6.5E.2.2.2 Spectrum emission mask for V2X concurrent operation

For the inter-band concurrent NR V2X operation, the general/additional SEM requirements specified in clause 6.5.2 shall apply for the uplink in licensed band and the general/additional SEM requirements specified in clause 6.5E.2.2.1 shall apply for the sidelink in licensed band or Band n47.

For intra-band NR V2X transmission with bandwidth class B where Uu and SL overlap in time the specifications in section 6.5A.2.2.1 and 6.5A.2.2.2 apply.

## 6.5E.2.3 Additional Spectrum emission mask

### 6.5E.2.3.1 Requirements for network signalling value "NS\_33"

The additional spectrum mask in Table 6.5E.2.3.1-1 applies for NR V2X UE within 5 855 MHz to 5 950 MHz according to ETSI EN 302 571. Additional spectrum emission requirements are signalled by the network to indicate that the UE shall meet an additional requirement for a specific deployment scenario as part of the cell handover/broadcast message.

When "NS\_33" is indicated in the cell or pre-configured radio parameters, the power of any V2X UE emission shall not exceed the levels specified in Table 6.5E.2.3.1-1.

**Table 6.5E.2.3.1-1: Additional spectrum mask requirements for 10MHz channel bandwidth**

Spectrum emission limit (dBm EIRP)/ Channel bandwidth		
$\Delta f_{\text{OOB}}$ (MHz)	10 MHz	Measurement bandwidth
$\pm 0-0.5$	$[-13 - 12 \left( \frac{ \Delta f_{\text{OOB}} }{\text{MHz}} \right)]$	100 kHz
$\pm 0.5-5$	$[-19 - \frac{16}{9} \left( \frac{ \Delta f_{\text{OOB}} }{\text{MHz}} - 0.5 \right)]$	100 kHz
$\pm 5-10$	$[-27 - 2 \left( \frac{ \Delta f_{\text{OOB}} }{\text{MHz}} - 5.0 \right)]$	100 kHz

NOTE 1: As a general rule, the resolution bandwidth of the measuring equipment should be equal to the measurement bandwidth. However, to improve measurement accuracy, sensitivity and efficiency, the resolution bandwidth may be smaller than the measurement bandwidth. When the resolution bandwidth is smaller than the measurement bandwidth, the result should be integrated over the measurement bandwidth in order to obtain the equivalent noise bandwidth of the measurement bandwidth.

NOTE 2: Additional SEM for NR V2X overrides any other requirements in frequency range 5855-5950MHz.

NOTE 3: The EIRP requirement is converted to conducted requirement depend on the supported post antenna connector gain  $G_{\text{post connector}}$  declared by the UE following the principle described in annex I in [11].

### 6.5E.2.3.2 Requirements for network signalling value "NS\_52"

The additional spectrum mask in Table 6.5E.2.3.2-1 applies for NR V2X UE within 5 765 MHz to 6 005 MHz according to FCC regulation. Additional spectrum emission requirements are signalled by the network to indicate that the UE shall meet an additional requirement for a specific deployment scenario as part of the cell handover/broadcast message.

When "NS\_52" is indicated in the cell or pre-configured radio parameters, the power of any V2X UE emission shall not exceed the levels specified in Table 6.5E.2.3.2-1.

**Table 6.5E.2.3.2-1: Additional spectrum mask requirements for 40MHz channel bandwidth (fc = 5885MHz)**

$\Delta f_{\text{OoB}}$ (MHz)	Emission Limit (dBm)	Measurement Bandwidth
$\pm 0-2$	-32	100kHz
$\pm 2-10$	-36	100kHz
$\pm 10-20$	-38	100kHz
$\pm 20-40$	-43	100kHz
$\pm 40-100$	-50	100kHz

NOTE: The ASE requirements for NS\_52 will not be verified until the corresponding regulation release a formal rule for C-V2X emission limits.

### 6.5E.2.3.3 Requirements for network signalling value "NS\_06"

The additional spectrum mask are signalled by the network to indicate that the public safety (PS) UE in NR band n14 shall meet an additional for a specific deployment scenarios.

When "NS\_06" is indicated by serving cell or pre-configured radio parameters, the power of any PS UE emission shall not exceed the levels specified in Table 6.5.2.3.4-1.

## 6.5E.2.4 Adjacent channel leakage ratio

### 6.5E.2.4.1 General

Adjacent Channel Leakage power Ratio (ACLR) is the ratio of the filtered mean power centred on the assigned channel frequency to the filtered mean power centred on an adjacent channel frequency.

For NR V2X UE, the existing ACLR requirement for NR uplink transmission in clause 6.5.2.4 are applied for NR V2X UE for NR V2X operating bands in 5.2E.1-1.

For NR V2X UE with two transmit antenna connectors, the requirements specified for single carrier shall apply to each transmit antenna connector. The requirements shall be met with SL MIMO configurations described in clause 6.2D.1.

If V2X UE transmits on one antenna connector at a time, the requirements specified for single carrier shall apply to the active antenna connector.

#### 6.5E.2.4.1A ACLR for sidelink CA

For SL intra-band contiguous CA, the general NR CA ACLR requirements for CA Bandwidth Class B specified in subclause 6.5A.2.4.1.1 shall be applied to the aggregated channel bandwidth with SL CA bandwidth class B.

#### 6.5E.2.4.2 ACLR for V2X concurrent operation

For the inter-band concurrent NR V2X operation, the ACLR requirement specified in clause 6.5.2.4 shall apply for the uplink in licensed band and the ACLR requirement specified in clause 6.5E.2.4.1 shall apply for the sidelink in licensed band or Band n47.

For the intra-band NR V2X operation with bandwidth classes B where Uu and SL transmission overlaps in time, the ACLR requirement specified in clause 6.5A.2.4.1 shall apply for the both uplink and sidelink transmission in licensed band.

### 6.5E.2F Out of band emission for Sidelink Unlicensed

#### 6.5E.2F.1 General

The Out of band emissions are unwanted emissions immediately outside the assigned channel bandwidth resulting from the modulation process and non-linearity in the transmitter but excluding spurious emissions. This out of band emission limit is specified in terms of a spectrum emission mask and an adjacent channel leakage power ratio.

To improve measurement accuracy, sensitivity and efficiency, the resolution bandwidth may be smaller than the measurement bandwidth. When the resolution bandwidth is smaller than the measurement bandwidth, the result should be integrated over the measurement bandwidth in order to obtain the equivalent noise bandwidth of the measurement bandwidth.

#### 6.5E.2F.2 Spectrum emission mask for operation with shared spectrum channel access

The requirements for spectrum emission mask in clause 6.5F.2.2 apply for SL-U operation.

##### 6.5E.2F.2.1 Spectrum emission mask for SL-U concurrent operation

For NR SL-U inter-band concurrent operation, the general/additional SEM requirements specified in clause 6.5.2 shall apply for NR Uu operation in licensed band and the general/additional SEM requirements specified in clause 6.5E.2F shall apply for NR sidelink operation in unlicensed band.

#### 6.5E.2F.3 Additional spectrum emission mask

There are no additional spectrum emission mask requirements for SL-U operation. in this version of the specification.

#### 6.5E.2F.4 Adjacent channel leakage ratio

The requirements for ACLR in clause 6.5F.2.4 apply for SL-U operation.

##### 6.5E.2F.4.1 Adjacent channel leakage ratio for SL-U concurrent operation

For NR SL-U inter-band concurrent operation, the ACLR requirement specified in clause 6.5.2.4 shall apply for NR Uu operation in licensed band and the ACLR requirement specified in clause 6.5E.2F.4 shall apply for NR sidelink operation in unlicensed band.

### 6.5E.3 Spurious emissions for V2X

#### 6.5E.3.1 General spurious emissions

When UE is configured for NR V2X sidelink transmissions non-concurrent with NR uplink transmissions for NR V2X operating bands specified in Table 5.2E.1-1, the general spurious emission requirements in clause 6.5.3.1 shall apply for NR V2X sidelink transmission.

For NR V2X UE with two transmit antenna connectors, the requirements specified for single carrier shall apply to each transmit antenna connector. The requirements shall be met with the SL MIMO configurations described in clause 6.2D.1.

### 6.5E.3.1A Spurious emissions for sidelink CA

For SL intra-band contiguous CA, the general NR CA general SE for CA Bandwidth specified in subclause 6.5A.3.1 shall be applied to the aggregated channel bandwidth with SL CA bandwidth class B.

### 6.5E.3.2 Spurious emissions for UE co-existence

When UE is configured for NR V2X sidelink transmissions non-concurrent with NR uplink transmissions for NR V2X operating bands specified in Table 5.2E.1-1, the requirements in clause 6.5.3.2 shall apply for NR V2X sidelink transmission.

For NR V2X UE with two transmit antenna connectors, the requirements specified for single carrier shall apply to each transmit antenna connector. The requirements shall be met with the SL MIMO configurations described in clause 6.2D.1.

### 6.5E.3.2A Spurious emissions band UE co-existence for sidelink CA

For SL intra-band contiguous CA, the protection operating band lists for n47 transmission is defined in Table 6.5.3.2-1 which shall be applied to NR SL intra-band contiguous CA UE.

### 6.5E.3.3 Spurious emissions for UE co-existence for V2X concurrent operation

This clause specifies the additional requirements for inter-band concurrent V2X operation with the single CC uplink assigned to two NR bands for coexistence with protected bands for the specified simultaneous transmission of the inter-band concurrent V2X configurations in Table 6.5E.3.3-1. The intersection of the requirements for the individual bands specified in clause 6.5.3.2 shall also apply for the specified simultaneous transmission of the inter-band concurrent V2X. Intersection of a requirement means that both UL or sidelink transmission constituent bands have the same protected band requirement specified and if one or both protected bands have note(s) associated those note(s) also apply.

For the inter-band concurrent NR V2X operation, the UE-coexistence requirements in Table 6.5E.3.3-1 apply for the corresponding inter-band concurrent operation with transmission assigned to both uplink in licensed band and sidelink in Band n47.

**NOTE:** For inter-band concurrent V2X operation with uplink assigned to NR band and sidelink transmission assigned to NR V2X operating bands, the requirements in Table 6.5E.3.3-1 could be verified by measuring spurious emissions at the specific frequencies where second and third order intermodulation products generated by the two transmitted carriers can occur; in that case, the requirements for remaining applicable frequencies in Table 6.5E.3.3-1 and in clause 6.5.3.2 would be considered to be verified by the measurements verifying the one uplink inter-band concurrent UE to UE co-existence requirements.

**Table 6.5E.3.3-1: Requirements for inter-band concurrent V2X operation**

V2X concurrent operating band configuration	Spurious emission						
	Protected band	Frequency range (MHz)			Maximum Level (dBm)	MBW (MHz)	NOTE
V2X_n1A-n47A	Frequency range	5925	-	5950	-30	1	3, 4
	Frequency range	5815	-	5855	-30	1	3
V2X_n3A-n47A	Frequency range	5925	-	5950	-30	1	3, 4
	Frequency range	5815	-	5855	-30	1	3

V2X_n8A-n47A	Frequency range	5925	-	5950	-30	1	3, 4
	Frequency range	5815	-	5855	-30	1	3
V2X_n34A-n47A	E-UTRA Band 1, 3, 7, 8, 22, 26, 28, 39, 40, 41, 42, 44, 45, 65, 72	F <sub>DL_low</sub>	-	F <sub>DL_high</sub>	-50	1	
	NR Band n77, n78, n79	F <sub>DL_low</sub>	-	F <sub>DL_high</sub>	-50	1	1
	Frequency range	5925	-	5950	-30	1	3, 4
V2X_n34A-n47A	Frequency range	5815	-	5855	-30	1	3
	Frequency range	5925	-	5950	-30	1	3, 4
V2X_n40A-n47A	Frequency range	5815	-	5855	-30	1	3
	Frequency range	5925	-	5950	-30	1	3, 4
V2X_n41A-n47A	Frequency range	5925	-	5950	-30	1	3, 4
	Frequency range	5815	-	5855	-30	1	3
V2X_n71A-n47A	Frequency range	5925	-	5950	-30	1	3, 4
	Frequency range	5815	-	5855	-30	1	3
V2X_n78A-n47A	Frequency range	5925	-	5950	-30	1	3, 4
	Frequency range	5815	-	5855	-30	1	3

NOTE 1: Void.  
NOTE 2: Void.  
NOTE 3: Applicable when NS\_33 is configured by the pre-configured radio parameters for power class 3 V2X UE.  
NOTE 4: In the frequency range x-5950MHz, SE requirement of -30dBm/MHz should be applied; where x = max (5925, fc + 15), where fc is the channel centre frequency.

For the intra-band NR V2X transmission where  $U_u$  and  $S_{Loverlap}$  in time, the UE-coexistence requirements in Table 6.5A.3.2.1-1 apply for the corresponding intra-band concurrent operation for the both uplink and sidelink transmission in licensed band.

### 6.5E.3.4 Additional spurious emissions requirements for V2X

#### 6.5E.3.4.1 General

This clause specifies additional spurious emission requirements for V2X operation

#### 6.5E.3.4.2 Requirements for network signalling value "NS\_33"

**Table 6.5E.3.4.2-1: Additional requirements for "NS\_33"**

Protected band	Frequency range (MHz)			Maximum Level (EIRP <sup>2</sup> )	MBW (MHz)	NOTE
Frequency range	5925	-	5950	-30	1	1
Frequency range	5815	-	5855	-30	1	3

NOTE 1: In the frequency range x-5950MHz, SE requirement of -30dBm/MHz should be applied; where x = max (5925, fc + 15), where fc is the channel centre frequency.  
NOTE 2: The EIRP requirement is converted to conducted requirement depend on the supported post antenna connector gain  $G_{post\ connector}$  declared by the UE following the principle described in annex I in [11].  
NOTE 3: Resolution BW is 10% of the measurement BW and the result should be integrated to achieve the measurement bandwidth. The sweep time shall be set larger than (symbol length)\*(number of points in sweep) to improve the measurement accuracy.

When "NS\_33" is configured from pre-configured radio parameters or the cell, and the indication from upper layers has indicated that the UE is within the protection zone of CEN DSRC devices or HDR DSRC devices, the power of any NR V2X UE emission shall fulfil either one of the two sets of conditions.

**Table 6.5E.3.4.2-2: Requirements for spurious emissions to protect CEN DSRC for V2X UE**

	Maximum Transmission Power (dBm EIRP <sup>1</sup> )	Emission Limit in Frequency Range 5795-5815 (dBm/MHz EIRP <sup>1</sup> )
Condition 1	10	-65
Condition 2	10	-45
NOTE 1: The EIRP requirement is converted to conducted requirement depend on the supported post antenna connector gain $G_{\text{post connector}}$ declared by the UE following the principle described in annex I in [11].		

6.5E.3.4.3 Void

## 6.5E.3F Spurious emissions for Sidelink Unlicensed

### 6.5E.3F.0 General

Spurious emissions are emissions which are caused by unwanted transmitter effects such as harmonics emission, parasitic emissions, intermodulation products and frequency conversion products, but exclude out of band emissions unless otherwise stated. The spurious emission limits are specified in terms of general requirements in line with SM.329 [9] and NR operating band requirement to address UE co-existence.

To improve measurement accuracy, sensitivity and efficiency, the resolution bandwidth may be smaller than the measurement bandwidth. When the resolution bandwidth is smaller than the measurement bandwidth, the result should be integrated over the measurement bandwidth in order to obtain the equivalent noise bandwidth of the measurement bandwidth.

NOTE: For measurement conditions at the edge of each frequency range, the lowest frequency of the measurement position in each frequency range should be set at the lowest boundary of the frequency range plus MBW/2. The highest frequency of the measurement position in each frequency range should be set at the highest boundary of the frequency range minus MBW/2. MBW denotes the measurement bandwidth defined for the protected band.

### 6.5E.3F.1 General spurious emissions

The requirements for general spurious emission requirements in clause 6.5.3.1 apply for SL-U operation..

### 6.5E.3F.2 Spurious emissions for UE co-existence

Spurious emissions requirements for UE coexistence are not applicable to bands restricted to stand-alone operation with shared spectrum channel access as identified in Table 5.2-1.

#### 6.5E.3F.2.1 Spurious emissions for UE co-existence for SL-U concurrent operation

For NR SL-U inter-band concurrent operation, the UE-coexistence requirements in Table 6.5A.3.2.3-1 apply for the corresponding inter-band concurrent operation with transmission assigned to both uplink in licensed band and NR sidelink in unlicensed band.

### 6.5E.3F.3 Additional spurious emissions

#### 6.5E.3F.3.0 General

These requirements are specified in terms of an additional spectrum emission requirement. Additional spurious emission requirements are signalled by the network to indicate that the UE shall meet an additional requirement for a specific deployment scenario as part of the cell handover/broadcast message.

Editor's note: Further new NS values with new requirements can be added here.

## 6.5E.4 Transmit intermodulation

### 6.5E.4.1 General

When UE is configured for NR V2X sidelink transmissions non-concurrent with NR uplink transmissions for NR V2X operating bands specified in Table 5.2E.1-1, the requirements in clause 6.5.4 apply for NR V2X sidelink transmission.

For NR V2X UE with two transmit antenna connectors, the requirements specified for single carrier shall apply to each transmit antenna connector. The requirements shall be met with the SL MIMO configurations described in clause 6.2D.1.

### 6.5E.4.1A Transmit intermodulation for sidelink CA

For SL intra-band contiguous CA, the general NR CA Transmit Intermodulation requirements for CA Bandwidth Class B specified in clause 6.5A.4.2.1 shall be applied to the aggregated channel bandwidth with SL CA bandwidth class B.

### 6.5E.4.2 Transmit intermodulation for V2X concurrent operation

For the inter-band concurrent NR V2X operation, the requirements specified in clause 6.5.4 shall apply for the uplink in licensed band and the requirements specified in clause 6.5E.4.1 shall apply for the sidelink in licensed band or Band n47.

For the intra-band NR V2X operation where Uu and SL transmission overlaps in time, the requirements specified in clause 6.5A.4 shall apply for both uplink and sidelink in licensed band.

## 6.5E.4F Transmit intermodulation for sidelink Unlicensed

The requirements for transmit intermodulation in clause 6.5.4 apply for SL-U operation.

### 6.5E.4F.1 Transmit intermodulation for SL-U concurrent operation

For NR-U SL inter-band concurrent operation, the requirements specified in clause 6.5.4 shall apply for NR Uu operation in licensed band and the requirements specified in clause 6.5E.4F shall apply for NR sidelink operation in unlicensed band.

## 6.5F Output RF spectrum emissions for shared spectrum channel access

### 6.5F.1 Occupied bandwidth

The requirements for occupied bandwidth in clause 6.5.1 apply for the specified NR-U channel bandwidths in Table 5.3.5-1.

### 6.5F.2 Out of band emission

#### 6.5F.2.1 General

The Out of band emissions are unwanted emissions immediately outside the assigned channel bandwidth resulting from the modulation process and non-linearity in the transmitter but excluding spurious emissions. This out of band emission limit is specified in terms of a spectrum emission mask and an adjacent channel leakage power ratio.

To improve measurement accuracy, sensitivity and efficiency, the resolution bandwidth may be smaller than the measurement bandwidth. When the resolution bandwidth is smaller than the measurement bandwidth, the result should



be integrated over the measurement bandwidth in order to obtain the equivalent noise bandwidth of the measurement bandwidth.

## 6.5F.2.2 Spectrum emission mask for operation with shared spectrum channel access

### 6.5F.2.2.0 General

Instead of the general spectrum emission mask requirement in clause 6.5.2.2, when operating with shared spectrum channel access the relative power of any UE emission shall not exceed the levels specified in Table 6.5F.2.2.0-1 for the specified channel bandwidth or -30 dBm/MHz whichever is the greatest. The spectrum emission mask for operation with shared spectrum channel access is defined relative to the maximum power density in a 1 MHz measurement bandwidth within the channel bandwidth.

The spectrum emission mask for operation with shared spectrum channel access applies to frequencies ( $\Delta f_{\text{OOB}}$ ) starting from the  $\pm$  edge of the assigned channel bandwidth. For offsets greater than  $\Delta f_{\text{OOB}}$ , the spurious requirements in clause 6.5.3 are applicable.

**Table 6.5F.2.2.0-1: Spectrum emission mask for operation with shared spectrum channel access**

Spectrum emission limit (dBr) / Channel bandwidth		
$\Delta f_{\text{OOB}}$ (MHz)	10, 20, 40, 60, 80, 100 MHz	Measurement bandwidth (MBW)
$\pm 0-1$	$-20  \Delta f_{\text{OOB}}  / 1 \text{ MHz}$	$[100\text{kHz}]^3$
$\pm 1-(\text{BW}_{\text{Channel}} / 2)$	$-20 - 8  \Delta f_{\text{OOB}} - 1 \text{ MHz}  / (\text{BW}_{\text{Channel}} / 2 - 1 \text{ MHz})$	1 MHz
$\pm (\text{BW}_{\text{Channel}} / 2) - \text{BW}_{\text{Channel}}$	$-16 - 24  \Delta f_{\text{OOB}}  / \text{BW}_{\text{Channel}}$	
$< -\text{BW}_{\text{Channel}} \text{ Or } > \text{BW}_{\text{Channel}}$	-40	
NOTE 1: Void		
NOTE 2: Void		
NOTE 3: The measured value shall be scaled by a factor equal to the ratio of the reference bandwidth (1 MHz) to the measurement bandwidth before the emission limit (dBr) is applied.		
NOTE 4: The carrier leakage exceptions from Table 6.4F.2.3-1 apply and carrier leakage contribution shall be removed prior to setting the 0dBr level of the mask, the reported carrier frequency location in <i>txDirectCurrentLocation</i> field of the <i>UplinkTxDirectCurrentBWP</i> can be used to cancel the carrier leakage contribution. If <i>txDirectCurrentLocation</i> is not available or is reported with value 3300 or 3301, a carrier frequency location at the center of the channel shall be assumed.		

For measurement conditions at the edge of each frequency range, the lowest frequency of the measurement position in each frequency range should be set at the lowest boundary of the frequency range plus MBW/2. The highest frequency of the measurement position in each frequency range should be set at the highest boundary of the frequency range minus MBW/2.

### 6.5F.2.2.1 Spectrum emission mask for non-transmitted channels

In the case of non-transmitted 20 MHz channel(s) on the edges of an assigned channel bandwidth the spectrum emission mask for operation with shared spectrum channel access, specified in Table 6.5F.2.2.0-1, is applied by using the total bandwidth of the remaining transmitted channels. The spectrum emission mask for non-transmitted channels is floored at -28dBr.

The relative power of any UE emission shall not exceed the most stringent levels given by the spectrum emission mask for operation with shared spectrum channel access with full channel bandwidth and the spectrum emission mask for non-transmitted channels with the channel bandwidth of the transmitted channels in the case of non-transmitted channels at the edge of an assigned channel bandwidth.

An exception to the spectrum emission mask for non-transmitted channels allows a single [2] MHz bandwidth to extend to [-28] dBc relative to total transmit power, or [-20] dBm, whichever is the greatest.

### 6.5F.2.3 Additional spectrum emission mask

There are no additional spectrum emission mask requirements in this version of the specification.

## 6.5F.2.4 Adjacent channel leakage ratio

### 6.5F.2.4.0 General

Adjacent Channel Leakage power Ratio (ACLR) is the ratio of the filtered mean power centred on the assigned channel frequency to the filtered mean power centred on an adjacent channel frequency.

To improve measurement accuracy, sensitivity and efficiency, the resolution bandwidth may be smaller than the measurement bandwidth. When the resolution bandwidth is smaller than the measurement bandwidth, the result should be integrated over the measurement bandwidth in order to obtain the equivalent noise bandwidth of the measurement bandwidth.

### 6.5F.2.4.1 Shared spectrum channel access ACLR

The Adjacent Channel Leakage power Ratio is the ratio of the filtered mean power centred on the assigned channel frequency to the filtered mean power centred on an adjacent channel frequency at nominal channel spacing. The assigned channel power and adjacent channel power are measured with rectangular filters with measurement bandwidths specified in Table 6.5.2.4.1-1.

Instead of the general ACLR requirement in clause 6.5.2.4, if the measured adjacent channel power is greater than  $-47$  dBm then the ACLR shall be higher than the value specified in Table 6.5F.2.4.1-1.

**Table 6.5F.2.4.1-1: Shared spectrum channel access ACLR requirement**

	Power class 5	Power class 3
ACLR	27 dB	27 dB

### 6.5F.2.4.2 Additional requirement for network signalled value "NS\_29"

When "NS\_29" is indicated in the cell, the UE emission shall meet the additional requirements specified in Table 6.5F.2.4.2-1 for shared spectrum channels assigned within 5150 – 5350 MHz and 5470 – 5730 MHz.

**Table 6.5F.2.4.2-1: ACLR2 requirement for "NS\_29"**

Power class 5	20 MHz	40 MHz	60, 80 MHz
ACLR2	40 dB	40 dB	N/A
Measurement bandwidth	20 MHz	40 MHz	N/A
Adjacent channel center frequency offset (MHz)	+40 / -40	+80 / -80	N/A

## 6.5F.2A Out of band emission for CA

### 6.5F.2A.1 Spectrum emission mask for CA

#### 6.5F.2A.1.1 Spectrum emission mask for Inter-band CA

For inter-band carrier aggregation with uplink assigned to two bands and including one of the bands listed in Table 6.2F.1-1, the spectrum emission mask requirements in clause 6.5.2.1 and 6.5.2.2 apply for the NR uplink carrier and clause 6.5F.2.1 and 6.5F.2.2 for the carrier operating with shared spectrum access.

For combinations of intra-band and inter-band carrier aggregation with three uplink component carriers (up to two contiguously aggregated carriers per operating band and including one of the bands listed in Table 6.2F.1-1), the spectrum emission mask of the UE is defined per band while all component carriers are active. For the NR band supporting two contiguous component carriers the requirements specified in subclause 6.5A.2.2.1 apply. For the shared spectrum defined band supporting one component carrier the requirements in subclauses 6.5F.2.2 apply.

## 6.5F.2A.1.2 Spectrum emission mask for Intra-band contiguous CA

### 6.5F.2A.1.2.1 General

For intra-band contiguous carrier aggregation operation with shared spectrum channel access, the relative power of any UE emission shall not exceed the levels specified in Table 6.5F.2A.1.1-1 for the specified aggregated channel bandwidth or -30 dBm/MHz whichever is the greatest. The spectrum emission mask for operation with shared spectrum channel access is defined relative to the maximum power density in a 1 MHz measurement bandwidth within the aggregated channel bandwidth.

The spectrum emission mask for operation with shared spectrum channel access applies to frequencies ( $\Delta f_{OOB}$ ) starting from the  $\pm$  edge of the assigned aggregated channel bandwidth. For frequencies offsets greater than  $\Delta f_{OOB}$ , the spurious requirements in clause 6.5.3 are applicable.

**Table 6.5F.2A.1.2-1: Spectrum emission mask for intra-band contiguous CA operation with shared spectrum channel access**

Spectrum emission limit (dBr) / Aggregated channel bandwidth		
$\Delta f_{OOB}$ (MHz)	10, 20, 40, 60, 80, 100 MHz	Measurement bandwidth (MBW)
$\pm 0-1$	$-20  \Delta f_{OOB}  / 1 \text{ MHz}$	$[100\text{kHz}]^3$
$\pm 1-(BW_{\text{Channel\_CA}} / 2)$	$-20 - 8  \Delta f_{OOB} - 1 \text{ MHz}  / (BW_{\text{Channel\_CA}} / 2 - 1 \text{ MHz})$	1 MHz
$\pm (BW_{\text{Channel\_CA}} / 2) - BW_{\text{Channel\_CA}}$	$-16 - 24  \Delta f_{OOB}  / BW_{\text{Channel\_CA}}$	
$< - BW_{\text{Channel\_CA}}$ or $> BW_{\text{Channel\_CA}}$	-40	
NOTE 1: Void NOTE 2: Void NOTE 3: The measured value shall be scaled by a factor equal to the ratio of the reference bandwidth (1 MHz) to the measurement bandwidth before the emission limit (dBr) is applied. NOTE 4: The carrier leakage exceptions from Table 6.4F.2.3-1 apply and carrier leakage contribution shall be removed prior to setting the 0dBr level of the mask, the reported carrier frequency location in <i>txDirectCurrentLocation</i> field of the <i>UplinkTxDirectCurrentBWP</i> can be used to cancel the carrier leakage contribution. If <i>txDirectCurrentLocation</i> is not available or is reported with value 3300 or 3301, a carrier frequency location at the center of the channel shall be assumed.		

For measurement conditions at the edge of each frequency range, the lowest frequency of the measurement position in each frequency range should be set at the lowest boundary of the frequency range plus MBW/2. The highest frequency of the measurement position in each frequency range should be set at the highest boundary of the frequency range minus MBW/2.

### 6.5F.2A.1.2.2 Intra-band contiguous CA spectrum emission mask for non-transmitted channels

In the case of non-transmitted 20 MHz channel(s) on the edges of an assigned aggregated channel bandwidth, the spectrum emission mask for operation with shared spectrum channel access specified in Table 6.5F.2A.1.2-1 is applied by using the total bandwidth of the remaining transmitted channels. The spectrum emission mask for non-transmitted channels is floored at -28dBr.

The relative power of any UE emission shall not exceed the most stringent levels given by the spectrum emission mask for operation with shared spectrum channel access with full aggregated channel bandwidth, and the spectrum emission mask for non-transmitted channels with the channel bandwidth of the transmitted channels in the case of non-transmitted channels at the edge of an assigned aggregated channel bandwidth.

An exception to the spectrum emission mask for non-transmitted channels allows a single [2] MHz bandwidth to extend to [-28] dBc relative to total transmit power, or [-20] dBm, whichever is the greatest.

## 6.5F.2A.2 Adjacent channel leakage ratio for CA

### 6.5F.2A.2.1 Adjacent channel leakage ratio for inter-band CA

For inter-band carrier aggregation with uplink assigned to two bands and including one of the bands listed in Table 6.2F.1-1, the ACLR requirements in clause 6.5.2.4 apply for the NR uplink carrier and clause 6.5F.2.4 for the carrier operating with shared spectrum access.

For combinations of intra-band and inter-band carrier aggregation with three uplink component carriers (up to two contiguously aggregated carriers per operating band and including one of the bands listed in Table 6.2F.1-1). For the NR band supporting two contiguous component carriers, the requirements in subclause 6.5A.2.4.1.1 apply. For the shared spectrum defined band supporting one component carrier, the requirements in subclause 6.5F.2.4.1 apply.

### 6.5F.2A.2.2 Adjacent channel leakage ratio for intra-band contiguous CA

For intra-band contiguous carrier aggregation, the Carrier Aggregation Adjacent Channel Leakage Power Ratio ( $CA_{ACLR}$ ) is the ratio of the filtered mean power centred on the aggregated channel bandwidth to the filtered mean power centred on an adjacent aggregated channel bandwidth at nominal channel spacing. The assigned aggregated channel bandwidth power and adjacent aggregated channel bandwidth power are measured with rectangular filters with measurement bandwidths specified in Table 6.5F.2A.2.2-1. If the measured adjacent channel power is greater than -47dBm then the ACLR shall be higher than the value specified in Table 6.5F.2A.2.2-1.

**Table 6.5F.2A.2.2-1: General requirements for intra-band contiguous CA ACLR power class 5**

	ACLR / Measurement bandwidth
CA ACLR	27 dB
CA Measurement bandwidth (NOTE 1)	Nominal channel space + $MBW_{ACLR,low}/2$ + $MBW_{ACLR,high}/2$
Adjacent channel centre frequency offset (in MHz)	+ $BW_{Channel\_CA}$ / - $BW_{Channel\_CA}$
Difference between ACLR MBW center and $F_{c,low}$	$MBW_{shift} = (MBW_{ACLR\_CA} - MBW_{ACLR,low})/2$
NOTE 1: $MBW_{ACLR,low}$ and $MBW_{ACLR,high}$ are the single-channel ACLR measurement bandwidths specified for channel bandwidths $BW_{channel(low)}$ and $BW_{channel(high)}$ in 6.5.2.4.1, respectively.	

## 6.5F.3 Spurious emissions

### 6.5F.3.0 General

Spurious emissions are emissions which are caused by unwanted transmitter effects such as harmonics emission, parasitic emissions, intermodulation products and frequency conversion products, but exclude out of band emissions unless otherwise stated. The spurious emission limits are specified in terms of general requirements in line with SM.329 [9] and NR operating band requirement to address UE co-existence.

To improve measurement accuracy, sensitivity and efficiency, the resolution bandwidth may be smaller than the measurement bandwidth. When the resolution bandwidth is smaller than the measurement bandwidth, the result should be integrated over the measurement bandwidth in order to obtain the equivalent noise bandwidth of the measurement bandwidth.

NOTE: For measurement conditions at the edge of each frequency range, the lowest frequency of the measurement position in each frequency range should be set at the lowest boundary of the frequency range plus  $MBW/2$ . The highest frequency of the measurement position in each frequency range should be set at the highest boundary of the frequency range minus  $MBW/2$ .  $MBW$  denotes the measurement bandwidth defined for the protected band.

### 6.5F.3.1 General spurious emissions

The requirements for general spurious emission requirements in clause 6.5.3.1 apply.

### 6.5F.3.2 Spurious emissions for UE co-existence

Spurious emissions requirements for UE coexistence are not applicable to bands restricted to stand-alone operation with shared spectrum channel access as identified in Table 5.2-1.

### 6.5F.3.3 Additional spurious emissions

#### 6.5F.3.3.0 General

These requirements are specified in terms of an additional spectrum emission requirement. Additional spurious emission requirements are signalled by the network to indicate that the UE shall meet an additional requirement for a specific deployment scenario as part of the cell handover/broadcast message.

#### 6.5F.3.3.1 Requirement for network signalling value "NS\_28"

When "NS\_28" is indicated in the cell, the power of any UE emission for channels assigned within 5150-5350 and 5470-5725 MHz shall not exceed the levels specified in Table 6.5F.3.3.1-1. This requirement also applies for the frequency ranges that are less than  $F_{OOB}$  (MHz) in Table 6.5.3.1-1 from the edge of the channel bandwidth.

**Table 6.5F.3.3.1-1: Additional requirements**

Frequency band (MHz)	Channel bandwidth / Spectrum emission limit (dBm)	Measurement bandwidth
	20, 40, 60, 80, [100] MHz	
$47 \leq f \leq 74$	-54	100 kHz
$87.5 \leq f \leq 118$	-54	100 kHz
$174 \leq f \leq 230$	-54	100 kHz
$470 \leq f \leq 862$	-54	100 kHz
$1000 \leq f \leq 5150$	-30	1 MHz
$5350 \leq f \leq 5470$	-30	1 MHz
$5725 \leq f \leq 26000$	-30	1 MHz

#### 6.5F.3.3.2 Requirement for network signalling value "NS\_29"

When "NS\_29" is indicated in the cell, the power of any UE emission for channels assigned within 5150-5350 and 5470-5730 MHz shall not exceed the levels specified in Table 6.5F.3.3.2-1, Table 6.5F.3.3.2-2, and Table 6.F.3.3.2-3. This requirement also applies for the frequency ranges that are less than  $F_{OOB}$  (MHz) in Table 6.5.3.1-1 from the edge of the channel bandwidth.

**Table 6.5F.3.3.2-1: Additional requirements for 20 MHz channel bandwidth**

Center Frequency $F_c$ [MHz]	Protected range [MHz]	Minimum requirement [dBm]	Measurement bandwidth
$5179.98 \leq F_c \leq 5239.98$	$5135 \leq f \leq 5142$	-26	1 MHz
	$5142 < f \leq 5150$	-18	
	$5250 \leq f < 5250.2$	3 to -2	
	$5250.2 \leq f < 5251$	-2 to -10	
	$5251 \leq f < 5260$	-10 to -18	
	$5260 \leq f < 5266.7$	-18 to -26	
	$5266.7 \leq f \leq 5365$	-26	
$5260.02 \leq F_c \leq 5320.02$	$5135 \leq f \leq 5233.3$	-26	1 MHz
	$5233.3 < f \leq 5240$	-26 to -18	
	$5240 < f \leq 5249$	-18 to -10	
	$5249 < f \leq 5249.8$	-10 to -2	
	$5249.8 < f \leq 5250$	-2 to 3	
	$5350 \leq f \leq 5365$	-26	
$5500.02 \leq F_c \leq 5719.98$	$5420 \leq f \leq 5460$	-26	1 MHz
	$5460 < f \leq 5470$	-19	
	$5745 \leq f < 5765$	-19	
	$5765 \leq f \leq 5800$	-26	
NOTE: The minimum requirement when specified as a range denotes the emission requirement at the end points of the protected range. The requirement within the			

protected range is obtained by linear interpolation between the requirements at the end points.

**Table 6.5F.3.3.2-2: Additional requirements for 40 MHz channel bandwidth**

Center Frequency $F_c$ [MHz]	Protected range [MHz]	Minimum requirement [dBm]	Measurement bandwidth
$5190 \leq F_c \leq 5230.02$	$5100 \leq f \leq 5141.6$	-26	1 MHz
	$5141.6 < f \leq 5150$	-18	
	$5250 \leq f < 5251$	-3 to -13	
	$5251 \leq f < 5270$	-13 to -21	
	$5270 \leq f < 5278.4$	-21 to -26	
$5278.4 \leq f \leq 5400$	-26		
$5269.98 \leq F_c \leq 5310$	$5210 < f \leq 5221.6$	-26	
	$5221.6 < f \leq 5230$	-26 to -21	
	$5230 < f \leq 5249$	-21 to -13	
	$5249 \leq f \leq 5250$	-13 to -3	
	$5350 \leq f \leq 5358.4$	-18	
$5509.98 \leq F_c \leq 5670$	$5358.4 < f \leq 5400$	-26	
	$5420 \leq f \leq 5460$	-19	
	$5460 < f \leq 5470$	-13	
	$5770 \leq f \leq 5800$	-19	
NOTE: The minimum requirement when specified as a range denotes the emission requirement at the end points of the protected range. The requirement within the protected range is obtained by linear interpolation between the requirements at the end points.			

**Table 6.5F.3.3.2-3: Additional requirements for 60 and 80 MHz channel bandwidth**

Center Frequency $F_c$ [MHz]	Protected range [MHz]	Minimum requirement [dBm]	Measurement bandwidth
$5200.02 \leq F_c \leq 5220$	$5020 \leq f \leq 5123.2$	-26	1 MHz
	$5123.2 < f \leq 5150$	-18	
	$5250 \leq f < 5251$	-6 to -16	
	$5251 \leq f < 5290$	-16 to -24	
	$5290 \leq f < 5296.7$	-24 to -26	
$5280 \leq F_c \leq 5299.98$	$5296.7 \leq f \leq 5480$	-26	
	$5020 \leq f \leq 5203.3$	-26	
	$5203.3 < f \leq 5210$	-26 to -24	
	$5210 < f \leq 5249$	-24 to -16	
	$5249 < f \leq 5250$	-16 to -6	
$5520 \leq F_c \leq 5689.98$	$5350 \leq f < 5376.8$	-18	
	$5376.8 \leq f \leq 5480$	-26	
	$5340 \leq f \leq 5460$	-19	
	$5460 < f \leq 5469.5$	-13	
	$5469.5 < f \leq 5470$	-13	
	$5770 \leq f \leq 5800$	-19	
NOTE: The minimum requirement when specified as a range denotes the emission requirement at the end points of the protected range. The requirement within the protected range is obtained by linear interpolation between the requirements at the end points.			

6.5F.3.3.3 Requirement for network signalling value "NS\_30"

When "NS\_30" is indicated in the cell, the power of any UE emission for channels assigned within 5150-5350 MHz, 5470-5725 MHz and 5725-5850 MHz shall not exceed the levels specified in Table 6.5F.3.3.3-1-1, Table 6.5F.3.3.3-1-2 and Table 6.5F.3.3.3-1-3, respectively. These requirements also apply for the frequency ranges that are less than  $F_{OOB}$  (MHz) in Table 6.5.3.1-1 from the edge of the channel bandwidth.

**Table 6.5F.3.3.3-1: Additional requirements for shared access channels assigned within 5150-5350 MHz**

Protected range (MHz)	Channel bandwidth / Spectrum emission limit (dBm)	Measurement bandwidth
	20, 40, 60, 80 MHz	
$4500 \leq f \leq 5150$	-41	1 MHz
$5350 \leq f \leq 5460$	-41	

**Table 6.5F.3.3.3-2: Additional requirements for shared access channels assigned within 5470-5725 MHz**

Protected range (MHz)	Channel bandwidth / Spectrum emission limit (dBm)	Measurement bandwidth
	20, 40, 60, 80 MHz	
$4500 \leq f \leq 5150$	-41	1 MHz
$5350 \leq f \leq 5460$	-41	
$5460 < f \leq 5470$	-27	
$5725 \leq f$	-27	

**Table 6.5F.3.3.3-3: Additional requirements for shared access channels assigned within 5725-5850 MHz**

Protected range (MHz)	Channel bandwidth / Spectrum emission limit (dBm)	Measurement bandwidth
	20, 40, 60, 80, [100] MHz	
$f < 5650$	-27	1 MHz
$5650 \leq f < 5700$	-27 to 10	
$5700 \leq f < 5720$	10 to 15.6	
$5720 < f \leq 5725$	15.6 to 27	
$5850 \leq f \leq 5855$	27 to 15.6	
$5855 < f \leq 5875$	15.6 to 10	
$5875 < f \leq 5925$	10 to -27	
$5925 < f$	-27	
NOTE: The minimum requirement when specified as a range denotes the emission requirement at the end points of the protected range. The requirement within the protected range is obtained by linear interpolation between the requirements at the end points.		

6.5F.3.3.4 Requirement for network signalling value "NS\_31"

When "NS\_31" is indicated in the cell, the power of any UE emission for channels assigned within 5150-5250 MHz, 5250-5350 MHz, 5470-5725 MHz and 5725-5850 MHz shall not exceed the levels specified in Table 6.5F.3.3.4-1, Table 6.5F.3.3.4-2, Table 6.5F.3.3.4-3 and Table 6.5F.3.3.4-4, respectively. These requirements also apply for the frequency ranges that are less than  $F_{OOB}$  (MHz) in Table 6.5.3.1-1 from the edge of the channel bandwidth.

**Table 6.5F.3.3.4-1: Additional requirements for NR-U channels assigned within 5150-5250 MHz**

Frequency band (MHz)	Channel bandwidth / Spectrum emission limit (dBm)	Measurement bandwidth
----------------------	---	-----------------------

	20, 40, 60, 80 MHz	
$f \leq 5150$	-27	1 MHz
$f \geq 5250$	-27	

**Table 6.5F.3.3.4-2: Additional requirements for NR-U channels assigned within 5250-5350 MHz**

Frequency band (MHz)	Channel bandwidth / Spectrum emission limit (dBm)	Measurement bandwidth
	20, 40, 60, 80 MHz	
$f \leq 5250$	-27	1 MHz
$f \geq 5350$	-27	

**Table 6.5F.3.3.4-3: Additional requirements for NR-U channels assigned within 5470-5725 MHz**

Frequency band (MHz)	Channel bandwidth / Spectrum emission limit (dBm)	Measurement bandwidth
	20, 40, 60, 80 MHz	
$f \leq 5470$	-27	1 MHz
$f \geq 5725$	-27	

**Table 6.5F.3.3.4-4: Additional requirements for NR-U channels assigned within 5725-5850 MHz**

Frequency band (MHz)	Channel bandwidth / Spectrum emission limit (dBm)	Measurement bandwidth
	20, 40, 60, 80 MHz	
$f \leq 5725$	-27	1 MHz
$f \geq 5850$	-27	

#### 6.5F.3.3.5 Requirements for network signalling value "NS\_53" or "NS\_54" or "NS\_60" or "NS\_66" or "NS\_67" or "NS\_71"

When "NS\_53" or "NS\_54" or "NS\_60" or "NS\_66" or "NS\_67" or "NS\_71" is indicated in the cell, the power of any UE emission shall not exceed the levels specified in Table 6.5F.3.3.5-1. These requirements also apply for the frequency ranges that are less than  $F_{OOB}$  (MHz) in Table 6.5.3.1-1 from the edge of the channel bandwidth.

**Table 6.5F.3.3.5-1: Additional requirements**

Frequency band (MHz)	Spectrum emission limit (dBm)	Measurement bandwidth
$f \leq 5925$	-27	1 MHz
$f \geq 7125$	-27	

#### 6.5F.3.3.6 Requirements for network signalling value "NS\_58"

When "NS\_58" is indicated in the cell, the power of any UE emission for channels assigned within 5945-6425 MHz shall not exceed the levels specified in Table 6.5F.3.3.6-1. These requirements also apply for frequency ranges that are less than  $F_{OOB}$  (MHz) in Table 6.5.3.1-1 from the edge of the channel bandwidth.

**Table 6.5F.3.3.6-1: Additional requirements**

Frequency band (MHz)	Channel bandwidth / Spectrum emission limit (dBm)	Measurement bandwidth
$87.5 \leq f \leq 118$	-54	100 kHz
$174 \leq f \leq 230$	-54	100 kHz



$470 \leq f \leq 694$	-54	100 kHz
$f \leq 5935$	-22	1 MHz

### 6.5F.3.3.7 Requirements for network signalling value "NS\_61"

When "NS\_61" is indicated in the cell, the power of any UE emission shall not exceed the levels specified in Table 6.5F.3.3.7-1. These requirements also apply for the frequency ranges that are less than  $F_{OOB}$  (MHz) in Table 6.5.3.1-1 from the edge of the channel bandwidth.

**Table 6.5F.3.3.7-1: Additional requirements**

Frequency band (MHz)	Channel bandwidth / Spectrum emission limit (dBm)	Measurement bandwidth
$f \leq 5925$	-34	1 MHz
$f \geq 6445$	-34	

### 6.5F.3.3.8 Requirements for network signalling value "NS\_63" or "NS\_69"

When "NS\_63" or "NS\_69" is indicated in the cell, the power of any UE emission for channels assigned within 5945-6425 MHz shall not exceed the levels specified in Table 6.5F.3.3.8-1. These requirements also apply for frequency ranges that are less than  $F_{OOB}$  (MHz) in Table 6.5.3.1-1 from the edge of the channel bandwidth.

**Table 6.5F.3.3.8-1: Additional requirements**

Frequency band (MHz)	Channel bandwidth / Spectrum emission limit (dBm)	Measurement bandwidth
$f \leq 5925$	-27	1 MHz
$6425 \leq f \leq X$	-13	1 MHz
$f \geq X$	-19	1 MHz
Note 1: In case of NS_63 the parameter X is defined as 6435.9MHz for 20MHz channel, 6440.1MHz for 40MHz channel, and 6440.4MHz for 80MHz.		
Note 2: In case of NS_69 the parameter X is defined as 6425.5MHz for 20MHz channel, 6425.4MHz for 40MHz channel, and 6425.2MHz for 80MHz.		

ACLR is specified for the first adjacent channel (ACLR1) which centre frequency is  $\pm CBW$  from assigned channel centre and for the 2<sup>nd</sup> adjacent channel (ACLR2) which centre frequency is  $\pm 2 * CBW$  from assigned channel centre. The assigned channel power and ACLR1/ACLR2 are measured with rectangular filters with measurement bandwidth of CBW.

Instead of the general ACLR requirement in clause 6.5.2.4 and 6.5F.2.4.1, if the measured adjacent channel power is greater than  $-47$  dBm then the ACLR shall be higher than the value specified in Table 6.5F.3.3.10-2.

**Table 6.5F.3.3.10-2: Shared spectrum channel access ACLR requirement**

	ACLR1	ACLR2
Spectrum emission limit (dB)	25	40

### 6.5F.3.3.9 Requirements for network signalling value "NS\_64"

When "NS\_64" is indicated in the cell, the power of any UE emission for channels assigned within 5945-6425 MHz shall not exceed the levels specified in Table 6.5F.3.3.9-1. These requirements also apply for frequency ranges that are less than  $F_{OOB}$  (MHz) in Table 6.5.3.1-1 from the edge of the channel bandwidth.

**Table 6.5F.3.3.9-1: Additional requirements**

Frequency band (MHz)	Channel bandwidth / Spectrum emission limit	Measurement bandwidth
----------------------	---	-----------------------

	(dBm)	
$87.5 \leq f \leq 118$	-54	100 kHz
$174 \leq f \leq 230$	-54	100 kHz
$470 \leq f \leq 694$	-54	100 kHz
$f \leq 5935$	-45	1 MHz

## 6.5F.3A Spurious emissions for CA

### 6.5F.3A.0 General

To improve measurement accuracy, sensitivity and efficiency, the resolution bandwidth may be smaller than the measurement bandwidth. When the resolution bandwidth is smaller than the measurement bandwidth, the result should be integrated over the measurement bandwidth in order to obtain the equivalent noise bandwidth of the measurement bandwidth.

**NOTE:** For measurement conditions at the edge of each frequency range, the lowest frequency of the measurement position in each frequency range should be set at the lowest boundary of the frequency range plus MBW/2. The highest frequency of the measurement position in each frequency range should be set at the highest boundary of the frequency range minus MBW/2. MBW denotes the measurement bandwidth defined for the protected band.

### 6.5F.3A.1 General spurious emissions

For intra-band contiguous carrier aggregation, the spurious emission limits apply for the frequency ranges that are more than FOOB (MHz) in Table 6.5F.3A.1-1 from the edge of the aggregated channel bandwidth. For frequencies  $\Delta f_{\text{OOB}}$  greater than FOOB as specified in Table 6.5F.3A.1-1 the spurious emission requirements in Table 6.5.3.1-2 are applicable.

**Table 6.5F.3A.1-1: Boundary between out of band and spurious emission domain for intra-band contiguous carrier aggregation**

Aggregated channel bandwidth	OOB boundary $F_{\text{OOB}}$ (MHz)
$BW_{\text{Channel\_CA}}$	$BW_{\text{Channel\_CA}} + 5$

### 6.5F.3A.2 Spurious emissions for UE co-existence

Spurious emissions requirements for UE coexistence are not applicable to bands restricted to stand-alone operation with shared spectrum channel access as identified in Table 5.2-1.

### 6.5F.3A.3 Additional spurious emissions

#### 6.5F.3A.3.0 General

These requirements are specified in terms of an additional spectrum emission requirement. Additional spurious emission requirements are signalled by the network to indicate that the UE shall meet an additional requirement for a specific deployment scenario as part of the cell handover/broadcast message.

#### 6.5F.3A.3.1 Requirements for network signalling value "CA\_NS\_53" or "CA\_NS\_54"

When "CA\_NS\_53" or "CA\_NS\_54" is indicated in the cell, the power of any UE emission shall not exceed the levels specified in Table 6.5F.3A.3.1-1. These requirements also apply for the frequency ranges that are less than  $F_{\text{OOB}}$  (MHz) in Table 6.5.3.1-1 from the edge of the aggregated channel bandwidth.

**Table 6.5F.3A.3.1-1: Additional requirements**

Frequency band (MHz)	Spectrum emission limit (dBm)	Measurement bandwidth
$f \leq 5925$	-27	1 MHz
$f \geq 7125$	-27	

## 6.5F.4 Transmit intermodulation

The requirements for transmit intermodulation in clause 6.5F.4 apply.

## 6.5G Output RF spectrum emissions for Tx Diversity

### 6.5G.1 Occupied bandwidth for Tx Diversity

For UE supporting Tx diversity, the requirements for occupied bandwidth apply to the transmitted spectrum as measured as the sum of the power from all UE transmit antenna connectors. The occupied bandwidth is defined as the bandwidth containing 99 % of the total integrated mean power of the transmitted spectrum on the assigned channel at each transmit antenna connector.

### 6.5G.2 Out of band emission for Tx Diversity

For UE supporting Tx diversity, the requirements for Out of band emissions resulting from the modulation process and non-linearity in the transmitters apply to the sum of the emissions from all UE transmit antenna connectors.

If UE indicates Tx diversity capability, Adjacent Channel Leakage power Ratio (ACLR) is defined as the ratio of sum of the filtered mean power at each antenna connector centred on the assigned channel frequency to sum of the filtered mean power at each antenna connector centred on an adjacent channel frequency.

The requirements specified in clause 6.5.2 apply.

### 6.5G.3 Spurious emission for Tx Diversity

For UE supporting Tx diversity, the requirements for Spurious emissions which are caused by unwanted transmitter effects such as harmonics emission, parasitic emissions, intermodulation products and frequency conversion products apply to the sum of the emissions from all UE transmit antenna connectors.

The requirements specified in clause 6.5.3 apply.

### 6.5G.4 Transmit intermodulation for Tx Diversity

For UE supporting Tx diversity, the transmit intermodulation requirements are specified at each transmit antenna connector and the wanted signal is defined as the sum of output power from all UE transmit antenna connectors.

The requirements specified in clause 6.5.4 apply.

## 6.5H Output RF spectrum emissions for CA with UL MIMO

### 6.5H.1 Output RF spectrum emissions for intra-band UL contiguous CA with UL MIMO

#### 6.5H.1.1 Occupied bandwidth for intra-band UL contiguous CA with UL MIMO

For UE supporting intra-band UL contiguous CA and UL MIMO, the requirements for occupied bandwidth specified in clause 6.5A.1.1a apply to the sum of the powers from both UE transmit antenna connectors and all UL CCs. The requirements shall be met with UL MIMO configurations described in Table 6.2D.1-2.

If UE is scheduled for single antenna-port PUSCH transmission by DCI format 0\_0 or by DCI format 0\_1 for single antenna port codebook based transmission with precoding matrix  $W=1$  [6.3.1.5 TS 38.211], the requirements in clause 6.5A.1.1a apply.

#### 6.5H.1.2 Out of band emission for intra-band UL contiguous CA with UL MIMO

For UE supporting intra-band UL contiguous CA and UL MIMO, the requirements for Out of band emissions resulting from the modulation process and non-linearity in the transmitters is defined as the sum of the emissions from both UE transmit antenna connectors and all UL CCs, the requirements in subclause 6.5A.2.2.1, 6.5A.2.3.1 and 6.5A.2.4.1.1 apply. The requirements shall be met with UL MIMO configurations described in Table 6.2D.1-2.

If UE is scheduled for single antenna-port PUSCH transmission by DCI format 0\_0 or by DCI format 0\_1 for single antenna port codebook based transmission with precoding matrix  $W=1$  [6.3.1.5 TS 38.211], the requirements in clause 6.5A.2.2.1, 6.5A.2.3.1 and 6.5A.2.4.1.1 apply.

#### 6.5H.1.3 Spurious emission for intra-band UL contiguous CA with UL MIMO

For UE supporting intra-band UL contiguous CA and UL MIMO, the requirements for Spurious emissions is defined as the sum of the emissions from both UE transmit antenna connectors and all UL CCs, the requirements specified in subclause 6.5A.3.1, 6.5A.3.2.1 and 6.5A.3.3.1 apply. The requirements shall be met with the UL MIMO configurations described in Table 6.2D.1-2.

If UE is scheduled for single antenna-port PUSCH transmission by DCI format 0\_0 or by DCI format 0\_1 for single antenna port codebook based transmission with precoding matrix  $W=1$  [6.3.1.5 TS 38.211], the requirements in clause 6.5A.3.1, 6.5A.3.2.1 and 6.5A.3.3.1 apply.

#### 6.5H.1.4 Transmit intermodulation for intra-band UL contiguous CA with UL MIMO

For UE supporting intra-band UL contiguous CA and UL MIMO, the transmit intermodulation requirements are specified at each transmit antenna connector and the wanted signal is defined as the sum of output powers from both UE transmit antenna connectors, the requirements specified in clause 6.5A.4.2.1 apply. The requirements shall be met with the UL MIMO configurations described in Table 6.2D.1-2.

If UE is scheduled for single antenna-port PUSCH transmission by DCI format 0\_0 or by DCI format 0\_1 for single antenna port codebook based transmission with precoding matrix  $W=1$  [6.3.1.5 TS 38.211], the requirements in clause 6.5A.4.2.1 apply.

## 6.5H.2 Void

## 6.5H.3 Output RF spectrum emissions for inter-band UL CA with UL MIMO

### 6.5H.3.1 Occupied bandwidth for inter-band UL CA with UL MIMO

For inter-band UL CA with UL MIMO in one of the two frequency bands, the occupied bandwidth is defined per component carrier. The requirement specified in clause 6.5.1 shall apply for the component carrier without UL MIMO and the requirement specified in clause 6.5D.1 shall apply for the component carrier configured with UL MIMO.

### 6.5H.3.2 Out of band emission for inter-band UL CA with UL MIMO

For inter-band UL CA with UL MIMO in one of the two frequency bands, the out of band emission requirement is defined per component carrier while both component carriers are active. The requirements specified in clauses 6.5.2.1 and 6.5.2.2 shall apply for the component carrier without UL MIMO and the requirements specified in clause 6.5D.2 shall apply for the component carrier configured with UL MIMO. If for some frequency spectrum emission masks of component carriers overlap, then spectrum emission mask allowing higher power spectral density applies for that frequency. If for some frequency a component carrier spectrum emission mask overlaps with the channel bandwidth of another component carrier, then the emission mask does not apply for that frequency.

### 6.5H.3.3 Spurious emission for inter-band UL CA with UL MIMO

For inter-band UL CA with UL MIMO in one of the two frequency bands, the general spurious emission requirements in Table 6.5.3.1-2 apply for the frequency ranges that are more than  $F_{\text{OOB}}$  as defined in Table 6.5.3.1-1 away from edges of the assigned channel bandwidth on a component carrier. The spurious emission requirements for co-existence in Table 6.5A.3.2.3-1 apply with all component carriers are active.

### 6.5H.3.4 Transmit intermodulation for inter-band UL CA with UL MIMO

For inter-band UL CA with UL MIMO in one of the two frequency bands, the transmit intermodulation requirement specified in clause 6.5.4 shall apply for the component carrier without UL MIMO and the transmit intermodulation requirement specified in Table 6.5D.4 shall apply for the component carrier configured with UL MIMO with all component carriers active.

## 6.5I (Reserved)

## 6.5J Output RF spectrum emissions for ATG

### 6.5J.1 Occupied bandwidth for ATG

The requirements for occupied bandwidth in clause 6.5.1 apply. For ATG UE, the requirements for occupied bandwidth are defined at each transmit antenna connector or each TAB connector.

### 6.5J.2 Out of band emission for ATG

#### 6.5J.2.1 General

This clause contains requirements for out of band emissions for ATG UE, the requirement defined in general part of clause 6.5.2.1 should apply.

#### 6.5J.2.2 Spectrum emission mask

If the actual transmission power of ATG UE is less than or equal to 31dBm, the requirements for spectrum emission mask in clause 6.5.2.2 apply; if the actual transmission power of ATG UE is larger than 31dBm, the requirements of spectrum emission mask in clause 6.5.2.2 shall be relaxed with scaling factor equal to (the actual transmission power

minus 31) dB. For ATG UE, the requirements for spectrum emission mask are defined as the sum of the emissions from all UE transmit antenna connectors or all TAB connectors.

NOTE: This scaling factor is only applicable to ATG airborne UE.

### 6.5J.2.3 Adjacent channel leakage ratio

NR Adjacent Channel Leakage power Ratio ( $NR_{ACLR}$ ) is the ratio of the filtered mean power centred on the assigned NR channel frequency to the filtered mean power centred on an adjacent NR channel frequency at nominal channel spacing. For ATG UE, the requirements for ACLR are defined as the sum of the emissions from all UE transmit antenna connectors or all TAB connectors.

The assigned NR channel power and adjacent NR channel power are measured with rectangular filters with measurement bandwidths specified in Table 6.5J.2.3-1.

If the measured adjacent channel power is greater than  $-50$  dBm then the  $NR_{ACLR}$  shall be higher than the value 30dBc.

**Table 6.5J.2.3-1: NR ACLR measurement bandwidth**

<b>Channel bandwidth</b>	(MHz)	5,10,15,20,25,30,35,40,45,50	60,70,80,90,100
<b>REF_SCS</b>	(kHz)	15	30
<b>NR ACLR measurement bandwidth</b>	(MHz)	$MBW=REF\_SCS*(12*N_{RB}+1)/1000$	
NOTE : "N <sub>RB</sub> " in the formula is the maximum transmission bandwidth configuration as defined in Table 5.3.2-1.			

### 6.5J.3 Spurious emissions for ATG

The requirements for spurious emission in general part of clause 6.5.3.0 and clause 6.5.3.1 apply. For ATG UE, the requirements for Spurious emissions are defined as the sum of the emissions from all UE transmit antenna connectors or all TAB connectors.

## 6.5K Output RF spectrum emissions for Aerial UE

### 6.5K.1 Occupied bandwidth for Aerial UE

For Aerial UE, the requirements specified in clause 6.5.1 apply.

### 6.5K.2 Out of band emission for Aerial UE

For Aerial UE, the requirements specified in clause 6.5.2 apply.

### 6.5K.3 Spurious emissions for Aerial UE

#### 6.5K.3.0 General

For Aerial UE, the requirements specified in clause 6.5.3.0 apply.

#### 6.5K.3.1 General spurious emissions

For Aerial UE, the requirements specified in clause 6.5.3.1 apply.

### 6.5K.3.2 Spurious emissions for UE co-existence

For Aerial UE, the requirements specified in clause 6.5.3.2 apply.

### 6.5K.3.3 Additional spurious emissions

#### 6.5K.3.3.1 Requirement for network signalling value "NS\_UAV\_44"

When "NS\_UAV\_44" is indicated in the cell, the power of any UE emission shall not exceed the levels specified in Table 6.5K.3.3.1-1. This requirement also applies for the frequency ranges that are less than  $F_{OOB}$  (MHz) in Table 6.5.3.1-1 from the edge of the channel bandwidth.

**Table 6.5K.3.3.1-1: Additional requirements for "NS\_UAV\_44"**

Frequency range (MHz)	Channel bandwidth (MHz) / Spectrum emission limit (dBm)	Measurement bandwidth	Note
	5, 10, 15, 20, 25, 30, 40 MHz		
$2620 \leq f < 2645$	-15.5	5 MHz	1
$2645 \leq f < 2690$	-40	1 MHz	
$2690 \leq f \leq 2900$	-50	1 MHz	
NOTE 1: For these adjacent bands, the emission limit could imply risk of harmful interference to UE(s) operating in the protected operating band.			

#### 6.5K.3.3.2 Requirement for network signalling value "NS\_UAV\_46"

When "NS\_UAV\_46" is indicated in the cell, the power of any UE emission shall not exceed the levels specified in Table 6.5K.3.3.2-1. This requirement also applies for the frequency ranges that are less than  $F_{OOB}$  (MHz) in Table 6.5.3.1-1 from the edge of the channel bandwidth.

**Table 6.5K.3.3.2-1: Additional requirements for "NS\_UAV\_46"**

Frequency range (MHz)	Channel bandwidth (MHz) / Spectrum emission limit (dBm)	Measurement bandwidth
	5, 10, 15, 20, 25, 30, 35, 40, 50 MHz	
$2690 \leq f \leq 2900$	-50	1 MHz

#### 6.5K.3.3.3 Requirement for network signalling value "NS\_UAV\_70"

When "NS\_UAV\_70" is indicated in the cell, the power of any UE emission shall not exceed the levels specified in Table 6.5K.3.3.3-1. This requirement also applies for the frequency ranges that are less than  $F_{OOB}$  (MHz) in Table 6.5.3.1-1 from the edge of the channel bandwidth.

**Table 6.5K.3.3.3-1: Additional requirements for "NS\_UAV\_70"**

Frequency range (MHz)	Channel bandwidth (MHz) / Spectrum emission limit (dBm)	Measurement bandwidth
	5, 10, 15, 20, 25, 30, 35, 40, 45, 50 MHz	
$1675 \leq f \leq 1710$	-40	1 MHz

## 6.5L Output RF spectrum emissions for CA with Tx Diversity

### 6.5L.1 Void

### 6.5L.2 Void

### 6.5L.3 Output RF spectrum emissions for inter-band UL CA with Tx Diversity

#### 6.5L.3.1 Occupied bandwidth for inter-band UL CA with Tx Diversity

For inter-band UL CA with Tx Diversity in one of the two frequency bands, the occupied bandwidth is defined per component carrier. The requirement specified in clause 6.5.1 shall apply for the component carrier without Tx Diversity and the requirement specified in clause 6.5G.1 shall apply for the component carrier configured with Tx Diversity.

#### 6.5L.3.2 Out of band emission for inter-band UL CA with Tx Diversity

For inter-band UL CA with Tx Diversity in one of the two frequency bands, the out of band emission requirement is defined per component carrier while both component carriers are active. The requirements specified in clauses 6.5.2.1 and 6.5.2.2 shall apply for the component carrier without Tx Diversity and the requirements specified in clause 6.5G.2 shall apply for the component carrier configured with Tx Diversity. If for some frequency spectrum emission masks of component carriers overlap, then spectrum emission mask allowing higher power spectral density applies for that frequency. If for some frequency a component carrier spectrum emission mask overlaps with the channel bandwidth of another component carrier, then the emission mask does not apply for that frequency.

#### 6.5L.3.3 Spurious emission for inter-band UL CA with Tx Diversity

For inter-band UL CA with Tx Diversity in one of the two frequency bands, the general spurious emission requirements in Table 6.5.3.1-2 apply for the frequency ranges that are more than  $F_{OOB}$  as defined in Table 6.5.3.1-1 away from edges of the assigned channel bandwidth on a component carrier. The spurious emission requirements for co-existence in Table 6.5A.3.2.3-1 apply with all component carriers are active.

#### 6.5L.3.4 Transmit intermodulation for inter-band UL CA with Tx Diversity

For inter-band UL CA with Tx Diversity in one of the two frequency bands, the transmit intermodulation requirement specified in clause 6.5.4 shall apply for the component carrier without Tx Diversity and the transmit intermodulation requirement specified in Table 6.5G.4 shall apply for the component carrier configured with Tx Diversity with all component carriers active.

## 6.6 Void

### 6.6E Time alignment error

For V2X UE(s) with two transmit antenna connectors in SL MIMO, this requirement applies to slot timing differences between transmissions on two transmit antenna connectors. The Time Alignment Error (TAE) shall not exceed 260 ns.



## 7 Receiver characteristics

### 7.1 General

Unless otherwise stated the receiver characteristics are specified at the antenna connector(s) of the UE. For UE(s) with an integral antenna only, a reference antenna(s) with a gain of 0 dBi is assumed for each antenna port(s). UE with an integral antenna(s) may be taken into account by converting these power levels into field strength requirements, assuming a 0 dBi gain antenna. For UEs with more than one receiver antenna connector, identical interfering signals shall be applied to each receiver antenna port if more than one of these is used (diversity).

The levels of the test signal applied to each of the antenna connectors shall be as defined in the respective clauses below.

The applicability of receiver requirements for Band n90 is in accordance with that for Band n41; a UE supporting Band n90 shall meet the minimum requirements for Band n41.

With the exception of clause 7.3, the requirements shall be verified with the network signalling value NS\_01 configured (Table 6.2.3-1).

All the parameters in clause 7 are defined using the UL reference measurement channels specified in Annex A.2.2, the DL reference measurement channels specified in Annex A.3.2 and using the set-up specified in Annex C.3.1.

The minimum requirements specified in clauses 7.5, 7.6, 7.7 and 7.8 for NR band n48 refer to the minimum requirements for NR bands < 2.7 GHz.

For the additional requirements for intra-band non-contiguous carrier aggregation of two or more sub-blocks, an in-gap test refers to the case when the interfering signal is located at a negative offset with respect to the assigned lowest channel frequency of the highest sub-block and located at a positive offset with respect to the assigned highest channel frequency of the lowest sub-block.

For the additional requirements for intra-band non-contiguous carrier aggregation of two or more sub-blocks, an out-of-gap test refers to the case when the interfering signal(s) is (are) located at a positive offset with respect to the assigned channel frequency of the highest carrier frequency, or located at a negative offset with respect to the assigned channel frequency of the lowest carrier frequency.

For the additional requirements for intra-band non-contiguous carrier aggregation of two or more sub-blocks with channel bandwidth larger than or equal to 5 MHz, the existing adjacent channel selectivity requirements, in-band blocking requirements (for each case), and narrow band blocking requirements apply for in-gap tests only if the corresponding interferer frequency offsets with respect to the two measured carriers satisfy the following condition in relation to the sub-block gap size  $W_{\text{gap}}$  for at least one of these carriers  $j = 1, 2$ , so that the interferer frequency position does not change the nature of the core requirement tested:

$$W_{\text{gap}} \geq 2 \cdot |F_{\text{Interferer (offset)}_j} - BW_{\text{Channel}(j)}|$$

where  $F_{\text{Interferer (offset)}_j}$  for a sub-block with a single component carrier is the interferer frequency offset with respect to carrier  $j$  as specified in clause 7.5, clause 7.6.2 and clause 7.6.4 for the respective requirement and  $BW_{\text{Channel}(j)}$  the channel bandwidth of carrier  $j$ .  $F_{\text{Interferer (offset)}_j}$  for a sub-block with two or more contiguous component carriers is the interference frequency offset with respect to the carrier adjacent to the gap is specified in clause 7.5A, 7.6A.2 and 7.6A.3. The interferer frequency offsets for adjacent channel selectivity, each in-band blocking case and narrow-band blocking shall be tested separately with a single in-gap interferer at a time.

For the additional requirements for operation with shared spectrum channel access, the receiver requirements apply under the assumption that all 20 MHz sub-bands and all RB's of each sub-band within the downlink channel are allocated with intra-cell guard bands configured to zero.

Unless otherwise stated, the receiver requirements of inter-band UL CA are applicable to UE with one Tx antenna connector in each of the two bands, or UE with one Tx antenna connector in one band and two Tx antenna connectors in the other band.

Unless otherwise stated, the receiver requirements of single carrier or CA operation are applicable to UE with one Tx antenna connector or multiple Tx antenna connectors with UL MIMO or Tx diversity operation in the UL band(s).

## 7.1A General

The minimum requirements for band combinations including Band n41 also apply for the corresponding band combinations with Band n90 replacing Band n41 but with otherwise identical parameters. For brevity the said band combinations with Band n90 are not listed in the tables below but are covered by this specification.

The minimum requirements specified in clauses 7.5A, 7.6A, 7.7A and 7.8A for NR band n48 refer to the minimum requirements for NR bands < 2.7 GHz.

## 7.1F General

For wideband operations, the minimum requirements for the receiver characteristics are specified when zero width intra-cell guardbands are configured and with all RB set(s) within the channel scheduled and with all RB sets available for DL transmissions according to the channel access procedures in [14].

Unless stated otherwise, when a clause is not present for shared spectrum channel access, the general requirements and the additional clause requirements (suffices A,B,D) in clause 7 apply.

## 7.1G (Reserved)

## 7.1H (Reserved)

## 7.1I General

For a Redcap UE the requirements in Section 7 shall be verified with the channel bandwidth up to 20MHz and REFSSENS specified in clause 7.3I.

## 7.1J General for ATG

Unless otherwise stated, the receiver characteristics are specified at the antenna connector(s) of the ATG UE with one or multiple omni-directional antenna(s) or at the *transceiver array boundary* (TAB) connectors of the ATG UE with the antenna array. The definition about *transceiver array boundary* (TAB) is specified in clause 4.3.2 of TS 38.104 [16].

For ATG UE with multiple omni-directional antennas not indicating the capability *antennaArrayType-r18*, the receiver RF requirements are defined on top of each antenna connector.

For ATG UE with antenna array indicating the capability *antennaArrayType-r18*, the receiver RF requirements are defined on top of each TAB connector.

## 7.1K (Reserved)

## 7.1L (Reserved)

## 7.2 Diversity characteristics

The UE is required to be equipped with a minimum of two Rx antenna ports in all operating bands except for the bands n7, n38, n41, n48, n77, n78, n79, n104 where the UE is required to be equipped with a minimum of four Rx antenna ports. This requirement applies when the band is used as a standalone band or as part of a band combination.

Unless otherwise stated, the following applicability rules apply,

- For the single carrier REFSENS requirements in Clause 7, the UE shall be verified with two Rx antenna ports in all supported frequency bands, additional requirements for four Rx ports shall be verified in operating bands where the UE is equipped with four Rx antenna ports, and additional requirements for four and eight Rx ports shall be verified in operating bands where the UE is equipped with eight Rx antenna ports.
- For Rx requirements other than single carrier REFSENS in Clause 7, the UE shall be verified with four Rx antenna ports and skip two Rx antenna ports requirements in operating bands where the UE is equipped with four Rx antenna ports, the UE shall be verified with eight Rx antenna ports and skip both two and four Rx antenna ports requirements in operating bands where the UE is equipped with eight Rx antenna ports unless the UE does not support eight Rx ports for band(s) in a band combination in which case those band(s) shall be verified with four Rx antenna ports, otherwise, the UE shall be verified with two Rx antenna ports.
- The above rules apply for all clauses except for clause 7.9.

A Redcap UE is required to be equipped with a minimum of single Rx antenna port and maximum of two Rx antenna ports. Clause 7 requirements for four Rx antenna ports do not apply to a RedCap UE.

If a UE indicates *intraBandNR-CA-non-collocated-r18*, both Rx power imbalance requirements as specified in clause 7.10A and Rx requirements in clauses 7.3 – 7.9 shall be verified.

## 7.2J Diversity characteristics for ATG

The ATG UE is required to be equipped with a minimum of two Rx antenna ports in all operating bands. ATG UE is required optionally to be equipped with four Rx antenna ports.

## 7.3 Reference sensitivity

### 7.3.1 General

The reference sensitivity power level REFSENS is the minimum mean power applied to each one of the UE antenna ports for all UE categories, at which the throughput shall meet or exceed the requirements for the specified reference measurement channel.

In later clauses of Clause 7 where the value of REFSENS is used as a reference to set the corresponding requirement:

- when the UE is verified with 2 Rx antenna ports, it shall be verified against those requirements by applying the REFSENS value in Table 7.3.2-1a, Table 7.3.2-1b and Table 7.3.2-1c or Table 7.3.2-1d with 2 Rx antenna ports tested;
- when the UE is verified with 4 Rx antenna ports, it shall be verified against those requirements by applying the resulting REFSENS value derived from the requirement in Table 7.3.2-2 with 4 Rx antenna ports tested.
- when the UE is verified with 8 Rx antenna ports, it shall be verified against those requirements by applying the resulting REFSENS value derived from the requirement in Table 7.3.2-2a with 8 Rx antenna ports tested.

### 7.3.2 Reference sensitivity power level

The throughput shall be  $\geq 95\%$  of the maximum throughput of the reference measurement channels as specified in Annexes A.2.2.2, A3.2 and A.3.3 (with one sided dynamic OCNG Pattern OP.1 FDD/TDD for the DL-signal as described in Annex A.5.1.1/A.5.2.1) with parameters specified in Table 7.3.2-1a, Table 7.3.2-1b, Table 7.3.2-1c, Table 7.3.2-1d, Table 7.3.2-2 and Table 7.3.2-2a.

**Table 7.3.2-1a: Two antenna port reference sensitivity QPSK REFSENS for FDD bands**

Operating band / SCS / Channel bandwidth												
Operating Band	SCS kHz	3 MHz (dBm)	5 MHz (dBm)	10 MHz (dBm)	15 MHz (dBm)	20 MHz (dBm)	25 MHz (dBm)	30 MHz (dBm)	35 MHz (dBm)	40 MHz (dBm)	45 MHz (dBm)	50 MHz (dBm)
n1	15		-100.0	-96.8	-95.0	-93.8	-92.7	-91.9		-90.6	-90.1	-89.6

Operating band / SCS / Channel bandwidth												
Operating Band	SCS kHz	3 MHz (dBm)	5 MHz (dBm)	10 MHz (dBm)	15 MHz (dBm)	20 MHz (dBm)	25 MHz (dBm)	30 MHz (dBm)	35 MHz (dBm)	40 MHz (dBm)	45 MHz (dBm)	50 MHz (dBm)
	30			-97.1	-95.1	-94.0	-92.8	-92.0				
	60			-97.5	-95.4	-94.2	-93.0	-92.1		-90.9	-90.3	-89.7
n2	15		-98	-94.8	-93	-91.8	-90.7	-84.1	-83.6	-81.5		
	30			-95.1	-93.1	-92	-90.8	-84.2	-83.7	-81.6		
	60			-95.5	-93.4	-92.2	-90.9	-84.3	-83.8	-81.7		
n3	15		-97.0	-93.8	-92.0	-90.8	-89.7	-88.9	-86.2	-82.3	-81.3	-79.7
	30			-94.1	-92.1	-91.0	-89.8	-89.0	-86.3	-82.4	-81.4	-79.8
	60			-94.5	-92.4	-91.2	-90.0	-89.1	-86.4	-82.6	-81.5	-79.9
n5	15		-98.0	-94.8	-93.0	-86.8	-84.8					
	30			-95.1	-93.1	-88.6	-84.9					
n7 <sup>1</sup>	15		-98.0	-94.8	-93.0	-91.8	-90.7	-89.9	-89.2	-88.6		-81.5
	30			-95.1	-93.1	-92.0	-90.8	-90.0	-89.3	-88.7		-81.5
	60			-95.5	-93.4	-92.2	-91.0	-90.1	-89.4	-88.9		-81.5
n8	15		-97.0	-93.8	-91.4	-85.8	-83.6	-81.3	-78.4			
	30			-94.1	-91.7	-87.2	-84.7	-81.4	-78.5			
n12	15		-97.0	-93.8	-84.0							
	30			-94.1	-84.1							
n13	15		-97.0	-93.8								
	30			-94.1								
n14	15		-97.0	-93.8								
	30			-94.1								
n18	15		-100.0	-96.8	-95.0							
	30			-97.1	-95.1							
n20	15		-97.0	-93.8	-91.0	-89.8						
	30			-94.1	-91.1	-90.0						
n24	15		-100.0	-96.8								
	30			-97.1								
	60			-97.5								
n25	15		-96.5	-93.3	-91.5	-90.3	-89.3	-82.2	-81.7	-79.5	-77.6	
	30			-93.6	-91.6	-90.5	-89.4	-82.3	-81.8	-79.6	-77.7	
	60			-94.0	-91.9	-90.7	-89.6	-82.4	-81.9	-79.7	-77.8	
n26	15	-99.7	-97.5 <sup>6</sup>	-94.5 <sup>6</sup>	-92.7 <sup>6</sup>	-87.6	-84.5	-81.7				
	30			-94.8 <sup>6</sup>	-92.7 <sup>6</sup>	-87.7	-84.6	-81.8				
n28	15	-100.2	-98.5	-95.5	-93.5	-90.8	-84.2	-78.5				
	30			-95.6	-93.6	-91.0	-84.2	-78.6				
n30	15		-99.0	-95.8								
	30			-96.1								
n31	15	-95.7	-93.5									
n65	15		-99.5	-96.3	-94.5	-93.3						-89.2
	30			-96.6	-94.6	-93.5						-89.3
	60			-97.0	-94.9	-93.7						-89.4
n66	15		-99.5	-96.3	-94.5	-93.3	-92.2	-91.4	-90.7	-90.1	-89.6	
	30			-96.6	-94.6	-93.5	-92.3	-91.5	-90.8	-90.2	-89.7	
	60			-97.0	-94.9	-93.7	-92.5	-91.6	-90.9	-90.4	-89.8	
n70	15		-100.0	-96.8	-95.0	-93.8	-92.7					
	30			-97.1	-95.1	-94.0	-92.8					
	60			-97.5	-95.4	-94.2	-93.0					
n71	15		-97.2	-94.0	-91.6	-86.0	-84.1 <sup>9</sup> - 74.8 <sup>10</sup>	-82.5 <sup>9</sup> - 67.1 <sup>10</sup>	-80.7 <sup>9</sup> - 64.0 <sup>10</sup>			
	30			-94.3	-91.9	-87.4	-84.2 <sup>9</sup> - 74.9 <sup>10</sup>	-82.6 <sup>9</sup> - 67.2 <sup>10</sup>	-80.8 <sup>9</sup> - 64.1 <sup>10</sup>			
n72	15	-95.7	-93.5									
n74	15		-99.5 <sup>3</sup>	-96.3 <sup>3</sup>	-94.5 <sup>3</sup>	-89.3 <sup>3</sup>						
	30			-96.6 <sup>3</sup>	-94.6 <sup>3</sup>	-89.5 <sup>3</sup>						
	60			-97.0 <sup>3</sup>	-94.9 <sup>3</sup>	-89.6 <sup>3</sup>						
n85	15	-99.2	-97.0	-93.8	-84.0							
	30			-94.1	-84.1							
n100	15	-102.2	-100									
n105	15		-97.2 <sup>8</sup>	-94.0	-91.6	-86.9	-85.1	-83.8	-82.5			
	30			-94.3	-91.9	-87.9	-85.5	-84.3	-82.6			

Operating band / SCS / Channel bandwidth												
Operating Band	SCS kHz	3 MHz (dBm)	5 MHz (dBm)	10 MHz (dBm)	15 MHz (dBm)	20 MHz (dBm)	25 MHz (dBm)	30 MHz (dBm)	35 MHz (dBm)	40 MHz (dBm)	45 MHz (dBm)	50 MHz (dBm)
n106	15	-99.2										
NOTE 1: Four Rx antenna ports shall be the baseline for this operating band except for two Rx vehicular UE and two Rx antenna port XR UEs indicating UE capability <i>supportOf2RxXR-r18</i> . Four Rx antenna ports for RedCap UE is not supported for this operating band. NOTE 2: The transmitter shall be set to P <sub>UMAX</sub> as defined in clause 6.2.4 NOTE 3: The requirement is modified by -0.5 dB when the assigned NR channel bandwidth is confined within 1475.9 - 1510.9 MHz. NOTE 4: Void NOTE 5: Void NOTE 6: Values are modified by -0.5dB when carrier channel BW is between 865MHz and 894MHz. NOTE 7: Void. NOTE 8: DL channels overlapping the 612-617MHz range have 0.5dB added to the REFSSENS NOTE 9: Applies to UEs that support a maximum uplink BW of 20 MHz in this band. NOTE 10: Applies to UEs that support optional symmetric UL/DL for this BW.												

**Table 7.3.2-1b: Two antenna port reference sensitivity QPSK P<sub>REFSENS</sub> for TDD, SDL and FDD with variable duplex operation bands**

Operating band / SCS / Channel bandwidth / REFSSENS				
Operating band	SCS kHz	Channel bandwidth (MHz)	REFSENS (dBm) <sup>8</sup>	Duplex Mode
n29 <sup>7</sup>	15	5, 10	-97 + 10log <sub>10</sub> (N <sub>RB</sub> /25)	SDL
	30	10	-94.1 + 10log <sub>10</sub> (N <sub>RB</sub> /24)	
n34	15	5, 10, 15	-100 + 10log <sub>10</sub> (N <sub>RB</sub> /25)	TDD
	30	10, 15	-97.1 + 10log <sub>10</sub> (N <sub>RB</sub> /24)	
	60	10, 15	-97.5 + 10log <sub>10</sub> (N <sub>RB</sub> /11)	
n38 <sup>1</sup>	15	5, 10, 15, 20, 25, 30, 40	-100 + 10log <sub>10</sub> (N <sub>RB</sub> /25)	TDD
	30	10, 15, 20, 25, 30, 40	-97.1 + 10log <sub>10</sub> (N <sub>RB</sub> /24)	
	60	10, 15, 20, 25, 30, 40	-97.5 + 10log <sub>10</sub> (N <sub>RB</sub> /11)	
n39	15	5, 10, 15, 20, 25, 30, 35, 40	-100 + 10log <sub>10</sub> (N <sub>RB</sub> /25)	TDD
	30	10, 15, 20, 25, 30, 35, 40	-97.1 + 10log <sub>10</sub> (N <sub>RB</sub> /24)	
	60	10, 15, 20, 25, 30, 35, 40	-97.5 + 10log <sub>10</sub> (N <sub>RB</sub> /11)	
n40	15	5, 10, 15, 20, 25, 30, 40, 50	-100 + 10log <sub>10</sub> (N <sub>RB</sub> /25)	TDD
	30	10, 15, 20, 25, 30, 40, 50, 60, 70, 80, 90, 100	-97.1 + 10log <sub>10</sub> (N <sub>RB</sub> /24)	
	60	10, 15, 20, 25, 30, 40, 50, 60, 70, 80, 90, 100	-97.5 + 10log <sub>10</sub> (N <sub>RB</sub> /11)	
n41 <sup>1</sup> , n90 <sup>1</sup>	15	5, 10, 15, 20, 25, 30, 35, 40, 45, 50	-94.8 + 10log <sub>10</sub> (N <sub>RB</sub> /52)	TDD
	30	10, 15, 20, 25, 30, 35, 40, 45, 50, 60, 70, 80, 90, 100	-95.1 + 10log <sub>10</sub> (N <sub>RB</sub> /24)	
	60	10, 15, 20, 25, 30, 35, 40, 45, 50, 60, 70, 80, 90, 100	-95.5 + 10log <sub>10</sub> (N <sub>RB</sub> /11)	
n48 <sup>1</sup>	15	5, 10, 15, 20, 30, 40, 50 <sup>5</sup>	-99 + 10log <sub>10</sub> (N <sub>RB</sub> /25)	TDD
	30	10, 15, 20, 30, 40, 50 <sup>5</sup> , 60 <sup>5</sup> , 70 <sup>5</sup> , 80 <sup>5</sup> , 90 <sup>5</sup> , 100 <sup>5</sup>	-96.1 + 10log <sub>10</sub> (N <sub>RB</sub> /24)	
	60	10, 15, 20, 30, 40, 50 <sup>5</sup> , 60 <sup>5</sup> , 70 <sup>5</sup> , 80 <sup>5</sup> , 90 <sup>5</sup> , 100 <sup>5</sup>	-96.5 + 10log <sub>10</sub> (N <sub>RB</sub> /11)	
n50	15	5, 10, 15, 20, 30, 40, 50	-100 + 10log <sub>10</sub> (N <sub>RB</sub> /25)	TDD
	30	10, 15, 20, 30, 40, 50, 60, 80	-97.1 + 10log <sub>10</sub> (N <sub>RB</sub> /24)	
	60	10, 15, 20, 30, 40, 50, 60, 80	-97.5 + 10log <sub>10</sub> (N <sub>RB</sub> /11)	
n51	15	5	-100	TDD
n53	15	5, 10	-100 + 10log <sub>10</sub> (N <sub>RB</sub> /25)	TDD
	30	10	-97.1	
	60	10	-97.5	
n54	15	5	-100	TDD
n67 <sup>7</sup>	15	5, 10, 15, 20	-100 + 10log <sub>10</sub> (N <sub>RB</sub> /25)	SDL
	30	10, 15, 20	-97.1 + 10log <sub>10</sub> (N <sub>RB</sub> /24)	
n75 <sup>7</sup>	15	5, 10, 15, 20, 25, 30, 40, 50	-100 + 10log <sub>10</sub> (N <sub>RB</sub> /25)	SDL
	30	10, 15, 20, 25, 30, 40, 50	-97.1 + 10log <sub>10</sub> (N <sub>RB</sub> /24)	
	60	10, 15, 20, 25, 30, 40, 50	-97.5 + 10log <sub>10</sub> (N <sub>RB</sub> /11)	
n76 <sup>7</sup>	15	5	-95.3 + 10log <sub>10</sub> (N <sub>RB</sub> /52)	SDL
n77 <sup>1,4</sup>	15	10, 15, 20, 25, 30, 40, 50	-95.3 + 10log <sub>10</sub> (N <sub>RB</sub> /52)	TDD
	30	10, 15, 20, 25, 30, 40, 50, 60, 70, 80, 90, 100	-95.6 + 10log <sub>10</sub> (N <sub>RB</sub> /24)	

	60	10, 15, 20, 25, 30, 40, 50, 60, 70, 80, 90, 100	$-96.0 + 10\log_{10}(N_{RB}/11)$	
n78 <sup>1</sup>	15	10, 15, 20, 25, 30, 40, 50	$-95.8 + 10\log_{10}(N_{RB}/52)$	TDD
	30	10, 15, 20, 25, 30, 40, 50, 60, 70, 80, 90, 100	$-96.1 + 10\log_{10}(N_{RB}/24)$	
	60	10, 15, 20, 25, 30, 40, 50, 60, 70, 80, 90, 100	$-96.5 + 10\log_{10}(N_{RB}/11)$	
n79 <sup>1</sup>	15	10, 20, 30, 40, 50	$-95.8 + 10\log_{10}(N_{RB}/52)$	TDD
	30	10, 20, 30, 40, 50, 60, 70, 80, 90, 100	$-96.1 + 10\log_{10}(N_{RB}/24)$	
	60	10, 20, 30, 40, 50, 60, 70, 80, 90, 100	$-96.5 + 10\log_{10}(N_{RB}/11)$	
n91	15	5	-100	FDD
n92	15	5,10,15,20	$-100 + 10\log_{10}(N_{RB}/25)$	FDD
	30	10,15,20	$-97.1 + 10\log_{10}(N_{RB}/24)$	
n93	15	5	-100	FDD
n94	15	5,10,15,20	$-100 + 10\log_{10}(N_{RB}/25)$	FDD
	30	10,15,20	$-97.1 + 10\log_{10}(N_{RB}/24)$	
n101	15	5, 10	$-100 + 10\log_{10}(N_{RB}/25)$	TDD
	30	10	$-97.1 + 10\log_{10}(N_{RB}/24)$	
n104 <sup>1,10</sup>	15	20, 30, 40, 50	$-90.7 + 10\log_{10}(N_{RB}/106)$	TDD
	30	20, 30, 40, 50, 60, 70, 80, 90, 100	$-90.8 + 10\log_{10}(N_{RB}/51)$	
	60	20, 30, 40, 50, 60, 70, 80, 90, 100	$-91.1 + 10\log_{10}(N_{RB}/24)$	
n109 <sup>11</sup>	15	5,10,15,20,25,30,40,50	$-100 + 10\log_{10}(N_{RB}/25)$	FDD
	30	10,15,20,25,30,40,50	$-97.1 + 10\log_{10}(N_{RB}/24)$	

NOTE 1: Four Rx antenna ports shall be the baseline for this operating band except for two Rx vehicular UE and two Rx antenna port XR UEs indicating UE capability *supportOf2RxXR-r18*. Four Rx antenna ports for RedCap UE is not supported for this operating band.

NOTE 2: The transmitter shall be set to P<sub>UMAX</sub> as defined in clause 6.2.4.

NOTE 3: Void

NOTE 4: The requirement is modified by -0.5 dB when the assigned UE channel bandwidth is confined within 3300 - 3800 MHz.

NOTE 5: For these bandwidths, the minimum requirements are restricted to operation when carrier is configured as a downlink carrier part of CA configuration.

NOTE 6: Void

NOTE 7: For SDL bands, the reference sensitivity requirements shall be verified by inter-band CA combinations with SDL band, which are supported by UE.

NOTE 8: The REFSENS value is rounded to the nearest number down to one decimal point. "N<sub>RB</sub>" in REFSENS formula is the maximum transmission bandwidth configuration as defined in Table 5.3.2-1.

NOTE 9: Void.

NOTE 10: A UE may implement two RX antenna ports for band n104 when conditions are met. The exact conditions are FFS.

NOTE 11: Applies for DL channels for which channels edges are > 15 MHz away from 2xF<sub>UL</sub> at 15 kHz SCS and > 30 MHz away from 2xF<sub>UL</sub> at 30 kHz SCS. In case of UL second harmonic direct hit, the value is modified to -71.9 dBm for all channel bandwidths.

For power class 2 UEs, certain degradation of the reference sensitivity in Table 7.3.2-1a is allowed. The maximum amount of degradation is specified in Table 7.3.2-1c, and in Table 7.3.2-1d for a UE that indicates *txDiversity-r16* or *txDiversity2Tx-r18* [15].

**Table 7.3.2-1c Reference Sensitivity Degradation from PC3 to PC2 for FDD bands for UE not supporting Tx Diversity**

Operating Band	5 MHz (dB)	10 MHz (dB)	15 MHz (dB)	20 MHz (dB)	25 MHz (dB)	30 MHz (dB)	35 MHz (dB)	40 MHz (dB)	45 MHz (dB)	50 MHz (dB)
n1	0	0	0	0	0	0	-	0	0	0
n2	0.8	0.9	1.1	1.2	1.3	2.7	2.8	3.5		
n3	0.5	0.5	0.5	0.5	0.6	0.8	1.1	1.5	2.3	2.8
n7	0.5	0.5	0.5	0.5	0.5	0.5	0.5	0.5		2.0
n8	0.5	0.7	0.8	2.3	2.8	3.2	3.1			
n13	0.8	0.9								
n14	0.6	0.8								
n25	0.8	0.8	0.9	1.1	1.3	2.7	2.8	3.5	3.7	
n66	0	0	0	0	0	0	0	0	0	
n71	0.5	0.9	0.9	2.2	2.4 <sup>2</sup> 2.5 <sup>3</sup>	2.5 <sup>2</sup> 2.4 <sup>3</sup>	2.9 <sup>2</sup> 3.1 <sup>3</sup>			

Operating Band	5 MHz (dB)	10 MHz (dB)	15 MHz (dB)	20 MHz (dB)	25 MHz (dB)	30 MHz (dB)	35 MHz (dB)	40 MHz (dB)	45 MHz (dB)	50 MHz (dB)
n70	0	0	0	0	0					
n85	0.6	1.0	2.6							

NOTE 1: The transmitter shall be set to P<sub>UMAX</sub> as defined in clause 6.2.4  
 NOTE 2: Applies to UEs that support a maximum uplink BW of 20 MHz in this band.  
 NOTE 3: Applies to UEs that support optional symmetric UL/DL for this BW.

**Table 7.3.2-1d Reference Sensitivity Degradation from PC3 to PC2 for FDD bands for UE supporting Tx Diversity**

Operating Band	5 MHz (dB)	10 MHz (dB)	15 MHz (dB)	20 MHz (dB)	25 MHz (dB)	30 MHz (dB)	35 MHz (dB)	40 MHz (dB)	45 MHz (dB)	50 MHz (dB)
n1	0	0	0	0	0	0	-	0	0	0
n2	1.2	1.2	1.3	1.2	1.2	5.8	6.0	6.5		
n3	1.4	1.5	1.5	1.5	1.6	1.7	2.8	5	5.5	6.0
n7	0.9	1.0	1.0	1.0	1.1	1.1	1.1	1.1		5.3
n8	1.3	1.4	2.1	5.8	6.1	6.5	7.0			
n13	1.2	1.3								
n14	1.1	1.3								
n25	1.5	1.5	1.6	1.6	1.7	6.0	6.2	6.7	7.1	
n66	0	0	0	0	0	0	0	0	0	
n71	1.1	1.1	1.7	5.5	5.9 <sup>2</sup> 6.9 <sup>3</sup>	6.2 <sup>2</sup> 7.2 <sup>3</sup>	6.5 <sup>2</sup> 7.3 <sup>3</sup>			
n70	0	0	0	0	0					
n85	1.2	1.4	6.4							

NOTE 1: The transmitter shall be set to P<sub>UMAX</sub> as defined in clause 6.2G.4  
 NOTE 2: Applies to UEs that support a maximum uplink BW of 20 MHz in this band.  
 NOTE 3: Applies to UEs that support optional symmetric UL/DL for this BW.

For UE(s) equipped with 4 Rx antenna ports, reference sensitivity for 2Rx antenna ports in Table 7.3.2-1a and in Table 7.3.2-1b shall be modified by the amount given in ΔR<sub>IB,4R</sub> in Table 7.3.2-2 for the applicable operating bands. For operating band frequency range ≤ 1 GHz, the 4Rx operation is primarily for FWA form factor, and when 4Rx operation is supported by handheld UE, ΔR<sub>IB,4R</sub> as indicated in Table 7.3.2-2 NOTE 2 is applied.

**Table 7.3.2-2: Four antenna port reference sensitivity allowance ΔR<sub>IB,4R</sub>**

Operating band	ΔR <sub>IB,4R</sub> (dB)
n5, n8, n13, n26, n28, n71, n85, n105	-2.7 <sup>1</sup>
n5, n8, n28, n71, n20, n26	-2.4 <sup>2</sup>
n1, n2, n3, n25, n30, n40, n7, n34, n38, n39, n41, n66, n70	-2.7
n48, n77, n78, n79, n104	-2.2

NOTE 1: When 4 Rx operation is supported by FWA form factor  
 NOTE 2: When 4Rx operation is supported by handheld UE.

For UE(s) equipped with 8 Rx antenna ports, reference sensitivity for 2Rx antenna ports in Table 7.3.2-1a and in Table 7.3.2-1b shall be modified by the amount given in ΔR<sub>IB,8R</sub> in Table 7.3.2-2a for the applicable operating bands.

**Table 7.3.2-2a: Eight antenna port reference sensitivity allowance ΔR<sub>IB,8R</sub>**

Operating band	ΔR <sub>IB,8R</sub> (dB)
n7	-4.5
n41	-4.3
n77, n78, n79	-4.0

NOTE 1: 8 Rx operation is targeted for FWA/CPE/Vehicle/Industrial devices form factor.

For two Rx antenna port XR UE(s) indicating UE capability *supportOf2RxXR-r18*, reference sensitivity for two Rx antenna ports in Table 7.3.2-1a and in Table 7.3.2-1b shall be modified by the amount given in  $\Delta R_{XR,2R}$  in Table 7.3.2-2b for the applicable operating bands.

**Table 7.3.2-2b: Two antenna port XR UE reference sensitivity allowance  $\Delta R_{XR,2R}$**

Operating band	$\Delta R_{XR,2R}$ (dB)
n7, n38, n41, n48, n77, n78, n79	-1.0

The reference receive sensitivity (REFSENS) requirement specified in Table 7.3.2-1a, Table 7.3.2-1b, Table 7.3.2-1c, Table 7.3.2-1d, Table 7.3.2-2, Table 7.3.2-2a and Table 7.3.2-2b shall be met with uplink transmission bandwidth less than or equal to that specified in Table 7.3.2-3.



Table 7.3.2-3: Uplink configuration for reference sensitivity

Operating Band	SCS	Operating band / SCS (kHz) / Channel bandwidth (MHz) / Duplex mode														Duplex Mode			
		3	5	10	15	20	25	30	35	40	45	50	60	70	80		90	100	
n1	15		25	50 <sup>1</sup>	75 <sup>1</sup>	100 <sup>1</sup>	128 <sup>1</sup>	128 <sup>1</sup>		128 <sup>1</sup>	128 <sup>1</sup>	128 <sup>1</sup>							FDD
	30			24	36 <sup>1</sup>	50 <sup>1</sup>	64 <sup>1</sup>	64 <sup>1</sup>		64 <sup>1</sup>	64 <sup>1</sup>	64 <sup>1</sup>							
	60			10 <sup>1</sup>	18	24	30 <sup>1</sup>	30 <sup>1</sup>		30 <sup>1</sup>	30 <sup>1</sup>	30 <sup>1</sup>							
n2	15		25	50 <sup>1</sup>	50 <sup>1</sup>	50 <sup>1</sup>	50 <sup>1</sup>	48 <sup>1</sup>	40 <sup>1</sup>	40 <sup>1</sup>									FDD
	30		10 <sup>1</sup>	24	24 <sup>1</sup>	24 <sup>1</sup>	24 <sup>1</sup>	24 <sup>1</sup>	20 <sup>1</sup>	20 <sup>1</sup>									
	60			10 <sup>1</sup>	10 <sup>1</sup>	10 <sup>1</sup>	10 <sup>1</sup>	10 <sup>1</sup>	10 <sup>1</sup>	10 <sup>1</sup>	10 <sup>1</sup>								
n3	15		25	50 <sup>1</sup>	50 <sup>1</sup>	50 <sup>1</sup>	50 <sup>1</sup>	50 <sup>1</sup>	50 <sup>1</sup>	50 <sup>1</sup>	50 <sup>1</sup>	50 <sup>1</sup>	50 <sup>1</sup>						FDD
	30			24	24 <sup>1</sup>	24 <sup>1</sup>	24 <sup>1</sup>	24 <sup>1</sup>	24 <sup>1</sup>	24 <sup>1</sup>	24 <sup>1</sup>	24 <sup>1</sup>	24 <sup>1</sup>						
	60			10 <sup>1</sup>	10 <sup>1</sup>	10 <sup>1</sup>	10 <sup>1</sup>	10 <sup>1</sup>	10 <sup>1</sup>	10 <sup>1</sup>	10 <sup>1</sup>	10 <sup>1</sup>	10 <sup>1</sup>						
n5	15		25	25 <sup>1</sup>	20 <sup>1</sup>	20 <sup>1</sup>	Note 5												FDD
	30			12 <sup>1</sup>	10 <sup>1</sup>	10 <sup>1</sup>	Note 5												
n7	15		25	50 <sup>1</sup>	75 <sup>1</sup>	75 <sup>1</sup>	72 <sup>1</sup>	64 <sup>1</sup>	45 <sup>1</sup>	45 <sup>1</sup>		45 <sup>1</sup>							FDD
	30			24	36 <sup>1</sup>	36 <sup>1</sup>	36 <sup>1</sup>	32 <sup>1</sup>	20 <sup>1</sup>	20 <sup>1</sup>		20 <sup>1</sup>							
	60			10 <sup>1</sup>	18	18 <sup>1</sup>	18 <sup>1</sup>	16 <sup>1</sup>	10 <sup>1</sup>	10 <sup>1</sup>		10 <sup>1</sup>							
n8	15		25	25 <sup>1</sup>	20 <sup>1</sup>	20 <sup>1</sup>	Note 5	Note 5	Note 5										FDD
	30			12 <sup>1</sup>	10 <sup>1</sup>	10 <sup>1</sup>	Note 5	Note 5	Note 5										
n12	15		20 <sup>1</sup>	20 <sup>1</sup>	20 <sup>1</sup>														FDD
	30			10 <sup>1</sup>	10 <sup>1</sup>														
n13	15		20 <sup>1</sup>	20 <sup>1</sup>															FDD
	30			10 <sup>1</sup>															
n14	15		20 <sup>1</sup>	20 <sup>1</sup>															FDD
	30			10 <sup>1</sup>															
n18	15		25	25 <sup>1</sup>	25 <sup>1</sup>														FDD
	30			10 <sup>1</sup>	10 <sup>1</sup>														
n20	15		25	20 <sup>1</sup>	20 <sup>2</sup>	20 <sup>2</sup>													FDD
	30			10 <sup>1</sup>	10 <sup>2</sup>	10 <sup>2</sup>													
n24	15		25	50															FDD
	30			24															
	60			10															
n25	15		25	50 <sup>1</sup>	50 <sup>1</sup>	50 <sup>1</sup>	50 <sup>1</sup>	48 <sup>1</sup>	40 <sup>1</sup>	40 <sup>1</sup>	Note 5								FDD
	30			24	24 <sup>1</sup>	24 <sup>1</sup>	24 <sup>1</sup>	24 <sup>1</sup>	20 <sup>1</sup>	20 <sup>1</sup>	Note 5								
	60			10 <sup>1</sup>	10 <sup>1</sup>	10 <sup>1</sup>	10 <sup>1</sup>	10 <sup>1</sup>	10 <sup>1</sup>	10 <sup>1</sup>	Note 5								
n26	15	15	25	25 <sup>1</sup>	25 <sup>1</sup>	25 <sup>1</sup>	Note 5	Note 5											FDD
	30			12 <sup>1</sup>	12 <sup>1</sup>	12 <sup>1</sup>	Note 5	Note 5											
n28	15	15	25	25 <sup>1</sup>	25 <sup>1</sup>	25 <sup>1</sup>	25 <sup>1</sup>	25 <sup>1</sup>											FDD

Operating Band	SCS	Operating band / SCS (kHz) / Channel bandwidth (MHz) / Duplex mode																Duplex Mode	
		3	5	10	15	20	25	30	35	40	45	50	60	70	80	90	100		
n30	30			10 <sup>1</sup>	10 <sup>1</sup>	10 <sup>1</sup>	10 <sup>1</sup>	10 <sup>1</sup>											FDD
	15		20 <sup>1</sup>	20 <sup>1</sup>															
n31	30			10 <sup>1</sup>															FDD
n34	15	5 <sup>8</sup>	5 <sup>8</sup>																TDD
	30		25	50	75														
	60			24	36														
n38	15		25	50	75	100	128	160		216									TDD
	30			24	36	50	64	75		100									
	60			10	18	24	30	36		50									
n39	15		25	50	75	100	128	160	180	216									TDD
	30			24	36	50	64	75	90	100									
	60			10	18	24	30	36	40	50									
n40	15		25	50	75	100	128	160		216		270							TDD
	30			24	36	50	64	75		100		128	162	180	216	243	270		
	60			10	18	24	30	36		50		64	75	90	100	120	135		
n41, n90	15		25	50	75	100	128	160	180	216	240	270							TDD
	30			24	36	50	64	75	90	100	108	128	162	180	216	243	270		
	60			10	18	24	30	36	40	50	54	64	75	90	100	120	135		
n48	15		25	50	75	100		160		216									TDD
	30			24	36	50		75		100									
	60			10	18	24		36		50									
n50	15		25	50	75	100		160		216		270							TDD
	30			24	36	50		75		100		128	162		Note 3				
	60			10	18	24		36		50		64	75		Note 3				
n51	15		25																TDD
n53	15		25	50															TDD
	30			24															
	60			10															
n54	15		25																TDD
n65	15		25	50 <sup>1</sup>	75 <sup>1</sup>	100 <sup>1</sup>						128 <sup>1</sup>							FDD
	30			24	36 <sup>1</sup>	50 <sup>1</sup>						64 <sup>1</sup>							
	60			10 <sup>1</sup>	18	24						30 <sup>1</sup>							
n66	15		25	50 <sup>1</sup>	75 <sup>1</sup>	100 <sup>1</sup>	128 <sup>1</sup>	160	180 <sup>1</sup>	216	240 <sup>1</sup>								FDD
	30			24	36 <sup>1</sup>	50 <sup>1</sup>	64 <sup>1</sup>	75 <sup>1</sup>	90 <sup>1</sup>	100 <sup>1</sup>	108 <sup>1</sup>								
	60			10 <sup>1</sup>	18	24	30 <sup>1</sup>	36 <sup>1</sup>	40 <sup>1</sup>	50 <sup>1</sup>	54 <sup>1</sup>								
n70	15		25	50 <sup>1</sup>	75 <sup>1</sup>	Note 3	Note 3												FDD
	30			24	36 <sup>1</sup>	Note 3	Note 3												
	60			10 <sup>1</sup>	18	Note 3	Note 3												

Operating Band	Operating band / SCS (kHz) / Channel bandwidth (MHz) / Duplex mode																Duplex Mode	
	SCS	3	5	10	15	20	25	30	35	40	45	50	60	70	80	90		100
n71	15		25	25 <sup>1</sup>	20 <sup>1</sup>	20 <sup>1</sup>	20 <sup>1,6</sup>	20 <sup>1,6</sup>	20 <sup>1,6</sup>									FDD
	30			12 <sup>1</sup>	10 <sup>1</sup>	10 <sup>1</sup>	10 <sup>1,6</sup>	10 <sup>1,6</sup>	10 <sup>1,6</sup>									
n72	15	5 <sup>8</sup>	5 <sup>8</sup>															FDD
n74	15		25	25 <sup>1</sup>	25 <sup>1</sup>	25 <sup>1</sup>												FDD
	30			10 <sup>1</sup>	10 <sup>1</sup>	10 <sup>1</sup>												
	60			5 <sup>1</sup>	5 <sup>1</sup>	5 <sup>1</sup>												
n77	15			50	75	100	128	160		216		270						TDD
	30			24	36	50	64	75		100		128	162	180	216	243	270	
	60			10	18	24	30	36		50		64	75	90	100	120	135	
n78	15			50	75	100	128	160		216		270						TDD
	30			24	36	50	64	75		100		128	162	180	216	243	270	
	60			10	18	24	30	36		50		64	75	90	100	120	135	
n79	15			50		100		160		216		270						TDD
	30			24		50		75		100		128	162	180	216	243	270	
	60			10		24		36		50		64	75	90	100	120	135	
n85	15	15	20 <sup>1</sup>	20 <sup>1</sup>	20 <sup>1</sup>													FDD
	30			10 <sup>1</sup>	10 <sup>1</sup>													
n91	15		25 <sup>4</sup>	20 <sup>1,4</sup>														FDD
n92	15		25	20 <sup>1</sup>	20 <sup>1</sup>	20 <sup>1</sup>												FDD
	30			10 <sup>1</sup>	10 <sup>1</sup>	10 <sup>1</sup>												
n93	15		25 <sup>4</sup>	25 <sup>1,4</sup>														FDD
n94	15		25	25 <sup>1</sup>	20 <sup>1</sup>	20 <sup>1</sup>												FDD
	30			12 <sup>1</sup>	10 <sup>1</sup>	10 <sup>1</sup>												
n100	15	15	25															FDD
n101	15		25	50														TDD
	30			24														
n104	15					100				216		270						TDD
	30					50				100		128	162	180	216	243	270	
	60					24				50		64	75	90	100	120	135	
n105	15		25	25 <sup>1</sup>	20 <sup>1</sup>	20 <sup>1</sup>	Note 5	Note 5	Note 5									FDD
	30			12 <sup>1</sup>	10 <sup>1</sup>	10 <sup>1</sup>	Note 5	Note 5	Note 5									
n106	15	15																FDD
n109	15		25	Note 7	Note 7	Note 7	Note 7	Note 7		Note 7		Note 7						FDD
	30			24	Note 7	Note 7	Note 7	Note 7		Note 7		Note 7						

- ote 1: UL resource blocks shall be located as close as possible to the downlink operating band but confined within the transmission bandwidth configuration for the channel bandwidth (Table 5.3.2-1).
- ote 2: For band n20; for 15 kHz SCS, in the case of 15 MHz channel bandwidth, the UL resource blocks shall be located at RB<sub>start</sub> 11 and in the case of 20 MHz channel bandwidth, the UL resource blocks shall be located at RB<sub>start</sub> 16; for 30 kHz SCS, in the case of 15 MHz channel bandwidth, the UL resource blocks shall be located at RB<sub>start</sub> 6 and in the case of 20 MHz channel bandwidth, the UL resource blocks shall be located at RB<sub>start</sub> 8;

Operating Band	SCS	Operating band / SCS (kHz) / Channel bandwidth (MHz) / Duplex mode														Duplex Mode	
		3	5	10	15	20	25	30	35	40	45	50	60	70	80		90
ote 3:	For DL channel bandwidths that do not have symmetric UL channel bandwidth, highest valid UL configuration with lowest TX-RX separation (Table 5.4.4-1) shall be used unless otherwise specified.																
ote 4:	For band n91 and n93, largest supported UL bandwidth configuration shall be used.																
ote 5:	For this DL channel bandwidth, the UL configuration of the highest UL channel bandwidth specified in Table 5.3.6-1 and the nominal Tx-Rx frequency separation specified in Table 5.4.4-1 shall be used, i.e. $\Delta F_{TX-RX}$ as defined in clause 5.3.6 does not apply.																
ote 6:	UEs supporting the optional symmetrical UL/DL bandwidths shall use this UL configuration. For UEs not supporting this uplink channel bandwidth, the UL configuration of the 20MHz UL channel bandwidth and the nominal Tx-Rx frequency separation specified in Table 5.4.4-1 shall be used, i.e. $\Delta F_{TX-RX}$ as defined in clause 5.3.6 does not apply.																
ote 7:	For this DL channel bandwidth, the UL configuration of 5MHz for 15kHz SCS and 10MHz for 30kHz shall be used.																
ote 8:	In the case of 3 MHz channel bandwidth, the UL resource blocks shall be located at $RB_{start}$ 9 and in the case of 5 MHz channel bandwidth, the UL resource blocks shall be located at $RB_{start}$ 10.																

Unless given by Table 7.3.2-4, the minimum requirements specified in Tables 7.3.2-1a, Tables 7.3.2-1b, Tables 7.3.2-1c, Tables 7.3.2-1d and 7.3.2-2 shall be verified with the network signalling value NS\_01 (Table 6.2.3-1) configured.

**Table 7.3.2-4: Network signaling value for reference sensitivity**

Operating band	Network Signalling value
n2	NS_03
n12	NS_06
n13	NS_06
n14	NS_06
n24	NS_56
n25	NS_03
n30	NS_21
n48	NS_27
n53	NS_45
n54	NS_62
n66	NS_03
n70	NS_03
n71	NS_35
n85	NS_06

### 7.3.3 $\Delta R_{IB,c}$

For a UE supporting CA, SUL or DC band combination, the minimum requirement for reference sensitivity in Table 7.3.2-1a and Table 7.3.2-1b shall be increased by the amount given by  $\Delta R_{IB,c}$  defined in clause 7.3A, 7.3B, 7.3C in this specification and 7.3A, 7.3B in TS 38.101-3 [3] for the applicable operating bands.

In case the UE supports more than one of band combinations for CA, SUL or DC, and an operating band belongs to more than one band combinations then

- When the operating band frequency range is  $\leq 1$  GHz, the applicable additional  $\Delta R_{IB,c}$  shall be the average value for all band combinations defined in clause 7.3A, 7.3B, 7.3C in this specification and 7.3A, 7.3B in TS 38.101-3 [3], truncated to one decimal place that apply for that operating band among the supported band combinations. In case there is a harmonic relation between low band UL and high band DL, then the maximum  $\Delta R_{IB,c}$  among the different supported band combinations involving such band shall be applied
- When the operating band frequency range is  $> 1$  GHz, the applicable additional  $\Delta R_{IB,c}$  shall be the maximum value for all band combinations defined in clause 7.3A, 7.3B, 7.3C in this specification and 7.3A, 7.3B in TS 38.101-3 [3] for the applicable operating bands.

## 7.3A Reference sensitivity for CA

### 7.3A.1 General

The reference sensitivity power level REFSENS is the minimum mean power applied to each one of the UE antenna ports for all UE categories, at which the throughput shall meet or exceed the requirements for the specified reference measurement channel. For operations with 4 Rx or 8 Rx antenna ports, the MSD in the applicable bands shall be increased by the absolute value of  $\Delta R_{IB,4R}$  in Table 7.3.2-2 or  $\Delta R_{IB,8R}$  in Table 7.3.2-2a when  $MSD > 0$ .

For reference sensitivity exception test points where the specified carrier frequency does not correspond to a valid NR-ARFCN, the closest NR-ARFCN as specified in clause 5.4.2 applies.

For reference sensitivity level tests or reference sensitivity exception tests specified in clause 7.3A, SCS=15kHz based UL test configuration can be replaced by SCS=30kHz based UL test configuration. The equivalent substitution relationship between different SCS UL test configuration is shown in Table 7.3A.1-1 for the operating bands above 2.2GHz.

**Table 7.3A.1-1: Equivalent substitution relationship between different SCS UL test configuration**

SCS (kHz)	(BW[MHz], $L_{crb}$ )
-----------	-----------------------

15	(5, 25)	(10, 50)	(15, 75)	(20, 100)	(25, 128)	(30, 160)	(35, 180)	(40, 216)	(45, 240)	(50, 270)
30	(10, 12)	(10, 24)	(30, 36)	(20, 50)	(25, 64)	(30, 75)	(35, 90)	(40, 100)	(45, 108)	(50, 128)

## 7.3A.2 Reference sensitivity power level for CA

### 7.3A.2.1 Reference sensitivity power level for Intra-band contiguous CA

For intra-band contiguous carrier aggregation, the throughput of each component carrier shall be  $\geq 95\%$  of the maximum throughput of the reference measurement channels as specified in Annexes A.2.2.2, A.3.2, and A.3.3 (with one sided dynamic OCNG Pattern OP.1 FDD/TDD for the DL-signal as described in Annex A.5.1.1/A.5.2.1) with parameters specified in Table 7.3.2-1a, Table 7.3.2-1b, Table 7.3.2-2, Table 7.3.2-2a, and Table 7.3.2-3.

For UE(s) supporting one uplink carrier, the uplink configuration of the PCC shall be in accordance with Table 7.3.2-3 and the downlink PCC carrier center frequency shall be configured closer to uplink operating band than any of the downlink SCC center frequency. For power class 3, the reference sensitivity power level is increased by  $\Delta R_{IBC}$  for specific uplink and downlink test points which are specified in Table 7.3A.2.1-1a.

For aggregation of two or more downlink FDD carriers with two uplink carriers, the reference sensitivity is defined only for the specific uplink and downlink test points which are specified in Table 7.3A.2.1-1 and the power class 3 reference sensitivity power level increased by  $\Delta R_{IBC}$ . The requirements apply with all downlink carriers active. Unless given by Table 7.3.2-4, the reference sensitivity requirements shall be verified with the network signaling value NS\_01 (Table 6.2.3.1-1) configured.

**Table 7.3A.2.1-1: Power class 3 intra-band contiguous CA reference sensitivity with two uplink carriers**

CA configuration	SCS (PCC/SCC) (kHz)	Aggregated channel bandwidth (PCC+SCC)	UL PCC allocation (LCRB)	UL SCC allocation (LCRB)	PCC $\Delta R_{IBC}$ (dB)	SCC $\Delta R_{IBC}$ (dB)	Duplex mode
CA_n3B <sup>5</sup>	15/15	20MHz + 20MHz	25 (RB <sub>START</sub> = 0)	25 (RB <sub>START</sub> = 81)	25.1	12.4	FDD
CA_n5B	15/15	10MHz + 10MHz	10 (RB <sub>START</sub> = 0)	10 (RB <sub>START</sub> = 42)	30.8	26.1	FDD
CA_n5B <sup>5</sup>	15/15	5MHz + 20MHz	4 (RB <sub>START</sub> = 0)	16 (RB <sub>START</sub> = 90)	44.6	23.0	FDD
CA_n7B	15/15	10MHz + 40MHz	9 (RB <sub>START</sub> = 26)	36 (RB <sub>START</sub> = 180)	34	25	FDD

NOTE 1: All combinations of channel bandwidths defined in Table 5.5A.1-1.  
NOTE 2: The carrier centre frequency of SCC in the UL operating band is configured closer to the DL operating band.  
NOTE 3: The transmitted power over both PCC and SCC shall be set to  $P_{UMAX}$  as defined in subclause 6.2A.4.  
NOTE 4: The PCC allocation is same as Transmission bandwidth configuration  $N_{RB}$  as defined in Table 5.3.2-1.  
NOTE 5: Applicable only to BCS 1.

**Table 7.3A.2.1-1a: Power class 3 intra-band contiguous CA reference sensitivity with one uplink carrier.**

CA configuration	SCS (PCC/SCC) (kHz)	Aggregated channel bandwidth (PCC+SCC)	UL PCC allocation (LCRB)	SCC $\Delta R_{IBC}$ (dB)	Duplex mode
CA_n71B <sup>1</sup>	15/15	30MHz + 5MHz	20 (RB <sub>START</sub> = 0)	3.8	FDD

NOTE 1: Applicable only to BCS 4 and 5 and for UEs supporting the optional symmetrical UL/DL channel bandwidths.

**Table 7.3A.2.1-2: Void**

For power class 2, the reference sensitivity power level is increased by  $\Delta R_{IBC}$  for specific uplink and downlink test points which are specified in Table 7.3A.2.1-3. The requirements apply with all downlink carriers active. Unless given

by Table 7.3.2-4, the reference sensitivity requirements shall be verified with the network signalling value NS\_01 (Table 6.2.3.1-1) configured.

**Table 7.3A.2.1-3: Power class 2 intra-band contiguous CA reference sensitivity with two uplink carriers.**

CA configuration	SCS (kHz)	Aggregated channel bandwidth (PCC+SCC)	UL PCC allocation	SCC $\Delta R_{IBC}^1$ (dB)	SCC $\Delta R_{IBC}^2$ (dB)	Duplex mode
CA_n71B	15/15	30 MHz + 5 MHz	20 (RB <sub>start</sub> = 0)	5.6 <sup>3</sup>	7.7 <sup>3</sup>	FDD
NOTE 1: Applicable to UE supporting PC2 with single Tx. NOTE 2: Applicable to UE supporting PC2 with dual Tx. NOTE 3: Applicable only to BCS 4 and 5 and for UEs supporting the optional symmetrical UL/DL channel bandwidths.						

### 7.3A.2.2 Reference sensitivity power level for Intra-band non-contiguous CA

For intra-band non-contiguous carrier aggregation with one uplink carrier and two or more downlink sub-blocks, throughput of each downlink component carrier shall be  $\geq 95\%$  of the maximum throughput of the reference measurement channels as specified in Annexes A.2.2 and A.3.2 (with one sided dynamic OCNG Pattern OP.1 FDD/TDD for the DL-signal as described in Annex A.5.1.1/A.5.2.1) and parameters specified in Table 7.3.2-1a, Table 7.3.2-1b, Table 7.3.2-2, Table 7.3.2-2a and Table 7.3A.2.2-1.

For aggregation of two or more downlink FDD carriers with one uplink carrier, the power class 3 reference sensitivity is increased by  $\Delta R_{IBNC}$  only for the specific uplink and downlink test points which are specified in Table 7.3A.2.2-1. For power class 2, the reference sensitivity power level is increased by  $\Delta R_{IBNC}$  for specific uplink and downlink test points which are specified in Table 7.3A.2.2-1a. The requirements apply with all downlink carriers active. Unless given by Table 7.3.2-4, the reference sensitivity requirements shall be verified with the network signaling value NS\_01 (Table 6.2.3.1-1) configured.

**Table 7.3A.2.2-1: Power class 3 intra-band non-contiguous CA reference sensitivity with one uplink.**

CA configuration	SCS (PCC/SCC) (kHz)	Aggregated channel bandwidth (PCC+SCC)	$W_{gap}$ / [MHz]	UL PCC allocation (L <sub>CRB</sub> )	SCC $\Delta R_{IBNC}$ (dB)	Duplex mode
CA_n1(2A)	15/15	5MHz + 5MHz	$0.0 < W_{gap} \leq 50.0$	25	0.5	FDD
CA_n2(2A)	15/15	5MHz + 5MHz	$W_{gap} = 50.0$	10 <sup>5</sup>	5.0	FDD
			$W_{gap} = 30.0$	25	0.0	
CA_n3(2A)	15/15	5MHz + 5MHz	$W_{gap} = 65.0$	12 <sup>5</sup>	4.7	FDD
			$W_{gap} = 45.0$	25 <sup>5</sup>	0.0	
CA_n5(2A)	15/15	15MHz + 5MHz	$W_{gap} = 5.0$	5 <sup>5</sup>	6.3	FDD
CA_n7(2A)	15/15	10MHz + 5MHz	$W_{gap} = 55$	32 <sup>5</sup>	0.0	FDD
			$W_{gap} = 30$	50 <sup>5</sup>	0.0	
CA_n12(2A)	15/15	5MHz + 5MHz	$0.0 < W_{gap} \leq 7.0$	5 (RB <sub>start</sub> =12)	3	FDD
CA_n25(2A) <sup>9</sup>	15/15	5MHz + 5MHz	$W_{gap} = 55.0$	10 <sup>5</sup>	5.0	FDD
			$W_{gap} = 30.0$	25	0.0	
CA_n25(2A) <sub>10</sub>	15/15	40MHz + 5MHz	$W_{gap} = 20.0$	40 (RB <sub>start</sub> = 176)	[24.6] <sup>8</sup>	FDD
CA_n25(3A)						
CA_n26(2A)	15/15	15MHz + 10MHz	$W_{gap} = 10.0$	5 (RB <sub>start</sub> = 74)	25.2	FDD
CA_n66(2A) CA_n66(3A)	N/A	NOTE 1	NOTE 2	NOTE 3, NOTE 4	0.0	FDD
CA_n71(2A)	15/15					
		15MHz + 10MHz	$W_{gap} = 10.0$	5 (RB <sub>start</sub> = 2)	22.2	

		25MHz + 5MHz <sup>11</sup>	$W_{gap} = 5.0$	20 (RB <sub>start</sub> = 19)	25.1
<p>NOTE 1: All combinations of channel bandwidths defined in Table 5.5A.2-1.                  NOTE 2: All applicable sub-block gap sizes.                  NOTE 3: The PCC allocation is same as Transmission bandwidth configuration N<sub>RB</sub> as defined in Table 5.3.2-1.                  NOTE 4: The carrier center frequency of PCC in the DL operating band is configured closer to the UL operating band.                  NOTE 5: Refers to the UL resource blocks shall be located as close as possible to the downlink operating band but confined within the transmission.                  NOTE 6: <math>W_{gap}</math> is the sub-block gap between the two sub-blocks.                  NOTE 7: The carrier centre frequency of SCC in the DL operating band is configured closer to the UL operating band.                  NOTE 8: For operation with three or more non-contiguous component carriers, <math>\Delta R_{IBNC}</math> applies to all secondary component carriers.                  NOTE 9: Bandwidth Combination Set 0.                  NOTE 10: Bandwidth Combination Set 1                  NOTE 11: Applicable only to Bandwidth Combination Set 4 and 5 and for UEs supporting the symmetrical UL/DL channel bandwidths.</p>					

**Table 7.3A.2.2-1a: Power class 2 intra-band non-contiguous CA reference sensitivity with one uplink carrier.**

CA configuration	SCS (kHz)	Aggregated channel bandwidth (PCC+SCC)	$W_{gap}$ / [MHz]	UL PCC allocation	SCC $\Delta R_{IBNC}^1$ (dB)	SCC $\Delta R_{IBNC}^2$ (dB)	Duplex mode
CA_n71(2A)	15/15	15MHz + 10MHz 25MHz + 5MHz <sup>1</sup>	$W_{gap} = 10.0$	5 (RB <sub>start</sub> = 2)	24.8	29.3	FDD
			$W_{gap} = 5.0$	20 (RB <sub>start</sub> = 8)	27.2 <sup>3</sup>	31.8 <sup>3</sup>	
CA_n25(2A) <sup>9</sup>	15/15	5MHz + 5MHz	$W_{gap} = 55.0$	10 <sup>5</sup>	7.3	10.0	FDD
			$W_{gap} = 30.0$	25	0.0	0.0	
CA_n25(2A) <sup>10</sup> CA_n25(3A)	15/15	40MHz + 5MHz	$W_{gap} = 20.0$	40 (RB <sub>start</sub> = 176)	[27.6] <sup>8</sup>	32.6 <sup>8</sup>	FDD
CA_n66(2A) CA_n66(3A)	N/A	NOTE 4	NOTE 5	NOTE 6, NOTE 7	0.0	0.0	FDD
<p>NOTE 1: Applicable to UE supporting PC2 with single Tx.                  NOTE 2: Applicable to UE supporting PC2 with dual Tx.                  NOTE 3: Applicable only to BCS 4 and 5 and for UEs supporting the optional symmetrical UL/DL channel bandwidths.                  NOTE 4: All combinations of channel bandwidths defined in Table 5.5A.2-1.                  NOTE 5: All applicable sub-block gap sizes.                  NOTE 6: The PCC allocation is same as Transmission bandwidth configuration N<sub>RB</sub> as defined in Table 5.3.2-1.                  NOTE 7: The carrier center frequency of PCC in the DL operating band is configured closer to the UL operating band.                  NOTE 9: Bandwidth Combination Set 0.                  NOTE 10: Bandwidth Combination Set 1</p>							

For intra-band non-contiguous carrier aggregation with two uplink carriers and two or more downlink sub-blocks, throughput of each downlink component carrier shall be  $\geq 95\%$  of the maximum throughput of the reference measurement channels as specified in Annexes A.2.2 and A.3.2 (with one sided dynamic OCNG Pattern OP.1 FDD/TDD for the DL-signal as described in Annex A.5.1.1/A.5.2.1) and parameters specified in Table 7.3.2-1a, Table 7.3.2-1b, Table 7.3.2-2, Table 7.3.2-2a and Table 7.3A.2.2-2 with the power class 3 reference sensitivity power level increased by  $\Delta R_{IBNC}$  only for the specific uplink and downlink test points which are specified in Table 7.3A.2.2-2. The requirements apply with all downlink carriers and two uplink carriers active. The reference sensitivity requirements shall be verified with the network signaling value NS\_01 (Table 6.2.3.1-1) configured.

**Table 7.3A.2.2-2: Power class 3 intra-band non-contiguous CA reference sensitivity with two uplink carriers.**

CA configuration	PCC/SCC (SCS, BW)	PCC/SCC UL Fc (MHz)	UL PCC/SCC allocation (LCRB)	PCC/SCC DL Fc (MHz)	PCC $\Delta R_{IBNC}$ (dB)	SCC $\Delta R_{IBNC}$ (dB)	Duplex mode
CA_n26(2A)	(15kHz, 5MHz)/ (15kHz, 5MHz)	816.5 / 839	12 (RB <sub>START</sub> = 0) / 12 (RB <sub>START</sub> = 3)	861.5 / 884	38.0	13.0	FDD



### 7.3A.2.3 Reference sensitivity power level for Inter-band CA

For inter-band carrier aggregation with one component carrier per operating band and the uplink assigned to one NR band the throughput shall be  $\geq 95\%$  of the maximum throughput of the reference measurement channels as specified in Annexes A.2.2.2, A.3.2, and A.3.3 (with one sided dynamic OCNG Pattern OP.1 FDD/TDD for the DL-signal as described in Annex A.5.1.1/A.5.2.1 with parameters specified in Table 7.3.2-1a, Table 7.3.2-1b, Table 7.3.2-2, Table 7.3.2-2a, Table 7.3.2-3, and in Table 7.3F.2-1, Table 7.3F.2-2, Table 7.3F.2-3 for inter-band CA with one shared spectrum channel access band, modified in accordance with clause 7.3A.3.2. The reference sensitivity is defined to be met with all downlink component carriers active and one of the uplink carriers active. Exceptions to reference sensitivity are allowed in accordance with clause 7.3A.4, 7.3A.5 and 7.3A.6.

For the combination of intra-band and inter-band carrier aggregation, the intra-band CA relaxation,  $\Delta R_{IBC}$  and  $\Delta R_{IBNC}$ , are also applied according to the clause 7.3A.2.1 and 7.3A.2.2.

The reference sensitivity exceptions due to harmonic, harmonic mixing, cross band isolation and power class 2 or power class 3 CA intermodulation interferences are applicable to the UL aggressor band configured with either one Tx antenna connector or two Tx antenna connectors with UL MIMO or Tx diversity operation.

### 7.3A.2.4 Void

## 7.3A.3 $\Delta R_{IB,c}$ for CA

### 7.3A.3.1 General

For a UE supporting a CA configuration, the  $\Delta R_{IB,c}$  applies for both SC and CA operation.

### 7.3A.3.2 $\Delta R_{IB,c}$ for Inter-band CA

For the UE which supports inter-band carrier aggregation, the minimum requirement for reference sensitivity in clause 7.3A.2 shall be increased by the amount given by  $\Delta R_{IB,c}$  defined in clause 7.3A.3.2 for the applicable operating bands. Unless otherwise stated,  $\Delta R_{IB,c}$  is set to zero.

In case the UE supports more than one of band combinations for CA, SUL or DC, and an operating band belongs to more than one band combinations then

- When the operating band frequency range is  $\leq 1$  GHz, the applicable additional  $\Delta R_{IB,c}$  shall be the average value for all band combinations defined in clause 7.3A, 7.3B, 7.3C in this specification and 7.3A, 7.3B in TS 38.101-3 [3], truncated to one decimal place that apply for that operating band among the supported band combinations. In case there is a harmonic relation between low band UL and high band DL, then the maximum  $\Delta R_{IB,c}$  among the different supported band combinations involving such band shall be applied
- When the operating band frequency range is  $> 1$  GHz, the applicable additional  $\Delta R_{IB,c}$  shall be the maximum value for all band combinations defined in clause 7.3A, 7.3B, 7.3C in this specification and 7.3A, 7.3B in TS 38.101-3 [3] for the applicable operating bands.

### 7.3A.3.2.1 $\Delta R_{IB,c}$ for two bands

**Table 7.3A.3.2.1-1:  $\Delta R_{IB,c}$  due to CA (two bands)**

Inter-band CA combination	$\Delta R_{IB,c}$ for NR bands (dB) <sup>8</sup>	
	Component band in order of bands in configuration <sup>9</sup>	
CA_n1-n28	-	0.2
CA_n1-n67	-	0.2
CA_n1-n77	0.2	0.5
CA_n1-n78	-	0.5
CA_n1-n102	0.2	0.5
CA_n1-n105	-	0.3

CA_n2-n48	0.2	0.5
CA_n2-n66	0.3	0.3
CA_n2-n71	-	0.3
CA_n2-n77	0.2	0.5
CA_n2-n78	0.2	0.5
CA_n3-n41	-	0 <sup>4</sup> / 0.5 <sup>5</sup>
CA_n3-n67	0.3	-
CA_n3-n74	0.3	0.5
CA_n3-n77	0.2	0.5
CA_n3-n78	0.2	0.5
CA_n3-n79	-	0.5
CA_n3-n102	-	0.5
CA_n3-n105	-	0.3
CA_n5-n8	0.4	0.4
CA_n5-n12	0.5	0.3
CA_n5-n28	0.2	0.2
CA_n5-n41	0.2	-
CA_n5-n77	0.2	0.5
CA_n5-n78	0.2	0.5
CA_n5-n105	0.1	0.1
CA_n7-n8	-	0.2
CA_n7-n20	0.5	-
CA_n7-n40	-	0.5
CA_n7-n46	0.3	-
CA_n7-n66	0.5	0.5
CA_n7-n71	0.2	-
CA_n7-n77	-	0.5
CA_n7-n78	0.5	0.5
CA_n7-n79	-	0.5
CA_n7-n102	-	0.5
CA_n7-n105	-	0.2
CA_n8-n28	0.2	0.2
CA_n8-n77	0.2	0.5
CA_n8-n78	0.2	0.5
CA_n8-n79	-	0.5
CA_n12-n66	0.5	-
CA_n12-n71	0.8	0.8
CA_n12-n77	0.2	0.5
CA_n12-n78	0.2	0.5
CA_n13-n77	0.2	0.5
CA_n14-n77	0.2	0.5
CA_n18-n77	-	0.5
CA_n18-n78	-	0.5
CA_n20-n78	-	0.5
CA_n20-n40	-	0.5
CA_n24-n48	0.2	0.5
CA_n24-n77	0.2	0.5
CA_n25-n48	0.2	0.5
CA_n25-n66	0.3	0.3
CA_n25-n71	-	0.3
CA_n25-n77	0.2	0.5
CA_n25-n78	0.2	0.5
CA_n25-n85	-	0.3
CA_n26-n28	0.2	0.2
CA_n26-n29	0.5	0.3
CA_n26-n48	-	0.5
CA_n26-n71	0.5	0.3
CA_n26-n77	-	0.5
CA_n26-n78	-	0.5
CA_n28-n71	0.7	0.7
CA_n28-n74	0.2	-
CA_n28-n75	0.2	-
CA_n28-n77	0.2	0.5
CA_n28-n78	0.2	0.5
CA_n28-n79	0.2	0.5

CA_n28-n102	0.2	0.5
CA_n28-n105	0.7	0.7
CA_n29-n48	0.2	0.5
CA_n29-n71	0.5	0.7
CA_n29-n77	0.2	0.5
CA_n28-n94	0.1	0.2
CA_n30-n66	0.5	0.4
CA_n30-n77	-	0.5
CA_n34-n39	0.3	0.3
CA_n34-n40	0.3	0.3
CA_n34-n79	-	0.5
CA_n38-n66	0.5	0.5
CA_n38-n78	0.4	0.5
CA_n38-n79	0.5	0.5
CA_n39-n40	0.3	0.3
CA_n39-n41	0.2	0.2
CA_n39-n79	-	0.5
CA_n40-n77	0.4	0.5
CA_n40-n78	0.4	0.5
CA_n40-n79	-	0.5
CA_n40-n105	-	0.2
CA_n41-n48	0.5	0.5
CA_n41-n66	$0.5^6 / 1^7$	0.5
CA_n41-n71	-	0.2
CA_n41-n77 <sup>1</sup>	-	0.5
CA_n41-n78 <sup>1</sup>	-	0.5
CA_n41-n79	0.5	0.5
CA_n41-n85	-	0.2
CA_n46-n48	-	0.5
CA_n46-n77	-	0.5
CA_n46-n78	-	0.5
CA_n48-n53	$0.5^3$	-
CA_n48-n66	0.5	0.2
CA_n48-n70	0.5	0.2
CA_n48-n96	0.5	-
CA_n50-n78	$0.2^2 / 0.2^3$	$0.2^2 / 0.2^3$
CA_n66-n77	0.2	0.5
CA_n66-n78	0.2	0.5
CA_n67-n78	0.2	0.5
CA_n70-n77	0.2	0.5
CA_n70-n78	0.2	0.5
CA_n71-n77	0.2	0.5
CA_n71-n78	0.2	0.5
CA_n71-n85	0.8	0.8
CA_n74-n77	-	0.5
CA_n74-n78	-	0.5
CA_n75-n78	-	0.5
CA_n76-n78	-	0.5
CA_n77-n85	0.5	0.2
CA_n77-n102	0.5	-
CA_n78-n92	0.5	-
CA_n78-n102	0.5	-
CA_n78-n104	0.7	0.8
CA_n78-n105	0.5	0.2
NOTE 1: The requirements only apply when the sub-frame and Tx-Rx timings are synchronized between the component carriers. In the absence of synchronization, the requirements are not within scope of these specifications.		
NOTE 2: Only applicable for UE supporting inter-band carrier aggregation with uplink in one NR band and without simultaneous Rx/Tx.		
NOTE 3: Applicable for UE supporting inter-band carrier aggregation without simultaneous Rx/Tx.		
NOTE 4: The requirement is applied for UE transmitting on the frequency range of 2515 – 2690 MHz.		
NOTE 5: The requirement is applied for UE transmitting on the frequency range of 2496 – 2515 MHz.		

NOTE 6: The requirement is applied for UE transmitting on the frequency range of 2545-2690 MHz.  
 NOTE 7: The requirement is applied for UE transmitting on the frequency range of 2496-2545 MHz  
 NOTE 8: “-” denotes  $\Delta R_{IB,c} = 0$ .  
 NOTE 9: The component band order in the configuration should be listed by the order of NR bands, such as for CA\_n1-n77 the band order from left to right is n1 and n77.

**Table 7.3A.3.2.1-2: void**

7.3A.3.2.2 Void

7.3A.3.2.3  $\Delta R_{IB,c}$  for three bands

**Table 7.3A.3.2.3-1:  $\Delta R_{IB,c}$  due to CA (three bands)**

Inter-band CA combination	$\Delta R_{IB,c}$ for NR bands (dB) <sup>9</sup>		
	Component band in order of bands in configuration <sup>10</sup>		
CA_n1-n3-n8	0.2	0.2	0.5
CA_n1-n3-n28	-	-	0.2
CA_n1-n3-n38	0.2	0.2	-
CA_n1-n3-n41	-	-	0 <sup>5</sup> / 0.5 <sup>6</sup>
CA_n1-n3-n78	0.2	0.2	0.5
CA_n1-n3-n77	0.2	0.2	0.5
CA_n1-n3-n79	-	-	0.5
CA_n1-n3-n105	0.3	0.3	0.3
CA_n1-n5-n28	-	0.2	0.2
CA_n1-n5-n40	-	0.2	-
CA_n1-n5-n78	0.2	0.2	0.5
CA_n1-n5-n79	0.2	0.2	0.5
CA_n1-n5-n105	-	0.2	0.3
CA_n1-n7-n8	-	-	0.2
CA_n1-n7-n28	-	-	0.2
CA_n1-n7-n40	-	0.3	0.8
CA_n1-n7-n78	0.2	0.2	0.5
CA_n1-n7-n79	0.2	0.2	0.5
CA_n1-n7-n105	-	-	0.3
CA_n1-n8-n28	-	0.2	0.2
CA_n1-n8-n40	-	0.2	0.5
CA_n1-n8-n77	-	0.2	0.5
CA_n1-n8-n78	-	0.2	0.5
CA_n1-n8-n79	-	0.2	0.5
CA_n1-n18-n77	-	-	0.5
CA_n1-n20-n67	-	0.2	0.2
CA_n1-n20-n78	-	-	0.5
CA_n1-n26-n78	0.2	0.2	0.5
CA_n1-n28-n38	-	0.2	-
CA_n1-n28-n40	-	0.2	-
CA_n1-n28-n41	-	0.2	-
CA_n1-n28-n46	-	-	0.5
CA_n1-n28-n75	-	0.2	-
CA_n1-n28-n77	0.2	0.2	0.5
CA_n1-n28-n78	-	0.2	0.5
CA_n1-n28-n102	0.2	0.2	0.5
CA_n1-n38-n78	-	-	0.5
CA_n1-n40-n77	-	-	0.5
CA_n1-n40-n78	-	-	0.5
CA_n1-n40-n105	-	-	0.3
CA_n1-n41-n77	0.2	-	0.5
CA_n1-n41-n79	-	0.5	0.5

CA_n1-n46-n78	-	-	0.5
CA_n1-n67-n78	-	-	0.5
CA_n1-n75-n78	-	-	0.5
CA_n1-n77-n79	0.2	0.5	-
CA_n1-n78-n79	-	0.5	-
CA_n1-n78-n102	0.2	0.5	0.5
CA_n1-n78-n105	-	0.5	0.2
CA_n2-n5-n30	0.4	-	0.5
CA_n2-n5-n41	-	0.2	-
CA_n2-n5-n48	0.2	-	0.5
CA_n2-n5-n66	0.3	-	0.3
CA_n2-n5-n77	0.2	0.5	0.5
CA_n2-n7-n71	-	-	0.2
CA_n2-n7-n66	0.3	0.5	0.5
CA_n2-n7-n77	0.2	-	0.5
CA_n2-n12-n30	0.4	-	0.5
CA_n2-n12-n41	0.5	0.3	$0.4^5 / 0.9^6$
CA_n2-n12-n66	0.3	0.5	0.3
CA_n2-n12-n71	-	0.8	0.8
CA_n2-n12-n77	0.2	0.2	0.5
CA_n2-n14-n30	0.3	-	0.3
CA_n2-n14-n66	0.3	-	0.3
CA_n2-n14-n77	0.2	0.2	0.5
CA_n2-n29-n30	0.3	-	0.3
CA_n2-n29-n66	0.3	-	0.3
CA_n2-n29-n77	0.2	0.2	0.5
CA_n2-n30-n66	0.4	0.5	0.4
CA_n2-n30-n77	0.2	-	0.5
CA_n2-n41-n66	0.3	$0.5^6 / 1^7$	0.5
CA_n2-n41-n71	-	-	0.3
CA_n2-n48-n66	0.3	0.5	0.3
CA_n2-n48-n77	0.2	0.5	0.5
CA_n2-n66-n71	0.3	0.3	-
CA_n2-n66-n77	0.2	0.2	0.5
CA_n2-n66-n78	0.3	0.3	0.5
CA_n2-n71-n77	0.2	0.2	0.5
CA_n3-n5-n28	-	0.2	0.1
CA_n3-n5-n79	-	0.2	0.5
CA_n3-n7-n8	-	-	0.2
CA_n3-n7-n38	-	0.5	0.5
CA_n3-n7-n40	0.2	0.2	0.3
CA_n3-n7-n78	0.2	0.2	0.5
CA_n3-n7-n79	-	-	0.5
CA_n3-n7-n105	-	-	0.3
CA_n3-n8-n28	-	0.2	0.1
CA_n3-n8-n77	0.2	0.2	0.5
CA_n3-n8-n41	-	-	$0^1 / 0.5^2$
CA_n3-n5-n78	0.2	0.2	0.5
CA_n3-n8-n78	0.2	0.2	0.5
CA_n3-n18-n41	-	-	$0^1 / 0.5^2$
CA_n3-n18-n77	0.2	-	0.5
CA_n3-n20-n28	-	0.1	0.1
CA_n3-n20-n67	-	0.1	0.1
CA_n3-n20-n78	0.2	-	0.5
CA_n3-n26-n78	0.2	0.2	0.5
CA_n3-n28-n41	-	-	$0^1 / 0.5^2$
CA_n3-n28-n77	0.2	0.2	0.5
CA_n3-n28-n78	-	0.2	0.5
CA_n3-n28-n79	-	0.2	0.5
CA_n3-n39-n41	0.2	0.2	$0.2^4 / 0.7^5$
CA_n3-n39-n79	-	-	0.5
CA_n3-n40-n78	0.2	-	0.5
CA_n3-n40-n105	-	-	0.3
CA_n3-n67-n78	-	0.2	0.5
CA_n3-n77-n79	0.2	0.5	-

CA_n3-n78-n79	0.2	0.5	0.5
CA_n3-n40-n41	-	-	0 <sup>1</sup> / 0.5 <sup>2</sup>
CA_n3-n41-n77	0.2	0 <sup>1</sup> / 0.5 <sup>2</sup>	0.5
CA_n3-n41-n78	0.2	0 <sup>1</sup> / 0.5 <sup>2</sup>	0.5
CA_n3-n41-n79	-	0.5	0.5
CA_n3-n75-n78	0.2	-	0.5
CA_n3-n78-n105	0.2	0.5	0.3
CA_n5-n7-n28	-	-	0.2
CA_n5-n7-n40	0.2	0.3	0.7
CA_n5-n7-n66	-	0.5	0.5
CA_n5-n7-n77	0.2	0.2	0.5
CA_n5-n7-n78	0.2	0.2	0.5
CA_n5-n12-n77	0.5	0.3	0.5
CA_n5-n14-n77	0.2	0.2	0.5
CA_n5-n25-n29	0.5	-	0.3
CA_n5-n25-n41	0.2	-	-
CA_n5-n25-n77	0.2	0.2	0.5
CA_n5-n25-n78	0.2	0.2	0.5
CA_n5-n28-n78	0.2	0.2	0.5
CA_n5-n28-n79	0.2	0.2	0.5
CA_n5-n28-n105	0.2	0.7	0.7
CA_n5-n29-n66	0.5	0.3	-
CA_n5-n29-n77	0.5	0.3	0.5
CA_n5-n30-n66	-	0.5	0.4
CA_n5-n30-n77	0.2	-	0.5
CA_n5-n40-n78	0.2	0.4	0.5
CA_n5-n40-n105	0.2	0.8	0.2
CA_n5-n41-n66	0.2	0.5 <sup>5</sup> / 1 <sup>6</sup>	0.5
CA_n5-n41-n77	0.2	-	0.5
CA_n5-n48-n66	-	0.5	0.2
CA_n5-n48-n77	0.2	0.5	0.5
CA_n5-n66-n77	0.2	0.2	0.5
CA_n5-n66-n78	0.5	0.2	0.5
CA_n5-n78-n79	0.2	0.5	-
CA_n5-n78-n105	0.2	0.5	0.2
CA_n7-n8-n28	-	0.2	0.1
CA_n7-n8-n40	-	0.2	0.5
CA_n7-n8-n78	-	0.2	0.5
CA_n7-n12-n71	0.2	0.8	0.8
CA_n7-n12-n77	0.2	0.5	0.5
CA_n7-n20-n67	-	0.2	0.2
CA_n7-n20-n78	-	-	0.5
CA_n7-n25-n66	0.5	0.3	0.5
CA_n7-n25-n71	0.3	0.3	-
CA_n7-n25-n77	0.5	0.2	0.5
CA_n7-n25-n78	0.5	0.2	0.5
CA_n7-n26-n78	0.2	0.2	0.5
CA_n7-n28-n40	-	-	0.5
CA_n7-n28-n78	-	-	0.5
CA_n7-n40-n105	-	0.5	0.2
CA_n7-n46-n78	0.5	-	0.5
CA_n7-n66-n71	0.5	0.5	0.1
CA_n7-n66-n77	0.5	0.5	0.5
CA_n7-n66-n78	0.5	0.5	0.5
CA_n7-n67-n78	-	-	0.5
CA_n7-n71-n77	-	0.2	0.5
CA_n7-n75-n78	-	-	0.5
CA_n7-n78-n102	-	0.5	0.5
CA_n7-n78-n105	-	0.5	0.2
CA_n8-n20-n28	0.3	0.2	0.2
CA_n8-n28-n40	0.2	0.2	-
CA_n8-n28-n75	0.2	0.2	-
CA_n8-n28-n77	0.2	0.2	0.5
CA_n8-n28-n78	0.2	0.2	0.5
CA_n8-n39-n40	-	0.3	0.3

CA_n8-n39-n41	-	0.2 <sup>4</sup>	0.2
CA_n8-n40-n77	0.2	0.4	0.5
CA_n8-n40-n78	0.2	0.4	0.5
CA_n8-n40-n79	-	-	0.5
CA_n8-n41-n79	-	0.5	0.5
CA_n8-n78-n79	0.2	0.5	0.5
CA_n12-n25-n66	0.5	0.3	0.3
CA_n12-n30-n66	0.5	0.5	0.4
CA_n12-n30-n77	0.2	-	0.5
CA_n12-n41-n66	0.1	0.5	0.5
CA_n12-n41-n77	0.5	0.2	0.5
CA_n12-n66-n77	0.5	0.5	0.5
CA_n12-n71-n77	0.8	0.8	0.5
CA_n13-n25-n66	-	0.3	0.3
CA_n13-n25-n77	-	0.2	0.5
CA_n13-n66-n77	0.3	0.3	0.5
CA_n14-n30-n66	-	0.5	0.4
CA_n14-n30-n77	0.2	-	0.5
CA_n14-n66-n77	0.2	0.5	0.5
CA_n18-n28-n77	-	-	0.5
CA_n18-n41-n77	-	-	0.5
CA_n20-n28-n75	-	0.2	-
CA_n20-n28-n78	-	0.2	0.5
CA_n20-n67-n78	0.2	0.2	0.5
CA_n24-n41-n48	-	-	0.5
CA_n24-n41-n77	0.2	-	0.5
CA_n24-n48-n77	0.2	0.5	0.5
CA_n25-n29-n66	0.3	-	0.3
CA_n25-n38-n78	0.2	0.4	0.5
CA_n25-n41-n66	0.3	0.5 <sup>5</sup> / 1 <sup>6</sup>	0.3
CA_n25-n41-n71	-	-	0.2
CA_n25-n41-n78	0.2	0.5	0.5
CA_n25-n48-n66	0.3	0.5	0.3
CA_n25-n66-n71	0.3	0.3	0.3
CA_n25-n66-n78	0.3	0.3	0.5
CA_n25-n66-n77	0.3	0.3	0.5
CA_n25-n66-n85	0.3	0.3	0.5
CA_n25-n71-n77	0.2	0.2	0.5
CA_n25-n71-n78	0.2	0.3	0.5
CA_n25-n71-n85	-	0.8	0.8
CA_n25-n77-n85	0.2	0.5	0.2
CA_n26-n29-n66	0.5	0.3	-
CA_n26-n29-n70	0.5	0.3	-
CA_n26-n48-n66	-	0.5	0.2
CA_n26-n48-n70	-	0.5	0.2
CA_n26-n66-n71	0.5	-	0.3
CA_n26-n66-n77	0.2	0.2	0.5
CA_n26-n70-n71	0.5	-	0.3
CA_n26-n70-n77	0.2	0.2	0.5
CA_n28-n38-n78	0.2	-	0.5
CA_n28-n39-n40	-	0.3	0.3
CA_n28-n39-n41	-	0.2	0.2
CA_n28-n39-n79	0.2	-	0.5
CA_n28-n40-n77	-	-	0.5
CA_n28-n40-n78	-	-	0.5
CA_n28-n40-n79	0.2	-	0.5
CA_n28-n41-n77	0.2	-	0.5
CA_n28-n41-n78	0.2	-	0.5
CA_n28-n41-n79	0.2	0.5	0.5
CA_n28-n46-n78	0.2	-	0.5
CA_n28-n75-n78	0.2	-	0.5
CA_n28-n77-n79	0.2	0.5	-
CA_n28-n78-n79	0.2	0.5	-
CA_n28-n78-n102	0.2	0.5	0.5
CA_n29-n30-n66	-	0.5	0.4

CA_n29-n30-n77	0.2	-	0.5
CA_n29-n66-n71	0.5	0.3	0.7
CA_n29-n66-n77	0.5	0.5	0.5
CA_n29-n70-n71	0.2	0.2	0.2
CA_n30-n66-n77	0.5	0.4	0.5
CA_n34-n39-n40	0.3	0.3	0.3
CA_n34-n39-n41	0.3	0.3	0.2
CA_n34-n40-n41	0.3	0.3	-
CA_n34-n41-n78	-	0.5	0.5
CA_n39-n40-n41	0.3	0.6	0.6
CA_n39-n40-n79	0.3	0.3	0.5
CA_n39-n41-n79	0	0.5	0.8
CA_n40-n41-n79	0 <sup>8</sup>	0.5 <sup>8</sup>	0.5
CA_n40-n78-n105	0.4	0.5	0.2
CA_n41-n66-n71	0.5 <sup>1</sup> / 1 <sup>2</sup>	0.5	-
CA_n41-n66-n77	0.2	0.2	0.5
CA_n41-n66-n78	0.2	0.2	0.5
CA_n41-n66-n85	0.5 <sup>1</sup> / 1 <sup>2</sup>	0.5	0.5
CA_n41-n70-n78	0.2	0.2	0.5
CA_n41-n71-n77	-	0.2	0.5
CA_n41-n71-n78	-	0.2	0.5
CA_n41-n71-n85	-	0.8	0.8
CA_n41-n77-n79	0.5	0.5	0.5
CA_n41-n77-n85	0.5	0.5	0.5
CA_n46-n48-n96	0.5	0.5	0.6
CA_n48-n66-n70	0.5	0.2	0.2
CA_n46-n78-n102	-	0.5	-
CA_n48-n66-n71	0.2	0.2	0.2
CA_n48-n66-n77	0.5	0.2	0.5
CA_n48-n70-n71	0.2	0.2	0.2
CA_n48-n70-n77	0.5	0.2	0.5
CA_n48-n71-n77	0.5	0.2	0.5
CA_n66-n70-n77	0.2	0.2	0.5
CA_n66-n71-n77	0.2	0.2	0.5
CA_n66-n71-n78	0.2	0.2	0.5
CA_n66-n71-n85	-	0.8	0.8
CA_n66-n77-n85	0.5	0.5	0.5
CA_n70-n71-n77	0.2	0.2	0.5
NOTE 1: Applicable for the frequency range of 2515-2690 MHz. NOTE 2: Applicable for the frequency range of 2496-2515 MHz. NOTE 3: Void. NOTE 4: Void. NOTE 5: The requirement is applied for UE transmitting on the frequency range of 2545 - 2690 MHz. NOTE 6: The requirement is applied for UE transmitting on the frequency range of 2496 - 2545 MHz. NOTE 7: Void. NOTE 8: Void. NOTE 9: “-” denotes $\Delta R_{IB,c} = 0$ . NOTE 10: The component band order in the configuration should be listed by the order of NR bands, such as for CA_n1-n3-n8 the band order from left to right is n1, n3 and n8.			

7.3A.3.2.4  $\Delta R_{IB,c}$  for four bands

Table 7.3A.3.2.4-1:  $\Delta R_{IB,c}$  due to CA (four bands)

Inter-band CA combination	$\Delta R_{IB,c}$ for NR bands (dB) <sup>7</sup>			
	Component band in order of bands in configuration <sup>8</sup>			
CA_n1-n3-n5-n28	0.2	0.2	0.2	0.2
CA_n1-n3-n5-n78	0.2	0.2	-	0.5
CA_n1-n3-n7-n8	-	-	-	0.2
CA_n1-n3-n7-n26	-	-	-	0.2
CA_n1-n3-n7-n28	-	-	-	0.2



CA_n1-n3-n7-n40	0.2	0.2	0.2	0.3
CA_n1-n3-n7-n67	-	-	-	0.2
CA_n1-n3-n7-n78	0.3	0.3	0.3	0.5
CA_n1-n3-n7-n79	0.2	-	0.2	0.5
CA_n1-n3-n7-n105	0.2	-	0.2	0.3
CA_n1-n3-n8-n77	0.2	0.2	0.2	0.5
CA_n1-n3-n8-n78	0.2	0.2	0.2	0.5
CA_n1-n3-n18-n28	-	-	-	0.2
CA_n1-n3-n18-n41	-	-	-	0 <sup>5</sup> / 0.5 <sup>6</sup>
CA_n1-n3-n18-n77	0.2	0.2	-	0.5
CA_n1-n3-n20-n67	-	-	-	0.2
CA_n1-n3-n26-n78	0.2	0.2	0.2	0.5
CA_n1-n3-n28-n38	-	-	0.2	-
CA_n1-n3-n28-n41	-	-	0.2	0 <sup>5</sup> / 0.5 <sup>6</sup>
CA_n1-n3-n28-n77	0.2	0.2	0.2	0.5
CA_n1-n3-n28-n78	0.2	0.2	0.2	0.5
CA_n1-n3-n28-n79	-	-	0.2	0.5
CA_n1-n3-n40-n77	0.3	0.3	0.3	0.5
CA_n1-n3-n40-n78	0.2	0.2	0.3	0.5
CA_n1-n3-n40-n105	0.3	0.3	0.3	0.3
CA_n1-n3-n41-n77	0.2	0.2	0 <sup>5</sup> / 0.5 <sup>6</sup>	0.5
CA_n1-n3-n41-n79	-	-	0 <sup>5</sup> / 0.5 <sup>6</sup>	0.5
CA_n1-n3-n67-n78	0.2	0.2	0.2	0.5
CA_n1-n3-n75-n78	-	-	-	0.5
CA_n1-n3-n77-n79	0.2	0.2	0.5	0.5
CA_n1-n5-n7-n40	0.2	0.2	0.3	0.3
CA_n1-n5-n7-n78	0.2	0.2	0.2	0.5
CA_n1-n5-n7-n105	0.2	0.2	0.2	0.3
CA_n1-n5-n28-n78	0.2	0.2	0.2	0.5
CA_n1-n5-n28-n79	0.2	0.2	0.2	0.5
CA_n1-n5-n40-n78	0.2	0.2	0.4	0.5
CA_n1-n5-n40-n105	0.2	0.2	0.3	0.3
CA_n1-n5-n78-n79	0.2	0.2	0.5	0.5
CA_n1-n5-n78-n105	0.2	0.2	0.5	0.3
CA_n1-n7-n8-n40	-	-	0.3	0.8
CA_n1-n7-n8-n78	0.2	0.2	0.2	0.5
CA_n1-n7-n26-n78	0.2	0.2	-	-
CA_n1-n7-n28-n38	-	-	0.2	-
CA_n1-n7-n28-n78	0.2	0.2	-	-
CA_n1-n7-n40-n78	0.2	-	0.4	0.5
CA_n1-n7-n40-n105	0.2	-	0.4	0.3
CA_n1-n7-n67-n78	0.2	0.2	-	-
CA_n1-n7-n75-n78	-	-	-	0.5
CA_n1-n7-n78-n105	0.2	0.2	0.5	0.3
CA_n1-n8-n40-n78	0.2	-	0.4	0.5
CA_n1-n8-n78-n79	0.3	0.3	0.5	-
CA_n1-n18-n28-n41	0.2	-	0.2	-
CA_n1-n18-n28-n77	0.2	-	0.2	0.5
CA_n1-n18-n41-n77	0.2	-	-	0.5
CA_n1-n28-n38-n78	0.2	0.2	-	0.5
CA_n1-n28-n40-n77	-	0.2	-	0.5
CA_n1-n28-n40-n78	-	0.2	-	0.5
CA_n1-n28-n41-n77	0.2	0.2	-	0.5
CA_n1-n28-n41-n79	-	0.2	0.5	0.5
CA_n1-n28-n75-n78	-	0.2	-	0.5
CA_n1-n28-n77-n79	0.2	0.2	0.5	0.5
CA_n1-n28-n78-n79	0.2	0.2	0.5	0.5
CA_n1-n41-n77-n79	0.2	0.5	0.5	0.5
CA_n2-n5-n30-n66	0.4	-	0.5	0.4
CA_n2-n5-n30-n77	0.2	0.2	-	0.5
CA_n2-n5-n48-n66	0.2	-	0.5	0.2
CA_n2-n5-n48-n77	0.2	-	0.5	0.5
CA_n2-n5-n66-n77	0.3	-	0.3	0.5
CA_n2-n12-n30-n66	0.4	0.5	0.5	0.4
CA_n2-n12-n30-n77	0.2	0.2	-	0.5

CA_n2-n12-n66-n77	0.2	0.5	0.5	0.5
CA_n2-n14-n30-n66	0.4	-	0.5	0.4
CA_n2-n14-n30-n77	0.2	0.2	-	0.5
CA_n2-n14-n66-n77	0.2	0.2	0.5	0.5
CA_n2-n29-n30-n66	0.4	-	0.5	0.4
CA_n2-n29-n30-n77	0.2	0.2	-	0.5
CA_n2-n30-n66-n77	0.2	0.5	0.4	0.5
CA_n2-n41-n66-n71	0.3	$0.5^1 / 1^2$	0.5	0.3
CA_n2-n48-n66-n77	0.3	0.5	0.3	0.5
CA_n2-n66-n71-n77	0.3	0.5	-	0.5
CA_n2-n66-n71-n78	0.3	0.5	-	0.5
CA_n3-n5-n7-n78	0.2	0.2	0.2	0.5
CA_n3-n5-n28-n78	0.2	0.2	0.2	0.5
CA_n3-n5-n28-n79	0.2	0.2	0.2	0.5
CA_n3-n7-n8-n78	0.2	0.2	0.2	0.5
CA_n3-n7-n20-n78	0.2	0.2	0.2	0.5
CA_n3-n7-n26-n78	0.2	0.2	0.2	0.5
CA_n3-n7-n28-n78	0.2	0.2	0.2	0.5
CA_n3-n7-n40-n78	0.2	0.2	0.3	0.5
CA_n3-n7-n40-n105	0.2	0.2	0.2	0.3
CA_n3-n7-n67-n78	0.2	0.2	0.2	0.5
CA_n3-n7-n75-n78	-	-	-	0.5
CA_n3-n7-n78-n105	0.2	0.2	0.5	0.3
CA_n3-n8-n41-n79	-	0.2	0.5	0.5
CA_n3-n18-n28-n41	-	-	-	$0^5 / 0.5^6$
CA_n3-n18-n28-n77	0.2	-	0.2	0.5
CA_n3-n18-n41-n77	0.2	-	$0^5 / 0.5^6$	0.5
CA_n3-n20-n67-n78	0.2	0.2	0.2	0.5
CA_n3-n28-n40-n77	0.2	0.2	0.2	0.5
CA_n3-n28-n41-n77	0.5	0.2	$0^1 / 0.5^2$	0.5
CA_n3-n28-n41-n78	0.5	0.2	$0^1 / 0.5^2$	0.5
CA_n3-n28-n41-n79	-	0.2	0.5	0.5
CA_n3-n28-n77-n79	0.2	0.2	0.5	0.5
CA_n3-n41-n77-n79	0.2	0.5	0.5	0.5
CA_n5-n7-n40-n78	0.2	0.2	0.5	0.5
CA_n5-n7-n40-n105	0.2	0.2	0.5	0.3
CA_n5-n7-n66-n77	0.2	0.5	0.5	0.5
CA_n5-n7-n78-n105	0.2	0.2	0.5	0.3
CA_n5-n25-n29-n66	0.5	-	0.3	-
CA_n5-n25-n66-n77	0.5	0.3	0.3	0.5
CA_n5-n25-n66-n78	0.5	0.3	0.3	0.5
CA_n5-n28-n78-n79	0.2	0.2	0.5	0.5
CA_n5-n30-n66-n77	0.2	0.4	0.4	0.5
CA_n5-n40-n78-n105	0.2	0.4	0.5	0.3
CA_n5-n48-n66-n77	0.2	0.5	0.2	0.5
CA_n7-n8-n40-n78	-	0.2	0.4	0.5
CA_n7-n12-n25-n66	0.5	0.5	0.3	0.5
CA_n7-n20-n67-n78	0.2	0.2	0.2	0.5
CA_n7-n25-n66-n71	0.5	0.3	0.5	0.3
CA_n7-n25-n66-n77	0.5	0.6	0.6	0.8
CA_n7-n25-n66-n78	0.5	0.6	0.6	0.8
CA_n7-n40-n78-n105	0.5	0.5	0.8	0.3
CA_n7-n66-n71-n77	0.5	0.5	0.2	0.5
CA_n8-n20-n28-n75	0.3	0.2	0.2	-
CA_n8-n39-n41-n79	0.2	-	0.5	0.5
CA_n12-n30-n66-n77	0.5	0.5	0.5	0.5
CA_n13-n25-n66-n77	0.3	0.3	0.3	0.5
CA_n14-n30-n66-n77	0.2	0.5	0.5	0.5
CA_n18-n28-n41-n77	-	0.2	$0^5 / 0.5^6$	0.5
CA_n25-n38-n66-n78	0.3	0.4	0.3	0.5
CA_n25-n41-n66-n71	0.3	0.5	0.5	-
CA_n25-n41-n66-n77	0.3	$0.5^3 / 1.0^4$	0.3	0.5
CA_n25-n41-n66-n78	0.3	$0.5^3 / 1.0^4$	0.3	0.5
CA_n25-n41-n66-n85	0.3	0.5	0.5	-
CA_n25-n41-n71-n77	-	-	0.2	0.5

CA_n25-n41-n77-n85	-	-	0.5	0.2
CA_n25-n41-n71-n78	-	-	0.2	0.5
CA_n25-n41-n71-n85	0.3	0.5	-	0.2
CA_n25-n66-n71-n77	0.3	0.3	0.3	0.5
CA_n25-n66-n71-n78	0.3	0.3	0.3	0.5
CA_n25-n66-n71-n85	0.3	0.3	0.8	0.8
CA_n25-n66-n77-n85	0.2	0.5	0.5	0.5
CA_n28-n41-n77-n79	0.2	0.5	0.5	0.5
CA_n29-n30-n66-n77	0.5	0.5	0.5	0.5
CA_n29-n66-n70-n71	0.5	0.3	0.2	0.7
CA_n41-n66-n70-n78	-	0.2	0.2	0.5
CA_n41-n66-n71-n77	0 <sup>3</sup> / 0.5 <sup>4</sup>	0.5	0.2	0.5
CA_n41-n66-n71-n78	0 <sup>3</sup> / 0.5 <sup>4</sup>	0.5	0.2	0.5
CA_n41-n66-n71-n85	0.5	0.3	-	0.2
CA_n41-n66-n77-n85	0 <sup>3</sup> / 0.5 <sup>4</sup>	0.5	0.5	0.2
CA_n48-n66-n70-n77	0.5	0.2	0.2	0.5

NOTE 1: Applicable for the frequency range of 2515-2690 MHz.  
 NOTE 2: Applicable for the frequency range of 2496-2515 MHz  
 NOTE 5: The requirement is applied for UE transmitting on the frequency range of 2545 - 2690 MHz.  
 NOTE 6: The requirement is applied for UE transmitting on the frequency range of 2496 - 2545 MHz  
 NOTE 7: “-” denotes  $\Delta R_{IB,c} = 0$ .  
 NOTE 8: The component band order in the configuration should be listed by the order of NR bands, such as for CA\_n1-n3-n7-n78 the band order from left to right is n1 n3, n7 and n78.

7.3A.3.2.5  $\Delta R_{IB,c}$  for five bands

Table 7.3A.3.2.5-1:  $\Delta R_{IB,c}$  due to CA (five bands)

Inter-band CA combination	$\Delta R_{IB,c}$ for NR bands (dB) <sup>1</sup>				
	Component band in order of bands in configuration <sup>2</sup>				
CA_n1-n3-n5-n7-n78	0.2	0.2	0.2	0.2	0.5
CA_n1-n3-n5-n28-n78	0.2	0.2	0.2	0.2	0.5
CA_n1-n3-n7-n26-n78	0.2	0.2	0.2	0.2	0.5
CA_n1-n3-n7-n28-n38	-	-	-	0.2	-
CA_n1-n3-n7-n28-n78	0.2	0.2	0.2	0.2	0.5
CA_n1-n3-n7-n40-n78	0.2	0.2	0.2	0.3	0.5
CA_n1-n3-n7-n67-n78	0.2	0.2	0.2	0.2	0.5
CA_n1-n3-n7-n78-n105	0.2	0.2	0.2	0.5	0.3
CA_n1-n3-n7-n75-n78	0.2	0.2	0.2	0.2	0.5
CA_n1-n3-n28-n41-n77	0.2	0.5	0.2	0 <sup>3</sup> /0.5 <sup>4</sup>	0.5
CA_n1-n3-n28-n41-n79	-	-	0.2	0.5	0.5
CA_n1-n3-n28-n77-n79	0.2	0.2	0.2	0.5	0.5
CA_n1-n3-n40-n78-n105	0.2	0.2	0.2	0.5	0.2
CA_n1-n3-n41-n77-n79	0.2	0.2	0.5	0.5	0.5
CA_n1-n5-n7-n40-n78	0.2	0.2	0.2	0.5	0.5
CA_n1-n5-n7-n40-n105	0.2	0.2	0.3	0.5	0.3
CA_n1-n5-n7-n78-n105	0.2	0.2	0.2	0.5	0.3
CA_n1-n5-n28-n78-n79	0.2	0.2	0.2	0.5	0.5
CA_n1-n5-n40-n78-n105	0.2	0.2	0.2	0.5	0.3
CA_n1-n7-n40-n78-n105	0.2	0.2	0.2	0.5	0.2
CA_n1-n28-n41-n77-n79	0.2	0.2	0.5	0.5	0.5
CA_n2-n5-n30-n66-n77	0.3	0.2	0.5	0.4	0.5
CA_n2-n5-n48-n66-n77	0.2	-	0.5	0.2	0.5
CA_n2-n12-n30-n66-n77	0.2	0.5	0.5	0.5	0.5
CA_n2-n14-n30-n66-n77	0.2	0.2	0.5	0.5	0.5
CA_n2-n29-n30-n66-n77	0.2	0.5	0.5	0.5	0.5
CA_n3-n7-n20-n67-n78	0.2	0.2	0.2	0.2	0.5
CA_n3-n7-n40-n78-n105	0.2	0.5	0.2	0.5	0.2
CA_n3-n28-n41-n77-n79	0.5	0.2	0.5	0.5	0.5
CA_n5-n7-n40-n78-n105	0.2	0.2	0.5	0.5	0.3

NOTE 1: “-” denotes  $\Delta R_{IB,c} = 0$ .

NOTE 2: The component band order in the configuration should be listed by the order of NR bands, such as for CA\_n1-n3-n5-n7-n78 the band order from left to right is n1 n3, n5, n7 and n78.  
 NOTE 3: The requirement is applied for UE transmitting on the frequency range of 2545 - 2690 MHz.  
 NOTE 4: The requirement is applied for UE transmitting on the frequency range of 2496 - 2545 MHz

7.3A.3.2.6  $\Delta R_{IB,c}$  for six bands

**Table 7.3A.3.2.6-1:  $\Delta R_{IB,c}$  due to CA (six bands)**

Inter-band CA combination	$\Delta R_{IB,c}$ for NR bands (dB) <sup>1</sup>					
	Component band in order of bands in configuration <sup>2</sup>					
CA_n1-n3-n7-n28-n38-n78	0.2	0.2	0.2	0.2	0.2	0.5
CA_n1-n3-n7-n40-n78-n105	0.2	0.2	0.2	0.3	0.5	0.3
CA_n1-n5-n7-n40-n78-n105	0.2	0.2	0.2	0.3	0.5	0.3

NOTE 1: "-" denotes  $\Delta R_{IB,c} = 0$ .  
 NOTE 2: The component band order in the configuration should be listed by the order of NR bands, such as for CA\_n1-n3-n5-n7-n78 the band order from left to right is n1 n3, n5, n7 and n78.

7.3A.3.3  $\Delta R_{IB,c}$  for Intra-band CA

**Table 7.3A.3.3-1:  $\Delta R_{IB,c}$  due to Intra-band contiguous CA**

Intra-band CA	Operating Band	$\Delta R_{IB,c}$ (dB)
CA_n96E	n96	0.5

**Table 7.3A.3.3-2:  $\Delta R_{IB,c}$  due to Intra-band non-contiguous CA**

CA configuration	SCS (PCC/SCC) (kHz)	Aggregated channel bandwidth (PCC+SCC)	$\Delta R_{IBNC}$ (dB)	Duplex mode
CA_n96(4A)	15/30/60	320MHz	0.5	TDD

7.3A.4 Reference sensitivity exceptions due to harmonic interference for CA

Sensitivity degradation is allowed for different combinations of UL configurations and DL channel bandwidths if a band in frequency range 1 is impacted by UL harmonic interference from another band which belongs to NR band in frequency range 1 of the same downlink CA configuration. Reference sensitivity exceptions and uplink/downlink configurations due to UL harmonic from a PC3 aggressor NR UL band for either single band uplink or PC3 or PC2 CA are specified in Table 7.3A.4-1. For these exceptions, only the listed test points in Table 7.3A.4-1 are needed to be tested.

**Table 7.3A.4-1: Reference sensitivity exceptions and uplink/downlink configurations due to UL harmonic from a PC3 aggressor NR UL band for NR DL CA FR1**

UL band	DL band	UL BW	SCS of UL band	UL RB Allocation	DL BW	MSD	UL/DL fc condition	UL/DL harmonic order
		(MHz)	(kHz)	LCRB	(MHz)	(dB)		
n1	n77	5	15	12	10	23.9	NOTE 2	UL2/DL1 direct-hit
n1	n77	5	15	12	100	13.8	NOTE 2	UL2/DL1 direct-hit

n2	n48	5	15	25	5	8.1	NOTE 6	UL2/DL1 near-miss
n2	n77	5	15	12	10	23.9	NOTE 2	UL2/DL1 direct-hit
n2	n77	5	15	12	100	13.8	NOTE 2	UL2/DL1 direct-hit
n2	n78	5	15	12	10	23.9	NOTE 2	UL2/DL1 direct-hit
n2	n78	5	15	12	100	13.8	NOTE 2	UL2/DL1 direct-hit
n3	n77	5	15	12	10	23.9	NOTE 2	UL2/DL1 direct-hit
n3	n77	5	15	12	100	13.8	NOTE 2	UL2/DL1 direct-hit
n3	n78	5	15	12	10	23.9	NOTE 2	UL2/DL1 direct-hit
n3	n78	5	15	12	100	13.8	NOTE 2	UL2/DL1 direct-hit
n5	n41 <sup>1</sup>	5	15	8	10	10.3	NOTE 3	UL3/DL1 direct-hit
n5	n77 <sup>8</sup>	5	15	6	10	10.5	NOTE 4	UL4/DL1 direct-hit
n5	n77 <sup>8</sup>	5	15	6	100	2.9	NOTE 4	UL4/DL1 direct-hit
n5	n77 <sup>8</sup>	5	15	6	10	10.4	NOTE 5	UL5/DL1 direct-hit
n5	n77 <sup>8</sup>	5	15	6	100	2.9	NOTE 5	UL5/DL1 direct-hit
n5	n78	5	15	6	10	10.5	NOTE 4	UL4/DL1 direct-hit
n5	n78	5	15	6	100	2.9	NOTE 4	UL4/DL1 direct-hit
n7	n79	5	15	25	10	9.3	NOTE 6	UL2/DL1 near-miss
n8	n3 <sup>13</sup>	N/A	N/A	N/A	N/A	N/A	NOTE 2	UL2/DL1 direct-hit
n8	n7	5	15	8	5	10	NOTE 3	UL3/DL1 direct-hit
n8	n7	5	15	8	50	1.1	NOTE 3	UL3/DL1 direct-hit
n8	n41	5	15	8	10	13	NOTE 3	UL3/DL1 direct-hit
n8	n41	5	15	8	100	4.5	NOTE 3	UL3/DL1 direct-hit
n8	n77	5	15	6	10	10.8	NOTE 4	UL4/DL1 direct-hit
n8	n77	5	15	6	100	3.1	NOTE 4	UL4/DL1 direct-hit
n8	n78	5	15	6	10	10.8	NOTE 4	UL4/DL1 direct-hit
n8	n78	5	15	6	100	3.1	NOTE 4	UL4/DL1 direct-hit
n8	n79	5	15	5	10	12.0	NOTE 5	UL5/DL1 direct-hit
n8	n79	5	15	5	100	3.8	NOTE 5	UL5/DL1 direct-hit
n12	n48	5	15	5	5	13	NOTE 5	UL5/DL1 direct-hit
n12	n48	5	15	5	40	3.3	NOTE 5	UL5/DL1 direct-hit
n12	n66	5	15	8	5	10	NOTE 3	UL3/DL1 direct-hit
n12	n66	5	15	8	40	3.1	NOTE 3	UL3/DL1 direct-hit
n12	n77	5	15	5	10	10.4	NOTE 5	UL5/DL1 direct-hit

n12	n77	5	15	5	100	2.9	NOTE 5	UL5/DL1 direct-hit
n12	n78 <sup>1</sup>	5	15	5	10	10.4	NOTE 5	UL5/DL1 direct-hit
n13	n77	5	15	5	10	10.4	NOTE 5	UL5/DL1 direct-hit
n13	n77	5	15	5	100	2.9	NOTE 5	UL5/DL1 direct-hit
n14	n77	5	15	5	10	10.4	NOTE 5	UL5/DL1 direct-hit
n14	n77	5	15	5	100	2.9	NOTE 5	UL5/DL1 direct-hit
n18	n77	5	15	5	10	10.4	NOTE 5	UL5/DL1 direct-hit
n18	n77	5	15	5	100	2.9	NOTE 5	UL5/DL1 direct-hit
n18	n78	5	15	5	10	10.4	NOTE 5	UL5/DL1 direct-hit
n20	n78	5	15	6	10	10.8	NOTE 4	UL4/DL1 direct-hit
n20	n78	5	15	6	100	3.1	NOTE 4	UL4/DL1 direct-hit
n24	n77 <sup>8</sup>	5	15	12	10	N/A	NOTE 2	UL2/DL1 direct-hit
n25	n48	5	15	25	5	8.1	NOTE 6	UL2/DL1 near-miss
n25	n77	5	15	12	10	23.9	NOTE 2	UL2/DL1 direct-hit
n25	n77	5	15	12	100	13.8	NOTE 2	UL2/DL1 direct-hit
n25	n78	5	15	12	10	23.9	NOTE 2	UL2/DL1 direct-hit
n25	n78	5	15	12	100	13.8	NOTE 2	UL2/DL1 direct-hit
n26	n77 <sup>8</sup>	5	15	6	10	N/A	NOTE 4	UL4/DL1 direct-hit
n26	n77 <sup>8</sup>	5	15	5	10	N/A	NOTE 5	UL5/DL1 direct-hit
n26	n78	5	15	6	10	10.8	NOTE 4	UL4/DL1 direct-hit
n26	n78	5	15	6	100	3	NOTE 4	UL4/DL1 direct-hit
n28	n1	5	15	8	5	10.2	NOTE 3	UL3/DL1 direct-hit
n28	n1	5	15	8	50	2.6	NOTE 3	UL3/DL1 direct-hit
n28	n50	5	15	12	5	28.1	NOTE 2	UL2/DL1 direct-hit
n28	n50	5	15	12	80	15.8	NOTE 2	UL2/DL1 direct-hit
n28	n74	5	15	12	5	28.1	NOTE 2	UL2/DL1 direct-hit
n28	n74	5	15	12	20	18	NOTE 2	UL2/DL1 direct-hit
n28	n75	5	15	12	5	28.1	NOTE 2	UL2/DL1 direct-hit
n28	n75	5	15	12	50	17.9	NOTE 2	UL2/DL1 direct-hit
n28	n77	5	15	5	10	10.4	NOTE 5	UL5/DL1 direct-hit
n28	n77	5	15	5	100	2.9	NOTE 5	UL5/DL1 direct-hit
n28	n78	5	15	5	10	10.4	NOTE 5	UL5/DL1 direct-hit
n28	n78	5	15	5	100	2.9	NOTE 5	UL5/DL1 direct-hit

n28	n94	5	15	12	5	28.1	NOTE 2	UL2/DL1 direct-hit
n28	n94	5	15	12	20	21.9	NOTE 2	UL2/DL1 direct-hit
n66	n48	5	15	12	5	27.1	NOTE 2	UL2/DL1 direct-hit
n66	n48	5	15	12	100 <sup>7</sup>	13.8	NOTE 2	UL2/DL1 direct-hit
n66	n77	5	15	12	10	23.9	NOTE 2	UL2/DL1 direct-hit
n66	n77	5	15	12	100	13.8	NOTE 2	UL2/DL1 direct-hit
n66	n78	5	15	12	10	23.9	NOTE 2	UL2/DL1 direct-hit
n66	n78	5	15	12	100	13.8	NOTE 2	UL2/DL1 direct-hit
n70	n77	5	15	12	10	23.9	NOTE 2	UL2/DL1 direct-hit
n70	n77	5	15	12	100	13.8	NOTE 2	UL2/DL1 direct-hit
n70	n78	5	15	12	10	23.9	NOTE 2	UL2/DL1 direct-hit
n70	n78	5	15	12	100	13.8	NOTE 2	UL2/DL1 direct-hit
n71	n2 <sup>10</sup>	5	15	8	5	1.7	NOTE 6	UL3/DL1 near-miss
n71	n7 <sup>1</sup>	5	15	6	5	14.6	NOTE 4	UL4/DL1 direct-hit
n71	n25 <sup>11</sup>	5	15	8	5	6.9	NOTE 3	UL3/DL1 direct-hit
n71	n41	5	15	6	10	10.8	NOTE 4	UL4/DL1 direct-hit
n71	n41	5	15	6	100	3.1	NOTE 4	UL4/DL1 direct-hit
n71	n70	5	15	8	5	9.9	NOTE 3	UL3/DL1 direct-hit
n71	n70	5	15	8	25	4.1	NOTE 3	UL3/DL1 direct-hit
n71	n77	5	15	5	10	10.4	NOTE 5	UL5/DL1 direct-hit
n71	n78	5	15	5	10	10.4	NOTE 5	UL5/DL1 direct-hit
n78	n104	10	15	12	20	37.5	NOTE 2	UL2/DL1 direct-hit
n85	n66	5	15	8	5	10	NOTE 3	UL3/DL1 direct-hit
n85	n66	5	15	8	40	3.1	NOTE 3	UL3/DL1 direct-hit
n85	n77	5	15	5	10	10.4	NOTE 5	UL5/DL1 direct-hit
n85	n77	5	15	5	100	2.9	NOTE 5	UL5/DL1 direct-hit
n92	n78	5	15	6	10	10.8	NOTE 4	UL4/DL1 direct-hit
n92	n78	5	15	6	100	3.1	NOTE 4	UL4/DL1 direct-hit
n94	n78	5	15	6	10	10.8	NOTE 4	UL4/DL1 direct-hit
n94	n78	5	15	6	100	3.1	NOTE 4	UL4/DL1 direct-hit
n105	n7	5	15	8	5	18	NOTE 3	UL3/DL1 direct-hit
n105	n78	5	15	5	10	11.8	NOTE 5	UL5/DL1 direct-hit

NOTE 1: The direct-hit requirements apply when there is at least one individual RE within the uplink transmission bandwidth of the aggressor (lower) band for which the 2<sup>nd</sup> / 3<sup>rd</sup> / 4<sup>th</sup> / 5<sup>th</sup> transmitter harmonic is within the downlink transmission bandwidth of a victim (higher) band. The requirements should be verified using RBstart =

floor((N<sub>RB</sub>-L<sub>CRB</sub>)/2), where floor(x) is the greatest integer less than or equal to x, and where the UL parameters N<sub>RB</sub> and L<sub>CRB</sub> are respectively, the transmission bandwidth configuration and the number of RB's for the specified UL band channel bandwidth and the UL band subcarrier spacing.

NOTE 2: The requirements should be verified for UL NR ARFCN of the aggressor (lower) band (superscript LB) such that  $f_{UL}^{LB} = \lfloor f_{DL}^{HB} / 0.2 \rfloor \cdot 0.1$  in MHz and  $F_{UL\_low}^{LB} + BW_{Channel}^{LB} / 2 \leq f_{UL}^{LB} \leq F_{UL\_high}^{LB} - BW_{Channel}^{LB} / 2$  with carrier frequency in the victim (higher) band in MHz and the channel bandwidth configured in the lower band. This DL band may be affected by near-miss interference for which the MSD is not specified.

NOTE 3: The requirements should be verified for UL NR ARFCN of the aggressor (lower) band (superscript LB) such that  $f_{UL}^{LB} = \lfloor f_{DL}^{HB} / 0.3 \rfloor \cdot 0.1$  in MHz and  $F_{UL\_low}^{LB} + BW_{Channel}^{LB} / 2 \leq f_{UL}^{LB} \leq F_{UL\_high}^{LB} - BW_{Channel}^{LB} / 2$  with the carrier frequency in the victim (higher) band in MHz and the channel bandwidth configured in the low band.

NOTE 4: The requirements should be verified for UL NR-ARFCN of the aggressor (lower) band (superscript LB) such that  $f_{UL}^{LB} = \lfloor f_{DL}^{HB} / 0.4 \rfloor \cdot 0.1$  in MHz and  $F_{UL\_low}^{LB} + BW_{Channel}^{LB} / 2 \leq f_{UL}^{LB} \leq F_{UL\_high}^{LB} - BW_{Channel}^{LB} / 2$  with  $f_{DL}^{HB}$  carrier frequency in the victim (higher) band in MHz and  $BW_{Channel}^{LB}$  the channel bandwidth configured in the lower band.

NOTE 5: The requirements should be verified for UL NR-ARFCN of the aggressor (lower) band (superscript LB) such that  $f_{UL}^{LB} = \lfloor f_{DL}^{HB} / 0.5 \rfloor \cdot 0.1$  in MHz and  $F_{UL\_low}^{LB} + BW_{Channel}^{LB} / 2 \leq f_{UL}^{LB} \leq F_{UL\_high}^{LB} - BW_{Channel}^{LB} / 2$  with  $f_{DL}^{HB}$  carrier frequency in the victim (higher) band in MHz and  $BW_{Channel}^{LB}$  the channel bandwidth configured in the lower band.

NOTE 6: The near-miss requirements are only applicable when direct-hit requirements do not apply. These requirements should be verified for downlink channel bandwidths no larger than 10 MHz and with a carrier frequency at  $\pm(10 + BW_{Channel}^{HB}/2)$  MHz offset from  $2 f_{UL}^{LB}$  in the victim (higher band) with  $F_{UL\_low}^{LB} + BW_{Channel}^{LB} / 2 \leq f_{UL}^{LB} \leq F_{UL\_high}^{LB} - BW_{Channel}^{LB} / 2$ , where  $BW_{Channel}^{LB}$  and  $BW_{Channel}^{HB}$  are the channel bandwidths configured in the aggressor (lower) and victim (higher) bands in MHz, respectively.

NOTE 7: For these bandwidths, the minimum requirements are restricted to operation when carrier is configured as a downlink carrier part of CA configuration.

NOTE 8: For a UE which supports this band combination only when the Band n77 frequency range restriction defined in NOTE 12 of Table 5.2-1 applies, the MSD test point(s) cannot be verified for the band combination and the test point(s) can be skipped.

NOTE 9: Void.

NOTE 10: These requirements apply when the upper edge frequency of the 5 MHz uplink channel in Band n71 is located at 668 MHz and the downlink channel in Band n2 is located with its upper edge at 1990 MHz.

NOTE 11: These requirements apply when the upper edge frequency of the 5 MHz uplink channel in Band n71 is located at 668 MHz and the downlink channel in Band n25 is located with its upper edge at 1995 MHz.

NOTE 12: Void.

NOTE 13: No requirements apply when there is at least one individual RE within the uplink transmission bandwidth of the low band for which the 2nd transmitter harmonic is within the downlink transmission bandwidth of the high band. The reference sensitivity for all active downlink component carriers is only verified when this is not the case (the requirements specified in clause 7.3.2 apply unless otherwise specified).

The reference sensitivity for the shared access band does not apply when there is at least one individual RE within the shared access downlink transmission bandwidth which falls into the reference sensitivity exclusion region as specified in Table 7.3A.4-1a.

**Table 7.3A.4-1a: NR-U reference sensitivity measurement exclusion region in MHz.**

NR Band / Harmonic order / Channel BW in UL											
UL Band	Harmonic order	DL Band	5MHz	10MHz	15MHz	20 MHz	25 MHz	30 MHz	40MHz	45MHz	50 MHz
n1	3	n46	+/- 15	+/- 23	+/- 35	+/- 45	+/- 60	+/- 70	+/- 90	+/- 100	+/- 115
n1	3	n102	+/- 10	+/- 20	+/- 30	+/- 40	+/- 50	+/- 60	+/- 80		+/- 100
n7	2	n46	+/- 10	+/- 20	+/- 30	+/- 40	+/- 50	+/- 60	+/- 80		+/- 100
n25	3	n46	+/- 15	+/- 23	+/- 35	+/- 45	+/- 60	+/- 70	+/- 90		
n48	2	n96	+/- 10	+/- 20	+/- 30	+/- 40		+/- 60	+/- 80		
n66	3	n46	+/- 15	+/- 23	+/- 35	+/- 45	+/- 60	+/- 70	+/- 90		

NOTE 1: Even though UL harmonic does not fall directly into NR-U band the exclusion region still applies.

NOTE 2: The center of the exclusion region is obtained by multiplying the UL channel center frequency by the harmonic order.



Table 7.3A.4-2: Void

For a PC2 aggressor NR UL band for NR DL CA FR1, the maximum amount of REFSENS degradation is specified in Table 7.3A.4-2a.

Table 7.3A.4-2a: Reference sensitivity exceptions and uplink/downlink configurations due to UL harmonic from a PC2 aggressor NR UL band for NR DL CA FR1

UL band	DL band	UL BW	SCS of UL band	UL RB Allocation	DL BW	MSD	MSD	UL/DL fc condition	UL/DL harmonic order
		(MHz)	(kHz)	LCRB	(MHz)	(dB)	(dB)		
n3	n78	5	15	12	10	27.1	32.3	NOTE 2	UL2/DL1 direct-hit
n3	n78	10	15	12	100	16.6	20.8	NOTE 2	UL2/DL1 direct-hit
n8	n41	5	15	8	10	15.9	20	NOTE 2	UL3/DL1 direct-hit
n8	n41	5	15	8	100	6.5	9.5	NOTE 2	UL3/DL1 direct-hit
n8	n79	5	15	5	10	14.9	19	NOTE 2	UL5/DL1 direct-hit
n8	n79	5	15	5	100	6.2	8.4	NOTE 2	UL5/DL1 direct-hit
n25	n77	5	15	12	10	26.9	31.9	NOTE 2	UL2/DL1 direct-hit
n25	n77	10	15	12	100	16.8	20.8	NOTE 2	UL2/DL1 direct-hit
n66	n77	5	15	12	10	26.9	31.9	NOTE 2	UL2/DL1 direct-hit
n66	n77	20	15	12	100	16.7	20.8	NOTE 2	UL2/DL1 direct-hit
n71	n25 <sup>10,11</sup>	5	15	8	5	9.4	12.9	NOTE 3	UL3/DL1 direct-hit
n71	n25 <sup>10,11</sup>	5	15	8	40	0.7	1.1	NOTE 3	UL3/DL1 direct-hit
n71	n41	5	15	6	10	13.6	17.8	NOTE 4	UL4/DL1 direct-hit
n71	n41	5	15	6	100	5.1	6.1	NOTE 4	UL4/DL1 direct-hit
n71	n77	5	15	5	10	13.2	17.4	NOTE 5	UL5/DL1 direct-hit

NOTE 1: Void

NOTE 2: The requirements should be verified for UL NR-ARFCN of the aggressor (lower) band (superscript LB) such that  $f_{UL}^{LB} = \lfloor f_{DL}^{HB} / 0.2 \rfloor \cdot 0.1$  in MHz and  $F_{UL\_low}^{LB} + BW_{Channel}^{LB} / 2 \leq f_{UL}^{LB} \leq F_{UL\_high}^{LB} - BW_{Channel}^{LB} / 2$  with carrier frequency in the victim (higher) band in MHz and the channel bandwidth configured in the lower band.

NOTE 3: The requirements should be verified for UL NR ARFCN of the aggressor (lower) band (superscript LB) such that  $f_{UL}^{LB} = \lfloor f_{DL}^{HB} / 0.3 \rfloor \cdot 0.1$  in MHz and  $F_{UL\_low}^{LB} + BW_{Channel}^{LB} / 2 \leq f_{UL}^{LB} \leq F_{UL\_high}^{LB} - BW_{Channel}^{LB} / 2$  with the carrier frequency in the victim (higher) band in MHz and the channel bandwidth configured in the low band.

NOTE 4: The requirements should be verified for UL NR-ARFCN of the aggressor (lower) band (superscript LB) such that  $f_{UL}^{LB} = \lfloor f_{DL}^{HB} / 0.4 \rfloor \cdot 0.1$  in MHz and  $F_{UL\_low}^{LB} + BW_{Channel}^{LB} / 2 \leq f_{UL}^{LB} \leq F_{UL\_high}^{LB} - BW_{Channel}^{LB} / 2$  with  $f_{DL}^{HB}$  carrier frequency in the victim (higher) band in MHz and  $BW_{Channel}^{LB}$  the channel bandwidth configured in the lower band.

NOTE 5: The requirements should be verified for UL NR-ARFCN of the aggressor (lower) band (superscript LB) such that  $f_{UL}^{LB} = \lfloor f_{DL}^{HB} / 0.5 \rfloor \cdot 0.1$  in MHz and  $F_{UL\_low}^{LB} + BW_{Channel}^{LB} / 2 \leq f_{UL}^{LB} \leq F_{UL\_high}^{LB} - BW_{Channel}^{LB} / 2$  with  $f_{DL}^{HB}$  carrier frequency in the victim (higher) band in MHz and  $BW_{Channel}^{LB}$  the channel bandwidth configured in the lower band.

NOTE 6: The near-miss requirements are only applicable when direct-hit requirements do not apply. These requirements should be verified for downlink channel bandwidths no larger than 10 MHz and with a carrier frequency at  $\pm(10 + BW_{Channel}^{HB}/2)$  MHz offset from  $f_{UL}^{LB}$  in the victim (higher band) with

$$F_{UL\_low}^{LB} + BW_{Channel}^{LB} / 2 \leq f_{UL}^{LB} \leq F_{UL\_high}^{LB} - BW_{Channel}^{LB} / 2$$
, where  $BW_{Channel}^{LB}$  and  $BW_{Channel}^{HB}$  are the channel bandwidths configured in the aggressor (lower) and victim (higher) bands in MHz, respectively.

NOTE 7: Applicable to UEs supporting PC2 with single Tx.

NOTE 8: Applicable to UEs supporting PC2 with dual Tx.

NOTE 9: These requirements apply when the upper edge frequency of the 5 MHz uplink channel in Band n71 is located at 668 MHz and the downlink channel in Band n25 is located with its upper edge at 1995 MHz.

NOTE 10: The direct-hit requirements apply when there is at least one individual RE within the uplink transmission bandwidth of the aggressor (lower) band for which the 2<sup>nd</sup> / 3<sup>rd</sup> / 4<sup>th</sup> / 5<sup>th</sup> transmitter harmonic is within the downlink transmission bandwidth of a victim (higher) band. The requirements should be verified using  $RB_{start} = \text{floor}((N_{RB} - L_{CRB})/2)$ , where floor(x) is the greatest integer less than or equal to x, and where the UL parameters  $N_{RB}$  and  $L_{CRB}$  are respectively, the transmission bandwidth configuration and the number of RB's for the specified UL band channel bandwidth and the UL band subcarrier spacing.

NOTE 11: Void.

**Table 7.3A.4-2b: Void**

**Table 7.3A.4-3: Void**

**Table 7.3A.4-3a: Void**

Sensitivity degradation is allowed for different combinations of UL configurations and DL channel bandwidths if a band is impacted by receiver harmonic mixing due to another band part which belongs to PC3 NR band or PC2 NR band of the same CA configuration. Reference sensitivity exceptions and uplink/downlink configurations due to harmonic mixing from a PC3 aggressor NR UL band for either PC3 or PC2 CA are specified in Table 7.3A.4-4 and from a PC2 aggressor NR UL band for PC2 CA are specified in Table 7.3A.4-4a. For these exceptions, only the listed test points in Table 7.3A.4-4, Table 7.3A.4-4a and Table 7.3A.4-4b are needed to be tested. Sensitivity degradation is not required for receiver even order harmonic mixing with aggressor 3rd order and above harmonic interference.

**Table 7.3A.4-4: Reference sensitivity exceptions and uplink/downlink configurations due to harmonic mixing from a PC3 aggressor NR UL band for DL NR CA FR1**

UL band	DL band	UL BW	SCS of UL band	UL RB Allocation	DL BW	MSD	UL/DL fc condition	UL/DL harmonic order
		(MHz)	(kHz)	L <sub>CRB</sub>	(MHz)	(dB)		
n1	n105 <sup>3</sup>	5	15	25	5	26.8	NOTE 4	UL1/DL3
n2	n71 <sup>3</sup>	5	15	25	5	26.8	NOTE 4	UL1/DL3
n2	n71 <sup>3</sup>	5	15	25	20	15.6	NOTE 4	UL1/DL3
n3	n5	5	15	25	5	4	NOTE 7	UL1/DL2
n3	n26	5	15	25	5	3.7	NOTE 7	UL1/DL2
n7	n26 <sup>3</sup>	5	15	25	5	2.0	NOTE 10	UL1/DL3 Near miss
n7	n71	5	15	25	5	5.7	NOTE 8	UL1/DL4
n25	n41	5	15	25	10	1.3	NOTE 11	UL4/DL3
n25	n71 <sup>3</sup>	5	15	25	5	26.8	NOTE 4	UL1/DL3
n25	n71 <sup>3</sup>	5	15	25	20	15.6	NOTE 4	UL1/DL3
n39	n41	5	15	6	10	9.3	NOTE 11	UL4/DL3
n39	n41	5	15	6	100	2.2	NOTE 11	UL4/DL3
n40	n20 <sup>3</sup>	10	15	25	5	27.8	NOTE 4	UL1/DL3
n40	n20 <sup>3</sup>	10	15	25	20	20.6	NOTE 4	UL1/DL3
n40	n28 <sup>3</sup>	10	15	25	5	37.8	NOTE 4	UL1/DL3
n40	n28 <sup>3</sup>	10	15	25	20	30.1	NOTE 4	UL1/DL3
n41	n5 <sup>3</sup>	10	15	25	5	24.3	NOTE 4	UL1/DL3

n41	n18 <sup>3</sup>	10	15	25	5	26.3	NOTE 4	UL1/DL3
n41	n18 <sup>3</sup>	10	15	25	15	21.3	NOTE 4	UL1/DL3
n41	n39	10	15	8	5	4.3	NOTE 12	UL3/DL4
n41	n39	10	15	8	40	0.8	NOTE 12	UL3/DL4
n41	n48	10	15	6	5	12.3	NOTE 9	UL4/DL3
n41	n48	10	15	6	100	2.3	NOTE 9	UL4/DL3
n41	n77	10	15	6	10	8.9	NOTE 9	UL4/DL3
n41	n77	10	15	6	100	2.1	NOTE 9	UL4/DL3
n41	n78	10	15	6	10	9.3	NOTE 9	UL4/DL3
n41	n78	10	15	6	100	2.3	NOTE 9	UL4/DL3
n46	n7	20	15	25	5	10.9	NOTE 7	UL1/DL2
n46	n7	20	15	25	50	1	NOTE 7	UL1/DL2
n46	n48	20	15	12	5	26.8	NOTE 2	UL2/DL3
n46	n48	20	15	12	100	13.5	NOTE 2	UL2/DL3
n46	n77	20	15	25	10	20.6	NOTE 2	UL2/DL3
n46	n77	20	15	25	100	10.6	NOTE 2	UL2/DL3
n46	n78	20	15	25	10	21.1	NOTE 2	UL2/DL3
n46	n78	20	15	25	100	11.1	NOTE 2	UL2/DL3
n48	n12	10	15	25	5	31	NOTE 5	UL1/DL5
n48	n12	10	15	25	15	18	NOTE 5	UL1/DL5
n48	n26	10	15	25	5	5.4	NOTE 8	UL1/DL4
n48	n26	10	15	25	20	1	NOTE 8	UL1/DL4
n48	n29	10	15	25	5	31	NOTE 5	UL1/DL5
n48	n29	10	15	25	10	27.8	NOTE 5	UL1/DL5
n77	n2	10	15	25	5	6.7	NOTE 7	UL1/DL2
n77	n2	10	15	25	20	2.8	NOTE 7	UL1/DL2
n77	n3	10	15	25	5	5.7	NOTE 7	UL1/DL2
n77	n3	10	15	25	20	2.2	NOTE 7	UL1/DL2
n77	n5	10	15	25	5	[5.7]	NOTE 8	UL1/DL4
n77	n5	10	15	25	20	[0.8]	NOTE 8	UL1/DL4
n77	n7	10	15	12	5	14.7	NOTE 2	UL2/DL3
n77	n7	10	15	12	50	2.2	NOTE 2	UL2/DL3
n77	n8	10	15	25	5	[5.7]	NOTE 8	UL1/DL4
n77	n8	10	15	25	20	[0.8]	NOTE 8	UL1/DL4
n77	n12	10	15	25	5	31	NOTE 5	UL1/DL5
n77	n12	10	15	25	15	18	NOTE 5	UL1/DL5
n77	n13	10	15	25	5	31	NOTE 5	UL1/DL5
n77	n13	10	15	25	10	27.8	NOTE 5	UL1/DL5
n77	n14	10	15	25	5	31	NOTE 5	UL1/DL5
n77	n14	10	15	25	10	27.8	NOTE 5	UL1/DL5
n77	n25	10	15	25	5	5.6	NOTE 7	UL1/DL2
n77	n25	10	15	25	40	0.3	NOTE 7	UL1/DL2
n77	n26	10	15	25	5	5.4	NOTE 8	UL1/DL4
n77	n28	10	15	25	5	31	NOTE 5	UL1/DL5
n77	n28	10	15	25	10	28	NOTE 5	UL1/DL5
n77 <sup>6</sup>	n29	10	15	25	5	31	NOTE 5	UL1/DL5

n77 <sup>6</sup>	n29	10	15	25	10	27.8	NOTE 5	UL1/DL5
n77	n30	10	15	12	5	10.4	NOTE 2	UL2/DL3
n77	n30	10	15	12	10	7.6	NOTE 2	UL2/DL3
n77	n40	10	15	12	10	11.7	NOTE 2	UL2/DL3
n77	n40	10	15	12	100	3.6	NOTE 2	UL2/DL3
n77	n41	10	15	12	10	11.7	NOTE 2	UL2/DL3
n77	n41	10	15	12	100	3.6	NOTE 2	UL2/DL3
n77 <sup>6</sup>	n70	N/A	N/A	N/A	N/A	N/A	NOTE 7	UL1/DL2
n77	n85	10	15	25	5	31	NOTE 5	UL1/DL5
n77	n85	10	15	25	15	18	NOTE 5	UL1/DL5
n78	n2	10	15	25	5	6.7	NOTE 7	UL1/DL2
n78	n2	10	15	25	20	2.8	NOTE 7	UL1/DL2
n78	n3	10	15	25	5	5.7	NOTE 7	UL1/DL2
n78	n3	10	15	25	20	2.2	NOTE 7	UL1/DL2
n78	n5	10	15	25	5	[5.7]	NOTE 8	UL1/DL4
n78	n8	10	15	25	5	[5.7]	NOTE 8	UL1/DL4
n78	n12	10	15	25	5	31	NOTE 5	UL1/DL5
n78	n26	10	15	25	5	5.4	NOTE 8	UL1/DL4
n78	n28	10	15	25	5	31	NOTE 5	UL1/DL5
n78	n40	10	15	12	5	14.7	NOTE 2	UL2/DL3
n78	n40	10	15	12	100	3.6	NOTE 2	UL2/DL3
n78	n41	10	15	12	10	11.7	NOTE 2	UL2/DL3
n78	n41	10	15	12	100	3.6	NOTE 2	UL2/DL3
n78	n67	10	15	25	5	31	NOTE 5	UL1/DL5
n78	n67	10	15	25	10	27.8	NOTE 5	UL1/DL5
n79	n5	10	15	25	5	27.5	NOTE 5	UL1/DL5
n79	n8	10	15	25	5	25	NOTE 5	UL1/DL5
n96	n48	20	15	25	5	[31]	NOTE 7	UL1/DL2
n96	n48	20	15	25	100	[17.5]	NOTE 7	UL1/DL2
n102	n1 <sup>3</sup>	20	15	25	5	30	NOTE 4	UL1/DL3
n104	n78	20	15	50	10	29	NOTE 1	UL1/DL2
n104	n78	20	15	50	100	18.8	NOTE 1	UL1/DL2

NOTE 1: Void.

NOTE 2: The requirements should be verified for DL NR-ARFCN of the Victim (lower) band (superscript LB) such that  $f_{DL}^{LB} = \lfloor f_{UL}^{HB} / 0.15 \rfloor 0.1$  and  $F_{UL,low}^{HB} + BW_{Channel}^{HB} / 2 \leq f_{UL}^{HB} \leq F_{UL,high}^{HB} - BW_{Channel}^{HB} / 2$  with  $f_{UL}^{HB}$  the UL carrier frequency and  $BW_{Channel}^{HB}$  the channel bandwidth configured in the higher band, both in MHz.

NOTE 3: These requirements apply when there is at least one individual RE within the downlink transmission bandwidth of the victim (lower) band for which the 3<sup>rd</sup> harmonic is within the uplink transmission bandwidth or the uplink adjacent channel's transmission bandwidth of an aggressor (higher) band.

NOTE 4: The requirements should be verified for UL NR-ARFCN of the aggressor (higher) band (superscript HB) such that  $f_{DL}^{LB} = \lfloor f_{UL}^{HB} / 0.3 \rfloor 0.1$  in MHz and  $F_{UL,low}^{HB} + BW_{Channel}^{HB} / 2 \leq f_{UL}^{HB} \leq F_{UL,high}^{HB} - BW_{Channel}^{HB} / 2$  with  $f_{DL}^{LB}$  the carrier frequency in the victim (lower) band and  $BW_{Channel}^{HB}$  the channel bandwidth configured in the higher band.

NOTE 5: The requirements should be verified for DL EARFCN of the victim (lower) band (superscript LB) such that  $f_{DL}^{LB} = \lfloor f_{UL}^{HB} / 0.5 \rfloor 0.1$  and  $F_{UL,low}^{HB} + BW_{Channel}^{HB} / 2 \leq f_{UL}^{HB} \leq F_{UL,high}^{HB} - BW_{Channel}^{HB} / 2$  with  $f_{UL}^{HB}$  the UL carrier frequency and  $BW_{Channel}^{HB}$  the channel bandwidth configured in the higher band, both in MHz.

- NOTE 6: For a UE which supports this band combination only when the Band n77 frequency range restriction defined in NOTE 12 of Table 5.2-1 applies, the MSD test point(s) cannot be verified for the band combination and the test point(s) can be skipped.
- NOTE 7: The requirements should be verified for UL NR-ARFCN of the aggressor (higher) band (superscript HB) such that  $f_{DL}^{LB} = \lfloor f_{UL}^{HB} / 0.2 \rfloor \cdot 0.1$  in MHz and  $F_{UL\_low}^{HB} + BW_{Channel}^{HB} / 2 \leq f_{UL}^{HB} \leq F_{UL\_high}^{HB} - BW_{Channel}^{HB} / 2$  with  $f_{DL}^{LB}$  the carrier frequency in the victim (lower) band and  $BW_{Channel}^{HB}$  the channel bandwidth configured in the higher band.
- NOTE 8: The requirements should be verified for UL NR-ARFCN of the aggressor (higher) band (superscript HB) such that  $f_{DL}^{LB} = \lfloor f_{UL}^{HB} / 0.4 \rfloor \cdot 0.1$  in MHz and  $F_{UL\_low}^{HB} + BW_{Channel}^{HB} / 2 \leq f_{UL}^{HB} \leq F_{UL\_high}^{HB} - BW_{Channel}^{HB} / 2$  with  $f_{DL}^{LB}$  the carrier frequency in the victim (lower) band and  $BW_{Channel}^{HB}$  the channel bandwidth configured in the higher band.
- NOTE 9: The requirements should be verified for DL NR-ARFCN of the victim (higher) band (superscript HB) such that  $f_{DL}^{HB} = \lfloor f_{UL}^{LB} / 0.75 \rfloor$  and  $F_{UL\_low}^{LB} + BW_{Channel}^{LB} / 2 \leq f_{UL}^{LB} \leq F_{UL\_high}^{LB} - BW_{Channel}^{LB} / 2$  with  $f_{UL}^{LB}$  the UL carrier frequency and  $BW_{Channel}^{LB}$  the channel bandwidth configured in the lower band, both in MHz.
- NOTE 10: The requirements should be verified for the lowest NR ARFCN of the affected DL (lower) band and for the highest NR ARFCN of the UL (higher) band
- NOTE 11: The requirements should be verified for UL NR-ARFCN of the aggressor (lower) band (superscript LB) such that  $f_{UL}^{LB} = \lfloor 7.5 * f_{DL}^{HB} \rfloor \cdot 0.1$  in MHz and  $F_{UL\_low}^{LB} + BW_{Channel}^{LB} / 2 \leq f_{UL}^{LB} \leq F_{UL\_high}^{LB} - BW_{Channel}^{LB} / 2$  with  $f_{DL}^{HB}$  carrier frequency in the victim (higher) band in MHz and  $BW_{Channel}^{LB}$  the channel bandwidth configured in the lower band.
- NOTE 12: The requirements should be verified for UL NR-ARFCN of the aggressor (lower) band (superscript LB) such that  $f_{UL}^{LB} = \lfloor f_{DL}^{HB} / 0.075 \rfloor \cdot 0.1$  in MHz and  $F_{UL\_low}^{LB} + BW_{Channel}^{LB} / 2 \leq f_{UL}^{LB} \leq F_{UL\_high}^{LB} - BW_{Channel}^{LB} / 2$  with  $f_{DL}^{HB}$  carrier frequency in the victim (higher) band in MHz and  $BW_{Channel}^{LB}$  the channel bandwidth configured in the lower band.
- NOTE 13: The requirements should be verified using  $RB_{start} = \text{floor}((NRB - LCRB) / 2)$ , where  $\text{floor}(x)$  is the greatest integer less than or equal to  $x$ , and where the UL parameters NRB and LCRB are respectively, the transmission bandwidth configuration and the number of RB's for the specified UL band channel bandwidth and the UL band subcarrier spacing.

**Table 7.3A.4-4a-1: Reference sensitivity exceptions and uplink/downlink configurations due to harmonic mixing from a PC2 aggressor NR UL band for NR DL CA FR1 for UE not supporting Tx Diversity**

UL band	DL band	UL BW	SCS of UL band	UL RB Allocation	DL BW	MSD	UL/DL fc condition	UL/DL harmonic order
		(MHz)	(kHz)	LCRB		(MHz)		
n25	n41	5	15	25	10	2.2	NOTE 11	UL4/DL3
n25	n71 <sup>3</sup>	5	15	25	5	29.5	NOTE 4	UL1/DL3
n25	n71 <sup>3</sup>	20	15	25	20	18.2	NOTE 4	UL1/DL3
n39	n41	5	15	6	5	10.6	NOTE 8	UL4/DL3
n39	n41	5	15	6	100	4.9	NOTE 8	UL4/DL3
n40	n28	5	15	6	5	40.8	NOTE 7	UL1/DL3
n40	n28	20	15	6	20	33.3	NOTE 7	UL1/DL3
n41	n18 <sup>6</sup>	10	15	25	5	29.3	NOTE 7	UL1/DL3
n41	n18 <sup>6</sup>	10	15	25	15	24.3	NOTE 7	UL1/DL3
n41	n39	10	15	8	5	6.1	NOTE 9	UL3/DL4
n41	n39	10	15	8	40	1.5	NOTE 9	UL3/DL4
n41	n77	10	15	6	10	11.6	NOTE 8	UL4/DL3
n41	n77	10	15	6	100	3.6	NOTE 8	UL4/DL3

n41	n78	10	15	6	10	12.1	NOTE 8	UL4/DL3
n41	n78	10	15	6	100	3.8	NOTE 8	UL4/DL3
n77	n2	10	15	25	5	9.2	NOTE 4	UL1/DL2
n77	n2	10	15	25	20	4.4	NOTE 4	UL1/DL2
n77	n3	10	15	25	5	8.1	NOTE 4	UL1/DL2
n77	n3	10	15	25	40	0.8	NOTE 4	UL1/DL2
n77	n5	10	15	25	5	8.1	NOTE 5	UL1/DL4
n77	n5	10	15	25	20	1.5	NOTE 5	UL1/DL4
n77	n7	10	15	12	5	17.7	NOTE 3	UL2/DL3
n77	n7	10	15	12	50	3.6	NOTE 3	UL2/DL3
n77	n8	10	15	25	5	8.1	NOTE 5	UL1/DL4
n77	n8	10	15	25	20	1.5	NOTE 5	UL1/DL4
n77	n12	10	15	25	5	34	NOTE 1	UL1/DL5
n77	n12	10	15	25	15	21	NOTE 1	UL1/DL5
n77	n13	10	15	25	5	34	NOTE 1	UL1/DL5
n77	n13	10	15	25	10	30.8	NOTE 1	UL1/DL5
n77	n14	10	15	25	5	34	NOTE 1	UL1/DL5
n77	n14	10	15	25	10	30.8	NOTE 1	UL1/DL5
n77	n25	10	15	25	5	7.9	NOTE 4	UL1/DL2
n77	n25	10	15	25	40	0.5	NOTE 4	UL1/DL2
n77	n28	10	15	25	5	34	NOTE 1	UL1/DL5
n77	n28	10	15	25	30	14.1	NOTE 1	UL1/DL5
n77 <sup>2</sup>	n29	10	15	25	5	34	NOTE 1	UL1/DL5
n77 <sup>2</sup>	n29	10	15	25	10	30.8	NOTE 1	UL1/DL5
n77	n30	10	15	12	5	13.2	NOTE 3	UL2/DL3
n77	n30	10	15	12	10	10.2	NOTE 3	UL2/DL3
n77	n40	10	15	12	10	14.5	NOTE 3	UL2/DL3
n77	n40	10	15	12	100	5.5	NOTE 3	UL2/DL3
n77	n41	10	15	12	10	14.5	NOTE 3	UL2/DL3
n77	n41	10	15	12	100	5.5	NOTE 3	UL2/DL3
n77 <sup>2</sup>	n70	N/A	N/A	N/A	N/A	N/A	NOTE 4	UL1/DL2
n77	n85	10	15	25	5	34	NOTE 1	UL1/DL5
n77	n85	10	15	25	15	21	NOTE 1	UL1/DL5
n78	n3	10	15	25	5	8.1	NOTE 4	UL1/DL2
n78	n3	10	15	25	40	0.8	NOTE 4	UL1/DL2
n78	n5	10	15	25	5	[8.1]	NOTE 5	UL1/DL4
n78	n5	10	15	25	20	[1.5]	NOTE 5	UL1/DL4
n78	n8	10	15	25	5	8.1	NOTE 5	UL1/DL4
n78	n8	10	15	25	20	1.5	NOTE 5	UL1/DL4
n78	n28	10	15	25	5	34	NOTE 1	UL1/DL5
n78	n28	10	15	25	30	11.3	NOTE 1	UL1/DL5
n78	n40	10	15	12	10	13.2	NOTE 3	UL2/DL3
n78	n40	10	15	12	100	4.4	NOTE 3	UL2/DL3
n79	n8	10	15	25	5	28.0	NOTE 1	UL1/DL5

NOTE 1: The requirements should be verified for DL NR-ARFCN of the victim (lower) band (superscript LB) such that  $f_{DL}^{LB} = \lfloor f_{UL}^{HB} / 0.5 \rfloor \cdot 0.1$  and  $F_{UL\_low}^{HB} + BW_{Channel}^{HB} / 2 \leq f_{UL}^{HB} \leq F_{UL\_high}^{HB} - BW_{Channel}^{HB} / 2$  with  $f_{UL}^{HB}$  the UL carrier frequency and  $BW_{Channel}^{HB}$  the channel bandwidth configured in the higher band, both in MHz.

NOTE 2: For a UE which supports this band combination only when the Band n77 frequency range restriction defined in NOTE 12 of Table 5.2-1 from TS 38.101-1 applies, the MSD test point(s) cannot be verified for the band combination and the test point(s) can be skipped.

NOTE 3: The requirements should be verified for DL NR-ARFCN of the Victim (lower) band (superscript LB) such that  $f_{DL}^{LB} = \lfloor f_{UL}^{HB} / 0.15 \rfloor \cdot 0.1$  and  $F_{UL\_low}^{HB} + BW_{Channel}^{HB} / 2 \leq f_{UL}^{HB} \leq F_{UL\_high}^{HB} - BW_{Channel}^{HB} / 2$  with  $f_{UL}^{HB}$  the UL carrier frequency and  $BW_{Channel}^{HB}$  the channel bandwidth configured in the higher band, both in MHz.

NOTE 4: The requirements should be verified for UL NR-ARFCN of the aggressor (higher) band (superscript HB) such that  $f_{DL}^{LB} = \lfloor f_{UL}^{HB} / 0.2 \rfloor \cdot 0.1$  in MHz and  $F_{UL\_low}^{HB} + BW_{Channel}^{HB} / 2 \leq f_{UL}^{HB} \leq F_{UL\_high}^{HB} - BW_{Channel}^{HB} / 2$  with  $f_{DL}^{LB}$  the carrier frequency in the victim (lower) band and  $BW_{Channel}^{HB}$  the channel bandwidth configured in the higher band.

NOTE 5: The requirements should be verified for UL NR-ARFCN of the aggressor (higher) band (superscript HB) such that  $f_{DL}^{LB} = \lfloor f_{UL}^{HB} / 0.4 \rfloor \cdot 0.1$  in MHz and  $F_{UL\_low}^{HB} + BW_{Channel}^{HB} / 2 \leq f_{UL}^{HB} \leq F_{UL\_high}^{HB} - BW_{Channel}^{HB} / 2$  with  $f_{DL}^{LB}$  the carrier frequency in the victim (lower) band and  $BW_{Channel}^{HB}$  the channel bandwidth configured in the higher band.

NOTE 6: These requirements apply when there is at least one individual RE within the downlink transmission bandwidth of the victim (lower) band for which the 3<sup>rd</sup> harmonic is within the uplink transmission bandwidth or the uplink adjacent channel's transmission bandwidth of an aggressor (higher) band.

NOTE 7: The requirements should be verified for UL NR-ARFCN of the aggressor (higher) band (superscript HB) such that  $f_{DL}^{LB} = \lfloor f_{UL}^{HB} / 0.3 \rfloor \cdot 0.1$  in MHz and  $F_{UL\_low}^{HB} + BW_{Channel}^{HB} / 2 \leq f_{UL}^{HB} \leq F_{UL\_high}^{HB} - BW_{Channel}^{HB} / 2$  with  $f_{DL}^{LB}$  the carrier frequency in the victim (lower) band and  $BW_{Channel}^{HB}$  the channel bandwidth configured in the higher band.

NOTE 8: The requirements should be verified for UL NR-ARFCN of the aggressor (lower) band (superscript LB) such that  $f_{DL}^{LB} = \lfloor 7.5 * f_{DL}^{HB} \rfloor \cdot 0.1$  in MHz and  $F_{UL\_low}^{LB} + BW_{Channel}^{LB} / 2 \leq f_{UL}^{LB} \leq F_{UL\_high}^{LB} - BW_{Channel}^{LB} / 2$  with  $f_{DL}^{LB}$  carrier frequency in the victim (higher) band in MHz and  $BW_{Channel}^{LB}$  the channel bandwidth configured in the lower band.

NOTE 9: The requirements should be verified for UL NR-ARFCN of the aggressor (lower) band (superscript LB) such that  $f_{DL}^{LB} = \lfloor f_{DL}^{HB} / 0.075 \rfloor \cdot 0.1$  in MHz and  $F_{UL\_low}^{LB} + BW_{Channel}^{LB} / 2 \leq f_{UL}^{LB} \leq F_{UL\_high}^{LB} - BW_{Channel}^{LB} / 2$  with  $f_{DL}^{HB}$  carrier frequency in the victim (higher) band in MHz and  $BW_{Channel}^{LB}$  the channel bandwidth configured in the lower band.

NOTE 10: Void

NOTE 11: The requirements should be verified for UL NR-ARFCN of the aggressor (lower) band (superscript LB) such that  $f_{DL}^{LB} = \lfloor 7.5 * f_{DL}^{HB} \rfloor \cdot 0.1$  in MHz and  $F_{UL\_low}^{LB} + BW_{Channel}^{LB} / 2 \leq f_{UL}^{LB} \leq F_{UL\_high}^{LB} - BW_{Channel}^{LB} / 2$  with  $f_{DL}^{HB}$  carrier frequency in the victim (higher) band in MHz and  $BW_{Channel}^{LB}$  the channel bandwidth configured in the lower band.

NOTE 12: The requirements should be verified using  $RB_{start} = \text{floor}((NRB - LCRB) / 2)$ , where  $\text{floor}(x)$  is the greatest integer less than or equal to  $x$ , and where the UL parameters  $NRB$  and  $LCRB$  are respectively, the transmission bandwidth configuration and the number of RB's for the specified UL band channel bandwidth and the UL band subcarrier spacing.

**Table 7.3A.4-4a-2: Reference sensitivity exceptions and uplink/downlink configurations due to harmonic mixing from a PC2 aggressor NR UL band for NR DL CA FR1 for UE supporting Tx Diversity**

UL band	DL band	UL BW	SCS of UL band	UL RB Allocation	DL BW	MSD	UL/DL fc condition	UL/DL harmonic order
		(MHz)	(kHz)	LCRB				
n25	n71 <sup>3</sup>	5	15	25	5	34.5	NOTE 4	UL1/DL3

n25	n71 <sup>3</sup>	5	15	25	20	23.3	NOTE 4	UL1/DL3
n25	n41	5	15	6	10	3.2	NOTE 11	UL4/DL3

NOTE 1: Void  
 NOTE2: Void  
 NOTE3: Void  
 NOTE 4: The requirements should be verified for UL NR-ARFCN of the aggressor (higher) band (superscript HB) such that  $f_{DL}^{LB} = \lfloor f_{UL}^{HB} / 0.2 \rfloor \cdot 0.1$  in MHz and  $F_{UL\_low}^{HB} + BW_{Channel}^{HB} / 2 \leq f_{UL}^{HB} \leq F_{UL\_high}^{HB} - BW_{Channel}^{HB} / 2$  with  $f_{DL}^{LB}$  the carrier frequency in the victim (lower) band and  $BW_{Channel}^{HB}$  the channel bandwidth configured in the higher band.

NOTE 5: Void  
 NOTE 6: Void  
 NOTE7: Void  
 NOTE 8: Void  
 NOTE 9: Void  
 NOTE 10: Void  
 NOTE 11: The requirements should be verified for UL NR-ARFCN of the aggressor (lower) band (superscript LB) such that  $f_{UL}^{LB} = \lfloor 7.5 * f_{DL}^{HB} \rfloor \cdot 0.1$  in MHz and  $F_{UL\_low}^{LB} + BW_{Channel}^{LB} / 2 \leq f_{UL}^{LB} \leq F_{UL\_high}^{LB} - BW_{Channel}^{LB} / 2$  with  $f_{DL}^{HB}$  carrier frequency in the victim (higher) band in MHz and  $BW_{Channel}^{LB}$  the channel bandwidth configured in the lower band.

NOTE 12: The requirements should be verified using  $RB_{start} = \text{floor}((NRB-LCRB)/2)$ , where floor(x) is the greatest integer less than or equal to x, and where the UL parameters NRB and LCRB are respectively, the transmission bandwidth configuration and the number of RB's for the specified UL band channel bandwidth and the UL band subcarrier spacing.

**Table 7.3A.4-4b: Reference sensitivity exceptions and uplink/downlink configurations due to harmonic mixing from a PC1.5 aggressor NR UL band for NR DL CA FR1**

UL band	DL band	UL BW	SCS of UL band	UL RB Allocation	DL BW	MSD	UL/DL fc condition	UL/DL harmonic order
		(MHz)	(kHz)	LCRB				
n40	n28	5	15	25	5	43.8	NOTE 7	UL1/DL3
n40	n28	5	15	25	20	36.3	NOTE 7	UL1/DL3
n41	n39	10	15	8	5	10.5	NOTE 6	UL3/DL4
n41	n39	10	15	8	40	3.0	NOTE 6	UL3/DL4
n41	n77	10	15	6	10	14.5	NOTE 8	UL4/DL3
n41	n77	10	15	6	100	5.5	NOTE 8	UL4/DL3
n41	n78	10	15	6	10	14.9	NOTE 8	UL4/DL3
n41	n78	10	15	6	100	5.8	NOTE 8	UL4/DL3
n77	n2	10	15	25	5	11.8	NOTE 4	UL1/DL2
n77	n2	10	15	25	20	6.5	NOTE 4	UL1/DL2
n77	n3	10	15	25	5	10.7	NOTE 4	UL1/DL2
n77	n3	10	15	25	40	1.4	NOTE 4	UL1/DL2
n77	n5	10	15	25	5	10.7	NOTE 5	UL1/DL4
n77	n5	10	15	25	20	2.6	NOTE 5	UL1/DL4
n77	n7	10	15	12	10	17.5	NOTE 3	UL2/DL3
n77	n7	10	15	12	100	5.5	NOTE 3	UL2/DL3
n77	n12	10	15	25	5	37	NOTE 1	UL1/DL5
n77	n12	10	15	25	15	24	NOTE 1	UL1/DL5
n77	n13	10	15	25	5	37	NOTE 1	UL1/DL5
n77	n13	10	15	25	10	33.8	NOTE 1	UL1/DL5



n77	n14	10	15	25	5	37	NOTE 1	UL1/DL5
n77	n14	10	15	25	10	33.8	NOTE 1	UL1/DL5
n77	n25	10	15	25	5	10.6	NOTE 4	UL1/DL2
n77	n25	10	15	25	40	0.8	NOTE 4	UL1/DL2
n77	n28	10	15	25	5	37	NOTE 1	UL1/DL5
n77	n28	10	15	25	30	17	NOTE 1	UL1/DL5
n77 <sup>2</sup>	n29	10	15	25	5	37	NOTE 1	UL1/DL5
n77 <sup>2</sup>	n29	10	15	25	10	33.8	NOTE 1	UL1/DL5
n77	n30	10	15	12	5	16.1	NOTE 3	UL2/DL3
n77	n30	10	15	12	10	13	NOTE 3	UL2/DL3
n77	n40	10	15	12	10	16.1	NOTE 3	UL2/DL3
n77	n40	10	15	12	100	6.7	NOTE 3	UL2/DL3
n77	n41	10	15	12	10	17.5	NOTE 3	UL2/DL3
n77	n41	10	15	12	100	7.9	NOTE 3	UL2/DL3
n77 <sup>2</sup>	n70	N/A	N/A	N/A	N/A	N/A	NOTE 4	UL1/DL2
n77	n85	10	15	25	5	37	NOTE 1	UL1/DL5
n77	n85	10	15	25	15	24	NOTE 1	UL1/DL5
n78	n3	10	15	25	5	10.7	NOTE 4	UL1/DL2
n78	n3	10	15	25	40	1.4	NOTE 4	UL1/DL2
n78	n8	10	15	25	5	10.6	NOTE 5	UL1/DL4
n78	n8	10	15	25	20	2.6	NOTE 5	UL1/DL4
n78	n26	10	15	25	5	10.1	NOTE 5	UL1/DL4
n78	n28	10	15	25	5	37	NOTE 1	UL1/DL5
n78	n28	10	15	25	30	17	NOTE 1	UL1/DL5
n78	n40	10	15	12	10	16.1	NOTE 3	UL2/DL3
n78	n40	10	15	12	100	6.7	NOTE 3	UL2/DL3
n79	n8	10	15	25	5	31.0	NOTE 1	UL1/DL5

- NOTE 1: The requirements should be verified for DL NR-ARFCN of the victim (lower) band (superscript LB) such that  $f_{DL}^{LB} = \lfloor f_{UL}^{HB} / 0.5 \rfloor 0.1$  and  $F_{UL\_low}^{HB} + BW_{Channel}^{HB} / 2 \leq f_{UL}^{HB} \leq F_{UL\_high}^{HB} - BW_{Channel}^{HB} / 2$  with  $f_{UL}^{HB}$  the UL carrier frequency and  $BW_{Channel}^{HB}$  the channel bandwidth configured in the higher band, both in MHz.
- NOTE 2: For a UE which supports this band combination only when the Band n77 frequency range restriction defined in NOTE 12 of Table 5.2-1 from TS 38.101-1 applies, the MSD test point(s) cannot be verified for the band combination and the test point(s) can be skipped.
- NOTE 3: The requirements should be verified for DL NR-ARFCN of the Victim (lower) band (superscript LB) such that  $f_{DL}^{LB} = \lfloor f_{UL}^{HB} / 0.15 \rfloor 0.1$  and  $F_{UL\_low}^{HB} + BW_{Channel}^{HB} / 2 \leq f_{UL}^{HB} \leq F_{UL\_high}^{HB} - BW_{Channel}^{HB} / 2$  with  $f_{UL}^{HB}$  the UL carrier frequency and  $BW_{Channel}^{HB}$  the channel bandwidth configured in the higher band, both in MHz.
- NOTE 4: The requirements should be verified for UL NR-ARFCN of the aggressor (higher) band (superscript HB) such that  $f_{DL}^{LB} = \lfloor f_{UL}^{HB} / 0.2 \rfloor 0.1$  in MHz and  $F_{UL\_low}^{HB} + BW_{Channel}^{HB} / 2 \leq f_{UL}^{HB} \leq F_{UL\_high}^{HB} - BW_{Channel}^{HB} / 2$  with  $f_{DL}^{LB}$  the carrier frequency in the victim (lower) band and  $BW_{Channel}^{HB}$  the channel bandwidth configured in the higher band.
- NOTE 5: The requirements should be verified for UL NR-ARFCN of the aggressor (higher) band (superscript HB) such that  $f_{DL}^{LB} = \lfloor f_{UL}^{HB} / 0.4 \rfloor 0.1$  in MHz and  $F_{UL\_low}^{HB} + BW_{Channel}^{HB} / 2 \leq f_{UL}^{HB} \leq F_{UL\_high}^{HB} - BW_{Channel}^{HB} / 2$  with  $f_{DL}^{LB}$  the carrier frequency in the victim (lower) band and  $BW_{Channel}^{HB}$  the channel bandwidth configured in the higher band.
- NOTE 6: The requirements should be verified for UL NR-ARFCN of the aggressor (lower) band (superscript LB) such that  $f_{UL}^{LB} = \lfloor f_{DL}^{HB} / 0.075 \rfloor 0.1$  in MHz and  $F_{UL\_low}^{LB} + BW_{Channel}^{LB} / 2 \leq f_{UL}^{LB} \leq F_{UL\_high}^{LB} - BW_{Channel}^{LB} / 2$  with  $f_{DL}^{HB}$  carrier frequency in the victim (higher) band in MHz and  $BW_{Channel}^{LB}$  the channel bandwidth configured in the lower band.

NOTE 7: The requirements should be verified for UL NR-ARFCN of the aggressor (higher) band (superscript HB) such that  $f_{DL}^{LB} = \lfloor f_{UL}^{HB} / 0.3 \rfloor \cdot 0.1$  in MHz and  $F_{UL\_low}^{HB} + BW_{Channel}^{HB} / 2 \leq f_{UL}^{HB} \leq F_{UL\_high}^{HB} - BW_{Channel}^{HB} / 2$  with  $f_{DL}^{LB}$  the carrier frequency in the victim (lower) band and  $BW_{Channel}^{HB}$  the channel bandwidth configured in the higher band.

NOTE 8: The requirements should be verified for DL NR-ARFCN of the victim (higher) band (superscript HB) such that  $f_{DL}^{HB} = \lfloor f_{UL}^{LB} / 0.75 \rfloor$  and  $F_{UL\_low}^{LB} + BW_{Channel}^{LB} / 2 \leq f_{UL}^{LB} \leq F_{UL\_high}^{LB} - BW_{Channel}^{LB} / 2$  with  $f_{UL}^{LB}$  the UL carrier frequency and  $BW_{Channel}^{LB}$  the channel bandwidth configured in the lower band, both in MHz.

NOTE 9: The requirements should be verified using  $RB_{start} = \text{floor}((NRB - LCRB) / 2)$ , where  $\text{floor}(x)$  is the greatest integer less than or equal to  $x$ , and where the UL parameters NRB and LCRB are respectively, the transmission bandwidth configuration and the number of RB's for the specified UL band channel bandwidth and the UL band subcarrier spacing.

The reference sensitivity for the shared access band does not apply when there is at least one individual RE within the shared access downlink transmission bandwidth which falls into the reference sensitivity exclusion region as specified in Table 7.3A.4-1c.

**Table 7.3A.4-4c: NR-U reference sensitivity measurement exclusion region in MHz.**

NR Band / Harmonic order / Channel BW (MHz) in UL															
UL Band	UL/DL Harmonic Order	DL Band	5	10	15	20	25	30	40	50	60	70	80	90	100
n77	UL3/DL2	n46		+/- 23	+/- 35	+/-45	+/-60	+/-70	+/- 90	+/-115	+/-140	+/-160	+/-180	+/-210	+/-230
n78	UL3/DL2	n46		+/- 23	+/- 35	+/-45	+/-60	+/-70	+/- 90	+/-115	+/-140	+/-160	+/-180	+/-210	+/-230

NOTE 1: Even though UL harmonic does not fall directly into NR-U band the exclusion region still applies.  
 NOTE 2: The center of the exclusion region is obtained by multiplying the UL channel center frequency by the ratio of the UL harmonic order over the DL harmonic order.

**Table 7.3A.4-4d: Reference sensitivity exceptions and uplink/downlink configurations due to harmonic mixing from a power class 5 aggressor NR UL band for NR DL CA FR1**

UL band	DL band	UL BW	SCS of UL band	UL RB Allocation	DL BW	MSD	UL/DL fc condition	UL/DL harmonic order
		(MHz)	(kHz)	LCRB	(MHz)	(dB)		
n46	n7	20	15	25	5	8.3	NOTE 7	UL1/DL2
n46	n7	20	15	25	30	2.8	NOTE 7	UL1/DL2
n46	n48	20	15	12	5	23.8	NOTE 2	UL2/DL3
n46	n48	20	15	12	100	10.7	NOTE 2	UL2/DL3
n46	n78	20	15	12	10	18.1	NOTE 2	UL2/DL3
n46	n78	20	15	12	100	8.4	NOTE 2	UL2/DL3
n96	n48	20	15	25	5	[28]	NOTE 2	UL1/DL2
n96	n48	20	15	25	15	[23]	NOTE 2	UL1/DL2

NOTE 1: Void.  
 NOTE 2: The requirements should be verified for UL NR-ARFCN of the aggressor (high) band (superscript HB) such that  $f_{UL}^{LB} = \lfloor 15 * f_{DL}^{HB} \rfloor \cdot 0.1$  in MHz and  $F_{UL\_low}^{LB} + BW_{Channel}^{LB} / 2 \leq f_{UL}^{LB} \leq F_{UL\_high}^{LB} - BW_{Channel}^{LB} / 2$  with  $f_{DL}^{HB}$  carrier frequency in the victim (lower) band in MHz and  $BW_{Channel}^{LB}$  the channel bandwidth configured in the higher band.  
 NOTE 3: These requirements apply when there is at least one individual RE within the downlink transmission bandwidth of the victim (lower) band for which the 3<sup>rd</sup> harmonic is within the uplink transmission bandwidth or the uplink adjacent channel's transmission bandwidth of an aggressor (higher) band.  
 NOTE 4: Void.  
 NOTE 5: Void.

NOTE 6: Void.  
 NOTE 7: The requirements should be verified for UL NR-ARFCN of the aggressor (higher) band (superscript HB) such that  $f_{DL}^{LB} = \lfloor f_{UL}^{HB} / 0.2 \rfloor \cdot 0.1$  in MHz and  $F_{UL,low}^{HB} + BW_{Channel}^{HB} / 2 \leq f_{UL}^{HB} \leq F_{UL,high}^{HB} - BW_{Channel}^{HB} / 2$  with  $f_{DL}^{LB}$  the carrier frequency in the victim (lower) band and  $BW_{Channel}^{HB}$  the channel bandwidth configured in the higher band.  
 NOTE 8: The requirements should be verified using  $RB_{start} = \text{floor}((NRB - LCRB) / 2)$ , where  $\text{floor}(x)$  is the greatest integer less than or equal to  $x$ , and where the UL parameters  $NRB$  and  $LCRB$  are respectively, the transmission bandwidth configuration and the number of RB's for the specified UL band channel bandwidth and the UL band subcarrier spacing.

Table 7.3A.4-5: Void

### 7.3A.5 Reference sensitivity exceptions due to intermodulation interference due to 2UL CA

For inter-band carrier aggregation with uplink assigned to two NR bands given in Table 7.3A.5-1, Table 7.3A.5-1a, Table 7.3A.5-2 and Table 7.3A.5-2a the reference sensitivity is defined only for the specific uplink and downlink test points specified in Table 7.3A.5-1, Table 7.3A.5-1a, Table 7.3A.5-2 and Table 7.3A.5-2a. For these test points the reference sensitivity requirement specified in Table 7.3.2-1a, Table 7.3.2-1b, Table 7.3.2-2 and Table 7.3.2-2a are relaxed by the amount of the corresponding parameter MSD given in Table 7.3A.5-1, Table 7.3A.5-1a, Table 7.3A.5-2 and Table 7.3A.5-2a.

Table 7.3A.5-1: 2DL/2UL inter-band Reference sensitivity QPSK  $P_{REFSENS}$  and uplink/downlink configurations for PC3 CA

Band / Channel bandwidth / $N_{RB}$ / Duplex mode								Source of IMD
NR CA band combination	NR band	UL $F_c$ (MHz)	UL/DL BW (MHz)	UL $LCRB$	DL $F_c$ (MHz)	MSD (dB)	Duplex mode	
CA_n1-n3	n1	1950	5	25	2140	23	FDD	IMD3
	n3	1760	5	25	1855	N/A	TDD	N/A
CA_n1-n8	n1	1965	5	25	2155	6.0	FDD	IMD4
	n8	887.5	5	25	932.5	N/A	FDD	N/A
CA_n1-n46	n1	1950	5	25	2140	5	FDD	IMD5
	n46	5660	20	100	5660	N/A	TDD	N/A
CA_n1-n77	n1	1950	5	25	2140	29.8	FDD	IMD2 <sup>4</sup>
	n77	4090	10	50	4090	N/A	TDD	N/A
	n1	1950	5	25	2140	8.0	FDD	IMD4 <sup>4</sup>
	n77	3710	10	50	3710	N/A	TDD	N/A
	n1	N/A	5	N/A	2130	17	FDD	IMD5 <sup>16</sup>
	n77 <sup>12</sup>	3310	10	1 ( $RB_{START}=25$ )	3310	N/A	TDD	N/A
	3900	10	1 ( $RB_{START}=25$ )	3900	N/A	TDD	N/A	
CA_n1-n78	n1	1950	5	25	2140	8.0	FDD	IMD4
	n78	3710	10	50	3710	N/A	TDD	N/A
	n1	N/A	5	N/A	2167.5	1.7	FDD	IMD7 <sup>17</sup>
	n78 <sup>12</sup>	3305 3675	10 10	1 ( $RB_{START}=0$ ) 1 ( $RB_{START}=44$ )	3305 3675	N/A	TDD	N/A
CA_n1-n102	n1	1922.5	5	25	2112.5	13	FDD	IMD3
	n102	5957.5	20	100	5957.5	N/A	TDD	N/A
CA_n1-n105	n1	1958	5	25	2148	N/A	FDD	N/A
	n105	673	5	25	622	15.1	FDD	IMD3
CA_n2-n48	n2	1852.5	5	25	1932.5	12	FDD	IMD4
	n48	3625	20	100	3625	N/A	TDD	N/A
CA_n2-n66	n2	1855	5	25	1935	20	FDD	IMD3
	n66	1775	5	25	2175	N/A	FDD	N/A
	n2	1883.3	5	25	1963.3	N/A	FDD	N/A

CA_n2-n77	n66	1750	5	25	2150	4	FDD	IMD5
	n2	1855	5	25	1935	26	FDD	IMD2
	n77	3790	10	50	3790	N/A	TDD	N/A
	n2	1900	5	25	1980	8.0	FDD	IMD4
	n77	3720	10	50	3720	N/A	TDD	N/A
	n2	1885	5	25	1965	5	FDD	IMD5
	n77	3810	10	50	3810	N/A	TDD	N/A
	n2	N/A	5	N/A	1987.5	2.7	FDD	IMD7
n77 <sup>12</sup>	3455	10	1	3455	N/A	TDD	N/A	
	3945	10	(RB <sub>START</sub> =10) 1 (RB <sub>START</sub> =0)	3945				
CA_n2-n78	n2	1855	5	25	1935	26	FDD	IMD2 <sup>4</sup>
	n78	3790	10	50	3790	N/A	TDD	N/A
CA_n3-n5	n3	1771	10	50	1866	4	FDD	IMD4
	n5	838	5	25	883	N/A	FDD	N/A
	n3	1721	10	50	1816	N/A	FDD	N/A
	n5	838	5	25	883	24	FDD	IMD2 <sup>3</sup>
CA_n3-n7	n3	1730	5	25	1825	N/A	FDD	N/A
	n7	2535	10	50	2655	10.2	FDD	IMD4
CA_n3-n8	n3	1755	10	50	1850	N/A	FDD	N/A
	n8	900	5	25	945	8	FDD	IMD4 <sup>4</sup>
	n3	1747.5	10	50	1842.5	6.4	FDD	IMD5
	n8	897.5	5	25	942.5	N/A	FDD	N/A
CA_n3-n18	n18	818	5	25	863	N/A	FDD	N/A
	n3	1731	5	25	1826	4	FDD	IMD4
CA_n3-n26	n3	1771	5	25	1866	4	FDD	IMD4
	n26	838	5	25	883	N/A	FDD	N/A
	n3	1721	5	25	1816	N/A	FDD	N/A
	n26	838	5	25	883	26	FDD	IMD2 <sup>4</sup>
CA_n3-n20	n3	1775	5	25	1870	4	FDD	IMD4
	n20	840	5	25	799	N/A	FDD	N/A
	n3	1735	5	25	1830	N/A	FDD	N/A
	n20	847	5	25	806	9	FDD	IMD4
CA_n3-n38	n3	1713	5	25	1808	8.2	FDD	IMD4
	n38	2617	5	25	2617	N/A	TDD	N/A
CA_n3-n41	n3	1740	5	25	1835	8.2	FDD	IMD4
	n41	2657.5	10	50	2657.5	N/A	TDD	N/A
	n3	N/A	5	N/A	1877.5	N/A	FDD	IMD9 <sup>14</sup>
	n41	2545	60	1 (RB <sub>START</sub> =0)	2545	N/A	TDD	N/A
		2625	100	1 (RB <sub>START</sub> =272)	2625			
	n3	1747.5	5	25 (RB <sub>START</sub> =0)	1842.5	15.3	FDD	IMD3
	n41	2560	60	1 (RB <sub>START</sub> =30)	2560	N/A	TDD	N/A
		2620	60	1 (RB <sub>START</sub> =127)	2620			
CA_n3-n77	n3	1740	5	25	1835	26	FDD	IMD2 <sup>4</sup>
	n77	3575	10	50	3575	N/A	TDD	N/A
	n3	1765	5	25	1860	8.0	FDD	IMD4 <sup>4</sup>
	n77	3435	10	50	3435	N/A	TDD	N/A
	n3	N/A	N/A	N/A	N/A	N/A	FDD	IMD5 <sup>7</sup>
	n77 <sup>12</sup>	N/A	N/A	N/A	N/A	N/A	TDD	N/A
	n3	N/A	5	N/A	1877.5	[2,2]	FDD	IMD7
	n77 <sup>12</sup>	3427.5	10	1	3427.5	N/A	TDD	N/A
n77 <sup>12</sup>	3945	10	(RB <sub>START</sub> =10) 1 (RB <sub>START</sub> =0)	3945				
CA_n3-n78	n3	1740	5	25	1835	26	FDD	IMD2 <sup>4</sup>
	n78	3575	10	25	3575	N/A	TDD	N/A
	n3	1765	5	25	1860	8.0	FDD	IMD4 <sup>4</sup>
	n78	3435	10	25	3435	N/A	TDD	N/A
	n3	N/A	5	N/A	1877.5	2.2	FDD	IMD7
	n78 <sup>12</sup>	3305	10	1 (RB <sub>START</sub> =3)	3305	N/A	TDD	N/A
n78 <sup>12</sup>	3780	10	1 (RB <sub>START</sub> =0)	3780				
CA_n5-n7	n5	834	5	25	879	12	FDD	IMD3 <sup>4</sup>

CA_n5-n12	n7	2547	10	50	2667	N/A	FDD	N/A
	n5	829	10	10	874	N/A <sup>18</sup>	FDD	N/A
		838.9	10	10 (RB <sub>START</sub> =0)	883.9			
	n12	N/A	5	N/A	743.5	20.8	FDD	IMD11
CA_n5-n13	n5	828	5	25	873	25	FDD	IMD3
	n13	783	5	25	752	N/A	FDD	N/A
CA_n5-n14	n5	836	5	25	881	25	FDD	IMD3 <sup>4</sup>
	n14	791	5	25	761	N/A	FDD	N/A
	n5	826.5	5	25	871.5	N/A	FDD	N/A
	n14	795.5	5	25	765.5	25	FDD	IMD3
	n5	829	10	10	874	N/A <sup>18</sup>	FDD	N/A
		838.9	10	10 (RB <sub>START</sub> =0)	883.9			
		n14	N/A	5	N/A	765.5	26.2	FDD
CA_n5-n29	n5	829	10	10	874	N/A <sup>18</sup>	FDD	N/A
		838.9	10	10 (RB <sub>START</sub> =0)	883.9			
	n29	N/A	5	N/A	725.5	16.0	FDD	IMD13
CA_n5_n41	n5	839	5	25	884	15.6	FDD	IMD3 <sup>3</sup>
	n41	2562	10	50	2562	N/A	TDD	N/A
CA_n5-n66	n5	838	5	25	883	30	FDD	IMD2 <sup>4</sup>
	n66	1721	5	25	2121	N/A	FDD	N/A
CA_n5-n77	n5	N/A	N/A	N/A	N/A	N/A	FDD	IMD2 <sup>7</sup>
	n77 <sup>12</sup>	N/A	N/A	N/A	N/A	N/A	TDD	N/A
	n5	844	5	25	889	8.3	FDD	IMD4 <sup>13</sup>
	n77	3421	10	50	3421	N/A	TDD	N/A
	n5	829	5	25	874	5.5	FDD	IMD5 <sup>13</sup>
	n77	4190	10	50	4190	N/A	TDD	N/A
	n5	N/A	5	N/A	880	8.6	FDD	IMD4
	n77 <sup>12</sup>	3410	10	1 (RB <sub>START</sub> =25)	3410	N/A	TDD	N/A
3850		10	1 (RB <sub>START</sub> =25)	3850				
CA_n5-n78	n5	844	5	25	889	8.3	FDD	IMD4
	n78	3421	10	50	3421	N/A	TDD	N/A
	n5	N/A	5	N/A	880	8.6	FDD	IMD4 <sup>17</sup>
	n78 <sup>12</sup>	3340	10	1 (RB <sub>START</sub> =25)	3340	N/A	TDD	N/A
3780		10	1 (RB <sub>START</sub> =25)	3780				
CA_n7-n26	n7	2556	5	25	2676	N/A	FDD	N/A
	n26	837	5	25	882	16.0	FDD	IMD3 <sup>4</sup>
	n7	2567.5	5	25	2687.5	2.5	FDD	IMD5
	n26	816.5	5	25	861.5	N/A	FDD	N/A
CA_n7-n40	n7	2510	5	25	2630	23	FDD	IMD3
	n40	2390	5	25	2390	N/A	TDD	N/A
CA_n7-n46	n7	2550	10	50	2670	26.8	FDD	IMD2 <sup>4</sup>
	n46	5220	20	100	5220	N/A	TDD	N/A
CA_n7-n66	n7	2535	10	50	2655	15	FDD	IMD4
	n66	1730	5	25	2130	N/A	FDD	N/A
CA_n7-n77	n7	2540	5	25	2660	7.1	FDD	IMD4
	n77	3870	10	50	3870	N/A	TDD	N/A
	n7	N/A	5	N/A	2687.5	15	FDD	IMD5
	n77 <sup>12</sup>	3455	10	1 (RB <sub>START</sub> =0)	3455	N/A	TDD	N/A
3835		10	1 (RB <sub>START</sub> =7)	3835				
CA_n7-n78	n7	N/A	5	N/A	2650	15	FDD	IMD5
	n78 <sup>12</sup>	3350	10	1 (RB <sub>START</sub> =25)	3350	N/A	TDD	N/A
		3700	10	1 (RB <sub>START</sub> =25)	3700			
CA_n8-n20	n8	892.5	5	25	937.5	25	FDD	IMD3
	n20	849.5	5	25	808.5	25	FDD	IMD3

CA_n8-n41	n8	882.5	5	25	927.5	12.1	FDD	IMD3 <sup>4</sup>
	n41	2685	10	50	2685	N/A	TDD	N/A
CA_n8-n78	n8	897.5	5	25	942.5	8.3	FDD	IMD4
	n78	3635	10	50	3635	N/A	TDD	N/A
CA_n8-n79	n8	897.5	5	25	942.5	4.8	FDD	IMD5
	n79	4532.5	40	216	4532.5	N/A	TDD	N/A
CA_n12-n66	n12	707.5	5	25	737.5	N/A	FDD	N/A
	n66	1765	5	25	2115	5.0	FDD	IMD4
CA_n12-n77	n12	702	5	20	732	5.5	FDD	IMD5
	n77	3540	10	50	3540	N/A	TDD	N/A
CA_n12-n78	n12	710	5	25	740	5.5	FDD	IMD5
	n78	3580	10	50	3580	N/A	TDD	N/A
CA_n13-n77	n13	782	5	20	751	5.5	FDD	IMD5
	n77	3880	10	50	3880	N/A	TDD	N/A
CA_n14-n77	n14	793	5	20	763	5.5	FDD	IMD5
	n77	3935	10	50	3935	N/A	TDD	N/A
CA_n18-n41	n18	820	5	25	865	15.6	FDD	IMD3
	n41	2505	5	25	2505	N/A	TDD	N/A
CA_n18-n77	n18	827.5	5	25	872.5	8.4	FDD	IMD4 <sup>8</sup>
	n77	3355	10	50	3355	N/A	TDD	N/A
	n18	817.5	5	25	862.5	4.5	FDD	IMD5 <sup>8</sup>
	n77	4130	10	50	4130	N/A	TDD	N/A
CA_n18-n78	n18	827.5	5	25	872.5	8.3	FDD	IMD4 <sup>9</sup>
	n78	3355	10	50	3355	N/A	TDD	N/A
CA_n20-n78	n20	850	5	25	809	11	FDD	IMD4
	n78	3359	10	50	3359	N/A	TDD	N/A
CA_n24-n77	n24	N/A	N/A	N/A	N/A	N/A	FDD	IMD4 <sup>10</sup>
	n77	N/A	N/A	N/A	N/A	N/A	TDD	N/A
CA_n25-n41	n25	N/A	5	N/A	1992.5	8.5	FDD	IMD7
	n41	2545 2640	90 100	1 (RB <sub>START</sub> =0) 1 (RB <sub>START</sub> =221 )	2545 2640	N/A	TDD	N/A
CA_n25-n48	n25	1852.5	5	25	1932.5	12	FDD	IMD4
	n48	3625	20	100	3625	N/A	TDD	N/A
CA_n25-n66	n66	1775	5	25	2175	N/A	FDD	N/A
	n25	1855	5	25	1935	20	FDD	IMD3
	n66	1712.5	5	25	2112.5	23	FDD	IMD3
	n25	1912.5	5	25	1992.5	N/A	FDD	N/A
	n66	1750	5	25	2150	4	FDD	IMD5
	n25	1883.3	5	25	1963.3	N/A	FDD	N/A
CA_n25-n77	n25	1855	5	25	1935	26	FDD	IMD2
	n77	3790	10	50	3790	N/A	TDD	N/A
	n25	1900	5	25	1980	8.0	FDD	IMD4
	n77	3690	10	50	3690	N/A	TDD	N/A
	n25	1885	5	25	1965	5	FDD	IMD5
	n77	3790	10	50	3790	N/A	TDD	N/A
	n25	N/A	5	N/A	1987.5	2.7	FDD	IMD7
	n77 <sup>12</sup>	3455	10	1 (RB <sub>START</sub> =10)	3455	N/A	TDD	N/A
CA_n25-n78	n25	1855	5	25	1935	26	FDD	IMD2 <sup>4</sup>
	n78	3790	10	50	3790	N/A	TDD	N/A
	n25	N/A	5	N/A	1980	2.7	FDD	IMD7
	n78 <sup>12</sup>	3315	10	1 (RB <sub>START</sub> =7)	3315	N/A	TDD	N/A
		3760	10	1 (RB <sub>START</sub> =0)	3760			
CA_n26-n66	n26	838	5	25	883	30	FDD	IMD2 <sup>4</sup>
	n66	1721	5	25	2121	N/A	FDD	N/A
CA_n26-n70	n26	831	5	25	876	30	FDD	IMD2 <sup>4</sup>
	n70	1707.5	5	25	2007.5	N/A	FDD	N/A
CA_n26-n77	n26	N/A	N/A	N/A	N/A	N/A	FDD	IMD4 <sup>13</sup>
	n77	N/A	N/A	N/A	N/A	N/A	TDD	N/A
	n26	N/A	N/A	N/A	N/A	N/A	FDD	IMD5 <sup>13</sup>
	n77	N/A	N/A	N/A	N/A	N/A	TDD	N/A
CA_n26-n78	n26	836.5	5	25	881.5	11.1	FDD	IMD4

	n78	3391	10	50	3391	N/A	TDD	N/A	
	n78	N/A	10	N/A	3336	11.1	FDD	IMD4	
	n26	824	5	12 (RB <sub>START</sub> =0)	869	N/A	TDD	N/A	
		839	5	12 (RB <sub>START</sub> =0)	884				
CA_n28-n50	n28	730	10	50	775	15.3	FDD	IMD2	
	n50	1500	10	50	1500	N/A	TDD	N/A	
	n28	740	10	50	785	6.0	FDD	IMD4 <sup>4</sup>	
	n50	1500	10	50	1500	N/A	TDD	N/A	
CA_n28-n74	n28	705.5	5	25	760.5	24.6	FDD	IMD2	
	n74	1466	5	25	1514	N/A	FDD	N/A	
	n28	743	5	25	798	11.3	FDD	IMD4 <sup>4</sup>	
	n74	1431	5	25	1479	N/A	FDD	N/A	
	n28	709	5	25	764	N/A	FDD	N/A	
	n74	1466	5	25	1514	14.6	FDD	IMD4	
	n28	735.5	5	25	790.5	N/A	FDD	N/A	
	n74	1450.4	5	25	1498.4	2.5	FDD	IMD5	
	CA_n28-n77	n28	N/A	N/A	N/A	N/A	N/A	FDD	IMD2 <sup>7</sup>
		n77 <sup>12</sup>	N/A	N/A	N/A	N/A	N/A	TDD	N/A
	n28	705.5	5	25	760.5	5.5	FDD	IMD5	
	n77	3582.5	10	50	3582.5	N/A	TDD	N/A	
	n28	N/A	5	N/A	780	8.5	FDD	IMD4 <sup>15</sup>	
	n77 <sup>12</sup>	3510	10	1 (RB <sub>START</sub> =25)	3510	N/A	TDD	N/A	
		3900	10	1 (RB <sub>START</sub> =25)	3900	N/A	TDD	N/A	
	n28	N/A	5	N/A	705.5	[8.6]	FDD	IMD4	
	n77 <sup>12</sup>	3455	10	1	3455	N/A	TDD	N/A	
		3805	10	(RB <sub>START</sub> =17) 1 (RB <sub>START</sub> =0)	3805				
CA_n28-n78	n28	705.5	5	25	760.5	5.5	FDD	IMD5	
	n78	3582.5	10	50	3582.5	N/A	TDD	N/A	
CA_n30-n77	n30	2310	5	25	2355	8.0	FDD	IMD4	
	n77	3487.5	10	50	3487.5	N/A	TDD	N/A	
	n30	N/A	5	N/A	2352.5	3.2	FDD	IMD7	
	n77 <sup>12</sup>	3455	10	1	3455	N/A	TDD	N/A	
3825		10	(RB <sub>START</sub> =17) 1 (RB <sub>START</sub> =0)	3825					
CA_n41-n66	n41	2545	90	1 (RB <sub>START</sub> =0)	2545	N/A	TDD	N/A	
		2640	100	1 (RB <sub>START</sub> =171)	2640				
	n66	N/A	5	N/A	2197.5	32.5	FDD	IMD5	
CA_n41-n71	n41	2614	5	25	2614	N/A	TDD	N/A	
	n71	665	5	25	619	11	FDD	IMD4	
CA_n41-n77	n41	2545	60	1 (RB <sub>START</sub> =0)	2545	N/A	TDD	N/A	
		2625	100	1 (RB <sub>START</sub> =272)	2625				
	n77	N/A	10	N/A	3305	2.7	TDD	IMD9	
	n41	N/A	10	N/A	2565	17	TDD	IMD5 <sup>16</sup>	
	n77 <sup>12</sup>	3485	10	1 (RB <sub>START</sub> =25)	3485	N/A	TDD	N/A	
		3945	10	1 (RB <sub>START</sub> =25)	3945				
CA_n46-n77	n46	N/A	20	N/A	5155	N/A	TDD	IMD5	
	n77 <sup>12</sup>	3385	10	1 (RB <sub>START</sub> =25)	3385	N/A	TDD	N/A	
		3975	10	1 (RB <sub>START</sub> =25)	3975				
	n46	N/A	20	N/A	5660	N/A	TDD	IMD6	
	n77 <sup>12</sup>	3310	10	1 (RB <sub>START</sub> =25)	3310	N/A	TDD	N/A	
3790		10	1 (RB <sub>START</sub> =25)	3790					

	n46	N/A	20	N/A	5230	N/A	TDD	IMD7
	n77 <sup>12</sup>	3310	10	1 (RB <sub>START</sub> =25)	3310	N/A	TDD	N/A
		3790	10	1 (RB <sub>START</sub> =25)	3790			
CA_n46-n78	n46	N/A	20	N/A	5660	N/A	TDD	IMD6
	n78 <sup>12</sup>	3310	10	1 (RB <sub>START</sub> =25)	3310	N/A	TDD	N/A
		3790	10	1 (RB <sub>START</sub> =25)	3790			
	n46	N/A	20	N/A	5230	N/A	TDD	IMD7
	n78 <sup>12</sup>	3310	10	1 (RB <sub>START</sub> =25)	3310	N/A	TDD	N/A
3790		10	1 (RB <sub>START</sub> =25)	3790				
CA_n48-n66	n48	3660	5	25	3660	N/A	TDD	N/A
	n66	1730	5	25	2130	5.0	FDD	IMD5
CA_n48-n70	n70	1697.5	25/15	25	1997.5	26	FDD	IMD2 <sup>4</sup>
	n48	3695	10	50	3695	N/A	TDD	N/A
CA_n66-n71	n66	1750	5	25	2150	5	FDD	IMD4
	n71	675	5	25	629	N/A	FDD	N/A
CA_n66-n77	n66	1775	5	25	2175	31	FDD	IMD2
	n77	3950	10	50	3950	N/A	TDD	N/A
	n66	1760	5	25	2160	5.0	FDD	IMD5
	n77	3720	10	50	3720	N/A	TDD	N/A
	n66	N/A	5	N/A	2197.5	15	FDD	IMD5 <sup>13</sup>
	n77 <sup>12</sup>	3305	10	1 (RB <sub>START</sub> =0)	3305	N/A	TDD	N/A
		3855	10	1 (RB <sub>START</sub> =8)	3855			
	n66	1730	5	25	2130	1.7	FDD	IMD7
	n77 <sup>12</sup>	3455	10	1 (RB <sub>START</sub> =10) 1 (RB <sub>START</sub> =0)	3455	N/A	TDD	N/A
CA_n66-n78	n66	1730	5	25	2130	5.0	FDD	IMD5
	n78	3660	10	50	3660	N/A	TDD	N/A
	n66	N/A	5	25	2150	1.7	FDD	IMD7
	n78 <sup>12</sup>	3350	10	1 (RB <sub>START</sub> =7)	3350	N/A	TDD	N/A
		3750	10	1 (RB <sub>START</sub> =0)	3750			
CA_n66-n85	n66	1770	5	25	2138	5	FDD	IMD4
	n85	701	5	25	731	N/A	FDD	N/A
CA_n67-n78	n67	N/A	5	N/A	748	8.6	SDL	IMD4 <sup>15</sup>
	n78 <sup>12</sup>	3376	10	1 (RB <sub>START</sub> =25)	3376	N/A	TDD	N/A
		3750	10	1 (RB <sub>START</sub> =25)	3750			
CA_n70-n71	n70	1697.5	5	25	1997.5	5	FDD	IMD4
	n71	695.5	5	25	649.5	N/A	FDD	N/A
CA_n70-n77	n70	1702.5	5	25	2002.5	31	FDD	IMD2
	n77	3705	10	50	3705	N/A	TDD	N/A
	n70	1697.5	5	25	1997.5	5.0	FDD	IMD5
	n77	3545	10	50	3545	N/A	TDD	N/A
CA_n70-n78	n70	1705	5	25	2005	31	FDD	IMD2
	n78	3710	10	50	3710	N/A	TDD	N/A
	n70	1705	5	25	2005	5.0	FDD	IMD5
	n78	3560	10	50	3560	N/A	TDD	N/A
CA_n71-n77	n71	671	5	25	625	5.5	FDD	IMD5 <sup>13</sup>
	n77	3309	10	50	3309	N/A	TDD	N/A
	n71	N/A	5	N/A	640	8.6	FDD	IMD4
	n77 <sup>12</sup>	3480	10	1 (RB <sub>START</sub> =25)	3480	N/A	TDD	N/A
		3800	10	1 (RB <sub>START</sub> =25)	3800			
CA_n71-n78	n71	681.5	5	25	635.5	5.5	FDD	IMD5
	n78	3361.5	10	50	3361.5	N/A	TDD	N/A
CA_n77-n85	n77	3590	10	25	3590	N/A	TDD	N/A
	n85	712	5	25	742	5.5	FDD	IMD5



CA_n78-n102	n78 <sup>12</sup>	3320	10	1 (RB <sub>START</sub> =25)	3320	N/A	TDD	N/A
		3680	10	1 (RB <sub>START</sub> =25)	3680			
	n102	6280	20	100	6280	N/A	TDD	IMD4 <sup>4</sup>
CA_n78-n105	n78	3361.5	10	50	3361.5	N/A	TDD	N/A
	n105	682.5	5	25	631.5	5.5	FDD	IMD5

NOTE 1: Both of the transmitters shall be set min(+20 dBm, P<sub>C<sub>MAX</sub>L,f,c</sub>) as defined in clause 6.2A.4

NOTE 2: RB<sub>START</sub> = 0, 15 kHz SCS is assumed.

NOTE 3: No requirements apply when there is at least one individual RE within the intermodulation generated by the dual uplink is within the downlink transmission bandwidth of the FDD band. The reference sensitivity should only be verified when this is not the case (the requirements specified in clause 7.3 apply).

NOTE 4: This band is subject to IMD5 also which MSD is not specified.

NOTE 5: Void.

NOTE 6: Void.

NOTE 7: In current release the maximum separation bandwidth class is 600MHz, therefore, no IMD MSD requirement apply for this CA configuration when two uplink sub blocks are assigned within CA\_77(2A).

NOTE8: For a UE which supports this band combination only when the Band n77 frequency range restriction of 3400 – 4100 MHz applies, the MSD test point(s) cannot be verified for the band combination and the test point(s) can be skipped.

NOTE 9: For a UE which supports this band combination only when the Band n78 frequency range restriction of 3400 – 3800 MHz, the MSD test point(s) cannot be verified for the band combination and the test point(s) can be skipped.

NOTE 10: There is no IMD4 product in band n24 downlink for n77 operating in 3450 – 3980 MHz and n24 uplink restricted to between 1627.5 – 1637.5 MHz and between 1646.5 – 1656.5 MHz.

NOTE 11: Void.

NOTE 12: This band supports intra-band non-contiguous uplink configuration.

NOTE 13: For a UE which supports this band combination only when the Band n77 frequency range restriction defined in NOTE 12 of Table 5.2-1 applies, the MSD test point(s) cannot be verified for the band combination and the test point(s) can be skipped.

NOTE 14: Applicable when n41 spectrum is restricted to 2515-2675MHz

NOTE 15: This band is subject to IMD6 also which MSD is not specified

NOTE 16: This band is subject to IMD7 also which MSD is not specified.

NOTE 17: For a UE which supports this band combination only when the Band n78 frequency range restriction of 3400 – 3800 MHz or 3300 – 3600 MHz applies, the MSD test point(s) cannot be verified for the band combination and the test point(s) can be skipped.

NOTE 18: This component carrier is affected by IMD due to CA\_n5B for which the MSD is not specified.

**Table 7.3A.5-1a: 2DL/2UL inter-band Reference sensitivity QPSK P<sub>REFSENS</sub> and uplink/downlink configurations for PC2 CA**

Band / Channel bandwidth / N <sub>RB</sub> / Duplex mode								Source of IMD
NR CA Configuration	NR band	UL F <sub>c</sub> (MHz)	UL/DL BW (MHz)	UL L <sub>CRB</sub>	DL F <sub>c</sub> (MHz)	MSD (dB)	Duplex mode	
CA_n1-n77 <sup>4</sup>	n1	1950	5	25	2140	35.8	FDD	IMD2
	n77	4090	10	50	4090	N/A	TDD	N/A
	n1	1950	5	25	2140	17.8	FDD	IMD4
	n77	3710	10	50	3710	N/A	TDD	N/A
	n1	N/A	5	N/A	2130	31	FDD	IMD5 <sup>15</sup>
	n77 <sup>12</sup>	3310	10	1 (RB <sub>START</sub> =25)	3310	N/A	TDD	N/A
		3900	10	1 (RB <sub>START</sub> =25)	3900	N/A	TDD	N/A
CA_n1-n78	n1	1950	5	25	2140	17.8	FDD	IMD4
	n78	3710	10	50	3710	N/A	TDD	N/A
	n1	N/A	5	N/A	2140	13.6	FDD	IMD7
	n78 <sup>12</sup>	3305	10	1 (RB <sub>START</sub> =0)	3305	N/A	TDD	N/A
		3675	10	1 (RB <sub>START</sub> =44)	3675			
CA_n2-n77	n2	1855	5	25	1935	32.10	FDD	IMD2

	n77	3790	10	50	3790	N/A	TDD	N/A
	n2	1885	5	25	1965	20.0	FDD	IMD5
	n77	3810	10	50	3810	N/A	TDD	N/A
	n2	1900	5	25	1980	19.10	FDD	IMD4
	n77	3720	10	50	3720	N/A	TDD	N/A
CA_n3-n41	n3	1740	5	25	1835	18.4	FDD	IMD4
	n41	2657.5	10	50	2657.5	N/A	TDD	N/A
	n3	1747.5	5	25 (RB <sub>START</sub> =0)	1842.5	23.3	FDD	IMD3
	n41	2560	60	1 (RB <sub>START</sub> =30)	2560	N/A	TDD	N/A
		2620	60	1 (RB <sub>START</sub> =127)	2620			
	n3	N/A	5	N/A	1877.5	N/A <sup>17</sup>	FDD	IMD9
	n41	2545	60	1 (RB <sub>START</sub> =0)	2545	N/A	TDD	N/A
			2625	100	1 (RB <sub>START</sub> =272)	2625		
	CA_n3-n77 <sup>4</sup>	n3	1740	5	25	1835	31.9	FDD
n77		3575	10	50	3575	N/A	TDD	N/A
n3		1765	5	25	1860	18.5	FDD	IMD4
n77		3435	10	50	3435	N/A	TDD	N/A
n3		N/A	N/A	N/A	N/A	N/A <sup>6</sup>	FDD	IMD5
n77		N/A	N/A	N/A	N/A	N/A	TDD	N/A
n3		N/A	5	N/A	1877.5	13.6	FDD	IMD7
n77 <sup>12</sup>		3427.5	10	1 (RB <sub>start</sub> =10)	3427.5	N/A	TDD	N/A
		3945	10	1 (RB <sub>start</sub> =0)	3945	N/A	TDD	N/A
CA_n3-n78	n3	1740	5	25	1835	31.9	FDD	IMD2
	n78	3575	10	50	3575	N/A	TDD	N/A
	n3	1765	5	25	1860	18.5	FDD	IMD4
	n78	3435	10	50	3435	N/A	TDD	N/A
	n3	N/A	5	N/A	1877.5	13.6	FDD	IMD7
	n78 <sup>12</sup>	3305	10	1 (RB <sub>START</sub> =3)	3305	N/A	TDD	N/A
3780		10	1 (RB <sub>START</sub> =0)	3780				
CA_n5-n77	n5	844	5	25	889	18.6	FDD	IMD4 <sup>4,13</sup>
	n77	3421	10	50	3421	N/A	TDD	N/A
	n5	N/A	5	N/A	880	18.5	FDD	IMD4
	n77 <sup>12</sup>	3410	10	1 (RB <sub>START</sub> =25)	3410	N/A	TDD	N/A
		3850	10	1 (RB <sub>START</sub> =25)	3850	N/A	TDD	N/A
CA_n5-n78	n5	844	5	25	889	18.6	FDD	IMD4
	n78	3421	10	50	3421	N/A	TDD	N/A
CA_n5-n78 <sup>4</sup>	n5	N/A	5	N/A	880	18.5	FDD	IMD4
	n78 <sup>12</sup>	3340	10	1 (RB <sub>START</sub> =25)	3340	N/A	TDD	N/A
		3780	10	1 (RB <sub>START</sub> =25)	3780			
CA_n7-n20	n7	2512	10	50	2632	N/A	FDD	N/A
	n20	851	5	25	810	12	FDD	IMD3 <sup>11</sup>
CA_n7-n77	n7	2540	5	25	2660	[15.8]	FDD	IMD4
	n77	3870	10	50	3870	N/A	TDD	N/A
	n7	N/A	5	N/A	2687.5	29.9	FDD	IMD5 <sup>15</sup>
	n77 <sup>12</sup>	3455	10	1 (RB <sub>START</sub> =0)	3455	N/A	TDD	N/A
			3835	10	1 (RB <sub>START</sub> =7)	3835	N/A	TDD
CA_n7-n78	n7	N/A	5	N/A	2650	29.9	FDD	IMD5 <sup>15</sup>

	n78 <sup>12</sup>	3350	10	1 (RB <sub>START</sub> =25)	3350	N/A	TDD	N/A
		3700	10	1 (RB <sub>START</sub> =25)	3700	N/A	TDD	N/A
CA_n8-n77	n8	897.5	5	25	942.5	15.5	FDD	IMD4
	n77	3635	10	50	3635	N/A	TDD	N/A
CA_n8-n78	n8	897.5	5	25	942.5	15.5	FDD	IMD4
	n78	3635	10	50	3635	N/A	TDD	N/A
CA_n8-n79	n8	897.5	5	25	942.5	21.5	FDD	IMD5
	n79	4532.5	40	216	4532.5	N/A	TDD	N/A
CA_n12-n77	n12	702	5	20	732	11.7	FDD	IMD5
	n77	3540	10	50	3540	N/A	TDD	N/A
CA_n13-n77	n13	N/A	5	N/A	750	8.6	FDD	IMD4 <sup>15</sup>
	n77 <sup>12</sup>	3510	10	1 (RB <sub>START</sub> =25)	3510	N/A	TDD	N/A
		3885	10	1 (RB <sub>START</sub> =25)	3885			
	n13	781	5	25	750	18.5	FDD	IMD4 <sup>14</sup>
	n77 <sup>12</sup>	3510	10	1 (RB <sub>START</sub> =25)	3510	N/A	TDD	N/A
		3885	10	1 (RB <sub>START</sub> =25)	3885	N/A	TDD	N/A
	n13	782	5	20	751	20.5	FDD	IMD5
	n77	3880	10	50	3880	N/A	TDD	N/A
CA_n14-n77	n14	795.5	5	15	765.5	11.7	FDD	IMD5
	n77	3947.5	10	50	3947.5	N/A	TDD	N/A
CA_n18-n41	n18	820	5	25	865	24.6	FDD	IMD3
	n41	2505	5	25	2505	N/A	TDD	N/A
CA_n18-n77	n18	827.5	5	25	872.5	17.5	FDD	IMD4 <sup>16</sup>
	n77	3355	10	50	3355	N/A	TDD	N/A
	n18	817.5	5	25	862.5	10.5	FDD	IMD5 <sup>16</sup>
	n77	4130	10	50	4130	N/A	TDD	N/A
	n18	827.5	5	25	872.5	18.4	FDD	IMD4 <sup>8</sup>
	n77	3355	10	50	3355	N/A	TDD	N/A
	n18	817.5	5	25	862.5	11.7	FDD	IMD5 <sup>8</sup>
	n77	4130	10	50	4130	N/A	TDD	N/A
CA_n20-n78	n20	N/A	5	N/A	800	8.6	FDD	IMD4 <sup>15</sup>
	n78 <sup>12</sup>	3350	10	1 (RB <sub>START</sub> =25)	3350	N/A	TDD	N/A
		3750	10	1 (RB <sub>START</sub> =25)	3750			
CA_n25-n41	n25	N/A	5	N/A	1992.5	8.5	FDD	IMD7
	n41	2545	90	1 (RB <sub>start</sub> =0)	2545	N/A	TDD	N/A
		2640	100	1 (RB <sub>start</sub> =221)	2640			
	n25	1860	5	25	1940	15.3	FDD	IMD3
	n41	2501	10	1 (RB <sub>start</sub> = 25)	2501	N/A	TDD	N/A
		2556	100	1 (RB <sub>start</sub> = 208)	2556			
CA_n25-n77	n25	1855	5	25	1935	32.1	FDD	IMD2 <sup>4</sup>
	n77	3790	10	50	3790	N/A	TDD	N/A
	n25	1900	5	25	1980	19.1	FDD	IMD4
	n77	3720	10	50	3720	N/A	TDD	N/A
	n25	N/A	5	N/A	1987.5	13.6	FDD	IMD7

	n77 <sup>12</sup>	3455	10	1 (RB <sub>START</sub> =10)	3455	N/A	TDD	N/A
		3945	10	1 (RB <sub>START</sub> =0)	3945	N/A	TDD	N/A
CA_n25-n78	n25	1855	5	25	1935	32.10	FDD	IMD2 <sup>4</sup>
	n78	3790	10	50	3790	N/A	TDD	N/A
	n25	N/A	5	N/A	1980	13.6	FDD	IMD7
	n78 <sup>12</sup>	3315	10	1 (RB <sub>START</sub> =7)	3315	N/A	TDD	N/A
		3760	10	1 (RB <sub>START</sub> =0)	3760			
CA_n26-n78	n26	836.5	5	25	881.5	23.8	FDD	IMD4
	n78	3391	10	50	3391	N/A	TDD	N/A
CA_n28-n77	n28	N/A	N/A	N/A	N/A	N/A	FDD	IMD2 <sup>7</sup>
	n77 <sup>12</sup>	N/A	N/A	N/A	N/A	N/A	TDD	N/A
	n28	705.5	5	25	760.5	19.2	FDD	IMD5
	n77	3582.5	10	50	3582.5	N/A	TDD	N/A
	n28	725	5	25	780	18.5	FDD	IMD4 <sup>14</sup>
	n77 <sup>12</sup>	3510	10	1 (RB <sub>START</sub> =25)	3510	N/A	TDD	N/A
		3900	10	1 (RB <sub>START</sub> =25)	3900	N/A	TDD	N/A
CA_n28-n78	n28	N/A	5	N/A	780	18.5	FDD	IMD4 <sup>14</sup>
	n78 <sup>12</sup>	3310	10	1 (RB <sub>START</sub> =7)	3310	N/A	TDD	N/A
		3700	10	1 (RB <sub>START</sub> =0)	3700			
CA_n30-n77	n30	2310	5	25	2355	17.6	FDD	IMD4
	n77	3487.5	10	50	3487.5	N/A	TDD	N/A
CA_n41-n66	n41	2545	90	1 (RB <sub>START</sub> =0)	2545	N/A	TDD	N/A
		2640	100	1 (RB <sub>START</sub> =17)	2640			
	n66	N/A	5	N/A	2197.5	32.5	FDD	IMD5
CA_n41-n71	n41	2614	5	25	2614	N/A	TDD	N/A
	n71	665	5	25	619	16.3	FDD	IMD4
CA_n41-n77	n41	2545	60	1 (RB <sub>START</sub> =0)	2545	N/A	TDD	N/A
		2625	100	1 (RB <sub>START</sub> =27)	2625			
	n77	N/A	10	N/A	3305	[2.7]	TDD	IMD9
	n41	N/A	10	N/A	2565	32	TDD	IMD5 <sup>16</sup>
	n77 <sup>12</sup>	3485	10	1 (RB <sub>START</sub> =25)	3485	N/A	TDD	N/A
		3945	10	1 (RB <sub>START</sub> =25)	3945			
CA_n66-n77	n66	1775	5	25	2175	34.33	FDD	IMD2
	n77	3950	10	50	3950	N/A	TDD	N/A
	n66	1760	5	25	2160	11.27	FDD	IMD5
	n77	3720	10	50	3720	N/A	TDD	N/A
	n66	N/A	5	N/A	2197.5	31	FDD	IMD5 <sup>15</sup>
	n77 <sup>12</sup>	3305	10	1 (RB <sub>START</sub> =0)	3305	N/A	TDD	N/A
		3855	10	1 (RB <sub>START</sub> =8)	3855	N/A	TDD	N/A
CA_n66-n78	n66	1760	5	25	2160	11.27	FDD	IMD5
	n78	3720	10	50	3720	N/A	TDD	N/A
	n66	N/A	5	25	2150	13.6	FDD	IMD7
	n78 <sup>12</sup>	3350	10	1 (RB <sub>START</sub> =7)	3350	N/A	TDD	N/A

		3750	10	1 (RB <sub>START</sub> =0)	3750			
CA_n70-n77	n70	1702.5	5	25	2002.5	37	FDD	IMD2
	n77	3705	10	50	3705	N/A	TDD	N/A
	n70	1697.5	5	25	1997.5	18.4	FDD	IMD5
	n77	3545	10	50	3545	N/A	TDD	N/A
CA_n71-n77	n71	681.5	5	25	635.5	11.4	FDD	IMD5 <sup>13</sup>
	n77	3361.5	10	50	3361.5	N/A	TDD	N/A
	n71	N/A	5	N/A	640	18.5	FDD	IMD4 <sup>14</sup>
	n77 <sup>12</sup>	3480	10	1 (RB <sub>START</sub> =25)	3480	N/A	TDD	N/A
		3800	10	1 (RB <sub>START</sub> =25)	3800			
CA_n71-n78	n71	681.5	5	25	635.5	11.4	FDD	IMD5
	n78	3361.5	10	50	3361.5	N/A	TDD	N/A
CA_n77-n85	n77	3540	10	50	3540	N/A	TDD	N/A
	n85	702	5	20	732	11.7	FDD	IMD5

NOTE 1: Both of the transmitters shall be set min(+23 dBm, P<sub>CMAX\_L,f,c</sub>) as defined in clause 6.2A.4

NOTE 2: RB<sub>START</sub> = 0, 15 kHz SCS is assumed.

NOTE 3: No requirements apply when there is at least one individual RE within the intermodulation generated by the dual uplink is within the downlink transmission bandwidth of the FDD band. The reference sensitivity should only be verified when this is not the case (the requirements specified in clause 7.3 apply).

NOTE 4: This band is subject to IMD5 also which MSD is not specified.

NOTE 5: Void.

NOTE 6: Void.

NOTE 7: In current release the maximum separation bandwidth class is 600MHz, therefore, no IMD2 MSD requirement apply for this CA configuration when two uplink sub blocks are assigned within CA\_77(2A).

NOTE8: For a UE which supports this band combination only when the Band n77 frequency range restriction of 3400 – 4100 MHz applies, the MSD test point(s) cannot be verified for the band combination and the test point(s) can be skipped.

NOTE 9: Void.

NOTE 10: Void.

NOTE 11: Void.

NOTE 12: This band supports intra-band non-contiguous uplink configuration.

NOTE 13: For a UE which supports this band combination only when the Band n77 frequency range restriction defined in NOTE 12 of Table 5.2-1 applies, the MSD test point(s) cannot be verified for the band combination and the test point(s) can be skipped.

NOTE 14: This band is subject to IMD6 also which MSD is not specified.

NOTE 15: This band is subject to IMD7 also which MSD is not specified.

NOTE 16: In Japan, n77 band is restricted to 3400 – 4100 MHz frequency range, and there are no valid MSD test points when using this restricted frequency range.

NOTE 17: Applicable when n41 spectrum is restricted to 2515-2675MHz

**Table 7.3A.5-1b: 2DL/2UL inter-band Reference sensitivity QPSK P<sub>REFSENS</sub> and uplink/downlink configurations for PC1.5 CA**

Band / Channel bandwidth / N <sub>RB</sub> / Duplex mode								Source of IMD
NR CA Configuration	NR band	UL F <sub>c</sub> (MHz)	UL/DL BW (MHz)	UL C <sub>LRB</sub>	DL F <sub>c</sub> (MHz)	MSD (dB)	Duplex mode	
CA_n2-n77	n2	1855	5	25	1935	35.2	FDD	IMD2
	n77	3790	10	50	3790	N/A	TDD	N/A
	n2	1900	5	25	1980	26.4	FDD	IMD4
	n77	3720	10	50	3720	N/A	TDD	N/A
	n2	1885	5	25	1965	28.0	FDD	IMD5
	n77	3810	10	50	3810	N/A	TDD	N/A
CA_n5-n77 <sup>2</sup>	n5	844	5	25	889	25.5	FDD	IMD4
	n77	3421	10	50	3421	N/A	TDD	N/A
	n5	826.5	5	25	871.5	24.3	FDD	IMD5
	n77	4177.5	10	50	4177.5	N/A	TDD	N/A
CA_n7-n77	n7	2540	5	25	2660	29.7	FDD	IMD4
	n77	3870	10	50	3870	N/A	TDD	N/A
CA_n25-n77	n25	1855	5	25	1935	37.5	FDD	IMD2

	n77	3790	10	50	3790	N/A	TDD	N/A
	n25	1900	5	25	1980	25.8	FDD	IMD4
	n77	3720	10	50	3720	N/A	TDD	N/A
	n25	1885	5	25	1965	29.8	FDD	IMD5
	n77	3790	10	50	3790	N/A	TDD	N/A
CA_n41-n71	n41	2614	5	25	2614	N/A	TDD	N/A
	n71	665	5	25	619	25.4	FDD	IMD4
CA_n66-n77	n66	1775	5	25	2175	40.0	FDD	IMD2
	n77	3950	10	50	3950	N/A	TDD	N/A
	n66	1760	5	25	2160	26.0	FDD	IMD5
	n77	3720	10	50	3720	N/A	TDD	N/A
CA_n70-n77	n70	1702.5	5	25	2002.5	41.8	FDD	IMD2
	n77	3705	10	50	3705	N/A	TDD	N/A
	n70	1697.5	5	25	1997.5	27.9	FDD	IMD5
	n77	3545	10	50	3545	N/A	TDD	N/A
CA_n71-n77	n71	681.5	5	25	635.5	16.0	FDD	IMD5 <sup>3</sup>
	n77	3361.5	10	50	3361.5	N/A	TDD	N/A

NOTE 1: This band combination is specified for inter-band UL CA with UL MIMO or Tx diversity capabilities, and the transmitter shall be set at min (+23 dBm, P<sub>C<sub>MAX</sub>L,f,c</sub>) for the band with single Tx antenna connector as defined in clause 6.2A.4, and set at min (+27.8 dBm, P<sub>C<sub>MAX</sub>L,f,c</sub>) for the band with two Tx antenna connectors as defined in clause 6.2H.3 or 6.2L.3.4.

NOTE 2: For a UE which supports this band combination only when the Band n77 frequency range restriction defined in NOTE 12 of Table 5.2-1 applies, the MSD test point(s) cannot be verified for the band combination and the test point(s) can be skipped.

NOTE 3: In current release the maximum separation bandwidth class is 600MHz, therefore, no IMD2 MSD requirement apply for this CA configuration when two uplink sub blocks are assigned within CA\_77(2A).

**Table 7.3A.5-2: 3DL/2UL interband Reference sensitivity QPSK P<sub>REFSENS</sub> and uplink/downlink configurations**

Band / Channel bandwidth / N <sub>RB</sub> / Duplex mode								Source of IMD
NR CA band combination	NR band	UL F <sub>c</sub> (MHz)	UL/DL BW (MHz)	UL L <sub>CRB</sub>	DL F <sub>c</sub> (MHz)	MSD (dB)	Duplex mode	
CA_n1-n3-n28	n1	1975	5	25	2165	N/A	FDD	N/A
	n28	710.5	5	25	765.5	N/A	FDD	N/A
	n3	N/A	5	N/A	1818.5	4.0	FDD	IMD5
	n3	1780	5	25	1875	N/A	FDD	N/A
	n28	710.5	5	25	765.5	N/A	FDD	N/A
	n1	N/A	5	N/A	2139	11.0	FDD	IMD4
CA_n1-n3-n40	n1	1950	5	25	2140	N/A	FDD	N/A
	n3	1735	5	25	1830	N/A	FDD	N/A
	n40	N/A	5	N/A	2380	8.0	TDD	IMD5
CA_n1-n3-n41	n1	1977.5	5	25	2167.5	N/A	FDD	N/A
	n3	1712.5	5	25	1807.5	N/A	FDD	N/A
	n41	N/A	10	N/A	2507.5	5.0	TDD	IMD5
CA_n1-n3-n77	n1	1950	5	25	2140	N/A	FDD	N/A
	n3	1750	5	25	1845	N/A	FDD	N/A
	n77	N/A	10	N/A	3700	28.4	TDD	IMD2 <sup>2</sup>
	n1	1950	5	25	2140	N/A	FDD	N/A
	n3	N/A	5	N/A	1807.5	31.5	FDD	IMD2 <sup>1,2</sup>
	n77	3757.5	10	50	3757.5	N/A	TDD	N/A
	n1	N/A	5	N/A	2140	31.0	FDD	IMD2 <sup>1</sup>
	n3	1775	5	25	1870	N/A	FDD	N/A
	n77	3915	10	50	3915	N/A	TDD	N/A
CA_n1-n3-n78	n1	1950	5	25	2140	N/A	FDD	N/A
	n3	1750	5	25	1845	N/A	FDD	N/A
	n78	N/A	10	N/A	3700	28.4	TDD	IMD2
	n1	1950	5	25	2140	N/A	FDD	N/A
	n3	1770	5	25	1865	N/A	FDD	N/A
	n78	N/A	10	N/A	3360	11.2	TDD	IMD4
	n1	1950	5	25	2140	N/A	FDD	N/A
	n3	N/A	5	N/A	1830	27.9	FDD	IMD2
	n78	3780	10	50	3780	N/A	TDD	N/A

CA_n1-n3-n79	n1	1930	5	25	2120	N/A	FDD	N/A	
	n3	1720	5	25	1815	N/A	FDD	N/A	
	n79	N/A	40	N/A	4950	4.7	TDD	IMD5	
	n3	1750	5	25	1845	N/A	FDD	N/A	
	n79	4860	40	216	4860	N/A	TDD	N/A	
CA_n1-n3-n105	n1	N/A	5	N/A	2140	3.6	FDD	IMD5	
	n1	1970	5	25	2160	N/A	FDD	N/A	
	n3	N/A	5	N/A	1855	4	FDD	IMD5	
	n105	695	5	25	644	N/A	FDD	N/A	
	n1	N/A	5	N/A	2160	5	FDD	IMD4	
CA_n1-n5-n7	n3	1775	5	25	1870	N/A	FDD	N/A	
	n105	695	5	25	644	N/A	FDD	N/A	
	CA_n1-n5-n7	n1	1968	5	25	2158	N/A	FDD	N/A
		n7	2512	10	50	2632	N/A	FDD	N/A
		n5	N/A	5	N/A	880	1.0	FDD	IMD5
CA_n1-n5-n28	n1	N/A	5	N/A	2123	4	FDD	IMD5	
	n5	829	5	25	874	N/A	FDD	N/A	
	n28	738	5	25	793	N/A	FDD	N/A	
	n1	1965	5	25	2155	N/A	FDD	N/A	
	n5	N/A	5	N/A	875	4.6	FDD	IMD5	
CA_n1-n5-n40	n28	710	5	25	765	N/A	FDD	N/A	
	n1	N/A	5	N/A	2144	4.0	FDD	IMD5	
	n5	832	5	25	877	N/A	FDD	N/A	
	n40	2320	5	25	2320	N/A	TDD	N/A	
	n1	1945	5	25	2135	N/A	FDD	N/A	
	n5	N/A	5	N/A	880	8.0	FDD	IMD4	
	n40	2385	5	25	2385	N/A	TDD	N/A	
	n1	1977.5	5	25	2167.5	N/A	FDD	N/A	
CA_n1-n5-n78	n5	826.5	5	25	871.5	N/A	FDD	N/A	
	n40	N/A	5	N/A	2305	9.0	TDD	IMD4	
	n1	N/A	5	N/A	2122	18.1	FDD	IMD3	
	n5	829	5	25	874	N/A	FDD	N/A	
	n78	3780	10	50	3780	N/A	TDD	N/A	
	n1	1975	5	25	2165	N/A	FDD	N/A	
	n5	N/A	5	N/A	885	3.1	FDD	IMD5	
	n78	3405	10	50	3405	N/A	TDD	N/A	
CA_n1-n5-n79	n1	1950	5	25	2140	N/A	FDD	N/A	
	n5	830	5	25	875	N/A	FDD	N/A	
	n78	N/A	10	N/A	3610	15.7	TDD	IMD3	
	n1	N/A	5	N/A	2160	1.2	FDD	IMD4	
	n5	830	5	25	875	N/A	FDD	N/A	
	n79	4650	40	100	4650	N/A	TDD	N/A	
	n1	1930	5	25	2120	N/A	FDD	N/A	
	n5	N/A	5	N/A	890	15.2	FDD	IMD3	
	n79	4750	40	100	4750	N/A	TDD	N/A	
	n1	1923	5	25	2113	N/A	FDD	N/A	
	n5	N/A	5	N/A	879	10.3	FDD	IMD4	
	n79	4890	40	100	4890	N/A	TDD	N/A	
	n1	1970	5	25	2160	N/A	FDD	N/A	
CA_n1-n5-n105	n5	845	5	25	890	N/A	FDD	N/A	
	n79	N/A	40	N/A	4785	14.9	TDD	IMD3	
	n1	1940	5	25	2130	N/A	FDD	N/A	
	n5	830	5	25	874	N/A	FDD	N/A	
	n79	N/A	40	N/A	4430	9.4	TDD	IMD4	
	n1	1925	5	25	2115	N/A	FDD	N/A	
	n5	846.5	5	25	891.5	N/A	FDD	N/A	
	n105	N/A	5	N/A	614.5	9.4	FDD	IMD4	
CA_n1-n7-n8	n1	1929	5	25	2119	N/A	FDD	N/A	
	n5	N/A	5	N/A	873	4.6	FDD	IMD5	
	n105	700.5	5	25	649.5	N/A	FDD	NA	
	n1	N/A	5	N/A	2162	16	FDD	IMD3	
	n5	830	5	25	875	N/A	FDD	N/A	
	n105	635	5	25	615	N/A	FDD	NA	
	n1	1977.5	5	25	2167.5	N/A	FDD	N/A	
n7	2502.5	5	25	2622.5	N/A	FDD	N/A		

	n8	N/A	5	N/A	927.5	1.0	FDD	IMD5
CA_n1-n7-n26	n1	1965	5	25	2155	N/A	FDD	N/A
	n7	2510	10	50	2630	N/A	FDD	N/A
	n26	N/A	5	N/A	875	3.5	FDD	IMD5
CA_n1-n7-n28	n1	1935	5	25	2125	N/A	FDD	N/A
	n7	N/A	10	N/A	2653	30.0	FDD	IMD2
	n28	718	5	25	773	N/A	FDD	N/A
	n1	1935	5	25	2125	N/A	FDD	N/A
CA_n1-n7-n40	n7	2510	10	50	2630	N/A	FDD	N/A
	n28	N/A	10	N/A	785	4.5	FDD	IMD5
	n1	1970	5	25	2160	N/A	FDD	N/A
	n7	N/A	5	N/A	2630	23	FDD	IMD3
CA_n1-n7-n40	n40	2390	5	25	2390	N/A	TDD	N/A
	n1	N/A	5	N/A	2120	16.4	FDD	IMD3
	n7	2530	5	25	2650	N/A	FDD	N/A
	n40	2310	5	25	2310	N/A	TDD	N/A
CA_n1-n7-n67	n1	1948	5	25	2138	N/A	FDD	N/A
	n7	2548	5	25	2668	N/A	FDD	N/A
	n67	N/A	5	N/A	748	3.3	SDL	IMD5
CA_n1-n7-n78	n1	1977.5	5	25	2167.5	N/A	FDD	N/A
	n7	N/A	5	N/A	2627.5	9.1	FDD	IMD4
	n78	3305	10	50	3305	N/A	TDD	N/A
	n1	N/A	5	N/A	2140	8.7	FDD	IMD4
	n7	2510	10	50	2630	N/A	FDD	N/A
	n78	3580	10	50	3580	N/A	TDD	N/A
	n1	1970	5	25	2160	N/A	FDD	N/A
CA_n1-n7-n105	n7	2520	5	25	2640	N/A	FDD	N/A
	n78	N/A	10	N/A	3390	10.1	TDD	IMD4
	n1	1935	5	25	2125	N/A	FDD	N/A
	n7	2565	10	50	2685	N/A	FDD	N/A
	n105	N/A	5	N/A	630	28.7	FDD	IMD2
	n1	1925	5	25	2115	N/A	FDD	N/A
	n7	2565	10	50	2565	N/A	FDD	N/A
CA_n1-n7-n105	n105	N/A	5	N/A	645	1	FDD	IMD5
	n1	1968.5	5	25	2158.5	N/A	FDD	N/A
	n7	N/A	5	N/A	2634.5	30	FDD	IMD2 <sup>2</sup>
	n105	666	5	25	615	N/A	FDD	N/A
	n1	1930	5	25	2120	N/A	FDD	N/A
	n8	N/A	5	N/A	930	8.0	FDD	IMD4
	n40	2395	5	25	2395	N/A	TDD	N/A
CA_n1-n8-n78	n1	1945	5	25	2135	N/A	FDD	N/A
	n8	900	5	25	945	N/A	FDD	N/A
	n78	N/A	10	N/A	3745	14.9	TDD	IMD3
	n1	1940	5	25	2130	N/A	FDD	N/A
	n8	N/A	5	N/A	940	3.3	FDD	IMD5
CA_n1-n8-n78	n78	3380	10	50	3380	N/A	TDD	N/A
	n1	1965	5	25	2155	N/A	FDD	N/A
	n28	708	5	25	763	N/A	FDD	N/A
	n18	N/A	5	N/A	867	4.6	FDD	IMD5
	n18	825	5	25	870	N/A	FDD	N/A
	n28	738	5	25	793	N/A	FDD	N/A
	n1	N/A	5	N/A	2127	4	FDD	IMD5
CA_n1-n18-n41	n1	1960	5	25	2150	N/A	FDD	N/A
	n41	2505	10	50	2505	N/A	TDD	N/A
	n18	N/A	5	N/A	870	3.3	FDD	IMD5
CA_n1-n18-n77	n1	1950	5	25	2140	N/A	FDD	N/A
	n18	825	5	25	870	N/A	FDD	N/A
	n77	N/A	10	N/A	3600	15.7	TDD	IMD3 <sup>1</sup>
	n1	1970	5	25	2160	N/A	FDD	N/A
	n77	3390	10	50	3390	N/A	TDD	N/A
	n18	N/A	5	N/A	870	3.5	FDD	IMD5
	n1	N/A	5	N/A	2120	16.4	FDD	IMD3
	n18	825	5	25	870	N/A	FDD	N/A
CA_n1-n26-n78	n77	3770	10	50	3770	N/A	TDD	N/A
	n1	N/A	5	N/A	2122	18.1	FDD	IMD3



	n26	829	5	25	874	N/A	FDD	N/A
	n78	3780	10	50	3780	N/A	TDD	N/A
	n1	1975	5	25	2165	N/A	FDD	N/A
	n26	N/A	5	N/A	885	3.1	FDD	IMD5
	n78	3405	10	50	3405	N/A	TDD	N/A
	n1	1950	5	25	2140	N/A	FDD	N/A
	n26	830	5	25	875	N/A	FDD	N/A
	n78	N/A	10	N/A	3610	15.7	TDD	IMD3
CA_n1-n28-n41	n1	1935	5	25	2125	N/A	FDD	N/A
	n28	718	5	25	773	N/A	FDD	N/A
	n41	N/A	10	N/A	2653	30.1	TDD	IMD2 <sup>2</sup>
	n1	1923	5	25	2113	N/A	FDD	N/A
	n41	2685	10	50	2685	N/A	TDD	N/A
	n28	N/A	5	N/A	762	29.3	FDD	IMD2 <sup>1</sup>
CA_n1-n28-n46	n1	1975	5	25	2165	N/A	FDD	N/A
	n28	710	5	25	765	N/A	FDD	N/A
	n46	N/A	20	N/A	5215	N/A	TDD	IMD4
	n1	1975	5	25	2165	N/A	FDD	N/A
	n28	N/A	5	N/A	765	10.5	FDD	IMD4
	n46	5160	20	100	5160	N/A	TDD	N/A
CA_n1-n28-n77	n1	1950	5	25	2140	N/A	FDD	N/A
	n28	733	5	25	788	N/A	FDD	N/A
	n77	N/A	10	N/A	3416	15.7	TDD	IMD3 <sup>2</sup>
	n1	1950	5	25	2140	N/A	FDD	N/A
	n77	3320	10	50	3320	N/A	TDD	N/A
	n28	N/A	5	N/A	790	4.2	FDD	IMD5
	n28	740	5	25	795	N/A	FDD	N/A
	n77	3630	10	50	3630	N/A	TDD	N/A
	n1	N/A	5	N/A	2150	15.7	FDD	IMD3
CA_n1-n28-n78	n1	N/A	5	N/A	2150	15.7	FDD	IMD3
	n28	740	5	25	795	N/A	FDD	N/A
	n78	3630	10	50	3630	N/A	TDD	N/A
	n1	1970	5	25	2160	N/A	FDD	N/A
	n28	N/A	5	N/A	794	4.2	FDD	IMD5
	n78	3352	10	50	3352	N/A	TDD	N/A
	n1	1950	5	25	2140	N/A	FDD	N/A
	n28	733	5	25	788	N/A	FDD	N/A
	n78	N/A	10	N/A	3416	15.7	TDD	IMD3
CA_n1-n28-n79	n1	1950	5	25	2140	N/A	FDD	N/A
	n28	730	5	25	785	N/A	FDD	N/A
	n79	N/A	40	N/A	4630	14.9	TDD	IMD3 <sup>1</sup>
	n1	1930	5	25	2120	N/A	FDD	N/A
	n79	4648	40	216	4648	N/A	TDD	N/A
	n28	N/A	5	N/A	788	15.2	FDD	IMD3 <sup>2</sup>
	n28	745.5	5	25	800.5	N/A	FDD	N/A
	n79	4420	40	216	4420	N/A	TDD	N/A
	n1	N/A	5	N/A	2167.5	1.2	FDD	IMD4 <sup>1</sup>
CA_n1-n28-n102	n1	1930	5	25	2120	N/A	FDD	N/A
	n28	706	5	25	761	N/A	FDD	N/A
	n102	N/A	40	N/A	5978	N/A <sup>12</sup>	TDD	IMD5
CA_n1-n40-n77	n1	1930	5	25	2120	N/A	FDD	N/A
	n40	2310	5	25	2310	N/A	TDD	N/A
	n77	N/A	10	N/A	3480	9.8	TDD	IMD4 <sup>1</sup>
	n1	1930	5	25	2120	N/A	FDD	N/A
	n40	N/A	5	N/A	2340	10.6	TDD	IMD4 <sup>1</sup>
	n77	3450	10	50	3450	N/A	TDD	N/A
	n1	N/A	5	N/A	2140	9.1	FDD	IMD4
	n40	2380	5	25	2380	N/A	TDD	N/A
	n77	3450	10	50	3450	N/A	TDD	N/A
CA_n1-n40-n78	n1	1930	5	25	2120	N/A	FDD	N/A
	n40	2310	5	25	2310	N/A	TDD	N/A
	n78	N/A	10	N/A	3480	9.8	TDD	IMD4 <sup>1</sup>
	n1	1930	5	25	2120	N/A	FDD	N/A
	n40	N/A	5	N/A	2340	10.6	TDD	IMD4
	n78	3450	10	50	3450	N/A	TDD	N/A

	n1	N/A	5	N/A	2140	9.1	FDD	IMD4
	n40	2380	5	25	2380	N/A	TDD	N/A
	n78	3450	10	50	3450	N/A	TDD	N/A
CA_n1-n40-n105	n1	1977	5	25	2167	N/A	FDD	N/A
	n40	2305	10	50	2305	N/A	TDD	N/A
	n105	N/A	5	N/A	649	1dB	FDD	IMD4
CA_n1-n41-n77	n1	1970	5	25	2160	N/A	FDD	N/A
	n41	2650	10	50	2650	N/A	TDD	N/A
	n77	N/A	10	N/A	3330	19.6	TDD	IMD3 <sup>1,2</sup>
	n1	1975	5	10	2165	N/A	FDD	N/A
	n77	3410	10	50	3410	N/A	TDD	N/A
	n41	N/A	10	N/A	2515	11.5	TDD	IMD4 <sup>1</sup>
	n41	2640	10	50	2640	N/A	TDD	N/A
	n77	3710	10	50	3710	N/A	TDD	N/A
	n1	N/A	5	N/A	2140	9.3	FDD	IMD4
CA_n1-n41-n79	n1	1970	5	25	2160	N/A	FDD	N/A
	n41	2530	10	50	2530	N/A	TDD	N/A
	n79	N/A	40	N/A	4500	19.0	TDD	IMD2 <sup>1</sup>
	n1	1970	5	25	2160	N/A	FDD	N/A
	n79	4500	40	216	4500	N/A	TDD	N/A
	n41	N/A	10	N/A	2530	29.4	TDD	IMD2 <sup>1</sup>
	n41	2530	10	50	2530	N/A	TDD	N/A
	n79	4690	40	216	4690	N/A	TDD	N/A
	n1	N/A	5	N/A	2160	29.9	FDD	IMD2 <sup>1</sup>
CA_n1-n46-n78	n1	1930	5	25	2120	N/A	FDD	N/A
	n46	5430	20	100	5430	N/A	TDD	N/A
	n78	N/A	10	N/A	3500	29	TDD	IMD2
	n1	N/A	5	N/A	2130	30	FDD	IMD2
	n46	5630	20	100	5630	N/A	TDD	N/A
	n78	3500	10	50	3500	N/A	TDD	N/A
	n1	N/A	5	N/A	2120	15	FDD	IMD3
	n46	5160	20	100	5160	N/A	TDD	N/A
	n78	3640	10	50	3640	N/A	TDD	N/A
	n1	1930	5	25	2120	N/A	FDD	N/A
	n46	N/A	20	N/A	5430	N/A	TDD	IMD2
	n78	3500	10	50	3500	N/A	TDD	N/A
	n1	1930	5	25	2120	N/A	FDD	N/A
	n46	N/A	20	N/A	5250	N/A	TDD	IMD3
	n78	3590	10	50	3590	N/A	TDD	N/A
CA_n1-n67-n78	n1	1970	5	25	2160	N/A	FDD	N/A
	n67	N/A	5	N/A	748	3.5	SDL	IMD5
	n78	3329	10	50	3329	N/A	TDD	N/A
CA_n1-n77-n79	n1	N/A	5	N/A	2140	15.6	FDD	IMD3 <sup>1,2</sup>
	n77	3400	10	50	3400	N/A	TDD	N/A
	n79	4660	40	216	4660	N/A	TDD	N/A
CA_n1-n78-n79	n1	1950	5	25	2140	N/A	FDD	N/A
	n78	3410	10	50	3410	N/A	TDD	N/A
	n79	N/A	40	N/A	4870	15.9	TDD	IMD3 <sup>1,3</sup>
	n1	1950	5	25	2140	N/A	FDD	N/A
	n78	N/A	10	N/A	3490	4.6	TDD	IMD5 <sup>3</sup>
	n79	4670	40	216	4670	N/A	TDD	N/A
	n1	N/A	5	N/A	2140	15.6	FDD	IMD3 <sup>1,2</sup>
	n78	3400	10	50	3400	N/A	TDD	N/A
	n79	4660	40	216	4660	N/A	TDD	N/A
CA_n1-n78-n102	n1	1970	5	25	2160	N/A	FDD	N/A
	n78	3320	5	25	3320	N/A	TDD	N/A
	n102	N/A	40	N/A	6020	N/A <sup>12</sup>	TDD	IMD5
	n1	N/A	5	N/A	2155	29.9	FDD	IMD2 <sup>1</sup>
	n78	3790	5	25	3790	N/A	TDD	N/A
	n102	5945	40	216	5945	N/A	TDD	N/A
CA_n1-n78-n105	n1	1970	5	25	2160	N/A	FDD	N/A
	n78	3305	10	50	3305	N/A	TDD	N/A
	n105	N/A	5	N/A	635	15.2	FDD	IMD3
	n1	1970	5	25	2160	N/A	FDD	N/A
	n78	N/A	10	N/A	3342	15.7	TDD	IMD3

	n105	686	5	25	635	N/A	FDD	N/A
	n1	N/A	5	N/A	2160	15.7	FDD	IMD3
	n78	3532	10	50	3532	N/A	TDD	N/A
	n105	686	5	25	635	N/A	FDD	N/A
CA_n2-n5-n30	n2	1870	5	25	1959	N/A	FDD	N/A
	n5	N/A	5	N/A	880	9.7	FDD	IMD4
	n30	2310	10	50	2355	N/A	FDD	N/A
CA_n2-n5-n41	n2	1855	10	50	1935	N/A	FDD	N/A
	n5	830	5	25	875	N/A	FDD	N/A
	n41	N/A	10	N/A	2685	30.0	TDD	IMD2
CA_n2-n5-n48	n2	N/A	5	N/A	1962	15.6	FDD	IMD3
	n5	839	5	25	884	N/A	FDD	N/A
	n48	3640	10	50	3640	N/A	TDD	N/A
	n2	1905	5	25	1985	N/A	FDD	N/A
	n5	844	5	25	889	N/A	FDD	N/A
	n48	N/A	10	50	3593	16.6	TDD	IMD3
CA_n2-n5-n66	n2	1900	5	25	1980	N/A	FDD	N/A
	n5	830	5	25	875	N/A	FDD	N/A
	n66	N/A	5	N/A	2140	7.2	FDD	IMD4
CA_n2-n5-n77	n2	1907.5	5	25	1987.5	N/A	FDD	N/A
	n5	N/A	5	N/A	887.5	3.8	FDD	IMD5 <sup>5</sup>
	n77	3305	10	50	3305	N/A	TDD	N/A
	n2	N/A	5	N/A	1987	16.5	FDD	IMD3 <sup>5</sup>
	n5	846.5	5	25	891.5	N/A	FDD	N/A
	n77	3680	10	50	3680	N/A	TDD	N/A
	n2	1880	5	25	1960	N/A	FDD	N/A
	n5	830	5	25	875	N/A	FDD	N/A
	n77	N/A	10	N/A	3540	16.0	TDD	IMD3 <sup>1</sup>
CA_n2-n12-n30	n2	1885	5	25	1965	N/A	FDD	N/A
	n12	708.5	5	25	738.5	N/A	FDD	N/A
	n30	N/A	5	N/A	2353	12.0	FDD	IMD4
CA_n2-n12-n71	n2	1907.5	5	25	1987.5	N/A	FDD	N/A
	n12	N/A	5	N/A	743.5	4.2	FDD	IMD5
	n71	665.5	5	25	649.5	N/A	FDD	N/A
CA_n2-n12-n77	n2	N/A	5	N/A	1960	16.5	FDD	IMD3 <sup>2,5</sup>
	n12	707.5	5	25	737.5	N/A	FDD	N/A
	n77	3375	10	50	3375	N/A	TDD	N/A
	n2	1900	5	25	1980	N/A	FDD	N/A
	n12	707.5	5	25	737.5	N/A	FDD	N/A
	n77	N/A	10	N/A	3315	16.0	TDD	IMD3 <sup>1,2,5</sup>
CA_n2-n14-n66	n2	1874	5	25	1954	N/A	FDD	N/A
	n14	793	5	25	763	N/A	FDD	N/A
	n66	N/A	5	N/A	2162	7.6	FDD	IMD4
	n2	N/A	5	N/A	1954	7.2	FDD	IMD4
	n14	793	5	25	763	N/A	FDD	N/A
	n66	1770	5	25	2170	N/A	FDD	N/A
CA_n2-n14-n77	n2	N/A	5	N/A	1954	16.5	FDD	IMD3
	n14	793	5	25	763	N/A	FDD	N/A
	n77	3540	10	50	3540	N/A	TDD	N/A
	n2	1880	5	25	1960	N/A	FDD	N/A
	n14	793	5	25	763	N/A	FDD	N/A
	n77	N/A	10	N/A	3466	16.0	TDD	IMD3 <sup>1</sup>
CA_n2-n30-n77	n2	N/A	5	N/A	1986	8.6	FDD	IMD4 <sup>5</sup>
	n30	2312	5	25	2357	N/A	FDD	N/A
	n77	3305	10	50	3305	N/A	TDD	N/A
	n2	1905	5	25	1985	N/A	FDD	N/A
	n30	N/A	5	N/A	2354	10.6	FDD	IMD4 <sup>5</sup>
	n77	3361	10	50	3361	N/A	TDD	N/A
	n2	1860	5	25	1940	N/A	FDD	N/A
	n30	N/A	5	N/A	2354	3.4	FDD	IMD5
	n77	3967	10	50	3967	N/A	TDD	N/A
	n2	1870	5	25	1950	N/A	FDD	N/A
	n30	2310	5	25	2355	N/A	FDD	N/A
	n77	N/A	10	N/A	4180	29.4	TDD	IMD2 <sup>2,5</sup>
CA_n2-n48-n66	n2	1855	5	25	1935	N/A	FDD	N/A

	n48	N/A	10	50	3625	32.0	TDD	IMD2
	n66	1770	5	25	2190	N/A	FDD	N/A
	n2	1905	5	25	1985	N/A	FDD	N/A
	n48	3560	10	50	3560	N/A	TDD	N/A
	n66	N/A	5	N/A	2155	12.1	FDD	IMD4
	n2	N/A	5	N/A	1960	28.3	FDD	IMD2 <sup>1</sup>
	n48	3695	10	50	3695	N/A	TDD	N/A
	n66	1735	5	25	2135	N/A	FDD	N/A
CA_n2-n66-n77	n2	1880	5	25	1960	N/A	FDD	N/A
	n66	1740	5	25	2140	N/A	FDD	N/A
	n77	N/A	10	N/A	3620	29.4	TDD	IMD2 <sup>5</sup>
	n2	1880	5	25	1960	N/A	FDD	N/A
	n66	1740	5	25	2140	N/A	FDD	N/A
	n77	N/A	10	N/A	3900	8.9	TDD	IMD4
	n2	1855	5	25	1935	N/A	FDD	N/A
	n66	N/A	5	N/A	2115	29.2	FDD	IMD2
	n77	3970	10	50	3970	N/A	TDD	N/A
	n2	1880	5	25	1960	N/A	FDD	N/A
	n66	N/A	5	N/A	2140	10.4	FDD	IMD4
	n77	3500	10	50	3500	N/A	TDD	N/A
	n2	1885	5	25	1965	N/A	FDD	N/A
	n66	N/A	5	N/A	2175	4.0	FDD	IMD5
	n77	3915	10	50	3915	N/A	TDD	N/A
	n2	N/A	5	N/A	1960	32.1	FDD	IMD2
	n66	1760	5	25	2160	N/A	FDD	N/A
	n77	3720	10	50	3720	N/A	TDD	N/A
	n2	N/A	5	N/A	1960	9.1	FDD	IMD4 <sup>5</sup>
	n66	1770	5	25	2170	N/A	FDD	N/A
	n77	3350	10	50	3350	N/A	TDD	N/A
	n2	N/A	5	N/A	1960	2.1	FDD	IMD5 <sup>5</sup>
	n66	1760	5	25	2160	N/A	FDD	N/A
	n77	3620	10	50	3620	N/A	TDD	N/A
CA_n3-n5-n7	n3	1780	5	25	1875	N/A	FDD	N/A
	n5	845	5	25	890	N/A	FDD	N/A
	n7	N/A	10	N/A	2625	30.0	FDD	IMD2 <sup>4</sup>
	n3	1720	5	25	1815	N/A	FDD	N/A
	n5	N/A	5	N/A	880	19.0	FDD	IMD3
	n7	2560	10	50	2680	N/A	FDD	N/A
CA_n3-n5-n28	n3	N/A	5	N/A	1829.5	8.7	FDD	IMD4
	n5	845	5	25	890	N/A	FDD	N/A
	n28	705.5	5	25	760.5	N/A	FDD	N/A
	n3	1713	5	25	1808	N/A	FDD	N/A
	n5	827	5	25	872	N/A	FDD	N/A
	n28	N/A	5	N/A	768	9.4	FDD	IMD4
CA_n3-n5-n78	n3	1730	5	25	1825	N/A	FDD	N/A
	n5	839	5	25	884	N/A	FDD	N/A
	n78	N/A	10	N/A	3408	16.1	TDD	IMD3
	n3	1730	5	25	1825	N/A	FDD	N/A
	n5	839	5	25	884	N/A	FDD	N/A
	n78	N/A	10	N/A	3512	4.5	TDD	IMD5
	n3	N/A	5	N/A	1862	15.7	FDD	IMD3
	n5	839	5	25	884	N/A	FDD	N/A
	n78	3540	10	50	3540	N/A	TDD	N/A
CA_n3-n5-n79	n3	N/A	5	N/A	1877.5	8.8	FDD	IMD4
	n5	846.5	5	25	891.5	N/A	FDD	N/A
	n79	4420	40	216	4420	N/A	TDD	N/A
	n3	1780	5	25	1875	N/A	FDD	N/A
	n5	N/A	5	N/A	860	15.3	FDD	IMD3
	n79	4420	40	216	4420	N/A	TDD	N/A
	n3	1770	5	25	1865	N/A	FDD	N/A
	n5	N/A	5	N/A	890	10.3	FDD	IMD4
	n79	4420	40	216	4420	N/A	TDD	N/A
	n3	1782.5	5	25	1875.5	N/A	FDD	N/A
	n5	846.5	5	25	891.5	N/A	FDD	N/A
	n79	N/A	40	N/A	4420	15.7	TDD	IMD3

	n3	1780	5	25	1875	N/A	FDD	N/A
	n5	846	5	25	891	N/A	FDD	N/A
	n79	N/A	40	N/A	4494	9.4	TDD	IMD4
CA_n3-n7-n8	n3	1735	5	25	1830	N/A	FDD	N/A
	n7	2530	10	50	2650	N/A	FDD	N/A
	n8	N/A	5	N/A	940	18.0	FDD	IMD3
	n3	1780	5	25	1875	N/A	FDD	N/A
	n7	N/A	10	N/A	2670	29.0	FDD	IMD2 <sup>11</sup>
	n8	890	5	25	935	N/A	FDD	N/A
CA_n3-n7-n20	n3	1747	5	25	1842	N/A	FDD	N/A
	n7	2543	10	50	2663	N/A	FDD	N/A
	n20	N/A	5	N/A	796	20.0	FDD	IMD2
	n3	1780	5	25	1875	N/A	FDD	N/A
	n7	N/A	10	N/A	2625	29.0	FDD	IMD2
	n20	845	5	25	804	N/A	FDD	N/A
	n3	1750	5	25	1845	N/A	FDD	N/A
	n7	N/A	5	25	N/A	17.0	FDD	IMD3
	n20	835	5	25	794	N/A	FDD	N/A
CA_n3-n7-n26	n3	1720	5	25	1815	N/A	FDD	N/A
	n7	2560	10	50	2680	N/A	FDD	N/A
	n26	N/A	5	N/A	880	17.5	FDD	IMD3
	n3	1780	5	25	1875	N/A	FDD	N/A
	n7	N/A	10	N/A	2625	29.0	FDD	IMD2 <sup>4</sup>
	n26	845	5	25	890	N/A	FDD	N/A
CA_n3-n7-n28	n3	1747	5	25	1842	N/A	FDD	N/A
	n7	2543	5	25	2663	N/A	FDD	N/A
	n28	N/A	5	N/A	796	20.0	FDD	IMD2
	n3	1712.5	5	25	1807.5	N/A	FDD	N/A
	n7	N/A	5	N/A	2682	17.0	FDD	IMD3
	n28	743	5	25	798	N/A	FDD	N/A
	n3	N/A	5	N/A	1832.5	26	FDD	IMD2
	n7	2543	5	25	2663	N/A	FDD	N/A
	n28	710.5	5	25	765.5	N/A	FDD	N/A
CA_n3-n7-n40	n3	1770	10	50	1865	4.5	FDD	IMD5
	n7	2525	10	50	2645	N/A	FDD	N/A
	n40	2305	10	50	2305	N/A	TDD	N/A
CA_n3-n7-n67	n3	1770	5	25	1865	N/A	FDD	N/A
	n7	2520	5	25	2640	N/A	FDD	N/A
	n67	N/A	5	N/A	750	20	SDL	IMD2
CA_n3-n7-n78	n3	N/A	5	N/A	1820	17.6	FDD	IMD3
	n7	2565	5	25	2685	N/A	FDD	N/A
	n78	3310	10	50	3310	N/A	TDD	N/A
	n3	N/A	5	N/A	1820	8.6	FDD	IMD4
	n7	2565	5	25	2685	N/A	FDD	N/A
	n78	3475	10	50	3475	N/A	TDD	N/A
	n3	1730	5	25	1825	N/A	FDD	N/A
	n7	2560	5	25	2680	N/A	FDD	N/A
	n78	N/A	10	N/A	3390	16.1	TDD	IMD3
CA_n3-n7-n105	n3	N/A	5	N/A	1875	16.5	FDD	IMD2
	n7	2550	5	25	2670	N/A	FDD	N/A
	n105	675	5	25	624	N/A	FDD	N/A
CA_n3-n8-n40	n3	N/A	5	N/A	1874	4	FDD	IMD5
	n8	912	5	25	957	N/A	FDD	N/A
	n40	2305	5	25	2305	N/A	TDD	N/A
CA_n3-n8-n41	n3	1722.5	5	25	1817.5	N/A	FDD	N/A
	n8	887.5	5	25	932.5	N/A	FDD	N/A
	n41	N/A	10	N/A	2610	28.0	FDD	IMD2 <sup>4</sup>
	n3	1725	5	25	1820	N/A	FDD	N/A
	n8	N/A	5	N/A	945	26.0	FDD	IMD2 <sup>4</sup>
	n41	2516	10	50	2516	N/A	FDD	N/A
CA_n3-n8-n78	n3	1730	5	25	1825	N/A	FDD	N/A
	n8	910	5	25	955	N/A	FDD	N/A
	n78	N/A	10	N/A	3550	16.1	TDD	IMD3
	n3	1730	5	25	1825	N/A	FDD	N/A
	n8	910	5	25	955	N/A	FDD	N/A

	n78	N/A	10	N/A	3370	4.5	TDD	IMD5
	n3	N/A	5	N/A	1820	15.7	FDD	IMD3
	n8	910	5	25	955	N/A	FDD	N/A
	n78	3640	10	50	3640	N/A	TDD	N/A
CA_n3-n8-n79	n3	1770	5	25	1865	N/A	FDD	N/A
	n8	885	5	25	930	N/A	FDD	N/A
	n79	N/A	40	N/A	4425	15.7	TDD	IMD3 <sup>2</sup>
	n3	1755	5	25	1850	N/A	FDD	N/A
	n8	N/A	5	N/A	955	15.3	FDD	IMD3
	n79	4465	40	216	4465	N/A	FDD	N/A
	n3	N/A	5	N/A	1850	8.8	FDD	IMD4
	n8	910	5	25	955	N/A	FDD	N/A
	n79	4580	40	216	4580	N/A	FDD	N/A
	CA_n3-n18-n28	n3	1712.5	5	25	1807.5	N/A	FDD
n28		N/A	5	N/A	770	9.4	FDD	IMD4
n18		827.5	5	25	872.5	N/A	FDD	N/A
CA_n3-n18-n41	n18	820	5	25	865	N/A	FDD	N/A
	n3	1720	5	25	1815	N/A	FDD	N/A
	n41	N/A	10	N/A	2540	[N/A]1	TDD	IMD2
	n18	820	5	25	865	N/A	FDD	N/A
	n3	1725	5	25	1820	N/A	FDD	N/A
	n41	N/A	10	N/A	2630	16.0	TDD	IMD3
	n18	N/A	5	N/A	865	28.9	FDD	IMD2
	n3	1765	5	25	1860	N/A	FDD	N/A
	n41	2630	10	50	2630	N/A	TDD	N/A
	n18	N/A	5	N/A	875	[19.0]	FDD	IMD3
	n3	1725	5	25	1820	N/A	FDD	N/A
	n41	2670	5	25	2670	N/A	TDD	N/A
	n3	N/A	5	N/A	1850	28.8	FDD	IMD2
n41	2670	10	50	2670	N/A	TDD	N/A	
CA_n3-n18-n77	n18	820	5	25	865	N/A	FDD	N/A
	n3	1770	5	25	1865	N/A	FDD	N/A
	n77	N/A	10	N/A	3410	16.3	TDD	IMD3 <sup>1,2</sup>
	n18	820	5	25	865	N/A	FDD	N/A
	n3	N/A	5	N/A	1865	15.7	FDD	IMD3
n77	3505	10	50	3505	N/A	TDD	N/A	
CA_n3-n20-n28	n3	N/A	5	N/A	1828	9.4	FDD	IMD4
	n20	852	5	25	811	N/A	FDD	N/A
	n28	728	5	25	783	N/A	FDD	N/A
	n3	1748	5	25	1843	N/A	FDD	N/A
	n20	847	5	25	806	N/A	FDD	N/A
n28	N/A	5	N/A	793	9.4	FDD	IMD4	
CA_n3-n20-n67	n3	1775	5	25	1870	N/A	FDD	N/A
	n20	840	5	25	799	N/A	FDD	N/A
	n67	N/A	5	N/A	745	9.4	FDD	IMD4
CA_n3-n20-n78	n3	1730	5	25	1825	N/A	FDD	N/A
	n20	845	5	25	804	N/A	FDD	N/A
	n78	N/A	10	N/A	3420	16.1	TDD	IMD3 <sup>1</sup>
	n3	N/A	5	N/A	1820	17.3	FDD	IMD3
	n20	845	5	25	804	N/A	FDD	N/A
n78	3510	10	50	3510	N/A	TDD	N/A	
CA_n3-n26-n78	n3	1730	5	25	1825	N/A	FDD	N/A
	n26	839	5	25	884	N/A	FDD	N/A
	n78	N/A	10	N/A	3408	16.1	TDD	IMD3
	n3	1730	5	25	1825	N/A	FDD	N/A
	n26	839	5	25	884	N/A	FDD	N/A
	n78	N/A	10	N/A	3512	4.5	TDD	IMD5
	n3	N/A	5	N/A	1862	15.7	FDD	IMD3
	n26	839	5	25	884	N/A	FDD	N/A
n78	3540	10	50	3540	N/A	TDD	N/A	
CA_n3-n28-n41	n3	1715	5	25	1810	N/A	FDD	N/A
	n28	743	5	25	798	N/A	FDD	N/A
	n41	N/A	5	N/A	2518	27.4	TDD	IMD2
	n3	1715	5	25	1810	N/A	FDD	N/A

	n28	743	5	25	798	N/A	FDD	N/A
	n41	N/A	5	N/A	2687	15.9	TDD	IMD3
	n3	1720	5	25	1815	N/A	FDD	N/A
	n41	2510	5	25	2510	N/A	TDD	N/A
	n28	N/A	5	N/A	790	26.0	FDD	IMD2 <sup>4</sup>
	n28	710.5	5	25	765.5	N/A	FDD	N/A
	n41	2543	10	50	2543	N/A	TDD	N/A
	n3	N/A	5	N/A	1832.5	26.0	FDD	IMD2
CA_n3-n28-n77	n3	1720	5	25	1815	N/A	FDD	N/A
	n28	733	5	25	788	N/A	FDD	N/A
	n77	N/A	10	N/A	4173	15.9	TDD	IMD3
	n28	735	5	25	790	N/A	FDD	N/A
	n77	3320	10	50	3320	N/A	TDD	N/A
	n3	N/A	5	N/A	1850	17.0	FDD	IMD3
	n3	1712.5	5	25	1807.5	N/A	FDD	N/A
	n77	4195	10	50	4195	N/A	TDD	N/A
	n28	N/A	5	N/A	770	15.3	FDD	IMD3
CA_n3-n28-n78	n28	735	5	25	790	N/A	FDD	N/A
	n78	N/A	10	N/A	3320	N/A	TDD	IMD3
	n3	1755	5	25	1850	17.3	FDD	N/A
	n3	1750	5	25	1845	N/A	FDD	N/A
	n28	743	5	25	798	N/A	FDD	N/A
	n78	N/A	10	N/A	3764	4.5	TDD	IMD5
CA_n3-n28-n79	n3	1770	5	25	1865	N/A	FDD	N/A
	n28	725	5	25	780	N/A	FDD	N/A
	n79	N/A	40	N/A	4585	9.4	TDD	IMD4 <sup>1</sup>
	n3	1770	5	25	1865	N/A	FDD	N/A
	n79	4530	40	216	4530	N/A	TDD	N/A
	n28	725	5	25	780	10.3	FDD	IMD4 $ 3 \cdot f_{Bn3} - f_{Bn79} $
	n28	725	5	25	780	N/A	FDD	N/A
	n79	4770	40	216	4770	N/A	TDD	N/A
	n3	1775	5	25	1870	5.7	FDD	IMD5 $ 4 \cdot f_{Bn28} - f_{Bn79} $
CA_n3-40-n41	n3	N/A	5	N/A	1842.5	1.0	FDD	IMD5
	n40	2347.5	5	25	2347.5	N/A	TDD	N/A
	n41	2600	10	50	2600	N/A	TDD	N/A
CA_n3-n40-n77	n3	1730	5	25	1825	N/A	FDD	N/A
	n40	2320	5	25	2320	N/A	TDD	N/A
	n77	N/A	10	N/A	4050	19.0	TDD	IMD2 <sup>1</sup>
	n3	1720	5	25	1815	N/A	FDD	N/A
	n40	N/A	5	N/A	2310	29.4	TDD	IMD2 <sup>1</sup>
	n77	4030	10	50	4030	N/A	TDD	N/A
	n3	N/A	5	N/A	1820	29.9	FDD	IMD2 <sup>2</sup>
	n40	2310	5	25	2310	N/A	TDD	N/A
	n77	4130	10	50	4130	N/A	TDD	N/A
CA_n3-n40-n105	n3	1745	5	25	1840	N/A	FDD	N/A
	n40	2380	10	50	2380	N/A	TDD	N/A
	n105	N/A	5	N/A	635	26.0	FDD	IMD2 <sup>4</sup>
	n3	1720	5	25	1815	N/A	FDD	N/A
	n40	N/A	10	N/A	2388	26.0	TDD	IMD2
	n105	668	5	25	617	N/A	FDD	N/A
CA_n3-n41-n77	n3	1720	5	25	1815	N/A	FDD	N/A
	n77	3900	10	50	3900	N/A	TDD	N/A
	n41	N/A	5	N/A	2640	5.3	TDD	IMD5
	n41	2620	5	25	2620	N/A	TDD	N/A
	n77	3400	10	50	3400	N/A	TDD	N/A
	n3	N/A	5	N/A	1840	16.4	FDD	IMD3
	n41	2580	5	25	2580	N/A	TDD	N/A
	n3	1720	5	25	1815	N/A	FDD	N/A
	n77	N/A	10	N/A	3440	16.8	TDD	IMD3 <sup>1</sup>
CA_n3-n41-n78	n3	1730	5	25	1825	N/A	FDD	N/A
	n41	2560	10	50	2560	N/A	TDD	N/A

	n78	N/A	10	N/A	3390	16.4	TDD	IMD3
	n3	N/A	5	N/A	1840	16.4	TDD	IMD3
	n41	2620	5	25	2620	N/A	FDD	N/A
	n78	3400	10	50	3400	N/A	TDD	N/A
CA_n3-n41-n79	n3	N/A	5	N/A	1850	29.4	FDD	IMD2 <sup>1</sup>
	n41	2570	10	50	2570	N/A	TDD	N/A
	n79	4420	40	216	4420	N/A	TDD	N/A
	n3	1770	5	25	1865	N/A	FDD	N/A
	n41	N/A	10	N/A	2670	30.2	TDD	IMD2 <sup>1</sup>
	n79	4440	40	216	4440	N/A	TDD	N/A
	n3	1770	5	25	1865	N/A	FDD	N/A
	n41	2670	10	50	2670	N/A	TDD	N/A
	n79	N/A	40	N/A	4440	30.8	TDD	IMD2 <sup>1</sup>
	CA_n3-n67-n78	n3	N/A	5	N/A	1877.5	2.2	FDD
n67		N/A	5	N/A	N/A	N/A	SDL	N/A
n78 <sup>10</sup>		3305	10	1 (RB <sub>START</sub> = 25)	3305	N/A	TDD	N/A
		3780	10	1 (RB <sub>START</sub> = 25)	3780			
CA_n3-n77-n79	n77	3350	10	50	3350	N/A	FDD	N/A
	n79	4840	40	216	4840	N/A	TDD	N/A
	n3	1765	5	25	1860	15.7	TDD	IMD3 <sup>1, 2</sup> $ 2 \cdot f_{Bn77} - f_{Bn79} $
CA_n3-n78-n105	n3	1730	5	25	1825	N/A	FDD	N/A
	n78	N/A	10	N/A	3740	17.3	TDD	IMD4 <sup>4</sup>
	n105	670	5	25	619	N/A	FDD	N/A
CA_n5-n7-n25	n5	830	5	25	875	N/A	FDD	N/A
	n7	N/A	5	N/A	2685	30.0	FDD	IMD2
	n25	1855	5	25	1935	N/A	FDD	N/A
CA_n5-n7-n66	n5	846.5	5	25	891.5	N/A	FDD	N/A
	n7	N/A	5	N/A	2624	29.0	FDD	IMD2
	n66	1777.5	5	25	2177.5	N/A	FDD	N/A
	n5	830	5	25	875	N/A	FDD	N/A
	n7	N/A	5	N/A	2670	13	FDD	IMD3
	n66	1750	5	25	2150	N/A	FDD	N/A
	n5	N/A	5	N/A	880	13	FDD	IMD3
	n7	2560	5	25	2680	N/A	FDD	N/A
	n66	1720	5	25	2120	N/A	FDD	N/A
	CA_n5-n7-n77	n5	844	5	25	889	N/A	FDD
n7		N/A	5	N/A	2645	30.1	FDD	IMD2
n77		3489	10	50	3489	N/A	TDD	N/A
n5		N/A	5	N/A	879	30.2	FDD	IMD2 <sup>1, 4</sup>
n7		2550	5	25	2670	N/A	FDD	N/A
n77		3429	10	50	3429	N/A	TDD	N/A
n5		827	5	25	852	N/A	FDD	N/A
n7		2503	5	25	2623	N/A	FDD	N/A
CA_n5-n7-n78	n77	N/A	10	N/A	3330	30.2	TDD	IMD2 <sup>2, 4</sup>
	n5	N/A	5	N/A	879	30.2	FDD	IMD2
	n7	2550	5	25	2670	N/A	FDD	N/A
	n78	3429	10	50	3429	N/A	TDD	N/A
	n5	N/A	5	N/A	875	3.3	FDD	IMD5
	n7	2525	5	25	2645	N/A	FDD	N/A
	n78	3350	10	50	3350	N/A	TDD	N/A
	n5	844	5	25	889	N/A	FDD	N/A
	n7	N/A	5	N/A	2645	30.1	FDD	IMD2
	n78	3489	10	50	3489	N/A	TDD	N/A
	n5	835	5	25	880	N/A	FDD	N/A
	n7	2540	5	25	2660	N/A	FDD	N/A
	n78	N/A	10	N/A	3375	29.7	TDD	IMD2
	n5	835	5	25	880	N/A	FDD	N/A
	n7	2550	5	25	2670	N/A	FDD	N/A
n78	N/A	10	N/A	3430	9.7	TDD	IMD4	
CA_n5-n7-n105	n5	834.5	5	25	879.5	N/A	FDD	N/A



	n7	N/A	5	N/A	2655	6.5	FDD	IMD5
	n105	683	5	25	632	N/A	FDD	N/A
CA_n5-n12-n77	n5	N/A	5	N/A	880	3.9	FDD	IMD5
	n12	707.5	5	25	737.5	N/A	FDD	N/A
	n77	3710	10	50	3710	N/A	TDD	N/A
	n5	835	5	25	880	N/A	FDD	N/A
	n12	N/A	5	N/A	740	4.4	FDD	IMD5 <sup>5</sup>
	n77	4080	10	50	4080	N/A	TDD	N/A
	n5	830	5	25	875	N/A	FDD	N/A
	n12	707.5	5	25	737.5	N/A	FDD	N/A
	n77	N/A	10	N/A	3905	4.4	TDD	IMD5
CA_n5-n14-n77	n5	N/A	5	N/A	880	3.9	FDD	IMD5 <sup>5</sup>
	n14	793	5	25	763	N/A	FDD	N/A
	n77	4052	10	50	4052	N/A	TDD	N/A
	n5	846.5	5	25	891.5	N/A	FDD	N/A
	n14	N/A	5	N/A	765.5	11.6	FDD	IMD4 <sup>1,5</sup>
	n77	3305	10	50	3305	N/A	TDD	N/A
	n5	840	5	25	885	N/A	FDD	N/A
	n14	793	5	25	763	N/A	FDD	N/A
n77	N/A	10	N/A	3313	10.3	TDD	IMD4 <sup>1,5</sup>	
CA_n5-n25-n41	n5	830	5	25	875	N/A	FDD	N/A
	n25	1855	5	25	1935	N/A	FDD	N/A
	n41	N/A	5	N/A	2685	30.0	TDD	IMD2
CA_n5-n25-n66	n5	834	5	25	879	N/A	FDD	N/A
	n25	1900	5	25	1980	N/A	FDD	N/A
	n66	N/A	5	N/A	2132	7.2	FDD	IMD4
CA_n5-n25-n77	n5	830	5	25	875	N/A	FDD	N/A
	n25	1880	5	25	1960	N/A	FDD	N/A
	n77	N/A	10	N/A	3540	16.0	TDD	IMD3
	n5	N/A	5	N/A	889	3.8	FDD	IMD5 <sup>5</sup>
	n25	1907	5	25	1987	N/A	FDD	N/A
	n77	3305	10	50	3305	N/A	TDD	N/A
	n5	846.5	5	25	891.5	N/A	FDD	N/A
	n25	N/A	5	N/A	1987	16.5	FDD	IMD3
	n77	3680	10	25	3680	N/A	TDD	N/A
CA_n5-n25-n78	n5	830	5	25	875	N/A	FDD	N/A
	n25	1900	5	25	1980	N/A	FDD	N/A
	n78	N/A	10	N/A	3560	16.1	TDD	IMD3
	n5	846.5	5	25	891.5	N/A	FDD	N/A
	n25	N/A	5	N/A	1987	16.5	FDD	IMD3
	n78	3680	10	50	3680	N/A	TDD	N/A
	n5	N/A	5	N/A	887.5	3.8	FDD	IMD5
	n25	1907.5	5	25	1987.5	N/A	FDD	N/A
	n78	3305	10	50	3305	N/A	TDD	N/A
CA_n5-n28-n78	n5	N/A	5	N/A	874	3.8	FDD	IMD5
	n28	723	5	25	778	N/A	FDD	N/A
	n78	3766	10	50	3756	N/A	TDD	N/A
	n5	844	5	25	889	N/A	FDD	N/A
	n28	N/A	5	N/A	778	11.6	FDD	IMD4
	n78	3310	10	50	3310	N/A	TDD	N/A
	n5	830	5	25	875	N/A	FDD	N/A
	n28	707	5	25	762	N/A	FDD	N/A
n78	N/A	10	N/A	3781	4.0	TDD	IMD5	
CA_n5-n28-n105	n5	845	5	25	890	N/A	FDD	N/A
	n28	740	5	25	795	N/A	FDD	N/A
	n105	686	5	25	635	25.0	FDD	IMD3
CA_n5-n29-n66	n5	830	5	25	875	N/A	FDD	N/A
	n29	N/A	5	N/A	720	9.4	SDL	IMD4
	n66	1770	5	25	2170	N/A	FDD	N/A
CA_n5-n29-n77	n5	845	5	25	890	N/A	FDD	N/A
	n29	N/A	5	N/A	720	4.4	SDL	IMD5 <sup>5</sup>
	n77	4100	10	50	4100	N/A	TDD	N/A
CA_n5-n30-n66	n5	830	5	25	875	N/A	FDD	N/A
	n30	2307.5	5	25	2352.5	N/A	FDD	N/A
	n66	N/A	5	N/A	2125	4	FDD	IMD5

CA_n5-n30-n77	n5	N/A	5	N/A	880	15.2	FDD	IMD3 <sup>1</sup>	
	n30	2310	5	25	2355	N/A	FDD	N/A	
	n77	3740	10	50	3740	N/A	TDD	N/A	
	n5	835	5	25	880	N/A	FDD	N/A	
	n30	N/A	5	N/A	2355	13.2	FDD	IMD3 <sup>5</sup>	
	n77	4025	10	50	4025	N/A	TDD	N/A	
	n5	840	5	25	885	N/A	FDD	N/A	
	n30	2310	5	25	2355	N/A	FDD	N/A	
CA_n5-n40-n78	n77	N/A	10	N/A	3780	16.1	TDD	IMD3	
	n5	N/A	5	N/A	880	15.2	FDD	IMD3	
	n40	2310	5	25	2310	N/A	TDD	N/A	
	n78	3740	10	50	3740	N/A	TDD	N/A	
	n5	840	5	25	885	N/A	FDD	N/A	
CA_n5-n40-n105	n40	2310	5	25	2310	N/A	TDD	N/A	
	n78	N/A	10	N/A	3780	16.1	TDD	IMD3	
	n5	836.5	5	25	881.5	N/A	FDD	N/A	
	n40	2305	5	25	2305	N/A	TDD	N/A	
	n105	N/A	5	N/A	632	17	FDD	IMD3	
CA_n5-n41-n66	n5	836.5	5	25	881.5	N/A	FDD	N/A	
	n40	N/A	5	N/A	2356	18.8	TDD	IMD3	
	n105	683	5	25	632	N/A	FDD	NA	
	n5	846.5	5	25	891.5	N/A	FDD	N/A	
	n41	N/A	10	N/A	2624	29.0	TDD	IMD2 <sup>4</sup>	
CA_n5-n41-n77	n66	1777.5	5	25	2177.5	N/A	FDD	N/A	
	n5	N/A	5	N/A	875	28.9	FDD	IMD2 <sup>4</sup>	
	n41	2640	10	50	2640	N/A	TDD	N/A	
	n66	1765	5	25	2165	N/A	FDD	N/A	
	n5	835	5	25	880	N/A	FDD	N/A	
CA_n5-n41-n77	n41	2540	5	25	2540	N/A	TDD	N/A	
	n77	N/A	10	N/A	3375	29.7	TDD	IMD2 <sup>2</sup>	
	n5	840	5	25	885	N/A	FDD	N/A	
	n41	2500	5	25	2500	N/A	TDD	N/A	
	n77	N/A	10	N/A	4160	16.1	TDD	IMD3	
	n5	844	5	25	889	N/A	FDD	N/A	
	n41	N/A	5	N/A	2645	30.1	TDD	IMD2	
	n77	3489	10	50	3489	N/A	TDD	N/A	
	n5	835	5	25	880	N/A	FDD	N/A	
	n41	N/A	5	N/A	2510	13.2	FDD	IMD3	
	n77	4180	10	50	4180	N/A	TDD	N/A	
	n5	N/A	5	N/A	879	30.2	FDD	IMD2	
	n41	2550	5	25	2550	N/A	TDD	N/A	
	n77	3429	10	50	3429	N/A	TDD	N/A	
	n5	N/A	5	N/A	900	15.2	FDD	IMD3 <sup>1</sup>	
	n41	2500	5	25	2500	N/A	TDD	N/A	
	n77	4100	10	50	4100	N/A	TDD	N/A	
	CA_n5-n48-n66	n5	829	5	25	874	N/A	FDD	N/A
		n48	N/A	10	N/A	3622	3.6	TDD	IMD5
		n66	1760	5	25	2160	N/A	FDD	N/A
CA_n5-n66-n77	n5	845	5	25	890	N/A	FDD	N/A	
	n66	1775	5	25	2175	N/A	FDD	N/A	
	n77	N/A	10	N/A	3465	16.1	TDD	IMD3	
	n5	826.5	5	25	871.5	N/A	FDD	N/A	
	n66	1712.5	5	25	2112.5	N/A	FDD	N/A	
	n77	N/A	10	N/A	4192	8.2	TDD	IMD4 <sup>5</sup>	
	n5	835	5	25	880	N/A	FDD	N/A	
	n66	1735	5	25	2135	N/A	FDD	N/A	
	n77	N/A	10	N/A	3535	3.3	TDD	IMD5	
	n5	826.5	5	25	871.5	N/A	FDD	N/A	
CA_n5-n66-n78	n66	N/A	5	N/A	2142	13.2	FDD	IMD3	
	n77	3795	10	50	3795	N/A	TDD	N/A	
	n5	830	5	25	875	N/A	FDD	N/A	
	n66	1720	5	25	2120	N/A	FDD	N/A	
	n78	N/A	10	N/A	3380	16.1	TDD	IMD3	
	n5	830	5	25	875	N/A	FDD	N/A	
	n66	N/A	5	N/A	2120	13.2	FDD	IMD3	

CA_n5-n78-n79	n78	3780	10	50	3780	N/A	TDD	N/A
	n5	846	5	25	891	N/A	FDD	N/A
	n78	3790	10	50	3790	N/A	TDD	N/A
	n79	N/A	40	N/A	4636	26.2	TDD	IMD2
	n5	827	5	25	872	N/A	FDD	N/A
	n78	3305	10	50	3305	N/A	TDD	N/A
	n79	N/A	40	N/A	4959	22	TDD	IMD3
	n5	827	5	25	872	N/A	FDD	N/A
	n78	N/A	10	N/A	3593	26.9	TDD	IMD2
	n79	4420	40	216	4420	N/A	TDD	N/A
	n5	827	5	25	872	N/A	FDD	N/A
	n78	N/A	10	N/A	3326	17	TDD	IMD3
	n79	4980	40	216	4980	N/A	TDD	N/A
	n5	N/A	5	N/A	880	16.2	FDD	IMD2
	n78	3550	10	50	3550	N/A	TDD	N/A
n79	4430	40	216	4430	N/A	TDD	N/A	
n5	N/A	5	N/A	875	3	FDD	IMD5	
n78	3305	10	50	3305	N/A	TDD	N/A	
n79	4520	40	216	4520	N/A	TDD	N/A	
CA_n5-n78-n105	n5	836.5	5	25	881.5	N/A	FDD	N/A
	n78	N/A	10	N/A	3568.5	4	TDD	IMD5
	n105	683	5	25	632	N/A	FDD	N/A
	n5	N/A	5	N/A	881.5	3.8	FDD	IMD5
	n78	3613.5	10	52	3613.5	N/A	TDD	N/A
CA_n7-n8-n40	n105	683	5	25	632	N/A	FDD	N/A
	n7	2530	5	25	2650	N/A	FDD	N/A
	n8	905	5	25	950	N/A	FDD	N/A
CA_n7-n8-n78	n40	N/A	5	N/A	2345	3.0	TDD	IMD5
	n7	2555	5	25	2675	N/A	FDD	N/A
	n8	900	5	25	945	N/A	FDD	N/A
	n78	N/A	10	N/A	3455	28.5	TDD	IMD2 <sup>2</sup>
	n7	2555	5	25	2675	N/A	FDD	N/A
	n8	N/A	5	N/A	945	29.7	FDD	IMD2
	n78	3500	10	50	3500	N/A	TDD	N/A
	n7	2520	5	25	2640	N/A	FDD	N/A
	n8	N/A	5	N/A	940	3.1	FDD	IMD5
	n78	3310	10	50	3310	N/A	TDD	N/A
CA_n7-n20-n67	n7	N/A	5	N/A	2650	28	FDD	IMD2
	n8	895	5	25	940	N/A	FDD	N/A
	n78	3545	10	50	3545	N/A	TDD	N/A
	n7	2565	10	50	2685	N/A	TDD	N/A
	n20	834.5	5	25	793.5	N/A	FDD	N/A
	n67	N/A	5	N/A	773	3.9	FDD	IMD5
	CA_n7-n20-n78	n7	2560	5	25	2680	N/A	FDD
n20		N/A	5	N/A	810	30.5	FDD	IMD2 <sup>1</sup>
n78		3370	10	50	3370	N/A	TDD	N/A
n7		2560	5	25	2680	N/A	FDD	N/A
n20		N/A	5	N/A	810	3.0	FDD	IMD5
n78		3435	10	50	3435	N/A	TDD	N/A
n7		N/A	5	N/A	2675	30.8	FDD	IMD2
n20		845	5	25	804	N/A	FDD	N/A
n78		3520	10	50	3520	N/A	TDD	N/A
n7		2540	5	25	2660	N/A	FDD	N/A
n20		835	5	25	794	N/A	FDD	N/A
n78		N/A	10	N/A	3375	29.7	TDD	IMD2 <sup>2</sup>
CA_n7-n25-n77	n7	N/A	5	N/A	2640	5.3	FDD	IMD5
	n25	1870	5	25	1950	N/A	FDD	N/A
	n77	4125	10	50	4125	N/A	TDD	N/A
	n7	2550	5	25	2670	N/A	FDD	N/A
	n25	N/A	5	N/A	1950	8.6	FDD	IMD4
	n77	3525	10	50	3525	N/A	TDD	N/A
	n7	2520	5	25	2640	N/A	FDD	N/A
CA_n7-n25-n78	n25	1905	5	25	1985	N/A	FDD	N/A
	n77	N/A	10	N/A	3750	4.5	TDD	IMD5
	n7	2550	5	25	2670	N/A	FDD	N/A

	n25	N/A	5	N/A	1950	8.6	FDD	IMD4
	n78	3525	10	50	3525	N/A	TDD	N/A
	n7	2520	5	25	2640	N/A	FDD	N/A
	n25	1905	5	25	1985	N/A	FDD	N/A
	n78	N/A	10	N/A	3750	4.5	TDD	IMD5
CA_n7-n26-n78	n7	2550	5	25	2670	N/A	FDD	N/A
	n26	N/A	5	N/A	879	30.2	FDD	IMD2
	n78	3429	10	50	3429	N/A	TDD	N/A
	n7	2525	5	25	2645	N/A	FDD	N/A
	n26	N/A	5	N/A	875	3.3	FDD	IMD5
	n78	3350	10	50	3350	N/A	TDD	N/A
	n7	N/A	5	N/A	2645	30.1	FDD	IMD2
	n26	844	5	25	889	N/A	FDD	N/A
	n78	3489	10	50	3489	N/A	TDD	N/A
	n7	2540	5	25	2660	N/A	FDD	N/A
	n26	835	5	25	880	N/A	FDD	N/A
	n78	N/A	10	N/A	3375	29.7	TDD	IMD2
CA_n7-n28-n40	n7	N/A	5	N/A	2630	5.9	FDD	IMD5
	n28	743	5	25	798	N/A	FDD	N/A
	n40	2310	5	25	2310	N/A	TDD	N/A
CA_n7-n28-n78	n7	2567.5	5	25	2687.5	N/A	FDD	N/A
	n28	N/A	5	N/A	782.5	28.8	FDD	IMD2
	n78	3350	10	50	3350	N/A	TDD	N/A
	n7	2567.5	5	25	2687.5	N/A	FDD	N/A
	n28	N/A	5	N/A	782.5	3.0	FDD	IMD5
	n78	3460	10	50	3460	N/A	TDD	N/A
	n7	N/A	5	N/A	2650	30.5	FDD	IMD2
	n28	740	5	25	795	N/A	FDD	N/A
	n78	3390	10	50	3390	N/A	TDD	N/A
	n7	2565	5	25	2685	N/A	FDD	N/A
	n28	745	5	25	800	N/A	FDD	N/A
	n78	N/A	10	N/A	3310	29.7	TDD	IMD2
	n7	2550	5	25	2670	N/A	FDD	N/A
	n28	720	5	25	775	N/A	FDD	N/A
	n78	N/A	10	N/A	3714	9.7	TDD	IMD4
CA_n7-n40-n78	n7	N/A	5	N/A	2630	10.1	FDD	IMD4
	n40	2310	5	25	2310	N/A	TDD	N/A
	n78	3625	10	50	3625	N/A	TDD	N/A
	n7	2510	5	25	2630	N/A	FDD	N/A
	n40	N/A	5	N/A	2310	8.7	TDD	IMD4
	n78	3785	10	50	3785	N/A	TDD	N/A
CA_n7-n40-n105	n7	N/A	5	N/A	2655	5.9	FDD	IMD5
	n40	2352	5	25	2352	N/A	TDD	N/A
	n105	683	5	25	632	N/A	FDD	N/A
CA_n7-n46-n78	n7	2530	5	25	2650	N/A	FDD	N/A
	n46	5840	20	100	5840	N/A	TDD	N/A
	n78	N/A	10	N/A	3310	29,7	TDD	IMD2 <sup>1</sup>
	n7	2530	5	25	2650	N/A	FDD	N/A
	n46	N/A	20	N/A	5840	25.2	TDD	IMD2 <sup>1</sup>
	n78	3310	10	50	3310	N/A	TDD	N/A
CA_n7-n66-n77	n7	2560	5	25	2680	N/A	FDD	N/A
	n66	1730	5	25	2130	N/A	FDD	N/A
	n77	N/A	10	N/A	3390	16.1	TDD	IMD3
	n7	2550	5	25	2670	N/A	FDD	N/A
	n66	N/A	5	N/A	2150	8.7	FDD	IMD4
	n77	3625	10	50	3625	N/A	TDD	N/A
	n7	N/A	5	N/A	2640	3.4	FDD	IMD5
	n66	1720	5	25	2120	N/A	FDD	N/A
	n77	3900	10	50	3900	N/A	TDD	N/A
	n7	2520	5	25	2640	N/A	FDD	N/A
	n66	1760	5	25	2160	N/A	FDD	N/A
	n77	N/A	10	N/A	4040	4.2	TDD	IMD5
CA_n7-n66-n78	n7	2560	5	25	2680	N/A	FDD	N/A
	n66	1730	5	25	2130	N/A	FDD	N/A
	n78	N/A	10	N/A	3390	16.1	TDD	IMD3

	n7	2550	5	25	2670	N/A	FDD	N/A
	n66	N/A	5	N/A	2150	8.7	FDD	IMD4
	n78	3625	10	50	3625	N/A	TDD	N/A
CA_n7-n67-n78	n7	2562	5	25	2682	N/A	FDD	N/A
	n67	N/A	5	N/A	748	28.8	SDL	IMD2 <sup>1</sup>
	n78	3310	10	50	3310	N/A	TDD	N/A
CA_n7-n71-n77	n7	2505	5	25	2625	N/A	FDD	N/A
	n71	666	5	25	620	N/A	FDD	N/A
	n77	N/A	10	N/A	3837	16.0	TDD	IMD3
	n7	N/A	5	N/A	2670	29.6	FDD	IMD2
	n71	680	5	25	634	N/A	FDD	N/A
	n77	3350	10	50	3350	N/A	TDD	N/A
CA_n7-n78-n102	n7	2560	5	25	2680	N/A	FDD	N/A
	n78	3420	5	25	3420	N/A	TDD	N/A
	n102	N/A	40	N/A	5980	N/A <sup>12</sup>	TDD	IMD2 <sup>1</sup>
	n7	2560	5	25	2680	N/A	FDD	N/A
	n78	N/A	5	N/A	3420	29.6	TDD	IMD2 <sup>1</sup>
	n102	5980	40	216	5980	N/A	TDD	N/A
	n7	N/A	5	N/A	2680	29.6	FDD	IMD2 <sup>1</sup>
	n78	3320	5	25	3320	N/A	TDD	N/A
	n102	6000	40	216	6000	N/A	TDD	N/A
CA_n7-n78-n105	n7	2555	5	25	2675	N/A	FDD	N/A
	n78	3520	10	50	3520	N/A	TDD	N/A
	n105	N/A	5	N/A	625	3.9	FDD	IMD5
	n7	2550	5	25	2670	N/A	FDD	N/A
	n78	N/A	10	N/A	3714	9.7	TDD	IMD4
	n105	693	5	25	642	N/A	FDD	N/A
	n7	N/A	5	N/A	2625	28.7	FDD	IMD2
	n78	3308	10	50	3308	N/A	TDD	N/A
	n105	683	5	25	632	N/A	FDD	N/A
CA_n8-n20-n28	n8	N/A	5	25	951.5	24.3	FDD	IMD3
	n20	834.5	5	25	793.5	N/A	FDD	N/A
	n28	717.5	5	25	772.5	N/A	FDD	N/A
	n8	887.5	5	25	932.5	N/A	FDD	N/A
	n20	834.5	5	25	793.5	N/A	FDD	N/A
	n28	N/A	5	25	781.5	24	FDD	IMD3
CA_n8-n28-n40	n8	N/A	5	N/A	928	17.0	FDD	IMD3
	n28	706	5	25	761	N/A	FDD	N/A
	n40	2340	5	25	2340	N/A	TDD	N/A
	n8	910	5	25	955	N/A	FDD	N/A
	n28	706	5	25	761	N/A	FDD	N/A
	n40	N/A	5	N/A	2322	18.8	TDD	IMD3
CA_n8-n28-n77	n8	N/A	5	N/A	928	3.8	FDD	IMD5
	n28	743	5	25	798	N/A	FDD	N/A
	n77	3900	10	50	3900	N/A	TDD	N/A
	n8	883	5	25	928	N/A	FDD	N/A
	n28	N/A	5	N/A	761	11.6	FDD	IMD4
	n77	3410	10	50	3410	N/A	TDD	N/A
	n8	883	5	25	928	N/A	FDD	N/A
	n28	745	5	25	800	N/A	FDD	N/A
	n77	N/A	10	N/A	3394	10.3	TDD	IMD4
	n8	883	5	25	928	N/A	FDD	N/A
	n28	745	5	25	800	N/A	FDD	N/A
	n77	N/A	10	N/A	3863	4.0	TDD	IMD5
CA_n8-n39-n40	n8	N/A	5	N/A	940	8.6	FDD	IMD4
	n39	1920	5	25	1920	N/A	TDD	N/A
	n40	2370	5	25	2370	N/A	TDD	N/A
	n8	N/A	5	N/A	950	4.3	FDD	IMD5
	n39	1910	5	25	1910	N/A	TDD	N/A
	n40	2390	5	25	2390	N/A	TDD	N/A
	n8	905	5	25	950	N/A	FDD	N/A
	n39	N/A	5	N/A	1905	3.5	TDD	IMD5
	n40	2310	5	25	2310	N/A	TDD	N/A
CA_n8-n39-n79	n8	900	5	25	945	N/A	FDD	N/A
	n39	1890	10	50	1890	N/A	TDD	N/A

	n79	N/A	40	N/A	4680	15.9	TDD	IMD3
	n8	890	5	25	935	N/A	FDD	N/A
	n39	1890	10	50	1890	N/A	TDD	N/A
	n79	N/A	40	N/A	4560	12.1	TDD	IMD4
	n8	897.5	5	25	942.5	N/A	FDD	N/A
	n39	N/A	10	N/A	1907.5	13.8	TDD	IMD4
	n79	4600	40	216	4600	N/A	TDD	N/A
	n8	N/A	5	N/A	940	15.1	FDD	IMD3
	n39	1900	10	50	1900	N/A	TDD	N/A
	n79	4740	40	216	4740	N/A	TDD	N/A
	n8	N/A	5	N/A	940	7.1	FDD	IMD4
	n39	1900	10	50	1900	N/A	TDD	N/A
	n79	4750	40	216	4750	N/A	TDD	N/A
CA_n8-n40-n41	n8	895	5	25	940	N/A	FDD	N/A
	n40	2355	5	25	2355	4.9	TDD	IMD5
	n41	N/A	10	N/A	2520	N/A	TDD	N/A
CA_n8-n40-n77	n8	N/A	5	N/A	950	30.5	FDD	IMD2 <sup>1</sup>
	n40	2380	5	25	2380	N/A	TDD	N/A
	n77	3330	10	50	3330	N/A	TDD	N/A
	n8	N/A	5	N/A	935	19.8	FDD	IMD3 <sup>1</sup>
	n40	2320	5	25	2320	N/A	TDD	N/A
	n77	3705	10	50	3705	N/A	TDD	N/A
	n8	910	5	25	955	N/A	FDD	N/A
	n40	N/A	5	N/A	2395	28	TDD	IMD2
	n77	3305	10	50	3305	N/A	TDD	N/A
	n8	910	5	25	955	N/A	FDD	N/A
	n40	N/A	5	N/A	2330	13.2	TDD	IMD3
	n77	4150	10	50	4150	N/A	TDD	N/A
	n8	910	5	25	955	N/A	FDD	N/A
	n40	2395	5	25	2395	N/A	TDD	N/A
	n77	N/A	10	N/A	3305	28.8	TDD	IMD2
	n8	910	5	25	955	N/A	FDD	N/A
	n40	2310	5	25	2310	N/A	TDD	N/A
	n77	N/A	10	N/A	4130	16.1	TDD	IMD3
CA_n8-n40-n78	n8	N/A	5	N/A	950	30.5	FDD	IMD2
	n40	2380	5	25	2380	N/A	TDD	N/A
	n78	3330	10	50	3330	N/A	TDD	N/A
	n8	N/A	5	N/A	935	19.8	FDD	IMD3
	n40	2320	5	25	2320	N/A	TDD	N/A
	n78	3705	10	50	3705	N/A	TDD	N/A
	n8	910	5	25	955	N/A	FDD	N/A
	n40	N/A	5	N/A	2395	28	TDD	IMD2
	n78	3305	10	50	3305	N/A	TDD	N/A
	n8	910	5	25	955	N/A	FDD	N/A
	n40	2395	10	50	2395	N/A	TDD	N/A
	n78	N/A	10	N/A	3305	28.8	TDD	IMD2 <sup>4</sup>
CA_n8-n40-n79	n8	885	5	25	930	N/A	FDD	N/A
	n40	2305	5	25	2305	N/A	TDD	N/A
	n79	N/A	40	N/A	4960	10.7	TDD	IMD4
	n8	885	5	25	930	N/A	FDD	N/A
	n40	N/A	5	N/A	2305	9.2	TDD	IMD4
	n79	4960	40	216	4960	N/A	TDD	N/A
CA_n8-n41-n79	n8	910	5	25	955	N/A	FDD	N/A
	n41	2650	10	50	2650	N/A	TDD	N/A
	n79	4470	10	50	4470	16.3	TDD	IMD3
	n8	910	5	25	955	N/A	FDD	N/A
	n41	2650	10	50	2650	15.5	TDD	IMD3
	n79	4470	10	50	4470	N/A	TDD	N/A
	n8	895	5	25	940	11.8	FDD	IMD3 <sup>1</sup>
	n41	2680	10	50	2680	N/A	TDD	N/A
	n79	4420	10	50	4420	N/A	TDD	N/A
CA_n12-n30-n77	n12	N/A	5	N/A	740	15.2	FDD	IMD3 <sup>1</sup>
	n30	2310	5	25	2355	N/A	FDD	N/A
	n77	3880	10	50	3880	N/A	TDD	N/A
	n12	707.5	5	25	737.5	N/A	FDD	N/A

	n30	N/A	5	N/A	2355	13.2	FDD	IMD3
	n77	3770	10	50	3770	N/A	TDD	N/A
	n12	707	5	25	737	N/A	FDD	N/A
	n30	2310	5	25	2355	N/A	FDD	N/A
	n77	N/A	10	N/A	3913	16.0	TDD	IMD3
CA_n12-n66-n77	n12	N/A	5	N/A	740	15.2	FDD	IMD3 <sup>5</sup>
	n66	1720	5	25	2120	N/A	FDD	N/A
	n77	4180	10	50	4180	N/A	TDD	N/A
	n12	707	5	25	737	N/A	FDD	N/A
	n66	N/A	5	N/A	2126	13.2	FDD	IMD3
	n77	3540	10	50	3540	N/A	TDD	N/A
	n12	704	5	25	734	N/A	FDD	N/A
	n66	1723	5	25	2123	N/A	FDD	N/A
	n77	N/A	10	N/A	4150	16.0	TDD	IMD3 <sup>1,2,5</sup>
CA_n12-n71-n77	n12	N/A	5	N/A	732	4.4	FDD	IMD5
	n71	693	5	25	647	N/A	FDD	N/A
	n77	3504	10	50	3504	N/A	TDD	N/A
	n12	711	5	25	741	N/A	FDD	N/A
	n71	N/A	5	N/A	646	3.9	FDD	IMD5
	n77	3490	10	50	3490	N/A	TDD	N/A
CA_n13-n25-n66	n13	782	5	25	751	N/A	FDD	N/A
	n66	N/A	5	N/A	2156	7.2	FDD	IMD4
	n25	1860	5	25	1940	N/A	FDD	N/A
	n13	780	10	50	749	N/A	FDD	N/A
	n25	N/A	5	N/A	1940	6.2	FDD	IMD4
	n66	1750	5	25	2150	N/A	FDD	N/A
CA_n13-n25-n77	n13	782	5	25	751	N/A	FDD	N/A
	n25	1896	5	25	1976	N/A	FDD	N/A
	n77	N/A	10	N/A	3460	17.3	TDD	IMD3 <sup>1,2</sup>
	n13	782	5	25	751	N/A	FDD	N/A
	n25	N/A	5	N/A	1960	16.0	FDD	IMD3
	n77	3524	10	50	3524	N/A	TDD	N/A
CA_n13-n66-n77	n13	782	5	25	751	N/A	FDD	N/A
	n66	N/A	5	N/A	2146	17.1	FDD	IMD3
	n77	3710	10	50	3710	N/A	TDD	N/A
	n13	N/A	5	N/A	750	15.2	FDD	IMD3 <sup>5</sup>
	n66	1710	5	25	2110	N/A	FDD	N/A
	n77	4170	10	50	4170	N/A	TDD	N/A
	n13	782	5	25	751	N/A	FDD	N/A
	n66	1770	5	25	2170	N/A	FDD	N/A
	n77	N/A	10	N/A	3334	16.3	TDD	IMD3 <sup>1,2,5</sup>
CA_n14-n30-n77	n14	N/A	5	N/A	763	15.2	FDD	IMD3 <sup>1</sup>
	n30	2310	5	25	2355	N/A	FDD	N/A
	n77	3857	10	50	3857	N/A	TDD	N/A
	n14	793	5	25	763	N/A	FDD	N/A
	n30	N/A	5	N/A	2355	13.2	FDD	IMD3
	n77	3941	10	50	3941	N/A	TDD	N/A
	n14	793	5	25	763	N/A	FDD	N/A
	n30	2310	5	25	2355	N/A	FDD	N/A
	n77	N/A	10	N/A	3896	16.0	TDD	IMD3
CA_n14-n66-n77	n14	N/A	5	N/A	763	15.2	FDD	IMD3 <sup>5</sup>
	n66	1712.5	5	25	2112.5	N/A	FDD	N/A
	n77	4188	10	50	4188	N/A	TDD	N/A
	n14	793	5	25	763	N/A	FDD	N/A
	n66	N/A	5	N/A	2155	13.2	FDD	IMD3
	n77	3741	10	50	3741	N/A	TDD	N/A
	n14	793	5	25	763	N/A	FDD	N/A
	n66	1755	5	25	2155	N/A	FDD	N/A
	n77	N/A	10	N/A	3341	16.0	TDD	IMD3 <sup>1,2,5</sup>
CA_n18-n28-n41	n18	825	5	25	870	N/A	FDD	N/A
	n28	738	5	25	793	N/A	FDD	N/A
	n41	N/A	10	N/A	2562	4.4	TDD	IMD5
	n18	825	5	25	870	N/A	FDD	N/A
	n41	2505	10	50	2505	N/A	TDD	N/A
	n28	N/A	5	N/A	795	3.9	FDD	IMD5

CA_n18-n28-n77	n18	820	5	25	865	N/A	FDD	N/A
	n28	710	5	25	765	N/A	FDD	N/A
	n77	N/A	10	N/A	3770	4.0	TDD	IMD5
	n18	820	5	25	865	N/A	FDD	N/A
	n28	N/A	5	N/A	778	4.4	FDD	IMD5
	n77	4058	10	50	4058	N/A	TDD	N/A
	n18	N/A	5	N/A	865	3.9	FDD	IMD5
	n28	723	5	25	778	N/A	FDD	N/A
CA_n18-n41-n77	n77	3757	10	50	3757	N/A	TDD	N/A
	n18	820	5	25	865	N/A	FDD	N/A
	n41	2570	5	25	2570	N/A	TDD	N/A
	n77	N/A	10	N/A	3390	30.1	TDD	IMD2 <sup>2,4</sup>
	n18	820	5	25	865	N/A	FDD	N/A
	n77	3450	10	50	3450	N/A	TDD	N/A
	n41	N/A	5	N/A	2630	28.5	TDD	IMD2 <sup>4</sup>
	n41	2590	10	50	2590	N/A	TDD	N/A
CA_n20-n67-n78	n77	3460	10	50	3460	N/A	TDD	N/A
	n18	N/A	5	N/A	870	29.3	FDD	IMD2 <sup>1,4</sup>
	n20	855	5	25	814	N/A	FDD	N/A
	n67	N/A	5	N/A	755	11.6	FDD	IMD4
CA_n24-n41-n48	n78	3320	10	50	3320	N/A	TDD	N/A
	n24	1649	5	25	1528.5	N/A	FDD	N/A
	n41	2610	5	25	2610	N/A	TDD	N/A
CA_n24-n41-n77	n48	N/A	10	N/A	3571	16.8	TDD	IMD3
	n24	1630	5	25	1528.5	N/A	FDD	N/A
	n41	N/A	5	N/A	2500	5.3	TDD	IMD5
	n48	3695	10	50	3695	N/A	TDD	N/A
	n24	N/A	5	N/A	1530	16.4	FDD	IMD3
	n41	2592.5	5	25	2592.5	N/A	TDD	N/A
	n48	3655	10	50	3655	N/A	TDD	N/A
	n24	1630	5	25	1528.5	N/A	FDD	N/A
CA_n24-n41-n77	n41	2685	5	25	2685	N/A	TDD	N/A
	n77	N/A	10	N/A	3735	16.8	TDD	IMD3 <sup>1,5</sup>
	n24	1630	5	25	1528.5	N/A	FDD	N/A
	n41	N/A	5	N/A	2610	5.3	TDD	IMD5 <sup>5</sup>
	n77	3755	10	50	3755	N/A	TDD	N/A
	n24	N/A	5	N/A	1528.5	16.4	FDD	IMD3 <sup>2,5</sup>
	n41	2500	5	25	2500	N/A	TDD	N/A
	n77	3465	10	50	3465	N/A	TDD	N/A
CA_n25-n38-n78	n25	N/A	5	N/A	1932.5	16.4	FDD	IMD3
	n38	2617.5	5	25	2617.5	N/A	TDD	N/A
	n78	3305	10	50	3305	N/A	TDD	N/A
	n25	1870	5	25	1950	N/A	FDD	N/A
	n38	2610	5	25	2610	N/A	TDD	N/A
	n78	N/A	10	N/A	3350	14.8	TDD	IMD3
	n25	N/A	5	N/A	1960	8.6	TDD	IMD4
	n38	2570	5	25	2570	N/A	FDD	N/A
CA_n25-n41-n66	n78	3550	10	50	3550	N/A	TDD	N/A
	n25	N/A	5	N/A	1940	11.0	FDD	IMD4
	n41	2685	10	50	2685	N/A	TDD	N/A
CA_n25-n41-n66	n66	1715	5	25	2115	N/A	FDD	N/A
	n25	N/A	5	25	1950	15.3	FDD	IMD3
	n41	2546	100	1 (RB <sub>start</sub> =24)	2546	N/A	TDD	N/A
		2641	90	1 (RB <sub>start</sub> =232)	2641			
	n66	1775	5	25	2195	N/A	FDD	N/A
	n25	1912.5	5	25	1992.5	N/A	FDD	N/A
	n41	2546	100	1 (RB <sub>start</sub> =260)	2546	N/A	TDD	N/A
		2641	90	1 (RB <sub>start</sub> =121)	2641			
n66	N/A	5	25	1962.5	15.3	FDD	IMD3	
CA_n25-n41-n77	n25	1870	5	25	1950	N/A	FDD	N/A
	n41	2670	5	25	2670	N/A	TDD	N/A
	n77	N/A	10	N/A	3470	14.8	TDD	IMD3
	n25	1900	5	25	1980	N/A	FDD	N/A
	n41	2525	5	25	2645	N/A	TDD	N/A
	n77	N/A	10	N/A	3775	4.2	TDD	IMD5



	n25	1870	5	25	1950	N/A	FDD	N/A
	n41	N/A	5	N/A	2640	5.3	TDD	IMD5 <sup>5</sup>
	n77	4125	10	50	4125	N/A	TDD	N/A
	n25	N/A	5	N/A	1950	17.6	FDD	IMD3 <sup>5</sup>
	n41	2675	5	25	2675	N/A	TDD	N/A
	n77	3400	10	50	3400	N/A	TDD	N/A
	n25	N/A	5	N/A	1950	8.6	FDD	IMD4
	n41	2550	5	25	2685	N/A	TDD	N/A
	n77	3525	10	50	3525	N/A	TDD	N/A
CA_n25-n41-n78	n25	1870	5	25	1950	N/A	FDD	N/A
	n41	2610	5	25	2610	N/A	TDD	N/A
	n78	N/A	10	N/A	3350	14.8	TDD	IMD3
	n25	1900	5	25	1980	N/A	FDD	N/A
	n41	2525	5	25	2645	N/A	TDD	N/A
	n78	N/A	10	N/A	3775	4.2	TDD	IMD5
	n25	N/A	5	N/A	1950	17.6	FDD	IMD3
	n41	2565	5	25	2565	N/A	TDD	N/A
	n78	3180	10	50	3310	N/A	TDD	N/A
	n25	N/A	5	N/A	1950	8.6	FDD	IMD4
	n41	2550	5	25	2685	N/A	TDD	N/A
	n78	3525	10	50	3475	N/A	TDD	N/A
CA_n25-n41-n85	n25	1900	5	25	1980	N/A	FDD	N/A
	n41	2638	10	50	2638	N/A	TDD	N/A
	n85	N/A	5	N/A	738	28.7	FDD	IMD2 <sup>4</sup>
	n25	1900	5	25	1980	N/A	FDD	N/A
	n41	N/A	5	N/A	2608	28.7	TDD	IMD2
	n85	708	5	25	738	N/A	FDD	N/A
	n25	N/A	5	N/A	1952	26	FDD	IMD2
	n41	2660	10	50	2660	N/A	TDD	N/A
	n85	708	5	50	738	N/A	FDD	N/A
CA_n25-n48-n66	n25	1900	5	25	1980	N/A	FDD	N/A
	n48	3540	10	50	3540	N/A	TDD	N/A
	n66	N/A	5	N/A	2160	10.4	FDD	IMD4
	n25	1880	5	25	1960	N/A	FDD	N/A
	n48	N/A	10	N/A	3620	29.4	TDD	IMD2
	n66	1740	5	25	2140	N/A	FDD	N/A
	n25	N/A	5	N/A	1960	32.1	FDD	IMD2 <sup>1</sup>
	n48	3700	10	50	3700	N/A	TDD	N/A
	n66	1740	5	25	2140	N/A	FDD	N/A
CA_n25-n66-n77	n25	1855	5	25	1935	N/A	FDD	N/A
	n66	N/A	5	N/A	2115	29.2	FDD	IMD2
	n77	3970	10	50	3970	N/A	TDD	N/A
	n25	1900	5	25	1980	N/A	FDD	N/A
	n66	N/A	5	N/A	2160	10.4	FDD	IMD4
	n77	3540	10	50	3540	10	TDD	N/A
	n25	1900	5	25	1980	N/A	FDD	N/A
	n66	N/A	5	N/A	2160	4.0	FDD	IMD5
	n77	3930	10	50	3930	N/A	TDD	N/A
	n25	N/A	5	N/A	1960	32.1	FDD	IMD2
	n66	1760	5	25	2160	N/A	FDD	N/A
	n77	3720	10	50	3720	N/A	TDD	N/A
	n25	N/A	5	N/A	1960	9.1	FDD	IMD4 <sup>5</sup>
	n66	1770	5	25	2170	N/A	FDD	N/A
	n77	3350	10	50	3350	N/A	TDD	N/A
	n25	N/A	5	N/A	1960	2.1	FDD	IMD5 <sup>5</sup>
	n66	1760	5	25	2160	N/A	FDD	N/A
	n77	3620	10	50	3620	N/A	TDD	N/A
	n25	1880	5	25	1960	N/A	FDD	N/A
	n66	1740	5	25	2140	N/A	FDD	N/A
	n77	N/A	10	N/A	3620	29.4	TDD	IMD2 <sup>5</sup>
	n25	1880	5	25	1960	N/A	FDD	N/A
	n66	1740	5	25	2140	N/A	FDD	N/A
	n77	N/A	10	N/A	3900	8.9	TDD	IMD4
CA_n25-n66-n78	n25	1880	5	25	1960	N/A	FDD	N/A
	n66	1740	5	25	2140	N/A	FDD	N/A

	n78	N/A	10	N/A	3620	29.4	TDD	IMD2
	n25	1900	5	25	1980	N/A	FDD	N/A
	n66	N/A	5	N/A	2150	10.4	FDD	IMD4
	n78	3550	10	50	3550	N/A	TDD	N/A
	n25	N/A	5	N/A	1960	32.1	FDD	IMD2 <sup>1,2</sup>
	n66	1760	5	25	2160	N/A	FDD	N/A
	n78	3720	10	50	3720	N/A	TDD	N/A
CA_n25-n66-n85	n25	N/A	5	N/A	1992.5	11.0	FDD	IMD4
	n66	1712.5	5	25	2112.5	N/A	FDD	N/A
	n85	713.5	5	25	743.5	N/A	FDD	N/A
CA_n25-n71-n77	n25	1907.5	5	25	1987.5	N/A	FDD	N/A
	n71	695.5	5	25	649.5	N/A	FDD	N/A
	n77	N/A	10	N/A	3305	8.0	TDD	IMD3 <sup>1,2,5</sup>
	n25	N/A	5	N/A	1954	16.5	FDD	IMD3 <sup>2,5</sup>
	n71	693	5	25	647	N/A	FDD	N/A
	n77	3340	10	50	3340	N/A	TDD	N/A
CA_n25-n71-n78	n25	1907.5	5	25	1987.5	N/A	FDD	N/A
	n71	695.5	5	25	649.5	N/A	FDD	N/A
	n78	N/A	10	N/A	3305	8.0	TDD	IMD3
	n25	N/A	5	N/A	1954	16.5	FDD	IMD3
	n71	693	5	25	647	N/A	FDD	N/A
	n78	3340	10	50	3340	N/A	TDD	N/A
CA_n25-n71-n85	n25	1912.5	5	25	1992.5	N/A	FDD	N/A
	n71	665.5	5	25	619.5	N/A	FDD	N/A
	n85	N/A	5	25	743.5	4.2	FDD	IMD5
CA_n25-n77-n85	n25	N/A	5	N/A	1960	16.5	FDD	IMD3 <sup>2</sup>
	n77	3375	10	50	3375	N/A	TDD	N/A
	n85	707.5	5	25	737.5	N/A	FDD	N/A
	n25	1900	5	25	1980	N/A	FDD	N/A
	n77	N/A	10	N/A	3315	16.0	TDD	IMD3 <sup>1,2</sup>
	n85	707.5	5	25	737.5	N/A	FDD	N/A
CA_n26-n29-n66	n26	830	5	25	875	N/A	FDD	N/A
	n29	N/A	5	N/A	720	9.4	SDL	IMD4
	n66	1770	5	25	2170	N/A	FDD	N/A
CA_n26-n48-n66	n26	829	5	25	874	N/A	FDD	N/A
	n48	N/A	10	N/A	3622	3.6	TDD	IMD5
	n66	1760	5	25	2160	N/A	FDD	N/A
CA_n26-n48-n70	n26	826.5	5	25	871.5	N/A	FDD	N/A
	n48	3653	10	50	3653	N/A	TDD	N/A
	n70	N/A	5	N/A	2000	13.2	FDD	IMD3
CA_n26-n66-n71	n26	N/A	5	N/A	892	4.2	FDD	IMD5
	n66	1770	5	25	2170	N/A	FDD	N/A
	n71	665.5	5	25	619.5	N/A	FDD	N/A
CA_n26-n66-n77	n26	845	5	25	890	N/A	FDD	N/A
	n66	1775	5	25	2175	N/A	FDD	N/A
	n77	N/A	10	N/A	3465	16.1	TDD	IMD3
	n26	826.5	5	25	871.5	N/A	FDD	N/A
	n66	1712.5	5	25	2112.5	N/A	FDD	N/A
	n77	N/A	10	N/A	4192	8.2	TDD	IMD4
	n26	835	5	25	880	N/A	FDD	N/A
	n66	1735	5	25	2135	N/A	FDD	N/A
	n77	N/A	10	N/A	3535	3.3	TDD	IMD5
	n26	826.5	5	25	871.5	N/A	FDD	N/A
	n66	N/A	5	N/A	2142	13.2	FDD	IMD3
	n77	3795	10	50	3795	N/A	TDD	N/A
CA_n26-n70-n77	n26	845	5	25	890	N/A	FDD	N/A
	n70	1700	5	25	2000	N/A	FDD	N/A
	n77	N/A	10	N/A	3390	16.1	TDD	IMD3 <sup>5</sup>
	n26	826.5	5	25	871.5	N/A	FDD	N/A
	n70	1700	5	25	2000	N/A	FDD	N/A
	n77	N/A	10	N/A	4179.5	8.2	TDD	IMD4 <sup>5</sup>
	n26	835	5	25	880	N/A	FDD	N/A
	n70	1700	5	25	2000	N/A	FDD	N/A
	n77	N/A	10	N/A	3430	3.3	TDD	IMD5 <sup>5</sup>
	n26	826.5	5	25	871.5	N/A	FDD	N/A

	n70	N/A	5	N/A	2000	13.2	FDD	IMD3 <sup>5</sup>
	n77	3653	10	50	3653	N/A	TDD	N/A
CA_n28-n39-n40	n28	N/A	5	N/A	790	8.6	FDD	IMD4
	n39	1915	5	25	1915	N/A	FDD	N/A
	n40	2310	5	25	2310	N/A	FDD	N/A
CA_n28-n39-n41	n28	N/A	5	N/A	762	29.3	FDD	IMD2
	n39	1923	5	25	1923	N/A	TDD	N/A
	n41	2685	10	50	2685	N/A	TDD	N/A
CA_n28-n39-n79	n28	715	5	25	770	N/A	FDD	N/A
	n39	1902.5	5	25	1902.5	N/A	TDD	N/A
	n79	4520	40	216	4520	6.7	TDD	IMD3
	n28	727.5	5	25	782.5	N/A	FDD	N/A
	n39	1902.5	5	25	1902.5	N/A	TDD	N/A
	n79	4980	40	216	4980	4.0	TDD	IMD4 <sup>1</sup>
	n28	715.5	5	25	770.5	N/A	FDD	N/A
	n39	1898	5	25	1898	5.7	TDD	IMD5
	n79	4760	40	216	4760	N/A	TDD	N/A
	n28	730	5	25	785	15.6	FDD	IMD3
	n39	1887.5	5	25	1887.5	N/A	TDD	N/A
	n79	4560	40	216	4560	N/A	TDD	N/A
	n28	725	5	25	780	8.5	FDD	IMD4
	n39	1900	5	25	1900	N/A	TDD	N/A
	n79	4920	40	216	4920	N/A	TDD	N/A
CA_n28-n40-n41	n28	N/A	5	N/A	765	7.6	FDD	IMD4
	n40	2302.5	5	25	2302.5	N/A	TDD	N/A
	n41	2685	10	50	2685	N/A	TDD	N/A
	n28	740	5	25	795	N/A	TDD	N/A
	n40	2380	5	25	2380	N/A	TDD	N/A
CA_n28-n40-n77	n41	N/A	10	N/A	2540	11.4	TDD	IMD5
	n28	N/A	5	N/A	800.5	11	FDD	IMD3 <sup>1</sup>
	n40	2302.5	5	25	2302.5	N/A	TDD	N/A
	n77	3795	10	50	3795	N/A	TDD	N/A
	n28	708	5	25	2120	N/A	FDD	N/A
	n40	2310	5	25	2310	N/A	TDD	N/A
	n77	N/A	10	N/A	3736	16.0	TDD	IMD3 <sup>2</sup>
	n28	708	5	25	763	N/A	FDD	N/A
CA_n28-n40-n78	n40	N/A	5	N/A	2134	15.7	TDD	IMD3
	n77	3550	10	50	3550	N/A	TDD	N/A
	n28	N/A	5	N/A	800.5	11	FDD	IMD3
	n40	2302.5	5	25	2302.5	N/A	TDD	N/A
	n78	3795	10	50	3795	N/A	TDD	N/A
	n28	708	5	25	2120	N/A	FDD	N/A
	n40	2310	5	25	2310	N/A	TDD	N/A
	n78	N/A	10	N/A	3736	16.0	TDD	IMD3 <sup>2</sup>
CA_n28-n40-n79	n28	708	5	25	763	N/A	FDD	N/A
	n40	N/A	5	N/A	2134	15.7	TDD	IMD3
	n78	3550	10	50	3550	N/A	TDD	N/A
	n28	730	5	25	785	N/A	FDD	N/A
	n40	2350	5	50	2350	N/A	TDD	N/A
	n79	N/A	40	N/A	4540	10.7	TDD	IMD4
	n28	720	5	25	775	N/A	FDD	N/A
	n40	N/A	5	N/A	2340	9.2	TDD	IMD4
CA_n28-n41-n77	n79	4500	40	216	4500	N/A	TDD	N/A
	n41	2642	5	25	2642	N/A	TDD	N/A
	n77	3440	10	50	3440	N/A	TDD	N/A
	n28	N/A	5	N/A	798	30.8	FDD	IMD2 <sup>4</sup>
	n41	2567.5	10	50	2567.5	N/A	TDD	N/A
	n77	3460	10	50	3460	N/A	TDD	N/A
	n28	N/A	5	N/A	782.5	3.0	FDD	IMD5
	n28	738	5	25	793	N/A	FDD	N/A
	n77	3380	10	50	3380	N/A	TDD	N/A
	n41	N/A	5	N/A	2642	29.5	TDD	IMD2
	n41	2580	5	25	2580	N/A	TDD	N/A
	n28	743	5	25	798	N/A	FDD	N/A
n77	N/A	10	N/A	3323	28.2	TDD	IMD2 <sup>4</sup>	

CA_n28-n41-n78	n28	738	5	25	793	N/A	FDD	N/A
	n78	3380	10	50	3380	N/A	TDD	N/A
	n41	N/A	5	N/A	2642	29.5	TDD	IMD2
	n41	2642	5	25	2642	N/A	TDD	N/A
	n78	3440	10	50	3440	N/A	TDD	N/A
	n28	N/A	5	N/A	798	30.8	FDD	IMD2 <sup>1</sup>
	n41	2565	5	25	2565	N/A	TDD	N/A
	n28	745	5	25	800	N/A	FDD	N/A
n78	N/A	10	N/A	3310	29.7	TDD	IMD2 <sup>2</sup>	
CA_n28-n41-n79	n28	N/A	5	N/A	780	13.0	FDD	IMD3 <sup>1</sup>
	n41	2600	10	50	2600	N/A	TDD	N/A
	n79	4420	40	216	4420	N/A	TDD	N/A
	n28	720	5	25	775	N/A	FDD	N/A
	n41	2600	10	50	2600	N/A	TDD	N/A
	n79	N/A	40	N/A	4480	10.1	TDD	IMD3 <sup>2</sup>
	n28	735	5	25	790	N/A	FDD	N/A
	n41	N/A	10	N/A	2645	10.4	TDD	IMD4
n79	4850	40	216	4850	N/A	TDD	N/A	
CA_n28-n46-n78	n28	710	5	25	765	N/A	FDD	N/A
	n46	5170	20	100	5170	N/A	FDD	N/A
	n78	N/A	10	N/A	3750	17	TDD	IMD3 <sup>1</sup>
	n28	N/A	5	N/A	780	16	FDD	IMD3
	n46	5900	20	100	5900	N/A	FDD	N/A
	n78	3340	10	50	3340	N/A	TDD	N/A
	n28	740	5	25	795	N/A	FDD	N/A
	n46	N/A	20	N/A	5900	22	TDD	IMD3 <sup>1,2</sup>
n78	3320	10	50	3320	N/A	TDD	N/A	
CA_n28-n77-n79	n77	3620	10	50	3620	N/A	TDD	N/A
	n79	4420	40	216	4420	N/A	TDD	N/A
	n28	745	5	25	800	16.2	FDD	IMD2 <sup>1,2</sup>
CA_n28-n78-n79	n28	740	5	25	795	N/A	FDD	N/A
	n78	3700	10	50	3700	N/A	TDD	N/A
	n79	N/A	40	N/A	4440	26.2	TDD	IMD2 <sup>1,3,4</sup>
	n28	740	5	25	795	N/A	FDD	N/A
	n78	N/A	10	N/A	3700	26.9	TDD	IMD2 <sup>3,4</sup>
	n79	4440	40	216	4440	N/A	TDD	N/A
	n28	N/A	5	N/A	800	16.2	FDD	IMD2 <sup>1</sup>
	n78	3620	10	50	3620	N/A	TDD	N/A
n79	4420	40	216	4420	N/A	TDD	N/A	
CA_n28-n78-n102	n28	710	5	25	765	N/A	FDD	N/A
	n78	3380	5	25	3380	N/A	TDD	N/A
	n102	N/A	40	N/A	6050	22	TDD	IMD3 <sup>1,2</sup>
	n28	730	5	25	785	N/A	FDD	N/A
	n78	N/A	5	N/A	3755	10.3	TDD	IMD4 <sup>1</sup>
	n102	5945	40	216	5945	N/A	TDD	N/A
	n28	N/A	5	N/A	775	16	FDD	IMD3 <sup>1,2</sup>
	n78	3395	5	25	3395	N/A	TDD	N/A
n102	6015	40	216	6015	N/A	TDD	N/A	
CA_n29-n30-n66	n29	N/A	5	N/A	719.5	4.5	SDL	IMD5
	n30	2307.5	5	25	2352.5	N/A	FDD	N/A
	n66	1777.5	5	25	2177.5	N/A	FDD	N/A
CA_n29-n30-n77	n29	N/A	5	N/A	722	15.2	SDL	IMD3 <sup>1</sup>
	n30	2310	5	25	2355	N/A	FDD	N/A
	n77	3898	10	50	3898	N/A	TDD	N/A
CA_n29-n66-n77	n29	N/A	5	N/A	722	15.2	SDL	IMD3 <sup>5</sup>
	n66	1734	5	25	2134	N/A	FDD	N/A
	n77	4190	10	50	4190	N/A	TDD	N/A
CA_n30-n66-n77	n30	N/A	5	N/A	2355	29.2	FDD	IMD2 <sup>5</sup>
	n66	1745	5	25	2145	N/A	FDD	N/A
	n77	4100	10	50	4100	N/A	TDD	N/A
	n30	N/A	5	N/A	2355	3.4	FDD	IMD5
	n66	1735	5	25	2135	N/A	FDD	N/A
	n77	3780	10	50	3780	N/A	TDD	N/A
	n30	2310	5	25	2355	N/A	FDD	N/A
n66	N/A	5	N/A	2160	8.7	FDD	IMD4 <sup>5</sup>	

	n77	3390	10	50	3390	N/A	TDD	N/A
	n30	2310	5	25	2355	N/A	FDD	N/A
	n66	1745	5	25	2145	N/A	FDD	N/A
	n77	N/A	10	N/A	4055	28.4	TDD	IMD2 <sup>1,5</sup>
CA_n34-n39-n40	n34	2022.5	5	25	2022.5	N/A	TDD	N/A
	n39	1882.5	5	25	1882.5	N/A	TDD	N/A
	n40	N/A	5	N/A	2302.5	2.4	TDD	IMD5
CA_n34-n40-n41	n34	N/A	5	N/A	2015	18.3	TDD	IMD3 <sup>1</sup>
	n40	2302.5	5	25	2302.5	N/A	TDD	N/A
	n41	2590	10	50	2590	N/A	TDD	N/A
	n34	2020	5	25	2020	N/A	TDD	N/A
	n40	2320	5	25	2320	N/A	TDD	N/A
	n41	2620	10	50	2620	16.5	TDD	IMD3
CA_n34-n41-n79	n34	2020	5	25	2020	N/A	TDD	N/A
	n41	2660	5	25	2660	N/A	TDD	N/A
	n79	4680	40	216	4680	19.3	TDD	IMD2
	n34	2020	5	25	2020	N/A	TDD	N/A
	n41	2550	5	25	2550	27.2	TDD	IMD2
	n79	4570	40	216	4570	N/A	TDD	N/A
	n34	2015	5	25	2015	28.6	TDD	IMD2
	n41	2585	5	25	2585	N/A	TDD	N/A
	n79	4600	40	216	4600	N/A	TDD	N/A
	n34	2015	5	25	2015	7.5	TDD	IMD5
	n41	2515	5	25	2515	N/A	TDD	N/A
	n79	4780	40	216	4780	N/A	TDD	N/A
CA_n38-n66-n78	n38	2550	5	25	2550	N/A	TDD	N/A
	n66	N/A	5	N/A	2150	8.7	FDD	IMD4
	n78	3625	10	50	3625	N/A	TDD	N/A
	n38	2610	5	25	2610	N/A	TDD	N/A
	n66	1760	5	25	2160	N/A	FDD	N/A
	n78	N/A	10	N/A	3460	15.0	TDD	IMD3
CA_n39-n40-n41	n39	1917.5	5	25	1917.5	N/A	TDD	N/A
	n40	2302.5	5	25	2302.5	N/A	TDD	N/A
	n41	N/A	10	N/A	2685	30.3	TDD	IMD3
	n39	N/A	5	N/A	1915	27.4	TDD	IMD3 <sup>1</sup>
	n40	2302.5	5	25	2302.5	N/A	TDD	N/A
	n41	2685	10	50	2685	N/A	TDD	N/A
CA_n39-n40-n79	n39	1917.5	5	25	1917.5	N/A	TDD	N/A
	n40	2302.5	5	25	2302.5	N/A	TDD	N/A
	n79	N/A	40	N/A	4980	5.8	TDD	IMD4
CA_n39-n41-n79	n39	N/A	N/A	N/A	N/A	N/A	TDD	N/A
	n41	N/A	N/A	N/A	N/A	N/A	TDD	N/A
	n79	N/A	N/A	N/A	N/A	N/A	TDD	IMD2 <sup>9</sup>
	n39	1900	5	25	1900	N/A	TDD	N/A
	n41	N/A	10	N/A	2650	29.8	TDD	IMD2 <sup>1</sup>
	n79	4550	40	216	4550	N/A	TDD	N/A
	n39	N/A	5	N/A	1900	28.9	TDD	IMD2 <sup>1</sup>
	n41	2650	10	50	2650	N/A	TDD	N/A
	n79	4550	40	216	4550	N/A	TDD	N/A
CA_n40-n41-n79	n40	2340	5	25	2340	N/A	TDD	N/A
	n41	2600	10	50	2600	N/A	TDD	N/A
	n79	N/A	40	N/A	4940	30.5	TDD	IMD2
	n40	N/A	5	N/A	2335	31	TDD	IMD2 <sup>1</sup>
	n41	2545	10	50	2545	N/A	TDD	N/A
	n79	4880	40	216	4880	N/A	TDD	N/A
	n40	2340	5	25	2340	N/A	TDD	N/A
	n41	N/A	10	N/A	2600	29.4	TDD	IMD2 <sup>1</sup>
	n79	4880	40	216	4940	N/A	TDD	N/A
CA_n40-n78-n105	n40	2310	5	25	2310	N/A	TDD	N/A
	n78	3789	10	50	3789	N/A	TDD	N/A
	n105	N/A	5	N/A	648	3.3	FDD	IMD5
	n40	2310	5	25	2310	N/A	TDD	N/A
	n78	N/A	10	N/A	3708	16	TDD	IMD3
	n105	699	5	25	648	N/A	FDD	N/A
	n40	N/A	5	N/A	2310	15.7	TDD	IMD3

	n78	3708	10	50	3708	N/A	TDD	N/A
	n105	699	5	25	648	N/A	FDD	N/A
CA_n41-n66-n77	n41	2600	5	25	2600	N/A	TDD	N/A
	n66	1730	5	25	2130	N/A	FDD	N/A
	n77	N/A	10	N/A	3470	16.1	TDD	IMD3 <sup>1,2</sup>
	n41	N/A	5	N/A	2670	5.2	TDD	IMD5 <sup>5</sup>
	n66	1715	5	25	2115	N/A	FDD	N/A
	n77	4190	10	50	4190	N/A	TDD	N/A
	n41	2640	5	25	2640	N/A	TDD	N/A
	n66	N/A	5	N/A	2160	9.0	FDD	IMD4
	n77	3720	10	50	3720	N/A	TDD	N/A
CA_n41-n66-n78	n41	2560	5	25	2560	N/A	TDD	N/A
	n66	1730	5	25	2130	N/A	FDD	N/A
	n78	N/A	10	N/A	3390	16.1	TDD	IMD3 <sup>1</sup>
	n41	2530	5	25	2530	N/A	TDD	N/A
	n66	N/A	5	N/A	2160	9.0	FDD	IMD4
CA_n41-n66-n85	n78	3610	10	50	3610	N/A	TDD	N/A
	n41	N/A	5	N/A	2498.5	27.6	TDD	IMD2
	n66	1777.5	5	25	2197.5	N/A	FDD	N/A
	n85	713.5	5	25	743.5	N/A	FDD	N/A
	n41	2501	5	25	2501	N/A	TDD	N/A
CA_n41-n70-n78	n66	1770	5	25	2190	N/A	FDD	N/A
	n85	N/A	5	N/A	731	31	FDD	IMD2 <sup>1</sup>
	n41	2655	10	50	2655	N/A	TDD	N/A
	n70	N/A	5	N/A	2000	17.6	FDD	IMD3
	n78	3310	10	50	3310	N/A	TDD	N/A
	n41	2565	10	50	2565	N/A	TDD	N/A
	n70	N/A	5	N/A	2000	8.6	FDD	IMD4
	n78	3565	10	50	3565	N/A	TDD	N/A
	n41	N/A	10	N/A	2480	5.3	TDD	IMD5
	n70	1700	5	25	2000	N/A	FDD	N/A
	n78	3790	10	50	3790	N/A	TDD	N/A
	n41	2545	10	50	2545	N/A	FDD	N/A
	n70	1700	5	25	2000	N/A	FDD	N/A
n78	N/A	10	N/A	3390	16.1	TDD	IMD3	
CA_n41-n71-n77	n41	2615	5	25	2615	N/A	TDD	N/A
	n71	693	5	25	647	N/A	FDD	N/A
	n77	N/A	10	N/A	3308	29.1	TDD	IMD2 <sup>1,5</sup>
	n41	2564	5	25	2564	N/A	TDD	N/A
	n71	693	5	25	647	N/A	FDD	N/A
	n77	N/A	10	N/A	3950	16.3	TDD	IMD3 <sup>1</sup>
	n41	2580	5	25	2580	N/A	TDD	N/A
	n71	693	5	25	647	N/A	FDD	N/A
	n77	N/A	10	N/A	3774	10.3	TDD	IMD4 <sup>1</sup>
	n41	N/A	5	N/A	2615	28.7	TDD	IMD2 <sup>5</sup>
	n71	693	5	25	647	N/A	FDD	N/A
	n77	3308	10	50	3308	N/A	TDD	N/A
	n41	N/A	5	N/A	2564	15.5	TDD	IMD3
	n71	693	5	25	647	N/A	FDD	N/A
	n77	3950	10	50	3950	N/A	TDD	N/A
	41	2680	5	25	2680	N/A	TDD	N/A
	n71	N/A	5	N/A	640	30.8	FDD	IMD2 <sup>5</sup>
	n77	3320	10	50	3320	N/A	TDD	N/A
	CA_n41-n71-n78	n41	2615	5	25	2615	N/A	TDD
n71		693	5	25	647	N/A	FDD	N/A
n78		N/A	10	N/A	3308	29.1	TDD	IMD2 <sup>1</sup>
n41		2580	5	25	2580	N/A	TDD	N/A
n71		693	5	25	647	N/A	FDD	N/A
n78		N/A	10	N/A	3774	10.3	TDD	IMD4 <sup>1</sup>
n41		N/A	5	N/A	2615	28.7	TDD	IMD2
n71		693	5	25	647	N/A	FDD	N/A
n78		3308	10	50	3308	N/A	TDD	N/A
41		2642	5	25	2642	N/A	TDD	N/A
n71		N/A	5	N/A	798	30.8	FDD	IMD2
n78		3440	10	50	3440	N/A	TDD	N/A

CA_n41-n77-n79	n77	3600	10	50	3600	N/A	TDD	N/A
	n79	4600	40	216	4600	N/A	TDD	N/A
	n41	N/A	10	N/A	2600	10.7	TDD	IMD3 <sup>1,2</sup>
CA_n41-n77-n85	n41	2687	5	25	2687	N/A	TDD	N/A
	n77	3420	10	50	3420	N/A	TDD	N/A
	n85	N/A	5	N/A	733	30.8	FDD	IMD2 <sup>5</sup>
	n41	N/A	5	N/A	2 619	29.5	TDD	IMD2 <sup>4,5</sup>
	n77	3320	10	50	3320	N/A	TDD	N/A
	n85	701	5	25	731	N/A	FDD	N/A
	n41	2680	5	25	2680	N/A	TDD	N/A
	n77	3393	10	N/A	3393	28.2	TDD	IMD2 <sup>4,5</sup>
CA_n46-n78-n102	n85	713	5	25	743	N/A	FDD	N/A
	n46	5315	20	100	5315	N/A	TDD	N/A
	n78	3770	10	50	3770	N/A	TDD	N/A
	n102	N/A	40	N/A	5995	N/A <sup>12</sup>	TDD	IMD4
	n46	N/A	10	N/A	5530	N/A <sup>12</sup>	TDD	IMD4
	n78	3550	10	50	3550	N/A	TDD	N/A
CA_n48-n66-n70	n102	6315	40	216	6315	N/A	TDD	N/A
	n48	3625	10	50	3625	N/A	TDD	N/A
	n66	N/A	5	N/A	2142.5	2.8	FDD	IMD5
	n70	1702.5	5	25	2002.5	N/A	FDD	N/A
	n48	3645	10	50	3645	N/A	TDD	N/A
CA_n48-n66-n71	n66	1762.5	5	25	2162.5	N/A	FDD	N/A
	n70	N/A	5	N/A	2002.5	3.1	FDD	IMD5
	n48	3552.5	10	50	3552.5	N/A	TDD	N/A
	n66	N/A	5	N/A	2161.5	14.4	FDD	IMD3
CA_n48-n66-n71	n71	695.5	5	25	649.5	N/A	FDD	N/A
	n48	N/A	10	N/A	3695	5.2	TDD	IMD4
	n66	1712.5	5	25	2112.5	N/A	FDD	N/A
	n71	665.5	5	25	619.5	N/A	FDD	N/A
	n48	N/A	10	N/A	3694	9	TDD	IMD4 <sup>1</sup>
	n70	1697.5	5	25	1997.5	N/A	FDD	N/A
CA_n48-n70-n71	n71	665.5	5	25	619.5	N/A	FDD	N/A
	n48	N/A	N/A	N/A	N/A	N/A	FDD	N/A
	n71	N/A	N/A	N/A	N/A	N/A	FDD	N/A
CA_n48-n71-n77	n77	N/A	N/A	N/A	N/A	N/A	FDD	IMD2 <sup>5</sup>
	n48	N/A	N/A	N/A	N/A	N/A	FDD	IMD2 <sup>5</sup>
	n71	N/A	N/A	N/A	N/A	N/A	FDD	N/A
	n77	N/A	N/A	N/A	N/A	N/A	FDD	N/A
	n48	N/A	N/A	N/A	N/A	N/A	FDD	N/A
CA_n66-n70-n77	n66	1757.5	5	25	2157.5	N/A	FDD	N/A
	n70	N/A	5	N/A	2007.5	32.1	FDD	IMD2 <sup>2,1</sup>
	n77	3765	10	50	3765	N/A	TDD	N/A
	n66	N/A	5	N/A	2162.5	29.2	FDD	IMD2 <sup>1</sup>
	n70	1702.5	5	25	2002.5	N/A	FDD	N/A
	n77	3865	10	50	3865	N/A	TDD	N/A
CA_n66-n70-n78	n66	1760	5	25	2160	N/A	FDD	N/A
	n70	N/A	5	N/A	2000	32.1	FDD	IMD2
	n78	3760	10	50	3760	N/A	TDD	N/A
	n66	1770	5	25	2170	N/A	FDD	N/A
	n70	N/A	5	N/A	2000	9.1	FDD	IMD4
	n78	3310	10	50	3310	N/A	TDD	N/A
	n66	1760	5	25	2160	N/A	FDD	N/A
	n70	N/A	5	N/A	2000	2.1	FDD	IMD5
	n78	3640	10	50	3640	N/A	TDD	N/A
	n66	N/A	5	N/A	2160	5.0	FDD	IMD5
	n70	1700	5	25	2000	N/A	FDD	N/A
	n78	3630	10	50	3630	N/A	TDD	N/A
CA_n66-n71-n77	n66	1720	5	25	2120	N/A	FDD	N/A
	n71	668	5	25	622	N/A	FDD	N/A
	n77	N/A	10	N/A	4108	15.9	TDD	IMD3 <sup>1,2,5</sup>
	n66	N/A	5	N/A	2150	15.5	FDD	IMD3 <sup>2</sup>
	n71	690	5	25	644	N/A	FDD	N/A
	n77	3530	10	50	3530	N/A	TDD	N/A
	n66	1720	5	25	2120	N/A	FDD	N/A
	n71	N/A	5	N/A	640	15.3	FDD	IMD3 <sup>5</sup>

CA_n66-n71-n78	n77	4080	10	50	4080	N/A	TDD	N/A
	n66	1720	5	25	2120	N/A	FDD	N/A
	n71	668	5	25	622	N/A	FDD	N/A
	n78	N/A	10	N/A	3724	9	TDD	IMD4 <sup>1</sup>
	n66	N/A	5	N/A	2160	15.5	FDD	IMD3
	n71	693	5	25	647	N/A	FDD	N/A
CA_n66-n77-n85	n78	3546	10	50	3546	N/A	TDD	N/A
	n66	1720	5	25	2120	N/A	FDD	N/A
	n77	4180	10	50	4180	N/A	TDD	N/A
	n85	N/A	5	N/A	740	23.5	FDD	IMD3 <sup>5</sup>
	n66	N/A	5	N/A	2124	21.4	FDD	IMD3
	n77	3540	10	50	3540	N/A	TDD	N/A
CA_n70-n71-n77	n85	708	5	25	738	N/A	FDD	N/A
	n70	N/A	N/A	N/A	N/A	N/A	FDD	N/A
	n71	N/A	N/A	N/A	N/A	N/A	FDD	N/A
	n77	N/A	N/A	N/A	N/A	N/A	TDD	IMD3 <sup>5</sup>
	n70	1702.5	5	25	2002.5	N/A	FDD	N/A
	n71	680.5	5	25	834.5	N/A	FDD	N/A
	n77	N/A	10	N/A	3745	8.2	TDD	IMD4
	n70	1702.5	5	25	2002.5	N/A	FDD	N/A
	n71	680.5	5	25	834.5	N/A	FDD	N/A
	n77	N/A	10	N/A	3745	3.3	TDD	IMD5
	n70	N/A	N/A	N/A	N/A	N/A	FDD	IMD3 <sup>5</sup>
	n71	N/A	N/A	N/A	N/A	N/A	FDD	N/A
	n77	N/A	N/A	N/A	N/A	N/A	TDD	N/A
	n70	N/A	N/A	N/A	N/A	N/A	FDD	IMD4 <sup>5</sup>
n71	N/A	N/A	N/A	N/A	N/A	FDD	N/A	
n77	N/A	N/A	N/A	N/A	N/A	TDD	N/A	

NOTE 1: This band is subject to IMD5 also which MSD is not specified.  
 NOTE 2: This band is subject to IMD4 also which MSD is not specified.  
 NOTE 3: The requirements only apply for UEs supporting inter-band carrier aggregation with simultaneous Rx/Tx capability. Simultaneous Rx/Tx capability does not apply for UEs supporting band n78 with a n77 implementation.  
 NOTE 4: This band is subject to IMD3 also which MSD is not specified.  
 NOTE 5: For a UE which supports this band combination only when the Band n77 frequency range restriction defined in NOTE 12 of Table 5.2-1 applies, the MSD test point(s) cannot be verified for the band combination and the test point(s) can be skipped.  
 NOTE 6: Void.  
 NOTE 7: Void.  
 NOTE 8: Both of the transmitters shall be set min(+20 dBm, P<sub>C<sub>MAX</sub>L,f,c</sub>) as defined in clause 6.2A.4  
 NOTE 9: There is no IMD2 product in band n79 downlink for n79 operating in 4800 – 5000 MHz frequency range.  
 NOTE 10: This band supports intra-band non-contiguous uplink configuration.  
 NOTE 11: This MSD requirement applies with both IMD2 and IMD3 products should be generated.  
 NOTE 12: This is a share spectrum access band, hence no MSD is defined.  
 NOTE 13: This band is also subject to a near missed IMD2 that is not specified and is not applicable for band n77 spectrum ranges of 3450-3550MHz and 3700-3980MHz.

**Table 7.3A.5-2a: 3DL/2UL interband Reference sensitivity QPSK P<sub>REFSENS</sub> and uplink/downlink configurations for PC2 CA**

Band / Channel bandwidth / N <sub>RB</sub> / Duplex mode								Source of IMD
NR CA band combination	NR band	UL F <sub>c</sub> (MHz)	UL/DL BW (MHz)	UL L <sub>CRB</sub>	DL F <sub>c</sub> (MHz)	MSD (dB)	Duplex mode	
CA_n1-n3-n77	n1	1950	5	25	2140	N/A	FDD	N/A
	n3	N/A	5	N/A	1807.5	37.5	FDD	IMD2 <sup>1,2</sup>
	n77	3757.5	10	50	3757.5	N/A	TDD	N/A
	n1	N/A	5	N/A	2140	37.0	FDD	IMD2 <sup>1</sup>
	n3	1775	5	25	1870	N/A	FDD	N/A
	n77	3915	10	50	3915	N/A	TDD	N/A
CA_n1-n3-n78	n1	1950	5	25	2140	N/A	FDD	N/A
	n3	N/A	5	N/A	1830	33.9	FDD	IMD2
	n78	3780	10	50	3780	N/A	TDD	N/A
CA_n1-n3-n79	n3	1750	5	25	1845	N/A	FDD	N/A



	n79	4860	40	216	4860	N/A	TDD	N/A
	n1	N/A	5	N/A	2140	18.7	FDD	IMD5
CA_n1-n7-n78	n1	1977.5	5	25	2167.5	N/A	FDD	N/A
	n7	N/A	5	N/A	2627.5	20.6	FDD	IMD4
	n78	3305	10	50	3305	N/A	TDD	N/A
	n1	N/A	5	N/A	2140	20.1	FDD	IMD4
	n7	2510	10	50	2630	N/A	FDD	N/A
	n78	3580	10	50	3580	N/A	TDD	N/A
CA_n1-n28-n41	n1	1923	5	25	2113	N/A	FDD	N/A
	n28	N/A	5	N/A	762	36.6	FDD	IMD2 <sup>1</sup>
	n41	2685	10	50	2685	N/A	TDD	N/A
CA_n1-n28-n77	n1	1950	5	25	2140	N/A	FDD	N/A
	n77	3320	10	50	3320	N/A	TDD	N/A
	n28	N/A	5	N/A	790	16.5	FDD	IMD5
	n28	740	5	25	795	N/A	FDD	N/A
	n77	3630	10	50	3630	N/A	TDD	N/A
	n1	N/A	5	N/A	2150	24.7	FDD	IMD3
CA_n1-n28-n78	n1	N/A	5	N/A	2150	24.6	FDD	IMD3
	n28	740	5	25	795	N/A	FDD	N/A
	n78	3630	10	50	3630	N/A	TDD	N/A
	n1	1970	5	25	2160	N/A	FDD	N/A
	n28	N/A	5	N/A	794	17.2	FDD	IMD5
	n78	3352	10	50	3352	N/A	TDD	N/A
CA_n1-n28-n79	n1	1930	5	25	2120	N/A	FDD	N/A
	n79	4648	40	216	4648	N/A	TDD	N/A
	n28	N/A	5	N/A	788	24.2	FDD	IMD3 <sup>2</sup>
	n28	745.5	5	25	800.5	N/A	FDD	N/A
	n79	4420	40	216	4420	N/A	TDD	N/A
	n1	N/A	5	N/A	2167.5	13.4	FDD	IMD4 <sup>1</sup>
CA_n1A-n77A-n79A	n1	1950	5	25	2140	24.6	FDD	IMD3 <sup>1,2</sup>
	n77	3400	10	50	3400	N/A	TDD	N/A
	n79	4660	40	216	4660	N/A	TDD	N/A
CA_n1-n41-n77	n1	1970	5	25	2160	N/A	FDD	N/A
	n41	2650	10	50	2650	N/A	TDD	N/A
	n77	N/A	10	N/A	3330	28.2	TDD	IMD3 <sup>1,2</sup>
	n1	1975	5	10	2165	N/A	FDD	N/A
	n77	3410	10	50	3410	N/A	TDD	N/A
	n41	N/A	10	N/A	2515	22.0	TDD	IMD4 <sup>1</sup>
	n41	2640	10	50	2640	N/A	TDD	N/A
	n77	3710	10	50	3710	N/A	TDD	N/A
	n1	N/A	5	N/A	2140	21.4	FDD	IMD4
CA_n2A-n5A-n77A	n2	1907.5	5	25	1987.5	N/A	FDD	N/A
	n5	N/A	5	N/A	887.5	13.6	FDD	IMD5 <sup>5</sup>
	n77	3305	10	50	3305	N/A	TDD	N/A
	n2	N/A	5	N/A	1987	24.8	FDD	IMD3 <sup>5</sup>
	n5	846.5	5	25	891.5	N/A	FDD	N/A
	n77	3680	10	50	3680	N/A	TDD	N/A
CA_n2A-n12A-n77A	n2	N/A	5	N/A	1960	24.8	FDD	IMD3 <sup>2,5</sup>
	n12	707.5	5	25	737.5	N/A	FDD	N/A
	n77	3375	10	50	3375	N/A	TDD	N/A
CA_n2A-n14A-n77A	n2	N/A	5	N/A	1954	24.8	FDD	IMD3
	n14	793	5	25	763	N/A	FDD	N/A
	n77	3540	10	50	3540	N/A	TDD	N/A
CA_n2A-n30A-n77A	n2	N/A	5	N/A	1986	19.3	FDD	IMD4 <sup>5</sup>
	n30	2312	5	25	2357	N/A	FDD	N/A
	n77	3305	10	50	3305	N/A	TDD	N/A
	n2	1905	5	25	1985	N/A	FDD	N/A
	n30	N/A	5	N/A	2354	22.2	FDD	IMD4 <sup>5</sup>
	n77	3361	10	50	3361	N/A	TDD	N/A
	n2	1860	5	25	1940	N/A	FDD	N/A
	n30	N/A	5	N/A	2354	12.9	FDD	IMD5
	n77	3967	10	50	3967	N/A	TDD	N/A
CA_n2-n66-n77	n2	1855	5	25	1935	N/A	FDD	N/A
	n66	N/A	5	N/A	2115	34.7	FDD	IMD2 <sup>1,2</sup>
	n77	3970	10	50	3970	N/A	TDD	N/A

	n2	N/A	5	N/A	1960	37.6	FDD	IMD2 <sup>1,2</sup>
	n66	1760	5	25	2160	N/A	FDD	N/A
	n77	3720	10	50	3720	N/A	TDD	N/A
CA_n3-n7-n78	n3	N/A	5	N/A	1820	26.6	FDD	IMD3
	n7	2565	5	25	2685	N/A	FDD	N/A
	n78	3310	10	50	3310	N/A	TDD	N/A
	n3	N/A	5	N/A	1820	17	FDD	IMD4
	n7	2565	5	25	2685	N/A	FDD	N/A
	n78	3475	10	50	3475	N/A	TDD	N/A
CA_n3-n18-n77	n18	820	5	25	865	N/A	TDD	N/A
	n3	N/A	5	N/A	1865	24.2	FDD	IMD3
	n77	3505	10	50	3505	N/A	TDD	N/A
CA_n3-n28-n41	n3	1720	5	25	1815	N/A	FDD	N/A
	n28	N/A	5	N/A	790	32	FDD	IMD2 <sup>4</sup>
	n41	2510	5	25	2510	N/A	TDD	N/A
	n3	N/A	5	N/A	1832.5	32	FDD	IMD2
	n28	710.5	5	25	765.5	N/A	FDD	N/A
	n41	2543	10	50	2543	N/A	TDD	N/A
CA_n3-n28-n77	n3	1712.5	5	25	1807.5	N/A	FDD	N/A
	n28	N/A	5	N/A	770	24.2	FDD	IMD3
	n77	4195	10	50	4195	N/A	TDD	N/A
	n3	N/A	5	N/A	1850	25.8	FDD	IMD3 <sup>2</sup>
	n28	735	5	25	790	N/A	FDD	N/A
	n77	3320	10	50	3320	N/A	TDD	N/A
CA_n3-n28-n78	n3	N/A	5	N/A	1850	29.2	FDD	IMD3
	n28	735	5	25	790	N/A	FDD	N/A
	n78	3320	10	50	3320	N/A	TDD	N/A
CA_n3-n28-n79	n3	1770	5	25	1865	N/A	FDD	N/A
	n79	4530	40	216	4530	N/A	TDD	N/A
	n28	N/A	5	N/A	780	21.5	FDD	IMD4 $ 3 \cdot f_{Bn3} - f_{Bn79} $
	n28	725	5	25	780	N/A	FDD	N/A
	n79	4770	40	216	4770	N/A	TDD	N/A
	n3	N/A	5	N/A	1870	20.5	FDD	IMD5 $ 4 \cdot f_{Bn28} - f_{Bn79} $
CA_n3-n41-n77	n3	1720	5	25	1815	N/A	FDD	N/A
	n41	2580	5	25	2580	N/A	TDD	N/A
	n77	N/A	10	N/A	3440	25.6	TDD	IMD3 <sup>1</sup>
	n3	N/A	5	N/A	1840	25.1	FDD	IMD3 <sup>2</sup>
	n41	2620	5	25	2620	N/A	TDD	N/A
	n77	3400	10	50	3400	N/A	TDD	N/A
	n3	1720	5	25	1815	N/A	FDD	N/A
	n41	N/A	5	N/A	2640	13	TDD	IMD5
	n77	3900	10	50	3900	N/A	TDD	N/A
CA_n3-n77-n79	n77	3350	10	50	3350	N/A	FDD	N/A
	n79	4840	40	216	4840	N/A	TDD	N/A
	n3	1765	5	25	1860	24.2	TDD	IMD3 <sup>1,2</sup> $ 2 \cdot f_{Bn77} - f_{Bn79} $
CA_n5-n7-n77	n5	N/A	5	N/A	879	35.2	FDD	IMD2 <sup>1,4</sup>
	n7	2550	5	25	2670	N/A	FDD	N/A
	n77	3429	10	50	3429	N/A	TDD	N/A
	n5	844	5	25	889	N/A	FDD	N/A
	n7	N/A	5	N/A	2645	35.1	FDD	IMD2
	n77	3489	10	50	3489	N/A	TDD	N/A
CA_n5-n7-n78	n5	N/A	5	N/A	879	35.2	FDD	IMD2 <sup>1</sup>
	n7	2550	5	25	2670	N/A	FDD	N/A
	n78	3429	10	50	3429	N/A	TDD	N/A
	n5	844	5	25	889	N/A	FDD	N/A
	n7	N/A	5	N/A	2645	35.1	FDD	IMD2
	n78	3489	10	50	3489	N/A	TDD	N/A
CA_n5A-n12A-n77A	n5	N/A	5	N/A	880	14.0	FDD	IMD5
	n12	707.5	5	25	737.5	N/A	FDD	N/A
	n77	3710	10	50	3710	N/A	TDD	N/A

	n5	835	5	25	880	N/A	FDD	N/A
	n12	N/A	5	N/A	740	14.9	FDD	IMD5 <sup>5</sup>
	n77	4080	10	50	4080	N/A	TDD	N/A
CA_n5A-n14A-n77A	n5	N/A	5	N/A	880	14.0	FDD	IMD5 <sup>5</sup>
	n14	793	5	25	763	N/A	FDD	N/A
	n77	4052	10	50	4052	N/A	TDD	N/A
	n5	846.5	5	25	891.5	N/A	FDD	N/A
	n14	N/A	5	N/A	765.5	20.3	FDD	IMD4 <sup>1,5</sup>
	n77	3305	10	50	3305	N/A	TDD	N/A
CA_n5-n25-n77	n5	N/A	5	N/A	889	13.6	FDD	IMD5 <sup>5</sup>
	n25	1907	5	25	1987	N/A	FDD	N/A
	n77	3305	10	50	3305	N/A	TDD	N/A
	n5	846.5	5	25	891.5	N/A	FDD	N/A
	n25	N/A	5	N/A	1987	24.8	FDD	IMD3
	n77	3680	10	25	3680	N/A	TDD	N/A
CA_n5-n25-n78	n5	N/A	5	N/A	889	13.6	FDD	IMD5
	n25	1907	5	25	1987	N/A	FDD	N/A
	n78	3305	10	50	3305	N/A	TDD	N/A
	n5	846.5	5	25	891.5	N/A	FDD	N/A
	n25	N/A	5	N/A	1987	24.8	FDD	IMD3
	n78	3680	10	50	3680	N/A	TDD	N/A
CA_n5-n29-n77	n5	835	5	25	880	N/A	FDD	N/A
	n29	N/A	5	N/A	722	14.9	FDD	IMD5 <sup>5</sup>
	n77	4062	10	50	4062	N/A	TDD	N/A
CA_n5A-n30A-n77A	n5	N/A	5	N/A	880	23.5	FDD	IMD3 <sup>1</sup>
	n30	2310	5	25	2355	N/A	FDD	N/A
	n77	3740	10	50	3740	N/A	TDD	N/A
	n5	835	5	25	880	N/A	FDD	N/A
	n30	N/A	5	N/A	2355	21.4	FDD	IMD3 <sup>5</sup>
	n77	4025	10	50	4025	N/A	TDD	N/A
CA_n5-n66-n77	n5	826.5	5	25	871.5	N/A	FDD	N/A
	n66	N/A	5	N/A	2142	22.2	FDD	IMD3
	n77	3795	10	50	3795	N/A	TDD	N/A
CA_n7-n25-n77	n7	2550	5	25	2670	N/A	FDD	N/A
	n25	N/A	5	N/A	1950	20.0	FDD	IMD4
	n77	3525	10	50	3525	N/A	TDD	N/A
	n7	N/A	5	N/A	2640	18.8	FDD	IMD5
	n25	1870	5	25	1950	N/A	FDD	N/A
	n77	4125	10	50	4125	N/A	TDD	N/A
CA_n7-n66-n77	n7	2550	5	25	2670	N/A	FDD	N/A
	n66	N/A	5	N/A	2150	20.5	FDD	IMD4
	n77	3625	10	50	3625	N/A	TDD	N/A
	n7	N/A	5	N/A	2640	18.8	FDD	IMD5
	n66	1720	5	25	2120	N/A	FDD	N/A
	n77	3900	10	50	3900	N/A	TDD	N/A
CA_n7-n71-n77	n7	N/A	5	N/A	2670	34.6	FDD	IMD2
	n71	680	5	25	634	N/A	FDD	N/A
	n77	3350	10	50	3350	N/A	TDD	N/A
CA_n7-n26-n78	n7	2550	5	25	2670	N/A	FDD	N/A
	n26	N/A	5	N/A	879	36.2	FDD	IMD2
	n78	3429	10	50	3429	N/A	TDD	N/A
	n7	2525	5	25	2645	N/A	FDD	N/A
	n26	N/A	5	N/A	875	15.7	FDD	IMD5
	n78	3350	10	50	3350	N/A	TDD	N/A
	n7	N/A	5	N/A	2645	36.1	FDD	IMD2
	n26	844	5	25	889	N/A	FDD	N/A
	n78	3489	10	50	3489	N/A	TDD	N/A
CA_n7-n28-n78	n7	2567.5	5	25	2687.5	N/A	FDD	N/A
	n28	N/A	5	N/A	782.5	33.8	FDD	IMD2 <sup>1</sup>
	n78	3350	10	50	3350	N/A	TDD	N/A
	n7	N/A	5	N/A	2650	35.5	FDD	IMD2
	n28	740	5	25	795	N/A	FDD	N/A
	n78	3390	10	50	3390	N/A	TDD	N/A
CA_n7-n66-n78	n7	2540	5	25	2660	N/A	FDD	N/A
	n66	1760	5	25	2160	20.5	FDD	IMD4

CA_n12A-n30A-n77A	n78	3620	10	50	3620	N/A	TDD	N/A
	n12	N/A	5	N/A	740	23.5	FDD	IMD3 <sup>1</sup>
	n30	2310	5	25	2355	N/A	FDD	N/A
	n77	3880	10	50	3880	N/A	TDD	N/A
	n12	707.5	5	25	737.5	N/A	FDD	N/A
	n30	N/A	5	N/A	2355	21.4	FDD	IMD3
CA_n12A-n66A-n77A	n77	3770	10	50	3770	N/A	TDD	N/A
	n12	N/A	5	N/A	740	23.5	FDD	IMD3 <sup>5</sup>
	n66	1720	5	25	2120	N/A	FDD	N/A
	n77	4180	10	50	4180	N/A	TDD	N/A
	n12	707	5	25	737	N/A	FDD	N/A
	n66	N/A	5	N/A	2126	21.4	FDD	IMD3
CA_n13-n25-n77	n77	3540	10	50	3540	N/A	TDD	N/A
	n13	782	5	25	751	N/A	FDD	N/A
	n25	N/A	5	N/A	1960	24.0	FDD	IMD3
CA_n13-n66-n77	n77	3524	10	50	3524	N/A	TDD	N/A
	n13	782	5	25	751	N/A	FDD	N/A
	n66	N/A	5	N/A	2146	26.0	FDD	IMD3
	n77	3710	10	50	3710	N/A	TDD	N/A
	n13	N/A	5	N/A	750	24.1	FDD	IMD3
	n66	1710	5	25	2110	N/A	FDD	N/A
CA_n14A-n30A-n77A	n77	4170	10	50	4170	N/A	TDD	N/A
	n14	N/A	5	N/A	763	23.5	FDD	IMD3 <sup>1</sup>
	n30	2310	5	25	2355	N/A	FDD	N/A
	n77	3857	10	50	3857	N/A	TDD	N/A
	n14	793	5	25	763	N/A	FDD	N/A
	n30	N/A	5	N/A	2355	21.4	FDD	IMD3
CA_n14A-n66A-n77A	n77	3941	10	50	3941	N/A	TDD	N/A
	n14	N/A	5	N/A	763	23.5	FDD	IMD3 <sup>5</sup>
	n66	1712.5	5	25	2112.5	N/A	FDD	N/A
	n77	4188	10	50	4188	N/A	TDD	N/A
	n14	793	5	25	763	N/A	FDD	N/A
	n66	N/A	5	N/A	2155	21.4	FDD	IMD3
CA_n18-n28-n77	n77	3741	10	50	3741	N/A	TDD	N/A
	n18	820	5	25	865	N/A	FDD	N/A
	n28	N/A	5	N/A	778	17.5	FDD	IMD5
	n77	4058	10	50	4058	N/A	TDD	N/A
	n18	N/A	5	N/A	865	12.1	FDD	IMD5
	n28	723	5	25	778	N/A	FDD	N/A
CA_n18-n41-n77	n77	3757	10	50	3757	N/A	TDD	N/A
	n18	820	5	25	865	N/A	FDD	N/A
	n41	2570	5	25	2570	N/A	TDD	N/A
	n77	N/A	10	N/A	3390	33.0	TDD	IMD2 <sup>2,4</sup>
	n18	820	5	25	865	N/A	FDD	N/A
	n77	3450	10	50	3450	N/A	TDD	N/A
	n41	N/A	5	N/A	2630	32.6	TDD	IMD2 <sup>4</sup>
	n41	2590	10	50	2590	N/A	TDD	N/A
CA_n25-n41-n66	n77	3460	10	50	3460	N/A	TDD	N/A
	n18	N/A	5	N/A	870	33.8	FDD	IMD2 <sup>1,4</sup>
	n25	N/A	5	N/A	1940	22.7	FDD	IMD4
CA_n25-n41-n77	n41	2685	10	50	2685	N/A	TDD	N/A
	n66	1715	5	25	2115	N/A	FDD	N/A
	n25	1870	5	25	1950	N/A	FDD	N/A
	n41	2670	5	25	2670	N/A	TDD	N/A
	n77	N/A	10	N/A	3470	23.7	TDD	IMD3
	n25	1900	5	25	1980	N/A	FDD	N/A
	n41	2525	5	25	2645	N/A	TDD	N/A
	n77	N/A	10	N/A	3775	17.2	TDD	IMD5
	n25	1870	5	25	1950	N/A	FDD	N/A
	n41	N/A	5	N/A	2640	18.8	TDD	IMD5 <sup>5</sup>
	n77	4125	10	50	4125	N/A	TDD	N/A
	n25	N/A	5	N/A	1950	26.5	FDD	IMD3 <sup>5</sup>
CA_n25-n41-n77	n41	2675	5	25	2675	N/A	TDD	N/A
	n77	3400	10	50	3400	N/A	TDD	N/A
	n25	N/A	5	N/A	1950	20.0	FDD	IMD4
	n25	N/A	5	N/A	1950	20.0	FDD	IMD4

	n41	2550	5	25	2685	N/A	TDD	N/A
	n77	3525	10	50	3525	N/A	TDD	N/A
CA_n25-n66-n77	n25	1855	5	25	1935	N/A	FDD	N/A
	n66	N/A	5	N/A	2115	35.2	FDD	IMD2
	n77	3970	10	50	3970	N/A	TDD	N/A
	n25	1900	5	25	1980	N/A	FDD	N/A
	n66	N/A	5	N/A	2160	22.0	FDD	IMD4
	n77	3540	10	50	3540	N/A	TDD	N/A
	n25	1900	5	25	1980	N/A	FDD	N/A
	n66	N/A	5	N/A	2160	16.9	FDD	IMD5
	n77	3930	10	50	3930	N/A	TDD	N/A
	n25	N/A	5	N/A	1960	38.1	FDD	IMD2
	n66	1760	5	25	2160	N/A	FDD	N/A
	n77	3720	10	50	3720	N/A	TDD	N/A
	n25	N/A	5	N/A	1960	20.6	FDD	IMD4 <sup>5</sup>
	n66	1770	5	25	2170	N/A	FDD	N/A
	n77	3350	10	50	3350	N/A	TDD	N/A
n25	N/A	5	N/A	1960	13.2	FDD	IMD5 <sup>5</sup>	
n66	1760	5	25	2160	N/A	FDD	N/A	
n77	3620	10	50	3620	N/A	TDD	N/A	
CA_n25-n66-n78	n25	1880	5	25	1960	M/A	FDD	N/A
	n66	1740	5	25	2140	21.1	FDD	IMD4
	n78	3500	10	50	3500	N/A	TDD	N/A
	n25	1880	5	25	1960	37.6	FDD	IMD2 <sup>1,2</sup>
	n66	1760	5	25	2160	N/A	FDD	N/A
CA_n25-n71-n77	n78	3720	10	50	3720	N/A	TDD	N/A
	n25	N/A	5	N/A	1954	25.4	FDD	IMD3 <sup>2,5</sup>
	n71	693	5	25	647	N/A	FDD	N/A
CA_n28-n41-n77	n77	3340	10	50	3340	N/A	TDD	N/A
	n28	743	5	25	798	N/A	FDD	N/A
	n41	2580	5	25	2580	N/A	TDD	N/A
	n77	N/A	10	N/A	3323	34.2	TDD	IMD2 <sup>2,4</sup>
	n28	N/A	5	N/A	798	36.8	FDD	IMD2 <sup>1,4</sup>
	n41	2642	5	25	2642	N/A	TDD	N/A
	n77	3440	10	50	3440	N/A	TDD	N/A
	n28	738	5	25	793	N/A	FDD	N/A
CA_n28-n77-n79	n41	N/A	5	N/A	2642	35.5	TDD	IMD2 <sup>4</sup>
	n77	3380	10	50	3380	N/A	TDD	N/A
	n77	3620	10	50	3620	N/A	TDD	N/A
CA_n29-n30-n77	n79	4420	40	216	4420	N/A	TDD	N/A
	n28	745	5	25	800	22.7	FDD	IMD2 <sup>1,2</sup>
	n29	N/A	5	N/A	722	23.5	FDD	IMD3 <sup>1</sup>
CA_n29-n66-n77	n30	2310	5	25	2355	N/A	FDD	N/A
	n77	3898	10	50	3898	N/A	TDD	N/A
	n29	N/A	5	N/A	722	23.5	FDD	IMD3 <sup>5</sup>
CA_n30A-n66A-n77A	n66	1734	5	25	2134	N/A	FDD	N/A
	n77	4190	10	50	4190	N/A	TDD	N/A
	n30	N/A	5	N/A	2355	34.2	FDD	IMD2 <sup>5</sup>
	n66	1745	5	25	2145	N/A	FDD	N/A
	n77	4100	10	50	4100	N/A	TDD	N/A
	n30	N/A	5	N/A	2355	12.9	FDD	IMD5
	n66	1735	5	25	2135	N/A	FDD	N/A
	n77	3780	10	50	3780	N/A	TDD	N/A
CA_n41-n66-n77	n30	2310	5	25	2355	N/A	FDD	N/A
	n66	N/A	5	N/A	2160	19.2	FDD	IMD4 <sup>5</sup>
	n77	3390	10	50	3390	N/A	TDD	N/A
	n41	2600	5	25	2600	N/A	TDD	N/A
	n66	1730	5	25	2130	N/A	FDD	N/A
	n77	N/A	10	N/A	3470	25.0	TDD	IMD3 <sup>1,2</sup>
	n41	N/A	5	N/A	2670	18.7	TDD	IMD5 <sup>5</sup>
	n66	1715	5	25	2115	N/A	FDD	N/A
CA_n41-n66-n77	n77	4190	10	50	4190	N/A	TDD	N/A
	n41	2640	5	25	2640	N/A	TDD	N/A
	n66	N/A	5	N/A	2160	20.5	FDD	IMD4
	n77	3720	10	50	3720	N/A	TDD	N/A

CA_n41-n71-n77	n41	2615	5	25	2615	N/A	TDD	N/A
	n71	693	5	25	647	N/A	FDD	N/A
	n77	N/A	10	N/A	3308	35.1	TDD	IMD2 <sup>1,5</sup>
	n41	2564	5	25	2564	N/A	TDD	N/A
	n71	693	5	25	647	N/A	FDD	N/A
	n77	N/A	10	N/A	3950	25.2	TDD	IMD3 <sup>1</sup>
	n41	2580	5	25	2580	N/A	TDD	N/A
	n71	693	5	25	647	N/A	FDD	N/A
	n77	N/A	10	N/A	3774	21.9	TDD	IMD4 <sup>1</sup>
	n41	N/A	5	N/A	2615	34.7	TDD	IMD2 <sup>5</sup>
	n71	693	5	25	647	N/A	FDD	N/A
	n77	3308	10	50	3308	N/A	TDD	N/A
	n41	N/A	5	N/A	2564	24.4	TDD	IMD3
	n71	693	5	25	647	N/A	FDD	N/A
	n77	3950	10	50	3950	N/A	TDD	N/A
	CA_n66-n71-n77	41	2680	5	25	2680	N/A	TDD
n71		N/A	5	N/A	640	36.8	FDD	IMD2 <sup>5</sup>
n77		3320	10	50	3320	N/A	TDD	N/A
n66		N/A	5	N/A	2150	24.4	FDD	IMD3 <sup>2</sup>
n71		690	5	25	644	N/A	FDD	N/A
n77		3530	10	50	3530	N/A	TDD	N/A
NOTE 1: This band is subject to IMD5 also which MSD is not specified. NOTE 2: This band is subject to IMD4 also which MSD is not specified. NOTE 3: The requirements only apply for UEs supporting inter-band carrier aggregation with simultaneous Rx/Tx capability. Simultaneous Rx/Tx capability does not apply for UEs supporting band n78 with a n77 implementation. NOTE 4: This band is subject to IMD3 also which MSD is not specified. NOTE 5: For a UE which supports this band combination only when the Band n77 frequency range restriction defined in NOTE 12 of Table 5.2-1 applies, the MSD test point(s) cannot be verified for the band combination and the test point(s) can be skipped. NOTE 6: Both of the transmitters shall be set min(+23 dBm, P <sub>C<sub>MAX</sub>L<sub>f,c</sub></sub> ) as defined in clause 6.2A.4	n66	1720	5	25	2120	N/A	FDD	N/A
	n71	N/A	5	N/A	640	24.2	FDD	IMD3 <sup>5</sup>
	n77	4080	10	50	4080	N/A	TDD	N/A

### 7.3A.6 Reference sensitivity exceptions due to cross band isolation for CA

Sensitivity degradation is allowed for a band if it is impacted by UL of another band part which belongs to NR band of the same NR CA configuration due to cross band isolation issues. The reference sensitivity degradation for the victim band due to cross band isolation is specified only for the specific uplink and downlink test points specified in Table 7.3A.6-1 for either PC3 and PC2 NR CA from a PC3 aggressor NR UL band, and for PC2 NR CA, in Table 7.3A.6-1a from a PC2 aggressor NR UL band, and in Table 7.3A.6-1b from a PC1.5 aggressor NR single band uplink, and in Table 7.3A.6-3 when a DL band < 1 GHz is victim of two simultaneous PC3 aggressor NR UL bands.

In Tables 7.3A.6-1, 7.3A.6-1a and 7.3A.6-1b the following terminology is used to define the source of cross-band isolation interference:

- “ACLR1” indicates that the first adjacent channel of the aggressor UL band falls into the Rx channel of victim band.
- “ACLR2” indicates that the second adjacent channel of the aggressor UL band falls into the Rx channel of victim band.
- “>ACLR2” indicates that neither the first, nor the second adjacent channel of the aggressor UL band falls into the Rx channel of victim band.

In Table 7.3A.6-3 only two DL / two UL < 1 GHz bands cases where one DL is simultaneously victim of UL channel ACLR1 of one band and UL channel ACLR1 or 2 of the other band are specified.

**Table 7.3A.6-1: Reference sensitivity exceptions (MSD) and uplink/downlink configurations due to cross band isolation from a PC3 aggressor NR UL band for NR CA FR1**

UL band	DL band	UL F <sub>c</sub>	UL BW	SCS of UL band	UL RB Allocation	DL F <sub>c</sub>	DL BW	MSD	Cross-band Interference source
		(MHz)	(MHz)	(kHz)	L <sub>CRB</sub>	(MHz)	(MHz)	(dB)	
n1	n3	1922.5	5	15	25 (RBstart=0)	1877.5	5	3	>ACLR2
n1	n3	1945	50	15	128 (RBstart=0)	1877.5	5	19.7	ACLR1
n1	n38	1955	50	15	128 (RBstart=142)	2572.5	5	2.9	>ACLR2
n1	n38	1955	50	15	128 (RBstart=142)	2590	40	2.9	>ACLR2
n1	n40	1955	50	15	128 (RBstart=142)	2302.5	5	6.6	>ACLR2
n1	n40	1970	20	15	100 (RBstart=6)	2302.5	5	6.6	>ACLR2
n1	n41	1955	50	15	128 (RBstart=142)	2501	10	6.1	>ACLR2
n1	n41	1970	20	15	100 (RBstart=6)	2546	100	0.7	>ACLR2
n3	n39	1770	30	15	50 (RBstart=110)	1882.5	5	2.1	>ACLR2
n3	n41	1760	50	15	50 (RBstart=220)	2501	10	0.7	>ACLR2
n3	n41	1760	50	15	50 (RBstart=220)	2546	100	0.7	>ACLR2
n3	n74	1712.5	5	15	25 (RBstart=0)	1515.5	5	2.6	>ACLR2
n3	n75	1712.5	5	15	25 (RBstart=0)	1515.5	5	4.3	>ACLR2
n5	n8	844	10	15	25 (RBstart=27)	951.5	5	2.8	>ACLR2
n5	n13	834	20	15	20 (RBstart=0)	753.5	5	2.4	>ACLR2
n5	n28	834	20	15	20 (RBstart=0)	800.5	5	17.5	ACLR2
n5	n71	834	20	15	20 (RBstart=0)	649.5	5	3.9	>ACLR2
n5	n105	834	20	15	20 (RBstart=0)	649.5	5	3.3	>ACLR2
n7	n3	2525	50	15	45 (RBstart=0)	1877.5	5	0.6	>ACLR2
n7	n40	2525	50	15	45 (RBstart=0)	2397.5	5	3.7	>ACLR2
n12	n71	706.5	15	15	20 (RBstart=0)	649.5	5	3.8	>ACLR2
n13	n5	782	10	15	20 (RBstart=32)	871.5	5	2.1	>ACLR2
n18	n28 <sup>5</sup>	822.5	15	15	25 (RBstart=0)	800.5	5	31.3	ACLR1
n18	n28	822.5	15	15	25 (RBstart=0)	785.5	5	12.7	ACLR2
n26	n28	824	20	15	25 (RBstart=0)	800.5	5	36.9	ACLR1
n26	n29	824	20	15	25 (RBstart=0)	719.5	5	3.9	>ACLR2
n26	n71	824	20	15	20 (RBstart=0)	649.5	5	3.9	>ACLR2
n28	n71	718	30	15	25 (RBstart=0)	649.5	5	13.3	ACLR2
n28	n105	718	30	15	25 (RBstart=0)	649.5	5	12.1	ACLR2
n30	n66	2310	10	15	20 (RBstart=0)	2197.5	5	8.3	>ACLR2
n34	n3	2017.5	15	15	75 (RBstart=0)	1877.5	5	3	>ACLR2
n34	n40	2017.5	15	15	75 (RBstart=4)	2302.5	5	6	>ACLR2
n34	n41	2017.5	15	15	75 (RBstart=4)	2501	10	3.2	>ACLR2
n38	n1	2590	40	15	216 (RBstart=0)	2167.5	5	1.9	>ACLR2
n38	n2	2590	40	15	216 (RBstart=0)	1987.5	5	0.6	>ACLR2
n38	n25	2590	40	15	216 (RBstart=0)	1992.5	5	0.6	>ACLR2
n38	n66	2590	40	15	216 (RBstart=0)	2197.5	5	1.9	>ACLR2
n38	n78	2600	40	15	216 (RBstart=0)	3305	10	8.3	>ACLR2
n39	n41	1900	40	15	216 (RBstart=0)	2501	10	3.3	>ACLR2

n40	n1	2340	100	30	270 (RBstart=0)	2167.5	5	[21.9]	ACLR2
n40	n7	2350	100	30	270 (RBstart=3)	2622.5	5	22.3	>ACLR2
n40	n7	2350	100	30	270 (RBstart=3)	2645	50	15.6	>ACLR2
n40	n34	2350	100	30	270 (RBstart=0)	2022.5	5	17.9	>ACLR2
n40	n41	2350	100	30	270 (RBstart=3)	2501	10	28.1	ACLR2
n41	n1	2546	100	30	270 (RBstart=0)	2167.5	5	18.1	>ACLR2
n41	n2	2546	100	30	270 (RBstart=0)	1987.5	5	0.6	>ACLR2
n41	n3	2546	100	30	270 (RBstart=0)	1877.5	5	0.6	>ACLR2
n41	n25	2546	100	30	270 (RBstart=0)	1992.5	5	0.6	>ACLR2
n41	n34	2456	100	30	270 (RBstart=0)	2022.5	5	7.2	>ACLR2
n41	n39	2546	100	30	270 (RBstart=3)	1917.5	5	1.6	>ACLR2
n41	n40	2546	100	30	270 (RBstart=0)	2397.5	5	31.4	ACLR2
n41	n48	2680	100	30	270 (RBstart=3)	3552.5	5	8.3	>ACLR2
n41 <sup>1</sup>	n66	2546	100	30	270 (RBstart=0)	2197.5	5	10.5	>ACLR2
n41	n70	2546	100	30	270 (RBstart=0)	2017.5	5	0.6	>ACLR2
n41	n77	2640	100	30	270 (RBstart=3)	3305	10	8.3	>ACLR2
n41	n78	2640	100	30	270 (RBstart=3)	3305	10	8.3	>ACLR2
n46	n48	5190	80	30	216 (RBstart=0)	3697.5	5	13.3	>ACLR2
n46	n48	5190	80	30	216 (RBstart=0)	3650	100	6.2	>ACLR2
n46	n77	5190	80	30	216 (RBstart=0)	3975	10	10.5	>ACLR2
n46	n77	5190	80	30	216 (RBstart=0)	3930	100	5.5	>ACLR2
n46	n78	5190	80	30	216 (RBstart=0)	3795	10	10.4	>ACLR2
n46	n78	5190	80	30	216 (RBstart=0)	3750	100	5.1	>ACLR2
n48	n41 <sup>1</sup>	3570	40	15	216 (RBstart=0)	2685	10	4.5	>ACLR2
n48	n41 <sup>1</sup>	3570	40	15	216 (RBstart=0)	2640	100	4.5	>ACLR2
n48	n46	3680	40	15	216 (RBstart=0)	5160	20	15.7	>ACLR2
n48	n96	3680	40	15	216 (RBstart=0)	5935	20	15.7	>ACLR2
n66	n2	1760	40	15	216 (RBstart=0)	1932.5	5	1.2	>ACLR2
n66	n25	1757.5	45	15	240 (RBstart=2)	1932.5	5	1.4	>ACLR2
n66	n41	1760	40	15	216 (RBstart=0)	2501	10	0.4	>ACLR2
n71	n5	688	20	15	20 (RBstart=86)	871.5	5	2.0	>ACLR2
n71	n12	688	20	15	20 (RBstart=86)	731.5	5	8.2	ACLR2
n71	n26	688	20	15	20 (RBstart=86)	861.5	5	2.0	>ACLR2
n71	n28	688	20	15	20 (RBstart=86)	760.5	5	6.5	>ACLR2
n71	n29	688	20	15	20 (RBstart=86)	719.5	5	17.5	ACLR2
n71	n85	688	20	15	20 (RBstart=86)	730.5	5	8.2 <sup>6</sup>	ACLR2
n71	n85	680.5	35	15	20 (Rbstart=168)	730.5	5	23 <sup>7</sup>	ACLR1
n77	n7	3350	100	30	270 (RBstart=0)	2687.5	5	4.5	>ACLR2
n77	n40 <sup>1</sup>	3350	100	30	270 (RBstart=0)	2397.5	10	4.5	>ACLR2
n77	n40 <sup>1</sup>	3350	100	30	270 (RBstart=0)	2350	100	4.5	>ACLR2
n77	n41 <sup>1</sup>	3350	100	30	270 (RBstart=0)	2685	10	4.5	>ACLR2
n77	n41 <sup>1</sup>	3350	100	30	270 (RBstart=0)	2640	100	4.5	>ACLR2
n78	n7 <sup>1</sup>	3350	100	30	270 (RBstart=0)	2687.5	5	4.5	>ACLR2
n78	n38	3350	100	30	270 (RBstart=0)	2617.5	5	3.3	>ACLR2
n78	n38	3350	100	30	270 (RBstart=0)	2600	40	3.3	>ACLR2
n78	n40 <sup>1</sup>	3350	100	30	270 (RBstart=0)	2397.5	5	4.5	>ACLR2



n78	n40 <sup>1</sup>	3350	100	30	270 (RBstart=0)	2350	100	4.5	>ACLR2
n78	n41 <sup>1</sup>	3350	100	30	270 (RBstart=0)	2685	10	4.5	>ACLR2
n78	n41 <sup>1</sup>	3350	100	30	270 (RBstart=0)	2640	100	4.5	>ACLR2
n78	n46	3750	100	30	270 (RBstart=3)	5160	20	13.5	>ACLR2
n78 <sup>3</sup>	n79	3750	100	30	270 (RBstart=3)	4420	40	2	>ACLR2
n78 <sup>3</sup>	n79	3750	100	30	270 (RBstart=3)	4405	10	2	>ACLR2
n78	n104	3750	100	30	270 (RBstart=0)	6435	20	14.4	>ACLR2
n79	n78 <sup>3</sup>	4450	100	30	270 (RBstart=0)	3795	10	2.6	>ACLR2
n79	n78 <sup>3</sup>	4450	100	30	270 (RBstart=0)	3750	100	2.6	>ACLR2
n85	n71	705.5	15	15	20 (RBstart=0)	649.5	5	3.8	>ACLR2
n96	n48	5965	80	30	216 (RBstart=0)	3697.5	5	13.3	>ACLR2
n96	n48	5965	80	30	216 (RBstart=0)	3650	100	6.2	>ACLR2
n104	n78	6475	100	30	270 (RBstart=0)	3795	10	15.8	>ACLR2
n105	n5	693	20	15	20 (RBstart=86)	871.5	5	1.7	>ACLR2
n105	n28	693	20	15	20 (RBstart=86)	760.5	5	6.9	>ACLR2
NOTE 1: Applicable only when harmonic mixing MSD for this combination is not applied.									
NOTE 2: Void									
NOTE 3: The requirements only apply for UEs supporting inter-band carrier aggregation with simultaneous Rx/Tx capability. Simultaneous Rx/Tx capability does not apply for UEs supporting band n78 with a n77 implementation.									
NOTE 4: Void									
NOTE 5: The MSD exceptions are applicable to the case that interference of UL band 3 <sup>rd</sup> order IMD product falls into the affected DL channels.									
NOTE 6: Applicable to UE not supporting n71 optional maximum symmetrical UL/DL channel bandwidth									
NOTE 7: Applicable to UE supporting n71 optional maximum symmetrical UL/DL channel bandwidth									

**Table 7.3A.6-1a-1: Reference sensitivity exceptions (MSD) and uplink/downlink configurations due to cross band isolation from a PC2 aggressor NR UL band for NR CA FR1 for UE not supporting Tx Diversity**

UL band	DL band	UL F <sub>c</sub>	UL BW	SCS of UL band	UL RB Allocation	DL F <sub>c</sub>	DL BW	MSD	Cross-band Interference source
		(MHz)	(MHz)	(kHz)	L <sub>CRB</sub>	(MHz)	(MHz)	(dB)	
n2	n66	1900	20	15	50 (RBstart=56)	2112.5	5	0.7	>ACLR2
n3	n1	1760	50	15	50 (RBstart=220)	2112.5	5	0.8	>ALCR2
n3	n7	1760	50	15	50 (RBstart=220)	2622.5	5	0.5	>ALCR2
n7	n1	2525	50	15	45 (RBstart=0)	2167.5	5	0.8	>ALCR2
n7	n3	2525	50	15	45 (RBstart=0)	1877.5	5	0.4	>ALCR2
n25	n41	1760	40	15	40 (RBstart=176)	2501	10	0.8	>ACLR2
n25	n66	1895	40	15	40 (RBstart=176)	2112.5	5	0.7	>ACLR2
n39	n41	1900	40	15	216 (RBstart=0)	2501	10	4.7	>ACLR2
n40	n3	2350	100	30	270 (RBstart=0)	1877.5	5	0.6	>ACLR2
n40	n41	2350	100	30	270 (RBstart=3)	2501	10	31.1	ACLR2
n41	n1	2546	100	30	270 (RBstart=0)	2167.5	5	20.8	>ACLR2
n41	n3	2546	100	30	270 (RBstart=0)	1877.5	5	2.3	>ACLR2
n41	n25	2546	100	30	270 (RBstart=0)	1992.5	5	1.6	>ACLR2
n41	n39	2546	100	30	270 (RBstart=3)	1917.5	5	2.7	>ACLR2
n41	n40	2546	100	30	270 (RBstart=0)	2397.5	5	34.4	ACLR2

n41	n66	2521	50	30	128 (RBstart=0)	2197.5	5	5.4	>ACLR2
n41	n77	2640	100	30	270 (RBstart=3)	3305	10	10.5	>ACLR2
n41	n79	2640	100	30	270 (RBstart=3)	4405	10	3.1	>ACLR2
n66	n2	1760	40	15	216 (RBstart=0)	1932.5	5	1.9	>ACLR2
n66	n25	1757.5	45	15	240 (RBstart=2)	1932.5	5	2.2	>ACLR2
n66	n41	1760	40	15	216 (RBstart=0)	2501	50	0.8	>ACLR2
n71	n85	688	20	15	20 (RBstart=86)	730.5	5	10.9 <sup>4</sup>	ACLR2
n71	n85	680.5	35	15	20 (RBstart=168)	730.5	5	26 <sup>5</sup>	ACLR1
n77	n2	3350	100	30	270 (RBstart=0)	1987.5	5	1.0	>ACLR2
n77	n7	3350	100	30	270 (RBstart=0)	2687.5	5	6.5	>ACLR2
n77	n25	3350	100	30	270 (RBstart=0)	1992.5	5	1.0	>ACLR2
n77	n30	3350	100	30	270 (RBstart=0)	2357.5	5	1.0	>ACLR2
n77	n40 <sup>1</sup>	3350	100	30	270 (RBstart=0)	2397.5	10	6.5	>ACLR2
n77	n40 <sup>1</sup>	3350	100	30	270 (RBstart=0)	2350	100	6.5	>ACLR2
n77	n41 <sup>1</sup>	3350	100	30	270 (RBstart=0)	2685	10	6.5	>ACLR2
n77	n41 <sup>1</sup>	3350	100	30	270 (RBstart=0)	2640	100	6.5	>ACLR2
n77	n66	3350	100	30	270 (RBstart=0)	2197.5	5	1.0	>ACLR2
n78	n7	3350	100	30	270 (RBstart=0)	2687.5	5	6.5	>ACLR2
n78	n40 <sup>1</sup>	3350	100	30	270 (RBstart=0)	2395	10	6.5	>ACLR2
n78	n40 <sup>1</sup>	3350	100	30	270 (RBstart=0)	2350	100	1.2	>ACLR2
n78 <sup>3</sup>	n79	3750	100	30	270 (RBstart=3)	4405	10	5	>ACLR2
n78 <sup>3</sup>	n79	3750	100	30	270 (RBstart=3)	4420	40	5	>ACLR2
n78 <sup>3</sup>	n79	3750	100	30	270 (RBstart=3)	4450	100	5	>ACLR2
n79	n41	4450	100	30	270 (RBstart=0)	2685	10	3.5	>ACLR2
n79	n78 <sup>3</sup>	4450	100	30	270 (RBstart=0)	3795	10	5.6	>ACLR2
n79	n78 <sup>3</sup>	4450	100	30	270 (RBstart=0)	3750	100	5.6	>ACLR2

NOTE 1: Applicable only when harmonic mixing MSD for this combination is not applied.  
NOTE 2: Void.  
NOTE 3: The requirements only apply for UEs supporting inter-band carrier aggregation with simultaneous Rx/Tx capability. Simultaneous Rx/Tx capability does not apply for UEs supporting band n78 with a n77 implementation.  
NOTE 4: Applicable to UE not supporting n71 optional maximum symmetrical UL/DL channel bandwidth  
NOTE 5: Applicable to UE supporting n71 optional maximum symmetrical UL/DL channel bandwidth

**Table 7.3A.6-1a-2: Reference sensitivity exceptions (MSD) and uplink/downlink configurations due to cross band isolation from a PC2 aggressor NR UL band for NR CA FR1 for UE supporting Tx Diversity**

UL band	DL band	UL F <sub>c</sub>	UL BW	SCS of UL band	UL RB Allocation	DL F <sub>c</sub>	DL BW	MSD	Cross-band Interference source
		(MHz)	(MHz)	(kHz)	L <sub>CRB</sub>	(MHz)	(MHz)	(dB)	
n2	n66	1900	20	15	50 (RBstart=56)	2112.5	5	0.9	>ALCR2
n3	n1	1760	50	15	50 (RBstart=220)	2112.5	5	1.1	>ALCR2
n3	n7	1760	50	15	50 (RBstart=220)	2622.5	5	0.7	>ALCR2
n7	n1	2525	50	15	45 (RBstart=0)	2167.5	5	1.1	>ALCR2
n7	n3	2525	50	15	45 (RBstart=0)	1877.5	5	0.5	>ALCR2
n25	n41	1760	40	15	40 (RBstart=176)	2501	10	1.0	>ACLR2

n25	n66	1895	40	15	40 (RBstart=176)	2112.5	5	0.9	>ACLR2
n66	n2	1760	40	15	216 (RBstart=0)	1932.5	5	3.3	>ACLR2
n66	n25	1757.5	45	15	240 (RBstart=2)	1932.5	5	3.8	>ACLR2
n66	n41	1760	40	15	216 (RBstart=0)	2501	10	1.0	>ACLR2
n71	n85	688	20	15	20 (RBstart=86)	730.5	5	15.9 <sup>6</sup>	ACLR2
n71	n85	680.5	35	15	20 (RBstart=168)	730.5	5	32.3 <sup>7</sup>	ACLR1

NOTE 1: Applicable only when harmonic mixing MSD for this combination is not applied.  
NOTE 2: Void  
NOTE 3: The requirements only apply for UEs supporting inter-band carrier aggregation with simultaneous Rx/Tx capability. Simultaneous Rx/Tx capability does not apply for UEs supporting band n78 with a n77 implementation.  
NOTE 4: Void  
NOTE 5: The MSD exceptions are applicable to the case that interference of UL band 3<sup>rd</sup> order IMD product falls into the affected DL channels.  
NOTE 6: Applicable to UE not supporting n71 optional maximum symmetrical UL/DL channel bandwidth  
NOTE 7: Applicable to UE supporting n71 optional maximum symmetrical UL/DL channel bandwidth

**Table 7.3A.6-1b: Reference sensitivity exceptions (MSD) and uplink/downlink configurations due to cross band isolation from a PC1.5 aggressor NR single UL band for DL NR CA FR1**

UL band	DL band	UL F <sub>c</sub>	UL BW	SCS of UL band	UL RB Allocation	DL F <sub>c</sub>	DL BW	MSD	Cross-band Interference source
		(MHz)	(MHz)	(kHz)	L <sub>CRB</sub>	(MHz)	(MHz)	(dB)	
n40	n3	2350	100	30	270 (RBstart=0)	1877.5	5	1.2	>ACLR2
n40	n41	2350	100	30	270 (RBstart=3)	2501	10	[37.9]	ACLR2
n41	n1	2546	100	30	270 (RBstart=0)	2167.5	5	23.5	>ACLR2
n41	n3	2546	100	30	270 (RBstart=0)	1877.5	5	3.9	>ACLR2
n41	n25	2546	100	30	270 (RBstart=0)	1992.5	5	2.8	>ACLR2
n41	n40	2546	100	30	270 (RBstart=0)	2397.5	5	[41.2]	ACLR2
n41	n66	2521	50	30	128 (RBstart=0)	2197.5	5	7.7	>ACLR2
n41	n77	2640	100	30	270 (RBstart=3)	3305	10	13.3	>ACLR2
n41	n39	2546	100	30	270 (RBstart=3)	1917.5	5	6.7	>ACLR2
n77	n2	3350	100	30	270 (RBstart=0)	1987.5	5	1.8	>ACLR2
n77	n7	3350	100	30	270 (RBstart=0)	2687.5	5	9.0	>ACLR2
n77	n25	3350	100	30	270 (RBstart=0)	1992.5	5	1.8	>ACLR2
n77	n30	3350	100	30	270 (RBstart=0)	2357.5	5	1.8	>ACLR2
n77	n40 <sup>1</sup>	3350	100	30	270 (RBstart=0)	2395	10	9.0	>ACLR2
n77	n40 <sup>1</sup>	3350	100	30	270 (RBstart=0)	2350	100	2.2	>ACLR2
n77	n41 <sup>1</sup>	3350	100	30	270 (RBstart=0)	2685	10	9.0	>ACLR2
n77	n41 <sup>1</sup>	3350	100	30	270 (RBstart=0)	2640	100	9.0	>ACLR2
n77	n66	3350	100	30	270 (RBstart=0)	2197.5	5	1.8	>ACLR2
n78	n40 <sup>1</sup>	3350	100	30	270 (RBstart=0)	2395	10	9.0	>ACLR2
n78	n40 <sup>1</sup>	3350	100	30	270 (RBstart=0)	2350	100	2.2	>ACLR2
n78 <sup>3</sup>	n79	3750	100	30	270 (RBstart=3)	4405	10	8	>ACLR2
n78 <sup>3</sup>	n79	3750	100	30	270 (RBstart=3)	4420	40	8	>ACLR2
n78 <sup>3</sup>	n79	3750	100	30	270 (RBstart=3)	4450	100	8	>ACLR2
n79	n78 <sup>3</sup>	4450	100	30	270 (RBstart=0)	3795	10	8.6	>ACLR2
n79	n78 <sup>3</sup>	4450	100	30	270 (RBstart=0)	3750	100	8.6	>ACLR2

NOTE 1: Applicable only when harmonic mixing MSD for this combination is not applied.  
 NOTE 2: Void.  
 NOTE 3: The requirements only apply for UEs supporting inter-band carrier aggregation with simultaneous Rx/Tx capability. Simultaneous Rx/Tx capability does not apply for UEs supporting band n78 with a n77 implementation.

**Table 7.3A.6-1c: Reference sensitivity exceptions (MSD) and uplink/downlink configurations due to cross band isolation from a power class 5 aggressor NR single UL band for DL NR CA FR1**

UL band	DL band	UL F <sub>c</sub>	UL BW	SCS of UL band	UL RB Allocation	DL F <sub>c</sub>	DL BW	MSD	Cross-band Interference source
		(MHz)	(MHz)	(kHz)	L <sub>CRB</sub>	(MHz)	(MHz)	(dB)	
n46	n48	5190	80	30	216 (RBstart=0)	3697.5	5	11	>ACLR2
n46	n48	5190	80	30	216 (RBstart=0)	3650	100	3.9	>ACLR2
n46	n78	5190	80	30	216 (RBstart=0)	3795	10	8.1	>ACLR2
n46	n78	5190	80	30	216 (RBstart=0)	3750	100	2.8	>ACLR2
n96	n48	5965	80	30	216 (RBstart=0)	3697.5	5	11	>ACLR2
n96	n48	5965	80	30	216 (RBstart=0)	3650	100	3.9	>ACLR2

NOTE 1: Void

**Table 7.3A.6-2: Void**

**Table 7.3A.6-3: Reference sensitivity exceptions (MSD) and uplink/downlink configurations due to cross band isolation from two simultaneous PC3 aggressor NR UL bands for NR CA FR1**

UL band	DL band	UL F <sub>c</sub>	UL BW	SCS of UL band	UL RB Allocation	DL F <sub>c</sub>	DL BW	MSD	Cross-band Interference source
		(MHz)	(MHz)	(kHz)	L <sub>CRB</sub>	(MHz)	(MHz)	(dB)	
n5	n28	834	20	15	20 (RBstart=0)	788	30	3.1	ACLR2
n28		733	30	15	25 (RBstart=135)				ACLR1
n26	n28	824	20	15	25 (RBstart=0)	788	30	[13.5]	ACLR1
n28		733	30	15	25 (RBstart=135)				ACLR1

## 7.3A.7 Lower-MSD requirements for inter-band CA

A UE can report better MSD performance than the minimum requirements as specified in clause 7.3A.4, 7.3A.5 and 7.3A.6 by *lowerMSD-r18* capability, except that the reporting for MSD caused by IMD with order higher than 5, IMD of UL intra-band CA or triple-beat is not supported in this release of the specification. The MSD performance after improvement is categorized into different lower-MSD capability classes, which are defined in Table 7.3A.7-1.

**Table 7.3A.7-1: Lower-MSD capability classes**

Lower-MSD capability class	Maximum allowed actual MSD (i.e. Threshold)	Remark
I	0 dB	Actual MSD ≤ 0dB
II	3 dB	Actual MSD ≤ 3dB
III	6 dB	Actual MSD ≤ 6dB
IV	9 dB	Actual MSD ≤ 9dB
V	12 dB	Actual MSD ≤ 12dB

VI	15 dB	Actual MSD $\leq$ 15dB
VII	18 dB	Actual MSD $\leq$ 18dB
VIII	22 dB	Actual MSD $\leq$ 22dB

The reported lower-MSD capability classes are subject to the same uplink/downlink configurations as defined for the minimum MSD requirements in clause 7.3A.4, 7.3A.5 and 7.3A.6. If a UE can support more than one test points for a given REFSENS exception case, the reported lower-MSD capability class is applicable for the test point having the largest specified MSD value. Otherwise, it's only applicable for the test point which can be supported by the UE. If one or multiple power classes are requested by the network, the UE can, if supported, report *lowerMSD-r18* capability for the requested power classes; otherwise, the UE shall report *lowerMSD-r18* capability for the highest supported power class for the given CA configuration.

The UE shall meet one of the following conditions in order to report *lowerMSD-r18* capability for a given REFSENS exception case:

- If the specified minimum requirement is tightly bounded by the range of a lower-MSD capability class (i.e.,  $\text{Threshold}_{i-1} < \text{MSD} \leq \text{Threshold}_i$ , where  $i$  and  $(i-1)$  are two adjacent lower-MSD capability classes), the actual MSD shall be at least one-level lower (i.e.,  $\text{actual MSD} \leq \text{Threshold}_{i-1}$ ); or
- If the specified minimum requirement is larger than the maximum threshold (corresponding to lower-MSD capability class VIII), the actual MSD shall be no more than the maximum threshold.

Otherwise, the UE shall not report *lowerMSD-r18* capability for this REFSENS exception case.

If the special MSD type "ALL" is indicated in the *lowerMSD-r18* capability, the reporting conditions as specified above shall be met for each MSD type that has been specified in this release for the given CA configuration.

NOTE 1: The *lowerMSD-r18* capability is verified by reusing the MSD test point parameters and only replacing the minimum MSD requirement value by the threshold of the reported lower-MSD capability class. UE supporting lower MSD shall indicate the lower MSD capability for the requested power class if supported. If no power class is explicitly requested, the UE supporting lower MSD shall indicate the lower MSD capability for the highest supported power class of the band combination including victim band and aggressor band(s). And, similar to the specified MSD minimum requirements, only the highest supported power class or the power class required by the certification/regulation body per UL configuration is verified.

NOTE 2: If the UE is equipped with four or eight Rx antenna ports for the victim band of the BC, the *lowerMSD-r18* capability is verified with four or eight Rx antenna ports according to clause 7.2 under the condition mentioned above, but with the increased MSD values by the absolute value of  $\Delta R_{IB,4R}$  or  $\Delta R_{IB,8R}$  applied for the requirement based on the description in clause 7.3A.1.

## 7.3B Reference sensitivity for NR-DC

For inter-band NR-DC configurations, the reference sensitivity for the corresponding inter-band CA configuration as specified in clause 7.3A applies.

## 7.3C Reference sensitivity for SUL

### 7.3C.1 General

The reference sensitivity power level REFSENS is the minimum mean power applied to each one of the UE antenna ports for all UE categories, at which the throughput shall meet or exceed the requirements for the specified reference measurement channel. For operations with 4 Rx or 8 Rx antenna ports, the MSD in the applicable bands shall be increased by the absolute value of  $\Delta R_{IB,4R}$  in Table 7.3.2-2 or  $\Delta R_{IB,8R}$  in Table 7.3.2-2a when  $\text{MSD} > 0$ .

For reference sensitivity exception test points where the specified carrier frequency does not correspond to a valid NR-ARFCN, the closest NR-ARFCN as specified in clause 5.4.2 applies.

For reference sensitivity level tests or reference sensitivity exception tests specified in clause 7.3C,  $\text{SCS}=15\text{kHz}$  based UL test configuration can be replaced by  $\text{SCS}=30\text{kHz}$  based UL test configuration. The equivalent substitution

relationship between different SCS UL test configuration is shown in Table 7.3A.1-1 for the operating bands above 2.2GHz.

### 7.3C.2 Reference sensitivity power level for SUL

For SUL operation, the reference receive sensitivity (REFSENS) requirement for downlink bands specified in Table 7.3.2-1a, Table 7.3.2-1b, Table 7.3.2-2 and Table 7.3.2-2a shall be met for an uplink transmission bandwidth less than or equal to that specified in Table 7.3.2-3 or supplementary uplink transmission bandwidth less than or equal to that specified in Table 7.3C.2-1 with reference measurement channels as specified in Annexes A.2.2.2, A.3.2, and A.3.3 (with one sided dynamic OCNB Pattern OP.1 FDD/TDD for the DL-signal as described in Annex A.5.1.1/A.5.2.1), unless sensitivity degradation is allowed in this clause of this specification. These exceptions also apply to any higher order CA or DC combination containing one of the exception combinations in this clause as subset.

For SUL operation with downlink CA, the reference receive sensitivity (REFSENS) requirement for downlink bands specified in clause 7.3A.2 shall be met for an uplink transmission bandwidth less than or equal to that specified in Table 7.3.2-3 or supplementary uplink transmission bandwidth less than or equal to that specified in Table 7.3C.2-1 with reference measurement channels as specified in Annexes A.2.2.2, A.3.2, and A.3.3 (with one sided dynamic OCNB Pattern OP.1 FDD/TDD for the DL-signal as described in Annex A.5.1.1/A.5.2.1), unless sensitivity degradation is allowed in this clause of this specification. These exceptions also apply to any higher order CA or DC combination containing one of the exception combinations in this clause as subset.

**Table 7.3C.2-1: Supplementary uplink configuration for reference sensitivity**

NR Band / SCS of SUL band / Channel bandwidth of the DL band / N <sub>RB</sub>															
DL band	SUL band	SCS of SUL band (kHz)	5 MHz	10 MHz	15 MHz	20 MHz	25 MHz	30 MHz	40 MHz	50 MHz	60 MHz	70 MHz	80 MHz	90 MHz	100 MHz
n1	n80	15	160	160	160	160	160	160	160						
n1	n81	15	100	100	100	100	100	100	100	100					
n1	n84 <sup>1</sup>	15	25	50	75	100	128	128	128	128					
n1	n89	15	100	100	100	100	100	100	100	100					
n3	n80 <sup>1</sup>	15	25	50	50	50	50	50	50						
n3	n84	15	100	100	100	100	100	100	100						
n5	n84	15	100	100	100	100									
n8	n84	15	100	100	100	100									
n8	n81 <sup>1</sup>	15	25	25	20	20									
n24	n99 <sup>1</sup>	15	25	50											
n28	n83 <sup>1</sup>	15	25	25	25	25		25							
n41	n80	15		160	160	160		160	160	160	160		160	160	160
n41	n81	15		100	100	100			100	100	100		100	100	100
n41	n83	15		100	100	100		100	100	100	100		100	100	100
		30		50	50	50		50	50	50	50		50	50	50
n41	n95	15		75	75	75		75	75	75	75		75	75	75
n41	n97	30		216	216	216		216	216	216	216	216	216	216	216
n41	n98	15		216	216	216		216	216	216	216		216	216	216
n41	n99	15		50	50	50		50	50	50	50		50	50	50
n48	n99	15		50	50	50		50	50	50	50		50	50	50
n77	n80	15		160	160	160			160	160	160		160	160	160
n77	n84	15		100	100	100			100	100	100		100	100	100
n77	n99	15		50	50	50	50	50	50	50	50	50	50	50	50
n78	n80	15		160	160	160	160	160	160	160	160	160	160	160	160
n78	n81	15		100	100	100	100	100	100	100	100	100	100	100	100
n78	n82	15		100	100	100			100	100	100		100	100	100
n78	n83	15		100	100	100	100	100	100	100	100	100	100	100	100
n78	n84	15		100	100	100	100	100	100	100	100	100	100	100	100
n78	n86	15		216	216	216			216	216	216		216	216	216
n78	n89	15		100	100	100	100	100	100	100	100	100	100	100	100
n79	n80	15							160	160	160		160		160
n79	n83	15		100		100		100	100	100	100	100	100	100	100
		30		50		50		50	50	50	50	50	50	50	50
n79	n81	15							100	100	100		100		100
n79	n84	15							100	100	100		100		100

n79	n95	15							75	75	75		75		75
n79	n97	15							270	270	270		270		270
n79	n98	15							216	216	216		216		216

NOTE 1: The Tx-Rx carrier center frequency separation between SUL band and DL band is the same as the Tx-Rx carrier center frequency separation of DL band specified in Table 5.4.4-1 from TS 38.101-1. The channel bandwidth of SUL band is the same as DL band. This restriction of REFSENS configurations applies also for these carriers when applicable SUL configuration is part of a higher order configuration.

For the UE that supports any of the SUL operation given in Table 7.3C.2-2, exceptions to the requirements specified in Table 7.3.2-1a and Table 7.3.2-1b are allowed for different combinations of UL configurations and DL channel bandwidths when the uplink is active in a lower frequency band and is within a specified frequency range such that transmitter harmonics fall within the downlink transmission bandwidth assigned in a higher band as noted in Table 7.3C.2-2. For these exceptions, only the listed test points in Table 7.3C.2-2 are needed to be tested.

**Table 7.3C.2-2: Reference sensitivity and uplink/downlink configurations for SUL operation (exceptions due to uplink harmonic issue)**

UL band	DL band	UL BW	SCS of UL band	UL RB Allocation	DL BW	MSD	UL/DL fc condition	UL/DL harmonic order
		(MHz)	(kHz)	LCRB	(MHz)	(dB)		
n80	n77	5	15	25 (RBstart=0)	10	23.9	NOTE 2	UL2/DL1 direct-hit
n80	n77	10	15	50 (RBstart=0)	100	13.8	NOTE 2	UL2/DL1 direct-hit
n80	n77	5	15	25 (RBstart=0)	10	1.1	NOTE 6	UL2/DL1 near-miss
n80	n78	5	15	25 (RBstart=0)	10	23.9	NOTE 2	UL2/DL1 direct-hit
n80	n78	10	15	50 (RBstart=0)	100	13.8	NOTE 2	UL2/DL1 direct-hit
n80	n78	5	15	25 (RBstart=0)	10	1.1	NOTE 6	UL2/DL1 near-miss
n81	n41	5	15	16 (RBstart=4)	10	13	NOTE 3	UL3/DL1 direct-hit
n81	n41	5	15	25 (RBstart=0)	100	3.5	NOTE 3	UL3/DL1 direct-hit
n81	n78	5	15	16 (RBstart=4)	10	10.8	NOTE 4	UL4/DL1 direct-hit
n81	n78	5	15	25 (RBstart=0)	100	1.4	NOTE 4	UL4/DL1 direct-hit
n81	n79	5	15	25 (RBstart=0)	40	6.8	NOTE 5	UL5/DL1 direct-hit
n81	n79	5	15	25 (RBstart=0)	100	4.4	NOTE 5	UL5/DL1 direct-hit
n82	n78	5	15	16 (RBstart=4)	10	10.8	NOTE 4	UL4/DL1 direct-hit
n82	n78	5	15	20 (RBstart=2)	100	1.0	NOTE 4	UL4/DL1 direct-hit
n83	n78	5	15	10 (RBstart=8)	10	10.4	NOTE 5	UL5/DL1 direct-hit
n83	n78	5	15	25 (RBstart=0)	100	0.7	NOTE 5	UL5/DL1 direct-hit
n84	n77	5	15	25 (RBstart=0)	10	23.9	NOTE 2	UL2/DL1 direct-hit
n84	n77	10	15	100 (RBstart=0)	100	13.8	NOTE 2	UL2/DL1 direct-hit
n84	n77	5	15	25 (RBstart=0)	10	1.1	NOTE 6	UL2/DL1 near-miss
n86	n78	5	15	25 (RBstart=0)	10	23.9	NOTE 2	UL2/DL1 direct-hit
n86	n78	10	15	100 (RBstart=0)	100	13.8	NOTE 2	UL2/DL1 direct-hit

n86	n78	5	15	25 (RBstart=0)	10	1.1	NOTE 6	UL2/DL1 near-miss
n89	n78	5	15	16 (RBstart=0)	10	10.5	NOTE 4	UL4/DL1 direct-hit
n89	n78	20	15	25 (RBstart=0)	100	1.4	NOTE 4	UL4/DL1 direct-hit
n97	n79	5	15	100 (RBstart=0)	40	29.4	NOTE 2	UL2/DL1 direct-hit
n97	n79	5	15	270 (RBstart=0)	100	25.3	NOTE 2	UL2/DL1 direct-hit
n99	n77	5	15	25 (RBstart=0)	10	23.9	NOTE 2	UL2/DL1 direct-hit
n99	n77	10	15	100 (RBstart=0)	100	13.8	NOTE 2	UL2/DL1 direct-hit
n99	n77	5	15	25 (RBstart=0)	10	1.1	NOTE 6	UL2/DL1 near-miss

NOTE 1: These requirements apply when there is at least one individual RE within the uplink transmission bandwidth of the aggressor (lower) band for which the 2<sup>nd</sup> / 3<sup>rd</sup> / 4<sup>th</sup> / 5<sup>th</sup> transmitter harmonic is within the downlink transmission bandwidth of a victim (higher) band.

NOTE 2: The requirements should be verified for UL NR ARFCN of the aggressor (lower) band (superscript LB) such that  $f_{UL}^{LB} = \lfloor f_{DL}^{HB} / 0.2 \rfloor \cdot 0.1$  in MHz and  $F_{UL\_low}^{LB} + BW_{Channel}^{LB} / 2 \leq f_{UL}^{LB} \leq F_{UL\_high}^{LB} - BW_{Channel}^{LB} / 2$  with carrier frequency in the victim (higher) band in MHz and the channel bandwidth configured in the lower band.

NOTE 3: The requirements should be verified for UL NR ARFCN of the aggressor (lower) band (superscript LB) such that  $f_{UL}^{LB} = \lfloor f_{DL}^{HB} / 0.3 \rfloor \cdot 0.1$  in MHz and  $F_{UL\_low}^{LB} + BW_{Channel}^{LB} / 2 \leq f_{UL}^{LB} \leq F_{UL\_high}^{LB} - BW_{Channel}^{LB} / 2$  with the carrier frequency in the victim (higher) band in MHz and the channel bandwidth configured in the low band.

NOTE 4: The requirements should be verified for UL EARFCN of the aggressor (lower) band (superscript LB) such that  $f_{UL}^{LB} = \lfloor f_{DL}^{HB} / 0.4 \rfloor \cdot 0.1$  in MHz and  $F_{UL\_low}^{LB} + BW_{Channel}^{LB} / 2 \leq f_{UL}^{LB} \leq F_{UL\_high}^{LB} - BW_{Channel}^{LB} / 2$  with  $f_{DL}^{HB}$  carrier frequency in the victim (higher) band in MHz and  $BW_{Channel}^{LB}$  the channel bandwidth configured in the lower band.

NOTE 5: The requirements should be verified for UL NR-ARFCN of the aggressor (lower) band (superscript LB) such that  $f_{UL}^{LB} = \lfloor f_{DL}^{HB} / 0.5 \rfloor \cdot 0.1$  in MHz and  $F_{UL\_low}^{LB} + BW_{Channel}^{LB} / 2 \leq f_{UL}^{LB} \leq F_{UL\_high}^{LB} - BW_{Channel}^{LB} / 2$  with  $f_{DL}^{HB}$  carrier frequency in the victim (higher) band in MHz and  $BW_{Channel}^{LB}$  the channel bandwidth configured in the lower band.

NOTE 6: The requirements are only applicable to channel bandwidths no larger than 20 MHz and with a carrier frequency at  $\pm (20 + BW_{Channel}^{HB} / 2)$  MHz offset from  $f_{UL}^{LB}$  in the victim (higher band) with  $F_{UL\_low}^{LB} + BW_{Channel}^{LB} / 2 \leq f_{UL}^{LB} \leq F_{UL\_high}^{LB} - BW_{Channel}^{LB} / 2$ , where  $BW_{Channel}^{LB}$  and  $BW_{Channel}^{HB}$  are the channel bandwidths configured in the aggressor (lower) and victim (higher) bands in MHz, respectively.

Table 7.3C.2-3: Void

For the UE that supports any of the SUL operation given in Table 7.3C.2-4, reference sensitivity degradation is allowed for different combinations of UL configurations and DL channel bandwidths when a DL band is impacted by UL band due to cross band isolation issues. For these exceptions, only the listed test points in Table 7.3C.2-4 are needed to be tested.

Table 7.3C.2-4: Reference sensitivity and uplink/downlink configurations for SUL operation (exceptions due to cross band isolation)

UL band	DL band	UL F <sub>c</sub>	UL BW	SCS of UL band	UL RB Allocation	DL F <sub>c</sub>	DL BW	MSD	X band interference source
		(MHz)	(MHz)	(kHz)	L <sub>CRB</sub>	(MHz)	(MHz)	(dB)	
n80	n41	1765	40	15	50 (RBstart=166)	2501	10	0.7	>ACLR2
n80	n41	1765	40	15	50 (RBstart=166)	2546	100	0.7	>ACLR2
n84	n3	1945	50	15	128 (RBstart=0)	1877.5	5	19.7	ACLR1



n95	n41	2017.5	15	15	75 (RBstart=4)	2501	10	3.2	>ACLR2
n95	n41	2017.5	15	15	75 (RBstart=4)	2546	100	3.2	>ACLR2
n97	n41	2350	100	30	270 (RBstart=3)	2501	10	28.1	ACLR2
n97	n41	2360	80	30	216 (RBstart=1)	2546	100	10.6	ACLR2
n98	n41	1900	40	15	216 (RBstart=0)	2501	10	3.3	>ACLR2

Table 7.3C.2-5: Void

### 7.3C.3 $\Delta R_{IB,c}$ for SUL

#### 7.3C.3.1 General

For a UE supporting a SUL configuration, the  $\Delta R_{IB,c}$  applies for both SC and SUL operation.

#### 7.3C.3.2 SUL band combination

For the UE which supports SUL band combination, the minimum requirement for reference sensitivity in clause 7.3C.2 shall be increased by the amount given in  $\Delta R_{IB,c}$  defined in clause 7.3C.3.2 for the applicable operating bands. Unless otherwise stated,  $\Delta R_{IB,c}$  is set to zero.

In case the UE supports more than one of band combinations for CA, SUL or DC, and an operating band belongs to more than one band combinations then

- When the operating band frequency range is  $\leq 1$  GHz, the applicable additional  $\Delta R_{IB,c}$  shall be the average value for all band combinations defined in clause 7.3A, 7.3B, 7.3C in this specification and 7.3A, 7.3B in TS 38.101-3 [3], truncated to one decimal place that apply for that operating band among the supported band combinations. In case there is a harmonic relation between low band UL and high band DL, then the maximum  $\Delta R_{IB,c}$  among the different supported band combinations involving such band shall be applied
- When the operating band frequency range is  $> 1$  GHz, the applicable additional  $\Delta R_{IB,c}$  shall be the maximum value for all band combinations defined in clause 7.3A, 7.3B, 7.3C in this specification and 7.3A, 7.3B in TS 38.101-3 [3] for the applicable operating bands.

#### 7.3C.3.2.1 $\Delta R_{IB,c}$ for two bands

Table 7.3C.3.2.1-1:  $\Delta R_{IB,c}$  due to SUL (two bands)

Band combination for SUL	$\Delta R_{IB,c}$ for NR band (dB) <sup>2</sup>	
	Component band in order of bands in configuration <sup>3</sup>	
SUL_n41-n80	0.5 <sup>1</sup>	N/A
SUL_n41-n95	0.2	N/A
SUL_n41-n98	0.2	N/A
SUL_n48-n99	0.5	N/A
SUL_n77-n80	0.5	N/A
SUL_n77-n84	0.5	N/A
SUL_n77-n99	0.5	N/A
SUL_n78-n80	0.5	N/A
SUL_n78-n81	0.5	N/A
SUL_n78-n82	0.5	N/A
SUL_n78-n83	0.5	N/A
SUL_n78-n84	0.5	N/A
SUL_n78-n86	0.5	N/A
SUL_n79-n83	0.5	N/A
SUL_n79-n97	0.5	N/A
SUL_n79-n98	0.5	N/A

NOTE 1: The requirement is applied for UE transmitting on the frequency range of 2496 – 2515 MHz.

Band combination for SUL	$\Delta R_{IB,c}$ for NR band (dB) <sup>2</sup>		
	Component band in order of bands in configuration <sup>3</sup>		
NOTE 2: “-” denotes $\Delta R_{IB,c} = 0$ and $\Delta R_{IB,c}$ is not applicable to SUL band(s).			
NOTE 3: The component band order in the configuration should be listed by the order of NR band, such as for SUL_n41-n80 the order of band is n41 and n80.			

7.3C.3.2.2  $\Delta R_{IB,c}$  for three bandsTable 7.3C.3.2.2-1:  $\Delta R_{IB,c}$  due to SUL (three bands)

Band combination for SUL	$\Delta R_{IB,c}$ for NR bands (dB) <sup>2</sup>		
	Component band in order of bands in configuration <sup>3</sup>		
CA_n1_n78-n80	0.2	0.5	N/A
CA_n1_n78-n81	-	0.5	N/A
CA_n1_n78-n84	0.2	0.5	N/A
CA_n1_n78-n89	0.2	0.5	N/A
CA_n3_n41-n80	-	0.5 <sup>1</sup>	N/A
CA_n3_n78-n80	0.2	0.5	N/A
CA_n3_n78-n84	0.2	0.5	N/A
CA_n3_n79-n80	-	0.5	N/A
CA_n5_n78-n84	0.2	0.5	N/A
CA_n28_n41-n83	0.2	-	N/A
CA_n8_n78-n81	0.2	0.5	N/A
CA_n8_n78-n84	0.2	0.5	N/A
CA_n28_n79-n83	0.2	0.5	N/A
CA_n41_n79-n80	0.5	0.5	N/A
CA_n41_n79-n83	0.5	0.5	N/A
CA_n41_n79-n95	-	0.5	N/A
CA_n41_n79-n97	-	0.8	N/A
CA_n41_n79-n98	-	0.5	N/A
CA_n78_n1-n80	0.5	0.2	N/A
CA_n78_n1-n81	0.5	-	N/A
CA_n78_n1-n89	0.5	0.2	N/A
CA_n78_n3-n84	0.5	0.2	N/A
CA_n78_n5-n84	0.5	0.2	N/A
CA_n78_n8-n84	0.5	0.2	N/A
CA_n79_n41-n80	0.5	0.5	N/A
CA_n78_n80-n84	0.5	N/A	N/A
CA_n78_n81-n84	0.5	N/A	N/A
CA_n78_n84-n89	0.5	N/A	N/A
CA_n79_n41-n83	0.5	0.5	N/A
CA_n79_n41-n95	-	0.5	N/A
CA_n79_n41-n97	-	0.8	N/A
CA_n79_n41-n98	-	0.5	N/A
NOTE 1: The requirement is applied for UE transmitting on the frequency range of 2496 – 2515 MHz.			
NOTE 2: “-” denotes $\Delta R_{IB,c} = 0$ and $\Delta R_{IB,c}$ is not applicable to SUL band(s).			
NOTE 3: The component band order in the configuration should be listed by the order of NR bands, such as for CA_n1_n78-n80 the order of band is n1, n78 and n80.			

7.3C.3.2.3  $\Delta R_{IB,c}$  for four bandsTable 7.3C.3.2.3-1:  $\Delta R_{IB,c}$  due to SUL (four bands)

Band combination for SUL	$\Delta R_{IB,c}$ for NR bands (dB) <sup>1</sup>			
	Component band in order of bands in configuration <sup>2</sup>			
CA_n28-n79_n41-n83	0.2	-	0.8	N/A
CA_n28-n41_n79-n83	0.2	-	0.8	N/A
CA_n41A-n95A_n79A-n98A	0.5	0.5	N/A	N/A
CA_n41A-n98A_n79A-n95A	0.5	0.5	N/A	N/A

CA_n41A-n83A_n79A-n98A	0.5	0.5	N/A	N/A
CA_n41A-n83A_n79A-n95A	0.5	0.5	N/A	N/A
NOTE 1: “-” denotes $\Delta R_{IB,c} = 0$ and $\Delta R_{IB,c}$ is not applicable to SUL band(s).				
NOTE 2: The component band order in the configuration should be listed by the order of NR bands, such as for CA_n28-n79_n41-n83 the order of band is n28, n41, n79 and n83.				

## 7.3D Reference sensitivity for UL MIMO

For UE with two or four transmitter antenna connectors in closed-loop spatial multiplexing scheme, the minimum requirements specified in clause 7.3 shall be met with the UL MIMO configurations described in clause 6.2D.1 and clause 6.2F.1D for shared spectrum access operation, and the reference measurement channels as specified in Annex A.2.2 for CP-OFDM waveforms shall apply. For UL MIMO, the parameter  $P_{UMAX}$  is the total transmitter power over all transmit antenna connectors.

## 7.3E Reference sensitivity for V2X

### 7.3E.1 General

The reference sensitivity power level  $P_{REFSENS\_V2X}$  is the minimum mean power applied to each one of the UE antenna port for V2X UE, at which the throughput shall meet or exceed the requirements for the specified reference measurement channel.

### 7.3E.2 Minimum requirements

When UE is configured for NR V2X reception non-concurrent with NR uplink transmissions for NR V2X operating bands specified in Table 5.2E.1-1, the throughput shall be  $\geq 95\%$  of the maximum throughput of the reference measurement channels as specified in Annexes A.7.2 with parameters specified in Table 7.3E.2-1.

**Table 7.3E.2-1: Reference sensitivity of NR V2X Bands (PC5)**

NR V2X Band	SCS kHz	Channel bandwidth / $P_{REFSENS\_V2X}$ (dBm)					Duplex Mode
		5MHz <sup>4</sup>	10 MHz	20 MHz	30 MHz	40 MHz	
n14	15	-95.9	-92.7				HD
	30		-93.0				
	60						
n38	15		-96.5	-93.2	-91.4	-90.1	HD
	30		-96.1	-93.4	-91.7	-90.2	
	60		-96.9	-93.1	-91.9	-90.4	
n47	15		-92.5	-89.2	-87.4	-86.1	HD
	30		-92.1	-89.4	-87.7	-86.2	
	60		-92.9	-89.1	-87.9	-86.4	
n79 <sup>5</sup>	15		-95.5	-92.2	-90.4	-89.1	HD
	30		-95.1	-92.4	-90.7	-89.2	
	60		-95.9	-92.1	-90.9	-89.4	
NOTE 1: Reference measurement channel is defined in A.7.2.							
NOTE 2: The signal power is specified per antenna port.							
NOTE 3: Void.							
NOTE 4: The CBW is only applicable for PS UE in n14.							
NOTE 5: These REFSENS values do not consider the impact of the near/far effect							

**Table 7.3E.2-2: Sidelink TX configuration for reference sensitivity of NR V2X Bands (PC5)**

NR V2X Band	SCS kHz	NR Band / SCS / Channel bandwidth / Duplex mode					Duplex Mode
		5 MHz <sup>3</sup>	10 MHz	20 MHz	30 MHz	40 MHz	
n14	15	20	20				HD

	30		10				
	60						
n38	15		50	105	160	216	HD
	30		24	50	75	105	
	60		10 <sup>2</sup>	24	36	50	
n47	15		50	105	160	216	HD
	30		24	50	75	105	
	60		10 <sup>2</sup>	24	36	50	
n79	15		50	105	160	216	HD
	30		24	50	75	105	
	60		10 <sup>2</sup>	24	36	50	
NOTE 1: The sidelink allocated RB ( $L_{CRB}$ ) size could be adjusted according to resource pool configuration in [7].							
NOTE 2: For the case, 11 RB is allowed for S-SSB Block.							
NOTE 3: The CBW is only applicable for PS UE in n14.							

## 7.3E.2A Minimum requirements for Sidelink CA

The reference sensitivity power level REFSENS is the minimum mean power applied to each one of the UE antenna ports, at which the throughput shall meet or exceed the requirements for the specified reference measurement channel.

### 7.3E.2A.1 Reference sensitivity power level for Sidelink CA

For intra-band contiguous NR SL CA operation, the reference sensitivity requirement specified in Table 7.3E.2-1 shall apply for each component carrier with all carriers active. The requirement is applied for each carrier reception when 2 carrier transmissions are activated at the same time.

## 7.3E.2F Minimum requirements for Sidelink Unlicensed

### 7.3E.2F.1 General

The reference sensitivity power level REFSENS is the minimum mean power applied to each one of the UE antenna ports, at which the throughput shall meet or exceed the requirements for the specified reference measurement channel.

In later clauses of Clause 7 where the value of REFSENS is used as a reference to set the corresponding requirement, the UE shall be verified against those requirements by applying the REFSENS value in Table 7.3E.2F.2-1 with 2 Rx antenna ports tested.

### 7.3E.2F.2 Reference sensitivity power level

The throughput shall be  $\geq 95\%$  of the maximum throughput of the reference measurement channels as specified in Annexes A.7.2 with parameters specified in Table 7.3E.2F.2-1, Table 7.3E.2F.2-2, and Table 7.3E.2F.2-3.

**Table 7.3E.2F.2-1: Two antenna port reference sensitivity QPSK PREFSENS**

Operating band / SCS / Channel bandwidth / REFSENS				
Operating band	SCS kHz	Channel bandwidth (MHz)	REFSENS (dBm) <sup>1</sup>	Duplex Mode
n46	15	20, 40	$-89.2 + 10\log_{10}(N_{RB}/105)$	HD
	30	20, 40, 60, 80, 100	$-89.4 + 10\log_{10}(N_{RB}/50)$	
	60	20, 40, 60, 80, 100	$-89.6 + 10\log_{10}(N_{RB}/24)$	
n96, n102	15	20, 40	$-88.7 + 10\log_{10}(N_{RB}/105)$	HD
	30	20, 40, 60, 80, 100	$-88.9 + 10\log_{10}(N_{RB}/50)$	
	60	20, 40, 60, 80, 100	$-89.1 + 10\log_{10}(N_{RB}/24)$	
NOTE 1: The REFSENS value is rounded to the nearest number down to one decimal point. " $N_{RB}$ " in REFSENS formula is the maximum transmission bandwidth configuration as defined in Table 7.3E.2F.2-3				

For UE(s) equipped with 4 Rx antenna ports, reference sensitivity for 2Rx antenna ports in Table 7.3E.2F.2-1 shall be modified by the amount given in  $\Delta R_{IB,4R}$  in Table 7.3E.2F.2-2 for the applicable operating bands.

**Table 7.3E.2F.2-2: Four antenna port reference sensitivity allowance  $\Delta R_{IB,4R}$**

Operating band	$\Delta R_{IB,4R}$ (dB)
n46, n96, n102	-2.2

The reference receive sensitivity (REFSENS) requirement specified in Table 7.3E.2F.2-1 and Table 7.3E.2F.2-2 shall be met with sidelink transmission bandwidth less than or equal to that specified in Table 7.3E.2F.2-3.

**Table 7.3E.2F.2-3: Transmitted sidelink configuration for reference sensitivity**

Operating Band	Operating band / SCS / Channel bandwidth/ $N_{RB}$					
	SCS kHz	20 MHz	40 MHz	60 MHz	80 MHz	100 MHz
n46	15	105	216			
	30	50	105	160	216	270
	60	24	50	75	105	135
n96, n102	15	105	216			
	30	50	105	160	216	270
	60	24	50	75	105	135

Unless given by Table 7.3E.2F.2-4, the minimum requirements specified in Tables 7.3E.2F.2-1 and 7.3E.2F.2-2 shall be verified with the network signalling value NS\_01 (Table 6.2F.3.1-1) configured.

**Table 7.3F.2-4: Network signaling value for reference sensitivity**

Operating band	Network Signalling value
n46	NS_01
n96	NS_53
n102	NS_01

## 7.3E.3 Reference sensitivity power level for V2X concurrent operation

### 7.3E.3.1 General

When UE is configured for NR V2X reception on V2X carrier concurrent with NR uplink and downlink, NR V2X sidelink throughput for the carrier shall be  $\geq 95\%$  of the maximum throughput of the reference measurement channels as specified in Annexes A.7.2 with parameters specified in Table 7.3E.2-1 and 7.3E.2-2. Also, the NR downlink throughput shall be  $\geq 95\%$  of the maximum throughput of the reference measurement channels as specified in Annexes A.3 with parameters specified in Tables 7.3.2-1a, 7.3.2-1b, 7.3.2-2 and 7.3.2-3. The reference sensitivity is defined to be met with all downlink component carriers active. The REFSENS of Uu downlink and PC5 sidelink will be tested at the same time. Exceptions to reference sensitivity with different transmission and reception configurations are allowed for the combinations of aggressor and victim bands specified in Tables 7.3E.3-3 and 7.3E.3-4. The limited test configurations are specified in Tables 7.3E.3-3 and 7.3E.3-4 to verify MSD requirements.

For the intra-band concurrent NR V2X operation, the reference sensitivity power level shall be applied per carrier. The requirements in clause 7.3.2 shall be applied for NR downlink carrier and the requirements in clause 7.3E.2 shall be applied for NR sidelink carrier. NR V2X sidelink throughput for the carrier shall be  $\geq 95\%$  of the maximum throughput of the reference measurement channels as specified in Annexes A.7.2. Also, the NR downlink throughput shall be  $\geq 95\%$  of the maximum throughput of the reference measurement channels as specified in Annexes A.3.2 in TS38.101-1.

For reference sensitivity exception test points where the specified carrier frequency does not correspond to a valid NR-ARFCN, the closest NR-ARFCN as specified in clause 5.4.2 applies.

Table 7.3E.3-1: Void

Table 7.3E.3-2:  $\Delta R_{IB,V2X}$  (two bands)

V2X inter-band concurrent band Combination	NR Band	$\Delta R_{IB,V2X}$ [dB]
V2X_n71-n47	n71	0.0

Table 7.3E.3-3: Reference sensitivity exceptions (MSD) due to cross band isolation for inter-band concurrent operation

Aggressor band	Victim band	Aggressor band $F_c$	Aggressor band BW	SCS of Aggressor band	Aggressor band RB Allocation	Victim band $F_c$	Victim band BW	MSD
		(MHz)	(MHz)	(kHz)	$L_{CRB}$	(MHz)	(MHz)	
n79	n47	4980	40	15	216 (RBstart=0)	5860	10	3.3
n47	n79	5860	10	15	50 (RBstart=0)	4980	40	3.3

Table 7.3E.3-4: Reference sensitivity exceptions (MSD) due to harmonic interference for inter-band concurrent operation

Aggressor band	Victim band	Aggressor band BW	SCS of Aggressor band	Aggressor band RB Allocation	Victim band BW	MSD	UL/DL fc condition	UL/DL harmonic order
		(MHz)	(kHz)	$L_{CRB}$	(MHz)	(dB)		
n1	n47	5	15	16 (RBstart=4)	10	20.1	NOTE 2	UL3/DL1 direct-hit

NOTE 1: These requirements apply when there is at least one individual RE within the uplink transmission bandwidth of the aggressor (lower) band for which the 2<sup>nd</sup> / 3<sup>rd</sup> / 4<sup>th</sup> / 5<sup>th</sup> transmitter harmonic is within the downlink transmission bandwidth of a victim (higher) band.

NOTE 2: The requirements should be verified for UL NR ARFCN of the aggressor (lower) band (superscript LB) such that  $f_{UL}^{LB} = \lfloor f_{DL}^{HB} / 0.3 \rfloor \cdot 0.1$  in MHz and  $F_{UL\_low}^{LB} + BW_{Channel}^{LB} / 2 \leq f_{UL}^{LB} \leq F_{UL\_high}^{LB} - BW_{Channel}^{LB} / 2$  with the carrier frequency in the victim (higher) band in MHz and the channel bandwidth configured in the low band.

## 7.3E.3F Minimum requirements for SL-U concurrent operation

### 7.3E.3F.1 Reference sensitivity power level for SL-U concurrent operation

For the inter-band concurrent NR SL-U operation, the requirements specified in clause 7.3E.2F.2 shall apply for the NR sidelink reception in the operating bands in Table 5.2E.2F-1 and the requirements specified in clause 7.3.2 shall apply for the NR downlink reception in licensed band while all downlink carriers are active.

For the REFSSENS exception of SL\_n78-n46 inter-band concurrent NR SL-U operation, the existing CA\_n46-n78 MSD requirements in Table 7.3A.5-1 are applied. Also, the existing  $\Delta R_{IB}$  of CA\_n46-n78 in Table 7.3A.3.2.1-1 is applied for SL\_n78-n46 inter-band concurrent NR SL-U operation UE.

## 7.3F Reference sensitivity for shared spectrum channel access

### 7.3F.1 General

The reference sensitivity power level REFSENS is the minimum mean power applied to each one of the UE antenna ports, at which the throughput shall meet or exceed the requirements for the specified reference measurement channel.

In later clauses of Clause 7 where the value of REFSENS is used as a reference to set the corresponding requirement, the UE shall be verified against those requirements by applying the REFSENS value in Table 7.3G.2-1 with 2 Rx antenna ports tested.

### 7.3F.2 Reference sensitivity power level

The throughput shall be  $\geq 95\%$  of the maximum throughput of the reference measurement channels as specified in Annexes A.2.2.2, A3.2 and A.3.3 (with one sided dynamic OCNG Pattern OP.1 FDD/TDD for the DL-signal as described in Annex A.5.1.1/A.5.2.1) with parameters specified in Table 7.3F.2-1, Table 7.3F.2-2, and Table 7.3F.2-3.

**Table 7.3F.2-1: Two antenna port reference sensitivity QPSK PREFSENS**

Operating band / SCS / Channel bandwidth / REFSENS				
Operating band	SCS kHz	Channel bandwidth (MHz)	REFSENS (dBm) <sup>a</sup>	Duplex Mode
n46	15	20, 40	$-89.7 + 10\log_{10}(N_{RB}/106)$	TDD
	30	20, 40, 60, 80, 100	$-89.9 + 10\log_{10}(N_{RB}/51)$	
	60	60, 80, 100	$-90.1 + 10\log_{10}(N_{RB}/24)$	
n96, n102	15	20, 40	$-89.2 + 10\log_{10}(N_{RB}/106)$	TDD
	30	20, 40, 60, 80, 100	$-89.4 + 10\log_{10}(N_{RB}/51)$	
	60	60, 80, 100	$-89.6 + 10\log_{10}(N_{RB}/24)$	

NOTE 1: The REFSENS value is rounded to the nearest number down to one decimal point. "NRB" in REFSENS formula is the maximum transmission bandwidth configuration as defined in Table 5.3.2-1.

For UE(s) equipped with 4 Rx antenna ports, reference sensitivity for 2Rx antenna ports in Table 7.3F.2-1 shall be modified by the amount given in  $\Delta R_{IB,4R}$  in Table 7.3F.2-2 for the applicable operating bands.

**Table 7.3F.2-2: Four antenna port reference sensitivity allowance  $\Delta R_{IB,4R}$**

Operating band	$\Delta R_{IB,4R}$ (dB)
n46, n96, n102	-2.2

The reference receive sensitivity (REFSENS) requirement specified in Table 7.3F.2-1 and Table 7.3F.2-2 shall be met with uplink transmission bandwidth less than or equal to that specified in Table 7.3F.2-3.

**Table 7.3F.2-3: Uplink configuration for reference sensitivity**

Operating band / SCS / Channel bandwidth						
Operating Band	SCS kHz	20 MHz (dBm)	40 MHz (dBm)	60 MHz (dBm)	80 MHz (dBm)	100 MHz (dBm)
n46	15	100	216			
	30	50	100	162	216	270
	60	24	50	75	100	135
n96, n102	15	100	216			
	30	50	100	162	216	270
	60	24	50	75	100	135

Unless given by Table 7.3F.2-4, the minimum requirements specified in Tables 7.3F.2-1 and 7.3F.2-2 shall be verified with the network signalling value NS\_01 (Table 6.2F.3.1-1) configured.

**Table 7.3F.2-4: Network signaling value for reference sensitivity**

Operating band	Network Signalling value
n46	NS_01
n96	NS_53
n102	NS_01

7.3F.3 Void

7.3F.4 Void

### 7.3F.4A Shared spectrum channel access CA

#### 7.3F.4A.1 Intra-band contiguous shared spectrum channel access CA

For intra-band contiguous carrier aggregation, the throughput of each component carrier shall be  $\geq 95$  % of the maximum throughput of the reference measurement channels as specified in Annexes A.2.2.2, A.3.2, and A.3.3 (with one sided dynamic OCN Pattern OP.1 FDD/TDD for the DL-signal as described in Annex A.5.1.1/A.5.2.1) with parameters specified in Table 7.3F.2-1, Table 7.3F.2-2, and Table 7.3F.2-3.

7.3F.5 Void

7.3F.5.1 Void

7.3F.5.2 Void

7.3F.5.3 Void

### 7.3G Reference sensitivity for Tx Diversity

For UE supporting Tx diversity, the minimum requirements specified in Table 7.3.2-1a, Table 7.3.2-1b, Table 7.3.2-1d, Table 7.3.2-2 and Table 7.3.2-2a shall be met with Tx diversity configuration described in clause 6.2G.1. For Tx diversity, the parameter  $P_{UMAX}$  is defined in clause 6.2G.4 with the sum of the output power from all UE antenna connectors.



## 7.3G.5 Void

### 7.3G.5.0 Void

## 7.3H (Reserved)

## 7.3I Reference sensitivity for RedCap

### 7.3I.1 General

The reference sensitivity power level REFSSENS is the minimum mean power applied to each one of the UE antenna ports for all UE categories, at which the throughput shall meet or exceed the requirements for the specified reference measurement channel.

### 7.3I.2 Reference sensitivity power level

For a RedCap UE equipped with 2 Rx antenna ports, the throughput shall be  $\geq 95$  % of the maximum throughput of the reference measurement channels as specified in Annexes A.2.2.2, A3.2 and A.3.3 (with one sided dynamic OCNG Pattern OP.1 FDD/TDD for the DL-signal as described in Annex A.5.1.1/A.5.2.1) with parameters specified in Table 7.3.2-1a and Table 7.3.2-1b for the applicable operating bands. The reference sensitivity (REFSENS) requirement specified for a RedCap UE equipped with 2 Rx antenna ports shall be met with uplink transmission bandwidth less than or equal to that specified in Table 7.3.2-3 and, for FDD bands, with the Tx-Rx separation as defined in clause 5.4.4 for the applicable band and UE channel bandwidth.

For a RedCap UE equipped with 1 Rx antenna ports, reference sensitivity for 2Rx antenna ports in Table 7.3.2-1a and in Table 7.3.2-1b shall be modified by the amount given in  $\Delta R_{1R}$  in Table 7.3I.2-1 for the applicable operating bands. The reference sensitivity (REFSENS) requirement specified for a RedCap UE equipped with 1 Rx antenna ports shall be met with uplink transmission bandwidth less than or equal to that specified in Table 7.3.2-3 and, for FDD bands, with the Tx-Rx separation as defined in clause 5.4.4 for the applicable band and UE channel bandwidth.

**Table 7.3I.2-1: Single antenna port reference sensitivity allowance  $\Delta R_{1R}$**

Operating band	Channel bandwidth (MHz)	$\Delta R_{1R}$ (dB)
TDD band	5, 10, 15, 20	2.5
FDD band	5	2.5
FDD band	10, 15, 20	3.0

For a RedCap UE equipped with 2 Rx antenna ports operating in HD-FDD mode, reference sensitivity for 2Rx antenna ports in Table 7.3I.2-2 shall be met with uplink transmission bandwidth less than or equal to that specified in Table 7.3I.2-4.

**Table 7.3I.2-2: HD-FDD RedCap UE with 2 Rx antenna port reference sensitivity**

Operating Band	Operating band / SCS / Channel bandwidth				
	SCS kHz	5 MHz (dBm)	10 MHz (dBm)	15 MHz (dBm)	20 MHz (dBm)
n1	15	-100.0	-96.8	-95.0	-93.7
	30		-97.2	-95.2	-93.9
	60		-97.5	-95.4	-94.2
n2	15	-98.8	-95.6	-93.8	-92.5
	30		-96.0	-94.0	-92.7
	60		-96.3	-94.2	-93.0
n3	15	-97.8	-94.6	-92.8	-91.5
	30		-95.0	-93.0	-91.7

Operating band / SCS / Channel bandwidth					
Operating Band	SCS kHz	5 MHz (dBm)	10 MHz (dBm)	15 MHz (dBm)	20 MHz (dBm)
	60		-95.3	-93.2	-92.0
n5	15	-98.8	-95.6	-93.8	-92.5
	30		-96.0	-94.0	-92.7
n7	15	-98.8	-95.6	-93.8	-92.5
	30		-96.0	-94.0	-92.7
	60		-96.3	-94.2	-93.0
n8	15	-97.8	-94.6	-92.8	-91.5
	30		-95.0	-93.0	-91.7
n12	15	-97.8	-94.6	-92.8	
	30		-95.0	-93.0	
n13	15	-97.8	-94.6		
	30		-95.0		
n14	15	-97.8	-94.6		
	30		-95.0		
n18	15	-100.0	-96.8	-95.0	
	30		-97.2	-95.2	
n20	15	-97.8	-94.6	-92.8	-91.5
	30		-95.0	-93.0	-91.7
n24	15	-100.0	-96.8		
	30		-97.2		
	60		-97.5		
n25	15	-97.3	-94.1	-92.3	-91.0
	30		-94.5	-92.5	-91.2
	60		-94.8	-92.7	-91.5
n26	15	-98.3	-95.1	-93.3	-92.0
	30		-95.5	-93.5	-92.2
n28	15	-99.3	-96.1	-94.3	-93.0
	30		-96.5	-94.5	-93.2
n30	15	-99.5	-96.3		
	30		-96.7		
n65	15	-100.0	-96.8	-95.0	-93.7
	30		-97.2	-95.2	-93.9
	60		-97.5	-95.4	-94.2
n66	15	-100.0	-96.8	-95.0	-93.7
	30		-97.2	-95.2	-93.9
	60		-97.5	-95.4	-94.2
n70	15	-100.0	-96.8	-95.0	-93.7
	30		-97.2	-95.2	-93.9
	60		-97.5	-95.4	-94.2
n71	15	-98.0	-94.8	-93.0	-91.7
	30		-95.2	-93.2	-91.9
n74	15	-100.0	-96.8	-95.0	-93.7
	30		-97.2	-95.2	-93.9
	60		-97.5	-95.4	-94.2
n85	15	-97.8	-94.6	-92.8	
	30		-95.0	-93.0	
n91	15	-100.0			
n92	15	-100.0	-96.8	-95.0	-93.7
	30		-97.2	-95.2	-93.9
n93	15	-100.0			
n94	15	-100.0	-96.8	-95.0	-93.7
	30		-97.2	-95.2	-93.9
n105	15	-98 <sup>1</sup>	-94.8	-93	-91.7
	30		-95.2	-93.2	-91.9

NOTE 1: DL channels overlapping the 612-617MHz range have 0.5dB added to the REFSENS

For a RedCap UE equipped with 1 Rx antenna ports and operating in HD-FDD mode, reference sensitivity for 1Rx antenna ports in Table 7.3I.2-3 shall be met with uplink transmission bandwidth less than or equal to that specified in Table 7.3I.2-4.

Table 7.3I.2-3: HD-FDD RedCap UE with 1 Rx antenna port reference sensitivity

Operating band / SCS / Channel bandwidth					
Operating Band	SCS kHz	5 MHz (dBm)	10 MHz (dBm)	15 MHz (dBm)	20 MHz (dBm)
n1	15	-97.5	-94.3	-92.5	-91.2
	30		-94.7	-92.7	-91.4
	60		-95.0	-92.9	-91.7
n2	15	-96.3	-93.1	-91.3	-90.0
	30		-93.5	-91.5	-90.2
	60		-93.8	-91.7	-90.5
n3	15	-95.3	-92.1	-90.3	-89.0
	30		-92.5	-90.5	-89.2
	60		-92.8	-90.7	-89.5
n5	15	-96.3	-93.1	-91.3	-90.0
	30		-93.5	-91.5	-90.2
n7	15	-96.3	-93.1	-91.3	-90.0
	30		-93.5	-91.5	-90.2
	60		-93.8	-91.7	-90.5
n8	15	-95.3	-92.1	-90.3	-89.0
	30		-92.5	-90.5	-89.2
n12	15	-95.3	-92.1	-90.3	
	30		-92.5	-90.5	
n13	15	-95.3	-92.1		
	30		-92.5		
n14	15	-95.3	-92.1		
	30		-92.5		
n18	15	-97.5	-94.3	-92.5	
	30		-94.7	-92.7	
n20	15	-95.3	-92.1	-90.3	-89.0
	30		-92.5	-90.5	-89.2
n24	15	-97.5	-94.3		
	30		-94.7		
	60		-95.0		
n25	15	-94.8	-91.6	-89.8	-88.5
	30		-92.0	-90.0	-88.7
	60		-92.3	-90.2	-89.0
n26	15	-95.8	-92.6	-90.8	-89.5
	30		-93.0	-91.0	-89.7
n28	15	-96.8	-93.6	-91.8	-90.5
	30		-94.0	-92.0	-90.7
n30	15	-97.0	-93.8		
	30		-94.2		
n65	15	-97.5	-94.3	-92.5	-91.2
	30		-94.7	-92.7	-91.4
	60		-95.0	-92.9	-91.7
n66	15	-97.5	-94.3	-92.5	-91.2
	30		-94.7	-92.7	-91.4
	60		-95.0	-92.9	-91.7
n70	15	-97.5	-94.3	-92.5	-91.2
	30		-94.7	-92.7	-91.4
	60		-95.0	-92.9	-91.7
n71	15	-95.5	-92.3	-90.5	-89.2
	30		-92.7	-90.7	-89.4
n74	15	-97.5	-94.3	-92.5	-91.2
	30		-94.7	-92.7	-91.4
	60		-95.0	-92.9	-91.7
n85	15	-95.3	-92.1	-90.3	
	30		-92.5	-90.5	
n91	15	-97.5			
n92	15	-97.5	-94.3	-92.5	-91.2
	30		-94.7	-92.7	-91.4
n93	15	-97.5			
n94	15	-97.5	-94.3	-92.5	-91.2
	30		-94.7	-92.7	-91.4

Operating band / SCS / Channel bandwidth					
Operating Band	SCS kHz	5 MHz (dBm)	10 MHz (dBm)	15 MHz (dBm)	20 MHz (dBm)
n105	15	-95.5 <sup>1</sup>	-92.3	-90.5	-89.2
	30		-92.7	-90.7	-89.4
NOTE 1: DL channels overlapping the 612-617MHz range have 0.5dB added to the REFSENS					

Table 7.3I.2-4: Uplink configuration for HD-FDD reference sensitivity

Operating band / SCS / Channel bandwidth					
Operating Band	SCS kHz	5 MHz	10 MHz	15 MHz	20 MHz
n1	15	25	50	75	100
	30		24	36	50
	60		10	18	24
n2	15	25	50	75	100
	30		24	36	50
	60		10	18	24
n3	15	25	50	75	100
	30		24	36	50
	60		10	18	24
n5	15	25	50	75	100
	30		24	36	50
n7	15	25	50	75	100
	30		24	36	50
	60		10	18	24
n8	15	25	50	75	100
	30		24	36	50
n12	15	25	50	75	
	30		24	36	
n13	15	25	50		
	30		24		
n14	15	25	50		
	30		24		
n18	15	25	50	75	
	30		24	36	
n20	15	25	50	75	100
	30		24	36	50
n24	15	25	50		
	30		24		
	60		10		
n25	15	25	50	75	100
	30		24	36	50
	60		10	18	24
n26	15	25	50	75	100
	30		24	36	50
n28	15	25	50	75	100
	30		24	36	50
n30	15	25	50		
	30		24		
n65	15	25	50	75	100
	30		24	36	50
	60		10	18	24
n66	15	25	50	75	100
	30		24	36	50
	60		10	18	24
n70	15	25	50	75	NOTE 1
	30		24	36	NOTE 1
	60		10	18	NOTE 1
n71	15	25	50	75	100
	30		24	36	50
n74	15	25	50	75	100
	30		24	36	50

Operating band / SCS / Channel bandwidth					
Operating Band	SCS kHz	5 MHz	10 MHz	15 MHz	20 MHz
	60		10	18	24
n85	15	25	50	75	
	30		24	36	
n91	15	25			
n92	15	25	50	75	100
	30		24	36	50
n93	15	25			
n94	15	25	50	75	100
	30		24	36	50
n105	15	25	50	75	100
	30		24	36	50

NOTE 1: For DL channel bandwidths that do not have symmetric UL channel bandwidth, highest valid UL configuration with lowest TX-RX separation (Table 5.4.4-1) shall be used unless otherwise specified.

### 7.3I.3 Reference sensitivity power level for eRedCap

For UE supporting IE *supportOfERedCap-r18* and IE *eRedCapNotReducedBB-BW-r18*, the REFSSENS requirements for RedCap UE in clause 7.3I.2 apply.

For UE supporting IE *supportOfERedCap-r18* but not supporting *eRedCapNotReducedBB-BW-r18*, the reference sensitivity requirements for 5 MHz channel bandwidth with 15 kHz SCS defined in clause 7.3I.2 apply. These reference sensitivity requirements for 5 MHz channel bandwidth apply also for 10, 15 and 20 MHz channel bandwidths with 15 kHz SCS. In case the reference sensitivity requirements for 5 MHz channel bandwidth are not defined, the reference sensitivity requirements for 10 MHz channel bandwidth apply with the reference sensitivity level reduced by 3.2 dB, and the UL configuration shall be less than or equal to minimum between RB number specified in Table 7.3I.2-4 and 25 RBs for HD-FDD operation, and minimum between RB number specified in Table 7.3.2-3 and 25RBs otherwise. These reference sensitivity requirements for 10 MHz channel bandwidth apply also for 15 and 20 MHz channel bandwidths. Both Tx RBs in UL configuration and Rx RBs in FRC, when applicable, shall be allocated within the range from  $RB_{low} = \text{ceil}(N_{RB}/2 - N_{RB\_PR3}/2)$  to  $RB_{high} = RB_{low} + N_{RB\_PR3} - 1$ , where  $RB_{low}$  and  $RB_{high}$  are the lowest and highest available RB position and  $N_{RB\_PR3}$  is 25 RBs for 15 kHz SCS.

For UE supporting IE *supportOfERedCap-r18* but not supporting *eRedCapNotReducedBB-BW-r18*, for 30 kHz SCS, the reference sensitivity requirements defined for 10 MHz channel bandwidth in clause 7.3I.2 apply with reference sensitivity level reduced by 3.0 dB and the UL configuration shall be less than or equal to minimum between RB number specified in Table 7.3I.2-4 and 12 RBs for HD-FDD operation, and minimum between RB number specified in Table 7.3.2-3 and 12RBs otherwise. These reference sensitivity requirements for 10 MHz channel bandwidth apply also for 15 and 20 MHz channel bandwidths with 30 kHz SCS. Both Tx RBs in UL configuration and Rx RBs in FRC, when applicable, shall be allocated within the range from  $RB_{low} = \text{ceil}(N_{RB}/2 - N_{RB\_PR3}/2)$  to  $RB_{high} = RB_{low} + N_{RB\_PR3} - 1$ , where  $RB_{low}$  and  $RB_{high}$  are the lowest and highest available RB position and  $N_{RB\_PR3}$  is 12 RBs for 30 kHz SCS.

NOTE: It is not necessary to repeat verification when same requirement applies for multiple channel bandwidths.

## 7.3J Reference sensitivity for ATG

### 7.3J.1 General

For ATG UE with multiple omni-directional antennas not indicating the capability *antennaArrayType-r18*, the reference sensitivity power level REFSSENS is the minimum mean power per polarization at antenna connector, at which the throughput shall meet or exceed the requirements for the specified reference measurement channel.

For ATG UE with antenna array indicating the capability *antennaArrayType-r18*, the reference sensitivity power level REFSSENS is the minimum mean power per polarization at TAB antenna connector, at which the throughput shall meet or exceed the requirements for the specified reference measurement channel.

### 7.3J.2 Reference sensitivity power level

For a ATG UE(s) equipped with 2 Rx antenna ports, the throughput shall be  $\geq 95\%$  of the maximum throughput of the reference measurement channels as specified in Annexes A.2.2.2 and A.3.2 (with one sided dynamic OCNG Pattern OP.1 FDD for the DL-signal as described in Annex A.5.1.1) with parameters specified in Table 7.3.2-1a and Table 7.3.2-1b for the applicable operating bands.

For ATG UE(s) equipped with 4 Rx antenna ports, reference sensitivity for 2Rx antenna ports shall be modified by the amount given in  $\Delta_{RIB,4R}$  in Table 7.3.2-2 for the applicable operating bands.

The reference sensitivity (REFSENS) requirement for a ATG UE shall be met with uplink transmission bandwidth less than or equal to that specified in Table 7.3.2-3.

### 7.3K (Reserved)

### 7.3L (Reserved)

## 7.4 Maximum input level

Maximum input level is defined as the maximum mean power received at the UE antenna port, at which the specified relative throughput shall meet or exceed the minimum requirements for the specified reference measurement channel. The throughput shall be  $\geq 95\%$  of the maximum throughput of the reference measurement channels as specified in Annexes A.3.2 and A.3.3 (with one sided dynamic OCNG Pattern OP.1 FDD/TDD as described in Annex A.5.1.1/A.5.2.1) with parameters specified in Table 7.4-1.

**Table 7.4-1: Maximum input level**

Rx Parameter	Units	Channel bandwidth (MHz)		
		3, 5, 10, 15, 20	25, 30, 35, 40, 45, 50	60, 70, 80, 90, 100
Power in Transmission Bandwidth Configuration <sup>4</sup>	dBm	$-25^2$	$-25 + 10\log_{10}(BW_{Channel} / 20)^{Note\ 2}$	$-20^2$
		$-27^{3,5}$	$-27 + 10\log_{10}(BW_{Channel} / 20)^{Note\ 3,5}$	$-22^{3,5}$
NOTE 1: The transmitter shall be set to 4 dB below $P_{CMAX\_L,f,c}$ at the minimum uplink configuration specified in Table 7.3.2-3 and 7.3F.2-3 for shared spectrum channel access operation with $P_{CMAX\_L,f,c}$ as defined in clause 6.2.4. NOTE 2: Reference measurement channel is A.3.2.3 or A.3.3.3 for 64 QAM. NOTE 3: Reference measurement channel is A.3.2.4 or A.3.3.4 for 256 QAM. NOTE 4: $10\log_{10}(x)$ is rounded to the nearest 0.5dB value. NOTE 5: Reference measurement channel is A.3.2.5 or A.3.3.5 for 1024 QAM.				

### 7.4A Maximum input level for CA

#### 7.4A.1 Maximum input level for Intra-band contiguous CA

For intra-band contiguous carrier aggregation maximum input level is defined as the maximum mean power received at the UE antenna port, over the Transmission bandwidth configuration of each CC.

The throughput shall be  $\geq 95\%$  of the maximum throughput of the reference measurement channels as specified in Annexes A.3.2 and A.3.3 (with one sided dynamic OCNG Pattern OP.1 FDD/TDD as described in Annex A.5.1.1/A.5.2.1) with parameters specified in Table 7.4A.1-1 for each component carrier.

**Table 7.4A.1-1: Maximum input level for Intra-band contiguous CA**

Rx Parameter	Units	NR CA Bandwidth Class			
		B	C	D	

Power in largest transmission bandwidth configuration CC, $P_{\text{largest BW}}$	dBm	-23 <sup>2</sup>	-23 <sup>2</sup>	-25 <sup>2</sup>	
		-25 <sup>3,4</sup>	-25 <sup>3,4</sup>	-27 <sup>3,4</sup>	
Power in each other CC	dBm	$P_{\text{largest BW}} + 10 \cdot \log\left\{\frac{N_{\text{RB},c} \cdot \text{SCS}_c}{N_{\text{RB},\text{largest BW}} \cdot \text{SCS}_{\text{largest BW}}}\right\}$			
NOTE 1: The transmitter shall be set to 4 dB below $P_{\text{CMAX}_L,f,c}$ at the minimum uplink configuration specified in Table 7.3.2-3 and 7.3F.2-3 for shared spectrum channel access operation with $P_{\text{CMAX}_L,f,c}$ as defined in clause 6.2.4.					
NOTE 2: Reference measurement channel is A.3.2.3 or A.3.3.3 for 64 QAM.					
NOTE 3: Reference measurement channel is A.3.2.4 or A.3.3.4 for 256 QAM.					
NOTE 4: Reference measurement channel is A.3.2.5 or A.3.3.5 for 1024 QAM.					

## 7.4A.2 Maximum input level for Intra-band non-contiguous CA

For intra-band non-contiguous carrier aggregation with one uplink carrier and two or more downlink sub-blocks, each larger than or equal to 5 MHz, the maximum input level requirements are defined with the uplink configuration in accordance with 7.3A.2.2-1. For this uplink configuration, the UE shall meet the requirements for each sub-block as specified in Table 7.4-1 and Table 7.4A.1-1 for one component carrier and two component carriers per sub-block, respectively. The throughput of each downlink component carrier shall be  $\geq 95\%$  of the maximum throughput of the specified reference measurement channel as specified in Annex A.3.2 and A.3.3 (with one sided dynamic OCNG Pattern OP.1 FDD/TDD as described in Annex A.5.1.1 and A.5.2.1). The requirements apply with all downlink carriers active.

## 7.4A.3 Maximum input level for Inter-band CA

For inter-band carrier aggregation with one component carrier per operating band and the uplink assigned to one NR band, the maximum input level is defined with the uplink active on the band(s) other than the band whose downlink is being tested. For NR CA configurations including an operating band without uplink band or an operating band with an unpaired DL part (as noted in Table 5.2-1), the requirements for all downlinks shall be met with the single uplink carrier active in each band capable of UL operation. The UE shall meet the requirements specified in clause 7.4 for each component carrier while all downlink carriers are active.

The throughput shall be  $\geq 95\%$  of the maximum throughput of the reference measurement channels as specified in Annexes A.3.2 and A.3.3 (with one sided dynamic OCNG Pattern OP.1 FDD/TDD as described in Annex A.5.1.1/A.5.2.1) for each component carrier.

## 7.4B Maximum input level for NR-DC

For inter-band NR-DC configurations, the maximum input level for the corresponding inter-band CA configuration as specified in clause 7.4A applies.

## 7.4D Maximum input level for UL MIMO

For UE with two or four transmitter antenna connectors in closed-loop spatial multiplexing, the minimum requirements specified in clause 7.4 shall be met with the UL MIMO configurations described in clause 6.2D.1 and clause 6.2F.1D for shared spectrum access operation. For UL MIMO, the parameter  $P_{\text{CMAX}_L}$  is defined as the total transmitter power over all transmit antenna connectors.

## 7.4E Maximum input level for V2X

### 7.4E.1 General

Maximum input level is defined as the maximum mean power received at the UE antenna port, at which the specified relative throughput shall meet or exceed the minimum requirements for the specified reference measurement channel. When UE is configured for NR V2X reception non-concurrent with NR uplink transmissions for NR V2X operating bands specified in Table 5.2E.1-1, the throughput shall be  $\geq 95\%$  of the maximum throughput of the reference measurement channels as specified in Annexes A.7.3 and A.7.4 with parameters specified in Table 7.4E.1-1.

Table 7.4E.1-1: Maximum input level of NR V2X

Rx Parameter	Units	Channel bandwidth				
		5 MHz <sup>3</sup>	10 MHz	20 MHz	30 MHz	40 MHz
Power in Transmission Bandwidth Configuration	dBm	-25 <sup>1</sup>	-25 <sup>1</sup>	-25 <sup>1</sup>	-23 <sup>1</sup>	-22 <sup>1</sup>
		-27 <sup>2</sup>	-27 <sup>2</sup>	-27 <sup>2</sup>	-25 <sup>2</sup>	-24 <sup>2</sup>
NOTE 1: Reference measurement channel is A.7.3 for 64 QAM.						
NOTE 2: Reference measurement channel is A.7.4 for 256 QAM.						
NOTE 3: The CBW is only applicable for PS UE in n14.						

### 7.4E.1A Maximum input level for Sidelink CA

For intra-band contiguous NR SL CA operation, the following maximum input level requirement shall be applied to the SL CA bandwidth class B.

Table 7.4E.1A-1 Maximum input levels for intra-band contiguous CA UE

Rx Parameter	Units	SL CA Bandwidth Class	
		A	B
Power in largest Transmission Bandwidth Configuration CC	dBm		$-25 + 10\log_{10}(BW_{\text{Channel}}/20)$ <sup>Note 1</sup>
			$-27 + 10\log_{10}(BW_{\text{Channel}}/20)$ <sup>Note 2</sup>
NOTE 1: Reference measurement channel is A.7.3 for 64 QAM.			
NOTE 2: Reference measurement channel is A.7.4 for 256 QAM.			
NOTE 3: $10\log_{10}(x)$ is rounded to the nearest 0.5dB			

The throughput shall be  $\geq 95\%$  of the maximum throughput of the reference measurement channels as specified in Annex A.7.3 and A.7.4. The requirements apply with all downlink carriers active.

### 7.4E.1F General requirement for Sidelink Unlicensed

The maximum input level requirement of SL-U operation in clause 7.4 apply.

The throughput shall be  $\geq 95\%$  of the maximum throughput of the reference measurement channels as specified in Annexes A.7.3 and A.7.4..

### 7.4E.2 Maximum input level for V2X concurrent operation

For the inter-band concurrent NR V2X operation, the requirements specified in clause 7.4E.1 shall apply for the NR sidelink reception in the operating bands in Table 5.2E.2-1 and the requirements specified in clause 7.4 shall apply for the NR downlink reception in licensed band while all downlink carriers are active.

### 7.4E.2F Maximum input level for SL-U concurrent operation

For the inter-band concurrent NR SL-U operation, the requirements specified in clause 7.4E.1F shall apply for the NR sidelink reception in the operating bands in Table 5.2E.2F-1 and the requirements specified in clause 7.4 shall apply for the NR downlink reception in licensed band while all downlink carriers are active.



7.4F (Reserved)

7.4G (Reserved)

7.4H (Reserved)

7.4I (Reserved)

## 7.4J Maximum input level for ATG

Maximum input level is defined as the maximum mean power received at the UE antenna port, at which the specified relative throughput shall meet or exceed the minimum requirements for the specified reference measurement channel. The throughput shall be  $\geq 95\%$  of the maximum throughput of the reference measurement channels as specified in Annexes A.3.2 and A.3.3 (with one sided dynamic OCNG Pattern OP.1 FDD/TDD as described in Annex A.5.1.1/A.5.2.1) with parameters specified in Table 7.4J-1.

**Table 7.4J-1: Maximum input level for ATG**

Rx Parameter	Units	ATG UE Types		Reference measurement channel
		Omni-directional antenna: receiver characteristics specified at the antenna connector(s)	Antenna array: receiver characteristics specified at transceiver array boundary (TAB) connectors	
Power in Transmission Bandwidth Configuration	dBm	-42	-30	A.3.2.3 or A.3.3.3 for 64 QAM
		-44	-32	A.3.2.4 or A.3.3.4 for 256 QAM
The applicable channel bandwidths	MHz	5, 10, 15, 20, 25, 30, 35, 40, 45, 50, 60, 70, 80, 90, 100		
NOTE 1: The transmitter shall be set to 4 dB below $P_{\text{CMAX\_L,f,c}}$ at the minimum uplink configuration specified in Table 7.3.2-3 with $P_{\text{CMAX\_L,f,c}}$ as defined in clause 6.2J.2.				

7.4K (Reserved)

7.4L (Reserved)

## 7.5 Adjacent channel selectivity

Adjacent channel selectivity (ACS) is a measure of a receiver's ability to receive an NR signal at its assigned channel frequency in the presence of an adjacent channel signal at a given frequency offset from the centre frequency of the assigned channel. ACS is the ratio of the receive filter attenuation on the assigned channel frequency to the receive filter attenuation on the adjacent channel(s).

The UE shall fulfil the minimum requirements specified in Table 7.5-1 for NR bands with  $\text{FDL\_high} < 2700$  MHz and  $\text{FUL\_high} < 2700$  MHz and the minimum requirements specified in Table 7.5-2 for NR bands with  $\text{FDL\_low} \geq 3300$  MHz and  $\text{FUL\_low} \geq 3300$  MHz. These requirements apply for all values of an adjacent channel interferer up to -25 dBm and for any SCS specified for the channel bandwidth of the wanted signal. However, it is not possible to directly measure the ACS; instead the lower and upper range of test parameters are chosen as in Table 7.5-3 and Table 7.5-4 for verification of the requirements specified in Table 7.5-1, and as in Table 7.5-5 and Table 7.5-6 for verification of the requirements specified in Table 7.5-2. For these test parameters, the throughput shall be  $\geq 95\%$  of the maximum throughput of the reference measurement channels as specified in Annexes A.2.2, A.3.2, and A.3.3 (with one sided

dynamic OCNG Pattern OP.1 FDD/TDD for the DL-signal as described in Annex A.5.1.1/A.5.2.1). For operating bands with an unpaired DL part (as noted in Table 5.2-1), the requirements only apply for carriers assigned in the paired part.

**Table 7.5-1: ACS for NR bands with  $F_{DL\_high} < 2700$  MHz and  $F_{UL\_high} < 2700$  MHz**

RX parameter	Units	Channel bandwidth (MHz)		
		3, 5, 10	15	20, 25, 30, 35, 40, 45, 50, 60, 70, 80, 90, 100
ACS	dB	33	30	$27 - 10\log_{10}(BW_{Channel} / 20)$
NOTE1: ACS value is rounded to the next higher 0.5dB value				

**Table 7.5-2: ACS for NR bands with  $F_{DL\_low} \geq 3300$  MHz and  $F_{UL\_low} \geq 3300$  MHz**

RX parameter	Units	Channel bandwidth (MHz)
		10, 15, 20, 25, 30, 35, 40, 45, 50, 60, 70, 80, 90, 100
ACS	dB	33

**Table 7.5-3: Test parameters for NR bands with  $F_{DL\_high} < 2700$  MHz and  $F_{UL\_high} < 2700$  MHz, case 1**

RX parameter	Units	Channel bandwidth (MHz)			
		3	5, 10	15	20, 25, 30, 35, 40, 45, 50, 60, 70, 80, 90, 100
Power in transmission bandwidth configuration	dBm	REFSENS + 14 dB			
$P_{interferer}^4$	dBm		REFSENS + 45.5 dB	REFSENS + 42.5 dB	REFSENS + $39.5 - 10\log_{10}(BW_{Channel} / 20)$
$BW_{interferer}$	MHz	3	5		
$F_{interferer}$ (offset)	MHz	3 /- 3	$BW_{Channel} / 2 + 2.5$ / $-(BW_{Channel} / 2 + 2.5)$		
NOTE 1: The transmitter shall be set to 4 dB below $P_{CMAX\_L,f,c}$ at the minimum UL configuration specified in Table 7.3.2-3 with $P_{CMAX\_L,f,c}$ defined in clause 6.2.4.					
NOTE 2: The absolute value of the interferer offset $F_{interferer}$ (offset) shall be further adjusted to $(\lceil  F_{interferer}  / SCS \rceil + 0.5) SCS$ MHz with SCS the sub-carrier spacing of the wanted signal in MHz. The interferer is an NR signal with 15 kHz SCS.					
NOTE 3: The interferer consists of the NR interferer RMC specified in Annexes A.3.2.2 and A.3.3.2 with one sided dynamic OCNG Pattern OP.1 FDD/TDD for the DL-signal as described in Annex A.5.1.1/A.5.2.1.					
NOTE 4: $10\log_{10}(x)$ is rounded to the next higher 0.5dB value.					

**Table 7.5-4: Test parameters for NR bands with  $F_{DL\_high} < 2700$  MHz and  $F_{UL\_high} < 2700$  MHz, case 2**

RX parameter	Units	Channel bandwidth (MHz)			
		3	5, 10	15	20, 25, 30, 35, 40, 45, 50, 60, 70, 80, 90, 100
Power in transmission bandwidth configuration <sup>4</sup>	dBm	-56.5		-53.5	$-50.5 + 10\log_{10}(BW_{Channel} / 20)$
$P_{interferer}$	dBm	-25			
$BW_{interferer}$	MHz	3	5		
$F_{interferer}$ (offset)	MHz	3 /- 3	$BW_{Channel} / 2 + 2.5$ / $-(BW_{Channel} / 2 + 2.5)$		
NOTE 1: The transmitter shall be set to 24 dB below $P_{CMAX\_L,f,c}$ at the minimum UL configuration specified in Table 7.3.2-3 with $P_{CMAX\_L,f,c}$ defined in clause 6.2.4.					
NOTE 2: The absolute value of the interferer offset $F_{interferer}$ (offset) shall be further adjusted to $(\lceil  F_{interferer}  / SCS \rceil + 0.5) SCS$ MHz with SCS the sub-carrier spacing of the wanted signal in MHz. The interferer is an NR signal with 15 kHz SCS.					
NOTE 3: The interferer consists of the RMC specified in Annexes A.3.2.2 and A.3.3.2 with one sided dynamic OCNG Pattern OP.1 FDD/TDD for the DL-signal as described in Annex A.5.1.1/A.5.2.1					
NOTE 4: $10\log_{10}(x)$ is rounded to the next higher 0.5dB value.					

**Table 7.5-5: Test parameters for NR bands with  $F_{DL\_low} \geq 3300$  MHz and  $F_{UL\_low} \geq 3300$  MHz, case 1**

RX parameter	Units	Channel bandwidth (MHz)	
		10, 15, 20, 25, 30, 35, 40, 45, 50, 60, 70, 80, 90, 100	
Power in transmission bandwidth configuration	dBm	REFSENS + 14 dB	
$P_{interferer}$	dBm	REFSENS + 45.5 dB	
$BW_{interferer}$	MHZ	$BW_{Channel}$	
$F_{interferer}$ (offset)	MHZ	$BW_{Channel} / -BW_{Channel}$	
<p>NOTE 1: The transmitter shall be set to 4 dB below <math>P_{CMAX\_L,f,c}</math> at the minimum UL configuration specified in Table 7.3.2-3 with <math>P_{CMAX\_L,f,c}</math> defined in clause 6.2.4.</p> <p>NOTE 2: The absolute value of the interferer offset <math>F_{interferer}</math> (offset) shall be further adjusted to <math>(\lceil  F_{interferer}  / SCS \rceil + 0.5) SCS</math> MHz with SCS the sub-carrier spacing of the wanted signal in MHz. The interferer is an NR signal with an SCS equal to that of the wanted signal.</p> <p>NOTE 3: The interferer consists of the RMC specified in Annexes A.3.2.2 and A.3.3.2 with one sided dynamic OCNB Pattern OP.1 FDD/TDD for the DL-signal as described in Annex A.5.1.1/A.5.2.1.</p>			

**Table 7.5-6: Test parameters for NR bands with  $F_{DL\_low} \geq 3300$  MHz and  $F_{UL\_low} \geq 3300$  MHz, case 2**

RX parameter	Units	Channel bandwidth (MHz)	
		10, 15, 20, 25, 30, 35, 40, 45, 50, 60, 70, 80, 90, 100	
Power in transmission bandwidth configuration	dBm	-56.5	
$P_{interferer}$	dBm	-25	
$BW_{interferer}$	MHZ	$BW_{Channel}$	
$F_{interferer}$ (offset)	MHZ	$BW_{Channel} / -BW_{Channel}$	
<p>NOTE 1: The transmitter shall be set to 24 dB below <math>P_{CMAX\_L,f,c}</math> at the minimum UL configuration specified in Table 7.3.2-3 with <math>P_{CMAX\_L,f,c}</math> defined in clause 6.2.4.</p> <p>NOTE 2: The absolute value of the interferer offset <math>F_{interferer}</math> (offset) shall be further adjusted to <math>(\lceil  F_{interferer}  / SCS \rceil + 0.5) SCS</math> MHz with SCS the sub-carrier spacing of the wanted signal in MHz. The interferer is an NR signal with an SCS equal to that of the wanted signal.</p> <p>NOTE 3: The interferer consists of the RMC specified in Annexes A.3.2.2 and A.3.3.2 with one sided dynamic OCNB Pattern OP.1 FDD/TDD for the DL-signal as described in Annex A.5.1.1/A.5.2.1.</p>			

## 7.5A Adjacent channel selectivity for CA

### 7.5A.1 Adjacent channel selectivity for Intra-band contiguous CA

For intra-band contiguous carrier aggregation the downlink SCC(s) shall be configured at nominal channel spacing to the PCC. The UE shall fulfil the minimum requirement specified in Table 7.5A.1-1 and 7.5A.1-1a for an adjacent channel interferer on either side of the aggregated downlink signal at a specified frequency offset and for an interferer power up to -25 dBm.

The throughput of each carrier shall be  $\geq 95$  % of the maximum throughput of the reference measurement channels as specified in Annexes A.2.2, A.3.2, and A.3.3 (with one sided dynamic OCNB Pattern OP.1 FDD/TDD for the DL-signal as described in Annex A.5.1.1/A.5.2.1) with parameters specified in Tables 7.5A.1-2, 7.5A.1-2a, 7.5A.1-3 and 7.5A.1-3a.

**Table 7.5A.1-1: ACS for intra-band contiguous CA with  $F_{DL\_low} \geq 3300$  MHz and  $F_{UL\_low} \geq 3300$  MHz**

Rx Parameter	Units	NR CA bandwidth class		
		B	C	D

ACS	dB	26.0	33.0	25.2	
-----	----	------	------	------	--

**Table 7.5A.1-1a: ACS for intra-band contiguous CA with  $F_{DL\_high} < 2700$  MHz and  $F_{UL\_high} < 2700$  MHz**

Rx Parameter	Units	NR CA bandwidth class	
		B	C
ACS	dB	20.0	17.0

**Table 7.5A.1-2: Test parameters for intra-band contiguous CA with  $F_{DL\_low} \geq 3300$  MHz and  $F_{UL\_low} \geq 3300$  MHz, case 1**

Rx Parameter	Units	NR CA bandwidth class		
		B	C	D
Pw in Transmission Bandwidth Configuration, per CC	dBm	REFSENS + 14 dB	REFSENS + 14 dB	REFSENS + 14 dB
$P_{Interferer}$	dBm	Aggregated power + 24.5 dB	Aggregated power + 31.5 dB	Aggregated power + 23.7 dB
$BW_{Interferer}$	MHz	20	$BW_{channel\ CA}$	50
$F_{Interferer}$ (offset)	MHz	10 + Foffset / -10 - Foffset	$BW_{channel\ CA}/2 + F_{offset}$ / $-BW_{channel\ CA}/2 + F_{offset}$	25 + Foffset / -25 - Foffset

NOTE 1: The transmitter shall be set to 4 dB below  $P_{CMAX\_L,f,c}$  at the minimum UL configuration specified in Table 7.3.2-3 with  $P_{CMAX\_L,f,c}$  defined in clause 6.2.4 .

NOTE 2: The absolute value of the interferer offset  $F_{interferer}$  (offset) shall be further adjusted to  $(\lceil F_{interferer} / SCS \rceil + 0.5) SCS$  MHz with SCS the sub-carrier spacing of the carrier closest to the interferer in MHz. The interferer is an NR signal with an SCS equal to that of the closest carrier.

NOTE 3: The interferer consists of the RMC specified in Annexes A.3.2.2 and A.3.3.2 with one sided dynamic OCNG Pattern OP.1 FDD/TDD for the DL-signal as described in Annex A.5.1.1/A.5.2.1.

**Table 7.5A.1-2a: Test parameters for intra-band contiguous CA with  $F_{DL\_high} < 2700$  MHz and  $F_{UL\_high} < 2700$  MHz, case 1**

Rx Parameter	Units	NR CA bandwidth class	
		B	C
Pw in Transmission Bandwidth Configuration, per CC	dBm	REFSENS + 14 dB	REFSENS + 14 dB
$P_{Interferer}$	dBm	Aggregated power + 18.5 dB	Aggregated power + 15.5 dB
$BW_{Interferer}$	MHz	5	5
$F_{Interferer}$ (offset)	MHz	2.5 + Foffset / -2.5 - Foffset	2.5 + Foffset / -2.5 - Foffset

NOTE 1: The transmitter shall be set to 4 dB below  $P_{CMAX\_L,f,c}$  at the minimum UL configuration specified in Table 7.3.2-3 with  $P_{CMAX\_L,f,c}$  defined in clause 6.2.4 .

NOTE 2: The absolute value of the interferer offset  $F_{interferer}$  (offset) shall be further adjusted to  $(\lceil F_{interferer} / SCS \rceil + 0.5) SCS$  MHz with SCS the sub-carrier spacing of the carrier closest to the interferer in MHz. The interferer is an NR signal with 15 kHz SCS.

NOTE 3: The interferer consists of the RMC specified in Annexes A.3.2.2 and A.3.3.2 with one sided dynamic OCNG Pattern OP.1 FDD/TDD for the DL-signal as described in Annex A.5.1.1/A.5.2.1.

**Table 7.5A.1-3: Test parameters for intra-band contiguous CA with  $F_{DL\_low} \geq 3300$  MHz and  $F_{UL\_low} \geq 3300$  MHz, case 2**

Rx Parameter	Units	NR CA bandwidth class		
		B	C	D
Pw in Transmission Bandwidth Configuration, per CC	dBm	-49.5 + $10\log(N_{RB,c}/N_{RB\_agg})$	-56.5	$-48.7 + 10\log(N_{RB,c}/N_{RB\_agg})$
$P_{Interferer}$	dBm	-25	-25	-25

$BW_{\text{Interferer}}$	MHz	20	$BW_{\text{channel CA}}$	50	
$F_{\text{Interferer (offset)}}$	MHz	$10 + F_{\text{offset}}$ / $-10 - F_{\text{offset}}$	$BW_{\text{channel CA}}/2 + F_{\text{offset}}$ / $-BW_{\text{channel CA}}/2 + F_{\text{offset}}$	$25 + F_{\text{offset}}$ / $-25 - F_{\text{offset}}$	

NOTE 1: The transmitter shall be set to 24 dB below  $P_{\text{CMAX\_L,f,c}}$  at the minimum UL configuration specified in Table 7.3.2-3 with  $P_{\text{CMAX\_L,f,c}}$  defined in clause 6.2.4.

NOTE 2: The absolute value of the interferer offset  $F_{\text{Interferer (offset)}}$  shall be further adjusted to  $(\lceil F_{\text{interferer}} / SCS \rceil + 0.5) SCS$  MHz with SCS the sub-carrier spacing of the carrier closest to the interferer in MHz. The interferer is an NR signal with an SCS equal to that of the closest carrier.

NOTE 3: The interferer consists of the RMC specified in Annexes A.3.2.2 and A.3.3.2 with one sided dynamic OCNG Pattern OP.1 FDD/TDD for the DL-signal as described in Annex A.5.1.1/A.5.2.1.

**Table 7.5A.1-3a: Test parameters for intra-band contiguous CA with  $F_{\text{DL\_high}} < 2700$  MHz and  $F_{\text{UL\_high}} < 2700$  MHz, case 2**

Rx Parameter	Units	NR CA Bandwidth Class	
		B	C
Pw in Transmission Bandwidth Configuration, per CC	dBm	$-43.5 + 10\log(N_{\text{RB,c}}/N_{\text{RB\_agg}})$	$-40.5 + 10\log(N_{\text{RB,c}}/N_{\text{RB\_agg}})$
$P_{\text{Interferer}}$	dBm	-25	-25
$BW_{\text{Interferer}}$	MHz	5	5
$F_{\text{Interferer (offset)}}$	MHz	$2.5 + F_{\text{offset}}$ / $-2.5 - F_{\text{offset}}$	$2.5 + F_{\text{offset}}$ / $-2.5 - F_{\text{offset}}$

NOTE 1: The transmitter shall be set to 24 dB below  $P_{\text{CMAX\_L,f,c}}$  at the minimum UL configuration specified in Table 7.3.2-3 with  $P_{\text{CMAX\_L,f,c}}$  defined in clause 6.2.4.

NOTE 2: The absolute value of the interferer offset  $F_{\text{Interferer (offset)}}$  shall be further adjusted to  $(\lceil F_{\text{interferer}} / SCS \rceil + 0.5) SCS$  MHz with SCS the sub-carrier spacing of the carrier closest to the interferer in MHz. The interferer is an NR signal with 15 kHz SCS.

NOTE 3: The interferer consists of the RMC specified in Annexes A.3.2.2 and A.3.3.2 with one sided dynamic OCNG Pattern OP.1 FDD/TDD for the DL-signal as described in Annex A.5.1.1/A.5.2.1.

### 7.5A.2 Adjacent channel selectivity Intra-band non-contiguous CA

For intra-band non-contiguous carrier aggregation with  $F_{\text{DL\_high}} < 2700$  MHz and  $F_{\text{UL\_high}} < 2700$  MHz with one uplink carrier and two or more downlink sub-blocks, each larger than or equal to 5 MHz, the adjacent channel selectivity requirements are defined with the uplink configuration in accordance with Table 7.3A.2.2-1. For this uplink configuration, the UE shall meet the requirements for each sub-block as specified in clauses 7.5 and 7.5A.1 for one component carrier and two component carriers per sub-block, respectively. The UE shall fulfil the minimum requirements all values of a single adjacent channel interferer in-gap and out-of-gap up to a -25 dBm interferer power while all downlink carriers are active. For the lower range of test parameters (Case 1), the interferer power  $P_{\text{Interferer}}$  shall be set to the maximum of the levels given by the carriers of the respective sub-blocks as specified in Table 7.5-3 and Table 7.5A.1-2a for one component carrier and two component carriers per sub-block, respectively. The wanted signal power levels for the carriers of each sub-block shall then be adjusted relative to  $P_{\text{Interferer}}$  in accordance with the ACS requirement for each sub-block (Table 7.5-1 and Table 7.5A.1-1a). For the upper range of test parameters (Case 2) for which the interferer power  $P_{\text{Interferer}}$  is -25 dBm (Table 7.5-4 and Table 7.5A.1-3a) the wanted signal power levels for the carriers of each sub-block shall be adjusted relative to  $P_{\text{Interferer}}$  like for Case 1.

For intra-band non-contiguous carrier aggregation with  $F_{\text{DL\_low}} \geq 3300$  MHz and  $F_{\text{UL\_low}} \geq 3300$  MHz with one uplink carrier and two or more downlink sub-blocks, each larger than or equal to 5 MHz, the adjacent channel selectivity requirements are defined with the uplink configuration in accordance with Table 7.3A.2.2-1. For this uplink configuration, the UE shall meet the requirements for each sub-block as specified in clauses 7.5 and 7.5A.1 for one component carrier and two component carriers per sub-block, respectively. The UE shall fulfil the minimum requirements all values of a single adjacent channel interferer in-gap and out-of-gap up to a -25 dBm interferer power while all downlink carriers are active. For the lower range of test parameters (Case 1), the interferer power  $P_{\text{Interferer}}$  shall be set to the maximum of the levels given by the carriers of the respective sub-blocks as specified in Table 7.5-5 and Table 7.5A.1-2 for one component carrier and two component carriers per sub-block, respectively. The wanted signal power levels for the carriers of each sub-block shall then be adjusted relative to  $P_{\text{Interferer}}$  in accordance with the ACS requirement for each sub-block (Table 7.5-2 and Table 7.5A.1-1). For the upper range of test parameters (Case 2) for

which the interferer power  $P_{\text{interferer}}$  is -25 dBm (Table 7.5-6 and Table 7.5A.1-3) the wanted signal power levels for the carriers of each sub-block shall be adjusted relative to  $P_{\text{interferer}}$  like for Case 1.

The throughput of each carrier shall be  $\geq 95\%$  of the maximum throughput of the reference measurement channels as specified in Annexes A.2.2, A.3.2, and A.3.3 (with one sided dynamic OCNG Pattern OP.1 FDD/TDD for the DL-signal as described in Annex A.5.1.1/A.5.2.1).

### 7.5A.3 Adjacent channel selectivity Inter-band CA

For inter-band carrier aggregation with one component carrier per operating band and the uplink assigned to one NR band, the adjacent channel requirements are defined with the uplink active on the band(s) other than the band whose downlink is being tested. For NR CA configurations including an operating band without uplink operation or an operating band with an unpaired DL part (as noted in Table 5.2-1), the requirements for all downlinks shall be met with the single uplink carrier active in each band capable of UL operation. The UE shall meet the requirements specified in clause 7.5 and clause 7.5F when the downlink belongs to a spectrum sharing defined band, for each component carrier while all downlink carriers are active.

The throughput of each carrier shall be  $\geq 95\%$  of the maximum throughput of the reference measurement channels as specified in Annexes A.2.2, A.3.2, and A.3.3 (with one sided dynamic OCNG Pattern OP.1 FDD/TDD for the DL-signal as described in Annex A.5.1.1/A.5.2.1).

### 7.5B Adjacent channel selectivity for NR-DC

For inter-band NR-DC configurations, the adjacent channel selectivity for the corresponding inter-band CA configuration as specified in clause 7.5A applies.

### 7.5D Adjacent channel selectivity for UL MIMO

For UE(s) with two or four transmitter antenna connectors in closed-loop spatial multiplexing scheme, the minimum requirements specified in clause 7.5 shall be met with the UL MIMO configurations described in clause 6.2D.1 and clause 6.2F.1D for shared spectrum access operation. For UL MIMO, the parameter  $P_{\text{CMAX}_L}$  is defined as the total transmitter power over all transmit antenna connectors.

### 7.5E Adjacent channel selectivity for V2X

#### 7.5E.1 General

Adjacent channel selectivity (ACS) is a measure of a receiver's ability to receive an NR signal at its assigned channel frequency in the presence of an adjacent channel signal at a given frequency offset from the centre frequency of the assigned channel. ACS is the ratio of the receive filter attenuation on the assigned channel frequency to the receive filter attenuation on the adjacent channel(s).

The UE shall fulfil the minimum requirements specified in Table 7.5E.1-1 for NR V2X UE. These requirements apply for all values of an adjacent channel interferer up to -25 dBm and for any SCS specified for the channel bandwidth of the wanted signal. However, it is not possible to directly measure the ACS; instead the lower and upper range of test parameters are chosen as in Table 7.5E.1-2 and Table 7.5E.1-3 for verification of the requirements specified in Table 7.5E.1-1. For these test parameters, when UE is configured for NR V2X reception non-concurrent with NR uplink transmissions for NR V2X operating bands specified in Table 5.2E.1-1, the throughput shall be  $\geq 95\%$  of the maximum throughput of the reference measurement channels as specified in Annexes A.7.2.

In licensed band, the minimum requirements shall reuse the same ACS values with NR UE.

**Table 7.5E.1-1: Adjacent channel selectivity for NR V2X**

RX parameter	Units	Channel bandwidth				
		5 MHz <sup>1</sup>	10 MHz	20 MHz	30 MHz	40 MHz
ACS	dB	33.0	33.0	27.0	25.5	24.0
NOTE 1: The CBW is only applicable for PS UE in n14.						

**Table 7.5E.1-2: Test parameters for Adjacent channel selectivity for V2X, Case 1**

RX parameter	Units	Channel bandwidth			
		10 MHz	20 MHz	30 MHz	40 MHz
Power in transmission bandwidth configuration	dBm	P <sub>PREFSENS_V2X</sub> + 14 dB			
P <sub>interferer</sub>	dBm	P <sub>PREFSENS_V2X</sub> + 45.5 dB	P <sub>PREFSENS_V2X</sub> + 39.5 dB	P <sub>PREFSENS_V2X</sub> + 38.0 dB	P <sub>PREFSENS_V2X</sub> + 36.5 dB
BW <sub>interferer</sub>	MHz	10	10	10	10
F <sub>interferer</sub> (offset)	MHz	10 / -10	15 / -15	20 / -20	25 / -25
NOTE 1: The interferer is QPSK modulated PUSCH containing data and reference symbols. Normal cyclic prefix is used. NOTE 2: The absolute value of the interferer offset F <sub>interferer</sub> (offset) shall be further adjusted to $(\lceil  F_{interferer}  / SCS \rceil + 0.5) SCS$ MHz with SCS the sub-carrier spacing of the wanted signal in MHz. The interferer is an NR signal with 15 kHz SCS.					

**Table 7.5E.1-2a: Test parameters for Adjacent channel selectivity in n14, Case 1**

RX parameter	Units	Channel bandwidth				
		5 MHz	10 MHz	20 MHz	30 MHz	40 MHz
Power in transmission bandwidth configuration	dBm	P <sub>PREFSENS_V2X</sub> + 14 dB				
P <sub>interferer</sub>	dBm	P <sub>PREFSENS_V2X</sub> + 45.5 dB	P <sub>PREFSENS_V2X</sub> + 45.5 dB			
BW <sub>interferer</sub>	MHz	5	5			
F <sub>interferer</sub> (offset)	MHz	5 / -5	7.5 / -7.5			
NOTE 1: The interferer is QPSK modulated PUSCH containing data and reference symbols. Normal cyclic prefix is used. NOTE 2: The absolute value of the interferer offset F <sub>interferer</sub> (offset) shall be further adjusted to $(\lceil  F_{interferer}  / SCS \rceil + 0.5) SCS$ MHz with SCS the sub-carrier spacing of the wanted signal in MHz. The interferer is an NR signal with 15 kHz SCS.						

**Table 7.5E.1-3: Test parameters for Adjacent channel selectivity for V2X, Case 2**

RX parameter	Units	Channel bandwidth			
		10 MHz	20 MHz	30 MHz	40 MHz
Power in transmission bandwidth configuration	dBm	-56.5	-50.5	-49.0	-47.5
P <sub>interferer</sub>	dBm	-25			
BW <sub>interferer</sub>	MHz	10	10	10	10
F <sub>interferer</sub> (offset)	MHz	10 / -10	15 / -15	20 / -20	25 / -25
NOTE 1: The interferer is QPSK modulated PUSCH containing data and reference symbols. Normal cyclic prefix is used. NOTE 2: The absolute value of the interferer offset F <sub>interferer</sub> (offset) shall be further adjusted to $(\lceil  F_{interferer}  / SCS \rceil + 0.5) SCS$ MHz with SCS the sub-carrier spacing of the wanted signal in MHz. The interferer is an NR signal with 15 kHz SCS.					

**Table 7.5E.1-3a: Test parameters for Adjacent channel selectivity in n14, Case 2**

RX parameter	Unit s	Channel bandwidth				
		5 MHz	10 MHz	20 MHz	30 MHz	40 MHz
Power in transmission bandwidth configuration	dBm	-56.5	-56.5			
P <sub>interferer</sub>	dBm	-25				
BW <sub>interferer</sub>	MHz	5	5			
F <sub>interferer</sub> (offset)	MHz	5 / -5	7.5 / -7.5			

NOTE 1: The interferer is QPSK modulated PUSCH containing data and reference symbols. Normal cyclic prefix is used.  
 NOTE 2: The absolute value of the interferer offset  $F_{\text{interferer}}$  (offset) shall be further adjusted to  $(\lceil |F_{\text{interferer}}| / SCS \rceil + 0.5) SCS$  MHz with SCS the sub-carrier spacing of the wanted signal in MHz. The interferer is an NR signal with 15 kHz SCS.

### 7.5E.1A Adjacent channel selectivity requirement for Sidelink CA

For intra-band contiguous NR SL CA operation, the UE shall fulfil the minimum requirement specified in Table 7.5E.1A-1 to Table 7.5E.1A-3 where the throughput shall be  $\geq 95\%$  of the maximum throughput of the reference measurement channels as specified in Annex A.7.2.

**Table 7.5E.1A-1 ACS for intra-band contiguous NR SL CA UE**

Rx Parameter	Units	SL CA bandwidth class
		B
ACS	dB	20.0

**Table 7.5E.1A-2 Test parameters for intra-band contiguous SL CA UE, case 1**

Rx Parameter	Units	SL CA bandwidth class
		B
Pw in Transmission Bandwidth Configuration, per CC	dBm	PREFSENS_SL + 14 dB
$P_{\text{Interferer}}$	dBm	Aggregated power + 18.5 dB
$BW_{\text{Interferer}}$	MHz	10
$F_{\text{Interferer}}$ (offset)	MHz	5+Aggregated BW <sub>Channel</sub> /2 / -(5+Aggregated BW <sub>Channel</sub> /2)
NOTE 1: The interferer is QPSK modulated PUSCH containing data and reference symbols. Normal cyclic prefix is used.		
NOTE 2: The absolute value of the interferer offset $F_{\text{interferer}}$ (offset) shall be further adjusted to $(\lceil  F_{\text{interferer}}  / SCS \rceil + 0.5) SCS$ MHz with SCS the sub-carrier spacing of the carrier closest to the interferer in MHz. The interferer is an NR signal with 15 kHz SCS.		

**Table 7.5E.1A-3 Test parameters for intra-band contiguous SL CA UE, case 2**

Rx Parameter	Units	SL CA Bandwidth Class
		B
Pw in Transmission Bandwidth Configuration, per CC	dBm	-43.5 + 10log(N <sub>RB,c</sub> /N <sub>RB_agg</sub> )
$P_{\text{Interferer}}$	dBm	-25
$BW_{\text{Interferer}}$	MHz	10
$F_{\text{Interferer}}$ (offset)	MHz	5+Aggregated BW <sub>Channel</sub> /2 / -(5+Aggregated BW <sub>Channel</sub> /2)
NOTE 1: The interferer is QPSK modulated PUSCH containing data and reference symbols. Normal cyclic prefix is used.		
NOTE 2: The absolute value of the interferer offset $F_{\text{interferer}}$ (offset) shall be further adjusted to $(\lceil  F_{\text{interferer}}  / SCS \rceil + 0.5) SCS$ MHz with SCS the sub-carrier spacing of the carrier closest to the interferer in MHz. The interferer is an NR signal with 15 kHz SCS.		

### 7.5E.1F General requirement for Sidelink Unlicensed

The ACS requirement of SL-U operation in clause 7.5F.1 apply.

The throughput shall be  $\geq 95\%$  of the maximum throughput of the reference measurement channels as specified in Annexes A.7.2.



## 7.5E.2 Adjacent channel selectivity for V2X concurrent operation

For the inter-band concurrent NR V2X operation, the requirements specified in clause 7.5E.1 shall apply for the NR sidelink reception in the operating bands in Table 5.2E.2-1 and the requirements specified in clause 7.5 shall apply for the NR downlink reception in licensed band while all downlink carriers are active.

## 7.5E.2F Adjacent channel selectivity for SL-U concurrent operation

For the inter-band concurrent NR SL-U operation, the requirements specified in clause 7.5E.1F shall apply for the NR sidelink reception in the operating bands in Table 5.2E.2F-1 and the requirements specified in clause 7.5 shall apply for the NR downlink reception in licensed band while all downlink carriers are active.

## 7.5F Adjacent channel selectivity for shared spectrum channel access

### 7.5F.1 General

Adjacent channel selectivity (ACS) is a measure of a receiver's ability to receive an NR signal at its assigned channel frequency in the presence of an adjacent channel signal at a given frequency offset from the centre frequency of the assigned channel. ACS is the ratio of the receive filter attenuation on the assigned channel frequency to the receive filter attenuation on the adjacent channel(s).

Instead of the general ACS requirements specified in clause 7.5, the UE shall fulfil the minimum requirements specified in Table 7.5F.1-1. These requirements apply for any SCS specified for the channel bandwidth of the wanted signal. For the test parameters specified in Table 7.5F.1-2, the throughput shall be  $\geq 95\%$  of the maximum throughput of the reference measurement channels as specified in Annexes A.2.2, A.3.2, and A.3.3 (with one sided dynamic OCNG Pattern OP.1 FDD/TDD for the DL-signal as described in Annex A.5.1.1/A.5.2.1).

**Table 7.5F.1-1: ACS for shared spectrum channel access bands**

RX parameter	Units	Channel bandwidth
		20, 40, 60, 80, 100 MHz
ACS	dB	$24 - 10\log_{10}(BW_{\text{Channel}}/20)$
NOTE1: ACS value is rounded to the next higher 0.5dB value		

**Table 7.5F.1-2: Test parameters for shared spectrum channel access bands**

RX parameter	Units	Channel bandwidth
		20, 40, 60, 80, 100 MHz
Power in transmission bandwidth configuration	dBm	REFSENS + 14 dB
$P_{\text{interferer}}$	dBm	$\text{REFSENS} + 36.5 \text{ dB} - 10\log_{10}(BW_{\text{Channel}}/20)$ dB
$BW_{\text{interferer}}$	MHz	20
$F_{\text{interferer}}$ (offset)	MHz	20 / -20
NOTE 1: The transmitter shall be set to 4 dB below $P_{\text{CMAX\_L,f,c}}$ at the minimum UL configuration specified in Table 7.3.2-3 with $P_{\text{CMAX\_L,f,c}}$ defined in clause 6.2.4.		
NOTE 2: The absolute value of the interferer offset $F_{\text{interferer}}$ (offset) shall be further adjusted to $(\lceil F_{\text{interferer}} \rceil / SCS + 0.5) \cdot SCS$ MHz with SCS the sub-carrier spacing of the wanted signal in MHz. The interferer is an NR signal with an SCS equal to that of the wanted signal.		
NOTE 3: The interferer consists of the RMC specified in Annexes A.3.2.2 and A.3.3.2 with one sided dynamic OCNG Pattern OP.1 FDD/TDD for the DL-signal as described in Annex A.5.1.1/A.5.2.1.		

## 7.5F.1A Adjacent channel selectivity for shared spectrum channel access CA

### 7.5F.1A.1 Intra-band contiguous shared spectrum channel access CA

ACS for intra-band contiguous shared access CA requirements are specified in Table 7.5F.1A.1-1. These requirements apply for any SCS specified for the channel bandwidth of the wanted signal. For the test parameters specified in Table 7.5F.1A.1-2, the throughput of each carrier shall be  $\geq 95\%$  of the maximum throughput of the reference measurement channels as specified in Annexes A.2.2, A.3.2, and A.3.3 (with one sided dynamic OCNG Pattern OP.1 FDD/TDD for the DL-signal as described in Annex A.5.1.1/A.5.2.1).

**Table 7.5F.1A.1-1: ACS for intra-band contiguous shared access CA**

Rx Parameter	Units	NR-U CA bandwidth class							
		B	C	D	E	I	M	N	O
ACS	dB	$24 - 10\log_{10}(BW_{\text{Channel\_CA}}/20)$							
NOTE 1: ACS value is rounded to the next higher 0.5dB value									

**Table 7.5F.1A.1-2: Test parameters for intra-band contiguous NR-U CA**

Rx Parameter	Units	NR-U CA bandwidth class	
		B, C, D, E, M, N, O	
Pw in Transmission Bandwidth Configuration, per CC	dBm	REFSENS + 14 dB	
$P_{\text{Interferer}}$	dBm	Aggregated power + $22.5 - 10\log_{10}(BW_{\text{Channel\_CA}}/20)$ dB	
$BW_{\text{Interferer}}$	MHz	20	
$F_{\text{Interferer}}$ (offset)	MHz	$10 + F_{\text{offset}}$ $/$ $-10 - F_{\text{offset}}$	
NOTE 1: The transmitter shall be set to 4 dB below $P_{\text{CMAX\_L,f,c}}$ at the minimum UL configuration specified in Table 7.3F.2-3 with $P_{\text{CMAX\_L,f,c}}$ defined in clause 6.2.4 .			
NOTE 2: The absolute value of the interferer offset $F_{\text{interferer}}$ (offset) shall be further adjusted to $\left(\left\lceil \frac{F_{\text{interferer}}}{SCS} \right\rceil + 0.5\right) SCS$ MHz with SCS the sub-carrier spacing of the carrier closest to the interferer in MHz. The interferer is an NR signal with an SCS equal to that of the closest carrier.			
NOTE 3: The interferer consists of the RMC specified in Annexes A.3.2.2 and A.3.3.2 with one sided dynamic OCNG Pattern OP.1 FDD/TDD for the DL-signal as described in Annex A.5.1.1/A.5.2.1.			

### 7.5F.2 Void

### 7.5G (Reserved)

### 7.5H (Reserved)

### 7.5I (Reserved)

## 7.5J Adjacent channel selectivity for ATG

Adjacent channel selectivity (ACS) is a measure of a receiver's ability to receive an NR signal at its assigned channel frequency in the presence of an adjacent channel signal at a given frequency offset from the centre frequency of the assigned channel. ACS is the ratio of the receive filter attenuation on the assigned channel frequency to the receive filter attenuation on the adjacent channel(s).

The UE shall fulfil the minimum requirements specified in Table 7.5J-1 for NR bands with  $F_{DL\_high} < 2700$  MHz and  $F_{UL\_high} < 2700$  MHz and the minimum requirements specified in Table 7.5J-2 for NR bands with  $F_{DL\_low} \geq 3300$  MHz and  $F_{UL\_low} \geq 3300$  MHz. These requirements apply for all values of an adjacent channel interferer up to -42 dBm with omni-directional antenna and -30dBm with antenna array for any SCS specified for the channel bandwidth of the wanted signal. However, it is not possible to directly measure the ACS; instead the lower and upper range of test parameters are chosen as in Table 7.5J-3 and Table 7.5J-4 for verification of the requirements specified in Table 7.5J-1, and as in Table 7.5J-5 and Table 7.5J-6 for verification of the requirements specified in Table 7.5J-2. For these test parameters, the throughput shall be  $\geq 95$  % of the maximum throughput of the reference measurement channels as specified in Annexes A.2.2, A.3.2, and A.3.3 (with one sided dynamic OCNG Pattern OP.1 FDD/TDD for the DL-signal as described in Annex A.5.1.1/A.5.2.1).

**Table 7.5J-1: ACS for NR bands with  $F_{DL\_high} < 2700$  MHz and  $F_{UL\_high} < 2700$  MHz**

RX parameter	Units	Channel bandwidth (MHz)		
		5, 10	15	20, 25, 30, 35, 40, 45, 50, 60, 70, 80, 90, 100
ACS	dB	33	30	$27 - 10\log_{10}(BW_{Channel} / 20)$
NOTE1: ACS value is rounded to the next higher 0.5dB value				

**Table 7.5J-2: ACS for NR bands with  $F_{DL\_low} \geq 3300$  MHz and  $F_{UL\_low} \geq 3300$  MHz**

RX parameter	Units	Channel bandwidth (MHz)
		10, 15, 20, 25, 30, 35, 40, 45, 50, 60, 70, 80, 90, 100
ACS	dB	33

**Table 7.5J-3: Test parameters for NR bands with  $F_{DL\_high} < 2700$  MHz and  $F_{UL\_high} < 2700$  MHz, case 1**

RX parameter	Units	Channel bandwidth (MHz)			
		5, 10	15	20, 25, 30, 35, 40, 45, 50, 60, 70, 80, 90, 100	
Power in transmission bandwidth configuration	dBm	REFSENS + 14 dB			
$P_{interferer}^4$	dBm	REFSENS + 45.5 dB	REFSENS + 42.5 dB	$REFSENS + 39.5 - 10\log_{10}(BW_{Channel} / 20)$	
$BW_{interferer}$	MHz	5			
$F_{interferer}$ (offset)	MHz	$BW_{Channel} / 2 + 2.5$ / $-(BW_{Channel} / 2 + 2.5)$			
NOTE 1: The transmitter shall be set to 4 dB below $P_{CMAX\_L,f,c}$ at the minimum UL configuration specified in Table 7.3.2-3 with $P_{CMAX\_L,f,c}$ defined in clause 6.2J.2					
NOTE 2: The absolute value of the interferer offset $F_{interferer}$ (offset) shall be further adjusted to $(\lceil  F_{interferer}  / SCS \rceil + 0.5) SCS$ MHz with SCS the sub-carrier spacing of the wanted signal in MHz. The interferer is an NR signal with 15 kHz SCS.					
NOTE 3: The interferer consists of the NR interferer RMC specified in Annexes A.3.2.2 and A.3.3.2 with one sided dynamic OCNG Pattern OP.1 FDD/TDD for the DL-signal as described in Annex A.5.1.1/A.5.2.1.					
NOTE 4: $10\log_{10}(x)$ is rounded to the next higher 0.5dB value.					

**Table 7.5J-4: Test parameters for NR bands with  $F_{DL\_high} < 2700$  MHz and  $F_{UL\_high} < 2700$  MHz, case 2**

RX parameter	Units	Channel bandwidth (MHz)		
		5, 10	15	20, 25, 30, 35, 40, 45, 50, 60, 70, 80, 90, 100
Power in transmission bandwidth configuration <sup>4</sup>	dBm	-73.5 <sup>5</sup> -61.5 <sup>6</sup>	-70.5 <sup>5</sup> -58.5 <sup>6</sup>	$-67.5 + 10\log_{10}(BW_{Channel} / 20)^5$ $-55.5 + 10\log_{10}(BW_{Channel} / 20)^6$
$P_{interferer}$	dBm	$-42^5$ $-30^6$		
$BW_{interferer}$	MHz	5		
$F_{interferer}$ (offset)	MHz	$BW_{Channel} / 2 + 2.5$ / $-(BW_{Channel} / 2 + 2.5)$		

- NOTE 1: The transmitter shall be set to 24 dB below  $P_{\text{CMAX\_L,f,c}}$  at the minimum UL configuration specified in Table 7.3.2-3 with  $P_{\text{CMAX\_L,f,c}}$  defined in clause 6.2J.2.
- NOTE 2: The absolute value of the interferer offset  $F_{\text{interferer}}$  (offset) shall be further adjusted to  $(\lceil F_{\text{interferer}} / \text{SCS} \rceil + 0.5) \text{SCS}$  MHz with SCS the sub-carrier spacing of the wanted signal in MHz. The interferer is an NR signal with 15 kHz SCS.
- NOTE 3: The interferer consists of the RMC specified in Annexes A.3.2.2 and A.3.3.2 with one sided dynamic OCNNG Pattern OP.1 FDD/TDD for the DL-signal as described in Annex A.5.1.1/A.5.2.1
- NOTE 4:  $10\log_{10}(x)$  is rounded to the next higher 0.5dB value.
- NOTE 5:  $P_{\text{interferer}}$  shall be set to -42dBm for omni-directional antenna.
- NOTE 6:  $P_{\text{interferer}}$  shall be set to -30dBm for antenna array.

**Table 7.5J-5: Test parameters for NR bands with  $F_{\text{DL\_low}} \geq 3300$  MHz and  $F_{\text{UL\_low}} \geq 3300$  MHz, case 1**

RX parameter	Units	Channel bandwidth (MHz)
		10, 15, 20, 25, 30, <u>35</u> , 40, 45, 50, 60, 70, 80, 90, 100
Power in transmission bandwidth configuration	dBm	REFSENS + 14 dB
$P_{\text{interferer}}$	dBm	REFSENS + 45.5 dB
$BW_{\text{interferer}}$	MHz	$BW_{\text{Channel}}$
$F_{\text{interferer}}$ (offset)	MHz	$BW_{\text{Channel}} / -BW_{\text{Channel}}$
NOTE 1: The transmitter shall be set to 4 dB below $P_{\text{CMAX\_L,f,c}}$ at the minimum UL configuration specified in Table 7.3.2-3 with $P_{\text{CMAX\_L,f,c}}$ defined in clause 6.2J.2		
NOTE 2: The absolute value of the interferer offset $F_{\text{interferer}}$ (offset) shall be further adjusted to $(\lceil F_{\text{interferer}} / \text{SCS} \rceil + 0.5) \text{SCS}$ MHz with SCS the sub-carrier spacing of the wanted signal in MHz. The interferer is an NR signal with an SCS equal to that of the wanted signal.		
NOTE 3: The interferer consists of the RMC specified in Annexes A.3.2.2 and A.3.3.2 with one sided dynamic OCNNG Pattern OP.1 FDD/TDD for the DL-signal as described in Annex A.5.1.1/A.5.2.1.		

**Table 7.5J-6: Test parameters for NR bands with  $F_{\text{DL\_low}} \geq 3300$  MHz and  $F_{\text{UL\_low}} \geq 3300$  MHz, case 2**

RX parameter	Units	Channel bandwidth (MHz)
		10, 15, 20, 25, 30, 35, 40, 45, 50, 60, 70, 80, 90, 100
Power in transmission bandwidth configuration	dBm	-73.5 <sup>4</sup> -61.5 <sup>5</sup>
$P_{\text{interferer}}$	dBm	-42 <sup>4</sup> -30 <sup>5</sup>
$BW_{\text{interferer}}$	MHz	$BW_{\text{Channel}}$
$F_{\text{interferer}}$ (offset)	MHz	$BW_{\text{Channel}} / -BW_{\text{Channel}}$
NOTE 1: The transmitter shall be set to 24 dB below $P_{\text{CMAX\_L,f,c}}$ at the minimum UL configuration specified in Table 7.3.2-3 with $P_{\text{CMAX\_L,f,c}}$ defined in clause 6.2J.2		
NOTE 2: The absolute value of the interferer offset $F_{\text{interferer}}$ (offset) shall be further adjusted to $(\lceil F_{\text{interferer}} / \text{SCS} \rceil + 0.5) \text{SCS}$ MHz with SCS the sub-carrier spacing of the wanted signal in MHz. The interferer is an NR signal with an SCS equal to that of the wanted signal.		
NOTE 3: The interferer consists of the RMC specified in Annexes A.3.2.2 and A.3.3.2 with one sided dynamic OCNNG Pattern OP.1 FDD/TDD for the DL-signal as described in Annex A.5.1.1/A.5.2.1.		
NOTE 4: $P_{\text{interferer}}$ shall be set to -42dBm for omni-directional antenna.		
NOTE 5: $P_{\text{interferer}}$ shall be set to -30dBm for antenna array.		

7.5K (Reserved)

7.5L (Reserved)

## 7.6 Blocking characteristics

### 7.6.1 General

The blocking characteristic is a measure of the receiver's ability to receive a wanted signal at its assigned channel frequency in the presence of an unwanted interferer on frequencies other than those of the spurious response or the adjacent channels, without this unwanted input signal causing a degradation of the performance of the receiver beyond a specified limit. The blocking performance shall apply at all frequencies except those at which a spurious response occurs.

For shared spectrum channel access and band combinations with operating bands intended for shared spectrum channel access, the blocking characteristics is specified in clause 7.6F.

### 7.6.2 In-band blocking

For NR bands with  $F_{DL\_high} < 2700$  MHz and  $F_{UL\_high} < 2700$  MHz in-band blocking (IBB) is defined for an unwanted interfering signal falling into the UE receive band or into the first 15 MHz below or above the UE receive band. The throughput of the wanted signal shall be  $\geq 95$  % of the maximum throughput of the reference measurement channels as specified in Annexes A.2.2, A.3.2 and A.3.3 (with one sided dynamic OCNG Pattern OP.1 FDD/TDD for the DL-signal as described in Annex A.5.1.1/A.5.2.1) with parameters specified in Table 7.6.2-1 and Table 7.6.2-2. The relative throughput requirement shall be met for any SCS specified for the channel bandwidth of the wanted signal. For operating bands with an unpaired DL part (as noted in Table 5.2-1), the requirements only apply for carriers assigned in the paired part.

**Table 7.6.2-1: In-band blocking parameters for NR bands with  $F_{DL\_high} < 2700$  MHz and  $F_{UL\_high} < 2700$  MHz**

RX parameter	Units	Channel bandwidth (MHz)			
		3	5, 10	15	20, 25, 30, 35, 40, 45, 50, 60, 70, 80, 90, 100
Power in transmission bandwidth configuration <sup>3</sup>	dBm	REFSENS + 6 dB	REFSENS + 7 dB	REFSENS + (9 + 10log <sub>10</sub> (BW <sub>Channel</sub> / 20)) dB	
BW <sub>interferer</sub>	MHz	3	5		
F <sub>offset, case 1</sub>	MHz	4.5	7.5		
F <sub>offset, case 2</sub>	MHz	7.5	12.5		
NOTE 1: The transmitter shall be set to 4 dB below P <sub>C<sub>MAX</sub>L,f,c</sub> at the minimum UL configuration specified in Table 7.3.2-3 with P <sub>C<sub>MAX</sub>L,f,c</sub> defined in clause 6.2.4.					
NOTE 2: The interferer consists of the RMC specified in Annexes A.3.2.2 and A.3.3.2 with one sided dynamic OCNG Pattern OP.1 FDD/TDD for the DL-signal as described in Annex A.5.1.1/A.5.2.1 and 15 kHz SCS.					
NOTE 3: 10log <sub>10</sub> (x) is rounded to the next higher 0.5dB value.					

**Table 7.6.2-2: In-band blocking for NR bands with  $F_{DL\_high} < 2700$  MHz and  $F_{UL\_high} < 2700$  MHz**

NR band	Parameter	Unit	Case 1	Case 2	Case 3	Case 4	Case 5
	P <sub>interferer</sub>	dBm	-56	-44	-15	-38	-22 <sup>4</sup>
	F <sub>interferer (offset)</sub>	MHz	-BW <sub>Channel</sub> /2 – F <sub>offset, case 1</sub> and BW <sub>Channel</sub> /2 + F <sub>offset, case 1</sub>	$\leq$ -BW <sub>Channel</sub> /2 – F <sub>offset, case 2</sub> and $\geq$ BW <sub>Channel</sub> /2 + F <sub>offset, case 2</sub>		-BW <sub>Channel</sub> /2-11	
n1, n2, n3, n5, n7, n8, n12, n13, n14, n18, n20, n24, n25, n26,	F <sub>interferer</sub>	MHz	NOTE 2	F <sub>DL_low</sub> – 15 to F <sub>DL_high</sub> + 15			

n28, n29, n31, n34, n38, n39, n40, n41, n48 <sup>3</sup> , n50, n51, n53, n54, n65, n66, n67, n70, n72, n74, n75, n76, n85, n91, n92, n93, n94, n100, n101, n106							
n30	$F_{\text{interferer}}$	MHz	NOTE 2	$F_{\text{DL\_low}} - 15$ to $F_{\text{DL\_high}} + 15$		$F_{\text{DL\_low}} - 11$	
n71	$F_{\text{interferer}}$	MHz	NOTE 2	$F_{\text{DL\_low}} - 12$ to $F_{\text{DL\_high}} + 15$	$F_{\text{DL\_low}} - 12$		
n105	$F_{\text{interferer}}$	MHz	NOTE 2	$F_{\text{DL\_low}} - 12$ to $F_{\text{DL\_high}} + 15$			$F_{\text{DL\_low}} - 7$

- NOTE 1: The absolute value of the interferer offset  $F_{\text{interferer}}$  (offset) shall be further adjusted to  $(|F_{\text{interferer}}| / \text{SCS} + 0.5) \text{SCS}$  MHz with SCS the sub-carrier spacing of the wanted signal in MHz. The interferer is an NR signal with 15 kHz SCS.
- NOTE 2: For each carrier frequency, the requirement applies for two interferer carrier frequencies: a:  $-\text{BW}_{\text{Channel}}/2 - F_{\text{offset, case 1}}$ ; b:  $\text{BW}_{\text{Channel}}/2 + F_{\text{offset, case 1}}$
- NOTE 3: n48 follows the requirement in this frequency range according to the general requirement defined in Clause 7.1.
- NOTE 4: For Band n105 channels overlapping the 612 - 617 MHz frequency range,  $P_{\text{interferer}}$  is modified to -34 dBm.
- NOTE 5: For SDL bands, requirements shall be applied only for CA band combination cases.

NOTE: For bands n100 and n101, additional requirements for wideband cab-radio receiver are specified by ETSI TC RT based on ECC Decision (20)02 [19].

For NR bands with  $F_{\text{DL\_low}} \geq 3300$  MHz and  $F_{\text{UL\_low}} \geq 3300$  MHz in-band blocking (IBB) is defined for an unwanted interfering signal falling into the UE receive band or into an immediately adjacent frequency range up to  $3 \cdot \text{BW}_{\text{Channel}}$  below or above the UE receive band where  $\text{BW}_{\text{Channel}}$  is the bandwidth of the wanted signal. The throughput of the wanted signal shall be  $\geq 95\%$  of the maximum throughput of the reference measurement channels as specified in Annexes A.2.2, A.3.2 and A.3.3 (with one sided dynamic OCNG Pattern OP.1 FDD/TDD for the DL-signal as described in Annex A.5.1.1/A.5.2.1) with parameters specified in Table 7.6.2-3 and Table 7.6.2-4. The relative throughput requirement shall be met for any SCS specified for the channel bandwidth of the wanted signal.

**Table 7.6.2-3: In-band blocking parameters for NR bands with  $F_{\text{DL\_low}} \geq 3300$  MHz and  $F_{\text{UL\_low}} \geq 3300$  MHz**

RX parameter	Units	Channel bandwidth (MHz)
		10, 15, 20, 25, 30, 35, 40, 45, 50, 60, 70, 80, 90, 100
Power in transmission bandwidth configuration	dBm	REFSENS + 6 dB <sup>3</sup>
$\text{BW}_{\text{interferer}}$	MHz	$\text{BW}_{\text{Channel}}$
$F_{\text{offset, case 1}}$	MHz	$(3/2) \cdot \text{BW}_{\text{Channel}}$
$F_{\text{offset, case 2}}$	MHz	$(5/2) \cdot \text{BW}_{\text{Channel}}$
NOTE 1: The transmitter shall be set to 4 dB below $P_{\text{CMAX\_L,f,c}}$ at the minimum UL configuration specified in Table 7.3.2-3 with $P_{\text{CMAX\_L,f,c}}$ defined in clause 6.2.4.		
NOTE 2: The interferer consists of the RMC specified in Annexes A.3.2.2 and A.3.3.2 with one sided dynamic OCNG Pattern OP.1 FDD/TDD for the DL-signal as described in Annex A.5.1.1/A.5.2.1		
NOTE 3: For Band n104, the power in transmission bandwidth configuration is REFSENS + 9 dB		

**Table 7.6.2-4: In-band blocking for NR bands with  $F_{\text{DL\_low}} \geq 3300$  MHz and  $F_{\text{UL\_low}} \geq 3300$  MHz**

NR band	Parameter	Unit	Case 1	Case 2
---------	-----------	------	--------	--------

	$P_{\text{interferer}}$	dBm	-56	-44
n77, n78, n79, n104	$F_{\text{interferer}}$ (offset)	MHz	$-BW_{\text{Channel}}/2 - F_{\text{offset, case 1}}$ and $BW_{\text{Channel}}/2 + F_{\text{offset, case 1}}$	$\leq -BW_{\text{Channel}}/2 - F_{\text{offset, case 2}}$ and $\geq BW_{\text{Channel}}/2 + F_{\text{offset, case 2}}$
	$F_{\text{interferer}}$		NOTE 2	$F_{\text{DL\_low}} - 3 \cdot BW_{\text{Channel}}$ to $F_{\text{DL\_high}} + 3 \cdot BW_{\text{Channel}}$
<p>NOTE 1: The absolute value of the interferer offset <math>F_{\text{interferer}}</math> (offset) shall be further adjusted to <math>(\lceil  F_{\text{interferer}}  / SCS \rceil + 0.5) SCS</math> MHz with SCS the sub-carrier spacing of the wanted signal in MHz. The interferer is an NR signal with an SCS equal to that of the wanted signal.</p> <p>NOTE 2: For each carrier frequency, the requirement applies for two interferer carrier frequencies: a: <math>-BW_{\text{Channel}}/2 - F_{\text{offset, case 1}}</math>; b: <math>BW_{\text{Channel}}/2 + F_{\text{offset, case 1}}</math></p> <p>NOTE 3: <math>BW_{\text{Channel}}</math> denotes the channel bandwidth of the wanted signal</p>				

### 7.6.3 Out-of-band blocking

For NR bands with  $F_{\text{DL\_high}} < 2700$  MHz and  $F_{\text{UL\_high}} < 2700$  MHz out-of-band band blocking is defined for an unwanted CW interfering signal falling outside a frequency range 15 MHz below or above the UE receive band. The throughput of the wanted signal shall be  $\geq 95\%$  of the maximum throughput of the reference measurement channels as specified in Annexes A.2.2, A.3.2 and A.3.3 (with one sided dynamic OCNG Pattern OP.1 FDD/TDD for the DL-signal as described in Annex A.5.1.1/A.5.2.1) with parameters specified in Table 7.6.3-1 and Table 7.6.3-2. The relative throughput requirement shall be met for any SCS specified for the channel bandwidth of the wanted signal. For operating bands with an unpaired DL part (as noted in Table 5.2-1), the requirements only apply for carriers assigned in the paired part.

**Table 7.6.3-1: Out-of-band blocking parameters for NR bands with  $F_{\text{DL\_high}} < 2700$  MHz and  $F_{\text{UL\_high}} < 2700$  MHz**

Channel bandwidth	Power in transmission bandwidth configuration [dBm]
3 MHz	REFSENS + 6.0 dB
5 MHz	REFSENS + 6.0 dB
10 MHz	REFSENS + 6.0 dB
15 MHz	REFSENS + 7.0 dB
20 MHz	REFSENS + 9.0 dB
25 MHz	REFSENS + 10.0 dB
30 MHz	REFSENS + 11.0 dB
35 MHz	REFSENS + 11.5 dB
40 MHz	REFSENS + 12.0 dB
45 MHz	REFSENS + 12.5 dB
50 MHz	REFSENS + 13.0 dB
60 MHz	REFSENS + 14.0 dB
70 MHz	REFSENS + 14.5 dB
80 MHz	REFSENS + 15.0 dB
90 MHz	REFSENS + 15.5 dB
100 MHz	REFSENS + 16.0 dB
NOTE:	The transmitter shall be set to 4 dB below $P_{\text{CMAX\_L,f,c}}$ at the minimum UL configuration specified in Table 7.3.2-3 with $P_{\text{CMAX\_L,f,c}}$ defined in clause 6.2.4.

**Table 7.6.3-2: Out of-band blocking for NR bands with  $F_{\text{DL\_high}} < 2700$  MHz and  $F_{\text{UL\_high}} < 2700$  MHz**

NR band	Parameter	Unit	Range 1	Range 2	Range 3
n1, n2, n3,	$P_{\text{interferer}}$	dBm	-44	-30	-15
	$F_{\text{interferer}}$ (CW)	MHz	$-60 < f - F_{\text{DL\_low}} < -15$ or	$-85 < f - F_{\text{DL\_low}} \leq -60$ or	$1 \leq f \leq F_{\text{DL\_low}} - 85$ or

n5, n7, n8, n12, n13, n14, n18, n20, n24, n25, n26, n28, n29, n30, n31, n34, n38, n39, n40, n41, n48 <sup>5</sup> , n50, n51, n53 <sup>6</sup> , n54, n65, n66, n67, n70, n71, n72, n74, n75, n76, n85, n91, n92, n93, n94, n100, n101, n105, n106			$15 < f - F_{DL\_high} < 60$	$60 \leq f - F_{DL\_high} < 85$	$F_{DL\_high} + 85 \leq f \leq 12750$
NOTE 1: The power level of the interferer ( $P_{Interferer}$ ) for Range 3 shall be modified to -20 dBm for $F_{Interferer} > 6000$ MHz. NOTE 2: For band 51 the $F_{DL\_high}$ of band 50 is applied as $F_{DL\_high}$ for band 51. For band 50, the $F_{DL\_low}$ of band 51 is applied as $F_{DL\_low}$ for band 50. NOTE 3: For band 76 the $F_{DL\_high}$ of band 75 is applied as $F_{DL\_high}$ for band 76. For band 75, the $F_{DL\_low}$ of band 76 is applied as $F_{DL\_low}$ for band 75. NOTE 4: For UEs supporting both bands 38 and 41, the $F_{DL\_high}$ and $F_{DL\_low}$ of band 41 is applied as $F_{DL\_high}$ and $F_{DL\_low}$ for band 38. NOTE 5: n48 follows the requirement in this frequency range according to the general requirement defined in Clause 7.1. The power level of the interferer ( $P_{Interferer}$ ) for Range 3 shall be modified to -20 dBm for $F_{Interferer} > 2700$ MHz and $F_{Interferer} < 4800$ MHz. NOTE 6: The power level of the interferer ( $P_{Interferer}$ ) for Range 3 shall be modified to -20 dBm for $F_{Interferer} > 2580$ MHz and $F_{Interferer} < 2775$ MHz. NOTE 7 For UE supporting both bands 25 and 70, the $F_{DL\_high}$ of band 70 is applied as $F_{DL\_high}$ for band 25, and the $F_{DL\_low}$ of band 25 is applied as $F_{DL\_low}$ for band 70. NOTE 8: For bands 91 and 93 the $F_{DL\_high}$ of bands 92 and 94 are applied as $F_{DL\_high}$ for bands 91 and 93. For bands 92 and 94, the $F_{DL\_low}$ of bands 91 and 93 are applied as $F_{DL\_low}$ for bands 92 and 94 NOTE 9: For SDL bands, requirements shall be applied only for CA band combination cases. NOTE 10 For a UE supporting CA_20A-28A and higher order band combinations in which CA_20A-28A is a subset, the requirements for Band n20 and Band n28 apply with $F_{DL\_low}$ given by the lower limit of the restricted operating frequency range in Band n28 and $F_{DL\_high}$ by Band n20. NOTE 11: For a UE supporting CA_n3A-n39A and higher order band combinations in which CA_n3A-n39A is a subset, the requirements for Band n3 and Band n39 apply with $F_{DL\_low}$ given by the lower limit of the restricted operating frequency range in Band n3 and $F_{DL\_high}$ by Band n39.					

NOTE: For bands n100 and n101, additional requirements for wideband cab-radio receiver are specified by ETSI TC RT based on ECC Decision (20)02 [19].

For interferer frequencies across ranges 1, 2 and 3 in Table 7.6.3-2, a maximum of

$$\lfloor \max \{ 24, 6 \cdot \lceil n \cdot N_{RB} / 6 \rceil \} / \min \{ \lfloor n \cdot N_{RB} / 10 \rfloor, 5 \} \rfloor$$

exceptions are allowed for spurious response frequencies in each assigned frequency channel when measured using a step size of  $\min \left( \frac{BW_{Channel}}{2}, 5 \right)$  MHz with  $N_{RB}$  the number of resource blocks in the downlink transmission bandwidth configuration,  $BW_{Channel}$  the bandwidth of the frequency channel in MHz and  $n = 1, 2, 3$  for SCS = 15, 30, 60 kHz, respectively. For these exceptions, the requirements in clause 7.7 apply.

For NR bands with  $F_{DL\_low} \geq 3300$  MHz and  $F_{UL\_low} \geq 3300$  MHz out-of-band band blocking is defined for an unwanted CW interfering signal falling outside a frequency range up to  $3 \cdot BW_{Channel}$  below or from  $3 \cdot BW_{Channel}$  above the UE receive band, where  $BW_{Channel}$  is the channel bandwidth. The throughput of the wanted signal shall be  $\geq 95$  % of the maximum throughput of the reference measurement channels as specified in Annexes A.2.2, A.3.2 and A.3.3 (with one sided dynamic OCNG Pattern OP.1 FDD/TDD for the DL-signal as described in Annex A.5.1.1/A.5.2.1) with



parameters specified in Table 7.6.3-3 and Table 7.6.3-4. The relative throughput requirement shall be met for any SCS specified for the channel bandwidth of the wanted signal.

**Table 7.6.3-3: Out-of-band blocking parameters for NR bands with  $F_{DL\_low} \geq 3300$  MHz and  $F_{UL\_low} \geq 3300$  MHz**

RX parameter	Units	Channel bandwidth (MHz)		
		10	15	20, 25, 30, 35, 40, 45, 50, 60, 70, 80, 90, 100
Power in transmission bandwidth configuration	dBm	REFSENS + 6 dB	REFSENS + 7 dB	REFSENS + 9 dB
NOTE: The transmitter shall be set to 4 dB below $P_{CMAX\_L,f,c}$ at the minimum UL configuration specified in Table 7.3.2-3 with $P_{CMAX\_L,f,c}$ defined in clause 6.2.4.				

**Table 7.6.3-4: Out of-band blocking for NR bands with  $F_{DL\_low} \geq 3300$  MHz and  $F_{UL\_low} \geq 3300$  MHz**

NR band	Parameter	Unit	Range1	Range 2	Range 3
n77, n78 (NOTE 3)	$P_{interferer}$	dBm	-44	-30	-15
	$F_{interferer}$ (CW)	MHz	$-60 < f - F_{DL\_low} \leq -3 \cdot BW_{Channel}$ or $3 \cdot BW_{Channel} \leq f - F_{DL\_high} < 60$	$-200 < f - F_{DL\_low} \leq -MAX(60, 3 \cdot BW_{Channel})$ or $MAX(60, 3 \cdot BW_{Channel}) \leq f - F_{DL\_high} < 200$	$1 \leq f \leq F_{DL\_low} - MAX(200, 3 \cdot BW_{Channel})$ or $F_{DL\_high} + MAX(200, 3 \cdot BW_{Channel}) \leq f \leq 12750$
n79 (NOTE 4)	$F_{interferer}$ (CW)	MHz	N/A	$-150 < f - F_{DL\_low} \leq -MAX(60, 3 \cdot BW_{Channel})$ or $MAX(60, 3 \cdot BW_{Channel}) \leq f - F_{DL\_high} < 150$	$1 \leq f \leq F_{DL\_low} - MAX(150, 3 \cdot BW_{Channel})$ or $F_{DL\_high} + MAX(150, 3 \cdot BW_{Channel}) \leq f \leq 12750$
n104 (NOTE 5)	$F_{interferer}$ (CW)	MHz	N/A	$-150 < f - F_{DL\_low} \leq -MAX(60, 3 \cdot BW_{Channel})$ or $MAX(60, 3 \cdot BW_{Channel}) \leq f - F_{DL\_high} < 150$	$1 \leq f \leq F_{DL\_low} - MAX(150, 3 \cdot BW_{Channel})$ or $F_{DL\_high} + MAX(150, 3 \cdot BW_{Channel}) \leq f \leq 12750$
NOTE 1: The power level of the interferer ( $P_{interferer}$ ) for Range 3 shall be modified to -20 dBm for $F_{interferer} > 6000$ MHz.					
NOTE 2: $BW_{Channel}$ denotes the channel bandwidth of the wanted signal					
NOTE 3: The power level of the interferer ( $P_{interferer}$ ) for Range 3 shall be modified to -20 dBm, for $F_{interferer} > 2700$ MHz and $F_{interferer} < 4800$ MHz. For $BW_{Channel} > 15$ MHz, the requirement for Range 1 is not applicable and Range 2 applies from the frequency offset of $3 \cdot BW_{Channel}$ from the band edge. For $BW_{Channel}$ larger than 60 MHz, the requirement for Range 2 is not applicable and Range 3 applies from the frequency offset of $3 \cdot BW_{Channel}$ from the band edge.					
NOTE 4: The power level of the interferer ( $P_{interferer}$ ) for Range 3 shall be modified to -20 dBm, for $F_{interferer} > 3650$ MHz and $F_{interferer} < 5750$ MHz. For $BW_{Channel} \geq 40$ MHz, the requirement for Range 2 is not applicable and Range 3 applies from the frequency offset of $3 \cdot BW_{Channel}$ from the band edge.					
NOTE 5: The power level of the interferer ( $P_{interferer}$ ) for Range 3 shall be modified to -20 dBm, for $F_{interferer} > 5175$ MHz. For $BW_{Channel} > 60$ MHz, the requirement for Range 2 is not applicable and Range 3 applies from the frequency offset of $3 \cdot BW_{Channel}$ from the band edge. The power level of the interferer ( $P_{interferer}$ ) for Range 2 shall be modified to -33 dBm for the range $5925 - MAX(60, 3 \cdot CBW) \leq f < F_{DL\_low} - MAX(60, 3 \cdot CBW)$ .					

For interferer frequencies across ranges 1, 2 and 3 in Table 7.6.3-4, a maximum of

$$\lfloor \max \{24, 6 \cdot \lceil n \cdot N_{RB} / 6 \rceil\} / \min \{ \lfloor n \cdot N_{RB} / 10 \rfloor, 5 \} \rfloor$$

exceptions are allowed for spurious response frequencies in each assigned frequency channel when measured using a step size of  $\min(BW_{channel}/2, 5)$  MHz with  $N_{RB}$  the number of resource blocks in the downlink transmission bandwidth configuration,  $BW_{channel}$  the bandwidth of the frequency channel in MHz and  $n = 1, 2, 3$  for SCS = 15, 30, 60 kHz, respectively. For these exceptions, the requirements in clause 7.7 apply.

## 7.6.4 Narrow band blocking

This requirement is measure of a receiver's ability to receive a NR signal at its assigned channel frequency in the presence of an unwanted narrow band CW interferer at a frequency, which is less than the nominal channel spacing.

The relative throughput shall be  $\geq 95$  % of the maximum throughput of the reference measurement channels as specified in Annexes A.2.2, A.3.2 and A.3.3 (with one sided dynamic OCNG Pattern OP.1 FDD/TDD for the DL-signal as described in Annex A.5.1.1/A.5.2.1) with parameters specified in Table 7.6.4-1. For operating bands with an unpaired DL part (as noted in Table 5.2-1), the requirements only apply for carriers assigned in the paired part.

Table 7.6.4-1: Narrow Band Blocking

NR band	Parameter	Unit	Channel Bandwidth (MHz)							
			3	5	10	15	20	25, 30, 35, 40, 45, 50	60, 70, 80, 90, 100	
n1, n2, n3, n5, n7, n8, n12, n13, n14, n18, n20, n24, n25, n26, n28, n29, n30, n31, n34, n38, n39, n40, n41, n48, n50, n51, n53, n65, n66, n67, n70, n71, n72, n74, n75, n76, n85, n100, n101, n106	P <sub>w</sub>	dBm	P <sub>REFSENS</sub> + channel-bandwidth specific value below							
		dB	18	16	13	14	16	16	16	
	P <sub>uw</sub> (CW)	dBm	-55							
	F <sub>uw</sub> (offset SCS= 15 kHz) <sup>4</sup>	MHz	$\left( \left\lfloor \frac{\frac{BW_{channel}}{2} + 0.2}{SCS} + 0.5 \right\rfloor + 0.5 \right) SCS$			$\left( \left\lfloor \frac{\frac{BW_{channel}}{2} + BW_{GB,channel}}{SCS} + 0.5 \right\rfloor + 0.5 \right) SCS$				NA
	F <sub>uw</sub> (offset SCS= 30 kHz) <sup>4</sup>	MHz	NA					$\left( \left\lfloor \frac{\frac{BW_{channel}}{2} + BW_{GB,channel}}{SCS} + 0.5 \right\rfloor + 0.5 \right) SCS$		
<p>NOTE 1: The transmitter shall be set a 4 dB below P<sub>CMAX_L,f,c</sub> at the minimum UL configuration specified in Table 7.3.2-3 with P<sub>CMAX_L,f,c</sub> defined in clause 6.2.4</p> <p>NOTE 2: Reference measurement channel is specified in Annexes A.3.2 and A.3.3 with one sided dynamic OCNG Pattern OP.1 FDD/TDD as described in Annex A.5.1.1/A.5.2.1.</p> <p>NOTE 3: The P<sub>REFSENS</sub> power level is specified in Table 7.3.2-1a, Table 7.3.2-1b, Table 7.3.2-2 and Table 7.3.2-2a for two, four and eight antenna ports, respectively.</p> <p>NOTE 4: F<sub>uw</sub> shall be rounded to half of SCS.</p> <p>NOTE 5: For SDL bands, requirements shall be applied only for CA band combination cases.</p>										

NOTE: For bands n100 and n101, additional requirements for wideband cab-radio receiver are specified by ETSI TC RT based on ECC Decision (20)02 [19].

## 7.6A Blocking characteristics for CA

### 7.6A.1 General

### 7.6A.2 In-band blocking for CA

#### 7.6A.2.1 In-band blocking for Intra-band contiguous CA

For intra-band contiguous carrier aggregation the downlink SCC(s) shall be configured at nominal channel spacing to the PCC. The UE shall fulfil the minimum requirement specified in Table 7.6A.2.1-1 and 7.6A.2.1-1a for an adjacent channel interferer on either side of the aggregated downlink signal at a specified frequency offset and for an interferer power up to -25 dBm. The throughput of each carrier shall be  $\geq 95\%$  of the maximum throughput of the reference measurement channels as specified in Annexes A.2.2, A.3.2, and A.3.3 (with one sided dynamic OCNG Pattern OP.1 FDD/TDD for the DL-signal as described in Annex A.5.1.1/A.5.2.1).

**Table 7.6A.2.1-1: In-band blocking parameters for intra-band contiguous CA with  $F_{DL\_low} \geq 3300$  MHz and  $F_{UL\_low} \geq 3300$  MHz**

Rx Parameter	Units	NR CA bandwidth class			
		B	C	D	C
Pw in Transmission Bandwidth Configuration, per CC	dBm	REFSENS + CA bandwidth class specific value below			
	dB	10.0	6	13.8	
BW <sub>interferer</sub>	MHz	20	BW <sub>channel CA</sub>	50	
F <sub>offset, case 1</sub>	MHz	30	BW <sub>channel CA</sub> + BW <sub>channel CA</sub> /2	75	
F <sub>offset, case 2</sub>	MHz	50	BW <sub>interferer</sub> + F <sub>offset, case 1</sub>	125	
NOTE 1: The transmitter shall be set to 4dB below P <sub>C<sub>MAX</sub>L,f,c</sub> at the minimum UL configuration specified in Table 7.3.2-3 with P <sub>C<sub>MAX</sub>L,f,c</sub> defined in clause 6.2.4.					
NOTE 2: The interferer consists of the Reference measurement channel specified in Annexes A.3.2 and A.3.3 with one sided dynamic OCNG Pattern OP.1 FDD/TDD as described in Annex A.5.1.1/A.5.2.1 and set-up according to Annex C.3.1					

**Table 7.6A.2.1-1a: In-band blocking parameters for intra-band contiguous CA with  $F_{DL\_low} < 2700$  MHz and  $F_{UL\_low} < 2700$  MHz**

Rx Parameter	Units	NR CA bandwidth class	
		B	C
Pw in Transmission Bandwidth Configuration, per CC	dBm	REFSENS + NR CA bandwidth class specific value below	
	dB	16.0	19.0
BW <sub>interferer</sub>	MHz	5	5
F <sub>offset, case 1</sub>	MHz	7.5	7.5
F <sub>offset, case 2</sub>	MHz	12.5	12.5
NOTE 1: The transmitter shall be set to 4 dB below P <sub>C<sub>MAX</sub>L,f,c</sub> at the minimum UL configuration specified in Table 7.3.2-3 with P <sub>C<sub>MAX</sub>L,f,c</sub> defined in clause 6.2.4.			
NOTE 2: The interferer consists of the Reference measurement channel specified in Annexes A.3.2 and A.3.3 with one sided dynamic OCNG Pattern OP.1 FDD/TDD as described in Annex A.5.1.1/A.5.2.1 and set-up according to Annex C.3.1			

**Table 7.6A.2.1-2: In-band blocking for intra-band contiguous CA with  $F_{DL\_low} \geq 3300$  MHz and  $F_{UL\_low} \geq 3300$  MHz**

NR band	Parameter	Unit	Case 1	Case 2
	P <sub>interferer</sub>	dBm	-56	-44
n77, n78, n79	F <sub>interferer (offset)</sub>	MHz	- F <sub>offset</sub> /2 -F <sub>offset, case 1</sub> and F <sub>offset</sub> /2 +F <sub>offset, case 1</sub>	$\leq - F_{offset} /2 -F_{offset, case 2}$ and $\geq F_{offset} /2 +F_{offset, case 2}$
	F <sub>interferer</sub>	MHz	NOTE 2	F <sub>DL_low</sub> - 3BW <sub>channel CA</sub>

				to $F_{DL\_high} + 3BW_{channel\ CA}$
NOTE 1:	The absolute value of the interferer offset $F_{interferer}$ (offset) shall be further adjusted to $(\lceil F_{interferer} / SCS \rceil + 0.5) SCS$ MHz with SCS the sub-carrier spacing of the carrier closest to the interferer in MHz. The interferer is an NR signal with an SCS equal to that of the closest carrier.			
NOTE 2:	For each carrier frequency, the requirement applies for two interferer carrier frequencies: a: $-F_{offset} / 2 - F_{offset, case 1}$ ; b: $F_{offset} / 2 + F_{offset, case 1}$			
NOTE 3:	$BW_{channel\ CA}$ denotes the aggregated channel bandwidth of the wanted signal			

**Table 7.6A.2.1-2a: In-band blocking for intra-band contiguous CA with  $F_{DL\_low} < 2700$  MHz and  $F_{UL\_low} < 2700$  MHz**

NR band	Parameter	Unit	Case 1	Case 2	Case 3
		$P_{interferer}$	dBm	-56	-44
n2, n3, n25, n38, n41, n66, n48 <sup>4</sup> , n40	$F_{interferer}$ (offset)	MHz	$-F_{offset} / 2 - F_{offset, case 1}$ and $F_{offset} / 2 + F_{offset, case 1}$	$\leq -F_{offset} / 2 - F_{offset, case 2}$ and $\geq F_{offset} / 2 + F_{offset, case 2}$	
	$F_{interferer}$	MHz	NOTE 2	$F_{DL\_low} - 15$ to $F_{DL\_high} + 15$	
n71	$F_{interferer}$	MHz	NOTE 2	$F_{DL\_low} - 12$ to $F_{DL\_high} + 15$	$F_{DL\_low} - 12$
NOTE 1:	The absolute value of the interferer offset $F_{interferer}$ (offset) shall be further adjusted to $(\lceil F_{interferer} / SCS \rceil + 0.5) SCS$ MHz with SCS the sub-carrier spacing of the carrier closest to the interferer in MHz. The interferer is an NR signal with 15 kHz SCS.				
NOTE 2:	For each carrier frequency, the requirement applies for two interferer carrier frequencies: a: $-F_{offset} / 2 - F_{offset, case 1}$ ; b: $F_{offset} / 2 + F_{offset, case 1}$				
NOTE 3:	$BW_{channel\ CA}$ denotes the aggregated channel bandwidth of the wanted signal				
NOTE 4:	n48 follows the requirement in this frequency range according to the general requirement defined in Clause 7.1A.				

### 7.6A.2.2 In-band blocking for Intra-band non-contiguous CA

For intra-band non-contiguous carrier aggregation with one uplink carrier and two or more downlink sub-blocks, each larger than or equal to 5 MHz, the in-band blocking requirements are defined with the uplink configuration in accordance with Table 7.3A.2.2-1. For this uplink configuration, the UE shall meet the requirements for each sub-block as specified in clause 7.6.2 and 7.6A.2.1 for one component carrier and two component carriers per sub-block, respectively. The requirements apply for in-gap and out-of-gap interferers while all downlink carriers are active.

The throughput of each carrier shall be  $\geq 95$  % of the maximum throughput of the reference measurement channels as specified in Annexes A.2.2, A.3.2, and A.3.3 (with one sided dynamic OCNG Pattern OP.1 FDD/TDD for the DL-signal as described in Annex A.5.1.1/A.5.2.1).

### 7.6A.2.3 In-band blocking for Inter-band CA

For inter-band carrier aggregation with one component carrier per operating band and the uplink assigned to one NR band, the in-band blocking requirements are defined with the uplink active on the band(s) other than the band whose downlink is being tested. The UE shall meet the requirements specified in clause 7.6.2 and clause 7.6F.2 when the downlink belongs to a spectrum sharing defined band, for each component carrier while all downlink carriers are active.

For the UE which supports inter-band CA configuration in Table 7.3A.3.2.1-1,  $P_{interferer}$  power defined in Table 7.6.2-2 and 7.6.2-4, and Table 7.6F.2.1-2 for shared spectrum channel access, is increased by the amount given by  $\Delta R_{IB,c}$  in Table 7.3A.3.2.1-1 and in Table 7.3F.3-1 for shared spectrum channel access.

For NR CA configurations including an operating band without uplink operation or an operating band with an unpaired DL part (as noted in Table 5.2-1), the requirements for all downlinks shall be met with the single uplink carrier active in each band capable of UL operation. The requirements for the component carrier configured in the operating band without uplink operation are specified in clause 7.6.2 while all downlink carriers are active.

**Table 7.6A.2.3-1: Void**

The throughput of each carrier shall be  $\geq 95\%$  of the maximum throughput of the reference measurement channels as specified in Annexes A.2.2, A.3.2, and A.3.3 (with one sided dynamic OCNG Pattern OP.1 FDD/TDD for the DL-signal as described in Annex A.5.1.1/A.5.2.1).

### 7.6A.3 Out-of-band blocking for CA

#### 7.6A.3.1 Out-of-band blocking for Intra-band contiguous CA

For intra-band contiguous carrier aggregation the downlink SCC(s) shall be configured at nominal channel spacing to the PCC. For FDD, the PCC shall be configured closest to the uplink band. All downlink carriers shall be active throughout the test.

The UE shall fulfil the minimum requirement in presence of an interfering signal specified in Table 7.6A.3-1 and Table 7.6A.3-2 being on either side of the aggregated signal. The throughput of each carrier shall be  $\geq 95\%$  of the maximum throughput of the reference measurement channels as specified in Annexes A.2.2, A.3.2, and A.3.3 (with one sided dynamic OCNG Pattern OP.1 FDD/TDD for the DL-signal as described in Annex A.5.1.1/A.5.2.1).

**Table 7.6A.3-1: Out-of-band blocking parameters for intra-band contiguous CA**

RX parameter	Units	CA bandwidth class			
		B	C	D	
Power in transmission bandwidth configuration	dBm	REFSENS + CA bandwidth class specific value below			
	dB	9	9	9	

NOTE 1: The transmitter shall be set to 4 dB below  $P_{\text{CMAX\_L,f,c}}$  at the minimum UL configuration specified in Table 7.3.2-3 with  $P_{\text{CMAX\_L,f,c}}$  defined in clause 6.2.4.

**Table 7.6A.3-1a: Void**

**Table 7.6A.3-2: Out of-band blocking for intra-band contiguous CA**

NR band	Parameter	Unit	Range1	Range 2	Range 3
	$P_{\text{Interferer}}$	dBm	-45	-30	-15
n2, n3, n25, n38, n41, n66, n71, n48 <sup>5</sup> , n40	$F_{\text{Interferer}}$ (CW)	MHz	$-60 < f - F_{\text{DL\_low}} < -15$ or $15 < f - F_{\text{DL\_high}} < 60$	$-85 < f - F_{\text{DL\_low}} \leq -60$ or $60 \leq f - F_{\text{DL\_high}} < 85$	$1 \leq f \leq F_{\text{DL\_low}} - 85$ or $F_{\text{DL\_high}} + 85 \leq f \leq 12750$
n77, n78 (NOTE 3)	$F_{\text{Interferer}}$ (CW)	MHz	N/A	N/A	$1 \leq f \leq F_{\text{DL\_low}} - \text{MAX}(200, 3 \cdot \text{BW}_{\text{Channel\_CA}})$ or $F_{\text{DL\_high}} + \text{MAX}(200, 3 \cdot \text{BW}_{\text{Channel\_CA}}) \leq f \leq 12750$
n79 (NOTE 4)	$F_{\text{Interferer}}$ (CW)	MHz	N/A	N/A	$1 \leq f \leq F_{\text{DL\_low}} - \text{MAX}(150, 3 \cdot \text{BW}_{\text{Channel\_CA}})$ or $F_{\text{DL\_high}} + \text{MAX}(150, 3 \cdot \text{BW}_{\text{Channel\_CA}}) \leq f \leq 12750$

NOTE 1: The power level of the interferer ( $P_{\text{Interferer}}$ ) for Range 3 shall be modified to -20 dBm for  $F_{\text{Interferer}} > 6000$  MHz.  
 NOTE 2:  $\text{BW}_{\text{Channel\_CA}}$  denotes the aggregated channel bandwidth of the wanted signal  
 NOTE 3: The power level of the interferer ( $P_{\text{Interferer}}$ ) for Range 3 shall be modified to -20 dBm, for  $F_{\text{Interferer}} > 2700$  MHz and  $F_{\text{Interferer}} < 4800$  MHz. For  $\text{BW}_{\text{Channel\_CA}} > 15$  MHz, the requirement for Range 1 is not applicable and Range 2 applies from the frequency offset of  $3 \cdot \text{BW}_{\text{Channel\_CA}}$  from the band edge. For  $\text{BW}_{\text{Channel\_CA}} > 65$  MHz, the requirement for Range 2 is not applicable and Range 3 applies from the frequency offset of  $3 \cdot \text{BW}_{\text{Channel\_CA}}$  from the band edge.  
 NOTE 4: The power level of the interferer ( $P_{\text{Interferer}}$ ) for Range 3 shall be modified to -20 dBm, for  $F_{\text{Interferer}} > 3650$  MHz and  $F_{\text{Interferer}} < 5750$  MHz. For  $\text{BW}_{\text{Channel\_CA}} > 45$  MHz, the requirement for Range 2 is not applicable and Range 3 applies from the frequency offset of  $3 \cdot \text{BW}_{\text{Channel\_CA}}$  from the band edge.

NOTE 5: The power level of the interferer ( $P_{\text{Interferer}}$ ) for Range 3 shall be modified to -20 dBm for  $F_{\text{Interferer}} > 2700$  MHz and  $F_{\text{Interferer}} < 4800$  MHz

**Table 7.6A.3-2a: Void**

For interferer frequencies across ranges 1, 2 and 3 in Table 7.6A.3-2, a maximum of

$$\lfloor \max \{24, 6 \cdot \lceil n \cdot N_{RB} / 6 \rceil \} / \min \{ \lfloor n \cdot N_{RB} / 10 \rfloor, 5 \} \rfloor$$

exceptions are allowed for spurious response frequencies in each assigned frequency channel when measured using a step size of  $\min \{ \lfloor BW_{\text{channel}} / 2 \rfloor, 5 \}$  MHz with  $N_{RB}$  the number of resource blocks in the downlink transmission bandwidth configuration,  $BW_{\text{channel}}$  is the bandwidth of the frequency channel in MHz and  $n = 1, 2, 3$  for SCS = 15, 30, 60 kHz, respectively. For these exceptions, the requirements in subclause 7.7A.1 apply.

### 7.6A.3.2 Out-of-band blocking for Intra-band non-contiguous CA

For intra-band non-contiguous carrier aggregation with one uplink carrier and two or more downlink sub-blocks, the out-of-band blocking requirements are defined with the uplink configuration in accordance with Table 7.3A.2.2-1. For this uplink configuration, the UE shall meet the requirements for each sub-block as specified in clauses 7.6.3 and 7.6A.3.1 for one component carrier and two component carriers per sub-block, respectively. The requirements apply with all downlink carriers active.

The throughput of each carrier shall be  $\geq 95\%$  of the maximum throughput of the reference measurement channels as specified in Annexes A.2.2, A.3.2, and A.3.3 (with one sided dynamic OCNG Pattern OP.1 FDD/TDD for the DL-signal as described in Annex A.5.1.1/A.5.2.1).

### 7.6A.3.3 Out-of-band blocking for Inter-band CA

For inter-band carrier aggregation with one component carrier per operating band and the uplink assigned to one NR band, the out-of-band blocking requirements are defined with the uplink active on the band(s) other than the band whose downlink is being tested. For NR CA configurations including an operating band without uplink band or an operating band with an unpaired DL part (as noted in Table 5.2-1), the requirements for all downlinks shall be met with the single uplink carrier active in each band capable of UL operation. The UE shall meet the requirements specified in clause 7.6.3 for each component carrier while all downlink carriers are active.

For inter-band carrier aggregation with component carriers in operating bands  $< 2.7$ GHz including n48, and for  $F_{\text{DL\_Low}(j)} - 15 \text{ MHz} \leq f \leq F_{\text{DL\_High}(j)} + 15 \text{ MHz}$ , the appropriate adjacent channel selectivity and in-band blocking requirements in the respective clauses 7.5 and 7.6.2 shall be applied for carrier  $j$ . For inter-band carrier aggregation with component carriers in operating bands  $> 2.7$ GHz excluding n48, and for  $F_{\text{DL\_Low}(j)} - 3 \cdot BW_{\text{channel}} \leq f \leq F_{\text{DL\_High}(j)} + 3 \cdot BW_{\text{channel}}$ , the appropriate adjacent channel selectivity and in-band blocking requirements in the respective clauses 7.5 and 7.6.2 shall be applied for carrier  $j$ .  $F_{\text{DL\_Low}(j)}$  and  $F_{\text{DL\_High}(j)}$  denote the respective lower and upper frequency limits of the operating band containing carrier  $j$ ,  $j = 1, \dots, X$ , with carriers numbered in increasing order of carrier frequency and  $X$  the number of component carriers in the band combination.  $BW_{\text{channel}}$  denotes the channel bandwidth of the wanted signal component carrier  $j$ . If CW interferer falls in a gap between  $F_{\text{DL\_High}(j)}$  and  $F_{\text{DL\_Low}(j+1)}$  where the corresponding OOB ranges 1 and 2 overlap, then the lower level interferer limit of the overlapping OOB ranges applies.

If  $F_{\text{DL\_high}}$  of the lower NR band is greater than or equal to the  $F_{\text{DL\_low}}$  of the another upper NR band as in overlapping RX frequency ranges, then the OOB range shall start from the  $F_{\text{DL\_low}}$  of the lower NR band, and from the  $F_{\text{DL\_high}}$  of the upper NR band.

For inter-band carrier aggregation with uplink assigned to two NR bands, the out-of-band blocking requirements specified in clause 7.6.3 shall be met with the transmitter power for the uplink set to 7 dB below  $P_{\text{CMAX\_L,f,c}}$  for each serving cell  $c$ .

For the UE which supports inter-band CA configuration in Table 7.3A.3.2.1-1,  $P_{interferer}$  power defined in Table 7.6.3-2 and 7.6.3-4 and Table 7.6F.3.2-2 for shared spectrum channel access, is increased by the amount given by  $\Delta R_{IB,c}$  in Table 7.3A.3.2.1-1 and in Table 7.3F.3-1 for shared spectrum channel access.

For inter-band CA combination listed in Table 7.6A.3.3-1, exceptions to the requirement specified in Table 7.6A.3.3-2 are allowed when the second order intermodulation product of the lower frequency band UL carrier and the CW interfering signal fully or partially overlaps with the higher frequency band DL carrier. Unless otherwise stated, the exceptions apply to any power classes for the listed inter-band CA combinations.

**Table 7.6A.3.3-1: CA band combination with exceptions allowed**

CA band combination
CA_n1-n102
CA_n5-n77
CA_n5-n78
CA_n5-n79
CA_n7-n8
CA_n7-n46
CA_n7-n105
CA_n8-n77
CA_n8-n78
CA_n8-n79
CA_n12-n48
CA_n12-n77
CA_n12-n78
CA_n13-n77
CA_n14-n77
CA_n18-n77
CA_n18-n78
CA_n20-n78
CA_n26-n77
CA_n26-n78
CA_n28-n46
CA_n28-n77
CA_n28-n78
CA_n28-n79
CA_n28-n102
CA_n48-n71
CA_n48-n77
CA_n71-n77
CA_n71-n78
CA_n77-n85
CA_n78-n92
CA_n78-n105

**Table 7.6A.3.3-1a: Void**

**Table 7.6A.3.3-2: Requirement for out-of-band blocking exceptions**

Parameter	Unit	Level
$P_{interferer}$ (CW)	dBm	-44 <sup>1</sup>
NOTE 1: The requirement applies when $ f_{interferer} \pm f_{UL}^{LB} - f_{DL}^{HB}  \leq (BW_{UL}^{LB} + BW_{DL}^{HB})/2$ , where $f_{UL}^{LB}$ and $f_{DL}^{HB}$ are the carrier frequencies for lower frequency band UL and higher frequency band DL, respectively. $BW_{UL}^{LB}$ and $BW_{DL}^{HB}$ are the channel bandwidths configured for lower frequency band UL carrier and higher frequency band DL carrier in MHz, respectively.		

For all interferer frequency ranges specified in clause 7.6.3 a maximum of



$$\lfloor \max \{ 24, 6 \cdot \lceil n \cdot N_{RB} / 6 \rceil \} / \min \{ \lfloor n \cdot N_{RB} / 10 \rfloor, 5 \} \rfloor$$

exceptions are allowed for spurious response frequencies in each assigned frequency channel when measured using a step size of  $\min(BW_{channel}/2, 5)$  MHz with  $N_{RB}$  the number of resource blocks in the downlink transmission bandwidth configuration,  $BW_{channel}$  the bandwidth of the frequency channel in MHz and  $n = 1, 2, 3$  for SCS = 15, 30, 60 kHz, respectively. For these exceptions, the requirements in clause 7.7 apply.

The throughput of each carrier shall be  $\geq 95\%$  of the maximum throughput of the reference measurement channels as specified in Annexes A.2.2, A.3.2, and A.3.3 (with one sided dynamic OCNG Pattern OP.1 FDD/TDD for the DL-signal as described in Annex A.5.1.1/A.5.2.1).

## 7.6A.4 Narrow band blocking for CA

### 7.6A.4.1 Narrow band blocking for Intra-band contiguous CA

For intra-band contiguous carrier aggregation, the downlink SCC(s) shall be configured at nominal channel spacing to the PCC. For FDD, the PCC shall be configured closest to the uplink band. All downlink carriers shall be active throughout the test. The uplink output power shall be set as specified in Table 7.6A.4.1-1 with the uplink configuration. For UE(s) supporting one uplink, the uplink configuration of the PCC shall be in accordance with Table 7.3.2-3. The UE shall fulfil the minimum requirement in presence of an interfering signal specified in Table 7.6A.4.1-1 being on either side of the aggregated signal. The throughput of each carrier shall be  $\geq 95\%$  of the maximum throughput of the reference measurement channels as specified in Annexes A.2.2, A.3.2 and A.3.3 (with one sided dynamic OCNG Pattern OP.1 FDD/TDD for the DL-signal as described in Annex A.5.1.1/A.5.2.1) with parameters specified in Table 7.6A.4.1-1.

**Table 7.6A.4.1-1: Narrow-band blocking for intra-band contiguous CA**

NR band	Parameter	Unit	NR CA bandwidth class	
			B	C
n1, n2, n3, n25, n38, n41, n66, n71, n48, n40	P <sub>w</sub> in Transmission Bandwidth Configuration, per CC	dBm	REFSENS + NR CA Bandwidth Class specific value below	
			dB	16
	P <sub>uw</sub> (CW)	dBm	-55	-55
	F <sub>uw</sub> (offset for Δf = 15 kHz, 30 kHz)	MHz	- F <sub>offset</sub> - 0.2 / + F <sub>offset</sub> + 0.2	- F <sub>offset</sub> - 0.2 / + F <sub>offset</sub> + 0.2
<p>NOTE 1: The transmitter shall be set a 4 dB below P<sub>C<sub>MAX</sub>_L,f,c</sub> at the minimum UL configuration specified in Table 7.3.2-3 with P<sub>C<sub>MAX</sub>_L,f,c</sub> defined in clause 6.2.4.</p> <p>NOTE 2: Reference measurement channel is specified in Annexes A.3.2 and A3.2 with one sided dynamic OCNG Pattern OP.1 FDD/TDD as described in Annex A.5.1.1/A.5.2.1.</p> <p>NOTE 3: The PREFSENS power level is specified in Table 7.3.2-1a, Table 7.3.2-1b, Table 7.3.2-2 and Table 7.3.2-2a for two, four and eight antenna ports, respectively.</p> <p>NOTE 4: The F<sub>uw</sub> (offset) is the frequency separation of the center frequency of the carrier closest to the interferer and the center frequency of the interferer and shall be further adjusted to <math>\lfloor \frac{F_{interferer}}{SCS} + 0.5 \rfloor SCS + 0.5 SCS</math> MHz to be offset from the sub-carrier raster.</p>				

### 7.6A.4.2 Narrow band blocking for Intra-band non-contiguous CA

For intra-band non-contiguous carrier aggregation with  $F_{DL\_low} < 2700$  MHz and  $F_{UL\_low} < 2700$  MHz with one uplink carrier and two or more downlink sub-blocks, the narrow band blocking requirements are defined with the uplink configuration in accordance with Table 7.3A.2.2-1. For this uplink configuration, the UE shall meet the requirements for each sub-block as specified in clauses 7.6.4 and 7.6A.4.1 for one component carrier and two component carriers per sub-block, respectively. The requirements apply for in-gap and out-of-gap interferers while all downlink carriers are active.

The throughput of each carrier shall be  $\geq 95\%$  of the maximum throughput of the reference measurement channels as specified in Annexes A.2.2, A.3.2, and A.3.3 (with one sided dynamic OCNG Pattern OP.1 FDD/TDD for the DL-signal as described in Annex A.5.1.1/A.5.2.1).

### 7.6A.4.3 Narrow band blocking for Inter-band CA

For inter-band carrier aggregation with one component carrier per operating band and the uplink assigned to one NR band, the narrow band blocking requirements are defined with the uplink active on the band(s) other than the band whose downlink is being tested. For NR CA configurations including an operating band without uplink band or an operating band with an unpaired DL part (as noted in Table 5.2-1), the requirements for all downlinks shall be met with the single uplink carrier active in each band capable of UL operation. The UE shall meet the requirements specified in clause 7.6.4 for each component carrier while all downlink carriers are active.

For the UE which supports inter-band CA configuration in Table 7.3A.3.2.1-1,  $P_{UW}$  power defined in Table 7.6.4-1 is increased by the amount given by  $\Delta R_{IB,c}$  in Table 7.3A.3.2.1-1.

The throughput of each carrier shall be  $\geq 95\%$  of the maximum throughput of the reference measurement channels as specified in Annexes A.2.2, A.3.2, and A.3.3 (with one sided dynamic OCNG Pattern OP.1 FDD/TDD for the DL-signal as described in Annex A.5.1.1/A.5.2.1).

## 7.6B Blocking characteristics for NR-DC

For inter-band NR-DC configurations, the blocking characteristics for the corresponding inter-band CA configuration as specified in clause 7.6A applies.

## 7.6C Blocking characteristics for SUL

### 7.6C.1 General

### 7.6C.2 In-band blocking for SUL

For SUL operation, the in-band blocking requirement for downlink bands specified in clause 7.6.2 shall be met.

For SUL operation with downlink CA, the in-band blocking requirement for downlink bands specified in clause 7.6A.2 shall be met.

### 7.6C.3 Out-of-band blocking for SUL

For SUL operation, the out-of-band blocking requirement for downlink bands specified in clause 7.6.3 shall be met. For SUL operation with downlink CA, the out-of-band blocking requirement for downlink bands specified in clause 7.6A.3 shall be met. For operation band combination listed in Table 7.6C.3-1, exceptions to the requirement specified in Table 7.6C.3-2 are allowed when the second order intermodulation product of the SUL carrier and the CW interfering signal fully or partially overlaps with the DL carrier.

**Table 7.6C.3-1: SUL operating band combination with exceptions allowed**

NR Band combination for SUL
SUL_n78-n81
SUL_n78-n82
SUL_n78-n83
SUL_n79-n81
SUL_n79-n83

**Table 7.6C.3-2: Requirement for out-of-band blocking exceptions**

Parameter	Unit	Level
$P_{\text{Interferer (CW)}}$	dBm	-44 <sup>1</sup>

NOTE 1: The requirement applies when  $|f_{Interferer} \pm f_{SUL} - f_{DL}| \leq (BW_{SUL} + BW_{DL})/2$ , where  $BW_{SUL}$  and  $BW_{DL}$  are the channel bandwidths configured for SUL and DL (victim) bands in MHz, respectively.

For all interferer frequency ranges specified in clause 7.6.3 a maximum of

$$\lfloor \max \{24, 6 \cdot \lceil n \cdot N_{RB} / 6 \rceil \} / \min \{ \lfloor n \cdot N_{RB} / 10 \rfloor, 5 \} \rfloor$$

exceptions are allowed for spurious response frequencies in each assigned frequency channel when measured using a step size of  $\min(BW_{channel}/2, 5)$  MHz with  $N_{RB}$  the number of resource blocks in the downlink transmission bandwidth configuration,  $BW_{channel}$  the bandwidth of the frequency channel in MHz and  $n = 1, 2, 3$  for SCS = 15, 30, 60 kHz, respectively. For these exceptions, the requirements in clause 7.7 apply.

## 7.6C.4 Narrow band blocking for SUL

Narrow band blocking is not specified for SUL band combination.

## 7.6D Blocking characteristics for UL MIMO

For UE with two or four transmitter antenna connectors in closed-loop spatial multiplexing scheme, the minimum requirements specified in clause 7.6 shall be met with the UL MIMO configurations described in clause 6.2D.1 and in clause 6.2F.1D for shared spectrum access operation. For UL MIMO, the parameter  $P_{CMAX\_L}$  is defined as the total transmitter power over all transmit antenna connectors.

## 7.6E Blocking characteristics for V2X

### 7.6E.1 General

The blocking characteristic is a measure of the receiver's ability to receive a wanted signal at its assigned channel frequency in the presence of an unwanted interferer on frequencies other than those of the spurious response or the adjacent channels, without this unwanted input signal causing a degradation of the performance of the receiver beyond a specified limit. The blocking performance shall apply at all frequencies except those at which a spurious response occurs.

### 7.6E.2 In-band blocking

#### 7.6E.2.1 General

When UE is configured for NR V2X reception non-concurrent with NR uplink transmissions for NR V2X operating bands specified in Table 5.2E.1-1, the throughput of the wanted signal shall be  $\geq 95\%$  of the maximum throughput of the reference measurement channels as specified in Annex A.7.2 with parameters specified in Table 7.6E.2.1-1 and Table 7.6E.2.1-2. The relative throughput requirement shall be met for any SCS specified for the channel bandwidth of the wanted signal.

**Table 7.6E.2.1-1: In-band blocking parameters for NR V2X**

RX parameter	Units	Channel bandwidth			
		10 MHz	20 MHz	30 MHz	40 MHz
Power in transmission bandwidth configuration	dBm	$P_{REFSENS\_V2X}$ + channel bandwidth specific value below			
	dB	6	9	11	12
$BW_{interferer}$	MHz	10			
$F_{offset, case 1}$	MHz	15			
$F_{offset, case 2}$	MHz	25			
NOTE 1: The interferer is QPSK modulated PUSCH containing data and reference symbols. Normal cyclic prefix is used.					

**Table 7.6E.2.1-1a: In-band blocking parameters in n14**

RX parameter	Units	Channel bandwidth				
		5 MHz	10 MHz	20 MHz	30 MHz	40 MHz
Power in transmission bandwidth configuration	dBm	P <sub>PREFSENS_V2X</sub> + channel bandwidth specific value below				
	dB	6	6			
BW <sub>interferer</sub>	MHz	5				
F <sub>offset, case 1</sub>	MHz	7.5				
F <sub>offset, case 2</sub>	MHz	12.5				
NOTE 1: The interferer is QPSK modulated PUSCH containing data and reference symbols. Normal cyclic prefix is used.						

**Table 7.6E.2.1-2: In-band blocking for NR V2X**

NR band	Parameter	Unit	Case 1	Case 2
n14	P <sub>interferer</sub>	dBm	-56	-44
	F <sub>interferer (offset)</sub>	MHz	-BW/2 – F <sub>offset, case 1</sub> & BW/2 + F <sub>offset, case 1</sub>	≤ -BW/2 – F <sub>offset, case 2</sub> & ≥ BW/2 + F <sub>offset, case 2</sub>
	F <sub>interferer</sub>	MHz	NOTE 2	F <sub>DL, low</sub> – 15 to F <sub>DL, high</sub> + 15
n38, n47	P <sub>interferer</sub>	dBm	-44	-44
	F <sub>interferer (offset)</sub>	MHz	-BW/2 – F <sub>offset, case 1</sub> and BW/2 + F <sub>offset, case 1</sub>	≤ -BW/2 – F <sub>offset, case 2</sub> and ≥ BW/2 + F <sub>offset, case 2</sub>
	F <sub>interferer</sub>	MHz	NOTE 2	F <sub>DL, low</sub> – 30 to F <sub>DL, high</sub> + 30
NOTE 1: For certain bands, the unwanted modulated interfering signal may not fall inside the UE receive band, but within the first 15 MHz below or above the UE receive band.				
NOTE 2: For each carrier frequency the requirement is valid for two frequencies: a. the carrier frequency -BW/2 – F <sub>offset, case 1</sub> and b. the carrier frequency +BW/2 + F <sub>offset, case 1</sub>				
NOTE 3: F <sub>interferer</sub> range values for unwanted modulated interfering signal are interferer center frequencies				
NOTE 4: The absolute value of the interferer offset F <sub>interferer (offset)</sub> shall be further adjusted to $(\lceil  F_{interferer} / SCS \rceil + 0.5) SCS$ MHz with SCS the sub-carrier spacing of the wanted signal in MHz. The interferer is an NR signal with 15 kHz SCS.				

**7.6E.2.1A In-band blocking for Sidelink CA**

For intra-band contiguous SL CA operation, the UE shall fulfil the minimum requirement specified in Table 7.6E.2.1A-1 to Table 7.6E.2.1A-2 where the throughput shall be ≥ 95% of the maximum throughput of the reference measurement channels as specified in Annex A.7.2.

**Table 7.6E.2.1A-1 In-band blocking parameters for intra-band contiguous SL CA UE**

Rx Parameter	Units	SL CA bandwidth class
		B
P <sub>w</sub> in Transmission Bandwidth Configuration, per CC	dBm	P <sub>PREFSENS_SL</sub> + NR SL CA bandwidth class specific value below
	dB	16.0
BW <sub>interferer</sub>	MHz	10
F <sub>offset, case 1</sub>	MHz	15
F <sub>offset, case 2</sub>	MHz	25
NOTE 1: The interferer is QPSK modulated PUSCH containing data and reference symbols. Normal cyclic prefix is used.		

**Table 7.6E.2.1A-2 In-band blocking for intra-band contiguous SL CA UE**

NR SL CA band	Parameter	Unit	Case 1	Case 2
		$P_{\text{Interferer}}$	dBm	-44
SL_n47B	$F_{\text{Interferer}}$ (offset)	MHz	- $BW_{\text{channel CA}/2} - F_{\text{offset,case 1}}$ & + $BW_{\text{channel CA}/2} + F_{\text{offset,case 1}}$	$\leq - BW_{\text{channel CA}/2} - F_{\text{offset,case 2}}$ & $\geq + BW_{\text{channel CA}/2} + F_{\text{offset,case 2}}$
	$F_{\text{Interferer}}$ (Range)	MHz	NOTE 2	$F_{\text{DL\_low}} - 30$ to $F_{\text{DL\_high}} + 30$
NOTE 1: For certain bands, the unwanted modulated interfering signal may not fall inside the UE receive band, but within the first 30 MHz below or above the UE receive band				
NOTE 2: For each carrier frequency the requirement is valid for two frequencies: a. the carrier frequency - $BW_{\text{channel CA}/2} - F_{\text{offset, case 1}}$ and b. the carrier frequency + $BW_{\text{channel CA}/2} + F_{\text{offset, case 1}}$				
NOTE 3: $BW_{\text{channel CA}}$ denotes the aggregated channel bandwidth of the wanted signal				

### 7.6E.2.2 In-band blocking for V2X concurrent operation

For the inter-band concurrent NR V2X operation, the requirements specified in clause 7.6E.2.1 shall apply for the NR sidelink reception in the operating bands in Table 5.2E.2-1 and the requirements specified in clause 7.6.2 shall apply for the NR downlink reception in licensed band while all downlink carriers are active.

### 7.6E.2.2F In-band blocking for SL-U concurrent operation

For the inter-band concurrent NR SL-U operation, the requirements specified in clause 7.6E.2F shall apply for the NR sidelink reception in the operating bands in Table 5.2E.2F-1 and the requirements specified in clause 7.6.2 shall apply for the NR downlink reception in licensed band while all downlink carriers are active.

## 7.6E.3 Out-of-band blocking

### 7.6E.3.1 General

For NR V2X bands out-of-band band blocking is defined for an unwanted CW interfering signal falling outside a frequency range 30 MHz below or above the UE receive band. When UE is configured for NR V2X reception non-concurrent with NR uplink transmissions for NR V2X operating bands specified in Table 5.2E.1-1, the throughput of the wanted signal shall be  $\geq 95\%$  of the maximum throughput of the reference measurement channels as specified in Annexes A.7.2 with parameters specified in Table 7.6E.3.1-1 and Table 7.6E.3.1-2. The relative throughput requirement shall be met for any SCS specified for the channel bandwidth of the wanted signal.

**Table 7.6E.3.1-1: Out-of-band blocking parameters for NR V2X**

RX parameter	Units	Channel bandwidth				
		5 MHz <sup>2</sup>	10 MHz	20 MHz	30 MHz	40 MHz
Power in transmission bandwidth configuration	dBm	$P_{\text{REFSENS\_V2X}}$ + channel bandwidth specific value below				
	dB	6	6	9	11	12
NOTE 1: Reference measurement channel is A.7.2.						
NOTE 2: The CBW is only applicable for PS UE in n14.						

**Table 7.6E.3.1-2: Out of-band blocking for NR V2X**

NR band	Parameter	Units	Range 1	Range 2	Range 3
n14	$P_{\text{interferer}}$	dBm	-44	-30	-15
	$F_{\text{interferer}}$ (CW)	MHz	$-60 < f - F_{\text{DL\_low}} < -15$ or $15 < f - F_{\text{DL\_high}} < 60$	$-85 < f - F_{\text{DL\_low}} \leq -60$ or $60 \leq f - F_{\text{DL\_high}} < 85$	$1 \leq f \leq F_{\text{DL\_low}} - 85$ or $F_{\text{DL\_high}} + 85 \leq f$

n47	$P_{\text{interferer}}$	dBm	-44	-30	$\leq 12750$ -15
	$F_{\text{interferer}}$ (CW)	MHz	$F_{\text{DL\_low}} -30$ to $F_{\text{DL\_low}} -60$	$F_{\text{DL\_low}} -60$ to $F_{\text{DL\_low}} -85$	$F_{\text{DL\_low}} -85$ to 1 MHz
n38	$P_{\text{interferer}}$	dBm	-44	-30	-15
	$F_{\text{interferer}}$ (CW)	MHz	$F_{\text{DL\_high}} +30$ to $F_{\text{DL\_high}} + 60$	$F_{\text{DL\_high}} +60$ to $F_{\text{DL\_high}} +85$	$F_{\text{DL\_high}} +85$ to +12750 MHz
NOTE 1: The power level of the interferer ( $P_{\text{interferer}}$ ) for Range 3 shall be modified to -20 dBm for $F_{\text{interferer}} > 4400$ MHz.					

### 7.6E.3.1A Out-of-band blocking for Sidelink CA

For intra-band contiguous SL CA operation, the UE throughput shall be  $\geq 95\%$  of the maximum throughput of the reference measurement channels as specified in Annex A.7.2 with parameters specified in Tables 7.6E.3.1A-1 and 7.6E.3.1A-2.

For Table 7.6E.3.1A-2 in frequency range 1, 2 and 3, up to  $\max(24,6 \cdot \lceil N_{RB} \cdot /6 \rceil)$  exceptions are allowed for spurious response frequencies in each assigned frequency channel when measured using a 1MHz step size. For these exceptions the requirements of subclause 7.3.5 spurious response are applicable.

**Table 7.6E.3.1A-1: Out-of-band blocking parameters for intra-band contiguous SL CA UE**

Rx Parameter	Units	SL CA Bandwidth Class			
		B			
Pw in Transmission Bandwidth Configuration, per CC	dBm	$P_{\text{REFSENS\_SL}}$ + SL CA Bandwidth Class specific value below			
		9			

**Table 7.6E.3.1A-2: Out of band blocking for intra-band contiguous SL CA UE**

NR SL CA band	Parameter	Units	Frequency		
			Range 1	Range 2	Range 3
	$P_{\text{interferer}}$	dBm	-44	-30	-15
V2X_47B	$F_{\text{interferer}}$ (CW)	MHz	$-60 < f - F_{\text{DL\_low}} < -30$ or $30 < f - F_{\text{DL\_high}} < 60$	$-85 < f - F_{\text{DL\_low}} \leq -60$ or $60 \leq f - F_{\text{DL\_high}} < 85$	$1 \leq f \leq F_{\text{DL\_low}} - 85$ or $F_{\text{DL\_high}} + 85 \leq f \leq 12750$
NOTE 1: The power level of the interferer ( $P_{\text{interferer}}$ ) for Range 3 shall be modified to -20 dBm for $F_{\text{interferer}} > 6000$ MHz.					
NOTE 2: The requirement is applied for multi-carrier intra-band concurrent receptions when 2 carrier transmissions are activated at the same time.					

### 7.6E.3.2 Out-of-band blocking for V2X concurrent operation

For the inter-band concurrent NR V2X operation, the requirements specified in clause 7.6E.3.1 shall apply for the NR sidelink reception in Band n47 and the requirements specified in clause 7.6.3 shall apply for the NR downlink reception in licensed band while all downlink carriers are active.

### 7.6E.3.2F Out-of-band blocking for SL-U concurrent operation

For the inter-band concurrent NR SL-U operation, the requirements specified in clause 7.6E.3F shall apply for the NR sidelink reception in the operating bands in Table 5.2E.2F-1 and the requirements specified in clause 7.6.3 shall apply for the NR downlink reception in licensed band while all downlink carriers are active.

## 7.6E.3F Out-of-band blocking for Sidelink Unlicensed

Out-of-band band blocking is defined for an unwanted CW interfering signal falling outside a frequency range 60 MHz or greater below or above the UE receive band. The throughput of the wanted signal shall be  $\geq 95\%$  of the maximum throughput of the reference measurement channels as specified in Annex 7.2 with parameters specified in Table 7.6F.3.1-1 and Table 7.6F.3.1-2. The relative throughput requirement shall be met for any SCS specified for the channel bandwidth of the wanted signal.

## 7.6F Blocking characteristics for shared spectrum channel access

### 7.6F.1 General

The blocking characteristic is a measure of the receiver's ability to receive a wanted signal at its assigned channel frequency in the presence of an unwanted interferer on frequencies other than those of the spurious response or the adjacent channels, without this unwanted input signal causing a degradation of the performance of the receiver beyond a specified limit. The blocking performance shall apply at all frequencies except those at which a spurious response occurs.

### 7.6F.2 In-band blocking

#### 7.6F.2.1 General

In-band blocking (IBB) is defined for an unwanted interfering signal falling into the UE receive band or into the first 60 MHz below or above the UE receive band. The throughput of the wanted signal shall be  $\geq 95\%$  of the maximum throughput of the reference measurement channels as specified in Annexes A.2.2, A.3.2 and A.3.3 (with one sided dynamic OCNB Pattern OP.1 FDD/TDD for the DL-signal as described in Annex A.5.1.1/A.5.2.1) with parameters specified in Table 7.6F.2.1-1 and Table 7.6F.2.1-2. The relative throughput requirement shall be met for any SCS specified for the channel bandwidth of the wanted signal.

**Table 7.6F.2.1-1: In-band blocking parameters for shared access bands**

RX parameter	Units	Channel bandwidth
		20, 40, 60, 80, 100 MHz
Power in transmission bandwidth configuration	dBm	REFSENS + 9 dB + $10\log_{10}(BW_{\text{Channel}}/20)$ dB
$BW_{\text{interferer}}$	MHz	20
$F_{\text{offset, case 1}}$	MHz	30
$F_{\text{offset, case 2}}$	MHz	$\geq 50$

**Table 7.6F.2.1-2: In-band blocking for shared access bands**

Operating band	Parameter	Unit	Case 1	Case 2
	$P_{\text{interferer}}$	dBm	-56	-44
	$F_{\text{interferer}}$ (offset)	MHz	$-\text{CBW}/2 - F_{\text{offset, case 1}}$ and $\text{CBW}/2 + F_{\text{offset, case 1}}$	$\leq -\text{CBW}/2 - F_{\text{offset, case 2}}$ and $\geq \text{CBW}/2 + F_{\text{offset, case 2}}$
n46, n96, n102	$F_{\text{interferer}}$		NOTE 2	$F_{\text{DL\_low}} - 3*\text{CBW}$ to $F_{\text{DL\_high}} + 3*\text{CBW}$ , NOTE 4

NOTE 1: The absolute value of the interferer offset  $F_{interferer}$  (offset) shall be further adjusted to  $(\lceil F_{interferer} / SCS \rceil + 0.5) SCS$  MHz with SCS the sub-carrier spacing of the wanted signal in MHz. The interferer is an NR signal with an SCS equal to that of the wanted signal.

NOTE 2: For each carrier frequency, the requirement applies for two interferer carrier frequencies: a:  $-CBW/2 - F_{offset, case 1}$ ; b:  $CBW/2 + F_{offset, case 1}$

NOTE 3: CBW denotes the channel bandwidth of the wanted signal

NOTE 4: Interferer carrier frequencies in the frequency range for Case 2 shall be located at discrete frequencies in integer multiples of 20 MHz offset from  $-CBW/2 - F_{offset, case 2}$  and  $CBW/2 + F_{offset, case 2}$

7.6F.2.2 Void

7.6F.2A In-band blocking for shared spectrum CA

7.6F.2A.1 Intra-band contiguous shared spectrum channel access CA

In-band blocking for intra-band contiguous shared access CA requirements are specified in Table 7.6F.2A.1-1. These requirements apply for any SCS specified for the channel bandwidth of the wanted signal. For the test parameters specified in Table 7.6F.2A.1-2, the throughput of each carrier shall be  $\geq 95\%$  of the maximum throughput of the reference measurement channels as specified in Annexes A.2.2, A.3.2, and A.3.3 (with one sided dynamic OCNG Pattern OP.1 FDD/TDD for the DL-signal as described in Annex A.5.1.1/A.5.2.1).

**Table 7.6F.2A.1-1: In-band blocking parameters for intra-band contiguous shared access CA**

Rx Parameter	Units	Shared access CA bandwidth class
		B, C, D, E, M, N, O
Pw in Transmission Bandwidth Configuration, per CC	dBm	REFSENS + aggregated channel bandwidth value below
	dB	$9 + 10\log_{10}(BW_{Channel\_CA}/20)$
BW <sub>Interferer</sub>	MHz	20
F <sub>offset, case 1</sub>	MHz	30
F <sub>offset, case 2</sub>	MHz	$\geq 50$

NOTE 1: The transmitter shall be set to 4dB below P<sub>CMAX,L,f,c</sub> at the minimum UL configuration specified in Table 7.3.2-3 with P<sub>CMAX,L,f,c</sub> defined in clause 6.2.4.

NOTE 2: The interferer consists of the Reference measurement channel specified in Annexes A.3.2 and A.3.3 with one sided dynamic OCNG Pattern OP.1 FDD/TDD as described in Annex A.5.1.1/A.5.2.1 and set-up according to Annex C.3.1

**Table 7.6F.2A.1-2: In-band blocking for intra-band contiguous shared access CA**

Operating band	Parameter	Unit	Case 1	Case 2
	P <sub>interferer</sub>	dBm	-56	-44
	F <sub>interferer</sub> (offset)	MHz	$-BW_{channel\ CA}/2 - F_{offset, case 1}$ and $BW_{channel\ CA}/2 + F_{offset, case 1}$	$\leq -BW_{channel\ CA}/2 - F_{offset, case 2}$ and $\geq BW_{channel\ CA}/2 + F_{offset, case 2}$
n46	F <sub>interferer</sub>	MHz	NOTE 2	F <sub>DL_low</sub> - 3* BW <sub>channel CA</sub> to F <sub>DL_high</sub> + 3* BW <sub>channel CA</sub> NOTE 4

NOTE 1: The absolute value of the interferer offset  $F_{interferer}$  (offset) shall be further adjusted to  $(\lceil F_{interferer} / SCS \rceil + 0.5) SCS$  MHz with SCS the sub-carrier spacing of the carrier closest to the interferer in MHz. The interferer is an NR signal with an SCS equal to that of the closest carrier.

NOTE 2: For each carrier frequency, the requirement applies for two interferer carrier frequencies: a:  $-BW_{channel\ CA}/2 - F_{offset, case 1}$ ; b:  $BW_{channel\ CA}/2 + F_{offset, case 1}$

NOTE 3: BW<sub>channel CA</sub> denotes the aggregated channel bandwidth of the wanted signal



NOTE 4: Interferer carrier frequencies in the frequency range for Case 2 shall be located at discrete frequencies in integer multiples of 20 MHz offset from  $-BW_{\text{channel CA}}/2 - F_{\text{offset, case 2}}$  and  $BW_{\text{channel CA}}/2 + F_{\text{offset, case 2}}$

### 7.6F.3 Out-of-band blocking

#### 7.6F.3.1 General

Out-of-band band blocking is defined for an unwanted CW interfering signal falling outside a frequency range 60 MHz or greater below or above the UE receive band. The throughput of the wanted signal shall be  $\geq 95\%$  of the maximum throughput of the reference measurement channels as specified in Annexes A.2.2, A.3.2 and A.3.3 (with one sided dynamic OCNG Pattern OP.1 FDD/TDD for the DL-signal as described in Annex A.5.1.1/A.5.2.1) with parameters specified in Table 7.6F.3.1-1 and Table 7.6F.3.1-2. The relative throughput requirement shall be met for any SCS specified for the channel bandwidth of the wanted signal.

**Table 7.6F.3.1-1: Out-of-band blocking parameters for shared access bands**

RX parameter	Units	Channel bandwidth
		20, 40, 60, 80, 100 MHz
Power in transmission bandwidth configuration	dBm	REFSENS + 9 dB
NOTE 1: The transmitter shall be set to 4 dB below $P_{\text{CMAX\_L,f,c}}$ at the minimum UL configuration specified in Table 7.3.2-3 with $P_{\text{CMAX\_L,f,c}}$ defined in clause 6.2.4.		

**Table 7.6F.3.1-2: Out of-band blocking for shared access bands**

Operating band	Parameter	Unit	Range1	Range 2	Range 3
	$P_{\text{interferer}}$	dBm	-44	-30	-15
n46, n96	$F_{\text{interferer}}$ (CW)	MHz	N/A	$-200 < f - F_{\text{DL\_low}} \leq -3 \cdot \text{CBW}$ or $3 \cdot \text{CBW} \leq f - F_{\text{DL\_high}} < 200$	$1 \leq f \leq F_{\text{DL\_low}} - \text{MAX}(200, 3 \cdot \text{CBW})$ or $F_{\text{DL\_high}} + \text{MAX}(200, 3 \cdot \text{CBW}) \leq f \leq 12750$
n102	$F_{\text{interferer}}$ (CW)	MHz	N/A	$-200 < f - F_{\text{DL\_low}} \leq -3 \cdot \text{CBW}$ or $F_{\text{DL\_high}} + \text{MAX}(200, 3 \cdot \text{CBW}) \leq f < 7125 + \text{MAX}(375, 3 \cdot \text{CBW})$	$1 \leq f \leq F_{\text{DL\_low}} - \text{MAX}(200, 3 \cdot \text{CBW})$ or $7125 + \text{MAX}(375, 3 \cdot \text{CBW}) \leq f \leq 12750$
NOTE 1: The power level of the interferer ( $P_{\text{interferer}}$ ) for Range 3 shall be modified to -20 dBm for $F_{\text{interferer}} > 4200$ MHz.					
NOTE 2: CBW denotes the channel bandwidth of the wanted signal					
NOTE 3: For band n102, the power level of the interferer ( $P_{\text{interferer}}$ ) for Range 2 shall be modified to -33dBm for the range $F_{\text{DL\_high}} + \text{MAX}(200, 3 \cdot \text{CBW}) \leq f < 7125 + \text{MAX}(375, 3 \cdot \text{CBW})$ .					

For interferer frequencies across ranges 1, 2 and 3 in Table 7.6F.3.1-2, a maximum of

$$\lfloor \max \{24, 6 \cdot \lceil n \cdot N_{\text{RB}} / 6 \rceil \} / \min \{ \lfloor n \cdot N_{\text{RB}} / 10 \rfloor, 5 \} \rfloor$$

exceptions are allowed for spurious response frequencies in each assigned frequency channel when measured using a step size of  $\min(\lfloor \text{CBW} / 2 \rfloor, 5)$  MHz with  $N_{\text{RB}}$  the number of resource blocks in the downlink transmission bandwidth configuration,  $\text{CBW}$  the bandwidth of the frequency channel in MHz and  $n = 1, 2, 3$  for SCS = 15, 30, 60 kHz, respectively. For these exceptions, the requirements in clause 7.7F apply.

7.6F.3.2 Void

7.6F.3A Out-of-band blocking for shared spectrum CA

7.6F.3A.1 Intra-band contiguous shared spectrum channel access CA

Out-of-band blocking for intra-band contiguous shared access CA requirements are specified in Table 7.6F.3A.1-1. These requirements apply for any SCS specified for the channel bandwidth of the wanted signal. For the test parameters specified in Table 7.6F.3A.1-2, the throughput of each carrier shall be  $\geq 95\%$  of the maximum throughput of the reference measurement channels as specified in Annexes A.2.2, A.3.2, and A.3.3 (with one sided dynamic OCNG Pattern OP.1 FDD/TDD for the DL-signal as described in Annex A.5.1.1/A.5.2.1).

**Table 7.6F.3A.1-1: Out-of-band blocking parameters for intra-band contiguous shared access CA**

Rx Parameter	Units	Shared access CA bandwidth class
		B, C, D, E, M, N, O
Pw in Transmission Bandwidth Configuration, per CC	dBm	REFSENS + CA bandwidth class specific value below
	dB	9

NOTE 1: The transmitter shall be set to 4dB below  $P_{CMAX\_L,f,c}$  at the minimum UL configuration specified in Table 7.3F.2-3 with  $P_{CMAX\_L,f,c}$  defined in clause 6.2.4.

**Table 7.6F.3A.1-2: Out of-band blocking for intra-band contiguous CA**

Operating band	Parameter	Unit	Range1	Range 2	Range 3
		Pinterferer	dBm	-45	-30
n46	Finterferer (CW)	MHz	N/A	$-200 < f - F_{DL\_low} \leq -3 * BW_{Channel\_CA}$ or $3 * BW_{Channel\_CA} \leq f - F_{DL\_high} < 200$	$1 \leq f \leq F_{DL\_low} - MAX(200, 3 * BW_{Channel\_CA})$ or $F_{DL\_high} + MAX(200, 3 * BW_{Channel\_CA}) \leq f \leq 12750$

NOTE 1: The power level of the interferer ( $P_{Interferer}$ ) for Range 3 shall be modified to -20 dBm, for  $F_{Interferer} > 4200$  MHz.

7.6G (Reserved)

7.6H (Reserved)

7.6I (Reserved)

7.6J Blocking characteristics for ATG

7.6J.1 General

The blocking characteristic is a measure of the receiver's ability to receive a wanted signal at its assigned channel frequency in the presence of an unwanted interferer on frequencies other than those of the spurious response or the adjacent channels, without this unwanted input signal causing a degradation of the performance of the receiver beyond a specified limit. The blocking performance shall apply at all frequencies except those at which a spurious response occurs.

## 7.6J.2 In-band blocking for ATG

For ATG UE, the in-band blocking requirement defined in clause 7.6.2 applies.

## 7.6J.3 Out-of-band blocking for ATG

For ATG UE, the out-of-band blocking requirement defined in clause 7.6.3 applies.

NOTE: In 3GPP, the ATG UE out-of-band blocking specification is defined to ensure the telecommunication link and there may be other sources of interference and regulatory issues that need to be considered when designing ATG UE, i.e. avionic equipment.

## 7.6K (Reserved)

## 7.6L (Reserved)

## 7.7 Spurious response

Spurious response is a measure of the ability of the receiver to receive a wanted signal on its assigned channel frequency without exceeding a given degradation due to the presence of an unwanted CW interfering signal at any other frequency for which a response is obtained, i.e. for which the out-of-band blocking limit as specified in clause 7.6.3 is not met.

The throughput shall be  $\geq 95$  % of the maximum throughput of the reference measurement channels as specified in Annexes A.2.2, A.3.2 and A.3.3 (with one sided dynamic OCNG Pattern OP.1 FDD/TDD for the DL-signal as described in Annex A.5.1.1/A.5.2.1) with parameters for the wanted signal as specified in Table 7.7-1 for NR bands with  $F_{DL\_high} < 2700$  MHz and  $F_{UL\_high} < 2700$  MHz and in Table 7.7-1a for NR bands with  $F_{DL\_high} \geq 3300$  MHz and  $F_{UL\_high} \geq 3300$  MHz and for the interferer as specified in Table 7.7-2. The relative throughput requirement shall be met for any SCS specified for the channel bandwidth of the wanted signal. For operating bands with an unpaired DL part (as noted in Table 5.2-1), the requirements only apply for carriers assigned in the paired part.

**Table 7.7-1: Spurious response parameters for NR bands with  $F_{DL\_high} < 2700$  MHz and  $F_{UL\_high} < 2700$  MHz**

RX parameter	Units	Channel bandwidth (MHz)		
		3, 5, 10	15	20, 25, 30, 35, 40, 45, 50, 60, 70, 80, 90, 100
Power in transmission bandwidth configuration <sup>2</sup>	dBm	REFSENS + 6 dB	REFSENS + 7 dB	REFSENS + (9 + 10log <sub>10</sub> (BW <sub>Channel</sub> / 20)) dB
NOTE 1: The transmitter shall be set to 4 dB below P <sub>CMAX,L,f,c</sub> at the minimum UL configuration specified in Table 7.3.2-3 with P <sub>CMAX,L,f,c</sub> defined in clause 6.2.4.				
NOTE 2: 10log <sub>10</sub> (x) is rounded to the next higher 0.5dB value.				

**Table 7.7.1-1a: Spurious response parameters for NR bands with  $F_{DL\_low} \geq 3300$  MHz and  $F_{UL\_low} \geq 3300$  MHz**

RX parameter	Units	Channel bandwidth (MHz)		
		10	15	20, 25, 30, 35, 40, 45, 50, 60, 70, 80, 90, 100
Power in transmission bandwidth configuration	dBm	REFSENS + 6 dB	REFSENS + 7 dB	REFSENS + 9 dB
NOTE 1: The transmitter shall be set to 4 dB below P <sub>CMAX,L,f,c</sub> at the minimum UL configuration specified in Table 7.3.2-3 with P <sub>CMAX,L,f,c</sub> defined in clause 6.2.4.				

**Table 7.7-2: Spurious response**

Parameter	Unit	Level
$P_{\text{Interferer}}$ (CW)	dBm	-44
$F_{\text{Interferer}}$	MHz	Spurious response frequencies

## 7.7A Spurious response for CA

### 7.7A.1 Spurious response for Intra-band contiguous CA

**Table 7.7A-1: Spurious response parameters for intra-band contiguous CA**

RX parameter	Units	NR CA bandwidth class			
		B	C	D	
Power in transmission bandwidth configuration	dBm	REFSENS + CA bandwidth class specific value below			
	dB	9	9	9	

NOTE 1: The transmitter shall be set to 4 dB below  $P_{\text{CMAX\_L,f,c}}$  at the minimum UL configuration specified in Table 7.3.2-3 with  $P_{\text{CMAX\_L,f,c}}$  defined in clause 6.2.4.

**Table 7.7A-2: Spurious response for CA**

Parameter	Unit	Level
$P_{\text{Interferer}}$ (CW)	dBm	-44
$F_{\text{Interferer}}$	MHz	Spurious response frequencies

**Table 7.7A-3: Void****Table 7.7A-4: void**

### 7.7A.2 Spurious response for Intra-band non-contiguous CA

For intra-band non-contiguous carrier aggregation with one uplink carrier and two or more downlink sub-blocks, the spurious response requirements are defined with the uplink configuration in accordance with Table 7.3A.2.2-1. For this uplink configuration, the UE shall meet the requirements for each sub-block as specified in clauses 7.7 and 7.7A.1 for one component carrier and two component carriers per sub-block, respectively. The requirements apply with all downlink carriers active.

The throughput of each carrier shall be  $\geq 95\%$  of the maximum throughput of the reference measurement channels as specified in Annexes A.2.2, A.3.2, and A.3.3 (with one sided dynamic OCNG Pattern OP.1 FDD/TDD for the DL-signal as described in Annex A.5.1.1/A.5.2.1).

### 7.7A.3 Spurious response for Inter-band CA

For inter-band carrier aggregation with one component carrier per operating band and the uplink assigned to one NR band, the spurious response are defined with the uplink active on the band(s) other than the band whose downlink is being tested. The UE shall meet the requirements specified in clause 7.7 for each component carrier while all downlink carriers are active.

For the UE which supports inter-band CA configuration in Table 7.3A.3.2.1-1,  $P_{\text{interferer}}$  power defined in Table 7.7-2 and Table 7.7F.1-2 for shared spectrum channel access is increased by the amount given by  $\Delta R_{\text{IB,c}}$  in Table 7.3A.3.2.1-1 and in Table 7.3F.3-1 for shared spectrum channel access .

The throughput of each carrier shall be  $\geq 95\%$  of the maximum throughput of the reference measurement channels as specified in Annexes A.2.2, A.3.2, and A.3.3 (with one sided dynamic OCNG Pattern OP.1 FDD/TDD for the DL-signal as described in Annex A.5.1.1/A.5.2.1).

## 7.7B Spurious response for NR-DC

For inter-band NR-DC configurations, the spurious response for the corresponding inter-band CA configuration as specified in clause 7.7A applies.

## 7.7D Spurious response for UL MIMO

For UE with two or four transmitter antenna connectors in closed-loop spatial multiplexing scheme, the minimum requirements specified in clause 7.7 shall be met with the UL MIMO configurations described in clause 6.2D.1 and in clause 6.2F.1D for shared spectrum access operation. For UL MIMO, the parameter  $P_{\text{CMAX}_L}$  is defined as the total transmitter power over all transmit antenna connectors.

## 7.7E Spurious response for V2X

### 7.7E.1 General

Spurious response is a measure of the receiver’s ability to receive a wanted signal on its assigned channel frequency without exceeding a given degradation due to the presence of an unwanted CW interfering signal at any other frequency for which a response is obtained, i.e. for which the out-of-band blocking limit as specified in clause 7.6E.3.1 is not met.

When UE is configured for NR V2X reception non-concurrent with NR uplink transmissions for NR V2X operating bands specified in Table 5.2E.1-1, the throughput shall be  $\geq 95\%$  of the maximum throughput of the reference measurement channels as specified in Annexes A.7.2 with parameters for the wanted signal as specified in Table 7.7E.1-1 and Table 7.7E.1-2 for NR V2X bands. The relative throughput requirement shall be met for any SCS specified for the channel bandwidth of the wanted signal.

**Table 7.7E.1-1: Spurious response parameters for NR V2X**

RX parameter	Units	Channel bandwidth				
		5 MHz <sup>2</sup>	10 MHz	20 MHz	30 MHz	40 MHz
Power in transmission bandwidth configuration	dBm	$P_{\text{REFSENS\_V2X}}$ + channel bandwidth specific value below				
	dB	6	6	9	11	12
NOTE 1: Reference measurement channel is A.7.2						
NOTE 2: The CBW is only applicable for PS UE in n14.						

**Table 7.7E.1-2: Spurious response for NR V2X**

Parameter	Unit	Level
$P_{\text{Interferer (CW)}}$	dBm	-44
$F_{\text{Interferer}}$	MHz	Spurious response frequencies

### 7.7E.1A Spurious response requirements for Sidelink CA

For intra-band contiguous SL CA operation, the UE throughput shall be  $\geq 95\%$  of the maximum throughput of the reference measurement channels as specified in Annex A.7.2 with parameters specified in Table 7.7E.1A-1 and Table 7.7E.1A-2.

**Table 7.7E.1A-1: Spurious response parameters for intra-band contiguous SL CA UE**

Rx Parameter	Units	SL CA Bandwidth Class				
		B				
	dBm	$P_{\text{REFSENS\_SL}}$ + SL CA Bandwidth Class specific value below				

Pw in Transmission Bandwidth Configuration, per CC		9				
NOTE 1: The requirement is applied for multi-carrier intra-band concurrent receptions when 2 carrier transmissions are activated at the same time.						
NOTE 2: Reference measurement channel is A.7.2						

**Tables 7.7E.1A-2: Spurious response for intra-band contiguous SL CA UE**

Parameter	Unit	Level
$P_{\text{Interferer}}$ (CW)	dBm	-44
$F_{\text{Interferer}}$	MHz	Spurious response frequencies
NOTE 1: The requirement is applied for multi-carrier intra-band concurrent receptions when 2 carrier transmissions are activated at the same time.		

## 7.7E.1F General requirement for Sidelink Unlicensed

The spurious response requirement in clause 7.7F.1 apply.

For spurious responses, the throughput of the wanted signal shall be  $\geq 95\%$  of the maximum throughput of the reference measurement channels as specified in Annex 7.2

## 7.7E.2 Spurious response for V2X concurrent operation

For the inter-band concurrent NR V2X operation, the requirements specified in clause 7.7E.1 shall apply for the NR sidelink reception in the operating bands in Table 5.2E.2-1 and the requirements specified in clause 7.7 shall apply for the NR downlink reception in licensed band while all downlink carriers are active.

## 7.7E.2F Spurious response for SL-U concurrent operation

For the inter-band concurrent NR SL-U operation, the requirements specified in clause 7.7E.1F shall apply for the NR sidelink reception in the operating bands in Table 5.2E.2F-1 and the requirements specified in clause 7.7 shall apply for the NR downlink reception in licensed band while all downlink carriers are active.

## 7.7F Spurious response for shared spectrum channel access

### 7.7F.1 General

For spurious responses, the throughput of the wanted signal shall be  $\geq 95\%$  of the maximum throughput of the reference measurement channels as specified in Annexes A.2.2, A.3.2 and A.3.3 (with one sided dynamic OCNG Pattern OP.1 FDD/TDD for the DL-signal as described in Annex A.5.1.1/A.5.2.1) with parameters specified in Table 7.7F.1-1 and Table 7.7F.1-2. The relative throughput requirement shall be met for any SCS at any other frequency at which a response is obtained i.e. for which the limit as specified in clause 7.6F.3.1 is not met.

**Table 7.7F.1-1: Spurious response parameters for shared access bands**

RX parameter	Units	Channel bandwidth
		20, 40, 60, 80, 100 MHz
Power in transmission bandwidth configuration	dBm	REFSENS + 9 dB
NOTE 1: The transmitter shall be set to 4 dB below $P_{\text{CMAX\_L,f,c}}$ at the minimum UL configuration specified in Table 7.3.2-3 with $P_{\text{CMAX\_L,f,c}}$ defined in clause 6.2.4.		

**Table 7.7F.1-2: Spurious response for shared spectrum channel access**

Parameter	Unit	Level
$P_{\text{Interferer}}$ (CW)	dBm	-44
$F_{\text{Interferer}}$	MHz	Spurious response frequencies

## 7.7F.1A Spurious response for shared spectrum channel access CA

### 7.7F.1A.1 Intra-band contiguous shared spectrum channel access CA

For spurious responses, the throughput of each carrier shall be  $\geq 95\%$  of the maximum throughput of the reference measurement channels as specified in Annexes A.2.2, A.3.2, and A.3.3 (with one sided dynamic OCNNG Pattern OP.1 FDD/TDD for the DL-signal as described in Annex A.5.1.1/A.5.2.1) with parameters specified in Table 7.7F.1A.1-1 and Table 7.7F.1A.1-2. The relative throughput requirement shall be met for any SCS at any other frequency at which a response is obtained i.e. for which the limit as specified in clause 7.6F.3.2 is not met.

**Table 7.7F.1A.1-1: Spurious response parameters for intra-band contiguous shared access CA**

Rx Parameter	Units	Shared access CA bandwidth class
		B, C, D, E, I, M, N, O
Pw in Transmission Bandwidth Configuration, per CC	dBm	REFSENS + CA bandwidth class specific value below
	dB	9

NOTE 1: The transmitter shall be set to 4dB below  $P_{\text{CMAX\_L,f,c}}$  at the minimum UL configuration specified in Table 7.3F.2-3 with  $P_{\text{CMAX\_L,f,c}}$  defined in clause 6.2.4.

**Table 7.7F.1A.1-2: Spurious response for intra-band contiguous shared access CA**

Parameter	Unit	Level
$P_{\text{Interferer}}$ (CW)	dBm	-44
$F_{\text{Interferer}}$	MHz	Spurious response frequencies

7.7F.2 Void

7.7G (Reserved)

7.7H (Reserved)

7.7I (Reserved)

7.7J Spurious response for ATG

For ATG UE, the spurious response defined in clause 7.7 applies.

7.7K (Reserved)

7.7L (Reserved)

## 7.8 Intermodulation characteristics

### 7.8.1 General

Intermodulation response rejection is a measure of the capability of the receiver to receive a wanted signal on its assigned channel frequency in the presence of two or more interfering signals which have a specific frequency relationship to the wanted signal

### 7.8.2 Wide band Intermodulation

The wide band intermodulation requirement is defined using a CW carrier and modulated NR signal as interferer 1 and interferer 2 respectively.

The throughput shall be  $\geq 95$  % of the maximum throughput of the reference measurement channels as specified in Annexes A.2.2, A.3.2 and A.3.3 (with one sided dynamic OCNG Pattern OP.1 FDD/TDD for the DL-signal as described in Annex A.5.1.1/A.5.2.1) with parameters specified in Table 7.8.2-1 for NR bands with  $F_{DL\_high} < 2700$  MHz and  $F_{UL\_high} < 2700$  MHz and Table 7.8.2-2 for NR bands with  $F_{DL\_low} \geq 3300$  MHz and  $F_{UL\_low} \geq 3300$  MHz. The relative throughput requirement shall be met for any SCS specified for the channel bandwidth of the wanted signal. For operating bands with an unpaired DL part (as noted in Table 5.2-1), the requirements only apply for carriers assigned in the paired part.



**Table 7.8.2-1: Wide band intermodulation parameters for NR bands with  $F_{DL\_high} < 2700$  MHz and  $F_{UL\_high} < 2700$  MHz**

Rx parameter	Units	Channel bandwidth (MHz)			
		3	5, 10	15	20, 25, 30, 35, 40, 45, 50, 60, 70, 80, 90, 100
$P_w$ in Transmission Bandwidth Configuration, per CC <sup>5</sup>	dBm	REFSENS + 8 dB	REFSENS + 6 dB	REFSENS + 7 dB	REFSENS + (9 + 10log <sub>10</sub> (BW <sub>Channel</sub> /20)) dB
$P_{Interferer\ 1}$ (CW)	dBm	-46			
$P_{Interferer\ 2}$ (Modulated)	dBm	-46			
BW <sub>Interferer 2</sub>	MHz	3	5		
$F_{Interferer\ 1}$ (Offset)	MHz	-BW/2 – 4.5 /+BW/2 + 4.5	-BW <sub>Channel</sub> /2 – 7.5 / +BW <sub>Channel</sub> /2 + 7.5		
$F_{Interferer\ 2}$ (Offset)	MHz	$2 * F_{Interferer\ 1}$			
NOTE 1: The transmitter shall be set to 4 dB below $P_{CMAX\_L,f,c}$ at the minimum UL configuration specified in Table 7.3.2-3 with $P_{CMAX\_L,f,c}$ defined in clause 6.2.4.					
NOTE 2: Reference measurement channel is specified in Annexes A.2.2, A.3.2, and A.3.3 (with one sided dynamic OCNG Pattern OP.1 FDD/TDD for the DL-signal as described in Annex A.5.1.1/A.5.2.1).					
NOTE 3: The modulated interferer consists of the Reference measurement channel specified in Annexes A.3.2.2 and A.3.3.2 with one sided dynamic OCNG Pattern OP.1 FDD/TDD for the DL-signal as described in Annex A.5.1.1/A.5.2.1 and 15 kHz SCS.					
NOTE 4: The $F_{interferer\ 1}$ (offset) is the frequency separation of the center frequency of the carrier closest to the interferer and the center frequency of the CW interferer and $F_{interferer\ 2}$ (offset) is the frequency separation of the center frequency of the carrier closest to the interferer and the center frequency of the modulated interferer.					
NOTE 5: 10log <sub>10</sub> (x) is rounded to the next higher 0.5dB value.					

**Table 7.8.2-2: Wide band intermodulation parameters for NR bands with  $F_{DL\_low} \geq 3300$  MHz and  $F_{UL\_low} \geq 3300$  MHz**

Rx parameter	Units	Channel bandwidth (MHz)			
		10, 15, 20, 25, 30, 35, 40, 45, 50, 60, 70, 80, 90, 100			
$P_w$ in Transmission Bandwidth Configuration, per CC	dBm	REFSENS + 6 dB			
$P_{Interferer\ 1}$ (CW)	dBm	-46			
$P_{Interferer\ 2}$ (Modulated)	dBm	-46			
$BW_{Interferer\ 2}$	MHz	$BW_{Channel}$			
$F_{Interferer\ 1}$ (Offset)	MHz	- $2BW_{Channel}$ / $+2BW_{Channel}$			
$F_{Interferer\ 2}$ (Offset)	MHz	$2 * F_{Interferer\ 1}$			
NOTE 1: The transmitter shall be set to 4dB below $P_{C_{MAX\_L,f,c}}$ at the minimum UL configuration specified in Table 7.3.2-3 with $P_{C_{MAX\_L,f,c}}$ defined in clause 6.2.4.					
NOTE 2: Reference measurement channel is specified in Annexes A.2.2, A.2.3, A.3.2, and A.3.3 (with one sided dynamic OCNG Pattern OP.1 FDD/TDD for the DL-signal as described in Annex A.5.1.1/A.5.2.1).					
NOTE 3: The modulated interferer consists of the Reference measurement channel specified in Annexes A.3.2.2 and A.3.3.2 with one sided dynamic OCNG Pattern OP.1 FDD/TDD for the DL-signal as described in Annex A.5.1.1/A.5.2.1 and the same SCS as the wanted signal.					
NOTE 4: The $F_{Interferer\ 1}$ (offset) is the frequency separation of the center frequency of the carrier closest to the interferer and the center frequency of the CW interferer and $F_{Interferer\ 2}$ (offset) is the frequency separation of the center frequency of the carrier closest to the interferer and the center frequency of the modulated interferer.					

## 7.8A Intermodulation characteristics for CA

### 7.8A.1 General

### 7.8A.2 Wide band intermodulation for CA

#### 7.8A.2.1 Wide band intermodulation for Intra-band contiguous CA

**Table 7.8A.2.1-1: Wide band intermodulation parameters for intra-band contiguous CA with  $F_{DL\_low} \geq 3300$  MHz and  $F_{UL\_low} \geq 3300$  MHz**

Rx parameter	Units	NR CA bandwidth class			
		B	C	D	
$P_w$ in Transmission Bandwidth Configuration, per CC	dBm	REFSENS + 10 dB	REFSENS + 6 dB	REFSENS + 13.8 dB	
$P_{Interferer\ 1}$ (CW)	dBm	-46			
$P_{Interferer\ 2}$ (Modulated)	dBm	-46			
$BW_{Interferer\ 2}$	MHz	20	$BW_{Channel\_CA}$	50	
$F_{Interferer\ 1}$ (Offset)	MHz	- $F_{offset} - 30$ / $F_{offset} + 30$	- $2BW_{Channel\_CA}$ / $+2BW_{Channel\_CA}$	- $F_{offset} - 75$ / $F_{offset} + 75$	
$F_{Interferer\ 2}$ (Offset)	MHz	$2 * F_{Interferer\ 1}$			
NOTE 1: The transmitter shall be set to 4 dB below $P_{C_{MAX\_L,f,c}}$ at the minimum UL configuration specified in Table 7.3.2-3 with $P_{C_{MAX\_L,f,c}}$ defined in clause 6.2.4.					
NOTE 2: Reference measurement channel is specified in Annexes A.2.2, A.3.2, and A.3.3 (with one sided dynamic OCNG Pattern OP.1 FDD/TDD for the DL-signal as described in Annex A.5.1.1/A.5.2.1).					

NOTE 3: The modulated interferer consists of the Reference measurement channel specified in Annexes A.3.2.2 and A.3.3.2 with one sided dynamic OCNG Pattern OP.1 FDD/TDD for the DL-signal as described in Annex A.5.1.1/A.5.2.1 and the same SCS as the closest carrier.

NOTE 4: The  $F_{\text{interferer 1}}$  (offset) is the frequency separation of the center frequency of the carrier closest to the interferer and the center frequency of the CW interferer and  $F_{\text{interferer 2}}$  (offset) is the frequency separation of the center frequency of the carrier closest to the interferer and the center frequency of the modulated interferer.

**Table 7.8A.2.1-2: Wide band intermodulation parameters for intra-band contiguous CA with  $F_{\text{DL,low}} < 2700$  MHz and  $F_{\text{UL,low}} < 2700$  MHz**

Rx parameter	Units	NR CA bandwidth class	
		B	C
$P_w$ in Transmission Bandwidth Configuration, per CC	dBm	REFSENS + 16 dB	REFSENS + 19 dB
$P_{\text{Interferer 1}}$ (CW)	dBm	-46	-46
$P_{\text{Interferer 2}}$ (Modulated)	dBm	-46	-46
$BW_{\text{Interferer 2}}$	MHz	5	5
$F_{\text{Interferer 1}}$ (Offset)	MHz	$-F_{\text{offset}}-7.5$ / $F_{\text{offset}}+7.5$	$-F_{\text{offset}}-7.5$ / $F_{\text{offset}}+7.5$
$F_{\text{Interferer 2}}$ (Offset)	MHz	$2 \cdot F_{\text{Interferer 1}}$	$2 \cdot F_{\text{Interferer 1}}$
NOTE 1: The transmitter shall be set to 4 dB below $P_{\text{CMAX,L,f,c}}$ at the minimum UL configuration specified in Table 7.3.2-3 with $P_{\text{CMAX,L,f,c}}$ defined in clause 6.2.4.			
NOTE 2: Reference measurement channel is specified in Annexes A.2.2, A.3.2, and A.3.3 (with one sided dynamic OCNG Pattern OP.1 FDD/TDD for the DL-signal as described in Annex A.5.1.1/A.5.2.1)			
NOTE 3: The modulated interferer consists of the Reference measurement channel specified in Annexes A.3.2.2 and A.3.3.2 with one sided dynamic OCNG Pattern OP.1 FDD/TDD for the DL-signal as described in Annex A.5.1.1/A.5.2.1 and the same SCS as the 15 kHz SCS.			
NOTE 4: The $F_{\text{interferer 1}}$ (offset) is the frequency separation of the center frequency of the carrier closest to the interferer and the center frequency of the CW interferer and $F_{\text{interferer 2}}$ (offset) is the frequency separation of the center frequency of the carrier closest to the interferer and the center frequency of the modulated interferer.			

### 7.8A.2.2 Wide band intermodulation for Intra-band non-contiguous CA

For intra-band non-contiguous carrier aggregation with one uplink carrier and two or more downlink sub-blocks, the wide band intermodulation requirements are defined with the uplink configuration in accordance with Table 7.3A.2.2-1. For this uplink configuration, the UE shall meet the requirements for each sub-block as specified in clause 7.8.2 and 7.8A.2.1 for one component carrier and two component carriers per sub-block, respectively. The requirements apply for out-of-gap interferers while all downlink carriers are active.

The throughput of each carrier shall be  $\geq 95$  % of the maximum throughput of the reference measurement channels as specified in Annexes A.2.2, A.3.2, and A.3.3 (with one sided dynamic OCNG Pattern OP.1 FDD/TDD for the DL-signal as described in Annex A.5.1.1/A.5.2.1).

### 7.8A.2.3 Wide band intermodulation for Inter-band CA

For inter-band carrier aggregation with one component carrier per operating band and the uplink assigned to one NR band, the wide band intermodulation requirements are defined with the uplink active on the band(s) other than the band whose downlink is being tested. The UE shall meet the requirements specified in clause 7.8 for each component carrier while all downlink carriers are active.

For the UE which supports inter-band CA configuration in Table 7.3A.3.2.1-1,  $P_{\text{interferer}}$  power defined in Table 7.8.2-1 and 7.8.2-2 and Table 7.8F.2-1 for shared spectrum channel access is increased by the amount given by  $\Delta R_{\text{B,c}}$  in Table 7.3A.3.2.1-1 in Table 7.3F.3-1 for shared spectrum channel access .

The throughput of each carrier shall be  $\geq 95\%$  of the maximum throughput of the reference measurement channels as specified in Annexes A.2.2, A.3.2, and A.3.3 (with one sided dynamic OCNG Pattern OP.1 FDD/TDD for the DL-signal as described in Annex A.5.1.1/A.5.2.1).

## 7.8B Intermodulation characteristics for NR-DC

For inter-band NR-DC configurations, the intermodulation characteristics for the corresponding inter-band CA configuration as specified in clause 7.8A applies.

## 7.8D Intermodulation characteristics for UL MIMO

For UE(s) with two or four transmitter antenna connectors in closed-loop spatial multiplexing scheme, the minimum requirements in clause 7.8 shall be met with the UL MIMO configurations described in clause 6.2D.1 and in clause 6.2F.1D for shared spectrum access operation. For UL MIMO, the parameter  $P_{\text{CMAX}_L}$  is defined as the total transmitter power over all transmit antenna connectors.

## 7.8E Intermodulation characteristics for V2X

### 7.8E.1 General

Intermodulation response rejection is a measure of the capability of the receiver to receive a wanted signal on its assigned channel frequency in the presence of two or more interfering signals which have a specific frequency relationship to the wanted signal.

### 7.8E.2 Wide band Intermodulation

#### 7.8E.2.1 General

The wide band intermodulation requirement is defined using modulated NR carrier and a CW signal as interferer 1 and interferer 2 respectively. When UE is configured for NR V2X reception non-concurrent with NR uplink transmissions for NR V2X operating bands specified in Table 5.2E.1-1, the throughput shall be  $\geq 95\%$  of the maximum throughput of the reference measurement channels as specified in Annexes A.7.2 with parameters specified in Table 7.8E.2-1 for NR V2X bands. The relative throughput requirement shall be met for any SCS specified for the channel bandwidth of the wanted signal.

**Table 7.8E.2-1: Wide band intermodulation parameters for NR V2X**

NR band	Rx parameter	Units	Channel bandwidth			
			10 MHz	20 MHz	30 MHz	40 MHz
n38, n47	Power in Transmission Bandwidth Configuration	dBm	$P_{\text{REFSENS\_V2X}}$ + channel bandwidth specific value below			
		dB	6	9	11	12
	$P_{\text{Interferer 1 (CW)}}$	dBm	-46			
	$P_{\text{Interferer 2 (Modulated)}}$	dBm	-46			
	$BW_{\text{Interferer 2}}$	MHz	10MHz			
	$F_{\text{Interferer 1 (Offset)}}$	MHz	-BW/2 – 15 / +BW/2 + 15			
	$F_{\text{Interferer 2 (Offset)}}$	MHz	$2 * F_{\text{Interferer 1}}$			
NOTE 1: Reference measurement channel is A.7.2						
NOTE 2: The interferer is QPSK modulated PUSCH containing data and reference symbols. Normal cyclic prefix is used.						

**Table 7.8E.2-1a: Wide band intermodulation parameters in n14**

NR band	Rx parameter	Unit s	Channel bandwidth				
			5 MHz	10 MHz	20 MHz	30 MHz	40 MHz
n14		dBm	$P_{\text{REFSENS\_V2X}}$ + channel bandwidth specific value below				

Power in Transmission Bandwidth Configuration	dB	6	6			
$P_{\text{Interferer 1 (CW)}}$	dBm	-46				
$P_{\text{Interferer 2 (Modulated)}}$	dBm	-46				
$BW_{\text{Interferer 2}}$	MHz	5MHz				
$F_{\text{Interferer 1 (Offset)}}$	MHz	-BW/2 - 7.5 / +BW/2 + 7.5				
$F_{\text{Interferer 2 (Offset)}}$	MHz	$2 * F_{\text{Interferer 1}}$				
NOTE 1: Reference measurement channel is A.7.2.						
NOTE 2: The interferer is QPSK modulated PSSCH containing data and reference symbols. Normal cyclic prefix is used.						

### 7.8E.2.2 Wide band Intermodulation for V2X concurrent operation

For the inter-band concurrent NR V2X operation, the requirements specified in clause 7.8E.2.1 shall apply for the NR sidelink reception in the operating bands in Table 5.2E.2-1 and the requirements specified in clause 7.8 shall apply for the NR downlink reception in licensed band while all downlink carriers are active.

#### 7.8E.2.2A Wide band intermodulation for Sidelink CA

For intra-band contiguous SL CA operation, the UE throughput shall be  $\geq 95\%$  of the maximum throughput of the reference measurement channels as specified in Annex A.7.2 with parameters specified in Table 7.8E.2.1A-1 for the specified wanted signal mean power in the presence of two interfering signals.

**Table 7.8E.2.2A-1: Wide band intermodulation for intra-band contiguous SL CA UE**

Rx parameter	Units	SL CA Bandwidth Class				
		B				
$P_w$ in Transmission Bandwidth Configuration, per CC	dBm	PREFSENS_SL + SL CA Bandwidth Class specific value below				
		9				
$P_{\text{Interferer 1 (CW)}}$	dBm	-46				
$P_{\text{Interferer 2 (Modulated)}}$	dBm	-46				
$BW_{\text{Interferer 2}}$	MHz	10				
$F_{\text{Interferer 1 (Offset)}}$	MHz	-F <sub>offset</sub> -15 / + F <sub>offset</sub> +15				
$F_{\text{Interferer 2 (Offset)}}$	MHz	$2 * F_{\text{Interferer 1}}$				
NOTE 1: The requirement is applied for multi-carrier intra-band concurrent receptions when 2 carrier transmissions are activated at the same time.						
NOTE 2: The $F_{\text{interferer 1 (offset)}}$ is the frequency separation of the center frequency of the carrier closest to the interferer and the center frequency of the CW interferer and $F_{\text{interferer 2 (offset)}}$ is the frequency separation of the center frequency of the carrier closest to the interferer and the center frequency of the modulated interferer.						

### 7.8E.2.2F Wide band Intermodulation for SL-U concurrent operation

For the inter-band concurrent NR SL-U operation, the requirements specified in clause 7.8E.2F shall apply for the NR sidelink reception in the operating bands in Table [5.2E.2F-1] and the requirements specified in clause 7.8 shall apply for the NR downlink reception in licensed band while all downlink carriers are active.

## 7.8E.2F Wide band Intermodulation for Sidelink Unlicensed

The spurious response requirement in clause 7.8F.2 apply.

Instead of the general wideband intermodulation requirements specified in clause 7.8.2, the throughput shall be  $\geq 95\%$  of the maximum throughput of the reference measurement channels as specified in Annex 7.2 with parameters specified in Table 7.8F.2-1. The relative throughput requirement shall be met for any SCS specified for the channel bandwidth of the wanted signal.

## 7.8F Intermodulation characteristics for shared spectrum channel access

### 7.8F.1 General

Intermodulation response rejection is a measure of the capability of the receiver to receive a wanted signal on its assigned channel frequency in the presence of two or more interfering signals which have a specific frequency relationship to the wanted signal

### 7.8F.2 Wide band Intermodulation

The wide band intermodulation requirement is defined using a CW carrier and modulated NR signal as interferer 1 and interferer 2 respectively.

Instead of the general wideband intermodulation requirements specified in clause 7.8.2, the throughput shall be  $\geq 95\%$  of the maximum throughput of the reference measurement channels as specified in Annexes A.2.2, A.3.2 and A.3.3 (with one sided dynamic OCNG Pattern OP.1 FDD/TDD for the DL-signal as described in Annex A.5.1.1/A.5.2.1) with parameters specified in Table 7.8F.2-1. The relative throughput requirement shall be met for any SCS specified for the channel bandwidth of the wanted signal.

**Table 7.8F.2-1: Wide band intermodulation parameters for shared spectrum channel access**

Rx parameter	Units	Channel bandwidth
		20, 40, 60, 80, 100 MHz
$P_w$ in Transmission Bandwidth configuration, per CC	dBm	REFSENS + 9 dB + $10\log_{10}(BW_{\text{Channel}}/20)$ dB
$P_{\text{Interferer 1 (CW)}}$	dBm	-46
$P_{\text{Interferer 2 (Modulated)}}$	dBm	-46
$BW_{\text{Interferer 2}}$	MHz	20
$F_{\text{Interferer 1 (Offset)}}$	MHz	$-BW/2 - 30 / +BW/2 + 30$
$F_{\text{Interferer 2 (Offset)}}$	MHz	$2 * F_{\text{Interferer 1}}$
NOTE 1: The transmitter shall be set to 4dB below $P_{\text{CMAX\_L,f,c}}$ at the minimum UL configuration specified in Table 7.3F.2-3 with $P_{\text{CMAX\_L,f,c}}$ defined in clause 6.2.4.		
NOTE 2: Reference measurement channel is specified in Annexes A.2.2, A.3.2, and A.3.3 (with one sided dynamic OCNG Pattern OP.1 FDD/TDD for the DL-signal as described in Annex A.5.1.1/A.5.2.1).		
NOTE 3: The modulated interferer consists of the Reference measurement channel specified in Annexes A.3.2.2 and A.3.3.2 with one sided dynamic OCNG Pattern OP.1 FDD/TDD for the DL-signal as described in Annex A.5.1.1/A.5.2.1 and the same SCS as the wanted signal.		
NOTE 4: The $F_{\text{Interferer 1 (offset)}}$ is the frequency separation of the center frequency of the carrier closest to the interferer and the center frequency of the CW interferer and $F_{\text{Interferer 2 (offset)}}$ is the frequency separation of the center frequency of the carrier closest to the interferer and the center frequency of the modulated interferer.		

7.8G (Reserved)

7.8H (Reserved)

7.8I (Reserved)

## 7.8J Intermodulation characteristics for ATG

### 7.8J.1 General

Intermodulation response rejection is a measure of the capability of the receiver to receive a wanted signal on its assigned channel frequency in the presence of two or more interfering signals which have a specific frequency relationship to the wanted signal.

### 7.8J.2 Wide band intermodulation for ATG

For ATG UE, the wide band intermodulation requirement defined in clause 7.8.2 applies.

7.8K (Reserved)

7.8L (Reserved)

## 7.9 Spurious emissions

The spurious emissions power is the power of emissions generated or amplified in a receiver that appear at the UE antenna connector.

The power of any narrow band CW spurious emission shall not exceed the maximum level specified in Table 7.9-1

**Table 7.9-1: General receiver spurious emission requirements**

Frequency range	Measurement bandwidth	Maximum level	NOTE
$30 \text{ MHz} \leq f < 1 \text{ GHz}$	100 kHz	-57 dBm	
$1 \text{ GHz} \leq f \leq 12.75 \text{ GHz}$	1 MHz	-47 dBm	
$12.75 \text{ GHz} \leq f \leq 5^{\text{th}}$ harmonic of the upper frequency edge of the DL operating band in GHz	1 MHz	-47 dBm	2
12.75 GHz – 26 GHz	1 MHz	-47 dBm	3
NOTE 1: Unused PDCCH resources are padded with resource element groups with power level given by PDCCH as defined in Annex C.3.1.			
NOTE 2: Applies for Band that the upper frequency edge of the DL Band more than 2.69 GHz.			
NOTE 3: Applies for Band that the upper frequency edge of the DL Band more than 5.2 GHz.			

## 7.9A Spurious emissions for CA

### 7.9A.1 Void

### 7.9A.2 Void

### 7.9A.3 Spurious emissions for Inter-band CA

For inter-band carrier aggregation including an operating band without uplink band, the UE shall meet the Rx spurious emissions requirements specified in clause 7.9 for each component carrier while all downlink carriers are active.

## 7.9B Spurious emissions for NR-DC

For inter-band NR-DC configurations, the spurious emissions for the corresponding inter-band CA configuration as specified in clause 7.9A applies.

## 7.9J Spurious emissions for ATG

For ATG UE, the spurious emissions as specified in clause 7.9 applies.

## 7.10 Power imbalance

### 7.10A Power imbalance for CA

#### 7.10A.1 General

Power imbalance requirement is a measure of the receiver's ability to receive a wanted signal in the presence of another signal with a power imbalance and a specific frequency offset from the wanted signal.

Power imbalance requirement in this subclause is only applicable for a UE capable of *intraBandNR-CA-non-allocated-r18* and is not provided with *nonCollocatedTypeNR-CA-r18* and is configured with *maxMIMO-Layers* with value less than or equal to 2.

#### 7.10A.2 Minimum requirement

For the test parameters in Table 7.10A.2-1, the throughput shall be  $\geq 95$  % of the maximum throughput of the reference measurement channels as specified in Annexes A.2.2, A.3.2, and A.3.3 (with one sided dynamic OCN Pattern OP.1 TDD for the DL-signal as described in Annex A.5.2.1).

**Table 7.10A.2-1: Power imbalance parameters for intra-band non-contiguous CA**

Test configurations	Carriers	Rx Power in transmission bandwidth configuration (dBm)	channel bandwidth	Center of $BW_{\text{another}}$ Relative to edge of $BW_{\text{wanted}}$
1	Wanted carrier	REFSENS <sup>NOTE 4 + 1</sup>	$BW_{\text{wanted}} \leq BW_{\text{another}}$	< max ( $5/2 * BW_{\text{another}}$ , 50MHz)
	Another wanted carrier	Power of wanted carrier + 25		
2	Wanted carrier	REFSENS <sup>NOTE 4 + 1</sup>	$BW_{\text{wanted}} > BW_{\text{another}}$	
	Another wanted carrier	Power of wanted carrier + 25 – $10 * \log_{10}(BW_{\text{wanted}} / BW_{\text{another}})$		
3	Wanted carrier	REFSENS <sup>NOTE 4 + 1</sup>	NA	



	Another wanted carrier	Power of wanted carrier + 25		$\geq \max(5/2 * BW_{\text{another}}, 50\text{MHz})$
<p>NOTE 1: The transmitter shall be set to 24dB below <math>P_{\text{CMAX\_L,f,c}}</math> at the minimum uplink configuration specified in Table 7.3.2-3 with <math>P_{\text{CMAX\_L,f,c}}</math> as defined in clause 6.2A.4.</p> <p>NOTE 2: <math>BW_{\text{wanted}}</math> is the channel bandwidth of wanted carrier. <math>BW_{\text{another}}</math> is the channel bandwidth of another wanted carrier with 25 dB power imbalance.</p> <p>NOTE 3: It's allowed to use one of test configurations to verify the RX power imbalance requirement for type 2 UE.</p> <p>NOTE 4: REFSENS is the reference sensitivity level for two antenna port in Table 7.3.2-1b.</p> <p>NOTE 5: Void.</p>				

For a UE capable of *intraBandNR-CA-non-allocated-r18* for the following CA band combinations in Table 7.10A.2-2, the Power imbalance requirements are applicable with 2Rx antenna ports for each component carrier if it is not provided with *nonCollocatedTypeNR-CA-r18* and is configured with *maxMIMO-Layers* with value less than or equal to 2.

**Table 7.10A.2-2: NR CA combinations**

<b>CA combination</b>
CA_n77(2A) <sup>1</sup>
CA_n78(2A) <sup>1</sup>
NOTE 1: The applicability is specified in clause 4.2 d).

# Annex A (normative): Measurement channels

## A.1 General

The throughput values defined in the measurement channels specified in Annex A, are calculated and are valid per datastream (codeword). For multi-stream (more than one codeword) transmissions, the throughput referenced in the minimum requirements is the sum of throughputs of all datastreams (codewords).

The UE category entry in the definition of the reference measurement channel in Annex A is only informative and reveals the UE categories, which can support the corresponding measurement channel. Whether the measurement channel is used for testing a certain UE category or not is specified in the individual minimum requirements.

## A.2 UL reference measurement channels

### A.2.1 General

The measurement channels in the following clauses are defined to derive the requirements in clause 6 (Transmitter Characteristics) and clause 7 (Receiver Characteristics). The measurement channels represent example configurations of physical channels for different data rates.

The measurement channels in the following clauses are applicable to both FDD and TDD.

The active uplink slots for TDD configurations are specified in Table A.2.1-1. TDD slot patterns defined for reference sensitivity tests will be used for TDD UL RMCs, unless otherwise stated. The active uplink slots for additional TDD configuration specified in Table A.2.1-2, with the TDD pattern defined in Table A.2.1-3, is used for the phase continuity tests for DMRS bundling with 15 kHz SCS. The active uplink slots configuration specified in Table A.2.1-4 and the additional TDD pattern in Table A.2.1-5 are used for shorter transient period capability EVM tests at 15 kHz SCS.

**Table A.2.1-1: TDD active uplink slots**

SCS	Active Uplink slots
15 kHz	4, 9
30 kHz	8, 9, 18, 19
60 kHz	16, 17, 18, 19, 36, 37, 38, 39

**Table A.2.1-2: TDD active uplink slots for additional TDD configuration**

SCS	Active Uplink slots
15 kHz	8, 9

**Table A.2.1-3: TDD pattern for additional TDD configuration**

Parameter		Value
		SCS 15 kHz ( $\mu$ 0)
TDD Slot Configuration pattern (Note 1)		7DS2U
Special Slot Configuration (Note 2)		6D+4G+4U
referenceSubcarrierSpacing		15 kHz
UL-DL configuration	<i>dl-UL-TransmissionPeriodicity</i>	10 ms

	<i>nrofDownlinkSlots</i>	7
	<i>nrofDownlinkSymbols</i>	6
	<i>nrofUplinkSlot</i>	2
	<i>nrofUplinkSymbols</i>	4
NOTE 1: D denotes a slot with all DL symbols; S denotes a slot with a mix of DL, UL and guard symbols; U denotes a slot with all UL symbols. The field is for information.		
NOTE 2: D, G, U denote DL, guard and UL symbols, respectively. The field is for information.		

**Table A.2.1-4: TDD active uplink slots for shorter transient period capability**

SCS	Active Uplink slots
15 kHz	3,4

**Table A.2.1-5: Additional TDD pattern for shorter transient period capability**

Parameter		Value
		SCS 15 kHz ( $\mu$ 0)
TDD Slot Configuration pattern (Note 1)		2DS2U
Special Slot Configuration (Note 2)		10D+2G+2U
referenceSubcarrierSpacing		15 kHz
UL-DL configuration	<i>dl-UL-TransmissionPeriodicity</i>	5 ms
	<i>nrofDownlinkSlots</i>	2
	<i>nrofDownlinkSymbols</i>	10
	<i>nrofUplinkSlot</i>	2
	<i>nrofUplinkSymbols</i>	2
NOTE 1: D denotes a slot with all DL symbols; S denotes a slot with a mix of DL, UL and guard symbols; U denotes a slot with all UL symbols. The field is for information.		
NOTE 2: D, G, U denote DL, guard and UL symbols, respectively. The field is for information.		

## A.2.2 Reference measurement channels

### A.2.2.1 DFT-s-OFDM Pi/2-BPSK

Table A.2.2.1-1: Reference Channels for DFT-s-OFDM Pi/2-BPSK

Parameter	Allocated resource blocks (L <sub>CRB</sub> )	DFT-s-OFDM Symbols per slot (Note 1)	Modulation	MCS Index (Note 2)	Payload size	Transport block CRC	LDPC Base Graph	Number of code blocks per slot (Note 3)	Total number of bits per slot	Total modulated symbols per slot
Unit					Bits	Bits			Bits	
	1	11	pi/2 BPSK	0	24	16	2	1	132	132
	5	11	pi/2 BPSK	0	160	16	2	1	660	660
	9	11	pi/2 BPSK	0	288	16	2	1	1188	1188
	10	11	pi/2 BPSK	0	320	16	2	1	1320	1320
	12	11	pi/2 BPSK	0	384	16	2	1	1584	1584
	15	11	pi/2 BPSK	0	480	16	2	1	1980	1980
	18	11	pi/2 BPSK	0	576	16	2	1	2376	2376
	24	11	pi/2 BPSK	0	768	16	2	1	3168	3168
	25	11	pi/2 BPSK	0	808	16	2	1	3300	3300
	30	11	pi/2 BPSK	0	984	16	2	1	3960	3960
	32	11	pi/2 BPSK	0	1032	16	2	1	4224	4224
	36	11	pi/2 BPSK	0	1128	16	2	1	4752	4752
	45	11	pi/2 BPSK	0	1416	16	2	1	5940	5940
	50	11	pi/2 BPSK	0	1544	16	2	1	6600	6600
	60	11	pi/2 BPSK	0	1864	16	2	1	7920	7920
	64	11	pi/2 BPSK	0	2024	16	2	1	8448	8448
	75	11	pi/2 BPSK	0	2408	16	2	1	9900	9900
	80	11	pi/2 BPSK	0	2472	16	2	1	10560	10560
	81	11	pi/2 BPSK	0	2536	16	2	1	10692	10692
	90	11	pi/2 BPSK	0	2792	16	2	1	11880	11880
	100	11	pi/2 BPSK	0	3104	16	2	1	13200	13200
	108	11	pi/2 BPSK	0	3368	16	2	1	14256	14256
	120	11	pi/2 BPSK	0	3752	16	2	1	15840	15840
	128	11	pi/2 BPSK	0	3976	24	2	2	16896	16896
	135	11	pi/2 BPSK	0	4104	24	2	2	17820	17820
	160	11	pi/2 BPSK	0	4872	24	2	2	21120	21120
	162	11	pi/2 BPSK	0	5000	24	2	2	21384	21384
	180	11	pi/2 BPSK	0	5512	24	2	2	23760	23760
	216	11	pi/2 BPSK	0	6664	24	2	2	28512	28512
	243	11	pi/2 BPSK	0	7560	24	2	2	32076	32076
	270	11	pi/2 BPSK	0	8448	24	2	3	35640	35640

NOTE 1: PUSCH mapping Type-A and single-symbol DM-RS configuration Type-1 with 2 additional DM-RS symbols, such that the DM-RS positions are set to symbols 2, 7, 11. DMRS is [TDM'ed] with PUSCH data. DM-RS symbols are not counted.

NOTE 2: MCS Index is based on MCS Table 6.1.4.1-1 defined in TS 38.214 [10].

NOTE 3: If more than one Code Block is present, an additional CRC sequence of L = 24 Bits is attached to each Code Block (otherwise L = 0 Bit).

NOTE 4: The RMCs apply to all channel bandwidth where L<sub>CRB</sub> ≤ N<sub>RB</sub>.

Table A.2.2.1-2: Void

Table A.2.2.1-3: Void

## A.2.2.2 DFT-s-OFDM QPSK

Table A.2.2.2-1: Reference Channels for DFT-s-OFDM QPSK for

Parameter	Allocated resource blocks (L <sub>CRB</sub> )	DFT-s-OFDM Symbols per slot (Note 1)	Modulation	MCS Index (Note 2)	Payload size	Transport block CRC	LDPC Base Graph	Number of code blocks per slot (Note 3)	Total number of bits per slot	Total modulated symbols per slot
Unit					Bits	Bits			Bits	
	1	11	QPSK	2	48	16	2	1	264	132
	5	11	QPSK	2	256	16	2	1	1320	660
	9	11	QPSK	2	456	16	2	1	2376	1188
	10	11	QPSK	2	504	16	2	1	2640	1320
	12	11	QPSK	2	608	16	2	1	3168	1584
	15	11	QPSK	2	768	16	2	1	3960	1980
	18	11	QPSK	2	928	16	2	1	4752	2376
	20	11	QPSK	2	1032	16	2	1	5280	2640
	24	11	QPSK	2	1192	16	2	1	6336	3168
	25	11	QPSK	2	1256	16	2	1	6600	3300
	30	11	QPSK	2	1544	16	2	1	7920	3960
	32	11	QPSK	2	1608	16	2	1	8448	4224
	36	11	QPSK	2	1800	16	2	1	9504	4752
	45	11	QPKS	2	2208	16	2	1	11880	5940
	50	11	QPSK	2	2472	16	2	1	13200	6600
	60	11	QPSK	2	3104	16	2	1	15840	7920
	64	11	QPSK	2	3240	16	2	1	16896	8448
	75	11	QPSK	2	3752	16	2	1	19800	9900
	80	11	QPSK	2	3976	24	2	2	21120	10560
	81	11	QPSK	2	4040	24	2	2	21384	10692
	90	11	QPSK	2	4488	24	2	2	23760	11880
	100	11	QPSK	2	5000	24	2	2	26400	13200
	108	11	QPSK	2	5384	24	2	2	28512	14256
	120	11	QPSK	2	5896	24	2	2	31680	15840
	128	11	QPSK	2	6408	24	2	2	33792	16896
	135	11	QPSK	2	6664	24	2	2	35640	17820
	160	11	QPSK	2	7944	24	2	3	42240	21120
	162	11	QPSK	2	8064	24	2	3	42768	21384
	180	11	QPSK	2	8976	24	2	3	47520	23760
	216	11	QPSK	2	10752	24	2	3	57024	28512
	243	11	QPSK	2	12040	24	2	4	64152	32076
	270	11	QPSK	2	13320	24	2	4	71280	35640

NOTE 1: PUSCH mapping Type-A and single-symbol DM-RS configuration Type-1 with 2 additional DM-RS symbols, such that the DM-RS positions are set to symbols 2, 7, 11. DMRS is [TDM'ed] with PUSCH data. DM-RS symbols are not counted.

NOTE 2: MCS Index is based on MCS Table 6.1.4.1-1 defined in TS 38.214 [10].

NOTE 3: If more than one Code Block is present, an additional CRC sequence of L = 24 Bits is attached to each Code Block (otherwise L = 0 Bit).

NOTE 4: The RMCs apply to all channel bandwidth where L<sub>CRB</sub> ≤ N<sub>RB</sub>.

Table A.2.2.2-2: Void

Table A.2.2.2-3: Void

## A.2.2.3 DFT-s-OFDM 16QAM

Table A.2.2.3-1: Reference Channels for DFT-s-OFDM 16QAM

Parameter	Allocated resource	DFT-s-OFDM Symbols	Modulation	MCS Index (Note 2)	Payload size	Transport block CRC	LDPC Base Graph	Number of code blocks	Total number	Total modulated
-----------	--------------------	--------------------	------------	--------------------	--------------	---------------------	-----------------	-----------------------	--------------	-----------------

	blocks ( $L_{CRB}$ )	per slot (Note 1)						per slot (Note 3)	of bits per slot	symbols per slot
Unit					Bits	Bits			Bits	
	1	11	16QAM	10	176	16	2	1	528	132
	5	11	16QAM	10	888	16	2	1	2640	660
	9	11	16QAM	10	1608	16	2	1	4752	1188
	10	11	16QAM	10	1800	16	2	1	5280	1320
	12	11	16QAM	10	2088	16	2	1	6336	1584
	15	11	16QAM	10	2664	16	2	1	7920	1980
	18	11	16QAM	10	3240	16	2	1	9504	2376
	24	11	16QAM	10	4224	24	1	1	12672	3168
	25	11	16QAM	10	4352	24	1	1	13200	3300
	30	11	16QAM	10	5248	24	1	1	15840	3960
	32	11	16QAM	10	5632	24	1	1	16896	4224
	36	11	16QAM	10	6272	24	1	1	19008	4752
	45	11	16QAM	10	7808	24	1	1	23760	5940
	50	11	16QAM	10	8712	24	1	2	26400	6600
	60	11	16QAM	10	10504	24	1	2	31680	7920
	64	11	16QAM	10	11272	24	1	2	33792	8448
	75	11	16QAM	10	13064	24	1	2	39600	9900
	80	11	16QAM	10	14088	24	1	2	42240	10560
	81	11	16QAM	10	14088	24	1	2	42768	10692
	100	11	16QAM	10	17424	24	1	3	52800	13200
	108	11	16QAM	10	18960	24	1	3	57024	14256
	120	11	16QAM	10	21000	24	1	3	63360	15840
	128	11	16QAM	10	22536	24	1	3	67584	16896
	135	11	16QAM	10	23568	24	1	3	71280	17820
	160	11	16QAM	10	28168	24	1	4	84480	21120
	162	11	16QAM	10	28168	24	1	4	85536	21384
	216	11	16QAM	10	37896	24	1	5	114048	28512
	243	11	16QAM	10	43032	24	1	6	128304	32076
	270	11	16QAM	10	47112	24	1	6	142560	35640

NOTE 1: PUSCH mapping Type-A and single-symbol DM-RS configuration Type-1 with 2 additional DM-RS symbols, such that the DM-RS positions are set to symbols 2, 7, 11. DMRS is [TDM'ed] with PUSCH data. DM-RS symbols are not counted.

NOTE 2: MCS Index is based on MCS Table 6.1.4.1-1 defined in TS 38.214 [10].

NOTE 3: If more than one Code Block is present, an additional CRC sequence of  $L = 24$  Bits is attached to each Code Block (otherwise  $L = 0$  Bit).

NOTE 4: The RMCs apply to all channel bandwidth where  $L_{CRB} \leq N_{RB}$ .

Table A.2.2.3-2: Void

Table A.2.2.3-3: Void

## A.2.2.4 DFT-s-OFDM 64QAM

Table A.2.2.4-1: Reference Channels for DFT-s-OFDM 64QAM

Parameter	Allocated resource blocks (L <sub>CRB</sub> )	DFT-s-OFDM Symbols per slot (Note 1)	Modulation	MCS Index (Note 2)	Payload size	Transport block CRC	LDPC Base Graph	Number of code blocks per slot (Note 3)	Total number of bits per slot	Total modulated symbols per slot
Unit					Bits	Bits			Bits	
	1	11	64QAM	18	408	16	2	1	792	132
	5	11	64QAM	18	2024	16	2	1	3960	660
	9	11	64QAM	18	3624	16	2	1	7128	1188
	10	11	64QAM	18	3968	24	1	1	7920	1320
	12	11	64QAM	18	4736	24	1	1	9504	1584
	15	11	64QAM	18	6016	24	1	1	11880	1980
	18	11	64QAM	18	7168	24	1	1	14256	2376
	24	11	64QAM	18	9480	24	1	2	19008	3168
	25	11	64QAM	18	9992	24	1	2	19800	3300
	30	11	64QAM	18	12040	24	1	2	23760	3960
	32	11	64QAM	18	12808	24	1	2	25344	4224
	36	11	64QAM	18	14344	24	1	2	28512	4752
	45	11	64QAM	18	17928	24	1	3	35640	5940
	50	11	64QAM	18	19968	24	1	3	39600	6600
	60	11	64QAM	18	24072	24	1	3	47520	7920
	64	11	64QAM	18	25608	24	1	4	50688	8448
	75	11	64QAM	18	30216	24	1	4	59400	9900
	80	11	64QAM	18	31752	24	1	4	63360	10560
	81	11	64QAM	18	32264	24	1	4	64152	10692
	90	11	64QAM	18	35856	24	1	5	71280	11880
	100	11	64QAM	18	39936	24	1	5	79200	13200
	108	11	64QAM	18	43032	24	1	6	85536	14256
	120	11	64QAM	18	48168	24	1	6	95040	15840
	128	11	64QAM	18	51216	24	1	7	101376	16896
	135	11	64QAM	18	54296	24	1	7	106920	17820
	160	11	64QAM	18	63528	24	1	8	126720	21120
	162	11	64QAM	18	64552	24	1	8	128304	21384
	180	11	64QAM	18	71688	24	1	9	142560	23760
	216	11	64QAM	18	86040	24	1	11	171072	28512
	243	11	64QAM	18	96264	24	1	12	192456	32076
	270	11	64QAM	18	108552	24	1	13	213840	35640

NOTE 1: PUSCH mapping Type-A and single-symbol DM-RS configuration Type-1 with 2 additional DM-RS symbols, such that the DM-RS positions are set to symbols 2, 7, 11. DMRS is [TDM'ed] with PUSCH data. DM-RS symbols are not counted.

NOTE 2: MCS Index is based on MCS Table 6.1.4.1-1 defined in TS 38.214 [10].

NOTE 3: If more than one Code Block is present, an additional CRC sequence of L = 24 Bits is attached to each Code Block (otherwise L = 0 Bit).

NOTE 4: The RMCs apply to all channel bandwidth where  $L_{CRB} \leq N_{RB}$ .

Table A.2.2.4-2: Void

Table A.2.2.4-3: Void



## A.2.2.5 DFT-s-OFDM 256QAM

Table A.2.2.5-1: Reference Channels for DFT-s-OFDM 256QAM

Parameter	Allocated resource blocks (L <sub>CRB</sub> )	DFT-s-OFDM Symbols per slot (Note 1)	Modulation	MCS Index (Note 2)	Payload size	Transport block CRC	LDPC Base Graph	Number of code blocks per slot (Note 3)	Total number of bits per slot	Total modulated symbols per slot
Unit					Bits	Bits			Bits	
	1	11	256QAM	20	704	16	2	1	1056	132
	5	11	256QAM	20	3496	16	2	1	5280	660
	9	11	256QAM	20	6272	24	1	1	9504	1188
	10	11	256QAM	20	7040	24	1	1	10560	1320
	12	11	256QAM	20	8456	24	1	2	12672	1584
	15	11	256QAM	20	10504	24	1	2	15840	1980
	18	11	256QAM	20	12552	24	1	2	19008	2376
	24	11	256QAM	20	16896	24	1	3	25344	3168
	25	11	256QAM	20	17424	24	1	3	26400	3300
	30	11	256QAM	20	21000	24	1	3	31680	3960
	32	11	256QAM	20	22536	24	1	3	33792	4224
	36	11	256QAM	20	25104	24	1	3	38016	4752
	45	11	256QAM	20	31752	24	1	4	47520	5940
	50	11	256QAM	20	34816	24	1	5	52800	6600
	60	11	256QAM	20	42016	24	1	5	63360	7920
	64	11	256QAM	20	45096	24	1	6	67584	8448
	75	11	256QAM	20	53288	24	1	7	79200	9900
	80	11	256QAM	20	56368	24	1	7	84480	10560
	81	11	256QAM	20	57376	24	1	7	85536	10692
	90	11	256QAM	20	63528	24	1	8	95040	11880
	100	11	256QAM	20	69672	24	1	9	105600	13200
	108	11	256QAM	20	75792	24	1	9	114048	14256
	120	11	256QAM	20	83976	24	1	10	126720	15840
	128	11	256QAM	20	90176	24	1	11	135168	16896
	135	11	256QAM	20	94248	24	1	12	142560	17820
	160	11	256QAM	20	112648	24	1	14	168960	21120
	162	11	256QAM	20	114776	24	1	14	171072	21384
	180	11	256QAM	20	127080	24	1	16	190080	23760
	216	11	256QAM	20	151608	24	1	18	228096	28512
	243	11	256QAM	20	172176	24	1	21	256608	32076
	270	11	256QAM	20	188576	24	1	23	285120	35640

NOTE 1: PUSCH mapping Type-A and single-symbol DM-RS configuration Type-1 with 2 additional DM-RS symbols, such that the DM-RS positions are set to symbols 2, 7, 11. DMRS is [TDM'ed] with PUSCH data. DM-RS symbols are not counted.

NOTE 2: MCS Index is based on MCS Table 5.1.3.1-2 defined in TS 38.214 [10].

NOTE 3: If more than one Code Block is present, an additional CRC sequence of L = 24 Bits is attached to each Code Block (otherwise L = 0 Bit).

NOTE 4: The RMCs apply to all channel bandwidth where L<sub>CRB</sub> ≤ N<sub>RB</sub>.

Table A.2.2.5-2: Void

Table A.2.2.5-3: Void

## A.2.2.6 CP-OFDM QPSK

Table A.2.2.6-1: Reference Channels for CP-OFDM QPSK

Parameter	Allocated resource blocks (L <sub>CRB</sub> )	CP-OFDM Symbols per slot (Note 1)	Modulation	MCS Index (Note 2)	Payload size	Transport block CRC	LDPC Base Graph	Number of code blocks per slot (Note 3)	Total number of bits per slot	Total modulated symbols per slot
Unit					Bits	Bits			Bits	
	1	11	QPSK	2	48	16	2	1	264	132
	5	11	QPSK	2	256	16	2	1	1320	660
	6	11	QPSK	2	304	16	2	1	1584	792
	9	11	QPSK	2	456	16	2	1	2376	1188
	10	11	QPSK	2	504	16	2	1	2640	1320
	11	11	QPSK	2	552	16	2	1	2904	1452
	12	11	QPSK	2	608	16	2	1	3168	1584
	13	11	QPSK	2	672	16	2	1	3432	1716
	15	11	QPSK	2	768	16	2	1	3960	1980
	16	11	QPSK	2	808	16	2	1	4224	2112
	18	11	QPSK	2	928	16	2	1	4752	2376
	19	11	QPSK	2	984	16	2	1	5016	2508
	24	11	QPSK	2	1192	16	2	1	6336	3168
	25	11	QPSK	2	1256	16	2	1	6600	3300
	26	11	QPSK	2	1288	16	2	1	6864	3432
	31	11	QPSK	2	1544	16	2	1	8184	4092
	33	11	QPSK	2	1672	16	2	1	8712	4356
	38	11	QPSK	2	1928	16	2	1	10032	5016
	39	11	QPSK	2	2024	16	2	1	10296	5148
	40	11	QPSK	2	2024	16	2	1	10560	5280
	47	11	QPSK	2	2408	16	2	1	12408	6204
	51	11	QPSK	2	2536	16	2	1	13464	6732
	52	11	QPSK	2	2600	16	2	1	13728	6864
	53	11	QPSK	2	2664	16	2	1	13992	6996
	54	11	QPSK	2	2664	16	2	1	14256	7128
	61	11	QPSK	2	3104	16	2	1	16104	8052
	65	11	QPSK	2	3240	16	2	1	17160	8580
	67	11	QPSK	2	3368	16	2	1	17688	8844
	68	11	QPSK	2	3368	16	2	1	17952	8976
	78	11	QPSK	2	3848	24	2	2	20592	10296
	79	11	QPSK	2	3912	24	2	2	20856	10428
	80	11	QPSK	2	3976	24	2	2	21120	10560
	81	11	QPSK	2	4040	24	2	2	21384	10692
	93	11	QPSK	2	4616	24	2	2	24552	12276
	95	11	QPSK	2	4744	24	2	2	25080	12540
	106	11	QPSK	2	5256	24	2	2	27984	13992
	107	11	QPSK	2	5256	24	2	2	28248	14124
	108	11	QPSK	2	5384	24	2	2	28512	14256
	109	11	QPSK	2	5384	24	2	2	28776	14388
	121	11	QPSK	2	6024	24	2	2	31944	15972
	123	11	QPSK	2	6152	24	2	2	32472	16236
	133	11	QPSK	2	6664	24	2	2	35112	17556
	135	11	QPSK	2	6664	24	2	2	35640	17820
	137	11	QPSK	2	6792	24	2	2	36168	18084
	160	11	QPSK	2	7944	24	2	3	42240	21120
	162	11	QPSK	2	8064	24	2	3	42768	21384
	189	11	QPSK	2	9480	24	2	3	49896	24948
	216	11	QPSK	2	10752	24	2	3	57024	28512
	217	11	QPSK	2	10752	24	2	3	57288	28644
	245	11	QPSK	2	12296	24	2	4	64680	32340
	270	11	QPSK	2	13320	24	2	4	71280	35640
	273	11	QPSK	2	13576	24	2	4	72072	36036

NOTE 1: PUSCH mapping Type-A and single-symbol DM-RS configuration Type-1 with 2 additional DM-RS symbols, such that the DM-RS positions are set to symbols 2, 7, 11. DM-RS is [TDM'ed] with PUSCH data. DM-RS symbols are not counted.

NOTE 2: MCS Index is based on MCS Table 5.1.3.1-1 defined in TS 38.214 [10].

NOTE 3: If more than one Code Block is present, an additional CRC sequence of  $L = 24$  Bits is attached to each Code Block (otherwise  $L = 0$  Bit).

NOTE 4: The RMCs apply to all channel bandwidth where  $L_{CRB} \leq N_{RB}$ .

Table A.2.2.6-2: Void

Table A.2.2.6-3: Void

## A.2.2.7 CP-OFDM 16QAM

Table A.2.2.7-1: Reference Channels for CP-OFDM 16QAM

Parameter	Allocated resource blocks (L <sub>CRB</sub> )	CP-OFDM Symbols per slot (Note 1)	Modulation	MCS Index (Note 2)	Payload size	Transport block CRC	LDPC Base Graph	Number of code blocks per slot (Note 3)	Total number of bits per slot	Total modulated symbols per slot
Unit					Bits	Bits			Bits	
	1	11	16QAM	10	176	16	2	1	528	132
	5	11	16QAM	10	888	16	2	1	2640	660
	6	11	16QAM	10	1064	16	2	1	3168	792
	9	11	16QAM	10	1608	16	2	1	4752	1188
	10	11	16QAM	10	1800	16	2	1	5280	1320
	11	11	16QAM	10	1928	16	2	1	5808	1452
	12	11	16QAM	10	2088	16	2	1	6336	1584
	13	11	16QAM	10	2280	16	2	1	6864	1716
	15	11	16QAM	10	2664	16	2	1	7920	1980
	16	11	16QAM	10	2792	16	2	1	8448	2112
	18	11	16QAM	10	3240	16	2	1	9504	2376
	19	11	16QAM	10	3368	16	2	1	10032	2508
	24	11	16QAM	10	4224	24	1	1	12672	3168
	25	11	16QAM	10	4352	24	1	1	13200	3300
	26	11	16QAM	10	4480	24	1	1	13728	3432
	31	11	16QAM	10	5376	24	1	1	16368	4092
	33	11	16QAM	10	5760	24	1	1	17424	4356
	38	11	16QAM	10	6656	24	1	1	20064	5016
	39	11	16QAM	10	6784	24	1	1	20592	5148
	40	11	16QAM	10	7040	24	1	1	21120	5280
	47	11	16QAM	10	8192	24	1	1	24816	6204
	51	11	16QAM	10	8968	24	1	2	26928	6732
	52	11	16QAM	10	9224	24	1	2	27456	6864
	53	11	16QAM	10	9224	24	1	2	27984	6996
	54	11	16QAM	10	9480	24	1	2	28512	7128
	61	11	16QAM	10	10760	24	1	2	32208	8052
	65	11	16QAM	10	11272	24	1	2	34320	8580
	67	11	16QAM	10	11784	24	1	2	35376	8844
	68	11	16QAM	10	11784	24	1	2	35904	8976
	78	11	16QAM	10	13576	24	1	2	41184	10296
	79	11	16QAM	10	13832	24	1	2	41712	10428
	80	11	16QAM	10	14088	24	1	2	42240	10560
	81	11	16QAM	10	14088	24	1	2	42768	10692
	93	11	16QAM	10	16392	24	1	2	49404	12276
	95	11	16QMA	10	16392	24	1	2	50160	12540
	106	11	16QAM	10	18432	24	1	3	55968	13992
	107	11	16QAM	10	18960	24	1	3	56496	14124
	108	11	16QAM	10	18960	24	1	3	57024	14256
	109	11	16QAM	10	18960	24	1	3	57552	14388
	121	11	16QAM	10	21000	24	1	3	63888	15972
	123	11	16QAM	10	21504	24	1	3	64944	16236
	133	11	16QAM	10	23040	24	1	3	70224	17556
	135	11	16QAM	10	23568	24	1	3	71280	17820
	137	11	16QAM	10	24072	24	1	3	72336	18084
	160	11	16QAM	10	28168	24	1	4	84480	21120
	162	11	16QAM	10	28168	24	1	4	85536	21384
	189	11	16QAM	10	32776	24	1	4	99792	24948
	216	11	16QAM	10	37896	24	1	5	114048	28512

	217	11	16QAM	10	37896	24	1	5	114576	28644
	245	11	16QAM	10	43032	24	1	6	129360	32340
	270	11	16QAM	10	47112	24	1	6	142560	35640
	273	11	16QAM	10	48168	24	1	6	144144	36036

NOTE 1: PUSCH mapping Type-A and single-symbol DM-RS configuration Type-1 with 2 additional DM-RS symbols, such that the DM-RS positions are set to symbols 2, 7, 11. DMRS is [TDM'ed] with PUSCH data. DM-RS symbols are not counted.

NOTE 2: MCS Index is based on MCS Table 5.1.3.1-1 defined in TS 38.214 [10].

NOTE 3: If more than one Code Block is present, an additional CRC sequence of  $L = 24$  Bits is attached to each Code Block (otherwise  $L = 0$  Bit).

NOTE 4: The RMCs apply to all channel bandwidth where  $L_{CRB} \leq N_{RB}$ .

Table A.2.2.7-2: Void

Table A.2.2.7-3: Void

## A.2.2.8 CP-OFDM 64QAM

Table A.2.2.8-1: Reference Channels for CP-OFDM 64QAM

Parameter	Allocated resource blocks (L <sub>CRB</sub> )	CP-OFDM Symbols per slot (Note 1)	Modulation	MCS Index (Note 2)	Payload size	Transport block CRC	LDPC Base Graph	Number of code blocks per slot (Note 3)	Total number of bits per slot	Total modulated symbols per slot
Unit					Bits	Bits			Bits	
	1	11	64QAM	19	408	16	2	1	792	132
	5	11	64QAM	19	2024	16	2	1	3960	660
	9	11	64QAM	19	3624	16	2	1	7128	1188
	10	11	64QAM	19	3968	24	1	1	7920	1320
	11	11	64QAM	19	4352	24	1	1	8712	1452
	12	11	64QAM	19	4736	24	1	1	9504	1584
	13	11	64QAM	19	5120	24	1	1	10296	1716
	15	11	64QAM	19	6016	24	1	1	11880	1980
	18	11	64QAM	19	7168	24	1	1	14256	2376
	19	11	64QAM	19	7552	24	1		15048	2508
	24	11	64QAM	19	9480	24	1	2	19008	3168
	25	11	64QAM	19	9992	24	1	2	19800	3300
	26	11	64QAM	19	10504	24	1	2	20592	3432
	31	11	64QAM	19	12296	24	1	2	24552	4092
	33	11	64QAM	19	13064	24	1	2	26136	4356
	38	11	64QAM	19	15112	24	1	2	30096	5016
	39	11	64QAM	19	15624	24	1	2	30888	5148
	47	11	64QAM	19	18960	24	1	3	37224	6204
	51	11	64QAM	19	20496	24	1	3	40392	6732
	52	11	64QAM	19	21000	24	1	3	41184	6864
	53	11	64QAM	19	21000	24	1	3	41976	6996
	61	11	64QAM	19	24567	24	1	3	48312	8052
	65	11	64QAM	19	26120	24	1	4	51480	8580
	67	11	64QAM	19	26632	24	1	4	53064	8844
	78	11	64QAM	19	31240	24	1	4	61776	10296
	79	11	64QAM	19	31752	24	1	4	62568	10428
	80	11	64QAM	19	31752	24	1	4	63360	10560
	81	11	64QAM	19	32264	24	1	4	64152	10692
	93	11	64QAM	19	36896	24	1	5	73656	12276
	95	11	64QAM	19	37896	24	1	5	75240	12540
	93	11	64QAM	19	36896	24	1	5	73656	12276
	106	11	64QAM	19	42016	24	1	5	83952	13992
	107	11	64QAM	19	43032	24	1	6	84744	14124
	108	11	64QAM	19	43032	24	1	6	85536	14256
	109	11	64QAM	19	44040	24	1	6	86328	14388
	121	11	64QAM	19	48168	24	1	6	95832	15972
	123	11	64QAM	19	49176	24	1	6	97416	16236
	133	11	64QAM	19	53288	24	1	7	105336	17556
	135	11	64QAM	19	54296	24	1	7	106920	17820
	137	11	64QAM	19	54296	24	1	7	108504	18084
	160	11	64QAM	19	63528	24	1	8	126720	21120
	162	11	64QAM	19	64552	24	1	8	128304	21384
	189	11	64QAM	19	75792	24	1	9	149688	24948
	216	11	64QAM	19	86040	24	1	11	171072	28512
	217	11	64QAM	19	86040	24	1	11	171864	28644
	245	11	64QAM	19	98376	24	1	12	194040	32340
	270	11	64QAM	19	108552	24	1	13	213840	35640
	273	11	64QAM	19	108552	24	1	13	216216	36036

- NOTE 1: PUSCH mapping Type-A and single-symbol DM-RS configuration Type-1 with 2 additional DM-RS symbols, such that the DM-RS positions are set to symbols 2, 7, 11. DMRS is [TDM'ed] with PUSCH data. DM-RS symbols are not counted.
- NOTE 2: MCS Index is based on MCS Table 5.1.3.1-1 defined in TS 38.214 [10].
- NOTE 3: If more than one Code Block is present, an additional CRC sequence of  $L = 24$  Bits is attached to each Code Block (otherwise  $L = 0$  Bit).
- NOTE 4: The RMCs apply to all channel bandwidth where  $L_{CRB} \leq N_{RB}$ .



Table A.2.2.8-2: Void

Table A.2.2.8-3: Void

## A.2.2.9 CP-OFDM 256QAM

Table A.2.2.9-1: Reference Channels for CP-OFDM 256QAM

Parameter	Allocated resource blocks (L <sub>CRB</sub> )	CP-OFDM Symbols per slot (Note 1)	Modulation	MCS Index (Note 2)	Payload size	Transport block CRC	LDPC Base Graph	Number of code blocks per slot (Note 3)	Total number of bits per slot	Total modulated symbols per slot
Unit					Bits	Bits			Bits	
	1	11	256QAM	20	704	16	2	1	1056	132
	5	11	256QAM	20	3496	16	2	1	5280	660
	9	11	256QAM	20	6272	24	1	1	9504	1188
	10	11	256QAM	20	7040	24	1	1	10560	1320
	11	11	256QAM	20	7680	24	1	1	11616	1452
	12	11	256QAM	20	8456	24	1	2	12672	1584
	13	11	256QAM	20	9224	24	1	2	13728	1716
	15	11	256QAM	20	10504	24	1	2	15840	1980
	18	11	256QAM	20	12552	24	1	2	19008	2376
	19	11	256QAM	20	13320	24	1	2	20064	2508
	24	11	256QAM	20	16896	24	1	3	25344	3168
	25	11	256QAM	20	17424	24	1	3	26400	3300
	26	11	256QAM	20	18432	24	1	3	27456	3432
	31	11	256QAM	20	22032	24	1	3	32736	4092
	33	11	256QAM	20	23040	24	1	3	34848	4356
	38	11	256QAM	20	26632	24	1	4	40128	5016
	39	11	256QAM	20	27656	24	1	4	41184	5148
	47	11	256QAM	20	32776	24	1	4	49632	6204
	51	11	256QAM	20	35856	24	1	5	53856	6732
	52	11	256QAM	20	36896	24	1	5	54912	6864
	53	11	256QAM	20	36896	24	1	5	55968	6996
	61	11	256QAM	20	43032	24	1	6	64416	8052
	65	11	256QAM	20	46104	24	1	6	68640	8580
	67	11	256QAM	20	47112	24	1	6	70752	8844
	78	11	256QAM	20	55304	24	1	7	82368	10296
	79	11	256QAM	20	55304	24	1	7	83424	10428
	80	11	256QAM	20	56368	24	1	7	84480	10560
	81	11	256QAM	20	57376	24	1	7	85536	10692
	93	11	256QAM	20	65576	24	1	8	98208	12276
	95	11	256QAM	20	67584	24	1	8	100320	12540
	106	11	256QAM	20	73776	24	1	9	111936	13992
	107	11	256QAM	20	75792	24	1	9	112992	14124
	108	11	256QAM	20	75792	24	1	9	114048	14256
	109	11	256QAM	20	75792	24	1	9	115104	14388
	121	11	256QAM	20	86040	24	1	11	127776	15972
	123	11	256QAM	20	86040	24	1	11	129888	16236
	133	11	256QAM	20	94248	24	1	12	140448	17556
	135	11	256QAM	20	94248	24	1	12	142560	17820
	137	11	256QAM	20	96264	24	1	12	144672	18084
	160	11	256QAM	20	112648	24	1	14	168960	21120
	162	11	256QAM	20	114776	24	1	14	171072	21384
	189	11	256QAM	20	131176	24	1	16	199584	24948
	216	11	256QAM	20	151608	24	1	18	228096	28512
	217	11	256QAM	20	151608	24	1	18	229152	28644
	245	11	256QAM	20	172176	24	1	21	258720	32340
	270	11	256QAM	20	188576	24	1	23	285120	35640
	273	11	256QAM	20	192624	24	1	23	288288	36036

NOTE 1: PUSCH mapping Type-A and single-symbol DM-RS configuration Type-1 with 2 additional DM-RS symbols, such that the DM-RS positions are set to symbols 2, 7, 11. DMRS is [TDM'ed] with PUSCH data. DM-RS symbols are not counted.

NOTE 2: MCS Index is based on MCS Table 5.1.3.1-2 defined in TS 38.214 [10].

NOTE 3: If more than one Code Block is present, an additional CRC sequence of  $L = 24$  Bits is attached to each Code Block (otherwise  $L = 0$  Bit).

NOTE 4: The RMCs apply to all channel bandwidth where  $L_{CRB} \leq N_{RB}$ .

**Table A.2.2.9-2: Void**

**Table A.2.2.9-3: Void**

## A.2.3 Reference measurement channels for TDD

The TDD UL RMCs are defined in clause A.2.2 with the active UL slots specified in Table A.2.1-1 and TDD slot patterns as defined for reference sensitivity tests.

The TDD UL RMCs for the phase continuity tests for DMRS bundling are defined in clause A.2.2 with the active UL slots and TDD pattern specified in Tables A.2.1-2 and A.2.1-3.

### A.2.3.1 DFT-s-OFDM Pi/2-BPSK

**Table A.2.3.1-1: Void**

**Table A.2.3.1-2: Void**

**Table A.2.3.1-3: Void**

### A.2.3.2 DFT-s-OFDM QPSK

**Table A.2.3.2-1: Void**

**Table A.2.3.2-2: Void**

**Table A.2.3.2-3: Void**

### A.2.3.3 DFT-s-OFDM 16QAM

**Table A.2.3.3-1: Void**

**Table A.2.3.3-2: Void**

**Table A.2.3.3-3: Void**

### A.2.3.4 DFT-s-OFDM 64QAM

**Table A.2.3.4-1: Void**

**Table A.2.3.4-2: Void**

Table A.2.3.4-3: Void

#### A.2.3.5 DFT-s-OFDM 256QAM

Table A.2.3.5-1: Void

Table A.2.3.5-2: Void

Table A.2.3.5-3: Void

#### A.2.3.6 CP-OFDM QPSK

Table A.2.3.6-1: Void

Table A.2.3.6-2: Void

Table A.2.3.6-3: Void

#### A.2.3.7 CP-OFDM 16QAM

Table A.2.3.7-1: Void

Table A.2.3.7-2: Void

Table A.2.3.7-3: Void

#### A.2.3.8 CP-OFDM 64QAM

Table A.2.3.8-1: Void

Table A.2.3.8-2: Void

Table A.2.3.8-3: Void

## A.2.3.9 CP-OFDM 256QAM

Table A.2.3.9-1: Void

Table A.2.3.9-2: Void

Table A.2.3.9-3: Void

## A.3 DL reference measurement channels

### A.3.1 General

Unless otherwise stated, Tables A.3.2.2-1, A.3.2.2-2, A.3.2.2-3, A.3.3.2-1, A.3.3.2-2 and A.3.3.2-3 are applicable for measurements of the Receiver Characteristics (clause 7) with the exception of clauses 7.4 (Maximum input level).

Unless otherwise stated, Tables A.3.2.3-1, A.3.2.3-2, A.3.2.3-3, A.3.3.3-1, A.3.3.3-2 and A.3.3.3-3 are applicable for clauses 7.4 (Maximum input level) and for UE not supporting PDSCH 256QAM,

Unless otherwise stated, Tables A.3.2.4-1, A.3.2.4-2, A.3.2.4-3, A.3.3.4-1, A.3.3.4-2 and A.3.3.4-3 are applicable for clauses 7.4 (Maximum input level) and for UE supporting PDSCH 256QAM,

Unless otherwise stated, Tables A.3.2.2-1, A.3.2.2-2, A.3.2.2-3, A.3.3.2-1, A.3.3.2-2 and A.3.3.2-3 also apply for the modulated interferer used in Clauses 7.5, 7.6 and 7.8 with test specific bandwidths.

In case of carrier aggregation scenarios, the  $k_1$  values and number of HARQ processes of the Reference Measurement Channels specified in Annex A.3 shall be adapted as specified in Tables A.3.1-2 and A.3.1-3.

**Table A.3.1-1. Common reference channel parameters**

Parameter		Unit	Value
CORESET frequency domain allocation			Full BW
CORESET time domain allocation			2 OFDM symbols at the begin of each slot
PDSCH mapping type			Type A
PDSCH start symbol index (S)			2
Number of consecutive PDSCH symbols (L)			12
PDSCH PRB bundling		PRBs	2
Dynamic PRB bundling			false
Overhead value for TBS determination			0
First DMRS position for Type A PDSCH mapping			2
DMRS type			Type 1
Number of additional DMRS			2
FDM between DMRS and PDSCH			Disable
CSI-RS for tracking	First subcarrier index in the PRB used for CSI-RS ( $k_0$ )		0 for CSI-RS resource 1,2,3,4
	OFDM symbols in the PRB used for CSI-RS		$l_0 = 6$ for CSI-RS resource 1 and 3 $l_0 = 10$ for CSI-RS resource 2 and 4
	Number of CSI-RS ports		1 for CSI-RS resource 1,2,3,4
	CDM Type		'No CDM' for CSI-RS resource 1,2,3,4
	Density ( $\rho$ )		3 for CSI-RS resource 1,2,3,4
	CSI-RS periodicity	Slots	15 kHz SCS: 20 for CSI-RS resource 1,2,3,4 30 kHz SCS: 40 for CSI-RS resource 1,2,3,4 60 kHz SCS: 80 for CSI-RS resource 1,2,3,4
	CSI-RS offset	Slots	15 kHz SCS: 0 for CSI-RS resource 1 and 2 1 for CSI-RS resource 3 and 4  30 kHz SCS: 1 for CSI-RS resource 1 and 2 2 for CSI-RS resource 3 and 4  60 kHz SCS: 2 for CSI-RS resource 1 and 2 3 for CSI-RS resource 3 and 4
	Frequency Occupation		Start PRB 0 Number of PRB = BWP size
QCL info			TCI state #0
PTRS configuration			PTRS is not configured

Table A.3.1-2: Carrier aggregation test parameters for K1 values

The number of slots between PDSCH and corresponding HARQ-ACK information		CCs with the same duplex mode and SCS with Pcell	CCs with different duplex mode and/or SCS with Pcell
FDD 15 kHz + FDD 15 kHz CA	FDD PCell	{2}	N/A
FDD 15 kHz + FDD 30 kHz CA	15kHz PCell	{2}	{3}
	30kHz PCell	{2}	{2}
FDD 15 kHz + TDD 15 kHz CA	FDD PCell	{2}	{2}
	TDD PCell	{4,3,2}	{4,3,2,6,5}
FDD 15 kHz + TDD 30 kHz CA	FDD PCell	{2}	{3}
	TDD PCell	{8,7,6,5,4,3,2}	{8,6,4,2,10}
TDD 15 kHz + TDD 15 kHz CA	TDD PCell	{4,3,2}	N/A
TDD 15 kHz + TDD 30 kHz CA	15kHz PCell	{4,3,2}	{4,4,3,3,2,7,6}
	30kHz PCell	{8,7,6,5,4,3,2}	{7,5,4}
FDD 30 kHz + FDD 30 kHz CA	FDD PCell	{2}	N/A
FDD 30 kHz + TDD 15 kHz CA	FDD PCell	{2}	{2}
	TDD PCell	{4,3,2}	{4,4,3,3,7,7,6,6,5,5}
FDD 30 kHz + TDD 30 kHz CA	FDD PCell	{2}	{2}
	TDD PCell	{8,7,6,5,4,3,2}	{8,7,6,5,4,3,2,2,10,-} {NOTE 1}
TDD 30 kHz + TDD 30 kHz CA	TDD PCell	{8,7,6,5,4,3,2}	N/A

NOTE 1: No PDSCH shall be scheduled in slots 9 and 19 to avoid HARQ conflicts and maximize Throughput. Hence no K1 value is applicable for them.

Table A.3.1-3: Carrier Aggregation test parameters for number of HARQ processes

HARQ process number		CCs with the same duplex mode and SCS with Pcell	CCs with different duplex mode and/or SCS with Pcell
FDD 15 kHz + FDD 15 kHz CA	FDD PCell	4	N/A
FDD 15 kHz + FDD 30 kHz CA	15kHz PCell	8	8
	30kHz PCell	8	8
FDD 15 kHz + TDD 15 kHz CA	FDD PCell	4	8
	TDD PCell	8	8
FDD 15 kHz + TDD 30 kHz CA	FDD PCell	4	8
	TDD PCell	10	8
TDD 15 kHz + TDD 15 kHz CA	TDD PCell	8	N/A
TDD 15 kHz + TDD 30 kHz CA	15kHz PCell	8	12
	30kHz PCell	8	8
FDD 30 kHz + FDD 30 kHz CA	FDD PCell	8	N/A
FDD 30 kHz + TDD 15 kHz CA	FDD PCell	8	8
	TDD PCell	8	16

FDD 30 kHz + TDD 30 kHz CA	FDD PCell	8	8
	TDD PCell	8	16
TDD 30 kHz + TDD 30 kHz CA	TDD PCell	8	N/A

## A.3.2 DL reference measurement channels for FDD

### A.3.2.1 General

Table A.3.2.1-1 Additional reference channels parameters for FDD

Parameter	Unit	Value
Number of HARQ Processes		4
K1 value		2 for all slots

### A.3.2.2 FRC for receiver requirements for QPSK

Table A.3.2.2-1 Fixed reference channel for receiver requirements (SCS 15 kHz, FDD, QPSK 1/3)

Parameter	Unit	Value								
		3	5, 10, 15, 20 (Note 5)	10	15	20	25	30	40	50
Subcarrier spacing	kHz	15	15	15	15	15	15	15	15	15
Subcarrier spacing configuration $\mu$		0	0	0	0	0	0	0	0	0
Allocated resource blocks		15	25	52	79	106	133	160	216	270
Subcarriers per resource block		12	12	12	12	12	12	12	12	12
Allocated slots per Frame		8	8	8	8	8	8	8	8	8
MCS Index		4	4	4	4	4	4	4	4	4
MCS Table for TBS determination		64QAM								
Modulation		QPSK	QPSK	QPSK	QPSK	QPSK	QPSK	QPSK	QPSK	QPSK
Target Coding Rate		1/3	1/3	1/3	1/3	1/3	1/3	1/3	1/3	1/3
Maximum number of HARQ transmissions		1	1	1	1	1	1	1	1	1
<b>Information Bit Payload per Slot</b>										
For Slots 0,1	Bits	N/A	N/A	N/A	N/A	N/A	N/A	N/A	N/A	N/A
For Slots 2,3,4,5,6,7,8,9	Bits	984	1672	3368	5120	6912	8712	10504	14088	17424
Transport block CRC	Bits	16	16	16	24	24	24	24	24	24
LDPC base graph		2	2	2	1	1	1	1	1	1
<b>Number of Code Blocks per Slot</b>										
For Slots 0,1	CBs	N/A	N/A	N/A	N/A	N/A	N/A	N/A	N/A	N/A
For Slots 2,3,4,5,6,7,8,9	CBs	1	1	1	1	1	2	2	2	3
<b>Binary Channel Bits per Slot</b>										
For Slots 0,1	Bits	N/A	N/A	N/A	N/A	N/A	N/A	N/A	N/A	N/A
For Slots 2,3,4,5,6,7,8,9	Bits	3240	5400	11232	17064	22896	28728	34560	46656	58320
Max. Throughput averaged over 1 frame	Mbps	0.787	1.338	2.694	4.096	5.530	6.970	8.403	11.27 0	13.93 92

NOTE 1: Additional parameters are specified in Table A.3.1-1 and Table A.3.2.1-1.

NOTE 2: If more than one Code Block is present, an additional CRC sequence of L = 24 Bits is attached to each Code Block (otherwise L = 0 Bit).

NOTE 3: SS/PBCH block is transmitted in slot #0 of each frame

NOTE 4: Slot i is slot index per frame

NOTE 5: Channel bandwidths 10, 15, and 20 MHz in this column only apply to UEs supporting IE *supportOfRedCap-r18* but not *eRedCapNotReducedBB-BW-r18*.



Table A.3.2.2-2 Fixed reference channel for receiver requirements (SCS 30 kHz, FDD, QPSK 1/3)

Parameter	Unit	Value									
		10	10, 15, 20 (Note 5)	15	20	25	30	40	50	60	80
Channel bandwidth	MHz	1	1	1	1	1	1	1	1	1	1
Configuration $\mu$		1	1	1	1	1	1	1	1	1	1
Subcarriers		24	12	38	51	65	78	106	133	162	217
Subcarrier spacing		12	12	12	12	12	12	12	12	12	12
Subframe duration		17	17	17	17	17	17	17	17	17	17
Subframe duration		4	4	4	4	4	4	4	4	4	4
Modulation		64QAM									
		QPSK	QPSK	QPSK	QPSK	QPSK	QPSK	QPSK	QPSK	QPSK	QPSK
		1/3	1/3	1/3	1/3	1/3	1/3	1/3	1/3	1/3	1/3
HARQ transmissions		1	1	1	1	1	1	1	1	1	1
Bit Payload per Slot											
	Bits	N/A	N/A	N/A	N/A	N/A	N/A	N/A	N/A	N/A	N/A
	Bits	1608	808	2472	3368	4224	4992	6912	8712	10504	14088
	Bits	16	16	16	16	24	24	24	24	24	24
		2	2	2	2	1	1	1	1	1	1
Code Blocks per Slot											
	CBs	N/A	N/A	N/A	N/A	N/A	N/A	N/A	N/A	N/A	N/A
	CBs	1	1	1	1	1	1	1	2	2	2
Channel Bits per Slot											
	Bits	N/A	N/A	N/A	N/A	N/A	N/A	N/A	N/A	N/A	N/A
	Bits	5184	2592	8208	11016	14040	16848	22896	28728	34992	46872
Averaged over 1 frame	Mbps	2.734	1.374	4.202	5.726	7.181	8.486	11.750	14.810	17.857	23.950

Parameters are specified in Table A.3.1-1 and Table A.3.2.1-1.

If one Code Block is present, an additional CRC sequence of L = 24 Bits is attached to each Code Block (otherwise L = 0 Bit).

One Code Block is transmitted in slot #0 of each frame

Slot index per frame

Bandwidths 10, 15, and 20 MHz in this column only apply to UEs supporting IE *supportOfERedCap-r18* but not *eRedCapNotReducedBB-BW-r18*.

Table A.3.2.2-3 Fixed reference channel for receiver requirements (SCS 60 kHz, FDD, QPSK 1/3)

Parameter	Unit	Value									
		10	15	20	25	30	40	50	60	80	90
Channel bandwidth	MHz	10	15	20	25	30	40	50	60	80	90
Spacing configuration $\mu$		2	2	2	2	2	2	2	2	2	2
Source blocks		11	18	24	31	38	51	65	79	107	127
Per resource block		12	12	12	12	12	12	12	12	12	12
Slots per Frame		36	36	36	36	36	36	36	36	36	36
		4	4	4	4	4	4	4	4	4	4
For TBS Determination		64QAM									
		QPSK	QPSK	QPSK	QPSK	QPSK	QPSK	QPSK	QPSK	QPSK	QPSK
Coding Rate		1/3	1/3	1/3	1/3	1/3	1/3	1/3	1/3	1/3	1/3
Number of HARQ transmissions		1	1	1	1	1	1	1	1	1	1
Code Block Payload per Slot											
Slots 1,2,3	Bits	N/A	N/A	N/A	N/A	N/A	N/A	N/A	N/A	N/A	N/A
Slots ...,39	Bits	736	1192	1608	2024	2472	3368	4224	5120	6912	7808
Per block CRC	Bits	16	16	16	16	16	16	24	24	24	24
Per slot		2	2	2	2	2	2	1	1	1	1
Number of Code Blocks per Slot											
Slots 2,3	CBs	N/A	N/A	N/A	N/A	N/A	N/A	N/A	N/A	N/A	N/A
Slots ...,39	CBs	1	1	1	1	1	1	1	1	1	1
Channel Bits per Slot											
Slots 2,3	Bits	N/A	N/A	N/A	N/A	N/A	N/A	N/A	N/A	N/A	N/A
Slots ...,39	Bits	2376	3888	5184	6696	8208	11016	14040	17064	23112	26112
Input averaged over 1 frame	Mbps	2.650	4.291	5.789	7.286	8.899	12.125	15.206	18.432	24.883	28.125

Additional parameters are specified in Table A.3.1-1 and Table A.3.2.1-1.

More than one Code Block is present, an additional CRC sequence of L = 24 Bits is attached to each Code Block (otherwise L = 0 Bit).

Per PBCH block is transmitted in slot #0 of each frame

Slot i is slot index per frame

### A.3.2.3 FRC for maximum input level for 64QAM

**Table A.3.2.3-1 Fixed reference channel for maximum input level receiver requirements (SCS 15 kHz, FDD, 64QAM)**

Parameter	Unit	Value									
		3	5, 10, 15, 20 (Note 5)	5	10	15	20	25	30	40	50
Subcarrier spacing	kHz	15	15	15	15	15	15	15	15	15	15
Subcarrier spacing configuration $\mu$		0	0	0	0	0	0	0	0	0	0
Allocated resource blocks		15	20	25	52	79	106	133	160	216	270
Subcarriers per resource block		12	12	12	12	12	12	12	12	12	12
Allocated slots per Frame		8	8	8	8	8	8	8	8	8	8
MCS Index		24	24	24	24	24	24	24	24	24	24
MCS Table for TBS determination		64QAM									
Modulation		64 QAM	64 QAM	64 QAM	64 QAM	64 QAM	64 QAM	64 QAM	64 QAM	64 QAM	64 QAM
Target Coding Rate		3/4	3/4	3/4	3/4	3/4	3/4	3/4	3/4	3/4	3/4
Maximum number of HARQ transmissions		1	1	1	1	1	1	1	1	1	1
<b>Information Bit Payload per Slot</b>											
For Slots 0,1	Bits	N/A	N/A	N/A	N/A	N/A	N/A	N/A	N/A	N/A	N/A
For Slots 2,3,4,5,6,7,8,9	Bits	7296	9736	12296	25608	38936	52224	64552	77896	106576	131176
Transport block CRC	Bits	24	24	24	24	24	24	24	24	24	24
LDPC base graph		1	1	1	1	1	1	1	1	1	1
<b>Number of Code Blocks per Slot</b>											
For Slot 0,1	CBs	N/A	N/A	N/A	N/A	N/A	N/A	N/A	N/A	N/A	N/A
For Slots 2,3,4,5,6,7,8,9	CBs	1	2	2	4	5	7	8	10	13	16
<b>Binary Channel Bits per Slot</b>											
For Slot 0,1	Bits	N/A	N/A	N/A	N/A	N/A	N/A	N/A	N/A	N/A	N/A
For Slots 2,3,4,5,6,7,8,9	Bits	9720	12960	16200	33696	51192	68688	86184	103680	139968	174960

Max. Throughput averaged over 1 frame	Mbps	5.83 7	7.789	9.837	20.48 6	31.14 9	41.77 9	51.64 2	62.317	85.261	104.94 1
<p>NOTE 1: Additional parameters are specified in Table A.3.1-1 and Table A.3.2.1-1.</p> <p>NOTE 2: If more than one Code Block is present, an additional CRC sequence of L = 24 Bits is attached to each Code Block (otherwise L = 0 Bit).</p> <p>NOTE 3: SS/PBCH block is transmitted in slot 0 of each frame</p> <p>NOTE 4: Slot i is slot index per frame</p> <p>NOTE 5: Channel bandwidths in this column only apply to UEs supporting IE <i>supportOfERedCap-r18</i>.</p>											

**Table A.3.2.3-2 Fixed reference channel for maximum input level receiver requirements (SCS 30 kHz, FDD, 64QAM)**

Parameter	Unit	Value										
		10, 15, 20 (Note 5)	10	15	20	25	30	40	50	60	80	100
Subcarrier spacing configuration $\mu$		1	1	1	1	1	1	1	1	1	1	1
Allocated resource blocks		10	24	38	51	65	78	106	133	162	217	273
Subcarriers per resource block		12	12	12	12	12	12	12	12	12	12	12
Allocated slots per Frame		17	17	17	17	17	17	17	17	17	17	17
MCS Index		24	24	24	24	24	24	24	24	24	24	24
MCS Table for TBS determination		64QAM										
Modulation		64 QAM	64 QAM	64 QAM	64 QAM	64 QAM	64 QAM	64 QAM	64 QAM	64 QAM	64 QAM	64 QAM
Target Coding Rate		3/4	3/4	3/4	3/4	3/4	3/4	3/4	3/4	3/4	3/4	3/4
Maximum number of HARQ transmissions		1	1	1	1	1	1	1	1	1	1	1
<b>Information Bit Payload per Slot</b>												
For Slots 0,1,2	Bits	N/A	N/A	N/A	N/A	N/A	N/A	N/A	N/A	N/A	N/A	N/A
For Slots 3,...,19	Bits	4864	11784	18432	25104	31752	37896	52224	64552	79896	106576	135296
Transport block CRC	Bits	24	24	24	24	24	24	24	24	24	24	24
LDPC base graph		1	1	1	1	1	1	1	1	1	1	1
<b>Number of Code Blocks per Slot</b>												
For Slot2 0,1,2	CBs	N/A	N/A	N/A	N/A	N/A	N/A	N/A	N/A	N/A	N/A	N/A
For Slots 3,...,19	CBs	1	2	3	3	4	5	7	8	10	13	17
<b>Binary Channel Bits per Slot</b>												
For Slots 0,1,2	Bits	N/A	N/A	N/A	N/A	N/A	N/A	N/A	N/A	N/A	N/A	N/A
For Slots 3,...,19	Bits	6480	15552	24624	33048	42120	50544	68688	86184	104976	140616	176904
Max. Throughput averaged over 1 frame	Mbps	8.269	20.033	31.334	42.677	53.978	64.423	88.781	109.738	135.823	181.179	230.003
NOTE 1: Additional parameters are specified in Table A.3.1-1 and Table A.3.2.1-1.												
NOTE 2: If more than one Code Block is present, an additional CRC sequence of L = 24 Bits is attached to each Code Block (otherwise L = 0 Bit).												
NOTE 3: SS/PBCH block is transmitted in slot 0 of each frame												
NOTE 4: Slot i is slot index per frame												
NOTE 5: Channel bandwidths in this column only apply to UEs supporting IE <i>supportOfRedCap-r18</i> .												

Table A.3.2.3-3 Fixed Reference Channel for Maximum input level receiver requirements (SCS 60 kHz, FDD, 64QAM)

Parameter	Unit	Value									
		10	15	20	25	30	40	50	60	80	100
Channel bandwidth	MHz										
Subcarrier spacing configuration $\mu$		2	2	2	2	2	2	2	2	2	2
Allocated resource blocks		11	18	24	31	38	51	65	79	107	135
Subcarriers per resource block		12	12	12	12	12	12	12	12	12	12
Allocated slots per Frame		36	36	36	36	36	36	36	36	36	36
MCS Index		24	24	24	24	24	24	24	24	24	24
MCS Table for TBS determination		64QAM									
Modulation		64 QAM	64 QAM	64 QAM	64 QAM	64 QAM	64 QAM	64 QAM	64 QAM	64 QAM	64 QAM
Target Coding Rate		3/4	3/4	3/4	3/4	3/4	3/4	3/4	3/4	3/4	3/4
Maximum number of HARQ transmissions		1	1	1	1	1	1	1	1	1	1
<b>Information Bit Payload per Slot</b>											
For Slots 0,1,2,3	Bits	N/A	N/A	N/A	N/A	N/A	N/A	N/A	N/A	N/A	N/A
For Slots 4,...,39	Bits	5376	8712	11784	15112	18432	25104	31752	38936	52224	65576
Transport block CRC	Bits	24	24	24	24	24	24	24	24	24	24
LDPC base graph		1	1	1	1	1	1	1	1	1	1
<b>Number of Code Blocks per Slot</b>											
For Slots 0,1,2,3	CBs	N/A	N/A	N/A	N/A	N/A	N/A	N/A	N/A	N/A	N/A
For Slots 4,...,39	CBs	1	2	2	2	3	3	4	5	7	8
<b>Binary Channel Bits per Slot</b>											
For Slots 0,1,2,3	Bits	N/A	N/A	N/A	N/A	N/A	N/A	N/A	N/A	N/A	N/A
For Slots 4,...,39	Bits	7128	11664	15552	20088	24624	33048	42120	51192	69336	87480
Max. Throughput averaged over 1 frame	Mbps	19.354	31.363	42.422	54.403	66.355	90.374	114.307	140.170	188.006	236.074
NOTE 1: Additional parameters are specified in Table A.3.1-1 and Table A.3.2.1-1.											
NOTE 2: If more than one Code Block is present, an additional CRC sequence of L = 24 Bits is attached to each Code Block (otherwise L = 0 Bit).											
NOTE 3: SS/PBCH block is transmitted in slot #0 of each frame											
NOTE 4: Slot i is slot index per frame											

### A.3.2.4 FRC for maximum input level for 256 QAM

**Table A.3.2.4-1 Fixed reference channel for maximum input level receiver requirements (SCS 15 kHz, FDD, 256QAM)**

Parameter	Unit	Value								
		3, 5, 10, 15, 20 (NOT E 5)	5	10	15	20	25	30	40	50
Channel bandwidth	MHz									
Subcarrier spacing	kHz	15	15	15	15	15	15	15	15	15
Subcarrier spacing configuration $\mu$		0	0	0	0	0	0	0	0	0
Allocated resource blocks		15	25	52	79	106	133	160	216	270
Subcarriers per resource block		12	12	12	12	12	12	12	12	12
Allocated slots per Frame		8	8	8	8	8	8	8	8	8
MCS Index		23	23	23	23	23	23	23	23	23
MCS Table for TBS determination		256QAM								
Modulation		256 QAM	256 QAM	256 QAM	256 QAM	256 QAM	256 QAM	256 QAM	256 QAM	256 QAM
Target Coding Rate		4/5	4/5	4/5	4/5	4/5	4/5	4/5	4/5	4/5
Maximum number of HARQ transmissions		1	1	1	1	1	1	1	1	1
<b>Information Bit Payload per Slot</b>										
For Slots 0,1	Bits	N/A	N/A	N/A	N/A	N/A	N/A	N/A	N/A	N/A
For Slots 2,3,4,5,6,7,8,9	Bits	9992	16896	34816	53288	71688	90176	108552	143400	180376
Transport block CRC	Bits	24	24	24	24	24	24	24	24	24
LDPC base graph		1	1	1	1	1	1	1	1	1
<b>Number of Code Blocks per Slot</b>										
For Slot 0,1	CBs	N/A	N/A	N/A	N/A	N/A	N/A	N/A	N/A	N/A
For Slots 2,3,4,5,6,7,8,9	CBs	2	3	5	7	9	11	13	18	22
<b>Binary Channel Bits per Slot</b>										
For Slots 0,1	Bits	N/A	N/A	N/A	N/A	N/A	N/A	N/A	N/A	N/A
For Slots 2,3,4,5,6,7,8,9	Bits	12960	21600	44928	68256	91584	114912	138240	186624	233280
Max. Throughput averaged over 1 frame	Mbps	7.994	13.517	27.853	42.630	57.350	72.141	86.842	114.720	144.301
NOTE 1: Additional parameters are specified in Table A.3.1-1 and Table A.3.2.1-1.										
NOTE 2: If more than one Code Block is present, an additional CRC sequence of L = 24 Bits is attached to each Code Block (otherwise L = 0 Bit).										
NOTE 3: SS/PBCH block is transmitted in slot 0 of each frame										
NOTE 4: Slot i is slot index per frame										
NOTE 5: Channel bandwidths 5, 10, 15, and 20 MHz in this column only apply to UEs supporting IE <i>supportOfRedCap-r18</i> .										

**Table A.3.2.4-2 Fixed reference channel for maximum input level receiver requirements (SCS 30 kHz, FDD, 256QAM)**

Parameter	Unit	Value											
		10,15,20 (NOTE 5)	10	15	20	25	30	40	50	60	80	100	
Channel bandwidth	MHz												
Subcarrier spacing configuration $\mu$		1	1	1	1	1	1	1	1	1	1	1	1
Allocated resource blocks		7	24	38	51	65	78	106	133	162	217	273	
Subcarriers per resource block		12	12	12	12	12	12	12	12	12	12	12	
Allocated slots per Frame		17	17	17	17	17	17	17	17	17	17	17	
MCS Index		23	23	23	23	23	23	23	23	23	23	23	
MCS Table for TBS determination		256QAM											
Modulation		256 QAM	256 QAM	256 QAM	256 QAM	256 QAM	256 QAM	256 QAM	256 QAM	256 QAM	256 QAM	256 QAM	256 QAM
Target Coding Rate		4/5	4/5	4/5	4/5	4/5	4/5	4/5	4/5	4/5	4/5	4/5	4/5
Maximum number of HARQ transmissions		1	1	1	1	1	1	1	1	1	1	1	1
<b>Information Bit Payload per Slot</b>													
For Slots 0,1,2	Bits	N/A	N/A	N/A	N/A	N/A	N/A	N/A	N/A	N/A	N/A	N/A	N/A
For Slots 3,...,19	Bits	4736	16136	25608	33816	44040	52224	71688	90176	108552	147576	184424	
Transport block CRC	Bits	24	24	24	24	24	24	24	24	24	24	24	24
LDPC base graph		1	1	1	1	1	1	1	1	1	1	1	1
<b>Number of Code Blocks per Slot</b>													
For Slots 0,1,2	CBs	N/A	N/A	N/A	N/A	N/A	N/A	N/A	N/A	N/A	N/A	N/A	N/A
For Slots 3,...,19	CBs	1	2	4	5	6	7	9	11	13	18	22	
<b>Binary Channel Bits per Slot</b>													
For Slots 0,1,2	Bits	N/A	N/A	N/A	N/A	N/A	N/A	N/A	N/A	N/A	N/A	N/A	N/A
For Slots 3,...,19	Bits	6048	20736	32832	44064	56160	67392	91584	114912	139968	187488	235872	
Max. Throughput averaged over 1 frame	Mbps	8.051	27.431	43.534	57.487	74.868	88.781	121.870	153.299	184.538	250.879	313.521	
NOTE 1: Additional parameters are specified in Table A.3.1-1 and Table A.3.2.1-1.													
NOTE 2: If more than one Code Block is present, an additional CRC sequence of L = 24 Bits is attached to each Code Block (otherwise L = 0 Bit).													
NOTE 3: SS/PBCH block is transmitted in slot 0 of each frame													
NOTE 4: Slot i is slot index per frame													
NOTE 5: Channel bandwidths in this column only apply to UEs supporting IE <i>supportOfRedCap-r18</i> .													

**Table A.3.2.4-3 Fixed reference channel for maximum input level receiver requirements (SCS 60 kHz, FDD, 256QAM)**

Parameter	Unit	Value											
		10	15	20	25	30	40	50	60	80	100		
Channel bandwidth	MHz												
Subcarrier spacing configuration $\mu$		2	2	2	2	2	2	2	2	2	2	2	2



Allocated resource blocks		11	18	24	31	38	51	65	79	107	135
Subcarriers per resource block		12	12	12	12	12	12	12	12	12	12
Allocated slots per Frame		36	36	36	36	36	36	36	36	36	36
MCS Index		23	23	23	23	23	23	23	23	23	23
MCS Table for TBS determination		256QAM									
Modulation		256 QAM	256 QAM	256 QAM	256 QAM	256 QAM	256 QAM	256 QAM	256 QAM	256 QAM	256 QAM
Target Coding Rate		4/5	4/5	4/5	4/5	4/5	4/5	4/5	4/5	4/5	4/5
Maximum number of HARQ transmissions		1	1	1	1	1	1	1	1	1	1
<b>Information Bit Payload per Slot</b>											
For Slots 0,1,2,3	Bits	N/A	N/A	N/A	N/A	N/A	N/A	N/A	N/A	N/A	N/A
For Slots 4,...,39	Bits	7424	12040	16136	21000	25608	33816	44040	53288	71688	90176
Transport block CRC	Bits	24	24	24	24	24	24	24	24	24	24
LDPC base graph		1	1	1	1	1	1	1	1	1	1
<b>Number of Code Blocks per Slot</b>											
For Slots 0,1,2,3	CBs	N/A	N/A	N/A	N/A	N/A	N/A	N/A	N/A	N/A	N/A
For Slots 4,...,39	CBs	1	2	2	3	4	5	6	7	9	11
<b>Binary Channel Bits per Slot</b>											
For Slot 0,1,2,3	Bits	N/A	N/A	N/A	N/A	N/A	N/A	N/A	N/A	N/A	N/A
For Slots 4,...,39	Bits	9504	15552	20736	26784	32832	44064	56160	68256	92448	116640
Max. Throughput averaged over 1 frame	Mbps	26.726	43.344	58.090	75.600	92.189	121.73 8	158.54 4	191.83 7	258.07 7	324.63 4
NOTE 1: Additional parameters are specified in Table A.3.1-1 and Table A.3.2.1-1.											
NOTE 2: If more than one Code Block is present, an additional CRC sequence of L = 24 Bits is attached to each Code Block (otherwise L = 0 Bit).											
NOTE 3: SS/PBCH block is transmitted in slot #0 of each frame											
NOTE 4: Slot i is slot index per frame											

## A.3.2.5 FRC for maximum input level for 1024 QAM

Table A.3.2.5-1 Fixed reference channel for maximum input level receiver requirements (SCS 15 kHz, FDD, 1024QAM)

Parameter	Unit	Value								
		3	5	10	15	20	25	30	40	50
<b>Channel bandwidth</b>	<b>MHz</b>									
Subcarrier spacing	kHz	15	15	15	15	15	15	15	15	15
Subcarrier spacing configuration $\mu$		0	0	0	0	0	0	0	0	0
Allocated resource blocks		15	25	52	79	106	133	160	216	270
Subcarriers per resource block		12	12	12	12	12	12	12	12	12
Allocated slots per Frame		8	8	8	8	8	8	8	8	8
MCS Index		23	23	23	23	23	23	23	23	23
MCS Table for TBS determination		1024QAM								
Modulation		1024 QAM	1024 QAM	1024 QAM	1024 QAM	1024 QAM	1024 QAM	1024 QAM	1024 QAM	1024 QAM
Target Coding Rate		0.78	0.78	0.78	0.78	0.78	0.78	0.78	0.78	0.78
Maximum number of HARQ transmissions		1	1	1	1	1	1	1	1	1
<b>Information Bit Payload per Slot</b>										
For Slots 0,1	Bits	N/A	N/A	N/A	N/A	N/A	N/A	N/A	N/A	N/A
For Slots 2,3,4,5,6,7,8,9	Bits	12808	21000	44040	67584	90176	112648	135296	184424	229576
Transport block CRC	Bits	24	24	24	24	24	24	24	24	24
LDPC base graph		1	1	1	1	1	1	1	1	1
<b>Number of Code Blocks per Slot</b>										
For Slot 0,1	CBs	N/A	N/A	N/A	N/A	N/A	N/A	N/A	N/A	N/A
For Slots 2,3,4,5,6,7,8,9	CBs	2	3	6	9	11	14	17	22	28
<b>Binary Channel Bits per Slot</b>										
For Slots 0,1	Bits	N/A	N/A	N/A	N/A	N/A	N/A	N/A	N/A	N/A
For Slots 2,3,4,5,6,7,8,9	Bits	16200	27000	56160	85320	114480	143640	172800	233280	291600
Max. Throughput averaged over 1 frame	Mbps	10.24 6	16.80 0	35.23 2	54.06 7	72.14 1	90.11 8	108.2 37	147.5 39	183.6 61
NOTE 1: Additional parameters are specified in Table A.3.1-1 and Table A.3.2.1-1.										
NOTE 2: If more than one Code Block is present, an additional CRC sequence of L = 24 Bits is attached to each Code Block (otherwise L = 0 Bit).										
NOTE 3: SS/PBCH block is transmitted in slot 0 of each frame										
NOTE 4: Slot i is slot index per frame										

Table A.3.2.5-2 Fixed reference channel for maximum input level receiver requirements (SCS 30 kHz, FDD, 1024QAM)

Parameter	Unit	Value									
		10	15	20	25	30	40	50	60	80	100
Channel bandwidth	MHz										
Subcarrier spacing configuration $\mu$		1	1	1	1	1	1	1	1	1	1
Allocated resource blocks		24	38	51	65	78	106	133	162	217	273
Subcarriers per resource block		12	12	12	12	12	12	12	12	12	12
Allocated slots per Frame		17	17	17	17	17	17	17	17	17	17
MCS Index		23	23	23	23	23	23	23	23	23	23
MCS Table for TBS determination		1024QAM									
Modulation		1024 QAM	1024 QAM	1024 QAM	1024 QAM	1024 QAM	1024 QAM	1024 QAM	1024 QAM	1024 QAM	1024 QAM
Target Coding Rate		0.78	0.78	0.78	0.78	0.78	0.78	0.78	0.78	0.78	0.78
Maximum number of HARQ transmissions		1	1	1	1	1	1	1	1	1	1
<b>Information Bit Payload per Slot</b>											
For Slots 0,1,2	Bits	N/A	N/A	N/A	N/A	N/A	N/A	N/A	N/A	N/A	N/A
For Slots 3,...,19	Bits	20496	32264	43032	55304	65576	90176	112648	139376	184424	233608
Transport block CRC	Bits	24	24	24	24	24	24	24	24	24	24
LDPC base graph		1	1	1	1	1	1	1	1	1	1
<b>Number of Code Blocks per Slot</b>											
For Slots 0,1,2	CBs	N/A	N/A	N/A	N/A	N/A	N/A	N/A	N/A	N/A	N/A
For Slots 3,...,19	CBs	3	4	6	7	8	11	14	17	22	28
<b>Binary Channel Bits per Slot</b>											
For Slots 0,1,2	Bits	N/A	N/A	N/A	N/A	N/A	N/A	N/A	N/A	N/A	N/A
For Slots 3,...,19	Bits	25920	41040	55080	70200	84240	114480	143640	174960	234360	294840
Max. Throughput averaged over 1 frame	Mbps	34.843	54.849	73.154	94.017	111.479	153.299	191.502	236.939	313.521	397.134
NOTE 1: Additional parameters are specified in Table A.3.1-1 and Table A.3.2.1-1.											
NOTE 2: If more than one Code Block is present, an additional CRC sequence of L = 24 Bits is attached to each Code Block (otherwise L = 0 Bit).											
NOTE 3: SS/PBCH block is transmitted in slot 0 of each frame											
NOTE 4: Slot i is slot index per frame											

Table A.3.2.5-3 Fixed reference channel for maximum input level receiver requirements (SCS 60 kHz, FDD, 1024QAM)

Parameter	Unit	Value									
		10	15	20	25	30	40	50	60	80	100
Channel bandwidth	MHz										
Subcarrier spacing configuration $\mu$		2	2	2	2	2	2	2	2	2	2
Allocated resource blocks		11	18	24	31	38	51	65	79	107	135
Subcarriers per resource block		12	12	12	12	12	12	12	12	12	12
Allocated slots per Frame		36	36	36	36	36	36	36	36	36	36
MCS Index		23	23	23	23	23	23	23	23	23	23
MCS Table for TBS determination		1024QAM									

Modulation		1024 QAM	1024 QAM	1024 QAM	1024 QAM	1024 QAM	1024 QAM	1024 QAM	1024 QAM	1024 QAM	1024 QAM
Target Coding Rate		0.78	0.78	0.78	0.78	0.78	0.78	0.78	0.78	0.78	0.78
Maximum number of HARQ transmissions		1	1	1	1	1	1	1	1	1	1
<b>Information Bit Payload per Slot</b>											
For Slots 0,1,2,3	Bits	N/A	N/A	N/A	N/A	N/A	N/A	N/A	N/A	N/A	N/A
For Slots 4,...,39	Bits	9224	15368	20496	26120	32264	43032	55304	67584	90176	114776
Transport block CRC	Bits	24	24	24	24	24	24	24	24	24	24
LDPC base graph		1	1	1	1	1	1	1	1	1	1
<b>Number of Code Blocks per Slot</b>											
For Slots 0,1,2,3	CBs	N/A	N/A	N/A	N/A	N/A	N/A	N/A	N/A	N/A	N/A
For Slots 4,...,39	CBs	2	2	3	4	4	6	7	9	11	14
<b>Binary Channel Bits per Slot</b>											
For Slot 0,1,2,3	Bits	N/A	N/A	N/A	N/A	N/A	N/A	N/A	N/A	N/A	N/A
For Slots 4,...,39	Bits	11880	19440	25920	33480	41040	55080	70200	85320	115560	145800
Max. Throughput averaged over 1 frame	Mbps	33.206	55.325	73.786	94.032	116.15 0	154.91 5	199.09 4	243.30 2	324.63 4	413.19 4
NOTE 1: Additional parameters are specified in Table A.3.1-1 and Table A.3.2.1-1.											
NOTE 2: If more than one Code Block is present, an additional CRC sequence of L = 24 Bits is attached to each Code Block (otherwise L = 0 Bit).											
NOTE 3: SS/PBCH block is transmitted in slot #0 of each frame											
NOTE 4: Slot i is slot index per frame											

### A.3.3 DL reference measurement channels for TDD

#### A.3.3.1 General

**Table A.3.3.1-1 Additional reference channels parameters for TDD**

Parameter		Value		
		SCS 15 kHz ( $\mu=0$ )	SCS 30 kHz ( $\mu=1$ )	SCS 60 kHz ( $\mu=2$ )
TDD Slot Configuration pattern (Note 1)		DDDSU	7DS2U	14DS <sub>1</sub> S <sub>2</sub> 4U
Special Slot Configuration (Note 2)		10D+2G+2U	6D+4G+4U	S <sub>1</sub> =12D+2G, S <sub>2</sub> =6G+8U
referenceSubcarrierSpacing		15 kHz	30 kHz	60 kHz
UL-DL configuration	<i>dl-UL-TransmissionPeriodicity</i>	5 ms	5 ms	5 ms
	<i>nrofDownlinkSlots</i>	3	7	14
	<i>nrofDownlinkSymbols</i>	10	6	12
	<i>nrofUplinkSlots</i>	1	2	4
	<i>nrofUplinkSymbols</i>	2	4	8
Number of HARQ Processes		8	8	16
The number of slots between PDSCH and corresponding HARQ-ACK information (Note 3)		K1 = 4 if mod(i,5) = 0 K1 = 3 if mod(i,5) = 1 K1 = 2 if mod(i,5) = 2 where i is slot index per frame; i = {0,...,9}	K1 = 8 if mod(i,10) = 0 K1 = 7 if mod(i,10) = 1 K1 = 6 if mod(i,10) = 2 K1 = 5 if mod(i,10) = 3 K1 = 4 if mod(i,10) = 4 K1 = 3 if mod(i,10) = 5 K1 = 2 if mod(i,10) = 6 where i is slot index per frame; i = {0,...,19}	K1 = 13 if mod(i,20) = 2 K1 = 12 if mod(i,20) = 3 K1 = 11 if mod(i,20) = 4 K1 = 10 if mod(i,20) = 5 K1 = 9 if mod(i,20) = 6 K1 = 8 if mod(i,20) = 7 K1 = 7 if mod(i,20) = 8 K1 = 6 if mod(i,20) = 9 K1 = 6 if mod(i,20) = 10 K1 = 6 if mod(i,20) = 11 K1 = 6 if mod(i,20) = 12 K1 = 6 if mod(i,20) = 13 where i is slot index per frame; i = {0,...,39}
NOTE 1: D denotes a slot with all DL symbols; S denotes a slot with a mix of DL, UL and guard symbols; U denotes a slot with all UL symbols. The field is for information.				
NOTE 2: D, G, U denote DL, guard and UL symbols, respectively. The field is for information.				
NOTE 3: i is the slot index per frame.				
NOTE 4: A -2ms or +3ms time offset to the NR configuration pattern relative to the E-UTRA UL-DL configuration must be apply in the TDD intra-band EN-DC.				

#### A.3.3.2 FRC for receiver requirements for QPSK

**Table A.3.3.2-1 Fixed reference channel for receiver requirements (SCS 15 kHz, TDD, QPSK 1/3)**

Parameter	Unit	Value							
		5, 10, 15, 20 (Note 5)	10	15	20	25	30	40	50
Channel bandwidth	MHz								
Subcarrier spacing	kHz	15	15	15	15	15	15	15	15
Subcarrier spacing configuration $\mu$		0	0	0	0	0	0	0	0
Allocated resource blocks		25	52	79	106	133	160	216	270
Subcarriers per resource block		12	12	12	12	12	12	12	12
Allocated slots per Frame		4	4	4	4	4	4	4	4
MCS Index		4	4	4	4	4	4	4	4
MCS Table for TBS determination		64QAM							
Modulation		QPSK	QPSK	QPSK	QPSK	QPSK	QPSK	QPSK	QPSK

Target Coding Rate		1/3	1/3	1/3	1/3	1/3	1/3	1/3	1/3
Maximum number of HARQ transmissions		1	1	1	1	1	1	1	1
<b>Information Bit Payload per Slot</b>									
For Slots 0,1,3,4,8,9	Bits	N/A	N/A	N/A	N/A	N/A	N/A	N/A	N/A
For Slots 2,5,6,7	Bits	1672	3368	5120	6912	8712	10504	14088	17424
Transport block CRC	Bits	16	16	24	24	24	24	24	24
LDPC base graph		2	2	1	1	1	1	1	1
<b>Number of Code Blocks per Slot</b>									
For Slots 0,1,3,4,8,9	CBs	N/A	N/A	N/A	N/A	N/A	N/A	N/A	N/A
For Slots 2,5,6,7	CBs	1	1	1	1	2	2	2	3
<b>Binary Channel Bits per Slot</b>									
For Slots 0,1,3,4,8,9	Bits	N/A	N/A	N/A	N/A	N/A	N/A	N/A	N/A
For Slots 2,5,6,7	Bits	5400	11232	17064	22896	28728	34560	46656	58320
Max. Throughput averaged over 1 frame	Mbps	0.669	1.347	2.048	2.765	3.485	4.202	5.635	6.970

NOTE 1: Additional parameters are specified in Table A.3.1-1 and Table A.3.3.1-1.

NOTE 2: If more than one Code Block is present, an additional CRC sequence of L = 24 Bits is attached to each Code Block (otherwise L = 0 Bit).

NOTE 3: SS/PBCH block is transmitted in slot 0 of each frame

NOTE 4: Slot i is slot index per frame

NOTE 5: Channel bandwidths 10, 15, and 20 MHz in this column only apply to UEs supporting IE *supportOfERedCap-r18* but not *eRedCapNotReducedBB-BW-r18*.

Table A.3.3.2-2 Fixed reference channel for receiver requirements (SCS 30 kHz, TDD, QPSK 1/3)

Parameter	Unit	Value											
		10, 15, 20 (Note 5)	10	15	20	25	30	40	50	60	70	80	100
Channel bandwidth	MHz												
Subcarrier spacing configuration $\mu$		1	1	1	1	1	1	1	1	1	1	1	1
Allocated resource blocks		12	24	38	51	65	78	106	133	162	162	217	273
Subcarriers per resource block		12	12	12	12	12	12	12	12	12	12	12	12
Allocated slots per Frame		11	11	11	11	11	11	11	11	11	13	11	11
MCS Index		4	4	4	4	4	4	4	4	4	4	4	4
MCS Table for TBS determination		64QAM											
Modulation		QPSK	QPSK	QPSK	QPSK	QPSK	QPSK	QPSK	QPSK	QPSK	QPSK	QPSK	QPSK
Target Coding Rate		1/3	1/3	1/3	1/3	1/3	1/3	1/3	1/3	1/3	1/3	1/3	1/3
Maximum number of HARQ transmissions		1	1	1	1	1	1	1	1	1	1	1	1
<b>Information Bit Payload per Slot</b>													
For Slots 0,1,2 and Slot i, if mod(i, 10) = {7,8,9} for i from {0,...,19}	Bits	N/A	N/A	N/A	N/A	N/A	N/A	N/A	N/A	N/A	N/A	N/A	N/A
For Slot i, if mod(i, 10) = {0,1,2,3,4,5,6} for i from {3,...,19}	Bits	808	1608	2472	3368	4224	4992	6912	8712	10504	12296	14088	17928
Transport block CRC	Bits	16	16	16	16	24	24	24	24	24	24	24	24
LDPC base graph		2	2	2	2	1	1	1	1	1	1	1	1
<b>Number of Code Blocks per Slot</b>													
For Slots 0,1,2 and Slot i, if mod(i, 10) = {7,8,9} for i from {0,...,19}	CBs	N/A	N/A	N/A	N/A	N/A	N/A	N/A	N/A	N/A	N/A	N/A	N/A
For Slot i, if mod(i, 10) = {0,1,2,3,4,5,6} for i from {3,...,19}	CBs	1	1	1	1	1	1	1	1	2	2	2	3
<b>Binary Channel Bits per Slot</b>													
For Slots 0,1,2 and Slot i, if mod(i, 10) = {7,8,9} for i from {0,...,19}	Bits	N/A	N/A	N/A	N/A	N/A	N/A	N/A	N/A	N/A	N/A	N/A	N/A
For Slot i, if mod(i, 10) = {0,1,2,3,4,5,6} for i from {3,...,19}	Bits	2592	5184	8208	11016	14040	16848	22896	28728	34992	40824	46872	58968
Max. Throughput averaged over 1 frame	Mbps	0.889	1.7699	2.719	3.705	4.646	5.491	7.603	9.583	11.554	13.526	15.497	19.721
NOTE 1: Additional parameters are specified in Table A.3.1-1 and Table A.3.3.1-1.													
NOTE 2: If more than one Code Block is present, an additional CRC sequence of L = 24 Bits is attached to each Code Block (otherwise L = 0 Bit).													
NOTE 3: SS/PBCH block is transmitted in slot #0 of each frame													
NOTE 4: Slot i is slot index per frame													
NOTE 5: Channel bandwidths in this column only apply to UEs supporting IE <i>supportOfRedCap-r18</i> but not <i>eRedCapNotReducedBB-BW-r18</i> .													

Table A.3.3.2-3 Fixed reference channel for receiver requirements (SCS 60 kHz, TDD, QPSK 1/3)

Parameter	Unit	Value										
		10	15	20	25	30	40	50	60	70	80	100
Channel bandwidth	MHz	10	15	20	25	30	40	50	60	70	80	100
Subcarrier spacing configuration $\mu$		2	2	2	2	2	2	2	2	2	2	2
Allocated resource blocks		11	18	24	31	38	51	65	79	93	107	135
Subcarriers per resource block		12	12	12	12	12	12	12	12	12	12	12
Allocated slots per Frame		24	24	24	24	24	24	24	24	26	24	24
MCS Index		4	4	4	4	4	4	4	4	4	4	4
MCS Table for TBS determination		64QAM										
Modulation		QPSK	QPSK	QPSK	QPSK	QPSK	QPSK	QPSK	QPSK	QPSK	QPSK	QPSK
Target Coding Rate		1/3	1/3	1/3	1/3	1/3	1/3	1/3	1/3	1/3	1/3	1/3
Maximum number of HARQ transmissions		1	1	1	1	1	1	1	1	1	1	1
<b>Information Bit Payload per Slot</b>												
For Slots 0,1,2,3 and Slot i, if $\text{mod}(i, 20) = \{14,15,16,17,18,19\}$ for i from $\{0,\dots,39\}$	Bits	N/A	N/A	N/A	N/A	N/A	N/A	N/A	N/A	N/A	N/A	N/A
For Slot i, if $\text{mod}(i, 20) = \{0,\dots, 13\}$ for i from $\{4,\dots,39\}$	Bits	736	1192	1608	2024	2472	3368	4224	5120	6016	6912	8712
Transport block CRC	Bits	16	16	16	16	16	16	24	24	24	24	24
LDPC base graph		2	2	2	2	2	2	1	1	1	1	1
<b>Number of Code Blocks per Slot</b>												
For Slots 0,1,2,3 and Slot i, if $\text{mod}(i, 20) = \{14,15,16,17,18,19\}$ for i from $\{0,\dots,39\}$	CBs	N/A	N/A	N/A	N/A	N/A	N/A	N/A	N/A	N/A	N/A	N/A
For Slot i, if $\text{mod}(i, 20) = \{0,\dots, 13\}$ for i from $\{4,\dots,39\}$	CBs	1	1	1	1	1	1	1	1	1	1	2
<b>Binary Channel Bits per Slot</b>												
For Slots 0,1,2,3 and Slot i, if $\text{mod}(i, 20) = \{14,15,16,17,18,19\}$ for i from $\{0,\dots,39\}$	Bits	N/A	N/A	N/A	N/A	N/A	N/A	N/A	N/A	N/A	N/A	N/A
For Slot i, if $\text{mod}(i, 20) = \{0,\dots,13\}$ for i from $\{4,\dots,39\}$	Bits	2376	3888	5184	6696	8208	11016	14040	17064	20088	23112	29160
Max. Throughput averaged over 1 frame	Mbps	1.766	2.861	3.859	4.858	5.933	8.083	10.138	12.288	14.438	16.589	20.909
NOTE 1: Additional parameters are specified in Table A.3.1-1 and Table A.3.3.1-1.												
NOTE 2: If more than one Code Block is present, an additional CRC sequence of L = 24 Bits is attached to each Code Block (otherwise L = 0 Bit).												
NOTE 3: SS/PBCH block is transmitted in slot #0 of each frame												
NOTE 4: Slot i is slot index per frame												



## A.3.3.3 FRC for maximum input level for 64QAM

Table A.3.3.3-1 Fixed reference channel for maximum input level receiver requirements (SCS 15 kHz, TDD, 64QAM)

Parameter	Unit	Value								
		5, 10, 15, 20 (Note 5)	5	10	15	20	25	30	40	50
Channel bandwidth	MHz									
Subcarrier spacing	kHz	15	15	15	15	15	15	15	15	15
Subcarrier spacing configuration $\mu$		0	0	0	0	0	0	0	0	0
Allocated resource blocks		20	25	52	79	106	133	160	216	270
Subcarriers per resource block		12	12	12	12	12	12	12	12	12
Allocated slots per Frame		4	4	4	4	4	4	4	4	4
MCS Index		24	24	24	24	24	24	24	24	24
MCS Table for TBS determination		64QAM								
Modulation		64 QAM	64 QAM	64 QAM	64 QAM	64 QAM	64 QAM	64 QAM	64 QAM	64 QAM
Target Coding Rate		3/4	3/4	3/4	3/4	3/4	3/4	3/4	3/4	3/4
Maximum number of HARQ transmissions		1	1	1	1	1	1	1	1	1
<b>Information Bit Payload per Slot</b>										
For Slots 0,1,3,4,8,9	Bits	N/A	N/A	N/A	N/A	N/A	N/A	N/A	N/A	N/A
For Slots 2,5,6,7	Bits	9736	12296	25608	38936	52224	64552	77896	106576	131176
Transport block CRC	Bits	24	24	24	24	24	24	24	24	24
LDPC base graph		1	1	1	1	1	1	1	1	1
<b>Number of Code Blocks per Slot</b>										
For Slots 0,1,3,4,8,9	CBs	N/A	N/A	N/A	N/A	N/A	N/A	N/A	N/A	N/A
For Slots 2,5,6,7	CBs	2	2	4	5	7	8	10	13	16
<b>Binary Channel Bits per Slot</b>										
For Slots 0,1,3,4,8,9	Bits	N/A	N/A	N/A	N/A	N/A	N/A	N/A	N/A	N/A
For Slots 2,5,6,7	Bits	12960	16200	33696	51192	68688	86184	103680	139968	174960
Max. Throughput averaged over 1 frame	Mbps	3.894	4.918	10.243	15.574	20.890	20.890	31.158	42.630	52.470
NOTE 1: Additional parameters are specified in Table A.3.1-1 and Table A.3.3.1-1.										
NOTE 2: If more than one Code Block is present, an additional CRC sequence of L = 24 Bits is attached to each Code Block (otherwise L = 0 Bit).										
NOTE 3: SS/PBCH block is transmitted in slot 0 of each frame										
NOTE 4: Slot i is slot index per frame										
NOTE 5: Channel bandwidths in this column only apply to UEs supporting IE <i>supportOfRedCap-r18</i> .										

Table A.3.3.3-2 Fixed reference channel for maximum input level receiver requirements (SCS 30 kHz, TDD, 64QAM)

Parameter	Unit	Value											
		10, 15, 20 (Note 5)	10	15	20	25	30	40	50	60	70	80	100
Channel bandwidth	MHz												
Subcarrier spacing configuration $\mu$		1	1	1	1	1	1	1	1	1	1	1	1
Allocated resource blocks		10	24	38	51	65	78	106	133	162	189	217	273
Subcarriers per resource block		12	12	12	12	12	12	12	12	12	12	12	12
Allocated slots per Frame		11	11	11	11	11	11	11	11	11	13	11	11
MCS Index		24	24	24	24	24	24	24	24	24	24	24	24
MCS Table for TBS determination		64QAM											
Modulation		4864	64 QAM	64 QAM	64 QAM	64 QAM	64 QAM	64 QAM	64 QAM	64 QAM	64 QAM	64 QAM	64 QAM
Target Coding Rate		24	3/4	3/4	3/4	3/4	3/4	3/4	3/4	3/4	3/4	3/4	3/4
Maximum number of HARQ transmissions		1	1	1	1	1	1	1	1	1	1	1	1
<b>Information Bit Payload per Slot</b>													
For Slots 0,1,2 and Slot i, if mod(i, 10) = {7,8,9} for i from {0,...,19}	Bits	N/A	N/A	N/A	N/A	N/A	N/A	N/A	N/A	N/A	N/A	N/A	N/A
For Slot i, if mod(i, 10) = {0,1,2,3,4,5,6} for i from {3,...,19}	Bits	1	11784	18432	25104	31752	37896	52224	64552	79896	92200	106576	135296
Transport block CRC	Bits		24	24	24	24	24	24	24	24	24	24	24
LDPC base graph		N/A	1	1	1	1	1	1	1	1	1	1	1
<b>Number of Code Blocks per Slot</b>			6480										
For Slots 0,1,2 and Slot i, if mod(i, 10) = {7,8,9} for i from {0,...,19}	CBs	5.350	N/A	N/A	N/A	N/A	N/A	N/A	N/A	N/A	N/A	N/A	N/A
For Slot i, if mod(i, 10) = {0,1,2,3,4,5,6} for i from {3,...,19}	CBs	4864	2	3	3	4	5	7	8	10	11	13	17
<b>Binary Channel Bits per Slot</b>			24										
For Slots 0,1,2 and Slot i, if mod(i, 10) = {7,8,9} for i from {0,...,19}	Bits	1	N/A	N/A	N/A	N/A	N/A	N/A	N/A	N/A	N/A	N/A	N/A
For Slot i, if mod(i, 10) = {0,1,2,3,4,5,6} for i from {3,...,19}	Bits		15552	24624	33048	42120	50544	68688	86184	104976	122472	140616	176904
Max. Throughput averaged over 1 frame	Mbps	N/A	12.962	20.275	27.614	34.927	41.686	57.446	71.007	87.886	101.42	117.23 4	148.82 6
NOTE 1: Additional parameters are specified in Table A.3.1-1 and Table A.3.3.1-1.													
NOTE 2: If more than one Code Block is present, an additional CRC sequence of L = 24 Bits is attached to each Code Block (otherwise L = 0 Bit).													
NOTE 3: SS/PBCH block is transmitted in slot #0 of each frame													
NOTE 4: Slot i is slot index per frame													
NOTE 5: Channel bandwidths in this column only apply to UEs supporting IE <i>supportOfRedCap-r18</i> .													

**Table A.3.3.3-3. Fixed reference channel for maximum input level receiver requirements (SCS 60 kHz, TDD, 64QAM)**

Parameter	Unit	Value										
		10	15	20	25	30	40	50	60	70	80	100
<b>Channel bandwidth</b>	<b>MHz</b>	<b>10</b>	<b>15</b>	<b>20</b>	<b>25</b>	<b>30</b>	<b>40</b>	<b>50</b>	<b>60</b>	<b>70</b>	<b>80</b>	<b>100</b>
Subcarrier spacing configuration $\mu$		2	2	2	2	2	2	2	2	2	2	2
Allocated resource blocks		11	18	24	31	38	51	65	79	93	107	135
Subcarriers per resource block		12	12	12	12	12	12	12	12	12	12	12
Allocated slots per Frame		24	24	24	24	24	24	24	24	26	24	24
MCS Index		24	24	24	24	24	24	24	24	24	24	24
MCS Table for TBS determination		64QAM										
Modulation		64 QAM	64 QAM	64 QAM	64 QAM	64 QAM	64 QAM	64 QAM	64 QAM	64 QAM	64 QAM	64 QAM
Target Coding Rate		3/4	3/4	3/4	3/4	3/4	3/4	3/4	3/4	3/4	3/4	3/4
Maximum number of HARQ transmissions		1	1	1	1	1	1	1	1	1	1	1
<b>Information Bit Payload per Slot</b>												
For Slots 0,1,2,3 and Slot i, if mod(i, 20) = {14,15,16,17,18,19} for i from {0,...,39}	Bits	N/A	N/A	N/A	N/A	N/A	N/A	N/A	N/A	N/A	N/A	N/A
For Slot i, if mod(i, 20) = {0,..., 13} for i from {4,...,39}	Bits	5376	8712	11784	15112	18432	25104	31752	38936	45096	52224	65576
Transport block CRC	Bits	24	24	24	24	24	24	24	24	24	24	24
LDPC base graph		1	1	1	1	1	1	1	1	1	1	1
<b>Number of Code Blocks per Slot</b>												
For Slots 0,1,2,3 and Slot i, if mod(i, 20) = {14,15,16,17,18,19} for i from {0,...,39}	CBs	N/A	N/A	N/A	N/A	N/A	N/A	N/A	N/A	N/A	N/A	N/A
For Slot i, if mod(i, 20) = {0,..., 13} for i from {4,...,39}	CBs	1	2	2	2	3	3	4	5	6	7	8
<b>Binary Channel Bits per Slot</b>												
For Slots 0,1,2,3 and Slot i, if mod(i, 20) = {14,15,16,17,18,19} for i from {0,...,39}	Bits	N/A	N/A	N/A	N/A	N/A	N/A	N/A	N/A	N/A	N/A	N/A
For Slot i, if mod(i, 20) = {0,..., 13} for i from {4,...,39}	Bits	7128	11664	15552	20088	24624	33048	42120	51192	60264	69336	87480
Max. Throughput averaged over 1 frame	Mbps	12.902	20.909	28.282	36.269	44.237	60.250	76.205	93.446	108.23	125.33 8	157.38 2
NOTE 1: Additional parameters are specified in Table A.3.1-1 and Table A.3.3.1-1.												
NOTE 2: If more than one Code Block is present, an additional CRC sequence of L = 24 Bits is attached to each Code Block (otherwise L = 0 Bit).												
NOTE 3: SS/PBCH block is transmitted in slot #0 of each frame												
NOTE 4: Slot i is slot index per frame												

### A.3.3.4 FRC for maximum input level for 256 QAM

**Table A.3.3.4-1 Fixed reference channel for maximum input level receiver requirements (SCS 15 kHz, TDD, 256QAM)**

Parameter	Unit	Value								
		5, 10, 15, 20 (NOT E 5)	5	10	15	20	25	30	40	50
Channel bandwidth	MHz									
Subcarrier spacing	kHz	15	15	15	15	15	15	15	15	15
Subcarrier spacing configuration $\mu$		0	0	0	0	0	0	0	0	0
Allocated resource blocks		15	25	52	79	106	133	160	216	270
Subcarriers per resource block		12	12	12	12	12	12	12	12	12
Allocated slots per Frame		4	4	4	4	4	4	4	4	4
MCS Index		23	23	23	23	23	23	23	23	23
MCS table for TBS determination		256QAM								
Modulation		256 QAM	256 QAM	256 QAM	256 QAM	256 QAM	256 QAM	256 QAM	256 QAM	256 QAM
Target Coding Rate		4/5	4/5	4/5	4/5	4/5	4/5	4/5	4/5	4/5
Maximum number of HARQ transmissions		1	1	1	1	1	1	1	1	1
<b>Information Bit Payload per Slot</b>										
For Slots 0,1,3,4,8,9	Bits	N/A	N/A	N/A	N/A	N/A	N/A	N/A	N/A	N/A
For Slots 2,5,6,7	Bits	9992	16896	34816	53288	71688	90176	108552	143400	180376
Transport block CRC	Bits	24	24	24	24	24	24	24	24	24
LDPC base graph		1	1	1	1	1	1	1	1	1
<b>Number of Code Blocks per Slot</b>										
For Slots 0,1,3,4,8,9	CBs	N/A	N/A	N/A	N/A	N/A	N/A	N/A	N/A	N/A
For Slots 2,5,6,7	CBs	2	3	5	7	9	12	14	18	23
<b>Binary Channel Bits per Slot</b>										
For Slots 0,1,3,4,8,9	Bits	N/A	N/A	N/A	N/A	N/A	N/A	N/A	N/A	N/A
For Slots 2,5,6,7	Bits	12960	21600	44928	68256	91584	114912	138240	186624	233280
Max. Throughput averaged over 1 frame	Mbps	3.997	6.758	13.926	21.315	28.675	36.070	43.421	57.360	72.150
NOTE 1: Additional parameters are specified in Table A.3.1-1 and Table A.3.3.1-1.										
NOTE 2: If more than one Code Block is present, an additional CRC sequence of L = 24 Bits is attached to each Code Block (otherwise L = 0 Bit).										
NOTE 3: SS/PBCH block is transmitted in slot 0 of each frame										
NOTE 4: Slot i is slot index per frame										
NOTE 5: Channel bandwidths in this column only apply to UEs supporting IE <i>supportOfRedCap-r18</i> .										

Table A.3.3.4-2 Fixed Reference channel for maximum input level receiver requirements (SCS 30 kHz, TDD, 256QAM)

Parameter	Unit	Value											
		10, 15, 20 (NOTE 5)	10	15	20	25	30	40	50	60	70	80	100
Channel bandwidth	MHz												
Subcarrier spacing configuration $\mu$		1	1	1	1	1	1	1	1	1	1	1	1
Allocated resource blocks		7	24	38	51	65	78	106	133	162	189	217	273
Subcarriers per resource block		12	12	12	12	12	12	12	12	12	12	12	12
Allocated slots per Frame		11	11	11	11	11	11	11	11	11	13	11	11
MCS Index		23	23	23	23	23	23	23	23	23	23	23	23
MCS Table for TBS determination			256QAM										
Modulation		256 QAM	256 QAM	256 QAM	256 QAM	256 QAM	256 QAM	256 QAM	256 QAM	256 QAM	256 QAM	256 QAM	256 QAM
Target Coding Rate		4/5	4/5	4/5	4/5	4/5	4/5	4/5	4/5	4/5	4/5	4/5	4/5
Maximum number of HARQ transmissions		1	1	1	1	1	1	1	1	1	1	1	1
<b>Information Bit Payload per Slot</b>													
For Slots 0,1,2 and Slot i, if mod(i, 10) = {7,8,9} for i from {0,...,19}	Bits	N/A	N/A	N/A	N/A	N/A	N/A	N/A	N/A	N/A	N/A	N/A	N/A
For Slot i, if mod(i, 10) = {0,1,2,3,4,5,6} for i from {3,...,19}	Bits	4736	16136	25608	33816	44040	52224	71688	90176	108552	127080	147576	184424
Transport block CRC	Bits	24	24	24	24	24	24	24	24	24	24	24	24
LDPC base graph		1	1	1	1	1	1	1	1	1	1	1	1
<b>Number of Code Blocks per Slot</b>													
For Slots 0,1,2 and Slot i, if mod(i, 10) = {7,8,9} for i from {0,...,19}	CBs	N/A	N/A	N/A	N/A	N/A	N/A	N/A	N/A	N/A	N/A	N/A	N/A
For Slot i, if mod(i, 10) = {0,1,2,3,4,5,6} for i from {3,...,19}	CBs	1	1	1	1	1	1	1	2	2	2	2	3
<b>Binary Channel Bits per Slot</b>													
For Slots 0,1,2 and Slot i, if mod(i, 10) = {7,8,9} for i from {0,...,19}	Bits	N/A	N/A	N/A	N/A	N/A	N/A	N/A	N/A	N/A	N/A	N/A	N/A
For Slot i, if mod(i, 10) = {0,1,2,3,4,5,6} for i from {3,...,19}	Bits	6048	20736	32832	44064	56160	67392	91584	114912	139968	163296	187488	235872
Max. Throughput averaged over 1 frame	Mbps	5.210	17.750	28.169	37.198	48.444	57.446	78.857	99.194	119.40 7	139.78 8	162.33 4	202.86 6
NOTE 1: Additional parameters are specified in Table A.3.1-1 and Table A.3.3.1-1.													
NOTE 2: If more than one Code Block is present, an additional CRC sequence of L = 24 Bits is attached to each Code Block (otherwise L = 0 Bit).													
NOTE 3: SS/PBCH block is transmitted in slot #0 of each frame													
NOTE 4: Slot i is slot index per frame													
NOTE 5: Channel bandwidths in this column only apply to UEs supporting IE <i>supportOfERedCap-r18</i> .													



Table A.3.3.4-3 Fixed reference channel for maximum input level receiver requirements (SCS 60 kHz, TDD, 256QAM)

Parameter	Unit	Value										
		10	15	20	25	30	40	50	60	70	80	100
Channel bandwidth	MHz	10	15	20	25	30	40	50	60	70	80	100
Subcarrier spacing configuration $\mu$		2	2	2	2	2	2	2	2	2	2	2
Allocated resource blocks		11	18	24	31	38	51	65	79	93	107	135
Subcarriers per resource block		12	12	12	12	12	12	12	12	12	12	12
Allocated slots per Frame		24	24	24	24	24	24	24	24	26	24	24
MCS Index		23	23	23	23	23	23	23	23	23	23	23
MCS Table for TBS determination		256QAM										
Modulation		256 QAM	256 QAM	256 QAM	256 QAM	256 QAM	256 QAM	256 QAM	256 QAM	256 QAM	256 QAM	256 QAM
Target Coding Rate		4/5	4/5	4/5	4/5	4/5	4/5	4/5	4/5	4/5	4/5	4/5
Maximum number of HARQ transmissions		1	1	1	1	1	1	1	1	1	1	1
<b>Information Bit Payload per Slot</b>												
For Slots 0,1,2,3 and Slot i, if $\text{mod}(i, 20) = \{14,15,16,17,18,19\}$ for i from $\{0,\dots,39\}$	Bits	N/A	N/A	N/A	N/A	N/A	N/A	N/A	N/A	N/A	N/A	N/A
For Slot i, if $\text{mod}(i, 20) = \{0,\dots, 13\}$ for i from $\{4,\dots,39\}$	Bits	7424	12040	16136	21000	25608	33816	44040	53288	62504	71688	90176
Transport block CRC	Bits	24	24	24	24	24	24	24	24	24	24	24
LDPC base graph		1	1	1	1	1	1	1	1	1	1	1
<b>Number of Code Blocks per Slot</b>												
For Slots 0,1,2,3 and Slot i, if $\text{mod}(i, 20) = \{14,15,16,17,18,19\}$ for i from $\{0,\dots,39\}$	CBs	N/A	N/A	N/A	N/A	N/A	N/A	N/A	N/A	N/A	N/A	N/A
For Slot i, if $\text{mod}(i, 20) = \{0,\dots, 13\}$ for i from $\{4,\dots,39\}$	CBs	1	2	3	3	4	5	6	7	8	9	12
<b>Binary Channel Bits per Slot</b>												
For Slots 0,1,2,3 and Slot i, if $\text{mod}(i, 20) = \{14,15,16,17,18,19\}$ for i from $\{0,\dots,39\}$	Bits	N/A	N/A	N/A	N/A	N/A	N/A	N/A	N/A	N/A	N/A	N/A
For Slot i, if $\text{mod}(i, 20) = \{0,\dots, 13\}$ for i from $\{4,\dots,39\}$	Bits	9504	15552	20736	26784	32832	44064	56160	68256	80352	92448	116640
Max. Throughput averaged over 1 frame	Mbps	17.818	28.896	38.726	50.400	61.459	81.158	105.69 6	127.89 1	150.01 0	172.05 1	216.42 2
NOTE 1: Additional parameters are specified in Table A.3.1-1 and Table A.3.3.1-1.												
NOTE 2: If more than one Code Block is present, an additional CRC sequence of L = 24 Bits is attached to each Code Block (otherwise L = 0 Bit).												
NOTE 3: SS/PBCH block is transmitted in slot #0 of each frame												
NOTE 4: Slot i is slot index per frame												

## A.3.3.5 FRC for maximum input level for 1024 QAM

Table A.3.3.5-1 Fixed reference channel for maximum input level receiver requirements (SCS 15 kHz, TDD, 1024QAM)

Parameter	Unit	Value							
		5	10	15	20	25	30	40	50
Channel bandwidth	MHz	5	10	15	20	25	30	40	50
Subcarrier spacing	kHz	15	15	15	15	15	15	15	15
Subcarrier spacing configuration $\mu$		0	0	0	0	0	0	0	0
Allocated resource blocks		25	52	79	106	133	160	216	270
Subcarriers per resource block		12	12	12	12	12	12	12	12
Allocated slots per Frame		4	4	4	4	4	4	4	4
MCS Index		23	23	23	23	23	23	23	23
MCS table for TBS determination		1024QAM							
Modulation		1024 QAM	1024 QAM	1024 QAM	1024 QAM	1024 QAM	1024 QAM	1024 QAM	1024 QAM
Target Coding Rate		0.78	0.78	0.78	0.78	0.78	0.78	0.78	0.78
Maximum number of HARQ transmissions		1	1	1	1	1	1	1	1
<b>Information Bit Payload per Slot</b>									
For Slots 0,1,3,4,8,9	Bits	N/A	N/A	N/A	N/A	N/A	N/A	N/A	N/A
For Slots 2,5,6,7	Bits	21000	44040	67584	90176	112648	135296	184424	229576
Transport block CRC	Bits	24	24	24	24	24	24	24	24
LDPC base graph		1	1	1	1	1	1	1	1
<b>Number of Code Blocks per Slot</b>									
For Slots 0,1,3,4,8,9	CBs	N/A	N/A	N/A	N/A	N/A	N/A	N/A	N/A
For Slots 2,5,6,7	CBs	3	6	9	11	14	17	22	28
<b>Binary Channel Bits per Slot</b>									
For Slots 0,1,3,4,8,9	Bits	N/A	N/A	N/A	N/A	N/A	N/A	N/A	N/A
For Slots 2,5,6,7	Bits	27000	56160	85320	114480	143640	172800	233280	291600
Max. Throughput averaged over 1 frame	Mbps	8.400	17.616	27.034	36.070	45.059	54.118	73.770	91.830
NOTE 1: Additional parameters are specified in Table A.3.1-1 and Table A.3.3.1-1.									
NOTE 2: If more than one Code Block is present, an additional CRC sequence of L = 24 Bits is attached to each Code Block (otherwise L = 0 Bit).									
NOTE 3: SS/PBCH block is transmitted in slot 0 of each frame									
NOTE 4: Slot i is slot index per frame									



Table A.3.3.5-2 Fixed Reference channel for maximum input level receiver requirements (SCS 30 kHz, TDD, 1024QAM)

Parameter	Unit	Value										
		10	15	20	25	30	40	50	60	70	80	100
<b>Channel bandwidth</b>	<b>MHz</b>											
Subcarrier spacing configuration $\mu$		1	1	1	1	1	1	1	1	1	1	1
Allocated resource blocks		24	38	51	65	78	106	133	162	189	217	273
Subcarriers per resource block		12	12	12	12	12	12	12	12	12	12	12
Allocated slots per Frame		11	11	11	11	11	11	11	11	13	11	11
MCS Index		23	23	23	23	23	23	23	23	23	23	23
MCS Table for TBS determination		1024QAM										
Modulation		1024 QAM	1024 QAM	1024 QAM	1024 QAM	1024 QAM	1024 QAM	1024 QAM	1024 QAM	1024 QAM	1024 QAM	1024 QAM
Target Coding Rate		0.78	0.78	0.78	0.78	0.78	0.78	0.78	0.78	0.78	0.78	0.78
Maximum number of HARQ transmissions		1	1	1	1	1	1	1	1	1	1	1
<b>Information Bit Payload per Slot</b>												
For Slots 0,1,2 and Slot i, if $\text{mod}(i, 10) = \{7,8,9\}$ for i from $\{0, \dots, 19\}$	Bits	N/A	N/A	N/A	N/A	N/A	N/A	N/A	N/A	N/A	N/A	N/A
For Slot i, if $\text{mod}(i, 10) = \{0,1,2,3,4,5,6\}$ for i from $\{3, \dots, 19\}$	Bits	20496	32264	43032	55304	65576	90176	112648	139376	159800	184424	233608
Transport block CRC	Bits	24	24	24	24	24	24	24	24	24	24	24
LDPC base graph		1	1	1	1	1	1	1	1	1	1	1
<b>Number of Code Blocks per Slot</b>												
For Slots 0,1,2 and Slot i, if $\text{mod}(i, 10) = \{7,8,9\}$ for i from $\{0, \dots, 19\}$	CBs	N/A	N/A	N/A	N/A	N/A	N/A	N/A	N/A	N/A	N/A	N/A
For Slot i, if $\text{mod}(i, 10) = \{0,1,2,3,4,5,6\}$ for i from $\{3, \dots, 19\}$	CBs	3	4	6	7	8	11	14	17	19	22	28
<b>Binary Channel Bits per Slot</b>												
For Slots 0,1,2 and Slot i, if $\text{mod}(i, 10) = \{7,8,9\}$ for i from $\{0, \dots, 19\}$	Bits	N/A	N/A	N/A	N/A	N/A	N/A	N/A	N/A	N/A	N/A	N/A
For Slot i, if $\text{mod}(i, 10) = \{0,1,2,3,4,5,6\}$ for i from $\{3, \dots, 19\}$	Bits	25920	41040	55080	70200	84240	114480	143640	174960	204120	234360	294840
Max. Throughput averaged over 1 frame	Mbps	22.546	35.490	47.335	60.834	72.134	99.194	123.91 3	153.31 4	175.86 8	202.86 6	256.96 9
NOTE 1: Additional parameters are specified in Table A.3.1-1 and Table A.3.3.1-1.												
NOTE 2: If more than one Code Block is present, an additional CRC sequence of L = 24 Bits is attached to each Code Block (otherwise L = 0 Bit).												
NOTE 3: SS/PBCH block is transmitted in slot #0 of each frame												
NOTE 4: Slot i is slot index per frame												

Table A.3.3.5-3 Fixed reference channel for maximum input level receiver requirements (SCS 60 kHz, TDD, 1024QAM)

Parameter	Unit	Value										
		10	15	20	25	30	40	50	60	70	80	100
<b>Channel bandwidth</b>	<b>MHz</b>											
Subcarrier spacing configuration $\mu$		2	2	2	2	2	2	2	2	2	2	2

Allocated resource blocks		11	18	24	31	38	51	65	79	93	107	135
Subcarriers per resource block		12	12	12	12	12	12	12	12	12	12	12
Allocated slots per Frame		24	24	24	24	24	24	24	24	26	24	24
MCS Index		23	23	23	23	23	23	23	23	23	23	23
MCS Table for TBS determination		1024QAM										
Modulation		1024 QAM	1024 QAM	1024 QAM	1024 QAM	1024 QAM	1024 QAM	1024 QAM	1024 QAM	1024 QAM	1024 QAM	1024 QAM
Target Coding Rate		0.78	0.78	0.78	0.78	0.78	0.78	0.78	0.78	0.78	0.78	0.78
Maximum number of HARQ transmissions		1	1	1	1	1	1	1	1	1	1	1
<b>Information Bit Payload per Slot</b>												
For Slots 0,1,2,3 and Slot i, if $\text{mod}(i, 20) = \{14,15,16,17,18,19\}$ for i from $\{0,\dots,39\}$	Bits	N/A	N/A	N/A	N/A	N/A	N/A	N/A	N/A	N/A	N/A	N/A
For Slot i, if $\text{mod}(i, 20) = \{0,\dots, 13\}$ for i from $\{4,\dots,39\}$	Bits	9224	15368	20496	26120	32264	43032	55304	67584	79896	90176	114776
Transport block CRC	Bits	24	24	24	24	24	24	24	24	24	24	24
LDPC base graph		1	1	1	1	1	1	1	1	1	1	1
<b>Number of Code Blocks per Slot</b>												
For Slots 0,1,2,3 and Slot i, if $\text{mod}(i, 20) = \{14,15,16,17,18,19\}$ for i from $\{0,\dots,39\}$	CBs	N/A	N/A	N/A	N/A	N/A	N/A	N/A	N/A	N/A	N/A	N/A
For Slot i, if $\text{mod}(i, 20) = \{0,\dots, 13\}$ for i from $\{4,\dots,39\}$	CBs	2	2	3	4	4	6	7	9	10	11	14
<b>Binary Channel Bits per Slot</b>												
For Slots 0,1,2,3 and Slot i, if $\text{mod}(i, 20) = \{14,15,16,17,18,19\}$ for i from $\{0,\dots,39\}$	Bits	N/A	N/A	N/A	N/A	N/A	N/A	N/A	N/A	N/A	N/A	N/A
For Slot i, if $\text{mod}(i, 20) = \{0,\dots, 13\}$ for i from $\{4,\dots,39\}$	Bits	11880	19440	25920	33480	41040	55080	70200	85320	100440	115560	145800
Max. Throughput averaged over 1 frame	Mbps	22.138	36.883	49.190	62.688	77.434	103.27 7	132.73 0	162.20 2	191.75 0	216.42 2	275.46 2
NOTE 1: Additional parameters are specified in Table A.3.1-1 and Table A.3.3.1-1.												
NOTE 2: If more than one Code Block is present, an additional CRC sequence of L = 24 Bits is attached to each Code Block (otherwise L = 0 Bit).												
NOTE 3: SS/PBCH block is transmitted in slot #0 of each frame												
NOTE 4: Slot i is slot index per frame												

## A.4 CSI reference measurement channels

## A.5 OFDMA Channel Noise Generator (OCNG)

### A.5.1 OCNG Patterns for FDD

#### A.5.1.1 OCNG FDD pattern 1: Generic OCNG FDD Pattern for all unused REs

**Table A.5.1.1-1: OP.1 FDD: Generic OCNG FDD Pattern for all unused REs**

<b>OCNG Parameters</b>	<b>OCNG Appliance</b>	<b>Control Region (Core Set)</b>	<b>Data Region</b>
Resources allocated		All unused REs (Note 1)	All unused REs (Note 2)
Structure		PDCCH	PDSCH
Content		Uncorrelated pseudo random QPSK modulated data	Uncorrelated pseudo random QPSK modulated data
Transmission scheme for multiple antennas ports transmission		Single Tx port transmission	Spatial multiplexing using any precoding matrix with dimensions same as the precoding matrix for PDSCH
Subcarrier Spacing		Same as for RMC PDCCH in the active BWP	Same as for RMC PDSCH in the active BWP
Power Level		Same as for RMC PDCCH	Same as for RMC PDSCH
NOTE 1: All unused REs in the active CORESETS appointed by the search spaces in use.			
NOTE 2: Unused available REs refer to REs in PRBs not allocated for any physical channels, CORESETS, synchronization signals or reference signals in channel bandwidth.			

### A.5.2 OCNG Patterns for TDD

#### A.5.2.1 OCNG TDD pattern 1: Generic OCNG TDD Pattern for all unused REs

**Table A.5.2.1-1: OP.1 TDD: Generic OCNG TDD Pattern for all unused REs**

<b>OCNG Parameters</b>	<b>OCNG Appliance</b>	<b>Control Region (Core Set)</b>	<b>Data Region</b>
Resources allocated		All unused REs (Note 1)	All unused REs (Note 2)
Structure		PDCCH	PDSCH
Content		Uncorrelated pseudo random QPSK modulated data	Uncorrelated pseudo random QPSK modulated data
Transmission scheme for multiple antennas ports transmission		Single Tx port transmission	Spatial multiplexing using any precoding matrix with dimensions same as the precoding matrix for PDSCH
Subcarrier Spacing		Same as for RMC PDCCH in the active BWP	Same as for RMC PDSCH in the active BWP
Power Level		Same as for RMC PDCCH	Same as for RMC PDSCH
NOTE 1: All unused REs in the active CORESETS appointed by the search spaces in use.			
NOTE 2: Unused available REs refer to REs in PRBs not allocated for any physical channels, CORESETS, synchronization signals or reference signals in channel bandwidth.			

## A.6 Void

## A.7 V2X reference measurement channels

### A.7.1 General

The algorithm for determining the payload size  $A$  is as follows; given a desired coding rate  $R$  and radio block allocation  $NRB$

1. Calculate the RE number of 2nd stage SCI  $Q\_SCI2^A$  that can be transmitted in a given sub-frame, where in order to make sure that the code-rate of 2-A is approximate to SCI 1-A, a beta offset is selected based on MCS, and vacant resource elements  $\gamma$  value is determined based on  $NRB$  and DMRS frequency density.
2. Transport Block Size is determined according to clause 8.1.3.2 of TS 38.214 [13] based on Table A.7.1-1.
3. Calculate Binary Channel Bits per Slot for PSSCH as below

Binary Channel Bits per Slot =  $(NRB * \text{Subcarriers per resource block} * \text{CP-OFDM symbols per slot} - \text{DMRS resource REs} - \text{PSCCH resource Res} - Q\_SCI2^A) * Q_m$

Where  $Q_m$  is the modulation order corresponding to MCS.

In Table A.7.1-1 Common reference channel parameters are listed the Sidelink reference measurement channels specified in annexes A.7.2 to A.7.6.

**Table A.7.1-1: Common reference channel parameters**

Parameter	Value	remark
Number of HARQ Processes	1	
Channel state	AWGN	
Subcarriers per resource block	12	
sl-PSSCH-DMRS-TimePatternList	2	symbol4 and symbol 10 in each slot FDMed with PSSCH within DMRS symbol Frequency density is $\frac{1}{2}$
CP-OFDM symbols per slot (Note1)	12 for all slots	Excluding the first OFDM symbol in one SL slot used for AGC
PSCCH resource	10 PRBs, 3 symbols in time domain	
Slot number in 10ms	$10 * 2^\mu$	$\mu = 0,1,2$ for 15kHz, 30kHz, 60kHz
PT-RS	disable	
CSI-RS	disable	
x-overhead	0	
PSFCH period	0	
2 <sup>nd</sup> stage SCI payload size	59	35bits SCI-2A + 24bits CRC
Redundancy Version	RV0	For channel coding
Alpha value for SCI-2	1	

### A.7.2 FRC for V2X receiver requirements for QPSK

For V2X transmission over PC5, Table A.7.2-1, Table A.7.2-2 and Table A.7.2-3 are applicable for measurements on the Receiver Characteristics with the exception of Maximum input level.

**Table A.7.2-1: Fixed reference channel for V2X receiver requirements (SCS 15 kHz, QPSK)**

Parameter	Unit	Value				
Channel bandwidth	MHz	5 <sup>3</sup>	10	20	30	40
Subcarrier spacing	kHz	15	15	15	15	15

Subchannel size		12	10	15	10	12
Allocated resource blocks		24	50	105	160	216
MCS Index		4	4	4	4	4
MCS Table for TBS determination		64QAM				
Modulation		QPSK	QPSK	QPSK	QPSK	QPSK
Transport Block Size		1608	3624	7936	12296	16896
Transport block CRC	Bits	16	16	24	24	24
LDPC base graph		2	2	1	1	1
Number of Code Blocks per Slot		1	1	1	2	3
Beta offset for 2nd stage SCI		2.25	2.25	2.25	2.25	2.25
$\gamma$ value when 2nd stage SCI rate match		7	1	1	1	1
Binary Channel Bits per Slot		5160	12036	26556	41076	55860
Max. Throughput averaged over 100ms	Mbps	0.1608	0.3624	0.7936	1.2296	1.6896
NOTE 1: If more than one Code Block is present, an additional CRC sequence of L = 24 Bits is attached to each Code Block (otherwise L = 0 Bit).						
NOTE 2: $\gamma$ is the number of vacant resource elements in the resource block to which the last coded symbol of the 2 <sup>nd</sup> -stage SCI belongs.						
NOTE 3: The CBW is only applicable for PS UE in n14.						

**Table A.7.2-2: Fixed reference channel for V2X receiver requirements (SCS 30 kHz, QPSK)**

Parameter	Unit	Value						
Channel bandwidth	MHz	10	20	30	40	60	80	100
Subcarrier spacing	kHz	30	30	30	30	[30]	[30]	[30]
Subchannel size		12	10	15	15	[10]	[12]	[15]
Allocated resource blocks		24	50	75	105	[160]	[216]	[270]
MCS Index		4	4	4	4	[4]	[4]	[4]
MCS Table for TBS determination		64QAM						
Modulation		QPSK	QPSK	QPSK	QPSK	[QPSK]	[QPSK]	[QPSK]
Transport Block Size		1608	3624	5632	7936	[12296]	[16392]	[21000]
Transport block CRC	Bits	16	16	24	24	[24]	[24]	[24]
LDPC base graph		2	2	1	1	[1]	[1]	[1]
Number of Code Blocks per Slot		1	1	1	1	[2]	[2]	[3]
Beta offset for 2nd stage SCI		2.25	2.25	2.25	2.25	[2.25]	[2.25]	[2.25]
$\gamma$ value when 2nd stage SCI rate match		7	1	1	1	[1]	[1]	[1]
Binary Channel Bits per Slot		5160	12036	18636	26556	[41076]	[55860]	[70116]
Max. Throughput averaged over 100ms	Mbps	0.3216	0.7248	1.1264	1.5872	[2.4592]	[3.2784]	[4.2]
NOTE 1: If more than one Code Block is present, an additional CRC sequence of L = 24 Bits is attached to each Code Block (otherwise L = 0 Bit).								
NOTE 2: $\gamma$ is the number of vacant resource elements in the resource block to which the last coded symbol of the 2 <sup>nd</sup> -stage SCI belongs.								

**Table A.7.2-3: Fixed reference channel for V2X receiver requirements (SCS 60 kHz, QPSK)**

Parameter	Unit	Value						
Channel bandwidth	MHz	10	20	30	40	60	80	100
Subcarrier spacing	kHz	60	60	60	60	[60]	[60]	[60]
Subchannel size		10	12	12	10	[15]	[15]	[15]
Allocated resource blocks		10	24	36	50	[75]	[105]	[135]
MCS Index		4	4	4	4	[4]	[4]	[4]
MCS Table for TBS determination		64QAM						
Modulation		QPSK	QPSK	QPSK	QPSK	[QPSK]	[QPSK]	[QPSK]
Transport Block Size		456	1608	2536	3624	[5504]	[7936]	[10248]
Transport block CRC	Bits	16	16	16	16	[24]	[24]	[24]
LDPC base graph		2	2	2	2	[1]	[1]	[1]
Number of Code Blocks per Slot		1	1	1	1	[1]	[1]	[2]
Beta offset for 2nd stage SCI		2.25	2.25	2.25	2.25	[2.25]	[2.25]	[2.25]
$\gamma$ value when 2nd stage SCI rate match		7	7	7	1	[1]	[1]	[1]
Binary Channel Bits per Slot		1464	5160	8328	12036	[18636]	[26556]	[34476]
Max. Throughput averaged over 100ms	Mbps	0.1824	0.6432	1.0144	1.4496	[2.2016]	[3.1744]	[4.0992]

NOTE 1: If more than one Code Block is present, an additional CRC sequence of L = 24 Bits is attached to each Code Block (otherwise L = 0 Bit).  
 NOTE 2:  $\gamma$  is the number of vacant resource elements in the resource block to which the last coded symbol of the 2<sup>nd</sup>-stage SCI belongs.

### A.7.3 FRC for maximum input level for 64QAM

For V2X transmission over PC5, Table A.7.3-1, Table A.7.3-2 and TableA.7.3-3 are applicable for Maximum input level when the maximum modulation order is 64QAM.

**Table A.7.3-1: Fixed reference channel for V2X receiver requirements (SCS 15 kHz, 64QAM)**

Parameter	Unit	Value				
		5 <sup>3</sup>	10	20	30	40
Channel bandwidth	MHz	5 <sup>3</sup>	10	20	30	40
Subcarrier spacing	kHz	15	15	15	15	15
Subchannel size		12	10	15	10	12
Allocated resource blocks		24	50	105	160	216
MCS Index		24	24	24	24	24
MCS Table for TBS determination		64QAM				
Modulation		64QAM	64QAM	64QAM	64QAM	64QAM
Transport Block Size		11528	27144	60456	92200	127080
Transport block CRC	Bits	24	24	24	24	24
LDPC base graph		1	1	1	1	1
Number of Code Blocks per Slot		2	4	8	11	16
Beta offset for 2nd stage SCI		6.25	6.25	6.25	6.25	6.25
$\gamma$ value when 2nd stage SCI rate match		7	1	1	1	1
Binary Channel Bits per Slot		15336	35964	79524	123084	167436
Max. Throughput averaged over 100ms	Mbps	1.1528	2.7144	6.0456	9.22	12.708
NOTE 1: If more than one Code Block is present, an additional CRC sequence of L = 24 Bits is attached to each Code Block (otherwise L = 0 Bit).						
NOTE 2: $\gamma$ is the number of vacant resource elements in the resource block to which the last coded symbol of the 2 <sup>nd</sup> -stage SCI belongs.						
NOTE 3: The CBW is only applicable for PS UE in n14.						

**Table A.7.3-2: Fixed reference channel for V2X receiver requirements (SCS 30 kHz, 64QAM)**

Parameter	Unit	Value						
		10	20	30	40	60	80	100
Channel bandwidth	MHz	10	20	30	40	60	80	100
Subcarrier spacing	kHz	30	30	30	30	[30]	[30]	[30]
Subchannel size		12	10	15	15	[10]	[12]	[15]
Allocated resource blocks		24	50	75	105	[160]	[216]	[270]
MCS Index		24	24	24	24	[24]	[24]	[24]
MCS Table for TBS determination		64QAM						
Modulation		64QAM	64QAM	64QAM	64QAM	[64QAM]	[64QAM]	[64QAM]
Transport Block Size		11528	27144	42016	60456	[92200]	[125016]	[155776]
Transport block CRC	Bits	24	24	24	24	[24]	[24]	[24]
LDPC base graph		1	1	1	1	[1]	[1]	[1]
Number of Code Blocks per Slot		2	4	5	8	[11]	[15]	[19]
Beta offset for 2nd stage SCI		6.25	6.25	6.25	6.25	[6.25]	[6.25]	[6.25]
$\gamma$ value when 2nd stage SCI rate match		7	1	1	1	[1]	[1]	[1]
Binary Channel Bits per Slot		15336	35964	55764	79524	[123084]	[167436]	[210204]
Max. Throughput averaged over 100ms	Mbps	2.3056	5.4288	8.4032	12.091	[18.44]	[25.0032]	[31.1552]
NOTE 1: If more than one Code Block is present, an additional CRC sequence of L = 24 Bits is attached to each Code Block (otherwise L = 0 Bit).								
NOTE 2: $\gamma$ is the number of vacant resource elements in the resource block to which the last coded symbol of the 2 <sup>nd</sup> -stage SCI belongs.								

**Table A.7.3-3: Fixed reference channel for V2X receiver requirements (SCS 60 kHz, 64QAM)**

Parameter	Unit	Value						
		10	20	30	40	60	80	100
Channel bandwidth	MHz	10	20	30	40	60	80	100
Subcarrier spacing	kHz	60	60	60	60	[60]	[60]	[60]
Subchannel size		10	12	12	10	[15]	[15]	[15]
Allocated resource blocks		10	24	36	50	[75]	[105]	[135]
MCS Index		24	24	24	24	[24]	[24]	[24]
MCS Table for TBS determination		64QAM						
Modulation		64QAM	64QAM	64QAM	64QAM	[64QAM]	[64QAM]	[64QAM]
Transport Block Size		3240	11528	18960	27144	[42016]	[59432]	[77896]
Transport block CRC	Bits	16	24	24	24	[24]	[24]	[24]
LDPC base graph		2	1	1	1	[1]	[1]	[1]
Number of Code Blocks per Slot		1	2	3	4	[5]	[8]	[10]
Beta offset for 2nd stage SCI		6.25	6.25	6.25	6.25	[6.25]	[6.25]	[6.25]
$\gamma$ value when 2nd stage SCI rate match		7	7	7	1			
Binary Channel Bits per Slot		4248	15336	24840	35964	[55764]	[79524]	[103284]
Max. Throughput averaged over 100ms	Mbps	1.296	4.6112	7.584	10.858	[16.8064]	[23.7728]	[31.1584]
NOTE 1: If more than one Code Block is present, an additional CRC sequence of L = 24 Bits is attached to each Code Block (otherwise L = 0 Bit).								
NOTE 2: $\gamma$ is the number of vacant resource elements in the resource block to which the last coded symbol of the 2 <sup>nd</sup> -stage SCI belongs.								

## A.7.4 FRC for maximum input level for 256QAM

For V2X transmission over PC5, Table A.7.4-1, Table A.7.4-2 and Table A.7.4-3 are applicable for Maximum input level when the 256QAM is supported.

**Table A.7.4-1: Fixed reference channel for V2X receiver requirements (SCS 15 kHz, 256QAM)**

Parameter	Unit	Value				
		5 <sup>3</sup>	10	20	30	40
Channel bandwidth	MHz	5 <sup>3</sup>	10	20	30	40
Subcarrier spacing	kHz	15	15	15	15	15
Subchannel size		12	10	15	10	12
Allocated resource blocks		24	50	105	160	216
MCS Index		23	23	23	23	23
MCS Table for TBS determination		256QAM				
Modulation		256QAM	256QAM	256QAM	256QAM	256QAM
Transport Block Size		15880	36896	81976	127080	172176
Transport block CRC	Bits	24	24	24	24	24
LDPC base graph		1	1	1	1	1
Number of Code Blocks per Slot		2	5	10	16	21
Beta offset for 2nd stage SCI		6.25	6.25	6.25	6.25	6.25
$\gamma$ value when 2nd stage SCI rate match		3	3	3	3	3
Binary Channel Bits per Slot		20544	48000	106080	164160	223296
Max. Throughput averaged over 100ms	Mbps	1.588	3.6896	8.1976	12.708	17.218
NOTE 1: If more than one Code Block is present, an additional CRC sequence of L = 24 Bits is attached to each Code Block (otherwise L = 0 Bit).						
NOTE 2: $\gamma$ is the number of vacant resource elements in the resource block to which the last coded symbol of the 2 <sup>nd</sup> -stage SCI belongs.						
NOTE 3: The CBW is only applicable for PS UE in n14.						

**Table A.7.4-2: Fixed reference channel for V2X receiver requirements (SCS 30 kHz, 256QAM)**

Parameter	Unit	Value						
		10	20	30	40	60	80	100
Channel bandwidth	MHz	10	20	30	40	60	80	100
Subcarrier spacing	kHz	30	30	30	30	[30]	[30]	[30]
Subchannel size		12	10	15	15	[10]	[12]	[15]

Allocated resource blocks		24	50	75	105	[160]	[216]	[270]
MCS Index		23	23	23	23	[24]	[24]	[24]
MCS Table for TBS determination	256QAM							
Modulation		256QAM	256QAM	256QAM	256QAM	[256QAM]	[256QAM]	[256QAM]
Transport Block Size		15880	36896	58384	81976	[127080]	[172176]	[217128]
Transport block CRC	Bits	24	24	24	24	[24]	[24]	[24]
LDPC base graph		1	1	1	1	[1]	[1]	[1]
Number of Code Blocks per Slot		2	5	7	10	[16]	[21]	[26]
Beta offset for 2nd stage SCI		6.25	6.25	6.25	6.25	[6.25]	[6.25]	[6.25]
$\gamma$ value when 2nd stage SCI rate match		3	3	3	3	[3]	[3]	[3]
Binary Channel Bits per Slot		20544	48000	74400	106080	[164160]	[223296]	[280320]
Max. Throughput averaged over 100ms	Mbps	3.176	7.3792	11.677	16.395	[25.416]	[34.4352]	[43.4256]
NOTE 1: If more than one Code Block is present, an additional CRC sequence of L = 24 Bits is attached to each Code Block (otherwise L = 0 Bit).								
NOTE 2: $\gamma$ is the number of vacant resource elements in the resource block to which the last coded symbol of the 2 <sup>nd</sup> -stage SCI belongs.								

**Table A.7.4-3: Fixed reference channel for V2X receiver requirements (SCS 60kHz, 256QAM)**

Parameter	Unit	Value						
Channel bandwidth	MHz	<b>10</b>	<b>20</b>	<b>30</b>	<b>40</b>	<b>60</b>	<b>80</b>	<b>100</b>
Subcarrier spacing	kHz	60	60	60	60	[60]	[60]	[60]
Subchannel size		10	12	12	10	[15]	[15]	[15]
Allocated resource blocks		10	24	36	50	[75]	[105]	[135]
MCS Index		23	23	23	23	[23]	[23]	[23]
MCS Table for TBS determination	256QAM							
Modulation		256QAM	256QAM	256QAM	256QAM	[256QAM]	[256QAM]	[256QAM]
Transport Block Size		4480	15880	25608	36896	[57376]	[81976]	[106576]
Transport block CRC	Bits	24	24	24	24	[24]	[24]	[24]
LDPC base graph		1	1	1	1	[1]	[1]	[1]
Number of Code Blocks per Slot		1	2	4	5	[7]	[10]	[13]
Beta offset for 2nd stage SCI		6.25	6.25	6.25	6.25	[6.25]	[6.25]	[6.25]
$\gamma$ value when 2nd stage SCI rate match		3	3	3	3	[3]	[3]	[3]
Binary Channel Bits per Slot		5760	20544	33216	48000	[74400]	[106080]	[137760]
Max. Throughput averaged over 100ms	Mbps	1.792	6.352	10.243	14.758	[22.9504]	[32.7904]	[42.6304]
NOTE 1: If more than one Code Block is present, an additional CRC sequence of L = 24 Bits is attached to each Code Block (otherwise L = 0 Bit).								
NOTE 2: $\gamma$ is the number of vacant resource elements in the resource block to which the last coded symbol of the 2 <sup>nd</sup> -stage SCI belongs.								



## Annex B (informative): Void

# Annex C (informative): Downlink physical channels

## C.1 General

The following clauses, describes the downlink Physical Channels that are transmitted during a connection i.e., when measurements are done.

## C.2 Setup

Table C.2-1 describes the downlink Physical Channels that are required for connection set up.

**Table C.2-1: Downlink Physical Channels required for connection set-up**

Physical Channel
PBCH
SSS
PSS
PDCCH
PDSCH
PBCH DMRS
PDCCH DMRS
PDSCH DMRS
CSI-RS

## C.3 Connection

### C.3.1 Measurement of Receiver Characteristics

Unless otherwise stated, Table C.3.1-1 is applicable for measurements on the Receiver Characteristics (clause 7).

**Table C.3.1-1: Downlink Physical Channels transmitted during a connection (FDD and TDD)**

Parameter	Unit	Value
SSS transmit power	W	Test specific
EPRE ratio of PSS to SSS	dB	0
EPRE ratio of PBCH to SSS	dB	0
EPRE ratio of PBCH to PBCH DMRS	dB	0
EPRE ratio of PDCCH to SSS	dB	0
EPRE ratio of PDCCH to PDCCH DMRS	dB	0
EPRE ratio of PDSCH to SSS	dB	0
EPRE ratio of PDSCH to PDSCH DMRS (Note 1)	dB	-3
EPRE ratio of CSI-RS to SSS	dB	0
EPRE ratio of PTRS to PDSCH	dB	Test specific
EPRE ratio of OCNG DMRS to SSS	dB	0
EPRE ratio of OCNG to OCNG DMRS (Note 1)	dB	0
NOTE 1: No boosting is applied to any of the channels except PDSCH DMRS. For PDSCH DMRS, 3 dB power boosting is applied assuming DMRS Type 1 configuration when DMRS and PDSCH are TDM'ed and only half of the DMRS REs are occupied.		
NOTE 2: Number of DMRS CDM groups without data for PDSCH DMRS configuration for OCNG is set to 1.		



## Annex D (normative): Characteristics of the interfering signal

### D.1 General

Some RF performance requirements for the NR UE receiver are defined with interfering signals present in addition to the wanted signal.

For NR bands with  $F_{DL\_high} < 2700$  MHz and  $F_{UL\_high} < 2700$  MHz, a modulated 5 MHz full bandwidth NR down link signal, and in some cases an additional CW signal, are used as interfering signal. For intra-band contiguous CA bandwidth class B and C, a modulated 5 MHz NR downlink signal is used. And for some cases an additional CW signal is used.

For NR bands with  $F_{DL\_low} \geq 3300$  MHz and  $F_{UL\_low} \geq 3300$  MHz, a modulated NR downlink signal which equals to channel bandwidth of the wanted signal for single carrier and inter-band CA cases is used as interfering signal. For intra-band contiguous CA bandwidth Class C, a modulated NR downlink signal which equals to the aggregated channel bandwidth of the wanted signal is used. For intra-band contiguous CA bandwidth class D and E cases, a modulated 50 MHz NR downlink signal is used. And for some cases an additional CW signal is used.

### D.2 Interference signals

Table D.2-1 and Table D.2-4 describes the modulated interferer for different channel bandwidth options for NR band lower than 2700MHz.

**Table D.2-1: Description of modulated NR interferer for NR bands with  $F_{DL\_high} < 2700$  MHz and  $F_{UL\_high} < 2700$  MHz**

	Channel bandwidth					
	5 MHz	10MHz	15 MHz	20 MHz	25 MHz	30 MHz
RB	NOTE 1					
$BW_{Interferer}$	5 MHz					
	Channel bandwidth					
	40 MHz	50 MHz	60 MHz	80 MHz	90 MHz	100 MHz
RB	NOTE 1					
$BW_{Interferer}$	5 MHz					
NOTE 1: The RB configured for interfering signal is the same as maximum RB number defined in Table 5.3.2-1 for each sub-carrier spacing.						

Table D.2-2 and Table D.2-3 describe the modulated interferer for different channel bandwidth options for NR band higher than 3300MHz.

**Table D.2-2: Description of modulated NR interferer for NR bands with  $F_{DL\_low} \geq 3300$  MHz and  $F_{UL\_low} \geq 3300$  MHz**

	Channel bandwidth								
	10 MHz	15 MHz	20 MHz	40 MHz	50 MHz	60 MHz	80 MHz	90 MHz	100 MHz
RB	NOTE 1								
$BW_{Interferer}$	10 MHz	15 MHz	20 MHz	40 MHz	50 MHz	60 MHz	80 MHz	90 MHz	100 MHz
NOTE 1: The RB configured for interfering signal is the same as maximum RB number defined in Table 5.3.2-1 for each sub-carrier spacing.									

**Table D.2-3: Description of modulated NR interferer for NR bands with  $F_{DL\_low} \geq 3300$  MHz and  $F_{UL\_low} \geq 3300$  MHz for Intra-band contiguous CA**

	Aggregated Channel bandwidth of Bandwidth Class C								Bandwidth Class D/E
	110 MHz	120 MHz	130 MHz	140 MHz	150 MHz	160 MHz	180 MHz	200 MHz	
RB(SCS=30 kHz)	NOTE 1								133
RB(SCS=60 kHz)	NOTE 1								65
$BW_{interferer}$	110 MHz	120 MHz	130 MHz	140 MHz	150 MHz	160 MHz	180 MHz	<b>200 MHz</b>	50MHz
NOTE 1: The interfering signal shall be configured in the same way as the aggregated bandwidth of the wanted signal. The RB configurations for each component carrier are defined in Table 5.3.2-1 for each sub-carrier spacing.									

**Table D.2-4: Description of modulated NR interferer for NR bands with  $F_{DL\_low} < 2700$  MHz and  $F_{UL\_low} < 2700$  MHz for Intra-band contiguous CA**

	Bandwidth Class B	Bandwidth Class C
RB	NOTE 1	NOTE 1
$BW_{interferer}$	5 MHz	5 MHz
NOTE 1: The RB configured for interfering signal is the same as maximum RB number defined in Table 5.3.2-1 for each sub-carrier spacing.		

# Annex E (normative): Environmental conditions

## E.1 General

This normative annex specifies the environmental requirements of the UE. Within these limits the requirements of the present documents shall be fulfilled.

## E.2 Environmental

The requirements in this clause apply to all types of UE(s).

### E.2.1 Temperature

The UE shall fulfil all the requirements in the full temperature range of:

**Table E.2.1-1: Temperature conditions**

+15°C to +35°C	For normal conditions (with relative humidity up to 75 %)
-10°C to +55°C	For extreme conditions (see IEC publications 68-2-1 and 68-2-2)

Outside this temperature range the UE, if powered on, shall not make ineffective use of the radio frequency spectrum. In no case shall the UE exceed the transmitted levels as defined in clause 6.2 for extreme operation.

### E.2.2 Voltage

The UE shall fulfil all the requirements in the full voltage range, i.e. the voltage range between the extreme voltages.

The manufacturer shall declare the lower and higher extreme voltages and the approximate shutdown voltage. For the equipment that can be operated from one or more of the power sources listed below, the lower extreme voltage shall not be higher, and the higher extreme voltage shall not be lower than that specified below.

**Table E.2.2-1: Voltage conditions**

Power source	Lower extreme voltage	Higher extreme voltage	Normal conditions voltage
AC mains	0,9 * nominal	1,1 * nominal	nominal
Regulated lead acid battery	0,9 * nominal	1,3 * nominal	1,1 * nominal
Non regulated batteries:			
Leclanché	0,85 * nominal	Nominal	Nominal
Lithium	0,95 * nominal	1,1 * Nominal	1,1 * Nominal
Mercury/nickel & cadmium	0,90 * nominal		Nominal

Outside this voltage range the UE if powered on, shall not make ineffective use of the radio frequency spectrum. In no case shall the UE exceed the transmitted levels as defined in clause 6.2 for extreme operation. In particular, the UE shall inhibit all RF transmissions when the power supply voltage is below the manufacturer declared shutdown voltage.

## E.2.3 Vibration

The UE shall fulfil all the requirements when vibrated at the following frequency/amplitudes.

**Table E.2.3-1: Vibration conditions**

<b>Frequency</b>	<b>ASD (Acceleration Spectral Density) random vibration</b>
5 Hz to 20 Hz	0.96 m <sup>2</sup> /s <sup>3</sup>
20 Hz to 500 Hz	0.96 m <sup>2</sup> /s <sup>3</sup> at 20 Hz, thereafter -3 dB/Octave

Outside the specified frequency range the UE, if powered on, shall not make ineffective use of the radio frequency spectrum. In no case shall the UE exceed the transmitted levels as defined in TS 38.101-1 for extreme operation.

## Annex F (normative): Transmit modulation

### F.0 General

While measuring the transmit modulation quality of carriers, an existence of the carrier leakage needs to be taken into account indicated by the parameters in *UplinkTxDirectCurrent* IE, *UplinkTxDirectCurrentTwoCarrierList-r16* or *UplinkTxDirectCurrentMoreCarrierList*.

### F.1 Measurement Point

Figure F.1-1 shows the measurement point for the unwanted emission falling into non-allocated RB(s) and the EVM for the allocated RB(s).

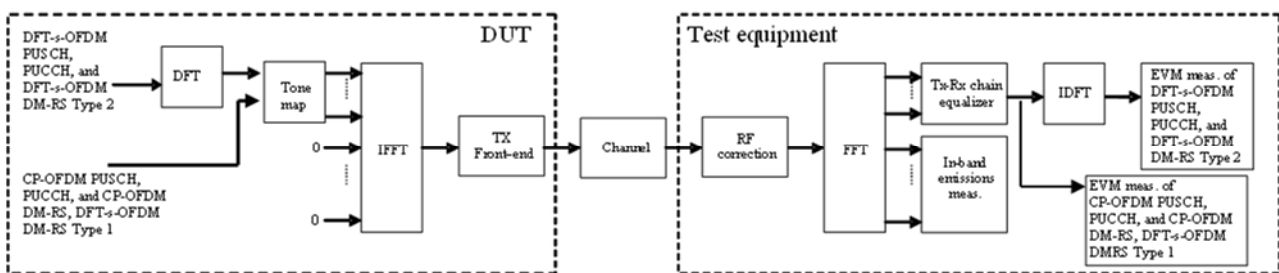

Figure F.1-1: EVM measurement points

### F.2 Basic Error Vector Magnitude measurement

The EVM is the difference between the ideal waveform and the measured waveform for the allocated RB(s)

$$EVM = \sqrt{\frac{\sum_{v \in T_m} |z'(v) - i(v)|^2}{|T_m| \cdot P_0}},$$

where

$T_m$  is a set of  $|T_m|$  modulation symbols with the considered modulation scheme being active within the measurement period,

$z'(v)$  are the samples of the signal evaluated for the EVM,

$i(v)$  is the ideal signal reconstructed by the measurement equipment, and



$P_0$  is the average power of the ideal signal. For normalized modulation symbols  $P_0$  is equal to 1.

The basic EVM measurement interval is defined over one slot in the time domain for PUCCH and PUSCH and over one preamble sequence for the PRACH.

## F.3 Basic in-band emissions measurement

The in-band emissions are a measure of the interference falling into the non-allocated resources blocks. The in-band emission requirement is evaluated for PUCCH and PUSCH transmissions. The in-band emission requirement is not evaluated for PRACH transmissions.

The in-band emissions are measured as follows

$$Emissions_{absolute}(\Delta_{RB}) = \begin{cases} \frac{1}{|T_s|} \sum_{t \in T_s} \sum_{f_i + (12 \cdot \Delta_{RB} + 11) \cdot \Delta f}^{\max(f_{\min}, f_l + 12 \cdot \Delta_{RB} \cdot \Delta f)} |Y(t, f)|^2, \Delta_{RB} < 0 \\ \frac{1}{|T_s|} \sum_{t \in T_s} \sum_{f_h + (12 \cdot \Delta_{RB} - 11) \cdot \Delta f}^{\min(f_{\max}, f_h + 12 \cdot \Delta_{RB} \cdot \Delta f)} |Y(t, f)|^2, \Delta_{RB} > 0 \end{cases},$$

where

$T_s$  is a set of  $|T_s|$  OFDM symbols with the considered modulation scheme being active within the measurement period,

$\Delta_{RB}$  is the starting frequency offset between the allocated RB and the measured non-allocated RB (e.g.  $\Delta_{RB} = 1$  or  $\Delta_{RB} = -1$  for the first adjacent RB),

$f_{\min}$  (resp.  $f_{\max}$ ) is the lower (resp. upper) edge of the UL UE channel bandwidth,

$f_l$  and  $f_h$  are the lower and upper edge of the allocated BW, and

$Y(t, f)$  is the frequency domain signal evaluated for in-band emissions as defined in the clause (ii)

The relative in-band emissions are, given by

$$Emissions_{relative}(\Delta_{RB}) = \frac{Emissions_{absolute}(\Delta_{RB})}{\frac{1}{|T_s| \cdot N_{RB}} \sum_{t \in T_s} \sum_{f_i}^{f_i + (12 \cdot N_{RB} - 1) \Delta f} |Y(t, f)|^2}$$

where

$N_{RB}$  is the number of allocated RBs

The basic in-band emissions measurement interval is defined over one slot in the time domain. When the PUSCH or PUCCH transmission slot is shortened due to multiplexing with SRS, the in-band emissions measurement interval is reduced by one OFDM symbol, accordingly.

In the evaluation of in-band emissions, the timing is set according to  $\tilde{\Delta f} = \tilde{\Delta c}$ , where sample time offsets  $\tilde{\Delta f}$  and  $\tilde{\Delta c}$  are defined in clause F.4.

## F.4 Modified signal under test

Implicit in the definition of EVM is an assumption that the receiver is able to compensate a number of transmitter impairments.

The DFT-s-OFDM modulated signals or PRACH signal under test is modified and, in the case of DFT-s-OFDM modulated signals, decoded according to:

$$Z'(t, f) = IDFT \left\{ \frac{FFT \left\{ z(v - \Delta\tilde{t}) \cdot e^{-j2\pi\Delta\tilde{f}v} \right\} e^{j2\pi f \Delta\tilde{t}}}{\tilde{a}(t, f) \cdot e^{j\tilde{\varphi}(t, f)}} \right\}$$

where

$z(v)$  is the time domain samples of the signal under test.

The CP-OFDM modulated signals or PUSCH demodulation reference signal or PUCCH data signal under test is equalised and, in the case of CP-OFDM modulated signals decoded according to:

$$Z'(t, f) = \frac{FFT \left\{ z(v - \Delta\tilde{t}) \cdot e^{-j2\pi\Delta\tilde{f}v} \right\} e^{j2\pi f \Delta\tilde{t}}}{\tilde{a}(t, f) \cdot e^{j\tilde{\varphi}(t, f)}}$$

where

$z(v)$  is the time domain samples of the signal under test.

To minimize the error, the signal under test should be modified with respect to a set of parameters following the procedure explained below.

Notation:

$\Delta\tilde{t}$  is the sample timing difference between the FFT processing window in relation to nominal timing of the ideal signal.

$\Delta\tilde{f}$  is the RF frequency offset.

$\tilde{\varphi}(t, f)$  is the phase response of the TX chain.

$\tilde{a}(t, f)$  is the amplitude response of the TX chain.

In the following  $\Delta\tilde{c}$  represents the middle sample of the EVM window of length  $w$  (defined in the next clauses) or the last sample of the first window half if  $w$  is even.

The EVM analyser shall

- detect the start of each slot and estimate  $\Delta\tilde{t}$  and  $\Delta\tilde{f}$ ,
- determine  $\Delta\tilde{c}$  so that the EVM window of length  $w$  is centred
  - on the time interval determined by the measured cyclic prefix minus  $16\kappa$  samples of the considered OFDM symbol for symbol  $l$  for subcarrier spacing configuration  $\mu$  in a subframe, with  $l = 0$  or  $l = 7 \cdot 2^\mu$  for normal CP, i.e. the first  $16\kappa$  samples of the CP should not be taken into account for this step. In the determination of the number of excluded samples, a sampling rate of  $1/T_c$  is assumed. If a different sampling rate is used, the number of excluded samples is scaled linearly.
  - on the measured cyclic prefix of the considered OFDM symbol for all other symbols for normal CP and for symbol 0 to 11 for extended CP.

- on the measured preamble cyclic prefix for the PRACH

To determine the other parameters a sample timing offset equal to  $\Delta\tilde{c}$  is corrected from the signal under test. The EVM analyser shall then

- correct the RF frequency offset  $\hat{\Delta f}$  for each time slot, and
- apply an FFT of appropriate size. The chosen FFT size shall ensure that in the case of an ideal signal under test, there is no measured inter-subcarrier interference.

The carrier leakage shall be removed from the evaluated signal before calculating the EVM and the in-band emissions; however, the removed relative carrier leakage power also has to satisfy the applicable requirement.

At this stage the allocated RBs shall be separated from the non-allocated RBs. In the case of PUCCH and PUSCH EVM, the signal on the non-allocated RB(s),  $y(t, f)$ , is used to evaluate the in-band emissions.

Moreover, the following procedure applies only to the signal on the allocated RB(s).

- In the case of PUCCH and PUSCH, the UL EVM analyzer shall estimate the TX chain equalizer coefficients  $\tilde{a}(t, f)$  and  $\tilde{\varphi}(t, f)$  used by the ZF equalizer for all subcarriers by time averaging at each signal subcarrier of the amplitude and phase of the reference and data symbols. The time-averaging length is 1 slot. This process creates an average amplitude and phase for each signal subcarrier used by the ZF equalizer. The knowledge of data modulation symbols may be required in this step because the determination of symbols by demodulation is not reliable before signal equalization.
- In the case of PRACH, the UL EVM analyzer shall estimate the TX chain coefficients  $\tilde{a}(t)$  and  $\tilde{\varphi}(t)$  used for phase and amplitude correction and are selected so as to minimize the resulting EVM. The TX chain coefficients are not dependent on frequency, i.e.  $\tilde{a}(t, f) = \tilde{a}(t)$  and  $\tilde{\varphi}(t, f) = \tilde{\varphi}(t)$ . The TX chain coefficients are chosen independently for each preamble transmission and for each  $\Delta\tilde{c}$ .

At this stage estimates of  $\hat{\Delta f}$ ,  $\tilde{a}(t, f)$ ,  $\tilde{\varphi}(t, f)$  and  $\Delta\tilde{c}$  are available.  $\Delta\tilde{c}$  is one of the extremities of the window  $W$ , i.e.  $\Delta\tilde{c}$  can be  $\Delta\tilde{c} + \alpha - \left\lfloor \frac{W}{2} \right\rfloor$  or  $\Delta\tilde{c} + \left\lfloor \frac{W}{2} \right\rfloor$ , where  $\alpha = 0$  if  $W$  is odd and  $\alpha = 1$  if  $W$  is even. The EVM analyser shall then

- calculate  $\text{EVM}_l$  with  $\Delta\tilde{c}$  set to  $\Delta\tilde{c} + \alpha - \left\lfloor \frac{W}{2} \right\rfloor$ ,
- calculate  $\text{EVM}_h$  with  $\Delta\tilde{c}$  set to  $\Delta\tilde{c} + \left\lfloor \frac{W}{2} \right\rfloor$ .

For the EVM calculation on the symbols with a transient period when the UE signals a transient period capability (tp) of 2, 4 or 7usec,  $\Delta\tilde{t}$  is given below.

- calculate  $\text{EVM}_{l, tp}$  with  $\Delta\tilde{t}$  set to  $\left\lfloor \frac{tp + tp_{start}}{T_c} \right\rfloor + 1$ , where  $1/T_c$  is the sampling rate
- calculate  $\text{EVM}_{h, tp}$  with  $\Delta\tilde{t}$  set to  $\left\lfloor \frac{CP + tp_{start}}{T_c} \right\rfloor - 1$ , where  $1/T_c$  is the sampling rate and the CP is the cyclic prefix of the symbol on which EVM is calculated (e.g. long CP for the first symbol of the slot) in seconds

A pictorial representation of the EVM measurement windows is given in Figure F.4-1.

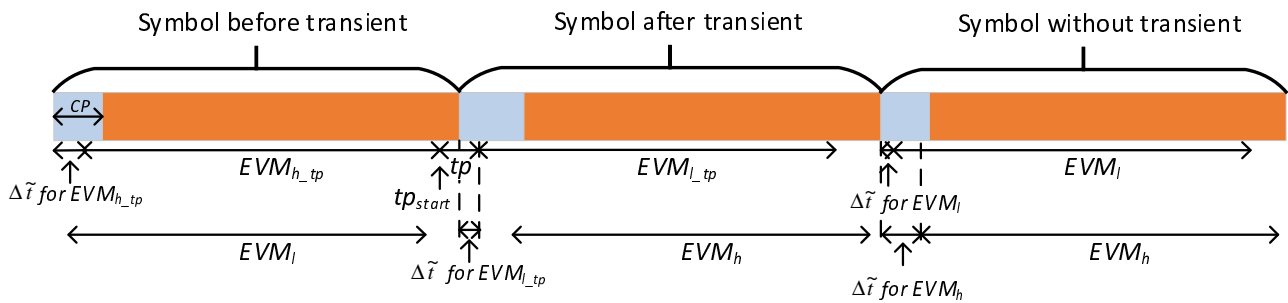

Figure F.4-1 EVM measruement window

## F.5 Window length

### F.5.1 Timing offset

As a result of using a cyclic prefix, there is a range of  $\Delta\tilde{\tau}$ , which, at least in the case of perfect Tx signal quality, would give close to minimum error vector magnitude. As a first order approximation, that range should be equal to the length of the cyclic prefix. Any time domain windowing or FIR pulse shaping applied by the transmitter reduces the  $\Delta\tilde{\tau}$  range within which the error vector is close to its minimum.

### F.5.2 Window length

The window length  $W$  affects the measured EVM and is expressed as a function of the configured cyclic prefix length. In the case where equalization is present, as with frequency domain EVM computation, the effect of FIR is reduced. This is because the equalization can correct most of the linear distortion introduced by the FIR. However, the time domain windowing effect can't be removed.

### F.5.3 Window length for normal CP

Tables F.5.3-1, F.5.3-2, and F.5.3-3 below specify the EVM window length ( $W$ ) for normal CP.

Table F.5.3-1: EVM window length for normal CP for NR, FR1, 15 kHz SCS

Channel Bandwidth (MHz)	FFT size	Cyclic prefix length for symbols 1-6 and 8-13 in FFT samples	EVM window length $W$	Ratio of $W$ to total CP length for symbols 1-6 and 8-13 <sup>1</sup> (%)
3	256	18	9	50
5	512	36	18	50
10	1024	72	36	50
15	1536	108	54	50
20	2048	144	72	50
25	2048	144	72	50
30	3072	216	108	50
35	3072	216	108	50
40	4096	288	144	50
45	4096	288	144	50
50	4096	288	144	50

NOTE 1: These percentages are informative and apply to a slot's symbols 1 to 6 and 8 to 13. Symbols 0 and 7 have a longer CP and therefore a lower percentage.

Table F.5.3-2: EVM window length for normal CP for NR, FR1, 30 kHz SCS

Channel Bandwidth (MHz)	FFT size	Cyclic prefix length for symbols 1-13 in FFT samples	EVM window length $W$	Ratio of $W$ to total CP length for symbols 1-13 <sup>1</sup> (%)
5	256	18	9	50
10	512	36	18	50
15	768	54	27	50
20	1024	72	36	50
25	1024	72	36	50
30	1536	108	54	50
35	1536	108	54	50
40	2048	144	72	50
45	2048	144	72	50
50	2048	144	72	50
60	3072	216	108	50
70	3072	216	108	50
80	4096	288	144	50
90	4096	288	144	50
100	4096	288	144	50

NOTE 1: These percentages are informative and apply to a slot's symbols 1 through 13. Symbol 0 has a longer CP and therefore a lower percentage.

Table F.5.3-3: EVM window length for normal CP for NR (60 kHz SCS)

Channel Bandwidth (MHz)	FFT size	Cyclic prefix length for symbols in FFT samples	EVM window length $W$	Ratio of $W$ to total CP length <sup>1</sup> (%)
10	256	18	9	50
15	384	27	14	50
20	512	36	18	50
25	512	36	18	50
30	768	54	27	50
35	768	54	27	50
40	1024	72	36	50
45	1024	72	36	50
50	1024	72	36	50
60	1536	108	54	50
70	1536	108	54	50
80	2048	144	72	50
90	2048	144	72	50
100	2048	144	72	50

NOTE 1: These percentages are informative and apply to all OFDM symbols within subframe except for symbol 0 of slot 0 and slot 2. Symbol 0 of slot 0 and slot 2 may have a longer CP and therefore a lower percentage.

## F.5.4 Window length for Extended CP

Table F.5.4-1 below specifies the EVM window length ( $W$ ) for extended CP. The number of CP samples excluded from the EVM window is the same as for normal CP length.

Table F.5.4-1: EVM window length for extended CP for NR, FR1, 60 kHz SCS

Channel Bandwidth (MHz)	FFT size	Cyclic prefix length in FFT samples	EVM window length $W$	Ratio of $W$ to total CP length <sup>1</sup> (%)
10	256	64	54	84.4
15	384	96	80	83.3
20	512	128	106	82.8
25	512	128	110	85.9
30	768	192	164	85.4
35	768	192	164	85.4
40	1024	256	220	85.9
45	1024	256	220	85.9
50	1024	256	220	85.9
60	1536	384	330	85.9
70	1536	384	330	85.9
80	2048	512	440	85.9
90	2048	512	440	85.9
100	2048	512	440	85.9

NOTE 1: These percentages are informative.

## F.5.5 Window length for PRACH

The table below specifies the EVM window length for PRACH preamble formats for  $L_{RA}=839$  and  $\Delta f^{RA} \in \{1.25, .5\}$  kHz

Table F.5.5-1 EVM window length for PRACH formats for  $L_{RA}=839$ 

Preamble format	Cyclic prefix length $N_{CP}$	Nominal FFT size <sup>1</sup>	EVM window length $W$ in FFT samples	Ratio of $W$ to CP <sup>2</sup>
0	3168	24576	2307	72.8%
1	21024	24576	20163	95.9%
2	4688	24576	3827	81.6%
3	3168	6144	2952	93.2%

NOTE 1: The use of other FFT sizes is possible as long as appropriate scaling of the window length is applied  
NOTE 2: These percentages are informative

The table below specifies the EVM window length for PRACH preamble formats for  $L_{RA}=139$  and  $\Delta f^{RA} = 15 \cdot 2^{-\mu}$  kHz where  $\mu \in \{0,1,2\}$ .

Table F.5.5-2 EVM window length for PRACH formats for  $L_{RA}=139$ 

Preamble format	Cyclic prefix length $N_{CP}$	Nominal FFT size <sup>1</sup>	EVM window length $W$ in FFT samples	Ratio of $W$ to CP <sup>2</sup>
A1	$288 \cdot 2^{-\mu}$	$2048 \cdot 2^{-\mu}$	$144 \cdot 2^{-\mu}$	50.0%
A2	$576 \cdot 2^{-\mu}$	$2048 \cdot 2^{-\mu}$	$432 \cdot 2^{-\mu}$	75.0%
A3	$864 \cdot 2^{-\mu}$	$2048 \cdot 2^{-\mu}$	$720 \cdot 2^{-\mu}$	83.3%
B1	$216 \cdot 2^{-\mu}$	$2048 \cdot 2^{-\mu}$	$72 \cdot 2^{-\mu}$	33.3%
B2	$360 \cdot 2^{-\mu}$	$2048 \cdot 2^{-\mu}$	$216 \cdot 2^{-\mu}$	60.0%
B3	$504 \cdot 2^{-\mu}$	$2048 \cdot 2^{-\mu}$	$360 \cdot 2^{-\mu}$	71.4%
B4	$936 \cdot 2^{-\mu}$	$2048 \cdot 2^{-\mu}$	$792 \cdot 2^{-\mu}$	84.6%
C0	$1240 \cdot 2^{-\mu}$	$2048 \cdot 2^{-\mu}$	$1096 \cdot 2^{-\mu}$	88.4%
C2	$2048 \cdot 2^{-\mu}$	$2048 \cdot 2^{-\mu}$	$1904 \cdot 2^{-\mu}$	93.0%

NOTE 1: The use of other FFT sizes is possible as long as appropriate scaling of the window length is applied  
NOTE 2: These percentages are informative

## F.6 Averaged EVM

The general EVM is averaged over basic EVM measurements for  $n$  slots in the time domain.

$$\overline{EVM} = \sqrt{\frac{1}{n} \sum_{i=1}^n EVM_i^2},$$

where  $n$  is

$$n = \begin{cases} 10, & \text{for 15 kHz SCS} \\ 20, & \text{for 30 kHz SCS} \\ 40, & \text{for 60 kHz SCS} \end{cases}$$

for PUCCH, PUSCH.

The EVM requirements shall be tested against the maximum of the RMS average at the window  $W$  extremities of the EVM measurements:

Thus  $\overline{EVM}_i$  is calculated using  $\Delta \tilde{\tau} = \Delta \tilde{\tau}_i$  in the expressions above and  $\overline{EVM}_h$  is calculated using  $\Delta \tilde{\tau} = \Delta \tilde{\tau}_h$ .

Thus we get:

$$EVM = \max(\overline{EVM}_i, \overline{EVM}_h)$$

The calculation of the EVM for the demodulation reference signal,  $EVM_{DMRS}$ , follows the same procedure as calculating the general EVM, with the exception that the modulation symbol set  $T_m$  defined in clause F.2 is restricted to symbols containing uplink demodulation reference signals.

The basic  $EVM_{DMRS}$  measurements are first averaged over  $n$  slots in the time domain to obtain an intermediate average  $\overline{EVM}_{DMRS}$ .

$$\overline{EVM}_{DMRS} = \sqrt{\frac{1}{n} \sum_{i=1}^n EVM_{DMRS,i}^2}$$

In the determination of each  $EVM_{DMRS,i}$ , the timing is set to  $\Delta \tilde{\tau} = \Delta \tilde{\tau}_i$  if  $\overline{EVM}_i > \overline{EVM}_h$ , and it is set to  $\Delta \tilde{\tau} = \Delta \tilde{\tau}_h$  otherwise, where  $\overline{EVM}_i$  and  $\overline{EVM}_h$  are the general average EVM values calculated in the same  $n$  slots over which the intermediate average  $\overline{EVM}_{DMRS}$  is calculated. Note that in some cases, the general average EVM may be calculated only for the purpose of timing selection for the demodulation reference signal EVM.

Then the results are further averaged to get the EVM for the demodulation reference signal,  $EVM_{DMRS}$ ,

$$EVM_{DMRS} = \sqrt{\frac{1}{6} \sum_{j=1}^6 \overline{EVM}_{DMRS,j}^2}$$

The PRACH EVM,  $EVM_{PRACH}$ , is averaged over 2 preamble sequence measurements for long preamble formats as defined in Table 6.3.3.1-1 in [6] and averaged over 10 preamble sequence measurements for short preamble formats as defined in Table 6.3.3.1-2 in [6].

The EVM requirements shall be tested against the maximum of the RMS average at the window  $W$  extremities of the EVM measurements:

Thus  $\overline{EVM}_{PRACH,i}$  is calculated using  $\Delta \tilde{\tau} = \Delta \tilde{\tau}_i$  and  $\overline{EVM}_{PRACH,h}$  is calculated using  $\Delta \tilde{\tau} = \Delta \tilde{\tau}_h$ .

Thus we get:

$$EVM_{PRACH} = \max(\overline{EVM}_{PRACH_1}, \overline{EVM}_{PRACH_2})$$

## F.7 Spectrum Flatness

The data shall be taken from FFT coded data symbols and the demodulation reference symbols of the allocated resource block.

## F.8 EVM measurement for multiple Tx

For UE with multiple transmission antennas, if UE indicates Tx diversity capability, EVM is measured at each antenna connector to get  $EVM_i$ , and the total EVM is calculated by values of  $EVM_i$  with weighting factor of linear power at each antenna connector.

$$EVM = \frac{\sum_{i=1}^k P_i * EVM_i}{\sum_{i=1}^k P_i}$$

where  $k=2, 4$ , and  $P_i$  denotes the linear power measured at each antenna connector respectively.

## F.9 Phase offset measurement for DMRS bundling

### F.9.1 Measurement point

The measurement point for phase offset measurement is defined in Figure F.9.1-1.

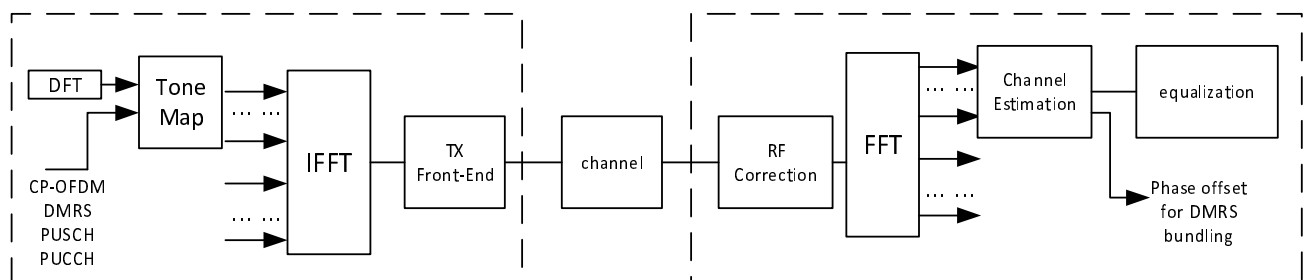

Figure F.9.1-1: Measurement point for phase offset for DMRS bundling

### F.9.2 Symbols used

Phase offset is determined based on DMRS REs (3 DMRS symbols per slot) with the option to use data symbols.

### F.9.3 Modified test signal

Same as described in Annex F.4.



### F.9.4 Phase offset measurement

The phase offset measurement is based on the phase response of the Tx chain  $\tilde{\varphi}(t, f)$  as derived based on Annex F.4.

The subcarrier at the carrier leakage frequency of the transmitted signal shall be excluded from the measured subcarriers.

The phase difference  $\Delta\tilde{\varphi}(f)$  for each measured subcarrier between a reference timeslot  $t_{ref}$  and the measurement timeslot  $t_m$  is then calculated as defined below.

$$\Delta\tilde{\varphi}(f) = \tilde{\varphi}(t_m, f) - \tilde{\varphi}(t_{ref}, f)$$

The phase offset between the reference and measurement timeslots are then calculated as the maximum over the results for all measured subcarriers as shown below:

$$PhaseOffset = \max_f(|\Delta\tilde{\varphi}(f)|)$$

## F.10 EVM for UL MIMO

### F10.1 General

EVM for UL MIMO is measured per layer. A zero-forcing (ZF) MIMO receiver architecture is used so that dual layer or 4-layer transmissions by the UE can be demodulated by the test equipment receiver.

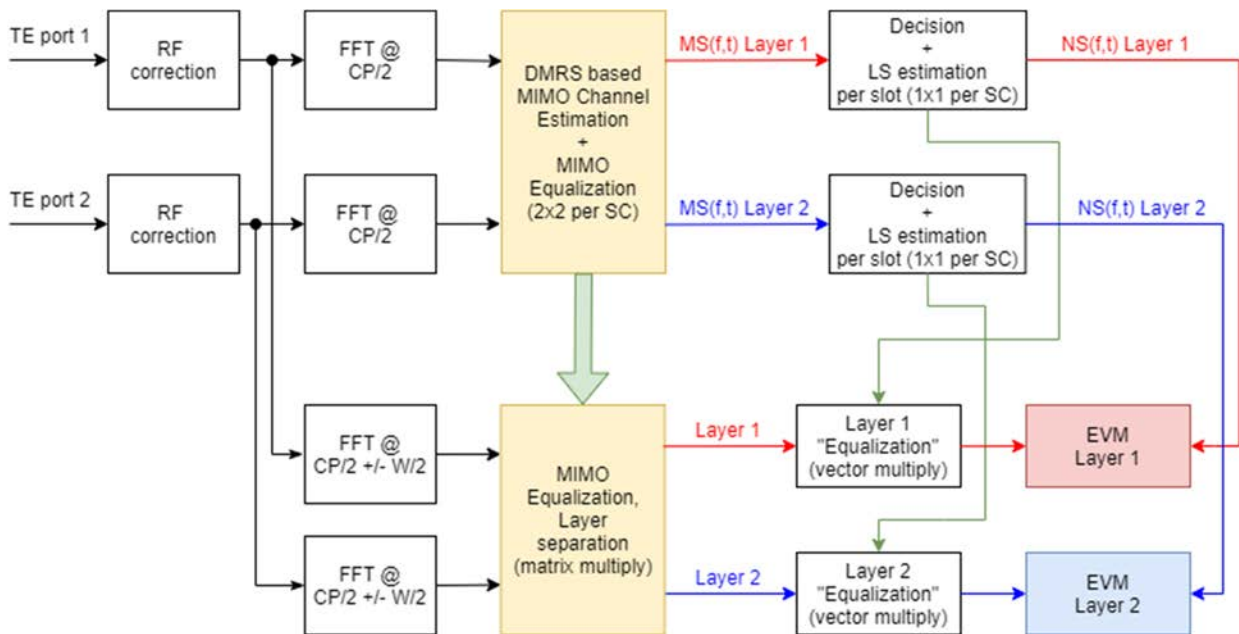

Figure F.10.1-1: EVM calculation block diagram for 2-Layer UL MIMO

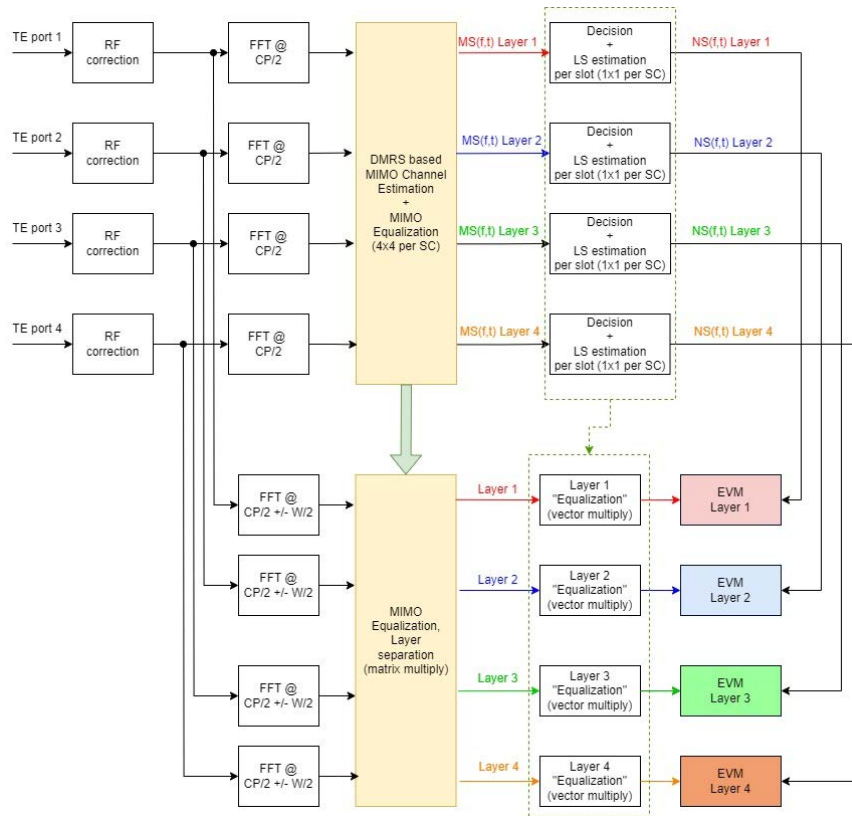

Figure F.10.1-2: EVM calculation block diagram for 4-Layer UL MIMO

The TE receives signals from 2 or 4 different ports which are connected to two or four antenna connectors in the test system.

For UL MIMO measurements a MIMO equalization step as described in section F.10.2 is performed to separate the layers.

Each layer is then processed as described in section F.10.3 to receive the measurement results for each individual layer.

## F10.2 MIMO Equalization

The MIMO equalization is based only on reference signals (DMRS) without using any data symbols. For the equalization process all available DMRS symbols shall be used.

The effective 2x2 or 4x4 channel matrix is estimated using reference signals of different subcarriers, e.g. in case of DMRS antenna ports 0 and 2. In case that same subcarriers are used, e.g. DMRS antenna ports 0 and 1, a channel decomposition is necessary taking advantage of the orthogonal codes  $w_f$  and  $w_t$  and assuming identical channel coefficients for adjacent subcarriers of same CDM group.

Effective channel including the precoding matrix  $P$  is:

$$\tilde{H} = HP = \begin{bmatrix} \tilde{h}_{0,0} & \tilde{h}_{0,1} \\ \tilde{h}_{1,0} & \tilde{h}_{1,1} \end{bmatrix} \text{ for 2-Layer UL MIMO, or } \tilde{H} = HP = \begin{bmatrix} \tilde{h}_{0,0} & \tilde{h}_{0,1} & \tilde{h}_{0,2} & \tilde{h}_{0,3} \\ \tilde{h}_{1,0} & \tilde{h}_{1,1} & \tilde{h}_{1,2} & \tilde{h}_{1,3} \\ \tilde{h}_{2,0} & \tilde{h}_{2,1} & \tilde{h}_{2,2} & \tilde{h}_{2,3} \\ \tilde{h}_{3,0} & \tilde{h}_{3,1} & \tilde{h}_{3,2} & \tilde{h}_{3,3} \end{bmatrix} \text{ for 4-Layer UL MIMO,}$$

with

$$\tilde{h}_{n,v} = \frac{y_n r_v^*}{|r_v|^2}$$

where  $y$  denotes the received symbol on port index  $n$  and  $r$  the reference signal for layer index  $v$ .

Since reference signals of a specific layer are transmitted only on subcarriers of one CDM group channel, interpolation is needed in order to obtain channel coefficients for all subcarriers. Channel interpolation is done using the channel coefficients of active CDM group in all other CDM groups.

The channel coefficients used to calculate the equalizer coefficients are obtained after channel smoothing in frequency domain by computing the moving average of interpolated channel coefficients. The moving average window size is 7. For subcarriers at or near the edge of allocation the window size is reduced accordingly.

The ZF equalizer coefficients are calculated as the inverse of the effective channel matrix, in general:

$$G_{ZF} = \tilde{H}^{-1}$$

## F10.3 Layer processing

After performing the MIMO equalization as described in section F.10.2 each layer is processed using the existing procedure as defined in Annex E of TS 38.521-1 [4].

Since the channel estimation is calculated only on the DMRS symbols, an averaging including all 14 symbols of one slot, i.e. data and reference signals, is needed in order to minimize EVM. The averaging is achieved by the least square (LS) equalization method described for single layer in Annex E.3. of TS 38.521-1 [4].

$MS(f,t)$  and  $NS(f,t)$  are processed with a LS estimator, to derive one equalizer coefficient per time slot and per allocated subcarrier.  $EC(f)$  is defined for each layer as:

$$EC_v(f) = \frac{\sum_{t=0}^{13} NS_v(f,t)^* NS_v(f,t)}{\sum_{t=0}^{13} MS_v(f,t)^* NS_v(f,t)}$$

With \* denoting complex conjugation.  $EC(f)$  are used to equalize layer data symbols.

EVM equalizer spectral flatness is derived from equalizer coefficients for each layer as follows:

$$c_v = |EC_v(f)| \sqrt{|g_{v,0}|^2 + |g_{v,1}|^2} \text{ for 2-Layer UL MIMO, or } c_v = |EC_v(f)| \sqrt{|g_{v,0}|^2 + |g_{v,1}|^2 + |g_{v,2}|^2 + |g_{v,3}|^2} \text{ for 4-Layer UL MIMO,}$$

# Annex G (normative): Difference of relative phase and power errors

## G.0 General

This annex gives further information needed for understanding and implementing 6.4D.4. The following terms should be understood as follows:

**Relative phase error:** refers to the phase difference between signals at different antenna connectors, which should be ideally 0. It should be understood as for a slot i.e. (slot) relative phase. It is calculated based on DMRS symbols of that slot or on SRS symbols.

**Difference of relative phase error:** refers to the difference between the relative phase error determined per slot and the relative phase error determined based on the SRS transmitted.

## G.1 Measurement Point

Figure G.1-1 shows the measurement point for the difference of relative phase and power errors.

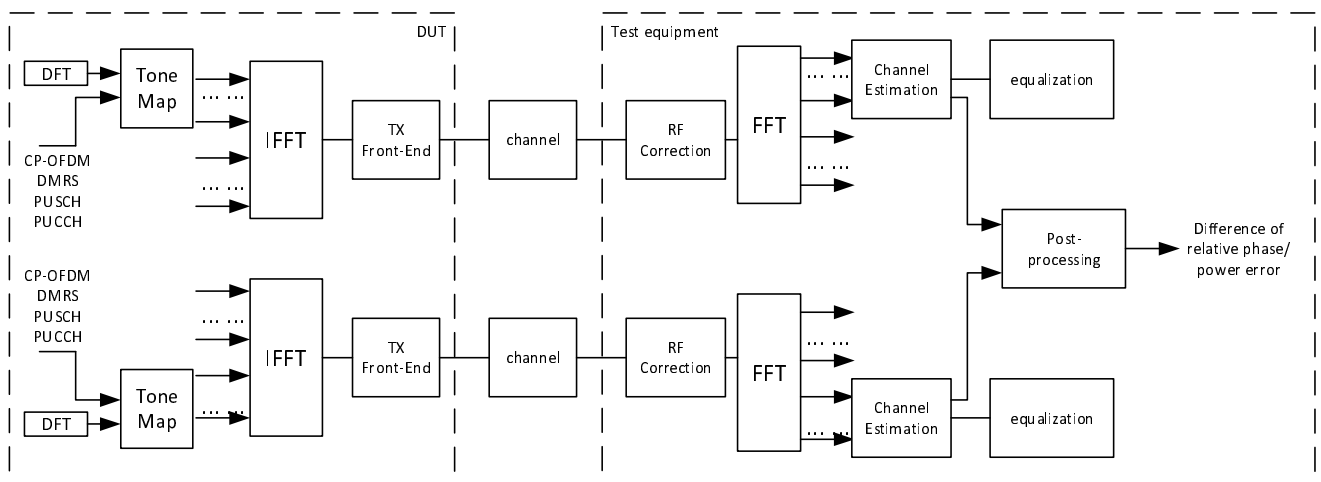

**Figure G.1-1 - Measurement point for difference of relative phase/power error for UL coherent MIMO**

## G.2 Relative Phase Error Measurement

Here are listed the different aspects that may lead to different interpretations.

### G.2.1 Symbols and subcarriers used

Phase error is determined based on DMRS REs (DMRS mapping type A with 3 DMRS symbols per slot, the REs corresponding to the odd subcarriers and DMRS symbols are non-allocated for data or DMRS.) and SRS REs (with 4 SRS symbols in the SRS slot, same SRS resource mapping is used for non-codebook-based and codebook-based precoding).

For the DMRS and SRS to occupy identical SCs and maximize their frequency density, DMRS configuration type 1 and SRS comb2 configuration are used.

UL RMC described in Annex A.2 is used.

## G.2.2 CFO (carrier frequency offset) correction

The TE performs a CFO correction on a slot-by-slot basis using a common frequency correction at the two uplink antenna connectors.

## G.2.3 Steps of the measurement method

Below are detailed the steps necessary to obtain the maximum difference of relative phase error during the 20ms time window.

- 1 Determination for each subcarrier and at each antenna, the SRS relative phase error based on the last SRS transmitted on Ant1 and Ant2, that relative phase error serves as a reference for the calculation of the difference of relative phase error for each slot inside the 20 ms time window.

The output is the “SRS relative phase error” vector for the last SRS transmitted:  $[1 \times \textit{number\_of\_subcarriers}]$ .

- 2 Calculation for the last SRS transmitted, for each RB of the SRS relative phase errors based on the arithmetic mean of the subcarrier SRS relative phase errors determined in previous step.

The output is the “SRS relative phase error” vector for the last SRS transmitted:  $[1 \times \textit{number\_of\_RBs}]$ .

- 3 CFO correction on slot-by-slot basis using a common frequency correction for both antenna outputs.

- 4 Determination for each subcarrier and at each antenna, the phase over the slot being analyzed. The phase is extracted from the channel estimate derived from the 3 DMRS symbols of the slot using the LSE technique.

The output is one vector of dimension  $[1 \times \textit{number\_of\_subcarriers}]$  for each antenna.

- 5 Calculation for a slot for each subcarrier of the relative phase error (difference between the vectors determined in the previous step).

The output is subcarrier relative phase errors of a slot:  $[1 \times \textit{number\_of\_subcarriers}]$ .

- 6 Calculation for a slot, for each RB of the relative phase errors based on the arithmetic mean of the subcarrier relative phase errors determined in previous step.

The output is a “slot relative phase error” vector for a slot:  $[1 \times \textit{number\_of\_RBs}]$ .

- 7 Calculation for a slot of the difference of relative phase errors based on the “SRS relative phase error” (reference) determined in step 2 and the “slot relative phase error” determined in previous step.

The output is a “difference of relative phase error” vector for a slot:  $[1 \times \textit{number\_of\_RBs}]$ .

- 8 Calculation for a slot of the arithmetic mean value of the “difference of relative phase error” vector determined in previous step, this value corresponds to an RB.

The output is a “difference of relative phase error” value for a slot:  $[1 \times 1]$ .

- 9 Perform for each slot of the 20ms time window, steps 3 to 8.

The output is a “difference of relative phase error” vector:  $[1 \times \textit{number\_of\_slots}]$ .

- 10 Calculation of the maximum value of the “difference of relative phase error”.

The output is the “difference of relative phase error” that should be verified as complying with the 40° maximum allowable difference of relative phase error requirement:  $[1 \times 1]$ .

## Annex H (informative): Void

## Annex I (informative): Void



## Annex J (informative): Void

## Annex K (informative): Void

# Annex L (normative): ModifiedMPR-Behavior

## L.1 Indication of modified MPR behavior

This annex contains the definitions of the bits in the field *modifiedMPR-Behavior* indicated per supported NR band in the IE *RF-Parameters* [7] by a UE supporting an MPR or A-MPR modified in a given version of this specification. A modified MPR or A-MPR behaviour can apply to a supported NR band in stand-alone operation (including CA and NN-DC operation) or in non-standalone operation with the said NR band as part of an EN-DC or NE-DC band combination.

NOTE 1: In the present release, the *modifiedMPR-Behavior* is indicated [7] by an 8-bit bitmap per supported NR band.

**Table L.1-1: Definitions of the bits in the field *modifiedMPR-Behavior***

NR Band	Index of field (bit number)	Definition (description of the supported functionality if indicator set to one)	Notes
n30	0 (leftmost bit)	Requirements for network signalling value NS_21 as defined in Clause 6.5.2.3.y of 38.101-1 v17.6.0 and A-MPR as defined in Clause 6.2.3.14 of 38.101-1 v17.6.0.	This bit shall be set to 1 by a UE supporting the Rel-17 version of the specification. If the bit is not set, then requirements for NS_21 as defined in Clause 6.5.2.3.3 of 38.101-1 v16.11.0 and A-MPR as defined in Clause 6.2.3.14 of 38.101-1 v16.11.0 apply.
n34	0 (leftmost bit)	PC 1.5 MPR as defined in Table 6.2D.2-3	This bit may be set to 1 by a UE of any release supporting power class 1.5. This bit is intended to be set by larger form factor FWA devices. If the bit is not set for a Rel-17 and later UE, PC 1.5 MPR as defined in Table 6.2D.2-2 applies. If the bit is not set for a Rel-16 and earlier UE, MPR in Table 6.2.2-4 of 38.101-1 v16.5.0 applies.
n39	0 (leftmost bit)	PC 1.5 MPR as defined in Table 6.2D.2-3	This bit may be set to 1 by a UE of any release supporting power class 1.5. This bit is intended to be set by larger form factor FWA devices. If the bit is not set for a Rel-17 and later UE, PC 1.5 MPR as defined in Table 6.2D.2-2 applies. If the bit is not set for a Rel-16 and earlier UE, MPR in Table 6.2.2-4 of 38.101-1 v16.5.0 applies.
n40	0 (leftmost bit)	PC 1.5 MPR as defined in Table 6.2D.2-3	This bit may be set to 1 by a UE of any release supporting power class 1.5. This bit is intended to be set by larger form factor FWA devices. If the bit is not set for a Rel-17 and later UE, PC 1.5 MPR as

			defined in Table 6.2D.2-2 applies. If the bit is not set for a Rel-16 and earlier UE, MPR in Table 6.2.2-4 of 38.101-1 v16.5.0 applies.
n41	0 (leftmost bit)	EN-DC contiguous intraband MPR as defined in clause 6.2B.2.1 of 38.101-3 v15.5.0	- This bit shall be set to 1 by a UE supporting DC_(n)41AA UE EN-DC
	1	EN-DC non-contiguous intraband MPR as defined in clause 6.2B.2.2 of 38.101-3 v15.5.0	- This bit shall be set to 1 by a UE supporting DC_41A_n41A EN-DC
	2	EN-DC contiguous and non-contiguous intraband MPR and A-MPR as defined in 38.101-3 v16.4.0. If this bit is not set the UE uses Rel-15 MPR or A-MPR for EN-DC contiguous and non-contiguous intraband MPR and A-MPR	-This bit may be set to 1 by a UE supporting DC_(n)41AA or DC_41A_n41A EN-DC
	3	PC 1.5 MPR as defined in Table 6.2D.2-3	This bit may be set to 1 by a UE of any release supporting power class 1.5. This bit is intended to be set by larger form factor FWA devices. If the bit is not set for a Rel-17 and later UE, PC 1.5 MPR as defined in Table 6.2D.2-2 applies. If the bit is not set for a Rel-16 and earlier UE, MPR in Table 6.2.2-4 of 38.101-1 v16.5.0 applies.
n71	0 (leftmost bit)	EN-DC contiguous intraband MPR as defined in clause 6.2B.2.1 of 38.101-3 v15.5.0	- This bit shall be set to 1 by a UE supporting DC_(n)71AA UE EN-DC
n77	0 (leftmost bit)	PC 1.5 MPR as defined in Table 6.2D.2-3	This bit may be set to 1 by a UE of any release supporting power class 1.5. This bit is intended to be set by larger form factor FWA devices. If the bit is not set for a Rel-17 and later UE, PC 1.5 MPR as defined in Table 6.2D.2-2 applies. If the bit is not set for a Rel-16 and earlier UE, MPR in Table 6.2.2-4 of 38.101-1 v16.5.0 applies.
n78	0 (leftmost bit)	PC 1.5 MPR as defined in Table 6.2D.2-3	This bit may be set to 1 by a UE of any release supporting power class 1.5. This bit is intended to be set by larger form factor FWA devices. If the bit is not set for a Rel-17 and later UE, PC 1.5 MPR as defined in Table 6.2D.2-2. If the bit is not set for a Rel-16 and earlier UE, MPR in Table 6.2.2-4 of 38.101-1 v16.5.0 applies.
n79	0 (leftmost bit)	PC 1.5 MPR as defined in Table 6.2D.2-3	This bit may be set to 1 by a UE of any release supporting power class 1.5. This bit is intended to be set by larger form factor FWA devices. If the bit is not set for a Rel-17 and later UE, PC 1.5 MPR as defined in Table 6.2D.2-2 applies. If the bit is not set

			for a Rel-16 and earlier UE, MPR in Table 6.2.2-4 of 38.101-1 v16.5.0 applies.
n96	0 (leftmost bit)	Support of all band n96 network signalling labels as defined in Table 6.2F.3.1-1 of 38.101-1 Rel-17	This bit may be set to 1 by a Rel-16 UE to indicate support of all network signalling labels for n96 as defined in Table 6.2F.3.1-1 of 38.101-1 Rel-17
	1	Support of all band n96 network signalling labels as defined in Table 6.2F.3.1-1 of 38.101-1 Rel-18	This bit may be set to 1 by a Rel-16 and Rel-17 UE to indicate support of all network signalling labels for n96 as defined in Table 6.2F.3.1-1 of 38.101-1 Rel-18
n102	0 (leftmost bit)	Support of all band n102 network signalling labels as defined in Table 6.2F.3.1-1 of 38.101-1 Rel-17	This bit may be set to 1 by a Rel-16 UE to indicate support of all network signalling labels for n102 as defined in Table 6.2F.3.1-1 of 38.101-1 Rel-17
	1	Support of all band n102 network signalling labels as defined in Table 6.2F.3.1-1 of 38.101-1 Rel-18	This bit may be set to 1 by a Rel-16 and Rel-17 UE to indicate support of all network signalling labels for n102 as defined in Table 6.2F.3.1-1 of 38.101-1 Rel-18

---

# Annex M (normative): Declared Supported Post Antenna Gain for UE

## M.1 FRMCS operating bands

Due to large form factor of the FRMCS (Future Railway Mobile Communication System) rooftop mounted cab-radio unit, UE in bands n100 and n101 can have external antenna placed far away from the chipset unit. In this case, the effective antenna gain is a UE specific condition. This effective antenna gain includes the feeding loss of all components after the chipset unit antenna connector and the peak directional gain of the external antenna and hence will be called the post connector gain  $G_{n100\text{post connector}}$  and  $G_{n101\text{post connector}}$  for band n100 and n101, respectively.

The 3GPP specifications mandate UE manufacturer declarations of the supported value of the post connector gain  $G_{n100\text{post connector}}$  and  $G_{n101\text{post connector}}$  as a way to accommodate the requirement without putting requirements on the UE specific condition. If external antenna is not used, the value of 0dBi will be used.

The applicable regional requirements for bands n100 and n101 in  $P_{\text{EIRP}}$  shall be converted to conducted requirements by subtracting  $G_{n100\text{post connector}}$  or  $G_{n101\text{post connector}}$  as:

$$P_{\text{Conducted}} = P_{\text{EIRP}} - G_{n100\text{post connector}} \text{ for band n100, and}$$

$$P_{\text{Conducted}} = P_{\text{EIRP}} - G_{n101\text{post connector}} \text{ for band n101.}$$

## Annex N (informative): Change history

Change history							
Date	Meeting	TDoc	CR	Rev	Cat	Subject/Comment	New version
2017-08	RAN4#84	R4-1708909				Initial Skeleton	0.0.1
2017-10	RAN4#84 Bis	R4-1709958				Added approved TPs in RAN4-NR-AH#3 R4-1709948, TP for TS 38.101-1: minimum output power, Huawei R4-1709454, TP for TS 38.101-1: UE Tx spurious emission for range 1, ZTE Corporation	0.1.0
2017-10	RAN4#84 Bis	R4-1711978				Embedded approved TPs in RAN4#84Bis R4-1711556, "TP to TS 38.101: Draft CR to Transmitter power clause", Nokia R4-1710962, "TP to TS 38.101-1: Draft CR to Output RF spectrum emissions" Nokia R4-1711608, "TP for TS38.101-1 on conducted UE transmitter intermodulation for FR1(section 6.5)" ZTE Corporation Number of TPs by editors	0.2.0
2017-12	RAN4#85	R4-1713805				Approved TPs in RAN4#85 R4-1713204, TP on general parts for 38.101-1 NR FR1, Ericsson R4-1714047, WF on MPR for sub6GHz, NTT DOCOMO, INC. R4-1714052, TP for TS 38.101-1 introduction of band n71 for transmitter characteristics, T-Mobile USA Inc. R4-1714162, TP to 38.101-1: ACS, Ericsson R4-1714163, TP to 36.101-1: In-band blocking, Ericsson R4-1714446, TP to 36.101-1: Out-of-band blocking and exceptions for spurious response, Ericsson R4-1714369, TP for NBB requirement for FR1, Intel Corporation R4-1714529, TP on introducing operating bands for NR-LTE DC including SUL band combinations in 38.101-1, Huawei R4-1714097, TP for TS 38.101-1: UE RF requirements for standalone SUL, Huawei R4-1714536, TP for TS 38.101-1: Channel Bandwidth Definition, Qualcomm Incorporated (Note, this TP was further discussed and edited in the reflector) R4-1714114, TP for TS 38.101-1: Channel Arrangement, Qualcomm Incorporated (Note, this TP was further discussed and edited in the reflector) R4-1714029, Sub6 Reference Sensitivity, Qualcomm Incorporated R4-1714329, TP to TR 38.101-01 v0.2.0: ON/OFF mask design for NR UE transmissions for FR1, Ericsson  Band list according to R4-1714542, List of bands and band combinations to be introduced into RAN4 NR core requirements by December 2017, RAN4 Chairmen Input from: R4-1714479, TP for TR 38.817-01 NR channel bandwidth, Huawei, HiSilicon	0.3.0
2017-12	RAN4#85	R4-1714569				Further corrections and alignments with 38.104 after email review	0.4.0
2017-12	RAN#78	RP-172475				v1.0.0 submitted for plenary approval. Contents same as 0.4.0	1.0.0
2017-12	RAN#78					Approved by plenary – Rel-15 spec under change control	15.0.0
2018-03	RAN#79	RP-180264	0003		F	Implementation of endorsed CRs to 38.101-1 Endorsed draft CRs F: R4-1800400, Editorial corrections for 38.101-1, Qualcomm B: R4-1801102, Draft CR for 30 MHz CBW support, Huawei F: R4-1800032, 38.101-1 n71 draft CR for section 6.2.3 - UE A-MPR - NS values, T-Mobile USA Inc. B: R4-1801121, Draft pCR for TS 38.101-1 version 15.0.0: Remaining ON/OFF masks for FR1 NR UE transmissions, Ericsson F: R4-1800417, Correction of NR SEM table and additional requirements table, vivo F: R4-1800033, 38.101-1 n71 draft CR for section 6.5.3.2 Spurious emissions for UE co-existence, T-Mobile USA Inc. F: R4-1801114, Proposal on protected band numbering in UE specs, Sprint Corporation	15.1.0

					<p>F: R4-1800407, Draft CR for TS 38.101-1: Mandatory 4Rx antenna performance for NR UE, Vodafone Group Plc  F: R4-1800451 Draft CR for TS 38.101-1: Clarification of 4Rx NR bands, Huawei, HiSilicon  F: R4-1801136, Draft CR for TS 38.101-1: REFSENS for NR bands, Huawei, HiSilicon  F: R4-1801137, Draft CR: n71 REFSENS, Dish Network  F: R4-1800395, Draft CR to 38.101-1: corrections to ACS and in-band blocking, Ericsson  F: R4-1800396, Draft CR to 38.101-1: corrections to out-of-band blocking, Ericsson  F: R4-1800397, Draft CR to 38.101-1: corrections to spurious response, Ericsson  F: R4-1800305, Draft CR for NR FR1 wide band intermodulation requirements, MediaTek Inc.  F: R4-1800320, Draft CR to 38.101-1: Rx Spurious emission for NR FR1 (section 7.9), ZTE Corporation  F: R4-1800473, Draft CR on UE RF requirements for SUL in TS 38.101-1, Huawei  F: R4-1800965, Draft CR to TS 38.101-1: Asymmetric CH BW operation, Dish Network  F: R4-1800882, Draft CR for correction of UE channel bandwidth for Bands n77 and n78 for TS 38.101-1, Orange UK  F: R4-1801012, Draft CR to 38.101-1: Clarifications to UE spectrum utilization section 5.3, Ericsson  F: R4-1800030, 38.101-1 n71 draft CR for section 5.4.4 - TX-RX frequency separation, T-Mobile USA Inc  F: R4-1801228, Draft CR to 38.101-1: Channel spacing for CA for NR FR1(section 5.4.1.2), ZTE Corporation  F: R4-1801231, Correction CR for channel spacing:38.101-1, Samsung  F: R4-1801235, Draft CR to TS 38.101-1: Corrections on channel raster calculation in section 5.4.2, ZTE Corporation  F: R4-1801318, Draft CR on synchronization raster, Huawei</p> <p>RAN4#86:  R4-1803053, Draft CR for new spec structure of 38.101-1, Ericsson  R4-1801479, Draft CR to 38.101-1: Default Tx-RX frequency separation for NR FR1(section 5.4.4), ZTE  R4-1801581, Draft CR for TS 38.101-1 update of 4Rx bands, Huawei Technologies France  R4-1802211, draft CR TS 38.101-1 Uplink configuration for FR1 NR REFSENS, Skyworks Solutions Inc.  R4-1802342, Draft CR for NR FR1 ACS case 2 transmitter power setting correction (Note 1), MediaTek Inc.  R4-1802509, Draft CR on 38.101-1 v15.0.0: Remaining ON/OFF masks for FR1 NR UE transmissions, Ericsson  R4-1802566, Draft CR to TS 38.101-1: Clarification of mixed numerology guardband size, Ericsson  R4-1802978, Draft CR to TS 38.101-1: Corrections on channel raster in Section 5.4.2.3, Intel Corporation  R4-1803064, Draft CR for 38.101-1: Correction of errors, Sprint Corporation  R4-1803065, Draft CR for 38.101-1 Introduction of n41requirements, Sprint Corporation  R4-1803242, Draft CR to 38.101-1: Corrections to n66, Dish Network  R4-1803285, Draft CR to 38.101-1: Correction to CH BWs without symmetric uplink Dish Network, Skyworks Solutions Inc.  R4-1803436, Introduction of UL subcarrier alignment for additional bands, AT&amp;T  R4-1803456, Draft CR for 38.101-1: Spurious Emissions for UE Coexistence, Sprint Corporation  R4-1803461, CR on configured transmitted power for TS 38.101-1, Huawei  R4-1803452, draft CR for introduction of completed band combinations from 37.865-01-01 into 38.101-1, Ericsson  R4-1803567, Draft CR for TS 38.101-1: Sync raster offset in re-farming bands (5.4.3), Ericsson  R4-1803365, CR to introduce MPR for PC2 and PC3 and A-MPR for UTRA protection, Nokia</p>	
2018-06	RAN#80	RP-181262	0011	F	<p>CR to TS 38.101-1: Implementation of endorsed draft CRs from RAN4 #86bis and RAN4 #87</p> <p>R4-1803900, Draft CR into TS 38.101-1 Introduction of band combinations for SUL, Huawei</p>	15.2.0



					<p>R4-1804021 CR for clarifications for NR FR1 CA BW Classes Nokia, Nokia Shanghai Bell</p> <p>R4-1804140 CR for Narrow Band Blocking requirement for FR1 Intel Corporation</p> <p>R4-1804219 Draft CR for 38.101-1: n41 SEM and additional spurious emissions SPRINT Corporation</p> <p>R4-1804266 Draft CR to 38.101-1 MPR channel bandwidth criteria Skyworks Solutions Inc.</p> <p>R4-1804267 Draft CR to 38.101-1 n3,n5,n8 REFSENS levels Skyworks Solutions Inc.</p> <p>R4-1804268 Draft CR to 38.101-1: Correction to n41 uplink configuration for reference sensitivity Skyworks Solutions Inc.</p> <p>R4-1804370 Draft CR to add missing NR inter-band DL CA in FR1 for TS 38.101-1 NTT DOCOMO, INC.</p> <p>R4-1804581 Draft CR to 38.101-1: On EVM Wording Qualcomm, Inc.</p> <p>R4-1804948 Corrections to 5.3.3 in TS 38.101-1 Nokia, Nokia Shanghai Bell</p> <p>R4-1804877 draft CR introduction completed band combinations 37.865-01-01 -&gt; 38.101-1 Ericsson</p> <p>R4-1805444 Draft CR to TS 38.101-1: Asymmetric CH BW operation Dish Network</p> <p>R4-1805447 draft CR for including SRS antenna switching in configured output power Qualcomm Incorporated</p> <p>R4-1805462 Editorial corrections to UE RF requirements in 38.101-1 Qualcomm Incorporated</p> <p>R4-1805659 Draft CR for CBW for n50 for 38.101-1 Huawei</p> <p>R4-1805664 Draft CR to 38.101-1: Addition of Annex F Rohde &amp; Schwarz</p> <p>R4-1805665 Correction to inner and outer definitions for MPR Qualcomm Incorporated</p> <p>R4-1805684 Draft CR to TS38.101-1: Channel Raster to Resource Element Mapping (Section 5.4.2.2) and RB alignment with different numerologies (Section 5.3.4) ZTE Corporation</p> <p>R4-1805698 Draft CR for 38.101-1 for Rx(Ch7) of Band n77, n78 and n79 RF requirements CMCC</p> <p>R4-1805699 Draft CR to 38.101-1:introduction of Tx/Rx requirements for inter-band CA ZTE Corporation</p> <p>R4-1805751 Draft CR on UE-to-UE coexistence requirements to protect band 29 from NR band 71 LG Electronics France</p> <p>R4-1805783 Draft CR for 38.101-1 for Tx(Ch6) of Band n77, n78 and n79 RF requirements CMCC</p> <p>R4-1805902 Draft CR into TS 38.101-1 Correction on SUL_n78-n80Huawei, HiSilicon</p> <p>R4-1805904 Draft CR into TS 38.101-1 Introduction of new band combinations for SUL Huawei, HiSilicon</p> <p>R4-1805921 Draft CR on NR UE REFSENS SNR FRC for FR1 Intel Corporation</p> <p>R4-1805981 Draft CR for TS38.101-1:Sync raster Samsung</p> <p>R4-1804548 Draft CR for CA BW class for FR1 NTT DOCOMO, INC.</p> <p>R4-1806170 Draft CR on frequency error for TS 38.101-1 ZTE Corporation</p> <p>R4-1806481 Draft CR for Environmental conditions in TS 38.101-1 Annex NTT DOCOMO, INC.</p> <p>R4-1806657 Draft CR to 38.101-1: Measurement BW for min and off power Skyworks Solutions Inc.</p> <p>R4-1806669 Draft CR to TS38.101-1_introduction of completed band combinations for inter-band 2UL CA ZTE Corporation</p> <p>R4-1806673 Draft CR to TS38.101-1_Remove brackets from Tx and Rx spurious emission table ZTE Corporation</p> <p>R4-1806677 Draft CR on including CA bandwidth class and band combinations for intra-band CA LG Electronics France</p> <p>R4-1806719 Introduction of 7.5 kHz frequency shift for Band n71 Ericsson, T-Mobile</p> <p>R4-1806844 Draft CR for 38.101-1 for Tx(Ch6): missing maximum power requirements for n1 and n8 SoftBank Corp.</p> <p>R4-1806945 Draft CR for TS 38.101-1: Channel raster and NR-ARFCN clarification (5.4.2) Ericsson</p> <p>R4-1807039 Intra-band CA terminology for UE ZTE Corporation</p> <p>R4-1807178 Corrections to n70 TX/RX frequency separation Dish Network</p> <p>R4-1807181 Corrections to spurious emissions UE co-existence table Dish Network</p> <p>R4-1807234 Draft CR into TS 38.101-1 Some Corrections for SUL Huawei, HiSilicon</p>	
--	--	--	--	--	--	--

					<p>R4-1807269 Corrections to Wide band intermodulation table &lt;2700MHz Dish Network</p> <p>R4-1807392 to remove the brackets for SU in 38.101-1 Huawei, HiSilicon</p> <p>R4-1807647 Draft CR to TS 38.101-1: Correction to Asymmetric CH BW operation Dish Network</p> <p>R4-1807680 Draft CR on 38.101-1 on channel raster to achieve alignment of data and SSB subcarrier grids Nokia, Nokia Shanghai Bell, Ericsson</p> <p>R4-1807705 CR for TS 38.101-1 A-MPR for n51 Huawei, Hisilicon</p> <p>R4-1807814 Draft CR for 38.101-1: SEM correction for n41 Sprint Corporation</p> <p>R4-1807851 Draft CR for 38.101-1: UE spurious emission protection requirements for n5 Sprint Corporation</p> <p>R4-1807920 General requirements for downlink inter-band CA Qualcomm Incorporated</p> <p>R4-1807923 Resolution bandwidth for ACLR Qualcomm Incorporated</p> <p>R4-1808084 Introduction of n12 into TS 38.101-1 Nokia</p> <p>R4-1808087 Draft CR 38.101-1: Introduction of n2, n25, n66 and n70 Sprint Corporation, Dishnetwork</p> <p>R4-1808090 Draft CR to TS 38.101-1: Inclusion of Simultaneous RxTx UE capability for some band combinations Ericsson, Vodafone, Orange</p> <p>R4-1808107 Draft CR to TS38.101-1_corrections on UE coexistence ZTE Corporation</p> <p>R4-1808111 TP to TS38.101-1 - UE ON/OFF masks Ericsson</p> <p>R4-1808116 Draft CR to 38.101-1: introduction of Band n34,n39 and n40 RF requirements ZTE Corporation,CMCC</p> <p>R4-1808136 Draft CR to 38.101-1: FR1 UE Power Control Qualcomm Incorporated</p> <p>R4-1808141 Correction to MPR for PC2 and spectrum emission mask measurement bandwidth Qualcomm Incorporated</p> <p>R4-1808142 Draft CR for 38.101-1 n41 A-MPR Sprint Corporation, Nokia, Nokia Shanghai Bell, Ericsson</p> <p>R4-1808143 Draft CR for TS 38.101-1 A-MPR for n20 Huawei, HiSilicon</p> <p>R4-1808155 Draft CR for TS 38.101-1: to correct requirements for n71 Samsung</p> <p>R4-1808178 Addition parameters about n50 &amp; n51 in TS 38.101-1 Huawei, Hisilicon, Etisalat (editors note: n50 not implemented per chairmans agreement)</p> <p>R4-1808182 Draft CR for TS 38.101-1 A-MPR for n28 Huawei, HiSilicon</p> <p>R4-1808187 CR for RF requirements for Coherent UL MIMO for FR1 Qualcomm Austria RFFE GmbH</p> <p>R4-1808207 Draft CR to 38.101-1: On EVM Averaging Length, Wording , Qualcomm</p> <p>R4-1808209 Draft CR for 38.101-1 for Tx (Ch6) of HPUE Qualcomm</p> <p>R4-1808466 Draft CR on UL RMC and OCNG pattern for FDD REFSENS tests RD session</p> <p>R4-1808493 Draft CR for TS 38.101-1: Channel and sync raster corrections (5.4) Ericsson</p> <p>R4-1808507 Draft CR for TS38.101-1 on addition of new 90MHz UE CBW for n41/n78 LG Electronics Inc., LG Uplus, Samsung</p> <p>R4-1808176, Draft CR for 38.101-1 : Introduction of A-MPR for n8, SoftBank</p> <p>R4-1808201, Draft CR for 38.101-1 : Introduction of A-MPR for n1, SoftBank</p> <p>R4-1807101, draft CR introduction completed band combinations 37.865-01-01 -&gt; 38.101-1, Ericsson</p>	
2018-09	RAN#81	RP-181896	0025	F	<p>Big CR for 38.101-1</p> <p>Endorced draft CRs from RAN4#NR-AH-1807</p> <p>R4-1809335, Draft CR on UL RMC for FR1 RF tests, Qualcomm Incorporated</p> <p>R4-1809337, Draft CR on NR UE REFSENS SNR FRC for FR1, Intel Corporation</p> <p>R4-1809339, Draft CR on measurement of receiver characteristics for FR1 RF Tests, Qualcomm Incorporated</p> <p>R4-1809396, Draft CR on NR UE maximum input level FRC for FR1, Intel</p> <p>R4-1809567, Draft CR on OCNG pattern for FR1 REFSENS tests, Qualcomm Incorporated, Rohde &amp; Schwarz</p>	15.3.0

					<p>Endorced draft CRs from RAN4#88</p> <p>R4-1809714, Draft CR to correct in-band blocking parameters for FR1, Anritsu Corporation</p> <p>R4-1809784, Draft CR to 38.101-1: Corrections on CA bandwidth classes for FR1, ZTE Corporation</p> <p>R4-1809785, Draft CR to TS 38.101-1 for Corrections on UE transmitter power, ZTE Corporation</p> <p>R4-1809793, Draft CR to 38.101-1: Corrections on additional spectrum emission mask, ZTE Corporation</p> <p>R4-1809919, Correction on UE receiver requirement for FR1, CATT</p> <p>R4-1810091, Draft CR TS 38.101-1 - UE ON-OFF mask clean up, Ericsson</p> <p>R4-1810210, Draft CR for TS 38.101-1: MPR inner and outer RB allocations formula correction, MediaTek, Inc.</p> <p>R4-1810229, Draft CR for TS 38.101-1: Spurious emission for UE coexistence table corrections, MediaTek, Inc.</p> <p>R4-1810230, Draft CR for TS38.101-1 to correct 90MHz UE CBW, LG Electronics, Inc.</p> <p>R4-1810232, Draft CR for TS 38.101-1: Table 7.3.2-1 n77 reference sensitivity corrections, MediaTek, Inc.</p> <p>R4-1810369, Draft CR to 38.101-1: Corrections on symbols and abbreviations in section 3, ZTE Corporation</p> <p>R4-1810376, Draft CR: General corrections to n71 requirements, Dish Network</p> <p>R4-1810428, Draft CR on TS38.101-1 for UE maximum output power for UL MIMO, OPPO</p> <p>R4-1810552, Correction of reference tables, OPPO</p> <p>R4-1810729, Draft CR for introduction of Band n74 for TS 38.101-1, NTT DOCOMO, Inc.</p> <p>R4-1810862, Draft CR to 38.101-1: Updates to Transmit Modulation Annex, Rohde &amp; Schwarz</p> <p>R4-1810892, CR to update Table 6.2D.1-2 for FR1, Qualcomm Incorporated</p> <p>R4-1810961, CR on ACS minimum requirement, Intel Corporation</p> <p>R4-1810965, CR on Out-of-Band Blocking minimum requirement, Intel Corporation</p> <p>R4-1810967, CR on Rx Intermodulation characteristics for CA, Intel Corporation</p> <p>R4-1810974, Annex lettering change for 38.101-1, Qualcomm Incorporated</p> <p>R4-1811189, CR to add more details to Coherent UL MIMO spec for FR1, Qualcomm Incorporated</p> <p>R4-1811280, Corrections of NR receiver characteristics titles, Vivo</p> <p>R4-1811455, Draft CR on DL Physical Channel for FR1 RF tests, Qualcomm Europe Inc. (Spain)</p> <p>R4-1811457, NS numbering, Qualcomm Incorporated</p> <p>R4-1811459, Correction on UE transmitter requirement for FR1, CATT</p> <p>R4-1811463, Draft CR for 38.101-1: Addition of missing NR CA configurations n8-n75 and n28-n75, VodafoneItalia SpA</p> <p>R4-1811472, Addition parameters about n51 in TS 38.101-1, Huawei, Hisilicon, Etisalat</p> <p>R4-1811474, CR CP- OFDM almost contiguous allocation, Nokia, Nokia Shanghai Bell</p> <p>R4-1811477, Draft CR to 38.101-1: FR1 Power Control, Qualcomm Incorporated</p> <p>R4-1811478, A-MPR correction for n20 and n28, Huawei, HiSilicon</p> <p>R4-1811490, Draft CR to 38.101-1: Addition of Carrier Leakage table, Rohde &amp; Schwarz</p> <p>R4-1811491, Draft CR for TS38.101-1 on transmit signal quality, OPPO</p> <p>R4-1811493, CR to TS 38.101-1: pi/2 BPSK with Spectrum Shaping, Indian Institute of Tech (M), Indian Institute of Tech (H), CEWiT, Nokia</p> <p>R4-1811513, A proposal on 2UL co-ex table modification, SoftBank Corp.</p> <p>R4-1811514, Draft CR to TS 38.101-1: Clarification on OCNG, Keysight Technologies UK Ltd</p> <p>R4-1811516, Draft CR on NR DL FRCs for FR1 UE RF requirements, Intel Corporation</p> <p>R4-1811550, Draft CR to TS 38.101-1 on channel bandwidth and spacing descriptions, Ericsson</p> <p>R4-1811553, Draft CR to 38.101-1: Corrections on description of channel raster entries, ZTE Corporation</p> <p>R4-1811783, Measurement period of PRACH time mask, CATT</p>	
--	--	--	--	--	--	--

						<p>R4-1811792, Draft CR for A-MPR revision for n1, NTT DOCOMO, INC.</p> <p>R4-1811798, Draft CR for Pcmx for FR1, Qualcomm Incorporated</p> <p>R4-1811799, Pcmx for inter-band NR CA FR1 draft CR, InterDigital, Inc.</p> <p>R4-1811812, Draft CR to 38.101-1: On FR1 AMPR Band n41 NS_04, Qualcomm Incorporated</p> <p>R4-1811816, CR to update the definition of Long and Short subslot for FR1, Qualcomm</p> <p>R4-1811894, Addition parameters about n50 in TS 38.101-1, Huawei</p> <p>R4-1811896, Draft CR for TS 38.101-1: n41 GSCN range modification, MediaTek Inc.</p> <p>R4-1811285, Draft CR TS 38.101-1: NS_04 A-MPR' and spurious emisison corrections, Sprint</p>	
2018-12	RAN#82	RP-182836	0029	1	F	<p>Endorced draft CRs from RAN4#88Bis:</p> <p>R4-1812050, CR Simplification of NR NS_08, Nokia</p> <p>R4-1812054, Correction for Inter-band CA operating bands table in TS 38.101-1, Nokia.</p> <p>R4-1812079, draft CR to introduce asymmetric UL DL channel BW combinations for n71, T-Mobile USA Inc.</p> <p>R4-1812121, Draft CR on Note1 Corrections in 38.101 RX tests, Qualcomm</p> <p>R4-1812128, draftCR on 256QAM UL power requirement, Intel Corporation</p> <p>R4-1812200, Draft CR to TS 38.101-1 Add clarification note to PC3 MPR table, Intel Corporation</p> <p>R4-1812217, Draft CR to 38.101-1: Corrections on the descriptions of UE channel bandwidth for CA, ZTE Corporation</p> <p>R4-1812319, Draft CR for TS 38.101-1: REFSENS UL configuration corrections, MediaTek Inc.</p> <p>R4-1812320, Draft CR for TS 38.101-1: Out-of-band blocking exceptions for CA, MediaTek Inc.</p> <p>R4-1812322, Draft CR for TS 38.101-1: Blocking characteristics for SUL, MediaTek Inc.</p> <p>R4-1812397, Clarification for almost contiguous CP-OFDM, Qualcomm Incorporated</p> <p>R4-1812508, Draft CR to 38.101-1: Corrections on channel raster &amp; SS raster for operating bands, ZTE Corporation</p> <p>R4-1812611, Draft CR to 38.101-1: Some corrections for inter-band CA combinations, ZTE Corporation</p> <p>R4-1813459, Draft CR for TS 38.101-1: Support 4Rx for n38, Huawei</p> <p>R4-1813469, draftCR on applicability of TDD configuratiin for CA in TS 38.101-1, Huawei</p> <p>R4-1813521, Addition of ?TC,c for single carrier Pcmx for FR1, vivo</p> <p>R4-1813798, Draft CR to 38.101-1: Corrections on UE additional maximum output power reduction, ZTE Corporation</p> <p>R4-1813811, Draft CR to 38.101-1: Correction to n12 reference sensitivity power levels, Skyworks Solutions Inc.</p> <p>R4-1813812, Band n41 spurious emission limits, Qualcomm Incorporated</p> <p>R4-1813813, Draft CR for TS 38.101-1: P-Max for 5G NR HPUE, CMCC</p> <p>R4-1814158, CR on Spurious emissions for UE co-existence, Intel Corporation</p> <p>R4-1814159, Draft CR for CA ACS/IBB for Bandwidth class C, Qualcomm</p> <p>R4-1813843, Draft CR to 38.101-1: Update of Annex F, Rohde &amp; Schwarz</p> <p>R4-1813845, Correction for PI/2 PBSK requiriements, Nokia</p> <p>Endorsed draft CR's from RAN4#89</p> <p>R4-1815950, dCR on TS38.101-1 merging draft CRs from RAN4#88Bis, Qualcomm Incorporated</p> <p>R4-1814752, DraftCR to TS 38.101-1 pi/2 BPSK in n41, CMCC</p> <p>R4-1814824, n50 A-MPR, Qualcomm Incorporated</p> <p>R4-1814959, Changes to Max input power UL and DL configuratgions in FR1, OPPO</p> <p>R4-1814970, NR FR1 relative power tolerance CR, Nokia</p> <p>R4-1814972, A-MPR for NS_03 and NS_03U and re-formulation of NS_100, Nokia</p> <p>R4-1815060, draft CR for adding note about the fallback of NR CA in FR1 for TS 38.101-1, NTT DOCOMO, INC.</p> <p>R4-1815392, Draft CR to 38.101-1: Update to NS_04 requirements, Rohde &amp; Schwarz</p>	15.4.0

						<p>R4-1815563, Draft CR to 38.101-1 on Clarification on 7.5 KHz raster shift in NR re-farmed bands, Ericsson  R4-1815863, Draft CR for 38.101-1: Nominal carrier spacing for 30 kHz raster, SPRINT Corporation  R4-1815898, draft CR on CA configuration on bandwidth class F, Huawei  R4-1815917, draftCR on DL RMC for TS 38.101-1, Huawei  R4-1816162, Draft CR on introduction of SRS switch IL in FR1, OPPO  R4-1816199, Draft CR on FR1-FR2 UE-to-UE coexistence for TS38.101-1, LG Electronics France  R4-1816200, Draft CR to 38.101-1 on intra-band contiguous CA configurations for FR1, ZTE Corporation  R4-1816240, Transient period for SRS Antenna Switching for FR1, Qualcomm  R4-1816243, Draft CR to TS38.101-1 _Clarifications on MSD and UL configuration tables for inter-band CA, ZTE Corporation  R4-1816466, Draft CR on some changes for SUL band combinations to TS 38.101-1, Huawei  R4-1816468, Support of 7.5 kHz carrier shift for additional operating bands, Ericsson  R4-1816604, TDD configuration for UE Tx test in FR1, Ericsson  R4-1816663, Draft CR to 38.101-1 (5.3.4) RB alignment, Huawei  R4-1816755, CR to 38.101-1: ACS and IBB intra-band contiguous CA, Intel Corporation</p> <p>Further changes in RAN#82  - 7.5 kHz frequency shift is specified for all FDD bands in clause 5.4.2.1</p>	
2018-12	RAN#82	RP-182814	0030	2	F	Company CR on 2Rx exception for NR vehicular UE at FR1	15.4.0
2019-03	RAN#83	RP-190403	0034		F	<p>CR to TS 38.101-1: Implementation of endorsed draft CRs from RAN4#90</p> <p>Endorced draft CR from Ran4#90  R4-1900032, Editorial corrections for 38.101-1, Qualcomm Incorporated  R4-1900031, draftCR on SRS IL for CA, Qualcomm Incorporated  R4-1900161, CR on Relative power tolerance, Intel Corporation  R4-1900162, CR on Minimum output power, Intel Corporation  R4-1900274, Draft CR to TS 38.101-1 on NR general spectrum emission mask, ZTE Corporation  R4-1900275, Draft CR to TS 38.101-1 on spurious emission for network signalled value NS_40, NS_41 and NS_42, ZTE Corporation  R4-1900424, Correction of table references and other typos, Ericsson  R4-1900508, Draft CR to TS 38.101-1 on UE transmitter power and some other editorial corrections, ZTE Corporation  R4-1900723, Draft CR on editorial error of TS38.101-1, LG Electronics Inc.  R4-1900727, Update to PRACH EVM window length for FR1, Rohde &amp; Schwarz  R4-1900840, Draft CR for 38.101-1 modification of Transmit intermodulation requirement, Huawei  R4-1900848, [RAN5 LS]Draft CR for 38.101-1: adding note for inter-band CA spurious emissions, Huawei  R4-1901033, Alignment of Foob related description for 38.101-1, vivo  R4-1901273, Correction of HARQ-ACK transmission timing for DL RMC for FR1 TDD SCS=60kHz, Ericsson  R4-1901766, draft_CR TS 38.101-1 Correction to UL configuration for reference sensitivity, Skyworks Solutions Inc.  R4-1901823, draft CR on spurious requirment for TS 38.101-1, Huawei, HiSilicon  R4-1901835, draftCR on MSD for CA_n41-n78 for TS 38.101-1, Huawei  R4-1901847, Draft CR for 38.101-1: Addition of default power class, Sprint Corporation  R4-1901873, Receiver requirement RMC references, Qualcomm Incorporated  R4-1901925, Draft CR to 38.101-1 to update and clarify Rx wide band intermod and spurious requirments for BW class C, D, E, Qualcomm Incorporated  R4-1901992, Draft CR to 38.101-1. Correct FR1 NS_41 AMPR for n50, Huawei  R4-1902001, Draft CR to 38.101-1 on n41 – B40 coexistence, Qualcomm Incorporated</p>	15.5.0

					<p>R4-1902150, Draft CR to TS38.101-1 _Clarifications on MSD and UL configuration tables for inter-band CA, ZTE Corporation</p> <p>R4-1902166, Tx ON/OFF time mask for FR1, Qualcomm Inc</p> <p>R4-1902174, Draft CR to 38.101-1: On FR1 A-MPR NS_08 for n8, Qualcomm Incorporated</p> <p>R4-1902175, Draft CR on AMPR requirements for NS_05U and NS_08U to TS 38.101-1, Huawei</p> <p>R4-1902194, [41 DL]Draft CR for 38.101-1 adding DL intra-band CA requirements for frequency less than 2700MHz, Huawei</p> <p>R4-1902196, Draft CR for 7.9A Spurious emissions for CA, CMCC</p> <p>R4-1902223, UE optional bandwidth for FR1, Nokia</p> <p>R4-1902225, CR to 38.101-1 on CA BW Classes fallback groups, Intel Corporation</p> <p>R4-1902233, Draft CR to 38.101-1: SUL clarifications, Nokia</p> <p>R4-1902339, Draft CR to TS 38.101-1 on FR1 extension, Ericsson</p> <p>R4-1902455, Completion of the Pcmx specification: additional P-max and P_Nr, Ericsson</p> <p>R4-1902468, Draft CR: Introduction of Annex on Characteristics of the Interfering Signal, Samsung</p> <p>R4-1902479, Draft CR on some errors to TS 38.101-1, Huawei</p> <p>R4-1902480, Draft CR for 38.101-1 modification of requirements for network signalled value NS_04, Huawei</p> <p>R4-1902655, CR to 38.101-1 on NR Uplink RBs location, Intel Corporation</p> <p>R4-1901610, Draft CR for 38.101-1 REFSENS for UL MIMO, Huawei</p> <p>Editorial changes after RAN#83</p> <p>To align the annex numbering with other specifications (TS 38.101-x series), annexes J and K were added and Change history was numbered as annex L.</p>	
2019-06	RAN#84	RP-191240	0047	F	<p>CR to TS 38.101-1: Implementation of endorsed draft CRs from RAN4#90bis and RAN4#91</p> <p>Endorced draft CRs from RAN4#90Bis</p> <p>R4-1902826, Draft CR for 38.101-1 modification of ACS test parameters case 2 for intra-band contiguous CA, Huawei</p> <p>R4-1902926, Draft CR to TS 38.101-1 Correction to Pcmx, Intel Corporation</p> <p>R4-1902975, Draft CR on PRACH and PUCCH format description for EVM in FR1, Anritsu corporation</p> <p>R4-1903032, Draft CR on editorial error of TS38.101-1, LG Electronics France</p> <p>R4-1903120, Draft CR on DL power allocation for TS 38.101-1, Intel Corporation</p> <p>R4-1903124, Draft CR on b41-n40 coexistence, Intel Corporation</p> <p>R4-1903151, Draft CR to TS38.101-1_removing DC sections, ZTE Corporation</p> <p>R4-1903195, Draft CR for 38.101-1: remove the bracket of UE capability "powerBoosting-pi2BPSK", Huawei</p> <p>R4-1903392, Draft CR for TS 38.101-1: Corrections to EVM equalizer spectrum flatness requirements, MediaTek Inc.</p> <p>R4-1903473, Draft CR on FREF,Shift, CMCC</p> <p>R4-1903508, Draft CR to TS 38.101-1 on spurious emissions for UE co-existence, ZTE Corporation</p> <p>R4-1904335, DraftCR TS 38.101 Corrections to NS_100 UTRA ACLR frequency band list, Skyworks Solutions Inc.</p> <p>R4-1904460, Draft CR for 38.101-1 CA Pcmx, Huawei</p> <p>R4-1904537, Draft CR for TR 38.101-1 correction of A-MPR for NS_04, Huawei</p> <p>R4-1904554, Draft CR to 38.101-1: FR1 power dynamics DTX removal, Qualcomm Incorporated</p> <p>R4-1904927, Draft CR to clarify frequency of carrier leakage in RBs for FR1, Anritsu corporation</p> <p>R4-1904928, Draft CR to TS 38.101-1 on description of UE additional output power reduction, ZTE Corporation</p> <p>R4-1904929, draft Rel-15 CR for editorial corrections in 38.101-1, Ericsson</p> <p>R4-1904941, draft CR to 38.101-1 Correction to Pi/2 BPSK power boosting, Intel Corporation</p> <p>R4-1904957, Draft CR for TR38.101-1 – Update to EVM averaging, Rohde &amp; Schwarz</p> <p>R4-1904958, Draft CR for TR38.101-1 – Update to spectrum flatness, Rohde &amp; Schwarz</p> <p>R4-1904967, Draft CR for 38.101-1 definition of Maximum input level for intra-band contiguous CA, Huawei</p> <p>R4-1904969, Draft CR for 38.101-1: editoral correction, Huawei</p> <p>R4-1904987, Draft CR for correction on TS38.101-1, CATT</p>	15.6.0

						<p>Endorced draft CRs from RAN4#91</p> <p>R4-1905339 removal of A-MPR brackets in FR1 Nokia</p> <p>R4-1905503 Change description 4.2(d) in Applicability of minimum requirements for TS 38.101-1 vivo</p> <p>R4-1905524 [Rx]Draft CR for 38.101-1 Removing the brackets in Rx requirements Huawei</p> <p>R4-1905526 [Rx]Draft CR for 38.101-1 defining NBB requirements&lt;2.7GHz Huawei</p> <p>R4-1905772 Draft CR to TS38.101-1 Almost contiguous MPR Intel Corporation</p> <p>R4-1905795 Correction to a description of PRB for in-band emission in FR1 Anritsu Corporation</p> <p>R4-1905797 Correction to power control in FR1 Anritsu Corporation</p> <p>R4-1906140 draft CR for TS 38.101-1 Rx requirement for CA Huawei</p> <p>R4-1906153 Draft CR for TS 38.101-1: Editorial corrections to intra-band contiguous CA ACS and in-band blocking requirements MediaTek Inc.</p> <p>R4-1906154 Draft CR for TS 38.101-1: Adding symbol definitions for intra-band contiguous CA Rx maximum input level and ACS requirements MediaTek Inc.</p> <p>R4-1906871 Draft CR for TS 38.101-1 UE optional bandwidth for FR1 Huawei</p> <p>R4-1907131 Draft CR to 38.101-1. Clarification to FR1 NS_43 AMPR frequency ranges Qualcomm Incorporated</p> <p>R4-1907135 Draft CR to 38.101-1 rel. 15 to fix missing Exceptions for Out-of-band Blocking Apple</p> <p>R4-1907419 Draft CR for TS 38.101-1: Editorial improvement to EVM equalizer spectrum flatness requirements for Pi/2 BPSK MediaTek Inc.</p> <p>R4-1907429 Draft CR to TS38.101-1 A-MPR for Inter-band CA Intel Corporation</p> <p>R4-1907434 [Rx]Draft CR for 38.101-1 modifying characteristics of the interfering signal in Annex D Huawei</p> <p>R4-1907435 Draft CR to TS38.101-1_introduction of n41C and corrections on Rx requirements for NR intra-band contiguous CA ZTE Corporation</p> <p>R4-1907439 Draft CR to TS 38.101-1 on CA bandwidth class description ZTE Corporation</p> <p>R4-1907471 Draft CR to 38.101-1. Clarify all RB reference so transmission BW applies for all SCS Qualcomm Incorporated</p> <p>R4-1907474 Draft CR for TS 38.101-1 Correction of channel bandwidth set for NR CA Huawei</p> <p>R4-1907477 Draft CR to TS 38.101-1 on maximum aggregated bandwidth for NR CA configurations ZTE Corporation</p> <p>R4-1907481 Correction of RefSens exceptions due to UL harmonic interference for NR CA in 38.101-1 vivo</p> <p>R4-1907687 Correction to CA carrier spacing Ericsson</p>	
2019-06	RAN#84	RP-191248	0037	1	B	Introduction of n48 in to TS 38.101-1	16.0.0
2019-06	RAN#84	RP-191241	0040		B	CR to REL-16 TS 38.101-1: Implementation of endorsed draft CRs on NR combinations and dual Connectivity combinations	16.0.0
2019-06	RAN#84	RP-191242	0041	1	B	CR to TS 38.101-1: Introduction of band n14 – Endorsed R4-1904008 in RAN4#90b	16.0.0
2019-06	RAN#84	RP-191246	0042	1	B	CR to TS 38.101-1: Introduction of band n30 + editorial in table 7.6.2-2	16.0.0
2019-06	RAN#84	RP-191244	0043	1	B	CR to introduce n18 to TS 38.101-1	16.0.0
2019-06	RAN#84	RP-191250	0044	1	B	n65 introduction to 38.101-1	16.0.0
2019-06	RAN#84	RP-191251	0045		B	Addition channel bandwidth of 30MHz for n50 in TS 38.101-1	16.0.0
2019-06	RAN#84	RP-191252	0046	1	B	Introduction of a new NR band for LTE/NR spectrum sharing in Band 41/n41	16.0.0
2019-06	RAN#84	RP-191241	0048		B	CR on introducing NR inter-band CA of 3DL Bands and 1UL band	16.0.0
2019-06	RAN#84	RP-191241	0049		B	CR to reflect the completed NR inter-band CA/DC combinations into Rel16 TS38.101-1	16.0.0
2019-06	RAN#84	RP-191241	0050		B	CR to reflect the completed NR inter-band CA/DC combinations for 3 bands DL with 2 bands UL into Rel16 TS38.101-1	16.0.0
2019-06	RAN#84	RP-191241	0051		B	CR introduction completed band combinations 38.716-01-01 -> 38.101-1	16.0.0
2019-09	RAN#85	RP-192038	0052		F	Correction to FR1 ASEM NS_27	16.1.0
2019-09	RAN#85	RP-192032	0053		B	Addition of NS information on 30MHz support for n41	16.1.0
2019-09	RAN#85	RP-192031	0054	1	B	Addition of new channel bandwidths for n7 into TS 38.101-1	16.1.0
2019-09	RAN#85	RP-192027	0055		B	CR on introducing NR intra-band CA for 3DL Bands and 1UL band	16.1.0
2019-09	RAN#85	RP-192027	0057	1	F	Minor corrections of intra-band non-contiguous CA operating bands in TS 38.101-1	16.1.0
2019-09	RAN#85	RP-192027	0058	1	F	Adding DeltaFHD for CA_n1-n77 refersense requirments	16.1.0

2019-09	RAN#85	RP-192032	0060		B	CR to introduce 30MHz bandwidth of n41 into TS 38.101-1	16.1.0
2019-09	RAN#85	RP-192026	0061	1	B	Characteristics of Interfering signal for Contiguous Intra-band CA Class B	16.1.0
2019-09	RAN#85	RP-192027	0062	1	F	Correction Inter-band CA configurations	16.1.0
2019-09	RAN#85	RP-192027	0063	1	F	Finalizing Generic Intra-band Contiguous CA Class B requirements	16.1.0
2019-09	RAN#85	RP-192034	0064	1	B	n29 introduction to 38.101	16.1.0
2019-09	RAN#85	RP-192027	0065		F	[SUL] CR on SUL band combinations into Rel-16 TS 38.101-1	16.1.0
2019-09	RAN#85	RP-192029	0066		B	CR on Introduction of SUL band n89 into Rel-16 TS 38.101-1	16.1.0
2019-09	RAN#85	RP-192046	0068	2	F	Correction to Band n66	16.1.0
2019-09	RAN#85	RP-192026	0070	1	F	CR to 38.101-1. Revamp CA ACS and IBB tables to differentiate by band numbers and not frequency	16.1.0
2019-09	RAN#85	RP-192038	0071		F	CR to 38.101-1. Add missing AMPR to NS27	16.1.0
2019-09	RAN#85	RP-192026	0072		B	CR for 38.101-1 Rx requirement for NR intra-band non-contiguous CA	16.1.0
2019-09	RAN#85	RP-192036	0073		F	CR for 38.101-1: Correction to the Spurious Emission for UE Coexistence table for n14	16.1.0
2019-09	RAN#85	RP-192037	0074		F	CR for 38.101-1: Correction to the Spurious Emission for UE Coexistence table for n30	16.1.0
2019-09	RAN#85	RP-192027	0075		B	CR introduction completed band combinations 38.716-01-01 -> 38.101-1	16.1.0
2019-09	RAN#85	RP-192027	0076		B	CR to reflect the completed NR inter band CA DC combinations for 2 bands DL with up to 2 bands UL into Rel16 TS 38.101-1	16.1.0
2019-09	RAN#85	RP-192027	0077		B	CR to reflect the completed NR inter band CA DC combinations for 3 bands DL with 2 bands UL into Rel16 TS 38.101-1	16.1.0
2019-09	RAN#85	RP-192049	0079		A	CR to TS 38.101-1: Implementation of endorsed draft CRs from RAN#92 (Rel-16) - Mirrors changes in R4-1910350 (of RAN#92) for Rel-15 TS 38.101-1	16.1.0
2019-12	RAN#86	RP-193022	0097		F	CR to align NS27 AMPR to CA_NS_10 AMPR for 40MHz BW at the center of band 48.	16.2.0
2019-12	RAN#86	RP-193028	0099		A	CR for 38.101- RX Out-of-Band Blocking for B38 and B41	16.2.0
2019-12	RAN#86	RP-193028	0103		A	CR for 38.101-1 n39 AMPR	16.2.0
2019-12	RAN#86	RP-193013	0105	1	B	Introduction of 2010-2025MHz SUL band into Rel-16 TS 38.101-1	16.2.0
2019-12	RAN#86	RP-193015	0110		B	Addition of 25, 30 and 40 MHz to NR band n25 in TS 38.101-1	16.2.0
2019-12	RAN#86	RP-193028	0112		A	Sync raster to SSB resource element mapping	16.2.0
2019-12	RAN#86	RP-193028	0114		A	CR to TS 38.101-1 Almost contiguous A-MPR (R16)	16.2.0
2019-12	RAN#86	RP-193028	0118		A	CR to 38.101-1 (Rel-16) to clarify measurement interval and observation window on frequency error	16.2.0
2019-12	RAN#86	RP-193020	0119		D	Format misalignment on NS_47 protection requirement table	16.2.0
2019-12	RAN#86	RP-193028	0121		A	CR to TS 38.101-1: Replace CBW with symbols defined in the specification	16.2.0
2019-12	RAN#86	RP-193012	0124		B	CR to reflect the completed NR inter band CA DC combinations for 2 bands DL with up to 2 bands UL into Rel16 TS 38.101-1	16.2.0
2019-12	RAN#86	RP-193012	0125		B	CR to reflect the completed NR inter band CA DC combinations for 3 bands DL with 2 bands UL into Rel16 TS 38.101-1	16.2.0
2019-12	RAN#86	RP-193012	0126		F	CR to remove square brackets for n90 in TS38.101-1	16.2.0
2019-12	RAN#86	RP-193028	0128		A	CR for TS38.101-1, Clarification and Editorial corrections	16.2.0
2019-12	RAN#86	RP-193012	0132		B	Introducing NR inter-band CA for 3DL Bands and 1UL band for 38.101-1	16.2.0
2019-12	RAN#86	RP-193029	0133		B	Adding band n71 and n28 to 4 Rx antenna ports support in 38.101-1	16.2.0
2019-12	RAN#86	RP-193028	0137		A	CR for TS 38.101-1: Editorial correction for n2 uplink configuration note index in Table 7.3.2-3	16.2.0
2019-12	RAN#86	RP-193028	0138		A	CR to TS 38.101-1 on A-MPR table cleanup (Rel-16)	16.2.0
2019-12	RAN#86	RP-193029	0140		A	CR for TS 38.101-1: Removing CA configurations for CA_n77D/E, CA_n78D/E, and CA_n79D/E	16.2.0
2019-12	RAN#86	RP-193029	0144		A	CR for TS 38.101-1: Fix out-of-band blocking issue for n50 and n75	16.2.0
2019-12	RAN#86	RP-193029	0146		A	CR to TS 38.101-1 on corrections to channel raster entries for NR band (Rel-16)	16.2.0
2019-12	RAN#86	RP-193029	0150		A	CR to transmit modulation quality in FR1	16.2.0
2019-12	RAN#86	RP-193012	0151		F	Corrections Intra-band CA simultaneous TX/RX requirements	16.2.0
2019-12	RAN#86	RP-193029	0153		F	Removal of brackets from receiver requirements in 38.101-1 REL-16	16.2.0
2019-12	RAN#86	RP-193012	0155		B	Extension of CA BW class B	16.2.0
2019-12	RAN#86	RP-193029	0157		A	CR to 38.101-1: Editorial correction of UL RMCs	16.2.0
2019-12	RAN#86	RP-193012	0164		B	CR for 38.101-1 introduce SUL band combination CA_n78(2A)_SUL_n78A-n86A	16.2.0
2019-12	RAN#86	RP-193010	0165		F	CR for 38.101-1: add BCS1 configurations for CA_n78(2A)	16.2.0
2019-12	RAN#86	RP-193017	0166		B	CR to 38.101-1 - Band n75 - wider CBW	16.2.0
2019-12	RAN#86	RP-193018	0167		B	CR for TS 38.101: adding wider channel bandwidths	16.2.0
2019-12	RAN#86	RP-193016	0168		B	CR to 38.101-1: Addition of channel bandwidth for band n38	16.2.0
2019-12	RAN#86	RP-193012	0169		B	CR introduction completed band combinations 38.716-01-01 -> 38.101-1	16.2.0
2019-12	RAN#86	RP-193012	0170		B	CR introduction completed band combinations 38.716-04-01 -> 38.101-1	16.2.0



2019-12	RAN#86	RP-193021	0171		C	CR for 38.101-1: Making 90 MHz channel bandwidth mandatory for n41, n78 and n90	16.2.0
2019-12	RAN#86	RP-193020	0172		B	CR for 38.101-1: adding 30 MHz CHBW to NS_04 for n41	16.2.0
2019-12	RAN#86	RP-193029	0174		A	CR to 38.101-1-g10 Corrections to Transient Time Masks	16.2.0
2019-12	RAN#86	RP-193010	0176	1	F	CR for intra-band DL contiguous CA RF requirements	16.2.0
2019-12	RAN#86	RP-193010	0179		B	Introduction of almost contiguous MPR for PC2	16.2.0
2019-12	RAN#86	RP-193029	0180		A	CR for asynchronous operation for NR CA n78-n79	16.2.0
2019-12	RAN#86	RP-193028	0182		A	CR to 38.101-1: DMRS Exceptions	16.2.0
2020-03	RAN#87	RP-200408	0191		F	Corrections to n65	16.3.0
2020-03	RAN#87	RP-200377	0201	1	F	CR for 38.101-1 to introduce BCS1 for CA_n77C and CA_n78C	16.3.0
2020-03	RAN#87	RP-200394	0203		A	CR to TS 38.101-1 on corrections to network signalling value (Rel-16)	16.3.0
2020-03	RAN#87	RP-200484	0208		A	CR for 38.101- n39 NS flag change due to conflict	16.3.0
2020-03	RAN#87	RP-200394	0210		A	Mirror CR for 38.101-1: n41 and n25 corrections	16.3.0
2020-03	RAN#87	RP-200380	0211	2	F	CR for 38.101-1: Corrections to intra-band CA tables	16.3.0
2020-03	RAN#87	RP-200387	0212		F	CR for 38.101-1: Missing 70 MHz for NS_01	16.3.0
2020-03	RAN#87	RP-200381	0215		B	CR for 38.101-1: Introduction of n26	16.3.0
2020-03	RAN#87	RP-200380	0216		F	CR to TS 38.101-1: Corrections on MSD tables for CA_n20-n78 and CA_n66-n78	16.3.0
2020-03	RAN#87	RP-200394	0218		A	CR to TS 38.101-1: corrections on ACS for intra-band contiguous CA	16.3.0
2020-03	RAN#87	RP-200380	0219	1	F	CR to TS 38.101-1: Improvement on NR 3DL inter-band CA combination	16.3.0
2020-03	RAN#87	RP-200394	0221		A	CR to TS 38.101-1: Replace CBW with symbols defined in the specification.  NOTE: The CR is based on something else than the latest version of the specification and therefore it is not implemented, e.g. Tables 6.2.3.1-1, 7.6.2-2 and Table 7.6.2-4 in CR0221 are different compared to those in 38.101-1 v16.2.0.	16.3.0
2020-03	RAN#87	RP-200380	0222		B	CR to reflect the completed NR inter band CA DC combinations for 2 bands DL with up to 2 bands UL into Rel16 TS 38.101-1	16.3.0
2020-03	RAN#87	RP-200380	0223		B	CR to reflect the completed NR inter band CA DC combinations for 3 bands DL with 2 bands UL into Rel16 TS 38.101-1	16.3.0
2020-03	RAN#87	RP-200394	0224	1	B	Introduction of n53 into TS 38.101-1	16.3.0
2020-03	RAN#87	RP-200394	0229		A	CR for TS38.101-1, Remove notes for UE channel bandwidth	16.3.0
2020-03	RAN#87	RP-200394	0231		A	CR for TS38.101-1, Correction of IE RF-Parameters name of maxUplinkDutyCycle	16.3.0
2020-03	RAN#87	RP-200380	0234	1	B	Introducing NR inter-band CA for 3DL Bands and 1UL band for 38.101-1	16.3.0
2020-03	RAN#87	RP-200377	0239	1	F	CR for TS 38.101-1: Corrections for n48 receiver requirements	16.3.0
2020-03	RAN#87	RP-200386	0240	1	B	CR for TS 38.101: adding wider channel bandwidths for n66	16.3.0
2020-03	RAN#87	RP-200392	0241	1	F	Maintenance on the UE BW for n92 and n94	16.3.0
2020-03	RAN#87	RP-200392	0242		F	Maintenance on the Rx-Tx separation terms	16.3.0
2020-03	RAN#87	RP-200394	0244		A	CR for 38.101-1: to remove fallback group 1 in table 5.5A.1-1	16.3.0
2020-03	RAN#87	RP-200389	0247		F	CR for 38.101-1: to correct CA_n8A-n75A REFSENS	16.3.0
2020-03	RAN#87	RP-200384	0249	1	B	CR for 38.101-1: to introduce UE RF requirements for adding wider channel bandwidth in band n28	16.3.0
2020-03	RAN#87	RP-200383	0250	1	B	CR to 38.101-1 Band n1 - wider CBW - Additional Channel BW	16.3.0
2020-03	RAN#87	RP-200385	0252	1	B	CR to 38.101-1 Band n38 - wider CBW - Additional Channel BW	16.3.0
2020-03	RAN#87	RP-200380	0260	1	F	Editorial corrections	16.3.0
2020-03	RAN#87	RP-200377	0263		F	CR for almost contiguous allocation applicability	16.3.0
2020-03	RAN#87	RP-200394	0265	1	A	CR for inter-band CA Tx requirement	16.3.0
2020-03	RAN#87	RP-200377	0266	1	F	CR for intra-band CA configuration and DL RF requirements	16.3.0
2020-03	RAN#87	RP-200391	0273		F	CR for 38.101-1: Mandatory support for n41 by UEs that support n90	16.3.0
2020-03	RAN#87	RP-200394	0275		A	CR for [agreed] asynchronous operation for NR CA n78-n79  NOTE: The CR is based on something else than the latest version of the specification and therefore it is not implemented, e.g. Tables 6.2A.4.2.3-1, Table 7.3A.6-1, 7.3A.6.2 and table notes are different compared to those in 38.101-1 v16.2.0.	16.3.0
2020-03	RAN#87	RP-200380	0280		F	CR for 38.101-1: delta Tib corrections	16.3.0
2020-03	RAN#87	RP-200394	0281		A	Removal of unnecessary definition of offset <sub>max,IMD3</sub> from Table 6.2.3.2-1	16.3.0
2020-06	RAN#88	RP-201338	0293	4	B	CR to TS 38.101-1: Switching time mask between two uplink carriers in UL CA and SUL	16.4.0
2020-06	RAN#88	RP-200959	0294		F	Corrections to CA n48	16.4.0
2020-06	RAN#88	RP-200985	0300		A	CR to asymmetric CBW operation in FR1	16.4.0
2020-06	RAN#88	RP-200985	0302		A	CR on ACLR MBW definition in FR1	16.4.0

2020-06	RAN#88	RP-200959	0305		B	Introducing NR inter-band CA for 3DL Bands and 1UL band for 38.101-1	16.4.0
2020-06	RAN#88	RP-200959	0307		F	CR Coexistence cleanup for 38101-1 Rel16	16.4.0
2020-06	RAN#88	RP-200985	0310		A	CR to TS 38.101-1 R16: corrections on ACS for intra-band contiguous CA	16.4.0
2020-06	RAN#88	RP-200966	0311		F	CR for TS 38.101-1: UL harmonic MSD and OOB exception	16.4.0
2020-06	RAN#88	RP-200981	0315		F	Update 4Rx Requirement for Band n30	16.4.0
2020-06	RAN#88	RP-200958	0317		B	CR on NR V2X UE RF requirements for single carrier in TS38.101-1	16.4.0
2020-06	RAN#88	RP-200985	0327		A	Maintenance CR to 38101-1 on relative power tolerance R16	16.4.0
2020-06	RAN#88	RP-200974	0329		F	Endorsed CR on default AMPR signaling for n91 n92 n93 and n94	16.4.0
2020-06	RAN#88	RP-200985	0331		A	Update of CSI-RS definition for FR1 DL RMCs	16.4.0
2020-06	RAN#88	RP-200985	0335		A	Correction to FR1 QPSK UL RMC	16.4.0
2020-06	RAN#88	RP-200966	0336		B	CR to TS38.101-1: Introduction of NR DC(Clauses 3	16.4.0
2020-06	RAN#88	RP-200985	0338		A	CR to TS 38.101-1: Correction on the CA nominal channel spacing	16.4.0
2020-06	RAN#88	RP-200985	0340		A	CR to TS 38.101-1: Replace CBW with symbols defined in the specification.	16.4.0
2020-06	RAN#88	RP-200959	0341		B	CR to reflect the completed NR inter band CA DC combinations for 2 bands DL with up to 2 bands UL into Rel16 TS 38.101-1	16.4.0
2020-06	RAN#88	RP-200985	0345		A	30k SSB SCS for n50	16.4.0
2020-06	RAN#88	RP-200985	0347		A	Addition of 30k SSB SCS for Band n38	16.4.0
2020-06	RAN#88	RP-200985	0354		A	IBE measurements for Pi/2 BPSK with spectrum shaping	16.4.0
2020-06	RAN#88	RP-200959	0357		B	CR to reflect the completed NR inter band CA DC combinations for 3 bands DL with 2 bands UL into Rel16 TS 38.101-1	16.4.0
2020-06	RAN#88	RP-200959	0360		B	CR introduction completed band combinations 38.716-01-01 -	16.4.0
2020-06	RAN#88	RP-200959	0361		B	CR introduction completed band combinations 38.716-04-01 -	16.4.0
2020-06	RAN#88	RP-200959	0364		B	CR on Introduction of completed SUL band combinations into TS 38.101-1	16.4.0
2020-06	RAN#88	RP-201045	0365		F	CR for 38.101-1 to introduce BCS2 for CA_n78(2A).	16.4.0
2020-06	RAN#88	RP-200985	0367		A	CR for 38.101-1 to remove the NR CA configuration for REFSENS exception due to cross band isolation for CA (mirror CR)	16.4.0
2020-06	RAN#88	RP-200985	0369		A	CR for 38.101-1 to add the REFSENS exception for inter band CA with SDL (mirror CR)	16.4.0
2020-06	RAN#88	RP-200979	0373		F	CR on introduce delta-MPR for inter-band CA in band n28 and review value with brackets	16.4.0
2020-06	RAN#88	RP-200985	0379		A	IBE requirement for almost contiguous allocations	16.4.0
2020-06	RAN#88	RP-200985	0385		A	OOB blocking for n70 adjacent to n25	16.4.0
2020-06	RAN#88	RP-200985	0394		F	CR for TS 38.101-1 UE co-existence correction (R16)	16.4.0
2020-06	RAN#88	RP-200985	0396		F	CR for 38.101-1 RFC corrections (R16)	16.4.0
2020-06	RAN#88	RP-200985	0400		A	TS38.101-1 CR on 30KHz SSB SCS for n40(Rel-16)	16.4.0
2020-06	RAN#88	RP-200959	0318	1	F	CR to add simultaneous RXTX capability for CA_n41-n79	16.4.0
2020-06	RAN#88	RP-200985	0404		A	CR for 38.101-1: to add some missing sub-clause title for NR inter-band CA	16.4.0
2020-06	RAN#88	RP-200985	0343	1	A	CR for [agreed] asynchronous operation for NR CA n78-n79	16.4.0
2020-06	RAN#88	RP-201045	0387	1	B	CR on FR1 UL contiguous CA requirement	16.4.0
2020-06	RAN#88	RP-200974	0325	1	F	CR on blocking requirements for n91 n92 n93 and n94	16.4.0
2020-06	RAN#88	RP-201045	0380	1	B	Addition of mutual UE coexistence between US bands and NR Band n77	16.4.0
2020-06	RAN#88	RP-200977	0356	1	B	CR for TS 38.101: adding 50 MHz CBW for n1	16.4.0
2020-06	RAN#88	RP-200980	0358	1	B	CR to TS 38.101-1 - Add 40 MHz CBW in band n3	16.4.0
2020-06	RAN#88	RP-200982	0359	1	B	CR to TS 38.101-1 - Add 50 MHz CBW in band n65	16.4.0
2020-06	RAN#88	RP-200985	0405		F	Corrections of UE co-ex tables for Japan-related bands (R16)	16.4.0
2020-06	RAN#88	RP-201045	0320	2	B	CR to 38.101-1: Introduce an operating band list and NR bands to UL MIMO	16.4.0
2020-06	RAN#88	RP-200966	0362	1	B	CR to 38.101-1 for Introduction of requirements for NR-DC	16.4.0
2020-09	RAN#89	RP-201495	0407	1	F	Correction to FR1 UL contiguous CA MPR regions	16.5.0
2020-09	RAN#89	RP-201506	0409		F	CR for n26 AMPR for 256QAM	16.5.0
2020-09	RAN#89	RP-201512	0411		A	OOB blocking for Inter-band CA	16.5.0
2020-09	RAN#89	RP-201512	0416	1	F	Correction to ASEM for NS_27	16.5.0
2020-09	RAN#89	RP-201507	0419		F	Introduction of UE PC2 for NR band n40	16.5.0
2020-09	RAN#89	RP-201502	0422	1	B	Introduction of LTE/NR spectrum sharing in band 48/n48 frequency range	16.5.0
2020-09	RAN#89	RP-201507	0423		F	Coexistence cleanup for 38101-1 Rel16	16.5.0
2020-09	RAN#89	RP-201506	0424		D	CR Editorial cleanup of band combination tables for 38101-1 Rel16	16.5.0
2020-09	RAN#89	RP-201512	0426		A	CR to TS 38.101-1: corrections on narrow band blocking for intra-band contiguous CA	16.5.0
2020-09	RAN#89	RP-201492	0428	1	F	CR for TS 38.101-1: Removal of table 6.5E.3.4.3-1 and table 6.5E.3.4.3-2	16.5.0
2020-09	RAN#89	RP-201503	0432	1	B	CR for 38.101-1: Introduction of Power Class 1.5	16.5.0
2020-09	RAN#89	RP-201488	0433	1	B	CR to TS38.101-1 on introduction of Uplink Full Power Transmission	16.5.0
2020-09	RAN#89	RP-201512	0435		A	Corrections of Japan-related CA co-ex tables for REL-15 combo	16.5.0
2020-09	RAN#89	RP-201492	0437	1	F	Correction on 5G V2X UE RF requirements in rel-16	16.5.0
2020-09	RAN#89	RP-201495	0438	2	B	A-MPR definition for CA_n48B, CA_n41B and CA_n41C	16.5.0

2020-09	RAN#89	RP-201495	0439		F	CR Restoring the clause structure of NR FR1 uplink contiguous intraband CA	16.5.0
2020-09	RAN#89	RP-201492	0440	1	F	CR on TS38.101-1 for NR V2X	16.5.0
2020-09	RAN#89	RP-201512	0442		A	30k SSB SCS for Band n34 and n39	16.5.0
2020-09	RAN#89	RP-201512	0444		F	Correction for 5 MHz channel bandwidth for n50 and introduction of Annex H	16.5.0
2020-09	RAN#89	RP-201512	0458		A	CR for 38.101-1 FRC corrections (R16)	16.5.0
2020-09	RAN#89	RP-201506	0459	1	F	CR for 38.101-1 to remove PHS system and 860~890 protection for NR CA band combination with band n1 and band n8	16.5.0
2020-09	RAN#89	RP-201506	0460	1	F	CR for 38.101-1 to add the missing region for NS_18 and maintenance the ?mprc	16.5.0
2020-09	RAN#89	RP-201512	0462		A	CR for 38.101-1 to add the missing MSD for CA_n41A-n78A	16.5.0
2020-09	RAN#89	RP-201512	0465		A	Correction to configured power with allowance for SRS switching	16.5.0
2020-09	RAN#89	RP-202117	0466		B	Introduce UE NR-U requirements to 38.101-1 including Band n46 (5 GHz) and Band n96 (6 GHz)	16.5.0
2020-09	RAN#89	RP-201495	0468	1	F	CR for intra-band UL CA non-contiguous CA requirement	16.5.0
2020-09	RAN#89	RP-201495	0469	1	F	CR for correction on intra-band UL CA contiguous CA requirement	16.5.0
2020-09	RAN#89	RP-201495	0470	1	F	CR for intra-band UL contiguous CA DC location	16.5.0
2020-09	RAN#89	RP-201495	0471	1	B	CR for intra-band UL CA non-contiguous CA requirement	16.5.0
2020-09	RAN#89	RP-201507	0480	1	F	CR to 38.101-1 - Correction to CA BCS and cross band isolation MSD tables	16.5.0
2020-09	RAN#89	RP-201512	0483		A	Correction of applicability of 2Rx requirements	16.5.0
2020-09	RAN#89	RP-201488	0486	2	B	CR to add PC3 Pi/2 BPSK DMRS for IE powerBoostPi2BPSK = 0	16.5.0
2020-09	RAN#89	RP-202098	0499	1	C	7.5 kHz UL shift for LTE/NR spectrum sharing in Band 38/n38	16.5.0
2020-12	RAN#90	RP-202440	0492	1	F	CR CatF n7 NS_46 AMPR and coexistence	16.6.0
2020-12	RAN#90	RP-202427	0498	1	F	Correction on 5G V2X UE RF requirements in TS38.101-1 in rel-16	16.6.0
2020-12	RAN#90	RP-202438	0506		F	n53 bracket removal	16.6.0
2020-12	RAN#90	RP-202442	0507	2	F	A-MPR definition for CA_n7B, CA_n48B, CA_n41B and CA_n41C	16.6.0
2020-12	RAN#90	RP-202485	0512		A	CR to TS38.101-1 on DC location correction	16.6.0
2020-12	RAN#90	RP-202509	0518		F	Coexistence cleanup for 38.101-1 Rel16	16.6.0
2020-12	RAN#90	RP-202509	0524	1	F	CR to TS 38.101-1 on simplification for inter-band CA configuration	16.6.0
2020-12	RAN#90	RP-202427	0525		F	CR on TS38.101-1 for NR V2X	16.6.0
2020-12	RAN#90	RP-202485	0527		A	CR to TS 38.101-1[R16]: Clarification of non-simultaneous Rx/Tx operation for CA_n77-n79 and CA_n78-n79 in TS 38.101-1.	16.6.0
2020-12	RAN#90	RP-202442	0533	1	F	CR to 38.101-1 Add requirement on the UL CA configurations with no DL interruption	16.6.0
2020-12	RAN#90	RP-202509	0534		F	Editorial correction on section 5.2C to 38.101-1 R16	16.6.0
2020-12	RAN#90	RP-202427	0535	1	F	CR on V2X bands reference table	16.6.0
2020-12	RAN#90	RP-202509	0536	1	F	CR on sum of power for multiple transmit connectors	16.6.0
2020-12	RAN#90	RP-202428	0540		F	CR for 38.101-1 to correct the notation of SUL band combinations in order to be aligned with 38.101-3	16.6.0
2020-12	RAN#90	RP-202485	0542		A	CR for 38.101-1 to adjust the structure of NR CA REFSSENS (Rel-16)	16.6.0
2020-12	RAN#90	RP-202509	0544		F	Reference measurement channels for 70 MHz CBW	16.6.0
2020-12	RAN#90	RP-202428	0547		F	Correction to supported channel bandwidths per SUL_n41A-n81A	16.6.0
2020-12	RAN#90	RP-202414	0550	3	F	Correction to the intra-cell guard band definition for wideband operation	16.6.0
2020-12	RAN#90	RP-202414	0552	1	F	Correction to receiver requirements for shared spectrum channel access	16.6.0
2020-12	RAN#90	RP-202442	0556		F	CR Correction to NS_27 and Band 10 protection 38101-1 Rel16	16.6.0
2020-12	RAN#90	RP-202428	0557	1	F	CR for editorial corrections 38.101-1	16.6.0
2020-12	RAN#90	RP-202414	0558	2	F	Removal of square brackets for 38.101-1 NR-U	16.6.0
2020-12	RAN#90	RP-202509	0562		F	CR to for 38.101-1: CA uplink power clarification	16.6.0
2020-12	RAN#90	RP-202509	0563		D	CR for 38.101-1: Editorial corrections	16.6.0
2020-12	RAN#90	RP-202427	0566	1	F	CR for 38.101-1 NR V2X FRC	16.6.0
2020-12	RAN#90	RP-202485	0571		A	CR for TS 38.101-1: correction of delta Tib for UE supporting multiple band combinations (R16)	16.6.0
2020-12	RAN#90	RP-202442	0574	1	B	CR for intra-band UL CA non-contiguous CA requirement	16.6.0
2020-12	RAN#90	RP-202485	0581		A	CR for 38.101-1 on corrections for AMPR-Rel-16	16.6.0
2020-12	RAN#90	RP-202485	0584		A	CR to DMRS position in UL RMC for FR1	16.6.0
2020-12	RAN#90	RP-202456	0408	3	B	LTE/NR spectrum sharing in Band 40/n40	17.0.0
2020-12	RAN#90	RP-202451	0499		B	Introduction of 1880-1920MHz SUL band into Rel-17 TS 38.101-1	17.0.0
2020-12	RAN#90	RP-202452	0500		B	introduction of 2300-2400MHz SUL band into Rel-17 TS 38.101-1	17.0.0
2020-12	RAN#90	RP-202450	0503	1	B	CR for TS 38.101-1, Introduce new band combination of V2X_n39A-n47A and V2X_n40A-n47A	17.0.0
2020-12	RAN#90	RP-202468	0504		B	CR on Introducing NR inter-band CA for 3DL Bands and 1UL band for 38.101-1	17.0.0
2020-12	RAN#90	RP-202471	0513		B	CR on introduction of completed NR CA/DC combs with 4DL/2UL within FR1	17.0.0
2020-12	RAN#90	RP-202472	0514		B	CR on Introduction of completed SUL band combinations into TS 38.101-1	17.0.0
2020-12	RAN#90	RP-202448	0543	1	B	CR to TS 38.101-1: introduction of NR band n13	17.0.0
2020-12	RAN#90	RP-202455	0545		B	CR to 38.101-1 Introduce band combination requirements for PC2 CA_n1A-n78A	17.0.0

2020-12	RAN#90	RP-202453	0546	1	B	Big CR to 38.101-1 - Additional Channel BW	17.0.0
2020-12	RAN#90	RP-202466	0548		B	CR introduction completed band combinations Rel-17 NR Intra-band -	17.0.0
2020-12	RAN#90	RP-202470	0549		B	CR introduction completed band combinations NR Inter-band 4 bands CA -	17.0.0
2020-12	RAN#90	RP-202467	0585		B	CR to reflect the completed NR inter band CA DC combinations for 2 bands DL with up to 2 bands UL into TS 38.101-1	17.0.0
2020-12	RAN#90	RP-202469	0586		B	CR to reflect the completed NR inter band CA DC combinations for 3 bands DL with 2 bands UL into TS 38.101-1	17.0.0
2021-03	RAN#91	RP-210190	0589		A	PC1 and PC3 Updates for Band n14	17.1.0
2021-03	RAN#91	RP-210117	0594	1	A	38.101 Void clean up R17	17.1.0
2021-03	RAN#91	RP-210097	0604	2	B	CR for TS 38.101-1 introduction of NR band n24	17.1.0
2021-03	RAN#91	RP-210072	0606		A	CR on editorial correction on V2X operation in TS38.101-1 in Rel-17	17.1.0
2021-03	RAN#91	RP-210178	0607		B	CR on Introduction of completed SUL band combinations into TS 38.101-1	17.1.0
2021-03	RAN#91	RP-210096	0609	2	B	CR to 38101-1 on introducing new SUL band n99	17.1.0
2021-03	RAN#91	RP-210117	0612		A	CR for TS38 101-1 Rel-17 Correction for definition of P-MPR	17.1.0
2021-03	RAN#91	RP-210117	0614		A	CR for TS38 101-1 Rel-17 Correction of condition for MPR and delta MPR	17.1.0
2021-03	RAN#91	RP-210094	0616	1	B	CR for TS 38.101-1, Introduce new band combination of V2X_n41A-n47A	17.1.0
2021-03	RAN#91	RP-210179	0617		B	CR on Introducing NR inter-band CA for 3DL Bands and 1UL band for 38.101-1	17.1.0
2021-03	RAN#91	RP-210094	0625		F	Revision of inter-band V2X con-currency table for V2X_n39A-n47A and V2X_n40A-n47A	17.1.0
2021-03	RAN#91	RP-210092	0628	1	B	Switching time mask for 2Tx-2Tx switching between two carriers and 1Tx-2Tx/2Tx-2Tx switching between two bands in Rel-17	17.1.0
2021-03	RAN#91	RP-210082	0630		F	CR for TS 38.101-1: Correction on 1Tx-2Tx switching between two uplink carriers (Rel-17)	17.1.0
2021-03	RAN#91	RP-210092	0631		B	CR on introducing NR SUL bands n80 to UL-MIMO configuration	17.1.0
2021-03	RAN#91	RP-210091	0633		A	CR for 38.101-1: Update of missing fallback NR-DC combinations Rel-17	17.1.0
2021-03	RAN#91	RP-210184	0636	1	B	CR on introduction of completed NR CA/DC combs with 4DL/2UL within FR1	17.1.0
2021-03	RAN#91	RP-210091	0642		A	CR on introduction of shorter Transient Period Capability	17.1.0
2021-03	RAN#91	RP-210100	0657		B	CR introduction completed band combinations Rel-17 NR Intra-band -	17.1.0
2021-03	RAN#91	RP-210091	0660		A	CR for 38.101-1 to add missing spurious emissions for band n38 UE co-existence (Rel-17)	17.1.0
2021-03	RAN#91	RP-210084	0663		A	CR to TS 38.101-1: system parameters maintenance for NR-U	17.1.0
2021-03	RAN#91	RP-210117	0665		A	Simplification of n70	17.1.0
2021-03	RAN#91	RP-210074	0669		A	CR for 38.101-1: Add CA_n25A-n41(2A)-n71A which was missing in the CR implementation	17.1.0
2021-03	RAN#91	RP-210189	0670	1	F	Big CR to TS 38.101-1 - New CBW Basket WI	17.1.0
2021-03	RAN#91	RP-210117	0674		A	CR to TS38.101-1: Correction on applicability of minimum requirements	17.1.0
2021-03	RAN#91	RP-210117	0677		A	CR to TS38.101-1: Correction on the Aggregated Channel Bandwidth	17.1.0
2021-03	RAN#91	RP-210117	0679		A	CR to TS38.101-1: Correction on configured transmitted power requirement	17.1.0
2021-03	RAN#91	RP-210100	0680	1	B	Rel-17 CR 38.101-1 for improvements Intra-band tables	17.1.0
2021-03	RAN#91	RP-210101	0681		F	Rel-17 CR 38.101-1 for corrections NR CA 2, 3 and 4 band configuration tables	17.1.0
2021-03	RAN#91	RP-210099	0688		B	CR for TS 38.101-1 Introduce NR SUL bands to PC3 UL-MIMO configuration	17.1.0
2021-03	RAN#91	RP-210117	0690		A	Missing parent clause for NR-DC PCMAX	17.1.0
2021-03	RAN#91	RP-210117	0692		A	Corrections to PCMAX for UL CA	17.1.0
2021-03	RAN#91	RP-210082	0695		A	CR CA_n7B REFSSENS	17.1.0
2021-03	RAN#91	RP-210117	0699		A	CR for TS 38.101-1: Correction to FR1 time mask for SRS antenna switching	17.1.0
2021-03	RAN#91	RP-210082	0701		A	CR for TS 38.101-1: Corrections to intra-band UL NC CA requirements	17.1.0
2021-03	RAN#91	RP-210091	0703		A	CR for TS 38.101-1: Cleanup for spurious emissions for UE co-existence table	17.1.0
2021-03	RAN#91	RP-210091	0713		A	CR on TS 38.101-1 NS_49	17.1.0
2021-03	RAN#91	RP-210176	0715		B	CR to reflect the completed NR inter band CA DC combinations for 2 bands DL with up to 2 bands UL into TS 38.101-1	17.1.0
2021-03	RAN#91	RP-210181	0716		B	CR to reflect the completed NR inter band CA DC combinations for 3 bands DL with 2 bands UL into TS 38.101-1	17.1.0
2021-03	RAN#91	RP-210101	0717		B	Introduction of specific Pcmx requirements for inter-band CA category A-B combs	17.1.0
2021-06	RAN#92	RP-211084	0736		A	Update of FR1 UL RMC tables	17.2.0
2021-06	RAN#92	RP-211104	0738		F	CR Removal of square brackets from n48 NS_27 R17 CAT F	17.2.0

2021-06	RAN#92	RP-211114	0740		A	CR TDD Intraband CA REFSENS requirement issue R17	17.2.0
2021-06	RAN#92	RP-211118	0745	1	A	CR on PC1.5 HPUE SAR issue into Rel-17 TS 38.101-1	17.2.0
2021-06	RAN#92	RP-211104	0750		A	CR on spurious emission between n40 and n41 into Rel-17 TS 38.101-1	17.2.0
2021-06	RAN#92	RP-211085	0751		F	Simplification of n70	17.2.0
2021-06	RAN#92	RP-211117	0752	1	F	CR for updates related to n24 in 38.101-1	17.2.0
2021-06	RAN#92	RP-211114	0755		B	CR on Introducing NR inter-band CA for 3DL Bands and 1UL band for 38.101-1	17.2.0
2021-06	RAN#92	RP-211114	0757		A	Correction on supported channel bandwidth for CA_n39-n41-n79	17.2.0
2021-06	RAN#92	RP-211080	0760	1	F	Correction of an improper usage of band edge relaxation for MOP	17.2.0
2021-06	RAN#92	RP-211085	0765		A	CR to TS38.101-1[R17]: Addition of UE co-existence requirements for n40	17.2.0
2021-06	RAN#92	RP-211115	0768		B	CR for P <sub>max</sub> - NR-DC for DC cat. A-B combinations	17.2.0
2021-06	RAN#92	RP-211114	0770		B	Add channel bandwidth configuration for CA_n46A-n48A	17.2.0
2021-06	RAN#92	RP-211114	0773		B	Adding new CA_n46N-n48A configurations	17.2.0
2021-06	RAN#92	RP-211077	0779		A	Cleanup for UE co-existence 38.101-1 Rel-17	17.2.0
2021-06	RAN#92	RP-211102	0780	1	F	Correction on DL interruption applicability for inter-band CA	17.2.0
2021-06	RAN#92	RP-211079	0781		F	CR to TS 38.101-1 on UE channel bandwidth per operating band	17.2.0
2021-06	RAN#92	RP-211105	0783		A	UL MIMO coherence for Tx switching between two carriers (Rel-17)	17.2.0
2021-06	RAN#92	RP-211115	0784		B	CR on introduction of completed NR CA/DC combs with 4DL/2UL within FR1	17.2.0
2021-06	RAN#92	RP-211077	0786		A	CR to 38.101-1 for missing MSD due to receiver harmonic mixing for combos with n46	17.2.0
2021-06	RAN#92	RP-211120	0787		B	CR on Introduction of completed SUL band combinations into TS 38.101-1	17.2.0
2021-06	RAN#92	RP-211115	0788		B	CR on Introduction of completed 5 bands inter-band CA into TS 38.101-1	17.2.0
2021-06	RAN#92	RP-211078	0792		A	CR for updating the note of mandatory simultaneous Rx/Tx capability for FR1 NR-CA combinations	17.2.0
2021-06	RAN#92	RP-211078	0800		A	Correction to MPR for serving cells of intra-band UL CA	17.2.0
2021-06	RAN#92	RP-211095	0802		A	Corrections to BCS for n46	17.2.0
2021-06	RAN#92	RP-211095	0804		A	Applicability of minimum requirements for shared spectrum access	17.2.0
2021-06	RAN#92	RP-211120	0805		B	CR to 38.101-1 Introduce RF requirements for HPUE CA with 2 bands downlink and x bands uplink (x=1,2)	17.2.0
2021-06	RAN#92	RP-211120	0806		B	CR to 38.101-1 Introduce DL interruption clarification for CA conducting Tx Switching	17.2.0
2021-06	RAN#92	RP-211115	0807		B	Big CR to TS 38.101-1: Adding channel BW support in existing NR bands	17.2.0
2021-06	RAN#92	RP-211116	0808	1	B	CR to TS 38.101-1: Introduction of band n67	17.2.0
2021-06	RAN#92	RP-211116	0809	2	B	CR to TS 38.101-1: Introduction of band n85	17.2.0
2021-06	RAN#92	RP-211095	0811		A	CR to 38.101-1 with correction of NR-U 60 MHz and 80 MHz channels	17.2.0
2021-06	RAN#92	RP-211086	0814		F	CR for Rel-17 38.101-1 to correct some errors in Delta TIB and Delta RIB table	17.2.0
2021-06	RAN#92	RP-211086	0816		A	CR for 38.101-1 Rel17 corrections on power tolerance for intra-band contiguous CA	17.2.0
2021-06	RAN#92	RP-211101	0821		A	CR for 38.101-1 to correct AMPR value for NR V2X NS_52(Rel-17)	17.2.0
2021-06	RAN#92	RP-211107	0823		A	CR to TS38.101-1: Correction on configured transmitted power for NR non-contiguous CA	17.2.0
2021-06	RAN#92	RP-211115	0825		A	CR to TS38.101-1: Add missing CA_n1A-n3A-n78A	17.2.0
2021-06	RAN#92	RP-211115	0826		B	CR to reflect the completed NR inter band CA DC combinations for 2 bands DL with up to 2 bands UL into TS 38.101-1	17.2.0
2021-06	RAN#92	RP-211115	0827		B	CR to reflect the completed NR inter band CA DC combinations for 3 bands DL with 2 bands UL into TS 38.101-1	17.2.0
2021-06	RAN#92	RP-211095	0836		A	Applicability of requirements for intra-band contiguous CA	17.2.0
2021-06	RAN#92	RP-211110	0838		A	Correction to Band n48 reference sensitivity	17.2.0
2021-06	RAN#92	RP-211115	0843		B	CR 38.101-1 new combinations Rel-17 NR Intra-band	17.2.0
2021-06	RAN#92	RP-211115	0844		B	CR 38.101-1 new combinations NR Inter-band 4 bands CA	17.2.0
2021-06	RAN#92	RP-211115	0845		F	CR 38.101-1 to re-introduce the 3DL/2UL configuration accidentally deleted in R4-2102320	17.2.0
2021-06	RAN#92	RP-211114	0847	1	F	Rel-17 CR 38101-1-h10 corrections 1 band NR and 2 band NR CA	17.2.0
2021-06	RAN#92	RP-211114	0848	1	F	Rel-17 CR 38101-1-h10 corrections 3 band NR CA	17.2.0
2021-06	RAN#92	RP-211115	0849		F	CR 38101-1-h10 correction non-contiguous intra-band config table	17.2.0
2021-06	RAN#92	RP-211110	0864		A	CR for TS 38.101-1 update configured transmitted power for V2X (R17)	17.2.0
2021-06	RAN#92	RP-211116	0870		A	CR for 38.101-1-h10: Corrections to NS_12, NS_13, NS_14, NS_15	17.2.0
2021-06	RAN#92	RP-211114	0871		A	CR for correction of Rel-17 NR inter-band CA DC configuration for 2DL with up to 2 bands UL	17.2.0
2021-06	RAN#92	RP-211122	0872		B	Big CR for 38.101, Introduce new band combinations for V2X concurrent operation	17.2.0
2021-06	RAN#92	RP-211114	0873		F	Rel-17 CR 38101-1-g70 corrections	17.2.0
2021-06	RAN#92	RP-211080	0874		F	CR for 38.101-1-h10: Corrections to intra-band non-contiguous CA REFSENS	17.2.0

2021-06	RAN#92	RP-211114	0875		F	CR for TS 38.101-1: introduction of MSD test configurations related to IMD for inter-band combinations with intra-band UL CA as UL configuration	17.2.0
2021-09	RAN#93	RP-211915	0884		B	CR on Introducing NR inter-band CA for 3DL Bands and 1UL band for 38.101-1	17.3.0
2021-09	RAN#93	RP-211909	0885	2	B	bigCR to TS 38.101-1 - Introduction of 35MHz and 45MHz channel bandwidth	17.3.0
2021-09	RAN#93	RP-211896	0888	1	F	CR for updates related to NR Band n24	17.3.0
2021-09	RAN#93	RP-211900	0889		B	Big CR on introduction of completed NR CA/DC combs with 4DL/2UL within FR1	17.3.0
2021-09	RAN#93	RP-211901	0890	1	B	CR to 38.101-1 Introduce SAR solution for UE power class 2 NR inter-band CA and SUL configurations	17.3.0
2021-09	RAN#93	RP-211901	0891		B	CR to 38.101-1 Introduce RF requirements for HPUE CA with 2 bands downlink and x bands uplink (x=1,2)	17.3.0
2021-09	RAN#93	RP-211902	0893		B	CR on Introduction of completed SUL band combinations into TS 38.101-1	17.3.0
2021-09	RAN#93	RP-211900	0894		B	CR on Introduction of completed 5 bands inter-band CA into TS 38.101-1	17.3.0
2021-09	RAN#93	RP-211901	0896		F	CR to TS 38.101-1: Correction on PC2 1UL_2DL table 6.2A.1.3-2	17.3.0
2021-09	RAN#93	RP-211900	0898		B	Big CR to reflect the completed NR inter band CA DC combinations for 2 bands DL with up to 2 bands UL into TS 38.101-1	17.3.0
2021-09	RAN#93	RP-211900	0899		B	Big CR to reflect the completed NR inter band CA DC combinations for 3 bands DL with 2 bands UL into TS 38.101-1	17.3.0
2021-09	RAN#93	RP-211900	0903		B	CR 38.101-1 new combinations Rel-17 NR Intra-band	17.3.0
2021-09	RAN#93	RP-211900	0904		B	CR 38.101-1 new combinations NR Inter-band 4 bands CA	17.3.0
2021-09	RAN#93	RP-211907	0905		B	Big CR to TS 38.101-1: Adding channel BW support in existing NR bands	17.3.0
2021-09	RAN#93	RP-211896	0906		B	CR for 38.101-1: Introduction of BCS4 and BCS5	17.3.0
2021-09	RAN#93	RP-211900	0907		F	CR for TS 38.101-1: Correcting CA frequency setup for 2UL interband reference sensitivity	17.3.0
2021-09	RAN#93	RP-211895	0908	1	F	CR for TS 38.101-1 Rel-17: Applying n40 and n41 spurious emissions on CA	17.3.0
2021-09	RAN#93	RP-211910	0911	1	B	Introduction of the UL 7.5kHz shift for NR TDD band n34 and n39	17.3.0
2021-09	RAN#93	RP-211895	0912		B	CR on contiguous CA with UL MIMO for power class 3	17.3.0
2021-09	RAN#93	RP-211895	0913	1	B	CR on PC2 intra-band UL contiguous CA RF requirements	17.3.0
2021-09	RAN#93	RP-211897	0914		B	CR for TS 38.101-1 Tx diversity requirements	17.3.0
						NOTE: The CR is partly implemented. The changes were ignored in CR0914's regarding PC1.5 in clause 6.2.2 due to conflict with CR0915	
2021-09	RAN#93	RP-211901	0915		B	CR to 38.101-1: Introduction of PC1.5 in Bands n77 and n78	17.3.0
2021-09	RAN#93	RP-211901	0916		B	CR to 38.101-1: Introduction of PC1.5 in Band n79	17.3.0
2021-09	RAN#93	RP-211888	0917		F	CR to 38.101-1: PC1.5 MPR for Band n41	17.3.0
2021-09	RAN#93	RP-211901	0918		B	CR to TS 38.101-1: Addition of PC2 A-MPR for NS_50	17.3.0
2021-09	RAN#93	RP-211921	0921		F	Big CR for TS 38.101-1 Maintenance part1 (Rel-17)	17.3.0
2021-09	RAN#93	RP-211907	0923		A	Big CR for TS 38.101-1 Maintenance part2 (Rel-17)	17.3.0
2021-09	RAN#93	RP-211900	0924		F	Rel-17 CR 38.101-1, band combination corrections	17.3.0
2021-09	RAN#93	RP-211905	0925		B	CR for updating the note of mandatory simultaneous Rx/Tx capability for Rel.17 FR1 NR-CA combinations	17.3.0
2021-09	RAN#93	RP-212600	0927	2	A	Introduction of NS value for distinguishing support of extended n77	17.3.0
2021-12	RAN#94	RP-212837	0930		F	Clarification on applicability of RB restriction for n39 and n98	17.4.0
2021-12	RAN#94	RP-212837	0932	1	B	CR on PC2 UE RF requirements of n34 in Rel-17 TS 38.101-1	17.4.0
2021-12	RAN#94	RP-212837	0933		B	CR on PC2 UE RF requirements of n39 in Rel-17 TS 38.101-1	17.4.0
2021-12	RAN#94	RP-212830	0940		B	CR on Introducing NR inter-band CA for 3DL Bands and 1UL band for 38.101-1	17.4.0
2021-12	RAN#94	RP-212826	0941		F	CR for 38.101-1 to remove UL MIMO restriction for SUL carrier	17.4.0
2021-12	RAN#94	RP-212833	0942		B	CR on UE maximum output power for n1 and n3 PC2	17.4.0
2021-12	RAN#94	RP-212825	0944	1	B	CR for TS 38.101-1: 1024QAM	17.4.0
2021-12	RAN#94	RP-212831	0945		B	Big CR on introduction of completed NR CA/DC combs with 4DL/2UL within FR1	17.4.0
2021-12	RAN#94	RP-212836	0947		F	CR: Rel-17 38.101-1 Corrections on spurious emission band UE co-existence	17.4.0
2021-12	RAN#94	RP-212830	0948	1	F	CR for TS 38.101-1: MSD test configurations modification for US inter-band CA combinations with n77	17.4.0
2021-12	RAN#94	RP-212835	0949	1	F	CR for TS 38.101-1: Remove unsupported channel BWs for n25 and n79	17.4.0
2021-12	RAN#94	RP-212835	0950		B	Big CR to TS 38.101-1: Adding channel BW support in existing NR bands	17.4.0
2021-12	RAN#94	RP-212832	0951	1	F	CR to TS38.101-1: Correction on MSD table to apply PC2 NR inter-band CA combination	17.4.0
2021-12	RAN#94	RP-212830	0952		F	CR to TS38.101-1: Inter-band NR CA Tx requirement including intra-band non-contiguous CA and combinations of intra-band and inter-band CA UL configuration	17.4.0

2021-12	RAN#94	RP-212830	0953		B	Big CR to reflect the completed NR inter band CA DC combinations for 2 bands DL with up to 2 bands UL into TS 38.101-1	17.4.0
2021-12	RAN#94	RP-212830	0954		B	Big CR to reflect the completed NR inter band CA DC combinations for 3 bands DL with 2 bands UL into TS 38.101-1	17.4.0
2021-12	RAN#94	RP-212832	0955		B	CR to 38.101-1 Introduce RF requirements for HPUE CA with 2 bands downlink and x bands uplink (x =1,2)	17.4.0
2021-12	RAN#94	RP-212834	0956		B	CR to 38.101-1 Introduce DL interruption clarification for CA conducting Tx Switching	17.4.0
2021-12	RAN#94	RP-212831	0957		B	CR on Introduction of completed SUL band combinations into TS 38.101-1	17.4.0
2021-12	RAN#94	RP-212831	0958		B	CR on Introduction of completed 5 bands inter-band CA into TS 38.101-1	17.4.0
2021-12	RAN#94	RP-212830	0959		B	CR 38.101-1 new combinations Rel-17 NR Intra-band	17.4.0
2021-12	RAN#94	RP-212831	0960		B	CR 38.101-1 new combinations NR Inter-band 4 bands CA	17.4.0
2021-12	RAN#94	RP-212904	0961		B	CR for 38.101-1 to introduce PC2 RF requirements for NR V2X	17.4.0
2021-12	RAN#94	RP-212837	0973	1	F	Correction to maxUplinkDutyCycle-MPE-FR1 for PC1.5	17.4.0
2021-12	RAN#94	RP-212832	0974		F	Correction to uplink Tx power for PC2 2UL CA MSD	17.4.0
2021-12	RAN#94	RP-212847	0977		A	CR to remove LO exceptions	17.4.0
2021-12	RAN#94	RP-212832	0979		B	CR to 38.101-1 Introduce RF requirements for HPUE CA with x (x>2) bands DL and y (y=1,2) bands UL	17.4.0
2021-12	RAN#94	RP-212827	0980		B	CR 38.101-1 to improve how to include BCS4 and BCS5	17.4.0
2021-12	RAN#94	RP-212845	0983		F	Big CR for TS 38.101-1 Maintenance (Rel-17)	17.4.0
2021-12	RAN#94	RP-213687	0984	1	B	Bandwidth class correction for DC_n46N-n48A DC_n46N-n48B DC_n46N-n48C combos	17.4.0
2022-03	RAN#95	RP-220357	0990	1	B	CR for introduction of the lower 6GHz unlicensed band	17.5.0
2022-03	RAN#95	RP-220357	0991	1	B	CR for introduction of operation in full unlicensed band 5925-7125MHz	17.5.0
2022-03	RAN#95	RP-220342	0993		F	CR on UL MIMO coherence for Tx switching	17.5.0
2022-03	RAN#95	RP-220359	0994		B	CR on Introducing NR inter-band CA for 3DL Bands and 1UL band for 38.101-1	17.5.0
2022-03	RAN#95	RP-220359	0995		B	Big CR to reflect the completed NR inter band CA DC combinations for 3 bands DL with 2 bands UL into TS 38.101-1	17.5.0
2022-03	RAN#95	RP-220352	0996		B	CR for 4 Rx antenna ports support of band n8	17.5.0
2022-03	RAN#95	RP-220343	0997		B	Big CR to 38.101-1 Introduce RF requirements for HPUE CA	17.5.0
2022-03	RAN#95	RP-220343	0998	1	B	CR to TS38101-1 Addition of MSD for FDD PC2	17.5.0
2022-03	RAN#95	RP-220343	0999	1	B	CR to TS38101-1 Addition of PC2 A-MPR for FDD PC2	17.5.0
2022-03	RAN#95	RP-220359	1000	1	F	CR to TS38101-1 Addition of DC configurations	17.5.0
2022-03	RAN#95	RP-220359	1001	1	F	Clarification of A-MPR/NS applicability for inter-band NR-DC	17.5.0
2022-03	RAN#95	RP-220365	1002		B	Formal big CR to introduce SL enhancements UE RF requirements in Rel-17	17.5.0
2022-03	RAN#95	RP-220358	1003		B	Big CR for 38.101-1, Introduce new band combination for V2X concurrent operation	17.5.0
2022-03	RAN#95	RP-220358	1004		B	Big CR for 38.101-3, Introduce new band combination for V2X concurrent operation  NOTE: The CR is allocated to 38.101-1 but was used for 38.101-3. The changes were ignored in CR1004 since it is not the correct spec. CR 1003 is related to 38.101-1. The changes in CR1004 will be implemented in 38.101-3 due to conflict with CR numbering	17.5.0
2022-03	RAN#95	RP-220343	1005		B	Big CR to 38.101-1 Introduce RF requirements for HPUE CA with 2 bands downlink and x bands uplink (x =1,2)	17.5.0
2022-03	RAN#95	RP-220347	1007	1	B	Introduction of upper 700MHz A block into TS 38.101	17.5.0
2022-03	RAN#95	RP-220359	1008		B	Big CR on introduction of completed NR CA/DC combs with 4DL/2UL within FR1	17.5.0
2022-03	RAN#95	RP-220359	1009		B	Big CR to reflect the completed NR inter band CA DC combinations for 2 bands DL with up to 2 bands UL into TS 38.101-1	17.5.0
2022-03	RAN#95	RP-220376	1011		B	38.101-1: Introduction of 1900 MHz to 5G NR for RMR	17.5.0
2022-03	RAN#95	RP-220343	1013		F	CR to TS38.101-1: Corrections on MOP tolerance for PC2 FDD n3	17.5.0
2022-03	RAN#95	RP-220358	1015		B	Big CR to TS 38.101-1: Adding channel BW support in existing NR bands	17.5.0
2022-03	RAN#95	RP-220359	1016	1	F	CR for TS 38.101-1 Rel-17: Corrections on UE co-existence	17.5.0
2022-03	RAN#95	RP-220359	1017		B	CR on Introduction of completed 5 bands inter-band CA into TS 38.101-1	17.5.0
2022-03	RAN#95	RP-220371	1019	2	B	CR for 38.101-1 to introduce RF requirements for RedCap UE	17.5.0
2022-03	RAN#95	RP-220344	1020		B	CR for 38.101-1 to correct the REFSSENS errors due to the new format(n41 n77 n78) (R17)	17.5.0
2022-03	RAN#95	RP-220349	1021		B	Big CR for TS 38.101-1 Tx diversity requirements (phase 2)	17.5.0
2022-03	RAN#95	RP-220342	1022		B	Big CR for TS 38.101-1 introduction of PC2 intra-band non-contiguous UL CA	17.5.0
2022-03	RAN#95	RP-220342	1023	1	B	Big CR for TS 38.101-1 contiguous CA with UL MIMO for power class 2	17.5.0
2022-03	RAN#95	RP-220363	1024	1	B	Big CR for TS38.101-1: introduction of new UL MIMO bands	17.5.0

2022-03	RAN#95	RP-220359	1025		B	Big CR 38.101-1 new combinations Rel-17 NR Intra-band	17.5.0
2022-03	RAN#95	RP-220359	1026		B	Big CR 38.101-1 new combinations NR CA Inter-band 4DL/1UL	17.5.0
2022-03	RAN#95	RP-220350	1027		F	Clarification of modifiedMPR-Behavior for PC1.5	17.5.0
2022-03	RAN#95	RP-220344	1030		F	CR R17 TS38.101-1 on TDD REFSENS and MSDs	17.5.0
2022-03	RAN#95	RP-220334	1031		F	CR to R17 TS38.101-1 on MSD for CA_n5-n28	17.5.0
2022-03	RAN#95	RP-220353	1032		F	Big CRs to TS 38.101-1 for NR_BCS4	17.5.0
2022-03	RAN#95	RP-220343	1033		B	CR to TS 38.101-1 on PC1 MPR table	17.5.0
2022-03	RAN#95	RP-220360	1034		B	CR on UE RF requirements for DMRS bundling in TS 38.101-1	17.5.0
						NOTE: The CR was not implemented.	
2022-03	RAN#95	RP-220337	1037		F	Big CR for TS 38.101-1 Maintenance Part-1 (Rel-17)	17.5.0
2022-03	RAN#95	RP-220337	1039		F	Big CR for TS 38.101-1 Maintenance Part-2 (Rel-17)	17.5.0
2022-03	RAN#95	RP-220360	1040		B	CR on measurement for DMRS bundling in TS 38.101-1	17.5.0
2022-03	RAN#95	RP-220360	1041		B	CR on measurement for DMRS bundling in TS 38.101-1	17.5.0
2022-03	RAN#95	RP-220371	1042		B	Big CR on RedCap UE FR1-RX	17.5.0
2022-03	RAN#95	RP-220786	1043		C	Mandatory 70 MHz and 90 MHz RF channel bandwidth in TS 38.101-1	17.5.0
2022-06	RAN#96	RP-221656	1048	1	F	V2X intra-band con-current operation	17.6.0
2022-06	RAN#96	RP-221677	1049		B	CR 38.101-1 DMRS for CA	17.6.0
2022-06	RAN#96	RP-221654	1050	1	F	CR 38101-1-h50 adding FR1 NR-CA fallbacks	17.6.0
2022-06	RAN#96	RP-221661	1051	1	F	CR: Update of UE capability and RRC parameter name for Tx switching	17.6.0
2022-06	RAN#96	RP-221666	1053		A	CR for 38.101-1-h50: Correction for n7 A-MPR (NS_46)	17.6.0
2022-06	RAN#96	RP-221668	1057		A	CR for 38.101-1 Rel17 Minor AMPR Corrections for n65 to account for SCS	17.6.0
2022-06	RAN#96	RP-221671	1058		F	CR for 38.101-1 Rel17 Minor Correction for n48 NS_27 30MHz inequality	17.6.0
2022-06	RAN#96	RP-221695	1063		B	Big CR for TS 38.101-1, Introduce new band combinations of V2X con-current operation	17.6.0
2022-06	RAN#96	RP-221686	1064		B	CR on Introducing NR inter-band CA for 3DL Bands and 1UL band for 38.101-1	17.6.0
2022-06	RAN#96	RP-221694	1065		B	Big CR to 38.101-1 Introduce RF requirements for HPUE CA with 2 bands downlink and x bands uplink (x =1,2)	17.6.0
2022-06	RAN#96	RP-221672	1067	1	F	CR on NR-U A-MPR for PC5 VLP in South Korea	17.6.0
2022-06	RAN#96	RP-221679	1070	1	F	CR to TS 38.101-1: Protection for band 103 from newly introduced CA combinations	17.6.0
2022-06	RAN#96	RP-221661	1071	1	F	CR to TS38.101-1[R17] Some Corrections for Transmitter characteristics	17.6.0
2022-06	RAN#96	RP-221683	1072	1	F	CR to TS38.101-1: Some corrections for the tables due to introduction of 35MHz_45MHz CBW	17.6.0
2022-06	RAN#96	RP-221676	1073	1	F	CR to TS38.101-1: Corrections on Redcap requirements	17.6.0
2022-06	RAN#96	RP-221687	1074	1	F	CR to TS38.101-1: Corrections on MSD for PC2 FDD band	17.6.0
2022-06	RAN#96	RP-221686	1075		B	Big CR to reflect the completed NR inter band CA DC combinations for 2 bands DL with up to 2 bands UL into TS 38.101-1	17.6.0
2022-06	RAN#96	RP-221671	1077		F	Correction to additional spurious emission requirements for n48	17.6.0
2022-06	RAN#96	RP-221681	1079	1	F	CR to TS38.101-1 for the corrections on Tx Diversity Requirement	17.6.0
2022-06	RAN#96	RP-221671	1080		B	Big CR to TS 38.101-1: Adding channel BW support in existing NR bands	17.6.0
2022-06	RAN#96	RP-221695	1081	1	B	Big CR to 38.101-1: update of simultaneous RxTx capability for band combinations	17.6.0
2022-06	RAN#96	RP-221675	1082		B	CR: Introduction of RMC for 1024QAM maximum input level	17.6.0
2022-06	RAN#96	RP-221684	1083		B	38.101-1: Introduction of 900 MHz to 5G NR for RMR	17.6.0
2022-06	RAN#96	RP-221677	1086		B	CR on UE RF requirements for DMRS bundling in TS 38.101-1	17.6.0
2022-06	RAN#96	RP-221694	1087		B	Big CR to 38.101-1 Introduce RF requirements for HPUE CA	17.6.0
2022-06	RAN#96	RP-221686	1089		B	Big CR on Introduction of completed SUL band combinations into TS 38.101-1	17.6.0
2022-06	RAN#96	RP-221686	1090		B	Big CR on Introduction of completed 5 bands inter-band CA into TS 38.101-1	17.6.0
2022-06	RAN#96	RP-221694	1092	1	F	CR for TS 38.101-1 Rel-17: Corrections on band combinations for UE co-existence	17.6.0
2022-06	RAN#96	RP-221680	1098		F	CR for 38.101-1 to introduce the missing requirements for BCS4	17.6.0
2022-06	RAN#96	RP-221677	1100	1	F	CR on DMRS bundling phase offset measurement FR1	17.6.0
2022-06	RAN#96	RP-221686	1103		B	big CR 38.101-1 new combinations Rel-17 NR Intra-band	17.6.0
2022-06	RAN#96	RP-221686	1104		B	big CR 38.101-1 new combinations NR CA Inter-band 4DL/1UL	17.6.0
2022-06	RAN#96	RP-221686	1105		B	Big CR to reflect the completed NR inter band CA DC combinations for 3 bands DL with 2 bands UL into TS 38.101-1	17.6.0
2022-06	RAN#96	RP-221670	1107		B	Big CR for TS38.101-1: introduction of new UL MIMO bands	17.6.0
2022-06	RAN#96	RP-221677	1110		F	CR to TS 38.101-1: update of NR-V2X MPR requirements (R17)	17.6.0
2022-06	RAN#96	RP-221694	1111	1	B	Big CR for TS 38.101-1: Introduce high power UE for NR TDD intra-band CA in FR1	17.6.0
2022-06	RAN#96	RP-221673	1112	1	B	Introduction of NR licensed band 6425 – 7125 MHz	17.6.0
						NOTE: The CR is covered in CR 1112 revision2	



2022-06	RAN#96	RP-221673	1112	2	B	Introduction of NR licensed band 6425 – 7125 MHz	17.6.0
2022-06	RAN#96	RP-221680	1113	1	B	Increasing the maximum power limit for inter-band UL CA	17.6.0
2022-06	RAN#96	RP-221661	1116	1	A	CR to R17 TS38.101-1 on transient period capability	17.6.0
2022-06	RAN#96	RP-221661	1117		F	CR for TS 38.101-1: Removing square brackets for Intra-band NC UL CA requirements	17.6.0
2022-06	RAN#96	RP-221655	1121		F	Big CR for TS 38.101-1 Maintenance Part-1 (Rel-17)	17.6.0
2022-06	RAN#96	RP-221676	1123		F	CR on RedCap FR1 RF	17.6.0
2022-06	RAN#96	RP-221681	1124		F	CR on Receiver requirements for TX diversity	17.6.0
2022-06	RAN#96	RP-221066	1125		F	CR for updating the note of mandatory simultaneous Rx/Tx capability for FR1 NR-CA combinations	17.6.0
2022-06	RAN#96	RP-221067	1126		F	CR for updating the note of mandatory simultaneous Rx/Tx capability for FR1 NR-CA combinations	17.6.0
2022-06	RAN#96	RP-221868	1128	2	F	CR to 38.101-1 on corrections of NS_21 requirements	17.6.0
2022-06	RAN#96	RP-221748	1129	1	B	CR for 38.101-1: Addition PC1.5 single uplink for 3DL combinations [NR_PC1.5_SingleUL_3DLCA]	17.6.0
2022-06	RAN#96	RP-221789	1130	1	C	Extension of operation in the n77 frequency range in Canada [n77 Canada]	17.6.0
2022-09	RAN#97	RP-222032	1135	1	F	CR: Maintenance of phase continuity requirements for DMRS bundling in FR1	17.7.0
2022-09	RAN#97	RP-222032	1136	1	F	V2X corrections	17.7.0
2022-09	RAN#97	RP-222050	1137		F	CR to R17 38.101-1 to correct NR-U 100MHz UL configuration	17.7.0
2022-09	RAN#97	RP-222050	1138		D	CR to R17 38.101-1 to correct table number for UL MIMO NR-U section	17.7.0
2022-09	RAN#97	RP-222032	1139	1	F	CR for TS 38.101-1, Correction of configured transmitted power for V2X	17.7.0
2022-09	RAN#97	RP-222032	1140	1	F	NR Band n14 PC1 MPR for NR Sidelink Operation	17.7.0
2022-09	RAN#97	RP-222028	1143	1	F	CR 38.101-1: Rel-17 Adding missing fallback combinations and bug fixes	17.7.0
2022-09	RAN#97	RP-222036	1145		F	CR for TS 38.101-1 Rel-17: Introducing missing UE coex requirements for CA_n7-n79	17.7.0
2022-09	RAN#97	RP-222034	1148		F	CR to 38.101-1: Corrections on Pcmx for TxD	17.7.0
2022-09	RAN#97	RP-222036	1149	1	F	CR to 38.101-1: Corrections on Pcmx for intra-band contiguous CA with UL MIMO	17.7.0
2022-09	RAN#97	RP-222033	1150	1	F	CR to 38.101-1 Maintenance for HPUE CA with 2 bands downlink and x bands uplink (x =1,2)	17.7.0
2022-09	RAN#97	RP-222036	1151		F	Removal of [] for Reference Sensitivity Degradation of PC2 FDD band	17.7.0
2022-09	RAN#97	RP-222036	1152		F	Corrections on the MSD tables for inter-band NR CA	17.7.0
2022-09	RAN#97	RP-222034	1155		F	Maintenance of NR TxD Tx requirements	17.7.0
2022-09	RAN#97	RP-222036	1157	1	F	CR 38.101-1 for editorial corrections to band combination tables	17.7.0
2022-09	RAN#97	RP-222032	1158		F	CR for 38.101-1 to correct the errors for FR1 RedCap UE	17.7.0
2022-09	RAN#97	RP-222050	1159		F	CR for 38.101-1 to update the requirements for V2X con-current band combinations	17.7.0
2022-09	RAN#97	RP-222036	1160	1	F	CR for 38.101-1 to introduce the missing MSD due to cross band isolation	17.7.0
2022-09	RAN#97	RP-222036	1161	1	F	CR for 38.101-1 to clarify the ambiguity of BCS4 and BCS5	17.7.0
2022-09	RAN#97	RP-222023	1162		A	Mirror CR for 38.101-1 to clarify the applicability of requirements for NS_xxU	17.7.0
2022-09	RAN#97	RP-222023	1164		F	CR to 38.101-1 Corrections to tables with wrong unit declarations	17.7.0
2022-09	RAN#97	RP-222036	1165	1	F	NOTE: The CR is allocated to 38.101-1 but the title on the coversheet is wrong as it says spec TS 38.101-3. This 38.101-1 CR. can not be implemented.	17.7.0
2022-09	RAN#97	RP-222032	1167	1	F	CR on RedCap RF to add section 6.11	17.7.0
2022-09	RAN#97	RP-222036	1169	1	F	Correction to RF requirements of NR_RF_FR1_enh	17.7.0
2022-09	RAN#97	RP-222032	1173	1	F	CR TS 38.101-1: Correction on NR V2X requirements in TS 38.101-1	17.7.0
2022-09	RAN#97	RP-222028	1174		F	CR for TS 38.101-1 on corrections to MOP band edge relaxation for intra-band contiguous and non-contiguous CA band combinations	17.7.0
2022-09	RAN#97	RP-222050	1177		F	CR to R17 TS38.101-1 on corrections to NRU 100MHz MPR	17.7.0
2022-09	RAN#97	RP-222034	1180	1	F	CR for 38.101-1: Corrections for PC2 MPR and PC1.5 fallback to PC2 MPR	17.7.0
2022-09	RAN#97	RP-222036	1181	1	B	CR for 38.101-1: Missing combinations for NR-CA	17.7.0
2022-09	RAN#97	RP-222050	1182	1	B	CR for 38.101-1: Addition of 5 MHz channel BW for n41	17.7.0
2022-09	RAN#97	RP-222032	1184	1	F	CR 38.101-1 DMRS DL CA	17.7.0
2022-09	RAN#97	RP-222028	1187		D	Editorial clean-up	17.7.0
2022-09	RAN#97	RP-222032	1188		F	CR: Correction of DMRS bundling requirements for FR1 CA	17.7.0
2022-09	RAN#97	RP-222023	1192		F	Big CR for 38.101-1 maintenance part1 (Rel-17)	17.7.0
2022-09	RAN#97	RP-222023	1194		F	Big CR for 38.101-1 maintenance part2 (Rel-17)	17.7.0
2022-09	RAN#97	RP-222686	1196	1	A	Extension of operation in the n77 frequency range in US [n77 US]	17.7.0
2022-09	RAN#97	RP-222683	1197	2	C	Extension of operation in the n77 frequency range in Canada [n77 Canada]	17.7.0

2022-09	RAN#97	RP-222490	1198		F	CR to 38.101-1 on new NS for Canadian WCS regulation R17	17.7.0
2022-12	RAN#98-e	RP-223298	1199		B	Introduction of intra band NC UL CA in the n77 frequency range in Canada [n77 Canada]	17.8.0
2022-12	RAN#98-e	RP-223307	1200	1	F	Corrections on the definition of RedCap UE	17.8.0
2022-12	RAN#98-e	RP-223306	1202	1	F	CR on clarification for DMRS bundling RF requirements for SUL in TS 38.101-1	17.8.0
2022-12	RAN#98-e	RP-223308	1205	3	F	CR to clarify UE requirements for DMRS bundling	17.8.0
2022-12	RAN#98-e	RP-223311	1206		F	CR for TS 38.101-1, Correction of maximum configured power for PSFCH in Rel-17 sidelink enhancement	17.8.0
2022-12	RAN#98-e	RP-223290	1210		A	Addition of FR1 UL MIMO EVM measurement description	17.8.0
2022-12	RAN#98-e	RP-223290	1213		A	Addition of FR2 UL MIMO EVM measurement description Note: The CR was not implementable and therefore was not implemented in the specification.	17.8.0
2022-12	RAN#98-e	RP-223309	1216		F	CR correction to n100 and n101 UE to UE coexistence tables and removal of brackets	17.8.0
2022-12	RAN#98-e	RP-223295	1218	1	A	Addition of CA_n77-n78 to CA Band table R17	17.8.0
2022-12	RAN#98-e	RP-223297	1220		A	Correction to n91,n92,n93 and n94 co-ex R17	17.8.0
2022-12	RAN#98-e	RP-223310	1223		F	Definition of Window lengths for 35 and 45 MHz channel bandwidths	17.8.0
2022-12	RAN#98-e	RP-223296	1225		A	CR for TS 38.101-1 Rel-17 CAT-A: Correcting critical error with co-existence for band CA_n8-n40	17.8.0
2022-12	RAN#98-e	RP-223291	1226	1	F	CR for TS 38.101-1 Rel-17: Corrections on band combinations for UE co-existence	17.8.0
2022-12	RAN#98-e	RP-223309	1230		F	CR on NR-U A-MPR for PC5 VLP	17.8.0
2022-12	RAN#98-e	RP-223290	1233		F	Rel17 Cat F CR Correct the DL configuration for harmonic MSD for CA_n12-n66 and CA_n25-n71	17.8.0
2022-12	RAN#98-e	RP-223481	1238	4	A	Clarification of the CA_NS indication the values for n77 in the US [n77 US]	17.8.0
2022-12	RAN#98-e	RP-223308	1242		F	CR to R17 TS38.101-1 maintenance for UE co-ex requirements for UL CA	17.8.0
2022-12	RAN#98-e	RP-223309	1245	2	F	CR to 38.101-1: 4 Rx support for n104	17.8.0
2022-12	RAN#98-e	RP-223311	1246		F	Correction on the HigherPowerLimitCADC and powerClassPerBand IE	17.8.0
2022-12	RAN#98-e	RP-223298	1251	1	F	CR for corrections on Rel-17 band combinations in TS38.101-1	17.8.0
2022-12	RAN#98-e	RP-223296	1253		A	CR to 38.101-1 on removing ambiguity in CA MPR definition	17.8.0
2022-12	RAN#98-e	RP-223308	1254		F	CR for 38.101-1: introduce UL MIMO configurations for band n40	17.8.0
2022-12	RAN#98-e	RP-223309	1262	1	F	CR TS38.101-1 R17 Re-construct NR-U clause structure and introduce missing requirements	17.8.0
2022-12	RAN#98-e	RP-223291	1263	1	F	CR TS38.101-1 R17 Corrections to Cross-band isolation and Rx harmonic mixing MSD	17.8.0
2022-12	RAN#98-e	RP-223291	1267		A	CR on 'Annex G Difference of relative phase and power errors' for FR1 UL coherent MIMO	17.8.0
2022-12	RAN#98-e	RP-223291	1270		A	CR on TDD RMC for Intra-band EN-DC - TS 38.101-1	17.8.0
2022-12	RAN#98-e	RP-223308	1273	1	F	CR for 38.101-1 DMRS bundling with FR1 uplink CA	17.8.0
2022-12	RAN#98-e	RP-223308	1275		F	CR for 38.101-1: Corrections for 5 MHz for n41 and other errors	17.8.0
2022-12	RAN#98-e	RP-223308	1276		F	CR for 38.101-1: NR CA table corrections	17.8.0
2022-12	RAN#98-e	RP-223308	1278		F	CR for updating the note of mandatory simultaneous Rx/Tx capability for FR1 NR-CA combinations	17.8.0
2022-12	RAN#98-e	RP-223308	1279		F	CR for 38.101-1 for DC location R17 method	17.8.0

Change history							
Date	Meeting	TDoc	CR	Rev	Cat	Subject/Comment	New version
2022-12	RAN#98-e	RP-223315	1207	1	B	CR related to Introduction of new LTE TDD Band in 1670 – 1675 MHz	18.0.0
2022-12	RAN#98-e	RP-223328	1217		B	Big CR for FWA MPR and A-MPR for n71 and n85	18.0.0
2022-12	RAN#98-e	RP-223331	1227		B	Big CR to 38.101-1 Introduce RF requirements for HPUE inter-band CA with y(y=2,3,4) bands downlink and x bands uplink (x=1,2)	18.0.0
2022-12	RAN#98-e	RP-223333	1228		B	Big CR for TS 38.101-1, Introduction of new R18 Uu+V2X band combinations	18.0.0
2022-12	RAN#98-e	RP-223332	1232		B	BigCR for High power UE for inter-band CA with power class 2 on single carrier uplink on FDD band	18.0.0
2022-12	RAN#98-e	RP-223324	1244		B	big CR 38.101-1 new combinations Rel-18 NR Intra-band	18.0.0
2022-12	RAN#98-e	RP-223326	1247		B	big CR 38.101-1 new combinations Rel-18 NR Inter-band CA/DC for y bands DL with x bands UL (y=4,5,6, x=1,2)	18.0.0
2022-12	RAN#98-e	RP-223325	1248		B	Big CR to reflect the completed NR inter band CA DC combinations for 2 bands DL with up to 2 bands UL into TS 38.101-1	18.0.0
2022-12	RAN#98-e	RP-223329	1250		B	Big CR on TS38.101-1 Addition of intra-band CA Combinations with PC2 and PC1.5	18.0.0
2022-12	RAN#98-e	RP-223318	1255		B	Big CR for 38.101-1 introduce UL MIMO configurations for Rel-18	18.0.0
2022-12	RAN#98-e	RP-223327	1256		B	Big CR on Introduction of completed SUL band combinations into TS 38.101-1	18.0.0

2022-12	RAN#98-e	RP-223325	1264		B	Big CR to reflect the completed NR inter-band CA DC combinations for 3 bands DL with x bands UL (x=1,2) into TS 38.101-1	18.0.0
2022-12	RAN#98-e	RP-223319	1280		B	Introduction of APT 600 MHz band	18.0.0
2023-03	RAN#99	RP-230527	1281		F	Updates to spurious emissions UE coexistence table	18.1.0
2023-03	RAN#99	RP-230535	1282		B	CR related to Introduction of NR TDD Band n54	18.1.0
2023-03	RAN#99	RP-230519	1289		A	CR TS 38.101-1: Correction on NR V2X requirements in Rel-18	18.1.0
2023-03	RAN#99	RP-230605	1294	1	B	UE RF requirements for supporting intra-band non-collocated CA for 2MIMO layer case	18.1.0
2023-03	RAN#99	RP-230501	1296		A	CR for TS 38.101-1 Rel-18: Adding missing harmonic mixing MSD for CA_n25-n71	18.1.0
2023-03	RAN#99	RP-230517	1298		A	TS 38.101-1 Rel-18 CAT-A: Correction to co-existence requirements of band n8 and n100	18.1.0
2023-03	RAN#99	RP-230504	1300		A	CR for TS 38.101-1 Rel-18 CAT-A: Corrections on band combinations for UE co-existence	18.1.0
2023-03	RAN#99	RP-230507	1302		A	CR for TS 38.101-1 Rel-18 CAT-A: Correction to NRU spectrum emission mask	18.1.0
2023-03	RAN#99	RP-230501	1305		A	CR for TS 38.101-1 Rel-18: Correction for wrong reference in NS_50	18.1.0
2023-03	RAN#99	RP-230544	1309	1	F	CR 38.101-1: Rel-18 Band combinations bug fixing and adding missing fallbacks	18.1.0
2023-03	RAN#99	RP-230512	1313		A	CR to 38.101-1: Correction of PC1 ACLR definition R18	18.1.0
2023-03	RAN#99	RP-230544	1315		A	NR CA corrections R18	18.1.0
2023-03	RAN#99	RP-230513	1317		A	CR 38.101-1 correction to A-MPR for NS_24 R18	18.1.0
2023-03	RAN#99	RP-230549	1318		B	Big CR for High-power UE operation for fixed-wireless/vehicle-mounted use cases in LTE bands and NR bands	18.1.0
2023-03	RAN#99	RP-230549	1320		A	CR to 38.101-1: Corection to PC1 UTRA ACLR for bands n71 and n85.	18.1.0
2023-03	RAN#99	RP-230502	1324		A	Addition of configuration for carrier aggregation RMCs	18.1.0
2023-03	RAN#99	RP-230516	1328	1	A	CR to introduce emissions specifications for certain LTE_V2X band combinations	18.1.0
2023-03	RAN#99	RP-230509	1338		A	Clarification of the CA_NS indication and NS values for n77 in Canada [n77 Canada]	18.1.0
2023-03	RAN#99	RP-230547	1339		B	Big CR for NR CA band combinations with two SUL cells in Rel-18	18.1.0
2023-03	RAN#99	RP-230519	1341		A	CR for 38.101-1 Corrections to the section 6.2D	18.1.0
2023-03	RAN#99	RP-230558	1342		B	Big CR to 38.101-1 Introduce DL interruption clarification for CA conducting Tx Switching	18.1.0
2023-03	RAN#99	RP-230519	1345		F	CR on NR-U A-MPR for PC5 VLP in NS_61	18.1.0
2023-03	RAN#99	RP-230543	1346		B	big CR 38.101-1 new combinations Rel-18 NR Intra-band	18.1.0
2023-03	RAN#99	RP-230519	1350		A	Rel18 Cat A CR Introduce the missing Pcmx tolerance requirement for PC2 intra-band NC UL CA	18.1.0
2023-03	RAN#99	RP-230519	1352		A	Rel18 Cat A CR Add verification clarification for OOB emission and SE emission for intra-band NC UL CA	18.1.0
2023-03	RAN#99	RP-230502	1355		A	Rel18 Cat A CR Correct the wrong table and clause that clause 6.2A.3.1.1 refer to	18.1.0
2023-03	RAN#99	RP-230504	1359	1	A	CR to clarify duplex mode of SDL bands	18.1.0
2023-03	RAN#99	RP-230501	1362		A	CR to add band n29 to blocking requirements	18.1.0
2023-03	RAN#99	RP-230507	1373		A	Correct the scaling number for MPR/A-MPR and NS_04 SEM requirement	18.1.0
2023-03	RAN#99	RP-230519	1375		A	Correct the Pcmx for intra-band non-contiguous CA to support HPUE	18.1.0
2023-03	RAN#99	RP-230544	1376		B	Big CR to reflect the completed NR inter band CA DC combinations for 2 bands DL with up to 2 bands UL into TS 38.101-1	18.1.0
2023-03	RAN#99	RP-230562	1377		B	Big CR to reflect the completed 4Rx support for NR FR1 bands (<2.6GHz) into TS 38.101-1	18.1.0
2023-03	RAN#99	RP-230519	1378		A	CR to 38.101-1 R18 corrections on A-MPR for CA_NC_NS_04	18.1.0
2023-03	RAN#99	RP-230502	1381		A	CR on Harmonic mixing MSD for CA_n8A-n79A (R18 CAT-A)	18.1.0
2023-03	RAN#99	RP-230559	1384		B	Big CR to TS 38.101-1: Adding channel BW support in existing NR bands	18.1.0
2023-03	RAN#99	RP-230546	1385		B	big CR 38.101-1 NR Inter-band CA/DC for y bands DL (y=4, 5, 6) with x bands UL (x=1, 2)	18.1.0
2023-03	RAN#99	RP-230514	1386		A	Frequency range definition update for TS 38.101-1 (Rel-18)	18.1.0
2023-03	RAN#99	RP-230519	1393		A	Clarification on Time mask for Tx switching for SA (Rel-18)	18.1.0
2023-03	RAN#99	RP-230503	1400		A	CR for Rel-18 38.101-1 to correct the configurations for CA_n46M/N/O	18.1.0
2023-03	RAN#99	RP-230532	1401		B	Big CR for 38.101-1 introduce UL MIMO configurations for Rel-18	18.1.0
2023-03	RAN#99	RP-230547	1403		B	Big CR on Introduction of completed SUL band combinations into TS 38.101-1	18.1.0
2023-03	RAN#99	RP-230549	1405		B	Big CR for Rel-18 Simultaneous Rx/Tx inter-band combinations	18.1.0
2023-03	RAN#99	RP-230513	1407		A	CR for TS 38.101-1 to correct the delta MPR (R18)	18.1.0
2023-03	RAN#99	RP-230503	1411		A	CR for TS 38.101-1 to clarify the inner outer condition for almost contiguous RB allocation (R18)	18.1.0
2023-03	RAN#99	RP-230501	1414		A	CR for TS 38.101-1 to clarify band n34 protection for band n1 and n65 (R18)	18.1.0

2023-03	RAN#99	RP-230501	1417		A	CR for TS 38.101-1 to clarify Out-of-band blocking exception for band n20 and n28 (R18)	18.1.0
2023-03	RAN#99	RP-230552	1418		B	Big CR on TS38.101-1 Addition of intra-band CA Combinations with PC2	18.1.0
2023-03	RAN#99	RP-230501	1427		A	Additional maximum power reduction for NS_21 (Rel-18)	18.1.0
2023-03	RAN#99	RP-230513	1430		A	CR for 38.101-1: Band combination corrections (Rel-18 Cat A)	18.1.0
2023-03	RAN#99	RP-230519	1432		A	CR for 38.101-1: Clarification of PC1.5 requirements (Rel-18 Cat A)	18.1.0
2023-03	RAN#99	RP-230503	1436		A	CR to TS 38.101-1 on humidity condition for normal temperature	18.1.0
2023-03	RAN#99	RP-230545	1439		B	Big CR to reflect the completed NR inter-band CA DC combinations for 3 bands DL with x bands UL (x=1,2) into TS 38.101-1	18.1.0
2023-03	RAN#99	RP-230516	1441		A	CR for TS 38.101-1 on cleanups for V2X operating bands and channel bandwidth (R18_CAT_A)	18.1.0
2023-03	RAN#99	RP-230504	1459		A	Output power for NS_38, NS_40, and NS_41	18.1.0
2023-03	RAN#99	RP-230504	1464	1	A	CR to TS 38.101-1 Rel-18 Minimum guardband and missing ULCA power class	18.1.0
2023-03	RAN#99	RP-230533	1467		F	Corection to Band n105 in coexistence table	18.1.0
2023-03	RAN#99	RP-230519	1469		A	CR for TS 38.101-1. Correction of minor errors in suffix E (NR V2X/Sidelink) requirements	18.1.0
2023-03	RAN#99	RP-230501	1471		A	CR to TS 38.101-1 Rel-18 4Rx for SUL	18.1.0
2023-03	RAN#99	RP-230519	1472		A	CR to update NS_50 PC2 A-MPR	18.1.0
2023-03	RAN#99	RP-230507	1475		F	CR to return he Eq1 for intra-band UL CA contiguous	18.1.0
2023-03	RAN#99	RP-230554	1476		B	Big CR for 38.101-1 on High power UE for FR1 NR inter-band CA/DC or SUL band combination with y DL-x UL and PCm (m<3) and high power on TDD	18.1.0
2023-06	RAN#100	RP-231355	1484		F	CR to K1 and PdschNumOfHargProcess for DL-CA	18.2.0
2023-06	RAN#100	RP-231356	1488		A	FR1 OOB requirements correction	18.2.0
2023-06	RAN#100	RP-231343	1501		A	Update to UL-MIMO requirements (Rel-18)	18.2.0
2023-06	RAN#100	RP-231350	1504		A	CR to correct the A-MPR table for NS_05/NS_05U	18.2.0
2023-06	RAN#100	RP-231389	1505	1	B	CR for 38.101-1: Time mask for switching across three or four uplink bands	18.2.0
2023-06	RAN#100	RP-231384	1513		B	BigCR for High power UE for inter-band CA with power class 2 on single carrier uplink on FDD band	18.2.0
2023-06	RAN#100	RP-231377	1515		B	Big CR on Introduction of completed SUL band combinations into TS 38.101-1	18.2.0
2023-06	RAN#100	RP-231348	1517		A	CR for TS 38.101-1 to modify the errors in table 7.6.4-1 due to the introduction of equation-based method (R18)	18.2.0
2023-06	RAN#100	RP-231343	1519		A	CR for TS 38.101-1 to modify the errors for SUL_n78A-n80A configuration (R18)	18.2.0
2023-06	RAN#100	RP-231367	1521		F	On RF requirements for intra-band non-collocated CA	18.2.0
2023-06	RAN#100	RP-231355	1531		A	CR to TS38.101-1 Correction to out-of-band blocking table	18.2.0
2023-06	RAN#100	RP-231374	1534		F	NR interband 2UL CA co-ex simplification R18	18.2.0
2023-06	RAN#100	RP-231378	1535	1	B	Big CR for FWA HPUE	18.2.0
2023-06	RAN#100	RP-231383	1538		B	Big CR to 38.101-1 new combinations for Rel-18 NR HPUE Inter-band	18.2.0
2023-06	RAN#100	RP-231375	1539	1	B	Big CR to reflect the completed NR inter-band CA DC combinations for 3 bands DL with x bands UL (x=1,2) into TS 38.101-1	18.2.0
2023-06	RAN#100	RP-231355	1543		A	CR for TS 38.101-1 on corrections to the minimum guardband calculation (R18_CAT_A)	18.2.0
2023-06	RAN#100	RP-231351	1546		A	Rel-18 CR to 38 101-1 for Clarification of UL Tx Switching	18.2.0
2023-06	RAN#100	RP-231355	1549		A	Rel18 Cat A CR for 38.101-1 Correct the MSD test configuration for CA_n18-n41	18.2.0
2023-06	RAN#100	RP-231343	1554		A	CR to TS38.101-1: Generalize the increase higher power limit requirements for current CA band combinations	18.2.0
2023-06	RAN#100	RP-231355	1557		A	CR to TS38.101-1: Correction on terms for NR DC Pcm	18.2.0
2023-06	RAN#100	RP-231374	1558		B	CR to reflect the completed NR inter band CA DC combinations for 2 bands DL with up to 2 bands UL into TS 38.101-1	18.2.0
2023-06	RAN#100	RP-231379	1560		B	CR on PC 1.5 for FR1 TDD single bands	18.2.0
2023-06	RAN#100	RP-231385	1565		B	Big CR to TS 38.101-1: Adding channel BW support in existing NR bands	18.2.0
2023-06	RAN#100	RP-231356	1569		A	CR for Rel-18 38.101-1 to correct CA_n46N_BCS0 to CA_n46N_BCS1 for inter-band CA including CA_n46N	18.2.0
2023-06	RAN#100	RP-231368	1570		B	Big CR for 38.101-1 introduce UL MIMO configurations for Rel-18	18.2.0
2023-06	RAN#100	RP-231349	1577		F	CR to 38.101-1 add the missing additional spurious emissions for CA_n5B	18.2.0
2023-06	RAN#100	RP-231350	1581		A	CR to TS38.101-1 on corrections for DMRS bundling with Tx Switching (Rel-18)	18.2.0
2023-06	RAN#100	RP-231388	1585	1	F	CR for TS 38.101-1 Rel-18 CAT-F: Corrections on band combinations for UE co-existence	18.2.0
2023-06	RAN#100	RP-231351	1588		A	CR for TS 38.101-1: Adding missing requirements for NR-U Rel-18 CAT-A	18.2.0
2023-06	RAN#100	RP-231351	1590		A	CR for TS 38.101-1: Adding missing requirements for NR-U Rel-18 CAT-A	18.2.0
2023-06	RAN#100	RP-231343	1591	2	B	Introduction of enhancements for unlicensed access to 38.101-1	18.2.0

2023-06	RAN#100	RP-231375	1592		F	CR for 38.101-1 18.1.0 Bug fixes for CA/DC tables	18.2.0
2023-06	RAN#100	RP-231377	1595		F	CR for 38.101-1: Single SUL CA combination notation modifications	18.2.0
2023-06	RAN#100	RP-231356	1599		A	Update of FR1 UL MIMO EVM measurement description	18.2.0
2023-06	RAN#100	RP-231356	1605		A	CR to 38.101-1 Rel-18 Cat A, FRC correction	18.2.0
2023-06	RAN#100	RP-231349	1610		A	CR to 38.101-1 Rel-18 Cat A, Missing MSD correction	18.2.0
2023-06	RAN#100	RP-231343	1615		A	CR to clarify DC location wording	18.2.0
2023-06	RAN#100	RP-231381	1616		B	Big CR on TS38.101-1 Addition of intra-band CA Combinations	18.2.0
2023-06	RAN#100	RP-231338	1617	1	F	CR on R18 TS38.101-1 Modification on the PC2 and PC1.5 note on the CA configuration with UL single carrier	18.2.0
2023-06	RAN#100	RP-231373	1618		B	big CR 38.101-1 new combinations Rel-18 NR Intra-band	18.2.0
2023-06	RAN#100	RP-231383	1622		A	CR to TS 38.101-1 (Rel-18): Alignment of PC2 uplink/downlink frequency locations to PC3 in configuration	18.2.0
2023-06	RAN#100	RP-231383	1625		A	CR to TS 38.101-1 (Rel-18): Correction of an invalid channel bandwidth in 3DL/2UL inter-band reference sensitivity testing for both PC3 and PC2	18.2.0
2023-06	RAN#100	RP-231376	1627		B	big CR 38.101-1 new combinations Rel-18 NR Inter-band CA/DC for y bands DL with x bands UL (y=4,5,6, x=1,2)	18.2.0
2023-06	RAN#100	RP-231385	1630	1	F	CR 38.101-1 for correction of Notes in Table 5.3.5-1	18.2.0
2023-06	RAN#100	RP-231356	1635		F	CR for 38.101-1: Foob clarification and n5 and n26 protection for B26/n26	18.2.0
2023-06	RAN#100	RP-231342	1636		A	CR on PC2 for adding note to CA_n77C and CA_n78C	18.2.0
2023-06	RAN#100	RP-231349	1637		A	CR on MSD for shared spectrum band	18.2.0
2023-06	RAN#100	RP-231389	1638		B	CR for 38.101-1 to clarify the time mask for switching with multiple TAGs	18.2.0
2023-06	RAN#100	RP-231343	1639		B	Addition of 30 KHz SCS for Sync Raster for Band n53	18.2.0
2023-06	RAN#100	RP-231386	1640		B	Big CR for TS 38.101-1 Rel-18 Simultaneous Rx/Tx inter-band combinations	18.2.0
2023-09	RAN#101	RP-232521	1642		B	Big CR to 38.101-1 new combinations for Rel-18 NR HPUE Inter-band	18.3.0
2023-09	RAN#101	RP-232520	1643		B	big CR 38.101-1 new combinations Rel-18 NR Intra-band	18.3.0
2023-09	RAN#101	RP-232505	1644		F	CR to TS 38.101-1 Rel-18 Corrections to UE co-existence requirements	18.3.0
2023-09	RAN#101	RP-232505	1646	1	A	CR to TS 38.101-1 Rel-18 Introduction of TDD uplink RMC for shorter transients	18.3.0
2023-09	RAN#101	RP-232505	1649	1	A	CR to TS 38.101-1 Rel-18 SUL MSD alignment	18.3.0
2023-09	RAN#101	RP-232505	1651	1	F	CR to TS 38.101-1 Rel-18 Corrections to cross-band MSD and CA_n7-n38 fallback	18.3.0
2023-09	RAN#101	RP-232505	1653		F	CR to TS 38.101-1 Rel-18 Removing triple uplink configurations and corrections to 2UL CA exceptions	18.3.0
2023-09	RAN#101	RP-232520	1655	1	F	CR for 38.101-1 18.2.0 Bug fixes for CA/DC tables	18.3.0
2023-09	RAN#101	RP-232487	1659		A	CR for TS 38.101-1 Rel-18 CAT-A: Introducing modification for NS_43 A-MPR region	18.3.0
2023-09	RAN#101	RP-232499	1660	1	F	[NR_unlic_enh-Core] CR for TS 38.101-1 Rel-18: Corrections to NS_53 A-MPR for 100MHz	18.3.0
2023-09	RAN#101	RP-232490	1662		A	CR for TS 38.101-1 Rel-18 CAT-A: Adding missing channel bandwidth for NS_01	18.3.0
2023-09	RAN#101	RP-232504	1666		A	CR to clarify pi2BPSK note	18.3.0
2023-09	RAN#101	RP-232489	1671		A	[NR_CADC_R16_2BDL_xBUL] Correction of a note number for CA_n77A-n78A (R18)	18.3.0
2023-09	RAN#101	RP-232525	1674		A	[TEI18] CR 38.101-1: Various maintenance issues R18	18.3.0
2023-09	RAN#101	RP-232515	1677	1	B	CR to 38.101-1 Introduction of dedicated spectrum less than 5MHz for FR1	18.3.0
2023-09	RAN#101	RP-232498	1680	1	A	[NR_RF_FR1-Core] Correction to EVM measurement point for DFTs-OFDM DM-RS Type 2	18.3.0
2023-09	RAN#101	RP-232521	1683		B	BigCR for High power UE for FDD single band PC2	18.3.0
2023-09	RAN#101	RP-232520	1685		A	Correction of band n77 channel bandwidth in configuration 2DL/2UL inter-band harmonic mixing testing for PC3	18.3.0
2023-09	RAN#101	RP-232520	1687		A	Correction of n48 channel bandwidth in configuration for PC3	18.3.0
2023-09	RAN#101	RP-232487	1692		A	CR for 38101-1: Almost contiguous NBC change reversal	18.3.0
2023-09	RAN#101	RP-232498	1695		A	CR for 38.101-1: CA_NS_27 and CA_NS_46 fix	18.3.0
2023-09	RAN#101	RP-232520	1696		B	Big CR for NR CA band combinations with two SUL cells in Rel-18	18.3.0
2023-09	RAN#101	RP-232525	1697	1	B	CR for TS 38.101-1: Adding asymmetric channel bandwidth of UL 15/ DL 35 MHz for n66 [n66_asymBW]	18.3.0
2023-09	RAN#101	RP-232513	1702	1	F	Correction of applicability of time mask for Tx switching with dual TAG	18.3.0
2023-09	RAN#101	RP-232489	1704		A	[NR_CADC_R17_2BDL_xBUL-Core]CR for missing MSD due to 4th order harmonic mixing requirements	18.3.0
2023-09	RAN#101	RP-232505	1710		A	CR to TS 38.101-1: correction of Pcmx tolerance for 2Tx (Rel-18)	18.3.0
2023-09	RAN#101	RP-232489	1716		A	[NR_CADC_R17_2BDL_xBUL-Core ] CR on MSD for shared spectrum band	18.3.0
2023-09	RAN#101	RP-232486	1718		A	[NR_6GHz-Core] CR to 38.101-1: applicability note for n104	18.3.0
2023-09	RAN#101	RP-232489	1720		A	[NR_DL1024QAM_FR1-Core] CR to 38.101-1: correction of FRC reference for maximum input level for 1024 QAM R18	18.3.0

2023-09	RAN#101	RP-232520	1721		B	Big CR to reflect the completed NR inter band CA DC combinations for 2 bands DL with up to 2 bands UL into TS 38.101-1	18.3.0
2023-09	RAN#101	RP-232522	1722		B	CR to reflect the completed 4Rx support for NR FR1 bands (<2.6GHz) into TS 38.101-1	18.3.0
2023-09	RAN#101	RP-232520	1723		B	Big CR to reflect the completed NR inter-band CA DC combinations for 3 bands DL with x bands UL (x=1,2) into TS 38.101-1	18.3.0
2023-09	RAN#101	RP-232487	1730		A	CR for Rel-18 38.101-1 to correct the superscript and some notes for 2 bands inter-band CA related to simultaneous Rx/Tx.	18.3.0
2023-09	RAN#101	RP-232502	1735		A	[NR_newRAT-Core]Editorial modification CR for TS 38.101-1_V2	18.3.0
2023-09	RAN#101	RP-232498	1736		A	[NR_RF_FR1_enh-Core] Editorial modification CR for TS 38.101-1	18.3.0
2023-09	RAN#101	RP-232498	1738		A	[NR_RF_FR1_enh] Supplementation of HPUE SAR schemes for Intra-band UL CA requirements (R18)	18.3.0
2023-09	RAN#101	RP-232496	1739		A	[NR_RF_TxD] Editorial modification CR for TS 38.101-1	18.3.0
2023-09	RAN#101	RP-232499	1743		A	CR for correcting the SEM for intra-band contiguous CA operation	18.3.0
2023-09	RAN#101	RP-232503	1750		A	[NR_newRAT-Perf] CR: Correction of FRC for maximum input level for 256QAM	18.3.0
2023-09	RAN#101	RP-232489	1753		A	[NR_CADC_R16_2BDL_xBUL-Core] CR to 38.101-1 R18 add the missing Tx requirement for CA_n25-n71	18.3.0
2023-09	RAN#101	RP-232501	1758		A	[NR_newRAT-Core] CR for TS 38.101-1 to modify MSD due to harmonic mixing interference (R18)	18.3.0
2023-09	RAN#101	RP-232496	1760		A	NR_SAR_PC2_interB_SUL_2BUL]Rel18 Cat A CR for 38.101-1 Correct ?PPowerClass,CA relevant requirement in clause 6.2A.1.3 for inter-band ULCA	18.3.0
2023-09	RAN#101	RP-232486	1763		A	[NR_6GHz_unlic_full] CR 38.101-1 correction to A-MPR requirements_R18	18.3.0
2023-09	RAN#101	RP-232503	1768		A	[NR_RF_FR1-Core] Editorial correction to 6.2A.4 (Rel-18)	18.3.0
2023-09	RAN#101	RP-232488	1771		A	[NR_cov_enh-Core] Update of FR1 DMRS bundling measurements	18.3.0
2023-09	RAN#101	RP-232518	1772		B	Big CR for 38.101-1 introduce UL MIMO configurations for Rel-18	18.3.0
2023-09	RAN#101	RP-232520	1773		B	big CR 38.101-1 new combinations Rel-18 NR Inter-band CA/DC for y bands DL with x bands UL (y=4,5,6, x=1,2)	18.3.0
2023-09	RAN#101	RP-232521	1775		B	Big CR on TS38.101-1 Addition of intra-band CA Combinations	18.3.0
2023-09	RAN#101	RP-232489	1777		A	[NR_CADC_R17_2BDL_xBUL-Core] CR on TS38.101-1 Modification on MSD due to UL harmonic interference for CA_n48A-n66A	18.3.0
2023-09	RAN#101	RP-232522	1780		B	Big CR to TS 38.101-1: Adding channel BW support in existing NR bands	18.3.0
2023-09	RAN#101	RP-232522	1785		F	CR to 38.101-1 correction on CA_n34-n41, CA_n40-n41-n79 for simultaneous RxTx	18.3.0
2023-09	RAN#101	RP-232501	1789		A	[NR_newRAT-Core] Correction of intraband contiguous CA ACS requirements	18.3.0
2023-09	RAN#101	RP-232498	1792		A	[NR_RF_FR1] Correction of intraband non-contiguous CA ACS requirements	18.3.0
2023-09	RAN#101	RP-232518	1797		B	CR adding REFSENS for HD-FDD RedCap UE for band n105	18.3.0
2023-09	RAN#101	RP-232498	1799		A	[NR_RF_FR1-Core] CR for TS38101-1 Clarifying applicable power classes for NR CA	18.3.0
2023-12	RAN#102	RP-233361	1810		B	Introduction of higherPowerLimit-r17 into NR CA of PC3+PC5 including UL Intra band CA	18.4.0
2023-12	RAN#102	RP-233361	1811		B	Introduction of delta PPowerClass report	18.4.0
2023-12	RAN#102	RP-233331	1815		A	Fc terminology update	18.4.0
2023-12	RAN#102	RP-233340	1818		A	CR for Intra-band UL CA MPR clarification	18.4.0
2023-12	RAN#102	RP-233369	1821		B	BigCR for High power UE for FDD single band PC2	18.4.0
2023-12	RAN#102	RP-233369	1822	1	B	CR to R18 TS38.101-1 to introduce PC2 UTRA ACLR	18.4.0
2023-12	RAN#102	RP-233348	1826		A	CR for TS 38.101 Rel-18 correcting the starting RB location for NS_07	18.4.0
2023-12	RAN#102	RP-233368	1828	1	B	TS 38.101-1 big CR for NR_700800900_combo_enh	18.4.0
2023-12	RAN#102	RP-233368	1829		F	CR Bug Fixes for Band Combinations in 38101-1-i30_s00-05	18.4.0
2023-12	RAN#102	RP-233336	1832		A	CR on TS38.101-1 for simplification of NR V2X UE coexistence in Rel-18 (Cat. A)	18.4.0
2023-12	RAN#102	RP-233351	1834		F	[NR_RF_TxD-Core] Correction to 7.3G REFSENS for TxD (Rel-18)	18.4.0
2023-12	RAN#102	RP-233368	1835		F	CR to R18 TS38.101-1 to align frequency range restriction for MSD	18.4.0
2023-12	RAN#102	RP-233368	1842		A	CR for 38.101-1 UE to UE coex R18	18.4.0
2023-12	RAN#102	RP-233366	1845	1	B	CR for 38.101-1: Introduction of n106	18.4.0
2023-12	RAN#102	RP-233363	1850		F	CR to TS 38.101-1 on clarification of applicable SS raster entries for 3 MHz channel bandwidth	18.4.0
2023-12	RAN#102	RP-233371	1851		F	Corrections on requirements for NR-U enhancements	18.4.0
2023-12	RAN#102	RP-233348	1857		A	CR to TS38.101-1 Rel-18 CAT-A: On harmonisation network signalling requirements	18.4.0
2023-12	RAN#102	RP-233369	1860		A	CR to TS 38.101-1 (Rel-18): Correction of an Fc location for a 100MHz channel bandwidth of band n77	18.4.0
2023-12	RAN#102	RP-233369	1868		B	CR for TS 38.101-1 to introduce indication of modified MPR behaviour for band n34 and n40	18.4.0
2023-12	RAN#102	RP-233364	1869	1	B	Big CR for TS 38.101-1 for NR ATG	18.4.0
2023-12	RAN#102	RP-233368	1870	1	B	CR for 38.101-1: Add delta RIB requirements for CA_n78C_n84A-n89A	18.4.0

2023-12	RAN#102	RP-233332	1875		A	[NR_newRAT] CR for clarification on applicability of Rx antenna number for Rx requirements for TS 38.101-1	18.4.0
2023-12	RAN#102	RP-233361	1876		B	CR for 38.101-1: Time mask for switching across three or four uplink bands	18.4.0
2023-12	RAN#102	RP-233365	1877	1	B	Introduction of an enhanced channel raster	18.4.0
2023-12	RAN#102	RP-233369	1880		B	Big CR to 38.101-1 new combinations for Rel-18 NR HPUE Inter-band	18.4.0
2023-12	RAN#102	RP-233332	1883		A	[NR_newRAT-Core] Editorial modification CR for TS 38.101-1	18.4.0
2023-12	RAN#102	RP-233364	1886	3	B	Rel-18 CR for 38.101-1 New BS signalling implementation for non-collocated scenario	18.4.0
2023-12	RAN#102	RP-233339	1887		A	[NR_n41_BW-Core] Support of PC1.5 for n41 30MHz in Japan (R18)	18.4.0
2023-12	RAN#102	RP-233361	1894		F	[NR_MC_enh-Core]CR for DL interruption note improvement	18.4.0
2023-12	RAN#102	RP-233339	1899		A	[NR_n30-Core] CR to add resolution BW for Additional SEM for NS_21 - TS38.101-1, Rel-18, Cat-A	18.4.0
2023-12	RAN#102	RP-233332	1903		A	[NR_newRAT-Core] CR to remove the word capable in power class 3 capable UE - TS38.101-1, Rel-18, Cat-A	18.4.0
2023-12	RAN#102	RP-233340	1906		A	[NR_RF_FR1-Core] CR concerning the RMS average used in EVM measurement with transient period - TS38.101-1, Rel-18, Cat-A	18.4.0
2023-12	RAN#102	RP-233370	1907	2	B	Big CR to 38.101-1 Simultaneous Rx-Tx basket	18.4.0
2023-12	RAN#102	RP-233370	1908		B	Big CR to TS 38.101-1: Adding channel BW support in existing NR bands	18.4.0
2023-12	RAN#102	RP-233362	1909	3	B	Running CR to TS 38.101-1 - Introduction of Aerial UEs support	18.4.0
2023-12	RAN#102	RP-233366	1910		B	CR to TS 38.101-1 - Introduction of bands n31 and n72	18.4.0
2023-12	RAN#102	RP-233339	1913		A	[NR_n38_BW2] Clarify A-MPR values for NS_44 - Rel18	18.4.0
2023-12	RAN#102	RP-233368	1914	1	B	Big CR to reflect the completed NR inter-band CA DC combinations for 3 bands DL with up to 2 bands UL into TS 38.101-1	18.4.0
2023-12	RAN#102	RP-233337	1917		A	[NR_CADC_R16_2BDL_xBUL] CR for TS 38.101-1 to correct inter-band NR DC configuration table (R18_CAT A)	18.4.0
2023-12	RAN#102	RP-233368	1918	1	B	big CR 38.101-1 new combinations Rel-18 NR Inter-band CA/DC for y bands DL with x bands UL (y=4,5,6, x=1,2)	18.4.0
2023-12	RAN#102	RP-233368	1921		A	Rel18 Cat A CR for 38.101-1 Add missing Uplink configurations for PC3 CA_n46M-n48B-n96A and CA_n46M-n48(4A)-n96D	18.4.0
2023-12	RAN#102	RP-233368	1923		A	Rel18 Cat A CR for 38.101-1 Add missing MSD due to UL harmonic interference for PC3 CA_n71-n78 in clause 7.3A.4	18.4.0
2023-12	RAN#102	RP-233368	1925		B	Big CR on Introduction of completed SUL band combinations into TS 38.101-1	18.4.0
2023-12	RAN#102	RP-233332	1929		A	[NR_newRAT-Core] CR for 38.101-1 to clarify the applicable bands for additional UTRA ACLR requirements. (R18)	18.4.0
2023-12	RAN#102	RP-233345	1931		A	[NR_BCS4-Core] CR for 38.101-1 to modify the MSD value for CA_20-n78 harmonic mixing and NOTE2 in harmonic mixing table (R18)	18.4.0
2023-12	RAN#102	RP-233370	1934	1	B	R18 38101-1 CR for 3Tx inter-band CA	18.4.0
2023-12	RAN#102	RP-233370	1935		B	R18 38101-1 CR for low band 4Rx	18.4.0
2023-12	RAN#102	RP-233361	1936		B	Big CR for NR SL evolution	18.4.0
2023-12	RAN#102	RP-233361	1938	1	B	CR to 38.101 for introduction of MPR reduction	18.4.0
2023-12	RAN#102	RP-233371	1939	1	F	Spectrum emission mask for operation with shared spectrum channel access R18	18.4.0
2023-12	RAN#102	RP-233363	1940	1	B	TS 38.101-1 big CR for NR_ENDC_RF_FR1_enh2	18.4.0
2023-12	RAN#102	RP-233366	1941	1	B	TS 38.101-1 big CR for NR_bands_UL_MIMO_R18	18.4.0
2023-12	RAN#102	RP-233368	1945	1	B	TS 38.101-1 big CR for NR_CADC_R18_2BDL_xBUL	18.4.0
2023-12	RAN#102	RP-233371	1948	1	F	CR for introducing NR-U uplink CA for NS_53 and NS_54	18.4.0
2023-12	RAN#102	RP-233371	1949		F	CR to TS38.101-1 for NR-U NS table reference	18.4.0
2023-12	RAN#102	RP-233345	1951	1	A	[NR_CADC_R17_3BDL_2BUL-Core] CR for 38.101-1 to add missing IMD5 for CA_n48-n66-n70 with UL CA_n48-n66 (Rel-18, Cat. A)	18.4.0
2023-12	RAN#102	RP-233368	1952		B	big CR for addition of NR CA Intra-band FR1	18.4.0
2023-12	RAN#102	RP-233369	1953		F	CR for 38.101-1: HPUE Band Combination Corrections	18.4.0
2023-12	RAN#102	RP-233366	1955	1	B	CR to TS38.101-1: Introduction of n109	18.4.0
2023-12	RAN#102	RP-233331	1959		A	[NR_newRAT] CR to 38.101-1 on FRC correction	18.4.0
2023-12	RAN#102	RP-233331	1963		A	[NR_newRAT] CR to 38.101-1 on FRC deletion for 5MHz 30 KHz	18.4.0
2023-12	RAN#102	RP-233361	1964	1	B	CR to 38.101-1: Introduction of eRedCap	18.4.0
2023-12	RAN#102	RP-233345	1966		A	[NR_CADC_R17_2BDL_xBUL] CR to 38.101-1, n3-n77(2A) test point correction	18.4.0
2023-12	RAN#102	RP-233340	1972		A	Correction of ?T_RxSRS for SRS resource set consisting of two SRS ports	18.4.0
2024-03	RAN#103	RP-240601	1984		F	CR: Correction to remedy 3GU error of CR1907r2	18.5.0
2024-03	RAN#103	RP-240613	1988	1	F	Adding support for the VLP mode in US	18.5.0
2024-03	RAN#103	RP-240597	1989		F	CR Bug Fixes for Band Combinations in 38101-1-i40_s00-05	18.5.0
2024-03	RAN#103	RP-240558	1991		A	CR to 38.101-1 on correction of CA_n2A-n78A UL configuration	18.5.0
2024-03	RAN#103	RP-240612	1994		B	CR for 38101-1 to add PC1.5 for band n39 and annex L for band n39	18.5.0
2024-03	RAN#103	RP-240607	1995	2	F	CR for 38101-1 to update ATG related signaling name	18.5.0

2024-03	RAN#103	RP-240603	1998		F	(NR_cov_enh2-Core) Correction on dpc-Reporting-FR1 related requirements	18.5.0
2024-03	RAN#103	RP-240606	1999	2	F	(NR_ENDC_RF_FR1_enh2-Core) Correction on delta TRxSRS related texts for 8Rx	18.5.0
2024-03	RAN#103	RP-240600	2000		B	BigCR for High power UE for intra-band and inter-band CA with power class 2 on single carrier uplink on FDD band	18.5.0
2024-03	RAN#103	RP-240599	2001		B	BigCR for High power UE for FDD single band PC2	18.5.0
2024-03	RAN#103	RP-240562	2002		F	CR to TS 38.101-1 Rel-18 Corrections to UL configuration for asymmetric UL DL	18.5.0
2024-03	RAN#103	RP-240607	2008	1	F	Modification on power imbalance requirements	18.5.0
2024-03	RAN#103	RP-240576	2011		A	CR to TS38.101-1 Rel-18 CAT-A: On corrections for NR-U R16 A-MPR requirements	18.5.0
2024-03	RAN#103	RP-240557	2013		A	CR to TS38.101-1 Rel-18 CAT-A: On corrections for NR-U R17 A-MPR requirements	18.5.0
2024-03	RAN#103	RP-240613	2014		F	CR to TS38.101-1 Rel-18 CAT-F: On corrections for NR-U R18 A-MPR requirements	18.5.0
2024-03	RAN#103	RP-240574	2018		A	(NR_RF_FR1) Introduction of missing DMRS configuration restriction for intra-ULCA in FR1	18.5.0
2024-03	RAN#103	RP-240599	2035		B	FWA Big CR	18.5.0
2024-03	RAN#103	RP-240614	2039		F	(TEI18) CR for 38.101-1 corrections for UL CA configurations R18	18.5.0
2024-03	RAN#103	RP-240552	2043		A	(TEI16) almost contiguous A-MPR for PC2	18.5.0
2024-03	RAN#103	RP-240597	2045		F	(NR_CADC_R18_2BDL_xBUL-Core) Correction for MSD IMD test points R18	18.5.0
2024-03	RAN#103	RP-240574	2048		A	CA MPR correction	18.5.0
2024-03	RAN#103	RP-240606	2049		F	(NR_ENDC_RF_FR1_enh2-Core ) 4Tx RF issues	18.5.0
2024-03	RAN#103	RP-240606	2050	1	F	(NR_ENDC_RF_FR1_enh2-Core ) Power class for Lower MSD verification – TS38.101-1	18.5.0
2024-03	RAN#103	RP-240587	2053		F	(NR_MC_enh-Core) CR for 38.101-1: Correction on time mask for Rel-18 Tx switching	18.5.0
2024-03	RAN#103	RP-240597	2057		A	CR to TS 38.101-1 (Rel-18): CR for removing n48(A-C) intra-band CA configuration	18.5.0
2024-03	RAN#103	RP-240597	2058		B	Big CR to reflect the completed NR inter-band CA DC combinations for 3 bands DL with up to 2 bands UL into TS 38.101-1	18.5.0
2024-03	RAN#103	RP-240558	2060		A	(NR_CADC_R17_3BDL_2BUL) CR for TS 38.101-1 on inter-band CA for n46-n48-n96 (R18_CAT_A)	18.5.0
2024-03	RAN#103	RP-240594	2065		B	TS 38.101-1 big CR for NR_bands_UL_MIMO_R18	18.5.0
2024-03	RAN#103	RP-240607	2068	3	F	Rel-18 CR for 38.101-1 NonCol_IntraB_ENDC_NR_CA	18.5.0
2024-03	RAN#103	RP-240600	2069		B	Big CR to 38.101-1 new combinations for Rel-18 NR HPUE Inter-band	18.5.0
2024-03	RAN#103	RP-240614	2076	1	F	CR for Rel-18 38.101-1 to unify the minimum guardband symbol	18.5.0
2024-03	RAN#103	RP-240603	2078	1	F	CR for Rel-18 38.101-1 is to modify the requirements for eRedCap	18.5.0
2024-03	RAN#103	RP-240597	2082		F	(NR_newRAT-Core) Correct the equation in the NOTE for harmonic mixing MSD	18.5.0
2024-03	RAN#103	RP-240597	2089		B	TS 38.101-1 big CR for NR_CADC_R18_2BDL_xBUL	18.5.0
2024-03	RAN#103	RP-240601	2090		B	CR to reflect the completed 4Rx support for NR FR1 bands (<2.6GHz) into TS 38.101-1	18.5.0
2024-03	RAN#103	RP-240558	2096		A	(NR_CADC_R17_2BDL_xBUL-Core) CR to correct carrier frequencies used in REFSENS exceptions due to IMD for CA_n26-n70 - TS38.101-1, Rel-18, Cat-A	18.5.0
2024-03	RAN#103	RP-240561	2100		F	(NR_n48-Core) CR to correct or add note applicable for specific channel bandwidths for CA including band n48 - TS38.101-1, Rel-18, Cat-F	18.5.0
2024-03	RAN#103	RP-240613	2102	1	F	(NR_RF_FR1_enh-Core, 4Rx_low_NR_band_handheld_3Tx_NR_CA_ENDC-Core) CR to add clarification regarding the configurations of the UL CCs for suffix H - TS38.101-1, Rel-18, Cat-F	18.5.0
2024-03	RAN#103	RP-240565	2106	1	A	(NR_newRAT-Core) CR to correct "Supplement" to "Supplementary" in the definition of the suffix used for SUL - TS38.101-1, Rel-18, Cat-F	18.5.0
2024-03	RAN#103	RP-240597	2108		B	big CR 38.101-1 new combinations Rel-18 NR Intra-band	18.5.0
2024-03	RAN#103	RP-240601	2109		F	CR 38.101-1 for corrections in tables 5.2-1 and 5.3.5-1	18.5.0
2024-03	RAN#103	RP-240597	2110		F	CR 38.101-1 correcting 2 bands configuration tables	18.5.0
2024-03	RAN#103	RP-240597	2111		F	CR 38.101-1 correcting 3 bands configuration tables	18.5.0
2024-03	RAN#103	RP-240598	2112		F	CR 38.101-1 correcting 4 and 5 bands configuration tables	18.5.0
2024-03	RAN#103	RP-240598	2113		B	Big CR on Introduction of completed SUL band combinations into TS 38.101-1	18.5.0
2024-03	RAN#103	RP-240557	2115		F	(NR_CA_R17_3BDL_1BUL-Core) CR for TS 38.101-1 to add missing combo CA_n3A-n8A-n79A (R18)	18.5.0
2024-03	RAN#103	RP-240564	2119		A	(NR_newRAT-Core) CR for TS 38.101-1 to correct the Finterferer (offset) for intra-band CA ACS and IBB requirements (R18)	18.5.0
2024-03	RAN#103	RP-240558	2121		A	(NR_CADC_R17_2BDL_xBUL-Core) CR for TS 38.101-1 to clarify the applicable SCS when UE testing (R18)	18.5.0
2024-03	RAN#103	RP-240601	2122		F	Big CR for 3Tx NR inter-band UL CA and EN-DC basket WI (38.101-1)	18.5.0



2024-03	RAN#103	RP-240613	2123		F	Big CR for Low band 4Rx for handheld UE and 3Tx for inter-band UL CA and EN-DC (38.101-1)	18.5.0
2024-03	RAN#103	RP-240603	2124		F	(NR_SL_enh2-Core) BigCR to TS38.101-1 for Sidelink enhancement	18.5.0
2024-03	RAN#103	RP-240611	2137	1	F	CR for TS 38.101-1 to maintain low band combos	18.5.0
2024-03	RAN#103	RP-240587	2138		F	bigCR to 38.101-1 Corrections for aerial NR UEs	18.5.0
2024-03	RAN#103	RP-240587	2139		F	BigCR to 38.101 for Corrections for MPR reduction	18.5.0
2024-03	RAN#103	RP-240608	2140	1	F	CR to TS 38.101-1: correction on enhanced channel raster	18.5.0
2024-03	RAN#103	RP-240574	2143		A	(NR_RF_FR1) CR to TS 38.101-1: Channel raster to resource element mapping	18.5.0
2024-03	RAN#103	RP-240606	2146		F	(NR_ENDC_RF_FR1_enh2-Core) Correction of Lower-MSD requirements for NR CA	18.5.0
2024-03	RAN#103	RP-240564	2150		A	(NR_newRAT-Core) CR to remove the word capable in power class related requirements	18.5.0
2024-03	RAN#103	RP-240564	2154		A	(NR_newRAT-Core) CR to TS38.101-1: Correction of band number in uplink configuration for reference sensitivity table	18.5.0
2024-03	RAN#103	RP-240599	2155		B	Big CR on TS38.101-1 Addition of intra-band CA Combinations	18.5.0
2024-03	RAN#103	RP-240598	2156		B	big CR 38.101-1 new combinations Rel-18 NR Inter-band CA/DC for y bands DL with x bands UL (y=4,5,6, x=1,2)	18.5.0
2024-03	RAN#103	RP-240606	2160	1	F	R18 Cat-F CR 38.101-1 correction CR for 4Tx requirements	18.5.0
2024-03	RAN#103	RP-240558	2167		A	[NR_CADC_R17_2BDL_xBUL] CR for 38.101-1: Correct missing CA_n71-n77 Harmonic	18.5.0
2024-03	RAN#103	RP-240597	2168		F	[NR_CADC_R18_2BDL_xBUL] CR for 38.101-1: Correct n25 instead of n41 for CA_n41(3A)-n85A	18.5.0
2024-03	RAN#103	RP-240557	2170		A	[NR_BCS4-Core] CR for 38.101-1: Maximum Aggregated BW for BCS5	18.5.0
2024-03	RAN#103	RP-240576	2172	1	A	(NR_unlic-Core) Correction CR for NS_59 in TS38.101-1_V2	18.5.0
2024-03	RAN#103	RP-240613	2173	1	F	(NR_unlic_enh-Core) Correction CR for NS_63, NS_64 in TS38.101-1	18.5.0
2024-03	RAN#103	RP-240606	2176	2	F	(NR_FR1_lessthan_5MHz_BW-Core) CR to TS 38.101-1 for sub 5MHz channel bandwidth	18.5.0
2024-03	RAN#103	RP-240603	2178		F	(NR_cov_enh2-Core) CR to TS38.101-1 on higher power limit for inter-band CA with an intra-band component	18.5.0
2024-03	RAN#103	RP-240597	2179	1	F	CR to R18 38101-1 to correct Note on PC2 CA_n71-n77 IMD5 MSD	18.5.0
2024-03	RAN#103	RP-240597	2183	1	F	(NR_CADC_R18_2BDL_xBUL) CR to R18 38101-1 to correct channel bandwidths in MSD test points	18.5.0
2024-03	RAN#103	RP-240588	2184		F	Big CR for 38.101-1 for SRS aggregation for positioning	18.5.0
2024-03	RAN#103	RP-240606	2185		F	Big CR for lower MSD for inter-band CA/EN-DC/DC	18.5.0
2024-03	RAN#103	RP-240606	2186		F	Big CR for 38.101-1 on less than 5MHz	18.5.0
2024-03	RAN#103	RP-240603	2187		F	Big CR for 38.101-1 on MC	18.5.0
2024-03	RAN#103	RP-240572	2189		A	Compensating for post antenna connector gain impact to unwanted emissions for n101 band	18.5.0
2024-03	RAN#103	RP-240598	2190		F	Big CR to 38.101-1 for two SUL cells	18.5.0
2024-03	RAN#103	RP-240855	2191	4	B	CR 38.101-1 addition of 2Rx XR exception for REFSSENS [2Rx_XR_Device]	18.5.0
2024-06	RAN#104	RP-241461	2200		B	CR: Simultaneous Rx-Tx to remedy the de-implementation of CR1907r2	18.6.0
2024-06	RAN#104	RP-241489	2201		F	Clarification for the mandatory support of enhanced channel raster for the TN bands	18.6.0
2024-06	RAN#104	RP-241382	2203		A	CR to fix CBW listing of NS_37 emission requirements	18.6.0
2024-06	RAN#104	RP-241394	2205		A	CR to 38.101-1 on Wgap correction for CA_n2(2A) REFSSENS requirement	18.6.0
2024-06	RAN#104	RP-241491	2206		F	CR to 38.101-1 on corrections for n109 UE channel BW table misalignment in Table 5.3.5-1	18.6.0
2024-06	RAN#104	RP-241393	2214		A	CR to align NR carrier centre frequencies with LTE for NS_24	18.6.0
2024-06	RAN#104	RP-241443	2215		F	CR Bugfix 38101-1-i50_s0505B-0505C	18.6.0
2024-06	RAN#104	RP-241443	2216	1	F	CR Bug Fixes 38101-1-i50_s0505A03-0505A03	18.6.0
2024-06	RAN#104	RP-241483	2218	2	F	(NR_ATG-Core) CR for 38101-1 on ATG UE Tx Rrequirement	18.6.0
2024-06	RAN#104	RP-241484	2220	1	F	(NonCol_intraB_ENDC_NR_CA-Core) On applicability of diversity characteristic	18.6.0
2024-06	RAN#104	RP-241494	2222		F	CR on updating UE capability name for 2Rx XR UEs [2Rx_XR_Device]	18.6.0
2024-06	RAN#104	RP-241393	2226		A	CR for TS 38.101-1 Rel-18 correcting maximum transmission bandwidth for NS_04	18.6.0
2024-06	RAN#104	RP-241483	2228	1	B	Big CR of TS 38.101-1 for ATG	18.6.0
2024-06	RAN#104	RP-241395	2230		A	(NR_CADC_R17_3BDL_2BUL) CR to 38.101-1: Adding note to CA_n7-n8-n78 for IMD4	18.6.0
2024-06	RAN#104	RP-241461	2231		B	Big CR to 38.101-1 on simultaneous Rx-Tx basket	18.6.0
2024-06	RAN#104	RP-241388	2234		A	CR 38.101-1 correction CR for Rx requirements with TxD indication	18.6.0
2024-06	RAN#104	RP-241493	2235		F	R18 Cat-F CR 38.101-1 correction CR for 3Tx requirements	18.6.0
2024-06	RAN#104	RP-241478	2236		F	R18 Cat-F CR 38.101-1 correction CR for 4Tx requirements	18.6.0
2024-06	RAN#104	RP-241460	2237		B	BigCR for High power UE for intra-band and inter-band CA with power class 2 on single carrier uplink on FDD band	18.6.0
2024-06	RAN#104	RP-241456	2238		B	BigCR for High power UE for FDD single band PC2	18.6.0

2024-06	RAN#104	RP-241465	2244		F	Correction of parameter name for dpc-Reporting-FR1 for range 1 SA	18.6.0
2024-06	RAN#104	RP-241453	2245		D	(NR_CADC_R18_yBDL_xBUL) CR for 38.101-1: Table format corrections	18.6.0
2024-06	RAN#104	RP-241459	2246		F	(HPUE_FR1_TDD_NR_CADC_SUL_R18) CR for 38.101-1: Corrections for missing PC2 CA_n41C and MOP Table	18.6.0
2024-06	RAN#104	RP-241402	2259		A	(NR_RF_FR1_enh-Core) CR to 38.101-1 R18 corrections on Pmax tolerance for intra-band contiguous CA with UL MIMO	18.6.0
2024-06	RAN#104	RP-241382	2261		A	CR for Rel-18 to correct the signalling IE for FR1 Intra-band non-contiguous CA in clause 6.2A.2.2.0.	18.6.0
2024-06	RAN#104	RP-241478	2262		F	CR for TS 38.101-1: some update on EVM requirement for 4Tx UL MIMO	18.6.0
2024-06	RAN#104	RP-241483	2266		F	CR on MOP and configured transmitted power for ATG UE	18.6.0
2024-06	RAN#104	RP-241391	2270		A	(LTE_NR_DC_CA_enh) CR to TS 38.101-1: correction of Pmax tolerance for NR DC (Rel-18)	18.6.0
2024-06	RAN#104	RP-241389	2273		F	(5G_V2X_NRSL) CR to TS 38.101-1: correction of Pmax tolerance for sidelink (Rel-18)	18.6.0
2024-06	RAN#104	RP-241394	2281	1	F	(NR_CA_R16_intra-Core, ) CR to add notes for SCS restrictions on CBWs in CA configurations - TS38.101-1, Rel-18	18.6.0
2024-06	RAN#104	RP-241395	2283		A	(NR_CADC_R17_3BDL_2BUL) CR to correct n66 transmission bandwidth used in REFSSENS exceptions due to IMD5 for CA_n5-n48-n66 - TS38.101-1, Rel-18	18.6.0
2024-06	RAN#104	RP-241383	2287		A	(NR_newRAT-Core)Correct the Pmax tolerance for inter-band CA and TxD	18.6.0
2024-06	RAN#104	RP-241478	2288		F	CR for TS 38.101-1: 4Rx/8Rx applicability for Lower-MSD requirements	18.6.0
2024-06	RAN#104	RP-241451	2289		B	TS 38.101-1 big draft CR for NR_CADC_R18_2BDL_xBUL	18.6.0
2024-06	RAN#104	RP-241492	2293		A	Cat A CR to TS 38.101-1 Rel-18 NR-U Nominal channel spacing	18.6.0
2024-06	RAN#104	RP-241450	2297		B	CR 38.101-1 adding intra-band NR CA configurations	18.6.0
2024-06	RAN#104	RP-241477	2302	1	F	Introduce asymmetric UL_DL channel BW combinations for n28	18.6.0
2024-06	RAN#104	RP-241405	2303	2	F	CR to 38.101-1 on Aerial Specific Pmax Values	18.6.0
2024-06	RAN#104	RP-241478	2304		F	CR on 38.101-1: adding missing 8Rx requirements	18.6.0
2024-06	RAN#104	RP-241477	2305		F	NS_17 correction on Band n28 3 MHz operation in Japan	18.6.0
2024-06	RAN#104	RP-241455	2308	1	F	CR to TS 38.101-1: n100-n101 Car radio receiver requirements	18.6.0
2024-06	RAN#104	RP-241455	2309		B	Big CR High-power UE operation for fixed-wireless/vehicle-mounted use cases in LTE bands and NR bands	18.6.0
2024-06	RAN#104	RP-241443	2310		F	CR for 38.101-1 Correction of cell issues	18.6.0
2024-06	RAN#104	RP-241462	2311		F	Big CR for 3Tx NR inter-band basket WI 38.101-1	18.6.0
2024-06	RAN#104	RP-241402	2313		A	(NR_RF_FR1_enh-Core) CR for TS 38.101-1: Add ACLR requirement for PC2 intra-band non-contiguous UL CA	18.6.0
2024-06	RAN#104	RP-241402	2315		A	(NR_RF_FR1_enh-Core) CR for TS 38.101-1: Corrections on intra-band UL contiguous CA with UL MIMO for PC3	18.6.0
2024-06	RAN#104	RP-241477	2317	1	F	CR for TS 38.101-1: Define the reserved GSCN / ARFCN-ValueNR and NR operating band	18.6.0
2024-06	RAN#104	RP-241456	2321	1	B	CR to TS 38.101-1: Addition of PC2 for n7	18.6.0
2024-06	RAN#104	RP-241467	2326		F	CR to TS38.101-1 for Sidelink enhancement cover RAN4#110bis	18.6.0
2024-06	RAN#104	RP-241464	2331		F	(NR_MC_enh-Core) CR for 38.101-1: Correction on time mask for Rel-18 Tx switching	18.6.0
2024-06	RAN#104	RP-241454	2335		B	Big CR on Introduction of completed SUL band combinations into TS 38.101-1	18.6.0
2024-06	RAN#104	RP-241483	2336	2	F	(NR_ATG-Core) CR for TS 38.101-1 to modify the note for ACS requirements 4dB below Pmax	18.6.0
2024-06	RAN#104	RP-241453	2339		B	big CR 38.101-1 new combinations Rel-18 NR Inter-band CA/DC for y bands DL with x bands UL (y=4,5,6, x=1,2)	18.6.0
2024-06	RAN#104	RP-241457	2341	1	B	Big CR on TS38.101-1 Addition of intra-band CA Combinations	18.6.0
2024-06	RAN#104	RP-241453	2343		B	(NR_CADC_R18_yBDL_xBUL) CR for TS 38101-1 to clarify 1 UL configuration for NR CA	18.6.0
2024-06	RAN#104	RP-241452	2344		B	Big CR to reflect the completed NR inter-band CA DC combinations for 3 bands DL with up to 2 bands UL into TS 38.101-1	18.6.0
2024-06	RAN#104	RP-241382	2348		A	(NR_newRAT-Core) CR for TS 38.101-1 on UE additional spurious emissions (R18_CAT_A)	18.6.0
2024-06	RAN#104	RP-241398	2351		A	CR to TS 38.101-1: Clarification on band-specific post antenna gain values for the FRMCS operation	18.6.0
2024-06	RAN#104	RP-241398	2353		A	CR to TS 38.104: clarifications on RMR terminology and related operating bands	18.6.0
2024-06	RAN#104	RP-241478	2361		F	(NR_ENDC_RF_FR1_enh2-Core) Correction on lowerMSD verification	18.6.0
2024-06	RAN#104	RP-241388	2367		A	Rel-18 SUL configuration correction for REFSSENS for DL in n24 and UL in n99	18.6.0
2024-06	RAN#104	RP-241493	2369		F	CR for correction of condition for 3Tx SAR solution	18.6.0
2024-06	RAN#104	RP-241494	2370		B	CR to support uplink Tx switching for CA with two contiguous aggregated carriers in each band [2CC-2CC_ULTx_switching]	18.6.0
2024-06	RAN#104	RP-241459	2371		B	Big CR to 38.101-1 new combinations for Rel-18 NR HPUE Inter-band	18.6.0
2024-09	RAN#105	RP-242156	2374		A	CR to R18 38.101-1 to add 25MHz CBW to NS_18 emissions requirement	18.7.0

2024-09	RAN#105	RP-242188	2376		F	CR for 38.101-1: Correction on the SL-U RB set and intra-cell guard band determination	18.7.0
2024-09	RAN#105	RP-242159	2377	1	F	Clarification for the enhanced channel raster and carrier aggregation	18.7.0
2024-09	RAN#105	RP-242163	2380		F	(NR_FDD_ULn28_DLn75_n76) CR to 38.101-1 on Channel raster for Band n109	18.7.0
2024-09	RAN#105	RP-242158	2387		A	(NR_CADC_R17_2BDL_xBUL) Removal of CA combinations containing n48(A-C)	18.7.0
2024-09	RAN#105	RP-242173	2391		A	CR for TS 38.101-1 Rel-18 correction on the terminology of emission bandwidth for NS_04	18.7.0
2024-09	RAN#105	RP-242196	2392	1	F	(NR_pos_enh2-Core) CR to 38.101-1 on positioning IE correction	18.7.0
2024-09	RAN#105	RP-242184	2394		A	(NR_redcap-Core) Correction of the channel raster for RedCap UEs by added entries	18.7.0
2024-09	RAN#105	RP-242155	2399		A	(NR_6GHz_unlic_EU-Core) CR for TS 38.101-1 on UE transmitter power for the P <sub>max</sub> tolerance for NR unlicensed operation (R18_CAT_A)	18.7.0
2024-09	RAN#105	RP-242158	2401		F	(NR_CADC_R18_3BDL_xBUL-Core) CR for TS 38.101-1 on UE configurable power relaxation for special component bands (R18)	18.7.0
2024-09	RAN#105	RP-242163	2402	1	F	(NR_FR1_less-than_5MHz_BW-Core) CR for TS 38.101-1 on narrow band blocking for 3MHz channel bandwidth	18.7.0
2024-09	RAN#105	RP-242186	2404		F	(NR_RF_FR1_enh-Core) CR for TS 38.101-1: Corrections on intra-band UL contiguous CA with UL MIMO for PC3	18.7.0
2024-09	RAN#105	RP-242159	2405		F	CR on 38.101-1 Update the IE names for coverage enhancement	18.7.0
2024-09	RAN#105	RP-242157	2407		A	Remove the superscript NOTE 1 for intra-band contiguous CA	18.7.0
2024-09	RAN#105	RP-242174	2410		A	(NR_n28_BW-Core) Apply ?MPR to the total MOP reduction	18.7.0
2024-09	RAN#105	RP-242183	2412	1	F	(NR_PC2_CA_R17_2BDL_2BUL) Remove superscript NOTE 6 for PC2 TDD-TDD inter-band CA	18.7.0
2024-09	RAN#105	RP-242152	2413		F	CR 38.101-1 addition of ETSI TC RT based on ECC Decision(20)02 reference to NB blocking	18.7.0
2024-09	RAN#105	RP-242155	2415	1	F	CR 38.101-1 Clarifications for non-collocated requirements	18.7.0
2024-09	RAN#105	RP-242190	2418		A	CR on typo for A-MPR of NR unlicensed band	18.7.0
2024-09	RAN#105	RP-242188	2419		F	CR on missing NS values for SL-U(R18)	18.7.0
2024-09	RAN#105	RP-242156	2425		F	CR 38.101-1 correcting the table for NR operating bands in FR1	18.7.0
2024-09	RAN#105	RP-242158	2426		F	CR 38.101-1 correcting 2 bands NR CA configuration tables	18.7.0
2024-09	RAN#105	RP-242158	2427		F	CR 38.101-1 correcting 3 bands NR CA configuration tables	18.7.0
2024-09	RAN#105	RP-242158	2428		F	CR 38.101-1 correcting 4 bands NR CA configuration tables	18.7.0
2024-09	RAN#105	RP-242158	2432		A	CR on MSD value correction for power class 5 cross band isolation	18.7.0
2024-09	RAN#105	RP-242174	2436		A	(NR_newRAT-core) CR for TS 38.101-1 R18 correction on AMPR for NS_10	18.7.0
2024-09	RAN#105	RP-242149	2442		A	(5G_V2X_NRSL-Core) CR to correct the name of the feature "V2X con-current operation" to "V2X concurrent operation" - TS38.101-1	18.7.0
2024-09	RAN#105	RP-242191	2447		A	(TEI16) CR to correct (typo) of the definitions of the symbols N <sub>rb_agg</sub> - TS38.101-1	18.7.0
2024-09	RAN#105	RP-242188	2449	1	F	(NR_SL_enh2-Core) CR to add third level clause suffixes for V2X - TS38.101-1	18.7.0
2024-09	RAN#105	RP-242186	2452	1	A	Correction for value B for non-contiguous uplink carrier aggregation	18.7.0
2024-09	RAN#105	RP-242158	2457	2	F	CR for NR CA Harmonic Mixing clean-up PC3 PC5	18.7.0
2024-09	RAN#105	RP-242158	2459	1	F	CR Adding missing MSD for CA_n2A-n66A and for CA_n25A-n66A PC3	18.7.0
2024-09	RAN#105	RP-242150	2460	2	F	CR for NR CA Harmonic Mixing clean-up PC2 PC1.5	18.7.0
2024-09	RAN#105	RP-242156	2461	1	F	(NR_ATG-Core) CR for TS 38.101-1 to clarify the Tx requirements definition for ATG UE	18.7.0
2024-09	RAN#105	RP-242189	2463		A	(NR_SUL_combos_R17-Core) CR for TS 38.101-1 to clarify the applicability for NUL carriers (R18)	18.7.0
2024-09	RAN#105	RP-242158	2465	1	F	CR to TS 38.101-1 Rel-18 NR CA Uplink Harmonic clean-up PC3	18.7.0
2024-09	RAN#105	RP-242150	2466	1	F	CR to TS 38.101-1 Rel-18 NR CA Uplink Harmonic clean-up PC2	18.7.0
2024-09	RAN#105	RP-242163	2470	1	F	Cat F CR to TS 38.101-1 Rel-18 REFSENS Corrections	18.7.0
2024-09	RAN#105	RP-242158	2471	1	F	CR to TS 38.101-1 Rel-18 Intra-band CA REFSENS corrections	18.7.0
2024-09	RAN#105	RP-242158	2472	1	F	CR to TS 38.101-1 Rel-18 Corrections to ACLR for CA_NC_NS_100	18.7.0
2024-09	RAN#105	RP-242191	2476		A	Cat A CR to TS 38.101-1 Rel-18 Power Class 4 clean-up	18.7.0
2024-09	RAN#105	RP-242158	2477	1	F	CR to TS 38.101-1 Rel-18 Dual-UL IMD corrections	18.7.0
2024-09	RAN#105	RP-242150	2478		F	( HPUE_FR1_TDD_NR_CADC_SUL_R18 ) CR to TS 38.101-1 for missing HPUE TDD configurations	18.7.0
2024-09	RAN#105	RP-242171	2481		A	(NR_n41_BW-Core) CR to TS 38.101-1: NS_47 correction	18.7.0
2024-09	RAN#105	RP-242150	2484		F	( HPUE_FR1_FDD_NR_CADC_R18 ) CR to TS 38.101-1 for missing HPUE FDD configurations	18.7.0
2024-09	RAN#105	RP-242191	2489		A	(TEI) On missing BCS set definition for asymmetric TDD	18.7.0
2024-09	RAN#105	RP-242156	2492		F	3MHz channel bandwidth optional for frequency bands n31 and n72	18.7.0
2024-09	RAN#105	RP-242152	2493		F	(LTE_NR_HPUE_FWVM_R18-Core) Clarification on FRMCS PC1 applicability for bands n100 and n101	18.7.0
2024-09	RAN#105	RP-242171	2496	1	F	(NR_n14-Core, TEI16) Correction of notes for UE output power	18.7.0
2024-09	RAN#105	RP-242150	2497		F	(HPUE_FR1_FDD_NR_CADC_R18-Core) CR for 38.101-1: Corrections for CA_n71A-n77A PC2 n71	18.7.0
2024-09	RAN#105	RP-242150	2498		F	( HPUE_NR_FR1_FDD ) CR for 38.101-1 NS_06 corrections	18.7.0

2024-09	RAN#105	RP-242158	2499	1	F	(CA and HPUE) CR for 38.101-1: Various corrections for CA and HPUE	18.7.0
2024-09	RAN#105	RP-242173	2503	1	A	CR to 38.101-1 Rel-18: Corrections of NR operating bands clause in FR1	18.7.0
2024-09	RAN#105	RP-242156	2505	1	F	CR to R18 38101-1 to add 35MHz CBW to NS_35 definition	18.7.0

---

# History

<b>Document history</b>		
V18.5.0	June 2024	Publication
V18.6.0	August 2024	Publication
V18.7.0	November 2024	Publication