

ETSI TS 138 104 V15.5.0 (2019-05)



**5G;
NR;
Base Station (BS) radio transmission and reception
(3GPP TS 38.104 version 15.5.0 Release 15)**



Reference

RTS/TSGR-0438104vf50

Keywords

5G

ETSI

650 Route des Lucioles
F-06921 Sophia Antipolis Cedex - FRANCE

Tel.: +33 4 92 94 42 00 Fax: +33 4 93 65 47 16

Siret N° 348 623 562 00017 - NAF 742 C
Association à but non lucratif enregistrée à la
Sous-Préfecture de Grasse (06) N° 7803/88

Important notice

The present document can be downloaded from:

<http://www.etsi.org/standards-search>

The present document may be made available in electronic versions and/or in print. The content of any electronic and/or print versions of the present document shall not be modified without the prior written authorization of ETSI. In case of any existing or perceived difference in contents between such versions and/or in print, the prevailing version of an ETSI deliverable is the one made publicly available in PDF format at www.etsi.org/deliver.

Users of the present document should be aware that the document may be subject to revision or change of status.

Information on the current status of this and other ETSI documents is available at

<https://portal.etsi.org/TB/ETSIDeliverableStatus.aspx>

If you find errors in the present document, please send your comment to one of the following services:

<https://portal.etsi.org/People/CommiteeSupportStaff.aspx>

Copyright Notification

No part may be reproduced or utilized in any form or by any means, electronic or mechanical, including photocopying and microfilm except as authorized by written permission of ETSI.

The content of the PDF version shall not be modified without the written authorization of ETSI.

The copyright and the foregoing restriction extend to reproduction in all media.

© ETSI 2019.

All rights reserved.

DECT™, **PLUGTESTS™**, **UMTS™** and the ETSI logo are trademarks of ETSI registered for the benefit of its Members.

3GPP™ and **LTE™** are trademarks of ETSI registered for the benefit of its Members and of the 3GPP Organizational Partners.

oneM2M™ logo is a trademark of ETSI registered for the benefit of its Members and of the oneM2M Partners.

GSM® and the GSM logo are trademarks registered and owned by the GSM Association.

Intellectual Property Rights

Essential patents

IPRs essential or potentially essential to normative deliverables may have been declared to ETSI. The information pertaining to these essential IPRs, if any, is publicly available for **ETSI members and non-members**, and can be found in ETSI SR 000 314: "*Intellectual Property Rights (IPRs); Essential, or potentially Essential, IPRs notified to ETSI in respect of ETSI standards*", which is available from the ETSI Secretariat. Latest updates are available on the ETSI Web server (<https://ipr.etsi.org/>).

Pursuant to the ETSI IPR Policy, no investigation, including IPR searches, has been carried out by ETSI. No guarantee can be given as to the existence of other IPRs not referenced in ETSI SR 000 314 (or the updates on the ETSI Web server) which are, or may be, or may become, essential to the present document.

Trademarks

The present document may include trademarks and/or tradenames which are asserted and/or registered by their owners. ETSI claims no ownership of these except for any which are indicated as being the property of ETSI, and conveys no right to use or reproduce any trademark and/or tradename. Mention of those trademarks in the present document does not constitute an endorsement by ETSI of products, services or organizations associated with those trademarks.

Foreword

This Technical Specification (TS) has been produced by ETSI 3rd Generation Partnership Project (3GPP).

The present document may refer to technical specifications or reports using their 3GPP identities, UMTS identities or GSM identities. These should be interpreted as being references to the corresponding ETSI deliverables.

The cross reference between GSM, UMTS, 3GPP and ETSI identities can be found under <http://webapp.etsi.org/key/queryform.asp>.

Modal verbs terminology

In the present document "**shall**", "**shall not**", "**should**", "**should not**", "**may**", "**need not**", "**will**", "**will not**", "**can**" and "**cannot**" are to be interpreted as described in clause 3.2 of the [ETSI Drafting Rules](#) (Verbal forms for the expression of provisions).

"**must**" and "**must not**" are **NOT** allowed in ETSI deliverables except when used in direct citation.

Contents

Intellectual Property Rights	2
Foreword.....	2
Modal verbs terminology.....	2
Foreword.....	11
1 Scope	12
2 References	12
3 Definitions, symbols and abbreviations	13
3.1 Definitions	13
3.2 Symbols.....	17
3.3 Abbreviations	19
4 General	21
4.1 Relationship with other core specifications.....	21
4.2 Relationship between minimum requirements and test requirements	21
4.3 Conducted and radiated requirement reference points	21
4.3.1 <i>BS type 1-C</i>	21
4.3.2 <i>BS type 1-H</i>	22
4.3.3 <i>BS type 1-O</i> and <i>BS type 2-O</i>	23
4.4 Base station classes	23
4.5 Regional requirements.....	24
4.6 Applicability of requirements.....	24
4.7 Requirements for contiguous and non-contiguous spectrum.....	25
4.8 Requirements for BS capable of multi-band operation	25
4.9 OTA co-location with other base stations	27
5 Operating bands and channel arrangement.....	28
5.1 General	28
5.2 Operating bands.....	28
5.3 <i>BS channel bandwidth</i>	29
5.3.1 General.....	29
5.3.2 Transmission bandwidth configuration.....	30
5.3.3 Minimum guardband and transmission bandwidth configuration.....	30
5.3.4 RB alignment	32
5.3.5 <i>BS channel bandwidth per operating band</i>	32
5.3A BS channel bandwidth for CA.....	36
5.3A.1 Transmission bandwidth configuration for CA.....	36
5.3A.2 Minimum guardband and transmission bandwidth configuration for CA	36
5.4 Channel arrangement.....	37
5.4.1 Channel spacing.....	37
5.4.1.1 Channel spacing for adjacent NR carriers	37
5.4.1.2 Channel spacing for CA	38
5.4.2 Channel raster	39
5.4.2.1 NR-ARFCN and channel raster.....	39
5.4.2.2 Channel raster to resource element mapping.....	39
5.4.2.3 Channel raster entries for each <i>operating band</i>	39
5.4.3 Synchronization raster	41
5.4.3.1 Synchronization raster and numbering.....	41
5.4.3.2 Synchronization raster to synchronization block resource element mapping.....	41
5.4.3.3 Synchronization raster entries for each operating band.....	41
6 Conducted transmitter characteristics	43
6.1 General	43
6.2 Base station output power	43
6.2.1 General.....	43
6.2.2 Minimum requirement for <i>BS type 1-C</i>	44

6.2.3	Minimum requirement for <i>BS type 1-H</i>	44
6.2.4	Additional requirements (regional).....	44
6.3	Output power dynamics.....	44
6.3.1	General.....	44
6.3.2	RE power control dynamic range	44
6.3.2.1	General	44
6.3.2.2	Minimum requirement for <i>BS type 1-C</i> and <i>BS type 1-H</i>	44
6.3.3	Total power dynamic range	45
6.3.3.1	General	45
6.3.3.2	Minimum requirement for <i>BS type 1-C</i> and <i>BS type 1-H</i>	45
6.4	Transmit ON/OFF power	46
6.4.1	Transmitter OFF power	46
6.4.1.1	General	46
6.4.1.2	Minimum requirement for <i>BS type 1-C</i>	46
6.4.1.3	Minimum requirement for <i>BS type 1-H</i>	46
6.4.2	Transmitter transient period.....	46
6.4.2.1	General	46
6.4.2.2	Minimum requirement for <i>BS type 1-C</i> and <i>BS type 1-H</i>	47
6.4.2.3	Void.....	47
6.5	Transmitted signal quality	47
6.5.1	Frequency error.....	47
6.5.1.1	General	47
6.5.1.2	Minimum requirement for <i>BS type 1-C</i> and <i>BS type 1-H</i>	48
6.5.2	Modulation quality.....	48
6.5.2.1	General	48
6.5.2.2	Minimum Requirement for <i>BS type 1-C</i> and <i>BS type 1-H</i>	48
6.5.2.3	EVM frame structure for measurement.....	48
6.5.3	Time alignment error	48
6.5.3.1	General	48
6.5.3.2	Minimum requirement for <i>BS type 1-C</i> and <i>1-H</i>	49
6.6	Unwanted emissions.....	49
6.6.1	General.....	49
6.6.2	Occupied bandwidth	50
6.6.2.1	General	50
6.6.2.2	Minimum requirement for <i>BS type 1-C</i> and <i>BS type 1-H</i>	50
6.6.3	Adjacent Channel Leakage Power Ratio	50
6.6.3.1	General	50
6.6.3.2	Limits and Basic limits.....	50
6.6.3.3	Minimum requirement for <i>BS type 1-C</i>	53
6.6.3.4	Minimum requirement for <i>BS type 1-H</i>	53
6.6.4	Operating band unwanted emissions	54
6.6.4.1	General	54
6.6.4.2	Basic limits.....	56
6.6.4.2.1	Basic limits for Wide Area BS (Category A)	56
6.6.4.2.2	Basic limits for Wide Area BS (Category B)	56
6.6.4.2.2.1	Category B requirements (Option 1).....	56
6.6.4.2.2.2	Category B requirements (Option 2).....	58
6.6.4.2.3	Basic limits for Medium Range BS (Category A and B).....	58
6.6.4.2.4	Basic limits for Local Area BS (Category A and B)	59
6.6.4.2.5	Basic limits for additional requirements.....	59
6.6.4.2.5.1	Limits in FCC Title 47.....	59
6.6.4.2.5.2	Protection of DTT.....	59
6.6.4.3	Minimum requirements for <i>BS type 1-C</i>	60
6.6.4.4	Minimum requirements for <i>BS type 1-H</i>	60
6.6.5	Transmitter spurious emissions.....	60
6.6.5.1	General	60
6.6.5.2	Basic limits.....	61
6.6.5.2.1	General transmitter spurious emissions requirements	61
6.6.5.2.2	Protection of the BS receiver of own or different BS	61
6.6.5.2.3	Additional spurious emissions requirements	62
6.6.5.2.4	Co-location with other base stations.....	69
6.6.5.3	Minimum requirements for <i>BS type 1-C</i>	74

6.6.5.4	Minimum requirements for <i>BS type 1-H</i>	74
6.7	Transmitter intermodulation	74
6.7.1	General	74
6.7.2	Minimum requirements for <i>BS type 1-C</i>	75
6.7.2.1	Co-location minimum requirements	75
6.7.2.2	Additional requirements	75
6.7.3	Minimum requirements for <i>BS type 1-H</i>	75
6.7.3.1	Co-location minimum requirements	75
6.7.3.2	Intra-system minimum requirements	76
6.7.3.3	Additional requirements	76
7	Conducted receiver characteristics	77
7.1	General	77
7.2	Reference sensitivity level	77
7.2.1	General	77
7.2.2	Minimum requirements for <i>BS type 1-C</i> and <i>BS type 1-H</i>	77
7.3	Dynamic range	79
7.3.1	General	79
7.3.2	Minimum requirement for <i>BS type 1-C</i> and <i>BS type 1-H</i>	79
7.4	In-band selectivity and blocking	81
7.4.1	Adjacent Channel Selectivity (ACS)	81
7.4.1.1	General	81
7.4.1.2	Minimum requirement for <i>BS type 1-C</i> and <i>BS type 1-H</i>	81
7.4.1.3	Void	83
7.4.1.4	Void	83
7.4.2	In-band blocking	83
7.4.2.1	General	83
7.4.2.2	Minimum requirement for <i>BS type 1-C</i> and <i>BS type 1-H</i>	83
7.4.2.3	Void	85
7.4.2.4	Void	85
7.5	Out-of-band blocking	85
7.5.1	General	85
7.5.2	Minimum requirement for <i>BS type 1-C</i> and <i>BS type 1-H</i>	86
7.5.3	Co-location minimum requirements for <i>BS type 1-C</i> and <i>BS type 1-H</i>	86
7.5.4	Void	87
7.6	Receiver spurious emissions	87
7.6.1	General	87
7.6.2	Basic limits	87
7.6.3	Minimum requirement for <i>BS type 1-C</i>	88
7.6.4	Minimum requirement for <i>BS type 1-H</i>	88
7.7	Receiver intermodulation	88
7.7.1	General	88
7.7.2	Minimum requirement for <i>BS type 1-C</i> and <i>BS type 1-H</i>	88
7.8	In-channel selectivity	93
7.8.1	General	93
7.8.2	Minimum requirement for <i>BS type 1-C</i> and <i>BS type 1-H</i>	93
8	Conducted performance requirements	96
8.1	General	96
8.1.1	Scope and definitions	96
8.1.2	Applicability rule	96
8.2	Performance requirements for PUSCH	96
8.2.1	Requirements for PUSCH with transform precoding disabled	96
8.2.1.1	General	96
8.2.1.2	Minimum requirements	97
8.2.2	Requirements for PUSCH with transform precoding enabled	104
8.2.2.1	General	104
8.2.2.2	Minimum requirements	105
8.3	Performance requirements for PUCCH	106
8.3.1	DTX to ACK probability	106
8.3.1.1	General	106
8.3.1.2	Minimum requirement	106

8.3.2	Performance requirements for PUCCH format 0.....	106
8.3.2.1	General.....	106
8.3.2.2	Minimum requirements.....	107
8.3.3	Performance requirements for PUCCH format 1.....	107
8.3.3.1	NACK to ACK requirements.....	107
8.3.3.1.1	General.....	107
8.3.3.1.2	Minimum requirements.....	108
8.3.3.2	ACK missed detection requirements.....	108
8.3.3.2.1	General.....	108
8.3.3.2.2	Minimum requirements.....	108
8.3.4	Performance requirements for PUCCH format 2.....	109
8.3.4.1	ACK missed detection requirements.....	109
8.3.4.1.1	General.....	109
8.3.4.1.2	Minimum requirements.....	109
8.3.4.2	UCI BLER performance requirements.....	110
8.3.4.2.1	General.....	110
8.3.4.2.2	Minimum requirements.....	110
8.3.5	Performance requirements for PUCCH format 3.....	111
8.3.5.1	General.....	111
8.3.5.2	Minimum requirements.....	111
8.3.6	Performance requirements for PUCCH format 4.....	113
8.3.6.1	General.....	113
8.3.6.2	Minimum requirement.....	113
8.4	Performance requirements for PRACH.....	114
8.4.1	PRACH False alarm probability.....	114
8.4.1.1	General.....	114
8.4.1.2	Minimum requirement.....	114
8.4.2	PRACH detection requirements.....	114
8.4.2.1	General.....	114
8.4.2.2	Minimum requirements.....	115
9	Radiated transmitter characteristics.....	116
9.1	General.....	116
9.2	Radiated transmit power.....	116
9.2.1	General.....	116
9.2.2	Minimum requirement for <i>BS type 1-H</i> and <i>BS type 1-O</i>	116
9.2.3	Minimum requirement for <i>BS type 2-O</i>	117
9.3	OTA base station output power.....	117
9.3.1	General.....	117
9.3.2	Minimum requirement for <i>BS type 1-O</i>	117
9.3.3	Minimum requirement for <i>BS type 2-O</i>	118
9.3.4	Additional requirements (regional).....	118
9.4	OTA output power dynamics.....	118
9.4.1	General.....	118
9.4.2	OTA RE power control dynamic range.....	118
9.4.2.1	General.....	118
9.4.2.2	Minimum requirement for <i>BS type 1-O</i>	118
9.4.3	OTA total power dynamic range.....	118
9.4.3.1	General.....	118
9.4.3.2	Minimum requirement for <i>BS type 1-O</i>	118
9.4.3.3	Minimum requirement for <i>BS type 2-O</i>	119
9.5	OTA transmit ON/OFF power.....	119
9.5.1	General.....	119
9.5.2	OTA transmitter OFF power.....	119
9.5.2.1	General.....	119
9.5.2.2	Minimum requirement for <i>BS type 1-O</i>	119
9.5.2.3	Minimum requirement for <i>BS type 2-O</i>	119
9.5.3	OTA transient period.....	119
9.5.3.1	General.....	119
9.5.3.2	Minimum requirement for <i>BS type 1-O</i>	120
9.5.3.3	Minimum requirement for <i>BS type 2-O</i>	120
9.6	OTA transmitted signal quality.....	120

9.6.1	OTA frequency error	120
9.6.1.1	General	120
9.6.1.2	Minimum requirement for <i>BS type 1-O</i>	120
9.6.1.3	Minimum requirement for <i>BS type 2-O</i>	120
9.6.2	OTA modulation quality	121
9.6.2.1	General	121
9.6.2.2	Minimum Requirement for <i>BS type 1-O</i>	121
9.6.2.3	Minimum Requirement for <i>BS type 2-O</i>	121
9.6.2.3.1	EVM frame structure for measurement	121
9.6.3	OTA time alignment error	121
9.6.3.1	General	121
9.6.3.2	Minimum requirement for <i>BS type 1-O</i>	121
9.6.3.3	Minimum requirement for <i>BS type 2-O</i>	122
9.7	OTA unwanted emissions	122
9.7.1	General.....	122
9.7.2	OTA occupied bandwidth.....	123
9.7.2.1	General	123
9.7.2.2	Minimum requirement for <i>BS type 1-O</i> and <i>BS type 2-O</i>	123
9.7.3	OTA Adjacent Channel Leakage Power Ratio (ACLR)	123
9.7.3.1	General	123
9.7.3.2	Minimum requirement for <i>BS type 1-O</i>	123
9.7.3.3	Minimum requirement for <i>BS type 2-O</i>	124
9.7.4	OTA operating band unwanted emissions	126
9.7.4.1	General	126
9.7.4.2	Minimum requirement for <i>BS type 1-O</i>	126
9.7.4.2.1	Additional requirements	126
9.7.4.2.1.1	Protection of DTT.....	126
9.7.4.3	Minimum requirement for <i>BS type 2-O</i>	127
9.7.4.3.1	General	127
9.7.4.3.2	OTA operating band unwanted emission limits	127
9.7.5	OTA transmitter spurious emissions.....	128
9.7.5.1	General	128
9.7.5.2	Minimum requirement for <i>BS type 1-O</i>	128
9.7.5.2.1	General	128
9.7.5.2.2	General OTA transmitter spurious emissions requirements	128
9.7.5.2.3	Protection of the BS receiver of own or different BS	128
9.7.5.2.4	Additional spurious emissions requirements	129
9.7.5.2.5	Co-location with other base stations.....	129
9.7.5.3	Minimum requirement for <i>BS type 2-O</i>	129
9.7.5.3.1	General	129
9.7.5.3.2	General OTA transmitter spurious emissions requirements	129
9.7.5.3.3	Additional OTA transmitter spurious emissions requirements.....	130
9.8	OTA transmitter intermodulation	130
9.8.1	General.....	130
9.8.2	Minimum requirement for <i>BS type 1-O</i>	130
10	Radiated receiver characteristics	131
10.1	General	131
10.2	OTA sensitivity	132
10.2.1	BS type 1-H and BS type 1-O.....	132
10.2.1.1	General	132
10.2.1.2	Minimum requirement	132
10.2.2	BS type 2-O	132
10.3	OTA reference sensitivity level.....	133
10.3.1	General.....	133
10.3.2	Minimum requirement for <i>BS type 1-O</i>	133
10.3.3	Minimum requirement for <i>BS type 2-O</i>	134
10.4	OTA Dynamic range	135
10.4.1	General.....	135
10.4.2	Minimum requirement for <i>BS type 1-O</i>	135
10.5	OTA in-band selectivity and blocking.....	144
10.5.1	OTA adjacent channel selectivity	144

10.5.1.1	General	144
10.5.1.2	Minimum requirement for <i>BS type 1-O</i>	144
10.5.1.3	Minimum requirement for <i>BS type 2-O</i>	145
10.5.2	OTA in-band blocking	146
10.5.2.1	General	146
10.5.2.2	Minimum requirement for <i>BS type 1-O</i>	146
10.5.2.3	Minimum requirement for <i>BS type 2-O</i>	149
10.6	OTA out-of-band blocking	150
10.6.1	General	150
10.6.2	Minimum requirement for <i>BS type 1-O</i>	150
10.6.2.1	General minimum requirement	150
10.6.2.2	Co-location minimum requirement	151
10.6.3	Minimum requirement for <i>BS type 2-O</i>	151
10.6.3.1	General minimum requirement	151
10.7	OTA receiver spurious emissions	152
10.7.1	General	152
10.7.2	Minimum requirement for <i>BS type 1-O</i>	152
10.7.3	Minimum requirement for <i>BS type 2-O</i>	152
10.8	OTA receiver intermodulation	153
10.8.1	General	153
10.8.2	Minimum requirement for <i>BS type 1-O</i>	153
10.8.3	Minimum requirement for <i>BS type 2-O</i>	157
10.9	OTA in-channel selectivity	158
10.9.1	General	158
10.9.2	Minimum requirement for <i>BS type 1-O</i>	158
10.9.3	Minimum requirement for <i>BS type 2-O</i>	161
11	Radiated performance requirements	163
11.1	General	163
11.1.1	Scope and definitions	163
11.1.2	OTA demodulation branches	163
11.1.3	Applicability rule	163
11.2	Performance requirements for PUSCH	164
11.2.1	Requirements for <i>BS type 1-O</i>	164
11.2.1.1	Requirements for PUSCH with transform precoding disabled	164
11.2.1.2	Requirements for PUSCH with transform precoding enabled	164
11.2.2	Requirements for <i>BS type 2-O</i>	164
11.2.2.1	Requirements for PUSCH with transform precoding disabled	164
11.2.2.1.1	General	164
11.2.2.1.2	Minimum requirements	164
11.2.2.2	Requirements for PUSCH with transform precoding enabled	166
11.2.2.2.1	General	166
11.2.2.2.2	Minimum requirements	166
11.3	Performance requirements for PUCCH	167
11.3.1	Requirements for <i>BS type 1-O</i>	167
11.3.1.1	DTX to ACK probability	167
11.3.1.2	Performance requirements for PUCCH format 0	167
11.3.1.3	Performance requirements for PUCCH format 1	167
11.3.1.4	Performance requirements for PUCCH format 2	167
11.3.1.5	Performance requirements for PUCCH format 3	167
11.3.1.6	Performance requirements for PUCCH format 4	167
11.3.2	Requirements for <i>BS type 2-O</i>	167
11.3.2.1	DTX to ACK probability	167
11.3.2.2	Performance requirements for PUCCH format 0	167
11.3.2.2.1	General	167
11.3.2.2.2	Minimum requirements	167
11.3.2.3	Performance requirements for PUCCH format 1	168
11.3.2.3.1	NACK to ACK requirements	168
11.3.2.3.1.1	General	168
11.3.2.3.1.2	Minimum requirements	169
11.3.2.3.2	ACK missed detection requirements	169
11.3.2.3.2.1	General	169

11.3.2.3.2.2	Minimum requirements.....	169
11.3.2.4	Performance requirements for PUCCH format 2	170
11.3.2.4.1	ACK missed detection requirements	170
11.3.2.4.1.1	General.....	170
11.3.2.4.1.2	Minimum requirements.....	170
11.3.2.4.2	UCI BLER performance requirements	170
11.3.2.4.2.1	General.....	170
11.3.2.4.2.2	Minimum requirements.....	171
11.3.2.5	Performance requirements for PUCCH format 3	171
11.3.2.5.1	General	171
11.3.2.5.2	Minimum requirements	172
11.3.2.6	Performance requirements for PUCCH format 4	172
11.3.2.6.1	General	172
11.3.2.6.2	Minimum requirements	172
11.4	Performance requirements for PRACH.....	173
11.4.1	Requirements for <i>BS type 1-O</i>	173
11.4.1.1	PRACH False alarm probability	173
11.4.1.2	PRACH detection requirements	173
11.4.2	Requirements for <i>BS type 2-O</i>	173
11.4.2.1	PRACH False alarm probability	173
11.4.2.1.1	General	173
11.4.2.1.2	Minimum requirement.....	173
11.4.2.2	PRACH detection requirements	173
11.4.2.2.1	General	173
11.4.2.2.2	Minimum requirements	174
Annex A (normative): Reference measurement channels		175
A.1	Fixed Reference Channels for receiver sensitivity and in-channel selectivity (QPSK, R=1/3)	175
A.2	Fixed Reference Channels for dynamic range (16QAM, R=2/3).....	176
A.3	Fixed Reference Channels for performance requirements (QPSK, R=193/1024)	177
A.4	Fixed Reference Channels for performance requirements (16QAM, R=658/1024)	181
A.5	Fixed Reference Channels for performance requirements (64QAM, R=567/1024)	184
A.6	PRACH Test preambles	186
Annex B (normative): Error Vector Magnitude (FR1)		187
B.1	Reference point for measurement.....	187
B.2	Basic unit of measurement	187
B.3	Modified signal under test.....	188
B.4	Estimation of frequency offset	188
B.5	Estimation of time offset	188
B.5.1	General	188
B.5.2	Window length	189
B.6	Estimation of TX chain amplitude and frequency response parameters	190
B.7	Averaged EVM	192
Annex C (normative): Error Vector Magnitude (FR2)		193
C.1	Reference point for measurement.....	193
C.2	Basic unit of measurement	193
C.3	Modified signal under test.....	194
C.4	Estimation of frequency offset	194
C.5	Estimation of time offset	194

C.5.1	General	194
C.5.2	Window length	195
C.6	Estimation of TX chain amplitude and frequency response parameters	195
C.7	Averaged EVM	197
Annex D (normative):	Characteristics of the interfering signals.....	199
Annex E:	Void	200
Annex F (normative):	Relationship between EIRP based regulatory requirements and 3GPP requirements.....	201
F.1	General	201
F.2	Relationship between EIRP based regulatory requirements and conducted requirements.....	201
F.3	Relationship between EIRP based regulatory requirements and OTA requirements.....	202
Annex G (Normative):	Propagation conditions.....	203
G.1	Static propagation condition.....	203
G.2	Multi-path fading propagation conditions	203
G.2.1	Delay profiles	203
G.2.1.1	Delay profiles for FR1	204
G.2.1.2	Delay profiles for FR2	205
G.2.2	Combinations of channel model parameters	206
G.2.3	MIMO Channel Correlation Matrices	206
G.2.3.1	MIMO Correlation Matrices using Uniform Linear Array (ULA)	206
G.2.3.1.1	Definition of MIMO Correlation Matrices.....	206
G.2.3.1.2	MIMO Correlation Matrices at High, Medium and Low Level	208
G.2.3.2	Multi-Antenna channel models using cross polarized antennas	210
G.2.3.2.1	Definition of MIMO Correlation Matrices using cross polarized antennas	211
G.2.3.2.2	Spatial Correlation Matrices at UE and gNB sides	211
G.2.3.2.2.1	Spatial Correlation Matrices at UE side	211
G.2.3.2.2.2	Spatial Correlation Matrices at gNB side	212
G.2.3.2.3	MIMO Correlation Matrices using cross polarized antennas	212
Annex H (informative):	Change history	213
History		218

Foreword

This Technical Specification has been produced by the 3rd Generation Partnership Project (3GPP).

The contents of the present document are subject to continuing work within the TSG and may change following formal TSG approval. Should the TSG modify the contents of the present document, it will be re-released by the TSG with an identifying change of release date and an increase in version number as follows:

Version x.y.z

where:

- x the first digit:
 - 1 presented to TSG for information;
 - 2 presented to TSG for approval;
 - 3 or greater indicates TSG approved document under change control.
- y the second digit is incremented for all changes of substance, i.e. technical enhancements, corrections, updates, etc.
- z the third digit is incremented when editorial only changes have been incorporated in the document.

1 Scope

The present document establishes the minimum RF characteristics and minimum performance requirements of NR Base Station (BS).

2 References

The following documents contain provisions which, through reference in this text, constitute provisions of the present document.

- References are either specific (identified by date of publication, edition number, version number, etc.) or non-specific.
- For a specific reference, subsequent revisions do not apply.
- For a non-specific reference, the latest version applies. In the case of a reference to a 3GPP document (including a GSM document), a non-specific reference implicitly refers to the latest version of that document *in the same Release as the present document*.

- [1] 3GPP TR 21.905: "Vocabulary for 3GPP Specifications".
- [2] ITU-R Recommendation SM.329: "Unwanted emissions in the spurious domain".
- [3] Recommendation ITU-R SM.328: "Spectra and bandwidth of emissions".
- [4] 3GPP TR 25.942: "RF system scenarios".
- [5] 3GPP TS 38.141-1: "NR; Base Station (BS) conformance testing; Part 1: Conducted conformance testing".
- [6] 3GPP TS 38.141-2: "NR; Base Station (BS) conformance testing; Part 2: Radiated conformance testing".
- [7] Recommendation ITU-R M.1545: "Measurement uncertainty as it applies to test limits for the terrestrial component of International Mobile Telecommunications-2000".
- [8] "Title 47 of the Code of Federal Regulations (CFR)", Federal Communications Commission.
- [9] 3GPP TS 38.211: "NR; Physical channels and modulation".
- [10] 3GPP TS 38.213: "NR; Physical layer procedures for control".
- [11] 3GPP TS 38.331: "NR; Radio Resource Control (RRC); Protocol specification".
- [12] ECC/DEC/(17)06: "The harmonised use of the frequency bands 1427-1452 MHz and 1492-1518 MHz for Mobile/Fixed Communications Networks Supplemental Downlink (MFCN SDL)"
- [13] 3GPP TS 36.104: "Evolved Universal Terrestrial Radio Access (E-UTRA); Base Station (BS) radio transmission and reception".
- [14] 3GPP TS 37.105: "Active Antenna System (AAS) Base Station (BS) transmission and reception".
- [15] 3GPP TS 38.212: "NR; Multiplexing and channel coding".
- [16] 3GPP TR 38.901: "Study on channel model for frequencies from 0.5 to 100 GHz"

3 Definitions, symbols and abbreviations

3.1 Definitions

For the purposes of the present document, the terms and definitions given in 3GPP TR 21.905 [1] and the following apply. A term defined in the present document takes precedence over the definition of the same term, if any, in 3GPP TR 21.905 [1].

Aggregated BS Channel Bandwidth: The RF bandwidth in which a Base Station transmits and receives multiple contiguously aggregated carriers. The *aggregated BS channel bandwidth* is measured in MHz.

antenna connector: connector at the conducted interface of the *BS type 1-C*

active transmitter unit: transmitter unit which is ON, and has the ability to send modulated data streams that are parallel and distinct to those sent from other transmitter units to a *BS type 1-C antenna connector*, or to one or more *BS type 1-H TAB connectors* at the *transceiver array boundary*

Base Station RF Bandwidth: RF bandwidth in which a base station transmits and/or receives single or multiple carrier(s) within a supported *operating band*

NOTE: In single carrier operation, the *Base Station RF Bandwidth* is equal to the *BS channel bandwidth*.

Base Station RF Bandwidth edge: frequency of one of the edges of the *Base Station RF Bandwidth*.

basic limit: emissions limit relating to the power supplied by a single transmitter to a single antenna transmission line in ITU-R SM.329 [2] used for the formulation of unwanted emission requirements for FR1

beam: beam (of the antenna) is the main lobe of the radiation pattern of an *antenna array*

NOTE: For certain *BS antenna array*, there may be more than one beam.

beam centre direction: direction equal to the geometric centre of the half-power contour of the beam

beam direction pair: data set consisting of the *beam centre direction* and the related *beam peak direction*

beam peak direction: direction where the maximum EIRP is found

beamwidth: beam which has a half-power contour that is essentially elliptical, the half-power beamwidths in the two pattern cuts that respectively contain the major and minor axis of the ellipse

BS channel bandwidth: RF bandwidth supporting a single NR RF carrier with the transmission bandwidth configured in the uplink or downlink

NOTE 1: The *BS channel bandwidth* is measured in MHz and is used as a reference for transmitter and receiver RF requirements.

NOTE 2: It is possible for the BS to transmit to and/or receive from one or more UE bandwidth parts that are smaller than or equal to the BS transmission bandwidth configuration, in any part of the BS transmission bandwidth configuration.

BS transmission bandwidth configuration: set of resource blocks located within the *BS channel bandwidth* which may be used for transmitting or receiving by the BS

BS type 1-C: NR base station operating at FR1 with requirements set consisting only of conducted requirements defined at individual *antenna connectors*

BS type 1-H: NR base station operating at FR1 with a requirement set consisting of conducted requirements defined at individual *TAB connectors* and OTA requirements defined at RIB

BS type 1-O: NR base station operating at FR1 with a requirement set consisting only of OTA requirements defined at the RIB

BS type 2-O: NR base station operating at FR2 with a requirement set consisting only of OTA requirements defined at the RIB

Channel edge: lowest or highest frequency of the NR carrier, separated by the *BS channel bandwidth*.

Carrier aggregation: aggregation of two or more component carriers in order to support wider transmission bandwidths

Carrier aggregation configuration: a set of one or more *operating bands* across which the BS aggregates carriers with a specific set of technical requirements

co-location reference antenna: a passive antenna used as reference for base station to base station co-location requirements

Contiguous carriers: set of two or more carriers configured in a spectrum block where there are no RF requirements based on co-existence for un-coordinated operation within the spectrum block.

Contiguous spectrum: spectrum consisting of a contiguous block of spectrum with no *sub-block gap(s)*.

directional requirement: requirement which is applied in a specific direction within the OTA coverage range for the Tx and when the AoA of the incident wave of a received signal is within the *OTA REFSENS RoAoA* or the *minSENS RoAoA* as appropriate for the receiver

equivalent isotropic radiated power: equivalent power radiated from an isotropic directivity device producing the same field intensity at a point of observation as the field intensity radiated in the direction of the same point of observation by the discussed device

NOTE: Isotropic directivity is equal in all directions (i.e. 0 dBi).

equivalent isotropic sensitivity: sensitivity for an isotropic directivity device equivalent to the sensitivity of the discussed device exposed to an incoming wave from a defined AoA

NOTE 1: The sensitivity is the minimum received power level at which specific requirement is met.

NOTE 2: Isotropic directivity is equal in all directions (i.e. 0 dBi).

fractional bandwidth: fractional bandwidth FBW is defined as $FBW = 200 \cdot \frac{F_{FBWhigh} - F_{FBWlow}}{F_{FBWhigh} + F_{FBWlow}} \%$

Highest Carrier: The carrier with the highest carrier frequency transmitted/received in a specified frequency band.

Inter-band carrier aggregation: carrier aggregation of component carriers in different *operating bands*.

NOTE: Carriers aggregated in each band can be contiguous or non-contiguous.

Inter-band gap: The frequency gap between two supported consecutive operating bands.

Intra-band contiguous carrier aggregation: *contiguous carriers* aggregated in the same *operating band*.

Intra-band non-contiguous carrier aggregation: non-contiguous carriers aggregated in the same *operating band*.

Inter RF Bandwidth gap: frequency gap between two consecutive Base Station RF Bandwidths that are placed within two supported *operating bands*

Lowest Carrier: The carrier with the lowest carrier frequency transmitted/received in a specified frequency band.

Lower sub-block edge: frequency at the lower edge of one *sub-block*.

NOTE: It is used as a frequency reference point for both transmitter and receiver requirements.

maximum carrier output power: mean power level measured per carrier at the indicated interface, during the *transmitter ON period* in a specified reference condition

maximum carrier TRP output power: mean power level measured per RIB during the *transmitter ON period* for a specific carrier in a specified reference condition and corresponding to the declared *rated carrier TRP output power* ($P_{\text{rated,c,TRP}}$)

maximum total output power: mean power level measured within the *operating band* at the indicated interface, during the *transmitter ON period* in a specified reference condition

maximum total TRP output power: mean power level measured per RIB during the *transmitter ON period* in a specified reference condition and corresponding to the declared *rated total TRP output power* ($P_{\text{rated,t,TRP}}$)

measurement bandwidth: RF bandwidth in which an emission level is specified

minimum EIRP level under extreme condition: For a declared beam and *beam direction pair*, the *minimum EIRP level under extreme condition* is the minimum power that the base station is declared to radiate at the associated *beam peak direction* during the *transmitter ON period* under extreme condition.

minSENS: the lowest declared EIS value for the OSDD's declared for OTA sensitivity requirement.

minSENS RoAoA: The reference RoAoA associated with the OSDD with the lowest declared EIS

multi-band connector: Antenna Connector of *BS type I-C* or *TAB connector of BS type I-H* associated with a transmitter or receiver that is characterized by the ability to process two or more carriers in common active RF components simultaneously, where at least one carrier is configured at a different *operating band* than the other carrier(s) and where this different *operating band* is not a sub-band or superseding-band of another supported *operating band*

multi-band RIB: *operating band* specific RIB associated with a transmitter or receiver that is characterized by the ability to process two or more carriers in common active RF components simultaneously, where at least one carrier is configured at a different *operating band* than the other carrier(s) and where this different *operating band* is not a sub-band or superseding-band of another supported *operating band*

Multi-carrier transmission configuration: set of one or more contiguous or non-contiguous carriers that a NR BS is able to transmit simultaneously according to the manufacturer's specification.

Non-contiguous spectrum: spectrum consisting of two or more sub-blocks separated by *sub-block gap(s)*.

operating band: frequency range in which NR operates (paired or unpaired), that is defined with a specific set of technical requirements

NOTE: The *operating band(s)* for a BS is declared by the manufacturer according to the designations in tables 5.2-1 and 5.2-2.

OTA coverage range: a common range of directions within which TX OTA requirements that are neither specified in the *OTA peak directions sets* nor as *TRP requirement* are intended to be met

OTA peak directions set: set(s) of *beam peak directions* within which certain TX OTA requirements are intended to be met, where all *OTA peak directions set(s)* are subsets of the *OTA coverage range*

NOTE: The *beam peak directions* are related to a corresponding contiguous range or discrete list of *beam centre directions* by the *beam direction pairs* included in the set.

OTA REFSENS RoAoA: the RoAoA determined by the contour defined by the points at which the achieved EIS is 3dB higher than the achieved EIS in the reference direction assuming that for any AoA, the receiver gain is optimized for that AoA

NOTE: This contour will be related to the average element/sub-array radiation pattern 3dB beam width.

OTA sensitivity directions declaration: set of manufacturer declarations comprising at least one set of declared minimum EIS values (with *BS channel bandwidth*), and related directions over which the EIS applies

NOTE: All the directions apply to all the EIS values in an OSDD.

polarization match: condition that exists when a plane wave, incident upon an antenna from a given direction, has a polarization that is the same as the receiving polarization of the antenna in that direction

radiated interface boundary: *operating band* specific radiated requirements reference where the radiated requirements apply

NOTE: For requirements based on EIRP/EIS, the *radiated interface boundary* is associated to the far-field region

Radio Bandwidth: frequency difference between the upper edge of the highest used carrier and the lower edge of the lowest used carrier

rated beam EIRP: For a declared beam and *beam direction pair*, the *rated beam EIRP* level is the maximum power that the base station is declared to radiate at the associated *beam peak direction* during the *transmitter ON period*

rated carrier output power: mean power level associated with a particular carrier the manufacturer has declared to be available at the indicated interface, during the *transmitter ON period* in a specified reference condition

rated carrier TRP output power: mean power level declared by the manufacturer per carrier, for BS operating in single carrier, multi-carrier, or carrier aggregation configurations that the manufacturer has declared to be available at the RIB during the *transmitter ON period*

rated total output power: mean power level associated with a particular *operating band* the manufacturer has declared to be available at the indicated interface, during the *transmitter ON period* in a specified reference condition

rated total TRP output power: mean power level declared by the manufacturer, that the manufacturer has declared to be available at the RIB during the *transmitter ON period*

reference beam direction pair: declared *beam direction pair*, including reference *beam centre direction* and reference *beam peak direction* where the reference *beam peak direction* is the direction for the intended maximum EIRP within the *OTA peak directions set*

receiver target: AoA in which reception is performed by *BS types 1-H* or *BS type 1-O*

receiver target redirection range: union of all the *sensitivity RoAoA* achievable through redirecting the *receiver target* related to particular OSDD

receiver target reference direction: direction inside the *OTA sensitivity directions declaration* declared by the manufacturer for conformance testing. For an OSDD without *receiver target redirection range*, this is a direction inside the *sensitivity RoAoA*

reference RoAoA: the *sensitivity RoAoA* associated with the receiver target reference direction for each OSDD.

requirement set: one of the NR base station requirement's set as defined for *BS type 1-C*, *BS type 1-H*, *BS type 1-O*, and *BS type 2-O*

sensitivity RoAoA: *RoAoA* within the *OTA sensitivity directions declaration*, within which the declared EIS(s) of an OSDD is intended to be achieved at any instance of time for a specific BS direction setting

single-band connector: *BS type 1-C* Antenna Connector or *BS type 1-H* TAB connector supporting operation either in a single *operating band* only, or in multiple *operating bands* but does not meet the conditions for a *multi-band connector*.

single-band RIB: *operating band* specific RIB supporting operation either in a single *operating band* only, or in multiple *operating bands* but does not meet the conditions for a *multi-band RIB*.

sub-band: A sub-band of an operating band contains a part of the uplink and downlink frequency range of the operating band.

sub-block bandwidth: bandwidth of one *sub-block*.

sub-block: one contiguous allocated block of spectrum for transmission and reception by the same base station

NOTE: There may be multiple instances of sub-blocks within a *Base Station RF Bandwidth*.

sub-block gap: frequency gap between two consecutive sub-blocks within a *Base Station RF Bandwidth*, where the RF requirements in the gap are based on co-existence for un-coordinated operation

superseding-band: A superseding-band of an operating band includes the whole of the uplink and downlink frequency range of the operating band.

TAB connector: *transceiver array boundary* connector

TAB connector RX min cell group: *operating band* specific declared group of *TAB connectors* to which *BS type 1-H* conducted RX requirements are applied

NOTE: Within this definition, the group corresponds to the group of *TAB connectors* which are responsible for receiving a cell when the *BS type 1-H* setting corresponding to the declared minimum number of cells with reception on all *TAB connectors* supporting an *operating band*, but its existence is not limited to that condition

TAB connector TX min cell group: *operating band* specific declared group of *TAB connectors* to which *BS type 1-H* conducted TX requirements are applied.

NOTE: Within this definition, the group corresponds to the group of *TAB connectors* which are responsible for transmitting a cell when the *BS type 1-H* setting corresponding to the declared minimum number of cells with transmission on all *TAB connectors* supporting an *operating band*, but its existence is not limited to that condition

total radiated power: is the total power radiated by the antenna

NOTE: The total radiated power is the power radiating in all direction for two orthogonal polarizations. Total radiated power is defined in both the near-field region and the far-field region

transceiver array boundary: conducted interface between the transceiver unit array and the composite antenna

transmission bandwidth: RF Bandwidth of an instantaneous transmission from a UE or BS, measured in resource block units

transmitter OFF period: time period during which the BS transmitter is not allowed to transmit

transmitter ON period: time period during which the BS transmitter is transmitting data and/or reference symbols

transmitter transient period: time period during which the transmitter is changing from the OFF period to the ON period or vice versa

UE transmission bandwidth configuration: set of resource blocks located within the *UE channel bandwidth* which may be used for transmitting or receiving by the UE

upper sub-block edge: frequency at the upper edge of one *sub-block*.

NOTE: It is used as a frequency reference point for both transmitter and receiver requirements.

3.2 Symbols

For the purposes of the present document, the following symbols apply:

β	Percentage of the mean transmitted power emitted outside the occupied bandwidth on the assigned channel
$BeW_{\theta,REFSENS}$	Beamwidth equivalent to the <i>OTA REFSENS RoAoA</i> in the θ -axis in degrees. Applicable for FR1 only.
$BeW_{\phi,REFSENS}$	Beamwidth equivalent to the <i>OTA REFSENS RoAoA</i> in the ϕ -axis in degrees. Applicable for FR1 only.
$BW_{Channel}$	<i>BS channel bandwidth</i>
$BW_{Channel_CA}$	<i>Aggregated BS Channel Bandwidth</i> , expressed in MHz. $BW_{Channel_CA} = F_{edge,high} - F_{edge,low}$.
$BW_{Channel,block}$	Sub-block bandwidth, expressed in MHz. $BW_{Channel,block} = F_{edge,block,high} - F_{edge,block,low}$.
BW_{Config}	Transmission bandwidth configuration, where $BW_{Config} = N_{RB} \times SCS \times 12$
$BW_{Contiguous}$	Contiguous transmission bandwidth, i.e. bandwidth from lowest edge of lowest transmitted channel in frequency to highest edge of highest transmitted channel in frequency. For non-contiguous operation with a band the term is applied per sub-block.
$BW_{GB, low}$	The minimum guard band defined in subclause 5.3.3 for lowest assigned component carrier
$BW_{GB, high}$	The minimum guard band defined in subclause 5.3.3 for highest assigned component carrier
Δf	Separation between the channel edge frequency and the nominal -3 dB point of the measuring filter closest to the carrier frequency
ΔF_{Global}	Global frequency raster granularity
Δf_{max}	$f_{offset,max}$ minus half of the bandwidth of the measuring filter
Δf_{OBUE}	Maximum offset of the <i>operating band</i> unwanted emissions mask from the downlink <i>operating band</i> edge
Δf_{OOB}	Maximum offset of the out-of-band boundary from the uplink <i>operating band</i> edge

$\Delta_{FR2_REFSENS}$	Offset applied to the FR2 OTA REFSENS depending on the AoA
$\Delta_{minSENS}$	Difference between conducted reference sensitivity and minSENS
$\Delta_{OTAREFSSENS}$	Difference between conducted reference sensitivity and OTA REFSENS
ΔF_{Raster}	Channel raster granularity
Δ_{shift}	Channel raster offset for SUL
$EIS_{minSENS}$	The EIS declared for the minSENS RoAoA
$EIS_{REFSENS}$	OTA REFSENS EIS value
$EIS_{REFSENS_50M}$	Declared OTA reference sensitivity basis level for FR2 based on a reference measurement channel with 50MHz <i>BS channel bandwidth</i>
$F_{FBWhigh}$	Highest supported frequency within supported <i>operating band</i> , for which <i>fractional bandwidth</i> support was declared
F_{FBWlow}	Lowest supported frequency within supported <i>operating band</i> , for which <i>fractional bandwidth</i> support was declared
F_C	<i>RF reference frequency</i> on the channel raster, given in table 5.4.2.2-1
$F_{C,block,high}$	Fc of the highest transmitted/received carrier in a sub-block.
$F_{C,block,low}$	Fc of the lowest transmitted/received carrier in a sub-block.
$F_{C,low}$	The Fc of the lowest carrier, expressed in MHz.
$F_{C,high}$	The Fc of the highest carrier, expressed in MHz.
$F_{edge,low}$	The lower edge of <i>Aggregated BS Channel Bandwidth</i> , expressed in MHz. $F_{edge,low} = F_{C,low} - F_{offset,low}$.
$F_{edge,high}$	The upper edge of <i>Aggregated BS Channel Bandwidth</i> , expressed in MHz. $F_{edge,high} = F_{C,high} + F_{offset,high}$.
$F_{edge,block,low}$	The lower sub-block edge, where $F_{edge,block,low} = F_{C,block,low} - F_{offset,low}$.
$F_{edge,block,high}$	The upper sub-block edge, where $F_{edge,block,high} = F_{C,block,high} + F_{offset,high}$.
F_{filter}	Filter centre frequency
$F_{offset,high}$	Frequency offset from $F_{C,high}$ to the upper <i>Base Station RF Bandwidth edge</i> , or from $F_{C,block,high}$ to the upper sub-block edge
$F_{offset,low}$	Frequency offset from $F_{C,low}$ to the lower <i>Base Station RF Bandwidth edge</i> , or from $F_{C,block,low}$ to the lower sub-block edge.
f_{offset}	Separation between the channel edge frequency and the centre of the measuring filter
$f_{offset_{max}}$	The offset to the frequency Δf_{OBUE} outside the downlink <i>operating band</i>
F_{REF}	RF reference frequency
$F_{REF-Offs}$	Offset used for calculating F_{REF}
$F_{REF,shift}$	RF reference frequency for Supplementary Uplink (SUL) bands
$F_{DL,low}$	The lowest frequency of the downlink <i>operating band</i>
$F_{DL,high}$	The highest frequency of the downlink <i>operating band</i>
$F_{UL,low}$	The lowest frequency of the uplink <i>operating band</i>
$F_{UL,high}$	The highest frequency of the uplink <i>operating band</i>
$GB_{channel}$	Minimum guard band defined in subclause 5.3.3
N_{cells}	The declared number corresponding to the minimum number of cells that can be transmitted by an <i>BS type I-H</i> in a particular <i>operating band</i>
n_{PRB}	Physical resource block number
N_{RB}	Transmission bandwidth configuration, expressed in resource blocks
$N_{RB,high}$	Transmission bandwidth configuration for the highest assigned component carrier within a sub-block in CA
$N_{RB,low}$	Transmission bandwidth configuration for the lowest assigned component carrier within a sub-block in CA
N_{REF}	NR Absolute Radio Frequency Channel Number (NR-ARFCN)
$N_{REF-Offs}$	Offset used for calculating N_{REF}
$N_{RXU,active}$	The number of active receiver units. The same as the number of <i>demodulation branches</i> to which compliance is declared for chapter 8 performance requirements
$N_{RXU,counted}$	The number of active receiver units that are taken into account for conducted Rx spurious emission scaling, as calculated in subclause 7.6.1
$N_{RXU,countedpercell}$	The number of active receiver units that are taken into account for conducted RX spurious emissions scaling per cell, as calculated in subclause 7.6.1
$N_{TXU,counted}$	The number of <i>active transmitter units</i> as calculated in subclause 6.1, that are taken into account for conducted TX output power limit in subclause 6.2.1, and for unwanted TX emissions scaling
$N_{TXU,countedpercell}$	The number of <i>active transmitter units</i> that are taken into account for conducted TX emissions scaling per cell, as calculated in subclause 6.1
$P_{EM,n50/n75,ind}$	Declared emission level for Band n50/n75; ind = a, b
$P_{EIRP,N}$	EIRP level for channel N

$P_{\max,c,AC}$	Maximum carrier output power measured per antenna connector
$P_{\max,c,cell}$	The maximum carrier output power per TAB connector TX min cell group
$P_{\max,c,TABC}$	The maximum carrier output power per TAB connector
$P_{\max,c,TRP}$	Maximum carrier TRP output power measured at the RIB(s), and corresponding to the declared rated carrier TRP output power ($P_{\text{rated},c,TRP}$)
$P_{\max,c,EIRP}$	The maximum carrier EIRP when the NR BS is configured at the maximum rated carrier output TRP ($P_{\text{rated},c,TRP}$)
$P_{\text{rated},c,AC}$	The rated carrier output power per antenna connector
$P_{\text{rated},c,cell}$	The rated carrier output power per TAB connector TX min cell group
$P_{\text{rated},c,FB\text{high}}$	The rated carrier EIRP for the higher supported frequency range within supported operating band, for which fractional bandwidth support was declared
$P_{\text{rated},c,FB\text{low}}$	The rated carrier EIRP for the lower supported frequency range within supported operating band, for which fractional bandwidth support was declared
$P_{\text{rated},c,sys}$	The sum of $P_{\text{rated},c,TABC}$ for all TAB connectors for a single carrier
$P_{\text{rated},c,TABC}$	The rated carrier output power per TAB connector
$P_{\text{rated},c,TRP}$	Rated carrier TRP output power declared per RIB
$P_{\text{rated},t,AC}$	The rated total output power declared at the antenna connector
$P_{\text{rated},t,TABC}$	The rated total output power declared at TAB connector
$P_{\text{rated},t,TRP}$	Rated total TRP output power declared per RIB
P_{REFSENS}	Conducted Reference Sensitivity power level
SCS_{low}	Sub-Carrier Spacing for the lowest assigned component carrier within a sub-block in CA
SCS_{high}	Sub-Carrier Spacing for the highest assigned component carrier within a sub-block in CA
SS_{REF}	SS block reference frequency position
W_{gap}	Sub-block gap or Inter RF Bandwidth gap size

3.3 Abbreviations

For the purposes of the present document, the abbreviations given in 3GPP TR 21.905 [1] and the following apply. An abbreviation defined in the present document takes precedence over the definition of the same abbreviation, if any, in 3GPP TR 21.905 [1].

AA	Antenna Array
AAS	Active Antenna System
ACLR	Adjacent Channel Leakage Ratio
ACS	Adjacent Channel Selectivity
AoA	Angle of Arrival
AWGN	Additive White Gaussian Noise
BS	Base Station
BW	Bandwidth
CA	Carrier Aggregation
CACLR	Cumulative ACLR
CPE	Common Phase Error
CP-OFDM	Cyclic Prefix-OFDM
CW	Continuous Wave
DFT-s-OFDM	Discrete Fourier Transform-spread-OFDM
DM-RS	Demodulation Reference Signal
EIS	Equivalent Isotropic Sensitivity
EIRP	Effective Isotropic Radiated Power
E-UTRA	Evolved UTRA
EVM	Error Vector Magnitude
FBW	Fractional Bandwidth
FR	Frequency Range
FRC	Fixed Reference Channel
GSCN	Global Synchronization Channel Number
GSM	Global System for Mobile communications
ITU-R	Radiocommunication Sector of the International Telecommunication Union
ICS	In-Channel Selectivity
LA	Local Area
LNA	Low Noise Amplifier
MCS	Modulation and Coding Scheme

MR	Medium Range
NR	New Radio
NR-ARFCN	NR Absolute Radio Frequency Channel Number
OBUE	Operating Band Unwanted Emissions
OOB	Out-of-band
OSDD	OTA Sensitivity Directions Declaration
OTA	Over-The-Air
PRB	Physical Resource Block
PT-RS	Phase Tracking Reference Signal
QAM	Quadrature Amplitude Modulation
RDN	Radio Distribution Network
RE	Resource Element
REFSENS	Reference Sensitivity
RF	Radio Frequency
RIB	Radiated Interface Boundary
RMS	Root Mean Square (value)
RoAoA	Range of Angles of Arrival
RS	Reference Signal
RX	Receiver
SCS	Sub-Carrier Spacing
SDL	Supplementary Downlink
SS	Synchronization Symbol
SSB	Synchronization Signal Block
SUL	Supplementary Uplink
TAB	Transceiver Array Boundary
TAE	Time Alignment Error
TX	Transmitter
TRP	Total Radiated Power
UEM	Unwanted Emissions Mask
UTRA	Universal Terrestrial Radio Access
WA	Wide Area
ZF	Zero Forcing

4 General

4.1 Relationship with other core specifications

The present document is a single-RAT specification for a BS, covering RF characteristics and minimum performance requirements. Conducted and radiated core requirements are defined for the BS architectures and BS types defined in subclause 4.3.

The applicability of each requirement is described in clause 5.

4.2 Relationship between minimum requirements and test requirements

Conformance to the present specification is demonstrated by fulfilling the test requirements specified in the conformance specification TS 38.141-1 [5] and TS 38.141-2 [6].

The minimum requirements given in this specification make no allowance for measurement uncertainty. The test specifications TS 38.141-1 [5] and TS 38.141-2 [6] define test tolerances. These test tolerances are individually calculated for each test. The test tolerances are used to relax the minimum requirements in this specification to create test requirements. For some requirements, including regulatory requirements, the test tolerance is set to zero.

The measurement results returned by the test system are compared - without any modification - against the test requirements as defined by the shared risk principle.

The shared risk principle is defined in recommendation ITU-R M.1545 [7].

4.3 Conducted and radiated requirement reference points

4.3.1 BS type 1-C

For *BS type 1-C*, the requirements are applied at the BS *antenna connector* (port A) for a single transmitter or receiver with a full complement of transceivers for the configuration in normal operating conditions. If any external apparatus such as an amplifier, a filter or the combination of such devices is used, requirements apply at the far end *antenna connector* (port B).

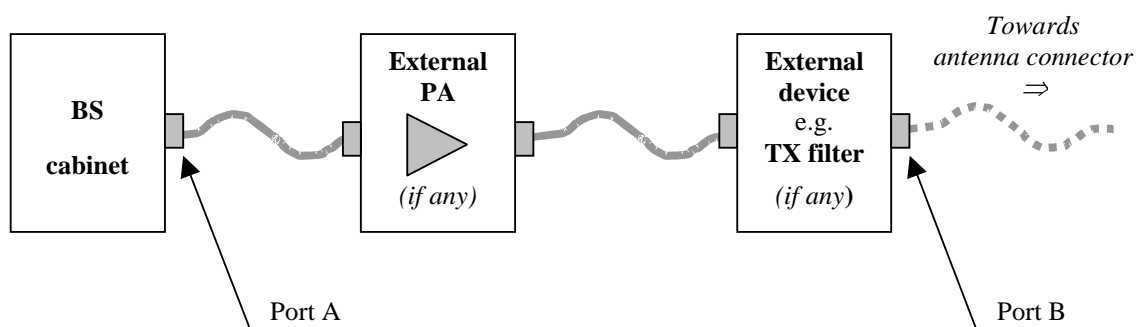

Figure 4.3.1-1: BS type 1-C transmitter interface

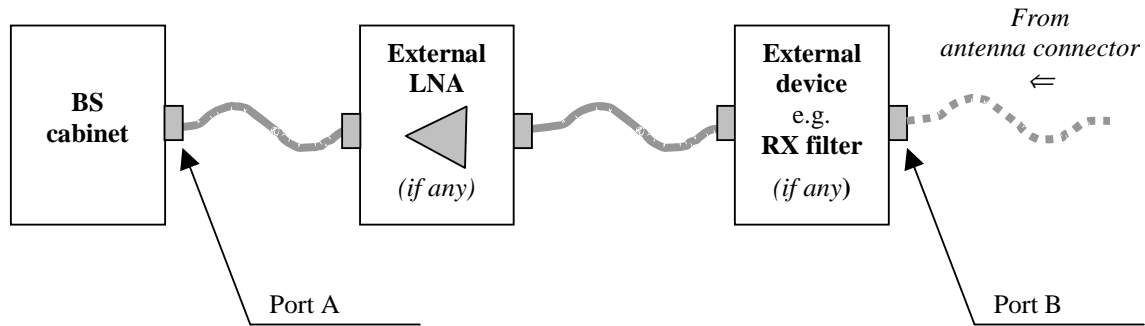

Figure 4.3.1-2: BS type 1-C receiver interface

4.3.2 BS type 1-H

For BS type 1-H, the requirements are defined for two points of reference, signified by radiated requirements and conducted requirements.

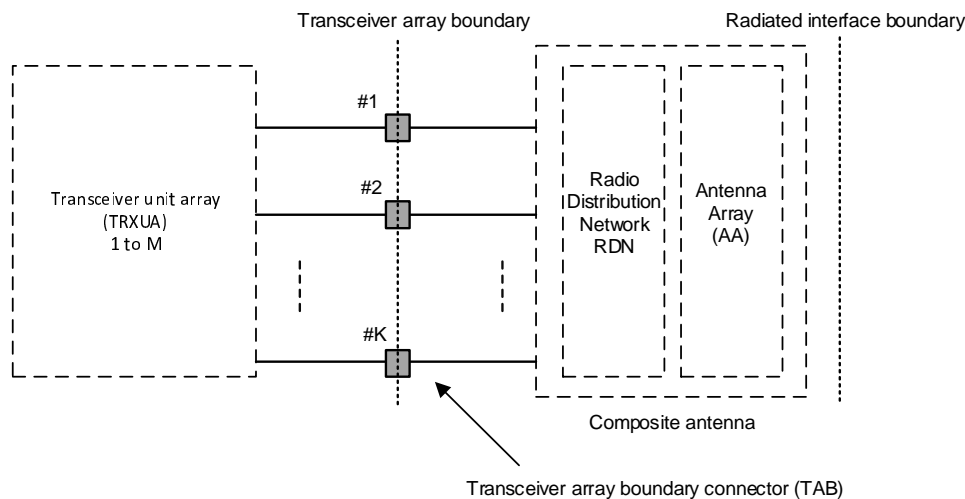

Figure 4.3.2-1: Radiated and conducted reference points for BS type 1-H

Radiated characteristics are defined over the air (OTA), where the *operating band* specific radiated interface is referred to as the *Radiated Interface Boundary* (RIB). Radiated requirements are also referred to as OTA requirements. The (spatial) characteristics in which the OTA requirements apply are detailed for each requirement.

Conducted characteristics are defined at individual or groups of *TAB connectors* at the *transceiver array boundary*, which is the conducted interface between the transceiver unit array and the composite antenna.

The transceiver unit array is part of the composite transceiver functionality generating modulated transmit signal structures and performing receiver combining and demodulation.

The transceiver unit array contains an implementation specific number of transmitter units and an implementation specific number of receiver units. Transmitter units and receiver units may be combined into transceiver units. The transmitter/receiver units have the ability to transmit/receive parallel independent modulated symbol streams.

The composite antenna contains a radio distribution network (RDN) and an antenna array. The RDN is a linear passive network which distributes the RF power generated by the transceiver unit array to the antenna array, and/or distributes the radio signals collected by the antenna array to the transceiver unit array, in an implementation specific way.

How a conducted requirement is applied to the *transceiver array boundary* is detailed in the respective requirement subclause.

4.3.3 BS type 1-O and BS type 2-O

For *BS type 1-O* and *BS type 2-O*, the radiated characteristics are defined over the air (OTA), where the *operating band* specific radiated interface is referred to as the *Radiated Interface Boundary* (RIB). Radiated requirements are also referred to as OTA requirements. The (spatial) characteristics in which the OTA requirements apply are detailed for each requirement.

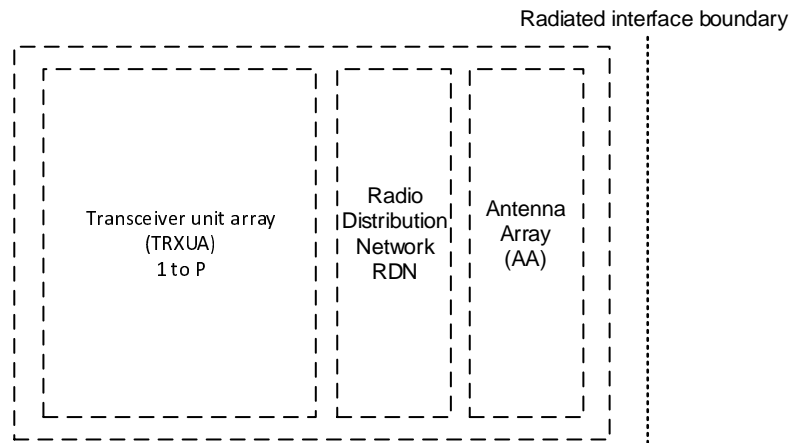

Figure 4.3.3-1: Radiated reference points for BS type 1-O and BS type 2-O

Co-location requirements are specified at the conducted interface of the co-location reference antenna, the *co-location reference antenna* does not form part of the BS under test but is a means to provide OTA power levels which are representative of a co-located system, further defined in subclause 4.9.

For a *BS type 1-O* the transceiver unit array must contain at least 8 transmitter units and at least 8 receiver units. Transmitter units and receiver units may be combined into transceiver units. The transmitter/receiver units have the ability to transmit/receive parallel independent modulated symbol streams.

4.4 Base station classes

The requirements in this specification apply to Wide Area Base Stations, Medium Range Base Stations and Local Area Base Stations unless otherwise stated. The associated deployment scenarios for each class are exactly the same for BS with and without connectors.

For *BS type 1-O* and 2-O, BS classes are defined as indicated below:

- Wide Area Base Stations are characterised by requirements derived from Macro Cell scenarios with a BS to UE minimum distance along the ground equal to 35 m.
- Medium Range Base Stations are characterised by requirements derived from Micro Cell scenarios with a BS to UE minimum distance along the ground equal to 5 m.
- Local Area Base Stations are characterised by requirements derived from Pico Cell scenarios with a BS to UE minimum distance along the ground equal to 2 m.

For *BS type 1-C* and 1-H, BS classes are defined as indicated below:

- Wide Area Base Stations are characterised by requirements derived from Macro Cell scenarios with a BS to UE minimum coupling loss equal to 70 dB.
- Medium Range Base Stations are characterised by requirements derived from Micro Cell scenarios with a BS to UE minimum coupling loss equals to 53 dB.
- Local Area Base Stations are characterised by requirements derived from Pico Cell scenarios with a BS to minimum coupling loss equal to 45 dB.

4.5 Regional requirements

Some requirements in the present document may only apply in certain regions either as optional requirements, or as mandatory requirements set by local and regional regulation. It is normally not stated in the 3GPP specifications under what exact circumstances the regional requirements apply, since this is defined by local or regional regulation.

Table 4.5-1 lists all requirements in the present specification that may be applied differently in different regions.

Table 4.5-1: List of regional requirements

Clause number	Requirement	Comments
5.2	Operating bands	Some NR <i>operating bands</i> may be applied regionally.
6.2.4	Additional requirements	These requirements may apply in certain regions as additional Operating band unwanted emission limits.
6.6.2, 9.7.2	Occupied bandwidth, OTA occupied bandwidth	The requirement may be applied regionally. There may also be regional requirements to declare the occupied bandwidth according to the definition in present specification.
6.6.4.2.5.1	Limits in FCC Title 47	The BS may have to comply with the additional requirements, when deployed in regions where those limits are applied, and under the conditions declared by the manufacturer.
6.6.5.2.1, 9.7.5.2	Tx spurious emissions, OTA Tx spurious emissions	Category A or Category B spurious emission limits, as defined in ITU-R Recommendation SM.329 [2], may apply regionally. The emission limits specified as the <i>basic limit</i> + X (dB) are applicable, unless stated differently in regional regulation.
6.6.5.2.3, 9.7.5.3.3	Tx spurious emissions: additional requirements, OTA Tx spurious emissions: additional requirements	These requirements may be applied for the protection of system operating in frequency ranges other than the BS <i>operating band</i> .
7.6.4, 10.7.2	Rx spurious emissions, OTA Rx spurious emissions	The emission limits specified as the <i>basic limit</i> + X (dB) are applicable, unless stated differently in regional regulation.

4.6 Applicability of requirements

In table 4.6-1, the requirement applicability for each requirement set is defined. For each requirement, the applicable requirement subclause in the specification is identified. Requirements not included in a requirement set is marked not applicable (NA).

Table 4.6-1: Requirement set applicability

Requirement	Requirement set				
	BS type 1-C	BS type 1-H	BS type 1-O	BS type 2-O	
BS output power	6.2	6.2	NA	NA	
Output power dynamics	6.3	6.3			
Transmit ON/OFF power	6.4	6.4			
Transmitted signal quality	6.5	6.5			
Occupied bandwidth	6.6.2	6.6.2			
ACLR	6.6.3	6.6.3			
Operating band unwanted emissions	6.6.4	6.6.4			
Transmitter spurious emissions	6.6.5	6.6.5			
Transmitter intermodulation	6.7	6.7			
Reference sensitivity level	7.2	7.2			
Dynamic range	7.3	7.3			
In-band selectivity and blocking	7.4	7.4			
Out-of-band blocking	7.5	7.5			
Receiver spurious emissions	7.6	7.6			
Receiver intermodulation	7.7	7.7			
In-channel selectivity	7.8	7.8			
Performance requirements	8	8			
Radiated transmit power	NA	9.2	9.2	9.2	
OTA base station output power		NA	9.3	9.3	9.3
OTA output power dynamics			9.4	9.4	9.4
OTA transmit ON/OFF power			9.5	9.5	9.5
OTA transmitted signal quality			9.6	9.6	9.6
OTA occupied bandwidth			9.7.2	9.7.2	9.7.2
OTA ACLR			9.7.3	9.7.3	9.7.3
OTA out-of-band emission			9.7.4	9.7.4	9.7.4
OTA transmitter spurious emission			9.7.5	9.7.5	9.7.5
OTA transmitter intermodulation			9.8	NA	NA
OTA sensitivity			10.2	10.2	NA
OTA reference sensitivity level		NA	10.3	10.3	10.3
OTA dynamic range			10.4	NA	NA
OTA in-band selectivity and blocking			10.5	10.5	10.5
OTA out-of-band blocking			10.6	10.6	10.6
OTA receiver spurious emission			10.7	10.7	10.7
OTA receiver intermodulation	10.8		10.8	10.8	
OTA in-channel selectivity	10.9	10.9	10.9		
Radiated performance requirements		11	11	11	

4.7 Requirements for contiguous and non-contiguous spectrum

A spectrum allocation where a BS operates can either be contiguous or non-contiguous. Unless otherwise stated, the requirements in the present specification apply for BS configured for both contiguous spectrum operation and non-contiguous spectrum operation.

For BS operation in non-contiguous spectrum, some requirements apply both at the Base Station RF Bandwidth edges and inside the sub-block gaps. For each such requirement, it is stated how the limits apply relative to the Base Station RF Bandwidth edges and the sub-block edges respectively.

4.8 Requirements for BS capable of multi-band operation

For *multi-band connector* or *multi-band RIB*, the RF requirements in clause 6, 7, 9 and 10 apply separately to each supported *operating band* unless otherwise stated. For some requirements, it is explicitly stated that specific additions or exclusions to the requirement apply at *multi-band connector(s)*, and *multi-band RIB(s)* as detailed in the requirement subclause. For *BS type 1-C* capable of multi-band operation, various structures in terms of combinations of different transmitter and receiver implementations (multi-band or single band) with mapping of transceivers to one or more *antenna connectors* for *BS type 1-C* or *TAB connectors* for *BS type 1-H* in different ways are possible. For *multi-band*

connector(s) the exclusions or provisions for multi-band apply. For *single-band antenna connector(s)*, the following applies:

- Single-band transmitter spurious emissions, *operating band* unwanted emissions, ACLR, transmitter intermodulation and receiver spurious emissions requirements apply to this *antenna connector* that is mapped to single-band.
- If the BS is configured for single-band operation, single-band requirements shall apply to this *antenna connector* configured for single-band operation and no exclusions or provisions for multi-band capable BS are applicable. Single-band requirements are tested separately at the *antenna connector* configured for single-band operation, with all other *antenna connectors* terminated.

A BS type 1-H may be capable of supporting operation in multiple *operating bands* with one of the following implementations of *TAB connectors* in the *transceiver array boundary*:

- All *TAB connectors* are *single-band connectors*.
 - Different sets of *single-band connectors* support different *operating bands*, but each *TAB connector* supports only operation in one single *operating band*.
 - Sets of *single-band connectors* support operation in multiple *operating bands* with some *single-band connectors* supporting more than one *operating band*.
- All *TAB connectors* are multi-band *connectors*.
- A combination of single-band sets and multi-band sets of *TAB connectors* provides support of the type BS type 1-H capability of operation in multiple *operating bands*.

Unless otherwise stated all requirements specified for an *operating band* apply only to the set of *TAB connectors* supporting that *operating band*.

In the case of an *operating band* being supported only by *single-band connectors* in a *TAB connector TX min cell group* or a *TAB connector RX min cell group*, *single-band requirements* apply to that set of *TAB connectors*.

In the case of an *operating band* being supported only by *multi-band connectors* supporting the same *operating band* combination in a *TAB connector TX min cell group* or a *TAB connector RX min cell group*, *multi-band requirements* apply to that set of *TAB connectors*.

The case of an *operating band* being supported by both *multi-band connectors* and *single-band connectors* in a *TAB connector TX min cell group* or a *TAB connector RX min cell group* is FFS and is not covered by the present release of this specification.

The case of an *operating band* being supported by *multi-band connectors* which are not all supporting the same *operating band* combination in a *TAB connector TX min cell group* or a *TAB connector RX min cell group* is FFS and is not covered by the present release of this specification.

BS type 1-O may be capable of supporting operation in multiple *operating bands* with one of the following implementations at the *radiated interface boundary*:

- All RIBs are *single-band RIBs*.
- All RIBs are *multi-band RIBs*.
- A combination of single-band *RIBs* and *multi-band RIBs* provides support of the BS type 1-O capability of operation in multiple *operating bands*.

For *multi-band connectors* and *multi-band RIBs* supporting the bands for TDD, the RF requirements in the present specification assume no simultaneous uplink and downlink occur between the bands.

The RF requirements for *multi-band connectors* and *multi-band RIBs* supporting bands for both FDD and TDD are FFS and are not covered by the present release of this specification.

4.9 OTA co-location with other base stations

Co-location requirements are requirements which are based on assuming the *BS type 1-O* is co-located with another BS of the same base station class, they ensure that both co-located systems can operate with minimal degradation to each other.

Unwanted emission and out of band blocking co-location requirements are optional requirements based on declaration. TX OFF and TX IMD are mandatory requirements and have the form of a co-location requirement as it represents the worst-case scenario of all the interference cases.

NOTE: Due to the low level of the unwanted emissions for the spurious emissions and TX OFF level co-location is the most suitable method to show conformance.

The *co-location reference antenna* shall be a single column passive antenna which has the same vertical radiating dimension (h), frequency range, polarization, as the composite antenna of the *BS type 1-O* and nominal 65° horizontal half-power beam width (suitable for 3-sector deployment) and is placed at a distance d from the edge of the *BS type 1-O*, as shown in figure 4.9-1.

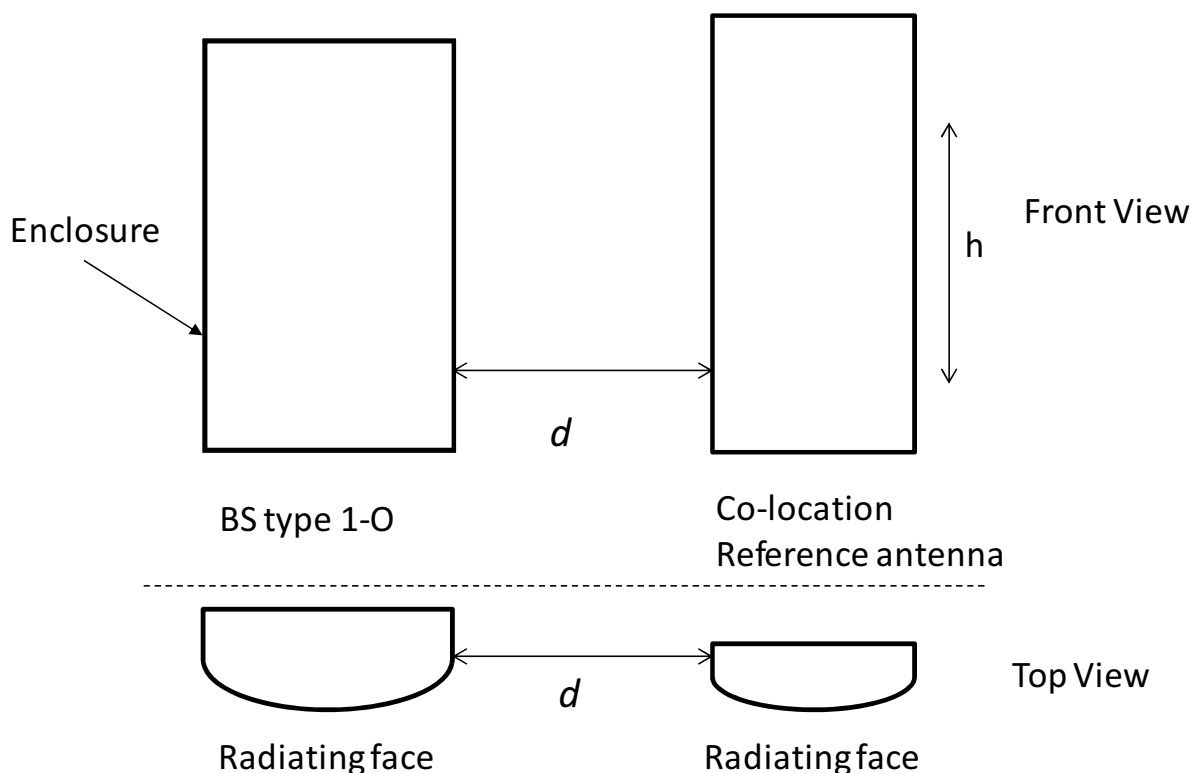

Figure 4.9-1: Illustration of *BS type 1-O* enclosure and co-location reference antenna

Edge-to-edge separation d between the *BS type 1-O* and the co-location reference antenna shall be set to 0.1 m.

The *BS type 1-O* and the co-location reference antenna shall be aligned in a common plane perpendicular to the mechanical bore-sight direction, as shown in figure 4.9-1.

The *co-location reference antenna* and the *BS type 1-O* can have different width.

The vertical radiating regions of the *co-location reference antenna* and the *BS type 1-O* composite antenna shall be aligned.

For co-location requirements where the frequency range of the signal at the co-location reference antenna is different from the *BS type 1-O*, a co-location reference antenna suitable for the frequency stated in the requirement is assumed.

OTA co-location requirements are based on the power at the conducted interface of a *co-location reference antenna*, depending on the requirement this interface is either an input or an output. For *BS type 1-O* with dual polarization the *co-location reference antenna* has two conducted interfaces each representing one polarization.

5 Operating bands and channel arrangement

5.1 General

The channel arrangements presented in this clause are based on the *operating bands* and *BS channel bandwidths* defined in the present release of specifications.

NOTE: Other *operating bands* and *BS channel bandwidths* may be considered in future releases.

Requirements throughout the RF specifications are in many cases defined separately for different frequency ranges (FR). The frequency ranges in which NR can operate according to the present version of the specification are identified as described in table 5.1-1.

Table 5.1-1: Definition of frequency ranges

Frequency range designation	Corresponding frequency range
FR1	410 MHz – 7125 MHz
FR2	24250 MHz – 52600 MHz

5.2 Operating bands

NR is designed to operate in the *operating bands* defined in table 5.2-1 and 5.2-2.

Table 5.2-1: NR operating bands in FR1

NR operating band	Uplink (UL) operating band BS receive / UE transmit	Downlink (DL) operating band BS transmit / UE receive	Duplex Mode
	$F_{UL,low} - F_{UL,high}$	$F_{DL,low} - F_{DL,high}$	
n1	1920 MHz – 1980 MHz	2110 MHz – 2170 MHz	FDD
n2	1850 MHz – 1910 MHz	1930 MHz – 1990 MHz	FDD
n3	1710 MHz – 1785 MHz	1805 MHz – 1880 MHz	FDD
n5	824 MHz – 849 MHz	869 MHz – 894 MHz	FDD
n7	2500 MHz – 2570 MHz	2620 MHz – 2690 MHz	FDD
n8	880 MHz – 915 MHz	925 MHz – 960 MHz	FDD
n12	699 MHz – 716 MHz	729 MHz – 746 MHz	FDD
n20	832 MHz – 862 MHz	791 MHz – 821 MHz	FDD
n25	1850 MHz – 1915 MHz	1930 MHz – 1995 MHz	FDD
n28	703 MHz – 748 MHz	758 MHz – 803 MHz	FDD
n34	2010 MHz – 2025 MHz	2010 MHz – 2025 MHz	TDD
n38	2570 MHz – 2620 MHz	2570 MHz – 2620 MHz	TDD
n39	1880 MHz – 1920 MHz	1880 MHz – 1920 MHz	TDD
n40	2300 MHz – 2400 MHz	2300 MHz – 2400 MHz	TDD
n41	2496 MHz – 2690 MHz	2496 MHz – 2690 MHz	TDD
n50	1432 MHz – 1517 MHz	1432 MHz – 1517 MHz	TDD
n51	1427 MHz – 1432 MHz	1427 MHz – 1432 MHz	TDD
n65	1920 MHz – 2010 MHz	2110 MHz – 2200 MHz	FDD
n66	1710 MHz – 1780 MHz	2110 MHz – 2200 MHz	FDD
n70	1695 MHz – 1710 MHz	1995 MHz – 2020 MHz	FDD
n71	663 MHz – 698 MHz	617 MHz – 652 MHz	FDD
n74	1427 MHz – 1470 MHz	1475 MHz – 1518 MHz	FDD
n75	N/A	1432 MHz – 1517 MHz	SDL
n76	N/A	1427 MHz – 1432 MHz	SDL
n77	3300 MHz – 4200 MHz	3300 MHz – 4200 MHz	TDD
n78	3300 MHz – 3800 MHz	3300 MHz – 3800 MHz	TDD
n79	4400 MHz – 5000 MHz	4400 MHz – 5000 MHz	TDD
n80	1710 MHz – 1785 MHz	N/A	SUL
n81	880 MHz – 915 MHz	N/A	SUL
n82	832 MHz – 862 MHz	N/A	SUL
n83	703 MHz – 748 MHz	N/A	SUL
n84	1920 MHz – 1980 MHz	N/A	SUL
n86	1710 MHz – 1780 MHz	N/A	SUL

Table 5.2-2: NR operating bands in FR2

NR operating band	Uplink (UL) and Downlink (DL) operating band BS transmit/receive UE transmit/receive	Duplex Mode
	$F_{UL,low} - F_{UL,high}$ $F_{DL,low} - F_{DL,high}$	
n257	26500 MHz – 29500 MHz	TDD
n258	24250 MHz – 27500 MHz	TDD
n260	37000 MHz – 40000 MHz	TDD
n261	27500 MHz – 28350 MHz	TDD

5.3 BS channel bandwidth

5.3.1 General

The *BS channel bandwidth* supports a single NR RF carrier in the uplink or downlink at the Base Station. Different *UE channel bandwidths* may be supported within the same spectrum for transmitting to and receiving from UEs connected to the BS. The placement of the *UE channel bandwidth* is flexible but can only be completely within the *BS channel bandwidth*. The BS shall be able to transmit to and/or receive from one or more UE Bandwidth parts that are smaller than or equal to the number of carrier resource blocks on the RF carrier, in any part of the carrier resource blocks.

The relationship between the channel bandwidth, the guardband and the transmission bandwidth configuration is shown in Figure 5.3.1-1.

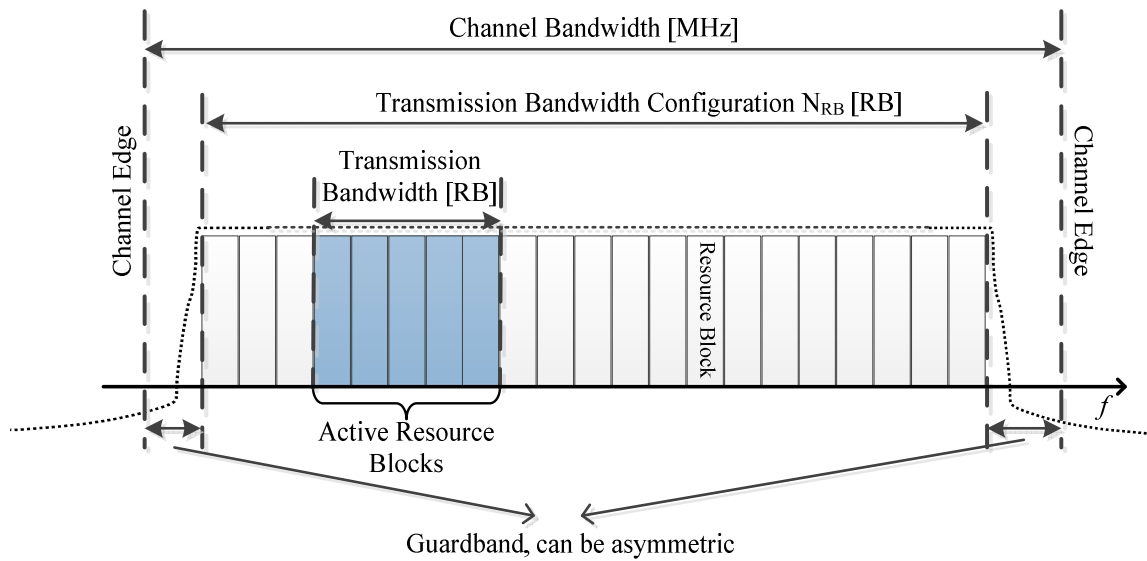

Figure 5.3.1-1: Definition of channel bandwidth and transmission bandwidth configuration for one NR channel

5.3.2 Transmission bandwidth configuration

The transmission bandwidth configuration N_{RB} for each *BS channel bandwidth* and subcarrier spacing is specified in table 5.3.2.-1 for FR1 and table 5.3.2-2 for FR2.

Table 5.3.2-1: Transmission bandwidth configuration N_{RB} for FR1

SCS (kHz)	5 MHz	10 MHz	15 MHz	20 MHz	25 MHz	30 MHz	40 MHz	50 MHz	60 MHz	70 MHz	80 MHz	90 MHz	100 MHz
	N_{RB}	N_{RB}	N_{RB}	N_{RB}	N_{RB}	N_{RB}	N_{RB}	N_{RB}	N_{RB}	N_{RB}	N_{RB}	N_{RB}	N_{RB}
15	25	52	79	106	133	160	216	270	N.A	N.A	N.A	N.A	N.A
30	11	24	38	51	65	78	106	133	162	189	217	245	273
60	N.A	11	18	24	31	38	51	65	79	93	107	121	135

Table 5.3.2-2: Transmission bandwidth configuration N_{RB} for FR2

SCS (kHz)	50 MHz	100 MHz	200 MHz	400 MHz
	N_{RB}	N_{RB}	N_{RB}	N_{RB}
60	66	132	264	N.A
120	32	66	132	264

NOTE: All Tx and Rx requirements are defined based on transmission bandwidth configuration specified in table 5.3.2-1 for FR1 and table 5.3.2-2 for FR2.

5.3.3 Minimum guardband and transmission bandwidth configuration

The minimum guardband for each *BS channel bandwidth* and SCS is specified in table 5.3.3-1 for FR1 and in table 5.3.3-2 for FR2.

Table 5.3.3-1: Minimum guardband (kHz) (FR1)

SCS (kHz)	5 MHz	10 MHz	15 MHz	20 MHz	25 MHz	30 MHz	40 MHz	50 MHz	60 MHz	70 MHz	80 MHz	90 MHz	100 MHz
15	242.5	312.5	382.5	452.5	522.5	592.5	552.5	692.5	N.A	N.A	N.A	N.A	N.A

30	505	665	645	805	785	945	905	1045	825	965	925	885	845
60	N.A	1010	990	1330	1310	1290	1610	1570	1530	1490	1450	1410	1370

Table: 5.3.3-2: Minimum guardband (kHz) (FR2)

SCS (kHz)	50 MHz	100 MHz	200 MHz	400 MHz
60	1210	2450	4930	N.A
120	1900	2420	4900	9860

The minimum guardband of SCS 240 kHz SS/PBCH block for each BS channel bandwidth is specified in table 5.3.3-3 for FR2.

Table: 5.3.3-3: Minimum guardband (kHz) of SCS 240 kHz SS/PBCH block (FR2)

SCS (kHz)	100 MHz	200 MHz	400 MHz
240	3800	7720	15560

NOTE: The minimum guardband in Table 5.3.3-3 is applicable only when the SCS 240 kHz SS/PBCH block is placed adjacent to the edge of the BS channel bandwidth within which the SS/PBCH block is located.

The number of RBs configured in any *BS channel bandwidth* shall ensure that the minimum guardband specified in this clause is met.

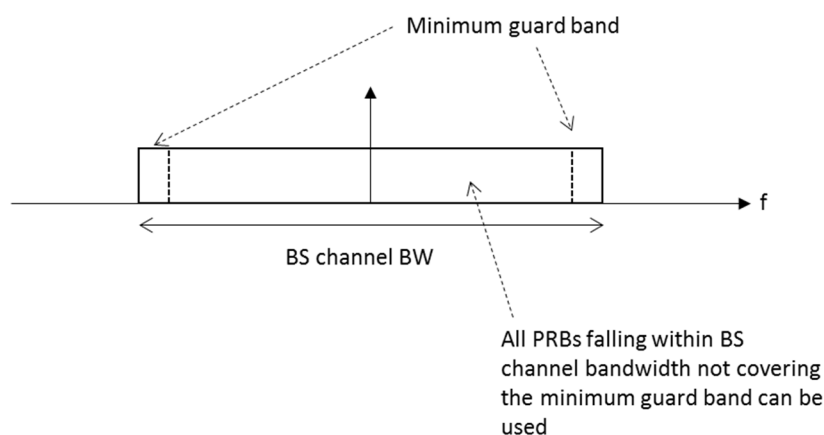
**Figure 5.3.3-1: BS PRB utilization**

In the case that multiple numerologies are multiplexed in the same symbol, the minimum guardband on each side of the carrier is the guardband applied at the configured *BS channel bandwidth* for the numerology that is transmitted/received immediately adjacent to the guard band.

For FR1, if multiple numerologies are multiplexed in the same symbol and the BS channel bandwidth is >50 MHz, the guardband applied adjacent to 15 kHz SCS shall be the same as the guardband defined for 30 kHz SCS for the same BS channel bandwidth.

For FR2, if multiple numerologies are multiplexed in the same symbol and the BS channel bandwidth is >200 MHz, the guardband applied adjacent to 60 kHz SCS shall be the same as the guardband defined for 120 kHz SCS for the same BS channel bandwidth.

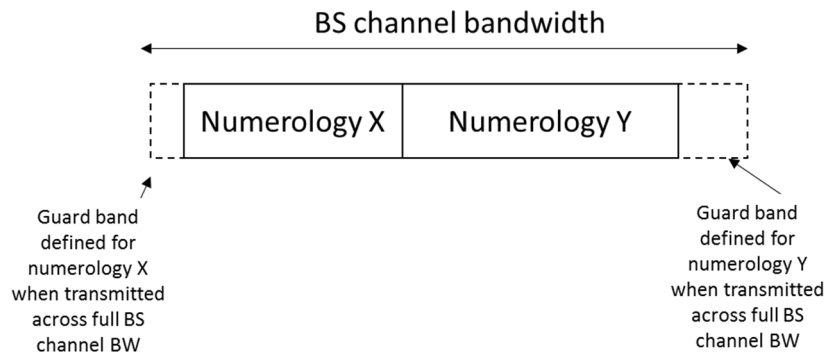

Figure 5.3.3-2: Guard band definition when transmitting multiple numerologies

NOTE: Figure 5.3.3-2 is not intended to imply the size of any guard between the two numerologies. Inter-numerology guard band within the carrier is implementation dependent.

Figure 5.3.3-3: Void

Figure 5.3.3-4: Void

Figure 5.3.3-5: Void

5.3.4 RB alignment

For each BS channel bandwidth and each numerology, *BS transmission bandwidth configuration* must fulfil the minimum guardband requirement specified in subclause 5.3.3.

For each numerology, its common resource blocks are specified in subclause 4.4.4.3 in [9], and the starting point of its transmission bandwidth configuration on the common resource block grid for a given channel bandwidth is indicated by an offset to “Reference point A” in the unit of the numerology.

For each numerology, all *UE transmission bandwidth configurations* indicated to UEs served by the BS by higher layer parameter *carrierBandwidth* [11] shall fall within the *BS transmission bandwidth configuration*.

5.3.5 *BS channel bandwidth per operating band*

The requirements in this specification apply to the combination of *BS channel bandwidths*, *SCS* and *operating bands* shown in table 5.3.5-1 for FR1 and in table 5.3.5-2 for FR2. The transmission bandwidth configuration in table 5.3.2-1 and table 5.3.2-2 shall be supported for each of the *BS channel bandwidths* within the BS capability. The *BS channel bandwidths* are specified for both the Tx and Rx path.

Table 5.3.5-1: *BS channel bandwidths and SCS per operating band in FR1*

NR band / SCS / BS channel bandwidth														
NR Band	SCS kHz	5 MHz	10 MHz	15 MHz	20 MHz	25 MHz	30 MHz	40 MHz	50 MHz	60 MHz	70 MHz	80 MHz	90 MHz	100 MHz
n1	15	Yes	Yes	Yes	Yes									
	30		Yes	Yes	Yes									
	60		Yes	Yes	Yes									
n2	15	Yes	Yes	Yes	Yes									
	30		Yes	Yes	Yes									
	60		Yes	Yes	Yes									
n3	15	Yes	Yes	Yes	Yes	Yes	Yes							
	30		Yes	Yes	Yes	Yes	Yes							
	60		Yes	Yes	Yes	Yes	Yes							
n5	15	Yes	Yes	Yes	Yes									
	30		Yes	Yes	Yes									
	60													
n7	15	Yes	Yes	Yes	Yes									
	30		Yes	Yes	Yes									
	60		Yes	Yes	Yes									
n8	15	Yes	Yes	Yes	Yes									
	30		Yes	Yes	Yes									
	60													
n12	15	Yes	Yes	Yes										
	30		Yes	Yes										
	60													
n20	15	Yes	Yes	Yes	Yes									
	30		Yes	Yes	Yes									
	60													
n25	15	Yes	Yes	Yes	Yes									
	30		Yes	Yes	Yes									
	60		Yes	Yes	Yes									
n28	15	Yes	Yes	Yes	Yes									
	30		Yes	Yes	Yes									
	60													
n34	15	Yes												
	30													
	60													
n38	15	Yes	Yes	Yes	Yes									
	30		Yes	Yes	Yes									
	60		Yes	Yes	Yes									
n39	15	Yes	Yes	Yes	Yes	Yes	Yes	Yes						
	30		Yes	Yes	Yes	Yes	Yes	Yes						
	60		Yes	Yes	Yes	Yes	Yes	Yes						
n40	15	Yes	Yes	Yes	Yes	Yes	Yes	Yes	Yes					
	30		Yes	Yes	Yes	Yes	Yes	Yes	Yes	Yes		Yes		Yes
	60		Yes	Yes	Yes	Yes	Yes	Yes	Yes	Yes		Yes		Yes
n41	15		Yes	Yes	Yes			Yes	Yes					
	30		Yes	Yes	Yes			Yes	Yes	Yes	Yes	Yes	Yes	Yes
	60		Yes	Yes	Yes			Yes	Yes	Yes	Yes	Yes	Yes	Yes
n50	15	Yes	Yes	Yes	Yes			Yes	Yes					
	30		Yes	Yes	Yes			Yes	Yes	Yes		Yes		
	60		Yes	Yes	Yes			Yes	Yes	Yes		Yes		
n51	15	Yes												
	30													
	60													
n65	15	Yes	Yes	Yes	Yes									
	30		Yes	Yes	Yes									
	60		Yes	Yes	Yes									
n66	15	Yes	Yes	Yes	Yes			Yes						
	30		Yes	Yes	Yes			Yes						
	60		Yes	Yes	Yes			Yes						

n70	15	Yes	Yes	Yes	Yes	Yes								
	30		Yes	Yes	Yes	Yes								
	60		Yes	Yes	Yes	Yes								
n71	15	Yes	Yes	Yes	Yes									
	30		Yes	Yes	Yes									
	60													
n74	15	Yes	Yes	Yes	Yes									
	30		Yes	Yes	Yes									
	60		Yes	Yes	Yes									
n75	15	Yes	Yes	Yes	Yes									
	30		Yes	Yes	Yes									
	60		Yes	Yes	Yes									
n76	15	Yes												
	30													
	60													
n77	15		Yes	Yes	Yes		Yes	Yes	Yes					
	30		Yes	Yes	Yes		Yes	Yes	Yes	Yes	Yes	Yes	Yes	Yes
	60		Yes	Yes	Yes		Yes	Yes	Yes	Yes	Yes	Yes	Yes	Yes
n78	15		Yes	Yes	Yes		Yes	Yes	Yes					
	30		Yes	Yes	Yes		Yes	Yes	Yes	Yes	Yes	Yes	Yes	Yes
	60		Yes	Yes	Yes		Yes	Yes	Yes	Yes	Yes	Yes	Yes	Yes
n79	15							Yes	Yes					
	30							Yes	Yes	Yes		Yes		Yes
	60							Yes	Yes	Yes		Yes		Yes
n80	15	Yes	Yes	Yes	Yes	Yes	Yes							
	30		Yes	Yes	Yes	Yes	Yes							
	60		Yes	Yes	Yes	Yes	Yes							
n81	15	Yes	Yes	Yes	Yes									
	30		Yes	Yes	Yes									
	60													
n82	15	Yes	Yes	Yes	Yes									
	30		Yes	Yes	Yes									
	60													
n83	15	Yes	Yes	Yes	Yes									
	30		Yes	Yes	Yes									
	60													
n84	15	Yes	Yes	Yes	Yes									
	30		Yes	Yes	Yes									
	60		Yes	Yes	Yes									
n86	15	Yes	Yes	Yes	Yes			Yes						
	30		Yes	Yes	Yes			Yes						
	60		Yes	Yes	Yes			Yes						

Table 5.3.5-2: BS channel bandwidths and SCS per operating band in FR2

NR band / SCS / BS channel bandwidth					
NR Band	SCS kHz	50 MHz	100 MHz	200 MHz	400 MHz
n257	60	Yes	Yes	Yes	
	120	Yes	Yes	Yes	Yes
n258	60	Yes	Yes	Yes	
	120	Yes	Yes	Yes	Yes
n260	60	Yes	Yes	Yes	
	120	Yes	Yes	Yes	Yes
n261	60	Yes	Yes	Yes	
	120	Yes	Yes	Yes	Yes

5.3A BS channel bandwidth for CA

5.3A.1 Transmission bandwidth configuration for CA

For carrier aggregation, the transmission bandwidth configuration is defined per component carrier and the requirement is specified in subclause 5.3.2.

5.3A.2 Minimum guardband and transmission bandwidth configuration for CA

For intra-band contiguous carrier aggregation, *Aggregated BS Channel Bandwidth* and *Guard Bands* are defined as follows, see Figure 5.3A.2-1.

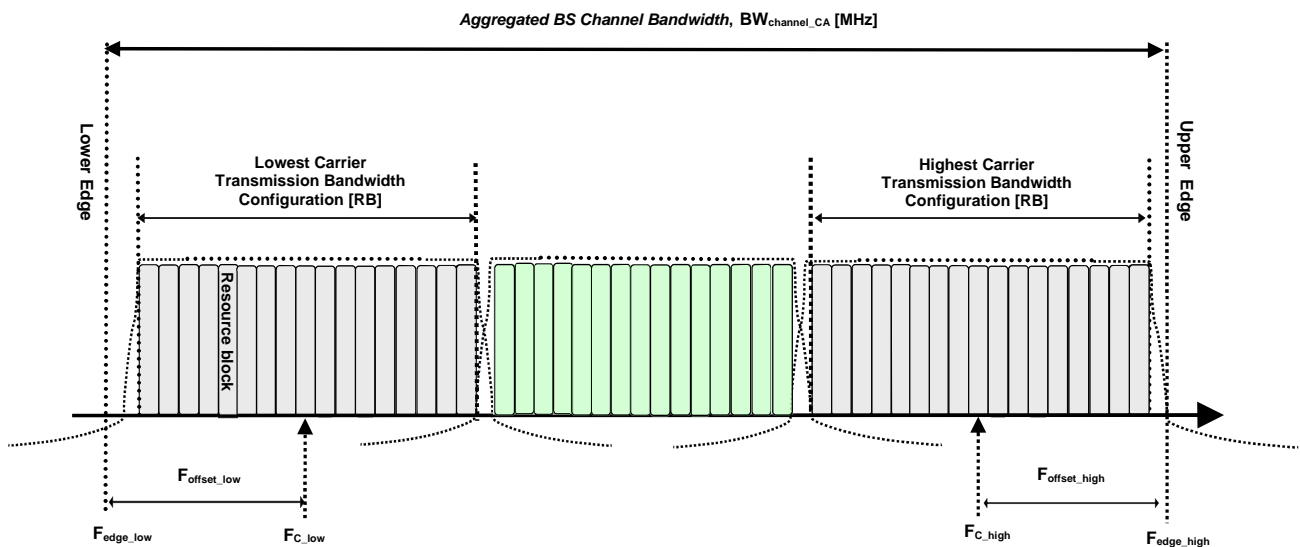

Figure 5.3A.2-1: Definition of *Aggregated BS Channel Bandwidth* for intra-band carrier aggregation

The *aggregated BS Channel Bandwidth*, $BW_{\text{Channel_CA}}$, is defined as

$$BW_{\text{Channel_CA}} = F_{\text{edge,high}} - F_{\text{edge,low}} \text{ [MHz]}$$

The lower bandwidth edge $F_{\text{edge,low}}$ and the upper bandwidth edge $F_{\text{edge,high}}$ of the aggregated BS channel bandwidth are used as frequency reference points for transmitter and receiver requirements and are defined by

$$F_{\text{edge,low}} = F_{\text{C,low}} - F_{\text{offset,low}}$$

$$F_{\text{edge,high}} = F_{\text{C,high}} + F_{\text{offset,high}}$$

The lower and upper frequency offsets depend on the transmission bandwidth configurations of the lowest and highest assigned edge component carrier and are defined as

$$F_{\text{offset,low}} = (N_{\text{RB,low}} * 12 + 1) * SCS_{\text{low}} / 2 + BW_{\text{GB}} \text{ (MHz)}$$

$$F_{\text{offset,high}} = (N_{\text{RB,high}} * 12 - 1) * SCS_{\text{high}} / 2 + BW_{\text{GB}} \text{ (MHz)}$$

$BW_{\text{GB,low}}$ and $BW_{\text{GB,high}}$ are the minimum guard band defined in subclause 5.3.3 for lowest and highest assigned component carrier, while $N_{\text{RB,low}}$ and $N_{\text{RB,high}}$ are the transmission bandwidth configurations according to Table 5.3.2-1 or Table 5.3.2-2 for the lowest and highest assigned component carrier, SCS_{low} and SCS_{high} are the sub-carrier spacing for the lowest and highest assigned component carrier respectively.

For intra-band non-contiguous carrier aggregation *Sub-block Bandwidth* and *Sub-block edges* are defined as follows, see Figure 5.3A.2-2.

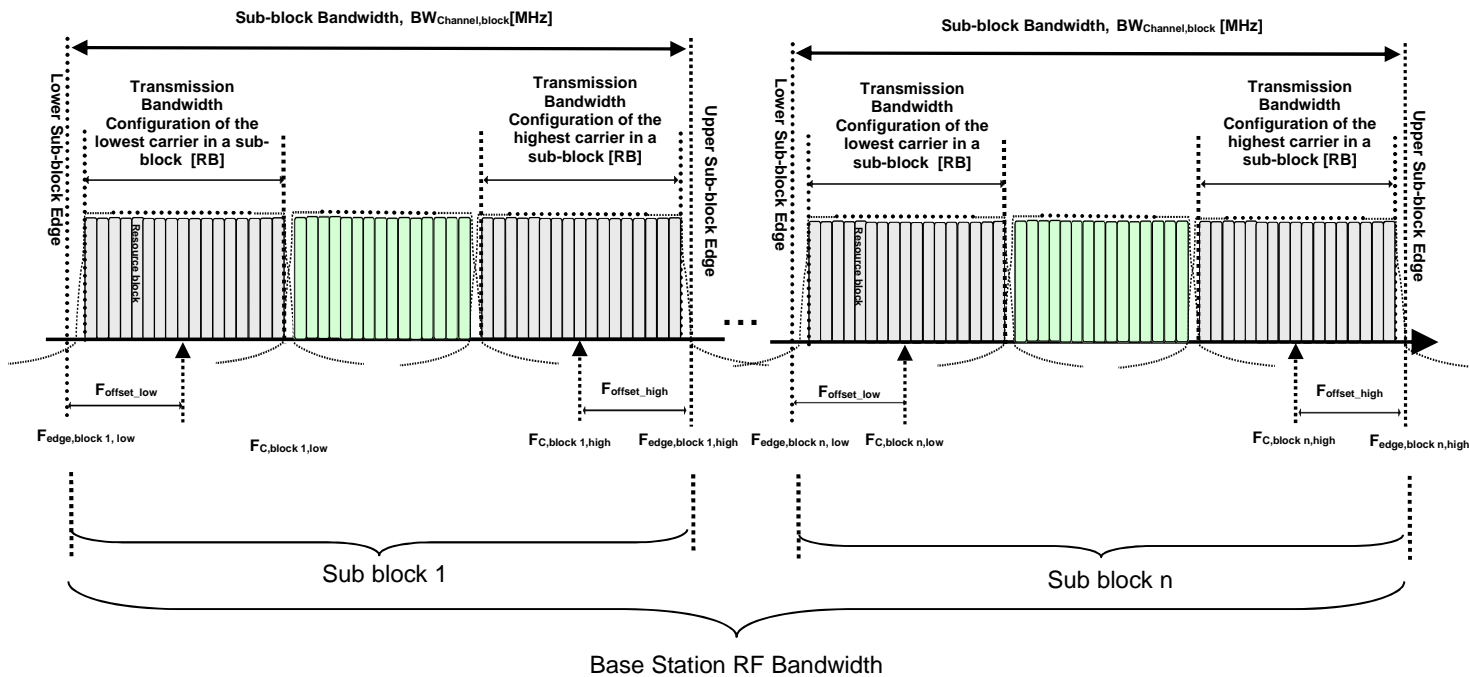

Figure 5.3A.2-2: Definition of sub-block bandwidth for intra-band non-contiguous spectrum

The lower sub-block edge of the Sub-block Bandwidth ($BW_{Channel,block}$) is defined as

$$F_{Edge,block,low} = F_{C,block,low} - F_{Offset,low}$$

The upper sub-block edge of the Sub-block Bandwidth is defined as

$$F_{Edge,block,high} = F_{C,block,high} + F_{Offset,high}$$

The Sub-block Bandwidth, $BW_{Channel,block}$, is defined as follows:

$$BW_{Channel,block} = F_{Edge,block,high} - F_{Edge,block,low} \text{ (MHz)}$$

The lower and upper frequency offsets $F_{Offset,block,low}$ and $F_{Offset,block,high}$ depend on the transmission bandwidth configurations of the lowest and highest assigned edge component carriers within a sub-block and are defined as

$$F_{Offset,block,low} = (N_{RB,low} * 12 + 1) * SCS_{low} / 2 + BW_{GB,low} \text{ (MHz)}$$

$$F_{Offset,block,high} = (N_{RB,high} * 12 - 1) * SCS_{high} / 2 + BW_{GB,high} \text{ (MHz)}$$

where $N_{RB,low}$ and $N_{RB,high}$ are the transmission bandwidth configurations according to Table 5.3.2-1 or Table 5.3.2-2 for the lowest and highest assigned component carrier within a sub-block, respectively. SCS_{low} and SCS_{high} are the sub-carrier spacing for the lowest and highest assigned component carrier within a sub-block, respectively. $BW_{GB,low}$ and $BW_{GB,high}$ are the minimum guard band defined in subclause 5.3.3 for the lowest and highest assigned component carrier respectively

The sub-block gap size between two consecutive sub-blocks W_{gap} is defined as

$$W_{gap} = F_{Edge,block n+1,low} - F_{Edge,block n,high} \text{ (MHz)}$$

5.4 Channel arrangement

5.4.1 Channel spacing

5.4.1.1 Channel spacing for adjacent NR carriers

The spacing between carriers will depend on the deployment scenario, the size of the frequency block available and the *BS channel bandwidths*. The nominal channel spacing between two adjacent NR carriers is defined as following:

- For NR FR1 *operating bands* with 100 kHz channel raster,

$$\text{Nominal Channel spacing} = (\text{BW}_{\text{Channel}(1)} + \text{BW}_{\text{Channel}(2)})/2$$

- For NR FR1 *operating bands* with 15 kHz channel raster,

$$\text{Nominal Channel spacing} = (\text{BW}_{\text{Channel}(1)} + \text{BW}_{\text{Channel}(2)})/2 + \{-5 \text{ kHz}, 0 \text{ kHz}, 5 \text{ kHz}\}$$

- For NR FR2 *operating bands* with 60 kHz channel raster,

$$\text{Nominal Channel spacing} = (\text{BW}_{\text{Channel}(1)} + \text{BW}_{\text{Channel}(2)})/2 + \{-20 \text{ kHz}, 0 \text{ kHz}, 20 \text{ kHz}\}$$

where $\text{BW}_{\text{Channel}(1)}$ and $\text{BW}_{\text{Channel}(2)}$ are the *BS channel bandwidths* of the two respective NR carriers. The channel spacing can be adjusted depending on the channel raster to optimize performance in a particular deployment scenario.

5.4.1.2 Channel spacing for CA

For intra-band contiguously aggregated carriers, the channel spacing between adjacent component carriers shall be multiple of least common multiple of channel raster and sub-carrier spacing.

The nominal channel spacing between two adjacent aggregated NR carriers is defined as follows:

For NR *operating bands* with 100 kHz channel raster:

$$\text{Nominal channel spacing} = \left\lfloor \frac{\text{BW}_{\text{Channel}(1)} + \text{BW}_{\text{Channel}(2)} - 2|\text{GB}_{\text{Channel}(1)} - \text{GB}_{\text{Channel}(2)}|}{0.6} \right\rfloor 0.3 \text{ [MHz]}$$

For NR *operating bands* with 15 kHz channel raster:

$$\text{Nominal channel spacing} = \left\lfloor \frac{\text{BW}_{\text{Channel}(1)} + \text{BW}_{\text{Channel}(2)} - 2|\text{GB}_{\text{Channel}(1)} - \text{GB}_{\text{Channel}(2)}|}{0.015 * 2^{n+1}} \right\rfloor 0.015 * 2^n \text{ [MHz]}$$

with

$$n = \max(\mu_1, \mu_2)$$

For NR *operating bands* with 60kHz channel raster:

$$\text{Nominal channel spacing} = \left\lfloor \frac{\text{BW}_{\text{Channel}(1)} + \text{BW}_{\text{Channel}(2)} - 2|\text{GB}_{\text{Channel}(1)} - \text{GB}_{\text{Channel}(2)}|}{0.06 * 2^{n+1}} \right\rfloor 0.06 * 2^n \text{ [MHz]}$$

with

$$n = \max(\mu_1, \mu_2) - 2$$

Where $\text{BW}_{\text{Channel}(1)}$ and $\text{BW}_{\text{Channel}(2)}$ are the *BS channel bandwidths* of the two respective NR component carriers according to Table 5.3.2-1 and 5.3.2-2 with values in MHz, and the $\text{GB}_{\text{Channel}(i)}$ is the minimum guard band defined in subclause 5.3.3, while μ_1 and μ_2 are the subcarrier spacing configurations of the component carriers as defined in TS 38.211.

The channel spacing for intra-band contiguous carrier aggregation can be adjusted to any multiple of least common multiple of channel raster and sub-carrier spacing less than the nominal channel spacing to optimize performance in a particular deployment scenario.

For intra-band non-contiguous carrier aggregation the channel spacing between two NR component carriers in different sub-blocks shall be larger than the nominal channel spacing defined in this subclause.

5.4.2 Channel raster

5.4.2.1 NR-ARFCN and channel raster

The global frequency raster defines a set of *RF reference frequencies* F_{REF} . The *RF reference frequency* is used in signalling to identify the position of RF channels, SS blocks and other elements. The global frequency raster is defined for all frequencies from 0 to 100 GHz. The granularity of the global frequency raster is ΔF_{Global} .

RF reference frequencies are designated by an NR Absolute Radio Frequency Channel Number (NR-ARFCN) in the range [0...3279165] on the global frequency raster. The relation between the NR-ARFCN and the *RF reference frequency* F_{REF} in MHz is given by the following equation, where $F_{\text{REF-Offs}}$ and $N_{\text{REF-Offs}}$ are given in table 5.4.2.1-1 and N_{REF} is the NR-ARFCN.

$$F_{\text{REF}} = F_{\text{REF-Offs}} + \Delta F_{\text{Global}} (N_{\text{REF}} - N_{\text{REF-Offs}})$$

Table 5.4.2.1-1: NR-ARFCN parameters for the global frequency raster

Frequency range (MHz)	ΔF_{Global} (kHz)	$F_{\text{REF-Offs}}$ (MHz)	$N_{\text{REF-Offs}}$	Range of N_{REF}
0 – 3000	5	0	0	0 – 599999
3000 – 24250	15	3000	600000	600000 – 2016666
24250 – 100000	60	24250.08	2016667	2016667 – 3279165

The *channel raster* defines a subset of *RF reference frequencies* that can be used to identify the RF channel position in the uplink and downlink. The *RF reference frequency* for an RF channel maps to a resource element on the carrier. For each *operating band*, a subset of frequencies from the global frequency raster are applicable for that band and forms a channel raster with a granularity ΔF_{Raster} , which may be equal to or larger than ΔF_{Global} .

For SUL bands and for the uplink of all FDD bands defined in table 5.2-1,

$$F_{\text{REF,shift}} = F_{\text{REF}} + \Delta_{\text{shift}}, \quad \Delta_{\text{shift}} = 0 \text{ kHz or } 7.5 \text{ kHz}$$

where Δ_{shift} is signalled by the network in higher layer parameter *frequencyShift7p5khz* [11].

The mapping between the *channel raster* and corresponding resource element is given in subclause 5.4.2.2. The applicable entries for each *operating band* are defined in subclause 5.4.2.3.

5.4.2.2 Channel raster to resource element mapping

The mapping between the *RF reference frequency* on the channel raster and the corresponding resource element is given in table 5.4.2.2-1 and can be used to identify the RF channel position. The mapping depends on the total number of RBs that are allocated in the channel and applies to both UL and DL. The mapping must apply to at least one numerology supported by the BS.

Table 5.4.2.2-1: Channel Raster to Resource Element Mapping

	$N_{\text{RB}} \bmod 2 = 0$	$N_{\text{RB}} \bmod 2 = 1$
Resource element index k	0	6
Physical resource block number n_{PRB}	$n_{\text{PRB}} = \left\lfloor \frac{N_{\text{RB}}}{2} \right\rfloor$	$n_{\text{PRB}} = \left\lfloor \frac{N_{\text{RB}}}{2} \right\rfloor$

k , n_{PRB} , N_{RB} are as defined in TS 38.211 [9].

5.4.2.3 Channel raster entries for each *operating band*

The RF channel positions on the channel raster in each NR *operating band* are given through the applicable NR-ARFCN in table 5.4.2.3-1 for FR1 and table 5.4.2.3-2 for FR2, using the channel raster to resource element mapping in subclause 5.4.2.2.

- For NR *operating bands* with 100 kHz channel raster, $\Delta F_{\text{Raster}} = 20 \times \Delta F_{\text{Global}}$. In this case, every 20th NR-ARFCN within the *operating band* are applicable for the channel raster within the *operating band* and the step size for the channel raster in table 5.4.2.3-1 is given as <20>.
- For NR *operating bands* with 15 kHz channel raster below 3 GHz, $\Delta F_{\text{Raster}} = I \times \Delta F_{\text{Global}}$, where $I \in \{3,6\}$. In this case, every I^{th} NR-ARFCN within the *operating band* are applicable for the channel raster within the *operating band* and the step size for the channel raster in table 5.4.2.3-1 is given as <I>.
- For NR *operating bands* with 15 kHz and 60 kHz channel raster above 3 GHz, $\Delta F_{\text{Raster}} = I \times \Delta F_{\text{Global}}$, where $I \in \{1, 2\}$. In this case, every I^{th} NR-ARFCN within the *operating band* are applicable for the channel raster within the *operating band* and the step size for the channel raster in table 5.4.2.3-1 and table 5.4.2.3-2 is given as <I>.
- In frequency bands with two ΔF_{Raster} , the higher ΔF_{Raster} applies to channels using only the SCS that equals the higher ΔF_{Raster} .

Table 5.4.2.3-1: Applicable NR-ARFCN per *operating band* in FR1

NR <i>Operating band</i>	ΔF_{Raster} (kHz)	Uplink Range of N _{REF} (First – <Step size> – Last)	Downlink Range of N _{REF} (First – <Step size> – Last)
n1	100	384000 – <20> – 396000	422000 – <20> – 434000
n2	100	370000 – <20> – 382000	386000 – <20> – 398000
n3	100	342000 – <20> – 357000	361000 – <20> – 376000
n5	100	164800 – <20> – 169800	173800 – <20> – 178800
n7	100	500000 – <20> – 514000	524000 – <20> – 538000
n8	100	176000 – <20> – 183000	185000 – <20> – 192000
n12	100	139800 – <20> – 143200	145800 – <20> – 149200
n20	100	166400 – <20> – 172400	158200 – <20> – 164200
n25	100	370000 – <20> – 383000	386000 – <20> – 399000
n28	100	140600 – <20> – 149600	151600 – <20> – 160600
n34	100	402000 – <20> – 405000	402000 – <20> – 405000
n38	100	514000 – <20> – 524000	514000 – <20> – 524000
n39	100	376000 – <20> – 384000	376000 – <20> – 384000
n40	100	460000 – <20> – 480000	460000 – <20> – 480000
n41	15	499200 – <3> – 537999	499200 – <3> – 537999
	30	499200 – <6> – 537996	499200 – <6> – 537996
n50	100	286400 – <20> – 303400	286400 – <20> – 303400
n51	100	285400 – <20> – 286400	285400 – <20> – 286400
n65	100	384000 – <20> – 402000	422000 – <20> – 440000
n66	100	342000 – <20> – 356000	422000 – <20> – 440000
n70	100	339000 – <20> – 342000	399000 – <20> – 404000
n71	100	132600 – <20> – 139600	123400 – <20> – 130400
n74	100	285400 – <20> – 294000	295000 – <20> – 303600
n75	100	N/A	286400 – <20> – 303400
n76	100	N/A	285400 – <20> – 286400
n77	15	620000 – <1> – 680000	620000 – <1> – 680000
	30	620000 – <2> – 680000	620000 – <2> – 680000
n78	15	620000 – <1> – 653333	620000 – <1> – 653333
	30	620000 – <2> – 653332	620000 – <2> – 653332
n79	15	693334 – <1> – 733333	693334 – <1> – 733333
	30	693334 – <2> – 733332	693334 – <2> – 733332
n80	100	342000 – <20> – 357000	N/A
n81	100	176000 – <20> – 183000	N/A
n82	100	166400 – <20> – 172400	N/A
n83	100	140600 – <20> – 149600	N/A
n84	100	384000 – <20> – 396000	N/A
n86	100	342000 – <20> – 356000	N/A

Table 5.4.2.3-2: Applicable NR-ARFCN per operating band in FR2

NR Operating band	ΔF_{Raster} (kHz)	Uplink and Downlink Range of N_{REF} (First – <Step size> – Last)
n257	60	2054166 – <1> – 2104165
	120	2054167 – <2> – 2104165
n258	60	2016667 – <1> – 2070832
	120	2016667 – <2> – 2070831
n260	60	2229166 – <1> – 2279165
	120	2229167 – <2> – 2279165
n261	60	2070833 – <1> – 2084999
	120	2070833 – <2> – 2084999

5.4.3 Synchronization raster

5.4.3.1 Synchronization raster and numbering

The synchronization raster indicates the frequency positions of the synchronization block that can be used by the UE for system acquisition when explicit signalling of the synchronization block position is not present.

A global synchronization raster is defined for all frequencies. The frequency position of the SS block is defined as SS_{REF} with corresponding number GSCN. The parameters defining the SS_{REF} and GSCN for all the frequency ranges are in table 5.4.3.1-1.

The resource element corresponding to the SS block reference frequency SS_{REF} is given in subclause 5.4.3.2. The synchronization raster and the subcarrier spacing of the synchronization block is defined separately for each band.

Table 5.4.3.1-1: GSCN parameters for the global frequency raster

Frequency range	SS block frequency position SS_{REF}	GSCN	Range of GSCN
0 – 3000 MHz	$N * 1200\text{kHz} + M * 50\text{ kHz}$, $N=1:2499$, $M \in \{1,3,5\}$ (Note)	$3N + (M-3)/2$	2 – 7498
3000 – 24250 MHz	$3000\text{ MHz} + N * 1.44\text{ MHz}$ $N= 0:14756$	$7499 + N$	7499 – 22255
24250 – 100000 MHz	$24250.08\text{ MHz} + N * 17.28\text{ MHz}$ $N= 0:4383$	$22256 + N$	22256 – 26639

NOTE: The default value for *operating bands* with SCS spaced channel raster is $M=3$.

5.4.3.2 Synchronization raster to synchronization block resource element mapping

The mapping between the synchronization raster and the corresponding resource element of the SS block is given in table 5.4.3.2-1. The mapping depends on the total number of RBs that are allocated in the channel and applies to both UL and DL.

Table 5.4.3.2-1: Synchronization Raster to SS block Resource Element Mapping

Resource element index k	0
Physical resource block number n_{PRB} of the SS block	$n_{\text{PRB}} = 10$

k , n_{PRB} , are as defined in TS 38.211 [9].

5.4.3.3 Synchronization raster entries for each operating band

The synchronization raster for each band is give in table 5.4.3.3-1. The distance between applicable GSCN entries is given by the <Step size> indicated in table 5.4.3.3-1 for FR1 and table 5.4.3.3-2 for FR2.

Table 5.4.3.3-1: Applicable SS raster entries per operating band (FR1)

NR Operating band	SS Block SCS	SS Block pattern ¹	Range of GSCN (First – <Step size> – Last)
n1	15 kHz	Case A	5279 – <1> – 5419
n2	15 kHz	Case A	4829 – <1> – 4969
n3	15 kHz	Case A	4517 – <1> – 4693
n5	15 kHz	Case A	2177 – <1> – 2230
	30 kHz	Case B	2183 – <1> – 2224
n7	15 kHz	Case A	6554 – <1> – 6718
n8	15 kHz	Case A	2318 – <1> – 2395
n12	15 kHz	Case A	1828 – <1> – 1858
n20	15 kHz	Case A	1982 – <1> – 2047
n25	15 kHz	Case A	4829 – <1> – 4981
n28	15 kHz	Case A	1901 – <1> – 2002
n34	15 kHz	Case A	5030 – <1> – 5056
n38	15 kHz	Case A	6431 – <1> – 6544
n39	15 kHz	Case A	4706 – <1> – 4795
n40	15 kHz	Case A	5756 – <1> – 5995
n41	15 kHz	Case A	6246 – <3> – 6717
	30 kHz	Case C	6252 – <3> – 6714
n50	15 kHz	Case A	3584 – <1> – 3787
n51	15 kHz	Case A	3572 – <1> – 3574
n65	15 kHz	Case A	5279 – <1> – 5494
n66	15 kHz	Case A	5279 – <1> – 5494
	30 kHz	Case B	5285 – <1> – 5488
n70	15 kHz	Case A	4993 – <1> – 5044
n71	15 kHz	Case A	1547 – <1> – 1624
n74	15 kHz	Case A	3692 – <1> – 3790
n75	15 kHz	Case A	3584 – <1> – 3787
n76	15 kHz	Case A	3572 – <1> – 3574
n77	30 kHz	Case C	7711 – <1> – 8329
n78	30 kHz	Case C	7711 – <1> – 8051
n79	30 kHz	Case C	8480 – <16> – 8880

NOTE 1: SS Block pattern is defined in section 4.1 in TS 38.213 [10].

Table 5.4.3.3-2: Applicable SS raster entries per operating band (FR2)

NR Operating band	SS Block SCS	SS Block pattern ¹	Range of GSCN (First – <Step size> – Last)
n257	120 kHz	Case D	22388 – <1> – 22558
	240 kHz	Case E	22390 – <2> – 22556
n258	120 kHz	Case D	22257 – <1> – 22443
	240 kHz	Case E	22258 – <2> – 22442
n260	120 kHz	Case D	22995 – <1> – 23166
	240 kHz	Case E	22996 – <2> – 23164
n261	120 kHz	Case D	22446 – <1> – 22492
	240 kHz	Case E	22446 – <2> – 22490

NOTE 1: SS Block pattern is defined in section 4.1 in TS 38.213 [10].

6 Conducted transmitter characteristics

6.1 General

Unless otherwise stated, the conducted transmitter characteristics are specified at the *antenna connector* for *BS type 1-C* and at the *TAB connector* for *BS type 1-H*, with a full complement of transceiver units for the configuration in normal operating conditions.

For *BS type 1-H* the manufacturer shall declare the minimum number of supported geographical cells (i.e. geographical areas covered by beams). The minimum number of supported geographical cells (N_{cells}) relates to the BS setting with the minimum amount of cell splitting supported with transmission on all *TAB connectors* supporting the *operating band*, or with minimum amount of transmitted beams.

For *BS type 1-H* manufacturer shall also declare *TAB connector TX min cell groups*. Every *TAB connector* of the *BS type 1-H* supporting transmission in an *operating band* shall map to one *TAB connector TX min cell group*, where mapping of *TAB connectors* to cells/beams is implementation dependent.

The number of *active transmitter units* that are considered when calculating the conducted TX emissions limits ($N_{\text{TXU,counted}}$) for *BS type 1-H* is calculated as follows:

$$N_{\text{TXU,counted}} = \min(N_{\text{TXU,active}}, 8 \times N_{\text{cells}})$$

$N_{\text{TXU,countedpercell}}$ is used for scaling of *basic limits* and is derived as $N_{\text{TXU,countedpercell}} = N_{\text{TXU,counted}} / N_{\text{cells}}$

NOTE: $N_{\text{TXU,active}}$ depends on the actual number of *active transmitter units* and is independent to the declaration of N_{cells} .

6.2 Base station output power

6.2.1 General

The BS conducted output power requirement is at *antenna connector* for *BS type 1-C*, or at *TAB connector* for *BS type 1-H*.

The rated carrier output power of the *BS type 1-C* shall be as specified in table 6.2.1-1.

Table 6.2.1-1: BS type 1-C rated output power limits for BS classes

BS class	$P_{\text{rated,c,AC}}$
Wide Area BS	(Note)
Medium Range BS	≤ 38 dBm
Local Area BS	≤ 24 dBm
NOTE: There is no upper limit for the $P_{\text{rated,c,AC}}$ rated output power of the Wide Area Base Station.	

The rated carrier output power of the *BS type 1-H* shall be as specified in table 6.2.1-2.

Table 6.2.1-2: BS type 1-H rated output power limits for BS classes

BS class	$P_{\text{rated,c,sys}}$	$P_{\text{rated,c,TABC}}$
Wide Area BS	(Note)	(Note)
Medium Range BS	≤ 38 dBm + $10\log(N_{\text{TXU,counted}})$	≤ 38 dBm
Local Area BS	≤ 24 dBm + $10\log(N_{\text{TXU,counted}})$	≤ 24 dBm
NOTE: There is no upper limit for the $P_{\text{rated,c,sys}}$ or $P_{\text{rated,c,TABC}}$ of the Wide Area Base Station.		

6.2.2 Minimum requirement for *BS type 1-C*

In normal conditions, $P_{\max,c,AC}$ shall remain within +2 dB and -2 dB of the rated carrier output power $P_{\text{rated},c,AC}$, declared by the manufacturer.

In extreme conditions, $P_{\max,c,AC}$ shall remain within +2.5 dB and -2.5 dB of the rated carrier output power $P_{\text{rated},c,AC}$, declared by the manufacturer.

In certain regions, the minimum requirement for normal conditions may apply also for some conditions outside the range of conditions defined as normal.

6.2.3 Minimum requirement for *BS type 1-H*

In normal conditions, $P_{\max,c,TABC}$ shall remain within +2 dB and -2 dB of the rated carrier output power $P_{\text{rated},c,TABC}$ for each *TAB connector* as declared by the manufacturer.

In extreme conditions, $P_{\max,c,TABC}$ shall remain within +2.5 dB and -2.5 dB of the rated carrier output power $P_{\text{rated},c,TABC}$ for each *TAB connector* as declared by the manufacturer.

In certain regions, the minimum requirement for normal conditions may apply also for some conditions outside the range of conditions defined as normal.

6.2.4 Additional requirements (regional)

In certain regions, additional regional requirements may apply.

6.3 Output power dynamics

6.3.1 General

The requirements in subclause 6.3 apply during the *transmitter ON period*. Transmitted signal quality (as specified in subclause 6.5) shall be maintained for the output power dynamics requirements of this subclause.

Power control is used to limit the interference level.

6.3.2 RE power control dynamic range

6.3.2.1 General

The RE power control dynamic range is the difference between the power of an RE and the average RE power for a BS at maximum output power ($P_{\max,c,TABC}$) for a specified reference condition.

For *BS type 1-C* this requirement shall apply at the *antenna connector* supporting transmission in the *operating band*.

For *BS type 1-H* this requirement shall apply at each *TAB connector* supporting transmission in the *operating band*.

6.3.2.2 Minimum requirement for *BS type 1-C* and *BS type 1-H*

RE power control dynamic range:

Table 6.3.2.2-1: RE power control dynamic range

Modulation scheme used on the RE	RE power control dynamic range (dB)	
	(down)	(up)
QPSK (PDCCH)	-6	+4
QPSK (PDSCH)	-6	+3
16QAM (PDSCH)	-3	+3
64QAM (PDSCH)	0	0
256QAM (PDSCH)	0	0

NOTE: The output power per carrier shall always be less or equal to the maximum output power of the base station.

6.3.3 Total power dynamic range

6.3.3.1 General

The BS total power dynamic range is the difference between the maximum and the minimum transmit power of an OFDM symbol for a specified reference condition.

For *BS type 1-C* this requirement shall apply at the *antenna connector* supporting transmission in the *operating band*.

For *BS type 1-H* this requirement shall apply at each *TAB connector* supporting transmission in the *operating band*.

NOTE: The upper limit of the dynamic range is the OFDM symbol power for a BS when transmitting on all RBs at maximum output power. The lower limit of the total power dynamic range is the average power for single RB transmission. The OFDM symbol shall carry PDSCH and not contain RS or SSB.

6.3.3.2 Minimum requirement for *BS type 1-C* and *BS type 1-H*

The downlink (DL) total power dynamic range for each NR carrier shall be larger than or equal to the level in table 6.3.3.2-1.

Table 6.3.3.2-1: Total power dynamic range

<i>BS channel bandwidth</i> (MHz)	Total power dynamic range (dB)		
	15 kHz SCS	30 kHz SCS	60 kHz SCS
5	13.9	10.4	N/A
10	17.1	13.8	10.4
15	18.9	15.7	12.5
20	20.2	17	13.8
25	21.2	18.1	14.9
30	22	18.9	15.7
40	23.3	20.2	17
50	24.3	21.2	18.1
60	N/A	22	18.9
70	N/A	22.7	19.6
80	N/A	23.3	20.2
90	N/A	23.8	20.8
100	N/A	24.3	21.3

6.4 Transmit ON/OFF power

6.4.1 Transmitter OFF power

6.4.1.1 General

Transmit OFF power requirements apply only to TDD operation of NR BS.

Transmitter OFF power is defined as the mean power measured over $70/N$ us filtered with a square filter of bandwidth equal to the transmission bandwidth configuration of the BS (BW_{Config}) centred on the assigned channel frequency during the *transmitter OFF period*. $N = \text{SCS}/15$, where SCS is Sub Carrier Spacing in kHz.

For *multi-band connectors* and for *single band connectors* supporting transmission in multiple *operating bands*, the requirement is only applicable during the *transmitter OFF period* in all supported *operating bands*.

For BS supporting intra-band contiguous CA, the transmitter OFF power is defined as the mean power measured over $70/N$ us filtered with a square filter of bandwidth equal to the *Aggregated BS Channel Bandwidth* $BW_{\text{Channel_CA}}$ centred on $(F_{\text{edge,high}}+F_{\text{edge,low}})/2$ during the *transmitter OFF period*. $N = \text{SCS}/15$, where SCS is the smallest supported Sub Carrier Spacing in kHz in the *Aggregated BS Channel Bandwidth*.

6.4.1.2 Minimum requirement for BS type 1-C

For *BS type 1-C*, the requirements for transmitter OFF power spectral density shall be less than -85 dBm/MHz per *antenna connector*.

6.4.1.3 Minimum requirement for BS type 1-H

For *BS type 1-H*, the requirements for transmitter OFF power spectral density shall be less than -85 dBm/MHz per *TAB connector*.

6.4.2 Transmitter transient period

6.4.2.1 General

Transmitter transient period requirements apply only to TDD operation of NR BS.

The *transmitter transient period* is the time period during which the transmitter is changing from the *transmitter OFF period* to the *transmitter ON period* or vice versa. The *transmitter transient period* is illustrated in figure 6.4.2.1-1.

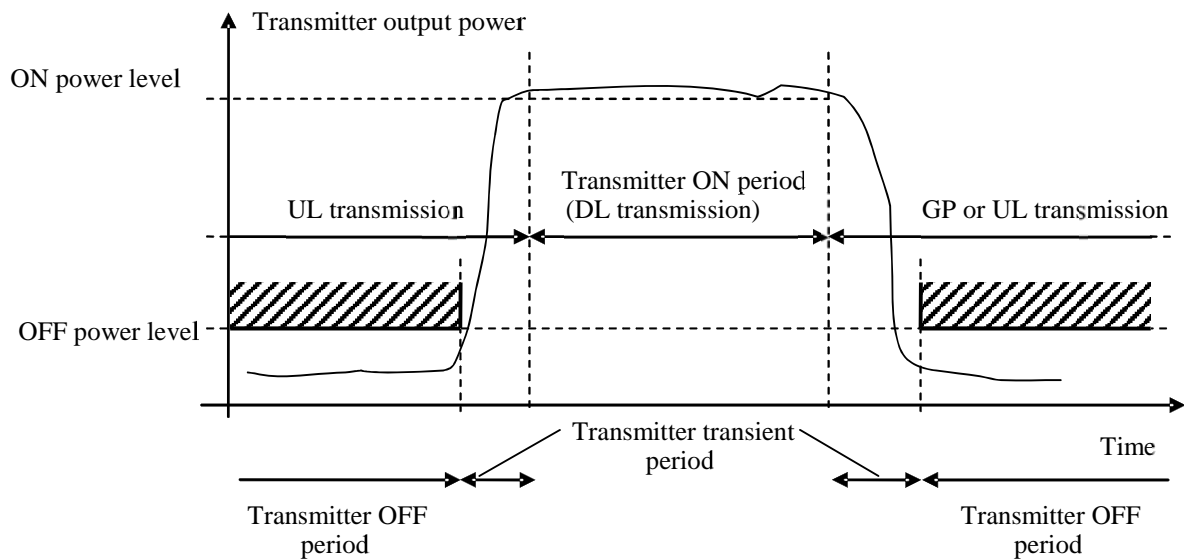

Figure 6.4.2.1-1: Example of relations between transmitter ON period, transmitter OFF period and transmitter transient period

For *BS type 1-C* this requirement shall be applied at the *antenna connector* supporting transmission in the *operating band*.

For *BS type 1-H* this requirement shall be applied at each *TAB connector* supporting transmission in the *operating band*.

6.4.2.2 Minimum requirement for BS type 1-C and BS type 1-H

For *BS type 1-C* and *BS type 1-H*, the *transmitter transient period* shall be shorter than the values listed in the minimum requirement table 6.4.2.2-1.

Table 6.4.2.2-1: Minimum requirement for the transmitter transient period for BS type 1-C and BS type 1-H

Transition	Transient period length (μs)
OFF to ON	10
ON to OFF	10

6.4.2.3 Void

6.5 Transmitted signal quality

6.5.1 Frequency error

6.5.1.1 General

The requirements in subclause 6.5.1 apply to the transmitter ON period.

Frequency error is the measure of the difference between the actual BS transmit frequency and the assigned frequency. The same source shall be used for RF frequency and data clock generation.

For *BS type 1-C* this requirement shall be applied at the *antenna connector* supporting transmission in the *operating band*.

For *BS type 1-H* this requirement shall be applied at each *TAB connector* supporting transmission in the *operating band*.

6.5.1.2 Minimum requirement for *BS type 1-C* and *BS type 1-H*

For *BS type 1-C* and *1-H*, the modulated carrier frequency of each NR carrier configured by the BS shall be accurate to within the accuracy range given in table 6.5.1.2-1 observed over 1 ms.

Table 6.5.1.2-1: Frequency error minimum requirement

BS class	Accuracy
Wide Area BS	± 0.05 ppm
Medium Range BS	± 0.1 ppm
Local Area BS	± 0.1 ppm

6.5.2 Modulation quality

6.5.2.1 General

Modulation quality is defined by the difference between the measured carrier signal and a reference signal. Modulation quality can e.g. be expressed as Error Vector Magnitude (EVM). The Error Vector Magnitude is a measure of the difference between the ideal symbols and the measured symbols after the equalization. This difference is called the error vector. Details about how the EVM is determined are specified in Annex B.

For *BS type 1-C* this requirement shall be applied at the *antenna connector* supporting transmission in the *operating band*.

For *BS type 1-H* this requirement shall be applied at each *TAB connector* supporting transmission in the *operating band*.

6.5.2.2 Minimum Requirement for *BS type 1-C* and *BS type 1-H*

For *BS type 1-C* and *1-H*, the EVM levels of each NR carrier for different modulation schemes on PDSCH outlined in table 6.5.2.2-1 shall be met using the frame structure described in subclause 6.5.2.3.

Table 6.5.2.2-1: EVM requirements for *BS type 1-C* and *BS type 1-H* carrier

Modulation scheme for PDSCH	Required EVM
QPSK	17.5 %
16QAM	12.5 %
64QAM	8 %
256QAM	3.5 %

6.5.2.3 EVM frame structure for measurement

EVM shall be evaluated for each NR carrier over all allocated resource blocks and downlink subframes. Different modulation schemes listed in table 6.5.2.2-1 shall be considered for rank 1.

For NR, for all bandwidths, the EVM measurement shall be performed for each NR carrier over all allocated resource blocks and downlink subframes within 10 ms measurement periods. The boundaries of the EVM measurement periods need not be aligned with radio frame boundaries.

EVM measurements start on the third symbol of a slot ($l=2$) when the first symbol of that slot is a downlink symbol.

6.5.3 Time alignment error

6.5.3.1 General

This requirement shall apply to frame timing in TX diversity, MIMO transmission, carrier aggregation and their combinations.

Frames of the NR signals present at the BS transmitter *antenna connectors* or *TAB connectors* are not perfectly aligned in time. The RF signals present at the BS transmitter *antenna connectors* or *transceiver array boundary* may experience certain timing differences in relation to each other.

The TAE is specified for a specific set of signals/transmitter configuration/transmission mode.

For *BS type 1-C*, the TAE is defined as the largest timing difference between any two signals belonging to different *antenna connectors* for a specific set of signals/transmitter configuration/transmission mode.

For *BS type 1-H*, the TAE is defined as the largest timing difference between any two signals belonging to *TAB connectors* belonging to different transmitter groups at the *transceiver array boundary*, where transmitter groups are associated with the *TAB connectors* in the transceiver unit array corresponding to TX diversity, MIMO transmission, *carrier aggregation* for a specific set of signals/transmitter configuration/transmission mode.

6.5.3.2 Minimum requirement for *BS type 1-C* and *1-H*

For MIMO or TX diversity transmissions, at each carrier frequency, TAE shall not exceed 65 ns.

For intra-band contiguous carrier aggregation, with or without MIMO or TX diversity, TAE shall not exceed 260ns.

For intra-band non-contiguous carrier aggregation, with or without MIMO or TX diversity, TAE shall not exceed 3 μ s.

For inter-band carrier aggregation, with or without MIMO or TX diversity, TAE shall not exceed 3 μ s.

Table 6.5.3.2-1: Void

Table 6.5.3.2-2: Void

Table 6.5.3.2-3: Void

6.6 Unwanted emissions

6.6.1 General

Unwanted emissions consist of out-of-band emissions and spurious emissions according to ITU definitions [2]. In ITU terminology, out of band emissions are unwanted emissions immediately outside the *BS channel bandwidth* resulting from the modulation process and non-linearity in the transmitter but excluding spurious emissions. Spurious emissions are emissions which are caused by unwanted transmitter effects such as harmonics emission, parasitic emission, intermodulation products and frequency conversion products, but exclude out of band emissions.

The out-of-band emissions requirement for the BS transmitter is specified both in terms of Adjacent Channel Leakage power Ratio (ACLR) and *operating band* unwanted emissions (OBUE).

The maximum offset of the *operating band* unwanted emissions mask from the *operating band* edge is Δf_{OBUE} . The Operating band unwanted emissions define all unwanted emissions in each supported downlink *operating band* plus the frequency ranges Δf_{OBUE} above and Δf_{OBUE} below each band. Unwanted emissions outside of this frequency range are limited by a spurious emissions requirement.

The values of Δf_{OBUE} are defined in table 6.6.1-1 for the NR *operating bands*.

Table 6.6.1-1: Maximum offset of OBUE outside the downlink *operating band*

BS type	Operating band characteristics	Δf_{OBUE} (MHz)
<i>BS type 1-H</i>	$F_{\text{DL,high}} - F_{\text{DL,low}} < 100$ MHz	10
	100 MHz $\leq F_{\text{DL,high}} - F_{\text{DL,low}} \leq 900$ MHz	40
<i>BS type 1-C</i>	$F_{\text{DL,high}} - F_{\text{DL,low}} \leq 200$ MHz	10
	200 MHz $< F_{\text{DL,high}} - F_{\text{DL,low}} \leq 900$ MHz	40

For *BS type 1-H* the unwanted emission requirements are applied per the *TAB connector TX min cell groups* for all the configurations supported by the BS. The *basic limits* and corresponding emissions scaling are defined in each relevant subclause.

There is in addition a requirement for occupied bandwidth.

6.6.2 Occupied bandwidth

6.6.2.1 General

The occupied bandwidth is the width of a frequency band such that, below the lower and above the upper frequency limits, the mean powers emitted are each equal to a specified percentage $\beta/2$ of the total mean transmitted power. See also Recommendation ITU-R SM.328 [3].

The value of $\beta/2$ shall be taken as 0.5%.

The occupied bandwidth requirement shall apply during the *transmitter ON period* for a single transmitted carrier. The minimum requirement below may be applied regionally. There may also be regional requirements to declare the occupied bandwidth according to the definition in the present clause.

For *BS type 1-C* this requirement shall be applied at the *antenna connector* supporting transmission in the *operating band*.

For *BS type 1-H* this requirement shall be applied at each *TAB connector* supporting transmission in the *operating band*.

6.6.2.2 Minimum requirement for *BS type 1-C* and *BS type 1-H*

The occupied bandwidth for each NR carrier shall be less than the *BS channel bandwidth*. For intra-band contiguous CA, the occupied bandwidth shall be less than or equal the *Aggregated BS Channel Bandwidth*.

6.6.3 Adjacent Channel Leakage Power Ratio

6.6.3.1 General

Adjacent Channel Leakage power Ratio (ACLR) is the ratio of the filtered mean power centred on the assigned channel frequency to the filtered mean power centred on an adjacent channel frequency.

The requirements shall apply outside the Base Station RF Bandwidth or Radio Bandwidth whatever the type of transmitter considered (single carrier or multi-carrier) and for all transmission modes foreseen by the manufacturer's specification.

For a BS operating in non-contiguous spectrum, the ACLR requirement in subclause 6.6.3.2 shall apply in *sub block gaps* for the frequency ranges defined in table 6.6.3.2-2a, while the CA CLR requirement in subclause 6.6.3.2 shall apply in *sub block gaps* for the frequency ranges defined in table 6.6.3.2-3.

For a *multi-band connector*, the ACLR requirement in subclause 6.6.3.2 shall apply in *Inter RF Bandwidth gaps* for the frequency ranges defined in table 6.6.3.2-2a, while the CA CLR requirement in subclause 6.6.3.2 shall apply in *Inter RF Bandwidth gaps* for the frequency ranges defined in table 6.6.3.2-3.

The requirement shall apply during the *transmitter ON period*.

6.6.3.2 Limits and Basic limits

The ACLR is defined with a square filter of bandwidth equal to the transmission bandwidth configuration of the transmitted signal (BW_{Config}) centred on the assigned channel frequency and a filter centred on the adjacent channel frequency according to the tables below.

For operation in paired and unpaired spectrum, the ACLR shall be higher than the value specified in table 6.6.3.2-1.

Table 6.6.3.2-1: Base station ACLR limit

BS channel bandwidth of lowest/highest NR carrier transmitted BW_{Channel} (MHz)	BS adjacent channel centre frequency offset below the lowest or above the highest carrier centre frequency transmitted	Assumed adjacent channel carrier (informative)	Filter on the adjacent channel frequency and corresponding filter bandwidth	ACLR limit
5, 10, 15, 20, 25, 30, 40, 50, 60, 70, 80, 90,100	BW _{Channel}	NR of same BW (Note 2)	Square (BW _{Config})	45 dB
	2 x BW _{Channel}	NR of same BW (Note 2)	Square (BW _{Config})	45 dB
	BW _{Channel} /2 + 2.5 MHz	5 MHz E-UTRA	Square (4.5 MHz)	45 dB (Note 3)
	BW _{Channel} /2 + 7.5 MHz	5 MHz E-UTRA	Square (4.5 MHz)	45 dB (Note 3)
NOTE 1: BW _{Channel} and BW _{Config} are the BS channel bandwidth and transmission bandwidth configuration of the lowest/highest NR carrier transmitted on the assigned channel frequency.				
NOTE 2: With SCS that provides largest transmission bandwidth configuration (BW _{Config}).				
NOTE 3: The requirements are applicable when the band is also defined for E-UTRA or UTRA.				

The ACLR absolute *basic limit* is specified in table 6.6.3.2-2.

Table 6.6.3.2-2: Base station ACLR absolute *basic limit*

BS category / BS class	ACLR absolute <i>basic limit</i>
Category A Wide Area BS	-13 dBm/MHz
Category B Wide Area BS	-15 dBm/MHz
Medium Range BS	-25 dBm/MHz
Local Area BS	-32 dBm/MHz

For operation in non-contiguous spectrum or multiple bands, the ACLR shall be higher than the value specified in Table 6.6.3.2-2a.

Table 6.6.3.2-2a: Base Station ACLR limit in non-contiguous spectrum or multiple bands

<i>BS channel bandwidth of lowest/highest NR carrier transmitted</i> BW_{Channel} (MHz)	<i>Sub-block or Inter RF Bandwidth gap size (W_{gap}) where the limit applies</i> (MHz)	<i>BS adjacent channel centre frequency offset below or above the sub-block or Base Station RF Bandwidth edge (inside the gap)</i>	<i>Assumed adjacent channel carrier</i>	<i>Filter on the adjacent channel frequency and corresponding filter bandwidth</i>	<i>ACLR limit</i>
5, 10, 15, 20	$W_{\text{gap}} \geq 15$ (Note 3) $W_{\text{gap}} \geq 45$ (Note 4)	2.5 MHz	5 MHz NR (Note 2)	Square (BW_{Config})	45 dB
	$W_{\text{gap}} \geq 20$ (Note 3) $W_{\text{gap}} \geq 50$ (Note 4)	7.5 MHz	5 MHz NR (Note 2)	Square (BW_{Config})	45 dB
25, 30, 40, 50, 60, 70, 80, 90, 100	$W_{\text{gap}} \geq 60$ (Note 4) $W_{\text{gap}} \geq 30$ (Note 3)	10 MHz	20 MHz NR (Note 2)	Square (BW_{Config})	45 dB
	$W_{\text{gap}} \geq 80$ (Note 4) $W_{\text{gap}} \geq 50$ (Note 3)	30 MHz	20 MHz NR (Note 2)	Square (BW_{Config})	45 dB
NOTE 1: BW_{Config} is the transmission bandwidth configuration of the assumed adjacent channel carrier. NOTE 2: With SCS that provides largest transmission bandwidth configuration (BW_{Config}). NOTE 3: Applicable in case the <i>BS channel bandwidth</i> of the NR carrier transmitted at the other edge of the gap is 5, 10, 15, 20 MHz. NOTE 4: Applicable in case the <i>BS channel bandwidth</i> of the NR carrier transmitted at the other edge of the gap is 25, 30, 40, 50, 60, 70, 80, 90, 100 MHz.					

The Cumulative Adjacent Channel Leakage power Ratio (CACLR) in a sub-block gap or the Inter RF Bandwidth gap is the ratio of:

- a) the sum of the filtered mean power centred on the assigned channel frequencies for the two carriers adjacent to each side of the sub-block gap or the Inter RF Bandwidth gap, and
- b) the filtered mean power centred on a frequency channel adjacent to one of the respective sub-block edges or Base Station RF Bandwidth edges.

The assumed filter for the adjacent channel frequency is defined in table 6.6.3.2-3 and the filters on the assigned channels are defined in table 6.6.3.2-4.

For operation in non-contiguous spectrum or multiple bands, the CACLR for NR carriers located on either side of the sub-block gap or the Inter RF Bandwidth gap shall be higher than the value specified in table 6.6.3.2-3.

Table 6.6.3.2-3: Base Station CA CLR limit

<i>BS channel bandwidth of lowest/highest NR carrier transmitted</i> BW_{Channel} (MHz)	<i>Sub-block or Inter RF Bandwidth gap size (W_{gap}) where the limit applies</i> (MHz)	<i>BS adjacent channel centre frequency offset below or above the sub-block or Base Station RF Bandwidth edge (inside the gap)</i>	<i>Assumed adjacent channel carrier</i>	<i>Filter on the adjacent channel frequency and corresponding filter bandwidth</i>	<i>CA CLR limit</i>
5, 10, 15, 20	$5 \leq W_{\text{gap}} < 15$ (Note 3) $5 \leq W_{\text{gap}} < 45$ (Note 4)	2.5 MHz	5 MHz NR (Note 2)	Square (BW_{Config})	45 dB
	$10 < W_{\text{gap}} < 20$ (Note 3) $10 \leq W_{\text{gap}} < 50$ (Note 4)	7.5 MHz	5 MHz NR (Note 2)	Square (BW_{Config})	45 dB
25, 30, 40, 50, 60, 70, 80, 90, 100	$20 \leq W_{\text{gap}} < 60$ (Note 4) $20 \leq W_{\text{gap}} < 30$ (Note 3)	10 MHz	20 MHz NR (Note 2)	Square (BW_{Config})	45 dB
	$40 < W_{\text{gap}} < 80$ (Note 4) $40 \leq W_{\text{gap}} < 50$ (Note 3)	30 MHz	20 MHz NR (Note 2)	Square (BW_{Config})	45 dB

NOTE 1: BW_{Config} is the transmission bandwidth configuration of the assumed adjacent channel carrier.
NOTE 2: With SCS that provides largest transmission bandwidth configuration (BW_{Config}).
NOTE 3: Applicable in case the *BS channel bandwidth* of the NR carrier transmitted at the other edge of the gap is 5, 10, 15, 20 MHz.
NOTE 4: Applicable in case the *BS channel bandwidth* of the NR carrier transmitted at the other edge of the gap is 25, 30, 40, 50, 60, 70, 80, 90, 100 MHz.

The CA CLR absolute *basic limit* is specified in table 6.6.3.2-3a.

Table 6.6.3.2-3a: Base station CA CLR absolute *basic limit*

BS category / BS class	CA CLR absolute <i>basic limit</i>
Category A Wide Area BS	-13 dBm/MHz
Category B Wide Area BS	-15 dBm/MHz
Medium Range BS	-25 dBm/MHz
Local Area BS	-32 dBm/MHz

Table 6.6.3.2-4: Filter parameters for the assigned channel

RAT of the carrier adjacent to the sub-block or Inter RF Bandwidth gap	Filter on the assigned channel frequency and corresponding filter bandwidth
NR	NR of same BW with SCS that provides largest transmission bandwidth configuration

6.6.3.3 Minimum requirement for *BS type 1-C*

The ACLR (CA CLR) absolute *basic limits* in table 6.6.3.2-2, 6.6.3.2-3a or the ACLR (CA CLR) *limits* in table 6.6.3.2-1, 6.6.3.2-2a or 6.6.3.2-3, whichever is less stringent, shall apply for each *antenna connector*.

6.6.3.4 Minimum requirement for *BS type 1-H*

The ACLR (CA CLR) absolute *basic limits* in table 6.6.3.2-2 + X, 6.6.3.2-3a + X (where $X = 10\log_{10}(N_{\text{TXU, counted per cell}})$) or the ACLR (CA CLR) *limits* in table 6.6.3.2-1, 6.6.3.2-2a or 6.6.3.2-3, whichever is less stringent, shall apply for each *TAB connector TX min cell group*.

NOTE: Conformance to the *BS type 1-H ACLR* requirement can be demonstrated by meeting at least one of the following criteria as determined by the manufacturer:

- 1) The ratio of the sum of the filtered mean power measured on each *TAB connector* in the *TAB connector TX min cell group* at the assigned channel frequency to the sum of the filtered mean power measured on each *TAB connector* in the *TAB connector TX min cell group* at the adjacent channel frequency shall be greater than or equal to the *ACLR basic limit* of the BS. This shall apply for each *TAB connector TX min cell group*.

Or

- 2) The ratio of the filtered mean power at the *TAB connector* centred on the assigned channel frequency to the filtered mean power at this *TAB connector* centred on the adjacent channel frequency shall be greater than or equal to the *ACLR basic limit* of the BS for every *TAB connector* in the *TAB connector TX min cell group*, for each *TAB connector TX min cell group*.

In case the *ACLR (CACLR) absolute basic limit* of *BS type 1-H* are applied, the conformance can be demonstrated by meeting at least one of the following criteria as determined by the manufacturer:

- 1) The sum of the filtered mean power measured on each *TAB connector* in the *TAB connector TX min cell group* at the adjacent channel frequency shall be less than or equal to the *ACLR (CACLR) absolute basic limit + X* of the BS. This shall apply to each *TAB connector TX min cell group*.

Or

- 2) The filtered mean power at each *TAB connector* centred on the adjacent channel frequency shall be less than or equal to the *ACLR (CACLR) absolute basic limit* of the BS scaled by $X \cdot -10 \log_{10}(n)$ for every *TAB connector* in the *TAB connector TX min cell group*, for each *TAB connector TX min cell group*, where n is the number of *TAB connectors* in the *TAB connector TX min cell group*.

6.6.4 Operating band unwanted emissions

6.6.4.1 General

Unless otherwise stated, the operating band unwanted emission (OBUE) limits in FR1 are defined from Δf_{OBUE} below the lowest frequency of each supported downlink *operating band* up to Δf_{OBUE} above the highest frequency of each supported downlink *operating band*. The values of Δf_{OBUE} are defined in table 6.6.1-1 for the NR *operating bands*.

The requirements shall apply whatever the type of transmitter considered and for all transmission modes foreseen by the manufacturer's specification. In addition, for a BS operating in non-contiguous spectrum, the requirements apply inside any sub-block gap. In addition, for a BS operating in multiple bands, the requirements apply inside any Inter RF Bandwidth gap.

Basic limits are specified in the tables below, where:

- Δf is the separation between the channel edge frequency and the nominal -3dB point of the measuring filter closest to the carrier frequency.
- f_{offset} is the separation between the channel edge frequency and the centre of the measuring filter.
- $f_{\text{offset,max}}$ is the offset to the frequency Δf_{OBUE} outside the downlink *operating band*, where Δf_{OBUE} is defined in table 6.6.1-1.
- Δf_{max} is equal to $f_{\text{offset,max}}$ minus half of the bandwidth of the measuring filter.

For a *multi-band connector* inside any *Inter RF Bandwidth gaps* with $W_{\text{gap}} < 2 \cdot \Delta f_{\text{OBUE}}$, a combined *basic limit* shall be applied which is the cumulative sum of the *basic limits* specified at the *Base Station RF Bandwidth edges* on each side of the *Inter RF Bandwidth gap*. The *basic limit* for *Base Station RF Bandwidth edge* is specified in subclaus 6.6.4.2.1 to 6.6.4.2.4 below, where in this case:

- Δf is the separation between the *Base Station RF Bandwidth edge* frequency and the nominal -3 dB point of the measuring filter closest to the *Base Station RF Bandwidth edge*.

- f_{offset} is the separation between the *Base Station RF Bandwidth edge* frequency and the centre of the measuring filter.
- $f_{\text{offset}_{\text{max}}}$ is equal to the *Inter RF Bandwidth gap* minus half of the bandwidth of the measuring filter.
- Δf_{max} is equal to $f_{\text{offset}_{\text{max}}}$ minus half of the bandwidth of the measuring filter.

For a *multi-band connector*, the operating band unwanted emission limits apply also in a supported *operating band* without any carrier transmitted, in the case where there are carrier(s) transmitted in another supported *operating band*. In this case, no cumulative *basic limit* is applied in the *inter-band gap* between a supported downlink *operating band* with carrier(s) transmitted and a supported downlink *operating band* without any carrier transmitted and

- In case the *inter-band gap* between a supported downlink *operating band* with carrier(s) transmitted and a supported downlink *operating band* without any carrier transmitted is less than $2 \cdot \Delta f_{\text{OBUE}}$, $f_{\text{offset}_{\text{max}}}$ shall be the offset to the frequency Δf_{OBUE} MHz outside the outermost edges of the two supported downlink *operating bands* and the operating band unwanted emission *basic limits* of the band where there are carriers transmitted, as defined in the tables of the present subclause, shall apply across both downlink bands.
- In other cases, the operating band unwanted emission *basic limits* of the band where there are carriers transmitted, as defined in the tables of the present subclause for the largest frequency offset (Δf_{max}), shall apply from Δf_{OBUE} MHz below the lowest frequency, up to Δf_{OBUE} MHz above the highest frequency of the supported downlink *operating band* without any carrier transmitted.

For a multicarrier *single-band connector* or a *single-band connector* configured for intra-band contiguous or non-contiguous carrier aggregation the definitions above apply to the lower edge of the carrier transmitted at the lowest carrier frequency and the upper edge of the carrier transmitted at the highest carrier frequency within a specified frequency band.

In addition inside any sub-block gap for a *single-band connector* operating in non-contiguous spectrum, a combined *basic limit* shall be applied which is the cumulative sum of the *basic limits* specified for the adjacent sub blocks on each side of the sub block gap. The *basic limit* for each sub block is specified in subclauses 6.6.4.2.1 to 6.6.4.2.4 below, where in this case:

- Δf is the separation between the sub block edge frequency and the nominal -3 dB point of the measuring filter closest to the sub block edge.
- f_{offset} is the separation between the sub block edge frequency and the centre of the measuring filter.
- $f_{\text{offset}_{\text{max}}}$ is equal to the sub block gap bandwidth minus half of the bandwidth of the measuring filter.
- Δf_{max} is equal to $f_{\text{offset}_{\text{max}}}$ minus half of the bandwidth of the measuring filter.

For Wide Area BS, the requirements of either subclause 6.6.4.2.1 (Category A limits) or subclause 6.6.4.2.2 (Category B limits) shall apply.

For Medium Range BS, the requirements in subclause 6.6.4.2.3 shall apply (Category A and B).

For Local Area BS, the requirements of subclause 6.6.4.2.4 shall apply (Category A and B).

The application of either Category A or Category B *basic limits* shall be the same as for Transmitter spurious emissions in subclause 6.6.5.

6.6.4.2 Basic limits

6.6.4.2.1 Basic limits for Wide Area BS (Category A)

For BS operating in Bands n5, n8, n12, n28, n71, *basic limits* are specified in table 6.6.4.2.1-1.

Table 6.6.4.2.1-1: Wide Area BS operating band unwanted emission limits (NR bands below 1 GHz) for Category A

Frequency offset of measurement filter -3dB point, Δf	Frequency offset of measurement filter centre frequency, f_{offset}	<i>Basic limits</i> (Note 1, 2)	Measurement bandwidth
$0 \text{ MHz} \leq \Delta f < 5 \text{ MHz}$	$0.05 \text{ MHz} \leq f_{\text{offset}} < 5.05 \text{ MHz}$	$-7 \text{ dBm} - \frac{7}{5} \cdot \left(\frac{f_{\text{offset}}}{\text{MHz}} - 0.05 \right) \text{ dB}$	100 kHz
$5 \text{ MHz} \leq \Delta f < \min(10 \text{ MHz}, \Delta f_{\text{max}})$	$5.05 \text{ MHz} \leq f_{\text{offset}} < \min(10.05 \text{ MHz}, f_{\text{offset}_{\text{max}}})$	-14 dBm	100 kHz
$10 \text{ MHz} \leq \Delta f \leq \Delta f_{\text{max}}$	$10.05 \text{ MHz} \leq f_{\text{offset}} < f_{\text{offset}_{\text{max}}}$	-13 dBm (Note 3)	100 kHz
NOTE 1: For a BS supporting non-contiguous spectrum operation within any <i>operating band</i> , the emission limits within sub-block gaps is calculated as a cumulative sum of contributions from adjacent sub blocks on each side of the sub block gap. Exception is $\Delta f \geq 10 \text{ MHz}$ from both adjacent sub blocks on each side of the sub-block gap, where the emission limits within sub-block gaps shall be -13 dBm/100 kHz.			
NOTE 2: For a <i>multi-band connector</i> with Inter RF Bandwidth gap $< 2 \cdot \Delta f_{\text{OBUe}}$ the emission limits within the Inter RF Bandwidth gaps is calculated as a cumulative sum of contributions from adjacent sub-blocks or RF Bandwidth on each side of the Inter RF Bandwidth gap.			
NOTE 3: The requirement is not applicable when $\Delta f_{\text{max}} < 10 \text{ MHz}$.			

For BS operating in Bands n1, n2, n3, n7, n25, n34, n38, n39, n40, n41, n50, n65, n66, n70, n74, n75, n77, n78, n79, *basic limits* are specified in table 6.6.4.2.1-2:

Table 6.6.4.2.1-2: Wide Area BS operating band unwanted emission limits (NR bands above 1 GHz) for Category A

Frequency offset of measurement filter -3dB point, Δf	Frequency offset of measurement filter centre frequency, f_{offset}	<i>Basic limits</i> (Note 1, 2)	Measurement bandwidth
$0 \text{ MHz} \leq \Delta f < 5 \text{ MHz}$	$0.05 \text{ MHz} \leq f_{\text{offset}} < 5.05 \text{ MHz}$	$-7 \text{ dBm} - \frac{7}{5} \cdot \left(\frac{f_{\text{offset}}}{\text{MHz}} - 0.05 \right) \text{ dB}$	100 kHz
$5 \text{ MHz} \leq \Delta f < \min(10 \text{ MHz}, \Delta f_{\text{max}})$	$5.05 \text{ MHz} \leq f_{\text{offset}} < \min(10.05 \text{ MHz}, f_{\text{offset}_{\text{max}}})$	-14 dBm	100 kHz
$10 \text{ MHz} \leq \Delta f \leq \Delta f_{\text{max}}$	$10.5 \text{ MHz} \leq f_{\text{offset}} < f_{\text{offset}_{\text{max}}}$	-13 dBm (Note 3)	1MHz
NOTE 1: For a BS supporting non-contiguous spectrum operation within any <i>operating band</i> , the emission limits within sub-block gaps is calculated as a cumulative sum of contributions from adjacent sub blocks on each side of the sub block gap, where the contribution from the far-end sub-block shall be scaled according to the measurement bandwidth of the near-end sub-block. Exception is $\Delta f \geq 10 \text{ MHz}$ from both adjacent sub blocks on each side of the sub-block gap, where the emission limits within sub-block gaps shall be -13 dBm/1 MHz.			
NOTE 2: For a <i>multi-band connector</i> with Inter RF Bandwidth gap $< 2 \cdot \Delta f_{\text{OBUe}}$ the emission limits within the Inter RF Bandwidth gaps is calculated as a cumulative sum of contributions from adjacent sub-blocks or RF Bandwidth on each side of the Inter RF Bandwidth gap, where the contribution from the far-end sub-block or RF Bandwidth shall be scaled according to the measurement bandwidth of the near-end sub-block or RF Bandwidth.			
NOTE 3: The requirement is not applicable when $\Delta f_{\text{max}} < 10 \text{ MHz}$.			

6.6.4.2.2 Basic limits for Wide Area BS (Category B)

For Category B Operating band unwanted emissions, there are two options for the *basic limits* that may be applied regionally. Either the *basic limits* in subclause 6.6.4.2.2.1 or subclause 6.6.4.2.2.2 shall be applied.

6.6.4.2.2.1 Category B requirements (Option 1)

For BS operating in Bands n5, n8, n12, n20, n28, n71, the *basic limits* are specified in table 6.6.4.2.2.1-1:

**Table 6.6.4.2.1-1: Wide Area BS operating band unwanted emission limits
(NR bands below 1 GHz) for Category B**

Frequency offset of measurement filter -3dB point, Δf	Frequency offset of measurement filter centre frequency, f_{offset}	Basic limits (Note 1, 2)	Measurement bandwidth
$0 \text{ MHz} \leq \Delta f < 5 \text{ MHz}$	$0.05 \text{ MHz} \leq f_{\text{offset}} < 5.05 \text{ MHz}$	$-7 \text{ dBm} - \frac{7}{5} \cdot \left(\frac{f_{\text{offset}}}{\text{MHz}} - 0.05 \right) \text{ dB}$	100 kHz
$5 \text{ MHz} \leq \Delta f < \min(10 \text{ MHz}, \Delta f_{\text{max}})$	$5.05 \text{ MHz} \leq f_{\text{offset}} < \min(10.05 \text{ MHz}, f_{\text{offset}_{\text{max}}})$	-14 dBm	100 kHz
$10 \text{ MHz} \leq \Delta f \leq \Delta f_{\text{max}}$	$10.05 \text{ MHz} \leq f_{\text{offset}} < f_{\text{offset}_{\text{max}}}$	-16 dBm (Note 3)	100 kHz
<p>NOTE 1: For a BS supporting non-contiguous spectrum operation within any <i>operating band</i>, the emission limits within sub-block gaps is calculated as a cumulative sum of contributions from adjacent sub blocks on each side of the sub block gap, where the contribution from the far-end sub-block shall be scaled according to the measurement bandwidth of the near-end sub-block. Exception is $\Delta f \geq 10 \text{ MHz}$ from both adjacent sub blocks on each side of the sub-block gap, where the emission limits within sub-block gaps shall be -16 dBm/100 kHz.</p> <p>NOTE 2: For a <i>multi-band connector</i> with Inter RF Bandwidth gap $< 2 \cdot \Delta f_{\text{OBUe}}$ the emission limits within the Inter RF Bandwidth gaps is calculated as a cumulative sum of contributions from adjacent sub-blocks or RF Bandwidth on each side of the Inter RF Bandwidth gap, where the contribution from the far-end sub-block or RF Bandwidth shall be scaled according to the measurement bandwidth of the near-end sub-block or RF Bandwidth.</p> <p>NOTE 3: The requirement is not applicable when $\Delta f_{\text{max}} < 10 \text{ MHz}$.</p>			

For BS operating in Bands n1, n2, n3, n7, n25, n34, n38, n39, n40, n41, n50, n65, n66, n70, n75, n77, n78, n79, *basic limits* are specified in tables 6.6.4.2.1-2:

**Table 6.6.4.2.1-2: Wide Area BS operating band unwanted emission limits
(NR bands above 1 GHz) for Category B**

Frequency offset of measurement filter -3dB point, Δf	Frequency offset of measurement filter centre frequency, f_{offset}	Basic limits (Note 1, 2)	Measurement bandwidth
$0 \text{ MHz} \leq \Delta f < 5 \text{ MHz}$	$0.05 \text{ MHz} \leq f_{\text{offset}} < 5.05 \text{ MHz}$	$-7 \text{ dBm} - \frac{7}{5} \cdot \left(\frac{f_{\text{offset}}}{\text{MHz}} - 0.05 \right) \text{ dB}$	100 kHz
$5 \text{ MHz} \leq \Delta f < \min(10 \text{ MHz}, \Delta f_{\text{max}})$	$5.05 \text{ MHz} \leq f_{\text{offset}} < \min(10.05 \text{ MHz}, f_{\text{offset}_{\text{max}}})$	-14 dBm	100 kHz
$10 \text{ MHz} \leq \Delta f \leq \Delta f_{\text{max}}$	$10.5 \text{ MHz} \leq f_{\text{offset}} < f_{\text{offset}_{\text{max}}}$	-15 dBm (Note 3)	1MHz
<p>NOTE 1: For a BS supporting non-contiguous spectrum operation within any <i>operating band</i>, the emission limits within sub-block gaps is calculated as a cumulative sum of contributions from adjacent sub blocks on each side of the sub block gap, where the contribution from the far-end sub-block shall be scaled according to the measurement bandwidth of the near-end sub-block. Exception is $\Delta f \geq 10 \text{ MHz}$ from both adjacent sub blocks on each side of the sub-block gap, where the emission limits within sub-block gaps shall be -15 dBm/1 MHz.</p> <p>NOTE 2: For a <i>multi-band connector</i> with Inter RF Bandwidth gap $< 2 \cdot \Delta f_{\text{OBUe}}$ the emission limits within the Inter RF Bandwidth gaps is calculated as a cumulative sum of contributions from adjacent sub-blocks or RF Bandwidth on each side of the Inter RF Bandwidth gap, where the contribution from the far-end sub-block or RF Bandwidth shall be scaled according to the measurement bandwidth of the near-end sub-block or RF Bandwidth.</p> <p>NOTE 3: The requirement is not applicable when $\Delta f_{\text{max}} < 10 \text{ MHz}$.</p>			

6.6.4.2.2.2 Category B requirements (Option 2)

The limits in this subclause are intended for Europe and may be applied regionally for BS operating in bands n1, n3, n8.

For a BS operating in bands n1, n3, n8, n65 *basic limits* are specified in Table 6.6.4.2.2.2-1:

Table 6.6.4.2.2.2-1: Regional Wide Area BS operating band unwanted emission limits for Category B

Frequency offset of measurement filter -3dB point, Δf	Frequency offset of measurement filter centre frequency, f_{offset}	<i>Basic limits</i> (Note 1, 2)	Measurement bandwidth
$0 \text{ MHz} \leq \Delta f < 0.2 \text{ MHz}$	$0.015 \text{ MHz} \leq f_{\text{offset}} < 0.215 \text{ MHz}$	-14 dBm	30 kHz
$0.2 \text{ MHz} \leq \Delta f < 1 \text{ MHz}$	$0.215 \text{ MHz} \leq f_{\text{offset}} < 1.015 \text{ MHz}$	$-14\text{dBm} - 15 \cdot \left(\frac{f_{\text{offset}}}{\text{MHz}} - 0.215 \right) \text{dB}$	30 kHz
(Note 4)	$1.015 \text{ MHz} \leq f_{\text{offset}} < 1.5 \text{ MHz}$	-26 dBm	30 kHz
$1 \text{ MHz} \leq \Delta f \leq \min(10 \text{ MHz}, \Delta f_{\text{max}})$	$1.5 \text{ MHz} \leq f_{\text{offset}} < \min(10.5 \text{ MHz}, f_{\text{offset}_{\text{max}}})$	-13 dBm	1 MHz
$10 \text{ MHz} \leq \Delta f \leq \Delta f_{\text{max}}$	$10.5 \text{ MHz} \leq f_{\text{offset}} < f_{\text{offset}_{\text{max}}}$	-15 dBm (Note 3)	1 MHz
<p>NOTE 1: For a BS supporting non-contiguous spectrum operation within any <i>operating band</i>, the minimum requirement within sub-block gaps is calculated as a cumulative sum of contributions from adjacent sub blocks on each side of the sub block gap, where the contribution from the far-end sub-block shall be scaled according to the measurement bandwidth of the near-end sub-block. Exception is $\Delta f \geq 10\text{MHz}$ from both adjacent sub blocks on each side of the sub-block gap, where the minimum requirement within sub-block gaps shall be -15dBm/1MHz.</p> <p>NOTE 2: For a <i>multi-band connector</i> with Inter RF Bandwidth gap $< 2 \cdot \Delta f_{\text{OBUe}}$ the minimum requirement within the Inter RF Bandwidth gaps is calculated as a cumulative sum of contributions from adjacent sub-blocks or RF Bandwidth on each side of the Inter RF Bandwidth gap, where the contribution from the far-end sub-block or RF Bandwidth shall be scaled according to the measurement bandwidth of the near-end sub-block or RF Bandwidth.</p> <p>NOTE 3: The requirement is not applicable when $\Delta f_{\text{max}} < 10 \text{ MHz}$.</p> <p>NOTE 4: This frequency range ensures that the range of values of f_{offset} is continuous.</p>			

6.6.4.2.3 Basic limits for Medium Range BS (Category A and B)

For Medium Range BS, *basic limits* are specified in table 6.6.4.2.3-1 and table 6.6.4.2.3-2.

For the tables in this subclause for *BS type I-C* $P_{\text{rated},x} = P_{\text{rated},c,AC}$, and for *BS type I-H* $P_{\text{rated},x} = P_{\text{rated},c,cell} - 10 \cdot \log_{10}(N_{\text{TXU,countedpercell}})$, and for *BS type I-O* $P_{\text{rated},x} = P_{\text{rated},c,TRP} - 9 \text{ dB}$.

Table 6.6.4.2.3-1: Medium Range BS operating band unwanted emission limits, $31 < P_{\text{rated},x} \leq 38 \text{ dBm}$

Frequency offset of measurement filter -3dB point, Δf	Frequency offset of measurement filter centre frequency, f_{offset}	<i>Basic limits</i> (Note 1, 2)	Measurement bandwidth
$0 \text{ MHz} \leq \Delta f < 5 \text{ MHz}$	$0.05 \text{ MHz} \leq f_{\text{offset}} < 5.05 \text{ MHz}$	$P_{\text{rated},x} - 53\text{dB} - \frac{7}{5} \left(\frac{f_{\text{offset}}}{\text{MHz}} - 0.05 \right) \text{dB}$	100 kHz
$5 \text{ MHz} \leq \Delta f < \min(10 \text{ MHz}, \Delta f_{\text{max}})$	$5.05 \text{ MHz} \leq f_{\text{offset}} < \min(10.05 \text{ MHz}, f_{\text{offset}_{\text{max}}})$	$P_{\text{rated},x} - 60\text{dB}$	100 kHz
$10 \text{ MHz} \leq \Delta f \leq \Delta f_{\text{max}}$	$10.05 \text{ MHz} \leq f_{\text{offset}} < f_{\text{offset}_{\text{max}}}$	$\text{Min}(P_{\text{rated},x} - 60\text{dB}, -25\text{dBm})$ (Note 3)	100 kHz
<p>NOTE 1: For a BS supporting non-contiguous spectrum operation within any <i>operating band</i> the emission limits within sub-block gaps is calculated as a cumulative sum of contributions from adjacent sub blocks on each side of the sub block gap. Exception is $\Delta f \geq 10\text{MHz}$ from both adjacent sub blocks on each side of the sub-block gap, where the emission limits within sub-block gaps shall be $\text{Min}(P_{\text{rated},x} - 60\text{dB}, -25\text{dBm})/100\text{kHz}$.</p> <p>NOTE 2: For a <i>multi-band connector</i> with Inter RF Bandwidth gap $< 2 \cdot \Delta f_{\text{OBUe}}$ the emission limits within the Inter RF Bandwidth gaps is calculated as a cumulative sum of contributions from adjacent sub-blocks or RF Bandwidth on each side of the Inter RF Bandwidth gap.</p> <p>NOTE 3: The requirement is not applicable when $\Delta f_{\text{max}} < 10 \text{ MHz}$.</p>			

Table 6.6.4.2.3-2: Medium Range BS operating band unwanted emission limits, $P_{\text{rated},x} \leq 31$ dBm

Frequency offset of measurement filter -3dB point, Δf	Frequency offset of measurement filter centre frequency, f_{offset}	Basic limits (Note 1, 2)	Measurement bandwidth
$0 \text{ MHz} \leq \Delta f < 5 \text{ MHz}$	$0.05 \text{ MHz} \leq f_{\text{offset}} < 5.05 \text{ MHz}$	$-22 \text{ dBm} - \frac{7}{5} \left(\frac{f_{\text{offset}}}{\text{MHz}} - 0.05 \right) \text{ dB}$	100 kHz
$5 \text{ MHz} \leq \Delta f < \min(10 \text{ MHz}, \Delta f_{\text{max}})$	$5.05 \text{ MHz} \leq f_{\text{offset}} < \min(10.05 \text{ MHz}, f_{\text{offset}_{\text{max}}})$	-29 dBm	100 kHz
$10 \text{ MHz} \leq \Delta f \leq \Delta f_{\text{max}}$	$10.05 \text{ MHz} \leq f_{\text{offset}} < f_{\text{offset}_{\text{max}}}$	-29 dBm (Note 3)	100 kHz
NOTE 1: For a BS supporting non-contiguous spectrum operation within any <i>operating band</i> the emission limits within sub-block gaps is calculated as a cumulative sum of contributions from adjacent sub blocks on each side of the sub block gap. Exception is $\Delta f \geq 10$ MHz from both adjacent sub blocks on each side of the sub-block gap, where the emission limits within sub-block gaps shall be -29dBm/100kHz.			
NOTE 2: For a <i>multi-band connector</i> with Inter RF Bandwidth gap $< 2 * \Delta f_{\text{OBUE}}$ the emission limits within the Inter RF Bandwidth gaps is calculated as a cumulative sum of contributions from adjacent sub-blocks or RF Bandwidth on each side of the Inter RF Bandwidth gap.			
NOTE 3: The requirement is not applicable when $\Delta f_{\text{max}} < 10$ MHz.			

6.6.4.2.4 Basic limits for Local Area BS (Category A and B)

For Local Area BS, *basic limits* are specified in table 6.6.4.2.4-1.

Table 6.6.4.2.4-1: Local Area BS operating band unwanted emission limits

Frequency offset of measurement filter -3dB point, Δf	Frequency offset of measurement filter centre frequency, f_{offset}	Basic limits (Note 1, 2)	Measurement bandwidth
$0 \text{ MHz} \leq \Delta f < 5 \text{ MHz}$	$0.05 \text{ MHz} \leq f_{\text{offset}} < 5.05 \text{ MHz}$	$-30 \text{ dBm} - \frac{7}{5} \left(\frac{f_{\text{offset}}}{\text{MHz}} - 0.05 \right) \text{ dB}$	100 kHz
$5 \text{ MHz} \leq \Delta f < \min(10 \text{ MHz}, \Delta f_{\text{max}})$	$5.05 \text{ MHz} \leq f_{\text{offset}} < \min(10.05 \text{ MHz}, f_{\text{offset}_{\text{max}}})$	-37 dBm	100 kHz
$10 \text{ MHz} \leq \Delta f \leq \Delta f_{\text{max}}$	$10.05 \text{ MHz} \leq f_{\text{offset}} < f_{\text{offset}_{\text{max}}}$	-37 dBm (Note 10)	100 kHz
NOTE 1: For a BS supporting non-contiguous spectrum operation within any <i>operating band</i> the emission limits within sub-block gaps is calculated as a cumulative sum of contributions from adjacent sub blocks on each side of the sub block gap. Exception is $\Delta f \geq 10$ MHz from both adjacent sub blocks on each side of the sub-block gap, where the emission limits within sub-block gaps shall be -37dBm/100kHz.			
NOTE 2: For a <i>multi-band connector</i> with Inter RF Bandwidth gap $< 2 * \Delta f_{\text{OBUE}}$ the emission limits within the Inter RF Bandwidth gaps is calculated as a cumulative sum of contributions from adjacent sub-blocks or RF Bandwidth on each side of the Inter RF Bandwidth gap			
NOTE 3: The requirement is not applicable when $\Delta f_{\text{max}} < 10$ MHz.			

6.6.4.2.5 Basic limits for additional requirements

6.6.4.2.5.1 Limits in FCC Title 47

In addition to the requirements in subclauses 6.6.4.2.1, 6.6.4.2.2, 6.6.4.2.3 and 6.6.4.2.4, the BS may have to comply with the applicable emission limits established by FCC Title 47 [8], when deployed in regions where those limits are applied, and under the conditions declared by the manufacturer.

6.6.4.2.5.2 Protection of DTT

In certain regions the following requirement may apply for protection of DTT. For *BS type I-C* or *BS type I-H* operating in Band n20, the level of emissions in the band 470-790 MHz, measured in an 8 MHz filter bandwidth on centre frequencies F_{filter} according to table 6.6.4.2.5.2-1, a *basic limits* $P_{\text{EM},N}$ is declared by the manufacturer. This requirement applies in the frequency range 470-790 MHz even though part of the range falls in the spurious domain.

Table 6.6.4.2.5-1: Declared emissions *basic limit* for protection of DTT

Filter centre frequency, F_{filter}	Measurement bandwidth	Declared emission <i>basic limit</i> (dBm)
$F_{\text{filter}} = 8 \cdot N + 306$ (MHz); $21 \leq N \leq 60$	8 MHz	$P_{\text{EM},N}$

Note: The regional requirement is defined in terms of EIRP (effective isotropic radiated power), which is dependent on both the BS emissions at the *antenna connector* and the deployment (including antenna gain and feeder loss). The requirement defined above provides the characteristics of the BS needed to verify compliance with the regional requirement. Compliance with the regional requirement can be determined using the method outlined in TS 36.104 [13], annex G.

6.6.4.3 Minimum requirements for *BS type 1-C*

The operating band unwanted emissions for *BS type 1-C* for each *antenna connector* shall be below the applicable *basic limits* defined in subclause 6.6.4.2.

6.6.4.4 Minimum requirements for *BS type 1-H*

The operating band unwanted emissions requirements for *BS type 1-H* are that for each *TAB connector TX min cell group* and each applicable *basic limit* in subclause 6.6.4.2, the power summation emissions at the *TAB connectors* of the *TAB connector TX min cell group* shall not exceed a BS limit specified as the *basic limit* + X, where $X = 10 \log_{10}(N_{\text{TXU, counted per cell}})$.

NOTE: Conformance to the *BS type 1-H* spurious emission requirement can be demonstrated by meeting at least one of the following criteria as determined by the manufacturer:

1) The sum of the emissions power measured on each *TAB connector* in the *TAB connector TX min cell group* shall be less than or equal to the limit as defined in this subclause for the respective frequency span.

Or

2) The unwanted emissions power at each *TAB connector* shall be less than or equal to the *BS type 1-H* limit as defined in this subclause for the respective frequency span, scaled by $-10 \log_{10}(n)$, where n is the number of *TAB connectors* in the *TAB connector TX min cell group*.

6.6.5 Transmitter spurious emissions

6.6.5.1 General

The transmitter spurious emission limits shall apply from 9 kHz to 12.75 GHz, excluding the frequency range from Δf_{OBUE} below the lowest frequency of each supported downlink *operating band*, up to Δf_{OBUE} above the highest frequency of each supported downlink *operating band*, where the Δf_{OBUE} is defined in table 6.6.1-1. For some *operating bands*, the upper limit is higher than 12.75 GHz in order to comply with the 5th harmonic limit of the downlink *operating band*, as specified in ITU-R recommendation SM.329 [2].

For a *multi-band connector*, for each supported *operating band* together with Δf_{OBUE} around the band is excluded from the transmitter spurious emissions requirement.

The requirements shall apply whatever the type of transmitter considered (single carrier or multi-carrier). It applies for all transmission modes foreseen by the manufacturer's specification.

Unless otherwise stated, all requirements are measured as mean power (RMS).

6.6.5.2 Basic limits

6.6.5.2.1 General transmitter spurious emissions requirements

The *basic limits* of either table 6.6.5.2.1-1 (Category A limits) or table 6.6.5.2.1-2 (Category B limits) shall apply. The application of either Category A or Category B limits shall be the same as for operating band unwanted emissions in subclause 6.6.4.

Table 6.6.5.2.1-1: General BS transmitter spurious emission limits in FR1, Category A

Spurious frequency range	Basic limit	Measurement bandwidth	Notes
9 kHz – 150 kHz	-13 dBm	1 kHz	Note 1, Note 4
150 kHz – 30 MHz		10 kHz	Note 1, Note 4
30 MHz – 1 GHz		100 kHz	Note 1
1 GHz – 12.75 GHz		1 MHz	Note 1, Note 2
12.75 GHz – 5 th harmonic of the upper frequency edge of the DL <i>operating band</i> in GHz		1 MHz	Note 1, Note 2, Note 3
NOTE 1: Measurement bandwidths as in ITU-R SM.329 [2], s4.1.			
NOTE 2: Upper frequency as in ITU-R SM.329 [2], s2.5 table 1.			
NOTE 3: This spurious frequency range applies only for <i>operating bands</i> for which the 5 th harmonic of the upper frequency edge of the DL <i>operating band</i> is reaching beyond 12.75 GHz.			
NOTE 4: This spurious frequency range applies only to <i>BS type 1-C</i> and <i>BS type 1-H</i> .			

Table 6.6.5.2.1-2: General BS transmitter spurious emission limits in FR1, Category B

Spurious frequency range	Basic limit	Measurement bandwidth	Notes
9 kHz – 150 kHz	-36 dBm	1 kHz	Note 1, Note 4
150 kHz – 30 MHz		10 kHz	Note 1, Note 4
30 MHz – 1 GHz		100 kHz	Note 1
1 GHz – 12.75 GHz	-30 dBm	1 MHz	Note 1, Note 2
12.75 GHz – 5 th harmonic of the upper frequency edge of the DL <i>operating band</i> in GHz		1 MHz	Note 1, Note 2, Note 3
NOTE 1: Measurement bandwidths as in ITU-R SM.329 [2], s4.1.			
NOTE 2: Upper frequency as in ITU-R SM.329 [2], s2.5 table 1.			
NOTE 3: This spurious frequency range applies only for <i>operating bands</i> for which the 5 th harmonic of the upper frequency edge is reaching beyond 12.75 GHz.			
NOTE 4: This spurious frequency range applies only to <i>BS type 1-C</i> and <i>BS type 1-H</i> .			

6.6.5.2.2 Protection of the BS receiver of own or different BS

This requirement shall be applied for NR FDD operation in order to prevent the receivers of the BSs being desensitised by emissions from a BS transmitter. It is measured at the transmit *antenna connector* for *BS type 1-C* or at the *TAB connector* for *BS type 1-H* for any type of BS which has common or separate Tx/Rx *antenna connectors* / *TAB connectors*.

The spurious emission *basic limits* are provided in table 6.6.5.2.2-1.

Table 6.6.5.2.2-1: BS spurious emissions *basic limits* for protection of the BS receiver

BS class	Frequency range	Basic limits	Measurement bandwidth	Note
Wide Area BS	$F_{UL,low} - F_{UL,high}$	-96 dBm	100 kHz	
Medium Range BS	$F_{UL,low} - F_{UL,high}$	-91 dBm	100 kHz	
Local Area BS	$F_{UL,low} - F_{UL,high}$	-88 dBm	100 kHz	

6.6.5.2.3 Additional spurious emissions requirements

These requirements may be applied for the protection of system operating in frequency ranges other than the BS downlink *operating band*. The limits may apply as an optional protection of such systems that are deployed in the same geographical area as the BS, or they may be set by local or regional regulation as a mandatory requirement for an NR *operating band*. It is in some cases not stated in the present document whether a requirement is mandatory or under what exact circumstances that a limit applies, since this is set by local or regional regulation. An overview of regional requirements in the present document is given in subclause 4.5.

Some requirements may apply for the protection of specific equipment (UE, MS and/or BS) or equipment operating in specific systems (GSM, CDMA, UTRA, E-UTRA, NR, etc.) as listed below.

The spurious emission *basic limits* are provided in table 6.6.5.2.3 -1 for a BS where requirements for co-existence with the system listed in the first column apply. For a *multi-band connector*, the exclusions and conditions in the Note column of table 6.6.5.2.3 -1 apply for each supported *operating band*.

Table 6.6.5.2.3-1: BS spurious emissions *basic limits* for BS for co-existence with systems operating in other frequency bands

System type for NR to co-exist with	Frequency range for co-existence requirement	Basic limits	Measurement bandwidth	Note
GSM900	921 – 960 MHz	-57 dBm	100 kHz	This requirement does not apply to BS operating in band n8
	876 – 915 MHz	-61 dBm	100 kHz	For the frequency range 880-915 MHz, this requirement does not apply to BS operating in band n8, since it is already covered by the requirement in subclause 6.6.5.2.2.
DCS1800	1805 – 1880 MHz	-47 dBm	100 kHz	This requirement does not apply to BS operating in band n3.
	1710 – 1785 MHz	-61 dBm	100 kHz	This requirement does not apply to BS operating in band n3, since it is already covered by the requirement in subclause 6.6.5.2.2.
PCS1900	1930 – 1990 MHz	-47 dBm	100 kHz	This requirement does not apply to BS operating in band n2, n25 or band n70.
	1850 – 1910 MHz	-61 dBm	100 kHz	This requirement does not apply to BS operating in band n2 or n25 since it is already covered by the requirement in subclause 6.6.5.2.2.
GSM850 or CDMA850	869 – 894 MHz	-57 dBm	100 kHz	This requirement does not apply to BS operating in band n5.
	824 – 849 MHz	-61 dBm	100 kHz	This requirement does not apply to BS operating in band n5, since it is already covered by the requirement in subclause 6.6.5.2.2.
UTRA FDD Band I or E-UTRA Band 1 or NR Band n1	2110 – 2170 MHz	-52 dBm	1 MHz	This requirement does not apply to BS operating in band n1 or n65
	1920 – 1980 MHz	-49 dBm	1 MHz	This requirement does not apply to BS operating in band n1 or n65, since it is already covered by the requirement in subclause 6.6.5.2.2.
UTRA FDD Band II or E-UTRA Band 2 or NR Band n2	1930 – 1990 MHz	-52 dBm	1 MHz	This requirement does not apply to BS operating in band n2 or n70.
	1850 – 1910 MHz	-49 dBm	1 MHz	This requirement does not apply to BS operating in band n2, since it is already covered by the requirement in subclause 6.6.5.2.2.
UTRA FDD Band III or E-UTRA Band 3 or NR Band n3	1805 – 1880 MHz	-52 dBm	1 MHz	This requirement does not apply to BS operating in band n3.
	1710 – 1785 MHz	-49 dBm	1 MHz	This requirement does not apply to BS operating in band n3, since it is already covered by the requirement in subclause 6.6.5.2.2.
UTRA FDD Band IV or E-UTRA Band 4	2110 – 2155 MHz	-52 dBm	1 MHz	This requirement does not apply to BS operating in band n66
	1710 – 1755 MHz	-49 dBm	1 MHz	This requirement does not apply to BS operating in band n66, since it is already covered by the requirement in subclause 6.6.5.2.2.
UTRA FDD Band V or E-UTRA Band 5 or NR Band n5	869 – 894 MHz	-52 dBm	1 MHz	This requirement does not apply to BS operating in band n5.
	824 – 849 MHz	-49 dBm	1 MHz	This requirement does not apply to BS operating in band n5, since it is already covered by the requirement in subclause 6.6.5.2.2.
UTRA FDD Band VI, XIX or E-UTRA Band 6, 18, 19	860 – 890 MHz	-52 dBm	1 MHz	
	815 – 830 MHz	-49 dBm	1 MHz	
	830 – 845 MHz	-49 dBm	1 MHz	
UTRA FDD Band VII or E-UTRA Band 7 or NR Band n7	2620 – 2690 MHz	-52 dBm	1 MHz	This requirement does not apply to BS operating in band n7.
	2500 – 2570 MHz	-49 dBm	1 MHz	This requirement does not apply to BS operating in band n7, since it is already covered by the requirement in subclause 6.6.5.2.2.
UTRA FDD Band VIII or E-UTRA Band 8 or NR Band n8	925 – 960 MHz	-52 dBm	1 MHz	This requirement does not apply to BS operating in band n8.
	880 – 915 MHz	-49 dBm	1 MHz	This requirement does not apply to BS operating in band n8, since it is already covered by the requirement in subclause 6.6.5.2.2.
	1844.9 – 1879.9 MHz	-52 dBm	1 MHz	This requirement does not apply to BS operating in band n3.

UTRA FDD Band IX or E-UTRA Band 9	1749.9 – 1784.9 MHz	-49 dBm	1 MHz	This requirement does not apply to BS operating in band n3, since it is already covered by the requirement in subclause 6.6.5.2.2.
UTRA FDD Band X or E-UTRA Band 10	2110 – 2170 MHz	-52 dBm	1 MHz	This requirement does not apply to BS operating in band n66
	1710 – 1770 MHz	-49 dBm	1 MHz	This requirement does not apply to BS operating in band n66, since it is already covered by the requirement in subclause 6.6.5.2.2.
UTRA FDD Band XI or XXI or E-UTRA Band 11 or 21	1475.9 – 1510.9 MHz	-52 dBm	1 MHz	This requirement does not apply to BS operating in band n50, n74 or n75.
	1427.9 – 1447.9 MHz	-49 dBm	1 MHz	This requirement does not apply to BS operating in band n50, n51, n74, n75 or n76.
	1447.9 – 1462.9 MHz	-49 dBm	1 MHz	This requirement does not apply to BS operating in band n50, n74 or n75.
UTRA FDD Band XII or E-UTRA Band 12 or NR Band n12	729 – 746 MHz	-52 dBm	1 MHz	This requirement does not apply to BS operating in band n12.
	699 – 716 MHz	-49 dBm	1 MHz	This requirement does not apply to BS operating in band n12, since it is already covered by the requirement in subclause 6.6.5.2.2.
UTRA FDD Band XIII or E-UTRA Band 13	746 – 756 MHz	-52 dBm	1 MHz	
	777 – 787 MHz	-49 dBm	1 MHz	
UTRA FDD Band XIV or E-UTRA Band 14	758 – 768 MHz	-52 dBm	1 MHz	
	788 – 798 MHz	-49 dBm	1 MHz	
E-UTRA Band 17	734 – 746 MHz	-52 dBm	1 MHz	
	704 – 716 MHz	-49 dBm	1 MHz	
UTRA FDD Band XX or E-UTRA Band 20 or NR Band n20	791 – 821 MHz	-52 dBm	1 MHz	This requirement does not apply to BS operating in band n20 or n28.
	832 – 862 MHz	-49 dBm	1 MHz	This requirement does not apply to BS operating in band n20, since it is already covered by the requirement in subclause 6.6.5.2.2.
UTRA FDD Band XXII or E-UTRA Band 22	3510 – 3590 MHz	-52 dBm	1 MHz	This requirement does not apply to BS operating in band n77 or n78.
	3410 – 3490 MHz	-49 dBm	1 MHz	This requirement does not apply to BS operating in band n77 or n78.
E-UTRA Band 24	1525 – 1559 MHz	-52 dBm	1 MHz	
	1626.5 – 1660.5 MHz	-49 dBm	1 MHz	
UTRA FDD Band XXV or E-UTRA Band 25 or NR band n25	1930 – 1995 MHz	-52 dBm	1 MHz	This requirement does not apply to BS operating in band n2, n25 or n70.
	1850 – 1915 MHz	-49 dBm	1 MHz	This requirement does not apply to BS operating in band n25 since it is already covered by the requirement in subclause 6.6.5.2.2. For BS operating in Band n2, it applies for 1910 MHz to 1915 MHz, while the rest is covered in subclause 6.6.5.2.2.
UTRA FDD Band XXVI or E-UTRA Band 26	859 – 894 MHz	-52 dBm	1 MHz	This requirement does not apply to BS operating in band n5.
	814 – 849 MHz	-49 dBm	1 MHz	For BS operating in Band n5, it applies for 814 MHz to 824 MHz, while the rest is covered in subclause 6.6.5.2.2.
E-UTRA Band 27	852 – 869 MHz	-52 dBm	1 MHz	This requirement does not apply to BS operating in Band n5.
	807 – 824 MHz	-49 dBm	1 MHz	This requirement also applies to BS operating in Band n28, starting 4 MHz above the Band n28 downlink <i>operating band</i> (Note 5).
E-UTRA Band 28 or NR Band n28	758 – 803 MHz	-52 dBm	1 MHz	This requirement does not apply to BS operating in band n20 or n28.
	703 – 748 MHz	-49 dBm	1 MHz	This requirement does not apply to BS operating in band n28, since it is already covered by the requirement in subclause 6.6.5.2.2.
E-UTRA Band 29	717 – 728 MHz	-52 dBm	1 MHz	
	2350 – 2360 MHz	-52 dBm	1 MHz	

E-UTRA Band 30	2305 – 2315 MHz	-49 dBm	1 MHz	
E-UTRA Band 31	462.5 – 467.5 MHz	-52 dBm	1 MHz	
	452.5 – 457.5 MHz	-49 dBm	1 MHz	
UTRA FDD band XXXII or E-UTRA band 32	1452 – 1496 MHz	-52 dBm	1 MHz	This requirement does not apply to BS operating in band n50, n74 or n75.
UTRA TDD Band a) or E-UTRA Band 33	1900 – 1920 MHz	-52 dBm	1 MHz	
UTRA TDD Band a) or E-UTRA Band 34 or NR band n34	2010 – 2025 MHz	-52 dBm	1 MHz	This requirement does not apply to BS operating in Band n34.
UTRA TDD Band b) or E-UTRA Band 35	1850 – 1910 MHz	-52 dBm	1 MHz	
UTRA TDD Band b) or E-UTRA Band 36	1930 – 1990 MHz	-52 dBm	1 MHz	This requirement does not apply to BS operating in Band n2 or n25.
UTRA TDD Band c) or E-UTRA Band 37	1910 – 1930 MHz	-52 dBm	1 MHz	
UTRA TDD Band d) or E-UTRA Band 38 or NR Band n38	2570 – 2620 MHz	-52 dBm	1 MHz	This requirement does not apply to BS operating in Band n38.
UTRA TDD Band f) or E-UTRA Band 39 or NR band n39	1880 – 1920MHz	-52 dBm	1 MHz	This requirement does not apply to BS operating in Band n39.
UTRA TDD Band e) or E-UTRA Band 40 or NR Band n40	2300 – 2400MHz	-52 dBm	1 MHz	This requirement does not apply to BS operating in Band n40.
E-UTRA Band 41 or NR Band n41	2496 – 2690 MHz	-52 dBm	1 MHz	This is not applicable to BS operating in Band n41.
E-UTRA Band 42	3400 – 3600 MHz	-52 dBm	1 MHz	This is not applicable to BS operating in Band n77 or n78.
E-UTRA Band 43	3600 – 3800 MHz	-52 dBm	1 MHz	This is not applicable to BS operating in Band n77 or n78.
E-UTRA Band 44	703 – 803 MHz	-52 dBm	1 MHz	This is not applicable to BS operating in Band n28.
E-UTRA Band 45	1447 – 1467 MHz	-52 dBm	1 MHz	
E-UTRA Band 46	5150 – 5925 MHz	-52 dBm	1 MHz	
E-UTRA Band 47	5855 – 5925 MHz	-52 dBm	1 MHz	
E-UTRA Band 48	3550 – 3700 MHz	-52 dBm	1 MHz	This is not applicable to BS operating in Band n77 or n78.
E-UTRA Band 50 or NR band n50	1432 – 1517 MHz	-52 dBm	1 MHz	This requirement does not apply to BS operating in Band n50, n51, n74, n75 or n76.
E-UTRA Band 51 or NR Band n51	1427 – 1432 MHz	-52 dBm	1 MHz	This requirement does not apply to BS operating in Band n50, n51, n75 or n76.
	2110 – 2200 MHz	-52 dBm	1 MHz	This requirement does not apply to BS operating in band n1 or n65.

E-UTRA Band 65 or NR Band n65	1920 – 2010 MHz	-49 dBm	1 MHz	For BS operating in Band n1, it applies for 1980 MHz to 2010 MHz, while the rest is covered in subclause 6.6.5.2.2. This requirement does not apply to BS operating in band n65, since it is already covered by the requirement in subclause 6.6.5.2.2.
E-UTRA Band 66 or NR Band n66	2110 – 2200 MHz	-52 dBm	1 MHz	This requirement does not apply to BS operating in band n66.
	1710 – 1780 MHz	-49 dBm	1 MHz	This requirement does not apply to BS operating in band n66, since it is already covered by the requirement in subclause 6.6.5.2.2.
E-UTRA Band 67	738 – 758 MHz	-52 dBm	1 MHz	This requirement does not apply to BS operating in Band n28.
E-UTRA Band 68	753 -783 MHz	-52 dBm	1 MHz	This requirement does not apply to BS operating in band n28.
	698-728 MHz	-49 dBm	1 MHz	For BS operating in Band n28, this requirement applies between 698 MHz and 703 MHz, while the rest is covered in subclause 6.6.5.2.2.
E-UTRA Band 69	2570 – 2620 MHz	-52 dBm	1 MHz	This requirement does not apply to BS operating in Band n38.
E-UTRA Band 70 or NR Band n70	1995 – 2020 MHz	-52 dBm	1 MHz	This requirement does not apply to BS operating in band n2, n25 or n70
	1695 – 1710 MHz	-49 dBm	1 MHz	This requirement does not apply to BS operating in band n70, since it is already covered by the requirement in subclause 6.6.5.2.2.
E-UTRA Band 71 or NR Band n71	617 – 652 MHz	-52 dBm	1 MHz	This requirement does not apply to BS operating in band n71
	663 – 698 MHz	-49 dBm	1 MHz	This requirement does not apply to BS operating in band n71, since it is already covered by the requirement in subclause 6.6.5.2.2.
E-UTRA Band 72	461 – 466 MHz	-52 dBm	1 MHz	
	451 – 456 MHz	-49 dBm	1 MHz	
E-UTRA Band 74 or NR Band n74	1475 – 1518 MHz	-52 dBm	1 MHz	This requirement does not apply to BS operating in band n50, n74 or n75.
	1427 – 1470 MHz	-49 dBm	1MHz	This requirement does not apply to BS operating in band n50, n51, n74, n75 or n76.
E-UTRA Band 75 or NR Band n75	1432 – 1517 MHz	-52 dBm	1 MHz	This requirement does not apply to BS operating in Band n50, n51, n74, n75 or n76.
E-UTRA Band 76 or NR Band n76	1427 – 1432 MHz	-52 dBm	1 MHz	This requirement does not apply to BS operating in Band n50, n51, n75 or n76.
NR Band n77	3.3 – 4.2 GHz	-52 dBm	1 MHz	This requirement does not apply to BS operating in Band n77 or n78
NR Band n78	3.3 – 3.8 GHz	-52 dBm	1 MHz	This requirement does not apply to BS operating in Band n77 or n78
NR Band n79	4.4 – 5.0 GHz	-52 dBm	1 MHz	This requirement does not apply to BS operating in Band n79
NR Band n80	1710 – 1785 MHz	-49 dBm	1 MHz	This requirement does not apply to BS operating in band n3, since it is already covered by the requirement in subclause 6.6.5.2.2.
NR Band n81	880 – 915 MHz	-49 dBm	1 MHz	This requirement does not apply to BS operating in band n8, since it is already covered by the requirement in subclause 6.6.5.2.2.
NR Band n82	832 – 862 MHz	-49 dBm	1 MHz	This requirement does not apply to BS operating in band n20, since it is already covered by the requirement in subclause 6.6.5.2.2.
NR Band n83	703 – 748 MHz	-49 dBm	1 MHz	This requirement does not apply to BS operating in band n28, since it is already covered by the requirement in subclause 6.6.5.2.2.
NR Band n84	1920 – 1980 MHz	-49 dBm	1 MHz	This requirement does not apply to BS operating in band n1, since it is already covered by the requirement in subclause 6.6.5.2.2.
E-UTRA Band 85	728 – 746 MHz	-52 dBm	1 MHz	This requirement does not apply to BS operating in band n12.
	698 – 716 MHz	-49 dBm	1 MHz	This requirement does not apply to BS operating in band n12, since it is already covered by the requirement in subclause 6.6.5.2.2.

NR Band n86	1710 – 1780 MHz	-49 dBm	1 MHz	This requirement does not apply to BS operating in band n66, since it is already covered by the requirement in subclause 6.6.5.2.2.
-------------	-----------------	---------	-------	---

NOTE 1: As defined in the scope for spurious emissions in this clause, except for the cases where the noted requirements apply to a BS operating in Band n28, the co-existence requirements in table 6.6.5.2.3 -1 do not apply for the Δf_{OBUE} frequency range immediately outside the downlink *operating band* (see table 5.2-1). Emission limits for this excluded frequency range may be covered by local or regional requirements.

NOTE 2: Table 6.6.5.2.3 -1 assumes that two *operating bands*, where the frequency ranges in table 5.2-1 would be overlapping, are not deployed in the same geographical area. For such a case of operation with overlapping frequency arrangements in the same geographical area, special co-existence requirements may apply that are not covered by the 3GPP specifications.

NOTE 3: TDD base stations deployed in the same geographical area, that are synchronized and use the same or adjacent *operating bands* can transmit without additional co-existence requirements. For unsynchronized base stations, special co-existence requirements may apply that are not covered by the 3GPP specifications.

NOTE 4: For NR Band n28 BS, specific solutions may be required to fulfil the spurious emissions limits for BS for co-existence with E-UTRA Band 27 UL *operating band*.

The following requirement may be applied for the protection of PHS. This requirement is also applicable at specified frequencies falling between Δf_{OBUE} below the lowest BS transmitter frequency of the downlink *operating band* and Δf_{OBUE} above the highest BS transmitter frequency of the downlink *operating band*. Δf_{OBUE} is defined in subclause 6.6.1.

The spurious emission *basic limit* for this requirement is:

Table 6.6.5.2.3-2: BS spurious emissions *basic limits* for BS for co-existence with PHS

Frequency range	<i>Basic limit</i>	Measurement Bandwidth	Note
1884.5 – 1915.7 MHz	-41 dBm	300 kHz	Applicable when co-existence with PHS system operating in 1884.5 – 1915.7 MHz

Table 6.6.5.2.3-3: Void

In certain regions, the following requirement may apply to NR BS operating in Band n50 and n75 within the 1432 – 1452 MHz, and in Band n51 and Band n76. The *basic limit* is specified in Table 6.6.5.2.3-4. This requirement is also applicable at the frequency range from Δf_{OBUE} below the lowest frequency of the BS downlink *operating band* up to Δf_{OBUE} above the highest frequency of the BS downlink *operating band*.

Table 6.6.5.2.3-4: Additional operating band unwanted emission *basic limit* for NR BS operating in Band n50 and n75 within 1432 – 1452 MHz, and in Band n51 and n76

Filter centre frequency, F_{filter}	<i>Basic limit</i>	Measurement Bandwidth
$F_{\text{filter}} = 1413.5 \text{ MHz}$	-42 dBm	27 MHz

In certain regions, the following requirement may apply to BS operating in NR Band n50 and n75 within 1492-1517 MHz and in Band n74 within 1492-1518 MHz. The maximum level of emissions, measured on centre frequencies F_{filter} with filter bandwidth according to Table 6.6.5.2.3-5, shall be defined according to the *basic limits* $P_{\text{EM},n50/n75,a}$ nor $P_{\text{EM},n50/n75,b}$ declared by the manufacturer.

Table 6.6.5.2.3-5: *Operating band* n50, n74 and n75 declared emission above 1518 MHz

Filter centre frequency, F_{filter}	Declared <i>basic limits</i> (dBm)	Measurement bandwidth
$1518.5 \text{ MHz} \leq F_{\text{filter}} \leq 1519.5 \text{ MHz}$	$P_{\text{EM},n50/n75,a}$	1 MHz
$1520.5 \text{ MHz} \leq F_{\text{filter}} \leq 1558.5 \text{ MHz}$	$P_{\text{EM},n50/n75,b}$	1 MHz

NOTE: The regional requirement, included in [12], is defined in terms of EIRP, which is dependent on both the BS emissions at the antenna connector and the deployment (including antenna gain and feeder loss). The requirement defined above provides the characteristics of the base station needed to verify compliance with the regional requirement. The assessment of the EIRP level is described in Annex E.

6.6.5.2.4 Co-location with other base stations

These requirements may be applied for the protection of other BS receivers when GSM900, DCS1800, PCS1900, GSM850, CDMA850, UTRA FDD, UTRA TDD, E-UTRA and/or NR BS are co-located with a BS.

The requirements assume a 30 dB coupling loss between transmitter and receiver and are based on co-location with base stations of the same class.

The *basic limits* are in table 6.6.5.2.4-1 for a BS where requirements for co-location with a BS type listed in the first column apply, depending on the declared Base Station class. For a *multi-band connector*, the exclusions and conditions in the Note column of table 6.6.5.2.4-1 shall apply for each supported *operating band*.

Table 6.6.5.2.4-1: BS spurious emissions *basic limits* for BS co-located with another BS

Type of co-located BS	Frequency range for co-location requirement	Basic limits			Measurement bandwidth	Note
		WA BS	MR BS	LA BS		
GSM900	876 – 915 MHz	-98 dBm	-91 dBm	-70 dBm	100 kHz	
DCS1800	1710 – 1785 MHz	-98 dBm	-91 dBm	-80 dBm	100 kHz	
PCS1900	1850 – 1910 MHz	-98 dBm	-91 dBm	-80 dBm	100 kHz	
GSM850 or CDMA850	824 – 849 MHz	-98 dBm	-91 dBm	-70 dBm	100 kHz	
UTRA FDD Band I or E-UTRA Band 1 or NR Band n1	1920 – 1980 MHz	-96 dBm	-91 dBm	-88 dBm	100 kHz	
UTRA FDD Band II or E-UTRA Band 2 or NR Band n2	1850 – 1910 MHz	-96 dBm	-91 dBm	-88 dBm	100 kHz	
UTRA FDD Band III or E-UTRA Band 3 or NR Band n3	1710 – 1785 MHz	-96 dBm	-91 dBm	-88 dBm	100 kHz	
UTRA FDD Band IV or E-UTRA Band 4	1710 – 1755 MHz	-96 dBm	-91 dBm	-88 dBm	100 kHz	
UTRA FDD Band V or E-UTRA Band 5 or NR Band n5	824 – 849 MHz	-96 dBm	-91 dBm	-88 dBm	100 kHz	
UTRA FDD Band VI, XIX or E-UTRA Band 6, 19	830 – 845 MHz	-96 dBm	-91 dBm	-88 dBm	100 kHz	
UTRA FDD Band VII or E-UTRA Band 7 or NR Band n7	2500 – 2570 MHz	-96 dBm	-91 dBm	-88 dBm	100 kHz	
UTRA FDD Band VIII or E-UTRA Band 8 or NR Band n8	880 – 915 MHz	-96 dBm	-91 dBm	-88 dBm	100 kHz	
UTRA FDD Band IX or E-UTRA Band 9	1749.9 – 1784.9 MHz	-96 dBm	-91 dBm	-88 dBm	100 kHz	
UTRA FDD Band X or E-UTRA Band 10	1710 – 1770 MHz	-96 dBm	-91 dBm	-88 dBm	100 kHz	
UTRA FDD Band XI or E-UTRA Band 11	1427.9 – 1447.9 MHz	-96 dBm	-91 dBm	-88 dBm	100 kHz	This is not applicable to BS operating in Band n50 or n75
UTRA FDD Band XII or E-UTRA Band 12 or NR Band n12	699 – 716 MHz	-96 dBm	-91 dBm	-88 dBm	100 kHz	
UTRA FDD Band XIII or E-UTRA Band 13	777 – 787 MHz	-96 dBm	-91 dBm	-88 dBm	100 kHz	
UTRA FDD Band XIV or E-UTRA Band 14	788 – 798 MHz	-96 dBm	-91 dBm	-88 dBm	100 kHz	
E-UTRA Band 17	704 – 716 MHz	-96 dBm	-91 dBm	-88 dBm	100 kHz	
E-UTRA Band 18	815 – 830 MHz	-96 dBm	-91 dBm	-88 dBm	100 kHz	
UTRA FDD Band XX or E-UTRA Band 20 or NR Band n20	832 – 862 MHz	-96 dBm	-91 dBm	-88 dBm	100 kHz	
UTRA FDD Band XXI or E-UTRA Band 21	1447.9 – 1462.9 MHz	-96 dBm	-91 dBm	-88 dBm	100 kHz	This is not applicable to BS operating in Band n50 or n75
UTRA FDD Band XXII or E-UTRA Band 22	3410 – 3490 MHz	-96 dBm	-91 dBm	-88 dBm	100 kHz	This is not applicable to BS operating in Band n77 or n78
E-UTRA Band 23	2000 – 2020 MHz	-96 dBm	-91 dBm	-88 dBm	100 kHz	
E-UTRA Band 24	1626.5 – 1660.5 MHz	-96 dBm	-91 dBm	-88 dBm	100 kHz	

UTRA FDD Band XXV or E-UTRA Band 25 or NR Band n25	1850 – 1915 MHz	-96 dBm	-91 dBm	-88 dBm	100 kHz	
UTRA FDD Band XXVI or E-UTRA Band 26	814 – 849 MHz	-96 dBm	-91 dBm	-88 dBm	100 kHz	
E-UTRA Band 27	807 – 824 MHz	-96 dBm	-91 dBm	-88 dBm	100 kHz	
E-UTRA Band 28 or NR Band n28	703 – 748 MHz	-96 dBm	-91 dBm	-88 dBm	100 kHz	
E-UTRA Band 30	2305 – 2315 MHz	-96 dBm	-91 dBm	-88 dBm	100 kHz	
E-UTRA Band 31	452.5 – 457.5 MHz	-96 dBm	-91 dBm	-88 dBm	100 kHz	
UTRA TDD Band a) or E-UTRA Band 33	1900 – 1920 MHz	-96 dBm	-91 dBm	-88 dBm	100 kHz	
UTRA TDD Band a) or E-UTRA Band 34 or NR band n34	2010 – 2025 MHz	-96 dBm	-91 dBm	-88 dBm	100 kHz	This is not applicable to BS operating in Band n34
UTRA TDD Band b) or E-UTRA Band 35	1850 – 1910 MHz	-96 dBm	-91 dBm	-88 dBm	100 kHz	
UTRA TDD Band b) or E-UTRA Band 36	1930 – 1990 MHz	-96 dBm	-91 dBm	-88 dBm	100 kHz	This is not applicable to BS operating in Band n2 or band n25
UTRA TDD Band c) or E-UTRA Band 37	1910 – 1930 MHz	-96 dBm	-91 dBm	-88 dBm	100 kHz	
UTRA TDD Band d) or E-UTRA Band 38 or NR Band n38	2570 – 2620 MHz	-96 dBm	-91 dBm	-88 dBm	100 kHz	This is not applicable to BS operating in Band n38.
UTRA TDD Band f) or E-UTRA Band 39 or NR band n39	1880 – 1920MHz	-96 dBm	-91 dBm	-88 dBm	100 kHz	This is not applicable to BS operating in Band n39
UTRA TDD Band e) or E-UTRA Band 40 or NR Band n40	2300 – 2400MHz	-96 dBm	-91 dBm	-88 dBm	100 kHz	This is not applicable to BS operating in Band n40.
E-UTRA Band 41 or NR Band n41	2496 – 2690 MHz	-96 dBm	-91 dBm	-88 dBm	100 kHz	This is not applicable to BS operating in Band n41
E-UTRA Band 42	3400 – 3600 MHz	-96 dBm	-91 dBm	-88 dBm	100 kHz	This is not applicable to BS operating in Band n77 or n78
E-UTRA Band 43	3600 – 3800 MHz	-96 dBm	-91 dBm	-88 dBm	100 kHz	This is not applicable to BS operating in Band n77 or n78
E-UTRA Band 44	703 – 803 MHz	-96 dBm	-91 dBm	-88 dBm	100 kHz	This is not applicable to BS operating in Band n28
E-UTRA Band 45	1447 – 1467 MHz	-96 dBm	-91 dBm	-88 dBm	100 kHz	
E-UTRA Band 46	5150 – 5925 MHz	N/A	-91 dBm	-88 dBm	100 kHz	
E-UTRA Band 48	3550 – 3700 MHz	-96 dBm	-91 dBm	-88 dBm	100 kHz	This is not applicable to BS operating in Band n77 or n78

E-UTRA Band 50 or NR Band n50	1432 – 1517 MHz	-96 dBm	-91 dBm	-88 dBm	100 kHz	This is not applicable to BS operating in Band n51, n74 or n75
E-UTRA Band 51 or NR Band n51	1427 – 1432 MHz	N/A	N/A	-88 dBm	100 kHz	This is not applicable to BS operating in Band n50, n74, n75 or n76
E-UTRA Band 65 or NR Band n65	1920 – 2010 MHz	-96 dBm	-91 dBm	-88 dBm	100 kHz	
E-UTRA Band 66 or NR Band n66	1710 – 1780 MHz	-96 dBm	-91 dBm	-88 dBm	100 kHz	
E-UTRA Band 68	698 – 728 MHz	-96 dBm	-91 dBm	-88 dBm	100 kHz	
E-UTRA Band 70 or NR Band n70	1695 – 1710 MHz	-96 dBm	-91 dBm	-88 dBm	100 kHz	
E-UTRA Band 71 or NR Band n71	663 – 698 MHz	-96 dBm	-91 dBm	-88 dBm	100 kHz	
E-UTRA Band 72	451 – 456 MHz	-96 dBm	-91 dBm	-88 dBm	100 kHz	
E-UTRA Band 74 or NR Band n74	1427 – 1470 MHz	-96 dBm	-91 dBm	-88 dBm	100 kHz	This is not applicable to BS operating in Band n50 or n51
NR Band n77	3.3 – 4.2 GHz	-96 dBm	-91 dBm	-88 dBm	100 kHz	This is not applicable to BS operating in Band n77 or n78
NR Band n78	3.3 – 3.8 GHz	-96 dBm	-91 dBm	-88 dBm	100 kHz	This is not applicable to BS operating in Band n77 or n78
NR Band n79	4.4 – 5.0 GHz	-96 dBm	-91 dBm	-88 dBm	100 kHz	
NR Band n80	1710 – 1785 MHz	-96 dBm	-91 dBm	-88 dBm	100 kHz	
NR Band n81	880 – 915 MHz	-96 dBm	-91 dBm	-88 dBm	100 kHz	
NR Band n82	832 – 862 MHz	-96 dBm	-91 dBm	-88 dBm	100 kHz	
NR Band n83	703 – 748 MHz	-96 dBm	-91 dBm	-88 dBm	100 kHz	
NR Band n84	1920 – 1980 MHz	-96 dBm	-91 dBm	-88 dBm	100 kHz	
E-UTRA Band 85	698 – 716 MHz	-96 dBm	-91 dBm	-88 dBm	100 kHz	
NR Band n86	1710 – 1780 MHz	-96 dBm	-91 dBm	-88 dBm	100 kHz	

NOTE 1: As defined in the scope for spurious emissions in this clause, the co-location requirements in table 6.6.5.2.4-1 do not apply for the frequency range extending Δf_{OBUe} immediately outside the BS transmit frequency range of a downlink *operating band* (see table 5.2-1). The current state-of-the-art technology does not allow a single generic solution for co-location with other system on adjacent frequencies for 30dB BS-BS minimum coupling loss. However, there are certain site-engineering solutions that can be used. These techniques are addressed in TR 25.942 [4].

NOTE 2: Table 6.6.5.2.4-1 assumes that two *operating bands*, where the corresponding BS transmit and receive frequency ranges in table 5.2-1 would be overlapping, are not deployed in the same geographical area. For such a case of operation with overlapping frequency arrangements in the same geographical area, special co-location requirements may apply that are not covered by the 3GPP specifications.

NOTE 3: Co-located TDD base stations that are synchronized and using the same or adjacent *operating band* can transmit without special co-locations requirements. For unsynchronized base stations, special co-location requirements may apply that are not covered by the 3GPP specifications.

6.6.5.3 Minimum requirements for *BS type 1-C*

The Tx spurious emissions for *BS type 1-C* for each *antenna connector* shall not exceed the *basic limits* specified in subclause 6.6.5.2.

6.6.5.4 Minimum requirements for *BS type 1-H*

The Tx spurious emissions requirements for *BS type 1-H* are that for each *TAB connector TX min cell group* and each applicable *basic limit* in subclause 6.6.5.2, the power summation emissions at the *TAB connectors* of the *TAB connector TX min cell group* shall not exceed an OTA limit specified as the *basic limit* + X, where $X = 10\log_{10}(N_{\text{TXU, counted per cell}})$, unless stated differently in regional regulation.

NOTE: Conformance to the *BS type 1-H* spurious emission requirement can be demonstrated by meeting at least one of the following criteria as determined by the manufacturer:

1) The sum of the emissions power measured on each *TAB connector* in the *TAB connector TX min cell group* shall be less than or equal to the limit as defined in this subclause for the respective frequency span.

Or

2) The unwanted emissions power at each *TAB connector* shall be less than or equal to the *BS type 1-H* limit as defined in this subclause for the respective frequency span, scaled by $-10\log_{10}(n)$, where n is the number of *TAB connectors* in the *TAB connector TX min cell group*.

6.7 Transmitter intermodulation

6.7.1 General

The transmitter intermodulation requirement is a measure of the capability of the transmitter unit to inhibit the generation of signals in its non-linear elements caused by presence of the wanted signal and an interfering signal reaching the transmitter unit via the antenna, RDN and antenna array. The requirement shall apply during the transmitter ON period and the *transmitter transient period*.

For *BS type 1-C*, the transmitter intermodulation level is the power of the intermodulation products when an interfering signal is injected into the *antenna connector*.

For *BS type 1-H*, the transmitter intermodulation level is the power of the intermodulation products when an interfering signal is injected into the *TAB connector*.

For *BS type 1-H*, there are two types of transmitter intermodulation cases captured by the transmitter intermodulation requirement:

- 1) Co-location transmitter intermodulation in which the interfering signal is from a co-located base station.
- 2) Intra-system transmitter intermodulation in which the interfering signal is from other transmitter units within the *BS type 1-H*.

For *BS type 1-H*, the co-location transmitter intermodulation requirement is considered sufficient if the interference signal for the co-location requirement is higher than the declared interference signal for intra-system transmitter intermodulation requirement.

6.7.2 Minimum requirements for BS type 1-C

6.7.2.1 Co-location minimum requirements

For *BS type 1-C*, the wanted signal and interfering signal centre frequency is specified in table 6.7.2.1-1, where interfering signal level is Rated total output power ($P_{\text{rated,t,AC}}$) at *antenna connector* in the *operating band* – 30 dB.

The requirement is applicable outside the Base Station RF Bandwidth or Radio Bandwidth. The interfering signal offset is defined relative to the Base Station RF Bandwidth edges or Radio Bandwidth edges.

For a BS operating in non-contiguous spectrum, the requirement is also applicable inside a sub-block gap for interfering signal offsets where the interfering signal falls completely within the sub-block gap. The interfering signal offset is defined relative to the sub-block edges.

For a *multi-band connector*, the requirement shall apply relative to the Base Station RF Bandwidth edges of each supported *operating band*. In case the *Inter RF Bandwidth gap* is less than $3 \cdot BW_{\text{Channel}}$ (where BW_{Channel} is the minimal *BS channel bandwidth* of the band), the requirement in the gap shall apply only for interfering signal offsets where the interfering signal falls completely within the Inter RF Bandwidth gap.

The transmitter intermodulation level shall not exceed the unwanted emission limits in subclauses 6.6.3, 6.6.4 and 6.6.5 in the presence of an NR interfering signal according to table 6.7.2.1-1.

Table 6.7.2.1-1: Interfering and wanted signals for the co-location transmitter intermodulation requirement

Parameter	Value
Wanted signal type	NR single carrier, or multi-carrier, or multiple intra-band contiguously or non-contiguously aggregated carriers
Interfering signal type	NR signal, the supported minimum <i>BS channel bandwidth</i> (BW_{Channel}) with 15 kHz SCS of the band
Interfering signal level	Rated total output power ($P_{\text{rated,t,AC}}$) in the <i>operating band</i> – 30 dB
Interfering signal centre frequency offset from the lower/upper edge of the wanted signal or edge of sub-block inside a sub-block gap	$f_{\text{offset}} = \pm BW_{\text{Channel}} \left(n - \frac{1}{2} \right)$, for $n=1, 2$ and 3
NOTE:	Interfering signal positions that are partially or completely outside of any downlink <i>operating band</i> of the base station are excluded from the requirement, unless the interfering signal positions fall within the frequency range of adjacent downlink <i>operating bands</i> in the same geographical area. In case that none of the interfering signal positions fall completely within the frequency range of the downlink <i>operating band</i> , TS 38.141-1 [5] provides further guidance regarding appropriate test requirements.

6.7.2.2 Additional requirements

TBD

6.7.3 Minimum requirements for BS type 1-H

6.7.3.1 Co-location minimum requirements

The transmitter intermodulation level shall not exceed the unwanted emission limits in subclauses 6.6.3, 6.6.4 and 6.6.5 in the presence of an NR interfering signal according to table 6.7.3.1-1

The requirement is applicable outside the *Base Station RF Bandwidth edges*. The interfering signal offset is defined relative to the *Base Station RF Bandwidth edges* or *Radio Bandwidth edges*.

For *TAB connectors* supporting operation in *non-contiguous spectrum*, the requirement is also applicable inside a *sub-block gap* for interfering signal offsets where the interfering signal falls completely within the *sub-block gap*. The interfering signal offset is defined relative to the *sub-block edges*.

For *multi-band connector*, the requirement shall apply relative to the *Base Station RF Bandwidth edges* of each *operating band*. In case the *inter RF Bandwidth gap* is less than $3 \cdot BW_{\text{Channel}}$ (where BW_{Channel} is the minimal *BS channel bandwidth* of the band), the requirement in the gap shall apply only for interfering signal offsets where the interfering signal falls completely within the *inter RF Bandwidth gap*.

Table 6.7.3.1-1: Interfering and wanted signals for the co-location transmitter intermodulation requirement

Parameter	Value
Wanted signal type	NR single carrier, or multi-carrier, or multiple intra-band contiguously or non-contiguously aggregated carriers
Interfering signal type	NR signal, the minimum supported <i>BS channel bandwidth</i> (BW_{Channel}) with 15 kHz SCS of the band
Interfering signal level	Rated total output power per <i>TAB connector</i> ($P_{\text{rated,t,TABC}}$) in the <i>operating band</i> – 30 dB
Interfering signal centre frequency offset from the lower/upper edge of the wanted signal or edge of <i>sub-block</i> inside a gap	$f_{\text{offset}} = \pm BW_{\text{Channel}} \left(n - \frac{1}{2} \right)$, for $n=1, 2$ and 3
NOTE:	Interfering signal positions that are partially or completely outside of any downlink <i>operating band</i> of the <i>TAB connector</i> are excluded from the requirement, unless the interfering signal positions fall within the frequency range of adjacent downlink <i>operating bands</i> in the same geographical area. In case that none of the interfering signal positions fall completely within the frequency range of the downlink <i>operating band</i> , TS 38.141-1 [5] provides further guidance regarding appropriate test requirements.

6.7.3.2 Intra-system minimum requirements

The transmitter intermodulation level shall not exceed the unwanted emission limits in subclauses 6.6.3 and 6.6.4 in the presence of an NR interfering signal according to table 6.7.3.2-1.

Table 6.7.3.2-1: Interfering and wanted signals for intra-system transmitter intermodulation requirement

Parameter	Value
Wanted signal type	NR signal
Interfering signal type	NR signal of the same <i>BS channel bandwidth</i> and SCS as the wanted signal (Note 1).
Interfering signal level	Power level declared by the base station manufacturer (Note 2).
Frequency offset between interfering signal and wanted signal	0 MHz
NOTE 1:	The interfering signal shall be incoherent with the wanted signal.
NOTE 2:	The declared interfering signal power level at each <i>TAB connector</i> is the sum of the co-channel leakage power coupled via the combined RDN and Antenna Array from all the other <i>TAB connectors</i> , but does not comprise power radiated from the Antenna Array and reflected back from the environment. The power at each of the interfering <i>TAB connectors</i> is $P_{\text{rated,c,TABC}}$.

6.7.3.3 Additional requirements

TBD

7 Conducted receiver characteristics

7.1 General

Conducted receiver characteristics are specified at the *antenna connector* for *BS type 1-C* and at the *TAB connector* for *BS type 1-H*, with full complement of transceivers for the configuration in normal operating condition.

Unless otherwise stated, the following arrangements apply for conducted receiver characteristics requirements in clause 7:

- Requirements apply during the BS receive period.
- Requirements shall be met for any transmitter setting.
- For FDD operation the requirements shall be met with the transmitter unit(s) ON.
- Throughput requirements defined for the radiated receiver characteristics do not assume HARQ retransmissions.
- When BS is configured to receive multiple carriers, all the throughput requirements are applicable for each received carrier.
- For ACS, blocking and intermodulation characteristics, the negative offsets of the interfering signal apply relative to the lower edge and positive offsets of the interfering signal apply relative to the higher edge.

NOTE 1: In normal operating condition the BS in FDD operation is configured to transmit and receive at the same time.

NOTE 2: In normal operating condition the BS in TDD operation is configured to TX OFF power during *receive period*.

7.2 Reference sensitivity level

7.2.1 General

The reference sensitivity power level P_{REFSENS} is the minimum mean power received at the *antenna connector* for *BS type 1-C* or *TAB connector* for *BS type 1-H* at which a throughput requirement shall be met for a specified reference measurement channel.

7.2.2 Minimum requirements for *BS type 1-C* and *BS type 1-H*

For NR, the throughput shall be $\geq 95\%$ of the maximum throughput of the reference measurement channel as specified in Annex A with parameters specified in table 7.2.2-1 for Wide Area BS, in table 7.2.2-2 for Medium Range BS and in table 7.2.2-3 for Local Area BS.

Table 7.2.2-1: NR Wide Area BS reference sensitivity levels

<i>BS channel bandwidth</i> (MHz)	<i>Sub-carrier spacing</i> (kHz)	<i>Reference measurement channel</i>	<i>Reference sensitivity power level, P_{REFSENS}</i> (dBm)
5, 10, 15	15	G-FR1-A1-1	-101.7
10, 15	30	G- FR1-A1-2	-101.8
10, 15	60	G- FR1-A1-3	-98.9
20, 25, 30, 40, 50	15	G- FR1-A1-4	-95.3
20, 25, 30, 40, 50, 60, 70, 80, 90, 100	30	G- FR1-A1-5	-95.6
20, 25, 30, 40, 50, 60, 70, 80, 90, 100	60	G- FR1-A1-6	-95.7
NOTE: P _{REFSENS} is the power level of a single instance of the reference measurement channel. This requirement shall be met for each consecutive application of a single instance of the reference measurement channel mapped to disjoint frequency ranges with a width corresponding to the number of resource blocks of the reference measurement channel each, except for one instance that might overlap one other instance to cover the full <i>BS channel bandwidth</i> .			

Table 7.2.2-2: NR Medium Area BS reference sensitivity levels

<i>BS channel bandwidth</i> (MHz)	<i>Sub-carrier spacing</i> (kHz)	<i>Reference measurement channel</i>	<i>Reference sensitivity power level, P_{REFSENS}</i> (dBm)
5, 10, 15	15	G- FR1-A1-1	-96.7
10, 15	30	G- FR1-A1-2	-96.8
10, 15	60	G- FR1-A1-3	-93.9
20, 25, 30, 40, 50	15	G- FR1-A1-4	-90.3
20, 25, 30, 40, 50, 60, 70, 80, 90, 100	30	G- FR1-A1-5	-90.6
20, 25, 30, 40, 50, 60, 70, 80, 90, 100	60	G- FR1-A1-6	-90.7
NOTE: P _{REFSENS} is the power level of a single instance of the reference measurement channel. This requirement shall be met for each consecutive application of a single instance of the reference measurement channel mapped to disjoint frequency ranges with a width corresponding to the number of resource blocks of the reference measurement channel each, except for one instance that might overlap one other instance to cover the full <i>BS channel bandwidth</i> .			

Table 7.2.2-3: NR Local Area BS reference sensitivity levels

<i>BS channel bandwidth</i> (MHz)	<i>Sub-carrier spacing</i> (kHz)	<i>Reference measurement channel</i>	<i>Reference sensitivity power level, P_{REFSENS}</i> (dBm)
5, 10, 15	15	G- FR1-A1-1	-93.7
10, 15	30	G- FR1-A1-2	-93.8
10, 15	60	G- FR1-A1-3	-90.9
20, 25, 30, 40, 50	15	G- FR1-A1-4	-87.3
20, 25, 30, 40, 50, 60, 70, 80, 90, 100	30	G- FR1-A1-5	-87.6
20, 25, 30, 40, 50, 60, 70, 80, 90, 100	60	G- FR1-A1-6	-87.7
NOTE: P _{REFSENS} is the power level of a single instance of the reference measurement channel. This requirement shall be met for each consecutive application of a single instance of the reference measurement channel mapped to disjoint frequency ranges with a width corresponding to the number of resource blocks of the reference measurement channel each, except for one instance that might overlap one other instance to cover the full <i>BS channel bandwidth</i> .			

7.3 Dynamic range

7.3.1 General

The dynamic range is specified as a measure of the capability of the receiver to receive a wanted signal in the presence of an interfering signal at the *antenna connector* for *BS type 1-C* or *TAB connector* for *BS type 1-H* inside the received *BS channel bandwidth*. In this condition, a throughput requirement shall be met for a specified reference measurement channel. The interfering signal for the dynamic range requirement is an AWGN signal.

7.3.2 Minimum requirement for *BS type 1-C* and *BS type 1-H*

For NR, the throughput shall be $\geq 95\%$ of the maximum throughput of the reference measurement channel as specified in Annex A with parameters specified in table 7.3.2-1 for Wide Area BS, in table 7.3.2-2 for Medium Range BS and in table 7.3.2-3 for Local Area BS.

Table 7.3.2-1: Wide Area BS dynamic range

<i>BS channel bandwidth</i> (MHz)	Subcarrier spacing (kHz)	Reference measurement channel	Wanted signal mean power (dBm)	Interfering signal mean power (dBm) / BW_{Config}	Type of interfering signal
5	15	G-FR1-A2-1	-70.7	-82.5	AWGN
	30	G- FR1-A2-2	-71.4		
10	15	G-FR1-A2-1	-70.7	-79.3	AWGN
	30	G- FR1-A2-2	-71.4		
	60	G- FR1-A2-3	-68.4		
15	15	G-FR1-A2-1	-70.7	-77.5	AWGN
	30	G- FR1-A2-2	-71.4		
	60	G- FR1-A2-3	-68.4		
20	15	G- FR1-A2-4	-64.5	-76.2	AWGN
	30	G- FR1-A2-5	-64.5		
	60	G- FR1-A2-6	-64.8		
25	15	G- FR1-A2-4	-64.5	-75.2	AWGN
	30	G- FR1-A2-5	-64.5		
	60	G- FR1-A2-6	-64.8		
30	15	G- FR1-A2-4	-64.5	-74.4	AWGN
	30	G- FR1-A2-5	-64.5		
	60	G- FR1-A2-6	-64.8		
40	15	G- FR1-A2-4	-64.5	-73.1	AWGN
	30	G- FR1-A2-5	-64.5		
	60	G- FR1-A2-6	-64.8		
50	15	G- FR1-A2-4	-64.5	-72.2	AWGN
	30	G- FR1-A2-5	-64.5		
	60	G- FR1-A2-6	-64.8		
60	30	G- FR1-A2-5	-64.5	-71.4	AWGN
	60	G- FR1-A2-6	-64.8		
70	30	G- FR1-A2-5	-64.5	-70.8	AWGN
	60	G- FR1-A2-6	-64.8		
80	30	G- FR1-A2-5	-64.5	-70.1	AWGN
	60	G- FR1-A2-6	-64.8		
90	30	G- FR1-A2-5	-64.5	-69.6	AWGN
	60	G- FR1-A2-6	-64.8		
100	30	G- FR1-A2-5	-64.5	-69.1	AWGN
	60	G- FR1-A2-6	-64.8		

NOTE: The wanted signal mean power is the power level of a single instance of the corresponding reference measurement channel. This requirement shall be met for each consecutive application of a single instance of the reference measurement channel mapped to disjoint frequency ranges with a width corresponding to the number of resource blocks of the reference measurement channel each, except for one instance that might overlap one other instance to cover the full *BS channel bandwidth*.

Table 7.3.2-2: Medium Range BS dynamic range

<i>BS channel bandwidth (MHz)</i>	<i>Subcarrier spacing (kHz)</i>	<i>Reference measurement channel</i>	<i>Wanted signal mean power (dBm)</i>	<i>Interfering signal mean power (dBm) / BW_{Config}</i>	<i>Type of interfering signal</i>
5	15	G-FR1-A2-1	-65.7	-77.5	AWGN
	30	G- FR1-A2-2	-66.4		
10	15	G-FR1-A2-1	-65.7	-74.3	AWGN
	30	G- FR1-A2-2	-66.4		
	60	G- FR1-A2-3	-63.4		
15	15	G-FR1-A2-1	-65.7	-72.5	AWGN
	30	G- FR1-A2-2	-66.4		
	60	G- FR1-A2-3	-63.4		
20	15	G- FR1-A2-4	-59.5	-71.2	AWGN
	30	G- FR1-A2-5	-59.5		
	60	G- FR1-A2-6	-59.8		
25	15	G- FR1-A2-4	-59.5	-70.2	AWGN
	30	G- FR1-A2-5	-59.5		
	60	G- FR1-A2-6	-59.8		
30	15	G- FR1-A2-4	-59.5	-69.4	AWGN
	30	G- FR1-A2-5	-59.5		
	60	G- FR1-A2-6	-59.8		
40	15	G- FR1-A2-4	-59.5	-68.1	AWGN
	30	G- FR1-A2-5	-59.5		
	60	G- FR1-A2-6	-59.8		
50	15	G- FR1-A2-4	-59.5	-67.2	AWGN
	30	G- FR1-A2-5	-59.5		
	60	G- FR1-A2-6	-59.8		
60	30	G- FR1-A2-5	-59.5	-66.4	AWGN
	60	G- FR1-A2-6	-59.8		
70	30	G- FR1-A2-5	-59.5	-65.8	AWGN
	60	G- FR1-A2-6	-59.8		
80	30	G- FR1-A2-5	-59.5	-65.1	AWGN
	60	G- FR1-A2-6	-59.8		
90	30	G- FR1-A2-5	-59.5	-64.6	AWGN
	60	G- FR1-A2-6	-59.8		
100	30	G- FR1-A2-5	-59.5	-64.1	AWGN
	60	G- FR1-A2-6	-59.8		

NOTE: The wanted signal mean power is the power level of a single instance of the corresponding reference measurement channel. This requirement shall be met for each consecutive application of a single instance of the reference measurement channel mapped to disjoint frequency ranges with a width corresponding to the number of resource blocks of the reference measurement channel each, except for one instance that might overlap one other instance to cover the full *BS channel bandwidth*.

Table 7.3.2-3: Local Area BS dynamic range

<i>BS channel bandwidth (MHz)</i>	<i>Subcarrier spacing (kHz)</i>	<i>Reference measurement channel</i>	<i>Wanted signal mean power (dBm)</i>	<i>Interfering signal mean power (dBm) / BW_{Config}</i>	<i>Type of interfering signal</i>
5	15	G-FR1-A2-1	-62.7	-74.5	AWGN
	30	G- FR1-A2-2	-63.4		
10	15	G-FR1-A2-1	-62.7	-71.3	AWGN
	30	G- FR1-A2-2	-63.4		
	60	G- FR1-A2-3	-60.4		
15	15	G-FR1-A2-1	-62.7	-69.5	AWGN
	30	G- FR1-A2-2	-63.4		
	60	G- FR1-A2-3	-60.4		
20	15	G- FR1-A2-4	-56.5	-68.2	AWGN
	30	G- FR1-A2-5	-56.5		
	60	G- FR1-A2-6	-56.8		
25	15	G- FR1-A2-4	-56.5	-67.2	AWGN
	30	G- FR1-A2-5	-56.5		
	60	G- FR1-A2-6	-56.8		
30	15	G- FR1-A2-4	-56.5	-66.4	AWGN
	30	G- FR1-A2-5	-56.5		
	60	G- FR1-A2-6	-56.8		
40	15	G- FR1-A2-4	-56.5	-65.1	AWGN
	30	G- FR1-A2-5	-56.5		
	60	G- FR1-A2-6	-56.8		
50	15	G- FR1-A2-4	-56.5	-64.2	AWGN
	30	G- FR1-A2-5	-56.5		
	60	G- FR1-A2-6	-56.8		
60	30	G- FR1-A2-5	-56.5	-63.4	AWGN
	60	G- FR1-A2-6	-56.8		
70	30	G- FR1-A2-5	-56.5	-62.8	AWGN
	60	G- FR1-A2-6	-56.8		
80	30	G- FR1-A2-5	-56.5	-62.1	AWGN
	60	G- FR1-A2-6	-56.8		
90	30	G- FR1-A2-5	-56.5	-61.6	AWGN
	60	G- FR1-A2-6	-56.8		
100	30	G- FR1-A2-5	-56.5	-61.1	AWGN
	60	G- FR1-A2-6	-56.8		

NOTE: The wanted signal mean power is the power level of a single instance of the corresponding reference measurement channel. This requirement shall be met for each consecutive application of a single instance of the reference measurement channel mapped to disjoint frequency ranges with a width corresponding to the number of resource blocks of the reference measurement channel each, except for one instance that might overlap one other instance to cover the full *BS channel bandwidth*.

7.4 In-band selectivity and blocking

7.4.1 Adjacent Channel Selectivity (ACS)

7.4.1.1 General

Adjacent channel selectivity (ACS) is a measure of the receiver's ability to receive a wanted signal at its assigned channel frequency at the *antenna connector* for *BS type 1-C* or *TAB connector* for *BS type 1-H* in the presence of an adjacent channel signal with a specified centre frequency offset of the interfering signal to the band edge of a victim system.

7.4.1.2 Minimum requirement for *BS type 1-C* and *BS type 1-H*

The throughput shall be $\geq 95\%$ of the maximum throughput of the reference measurement channel.

For BS, the wanted and the interfering signal coupled to the *BS type 1-C antenna connector* or *BS type 1-H TAB connector* are specified in table 7.4.1.2-1 and the frequency offset between the wanted and interfering signal in table 7.4.1.2-2 for ACS. The reference measurement channel for the wanted signal is identified in table 7.2.2-1, 7.2.2-2 and 7.2.2-3 for each *BS channel bandwidth* and further specified in annex A. The characteristics of the interfering signal is further specified in annex D.

The ACS requirement is applicable outside the Base Station RF Bandwidth or Radio Bandwidth. The interfering signal offset is defined relative to the Base station RF Bandwidth edges or Radio Bandwidth edges.

For a BS operating in non-contiguous spectrum within any *operating band*, the ACS requirement shall apply in addition inside any sub-block gap, in case the sub-block gap size is at least as wide as the NR interfering signal in table 7.4.1.2-1. The interfering signal offset is defined relative to the sub-block edges inside the sub-block gap.

For a *multi-band connector*, the ACS requirement shall apply in addition inside any Inter RF Bandwidth gap, in case the Inter RF Bandwidth gap size is at least as wide as the NR interfering signal in table 7.4.1.2-2. The interfering signal offset is defined relative to the Base Station RF Bandwidth edges inside the Inter RF Bandwidth gap.

Minimum conducted requirement is defined at the *antenna connector* for *BS type 1-C* and at the *TAB connector* for *BS type 1-H*.

Table 7.4.1.2-1: Base station ACS requirement

<i>BS channel bandwidth of the lowest/highest carrier received (MHz)</i>	<i>Wanted signal mean power (dBm)</i>	<i>Interfering signal mean power (dBm)</i>
5, 10, 15, 20, 25, 30, 40, 50, 60, 70, 80, 90, 100 (Note 1)	$P_{\text{REFSENS}} + 6\text{dB}$	Wide Area: -52 Medium Range: -47 Local Area: -44
NOTE 1: The SCS for the lowest/highest carrier received is the lowest SCS supported by the BS for that bandwidth. NOTE 2: P_{REFSENS} depends on the <i>BS channel bandwidth</i> as specified in tables 7.2.2-1, 7.2.2-2, 7.2.2-3		

Table 7.4.1.2-2: Base Station ACS interferer frequency offset values

<i>BS channel bandwidth of the lowest/highest carrier received (MHz)</i>	<i>Interfering signal centre frequency offset from the lower/upper Base Station RF Bandwidth edge or sub-block edge inside a sub-block gap (MHz)</i>	<i>Type of interfering signal</i>
5	± 2.5025	5 MHz DFT-s-OFDM NR signal SCS: 15kHz, 25 RB
10	± 2.5075	
15	± 2.5125	
20	± 2.5025	
25	± 9.535	20 MHz DFT-s-OFDM NR signal SCS: 15kHz, 100 RB
30	± 9.585	
40	± 9.535	
50	± 9.485	
60	± 9.585	
70	± 9.535	
80	± 9.485	
90	± 9.585	
100	± 9.535	

7.4.1.3 Void

7.4.1.4 Void

7.4.2 In-band blocking

7.4.2.1 General

The in-band blocking characteristics is a measure of the receiver's ability to receive a wanted signal at its assigned channel at the *antenna connector* for *BS type 1-C* or *TAB connector* for *BS type 1-H* in the presence of an unwanted interferer, which is an NR signal for general blocking or an NR signal with one resource block for narrowband blocking.

7.4.2.2 Minimum requirement for *BS type 1-C* and *BS type 1-H*

The throughput shall be $\geq 95\%$ of the maximum throughput of the reference measurement channel, with a wanted and an interfering signal coupled to *BS type 1-C antenna connector* or *BS type 1-H TAB connector* using the parameters in tables 7.4.2.2-1, 7.4.2.2-2 and 7.4.2.2-3 for general blocking and narrowband blocking requirements. The reference measurement channel for the wanted signal is identified in subclause 7.2.2 for each *BS channel bandwidth* and further specified in annex A. The characteristics of the interfering signal is further specified in annex D.

The in-band blocking requirements apply outside the Base Station RF Bandwidth or Radio Bandwidth. The interfering signal offset is defined relative to the Base Station RF Bandwidth edges or Radio Bandwidth edges.

The in-band blocking requirement shall apply from $F_{UL,low} - \Delta f_{OOB}$ to $F_{UL,high} + \Delta f_{OOB}$, excluding the downlink frequency range of the *FDD operating band*. The Δf_{OOB} for *BS type 1-C* and *BS type 1-H* is defined in table 7.4.2.2-0.

Minimum conducted requirement is defined at the *antenna connector* for *BS type 1-C* and at the *TAB connector* for *BS type 1-H*.

Table 7.4.2.2-0: Δf_{OOB} offset for NR operating bands

BS type	Operating band characteristics	Δf_{OOB} (MHz)
<i>BS type 1-C</i>	$F_{UL,high} - F_{UL,low} \leq 200$ MHz	20
	200 MHz $< F_{UL,high} - F_{UL,low} \leq 900$ MHz	60
<i>BS type 1-H</i>	$F_{UL,high} - F_{UL,low} < 100$ MHz	20
	100 MHz $\leq F_{UL,high} - F_{UL,low} \leq 900$ MHz	60

For a BS operating in non-contiguous spectrum within any *operating band*, the in-band blocking requirements apply in addition inside any sub-block gap, in case the sub-block gap size is at least as wide as twice the interfering signal minimum offset in tables 7.4.2.2-1. The interfering signal offset is defined relative to the sub-block edges inside the sub-block gap.

For a *multi-band connector*, the blocking requirements apply in the in-band blocking frequency ranges for each supported *operating band*. The requirement shall apply in addition inside any Inter RF Bandwidth gap, in case the Inter RF Bandwidth gap size is at least as wide as twice the interfering signal minimum offset in tables 7.4.2.2-1.

For a BS operating in non-contiguous spectrum within any *operating band*, the narrowband blocking requirement shall apply in addition inside any sub-block gap, in case the sub-block gap size is at least as wide as the *channel bandwidth* of the NR interfering signal in Table 7.4.2.2-3. The interfering signal offset is defined relative to the sub-block edges inside the sub-block gap.

For a *multi-band connector*, the narrowband blocking requirement shall apply in addition inside any Inter RF Bandwidth gap, in case the Inter RF Bandwidth gap size is at least as wide as the NR interfering signal in Table 7.4.2.2-3. The interfering signal offset is defined relative to the Base Station RF Bandwidth edges inside the Inter RF Bandwidth gap.

Table 7.4.2.2-1: Base station general blocking requirement

<i>BS channel bandwidth of the lowest/highest carrier received (MHz)</i>	Wanted signal mean power (dBm)	Interfering signal mean power (dBm)	Interfering signal centre frequency minimum offset from the lower/upper Base Station RF Bandwidth edge or sub-block edge inside a sub-block gap (MHz)	Type of interfering signal
5, 10, 15, 20	$P_{\text{REFSENS}} + 6$ dB	Wide Area: -43 Medium Range: -38 Local Area: -35	± 7.5	5 MHz DFT-s-OFDM NR signal SCS: 15 kHz, 25 RB
25, 30, 40, 50, 60, 70, 80, 90, 100	$P_{\text{REFSENS}} + 6$ dB	Wide Area: -43 Medium Range: -38 Local Area: -35	± 30	20 MHz DFT-s-OFDM NR signal SCS: 15 kHz, 100 RB
NOTE: P_{REFSENS} depends on the <i>BS channel bandwidth</i> as specified in tables 7.2.2-1, 7.2.2-2 and 7.2.2-3.				

Table 7.4.2.2-2: Base Station narrowband blocking requirement

<i>BS channel bandwidth of the lowest/highest carrier received (MHz)</i>	Wanted signal mean power (dBm)	Interfering signal mean power (dBm)
5, 10, 15, 20, 25, 30, 40, 50, 60, 70, 80,90, 100 (Note 1)	$P_{\text{REFSENS}} + 6$ dB	Wide Area: -49 Medium Range: -44 Local Area: -41
NOTE 1: The SCS for the lowest/highest carrier received is the lowest SCS supported by the BS for that <i>BS channel bandwidth</i>		
NOTE 2: P_{REFSENS} depends on the <i>BS channel bandwidth</i> as specified in tables 7.2.2-1, 7.2.2-2 and 7.2.2-3.		

Table 7.4.2.2-3: Base Station narrowband blocking interferer frequency offsets

<i>BS channel bandwidth of the lowest/highest carrier received (MHz)</i>	<i>Interfering RB centre frequency offset to the lower/upper Base Station RF Bandwidth edge or sub-block edge inside a sub-block gap (kHz)</i>	<i>Type of interfering signal</i>
5	$\pm([342.5]+m*180)$, m=0, 1, 2, 3, 4, 9, 14, 19, 24	5 MHz DFT-s-OFDM NR signal, 1 RB SCS: 15 kHz
10	$\pm([347.5]+m*180)$, m=0, 1, 2, 3, 4, 9, 14, 19, 24	
15	$\pm([352.5]+m*180)$, m=0, 1, 2, 3, 4, 9, 14, 19, 24	
20	$\pm([342.5]+m*180)$, m=0, 1, 2, 3, 4, 9, 14, 19, 24	
25	$\pm([557.5]+m*180)$, m=0, 1, 2, 3, 4, 29, 54, 79, 100	20 MHz DFT-s-OFDM NR signal, 1 RB SCS: 15 kHz
30	$\pm([562.5]+m*180)$, m=0, 1, 2, 3, 4, 29, 54, 79, 100	
40	$\pm([557.5]+m*180)$, m=0, 1, 2, 3, 4, 29, 54, 79, 100	
50	$\pm([552.5]+m*180)$, m=0, 1, 2, 3, 4, 29, 54, 79, 100	
60	$\pm([562.5]+m*180)$, m=0, 1, 2, 3, 4, 29, 54, 79, 100	
70	$\pm([557.5]+m*180)$, m=0, 1, 2, 3, 4, 29, 54, 79, 100	
80	$\pm([552.5]+m*180)$, m=0, 1, 2, 3, 4, 29, 54, 79, 100	
90	$\pm([562.5]+m*180)$, m=0, 1, 2, 3, 4, 29, 54, 79, 100	
100	$\pm([557.5]+m*180)$, m=0, 1, 2, 3, 4, 29, 54, 79, 100	
NOTE: Interfering signal consisting of one resource block positioned at the stated offset, the <i>channel bandwidth</i> of the interfering signal is located adjacently to the lower/upper Base Station RF Bandwidth edge or sub-block edge inside a sub-block gap.		

7.4.2.3 Void

7.4.2.4 Void

7.5 Out-of-band blocking

7.5.1 General

The out-of-band blocking characteristics is a measure of the receiver ability to receive a wanted signal at its assigned channel at the *antenna connector* for *BS type 1-C* or *TAB connector* for *BS type 1-H* in the presence of an unwanted interferer out of the *operating band*, which is a CW signal for out-of-band blocking.

7.5.2 Minimum requirement for *BS type 1-C* and *BS type 1-H*

The throughput shall be $\geq 95\%$ of the maximum throughput of the reference measurement channel, with a wanted and an interfering signal coupled to *BS type 1-C antenna connector* or *BS type 1-H TAB connector* using the parameters in table 7.5.2-1. The reference measurement channel for the wanted signal is identified in subclause 7.2.2 for each *BS channel bandwidth* and further specified in annex A. The characteristics of the interfering signal is further specified in annex D.

The out-of-band blocking requirement apply from 1 MHz to $F_{UL,low} - \Delta f_{OOB}$ and from $F_{UL,high} + \Delta f_{OOB}$ up to 12750 MHz, including the downlink frequency range of the *FDD operating band*. The Δf_{OOB} for *BS type 1-C* and *BS type 1-H* is defined in table 7.4.2.2-0.

Minimum conducted requirement is defined at the *antenna connector* for *BS type 1-C* and at the *TAB connector* for *BS type 1-H*.

For a *multi-band connector*, the requirement in the out-of-band blocking frequency ranges apply for each *operating band*, with the exception that the in-band blocking frequency ranges of all supported *operating bands* according to subclause 7.4.2.2 shall be excluded from the out-of-band blocking requirement.

Table 7.5.2-1: Out-of-band blocking performance requirement for NR

Wanted Signal mean power (dBm)	Interfering Signal mean power (dBm)	Type of Interfering Signal
$P_{REFSENS} + 6$ dB (Note)	-15	CW carrier
NOTE: $P_{REFSENS}$ depends on the <i>BS channel bandwidth</i> as specified in Table 7.2.2-1, 7.2.2-2, and 7.2.2-3.		

7.5.3 Co-location minimum requirements for *BS type 1-C* and *BS type 1-H*

This additional blocking requirement may be applied for the protection of NR BS receivers when GSM, CDMA, UTRA, E-UTRA or NR BS operating in a different frequency band are co-located with a NR BS. The requirement is applicable to all *BS channel bandwidths* supported by the NR BS.

The requirements in this clause assume a 30 dB coupling loss between interfering transmitter and NR BS receiver and are based on co-location with base stations of the same class.

The throughput shall be $\geq 95\%$ of the maximum throughput of the reference measurement channel, with a wanted and an interfering signal coupled to *BS type 1-C antenna connector* or *BS type 1-H TAB connector* input using the parameters in Table 7.5.3-1 for all the BS classes. The reference measurement channel for the wanted signal is identified in Tables 7.2.2-1, 7.2.2-2 and 7.2.2-3 for each *BS channel bandwidth* and further specified in Annex A. The characteristics of the interfering signal is further specified in annex D.

The blocking requirement for co-location with BS in other bands is applied for all *operating bands* for which co-location protection is provided.

Minimum conducted requirement is defined at the *antenna connector* for *BS type 1-C* and at the *TAB connector* for *BS type 1-H*.

Table 7.5.3-1: Blocking performance requirement for NR BS when co-located with BS in other frequency bands.

Frequency range of interfering signal	Wanted signal mean power for WA BS (dBm)	Interfering signal mean power for WA BS (dBm)	Interfering signal mean power for MR BS (dBm)	Interfering signal mean power for LA BS (dBm)	Type of interfering signal
Frequency range of co-located downlink <i>operating band</i>	$P_{\text{REFSENS}} + 6\text{dB}$ (Note 1)	+16	+8	x (Note 2)	CW carrier
NOTE 1: P_{REFSENS} depends on the <i>BS channel bandwidth</i> as specified in Table 7.2.2-1, 7.2.2-2, and 7.2.2-3. NOTE 2: x = -7 dBm for NR BS co-located with Pico GSM850 or Pico CDMA850 x = -4 dBm for NR BS co-located with Pico DCS1800 or Pico PCS1900 x = -6 dBm for NR BS co-located with UTRA bands or E-UTRA bands or NR bands NOTE 3: The requirement does not apply when the interfering signal falls within any of the supported uplink <i>operating band(s)</i> or in Δf_{OOB} immediately outside any of the supported uplink <i>operating band(s)</i> .					

7.5.4 Void

7.6 Receiver spurious emissions

7.6.1 General

The receiver spurious emissions power is the power of emissions generated or amplified in a receiver unit that appear at the *antenna connector* (for *BS type 1-C*) or at the *TAB connector* (for *BS type 1-H*). The requirements apply to all BS with separate RX and TX *antenna connectors* / *TAB connectors*.

NOTE: In this case for FDD operation the test is performed when both TX and RX are ON, with the TX *antenna connectors* / *TAB connectors* terminated.

For *antenna connectors* / *TAB connectors* supporting both RX and TX in TDD, the requirements apply during the *transmitter OFF period*. For *antenna connectors* / *TAB connectors* supporting both RX and TX in FDD, the RX spurious emissions requirements are superseded by the TX spurious emissions requirements, as specified in subclause 6.6.5.

For RX-only *multi-band connectors*, the spurious emissions requirements are subject to exclusion zones in each supported *operating band*. For *multi-band connectors* that both transmit and receive in *operating band* supporting TDD, RX spurious emissions requirements are applicable during the *TX OFF period*, and are subject to exclusion zones in each supported *operating band*.

For *BS type 1-H* manufacturer shall declare *TAB connector RX min cell groups*. Every *TAB connector* of *BS type 1-H* supporting reception in an *operating band* shall map to one *TAB connector RX min cell group*, where mapping of *TAB connectors* to cells/beams is implementation dependent.

The number of active receiver units that are considered when calculating the conducted RX spurious emission limits ($N_{\text{RXU,counted}}$) for *BS type 1-H* is calculated as follows:

$$N_{\text{RXU,counted}} = \min(N_{\text{RXU,active}}, 8 \times N_{\text{cells}})$$

$N_{\text{RXU,countedpercell}}$ is used for scaling of *basic limits* and is derived as $N_{\text{RXU,countedpercell}} = N_{\text{RXU,counted}} / N_{\text{cells}}$, where N_{cells} is defined in subclause 6.1.

NOTE: $N_{\text{RXU,active}}$ is the number of actually active receiver units and is independent to the declaration of N_{cells} .

7.6.2 Basic limits

The receiver spurious emissions *basic limits* are provided in table 7.6.2-1.

Table 7.6.2-1: General BS receiver spurious emissions limits

Spurious frequency range	Basic limits	Measurement bandwidth	Note
30 MHz – 1 GHz	-57 dBm	100 kHz	Note 1
1 GHz – 12.75 GHz	-47 dBm	1 MHz	Note 1, Note 2
12.75 GHz – 5 th harmonic of the upper frequency edge of the UL <i>operating band</i> in GHz	-47 dBm	1 MHz	Note 1, Note 2, Note 3
NOTE 1: The frequency range from Δf_{OBUE} below the lowest frequency of the BS transmitter <i>operating band</i> to Δf_{OBUE} above the highest frequency of the BS transmitter <i>operating band</i> may be excluded from the requirement. Δf_{OBUE} is defined in subclause 6.6.1.			
NOTE 2: For <i>multi-band connectors</i> , the exclusion applies for all supported <i>operating bands</i> for those <i>antenna connectors / TAB connectors</i> .			

7.6.3 Minimum requirement for BS type 1-C

The RX spurious emissions requirements for BS type 1-C are that for each *antenna connector*, the power of emissions shall not exceed *basic limits* specified in table 7.6.2-1.

7.6.4 Minimum requirement for BS type 1-H

The RX spurious emissions requirements for BS type 1-H are that for each applicable *basic limit* specified in table 7.6.2-1 for each *TAB connector RX min cell group*, the power sum of emissions at respective *TAB connectors* shall not exceed the BS limits specified as the *basic limits* + X, where $X = 10\log_{10}(N_{\text{RXU, counted per cell}})$, unless stated differently in regional regulation.

The RX spurious emission requirements are applied per the *TAB connector RX min cell group* for all the configurations supported by the BS.

NOTE: Conformance to the BS receiver spurious emissions requirement can be demonstrated by meeting at least one of the following criteria as determined by the manufacturer:

- 1) The sum of the spurious emissions power measured on each *TAB connector* in the *TAB connector RX min cell group* shall be less than or equal to the BS limit above for the respective frequency span.

Or

- 2) The spurious emissions power at each *TAB connector* shall be less than or equal to the BS limit as defined above for the respective frequency span, scaled by $-10\log_{10}(n)$, where n is the number of *TAB connectors* in the *TAB connector RX min cell group*.

7.7 Receiver intermodulation

7.7.1 General

Third and higher order mixing of the two interfering RF signals can produce an interfering signal in the band of the desired channel. Intermodulation response rejection is a measure of the capability of the receiver to receive a wanted signal on its assigned channel frequency at the *antenna connector* for BS type 1-C or *TAB connector* for BS type 1-H in the presence of two interfering signals which have a specific frequency relationship to the wanted signal.

7.7.2 Minimum requirement for BS type 1-C and BS type 1-H

For NR, the throughput shall be $\geq 95\%$ of the maximum throughput of the reference measurement channel, with a wanted signal at the assigned channel frequency and two interfering signals coupled to the BS type 1-C *antenna connector* or BS type 1-H *TAB connector*, with the conditions specified in tables 7.7.2-1 and 7.7.2-2 for intermodulation performance and in tables 7.7.2-3, and 7.7.2-4 for narrowband intermodulation performance. The reference

measurement channel for the wanted signal is identified in tables 7.2.2-1, 7.2.2-2 and 7.2.2-3 for each *BS channel bandwidth* and further specified in annex A. The characteristics of the interfering signal is further specified in annex D.

The subcarrier spacing for the modulated interfering signal shall in general be the same as the subcarrier spacing for the wanted signal, except for the case of wanted signal subcarrier spacing 60 kHz and *BS channel bandwidth* ≤ 20 MHz, for which the subcarrier spacing of the interfering signal shall be 30 kHz.

The receiver intermodulation requirement is applicable outside the Base Station RF Bandwidth or Radio Bandwidth edges. The interfering signal offset is defined relative to the Base Station RF Bandwidth edges or Radio Bandwidth edges.

For a BS operating in non-contiguous spectrum within any *operating band*, the narrowband intermodulation requirement shall apply in addition inside any sub-block gap in case the sub-block gap is at least as wide as the *channel bandwidth* of the NR interfering signal in table 7.7.2-2 or 7.7.2-4. The interfering signal offset is defined relative to the sub-block edges inside the sub-block gap.

For a *multi-band connector*, the intermodulation requirement shall apply in addition inside any Inter RF Bandwidth gap, in case the gap size is at least twice as wide as the NR interfering signal centre frequency offset from the Base Station RF Bandwidth edge.

For a *multi-band connector*, the narrowband intermodulation requirement shall apply in addition inside any Inter RF Bandwidth gap in case the gap size is at least as wide as the NR interfering signal in tables 7.7.2-2 and 7.7.2-4. The interfering signal offset is defined relative to the Base Station RF Bandwidth edges inside the Inter RF Bandwidth gap.

Table 7.7.2-1: General intermodulation requirement

Base Station Type	Wanted Signal mean power (dBm)	Mean power of interfering signals (dBm)	Type of interfering signal
Wide Area BS	$P_{\text{REFSENS}} + 6$ dB	-52	See Table 7.7.2-2
Medium Range BS	$P_{\text{REFSENS}} + 6$ dB	-47	
Local Area BS	$P_{\text{REFSENS}} + 6$ dB	-44	
NOTE 1: P_{REFSENS} depends on the BS class and on the <i>BS channel bandwidth</i> , see subclause 7.2.			

Table 7.7.2-2: Interfering signals for intermodulation requirement

<i>BS channel bandwidth of the lowest/highest carrier received (MHz)</i>	Interfering signal centre frequency offset from the lower/upper Base Station RF Bandwidth edge (MHz)	Type of interfering signal
5	±7.5	CW
	±17.5	5 MHz DFT-s-OFDM NR signal (Note 1)
10	±7.45	CW
	±17.5	5 MHz DFT-s-OFDM NR signal (Note 1)
15	±7.43	CW
	±17.5	5 MHz DFT-s-OFDM NR signal (Note 1)
20	±7.38	CW
	±17.5	5 MHz DFT-s-OFDM NR signal (Note 1)
25	±7.45	CW
	±25	20MHz DFT-s-OFDM NR signal (Note 2)
30	±7.43	CW
	±25	20 MHz DFT-s-OFDM NR signal (Note 2)
40	±7.45	CW
	±25	20 MHz DFT-s-OFDM NR signal (Note 2)
50	±7.35	CW
	±25	20 MHz DFT-s-OFDM NR signal (Note 2)
60	±7.49	CW
	±25	20 MHz DFT-s-OFDM NR signal (Note 2)
70	±7.42	CW
	±25	20 MHz DFT-s-OFDM NR signal (Note 2)
80	±7.44	CW
	±25	20 MHz DFT-s-OFDM NR signal (Note 2)
90	±7.43	CW
	±25	20 MHz DFT-s-OFDM NR signal (Note 2)
100	±7.45	CW
	±25	20 MHz DFT-s-OFDM NR signal (Note 2)
NOTE 1: Number of RBs is 25 for 15 kHz subcarrier spacing and 10 for 30 kHz subcarrier spacing.		
NOTE 2: Number of RBs is 100 for 15 kHz subcarrier spacing, 50 for 30 kHz subcarrier spacing and 24 for 60 kHz subcarrier spacing.		

Table 7.7.2-3: Narrowband intermodulation performance requirement in FR1

BS type	Wanted signal mean power (dBm)	Interfering signal mean power (dBm)	Type of interfering signal
Wide Area BS	$P_{\text{REFSENS}} + 6\text{dB}$ (Note 1)	-52	See Table 7.7.2-4
Medium Range BS	$P_{\text{REFSENS}} + 6\text{dB}$ (Note 2)	-47	
Local Area BS	$P_{\text{REFSENS}} + 6\text{dB}$ (Note 3)	-44	
NOTE 1: P_{REFSENS} depends on the <i>BS channel bandwidth</i> as specified in table 7.2.2-1.			
NOTE 2: P_{REFSENS} depends on the <i>BS channel bandwidth</i> as specified in table 7.2.2-2.			
NOTE 3: P_{REFSENS} depends on the <i>BS channel bandwidth</i> as specified in table 7.2.2-3.			

Table 7.7.2-4: Interfering signals for narrowband intermodulation requirement in FR1

<i>BS channel bandwidth of the lowest/highest carrier received (MHz)</i>	Interfering RB centre frequency offset from the lower/upper Base Station RF Bandwidth edge or sub-block edge inside a sub-block gap (kHz)	Type of interfering signal
5	±360	CW
	±1420	5 MHz DFT-s-OFDM NR signal, 1 RB (Note 1)
10	±325	CW
	±1780	5 MHz DFT-s-OFDM NR signal, 1 RB (Note 1)
15 (Note 2)	±380	CW
	±1600	5 MHz DFT-s-OFDM NR signal, 1 RB (Note 1)
20 (Note 2)	±345	CW
	±1780	5 MHz DFT-s-OFDM NR signal, 1 RB (Note 1)
25 (Note 2)	±325	CW
	±1990	20 MHz DFT-s-OFDM NR signal, 1 RB (Note 1)
30 (Note 2)	±320	CW
	±1990	20 MHz DFT-s-OFDM NR signal, 1 RB (Note 1)
40 (Note 2)	±310	CW
	±2710	20 MHz DFT-s-OFDM NR signal, 1 RB (Note 1)
50 (Note 2)	±330	CW
	±3250	20 MHz DFT-s-OFDM NR signal, 1 RB (Note 1)
60 (Note 2)	±350	CW
	±3790	20 MHz DFT-s-OFDM NR signal, 1 RB (Note 1)
70 (Note 2)	±400	CW
	±4870	20 MHz DFT-s-OFDM NR signal, 1 RB (Note 1)
80 (Note 2)	±390	CW
	±4870	20 MHz DFT-s-OFDM NR signal, 1 RB (Note 1)
90 (Note 2)	±340	CW
	±5770	20 MHz DFT-s-OFDM NR signal, 1 RB (Note 1)
100 (Note 2)	±340	CW
	±5770	20 MHz DFT-s-OFDM NR signal, 1 RB (Note 1)
<p>NOTE 1: Interfering signal consisting of one resource block positioned at the stated offset, the <i>BS channel bandwidth</i> of the interfering signal is located adjacently to the lower/upper Base Station RF Bandwidth edge or sub-block edge inside a sub-block gap.</p> <p>NOTE 2: This requirement shall apply only for a G-FRC mapped to the frequency range at the channel edge adjacent to the interfering signals.</p>		

7.8 In-channel selectivity

7.8.1 General

In-channel selectivity (ICS) is a measure of the receiver ability to receive a wanted signal at its assigned resource block locations at the *antenna connector* for *BS type 1-C* or *TAB connector* for *BS type 1-H* in the presence of an interfering signal received at a larger power spectral density. In this condition a throughput requirement shall be met for a specified reference measurement channel. The interfering signal shall be an NR signal which is time aligned with the wanted signal.

7.8.2 Minimum requirement for *BS type 1-C* and *BS type 1-H*

For *BS type 1-C* and *1-H*, the throughput shall be $\geq 95\%$ of the maximum throughput of the reference measurement channel as specified in annex A with parameters specified in Table 7.8.2-1 for Wide Area BS, in Table 7.8.2-2 for Medium Range BS and in Table 7.8.2-3 for Local Area BS. The reference measurement channel for the wanted signal is identified in tables 7.8.2-1, 7.8.2-2 and 7.8.2-3 for each *BS channel bandwidth* and further specified in annex A. The characteristics of the interfering signal is further specified in annex D.

Table 7.8.2-1: Wide Area BS in-channel selectivity

<i>BS channel bandwidth</i> (MHz)	Subcarrier spacing (kHz)	Reference measurement channel	Wanted signal mean power (dBm)	Interfering signal mean power (dBm)	Type of interfering signal
5	15	G-FR1-A1-7	-100.6	-81.4	DFT-s-OFDM NR signal, SCS 15 kHz, 10 RB
10,15,20,25,30	15	G-FR1-A1-1	-98.7	-77.4	DFT-s-OFDM NR signal, SCS 15 kHz, 25 RB
40,50	15	G-FR1-A1-4	-92.3	-71.4	NR signal, SCS 15 kHz, 100 RB
5	30	G-FR1-A1-8	-101.3	-81.4	DFT-s-OFDM NR signal, SCS 30 kHz, 5 RB
10,15,20,25,30	30	G-FR1-A1-2	-98.8	-78.4	DFT-s-OFDM NR signal, SCS 30 kHz, 10 RB
40,50,60,70,80,90,100	30	G-FR1-A1-5	-92.6	-71.4	DFT-s-OFDM NR signal, SCS 30 kHz, 50 RB
10,15,20,25,30	60	G-FR1-A1-9	-98.2	-78.4	DFT-s-OFDM NR signal, SCS 60 kHz, 5 RB
40,50,60,70,80,90,100	60	G-FR1-A1-6	-92.7	-71.6	DFT-s-OFDM NR signal, SCS 60 kHz, 24 RB
NOTE: Wanted and interfering signal are placed adjacently around F_c , where the F_c is defined for <i>BS channel bandwidth</i> of the wanted signal according to the table 5.4.2.2-1. The aggregated wanted and interferer signal shall be centred in the BS channel bandwidth of the wanted signal.					

Table 7.8.2-2: Medium Range BS in-channel selectivity

<i>BS channel bandwidth (MHz)</i>	<i>Subcarrier spacing (kHz)</i>	<i>Reference measurement channel</i>	<i>Wanted signal mean power (dBm)</i>	<i>Interfering signal mean power (dBm)</i>	<i>Type of interfering signal</i>
5	15	G-FR1-A1-7	-95.6	-76.4	DFT-s-OFDM NR signal, SCS 15 kHz, 10 RB
10,15,20,25,30	15	G-FR1-A1-1	-93.7	-72.4	DFT-s-OFDM NR signal, SCS 15 kHz, 25 RB
40,50	15	G-FR1-A1-4	-87.3	-66.4	DFT-s-OFDM NR signal, SCS 15 kHz, 100 RB
5	30	G-FR1-A1-8	-96.3	-76.4	DFT-s-OFDM NR signal, SCS 30 kHz, 5 RB
10,15,20,25,30	30	G-FR1-A1-2	-93.8	-73.4	DFT-s-OFDM NR signal, SCS 30 kHz, 10 RB
40,50,60,70,80,90,100	30	G-FR1-A1-5	-87.6	-66.4	DFT-s-OFDM NR signal, SCS 30 kHz, 50 RB
10,15,20,25,30	60	G-FR1-A1-9	-93.2	-73.4	DFT-s-OFDM NR signal, SCS 60 kHz, 5 RB
40,50,60,70,80,90,100	60	G-FR1-A1-6	-87.7	-66.6	DFT-s-OFDM NR signal, SCS 60 kHz, 24 RB
NOTE: Wanted and interfering signal are placed adjacently around F_c , where the F_c is defined for <i>BS channel bandwidth</i> of the wanted signal according to the table 5.4.2.2-1. The aggregated wanted and interferer signal shall be centred in the BS channel bandwidth of the wanted signal.					

Table 7.8.2-3: Local area BS in-channel selectivity

<i>BS channel bandwidth (MHz)</i>	<i>Subcarrier spacing (kHz)</i>	<i>Reference measurement channel</i>	<i>Wanted signal mean power (dBm)</i>	<i>Interfering signal mean power (dBm)</i>	<i>Type of interfering signal</i>
5	15	G-FR1-A1-7	-92.6	-73.4	DFT-s-OFDM NR signal, SCS 15 kHz, 10 RB
10,15,20,25,30	15	G-FR1-A1-1	-90.7	-69.4	DFT-s-OFDM NR signal, SCS 15 kHz, 25 RB
40,50	15	G-FR1-A1-4	-84.3	-63.4	DFT-s-OFDM NR signal, SCS 15 kHz, 100 RB
5	30	G-FR1-A1-8	-93.3	-73.4	DFT-s-OFDM NR signal, SCS 30 kHz, 5 RB
10,15,20,25,30	30	G-FR1-A1-2	-90.8	-70.4	DFT-s-OFDM NR signal, SCS 30 kHz, 10 RB
40,50,60,70,80,90,100	30	G-FR1-A1-5	-84.6	-63.4	DFT-s-OFDM NR signal, SCS 30 kHz, 50 RB
10,15,20,25,30	60	G-FR1-A1-9	-90.2	-70.4	DFT-s-OFDM NR signal, SCS 60 kHz, 5 RB
40,50,60,70,80,90,100	60	G-FR1-A1-6	-84.7	-63.6	DFT-s-OFDM NR signal, SCS 60 kHz, 24 RB
NOTE: Wanted and interfering signal are placed adjacently around F_c , where the F_c is defined for <i>BS channel bandwidth</i> of the wanted signal according to the table 5.4.2.2-1. The aggregated wanted and interferer signal shall be centred in the BS channel bandwidth of the wanted signal.					

8 Conducted performance requirements

8.1 General

8.1.1 Scope and definitions

Conducted performance requirements specify the ability of the *BS type 1-C* or *BS type 1-H* to correctly demodulate signals in various conditions and configurations. Conducted performance requirements are specified at the *antenna connector(s)* (for *BS type 1-C*) and at the *TAB connector(s)* (for *BS type 1-H*).

Conducted performance requirements for the BS are specified for the fixed reference channels defined in annex A and the propagation conditions in annex G. The requirements only apply to those FRCs that are supported by the base station.

Unless stated otherwise, performance requirements apply for a single carrier only. Performance requirements for a BS supporting carrier aggregation are defined in terms of single carrier requirements.

For FDD operation the requirements in clause 8 shall be met with the transmitter units associated with *antenna connectors* (for *BS type 1-C*) or *TAB connectors* (for *BS type 1-H*) in the *operating band* turned ON.

NOTE: In normal operating conditions, antenna connectors (for *BS type 1-C*) or *TAB connectors* (for *BS type 1-H*) in FDD operation are configured to transmit and receive at the same time. The associated transmitter unit(s) may be OFF for some of the tests as specified in TS 38.141-1 [5].

The SNR used in this clause is specified based on a single carrier and defined as:

$$\text{SNR} = S / N$$

Where:

S is the total signal energy in the slot on a single *antenna connector* (for *BS type 1-C*) or on a single *TAB connector* (for *BS type 1-H*).

N is the noise energy in a bandwidth corresponding to the transmission bandwidth over the duration of a slot on a single *antenna connector* (for *BS type 1-C*) or on a single *TAB connector* (for *BS type 1-H*).

8.1.2 Applicability rule

Text to be added.

8.2 Performance requirements for PUSCH

8.2.1 Requirements for PUSCH with transform precoding disabled

8.2.1.1 General

The performance requirement of PUSCH is determined by a minimum required throughput for a given SNR. The required throughput is expressed as a fraction of maximum throughput for the FRCs listed in annex A. The performance requirements assume HARQ retransmissions.

Table: 8.2.1.1-1 Test parameters for testing PUSCH

Parameter		Value
Transform precoding		Disabled
Uplink-downlink allocation for TDD		15 kHz SCS: 3D1S1U, S=10D:2G:2U 30 kHz SCS: 7D1S2U, S=6D:4G:4U
HARQ	Maximum number of HARQ transmissions	4
	RV sequence	0, 2, 3, 1
DMRS	DMRS configuration type	1
	Maximum number of OFDM symbols for front loaded DMRS	1
	Number of additional DMRS symbols	0, 1
	Number of DMRS CDM group(s) without data	2
	EPRE ratio of PUSCH to DMRS	-3 dB
	DMRS port	{0}, {0, 1}
DMRS sequence generation		$N_{ID}=0, n_{SCID}=0$
Time domain resource	PUSCH mapping type	A
	PUSCH starting symbol index	0
	PUSCH symbol length	14
Frequency domain resource	RB assignment	Full applicable test bandwidth
	Frequency hopping	Disabled
TPMI index for 2Tx two-layer spatial multiplexing transmission		0
Code block group based PUSCH transmission		Disabled

8.2.1.2 Minimum requirements

The throughput shall be equal to or larger than the fraction of maximum throughput for the FRCs stated in tables 8.2.1.2-1 to 8.2.1.2-7 at the given SNR for 1Tx or for 2Tx two-layer spatial multiplexing transmission. FRCs are defined in annex A.

Table 8.2.1.2-1: Minimum requirements for PUSCH, 5 MHz channel bandwidth, 15 kHz SCS

Number of TX antennas	Number of RX antennas	Cyclic prefix	Propagation conditions and correlation matrix (Annex G)	Fraction of maximum throughput	FRC (Annex A)	DMRS configuration	SNR (dB)
1	2	Normal	TDLB100-400 Low	70 %	G-FR1-A3-1	1+0	[2,08]
					G-FR1-A3-8	1+1	[-1,99]
		Normal	TDLC300-100 Low	70 %	G-FR1-A4-1	1+0	[12,77]
	G-FR1-A4-8				1+1	[10,54]	
	Normal	TDLA30-10 Low	70 %	G-FR1-A5-1	1+0	[13,79]	
				G-FR1-A5-8	1+1	[13,69]	
	4	Normal	TDLB100-400 Low	70 %	G-FR1-A3-1	1+0	[-2,53]
					G-FR1-A3-8	1+1	[-5,57]
		Normal	TDLC300-100 Low	70 %	G-FR1-A4-1	1+0	[7,37]
	G-FR1-A4-8				1+1	[6,53]	
	Normal	TDLA30-10 Low	70 %	G-FR1-A5-1	1+0	[9,54]	
				G-FR1-A5-8	1+1	[9,38]	
8	Normal	TDLB100-400 Low	70 %	G-FR1-A3-1	1+0	[-6,11]	
				G-FR1-A3-8	1+1	[-8,44]	
	Normal	TDLC300-100 Low	70 %	G-FR1-A4-1	1+0	[3,50]	
G-FR1-A4-8				1+1	[3,07]		
Normal	TDLA30-10 Low	70 %	G-FR1-A5-1	1+0	[6,02]		
			G-FR1-A5-8	1+1	[5,93]		
2	2	Normal	TDLB100-400 Low	70 %	G-FR1-A3-22		[TBD]
					G-FR1-A4-22		[18,09]
	4	Normal	TDLB100-400 Low	70 %	G-FR1-A3-15	1+0	[TBD]
					G-FR1-A3-22	1+1	[-1,78]
	Normal	TDLC300-100 Low	70 %	G-FR1-A4-15	1+0	[TBD]	
				G-FR1-A4-22	1+1	[10,78]	
	8	Normal	TDLB100-400 Low	70 %	G-FR1-A3-15		[TBD]
					G-FR1-A3-22		[TBD]
Normal	TDLC300-100 Low	70 %	G-FR1-A4-15	1+0	[7,63]		
			G-FR1-A4-22	1+1	[6,53]		

Table 8.2.1.2-2: Minimum requirements for PUSCH, 10 MHz channel bandwidth, 15 kHz SCS

Number of TX antennas	Number of RX antennas	Cyclic prefix	Propagation conditions and correlation matrix (Annex G)	Fraction of maximum throughput	FRC (Annex A)	DMRS configuration	SNR (dB)
1	2	Normal	TDLB100-400 Low	70 %	G-FR1-A3-2	1+0	[1,07]
					G-FR1-A3-9	1+1	[-2,51]
		Normal	TDLC300-100 Low	70 %	G-FR1-A4-2	1+0	[12,77]
					G-FR1-A4-9	1+1	[10,54]
		Normal	TDLA30-10 Low	70 %	G-FR1-A5-2	1+0	[13,22]
					G-FR1-A5-9	1+1	[13,45]
	4	Normal	TDLB100-400 Low	70 %	G-FR1-A3-2	1+0	[-3,07]
					G-FR1-A3-9	1+1	[-5,84]
		Normal	TDLC300-100 Low	70 %	G-FR1-A4-2	1+0	[7,74]
					G-FR1-A4-9	1+1	[6,58]
		Normal	TDLA30-10 Low	70 %	G-FR1-A5-2	1+0	[9,31]
					G-FR1-A5-9	1+1	[9,37]
8	Normal	TDLB100-400 Low	70 %	G-FR1-A3-2	1+0	[-6,51]	
				G-FR1-A3-9	1+1	[-8,71]	
	Normal	TDLC300-100 Low	70 %	G-FR1-A4-2	1+0	[3,79]	
				G-FR1-A4-9	1+1	[3,14]	
	Normal	TDLA30-10 Low	70 %	G-FR1-A5-2	1+0	[5,95]	
				G-FR1-A5-9	1+1	[5,73]	
2	2	Normal	TDLB100-400 Low	70 %	G-FR1-A3-23	1+1	[0,43]
		Normal	TDLC300-100 Low	70 %	G-FR1-A4-23	1+1	[18,33]
	4	Normal	TDLB100-400 Low	70 %	G-FR1-A3-16	1+0	[TBD]
					G-FR1-A3-23	1+1	[-1,58]
		Normal	TDLC300-100 Low	70 %	G-FR1-A4-16	1+0	[TBD]
	G-FR1-A4-23				1+1	[10,91]	
	8	Normal	TDLB100-400 Low	70 %	G-FR1-A3-16	1+0	[TBD]
					G-FR1-A3-23	1+1	[-5,21]
		Normal	TDLC300-100 Low	70 %	G-FR1-A4-16	1+0	[7,73]
					G-FR1-A4-23	1+1	[6,52]

Table 8.2.1.2-3: Minimum requirements for PUSCH, 20 MHz channel bandwidth, 15 kHz SCS

Number of TX antennas	Number of RX antennas	Cyclic prefix	Propagation conditions and correlation matrix (Annex G)	Fraction of maximum throughput	FRC (Annex A)	DMRS configuration	SNR (dB)
1	2	Normal	TDLB100-400 Low	70 %	G-FR1-A3-3	1+0	[TBD]
					G-FR1-A3-10	1+1	[-1,80]
		Normal	TDLC300-100 Low	70 %	G-FR1-A4-3	1+0	[13,56]
	G-FR1-A4-10				1+1	[10,53]	
	Normal	TDLA30-10 Low	70 %	G-FR1-A5-3	1+0	[13,48]	
				G-FR1-A5-10	1+1	[13,13]	
	4	Normal	TDLB100-400 Low	70 %	G-FR1-A3-3	1+0	[1,43]
					G-FR1-A3-10	1+1	[-5,31]
		Normal	TDLC300-100 Low	70 %	G-FR1-A4-3	1+0	[7,83]
	G-FR1-A4-10				1+1	[6,58]	
	Normal	TDLA30-10 Low	70 %	G-FR1-A5-3	1+0	[9,60]	
				G-FR1-A5-10	1+1	[9,17]	
8	Normal	TDLB100-400 Low	70 %	G-FR1-A3-3	1+0	[-2,72]	
				G-FR1-A3-10	1+1	[-8,43]	
	Normal	TDLC300-100 Low	70 %	G-FR1-A4-3	1+0	[3,71]	
G-FR1-A4-10				1+1	[3,12]		
Normal	TDLA30-10 Low	70 %	G-FR1-A5-3	1+0	[6,12]		
			G-FR1-A5-10	1+1	[5,74]		
2	2	Normal	TDLB100-400 Low	70 %	G-FR1-A3-24		[TBD]
					G-FR1-A4-24		[18,37]
	4	Normal	TDLB100-400 Low	70 %	G-FR1-A3-17		[TBD]
					G-FR1-A3-24		[TBD]
	Normal	TDLC300-100 Low	70 %	G-FR1-A4-17		[TBD]	
				G-FR1-A4-24		[10,85]	
	8	Normal	TDLB100-400 Low	70 %	G-FR1-A3-17		[TBD]
					G-FR1-A3-24		[TBD]
		Normal	TDLC300-100 Low	70 %	G-FR1-A4-17		[8,00]
G-FR1-A4-24					[6,55]		

Table 8.2.1.2-4: Minimum requirements for PUSCH, 10 MHz channel bandwidth, 30 kHz SCS

Number of TX antennas	Number of RX antennas	Cyclic prefix	Propagation conditions and correlation matrix (Annex G)	Fraction of maximum throughput	FRC (Annex A)	DMRS configuration	SNR (dB)
1	2	Normal	TDLB100-400 Low	70 %	G-FR1-A3-4	1+0	[-1,80]
					G-FR1-A3-11	1+1	[-2,49]
		Normal	TDLC300-100 Low	70 %	G-FR1-A4-4	1+0	[10,72]
					G-FR1-A4-11	1+1	[10,48]
		Normal	TDLA30-10 Low	70 %	G-FR1-A5-4	1+0	[12,62]
					G-FR1-A5-11	1+1	[12,84]
	4	Normal	TDLB100-400 Low	70 %	G-FR1-A3-4	1+0	[-5,45]
					G-FR1-A3-11	1+1	[-5,86]
		Normal	TDLC300-100 Low	70 %	G-FR1-A4-4	1+0	[6,44]
					G-FR1-A4-11	1+1	[6,18]
		Normal	TDLA30-10 Low	70 %	G-FR1-A5-4	1+0	[TBD]
					G-FR1-A5-11	1+1	[7,96]
8	Normal	TDLB100-400 Low	70 %	G-FR1-A3-4	1+0	[-8,63]	
				G-FR1-A3-11	1+1	[-8,83]	
	Normal	TDLC300-100 Low	70 %	G-FR1-A4-4	1+0	[2,94]	
				G-FR1-A4-11	1+1	[2,93]	
	Normal	TDLA30-10 Low	70 %	G-FR1-A5-4	1+0	[5,15]	
				G-FR1-A5-11	1+1	[TBD]	
2	2	Normal	TDLB100-400 Low	70 %	G-FR1-A3-25	1+1	[1,12]
		Normal	TDLC300-100 Low	70 %	G-FR1-A4-25	1+1	[18,32]
	4	Normal	TDLB100-400 Low	70 %	G-FR1-A3-18	1+0	[-1,91]
					G-FR1-A3-25	1+1	[-2,40]
	Normal	TDLC300-100 Low	70 %	G-FR1-A4-18	1+0	[12,00]	
				G-FR1-A4-25	1+1	[11,06]	
	8	Normal	TDLB100-400 Low	70 %	G-FR1-A3-18	1+0	[-4,63]
					G-FR1-A3-25	1+1	[-5,36]
		Normal	TDLC300-100 Low	70 %	G-FR1-A4-18	1+0	[7,36]
					G-FR1-A4-25	1+1	[6,78]

Table 8.2.1.2-5: Minimum requirements for PUSCH, 20 MHz channel bandwidth, 30 kHz SCS

Number of TX antennas	Number of RX antennas	Cyclic prefix	Propagation conditions and correlation matrix (Annex G)	Fraction of maximum throughput	FRC (Annex A)	DMRS configuration	SNR (dB)
1	2	Normal	TDLB100-400 Low	70 %	G-FR1-A3-5	1+0	[-2,03]
					G-FR1-A3-12	1+1	[-2,87]
		Normal	TDLC300-100 Low	70 %	G-FR1-A4-5	1+0	[10,88]
					G-FR1-A4-12	1+1	[10,40]
		Normal	TDLA30-10 Low	70 %	G-FR1-A5-5	1+0	[12,79]
					G-FR1-A5-12	1+1	[12,72]
	4	Normal	TDLB100-400 Low	70 %	G-FR1-A3-5	1+0	[-5,65]
					G-FR1-A3-12	1+1	[-6,20]
		Normal	TDLC300-100 Low	70 %	G-FR1-A4-5	1+0	[6,60]
					G-FR1-A4-12	1+1	[6,11]
		Normal	TDLA30-10 Low	70 %	G-FR1-A5-5	1+0	[8,28]
					G-FR1-A5-12	1+1	[7,96]
8	Normal	TDLB100-400 Low	70 %	G-FR1-A3-5	1+0	[-8,49]	
				G-FR1-A3-12	1+1	[-9,05]	
	Normal	TDLC300-100 Low	70 %	G-FR1-A4-5	1+0	[3,04]	
				G-FR1-A4-12	1+1	[2,83]	
	Normal	TDLA30-10 Low	70 %	G-FR1-A5-5	1+0	[5,39]	
				G-FR1-A5-12	1+1	[TBD]	
2	2	Normal	TDLB100-400 Low	70 %	G-FR1-A3-26	1+1	[1,00]
		Normal	TDLC300-100 Low	70 %	G-FR1-A4-26	1+1	[19,08]
	4	Normal	TDLB100-400 Low	70 %	G-FR1-A3-19	1+0	[-1,24]
					G-FR1-A3-26	1+1	[-2,45]
		Normal	TDLC300-100 Low	70 %	G-FR1-A4-19	1+0	[11,86]
	8	Normal	TDLB100-400 Low	70 %	G-FR1-A4-26	1+1	[11,12]
					G-FR1-A3-19	1+0	[-4,23]
		Normal	TDLC300-100 Low	70 %	G-FR1-A3-26	1+1	[-5,49]
					G-FR1-A4-19	1+0	[7,24]
					G-FR1-A4-26	1+1	[6,60]

Table 8.2.1.2-6: Minimum requirements for PUSCH, 40 MHz channel bandwidth, 30 kHz SCS

Number of TX antennas	Number of RX antennas	Cyclic prefix	Propagation conditions and correlation matrix (Annex G)	Fraction of maximum throughput	FRC (Annex A)	DMRS configuration	SNR (dB)
1	2	Normal	TDLB100-400 Low	70 %	G-FR1-A3-6	1+0	[-1,69]
					G-FR1-A3-13	1+1	[-2,73]
		Normal	TDLC300-100 Low	70 %	G-FR1-A4-6	1+0	[10,73]
					G-FR1-A4-13	1+1	[10,17]
		Normal	TDLA30-10 Low	70 %	G-FR1-A5-6	1+0	[12,15]
					G-FR1-A5-13	1+1	[12,13]
	4	Normal	TDLB100-400 Low	70 %	G-FR1-A3-6	1+0	[-4,92]
					G-FR1-A3-13	1+1	[-6,01]
		Normal	TDLC300-100 Low	70 %	G-FR1-A4-6	1+0	[6,48]
					G-FR1-A4-13	1+1	[6,03]
		Normal	TDLA30-10 Low	70 %	G-FR1-A5-6	1+0	[8,74]
					G-FR1-A5-13	1+1	[TBD]
8	Normal	TDLB100-400 Low	70 %	G-FR1-A3-6	1+0	[-8,34]	
				G-FR1-A3-13	1+1	[-8,93]	
	Normal	TDLC300-100 Low	70 %	G-FR1-A4-6	1+0	[2,96]	
				G-FR1-A4-13	1+1	[2,77]	
	Normal	TDLA30-10 Low	70 %	G-FR1-A5-6	1+0	[5,42]	
				G-FR1-A5-13	1+1	[5,04]	
2	2	Normal	TDLB100-400 Low	70 %	G-FR1-A3-27	1+1	[1,08]
		Normal	TDLC300-100 Low	70 %	G-FR1-A4-27	1+1	[19,17]
	4	Normal	TDLB100-400 Low	70 %	G-FR1-A3-20	1+0	[-0,63]
					G-FR1-A3-27	1+1	[-2,57]
		Normal	TDLC300-100 Low	70 %	G-FR1-A4-20	1+0	[11,84]
	G-FR1-A4-27				1+1	[11,10]	
	8	Normal	TDLB100-400 Low	70 %	G-FR1-A3-20	1+0	[-3,97]
					G-FR1-A3-27	1+1	[-5,42]
		Normal	TDLC300-100 Low	70 %	G-FR1-A4-20	1+0	[7,13]
	G-FR1-A4-27				1+1	[6,71]	

Table 8.2.1.2-7: Minimum requirements for PUSCH, 100 MHz channel bandwidth, 30 kHz SCS

Number of TX antennas	Number of RX antennas	Cyclic prefix	Propagation conditions and correlation matrix (Annex G)	Fraction of maximum throughput	FRC (Annex A)	DMRS configuration	SNR (dB)
1	2	Normal	TDLB100-400 Low	70 %	G-FR1-A3-7	1+0	[-1,09]
					G-FR1-A3-14	1+1	[-2,92]
		Normal	TDLC300-100 Low	70 %	G-FR1-A4-7	1+0	[10,95]
	G-FR1-A4-14				1+1	[10,28]	
	Normal	TDLA30-10 Low	70 %	G-FR1-A5-7	1+0	[TBD]	
				G-FR1-A5-14	1+1	[TBD]	
	4	Normal	TDLB100-400 Low	70 %	G-FR1-A3-7	1+0	[TBD]
					G-FR1-A3-14	1+1	[-6,11]
		Normal	TDLC300-100 Low	70 %	G-FR1-A4-7	1+0	[6,65]
	G-FR1-A4-14				1+1	[6,17]	
	Normal	TDLA30-10 Low	70 %	G-FR1-A5-7	1+0	[9,84]	
				G-FR1-A5-14	1+1	[TBD]	
8	Normal	TDLB100-400 Low	70 %	G-FR1-A3-7	1+0	[-7,34]	
				G-FR1-A3-14	1+1	[-8,98]	
	Normal	TDLC300-100 Low	70 %	G-FR1-A4-7	1+0	[3,02]	
G-FR1-A4-14				1+1	[2,85]		
Normal	TDLA30-10 Low	70 %	G-FR1-A5-7	1+0	[TBD]		
			G-FR1-A5-14	1+1	[TBD]		
2	2	Normal	TDLB100-400 Low	70 %	G-FR1-A3-28		[1,03]
					G-FR1-A4-28		[18,67]
	4	Normal	TDLB100-400 Low	70 %	G-FR1-A3-21	1+0	[TBD]
					G-FR1-A3-28	1+1	[-2,52]
		Normal	TDLC300-100 Low	70 %	G-FR1-A4-21	1+0	[12,36]
	G-FR1-A4-28				1+1	[11,27]	
	8	Normal	TDLB100-400 Low	70 %	G-FR1-A3-21	1+0	[-3,45]
					G-FR1-A3-28	1+1	[-5,48]
		Normal	TDLC300-100 Low	70 %	G-FR1-A4-21	1+0	[7,39]
G-FR1-A4-28	1+1				[6,77]		

8.2.2 Requirements for PUSCH with transform precoding enabled

8.2.2.1 General

The performance requirement of PUSCH is determined by a minimum required throughput for a given SNR. The required throughput is expressed as a fraction of maximum throughput for the FRCs listed in annex A. The performance requirements assume HARQ retransmissions.

Table 8.2.2.1-1: Test parameters for testing PUSCH

Parameter		Value
Transform precoding		Enabled
Uplink-downlink allocation for TDD		15 kHz SCS: 3D1S1U, S=10D:2G:2U 30 kHz SCS: 7D1S2U, S=6D:4G:4U
HARQ	Maximum number of HARQ transmissions	4
	RV sequence	0, 2, 3, 1
DMRS	DMRS configuration type	1
	Maximum number of OFDM symbols for front loaded DMRS	1
	Number of additional DMRS symbols	0, 1
	Number of DMRS CDM group(s) without data	2
	EPRE ratio of PUSCH to DMRS	-3 dB
	DMRS port	0
DMRS sequence generation		$N_{ID}=0$, group hopping and sequence hopping are disabled
Time domain resource	PUSCH mapping type	A
	PUSCH starting symbol index	0
	PUSCH symbol length	14
Frequency domain resource	RB assignment	15 kHz SCS: 25 PRBs in the middle of the test bandwidth 30 kHz SCS: 24 PRBs in the middle of the test bandwidth
	Frequency hopping	Disabled
Code block group based PUSCH transmission		Disabled

8.2.2.2 Minimum requirements

The throughput shall be equal to or larger than the fraction of maximum throughput for the FRCs stated in tables 8.2.2.2-1 to 8.2.2.2-2 at the given SNR. FRCs are defined in annex A.

Table 8.2.2.2-1: Minimum requirements for PUSCH, 5 MHz channel bandwidth, 15 kHz SCS

Number of TX antennas	Number of RX antennas	Cyclic prefix	Propagation conditions and correlation matrix (Annex G)	Fraction of maximum throughput	FRC (Annex A)	DMRS configuration	SNR (dB)
1	2	Normal	TDLB100-400	70 %	G-FR1-A3-29	1+0	[1.6]
					G-FR1-A3-31	1+1	[-2.5]
	4	Normal	TDLB100-400	70 %	G-FR1-A3-29	1+0	[-3.5]
					G-FR1-A3-31	1+1	[-6.4]
	8	Normal	TDLB100-400	70 %	G-FR1-A3-29	1+0	[-6.9]
					G-FR1-A3-31	1+1	[-8.3]

Table 8.2.2.2-2: Minimum requirements for PUSCH, 10 MHz channel bandwidth, 30 kHz SCS

Number of TX antennas	Number of RX antennas	Cyclic prefix	Propagation conditions and correlation matrix (Annex G)	Fraction of maximum throughput	FRC (Annex A)	DMRS configuration	SNR (dB)
1	2	Normal	TDLB100-400	70 %	G-FR1-A3-30	1+0	[-1.8]
					G-FR1-A3-32	1+1	TBD
	4	Normal	TDLB100-400	70 %	G-FR1-A3-30	1+0	[-5.6]
					G-FR1-A3-32	1+1	[-5.9]
	8	Normal	TDLB100-400	70 %	G-FR1-A3-30	1+0	TBD
					G-FR1-A3-32	1+1	[-8.7]

8.3 Performance requirements for PUCCH

8.3.1 DTX to ACK probability

8.3.1.1 General

The DTX to ACK probability, i.e. the probability that ACK is detected when nothing was sent:

$$\text{Prob}(\text{PUCCH DTX} \rightarrow \text{Ack bits}) = \frac{\#(\text{false ACK bits})}{\#(\text{PUCCH DTX}) * \#(\text{ACK/NACK bits})}$$

where:

- #(false ACK bits) denotes the number of detected ACK bits.
- #(ACK/NACK bits) denotes the number of encoded bits per slot
- #(PUCCH DTX) denotes the number of DTX occasions

8.3.1.2 Minimum requirement

The DTX to ACK probability shall not exceed 1% for all PUCCH formats carrying ACK/NACK bits:

$$\text{Prob}(\text{PUCCH DTX} \rightarrow \text{Ack bits}) \leq 10^{-2}$$

8.3.2 Performance requirements for PUCCH format 0

8.3.2.1 General

The ACK missed detection probability is the probability of not detecting an ACK when an ACK was sent.

Table 8.3.2.1-1: Test Parameters

Parameter	Test
nrofBits	1
nrofPRBs	1
startingPRB	0
intraSlotFrequencyHopping	enabled
secondHopPRB	The largest PRB index - nrofPRBs
initialCyclicShift	0
startingSymbolIndex	13 for 1 symbol 12 for 2 symbols

8.3.2.2 Minimum requirements

The ACK missed detection probability shall not exceed 1% at the SNR given in table 8.3.2.2-1 and in table 8.3.2.2-2.

Table 8.3.2.2-1: Minimum requirements for PUCCH format 0 and 15kHz SCS

Number of TX antennas	Number of RX antennas	Propagation conditions and correlation matrix (Annex G)	Number of OFDM symbols	Channel bandwidth / SNR (dB)		
				5 MHz	10 MHz	20 MHz
1	2	TDLC300-100 Low	1	[9.3]	[8.9]	[9.1]
			2	TBD	[4.8]	[3.6]
1	4	TDLC300-100 Low	1	TBD	[3.1]	TBD
			2	TBD	TBD	TBD
1	8	TDLC300-100 Low	1	TBD	[-1.0]	TBD
			2	TBD	[-3.6]	TBD

Table 8.3.2.2-2: Minimum requirements for PUCCH format 0 and 30kHz SCS

Number of TX antennas	Number of RX antennas	Propagation conditions and correlation matrix (Annex G)	Number of OFDM symbols	Channel bandwidth / SNR (dB)			
				10 MHz	20 MHz	40 MHz	100 MHz
1	2	TDLC300-100 Low	1	TBD	TBD	[10.4]	TBD
			2	TBD	TBD	TBD	TBD
1	4	TDLC300-100 Low	1	TBD	TBD	[3.4]	TBD
			2	TBD	TBD	[-0.3]	TBD
1	8	TDLC300-100 Low	1	TBD	TBD	[-0.8]	TBD
			2	TBD	TBD	[-3.7]	TBD

8.3.3 Performance requirements for PUCCH format 1

8.3.3.1 NACK to ACK requirements

8.3.3.1.1 General

The NACK to ACK detection probability is the probability that an ACK bit is falsely detected when an NACK bit was sent on the particular bit position, where the NACK to ACK detection probability is defined as follows:

$$\text{Prob}(\text{PUCCH NACK} \rightarrow \text{ACK bits}) = \frac{\#(\text{NACK bits decoded as ACK bits})}{\#(\text{Total NACK bits})},$$

where:

- $\#(\text{Total NACK bits})$ denotes the total number of NACK bits transmitted
- $\#(\text{NACK bits decoded as ACK bits})$ denotes the number of NACK bits decoded as ACK bits at the receiver, i.e. the number of received ACK bits
- NACK bits in the definition do not contain the NACK bits which are mapped from DTX, i.e. NACK bits received when DTX is sent should not be considered.

Random codeword selection is assumed.

Table 8.3.3.1.1-1: Test Parameters

Parameter	Test
nrofBits	2
nrofPRBs	1
nrofSymbols	14
startingPRB	0
intraSlotFrequencyHopping	enabled
secondHopPRB	The largest PRB index - nrofPRBs
initialCyclicShift	0
startingSymbolIndex	0
Index of orthogonal sequence (time-domain-OCC)	0

8.3.3.1.2 Minimum requirements

The NACK to ACK probability shall not exceed 0.1% at the SNR given in table 8.3.3.1.2-1 and table 8.3.3.1.2-2.

Table 8.3.3.1.2-1: Minimum requirements for PUCCH format 1 with 15 kHz SCS

Number of TX antennas	Number of RX antennas	Cyclic Prefix	Propagation conditions and correlation matrix (Annex G)	Channel bandwidth / SNR (dB)		
				5 MHz	10 MHz	20 MHz
1	2	Normal	TDLC-300-100 Low	[-3.7]	[-3.6]	[-3.6]
	4	Normal	TDLC-300-100 Low	[-8.4]	[-7.4]	[-8.3]
	8	Normal	TDLC-300-100 Low	[-11.6]	[-11.3]	[-11.5]

Table 8.3.3.1.2-2: Minimum requirements for PUCCH format 1 with 30 kHz SCS

Number of TX antennas	Number of RX antennas	Cyclic Prefix	Propagation conditions and correlation matrix (Annex G)	Channel bandwidth (MHz) / SNR (dB)			
				10 MHz	20 MHz	40 MHz	100 MHz
1	2	Normal	TDLC-300-100 Low	[-4.0]	[TBD]	[-2.9]	[TBD]
	4	Normal	TDLC-300-100 Low	[-7.7]	[-8.2]	[-7.0]	[TBD]
	8	Normal	TDLC-300-100 Low	[-11.4]	[-11.2]	[-11.3]	[-11.4]

8.3.3.2 ACK missed detection requirements

8.3.3.2.1 General

The ACK missed detection probability is the probability of not detecting an ACK when an ACK was sent. The test parameters in table 8.3.3.1.1-1 are configured.

8.3.3.2.2 Minimum requirements

The ACK missed detection probability shall not exceed 1% at the SNR given in table 8.3.3.2.2-1 and in table 8.3.3.2.2-2.

Table 8.3.3.2.2-1: Minimum requirements for PUCCH format 1 with 15 kHz SCS

Number of TX antennas	Number of RX antennas	Cyclic Prefix	Propagation conditions and correlation matrix (Annex G)	Channel bandwidth / SNR (dB)		
				5 MHz	10 MHz	20 MHz
1	2	Normal	TDLC-300-100 Low	[-4.8]	[-4.3]	[-4.9]
	4	Normal	TDLC-300-100 Low	[-8.6]	[-8.0]	[-8.5]
	8	Normal	TDLC-300-100 Low	[-11.5]	[-11.3]	[-11.3]

Table 8.3.3.2.2-2: Minimum requirements for PUCCH format 1 with 30 kHz SCS

Number of TX antennas	Number of RX antennas	Cyclic Prefix	Propagation conditions and correlation matrix (Annex G)	Channel bandwidth (MHz) / SNR (dB)			
				10 MHz	20 MHz	40 MHz	100 MHz
1	2	Normal	TDLC-300-100 Low	[-4.0]	[-4.4]	[-4.4]	[-4.3]
	4	Normal	TDLC-300-100 Low	[-7.9]	[-8.3]	[-8.3]	[-8.3]
	8	Normal	TDLC-300-100 Low	[-11.1]	[-11.2]	[-11.3]	[-11.1]

8.3.4 Performance requirements for PUCCH format 2

8.3.4.1 ACK missed detection requirements

8.3.4.1.1 General

The ACK missed detection probability is the probability of not detecting an ACK when an ACK was sent.

The ACK missed detection requirement only applies to the PUCCH format 2 with 4 UCI bits.

Table 8.3.4.1.1-1: Test Parameters

Parameter	Value
Modulation	QSPK
startingPRB	0
intraSlotFrequencyHopping	enable
secondHopPRB	The largest PRB index - nrofPRB
nrofPRB	4
nrofSymbols	1
the number of UCI bits	4
startingSymbolIndex	13

8.3.4.1.2 Minimum requirements

The ACK missed detection probability shall not exceed 1% at the SNR given in table 8.3.4.1.2-1 and table 8.3.4.1.2-2 for 4UCI bits.

Table 8.3.4.1.2-1: Minimum requirements for PUCCH format 2 with 15 kHz SCS

Number of TX antennas	Number of RX antennas	Cyclic Prefix	Propagation conditions and correlation matrix (Annex G)	Channel bandwidth / SNR (dB)		
				5 MHz	10 MHz	20 MHz
1	2	Normal	TDLC300-100 Low	[TBD]	[5.5]	[TBD]
	4	Normal	TDLC300-100 Low	[TBD]	[TBD]	[TBD]
	8	Normal	TDLC300-100 Low	[TBD]	[TBD]	[TBD]

Table 8.3.4.1.2-2: Minimum requirements for PUCCH format 2 with 30 kHz SCS

Number of TX antennas	Number of RX antennas	Cyclic Prefix	Propagation conditions and correlation matrix (Annex G)	Channel bandwidth / SNR (dB)			
				10MHz	20MHz	40MHz	100MHz
1	2	Normal	TDLC300-100 Low	[TBD]	[TBD]	[TBD]	[TBD]
	4	Normal	TDLC300-100 Low	[TBD]	[TBD]	[TBD]	[TBD]
	8	Normal	TDLC300-100 Low	[TBD]	[TBD]	[TBD]	[TBD]

8.3.4.2 UCI BLER performance requirements

8.3.4.2.1 General

The UCI block error probability (BLER) is defined as the conditional probability of incorrectly decoding the UCI information when the UCI information is sent. All UCI information shall be decoded.

The UCI block error probability performance requirement only applies to the PUCCH format 2 with 22 UCI bits.

Table 8.3.4.2.1-1: Test Parameters

Parameter	Value
Modulation	QSPK
startingPRB	0
intraSlotFrequencyHopping	enable
secondHopPRB	The largest PRB index - nrofPRB
nrofPRB	9
nrofSymbols	2
the number of UCI bits	22
startingSymbolIndex	12

8.3.4.2.2 Minimum requirements

The UCI block error probability shall not exceed 1% at the SNR given in table 8.3.4.2.2-1 and table 8.3.4.2.2-2 for 22 UCI bits.

Table 8.3.4.2.2-1: Minimum requirements for PUCCH format 2 with 15 kHz SCS

Number of TX antennas	Number of RX antennas	Cyclic Prefix	Propagation conditions and correlation matrix (Annex G)	Channel bandwidth / SNR (dB)		
				5 MHz	10 MHz	20 MHz
1	2	Normal	TDLC300-100 Low	[TBD]	[1.05]	[TBD]
	4	Normal	TDLC300-100 Low	[TBD]	[TBD]	[TBD]
	8	Normal	TDLC300-100 Low	[-6.6]	[-6.5]	[-6.5]

Table 8.3.4.2.2-2: Minimum requirements for PUCCH format 2 with 30 kHz SCS

Number of TX antennas	Number of RX antennas	Cyclic Prefix	Propagation conditions and correlation matrix (Annex G)	Channel bandwidth / SNR (dB)			
				10MHz	20MHz	40MHz	100MHz
1	2	Normal	TDLC300-100 Low	[TBD]	[TBD]	[0.4]	[TBD]
	4	Normal	TDLC300-100 Low	[TBD]	[TBD]	[TBD]	[TBD]
	8	Normal	TDLC300-100 Low	[TBD]	[TBD]	[TBD]	[TBD]

8.3.5 Performance requirements for PUCCH format 3

8.3.5.1 General

The performance is measured by the required SNR at UCI block error probability not exceeding 1%.

The UCI block error probability is defined as the conditional probability of incorrectly decoding the UCI information when the UCI information is sent. All UCI information shall be decoded.

Table 8.3.5.1-1: Test Parameters

Parameter	Test 1	Test 2
Modulation	QPSK	
startingPRB	0	
intraSlotFrequencyHopping	enabled	
secondHopPRB	The largest PRB index - nrofPRBs	
nrofPRBs	1	3
nrofSymbols	14	4
the number of UCI bits	16	16
startingSymbolIndex	0	0

8.3.5.2 Minimum requirements

The UCI block error probability shall not exceed 1% at the SNR given in Table 8.3.5.2-1 and Table 8.3.5.2-2.

Table 8.3.5.2-1: Minimum requirements for PUCCH format 3 with 15 kHz SCS

Test Number	Number of TX antennas	Number of RX antennas	Cyclic Prefix	Propagation conditions and correlation matrix (Annex G)	Additional DMRS configuration	Channel bandwidth / SNR (dB)		
						5 MHz	10 MHz	20 MHz
1	1	2	Normal	TDLC300-100 Low	No additional DM-RS	TBD	[1.1]	TBD
					Additional DMRS	TBD	[0.5]	[-0.3]
		4	Normal	TDLC300-100 Low	No additional DM-RS	[-3.7]	[-3.4]	[-3.8]
					Additional DMRS	[-4.4]	[-4.0]	[-4.5]
		8	Normal	TDLC300-100 Low	No additional DM-RS	[-7.0]	[-6.7]	[-6.8]
					Additional DMRS	[-7.7]	[-7.5]	[-7.7]
2	1	2	Normal	TDLC300-100 Low	No additional DM-RS	TBD	[1.9]	TBD
		4	Normal	TDLC300-100 Low	No additional DM-RS	TBD	TBD	TBD
		8	Normal	TDLC300-100 Low	No additional DM-RS	TBD	TBD	TBD

Table 8.3.5.2-2: Minimum requirements for PUCCH format 3 with 30 kHz SCS

Test Number	Number of TX antennas	Number of RX antennas	Cyclic Prefix	Propagation conditions and correlation matrix (Annex G)	Additional DMRS configuration	Channel bandwidth / SNR (dB)			
						10 MHz	20 MHz	40 MHz	100 MHz
1	1	2	Normal	TDLC300-100 Low	No additional DM-RS	TBD	TBD	[0.5]	TBD
					Additional DMRS	TBD	TBD	[0.9]	TBD
		4	Normal	TDLC300-100 Low	No additional DM-RS	[-2.9]	[-3.4]	[-3.3]	TBD
					Additional DMRS	[-3.6]	[-4.2]	[-4.0]	TBD
		8	Normal	TDLC300-100 Low	No additional DM-RS	[-6.4]	[-6.6]	[-6.8]	TBD
					Additional DMRS	[-7.3]	[-7.5]	[-7.5]	TBD
2	1	2	Normal	TDLC300-100 Low	No additional DM-RS	TBD	TBD	[0.9]	TBD
		4	Normal	TDLC300-100 Low	No additional DM-RS	TBD	TBD	TBD	TBD
		8	Normal	TDLC300-100 Low	No additional DM-RS	TBD	TBD	TBD	TBD

8.3.6 Performance requirements for PUCCH format 4

8.3.6.1 General

The performance is measured by the required SNR at UCI block error probability not exceeding 1%.

The UCI block error probability is defined as the conditional probability of incorrectly decoding the UCI information when the UCI information is sent. All UCI information shall be decoded.

Table 8.3.6.1-1: Test parameters

Parameter	Value
Modulation	QPSK
startingPRB	0
intraSlotFrequencyHopping	enabled
secondHopPRB	The largest PRB index - nrofPRBs
nrofSymbols	14
the number of UCI bits	22
startingSymbolIndex	0
occ-Length	n2
occ-Index	n0

8.3.6.2 Minimum requirement

The UCI block error probability shall not exceed 1% at the SNR given in Table 8.3.6.2-1 and Table 8.3.6.2-2.

Table 8.3.6.2-1: Required SNR for PUCCH format 4 with 15 kHz SCS

Number of TX antennas	Number of RX antennas	Cyclic Prefix	Propagation conditions and correlation matrix (Annex G)	Additional DMRS configuration	Channel bandwidth / SNR (dB)		
					5 MHz	10 MHz	20 MHz
1	2	Normal	TDLC300-100 Low	No additional DM-RS	[1.8]	[2.5]	[2.1]
				Additional DMRS	[1.6]	[2.3]	[1.8]
	4	Normal	TDLC300-100 Low	No additional DM-RS	[-2.5]	[-2.2]	[-2.4]
				Additional DMRS	[-3.0]	[-2.8]	[-2.9]
	8	Normal	TDLC300-100 Low	No additional DM-RS	[-5.7]	[-5.8]	[-5.7]
				Additional DMRS	[-6.4]	[-6.4]	[-6.4]

Table 8.3.6.2-2: Required SNR for PUCCH format 4 with 30 kHz SCS

Number of TX antennas	Number of RX antennas	Cyclic Prefix	Propagation conditions and correlation matrix (Annex G)	Additional DMRS configuration	Channel bandwidth / SNR (dB)			
					10 MHz	20 MHz	40 MHz	100 MHz
1	2	Normal	TDLC300-100 Low	No additional DM-RS	[3.2]	[2.3]	[3.1]	TBD
				Additional DMRS	[3.0]	[2.3]	[2.8]	TBD
	4	Normal	TDLC300-100 Low	No additional DM-RS	[-1.5]	[-2.1]	[-1.9]	TBD
				Additional DMRS	[-2.1]	[-2.6]	[-2.6]	TBD
	8	Normal	TDLC300-100 Low	No additional DM-RS	[-5.3]	[-5.5]	[-5.6]	TBD
				Additional DMRS	[-5.9]	[-6.1]	[-6.4]	TBD

8.4 Performance requirements for PRACH

8.4.1 PRACH False alarm probability

8.4.1.1 General

The false alarm requirement is valid for any number of receive antennas, for any channel bandwidth.

The false alarm probability is the conditional total probability of erroneous detection of the preamble (i.e. erroneous detection from any detector) when input is only noise.

8.4.1.2 Minimum requirement

The false alarm probability shall be less than or equal to 0.1%.

8.4.2 PRACH detection requirements

8.4.2.1 General

The probability of detection is the conditional probability of correct detection of the preamble when the signal is present. There are several error cases – detecting different preamble than the one that was sent, not detecting a preamble at all or correct preamble detection but with the wrong timing estimation. For AWGN and TDLC300-100, a timing estimation error occurs if the estimation error of the timing of the strongest path is larger than the time error tolerance given in Table 8.4.2.1-1.

Table 8.4.2.1-1: Time error tolerance for AWGN and TDLC300-100

PRACH preamble	PRACH SCS (KHz)	Time error tolerance	
		AWGN	TDLC300-100
0	1.25	1.04 us	2.55 us
A1, A2, A3, B4, C0, C2	15	0.52 us	2.03 us
	30	0.26 us	1.77 us

The test preambles for normal mode are listed in table A.6-1.

8.4.2.2 Minimum requirements

The probability of detection shall be equal to or exceed 99% for the SNR levels listed in tables 8.4.2.2-1 to 8.4.2.2-3.

Table 8.4.2.2-1: PRACH missed detection requirements for Normal Mode, 1.25 kHz SCS

Number of TX antennas	Number of RX antennas	Propagation conditions and correlation matrix (Annex G)	Frequency offset	SNR (dB)
				Burst format 0
1	2	AWGN	0	[-14.5]
		TDLC300-100 Low	400 Hz	[-6.6]
	4	AWGN	0	[-17.3]
		TDLC300-100 Low	400 Hz	[-12.2]
	8	AWGN	0	[-18.9]
		TDLC300-100 Low	400 Hz	[-15.8]

Table 8.4.2.2-2: PRACH missed detection requirements for Normal Mode, 15 kHz SCS

Number of TX antennas	Number of RX antennas	Propagation conditions and correlation matrix (Annex G)	Frequency offset	SNR (dB)					
				Burst format A1	Burst format A2	Burst format A3	Burst format B4	Burst format C0	Burst format C2
1	2	AWGN	0	[-9.3]	TBD	[-14.3]	[16.9]	[-6.3]	TBD
		TDLC300-100 Low	400 Hz	[-2.2]	[-4.8]	[-6.8]	[-8.8]	[0.7]	[-4.9]
	4	AWGN	0	[-12.2]	[-15.0]	[-16.4]	[-19.1]	TBD	[-15.0]
		TDLC300-100 Low	400 Hz	TBD	[-10.2]	[-11.6]	[-13.8]	TBD	[-10.2]
	8	AWGN	0	[-14.0]	[-17.1]	[-18.7]	[-21.2]	[-11.1]	[-17.1]
		TDLC300-100 Low	400 Hz	[-11.1]	[-14.0]	[-15.5]	[-17.3]	[-8.2]	[-14.0]

Table 8.4.2.2-3: PRACH missed detection requirements for Normal Mode, 30 kHz SCS

Number of TX antennas	Number of RX antennas	Propagation conditions and correlation matrix (Annex G)	Frequency offset	SNR (dB)					
				Burst format A1	Burst format A2	Burst format A3	Burst format B4	Burst format C0	Burst format C2
1	2	AWGN	0	[-9.1]	[-12.0]	[-13.9]	[-16.6]	[-6.1]	[-12.0]
		TDLC300-100 Low	400 Hz	[-2.8]	[-5.8]	[-7.5]	[-10.1]	[0.0]	[-5.7]
	4	AWGN	0	[-12.0]	[-14.9]	[-16.3]	[-19.0]	TBD	[-14.8]
		TDLC300-100 Low	400 Hz	TBD	[-10.4]	[-12.0]	[-14.5]	TBD	[-10.5]
	8	AWGN	0	[-13.8]	[-16.9]	[-18.5]	[-21.0]	[-11.0]	[-16.6]
		TDLC300-100 Low	400 Hz	[-10.7]	[-13.8]	[-15.4]	[-17.6]	[-8.0]	[-13.9]

9 Radiated transmitter characteristics

9.1 General

Radiated transmitter characteristics requirements apply on the *BS type 1-H*, *BS type 1-O*, or *BS type 2-O* including all its functional components active and for all foreseen modes of operation of the BS unless otherwise stated.

9.2 Radiated transmit power

9.2.1 General

BS type 1-H, *BS type 1-O* and *BS type 2-O* are declared to support one or more beams, as per manufacturer's declarations specified in TS 38.141-2 [6]. Radiated transmit power is defined as the EIRP level for a declared beam at a specific *beam peak direction*.

For each beam, the requirement is based on declaration of a beam identity, *reference beam direction pair*, *beamwidth*, *rated beam EIRP*, *OTA peak directions set*, the *beam direction pairs* at the maximum steering directions and their associated *rated beam EIRP* and *beamwidth(s)*.

For a declared beam and *beam direction pair*, the *rated beam EIRP* level is the maximum power that the base station is declared to radiate at the associated *beam peak direction* during the *transmitter ON period*.

For each *beam peak direction* associated with a *beam direction pair* within the *OTA peak directions set*, a specific *rated beam EIRP* level may be claimed. Any claimed value shall be met within the accuracy requirement as described below. *Rated beam EIRP* is only required to be declared for the *beam direction pairs* subject to conformance testing as detailed in TS 38.141-2 [6].

NOTE 1: *OTA peak directions set* is set of *beam peak directions* for which the EIRP accuracy requirement is intended to be met. The *beam peak directions* are related to a corresponding contiguous range or discrete list of *beam centre directions* by the *beam direction pairs* included in the set.

NOTE 2: A *beam direction pair* is data set consisting of the *beam centre direction* and the related *beam peak direction*.

NOTE 3: A declared EIRP value is a value provided by the manufacturer for verification according to the conformance specification declaration requirements, whereas a claimed EIRP value is provided by the manufacturer to the equipment user for normal operation of the equipment and is not subject to formal conformance testing.

For *operating bands* where the supported fractional bandwidth (FBW) is larger than 6%, two rated carrier EIRP may be declared by manufacturer:

- $P_{\text{rated,c,FBWlow}}$ for lower supported frequency range, and
- $P_{\text{rated,c,FBWhigh}}$ for higher supported frequency range.

For frequencies in between F_{FBWlow} and F_{FBWhigh} the rated carrier EIRP is:

- $P_{\text{rated,c,FBWlow}}$, for the carrier whose carrier frequency is within frequency range $F_{\text{FBWlow}} \leq f < (F_{\text{FBWlow}} + F_{\text{FBWhigh}}) / 2$,
- $P_{\text{rated,c,FBWhigh}}$, for the carrier whose carrier frequency is within frequency range $(F_{\text{FBWlow}} + F_{\text{FBWhigh}}) / 2 \leq f \leq F_{\text{FBWhigh}}$.

9.2.2 Minimum requirement for *BS type 1-H* and *BS type 1-O*

For each declared beam, in normal conditions, for any specific *beam peak direction* associated with a *beam direction pair* within the *OTA peak directions set*, a manufacturer claimed EIRP level in the corresponding *beam peak direction* shall be achievable to within ± 2.2 dB of the claimed value.

For *BS type 1-O* only, for each declared beam, in extreme conditions, for any specific *beam peak direction* associated with a *beam direction pair* within the *OTA peak directions set*, a manufacturer claimed EIRP level in the corresponding *beam peak direction* shall be achievable to within ± 2.7 dB of the claimed value.

Normal and extreme conditions are defined in TS 38.141-2, annex B [6].

In certain regions, the minimum requirement for normal conditions may apply also for some conditions outside the range of conditions defined as normal.

9.2.3 Minimum requirement for *BS type 2-O*

For each declared beam, in normal conditions, for any specific *beam peak direction* associated with a *beam direction pair* within the *OTA peak directions set*, a manufacturer claimed EIRP level in the corresponding *beam peak direction* shall be achievable to within ± 3.4 dB of the claimed value.

For each declared beam, in extreme conditions, for any specific *beam peak direction* associated with a *beam direction pair* within the *OTA peak directions set*, a manufacturer claimed EIRP level in the corresponding *beam peak direction* shall be achievable to within ± 4.5 dB of the claimed value.

Normal and extreme conditions are defined in TS 38.141-2, annex B [6].

In certain regions, the minimum requirement for normal conditions may apply also for some conditions outside the range of conditions defined as normal.

9.3 OTA base station output power

9.3.1 General

OTA BS output power is declared as the TRP radiated requirement, with the output power accuracy requirement defined at the RIB during the *transmitter ON period*. TRP does not change with beamforming settings as long as the *beam peak direction* is within the *OTA peak directions set*. Thus the TRP accuracy requirement must be met for any beamforming setting for which the *beam peak direction* is within the *OTA peak directions set*.

The BS *rated carrier TRP output power* for *BS type 1-O* shall be within limits as specified in table 9.3.1-1.

Table 9.3.1-1: BS rated carrier TRP output power limits for *BS type 1-O*

BS class	$P_{\text{rated,c,TRP}}$
Wide Area BS	(note)
Medium Range BS	$\leq + 47$ dBm
Local Area BS	$\leq + 33$ dBm
NOTE: There is no upper limit for the $P_{\text{rated,c,TRP}}$ of the Wide Area Base Station.	

There is no upper limit for the *rated carrier TRP output power* of *BS type 2-O*.

Despite the general requirements for the BS output power described in subclauses 9.3.2 – 9.3.3, additional regional requirements might be applicable.

NOTE: In certain regions, power limits corresponding to BS classes may apply for *BS type 2-O*.

9.3.2 Minimum requirement for *BS type 1-O*

In normal conditions, the *BS type 1-O maximum carrier TRP output power*, $P_{\text{max,c,TRP}}$ measured at the RIB shall remain within ± 2 dB of the *rated carrier TRP output power* $P_{\text{rated,c,TRP}}$, as declared by the manufacturer.

Normal conditions are defined in TS 38.141-1, annex B [6].

9.3.3 Minimum requirement for *BS type 2-O*

In normal conditions, the *BS type 2-O maximum carrier TRP output power*, $P_{\max,c,TRP}$ measured at the RIB shall remain within ± 3 dB of the *rated carrier TRP output power* $P_{\text{rated},c,TRP}$, as declared by the manufacturer.

Normal conditions are defined in TS 38.141-2, annex B [6].

9.3.4 Additional requirements (regional)

In certain regions, additional regional requirements may apply.

9.4 OTA output power dynamics

9.4.1 General

The requirements in subclause 9.4 apply during the *transmitter ON period*. Transmit signal quality (as specified in subclause 9.6) shall be maintained for the output power dynamics requirements.

The OTA output power requirements are *directional requirements* and apply to the *beam peak directions* over the *OTA peak directions set*.

9.4.2 OTA RE power control dynamic range

9.4.2.1 General

The OTA RE power control dynamic range is the difference between the power of an RE and the average RE power for a BS at maximum output power ($P_{\max,c,EIRP}$) for a specified reference condition.

This requirement shall apply at each RIB supporting transmission in the *operating band*.

9.4.2.2 Minimum requirement for *BS type 1-O*

The OTA RE power control dynamic range is specified the same as the conducted RE power control dynamic range requirement for *BS type 1-C* and *BS type 1-H* in table 6.3.2.2-1.

9.4.3 OTA total power dynamic range

9.4.3.1 General

The OTA total power dynamic range is the difference between the maximum and the minimum transmit power of an OFDM symbol for a specified reference condition.

This requirement shall apply at each RIB supporting transmission in the *operating band*.

NOTE 1: The upper limit of the OTA total power dynamic range is the BS maximum carrier EIRP ($P_{\max,c,EIRP}$) when transmitting on all RBs. The lower limit of the OTA total power dynamic range is the average EIRP for single RB transmission in the same direction using the same beam. The OFDM symbol carries PDSCH and not contain RS or SSB.

9.4.3.2 Minimum requirement for *BS type 1-O*

OTA total power dynamic range minimum requirement for *BS type 1-O* is specified such as for each NR carrier it shall be larger than or equal to the levels specified for the conducted requirement for *BS type 1-C* and *BS type 1-H* in table 6.3.3.2-1.

9.4.3.3 Minimum requirement for *BS type 2-O*

OTA total power dynamic range minimum requirement for *BS type 2-O* is specified such as for each NR carrier it shall be larger than or equal to the levels specified in table 9.4.3.3-1.

Table 9.4.3.3-1: Minimum requirement for *BS type 2-O* total power dynamic range

SCS (kHz)	50 MHz	100 MHz	200 MHz	400 MHz
	OTA total power dynamic range (dB)			
60	18.1	21.2	24.2	N.A
120	15.0	18.1	21.2	24.2

9.5 OTA transmit ON/OFF power

9.5.1 General

OTA transmit ON/OFF power requirements apply only to TDD operation of NR BS.

9.5.2 OTA transmitter OFF power

9.5.2.1 General

OTA transmitter OFF power is defined as the mean power measured over $70/N$ μ s filtered with a square filter of bandwidth equal to the transmission bandwidth configuration of the BS (BW_{Config}) centred on the assigned channel frequency during the *transmitter OFF period*. $N = \text{SCS}/15$, where SCS is Sub Carrier Spacing in kHz.

For BS supporting intra-band contiguous CA, the OTA transmitter OFF power is defined as the mean power measured over $70/N$ μ s filtered with a square filter of bandwidth equal to the *Aggregated BS Channel Bandwidth* $BW_{\text{Channel_CA}}$ centred on $(F_{\text{edge,high}} + F_{\text{edge,low}})/2$ during the *transmitter OFF period*. $N = \text{SCS}/15$, where SCS is the smallest supported Sub Carrier Spacing in kHz in the *Aggregated BS Channel Bandwidth*.

For *BS type 1-O*, the transmitter OFF power is defined as the output power at the *co-location reference antenna* conducted output(s). For *BS type 2-O* the transmitter OFF power is defined as TRP.

For *multi-band RIBs* and *single band RIBs* supporting transmission in multiple bands, the requirement is only applicable during the *transmitter OFF period* in all supported *operating bands*.

9.5.2.2 Minimum requirement for *BS type 1-O*

The total power from all *co-location reference antenna* conducted output(s) shall be less than -106 dBm/MHz.

9.5.2.3 Minimum requirement for *BS type 2-O*

The OTA transmitter OFF power spectral density for *BS type 2-O* shall be less than -36 dBm/MHz.

NOTE: The OTA transmitter OFF power is measured together with the OTA transmitter transient period. As the OTA transmitter OFF power for *BS type 2-O* is defined as TRP, the measurement procedure for the OTA transient period is FFS.

9.5.3 OTA transient period

9.5.3.1 General

The OTA transmitter transient period is the time period during which the transmitter is changing from the *transmitter OFF period* to the *transmitter ON period* or vice versa. The transmitter transient period is illustrated in figure 6.4.2.1-1.

This requirement shall be applied at each RIB supporting transmission in the *operating band*.

9.5.3.2 Minimum requirement for *BS type 1-0*

For *BS type 1-0*, the OTA transmitter transient period shall be shorter than the values listed in the minimum requirement table 9.5.3.2-1.

Table 9.5.3.2-1: Minimum requirement for the OTA transmitter transient period for *BS type 1-0*

Transition	Transient period length (μs)
OFF to ON	10
ON to OFF	10

9.5.3.3 Minimum requirement for *BS type 2-0*

For *BS type 2-0*, the OTA transmitter transient period shall be shorter than the values listed in the minimum requirement table 9.5.3.3-1.

Table 9.5.3.3-1: Minimum requirement for the OTA transmitter transient period for *BS type 2-0*

Transition	Transient period length (μs)
OFF to ON	3
ON to OFF	3

9.6 OTA transmitted signal quality

9.6.1 OTA frequency error

9.6.1.1 General

The requirements in subclause 9.6.1 apply to the *transmitter ON period*.

OTA frequency error is the measure of the difference between the actual BS transmit frequency and the assigned frequency. The same source shall be used for RF frequency and data clock generation.

OTA frequency error requirement is defined as a directional requirement at the RIB and shall be met within the OTA coverage range.

9.6.1.2 Minimum requirement for *BS type 1-0*

For *BS type 1-0*, the modulated carrier frequency of each NR carrier configured by the BS shall be accurate to within the accuracy range given in table 6.5.1.2-1 observed over 1 ms.

9.6.1.3 Minimum requirement for *BS type 2-0*

For *BS type 2-0*, the modulated carrier frequency of each NR carrier configured by the BS shall be accurate to within the accuracy range given in table 9.6.1.3-1 observed over 1 ms.

Table 9.6.1.3-1: OTA frequency error minimum requirement

BS class	Accuracy
Wide Area BS	± 0.05 ppm
Medium Range BS	± 0.1 ppm
Local Area BS	± 0.1 ppm

9.6.2 OTA modulation quality

9.6.2.1 General

Modulation quality is defined by the difference between the measured carrier signal and a reference signal. Modulation quality can e.g. be expressed as Error Vector Magnitude (EVM). Details about how the EVM is determined are specified in Annex B for FR1 and Annex C for FR2.

OTA modulation quality requirement is defined as a directional requirement at the RIB and shall be met within the *OTA coverage range*.

9.6.2.2 Minimum Requirement for *BS type 1-O*

For *BS type 1-O*, the EVM levels of each NR carrier for different modulation schemes on PDSCH outlined in table 6.5.2.2-1 shall be met. Requirements shall be the same as subclause 6.5.2.2 and follow EVM frame structure from subclause 6.5.2.3.

9.6.2.3 Minimum Requirement for *BS type 2-O*

For *BS type 2-O*, the EVM levels of each NR carrier for different modulation schemes on PDSCH outlined in table 9.6.2.3-1 shall be met, following the EVM frame structure described in subclause 9.6.2.3.1.

Table 9.6.2.3-1: EVM requirements for *BS type 2-O* carrier

Modulation scheme for PDSCH	Required EVM (%)
QPSK	17.5
16QAM	12.5
64QAM	8

9.6.2.3.1 EVM frame structure for measurement

EVM requirements shall apply for each NR carrier over all allocated resource blocks. Different modulation schemes listed in table 9.6.2.3-1 shall be considered for rank 1.

For NR, for all bandwidths, the EVM measurement shall be performed for each NR carrier over all allocated resource blocks and downlink subframes within 10 ms measurement periods. The boundaries of the EVM measurement periods need not be aligned with radio frame boundaries.

EVM measurements start on the third symbol of a slot ($l=2$) when the first symbol of that slot is a downlink symbol.

9.6.3 OTA time alignment error

9.6.3.1 General

This requirement shall apply to frame timing in TX diversity, MIMO transmission, carrier aggregation and their combinations.

Frames of the NR signals present in the radiated domain are not perfectly aligned in time. In relation to each other, the RF signals present in the radiated domain may experience certain timing differences.

The TAE is specified for a specific set of signals/transmitter configuration/transmission mode.

[For a specific set of signals/transmitter configuration/transmission mode, the OTA Time Alignment Error (OTA TAE) is defined as the largest timing difference between any two different NR signals.] The OTA time alignment error requirement is defined as a *directional requirement* at the RIB and shall be met within the *OTA coverage range*.

9.6.3.2 Minimum requirement for *BS type 1-O*

For MIMO or TX diversity transmissions, at each carrier frequency, OTA TAE shall not exceed 65 ns.

For intra-band contiguous carrier aggregation, with or without MIMO or TX diversity, OTA TAE shall not exceed 260 ns.

For intra-band non-contiguous carrier aggregation, with or without MIMO or TX diversity, OTA TAE shall not exceed 3 μ s.

For inter-band carrier aggregation, with or without MIMO or TX diversity, OTA TAE shall not exceed 3 μ s.

Table 9.6.3.2-1: Void

Table 9.6.3.2-2: Void

Table 9.6.3.2-3: Void

9.6.3.3 Minimum requirement for *BS type 2-O*

For MIMO or TX diversity transmissions, at each carrier frequency, OTA TAE shall not exceed 65 ns.

For intra-band contiguous carrier aggregation, with or without MIMO or TX diversity, OTA TAE shall not exceed 130 ns.

For intra-band non-contiguous carrier aggregation, with or without MIMO or TX diversity, OTA TAE shall not exceed 3 μ s.

For inter-band carrier aggregation, with or without MIMO or TX diversity, OTA TAE shall not exceed 3 μ s.

Table 9.6.3.3-1: Void

Table 9.6.3.3-2: Void

Table 9.6.3.3-3: Void

9.7 OTA unwanted emissions

9.7.1 General

Unwanted emissions consist of so-called out-of-band emissions and spurious emissions according to ITU definitions ITU-R SM.329 [2]. In ITU terminology, out of band emissions are unwanted emissions immediately outside the *BS channel bandwidth* resulting from the modulation process and non-linearity in the transmitter but excluding spurious emissions. Spurious emissions are emissions which are caused by unwanted transmitter effects such as harmonics emission, parasitic emission, intermodulation products and frequency conversion products, but exclude out of band emissions.

The OTA out-of-band emissions requirement for the BS type 1-O and *BS type 2-O* transmitter is specified both in terms of Adjacent Channel Leakage power Ratio (ACLR) and operating band unwanted emissions (OBUE). The OTA Operating band unwanted emissions define all unwanted emissions in each supported downlink *operating band* plus the frequency ranges Δf_{OBUE} above and Δf_{OBUE} below each band. OTA Unwanted emissions outside of this frequency range are limited by an OTA spurious emissions requirement.

The maximum offset of the operating band unwanted emissions mask from the *operating band* edge is Δf_{OBUE} . The value of Δf_{OBUE} is defined in table 9.7.1-1 for *BS type 1-O* and *BS type 2-O* for the NR *operating bands*.

Table 9.7.1-1: Maximum offset Δf_{OBUE} outside the downlink operating band

BS type	Operating band characteristics	Δf_{OBUE} (MHz)
BS type 1-O	$F_{\text{DL,high}} - F_{\text{DL,low}} < 100$ MHz	10
	$100 \text{ MHz} \leq F_{\text{DL,high}} - F_{\text{DL,low}} \leq 900$ MHz	40
BS type 2-O	$F_{\text{DL,high}} - F_{\text{DL,low}} \leq 3250$ MHz	1500

The unwanted emission requirements are applied per cell for all the configurations. Requirements for OTA unwanted emissions are captured using TRP, *directional requirements* or co-location requirements as described per requirement.

There is in addition a requirement for occupied bandwidth.

9.7.2 OTA occupied bandwidth

9.7.2.1 General

The OTA occupied bandwidth is the width of a frequency band such that, below the lower and above the upper frequency limits, the mean powers emitted are each equal to a specified percentage $\beta/2$ of the total mean transmitted power. See also recommendation ITU-R SM.328 [3].

The value of $\beta/2$ shall be taken as 0.5%.

The OTA occupied bandwidth requirement shall apply during the *transmitter ON period* for a single transmitted carrier. The minimum requirement below may be applied regionally. There may also be regional requirements to declare the OTA occupied bandwidth according to the definition in the present clause.

The OTA occupied bandwidth is defined as a *directional requirement* and shall be met in the manufacturer's declared *OTA coverage range* at the RIB.

9.7.2.2 Minimum requirement for BS type 1-O and BS type 2-O

The OTA occupied bandwidth for each NR carrier shall be less than the *BS channel bandwidth*. For intra-band contiguous CA, the OTA occupied bandwidth shall be less than or equal to the *Aggregated BS Channel Bandwidth*.

9.7.3 OTA Adjacent Channel Leakage Power Ratio (ACLR)

9.7.3.1 General

OTA Adjacent Channel Leakage power Ratio (ACLR) is the ratio of the filtered mean power centred on the assigned channel frequency to the filtered mean power centred on an adjacent channel frequency. The measured power is TRP.

The requirement shall be applied per RIB during the *transmitter ON period*.

9.7.3.2 Minimum requirement for BS type 1-O

The ACLR (CACLR) absolute *basic limits* in table 6.6.3.2-2 + X, 6.6.3.2-2a + X (where X = 9 dB) or the ACLR (CACLR) *basic limit* in table 6.6.3.2-1, 6.6.3.2-2a or 6.6.3.2-3, whichever is less stringent, shall apply.

For a *RIB* operating in multi-carrier or contiguous CA, the ACLR requirements in subclause 6.6.3.2 shall apply to *BS channel bandwidths* of the outermost carrier for the frequency ranges defined in table 6.6.3.2-1. For a *RIB* operating in non-contiguous spectrum, the ACLR requirement in subclause 6.6.3.2 shall apply in sub block gaps for the frequency ranges defined in table 6.6.3.2-2a, while the CACLR requirement in subclause 6.6.3.2 shall apply in sub block gaps for the frequency ranges defined in table 6.6.3.2-3.

For a *multi-band RIB*, the ACLR requirement in subclause 6.6.3.2 shall apply in Inter RF Bandwidth gaps for the frequency ranges defined in table 6.6.3.2-2a, while the CACLR requirement in subclause 6.6.3.2 shall apply in Inter RF Bandwidth gaps for the frequency ranges defined in table 6.6.3.2-3.

9.7.3.3 Minimum requirement for *BS type 2-O*

The OTA ACLR limit is specified in table 9.7.3.3-1.

The OTA ACLR absolute limit is specified in table 9.7.3.3-2.

The OTA ACLR (CACLR) absolute limit in table 9.7.3.3-2 or 9.7.3.3-4a or the ACLR (CACLR) limit in table 9.7.3.3-1, 9.7.3.3-3 or 9.7.3.3-4, whichever is less stringent, shall apply.

For a *RIB* operating in multi-carrier or contiguous CA, the OTA ACLR requirements in table 9.7.3.3-1 shall apply to *BS channel bandwidths* of the outermost carrier for the frequency ranges defined in the table. For a *RIB* operating in non-contiguous spectrum, the OTA ACLR requirement in table 9.7.3.3-3 shall apply in sub-block gaps for the frequency ranges defined in the table, while the OTA CACLR requirement in table 9.7.3.3-4 shall apply in sub-block gaps for the frequency ranges defined in the table.

The CACLR in a sub-block gap is the ratio of:

- a) the sum of the filtered mean power centred on the assigned channel frequencies for the two carriers adjacent to each side of the sub-block gap, and
- b) the filtered mean power centred on a frequency channel adjacent to one of the respective sub-block edges.

The assumed filter for the adjacent channel frequency is defined in table 9.7.3.3-4 and the filters on the assigned channels are defined in table 9.7.3.3-5.

For operation in non-contiguous spectrum, the CACLR for NR carriers located on either side of the sub-block gap shall be higher than the value specified in table 9.7.3.3-4.

Table 9.7.3.3-1: *BS type 2-O* ACLR limit

<i>BS channel bandwidth of lowest/highest NR carrier transmitted</i> BW_{Channel} (MHz)	<i>BS adjacent channel centre frequency offset below the lowest or above the highest carrier centre frequency transmitted</i>	<i>Assumed adjacent channel carrier</i>	<i>Filter on the adjacent channel frequency and corresponding filter bandwidth</i>	<i>ACLR limit (dB)</i>
50, 100, 200, 400	BW_{Channel}	NR of same BW (Note 2)	Square (BW_{Config})	28 (Note 3) 26 (Note 4)
NOTE 1: BW_{Channel} and BW_{Config} are the <i>BS channel bandwidth</i> and transmission bandwidth configuration of the lowest/highest NR carrier transmitted on the assigned channel frequency.				
NOTE 2: With SCS that provides largest transmission bandwidth configuration (BW_{Config}).				
NOTE 3: Applicable to bands defined within the frequency spectrum range of 24.25 – 33.4 GHz				
NOTE 4: Applicable to bands defined within the frequency spectrum range of 37 – 52.6 GHz				

Table 9.7.3.3-2: *BS type 2-O* ACLR absolute limit

<i>BS class</i>	<i>ACLR absolute limit</i>
Wide area BS	-13 dBm/MHz
Medium range BS	-20 dBm/MHz
Local area BS	-20 dBm/MHz

Table 9.7.3.3-3: BS type 2-O ACLR limit in non-contiguous spectrum

BS channel bandwidth of lowest/highest NR carrier transmitted (MHz)	Sub-block gap size (W_{gap}) where the limit applies (MHz)	BS adjacent channel centre frequency offset below or above the sub-block edge (inside the gap)	Assumed adjacent channel carrier	Filter on the adjacent channel frequency and corresponding filter bandwidth	ACLR limit
50, 100	$W_{\text{gap}} \geq 100$ (Note 5)	25 MHz	50 MHz NR (Note 2)	Square (BW_{Config})	28 (Note 3)
	$W_{\text{gap}} \geq 250$ (Note 6)				26 (Note 4)
200, 400	$W_{\text{gap}} \geq 400$ (Note 6)	100 MHz	200 MHz NR (Note 2)	Square (BW_{Config})	28 (Note 3)
	$W_{\text{gap}} \geq 250$ (Note 5)				26 (Note 4)

NOTE 1: BW_{Config} is the transmission bandwidth configuration of the assumed adjacent channel carrier.
NOTE 2: With SCS that provides largest transmission bandwidth configuration (BW_{Config}).
NOTE 3: Applicable to bands defined within the frequency spectrum range of 24.25 – 33.4 GHz.
NOTE 4: Applicable to bands defined within the frequency spectrum range of 37 – 52.6 GHz.
NOTE 5: Applicable in case the *BS channel bandwidth* of the NR carrier transmitted at the other edge of the gap is 50 or 100 MHz.
NOTE 6: Applicable in case the *BS channel bandwidth* of the NR carrier transmitted at the other edge of the gap is 200 or 400 MHz.

Table 9.7.3.3-4: BS type 2-O CACLR limit in non-contiguous spectrum

BS channel bandwidth of lowest/highest NR carrier transmitted (MHz)	Sub-block gap size (W_{gap}) where the limit applies (MHz)	BS adjacent channel centre frequency offset below or above the sub-block edge (inside the gap)	Assumed adjacent channel carrier	Filter on the adjacent channel frequency and corresponding filter bandwidth	CACLR limit
50, 100	$50 \leq W_{\text{gap}} < 100$ (Note 5)	25 MHz	50 MHz NR (Note 2)	Square (BW_{Config})	28 (Note 3)
	$50 \leq W_{\text{gap}} < 250$ (Note 6)				26 (Note 4)
200, 400	$200 \leq W_{\text{gap}} < 400$ (Note 6)	100 MHz	200 MHz NR (Note 2)	Square (BW_{Config})	28 (Note 3)
	$200 \leq W_{\text{gap}} < 250$ (Note 5)				26 (Note 4)

NOTE 1: BW_{Config} is the transmission bandwidth configuration of the assumed adjacent channel carrier.
NOTE 2: With SCS that provides largest transmission bandwidth configuration (BW_{Config}).
NOTE 3: Applicable to bands defined within the frequency spectrum range of 24.25 – 33.4 GHz.
NOTE 4: Applicable to bands defined within the frequency spectrum range of 37 – 52.6 GHz.
NOTE 5: Applicable in case the *BS channel bandwidth* of the NR carrier transmitted at the other edge of the gap is 50 or 100 MHz.
NOTE 6: Applicable in case the *BS channel bandwidth* of the NR carrier transmitted at the other edge of the gap is 200 or 400 MHz.

Table 9.7.3.3-4a: BS type 2-O CACLR absolute limit

BS class	CACLR absolute limit
Wide area BS	-13 dBm/MHz
Medium range BS	-20 dBm/MHz
Local area BS	-20 dBm/MHz

Table 9.7.3.3-5: Filter parameters for the assigned channel

RAT of the carrier adjacent to the sub-block gap	Filter on the assigned channel frequency and corresponding filter bandwidth
NR	NR of same BW with SCS that provides largest transmission bandwidth configuration

9.7.4 OTA operating band unwanted emissions

9.7.4.1 General

The OTA limits for operating band unwanted emissions are specified as TRP per RIB unless otherwise stated.

9.7.4.2 Minimum requirement for *BS type 1-O*

Out-of-band emissions in FR1 are limited by OTA operating band unwanted emission limits. Unless otherwise stated, the operating band unwanted emission limits in FR1 are defined from Δf_{OBUE} below the lowest frequency of each supported downlink *operating band* up to Δf_{OBUE} above the highest frequency of each supported downlink *operating band*. The values of Δf_{OBUE} are defined in table 9.7.1-1 for the NR *operating bands*.

The requirements shall apply whatever the type of transmitter considered and for all transmission modes foreseen by the manufacturer's specification. For a *RIB* operating in multi-carrier or contiguous CA, the requirements apply to *BS channel bandwidths* of the outermost carrier for the frequency ranges defined in subclause 6.6.4.1.

For a *RIB* operating in non-contiguous spectrum, the requirements shall apply inside any sub-block gap for the frequency ranges defined in subclause 6.6.4.1.

For a *multi-band RIB*, the requirements shall apply inside any Inter RF Bandwidth gap for the frequency ranges defined in subclause 6.6.4.1.

The OTA operating band unwanted emission requirement for *BS type 1-O* is that for each applicable *basic limit* in subclause 6.6.4.2, the power of any unwanted emission shall not exceed an OTA limit specified as the *basic limit* + X, where X = 9 dB.

9.7.4.2.1 Additional requirements

9.7.4.2.1.1 Protection of DTT

In certain regions the following requirement may apply for protection of DTT. For *BS type 1-O* operating in Band n20, the level of emissions in the band 470-790 MHz, measured in an 8 MHz filter bandwidth on centre frequencies F_{filter} according to table 9.7.4.2.1.1-1, shall not exceed the maximum emission TRP level shown in the table. This requirement applies in the frequency range 470-790 MHz even though part of the range falls in the spurious domain.

Table 9.7.4.2.1.1-1: Declared emissions levels for protection of DTT

Case	Measurement filter centre frequency	Condition on BS maximum aggregate TRP / 10 MHz, $P_{\text{TRP_10MHz}}$ (NOTE)	Maximum level $P_{\text{TRP,N,MAX}}$	Measurement bandwidth
A: for DTT frequencies where broadcasting is protected	$N*8 + 306 \text{ MHz}$, $21 \leq N \leq 60$	$P_{\text{TRP_10MHz}} \geq 59 \text{ dBm}$	0 dBm	8 MHz
	$N*8 + 306 \text{ MHz}$, $21 \leq N \leq 60$	$36 \leq P_{\text{TRP_10MHz}} < 59 \text{ dBm}$	$P_{\text{TRP_10MHz}} - 59 \text{ dBm}$	8 MHz
	$N*8 + 306 \text{ MHz}$, $21 \leq N \leq 60$	$P_{\text{TRP_10MHz}} < 36 \text{ dBm}$	-23 dBm	8 MHz
B: for DTT frequencies where broadcasting is subject to an intermediate level of protection	$N*8 + 306 \text{ MHz}$, $21 \leq N \leq 60$	$P_{\text{TRP_10MHz}} \geq 59 \text{ dBm}$	10 dBm	8 MHz
	$N*8 + 306 \text{ MHz}$, $21 \leq N \leq 60$	$36 \leq P_{\text{TRP_10MHz}} < 59 \text{ dBm}$	$P_{\text{TRP_10MHz}} - 49 \text{ dBm}$	8 MHz
	$N*8 + 306 \text{ MHz}$, $21 \leq N \leq 60$	$P_{\text{TRP_10MHz}} < 36 \text{ dBm}$	-13 dBm	8 MHz
C: for DTT frequencies where broadcasting is not protected	$N*8 + 306 \text{ MHz}$, $21 \leq N \leq 60$	N.A.	22 dBm	8 MHz
NOTE: $P_{\text{TRP_10MHz}}$ (dBm) is defined by $P_{\text{TRP_10MHz}} = P_{10\text{MHz}} + G_{\text{ant}} + 9\text{dB}$, where G_{ant} is 17 dBi.				

9.7.4.3 Minimum requirement for *BS type 2-0*

9.7.4.3.1 General

Out-of-band emissions in FR2 are limited by OTA operating band unwanted emission limits. Unless otherwise stated, the OTA operating band unwanted emission limits in FR2 are defined from Δf_{OBUE} below the lowest frequency of each supported downlink *operating band* up to Δf_{OBUE} above the highest frequency of each supported downlink *operating band*. The values of Δf_{OBUE} are defined in table 9.7.1-1 for the NR *operating bands*.

The requirements shall apply whatever the type of transmitter considered and for all transmission modes foreseen by the manufacturer's specification. For a *RIB* operating in multi-carrier or contiguous CA, the requirements apply to the frequencies (Δf_{OBUE}) starting from the edge of the *contiguous transmission bandwidth*. In addition, for a *RIB* operating in non-contiguous spectrum, the requirements apply inside any sub-block gap.

Emissions shall not exceed the maximum levels specified in the tables below, where:

- Δf is the separation between the *contiguous transmission bandwidth* edge frequency and the nominal -3dB point of the measuring filter closest to the *contiguous transmission bandwidth* edge.
- f_{offset} is the separation between the *contiguous transmission bandwidth* edge frequency and the centre of the measuring filter.
- $f_{\text{offset}_{\text{max}}}$ is the offset to the frequency Δf_{OBUE} outside the downlink *operating band*, where Δf_{OBUE} is defined in table 9.7.1-1.
- Δf_{max} is equal to $f_{\text{offset}_{\text{max}}}$ minus half of the bandwidth of the measuring filter. In addition, inside any sub-block gap for a *RIB* operating in non-contiguous spectrum, emissions shall not exceed the cumulative sum of the limits specified for the adjacent sub blocks on each side of the sub block gap. The limit for each sub-block is specified in the tables subclause 9.7.4.3.2-1 below, where in this case:
 - Δf is the separation between the sub block edge frequency and the nominal -3 dB point of the measuring filter closest to the sub block edge.
 - f_{offset} is the separation between the sub block edge frequency and the centre of the measuring filter.
 - $f_{\text{offset}_{\text{max}}}$ is equal to the sub block gap bandwidth minus half of the bandwidth of the measuring filter.
 - Δf_{max} is equal to $f_{\text{offset}_{\text{max}}}$ minus half of the bandwidth of the measuring filter.

9.7.4.3.2 OTA operating band unwanted emission limits

BS unwanted emissions shall not exceed the maximum levels specified in table 9.7.4.3.2-1 and 9.7.4.3.2-2.

Table 9.7.4.3.2-1: OBUE limits applicable in the frequency range 24.25 – 33.4 GHz

Frequency offset of measurement filter -3B point, Δf	Frequency offset of measurement filter centre frequency, f_{offset}	Limit	Measurement bandwidth
$0 \text{ MHz} \leq \Delta f < 0.1 * \text{BW}_{\text{contiguous}}$	$0.5 \text{ MHz} \leq f_{\text{offset}} < 0.1 * \text{BW}_{\text{contiguous}} + 0.5 \text{ MHz}$	Min(-5 dBm, Max($P_{\text{rated,t,TRP}} - 35 \text{ dB}$, -12 dBm))	1 MHz
$0.1 * \text{BW}_{\text{contiguous}} \leq \Delta f < \Delta f_{\text{max}}$	$0.1 * \text{BW}_{\text{contiguous}} + 0.5 \text{ MHz} \leq f_{\text{offset}} < f_{\text{offset}_{\text{max}}}$	Min(-13 dBm, Max($P_{\text{rated,t,TRP}} - 43 \text{ dB}$, -20 dBm))	1 MHz
NOTE 1: For non-contiguous spectrum operation within any <i>operating band</i> the limit within sub-block gaps is calculated as a cumulative sum of contributions from adjacent sub blocks on each side of the sub block gap.			

Table 9.7.4.3.2-2: OBUE limits applicable in the frequency range 37 – 52.6 GHz

Frequency offset of measurement filter -3B point, Δf	Frequency offset of measurement filter centre frequency, f_{offset}	Limit	Measurement bandwidth
$0 \text{ MHz} \leq \Delta f < 0.1 * \text{BW}_{\text{contiguous}}$	$0.5 \text{ MHz} \leq f_{\text{offset}} < 0.1 * \text{BW}_{\text{contiguous}} + 0.5 \text{ MHz}$	Min(-5 dBm, Max($P_{\text{rated,t,TRP}} - 33 \text{ dB}$, -12 dBm))	1 MHz
$0.1 * \text{BW}_{\text{contiguous}} \leq \Delta f < \Delta f_{\text{max}}$	$0.1 * \text{BW}_{\text{contiguous}} + 0.5 \text{ MHz} \leq f_{\text{offset}} < f_{\text{offsetmax}}$	Min(-13 dBm, Max($P_{\text{rated,t,TRP}} - 41 \text{ dB}$, -20 dBm))	1 MHz
NOTE 1: For non-contiguous spectrum operation within any <i>operating band</i> the limit within sub-block gaps is calculated as a cumulative sum of contributions from adjacent sub blocks on each side of the sub block gap.			

Table 9.7.4.3.2-3: Void

9.7.5 OTA transmitter spurious emissions

9.7.5.1 General

Unless otherwise stated, all requirements are measured as mean power.

The OTA spurious emissions limits are specified as TRP per RIB unless otherwise stated.

9.7.5.2 Minimum requirement for *BS type 1-O*

9.7.5.2.1 General

The OTA transmitter spurious emission limits for FR1 shall apply from 30 MHz to 12.75 GHz, excluding the frequency range from Δf_{OBUE} below the lowest frequency of each supported downlink *operating band*, up to Δf_{OBUE} above the highest frequency of each supported downlink *operating band*, where the Δf_{OBUE} is defined in table 9.7.1-1. For some FR1 *operating bands*, the upper limit is higher than 12.75 GHz in order to comply with the 5th harmonic limit of the downlink *operating band*, as specified in ITU-R recommendation SM.329 [2].

For multi-band RIB each supported *operating band* and Δf_{OBUE} MHz around each band are excluded from the OTA transmitter spurious emissions requirements.

The requirements shall apply whatever the type of transmitter considered (single carrier or multi-carrier). It applies for all transmission modes foreseen by the manufacturer's specification.

BS type 1-O requirements consists of OTA transmitter spurious emission requirements based on TRP and co-location requirements not based on TRP.

9.7.5.2.2 General OTA transmitter spurious emissions requirements

The Tx spurious emissions requirements for *BS type 1-O* are that for each applicable *basic limit* in subclause 6.6.5.2.1, the TRP of any spurious emission shall not exceed an OTA limit specified as the *basic limit* + X, where X = 9 dB, unless stated differently in regional regulation.

9.7.5.2.3 Protection of the BS receiver of own or different BS

This requirement shall be applied for NR FDD operation in order to prevent the receivers of own or a different BS of the same band being desensitised by emissions from a type 1-O BS.

This requirement is a co-location requirement as defined in subclause 4.9, the power levels are specified at the *co-location reference antenna* output.

The total power of any spurious emission from both polarizations of the *co-location reference antenna* connector output shall not exceed the *basic limits* in subclause 6.6.5.2.2 + X dB, where X = -21 dB.

9.7.5.2.4 Additional spurious emissions requirements

These requirements may be applied for the protection of systems operating in frequency ranges other than the BS downlink *operating band*. The limits may apply as an optional protection of such systems that are deployed in the same geographical area as the BS, or they may be set by local or regional regulation as a mandatory requirement for an NR *operating band*. It is in some cases not stated in the present document whether a requirement is mandatory or under what exact circumstances that a limit applies, since this is set by local or regional regulation. An overview of regional requirements in the present document is given in subclause 4.5.

Some requirements may apply for the protection of specific equipment (UE, MS and/or BS) or equipment operating in specific systems (GSM, CDMA, UTRA, E-UTRA, NR, etc.). The Tx additional spurious emissions requirements for BS *type 1-O* are that for each applicable *basic limit* in subclause 6.6.5.2.3, the TRP of any spurious emission shall not exceed an OTA limit specified as the *basic limit* + X, where X = 9 dB.

9.7.5.2.5 Co-location with other base stations

These requirements may be applied for the protection of other BS receivers when GSM900, DCS1800, PCS1900, GSM850, CDMA850, UTRA FDD, UTRA TDD, E-UTRA and/or NR BS are co-located with a BS.

The requirements assume co-location with base stations of the same class.

NOTE: For co-location with UTRA, the requirements are based on co-location with UTRA FDD or TDD base stations.

This requirement is a co-location requirement as defined in subclause 4.9, the power levels are specified at the *co-location reference antenna* output(s).

The power sum of any spurious emission is specified over all supported polarizations at the output(s) of the *co-location reference antenna* and shall not exceed the *basic limits* in subclause 6.6.5.2.4 + X dB, where X = -21 dB.

For a *multi-band RIB*, the exclusions and conditions in the notes column of table 6.6.5.2.4-1 apply for each supported *operating band*.

9.7.5.3 Minimum requirement for BS type 2-O

9.7.5.3.1 General

In FR2, the OTA transmitter spurious emission limits apply from 30 MHz to 2nd harmonic of the upper frequency edge of the downlink *operating band*, excluding the frequency range from Δf_{OBUE} below the lowest frequency of the downlink *operating band*, up to Δf_{OBUE} above the highest frequency of the downlink *operating band*, where the Δf_{OBUE} is defined in table 9.7.1-1.

9.7.5.3.2 General OTA transmitter spurious emissions requirements

The power of any spurious emission shall not exceed the limits in table 9.7.5.3.2-1

Editor's note: The spurious emission limits may be updated, pending further input concerning recommended Category B limits.

Table 9.7.5.3.2-1: BS radiated Tx spurious emission limits in FR2

Frequency range	Limit	Measurement Bandwidth	Note
30 MHz – 1 GHz	-13 dBm	100 kHz	Note 1
1 GHz – 2 nd harmonic of the upper frequency edge of the DL <i>operating band</i>		1 MHz	Note 1, Note 2
NOTE 1: Bandwidth as in ITU-R SM.329 [2], s4.1			
NOTE 2: Upper frequency as in ITU-R SM.329 [2], s2.5 table 1.			

9.7.5.3.3 Additional OTA transmitter spurious emissions requirements

Editor's note: Additional spurious emissions requirement for protecting specific services are ffs.

9.8 OTA transmitter intermodulation

9.8.1 General

The OTA transmitter intermodulation requirement is a measure of the capability of the transmitter unit to inhibit the generation of signals in its non-linear elements caused by presence of the wanted signal and an interfering signal reaching the transmitter unit via the RDN and antenna array from a co-located base station. The requirement shall apply during the *transmitter ON period* and the *transmitter transient period*.

The requirement shall apply at each RIB supporting transmission in the *operating band*.

The transmitter intermodulation level is the total radiated power of the intermodulation products when an interfering signal is injected into the *co-location reference antenna*.

The OTA transmitter intermodulation requirement is not applicable for *BS type 2-O*.

9.8.2 Minimum requirement for *BS type 1-O*

For *BS type 1-O* the transmitter intermodulation level shall not exceed the TRP unwanted emission limits specified for OTA transmitter spurious emission in subclause 9.7.5.2 (except subclause 9.7.5.2.3 and subclause 9.7.5.2.5), OTA operating band unwanted emissions in subclause 9.7.4.2 and OTA ACLR in subclause 9.7.3.2 in the presence of a wanted signal and an interfering signal, defined in table 9.8.2-1.

The requirement is applicable outside the *Base Station RF Bandwidth edges*. The interfering signal offset is defined relative to the *Base Station RF Bandwidth edges* or *Radio Bandwidth edges*.

For RIBs supporting operation in *non-contiguous spectrum*, the requirement is also applicable inside a *sub-block gap* for interfering signal offsets where the interfering signal falls completely within the *sub-block gap*. The interfering signal offset is defined relative to the *sub-block edges*.

For RIBs supporting operation in multiple *operating bands*, the requirement shall apply relative to the *Base Station RF Bandwidth edges* of each *operating band*. In case the *inter RF Bandwidth gap* is less than $3 \cdot BW_{\text{Channel}}$ (where BW_{Channel} is the minimal *BS channel bandwidth* of the band), the requirement in the gap shall apply only for interfering signal offsets where the interfering signal falls completely within the *inter RF Bandwidth gap*.

Table 9.8.2-1: Interfering and wanted signals for the OTA transmitter intermodulation requirement

Parameter	Value
Wanted signal	NR signal or multi-carrier, or multiple intra-band contiguously or non-contiguously aggregated carriers
Interfering signal type	NR signal of minimum supported <i>BS channel bandwidth</i> (BW_{Channel}) and SCS set to 15 kHz
Interfering signal level	The interfering signal level is the same power level as the BS ($P_{\text{rated,t,TRP}}$) fed into a <i>co-location reference antenna</i> .
Interfering signal centre frequency offset from the lower (upper) edge of the wanted signal or edge of <i>sub-block</i> inside a gap	$f_{\text{offset}} = \pm BW_{\text{Channel}} \left(n - \frac{1}{2} \right)$, for $n=1, 2$ and 3
NOTE: The $P_{\text{rated,t,TRP}}$ is split between polarizations at the co-location reference antenna.	

10 Radiated receiver characteristics

10.1 General

Radiated receiver characteristics are specified at RIB for *BS type 1-H*, *BS type 1-O*, or *BS type 2-O*, with full complement of transceivers for the configuration in normal operating condition.

Unless otherwise stated, the following arrangements apply for the radiated receiver characteristics requirements in clause 10:

- Requirements apply during the BS receive period.
- Requirements shall be met for any transmitter setting.
- For FDD operation the requirements shall be met with the transmitter unit(s) ON.
- Throughput requirements defined for the radiated receiver characteristics do not assume HARQ retransmissions.
- When BS is configured to receive multiple carriers, all the throughput requirements are applicable for each received carrier.
- For ACS, blocking and intermodulation characteristics, the negative offsets of the interfering signal apply relative to the lower edge and positive offsets of the interfering signal apply relative to the higher edge.
- Each requirement shall be met over the RoAoA specified.

NOTE 1: In normal operating condition the BS in FDD operation is configured to transmit and receive at the same time.

NOTE 2: In normal operating condition the BS in TDD operation is configured to TX OFF power during *receive period*.

For FR1 requirements which are to be met over the *OTA REFSENS RoAoA* absolute requirement values are offset by the following term:

$$\Delta_{\text{OTAREFSENS}} = 44.1 - 10 \cdot \log_{10}(\text{Be}W_{\theta, \text{REFSENS}} \cdot \text{Be}W_{\phi, \text{REFSENS}}) \text{ dB for the reference direction}$$

and

$$\Delta_{\text{OTAREFSENS}} = 41.1 - 10 \cdot \log_{10}(\text{Be}W_{\theta, \text{REFSENS}} \cdot \text{Be}W_{\phi, \text{REFSENS}}) \text{ dB for all other directions}$$

For requirements which are to be met over the *minSENS RoAoA* absolute requirement values are offset by the following term:

$$\Delta_{\text{minSENS}} = P_{\text{REFSENS}} - \text{EIS}_{\text{minSENS}} \text{ (dB)}$$

For FR2 requirements which are to be met over the *OTA REFSENS RoAoA* absolute requirement values are offset by the following term:

$$\Delta_{\text{FR2_REFSENS}} = -3 \text{ dB for the reference direction}$$

and

$$\Delta_{\text{FR2_REFSENS}} = 0 \text{ dB for all other directions}$$

10.2 OTA sensitivity

10.2.1 BS type 1-H and BS type 1-O

10.2.1.1 General

The OTA sensitivity requirement is a directional requirement based upon the declaration of one or more *OTA sensitivity direction declarations* (OSDD), related to a *BS type 1-H* and *BS type 1-O* receiver.

The *BS type 1-H* and *BS type 1-O* may optionally be capable of redirecting/changing the *receiver target* by means of adjusting BS settings resulting in multiple *sensitivity RoAoA*. The *sensitivity RoAoA* resulting from the current BS settings is the active *sensitivity RoAoA*.

If the BS is capable of redirecting the *receiver target* related to the OSDD then the OSDD shall include:

- The set(s) of RAT, *BS channel bandwidth* and declared minimum EIS level applicable to any active *sensitivity RoAoA* inside the *receiver target redirection range* in the OSDD.
- A declared *receiver target redirection range*, describing all the angles of arrival that can be addressed for the OSDD through alternative settings in the BS.
- Five declared *sensitivity RoAoA* comprising the conformance testing directions as detailed in TS 38.141-2 [6].
- The *receiver target reference direction*.

NOTE 1: Some of the declared *sensitivity RoAoA* may coincide depending on the redirection capability.

NOTE 2: In addition to the declared *sensitivity RoAoA*, several *sensitivity RoAoA* may be implicitly defined by the *receiver target redirection range* without being explicitly declared in the OSDD.

NOTE 3: (Void)

If the BS is not capable of redirecting the *receiver target* related to the OSDD, then the OSDD includes only:

- The set(s) of RAT, *BS channel bandwidth* and declared minimum EIS level applicable to the *sensitivity RoAoA* in the OSDD.
- One declared active *sensitivity RoAoA*.
- The *receiver target reference direction*.

NOTE 4: For BS without target redirection capability, the declared (fixed) *sensitivity RoAoA* is always the active *sensitivity RoAoA*.

The OTA sensitivity EIS level declaration shall apply to all supported polarizations, under the assumption of *polarization match*.

10.2.1.2 Minimum requirement

For a received signal whose AoA of the incident wave is within the active *sensitivity RoAoA* of an OSDD, the error rate criterion as described in subclause 7.2 shall be met when the level of the arriving signal is equal to the minimum EIS level in the respective declared set of EIS level and *BS channel bandwidth*.

10.2.2 BS type 2-O

There is no OTA sensitivity requirement for FR2, the OTA sensitivity is the same as the OTA reference sensitivity in subclause 10.3.

10.3 OTA reference sensitivity level

10.3.1 General

The OTA REFSENS requirement is a directional requirement and is intended to ensure the minimum OTA reference sensitivity level for a declared *OTA REFSENS RoAoA*. The OTA reference sensitivity power level $EIS_{REFSENS}$ is the minimum mean power received at the RIB at which a reference performance requirement shall be met for a specified reference measurement channel.

The OTA REFSENS requirement shall apply to all supported polarizations, under the assumption of *polarization match*.

10.3.2 Minimum requirement for *BS type 1-0*

The throughput shall be $\geq 95\%$ of the maximum throughput of the reference measurement channel as specified in the corresponding table and annex A when the OTA test signal is at the corresponding $EIS_{REFSENS}$ level and arrives from any direction within the *OTA REFSENS RoAoA*.

Table 10.3.2-1: Wide Area BS reference sensitivity levels

<i>BS channel bandwidth</i> (MHz)	Sub-carrier spacing (kHz)	Reference measurement channel	OTA Reference sensitivity level, $EIS_{REFSENS}$ (dBm)
5, 10, 15	15	G- FR1-A1-1	-101.7 - $\Delta_{OTAREFSNS}$
10, 15	30	G- FR1-A1-2	-101.8 - $\Delta_{OTAREFSNS}$
10, 15	60	G- FR1-A1-3	-98.9 - $\Delta_{OTAREFSNS}$
20, 25, 30, 40, 50	15	G- FR1-A1-4	-95.3 - $\Delta_{OTAREFSNS}$
20, 25, 30, 40, 50, 60, 70, 80, 90, 100	30	G- FR1-A1-5	-95.6 - $\Delta_{OTAREFSNS}$
20, 25, 30, 40, 50, 60, 70, 80, 90, 100	60	G- FR1-A1-6	-95.7 - $\Delta_{OTAREFSNS}$

NOTE: $EIS_{REFSENS}$ is the power level of a single instance of the reference measurement channel. This requirement shall be met for each consecutive application of a single instance of the reference measurement channel mapped to disjoint frequency ranges with a width corresponding to the number of resource blocks of the reference measurement channel each, except for one instance that might overlap one other instance to cover the full *BS channel bandwidth*.

Table 10.3.2-2: Medium Range BS reference sensitivity levels

<i>BS channel bandwidth</i> (MHz)	Sub-carrier spacing (kHz)	Reference measurement channel	OTA Reference sensitivity level, $EIS_{REFSENS}$ (dBm)
5, 10, 15	15	G- FR1-A1-1	-96.7 - $\Delta_{OTAREFSNS}$
10, 15	30	G- FR1-A1-2	-96.8 - $\Delta_{OTAREFSNS}$
10, 15	60	G- FR1-A1-3	-93.9 - $\Delta_{OTAREFSNS}$
20, 25, 30, 40, 50	15	G- FR1-A1-4	-90.3 - $\Delta_{OTAREFSNS}$
20, 25, 30, 40, 50, 60, 70, 80, 90, 100	30	G- FR1-A1-5	-90.6 - $\Delta_{OTAREFSNS}$
20, 25, 30, 40, 50, 60, 70, 80, 90, 100	60	G- FR1-A1-6	-90.7 - $\Delta_{OTAREFSNS}$

NOTE: $EIS_{REFSENS}$ is the power level of a single instance of the reference measurement channel. This requirement shall be met for each consecutive application of a single instance of the reference measurement channel mapped to disjoint frequency ranges with a width corresponding to the number of resource blocks of the reference measurement channel each, except for one instance that might overlap one other instance to cover the full *BS channel bandwidth*.

Table 10.3.2-3: Local Area BS reference sensitivity levels

BS channel bandwidth (MHz)	Sub-carrier spacing (kHz)	Reference measurement channel	OTA Reference sensitivity level, $EIS_{REFSENS}$ (dBm)
5, 10, 15	15	G- FR1-A1-1	-93.7 - $\Delta_{OTAREFSNS}$
10, 15	30	G- FR1-A1-2	-93.8 - $\Delta_{OTAREFSNS}$
10, 15	60	G- FR1-A1-3	-90.9 - $\Delta_{OTAREFSNS}$
20, 25, 30, 40, 50	15	G- FR1-A1-4	-87.3 - $\Delta_{OTAREFSNS}$
20, 25, 30, 40, 50, 60, 70, 80, 90, 100	30	G- FR1-A1-5	-87.6 - $\Delta_{OTAREFSNS}$
20, 25, 30, 40, 50, 60, 70, 80, 90, 100	60	G- FR1-A1-6	-87.7 - $\Delta_{OTAREFSNS}$
NOTE: $EIS_{REFSENS}$ is the power level of a single instance of the reference measurement channel. This requirement shall be met for each consecutive application of a single instance of the reference measurement channel mapped to disjoint frequency ranges with a width corresponding to the number of resource blocks of the reference measurement channel each, except for one instance that might overlap one other instance to cover the full BS channel bandwidth.			

10.3.3 Minimum requirement for BS type 2-O

The throughput shall be $\geq 95\%$ of the maximum throughput of the reference measurement channel as specified in the corresponding table and annex A when the OTA test signal is at the corresponding $EIS_{REFSENS}$ level and arrives from any direction within the *OTA REFSENS RoAoA*.

$EIS_{REFSENS}$ levels are derived from a single declared basis level $EIS_{REFSENS_50M}$, which is based on a reference measurement channel with 50MHz BS channel bandwidth. $EIS_{REFSENS_50M}$ itself is not a requirement and although it is based on a reference measurement channel with 50MHz BS channel bandwidth it does not imply that BS has to support 50MHz BS channel bandwidth.

For wide area BS, $EIS_{REFSENS_50M}$ is an integer value in the range -96 to -119 dBm. The specific value is declared by the vendor.

For medium range BS, $EIS_{REFSENS_50M}$ is an integer value in the range -91 to -114 dBm. The specific value is declared by the vendor.

For local area BS, $EIS_{REFSENS_50M}$ is an integer value in the range -86- to -109 dBm. The specific value is declared by the vendor.

Table 10.3.3-1: FR2 OTA Reference sensitivity requirement

BS channel Bandwidth (MHz)	Sub-carrier spacing (kHz)	FRC	$EIS_{REFSENS}$ level (dBm)
50, 100, 200	60	G-FR2-A1-1	$EIS_{REFSENS_50M} + \Delta_{FR2_REFSENS}$
50	120	G-FR2-A1-2	$EIS_{REFSENS_50M} + \Delta_{FR2_REFSENS}$
100, 200, 400	120	G-FR2-A1-3	$EIS_{REFSENS_50M} + 3 + \Delta_{FR2_REFSENS}$
NOTE 1: $EIS_{REFSENS}$ is the power level of a single instance of the reference measurement channel. This requirement shall be met for each consecutive application of a single instance of the reference measurement channel mapped to disjoint frequency ranges with a width corresponding to the number of resource blocks of the reference measurement channel each, except for one instance that might overlap one other instance to cover the full BS channel bandwidth.			
NOTE 2: The declared $EIS_{REFSENS_50M}$ shall be within the range specified above.			

10.4 OTA Dynamic range

10.4.1 General

The OTA dynamic range is a measure of the capability of the receiver unit to receive a wanted signal in the presence of an interfering signal inside the received *BS channel bandwidth*.

The requirement shall apply at the RIB when the AoA of the incident wave of a received signal and the interfering signal are from the same direction and are within the *OTA REFSENS RoAoA*.

The wanted and interfering signals apply to all supported polarizations, under the assumption of *polarization match*.

10.4.2 Minimum requirement for *BS type 1-0*

For NR, the throughput shall be $\geq 95\%$ of the maximum throughput of the reference measurement channel.

Table 10.4.2-1: Wide Area BS OTA dynamic range for NR carrier

BS channel bandwidth (MHz)	Subcarrier spacing (kHz)	Reference measurement channel	Wanted signal mean power (dBm)	Interfering signal mean power (dBm) / BW_{Config}	Type of interfering signal
5	15	G-FR1-A2-1	-70.7- $\Delta_{OTAREFSENS}$	-82.5- $\Delta_{OTAREFSENS}$	AWGN
	30	G- FR1-A2-2	-71.4- $\Delta_{OTAREFSENS}$		
10	15	G-FR1-A2-1	-70.7- $\Delta_{OTAREFSENS}$	-79.3- $\Delta_{OTAREFSENS}$	AWGN
	30	G- FR1-A2-2	-71.4- $\Delta_{OTAREFSENS}$		
	60	G- FR1-A2-3	-68.4- $\Delta_{OTAREFSENS}$		
15	15	G-FR1-A2-1	-70.7- $\Delta_{OTAREFSENS}$	-77.5- $\Delta_{OTAREFSENS}$	AWGN
	30	G- FR1-A2-2	-71.4- $\Delta_{OTAREFSENS}$		
	60	G- FR1-A2-3	-68.4- $\Delta_{OTAREFSENS}$		
20	15	G- FR1-A2-4	-64.5- $\Delta_{OTAREFSENS}$	-76.2- $\Delta_{OTAREFSENS}$	AWGN
	30	G- FR1-A2-5	-64.5- $\Delta_{OTAREFSENS}$		
	60	G- FR1-A2-6	-64.8- $\Delta_{OTAREFSENS}$		
25	15	G- FR1-A2-4	-64.5- $\Delta_{OTAREFSENS}$	-75.2- $\Delta_{OTAREFSENS}$	AWGN
	30	G- FR1-A2-5	-64.5- $\Delta_{OTAREFSENS}$		
	60	G- FR1-A2-6	-64.8- $\Delta_{OTAREFSENS}$		
30	15	G- FR1-A2-4	-64.5- $\Delta_{OTAREFSENS}$	-74.4- $\Delta_{OTAREFSENS}$	AWGN
	30	G- FR1-A2-5	-64.5- $\Delta_{OTAREFSENS}$		
	60	G- FR1-A2-6	-64.8- $\Delta_{OTAREFSENS}$		
40	15	G- FR1-A2-4	-64.5- $\Delta_{OTAREFSENS}$	-73.1- $\Delta_{OTAREFSENS}$	AWGN
	30	G- FR1-A2-5	-64.5- $\Delta_{OTAREFSENS}$		
	60	G- FR1-A2-6	-64.8- $\Delta_{OTAREFSENS}$		
50	15	G- FR1-A2-4	-64.5- $\Delta_{OTAREFSENS}$	-72.2- $\Delta_{OTAREFSENS}$	AWGN
	30	G- FR1-A2-5	-64.5- $\Delta_{OTAREFSENS}$		
	60	G- FR1-A2-6	-64.8- $\Delta_{OTAREFSENS}$		
60	30	G- FR1-A2-5	-64.5- $\Delta_{OTAREFSENS}$	-71.4- $\Delta_{OTAREFSENS}$	AWGN
	60	G- FR1-A2-6	-64.8- $\Delta_{OTAREFSENS}$		
70	30	G- FR1-A2-5	-64.5- $\Delta_{OTAREFSENS}$	-70.8- $\Delta_{OTAREFSENS}$	AWGN
	60	G- FR1-A2-6	-64.8- $\Delta_{OTAREFSENS}$		
80	30	G- FR1-A2-5	-64.5- $\Delta_{OTAREFSENS}$	-70.1- $\Delta_{OTAREFSENS}$	AWGN
	60	G- FR1-A2-6	-64.8- $\Delta_{OTAREFSENS}$		
90	30	G- FR1-A2-5	-64.5- $\Delta_{OTAREFSENS}$	-69.6- $\Delta_{OTAREFSENS}$	AWGN
	60	G- FR1-A2-6	-64.8- $\Delta_{OTAREFSENS}$		
100	30	G- FR1-A2-5	-64.5- $\Delta_{OTAREFSENS}$	-69.1- $\Delta_{OTAREFSENS}$	AWGN

	60	G- FR1-A2-6	-64.8- $\Delta_{OTAREFSENS}$		
NOTE:	The wanted signal mean power is the power level of a single instance of the corresponding reference measurement channel. This requirement shall be met for each consecutive application of a single instance of the reference measurement channel mapped to disjoint frequency ranges with a width corresponding to the number of resource blocks of the reference measurement channel each, except for one instance that might overlap one other instance to cover the full <i>BS channel bandwidth</i> .				

Table 10.4.2-2: Medium Area BS OTA dynamic range for NR carrier

BS channel bandwidth (MHz)	Subcarrier spacing (kHz)	Reference measurement channel	Wanted signal mean power (dBm)	Interfering signal mean power (dBm) / BW _{Config}	Type of interfering signal
5	15	G-FR1-A2-1	-65.7- $\Delta_{\text{OTAREFSENS}}$	-77.5- $\Delta_{\text{OTAREFSENS}}$	AWGN
	30	G- FR1-A2-2	-66.4- $\Delta_{\text{OTAREFSENS}}$		
10	15	G-FR1-A2-1	-65.7- $\Delta_{\text{OTAREFSENS}}$	-74.3- $\Delta_{\text{OTAREFSENS}}$	AWGN
	30	G- FR1-A2-2	-66.4- $\Delta_{\text{OTAREFSENS}}$		
	60	G- FR1-A2-3	-63.4- $\Delta_{\text{OTAREFSENS}}$		
15	15	G-FR1-A2-1	-65.7- $\Delta_{\text{OTAREFSENS}}$	-72.5- $\Delta_{\text{OTAREFSENS}}$	AWGN
	30	G- FR1-A2-2	-66.4- $\Delta_{\text{OTAREFSENS}}$		
	60	G- FR1-A2-3	-63.4- $\Delta_{\text{OTAREFSENS}}$		
20	15	G- FR1-A2-4	-59.5- $\Delta_{\text{OTAREFSENS}}$	-71.2- $\Delta_{\text{OTAREFSENS}}$	AWGN
	30	G- FR1-A2-5	-59.5- $\Delta_{\text{OTAREFSENS}}$		
	60	G- FR1-A2-6	-59.8- $\Delta_{\text{OTAREFSENS}}$		
25	15	G- FR1-A2-4	-59.5- $\Delta_{\text{OTAREFSENS}}$	-70.2- $\Delta_{\text{OTAREFSENS}}$	AWGN
	30	G- FR1-A2-5	-59.5- $\Delta_{\text{OTAREFSENS}}$		
	60	G- FR1-A2-6	-59.8- $\Delta_{\text{OTAREFSENS}}$		
30	15	G- FR1-A2-4	-59.5- $\Delta_{\text{OTAREFSENS}}$	-69.4- $\Delta_{\text{OTAREFSENS}}$	AWGN
	30	G- FR1-A2-5	-59.5- $\Delta_{\text{OTAREFSENS}}$		
	60	G- FR1-A2-6	-59.8- $\Delta_{\text{OTAREFSENS}}$		
40	15	G- FR1-A2-4	-59.5- $\Delta_{\text{OTAREFSENS}}$	-68.1- $\Delta_{\text{OTAREFSENS}}$	AWGN
	30	G- FR1-A2-5	-59.5- $\Delta_{\text{OTAREFSENS}}$		
	60	G- FR1-A2-6	-59.8- $\Delta_{\text{OTAREFSENS}}$		
50	15	G- FR1-A2-4	-59.5- $\Delta_{\text{OTAREFSENS}}$	-67.2- $\Delta_{\text{OTAREFSENS}}$	AWGN
	30	G- FR1-A2-5	-59.5- $\Delta_{\text{OTAREFSENS}}$		
	60	G- FR1-A2-6	-59.8- $\Delta_{\text{OTAREFSENS}}$		
60	30	G- FR1-A2-5	-59.5- $\Delta_{\text{OTAREFSENS}}$	-66.4- $\Delta_{\text{OTAREFSENS}}$	AWGN
	60	G- FR1-A2-6	-59.8- $\Delta_{\text{OTAREFSENS}}$		
70	30	G- FR1-A2-5	-59.5- $\Delta_{\text{OTAREFSENS}}$	-65.8- $\Delta_{\text{OTAREFSENS}}$	AWGN
	60	G- FR1-A2-6	-59.8- $\Delta_{\text{OTAREFSENS}}$		
80	30	G- FR1-A2-5	-59.5- $\Delta_{\text{OTAREFSENS}}$	-65.1- $\Delta_{\text{OTAREFSENS}}$	AWGN
	60	G- FR1-A2-6	-59.8- $\Delta_{\text{OTAREFSENS}}$		
90	30	G- FR1-A2-5	-59.5- $\Delta_{\text{OTAREFSENS}}$	-64.6- $\Delta_{\text{OTAREFSENS}}$	AWGN
	60	G- FR1-A2-6	-59.8- $\Delta_{\text{OTAREFSENS}}$		
100	30	G- FR1-A2-5	-59.5- $\Delta_{\text{OTAREFSENS}}$	-64.1- $\Delta_{\text{OTAREFSENS}}$	AWGN

	60	G- FR1-A2-6	-59.8- $\Delta_{OTAREFSENS}$		
NOTE:	The wanted signal mean power is the power level of a single instance of the corresponding reference measurement channel. This requirement shall be met for each consecutive application of a single instance of the reference measurement channel mapped to disjoint frequency ranges with a width corresponding to the number of resource blocks of the reference measurement channel each, except for one instance that might overlap one other instance to cover the full <i>BS channel bandwidth</i> .				

Table 10.4.2-3: Local Area BS OTA dynamic range for NR carrier

BS channel bandwidth (MHz)	Subcarrier spacing (kHz)	Reference measurement channel	Wanted signal mean power (dBm)	Interfering signal mean power (dBm) / BW_{Config}	Type of interfering signal
5	15	G-FR1-A2-1	-62.7- $\Delta_{OTAREFSENS}$	-74.5- $\Delta_{OTAREFSENS}$	AWGN
	30	G- FR1-A2-2	-64.4- $\Delta_{OTAREFSENS}$		
10	15	G-FR1-A2-1	-62.7- $\Delta_{OTAREFSENS}$	-71.3- $\Delta_{OTAREFSENS}$	AWGN
	30	G- FR1-A2-2	-64.4- $\Delta_{OTAREFSENS}$		
	60	G- FR1-A2-3	-60.4- $\Delta_{OTAREFSENS}$		
15	15	G-FR1-A2-1	-62.7- $\Delta_{OTAREFSENS}$	-69.5- $\Delta_{OTAREFSENS}$	AWGN
	30	G- FR1-A2-2	-64.4- $\Delta_{OTAREFSENS}$		
	60	G- FR1-A2-3	-60.4- $\Delta_{OTAREFSENS}$		
20	15	G- FR1-A2-4	-56.5- $\Delta_{OTAREFSENS}$	-68.2- $\Delta_{OTAREFSENS}$	AWGN
	30	G- FR1-A2-5	-56.5- $\Delta_{OTAREFSENS}$		
	60	G- FR1-A2-6	-56.8- $\Delta_{OTAREFSENS}$		
25	15	G- FR1-A2-4	-56.5- $\Delta_{OTAREFSENS}$	-67.2- $\Delta_{OTAREFSENS}$	AWGN
	30	G- FR1-A2-5	-56.5- $\Delta_{OTAREFSENS}$		
	60	G- FR1-A2-6	-56.8- $\Delta_{OTAREFSENS}$		
30	15	G- FR1-A2-4	-56.5- $\Delta_{OTAREFSENS}$	-66.4- $\Delta_{OTAREFSENS}$	AWGN
	30	G- FR1-A2-5	-56.5- $\Delta_{OTAREFSENS}$		
	60	G- FR1-A2-6	-56.8- $\Delta_{OTAREFSENS}$		
40	15	G- FR1-A2-4	-56.5- $\Delta_{OTAREFSENS}$	-65.1- $\Delta_{OTAREFSENS}$	AWGN
	30	G- FR1-A2-5	-56.5- $\Delta_{OTAREFSENS}$		
	60	G- FR1-A2-6	-56.8- $\Delta_{OTAREFSENS}$		
50	15	G- FR1-A2-4	-56.5- $\Delta_{OTAREFSENS}$	-64.2- $\Delta_{OTAREFSENS}$	AWGN
	30	G- FR1-A2-5	-56.5- $\Delta_{OTAREFSENS}$		
	60	G- FR1-A2-6	-56.8- $\Delta_{OTAREFSENS}$		
60	30	G- FR1-A2-5	-56.5- $\Delta_{OTAREFSENS}$	-63.4- $\Delta_{OTAREFSENS}$	AWGN
	60	G- FR1-A2-6	-56.8- $\Delta_{OTAREFSENS}$		
70	30	G- FR1-A2-5	-56.5- $\Delta_{OTAREFSENS}$	-62.8- $\Delta_{OTAREFSENS}$	AWGN
	60	G- FR1-A2-6	-56.8- $\Delta_{OTAREFSENS}$		
80	30	G- FR1-A2-5	-56.5- $\Delta_{OTAREFSENS}$	-62.1- $\Delta_{OTAREFSENS}$	AWGN
	60	G- FR1-A2-6	-56.8- $\Delta_{OTAREFSENS}$		
90	30	G- FR1-A2-5	-56.5- $\Delta_{OTAREFSENS}$	-61.6- $\Delta_{OTAREFSENS}$	AWGN
	60	G- FR1-A2-6	-56.8- $\Delta_{OTAREFSENS}$		
100	30	G- FR1-A2-5	-56.5- $\Delta_{OTAREFSENS}$	-61.1- $\Delta_{OTAREFSENS}$	AWGN

	60	G- FR1-A2-6	-56.8- $\Delta_{\text{OTAREFSENS}}$		
NOTE: The wanted signal mean power is the power level of a single instance of the corresponding reference measurement channel. This requirement shall be met for each consecutive application of a single instance of the reference measurement channel mapped to disjoint frequency ranges with a width corresponding to the number of resource blocks of the reference measurement channel each, except for one instance that might overlap one other instance to cover the full <i>BS channel bandwidth</i> .					

10.5 OTA in-band selectivity and blocking

10.5.1 OTA adjacent channel selectivity

10.5.1.1 General

OTA Adjacent channel selectivity (ACS) is a measure of the receiver's ability to receive a OTA wanted signal at its assigned channel frequency in the presence of an OTA adjacent channel signal with a specified centre frequency offset of the interfering signal to the band edge of a victim system.

10.5.1.2 Minimum requirement for *BS type 1-0*

The requirement shall apply at the RIB when the AoA of the incident wave of a received signal and the interfering signal are from the same direction and are within the *minSENS RoAoA*.

The wanted and interfering signals apply to all supported polarizations, under the assumption of *polarization match*.

The throughput shall be $\geq 95\%$ of the maximum throughput of the reference measurement channel.

For FR1, the OTA wanted and the interfering signal are specified in table 10.5.1.2-1 and table 10.5.1.2-2 for ACS. The reference measurement channel for the OTA wanted signal is further specified in annex A. The characteristics of the interfering signal is further specified in annex D.

The OTA ACS requirement is applicable outside the Base Station RF Bandwidth or Radio Bandwidth. The OTA interfering signal offset is defined relative to the Base station RF Bandwidth edges or Radio Bandwidth edges.

For RIBs supporting operation in *non-contiguous spectrum* within any *operating band*, the OTA ACS requirement shall apply in addition inside any sub-block gap, in case the sub-block gap size is at least as wide as the NR interfering signal in table 10.5.1.2-2. The OTA interfering signal offset is defined relative to the sub-block edges inside the sub-block gap.

For *multi-band RIBs*, the OTA ACS requirement shall apply in addition inside any Inter RF Bandwidth gap, in case the Inter RF Bandwidth gap size is at least as wide as the NR interfering signal in table 10.5.1.2-2. The interfering signal offset is defined relative to the Base Station RF Bandwidth edges inside the Inter RF Bandwidth gap.

Table 10.5.1.2-1: OTA ACS requirement for *BS type 1-0*

<i>BS channel bandwidth of the lowest/highest carrier received (MHz)</i>	<i>Wanted signal mean power (dBm) (Note 2)</i>	<i>Interfering signal mean power (dBm)</i>
5, 10, 15, 20, 25, 30, 40, 50, 60, 70, 80,90, 100 (Note 1)	EIS _{minSENS} + 6dB	Wide Area: -52 – Δ_{minSENS} Medium Range: -47 – Δ_{minSENS} Local Area: -44 – Δ_{minSENS}
NOTE 1: The SCS for the lowest/highest carrier received is the lowest SCS supported by the BS for that bandwidth		
NOTE 2: EIS _{minSENS} depends on the <i>BS channel bandwidth</i>		

Table 10.5.1.2-2: OTA ACS interferer frequency offset for *BS type 1-0*

<i>BS channel bandwidth of the lowest/highest carrier received (MHz)</i>	<i>Interfering signal centre frequency offset from the lower/upper Base Station RF Bandwidth edge or sub-block edge inside a sub-block gap (MHz)</i>	<i>Type of interfering signal</i>
5	±2.5025	5 MHz DFT-s-OFDM NR signal SCS: 15kHz, 25 RB
10	±2.5075	5 MHz DFT-s-OFDM NR signal SCS: 15kHz, 25 RB
15	±2.5125	5 MHz DFT-s-OFDM NR signal SCS: 15kHz, 25 RB
20	±2.5025	5 MHz DFT-s-OFDM NR signal SCS: 15kHz, 25 RB
25	±9.535	20 MHz DFT-s-OFDM NR signal SCS: 15kHz, 100 RB
30	±9.585	20 MHz DFT-s-OFDM NR signal SCS: 15kHz, 100 RB
40	±9.535	20 MHz DFT-s-OFDM NR signal SCS: 15kHz, 100 RB
50	±9.485	20 MHz DFT-s-OFDM NR signal SCS: 15kHz, 100 RB
60	±9.585	20 MHz DFT-s-OFDM NR signal SCS: 15kHz, 100 RB
70	±9.535	20 MHz DFT-s-OFDM NR signal SCS: 15kHz, 100 RB
80	±9.485	20 MHz DFT-s-OFDM NR signal SCS: 15kHz, 100 RB
90	±9.585	20 MHz DFT-s-OFDM NR signal SCS: 15kHz, 100 RB
100	±9.535	20 MHz DFT-s-OFDM NR signal SCS: 15kHz, 100 RB

10.5.1.3 Minimum requirement for *BS type 2-0*

The requirement shall apply at the RIB when the AoA of the incident wave of a received signal and the interfering signal are from the same direction and are within the *OTA REFSENS RoAoA*.

The wanted and interfering signals apply to all supported polarizations, under the assumption of *polarization match*.

The throughput shall be $\geq 95\%$ of the maximum throughput of the reference measurement channel.

For FR2, the OTA wanted and the interfering signal are specified in table 10.5.1.3-1 and table 10.5.1.3-2 for ACS. The reference measurement channel for the OTA wanted signal is further specified in annex A. The characteristics of the interfering signal is further specified in annex D.

The OTA ACS requirement is applicable outside the Base Station RF Bandwidth. The OTA interfering signal offset is defined relative to the Base station RF Bandwidth edges.

For RIBs supporting operation in *non-contiguous spectrum* within any *operating band*, the OTA ACS requirement shall apply in addition inside any sub-block gap, in case the sub-block gap size is at least as wide as the NR interfering signal in table 10.5.1.3-2. The OTA interfering signal offset is defined relative to the sub-block edges inside the sub-block gap.

Table 10.5.1.3-1: OTA ACS requirement for *BS type 2-O*

<i>BS channel bandwidth of the lowest/highest carrier received (MHz)</i>	<i>Wanted signal mean power (dBm)</i>	<i>Interfering signal mean power (dBm)</i>
50, 100, 200, 400	$EIS_{REFSENS} + 6\text{dB}$ (Note 3)	$EIS_{REFSENS_50M} + 27.7 + \Delta_{FR2_REFSENS}$ (Note 1) $EIS_{REFSENS_50M} + 26.7 + \Delta_{FR2_REFSENS}$ (Note 2)
NOTE 1: Applicable to bands defined within the frequency spectrum range of 24.25 – 33.4 GHz		
NOTE 2: Applicable to bands defined within the frequency spectrum range of 37 – 52.6 GHz		
NOTE 3: $EIS_{REFSENS}$ is given in subclause 10.3.3		

Table 10.5.1.3-2: OTA ACS interferer frequency offset for *BS type 2-O*

<i>BS channel bandwidth of the lowest/highest carrier received (MHz)</i>	<i>Interfering signal centre frequency offset from the lower/upper Base Station RF Bandwidth edge or sub-block edge inside a sub-block gap (MHz)</i>	<i>Type of interfering signal</i>
50	± 24.29	50MHz DFT-s-OFDM NR signal 60 kHz SCS, 64 RB
100	± 24.31	50MHz DFT-s-OFDM NR signal 60 kHz SCS, 64 RB
200	± 24.29	50MHz DFT-s-OFDM NR signal 60 kHz SCS, 64 RB
400	± 24.31	50MHz DFT-s-OFDM NR signal 60 kHz SCS, 64 RB

10.5.2 OTA in-band blocking

10.5.2.1 General

The OTA in-band blocking characteristics is a measure of the receiver's ability to receive a OTA wanted signal at its assigned channel in the presence of an unwanted OTA interferer, which is an NR signal for general blocking or an NR signal with one RB for narrowband blocking.

10.5.2.2 Minimum requirement for *BS type 1-O*

The requirement shall apply at the RIB when the AoA of the incident wave of a received signal and the interfering signal are from the same direction, and:

- when the wanted signal is based on $EIS_{REFSENS}$: the AoA of the incident wave of a received signal and the interfering signal are within the *OTA REFSENS RoAoA*.
- when the wanted signal is based on $EIS_{minSENS}$: the AoA of the incident wave of a received signal and the interfering signal are within the *minSENS RoAoA*.

The wanted and interfering signals apply to all supported polarizations, under the assumption of *polarization match*.

The throughput shall be $\geq 95\%$ of the maximum throughput of the reference measurement channel, with OTA wanted and OTA interfering signal specified in tables 10.5.2.2-1, table 10.5.2.2-2 and table 10.5.2.2-3 for general OTA and narrowband OTA blocking requirements. The reference measurement channel for the OTA wanted signal is identified in subclause 10.3.2 and are further specified in annex A. The characteristics of the interfering signal is further specified in annex D.

The OTA in-band blocking requirements apply outside the Base Station RF Bandwidth or Radio Bandwidth. The interfering signal offset is defined relative to the Base Station RF Bandwidth edges or Radio Bandwidth edges.

For *BS type 1-O* the OTA in-band blocking requirement shall apply in the in-band blocking frequency range, which is from $F_{UL,low} - \Delta f_{OOB}$ to $F_{UL,high} + \Delta f_{OOB}$, excluding the downlink frequency range of the *FDD operating band*. The Δf_{OOB} for *BS type 1-O* is defined in table 10.5.2.2-0.

Table 10.5.2.2-0: Δf_{OOB} offset for NR operating bands in FR1

BS type	Operating band characteristics	Δf_{OOB} (MHz)
BS type 1-O	$F_{UL,high} - F_{UL,low} < 100$ MHz	20
	$100 \text{ MHz} \leq F_{UL,high} - F_{UL,low} \leq 900$ MHz	60

For RIBs supporting operation in *non-contiguous spectrum* within any *operating band*, the OTA in-band blocking requirements apply in addition inside any sub-block gap, in case the sub-block gap size is at least as wide as twice the interfering signal minimum offset in table 10.5.2.2-1. The interfering signal offset is defined relative to the sub-block edges inside the sub-block gap.

For *multi-band RIBs*, the OTA in-band blocking requirements apply in the in-band blocking frequency ranges for each supported *operating band*. The requirement shall apply in addition inside any Inter RF Bandwidth gap, in case the Inter RF Bandwidth gap size is at least as wide as twice the interfering signal minimum offset in tables 10.5.2.2-1 and 10.5.2.2-3.

For a RIBs supporting operation in *non-contiguous spectrum* within any *operating band*, the OTA narrowband blocking requirements apply in addition inside any sub-block gap, in case the sub-block gap size is at least as wide as the interfering signal minimum offset in table 10.5.2.2-3. The interfering signal offset is defined relative to the sub-block edges inside the sub-block gap.

For a *multi-band RIBs*, the OTA narrowband blocking requirements apply in the narrowband blocking frequency ranges for each supported *operating band*. The requirement shall apply in addition inside any Inter RF Bandwidth gap, in case the Inter RF Bandwidth gap size is at least as wide as the interfering signal minimum offset in table 10.5.2.2-3.

Table 10.5.2.2-1: General OTA blocking requirement for *BS type 1-O*

<i>BS channel bandwidth of the lowest/highest carrier received (MHz)</i>	<i>Wanted signal mean power (dBm)</i>	<i>Interfering signal mean power (dBm)</i>	<i>Interfering signal centre frequency minimum offset from the lower/upper Base Station RF Bandwidth edge or sub-block edge inside a sub-block gap (MHz)</i>	<i>Type of interfering signal</i>
5, 10, 15, 20	$EIS_{REFSENS} + 6 \text{ dB}$	Wide Area: $-43 - \Delta_{OTAREFSENS}$ Medium Range: $-38 - \Delta_{OTAREFSENS}$ Local Area: $-35 - \Delta_{OTAREFSENS}$	± 7.5	5 MHz DFT-s-OFDM NR signal SCS: 15 kHz, 25 RB
	$EIS_{minSENS} + 6 \text{ dB}$	Wide Area: $-43 - \Delta_{minSENS}$ Medium Range: $-38 - \Delta_{minSENS}$ Local Area: $-35 - \Delta_{minSENS}$	± 7.5	5 MHz DFT-s-OFDM NR signal SCS: 15 kHz, 25 RB
25, 30, 40, 50, 60, 70, 80, 90, 100	$EIS_{REFSENS} + 6 \text{ dB}$	Wide Area: $-43 - \Delta_{OTAREFSENS}$ Medium Range: $-38 - \Delta_{OTAREFSENS}$ Local Area: $-35 - \Delta_{OTAREFSENS}$	± 30	20 MHz DFT-s-OFDM NR signal SCS: 15 kHz, 100 RB
	$EIS_{minSENS} + 6 \text{ dB}$	Wide Area: $-43 - \Delta_{minSENS}$ Medium Range: $-38 - \Delta_{minSENS}$ Local Area: $-35 - \Delta_{minSENS}$	± 30	20 MHz DFT-s-OFDM NR signal SCS: 15 kHz, 100 RB

Table 10.5.2.2-2: OTA narrowband blocking requirement for *BS type 1-O*

<i>BS channel bandwidth of the lowest/highest carrier received (MHz)</i>	<i>OTA Wanted signal mean power (dBm)</i>	<i>OTA Interfering signal mean power (dBm)</i>
5, 10, 15, 20	$EIS_{REFSENS} + 6 \text{ dB}$	Wide Area: $-49 - \Delta_{OTAREFSENS}$ Medium Range: $-44 - \Delta_{OTAREFSENS}$ Local Area: $-41 - \Delta_{OTAREFSENS}$
	$EIS_{minSENS} + 6 \text{ dB}$	Wide Area: $-49 - \Delta_{minSENS}$ Medium Range: $-44 - \Delta_{minSENS}$ Local Area: $-41 - \Delta_{minSENS}$
25, 30, 40, 50, 60, 70, 80, 90, 100	$EIS_{REFSENS} + 6 \text{ dB}$	Wide Area: $-49 - \Delta_{OTAREFSENS}$ Medium Range: $-44 - \Delta_{OTAREFSENS}$ Local Area: $-41 - \Delta_{OTAREFSENS}$
	$EIS_{minSENS} + 6 \text{ dB}$	Wide Area: $-49 - \Delta_{minSENS}$ Medium Range: $-44 - \Delta_{minSENS}$ Local Area: $-41 - \Delta_{minSENS}$
NOTE: The SCS for the lowest/highest carrier received is the lowest SCS supported by the BS for that bandwidth		

Table 10.5.2.2-3: OTA narrowband blocking interferer frequency offsets for *BS type 1-O*

<i>BS channel bandwidth of the lowest/highest carrier received (MHz)</i>	<i>Interfering RB centre frequency offset to the lower/upper Base Station RF Bandwidth edge or sub-block edge inside a sub-block gap (kHz)</i>	<i>Type of interfering signal</i>
5	$\pm([342.5] + m \cdot 180)$, m=0, 1, 2, 3, 4, 9, 14, 19, 24	5 MHz DFT-s-OFDM NR signal, 1 RB SCS: 15 kHz
10	$\pm([347.5] + m \cdot 180)$, m=0, 1, 2, 3, 4, 9, 14, 19, 24	
15	$\pm([352.5] + m \cdot 180)$, m=0, 1, 2, 3, 4, 9, 14, 19, 24	
20	$\pm([342.5] + m \cdot 180)$, m=0, 1, 2, 3, 4, 9, 14, 19, 24	
25	$\pm([557.5] + m \cdot 180)$, m=0, 1, 2, 3, 4, 29, 54, 79, 100	20 MHz DFT-s-OFDM NR signal, 1 RB SCS: 15 kHz
30	$\pm([562.5] + m \cdot 180)$, m=0, 1, 2, 3, 4, 29, 54, 79, 100	
40	$\pm([557.5] + m \cdot 180)$, m=0, 1, 2, 3, 4, 29, 54, 79, 100	
50	$\pm([552.5] + m \cdot 180)$, m=0, 1, 2, 3, 4, 29, 54, 79, 100	
60	$\pm([562.5] + m \cdot 180)$, m=0, 1, 2, 3, 4, 29, 54, 79, 100	
70	$\pm([557.5] + m \cdot 180)$, m=0, 1, 2, 3, 4, 29, 54, 79, 100	
80	$\pm([552.5] + m \cdot 180)$, m=0, 1, 2, 3, 4, 29, 54, 79, 100	
90	$\pm([562.5] + m \cdot 180)$, m=0, 1, 2, 3, 4, 29, 54, 79, 100	
100	$\pm([557.5] + m \cdot 180)$, m=0, 1, 2, 3, 4, 29, 54, 79, 100	
NOTE: Interfering signal consisting of one resource block is positioned at the stated offset, the channel bandwidth of the interfering signal is located adjacently to the lower/upper Base Station RF Bandwidth edge or sub-block edge inside a sub-block gap.		

10.5.2.3 Minimum requirement for *BS type 2-O*

The requirement shall apply at the RIB when the AoA of the incident wave of a received signal and the interfering signal are from the same direction and are within the *OTA REFSENS RoAoA*.

The wanted and interfering signals apply to each supported polarization, under the assumption of *polarization match*.

The throughput shall be $\geq 95\%$ of the maximum throughput of the reference measurement channel.

For *BS type 2-O*, the OTA wanted and OTA interfering signals are provided at RIB using the parameters in table 10.5.2.3-1 for general OTA blocking requirements. The reference measurement channel for the wanted signal is further specified in annex A. The characteristics of the interfering signal is further specified in annex D.

The OTA blocking requirements are applicable outside the Base Station RF Bandwidth. The interfering signal offset is defined relative to the Base Station RF Bandwidth edges.

For *BS type 2-0* the OTA in-band blocking requirement shall apply from $F_{UL_low} - \Delta f_{OOB}$ to $F_{UL_high} + \Delta f_{OOB}$. The Δf_{OOB} for *BS type 2-0* is defined in table 10.5.2.3-0.

Table 10.5.2.3-0: Δf_{OOB} offset for NR operating bands in FR2

BS type	Operating band characteristics	Δf_{OOB} (MHz)
<i>BS type 2-0</i>	$F_{UL_high} - F_{UL_low} \leq 3250$ MHz	1500

For a RIBs supporting operation in *non-contiguous spectrum* within any *operating band*, the OTA blocking requirements apply in addition inside any sub-block gap, in case the sub-block gap size is at least as wide as twice the interfering signal minimum offset in table 10.5.2.3-1. The interfering signal offset is defined relative to the sub-block edges inside the sub-block gap.

Table 10.5.2.3-1: General OTA blocking requirement for *BS type 2-0*

BS channel bandwidth of the lowest/highest carrier received (MHz)	OTA wanted signal mean power (dBm)	OTA interfering signal mean power (dBm)	OTA interfering signal centre frequency offset from the lower/upper Base Station RF Bandwidth edge or sub-block edge inside a sub-block gap (MHz)	Type of OTA interfering signal
50, 100, 200, 400	$EIS_{REFSENS} + 6$	$EIS_{REFSENS_50M} + 33 + \Delta_{FR2_REFSENS}$	± 75	50 MHz DFT-s-OFDM NR signal 60 kHz SCS, 64 RB
NOTE: $EIS_{REFSENS}$ and $EIS_{REFSENS_50M}$ are given in subclause 10.3.3.				

10.6 OTA out-of-band blocking

10.6.1 General

The OTA out-of-band blocking characteristics are a measure of the receiver unit ability to receive a wanted signal at the *RIB* at its assigned channel in the presence of an unwanted interferer.

10.6.2 Minimum requirement for *BS type 1-0*

10.6.2.1 General minimum requirement

The requirement shall apply at the *RIB* when the AoA of the incident wave of the received signal and the interfering signal are from the same direction and are within the *minSENS RoAoA*.

The wanted signal applies to all supported polarizations, under the assumption of *polarization match*. The interferer shall be polarization matched in-band and the polarization maintained for out-of-band frequencies.

For OTA wanted and OTA interfering signals provided at the *RIB* using the parameters in table 10.6.2.1-1, the following requirements shall be met:

- The throughput shall be $\geq 95\%$ of the maximum throughput of the reference measurement channel. The reference measurement channel for the OTA wanted signal is identified in subclause 10.3.2 for each *BS channel bandwidth* and further specified in annex A. The characteristics of the interfering signal is further specified in annex D.

For a *multi-band RIB*, the OTA out-of-band requirement shall apply for each supported *operating band*, with the exception that the in-band blocking frequency ranges of all supported *operating bands* according to subclause 7.4.2.2 shall be excluded from the OTA out-of-band blocking requirement.

For *BS type 1-O* the OTA out-of-band blocking requirement apply from 30 MHz to $F_{UL,low} - \Delta f_{OOB}$ and from $F_{UL,high} + \Delta f_{OOB}$ up to 12750 MHz, including the downlink frequency range of the *FDD operating band*. The Δf_{OOB} for *BS type 1-O* is defined in table 10.5.2.2-0.

Table 10.6.2.1-1: OTA out-of-band blocking performance requirement

Wanted signal mean power (dBm)	Interfering signal RMS field-strength (V/m)	Type of interfering Signal
$EIS_{minSENS} + 6$ dB (Note 1)	0.36	CW carrier
NOTE 1: $EIS_{minSENS}$ depends on the <i>channel bandwidth</i> as specified in subclause 9.2.		
NOTE 2: The RMS field-strength level in V/m is related to the interferer EIRP level at a distance described as $E = \frac{\sqrt{30EIRP}}{r}$, where EIRP is in W and r is in m; for example, 0.36 V/m is equivalent to 36 dBm at fixed distance of 30 m.		

10.6.2.2 Co-location minimum requirement

This additional OTA out-of-band blocking requirement may be applied for the protection of BS receivers when NR, E-UTRA BS, UTRA BS, CDMA BS or GSM/EDGE BS operating in a different frequency band are co-located with a BS.

The requirement is a co-location requirement. The interferer power levels are specified at the *co-location reference antenna* conducted input. The interfering signal power is specified per supported polarization.

The requirement is valid over the *minSENS RoAoA*.

For OTA wanted and OTA interfering signal provided at the RIB using the parameters in table 10.6.2.1-1, the following requirements shall be met:

- The throughput shall be $\geq 95\%$ of the maximum throughput of the reference measurement channel. The reference measurement channel for the OTA wanted signal is identified in subclause 10.3.2 for each *BS channel bandwidth* and further specified in annex A. The characteristics of the interfering signal is further specified in annex D.

For *BS type 1-O* the OTA blocking requirement for co-location with BS in other frequency bands is applied for all *operating bands* for which co-location protection is provided.

Table 10.6.2.2-1: OTA blocking requirement for co-location with BS in other frequency bands

Frequency range of interfering signal	Wanted signal mean power (dBm)	Interfering signal mean power for WA BS (dBm)	Interfering signal mean power for MR BS (dBm)	Interfering signal mean power for LA BS (dBm)	Type of interfering signal
Frequency range of co-located downlink <i>operating band</i>	$EIS_{minSENS} + 6$ dB (Note 1)	+46	+38	+24	CW carrier
NOTE 1: $EIS_{minSENS}$ depends on the BS class and on the <i>BS channel bandwidth</i> , see subclause 10.3.					
NOTE 2: The requirement does not apply when the interfering signal falls within any of the supported uplink <i>operating band(s)</i> or in Δf_{OOB} immediately outside any of the supported uplink <i>operating band(s)</i> .					

10.6.3 Minimum requirement for *BS type 2-O*

10.6.3.1 General minimum requirement

The requirement shall apply at the RIB when the AoA of the incident wave of the received signal and the interfering signal are from the same direction and are within the *OTA REFSSENS RoAoA*.

The wanted signal applies to all supported polarizations, under the assumption of *polarization match*. The interferer shall be polarization matched in-band and the polarization maintained for out-of-band frequencies.

For *BS type 2-O* the OTA out-of-band blocking requirement apply from 30 MHz to $F_{UL,low} - 1500$ MHz and from $F_{UL,high} + 1500$ MHz up to 2nd harmonic of the upper frequency edge of the *operating band*.

For OTA wanted and OTA interfering signals provided at the RIB using the parameters in table 10.6.3.1-1, the following requirements shall be met:

- The throughput shall be $\geq 95\%$ of the maximum throughput of the reference measurement channel. The reference measurement channel for the OTA wanted signal is identified in subclause 10.3.3 for each *BS channel bandwidth* and further specified in annex A.

Table 10.6.3.1-1: OTA out-of-band blocking performance requirement

Frequency range of interfering signal (MHz)	Wanted signal mean power (dBm)	Interferer RMS field-strength (V/m)	Type of interfering signal
30 to 12750	$EIS_{REFSENS} + 6$ dB	0.36	CW
12750 to $F_{UL,low} - 1500$	$EIS_{REFSENS} + 6$ dB	0.1	CW
$F_{UL,high} + 1500$ to 2 nd harmonic of the upper frequency edge of the <i>operating band</i>	$EIS_{REFSENS} + 6$ dB	0.1	CW

10.7 OTA receiver spurious emissions

10.7.1 General

The OTA RX spurious emission is the power of the emissions radiated from the antenna array from a receiver unit.

The metric used to capture OTA receiver spurious emissions for *BS type 1-O* and *BS type 2-O* is total radiated power (TRP), with the requirement defined at the RIB.

10.7.2 Minimum requirement for *BS type 1-O*

For a BS operating in FDD, OTA RX spurious emissions requirement do not apply as they are superseded by the OTA TX spurious emissions requirement. This is due to the fact that TX and RX spurious emissions cannot be distinguished in OTA domain.

For a BS operating in TDD, the OTA RX spurious emissions requirement shall apply during the *transmitter OFF period* only.

For RX only *multi-band RIB*, the OTA RX spurious emissions requirements are subject to exclusion zones in each supported *operating band*.

The OTA RX spurious emissions for *BS type 1-O* are that for each *basic limit* specified in table 7.6.2-1, the power sum of emissions at the RIB shall not exceed limits specified as the *basic limit* + X, where X = 9 dB, unless stated differently in regional regulation.

10.7.3 Minimum requirement for *BS type 2-O*

For the *BS type 2-O*, the power of any RX spurious emission shall not exceed the limits in table 10.7.3-1.

Table 10.7.3-1: Radiated Rx spurious emission limits for *BS type 2-O*

Frequency range	Limit	Measurement bandwidth	Note
30 MHz – 1 GHz	-57 dBm	100 kHz	Note 1
1 GHz – 12.75 GHz	-47 dBm	1 MHz	Note 1
12.75 GHz – 2 nd harmonic of the upper frequency edge of the UL <i>operating band</i>	-36 dBm	1 MHz	Note 1, Note 2
NOTE 1: Bandwidth as in ITU-R SM.329 [3], s4.1 NOTE 2: Upper frequency as in ITU-R SM.329 [3], s2.5 table 1. NOTE 3: The frequency range from Δf_{OBUE} below the lowest frequency of the BS transmitter <i>operating band</i> to Δf_{OBUE} above the highest frequency of the BS transmitter <i>operating band</i> may be excluded from the requirement. Δf_{OBUE} is defined in subclause 9.7.1			

10.8 OTA receiver intermodulation

10.8.1 General

Third and higher order mixing of the two interfering RF signals can produce an interfering signal in the band of the desired channel. Intermodulation response rejection is a measure of the capability of the receiver unit to receive a wanted signal on its assigned channel frequency in the presence of two interfering signals which have a specific frequency relationship to the wanted signal. The requirement is defined as a directional requirement at the *RIB*.

10.8.2 Minimum requirement for *BS type 1-O*

The requirement shall apply at the *RIB* when the AoA of the incident wave of a received signal and the interfering signal are from the same direction, and:

- when the wanted signal is based on EIS_{REFSENS} : the AoA of the incident wave of a received signal and the interfering signal are within the *OTA REFSENS RoAoA*.
- when the wanted signal is based on EIS_{minSENS} : the AoA of the incident wave of a received signal and the interfering signal are within the *minSENS RoAoA*.

The wanted and interfering signals apply to all supported polarizations, under the assumption of polarization match.

For NR, the throughput shall be $\geq 95\%$ of the maximum throughput of the reference measurement channel, with a wanted signal at the assigned channel frequency and two interfering signals at the *RIB*. with the conditions specified in tables 10.8.2-1 and 10.8.2-2 for intermodulation performance and in tables 10.8.2-3 and 10.8.2-4 for narrowband intermodulation performance.

The reference measurement channel for the wanted signal is identified in table 10.3.2-1, table 10.3.2-2 and table 10.3.2-3 for each *BS channel bandwidth* and further specified in annex A. The characteristics of the interfering signal is further specified in annex D.

The subcarrier spacing for the modulated interfering signal shall be the same as the subcarrier spacing for the wanted signal, except for the case of wanted signal subcarrier spacing 60kHz and *BS channel bandwidth* $\leq 20\text{MHz}$, for which the subcarrier spacing of the interfering signal shall be 30kHz.

The receiver intermodulation requirement is applicable outside the Base Station RF Bandwidth or Radio Bandwidth edges. The interfering signal offset is defined relative to the Base Station RF Bandwidth edges or Radio Bandwidth edges.

For a *RIBs* supporting operation in non-contiguous spectrum within any *operating band*, the narrowband intermodulation requirement shall apply in addition inside any sub-block gap in case the sub-block gap is at least as wide as the *BS channel bandwidth* of the NR interfering signal in tables 10.8.2-2 and 10.8.2-4. The interfering signal offset is defined relative to the sub-block edges inside the sub-block gap.

For *multi-band RIBs*, the intermodulation requirement shall apply in addition inside any Inter RF Bandwidth gap, in case the gap size is at least twice as wide as the NR interfering signal centre frequency offset from the Base Station RF Bandwidth edge.

For *multi-band RIBs*, the narrowband intermodulation requirement shall apply in addition inside any Inter RF Bandwidth gap in case the gap size is at least as wide as the NR interfering signal in tables 10.8.2-2 and 10.8.2-4. The interfering signal offset is defined relative to the Base Station RF Bandwidth edges inside the Inter RF Bandwidth gap.

Table 10.8.2-1: General intermodulation requirement

BS class	Wanted Signal mean power (dBm)	Interfering signal mean power (dBm)	Type of interfering signal
Wide Area BS	$EIS_{REFSENS} + 6 \text{ dB}$	$-52 - \Delta_{OTAREFSENS}$	See Table 10.8.2-2
	$EIS_{minSENS} + 6 \text{ dB}$	$-52 - \Delta_{minSENS}$	
Medium Range BS	$EIS_{REFSENS} + 6 \text{ dB}$	$-47 - \Delta_{OTAREFSENS}$	
	$EIS_{minSENS} + 6 \text{ dB}$	$-47 - \Delta_{minSENS}$	
Local Area BS	$EIS_{REFSENS} + 6 \text{ dB}$	$-44 - \Delta_{OTAREFSENS}$	
	$EIS_{minSENS} + 6 \text{ dB}$	$-44 - \Delta_{minSENS}$	
NOTE 1: $EIS_{REFSENS}$ and $EIS_{minSENS}$ depend on the BS class and on the BS channel bandwidth, see subclause 10.3 and 10.2.			

Table 10.8.2-2: Interfering signals for intermodulation requirement

BS channel bandwidth of the lowest/highest carrier received (MHz)	Interfering signal centre frequency offset from the lower/upper base station RF Bandwidth edge (MHz)	Type of interfering signal
5	± 7.5	CW
	± 17.5	5 MHz DFT-s-OFDM NR signal (Note 1)
10	± 7.45	CW
	± 17.5	5 MHz DFT-s-OFDM NR signal (Note 1)
15	± 7.43	CW
	± 17.5	5 MHz DFT-s-OFDM NR signal (Note 1)
20	± 7.38	CW
	± 17.5	5 MHz DFT-s-OFDM NR signal (Note 1)
25	± 7.45	CW
	± 25	20 MHz DFT-s-OFDM NR signal (Note 2)
30	± 7.43	CW
	± 25	20 MHz DFT-s-OFDM NR signal (Note 2)
40	± 7.45	CW
	± 25	20 MHz DFT-s-OFDM NR signal (Note 2)
50	± 7.35	CW
	± 25	20 MHz DFT-s-OFDM NR signal (Note 2)
60	± 7.49	CW
	± 25	20 MHz DFT-s-OFDM NR signal (Note 2)
70	± 7.42	CW
	± 25	20 MHz DFT-s-OFDM NR signal (Note 2)
80	± 7.44	CW
	± 25	20 MHz DFT-s-OFDM NR signal (Note 2)
90	± 7.43	CW
	± 25	20 MHz DFT-s-OFDM NR signal (Note 2)
100	± 7.45	CW
	± 25	20 MHz DFT-s-OFDM NR signal (Note 2)
NOTE 1: Number of RBs is 25 for 15 kHz subcarrier spacing and 10 for 30 kHz subcarrier spacing.		
NOTE 2: Number of RBs is 100 for 15 kHz subcarrier spacing, 50 for 30 kHz subcarrier spacing and 24 for 60 kHz subcarrier spacing.		

Table 10.8.2-3: Narrowband intermodulation performance requirement in FR1

BS class	Wanted signal mean power (dBm)	Interfering signal mean power (dBm)	Type of interfering signal
Wide Area BS	$EIS_{REFSENS} + 6$ dB (Note 1)	$-52 - \Delta_{OTAREFSENS}$	See Table 10.8.2-4
	$EIS_{minSENS} + 6$ dB (Note 1)	$-52 - \Delta_{minSENS}$	
Medium Range BS	$EIS_{REFSENS} + 6$ dB (Note 1)	$-47 - \Delta_{OTAREFSENS}$	
	$EIS_{minSENS} + 6$ dB (Note 1)	$-47 - \Delta_{minSENS}$	
Local Area BS	$EIS_{REFSENS} + 6$ dB (Note 1)	$-44 - \Delta_{OTAREFSENS}$	
	$EIS_{minSENS} + 6$ dB (Note 1)	$-44 - \Delta_{minSENS}$	

NOTE 1: $EIS_{REFSENS} / EIS_{minSENS}$ depends on the *BS channel bandwidth*, see subclause 10.3 and 10.2.

Table 10.8.2-4: Interfering signals for narrowband intermodulation requirement in FR1

<i>BS channel bandwidth of the lowest/highest carrier received (MHz)</i>	Interfering RB centre frequency offset from the lower/upper Base Station RF Bandwidth edge or sub-block edge inside a sub-block gap (kHz)	Type of interfering signal
5	±360	CW
	±1420	5 MHz DFT-s-OFDM NR signal, 1 RB (NOTE 1)
10	±325	CW
	±1780	5 MHz DFT-s-OFDM NR signal, 1 RB (NOTE 1)
15 (NOTE 2)	±380	CW
	±1600	5 MHz DFT-s-OFDM NR signal, 1 RB (NOTE 1)
20 (NOTE 2)	±345	CW
	±1780	5 MHz DFT-s-OFDM NR signal, 1 RB (NOTE 1)
25 (NOTE 2)	±325	CW
	±1990	20 MHz DFT-s-OFDM NR signal, 1 RB (NOTE 1)
30 (NOTE 2)	±320	CW
	±1990	20 MHz DFT-s-OFDM NR signal, 1 RB (NOTE 1)
40 (NOTE 2)	±310	CW
	±2710	20 MHz DFT-s-OFDM NR signal, 1 RB (NOTE 1)
50 (NOTE 2)	±330	CW
	±3250	20 MHz DFT-s-OFDM NR signal, 1 RB (NOTE 1)
60 (NOTE 2)	±350	CW
	±3790	20 MHz DFT-s-OFDM NR signal, 1 RB (NOTE 1)
70 (NOTE 2)	±400	CW
	±4870	20 MHz DFT-s-OFDM NR signal, 1 RB (NOTE 1)
80 (NOTE 2)	±390	CW
	±4870	20 MHz DFT-s-OFDM NR signal, 1 RB (NOTE 1)
90 (NOTE 2)	±340	CW
	±5770	20 MHz DFT-s-OFDM NR signal, 1 RB (NOTE 1)
100 (NOTE 2)	±340	CW
	±5770	20 MHz DFT-s-OFDM NR signal, 1 RB (NOTE 1)
NOTE 1: Interfering signal consisting of one resource block positioned at the stated offset, the <i>BS channel bandwidth</i> of the interfering signal is located adjacently to the lower/upper Base Station RF Bandwidth edge or sub-block edge inside a sub-block gap.		
NOTE 2: This requirement shall apply only for a G-FRC mapped to the frequency range at the channel edge adjacent to the interfering signals.		

10.8.3 Minimum requirement for *BS type 2-O*

The requirement shall apply at the RIB when the AoA of the incident wave of the received signal and the interfering signal are from the same direction and are within the *OTA REFSENS RoAoA*.

The wanted and interfering signals applies to all supported polarizations, under the assumption of *polarization match*.

Throughput shall be $\geq 95\%$ of the maximum throughput of the reference measurement channel, with OTA wanted signal at the assigned channel frequency and two OTA interfering signals provided at the RIB using the parameters in tables 10.8.3-1 and 10.8.3-2. All of the OTA test signals arrive from the same direction, and the requirement is valid if the signals arrive from any direction within the *OTA REFSENS RoAoA*. The reference measurement channel for the wanted signal is identified in [table 10.3.2-1] for each *BS channel bandwidth* and further specified in annex A. The characteristics of the interfering signal is further specified in annex D.

The subcarrier spacing for the modulated interfering signal shall be the same as the subcarrier spacing for the wanted signal.

The receiver intermodulation requirement is applicable outside the Base Station RF Bandwidth. The interfering signal offset is defined relative to the Base Station RF Bandwidth edges.

Table 10.8.3-1: General intermodulation requirement

<i>BS channel bandwidth of the lowest/highest carrier received (MHz)</i>	<i>Wanted signal mean power (dBm)</i>	<i>Interfering signal mean power (dBm)</i>	<i>Type of interfering signal</i>
50, 100, 200, 400	$EIS_{REFSENS} + 6$	$EIS_{REFSENS_50M} + 25 + \Delta_{FR2_REFSENS}$	See Table 10.8.3-2
NOTE: $EIS_{REFSENS}$ and $EIS_{REFSENS_50M}$ are given in subclause 10.3.3.			

Table 10.8.3-2: Interfering signals for intermodulation requirement

<i>BS channel bandwidth of the lowest/highest carrier received (MHz)</i>	<i>Interfering signal centre frequency offset from the lower/upper Base Station RF Bandwidth edge (MHz)</i>	<i>Type of interfering signal</i>
50 MHz	± 7.5	CW
	± 40	50MHz DFT-s-OFDM NR signal (Note 1)
100 MHz	± 6.88	CW
	± 40	50MHz DFT-s-OFDM NR signal (Note 1)
200 MHz	± 5.64	CW
	± 40	50MHz DFT-s-OFDM NR signal (Note 1)
400 MHz	± 6.02	CW
	± 45	50MHz DFT-s-OFDM NR signal (Note 1)
NOTE 1: Number of RBs is 64 for the 60 kHz subcarrier spacing, 32 for the 120 kHz subcarrier spacing		

10.9 OTA in-channel selectivity

10.9.1 General

In-channel selectivity (ICS) is a measure of the receiver ability to receive a wanted signal at its assigned resource block locations in the presence of an interfering signal received at a larger power spectral density. In this condition a throughput requirement shall be met for a specified reference measurement channel. The interfering signal shall be an NR signal as specified in annex A and shall be time aligned with the wanted signal.

10.9.2 Minimum requirement for *BS type 1-0*

The requirement shall apply at the RIB when the AoA of the incident wave of the received signal and the interfering signal are the same direction and are within the *minSENS RoAoA*

The wanted and interfering signals applies to all supported polarizations, under the assumption of *polarization match*.

For a wanted and an interfering signal coupled to the RIB, the following requirements shall be met:

- For *BS type I-O*, the throughput shall be $\geq 95\%$ of the maximum throughput of the reference measurement channel as specified in annex A with parameters specified in table 10.9.2-1 for Wide Area BS, in table 10.9.2-2 for Medium Range BS and in table 10.9.2-3 for Local Area BS. The characteristics of the interfering signal is further specified in annex D.

Table 10.9.2-1: Wide Area BS in-channel selectivity

<i>BS channel bandwidth</i> (MHz)	<i>Subcarrier spacing</i> (kHz)	<i>Reference measurement channel</i>	<i>Wanted signal mean power</i> (dBm)	<i>Interfering signal mean power</i> (dBm)	<i>Type of interfering signal</i>
5	15	G-FR1-A1-7	-100.6- Δ_{minSENS}	-81.4 - Δ_{minSENS}	DFT-s-OFDM NR signal, SCS 15 kHz, 10 RB
10,15,20,25,30	15	G-FR1-A1-1	-98.7- Δ_{minSENS}	-77.4 - Δ_{minSENS}	DFT-s-OFDM NR signal, SCS 15 kHz, 25 RB
40,50	15	G-FR1-A1-4	-92.3- Δ_{minSENS}	-71.4 - Δ_{minSENS}	DFT-s-OFDM NR signal, SCS 15 kHz, 100 RB
5	30	G-FR1-A1-8	-101.3- Δ_{minSENS}	-81.4 - Δ_{minSENS}	DFT-s-OFDM NR signal, SCS 30 kHz, 5 RB
10,15,20,25,30	30	G-FR1-A1-2	-98.8- Δ_{minSENS}	-78.4 - Δ_{minSENS}	DFT-s-OFDM NR signal, SCS 30 kHz, 10 RB
40,50,60,70,80,90,100	30	G-FR1-A1-5	-92.6- Δ_{minSENS}	-71.4 - Δ_{minSENS}	DFT-s-OFDM NR signal, SCS 30 kHz, 50 RB
10,15,20,25,30	60	G-FR1-A1-9	-98.2- Δ_{minSENS}	-78.4 - Δ_{minSENS}	DFT-s-OFDM NR signal, SCS 60 kHz, 5 RB
40,50,60,70,80,90,100	60	G-FR1-A1-6	-92.7- Δ_{minSENS}	-71.6 - Δ_{minSENS}	DFT-s-OFDM NR signal, SCS 60 kHz, 24 RB
NOTE: Wanted and interfering signal are placed adjacently around F_c , where the F_c is defined for <i>BS channel bandwidth</i> of the wanted signal according to the table 5.4.2.2-1 . The aggregated wanted and interferer signal shall be centred in the BS channel bandwidth of the wanted signal.					

Table 10.9.2-2: Medium Range BS in-channel selectivity

<i>BS channel bandwidth</i> (MHz)	<i>Subcarrier spacing</i> (kHz)	<i>Reference measurement channel</i>	<i>Wanted signal mean power</i> (dBm)	<i>Interfering signal mean power</i> (dBm)	<i>Type of interfering signal</i>
5	15	G-FR1-A1-7	-95.6- Δ_{minSENS}	-76.4 - Δ_{minSENS}	DFT-s-OFDM NR signal, SCS 15 kHz, 10 RB
10,15,20,25,30	15	G-FR1-A1-1	-93.7- Δ_{minSENS}	-72.4 - Δ_{minSENS}	DFT-s-OFDM NR signal, SCS 15 kHz, 25 RB
40,50	15	G-FR1-A1-4	-87.3- Δ_{minSENS}	-66.4 - Δ_{minSENS}	DFT-s-OFDM NR signal, SCS 15 kHz, 100 RB
5	30	G-FR1-A1-8	-96.3- Δ_{minSENS}	-76.4 - Δ_{minSENS}	DFT-s-OFDM NR signal, SCS 30 kHz, 5 RB
10,15,20,25,30	30	G-FR1-A1-2	-93.8- Δ_{minSENS}	-73.4 - Δ_{minSENS}	DFT-s-OFDM NR signal, SCS 30 kHz, 10 RB
40,50,60,70,80,90,100	30	G-FR1-A1-5	-87.6- Δ_{minSENS}	-66.4 - Δ_{minSENS}	DFT-s-OFDM NR signal, SCS 30 kHz, 50 RB
10,15,20,25,30	60	G-FR1-A1-9	-93.2- Δ_{minSENS}	-73.4 - Δ_{minSENS}	DFT-s-OFDM NR signal, SCS 60 kHz, 5 RB
40,50,60,70,80,90,100	60	G-FR1-A1-6	-87.7- Δ_{minSENS}	-66.6 - Δ_{minSENS}	DFT-s-OFDM NR signal, SCS 60 kHz, 24 RB
NOTE: Wanted and interfering signal are placed adjacently around F_c , where the F_c is defined for <i>BS channel bandwidth</i> of the wanted signal according to the table 5.4.2.2-1 . The aggregated wanted and interferer signal shall be centred in the BS channel bandwidth of the wanted signal.					

Table 10.9.2-3: Local area BS in-channel selectivity

<i>BS channel bandwidth (MHz)</i>	<i>Subcarrier spacing (kHz)</i>	<i>Reference measurement channel</i>	<i>Wanted signal mean power (dBm)</i>	<i>Interfering signal mean power (dBm)</i>	<i>Type of interfering signal</i>
5	15	G-FR1-A1-7	-92.6- Δ_{minSENS}	-73.4 - Δ_{minSENS}	DFT-s-OFDM NR signal, SCS 15 kHz, 10 RB
10,15,20,25,30	15	G-FR1-A1-1	-90.7- Δ_{minSENS}	-69.4 - Δ_{minSENS}	DFT-s-OFDM NR signal, SCS 15 kHz, 25 RB
40,50	15	G-FR1-A1-4	-84.3- Δ_{minSENS}	-63.4 - Δ_{minSENS}	DFT-s-OFDM NR signal, SCS 15 kHz, 100 RB
5	30	G-FR1-A1-8	-93.3- Δ_{minSENS}	-73.4 - Δ_{minSENS}	DFT-s-OFDM NR signal, SCS 30 kHz, 5 RB
10,15,20,25,30	30	G-FR1-A1-2	-90.8- Δ_{minSENS}	-70.4 - Δ_{minSENS}	DFT-s-OFDM NR signal, SCS 30 kHz, 10 RB
40,50,60,70,80,90,100	30	G-FR1-A1-5	-84.6- Δ_{minSENS}	-63.4 - Δ_{minSENS}	DFT-s-OFDM NR signal, SCS 30 kHz, 50 RB
10,15,20,25,30	60	G-FR1-A1-9	-90.2- Δ_{minSENS}	-70.4 - Δ_{minSENS}	DFT-s-OFDM NR signal, SCS 60 kHz, 5 RB
40,50,60,70,80,90,100	60	G-FR1-A1-6	-84.7- Δ_{minSENS}	-63.6 - Δ_{minSENS}	DFT-s-OFDM NR signal, SCS 60 kHz, 24 RB
NOTE: Wanted and interfering signal are placed adjacently around F_c , where the F_c is defined for <i>BS channel bandwidth</i> of the wanted signal according to the table 5.4.2.2-1. The aggregated wanted and interferer signal shall be centred in the BS channel bandwidth of the wanted signal.					

10.9.3 Minimum requirement for *BS type 2-0*

The requirement shall apply at the RIB when the AoA of the incident wave of the received signal and the interfering signal are from the same direction and are within the *OTA REFSENS RoAoA*.

The wanted and interfering signals applies to all supported polarizations, under the assumption of *polarization match*.

For *BS type 2-O*, the throughput shall be $\geq 95\%$ of the maximum throughput of the reference measurement channel as specified in annex A with parameters specified in table 10.9.3-1. The characteristics of the interfering signal is further specified in annex D.

Table 10.9.3-1: OTA in-channel selectivity requirement for *BS type 2-O*

<i>BS channel bandwidth</i> (MHz)	Subcarrier spacing (kHz)	Reference measurement channel	Wanted signal mean power (dBm) (Note 2)	Interfering signal mean power (dBm) (Note 2)	Type of interfering signal
50	60	G-FR2-A1-4	$EIS_{REFSENS_50M} + \Delta_{FR2_REFSENS}$	$EIS_{REFSENS_50M} + 10 + \Delta_{FR2_REFSENS}$	DFT-s-OFDM NR signal, SCS 60 kHz, 32 RB
100,200	60	G-FR2-A1-1	$EIS_{REFSENS_50M} + 3 + \Delta_{FR2_REFSENS}$	$EIS_{REFSENS_50M} + 13 + \Delta_{FR2_REFSENS}$	DFT-s-OFDM NR signal, SCS 60 kHz, 64 RB
50	120	G-FR2-A1-5	$EIS_{REFSENS_50M} + \Delta_{FR2_REFSENS}$	$EIS_{REFSENS_50M} + 10 + \Delta_{FR2_REFSENS}$	DFT-s-OFDM NR signal, SCS 120 kHz, 16 RB
100,200,400	120	G-FR2-A1-2	$EIS_{REFSENS_50M} + 3 + \Delta_{FR2_REFSENS}$	$EIS_{REFSENS_50M} + 13 + \Delta_{FR2_REFSENS}$	DFT-s-OFDM NR signal, SCS 120 kHz, 32 RB
NOTE 1: Wanted and interfering signal are placed adjacently around F_c , where the F_c is defined for <i>BS channel bandwidth</i> of the wanted signal according to the table 5.4.2.2-1. The aggregated wanted and interferer signal shall be centred in the BS channel bandwidth of the wanted signal.					
NOTE 2: $EIS_{REFSENS_50M}$ is defined in subclause 10.3.3.					

Table 10.9.3-2: (Void)

Table 10.9.3-3: (Void)

11 Radiated performance requirements

11.1 General

11.1.1 Scope and definitions

Radiated performance requirements specify the ability of the *BS type 1-O* or *BS type 2-O* to correctly demodulate radiated signals in various conditions and configurations. Radiated performance requirements are specified at the RIB.

Radiated performance requirements for the BS are specified for the fixed reference channels defined in annex A and the propagation conditions in annex G. The requirements only apply to those FRCs that are supported by the BS.

The radiated performance requirements for *BS type 1-O* and for the *BS type 2-O* are limited to two OTA *demodulation branches* as described in subclause 11.1.2. Conformance requirements can only be tested for 1 or 2 *demodulation branches* depending on the number of polarizations supported by the BS, with the required SNR applied separately per polarization.

NOTE 1: The BS can support more than 2 *demodulation branches*, however OTA conformance testing can only be performed for 1 or 2 *demodulation branches*.

Unless stated otherwise, radiated performance requirements apply for a single carrier only. Radiated performance requirements for a BS supporting CA are defined in terms of single carrier requirements.

For *BS type 1-O* in FDD operation the requirements in clause 8 shall be met with the transmitter units associated with the RIB in the *operating band* turned ON.

NOTE 2: *BS type 1-O* in normal operating conditions in FDD operation is configured to transmit and receive at the same time. The transmitter unit(s) associated with the RIB may be OFF for some of the tests.

In tests performed with signal generators a synchronization signal may be provided from the BS to the signal generator, to enable correct timing of the wanted signal.

Whenever the "RX antennas" term is used for the radiated performance requirements description, it shall refer to the *demodulation branches* (i.e. not physical antennas of the antenna array).

The SNR used in this clause is specified based on a single carrier and defined as:

$$\text{SNR} = S / N$$

Where:

S is the total signal energy in a slot on a RIB.

N is the noise energy in a bandwidth corresponding to the transmission bandwidth over the duration of a slot on a RIB.

11.1.2 OTA demodulation branches

Radiated performance requirements are only specified for up to 2 *demodulation branches*.

If the *BS type 1-O*, or the *BS type 2-O* uses polarization diversity and has the ability to maintain isolation between the signals for each of the *demodulation branches*, then radiated performance requirements can be tested for up to two *demodulation branches* (i.e. 1RX or 2RX test setups). When tested for two *demodulation branches*, each demodulation branch maps to one polarization.

If the *BS type 1-O*, or the *BS type 2-O* does not use polarization diversity then radiated performance requirements can only be tested for a single *demodulation branch* (i.e. 1RX test setup).

11.1.3 Applicability rule

Text to be added.

11.2 Performance requirements for PUSCH

11.2.1 Requirements for *BS type 1-0*

11.2.1.1 Requirements for PUSCH with transform precoding disabled

Apply the requirements defined in subclause 8.2.1 for 2Rx.

11.2.1.2 Requirements for PUSCH with transform precoding enabled

Apply the requirements defined in subclause 8.2.2 for 2Rx.

11.2.2 Requirements for *BS type 2-0*

11.2.2.1 Requirements for PUSCH with transform precoding disabled

11.2.2.1.1 General

The performance requirement of PUSCH is determined by a minimum required throughput for a given SNR. The required throughput is expressed as a fraction of maximum throughput for the FRCs listed in annex A. The performance requirements assume HARQ retransmissions.

Table 11.2.2.1.1-1: Test parameters for testing PUSCH

Parameter		Value
Transform precoding		Disabled
Uplink-downlink allocation for TDD		60 kHz and 120kHz SCS: 3D1S1U, S=10D:2G:2U
HARQ	Maximum number of HARQ transmissions	4
	RV sequence	0, 2, 3, 1
DMRS	DMRS configuration type	1
	Maximum number of OFDM symbols for front loaded DMRS	1
	Number of additional DMRS symbols	0
	Number of DMRS CDM group(s) without data	2
	EPRE ratio of PUSCH to DMRS	-3 dB
	DMRS port	{0}, {0, 1}
DMRS sequence generation		$N_{ID}=0, n_{SCID}=0$
Time domain resource	PUSCH mapping type	B
	PUSCH starting symbol index	0
	PUSCH symbol length	10
Frequency domain resource	RB assignment	Full applicable test bandwidth
	Frequency hopping	Disabled
TPMI index for 2Tx two-layer spatial multiplexing transmission		0
Code block group based PUSCH transmission		Disabled
PTRS configuration	Frequency density (K_{PT-RS})	2
	Time density (L_{PT-RS})	1

11.2.2.1.2 Minimum requirements

The throughput shall be equal to or larger than the fraction of maximum throughput stated in the tables 11.2.2.1.2-1 to 11.2.2.1.2-5 at the given SNR for 1Tx and for 2Tx two-layer spatial multiplexing transmission.

Table 11.2.2.1.2-1: Minimum requirements for PUSCH, 50 MHz channel bandwidth, 60 kHz SCS

Number of TX antennas	Number of demodulation branches	Cyclic prefix	Propagation conditions and correlation matrix (Annex G)	Fraction of maximum throughput	FRC (Annex A)	DMRS configuration	SNR (dB)
1	2	Normal	TDLA30-300 Low	70 %	G-FR2-A3-1	1+0	[-1.1]
		Normal	TDLA30-300 Low	70 %	G-FR2-A4-1	1+0	[12.5]
		Normal	TDLA30-75 Low	70 %	G-FR2-A5-1	1+0	[14.7]
2		Normal	TDLA30-300 Low	70 %	G-FR2-A3-6	1+0	[2.6]
		Normal	TDLA30-300 Low	70 %	G-FR2-A4-6	1+0	[NA]

Table 11.2.2.1.2-2: Minimum requirements for PUSCH, 100 MHz channel bandwidth, 60 kHz SCS

Number of TX antennas	Number of demodulation branches	Cyclic prefix	Propagation conditions and correlation matrix (Annex G)	Fraction of maximum throughput	FRC (Annex A)	DMRS configuration	SNR (dB)
1	2	Normal	TDLA30-300 Low	70 %	G-FR2-A3-2	1+0	[-1.4]
		Normal	TDLA30-300 Low	70 %	G-FR2-A4-2	1+0	[12.9]
		Normal	TDLA30-75 Low	70 %	G-FR2-A5-2	1+0	[15.0]
2		Normal	TDLA30-300 Low	70 %	G-FR2-A3-7	1+0	[2.3]

Table 11.2.2.1.2-3: Minimum requirements for PUSCH, 50 MHz channel bandwidth, 120 kHz SCS

Number of TX antennas	Number of demodulation branches	Cyclic prefix	Propagation conditions and correlation matrix (Annex G)	Fraction of maximum throughput	FRC (Annex A)	DMRS configuration	SNR (dB)
1	2	Normal	TDLA30-300 Low	70 %	G-FR2-A3-3	1+0	[-0.9]
		Normal	TDLA30-300 Low	70 %	G-FR2-A4-3	1+0	[12.0]
		Normal	TDLA30-75 Low	70 %	G-FR2-A5-3	1+0	[14.6]
2		Normal	TDLA30-300 Low	70 %	G-FR2-A3-8	1+0	[2.2]
		Normal	TDLA30-300 Low	70 %	G-FR2-A4-8	1+0	[21.1]

Table 11.2.2.1.2-4: Minimum requirements for PUSCH, 100 MHz channel bandwidth, 120 kHz SCS

Number of TX antennas	Number of demodulation branches	Cyclic prefix	Propagation conditions and correlation matrix (Annex G)	Fraction of maximum throughput	FRC (Annex A)	DMRS configuration	SNR (dB)
1	2	Normal	TDLA30-300 Low	70 %	G-FR2-A3-4	1+0	[-1.4]
		Normal	TDLA30-300 Low	70 %	G-FR2-A4-4	1+0	[11.9]
		Normal	TDLA30-75 Low	70 %	G-FR2-A5-4	1+0	[14.4]
2		Normal	TDLA30-300 Low	70 %	G-FR2-A3-9	1+0	[2.3]

Table 11.2.2.1.2-5: Minimum requirements for PUSCH, 200 MHz channel bandwidth, 120 kHz SCS

Number of TX antennas	Number of demodulation branches	Cyclic prefix	Propagation conditions and correlation matrix (Annex G)	Fraction of maximum throughput	FRC (Annex A)	DMRS configuration	SNR (dB)
1	2	Normal	TDLA30-300	70 %	G-FR2-A3-5	1+0	[-1.2]
		Normal	TDLA30-300	70 %	G-FR2-A4-5	1+0	[12.0]
		Normal	TDLA30-75	70 %	G-FR2-A5-5	1+0	[15.5]
2		Normal	TDLA30-300	70 %	G-FR2-A3-10	1+0	[2.3]
		Normal	TDLA30-300	70 %	G-FR2-A4-10	1+0	[21.9]

11.2.2.2 Requirements for PUSCH with transform precoding enabled

11.2.2.2.1 General

The performance requirement of PUSCH is determined by a minimum required throughput for a given SNR. The required throughput is expressed as a fraction of maximum throughput for the FRCs listed in Annex A. The performance requirements assume HARQ retransmissions.

Table 11.2.2.2.1-1: Test parameters for testing PUSCH

Parameter		Value
Transform precoding		Enabled
Uplink-downlink allocation for TDD		60 kHz and 120kHz SCS: 3D1S1U, S=10D:2G:2U
HARQ	Maximum number of HARQ transmissions	4
	RV sequence	0, 2, 3, 1
DMRS	DMRS configuration type	1
	Maximum number of OFDM symbols for front loaded DMRS	1
	Number of additional DMRS symbols	0
	Number of DMRS CDM group(s) without data	2
	EPRE ratio of PUSCH to DMRS	-3 dB
	DMRS port	0
DMRS sequence generation		$N_{ID}=0$, group hopping and sequence hopping are disabled
Time domain resource	PUSCH mapping type	B
	PUSCH starting symbol index	0
	PUSCH symbol length	10
Frequency domain resource	RB assignment	30 PRBs in the middle of the test bandwidth
	Frequency hopping	Disabled
Code block group based PUSCH transmission		Disabled
PTRS		Not configured

11.2.2.2.2 Minimum requirements

The throughput shall be equal to or larger than the fraction of maximum throughput stated in the tables 11.2.2.2.2-1 to 11.2.2.2.2-2 at the given SNR.

Table 11.2.2.2.2-1: Minimum requirements for PUSCH, 50 MHz Channel Bandwidth, 60 kHz SCS

Number of TX antennas	Number of demodulation branches	Cyclic prefix	Propagation conditions and correlation matrix (Annex G)	Fraction of maximum throughput	FRC (Annex A)	DMRS configuration	SNR (dB)
1	2	Normal	TDLA30-300	70 %	G-FR2-A3-11	1+0	[TBD]

Table 11.2.2.2.2-2: Minimum requirements for PUSCH, 50 MHz Channel Bandwidth, 120 kHz SCS

Number of TX antennas	Number of demodulation branches	Cyclic prefix	Propagation conditions and correlation matrix (Annex G)	Fraction of maximum throughput	FRC (Annex A)	DMRS configuration	SNR (dB)
1	2	Normal	TDLA30-300	70 %	G-FR2-A3-12	1+0	[TBD]

11.3 Performance requirements for PUCCH

11.3.1 Requirements for *BS type 1-0*

11.3.1.1 DTX to ACK probability

Apply the requirements defined in subclause 8.3.1

11.3.1.2 Performance requirements for PUCCH format 0

Apply the requirements defined in subclause 8.3.2 for 2 Rx.

11.3.1.3 Performance requirements for PUCCH format 1

Apply the requirements defined in sub-clause 8.3.3 for 2Rx.

11.3.1.4 Performance requirements for PUCCH format 2

Apply the requirements defined in subclause 8.3.4 for 2Rx.

11.3.1.5 Performance requirements for PUCCH format 3

Apply the requirements defined in subclause 8.3.5 for 2Rx.

11.3.1.6 Performance requirements for PUCCH format 4

Apply the requirements defined in subclause 8.3.6 for 2Rx.

11.3.2 Requirements for *BS type 2-0*

11.3.2.1 DTX to ACK probability

Apply the requirements defined in subclause 8.3.1.

11.3.2.2 Performance requirements for PUCCH format 0

11.3.2.2.1 General

The ACK missed detection probability is the probability of not detecting an ACK when an ACK was sent.

Table 11.3.2.2.1-1: Test Parameters

Parameter	Test
nrofBits	1
nrofPRBs	1
startingPRB	0
intraSlotFrequencyHopping	enabled
secondHopPRB	The largest PRB index - nrofPRBs
initialCyclicShift	0
startingSymbolIndex	13 for 1 symbol 12 for 2 symbols

11.3.2.2.2 Minimum requirements

The ACK missed detection probability shall not exceed 1% at the SNR given in table 11.3.2.2.2-1 and in table 11.3.2.2.2-2.

Table 11.3.2.2.2-1: Minimum requirements for PUCCH format 0 and 60kHz SCS

Number of TX antennas	Number of demodulation branches	Propagation conditions and correlation matrix (Annex G)	Number of OFDM symbols	Channel bandwidth / SNR (dB)	
				50 MHz	100 MHz
1	2	TDLA30-300 Low	1	[8.8]	[9.1]
			2	[4.5]	[3.8]

Table 11.3.2.2.2-2: Minimum requirements for PUCCH format 0 and 120kHz SCS

Number of TX antennas	Number of demodulation branches	Propagation conditions and correlation matrix (Annex G)	Number of OFDM symbols	Channel bandwidth / SNR (dB)		
				50 MHz	100 MHz	200 MHz
1	2	TDLA30-300 Low	1	TBD	TBD	[8.7]
			2	TBD	TBD	[3.2]

11.3.2.3 Performance requirements for PUCCH format 1

11.3.2.3.1 NACK to ACK requirements

11.3.2.3.1.1 General

The NACK to ACK detection probability is the probability that an ACK bit is falsely detected when a NACK bit was sent on the particular bit position, where the NACK to ACK detection probability is defined as follows:

$$\text{Prob}(\text{PUCCHNACK} \rightarrow \text{ACK bits}) = \frac{\#(\text{NACK bits decoded as ACK bits})}{\#(\text{Total NACK bits})}$$

where:

- $\#(\text{Total NACK bits})$ denotes the total number of NACK bits transmitted
- $\#(\text{NACK bits decoded as ACK bits})$ denotes the number of NACK bits decoded as ACK bits at the receiver, i.e. the number of received ACK bits
- NACK bits in the definition do not contain the NACK bits which are mapped from DTX, i.e. NACK bits received when DTX is sent should not be considered.

Random codeword selection is assumed.

Table 11.3.2.3.1.1-1: Test Parameters

Parameter	Test
nrofBits	2
nrofPRBs	1
nrofSymbols	14
startingPRB	0
intraSlotFrequencyHopping	enabled
secondHopPRB	The largest PRB index - nrofPRBs
initialCyclicShift	0
startingSymbolIndex	0
Index of orthogonal sequence (time-domain-OCC)	0

11.3.2.3.1.2 Minimum requirements

The NACK to ACK probability shall not exceed 0.1% at the SNR given in Table 11.3.2.3.1.2-1 and Table 11.3.2.3.1.2-2.

Table 11.3.2.3.1.2-1: Minimum requirements for PUCCH format 1 with 60 kHz SCS

Number of TX antennas	Number of Demodulation Branches	Cyclic Prefix	Propagation conditions and correlation matrix (Annex G)	Channel bandwidth / SNR (dB)	
				50 MHz	100 MHz
1	2	Normal	TDLA30-300 Low	[TBD]	[TBD]

Table 11.3.2.3.1.2-2: Minimum requirements for PUCCH format 1 with 120 kHz SCS

Number of TX antennas	Number of Demodulation Branches	Cyclic Prefix	Propagation conditions and correlation matrix (Annex G)	Channel bandwidth / SNR (dB)		
				50 MHz	100 MHz	200 MHz
1	2	Normal	TDLA30-300 Low	[TBD]	[-2.7]	[TBD]

11.3.2.3.2 ACK missed detection requirements

11.3.2.3.2.1 General

The ACK missed detection probability is the probability of not detecting an ACK when an ACK was sent. The test parameters in Table 11.3.2.3.1.1-1 are configured.

11.3.2.3.2.2 Minimum requirements

The ACK missed detection probability shall not exceed 1% at the SNR given in Table 11.3.2.3.2.2-1 and in Table 11.3.2.3.2.2-2.

Table 11.3.2.3.2.2-1: Minimum requirements for PUCCH format 1 with 60 kHz SCS

Number of TX antennas	Number of Demodulation Branches	Cyclic Prefix	Propagation conditions and correlation matrix (Annex G)	Channel bandwidth / SNR (dB)	
				50 MHz	100 MHz
1	2	Normal	TDLA30-300 Low	[-4.4]	[-4.1]

Table 11.3.2.3.2.2-2: Minimum requirements for PUCCH format 1 with 120 kHz SCS

Number of TX antennas	Number of Demodulation Branches	Cyclic Prefix	Propagation conditions and correlation matrix (Annex G)	Channel bandwidth / SNR (dB)		
				50 MHz	100 MHz	200 MHz
1	2	Normal	TDLA30-300 Low	[-4.7]	[-4.0]	[-5.4]

11.3.2.4 Performance requirements for PUCCH format 2

11.3.2.4.1 ACK missed detection requirements

11.3.2.4.1.1 General

The ACK missed detection probability is the probability of not detecting an ACK when an ACK was sent.

The ACK missed detection requirement only applies to the PUCCH format 2 with 4 UCI bits.

Table 11.3.2.4.1.1-1: Test Parameters

Parameter	Value
Modulation	QSPK
startingPRB	0
intraSlotFrequencyHopping	enable
secondHopPRB	The largest PRB index - nrofPRB
nrofPRB	4
nrofSymbols	1
the number of UCI bits	4
startingSymbolIndex	13

11.3.2.4.1.2 Minimum requirements

The ACK missed detection probability shall not exceed 1% at the SNR given in table 11.3.2.4.1.2-1 and table 11.3.2.4.1.2-2 for 4UCI bits.

Table 11.3.2.4.1.2-1: Minimum requirements for PUCCH format 2 with 60 kHz SCS

Number of TX antennas	Number of demodulation branches	Cyclic Prefix	Propagation conditions and correlation matrix (Annex [G])	Channel bandwidth / SNR (dB)	
				50 MHz	100 MHz
1	2	Normal	TDLA30-300 Low	[TBD]	[TBD]

Table 11.3.2.4.1.2-2: Minimum requirements for PUCCH format 2 with 120 kHz SCS

Number of TX antennas	Number of demodulation branches	Cyclic Prefix	Propagation conditions and correlation matrix (Annex [G])	Channel bandwidth / SNR (dB)		
				50 MHz	100 MHz	200 MHz
1	2	Normal	TDLA30-300 Low	[TBD]	[6.3]	[TBD]

11.3.2.4.2 UCI BLER performance requirements

11.3.2.4.2.1 General

The UCI block error probability (BLER) is defined as the conditional probability of incorrectly decoding the UCI information when the UCI information is sent. All UCI information shall be decoded.

The UCI performance only applies to the PUCCH format 2 with 22 UCI bits.

Table 11.3.2.4.2.1-1: Test Parameters

Parameter	Value
Modulation	QSPK
startingPRB	0
intraSlotFrequencyHopping	enabled
secondHopPRB	The largest PRB index - nrofPRB
nrofPRB	9
nrofSymbols	2
the number of UCI bits	22
startingSymbolIndex	12

11.3.2.4.2.2 Minimum requirements

The UCI block error probability shall not exceed 1% at the SNR given in table 11.3.2.4.2.2-1 and table 11.3.2.4.2.2-2 for 22 UCI bits.

Table 11.3.2.4.2.2-1: Minimum requirements for PUCCH format 2 with 60 kHz SCS

Number of TX antennas	Number of demodulation branches	Cyclic Prefix	Propagation conditions and correlation matrix (Annex [G])	Channel bandwidth / SNR (dB)	
				50 MHz	100 MHz
1	2	Normal	TDLA30-300 Low	[TBD]	[1.0]

Table 11.3.2.4.2.2-2: Minimum requirements for PUCCH format 2 with 120 kHz SCS

Number of TX antennas	Number of demodulation branches	Cyclic Prefix	Propagation conditions and correlation matrix (Annex [G])	Channel bandwidth / SNR (dB)		
				50 MHz	100 MHz	200 MHz
1	2	Normal	TDLA30-300 Low	[TBD]	[1.1]	[1.4]

11.3.2.5 Performance requirements for PUCCH format 3

11.3.2.5.1 General

The performance is measured by the required SNR at UCI block error probability not exceeding 1%.

The UCI block error probability is defined as the conditional probability of incorrectly decoding the UCI information when the UCI information is sent. All UCI information shall be decoded.

Table 11.3.2.5.1-1: Test parameters

Parameter	Test 1	Test 2
Modulation	QPSK	
startingPRB	0	
intraSlotFrequencyHopping	enabled	
secondHopPRB	The largest PRB index - nrofPRBs	
nrofPRBs	1	3
nrofSymbols	14	4
the number of UCI bits	16	16
startingSymbolIndex	0	0

11.3.2.5.2 Minimum requirements

The UCI block error probability shall not exceed 1% at the SNR given in Table 11.3.2.5.2-1 and Table 11.3.2.5.2-2.

Table 11.3.2.5.2-1: Required SNR for PUCCH format 3 with 60kHz SCS

Test Number	Number of TX antennas	Number of demodulation branches	Cyclic Prefix	Propagation conditions and correlation matrix (Annex G)	Additional DMRS configuration	Channel Bandwidth / SNR (dB)	
						50 MHz	100 MHz
1	1	2	Normal	TDLA30-300 Low	No additional DM-RS	[1.3]	[0.8]
2	1	2	Normal	TDLA30-300 Low	No additional DM-RS	[2.3]	[1.9]

Table 8.3.2.5.2-2: Required SNR for PUCCH format 3 with 120kHz SCS

Test Number	Number of TX antennas	Number of demodulation branches	Cyclic Prefix	Propagation conditions and correlation matrix (Annex G)	Additional DMRS configuration	Channel Bandwidth / SNR (dB)		
						50 MHz	100 MHz	200 MHz
1	1	2	Normal	TDLA30-300 Low	No additional DM-RS	[0.9]	[0.8]	[1.3]
2	1	2	Normal	TDLA30-300 Low	No additional DM-RS	TBD	[2.4]	[1.5]

11.3.2.6 Performance requirements for PUCCH format 4

11.3.2.6.1 General

The performance is measured by the required SNR at UCI block error probability not exceeding 1%.

The UCI block error probability is defined as the conditional probability of incorrectly decoding the UCI information when the UCI information is sent. All UCI information shall be decoded.

Table 11.3.2.6.1-1: Test parameters

Parameter	Value
Modulation	QPSK
startingPRB	0
intraSlotFrequencyHopping	enabled
secondHopPRB	The largest PRB index - nrofPRBs
nrofSymbols	14
the number of UCI bits	22
startingSymbolIndex	0
occ-Length	n2
occ-Index	n0

11.3.2.6.2 Minimum requirements

The UCI block error probability shall not exceed 1% at the SNR given in Table 11.3.2.6.2-1 and Table 11.3.2.6.2-2.

Table 11.3.2.6.2-1: Required SNR for PUCCH format 3 with 60kHz SCS

Number of TX antennas	Number of demodulation branches	Cyclic Prefix	Propagation conditions and correlation matrix (Annex G)	Additional DMRS configuration	Channel Bandwidth / SNR (dB)	
					50 MHz	100 MHz
1	2	Normal	TDLA30-300 Low	No additional DM-RS	TBD	[2.7]

Table 8.3.2.6.2-2: Required SNR for PUCCH format 3 with 120kHz SCS

Number of TX antennas	Number of demodulation branches	Cyclic Prefix	Propagation conditions and correlation matrix (Annex G)	Additional DMRS configuration	Channel Bandwidth / SNR (dB)		
					50 MHz	100 MHz	200MHz
1	2	Normal	TDLA30-300 Low	No additional DM-RS	[2.8]	[2.8]	[3.0]

11.4 Performance requirements for PRACH

11.4.1 Requirements for *BS type 1-0*

11.4.1.1 PRACH False alarm probability

Apply the requirements defined in subclause 8.4.1 for 2Rx.

11.4.1.2 PRACH detection requirements

Apply the requirements defined in subclause 8.4.2 for 2Rx.

11.4.2 Requirements for *BS type 2-0*

11.4.2.1 PRACH False alarm probability

11.4.2.1.1 General

The false alarm requirement is valid for any number of receive antennas, for any channel bandwidth.

The false alarm probability is the conditional total probability of erroneous detection of the preamble (i.e. erroneous detection from any detector) when input is only noise.

11.4.2.1.2 Minimum requirement

The false alarm probability shall be less than or equal to 0.1%.

11.4.2.2 PRACH detection requirements

11.4.2.2.1 General

The probability of detection is the conditional probability of correct detection of the preamble when the signal is present. There are several error cases – detecting different preamble than the one that was sent, not detecting a preamble at all or correct preamble detection but with the wrong timing estimation. For AWGN and TDLA30-300, a timing estimation error occurs if the estimation error of the timing of the strongest path is larger than the time error tolerance given in Table 11.4.2.2-1.

Table 11.4.2.2-1: Time error tolerance for AWGN and TDLA30-300

PRACH preamble	PRACH SCS (KHz)	Time error tolerance	
		AWGN	TDLA30-300
A1, A2, A3, B4, C0, C2	60	0.13 us	0.28 us
	120	0.07 us	0.22 us

The test preambles for normal mode are listed in table A.6-2.

11.4.2.2.2 Minimum requirements

The probability of detection shall be equal to or exceed 99% for the SNR levels listed in Tables 11.4.2.2.2-1 to 11.4.2.2.2-2.

Table 11.4.2.2.2-1: PRACH missed detection requirements for Normal Mode, 60KHz SCS

Number of TX antennas	Number of demodulation branches	Propagation conditions and correlation matrix (Annex G)	Frequency offset	SNR (dB)					
				Burst format A1	Burst format A2	Burst format A3	Burst format B4	Burst format C0	Burst format C2
1	2	AWGN	0	TBD	TBD	TBD	TBD	TBD	TBD
		TDLA30-300 Low	4000 Hz	TBD	TBD	TBD	TBD	TBD	TBD

Table 11.4.2.2.2-2: PRACH missed detection requirements for Normal Mode, 120KHz SCS

Number of TX antennas	Number of demodulation branches	Propagation conditions and correlation matrix (Annex G)	Frequency offset	SNR (dB)					
				Burst format A1	Burst format A2	Burst format A3	Burst format B4	Burst format C0	Burst format C2
1	2	AWGN	0	TBD	TBD	TBD	TBD	TBD	TBD
		TDLA30-300 Low	4000 Hz	TBD	TBD	TBD	TBD	TBD	TBD

Annex A (normative): Reference measurement channels

A.1 Fixed Reference Channels for receiver sensitivity and in-channel selectivity (QPSK, R=1/3)

The parameters for the reference measurement channels are specified in table A.1-1 for FR1 receiver sensitivity and in-channel selectivity.

The parameters for the reference measurement channels are specified in table A.1-2 for FR2 receiver sensitivity and in-channel selectivity.

Table A.1-1: FRC parameters for FR1 receiver sensitivity and in-channel selectivity

Reference channel	G-FR1-A1-1	G-FR1-A1-2	G-FR1-A1-3	G-FR1-A1-4	G-FR1-A1-5	G-FR1-A1-6	G-FR1-A1-7	G-FR1-A1-8	G-FR1-A1-9
Subcarrier spacing (kHz)	15	30	60	15	30	60	15	30	60
Allocated resource blocks	25	11	11	106	51	24	15	6	6
CP-OFDM Symbols per slot (Note 1)	12	12	12	12	12	12	12	12	12
Modulation	QPSK	QPSK	QPSK	QPSK	QPSK	QPSK	QPSK	QPSK	QPSK
Code rate (Note 2)	1/3	1/3	1/3	1/3	1/3	1/3	1/3	1/3	1/3
Payload size (bits)	2152	984	984	9224	4352	2088	1320	528	528
Transport block CRC (bits)	16	16	16	24	24	16	16	16	16
Code block CRC size (bits)	-	-	-	24	-	-	-	-	-
Number of code blocks - C	1	1	1	2	1	1	1	1	1
Code block size including CRC (bits) (Note 3)	2168	1000	1000	4648	4376	2104	1336	544	544
Total number of bits per slot	7200	3168	3168	30528	14688	6912	4320	1728	1728
Total symbols per slot	3600	1584	1584	15264	7344	3456	2160	864	864
NOTE 1: <i>UL-DMRS-config-type</i> = 1 with <i>UL-DMRS-max-len</i> = 1, <i>UL-DMRS-add-pos</i> = 1 with $l_0 = 2$, $l = 11$ as per table 6.4.1.1.3-3 of TS 38.211 [5].									
NOTE 2: MCS index 4 and target coding rate = 308/1024 are adopted to calculate payload size for receiver sensitivity and in-channel selectivity									
NOTE 3: Code block size including CRC (bits) equals to K' in sub-clause 5.2.2 of TS 38.212 [15].									

Table A.1-2: FRC parameters for FR2 receiver sensitivity and in-channel selectivity

Reference channel	G-FR2-A1-1	G-FR2-A1-2	G-FR2-A1-3	G-FR2-A1-4	G-FR2-A1-5
Subcarrier spacing (kHz)	60	120	120	60	120
Allocated resource blocks	66	32	66	33	16
CP-OFDM Symbols per slot (Note 1)	12	12	12	12	12
Modulation	QPSK	QPSK	QPSK	QPSK	QPSK
Code rate (Note 2)	1/3	1/3	1/3	1/3	1/3
Payload size (bits)	5632	2792	5632	2856	1416
Transport block CRC (bits)	24	16	24	16	16
Code block CRC size (bits)	-	-	-	-	-
Number of code blocks - C	1	1	1	1	1
Code block size including CRC (bits) (Note 3)	5656	2808	5656	2872	1432
Total number of bits per slot	19008	9216	19008	9504	4608
Total symbols per slot	9504	4608	9504	4752	2304
NOTE 1: $UL-DMRS-config-type = 1$ with $UL-DMRS-max-len = 1$, $UL-DMRS-add-pos = 1$ with $l_0 = 2$, $l = 11$ as per table 6.4.1.1.3-3 of TS 38.211 [5].					
NOTE 2: MCS index 4 and target coding rate = 308/1024 are adopted to calculate payload size for receiver sensitivity and in-channel selectivity.					
NOTE 3: Code block size including CRC (bits) equals to K' in sub-clause 5.2.2 of TS 38.212 [15].					

A.2 Fixed Reference Channels for dynamic range (16QAM, R=2/3)

The parameters for the reference measurement channels are specified in table A.2-1 for dynamic range.

Table A.2-1: FRC parameters for dynamic range

Reference channel	G-FR1-A2-1	G-FR1-A2-2	G-FR1-A2-3	G-FR1-A2-4	G-FR1-A2-5	G-FR1-A2-6
Subcarrier spacing (kHz)	15	30	60	15	30	60
Allocated resource blocks	25	11	11	106	51	24
CP-OFDM Symbols per slot (Note 1)	12	12	12	12	12	12
Modulation	16QAM	16QAM	16QAM	16QAM	16QAM	16QAM
Code rate (Note 2)	2/3	2/3	2/3	2/3	2/3	2/3
Payload size (bits)	9224	4032	4032	38936	18960	8968
Transport block CRC (bits)	24	24	24	24	24	24
Code block CRC size (bits)	24	-	-	24	24	24
Number of code blocks - C	2	1	1	5	3	2
Code block size including CRC (bits) (Note 3)	4648	4056	4056	7816	6352	4520
Total number of bits per slot	14400	6336	6336	61056	29376	13824
Total symbols per slot	3600	1584	1584	15264	7344	3456
NOTE 1: $UL-DMRS-config-type = 1$ with $UL-DMRS-max-len = 1$, $UL-DMRS-add-pos = 1$ with $l_0 = 2$, $l = 11$ as per table 6.4.1.1.3-3 of TS 38.211 [5].						
NOTE 2: MCS index 16 and target coding rate = 658/1024 are adopted to calculate payload size for dynamic range.						
NOTE 3: Code block size including CRC (bits) equals to K' in sub-clause 5.2.2 of TS 38.212 [15].						

A.3 Fixed Reference Channels for performance requirements (QPSK, R=193/1024)

The parameters for the reference measurement channels are specified in table A.3-1 to table A.3-6 for FR1 PUSCH performance requirements:

- FRC parameters are specified in table A.3-1 for FR1 PUSCH with transform precoding disabled, *UL-DMRS-add-pos* = 0 and 1 transmission layer.
- FRC parameters are specified in table A.3-2 for FR1 PUSCH with transform precoding disabled, *UL-DMRS-add-pos* = 1 and 1 transmission layer.
- FRC parameters are specified in table A.3-3 for FR1 PUSCH with transform precoding disabled, *UL-DMRS-add-pos* = 0 and 2 transmission layers.
- FRC parameters are specified in table A.3-4 for FR1 PUSCH with transform precoding disabled, *UL-DMRS-add-pos* = 1 and 2 transmission layers.
- FRC parameters are specified in table A.3-5 for FR1 PUSCH with transform precoding enabled, *UL-DMRS-add-pos* = 0 and 1 transmission layer.
- FRC parameters are specified in table A.3-6 for FR1 PUSCH with transform precoding enabled, *UL-DMRS-add-pos* = 1 and 1 transmission layer.

The parameters for the reference measurement channels are specified in table A.3-7 to table A.3-9 for FR2 PUSCH performance requirements:

- FRC parameters are specified in table A.3-7 for FR2 PUSCH with transform precoding disabled, *UL-DMRS-add-pos* = 0 and 1 transmission layer.
- FRC parameters are specified in table A.3-8 for FR2 PUSCH with transform precoding disabled, *UL-DMRS-add-pos* = 0 and 2 transmission layer.
- FRC parameters are specified in table A.3-9 for FR2 PUSCH with transform precoding enabled, *UL-DMRS-add-pos* = 0 and 1 transmission layer.

Table A.3-1: FRC parameters for FR1 PUSCH performance requirements, transform precoding disabled, *UL-DMRS-add-pos* = 0 and 1 transmission layer (QPSK, R=193/1024)

Reference channel	G-FR1-A3-1	G-FR1-A3-2	G-FR1-A3-3	G-FR1-A3-4	G-FR1-A3-5	G-FR1-A3-6	G-FR1-A3-7
Subcarrier spacing [kHz]	15	15	15	30	30	30	30
Allocated resource blocks	25	52	106	24	51	106	273
CP-OFDM Symbols per slot (Note 1)	13	13	13	13	13	13	13
Modulation	QPSK	QPSK	QPSK	QPSK	QPSK	QPSK	QPSK
Code rate (Note 2)	193/1024	193/1024	193/1024	193/1024	193/1024	193/1024	193/1024
Payload size (bits)	1480	3104	6280	1416	2976	6280	16136
Transport block CRC (bits)	16	16	24	16	16	24	24
Code block CRC size (bits)	-	-	24	-	-	24	24
Number of code blocks - C	1	1	2	1	1	2	5
Code block size including CRC (bits) (Note 2)	1496	3120	3176	1432	2992	3176	3256
Total number of bits per slot	7800	16224	33072	7488	15912	33072	85176
Total symbols per slot	3900	8112	16536	3744	7956	16536	42588
NOTE 1: <i>UL-DMRS-config-type</i> = 1 with <i>UL-DMRS-max-len</i> = 1 and the number of DM-RS CDM groups without data is 2, <i>UL-DMRS-add-pos</i> = 0 with $l_0 = 2$ as per table 6.4.1.1.3-3 of TS 38.211 [5].							
NOTE 2: Code block size including CRC (bits) equals to K' in subclause 5.2.2 of TS 38.212 [15].							

Table A.3-2: FRC parameters for FR1 PUSCH performance requirements, transform precoding disabled, $UL\text{-DMRS}\text{-add}\text{-pos} = 1$ and 1 transmission layer (QPSK, $R=193/1024$)

Reference channel	G-FR1-A3-8	G-FR1-A3-9	G-FR1-A3-10	G-FR1-A3-11	G-FR1-A3-12	G-FR1-A3-13	G-FR1-A3-14
Subcarrier spacing [kHz]	15	15	15	30	30	30	30
Allocated resource blocks	25	52	106	24	51	106	273
CP-OFDM Symbols per slot (Note 1)	12	12	12	12	12	12	12
Modulation	QPSK	QPSK	QPSK	QPSK	QPSK	QPSK	QPSK
Code rate (Note 2)	193/1024	193/1024	193/1024	193/1024	193/1024	193/1024	193/1024
Payload size (bits)	1352	2856	5768	1320	2792	5768	14856
Transport block CRC (bits)	16	16	24	16	16	24	24
Code block CRC size (bits)	-	-	24	-	-	24	24
Number of code blocks - C	1	1	2	1	1	2	4
Code block size including CRC (bits) (Note 2)	1368	2872	2920	1336	2808	2920	3744
Total number of bits per slot	7200	14976	30528	6912	14688	30528	78624
Total symbols per slot	3600	7488	15264	3456	7344	15264	39312
NOTE 1: $UL\text{-DMRS}\text{-config}\text{-type} = 1$ with $UL\text{-DMRS}\text{-max}\text{-len} = 1$ and the number of DM-RS CDM groups without data is 2, $UL\text{-DMRS}\text{-add}\text{-pos} = 1$ with $l_0 = 2$, $l = 11$ as per table 6.4.1.1.3-3 of TS 38.211 [5].							
NOTE 2: Code block size including CRC (bits) equals to K' in subclause 5.2.2 of TS 38.212 [15].							

Table A.3-3: FRC parameters for FR1 PUSCH performance requirements, transform precoding disabled, $UL\text{-DMRS}\text{-add}\text{-pos} = 0$ and 2 transmission layers (QPSK, $R=193/1024$)

Reference channel	G-FR1-A3-15	G-FR1-A3-16	G-FR1-A3-17	G-FR1-A3-18	G-FR1-A3-19	G-FR1-A3-20	G-FR1-A3-21
Subcarrier spacing [kHz]	15	15	15	30	30	30	30
Allocated resource blocks	25	52	106	24	51	106	273
CP-OFDM Symbols per slot (Note 1)	13	13	13	13	13	13	13
Modulation	QPSK	QPSK	QPSK	QPSK	QPSK	QPSK	QPSK
Code rate (Note 2)	193/1024	193/1024	193/1024	193/1024	193/1024	193/1024	193/1024
Payload size (bits)	2976	6152	12552	2856	6024	12552	32304
Transport block CRC (bits)	16	24	24	16	24	24	24
Code block CRC size (bits)	-	24	24	-	24	24	24
Number of code blocks - C	1	2	4	1	2	4	9
Code block size including CRC (bits) (Note 2)	2992	3112	3168	2872	3048	3168	3616
Total number of bits per slot	15600	32448	66144	14976	31824	66144	170352
Total symbols per slot	7800	16224	33072	7488	15912	33072	85176
NOTE 1: $UL\text{-DMRS}\text{-config}\text{-type} = 1$ with $UL\text{-DMRS}\text{-max}\text{-len} = 1$ and the number of DM-RS CDM groups without data is 2, $UL\text{-DMRS}\text{-add}\text{-pos} = 0$ with $l_0 = 2$ as per table 6.4.1.1.3-3 of TS 38.211 [5].							
NOTE 2: Code block size including CRC (bits) equals to K' in subclause 5.2.2 of TS 38.212 [15].							

Table A.3-4: FRC parameters for FR1 PUSCH performance requirements, transform precoding disabled, *UL-DMRS-add-pos* = 1 and 2 transmission layers (QPSK, R=193/1024)

Reference channel	G-FR1-A3-22	G-FR1-A3-23	G-FR1-A3-24	G-FR1-A3-25	G-FR1-A3-26	G-FR1-A3-27	G-FR1-A3-28
Subcarrier spacing [kHz]	15	15	15	30	30	30	30
Allocated resource blocks	25	52	106	24	51	106	273
CP-OFDM Symbols per slot (Note 1)	12	12	12	12	12	12	12
Modulation	QPSK	QPSK	QPSK	QPSK	QPSK	QPSK	QPSK
Code rate (Note 2)	193/1024	193/1024	193/1024	193/1024	193/1024	193/1024	193/1024
Payload size (bits)	2728	5640	11528	2600	5512	11528	29736
Transport block CRC (bits)	16	24	24	16	24	24	24
Code block CRC size (bits)	-	24	24	-	24	24	24
Number of code blocks - C	1	2	4	1	2	4	8
Code block size including CRC (bits) (Note 2)	2744	2856	2912	2616	2792	2912	3744
Total number of bits per slot	14400	29952	61056	13824	29376	61056	157248
Total symbols per slot	7200	14976	30528	6912	14688	30528	78624
NOTE 1: <i>UL-DMRS-config-type</i> = 1 with <i>UL-DMRS-max-len</i> = 1 and the number of DM-RS CDM groups without data is 2, <i>UL-DMRS-add-pos</i> = 1 with $l_0=2$, $l=11$ as per table 6.4.1.1.3-3 of TS 38.211 [5].							
NOTE 2: Code block size including CRC (bits) equals to K' in subclause 5.2.2 of TS 38.212 [15].							

Table A.3-5: FRC parameters for FR1 PUSCH performance requirements, transform precoding enabled, *UL-DMRS-add-pos* = 0 and 1 transmission layer (QPSK, R=193/1024)

Reference channel	G-FR1-A3-29	G-FR1-A3-30
Subcarrier spacing [kHz]	15	30
Allocated resource blocks	25	24
DFT-s-OFDM Symbols per slot (Note 1)	13	13
Modulation	QPSK	QPSK
Code rate (Note 2)	193/1024	193/1024
Payload size (bits)	1480	1416
Transport block CRC (bits)	16	16
Code block CRC size (bits)	-	-
Number of code blocks - C	1	1
Code block size including CRC (bits) (Note 2)	1496	1432
Total number of bits per slot	7800	7488
Total symbols per slot	3900	3744
NOTE 1: <i>UL-DMRS-config-type</i> = 1 with <i>UL-DMRS-max-len</i> = 1 and the number of DM-RS CDM groups without data is 2, <i>UL-DMRS-add-pos</i> = 0 with $l_0=2$ as per Table 6.4.1.1.3-3 of TS 38.211 [5].		
NOTE 2: Code block size including CRC (bits) equals to K' in sub-clause 5.2.2 of TS 38.212 [15].		

Table A.3-6: FRC parameters for FR1 PUSCH performance requirements, transform precoding enabled, $UL-DMRS-add-pos = 1$ and 1 transmission layer (QPSK, $R=193/1024$)

Reference channel	G-FR1-A3-31	G-FR1-A3-32
Subcarrier spacing [kHz]	15	30
Allocated resource blocks	25	24
DFT-s-OFDM Symbols per slot (Note 1)	12	12
Modulation	QPSK	QPSK
Code rate (Note 2)	193/1024	193/1024
Payload size (bits)	1352	1320
Transport block CRC (bits)	16	16
Code block CRC size (bits)	-	-
Number of code blocks - C	1	1
Code block size including CRC (bits) (Note 2)	1368	1336
Total number of bits per slot	7200	6912
Total symbols per slot	3600	3456

NOTE 1: $UL-DMRS-config-type = 1$ with $UL-DMRS-max-len = 1$ and the number of DM-RS CDM groups without data is 2, $UL-DMRS-add-pos = 1$ with $l_0 = 2$, $l = 11$ as per Table 6.4.1.1.3-3 of TS 38.211 [5].

NOTE 2: Code block size including CRC (bits) equals to K' in sub-clause 5.2.2 of TS 38.212 [15].

Table A.3-7: FRC parameters for FR2 PUSCH performance requirements, transform precoding disabled, $UL-DMRS-add-pos = 0$ and 1 transmission layer (QPSK, $R=193/1024$)

Reference channel	G-FR2-A3-1	G-FR2-A3-2	G-FR2-A3-3	G-FR2-A3-4	G-FR2-A3-5
Subcarrier spacing [kHz]	60	60	120	120	120
Allocated resource blocks	66	132	32	66	132
CP-OFDM Symbols per slot (Note 1)	9	9	9	9	9
Modulation	QPSK	QPSK	QPSK	QPSK	QPSK
Code rate (Note 2)	193/1024	193/1024	193/1024	193/1024	193/1024
Payload size (bits)	2664	5384	1320	2664	5384
Transport block CRC (bits)	16	24	16	16	24
Code block CRC size (bits)	-	24	-	-	24
Number of code blocks - C	1	2	1	1	2
Code block size including CRC (bits) (Note 2)	2680	2728	1336	2680	2728
Total number of bits per slot	14256	28512	6912	14256	28512
Total symbols per slot	7128	14256	3456	7128	14256

NOTE 1: $UL-DMRS-config-type = 1$ with $UL-DMRS-max-len = 1$ and the number of DM-RS CDM groups without data is 2, $UL-DMRS-add-pos = 0$ with $l_0 = 0$ as per Table 6.4.1.1.3-3 of TS 38.211 [5].

NOTE 2: Code block size including CRC (bits) equals to K' in sub-clause 5.2.2 of TS 38.212 [15].

Table A.3-8: FRC parameters for FR2 PUSCH performance requirements, transform precoding disabled, $UL-DMRS-add-pos = 0$ and 2 transmission layers (QPSK, $R=193/1024$)

Reference channel	G-FR2-A3-6	G-FR2-A3-7	G-FR2-A3-8	G-FR2-A3-9	G-FR2-A3-10
Subcarrier spacing [kHz]	60	60	120	120	120
Allocated resource blocks	66	132	32	66	132
CP-OFDM Symbols per slot (Note 1)	9	9	9	9	9
Modulation	QPSK	QPSK	QPSK	QPSK	QPSK
Code rate (Note 2)	193/1024	193/1024	193/1024	193/1024	193/1024
Payload size (bits)	5384	10752	2600	5384	10752
Transport block CRC (bits)	24	24	16	24	24
Code block CRC size (bits)	24	24	-	24	24
Number of code blocks - C	2	3	1	2	3
Code block size including CRC (bits) (Note 2)	2728	3616	2616	2728	3616
Total number of bits per slot	28512	57024	13824	28512	57024
Total symbols per slot	14256	28512	6912	14256	28512

NOTE 1: $UL-DMRS-config-type = 1$ with $UL-DMRS-max-len = 1$ and the number of DM-RS CDM groups without data is 2, $UL-DMRS-add-pos = 0$ with $l_0 = 0$ as per Table 6.4.1.1.3-3 of TS 38.211 [5].

NOTE 2: Code block size including CRC (bits) equals to K' in sub-clause 5.2.2 of TS 38.212 [15].

Table A.3-9: FRC parameters for FR2 PUSCH performance requirements, transform precoding enabled, $UL\text{-DMRS}\text{-add}\text{-pos} = 0$ and 1 transmission layer (QPSK, $R=193/1024$)

Reference channel	G-FR2-A3-11	G-FR2-A3-12
Subcarrier spacing [kHz]	60	120
Allocated resource blocks	30	30
DFT-s-OFDM Symbols per slot (Note 1)	9	9
Modulation	QPSK	QPSK
Code rate (Note 2)	193/1024	193/1024
Payload size (bits)	1224	1224
Transport block CRC (bits)	16	16
Code block CRC size (bits)	-	-
Number of code blocks - C	1	1
Code block size including CRC (bits) (Note 2)	1240	1240
Total number of bits per slot	6480	6480
Total symbols per slot	3240	3240
NOTE 1: $UL\text{-DMRS}\text{-config}\text{-type} = 1$ with $UL\text{-DMRS}\text{-max}\text{-len} = 1$ and the number of DM-RS CDM groups without data is 2, $UL\text{-DMRS}\text{-add}\text{-pos} = 0$ with $l_0 = 0$ as per Table 6.4.1.1.3-3 of TS 38.211 [5].		
NOTE 2: Code block size including CRC (bits) equals to K' in sub-clause 5.2.2 of TS 38.212 [15].		

A.4 Fixed Reference Channels for performance requirements (16QAM, $R=658/1024$)

The parameters for the reference measurement channels are specified in table A.4-1 to table A.4-4 for FR1 PUSCH performance requirements:

- FRC parameters are specified in table A.4-1 for FR1 PUSCH with transform precoding disabled, $UL\text{-DMRS}\text{-add}\text{-pos} = 0$ and 1 transmission layer.
- FRC parameters are specified in table A.4-2 for FR1 PUSCH with transform precoding disabled, $UL\text{-DMRS}\text{-add}\text{-pos} = 1$ and 1 transmission layer.
- FRC parameters are specified in table A.4-3 for FR1 PUSCH with transform precoding disabled, $UL\text{-DMRS}\text{-add}\text{-pos} = 0$ and 2 transmission layers.
- FRC parameters are specified in table A.4-4 for FR1 PUSCH with transform precoding disabled, $UL\text{-DMRS}\text{-add}\text{-pos} = 1$ and 2 transmission layers.

The parameters for the reference measurement channels are specified in table A.4-5 to table A.4-6 for FR2 PUSCH performance requirements:

- FRC parameters are specified in table A.4-5 for FR2 PUSCH with transform precoding disabled, $UL\text{-DMRS}\text{-add}\text{-pos} = 0$ and 1 transmission layer.
- FRC parameters are specified in table A.4-6 for FR2 PUSCH with transform precoding disabled, $UL\text{-DMRS}\text{-add}\text{-pos} = 0$ and 2 transmission layers.

Table A.4-1: FRC parameters for FR1 PUSCH performance requirements, transform precoding disabled, $UL\text{-DMRS-add-pos} = 0$ and 1 transmission layer (16QAM, $R=658/1024$)

Reference channel	G-FR1-A4-1	G-FR1-A4-2	G-FR1-A4-3	G-FR1-A4-4	G-FR1-A4-5	G-FR1-A4-6	G-FR1-A4-7
Subcarrier spacing [kHz]	15	15	15	30	30	30	30
Allocated resource blocks	25	52	106	24	51	106	273
CP-OFDM Symbols per slot (Note 1)	13	13	13	13	13	13	13
Modulation	16QAM	16QAM	16QAM	16QAM	16QAM	16QAM	16QAM
Code rate (Note 2)	658/1024	658/1024	658/1024	658/1024	658/1024	658/1024	658/1024
Payload size (bits)	9992	21000	42016	9480	20496	42016	108552
Transport block CRC (bits)	24	24	24	24	24	24	24
Code block CRC size (bits)	24	24	24	24	24	24	24
Number of code blocks - C	2	3	5	2	3	5	13
Code block size including CRC (bits) (Note 2)	5032	7032	8432	4776	6864	8432	8376
Total number of bits per slot	15600	32448	66144	14976	31824	66144	170352
Total symbols per slot	3900	8112	16536	3744	7956	16536	42588
NOTE 1: $UL\text{-DMRS-config-type} = 1$ with $UL\text{-DMRS-max-len} = 1$ and the number of DM-RS CDM groups without data is 2, $UL\text{-DMRS-add-pos} = 0$ with $l_0 = 2$ as per table 6.4.1.1.3-3 of TS 38.211 [5].							
NOTE 2: Code block size including CRC (bits) equals to K' in subclause 5.2.2 of TS 38.212 [15].							

Table A.4-2: FRC parameters for FR1 PUSCH performance requirements, transform precoding disabled, $UL\text{-DMRS-add-pos} = 1$ and 1 transmission layer (16QAM, $R=658/1024$)

Reference channel	G-FR1-A4-8	G-FR1-A4-9	G-FR1-A4-10	G-FR1-A4-11	G-FR1-A4-12	G-FR1-A4-13	G-FR1-A4-14
Subcarrier spacing [kHz]	15	15	15	30	30	30	30
Allocated resource blocks	25	52	106	24	51	106	273
CP-OFDM Symbols per slot (Note 1)	12	12	12	12	12	12	12
Modulation	16QAM	16QAM	16QAM	16QAM	16QAM	16QAM	16QAM
Code rate (Note 2)	658/1024	658/1024	658/1024	658/1024	658/1024	658/1024	658/1024
Payload size (bits)	9224	19464	38936	8968	18960	38936	100392
Transport block CRC (bits)	24	24	24	24	24	24	24
Code block CRC size (bits)	24	24	24	24	24	24	24
Number of code blocks - C	2	3	5	2	3	5	12
Code block size including CRC (bits) (Note 2)	4648	6052	7816	4520	6352	7816	8392
Total number of bits per slot	14400	29952	61056	13824	29376	61056	157248
Total symbols per slot	3600	7488	15264	3456	7344	15264	39312
NOTE 1: $UL\text{-DMRS-config-type} = 1$ with $UL\text{-DMRS-max-len} = 1$ and the number of DM-RS CDM groups without data is 2, $UL\text{-DMRS-add-pos} = 1$ with $l_0 = 2$, $l = 11$ as per table 6.4.1.1.3-3 of TS 38.211 [5].							
NOTE 2: Code block size including CRC (bits) equals to K' in subclause 5.2.2 of TS 38.212 [15].							

Table A.4-3: FRC parameters for FR1 PUSCH performance requirements, transform precoding disabled, $UL\text{-DMRS-add-pos} = 0$ and 2 transmission layers (16QAM, $R=658/1024$)

Reference channel	G-FR1-A4-15	G-FR1-A4-16	G-FR1-A4-17	G-FR1-A4-18	G-FR1-A4-19	G-FR1-A4-20	G-FR1-A4-21
Subcarrier spacing [kHz]	15	15	15	30	30	30	30
Allocated resource blocks	25	52	106	24	51	106	273
CP-OFDM Symbols per slot (Note 1)	13	13	13	13	13	13	13
Modulation	16QAM	16QAM	16QAM	16QAM	16QAM	16QAM	16QAM
Code rate (Note 2)	658/1024	658/1024	658/1024	658/1024	658/1024	658/1024	658/1024
Payload size (bits)	19968	42016	83976	19464	40976	83976	217128
Transport block CRC (bits)	24	24	24	24	24	24	24
Code block CRC size (bits)	24	24	24	24	24	24	24
Number of code blocks - C	3	5	10	3	5	10	26
Code block size including CRC (bits) (Note 2)	6688	8432	8424	6520	8224	8424	8376
Total number of bits per slot	31200	64896	132288	29952	63648	132288	340704
Total symbols per slot	7800	16224	33072	7488	15912	33072	85176
NOTE 1: $UL\text{-DMRS-config-type} = 1$ with $UL\text{-DMRS-max-len} = 1$ and the number of DM-RS CDM groups without data is 2, $UL\text{-DMRS-add-pos} = 0$ with $l_0 = 2$ as per table 6.4.1.1.3-3 of TS 38.211 [5].							
NOTE 2: Code block size including CRC (bits) equals to K' in subclause 5.2.2 of TS 38.212 [15].							

Table A.4-4: FRC parameters for FR1 PUSCH performance requirements, transform precoding disabled, $UL\text{-DMRS-add-pos} = 1$ and 2 transmission layers (16QAM, $R=658/1024$)

Reference channel	G-FR1-A4-22	G-FR1-A4-23	G-FR1-A4-24	G-FR1-A4-25	G-FR1-A4-26	G-FR1-A4-27	G-FR1-A4-28
Subcarrier spacing [kHz]	15	15	15	30	30	30	30
Allocated resource blocks	25	52	106	24	51	106	273
CP-OFDM Symbols per slot (Note 1)	12	12	12	12	12	12	12
Modulation	16QAM	16QAM	16QAM	16QAM	16QAM	16QAM	16QAM
Code rate (Note 2)	658/1024	658/1024	658/1024	658/1024	658/1024	658/1024	658/1024
Payload size (bits)	18432	38936	77896	17928	37896	77896	200808
Transport block CRC (bits)	24	24	24	24	24	24	24
Code block CRC size (bits)	24	24	24	24	24	24	24
Number of code blocks - C	3	5	10	3	5	10	24
Code block size including CRC (bits) (Note 2)	6176	7816	7816	6008	7608	7816	8392
Total number of bits per slot	28800	59904	122112	27648	58752	122112	314496
Total symbols per slot	7200	14976	30528	6912	14688	30528	78624
NOTE 1: $UL\text{-DMRS-config-type} = 1$ with $UL\text{-DMRS-max-len} = 1$ and the number of DM-RS CDM groups without data is 2, $UL\text{-DMRS-add-pos} = 1$ with $l_0 = 2$, $l = 11$ as per table 6.4.1.1.3-3 of TS 38.211 [5].							
NOTE 2: Code block size including CRC (bits) equals to K' in subclause 5.2.2 of TS 38.212 [15].							

Table A.4-5: FRC parameters for FR2 PUSCH performance requirements, transform precoding disabled, $UL\text{-DMRS}\text{-add}\text{-pos} = 0$ and 1 transmission layer (16QAM, $R=658/1024$)

Reference channel	G-FR2-A4-1	G-FR2-A4-2	G-FR2-A4-3	G-FR2-A4-4	G-FR2-A4-5
Subcarrier spacing [kHz]	60	60	120	120	120
Allocated resource blocks	66	132	32	66	132
CP-OFDM Symbols per slot (Note 1)	9	9	9	9	9
Modulation	16QAM	16QAM	16QAM	16QAM	16QAM
Code rate (Note 2)	658/1024	658/1024	658/1024	658/1024	658/1024
Payload size (bits)	18432	36896	8968	18432	36896
Transport block CRC (bits)	24	24	24	24	24
Code block CRC size (bits)	24	24	24	24	24
Number of code blocks - C	3	5	2	3	5
Code block size including CRC (bits) (Note 2)	6176	7408	4520	6176	7408
Total number of bits per slot	28512	57024	13824	28512	57024
Total symbols per slot	7128	14256	3456	7128	14256
NOTE 1: $UL\text{-DMRS}\text{-config}\text{-type} = 1$ with $UL\text{-DMRS}\text{-max}\text{-len} = 1$ and the number of DM-RS CDM groups without data is 2, $UL\text{-DMRS}\text{-add}\text{-pos} = 0$ with $l_0 = 0$ as per Table 6.4.1.1.3-3 of TS 38.211 [5].					
NOTE 2: Code block size including CRC (bits) equals to K' in sub-clause 5.2.2 of TS 38.212 [15].					

Table A.4-6: FRC parameters for FR2 PUSCH performance requirements, transform precoding disabled, $UL\text{-DMRS}\text{-add}\text{-pos} = 0$ and 2 transmission layers (16QAM, $R=658/1024$)

Reference channel	G-FR2-A4-6	G-FR2-A4-7	G-FR2-A4-8	G-FR2-A4-9	G-FR2-A4-10
Subcarrier spacing [kHz]	60	60	120	120	120
Allocated resource blocks	66	132	32	66	132
CP-OFDM Symbols per slot (Note 1)	9	9	9	9	9
Modulation	16QAM	16QAM	16QAM	16QAM	16QAM
Code rate (Note 2)	658/1024	658/1024	658/1024	658/1024	658/1024
Payload size (bits)	36896	73776	17928	36896	73776
Transport block CRC (bits)	24	24	24	24	24
Code block CRC size (bits)	24	24	24	24	24
Number of code blocks - C	5	9	3	5	9
Code block size including CRC (bits) (Note 2)	7408	8224	6008	7408	8224
Total number of bits per slot	57024	114048	27648	57024	114048
Total symbols per slot	14256	28512	6912	14256	28512
NOTE 1: $UL\text{-DMRS}\text{-config}\text{-type} = 1$ with $UL\text{-DMRS}\text{-max}\text{-len} = 1$ and the number of DM-RS CDM groups without data is 2, $UL\text{-DMRS}\text{-add}\text{-pos} = 0$ with $l_0 = 0$ as per Table 6.4.1.1.3-3 of TS 38.211 [5].					
NOTE 2: Code block size including CRC (bits) equals to K' in sub-clause 5.2.2 of TS 38.212 [15].					

A.5 Fixed Reference Channels for performance requirements (64QAM, $R=567/1024$)

The parameters for the reference measurement channels are specified in table A.5-1 to table A.5-2 for FR1 PUSCH performance requirements:

- FRC parameters are specified in table A.5-1 for FR1 PUSCH with transform precoding disabled, $UL\text{-DMRS}\text{-add}\text{-pos} = 0$ and 1 transmission layer.
- FRC parameters are specified in table A.5-2 for FR1 PUSCH with transform precoding disabled, $UL\text{-DMRS}\text{-add}\text{-pos} = 1$ and 1 transmission layer.

The parameters for the reference measurement channels are specified in table A.5-3 for FR2 PUSCH performance requirements:

- FRC parameters are specified in table A.5-3 for FR2 PUSCH with transform precoding disabled, $UL\text{-DMRS}\text{-add}\text{-pos} = 0$ and 1 transmission layer.

Table A.5-1: FRC parameters for FR1 PUSCH performance requirements, transform precoding disabled, $UL\text{-DMRS}\text{-add}\text{-pos} = 0$ and 1 transmission layer (64QAM, $R=567/1024$)

Reference channel	G-FR1-A5-1	G-FR1-A5-2	G-FR1-A5-3	G-FR1-A5-4	G-FR1-A5-5	G-FR1-A5-6	G-FR1-A5-7
Subcarrier spacing [kHz]	15	15	15	30	30	30	30
Allocated resource blocks	25	52	106	24	51	106	273
CP-OFDM Symbols per slot (Note 1)	13	13	13	13	13	13	13
Modulation	64QAM	64QAM	64QAM	64QAM	64QAM	64QAM	64QAM
Code rate (Note 2)	567/1024	567/1024	567/1024	567/1024	567/1024	567/1024	567/1024
Payload size (bits)	13064	27144	55304	12296	26632	55304	143400
Transport block CRC (bits)	24	24	24	24	24	24	24
Code block CRC size (bits)	24	24	24	24	24	24	24
Number of code blocks - C	2	4	7	2	4	7	18
Code block size including CRC (bits) (Note 2)	6568	6816	7928	6184	6688	7928	7992
Total number of bits per slot	23400	48672	99216	22464	47736	99216	255528
Total symbols per slot	3900	8112	16536	3744	7956	16536	42588
NOTE 1: $UL\text{-DMRS}\text{-config}\text{-type} = 1$ with $UL\text{-DMRS}\text{-max}\text{-len} = 1$ and the number of DM-RS CDM groups without data is 2, $UL\text{-DMRS}\text{-add}\text{-pos} = 0$ with $l_0 = 2$ as per table 6.4.1.1.3-3 of TS 38.211 [5].							
NOTE 2: Code block size including CRC (bits) equals to K' in subclause 5.2.2 of TS 38.212 [15].							

Table A.5-2: FRC parameters for FR1 PUSCH performance requirements, transform precoding disabled, $UL\text{-DMRS}\text{-add}\text{-pos} = 1$ and 1 transmission layer (64QAM, $R=567/1024$)

Reference channel	G-FR1-A5-8	G-FR1-A5-9	G-FR1-A5-10	G-FR1-A5-11	G-FR1-A5-12	G-FR1-A5-13	G-FR1-A5-14
Subcarrier spacing [kHz]	15	15	15	30	30	30	30
Allocated resource blocks	25	52	106	24	51	106	273
CP-OFDM Symbols per slot (Note 1)	12	12	12	12	12	12	12
Modulation	64QAM	64QAM	64QAM	64QAM	64QAM	64QAM	64QAM
Code rate (Note 2)	567/1024	567/1024	567/1024	567/1024	567/1024	567/1024	567/1024
Payload size (bits)	12040	25104	50184	11528	24576	50184	131176
Transport block CRC (bits)	24	24	24	24	24	24	24
Code block CRC size (bits)	24	24	24	24	24	24	24
Number of code blocks - C	2	3	6	2	3	6	16
Code block size including CRC (bits) (Note 2)	6056	8400	8392	5800	8224	8392	8224
Total number of bits per slot	21600	44928	91584	20736	44064	91584	235872
Total symbols per slot	3600	7488	15264	3456	7344	15264	39312
NOTE 1: $UL\text{-DMRS}\text{-config}\text{-type} = 1$ with $UL\text{-DMRS}\text{-max}\text{-len} = 1$ and the number of DM-RS CDM groups without data is 2, $UL\text{-DMRS}\text{-add}\text{-pos} = 1$ with $l_0 = 2$, $l = 11$ as per table 6.4.1.1.3-3 of TS 38.211 [5].							
NOTE 2: Code block size including CRC (bits) equals to K' in subclause 5.2.2 of TS 38.212 [15].							

Table A.5-3: FRC parameters for FR2 PUSCH performance requirements, transform precoding disabled, $UL\text{-DMRS}\text{-add}\text{-pos} = 0$ and 1 transmission layer (64QAM, $R=567/1024$)

Reference channel	G-FR2-A5-1	G-FR2-A5-2	G-FR2-A5-3	G-FR2-A5-4	G-FR2-A5-5
Subcarrier spacing [kHz]	60	60	120	120	120
Allocated resource blocks	66	132	32	66	132
CP-OFDM Symbols per slot (Note 1)	9	9	9	9	9
Modulation	64QAM	64QAM	64QAM	64QAM	64QAM
Code rate (Note 2)	567/1024	567/1024	567/1024	567/1024	567/1024
Payload size (bits)	23568	47112	11528	23568	47112
Transport block CRC (bits)	24	24	24	24	24
Code block CRC size (bits)	24	24	24	24	24
Number of code blocks - C	3	6	2	3	6
Code block size including CRC (bits) (Note 2)	7888	7880	5800	7888	7880
Total number of bits per slot	42768	85536	20736	42768	85536
Total symbols per slot	7128	14256	3456	7128	14256
NOTE 1: $UL\text{-DMRS}\text{-config}\text{-type} = 1$ with $UL\text{-DMRS}\text{-max}\text{-len} = 1$ and the number of DM-RS CDM groups without data is 2, $UL\text{-DMRS}\text{-add}\text{-pos} = 0$ with $l_0 = 0$ as per Table 6.4.1.1.3-3 of TS 38.211 [5].					
NOTE 2: Code block size including CRC (bits) equals to K' in sub-clause 5.2.2 of TS 38.212 [15].					

A.6 PRACH Test preambles

Table A.6-1: Test preambles for Normal Mode in FR1

Burst format	SCS (kHz)	Ncs	Logical sequence index	v
0	1.25	13	22	32
A1, A2, A3, B4, C0, C2	15	23	0	0
	30	46	0	0

Table A.6-2: Test preambles for Normal Mode in FR2

Burst format	SCS (kHz)	Ncs	Logical sequence index	v
A1, A2, A3, B4, C0, C2	60	69	0	0
	120	69	0	0

Annex B (normative): Error Vector Magnitude (FR1)

B.1 Reference point for measurement

The EVM shall be measured at the point after the FFT and a zero-forcing (ZF) equalizer in the receiver, as depicted in figure B.1-1 below.

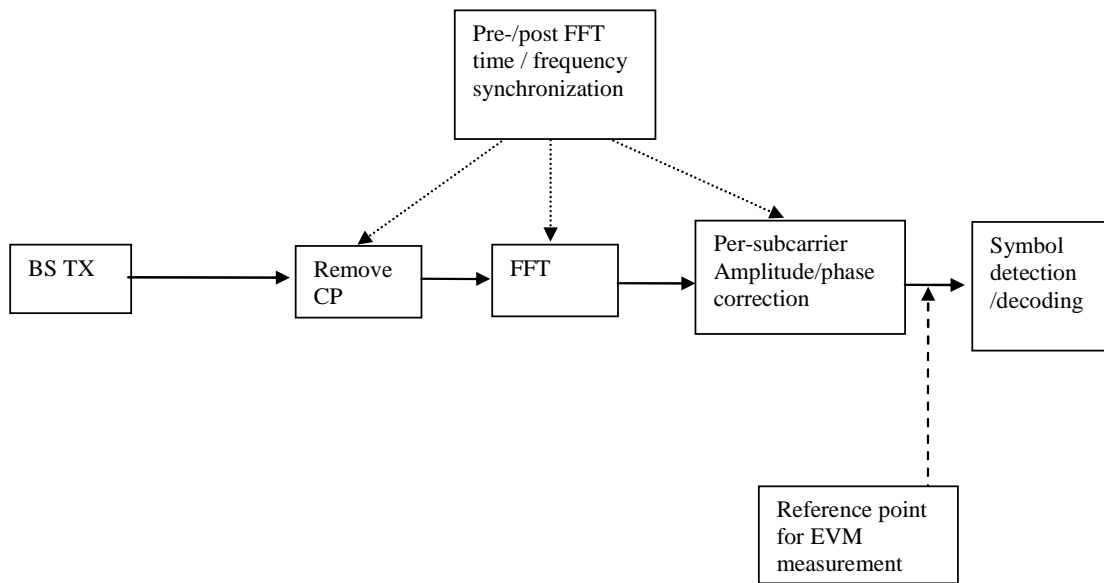

Figure B.1-1: Reference point for EVM measurement

B.2 Basic unit of measurement

The basic unit of EVM measurement is defined over one subframe (1ms) in the time domain and N_{BW}^{RB} subcarriers (180 kHz) in the frequency domain:

$$EVM = \sqrt{\frac{\sum_{t \in T} \sum_{f \in F(t)} |Z'(t, f) - I(t, f)|^2}{\sum_{t \in T} \sum_{f \in F(t)} |I(t, f)|^2}}$$

where

T is the set of symbols with the considered modulation scheme being active within the subframe,

$F(t)$ is the set of subcarriers within the N_{BW}^{RB} subcarriers with the considered modulation scheme being active in symbol t ,

$I(t, f)$ is the ideal signal reconstructed by the measurement equipment in accordance with relevant Tx models,

$Z'(t, f)$ is the modified signal under test defined in annex B.3.

NOTE: Although the basic unit of measurement is one subframe, the equalizer is calculated over 10 subframe measurement periods to reduce the impact of noise in the reference symbols. The boundaries of the 10 subframe measurement periods need not be aligned with radio frame boundaries.

B.3 Modified signal under test

Implicit in the definition of EVM is an assumption that the receiver is able to compensate a number of transmitter impairments. The signal under test is equalised and decoded according to:

$$Z'(t, f) = \frac{FFT \left\{ z(v - \Delta\tilde{t}) \cdot e^{-j2\pi\Delta\tilde{f}v} \right\} e^{j2\pi f\Delta\tilde{t}}}{\tilde{a}(f) \cdot e^{j\tilde{\varphi}(f)}}$$

where

$z(v)$ is the time domain samples of the signal under test.

$\Delta\tilde{t}$ is the sample timing difference between the FFT processing window in relation to nominal timing of the ideal signal. Note that two timing offsets are determined, the corresponding EVM is measured and the maximum used as described in annex B.7.

$\Delta\tilde{f}$ is the RF frequency offset.

$\tilde{\varphi}(f)$ is the phase response of the TX chain.

$\tilde{a}(f)$ is the amplitude response of the TX chain.

B.4 Estimation of frequency offset

The observation period for determining the frequency offset $\Delta\tilde{f}$ shall be 1 ms.

B.5 Estimation of time offset

B.5.1 General

The observation period for determining the sample timing difference $\Delta\tilde{t}$ shall be 1 ms.

In the following $\Delta\tilde{c}$ represents the middle sample of the EVM window of length W (defined in annex B.5.2) or the last sample of the first window half if W is even.

$\Delta\tilde{c}$ is estimated so that the EVM window of length W is centred on the measured cyclic prefix of the considered OFDM symbol. To minimize the estimation error the timing shall be based on the primary synchronization signal and reference signals. To limit time distortion of any transmit filter the reference signals in the 1 outer RBs are not taken into account in the timing estimation

Two values for $\Delta\tilde{t}$ are determined:

$$\Delta\tilde{t}_i = \Delta\tilde{c} + \alpha - \left\lfloor \frac{W}{2} \right\rfloor \text{ and}$$

$$\Delta\tilde{t}_h = \Delta\tilde{c} + \left\lfloor \frac{W}{2} \right\rfloor \text{ where } \alpha = 0 \text{ if } W \text{ is odd and } \alpha = 1 \text{ if } W \text{ is even.}$$

When the cyclic prefix length varies from symbol to symbol then T shall be further restricted to the subset of symbols with the considered modulation scheme being active and with the considered cyclic prefix length type.

B.5.2 Window length

Table B.5.2-1, B.5.2-2, B.5.2-3 specify the EVM window length (W) for normal CP.

Table B.5.2-1: EVM window length for normal CP, FR1, 15kHz SCS

Channel bandwidth (MHz)	FFT size	CP length for symbols 1-6 and 8-13 in FFT samples	EVM window length W	Ratio of W to total CP length for symbols 1-6 and 8-13 (Note) (%)
5	512	36	14	40
10	1024	72	28	40
15	1536	108	44	40
20	2048	144	58	40
25	2048	144	72	50
30	3072	216	108	50
40	4096	288	144	50
50	4096	288	144	50

NOTE: These percentages are informative and apply to a slot's symbols 1 to 6 and 8 to 13. Symbols 0 and 7 have a longer CP and therefore a lower percentage.

Table B.5.2-2: EVM window length for normal CP, FR1, 30kHz SCS

Channel bandwidth (MHz)	FFT size	CP length for symbols 1-13 in FFT samples	EVM window length W	Ratio of W to total CP length for symbols 1-13 (Note) (%)
5	256	18	8	40
10	512	36	14	40
15	768	54	22	40
20	1024	72	28	40
25	1024	72	36	50
30	1536	108	54	50
40	2048	144	72	50
50	2048	144	72	50
60	3072	216	130	60
70	3072	216	130	60
80	4096	288	172	60
90	4096	288	172	60
100	4096	288	172	60

NOTE: These percentages are informative and apply to a slot's symbols 1 through 13. Symbol 0 has a longer CP and therefore a lower percentage.

Table B.5.2-3: EVM window length for normal CP (60kHz SCS)

Channel bandwidth (MHz)	FFT size	CP length for symbols 1-13 in FFT samples	EVM window length W	Ratio of W to total CP length for symbols 1-13 (NOTE) (%)
10	256	18	8	40
15	384	27	11	40
20	512	36	14	40
25	512	36	18	50
30	768	54	26	50
40	1024	72	36	50
50	1024	72	36	50
60	1536	108	64	60
70	1536	108	64	60
80	2048	144	86	60
90	2048	144	86	60
100	2048	144	86	60

NOTE: These percentages are informative and apply to a slot's symbols 1 through 13. Symbol 0 may have a longer CP and therefore a lower percentage.

Table B.5.2-4 below specifies the EVM window length (W) for extended CP. The number of CP samples excluded from the EVM window is the same as for normal CP length.

Table B.5.2-4: EVM window length for extended CP, FR1, 60kHz SCS

Channel bandwidth (MHz)	FFT size	CP length in FFT samples	EVM window length W	Ratio of W to total CP length (Note) (%)
10	256	64	54	84
15	384	96	80	83
20	512	128	106	83
25	512	128	110	85.9
30	768	192	164	85.9
40	1024	256	220	85.9
50	1024	256	220	85.9
60	1536	384	340	88.6
70	1536	384	340	88.7
80	2048	512	454	88.7
90	2048	512	454	88.7
100	2048	512	454	88.7

NOTE: These percentages are informative.

B.6 Estimation of TX chain amplitude and frequency response parameters

The equalizer coefficients $\tilde{a}(f)$ and $\tilde{\varphi}(f)$ are determined as follows:

1. Calculate the complex ratios (amplitude and phase) of the post-FFT acquired signal $Z'(t, f)$ and the post-FFT Ideal signal $I_2(t, f)$, for each reference symbol, over [10 subframes]. This process creates a set of complex ratios:

$$a(t, f).e^{j\varphi(t, f)} = \frac{Z'(t, f)}{I_2(t, f)}$$

Where the post-FFT Ideal signal $I_2(t, f)$ is constructed by the measuring equipment according to the relevant TX specifications, using the following parameters: restricted content: i.e. nominal Reference Symbols and the Primary Synchronisation Channel, (all other modulation symbols are set to 0 V), nominal carrier frequency, nominal amplitude and phase for each applicable subcarrier, nominal timing.

2. Perform time averaging at each reference signal subcarrier of the complex ratios, the time-averaging length is [10 subframes]. Prior to the averaging of the phases $\varphi(t_i, f)$ an unwrap operation must be performed according to the following definition: The unwrap operation corrects the radian phase angles of $\varphi(t_i, f)$ by adding multiples of $2*\pi$ when absolute phase jumps between consecutive time instances t_i are greater than or equal to the jump tolerance of π radians. This process creates an average amplitude and phase for each reference signal subcarrier (i.e. every second subcarrier with the exception of the reference subcarrier spacing across the DC subcarrier).

$$a(f) = \frac{\sum_{i=1}^N a(t_i, f)}{N}$$

$$\varphi(f) = \frac{\sum_{i=1}^N \varphi(t_i, f)}{N}$$

Where N is the number of reference symbol time-domain locations t_i from $Z'(f,t)$ for each reference signal subcarrier f .

3. The equalizer coefficients for amplitude and phase $\hat{a}(f)$ and $\hat{\varphi}(f)$ at the reference signal subcarriers are obtained by computing the moving average in the frequency domain of the time-averaged reference signal subcarriers, i.e. every second subcarrier. The moving average window size is 19. For reference subcarriers at or near the edge of the channel the window size is reduced accordingly as per figure B.6-1.
4. Perform linear interpolation from the equalizer coefficients $\hat{a}(f)$ and $\hat{\varphi}(f)$ to compute coefficients $\tilde{a}(f)$, $\tilde{\varphi}(f)$ for each subcarrier.

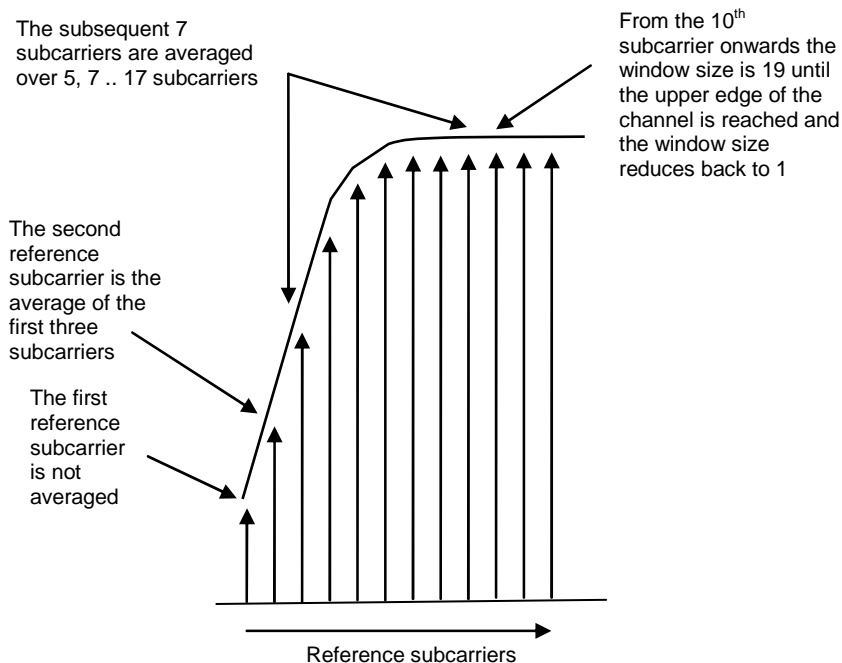

Figure B.6-1: Reference subcarrier smoothing in the frequency domain

B.7 Averaged EVM

EVM is averaged over all allocated downlink resource blocks with the considered modulation scheme in the frequency domain, and a minimum of 10 downlink subframes:

For FDD the averaging in the time domain equals the 10 subframe duration of the 10 subframes measurement period from the equalizer estimation step.

For TDD the averaging in the time domain can be calculated from subframes of different frames and shall have a minimum of 10 subframes averaging length. TDD special fields (i.e.GP) are not included in the averaging.

$$\overline{EVM}_{frame} = \sqrt{\frac{1}{\sum_{i=1}^{N_{dl}} N_i} \sum_{i=1}^{N_{dl}} \sum_{j=1}^{N_i} EVM_{i,j}^2}$$

Where N_i is the number of resource blocks with the considered modulation scheme in subframe i and N_{dl} is the number of allocated downlink subframes in one frame.

The EVM requirements shall be tested against the maximum of the RMS average at the window W extremities of the EVM measurements:

Thus $\overline{EVM}_{frame,1}$ is calculated using $\Delta\tilde{t} = \Delta\tilde{t}_l$ in the expressions above and $\overline{EVM}_{frame,h}$ is calculated using $\Delta\tilde{t} = \Delta\tilde{t}_h$ in the \overline{EVM}_{frame} calculation.

Thus we get:

$$\overline{EVM}_{frame} = \max(\overline{EVM}_{frame,1}, \overline{EVM}_{frame,h})$$

The averaged EVM with the minimum averaging length of at least 10 subframes is then achieved by further averaging of the \overline{EVM}_{frame} results

$$\overline{EVM} = \sqrt{\frac{1}{N_{frame}} \sum_{k=1}^{N_{frame}} \overline{EVM}_{frame,k}^2}, \quad N_{frame} = \left\lceil \frac{10}{N_{dl}} \right\rceil$$

Annex C (normative): Error Vector Magnitude (FR2)

C.1 Reference point for measurement

The EVM shall be measured at the point after the FFT and a zero-forcing (ZF) equalizer in the receiver, as depicted in figure C.1-1 below.

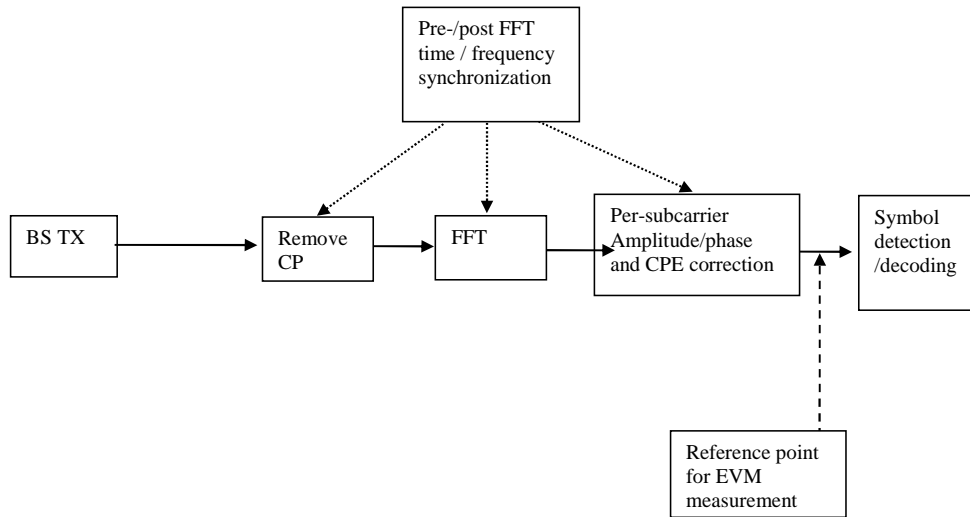

Figure C.1-1: Reference point for EVM measurement

C.2 Basic unit of measurement

The basic unit of EVM measurement is defined over one subframe (1ms) in the time domain and N_{BW}^{RB} subcarriers (180kHz) in the frequency domain:

$$EVM = \sqrt{\frac{\sum_{t \in T} \sum_{f \in F(t)} |Z'(t, f) - I(t, f)|^2}{\sum_{t \in T} \sum_{f \in F(t)} |I(t, f)|^2}}$$

where

T is the set of symbols with the considered modulation scheme being active within the subframe,

$F(t)$ is the set of subcarriers within the N_{BW}^{RB} subcarriers with the considered modulation scheme being active in symbol t ,

$I(t, f)$ is the ideal signal reconstructed by the measurement equipment in accordance with relevant Tx models,

$Z'(t, f)$ is the modified signal under test defined in C.3.

[Note: Although the basic unit of measurement is one subframe, the equalizer is calculated over 10 subframe measurement periods to reduce the impact of noise in the reference symbols. The boundaries of the 10 subframe measurement periods need not be aligned with radio frame boundaries.]

C.3 Modified signal under test

Implicit in the definition of EVM is an assumption that the receiver is able to compensate a number of transmitter impairments. The signal under test is equalised and decoded according to:

$$Z'(t, f) = \frac{FFT \left\{ z(v - \Delta\tilde{t}) \cdot e^{-j2\pi\Delta\tilde{f}v} \right\} e^{j2\pi f\Delta\tilde{t}}}{\tilde{a}(f) \cdot e^{j\tilde{\varphi}(f)}}$$

where

$z(v)$ is the time domain samples of the signal under test.

$\Delta\tilde{t}$ is the sample timing difference between the FFT processing window in relation to nominal timing of the ideal signal. Note that two timing offsets are determined, the corresponding EVM is measured and the maximum used as described in C.7.

$\Delta\tilde{f}$ is the RF frequency offset.

$\tilde{\varphi}(f)$ is the phase response of the TX chain.

$\tilde{a}(f)$ is the amplitude response of the TX chain.

C.4 Estimation of frequency offset

The observation period for determining the frequency offset $\Delta\tilde{f}$ shall be 1 ms.

C.5 Estimation of time offset

C.5.1 General

The observation period for determining the sample timing difference $\Delta\tilde{t}$ shall be 1 ms.

In the following $\Delta\tilde{c}$ represents the middle sample of the EVM window of length W (defined in C.5.2) or the last sample of the first window half if W is even.

$\Delta\tilde{c}$ is estimated so that the EVM window of length W is centred on the measured cyclic prefix of the considered OFDM symbol. To minimize the estimation error the timing shall be based on the primary synchronization signal and reference signals. To limit time distortion of any transmit filter the reference signals in the 1 outer RBs are not taken into account in the timing estimation

Two values for $\Delta\tilde{t}$ are determined:

$$\Delta\tilde{t}_l = \Delta\tilde{c} + \alpha - \left\lfloor \frac{W}{2} \right\rfloor \text{ and}$$

$$\Delta\tilde{t}_h = \Delta\tilde{c} + \left\lceil \frac{W}{2} \right\rceil \text{ where } \alpha = 0 \text{ if } W \text{ is odd and } \alpha = 1 \text{ if } W \text{ is even.}$$

When the cyclic prefix length varies from symbol to symbol (e.g. time multiplexed MBMS and unicast) then T shall be further restricted to the subset of symbols with the considered modulation scheme being active and with the considered cyclic prefix length type.

C.5.2 Window length

Table C.5.2-1 and Table C.5.2-2 specify the EVM window length (W) for normal CP for FR2 for normal CP.

Table C.5.2-1: EVM window length for normal CP, FR2, 60 kHz SCS

Channel bandwidth (MHz)	FFT size	CP length for symbols 1-13 in FFT samples	EVM window length W	Ratio of W to total CP length for symbols 1-13 (Note) (%)
50	1024	72	36	50
100	2048	144	72	50
200	4096	288	144	50

NOTE: These percentages are informative and apply to a slot's symbols 1 through 13. Symbol 0 may have a longer CP and therefore a lower percentage.

Table C.5.2-2: EVM window length for normal CP, FR2, 120 kHz SCS

Channel bandwidth (MHz)	FFT size	CP length for symbols 1-13 in FFT samples	EVM window length W	Ratio of W to total CP length for symbols 1-13 (note) (%)
50	512	36	18	50
100	1024	72	36	50
200	2048	144	72	50
400	4096	288	144	50

NOTE 1: These percentages are informative and apply to a slot's symbols 1 through 13. Symbol 0 may have a longer CP and therefore a lower percentage.

Table C.5.2-3 below specifies the EVM window length (W) for extended CP. The number of CP samples excluded from the EVM window is the same as for normal CP length.

Table C.5.2-3: EVM window length for extended CP, FR2, 60 kHz SCS

Channel bandwidth (MHz)	FFT size	CP length in FFT samples	EVM window length W	Ratio of W to total CP length (Note) (%)
50	1024	256	220	85.9
100	2048	512	440	85.9
200	4096	1024	880	85.9

NOTE: These percentages are informative.

C.6 Estimation of TX chain amplitude and frequency response parameters

The equalizer coefficients $\tilde{a}(f)$ and $\tilde{\varphi}(f)$ are determined as follows:

1. Calculate the complex ratios (amplitude and phase) of the post-FFT acquired signal $Z'(t, f)$ and the post-FFT Ideal signal $I_2(t, f)$, for each reference symbol, over [10 subframes]. This process creates a set of complex ratios:

$$a(t, f) \cdot e^{j\varphi(t, f)} = \frac{Z'(t, f)}{I_2(t, f)}$$

Where the post-FFT Ideal signal $I_2(t, f)$ is constructed by the measuring equipment according to the relevant TX specifications, using the following parameters: restricted content: i.e. nominal Demodulation Reference.

2. Perform time averaging at each reference signal subcarrier of the complex ratios, the time-averaging length is [10 subframes]. Prior to the averaging of the phases $\varphi(t_i, f)$ an unwrap operation must be performed according to the following definition: The unwrap operation corrects the radian phase angles of $\varphi(t_i, f)$ by adding multiples of 2π when absolute phase jumps between consecutive time instances t_i are greater than or equal to the jump tolerance of π radians. This process creates an average amplitude and phase for each reference signal subcarrier (i.e. every second subcarrier).

$$a(f) = \frac{\sum_{i=1}^N a(t_i, f)}{N}$$

$$\varphi(f) = \frac{\sum_{i=1}^N \varphi(t_i, f)}{N}$$

Where N is the number of reference symbol time-domain locations t_i from $Z'(f, t)$ for each reference signal subcarrier f .

3. The equalizer coefficients for amplitude and phase $\hat{a}(f)$ and $\hat{\varphi}(f)$ at the reference signal subcarriers are obtained by computing the moving average in the frequency domain of the time-averaged reference signal subcarriers, i.e. every second subcarrier. The moving average window size is 19. For reference subcarriers at or near the edge of the channel the window size is reduced accordingly as per figure C.6-1.
4. Perform linear interpolation from the equalizer coefficients $\hat{a}(f)$ and $\hat{\varphi}(f)$ to compute coefficients $\tilde{a}(f)$, $\tilde{\varphi}(f)$ for each subcarrier. To account for the common phase error (CPE) experienced in millimetre wave frequencies, $\bar{\varphi}(f)$, in the estimated coefficients contain phase rotation due to the CPE, θ , in addition to the phase of the equalizer coefficient $\tilde{\varphi}(f)$, that is

$$\bar{\varphi}(f) = \tilde{\varphi}(f) + \theta(t)$$

For OFDM symbols where PT-RS does not exist, $\theta(t)$ can be estimated by performing linear interpolation from neighboring symbols where PT-RS is present.

In order to separate component of the CPE, θ , contained in, $\bar{\varphi}(f)$, estimation and compensation of the CPE needs to follow. $\theta(t)$ is the common phase error (CPE), that rotates all the subcarriers of the OFDM symbol at time t .

Estimate of the CPE, $\theta(t)$, at OFDM symbol time, t , can then be obtained from using the PT-RS employing the expression

$$\tilde{\theta}(t) = \arg \left\{ \sum_{f \in f^{ptrs}} \left(\frac{Z'(t, f)}{I_{ptrs}(t, f)} \right) (\tilde{a}(f) e^{-j\tilde{\varphi}(f)}) \right\}$$

In the above equation, f^{ptrs} is the set of subcarriers where PT-RS are mapped, $t \in t^{ptrs}$ where t^{ptrs} is the set of OFDM symbols where PT-RS are mapped while $Z'(t, f)$ and $I_{ptrs}(t, f)$ are the post-FFT acquired signal and the ideal PT-RS signal respectively. That is, estimate of the CPE at a given OFDM symbol is obtained from frequency correlation of the complex ratios at the PT-RS positions with the conjugate of the estimated equalizer complex coefficients. The estimated CPE can be subtracted from $\bar{\varphi}(f)$ to remove influence of the CPE, and obtain estimate of the complex coefficient's phase

$$\tilde{\varphi}(f) = \bar{\varphi}(f) - \tilde{\theta}(t)$$

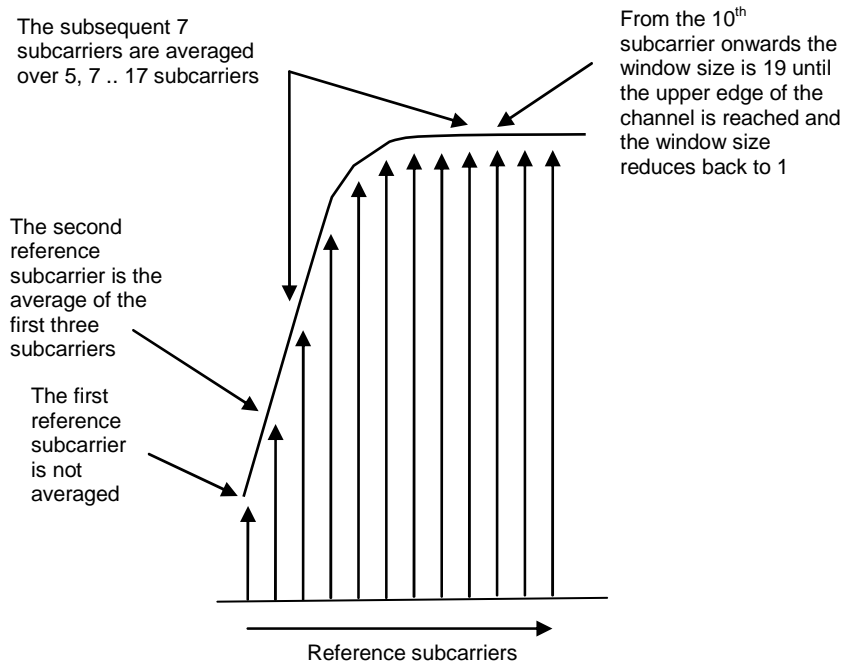

Figure C.6-1: Reference subcarrier smoothing in the frequency domain

C.7 Averaged EVM

EVM is averaged over all allocated downlink resource blocks with the considered modulation scheme in the frequency domain, and a minimum of [10] downlink subframes:

For FDD the averaging in the time domain equals the [10] subframe duration of the [10] subframes measurement period from the equalizer estimation step.

For TDD the averaging in the time domain can be calculated from subframes of different frames and shall have a minimum of [10] subframes averaging length. TDD special fields (i.e. GP) are not included in the averaging.

$$\overline{EVM}_{frame} = \sqrt{\frac{1}{\sum_{i=1}^{N_{dl}} N_i} \sum_{i=1}^{N_{dl}} \sum_{j=1}^{N_i} EVM_{i,j}^2}$$

Where N_i is the number of resource blocks with the considered modulation scheme in subframe i and N_{dl} is the number of allocated downlink subframes in one frame.

The EVM requirements shall be tested against the maximum of the RMS average at the window W extremities of the EVM measurements:

Thus $\overline{EVM}_{frame,1}$ is calculated using $\Delta\tilde{t} = \Delta\tilde{t}_l$ in the expressions above and $\overline{EVM}_{frame,h}$ is calculated using $\Delta\tilde{t} = \Delta\tilde{t}_h$ in the \overline{EVM}_{frame} calculation.

Thus, we get:

$$EVM_{frame} = \max(\overline{EVM}_{frame,1}, \overline{EVM}_{frame,h})$$

The averaged EVM with the minimum averaging length of at least [10] subframes is then achieved by further averaging of the EVM_{frame} results

$$\overline{EVM} = \sqrt{\frac{1}{N_{frame}} \sum_{k=1}^{N_{frame}} EVM_{frame,k}^2}, N_{frame} = \left\lceil \frac{10}{N_{dl}} \right\rceil$$

Annex D (normative): Characteristics of the interfering signals

The interfering signal shall be a PUSCH containing data and DMRS symbols. Normal cyclic prefix is used. The data content shall be uncorrelated to the wanted signal and modulated according to clause 6 of TS38.211 [9]. Mapping of PUSCH modulation to receiver requirement are specified in table D-1.

Table D-1: Modulation of the interfering signal

Receiver requirement	Modulation
In-channel selectivity	16QAM
Adjacent channel selectivity and narrow-band blocking	QPSK
General blocking	QPSK
Receiver intermodulation	QPSK

Annex E: Void

Annex F (normative): Relationship between EIRP based regulatory requirements and 3GPP requirements

F.1 General

This annex applies to FR1 *BS type 1-C*, *BS type 1-H* and *BS type 1-O*.

Some regional requirements are defined per effective isotropic radiated power (EIRP), which is a combination of the transmitted power (or in some cases spectral density) and the effective antenna gain which is a site-specific condition. Such requirements may be applied per antenna, per cell, or per base station. It shall be noted that the definition of BS or cell may differ between regulations.

The regulations are based on the assumption on 1-C conducted requirements and a passive antenna and must be interpreted for active antenna systems that have active beamforming. This annex describes how the power per connector and sum power over *TAB connectors* can be related to such requirements.

Where the regulator prescribes a method for EIRP calculation, that method supersedes the proposed assessment in this annex.

F.2 Relationship between EIRP based regulatory requirements and conducted requirements

When 3GPP specifications mandate manufacturer declarations of the (conducted) output power or power spectral density per connector for the base station under the reference conditions stated as a way to accommodate the referred regional requirements without putting requirements on the local site conditions.

For the case when the base station manufacturer maximum output power or unwanted emission declarations apply per antenna connector, the maximum EIRP can be estimated using the following formulas:

EIRP per antenna (applicable for 1-C): $P_{\text{EIRP}} = P_{\text{Tx}} + G_{\text{Ant}}$

EIRP per cell or per BS (applicable for 1-H): $P_{\text{EIRPcell}} = 10 * \log(\sum 10^{P_{\text{EIRPn}}/10})$

In case the EIRP requirement is set per polarisation, the summation shall be made per polarisation.

" P_{EIRP} " is the resulting effective isotropic radiated power (or radiated power spectral density) resulting from the power (or power spectral density) declared by the manufacturer in dBm (or dBm/measurement BW).

" P_{Tx} " is the conducted power or power spectral density declared by the manufacturer in dBm (or dBm/measurement BW)

" G_{Ant} " is the effective antenna gain, calculated as the antenna gain (dBi) minus the loss of the site infrastructure connecting the BS antenna connector with the antenna (dB) for the applied frequency. The antenna nominal gain is only applicable within a certain frequency range. For *BS type 1-H*, G_{Ant} shall be an assumption on the gain of a passive antenna system in order to provide a total power emissions level comparable to the level obtained when a 1-C is connected to a passive antenna. A typical example of a passive antenna gain, as used for 1-O, is 17dBi.

"n" is the index number of the co-located antennas illuminating the same cell. P_{EIRPn} is the P_{EIRP} of the n:th antenna.

"Cell" is in this annex used in the sense that it is the limited geographical area covered by the carrier transmitted from one site.

F.3 Relationship between EIRP based regulatory requirements and OTA requirements

The regulations set an EIRP limit considering a passive antenna BS. Although the gain of passive antennas may vary somewhat, the variation is in the order of a few dBs. The gain variation of a 1-O BS may be much larger. However, 1-O unwanted emissions requirements are defined as TRP, since TRP impacts co-existence properties.

In order to relate the EIRP values in the specifications to TRP, a fixed assumption has been made on the gain of a typical passive BS antenna.

Thus, the maximum TRP can be estimated using the following formulas:

$$\text{TRP limit per antenna: } P_{\text{TRP, antenna}} = P_{\text{EIRP}} - G_{\text{Ant}}$$

$$\text{TRP limit per cell or per BS: } P_{\text{TRP}} = P_{\text{TRP, antenna}} + 9\text{dB}$$

It is noted that the 1-O architecture assumes that a BS subject to OTA requirements will have at least 8 antennas.

In case the TRP requirement is set per polarisation, the summation shall be made per polarisation.

" P_{EIRP} " is the effective isotropic radiated power (or radiated power spectral density) set in the regulation (assuming a passive BS antenna) in dBm (or dBm/measurement BW).

" G_{Ant} " is the effective antenna gain, the antenna gain (dBi) is a fixed reference value of 17 dBi. Directivity value should be used in above equations, however with all antenna losses are assumed zero then we can use effective antenna gain.

Annex G (Normative): Propagation conditions

G.1 Static propagation condition

The propagation for the static performance measurement is an Additive White Gaussian Noise (AWGN) environment. No fading or multi-paths exist for this propagation model.

G.2 Multi-path fading propagation conditions

The multipath propagation conditions consist of several parts:

- A delay profile in the form of a "tapped delay-line", characterized by a number of taps at fixed positions on a sampling grid. The profile can be further characterized by the r.m.s. delay spread and the maximum delay spanned by the taps.
- A combination of channel model parameters that include the Delay profile and the Doppler spectrum that is characterized by a classical spectrum shape and a maximum Doppler frequency.
- Different models are used for FR1 (below 6 GHz) and FR2 (above 6 GHz).

G.2.1 Delay profiles

The delay profiles are simplified from the TR38.901 [16] TDL models. The simplification steps are shown below for information. These steps are only used when new delay profiles are created. Otherwise, the delay profiles specified in G.2.1.1 and G.2.1.2 can be used as such.

Step 1: Use the original TDL model from TR38.901[16].

Step 2: Re-order the taps in ascending delays

Step 3: Perform delay scaling according to the procedure described in subclause 7.7.3 in TR38.901[16].

Step 4: Apply the quantization to the delay resolution 5 ns. This is done simply by rounding the tap delays to the nearest multiple of the delay resolution.

Step 5: If multiple taps are rounded to the same delay bin, merge them by calculating their linear power sum.

Step 6: If there are more than 12 taps in the quantized model, merge the taps as follows

- Find the weakest tap from all taps (both merged and unmerged taps are considered)
 - If there are two or more taps having the same value and are the weakest, select the tap with the smallest delay as the weakest tap.
- When the weakest tap is the first delay tap, merge taps as follows
 - Update the power of the first delay tap as the linear power sum of the weakest tap and the second delay tap.
 - Remove the second delay tap.
- When the weakest tap is the last delay tap, merge taps as follows
 - Update the power of the last delay tap as the linear power sum of the second-to-last tap and the last tap.
 - Remove the second-to-last tap.

- Otherwise
 - For each side of the weakest tap, identify the neighbour tap that has the smaller delay difference to the weakest tap.
 - o When the delay difference between the weakest tap and the identified neighbour tap on one side equals the delay difference between the weakest tap and the identified neighbour tap on the other side.
 - Select the neighbour tap that is weaker in power for merging.
 - o Otherwise, select the neighbour tap that has smaller delay difference for merging.
 - To merge, the power of the merged tap is the linear sum of the power of the weakest tap and the selected tap.
 - When the selected tap is the first tap, the location of the merged tap is the location of the first tap. The weakest tap is removed.
 - When the selected tap is the last tap, the location of the merged tap is the location of the last tap. The weakest tap is removed.
 - Otherwise, the location of the merged tap is based on the average delay of the weakest tap and selected tap. If the average delay is on the sampling grid, the location of the merged tap is the average delay. Otherwise, the location of the merged tap is rounded towards the direction of the selected tap (e.g. 10 ns & 20 ns → 15 ns, 10 ns & 25 ns → 20 ns, if 25 ns had higher or equal power; 15 ns, if 10 ns had higher power) . The weakest tap and the selected tap are removed.
- Repeat step 6 until the final number of taps is 12.

Step 7: Round the amplitudes of taps to one decimal (e.g. -8.78 dB → -8.8 dB)

Step 8: If the delay spread has slightly changed due to the tap merge, adjust the final delay spread by increasing or decreasing the power of the last tap so that the delay spread is corrected.

Step 9: Re-normalize the highest tap to 0 dB.

Note: Some values of the delay profile created by the simplification steps may differ from the values in tables G.2.1.1-2, G.2.1.1-3, G.2.1.1-4, and G.2.1.2-2 for the corresponding model.

G.2.1.1 Delay profiles for FR1

The delay profiles for FR1 are selected to be representative of low, medium and high delay spread environment. The resulting model parameters are specified in G.2.1.1-1 and the tapped delay line models are specified in Tables G.2.1.1-2 ~ Table G.2.1.1-4.

Table G.2.1.1-1: Delay profiles for NR channel models

Model	Number of channel taps	Delay spread (r.m.s.)	Maximum excess tap delay (span)	Delay resolution
TDLA30	12	30 ns	290 ns	5 ns
TDLB100	12	100 ns	480 ns	5 ns
TDLC300	12	300 ns	2595 ns	5 ns

Table G.2.1.1-2: TDLA30 (DS = 30 ns)

Tap #	Delay [ns]	Power [dB]	Fading distribution
1	0	-15.5	Rayleigh
2	10	0	Rayleigh
3	15	-5.1	Rayleigh
4	20	-5.1	Rayleigh
5	25	-9.6	Rayleigh
6	50	-8.2	Rayleigh
7	65	-13.1	Rayleigh
8	75	-11.5	Rayleigh
9	105	-11.0	Rayleigh
10	135	-16.2	Rayleigh
11	150	-16.6	Rayleigh
12	290	-26.2	Rayleigh

Table G.2.1.1-3: TDLB100 (DS = 100ns)

Tap #	Delay [ns]	Power [dB]	Fading distribution
1	0	0	Rayleigh
2	10	-2.2	Rayleigh
3	20	-0.6	Rayleigh
4	30	-0.6	Rayleigh
5	35	-0.3	Rayleigh
6	45	-1.2	Rayleigh
7	55	-5.9	Rayleigh
8	120	-2.2	Rayleigh
9	170	-0.8	Rayleigh
10	245	-6.3	Rayleigh
11	330	-7.5	Rayleigh
12	480	-7.1	Rayleigh

Table G.2.1.1-4: TDLC300 (DS = 300 ns)

Tap #	Delay [ns]	Power [dB]	Fading distribution
1	0	-6.9	Rayleigh
2	65	0	Rayleigh
3	70	-7.7	Rayleigh
4	190	-2.5	Rayleigh
5	195	-2.4	Rayleigh
6	200	-9.9	Rayleigh
7	240	-8.0	Rayleigh
8	325	-6.6	Rayleigh
9	520	-7.1	Rayleigh
10	1045	-13.0	Rayleigh
11	1510	-14.2	Rayleigh
12	2595	-16.0	Rayleigh

G.2.1.2 Delay profiles for FR2

The delay profiles for FR2 are specified in G.2.1.2-1 and the tapped delay line models are specified in Tables G.2.1.2-2.

Table G.2.1.2-1: Delay profiles for NR channel models

Model	Number of channel taps	Delay spread (r.m.s.)	Maximum excess tap delay (span)	Delay resolution
TDLA30	12	30 ns	290 ns	5 ns

Table G.2.1.2-2: TDLA30 (DS = 30 ns)

Tap #	Delay [ns]	Power [dB]	Fading distribution
1	0	-15.5	Rayleigh
2	10	0	Rayleigh
3	15	-5.1	Rayleigh
4	20	-5.1	Rayleigh
5	25	-9.6	Rayleigh
6	50	-8.2	Rayleigh
7	65	-13.1	Rayleigh
8	75	-11.5	Rayleigh
9	105	-11.0	Rayleigh
10	135	-16.2	Rayleigh
11	150	-16.6	Rayleigh
12	290	-26.2	Rayleigh

G.2.2 Combinations of channel model parameters

The propagation conditions used for the performance measurements in multi-path fading environment are indicated as a combination of a channel model name and a maximum Doppler frequency, i.e., TDLA<DS>-<Doppler>, TDLB<DS>-<Doppler> or TDLC<DS>-<Doppler> where '<DS>' indicates the desired delay spread and '<Doppler>' indicates the maximum Doppler frequency (Hz).

Table G.2.2-1 and Table G.2.2-2 show the propagation conditions that are used for the performance measurements in multi-path fading environment for low, medium and high Doppler frequencies for FR1 and FR2, respectively.

Table G.2.2-1: Channel model parameters for FR1

Combination name	Model	Maximum Doppler frequency
TDLA30-5	TDLA30	5 Hz
TDLA30-10	TDLA30	10 Hz
TDLB100-400	TDLB100	400 Hz
TDLC300-100	TDLC300	100 Hz

Table G.2.2-2: Channel model parameters for FR2

Combination name	Model	Maximum Doppler frequency
TDLA30-75	TDLA30	75 Hz
TDLA30-300	TDLA30	300 Hz

G.2.3 MIMO Channel Correlation Matrices

The MIMO channel correlation matrices defined in G.2.3 apply for the antenna configuration using uniform linear arrays at both gNB and UE and for the antenna configuration using cross polarized antennas.

G.2.3.1 MIMO Correlation Matrices using Uniform Linear Array (ULA)

The MIMO channel correlation matrices defined in G.2.3.1 apply for the antenna configuration using uniform linear array (ULA) at both gNB and UE.

G.2.3.1.1 Definition of MIMO Correlation Matrices

Table G.2.3.1.1-1 defines the correlation matrix for the eNodeB:

Table G.2.3.1.1-1: gNodeB correlation matrix

	One antenna	Two antennas	Four antennas
gNode B Correlation	$R_{gNB} = 1$	$R_{gNB} = \begin{pmatrix} 1 & \alpha \\ \alpha^* & 1 \end{pmatrix}$	$R_{gNB} = \begin{pmatrix} 1 & \alpha^{1/9} & \alpha^{4/9} & \alpha \\ \alpha^{1/9*} & 1 & \alpha^{1/9} & \alpha^{4/9} \\ \alpha^{4/9*} & \alpha^{1/9*} & 1 & \alpha^{1/9} \\ \alpha^* & \alpha^{4/9*} & \alpha^{1/9*} & 1 \end{pmatrix}$

Table G.2.3.1.1-2 defines the correlation matrix for the UE:

Table G.2.3.1.1-2: UE correlation matrix

	One antenna	Two antennas	Four antennas
UE Correlation	$R_{UE} = 1$	$R_{UE} = \begin{pmatrix} 1 & \beta \\ \beta^* & 1 \end{pmatrix}$	$R_{UE} = \begin{pmatrix} 1 & \beta^{1/9} & \beta^{4/9} & \beta \\ \beta^{1/9*} & 1 & \beta^{1/9} & \beta^{4/9} \\ \beta^{4/9*} & \beta^{1/9*} & 1 & \beta^{1/9} \\ \beta^* & \beta^{4/9*} & \beta^{1/9*} & 1 \end{pmatrix}$

Table G.2.3.1.1-3 defines the channel spatial correlation matrix R_{spat} . The parameters α and β in Table G.2.3.1.1-3 defines the spatial correlation between the antennas at the gNodeB and UE respectively.

Table G.2.3.1.1-3: R_{spat} correlation matrices

1x2 case	$R_{spat} = R_{gNB} = \begin{pmatrix} 1 & \alpha \\ \alpha^* & 1 \end{pmatrix}$	
2x2 case	$R_{spat} = R_{UE} \otimes R_{gNB} = \begin{bmatrix} 1 & \beta \\ \beta^* & 1 \end{bmatrix} \otimes \begin{bmatrix} 1 & \alpha \\ \alpha^* & 1 \end{bmatrix} = \begin{bmatrix} 1 & \alpha & \beta & \beta\alpha \\ \alpha^* & 1 & \beta\alpha^* & \beta \\ \beta^* & \beta^*\alpha & 1 & \alpha \\ \beta^*\alpha^* & \beta^* & \alpha^* & 1 \end{bmatrix}$	
2x4 case	$R_{spat} = R_{UE} \otimes R_{gNB} = \begin{bmatrix} 1 & \beta \\ \beta^* & 1 \end{bmatrix} \otimes \begin{bmatrix} 1 & \alpha^{1/9} & \alpha^{4/9} & \alpha \\ \alpha^{1/9*} & 1 & \alpha^{1/9} & \alpha^{4/9} \\ \alpha^{4/9*} & \alpha^{1/9*} & 1 & \alpha^{1/9} \\ \alpha^* & \alpha^{4/9*} & \alpha^{1/9*} & 1 \end{bmatrix}$	
4x4 case	$R_{spat} = R_{UE} \otimes R_{gNB} = \begin{pmatrix} 1 & \beta^{1/9} & \beta^{4/9} & \beta \\ \beta^{1/9*} & 1 & \beta^{1/9} & \beta^{4/9} \\ \beta^{4/9*} & \beta^{1/9*} & 1 & \beta^{1/9} \\ \beta^* & \beta^{4/9*} & \beta^{1/9*} & 1 \end{pmatrix} \otimes \begin{bmatrix} 1 & \alpha^{1/9} & \alpha^{4/9} & \alpha \\ \alpha^{1/9*} & 1 & \alpha^{1/9} & \alpha^{4/9} \\ \alpha^{4/9*} & \alpha^{1/9*} & 1 & \alpha^{1/9} \\ \alpha^* & \alpha^{4/9*} & \alpha^{1/9*} & 1 \end{bmatrix}$	

For cases with more antennas at either gNodeB or UE or both, the channel spatial correlation matrix can still be expressed as the Kronecker product of R_{UE} and R_{gNB} according to $R_{spat} = R_{UE} \otimes R_{gNB}$.

G.2.3.1.2 MIMO Correlation Matrices at High, Medium and Low Level

The α and β for different correlation types are given in Table G.2.3.1.2-1.

Table G.2.3.1.2-1: Correlation for High Medium and Low Level

Low correlation		Medium Correlation		High Correlation	
α	β	α	β	α	β
0	0	0.9	0.3	0.9	0.9

The correlation matrices for high, medium and low correlation are defined in Table G.2.3.1.2-2, G.2.3.1.2-3 and G.2.3.1.2-4 as below.

The values in Table G.2.3.1.2-2 have been adjusted for the 2x4 and 4x4 high correlation cases to insure the correlation matrix is positive semi-definite after round-off to 4 digit precision. This is done using the equation:

$$\mathbf{R}_{high} = [\mathbf{R}_{spatial} + a\mathbf{I}_n] / (1 + a)$$

Where the value “a” is a scaling factor such that the smallest value is used to obtain a positive semi-definite result. For the 2x4 high correlation case, a=0.00010. For the 4x4 high correlation case, a=0.00012.

The same method is used to adjust the 4x4 medium correlation matrix in Table G.2.3.1.2-3 to insure the correlation matrix is positive semi-definite after round-off to 4 digit precision with a =0.00012.

Table G.2.3.1.2-2: MIMO correlation matrices for high correlation

1x2 case	$R_{high} = \begin{pmatrix} 1 & 0.9 \\ 0.9 & 1 \end{pmatrix}$
2x2 case	$R_{high} = \begin{pmatrix} 1 & 0.9 & 0.9 & 0.81 \\ 0.9 & 1 & 0.81 & 0.9 \\ 0.9 & 0.81 & 1 & 0.9 \\ 0.81 & 0.9 & 0.9 & 1 \end{pmatrix}$
2x4 case	$R_{high} = \begin{bmatrix} 1.0000 & 0.9883 & 0.9542 & 0.8999 & 0.8999 & 0.8894 & 0.8587 & 0.8099 \\ 0.9883 & 1.0000 & 0.9883 & 0.9542 & 0.8894 & 0.8999 & 0.8894 & 0.8587 \\ 0.9542 & 0.9883 & 1.0000 & 0.9883 & 0.8587 & 0.8894 & 0.8999 & 0.8894 \\ 0.8999 & 0.9542 & 0.9883 & 1.0000 & 0.8099 & 0.8587 & 0.8894 & 0.8999 \\ 0.8999 & 0.8894 & 0.8587 & 0.8099 & 1.0000 & 0.9883 & 0.9542 & 0.8999 \\ 0.8894 & 0.8999 & 0.8894 & 0.8587 & 0.9883 & 1.0000 & 0.9883 & 0.9542 \\ 0.8587 & 0.8894 & 0.8999 & 0.8894 & 0.8999 & 0.9542 & 0.9883 & 1.0000 \\ 0.8099 & 0.8587 & 0.8894 & 0.8999 & 0.8999 & 0.9542 & 0.9883 & 1.0000 \end{bmatrix}$
4x4 case	$R_{high} = \begin{bmatrix} 1.0000 & 0.9882 & 0.9541 & 0.8999 & 0.9882 & 0.9767 & 0.9430 & 0.8894 & 0.9541 & 0.9430 & 0.9105 & 0.8587 & 0.8999 & 0.8894 & 0.8587 & 0.8099 \\ 0.9882 & 1.0000 & 0.9882 & 0.9541 & 0.9767 & 0.9882 & 0.9767 & 0.9430 & 0.9430 & 0.9541 & 0.9430 & 0.9105 & 0.8894 & 0.8999 & 0.8894 & 0.8587 \\ 0.9541 & 0.9882 & 1.0000 & 0.9882 & 0.9430 & 0.9767 & 0.9882 & 0.9767 & 0.9105 & 0.9430 & 0.9541 & 0.9430 & 0.8587 & 0.8894 & 0.8999 & 0.8894 \\ 0.8999 & 0.9541 & 0.9882 & 1.0000 & 0.8894 & 0.9430 & 0.9767 & 0.9882 & 0.8587 & 0.9105 & 0.9430 & 0.9541 & 0.8099 & 0.8587 & 0.8894 & 0.8999 \\ 0.9882 & 0.9767 & 0.9430 & 0.8894 & 1.0000 & 0.9882 & 0.9541 & 0.8999 & 0.9882 & 0.9767 & 0.9430 & 0.8894 & 0.9541 & 0.9430 & 0.9105 & 0.8587 \\ 0.9767 & 0.9882 & 0.9767 & 0.9430 & 0.9882 & 1.0000 & 0.9882 & 0.9541 & 0.9767 & 0.9882 & 0.9767 & 0.9430 & 0.9430 & 0.9541 & 0.9430 & 0.9105 \\ 0.9430 & 0.9767 & 0.9882 & 0.9767 & 0.9541 & 0.9882 & 1.0000 & 0.9882 & 0.9430 & 0.9767 & 0.9882 & 0.9767 & 0.9105 & 0.9430 & 0.9541 & 0.9430 \\ 0.8894 & 0.9430 & 0.9767 & 0.9882 & 0.8999 & 0.9541 & 0.9882 & 1.0000 & 0.8894 & 0.9430 & 0.9767 & 0.9882 & 0.8587 & 0.9105 & 0.9430 & 0.9541 \\ 0.9541 & 0.9430 & 0.9105 & 0.8587 & 0.9882 & 0.9767 & 0.9430 & 0.8894 & 1.0000 & 0.9882 & 0.9541 & 0.8999 & 0.9882 & 0.9767 & 0.9430 & 0.8894 \\ 0.9430 & 0.9541 & 0.9430 & 0.9105 & 0.9767 & 0.9882 & 0.9767 & 0.9430 & 0.9882 & 1.0000 & 0.9882 & 0.9541 & 0.9767 & 0.9882 & 0.9767 & 0.9430 \\ 0.9105 & 0.9430 & 0.9541 & 0.9430 & 0.9430 & 0.9767 & 0.9882 & 0.9767 & 0.9541 & 0.9882 & 1.0000 & 0.9882 & 0.9430 & 0.9767 & 0.9882 & 0.9767 \\ 0.8587 & 0.9105 & 0.9430 & 0.9541 & 0.8894 & 0.9430 & 0.9767 & 0.9882 & 0.8999 & 0.9541 & 0.9882 & 1.0000 & 0.8894 & 0.9430 & 0.9767 & 0.9882 \\ 0.8999 & 0.8894 & 0.8587 & 0.8099 & 0.9541 & 0.9430 & 0.9105 & 0.8587 & 0.9882 & 0.9767 & 0.9430 & 0.8894 & 1.0000 & 0.9882 & 0.9541 & 0.8999 \\ 0.8894 & 0.8999 & 0.8894 & 0.8587 & 0.9430 & 0.9541 & 0.9430 & 0.9105 & 0.9767 & 0.9882 & 0.9767 & 0.9430 & 0.9882 & 1.0000 & 0.9882 & 0.9541 \\ 0.8587 & 0.8894 & 0.8999 & 0.8894 & 0.9105 & 0.9430 & 0.9541 & 0.9430 & 0.9430 & 0.9767 & 0.9882 & 0.9767 & 0.9541 & 0.9882 & 1.0000 & 0.9882 \\ 0.8099 & 0.8587 & 0.8894 & 0.8999 & 0.8587 & 0.9105 & 0.9430 & 0.9541 & 0.8894 & 0.9430 & 0.9767 & 0.9882 & 0.8999 & 0.9541 & 0.9882 & 1.0000 \end{bmatrix}$

Table G.2.3.1.2-3: MIMO correlation matrices for medium correlation

1x2 case	[N/A]
2x2 case	$R_{medium} = \begin{pmatrix} 1.0000 & 0.9000 & 0.3000 & 0.2700 \\ 0.9000 & 1.0000 & 0.2700 & 0.3000 \\ 0.3000 & 0.2700 & 1.0000 & 0.9000 \\ 0.2700 & 0.3000 & 0.9000 & 1.0000 \end{pmatrix}$
2x4 case	$R_{medium} = \begin{pmatrix} 1.0000 & 0.9884 & 0.9543 & 0.9000 & 0.3000 & 0.2965 & 0.2863 & 0.2700 \\ 0.9884 & 1.0000 & 0.9884 & 0.9543 & 0.2965 & 0.3000 & 0.2965 & 0.2863 \\ 0.9543 & 0.9884 & 1.0000 & 0.9884 & 0.2863 & 0.2965 & 0.3000 & 0.2965 \\ 0.9000 & 0.9543 & 0.9884 & 1.0000 & 0.2700 & 0.2863 & 0.2965 & 0.3000 \\ 0.3000 & 0.2965 & 0.2863 & 0.2700 & 1.0000 & 0.9884 & 0.9543 & 0.9000 \\ 0.2965 & 0.3000 & 0.2965 & 0.2863 & 0.9884 & 1.0000 & 0.9884 & 0.9543 \\ 0.2863 & 0.2965 & 0.3000 & 0.2965 & 0.9543 & 0.9884 & 1.0000 & 0.9884 \\ 0.2700 & 0.2863 & 0.2965 & 0.3000 & 0.9000 & 0.9543 & 0.9884 & 1.0000 \end{pmatrix}$
4x4 case	$R_{medium} = \begin{pmatrix} 1.0000 & 0.9882 & 0.9541 & 0.8999 & 0.8747 & 0.8645 & 0.8347 & 0.7872 & 0.5855 & 0.5787 & 0.5588 & 0.5270 & 0.3000 & 0.2965 & 0.2862 & 0.2700 \\ 0.9882 & 1.0000 & 0.9882 & 0.9541 & 0.8645 & 0.8747 & 0.8645 & 0.8347 & 0.5787 & 0.5855 & 0.5787 & 0.5588 & 0.2965 & 0.3000 & 0.2965 & 0.2862 \\ 0.9541 & 0.9882 & 1.0000 & 0.9882 & 0.8347 & 0.8645 & 0.8747 & 0.8645 & 0.5588 & 0.5787 & 0.5855 & 0.5787 & 0.2862 & 0.2965 & 0.3000 & 0.2965 \\ 0.8999 & 0.9541 & 0.9882 & 1.0000 & 0.7872 & 0.8347 & 0.8645 & 0.8747 & 0.5270 & 0.5588 & 0.5787 & 0.5855 & 0.2700 & 0.2862 & 0.2965 & 0.3000 \\ 0.8747 & 0.8645 & 0.8347 & 0.7872 & 1.0000 & 0.9882 & 0.9541 & 0.8999 & 0.8747 & 0.8645 & 0.8347 & 0.7872 & 0.5855 & 0.5787 & 0.5588 & 0.5270 \\ 0.8645 & 0.8747 & 0.8645 & 0.8347 & 0.9882 & 1.0000 & 0.9882 & 0.9541 & 0.8645 & 0.8747 & 0.8645 & 0.8347 & 0.5787 & 0.5855 & 0.5787 & 0.5588 \\ 0.8347 & 0.8645 & 0.8747 & 0.8645 & 0.9541 & 0.9882 & 1.0000 & 0.9882 & 0.8347 & 0.8645 & 0.8747 & 0.8645 & 0.5588 & 0.5787 & 0.5855 & 0.5787 \\ 0.7872 & 0.8347 & 0.8645 & 0.8747 & 0.8999 & 0.9541 & 0.9882 & 1.0000 & 0.7872 & 0.8347 & 0.8645 & 0.8747 & 0.5270 & 0.5588 & 0.5787 & 0.5855 \\ 0.5855 & 0.5787 & 0.5588 & 0.5270 & 0.8747 & 0.8645 & 0.8347 & 0.7872 & 1.0000 & 0.9882 & 0.9541 & 0.8999 & 0.8747 & 0.8645 & 0.8347 & 0.7872 \\ 0.5787 & 0.5855 & 0.5787 & 0.5588 & 0.8645 & 0.8747 & 0.8645 & 0.8347 & 0.9882 & 1.0000 & 0.9882 & 0.9541 & 0.8645 & 0.8747 & 0.8645 & 0.8347 \\ 0.5588 & 0.5787 & 0.5855 & 0.5787 & 0.8347 & 0.8645 & 0.8747 & 0.8645 & 0.9541 & 0.9882 & 1.0000 & 0.9882 & 0.8347 & 0.8645 & 0.8747 & 0.8645 \\ 0.5270 & 0.5588 & 0.5787 & 0.5855 & 0.7872 & 0.8347 & 0.8645 & 0.8747 & 0.8999 & 0.9541 & 0.9882 & 1.0000 & 0.7872 & 0.8347 & 0.8645 & 0.8747 \\ 0.3000 & 0.2965 & 0.2862 & 0.2700 & 0.5855 & 0.5787 & 0.5588 & 0.5270 & 0.8747 & 0.8645 & 0.8347 & 0.7872 & 1.0000 & 0.9882 & 0.9541 & 0.8999 \\ 0.2965 & 0.3000 & 0.2965 & 0.2862 & 0.5787 & 0.5855 & 0.5787 & 0.5588 & 0.8645 & 0.8747 & 0.8645 & 0.8347 & 0.9882 & 1.0000 & 0.9882 & 0.9541 \\ 0.2862 & 0.2965 & 0.3000 & 0.2965 & 0.5588 & 0.5787 & 0.5855 & 0.5787 & 0.8347 & 0.8645 & 0.8747 & 0.8645 & 0.9541 & 0.9882 & 1.0000 & 0.9882 \\ 0.2700 & 0.2862 & 0.2965 & 0.3000 & 0.5270 & 0.5588 & 0.5787 & 0.5855 & 0.7872 & 0.8347 & 0.8645 & 0.8747 & 0.8999 & 0.9541 & 0.9882 & 1.0000 \end{pmatrix}$

Table G.2.3.1.2-4: MIMO correlation matrices for low correlation

1x2 case	$R_{low} = \mathbf{I}_2$
1x4 case	$R_{low} = \mathbf{I}_4$
2x2 case	$R_{low} = \mathbf{I}_4$
2x4 case	$R_{low} = \mathbf{I}_8$
4x4 case	$R_{low} = \mathbf{I}_{16}$

In Table G.2.3.1.1-4, \mathbf{I}_d is a $d \times d$ identity matrix.

NOTE: For completeness, the 1x2 cases were defined for high, medium and low correlation but performance requirements exist only for low correlation.

G.2.3.2 Multi-Antenna channel models using cross polarized antennas

The MIMO channel correlation matrices defined in G.2.3.2 apply to two cases as presented below:

- One TX antenna and multiple RX antennas case, with cross polarized antennas used at gNodeB
- Multiple TX antennas and multiple RX antennas case, with cross polarized antennas used at both UE and gNodeB

The cross-polarized antenna elements with +/-45 degrees polarization slant angles are deployed at gNB. For one TX antenna case, antenna element with +90 degree polarization slant angle is deployed at UE. For multiple TX antennas case, cross-polarized antenna elements with +90/0 degrees polarization slant angles are deployed at UE.

For the cross-polarized antennas, the N antennas are labelled such that antennas for one polarization are listed from 1 to N/2 and antennas for the other polarization are listed from N/2+1 to N, where N is the number of TX or RX antennas.

G.2.3.2.1 Definition of MIMO Correlation Matrices using cross polarized antennas

For the channel spatial correlation matrix, the following is used:

$$R_{Spat} = P_{UL} (R_{UE} \otimes \Gamma_{UL} \otimes R_{gNB}) P_{UL}^T$$

Where

- R_{UE} is the spatial correlation matrix at the UE with same polarization,
- R_{gNB} is the spatial correlation matrix at the gNB with same polarization,
- Γ_{UL} is a polarization correlation matrix,
- P_{UL} is a permutation matrix, and
- $(\bullet)^T$ denotes transpose.

Table G.2.3.2.1-1 defines the polarization correlation matrix.

Table G.2.3.2.1-1: Polarization correlation matrix

	One TX antenna	Multiple TX antennas
Polarization correlation matrix	$\Gamma_{UL} = \begin{bmatrix} 1 & -\gamma \\ -\gamma & 1 \end{bmatrix}$	$\Gamma_{UL} = \begin{bmatrix} 1 & -\gamma & 0 & 0 \\ -\gamma & 1 & 0 & 0 \\ 0 & 0 & 1 & \gamma \\ 0 & 0 & \gamma & 1 \end{bmatrix}$

The matrix P_{UL} is defined as

$$P_{UL}(a,b) = \begin{cases} 1 & \text{for } a = (j-1)Nr + i \text{ and } b = 2(j-1)Nr + i, & i = 1, \dots, Nr, j = 1, \dots, \lceil Nt/2 \rceil \\ 1 & \text{for } a = (j-1)Nr + i \text{ and } b = 2(j - Nt/2)Nr - Nr + i, & i = 1, \dots, Nr, j = \lceil Nt/2 \rceil + 1, \dots, Nt \\ 0 & \text{otherwise} \end{cases}$$

where Nt and Nr is the number of TX and RX antennas respectively, and $\lceil \bullet \rceil$ is the ceiling operator.

The matrix P_{UL} is used to map the spatial correlation coefficients in accordance with the antenna element labelling system described in G.2.3.2.

G.2.3.2.2 Spatial Correlation Matrices at UE and gNB sides

G.2.3.2.2.1 Spatial Correlation Matrices at UE side

For 1-antenna transmitter, $R_{UE} = 1$.

For 2-antenna transmitter using one pair of cross-polarized antenna elements, $R_{UE} = 1$.

For 4-antenna transmitter using two pairs of cross-polarized antenna elements, $R_{UE} = \begin{pmatrix} 1 & \beta \\ \beta^* & 1 \end{pmatrix}$.

G.2.3.2.2.2 Spatial Correlation Matrices at gNB side

For 2-antenna receiver using one pair of cross-polarized antenna elements, $R_{gNB} = 1$.

For 4-antenna receiver using two pairs of cross-polarized antenna elements, $R_{gNB} = \begin{pmatrix} 1 & \alpha \\ \alpha^* & 1 \end{pmatrix}$.

For 8-antenna receiver using four pairs of cross-polarized antenna elements, $R_{gNB} = \begin{pmatrix} 1 & \alpha^{1/9} & \alpha^{4/9} & \alpha \\ \alpha^{1/9*} & 1 & \alpha^{1/9} & \alpha^{4/9} \\ \alpha^{4/9*} & \alpha^{1/9*} & 1 & \alpha^{1/9} \\ \alpha^* & \alpha^{4/9*} & \alpha^{1/9*} & 1 \end{pmatrix}$.

G.2.3.2.3 MIMO Correlation Matrices using cross polarized antennas

The values for parameters α , β and γ for low spatial correlation are given in Table G.2.3.2.3-1.

Table G.2.3.2.3-1: Values for parameters α , β and γ

Low spatial correlation		
α	β	γ
0	0	0
Note 1: Value of α applies when more than one pair of cross-polarized antenna elements at gNB side. Note 2: Value of β applies when more than one pair of cross-polarized antenna elements at UE side.		

The correlation matrices for low spatial correlation are defined in Table G.2.3.2.3-2 as below.

Table G.2.3.2.3-2: MIMO correlation matrices for low spatial correlation

1x8 case	$R_{low} = \mathbf{I}_8$
2x8 case	$R_{low} = \mathbf{I}_{16}$

In Table G.2.3.2.3-2, \mathbf{I}_d is a $d \times d$ identity matrix.

Annex H (informative): Change history

Change history							
Date	Meeting	TDoc	CR	Rev	Cat	Subject/Comment	New version
2017-05	RAN4#83	R4-1704619				Specification skeleton	0.0.1
2017-05	RAN4#83	R4-1705332				Specification skeleton (revised)	0.0.2
2017-05	RAN4#83	R4-1706228				Specification skeleton (revised)	0.0.3
2017-07	RAN4-NR AH #2	R4-1706983				Agreed Text Proposal in RAN4 NR AH #2: R4-1706955 , "TP to TS 38.104: BS classification for NR BS"	0.1.0
2018-08	RAN4#84	R4-1709212				Agreed Text Proposal in RAN4 #84: R4-1708872 , "TP to TS 38.104 BS transmitter transient period"	0.2.0

2018-10	RAN4#84 bis	R4- 1711970			<p>Agreed Text Proposal in RAN4 #84bis:</p> <p>R4-1710199, "TP for TS 38.104: out of band blocking (10.4)"</p> <p>R4-1710587, "TP for TS 38.104: Relationship with other core specifications (4.1)"</p> <p>R4-1710588, "TP for TS 38.104: Relationship between minimum requirements and test requirements (4.2)"</p> <p>R4-1710589, "TP for TS 38.104: Regional requirements (4.5)"</p> <p>R4-1710591, "TP for TS 38.104: Conducted transmitter characteristics (general) (6.1)"</p> <p>R4-1710593, "TP for TS 38.104: Operating band unwanted emissions (conducted) (6.6.4)"</p> <p>R4-1710594, "TP for TS 38.104: Conducted receiver characteristics (General) (7.1)"</p> <p>R4-1710595, "TP for TS 38.104: Radiated transmitter characteristics (General) (9.1)"</p> <p>R4-1710598, "TP for TS 38.104: Radiated receiver characteristics (General) (10.1)"</p> <p>R4-1711325, "TP to TS38.104: OTA Output power dynamics (9.4)"</p> <p>R4-1711363, "TP to TS 38.104 - Occupied bandwidth (6.6.2)"</p> <p>R4-1711745, "TP to TS 38.104 - Conducted and radiated requirement reference points (4.3)"</p> <p>R4-1711746, "TP for TS 38.104: Adding applicability table to subclause 4.6"</p> <p>R4-1711747, "TP for TS 38.104: Operating bands and channel arrangements. (5)"</p> <p>R4-1711748, "TP to TS38.104: conducted NR BS output power (6.2)"</p> <p>R4-1711750, "TP for TS 38.104: Transmit ON/OFF power (6.4)"</p> <p>R4-1711753, "TP for TS 38.104: Time alignment error requirements (6.5)"</p> <p>R4-1711754, "TP for TS 38.104: Unwanted emissions, General (Conducted) (6.6.1)"</p> <p>R4-1711755, "TP to TS 38.104: Occupied bandwidth for FR1 and FR2 NR BS (9.7)"</p> <p>R4-1711756, "TP to TS 38.104: Transmitter spurious emissions (conducted) (6.6.5)"</p> <p>R4-1711757, "TP for TS 38.104:Conducted BS transmitter intermodulation for FR1 (section 6.7)"</p> <p>R4-1711758, "TP to TS 38.104: Reference Sensitivity (conducted) (7.2)"</p> <p>R4-1711759, "TP to TS 38.104: NR BS conducted ACLR requirement in FR1 (6.6.3)"</p> <p>R4-1711760, "TP to TS38.104: conducted NR BS receiver spurious emissions (7.6)"</p> <p>R4-1711761, "TP to TS38.104: Radiated NR BS transmit power; FR1 (9.2)"</p> <p>R4-1711762, "TP to TS38.104: OTA base station output power, FR1 (9.3)"</p> <p>R4-1711763, "TP for TS 38.104: OTA Transmit ON/OFF power (9.5)"</p> <p>R4-1711764, "TP to TS 38.104 - OTA ACLR"</p> <p>R4-1711765, "TP for TS 38.104: OTA Operating band unwanted emissions and Spectrum emissions mask (9.7.4)"</p> <p>R4-1711766, "TP for TS 38.104: OTA Spurious emission (9.7.5)"</p> <p>R4-1711767, "TP for TS 38.104: Adding specification text for OTA TX IMD requirement in subclause 9.8"</p> <p>R4-1711768, "TP to TS 38.104: OTA Sensitivity (10.2)"</p> <p>R4-1711771, "TP to TS38.104: OTA receiver spurious emissions, FR1 (10.7)"</p> <p>R4-1711772, "TP to TS 38.104: Receiver Intermodulation (10.8)"</p> <p>R4-1711811, "TP to TS 38.104: NR BS conducted in-band selectivity and blocking requirements in FR1 (7.4)"</p> <p>R4-1711950, "TP to TS 38.104: Modulation Quality Skeleton (6.5)"</p> <p>R4-1711951, "TP to TS38.104: frequency error for FR1 NR BS (6.5&9.6)"</p> <p>R4-1711952, "TP to TS 38.104: OTA reference sensitivity (10.3)"</p>	0.3.0
2017-11	RAN4#84 bis	R4- 1711971			Alignment of structure, terminology, and definitions between clauses.	0.4.0

2017-12	RAN4#85	R4-1714544			<p>Agreed Text Proposal in RAN4 #85:</p> <p>R4-1712614, "TP to TS 38.104 - OTA sensitivity (10.2)"</p> <p>R4-1712648, "TP to TS 38.104: corrections for the applicability of "BS type" and "requirement set" definitions"</p> <p>R4-1712964, "TP for TS 38.104: out of band blocking (7.5)"</p> <p>R4-1713631, "TP to TS 38.104 on introduction of n71"</p> <p>R4-1713632, "TP to TS 38.104, clause 4.7 (Requirements for contiguous and non-contiguous spectrum)"</p> <p>R4-1713633, "TP to TS 38.104, clause 4.8 (Requirements for BS capable of multi-band operation)"</p> <p>R4-1713634, "TP to TS 38.104, clause 6.6.4.2.6 (basic limits for additional requirements for operating band unwanted emissions)"</p> <p>R4-1714116, "TP to TS 38.104: Revision of the TRP definition"</p> <p>R4-1714117, "TP to TS 38.104: Radiated NR BS transmit power; 2-O (9.2.3)"</p> <p>R4-1714121, "TP to TS 38.104: OTA Output power dynamics (9.4)"</p> <p>R4-1714125, "TP to TS 38.104 v0.4.0: OTA TDD Off power"</p> <p>R4-1714127, "TP for TS 38.104: OTA frequency error (9.6.1)"</p> <p>R4-1714129, "TP to TS 38.104: NR BS conducted ACLR requirements in FR1 (6.6.3)"</p> <p>R4-1714134, "TP to TS 38.104v0.4.0: Absolute levels for FR2 ACLR absolute levels for NR BS"</p> <p>R4-1714136, "TP for TS 38.104: Update of OTA TX IM requirement for sub-clause 4.9 and sub-clause 9.8"</p> <p>R4-1714141, "TP to TS 38.104: Reference Sensitivity (conducted) (7.2)"</p> <p>R4-1714142, "TP to TS 38.104: NR BS FRCs for receiver requirements"</p> <p>R4-1714150, "TP to TS 38.104 - OTA out of band blocking FR1 (10.6)"</p> <p>R4-1714306, "TP for TS 38.104: Adding of TRP in terminology in clause 3"</p> <p>R4-1714307, "TP to TS 38.104 - Conducted and radiated requirement reference points (4.3)"</p> <p>R4-1714308, "TP for TS 38.104: Base station classes (4.4)"</p> <p>R4-1714310, "TP to TS 38.104: Directional and TRP requirements identification (directional vs. TRP)"</p> <p>R4-1714312, "TP for TS 38.104: Update of applicability table in sub-clause 4.6"</p> <p>R4-1714313, "TP to TS 38.104: Operating bands (5.1-5.3)"</p> <p>R4-1714315, "TP to TS38.104: frequency error for NR BS (6.5&9.6)"</p> <p>R4-1714316, "TP for TS 38.104: Adding text for subclause 6.5.2 Modulation quality"</p> <p>R4-1714317, "TP to TS 38.104: Dynamic Range for FR1 (conducted)"</p> <p>R4-1714318, "TP to TS38.104: ICS requirement (7.8&10.9)"</p> <p>R4-1714319, "TP for TS 38.104: Adding text for subclause 9.6.4 Modulation quality"</p> <p>R4-1714320, "TP for TS 38.104: OTA Spurious emission (9.7.5)"</p> <p>R4-1714321, "TP for TS 38.104: OTA Dynamic range (10.4)"</p> <p>R4-1714390, "TP to TS 38.104: FR2 RX IM OTA, 10.8.3"</p> <p>R4-1714428, "TP to TS 38.104 v0.4.0: Time alignment for CA"</p> <p>R4-1714430, "TP to TS 38.104: Transmitter spurious emissions (conducted) (6.6.5)"</p> <p>R4-1714432, "TP to TS 38.104: Output Power Dynamics for FR1 (conducted)"</p> <p>R4-1714433, "TP to TS 38.104: OTA Rx spurious emissions for BS type O 2 (10.7.3)"</p> <p>R4-1714435, "TP to TS 38.104: FR2 REFSSENS"</p> <p>R4-1714437, "TP for TS 38.104: Conducted Adjacent Channel Leakage Power Ratio (ACLR) (6.6.3)"</p> <p>R4-1714439, "TP for TS 38.104: Receiver spurious emission (7.6)"</p> <p>R4-1714476, "TP to TR 38.104: Channel arrangement (5.4)"</p> <p>R4-1714493, "TP for TS 38.104: Operating band unwanted emissions (6.6.4)"</p> <p>R4-1714515, "TP for TS 38.104: OTA Out-of-band emissions (9.7.4)"</p> <p>R4-1714517, "TP to TS 38.104: OTA base station output power, 2-O (9.3.3)"</p> <p>R4-1714518, "TP to TS 38.104: ACS and blocking update"</p> <p>R4-1714520, "Draft TP to TS 38.104: OTA In-band selectivity and blocking (10.5)"</p> <p>R4-1714525, "TP to TS 38.104: FR1 RX IM conducted 7.7"</p> <p>R4-1714526, "TP to TS 38.104: FR1 RX IM OTA 10.8.2"</p>	0.5.0
2017-12	RAN#78	RP-172268			Presented to TSG RAN for approval.	1.0.0
2017-12	RAN#78				Approved by plenary – Rel-15 spec under change control	15.0.0
2018-03	RAN#79	RP-180264	0004	F	TS 38.104 Combined updates (NSA) from RAN4 #86 and AH-1801	15.1.0

2018-06	RAN#80	RP-181076	0005		F	TS 38.104 Combined updates (NSA) from RAN4 #86bis and RAN4 #87	15.2.0
2018-09	RAN#81	RP-181896	0008		F	TS 38.104 Combined updates from RAN4 #88	15.3.0
2018-12	RAN#82	RP-182837	0016	1	F	CR to TS 38.104 on Combined updates from RAN4 #88bis and #89 (including 7.5 kHz carrier shift in UL for remaining bands)	15.4.0
2018-12	RAN#82	RP-182362	0017		B	CR to 38.104 on Combined CRs for BS Demodulation performance	15.4.0
2019-03	RAN#83	RP-190403	0019		F	<p>CR to TS 38.104 on Combined updates from RAN4 #90</p> <p>This document combines the proposed changes in the following Draft CRs from RAN4 #90:</p> <ul style="list-style-type: none"> - R4-1900284, "Draft CR on NR PUCCH format2 performance requirements for TS 38.104" - R4-1900763, "Draft CR to TS 38.104: Update of performance requirement numbers for DFT-s-OFDM based PUSCH" - R4-1900876, "Draft CR to TS 38.104: On RX spurious emissions requirement" - R4-1900968, "Draft CR for 38.104: Performance requirements for NR PUCCH format 1" - R4-1901329, "Draft CR to 38.104: Annex C.6 correction" - R4-1901330, "Draft CR to 38.104: Abbreviations addition" - R4-1901387, "Draft CR to TS 38.104 BS demodulation PUCCH format 0 requirements" - R4-1901474, "Draft CR to TS 38.104: Corrections on transmitter co-existence and co-location requirements" - R4-1901483, "Draft CR to TS 38.104: Corrections on general intermodulation requirement" - R4-1902239, "Draft CR to TS 38.104: Addition of missing EIRP/EIS definitions in terminology in subclause 3.1" - R4-1902241, "Draft CR to 38.104; clarification of BS power limits" - R4-1902245, "Draft CR to 38.104: Correction to FR2 OTA Interfering signal mean power units" - R4-1902246, "Draft CR to 38.104; Correction to definition of OTA reference sensitivity" - R4-1902260, "draft CR to TS 38.104 - update emissions scaling" - R4-1902338, "Draft CR: Update on FR1 range extension for TS38.104" - R4-1902389, "draftCR for 38.104 on PUSCH requirements with CP-OFDM and FR1" - R4-1902394, "Draft CR to TS 38.104 – PUSCH requirements with CP-OFDM for FR2" - R4-1902396, "CR: Updates to PUCCH formats 3 and 4 performance requirements in TS 38.104" - R4-1902444, "Draft CR to TS 38.104: Editorial CR for BS demodulation requirements" - R4-1902561, "Draft CR for updating PRACH performance requirements in TS38.104" - R4-1902571, "Corrections to 38.104 Delay profile calculation" - R4-1902642, "Draft CR to TS 38.104: Correction on multi-band operation related requirements" 	15.5.0

History

Document history		
V15.2.0	July 2018	Publication
V15.3.0	October 2018	Publication
V15.4.0	April 2019	Publication
V15.5.0	May 2019	Publication