

ETSI TS 138 104 V17.15.0 (2024-10)



**5G;
NR;
Base Station (BS) radio transmission and reception
(3GPP TS 38.104 version 17.15.0 Release 17)**



Reference

RTS/TSGR-0438104vhf0

Keywords

5G

ETSI

650 Route des Lucioles
F-06921 Sophia Antipolis Cedex - FRANCE

Tel.: +33 4 92 94 42 00 Fax: +33 4 93 65 47 16

Siret N° 348 623 562 00017 - APE 7112B
Association à but non lucratif enregistrée à la
Sous-Préfecture de Grasse (06) N° w061004871

Important notice

The present document can be downloaded from the
ETSI [Search & Browse Standards application](#).

The present document may be made available in electronic versions and/or in print. The content of any electronic and/or print versions of the present document shall not be modified without the prior written authorization of ETSI. In case of any existing or perceived difference in contents between such versions and/or in print, the prevailing version of an ETSI deliverable is the one made publicly available in PDF format on [ETSI deliver](#).

Users should be aware that the present document may be revised or have its status changed,
this information is available in the [Milestones listing](#).

If you find errors in the present document, please send your comments to
the relevant service listed under [Committee Support Staff](#).

If you find a security vulnerability in the present document, please report it through our
[Coordinated Vulnerability Disclosure \(CVD\)](#) program.

Notice of disclaimer & limitation of liability

The information provided in the present deliverable is directed solely to professionals who have the appropriate degree of experience to understand and interpret its content in accordance with generally accepted engineering or other professional standard and applicable regulations.

No recommendation as to products and services or vendors is made or should be implied.

No representation or warranty is made that this deliverable is technically accurate or sufficient or conforms to any law and/or governmental rule and/or regulation and further, no representation or warranty is made of merchantability or fitness for any particular purpose or against infringement of intellectual property rights.

In no event shall ETSI be held liable for loss of profits or any other incidental or consequential damages.

Any software contained in this deliverable is provided "AS IS" with no warranties, express or implied, including but not limited to, the warranties of merchantability, fitness for a particular purpose and non-infringement of intellectual property rights and ETSI shall not be held liable in any event for any damages whatsoever (including, without limitation, damages for loss of profits, business interruption, loss of information, or any other pecuniary loss) arising out of or related to the use of or inability to use the software.

Copyright Notification

No part may be reproduced or utilized in any form or by any means, electronic or mechanical, including photocopying and microfilm except as authorized by written permission of ETSI.

The content of the PDF version shall not be modified without the written authorization of ETSI.

The copyright and the foregoing restriction extend to reproduction in all media.

© ETSI 2024.
All rights reserved.

Intellectual Property Rights

Essential patents

IPRs essential or potentially essential to normative deliverables may have been declared to ETSI. The declarations pertaining to these essential IPRs, if any, are publicly available for **ETSI members and non-members**, and can be found in ETSI SR 000 314: "*Intellectual Property Rights (IPRs); Essential, or potentially Essential, IPRs notified to ETSI in respect of ETSI standards*", which is available from the ETSI Secretariat. Latest updates are available on the ETSI Web server (<https://ipr.etsi.org/>).

Pursuant to the ETSI Directives including the ETSI IPR Policy, no investigation regarding the essentiality of IPRs, including IPR searches, has been carried out by ETSI. No guarantee can be given as to the existence of other IPRs not referenced in ETSI SR 000 314 (or the updates on the ETSI Web server) which are, or may be, or may become, essential to the present document.

Trademarks

The present document may include trademarks and/or tradenames which are asserted and/or registered by their owners. ETSI claims no ownership of these except for any which are indicated as being the property of ETSI, and conveys no right to use or reproduce any trademark and/or tradename. Mention of those trademarks in the present document does not constitute an endorsement by ETSI of products, services or organizations associated with those trademarks.

DECT™, **PLUGTESTS™**, **UMTS™** and the ETSI logo are trademarks of ETSI registered for the benefit of its Members. **3GPP™** and **LTE™** are trademarks of ETSI registered for the benefit of its Members and of the 3GPP Organizational Partners. **oneM2M™** logo is a trademark of ETSI registered for the benefit of its Members and of the oneM2M Partners. **GSM®** and the GSM logo are trademarks registered and owned by the GSM Association.

Legal Notice

This Technical Specification (TS) has been produced by ETSI 3rd Generation Partnership Project (3GPP).

The present document may refer to technical specifications or reports using their 3GPP identities. These shall be interpreted as being references to the corresponding ETSI deliverables.

The cross reference between 3GPP and ETSI identities can be found under <https://webapp.etsi.org/key/queryform.asp>.

Modal verbs terminology

In the present document "**shall**", "**shall not**", "**should**", "**should not**", "**may**", "**need not**", "**will**", "**will not**", "**can**" and "**cannot**" are to be interpreted as described in clause 3.2 of the [ETSI Drafting Rules](#) (Verbal forms for the expression of provisions).

"**must**" and "**must not**" are **NOT** allowed in ETSI deliverables except when used in direct citation.

Contents

Intellectual Property Rights	2
Legal Notice	2
Modal verbs terminology.....	2
Foreword.....	13
1 Scope	15
2 References	15
3 Definitions, symbols and abbreviations	16
3.1 Definitions	16
3.2 Symbols.....	21
3.3 Abbreviations	23
4 General	25
4.1 Relationship with other core specifications.....	25
4.2 Relationship between minimum requirements and test requirements	25
4.3 Conducted and radiated requirement reference points	25
4.3.1 <i>BS type 1-C</i>	25
4.3.2 <i>BS type 1-H</i>	26
4.3.3 <i>BS type 1-O</i> and <i>BS type 2-O</i>	27
4.4 Base station classes	27
4.5 Regional requirements.....	28
4.6 Applicability of requirements.....	31
4.7 Requirements for contiguous and <i>non-contiguous spectrum</i>	31
4.8 Requirements for BS capable of multi-band operation	32
4.9 OTA co-location with other base stations	33
5 <i>Operating bands</i> and channel arrangement.....	35
5.1 General	35
5.2 <i>Operating bands</i>	35
5.3 <i>BS channel bandwidth</i>	38
5.3.1 General.....	38
5.3.2 <i>Transmission bandwidth configuration</i>	39
5.3.3 Minimum guardband and <i>transmission bandwidth configuration</i>	40
5.3.4 RB alignment.....	41
5.3.5 <i>BS channel bandwidth per operating band</i>	41
5.3A <i>BS channel bandwidth for CA</i>	46
5.3A.1 <i>Transmission bandwidth configuration for CA</i>	46
5.3A.2 Minimum guardband and <i>transmission bandwidth configuration for CA</i>	46
5.4 Channel arrangement.....	48
5.4.1 Channel spacing.....	48
5.4.1.1 Channel spacing for adjacent NR carriers	48
5.4.1.2 Channel spacing for CA	48
5.4.2 Channel raster	49
5.4.2.1 NR-ARFCN and channel raster.....	49
5.4.2.1A NB-IoT carrier frequency numbering.....	50
5.4.2.2 Channel raster to resource element mapping.....	50
5.4.2.3 Channel raster entries for each <i>operating band</i>	50
5.4.3 Synchronization raster	54
5.4.3.1 Synchronization raster and numbering.....	54
5.4.3.3 Synchronization raster entries for each operating band.....	55
6 Conducted transmitter characteristics	59
6.1 General	59
6.2 Base station output power	59
6.2.1 General.....	59
6.2.2 Minimum requirement for <i>BS type 1-C</i>	60

6.2.3	Minimum requirement for <i>BS type 1-H</i>	60
6.2.4	Additional requirements (regional).....	60
6.3	Output power dynamics.....	61
6.3.1	General.....	61
6.3.2	RE power control dynamic range	61
6.3.2.1	General	61
6.3.2.2	Minimum requirement for <i>BS type 1-C</i> and <i>BS type 1-H</i>	61
6.3.3	Total power dynamic range	61
6.3.3.1	General	61
6.3.3.2	Minimum requirement for <i>BS type 1-C</i> and <i>BS type 1-H</i>	62
6.3.4	NB-IoT RB power dynamic range for NB-IoT operation in NR in-band	62
6.3.4.1	General	62
6.3.4.2	Minimum Requirement	62
6.4	Transmit ON/OFF power	63
6.4.1	Transmitter OFF power	63
6.4.1.1	General	63
6.4.1.2	Minimum requirement for <i>BS type 1-C</i>	63
6.4.1.3	Minimum requirement for <i>BS type 1-H</i>	63
6.4.2	<i>Transmitter transient period</i>	63
6.4.2.1	General	63
6.4.2.2	Minimum requirement for <i>BS type 1-C</i> and <i>BS type 1-H 1-H</i>	64
6.4.2.3	Void.....	64
6.5	Transmitted signal quality	64
6.5.1	Frequency error.....	64
6.5.1.1	General	64
6.5.1.2	Minimum requirement for <i>BS type 1-C</i> and <i>BS type 1-H</i>	65
6.5.2	Modulation quality.....	65
6.5.2.1	General	65
6.5.2.2	Minimum Requirement for <i>BS type 1-C</i> and <i>BS type 1-H</i>	65
6.5.2.3	EVM frame structure for measurement.....	65
6.5.3	Time alignment error	66
6.5.3.1	General	66
6.5.3.2	Minimum requirement for <i>BS type 1-C</i> and <i>BS type 1-H</i>	66
6.6	Unwanted emissions.....	66
6.6.1	General.....	66
6.6.2	Occupied bandwidth	67
6.6.2.1	General	67
6.6.2.2	Minimum requirement for <i>BS type 1-C</i> and <i>BS type 1-H</i>	67
6.6.3	Adjacent Channel Leakage Power Ratio	68
6.6.3.1	General	68
6.6.3.2	Limits and <i>Basic limits</i>	68
6.6.3.3	Minimum requirement for <i>BS type 1-C</i>	71
6.6.3.4	Minimum requirement for <i>BS type 1-H</i>	71
6.6.4	Operating band unwanted emissions	72
6.6.4.1	General	72
6.6.4.2	<i>Basic limits</i>	73
6.6.4.2.1	<i>Basic limits</i> for Wide Area BS (Category A)	73
6.6.4.2.2	<i>Basic limits</i> for Wide Area BS (Category B)	74
6.6.4.2.3	<i>Basic limits</i> for Medium Range BS (Category A and B).....	78
6.6.4.2.4	<i>Basic limits</i> for Local Area BS (Category A and B).....	80
6.6.4.2.4A	<i>Basic limits</i> for Local Area and Medium Range BS for bands n46, n96 and n102 (Category A and B)	81
6.6.4.2.5	<i>Basic limits</i> for additional requirements	84
6.6.4.3	Minimum requirements for <i>BS type 1-C</i>	86
6.6.4.4	Minimum requirements for <i>BS type 1-H</i>	86
6.6.5	Transmitter spurious emissions.....	87
6.6.5.1	General	87
6.6.5.2	<i>Basic limits</i>	87
6.6.5.2.1	General transmitter spurious emissions requirements	87
6.6.5.2.2	Protection of the BS receiver of own or different BS	88
6.6.5.2.3	Additional spurious emissions requirements	88
6.6.5.2.4	Co-location with other base stations.....	98

6.6.5.3	Minimum requirements for <i>BS type 1-C</i>	105
6.6.5.4	Minimum requirements for <i>BS type 1-H</i>	105
6.7	Transmitter intermodulation	105
6.7.1	General	105
6.7.2	Minimum requirements for <i>BS type 1-C</i>	105
6.7.2.1	Co-location minimum requirements	105
6.7.2.2	Additional requirements	106
6.7.3	Minimum requirements for <i>BS type 1-H</i>	107
6.7.3.1	Co-location minimum requirements	107
6.7.3.2	Intra-system minimum requirements	108
6.7.3.3	Additional requirements	108
7	Conducted receiver characteristics	109
7.1	General	109
7.2	Reference sensitivity level	109
7.2.1	General	109
7.2.2	Minimum requirements for <i>BS type 1-C</i> and <i>BS type 1-H</i>	109
7.3	Dynamic range	114
7.3.1	General	114
7.3.2	Minimum requirement for <i>BS type 1-C</i> and <i>BS type 1-H</i>	114
7.4	In-band selectivity and blocking	126
7.4.1	Adjacent Channel Selectivity (ACS)	126
7.4.1.1	General	126
7.4.1.2	Minimum requirement for <i>BS type 1-C</i> and <i>BS type 1-H</i>	126
7.4.1.3	Void	129
7.4.1.4	Void	129
7.4.2	In-band blocking	129
7.4.2.1	General	129
7.4.2.2	Minimum requirement for <i>BS type 1-C</i> and <i>BS type 1-H</i>	129
7.4.2.3	Void	133
7.4.2.4	Void	133
7.4.2.5	Additional narrowband blocking requirement for Band n100	133
7.5	Out-of-band blocking	133
7.5.1	General	133
7.5.2	Minimum requirement for <i>BS type 1-C</i> and <i>BS type 1-H</i>	134
7.5.3	Co-location minimum requirements for <i>BS type 1-C</i> and <i>BS type 1-H</i>	135
7.5.4	Void	136
7.5.5	Additional out-of-band blocking requirements for the use of RMR bands	136
7.6	Receiver spurious emissions	136
7.6.1	General	136
7.6.2	<i>Basic limits</i>	136
7.6.3	Minimum requirement for <i>BS type 1-C</i>	137
7.6.4	Minimum requirement for <i>BS type 1-H</i>	137
7.7	Receiver intermodulation	138
7.7.1	General	138
7.7.2	Minimum requirement for <i>BS type 1-C</i> and <i>BS type 1-H</i>	138
7.7.3	Additional narrowband intermodulation requirement for Band n100	143
7.8	In-channel selectivity	143
7.8.1	General	143
7.8.2	Minimum requirement for <i>BS type 1-C</i> and <i>BS type 1-H</i>	143
8	Conducted performance requirements	154
8.1	General	154
8.1.1	Scope and definitions	154
8.1.2	Void	154
8.2	Performance requirements for PUSCH	154
8.2.1	Requirements for PUSCH with transform precoding disabled	154
8.2.1.1	General	154
8.2.1.2	Minimum requirements	155
8.2.2	Requirements for PUSCH with transform precoding enabled	163
8.2.2.1	General	163
8.2.2.2	Minimum requirements	163

8.2.3	Requirements for UCI multiplexed on PUSCH.....	164
8.2.3.1	General.....	164
8.2.3.2	Minimum requirements.....	165
8.2.4	Requirements for PUSCH for high speed train.....	166
8.2.4.1	General.....	166
8.2.4.2	Minimum requirements.....	167
8.2.5	Requirements for UL timing adjustment.....	169
8.2.5.1	Minimum requirements for high speed train.....	170
8.2.5.2	Minimum requirements for normal mode.....	171
8.2.6	Requirements for PUSCH 0.001% BLER.....	172
8.2.6.1	General.....	172
8.2.6.2	Minimum requirements.....	172
8.2.7	Requirements for PUSCH repetition Type A.....	173
8.2.7.1	General.....	173
8.2.7.2	Minimum requirements.....	174
8.2.8	Requirements for PUSCH mapping Type B with non-slot transmission.....	176
8.2.8.1	General.....	176
8.2.8.2	Minimum requirements.....	176
8.2.9	Requirements of PUSCH for 2-step RA type.....	177
8.2.9.1	General.....	177
8.2.9.2	Minimum requirements.....	178
8.2.10	Requirements for interlaced PUSCH.....	178
8.2.10.1	General.....	178
8.2.10.2	Minimum requirements.....	179
8.2.11	Performance requirements for CG-UCI multiplexed on interlaced PUSCH.....	180
8.2.11.1	General.....	180
8.2.11.2	Minimum requirements.....	181
8.2.12	Requirements for TB processing over multi-slot PUSCH (TBoMS).....	182
8.2.12.1	General.....	182
8.2.12.2	Minimum requirements.....	182
8.2.13	Requirements for PUSCH with DM-RS bundling.....	183
8.2.13.1	General.....	183
8.2.13.2	Minimum requirements.....	184
8.3	Performance requirements for PUCCH.....	186
8.3.1	DTX to ACK probability.....	186
8.3.1.1	General.....	186
8.3.1.2	Minimum requirement.....	187
8.3.2	Performance requirements for PUCCH format 0.....	187
8.3.2.1	General.....	187
8.3.2.2	Minimum requirements.....	187
8.3.3	Performance requirements for PUCCH format 1.....	188
8.3.3.1	NACK to ACK requirements.....	188
8.3.3.1.1	General.....	188
8.3.3.1.2	Minimum requirements.....	188
8.3.3.2	ACK missed detection requirements.....	189
8.3.3.2.1	General.....	189
8.3.3.2.2	Minimum requirements.....	189
8.3.4	Performance requirements for PUCCH format 2.....	190
8.3.4.1	ACK missed detection requirements.....	190
8.3.4.1.1	General.....	190
8.3.4.1.2	Minimum requirements.....	190
8.3.4.2	UCI BLER performance requirements.....	191
8.3.4.2.1	General.....	191
8.3.4.2.2	Minimum requirements.....	191
8.3.5	Performance requirements for PUCCH format 3.....	192
8.3.5.1	General.....	192
8.3.5.2	Minimum requirements.....	192
8.3.6	Performance requirements for PUCCH format 4.....	193
8.3.6.1	General.....	193
8.3.6.2	Minimum requirement.....	194
8.3.7	Performance requirements for multi-slot PUCCH.....	195
8.3.7.1	General.....	195

8.3.7.2	Performance requirements for multi-slot PUCCH format 1	195
8.3.7.2.1	NACK to ACK requirements	195
8.3.7.2.1.1	General	195
8.3.7.2.1.2	Minimum requirements	196
8.3.7.2.2	ACK missed detection requirements	196
8.3.8	Performance requirements for interlaced PUCCH format 0	196
8.3.8.1	General	196
8.3.8.2	Minimum requirements	197
8.3.9	Performance requirements for interlaced PUCCH format 1	197
8.3.9.1	NACK to ACK requirements	197
8.3.9.1.1	General	197
8.3.9.1.2	Minimum requirements	198
8.3.9.2	ACK missed detection requirements	198
8.3.9.2.1	General	198
8.3.9.2.2	Minimum requirements	198
8.3.10	Performance requirements for interlaced PUCCH format 2	199
8.3.10.1	General	199
8.3.10.2	Minimum requirements	199
8.3.11	Performance requirements for interlaced PUCCH format 3	200
8.3.11.1	General	200
8.3.11.2	Minimum requirements	200
8.3.12	Performance requirements for PUCCH format 1 with DM-RS bundling	201
8.3.12.1	NACK to ACK requirements	201
8.3.12.1.1	General	201
8.3.12.1.2	Minimum requirements	201
8.3.12.2	ACK missed detection requirements	202
8.3.12.2.1	General	202
8.3.12.2.2	Minimum requirements	202
8.3.13	Performance requirements for PUCCH format 3 with DMRS bundling	202
8.3.13.1	General	202
8.3.13.2	Minimum requirements	203
8.3.14	Performance requirements for sub-slot repetition PUCCH format 0	204
8.3.14.1	General	204
8.3.14.2	Minimum requirements	204
8.4	Performance requirements for PRACH	205
8.4.1	PRACH False alarm probability	205
8.4.1.1	General	205
8.4.1.2	Minimum requirement	205
8.4.2	PRACH detection requirements	205
8.4.2.1	General	205
8.4.2.2	Minimum requirements for Normal Mode	205
8.4.2.3	Minimum requirements for high speed train	206
8.4.2.4	Minimum requirements for PRACH with $L_{RA}=1151$ and $L_{RA}=571$	207
9	Radiated transmitter characteristics	209
9.1	General	209
9.2	Radiated transmit power	209
9.2.1	General	209
9.2.2	Minimum requirement for <i>BS type 1-H</i> and <i>BS type 1-O</i>	210
9.2.3	Minimum requirement for <i>BS type 2-O</i>	210
9.3	OTA base station output power	210
9.3.1	General	210
9.3.2	Minimum requirement for <i>BS type 1-O</i>	211
9.3.3	Minimum requirement for <i>BS type 2-O</i>	211
9.3.4	Additional requirements (regional)	211
9.4	OTA output power dynamics	211
9.4.1	General	211
9.4.2	OTA RE power control dynamic range	211
9.4.2.1	General	211
9.4.2.2	Minimum requirement for <i>BS type 1-O</i>	211
9.4.3	OTA total power dynamic range	211
9.4.3.1	General	211

9.4.3.2	Minimum requirement for <i>BS type 1-O</i>	212
9.4.3.3	Minimum requirement for <i>BS type 2-O</i>	212
9.5	OTA transmit ON/OFF power.....	212
9.5.1	General.....	212
9.5.2	OTA transmitter OFF power.....	212
9.5.2.1	General.....	212
9.5.2.2	Minimum requirement for <i>BS type 1-O</i>	212
9.5.2.3	Minimum requirement for <i>BS type 2-O</i>	213
9.5.3	OTA transient period.....	213
9.5.3.1	General.....	213
9.5.3.2	Minimum requirement for <i>BS type 1-O</i>	213
9.5.3.3	Minimum requirement for <i>BS type 2-O</i>	213
9.6	OTA transmitted signal quality.....	213
9.6.1	OTA frequency error.....	213
9.6.1.1	General.....	213
9.6.1.2	Minimum requirement for <i>BS type 1-O</i>	213
9.6.1.3	Minimum requirement for <i>BS type 2-O</i>	214
9.6.2	OTA modulation quality.....	214
9.6.2.1	General.....	214
9.6.2.2	Minimum Requirement for <i>BS type 1-O</i>	214
9.6.2.3	Minimum Requirement for <i>BS type 2-O</i>	214
9.6.2.3.1	EVM frame structure for measurement.....	214
9.6.3	OTA time alignment error.....	214
9.6.3.1	General.....	214
9.6.3.2	Minimum requirement for <i>BS type 1-O</i>	215
9.6.3.3	Minimum requirement for <i>BS type 2-O</i>	215
9.7	OTA unwanted emissions.....	215
9.7.1	General.....	215
9.7.2	OTA occupied bandwidth.....	216
9.7.2.1	General.....	216
9.7.2.2	Minimum requirement for <i>BS type 1-O</i> and <i>BS type 2-O</i>	216
9.7.3	OTA Adjacent Channel Leakage Power Ratio (ACLR).....	217
9.7.3.1	General.....	217
9.7.3.2	Minimum requirement for <i>BS type 1-O</i>	217
9.7.3.3	Minimum requirement for <i>BS type 2-O</i>	217
9.7.4	OTA operating band unwanted emissions.....	219
9.7.4.1	General.....	219
9.7.4.2	Minimum requirement for <i>BS type 1-O</i>	219
9.7.4.2.1	Additional requirements.....	220
9.7.4.2.1.1	Protection of DTT.....	220
9.7.4.2.1.2	Limits in FCC Title 47.....	220
9.7.4.3	Minimum requirement for <i>BS type 2-O</i>	220
9.7.4.3.1	General.....	220
9.7.4.3.2	OTA operating band unwanted emission limits (Category A).....	221
9.7.4.3.3	OTA operating band unwanted emission limits (Category B).....	222
9.7.4.3.4	Additional OTA operating band unwanted emission requirements.....	223
9.7.5	OTA transmitter spurious emissions.....	223
9.7.5.1	General.....	223
9.7.5.2	Minimum requirement for <i>BS type 1-O</i>	223
9.7.5.2.1	General.....	223
9.7.5.2.2	General OTA transmitter spurious emissions requirements.....	224
9.7.5.2.3	Protection of the BS receiver of own or different BS.....	224
9.7.5.2.4	Additional spurious emissions requirements.....	224
9.7.5.2.5	Co-location with other base stations.....	224
9.7.5.3	Minimum requirement for <i>BS type 2-O</i>	224
9.7.5.3.1	General.....	224
9.7.5.3.2	General OTA transmitter spurious emissions requirements.....	225
9.7.5.3.3	Additional OTA transmitter spurious emissions requirements.....	226
9.8	OTA transmitter intermodulation.....	226
9.8.1	General.....	226
9.8.2	Minimum requirement for <i>BS type 1-O</i>	226
9.8.3	Additional requirements (regional).....	227

10	Radiated receiver characteristics	228
10.1	General	228
10.2	OTA sensitivity	229
10.2.1	<i>BS type 1-H</i> and <i>BS type 1-O</i>	229
10.2.1.1	General	229
10.2.1.2	Minimum requirement	229
10.2.2	<i>BS type 2-O</i>	229
10.3	OTA reference sensitivity level	230
10.3.1	General	230
10.3.2	Minimum requirement for <i>BS type 1-O</i>	230
10.3.3	Minimum requirement for <i>BS type 2-O</i>	232
10.4	OTA dynamic range	233
10.4.1	General	233
10.4.2	Minimum requirement for <i>BS type 1-O</i>	233
10.5	OTA in-band selectivity and blocking	246
10.5.1	OTA adjacent channel selectivity	246
10.5.1.1	General	246
10.5.1.2	Minimum requirement for <i>BS type 1-O</i>	246
10.5.1.3	Minimum requirement for <i>BS type 2-O</i>	247
10.5.2	OTA in-band blocking	248
10.5.2.1	General	248
10.5.2.2	Minimum requirement for <i>BS type 1-O</i>	248
10.5.2.3	Minimum requirement for <i>BS type 2-O</i>	251
10.6	OTA out-of-band blocking	252
10.6.1	General	252
10.6.2	Minimum requirement for <i>BS type 1-O</i>	252
10.6.2.1	General minimum requirement	252
10.6.2.2	Co-location minimum requirement	253
10.6.3	Minimum requirement for <i>BS type 2-O</i>	253
10.6.3.1	General minimum requirement	253
10.7	OTA receiver spurious emissions	254
10.7.1	General	254
10.7.2	Minimum requirement for <i>BS type 1-O</i>	254
10.7.3	Minimum requirement for <i>BS type 2-O</i>	255
10.8	OTA receiver intermodulation	256
10.8.1	General	256
10.8.2	Minimum requirement for <i>BS type 1-O</i>	256
10.8.3	Minimum requirement for <i>BS type 2-O</i>	261
10.9	OTA in-channel selectivity	262
10.9.1	General	262
10.9.2	Minimum requirement for <i>BS type 1-O</i>	262
10.9.3	Minimum requirement for <i>BS type 2-O</i>	266
11	Radiated performance requirements	268
11.1	General	268
11.1.1	Scope and definitions	268
11.1.2	OTA demodulation branches	268
11.1.3	Void	269
11.2	Performance requirements for PUSCH	269
11.2.1	Requirements for <i>BS type 1-O</i>	269
11.2.1.1	Requirements for PUSCH with transform precoding disabled	269
11.2.1.2	Requirements for PUSCH with transform precoding enabled	269
11.2.1.3	Requirements for UCI multiplexed on PUSCH	269
11.2.1.4	Requirements for PUSCH for high speed train	269
11.2.1.5	Requirements for UL timing adjustment	269
11.2.1.6	Requirements for PUSCH 0.001% BLER	269
11.2.1.7	Requirements for PUSCH repetition Type A	269
11.2.1.8	Requirements for PUSCH mapping Type B with non-slot transmission	269
11.2.1.9	Requirements for PUSCH for 2-step RA type	269
11.2.1.10	Requirements for interlaced PUSCH	269
11.2.1.11	Requirements for CG-UCI multiplexed on interlaced PUSCH	269
11.2.1.12	Requirements for TB processing over multi-slot PUSCH (TBoMS)	269

11.2.1.13	Requirements for PUSCH with DM-RS bundling	270
11.2.2	Requirements for <i>BS type 2-O</i>	270
11.2.2.1	Requirements for PUSCH with transform precoding disabled	270
11.2.2.1.1	General	270
11.2.2.1.2	Minimum requirements	270
11.2.2.2	Requirements for PUSCH with transform precoding enabled	275
11.2.2.2.1	General	275
11.2.2.2.2	Minimum requirements	275
11.2.2.3	Requirements for UCI multiplexed on PUSCH	276
11.2.2.3.1	General	276
11.2.2.3.2	Minimum requirements	277
11.2.2.4	Requirements for PUSCH for 2-step RA type	279
11.2.2.4.1	General	279
11.2.2.4.2	Minimum requirements	280
11.2.2.5	Requirements for PUSCH repetition Type A	280
11.2.2.5.1	General	280
11.2.2.5.2	Minimum requirements	281
11.2.2.6	Requirements for PUSCH mapping Type B with non-slot transmission	282
11.2.2.6.1	General	282
11.2.2.6.2	Minimum requirements	282
11.2.2.7	Requirements for PUSCH for high speed train	283
11.2.2.7.1	General	283
11.2.2.7.2	Minimum requirements	283
11.2.2.8	Requirements for UL timing adjustment	284
11.2.2.8.1	General	284
11.2.2.8.2	Minimum requirements for high speed train	285
11.2.2.9	Requirements for TB processing over multi-slot PUSCH (TBoMS)	286
11.2.2.9.1	General	286
11.2.2.9.2	Minimum requirements	286
11.2.2.10	Requirements for PUSCH with DM-RS bundling	287
11.2.2.10.1	General	287
11.2.2.10.2	Minimum requirements	287
11.3	Performance requirements for PUCCH	288
11.3.1	Requirements for <i>BS type 1-O</i>	288
11.3.1.1	DTX to ACK probability	288
11.3.1.2	Performance requirements for PUCCH format 0	288
11.3.1.3	Performance requirements for PUCCH format 1	288
11.3.1.4	Performance requirements for PUCCH format 2	288
11.3.1.5	Performance requirements for PUCCH format 3	288
11.3.1.6	Performance requirements for PUCCH format 4	288
11.3.1.7	Performance requirements for multi-slot PUCCH	288
11.3.1.8	Performance requirements for PUCCH format 1 with DMRS bundling	288
11.3.1.9	Performance requirements for PUCCH format 3 with DMRS bundling	289
11.3.1.10	Performance requirements for sub-slot repetition PUCCH format 0	289
11.3.2	Requirements for <i>BS type 2-O</i>	289
11.3.2.1	DTX to ACK probability	289
11.3.2.2	Performance requirements for PUCCH format 0	289
11.3.2.2.1	General	289
11.3.2.2.2	Minimum requirements	289
11.3.2.3	Performance requirements for PUCCH format 1	290
11.3.2.3.1	NACK to ACK requirements	290
11.3.2.3.1.1	General	290
11.3.2.3.1.2	Minimum requirements	291
11.3.2.3.2	ACK missed detection requirements	292
11.3.2.3.2.1	General	292
11.3.2.3.2.2	Minimum requirements	292
11.3.2.4	Performance requirements for PUCCH format 2	293
11.3.2.4.1	ACK missed detection requirements	293
11.3.2.4.1.1	General	293
11.3.2.4.1.2	Minimum requirements	293
11.3.2.4.2	UCI BLER performance requirements	294
11.3.2.4.2.1	General	294

11.3.2.4.2.2	Minimum requirements.....	294
11.3.2.5	Performance requirements for PUCCH format 3	295
11.3.2.5.1	General	295
11.3.2.5.2	Minimum requirements	295
11.3.2.6	Performance requirements for PUCCH format 4	296
11.3.2.6.1	General	296
11.3.2.6.2	Minimum requirements	297
11.3.2.7	Performance requirements for PUCCH format 1 with DMRS bundling.....	298
11.3.2.7.1	NACK to ACK requirements	298
11.3.2.7.1.1	General.....	298
11.3.2.7.1.2	Minimum requirements.....	299
11.3.2.7.2	ACK missed detection requirements	299
11.3.2.7.2.1	General.....	299
11.3.2.7.2.2	Minimum requirements.....	300
11.3.2.8	Performance requirements for PUCCH format 3 with DMRS bundling.....	300
11.3.2.8.1	General	300
11.3.2.8.2	Minimum requirements	301
11.4	Performance requirements for PRACH.....	301
11.4.1	Requirements for <i>BS type 1-O</i>	301
11.4.1.1	PRACH False alarm probability	301
11.4.1.2	PRACH detection requirements	301
11.4.2	Requirements for <i>BS type 2-O</i>	301
11.4.2.1	PRACH False alarm probability	301
11.4.2.1.1	General	301
11.4.2.1.2	Minimum requirement.....	301
11.4.2.2	PRACH detection requirements	302
11.4.2.2.1	General	302
11.4.2.2.2	Minimum requirements for Normal mode.....	302
11.4.2.2.3	Minimum requirements for high speed train	303
11.4.2.2.4	Minimum requirements for PRACH with $L_{RA}=1151$ and $L_{RA}=571$	303
Annex A (normative): Reference measurement channels		305
A.1	Fixed Reference Channels for reference sensitivity level, ACS, in-band blocking, out-of-band blocking, receiver intermodulation and in-channel selectivity (QPSK, R=1/3).....	305
A.2	Fixed Reference Channels for dynamic range (16QAM, R=2/3).....	308
A.3	Fixed Reference Channels for performance requirements (QPSK, R=193/1024)	310
A.3A	Fixed Reference Channels for performance requirements (QPSK, R=99/1024)	317
A.3B	Fixed Reference Channels for performance requirements (QPSK, R=308/1024)	319
A.4	Fixed Reference Channels for performance requirements (16QAM, R=658/1024)	323
A.5	Fixed Reference Channels for performance requirements (64QAM, R=567/1024)	328
A.6	PRACH Test preambles	331
A.7	Fixed Reference Channels for performance requirements (16QAM, R=434/1024)	332
A.8	Fixed Reference Channels for performance requirements (QPSK, R=157/1024)	334
A.9	Fixed Reference Channels for performance requirements (256QAM, R=682.5/1024)	335
A.10	Fixed Reference Channels for performance requirements (64QAM, R=517/1024)	336
Annex B (normative): Error Vector Magnitude (FR1)		340
B.1	Reference point for measurement.....	340
B.2	Basic unit of measurement	340
B.3	Modified signal under test.....	341
B.4	Estimation of frequency offset	341

B.5	Estimation of time offset	341
B.5.1	General	341
B.5.2	Window length	342
B.6	Estimation of TX chain amplitude and frequency response parameters	343
B.7	Averaged EVM	345
Annex C (normative):	Error Vector Magnitude (FR2)	347
C.1	Reference point for measurement	347
C.2	Basic unit of measurement	347
C.3	Modified signal under test	348
C.4	Estimation of frequency offset	348
C.5	Estimation of time offset	348
C.5.1	General	348
C.5.2	Window length	349
C.6	Estimation of TX chain amplitude and frequency response parameters	350
C.7	Averaged EVM	352
Annex D (normative):	Characteristics of the interfering signals	354
Annex E:	Void	355
Annex F (normative):	Relationship between EIRP based regulatory requirements and 3GPP requirements	356
F.1	General	356
F.2	Relationship between EIRP based regulatory requirements and conducted requirements	356
F.3	Relationship between EIRP based regulatory requirements and OTA requirements	357
Annex G (Normative):	Propagation conditions	358
G.1	Static propagation condition	358
G.2	Multi-path fading propagation conditions	358
G.2.1	Delay profiles	358
G.2.1.1	Delay profiles for FR1	359
G.2.1.2	Delay profiles for FR2	360
G.2.2	Combinations of channel model parameters	362
G.2.3	MIMO Channel Correlation Matrices	363
G.2.3.1	MIMO Correlation Matrices using Uniform Linear Array (ULA)	363
G.2.3.1.1	Definition of MIMO Correlation Matrices	363
G.2.3.1.2	MIMO Correlation Matrices at High, Medium and Low Level	367
G.2.3.2	Multi-Antenna channel models using cross polarized antennas	369
G.2.3.2.1	Definition of MIMO Correlation Matrices using cross polarized antennas	370
G.2.3.2.2	Spatial Correlation Matrices at UE and gNB sides	370
G.2.3.2.2.1	Spatial Correlation Matrices at UE side	370
G.2.3.2.2.2	Spatial Correlation Matrices at gNB side	371
G.2.3.2.3	MIMO Correlation Matrices using cross polarized antennas	371
G.3	High speed train condition	371
G.4	Moving propagation conditions	376
Annex H (informative):	Change history	378
History	390

Foreword

This Technical Specification has been produced by the 3rd Generation Partnership Project (3GPP).

The contents of the present document are subject to continuing work within the TSG and may change following formal TSG approval. Should the TSG modify the contents of the present document, it will be re-released by the TSG with an identifying change of release date and an increase in version number as follows:

Version x.y.z

where:

- x the first digit:
 - 1 presented to TSG for information;
 - 2 presented to TSG for approval;
 - 3 or greater indicates TSG approved document under change control.
- y the second digit is incremented for all changes of substance, i.e. technical enhancements, corrections, updates, etc.
- z the third digit is incremented when editorial only changes have been incorporated in the document.

In the present document, modal verbs have the following meanings:

- shall** indicates a mandatory requirement to do something
- shall not** indicates an interdiction (prohibition) to do something

The constructions "shall" and "shall not" are confined to the context of normative provisions, and do not appear in Technical Reports.

The constructions "must" and "must not" are not used as substitutes for "shall" and "shall not". Their use is avoided insofar as possible, and they are not used in a normative context except in a direct citation from an external, referenced, non-3GPP document, or so as to maintain continuity of style when extending or modifying the provisions of such a referenced document.

- should** indicates a recommendation to do something
- should not** indicates a recommendation not to do something
- may** indicates permission to do something
- need not** indicates permission not to do something

The construction "may not" is ambiguous and is not used in normative elements. The unambiguous constructions "might not" or "shall not" are used instead, depending upon the meaning intended.

- can** indicates that something is possible
- cannot** indicates that something is impossible

The constructions "can" and "cannot" are not substitutes for "may" and "need not".

- will** indicates that something is certain or expected to happen as a result of action taken by an agency the behaviour of which is outside the scope of the present document
- will not** indicates that something is certain or expected not to happen as a result of action taken by an agency the behaviour of which is outside the scope of the present document
- might** indicates a likelihood that something will happen as a result of action taken by some agency the behaviour of which is outside the scope of the present document

might not indicates a likelihood that something will not happen as a result of action taken by some agency the behaviour of which is outside the scope of the present document

In addition:

is (or any other verb in the indicative mood) indicates a statement of fact

is not (or any other negative verb in the indicative mood) indicates a statement of fact

The constructions "is" and "is not" do not indicate requirements.

1 Scope

The present document establishes the minimum RF characteristics and minimum performance requirements of NR and NB-IoT operation in NR in-band Base Station (BS).

2 References

The following documents contain provisions which, through reference in this text, constitute provisions of the present document.

- References are either specific (identified by date of publication, edition number, version number, etc.) or non-specific.
- For a specific reference, subsequent revisions do not apply.
- For a non-specific reference, the latest version applies. In the case of a reference to a 3GPP document (including a GSM document), a non-specific reference implicitly refers to the latest version of that document *in the same Release as the present document*.

- [1] 3GPP TR 21.905: "Vocabulary for 3GPP Specifications".
- [2] ITU-R Recommendation SM.329: "Unwanted emissions in the spurious domain".
- [3] Recommendation ITU-R SM.328: "Spectra and bandwidth of emissions".
- [4] 3GPP TR 25.942: "RF system scenarios".
- [5] 3GPP TS 38.141-1: "NR; Base Station (BS) conformance testing; Part 1: Conducted conformance testing".
- [6] 3GPP TS 38.141-2: "NR; Base Station (BS) conformance testing; Part 2: Radiated conformance testing".
- [7] Recommendation ITU-R M.1545: "Measurement uncertainty as it applies to test limits for the terrestrial component of International Mobile Telecommunications-2000".
- [8] "Title 47 of the Code of Federal Regulations (CFR)", Federal Communications Commission.
- [9] 3GPP TS 38.211: "NR; Physical channels and modulation".
- [10] 3GPP TS 38.213: "NR; Physical layer procedures for control".
- [11] 3GPP TS 38.331: "NR; Radio Resource Control (RRC); Protocol specification".
- [12] ECC/DEC/(17)06: "The harmonised use of the frequency bands 1427-1452 MHz and 1492-1518 MHz for Mobile/Fixed Communications Networks Supplemental Downlink (MFCN SDL)"
- [13] 3GPP TS 36.104: "Evolved Universal Terrestrial Radio Access (E-UTRA); Base Station (BS) radio transmission and reception".
- [14] 3GPP TS 37.105: "Active Antenna System (AAS) Base Station (BS) transmission and reception".
- [15] 3GPP TS 38.212: "NR; Multiplexing and channel coding".
- [16] 3GPP TR 38.901: "Study on channel model for frequencies from 0.5 to 100 GHz"
- [17] 3GPP TS 38.101-1: "NR; User Equipment (UE) radio transmission and reception; Part 1: Range 1 Standalone".
- [18] 3GPP TS 38.101-2: "NR; User Equipment (UE) radio transmission and reception; Part 2: Range 2 Standalone"
- [19] ERC Recommendation 74-01, "Unwanted emissions in the spurious domain".

- [20] 3GPP TS 37.213: "Physical layer procedures for shared spectrum channel access".
- [21] ECC Decision(20)02: "Harmonised use of the paired frequency bands 874.4-880.0 MHz and 919.4-925.0 MHz and of the unpaired frequency band 1900-1910 MHz for Railway Mobile Radio (RMR)"
- [22] 3GPP TR 38.852: Introduction of 1900MHz NR band for Europe for Rail Mobile Radio (RMR)
- [23] 3GPP TR 38.853: Introduction of 900MHz NR band for Europe for Rail Mobile Radio (RMR)
- [24] FCC Report And Order And Further Notice Of Proposed Rulemaking FCC 20-51, April 2020.
- [25] FCC Order DA 20-48, April 2020

3 Definitions, symbols and abbreviations

3.1 Definitions

For the purposes of the present document, the terms and definitions given in 3GPP TR 21.905 [1] and the following apply. A term defined in the present document takes precedence over the definition of the same term, if any, in 3GPP TR 21.905 [1].

Aggregated BS Channel Bandwidth: The RF bandwidth in which a Base Station transmits and receives multiple contiguously aggregated carriers. The *aggregated BS channel bandwidth* is measured in MHz.

antenna connector: connector at the conducted interface of the *BS type 1-C*

active transmitter unit: transmitter unit which is ON, and has the ability to send modulated data streams that are parallel and distinct to those sent from other transmitter units to a *BS type 1-C antenna connector*, or to one or more *BS type 1-H TAB connectors* at the *transceiver array boundary*

Base Station RF Bandwidth: RF bandwidth in which a base station transmits and/or receives single or multiple carrier(s) within a supported *operating band*

NOTE: In single carrier operation, the *Base Station RF Bandwidth* is equal to the *BS channel bandwidth*.

Base Station RF Bandwidth edge: frequency of one of the edges of the *Base Station RF Bandwidth*.

basic limit: emissions limit relating to the power supplied by a single transmitter to a single antenna transmission line in ITU-R SM.329 [2] used for the formulation of unwanted emission requirements for FR1

beam: beam (of the antenna) is the main lobe of the radiation pattern of an *antenna array*

NOTE: For certain *BS antenna array*, there may be more than one beam.

beam centre direction: direction equal to the geometric centre of the half-power contour of the beam

beam direction pair: data set consisting of the *beam centre direction* and the related *beam peak direction*

beam peak direction: direction where the maximum EIRP is found

beamwidth: beam which has a half-power contour that is essentially elliptical, the half-power beamwidths in the two pattern cuts that respectively contain the major and minor axis of the ellipse

BS channel bandwidth: RF bandwidth supporting a single NR RF carrier with the *transmission bandwidth* configured in the uplink or downlink

NOTE 1: The *BS channel bandwidth* is measured in MHz and is used as a reference for transmitter and receiver RF requirements.

NOTE 2: It is possible for the BS to transmit to and/or receive from one or more UE bandwidth parts that are smaller than or equal to the *BS transmission bandwidth configuration*, in any part of the *BS transmission bandwidth configuration*.

BS transmission bandwidth configuration: set of resource blocks located within the *BS channel bandwidth* which may be used for transmitting or receiving by the BS

BS type 1-C: NR base station operating at FR1 with requirements set consisting only of conducted requirements defined at individual *antenna connectors*

BS type 1-H: NR base station operating at FR1 with a *requirement set* consisting of conducted requirements defined at individual *TAB connectors* and OTA requirements defined at RIB

BS type 1-O: NR base station operating at FR1 with a *requirement set* consisting only of OTA requirements defined at the RIB

BS type 2-O: NR base station operating at FR2 with a *requirement set* consisting only of OTA requirements defined at the RIB

Channel edge: lowest or highest frequency of the NR carrier, separated by the *BS channel bandwidth*.

Carrier aggregation: aggregation of two or more component carriers in order to support wider *transmission bandwidths*

Carrier aggregation configuration: a set of one or more *operating bands* across which the BS aggregates carriers with a specific set of technical requirements

co-location reference antenna: a passive antenna used as reference for base station to base station co-location requirements

Contiguous carriers: set of two or more carriers configured in a spectrum block where there are no RF requirements based on co-existence for un-coordinated operation within the spectrum block.

Contiguous spectrum: spectrum consisting of a contiguous block of spectrum with no *sub-block gap(s)*.

directional requirement: requirement which is applied in a specific direction within the *OTA coverage range* for the Tx and when the AoA of the incident wave of a received signal is within the *OTA REFSENS RoAoA* or the *minSENS RoAoA* as appropriate for the receiver

equivalent isotropic radiated power: equivalent power radiated from an isotropic directivity device producing the same field intensity at a point of observation as the field intensity radiated in the direction of the same point of observation by the discussed device

NOTE: Isotropic directivity is equal in all directions (i.e. 0 dBi).

equivalent isotropic sensitivity: sensitivity for an isotropic directivity device equivalent to the sensitivity of the discussed device exposed to an incoming wave from a defined AoA

NOTE 1: The sensitivity is the minimum received power level at which specific requirement is met.

NOTE 2: Isotropic directivity is equal in all directions (i.e. 0 dBi).

fractional bandwidth: *fractional bandwidth* FBW is defined as $FBW = 200 \cdot \frac{F_{FBW_{high}} - F_{FBW_{low}}}{F_{FBW_{high}} + F_{FBW_{low}}} \%$

Highest Carrier: The carrier with the highest carrier frequency transmitted/received in a specified frequency band.

Inter-band carrier aggregation: *carrier aggregation* of component carriers in different *operating bands*.

NOTE: Carriers aggregated in each band can be contiguous or non-contiguous.

Inter-band gap: The frequency gap between two supported consecutive *operating bands*.

Intra-band contiguous carrier aggregation: *contiguous carriers* aggregated in the same *operating band*.

Intra-band non-contiguous carrier aggregation: non-contiguous carriers aggregated in the same *operating band*.

Inter RF Bandwidth gap: frequency gap between two consecutive *Base Station RF Bandwidths* that are placed within two supported *operating bands*

Lowest Carrier: The carrier with the lowest carrier frequency transmitted/received in a specified frequency band.

Lower sub-block edge: frequency at the lower edge of one *sub-block*.

NOTE: It is used as a frequency reference point for both transmitter and receiver requirements.

maximum carrier output power: mean power level measured per carrier at the indicated interface, during the *transmitter ON period* in a specified reference condition

maximum carrier TRP output power: mean power level measured per RIB during the *transmitter ON period* for a specific carrier in a specified reference condition and corresponding to the declared *rated carrier TRP output power* ($P_{\text{rated,c,TRP}}$)

maximum total output power: mean power level measured within the *operating band* at the indicated interface, during the *transmitter ON period* in a specified reference condition

maximum total TRP output power: mean power level measured per RIB during the *transmitter ON period* in a specified reference condition and corresponding to the declared *rated total TRP output power* ($P_{\text{rated,t,TRP}}$)

measurement bandwidth: RF bandwidth in which an emission level is specified

minSENS: the lowest declared EIS value for the OSDD's declared for OTA sensitivity requirement.

minSENS RoAoA: The *reference RoAoA* associated with the OSDD with the lowest declared EIS

multi-band connector: *Antenna Connector of BS type 1-C* or *TAB connector of BS type 1-H* associated with a transmitter or receiver that is characterized by the ability to process two or more carriers in common active RF components simultaneously, where at least one carrier is configured at a different *operating band* than the other carrier(s) and where this different *operating band* is not a *sub-band* or *superseding-band* of another supported *operating band*

multi-band RIB: *operating band* specific RIB associated with a transmitter or receiver that is characterized by the ability to process two or more carriers in common active RF components simultaneously, where at least one carrier is configured at a different *operating band* than the other carrier(s) and where this different *operating band* is not a *sub-band* or *superseding-band* of another supported *operating band*

Multi-carrier transmission configuration: set of one or more contiguous or non-contiguous carriers that a NR BS is able to transmit simultaneously according to the manufacturer's specification.

NB-IoT operation in NR in-band: NB-IoT is operating in-band when it is located within a NR transmission bandwidth configuration plus 15 kHz at each edge but not within the NR minimum guard band GB_{Channel} .

NB-IoT operation in NR guard band: NB-IoT is operating in guard band when it is located within a NR BS channel bandwidth but is not NB-IoT operation in NR in-band.

Non-contiguous spectrum: spectrum consisting of two or more *sub-blocks* separated by *sub-block gap(s)*.

operating band: frequency range in which NR operates (paired or unpaired), that is defined with a specific set of technical requirements

NOTE: The *operating band(s)* for a BS is declared by the manufacturer according to the designations in tables 5.2-1 and 5.2-2.

OTA coverage range: a common range of directions within which TX OTA requirements that are neither specified in the *OTA peak directions sets* nor as *TRP requirement* are intended to be met

OTA peak directions set: set(s) of *beam peak directions* within which certain TX OTA requirements are intended to be met, where all *OTA peak directions set(s)* are subsets of the *OTA coverage range*

NOTE: The *beam peak directions* are related to a corresponding contiguous range or discrete list of *beam centre directions* by the *beam direction pairs* included in the set.

OTA REFSENS RoAoA: the RoAoA determined by the contour defined by the points at which the achieved EIS is 3dB higher than the achieved EIS in the reference direction assuming that for any AoA, the receiver gain is optimized for that AoA

NOTE: This contour will be related to the average element/sub-array radiation pattern 3dB beamwidth.

OTA sensitivity directions declaration: set of manufacturer declarations comprising at least one set of declared minimum EIS values (with *BS channel bandwidth*), and related directions over which the EIS applies

NOTE: All the directions apply to all the EIS values in an OSDD.

polarization match: condition that exists when a plane wave, incident upon an antenna from a given direction, has a polarization that is the same as the receiving polarization of the antenna in that direction

radiated interface boundary: *operating band* specific radiated requirements reference where the radiated requirements apply

NOTE: For requirements based on EIRP/EIS, the *radiated interface boundary* is associated to the far-field region

Radio Bandwidth: frequency difference between the upper edge of the highest used carrier and the lower edge of the lowest used carrier

Railway Mobile Radio: railway operations encompassing GSM-R and its successor(s), including the Future Railway Mobile Communication System (FRMCS); in the context of this specification the Railway Mobile Radio is limited to NR operation in band n100, or n101

rated beam EIRP: For a declared beam and *beam direction pair*, the *rated beam EIRP* level is the maximum power that the base station is declared to radiate at the associated *beam peak direction* during the *transmitter ON period*

rated carrier output power: mean power level associated with a particular carrier the manufacturer has declared to be available at the indicated interface, during the *transmitter ON period* in a specified reference condition

rated carrier TRP output power: mean power level declared by the manufacturer per carrier, for BS operating in single carrier, multi-carrier, or carrier aggregation configurations that the manufacturer has declared to be available at the RIB during the *transmitter ON period*

rated total output power: mean power level associated with a particular *operating band* the manufacturer has declared to be available at the indicated interface, during the *transmitter ON period* in a specified reference condition

rated total TRP output power: mean power level declared by the manufacturer, that the manufacturer has declared to be available at the RIB during the *transmitter ON period*

reference beam direction pair: declared *beam direction pair*, including reference *beam centre direction* and reference *beam peak direction* where the reference *beam peak direction* is the direction for the intended maximum EIRP within the *OTA peak directions set*

receiver target: AoA in which reception is performed by *BS types 1-H* or *BS type 1-O*

receiver target redirection range: union of all the *sensitivity RoAoA* achievable through redirecting the *receiver target* related to particular OSDD

receiver target reference direction: direction inside the *OTA sensitivity directions declaration* declared by the manufacturer for conformance testing. For an OSDD without *receiver target redirection range*, this is a direction inside the *sensitivity RoAoA*

reference RoAoA: the *sensitivity RoAoA* associated with the *receiver target reference direction* for each OSDD.

requirement set: one of the NR base station requirement's set as defined for *BS type 1-C*, *BS type 1-H*, *BS type 1-O*, and *BS type 2-O*

sensitivity RoAoA: RoAoA within the *OTA sensitivity directions declaration*, within which the declared EIS(s) of an OSDD is intended to be achieved at any instance of time for a specific BS direction setting

single-band connector: *BS type 1-C antenna connector* or *BS type 1-H TAB connector* supporting operation either in a single *operating band* only, or in multiple *operating bands* but does not meet the conditions for a *multi-band connector*.

single-band RIB: *operating band* specific RIB supporting operation either in a single *operating band* only, or in multiple *operating bands* but does not meet the conditions for a *multi-band RIB*.

sub-band: A *sub-band* of an operating band contains a part of the uplink and downlink frequency range of the operating band.

sub-block bandwidth: bandwidth of one *sub-block*.

sub-block: one contiguous allocated block of spectrum for transmission and reception by the same base station

NOTE: There may be multiple instances of *sub-blocks* within a *Base Station RF Bandwidth*.

sub-block gap: frequency gap between two consecutive sub-blocks within a *Base Station RF Bandwidth*, where the RF requirements in the gap are based on co-existence for un-coordinated operation

superseding-band: A *superseding-band* of an operating band includes the whole of the uplink and downlink frequency range of the operating band.

TAB connector: *transceiver array boundary* connector

TAB connector RX min cell group: *operating band* specific declared group of *TAB connectors* to which *BS type 1-H* conducted RX requirements are applied

NOTE: Within this definition, the group corresponds to the group of *TAB connectors* which are responsible for receiving a cell when the *BS type 1-H* setting corresponding to the declared minimum number of cells with reception on all *TAB connectors* supporting an *operating band*, but its existence is not limited to that condition

TAB connector TX min cell group: *operating band* specific declared group of *TAB connectors* to which *BS type 1-H* conducted TX requirements are applied.

NOTE: Within this definition, the group corresponds to the group of *TAB connectors* which are responsible for transmitting a cell when the *BS type 1-H* setting corresponding to the declared minimum number of cells with transmission on all *TAB connectors* supporting an *operating band*, but its existence is not limited to that condition

total radiated power: is the total power radiated by the antenna

NOTE: The *total radiated power* is the power radiating in all direction for two orthogonal polarizations. *Total radiated power* is defined in both the near-field region and the far-field region

transceiver array boundary: conducted interface between the transceiver unit array and the composite antenna

transmission bandwidth: RF Bandwidth of an instantaneous transmission from a UE or BS, measured in resource block units

transmitter OFF period: time period during which the BS transmitter is not allowed to transmit

transmitter ON period: time period during which the BS transmitter is transmitting data and/or reference symbols

transmitter transient period: time period during which the transmitter is changing from the OFF period to the ON period or vice versa

UE transmission bandwidth configuration: set of resource blocks located within the UE channel bandwidth which may be used for transmitting or receiving by the UE

upper sub-block edge: frequency at the upper edge of one *sub-block*.

NOTE: It is used as a frequency reference point for both transmitter and receiver requirements.

3.2 Symbols

For the purposes of the present document, the following symbols apply:

β	Percentage of the mean transmitted power emitted outside the occupied bandwidth on the assigned channel
$BeW_{\theta,REFSENS}$	Beamwidth equivalent to the <i>OTA REFSENS RoAoA</i> in the θ -axis in degrees. Applicable for FR1 only.
$BeW_{\varphi,REFSENS}$	Beamwidth equivalent to the <i>OTA REFSENS RoAoA</i> in the φ -axis in degrees. Applicable for FR1 only.
$BW_{Channel}$	<i>BS channel bandwidth</i>
$BW_{Channel,CA}$	<i>Aggregated BS Channel Bandwidth</i> , expressed in MHz. $BW_{Channel,CA} = F_{edge,high} - F_{edge,low}$.
$BW_{Channel,block}$	<i>Sub-block bandwidth</i> , expressed in MHz. $BW_{Channel,block} = F_{edge,block,high} - F_{edge,block,low}$.
BW_{Config}	<i>Transmission bandwidth configuration</i> , where $BW_{Config} = N_{RB} \times SCS \times 12$
$BW_{Contiguous}$	<i>Contiguous transmission bandwidth</i> , i.e. <i>BS channel bandwidth</i> for single carrier or <i>Aggregated BS channel bandwidth</i> for contiguously aggregated carriers. For non-contiguous operation within a band the term is applied per <i>sub-block</i> .
$BW_{GB,low}$	The minimum guard band defined in clause 5.3.3 for lowest assigned component carrier
$BW_{GB,high}$	The minimum guard band defined in clause 5.3.3 for highest assigned component carrier
Δf	Separation between the <i>channel edge</i> frequency and the nominal -3 dB point of the measuring filter closest to the carrier frequency
Δf_{BE_offset}	Separation between the edge of the last transmitted channel of the channels assigned for NR-U channel bandwidth and the nominal -3 dB point of the measuring filter closest to the carrier frequency
ΔF_{Global}	Global frequency raster granularity
Δf_{max}	$f_{offset,max}$ minus half of the bandwidth of the measuring filter
Δf_{OBUE}	Maximum offset of the <i>operating band</i> unwanted emissions mask from the downlink <i>operating band edge</i>
Δf_{OOB}	Maximum offset of the out-of-band boundary from the uplink <i>operating band edge</i>
$\Delta f_{FR2_REFSENS}$	Offset applied to the FR2 OTA REFSENS depending on the AoA
$\Delta f_{minSENS}$	Difference between conducted reference sensitivity and minSENS
$\Delta f_{OTAREFSNS}$	Difference between conducted reference sensitivity and OTA REFSENS
ΔF_{Raster}	Channel raster granularity
Δf_{shift}	Channel raster offset for SUL
$EIS_{minSENS}$	The EIS declared for the <i>minSENS RoAoA</i>
$EIS_{REFSENS}$	OTA REFSENS EIS value
$EIS_{REFSENS_50M}$	Declared OTA reference sensitivity basis level for FR2 based on a reference measurement channel with 50MHz <i>BS channel bandwidth</i>
$F_{FBWhigh}$	Highest supported frequency within supported <i>operating band</i> , for which <i>fractional bandwidth</i> support was declared
F_{FBWlow}	Lowest supported frequency within supported <i>operating band</i> , for which <i>fractional bandwidth</i> support was declared
F_C	<i>RF reference frequency</i> on the channel raster, given in table 5.4.2.2-1
$F_{C,block,high}$	F_C of the highest transmitted/received carrier in a <i>sub-block</i> .
$F_{C,block,low}$	F_C of the lowest transmitted/received carrier in a <i>sub-block</i> .
$F_{C,low}$	The F_C of the <i>lowest carrier</i> , expressed in MHz.
$F_{C,high}$	The F_C of the <i>highest carrier</i> , expressed in MHz.
$F_{DL,low}$	The lowest frequency of the downlink <i>operating band</i>
$F_{DL,high}$	The highest frequency of the downlink <i>operating band</i>
$F_{edge,low}$	The lower edge of <i>Aggregated BS Channel Bandwidth</i> , expressed in MHz. $F_{edge,low} = F_{C,low} - F_{offset,low}$.
$F_{edge,high}$	The upper edge of <i>Aggregated BS Channel Bandwidth</i> , expressed in MHz. $F_{edge,high} = F_{C,high} + F_{offset,high}$.
$F_{edge,block,low}$	The <i>lower sub-block edge</i> , where $F_{edge,block,low} = F_{C,block,low} - F_{offset,low}$.
$F_{edge,block,high}$	The <i>upper sub-block edge</i> , where $F_{edge,block,high} = F_{C,block,high} + F_{offset,high}$.
F_{filter}	Filter centre frequency
$F_{offset,high}$	Frequency offset from $F_{C,high}$ to the upper <i>Base Station RF Bandwidth edge</i> , or from $F_{C,block,high}$ to the <i>upper sub-block edge</i>
$F_{offset,low}$	Frequency offset from $F_{C,low}$ to the lower <i>Base Station RF Bandwidth edge</i> , or from $F_{C,block,low}$ to the <i>lower sub-block edge</i> .

f_{BE_offset}	Separation between the edge of the last transmitted channel of the channels assigned for NR-U channel bandwidth and the centre of the measuring
f_{offset}	Separation between the <i>channel edge</i> frequency and the centre of the measuring
$f_{offset_{max}}$	The offset to the frequency Δf_{OBUe} outside the downlink <i>operating band</i>
F_{REF}	RF reference frequency
$F_{REF-Offs}$	Offset used for calculating F_{REF}
$F_{REF,shift}$	RF reference frequency for Supplementary Uplink (SUL) bands
$F_{step,X}$	Frequency steps for the OTA transmitter spurious emissions (Category B)
$F_{UL,low}$	The lowest frequency of the uplink <i>operating band</i>
$F_{UL,high}$	The highest frequency of the uplink <i>operating band</i>
$GB_{Channel}$	Minimum guard band defined in clause 5.3.3
N_{cells}	The declared number corresponding to the minimum number of cells that can be transmitted by an <i>BS type 1-H</i> in a particular <i>operating band</i>
n_{PRB}	Physical resource block number
N_{RB}	<i>Transmission bandwidth configuration</i> , expressed in resource blocks
$N_{RB,high}$	<i>Transmission bandwidth configuration</i> for the highest assigned component carrier within a <i>sub-block</i> in CA
$N_{RB,low}$	<i>Transmission bandwidth configuration</i> for the lowest assigned component carrier within a <i>sub-block</i> in CA
N_{REF}	NR Absolute Radio Frequency Channel Number (NR-ARFCN)
$N_{REF-Offs}$	Offset used for calculating N_{REF}
$N_{RXU,active}$	The number of active receiver units. The same as the number of <i>demodulation branches</i> to which compliance is declared for chapter 8 performance requirements
$N_{RXU,counted}$	The number of active receiver units that are taken into account for conducted Rx spurious emission scaling, as calculated in clause 7.6.1
$N_{RXU,countedpercell}$	The number of active receiver units that are taken into account for conducted RX spurious emissions scaling per cell, as calculated in clause 7.6.1
$N_{TXU,counted}$	The number of <i>active transmitter units</i> as calculated in clause 6.1, that are taken into account for conducted TX output power limit in clause 6.2.1, and for unwanted TX emissions scaling
$N_{TXU,countedpercell}$	The number of <i>active transmitter units</i> that are taken into account for conducted TX emissions scaling per cell, as calculated in clause 6.1
$P_{EM,n50/n75,ind}$	Declared emission level for Band n50/n75; ind = a, b
$P_{EIRP,N}$	EIRP level for channel N
$P_{max,c,AC}$	<i>Maximum carrier output power</i> measured per <i>antenna connector</i>
$P_{max,c,cell}$	The <i>maximum carrier output power</i> per <i>TAB connector TX min cell group</i>
$P_{max,c,TABC}$	The <i>maximum carrier output power</i> per <i>TAB connector</i>
$P_{max,c,TRP}$	<i>Maximum carrier TRP output power</i> measured at the RIB(s), and corresponding to the declared <i>rated carrier TRP output power</i> ($P_{rated,c,TRP}$)
$P_{max,c,EIRP}$	The maximum carrier EIRP when the NR BS is configured at the maximum rated carrier output TRP ($P_{rated,c,TRP}$)
$P_{rated,c,AC}$	The <i>rated carrier output power</i> per <i>antenna connector</i>
$P_{rated,c,cell}$	The <i>rated carrier output power</i> per <i>TAB connector TX min cell group</i>
$P_{rated,c,FBWhigh}$	The rated carrier EIRP for the higher supported frequency range within supported <i>operating band</i> , for which <i>fractional bandwidth</i> support was declared
$P_{rated,c,FBWlow}$	The rated carrier EIRP for the lower supported frequency range within supported <i>operating band</i> , for which <i>fractional bandwidth</i> support was declared
$P_{rated,c,sys}$	The sum of $P_{rated,c,TABC}$ for all <i>TAB connectors</i> for a single carrier
$P_{rated,c,TABC}$	The <i>rated carrier output power</i> per <i>TAB connector</i>
$P_{rated,c,TRP}$	<i>Rated carrier TRP output power</i> declared per RIB
$P_{rated,t,AC}$	The <i>rated total output power</i> declared at the <i>antenna connector</i>
$P_{rated,t,TABC}$	The <i>rated total output power</i> declared at <i>TAB connector</i>
$P_{rated,t,TRP}$	<i>Rated total TRP output power</i> declared per RIB
$P_{REFSENS}$	Conducted Reference Sensitivity power level
SCS_{low}	Sub-Carrier Spacing for the lowest assigned component carrier within a <i>sub-block</i> in CA
SCS_{high}	Sub-Carrier Spacing for the highest assigned component carrier within a <i>sub-block</i> in CA
SS_{REF}	SS block reference frequency position
W_{gap}	<i>Sub-block gap</i> or <i>Inter RF Bandwidth gap</i> size

3.3 Abbreviations

For the purposes of the present document, the abbreviations given in 3GPP TR 21.905 [1] and the following apply. An abbreviation defined in the present document takes precedence over the definition of the same abbreviation, if any, in 3GPP TR 21.905 [1].

AA	Antenna Array
AAS	Active Antenna System
ACLR	Adjacent Channel Leakage Ratio
ACS	Adjacent Channel Selectivity
AoA	Angle of Arrival
AWGN	Additive White Gaussian Noise
BS	Base Station
BW	Bandwidth
CA	Carrier Aggregation
CACLR	Cumulative ACLR
CPE	Common Phase Error
CP-OFDM	Cyclic Prefix-OFDM
CW	Continuous Wave
DFT-s-OFDM	Discrete Fourier Transform-spread-OFDM
DM-RS	Demodulation Reference Signal
EIS	Equivalent Isotropic Sensitivity
EIRP	Effective Isotropic Radiated Power
E-UTRA	Evolved UTRA
EVM	Error Vector Magnitude
FBW	Fractional Bandwidth
FR	Frequency Range
FRC	Fixed Reference Channel
FRMCS	Future Railway Mobile Communication System
GSCN	Global Synchronization Channel Number
GSM	Global System for Mobile communications
HAPS	High Altitude Platform Station
ITU-R	Radiocommunication Sector of the International Telecommunication Union
ICS	In-Channel Selectivity
LA	Local Area
LNA	Low Noise Amplifier
MCS	Modulation and Coding Scheme
MR	Medium Range
NB-IoT	Narrowband – Internet of Things
NR	New Radio
NR-ARFCN	NR Absolute Radio Frequency Channel Number
OBUE	Operating Band Unwanted Emissions
OCC	Orthogonal Covering Code
OOB	Out-of-band
OSDD	OTA Sensitivity Directions Declaration
OTA	Over-The-Air
PRB	Physical Resource Block
PT-RS	Phase Tracking Reference Signal
QAM	Quadrature Amplitude Modulation
RB	Resource Block
RDN	Radio Distribution Network
RE	Resource Element
REFSENS	Reference Sensitivity
RF	Radio Frequency
RIB	Radiated Interface Boundary
RMR	Railway Mobile Radio
RMS	Root Mean Square (value)
RoAoA	Range of Angles of Arrival
QAM	Quadrature Amplitude Modulation
RB	Resource Block
RX	Receiver

SCS	Sub-Carrier Spacing
SDL	Supplementary Downlink
SS	Synchronization Symbol
SSB	Synchronization Signal Block
SUL	Supplementary Uplink
TAB	Transceiver Array Boundary
TAE	Time Alignment Error
TDL	Tapped Delay Line
TX	Transmitter
TRP	Total Radiated Power
UCI	Uplink Control Information
UEM	Unwanted Emissions Mask
UTRA	Universal Terrestrial Radio Access
WA	Wide Area
ZF	Zero Forcing

4 General

4.1 Relationship with other core specifications

The present document is a single-RAT specification for a BS, covering RF characteristics and minimum performance requirements. Conducted and radiated core requirements are defined for the BS architectures and BS types defined in clause 4.3.

The applicability of each requirement is described in clause 5.

4.2 Relationship between minimum requirements and test requirements

Conformance to the present specification is demonstrated by fulfilling the test requirements specified in the conformance specification TS 38.141-1 [5] and TS 38.141-2 [6].

The minimum requirements given in this specification make no allowance for measurement uncertainty. The test specifications TS 38.141-1 [5] and TS 38.141-2 [6] define test tolerances. These test tolerances are individually calculated for each test. The test tolerances are used to relax the minimum requirements in this specification to create test requirements. For some requirements, including regulatory requirements, the test tolerance is set to zero.

The measurement results returned by the test system are compared - without any modification - against the test requirements as defined by the shared risk principle.

The shared risk principle is defined in recommendation ITU-R M.1545 [7].

4.3 Conducted and radiated requirement reference points

4.3.1 BS type 1-C

For *BS type 1-C*, the requirements are applied at the BS *antenna connector* (port A) for a single transmitter or receiver with a full complement of transceivers for the configuration in normal operating conditions. If any external apparatus such as an amplifier, a filter or the combination of such devices is used, requirements apply at the far end *antenna connector* (port B).

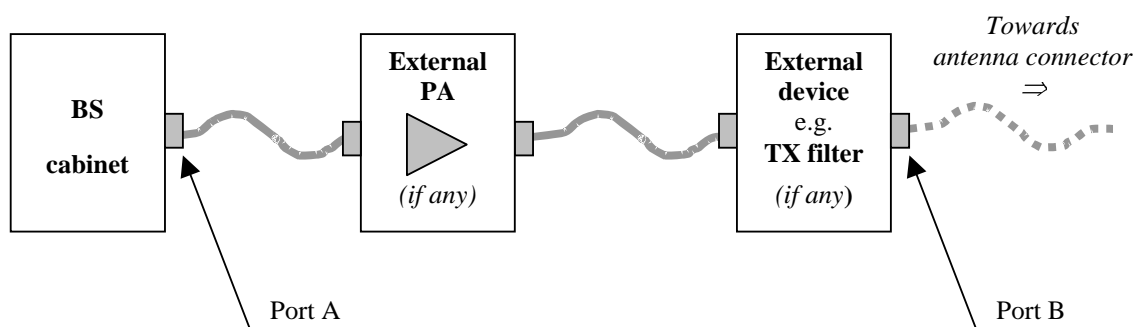

Figure 4.3.1-1: *BS type 1-C* transmitter interface

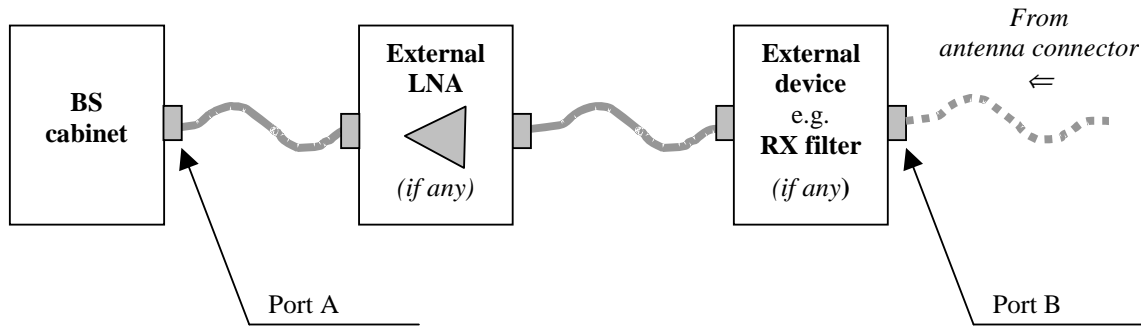

Figure 4.3.1-2: BS type 1-C receiver interface

4.3.2 BS type 1-H

For BS type 1-H, the requirements are defined for two points of reference, signified by radiated requirements and conducted requirements.

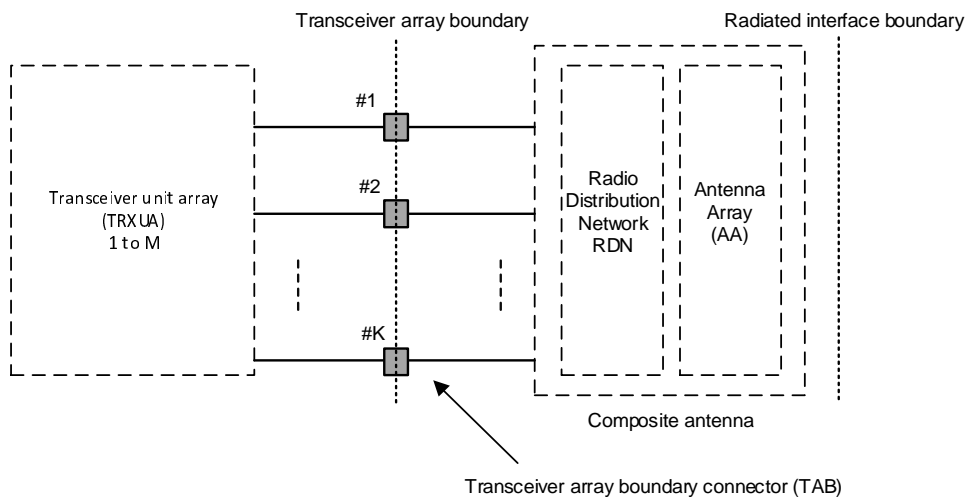

Figure 4.3.2-1: Radiated and conducted reference points for BS type 1-H

Radiated characteristics are defined over the air (OTA), where the *operating band* specific radiated interface is referred to as the *Radiated Interface Boundary* (RIB). Radiated requirements are also referred to as OTA requirements. The (spatial) characteristics in which the OTA requirements apply are detailed for each requirement.

Conducted characteristics are defined at individual or groups of *TAB connectors* at the *transceiver array boundary*, which is the conducted interface between the transceiver unit array and the composite antenna.

The transceiver unit array is part of the composite transceiver functionality generating modulated transmit signal structures and performing receiver combining and demodulation.

The transceiver unit array contains an implementation specific number of transmitter units and an implementation specific number of receiver units. Transmitter units and receiver units may be combined into transceiver units. The transmitter/receiver units have the ability to transmit/receive parallel independent modulated symbol streams.

The composite antenna contains a radio distribution network (RDN) and an antenna array. The RDN is a linear passive network which distributes the RF power generated by the transceiver unit array to the antenna array, and/or distributes the radio signals collected by the antenna array to the transceiver unit array, in an implementation specific way.

How a conducted requirement is applied to the *transceiver array boundary* is detailed in the respective requirement clause.

4.3.3 BS type 1-O and BS type 2-O

For *BS type 1-O* and *BS type 2-O*, the radiated characteristics are defined over the air (OTA), where the *operating band* specific radiated interface is referred to as the *Radiated Interface Boundary* (RIB). Radiated requirements are also referred to as OTA requirements. The (spatial) characteristics in which the OTA requirements apply are detailed for each requirement.

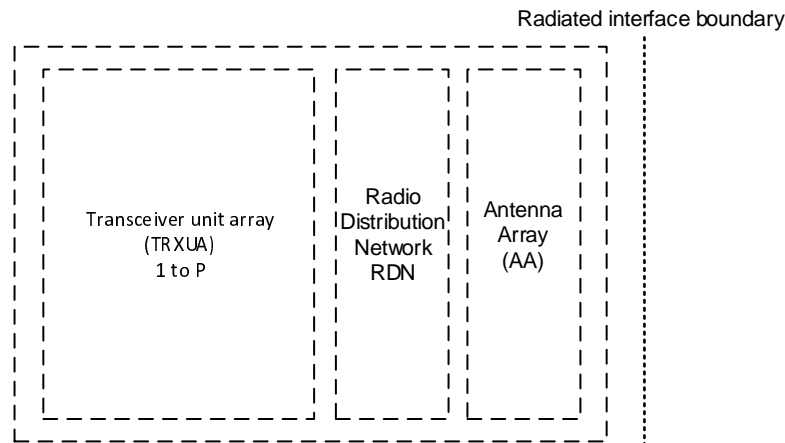

Figure 4.3.3-1: Radiated reference points for BS type 1-O and BS type 2-O

Co-location requirements are specified at the conducted interface of the *co-location reference antenna*, the *co-location reference antenna* does not form part of the BS under test but is a means to provide OTA power levels which are representative of a co-located system, further defined in clause 4.9.

For a *BS type 1-O* the transceiver unit array must contain at least 8 transmitter units and at least 8 receiver units. Transmitter units and receiver units may be combined into transceiver units. The transmitter/receiver units have the ability to transmit/receive parallel independent modulated symbol streams.

4.4 Base station classes

The requirements in this specification apply to Wide Area Base Stations, Medium Range Base Stations and Local Area Base Stations unless otherwise stated. The associated deployment scenarios for each class are exactly the same for BS with and without connectors.

For *BS type 1-O* and 2-O, BS classes are defined as indicated below:

- Wide Area Base Stations are characterised by requirements derived from Macro Cell scenarios with a BS to UE minimum distance along the ground equal to 35 m.
- Medium Range Base Stations are characterised by requirements derived from Micro Cell scenarios with a BS to UE minimum distance along the ground equal to 5 m.
- Local Area Base Stations are characterised by requirements derived from Pico Cell scenarios with a BS to UE minimum distance along the ground equal to 2 m.

For *BS type 1-C* and 1-H, BS classes are defined as indicated below:

- Wide Area Base Stations are characterised by requirements derived from Macro Cell scenarios with a BS to UE minimum coupling loss equal to 70 dB.
- Medium Range Base Stations are characterised by requirements derived from Micro Cell scenarios with a BS to UE minimum coupling loss equals to 53 dB.
- Local Area Base Stations are characterised by requirements derived from Pico Cell scenarios with a BS to UE minimum coupling loss equal to 45 dB.

NOTE: Local Area Base stations are applicable also in Femto Cell scenarios.

For BS type *1-C, 1-H and 1-O*, HAPS BS class is defined as indicated below:

- HAPS Base Stations are characterised by requirements derived from High Altitude Platform scenarios with a BS to ground UE minimum distance of typically around 20km.
- Unless otherwise stated, HAPS BS class would refer to Wide Area BS class, which is specified in clause 4.4.

4.5 Regional requirements

Some requirements in the present document may only apply in certain regions either as optional requirements, or as mandatory requirements set by local and regional regulation. It is normally not stated in the 3GPP specifications under what exact circumstances the regional requirements apply, since this is defined by local or regional regulation.

Table 4.5-1 lists all requirements in the present specification that may be applied differently in different regions.

Table 4.5-1: List of regional requirements

Clause number	Requirement	Comments
5.2	<i>Operating bands</i>	Some NR <i>operating bands</i> may be applied regionally.
6.2.1, 9.3.1	Base station output power, OTA base station output power:	For Band n41 and n90 operation in Japan, additional output power limits shall be applied.
6.2.4, 9.3.4	Base station output power, OTA base station output power: Additional requirements	These requirements may be applied regionally as additional base station output power requirements. For operation with shared spectrum channel access, the BS may have to comply with the applicable BS power limits established regionally, when deployed in regions where those limits apply and under the conditions declared by the manufacturer.
6.6.2, 9.7.2	Occupied bandwidth, OTA occupied bandwidth	The requirement may be applied regionally. There may also be regional requirements to declare the occupied bandwidth according to the definition in present specification.
6.6.3.3	Adjacent Channel Leakage Power Ratio	For Band n41 and n90 operation in Japan, absolute ACLR limits shall be applied to the sum of the absolute ACLR power over all <i>antenna connectors</i> for <i>BS type 1-C</i> .
6.6.4.2, 9.7.4.2	Operating band unwanted emission, OTA operating band unwanted emissions	Category A or Category B operating band unwanted emissions limits may be applied regionally. In addition, for operation with shared spectrum channel access, the BS may have to comply with the applicable operating band unwanted emission limits established regionally, when deployed in regions where those limits apply and under the conditions declared by the manufacturer.
6.6.4.2.5.1, 9.7.4.2.1.2	Operating band unwanted emission, OTA operating band unwanted emissions: Limits in FCC Title 47	The BS may have to comply with the additional requirements, when deployed in regions where those limits are applied, and under the conditions declared by the manufacturer.
6.6.4.2.5.2, 9.7.4.2.1.1	Operating band unwanted emission, OTA operating band unwanted emissions Protection of DTT	The BS operating in Band n20 may have to comply with the additional requirements for protection of DTT, when deployed in certain regions.
6.6.4.3	Operating band unwanted emissions	For Band n41 and n90 operation in Japan, the operating band unwanted emissions limits shall be applied to the sum of the emission power over all <i>antenna connectors</i> for <i>BS type 1-C</i> .
6.6.5.2.1, 9.7.5.2	Tx spurious emissions, OTA Tx spurious emissions	Category A or Category B spurious emission limits, as defined in ITU-R Recommendation SM.329 [2], may apply regionally. The emission limits for <i>BS type 1-H</i> and <i>BS type 1-O</i> specified as the <i>basic limit</i> + X (dB) are applicable, unless stated differently in regional regulation. In addition, for operation with shared spectrum channel access, the BS may have to comply with the applicable spurious emission limits established regionally, when deployed in regions where those limits apply and under the conditions declared by the manufacturer.
6.6.5.2.3, 9.7.5.3.3	Tx spurious emissions: additional requirements, OTA Tx spurious emissions: additional requirements	These requirements may be applied for the protection of system operating in frequency ranges other than the <i>BS operating band</i> .
6.6.5.3	Transmitter spurious emissions	For Band n41 and n90 operation in Japan, the sum of the spurious emissions over all <i>antenna connectors</i> for <i>BS type 1-C</i> shall not exceed the <i>basic limits</i> .
6.7.2.1.1, 6.7.3.1.1 9.8.2	Transmitter intermodulation, OTA transmitter intermodulation	Interfering signal positions that are partially or completely outside of any downlink <i>operating band</i> of the base station are not excluded from the requirement in Japan in Band n77, n78, n79.
6.7.2.2, 6.7.3.3	Transmitter intermodulation	For Band n41 and n90 operation in Japan, the BS may have to comply with the additional requirements, when deployed in certain regions.
6.7.2.2, 6.7.3.3, 9.8.3	Transmitter intermodulation, OTA transmitter intermodulation	For Band n79 operation in Japan, the BS shall comply with the additional requirements.
7.6.3	Rx spurious emissions,	For Band n41 and n90 operation in Japan, the emission limits for <i>BS type 1-C</i> may apply to the sum of the emission power over all <i>antenna connectors</i> .

Clause number	Requirement	Comments
7.6.4, 10.7.2 10.7.3	Rx spurious emissions, OTA Rx spurious emissions	The emission limits for BS type 1-H and BS type 1-O specified as the basic limit + X (dB) are applicable, unless stated differently in regional regulation. Additional limits for BS type 2-O may apply regionally.

4.6 Applicability of requirements

In table 4.6-1, the requirement applicability for each *requirement set* is defined. For each requirement, the applicable requirement clause in the specification is identified. Requirements not included in a *requirement set* is marked not applicable (NA).

Table 4.6-1: Requirement set applicability

Requirement	Requirement set			
	BS type 1-C	BS type 1-H	BS type 1-O	BS type 2-O
BS output power	6.2	6.2	NA	NA
Output power dynamics	6.3	6.3		
Transmit ON/OFF power	6.4	6.4		
Transmitted signal quality	6.5	6.5		
Occupied bandwidth	6.6.2	6.6.2		
ACLR	6.6.3	6.6.3		
Operating band unwanted emissions	6.6.4	6.6.4		
Transmitter spurious emissions	6.6.5	6.6.5		
Transmitter intermodulation	6.7	6.7		
Reference sensitivity level	7.2	7.2		
Dynamic range	7.3	7.3		
In-band selectivity and blocking	7.4	7.4		
Out-of-band blocking	7.5	7.5		
Receiver spurious emissions	7.6	7.6		
Receiver intermodulation	7.7	7.7		
In-channel selectivity	7.8	7.8		
Performance requirements	8	8	9.2	9.2
Radiated transmit power	NA	9.2	9.3	9.3
OTA base station output power		9.4	9.4	
OTA output power dynamics		9.5	9.5	
OTA transmit ON/OFF power		9.6	9.6	
OTA transmitted signal quality		9.7.2	9.7.2	
OTA occupied bandwidth		9.7.3	9.7.3	
OTA ACLR		9.7.4	9.7.4	
OTA out-of-band emission		9.7.5	9.7.5	
OTA transmitter spurious emission		9.8	NA	
OTA transmitter intermodulation		10.2	10.2	NA
OTA sensitivity		NA	10.3	10.3
OTA reference sensitivity level			10.4	NA
OTA dynamic range			10.5	10.5
OTA in-band selectivity and blocking			10.6	10.6
OTA out-of-band blocking			10.7	10.7
OTA receiver spurious emission			10.8	10.8
OTA receiver intermodulation	10.9		10.9	
OTA in-channel selectivity	11		11	
Radiated performance requirements				

4.7 Requirements for contiguous and *non-contiguous spectrum*

A spectrum allocation where a BS operates can either be contiguous or non-contiguous. Unless otherwise stated, the requirements in the present specification apply for BS configured for both *contiguous spectrum* operation and *non-contiguous spectrum* operation.

For BS operation in *non-contiguous spectrum*, some requirements apply both at the *Base Station RF Bandwidth edges* and inside the *sub-block gaps*. For each such requirement, it is stated how the limits apply relative to the *Base Station RF Bandwidth edges* and the *sub-block edges* respectively.

4.8 Requirements for BS capable of multi-band operation

For *multi-band connector* or *multi-band RIB*, the RF requirements in clause 6, 7, 9 and 10 apply separately to each supported *operating band* unless otherwise stated. For some requirements, it is explicitly stated that specific additions or exclusions to the requirement apply at *multi-band connector(s)*, and *multi-band RIB(s)* as detailed in the requirement clause. For BS capable of multi-band operation, various structures in terms of combinations of different transmitter and receiver implementations (multi-band or single band) with mapping of transceivers to one or more *antenna connectors* for BS type 1-C or TAB connectors for BS type 1-H in different ways are possible. For *multi-band connector(s)* the exclusions or provisions for multi-band apply. For *single-band connector(s)*, the following applies:

- Single-band transmitter spurious emissions, *operating band* unwanted emissions, ACLR, transmitter intermodulation and receiver spurious emissions requirements apply to this *connector* that is mapped to single-band.
- If the BS is configured for single-band operation, single-band requirements shall apply to this *connector* configured for single-band operation and no exclusions or provisions for multi-band capable BS are applicable. Single-band requirements are tested separately at the *connector* configured for single-band operation, with all other *antenna connectors* terminated.

A BS type 1-H may be capable of supporting operation in multiple *operating bands* with one of the following implementations of TAB connectors in the *transceiver array boundary*:

- All TAB connectors are *single-band connectors*.
- Different sets of *single-band connectors* support different *operating bands*, but each TAB connector supports only operation in one *single operating band*.
- Sets of *single-band connectors* support operation in multiple *operating bands* with some *single-band connectors* supporting more than one *operating band*.
- All TAB connectors are *multi-band connectors*.
- A combination of single-band sets and multi-band sets of TAB connectors provides support of the type BS type 1-H capability of operation in multiple *operating bands*.

Unless otherwise stated all requirements specified for an *operating band* apply only to the set of TAB connectors supporting that *operating band*.

In the case of an *operating band* being supported only by *single-band connectors* in a TAB connector TX min cell group or a TAB connector RX min cell group, *single-band requirements* apply to that set of TAB connectors.

In the case of an *operating band* being supported only by *multi-band connectors* supporting the same *operating band* combination in a TAB connector TX min cell group or a TAB connector RX min cell group, *multi-band requirements* apply to that set of TAB connectors.

The case of an *operating band* being supported by both *multi-band connectors* and *single-band connectors* in a TAB connector TX min cell group or a TAB connector RX min cell group is not covered by the present release of this specification.

The case of an *operating band* being supported by *multi-band connectors* which are not all supporting the same *operating band* combination in a TAB connector TX min cell group or a TAB connector RX min cell group is not covered by the present release of this specification.

BS type 1-O may be capable of supporting operation in multiple *operating bands* with one of the following implementations at the *radiated interface boundary*:

- All RIBs are *single-band RIBs*.
- All RIBs are *multi-band RIBs*.

- A combination of single-band *RIBs* and *multi-band RIBs* provides support of the *BS type 1-O* capability of operation in multiple *operating bands*.

For *multi-band connectors* and *multi-band RIBs* supporting the bands for TDD, the RF requirements in the present specification assume no simultaneous uplink and downlink occur between the bands.

The RF requirements for *multi-band connectors* and *multi-band RIBs* supporting bands for both FDD and TDD are not covered by the present release of this specification.

4.9 OTA co-location with other base stations

Co-location requirements are requirements which are based on assuming the *BS type 1-O* is co-located with another BS of the same base station class, they ensure that both co-located systems can operate with minimal degradation to each other.

Unwanted emission and out of band blocking co-location requirements are optional requirements based on declaration. TX OFF and TX IMD are mandatory requirements and have the form of a co-location requirement as it represents the worst-case scenario of all the interference cases.

NOTE: Due to the low level of the unwanted emissions for the spurious emissions and TX OFF level co-location is the most suitable method to show conformance.

The *co-location reference antenna* shall be a single column passive antenna which has the same vertical radiating dimension (h), frequency range, polarization, as the composite antenna of the *BS type 1-O* and nominal 65° horizontal half-power beamwidth (suitable for 3-sector deployment) and is placed at a distance d from the edge of the *BS type 1-O*, as shown in figure 4.9-1.

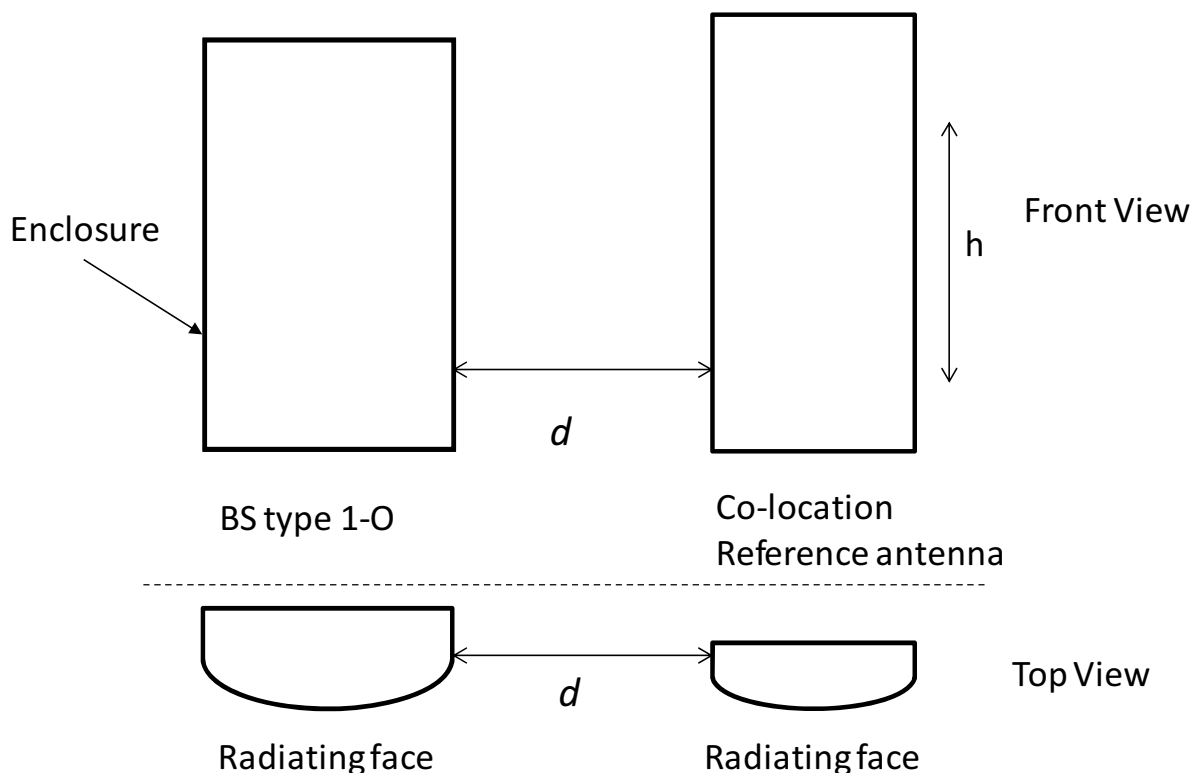

Figure 4.9-1: Illustration of *BS type 1-O* enclosure and co-location reference antenna

Edge-to-edge separation d between the *BS type 1-O* and the *co-location reference antenna* shall be set to 0.1 m.

The *BS type 1-O* and the *co-location reference antenna* shall be aligned in a common plane perpendicular to the mechanical bore-sight direction, as shown in figure 4.9-1.

The *co-location reference antenna* and the *BS type 1-O* can have different width.

The vertical radiating regions of the *co-location reference antenna* and the *BS type I-O* composite antenna shall be aligned.

For co-location requirements where the frequency range of the signal at the *co-location reference antenna* is different from the *BS type I-O*, a *co-location reference antenna* suitable for the frequency stated in the requirement is assumed.

OTA co-location requirements are based on the power at the conducted interface of a *co-location reference antenna*, depending on the requirement this interface is either an input or an output. For *BS type I-O* with dual polarization the *co-location reference antenna* has two conducted interfaces each representing one polarization.

5 *Operating bands* and channel arrangement

5.1 General

The channel arrangements presented in this clause are based on the *operating bands* and *BS channel bandwidths* defined in the present release of specifications.

NOTE: Other *operating bands* and *BS channel bandwidths* may be considered in future releases.

Requirements throughout the RF specifications are in many cases defined separately for different frequency ranges (FR). The frequency ranges in which NR can operate according to the present version of the specification are identified as described in table 5.1-1. Whenever FR2 is referred, both FR2-1 and FR2-2 frequency sub-ranges shall be applied, unless otherwise stated.

Table 5.1-1: Definition of frequency ranges

Frequency range designation		Corresponding frequency range
	FR1	410 MHz – 7125 MHz
FR2	FR2-1	24250 MHz – 52600 MHz
	FR2-2	52600 MHz – 71000 MHz

5.2 *Operating bands*

NR is designed to operate in the *operating bands* defined in table 5.2-1 and 5.2-2.

NR operating band n1, which is defined in Table 5.2-1, can be applied for HAPS operation.

NB-IoT is designed to operate in the NR operating bands n1, n2, n3, n5, n7, n8, n12, n13, n14, n18, n20, n25, n26, n28, n41, n65, n66, n70, n71, n74, n85, n90 which are defined in Table 5.2-1.

Table 5.2-1: NR *operating bands* in FR1

NR operating band	Uplink (UL) operating band BS receive / UE transmit $F_{UL,low} - F_{UL,high}$ (MHz)	Downlink (DL) operating band BS transmit / UE receive $F_{DL,low} - F_{DL,high}$ (MHz)	Duplex mode	Notes
n1	1920 – 1980	2110 – 2170	FDD	
n2	1850 – 1910	1930 – 1990	FDD	
n3	1710 – 1785	1805 – 1880	FDD	
n5	824 – 849	869 – 894	FDD	
n7	2500 – 2570	2620 – 2690	FDD	
n8	880 – 915	925 – 960	FDD	
n12	699 – 716	729 – 746	FDD	
n13	777 – 787	746 – 756	FDD	
n14	788 – 798	758 – 768	FDD	
n18	815 – 830	860 – 875	FDD	
n20	832 – 862	791 – 821	FDD	
n24	1626.5 – 1660.5	1525 – 1559	FDD	Note 7
n25	1850 – 1915	1930 – 1995	FDD	
n26	814 – 849	859 – 894	FDD	
n28	703 – 748	758 – 803	FDD	
n29	N/A	717 – 728	SDL	
n30	2305 – 2315	2350 – 2360	FDD	
n34	2010 – 2025	2010 – 2025	TDD	
n38	2570 – 2620	2570 – 2620	TDD	
n39	1880 – 1920	1880 – 1920	TDD	
n40	2300 – 2400	2300 – 2400	TDD	
n41	2496 – 2690	2496 – 2690	TDD	
n46	5150 – 5925	5150 – 5925	TDD	Note 3
n48	3550 – 3700	3550 – 3700	TDD	
n50	1432 – 1517	1432 – 1517	TDD	
n51	1427 – 1432	1427 – 1432	TDD	
n53	2483.5 – 2495	2483.5 – 2495	TDD	
n65	1920 – 2010	2110 – 2200	FDD	
n66	1710 – 1780	2110 – 2200	FDD	
n67	N/A	738 – 758	SDL	
n70	1695 – 1710	1995 – 2020	FDD	
n71	663 – 698	617 – 652	FDD	
n74	1427 – 1470	1475 – 1518	FDD	
n75	N/A	1432 – 1517	SDL	
n76	N/A	1427 – 1432	SDL	
n77	3300 – 4200	3300 – 4200	TDD	Note 10
n78	3300 – 3800	3300 – 3800	TDD	
n79	4400 – 5000	4400 – 5000	TDD	
n80	1710 – 1785	N/A	SUL	
n81	880 – 915	N/A	SUL	
n82	832 – 862	N/A	SUL	
n83	703 – 748	N/A	SUL	
n84	1920 – 1980	N/A	SUL	
n85	698 – 716	728 – 746	FDD	
n86	1710 – 1780	N/A	SUL	
n89	824 – 849	N/A	SUL	
n90	2496 – 2690	2496 – 2690	TDD	
n91	832 – 862	1427 – 1432	FDD	Note 2
n92	832 – 862	1432 – 1517	FDD	Note 2
n93	880 – 915	1427 – 1432	FDD	Note 2
n94	880 – 915	1432 – 1517	FDD	Note 2
n95	2010 – 2025	N/A	SUL	Note 1
n96	5925 – 7125	5925 – 7125	TDD	Note 3, Note 4
n97	2300 – 2400	N/A	SUL	Note 5
n98	1880 – 1920	N/A	SUL	Note 5
n99	1626.5 – 1660.5	N/A	SUL	Note 6
n100	874.4 – 880	919.4 – 925	FDD	Note 9
n101	1900 – 1910	1900 – 1910	TDD	Note 9
n102	5925 – 6425	5925 – 6425	TDD	Note 3, Note 4
n104	6425 – 7125	6425 – 7125	TDD	Note 8

- NOTE 1: This band is applicable in China only.
- NOTE 2: Variable duplex operation does not enable dynamic variable duplex configuration by the network, and is used such that DL and UL frequency ranges are supported independently in any valid frequency range for the band.
- NOTE 3: This band is restricted to operation with shared spectrum channel access as defined in TS 37.213 [20].
- NOTE 4: This band is applicable only in countries/regions designating this band for shared-spectrum access use subject to country-specific conditions.
- NOTE 5: The requirements for this band are applicable only where no other NR or E-UTRA TDD operating band(s) are used within the frequency range of this band in the same geographical area. For scenarios where other NR or E-UTRA TDD operating band(s) are used within the frequency range of this band in the same geographical area, special co-existence requirements may apply that are not covered by the 3GPP specifications.
- NOTE 6: UL operation is restricted to 1627.5 – 1637.5 MHz and 1646.5 – 1656.5 MHz per FCC Order DA 20-48 [25].
- NOTE 7: DL operation is restricted to 1526-1536 MHz frequency range. UL operation is restricted to 1627.5 – 1637.5 MHz and 1646.5 – 1656.5 MHz per FCC Order 20-51 [24].
- NOTE 8: This band is applicable only in countries/regions designating this band for IMT licensed operation subject to country-specific conditions.
- NOTE 9: This band is applicable to CEPT countries subject to ECC Decision (20)02 [21], for the RMR application.
- NOTE 10: In the USA this band is restricted to 3450 – 3550 MHz and 3700 – 3980 MHz. In Canada this band is restricted to 3450 – 3650 MHz and 3650 – 3980 MHz.

Table 5.2-2: NR operating bands in FR2

NR operating band	Uplink (UL) and Downlink (DL) operating band BS transmit/receive UE transmit/receive $F_{UL,low} - F_{UL,high}$ $F_{DL,low} - F_{DL,high}$ (MHz)	Duplex mode
n257	26500 – 29500	TDD
n258	24250 – 27500	TDD
n259	39500 – 43500	TDD
n260	37000 – 40000	TDD
n261	27500 – 28350	TDD
n262	47200 – 48200	TDD
n263	57000 – 71000	TDD

5.3 BS channel bandwidth

5.3.1 General

The *BS channel bandwidth* supports a single NR RF carrier in the uplink or downlink at the Base Station. Different UE channel bandwidths may be supported within the same spectrum for transmitting to and receiving from UEs connected to the BS. The placement of the UE channel bandwidth is flexible but can only be completely within the *BS channel bandwidth*. The BS shall be able to transmit to and/or receive from one or more UE bandwidth parts that are smaller than or equal to the number of carrier resource blocks on the RF carrier, in any part of the carrier resource blocks.

The relationship between the channel bandwidth, the guardband and the *transmission bandwidth configuration* is shown in figure 5.3.1-1.

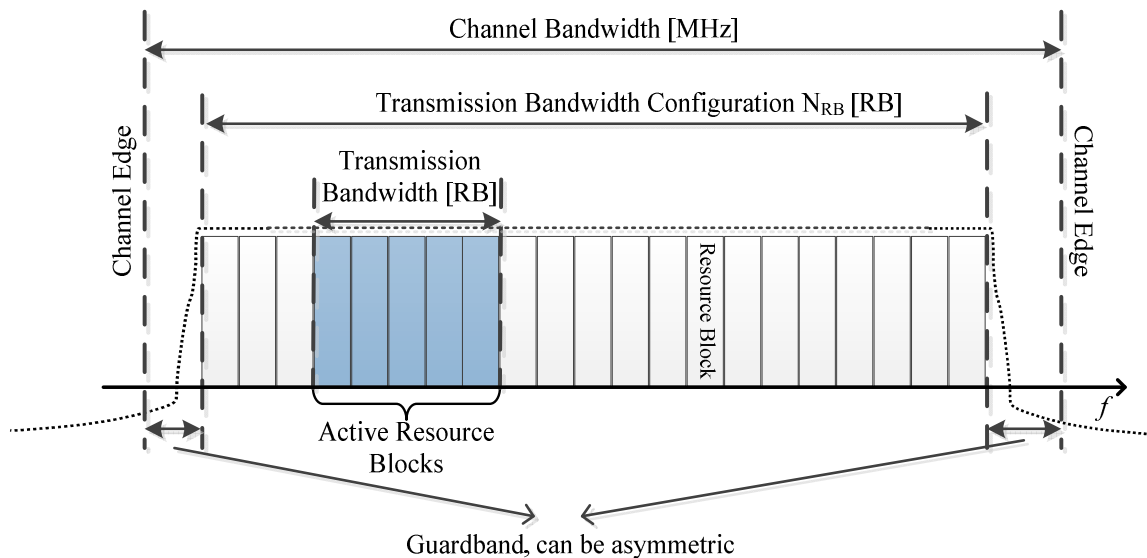

Figure 5.3.1-1: Definition of channel bandwidth and *transmission bandwidth configuration* for one NR channel

5.3.2 Transmission bandwidth configuration

The *transmission bandwidth configuration* N_{RB} for each *BS channel bandwidth* and subcarrier spacing is specified in table 5.3.2.-1 for FR1 and table 5.3.2-2 for FR2.

Table 5.3.2-1: *Transmission bandwidth configuration* N_{RB} for FR1

SCS (kHz)	5 MHz	10 MHz	15 MHz	20 MHz	25 MHz	30 MHz	35 MHz	40 MHz	45 MHz	50 MHz	60 MHz	70 MHz	80 MHz	90 MHz	100 MHz
	N_{RB}	N_{RB}	N_{RB}	N_{RB}	N_{RB}	N_{RB}	N_{RB}	N_{RB}	N_{RB}	N_{RB}	N_{RB}	N_{RB}	N_{RB}	N_{RB}	N_{RB}
15	25	52	79	106	133	160	188	216	242	270	N/A	N/A	N/A	N/A	N/A
30	11	24	38	51	65	78	92	106	119	133	162	189	217	245	273
60	N/A	11	18	24	31	38	44	51	58	65	79	93	107	121	135

Table 5.3.2-2: *Transmission bandwidth configuration* N_{RB} for FR2-1

SCS (kHz)	50 MHz	100 MHz	200 MHz	400 MHz
	N_{RB}	N_{RB}	N_{RB}	N_{RB}
60	66	132	264	N/A
120	32	66	132	264

Table 5.3.2-3: *Transmission bandwidth configuration* N_{RB} for FR2-2

SCS (kHz)	100 MHz	400 MHz	800 MHz	1600 MHz	2000 MHz
	N_{RB}	N_{RB}	N_{RB}	N_{RB}	N_{RB}
120	66	264	N/A	N/A	N/A
480	N/A	66	124	248	N/A
960	N/A	33	62	124	148

NOTE: All Tx and Rx requirements are defined based on *transmission bandwidth configuration* specified in table 5.3.2-1 for FR1 and table 5.3.2-2 and table 5.3.2-3 for FR2.

The transmission bandwidth configuration for NB-IoT is specified in TS 36.104 [13] clause 5.6.

5.3.3 Minimum guardband and *transmission bandwidth configuration*

The minimum guardband for each *BS channel bandwidth* and SCS is specified in table 5.3.3-1 for FR1 and in table 5.3.3-2 and table 5.3.3-2a for FR2.

Table 5.3.3-1: Minimum guardband (kHz) (FR1)

SCS (kHz)	5 MHz	10 MHz	15 MHz	20 MHz	25 MHz	30 MHz	35 MHz	40 MHz	45 MHz	50 MHz	60 MHz	70 MHz	80 MHz	90 MHz	100 MHz
15	242.5	312.5	382.5	452.5	522.5	592.5	572.5	552.5	712.5	692.5	N/A	N/A	N/A	N/A	N/A
30	505	665	645	805	785	945	925	905	1065	1045	825	965	925	885	845
60	N/A	1010	990	1330	1310	1290	1630	1610	1590	1570	1530	1490	1450	1410	1370

Table 5.3.3-2: Minimum guardband (kHz) (FR2-1)

SCS (kHz)	50 MHz	100 MHz	200 MHz	400 MHz
60	1210	2450	4930	N/A
120	1900	2420	4900	9860

Table 5.3.3-2a: Minimum guardband (kHz) (FR2-2)

SCS (kHz)	100 MHz	400 MHz	800 MHz	1600 MHz	2000 MHz
120	2420	9860	N/A	N/A	N/A
480	N/A	9680	42640	85520	N/A
960	N/A	9440	[42400]	85280	147040

The minimum guardband of SCS 240 kHz SS/PBCH block for each *BS channel bandwidth* is specified in table 5.3.3-3 for FR2.

Table 5.3.3-3: Minimum guardband (kHz) of SCS 240 kHz SS/PBCH block (FR2)

SCS (kHz)	100 MHz	200 MHz	400 MHz
240	3800	7720	15560

NOTE: The minimum guardband in Table 5.3.3-3 is applicable only when the SCS 240 kHz SS/PBCH block is placed adjacent to the edge of the *BS channel bandwidth* within which the SS/PBCH block is located.

The number of RBs configured in any *BS channel bandwidth* shall ensure that the minimum guardband specified in this clause is met.

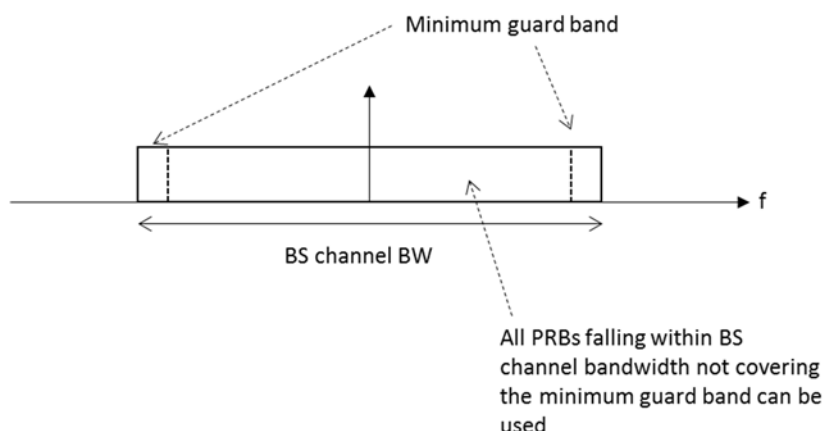

Figure 5.3.3-1: BS PRB utilization

In the case that multiple numerologies are multiplexed in the same symbol, the minimum guardband on each side of the carrier is the guardband applied at the configured *BS channel bandwidth* for the numerology that is transmitted/received immediately adjacent to the guard band.

For FR1, if multiple numerologies are multiplexed in the same symbol and the *BS channel bandwidth* is >50 MHz, the guardband applied adjacent to 15 kHz SCS shall be the same as the guardband defined for 30 kHz SCS for the same *BS channel bandwidth*.

For FR2, if multiple numerologies are multiplexed in the same symbol and the *BS channel bandwidth* is >200 MHz, the guardband applied adjacent to 60 kHz SCS shall be the same as the guardband defined for 120 kHz SCS for the same *BS channel bandwidth*.

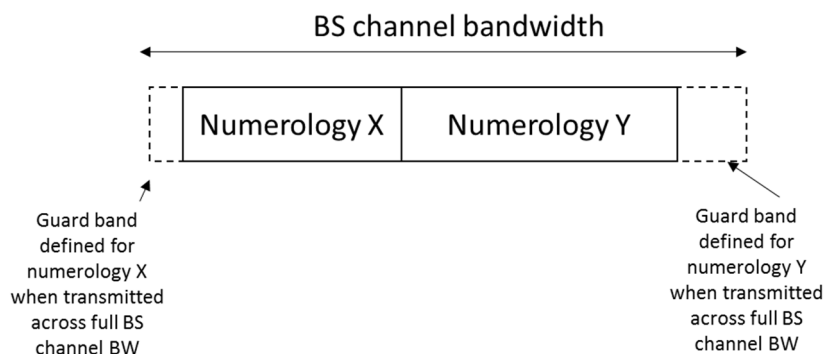

Figure 5.3.3-2: Guard band definition when transmitting multiple numerologies

NOTE: Figure 5.3.3-2 is not intended to imply the size of any guard between the two numerologies. Inter-numerology guard band within the carrier is implementation dependent.

Figure 5.3.3-3: Void

Figure 5.3.3-4: Void

Figure 5.3.3-5: Void

5.3.4 RB alignment

For each *BS channel bandwidth* and each numerology, *BS transmission bandwidth configuration* must fulfil the minimum guardband requirement specified in clause 5.3.3.

For each numerology, its common resource blocks are specified in clause 4.4.4.3 in [9], and the starting point of its *transmission bandwidth configuration* on the common resource block grid for a given channel bandwidth is indicated by an offset to “Reference point A” in the unit of the numerology.

For each numerology, all *UE transmission bandwidth configurations* indicated to UEs served by the BS by higher layer parameter *carrierBandwidth* defined in TS 38.331 [11] shall fall within the *BS transmission bandwidth configuration*.

5.3.5 BS channel bandwidth per operating band

The requirements in this specification apply to the combination of *BS channel bandwidths*, SCS and *operating bands* shown in table 5.3.5-1 for FR1 and in table 5.3.5-2 and table 5.3.5-3 for FR2. The *transmission bandwidth configuration* in table 5.3.2-1, table 5.3.2-2 and table 5.3.2-3 shall be supported for each of the *BS channel bandwidths* within the BS capability. The *BS channel bandwidths* are specified for both the Tx and Rx path.

Table 5.3.5-1: BS channel bandwidths and SCS per operating band in FR1

NR Band	SCS (kHz)	BS channel bandwidth (MHz)														
		5	10	15	20	25	30	35	40	45	50	60	70	80	90	100
n1	15	5	10	15	20	25	30		40	45	50					
	30		10	15	20	25	30		40	45	50					
	60		10	15	20	25	30		40	45	50					
n2	15	5	10	15	20	25	30	35	40							
	30		10	15	20	25	30	35	40							
	60		10	15	20	25	30	35	40							
n3	15	5	10	15	20	25	30	35	40	45	50					
	30		10	15	20	25	30	35	40	45	50					
	60		10	15	20	25	30	35	40	45	50					
n5	15	5	10	15	20	25 ⁷										
	30		10	15	20	25 ⁷										
	60															
n7	15	5	10	15	20	25	30	35	40		50					
	30		10	15	20	25	30	35	40		50					
	60		10	15	20	25	30	35	40		50					
n8	15	5	10	15	20			35								
	30		10	15	20			35								
	60															
n12	15	5	10	15												
	30		10	15												
	60															
n13	15	5	10													
	30		10													
	60															
n14	15	5	10													
	30		10													
	60															
n18	15	5	10	15												
	30		10	15												
	60															
n20	15	5	10	15	20											
	30		10	15	20											
	60															
n24	15	5	10													
	30		10													
	60		10													
n25	15	5	10	15	20	25	30	35	40	45						
	30		10	15	20	25	30	35	40	45						
	60		10	15	20	25	30	35	40	45						
n26	15	5	10	15	20	25 ⁷	30 ⁷									
	30		10	15	20	25 ⁷	30 ⁷									
	60															
n28	15	5	10	15	20	25	30		40							
	30		10	15	20	25	30		40							
	60															
n29	15	5	10													
	30		10													
	60															
n30	15	5	10													
	30		10													
	60															
n34	15	5	10	15												
	30		10	15												
	60		10	15												
n38	15	5	10	15	20	25	30		40							
	30		10	15	20	25	30		40							
	60		10	15	20	25	30		40							
n39	15	5	10	15	20	25	30		40							
	30		10	15	20	25	30		40							
	60		10	15	20	25	30		40							
n40	15	5 ⁴	10	15	20	25	30		40		50					
	30		10	15	20	25	30		40		50	60	70	80	90	100

NR Band	SCS (kHz)	BS channel bandwidth (MHz)														
		5	10	15	20	25	30	35	40	45	50	60	70	80	90	100
n41	60		10	15	20	25	30		40		50	60	70	80	90	100
	15	5 ⁸	10	15	20	25	30	35	40	45	50					
	30		10	15	20	25	30	35	40	45	50	60	70	80	90	100
n46	60		10	15	20	25	30	35	40	45	50	60	70	80	90	100
	15		10 ⁶		20				40							
	30		10 ⁶		20				40			60		80		100
n48	60		10 ⁶		20				40		60		80		100	
	15	5 ²	10	15	20		30		40		50 ¹					
	30		10	15	20		30		40		50 ¹	60 ¹	70 ¹	80 ¹	90 ¹	100 ¹
n50	60		10	15	20		30		40		50 ¹	60 ¹	70 ¹	80 ¹	90 ¹	100 ¹
	15	5 ²	10	15	20		30		40		50					
	30		10	15	20		30		40		50	60		80		
n51	60		10	15	20		30		40		50	60		80		
	15	5														
	30															
n53	60															
	15	5	10													
	30		10													
n65	60		10													
	15	5	10	15	20						50					
	30		10	15	20						50					
n66	60		10	15	20						50					
	15	5	10	15	20	25	30	35	40	45						
	30		10	15	20	25	30	35	40	45						
n67	60		10	15	20	25	30	35	40	45						
	15	5	10	15	20											
	30		10	15	20											
n70	60															
	15	5	10	15	20	25										
	30		10	15	20	25										
n71	60		10	15	20	25	30	35								
	15	5	10	15	20	25	30	35								
	30		10	15	20	25	30	35								
n74	60															
	15	5	10	15	20											
	30		10	15	20											
n75	60		10	15	20											
	15	5	10	15	20	25	30		40		50					
	30		10	15	20	25	30		40		50					
n76	60		10	15	20	25	30		40		50					
	15	5														
	30															
n77	60															
	15		10	15	20	25	30		40		50					
	30		10	15	20	25	30		40		50	60	70	80	90	100
n78	60		10	15	20	25	30		40		50	60	70	80	90	100
	15		10	15	20	25	30		40		50					
	30		10	15	20	25	30		40		50	60	70	80	90	100
n79	60		10	15	20	25	30		40		50	60	70	80	90	100
	15		10		20		30		40		50					
	30		10		20		30		40		50	60	70	80	90	100
n80	60		10	15	20	25	30		40		50	60	70	80	90	100
	15	5	10	15	20	25	30		40		50					
	30		10	15	20	25	30		40		50					
n81	60		10	15	20	25	30		40		50					
	15	5	10	15	20											
	30		10	15	20											
n82	60															
	15	5	10	15	20											
	30		10	15	20											
n83	60															
	15	5	10	15	20	25	30		40		50					
30		10	15	20	25	30		40		50						

NR Band	SCS (kHz)	BS channel bandwidth (MHz)														
		5	10	15	20	25	30	35	40	45	50	60	70	80	90	100
n84	60															
	15	5	10	15	20	25	30		40		50					
	30		10	15	20	25	30		40		50					
n85	60															
	15	5	10	15												
	30		10	15												
n86	60															
	15	5	10	15	20				40							
	30		10	15	20				40							
n89	60															
	15	5	10	15	20											
	30		10	15	20											
n90	60															
	15	5	10	15	20	25	30	35	40	45	50					
	30		10	15	20	25	30	35	40	45	50	60	70	80	90	100
n91	60															
	15	5	10 ³													
	30															
n92	60															
	15	5	10	15	20											
	30		10	15	20											
n93	60															
	15	5	10 ³													
	30															
n94	60															
	15	5	10	15	20											
	30		10	15	20											
n95	60															
	15	5	10	15												
	30		10	15												

NR Band	SCS (kHz)	BS channel bandwidth (MHz)														
		5	10	15	20	25	30	35	40	45	50	60	70	80	90	100
n96	60		10	15												
	15				20				40							
	30				20				40		60		80		100	
n97	60				20				40		60		80		100	
	15	5	10	15	20	25	30		40		50					
	30		10	15	20	25	30		40		50	60	70	80	90	100
n98	60		10	15	20	25	30		40		50	60	70	80	90	100
	15	5	10	15	20	25	30		40							
	30		10	15	20	25	30		40							
n99	60		10	15	20	25	30		40							
	15	5	10													
	30		10													
n100	60		10													
	15	5														
	30															
n101	60		10													
	15	5	10													
	30		10													
n102	60				20				40							
	15				20				40		60		80		100	
	30				20				40		60		80		100	
n104	60				20		30		40		50					
	15				20		30		40		50	60	70	80	90	100
	30				20		30		40		50	60	70	80	90	100

- NOTE 1: For this bandwidth, the minimum requirements are restricted to operation when carrier is configured as an downlink SCell part of CA configuration.
- NOTE 2: For this bandwidth, the minimum requirements are restricted to operation when carrier is configured as an SCell part of DC or CA configuration.
- NOTE 3: For this bandwidth, it only applies for UL transmission.
- NOTE 4: For this bandwidth, the minimum requirements are restricted to operation when carrier is configured as an SCell part of DC or CA configuration.
- NOTE 5: Void.
- NOTE 6: This bandwidth can only be applied in certain regions where the absence of non 3GPP technologies can be guaranteed on a long term basis in this version of specification.
- NOTE 7: For this bandwidth, it only applies for DL transmission.
- NOTE 8: Not all frequency positions of 5 MHz carriers are possible due limitations of the SSB position relative to the 5 MHz channels. 5 MHz channels with F_c such that $2499+N*1.2 \leq F_c < 2499.3+N*1.2$ MHz for $0 \leq N < 157$ are not compatible with SSB positions and cannot be used for 5 MHz n41.

Table 5.3.5-2: BS channel bandwidths and SCS per operating band in FR2-1

NR Band	SCS (kHz)	BS channel bandwidth (MHz)			
		50	100	200	400
n257	60	50	100	200	
	120	50	100	200	400
n258	60	50	100	200	
	120	50	100	200	400
n259	60	50	100	200	
	120	50	100	200	400
n260	60	50	100	200	
	120	50	100	200	400
n261	60	50	100	200	
	120	50	100	200	400
n262	60	50	100	200	
	120	50	100	200	400

Table 5.3.5-3: BS channel bandwidths and SCS per operating band in FR2-2

NR Band	SCS (kHz)	BS channel bandwidth (MHz)				
		100	400	800	1600	2000
n263	120	100	400			
	480		400	800	1600	
	960		400	800	1600	2000

5.3A BS channel bandwidth for CA

5.3A.1 Transmission bandwidth configuration for CA

For carrier aggregation, the transmission bandwidth configuration is defined per component carrier and the requirement is specified in clause 5.3.2.

5.3A.2 Minimum guardband and transmission bandwidth configuration for CA

For intra-band contiguous carrier aggregation, Aggregated BS Channel Bandwidth and Guard Bands are defined as follows, see Figure 5.3A.2-1.

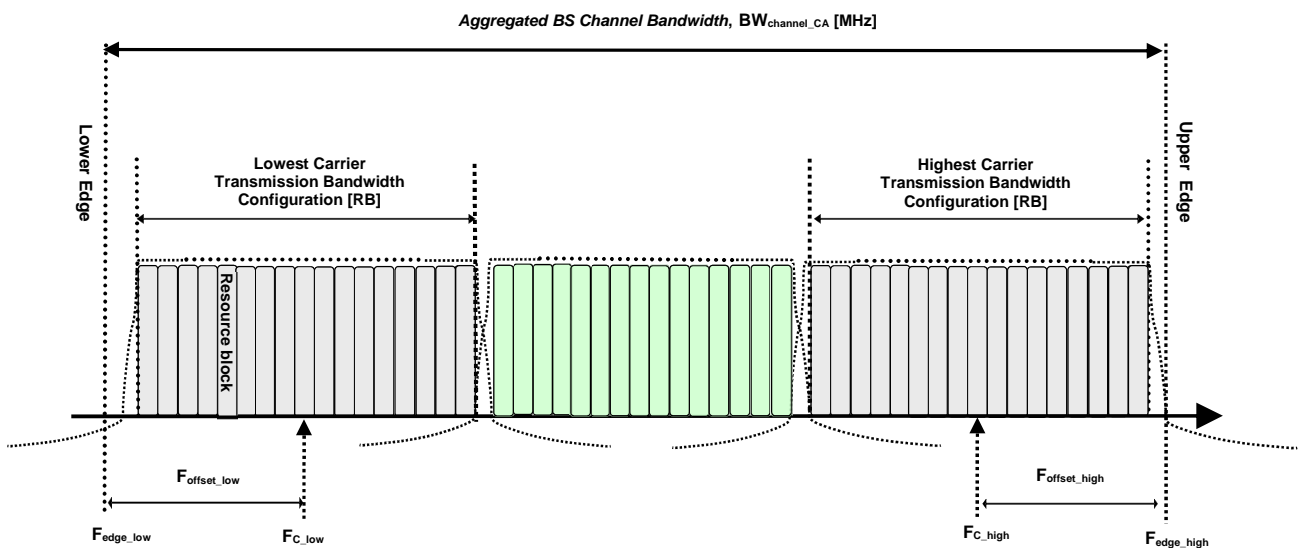

Figure 5.3A.2-1: Definition of Aggregated BS Channel Bandwidth for intra-band carrier aggregation

The aggregated BS Channel Bandwidth, $BW_{Channel_CA}$, is defined as

$$BW_{Channel_CA} = F_{edge,high} - F_{edge,low} \text{ (MHz)}$$

The lower bandwidth edge $F_{edge,low}$ and the upper bandwidth edge $F_{edge,high}$ of the aggregated BS channel bandwidth are used as frequency reference points for transmitter and receiver requirements and are defined by

$$F_{edge,low} = F_{C,low} - F_{offset,low}$$

$$F_{edge,high} = F_{C,high} + F_{offset,high}$$

The lower and upper frequency offsets depend on the transmission bandwidth configurations of the lowest and highest assigned edge component carrier and are defined as

$$F_{\text{offset,low}} = (N_{\text{RB,low}} * 12 + 1) * \text{SCS}_{\text{low}} / 2 + \text{BW}_{\text{GB,low}} \text{ (MHz)}$$

$$F_{\text{offset,high}} = (N_{\text{RB,high}} * 12 - 1) * \text{SCS}_{\text{high}} / 2 + \text{BW}_{\text{GB,high}} \text{ (MHz)}$$

$N_{\text{RB,low}}$ and $N_{\text{RB,high}}$ are the *transmission bandwidth configurations* according to Table 5.3.2-1 or Table 5.3.2-2 or Table 5.3.2-3 for the lowest and highest assigned component carrier, SCS_{low} and SCS_{high} are the sub-carrier spacing for the lowest and highest assigned component carrier respectively. SCS_{low} , SCS_{high} , $N_{\text{RB,low}}$, $N_{\text{RB,high}}$, $\text{BW}_{\text{GB,low}}$ and $\text{BW}_{\text{GB,high}}$ use the largest μ value among the subcarrier spacing configurations supported in the operating band for both of the channel bandwidths according to Table 5.3.5-1 and $\text{BW}_{\text{GB,low}}$ and $\text{BW}_{\text{GB,high}}$ are the minimum guard band for lowest and highest assigned component carrier according to Table 5.3.3-1 for the said μ value. In case there is no common μ value for both of the channel bandwidths, $\mu=1$ is used for SCS_{low} , SCS_{high} , $N_{\text{RB,low}}$, $N_{\text{RB,high}}$, $\text{BW}_{\text{GB,low}}$ and $\text{BW}_{\text{GB,high}}$.

For *intra-band non-contiguous carrier aggregation sub-block bandwidth* and *sub-block edges* are defined as follows, see figure 5.3A.2-2.

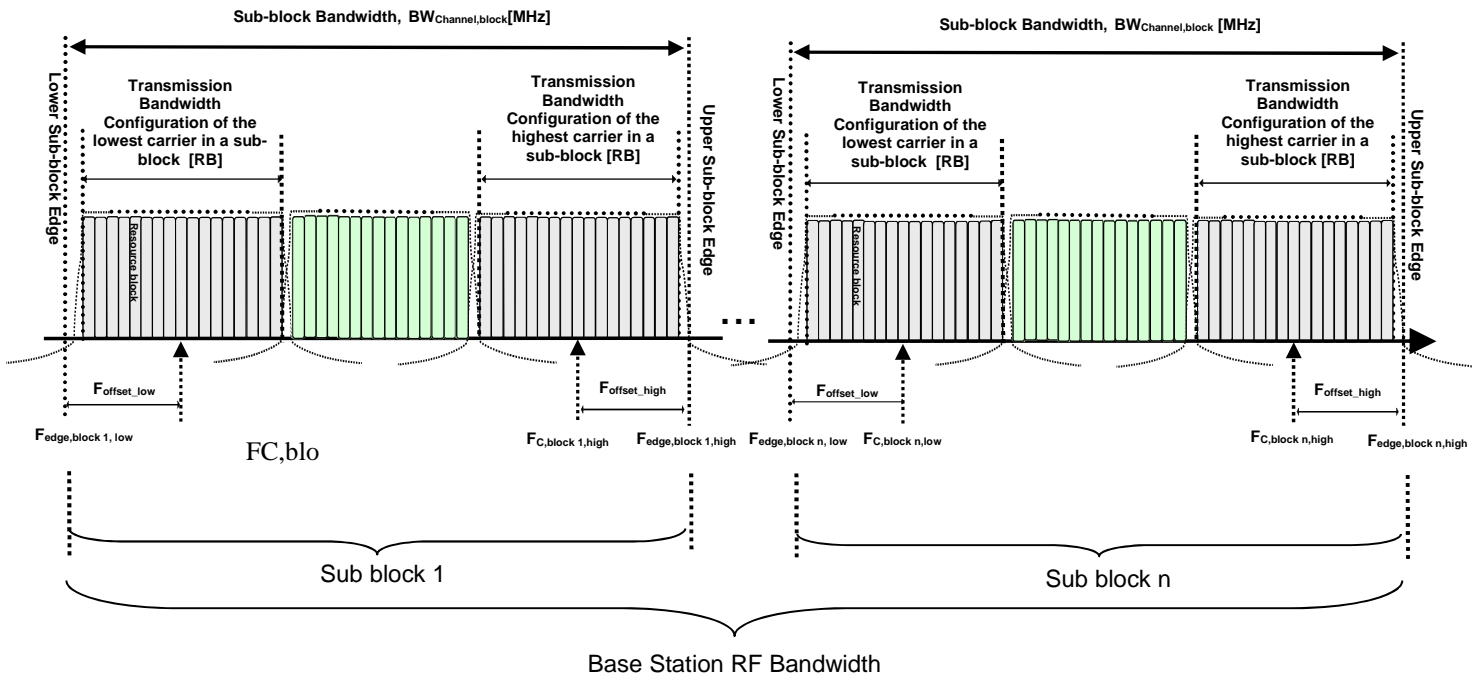

Figure 5.3A.2-2: Definition of *sub-block bandwidth* for intra-band *non-contiguous spectrum*

The *lower sub-block edge* of the *sub-block bandwidth* ($\text{BW}_{\text{Channel,block}}$) is defined as follows:

$$F_{\text{edge,block,low}} = F_{\text{C,block,low}} - F_{\text{offset,low}}$$

The *upper sub-block edge* of the *sub-block bandwidth* is defined as follows:

$$F_{\text{edge,block,high}} = F_{\text{C,block,high}} + F_{\text{offset,high}}$$

The *sub-block bandwidth*, $\text{BW}_{\text{Channel,block}}$, is defined as follows:

$$\text{BW}_{\text{Channel,block}} = F_{\text{edge,block,high}} - F_{\text{edge,block,low}} \text{ (MHz)}$$

The lower and upper frequency offsets $F_{\text{offset,block,low}}$ and $F_{\text{offset,block,high}}$ depend on the *transmission bandwidth configurations* of the lowest and highest assigned edge component carriers within a *sub-block* and are defined as

$$F_{\text{offset,block,low}} = (N_{\text{RB,low}} * 12 + 1) * \text{SCS}_{\text{low}} / 2 + \text{BW}_{\text{GB,low}} \text{ (MHz)}$$

$$F_{\text{offset,block,high}} = (N_{\text{RB,high}} * 12 - 1) * \text{SCS}_{\text{high}} / 2 + \text{BW}_{\text{GB,high}} \text{ (MHz)}$$

where $N_{\text{RB,low}}$ and $N_{\text{RB,high}}$ are the *transmission bandwidth configurations* according to Table 5.3.2-1 or Table 5.3.2-2 for the lowest and highest assigned component carrier within a *sub-block*, respectively. SCS_{low} and SCS_{high} are the sub-carrier spacing for the lowest and highest assigned component carrier within a *sub-block*, respectively. SCS_{low} , SCS_{high} ,

$N_{RB,low}$, $N_{RB,high}$, $BW_{GB,low}$ and $BW_{GB,high}$ use the largest μ value among the subcarrier spacing configurations supported in the operating band for both of the channel bandwidths according to Table 5.3.5-1 and $BW_{GB,low}$ and $BW_{GB,high}$ are the minimum guard band for lowest and highest assigned component carrier according to Table 5.3.3-1 for the said μ value. In case there is no common μ value for both of the channel bandwidths, $\mu=1$ is used for SCS_{low} , SCS_{high} , $N_{RB,low}$, $N_{RB,high}$, $BW_{GB,low}$ and $BW_{GB,high}$.

The *sub-block gap size* between two consecutive *sub-blocks* W_{gap} is defined as follows:

$$W_{gap} = F_{edge,block\ n+1,low} - F_{edge,block\ n,high} \text{ (MHz)}$$

5.4 Channel arrangement

5.4.1 Channel spacing

5.4.1.1 Channel spacing for adjacent NR carriers

The spacing between carriers will depend on the deployment scenario, the size of the frequency block available and the *BS channel bandwidths*. The nominal channel spacing between two adjacent NR carriers is defined as following:

- For NR FR1 *operating bands* with 100 kHz channel raster,
 - Nominal Channel spacing = $(BW_{Channel(1)} + BW_{Channel(2)})/2$
- For NR FR1 *operating bands* with 15 kHz channel raster,
 - Nominal Channel spacing = $(BW_{Channel(1)} + BW_{Channel(2)})/2 + \{-5 \text{ kHz}, 0 \text{ kHz}, 5 \text{ kHz}\}$ for ΔF_{Raster} equals to 15 kHz
 - Nominal Channel spacing = $(BW_{Channel(1)} + BW_{Channel(2)})/2 + \{-10 \text{ kHz}, 0 \text{ kHz}, 10 \text{ kHz}\}$ for ΔF_{Raster} equals to 30 kHz
- For NR FR2 *operating bands* with 60 kHz channel raster,
 - Nominal Channel spacing = $(BW_{Channel(1)} + BW_{Channel(2)})/2 + \{-20 \text{ kHz}, 0 \text{ kHz}, 20 \text{ kHz}\}$ for ΔF_{Raster} equals to 60 kHz
 - Nominal Channel spacing = $(BW_{Channel(1)} + BW_{Channel(2)})/2 + \{-40 \text{ kHz}, 0 \text{ kHz}, 40 \text{ kHz}\}$ for ΔF_{Raster} equals to 120 kHz
- For operating band n263
 - Nominal Channel spacing = $\text{ceil}((BW_{Channel(1)} + BW_{Channel(2)})/100.8)*50.4 \text{ MHz}$,

where $BW_{Channel(1)}$ and $BW_{Channel(2)}$ are the *BS channel bandwidths* of the two respective NR carriers. The channel spacing can be adjusted depending on the channel raster to optimize performance in a particular deployment scenario.

For NR bands restricted to operation with shared-spectrum channel access, the maximum deviation from the nominal channel spacing is 40 kHz.

5.4.1.2 Channel spacing for CA

For intra-band contiguously aggregated carriers, the channel spacing between adjacent component carriers shall be multiple of least common multiple of channel raster and sub-carrier spacing.

The nominal channel spacing between two adjacent aggregated NR carriers is defined as follows:

For NR *operating bands* with 100 kHz channel raster:

$$\text{Nominal channel spacing} = \left\lceil \frac{BW_{Channel(1)} + BW_{Channel(2)} - 2|GB_{Channel(1)} - GB_{Channel(2)}|}{0.6} \right\rceil 0.3 \text{ (MHz)}$$

For NR *operating bands* with 15 kHz channel raster:

$$\text{Nominal channel spacing} = \left\lceil \frac{BW_{\text{Channel}(1)} + BW_{\text{Channel}(2)} - 2|GB_{\text{Channel}(1)} - GB_{\text{Channel}(2)}|}{0.015 \cdot 2^{n+1}} \right\rceil 0.015 \cdot 2^n \text{ (MHz)}$$

with

$$n = \mu_0$$

For NR *operating bands* with 60kHz channel raster:

$$\text{Nominal channel spacing} = \left\lceil \frac{BW_{\text{Channel}(1)} + BW_{\text{Channel}(2)} - 2|GB_{\text{Channel}(1)} - GB_{\text{Channel}(2)}|}{0.06 \cdot 2^{n+1}} \right\rceil 0.06 \cdot 2^n \text{ (MHz)}$$

with

$$n = \mu_0 - 2$$

For operating band n263

$$\text{Nominal Channel spacing} = \text{ceil}((BW_{\text{Channel}(1)} + BW_{\text{Channel}(2)})/100.8) * 50.4 \text{ MHz,}$$

where $BW_{\text{Channel}(1)}$ and $BW_{\text{Channel}(2)}$ are the *BS channel bandwidths* of the two respective NR component carriers according to Table 5.3.2-1, 5.3.2-2 and 5.3.2-3 with values in MHz, μ_0 the largest μ value among the subcarrier spacing configurations supported in the operating band for both of the channel bandwidths according to Table 5.3.5-1 and Table 5.3.5-2 and $GB_{\text{Channel}(i)}$ the minimum guard band for channel bandwidth i according to Table 5.3.3-1, Table 5.3.3-2 and Table 5.3.3-2a for the said μ value, with μ as defined in TS 38.211 [9]. In case there is no common μ value for both of the channel bandwidths, $\mu_0=1$ is selected for NR *operating bands* with 15 kHz channel raster and $GB_{\text{Channel}(i)}$ is the minimum guard band for channel bandwidth i according to Table 5.3.3-1 for $\mu=1$ with μ as defined in TS 38.211[9].

The channel spacing for *intra-band contiguous carrier aggregation* can be adjusted to any multiple of least common multiple of channel raster and sub-carrier spacing less than the nominal channel spacing to optimize performance in a particular deployment scenario.

For *intra-band contiguous carrier aggregation* in NR bands restricted to operation with shared-spectrum channel access, the maximum deviation from the nominal channel spacing is 300 kHz.

For *intra-band non-contiguous carrier aggregation*, the channel spacing between two NR component carriers in different *sub-blocks* shall be larger than the nominal channel spacing defined in this clause.

5.4.2 Channel raster

5.4.2.1 NR-ARFCN and channel raster

The global frequency raster defines a set of *RF reference frequencies* F_{REF} . The *RF reference frequency* is used in signalling to identify the position of RF channels, SS blocks and other elements. The global frequency raster is defined for all frequencies from 0 to 100 GHz. The granularity of the global frequency raster is ΔF_{Global} .

RF reference frequencies are designated by an NR Absolute Radio Frequency Channel Number (NR-ARFCN) in the range [0...3279165] on the global frequency raster. The relation between the NR-ARFCN and the *RF reference frequency* F_{REF} in MHz is given by the following equation, where $F_{\text{REF-Offs}}$ and $N_{\text{Ref-Offs}}$ are given in table 5.4.2.1-1 and N_{REF} is the NR-ARFCN.

$$F_{\text{REF}} = F_{\text{REF-Offs}} + \Delta F_{\text{Global}} (N_{\text{REF}} - N_{\text{REF-Offs}})$$

Table 5.4.2.1-1: NR-ARFCN parameters for the global frequency raster

Range of frequencies (MHz)	ΔF_{Global} (kHz)	$F_{\text{REF-Offs}}$ (MHz)	$N_{\text{REF-Offs}}$	Range of N_{REF}
0 – 3000	5	0	0	0 – 599999
3000 – 24250	15	3000	600000	600000 – 2016666
24250 – 100000	60	24250.08	2016667	2016667 – 3279165

The *channel raster* defines a subset of *RF reference frequencies* that can be used to identify the RF channel position in the uplink and downlink. The *RF reference frequency* for an RF channel maps to a resource element on the carrier. For

each *operating band*, a subset of frequencies from the global frequency raster are applicable for that band and forms a channel raster with a granularity ΔF_{Raster} , which may be equal to or larger than ΔF_{Global} .

For SUL bands except n95, n97, n98 and for the uplink of all FDD bands defined in table 5.2-1, for TDD bands n34, n38, n39, n48, n90, and n40,

$$F_{\text{REF,shift}} = F_{\text{REF}} + \Delta_{\text{shift}}, \text{ where } \Delta_{\text{shift}} = 0 \text{ kHz or } 7.5 \text{ kHz}$$

where Δ_{shift} is signalled by the network in higher layer parameter *frequencyShift7p5khz* as defined in TS 38.331 [11].

For bands n34, n38, n39, n48 and n40, $F_{\text{REF,shift}}$ is only applicable to uplink transmissions using a 15 kHz SCS.

The mapping between the *channel raster* and corresponding resource element is given in clause 5.4.2.2. The applicable entries for each *operating band* are defined in clause 5.4.2.3.

5.4.2.1A NB-IoT carrier frequency numbering

The NB-IoT carrier frequency numbering (EARFCN) is defined in clause 5.7 of TS 36.104 [4].

5.4.2.2 Channel raster to resource element mapping

The mapping between the *RF reference frequency* on the channel raster and the corresponding resource element is given in table 5.4.2.2-1 and can be used to identify the RF channel position. The mapping depends on the total number of RBs that are allocated in the channel and applies to both UL and DL. The mapping must apply to at least one numerology supported by the BS.

Table 5.4.2.2-1: Channel Raster to Resource Element Mapping

	$N_{\text{RB}} \bmod 2 = 0$	$N_{\text{RB}} \bmod 2 = 1$
Resource element index k	0	6
Physical resource block index n_{PRB}	$n_{\text{PRB}} = \left\lfloor \frac{N_{\text{RB}}}{2} \right\rfloor$	$n_{\text{PRB}} = \left\lfloor \frac{N_{\text{RB}}}{2} \right\rfloor$

N_{RB} is the transmission bandwidth configuration specified in sub-clause 5.3.2, n_{PRB} is the PRB index within the N_{RB} , and k is the resource element index within this PRB

5.4.2.3 Channel raster entries for each *operating band*

The RF channel positions on the channel raster in each NR *operating band* are given through the applicable NR-ARFCN in table 5.4.2.3-1 for FR1 and table 5.4.2.3-2 for FR2, using the channel raster to resource element mapping in clause 5.4.2.2.

- For NR *operating bands* with 100 kHz channel raster, $\Delta F_{\text{Raster}} = 20 \times \Delta F_{\text{Global}}$. In this case, every 20th NR-ARFCN within the *operating band* are applicable for the channel raster within the *operating band* and the step size for the channel raster in table 5.4.2.3-1 is given as $\langle 20 \rangle$.
- For NR *operating bands* with 15 kHz channel raster below 3 GHz, $\Delta F_{\text{Raster}} = I \times \Delta F_{\text{Global}}$, where $I \in \{3,6\}$. In this case, every I^{th} NR-ARFCN within the *operating band* are applicable for the channel raster within the *operating band* and the step size for the channel raster in table 5.4.2.3-1 is given as $\langle I \rangle$.
- For NR *operating bands* with 15 kHz and 60 kHz channel raster above 3 GHz, $\Delta F_{\text{Raster}} = I \times \Delta F_{\text{Global}}$, where $I \in \{1, 2\}$. In this case, every I^{th} NR-ARFCN within the *operating band* are applicable for the channel raster within the *operating band* and the step size for the channel raster in table 5.4.2.3-1 and table 5.4.2.3-2 is given as $\langle I \rangle$.
- For frequency bands with two ΔF_{Raster} in FR1, the higher ΔF_{Raster} applies to channels using only the SCS that is equal to or larger than the higher ΔF_{Raster} and SSB SCS is equal to the higher ΔF_{Raster} .
- For frequency bands with two ΔF_{Raster} in FR2, the higher ΔF_{Raster} applies to channels using only the SCS that is equal to the higher ΔF_{Raster} and the SSB SCS that is equal to or larger than the higher ΔF_{Raster} .

Table 5.4.2.3-1: Applicable NR-ARFCN per *operating band* in FR1

NR operating band	ΔF_{Raster} (kHz)	Uplink range of N_{REF} (First – <Step size> – Last)	Downlink range of N_{REF} (First – <Step size> – Last)
n1	100	384000 – <20> – 396000	422000 – <20> – 434000
n2	100	370000 – <20> – 382000	386000 – <20> – 398000
n3	100	342000 – <20> – 357000	361000 – <20> – 376000
n5	100	164800 – <20> – 169800	173800 – <20> – 178800
n7	100	500000 – <20> – 514000	524000 – <20> – 538000
n8	100	176000 – <20> – 183000	185000 – <20> – 192000
n12	100	139800 – <20> – 143200	145800 – <20> – 149200
n13	100	155400 – <20> – 157400	149200 – <20> – 151200
n14	100	157600 – <20> – 159600	151600 – <20> – 153600
n18	100	163000 – <20> – 166000	172000 – <20> – 175000
n20	100	166400 – <20> – 172400	158200 – <20> – 164200
n25	100	370000 – <20> – 383000	386000 – <20> – 399000
n24	100	325300 – <20> – 332100	305000 – <20> – 311800
n26	100	162800 – <20> – 169800	171800 – <20> – 178800
n28	100	140600 – <20> – 149600	151600 – <20> – 160600
		144608 ⁴	155608 ⁴
n29	100	N/A	143400 – <20> – 145600
n30	100	461000 – <20> – 463000	470000 – <20> – 472000
n34	100	402000 – <20> – 405000	402000 – <20> – 405000
n38	100	514000 – <20> – 524000	514000 – <20> – 524000
n39	100	376000 – <20> – 384000	376000 – <20> – 384000
n40	100	460000 – <20> – 480000	460000 – <20> – 480000
n41	15	499200 – <3> – 537999	499200 – <3> – 537999
	30	499200 – <6> – 537996	499200 – <6> – 537996
n46 ¹	15	743334 – <1> – 795000	743334 – <1> – 795000
n48	15	636667 – <1> – 646666	636667 – <1> – 646666
	30	636668 – <2> – 646666	636668 – <2> – 646666
n50	100	286400 – <20> – 303400	286400 – <20> – 303400
n51	100	285400 – <20> – 286400	285400 – <20> – 286400
n53	100	496700 – <20> – 499000	496700 – <20> – 499000
n65	100	384000 – <20> – 402000	422000 – <20> – 440000
n66	100	342000 – <20> – 356000	422000 – <20> – 440000
n67	100	N/A	147600 – <20> – 151600
n70	100	339000 – <20> – 342000	399000 – <20> – 404000
n71	100	132600 – <20> – 139600	123400 – <20> – 130400
n74	100	285400 – <20> – 294000	295000 – <20> – 303600
n75	100	N/A	286400 – <20> – 303400
n76	100	N/A	285400 – <20> – 286400
n77	15	620000 – <1> – 680000	620000 – <1> – 680000
	30	620000 – <2> – 680000	620000 – <2> – 680000
n78	15	620000 – <1> – 653333	620000 – <1> – 653333
	30	620000 – <2> – 653332	620000 – <2> – 653332
n79	15	693334 – <1> – 733333	693334 – <1> – 733333
	30	693334 – <2> – 733332	693334 – <2> – 733332
n80	100	342000 – <20> – 357000	N/A
n81	100	176000 – <20> – 183000	N/A
n82	100	166400 – <20> – 172400	N/A
n83	100	140600 – <20> – 149600	N/A
n84	100	384000 – <20> – 396000	N/A
n85	100	139600 – <20> – 143200	145600 – <20> – 149200
n86	100	342000 – <20> – 356000	N/A
n89	100	164800 – <20> – 169800	N/A
n90	15	499200 – <3> – 537999	499200 – <3> – 537999
	30	499200 – <6> – 537996	499200 – <6> – 537996
	100	499200 – <20> – 538000	499200 – <20> – 538000
n91	100	166400 – <20> – 172400	285400 – <20> – 286400
n92	100	166400 – <20> – 172400	286400 – <20> – 303400
n93	100	176000 – <20> – 183000	285400 – <20> – 286400
n94	100	176000 – <20> – 183000	286400 – <20> – 303400
n95	100	402000 – <20> – 405000	N/A
n96 ²	15	795000 – <1> – 875000	795000 – <1> – 875000
n97	100	460000 – <20> – 480000	N/A

n98	100	376000 – <20> – 384000	N/A
n99	100	325300 – <20> – 332100	N/A
n100	100	174880 – <20> – 176000	183880 – <20> – 185000
n101	100	380000 – <20> – 382000	380000 – <20> – 382000
n102 ³	15	796334 – <1> – 828333	796334 – <1> – 828333
n104	15	828334 – <1> – 875000	828334 – <1> – 875000
	30	828334 – <2> – 875000	828334 – <2> – 875000

NOTE 1: Applicable NR-ARFCN for band n46
for 10 MHz channel bandwidth, N_{REF} = {782000, 788668}
for 20 MHz channel bandwidth, N_{REF} = {744000, 745332, 746668, 748000, 749332, 750668, 752000, 753332, 754668, 756000, 765332, 766668, 768000, 769332, 770668, 772000, 773332, 774668, 776000, 777332, 778668, 780000, 781332, 783000, 784332, 785668, 787000, 788332, 789668, 791000, 792332, 793668};
for 40 MHz channel bandwidth, N_{REF} = {744668, 746000, 748668, 751332, 754000, 755332, 766000, 767332, 770000, 772668, 775332, 778000, 780668, 783668, 786332, 787668, 790332, 793000};
for 60 MHz channel bandwidth, N_{REF} = {745332, 746668, 748000, 752000, 753332, 754668, 766668, 768000, 769332, 773332, 774668, 778668, 780000, 784332, 785668, 791000, 792332};
for 80 MHz channel bandwidth, N_{REF} = {746000, 747332, 752668, 754000, 767332, 768668, 774000, 779332, 785000, 791668}
for 100 MHz channel bandwidth, N_{REF} = {746668, 753332, 768000, 791000}

NOTE 2: Applicable NR-ARFCN for band n96
for 20 MHz channel bandwidth, N_{REF} = {797000, 798332, 799668, 801000, 802332, 803668, 805000, 806332, 807668, 809000, 810332, 811668, 813000, 814332, 815668, 817000, 818332, 819668, 821000, 822332, 823668, 825000, 826332, 827668, 829000, 830332, 831668, 833000, 834332, 835668, 837000, 838332, 839668, 841000, 842332, 843668, 845000, 846332, 847668, 849000, 850332, 851668, 853000, 854332, 855668, 857000, 858332, 859668, 861000, 862332, 863668, 865000, 866332, 867668, 869000, 870332, 871668, 873000, 874332}
for 40 MHz channel bandwidth, N_{REF} = {797668, 800332, 803000, 805668, 808332, 811000, 813668, 816332, 819000, 821668, 824332, 827000, 829668, 832332, 835000, 837668, 840332, 843000, 845668, 848332, 851000, 853668, 856332, 859000, 861668, 864332, 867000, 869668, 872332}
for 60 MHz channel bandwidth, N_{REF} = {798332, 799668, 803668, 805000, 809000, 810332, 814332, 815668, 819668, 821000, 825000, 826332, 830332, 831668, 835668, 837000, 841000, 842332, 846332, 847668, 851668, 853000, 857000, 858332, 862332, 863668, 867668, 869000, 873000}
for 80 MHz channel bandwidth, N_{REF} = {799000, 804332, 809668, 815000, 820332, 825668, 831000, 836332, 841668, 847000, 852332, 857668, 863000, 868332}
for 100 MHz channel bandwidth, N_{REF} = {799668, 803668, 810332, 814332, 821000, 825000, 831668, 835668, 842332, 846332, 853000, 857000, 863668, 867668, 869000, 870332, 871668}

NOTE 3: Applicable NR-ARFCN for band n102
for 20 MHz channel bandwidth, N_{REF} = {797000, 798332, 799668, 801000, 802332, 803668, 805000, 806332, 807668, 809000, 810332, 811668, 813000, 814332, 815668, 817000, 818332, 819668, 821000, 822332, 823668, 825000, 826332, 827668}
for 40 MHz channel bandwidth, N_{REF} = {797668, 800332, 803000, 805668, 808332, 811000, 813668, 816332, 819000, 821668, 824332, 827000}
for 60 MHz channel bandwidth, N_{REF} = {798332, 799668, 803668, 805000, 809000, 810332, 814332, 815668, 819668, 821000, 825000, 826332}
for 80 MHz channel bandwidth, N_{REF} = {799000, 804332, 809668, 815000, 820332, 825668}
for 100 MHz channel bandwidth, N_{REF} = {799668, 803668, 810332, 814332, 821000, 825000}

NOTE 4: This exceptional raster point is applicable only to n28 and is only applicable for 40MHz BS channel bandwidth to ensure the guardband with 30MHz UE channel bandwidth.

Table 5.4.2.3-2: Applicable NR-ARFCN per operating band in FR2

NR operating band	ΔF_{Raster} (kHz)	Uplink and Downlink range of N_{REF} (First – <Step size> – Last)
n257	60	2054166 – <1> – 2104165
	120	2054167 – <2> – 2104165
n258	60	2016667 – <1> – 2070832
	120	2016667 – <2> – 2070831
n259	60	2270833 – <1> – 2337499
	120	2270833 – <2> – 2337499
n260	60	2229166 – <1> – 2279165
	120	2229167 – <2> – 2279165
n261	60	2070833 – <1> – 2084999
	120	2070833 – <2> – 2084999
n262	60	2399166 – <1> – 2415832
	120	2399167 – <2> – 2415831
n263	120	See Table 5.4.2.3-3
	480	
	960	

Table 5.4.2.3-3: Applicable NR-ARFCN for operation in band n263

Channel Bandwidth	Applicable NR-ARFCN
100 MHz	2564083 + 1680 * N, N = 0:137
400 MHz	2566603 + 6720 * N, N = 0:33
800 MHz	2569963 + 6720 * N, N = 0:32
1600 MHz	2576683 + 6720 * N, N = 0:30
2000 MHz	2580043 + 6720 * N, N = 0:29, 2585083, 2655643, 2692603, 2764843

5.4.3 Synchronization raster

5.4.3.1 Synchronization raster and numbering

The synchronization raster indicates the frequency positions of the synchronization block that can be used by the UE for system acquisition when explicit signalling of the synchronization block position is not present.

A global synchronization raster is defined for all frequencies. The frequency position of the SS block is defined as SS_{REF} with corresponding number GSCN. The parameters defining the SS_{REF} and GSCN for all the frequency ranges are in table 5.4.3.1-1.

The resource element corresponding to the SS block reference frequency SS_{REF} is given in clause 5.4.3.2. The synchronization raster and the subcarrier spacing of the synchronization block is defined separately for each band.

Table 5.4.3.1-1: GSCN parameters for the global frequency raster

Range of frequencies (MHz)	SS block frequency position SS_{REF}	GSCN	Range of GSCN
0 – 3000	$N * 1200 \text{ kHz} + M * 50 \text{ kHz}$, $N = 1:2499$, $M \in \{1,3,5\}$ (Note)	$3N + (M-3)/2$	2 – 7498
3000 – 24250	$3000 \text{ MHz} + N * 1.44 \text{ MHz}$, $N = 0:14756$	$7499 + N$	7499 – 22255
24250 – 100000	$24250.08 \text{ MHz} + N * 17.28 \text{ MHz}$, $N = 0:4383$	$22256 + N$	22256 – 26639
NOTE: The default value for operating bands which only support SCS spaced channel raster(s) is M=3.			

5.4.3.2 Synchronization raster to synchronization block resource element mapping

The mapping between the synchronization raster and the corresponding resource element of the SS block is given in table 5.4.3.2-1.

Table 5.4.3.2-1: Synchronization Raster to SS block Resource Element Mapping

Resource element index k	120

k is the subcarrier number of SS/PBCH block defined in TS 38.211 clause 7.4.3.1 [9].

5.4.3.3 Synchronization raster entries for each operating band

The synchronization raster for each band is give in table 5.4.3.3-1. The distance between applicable GSCN entries is given by the <Step size> indicated in table 5.4.3.3-1 for FR1 and table 5.4.3.3-2 for FR2.

Table 5.4.3.3-1: Applicable SS raster entries per *operating band* (FR1)

NR operating band	SS Block SCS	SS Block pattern (NOTE 1)	Range of GSCN (First – <Step size> – Last)
n1	15 kHz	Case A	5279 – <1> – 5419
n2	15 kHz	Case A	4829 – <1> – 4969
n3	15 kHz	Case A	4517 – <1> – 4693
n5	15 kHz	Case A	2177 – <1> – 2230
	30 kHz	Case B	2183 – <1> – 2224
n7	15 kHz	Case A	6554 – <1> – 6718
n8	15 kHz	Case A	2318 – <1> – 2395
n12	15 kHz	Case A	1828 – <1> – 1858
n13	15 kHz	Case A	1871 – <1> – 1885
n14	15 kHz	Case A	1901 – <1> – 1915
n18	15 kHz	Case A	2156 – <1> – 2182
n20	15 kHz	Case A	1982 – <1> – 2047
n24	15 kHz	Case A	3818 – <1> – 3892
	30 kHz	Case B	3824 – <1> – 3886
n25	15 kHz	Case A	4829 – <1> – 4981
n26	15 kHz	Case A	2153 – <1> – 2230
n28	15 kHz	Case A	1901 – <1> – 2002
n29	15 kHz	Case A	1798 – <1> – 1813
n30	15 kHz	Case A	5879 – <1> – 5893
n34	15 kHz	Case A	NOTE 3
	30 kHz	Case C	5036 – <1> – 5050
n38	15 kHz	Case A	NOTE 2
	30 kHz	Case C	6437 – <1> – 6538
n39	15 kHz	Case A	NOTE 4
	30 kHz	Case C	4712 – <1> – 4789
n40	30 kHz	Case C	5762 – <1> – 5989
n41	15 kHz	Case A	6246 – <3> – 6717
	30 kHz	Case C	6252 – <3> – 6714
n46 ⁵	30 kHz	Case C	8993 – <1> – 9530
n48	30 kHz	Case C	7884 – <1> – 7982
n50	30 kHz	Case C	3590 – <1> – 3781
n51	15 kHz	Case A	3572 – <1> – 3574
n53	15 kHz	Case A	6215 – <1> – 6232
	30 kHz	Case C	6221 – <1> – 6226
n65	15 kHz	Case A	5279 – <1> – 5494
n66	15 kHz	Case A	5279 – <1> – 5494
	30 kHz	Case B	5285 – <1> – 5488
n67	15 kHz	Case A	1850 – <1> – 1888
n70	15 kHz	Case A	4993 – <1> – 5044
n71	15 kHz	Case A	1547 – <1> – 1624
n74	15 kHz	Case A	3692 – <1> – 3790
n75	15 kHz	Case A	3584 – <1> – 3787
n76	15 kHz	Case A	3572 – <1> – 3574
n77	30 kHz	Case C	7711 – <1> – 8329
n78	30 kHz	Case C	7711 – <1> – 8051
n79	30 kHz	Case C	8480 – <16> – 8880 ⁷
			8475 – <1> – 8884 ⁸
n85	15 kHz	Case A	1826 – <1> – 1858
n90	15 kHz	Case A	6246 – <1> – 6717 ¹⁰
	15 kHz	Case A	6245 – <1> – 6718 ¹¹
	30 kHz	Case C	6252 – <1> – 6714
n91	15 kHz	Case A	3572 – <1> – 3574
n92	15 kHz	Case A	3584 – <1> – 3787
n93	15 kHz	Case A	3572 – <1> – 3574
n94	15 kHz	Case A	3584 – <1> – 3787
n96 ⁶	30 kHz	Case C	9531 – <1> – 10363
n100	15 kHz	Case A	2303 – <1> – 2307
n101	15 kHz	Case A	4754 – <1> – 4768
	30 kHz	Case C	4760 – <1> – 4764
n102 ⁹	30 kHz	Case C	9531 – <1> – 9877
n104	30 kHz	Case C	9882 – <7> – 10358

NOTE 1: SS Block pattern is defined in clause 4.1 in TS 38.213 [10].
 NOTE 2: The applicable SS raster entries are GSCN = {6432, 6443, 6457, 6468, 6479, 6493, 6507, 6518, 6532, 6543}
 NOTE 3: The applicable SS raster entries are GSCN = {5032, 5043, 5054}
 NOTE 4: The applicable SS raster entries are GSCN = {4707, 4715, 4718, 4729, 4732, 4743, 4747, 4754, 4761, 4768, 4772, 4782, 4786, 4793}
 NOTE 5: The following GSCN are allowed for operation in band n46:
 GSCN = {8996, 9010, 9024, 9038, 9051, 9065, 9079, 9093, 9107, 9121, 9218, 9232, 9246, 9260, 9274, 9288, 9301, 9315, 9329, 9343, 9357, 9371, 9385, 9402, 9416, 9430, 9444, 9458, 9472, 9485, 9499, 9513}.
 NOTE 6: The following GSCN are allowed for operation in band n96:
 GSCN = { 9548, 9562, 9576, 9590, 9603, 9617, 9631, 9645, 9659, 9673, 9687, 9701, 9714, 9728, 9742, 9756, 9770, 9784, 9798, 9812, 9826, 9840, 9853, 9867, 9881, 9895, 9909, 9923, 9937, 9951, 9964, 9978, 9992, 10006, 10020, 10034, 10048, 10062, 10076, 10090, 10103, 10117, 10131, 10145, 10159, 10173, 10187, 10201, 10214, 10228, 10242, 10256, 10270, 10284, 10298, 10312, 10325, 10339, 10353}.
 NOTE 7: The SS raster entries apply for channel bandwidths larger than or equal to 40 MHz.
 NOTE 8: The SS raster entries apply for channel bandwidths smaller than 40 MHz.
 NOTE 9: The following GSCN are allowed for operation in band n102:
 GSCN = {9535, 9548, 9562, 9576, 9590, 9603, 9617, 9631, 9645, 9659, 9673, 9687, 9701, 9714, 9728, 9742, 9756, 9770, 9784, 9798, 9812, 9826, 9840, 9853, 9867}
 NOTE 10: The SS raster entries apply for channel bandwidths larger than or equal to 10 MHz.
 NOTE 11: The SS raster entries apply for channel bandwidth equal to 5 MHz.

Table 5.4.3.3-2: Applicable SS raster entries per operating band (FR2)

NR operating band	SS Block SCS	SS Block pattern (note 1)	Range of GSCN (First – <Step size> – Last)
n257	120 kHz	Case D	22388 – <1> – 22558
	240 kHz	Case E	22390 – <2> – 22556
n258	120 kHz	Case D	22257 – <1> – 22443
	240 kHz	Case E	22258 – <2> – 22442
n259	120 kHz	Case D	23140 – <1> – 23369
	240 kHz	Case E	23142 – <2> – 23368
n260	120 kHz	Case D	22995 – <1> – 23166
	240 kHz	Case E	22996 – <2> – 23164
n261	120 kHz	Case D	22446 – <1> – 22492
	240 kHz	Case E	22446 – <2> – 22490
n262	120 kHz	Case D	23586 – <1> – 23641
	240 kHz	Case E	23588 – <2> – 23640
n263	120 kHz	Case D	Table 5.4.3.3-3
	480 kHz	Case F	
	960 kHz ²	Case G	

NOTE 1: SS Block pattern is defined in section 4.1 in TS 38.213 [10].
 NOTE 2: SS Block SCS of 960 kHz is not used for initial access.

Table 5.4.3.3-3: Allowed GSCN for operation in band n263 for 120 kHz and 480 kHz

SS Block SCS	Range of GSCN
120 kHz	$24156 + 6 * N - 3 * \text{floor}((N+5)/18)$, N=0:137
480 kHz	$24162 + 24 * N - 12 * \text{floor}((N+4)/18)$, N=0:33

6 Conducted transmitter characteristics

6.1 General

Unless otherwise stated, the conducted transmitter characteristics are specified at the *antenna connector* for *BS type 1-C* and at the *TAB connector* for *BS type 1-H*, with a full complement of transceiver units for the configuration in normal operating conditions.

For *BS type 1-H* the manufacturer shall declare the minimum number of supported geographical cells (i.e. geographical areas covered by beams). The minimum number of supported geographical cells (N_{cells}) relates to the BS setting with the minimum amount of cell splitting supported with transmission on all *TAB connectors* supporting the *operating band*, or with minimum amount of transmitted beams.

For *BS type 1-H* manufacturer shall also declare *TAB connector TX min cell groups*. Every *TAB connector* of the *BS type 1-H* supporting transmission in an *operating band* shall map to one *TAB connector TX min cell group* supporting the same *operating band*, where mapping of *TAB connectors* to cells/beams is implementation dependent.

The number of *active transmitter units* that are considered when calculating the conducted TX emissions limits ($N_{\text{TXU,counted}}$) for *BS type 1-H* is calculated as follows:

$$N_{\text{TXU,counted}} = \min(N_{\text{TXU,active}}, 8 \times N_{\text{cells}})$$

$N_{\text{TXU,countedpercell}}$ is used for scaling of *basic limits* and is derived as $N_{\text{TXU,countedpercell}} = N_{\text{TXU,counted}} / N_{\text{cells}}$

NOTE: $N_{\text{TXU,active}}$ depends on the actual number of *active transmitter units* and is independent to the declaration of N_{cells} .

For *BS type 1-H* there is no requirement specified for band n46, n100 and n101 and n102.

6.2 Base station output power

6.2.1 General

The BS conducted output power requirement is at *antenna connector* for *BS type 1-C*, or at *TAB connector* for *BS type 1-H*.

The *rated carrier output power* of the *BS type 1-C* shall be as specified in table 6.2.1-1.

Table 6.2.1-1: BS type 1-C rated output power limits for BS classes

BS class	$P_{\text{rated,c,AC}}$
Wide Area BS	(Note)
Medium Range BS	≤ 38 dBm
Local Area BS	≤ 24 dBm
NOTE: There is no upper limit for the $P_{\text{rated,c,AC}}$ rated output power of the Wide Area Base Station.	

For operation in bands n100 and n101 in CEPT countries subject to the ECC Decision (20)02 [21], the WA BS requirement in table 6.2.1-1 apply in case of coordinated RMR BS deployments, while the requirements in clause 6.2.4 apply in case of uncoordinated RMR BS deployments.

The *rated carrier output power* of the *BS type 1-H* shall be as specified in table 6.2.1-2.

Table 6.2.1-2: BS type 1-H rated output power limits for BS classes

BS class	$P_{\text{rated,c,sys}}$	$P_{\text{rated,c,TABC}}$
Wide Area BS	(Note)	(Note)
Medium Range BS	$\leq 38 \text{ dBm} + 10\log(N_{\text{TXU,counted}})$	$\leq 38 \text{ dBm}$
Local Area BS	$\leq 24 \text{ dBm} + 10\log(N_{\text{TXU,counted}})$	$\leq 24 \text{ dBm}$
NOTE: There is no upper limit for the $P_{\text{rated,c,sys}}$ or $P_{\text{rated,c,TABC}}$ of the Wide Area Base Station.		

In addition, for operation with shared spectrum channel access operation, the BS may have to comply with the applicable BS power limits established regionally, when deployed in regions where those limits apply and under the conditions declared by the manufacturer.

6.2.2 Minimum requirement for BS type 1-C

In normal conditions, $P_{\text{max,c,AC}}$ shall remain within +2 dB and -2 dB of the *rated carrier output power* $P_{\text{rated,c,AC}}$, declared by the manufacturer.

In extreme conditions, $P_{\text{max,c,AC}}$ shall remain within +2.5 dB and -2.5 dB of the *rated carrier output power* $P_{\text{rated,c,AC}}$, declared by the manufacturer.

In certain regions, the minimum requirement for normal conditions may apply also for some conditions outside the range of conditions defined as normal.

NOTE: For NB-IoT operation in NR in-band, the NR carrier and NB-IoT carrier shall be seen as a single carrier occupied NR channel bandwidth, the output power over this carrier is shared between NR and NB-IoT. This note shall apply for $P_{\text{max,c,AC}}$ and $P_{\text{rated,c,AC}}$.

6.2.3 Minimum requirement for BS type 1-H

In normal conditions, $P_{\text{max,c,TABC}}$ shall remain within +2 dB and -2 dB of the *rated carrier output power* $P_{\text{rated,c,TABC}}$ for each *TAB connector* as declared by the manufacturer.

In extreme conditions, $P_{\text{max,c,TABC}}$ shall remain within +2.5 dB and -2.5 dB of the *rated carrier output power* $P_{\text{rated,c,TABC}}$ for each *TAB connector* as declared by the manufacturer.

In certain regions, the minimum requirement for normal conditions may apply also for some conditions outside the range of conditions defined as normal.

6.2.4 Additional requirements (regional)

In certain regions, additional regional requirements may apply.

For Band n41 and n90 operation in Japan, the rated output power, $P_{\text{rated,c,sys}}$ for BS type 1-H or sum of $P_{\text{rated,c,AC}}$ over all *antenna connectors* for BS type 1-C declared by the manufacturer shall be equal to or less than 20 W per 10 MHz bandwidth.

For band n100 in CEPT countries subject to the ECC Decision (20)02 [21], $P_{\text{rated,c,AC}}$ of the WA BS shall not exceed 51.5 dBm/5MHz + $(f_{\text{DL}} - 922.1) \times 40/3$ dB, with f_{DL} being the centre frequency in MHz. This limit is derived from ECC Decision (20)02 [21] assuming a 17 dBi maximum antenna gain and 4 dB losses, and assuming one antenna connector. The above rated output power limit for band n100 applies to uncoordinated deployments and in case of coordinated deployments, higher output power values may be allowed.

For CEPT countries subject to the ECC Decision (20)02 [21], administrations wishing to allow multiple carriers, i.e. more than one wideband carrier (LTE, NR, NB-IoT standalone or NR/LTE with NB-IoT in-band) in band n100, should consider the implementation of a coordination procedure or other mitigation measures.

NOTE: For more details on the maximum level derivation, refer to TR 38.853 [23].

For band n101 in CEPT countries subject to the ECC Decision (20)02 [21], $P_{\text{rated,c,AC}}$ shall not exceed 51 dBm/10MHz or 48 dBm/5MHz. This limit is derived from ECC Decision (20)02 [21] assuming a 18 dBi maximum antenna gain and 4 dB losses, and assuming one antenna connector. The above rated output power limit for band n101 applies to uncoordinated deployments and in case of coordinated deployments, higher output power values may be allowed.

For CEPT countries subject to the ECC Decision (20)02 [21], administrations wishing to allow multiple carriers, i.e. more than one wideband carrier (LTE, NR, NB-IoT standalone or NR/LTE with NB-IoT in-band) in band n101, should consider the implementation of a coordination procedure or other mitigation measures.

NOTE: For more details on the maximum level derivation, refer to TR 38.852 [22].

6.3 Output power dynamics

6.3.1 General

The requirements in clause 6.3 apply during the *transmitter ON period*. Transmitted signal quality (as specified in clause 6.5) shall be maintained for the output power dynamics requirements of this clause.

Power control is used to limit the interference level.

6.3.2 RE power control dynamic range

6.3.2.1 General

The RE power control dynamic range is the difference between the power of an RE and the average RE power for a BS at maximum output power ($P_{\max,c,AC}$ or $P_{\max,c,TABC}$) for a specified reference condition.

For *BS type 1-C* this requirement shall apply at the *antenna connector* supporting transmission in the *operating band*.

For *BS type 1-H* this requirement shall apply at each *TAB connector* supporting transmission in the *operating band*.

6.3.2.2 Minimum requirement for *BS type 1-C* and *BS type 1-H*

RE power control dynamic range:

Table 6.3.2.2-1: RE power control dynamic range

Modulation scheme used on the RE	RE power control dynamic range (dB)	
	(down)	(up)
QPSK (PDCCH)	-6	+4
QPSK (PDSCH)	-6	+3
16QAM (PDSCH)	-3	+3
64QAM (PDSCH)	0	0
256QAM (PDSCH)	0	0
1024QAM (PDSCH)	0	0
NOTE: The output power per carrier shall always be less or equal to the maximum output power of the base station.		

6.3.3 Total power dynamic range

6.3.3.1 General

The BS total power dynamic range is the difference between the maximum and the minimum transmit power of an OFDM symbol for a specified reference condition.

For *BS type 1-C* this requirement shall apply at the *antenna connector* supporting transmission in the *operating band*.

For *BS type 1-H* this requirement shall apply at each *TAB connector* supporting transmission in the *operating band*.

NOTE 1: The upper limit of the dynamic range is the OFDM symbol power for a BS when transmitting on all RBs at maximum output power. The lower limit of the total power dynamic range is the average power for single RB transmission. The OFDM symbol shall carry PDSCH and not contain RS or SSB.

NOTE 2: The requirement does not apply to operation with shared spectrum channel access.

6.3.3.2 Minimum requirement for *BS type 1-C* and *BS type 1-H*

The downlink (DL) total power dynamic range for each NR carrier shall be larger than or equal to the level in table 6.3.3.2-1.

Table 6.3.3.2-1: Total power dynamic range

BS channel bandwidth (MHz)	Total power dynamic range (dB)		
	15 kHz SCS	30 kHz SCS	60 kHz SCS
5	13.9	10.4	N/A
10	17.1	13.8	10.4
15	18.9	15.7	12.5
20	20.2	17	13.8
25	21.2	18.1	14.9
30	22	18.9	15.7
35	22.7	19.6	16.4
40	23.3	20.2	17
45	23.8	20.7	17.6
50	24.3	21.2	18.1
60	N/A	22	18.9
70	N/A	22.7	19.6
80	N/A	23.3	20.2
90	N/A	23.8	20.8
100	N/A	24.3	21.3

6.3.4 NB-IoT RB power dynamic range for NB-IoT operation in NR in-band

6.3.4.1 General

The NB-IoT RB power dynamic range (or NB-IoT power boosting) is the difference between the average power of NB-IoT REs (which occupy certain REs within a NR transmission bandwidth configuration plus 15 kHz at each edge but not within the NR minimum guard band GB_{Channel}) and the average power over all REs (from both NB-IoT and the NR carrier containing the NB-IoT REs).

6.3.4.2 Minimum Requirement

NB-IoT RB power dynamic range for NB-IoT operation in NR in-band shall be larger than or equal to the level specified in Table 6.3.4.2-1. This power dynamic range level is only required for one NB-IoT RB.

Table 6.3.4.2-1: NB-IoT RB power dynamic range for NB-IoT operation in NR in-band

BS channel bandwidth (MHz)	NB-IoT RB frequency position	NB-IoT RB power dynamic range (dB)
5, 10	Any	+6
15	Within center $77 \cdot 180\text{kHz} + 15\text{kHz}$ at each edge	+6
	Other	+3
20	Within center $102 \cdot 180\text{kHz} + 15\text{kHz}$ at each edge	+6
	Other	+3
25, 30, 35, 40, 45, 50, 60, 70, 80, 90, 100	Within center 90% of BS channel bandwidth	+6
	Other	+3

6.4 Transmit ON/OFF power

6.4.1 Transmitter OFF power

6.4.1.1 General

Transmit OFF power requirements apply only to TDD operation of the BS.

Transmitter OFF power is defined as the mean power measured over $70/N$ us filtered with a square filter of bandwidth equal to the *transmission bandwidth configuration* of the BS (BW_{Config}) centred on the assigned channel frequency during the *transmitter OFF period*. $N = \text{SCS}/15$, where SCS is Sub Carrier Spacing in kHz.

For *multi-band connectors* and for *single band connectors* supporting transmission in multiple *operating bands*, the requirement is only applicable during the *transmitter OFF period* in all supported *operating bands*.

For BS supporting intra-band contiguous CA, the transmitter OFF power is defined as the mean power measured over $70/N$ us filtered with a square filter of bandwidth equal to the *Aggregated BS Channel Bandwidth* $BW_{\text{Channel_CA}}$ centred on $(F_{\text{edge,high}}+F_{\text{edge,low}})/2$ during the *transmitter OFF period*. $N = \text{SCS}/15$, where SCS is the smallest supported Sub Carrier Spacing in kHz in the *Aggregated BS Channel Bandwidth*.

6.4.1.2 Minimum requirement for *BS type 1-C*

For *BS type 1-C*, the requirements for transmitter OFF power spectral density shall be less than -85 dBm/MHz per *antenna connector*.

6.4.1.3 Minimum requirement for *BS type 1-H*

For *BS type 1-H*, the requirements for transmitter OFF power spectral density shall be less than -85 dBm/MHz per *TAB connector*.

6.4.2 Transmitter transient period

6.4.2.1 General

Transmitter transient period requirements apply only to TDD operation of the BS.

The *transmitter transient period* is the time period during which the transmitter is changing from the *transmitter OFF period* to the *transmitter ON period* or vice versa. The *transmitter transient period* is illustrated in figure 6.4.2.1-1.

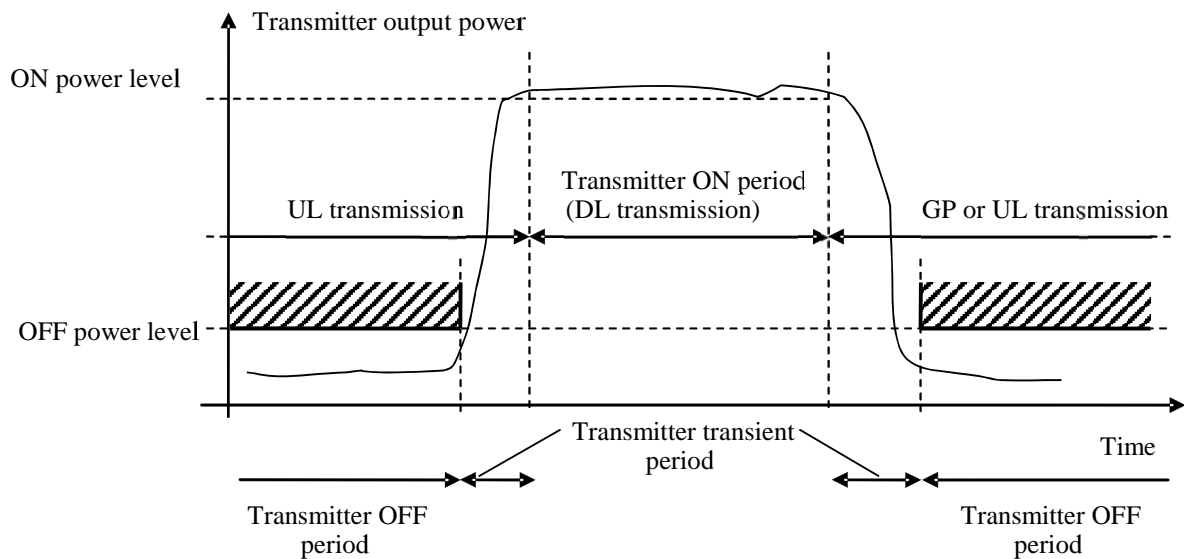

Figure 6.4.2.1-1: Example of relations between transmitter ON period, transmitter OFF period and transmitter transient period

For *BS type 1-C* this requirement shall be applied at the *antenna connector* supporting transmission in the *operating band*.

For *BS type 1-H* this requirement shall be applied at each *TAB connector* supporting transmission in the *operating band*.

6.4.2.2 Minimum requirement for *BS type 1-C* and *BS type 1-H* 1-H

For *BS type 1-C* and *BS type 1-H*, the *transmitter transient period* shall be shorter than the values listed in the minimum requirement table 6.4.2.2-1.

Table 6.4.2.2-1: Minimum requirement for the transmitter transient period for *BS type 1-C* and *BS type 1-H*

Transition	Transient period length (µs)
OFF to ON	10
ON to OFF	10

6.4.2.3 Void

6.5 Transmitted signal quality

6.5.1 Frequency error

6.5.1.1 General

The requirements in clause 6.5.1 apply to the *transmitter ON period*.

Frequency error is the measure of the difference between the actual BS transmit frequency and the assigned frequency. The same source shall be used for RF frequency and data clock generation.

For *BS type 1-C* this requirement shall be applied at the *antenna connector* supporting transmission in the *operating band*.

For *BS type 1-H* this requirement shall be applied at each *TAB connector* supporting transmission in the *operating band*.

6.5.1.2 Minimum requirement for *BS type 1-C* and *BS type 1-H*

For *BS type 1-C* and *BS type 1-H*, the modulated carrier frequency of each NR carrier configured by the BS shall be accurate to within the accuracy range given in table 6.5.1.2-1 observed over 1 ms.

The frequency error requirement for NB-IoT are specified in TS 36.104 [13] clause 6.5.1.

Table 6.5.1.2-1: Frequency error minimum requirement

BS class	Accuracy
Wide Area BS	± 0.05 ppm
Medium Range BS	± 0.1 ppm
Local Area BS	± 0.1 ppm

6.5.2 Modulation quality

6.5.2.1 General

Modulation quality is defined by the difference between the measured carrier signal and an ideal signal. Modulation quality can e.g. be expressed as Error Vector Magnitude (EVM). The Error Vector Magnitude is a measure of the difference between the ideal symbols and the measured symbols after the equalization. This difference is called the error vector. Details about how the EVM is determined are specified in Annex B.

For *BS type 1-C* this requirement shall be applied at the *antenna connector* supporting transmission in the *operating band*.

For *BS type 1-H* this requirement shall be applied at each *TAB connector* supporting transmission in the *operating band*.

6.5.2.2 Minimum Requirement for *BS type 1-C* and *BS type 1-H*

For *BS type 1-C* and *1-H*, the EVM levels of each NR carrier for different modulation schemes on PDSCH outlined in table 6.5.2.2-1 shall be met using the frame structure described in clause 6.5.2.3.

Table 6.5.2.2-1: EVM requirements for *BS type 1-C* and *BS type 1-H* carrier

Modulation scheme for PDSCH	Required EVM
QPSK	17.5 %
16QAM	12.5 %
64QAM	8 %
256QAM	3.5 %
1024QAM	2.5 % ¹ 2.8 % ²
Note 1:	This requirement is applicable for frequencies equal to or below 4.2 GHz.
Note 2:	This requirement is applicable for frequencies above 4.2 GHz.

The modulation quality requirements for NB-IoT are specified in TS 36.104 [13] clause 6.5.2.

6.5.2.3 EVM frame structure for measurement

EVM shall be evaluated for each NR carrier over all allocated resource blocks and downlink subframes. Different modulation schemes listed in table 6.5.2.2-1 shall be considered for rank 1.

For NR, for all bandwidths, the EVM measurement shall be performed for each NR carrier over all allocated resource blocks and downlink subframes within 10 ms measurement periods. The boundaries of the EVM measurement periods need not be aligned with radio frame boundaries.

6.5.3 Time alignment error

6.5.3.1 General

This requirement shall apply to frame timing in MIMO transmission, *carrier aggregation* and their combinations.

Frames of the NR signals present at the BS transmitter *antenna connectors* or *TAB connectors* are not perfectly aligned in time. The RF signals present at the BS transmitter *antenna connectors* or *transceiver array boundary* may experience certain timing differences in relation to each other.

The TAE is specified for a specific set of signals/transmitter configuration/transmission mode.

For *BS type 1-C*, the TAE is defined as the largest timing difference between any two signals belonging to different *antenna connectors* for a specific set of signals/transmitter configuration/transmission mode.

For *BS type 1-H*, the TAE is defined as the largest timing difference between any two signals belonging to *TAB connectors* belonging to different transmitter groups at the *transceiver array boundary*, where transmitter groups are associated with the *TAB connectors* in the transceiver unit array corresponding to MIMO transmission, *carrier aggregation* for a specific set of signals/transmitter configuration/transmission mode.

6.5.3.2 Minimum requirement for *BS type 1-C* and *BS type 1-H*

For MIMO transmission, at each carrier frequency, TAE shall not exceed 65 ns.

For *intra-band contiguous carrier aggregation*, with or without MIMO, TAE shall not exceed 260ns.

For *intra-band non-contiguous carrier aggregation*, with or without MIMO, TAE shall not exceed 3 μ s.

For inter-band *carrier aggregation*, with or without MIMO, TAE shall not exceed 3 μ s.

The time alignment error requirements for NB-IoT are specified in TS 36.104 [13] clause 6.5.3.

Table 6.5.3.2-1: Void

Table 6.5.3.2-2: Void

Table 6.5.3.2-3: Void

6.6 Unwanted emissions

6.6.1 General

Unwanted emissions consist of out-of-band emissions and spurious emissions according to ITU definitions [2]. In ITU terminology, out of band emissions are unwanted emissions immediately outside the *BS channel bandwidth* resulting from the modulation process and non-linearity in the transmitter but excluding spurious emissions. Spurious emissions are emissions which are caused by unwanted transmitter effects such as harmonics emission, parasitic emission, intermodulation products and frequency conversion products, but exclude out of band emissions.

The out-of-band emissions requirement for the BS transmitter is specified both in terms of Adjacent Channel Leakage power Ratio (ACLR) and *operating band* unwanted emissions (OBUE).

The maximum offset of the *operating band* unwanted emissions mask from the *operating band* edge is Δf_{OBUE} . The Operating band unwanted emissions define all unwanted emissions in each supported downlink *operating band* plus the frequency ranges Δf_{OBUE} above and Δf_{OBUE} below each band. Unwanted emissions outside of this frequency range are limited by a spurious emissions requirement.

The values of Δf_{OBUE} are defined in table 6.6.1-1 for the NR *operating bands*.

Table 6.6.1-1: Maximum offset of OBUE outside the downlink operating band

BS type	Operating band characteristics	Δf_{OBUE} (MHz)
BS type 1-H	$F_{\text{DL,high}} - F_{\text{DL,low}} < 100$ MHz	10
	$100 \text{ MHz} \leq F_{\text{DL,high}} - F_{\text{DL,low}} \leq 900$ MHz	40
BS type 1-C	$F_{\text{DL,high}} - F_{\text{DL,low}} \leq 200$ MHz	10
	$200 \text{ MHz} < F_{\text{DL,high}} - F_{\text{DL,low}} \leq 900$ MHz	40

For band n46, n96 and n102, the values of Δf_{OBUE} are defined in table 6.6.1-1a.

Table 6.6.1-1a: Maximum offset of OBUE outside the downlink operating band for band n46, n96 and n102

Operating band	Δf_{OBUE} (MHz)
n46, n102	40
n96	50

For band n104, the values of Δf_{OBUE} are defined in table 6.6.1-1b.

Table 6.6.1-1b: Maximum offset of OBUE outside the downlink operating band for band n104

BS type	Operating band	Δf_{OBUE} (MHz)
BS type 1-H	n104	100
BS type 1-C	n104	40

For *BS type 1-H* the unwanted emission requirements are applied per the *TAB connector TX min cell groups* for all the configurations supported by the BS. The *basic limits* and corresponding emissions scaling are defined in each relevant clause.

There is in addition a requirement for occupied bandwidth.

6.6.2 Occupied bandwidth

6.6.2.1 General

The occupied bandwidth is the width of a frequency band such that, below the lower and above the upper frequency limits, the mean powers emitted are each equal to a specified percentage $\beta/2$ of the total mean transmitted power. See also Recommendation ITU-R SM.328 [3].

The value of $\beta/2$ shall be taken as 0.5%.

The occupied bandwidth requirement shall apply during the *transmitter ON period* for a single transmitted carrier. The minimum requirement below may be applied regionally. There may also be regional requirements to declare the occupied bandwidth according to the definition in the present clause.

For *BS type 1-C* this requirement shall be applied at the *antenna connector* supporting transmission in the *operating band*.

For *BS type 1-H* this requirement shall be applied at each *TAB connector* supporting transmission in the *operating band*.

6.6.2.2 Minimum requirement for *BS type 1-C* and *BS type 1-H*

The occupied bandwidth for each NR carrier shall be less than the *BS channel bandwidth*. For intra-band contiguous CA, the occupied bandwidth shall be less than or equal the *Aggregated BS Channel Bandwidth*.

For NB-IoT operation in NR in-band, the occupied bandwidth for each NR carrier with NB-IoT shall be less than the *BS channel bandwidth*.

6.6.3 Adjacent Channel Leakage Power Ratio

6.6.3.1 General

Adjacent Channel Leakage power Ratio (ACLR) is the ratio of the filtered mean power centred on the assigned channel frequency to the filtered mean power centred on an adjacent channel frequency.

The requirements shall apply outside the *Base Station RF Bandwidth* or *Radio Bandwidth* whatever the type of transmitter considered (single carrier or multi-carrier) and for all transmission modes foreseen by the manufacturer's specification.

The requirements shall also apply if the BS supports NB-IoT operation in NR in-band.

For a BS operating in *non-contiguous spectrum*, the ACLR or the CACLR requirement in Tables 6.6.3.2-2a to 6.6.3.2-3aa shall apply in *sub-block gaps*, depending on the *operating band* and the *sub-block gap size* (W_{gap}) where the limit applies.

For a *multi-band connector*, the ACLR or the CACLR requirement in Tables 6.6.3.2-2a to 6.6.3.2-3aa shall apply in *Inter RF Bandwidth gaps*, depending on the *operating band* and the *Inter RF Bandwidth gap size* (W_{gap}) where the limit applies.

The requirement shall apply during the *transmitter ON period*.

6.6.3.2 Limits and Basic limits

The ACLR is defined with a square filter of bandwidth equal to the transmission bandwidth configuration of the transmitted signal (BW_{Config}) centred on the assigned channel frequency and a filter centred on the adjacent channel frequency according to the tables below.

For operation in paired and unpaired spectrum, the ACLR shall be higher than the value specified in table 6.6.3.2-1 in any operating band except for band n46, n96 and n102.

Table 6.6.3.2-1: Base station ACLR limit

BS channel bandwidth of lowest/highest carrier transmitted BW_{Channel} (MHz)	BS adjacent channel centre frequency offset below the lowest or above the highest carrier centre frequency transmitted	Assumed adjacent channel carrier (informative)	Filter on the adjacent channel frequency and corresponding filter bandwidth	ACLR limit
5, 10, 15, 20, 25, 30, 35, 40, 45, 50, 60, 70, 80, 90,100	BW_{Channel}	NR of same BW (Note 2)	Square (BW_{Config})	45 dB, 38 dB (Note 4)
	$2 \times BW_{\text{Channel}}$	NR of same BW (Note 2)	Square (BW_{Config})	45 dB, 38 dB (Note 4)
	$BW_{\text{Channel}}/2 + 2.5$ MHz	5 MHz E-UTRA	Square (4.5 MHz)	45 dB (Note 3)
	$BW_{\text{Channel}}/2 + 7.5$ MHz	5 MHz E-UTRA	Square (4.5 MHz)	45 dB (Note 3)
NOTE 1: BW_{Channel} and BW_{Config} are the <i>BS channel bandwidth</i> and <i>transmission bandwidth configuration</i> of the <i>lowest/highest carrier</i> transmitted on the assigned channel frequency.				
NOTE 2: With SCS that provides largest transmission bandwidth configuration (BW_{Config}).				
NOTE 3: The requirements are applicable when the band is also defined for E-UTRA or UTRA.				
NOTE 4: For BS operating in band n104, ACLR requirement 38 dB applies. For BS operating in other bands, ACLR requirement 45 dB applies.				

For band n46, n96 and n102, the ACLR shall be higher than the value specified in Table 6.6.3.2-1a.

Table 6.6.3.2-1a: Base station ACLR limit for band n46, n96 and n102

BS channel bandwidth of lowest/highest NR carrier transmitted BW_{Channel} (MHz)	BS adjacent channel centre frequency offset below the lowest or above the highest carrier centre frequency transmitted	Assumed adjacent channel carrier (informative)	Filter on the adjacent channel frequency and corresponding filter bandwidth	ACLR limit
10, 20, 40, 60, 80	BW_{Channel}	NR of same BW (Note 2)	Square (BW_{Config})	35 dB
	$2 \times BW_{\text{Channel}}$	NR of same BW (Note 2)	Square (BW_{Config})	40 dB
NOTE 1: BW_{Channel} and BW_{Config} are the BS channel bandwidth and transmission bandwidth configuration of the lowest/highest NR carrier transmitted on the assigned channel frequency.				
NOTE 2: With SCS that provides largest transmission bandwidth configuration (BW_{Config}).				

The ACLR absolute *basic limit* is specified in table 6.6.3.2-2.

Table 6.6.3.2-2: Base station ACLR absolute *basic limit*

BS category / BS class	ACLR absolute <i>basic limit</i>
Category A Wide Area BS	-13 dBm/MHz
Category B Wide Area BS	-15 dBm/MHz
Medium Range BS	-25 dBm/MHz
Local Area BS	-32 dBm/MHz

For operation in non-contiguous spectrum or multiple bands, the ACLR shall be higher than the value specified in Table 6.6.3.2-2a in any operating band except for band n46, n96 and n102.

Table 6.6.3.2-2a: Base Station ACLR limit in non-contiguous spectrum or multiple bands

BS channel bandwidth of carrier transmitted adjacent to sub-block gap or inter RF Bandwidth gap BW_{Channel} (MHz)	Sub-block or Inter RF Bandwidth gap size (W_{gap}) where the limit applies (MHz)	BS adjacent channel centre frequency offset below or above the sub-block or Base Station RF Bandwidth edge (inside the gap)	Assumed adjacent channel carrier	Filter on the adjacent channel frequency and corresponding filter bandwidth	ACLR limit
5, 10, 15, 20	$W_{\text{gap}} \geq 15$ (Note 3) $W_{\text{gap}} \geq 45$ (Note 4)	2.5 MHz	5 MHz NR (Note 2)	Square (BW_{Config})	45 dB, 38 dB (Note 5)
	$W_{\text{gap}} \geq 20$ (Note 3) $W_{\text{gap}} \geq 50$ (Note 4)	7.5 MHz	5 MHz NR (Note 2)	Square (BW_{Config})	45 dB, 38 dB (Note 5)
25, 30, 35, 40, 45, 50, 60, 70, 80, 90, 100	$W_{\text{gap}} \geq 60$ (Note 4) $W_{\text{gap}} \geq 30$ (Note 3)	10 MHz	20 MHz NR (Note 2)	Square (BW_{Config})	45 dB, 38 dB (Note 5)
	$W_{\text{gap}} \geq 80$ (Note 4) $W_{\text{gap}} \geq 50$ (Note 3)	30 MHz	20 MHz NR (Note 2)	Square (BW_{Config})	45 dB, 38 dB (Note 5)
NOTE 1: BW_{Config} is the transmission bandwidth configuration of the assumed adjacent channel carrier.					
NOTE 2: With SCS that provides largest transmission bandwidth configuration (BW_{Config}).					
NOTE 3: Applicable in case the BS channel bandwidth of the NR carrier transmitted at the other edge of the gap is 5, 10, 15, 20 MHz.					
NOTE 4: Applicable in case the BS channel bandwidth of the NR carrier transmitted at the other edge of the gap is 25, 30, 35, 40, 45, 50, 60, 70, 80, 90, 100 MHz.					
NOTE 5: For BS operating in band n104, ACLR requirement 38 dB applies. For BS operating in other bands, ACLR requirement 45 dB applies.					

For operation in non-contiguous spectrum for band n46, n96 and n102, the ACLR shall be higher than the value specified in Table 6.6.3.2-2b.

Table 6.6.3.2-2b: Base Station ACLR limit in non-contiguous spectrum for band n46, n96 and n102

<i>BS channel bandwidth of NR carrier transmitted BW_{Channel} adjacent to sub-block gap or inter RF Bandwidth gap (MHz)</i>	<i>Sub-block or Inter RF Bandwidth gap size (W_{gap}) where the limit applies (MHz)</i>	<i>BS adjacent channel centre frequency offset below or above the sub-block or Base Station RF Bandwidth edge (inside the gap)</i>	<i>Assumed adjacent channel carrier</i>	<i>Filter on the adjacent channel frequency and corresponding filter bandwidth</i>	<i>ACLR limit</i>
10, 20, 40, 60, 80	$W_{\text{gap}} \geq 60$	10 MHz	20 MHz NR (Note 2)	Square (BW _{Config})	35 dB
	$W_{\text{gap}} \geq 80$	30 MHz	20 MHz NR (Note 2)	Square (BW _{Config})	40 dB
NOTE 1: BW _{Config} is the transmission bandwidth configuration of the assumed adjacent channel carrier.					
NOTE 2: With SCS that provides largest transmission bandwidth configuration (BW _{Config}).					

The Cumulative Adjacent Channel Leakage power Ratio (CACLR) in a *sub-block gap* or the *Inter RF Bandwidth gap* is the ratio of:

- the sum of the filtered mean power centred on the assigned channel frequencies for the two carriers adjacent to each side of the *sub-block gap* or the *Inter RF Bandwidth gap*, and
- the filtered mean power centred on a frequency channel adjacent to one of the respective *sub-block* edges or *Base Station RF Bandwidth edges*.

The assumed filter for the adjacent channel frequency is defined in table 6.6.3.2-3 and the filters on the assigned channels are defined in table 6.6.3.2-4.

For operation in *non-contiguous spectrum* or multiple bands, the CACLR for NR carriers located on either side of the *sub-block gap* or the *Inter RF Bandwidth gap* shall be higher than the value specified in table 6.6.3.2-3.

The CACLR requirements in Table 6.6.3.2-3 apply to BS that supports NR, in any operating band except for band n46, n96 and n102. The CACLR requirements for band n46, n96 and n102 are in Table 6.6.3.2-3aa.

Table 6.6.3.2-3: Base Station CACLR limit

<i>BS channel bandwidth of carrier transmitted adjacent to sub-block gap or inter RF Bandwidth gap BW_{Channel} (MHz)</i>	<i>Sub-block or Inter RF Bandwidth gap size (W_{gap}) where the limit applies (MHz)</i>	<i>BS adjacent channel centre frequency offset below or above the sub-block or Base Station RF Bandwidth edge (inside the gap)</i>	<i>Assumed adjacent channel carrier</i>	<i>Filter on the adjacent channel frequency and corresponding filter bandwidth</i>	<i>CACLR limit</i>
5, 10, 15, 20	$5 \leq W_{\text{gap}} < 15$ (Note 3) $5 \leq W_{\text{gap}} < 45$ (Note 4)	2.5 MHz	5 MHz NR (Note 2)	Square (BW _{Config})	45 dB, 38 dB (Note 5)
	$10 < W_{\text{gap}} < 20$ (Note 3) $10 \leq W_{\text{gap}} < 50$ (Note 4)	7.5 MHz	5 MHz NR (Note 2)	Square (BW _{Config})	45 dB, 38 dB (Note 5)
25, 30, 35, 40, 45, 50, 60, 70, 80, 90, 100	$20 \leq W_{\text{gap}} < 60$ (Note 4) $20 \leq W_{\text{gap}} < 30$ (Note 3)	10 MHz	20 MHz NR (Note 2)	Square (BW _{Config})	45 dB, 38 dB (Note 5)
	$40 < W_{\text{gap}} < 80$ (Note 4) $40 \leq W_{\text{gap}} < 50$ (Note 3)	30 MHz	20 MHz NR (Note 2)	Square (BW _{Config})	45 dB, 38 dB (Note 5)
NOTE 1: BW _{Config} is the transmission bandwidth configuration of the assumed adjacent channel carrier.					
NOTE 2: With SCS that provides largest transmission bandwidth configuration (BW _{Config}).					
NOTE 3: Applicable in case the <i>BS channel bandwidth</i> of the NR carrier transmitted at the other edge of the gap is 5, 10, 15, 20 MHz.					
NOTE 4: Applicable in case the <i>BS channel bandwidth</i> of the NR carrier transmitted at the other edge of the gap is 25, 30, 35, 40, 45, 50, 60, 70, 80, 90, 100 MHz.					
NOTE 5: For BS operating in band n104, ACLR requirement 38 dB applies. For BS operating in other bands, ACLR requirement 45 dB applies.					

For operation in non-contiguous spectrum for band n46, n96 and n102, the CACLR for NR carriers located on either side of the *sub-block gap* shall be higher than the value specified in Table 6.6.3.2-3aa.

Table 6.6.3.2-3aa: Base Station CACLR limit for band n46, n96 and n102

BS channel bandwidth of NR carrier transmitted BW_{Channel} adjacent to sub-block gap or inter RF Bandwidth gap (MHz)	Sub-block or Inter RF Bandwidth gap size (W_{gap}) where the limit applies (MHz)	BS adjacent channel centre frequency offset below or above the sub-block or Base Station RF Bandwidth edge (inside the gap)	Assumed adjacent channel carrier	Filter on the adjacent channel frequency and corresponding filter bandwidth	CACLR limit
10, 20, 40, 60, 80	$20 \leq W_{\text{gap}} < 60$	10 MHz	20 MHz NR (Note 2)	Square (BW _{Config})	35 dB
	$40 < W_{\text{gap}} < 80$	30 MHz	20 MHz NR (Note 2)	Square (BW _{Config})	40 dB
NOTE 1: BW _{Config} is the transmission bandwidth configuration of the assumed adjacent channel carrier.					
NOTE 2: With SCS that provides largest transmission bandwidth configuration (BW _{Config}).					

The CACLR absolute *basic limit* is specified in table 6.6.3.2-3a.

Table 6.6.3.2-3a: Base station CACLR absolute *basic limit*

BS category / BS class	CACLR absolute <i>basic limit</i>
Category A Wide Area BS	-13 dBm/MHz
Category B Wide Area BS	-15 dBm/MHz
Medium Range BS	-25 dBm/MHz
Local Area BS	-32 dBm/MHz

Table 6.6.3.2-4: Filter parameters for the assigned channel

RAT of the carrier adjacent to the sub-block or Inter RF Bandwidth gap	Filter on the assigned channel frequency and corresponding filter bandwidth
NR	NR of same BW with SCS that provides largest <i>transmission bandwidth configuration</i>

6.6.3.3 Minimum requirement for BS type 1-C

The ACLR (CACLR) absolute *basic limits* in table 6.6.3.2-2, 6.6.3.2-3a or the ACLR (CACLR) *limits* in table 6.6.3.2-1, 6.6.3.2-2a or 6.6.3.2-3, whichever is less stringent, shall apply for each *antenna connector*.

For Band n41 and n90 operation in Japan, absolute ACLR limits shall be applied to the sum of the absolute ACLR power over all *antenna connectors* for BS type 1-C.

6.6.3.4 Minimum requirement for BS type 1-H

The ACLR (CACLR) absolute *basic limits* in table 6.6.3.2-2 + X, 6.6.3.2-3a + X (where $X = 10 \log_{10}(N_{\text{TXU, counted per cell}})$) or the ACLR (CACLR) *limits* in table 6.6.3.2-1, 6.6.3.2-2a or 6.6.3.2-3, whichever is less stringent, shall apply for each *TAB connector TX min cell group*.

NOTE: Conformance to the BS type 1-H ACLR requirement can be demonstrated by meeting at least one of the following criteria as determined by the manufacturer:

- 1) The ratio of the sum of the filtered mean power measured on each *TAB connector* in the *TAB connector TX min cell group* at the assigned channel frequency to the sum of the filtered mean power measured on each *TAB connector* in the *TAB connector TX min cell group* at the adjacent channel frequency shall be greater than or equal to the ACLR *basic limit* of the BS. This shall apply for each *TAB connector TX min cell group*.

Or

- 2) The ratio of the filtered mean power at the *TAB connector* centred on the assigned channel frequency to the filtered mean power at this *TAB connector* centred on the adjacent channel frequency shall be greater than or equal to the ACLR *basic limit* of the BS for every *TAB connector* in the *TAB connector TX min cell group*, for each *TAB connector TX min cell group*.

In case the ACLR (CACLR) absolute *basic limit* of BS type I-H are applied, the conformance can be demonstrated by meeting at least one of the following criteria as determined by the manufacturer:

- 1) The sum of the filtered mean power measured on each *TAB connector* in the *TAB connector TX min cell group* at the adjacent channel frequency shall be less than or equal to the ACLR (CACLR) absolute *basic limit* + X of the BS. This shall apply to each *TAB connector TX min cell group*.

Or

- 2) The filtered mean power at each *TAB connector* centred on the adjacent channel frequency shall be less than or equal to the ACLR (CACLR) absolute *basic limit* of the BS scaled by $X - 10\log_{10}(n)$ for every *TAB connector* in the *TAB connector TX min cell group*, for each *TAB connector TX min cell group*, where n is the number of *TAB connectors* in the *TAB connector TX min cell group*.

6.6.4 Operating band unwanted emissions

6.6.4.1 General

Unless otherwise stated, the operating band unwanted emission (OBUE) limits in FR1 are defined from Δf_{OBUE} below the lowest frequency of each supported downlink *operating band* up to Δf_{OBUE} above the highest frequency of each supported downlink *operating band*. The values of Δf_{OBUE} are defined in table 6.6.1-1 for the NR *operating bands*.

The requirements shall apply whatever the type of transmitter considered and for all transmission modes foreseen by the manufacturer's specification. In addition, for a BS operating in *non-contiguous spectrum*, the requirements apply inside any *sub-block gap*. In addition, for a BS operating in multiple bands, the requirements apply inside any *Inter RF Bandwidth gap*.

Basic limits are specified in the tables below, where:

- Δf is the separation between the *channel edge* frequency and the nominal -3dB point of the measuring filter closest to the carrier frequency.
- f_{offset} is the separation between the *channel edge* frequency and the centre of the measuring filter.
- $f_{\text{offset}_{\text{max}}}$ is the offset to the frequency Δf_{OBUE} outside the downlink *operating band*, where Δf_{OBUE} is defined in table 6.6.1-1.
- Δf_{max} is equal to $f_{\text{offset}_{\text{max}}}$ minus half of the bandwidth of the measuring filter.

For a *multi-band connector* inside any *Inter RF Bandwidth gaps* with $W_{\text{gap}} < 2 * \Delta f_{\text{OBUE}}$, a combined *basic limit* shall be applied which is the cumulative sum of the *basic limits* specified at the *Base Station RF Bandwidth edges* on each side of the *Inter RF Bandwidth gap*. The *basic limit* for *Base Station RF Bandwidth edge* is specified in clauses 6.6.4.2.1 to 6.6.4.2.4 below, where in this case:

- Δf is the separation between the *Base Station RF Bandwidth edge* frequency and the nominal -3 dB point of the measuring filter closest to the *Base Station RF Bandwidth edge*.
- f_{offset} is the separation between the *Base Station RF Bandwidth edge* frequency and the centre of the measuring filter.
- $f_{\text{offset}_{\text{max}}}$ is equal to the *Inter RF Bandwidth gap* minus half of the bandwidth of the measuring filter.
- Δf_{max} is equal to $f_{\text{offset}_{\text{max}}}$ minus half of the bandwidth of the measuring filter.

For a multi-carrier *single-band connector* or a *single-band connector* configured for intra-band contiguous or non-contiguous *carrier aggregation* the definitions above apply to the lower edge of the carrier transmitted at the *lowest carrier* frequency and the upper edge of the carrier transmitted at the *highest carrier* frequency within a specified frequency band.

- In case the *inter-band gap* between a supported downlink *operating band* with carrier(s) transmitted and a supported downlink *operating band* without any carrier transmitted is less than $2 \cdot \Delta f_{\text{OBUE}}$, $f_{\text{offset}_{\text{max}}}$ shall be the offset to the frequency Δf_{OBUE} MHz outside the outermost edges of the two supported downlink *operating bands* and the operating band unwanted emission *basic limits* of the band where there are carriers transmitted, as defined in the tables of the present clause, shall apply across both downlink bands.
- In other cases, the operating band unwanted emission *basic limits* of the band where there are carriers transmitted, as defined in the tables of the present clause for the largest frequency offset (Δf_{max}), shall apply from Δf_{OBUE} MHz below the lowest frequency, up to Δf_{OBUE} MHz above the highest frequency of the supported downlink *operating band* without any carrier transmitted.

For a multicarrier *single-band connector* or a *single-band connector* configured for intra-band contiguous or non-contiguous *carrier aggregation* the definitions above apply to the lower edge of the carrier transmitted at the *lowest carrier* frequency and the upper edge of the carrier transmitted at the *highest carrier* frequency within a specified frequency band.

In addition inside any *sub-block gap* for a *single-band connector* operating in *non-contiguous spectrum*, a combined *basic limit* shall be applied which is the cumulative sum of the *basic limits* specified for the adjacent *sub-blocks* on each side of the *sub-block gap*. The *basic limit* for each *sub-block* is specified in clauses 6.6.4.2.1 to 6.6.4.2.4 below, where in this case:

- Δf is the separation between the *sub-block* edge frequency and the nominal -3 dB point of the measuring filter closest to the *sub-block* edge.
- f_{offset} is the separation between the *sub-block* edge frequency and the centre of the measuring filter.
- $f_{\text{offset}_{\text{max}}}$ is equal to the *sub-block gap* bandwidth minus half of the bandwidth of the measuring filter.
- Δf_{max} is equal to $f_{\text{offset}_{\text{max}}}$ minus half of the bandwidth of the measuring filter.

For Wide Area BS, the requirements of either clause 6.6.4.2.1 (Category A limits) or clause 6.6.4.2.2 (Category B limits) shall apply.

For Medium Range BS, the requirements in clause 6.6.4.2.3 shall apply (Category A and B).

For Local Area BS, the requirements of clause 6.6.4.2.4 shall apply (Category A and B).

The requirements shall also apply if the BS supports NB-IoT operation in NR in-band.

The application of either Category A or Category B *basic limits* shall be the same as for Transmitter spurious emissions in clause 6.6.5.

6.6.4.2 *Basic limits*

6.6.4.2.1 *Basic limits for Wide Area BS (Category A)*

For BS operating in Bands n5, n8, n12, n13, n14, n18, n26, n28, n29, n71, n85, *basic limits* are specified in table 6.6.4.2.1-1.

Table 6.6.4.2.1-1: Wide Area BS operating band unwanted emission limits (NR bands below 1 GHz) for Category A

Frequency offset of measurement filter -3dB point, Δf	Frequency offset of measurement filter centre frequency, f_{offset}	Basic limits (Note 1, 2)	Measurement bandwidth
$0 \text{ MHz} \leq \Delta f < 5 \text{ MHz}$	$0.05 \text{ MHz} \leq f_{\text{offset}} < 5.05 \text{ MHz}$	$-7 \text{ dBm} - \frac{7}{5} \cdot \left(\frac{f_{\text{offset}}}{\text{MHz}} - 0.05 \right) \text{ dB}$	100 kHz
$5 \text{ MHz} \leq \Delta f < \min(10 \text{ MHz}, \Delta f_{\text{max}})$	$5.05 \text{ MHz} \leq f_{\text{offset}} < \min(10.05 \text{ MHz}, f_{\text{offset}_{\text{max}}})$	-14 dBm	100 kHz
$10 \text{ MHz} \leq \Delta f \leq \Delta f_{\text{max}}$	$10.05 \text{ MHz} \leq f_{\text{offset}} < f_{\text{offset}_{\text{max}}}$	-13 dBm (Note 3)	100 kHz
<p>NOTE 1: For a BS supporting <i>non-contiguous spectrum</i> operation within any <i>operating band</i>, the emission limits within <i>sub-block gaps</i> is calculated as a cumulative sum of contributions from adjacent <i>sub-blocks</i> on each side of the <i>sub-block gap</i>. Exception is $\Delta f \geq 10 \text{ MHz}$ from both adjacent <i>sub-blocks</i> on each side of the <i>sub-block gap</i>, where the emission limits within <i>sub-block gaps</i> shall be -13 dBm/100 kHz.</p> <p>NOTE 2: For a <i>multi-band connector</i> with <i>Inter RF Bandwidth gap</i> $< 2 \cdot \Delta f_{\text{OBUe}}$ the emission limits within the <i>Inter RF Bandwidth gaps</i> is calculated as a cumulative sum of contributions from adjacent <i>sub-blocks</i> or RF Bandwidth on each side of the <i>Inter RF Bandwidth gap</i>.</p> <p>NOTE 3: The requirement is not applicable when $\Delta f_{\text{max}} < 10 \text{ MHz}$.</p>			

For BS operating in Bands n1, n2, n3, n7, n24, n25, n30, n34, n38, n39, n40, n41, n48, n50, n65, n66, n70, n74, n75, n77, n78, n79, n90, n92, n94, *basic limits* are specified in table 6.6.4.2.1-2:

Table 6.6.4.2.1-2: Wide Area BS operating band unwanted emission limits (NR bands above 1 GHz) for Category A

Frequency offset of measurement filter -3dB point, Δf	Frequency offset of measurement filter centre frequency, f_{offset}	Basic limits (Note 1, 2)	Measurement bandwidth
$0 \text{ MHz} \leq \Delta f < 5 \text{ MHz}$	$0.05 \text{ MHz} \leq f_{\text{offset}} < 5.05 \text{ MHz}$	$-7 \text{ dBm} - \frac{7}{5} \cdot \left(\frac{f_{\text{offset}}}{\text{MHz}} - 0.05 \right) \text{ dB}$	100 kHz
$5 \text{ MHz} \leq \Delta f < \min(10 \text{ MHz}, \Delta f_{\text{max}})$	$5.05 \text{ MHz} \leq f_{\text{offset}} < \min(10.05 \text{ MHz}, f_{\text{offset}_{\text{max}}})$	-14 dBm	100 kHz
$10 \text{ MHz} \leq \Delta f \leq \Delta f_{\text{max}}$	$10.5 \text{ MHz} \leq f_{\text{offset}} < f_{\text{offset}_{\text{max}}}$	-13 dBm (Note 3)	1MHz
<p>NOTE 1: For a BS supporting <i>non-contiguous spectrum</i> operation within any <i>operating band</i>, the emission limits within <i>sub-block gaps</i> is calculated as a cumulative sum of contributions from adjacent <i>sub-blocks</i> on each side of the <i>sub-block gap</i>, where the contribution from the far-end <i>sub-block</i> shall be scaled according to the <i>measurement bandwidth</i> of the near-end <i>sub-block</i>. Exception is $\Delta f \geq 10 \text{ MHz}$ from both adjacent <i>sub-blocks</i> on each side of the <i>sub-block gap</i>, where the emission limits within <i>sub-block gaps</i> shall be -13 dBm/1 MHz.</p> <p>NOTE 2: For a <i>multi-band connector</i> with <i>Inter RF Bandwidth gap</i> $< 2 \cdot \Delta f_{\text{OBUe}}$ the emission limits within the <i>Inter RF Bandwidth gaps</i> is calculated as a cumulative sum of contributions from adjacent <i>sub-blocks</i> or RF Bandwidth on each side of the <i>Inter RF Bandwidth gap</i>, where the contribution from the far-end <i>sub-block</i> or RF Bandwidth shall be scaled according to the <i>measurement bandwidth</i> of the near-end <i>sub-block</i> or RF Bandwidth.</p> <p>NOTE 3: The requirement is not applicable when $\Delta f_{\text{max}} < 10 \text{ MHz}$.</p>			

6.6.4.2.2 Basic limits for Wide Area BS (Category B)

For Category B Operating band unwanted emissions, there are two options for the *basic limits* that may be applied regionally. Either the *basic limits* in clause 6.6.4.2.2.1 or clause 6.6.4.2.2.2 shall be applied.

6.6.4.2.2.1 Category B requirements (Option 1)

For BS operating in Bands n5, n8, n12, n20, n26, n28, n29, n67, n71, n85, the *basic limits* are specified in table 6.6.4.2.2.1-1:

Table 6.6.4.2.1-1: Wide Area BS operating band unwanted emission limits (NR bands below 1 GHz) for Category B

Frequency offset of measurement filter -3dB point, Δf	Frequency offset of measurement filter centre frequency, f_{offset}	Basic limits (Note 1, 2)	Measurement bandwidth
$0 \text{ MHz} \leq \Delta f < 5 \text{ MHz}$	$0.05 \text{ MHz} \leq f_{\text{offset}} < 5.05 \text{ MHz}$	$-7 \text{ dBm} - \frac{7}{5} \cdot \left(\frac{f_{\text{offset}}}{\text{MHz}} - 0.05 \right) \text{ dB}$	100 kHz
$5 \text{ MHz} \leq \Delta f < \min(10 \text{ MHz}, \Delta f_{\text{max}})$	$5.05 \text{ MHz} \leq f_{\text{offset}} < \min(10.05 \text{ MHz}, f_{\text{offset}_{\text{max}}})$	-14 dBm	100 kHz
$10 \text{ MHz} \leq \Delta f \leq \Delta f_{\text{max}}$	$10.05 \text{ MHz} \leq f_{\text{offset}} < f_{\text{offset}_{\text{max}}}$	-16 dBm (Note 3)	100 kHz
<p>NOTE 1: For a BS supporting <i>non-contiguous spectrum</i> operation within any <i>operating band</i>, the emission limits within <i>sub-block gaps</i> is calculated as a cumulative sum of contributions from adjacent <i>sub-blocks</i> on each side of the <i>sub-block gap</i>. Exception is $\Delta f \geq 10 \text{ MHz}$ from both adjacent <i>sub-blocks</i> on each side of the <i>sub-block gap</i>, where the emission limits within <i>sub-block gaps</i> shall be -16 dBm/100 kHz.</p> <p>NOTE 2: For a <i>multi-band connector</i> with <i>Inter RF Bandwidth gap</i> $< 2 \cdot \Delta f_{\text{OBUe}}$ the emission limits within the <i>Inter RF Bandwidth gaps</i> is calculated as a cumulative sum of contributions from adjacent <i>sub-blocks</i> or RF Bandwidth on each side of the <i>Inter RF Bandwidth gap</i>, where the contribution from the far-end <i>sub-block</i> or RF Bandwidth shall be scaled according to the <i>measurement bandwidth</i> of the near-end <i>sub-block</i> or RF Bandwidth.</p> <p>NOTE 3: The requirement is not applicable when $\Delta f_{\text{max}} < 10 \text{ MHz}$.</p>			

For BS operating in Bands n1, n2, n3, n7, n25, n34, n38, n39, n40, n41, n48, n50, n65, n66, n70, n75, n77, n78, n79, n90, n92, n94, *basic limits* are specified in tables 6.6.4.2.1-2:

Table 6.6.4.2.1-2: Wide Area BS operating band unwanted emission limits (NR bands above 1 GHz) for Category B

Frequency offset of measurement filter -3dB point, Δf	Frequency offset of measurement filter centre frequency, f_{offset}	Basic limits (Note 1, 2)	Measurement bandwidth
$0 \text{ MHz} \leq \Delta f < 5 \text{ MHz}$	$0.05 \text{ MHz} \leq f_{\text{offset}} < 5.05 \text{ MHz}$	$-7 \text{ dBm} - \frac{7}{5} \cdot \left(\frac{f_{\text{offset}}}{\text{MHz}} - 0.05 \right) \text{ dB}$	100 kHz
$5 \text{ MHz} \leq \Delta f < \min(10 \text{ MHz}, \Delta f_{\text{max}})$	$5.05 \text{ MHz} \leq f_{\text{offset}} < \min(10.05 \text{ MHz}, f_{\text{offset}_{\text{max}}})$	-14 dBm	100 kHz
$10 \text{ MHz} \leq \Delta f \leq \Delta f_{\text{max}}$	$10.5 \text{ MHz} \leq f_{\text{offset}} < f_{\text{offset}_{\text{max}}}$	-15 dBm (Note 3)	1 MHz
<p>NOTE 1: For a BS supporting <i>non-contiguous spectrum</i> operation within any <i>operating band</i>, the emission limits within <i>sub-block gaps</i> is calculated as a cumulative sum of contributions from adjacent <i>sub-blocks</i> on each side of the <i>sub-block gap</i>, where the contribution from the far-end <i>sub-block</i> shall be scaled according to the <i>measurement bandwidth</i> of the near-end <i>sub-block</i>. Exception is $\Delta f \geq 10 \text{ MHz}$ from both adjacent <i>sub-blocks</i> on each side of the <i>sub-block gap</i>, where the emission limits within <i>sub-block gaps</i> shall be -15 dBm/1 MHz.</p> <p>NOTE 2: For a <i>multi-band connector</i> with <i>Inter RF Bandwidth gap</i> $< 2 \cdot \Delta f_{\text{OBUe}}$ the emission limits within the <i>Inter RF Bandwidth gaps</i> is calculated as a cumulative sum of contributions from adjacent <i>sub-blocks</i> or RF Bandwidth on each side of the <i>Inter RF Bandwidth gap</i>, where the contribution from the far-end <i>sub-block</i> or RF Bandwidth shall be scaled according to the <i>measurement bandwidth</i> of the near-end <i>sub-block</i> or RF Bandwidth.</p> <p>NOTE 3: The requirement is not applicable when $\Delta f_{\text{max}} < 10 \text{ MHz}$.</p>			

For BS type I-C operating in Band n104, the limits are specified in tables 6.6.4.2.1-2a:

Table 6.6.4.2.2.1-2a: Wide Area BS type 1-C operating band unwanted emission limits for band n104 for Category B

Frequency offset of measurement filter -3dB point, Δf	Frequency offset of measurement filter centre frequency, f_{offset}	Basic limits	Measurement bandwidth
$0 \text{ MHz} \leq \Delta f < 20 \text{ MHz}$	$0.05 \text{ MHz} \leq f_{\text{offset}} < 20.05 \text{ MHz}$	$-7 \text{ dBm} - \frac{7}{20} \left(\frac{f_{\text{offset}}}{\text{MHz}} - 0.05 \right)$	100 kHz
$20 \text{ MHz} \leq \Delta f < \min(40 \text{ MHz}, \Delta f_{\text{max}})$	$20.05 \text{ MHz} \leq f_{\text{offset}} < \min(40.05 \text{ MHz}, f_{\text{offset}_{\text{max}}})$	-14 dBm	100 kHz
$40 \text{ MHz} \leq \Delta f \leq \Delta f_{\text{max}}$	$40.5 \text{ MHz} \leq f_{\text{offset}} < f_{\text{offset}_{\text{max}}}$	-15 dBm (Note 3)	1MHz
NOTE 1: For a BS supporting <i>non-contiguous spectrum</i> operation within any <i>operating band</i> the emission limits within <i>sub-block gaps</i> is calculated as a cumulative sum of contributions from adjacent <i>sub-blocks</i> on each side of the <i>sub-block gap</i> . Exception is $\Delta f \geq 40 \text{ MHz}$ from both adjacent <i>sub-blocks</i> on each side of the <i>sub-block gap</i> , where the emission limits within <i>sub-block gaps</i> shall be -15 dBm/1 MHz.			
NOTE 2: For a <i>multi-band connector</i> with <i>Inter RF Bandwidth gap</i> $< 2 * \Delta f_{\text{OBUe}}$ the emission limits within the <i>Inter RF Bandwidth gaps</i> is calculated as a cumulative sum of contributions from adjacent <i>sub-blocks</i> or RF Bandwidth on each side of the <i>Inter RF Bandwidth gap</i> .			
NOTE 3: The requirement is not applicable when $\Delta f_{\text{max}} < 40 \text{ MHz}$.			

For BS type 1-H operating in Band n104, *basic limits* are specified in tables 6.6.4.2.2.1-2b:

Table 6.6.4.2.2.1-2b: Wide Area BS type 1-H operating band unwanted emission limits for band n104 for Category B

Frequency offset of measurement filter -3dB point, Δf	Frequency offset of measurement filter centre frequency, f_{offset}	Basic limits	Measurement bandwidth
$0 \text{ MHz} \leq \Delta f < 50 \text{ MHz}$	$0.05 \text{ MHz} \leq f_{\text{offset}} < 50.05 \text{ MHz}$	$-7 \text{ dBm} - \frac{7}{50} \left(\frac{f_{\text{offset}}}{\text{MHz}} - 0.05 \right)$	100 kHz
$50 \text{ MHz} \leq \Delta f < \min(100 \text{ MHz}, \Delta f_{\text{max}})$	$50.05 \text{ MHz} \leq f_{\text{offset}} < \min(100.05 \text{ MHz}, f_{\text{offset}_{\text{max}}})$	-14 dBm	100 kHz
$100 \text{ MHz} \leq \Delta f \leq \Delta f_{\text{max}}$	$100.5 \text{ MHz} \leq f_{\text{offset}} < f_{\text{offset}_{\text{max}}}$	-15 dBm (Note 3)	1MHz
NOTE 1: For a BS supporting <i>non-contiguous spectrum</i> operation within any <i>operating band</i> the emission limits within <i>sub-block gaps</i> is calculated as a cumulative sum of contributions from adjacent <i>sub-blocks</i> on each side of the <i>sub-block gap</i> . Exception is $\Delta f \geq 100 \text{ MHz}$ from both adjacent <i>sub-blocks</i> on each side of the <i>sub-block gap</i> , where the emission limits within <i>sub-block gaps</i> shall be -15 dBm/1 MHz.			
NOTE 2: For a <i>multi-band connector</i> with <i>Inter RF Bandwidth gap</i> $< 2 * \Delta f_{\text{OBUe}}$ the emission limits within the <i>Inter RF Bandwidth gaps</i> is calculated as a cumulative sum of contributions from adjacent <i>sub-blocks</i> or RF Bandwidth on each side of the <i>Inter RF Bandwidth gap</i> .			
NOTE 3: The requirement is not applicable when $\Delta f_{\text{max}} < 100 \text{ MHz}$.			

6.6.4.2.2.2 Category B requirements (Option 2)

The limits in this clause are intended for Europe and may be applied regionally for BS operating in bands n1, n3, n7, n8, n38, n65, n100, n101.

For a BS operating in bands n1, n3, n8, n65 or *BS type I-C* operating in bands n7, n38, n100 or n101, *basic limits* are specified in Table 6.6.4.2.2.2-1:

Table 6.6.4.2.2-1: Regional Wide Area BS operating band unwanted emission limits for Category B

Frequency offset of measurement filter -3dB point, Δf	Frequency offset of measurement filter centre frequency, f_{offset}	Basic limits (Note 1, 2)	Measurement bandwidth
$0 \text{ MHz} \leq \Delta f < 0.2 \text{ MHz}$	$0.015 \text{ MHz} \leq f_{\text{offset}} < 0.215 \text{ MHz}$	-14 dBm	30 kHz
$0.2 \text{ MHz} \leq \Delta f < 1 \text{ MHz}$	$0.215 \text{ MHz} \leq f_{\text{offset}} < 1.015 \text{ MHz}$	$-14\text{dBm} - 15 \cdot \left(\frac{f_{\text{offset}}}{\text{MHz}} - 0.215 \right) \text{dB}$ (Note 5)	30 kHz
(Note 4)	$1.015 \text{ MHz} \leq f_{\text{offset}} < 1.5 \text{ MHz}$	-26 dBm (Note 5)	30 kHz
$1 \text{ MHz} \leq \Delta f \leq \min(10 \text{ MHz}, \Delta f_{\text{max}})$	$1.5 \text{ MHz} \leq f_{\text{offset}} < \min(10.5 \text{ MHz}, f_{\text{offset}_{\text{max}}})$	-13 dBm (Note 5)	1 MHz
$10 \text{ MHz} \leq \Delta f \leq \Delta f_{\text{max}}$	$10.5 \text{ MHz} \leq f_{\text{offset}} < f_{\text{offset}_{\text{max}}}$	-15 dBm (Note 3) (Note 5)	1 MHz
<p>NOTE 1: For a BS supporting <i>non-contiguous spectrum</i> operation within any <i>operating band</i>, the minimum requirement within <i>sub-block gaps</i> is calculated as a cumulative sum of contributions from adjacent <i>sub-blocks</i> on each side of the <i>sub-block gap</i>, where the contribution from the far-end <i>sub-block</i> shall be scaled according to the <i>measurement bandwidth</i> of the near-end <i>sub-block</i>. Exception is $\Delta f \geq 10\text{MHz}$ from both adjacent <i>sub-blocks</i> on each side of the <i>sub-block gap</i>, where the minimum requirement within <i>sub-block gaps</i> shall be -15dBm/1MHz. For BS supporting multi-band operation, either this limit or -16dBm/100kHz (f_{offset} adjusted according to the measurement bandwidth), whichever is less stringent, shall apply at $\Delta f \geq 10\text{MHz}$ for operating bands <1GHz.</p> <p>NOTE 2: For a <i>multi-band connector</i> with <i>Inter RF Bandwidth gap</i> $< 2 \cdot \Delta f_{\text{OBUe}}$ the minimum requirement within the <i>Inter RF Bandwidth gaps</i> is calculated as a cumulative sum of contributions from adjacent <i>sub-blocks</i> or RF Bandwidth on each side of the <i>Inter RF Bandwidth gap</i>, where the contribution from the far-end <i>sub-block</i> or RF Bandwidth shall be scaled according to the <i>measurement bandwidth</i> of the near-end <i>sub-block</i> or RF Bandwidth.</p> <p>NOTE 3: The requirement is not applicable when $\Delta f_{\text{max}} < 10 \text{ MHz}$.</p> <p>NOTE 4: This frequency range ensures that the range of values of f_{offset} is continuous.</p> <p>NOTE 5: For BS supporting multi-band operation, either this limit or -16dBm/100kHz (f_{offset} adjusted according to the measurement bandwidth), whichever is less stringent, shall apply for operating bands <1GHz.</p>			

6.6.4.2.3 Basic limits for Medium Range BS (Category A and B)

For Medium Range BS, *basic limits* are specified in table 6.6.4.2.3-1 and table 6.6.4.2.3-2 except for Band n104.

For the tables in this clause for *BS type I-C* $P_{\text{rated},x} = P_{\text{rated},c,AC}$, and for *BS type I-H* $P_{\text{rated},x} = P_{\text{rated},c,cell} - 10 \cdot \log_{10}(N_{\text{TXU,countedpercell}})$, and for *BS type I-O* $P_{\text{rated},x} = P_{\text{rated},c,TRP} - 9 \text{ dB}$.

Table 6.6.4.2.3-1: Medium Range BS operating band unwanted emission limits, $31 < P_{\text{rated},x} \leq 38 \text{ dBm}$

Frequency offset of measurement filter -3dB point, Δf	Frequency offset of measurement filter centre frequency, f_{offset}	Basic limits (Note 1, 2)	Measurement bandwidth
$0 \text{ MHz} \leq \Delta f < 5 \text{ MHz}$	$0.05 \text{ MHz} \leq f_{\text{offset}} < 5.05 \text{ MHz}$	$P_{\text{rated},x} - 53 \text{ dB} - \frac{7}{5} \left(\frac{f_{\text{offset}}}{\text{MHz}} - 0.05 \right) \text{ dB}$	100 kHz
$5 \text{ MHz} \leq \Delta f < \min(10 \text{ MHz}, \Delta f_{\text{max}})$	$5.05 \text{ MHz} \leq f_{\text{offset}} < \min(10.05 \text{ MHz}, f_{\text{offset}_{\text{max}}})$	$P_{\text{rated},x} - 60 \text{ dB}$	100 kHz
$10 \text{ MHz} \leq \Delta f \leq \Delta f_{\text{max}}$	$10.05 \text{ MHz} \leq f_{\text{offset}} < f_{\text{offset}_{\text{max}}}$	$\text{Min}(P_{\text{rated},x} - 60 \text{ dB}, -25 \text{ dBm})$ (Note 3)	100 kHz
NOTE 1: For a BS supporting <i>non-contiguous spectrum</i> operation within any <i>operating band</i> the emission limits within <i>sub-block gaps</i> is calculated as a cumulative sum of contributions from adjacent <i>sub-blocks</i> on each side of the <i>sub-block gap</i> . Exception is $\Delta f \geq 10 \text{ MHz}$ from both adjacent <i>sub-blocks</i> on each side of the <i>sub-block gap</i> , where the emission limits within <i>sub-block gaps</i> shall be $\text{Min}(P_{\text{rated},x} - 60 \text{ dB}, -25 \text{ dBm})/100 \text{ kHz}$.			
NOTE 2: For a <i>multi-band connector</i> with <i>Inter RF Bandwidth gap</i> $< 2 \cdot \Delta f_{\text{OBUe}}$ the emission limits within the <i>Inter RF Bandwidth gaps</i> is calculated as a cumulative sum of contributions from adjacent <i>sub-blocks</i> or RF Bandwidth on each side of the <i>Inter RF Bandwidth gap</i> .			
NOTE 3: The requirement is not applicable when $\Delta f_{\text{max}} < 10 \text{ MHz}$.			

For *BS type I-C* operating in Band n104, the limits are specified in Table 6.6.4.2.3-1a and Table 6.6.4.2.3-2a.

Table 6.6.4.2.3-1a. Medium Range BS type 1-C operating band unwanted emission limits for band n104, $31 < P_{\text{rated},x} \leq 38 \text{ dBm}$

Frequency offset of measurement filter -3dB point, Δf	Frequency offset of measurement filter centre frequency, f_{offset}	Basic limits	Measurement bandwidth
$0 \text{ MHz} \leq \Delta f < 20 \text{ MHz}$	$0.05 \text{ MHz} \leq f_{\text{offset}} < 20.05 \text{ MHz}$	$P_{\text{rated},x} - 53 \text{ dB} - \frac{7}{20} \left(\frac{f_{\text{offset}}}{\text{MHz}} - 0.05 \right)$	100 kHz
$20 \text{ MHz} \leq \Delta f < \min(40 \text{ MHz}, \Delta f_{\text{max}})$	$20.05 \text{ MHz} \leq f_{\text{offset}} < \min(40.05 \text{ MHz}, f_{\text{offset}_{\text{max}}})$	$P_{\text{rated},x} - 60 \text{ dB}$	100 kHz
$40 \text{ MHz} \leq \Delta f \leq \Delta f_{\text{max}}$	$40.05 \text{ MHz} \leq f_{\text{offset}} < f_{\text{offset}_{\text{max}}}$	$\text{Min}(P_{\text{rated},x} - 60 \text{ dB}, -25 \text{ dBm})$ (Note 3)	100 kHz
NOTE 1: For a BS supporting <i>non-contiguous spectrum</i> operation within any <i>operating band</i> the emission limits within <i>sub-block gaps</i> is calculated as a cumulative sum of contributions from adjacent <i>sub-blocks</i> on each side of the <i>sub-block gap</i> . Exception is $\Delta f \geq 40 \text{ MHz}$ from both adjacent <i>sub-blocks</i> on each side of the <i>sub-block gap</i> , where the emission limits within <i>sub-block gaps</i> shall be $\text{Min}(P_{\text{rated},x} - 60 \text{ dB}, -25 \text{ dBm})/100 \text{ kHz}$.			
NOTE 2: For a <i>multi-band connector</i> with <i>Inter RF Bandwidth gap</i> $< 2 \cdot \Delta f_{\text{OBUe}}$ the emission limits within the <i>Inter RF Bandwidth gaps</i> is calculated as a cumulative sum of contributions from adjacent <i>sub-blocks</i> or RF Bandwidth on each side of the <i>Inter RF Bandwidth gap</i> .			
NOTE 3: The requirement is not applicable when $\Delta f_{\text{max}} < 40 \text{ MHz}$.			

For *BS type I-H* operating in Band n104, *basic limits* are specified in Table 6.6.4.2.3-1b and Table 6.6.4.2.3-2b:

Table 6.6.4.2.3-1b. Medium Range BS type 1-H operating band unwanted emission limits for band n104, $31 < P_{\text{rated},x} \leq 38$ dBm

Frequency offset of measurement filter -3dB point, Δf	Frequency offset of measurement filter centre frequency, f_{offset}	Basic limits	Measurement bandwidth
$0 \text{ MHz} \leq \Delta f < 50 \text{ MHz}$	$0.05 \text{ MHz} \leq f_{\text{offset}} < 50.05 \text{ MHz}$	$P_{\text{rated},x} - 53\text{dB} - \frac{7}{50} \left(\frac{f_{\text{offset}}}{\text{MHz}} - 0.05 \right)$	100 kHz
$50 \text{ MHz} \leq \Delta f < \min(100 \text{ MHz}, \Delta f_{\text{max}})$	$50.05 \text{ MHz} \leq f_{\text{offset}} < \min(100.05 \text{ MHz}, f_{\text{offset}_{\text{max}}})$	$P_{\text{rated},x} - 60\text{dB}$	100 kHz
$100 \text{ MHz} \leq \Delta f \leq \Delta f_{\text{max}}$	$100.05 \text{ MHz} \leq f_{\text{offset}} < f_{\text{offset}_{\text{max}}}$	$\text{Min}(P_{\text{rated},x} - 60\text{dB}, -25\text{dBm})$ (Note 3)	100 kHz

NOTE 1: For a BS supporting *non-contiguous spectrum* operation within any *operating band* the emission limits within *sub-block gaps* is calculated as a cumulative sum of contributions from adjacent *sub-blocks* on each side of the *sub-block gap*. Exception is $\Delta f \geq 100\text{MHz}$ from both adjacent *sub-blocks* on each side of the *sub-block gap*, where the emission limits within *sub-block gaps* shall be $\text{Min}(P_{\text{rated},x} - 60\text{dB}, -25\text{dBm})/100\text{kHz}$.

NOTE 2: For a *multi-band connector* with *Inter RF Bandwidth gap* $< 2 * \Delta f_{\text{OBUe}}$ the emission limits within the *Inter RF Bandwidth gaps* is calculated as a cumulative sum of contributions from adjacent *sub-blocks* or RF Bandwidth on each side of the *Inter RF Bandwidth gap*.

NOTE 3: The requirement is not applicable when $\Delta f_{\text{max}} < 100 \text{ MHz}$.

Table 6.6.4.2.3-2: Medium Range BS operating band unwanted emission limits, $P_{\text{rated},x} \leq 31$ dBm

Frequency offset of measurement filter -3dB point, Δf	Frequency offset of measurement filter centre frequency, f_{offset}	Basic limits (Note 1, 2)	Measurement bandwidth
$0 \text{ MHz} \leq \Delta f < 5 \text{ MHz}$	$0.05 \text{ MHz} \leq f_{\text{offset}} < 5.05 \text{ MHz}$	$-22\text{dBm} - \frac{7}{5} \left(\frac{f_{\text{offset}}}{\text{MHz}} - 0.05 \right) \text{dB}$	100 kHz
$5 \text{ MHz} \leq \Delta f < \min(10 \text{ MHz}, \Delta f_{\text{max}})$	$5.05 \text{ MHz} \leq f_{\text{offset}} < \min(10.05 \text{ MHz}, f_{\text{offset}_{\text{max}}})$	-29 dBm	100 kHz
$10 \text{ MHz} \leq \Delta f \leq \Delta f_{\text{max}}$	$10.05 \text{ MHz} \leq f_{\text{offset}} < f_{\text{offset}_{\text{max}}}$	-29 dBm (Note 3)	100 kHz

NOTE 1: For a BS supporting *non-contiguous spectrum* operation within any *operating band* the emission limits within *sub-block gaps* is calculated as a cumulative sum of contributions from adjacent *sub-blocks* on each side of the *sub-block gap*. Exception is $\Delta f \geq 10\text{MHz}$ from both adjacent *sub-blocks* on each side of the *sub-block gap*, where the emission limits within *sub-block gaps* shall be $-29\text{dBm}/100\text{kHz}$.

NOTE 2: For a *multi-band connector* with *Inter RF Bandwidth gap* $< 2 * \Delta f_{\text{OBUe}}$ the emission limits within the *Inter RF Bandwidth gaps* is calculated as a cumulative sum of contributions from adjacent *sub-blocks* or RF Bandwidth on each side of the *Inter RF Bandwidth gap*.

NOTE 3: The requirement is not applicable when $\Delta f_{\text{max}} < 10 \text{ MHz}$.

Table 6.6.4.2.3-2a. Medium Range BS type 1-C operating band unwanted emission limits for band 104, $P_{\text{rated},x} \leq 31$ dBm

Frequency offset of measurement filter -3dB point, Δf	Frequency offset of measurement filter centre frequency, f_{offset}	Basic limits	Measurement bandwidth
$0 \text{ MHz} \leq \Delta f < 20 \text{ MHz}$	$0.05 \text{ MHz} \leq f_{\text{offset}} < 20.05 \text{ MHz}$	$-22\text{dBm} - \frac{7}{20} \left(\frac{f_{\text{offset}}}{\text{MHz}} - 0.05 \right)$	100 kHz
$20 \text{ MHz} \leq \Delta f < \min(40 \text{ MHz}, \Delta f_{\text{max}})$	$20.05 \text{ MHz} \leq f_{\text{offset}} < \min(40.05 \text{ MHz}, f_{\text{offset}_{\text{max}}})$	-29 dBm	100 kHz
$40 \text{ MHz} \leq \Delta f \leq \Delta f_{\text{max}}$	$40.05 \text{ MHz} \leq f_{\text{offset}} < f_{\text{offset}_{\text{max}}}$	-29 dBm	100 kHz

NOTE 1: For a BS supporting *non-contiguous spectrum* operation within any *operating band* the emission limits within *sub-block gaps* is calculated as a cumulative sum of contributions from adjacent *sub-blocks* on each side of the *sub-block gap*. Exception is $\Delta f \geq 40\text{MHz}$ from both adjacent *sub-blocks* on each side of the *sub-block gap*, where the emission limits within *sub-block gaps* shall be $-29 \text{ dBm}/100\text{kHz}$.

NOTE 2: For a *multi-band connector* with *Inter RF Bandwidth gap* $< 2 * \Delta f_{\text{OBUe}}$ the emission limits within the *Inter RF Bandwidth gaps* is calculated as a cumulative sum of contributions from adjacent *sub-blocks* or RF Bandwidth on each side of the *Inter RF Bandwidth gap*.

NOTE 3: The requirement is not applicable when $\Delta f_{\text{max}} < 40 \text{ MHz}$.

Table 6.6.4.2.3-2b. Medium Range BS type 1-H operating band unwanted emission limits for band 104, $P_{\text{rated},x} \leq 31$ dBm

Frequency offset of measurement filter -3dB point, Δf	Frequency offset of measurement filter centre frequency, f_{offset}	Basic limits	Measurement bandwidth
$0 \text{ MHz} \leq \Delta f < 50 \text{ MHz}$	$0.05 \text{ MHz} \leq f_{\text{offset}} < 50.05 \text{ MHz}$	$-22 \text{ dBm} - \frac{7}{50} \left(\frac{f_{\text{offset}}}{\text{MHz}} - 0.05 \right)$	100 kHz
$50 \text{ MHz} \leq \Delta f < \min(100 \text{ MHz}, \Delta f_{\text{max}})$	$50.05 \text{ MHz} \leq f_{\text{offset}} < \min(100.05 \text{ MHz}, f_{\text{offset}_{\text{max}}})$	-29 dBm	100 kHz
$100 \text{ MHz} \leq \Delta f \leq \Delta f_{\text{max}}$	$100.05 \text{ MHz} \leq f_{\text{offset}} < f_{\text{offset}_{\text{max}}}$	-29 dBm	100 kHz

NOTE 1: For a BS supporting *non-contiguous spectrum* operation within any *operating band* the emission limits within *sub-block gaps* is calculated as a cumulative sum of contributions from adjacent *sub-blocks* on each side of the *sub-block gap*. Exception is $\Delta f \geq 100$ MHz from both adjacent *sub-blocks* on each side of the *sub-block gap*, where the emission limits within *sub-block gaps* shall be -29 dBm/100kHz.

NOTE 2: For a *multi-band connector* with *Inter RF Bandwidth gap* $< 2 * \Delta f_{\text{OBUe}}$ the emission limits within the *Inter RF Bandwidth gaps* is calculated as a cumulative sum of contributions from adjacent *sub-blocks* or RF Bandwidth on each side of the *Inter RF Bandwidth gap*.

NOTE 3: The requirement is not applicable when $\Delta f_{\text{max}} < 100$ MHz.

6.6.4.2.4 Basic limits for Local Area BS (Category A and B)

For Local Area BS, *basic limits* are specified in table 6.6.4.2.4-1 except for n46, n96, n102 and n104.

Table 6.6.4.2.4-1: Local Area BS operating band unwanted emission limits

Frequency offset of measurement filter -3dB point, Δf	Frequency offset of measurement filter centre frequency, f_{offset}	Basic limits (Note 1, 2)	Measurement bandwidth
$0 \text{ MHz} \leq \Delta f < 5 \text{ MHz}$	$0.05 \text{ MHz} \leq f_{\text{offset}} < 5.05 \text{ MHz}$	$-30 \text{ dBm} - \frac{7}{5} \left(\frac{f_{\text{offset}}}{\text{MHz}} - 0.05 \right) \text{ dB}$	100 kHz
$5 \text{ MHz} \leq \Delta f < \min(10 \text{ MHz}, \Delta f_{\text{max}})$	$5.05 \text{ MHz} \leq f_{\text{offset}} < \min(10.05 \text{ MHz}, f_{\text{offset}_{\text{max}}})$	-37 dBm	100 kHz
$10 \text{ MHz} \leq \Delta f \leq \Delta f_{\text{max}}$	$10.05 \text{ MHz} \leq f_{\text{offset}} < f_{\text{offset}_{\text{max}}}$	-37 dBm (Note 10)	100 kHz

NOTE 1: For a BS supporting *non-contiguous spectrum* operation within any *operating band* the emission limits within *sub-block gaps* is calculated as a cumulative sum of contributions from adjacent *sub-blocks* on each side of the *sub-block gap*. Exception is $\Delta f \geq 10$ MHz from both adjacent *sub-blocks* on each side of the *sub-block gap*, where the emission limits within *sub-block gaps* shall be -37dBm/100kHz.

NOTE 2: For a *multi-band connector* with *Inter RF Bandwidth gap* $< 2 * \Delta f_{\text{OBUe}}$ the emission limits within the *Inter RF Bandwidth gaps* is calculated as a cumulative sum of contributions from adjacent *sub-blocks* or RF Bandwidth on each side of the *Inter RF Bandwidth gap*.

NOTE 3: The requirement is not applicable when $\Delta f_{\text{max}} < 10$ MHz.

For BS type 1-C operating in Band n104, the limits are specified in Table 6.6.4.2.4-1a.

Table 6.6.4.2.4-1a. Local Area *BS type 1-C* operating band unwanted emission limits for band n104

Frequency offset of measurement filter -3dB point, Δf	Frequency offset of measurement filter centre frequency, f_{offset}	Basic limits (Note 1, 2)	Measurement bandwidth
$0 \text{ MHz} \leq \Delta f < 20 \text{ MHz}$	$0.05 \text{ MHz} \leq f_{\text{offset}} < 20.05 \text{ MHz}$	$-30\text{dBm} - \frac{7}{20} \left(\frac{f_{\text{offset}}}{\text{MHz}} - 0.05 \right)$	100 kHz
$20 \text{ MHz} \leq \Delta f < \min(40 \text{ MHz}, \Delta f_{\text{max}})$	$20.05 \text{ MHz} \leq f_{\text{offset}} < \min(40.05 \text{ MHz}, f_{\text{offset}_{\text{max}}})$	-37 dBm	100 kHz
$40 \text{ MHz} \leq \Delta f \leq \Delta f_{\text{max}}$	$40.05 \text{ MHz} \leq f_{\text{offset}} < f_{\text{offset}_{\text{max}}}$	-37 dBm	100 kHz
NOTE 1: For a BS supporting <i>non-contiguous spectrum</i> operation within any <i>operating band</i> the emission limits within <i>sub-block gaps</i> is calculated as a cumulative sum of contributions from adjacent <i>sub-blocks</i> on each side of the <i>sub-block gap</i> . Exception is $\Delta f \geq 40\text{MHz}$ from both adjacent <i>sub-blocks</i> on each side of the <i>sub-block gap</i> , where the emission limits within <i>sub-block gaps</i> shall be -37dBm/100kHz.			
NOTE 2: For a <i>multi-band connector</i> with <i>Inter RF Bandwidth gap</i> $< 2 \cdot \Delta f_{\text{OBUe}}$ the emission limits within the <i>Inter RF Bandwidth gaps</i> is calculated as a cumulative sum of contributions from adjacent <i>sub-blocks</i> or RF Bandwidth on each side of the <i>Inter RF Bandwidth gap</i>			
NOTE 3: The requirement is not applicable when $\Delta f_{\text{max}} < 40 \text{ MHz}$.			

For *BS type 1-H* operating in Band n104, *basic limits* are specified in Table 6.6.4.2.4-1b:

Table 6.6.4.2.4-1b. Local Area *BS type 1-H* operating band unwanted emission limits for band n104

Frequency offset of measurement filter -3dB point, Δf	Frequency offset of measurement filter centre frequency, f_{offset}	Basic limits (Note 1, 2)	Measurement bandwidth
$0 \text{ MHz} \leq \Delta f < 50 \text{ MHz}$	$0.05 \text{ MHz} \leq f_{\text{offset}} < 50.05 \text{ MHz}$	$-30\text{dBm} - \frac{7}{50} \left(\frac{f_{\text{offset}}}{\text{MHz}} - 0.05 \right)$	100 kHz
$50 \text{ MHz} \leq \Delta f < \min(100 \text{ MHz}, \Delta f_{\text{max}})$	$50.05 \text{ MHz} \leq f_{\text{offset}} < \min(100.05 \text{ MHz}, f_{\text{offset}_{\text{max}}})$	-37 dBm	100 kHz
$100 \text{ MHz} \leq \Delta f \leq \Delta f_{\text{max}}$	$100.05 \text{ MHz} \leq f_{\text{offset}} < f_{\text{offset}_{\text{max}}}$	-37 dBm	100 kHz
NOTE 1: For a BS supporting <i>non-contiguous spectrum</i> operation within any <i>operating band</i> the emission limits within <i>sub-block gaps</i> is calculated as a cumulative sum of contributions from adjacent <i>sub-blocks</i> on each side of the <i>sub-block gap</i> . Exception is $\Delta f \geq 100\text{MHz}$ from both adjacent <i>sub-blocks</i> on each side of the <i>sub-block gap</i> , where the emission limits within <i>sub-block gaps</i> shall be -37dBm/100kHz.			
NOTE 2: For a <i>multi-band connector</i> with <i>Inter RF Bandwidth gap</i> $< 2 \cdot \Delta f_{\text{OBUe}}$ the emission limits within the <i>Inter RF Bandwidth gaps</i> is calculated as a cumulative sum of contributions from adjacent <i>sub-blocks</i> or RF Bandwidth on each side of the <i>Inter RF Bandwidth gap</i>			
NOTE 3: The requirement is not applicable when $\Delta f_{\text{max}} < 100 \text{ MHz}$.			

6.6.4.2.4A Basic limits for Local Area and Medium Range BS for bands n46, n96 and n102 (Category A and B)

For Local Area and Medium Range BS operating in band n46, basic limits for 10 MHz channel bandwidth are specified in table 6.6.4.2.4A-1. For Local Area and Medium Range BS operating in bands n46, n96 and n102, basic limits for 20 MHz, 40 MHz, 60 MHz, 80 MHz and 100 MHz channel bandwidth are specified in table 6.6.4.2.4A-2. The nominal bandwidth $N = \text{BW}_{\text{Channel}}$ of the transmitted carrier. For one non-transmitted channel basic limits are specified in table 6.6.4.2.4A-3, and for two non-transmitted channels basic limits are specified in table 6.6.4.2.4A-4, and for three non-transmitted channels basic limits are specified in table 6.6.4.2.4A-5.

Table 6.6.4.2.4A-1: Medium Range BS and Local Area BS operating band unwanted emission limits for 10 MHz channel bandwidth for band n46

Frequency offset of measurement filter -3dB point, Δf	Frequency offset of measurement filter centre frequency, f_{offset}	Basic limits (Note 1)	Measurement bandwidth
$0 \text{ MHz} \leq \Delta f < 0.5 \text{ MHz}$	$0.05 \text{ MHz} \leq f_{\text{offset}} < 0.55 \text{ MHz}$	$\text{Max}(P_{\text{rated},x} - 19.5 \text{ dB} - 20 \left(\frac{f_{\text{offset}}}{\text{MHz}} - 0.05 \right) \text{ dB}, -40 \text{ dBm})$	100 kHz
$0.5 \text{ MHz} \leq \Delta f < 5 \text{ MHz}$	$0.55 \text{ MHz} \leq f_{\text{offset}} < \min(5.05 \text{ MHz}, f_{\text{offset}_{\text{max}}})$	$\text{Max}(P_{\text{rated},x} - 29.5 \text{ dB} - \frac{16}{9} \left(\frac{f_{\text{offset}}}{\text{MHz}} - 0.55 \right) \text{ dB}, -40 \text{ dBm})$	100 kHz
$5 \text{ MHz} \leq \Delta f < \min(10 \text{ MHz}, \Delta f_{\text{max}})$	$5.05 \text{ MHz} \leq f_{\text{offset}} < \min(10.05 \text{ MHz}, f_{\text{offset}_{\text{max}}})$	$\text{Max}(P_{\text{rated},x} - 37.5 \text{ dB} - \frac{12}{5} \left(\frac{f_{\text{offset}}}{\text{MHz}} - 5.05 \right) \text{ dB}, -40 \text{ dBm})$	100 kHz
$10 \text{ MHz} \leq \Delta f < \min(85 \text{ MHz}, \Delta f_{\text{max}})$	$10.05 \text{ MHz} \leq f_{\text{offset}} < \min(85.05 \text{ MHz}, f_{\text{offset}_{\text{max}}})$	$\text{Max}(P_{\text{rated},x} - 59.5 \text{ dB}, -40 \text{ dBm})$	100 kHz
$85 \text{ MHz} \leq \Delta f < \min(103 \text{ MHz}, \Delta f_{\text{max}})$	$85.05 \text{ MHz} \leq f_{\text{offset}} < \min(103.05 \text{ MHz}, f_{\text{offset}_{\text{max}}})$	$\text{Max}(P_{\text{rated},x} - 61.5 \text{ dB}, -40 \text{ dBm})$	100 kHz
$103 \text{ MHz} \leq \Delta f \leq \Delta f_{\text{max}}$	$103.05 \text{ MHz} \leq f_{\text{offset}} < f_{\text{offset}_{\text{max}}}$	$\text{Max}(P_{\text{rated},x} - 66.5 \text{ dB}, -40 \text{ dBm})$	100 kHz

NOTE 1: For a BS supporting non-contiguous spectrum operation within any operating band, the minimum requirement within *sub-block gaps* is calculated as a cumulative sum of contributions from adjacent *sub-blocks* on each side of the *sub-block gap*. Exception is $\Delta f \geq 10 \text{ MHz}$ from both adjacent *sub-blocks* on each side of the *sub-block gap*, where the minimum requirement within *sub-block gaps* shall be $\text{Max}(P_{\text{rated},x} - 59.5 \text{ dB}, -40 \text{ dBm})/100 \text{ kHz}$.

Table 6.6.4.2.4A-2: Medium Range BS and Local Area BS operating band unwanted emission limits for 20 MHz, 40 MHz, 60 MHz, 80 MHz and 100 MHz channel bandwidth for bands n46, n96 and n102

Frequency offset of measurement filter -3dB point, Δf	Frequency offset of measurement filter centre frequency, f_{offset}	Basic limits (Note 1)	Measurement bandwidth
$0 \text{ MHz} \leq \Delta f < 1 \text{ MHz}$	$0.05 \text{ MHz} \leq f_{\text{offset}} < 1.05 \text{ MHz}$	$\text{Max}(P_{\text{rated},x} - 10 \log_{10} \left(\frac{BW_{\text{channel}}}{100 \text{ kHz}} \right) - 20 \left(\frac{f_{\text{offset}}}{\text{MHz}} - 0.05 \right) \text{ dB}, -40 \text{ dBm})$	100 kHz
$1 \text{ MHz} \leq \Delta f < \min(0.5N \text{ MHz}, \Delta f_{\text{max}})$	$1.05 \text{ MHz} \leq f_{\text{offset}} < \min((0.5N+0.05) \text{ MHz}, f_{\text{offset}_{\text{max}}})$	$\text{Max}(P_{\text{rated},x} - 10 \log_{10} \left(\frac{BW_{\text{channel}}}{100 \text{ kHz}} \right) - 20 - \frac{8}{0.5N-1} \left(\frac{f_{\text{offset}}}{\text{MHz}} - 1.05 \right) \text{ dB}, -40 \text{ dBm})$	100 kHz
$0.5N \text{ MHz} \leq \Delta f < \min(N \text{ MHz}, \Delta f_{\text{max}})$	$(0.5N+0.05) \text{ MHz} \leq f_{\text{offset}} < \min((N+0.05) \text{ MHz}, f_{\text{offset}_{\text{max}}})$	$\text{Max}(P_{\text{rated},x} - 10 \log_{10} \left(\frac{BW_{\text{channel}}}{100 \text{ kHz}} \right) - 28 - \frac{12}{0.5N} \left(\frac{f_{\text{offset}}}{\text{MHz}} - 0.5N - 0.05 \right) \text{ dB}, -40 \text{ dBm})$	100 kHz
$N \text{ MHz} \leq \Delta f < \min(8.5N \text{ MHz}, \Delta f_{\text{max}})$	$(N+0.05) \text{ MHz} \leq f_{\text{offset}} < \min((8.5N+0.05) \text{ MHz}, f_{\text{offset}_{\text{max}}})$	$\text{Max}(P_{\text{rated},x} - 10 \log_{10} \left(\frac{BW_{\text{channel}}}{100 \text{ kHz}} \right) - 40 \text{ dB}, -40 \text{ dBm})$	100 kHz
$8.5N \text{ MHz} \leq \Delta f < \min(10.3N \text{ MHz}, \Delta f_{\text{max}})$	$(8.5N+0.05) \text{ MHz} \leq f_{\text{offset}} < \min((10.3N+0.05) \text{ MHz}, f_{\text{offset}_{\text{max}}})$	$\text{Max}(P_{\text{rated},x} - 10 \log_{10} \left(\frac{BW_{\text{channel}}}{100 \text{ kHz}} \right) - 42 \text{ dB}, -40 \text{ dBm})$	100 kHz
$10.3N \text{ MHz} \leq \Delta f \leq \Delta f_{\text{max}}$	$(10.3N+0.05) \text{ MHz} \leq f_{\text{offset}} < f_{\text{offset}_{\text{max}}}$	$\text{Max}(P_{\text{rated},x} - 10 \log_{10} \left(\frac{BW_{\text{channel}}}{100 \text{ kHz}} \right) - 47 \text{ dB}, -40 \text{ dBm})$	100 kHz

NOTE 1: For a BS supporting non-contiguous spectrum operation within any operating band, the minimum requirement within *sub-block gaps* is calculated as a cumulative sum of contributions from adjacent *sub-blocks* on each side of the *sub-block gap*. Exception is $\Delta f \geq N \text{ MHz}$ from both adjacent *sub-blocks* on each side of the *sub-block gap*, where the minimum requirement within *sub-block gaps* shall be $\text{Max}(P_{\text{rated},x} - 10 \log_{10} \left(\frac{BW_{\text{channel}}}{100 \text{ kHz}} \right) - 40 \text{ dB}, -40 \text{ dBm})$

In the case of one, two or three non-transmitted 20 MHz channels between transmitted channels, when a NR-U channel bandwidth of 60 MHz, 80 MHz or 100 MHz have been assigned, the spectrum emission mask for non-transmitted

channels specified in Table 6.6.4.2.4A-3, Table 6.6.4.2.4A-4 and Table 6.6.4.2.4A-5 applies for one, two, and three non-transmitted channels respectively. The spectrum emission mask for non-transmitted channels apply to frequencies (Δf_{BE_offset}) starting from the edge of the last transmitted channel of the channels assigned for NR-U channel bandwidth. The relative power of any BS emission shall not exceed the most stringent levels given by Table 6.6.4.2.4A-3, Table 6.6.4.2.4A-4 and Table 6.6.4.2.4A-5 in the case of non-transmitted channels between transmitted channels.

Table 6.6.4.2.4A-3: Medium Range BS and Local Area BS operating band unwanted emission limits for one non-transmitted channel for 60 MHz, 80MHz and 100 MHz channel bandwidth for bands n46, n96 and n102

Frequency offset of measurement filter -3dB point, Δf_{BE_offset}	Frequency offset of measurement filter centre frequency, f_{BE_offset}	Basic limits	Measurement bandwidth
$0 \text{ MHz} \leq \Delta f_{BE_offset} < 1 \text{ MHz}$	$0.05 \text{ MHz} \leq f_{BE_offset} < 1.05 \text{ MHz}$	$P_{rated,x} - 10 \log_{10} \left(\frac{BW_{Channel}}{100kHz} \right) - 20 \left(\frac{f_{BE_offset}}{MHz} - 0.05 \right) dB$	100 kHz
$1 \text{ MHz} \leq \Delta f_{BE_offset} < 10 \text{ MHz}$	$1.05 \text{ MHz} \leq f_{BE_offset} < 10.05 \text{ MHz}$	$P_{rated,x} - 10 \log_{10} \left(\frac{BW_{Channel}}{100kHz} \right) - 20 - \frac{1}{3} \left(\frac{f_{BE_offset}}{MHz} - 1.05 \right) dB$	100 kHz
$10 \text{ MHz} \leq \Delta f_{BE_offset} < 19 \text{ MHz}$	$10.05 \text{ MHz} \leq f_{BE_offset} < 19.05 \text{ MHz}$	$P_{rated,x} - 10 \log_{10} \left(\frac{BW_{Channel}}{100kHz} \right) - 23 + \frac{1}{3} \left(\frac{f_{BE_offset}}{MHz} - 10.05 \right) dB$	100 kHz
$19 \text{ MHz} \leq \Delta f_{BE_offset} < 19.9 \text{ MHz}$	$19.05 \text{ MHz} \leq f_{BE_offset} < 19.95 \text{ MHz}$	$P_{rated,x} - 10 \log_{10} \left(\frac{BW_{Channel}}{100kHz} \right) - 20 + 20 \left(\frac{f_{BE_offset}}{MHz} - 19.05 \right) dB$	100 kHz

Table 6.6.4.2.4A-4: Medium Range BS and Local Area BS operating band unwanted emission limits for two non-transmitted channels for 80 MHz and 100 MHz channel bandwidth for bands n46, n96 and n102

Frequency offset of measurement filter -3dB point, Δf_{BE_offset}	Frequency offset of measurement filter centre frequency, f_{BE_offset}	Basic limits	Measurement bandwidth
$0 \text{ MHz} \leq \Delta f_{BE_offset} < 1 \text{ MHz}$	$0.05 \text{ MHz} \leq f_{BE_offset} < 1.05 \text{ MHz}$	$P_{rated,x} - 10 \log_{10} \left(\frac{BW_{Channel}}{100kHz} \right) - 20 \left(\frac{f_{BE_offset}}{MHz} - 0.05 \right) dB$	100 kHz
$1 \text{ MHz} \leq \Delta f_{BE_offset} < 10 \text{ MHz}$	$1.05 \text{ MHz} \leq f_{BE_offset} < 10.05 \text{ MHz}$	$P_{rated,x} - 10 \log_{10} \left(\frac{BW_{Channel}}{100kHz} \right) - 20 - \frac{5}{9} \left(\frac{f_{BE_offset}}{MHz} - 1.05 \right) dB$	100 kHz
$10 \text{ MHz} \leq \Delta f_{BE_offset} < 30 \text{ MHz}$	$10.05 \text{ MHz} \leq f_{BE_offset} < 30.05 \text{ MHz}$	$P_{rated,x} - 10 \log_{10} \left(\frac{BW_{Channel}}{100kHz} \right) - 25 dB$	100 kHz
$30 \text{ MHz} \leq \Delta f_{BE_offset} < 39 \text{ MHz}$	$30.05 \text{ MHz} \leq f_{BE_offset} < 39.05 \text{ MHz}$	$P_{rated,x} - 10 \log_{10} \left(\frac{BW_{Channel}}{100kHz} \right) - 25 + \frac{5}{9} \left(\frac{f_{BE_offset}}{MHz} - 30.05 \right) dB$	100 kHz
$39 \text{ MHz} \leq \Delta f_{BE_offset} < 39.9 \text{ MHz}$	$39.05 \text{ MHz} \leq f_{BE_offset} < 39.95 \text{ MHz}$	$P_{rated,x} - 10 \log_{10} \left(\frac{BW_{Channel}}{100kHz} \right) - 20 + 20 \left(\frac{f_{BE_offset}}{MHz} - 39.05 \right) dB$	100 kHz

Table 6.6.4.2.4A-5: Medium Range BS and Local Area BS operating band unwanted emission limits for three non-transmitted channels for 100 MHz channel bandwidth for bands n46, n96 and n102

Frequency offset of measurement filter -3dB point, Δf_{BE_offset}	Frequency offset of measurement filter centre frequency, f_{BE_offset}	Basic limits	Measurement bandwidth
$0 \text{ MHz} \leq \Delta f_{BE_offset} < 1 \text{ MHz}$	$0.05 \text{ MHz} \leq f_{BE_offset} < 1.05 \text{ MHz}$	$P_{rated,x} - 10 \log_{10} \left(\frac{BW_{Channel}}{100 \text{ kHz}} \right) - 20 \left(\frac{f_{BE_offset}}{\text{MHz}} - 0.05 \right) \text{ dB}$	100 kHz
$1 \text{ MHz} \leq \Delta f_{BE_offset} < 10 \text{ MHz}$	$1.05 \text{ MHz} \leq f_{BE_offset} < 10.05 \text{ MHz}$	$P_{rated,x} - 10 \log_{10} \left(\frac{BW_{Channel}}{100 \text{ kHz}} \right) - 20 - \frac{5}{9} \left(\frac{f_{BE_offset}}{\text{MHz}} - 1.05 \right) \text{ dB}$	100 kHz
$10 \text{ MHz} \leq \Delta f_{BE_offset} < 50 \text{ MHz}$	$10.05 \text{ MHz} \leq f_{BE_offset} < 50.05 \text{ MHz}$	$P_{rated,x} - 10 \log_{10} \left(\frac{BW_{Channel}}{100 \text{ kHz}} \right) - 25 \text{ dB}$	100 kHz
$50 \text{ MHz} \leq \Delta f_{BE_offset} < 59 \text{ MHz}$	$50.05 \text{ MHz} \leq f_{BE_offset} < 59.05 \text{ MHz}$	$P_{rated,x} - 10 \log_{10} \left(\frac{BW_{Channel}}{100 \text{ kHz}} \right) - 25 + \frac{5}{9} \left(\frac{f_{BE_offset}}{\text{MHz}} - 50.05 \right) \text{ dB}$	100 kHz
$59 \text{ MHz} \leq \Delta f_{BE_offset} < 59.9 \text{ MHz}$	$59.05 \text{ MHz} \leq f_{BE_offset} < 59.95 \text{ MHz}$	$P_{rated,x} - 10 \log_{10} \left(\frac{BW_{Channel}}{100 \text{ kHz}} \right) - 20 + 20 \left(\frac{f_{BE_offset}}{\text{MHz}} - 59.05 \right) \text{ dB}$	100 kHz

In the case of non-transmitted 20 MHz channel(s) on the edges of an assigned NR-U channel bandwidth the general spectrum emission mask specified in Table 6.6.4.2.4A-2 is applied to the remaining transmitted channels to form an additional spectrum emission mask. The additional spectrum emission mask is applied to the total bandwidth of the remaining transmitted channels.

The additional spectrum emission mask is floored at: $P_{rated,x} - 10 \log_{10} \left(\frac{BW_{Channel}}{100 \text{ kHz}} \right) - 28 \text{ dB}$.

The relative power of any BS emission shall not exceed the most stringent levels given by the initial general spectrum emission mask with full channel bandwidth and the additional spectrum emission mask with the channel bandwidth of the transmitted channels in the case of non-transmitted channels at the edge of an assigned NR-U channel bandwidth.

6.6.4.2.5 Basic limits for additional requirements

6.6.4.2.5.1 Limits in FCC Title 47

In addition to the requirements in clauses 6.6.4.2.1, 6.6.4.2.2, 6.6.4.2.3 and 6.6.4.2.4, the BS may have to comply with the applicable emission limits established by FCC Title 47 [8], when deployed in regions where those limits are applied, and under the conditions declared by the manufacturer.

6.6.4.2.5.2 Protection of DTT

In certain regions the following requirement may apply for protection of DTT. For BS type 1-C or BS type 1-H operating in Band n20, the level of emissions in the band 470-790 MHz, measured in an 8 MHz filter bandwidth on centre frequencies F_{filter} according to table 6.6.4.2.5.2-1, a basic limits $P_{EM,N}$ is declared by the manufacturer. This requirement applies in the frequency range 470-790 MHz even though part of the range falls in the spurious domain.

Table 6.6.4.2.5.2-1: Declared emissions basic limit for protection of DTT

Filter centre frequency, F_{filter}	Measurement bandwidth	Declared emission basic limit (dBm)
$F_{filter} = 8^{\circ}N + 306 \text{ (MHz)}$; $21 \leq N \leq 60$	8 MHz	$P_{EM,N}$

Note: The regional requirement is defined in terms of EIRP (effective isotropic radiated power), which is dependent on both the BS emissions at the *antenna connector* and the deployment (including antenna gain and feeder loss). The requirement defined above provides the characteristics of the BS needed to verify compliance with the regional requirement. Compliance with the regional requirement can be determined using the method outlined in TS 36.104 [13], annex F.

6.6.4.2.5.3 Additional operating band unwanted emissions limits for Band n48

The following requirement may apply to BS operating in Band n48 in certain regions. Emissions shall not exceed the maximum levels specified in table 6.6.4.2.5.3-1.

Table 6.6.4.2.5.3-1: Additional operating band unwanted emission limits for Band n48

Channel bandwidth	Frequency offset of measurement filter -3dB point, Δf	Frequency offset of measurement filter centre frequency, f_{offset}	Minimum requirement	Measurement bandwidth (Note)
All	$0 \text{ MHz} \leq \Delta f < 10 \text{ MHz}$	$0.5 \text{ MHz} \leq f_{\text{offset}} < 9.5 \text{ MHz}$	-13 dBm	1 MHz

NOTE: The resolution bandwidth of the measuring equipment should be equal to the *measurement bandwidth*. However, to improve measurement accuracy, sensitivity and efficiency, the resolution bandwidth may be smaller than the *measurement bandwidth*. When the resolution bandwidth is smaller than the *measurement bandwidth*, the result should be integrated over the *measurement bandwidth* in order to obtain the equivalent noise bandwidth of the *measurement bandwidth*.

6.6.4.2.5.4 Additional operating band unwanted emissions limits for Band n53

The following requirement may apply to BS operating in Band n53 in certain regions. Emissions shall not exceed the maximum levels specified in table 6.6.4.2.5.4-1.

Table 6.6.4.2.5.4-1: Additional operating band unwanted emission limits for Band n53

Channel bandwidth [MHz]	Frequency range [MHz]	Frequency offset of measurement filter -3dB point, Δf	Frequency offset of measurement filter centre frequency, f_{offset}	Minimum requirement	Measurement bandwidth (Note)
5	2400 - 2477.5	$6 \text{ MHz} \leq \Delta f < 83.5 \text{ MHz}$	$6.5 \text{ MHz} \leq f_{\text{offset}} < 83 \text{ MHz}$	-25 dBm	1 MHz
10	2400 - 2473.5	$10 \text{ MHz} \leq \Delta f < 83.5 \text{ MHz}$	$10.5 \text{ MHz} \leq f_{\text{offset}} < 83 \text{ MHz}$	-25 dBm	1 MHz
5	2477.5 - 2478.5	$5 \text{ MHz} \leq \Delta f < 6 \text{ MHz}$	5.5 MHz	-13 dBm	1 MHz
10	2473.5 - 2478.5	$5 \text{ MHz} \leq \Delta f < 10 \text{ MHz}$	$5.5 \text{ MHz} \leq f_{\text{offset}} < 9.5 \text{ MHz}$	-13 dBm	1 MHz
All	2478.5 - 2483.5	$0 \text{ MHz} \leq \Delta f < 5 \text{ MHz}$	$0.5 \text{ MHz} \leq f_{\text{offset}} < 4.5 \text{ MHz}$	-10 dBm	1 MHz
5	2495 - 2501	$0 \text{ MHz} \leq \Delta f < 6 \text{ MHz}$	$0.5 \text{ MHz} \leq f_{\text{offset}} < 5.5 \text{ MHz}$	-13 dBm	1 MHz
10	2495 - 2505	$0 \text{ MHz} \leq \Delta f < 10 \text{ MHz}$	$0.5 \text{ MHz} \leq f_{\text{offset}} < 9.5 \text{ MHz}$	-13 dBm	1 MHz
5	2501 - 2690	$6 \text{ MHz} \leq \Delta f < 195 \text{ MHz}$	$6.5 \text{ MHz} \leq f_{\text{offset}} < 194.5 \text{ MHz}$	-25 dBm	1 MHz
10	2505 - 2690	$10 \text{ MHz} \leq \Delta f < 195 \text{ MHz}$	$10.5 \text{ MHz} \leq f_{\text{offset}} < 194.5 \text{ MHz}$	-25 dBm	1 MHz

NOTE: The resolution bandwidth of the measuring equipment should be equal to the *measurement bandwidth*. However, to improve measurement accuracy, sensitivity and efficiency, the resolution bandwidth may be smaller than the *measurement bandwidth*. When the resolution bandwidth is smaller than the *measurement bandwidth*, the result should be integrated over the *measurement bandwidth* in order to obtain the equivalent noise bandwidth of the *measurement bandwidth*.

6.6.4.2.5.5 Additional operating band unwanted emissions limits for operation with shared spectrum channel access

In addition, for operation with shared spectrum channel access, the BS may have to comply with the applicable operating band unwanted emission limits established regionally, when deployed in regions where those limits apply and under the conditions declared by the manufacturer. The regional requirements may be in the form of conducted power, power spectral density, EIRP and other types of limits. In case of regulatory limits based on EIRP, assessment of the EIRP level is described in Annex F.2.

6.6.4.2.5.6 Additional operating band unwanted emissions limits for Band n24

In regions where FCC regulation applies, requirements for protection of GPS according to FCC Order DA 20-48 [25] applies for operation in Band n24. The following normative requirement covers the base station, to be used together with other information about the site installation to verify compliance with the requirement in FCC Order DA 20-48 [25]. The requirement applies to BS operating in Band n24 to ensure that appropriate interference protection is provided to the 1541 – 1650 MHz band. This requirement applies to the frequency range 1541-1650 MHz, even though part of this range falls within the spurious domain.

The level of emissions in the 1541 – 1650 MHz band, measured in measurement bandwidth according to Table 6.6.4.2.5.6-1 shall not exceed the maximum emission levels $P_{EM,B24,a}$, $P_{EM,B24,b}$, $P_{EM,B24,c}$, $P_{EM,B24,d}$, $P_{EM,B24,e}$ and $P_{EM,B24,f}$ declared by the manufacturer.

Table 6.6.4.2.5.6-1: Declared emissions levels for protection of the 1541-1650 MHz band

Operating Band	Frequency range	Declared emission level (dBW) (Measurement bandwidth = 1 MHz)	Declared emission level (dBW) of discrete emissions of less than 700 Hz bandwidth (Measurement bandwidth = 1 kHz)	Declared emission level (dBW) of discrete emissions of less than 2 kHz bandwidth (Measurement bandwidth = 1 kHz)
n24	1541 - 1559 MHz	$P_{EM,B24,a}$		$P_{EM,B24,f}$
	1559 - 1610 MHz	$P_{EM,B24,b}$	$P_{EM,B24,d}$	
	1610 - 1650 MHz	$P_{EM,B24,c}$	$P_{EM,B24,e}$	

Note: The regional requirements in FCC Order DA 20-48 [25] are defined in terms of EIRP (effective isotropic radiated power), which is dependent on both the BS emissions at the antenna connector and the deployment (including antenna gain and feeder loss). The EIRP level is calculated using: $P_{EIRP} = P_E + G_{ant}$ where P_E denotes the BS unwanted emission level at the antenna connector, G_{ant} equals the BS antenna gain minus feeder loss. The requirement defined above provides the characteristics of the base station needed to verify compliance with the regional requirement.

6.6.4.2.5.7 Void

6.6.4.3 Minimum requirements for BS type 1-C

The operating band unwanted emissions for *BS type 1-C* for each *antenna connector* shall be below the applicable *basic limits* defined in clause 6.6.4.2.

For Band n41 and n90 operation in Japan, the operating band unwanted emissions limits shall be applied to the sum of the emission power over all *antenna connectors* for *BS type 1-C*.

6.6.4.4 Minimum requirements for BS type 1-H

The operating band unwanted emissions requirements for *BS type 1-H* are that for each *TAB connector TX min cell group* and each applicable *basic limit* in clause 6.6.4.2, the power summation emissions at the *TAB connectors* of the *TAB connector TX min cell group* shall not exceed a BS limit specified as the *basic limit* + X, where $X = 10\log_{10}(N_{TXU, \text{countedpercell}})$.

NOTE: Conformance to the *BS type 1-H* spurious emission requirement can be demonstrated by meeting at least one of the following criteria as determined by the manufacturer:

- 1) The sum of the emissions power measured on each *TAB connector* in the *TAB connector TX min cell group* shall be less than or equal to the limit as defined in this clause for the respective frequency span.

Or

- 2) The unwanted emissions power at each *TAB connector* shall be less than or equal to the *BS type 1-H* limit as defined in this clause for the respective frequency span, scaled by $-10\log_{10}(n)$, where n is the number of *TAB connectors* in the *TAB connector TX min cell group*.

6.6.5 Transmitter spurious emissions

6.6.5.1 General

The transmitter spurious emission limits shall apply from 9 kHz to 12.75 GHz, excluding the frequency range from Δf_{OBUE} below the lowest frequency of each supported downlink *operating band*, up to Δf_{OBUE} above the highest frequency of each supported downlink *operating band*, where the Δf_{OBUE} is defined in table 6.6.1-1. For some *operating bands*, the upper limit is higher than 12.75 GHz in order to comply with the 5th harmonic limit of the downlink *operating band*, as specified in ITU-R recommendation SM.329 [2].

For a *multi-band connector*, for each supported *operating band* together with Δf_{OBUE} around the band is excluded from the transmitter spurious emissions requirement.

The requirements shall apply whatever the type of transmitter considered (single carrier or multi-carrier). It applies for all transmission modes foreseen by the manufacturer's specification.

The requirements shall also apply if the BS supports NB-IoT operation in NR in-band.

Unless otherwise stated, all requirements are measured as mean power (RMS).

6.6.5.2 Basic limits

6.6.5.2.1 General transmitter spurious emissions requirements

The *basic limits* of either table 6.6.5.2.1-1 (Category A limits) or table 6.6.5. 2.1-2 (Category B limits) shall apply. The application of either Category A or Category B limits shall be the same as for operating band unwanted emissions in clause 6.6.4.

Table 6.6.5.2.1-1: General BS transmitter spurious emission limits in FR1, Category A

Spurious frequency range	Basic limit	Measurement bandwidth	Notes
9 kHz – 150 kHz	-13 dBm	1 kHz	Note 1, Note 4
150 kHz – 30 MHz		10 kHz	Note 1, Note 4
30 MHz – 1 GHz		100 kHz	Note 1
1 GHz – 12.75 GHz		1 MHz	Note 1, Note 2
12.75 GHz – 5 th harmonic of the upper frequency edge of the DL <i>operating band</i> in GHz		1 MHz	Note 1, Note 2, Note 3
12.75 GHz - 26 GHz	-13 dBm	1 MHz	Note 1, Note 2, Note 5
NOTE 1: <i>Measurement bandwidths</i> as in ITU-R SM.329 [2], s4.1.			
NOTE 2: Upper frequency as in ITU-R SM.329 [2], s2.5 table 1.			
NOTE 3: Applies for Band for which the upper frequency edge of the DL <i>operating band</i> is greater than 2.55 GHz and less than or equal to 5.2 GHz..			
NOTE 4: This spurious frequency range applies only to <i>BS type 1-C</i> and <i>BS type 1-H</i> .			
NOTE 5: Applies for Band for which the upper frequency edge of the DL <i>operating band</i> is greater than 5.2 GHz.			

Table 6.6.5.2.1-2: General BS transmitter spurious emission limits in FR1, Category B

Spurious frequency range	Basic limit	Measurement bandwidth	Notes
9 kHz – 150 kHz	-36 dBm	1 kHz	Note 1, Note 4
150 kHz – 30 MHz		10 kHz	Note 1, Note 4
30 MHz – 1 GHz		100 kHz	Note 1
1 GHz – 12.75 GHz	-30 dBm	1 MHz	Note 1, Note 2
12.75 GHz – 5 th harmonic of the upper frequency edge of the DL <i>operating band</i> in GHz		1 MHz	Note 1, Note 2, Note 3
12.75 GHz - 26 GHz	- 30 dBm	1 MHz	Note 1, Note 2, Note 5
NOTE 1: <i>Measurement bandwidths</i> as in ITU-R SM.329 [2], s4.1.			
NOTE 2: Upper frequency as in ITU-R SM.329 [2], s2.5 table 1.			
NOTE 3: Applies for Band for which the upper frequency edge of the DL <i>operating band</i> is greater than 2.55 GHz and less than or equal to 5.2 GHz.			
NOTE 4: This spurious frequency range applies only to <i>BS type 1-C</i> and <i>BS type 1-H</i> .			
NOTE 5: Applies for Band for which the upper frequency edge of the DL <i>operating band</i> is greater than 5.2 GHz.			

6.6.5.2.2 Protection of the BS receiver of own or different BS

This requirement shall be applied for NR FDD operation in order to prevent the receivers of the BSs being desensitised by emissions from a BS transmitter. It is measured at the transmit *antenna connector* for *BS type 1-C* or at the *TAB connector* for *BS type 1-H* for any type of BS which has common or separate Tx/Rx *antenna connectors* / *TAB connectors*.

The spurious emission *basic limits* are provided in table 6.6.5.2.2-1.

Table 6.6.5.2.2-1: BS spurious emissions *basic limits* for protection of the BS receiver

BS class	Frequency range	Basic limits	Measurement bandwidth	Note
Wide Area BS	$F_{UL,low} - F_{UL,high}$	-96 dBm	100 kHz	
Medium Range BS	$F_{UL,low} - F_{UL,high}$	-91 dBm	100 kHz	
Local Area BS	$F_{UL,low} - F_{UL,high}$	-88 dBm	100 kHz	
NOTE 1: For BS operating in band n104, the basic limit is increased by 1dB.				
NOTE 2: For BS operating in regions where a band is only partially allocated for NR operations (e.g. band n28), this requirement only applies in the UL frequency range of the partial allocation.				
NOTE 3: For BS capable of multi-band operation, Table 6.6.5.2.2-1 assumes that the supported <i>operating bands</i> , where the corresponding BS transmit and receive frequency ranges in table 5.2-1 would be overlapping, are not deployed in the same geographical area. For such a case of operation with overlapping frequency arrangements in the same geographical area, special protection requirements may apply that are not covered by the 3GPP specifications.				

6.6.5.2.3 Additional spurious emissions requirements

These requirements may be applied for the protection of system operating in frequency ranges other than the BS downlink *operating band*. The limits may apply as an optional protection of such systems that are deployed in the same geographical area as the BS, or they may be set by local or regional regulation as a mandatory requirement for an NR *operating band*. It is in some cases not stated in the present document whether a requirement is mandatory or under what exact circumstances that a limit applies, since this is set by local or regional regulation. An overview of regional requirements in the present document is given in clause 4.5.

Some requirements may apply for the protection of specific equipment (UE, MS and/or BS) or equipment operating in specific systems (GSM, CDMA, UTRA, E-UTRA, NR, etc.) as listed below.

The spurious emission *basic limits* are provided in table 6.6.5.2.3 -1 for a BS where requirements for co-existence with the system listed in the first column apply. For a *multi-band connector*, the exclusions and conditions in the Note column of table 6.6.5.2.3 -1 apply for each supported *operating band*.

Table 6.6.5.2.3-1: BS spurious emissions *basic limits* for BS for co-existence with systems operating in other frequency bands

System type for NR to co-exist with	Frequency range for co-existence requirement	Basic limits	Measurement bandwidth	Note
GSM900	921 – 960 MHz	-57 dBm	100 kHz	This requirement does not apply to BS operating in band n8
	876 – 915 MHz	-61 dBm	100 kHz	For the frequency range 880-915 MHz, this requirement does not apply to BS operating in band n8, since it is already covered by the requirement in clause 6.6.5.2.2.
DCS1800	1805 – 1880 MHz	-47 dBm	100 kHz	This requirement does not apply to BS operating in band n3.
	1710 – 1785 MHz	-61 dBm	100 kHz	This requirement does not apply to BS operating in band n3, since it is already covered by the requirement in clause 6.6.5.2.2.
PCS1900	1930 – 1990 MHz	-47 dBm	100 kHz	This requirement does not apply to BS operating in band n2, n25 or band n70.
	1850 – 1910 MHz	-61 dBm	100 kHz	This requirement does not apply to BS operating in band n2 or n25 since it is already covered by the requirement in clause 6.6.5.2.2.
GSM850 or CDMA850	869 – 894 MHz	-57 dBm	100 kHz	This requirement does not apply to BS operating in band n5 or n26.
	824 – 849 MHz	-61 dBm	100 kHz	This requirement does not apply to BS operating in band n5 or n26, since it is already covered by the requirement in clause 6.6.5.2.2.
UTRA FDD Band I or E-UTRA Band 1 or NR Band n1	2110 – 2170 MHz	-52 dBm	1 MHz	This requirement does not apply to BS operating in band n1 or n65
	1920 – 1980 MHz	-49 dBm	1 MHz	This requirement does not apply to BS operating in band n1 or n65, since it is already covered by the requirement in clause 6.6.5.2.2.
UTRA FDD Band II or E-UTRA Band 2 or NR Band n2	1930 – 1990 MHz	-52 dBm	1 MHz	This requirement does not apply to BS operating in band n2 or n70.
	1850 – 1910 MHz	-49 dBm	1 MHz	This requirement does not apply to BS operating in band n2, since it is already covered by the requirement in clause 6.6.5.2.2.
UTRA FDD Band III or E-UTRA Band 3 or NR Band n3	1805 – 1880 MHz	-52 dBm	1 MHz	This requirement does not apply to BS operating in band n3.
	1710 – 1785 MHz	-49 dBm	1 MHz	This requirement does not apply to BS operating in band n3, since it is already covered by the requirement in clause 6.6.5.2.2.
UTRA FDD Band IV or E-UTRA Band 4	2110 – 2155 MHz	-52 dBm	1 MHz	This requirement does not apply to BS operating in band n66
	1710 – 1755 MHz	-49 dBm	1 MHz	This requirement does not apply to BS operating in band n66, since it is already covered by the requirement in clause 6.6.5.2.2.
UTRA FDD Band V or E-UTRA Band 5 or NR Band n5	869 – 894 MHz	-52 dBm	1 MHz	This requirement does not apply to BS operating in band n5 or n26.
	824 – 849 MHz	-49 dBm	1 MHz	This requirement does not apply to BS operating in band n5 or n26, since it is already covered by the requirement in clause 6.6.5.2.2.
UTRA FDD Band VI, XIX or E-UTRA Band 6, 18, 19 or NR Band n18	860 – 890 MHz	-52 dBm	1 MHz	This requirement does not apply to BS operating in band n18.
	815 – 830 MHz	-49 dBm	1 MHz	This requirement does not apply to BS operating in band n18, since it is already covered by the requirement in clause 6.6.5.2.2.
	830 – 845 MHz	-49 dBm	1 MHz	
UTRA FDD Band VII or E-UTRA Band 7 or NR Band n7	2620 – 2690 MHz	-52 dBm	1 MHz	This requirement does not apply to BS operating in band n7.
	2500 – 2570 MHz	-49 dBm	1 MHz	This requirement does not apply to BS operating in band n7, since it is already covered by the requirement in clause 6.6.5.2.2.
UTRA FDD Band VIII or	925 – 960 MHz	-52 dBm	1 MHz	This requirement does not apply to BS operating in band n8 or n100.

System type for NR to co-exist with	Frequency range for co-existence requirement	Basic limits	Measurement bandwidth	Note
E-UTRA Band 8 or NR Band n8	880 – 915 MHz	-49 dBm	1 MHz	This requirement does not apply to BS operating in band n8, since it is already covered by the requirement in clause 6.6.5.2.2.
UTRA FDD Band IX or E-UTRA Band 9	1844.9 – 1879.9 MHz 1749.9 – 1784.9 MHz	-52 dBm -49 dBm	1 MHz 1 MHz	This requirement does not apply to BS operating in band n3. This requirement does not apply to BS operating in band n3, since it is already covered by the requirement in clause 6.6.5.2.2.
UTRA FDD Band X or E-UTRA Band 10	2110 – 2170 MHz 1710 – 1770 MHz	-52 dBm -49 dBm	1 MHz 1 MHz	This requirement does not apply to BS operating in band n66. This requirement does not apply to BS operating in band n66, since it is already covered by the requirement in clause 6.6.5.2.2.
UTRA FDD Band XI or XXI or E-UTRA Band 11 or 21	1475.9 – 1510.9 MHz 1427.9 – 1447.9 MHz 1447.9 – 1462.9 MHz	-52 dBm -49 dBm -49 dBm	1 MHz 1 MHz 1 MHz	This requirement does not apply to BS operating in band n50, n74, n75, n92 or n94. This requirement does not apply to BS operating in band n50, n51, n74, n75, n76, n91, n92, n93 or n94. This requirement does not apply to BS operating in band n50, n74, n75, n92 or n94.
UTRA FDD Band XII or E-UTRA Band 12 or NR Band n12	729 – 746 MHz 699 – 716 MHz	-52 dBm -49 dBm	1 MHz 1 MHz	This requirement does not apply to BS operating in band n12 or n85. This requirement does not apply to BS operating in band n12 or n85, since it is already covered by the requirement in clause 6.6.5.2.2. For NR BS operating in n29, it applies 1 MHz below the Band n29 downlink operating band (Note 5).
UTRA FDD Band XIII or E-UTRA Band 13 or NR Band n13	746 – 756 MHz 777 – 787 MHz	-52 dBm -49 dBm	1 MHz 1 MHz	This requirement does not apply to BS operating in band n13. This requirement does not apply to BS operating in band n13, since it is already covered by the requirement in clause 6.6.5.2.2.
UTRA FDD Band XIV or E-UTRA Band 14 or NR band n14	758 – 768 MHz 788 – 798 MHz	-52 dBm -49 dBm	1 MHz 1 MHz	This requirement does not apply to BS operating in band n14. This requirement does not apply to BS operating in band n14, since it is already covered by the requirement in clause 6.6.5.2.2.
E-UTRA Band 17	734 – 746 MHz 704 – 716 MHz	-52 dBm -49 dBm	1 MHz 1 MHz	 For NR BS operating in n29, it applies 1 MHz below the Band n29 downlink operating band (Note 5).
UTRA FDD Band XX or E-UTRA Band 20 or NR Band n20	791 – 821 MHz 832 – 862 MHz	-52 dBm -49 dBm	1 MHz 1 MHz	This requirement does not apply to BS operating in band n20 or n28. This requirement does not apply to BS operating in band n20, since it is already covered by the requirement in clause 6.6.5.2.2.
UTRA FDD Band XXII or E-UTRA Band 22	3510 – 3590 MHz 3410 – 3490 MHz	-52 dBm -49 dBm	1 MHz 1 MHz	This requirement does not apply to BS operating in band n48, n77 or n78. This requirement does not apply to BS operating in band n77 or n78.
E-UTRA Band 24 or NR Band n24	1525 – 1559 MHz 1626.5 – 1660.5 MHz	-52 dBm -49 dBm	1 MHz 1 MHz	This requirement does not apply to BS operating in band n24. This requirement does not apply to BS operating in band n24, since it is already covered by the requirement in clause 6.6.5.2.2.
UTRA FDD Band XXV or E-UTRA Band 25 or NR band n25	1930 – 1995 MHz 1850 – 1915 MHz	-52 dBm -49 dBm	1 MHz 1 MHz	This requirement does not apply to BS operating in band n2, n25 or n70. This requirement does not apply to BS operating in band n25 since it is already covered by the requirement in clause 6.6.5.2.2. For BS operating in Band n2, it applies for 1910 MHz to 1915 MHz, while the rest is covered in clause 6.6.5.2.2.

System type for NR to co-exist with	Frequency range for co-existence requirement	Basic limits	Measurement bandwidth	Note
UTRA FDD Band XXVI or E-UTRA Band 26 or NR Band n26	859 – 894 MHz	-52 dBm	1 MHz	This requirement does not apply to BS operating in band n5 or n26.
	814 – 849 MHz	-49 dBm	1 MHz	This requirement does not apply to BS operating in band n26 since it is already covered by the requirement in clause 6.6.5.2.2. For BS operating in Band n5, it applies for 814 MHz to 824 MHz, while the rest is covered in clause 6.6.5.2.2.
E-UTRA Band 27	852 – 869 MHz	-52 dBm	1 MHz	This requirement does not apply to BS operating in Band n5.
	807 – 824 MHz	-49 dBm	1 MHz	This requirement also applies to BS operating in Band n28, starting 4 MHz above the Band n28 downlink <i>operating band</i> (Note 5).
E-UTRA Band 28 or NR Band n28	758 – 803 MHz	-52 dBm	1 MHz	This requirement does not apply to BS operating in band n20, n67 or n28.
	703 – 748 MHz	-49 dBm	1 MHz	This requirement does not apply to BS operating in band n28, since it is already covered by the requirement in clause 6.6.5.2.2. For BS operating in band n67, it applies for 703 MHz to 736 MHz.
E-UTRA Band 29 or NR Band n29	717 – 728 MHz	-52 dBm	1 MHz	This requirement does not apply to BS operating in Band n29 or n85
E-UTRA Band 30 or NR Band n30	2350 – 2360 MHz	-52 dBm	1 MHz	This requirement does not apply to BS operating in band n30
	2305 – 2315 MHz	-49 dBm	1 MHz	This requirement does not apply to BS operating in band n30, since it is already covered by the requirement in clause 6.6.5.2.2.
E-UTRA Band 31	462.5 – 467.5 MHz	-52 dBm	1 MHz	
	452.5 – 457.5 MHz	-49 dBm	1 MHz	
UTRA FDD band XXXII or E-UTRA band 32	1452 – 1496 MHz	-52 dBm	1 MHz	This requirement does not apply to BS operating in band n50, n74, n75, n92 or n94.
UTRA TDD Band a) or E-UTRA Band 33	1900 – 1920 MHz	-52 dBm	1 MHz	
UTRA TDD Band a) or E-UTRA Band 34 or NR band n34	2010 – 2025 MHz	-52 dBm	1 MHz	This requirement does not apply to BS operating in Band n34.
UTRA TDD Band b) or E-UTRA Band 35	1850 – 1910 MHz	-52 dBm	1 MHz	
UTRA TDD Band b) or E-UTRA Band 36	1930 – 1990 MHz	-52 dBm	1 MHz	This requirement does not apply to BS operating in Band n2 or n25.
UTRA TDD Band c) or E-UTRA Band 37	1910 – 1930 MHz	-52 dBm	1 MHz	
UTRA TDD Band d) or E-UTRA Band 38 or NR Band n38	2570 – 2620 MHz	-52 dBm	1 MHz	This requirement does not apply to BS operating in Band n38.

System type for NR to co-exist with	Frequency range for co-existence requirement	Basic limits	Measurement bandwidth	Note
UTRA TDD Band f) or E-UTRA Band 39 or NR band n39	1880 – 1920MHz	-52 dBm	1 MHz	This requirement does not apply to BS operating in Band n39.
UTRA TDD Band e) or E-UTRA Band 40 or NR Band n40	2300 – 2400MHz	-52 dBm	1 MHz	This requirement does not apply to BS operating in Band n30 or n40.
E-UTRA Band 41 or NR Band n41, n90	2496 – 2690 MHz	-52 dBm	1 MHz	This is not applicable to BS operating in Band n41, n53 or [n90].
E-UTRA Band 42	3400 – 3600 MHz	-52 dBm	1 MHz	This is not applicable to BS operating in Band n48, n77 or n78.
E-UTRA Band 43	3600 – 3800 MHz	-52 dBm	1 MHz	This is not applicable to BS operating in Band n48, n77 or n78.
E-UTRA Band 44	703 – 803 MHz	-52 dBm	1 MHz	This is not applicable to BS operating in Band n28.
E-UTRA Band 45	1447 – 1467 MHz	-52 dBm	1 MHz	
E-UTRA Band 46 or NR Band n46	5150 – 5925 MHz	-52 dBm	1 MHz	This is not applicable to BS operating in Band n46, n96 or n102.
E-UTRA Band 47	5855 – 5925 MHz	-52 dBm	1 MHz	
E-UTRA Band 48 or NR Band n48	3550 – 3700 MHz	-52 dBm	1 MHz	This is not applicable to BS operating in Band n48, n77 or n78.
E-UTRA Band 50 or NR band n50	1432 – 1517 MHz	-52 dBm	1 MHz	This requirement does not apply to BS operating in Band n50, n51, n74, n75, n76, n91, n92, n93 or n94.
E-UTRA Band 51 or NR Band n51	1427 – 1432 MHz	-52 dBm	1 MHz	This requirement does not apply to BS operating in Band n50, n51, n75, n76, n91, n92, n93 or n94.
E-UTRA Band 53 or NR Band n53	2483.5 - 2495 MHz	-52 dBm	1 MHz	This requirement does not apply to BS operating in Band n41, n53 or n90.
E-UTRA Band 65 or NR Band n65	2110 – 2200 MHz	-52 dBm	1 MHz	This requirement does not apply to BS operating in band n1 or n65.
	1920 – 2010 MHz	-49 dBm	1 MHz	For BS operating in Band n1, it applies for 1980 MHz to 2010 MHz, while the rest is covered in clause 6.6.5.2.2. This requirement does not apply to BS operating in band n65, since it is already covered by the requirement in clause 6.6.5.2.2.
E-UTRA Band 66 or NR Band n66	2110 – 2200 MHz	-52 dBm	1 MHz	This requirement does not apply to BS operating in band n66.
	1710 – 1780 MHz	-49 dBm	1 MHz	This requirement does not apply to BS operating in band n66, since it is already covered by the requirement in clause 6.6.5.2.2.
E-UTRA Band 67 or NR Band n67	738 – 758 MHz	-52 dBm	1 MHz	This requirement does not apply to BS operating in Band n28 or n67.
E-UTRA Band 68	753 - 783 MHz	-52 dBm	1 MHz	This requirement does not apply to BS operating in band n28.
	698-728 MHz	-49 dBm	1 MHz	For BS operating in Band n28, this requirement applies between 698 MHz and 703 MHz, while the rest is covered in clause 6.6.5.2.2.
E-UTRA Band 69	2570 – 2620 MHz	-52 dBm	1 MHz	This requirement does not apply to BS operating in Band n38.
E-UTRA Band 70 or	1995 – 2020 MHz	-52 dBm	1 MHz	This requirement does not apply to BS operating in band n2, n25 or n70

System type for NR to co-exist with	Frequency range for co-existence requirement	Basic limits	Measurement bandwidth	Note
NR Band n70	1695 – 1710 MHz	-49 dBm	1 MHz	This requirement does not apply to BS operating in band n70, since it is already covered by the requirement in clause 6.6.5.2.2.
E-UTRA Band 71 or NR Band n71	617 – 652 MHz	-52 dBm	1 MHz	This requirement does not apply to BS operating in band n71
	663 – 698 MHz	-49 dBm	1 MHz	This requirement does not apply to BS operating in band n71, since it is already covered by the requirement in clause 6.6.5.2.2.
E-UTRA Band 72	461 – 466 MHz	-52 dBm	1 MHz	
	451 – 456 MHz	-49 dBm	1 MHz	
E-UTRA Band 74 or NR Band n74	1475 – 1518 MHz	-52 dBm	1 MHz	This requirement does not apply to BS operating in band n50, n74, n75, n92 or n94.
	1427 – 1470 MHz	-49 dBm	1 MHz	This requirement does not apply to BS operating in band n50, n51, n74, n75, n76, n91, n92, n93 or n94.
E-UTRA Band 75 or NR Band n75	1432 – 1517 MHz	-52 dBm	1 MHz	This requirement does not apply to BS operating in Band n50, n51, n74, n75, n76, n91, n92, n93 or n94.
E-UTRA Band 76 or NR Band n76	1427 – 1432 MHz	-52 dBm	1 MHz	This requirement does not apply to BS operating in Band n50, n51, n75, n76, n91, n92, n93 or n94.
NR Band n77	3.3 – 4.2 GHz	-52 dBm	1 MHz	This requirement does not apply to BS operating in Band n48, n77 or n78
NR Band n78	3.3 – 3.8 GHz	-52 dBm	1 MHz	This requirement does not apply to BS operating in Band n48, n77 or n78
NR Band n79	4.4 – 5.0 GHz	-52 dBm	1 MHz	This requirement does not apply to BS operating in Band n79
NR Band n80	1710 – 1785 MHz	-49 dBm	1 MHz	This requirement does not apply to BS operating in band n3, since it is already covered by the requirement in clause 6.6.5.2.2.
NR Band n81	880 – 915 MHz	-49 dBm	1 MHz	This requirement does not apply to BS operating in band n8, since it is already covered by the requirement in clause 6.6.5.2.2.
NR Band n82	832 – 862 MHz	-49 dBm	1 MHz	This requirement does not apply to BS operating in band n20, since it is already covered by the requirement in clause 6.6.5.2.2.
NR Band n83	703 – 748 MHz	-49 dBm	1 MHz	This requirement does not apply to BS operating in band n28, since it is already covered by the requirement in clause 6.6.5.2.2. For BS operating in Band n67, it applies for 703 MHz to 736 MHz.
NR Band n84	1920 – 1980 MHz	-49 dBm	1 MHz	This requirement does not apply to BS operating in band n1, since it is already covered by the requirement in clause 6.6.5.2.2.
E-UTRA Band 85 or NR Band n85	728 – 746 MHz	-52 dBm	1 MHz	This requirement does not apply to BS operating in band n12 or n85. For NR BS operating in n29, it applies 1 MHz below the Band n29 downlink operating band (Note 5).
	698 – 716 MHz	-49 dBm	1 MHz	This requirement does not apply to BS operating in band n12 or n85, since it is already covered by the requirement in clause 6.6.5.2.2.
NR Band n86	1710 – 1780 MHz	-49 dBm	1 MHz	This requirement does not apply to BS operating in band n66, since it is already covered by the requirement in clause 6.6.5.2.2.
NR Band n89	824 – 849 MHz	-49 dBm	1 MHz	This requirement does not apply to BS operating in band n5, since it is already covered by the requirement in clause 6.6.5.2.2.
NR Band n91	1427 – 1432 MHz	-52 dBm	1 MHz	This requirement does not apply to BS operating in Band n50, n51, n75 or n76.
	832 – 862 MHz	-49 dBm	1 MHz	This requirement does not apply to BS operating in band n20, since it is already covered by the requirement in clause 6.6.5.2.2.

System type for NR to co-exist with	Frequency range for co-existence requirement	Basic limits	Measurement bandwidth	Note
NR Band n92	1432 – 1517 MHz	-52 dBm	1 MHz	This requirement does not apply to BS operating in Band n50, n51, n74, n75 or n76.
	832 – 862 MHz	-49 dBm	1 MHz	This requirement does not apply to BS operating in band n20, since it is already covered by the requirement in clause 6.6.5.2.2.
NR Band n93	1427 – 1432 MHz	-52 dBm	1 MHz	This requirement does not apply to BS operating in Band n50, n51, n75 or n76.
	880 – 915 MHz	-49 dBm	1 MHz	This requirement does not apply to BS operating in band n8, since it is already covered by the requirement in clause 6.6.5.2.2.
NR Band n94	1432 – 1517 MHz	-52 dBm	1 MHz	This requirement does not apply to BS operating in Band n50, n51, n74, n75 or n76.
	880 – 915 MHz	-49 dBm	1 MHz	This requirement does not apply to BS operating in band n8, since it is already covered by the requirement in clause 6.6.5.2.2.
NR Band n95	2010 – 2025 MHz	-52 dBm	1 MHz	
NR Band n96	5925 – 7125 MHz	-52 dBm	1 MHz	This requirement does not apply to BS operating in Band n46, n96, n102 or n104.
NR Band n97	2300 – 2400MHz	-52 dBm	1 MHz	
NR Band n98	1880 – 1920MHz	-52 dBm	1 MHz	
NR Band n99	1626.5 – 1660.5 MHz	-49 dBm	1 MHz	This requirement does not apply to BS operating in band n24, since it is already covered by the requirement in clause 6.6.5.2.2.
NR band n100	919.4 – 925 MHz	-52 dBm	1 MHz	This requirement does not apply to BS operating in Band n8 or n100.
	874.4 – 880 MHz	-49 dBm	1 MHz	This requirement does not apply to BS operating in band n100, since it is already covered by the requirement in clause 6.6.5.2.2.
NR band n101	1900 – 1910 MHz	-52 dBm	1 MHz	This requirement does not apply to BS operating in Band n101.
NR Band n102	5925 – 6425 MHz	-52 dBm	1 MHz	This requirement does not apply to BS operating in Band n46, n96, n102 or n104.
E-UTRA Band 103	757 – 758 MHz	-52 dBm	1 MHz	
	787 – 788 MHz	-49 dBm	1 MHz	
NR Band n104	6425 – 7125 MHz	-52 dBm	1 MHz	This requirement does not apply to BS operating in Band n96, n102 or n104

NOTE 1: As defined in the scope for spurious emissions in this clause, except for the cases where the noted requirements apply to a BS operating in Band n28, the co-existence requirements in table 6.6.5.2.3 -1 do not apply for the Δf_{OBUE} frequency range immediately outside the downlink *operating band* (see table 5.2-1). Emission limits for this excluded frequency range may be covered by local or regional requirements.

NOTE 2: Table 6.6.5.2.3 -1 assumes that two *operating bands*, where the frequency ranges in table 5.2-1 would be overlapping, are not deployed in the same geographical area. For such a case of operation with overlapping frequency arrangements in the same geographical area, special co-existence requirements may apply that are not covered by the 3GPP specifications.

NOTE 3: TDD base stations deployed in the same geographical area, that are synchronized and use the same or adjacent *operating bands* can transmit without additional co-existence requirements. For unsynchronized base stations, special co-existence requirements may apply that are not covered by the 3GPP specifications.

NOTE 4: For NR Band n28 BS, specific solutions may be required to fulfil the spurious emissions limits for BS for co-existence with E-UTRA Band 27 UL *operating band*.

NOTE 5: For NR Band n29 BS, specific solutions may be required to fulfil the spurious emissions limits for NR BS for co-existence with UTRA Band XII, E-UTRA Band 12 or NR Band n12 UL operating band, E-UTRA Band 17 UL operating band or E-UTRA Band 85 UL or NR Band n85 UL operating band.

The following requirement may be applied for the protection of PHS. This requirement is also applicable at specified frequencies falling between Δf_{OBUE} below the lowest BS transmitter frequency of the downlink *operating band* and Δf_{OBUE} above the highest BS transmitter frequency of the downlink *operating band*. Δf_{OBUE} is defined in clause 6.6.1.

The spurious emission *basic limit* for this requirement is:

Table 6.6.5.2.3-2: BS spurious emissions *basic limits* for BS for co-existence with PHS

Frequency range	Basic limit	Measurement Bandwidth	Note
1884.5 – 1915.7 MHz	-41 dBm	300 kHz	Applicable when co-existence with PHS system operating in 1884.5 – 1915.7 MHz

Table 6.6.5.2.3-3: Void

In certain regions, the following requirement may apply to NR BS operating in Band n50 and n75 within the 1432 – 1452 MHz, and in Band n51 and Band n76. The *basic limit* is specified in Table 6.6.5.2.3-4. This requirement is also applicable at the frequency range from Δf_{OBUE} below the lowest frequency of the BS downlink *operating band* up to Δf_{OBUE} above the highest frequency of the BS downlink *operating band*.

Table 6.6.5.2.3-4: Additional operating band unwanted emission *basic limit* for NR BS operating in Band n50 and n75 within 1432 – 1452 MHz, and in Band n51 and n76

Filter centre frequency, F_{filter}	Basic limit	Measurement Bandwidth
$F_{\text{filter}} = 1413.5$ MHz	-42 dBm	27 MHz

In certain regions, the following requirement may apply to BS operating in NR Band n50 and n75 within 1492-1517 MHz and in Band n74 within 1492-1518 MHz. The maximum level of emissions, measured on centre frequencies F_{filter} with filter bandwidth according to Table 6.6.5.2.3-5, shall be defined according to the *basic limits* $P_{\text{EM},n50/n75,a}$ nor $P_{\text{EM},n50/n75,b}$ declared by the manufacturer.

Table 6.6.5.2.3-5: Operating band n50, n74 and n75 declared emission above 1518 MHz

Filter centre frequency, F_{filter}	Declared <i>basic limits</i> (dBm)	Measurement bandwidth
$1518.5 \text{ MHz} \leq F_{\text{filter}} \leq 1519.5 \text{ MHz}$	$P_{\text{EM},n50/n75,a}$	1 MHz
$1520.5 \text{ MHz} \leq F_{\text{filter}} \leq 1558.5 \text{ MHz}$	$P_{\text{EM},n50/n75,b}$	1 MHz

In certain regions, the following requirement shall be applied to BS operating in Band n13 and n14 to ensure that appropriate interference protection is provided to 700 MHz public safety operations. This requirement is also applicable at the frequency range from 10 MHz below the lowest frequency of the BS downlink operating band up to 10 MHz above the highest frequency of the BS downlink operating band.

The power of any spurious emission shall not exceed:

Table 6.6.5.2.3-6: BS Spurious emissions limits for protection of 700 MHz public safety operations

Operating Band	Frequency range	Basic limit	Measurement Bandwidth
n13	763 - 775 MHz	-46 dBm	6.25 kHz
n13	793 - 805 MHz	-46 dBm	6.25 kHz
n14	769 - 775 MHz	-46 dBm	6.25 kHz
n14	799 - 805 MHz	-46 dBm	6.25 kHz

In certain regions, the following requirement may apply to NR BS operating in Band n30. This requirement is also applicable at the frequency range from 10 MHz below the lowest frequency of the BS downlink operating band up to 10 MHz above the highest frequency of the BS downlink operating band.

The power of any spurious emission shall not exceed:

Table 6.6.5.2.3-7: Additional NR BS Spurious emissions limits for Band n30

Frequency range	Basic limit	Measurement Bandwidth	Note
2200 – 2345 MHz	-45 dBm	1 MHz	
2362.5 – 2365 MHz	-25 dBm	1 MHz	
2365 – 2367.5 MHz	-40 dBm	1 MHz	
2367.5 – 2370 MHz	-42 dBm	1 MHz	
2370 – 2395 MHz	-45 dBm	1 MHz	

The following requirement may apply to BS operating in Band n48 in certain regions. The power of any spurious emission shall not exceed:

Table 6.6.5.2.3-8: Additional BS Spurious emissions limits for Band n48

Frequency range	Basic limit	Measurement Bandwidth (NOTE 1)	Note
3530 MHz – 3720 MHz	-25 dBm	1 MHz	Applicable 10 MHz from the assigned <i>channel edge</i>
3100 MHz – 3530 MHz 3720 MHz – 4200 MHz	-40 dBm	1 MHz	

NOTE 1: The resolution bandwidth of the measuring equipment should be equal to the measurement bandwidth. However, to improve measurement accuracy, sensitivity and efficiency, the resolution bandwidth may be smaller than the measurement bandwidth. When the resolution bandwidth is smaller than the measurement bandwidth, the result should be integrated over the measurement bandwidth in order to obtain the equivalent noise bandwidth of the measurement bandwidth.

NOTE 2: The regional requirement, included in [12], is defined in terms of EIRP, which is dependent on both the BS emissions at the *antenna connector* and the deployment (including antenna gain and feeder loss). The requirement defined above provides the characteristics of the base station needed to verify compliance with the regional requirement. The assessment of the EIRP level is described in Annex F.

The following requirement shall be applied to BS operating in Band n26 to ensure that appropriate interference protection is provided to 800 MHz public safety operations. This requirement is also applicable at the frequency range from 10 MHz below the lowest frequency of the BS downlink operating band up to 10 MHz above the highest frequency of the BS downlink operating band.

The power of any spurious emission shall not exceed:

Table 6.6.5.2.3-9: BS Spurious emissions limits for protection of 800 MHz public safety operations

Operating Band	Frequency range	Basic limit	Measurement Bandwidth	Note
n26	851 - 859 MHz	-13 dBm	100 kHz	Applicable for offsets > 37.5kHz from the channel edge

The following requirement may apply to BS for Band n41 and n90 operation in Japan. This requirement is also applicable at the frequency range from Δf_{OBUE} below the lowest frequency of the BS downlink operating band up to Δf_{OBUE} above the highest frequency of the BS downlink operating band.

The power of any spurious emission shall not exceed:

Table 6.6.5.2.3-10: Additional BS Spurious emissions limits for Band n41 and n90

Frequency range	Basic limit	Measurement Bandwidth
2505 MHz – 2535 MHz	-42 dBm	1 MHz
NOTE: This requirement applies for carriers allocated within 2545-2645 MHz.		

The following requirement may apply to BS operating in 3.45-3.55 GHz in Band n77 in certain regions. The power of any spurious emission shall not exceed:

Table 6.6.5.2.3-11: Additional BS spurious emissions limits for Band n77

Channel bandwidth [MHz]	Frequency range [MHz]	Filter centre frequency, F_{filter} [MHz]	Basic limit [dBm]	Measurement bandwidth [MHz]
All	3430 – 3440 3560 – 3570	$3430.5 \leq F_{\text{filter}} < 3439.5$ $3560.5 \leq F_{\text{filter}} < 3569.5$	-25	1
All	≤ 3430 > 3570	$F_{\text{filter}} < 3429.5$ $3570.5 \leq F_{\text{filter}}$	-40	1

NOTE: The resolution bandwidth of the measuring equipment should be equal to the measurement bandwidth. However, to improve measurement accuracy, sensitivity and efficiency, the resolution bandwidth may be smaller than the measurement bandwidth. When the resolution bandwidth is smaller than the measurement bandwidth, the result should be integrated over the measurement bandwidth in order to obtain the equivalent noise bandwidth of the measurement bandwidth.

The following requirement shall apply to BS operating in Band n101 in CEPT countries. The power of any spurious emission shall not exceed:

Table 6.6.5.2.3-12: Additional BS Spurious emissions limits for Band n101

Frequency range	Maximum Level	Measurement Bandwidth	Note
1920 MHz – 1980 MHz	-57 dBm	5 MHz	This limit is derived from ECC Decision(20)02 [21] assuming a 18 dBi maximum antenna gain and 4 dB losses, and assuming one antenna connector. For more details on the maximum level derivation, refer to TR 38.852 [23]

The following requirement shall apply to BS operating in Band n100 in CEPT countries. The power of any spurious emission shall not exceed:

Table 6.6.5.2.3-13: Additional BS Spurious emissions limits for Band n100

Frequency range	Maximum Level	Measurement Bandwidth	Note
880 MHz – 915 MHz	-62 dBm	5 MHz	This limit is derived from ECC Decision(20)02 [21] assuming a 17 dBi maximum antenna gain and 4 dB losses, and assuming one antenna connector. For more details on the maximum level derivation, refer to TR 38.853 [23].

6.6.5.2.4 Co-location with other base stations

These requirements may be applied for the protection of other BS receivers when GSM900, DCS1800, PCS1900, GSM850, CDMA850, UTRA FDD, UTRA TDD, E-UTRA and/or NR BS are co-located with a BS.

The requirements assume a 30 dB coupling loss between transmitter and receiver and are based on co-location with base stations of the same class.

The *basic limits* are in table 6.6.5.2.4-1 for a BS where requirements for co-location with a BS type listed in the first column apply, depending on the declared Base Station class. For a *multi-band connector*, the exclusions and conditions in the Note column of table 6.6.5.2.4-1 shall apply for each supported *operating band*.

Table 6.6.5.2.4-1: BS spurious emissions *basic limits* for BS co-located with another BS

Type of co-located BS	Frequency range for co-location requirement	Basic limits			Measurement bandwidth	Note
		WA BS	MR BS	LA BS		
GSM900	876 – 915 MHz	-98 dBm	-91 dBm	-70 dBm	100 kHz	
DCS1800	1710 – 1785 MHz	-98 dBm	-91 dBm	-80 dBm	100 kHz	
PCS1900	1850 – 1910 MHz	-98 dBm	-91 dBm	-80 dBm	100 kHz	
GSM850 or CDMA850	824 – 849 MHz	-98 dBm	-91 dBm	-70 dBm	100 kHz	
UTRA FDD Band I or E-UTRA Band 1 or NR Band n1	1920 – 1980 MHz	-96 dBm	-91 dBm	-88 dBm	100 kHz	
UTRA FDD Band II or E-UTRA Band 2 or NR Band n2	1850 – 1910 MHz	-96 dBm	-91 dBm	-88 dBm	100 kHz	
UTRA FDD Band III or E-UTRA Band 3 or NR Band n3	1710 – 1785 MHz	-96 dBm	-91 dBm	-88 dBm	100 kHz	
UTRA FDD Band IV or E-UTRA Band 4	1710 – 1755 MHz	-96 dBm	-91 dBm	-88 dBm	100 kHz	
UTRA FDD Band V or E-UTRA Band 5 or NR Band n5	824 – 849 MHz	-96 dBm	-91 dBm	-88 dBm	100 kHz	
UTRA FDD Band VI, XIX or E-UTRA Band 6, 19	830 – 845 MHz	-96 dBm	-91 dBm	-88 dBm	100 kHz	
UTRA FDD Band VII or E-UTRA Band 7 or NR Band n7	2500 – 2570 MHz	-96 dBm	-91 dBm	-88 dBm	100 kHz	
UTRA FDD Band VIII or E-UTRA Band 8 or NR Band n8	880 – 915 MHz	-96 dBm	-91 dBm	-88 dBm	100 kHz	
UTRA FDD Band IX or E-UTRA Band 9	1749.9 – 1784.9 MHz	-96 dBm	-91 dBm	-88 dBm	100 kHz	
UTRA FDD Band X or E-UTRA Band 10	1710 – 1770 MHz	-96 dBm	-91 dBm	-88 dBm	100 kHz	
UTRA FDD Band XI or E-UTRA Band 11	1427.9 – 1447.9 MHz	-96 dBm	-91 dBm	-88 dBm	100 kHz	This is not applicable to BS operating in Band n50, n75, n91, n92, n93 or n94
UTRA FDD Band XII or E-UTRA Band 12 or NR Band n12	699 – 716 MHz	-96 dBm	-91 dBm	-88 dBm	100 kHz	
UTRA FDD Band XIII or E-UTRA Band 13 or NR Band n13	777 – 787 MHz	-96 dBm	-91 dBm	-88 dBm	100 kHz	
UTRA FDD Band XIV or E-UTRA Band 14 or NR Band n14	788 – 798 MHz	-96 dBm	-91 dBm	-88 dBm	100 kHz	
E-UTRA Band 17	704 – 716 MHz	-96 dBm	-91 dBm	-88 dBm	100 kHz	
E-UTRA Band 18 or NR Band n18	815 – 830 MHz	-96 dBm	-91 dBm	-88 dBm	100 kHz	
UTRA FDD Band XX or E-UTRA Band 20 or NR Band n20	832 – 862 MHz	-96 dBm	-91 dBm	-88 dBm	100 kHz	
UTRA FDD Band XXI or E-UTRA Band 21	1447.9 – 1462.9 MHz	-96 dBm	-91 dBm	-88 dBm	100 kHz	This is not applicable to BS operating in Band n50, n75, n92 or n94

UTRA FDD Band XXII or E-UTRA Band 22	3410 – 3490 MHz	-96 dBm	-91 dBm	-88 dBm	100 kHz	This is not applicable to BS operating in Band n48, n77 or n78
E-UTRA Band 24 or NR Band n24	1626.5 – 1660.5 MHz	-96 dBm	-91 dBm	-88 dBm	100 kHz	
UTRA FDD Band XXV or E-UTRA Band 25 or NR Band n25	1850 – 1915 MHz	-96 dBm	-91 dBm	-88 dBm	100 kHz	
UTRA FDD Band XXVI or E-UTRA Band 26 or NR Band n26	814 – 849 MHz	-96 dBm	-91 dBm	-88 dBm	100 kHz	
E-UTRA Band 27	807 – 824 MHz	-96 dBm	-91 dBm	-88 dBm	100 kHz	
E-UTRA Band 28 or NR Band n28	703 – 748 MHz	-96 dBm	-91 dBm	-88 dBm	100 kHz	
E-UTRA Band 30 or NR Band n30	2305 – 2315 MHz	-96 dBm	-91 dBm	-88 dBm	100 kHz	
E-UTRA Band 31	452.5 – 457.5 MHz	-96 dBm	-91 dBm	-88 dBm	100 kHz	
UTRA TDD Band a) or E-UTRA Band 33	1900 – 1920 MHz	-96 dBm	-91 dBm	-88 dBm	100 kHz	
UTRA TDD Band a) or E-UTRA Band 34 or NR band n34	2010 – 2025 MHz	-96 dBm	-91 dBm	-88 dBm	100 kHz	This is not applicable to BS operating in Band n34
UTRA TDD Band b) or E-UTRA Band 35	1850 – 1910 MHz	-96 dBm	-91 dBm	-88 dBm	100 kHz	
UTRA TDD Band b) or E-UTRA Band 36	1930 – 1990 MHz	-96 dBm	-91 dBm	-88 dBm	100 kHz	This is not applicable to BS operating in Band n2 or band n25
UTRA TDD Band c) or E-UTRA Band 37	1910 – 1930 MHz	-96 dBm	-91 dBm	-88 dBm	100 kHz	
UTRA TDD Band d) or E-UTRA Band 38 or NR Band n38	2570 – 2620 MHz	-96 dBm	-91 dBm	-88 dBm	100 kHz	This is not applicable to BS operating in Band n38.
UTRA TDD Band f) or E-UTRA Band 39 or NR band n39	1880 – 1920MHz	-96 dBm	-91 dBm	-88 dBm	100 kHz	This is not applicable to BS operating in Band n39
UTRA TDD Band e) or E-UTRA Band 40 or NR Band n40	2300 – 2400MHz	-96 dBm	-91 dBm	-88 dBm	100 kHz	This is not applicable to BS operating in Band n30 or n40.
E-UTRA Band 41 or NR Band n41, n90	2496 – 2690 MHz	-96 dBm	-91 dBm	-88 dBm	100 kHz	This is not applicable to BS operating in Band n41, n53 or [n90]
E-UTRA Band 42	3400 – 3600 MHz	-96 dBm	-91 dBm	-88 dBm	100 kHz	This is not applicable to BS operating in Band n48, n77 or n78
E-UTRA Band 43	3600 – 3800 MHz	-96 dBm	-91 dBm	-88 dBm	100 kHz	This is not applicable to BS operating in Band n48, n77 or n78
E-UTRA Band 44	703 – 803 MHz	-96 dBm	-91 dBm	-88 dBm	100 kHz	This is not applicable to BS operating in Band n28

E-UTRA Band 45	1447 – 1467 MHz	-96 dBm	-91 dBm	-88 dBm	100 kHz	
E-UTRA Band 46 or NR Band n46	5150 – 5925 MHz	N/A	-91 dBm	-88 dBm	100 kHz	This is not applicable to BS operating in Band n46, n96 or n102
E-UTRA Band 48 or NR Band n48	3550 – 3700 MHz	-96 dBm	-91 dBm	-88 dBm	100 kHz	This is not applicable to BS operating in Band n48, n77 or n78
E-UTRA Band 50 or NR Band n50	1432 – 1517 MHz	-96 dBm	-91 dBm	-88 dBm	100 kHz	This is not applicable to BS operating in Band n51, n74, n75, n91, n92, n93 or n94
E-UTRA Band 51 or NR Band n51	1427 – 1432 MHz	N/A	N/A	-88 dBm	100 kHz	This is not applicable to BS operating in Band n50, n74, n75, n76, n91, n92, n93 or n94
E-UTRA Band 53 or NR Band n53	2483.5 – 2495 MHz	N/A	-91 dBm	-88 dBm	100 kHz	This is not applicable to BS operating in Band n41, n53 or n90
E-UTRA Band 65 or NR Band n65	1920 – 2010 MHz	-96 dBm	-91 dBm	-88 dBm	100 kHz	
E-UTRA Band 66 or NR Band n66	1710 – 1780 MHz	-96 dBm	-91 dBm	-88 dBm	100 kHz	
E-UTRA Band 68	698 – 728 MHz	-96 dBm	-91 dBm	-88 dBm	100 kHz	
E-UTRA Band 70 or NR Band n70	1695 – 1710 MHz	-96 dBm	-91 dBm	-88 dBm	100 kHz	
E-UTRA Band 71 or NR Band n71	663 – 698 MHz	-96 dBm	-91 dBm	-88 dBm	100 kHz	
E-UTRA Band 72	451 – 456 MHz	-96 dBm	-91 dBm	-88 dBm	100 kHz	
E-UTRA Band 74 or NR Band n74	1427 – 1470 MHz	-96 dBm	-91 dBm	-88 dBm	100 kHz	This is not applicable to BS operating in Band n50, n51, n91, n92, n93 or n94
NR Band n77	3.3 – 4.2 GHz	-96 dBm	-91 dBm	-88 dBm	100 kHz	This is not applicable to BS operating in Band n48, n77 or n78
NR Band n78	3.3 – 3.8 GHz	-96 dBm	-91 dBm	-88 dBm	100 kHz	This is not applicable to BS operating in Band n48, n77 or n78
NR Band n79	4.4 – 5.0 GHz	-96 dBm	-91 dBm	-88 dBm	100 kHz	
NR Band n80	1710 – 1785 MHz	-96 dBm	-91 dBm	-88 dBm	100 kHz	
NR Band n81	880 – 915 MHz	-96 dBm	-91 dBm	-88 dBm	100 kHz	
NR Band n82	832 – 862 MHz	-96 dBm	-91 dBm	-88 dBm	100 kHz	
NR Band n83	703 – 748 MHz	-96 dBm	-91 dBm	-88 dBm	100 kHz	

NR Band n84	1920 – 1980 MHz	-96 dBm	-91 dBm	-88 dBm	100 kHz	
E-UTRA Band 85 or NR Band 85	698 – 716 MHz	-96 dBm	-91 dBm	-88 dBm	100 kHz	
NR Band n86	1710 – 1780 MHz	-96 dBm	-91 dBm	-88 dBm	100 kHz	
NR Band n89	824 – 849 MHz	-96 dBm	-91 dBm	-88 dBm	100 kHz	
NR Band n91	832 – 862 MHz	N/A	N/A	-88 dBm	100 kHz	
NR Band n92	832 – 862 MHz	-96 dBm	-91 dBm	-88 dBm	100 kHz	
NR Band n93	880 – 915 MHz	N/A	N/A	-88 dBm	100 kHz	
NR Band n94	880 – 915 MHz	-96 dBm	-91 dBm	-88 dBm	100 kHz	
NR Band n95	2010 – 2025 MHz	-96 dBm	-91 dBm	-88 dBm	100 kHz	
NR Band n96	5925 – 7125 MHz	N/A	-90 dBm	-87 dBm	100 kHz	This is not applicable to BS operating in Band n46, n96, n102 or n104
NR Band n97	2300 – 2400MHz	-96 dBm	-91 dBm	-88 dBm	100 kHz	
NR Band n98	1880 – 1920MHz	-96 dBm	-91 dBm	-88 dBm	100 kHz	
NR Band n99	1626.5 – 1660.5 MHz	-96 dBm	-91 dBm	-88 dBm	100 kHz	
NR Band n100	874.4 – 880 MHz	-96 dBm	NA	NA	100 kHz	
NR Band n101	1900 – 1910 MHz	-96 dBm	NA	NA	100 kHz	
NR Band n102	5925 – 6425 MHz	N/A	-90 dBm	-87 dBm	100 kHz	This is not applicable to BS operating in Band n46, n96, n102 or n104
E-UTRA Band 103	787 – 788 MHz	-96 dBm	-91 dBm	-88 dBm	100 kHz	
NR Band n104	6425 – 7125 MHz	-95 dBm	-90 dBm	-87 dBm	100 kHz	This requirement does not apply to BS operating in Band n96, n102 or n104.

NOTE 1: As defined in the scope for spurious emissions in this clause, the co-location requirements in table 6.6.5.2.4-1 do not apply for the frequency range extending Δf_{OBUE} immediately outside the BS transmit frequency range of a downlink *operating band* (see table 5.2-1). The current state-of-the-art technology does not allow a single generic solution for co-location with other system on adjacent frequencies for 30dB BS-BS minimum coupling loss. However, there are certain site-engineering solutions that can be used. These techniques are addressed in TR 25.942 [4].

NOTE 2: Table 6.6.5.2.4-1 assumes that two *operating bands*, where the corresponding BS transmit and receive frequency ranges in table 5.2-1 would be overlapping, are not deployed in the same geographical area. For such a case of operation with overlapping frequency arrangements in the same geographical area, special co-location requirements may apply that are not covered by the 3GPP specifications.

NOTE 3: Co-located TDD base stations that are synchronized and using the same or adjacent *operating band* can transmit without special co-locations requirements. For unsynchronized base stations, special co-location requirements may apply that are not covered by the 3GPP specifications.

6.6.5.3 Minimum requirements for *BS type 1-C*

The Tx spurious emissions for *BS type 1-C* for each *antenna connector* shall not exceed the *basic limits* specified in clause 6.6.5.2.

For Band n41 and n90 operation in Japan, the sum of the spurious emissions over all *antenna connectors* for *BS type 1-C* shall not exceed the *basic limits* defined in clause 6.6.5.2.

6.6.5.4 Minimum requirements for *BS type 1-H*

The Tx spurious emissions requirements for *BS type 1-H* are that for each *TAB connector TX min cell group* and each applicable *basic limit* in clause 6.6.5.2, the power summation emissions at the *TAB connectors* of the *TAB connectors* of the *TAB connector TX min cell group* shall not exceed a limit specified as the *basic limit* + X, where $X = 10\log_{10}(N_{\text{TXU, counted per cell}})$, unless stated differently in regional regulation.

NOTE: Conformance to the *BS type 1-H* spurious emission requirement can be demonstrated by meeting at least one of the following criteria as determined by the manufacturer:

- 1) The sum of the emissions power measured on each *TAB connector* in the *TAB connector TX min cell group* shall be less than or equal to the limit as defined in this clause for the respective frequency span.
- Or
- 2) The unwanted emissions power at each *TAB connector* shall be less than or equal to the *BS type 1-H* limit as defined in this clause for the respective frequency span, scaled by $-10\log_{10}(n)$, where n is the number of *TAB connectors* in the *TAB connector TX min cell group*.

6.7 Transmitter intermodulation

6.7.1 General

The transmitter intermodulation requirement is a measure of the capability of the transmitter unit to inhibit the generation of signals in its non-linear elements caused by presence of the wanted signal and an interfering signal reaching the transmitter unit via the antenna, RDN and antenna array. The requirement shall apply during the *transmitter ON period* and the *transmitter transient period*.

For *BS type 1-C*, the transmitter intermodulation level is the power of the intermodulation products when an interfering signal is injected into the *antenna connector*.

For *BS type 1-H*, the transmitter intermodulation level is the power of the intermodulation products when an interfering signal is injected into the *TAB connector*.

For *BS type 1-H*, there are two types of transmitter intermodulation cases captured by the transmitter intermodulation requirement:

- 1) Co-location transmitter intermodulation in which the interfering signal is from a co-located base station.
- 2) Intra-system transmitter intermodulation in which the interfering signal is from other transmitter units within the *BS type 1-H*.

For *BS type 1-H*, the co-location transmitter intermodulation requirement is considered sufficient if the interference signal for the co-location requirement is higher than the declared interference signal for intra-system transmitter intermodulation requirement.

6.7.2 Minimum requirements for *BS type 1-C*

6.7.2.1 Co-location minimum requirements

For *BS type 1-C*, the wanted signal and interfering signal centre frequency is specified in table 6.7.2.1-1, where interfering signal level is *Rated total output power* ($P_{\text{rated,t,AC}}$) at *antenna connector* in the *operating band* – 30 dB.

The requirement is applicable outside the *Base Station RF Bandwidth* or *Radio Bandwidth*. The interfering signal offset is defined relative to the *Base Station RF Bandwidth edges* or *Radio Bandwidth edges*.

For a BS operating in *non-contiguous spectrum*, the requirement is also applicable inside a *sub-block gap* for interfering signal offsets where the interfering signal falls completely within the *sub-block gap*. The interfering signal offset is defined relative to the *sub-block edges*.

For a *multi-band connector*, the requirement shall apply relative to the *Base Station RF Bandwidth edges* of each supported *operating band*. In case the *Inter RF Bandwidth gap* is less than $3 \cdot BW_{\text{Channel}}$ (where BW_{Channel} is the minimal *BS channel bandwidth* of the band), the requirement in the gap shall apply only for interfering signal offsets where the interfering signal falls completely within the *Inter RF Bandwidth gap*.

The transmitter intermodulation level shall not exceed the unwanted emission limits in clauses 6.6.3, 6.6.4 and 6.6.5 in the presence of an NR interfering signal according to table 6.7.2.1-1.

Table 6.7.2.1-1: Interfering and wanted signals for the co-location transmitter intermodulation requirement

Parameter	Value
Wanted signal type	NR single carrier, or multi-carrier, or multiple intra-band contiguously or non-contiguously aggregated carriers, with NB-IoT operation in NR in-band if supported.
Interfering signal type	NR signal, the minimum <i>BS channel bandwidth</i> (BW_{Channel}) with 15 kHz SCS of the band defined in clause 5.3.5.
Interfering signal level	<i>Rated total output power</i> ($P_{\text{rated,t,AC}}$) in the <i>operating band</i> – 30 dB
Interfering signal centre frequency offset from the lower/upper edge of the wanted signal or edge of <i>sub-block</i> inside a <i>sub-block gap</i>	$f_{\text{offset}} = \pm BW_{\text{Channel}} \left(n - \frac{1}{2} \right)$, for $n=1, 2$ and 3
NOTE 1: Interfering signal positions that are partially or completely outside of any downlink <i>operating band</i> of the base station are excluded from the requirement, unless the interfering signal positions fall within the frequency range of adjacent downlink <i>operating bands</i> in the same geographical area. In case that none of the interfering signal positions fall completely within the frequency range of the downlink <i>operating band</i> , TS 38.141-1 [5] provides further guidance regarding appropriate test requirements.	
NOTE 2: In Japan, NOTE 1 is not applied in Band n77, n78, n79.	

6.7.2.2 Additional requirements

For Band n41 and n90 operation in Japan, the sum of transmitter intermodulation level over all *antenna connectors* shall not exceed the unwanted emission limits in clauses 6.6.3, 6.6.4 and 6.6.5 in the presence of an NR interfering signal according to table 6.7.2.2-1.

Table 6.7.2.2-1 Interfering and wanted signals for the additional transmitter intermodulation requirement for Band n41 and n90

Parameter	Value
Wanted signal	NR single carrier (NOTE)
Interfering signal type	NR signal of 10 MHz <i>channel bandwidth</i>
Interfering signal level	Rated total output power in the operating band – 30 dB
Interfering signal centre frequency offset from the lower (upper) edge of the wanted signal	± 5 MHz ± 15 MHz ± 25 MHz
NOTE: This requirement applies for NR carriers allocated within 2545-2645 MHz.	

Table 6.7.2.2-2: Void

For Band n79 operation in Japan, the transmitter intermodulation level shall not exceed the unwanted emission limits in clauses 6.6.3, 6.6.4 and 6.6.5 in the presence of an NR interfering signal according to table 6.7.2.2-3.

Table 6.7.2-3: Interfering and wanted signals for the additional transmitter intermodulation requirement for Band n79

Parameter	Value
Wanted signal	NR single carrier
Interfering signal type	NR signal of 40 MHz <i>channel bandwidth</i>
Interfering signal level	Rated total output power in the operating band – 30 dB
Interfering signal centre frequency offset from the lower/upper edge of the wanted signal	± 20 MHz ± 60 MHz ± 100 MHz

6.7.3 Minimum requirements for *BS type 1-H*

6.7.3.1 Co-location minimum requirements

The transmitter intermodulation level shall not exceed the unwanted emission limits in clauses 6.6.3, 6.6.4 and 6.6.5 in the presence of an NR interfering signal according to table 6.7.3.1-1

The requirement is applicable outside the *Base Station RF Bandwidth edges*. The interfering signal offset is defined relative to the *Base Station RF Bandwidth edges* or *Radio Bandwidth edges*.

For *TAB connectors* supporting operation in *non-contiguous spectrum*, the requirement is also applicable inside a *sub-block gap* for interfering signal offsets where the interfering signal falls completely within the *sub-block gap*. The interfering signal offset is defined relative to the *sub-block edges*.

For *multi-band connector*, the requirement shall apply relative to the *Base Station RF Bandwidth edges* of each *operating band*. In case the *inter RF Bandwidth gap* is less than $3 \cdot BW_{\text{Channel}}$ (where BW_{Channel} is the minimal *BS channel bandwidth* of the band), the requirement in the gap shall apply only for interfering signal offsets where the interfering signal falls completely within the *inter RF Bandwidth gap*.

Table 6.7.3.1-1: Interfering and wanted signals for the co-location transmitter intermodulation requirement

Parameter	Value
Wanted signal type	NR single carrier, or multi-carrier, or multiple intra-band contiguously or non-contiguously aggregated carriers
Interfering signal type	NR signal, the minimum <i>BS channel bandwidth</i> (BW_{Channel}) with 15 kHz SCS of the band defined in clause 5.3.5.
Interfering signal level	<i>Rated total output power per TAB connector</i> ($P_{\text{rated,t,TABC}}$) in the <i>operating band</i> – 30 dB
Interfering signal centre frequency offset from the lower/upper edge of the wanted signal or edge of <i>sub-block</i> inside a gap	$f_{\text{offset}} = \pm BW_{\text{Channel}} \left(n - \frac{1}{2} \right)$, for $n=1, 2$ and 3
NOTE 1: Interfering signal positions that are partially or completely outside of any downlink <i>operating band</i> of the <i>TAB connector</i> are excluded from the requirement, unless the interfering signal positions fall within the frequency range of adjacent downlink <i>operating bands</i> in the same geographical area. In case that none of the interfering signal positions fall completely within the frequency range of the downlink <i>operating band</i> , TS 38.141-1 [5] provides further guidance regarding appropriate test requirements.	
NOTE 2: In Japan, NOTE 1 is not applied in Band n77, n78, n79.	

6.7.3.2 Intra-system minimum requirements

The transmitter intermodulation level shall not exceed the unwanted emission limits in clauses 6.6.3 and 6.6.4 in the presence of an NR interfering signal according to table 6.7.3.2-1.

Table 6.7.3.2-1: Interfering and wanted signals for intra-system transmitter intermodulation requirement

Parameter	Value
Wanted signal type	NR signal
Interfering signal type	NR signal of the same <i>BS channel bandwidth</i> and SCS as the wanted signal (Note 1).
Interfering signal level	Power level declared by the base station manufacturer (Note 2).
Frequency offset between interfering signal and wanted signal	0 MHz
NOTE 1: The interfering signal shall be incoherent with the wanted signal.	
NOTE 2: The declared interfering signal power level at each <i>TAB connector</i> is the sum of the co-channel leakage power coupled via the combined RDN and Antenna Array from all the other <i>TAB connectors</i> , but does not comprise power radiated from the Antenna Array and reflected back from the environment. The power at each of the interfering <i>TAB connectors</i> is $P_{\text{rated,c,TABC}}$.	

6.7.3.3 Additional requirements

For Band n41 and n90 operation in Japan, the transmitter intermodulation level shall not exceed the unwanted emission limits in clauses 6.6.3, 6.6.4 and 6.6.5 in the presence of an NR interfering signal according to table 6.7.3.3-1.

Table 6.7.3.3-1 Interfering and wanted signals for the additional transmitter intermodulation requirement for Band n41 and n90

Parameter	Value
Wanted signal	NR single carrier (NOTE)
Interfering signal type	NR signal of 10 MHz <i>channel bandwidth</i>
Interfering signal level	Rated total output power in the operating band – 30 dB
Interfering signal centre frequency offset from the lower (upper) edge of the wanted signal	± 5 MHz ± 15 MHz ± 25 MHz
NOTE: This requirement applies for NR carriers allocated within 2545-2645 MHz.	

Table 6.7.3.3-2: Void

For Band n79 operation in Japan, the transmitter intermodulation level shall not exceed the unwanted emission limits in clauses 6.6.3, 6.6.4 and 6.6.5 in the presence of an NR interfering signal according to table 6.7.3.3-3.

Table 6.7.3.3-3: Interfering and wanted signals for the additional transmitter intermodulation requirement for Band n79

Parameter	Value
Wanted signal	NR single carrier
Interfering signal type	NR signal of 40 MHz <i>channel bandwidth</i>
Interfering signal level	<i>Rated total output power</i> per <i>TAB connector</i> ($P_{\text{rated,t,TABC}}$) in the <i>operating band</i> – 30 dB
Interfering signal centre frequency offset from the lower/upper edge of the wanted signal	± 20 MHz ± 60 MHz ± 100 MHz

7 Conducted receiver characteristics

7.1 General

Conducted receiver characteristics are specified at the *antenna connector* for *BS type 1-C* and at the *TAB connector* for *BS type 1-H*, with full complement of transceivers for the configuration in normal operating condition.

Unless otherwise stated, the following arrangements apply for conducted receiver characteristics requirements in clause 7:

- Requirements apply during the BS receive period.
- Requirements shall be met for any transmitter setting.
- For FDD operation the requirements shall be met with the transmitter unit(s) ON.
- Throughput requirements defined for the radiated receiver characteristics do not assume HARQ retransmissions.
- When BS is configured to receive multiple carriers, all the throughput requirements are applicable for each received carrier.
- For ACS, blocking and intermodulation characteristics, the negative offsets of the interfering signal apply relative to the lower *Base Station RF Bandwidth* edge or *sub-block* edge inside a *sub-block gap*, and the positive offsets of the interfering signal apply relative to the upper *Base Station RF Bandwidth* edge or *sub-block* edge inside a *sub-block gap*.
- Requirements shall also apply for BS supporting NB-IoT operation in NR in-band. The corresponding NB-IoT requirements are specified in TS 36.104 [13] clause 7.

NOTE 1: In normal operating condition the BS in FDD operation is configured to transmit and receive at the same time.

NOTE 2: In normal operating condition the BS in TDD operation is configured to TX OFF power during *receive period*.

For BS *type 1-H* there is no requirement specified for band n46 and n102.

7.2 Reference sensitivity level

7.2.1 General

The reference sensitivity power level P_{REFSENS} is the minimum mean power received at the *antenna connector* for *BS type 1-C* or *TAB connector* for *BS type 1-H* at which a throughput requirement shall be met for a specified reference measurement channel.

7.2.2 Minimum requirements for *BS type 1-C* and *BS type 1-H*

The throughput shall be $\geq 95\%$ of the maximum throughput of the reference measurement channel as specified in annex A.1 with parameters specified in table 7.2.2-1 for Wide Area BS, in table 7.2.2-2 for Medium Range BS and in table 7.2.2-3 for Local Area BS in any operating band except for band n46, n96, n102 and n104.

The throughput shall be $\geq 95\%$ of the maximum throughput of the reference measurement channel as specified in annex A.1 with parameters specified in table 7.2.2-2a for Medium Range BS and in table 7.2.2-3a for Local Area BS, for band n46 and n102.

The throughput shall be $\geq 95\%$ of the maximum throughput of the reference measurement channel as specified in annex A.1 with parameters specified in table 7.2.2-2b for Medium Range BS and in table 7.2.2-3b for Local Area BS, for band n96.

The throughput shall be $\geq 95\%$ of the maximum throughput of the reference measurement channel as specified in annex A.1 with parameters specified in table 7.2.2-1a for Wide Area BS, in table 7.2.2-2c for Medium Range BS and in table 7.2.2-3c for Local Area BS for band n104.

Table 7.2.2-1: NR Wide Area BS reference sensitivity levels

BS channel bandwidth (MHz)	Sub-carrier spacing (kHz)	Reference measurement channel	Reference sensitivity power level, P_{REFSENS} (dBm)
5, 10, 15	15	G-FR1-A1-1 (Note 1)	-101.7
		G-FR1-A1-10 (Note 3)	-101.7 (Note 2)
10, 15	30	G-FR1-A1-2 (Note 1)	-101.8
10, 15	60	G-FR1-A1-3 (Note 1)	-98.9
20, 25, 30, 35, 40, 45, 50	15	G-FR1-A1-4 (Note 1)	-95.3
		G-FR1-A1-11 (Note 4)	-95.3 (Note 2)
20, 25, 30, 35, 40, 45, 50, 60, 70, 80, 90, 100	30	G-FR1-A1-5 (Note 1)	-95.6
20, 25, 30, 35, 40, 45, 50, 60, 70, 80, 90, 100	60	G-FR1-A1-6 (Note 1)	-95.7
<p>NOTE 1: P_{REFSENS} is the power level of a single instance of the reference measurement channel. This requirement shall be met for each consecutive application of a single instance of the reference measurement channel mapped to disjoint frequency ranges with a width corresponding to the number of resource blocks of the reference measurement channel each, except for one instance that might overlap one other instance to cover the full <i>BS channel bandwidth</i>.</p> <p>NOTE 2: The requirements apply to BS that supports NB-IoT operation in NR in-band.</p> <p>NOTE 3: P_{REFSENS} is the power level of a single instance of the reference measurement channel. This requirement shall be met for a single instance of G-FR1-A1-10 mapped to the 24 NR resource blocks adjacent to the NB-IoT PRB, and for each consecutive application of a single instance of G-FR1-A1-1 mapped to disjoint frequency ranges with a width of 25 resource blocks each.</p> <p>NOTE 4: P_{REFSENS} is the power level of a single instance of the reference measurement channel. This requirement shall be met for a single instance of G-FR1-A1-11 mapped to the 105 NR resource blocks adjacent to the NB-IoT PRB, and for each consecutive application of a single instance of G-FR1-A1-4 mapped to disjoint frequency ranges with a width of 106 resource blocks each.</p> <p>NOTE 5: Void.</p>			

Table 7.2.2-1a: NR Wide Area BS reference sensitivity levels for band n104

BS channel bandwidth (MHz)	Sub-carrier spacing (kHz)	Reference measurement channel	Reference sensitivity power level, P_{REFSENS} (dBm) (Note 6)
20, 30, 40, 50	15	G-FR1-A1-4 (Note 1)	-94.3
20, 30, 40, 50, 60, 70, 80, 90, 100	30	G-FR1-A1-5 (Note 1)	-94.6
20, 30, 40, 50, 60, 70, 80, 90, 100	60	G-FR1-A1-6 (Note 1)	-94.7
<p>Note 1: P_{REFSENS} is the power level of a single instance of the reference measurement channel. This requirement shall be met for each consecutive application of a single instance of the reference measurement channel mapped to disjoint frequency ranges with a width corresponding to the number of resource blocks of the reference measurement channel each, except for one instance that might overlap one other instance to cover the full <i>BS channel bandwidth</i>.</p>			

Table 7.2.2-2: NR Medium Range BS reference sensitivity levels

<i>BS channel bandwidth</i> (MHz)	<i>Sub-carrier spacing</i> (kHz)	<i>Reference measurement channel</i> (Note 5)	<i>Reference sensitivity power level, P_{PREFSENS}</i> (dBm)
5, 10, 15	15	G-FR1-A1-1 (Note 1)	-96.7
		G-FR1-A1-10 (Note 3)	-96.7 (Note 2)
10, 15	30	G-FR1-A1-2 (Note 1)	-96.8
10, 15	60	G-FR1-A1-3 (Note 1)	-93.9
20, 25, 30, 35, 40, 45, 50	15	G-FR1-A1-4 (Note 1)	-90.3
		G-FR1-A1-11 (Note 4)	-90.3 (Note 2)
20, 25, 30, 35, 40, 45, 50, 60, 70, 80, 90, 100	30	G-FR1-A1-5 (Note 1)	-90.6
20, 25, 30, 35, 40, 45, 50, 60, 70, 80, 90, 100	60	G-FR1-A1-6 (Note 1)	-90.7
<p>Note 1: P_{PREFSENS} is the power level of a single instance of the reference measurement channel. This requirement shall be met for each consecutive application of a single instance of the reference measurement channel mapped to disjoint frequency ranges with a width corresponding to the number of resource blocks of the reference measurement channel each, except for one instance that might overlap one other instance to cover the full <i>BS channel bandwidth</i>.</p> <p>Note 2: The requirements apply to BS that supports NB-IoT operation in NR in-band.</p> <p>Note 3: P_{PREFSENS} is the power level of a single instance of the reference measurement channel. This requirement shall be met for a single instance of G-FR1-A1-10 mapped to the 24 NR resource blocks adjacent to the NB-IoT PRB, and for each consecutive application of a single instance of G-FR1-A1-1 mapped to disjoint frequency ranges with a width of 25 resource blocks each.</p> <p>Note 4: P_{PREFSENS} is the power level of a single instance of the reference measurement channel. This requirement shall be met for a single instance of G-FR1-A1-11 mapped to the 105 NR resource blocks adjacent to the NB-IoT PRB, and for each consecutive application of a single instance of G-FR1-A1-4 mapped to disjoint frequency ranges with a width of 106 resource blocks each.</p> <p>Note 5: These reference measurement channels are not applied for band n46, n96 and n102.</p>			

Table 7.2.2-2a: NR Medium Range BS reference sensitivity levels for band n46

<i>BS channel bandwidth</i> (MHz)	<i>Sub-carrier spacing</i> (kHz)	<i>Reference measurement channel</i>	<i>Reference sensitivity power level, P_{PREFSENS}</i> (dBm)
10	15	G-FR1-A1-12 (Note 2)	-103.0
	30	G-FR1-A1-13 (Note 2)	-100.7
	60	G-FR1-A1-3 (Note 1)	-93.9
20	15	G-FR1-A1-14 (Note 2)	-100.1
	30	G-FR1-A1-15 (Note 2)	-97.1
	60	G-FR1-A1-6 (Note 1)	-90.7
40	15	G-FR1-A1-16 (Note 2)	-97.0
	30	G-FR1-A1-17 (Note 2)	-94.0
	60	G-FR1-A1-6 (Note 1)	-90.7
60	30	G-FR1-A1-18 (Note 2)	-92.4
	60	G-FR1-A1-6 (Note 1)	-90.7
80	30	G-FR1-A1-19 (Note 2)	-91.1
	60	G-FR1-A1-6 (Note 1)	-90.7
<p>Note 1: P_{PREFSENS} is the power level of a single instance of the reference measurement channel. This requirement shall be met for each consecutive application of a single instance of the reference measurement channel mapped to disjoint frequency ranges with a width corresponding to the number of resource blocks of the reference measurement channel each, except for one instance that might overlap one other instance to cover the full <i>BS channel bandwidth</i>.</p> <p>Note 2: P_{PREFSENS} is the power level of a single instance of the reference measurement channel. This requirement shall be met for each interleaved application of a single instance of the reference measurement channel mapped to disjoint frequency ranges with a width corresponding to the number of resource blocks of the reference measurement channel each, except for one instance that might overlap one other instance to cover the full <i>BS channel bandwidth</i>.</p> <p>Note 3: For 60kHz SCS reference measurement channel is reused from Table 7.2.2-2. P_{PREFSENS} is the power level of a single instance of the reference measurement channel. This requirement shall be met for each single interlace of FRC G-FR1-A1-12 and G-FR1-A1-19, except for one instance that might overlap one other instance to cover the full <i>BS channel bandwidth</i>.</p>			

Table 7.2.2-2b: NR Medium Range BS reference sensitivity levels for band n96 and n102

<i>BS channel bandwidth</i> (MHz)	Sub-carrier spacing (kHz)	Reference measurement channel	Reference sensitivity power level, P_{REFSENS} (dBm)
20	15	G-FR1-A1-14 (Note 2)	-99.1
	30	G-FR1-A1-15 (Note 2)	-96.1
	60	G-FR1-A1-6 (Note 1)	-89.7
40	15	G-FR1-A1-16 (Note 2)	-96.0
	30	G-FR1-A1-17 (Note 2)	-93.0
	60	G-FR1-A1-6 (Note 1)	-89.7
60	30	G-FR1-A1-18 (Note 2)	-91.4
	60	G-FR1-A1-6 (Note 1)	-89.7
80	30	G-FR1-A1-19 (Note 2)	-90.1
	60	G-FR1-A1-6 (Note 1)	-89.7
<p>Note 1: P_{REFSENS} is the power level of a single instance of the reference measurement channel. This requirement shall be met for each consecutive application of a single instance of the reference measurement channel mapped to disjoint frequency ranges with a width corresponding to the number of resource blocks of the reference measurement channel each, except for one instance that might overlap one other instance to cover the full <i>BS channel bandwidth</i>.</p> <p>Note 2: P_{REFSENS} is the power level of a single instance of the reference measurement channel. This requirement shall be met for each interleaved application of a single instance of the reference measurement channel mapped to disjoint frequency ranges with a width corresponding to the number of resource blocks of the reference measurement channel each, except for one instance that might overlap one other instance to cover the full <i>BS channel bandwidth</i>.</p> <p>Note 3: For 60kHz SCS reference measurement channel is reused from Table 7.2.2-2.</p>			

Table 7.2.2-2c: NR Medium Range BS reference sensitivity levels for band n104

BS channel bandwidth (MHz)	Sub-carrier spacing (kHz)	Reference measurement channel (Note 5)	Reference sensitivity power level, P_{REFSENS} (dBm)
20, 30, 40, 50	15	G-FR1-A1-4 (Note 1)	-89.3
20, 30, 40, 50, 60, 70, 80, 90, 100	30	G-FR1-A1-5 (Note 1)	-89.6
20, 30, 40, 50, 60, 70, 80, 90, 100	60	G-FR1-A1-6 (Note 1)	-89.7
<p>Note 1: P_{REFSENS} is the power level of a single instance of the reference measurement channel. This requirement shall be met for each consecutive application of a single instance of the reference measurement channel mapped to disjoint frequency ranges with a width corresponding to the number of resource blocks of the reference measurement channel each, except for one instance that might overlap one other instance to cover the full <i>BS channel bandwidth</i>.</p>			

Table 7.2.2-3: NR Local Area BS reference sensitivity levels

<i>BS channel bandwidth</i> (MHz)	<i>Sub-carrier spacing</i> (kHz)	<i>Reference measurement channel</i> (Note 5)	<i>Reference sensitivity power level, P_{REFSENS}</i> (dBm)
5, 10, 15	15	G-FR1-A1-1 (Note 1)	-93.7
		G-FR1-A1-10 (Note 3)	-93.7 (Note 2)
10, 15	30	G-FR1-A1-2 (Note 1)	-93.8
10, 15	60	G-FR1-A1-3 (Note 1)	-90.9
20, 25, 30, 35, 40, 45, 50	15	G-FR1-A1-4 (Note 1)	-87.3
		G-FR1-A1-11 (Note 4)	-87.3 (Note 2)
20, 25, 30, 35, 40, 45, 50, 60, 70, 80, 90, 100	30	G-FR1-A1-5 (Note 1)	-87.6
20, 25, 30, 35, 40, 45, 50, 60, 70, 80, 90, 100	60	G-FR1-A1-6 (Note 1)	-87.7
<p>Note 1: P_{REFSENS} is the power level of a single instance of the reference measurement channel. This requirement shall be met for each consecutive application of a single instance of the reference measurement channel mapped to disjoint frequency ranges with a width corresponding to the number of resource blocks of the reference measurement channel each, except for one instance that might overlap one other instance to cover the full <i>BS channel bandwidth</i>.</p> <p>Note 2: The requirements apply to BS that supports NB-IoT operation in NR in-band.</p> <p>Note 3: P_{REFSENS} is the power level of a single instance of the reference measurement channel. This requirement shall be met for a single instance of G-FR1-A1-10 mapped to the 24 NR resource blocks adjacent to the NB-IoT PRB, and for each consecutive application of a single instance of G-FR1-A1-1 mapped to disjoint frequency ranges with a width of 25 resource blocks each.</p> <p>Note 4: P_{REFSENS} is the power level of a single instance of the reference measurement channel. This requirement shall be met for a single instance of G-FR1-A1-11 mapped to the 105 NR resource blocks adjacent to the NB-IoT PRB, and for each consecutive application of a single instance of G-FR1-A1-4 mapped to disjoint frequency ranges with a width of 106 resource blocks each.</p> <p>Note 5: These reference measurement channels are not applied for band n46, n96 and n102.</p>			

Table 7.2.2-3a: NR Local Area BS reference sensitivity levels for band n46

<i>BS channel bandwidth</i> (MHz)	<i>Sub-carrier spacing</i> (kHz)	<i>Reference measurement channel</i>	<i>Reference sensitivity power level, P_{REFSENS}</i> (dBm)
10	15	G-FR1-A1-12 (Note 2)	-100.0
	30	G-FR1-A1-13 (Note 2)	-97.7
	60	G-FR1-A1-3 (Note 1)	-90.9
20	15	G-FR1-A1-14 (Note 2)	-97.1
	30	G-FR1-A1-15 (Note 2)	-94.1
	60	G-FR1-A1-6 (Note 1)	-87.7
40	15	G-FR1-A1-16 (Note 2)	-94.0
	30	G-FR1-A1-17 (Note 2)	-91.0
	60	G-FR1-A1-6 (Note 1)	-87.7
60	30	G-FR1-A1-18 (Note 2)	-89.4
	60	G-FR1-A1-6 (Note 1)	-87.7
80	30	G-FR1-A1-19 (Note 2)	-88.1
	60	G-FR1-A1-6 (Note 1)	-87.7
<p>Note 1: P_{REFSENS} is the power level of a single instance of the reference measurement channel. This requirement shall be met for each consecutive application of a single instance of the reference measurement channel mapped to disjoint frequency ranges with a width corresponding to the number of resource blocks of the reference measurement channel each, except for one instance that might overlap one other instance to cover the full <i>BS channel bandwidth</i>.</p> <p>Note 2: P_{REFSENS} is the power level of a single instance of the reference measurement channel. This requirement shall be met for each interleaved application of a single instance of the reference measurement channel mapped to disjoint frequency ranges with a width corresponding to the number of resource blocks of the reference measurement channel each, except for one instance that might overlap one other instance to cover the full <i>BS channel bandwidth</i>.</p> <p>Note 3: For 60kHz SCS reference measurement channel is reused from Table 7.2.2-3.</p>			

Table 7.2.2-3b: NR Local Area BS reference sensitivity levels for band n96 and n102

<i>BS channel bandwidth</i> (MHz)	Sub-carrier spacing (kHz)	Reference measurement channel	Reference sensitivity power level, P_{REFSENS} (dBm)
20	15	G-FR1-A1-14 (Note 2)	-96.1
	30	G-FR1-A1-15 (Note 2)	-93.1
	60	G-FR1-A1-6 (Note 1)	-86.7
40	15	G-FR1-A1-16 (Note 2)	-93.0
	30	G-FR1-A1-17 (Note 2)	-90.0
	60	G-FR1-A1-6 (Note 1)	-86.7
60	30	G-FR1-A1-18 (Note 2)	-88.4
	60	G-FR1-A1-6 (Note 1)	-86.7
80	30	G-FR1-A1-19 (Note 2)	-87.1
	60	G-FR1-A1-6 (Note 1)	-86.7
Note 1: P_{REFSENS} is the power level of a single instance of the reference measurement channel. This requirement shall be met for each consecutive application of a single instance of the reference measurement channel mapped to disjoint frequency ranges with a width corresponding to the number of resource blocks of the reference measurement channel each, except for one instance that might overlap one other instance to cover the full <i>BS channel bandwidth</i> .			
Note 2: P_{REFSENS} is the power level of a single instance of the reference measurement channel. This requirement shall be met for each interleaved application of a single instance of the reference measurement channel mapped to disjoint frequency ranges with a width corresponding to the number of resource blocks of the reference measurement channel each, except for one instance that might overlap one other instance to cover the full <i>BS channel bandwidth</i> .			
Note 3: For 60kHz SCS reference measurement channel is reused from Table 7.2.2-3.			

Table 7.2.2-3c: NR Local Area BS reference sensitivity levels for band n104

BS channel bandwidth (MHz)	Sub-carrier spacing (kHz)	Reference measurement channel (Note 5)	Reference sensitivity power level, P_{REFSENS} (dBm)
20, 30, 40, 50	15	G-FR1-A1-4 (Note 1)	-86.3
20, 30, 40, 50, 60, 70, 80, 90, 100	30	G-FR1-A1-5 (Note 1)	-86.6
20, 30, 40, 50, 60, 70, 80, 90, 100	60	G-FR1-A1-6 (Note 1)	-86.7
Note 1: P_{REFSENS} is the power level of a single instance of the reference measurement channel. This requirement shall be met for each consecutive application of a single instance of the reference measurement channel mapped to disjoint frequency ranges with a width corresponding to the number of resource blocks of the reference measurement channel each, except for one instance that might overlap one other instance to cover the full <i>BS channel bandwidth</i> .			

7.3 Dynamic range

7.3.1 General

The dynamic range is specified as a measure of the capability of the receiver to receive a wanted signal in the presence of an interfering signal at the *antenna connector* for *BS type 1-C* or *TAB connector* for *BS type 1-H* inside the received *BS channel bandwidth*. In this condition, a throughput requirement shall be met for a specified reference measurement channel. The interfering signal for the dynamic range requirement is an AWGN signal.

7.3.2 Minimum requirement for *BS type 1-C* and *BS type 1-H*

The throughput shall be $\geq 95\%$ of the maximum throughput of the reference measurement channel as specified in annex A.2 with parameters specified in table 7.3.2-1 for Wide Area BS, in table 7.3.2-2 for Medium Range BS and in table 7.3.2-3 for Local Area BS in any operating band except for band n46, n96, n102 and n104.

The throughput shall be $\geq 95\%$ of the maximum throughput of the reference measurement channel as specified in annex A.2 with parameters specified in table 7.3.2-2b for Medium Range BS and in table 7.3.2-3b for Local Area BS, for band n46.

The throughput shall be $\geq 95\%$ of the maximum throughput of the reference measurement channel as specified in annex A.2 with parameters specified in table 7.3.2-2c for Medium Range BS and in table 7.3.2-3c for Local Area BS, for band n96 and n102.

The throughput shall be $\geq 95\%$ of the maximum throughput of the reference measurement channel as specified in annex A.2 with parameters specified in table 7.3.2-1b for Wide Area BS, in table 7.3.2-2d for Medium Range BS and in table 7.3.2-3d for Local Area BS in band n104.

For NB-IoT operation in NR in-band, the throughput shall be $\geq 95\%$ of the maximum throughput of the reference measurement channel as specified in Annex A of TS 36.104 [13] with parameters specified in table 7.3.2-1a for Wide Area BS, in table 7.3.2-2a for Medium Range BS and in table 7.3.2-3a for Local Area BS.

Table 7.3.2-1: Wide Area BS dynamic range

<i>BS channel bandwidth (MHz)</i>	<i>Subcarrier spacing (kHz)</i>	<i>Reference measurement channel</i>	<i>Wanted signal mean power (dBm)</i>	<i>Interfering signal mean power (dBm) / BW_{Config}</i>	<i>Type of interfering signal</i>
5	15	G-FR1-A2-1	-70.7	-82.5	AWGN
	30	G-FR1-A2-2	-71.4		
10	15	G-FR1-A2-1	-70.7	-79.3	AWGN
	30	G-FR1-A2-2	-71.4		
	60	G-FR1-A2-3	-68.4		
15	15	G-FR1-A2-1	-70.7	-77.5	AWGN
	30	G-FR1-A2-2	-71.4		
	60	G-FR1-A2-3	-68.4		
20	15	G-FR1-A2-4	-64.5	-76.2	AWGN
	30	G-FR1-A2-5	-64.5		
	60	G-FR1-A2-6	-64.8		
25	15	G-FR1-A2-4	-64.5	-75.2	AWGN
	30	G-FR1-A2-5	-64.5		
	60	G-FR1-A2-6	-64.8		
30	15	G-FR1-A2-4	-64.5	-74.4	AWGN
	30	G-FR1-A2-5	-64.5		
	60	G-FR1-A2-6	-64.8		
35	15	G-FR1-A2-4	-64.5	-73.7	AWGN
	30	G-FR1-A2-5	-64.5		
	60	G-FR1-A2-6	-64.8		
40	15	G-FR1-A2-4	-64.5	-73.1	AWGN
	30	G-FR1-A2-5	-64.5		
	60	G-FR1-A2-6	-64.8		
45	15	G-FR1-A2-4	-64.5	-72.6	AWGN
	30	G-FR1-A2-5	-64.5		
	60	G-FR1-A2-6	-64.8		
50	15	G-FR1-A2-4	-64.5	-72.1	AWGN
	30	G-FR1-A2-5	-64.5		
	60	G-FR1-A2-6	-64.8		
60	30	G-FR1-A2-5	-64.5	-71.3	AWGN
	60	G-FR1-A2-6	-64.8		
70	30	G-FR1-A2-5	-64.5	-70.7	AWGN
	60	G-FR1-A2-6	-64.8		
80	30	G-FR1-A2-5	-64.5	-70.1	AWGN
	60	G-FR1-A2-6	-64.8		
90	30	G-FR1-A2-5	-64.5	-69.5	AWGN
	60	G-FR1-A2-6	-64.8		
100	30	G-FR1-A2-5	-64.5	-69.1	AWGN
	60	G-FR1-A2-6	-64.8		

NOTE: The wanted signal mean power is the power level of a single instance of the corresponding reference measurement channel. This requirement shall be met for each consecutive application of a single instance of the reference measurement channel mapped to disjoint frequency ranges with a width corresponding to the number of resource blocks of the reference measurement channel each, except for one instance that might overlap one other instance to cover the full *BS channel bandwidth*.

Table 7.3.2-1a: Wide Area BS dynamic range for NB-IoT operation in NR in-band

BS channel bandwidth (MHz)	Reference measurement channel	Wanted signal mean power (dBm)	Interfering signal mean power (dBm) / BW _{Config}	Type of interfering signal
5	FRC A15-1 in Annex A.15 in TS 36.104 [13]	-99.7	-82.5	AWGN
10			-79.3	
15			-77.5	
20			-76.2	
25			-75.2	
30			-74.4	
35			-73.7	
40			-73.1	
45			-72.6	
50			-72.1	
5	FRC A15-2 in Annex A.15 in TS 36.104 [13]	-105.6	-82.5	AWGN
10			-79.3	
15			-77.5	
20			-76.2	
25			-75.2	
30			-74.4	
35			-73.7	
40			-73.1	
45			-72.6	
50			-72.1	

Table 7.3.2-1b: Wide Area BS dynamic range for n104

BS channel bandwidth (MHz)	Subcarrier spacing (kHz)	Reference measurement channel	Wanted signal mean power (dBm)	Interfering signal mean power (dBm) / BW _{Config}	Type of interfering signal
20	15	G-FR1-A2-4	-63.5	-75.2	AWGN
	30	G-FR1-A2-5	-63.5		
	60	G-FR1-A2-6	-63.8		
30	15	G-FR1-A2-4	-63.5	-73.4	AWGN
	30	G-FR1-A2-5	-63.5		
	60	G-FR1-A2-6	-63.8		
40	15	G-FR1-A2-4	-63.5	-72.1	AWGN
	30	G-FR1-A2-5	-63.5		
	60	G-FR1-A2-6	-63.8		
50	15	G-FR1-A2-4	-63.5	-71.1	AWGN
	30	G-FR1-A2-5	-63.5		
	60	G-FR1-A2-6	-63.8		
60	30	G-FR1-A2-5	-63.5	-70.3	AWGN
	60	G-FR1-A2-6	-63.8		
70	30	G-FR1-A2-5	-63.5	-69.7	AWGN
	60	G-FR1-A2-6	-63.8		
80	30	G-FR1-A2-5	-63.5	-69.1	AWGN
	60	G-FR1-A2-6	-63.8		
90	30	G-FR1-A2-5	-63.5	-68.5	AWGN
	60	G-FR1-A2-6	-63.8		
100	30	G-FR1-A2-5	-63.5	-68.1	AWGN
	60	G-FR1-A2-6	-63.8		

NOTE 1: The wanted signal mean power is the power level of a single instance of the corresponding reference measurement channel. This requirement shall be met for each consecutive application of a single instance of the reference measurement channel mapped to disjoint frequency ranges with a width corresponding to the number of resource blocks of the reference measurement channel each, except for one instance that might overlap one other instance to cover the full BS channel bandwidth.

Table 7.3.2-2: Medium Range BS dynamic range

BS channel bandwidth (MHz)	Subcarrier spacing (kHz)	Reference measurement channel (Note 2)	Wanted signal mean power (dBm)	Interfering signal mean power (dBm) / BW_{Config}	Type of interfering signal
5	15	G-FR1-A2-1	-65.7	-77.5	AWGN
	30	G-FR1-A2-2	-66.4		
10	15	G-FR1-A2-1	-65.7	-74.3	AWGN
	30	G-FR1-A2-2	-66.4		
	60	G-FR1-A2-3	-63.4		
15	15	G-FR1-A2-1	-65.7	-72.5	AWGN
	30	G-FR1-A2-2	-66.4		
	60	G-FR1-A2-3	-63.4		
20	15	G-FR1-A2-4	-59.5	-71.2	AWGN
	30	G-FR1-A2-5	-59.5		
	60	G-FR1-A2-6	-59.8		
25	15	G-FR1-A2-4	-59.5	-70.2	AWGN
	30	G-FR1-A2-5	-59.5		
	60	G-FR1-A2-6	-59.8		
30	15	G-FR1-A2-4	-59.5	-69.4	AWGN
	30	G-FR1-A2-5	-59.5		
	60	G-FR1-A2-6	-59.8		
35	15	G-FR1-A2-4	-59.5	-68.7	AWGN
	30	G-FR1-A2-5	-59.5		
	60	G-FR1-A2-6	-59.8		
40	15	G-FR1-A2-4	-59.5	-68.1	AWGN
	30	G-FR1-A2-5	-59.5		
	60	G-FR1-A2-6	-59.8		
45	15	G-FR1-A2-4	-59.5	-67.6	AWGN
	30	G-FR1-A2-5	-59.5		
	60	G-FR1-A2-6	-59.8		
50	15	G-FR1-A2-4	-59.5	-67.1	AWGN
	30	G-FR1-A2-5	-59.5		
	60	G-FR1-A2-6	-59.8		
60	30	G-FR1-A2-5	-59.5	-66.3	AWGN
	60	G-FR1-A2-6	-59.8		
70	30	G-FR1-A2-5	-59.5	-65.7	AWGN
	60	G-FR1-A2-6	-59.8		
80	30	G-FR1-A2-5	-59.5	-65.1	AWGN
	60	G-FR1-A2-6	-59.8		
90	30	G-FR1-A2-5	-59.5	-64.5	AWGN
	60	G-FR1-A2-6	-59.8		
100	30	G-FR1-A2-5	-59.5	-64.1	AWGN
	60	G-FR1-A2-6	-59.8		

NOTE 1: The wanted signal mean power is the power level of a single instance of the corresponding reference measurement channel. This requirement shall be met for each consecutive application of a single instance of the reference measurement channel mapped to disjoint frequency ranges with a width corresponding to the number of resource blocks of the reference measurement channel each, except for one instance that might overlap one other instance to cover the full BS channel bandwidth.

NOTE 2: These reference measurement channels are not applied for band n46, n96 and n102.

Table 7.3.2-2a: Medium Range BS dynamic range for NB-IoT operation in NR in-band

BS channel bandwidth (MHz)	Reference measurement channel	Wanted signal mean power (dBm)	Interfering signal mean power (dBm) / BW_{Config}	Type of interfering signal
5	FRC A15-1 in Annex A.15 in TS 36.104 [13]	-94.7	-77.5	AWGN
10			-74.3	
15			-72.5	
20			-71.2	
25			-70.2	
30			-69.4	
35			-68.7	
40			-68.1	
45			-67.6	
50			-67.1	
5	FRC A15-2 in Annex A.15 in TS 36.104 [13]	-100.6	-77.5	AWGN
10			-74.3	
15			-72.5	
20			-71.2	
25			-70.2	
30			-69.4	
35			-68.7	
40			-68.1	
45			-67.6	
50			-67.1	

Table 7.3.2-2b: Medium Range BS dynamic range for band n46

<i>BS channel bandwidth (MHz)</i>	<i>Subcarrier spacing (kHz)</i>	<i>Reference measurement channel</i>	<i>Wanted signal mean power (dBm)</i>	<i>Interfering signal mean power (dBm) / BW_{Config}</i>	<i>Type of interfering signal</i>
10	15	G-FR1-A2-7 (Note 2)	-72.8	-74.3	AWGN
	30	G-FR1-A2-8 (Note 2)	-70.6		
	60	G-FR1-A2-3 (Note 1, 3)	-63.4		
20	15	G-FR1-A2-9 (Note 2)	-69.8	-71.2	AWGN
	30	G-FR1-A2-10 (Note 2)	-66.8		
	60	G-FR1-A2-6 (Note 1, 3)	-59.8		
40	15	G-FR1-A2-11 (Note 2)	-66.7	-68.1	AWGN
	30	G-FR1-A2-12 (Note 2)	-63.7		
	60	G-FR1-A2-6 (Note 1, 3)	-59.8		
60	30	G-FR1-A2-13 (Note 2)	-61.9	-66.3	AWGN
	60	G-FR1-A2-6 (Note 1, 3)	-59.8		
80	30	G-FR1-A2-14 (Note 2)	-60.7	-65.1	AWGN
	60	G-FR1-A2-6 (Note 1, 3)	-59.8		
<p>Note 1: The wanted signal mean power is the power level of a single instance of the corresponding reference measurement channel. This requirement shall be met for each consecutive application of a single instance of the reference measurement channel mapped to disjoint frequency ranges with a width corresponding to the number of resource blocks of the reference measurement channel each, except for one instance that might overlap one other instance to cover the full <i>BS channel bandwidth</i>.</p> <p>Note 2: The wanted signal mean power is the power level of a single instance of the corresponding reference measurement channel. This requirement shall be met for each interleaved application of a single instance of the reference measurement channel mapped to disjoint frequency ranges with a width corresponding to the number of resource blocks of the reference measurement channel each, except for one instance that might overlap one other instance to cover the full <i>BS channel bandwidth</i>.</p> <p>Note 3: For 60kHz SCS reference measurement channel is reused from Table 7.3.2-2.</p>					

Table 7.3.2-2c: Medium Range BS dynamic range for band n96 and n102

<i>BS channel bandwidth (MHz)</i>	<i>Subcarrier spacing (kHz)</i>	<i>Reference measurement channel</i>	<i>Wanted signal mean power (dBm)</i>	<i>Interfering signal mean power (dBm) / BW_{Config}</i>	<i>Type of interfering signal</i>
20	15	G-FR1-A2-9 (Note 2)	-68.8	-70.2	AWGN
	30	G-FR1-A2-10 (Note 2)	-65.8		
	60	G-FR1-A2-6 (Note 1, 3)	-58.8		
40	15	G-FR1-A2-11 (Note 2)	-65.7	-67.1	AWGN
	30	G-FR1-A2-12 (Note 2)	-62.7		
	60	G-FR1-A2-6 (Note 1, 3)	-58.8		
60	30	G-FR1-A2-13 (Note 2)	-60.9	-65.3	AWGN
	60	G-FR1-A2-6 (Note 1, 3)	-58.8		
80	30	G-FR1-A2-14 (Note 2)	-59.7	-64.1	AWGN
	60	G-FR1-A2-6 (Note 1, 3)	-58.8		
<p>Note 1: The wanted signal mean power is the power level of a single instance of the corresponding reference measurement channel. This requirement shall be met for each consecutive application of a single instance of the reference measurement channel mapped to disjoint frequency ranges with a width corresponding to the number of resource blocks of the reference measurement channel each, except for one instance that might overlap one other instance to cover the full <i>BS channel bandwidth</i>.</p> <p>Note 2: The wanted signal mean power is the power level of a single instance of the corresponding reference measurement channel. This requirement shall be met for each interleaved application of a single instance of the reference measurement channel mapped to disjoint frequency ranges with a width corresponding to the number of resource blocks of the reference measurement channel each, except for one instance that might overlap one other instance to cover the full <i>BS channel bandwidth</i>.</p> <p>Note 3: For 60kHz SCS reference measurement channel is reused from Table 7.3.2-2.</p>					

Table 7.3.2-2d: Medium Range BS dynamic range for n104

BS channel bandwidth (MHz)	Subcarrier spacing (kHz)	Reference measurement channel (Note 2)	Wanted signal mean power (dBm)	Interfering signal mean power (dBm) / BW_{Config}	Type of interfering signal
20	15	G-FR1-A2-4	-58.5	-70.2	AWGN
	30	G-FR1-A2-5	-58.5		
	60	G-FR1-A2-6	-58.8		
30	15	G-FR1-A2-4	-58.5	-68.4	AWGN
	30	G-FR1-A2-5	-58.5		
	60	G-FR1-A2-6	-58.8		
40	15	G-FR1-A2-4	-58.5	-67.1	AWGN
	30	G-FR1-A2-5	-58.5		
	60	G-FR1-A2-6	-58.8		
50	15	G-FR1-A2-4	-58.5	-66.1	AWGN
	30	G-FR1-A2-5	-58.5		
	60	G-FR1-A2-6	-58.8		
60	30	G-FR1-A2-5	-58.5	-65.3	AWGN
	60	G-FR1-A2-6	-58.8		
70	30	G-FR1-A2-5	-58.5	-64.7	AWGN
	60	G-FR1-A2-6	-58.8		
80	30	G-FR1-A2-5	-58.5	-64.1	AWGN
	60	G-FR1-A2-6	-58.8		
90	30	G-FR1-A2-5	-58.5	-63.5	AWGN
	60	G-FR1-A2-6	-58.8		
100	30	G-FR1-A2-5	-58.5	-63.1	AWGN
	60	G-FR1-A2-6	-58.8		

NOTE 1: The wanted signal mean power is the power level of a single instance of the corresponding reference measurement channel. This requirement shall be met for each consecutive application of a single instance of the reference measurement channel mapped to disjoint frequency ranges with a width corresponding to the number of resource blocks of the reference measurement channel each, except for one instance that might overlap one other instance to cover the full BS channel bandwidth.

Table 7.3.2-3: Local Area BS dynamic range

BS channel bandwidth (MHz)	Subcarrier spacing (kHz)	Reference measurement channel	Wanted signal mean power (dBm)	Interfering signal mean power (dBm) / BW_{Config}	Type of interfering signal
5	15	G-FR1-A2-1	-62.7	-74.5	AWGN
	30	G-FR1-A2-2	-63.4		
10	15	G-FR1-A2-1	-62.7	-71.3	AWGN
	30	G-FR1-A2-2	-63.4		
	60	G-FR1-A2-3	-60.4		
15	15	G-FR1-A2-1	-62.7	-69.5	AWGN
	30	G-FR1-A2-2	-63.4		
	60	G-FR1-A2-3	-60.4		
20	15	G-FR1-A2-4	-56.5	-68.2	AWGN
	30	G-FR1-A2-5	-56.5		
	60	G-FR1-A2-6	-56.8		
25	15	G-FR1-A2-4	-56.5	-67.2	AWGN
	30	G-FR1-A2-5	-56.5		
	60	G-FR1-A2-6	-56.8		
30	15	G-FR1-A2-4	-56.5	-66.4	AWGN
	30	G-FR1-A2-5	-56.5		
	60	G-FR1-A2-6	-56.8		
35	15	G-FR1-A2-4	-56.5	-65.7	AWGN
	30	G-FR1-A2-5	-56.5		
	60	G-FR1-A2-6	-56.8		
40	15	G-FR1-A2-4	-56.5	-65.1	AWGN
	30	G-FR1-A2-5	-56.5		
	60	G-FR1-A2-6	-56.8		
45	15	G-FR1-A2-4	-56.5	-64.6	AWGN
	30	G-FR1-A2-5	-56.5		
	60	G-FR1-A2-6	-56.8		
50	15	G-FR1-A2-4	-56.5	-64.1	AWGN
	30	G-FR1-A2-5	-56.5		
	60	G-FR1-A2-6	-56.8		
60	30	G-FR1-A2-5	-56.5	-63.3	AWGN
	60	G-FR1-A2-6	-56.8		
70	30	G-FR1-A2-5	-56.5	-62.7	AWGN
	60	G-FR1-A2-6	-56.8		
80	30	G-FR1-A2-5	-56.5	-62.1	AWGN
	60	G-FR1-A2-6	-56.8		
90	30	G-FR1-A2-5	-56.5	-61.5	AWGN
	60	G-FR1-A2-6	-56.8		
100	30	G-FR1-A2-5	-56.5	-61.1	AWGN
	60	G-FR1-A2-6	-56.8		

NOTE 1: The wanted signal mean power is the power level of a single instance of the corresponding reference measurement channel. This requirement shall be met for each consecutive application of a single instance of the reference measurement channel mapped to disjoint frequency ranges with a width corresponding to the number of resource blocks of the reference measurement channel each, except for one instance that might overlap one other instance to cover the full BS channel bandwidth.

NOTE 2: These reference measurement channels are not applied for band n46, n96 and n102.

Table 7.3.2-3a: Local Area BS dynamic range for NB-IoT operation in NR in-band

BS channel bandwidth (MHz)	Reference measurement channel	Wanted signal mean power (dBm)	Interfering signal mean power (dBm) / BW_{Config}	Type of interfering signal
5	FRC A15-1 in Annex A.15 in TS 36.104 [13]	-91.7	-74.5	AWGN
10			-71.3	
15			-69.5	
20			-68.2	
25			-67.2	
30			-66.4	
35			-65.7	
40			-65.1	
45			-64.6	
50			-64.1	
5	FRC A15-2 in Annex A.15 in TS 36.104 [13]	-97.6	-74.5	AWGN
10			-71.3	
15			-69.5	
20			-68.2	
25			-67.2	
30			-66.4	
35			-65.7	
40			-65.1	
45			-64.6	
50			-64.1	

Table 7.3.2-3b: Local Area BS dynamic range for band n46

BS channel bandwidth (MHz)	Subcarrier spacing (kHz)	Reference measurement channel	Wanted signal mean power (dBm)	Interfering signal mean power (dBm) / BW_{Config}	Type of interfering signal
10	15	G-FR1-A2-7 (Note 2)	-69.8	-71.3	AWGN
	30	G-FR1-A2-8 (Note 2)	-67.6		
	60	G-FR1-A2-3 (Note 1, 3)	-60.4		
20	15	G-FR1-A2-9 (Note 2)	-66.8	-68.2	AWGN
	30	G-FR1-A2-10 (Note 2)	-63.8		
	60	G-FR1-A2-6 (Note 1, 3)	-56.8		
40	15	G-FR1-A2-11 (Note 2)	-63.7	-65.1	AWGN
	30	G-FR1-A2-12 (Note 2)	-60.7		
	60	G-FR1-A2-6 (Note 1, 3)	-56.8		
60	30	G-FR1-A2-13 (Note 2)	-58.9	-63.3	AWGN
	60	G-FR1-A2-6 (Note 1, 3)	-56.8		
80	30	G-FR1-A2-14 (Note 2)	-57.7	-62.1	AWGN
	60	G-FR1-A2-6 (Note 1, 3)	-56.8		
<p>Note 1: The wanted signal mean power is the power level of a single instance of the corresponding reference measurement channel. This requirement shall be met for each consecutive application of a single instance of the reference measurement channel mapped to disjoint frequency ranges with a width corresponding to the number of resource blocks of the reference measurement channel each, except for one instance that might overlap one other instance to cover the full <i>BS channel bandwidth</i>.</p> <p>Note 2: The wanted signal mean power is the power level of a single instance of the corresponding reference measurement channel. This requirement shall be met for each interleaved application of a single instance of the reference measurement channel mapped to disjoint frequency ranges with a width corresponding to the number of resource blocks of the reference measurement channel each, except for one instance that might overlap one other instance to cover the full <i>BS channel bandwidth</i>.</p> <p>Note 3: For 60kHz SCS reference measurement channel is reused from Table 7.3.2-3.</p>					

Table 7.3.2-3c: Local area BS dynamic range for band n96 and n102

<i>BS channel bandwidth (MHz)</i>	<i>Subcarrier spacing (kHz)</i>	<i>Reference measurement channel</i>	<i>Wanted signal mean power (dBm)</i>	<i>Interfering signal mean power (dBm) / BW_{Config}</i>	<i>Type of interfering signal</i>
20	15	G-FR1-A2-9 (Note 2)	-65.8	-67.2	AWGN
	30	G-FR1-A2-10 (Note 2)	-62.8		
	60	G-FR1-A2-6 (Note 1, 3)	-55.8		
40	15	G-FR1-A2-11 (Note 2)	-62.7	-64.1	AWGN
	30	G-FR1-A2-12 (Note 2)	-59.7		
	60	G-FR1-A2-6 (Note 1, 3)	-55.8		
60	30	G-FR1-A2-13 (Note 2)	-57.9	-62.3	AWGN
	60	G-FR1-A2-6 (Note 1, 3)	-55.8		
80	30	G-FR1-A2-14 (Note 2)	-56.7	-61.1	AWGN
	60	G-FR1-A2-6 (Note 1, 3)	-55.8		
<p>Note 1: The wanted signal mean power is the power level of a single instance of the corresponding reference measurement channel. This requirement shall be met for each consecutive application of a single instance of the reference measurement channel mapped to disjoint frequency ranges with a width corresponding to the number of resource blocks of the reference measurement channel each, except for one instance that might overlap one other instance to cover the full <i>BS channel bandwidth</i>.</p> <p>Note 2: The wanted signal mean power is the power level of a single instance of the corresponding reference measurement channel. This requirement shall be met for each interleaved application of a single instance of the reference measurement channel mapped to disjoint frequency ranges with a width corresponding to the number of resource blocks of the reference measurement channel each, except for one instance that might overlap one other instance to cover the full <i>BS channel bandwidth</i>.</p> <p>Note 3: For 60kHz SCS reference measurement channel is reused from Table 7.3.2-3.</p>					

Table 7.3.2-3d: Local Area BS dynamic range for n104

BS channel bandwidth (MHz)	Subcarrier spacing (kHz)	Reference measurement channel	Wanted signal mean power (dBm)	Interfering signal mean power (dBm) / BW_{Config}	Type of interfering signal
20	15	G-FR1-A2-4	-55.5	-67.2	AWGN
	30	G-FR1-A2-5	-55.5		
	60	G-FR1-A2-6	-55.8		
30	15	G-FR1-A2-4	-55.5	-65.4	AWGN
	30	G-FR1-A2-5	-55.5		
	60	G-FR1-A2-6	-55.8		
40	15	G-FR1-A2-4	-55.5	-64.1	AWGN
	30	G-FR1-A2-5	-55.5		
	60	G-FR1-A2-6	-55.8		
50	15	G-FR1-A2-4	-55.5	-63.1	AWGN
	30	G-FR1-A2-5	-55.5		
	60	G-FR1-A2-6	-55.8		
60	30	G-FR1-A2-5	-55.5	-62.3	AWGN
	60	G-FR1-A2-6	-55.8		
70	30	G-FR1-A2-5	-55.5	-61.7	AWGN
	60	G-FR1-A2-6	-55.8		
80	30	G-FR1-A2-5	-55.5	-61.1	AWGN
	60	G-FR1-A2-6	-55.8		
90	30	G-FR1-A2-5	-55.5	-60.5	AWGN
	60	G-FR1-A2-6	-55.8		
100	30	G-FR1-A2-5	-55.5	-60.1	AWGN
	60	G-FR1-A2-6	-55.8		

NOTE 1: The wanted signal mean power is the power level of a single instance of the corresponding reference measurement channel. This requirement shall be met for each consecutive application of a single instance of the reference measurement channel mapped to disjoint frequency ranges with a width corresponding to the number of resource blocks of the reference measurement channel each, except for one instance that might overlap one other instance to cover the full BS channel bandwidth.

7.4 In-band selectivity and blocking

7.4.1 Adjacent Channel Selectivity (ACS)

7.4.1.1 General

Adjacent channel selectivity (ACS) is a measure of the receiver's ability to receive a wanted signal at its assigned channel frequency at the *antenna connector* for BS type 1-C or *TAB connector* for BS type 1-H in the presence of an adjacent channel signal with a specified centre frequency offset of the interfering signal to the band edge of a victim system.

7.4.1.2 Minimum requirement for BS type 1-C and BS type 1-H

The throughput shall be $\geq 95\%$ of the maximum throughput of the reference measurement channel.

For BS operating except for band n46, n96, n102 and n104, the wanted and the interfering signal coupled to the BS type 1-C antenna connector or BS type 1-H TAB connector are specified in table 7.4.1.2-1 and the frequency offset between the wanted and interfering signal in table 7.4.1.2-2 for ACS. The reference measurement channel for the wanted signal is identified in table 7.2.2-1, 7.2.2-2 and 7.2.2-3 for each BS channel bandwidth in any operating band except for band n46, n96, n102 and n104 and further specified in annex A.1. The characteristics of the interfering signal is further specified in annex D.

For BS operating in band n46, n96 and n102, the wanted and the interfering signal coupled to the BS type 1-C antenna connector or BS type 1-H TAB connector are specified in table 7.4.1.2-1a and the frequency offset between the wanted and interfering signal in table 7.4.1.2-2a for ACS. The reference measurement channel for the wanted signal is

identified in table 7.2.2-2a and 7.2.2-3a for each *BS channel bandwidth* and further specified in annex A.1a. The characteristics of the interfering signal is further specified in annex D.

For BS operating in band n104, the wanted and the interfering signal coupled to the BS type 1-C antenna connector or BS type 1-H TAB connector are specified in table 7.4.1.2-1b and the frequency offset between the wanted and interfering signal in table 7.4.1.2-2 for ACS. The reference measurement channel for the wanted signal is identified in 7.2.2-1a, 7.2.2-2c, 7.2.2-3c for each *BS channel bandwidth* and further specified in annex A.1. The characteristics of the interfering signal is further specified in annex D.

For BS supporting NB-IoT operation in NR in-band, the wanted and the interfering signal coupled to the *BS type 1-C antenna connector* are specified in table 7.4.1.2-1 and the frequency offset between the wanted and interfering signal in table 7.4.1.2-2 for ACS. The reference measurement channel for the NB-IoT wanted signal is identified in clause 7.2.1 of TS 36.104 [13]. The characteristics of the interfering signal is further specified in annex D.

The ACS requirement is applicable outside the *Base Station RF Bandwidth* or *Radio Bandwidth*. The interfering signal offset is defined relative to the *Base station RF Bandwidth* edges or *Radio Bandwidth* edges.

For a BS operating in *non-contiguous spectrum* within any *operating band*, the ACS requirement shall apply in addition inside any *sub-block gap*, in case the *sub-block gap size* is at least as wide as the NR interfering signal in table 7.4.1.2-2. The interfering signal offset is defined relative to the *sub-block* edges inside the *sub-block gap*.

For a *multi-band connector*, the ACS requirement shall apply in addition inside any *Inter RF Bandwidth gap*, in case the *Inter RF Bandwidth gap size* is at least as wide as the NR interfering signal in table 7.4.1.2-2. The interfering signal offset is defined relative to the *Base Station RF Bandwidth edges* inside the *Inter RF Bandwidth gap*.

Minimum conducted requirement is defined at the *antenna connector* for *BS type 1-C* and at the *TAB connector* for *BS type 1-H*.

Table 7.4.1.2-1: Base station ACS requirement

<i>BS channel bandwidth of the lowest/highest carrier received (MHz)</i>	<i>Wanted signal mean power (dBm)</i>	<i>Interfering signal mean power (dBm)</i>
5, 10, 15, 20, 25, 30, 35, 40, 45, 50, 60, 70, 80, 90, 100 (Note 1)	$P_{\text{REFSENS}} + 6 \text{ dB}$	Wide Area BS: -52 Medium Range BS: -47 Local Area BS: -44
NOTE 1: The SCS for the lowest/highest carrier received is the lowest SCS supported by the BS for that bandwidth. NOTE 2: P_{REFSENS} depends on the RAT. For NR, P_{REFSENS} depends also on the <i>BS channel bandwidth</i> as specified in tables 7.2.2-1, 7.2.2-2, 7.2.2-3. For NB-IoT, P_{REFSENS} depends also on the <i>sub-carrier spacing</i> as specified in tables 7.2.1-5, 7.2.1-5a and 7.2.1-5c of TS 36.104 [13].		

Table 7.4.1.2-1a: Base station ACS requirement for band n46, n96 and n102

<i>BS channel bandwidth of the lowest/highest carrier received (MHz)</i>	<i>Wanted signal mean power (dBm)</i>	<i>Interfering signal mean power (dBm)</i>
10, 20, 40, 60, 80 (Note 1)	$P_{\text{REFSENS}} + 6 \text{ dB}$	Medium Range BS: -47 Local Area BS: -44
NOTE 1: The SCS for the lowest/highest carrier received is the lowest SCS supported by the BS for that bandwidth. NOTE 2: P_{REFSENS} depends on the RAT. For NR, P_{REFSENS} depends also on the <i>BS channel bandwidth</i> as specified in tables 7.2.2-2a, 7.2.2-2b, 7.2.2-3a, 7.2.2-3b. NOTE 3: Void.		

Table 7.4.1.2-1b: Base station ACS requirement for band n104

BS channel bandwidth of the lowest/highest carrier received (MHz)	Wanted signal mean power (dBm)	Interfering signal mean power (dBm)
20, 30, 40, 50, 60, 70, 80, 90, 100 (Note 1)	$P_{\text{REFSENS}} + 6 \text{ dB}$	Wide Area BS: -55 Medium Range BS: -50 Local Area BS: -47
NOTE 1: The SCS for the lowest/highest carrier received is the lowest SCS supported by the BS for that bandwidth.		
NOTE 2: P_{REFSENS} depends on the RAT. For NR, P_{REFSENS} depends also on the <i>BS channel bandwidth</i> as specified in tables 7.2.2-1a, 7.2.2-2c, 7.2.2-3c.		

Table 7.4.1.2-2: Base Station ACS interferer frequency offset values

BS channel bandwidth of the lowest/highest carrier received (MHz)	Interfering signal centre frequency offset from the lower/upper Base Station RF Bandwidth edge or sub-block edge inside a sub-block gap (MHz)	Type of interfering signal
5	± 2.5025	5 MHz DFT-s-OFDM NR signal 15 kHz SCS, 25 RBs
10	± 2.5075	
15	± 2.5125	
20	± 2.5025	
25	± 9.4675	20 MHz DFT-s-OFDM NR signal 15 kHz SCS, 100 RBs
30	± 9.4725	
35	± 9.4625	
40	± 9.4675	
45	± 9.4725	
50	± 9.4625	
60	± 9.4725	
70	± 9.4675	
80	± 9.4625	
90	± 9.4725	
100	± 9.4675	

Table 7.4.1.2-2: Base Station ACS interferer frequency offset values for band n46, n96 and n102

BS channel bandwidth of the lowest/highest carrier received (MHz)	Interfering signal centre frequency offset from the lower/upper Base Station RF Bandwidth edge or sub-block edge inside a sub-block gap (MHz)	Type of interfering signal
10	± 9.4675	20 MHz DFT-s-OFDM NR signal 15 kHz SCS, 100 RBs
20	± 9.4625	
40	± 9.4675	
60	± 9.4725	
80	± 9.4625	

7.4.1.3 Void

7.4.1.4 Void

7.4.2 In-band blocking

7.4.2.1 General

The in-band blocking characteristics is a measure of the receiver's ability to receive a wanted signal at its assigned channel at the *antenna connector* for *BS type 1-C* or *TAB connector* for *BS type 1-H* in the presence of an unwanted interferer, which is an NR signal for general blocking or an NR signal with one resource block for narrowband blocking.

7.4.2.2 Minimum requirement for *BS type 1-C* and *BS type 1-H*

The throughput shall be $\geq 95\%$ of the maximum throughput of the reference measurement channel, with a wanted and an interfering signal coupled to *BS type 1-C antenna connector* or *BS type 1-H TAB connector* using the parameters in tables 7.4.2.2-1, 7.4.2.2-2 and 7.4.2.2-3 for general blocking and narrowband blocking requirements. Narrowband blocking requirements are not applied for band n46, n96, n102 and n104. The reference measurement channel for the wanted signal is identified in clause 7.2.2 for each *BS channel bandwidth* and further specified in annex A.1. The characteristics of the interfering signal is further specified in annex D.

For NB-IoT operation in NR in-band, the throughput shall be $\geq 95\%$ of the maximum throughput of the reference measurement channel, with a wanted and an interfering signal coupled to *BS type 1-C antenna connector* using the parameters in tables 7.4.2.2-1, 7.4.2.2-2a and 7.4.2.2-3 for general blocking and narrowband blocking requirements. The reference measurement channel for the NB-IoT wanted signal is identified in clause 7.2.1 of TS 36.104 [13]. The characteristics of the interfering signal is further specified in annex D.

The in-band blocking requirements apply outside the *Base Station RF Bandwidth* or *Radio Bandwidth*. The interfering signal offset is defined relative to the *Base Station RF Bandwidth edges* or *Radio Bandwidth edges*.

The in-band blocking requirement shall apply from $F_{UL,low} - \Delta f_{OOB}$ to $F_{UL,high} + \Delta f_{OOB}$, excluding the downlink frequency range of the *FDD operating band*. The Δf_{OOB} for *BS type 1-C* and *BS type 1-H* is defined in table 7.4.2.2-0.

Minimum conducted requirement is defined at the *antenna connector* for *BS type 1-C* and at the *TAB connector* for *BS type 1-H*.

Table 7.4.2.2-0: Δf_{OOB} offset for NR operating bands

BS type	Operating band characteristics	Δf_{OOB} (MHz)
BS type 1-C	$F_{UL,high} - F_{UL,low} \leq 200$ MHz	20
	200 MHz $< F_{UL,high} - F_{UL,low} \leq 900$ MHz	60
BS type 1-H	$F_{UL,high} - F_{UL,low} < 100$ MHz	20
	100 MHz $\leq F_{UL,high} - F_{UL,low} \leq 900$ MHz	60

For band n46, n96 and n102, Δf_{OOB} is defined in table 7.4.2.2-0a.

Table 7.4.2.2-0a: Δf_{OOB} offset for NR operating bands for band n46, n96 and n102

Operating band	Δf_{OOB} (MHz)
n46, n102	60
n96	70

For band n104, Δf_{OOB} for *BS type 1-C* and *BS type 1-H* is defined in table 7.4.2.2-0b.

Table 7.4.2.2-0b: Δf_{OOB} offset for NR operating bands for band n104

BS type	Operating band	Δf_{OOB} (MHz)
BS type 1-H	n104	100
BS type 1-C	n104	60

For a BS operating in *non-contiguous spectrum* within any *operating band*, the in-band blocking requirements apply in addition inside any *sub-block gap*, in case the *sub-block gap* size is at least as wide as twice the interfering signal minimum offset in tables 7.4.2.2-1. The interfering signal offset is defined relative to the *sub-block* edges inside the *sub-block gap*.

For a *multi-band connector*, the blocking requirements apply in the in-band blocking frequency ranges for each supported *operating band*. The requirement shall apply in addition inside any *Inter RF Bandwidth gap*, in case the *Inter RF Bandwidth gap* size is at least as wide as twice the interfering signal minimum offset in tables 7.4.2.2-1.

For a BS operating in *non-contiguous spectrum* within any *operating band*, the narrowband blocking requirement shall apply in addition inside any *sub-block gap*, in case the *sub-block gap* size is at least as wide as the *channel bandwidth* of the NR interfering signal in Table 7.4.2.2-3. The interfering signal offset is defined relative to the *sub-block* edges inside the *sub-block gap*.

For a *multi-band connector*, the narrowband blocking requirement shall apply in addition inside any *Inter RF Bandwidth gap*, in case the *Inter RF Bandwidth gap* size is at least as wide as the NR interfering signal in Table 7.4.2.2-3. The interfering signal offset is defined relative to the *Base Station RF Bandwidth* edges inside the *Inter RF Bandwidth gap*.

Table 7.4.2.2-1: Base station general blocking requirement

BS channel bandwidth of the lowest/highest carrier received (MHz)	Wanted signal mean power (dBm) (Note 2)	Interfering signal mean power (dBm)	Interfering signal centre frequency minimum offset from the lower/upper Base Station RF Bandwidth edge or sub-block edge inside a sub-block gap (MHz)	Type of interfering signal
5, 10, 15, 20	$P_{\text{REFSENS}} + x$ dB	Wide Area BS: -43 Medium Range BS: -38 Local Area BS: -35	± 7.5	5 MHz DFT-s-OFDM NR signal 15 kHz SCS, 25 RBs
25, 30, 35, 40, 45, 50, 60, 70, 80, 90, 100	$P_{\text{REFSENS}} + x$ dB	Wide Area BS: -43 Medium Range BS: -38 Local Area BS: -35	± 30	20 MHz DFT-s-OFDM NR signal 15 kHz SCS, 100 RBs
NOTE 1: P_{REFSENS} depends on the RAT. For NR, P_{REFSENS} depends also on the <i>BS channel bandwidth</i> as specified in tables 7.2.2-1, 7.2.2-2 and 7.2.2-3. For band n104, P_{REFSENS} depends on the <i>BS channel bandwidth</i> as specified in tables 7.2.2-1a, 7.2.2-2c, and 7.2.2-3c. For NB-IoT, P_{REFSENS} depends also on the <i>sub-carrier spacing</i> as specified in tables 7.2.1-5, 7.2.1-5a and 7.2.1-5c of TS 36.104 [13].				
NOTE 2: For a BS capable of single band operation only, "x" is equal to 6 dB. For a BS capable of multi-band operation, "x" is equal to 6 dB in case of interfering signals that are in the in-band blocking frequency range of the operating band where the wanted signal is present or in the in-band blocking frequency range of an adjacent or overlapping operating band. For other in-band blocking frequency ranges of the interfering signal for the supported operating bands, "x" is equal to 1.4 dB.				

Table 7.4.2.2-1a: Base station general blocking requirement for n46

BS channel bandwidth of the lowest/highest carrier received (MHz)	Wanted signal mean power (dBm)	Interfering signal mean power (dBm)	Interfering signal centre frequency minimum offset from the lower/upper Base Station RF Bandwidth edge or sub-block edge inside a sub-block gap (MHz)	Type of interfering signal
10, 20, 40, 60, 80	$P_{\text{REFSENS}} + 6$ dB	Medium Range BS: -38 Local Area BS: -35	± 30	20 MHz DFT-s-OFDM NR signal 15 kHz SCS, 100 RBs
NOTE: P_{REFSENS} depends on the RAT. For NR, P_{REFSENS} depends also on the <i>BS channel bandwidth</i> as specified in tables 7.2.2-2a and 7.2.2-3a.				

Table 7.4.2.2-1b: Base station general blocking requirement for n96 and n102

BS channel bandwidth of the lowest/highest carrier received (MHz)	Wanted signal mean power (dBm)	Interfering signal mean power (dBm)	Interfering signal centre frequency minimum offset from the lower/upper Base Station RF Bandwidth edge or sub-block edge inside a sub-block gap (MHz)	Type of interfering signal
20, 40, 60, 80	$P_{\text{REFSENS}} + 6$ dB	Medium Range BS: -38 Local Area BS: -35	± 30	20 MHz DFT-s-OFDM NR signal 15 kHz SCS, 100 RBs
NOTE 1: P_{REFSENS} depends on the RAT. For NR, P_{REFSENS} depends also on the <i>BS channel bandwidth</i> as specified in tables 7.2.2-2b and 7.2.2-3b.				

Table 7.4.2.2-2: Base Station narrowband blocking requirement

<i>BS channel bandwidth of the lowest/highest carrier received (MHz)</i>	Wanted signal mean power (dBm)	Interfering signal mean power (dBm)
5, 10, 15, 20, 25, 30, 35, 40, 45, 50, 60, 70, 80, 90, 100 (Note 1)	$P_{\text{REFSENS}} + 6$ dB	Wide Area BS: -49 Medium Range BS: -44 Local Area BS: -41
NOTE 1: The SCS for the <i>lowest/highest carrier</i> received is the lowest SCS supported by the BS for that <i>BS channel bandwidth</i>		
NOTE 2: P_{REFSENS} depends on the <i>BS channel bandwidth</i> as specified in tables 7.2.2-1, 7.2.2-2 and 7.2.2-3.		
NOTE 3: 7.5 kHz shift is not applied to the wanted signal.		

Table 7.4.2.2-2a: Base Station narrowband blocking requirement for NB-IoT operation in NR in-band

BS channel bandwidth (MHz)	Wanted signal mean power (dBm)	Interfering signal mean power (dBm)
5, 10, 15, 20, 25, 30, 35, 40, 45, 50	$P_{\text{REFSENS}} + x$ dB (Note 2)	Wide Area: -49 Medium Range: -44 Local Area: -41
NOTE 1: P_{REFSENS} depends on the <i>sub-carrier spacing</i> as specified in tables 7.2.1-5, 7.2.1-5a and 7.2.1-5c of TS 36.104 [13].		
NOTE 2: "x" is equal to 8 in case of 5 MHz channel bandwidth and equal to 6 otherwise.		

Table 7.4.2.2-3: Base Station narrowband blocking interferer frequency offsets

BS channel bandwidth of the lowest/highest carrier received (MHz)	Interfering RB centre frequency offset to the lower/upper Base Station RF Bandwidth edge or sub-block edge inside a sub-block gap (kHz) (Note 2)	Type of interfering signal	
5	$\pm(350+m*180)$, m=0, 1, 2, 3, 4, 9, 14, 19, 24	5 MHz DFT-s-OFDM NR signal, 15 kHz SCS, 1 RB	
10	$\pm(355+m*180)$, m=0, 1, 2, 3, 4, 9, 14, 19, 24		
15	$\pm(360+m*180)$, m=0, 1, 2, 3, 4, 9, 14, 19, 24		
20	$\pm(350+m*180)$, m=0, 1, 2, 3, 4, 9, 14, 19, 24		
25	$\pm(565+m*180)$, m=0, 1, 2, 3, 4, 29, 54, 79, 99	20 MHz DFT-s-OFDM NR signal, 15 kHz SCS, 1 RB	
30	$\pm(570+m*180)$, m=0, 1, 2, 3, 4, 29, 54, 79, 99		
35	$\pm(560+m*180)$, m=0, 1, 2, 3, 4, 29, 54, 79, 99		
40	$\pm(565+m*180)$, m=0, 1, 2, 3, 4, 29, 54, 79, 99		
45	$\pm(570+m*180)$, m=0, 1, 2, 3, 4, 29, 54, 79, 99		
50	$\pm(560+m*180)$, m=0, 1, 2, 3, 4, 29, 54, 79, 99		
60	$\pm(570+m*180)$, m=0, 1, 2, 3, 4, 29, 54, 79, 99		
70	$\pm(565+m*180)$, m=0, 1, 2, 3, 4, 29, 54, 79, 99		
80	$\pm(560+m*180)$, m=0, 1, 2, 3, 4, 29, 54, 79, 99		
90	$\pm(570+m*180)$, m=0, 1, 2, 3, 4, 29, 54, 79, 99		
100	$\pm(565+m*180)$, m=0, 1, 2, 3, 4, 29, 54, 79, 99		
NOTE 1: Interfering signal consisting of one resource block positioned at the stated offset, the <i>channel bandwidth</i> of the interfering signal is located adjacently to the lower/upper <i>Base Station RF Bandwidth edge</i> or <i>sub-block edge</i> inside a <i>sub-block gap</i> .			
NOTE 2: The centre of the interfering RB refers to the frequency location between the two central subcarriers.			

7.4.2.3 Void

7.4.2.4 Void

7.4.2.5 Additional narrowband blocking requirement for Band n100

The following requirement shall apply to BS operating in Band n100 in CEPT countries. For the wanted and interfering signal coupled to the antenna connector, using the parameters in table 7.4.2.5-1 and 7.4.2.5-2, the throughput shall be $\geq 95\%$ of the maximum throughput of the reference measurement channel.

Table 7.4.2.5-1: Additional narrowband blocking requirement for RMR BS operating in n100

BS channel bandwidth of the lowest carrier received (MHz)	Wanted signal mean power (dBm)	Interfering signal mean power (dBm)
5	$P_{\text{REFSENS}} + 6$ dB	Wide Area BS: -39 (Note 2)
NOTE 1: P_{REFSENS} depends on the <i>BS channel bandwidth</i> as specified in clause 7.2.2.		
NOTE 2: Interfering signal mean power level was derived considering an interfering signal with 10% duty cycle. For more details, refer to TR 38.853 [23].		

Table 7.4.2.5-2: Interferer frequency for additional narrowband blocking requirement for RMR BS operating in n100

BS channel bandwidth of the lowest carrier received (MHz)	Interfering RB centre frequency (Note 2)	Type of interfering signal
5	874.4 MHz - (350 kHz + $m \cdot 180$ kHz), $m=0, 1, 2, 3, 4, 9, 14, 19$	5 MHz DFT-s-OFDM NR signal, 15 kHz SCS, 1 RB
NOTE 1: Interfering signal consisting of one resource block positioned at the stated frequency, the <i>channel bandwidth</i> of the interfering signal is located adjacently to the lower UL <i>operating band</i> edge.		
NOTE 2: The centre of the interfering RB refers to the frequency location between the two central subcarriers.		

7.5 Out-of-band blocking

7.5.1 General

The out-of-band blocking characteristics is a measure of the receiver ability to receive a wanted signal at its assigned channel at the *antenna connector* for *BS type I-C* or *TAB connector* for *BS type I-H* in the presence of an unwanted interferer out of the *operating band*, which is a CW signal for out-of-band blocking.

7.5.2 Minimum requirement for *BS type 1-C* and *BS type 1-H*

Except for band n46, n96, n102 and n104, the throughput shall be $\geq 95\%$ of the maximum throughput of the reference measurement channel, with a wanted and an interfering signal coupled to *BS type 1-C antenna connector* or *BS type 1-H TAB connector* using the parameters in table 7.5.2-1.

For band n46, n96 and n102, the throughput shall be $\geq 95\%$ of the maximum throughput of the reference measurement channel, with a wanted and an interfering signal coupled to *BS type 1-C antenna connector* or *BS type 1-H TAB connector* using the parameters in table 7.5.2-1a.

For *BS type 1-C* operating in band n104, the throughput shall be $\geq 95\%$ of the maximum throughput of the reference measurement channel, with a wanted and an interfering signal coupled to *BS type 1-C antenna connector* using the parameters in table 7.5.2-1a.

For *BS type 1-H* operating in band n104, the throughput shall be $\geq 95\%$ of the maximum throughput of the reference measurement channel, with a wanted and an interfering signal coupled to *BS type 1-H TAB connector* using the parameters in table 7.5.2-1.

The reference measurement channel for the wanted signal is identified in clause 7.2.2 for each *BS channel bandwidth* and further specified in annex A.1. The characteristics of the interfering signal is further specified in annex D.

For NB-IoT operation in NR in-band, the throughput shall be $\geq 95\%$ of the maximum throughput of the reference measurement channel, with a wanted and an interfering signal coupled to *BS type 1-C antenna connector* using the parameters in table 7.5.2-1. The reference measurement channel for the NB-IoT wanted signal is identified in clause 7.2.1 of TS 36.104 [13].

The out-of-band blocking requirement apply from 1 MHz to $F_{UL,low} - \Delta f_{OOB}$ and from $F_{UL,high} + \Delta f_{OOB}$ up to 12750 MHz, including the downlink frequency range of the *FDD operating band* for BS supporting FDD. The Δf_{OOB} for *BS type 1-C* and *BS type 1-H* is defined in table 7.4.2.2-0.

Minimum conducted requirement is defined at the *antenna connector* for *BS type 1-C* and at the *TAB connector* for *BS type 1-H*.

For a *multi-band connector*, the requirement in the out-of-band blocking frequency ranges apply for each *operating band*, with the exception that the in-band blocking frequency ranges of all supported *operating bands* according to clause 7.4.2.2 shall be excluded from the out-of-band blocking requirement.

Table 7.5.2-1: Out-of-band blocking performance requirement for NR

Wanted Signal mean power (dBm)	Interfering Signal mean power (dBm)	Type of Interfering Signal
$P_{\text{REFSENS}} + 6$ dB (Note)	-15	CW carrier
<p>NOTE 1: P_{REFSENS} depends on the RAT. For NR, P_{REFSENS} depends also on the <i>BS channel bandwidth</i> as specified in Table 7.2.2-1, 7.2.2-2, and 7.2.2-3. For band n104, P_{REFSENS} depends on the <i>BS channel bandwidth</i> as specified in tables 7.2.2-1a, 7.2.2-2c, and 7.2.2-3c. For NB-IoT, P_{REFSENS} depends also on the <i>sub-carrier spacing</i> as specified in tables 7.2.1-5, 7.2.1-5a and 7.2.1-5c of TS 36.104 [13].</p> <p>NOTE 2: For NB-IoT, up to 24 exceptions are allowed for spurious response frequencies in each wanted signal frequency when measured using a 1MHz step size. For these exceptions the above throughput requirement shall be met when the blocking signal is set to a level of -40 dBm for 15 kHz subcarrier spacing and -46 dBm for 3.75 kHz subcarrier spacing. In addition, each group of exceptions shall not exceed three contiguous measurements using a 1MHz step size.</p> <p>NOTE 3: Void</p>		

Table 7.5.2-1a: Out-of-band blocking performance requirement for NR band n46, n96, n102 and n104 for BS type 1-C

Operating Band	Centre Frequency of Interfering Signal [MHz]	Wanted Signal mean power (dBm)	Interfering Signal mean power (dBm)	Type of Interfering Signal
n46, n96, n102	($F_{UL_low} - 500$) to ($F_{UL_low} - \Delta f_{OOB}$) ($F_{UL_high} + \Delta f_{OOB}$) to ($F_{UL_high} + 500$)	$P_{REFSENS} + 6\text{dB}$	-35	CW carrier
	1 to ($F_{UL_low} - 500$) ($F_{UL_high} + 500$) to 12750	$P_{REFSENS} + 6\text{dB}$	-15	CW carrier
n104	($F_{UL_low} - 100$) to ($F_{UL_low} - \Delta f_{OOB}$) ($F_{UL_high} + \Delta f_{OOB}$) to ($F_{UL_high} + 100$)	$P_{REFSENS} + 6\text{dB}$	-35	CW carrier
	1 to ($F_{UL_low} - 100$) ($F_{UL_high} + 100$) to 12750	$P_{REFSENS} + 6\text{dB}$	-15	CW carrier
NOTE 1: For band n46, n96, n102, $P_{REFSENS}$ depends on the <i>BS channel bandwidth</i> as specified in tables 7.2.2-2a, 7.2.2-2b, 7.2.2-3a, 7.2.2-3b.				
NOTE 2: For band n104, $P_{REFSENS}$ depends on the <i>BS channel bandwidth</i> as specified in tables 7.2.2-1a, 7.2.2-2c, 7.2.2-3c.				

7.5.3 Co-location minimum requirements for *BS type 1-C* and *BS type 1-H*

This additional blocking requirement may be applied for the protection of NR BS receivers when GSM, CDMA, UTRA, E-UTRA or NR BS operating in a different frequency band are co-located with a NR BS. The requirement is applicable to all *BS channel bandwidths* supported by the NR BS.

The requirements in this clause assume a 30 dB coupling loss between interfering transmitter and NR BS receiver and are based on co-location with base stations of the same class.

The throughput shall be $\geq 95\%$ of the maximum throughput of the reference measurement channel, with a wanted and an interfering signal coupled to *BS type 1-C antenna connector* or *BS type 1-H TAB connector* input using the parameters in table 7.5.3-1 for all the BS classes. The reference measurement channel for the wanted signal is identified in tables 7.2.2-1, 7.2.2-2 and 7.2.2-3 for each *BS channel bandwidth* and further specified in annex A.1.

The blocking requirement for co-location with BS in other bands is applied for all *operating bands* for which co-location protection is provided.

Minimum conducted requirement is defined at the *antenna connector* for *BS type 1-C* and at the *TAB connector* for *BS type 1-H*.

Table 7.5.3-1: Blocking performance requirement for NR BS when co-located with BS in other frequency bands.

Frequency range of interfering signal	Wanted signal mean power (dBm)	Interfering signal mean power for WA BS (dBm)	Interfering signal mean power for MR BS (dBm)	Interfering signal mean power for LA BS (dBm)	Type of interfering signal
Frequency range of co-located downlink <i>operating band</i>	$P_{REFSENS} + 6\text{dB}$ (Note 1)	+16	+8	x (Note 2)	CW carrier
NOTE 1: $P_{REFSENS}$ depends on the <i>BS channel bandwidth</i> as specified in Table 7.2.2-1, 7.2.2-2, and 7.2.2-3.					
NOTE 2: x = -7 dBm for NR BS co-located with Pico GSM850 or Pico CDMA850 x = -4 dBm for NR BS co-located with Pico DCS1800 or Pico PCS1900 x = -6 dBm for NR BS co-located with UTRA bands or E-UTRA bands or NR bands					
NOTE 3: The requirement does not apply when the interfering signal falls within any of the supported uplink <i>operating band(s)</i> or in Δf_{OOB} immediately outside any of the supported uplink <i>operating band(s)</i> .					
NOTE 4: For unsynchronized base stations (except in band n46, n96 and n102), special co-location requirements may apply that are not covered by the 3GPP specifications.					

7.5.4 Void

7.5.5 Additional out-of-band blocking requirements for the use of RMR bands

For the additional out-of-band blocking requirements, the interfering signal differs from the one used for the general out-of-band blocking requirement.

The throughput shall be $\geq 95\%$ of the maximum throughput of the reference measurement channel, with a wanted and an interfering signal coupled to *BS type 1-C antenna connector* using the parameters in table 7.5.5-1. The reference measurement channel for the wanted signal is identified in clause 7.2.2 for each *BS channel bandwidth* and further specified in annex A.1.

The following requirement may apply to BS operating in band n101 in certain regions.

Table 7.5.5-1: Additional out-of-band blocking requirement for RMR BS operating in n101

BS channel bandwidth of the lowest/highest carrier received (MHz)	Wanted signal mean power (dBm)	Interfering signal mean power (dBm)	Centre frequency of interfering signal (MHz)	Type of interfering signal
5, 10	$P_{\text{REFSENS}} + 3 \text{ dB}$	Wide Area BS: -20	1807.5 - 1877.5	5 MHz LTE signal
NOTE: P_{REFSENS} depends on the <i>BS channel bandwidth</i> as specified in table 7.2.2-1.				

7.6 Receiver spurious emissions

7.6.1 General

The receiver spurious emissions power is the power of emissions generated or amplified in a receiver unit that appear at the *antenna connector* (for *BS type 1-C*) or at the *TAB connector* (for *BS type 1-H*). The requirements apply to all BS with separate RX and TX *antenna connectors* / *TAB connectors*.

NOTE: In this case for FDD operation the test is performed when both TX and RX are ON, with the TX *antenna connectors* / *TAB connectors* terminated.

For *antenna connectors* / *TAB connectors* supporting both RX and TX in TDD, the requirements apply during the *transmitter OFF period*. For *antenna connectors* / *TAB connectors* supporting both RX and TX in FDD, the RX spurious emissions requirements are superseded by the TX spurious emissions requirements, as specified in clause 6.6.5.

For RX-only *multi-band connectors*, the spurious emissions requirements are subject to exclusion zones in each supported *operating band*. For *multi-band connectors* that both transmit and receive in *operating band* supporting TDD, RX spurious emissions requirements are applicable during the *TX OFF period*, and are subject to exclusion zones in each supported *operating band*.

For *BS type 1-H* manufacturer shall declare *TAB connector RX min cell groups*. Every *TAB connector* of *BS type 1-H* supporting reception in an *operating band* shall map to one *TAB connector RX min cell group*, where mapping of *TAB connectors* to cells/beams is implementation dependent.

The number of active receiver units that are considered when calculating the conducted RX spurious emission limits ($N_{\text{RXU,counted}}$) for *BS type 1-H* is calculated as follows:

$$N_{\text{RXU,counted}} = \min(N_{\text{RXU,active}}, 8 \times N_{\text{cells}})$$

$N_{\text{RXU,countedpercell}}$ is used for scaling of *basic limits* and is derived as $N_{\text{RXU,countedpercell}} = N_{\text{RXU,counted}} / N_{\text{cells}}$, where N_{cells} is defined in clause 6.1.

NOTE: $N_{\text{RXU,active}}$ is the number of actually active receiver units and is independent to the declaration of N_{cells} .

7.6.2 Basic limits

The receiver spurious emissions *basic limits* are provided in table 7.6.2-1.

Table 7.6.2-1: General BS receiver spurious emissions limits

Spurious frequency range	Basic limits	Measurement bandwidth	Note
30 MHz – 1 GHz	-57 dBm	100 kHz	Note 1
1 GHz – 12.75 GHz	-47 dBm	1 MHz	Note 1, Note 2
12.75 GHz – 5 th harmonic of the upper frequency edge of the UL <i>operating band</i> in GHz	-47 dBm	1 MHz	Note 1, Note 2, Note 3
12.75 GHz - 26 GHz	-47 dBm	1 MHz	Note 1, Note 2, Note 5
NOTE 1: <i>Measurement bandwidths</i> as in ITU-R SM.329 [2], s4.1.			
NOTE 2: Upper frequency as in ITU-R SM.329 [2], s2.5 table 1.			
NOTE 3: Applies for Band for which the upper frequency edge of the UL <i>operating band</i> is greater than 2.55 GHz and less than or equal to 5.2 GHz.			
NOTE 4: The frequency range from Δf_{OBUE} below the lowest frequency of the BS transmitter <i>operating band</i> to Δf_{OBUE} above the highest frequency of the BS transmitter <i>operating band</i> may be excluded from the requirement. Δf_{OBUE} is defined in clause 6.6.1. For <i>multi-band connectors</i> , the exclusion applies for all supported <i>operating bands</i> .			
NOTE 5: Applies for Band for which the upper frequency edge of the UL <i>operating band</i> is greater than 5.2 GHz.			

7.6.3 Minimum requirement for BS type 1-C

The RX spurious emissions requirements for BS type 1-C are that for each *antenna connector*, the power of emissions shall not exceed *basic limits* specified in table 7.6.2-1.

For Band n41 and n90 operation in Japan, the sum of RX spurious emissions requirements over all *antenna connectors* for BS type 1-C shall not exceed *basic limits* specified in table 7.6.2-1.

The Rx spurious emissions requirements shall apply to BS that support NR or NR with NB-IoT operation in NR in-band.

7.6.4 Minimum requirement for BS type 1-H

The RX spurious emissions requirements for BS type 1-H are that for each applicable *basic limit* specified in table 7.6.2-1 for each *TAB connector RX min cell group*, the power sum of emissions at respective *TAB connectors* shall not exceed the BS limits specified as the *basic limits* + X, where $X = 10\log_{10}(N_{\text{RXU, counted per cell}})$, unless stated differently in regional regulation.

The RX spurious emission requirements are applied per the *TAB connector RX min cell group* for all the configurations supported by the BS.

NOTE: Conformance to the BS receiver spurious emissions requirement can be demonstrated by meeting at least one of the following criteria as determined by the manufacturer:

- 1) The sum of the spurious emissions power measured on each *TAB connector* in the *TAB connector RX min cell group* shall be less than or equal to the BS limit above for the respective frequency span.

Or

- 2) The spurious emissions power at each *TAB connector* shall be less than or equal to the BS limit as defined above for the respective frequency span, scaled by $-10\log_{10}(n)$, where n is the number of *TAB connectors* in the *TAB connector RX min cell group*.

7.7 Receiver intermodulation

7.7.1 General

Third and higher order mixing of the two interfering RF signals can produce an interfering signal in the band of the desired channel. Intermodulation response rejection is a measure of the capability of the receiver to receive a wanted signal on its assigned channel frequency at the *antenna connector* for *BS type 1-C* or *TAB connector* for *BS type 1-H* in the presence of two interfering signals which have a specific frequency relationship to the wanted signal.

7.7.2 Minimum requirement for *BS type 1-C* and *BS type 1-H*

The throughput shall be $\geq 95\%$ of the maximum throughput of the reference measurement channel, with a wanted signal at the assigned channel frequency and two interfering signals coupled to the *BS type 1-C antenna connector* or *BS type 1-H TAB connector*, with the conditions specified in tables 7.7.2-1 and 7.7.2-2 for intermodulation performance in any operating band except for band n46, n96 and n102, and 7.7.2-2a for band n46, n96 and n102 and in tables 7.7.2-3, and 7.7.2-4 for narrowband intermodulation performance. Narrowband intermodulation requirements are not applied for band n46, n96, n102 and n104. The reference measurement channel for the wanted signal is identified in tables 7.2.2-1, 7.2.2-2 and 7.2.2-3 for each *BS channel bandwidth* and further specified in annex A.1. The characteristics of the interfering signal is further specified in annex D.

For NB-IoT operation in NR in-band, the throughput shall be $\geq 95\%$ of the maximum throughput of the reference measurement channel, with a wanted signal at the assigned channel frequency and two interfering signals coupled to the *BS type 1-C antenna connector*, with the conditions specified in tables 7.7.2-1 and 7.7.2-2 for intermodulation performance and in tables 7.7.2-3, and 7.7.2-4 for narrowband intermodulation performance. The reference measurement channel for the NB-IoT wanted signal is identified in clause 7.2.1 of TS 36.104 [13]. The characteristics of the interfering signal is further specified in annex D.

The subcarrier spacing for the modulated interfering signal shall in general be the same as the subcarrier spacing for the wanted signal, except for the case of wanted signal subcarrier spacing 60 kHz and *BS channel bandwidth* ≤ 20 MHz, for which the subcarrier spacing of the interfering signal shall be 30 kHz.

The receiver intermodulation requirement is applicable outside the *Base Station RF Bandwidth* or *Radio Bandwidth edges*. The interfering signal offset is defined relative to the *Base Station RF Bandwidth edges* or *Radio Bandwidth edges*.

For a BS operating in *non-contiguous spectrum* within any *operating band*, the narrowband intermodulation requirement shall apply in addition inside any *sub-block gap* in case the *sub-block gap* is at least as wide as the *channel bandwidth* of the NR interfering signal in table 7.7.2-2 or 7.7.2-4. The interfering signal offset is defined relative to the *sub-block edges* inside the *sub-block gap*.

For a *multi-band connector*, the intermodulation requirement shall apply in addition inside any *Inter RF Bandwidth gap*, in case the gap size is at least twice as wide as the NR interfering signal centre frequency offset from the *Base Station RF Bandwidth edge*.

For a *multi-band connector*, the narrowband intermodulation requirement shall apply in addition inside any *Inter RF Bandwidth gap* in case the gap size is at least as wide as the NR interfering signal in tables 7.7.2-2 and 7.7.2-4. The interfering signal offset is defined relative to the *Base Station RF Bandwidth edges* inside the *Inter RF Bandwidth gap*.

Table 7.7.2-1: General intermodulation requirement

Base Station Type	Wanted Signal mean power (dBm)	Mean power of interfering signals (dBm)	Type of interfering signals
Wide Area BS	$P_{\text{REFSENS}} + 6$ dB	-52	See Table 7.7.2-2
Medium Range BS	$P_{\text{REFSENS}} + 6$ dB	-47	
Local Area BS	$P_{\text{REFSENS}} + 6$ dB	-44	
NOTE 1: P_{REFSENS} depends on the RAT and the BS class. For NR, P_{REFSENS} depends also on the <i>BS channel bandwidth</i> , see clause 7.2. For NB-IoT, P_{REFSENS} depends also on the <i>sub-carrier spacing</i> as specified in tables 7.2.1-5, 7.2.1-5a and 7.2.1-5c of TS 36.104 [13].			

Table 7.7.2-1a: General intermodulation requirement for band n46, n96 and n102

Base Station Type	Wanted Signal mean power (dBm)	Mean power of interfering signals (dBm)	Type of interfering signals
Medium Range BS	$P_{\text{REFSENS}} + 6$ dB	-47	See Table 7.7.2-2a
Local Area BS	$P_{\text{REFSENS}} + 6$ dB	-44	

NOTE 1: P_{REFSENS} depends on the RAT and the BS class. For NR, P_{REFSENS} depends also on the *BS channel bandwidth*, see clause 7.2.5.

Table 7.7.2-2: Interfering signals for intermodulation requirement

<i>BS channel bandwidth of the lowest/highest carrier received (MHz)</i>	<i>Interfering signal centre frequency offset from the lower/upper Base Station RF Bandwidth edge (MHz)</i>	<i>Type of interfering signal (Note 3)</i>
5	± 7.5	CW
	± 17.5	5 MHz DFT-s-OFDM NR signal (Note 1)
10	± 7.465	CW
	± 17.5	5 MHz DFT-s-OFDM NR signal (Note 1)
15	± 7.43	CW
	± 17.5	5 MHz DFT-s-OFDM NR signal (Note 1)
20	± 7.395	CW
	± 17.5	5 MHz DFT-s-OFDM NR signal (Note 1)
25	± 7.465	CW
	± 25	20MHz DFT-s-OFDM NR signal (Note 2)
30	± 7.43	CW
	± 25	20 MHz DFT-s-OFDM NR signal (Note 2)
35	± 7.44	CW
	± 25	20 MHz DFT-s-OFDM NR signal (Note 2)
40	± 7.45	CW
	± 25	20 MHz DFT-s-OFDM NR signal (Note 2)
45	± 7.37	CW
	± 25	20 MHz DFT-s-OFDM NR signal (Note 2)
50	± 7.35	CW
	± 25	20 MHz DFT-s-OFDM NR signal (Note 2)
60	± 7.49	CW
	± 25	20 MHz DFT-s-OFDM NR signal (Note 2)
70	± 7.42	CW
	± 25	20 MHz DFT-s-OFDM NR signal (Note 2)
80	± 7.44	CW
	± 25	20 MHz DFT-s-OFDM NR signal (Note 2)
90	± 7.46	CW
	± 25	20 MHz DFT-s-OFDM NR signal (Note 2)
100	± 7.48	CW
	± 25	20 MHz DFT-s-OFDM NR signal (Note 2)
<p>NOTE 1: Number of RBs is 25 for 15 kHz subcarrier spacing and 10 for 30 kHz subcarrier spacing.</p> <p>NOTE 2: Number of RBs is 100 for 15 kHz subcarrier spacing, 50 for 30 kHz subcarrier spacing and 24 for 60 kHz subcarrier spacing.</p> <p>NOTE 3: The RBs shall be placed adjacent to the transmission bandwidth configuration edge which is closer to the <i>Base Station RF Bandwidth edge</i>.</p>		

Table 7.7.2-2a: Interfering signals for intermodulation requirement for band n46, n96 and n102

<i>BS channel bandwidth of the lowest/highest carrier received (MHz)</i>	<i>Interfering signal centre frequency offset from the lower/upper Base Station RF Bandwidth edge (MHz)</i>	<i>Type of interfering signal (Note 2)</i>
10	±7.57	CW (Note 3)
	±25	20 MHz DFT-s-OFDM NR signal (Note 1, 3)
20	±7.50	CW
	±25	20 MHz DFT-s-OFDM NR signal (Note 1)
40	±7.45	CW
	±25	20 MHz DFT-s-OFDM NR signal (Note 1)
60	±7.49	CW
	±25	20 MHz DFT-s-OFDM NR signal (Note 1)
80	±7.44	CW
	±25	20 MHz DFT-s-OFDM NR signal (Note 1)
NOTE 1: Number of RBs is 100 for 15 kHz subcarrier spacing and 50 for 30 kHz subcarrier spacing. NOTE 2: The RBs shall be placed adjacent to the transmission bandwidth configuration edge which is closer to the <i>Base Station RF Bandwidth edge</i> . NOTE 3: This type of interfering signal is only applied for band n46.		

Table 7.7.2-3: Narrowband intermodulation performance requirement in FR1

BS type	Wanted signal mean power (dBm)	Interfering signal mean power (dBm)	Type of interfering signals
Wide Area BS	$P_{\text{REFSENS}} + 6\text{dB}$ (Note 1)	-52	See Table 7.7.2-4
Medium Range BS	$P_{\text{REFSENS}} + 6\text{dB}$ (Note 2)	-47	
Local Area BS	$P_{\text{REFSENS}} + 6\text{dB}$ (Note 3)	-44	
NOTE 1: P_{REFSENS} depends on the RAT. For NR, P_{REFSENS} depends also on the <i>BS channel bandwidth</i> as specified in table 7.2.2-1. For NB-IoT, P_{REFSENS} depends also on the <i>sub-carrier spacing</i> as specified in tables 7.2.1-5 of TS 36.104 [13]. NOTE 2: P_{REFSENS} depends on the RAT. For NR, P_{REFSENS} depends also on the <i>BS channel bandwidth</i> as specified in table 7.2.2-2. For NB-IoT, P_{REFSENS} depends also on the <i>sub-carrier spacing</i> as specified in tables 7.2.1-5c of TS 36.104 [13]. NOTE 3: P_{REFSENS} depends on the RAT. For NR, P_{REFSENS} depends also on the <i>BS channel bandwidth</i> as specified in table 7.2.2-3. For NB-IoT, P_{REFSENS} depends also on the <i>sub-carrier spacing</i> as specified in tables 7.2.1-5a of TS 36.104 [13]. NOTE 4: For NB-IoT, the requirement shall apply only for a FRC A1-3 of TS 36.104 [13] mapped to the frequency range at the channel edge adjacent to the interfering signals. NOTE 5: For NB-IoT, the frequency offset shall be adjusted to accommodate the IMD product to fall in the NB-IoT RB for NB-IoT operation in NR in-band. NOTE 6: For NB-IoT, if a BS RF receiver fails the test of the requirement, the test shall be performed with the CW interfering signal frequency shifted away from the wanted signal by 180 kHz and the NR interfering signal frequency shifted away from the wanted signal by 360 kHz. If the BS RF receiver still fails the test after the frequency shift, then the BS RF receiver shall be deemed to fail the requirement.			

Table 7.7.2-4: Interfering signals for narrowband intermodulation requirement in FR1

<i>BS channel bandwidth of the lowest/highest carrier received (MHz)</i>	<i>Interfering RB centre frequency offset from the lower/upper Base Station RF Bandwidth edge or sub-block edge inside a sub-block gap (kHz) (Note 3)</i>	<i>Type of interfering signal</i>
5	±360	CW
	±1420	5 MHz DFT-s-OFDM NR signal, 1 RB (Note 1)
10	±370	CW
	±1960	5 MHz DFT-s-OFDM NR signal, 1 RB (Note 1)
15 (Note 2)	±380	CW
	±1960	5 MHz DFT-s-OFDM NR signal, 1 RB (Note 1)
20 (Note 2)	±390	CW
	±2320	5 MHz DFT-s-OFDM NR signal, 1 RB (Note 1)
25 (Note 2)	±325	CW
	±2350	20 MHz DFT-s-OFDM NR signal, 1 RB (Note 1)
30 (Note 2)	±335	CW
	±2350	20 MHz DFT-s-OFDM NR signal, 1 RB (Note 1)
35 (Note 2)	±345	CW
	±2710	20 MHz DFT-s-OFDM NR signal, 1 RB (Note 1)
40 (Note 2)	±355	CW
	±2710	20 MHz DFT-s-OFDM NR signal, 1 RB (Note 1)
45 (Note 2)	±365	CW
	±2710	20 MHz DFT-s-OFDM NR signal, 1 RB (Note 1)
50 (Note 2)	±375	CW
	±2710	20 MHz DFT-s-OFDM NR signal, 1 RB (Note 1)
60 (Note 2)	±395	CW
	±2710	20 MHz DFT-s-OFDM NR signal, 1 RB (Note 1)
70 (Note 2)	±415	CW
	±2710	20 MHz DFT-s-OFDM NR signal, 1 RB (Note 1)
80 (Note 2)	±435	CW
	±2710	20 MHz DFT-s-OFDM NR signal, 1 RB (Note 1)
90 (Note 2)	±365	CW
	±2530	20 MHz DFT-s-OFDM NR signal, 1 RB (Note 1)
100 (Note 2)	±385	CW
	±2530	20 MHz DFT-s-OFDM NR signal, 1 RB (Note 1)
<p>NOTE 1: Interfering signal consisting of one resource block positioned at the stated offset, the <i>BS channel bandwidth</i> of the interfering signal is located adjacently to the lower/upper <i>Base Station RF Bandwidth edge</i> or <i>sub-block edge</i> inside a <i>sub-block gap</i>.</p> <p>NOTE 2: This requirement shall apply only for a G-FRC mapped to the frequency range at the <i>channel edge</i> adjacent to the interfering signals.</p> <p>NOTE 3: The centre of the interfering RB refers to the frequency location between the two central subcarriers.</p>		

7.7.3 Additional narrowband intermodulation requirement for Band n100

The following requirement shall apply to BS operating in Band n100 in CEPT countries. The throughput shall be $\geq 95\%$ of the maximum throughput of the reference measurement channel, with a wanted signal at the assigned channel frequency and two interfering signals coupled to the *BS type 1-C antenna connector* operating in Band n100, with the conditions specified in tables 7.7.3-1 and 7.7.3-2 for narrowband intermodulation performance. The reference measurement channel for the wanted signal is identified in table 7.2.2-1 and further specified in annex A.1. The characteristics of the interfering signal is further specified in annex D.

The receiver intermodulation requirement is applicable outside the *Base Station RF Bandwidth*. The interfering signal offset is defined relative to the *Base Station RF Bandwidth edges*.

Table 7.7.3-1: Additional narrowband intermodulation requirement for RMR BS operating in n100

Wanted signal mean power (dBm)	Interfering signal mean power (dBm)	Type of interfering signals
$P_{\text{PRESENSE}} + 6\text{dB}$	Wide Area BS: -39 (Note 2)	See Table 7.7.3-2
NOTE 1: P_{PRESENSE} depends also on the <i>BS channel bandwidth</i> as specified in clause 7.2.2.		
NOTE 2: Interfering signal mean power level was derived considering an interfering signal with 10% duty cycle. For more details, refer to TR 38.853 [23].		

Table 7.7.3-2: Interfering signals for the additional narrowband intermodulation requirement for RMR BS operating in n100

BS channel bandwidth of the lowest carrier received (MHz)	Interfering RB centre frequency offset from the lower Base Station RF Bandwidth edge (kHz) (Note 3)	Type of interfering signal
5	-360	CW
	-1420	5 MHz DFT-s-OFDM NR signal, 15 kHz SCS, 1 RB (Note 1)
NOTE 1: Interfering signal consisting of one resource block positioned at the stated offset, the <i>BS channel bandwidth</i> of the interfering signal is located adjacently to the lower <i>Base Station RF Bandwidth edge</i> .		
NOTE 2: This requirement shall apply only for a G-FRC mapped to the frequency range at the <i>channel edge</i> adjacent to the interfering signals.		
NOTE 3: The centre of the interfering RB refers to the frequency location between the two central subcarriers.		

7.8 In-channel selectivity

7.8.1 General

In-channel selectivity (ICS) is a measure of the receiver ability to receive a wanted signal at its assigned resource block locations at the *antenna connector* for *BS type 1-C* or *TAB connector* for *BS type 1-H* in the presence of an interfering signal received at a larger power spectral density. In this condition a throughput requirement shall be met for a specified reference measurement channel. The interfering signal shall be an NR signal which is time aligned with the wanted signal.

7.8.2 Minimum requirement for *BS type 1-C* and *BS type 1-H*

For *BS type 1-C* and *BS type 1-H*, the throughput shall be $\geq 95\%$ of the maximum throughput of the reference measurement channel as specified in annex A.1 with parameters specified in table 7.8.2-1 for Wide Area BS except for band n104, in table 7.8.2-1b for Wide Area BS for band n104, in table 7.8.2-2 for Medium Range BS except for band n46, n96, n102 and n104, in table 7.8.2-2b for Medium Range BS for band n46, in table 7.8.2-2c for Medium Range BS for band n96 and n102, in table 7.8.2-2d for Medium Range BS for band n104, in table 7.8.2-3 for Local Area BS except for band n46, n96, n102 and n104, in table 7.8.2-3b for Local Area BS for band n46, in table 7.8.2-3c for Local Area BS for band n96 and n102 and in table 7.8.2-3d for Local Area BS. The characteristics of the interfering signal is further specified in annex D.

For NB-IoT operation in NR in-band, the throughput shall be $\geq 95\%$ of the maximum throughput of the NB-IoT reference measurement channel as specified in Annex A of TS 36.104 [13] with parameters specified in table 7.8.2-1a for Wide Area BS, in table 7.8.2-2a for Medium Range BS and in table 7.8.2-3a for Local Area BS.

Table 7.8.2-1: Wide Area BS in-channel selectivity

<i>BS channel bandwidth (MHz)</i>	<i>Subcarrier spacing (kHz)</i>	<i>Reference measurement channel</i>	<i>Wanted signal mean power (dBm)</i>	<i>Interfering signal mean power (dBm)</i>	<i>Type of interfering signal</i>
5	15	G-FR1-A1-7	-100.6	-81.4	DFT-s-OFDM NR signal, 15 kHz SCS, 10 RBs
10, 15, 20, 25, 30, 35	15	G-FR1-A1-1	-98.7	-77.4	DFT-s-OFDM NR signal, 15 kHz SCS, 25 RBs
40, 45, 50	15	G-FR1-A1-4	-92.3	-71.4	DFT-s-OFDM NR signal, 15 kHz SCS, 100 RBs
5	30	G-FR1-A1-8	-101.3	-81.4	DFT-s-OFDM NR signal, 30 kHz SCS, 5 RBs
10, 15, 20, 25, 30, 35	30	G-FR1-A1-2	-98.8	-78.4	DFT-s-OFDM NR signal, 30 kHz SCS, 10 RBs
40, 45, 50, 60, 70, 80, 90, 100	30	G-FR1-A1-5	-92.6	-71.4	DFT-s-OFDM NR signal, 30 kHz SCS, 50 RBs
10, 15, 20, 25, 30, 35	60	G-FR1-A1-9	-98.2	-78.4	DFT-s-OFDM NR signal, 60 kHz SCS, 5 RBs
40, 45, 50, 60, 70, 80, 90, 100	60	G-FR1-A1-6	-92.7	-71.6	DFT-s-OFDM NR signal, 60 kHz SCS, 24 RBs
NOTE: Wanted and interfering signal are placed adjacently around F_c , where the F_c is defined for <i>BS channel bandwidth</i> of the wanted signal according to the table 5.4.2.2-1. The aggregated wanted and interferer signal shall be centred in the <i>BS channel bandwidth</i> of the wanted signal.					

Table 7.8.2-1a: Wide Area BS in-channel selectivity for NB-IoT operation in NR in-band

BS channel bandwidth (MHz)	Reference measurement channel	Wanted signal mean power (dBm)	Interfering signal mean power (dBm) / BW_{Config}	Type of interfering signal
5	FRC A14-1 in Annex A.14 in TS 36.104 [13]	-124.3	-81.4	DFT-s-OFDM NR signal, 15 kHz SCS, 10 RBs
10, 15, 20, 25, 30, 35			-77.4	DFT-s-OFDM NR signal, 15 kHz SCS, 25 RBs
40, 45, 50			-71.4	DFT-s-OFDM NR signal, 15 kHz SCS, 100 RBs
5	FRC A14-2 in Annex A.14 in TS 36.104 [13]	-130.2	-81.4	DFT-s-OFDM NR signal, 15 kHz SCS, 10 RBs
10, 15, 20, 25, 30, 35			-77.4	DFT-s-OFDM NR signal, 15 kHz SCS, 25 RBs
40, 45, 50			-71.4	DFT-s-OFDM NR signal, 15 kHz SCS, 100 RBs
NOTE: Interfering signal is placed in one side of the F_c , while the NB-IoT PRB is placed on the other side. Both interfering signal and NB-IoT PRB are placed at the middle of the available PRB locations. The wanted NB-IoT tone is placed at the centre of this NB-IoT PRB.				

Table 7.8.2-1b: Wide Area BS in-channel selectivity for band n104

BS channel bandwidth (MHz)	Subcarrier spacing (kHz)	Reference measurement channel	Wanted signal mean power (dBm)	Interfering signal mean power (dBm)	Type of interfering signal
20, 30	15	G-FR1-A1-1	-97.7	-76.4	DFT-s-OFDM NR signal, 15 kHz SCS, 25 RBs
40, 50	15	G-FR1-A1-4	-91.3	-70.4	DFT-s-OFDM NR signal, 15 kHz SCS, 100 RBs
20, 30	30	G-FR1-A1-2	-97.8	-77.4	DFT-s-OFDM NR signal, 30 kHz SCS, 10 RBs
40, 50, 60, 70, 80, 90, 100	30	G-FR1-A1-5	-91.6	-70.4	DFT-s-OFDM NR signal, 30 kHz SCS, 50 RBs
20, 30	60	G-FR1-A1-9	-97.2	-77.4	DFT-s-OFDM NR signal, 60 kHz SCS, 5 RBs
40, 50, 60, 70, 80, 90, 100	60	G-FR1-A1-6	-91.7	-70.6	DFT-s-OFDM NR signal, 60 kHz SCS, 24 RBs
NOTE 1: Wanted and interfering signal are placed adjacently around F_c , where the F_c is defined for BS channel bandwidth of the wanted signal according to the table 5.4.2.2-1. The aggregated wanted and interferer signal shall be centred in the BS channel bandwidth of the wanted signal.					

Table 7.8.2-2: Medium Range BS in-channel selectivity

<i>BS channel bandwidth</i> (MHz)	<i>Subcarrier spacing</i> (kHz)	<i>Reference measurement channel</i>	<i>Wanted signal mean power</i> (dBm)	<i>Interfering signal mean power</i> (dBm)	<i>Type of interfering signal</i>
5	15	G-FR1-A1-7	-95.6	-76.4	DFT-s-OFDM NR signal, 15 kHz SCS, 10 RBs
10, 15, 20, 25, 30, 35	15	G-FR1-A1-1	-93.7	-72.4	DFT-s-OFDM NR signal, 15 kHz SCS, 25 RBs
40, 45, 50	15	G-FR1-A1-4	-87.3	-66.4	DFT-s-OFDM NR signal, 15 kHz SCS, 100 RBs
5	30	G-FR1-A1-8	-96.3	-76.4	DFT-s-OFDM NR signal, 30 kHz SCS, 5 RBs
10, 15, 20, 25, 30, 35	30	G-FR1-A1-2	-93.8	-73.4	DFT-s-OFDM NR signal, 30 kHz SCS, 10 RBs
40, 45, 50, 60, 70, 80, 90, 100	30	G-FR1-A1-5	-87.6	-66.4	DFT-s-OFDM NR signal, 30 kHz SCS, 50 RBs
10, 15, 20, 25, 30, 35	60	G-FR1-A1-9	-93.2	-73.4	DFT-s-OFDM NR signal, 60 kHz SCS, 5 RBs
40, 45, 50, 60, 70, 80, 90, 100	60	G-FR1-A1-6	-87.7	-66.6	DFT-s-OFDM NR signal, 60 kHz SCS, 24 RBs
NOTE: Wanted and interfering signal are placed adjacently around F_c , where the F_c is defined for <i>BS channel bandwidth</i> of the wanted signal according to the table 5.4.2.2-1. The aggregated wanted and interferer signal shall be centred in the <i>BS channel bandwidth</i> of the wanted signal.					

Table 7.8.2-2a: Medium Range BS in-channel selectivity for NB-IoT operation in NR in-band

<i>BS channel bandwidth</i> (MHz)	<i>Reference measurement channel</i>	<i>Wanted signal mean power</i> (dBm)	<i>Interfering signal mean power</i> (dBm) / BW_{Config}	<i>Type of interfering signal</i>
5	FRC A14-1 in Annex A.14 in TS 36.104 [13]	-119.3	-76.4	DFT-s-OFDM NR signal, 15 kHz SCS, 10 RBs
10, 15, 20, 25, 30, 35			-72.4	DFT-s-OFDM NR signal, 15 kHz SCS, 25 RBs
40, 45, 50			-66.4	DFT-s-OFDM NR signal, 15 kHz SCS, 100 RBs
5	FRC A14-2 in Annex A.14 in TS 36.104 [13]	-125.2	-76.4	DFT-s-OFDM NR signal, 15 kHz SCS, 10 RBs
10, 15, 20, 25, 30, 35			-72.4	DFT-s-OFDM NR signal, 15 kHz SCS, 25 RBs
40, 45, 50			-66.4	DFT-s-OFDM NR signal, 15 kHz SCS, 100 RBs
NOTE: Interfering signal is placed in one side of the F_c , while the NB-IoT PRB is placed on the other side. Both interfering signal and NB-IoT PRB are placed at the middle of the available PRB locations. The wanted NB-IoT tone is placed at the centre of this NB-IoT PRB.				

Table 7.8.2-2b: Medium Range BS in-channel selectivity for band n46

<i>BS channel bandwidth</i> (MHz)	Subcarrier spacing (kHz)	Reference measurement channel	Wanted signal mean power (dBm)	Interfering signal mean power (dBm)	Type of interfering signal
10	15	G-FR1-A1-12	-100.0	-79.5	CP-OFDM NR signal, 15 kHz SCS, 10 RBs
	30	G-FR1-A1-13	-97.7	-77.4	CP-OFDM NR signal, 30 kHz SCS, 10 RBs
	60	G-FR1-A1-9	-93.2	-73.4	DFT-s-OFDM NR signal, 60 kHz SCS, 5 RBs
20	15	G-FR1-A1-14	-97.1	-76.4	CP-OFDM NR signal, 15 kHz SCS, 10 RBs
	30	G-FR1-A1-15	-94.1	-73.4	CP-OFDM NR signal, 30 kHz SCS, 10 RBs
	60	G-FR1-A1-9	-93.2	-73.4	DFT-s-OFDM NR signal, 60 kHz SCS, 5 RBs
40	15	G-FR1-A1-16	-94.0	-73.2	CP-OFDM NR signal, 15 kHz SCS, 20 RBs
	30	G-FR1-A1-17	-91.0	-70.2	CP-OFDM NR signal, 30 kHz SCS, 10 RBs
	60	G-FR1-A1-6	-87.7	-66.6	DFT-s-OFDM NR signal, 60 kHz SCS, 24 RBs
60	30	G-FR1-A1-18	-89.4	-68.4	CP-OFDM NR signal, 30 kHz SCS, 20 RBs
	60	G-FR1-A1-6	-87.7	-66.6	DFT-s-OFDM NR signal, 60 kHz SCS, 24 RBs
80	30	G-FR1-A1-19	-88.1	-67.1	CP-OFDM NR signal, 30 kHz SCS, 20 RBs
	60	G-FR1-A1-6	-87.7	-66.6	DFT-s-OFDM NR signal, 60 kHz SCS, 24 RBs
NOTE: Wanted and interfering signal are placed adjacently around F_c , where the F_c is defined for <i>BS channel bandwidth</i> of the wanted signal according to the table 5.4.2.2-1. The aggregated wanted and interferer signal shall be centred in the BS channel bandwidth of the wanted signal.					

Table 7.8.2-2c: Medium Range BS in-channel selectivity for band n96 and n102

<i>BS channel bandwidth</i> (MHz)	Subcarrier spacing (kHz)	Reference measurement channel	Wanted signal mean power (dBm)	Interfering signal mean power (dBm)	Type of interfering signal
20	15	G-FR1-A1-14	-96.1	-75.4	CP-OFDM NR signal, 15 kHz SCS, 10 RBs
	30	G-FR1-A1-15	-93.1	-72.4	CP-OFDM NR signal, 30 kHz SCS, 10 RBs
	60	G-FR1-A1-9	-92.2	-72.4	DFT-s-OFDM NR signal, 60 kHz SCS, 5 RBs
40	15	G-FR1-A1-16	-93.0	-72.2	CP-OFDM NR signal, 15 kHz SCS, 20 RBs
	30	G-FR1-A1-17	-90.0	-69.2	CP-OFDM NR signal, 30 kHz SCS, 10 RBs
	60	G-FR1-A1-6	-86.7	-65.6	DFT-s-OFDM NR signal, 60 kHz SCS, 24 RBs
60	30	G-FR1-A1-18	-88.4	-67.4	CP-OFDM NR signal, 30 kHz SCS, 20 RBs
	60	G-FR1-A1-6	-86.7	-65.6	DFT-s-OFDM NR signal, 60 kHz SCS, 24 RBs
80	30	G-FR1-A1-19	-87.1	-66.1	CP-OFDM NR signal, 30 kHz SCS, 20 RBs
	60	G-FR1-A1-6	-86.7	-65.6	DFT-s-OFDM NR signal, 60 kHz SCS, 24 RBs
NOTE: Wanted and interfering signal are placed adjacently around F_c , where the F_c is defined for <i>BS channel bandwidth</i> of the wanted signal according to the table 5.4.2.2-1. The aggregated wanted and interferer signal shall be centred in the BS channel bandwidth of the wanted signal.					

Table 7.8.2-2d: Medium Range BS in-channel selectivity for band n104

BS channel bandwidth (MHz)	Subcarrier spacing (kHz)	Reference measurement channel	Wanted signal mean power (dBm)	Interfering signal mean power (dBm)	Type of interfering signal
20, 30	15	G-FR1-A1-1	-92.7	-71.4	DFT-s-OFDM NR signal, 15 kHz SCS, 25 RBs
40, 50	15	G-FR1-A1-4	-86.3	-65.4	DFT-s-OFDM NR signal, 15 kHz SCS, 100 RBs
20, 30	30	G-FR1-A1-2	-92.8	-72.4	DFT-s-OFDM NR signal, 30 kHz SCS, 10 RBs
40, 50, 60, 70, 80, 90, 100	30	G-FR1-A1-5	-86.6	-65.4	DFT-s-OFDM NR signal, 30 kHz SCS, 50 RBs
20, 30	60	G-FR1-A1-9	-92.2	-72.4	DFT-s-OFDM NR signal, 60 kHz SCS, 5 RBs
40, 50, 60, 70, 80, 90, 100	60	G-FR1-A1-6	-86.7	-65.6	DFT-s-OFDM NR signal, 60 kHz SCS, 24 RBs
NOTE: Wanted and interfering signal are placed adjacently around F_c , where the F_c is defined for <i>BS channel bandwidth</i> of the wanted signal according to the table 5.4.2.2-1. The aggregated wanted and interferer signal shall be centred in the <i>BS channel bandwidth</i> of the wanted signal.					

Table 7.8.2-3: Local area BS in-channel selectivity

<i>BS channel bandwidth</i> (MHz)	<i>Subcarrier spacing</i> (kHz)	<i>Reference measurement channel</i>	<i>Wanted signal mean power</i> (dBm)	<i>Interfering signal mean power</i> (dBm)	<i>Type of interfering signal</i>
5	15	G-FR1-A1-7	-92.6	-73.4	DFT-s-OFDM NR signal, 15 kHz SCS, 10 RBs
10, 15, 20, 25, 30, 35	15	G-FR1-A1-1	-90.7	-69.4	DFT-s-OFDM NR signal, 15 kHz SCS, 25 RBs
40, 45, 50	15	G-FR1-A1-4	-84.3	-63.4	DFT-s-OFDM NR signal, 15 kHz SCS, 100 RBs
5	30	G-FR1-A1-8	-93.3	-73.4	DFT-s-OFDM NR signal, 30 kHz SCS, 5 RBs
10, 15, 20, 25, 30, 35	30	G-FR1-A1-2	-90.8	-70.4	DFT-s-OFDM NR signal, 30 kHz SCS, 10 RBs
40, 45, 50, 60, 70, 80, 90, 100	30	G-FR1-A1-5	-84.6	-63.4	DFT-s-OFDM NR signal, 30 kHz SCS, 50 RBs
10, 15, 20, 25, 30, 35	60	G-FR1-A1-9	-90.2	-70.4	DFT-s-OFDM NR signal, 60 kHz SCS, 5 RBs
40, 45, 50, 60, 70, 80, 90, 100	60	G-FR1-A1-6	-84.7	-63.6	DFT-s-OFDM NR signal, 60 kHz SCS, 24 RBs
NOTE: Wanted and interfering signal are placed adjacently around F_c , where the F_c is defined for <i>BS channel bandwidth</i> of the wanted signal according to the table 5.4.2.2-1. The aggregated wanted and interferer signal shall be centred in the <i>BS channel bandwidth</i> of the wanted signal.					

Table 7.8.2-3a: Local Area BS in-channel selectivity for NB-IoT operation in NR in-band

<i>BS channel bandwidth</i> (MHz)	<i>Reference measurement channel</i>	<i>Wanted signal mean power</i> (dBm)	<i>Interfering signal mean power</i> (dBm) / BW_{Config}	<i>Type of interfering signal</i>
5	FRC A14-1 in Annex A.14 in TS 36.104 [13]	-116.3	-73.4	DFT-s-OFDM NR signal, 15 kHz SCS, 10 RBs
10, 15, 20, 25, 30, 35			-69.4	DFT-s-OFDM NR signal, 15 kHz SCS, 25 RBs
40, 45, 50			-63.4	DFT-s-OFDM NR signal, 15 kHz SCS, 100 RBs
5	FRC A14-2 in Annex A.14 in TS 36.104 [13]	-122.2	-73.4	DFT-s-OFDM NR signal, 15 kHz SCS, 10 RBs
10, 15, 20, 25, 30, 35			-69.4	DFT-s-OFDM NR signal, 15 kHz SCS, 25 RBs
40, 45, 50			-63.4	DFT-s-OFDM NR signal, 15 kHz SCS, 100 RBs
NOTE: Interfering signal is placed in one side of the F_c , while the NB-IoT PRB is placed on the other side. Both interfering signal and NB-IoT PRB are placed at the middle of the available PRB locations. The wanted NB-IoT tone is placed at the centre of this NB-IoT PRB.				

Table 7.8.2-3b: Local Area BS in-channel selectivity for band n46

<i>BS channel bandwidth</i> (MHz)	Subcarrier spacing (kHz)	Reference measurement channel	Wanted signal mean power (dBm)	Interfering signal mean power (dBm)	Type of interfering signal
10	15	G-FR1-A1-12	-97.0	-76.5	CP-OFDM NR signal, 15 kHz SCS, 10 RBs
	30	G-FR1-A1-13	-94.7	-74.4	CP-OFDM NR signal, 30 kHz SCS, 10 RBs
	60	G-FR1-A1-9	-90.2	-70.4	DFT-s-OFDM NR signal, 60 kHz SCS, 5 RBs
20	15	G-FR1-A1-14	-94.1	-73.4	CP-OFDM NR signal, 15 kHz SCS, 10 RBs
	30	G-FR1-A1-15	-91.1	-70.4	CP-OFDM NR signal, 30 kHz SCS, 10 RBs
	60	G-FR1-A1-9	-90.2	-70.4	DFT-s-OFDM NR signal, 60 kHz SCS, 5 RBs
40	15	G-FR1-A1-16	-91.0	-70.2	CP-OFDM NR signal, 15 kHz SCS, 20 RBs
	30	G-FR1-A1-17	-88.0	-67.2	CP-OFDM NR signal, 30 kHz SCS, 10 RBs
	60	G-FR1-A1-6	-84.7	-63.6	DFT-s-OFDM NR signal, 60 kHz SCS, 24 RBs
60	30	G-FR1-A1-18	-86.4	-65.4	CP-OFDM NR signal, 30 kHz SCS, 20 RBs
	60	G-FR1-A1-6	-84.7	-63.6	DFT-s-OFDM NR signal, 60 kHz SCS, 24 RBs
80	30	G-FR1-A1-19	-85.1	-64.1	CP-OFDM NR signal, 30 kHz SCS, 20 RBs
	60	G-FR1-A1-6	-84.7	-63.6	DFT-s-OFDM NR signal, 60 kHz SCS, 24 RBs
NOTE: Wanted and interfering signal are placed adjacently around F_c , where the F_c is defined for <i>BS channel bandwidth</i> of the wanted signal according to the table 5.4.2.2-1. The aggregated wanted and interferer signal shall be centred in the BS channel bandwidth of the wanted signal.					

Table 7.8.2-3c: Local Area BS in-channel selectivity for band n96 and n102

<i>BS channel bandwidth</i> (MHz)	Subcarrier spacing (kHz)	Reference measurement channel	Wanted signal mean power (dBm)	Interfering signal mean power (dBm)	Type of interfering signal
20	15	G-FR1-A1-14	-93.1	-72.4	CP-OFDM NR signal, 15 kHz SCS, 10 RBs
	30	G-FR1-A1-15	-90.1	-69.4	CP-OFDM NR signal, 30 kHz SCS, 10 RBs
	60	G-FR1-A1-9	-89.2	-69.4	DFT-s-OFDM NR signal, 60 kHz SCS, 5 RBs
40	15	G-FR1-A1-16	-90.0	-69.2	CP-OFDM NR signal, 15 kHz SCS, 20 RBs
	30	G-FR1-A1-17	-87.0	-66.2	CP-OFDM NR signal, 30 kHz SCS, 10 RBs
	60	G-FR1-A1-6	-83.7	-62.6	DFT-s-OFDM NR signal, 60 kHz SCS, 24 RBs
60	30	G-FR1-A1-18	-85.4	-64.4	CP-OFDM NR signal, 30 kHz SCS, 20 RBs
	60	G-FR1-A1-6	-83.7	-62.6	DFT-s-OFDM NR signal, 60 kHz SCS, 24 RBs
80	30	G-FR1-A1-19	-84.1	-63.1	CP-OFDM NR signal, 30 kHz SCS, 20 RBs
	60	G-FR1-A1-6	-83.7	-62.6	DFT-s-OFDM NR signal, 60 kHz SCS, 24 RBs
NOTE: Wanted and interfering signal are placed adjacently around F_c , where the F_c is defined for <i>BS channel bandwidth</i> of the wanted signal according to the table 5.4.2.2-1. The aggregated wanted and interferer signal shall be centred in the BS channel bandwidth of the wanted signal.					

Table 7.8.2-3d: Local area BS in-channel selectivity for band n104

BS channel bandwidth (MHz)	Subcarrier spacing (kHz)	Reference measurement channel	Wanted signal mean power (dBm)	Interfering signal mean power (dBm)	Type of interfering signal
20, 30	15	G-FR1-A1-1	-89.7	-68.4	DFT-s-OFDM NR signal, 15 kHz SCS, 25 RBs
40, 50	15	G-FR1-A1-4	-83.3	-62.4	DFT-s-OFDM NR signal, 15 kHz SCS, 100 RBs
20, 30	30	G-FR1-A1-2	-89.8	-69.4	DFT-s-OFDM NR signal, 30 kHz SCS, 10 RBs
40, 50, 60, 70, 80, 90, 100	30	G-FR1-A1-5	-83.6	-62.4	DFT-s-OFDM NR signal, 30 kHz SCS, 50 RBs
20, 30	60	G-FR1-A1-9	-89.2	-69.4	DFT-s-OFDM NR signal, 60 kHz SCS, 5 RBs
40, 50, 60, 70, 80, 90, 100	60	G-FR1-A1-6	-83.7	-62.6	DFT-s-OFDM NR signal, 60 kHz SCS, 24 RBs
NOTE: Wanted and interfering signal are placed adjacently around F_c , where the F_c is defined for <i>BS channel bandwidth</i> of the wanted signal according to the table 5.4.2.2-1. The aggregated wanted and interferer signal shall be centred in the <i>BS channel bandwidth</i> of the wanted signal.					

8 Conducted performance requirements

8.1 General

8.1.1 Scope and definitions

Conducted performance requirements specify the ability of the *BS type 1-C* or *BS type 1-H* to correctly demodulate signals in various conditions and configurations. Conducted performance requirements are specified at the *antenna connector(s)* (for *BS type 1-C*) and at the *TAB connector(s)* (for *BS type 1-H*).

Conducted performance requirements for the BS are specified for the fixed reference channels defined in annex A and the propagation conditions in annex G. The requirements only apply to those FRCs that are supported by the base station.

Unless stated otherwise, performance requirements apply for a single carrier only. Performance requirements for a BS supporting *carrier aggregation* are defined in terms of single carrier requirements.

For FDD operation the requirements in clause 8 shall be met with the transmitter units associated with *antenna connectors* (for *BS type 1-C*) or *TAB connectors* (for *BS type 1-H*) in the *operating band* turned ON.

NOTE: In normal operating conditions, *antenna connectors* (for *BS type 1-C*) or *TAB connectors* (for *BS type 1-H*) in FDD operation are configured to transmit and receive at the same time. The associated transmitter unit(s) may be OFF for some of the tests as specified in TS 38.141-1 [5].

The SNR used in this clause is specified based on a single carrier and defined as:

$$\text{SNR} = S / N$$

Where:

S is the total signal energy in the slot on a single *antenna connector* (for *BS type 1-C*) or on a single *TAB connector* (for *BS type 1-H*).

N is the noise energy in a bandwidth corresponding to the *transmission bandwidth* over the same duration where signal energy exists on a single *antenna connector* (for *BS type 1-C*) or on a single *TAB connector* (for *BS type 1-H*).

8.1.2 Void

8.2 Performance requirements for PUSCH

8.2.1 Requirements for PUSCH with transform precoding disabled

8.2.1.1 General

The performance requirement of PUSCH is determined by a minimum required throughput for a given SNR. The required throughput is expressed as a fraction of maximum throughput for the FRCs listed in annex A. The performance requirements assume HARQ retransmissions.

Table: 8.2.1.1-1 Test parameters for testing PUSCH

Parameter		Value
Transform precoding		Disabled
Default TDD UL-DL pattern (Note 1)		15 kHz SCS: 3D1S1U, S=10D:2G:2U 30 kHz SCS: 7D1S2U, S=6D:4G:4U
HARQ	Maximum number of HARQ transmissions	4
	RV sequence	0, 2, 3, 1
DM-RS	DM-RS configuration type	1
	DM-RS duration	single-symbol DM-RS
	Additional DM-RS position	pos1
	Number of DM-RS CDM group(s) without data	2
	Ratio of PUSCH EPRE to DM-RS EPRE	-3 dB
	DM-RS port	{0}, {0, 1}
	DM-RS sequence generation	$N_{ID}^0=0, n_{SCID}=0$
Time domain resource assignment	PUSCH mapping type	A, B
	Start symbol	0
	Allocation length	14
Frequency domain resource assignment	RB assignment	Full applicable test bandwidth
	Frequency hopping	Disabled
TPMI index for 2Tx two-layer spatial multiplexing transmission		0
Code block group based PUSCH transmission		Disabled
NOTE 1: The same requirements are applicable to FDD and TDD with different UL-DL pattern.		

8.2.1.2 Minimum requirements

The throughput shall be equal to or larger than the fraction of maximum throughput for the FRCs stated in tables 8.2.1.2-1 to 8.2.1.2-18 at the given SNR for 1Tx or for 2Tx two-layer spatial multiplexing transmission. FRCs are defined in annex A.

Table 8.2.1.2-1: Minimum requirements for PUSCH with 70% of maximum throughput, Type A, 5 MHz channel bandwidth, 15 kHz SCS

Number of TX antennas	Number of RX antennas	Cyclic prefix	Propagation conditions and correlation matrix (Annex G)	Fraction of maximum throughput	FRC (Annex A)	Additional DM-RS position	SNR (dB)
1	2	Normal	TDLB100-400 Low	70 %	G-FR1-A3-8	pos1	-2.3
		Normal	TDLC300-100 Low	70 %	G-FR1-A4-8	pos1	10.1
		Normal	TDLA30-10 Low	70 %	G-FR1-A5-8	pos1	12.3
		Normal	TDLA30-10 Low	70 %	G-FR1-A9-1	pos1	19.1
	4	Normal	TDLB100-400 Low	70 %	G-FR1-A3-8	pos1	-5.8
		Normal	TDLC300-100 Low	70 %	G-FR1-A4-8	pos1	6.2
		Normal	TDLA30-10 Low	70 %	G-FR1-A5-8	pos1	8.8
		Normal	TDLA30-10 Low	70 %	G-FR1-A9-1	pos1	15.5
	8	Normal	TDLB100-400 Low	70 %	G-FR1-A3-8	pos1	-8.7
		Normal	TDLC300-100 Low	70 %	G-FR1-A4-8	pos1	3.0
		Normal	TDLA30-10 Low	70 %	G-FR1-A5-8	pos1	5.6
		Normal	TDLA30-10 Low	70 %	G-FR1-A9-1	pos1	12.4
2	2	Normal	TDLB100-400 Low	70 %	G-FR1-A3-22	pos1	1.0
		Normal	TDLC300-100 Low	70 %	G-FR1-A4-22	pos1	18.2
	4	Normal	TDLB100-400 Low	70 %	G-FR1-A3-22	pos1	-2.3
		Normal	TDLC300-100 Low	70 %	G-FR1-A4-22	pos1	11.0
	8	Normal	TDLB100-400 Low	70 %	G-FR1-A3-22	pos1	-5.3
		Normal	TDLC300-100 Low	70 %	G-FR1-A4-22	pos1	6.8

Table 8.2.1.2-2: Minimum requirements for PUSCH with 70% of maximum throughput, Type A, 10 MHz channel bandwidth, 15 kHz SCS

Number of TX antennas	Number of RX antennas	Cyclic prefix	Propagation conditions and correlation matrix (Annex G)	Fraction of maximum throughput	FRC (Annex A)	Additional DM-RS position	SNR (dB)
1	2	Normal	TDLB100-400 Low	70 %	G-FR1-A3-9	pos1	-2.5
		Normal	TDLC300-100 Low	70 %	G-FR1-A4-9	pos1	10.2
		Normal	TDLA30-10 Low	70 %	G-FR1-A5-9	pos1	12.2
		Normal	TDLA30-10 Low	70 %	G-FR1-A9-2	pos1	19.5
	4	Normal	TDLB100-400 Low	70 %	G-FR1-A3-9	pos1	-6.0
		Normal	TDLC300-100 Low	70 %	G-FR1-A4-9	pos1	6.3
		Normal	TDLA30-10 Low	70 %	G-FR1-A5-9	pos1	8.6
		Normal	TDLA30-10 Low	70 %	G-FR1-A9-2	pos1	15.9
	8	Normal	TDLB100-400 Low	70 %	G-FR1-A3-9	pos1	-8.7
		Normal	TDLC300-100 Low	70 %	G-FR1-A4-9	pos1	3.1
		Normal	TDLA30-10 Low	70 %	G-FR1-A5-9	pos1	5.5
		Normal	TDLA30-10 Low	70 %	G-FR1-A9-2	pos1	12.6
2	2	Normal	TDLB100-400 Low	70 %	G-FR1-A3-23	pos1	1.7
		Normal	TDLC300-100 Low	70 %	G-FR1-A4-23	pos1	18.3
	4	Normal	TDLB100-400 Low	70 %	G-FR1-A3-23	pos1	-2.0
		Normal	TDLC300-100 Low	70 %	G-FR1-A4-23	pos1	11.2
	8	Normal	TDLB100-400 Low	70 %	G-FR1-A3-23	pos1	-5.5
		Normal	TDLC300-100 Low	70 %	G-FR1-A4-23	pos1	6.8

Table 8.2.1.2-3: Minimum requirements for PUSCH with 70% of maximum throughput, Type A, 20 MHz channel bandwidth, 15 kHz SCS

Number of TX antennas	Number of RX antennas	Cyclic prefix	Propagation conditions and correlation matrix (Annex G)	Fraction of maximum throughput	FRC (Annex A)	Additional DM-RS position	SNR (dB)
1	2	Normal	TDLB100-400 Low	70 %	G-FR1-A3-10	pos1	-2.1
		Normal	TDLC300-100 Low	70 %	G-FR1-A4-10	pos1	10.0
		Normal	TDLA30-10 Low	70 %	G-FR1-A5-10	pos1	12.4
	4	Normal	TDLB100-400 Low	70 %	G-FR1-A3-10	pos1	-5.5
		Normal	TDLC300-100 Low	70 %	G-FR1-A4-10	pos1	6.2
		Normal	TDLA30-10 Low	70 %	G-FR1-A5-10	pos1	8.6
	8	Normal	TDLB100-400 Low	70 %	G-FR1-A3-10	pos1	-8.5
		Normal	TDLC300-100 Low	70 %	G-FR1-A4-10	pos1	3.0
		Normal	TDLA30-10 Low	70 %	G-FR1-A5-10	pos1	5.5
2	2	Normal	TDLB100-400 Low	70 %	G-FR1-A3-24	pos1	2.1
		Normal	TDLC300-100 Low	70 %	G-FR1-A4-24	pos1	18.3
	4	Normal	TDLB100-400 Low	70 %	G-FR1-A3-24	pos1	-1.8
		Normal	TDLC300-100 Low	70 %	G-FR1-A4-24	pos1	11.1
	8	Normal	TDLB100-400 Low	70 %	G-FR1-A3-24	pos1	-5.3
		Normal	TDLC300-100 Low	70 %	G-FR1-A4-24	pos1	6.9

Table 8.2.1.2-4: Minimum requirements for PUSCH with 70% of maximum throughput, Type A, 10 MHz channel bandwidth, 30 kHz SCS

Number of TX antennas	Number of RX antennas	Cyclic prefix	Propagation conditions and correlation matrix (Annex G)	Fraction of maximum throughput	FRC (Annex A)	Additional DM-RS position	SNR (dB)
1	2	Normal	TDLB100-400 Low	70 %	G-FR1-A3-11	pos1	-2.3
		Normal	TDLC300-100 Low	70 %	G-FR1-A4-11	pos1	10.2
		Normal	TDLA30-10 Low	70 %	G-FR1-A5-11	pos1	12.8
		Normal	TDLA30-10 Low	70 %	G-FR1-A9-3	pos1	19.3
	4	Normal	TDLB100-400 Low	70 %	G-FR1-A3-11	pos1	-5.6
		Normal	TDLC300-100 Low	70 %	G-FR1-A4-11	pos1	6.4
		Normal	TDLA30-10 Low	70 %	G-FR1-A5-11	pos1	8.6
		Normal	TDLA30-10 Low	70 %	G-FR1-A9-3	pos1	15.6
	8	Normal	TDLB100-400 Low	70 %	G-FR1-A3-11	pos1	-8.6
		Normal	TDLC300-100 Low	70 %	G-FR1-A4-11	pos1	3.3
		Normal	TDLA30-10 Low	70 %	G-FR1-A5-11	pos1	5.5
		Normal	TDLA30-10 Low	70 %	G-FR1-A9-3	pos1	12.6
2	2	Normal	TDLB100-400 Low	70 %	G-FR1-A3-25	pos1	1.3
		Normal	TDLC300-100 Low	70 %	G-FR1-A4-25	pos1	18.4
	4	Normal	TDLB100-400 Low	70 %	G-FR1-A3-25	pos1	-2.2
		Normal	TDLC300-100 Low	70 %	G-FR1-A4-25	pos1	11.2
	8	Normal	TDLB100-400 Low	70 %	G-FR1-A3-25	pos1	-5.2
		Normal	TDLC300-100 Low	70 %	G-FR1-A4-25	pos1	7.0

Table 8.2.1.2-5: Minimum requirements for PUSCH with 70% of maximum throughput, Type A, 20 MHz channel bandwidth, 30 kHz SCS

Number of TX antennas	Number of RX antennas	Cyclic prefix	Propagation conditions and correlation matrix (Annex G)	Fraction of maximum throughput	FRC (Annex A)	Additional DM-RS position	SNR (dB)
1	2	Normal	TDLB100-400 Low	70 %	G-FR1-A3-12	pos1	-2.9
		Normal	TDLC300-100 Low	70 %	G-FR1-A4-12	pos1	10.2
		Normal	TDLA30-10 Low	70 %	G-FR1-A5-12	pos1	12.5
	4	Normal	TDLB100-400 Low	70 %	G-FR1-A3-12	pos1	-6.0
		Normal	TDLC300-100 Low	70 %	G-FR1-A4-12	pos1	6.4
		Normal	TDLA30-10 Low	70 %	G-FR1-A5-12	pos1	8.6
	8	Normal	TDLB100-400 Low	70 %	G-FR1-A3-12	pos1	-8.8
		Normal	TDLC300-100 Low	70 %	G-FR1-A4-12	pos1	3.2
		Normal	TDLA30-10 Low	70 %	G-FR1-A5-12	pos1	5.5
2	2	Normal	TDLB100-400 Low	70 %	G-FR1-A3-26	pos1	1.3
		Normal	TDLC300-100 Low	70 %	G-FR1-A4-26	pos1	18.1
	4	Normal	TDLB100-400 Low	70 %	G-FR1-A3-26	pos1	-2.2
		Normal	TDLC300-100 Low	70 %	G-FR1-A4-26	pos1	11.3
	8	Normal	TDLB100-400 Low	70 %	G-FR1-A3-26	pos1	-5.3
		Normal	TDLC300-100 Low	70 %	G-FR1-A4-26	pos1	6.9

Table 8.2.1.2-6: Minimum requirements for PUSCH with 70% of maximum throughput, Type A, 40 MHz channel bandwidth, 30 kHz SCS

Number of TX antennas	Number of RX antennas	Cyclic prefix	Propagation conditions and correlation matrix (Annex G)	Fraction of maximum throughput	FRC (Annex A)	Additional DM-RS position	SNR (dB)
1	2	Normal	TDLB100-400 Low	70 %	G-FR1-A3-13	pos1	-2.5
		Normal	TDLC300-100 Low	70 %	G-FR1-A4-13	pos1	10.0
		Normal	TDLA30-10 Low	70 %	G-FR1-A5-13	pos1	12.4
		Normal	TDLA30-10 Low	70 %	G-FR1-A9-4	pos1	19.9
	4	Normal	TDLB100-400 Low	70 %	G-FR1-A3-13	pos1	-5.8
		Normal	TDLC300-100 Low	70 %	G-FR1-A4-13	pos1	6.3
		Normal	TDLA30-10 Low	70 %	G-FR1-A5-13	pos1	8.5
		Normal	TDLA30-10 Low	70 %	G-FR1-A9-4	pos1	16.1
	8	Normal	TDLB100-400 Low	70 %	G-FR1-A3-13	pos1	-8.7
		Normal	TDLC300-100 Low	70 %	G-FR1-A4-13	pos1	3.1
		Normal	TDLA30-10 Low	70 %	G-FR1-A5-13	pos1	5.4
		Normal	TDLA30-10 Low	70 %	G-FR1-A9-4	pos1	12.6
2	2	Normal	TDLB100-400 Low	70 %	G-FR1-A3-27	pos1	1.3
		Normal	TDLC300-100 Low	70 %	G-FR1-A4-27	pos1	19.5
	4	Normal	TDLB100-400 Low	70 %	G-FR1-A3-27	pos1	-2.3
		Normal	TDLC300-100 Low	70 %	G-FR1-A4-27	pos1	11.3
	8	Normal	TDLB100-400 Low	70 %	G-FR1-A3-27	pos1	-5.2
		Normal	TDLC300-100 Low	70 %	G-FR1-A4-27	pos1	6.9

Table 8.2.1.2-7: Minimum requirements for PUSCH with 70% of maximum throughput, Type A, 100 MHz channel bandwidth, 30 kHz SCS

Number of TX antennas	Number of RX antennas	Cyclic prefix	Propagation conditions and correlation matrix (Annex G)	Fraction of maximum throughput	FRC (Annex A)	Additional DM-RS position	SNR (dB)
1	2	Normal	TDLB100-400 Low	70 %	G-FR1-A3-14	pos1	-2.8
		Normal	TDLC300-100 Low	70 %	G-FR1-A4-14	pos1	10.2
		Normal	TDLA30-10 Low	70 %	G-FR1-A5-14	pos1	13.0
		Normal	TDLA30-10 Low	70 %	G-FR1-A9-5	pos1	21.1
	4	Normal	TDLB100-400 Low	70 %	G-FR1-A3-14	pos1	-5.8
		Normal	TDLC300-100 Low	70 %	G-FR1-A4-14	pos1	6.5
		Normal	TDLA30-10 Low	70 %	G-FR1-A5-14	pos1	9.0
		Normal	TDLA30-10 Low	70 %	G-FR1-A9-5	pos1	16.7
	8	Normal	TDLB100-400 Low	70 %	G-FR1-A3-14	pos1	-8.7
		Normal	TDLC300-100 Low	70 %	G-FR1-A4-14	pos1	3.2
		Normal	TDLA30-10 Low	70 %	G-FR1-A5-14	pos1	5.8
		Normal	TDLA30-10 Low	70 %	G-FR1-A9-5	pos1	13.1
2	2	Normal	TDLB100-400 Low	70 %	G-FR1-A3-28	pos1	1.4
		Normal	TDLC300-100 Low	70 %	G-FR1-A4-28	pos1	19.2
	4	Normal	TDLB100-400 Low	70 %	G-FR1-A3-28	pos1	-2.2
		Normal	TDLC300-100 Low	70 %	G-FR1-A4-28	pos1	11.6
	8	Normal	TDLB100-400 Low	70 %	G-FR1-A3-28	pos1	-5.2
		Normal	TDLC300-100 Low	70 %	G-FR1-A4-28	pos1	7.1

Table 8.2.1.2-8: Minimum requirements for PUSCH with 70% of maximum throughput, Type B, 5 MHz channel bandwidth, 15 kHz SCS

Number of TX antennas	Number of RX antennas	Cyclic prefix	Propagation conditions and correlation matrix (Annex G)	Fraction of maximum throughput	FRC (Annex A)	Additional DM-RS position	SNR (dB)
1	2	Normal	TDLB100-400 Low	70 %	G-FR1-A3-8	pos1	-2.3
		Normal	TDLC300-100 Low	70 %	G-FR1-A4-8	pos1	10.2
		Normal	TDLA30-10 Low	70 %	G-FR1-A5-8	pos1	12.5
		Normal	TDLA30-10 Low	70 %	G-FR1-A9-1	pos1	19.1
	4	Normal	TDLB100-400 Low	70 %	G-FR1-A3-8	pos1	-5.7
		Normal	TDLC300-100 Low	70 %	G-FR1-A4-8	pos1	6.3
		Normal	TDLA30-10 Low	70 %	G-FR1-A5-8	pos1	8.9
		Normal	TDLA30-10 Low	70 %	G-FR1-A9-1	pos1	15.5
	8	Normal	TDLB100-400 Low	70 %	G-FR1-A3-8	pos1	-8.7
		Normal	TDLC300-100 Low	70 %	G-FR1-A4-8	pos1	3.0
		Normal	TDLA30-10 Low	70 %	G-FR1-A5-8	pos1	5.7
		Normal	TDLA30-10 Low	70 %	G-FR1-A9-1	pos1	12.3
2	2	Normal	TDLB100-400 Low	70 %	G-FR1-A3-22	pos1	1.5
		Normal	TDLC300-100 Low	70 %	G-FR1-A4-22	pos1	18.3
	4	Normal	TDLB100-400 Low	70 %	G-FR1-A3-22	pos1	-2.3
		Normal	TDLC300-100 Low	70 %	G-FR1-A4-22	pos1	11.1
	8	Normal	TDLB100-400 Low	70 %	G-FR1-A3-22	pos1	-5.4
		Normal	TDLC300-100 Low	70 %	G-FR1-A4-22	pos1	6.8

Table 8.2.1.2-9: Minimum requirements for PUSCH with 70% of maximum throughput, Type B, 10 MHz channel bandwidth, 15 kHz SCS

Number of TX antennas	Number of RX antennas	Cyclic prefix	Propagation conditions and correlation matrix (Annex G)	Fraction of maximum throughput	FRC (Annex A)	Additional DM-RS position	SNR (dB)
1	2	Normal	TDLB100-400 Low	70 %	G-FR1-A3-9	pos1	-2.3
		Normal	TDLC300-100 Low	70 %	G-FR1-A4-9	pos1	10.5
		Normal	TDLA30-10 Low	70 %	G-FR1-A5-9	pos1	12.6
		Normal	TDLA30-10 Low	70 %	G-FR1-A9-2	pos1	19.5
	4	Normal	TDLB100-400 Low	70 %	G-FR1-A3-9	pos1	-5.7
		Normal	TDLC300-100 Low	70 %	G-FR1-A4-9	pos1	6.5
		Normal	TDLA30-10 Low	70 %	G-FR1-A5-9	pos1	8.9
		Normal	TDLA30-10 Low	70 %	G-FR1-A9-2	pos1	15.9
	8	Normal	TDLB100-400 Low	70 %	G-FR1-A3-9	pos1	-9.0
		Normal	TDLC300-100 Low	70 %	G-FR1-A4-9	pos1	3.2
		Normal	TDLA30-10 Low	70 %	G-FR1-A5-9	pos1	5.8
		Normal	TDLA30-10 Low	70 %	G-FR1-A9-2	pos1	12.5
2	2	Normal	TDLB100-400 Low	70 %	G-FR1-A3-23	pos1	2.0
		Normal	TDLC300-100 Low	70 %	G-FR1-A4-23	pos1	18.7
	4	Normal	TDLB100-400 Low	70 %	G-FR1-A3-23	pos1	-2.3
		Normal	TDLC300-100 Low	70 %	G-FR1-A4-23	pos1	11.3
	8	Normal	TDLB100-400 Low	70 %	G-FR1-A3-23	pos1	-5.2
		Normal	TDLC300-100 Low	70 %	G-FR1-A4-23	pos1	7.0

Table 8.2.1.2-10: Minimum requirements for PUSCH with 70% of maximum throughput, Type B, 20 MHz channel bandwidth, 15 kHz SCS

Number of TX antennas	Number of RX antennas	Cyclic prefix	Propagation conditions and correlation matrix (Annex G)	Fraction of maximum throughput	FRC (Annex A)	Additional DM-RS position	SNR (dB)
1	2	Normal	TDLB100-400 Low	70 %	G-FR1-A3-10	pos1	-2.1
		Normal	TDLC300-100 Low	70 %	G-FR1-A4-10	pos1	10.4
		Normal	TDLA30-10 Low	70 %	G-FR1-A5-10	pos1	12.3
	4	Normal	TDLB100-400 Low	70 %	G-FR1-A3-10	pos1	-5.7
		Normal	TDLC300-100 Low	70 %	G-FR1-A4-10	pos1	6.3
		Normal	TDLA30-10 Low	70 %	G-FR1-A5-10	pos1	8.8
	8	Normal	TDLB100-400 Low	70 %	G-FR1-A3-10	pos1	-8.5
		Normal	TDLC300-100 Low	70 %	G-FR1-A4-10	pos1	3.1
		Normal	TDLA30-10 Low	70 %	G-FR1-A5-10	pos1	5.7
2	2	Normal	TDLB100-400 Low	70 %	G-FR1-A3-24	pos1	1.6
		Normal	TDLC300-100 Low	70 %	G-FR1-A4-24	pos1	18.1
	4	Normal	TDLB100-400 Low	70 %	G-FR1-A3-24	pos1	-2.0
		Normal	TDLC300-100 Low	70 %	G-FR1-A4-24	pos1	11.2
	8	Normal	TDLB100-400 Low	70 %	G-FR1-A3-24	pos1	-5.3
		Normal	TDLC300-100 Low	70 %	G-FR1-A4-24	pos1	6.9

Table 8.2.1.2-11: Minimum requirements for PUSCH with 70% of maximum throughput, Type B, 10 MHz channel bandwidth, 30 kHz SCS

Number of TX antennas	Number of RX antennas	Cyclic prefix	Propagation conditions and correlation matrix (Annex G)	Fraction of maximum throughput	FRC (Annex A)	Additional DM-RS position	SNR (dB)
1	2	Normal	TDLB100-400 Low	70 %	G-FR1-A3-11	pos1	-2.4
		Normal	TDLC300-100 Low	70 %	G-FR1-A4-11	pos1	10.1
		Normal	TDLA30-10 Low	70 %	G-FR1-A5-11	pos1	12.5
		Normal	TDLA30-10 Low	70 %	G-FR1-A9-3	pos1	19.2
	4	Normal	TDLB100-400 Low	70 %	G-FR1-A3-11	pos1	-5.7
		Normal	TDLC300-100 Low	70 %	G-FR1-A4-11	pos1	6.4
		Normal	TDLA30-10 Low	70 %	G-FR1-A5-11	pos1	8.6
		Normal	TDLA30-10 Low	70 %	G-FR1-A9-3	pos1	15.7
	8	Normal	TDLB100-400 Low	70 %	G-FR1-A3-11	pos1	-8.8
		Normal	TDLC300-100 Low	70 %	G-FR1-A4-11	pos1	3.2
		Normal	TDLA30-10 Low	70 %	G-FR1-A5-11	pos1	5.6
		Normal	TDLA30-10 Low	70 %	G-FR1-A9-3	pos1	12.4
2	2	Normal	TDLB100-400 Low	70 %	G-FR1-A3-25	pos1	1.1
		Normal	TDLC300-100 Low	70 %	G-FR1-A4-25	pos1	18.5
	4	Normal	TDLB100-400 Low	70 %	G-FR1-A3-25	pos1	-2.5
		Normal	TDLC300-100 Low	70 %	G-FR1-A4-25	pos1	11.3
	8	Normal	TDLB100-400 Low	70 %	G-FR1-A3-25	pos1	-5.6
		Normal	TDLC300-100 Low	70 %	G-FR1-A4-25	pos1	7.0

Table 8.2.1.2-12: Minimum requirements for PUSCH with 70% of maximum throughput, Type B, 20 MHz channel bandwidth, 30 kHz SCS

Number of TX antennas	Number of RX antennas	Cyclic prefix	Propagation conditions and correlation matrix (Annex G)	Fraction of maximum throughput	FRC (Annex A)	Additional DM-RS position	SNR (dB)
1	2	Normal	TDLB100-400 Low	70 %	G-FR1-A3-12	pos1	-2.9
		Normal	TDLC300-100 Low	70 %	G-FR1-A4-12	pos1	10.1
		Normal	TDLA30-10 Low	70 %	G-FR1-A5-12	pos1	12.5
	4	Normal	TDLB100-400 Low	70 %	G-FR1-A3-12	pos1	-6.0
		Normal	TDLC300-100 Low	70 %	G-FR1-A4-12	pos1	6.3
		Normal	TDLA30-10 Low	70 %	G-FR1-A5-12	pos1	8.6
	8	Normal	TDLB100-400 Low	70 %	G-FR1-A3-12	pos1	-9.0
		Normal	TDLC300-100 Low	70 %	G-FR1-A4-12	pos1	3.1
		Normal	TDLA30-10 Low	70 %	G-FR1-A5-12	pos1	5.6
2	2	Normal	TDLB100-400 Low	70 %	G-FR1-A3-26	pos1	1.3
		Normal	TDLC300-100 Low	70 %	G-FR1-A4-26	pos1	18.2
	4	Normal	TDLB100-400 Low	70 %	G-FR1-A3-26	pos1	-2.3
		Normal	TDLC300-100 Low	70 %	G-FR1-A4-26	pos1	11.2
	8	Normal	TDLB100-400 Low	70 %	G-FR1-A3-26	pos1	-5.4
		Normal	TDLC300-100 Low	70 %	G-FR1-A4-26	pos1	7.0

Table 8.2.1.2-13: Minimum requirements for PUSCH with 70% of maximum throughput, Type B, 40 MHz channel bandwidth, 30 kHz SCS

Number of TX antennas	Number of RX antennas	Cyclic prefix	Propagation conditions and correlation matrix (Annex G)	Fraction of maximum throughput	FRC (Annex A)	Additional DM-RS position	SNR (dB)
1	2	Normal	TDLB100-400 Low	70 %	G-FR1-A3-13	pos1	-2.5
		Normal	TDLC300-100 Low	70 %	G-FR1-A4-13	pos1	10.0
		Normal	TDLA30-10 Low	70 %	G-FR1-A5-13	pos1	12.5
		Normal	TDLA30-10 Low	70 %	G-FR1-A9-4	pos1	19.9
	4	Normal	TDLB100-400 Low	70 %	G-FR1-A3-13	pos1	-5.8
		Normal	TDLC300-100 Low	70 %	G-FR1-A4-13	pos1	6.2
		Normal	TDLA30-10 Low	70 %	G-FR1-A5-13	pos1	8.7
		Normal	TDLA30-10 Low	70 %	G-FR1-A9-4	pos1	16.0
	8	Normal	TDLB100-400 Low	70 %	G-FR1-A3-13	pos1	-8.8
		Normal	TDLC300-100 Low	70 %	G-FR1-A4-13	pos1	3.0
		Normal	TDLA30-10 Low	70 %	G-FR1-A5-13	pos1	5.5
		Normal	TDLA30-10 Low	70 %	G-FR1-A9-4	pos1	12.7
2	2	Normal	TDLB100-400 Low	70 %	G-FR1-A3-27	pos1	1.7
		Normal	TDLC300-100 Low	70 %	G-FR1-A4-27	pos1	18.7
	4	Normal	TDLB100-400 Low	70 %	G-FR1-A3-27	pos1	-2.1
		Normal	TDLC300-100 Low	70 %	G-FR1-A4-27	pos1	11.2
	8	Normal	TDLB100-400 Low	70 %	G-FR1-A3-27	pos1	-5.2
		Normal	TDLC300-100 Low	70 %	G-FR1-A4-27	pos1	6.9

Table 8.2.1.2-14: Minimum requirements for PUSCH with 70% of maximum throughput, Type B, 100 MHz channel bandwidth, 30 kHz SCS

Number of TX antennas	Number of RX antennas	Cyclic prefix	Propagation conditions and correlation matrix (Annex G)	Fraction of maximum throughput	FRC (Annex A)	Additional DM-RS position	SNR (dB)
1	2	Normal	TDLB100-400 Low	70 %	G-FR1-A3-14	pos1	-2.5
		Normal	TDLC300-100 Low	70 %	G-FR1-A4-14	pos1	10.1
		Normal	TDLA30-10 Low	70 %	G-FR1-A5-14	pos1	13.1
		Normal	TDLA30-10 Low	70 %	G-FR1-A9-5	pos1	21.1
	4	Normal	TDLB100-400 Low	70 %	G-FR1-A3-14	pos1	-5.8
		Normal	TDLC300-100 Low	70 %	G-FR1-A4-14	pos1	6.3
		Normal	TDLA30-10 Low	70 %	G-FR1-A5-14	pos1	9.2
		Normal	TDLA30-10 Low	70 %	G-FR1-A9-5	pos1	16.9
	8	Normal	TDLB100-400 Low	70 %	G-FR1-A3-14	pos1	-8.7
		Normal	TDLC300-100 Low	70 %	G-FR1-A4-14	pos1	3.1
		Normal	TDLA30-10 Low	70 %	G-FR1-A5-14	pos1	5.9
		Normal	TDLA30-10 Low	70 %	G-FR1-A9-5	pos1	13.2
2	2	Normal	TDLB100-400 Low	70 %	G-FR1-A3-28	pos1	1.6
		Normal	TDLC300-100 Low	70 %	G-FR1-A4-28	pos1	19.3
	4	Normal	TDLB100-400 Low	70 %	G-FR1-A3-28	pos1	-2.2
		Normal	TDLC300-100 Low	70 %	G-FR1-A4-28	pos1	11.6
	8	Normal	TDLB100-400 Low	70 %	G-FR1-A3-28	pos1	-5.3
		Normal	TDLC300-100 Low	70 %	G-FR1-A4-28	pos1	7.1

Table 8.2.1.2-15: Minimum requirements for PUSCH with 30% of maximum throughput, Type A, 5 MHz channel bandwidth, 15 kHz SCS

Number of TX antennas	Number of RX antennas	Cyclic prefix	Propagation conditions and correlation matrix (Annex G)	Fraction of maximum throughput	FRC (Annex A)	Additional DM-RS position	SNR (dB)
1	2	Normal	TDLC300-100 Low	30 %	G-FR1-A4-8	pos1	2.9

Table 8.2.1.2-16: Minimum requirements for PUSCH with 30% of maximum throughput, Type A, 10 MHz channel bandwidth, 30 kHz SCS

Number of TX antennas	Number of RX antennas	Cyclic prefix	Propagation conditions and correlation matrix (Annex G)	Fraction of maximum throughput	FRC (Annex A)	Additional DM-RS position	SNR (dB)
1	2	Normal	TDLC300-100 Low	30 %	G-FR1-A4-11	pos1	2.8

Table 8.2.1.2-17: Minimum requirements for PUSCH with 30% of maximum throughput, Type B, 5 MHz channel bandwidth, 15 kHz SCS

Number of TX antennas	Number of RX antennas	Cyclic prefix	Propagation conditions and correlation matrix (Annex G)	Fraction of maximum throughput	FRC (Annex A)	Additional DM-RS position	SNR (dB)
1	2	Normal	TDLC300-100 Low	30 %	G-FR1-A4-8	pos1	2.8

Table 8.2.1.2-18: Minimum requirements for PUSCH with 30% of maximum throughput, Type B, 10 MHz channel bandwidth, 30 kHz SCS

Number of TX antennas	Number of RX antennas	Cyclic prefix	Propagation conditions and correlation matrix (Annex G)	Fraction of maximum throughput	FRC (Annex A)	Additional DM-RS position	SNR (dB)
1	2	Normal	TDLC300-100 Low	30 %	G-FR1-A4-11	pos1	2.9

8.2.2 Requirements for PUSCH with transform precoding enabled

8.2.2.1 General

The performance requirement of PUSCH is determined by a minimum required throughput for a given SNR. The required throughput is expressed as a fraction of maximum throughput for the FRCs listed in annex A. The performance requirements assume HARQ retransmissions.

Table 8.2.2.1-1: Test parameters for testing PUSCH

Parameter		Value
Transform precoding		Enabled
Default TDD UL-DL pattern (Note 1)		15 kHz SCS: 3D1S1U, S=10D:2G:2U 30 kHz SCS: 7D1S2U, S=6D:4G:4U
HARQ	Maximum number of HARQ transmissions	4
	RV sequence	0, 2, 3, 1
DM-RS	DM-RS configuration type	1
	DM-RS duration	single-symbol DM-RS
	Additional DM-RS position	pos1
	Number of DM-RS CDM group(s) without data	2
	Ratio of PUSCH EPRE to DM-RS EPRE	-3 dB
	DM-RS port(s)	0
DM-RS sequence generation		$N_{ID}^0=0$, group hopping and sequence hopping are disabled
Time domain resource assignment	PUSCH mapping type	A, B
	Start symbol	0
	Allocation length	14
Frequency domain resource assignment	RB assignment	15 kHz SCS: 25 PRBs in the middle of the test bandwidth 30 kHz SCS: 24 PRBs in the middle of the test bandwidth
	Frequency hopping	Disabled
Code block group based PUSCH transmission		Disabled
NOTE 1: The same requirements are applicable to FDD and TDD with different UL-DL patterns.		

8.2.2.2 Minimum requirements

The throughput shall be equal to or larger than the fraction of maximum throughput for the FRCs stated in tables 8.2.2.2-1 to 8.2.2.2-4 at the given SNR. FRCs are defined in annex A.

Table 8.2.2.2-1: Minimum requirements for PUSCH with 70% of maximum throughput, Type A, 5 MHz channel bandwidth, 15 kHz SCS

Number of TX antennas	Number of RX antennas	Cyclic prefix	Propagation conditions and correlation matrix (Annex G)	Fraction of maximum throughput	FRC (Annex A)	Additional DM-RS position	SNR (dB)
1	2	Normal	TDLB100-400 Low	70 %	G-FR1-A3-31	pos1	-2.4
	4	Normal	TDLB100-400 Low	70 %	G-FR1-A3-31	pos1	-5.7
	8	Normal	TDLB100-400 Low	70 %	G-FR1-A3-31	pos1	-8.5

Table 8.2.2.2-2: Minimum requirements for PUSCH with 70% of maximum throughput, Type A, 10 MHz channel bandwidth, 30 kHz SCS

Number of TX antennas	Number of RX antennas	Cyclic prefix	Propagation conditions and correlation matrix (Annex G)	Fraction of maximum throughput	FRC (Annex A)	Additional DM-RS position	SNR (dB)
1	2	Normal	TDLB100-400 Low	70 %	G-FR1-A3-32	pos1	-2.5
	4	Normal	TDLB100-400 Low	70 %	G-FR1-A3-32	pos1	-5.7
	8	Normal	TDLB100-400 Low	70 %	G-FR1-A3-32	pos1	-8.4

Table 8.2.2.2-3: Minimum requirements for PUSCH with 70% of maximum throughput, Type B, 5 MHz channel bandwidth, 15 kHz SCS

Number of TX antennas	Number of RX antennas	Cyclic prefix	Propagation conditions and correlation matrix (Annex G)	Fraction of maximum throughput	FRC (Annex A)	Additional DM-RS position	SNR (dB)
1	2	Normal	TDLB100-400 Low	70 %	G-FR1-A3-31	pos1	-2.3
	4	Normal	TDLB100-400 Low	70 %	G-FR1-A3-31	pos1	-5.8
	8	Normal	TDLB100-400 Low	70 %	G-FR1-A3-31	pos1	-8.6

Table 8.2.2.2-4: Minimum requirements for PUSCH with 70% of maximum throughput, Type B, 10 MHz channel bandwidth, 30 kHz SCS

Number of TX antennas	Number of RX antennas	Cyclic prefix	Propagation conditions and correlation matrix (Annex G)	Fraction of maximum throughput	FRC (Annex A)	Additional DM-RS position	SNR (dB)
1	2	Normal	TDLB100-400 Low	70 %	G-FR1-A3-32	pos1	-2.7
	4	Normal	TDLB100-400 Low	70 %	G-FR1-A3-32	pos1	-6.0
	8	Normal	TDLB100-400 Low	70 %	G-FR1-A3-32	pos1	-8.8

8.2.3 Requirements for UCI multiplexed on PUSCH

8.2.3.1 General

In the tests for UCI multiplexed on PUSCH, the UCI information only contains CSI part 1 and CSI part 2 information, and there is no HACK/ACK information transmitted.

The CSI part 1 block error probability (BLER) is defined as the probability of incorrectly decoding the CSI part 1 information when the CSI part 1 information is sent as follow:

$$BLER_{CSI\ part\ 1} = \frac{\#(false\ CSI\ part\ 1)}{\#(CSI\ part\ 1)}$$

where:

- #(false CSI part 1) denotes the number of incorrectly decoded CSI part 1 information transmitted occasions

- #(CSI part 1) denotes the number of CSI part 1 information transmitted occasions.

The CSI part 2 block error probability is defined as the probability of incorrectly decoding the CSI part 2 information when the CSI part 2 information is sent as follows:

$$BLER_{CSI\ part\ 2} = \frac{\#(\text{false CSI part 2})}{\#(\text{CSI part 2})}$$

where:

- #(false CSI part 2) denotes the number of incorrectly decoded CSI part 2 information transmitted occasions
- #(CSI part 2) denotes the number of CSI part 2 information transmitted occasions.

The number of UCI information bit payload per slot is defined for two cases as follows:

- 5 bits in CSI part 1, 2 bits in CSI part 2
- 20 bits in CSI part 1, 20 bits in CSI part 2

The 7bits UCI case is further defined with the bitmap [c0 c1 c2 c3 c4] = [0 1 0 1 0] for CSI part 1 information, where c0 is mapping to the RI information, and with the bitmap [c0 c1] = [1 0] for CSI part2 information.

The 40bits UCI information case is assumed random information bit selection.

In both tests, PUSCH data, CSI part 1 and CSI part 2 information are transmitted simultaneously.

Table 8.2.3.1-1: Test parameters for testing UCI on PUSCH

Parameter		Value
Transform precoding		Disabled
Default TDD UL-DL pattern (Note 1)		30 kHz SCS: 7D1S2U, S=6D:4G:4U
HARQ	Maximum number of HARQ transmissions	1
	RV sequence	0
DM-RS	DM-RS configuration type	1
	DM-RS duration	Single-symbol DM-RS
	Additional DM-RS position	pos1
	Number of DM-RS CDM group(s) without data	2
	Ratio of PUSCH EPRE to DM-RS EPRE	-3 dB
	DM-RS port(s)	{0}
	DM-RS sequence generation	$N_{ID}^0=0, n_{SCID}=0$
Time domain resource assignment	PUSCH mapping type	A,B
	Start symbol	0
	Allocation length	14
Frequency domain resource assignment	RB assignment	Full applicable test bandwidth
	Frequency hopping	Disabled
Code block group based PUSCH transmission		Disabled
UCI	Number of CSI part 1 and CSI part 2 information bit payload	{5,2},{20,20}
	scaling	1
	betaOffsetACK-Index1	11
	betaOffsetCSI-Part1-Index1 and betaOffsetCSI-Part1-Index2	13
	betaOffsetCSI-Part2-Index1 and betaOffsetCSI-Part2-Index2	13
	UCI partition for frequency hopping	Disabled
NOTE 1: The same requirements are applicable to FDD and TDD with different UL-DL patterns.		

8.2.3.2 Minimum requirements

The CSI part 1 block error probability shall not exceed 0.1% at the SNR in table 8.2.3.2-1 and table 8.2.3.2-2. The CSI part 2 block error probability shall not exceed 1% at the SNR given in table 8.2.3.2-3 and table 8.2.3.2-4.

Table 8.2.3.2-1: Minimum requirements for UCI multiplexed on PUSCH, Type A, CSI part 1, 10 MHz Channel Bandwidth, 30 kHz SCS

Number of TX antennas	Number of RX antennas	Cyclic prefix	Propagation conditions and correlation matrix (Annex G)	UCI bits (CSI part 1, CSI part 2)	Additional DM-RS position	FRC (Annex A)	SNR (dB)
1	2	Normal	TDLC300-100 Low	7(5,2)	pos1	G-FR1-A4-11	5.4
	2	Normal	TDLC300-100 Low	40(20,20)	pos1	G-FR1-A4-11	4.3

Table 8.2.3.2-2: Minimum requirements for UCI multiplexed on PUSCH, Type B, CSI part 1, 10 MHz Channel Bandwidth, 30 kHz SCS

Number of TX antennas	Number of RX antennas	Cyclic prefix	Propagation conditions and correlation matrix (Annex G)	UCI bits (CSI part 1, CSI part 2)	Additional DM-RS position	FRC (Annex A)	SNR (dB)
1	2	Normal	TDLC300-100 Low	7(5,2)	pos1	G-FR1-A4-11	5.8
	2	Normal	TDLC300-100 Low	40(20,20)	pos1	G-FR1-A4-11	4.1

Table 8.2.3.2-3: Minimum requirements for UCI multiplexed on PUSCH, Type A, CSI part 2, 10 MHz Channel Bandwidth, 30 kHz SCS

Number of TX antennas	Number of RX antennas	Cyclic prefix	Propagation conditions and correlation matrix (Annex G)	UCI bits (CSI part 1, CSI part 2)	Additional DM-RS position	FRC (Annex A)	SNR (dB)
1	2	Normal	TDLC300-100 Low	7(5,2)	pos1	G-FR1-A4-11	-0.2
	2	Normal	TDLC300-100 Low	40(20,20)	pos1	G-FR1-A4-11	2.4

Table 8.2.3.2-4: Minimum requirements for UCI multiplexed on PUSCH, Type B, CSI part 2, 10 MHz Channel Bandwidth, 30 kHz SCS

Number of TX antennas	Number of RX antennas	Cyclic prefix	Propagation conditions and correlation matrix (Annex G)	UCI bits (CSI part 1, CSI part 2)	Additional DM-RS position	FRC (Annex A)	SNR (dB)
1	2	Normal	TDLC300-100 Low	7(5,2)	pos1	G-FR1-A4-11	0.3
	2	Normal	TDLC300-100 Low	40(20,20)	pos1	G-FR1-A4-11	2.6

8.2.4 Requirements for PUSCH for high speed train

8.2.4.1 General

The performance requirement of PUSCH is determined by a minimum required throughput for a given SNR. The required throughput is expressed as a fraction of maximum throughput for the FRCs listed in annex A. The performance requirements assume HARQ retransmissions. The performance requirements for high speed train are optional.

The performance requirements for PUSCH for high speed train only apply to Wide Area Base Stations and Medium Range Base Stations (subject to declaration).

Table: 8.2.4.1-1 Test parameters for testing high speed train PUSCH

Parameter		Value
Transform precoding		Disabled
Default TDD UL-DL pattern (Note 1)		15 kHz SCS: 3D1S1U, S=10D:2G:2U 30 kHz SCS: 7D1S2U, S=6D:4G:4U
HARQ	Maximum number of HARQ transmissions	4
	RV sequence	0, 2, 3, 1
DM-RS	DM-RS configuration type	1
	DM-RS duration	single-symbol DM-RS
	Additional DM-RS position	pos2
	Number of DM-RS CDM group(s) without data	2
	Ratio of PUSCH EPRE to DM-RS EPRE	-3 dB
	DM-RS port	0
	DM-RS sequence generation	$N_{ID}^0=0, n_{SCID}=0$
Time domain resource assignment	PUSCH mapping type	A
	Start symbol	0
	Allocation length	14
Frequency domain resource assignment	RB assignment	Full applicable test bandwidth
	Frequency hopping	Disabled
Code block group based PUSCH transmission		Disabled
NOTE 1: The same requirements are applicable to FDD and TDD with different UL-DL pattern.		

8.2.4.2 Minimum requirements

The throughput shall be equal to or larger than the fraction of maximum throughput for the FRCs stated in tables 8.2.4.2-1 to 8.2.4.2-10 at the given SNR for 1Tx. FRCs are defined in annex A. Unless stated otherwise, the MIMO correlation matrices for the gNB are defined in annex G for low correlation.

Table 8.2.4.2-1: Minimum requirements for PUSCH, Type A, 10 MHz channel bandwidth, 15 kHz SCS, 350km/h

Number of TX antennas	Number of RX antennas	Cyclic prefix	Propagation conditions (Annex G)	Fraction of maximum throughput	FRC (Annex A)	Additional DM-RS position	SNR (dB)
1	1	Normal	HST Scenario 3-NR350	70 %	G-FR1-A3-33	pos2	-0.8
	2	Normal	HST Scenario 1-NR350	70 %	G-FR1-A3-33	pos2	-3.7
		Normal	HST Scenario 1-NR350	70 %	G-FR1-A4-29	pos2	8.4
		Normal	HST Scenario 3-NR350	70 %	G-FR1-A3-33	pos2	-3.6
		Normal	HST Scenario 3-NR350	70 %	G-FR1-A4-29	pos2	8.7
		Normal	HST Scenario 1-NR350	70 %	G-FR1-A3-33	pos2	-9.2
	8	Normal	HST Scenario 1-NR350	70 %	G-FR1-A4-29	pos2	2.6

Table 8.2.4.2-2: Minimum requirements for PUSCH, Type A, 40 MHz channel bandwidth, 30 kHz SCS, 350km/h

Number of TX antennas	Number of RX antennas	Cyclic prefix	Propagation conditions (Annex G)	Fraction of maximum throughput	FRC (Annex A)	Additional DM-RS position	SNR (dB)
1	1	Normal	HST Scenario 3-NR350	70 %	G-FR1-A3-34	pos2	-0.6
	2	Normal	HST Scenario 1-NR350	70 %	G-FR1-A3-34	pos2	-3.7
		Normal	HST Scenario 1-NR350	70 %	G-FR1-A4-30	pos2	8.5
		Normal	HST Scenario 3-NR350	70 %	G-FR1-A3-34	pos2	-3.5
		Normal	HST Scenario 3-NR350	70 %	G-FR1-A4-30	pos2	8.8
		Normal	HST Scenario 1-NR350	70 %	G-FR1-A3-34	pos2	-9.1
	8	Normal	HST Scenario 1-NR350	70 %	G-FR1-A4-30	pos2	2.7

Table 8.2.4.2-3: Minimum requirements for PUSCH, Type A, 10 MHz channel bandwidth, 15 kHz SCS, 500km/h

Number of TX antennas	Number of RX antennas	Cyclic prefix	Propagation conditions (Annex G)	Fraction of maximum throughput	FRC (Annex A)	Additional DM-RS position	SNR (dB)
1	1	Normal	HST Scenario 3-NR500	70 %	G-FR1-A3-33	pos2	-0.7
	2	Normal	HST Scenario 1-NR500	70 %	G-FR1-A3-33	pos2	-3.9
		Normal	HST Scenario 1-NR500	70 %	G-FR1-A4-29	pos2	8.5
		Normal	HST Scenario 3-NR500	70 %	G-FR1-A3-33	pos2	-3.6
		Normal	HST Scenario 3-NR500	70 %	G-FR1-A4-29	pos2	9.2
		Normal	HST Scenario 1-NR500	70 %	G-FR1-A3-33	pos2	-9.4
	8	Normal	HST Scenario 1-NR500	70 %	G-FR1-A4-29	pos2	2.7

Table 8.2.4.2-4: Minimum requirements for PUSCH, Type A, 40 MHz channel bandwidth, 30 kHz SCS, 500km/h

Number of TX antennas	Number of RX antennas	Cyclic prefix	Propagation conditions (Annex G)	Fraction of maximum throughput	FRC (Annex A)	Additional DM-RS position	SNR (dB)
1	1	Normal	HST Scenario 3-NR500	70 %	G-FR1-A3-34	pos2	-0.5
	2	Normal	HST Scenario 1-NR500	70 %	G-FR1-A3-34	pos2	-3.9
		Normal	HST Scenario 1-NR500	70 %	G-FR1-A4-30	pos2	8.7
		Normal	HST Scenario 3-NR500	70 %	G-FR1-A3-34	pos2	-3.4
		Normal	HST Scenario 3-NR500	70 %	G-FR1-A4-30	pos2	10.2
		Normal	HST Scenario 1-NR500	70 %	G-FR1-A3-34	pos2	-9.2
	8	Normal	HST Scenario 1-NR500	70 %	G-FR1-A4-30	pos2	2.8

Table 8.2.4.2-5: Minimum requirements for PUSCH, Type A, 5 MHz channel bandwidth, 15 kHz SCS, 350km/h

Number of TX antennas	Number of RX antennas	Cyclic prefix	Propagation conditions (Annex G)	Fraction of maximum throughput	FRC (Annex A)	Additional DM-RS position	SNR (dB)
1	1	Normal	HST Scenario 3-NR350	70 %	G-FR1-A3-33A	pos2	-0.7
	2	Normal	HST Scenario 1-NR350	70 %	G-FR1-A3-33A	pos2	-3.7
		Normal	HST Scenario 1-NR350	70 %	G-FR1-A4-29A	pos2	8.5
		Normal	HST Scenario 3-NR350	70 %	G-FR1-A3-33A	pos2	-3.6
		Normal	HST Scenario 3-NR350	70 %	G-FR1-A4-29A	pos2	8.6
		Normal	HST Scenario 1-NR350	70 %	G-FR1-A3-33A	pos2	-9.1
	8	Normal	HST Scenario 1-NR350	70 %	G-FR1-A4-29A	pos2	2.8

Table 8.2.4.2-6: Minimum requirements for PUSCH, Type A, 10 MHz channel bandwidth, 30 kHz SCS, 350km/h

Number of TX antennas	Number of RX antennas	Cyclic prefix	Propagation conditions (Annex G)	Fraction of maximum throughput	FRC (Annex A)	Additional DM-RS position	SNR (dB)
1	1	Normal	HST Scenario 3-NR350	70 %	G-FR1-A3-34A	pos2	-0.7
	2	Normal	HST Scenario 1-NR350	70 %	G-FR1-A3-34A	pos2	-3.6
		Normal	HST Scenario 1-NR350	70 %	G-FR1-A4-30A	pos2	8.3
		Normal	HST Scenario 3-NR350	70 %	G-FR1-A3-34A	pos2	-3.6
		Normal	HST Scenario 3-NR350	70 %	G-FR1-A4-30A	pos2	8.6
		Normal	HST Scenario 1-NR350	70 %	G-FR1-A3-34A	pos2	-9.0
	8	Normal	HST Scenario 1-NR350	70 %	G-FR1-A4-30A	pos2	2.6

Table 8.2.4.2-7: Minimum requirements for PUSCH, Type A, 5 MHz channel bandwidth, 15 kHz SCS, 500km/h

Number of TX antennas	Number of RX antennas	Cyclic prefix	Propagation conditions (Annex G)	Fraction of maximum throughput	FRC (Annex A)	Additional DM-RS position	SNR (dB)
1	1	Normal	HST Scenario 3-NR500	70 %	G-FR1-A3-33A	pos2	-0.6
	2	Normal	HST Scenario 1-NR500	70 %	G-FR1-A3-33A	pos2	-3.6
		Normal	HST Scenario 1-NR500	70 %	G-FR1-A4-29A	pos2	8.7
		Normal	HST Scenario 3-NR500	70 %	G-FR1-A3-33A	pos2	-3.5
		Normal	HST Scenario 3-NR500	70 %	G-FR1-A4-29A	pos2	8.8
		Normal	HST Scenario 1-NR500	70 %	G-FR1-A3-33A	pos2	-9.1
	8	Normal	HST Scenario 1-NR500	70 %	G-FR1-A4-29A	pos2	3.0

Table 8.2.4.2-8: Minimum requirements for PUSCH, Type A, 10 MHz channel bandwidth, 30 kHz SCS, 500km/h

Number of TX antennas	Number of RX antennas	Cyclic prefix	Propagation conditions (Annex G)	Fraction of maximum throughput	FRC (Annex A)	Additional DM-RS position	SNR (dB)
1	1	Normal	HST Scenario 3-NR500	70 %	G-FR1-A3-34A	pos2	-0.5
	2	Normal	HST Scenario 1-NR500	70 %	G-FR1-A3-34A	pos2	-3.6
		Normal	HST Scenario 1-NR500	70 %	G-FR1-A4-30A	pos2	8.6
		Normal	HST Scenario 3-NR500	70 %	G-FR1-A3-34A	pos2	-3.4
		Normal	HST Scenario 3-NR500	70 %	G-FR1-A4-30A	pos2	8.6
		Normal	HST Scenario 1-NR500	70 %	G-FR1-A3-34A	pos2	-8.8
	8	Normal	HST Scenario 1-NR500	70 %	G-FR1-A4-30A	pos2	2.9

Table 8.2.4.2-9: Minimum requirements for PUSCH, Type A, 5 MHz channel bandwidth, 15 kHz SCS, 500km/h, multi-path fading channel requirements with high Doppler value

Number of TX antennas	Number of RX antennas	Cyclic prefix	Propagation conditions (Annex G)	Fraction of maximum throughput	FRC (Annex A)	Additional DM-RS position	SNR (dB)
1	2	Normal	TDLC300-600	70 %	G-FR1-A3-33A	pos2	-1.9

Table 8.2.4.2-10: Minimum requirements for PUSCH, Type A, 10 MHz channel bandwidth, 30 kHz SCS, 500km/h, multi-path fading channel requirements with high Doppler value

Number of TX antennas	Number of RX antennas	Cyclic prefix	Propagation conditions (Annex G)	Fraction of maximum throughput	FRC (Annex A)	Additional DM-RS position	SNR (dB)
1	2	Normal	TDLC300-1200	70 %	G-FR1-A3-34A	pos2	-2.0

8.2.5 Requirements for UL timing adjustment

The performance requirement of UL timing adjustment is determined by a minimum required throughput for the moving UE at given SNR. The performance requirements assume HARQ retransmissions. The performance requirements for UL timing adjustment scenario Y and scenario Z defined in Annex G.4 are optional.

In the tests for UL timing adjustment, two signals are configured, one being transmitted by a moving UE and the other being transmitted by a stationary UE. The transmission of SRS from UE is optional. FRC parameters in Table A.4-2B are applied for both UEs. The received power for both UEs is the same. The resource blocks allocated for both UEs are consecutive. In scenario Y and scenario Z Doppler shift is not taken into account.

Table 8.2.5-1 Test parameters for testing UL timing adjustment

Parameter		Value
Transform precoding		Disabled
Uplink-downlink allocation for TDD		15 kHz SCS: 3D1S1U, S=10D:2G:2U 30 kHz SCS: 7D1S2U, S=6D:4G:4U
Channel bandwidth		15 kHz SCS: 5MHz, 10 MHz 30 kHz SCS: 10MHz, 40 MHz
MCS		16
HARQ	Maximum number of HARQ transmissions	4
	RV sequence	0, 2, 3, 1
DM-RS	DM-RS configuration type	1
	DM-RS duration	single-symbol DM-RS
	DM-RS position (l_0)	2
	Additional DM-RS position	pos2
	Number of DM-RS CDM group(s) without data	2
	Ratio of PUSCH EPRE to DM-RS EPRE	-3 dB
Time domain resource assignment	DM-RS port	{0}
	DM-RS sequence generation	$N_{ID}^0=0, n_{SCID}=0$ for moving UE $N_{ID}^0=1, n_{SCID}=1$ for stationary UE
	PUSCH mapping type	Both A and B
Frequency domain resource assignment	Allocation length	14
	RB assignment	5 MHz CBW/15kHz SCS: 12 RB for each UE 10MHz CBW/15kHz SCS: 25 RB for each UE 10MHz CBW/30kHz SCS: 12 RB for each UE 40MHz CBW/30kHz SCS: 50 RB for each UE
	Starting PRB index	Moving UE: 0 Stationary UE: 12 for 5MHz, 25 for 10 MHz CBW for SCS 15kHz, and 12 for 10MHz, 50 for 40 MHz CBW for SCS 30kHz
SRS resource allocation	Frequency hopping	Disabled
	Slots in which sounding RS is transmitted (Note 1)	For FDD: slot #1 in radio frames For TDD: - last symbol in slot #3 in radio frames for 15KHz - last symbol in slot #7 in radio frames for 30KHz
SRS resource allocation	SRS resource allocation	15 kHz SCS: $C_{SRS} = 5, B_{SRS} = 0$, for 20 RB $C_{SRS} = 11, B_{SRS} = 0$, for 40 RB 30 kHz SCS: $C_{SRS} = 5, B_{SRS} = 0$, for 20 RB $C_{SRS} = 21, B_{SRS} = 0$, for 80 RB
	NOTE 1. The transmission of SRS is optional. And the transmission comb and SRS periodicity are configured as $K_{TC} = 2$, and $T_{SRS} = 10$ for 15 kHz SCS, $T_{SRS} = 20$ for 30 kHz SCS respectively.	

8.2.5.1 Minimum requirements for high speed train

The throughput shall be $\geq 70\%$ of the maximum throughput of the reference measurement channel as specified in Annex A for the moving UE at the SNR given in table 8.2.5.1-1 for mapping type A and table 8.2.5.1-2 for mapping type B respectively.

Table 8.2.5.1-1 Minimum requirements for UL timing adjustment with mapping type A for high speed train

Number of TX antennas	Number of RX antennas	Cyclic prefix	Channel Bandwidth [MHz]	SCS [kHz]	Moving propagation conditions and correlation matrix (Annex G)	FRC (Annex A)	SNR [dB]
1	2	Normal	5	15	Scenario Y	G-FR1-A4-31A	8.2
					Scenario Z	G-FR1-A4-31A	8.3
			10	15	Scenario Y	G-FR1-A4-31	8.5
					Scenario Z	G-FR1-A4-31	8.4
			10	30	Scenario Y	G-FR1-A4-32A	8.3
					Scenario Z	G-FR1-A4-32A	8.3
40	30	Scenario Y	G-FR1-A4-32	8.4			
		Scenario Z	G-FR1-A4-32	8.5			

Table 8.2.5.1-2 Minimum requirements for UL timing adjustment with mapping type B for high speed train

Number of TX antennas	Number of RX antennas	Cyclic prefix	Channel Bandwidth [MHz]	SCS [kHz]	Moving propagation conditions and correlation matrix (Annex G)	FRC (Annex A)	SNR [dB]
1	2	Normal	5	15	Scenario Y	G-FR1-A4-31A	8.3
					Scenario Z	G-FR1-A4-31A	8.3
			10	15	Scenario Y	G-FR1-A4-31	8.5
					Scenario Z	G-FR1-A4-31	8.5
			10	30	Scenario Y	G-FR1-A4-32A	8.3
					Scenario Z	G-FR1-A4-32A	8.4
40	30	Scenario Y	G-FR1-A4-32	8.4			
		Scenario Z	G-FR1-A4-32	8.5			

8.2.5.2 Minimum requirements for normal mode

The throughput shall be $\geq 70\%$ of the maximum throughput of the reference measurement channel as specified in Annex A for the moving UE at the SNR given in table 8.2.5.2-1 for mapping type A and table 8.2.5.2-2 for mapping type B respectively.

Table 8.2.5.2-1 Minimum requirements for UL timing adjustment with mapping type A for normal mode

Number of TX antennas	Number of RX antennas	Cyclic prefix	Channel Bandwidth [MHz]	SCS [kHz]	Moving propagation conditions and correlation matrix (Annex G)	FRC (Annex A)	SNR [dB]
1	2	Normal	5	15	Scenario X	G-FR1-A4-31A	10.6
			10	15	Scenario X	G-FR1-A4-31	11.2
			10	30	Scenario X	G-FR1-A4-32A	10.8
			40	30	Scenario X	G-FR1-A4-32	12.0

Table 8.2.5.2-2 Minimum requirements for UL timing adjustment with mapping type B for normal mode

Number of TX antennas	Number of RX antennas	Cyclic prefix	Channel Bandwidth [MHz]	SCS [kHz]	Moving propagation conditions and correlation matrix (Annex G)	FRC (Annex A)	SNR [dB]
1	2	Normal	5	15	Scenario X	G-FR1-A4-31A	10.6
			10	15	Scenario X	G-FR1-A4-31	11.3
			10	30	Scenario X	G-FR1-A4-32A	10.7
			40	30	Scenario X	G-FR1-A4-32	12.4

8.2.6 Requirements for PUSCH 0.001% BLER

8.2.6.1 General

The performance requirement of PUSCH is determined by a maximum required transport block error rate (BLER) for a given SNR. The required BLER is defined as the probability of incorrectly decoding the transport block after reaching the maximum number of HARQ transmissions for the FRCs listed in annex A.

Table: 8.2.6.1-1 Test parameters for testing PUSCH 0.001% BLER

Parameter		Value
Transform precoding		Disabled
Default TDD UL-DL pattern (Note 1)		15 kHz SCS: 3D1S1U, S=10D:2G:2U 30 kHz SCS: 7D1S2U, S=6D:4G:4U
HARQ	Maximum number of HARQ transmissions	1
	RV sequence	0
DM-RS	DM-RS configuration type	1
	DM-RS duration	single-symbol DM-RS
	Additional DM-RS position	pos1
	Number of DM-RS CDM group(s) without data	2
	Ratio of PUSCH EPRE to DM-RS EPRE	-3 dB
	DM-RS port(s)	{0}
	DM-RS sequence generation	$N_{ID}^0=0$, $n_{SCID}=0$
Time domain resource assignment	PUSCH mapping type	A, B
	Start symbol	0
	Allocation length	14
Frequency domain resource assignment	RB assignment	Full applicable test bandwidth
	Frequency hopping	Disabled
Code block group based PUSCH transmission		Disabled
Note 1: The same requirements are applicable to FDD and TDD with different UL-DL patterns.		

8.2.6.2 Minimum requirements

The BLER shall be equal to or smaller than the BLER stated in tables 8.2.6.2-1 to 8.2.6.2-8 at the given SNR for 1Tx. FRCs are defined in annex A. Unless stated otherwise, the MIMO correlation matrices for the gNB are defined in annex G for low correlation.

Table 8.2.6.2-1: Minimum requirements for PUSCH with 0.001%BLER, Type A, 5 MHz channel bandwidth, 15 kHz SCS

Number of TX antennas	Number of RX antennas	Cyclic prefix	Propagation conditions (Annex G)	BLER	FRC (annex A)	Additional DM-RS position	SNR (dB)
1	2	Normal	AWGN	0.001%	G-FR1-A3A-1	pos1	-5.1

Table 8.2.6.2-2: Minimum requirements for PUSCH with 0.001%BLER, Type A, 10 MHz channel bandwidth, 15 kHz SCS

Number of TX antennas	Number of RX antennas	Cyclic prefix	Propagation conditions (Annex G)	BLER	FRC (annex A)	Additional DM-RS position	SNR (dB)
1	2	Normal	AWGN	0.001%	G-FR1-A3A-2	pos1	-5.9

Table 8.2.6.2-3: Minimum requirements for PUSCH with 0.001%BLER, Type A, 10 MHz channel bandwidth, 30 kHz SCS

Number of TX antennas	Number of RX antennas	Cyclic prefix	Propagation conditions (Annex G)	BLER	FRC (annex A)	Additional DM-RS position	SNR (dB)
1	2	Normal	AWGN	0.001%	G-FR1-A3A-3	pos1	-5.4

Table 8.2.6.2-4: Minimum requirements for PUSCH with 0.001%BLER, Type A, 40 MHz channel bandwidth, 30 kHz SCS

Number of TX antennas	Number of RX antennas	Cyclic prefix	Propagation conditions (Annex G)	BLER	FRC (annex A)	Additional DM-RS position	SNR (dB)
1	2	Normal	AWGN	0.001%	G-FR1-A3A-4	pos1	-6.2

Table 8.2.6.2-5: Minimum requirements for PUSCH with 0.001%BLER, Type B, 5 MHz channel bandwidth, 15 kHz SCS

Number of TX antennas	Number of RX antennas	Cyclic prefix	Propagation conditions (Annex G)	BLER	FRC (annex A)	Additional DM-RS position	SNR (dB)
1	2	Normal	AWGN	0.001%	G-FR1-A3A-1	pos1	-5.2

Table 8.2.6.2-6: Minimum requirements for PUSCH with 0.001%BLER, Type B, 10 MHz channel bandwidth, 15 kHz SCS

Number of TX antennas	Number of RX antennas	Cyclic prefix	Propagation conditions (Annex G)	BLER	FRC (annex A)	Additional DM-RS position	SNR (dB)
1	2	Normal	AWGN	0.001%	G-FR1-A3A-2	pos1	-5.9

Table 8.2.6.2-7: Minimum requirements for PUSCH with 0.001%BLER, Type B, 10 MHz channel bandwidth, 30 kHz SCS

Number of TX antennas	Number of RX antennas	Cyclic prefix	Propagation conditions (Annex G)	BLER	FRC (annex A)	Additional DM-RS position	SNR (dB)
1	2	Normal	AWGN	0.001%	G-FR1-A3A-3	pos1	-5.4

Table 8.2.6.2-8: Minimum requirements for PUSCH with 0.001%BLER, Type B, 40 MHz channel bandwidth, 30 kHz SCS

Number of TX antennas	Number of RX antennas	Cyclic prefix	Propagation conditions (Annex G)	BLER	FRC (annex A)	Additional DM-RS position	SNR (dB)
1	2	Normal	AWGN	0.001%	G-FR1-A3A-4	pos1	-6.2

8.2.7 Requirements for PUSCH repetition Type A

8.2.7.1 General

The performance requirement of PUSCH is determined by a maximum block error probability (BLER) for a given SNR. The BLER is defined as the probability of incorrectly decoding the PUSCH information when the PUSCH information is sent. The performance requirements assume HARQ re-transmissions.

Table: 8.2.7.1-1 Test parameters for testing PUSCH repetition Type A

Parameter		Value
Transform precoding		Disabled
Default TDD UL-DL pattern (Note 1)		15 kHz SCS: 3D1S1U, S=10D:2G:2U 30 kHz SCS: 7D1S2U, S=6D:4G:4U
HARQ	Maximum number of HARQ transmissions	4
	RV sequence	0, 3, 0, 3 [Note 2]
DM-RS	DM-RS configuration type	1
	DM-RS duration	single-symbol DM-RS
	Additional DM-RS position	pos1
	Number of DM-RS CDM group(s) without data	2
	Ratio of PUSCH EPRE to DM-RS EPRE	-3 dB
	DM-RS port	0
DM-RS sequence generation		$N_{ID}^0=0, n_{SCID}=0$
Time domain resource assignment	PUSCH mapping type	A, B
	Start symbol	0
	Allocation length	14
	PUSCH aggregation factor	30 kHz SCS: n2 15 kHz SCS: n2 for FDD and n8 for TDD [Note 3]
Frequency domain resource assignment	RB assignment	Full applicable test bandwidth
	Frequency hopping	Disabled
Code block group based PUSCH transmission		Disabled
Note 1: The same requirements are applicable to FDD and TDD with different UL-DL pattern.		
Note 2: The effective RV sequence is {0, 2, 3, 1} with slot aggregation.		
Note 3: The intention of this configuration is to have two effective transmissions of the transport block. To achieve this for the standard TDD pattern captured in this table, a value of n8 is necessary, while for FDD a value of n2 is necessary.		

8.2.7.2 Minimum requirements

The BLER shall be equal to or smaller than the required target BLER for the FRCs stated in tables 8.2.7.2-1 to 8.2.7.2-8 at the given SNR for 1Tx. FRCs are defined in annex A.

Table 8.2.7.2-1: Minimum requirements for PUSCH, Type A, 5 MHz channel bandwidth, 15 kHz SCS

Number of TX antennas	Number of RX antennas	Cyclic prefix	Propagation conditions and correlation matrix (Annex G)	Target BLER	FRC (Annex A)	Additional DM-RS position	SNR (dB)
1	2	Normal	TDLB100-400 Low	1% (Note 1)	G-FR1-A3A-1	pos1	-8.4
Note 1: BLER is defined as residual BLER; i.e. ratio of incorrectly received transport blocks / sent transport blocks, independently of the number HARQ transmission(s) for each transport block.							

Table 8.2.7.2-2: Minimum requirements for PUSCH, Type A, 10 MHz channel bandwidth, 15 kHz SCS

Number of TX antennas	Number of RX antennas	Cyclic prefix	Propagation conditions and correlation matrix (Annex G)	Target BLER	FRC (Annex A)	Additional DM-RS position	SNR (dB)
1	2	Normal	TDLB100-400 Low	1% (Note 1)	G-FR1- A3A -2	pos1	-10.2
Note 1: BLER is defined as residual BLER; i.e. ratio of incorrectly received transport blocks / sent transport blocks, independently of the number HARQ transmission(s) for each transport block.							

Table 8.2.7.2-3: Minimum requirements for PUSCH, Type A, 10 MHz channel bandwidth, 30 kHz SCS

Number of TX antennas	Number of RX antennas	Cyclic prefix	Propagation conditions and correlation matrix (Annex G)	Target BLER	FRC (Annex A)	Additional DM-RS position	SNR (dB)
1	2	Normal	TDLB100-400 Low	1% (Note 1)	G-FR1- A3A -3	pos1	-10.8
Note 1: BLER is defined as residual BLER; i.e. ratio of incorrectly received transport blocks / sent transport blocks, independently of the number HARQ transmission(s) for each transport block.							

Table 8.2.7.2-4: Minimum requirements for PUSCH, Type A, 40 MHz channel bandwidth, 30 kHz SCS

Number of TX antennas	Number of RX antennas	Cyclic prefix	Propagation conditions and correlation matrix (Annex G)	Target BLER	FRC (Annex A)	Additional DM-RS position	SNR (dB)
1	2	Normal	TDLB100-400 Low	1% (Note 1)	G-FR1- A3A -4	pos1	-11.5
Note 1: BLER is defined as residual BLER; i.e. ratio of incorrectly received transport blocks / sent transport blocks, independently of the number HARQ transmission(s) for each transport block.							

Table 8.2.7.2-5: Minimum requirements for PUSCH, Type B, 5 MHz channel bandwidth, 15 kHz SCS

Number of TX antennas	Number of RX antennas	Cyclic prefix	Propagation conditions and correlation matrix (Annex G)	Target BLER	FRC (Annex A)	Additional DM-RS position	SNR (dB)
1	2	Normal	TDLB100-400 Low	1% (Note 1)	G-FR1- A3A -1	pos1	-8.2
Note 1: BLER is defined as residual BLER; i.e. ratio of incorrectly received transport blocks / sent transport blocks, independently of the number HARQ transmission(s) for each transport block.							

Table 8.2.7.2-6: Minimum requirements for PUSCH, Type B, 10 MHz channel bandwidth, 15 kHz SCS

Number of TX antennas	Number of RX antennas	Cyclic prefix	Propagation conditions and correlation matrix (Annex G)	Target BLER	FRC (Annex A)	Additional DM-RS position	SNR (dB)
1	2	Normal	TDLB100-400 Low	1% (Note 1)	G-FR1- A3A -2	pos1	-10.1
Note 1: BLER is defined as residual BLER; i.e. ratio of incorrectly received transport blocks / sent transport blocks, independently of the number HARQ transmission(s) for each transport block.							

Table 8.2.7.2-7: Minimum requirements for PUSCH, Type B, 10 MHz channel bandwidth, 30 kHz SCS

Number of TX antennas	Number of RX antennas	Cyclic prefix	Propagation conditions and correlation matrix (Annex G)	Target BLER	FRC (Annex A)	Additional DM-RS position	SNR (dB)
1	2	Normal	TDLB100-400 Low	1% (Note 1)	G-FR1- A3A -3	pos1	-10.8
Note 1: BLER is defined as residual BLER; i.e. ratio of incorrectly received transport blocks / sent transport blocks, independently of the number HARQ transmission(s) for each transport block.							

Table 8.2.7.2-8: Minimum requirements for PUSCH, Type B, 40 MHz channel bandwidth, 30 kHz SCS

Number of TX antennas	Number of RX antennas	Cyclic prefix	Propagation conditions and correlation matrix (Annex G)	Target BLER	FRC (Annex A)	Additional DM-RS position	SNR (dB)
1	2	Normal	TDLB100-400 Low	1% (Note 1)	G-FR1- A3A -4	pos1	-11.4
Note 1: BLER is defined as residual BLER; i.e. ratio of incorrectly received transport blocks / sent transport blocks, independently of the number HARQ transmission(s) for each transport block.							

8.2.8 Requirements for PUSCH mapping Type B with non-slot transmission

8.2.8.1 General

The performance requirement of PUSCH is determined by a minimum required throughput for a given SNR. The required throughput is expressed as a fraction of maximum throughput for the FRCs listed in annex A. The performance requirements do not assume HARQ retransmissions.

Table: 8.2.8.1-1 Test parameters for testing PUSCH mapping Type B with non-slot transmission

Parameter		Value
Transform precoding		Disabled
Default TDD UL-DL pattern (Note 1)		15 kHz SCS: 3D1S1U, S=10D:2G:2U 30 kHz SCS: 7D1S2U, S=6D:4G:4U
HARQ	Maximum number of HARQ transmissions	1
	RV sequence	0
DM-RS	DM-RS configuration type	1
	DM-RS duration	single-symbol DM-RS
	Additional DM-RS position	Pos0
	Number of DM-RS CDM group(s) without data	2
	Ratio of PUSCH EPRE to DM-RS EPRE	-3 dB
	DM-RS port(s)	{0}
	DM-RS sequence generation	$N_{ID}^0=0, n_{SCID}=0$
Time domain resource assignment	PUSCH mapping type	B
	Start symbol	0
	Allocation length	2
Frequency domain resource assignment	RB assignment	Full applicable test bandwidth
	Frequency hopping	Disabled
Code block group based PUSCH transmission		Disabled
Note 1: The same requirements are applicable to FDD and TDD with different UL-DL patterns.		

8.2.8.2 Minimum requirements

The throughput shall be equal to or larger than the fraction of maximum throughput for the FRCs stated in tables 8.2.4.8-1 to 8.2.4.8-4 at the given SNR for 1Tx. FRCs are defined in annex A. Unless stated otherwise, the MIMO correlation matrices for the gNB are defined in annex G for low correlation.

Table 8.2.8.2-1: Minimum requirements for PUSCH with 2 symbols, Type B, 5 MHz channel bandwidth, 15 kHz SCS

Number of TX antennas	Number of RX antennas	Cyclic prefix	Propagation conditions (Annex G)	Fraction of maximum throughput	FRC (Annex A)	Additional DM-RS position	SNR (dB)
1	2	Normal	TDLC300-100	70 %	G-FR1-A3B-1	pos0	0.5

Table 8.2.8.2-2: Minimum requirements for PUSCH with 2 symbols, Type B, 10 MHz channel bandwidth, 15 kHz SCS

Number of TX antennas	Number of RX antennas	Cyclic prefix	Propagation conditions (Annex G)	Fraction of maximum throughput	FRC (Annex A)	Additional DM-RS position	SNR (dB)
1	2	Normal	TDLC300-100	70 %	G-FR1-A3B-2	pos0	0.3

Table 8.2.8.2-3: Minimum requirements for PUSCH with 2 symbols, Type B, 10 MHz channel bandwidth, 30 kHz SCS

Number of TX antennas	Number of RX antennas	Cyclic prefix	Propagation conditions (Annex G)	Fraction of maximum throughput	FRC (Annex A)	Additional DM-RS position	SNR (dB)
1	2	Normal	TDLC300-100	70 %	G-FR1-A3B-3	pos0	0.3

Table 8.2.8.2-4: Minimum requirements for PUSCH with 2 symbols, Type B, 40 MHz channel bandwidth, 30 kHz SCS

Number of TX antennas	Number of RX antennas	Cyclic prefix	Propagation conditions (Annex G)	Fraction of maximum throughput	FRC (Annex A)	Additional DM-RS position	SNR (dB)
1	2	Normal	TDLC300-100	70 %	G-FR1-A3B-4	pos0	0.0

8.2.9 Requirements of PUSCH for 2-step RA type

8.2.9.1 General

The performance requirement of PUSCH for 2-step RA type is determined by a minimum required block error rate of MsgA received by BS at given SNR for the FRCs listed in Annex A. The performance requirements assume that the precedent preamble of MsgA is correctly detected in a 2-step RA type procedure, and no HARQ retransmissions.

The performance requirements are applicable for wide area and medium range BS that support 2-step RA type.

The performance requirements are not applied for a local area BS that supports 2-step RA type.

Table 8.2.9.1-1: Test parameters for testing PUSCH for 2-step RA type

Parameter		Value
Transform precoding		Disabled
Channel bandwidth		15 kHz SCS: 10 MHz 30 kHz SCS: 40 MHz
MCS		1
DM-RS	DM-RS configuration type	1
	DM-RS duration	single-symbol DM-RS
	DM-RS position (l_0)	2
	Additional DM-RS position	pos2 or pos1
	Number of DM-RS CDM group(s) without data	2
	Ratio of PUSCH EPRE to DM-RS EPRE	-3 dB
	DM-RS port	{0}
Time domain resource assignment	DM-RS sequence generation	$N_{ID}^0=0, n_{SCID} = 0$
	PUSCH mapping type	Both A and B
Frequency domain resource assignment	Allocation length	14
	RB assignment	2 PRBs
	Starting PRB index	0
Time offset (TO) Cycling (μ s)	Frequency hopping	Disabled
	start:end	15k SCS: 0:3.8 30k SCS: 0:2
Test Metric	BLER	0.01
NOTE 1: A single requirement is defined that is applicable regardless of whether pos1 or pos2 is configured for the additional DM-RS position		
NOTE 2: The power ratio between preamble and msgA (msgA-DeltaPreamble) is set to be sufficient to achieve 100% preamble detection. The SNR for the requirement is defined on the msgA PUSCH		

8.2.9.2 Minimum requirements

The block error rate of MsgA for the reference measurement channel as specified in Annex A at the SNR given shall not exceed 1% in table 8.2.9.2-1 for mapping type A and table 8.2.9.2-2 for mapping type B respectively.

Table 8.2.9.2-1: Minimum requirements of PUSCH for 2-step RA type with mapping type A

Number of TX antennas	Number of RX antennas	Cyclic prefix	Mapping Type	TO cycling (start:end) [μs]	Channel Bandwidth [MHz]	SCS [kHz]	Propagation conditions and correlation matrix (Annex G)	FRC (Annex A)	SNR [dB]
1	2	Normal	Type A	0:3.8	10	15	TDLC300-100 low	G-FR1-A8-1, or G-FR1-A8-3	7.3
				0:2	40	30	TDLC300-100 low	G-FR1-A8-2, or G-FR1-A8-4	7.1

Table 8.2.9.2-2: Minimum requirements of PUSCH for 2-step RA type with mapping type B

Number of TX antennas	Number of RX antennas	Cyclic prefix	Mapping Type	TO cycling (start:end) [μs]	Channel Bandwidth [MHz]	SCS [kHz]	Propagation conditions and correlation matrix (Annex G)	FRC (Annex A)	SNR [dB]
1	2	Normal	Type B	0:3.8	10	15	TDLC300-100 low	G-FR1-A8-1, or G-FR1-A8-3	7.0]
				0:2	40	30	TDLC300-100 low	G-FR1-A8-2, or G-FR1-A8-4	7.6

8.2.10 Requirements for interlaced PUSCH

8.2.10.1 General

The performance requirement of PUSCH with interlace allocation is determined by a minimum required throughput for a given SNR. The required throughput is expressed as a fraction of maximum throughput for the FRCs listed in annex A. The performance requirements assume HARQ retransmissions.

Table 8.2.10.1-1: Test parameters for testing PUSCH

Parameter		Value
Transform precoding		Disabled
Default TDD UL-DL pattern (Note 1)		15 kHz SCS: 3D1S1U, S=10D:2G:2U 30 kHz SCS: 7D1S2U, S=6D:4G:4U
HARQ	Maximum number of HARQ transmissions	4
	RV sequence	0, 2, 3, 1
DM-RS	DM-RS configuration type	1
	DM-RS duration	single-symbol DM-RS
	Additional DM-RS position	pos1
	Number of DM-RS CDM group(s) without data	2
	Ratio of PUSCH EPRE to DM-RS EPRE	-3 dB
	DM-RS port(s)	0
	DM-RS sequence generation	$N_{ID}^0=0, n_{SCID}=0$
Time domain resource assignment	PUSCH mapping type	A, B
	Start symbol	0
	Allocation length	14
Frequency domain resource assignment	RB assignment	Full applicable test bandwidth. First interlace with RBs 0,10,20,...,100 are allocated for tests with 15kHz and first interlace with RBs 0,5,10,...50 are allocated for tests with 30kHz.
	Frequency hopping	Disabled
Code block group based PUSCH transmission		Disabled
NOTE 1: The same requirements are applicable to FDD and TDD with different UL-DL patterns.		

8.2.10.2 Minimum requirements

The throughput shall be equal to or larger than the fraction of maximum throughput for the FRCs stated in tables 8.2.10.2-1 to 8.2.10.2-4 at the given SNR. FRCs are defined in annex A.

Table 8.2.10.2-1: Minimum requirements for PUSCH with 70% of maximum throughput, Type A, 20 MHz channel bandwidth, 15 kHz SCS

Number of TX antennas	Number of RX antennas	Cyclic prefix	Propagation conditions and correlation matrix (Annex G)	Fraction of maximum throughput	FRC (Annex A)	Additional DM-RS position	SNR (dB)
1	2	Normal	TDLA30-10 Low	70%	G-FR1-A5-15	pos1	12.3

Table 8.2.10.2-2: Minimum requirements for PUSCH with 70% of maximum throughput, Type A, 20 MHz channel bandwidth, 30 kHz SCS

Number of TX antennas	Number of RX antennas	Cyclic prefix	Propagation conditions and correlation matrix (Annex G)	Fraction of maximum throughput	FRC (Annex A)	Additional DM-RS position	SNR (dB)
1	2	Normal	TDLA30-10 Low	70%	G-FR1-A5-16	pos1	12.2

Table 8.2.10.2-3: Minimum requirements for PUSCH with 70% of maximum throughput, Type B, 20 MHz channel bandwidth, 15 kHz SCS

Number of TX antennas	Number of RX antennas	Cyclic prefix	Propagation conditions and correlation matrix (Annex G)	Fraction of maximum throughput	FRC (Annex A)	Additional DM-RS position	SNR (dB)
1	2	Normal	TDLA30-10 Low	70%	G-FR1-A5-15	pos1	12.3

Table 8.2.10.2-4: Minimum requirements for PUSCH with 70% of maximum throughput, Type B, 20 MHz channel bandwidth, 30 kHz SCS

Number of TX antennas	Number of RX antennas	Cyclic prefix	Propagation conditions and correlation matrix (Annex G)	Fraction of maximum throughput	FRC (Annex A)	Additional DM-RS position	SNR (dB)
1	2	Normal	TDLA30-10 Low	70%	G-FR1-A5-16	pos1	12.2

8.2.11 Performance requirements for CG-UCI multiplexed on interlaced PUSCH

8.2.11.1 General

The performance requirement of CG-UCI multiplexed on interlaced PUSCH is determined by the parameter: block error probability (BLER) of CG-UCI. The performance is measured by the required SNR at block error probability of CG-UCI not exceeding 1%.

The CG-UCI BLER is defined as the probability of incorrectly decoding the CG-UCI information when the CG-UCI information is sent.

In the test of UCI multiplexed on interlaced PUSCH, the UCI information only contains CG-UCI information, there is no HACK/ACK, CSI part 1 or CSI part 2 information transmitted.

The number of UCI information bit payload per slot is defined as 18 bits.

The 18 bits UCI information case is further defined with the bitmap [c0 c1 c2 c3 c4 ... c17] for CG-UCI information, where

- [c0 c1 c2 c3] = [0 0 0 1] is mapping to the HARQ process number information,
- [c4 c5] = [0 0] is mapping to the RV sequence information.
- [c6] = [1] is mapping to the NDI information.
- [c7 c8 ... c17] = [0 0 ... 0] is the COT sharing information field.

In the test, PUSCH data and CG-UCI are transmitted simultaneously.

Table 8.2.11.1-1: Test parameters for testing CG-UCI on interlaced PUSCH

Parameter		Value
Transform precoding		Disabled
Default TDD UL-DL pattern		30 kHz SCS: 7D1S2U, S=6D:4G:4U 15 kHz SCS: 3D1S1U S=10D:2G:2U
HARQ	Maximum number of HARQ transmissions	1
	RV sequence	0
DM-RS	DM-RS configuration type	1
	DM-RS duration	Single-symbol DM-RS
	Additional DM-RS position	pos1
	Number of DM-RS CDM group(s) without data	2
	Ratio of PUSCH EPRE to DM-RS EPRE	-3 dB
	DM-RS port(s)	{0}
	DM-RS sequence generation	$N_{ID}^0=0, n_{SCID}=0$
Time domain resource assignment	PUSCH mapping type	A,B
	Start symbol	0
	Allocation length	14
Frequency domain resource assignment	RB assignment	Full applicable test bandwidth. First interlace with RBs 0,10,20,...,100 are allocated for tests with 15kHz and first interlace with RBs 0,5,10,...50 are allocated for tests with 30kHz.
	Frequency hopping	Disabled
Code block group based PUSCH transmission		Disabled
PT-RS		Disabled
UCI	Number of information bits	18
	scaling	1
	betaOffsetCG-UCI-Index1	8
	UCI partition for frequency hopping	Disabled

8.2.11.2 Minimum requirements

The fraction of incorrectly decoded CG-UCI according to clause 8.2.11.1 shall be less than 1 % for the SNR listed in table 8.2.11.2-1 to .8.2.11.2-4.

Table 8.2.11.2-1: Minimum requirements for CG-UCI multiplexing on interlaced PUSCH, Type A, 20 MHz channel bandwidth, 15 kHz SCS

Number of TX antennas	Number of RX antennas	Cyclic prefix	Propagation conditions and correlation matrix (Annex G)	CG-UCI bits	FRC (Annex A)	Additional DM-RS position	SNR (dB)
1	2	Normal	TDLA30-10 Low	18	G-FR1-A5-15	pos1	4.6

Table 8.2.11.2-2: Minimum requirements for CG-UCI multiplexing on interlaced PUSCH, Type A, 20 MHz channel bandwidth, 30 kHz SCS

Number of TX antennas	Number of RX antennas	Cyclic prefix	Propagation conditions and correlation matrix (Annex G)	CG-UCI bits	FRC (Annex A)	Additional DM-RS position	SNR (dB)
1	2	Normal	TDLA30-10 Low	18	G-FR1-A5-16	pos1	4.7

Table 8.2.11.2-3: Minimum requirements for CG-UCI multiplexing on interlaced PUSCH, Type B, 20 MHz channel bandwidth, 15 kHz SCS

Number of TX antennas	Number of RX antennas	Cyclic prefix	Propagation conditions and correlation matrix (Annex G)	CG-UCI bits	FRC (Annex A)	Additional DM-RS position	SNR (dB)
1	2	Normal	TDLA30-10 Low	18	G-FR1-A5-15	pos1	4.6

Table 8.2.11.2-4: Minimum requirements for CG-UCI multiplexing on interlaced PUSCH, Type B, 20 MHz channel bandwidth, 30 kHz SCS

Number of TX antennas	Number of RX antennas	Cyclic prefix	Propagation conditions and correlation matrix (Annex G)	CG-UCI bits	FRC (Annex A)	Additional DM-RS position	SNR (dB)
1	2	Normal	TDLA30-10 Low	18	G-FR1-A5-16	pos1	5.0

8.2.12 Requirements for TB processing over multi-slot PUSCH (TBoMS)

8.2.12.1 General

The performance requirement of PUSCH TBoMS is determined by a minimum required throughput for a given SNR. The required throughput is expressed as a fraction of maximum throughput for the FRCs listed in annex A. The performance requirements assume HARQ retransmissions.

Table: 8.2.12.1-1: Test parameters for testing PUSCH TBoMS

Parameter		Value
Transform precoding		Disabled
Default TDD UL-DL pattern (Note 1)		15 kHz SCS: 3D1S1U, S=10D:2G:2U 30 kHz SCS: 7D1S2U, S=6D:4G:4U
HARQ	Maximum number of HARQ transmissions	4
	RV sequence	0, 2, 3, 1
DM-RS	DM-RS configuration type	1
	DM-RS duration	single-symbol DM-RS
	Additional DM-RS position	pos1
	Number of DM-RS CDM group(s) without data	2
	Ratio of PUSCH EPRE to DM-RS EPRE	-3 dB
	DM-RS port	0
DM-RS sequence generation		$N_{ID}^0=0, n_{SCID}=0$
Time domain resource assignment	PUSCH mapping type	A, B
	Start symbol	0
	Allocation length	14
	Number of slots allocated for TBoMS PUSCH	4 for FDD 2 for TDD
	Number of repetitions of a single TBoMS	1
Frequency domain resource assignment	RB assignment	5 RBs in the middle of the test bandwidth
	Frequency hopping	Disabled
Code block group based PUSCH transmission		Disabled
Note 1: The same requirements are applicable to TDD with different UL-DL pattern.		

8.2.12.2 Minimum requirements

The throughput shall be equal to or larger than the fraction of maximum throughput for the FRCs stated in tables 8.2.12.2-1 to 8.2.12.2-4 at the given SNR. FRCs are defined in annex A.

Table 8.2.12.2-1: Minimum requirements for PUSCH TBoMS, Type A, 5 MHz channel bandwidth, 15 kHz SCS

Number of TX antennas	Number of RX antennas	Cyclic prefix	Duplex	Propagation conditions and correlation matrix (Annex G)	Fraction of maximum throughput	FRC (Annex A)	Additional DM-RS position	SNR (dB)
1	2	Normal	FDD	TDLB100-400 Low	70%	G-FR1-A3-36	pos1	-2.3
1	2	Normal	TDD	TDLB100-400 Low	70%	G-FR1-A3-35	pos1	-2.5

Table 8.2.12.2-2: Minimum requirements for PUSCH TBoMS, Type A, 10 MHz channel bandwidth, 30 kHz SCS

Number of TX antennas	Number of RX antennas	Cyclic prefix	Duplex	Propagation conditions and correlation matrix (Annex G)	Fraction of maximum throughput	FRC (Annex A)	Additional DM-RS position	SNR (dB)
1	2	Normal	FDD	TDLB100-400 Low	70%	G-FR1-A3-38	pos1	-2.4
1	2	Normal	TDD	TDLB100-400 Low	70%	G-FR1-A3-37	pos1	-2.5

Table 8.2.12.2-3: Minimum requirements for PUSCH TBoMS, Type B, 5 MHz channel bandwidth, 15 kHz SCS

Number of TX antennas	Number of RX antennas	Cyclic prefix	Duplex	Propagation conditions and correlation matrix (Annex G)	Fraction of maximum throughput	FRC (Annex A)	Additional DM-RS position	SNR (dB)
1	2	Normal	FDD	TDLB100-400 Low	70%	G-FR1-A3-36	pos1	-2.1
1	2	Normal	TDD	TDLB100-400 Low	70%	G-FR1-A3-35	pos1	-2.5

Table 8.2.12.2-4: Minimum requirements for PUSCH TBoMS, Type B, 10 MHz channel bandwidth, 30 kHz SCS

Number of TX antennas	Number of RX antennas	Cyclic prefix	Duplex	Propagation conditions and correlation matrix (Annex G)	Fraction of maximum throughput	FRC (Annex A)	Additional DM-RS position	SNR (dB)
1	2	Normal	FDD	TDLB100-400 Low	70%	G-FR1-A3-38	pos1	-2.4
1	2	Normal	TDD	TDLB100-400 Low	70%	G-FR1-A3-37	pos1	-2.5

8.2.13 Requirements for PUSCH with DM-RS bundling

8.2.13.1 General

The performance requirement of PUSCH is determined by a minimum required throughput for a given SNR. The required throughput is expressed as a fraction of maximum throughput for the FRCs listed in annex A. The performance requirements assume HARQ re-transmissions.

Table 8.2.13.1-1: Test parameters for testing PUSCH with DM-RS bundling

Parameter		Value
Transform precoding		Disabled
Example UL-DL pattern [Note 1]		15 kHz SCS: FDD and TDD 7D1S2U, S=6D:4G:4U 30 kHz SCS: FDD and TDD 7D1S2U, S=6D:4G:4U
HARQ	Maximum number of HARQ transmissions	4
	RV sequence [Note 2]	0, 0, 0, 0 for FDD 0, 3, 0, 3 for TDD
DM-RS	DM-RS configuration type	1
	DM-RS duration	single-symbol DM-RS
	Additional DM-RS position	pos0, pos1
	Number of DM-RS CDM group(s) without data	2
	Ratio of PUSCH EPRE to DM-RS EPRE	-3 dB
	DM-RS port	0
DM-RS sequence generation		$N_{ID}^0=0, n_{SCID}=0$
Time domain resource assignment	PUSCH mapping type	A, B
	Start symbol	0
	Allocation length	14
	PUSCH aggregation factor	n8 for FDD n2 for TDD
pusch-TimeDomainWindowLength		8 slots for FDD 2 slots for TDD
Frequency domain resource assignment	RB assignment	Full applicable test bandwidth
	Frequency hopping	Disabled
Code block group based PUSCH transmission		Disabled
Note 1: The same TDD requirements are applicable to different UL-DL patterns with more than one consecutive UL slots when both pusch-TimeDomainWindowLength and PUSCH aggregation factor are configured as 2 slots. The UL (re)transmission of PUSCH is only scheduled for the actual TDW including 2 consecutive UL slots.		
Note 2: The effective RV sequence is {0, 2, 3, 1} with slot aggregation.		

8.2.13.2 Minimum requirements

The throughput shall be equal to or larger than the fraction of maximum throughput for the FRCs stated in tables 8.2.13.2-1 to 8.2.13.2-8 at the given SNR for 1Tx. FRCs are defined in annex A.

Table 8.2.13.2-1: Minimum requirements for PUSCH, Type A, 5 MHz channel bandwidth, 15 kHz SCS FDD

Number of TX antennas	Number of RX antennas	Cyclic prefix	Propagation conditions and correlation matrix (Annex G)	Fraction of maximum throughput	FRC (Annex A)	Additional DM-RS position	SNR (dB)
1	2	Normal	TDLA30-10 Low	70%	G-FR1-A3B-7	pos0	-7.9
					G-FR1-A3B-5	pos1	-9.9
	4	Normal	TDLA30-10 Low	70%	G-FR1-A3B-7	pos0	-11.8
					G-FR1-A3B-5	pos1	-12.3
	8	Normal	TDLA30-10 Low	70%	G-FR1-A3B-7	pos0	-15.0
					G-FR1-A3B-5	pos1	-15.6

Table 8.2.13.2-2: Minimum requirements for PUSCH, Type A, 5 MHz channel bandwidth, 15 kHz SCS TDD

Number of TX antennas	Number of RX antennas	Cyclic prefix	Propagation conditions and correlation matrix (Annex G)	Fraction of maximum throughput	FRC (Annex A)	Additional DM-RS position	SNR (dB)
1	2	Normal	TDLA30-10 Low	70%	G-FR1-A3B-7	pos0	-2.6
					G-FR1-A3B-5	pos1	-3.6
	4	Normal	TDLA30-10 Low	70%	G-FR1-A3B-7	pos0	-6.2
					G-FR1-A3B-5	pos1	-6.8
	8	Normal	TDLA30-10 Low	70%	G-FR1-A3B-7	pos0	-9.4
					G-FR1-A3B-5	pos1	-10.6

Table 8.2.13.2-3: Minimum requirements for PUSCH, Type A, 10 MHz channel bandwidth, 30 kHz SCS FDD

Number of TX antennas	Number of RX antennas	Cyclic prefix	Propagation conditions and correlation matrix (Annex G)	Fraction of maximum throughput	FRC (Annex A)	Additional DM-RS position	SNR (dB)
1	2	Normal	TDLA30-10 Low	70%	G-FR1-A3B-8	pos0	-9.8
					G-FR1-A3B-6	pos1	-9.5
	4	Normal	TDLA30-10 Low	70%	G-FR1-A3B-8	pos0	-13.0
					G-FR1-A3B-6	pos1	-13.1
	8	Normal	TDLA30-10 Low	70%	G-FR1-A3B-8	pos0	-15.3
					G-FR1-A3B-6	pos1	-15.8

Table 8.2.13.2-4: Minimum requirements for PUSCH, Type A, 10 MHz channel bandwidth, 30 kHz SCS TDD

Number of TX antennas	Number of RX antennas	Cyclic prefix	Propagation conditions and correlation matrix (Annex G)	Fraction of maximum throughput	FRC (Annex A)	Additional DM-RS position	SNR (dB)
1	2	Normal	TDLA30-10 Low	70%	G-FR1-A3B-8	pos0	-2.9
					G-FR1-A3B-6	pos1	-3.8
	4	Normal	TDLA30-10 Low	70%	G-FR1-A3B-8	pos0	-6.5
					G-FR1-A3B-6	pos1	-7.0
	8	Normal	TDLA30-10 Low	70%	G-FR1-A3B-8	pos0	-9.7
					G-FR1-A3B-6	pos1	-10.3

Table 8.2.13.2-5: Minimum requirements for PUSCH, Type B, 5 MHz channel bandwidth, 15 kHz SCS FDD

Number of TX antennas	Number of RX antennas	Cyclic prefix	Propagation conditions and correlation matrix (Annex G)	Fraction of maximum throughput	FRC (Annex A)	Additional DM-RS position	SNR (dB)
1	2	Normal	TDLA30-10 Low	70%	G-FR1-A3B-7	pos0	-8.3
					G-FR1-A3B-5	pos1	-9.9
	4	Normal	TDLA30-10 Low	70%	G-FR1-A3B-7	pos0	-11.8
					G-FR1-A3B-5	pos1	-12.3
	8	Normal	TDLA30-10 Low	70%	G-FR1-A3B-7	pos0	-15.0
					G-FR1-A3B-5	pos1	-15.6

Table 8.2.13.2-6: Minimum requirements for PUSCH, Type B, 5 MHz channel bandwidth, 15 kHz SCS TDD

Number of TX antennas	Number of RX antennas	Cyclic prefix	Propagation conditions and correlation matrix (Annex G)	Fraction of maximum throughput	FRC (Annex A)	Additional DM-RS position	SNR (dB)
1	2	Normal	TDLA30-10 Low	70%	G-FR1-A3B-7	pos0	-2.6
					G-FR1-A3B-5	pos1	-3.4
	4	Normal	TDLA30-10 Low	70%	G-FR1-A3B-7	pos0	-6.3
					G-FR1-A3B-5	pos1	-6.8
	8	Normal	TDLA30-10 Low	70%	G-FR1-A3B-7	pos0	-9.4
					G-FR1-A3B-5	pos1	-10.6

Table 8.2.13.2-7: Minimum requirements for PUSCH, Type B, 10 MHz channel bandwidth, 30 kHz SCS FDD

Number of TX antennas	Number of RX antennas	Cyclic prefix	Propagation conditions and correlation matrix (Annex G)	Fraction of maximum throughput	FRC (Annex A)	Additional DM-RS position	SNR (dB)
1	2	Normal	TDLA30-10 Low	70%	G-FR1-A3B-8	pos0	-9.8
					G-FR1-A3B-6	pos1	-9.5
	4	Normal	TDLA30-10 Low	70%	G-FR1-A3B-8	pos0	-13.3
					G-FR1-A3B-6	pos1	-13.1
	8	Normal	TDLA30-10 Low	70%	G-FR1-A3B-8	pos0	-15.5
					G-FR1-A3B-6	pos1	-15.8

Table 8.2.13.2-8: Minimum requirements for PUSCH, Type B, 10 MHz channel bandwidth, 30 kHz SCS TDD

Number of TX antennas	Number of RX antennas	Cyclic prefix	Propagation conditions and correlation matrix (Annex G)	Fraction of maximum throughput	FRC (Annex A)	Additional DM-RS position	SNR (dB)
1	2	Normal	TDLA30-10 Low	70%	G-FR1-A3B-8	pos0	-2.8
					G-FR1-A3B-6	pos1	-3.3
	4	Normal	TDLA30-10 Low	70%	G-FR1-A3B-8	pos0	-6.5
					G-FR1-A3B-6	pos1	-7.0
	8	Normal	TDLA30-10 Low	70%	G-FR1-A3B-8	pos0	-9.7
					G-FR1-A3B-6	pos1	-10.3

8.3 Performance requirements for PUCCH

8.3.1 DTX to ACK probability

8.3.1.1 General

The DTX to ACK probability, i.e. the probability that ACK is detected when nothing was sent:

$$\text{Prob}(\text{PUCCH DTX} \rightarrow \text{Ack bits}) = \frac{\#(\text{false ACK bits})}{\#(\text{PUCCH DTX}) * \#(\text{ACK/NACK bits})}$$

where:

- #(false ACK bits) denotes the number of detected ACK bits.
- #(ACK/NACK bits) denotes the number of encoded bits per slot
- #(PUCCH DTX) denotes the number of DTX occasions

8.3.1.2 Minimum requirement

The DTX to ACK probability shall not exceed 1% for all PUCCH formats carrying ACK/NACK bits:

$$\text{Prob}(\text{PUCCH DTX} \rightarrow \text{Ack bits}) \leq 10^{-2}$$

8.3.2 Performance requirements for PUCCH format 0

8.3.2.1 General

The ACK missed detection probability is the probability of not detecting an ACK when an ACK was sent.

Table 8.3.2.1-1: Test Parameters

Parameter	Test
Number of UCI information bits	1
Number of PRBs	1
First PRB prior to frequency hopping	0
Intra-slot frequency hopping	N/A for 1 symbol Enabled for 2 symbols
First PRB after frequency hopping	The largest PRB index – (Number of PRBs – 1)
Group and sequence hopping	neither
Hopping ID	0
Initial cyclic shift	0
First symbol	13 for 1 symbol 12 for 2 symbols

The transient period as specified in TS 38.101-1 [17] clause 6.3.3.1 is not taken into account for performance requirement testing, where the RB hopping is symmetric to the CC centre, i.e. intra-slot frequency hopping is enabled.

8.3.2.2 Minimum requirements

The ACK missed detection probability shall not exceed 1% at the SNR given in table 8.3.2.2-1 and in table 8.3.2.2-2.

Table 8.3.2.2-1: Minimum requirements for PUCCH format 0 and 15 kHz SCS

Number of TX antennas	Number of RX antennas	Propagation conditions and correlation matrix (Annex G)	Number of OFDM symbols	Channel bandwidth / SNR (dB)		
				5 MHz	10 MHz	20 MHz
1	2	TDLC300-100 Low	1	9.4	8.8	9.3
			2	2.8	3.7	3.3
1	4	TDLC300-100 Low	1	3.0	2.9	3.2
			2	-1.0	-0.5	-0.8
1	8	TDLC300-100 Low	1	-1.1	-1.1	-1.1
			2	-4.1	-3.9	-4.0

Table 8.3.2.2-2: Minimum requirements for PUCCH format 0 and 30 kHz SCS

Number of TX antennas	Number of RX antennas	Propagation conditions and correlation matrix (Annex G)	Number of OFDM symbols	Channel bandwidth / SNR (dB)			
				10 MHz	20 MHz	40 MHz	100 MHz
1	2	TDLC300-100 Low	1	9.8	9.8	9.5	9.2
			2	4.2	3.6	3.8	3.5
1	4	TDLC300-100 Low	1	3.4	3.4	3.0	3.3
			2	-0.3	-0.4	-0.5	-0.8
1	8	TDLC300-100 Low	1	-1.0	-1.0	-1.1	-1.0
			2	-3.7	-3.8	-4.0	-3.9

8.3.3 Performance requirements for PUCCH format 1

8.3.3.1 NACK to ACK requirements

8.3.3.1.1 General

The NACK to ACK detection probability is the probability that an ACK bit is falsely detected when an NACK bit was sent on the particular bit position, where the NACK to ACK detection probability is defined as follows:

$$\text{Prob}(\text{PUCCH NACK} \rightarrow \text{ACK bits}) = \frac{\#(\text{NACK bits decoded as ACK bits})}{\#(\text{Total NACK bits})},$$

where:

- $\#(\text{Total NACK bits})$ denotes the total number of NACK bits transmitted
- $\#(\text{NACK bits decoded as ACK bits})$ denotes the number of NACK bits decoded as ACK bits at the receiver, i.e. the number of received ACK bits
- NACK bits in the definition do not contain the NACK bits which are mapped from DTX, i.e. NACK bits received when DTX is sent should not be considered.

Random codeword selection is assumed.

Table 8.3.3.1.1-1: Test Parameters

Parameter	Test
Number of information bits	2
Number of PRBs	1
Number of symbols	14
First PRB prior to frequency hopping	0
Intra-slot frequency hopping	enabled
First PRB after frequency hopping	The largest PRB index – (nrofPRBs – 1)
Group and sequence hopping	neither
Hopping ID	0
Initial cyclic shift	0
First symbol	0
Index of orthogonal cover code (<i>timeDomainOCC</i>)	0

The transient period as specified in TS 38.101-1 [17] clause 6.3.3.1 is not taken into account for performance requirement testing, where the RB hopping is symmetric to the CC centre, i.e. intra-slot frequency hopping is enabled.

8.3.3.1.2 Minimum requirements

The NACK to ACK probability shall not exceed 0.1% at the SNR given in table 8.3.3.1.2-1 and table 8.3.3.1.2-2.

Table 8.3.3.1.2-1: Minimum requirements for PUCCH format 1 with 15 kHz SCS

Number of TX antennas	Number of RX antennas	Cyclic Prefix	Propagation conditions and correlation matrix (Annex G)	Channel bandwidth / SNR (dB)		
				5 MHz	10 MHz	20 MHz
1	2	Normal	TDLC-300-100 Low	-3.8	-3.6	-3.6
	4	Normal	TDLC-300-100 Low	-8.4	-7.6	-8.4
	8	Normal	TDLC-300-100 Low	-11.8	-11.4	-11.4

Table 8.3.3.1.2-2: Minimum requirements for PUCCH format 1 with 30 kHz SCS

Number of TX antennas	Number of RX antennas	Cyclic Prefix	Propagation conditions and correlation matrix (Annex G)	Channel bandwidth / SNR (dB)			
				10 MHz	20 MHz	40 MHz	100 MHz
1	2	Normal	TDLC-300-100 Low	-2.8	-3.3	-3.9	-3.5
	4	Normal	TDLC-300-100 Low	-8.1	-8.3	-7.5	-8.0
	8	Normal	TDLC-300-100 Low	-11.5	-11.2	-11.6	-11.3

8.3.3.2 ACK missed detection requirements

8.3.3.2.1 General

The ACK missed detection probability is the probability of not detecting an ACK when an ACK was sent. The test parameters in table 8.3.3.1.1-1 are configured.

The transient period as specified in TS 38.101-1 [17] clause 6.3.3.1 is not taken into account for performance requirement testing, where the RB hopping is symmetric to the centre, i.e. intra-slot frequency hopping is enabled.

8.3.3.2.2 Minimum requirements

The ACK missed detection probability shall not exceed 1% at the SNR given in table 8.3.3.2.2-1 and in table 8.3.3.2.2-2.

Table 8.3.3.2.2-1: Minimum requirements for PUCCH format 1 with 15 kHz SCS

Number of TX antennas	Number of RX antennas	Cyclic Prefix	Propagation conditions and correlation matrix (Annex G)	Channel bandwidth / SNR (dB)		
				5 MHz	10 MHz	20 MHz
1	2	Normal	TDLC-300-100 Low	-5.0	-4.4	-5.0
	4	Normal	TDLC-300-100 Low	-8.6	-8.2	-8.5
	8	Normal	TDLC-300-100 Low	-11.6	-11.5	-11.5

Table 8.3.3.2.2-2: Minimum requirements for PUCCH format 1 with 30 kHz SCS

Number of TX antennas	Number of RX antennas	Cyclic Prefix	Propagation conditions and correlation matrix (Annex G)	Channel bandwidth / SNR (dB)			
				10 MHz	20 MHz	40 MHz	100 MHz
1	2	Normal	TDLC-300-100 Low	-3.9	-4.4	-4.4	-4.2
	4	Normal	TDLC-300-100 Low	-8.0	-8.1	-8.4	-8.3
	8	Normal	TDLC-300-100 Low	-11.4	-11.4	-11.4	-11.4

8.3.4 Performance requirements for PUCCH format 2

8.3.4.1 ACK missed detection requirements

8.3.4.1.1 General

The ACK missed detection probability is the probability of not detecting an ACK when an ACK was sent.

The ACK missed detection requirement only applies to the PUCCH format 2 with 4 UCI bits.

Table 8.3.4.1.1-1: Test Parameters

Parameter	Value
Modulation order	QSPK
Starting RB location	0
Intra-slot frequency hopping	N/A
Number of PRBs	4
Number of symbols	1
The number of UCI information bits	4
First symbol	13
DM-RS sequence generation	$N_{ID}^0=0$

8.3.4.1.2 Minimum requirements

The ACK missed detection probability shall not exceed 1% at the SNR given in table 8.3.4.1.2-1 and table 8.3.4.1.2-2 for 4UCI bits.

Table 8.3.4.1.2-1: Minimum requirements for PUCCH format 2 with 15 kHz SCS

Number of TX antennas	Number of RX antennas	Cyclic Prefix	Propagation conditions and correlation matrix (Annex G)	Channel bandwidth / SNR (dB)		
				5 MHz	10 MHz	20 MHz
1	2	Normal	TDLC300-100 Low	5.8	5.6	5.9
	4	Normal	TDLC300-100 Low	0.4	0.5	0.3
	8	Normal	TDLC300-100 Low	-3.5	-3.5	-3.5

Table 8.3.4.1.2-2: Minimum requirements for PUCCH format 2 with 30 kHz SCS

Number of TX antennas	Number of RX antennas	Cyclic Prefix	Propagation conditions and correlation matrix (Annex G)	Channel bandwidth / SNR (dB)			
				10 MHz	20 MHz	40 MHz	100 MHz
1	2	Normal	TDLC300-100 Low	5.5	5.6	5.5	5.7
	4	Normal	TDLC300-100 Low	0.3	0.2	0.3	0.4
	8	Normal	TDLC300-100 Low	-3.6	-3.6	-3.5	-3.3

8.3.4.2 UCI BLER performance requirements

8.3.4.2.1 General

The UCI block error probability (BLER) is defined as the probability of incorrectly decoding the UCI information when the UCI information is sent. The UCI information does not contain CSI part 2.

The transient period as specified in TS 38.101-1 [17] clause 6.3.3.1 is not taken into account for performance requirement testing, where the RB hopping is symmetric to the CC centre, i.e. intra-slot frequency hopping is enabled.

The UCI block error probability performance requirement only applies to the PUCCH format 2 with 22 UCI bits.

Table 8.3.4.2.1-1: Test Parameters

Parameter	Value
Modulation order	QSPK
First PRB prior to frequency hopping	0
Intra-slot frequency hopping	enabled
Frist PRB after frequency hopping	The largest PRB index – (Number of PRBs – 1)
Number of PRBs	9
Number of symbols	2
The number of UCI information bits	22
First symbol	12
DM-RS sequence generation	$N_{ID}^0=0$

8.3.4.2.2 Minimum requirements

The UCI block error probability shall not exceed 1% at the SNR given in table 8.3.4.2.2-1 and table 8.3.4.2.2-2 for 22 UCI bits.

Table 8.3.4.2.2-1: Minimum requirements for PUCCH format 2 with 15 kHz SCS

Number of TX antennas	Number of RX antennas	Cyclic Prefix	Propagation conditions and correlation matrix (Annex G)	Channel bandwidth / SNR (dB)		
				5 MHz	10 MHz	20 MHz
1	2	Normal	TDLC300-100 Low	0.2	0.8	1.2
	4	Normal	TDLC300-100 Low	-3.6	-3.2	-3.2
	8	Normal	TDLC300-100 Low	-6.8	-6.7	-6.8

Table 8.3.4.2.2-2: Minimum requirements for PUCCH format 2 with 30 kHz SCS

Number of TX antennas	Number of RX antennas	Cyclic Prefix	Propagation conditions and correlation matrix (Annex G)	Channel bandwidth / SNR (dB)			
				10 MHz	20 MHz	40 MHz	100 MHz
1	2	Normal	TDLC300-100 Low	0.5	1.1	0.4	0.3
	4	Normal	TDLC300-100 Low	-3.3	-2.9	-3.3	-3.4
	8	Normal	TDLC300-100 Low	-5.8	-5.8	-6.7	-5.9

8.3.5 Performance requirements for PUCCH format 3

8.3.5.1 General

The performance is measured by the required SNR at UCI block error probability not exceeding 1%.

The UCI block error probability is defined as the conditional probability of incorrectly decoding the UCI information when the UCI information is sent. The UCI information does not contain CSI part 2.

The transient period as specified in TS 38.101-1 [17] clause 6.3.3.1 is not taken into account for performance requirement testing, where the RB hopping is symmetric to the centre, i.e. intra-slot frequency hopping is enabled.

Table 8.3.5.1-1: Test Parameters

Parameter	Test 1	Test 2
Modulation order	QPSK	
First PRB prior to frequency hopping	0	
Intra-slot frequency hopping	enabled	
First PRB after frequency hopping	The largest PRB index – (Number of PRBs – 1)	
Group and sequence hopping	neither	
Hopping ID	0	
Number of PRBs	1	3
Number of symbols	14	4
The number of UCI information bits	16	16
First symbol	0	0

8.3.5.2 Minimum requirements

The UCI block error probability shall not exceed 1% at the SNR given in Table 8.3.5.2-1 and Table 8.3.5.2-2.

Table 8.3.5.2-1: Minimum requirements for PUCCH format 3 with 15 kHz SCS

Test Number	Number of TX antennas	Number of RX antennas	Cyclic Prefix	Propagation conditions and correlation matrix (Annex G)	Additional DM-RS configuration	Channel bandwidth / SNR (dB)		
						5 MHz	10 MHz	20 MHz
1	1	2	Normal	TDLC300-100 Low	No additional DM-RS	0.2	1.1	0.3
					Additional DM-RS	-0.1	0.5	-0.1
		4	Normal	TDLC300-100 Low	No additional DM-RS	-3.8	-3.3	-3.8
					Additional DM-RS	-4.3	-4.0	-4.0
		8	Normal	TDLC300-100 Low	No additional DM-RS	-7.0	-6.7	-6.9
					Additional DM-RS	-7.7	-7.5	-7.7
2	1	2	Normal	TDLC300-100 Low	No additional DM-RS	1.4	2.2	2.0
		4	Normal	TDLC300-100 Low	No additional DM-RS	-3.1	-2.5	-2.5
		8	Normal	TDLC300-100 Low	No additional DM-RS	-6.5	-6.0	-6.2

Table 8.3.5.2-2: Minimum requirements for PUCCH format 3 with 30 kHz SCS

Test Number	Number of TX antennas	Number of RX antennas	Cyclic Prefix	Propagation conditions and correlation matrix (Annex G)	Additional DM-RS configuration	Channel bandwidth / SNR (dB)			
						10 MHz	20 MHz	40 MHz	100 MHz
1	1	2	Normal	TDLC300-100 Low	No additional DM-RS	0.9	0.6	0.6	0.9
					Additional DM-RS	0.5	0.3	0.0	0.1
		4	Normal	TDLC300-100 Low	No additional DM-RS	-3.1	-3.4	-3.2	-3.5
					Additional DM-RS	-3.7	-4.1	-4.0	-4.2
		8	Normal	TDLC300-100 Low	No additional DM-RS	-6.6	-6.7	-6.8	-6.8
					Additional DM-RS	-7.5	-7.6	-7.6	-7.7
2	1	2	Normal	TDLC300-100 Low	No additional DM-RS	1.8	2.0	2.0	1.5
		4	Normal	TDLC300-100 Low	No additional DM-RS	-2.9	-3.0	-2.4	-3.0
		8	Normal	TDLC300-100 Low	No additional DM-RS	-6.4	-6.0	-6.4	-6.2

8.3.6 Performance requirements for PUCCH format 4

8.3.6.1 General

The performance is measured by the required SNR at UCI block error probability not exceeding 1%.

The UCI block error probability is defined as the conditional probability of incorrectly decoding the UCI information when the UCI information is sent. The UCI information does not contain CSI part 2.

The transient period as specified in TS 38.101-1 [17] clause 6.3.3.1 is not taken into account for performance requirement testing, where the RB hopping is symmetric to the centre, i.e. intra-slot frequency hopping is enabled.

Table 8.3.6.1-1: Test parameters

Parameter	Value
Modulation order	QPSK
First PRB prior to frequency hopping	0
Number of PRBs	1
Intra-slot frequency hopping	enabled
First PRB after frequency hopping	The largest PRB index – (Number of PRBs – 1)
Group and sequence hopping	neither
Hopping ID	0
Number of symbols	14
The number of UCI information bits	22
First symbol	0
Length of the orthogonal cover code	n2
Index of the orthogonal cover code	n0

8.3.6.2 Minimum requirement

The UCI block error probability shall not exceed 1% at the SNR given in Table 8.3.6.2-1 and Table 8.3.6.2-2.

Table 8.3.6.2-1: Required SNR for PUCCH format 4 with 15 kHz SCS

Number of TX antennas	Number of RX antennas	Cyclic Prefix	Propagation conditions and correlation matrix (Annex G)	Additional DM-RS configuration	Channel bandwidth / SNR (dB)		
					5 MHz	10 MHz	20 MHz
1	2	Normal	TDLC300-100 Low	No additional DM-RS	1.8	2.6	2.2
				Additional DM-RS	1.6	2.4	1.8
	4	Normal	TDLC300-100 Low	No additional DM-RS	-2.3	-1.9	-2.2
				Additional DM-RS	-2.9	-2.6	-2.7
	8	Normal	TDLC300-100 Low	No additional DM-RS	-5.9	-5.7	-5.8
				Additional DM-RS	-6.6	-6.4	-6.3

Table 8.3.6.2-2: Required SNR for PUCCH format 4 with 30 kHz SCS

Number of TX antennas	Number of RX antennas	Cyclic Prefix	Propagation conditions and correlation matrix (Annex G)	Additional DM-RS configuration	Channel bandwidth / SNR (dB)			
					10 MHz	20 MHz	40 MHz	100 MHz
1	2	Normal	TDLC300-100 Low	No additional DM-RS	3.1	2.8	3.1	2.8
				Additional DM-RS	2.8	2.3	3.1	2.2
	4	Normal	TDLC300-100 Low	No additional DM-RS	-1.7	-1.9	-1.7	-2.1
				Additional DM-RS	-2.0	-2.5	-2.5	-2.4
	8	Normal	TDLC300-100 Low	No additional DM-RS	-5.6	-5.5	-5.5	-5.5
				Additional DM-RS	-6.2	-6.1	-6.4	-6.2

8.3.7 Performance requirements for multi-slot PUCCH

8.3.7.1 General

8.3.7.2 Performance requirements for multi-slot PUCCH format 1

8.3.7.2.1 NACK to ACK requirements

8.3.7.2.1.1 General

The NACK to ACK detection probability is the probability that an ACK bit is falsely detected when an NACK bit was sent on the particular bit position, where the NACK to ACK detection probability is defined as follows:

$$\text{Prob}(\text{PUCCH NACK} \rightarrow \text{ACK bits}) = \frac{\#(\text{NACK bits decoded as ACK bits})}{\#(\text{Total NACK bits})},$$

where:

- $\#(\text{Total NACK bits})$ denotes the total number of NACK bits transmitted
- $\#(\text{NACK bits decoded as ACK bits})$ denotes the number of NACK bits decoded as ACK bits at the receiver, i.e. the number of received ACK bits
- NACK bits in the definition do not contain the NACK bits which are mapped from DTX, i.e. NACK bits received when DTX is sent should not be considered.

Random codeword selection is assumed.

Table 8.3.7.2.1.1-1: Test Parameters for multi-slot PUCCH format 1

Parameter	Test
Number of information bits	2
Number of PRBs	1
Number of symbols	14
First PRB prior to frequency hopping	0
Intra-slot frequency hopping	disabled
Inter-slot frequency hopping	enabled
First PRB after frequency hopping	The largest PRB index – (nrofPRBs – 1)
Group and sequence hopping	neither
Hopping ID	0
Initial cyclic shift	0
First symbol	0
Index of orthogonal cover code (<i>timeDomainOCC</i>)	0
Number of slots for PUCCH repetition	2

8.3.7.2.1.2 Minimum requirements

The multi-slot NACK to ACK probability shall not exceed 0.1% at the SNR given in table 8.3.7.2.1.2-1.

Table 8.3.7.2.1.2-1: Minimum requirements for multi-slot PUCCH format 1 with 30kHz SCS

Number of TX antennas	Number of RX antennas	Cyclic Prefix	Propagation conditions and correlation matrix (Annex G)	Channel bandwidth / SNR (dB)
				40 MHz
1	2	Normal	TDLC-300-100 Low	-6.3

8.3.7.2.2 ACK missed detection requirements

8.3.7.2.2.1 General

The ACK missed detection probability is the probability of not detecting an ACK when an ACK was sent. The test parameters in table 8.3.7.2.1.1-1 are configured.

8.3.7.2.2.2 Minimum requirements

The multi-slot ACK missed detection probability shall not exceed 1% at the SNR given in table 8.3.7.2.2.2-1.

Table 8.3.7.2.2.2-1: Minimum requirements for multi-slot PUCCH format 1 with 30kHz SCS

Number of TX antennas	Number of RX antennas	Cyclic Prefix	Propagation conditions and correlation matrix (Annex G)	Channel bandwidth / SNR (dB)
				40 MHz
1	2	Normal	TDLC-300-100 Low	-7.6

8.3.8 Performance requirements for interlaced PUCCH format 0

8.3.8.1 General

The ACK missed detection probability is the probability of not detecting an ACK when an ACK was sent.

The ACK missed detection probability performance requirement only apply to PUCCH format 0 with 1 UCI bit. The UCI information only contain ACK information.

The 1bit UCI information is further defined with the bitmap as [1].

Table 8.3.8.1-1: Test Parameters

Parameter	Test
Number of UCI information bits	1
Number of symbols	1
Intra-slot frequency hopping	N/A
Group and sequence hopping	neither
Hopping ID	0
Initial cyclic shift	0
First symbol	13
Number of interlaces	1
Interlace index	0Note1
NOTE 1: RBs 0,10,20,..., 100 are allocated for 15kHz SCS and RBs 0,5,10,..., 50 are allocated for 30kHz SCS	

8.3.8.2 Minimum requirements

The ACK missed detection probability shall not exceed 1% at the SNR given in table 8.3.8.2-1

Table 8.3.8.2-1: Minimum requirements for interlaced PUCCH format 0 with 15 kHz SCS, 20MHz channel bandwidth

Number of Tx antennas	Number of RX antennas	Propagation conditions and correlation matrix (Annex G)	Number of OFDM symbols	SNR (dB)
1	2	TDLA30-10 Low	1	-2.8

Table 8.3.8.2-2: Minimum requirements for interlaced PUCCH format 0 with 30 kHz SCS, 20MHz channel bandwidth

Number of Tx antennas	Number of RX antennas	Propagation conditions and correlation matrix (Annex G)	Number of OFDM symbols	SNR (dB)
1	2	TDLA30-10 Low	1	-2.0

8.3.9 Performance requirements for interlaced PUCCH format 1

8.3.9.1 NACK to ACK requirements

8.3.9.1.1 General

The NACK to ACK detection probability is the probability that an ACK bit is falsely detected when a NACK bit was sent on the particular bit position, where the NACK to ACK detection probability is defined as follows:

$$\text{Prob}(\text{PUCCH NACK} \rightarrow \text{ACK bits}) = \frac{\#(\text{NACK bits decoded as ACK bits})}{\#(\text{Total NACK bits})},$$

where:

- $\#(\text{Total NACK bits})$ denotes the total number of NACK bits transmitted
- $\#(\text{NACK bits decoded as ACK bits})$ denotes the number of NACK bits decoded as ACK bits at the receiver, i.e. the number of received ACK bits
- NACK bits in the definition do not contain the NACK bits which are mapped from DTX, i.e. NACK bits received when DTX is sent should not be considered.

The NACK to ACK detection probability performance requirement only apply to PUCCH format 1 with 2 UCI bits. The UCI information only contain ACK/NACK information.

The 2bits UCI information is further defined with bitmap as [0 1].

Table 8.3.9.1.1-1: Test Parameters

Parameter	Test
Number of information bits	2
Number of symbols	14
Intra-slot frequency hopping	N/A
Group and sequence hopping	neither
Hopping ID	0
Initial cyclic shift	0
First symbol	0
Index of orthogonal cover code (<i>timeDomainOCC</i>)	0
Number of interlace	1
Interlace index	0 ^{Note1}
NOTE 1: RBs 0,10,20,..., 100 are allocated for 15kHz SCS and RBs 0,5,10,..., 50 are allocated for 30kHz SCS	

8.3.9.1.2 Minimum requirements

The NACK to ACK probability shall not exceed 0.1% at the SNR given in table 8.3.9.1.2-1.

Table 8.3.9.1.2-1: Minimum requirements for interlaced PUCCH format 1 with 15 kHz SCS, 20MHz channel bandwidth

Number of Tx antennas	Number of RX antennas	Cyclic-Prefix	Propagation conditions and correlation matrix (Annex G)	SNR (dB)
1	2	Normal	TDLA30-10 Low	-13.8

Table 8.3.9.1.2-2: Minimum requirements for interlaced PUCCH format 1 with 30 kHz SCS, 20MHz channel bandwidth

Number of Tx antennas	Number of RX antennas	Cyclic-Prefix	Propagation conditions and correlation matrix (Annex G)	SNR (dB)
1	2	Normal	TDLA30-10 Low	-13.3

8.3.9.2 ACK missed detection requirements

8.3.9.2.1 General

The ACK missed detection probability is the probability of not detecting an ACK when an ACK was sent. The test parameters in table 8.3.9.1.1-1 are configured.

The ACK missed detection probability performance requirement only apply to PUCCH format 1 with 2 UCI bits. The UCI information only contain ACK/NACK information.

The 2bits UCI information is further defined with bitmap as [0 1].

8.3.9.2.2 Minimum requirements

The ACK missed detection probability shall not exceed 1% at the SNR given in table 8.3.9.2.2-1.

Table 8.3.9.2.2-1: Minimum requirements for interlaced PUCCH format 1 with 15 kHz SCS, 20MHz channel bandwidth

Number of Tx antennas	Number of RX antennas	Cyclic-Prefix	Propagation conditions and correlation matrix (Annex G)	SNR (dB)
1	2	Normal	TDLA30-10 Low	-14.4

Table 8.3.9.2.2-2: Minimum requirements for interlaced PUCCH format 1 with 30 kHz SCS, 20MHz channel bandwidth

Number of Tx antennas	Number of RX antennas	Cyclic-Prefix	Propagation conditions and correlation matrix (Annex G)	SNR (dB)
1	2	Normal	TDLA30-10 Low	-14.1

8.3.10 Performance requirements for interlaced PUCCH format 2

8.3.10.1 General

The performance is measured by the required SNR at UCI block error probability not exceeding 1%.

The UCI block error probability (BLER) is defined as the probability of incorrectly decoding the UCI information when the UCI information is sent. The UCI information does not contain CSI part 2.

The UCI block error probability performance requirement only applies to the PUCCH format 2 with 22 UCI bits.

The 22bits UCI information case is assumed random information bit selection.

Table 8.3.10.1-1: Test Parameters

Parameter	Value
Modulation order	QSPK
Intra-slot frequency hopping	N/A
Number of symbols	1
The number of UCI information bits	22
First symbol	13
DM-RS sequence generation	$N_{ID}^0=0$
Number of interlaces	1
Interlace index	0(note 1)
OCC-length-r16	Not configured
NOTE 1: RBs 0,10,20,...,100 are allocated for 15kHz SCS and RBs 0,5,10,...,50 are allocated for 30kHz SCS	

8.3.10.2 Minimum requirements

The UCI block error probability shall not exceed 1% at the SNR given in table 8.3.10.2-1 and table 8.3.10.2-2 for 22 UCI bits.

Table 8.3.10.2-1: Minimum requirements for interlaced PUCCH format 2 with 15 kHz SCS, 20 MHz channel bandwidth

Number of Tx antennas	Number of RX antennas	Cyclic Prefix	Propagation conditions and correlation matrix (Annex G)	SNR(dB)
1	2	Normal	TDLA30-10 Low	3.5

Table 8.3.10.2-2: Minimum requirements for interlaced PUCCH format 2 with 30 kHz SCS, 20 MHz channel bandwidth

Number of Tx antennas	Number of RX antennas	Cyclic Prefix	Propagation conditions and correlation matrix (Annex G)	SNR(dB)
1	2	Normal	TDLA30-10 Low	3.9

8.3.11 Performance requirements for interlaced PUCCH format 3

8.3.11.1 General

The ACK missed detection probability is the probability of not detecting an ACK when an ACK was sent.

The ACK missed detection requirement only applies to the PUCCH format 3 with 4 UCI bits. The UCI information only contains ACK information.

The 4 bits UCI information case is further defined with the bitmap as [1 1 1 1].

Table 8.3.11.1-1: Test Parameters

Parameter	Value
Modulation order	QPSK
Intra-slot frequency hopping	N/A
Group and sequence hopping	Neither
Hopping ID	0
Number of symbols	4
The number of UCI information bits	4
Index of OCC	Not configured
Length of OCC	Not configured
Cyclic shift index for DMRS	0
Number of Interlace	1
Interlace index	0(note 1)
NOTE 1: RBs 0,10,20,...,90 are allocated for 15kHz SCS and RBs 0,5,10,...,45 are allocated for 30kHz SCS	

8.3.11.2 Minimum requirements

The ACK missed detection probability shall not exceed 1% at the SNR given in table 8.3.11.2-1 and table 8.3.11.2-2 for 4UCI bits.

Table 8.3.11.2-1: Minimum requirements for interlaced PUCCH format 3 with 15 kHz SCS, 20 MHz channel bandwidth

Number of Tx antennas	Number of RX antennas	Cyclic Prefix	Propagation conditions and correlation matrix (Annex G)	Additional DM-RS configuration	SNR(dB)
1	2	Normal	TDLA30-10 Low	No additional DM-RS	-6

Table 8.3.11.2-2: Minimum requirements for interlaced PUCCH format 3 with 30 kHz SCS, 20 MHz channel bandwidth

Number of Tx antennas	Number of RX antennas	Cyclic Prefix	Propagation conditions and correlation matrix (Annex G)	Additional DM-RS configuration	SNR(dB)
1	2	Normal	TDLA30-10 Low	No additional DM-RS	-5.4

8.3.12 Performance requirements for PUCCH format 1 with DM-RS bundling

8.3.12.1 NACK to ACK requirements

8.3.12.1.1 General

The NACK to ACK detection probability is the probability that an ACK bit is falsely detected when an NACK bit was sent on the particular bit position, where the NACK to ACK detection probability is defined as follows:

$$\text{Prob}(\text{PUCCH NACK} \rightarrow \text{ACK bits}) = \frac{\#(\text{NACK bits decoded as ACK bits})}{\#(\text{Total NACK bits})},$$

where:

- $\#(\text{Total NACK bits})$ denotes the total number of NACK bits transmitted
- $\#(\text{NACK bits decoded as ACK bits})$ denotes the number of NACK bits decoded as ACK bits at the receiver, i.e. the number of received ACK bits
- NACK bits in the definition do not contain the NACK bits which are mapped from DTX, i.e. NACK bits received when DTX is sent should not be considered.

The NACK to ACK detection probability performance requirement only apply to PUCCH format 1 with 2 UCI bits. The UCI information only contain ACK/NACK information.

The 2bits UCI information is further defined with bitmap as [0 1].

Table 8.3.12.1.1-1: Test Parameters

Parameter	Test 1	Test 2
Example TDD UL-DL pattern (Note1)	15 kHz SCS: 7D1S2U, S=6D:4G:4U 30 kHz SCS: TDD 7D1S2U, S=6D:4G:4U	15 kHz SCS: FDD 30 kHz SCS: FDD
Number of information bits	2	2
Number of PRBs	1	1
Number of symbols	14	14
First PRB prior to frequency hopping	0	0
Intra-slot frequency hopping	disabled	disabled
Group and sequence hopping	neither	neither
Hopping ID	0	0
Initial cyclic shift	0	0
First symbol	0	0
Index of orthogonal cover code (<i>timeDomainOCC</i>)	0	0
Number of slots for PUCCH repetition	2	8
PUCCH-TimeDomainWindowLength	2	8
Note 1:	The same TDD requirements are applicable to different UL-DL patterns with more than one consecutive UL slots when both <i>pucch-TimeDomainWindowLength</i> and PUCCH aggregation factor are configured as 2 slots. The UL (re)transmission of PUCCH is only scheduled for the actual TDW including 2 consecutive UL slots.	

8.3.12.1.2 Minimum requirements

The NACK to ACK probability shall not exceed 0.1% at the SNR given in table 8.3.12.1.2-1 and table 8.3.12.1.2-2

Table 8.3.12.1.2-1: Minimum requirements for PUCCH format 1 with DMRS bundling, 15 kHz SCS, 5MHz channel bandwidth,

Test number	Number of Tx antennas	Number of RX antennas	Cyclic-Prefix	Propagation conditions and correlation matrix (Annex G)	SNR (dB)
1	1	2	Normal	TDLA30-10 Low	-3.0
2	1	2	Normal	TDLA30-10 Low	-9.1

Table 8.3.12.1.2-2: Minimum requirements for PUCCH format 1 with DMRS bundling, 30 kHz SCS, 10MHz channel bandwidth,

Test number	Number of Tx antennas	Number of RX antennas	Cyclic-Prefix	Propagation conditions and correlation matrix (Annex G)	SNR (dB)
1	1	2	Normal	TDLA30-10 Low	-3.0
2	1	2	Normal	TDLA30-10 Low	-8.7

8.3.12.2 ACK missed detection requirements

8.3.12.2.1 General

The ACK missed detection probability is the probability of not detecting an ACK when an ACK was sent. The test parameters in table 8.3.12.1.1-1 are configured.

The ACK missed detection probability performance requirement only apply to PUCCH format 1 with 2 UCI bits. The UCI information only contain ACK/NACK information.

The 2bits UCI information is further defined with bitmap as [0 1].

8.3.12.2.2 Minimum requirements

The ACK missed detection probability shall not exceed 1% at the SNR given in table 8.3.12.2.2-1 and table 8.3.12.2.2-2

Table 8.3.12.2.2-1: Minimum requirements for PUCCH format 1 with DMRS bundling, 15 kHz SCS, 5MHz channel bandwidth,

Test number	Number of Tx antennas	Number of RX antennas	Cyclic-Prefix	Propagation conditions and correlation matrix (Annex G)	SNR (dB)
1	1	2	Normal	TDLA30-10 Low	-3.9
2	1	2	Normal	TDLA30-10 Low	-8.9

Table 8.3.12.2.2-2: Minimum requirements for PUCCH format 1 with DMRS bundling, 30 kHz SCS, 10MHz channel bandwidth,

Test number	Number of Tx antennas	Number of RX antennas	Cyclic-Prefix	Propagation conditions and correlation matrix (Annex G)	SNR (dB)
1	1	2	Normal	TDLA30-10 Low	-3.8
2	1	2	Normal	TDLA30-10 Low	-8.5

8.3.13 Performance requirements for PUCCH format 3 with DMRS bundling

8.3.13.1 General

The performance is measured by the required SNR at UCI block error probability not exceeding 1%.

The UCI block error probability is defined as the conditional probability of incorrectly decoding the UCI information when the UCI information is sent. The UCI information does not contain CSI part 2.

Table 8.3.13.1-1: Test Parameters

Parameter	Test 1	Test 2
Example TDD UL-DL pattern (Note1)	15 kHz SCS: 7D1S2U, S=6D:4G:4U 30 kHz SCS: TDD 7D1S2U, S=6D:4G:4U	15 kHz SCS: FDD 30 kHz SCS: FDD
Modulation order	QPSK	QPSK
First PRB prior to frequency hopping	0	0
Intra-slot frequency hopping	disabled	disabled
Group and sequence hopping	neither	neither
Hopping ID	0	0
Number of PRBs	1	1
Number of symbols	14	14
The number of UCI information bits	16	16
First symbol	0	0
Number of slots for PUCCH repetition	2	8
PUCCH-TimeDomainWindowLength	2	8
Note 1: The same TDD requirements are applicable to different UL-DL patterns with more than one consecutive UL slots when both pucch-TimeDomainWindowLength and PUCCH aggregation factor are configured as 2 slots. The UL (re)transmission of PUCCH is only scheduled for the actual TDW including 2 consecutive UL slots.		

8.3.13.2 Minimum requirements

The UCI block error probability shall not exceed 1% at the SNR given in Table 8.3.13.2-1 and Table 8.3.13.2-2.

Table 8.3.13.2-1: Minimum requirements for PUCCH format 3 with DMRS bundling, 15 kHz SCS, 5MHz channel bandwidth

Test Number	Number of TX antennas	Number of RX antennas	Cyclic Prefix	Propagation conditions and correlation matrix (Annex G)	Additional DM-RS configuration	Channel bandwidth / SNR (dB)
						5 MHz
1	1	2	Normal	TDLA30-10 Low	No additional DM-RS	0.3
					Additional DM-RS	-0.1
2	1	2	Normal	TDLA30-10 Low	No additional DM-RS	-5.3
					Additional DM-RS	-5.8

Table 8.3.13.2-2: Minimum requirements for PUCCH format 3 with DMRS bundling, 30 kHz SCS, 10MHz channel bandwidth

Test Number	Number of TX antennas	Number of RX antennas	Cyclic Prefix	Propagation conditions and correlation matrix (Annex G)	Additional DM-RS configuration	Channel bandwidth / SNR (dB)
						10 MHz
1	1	2	Normal	TDLA30-10 Low	No additional DM-RS	0.2
					Additional DM-RS	0.0
2	1	2	Normal	TDLA30-10 Low	No additional DM-RS	-5.2
					Additional DM-RS	-5.6

8.3.14 Performance requirements for sub-slot repetition PUCCH format 0

8.3.14.1 General

The ACK missed detection probability is the probability of not detecting an ACK when an ACK was sent.

The ACK missed detection probability performance requirement only apply to PUCCH format 0 with 1 UCI bit. The UCI information only contain ACK information.

The 1bit UCI information is further defined with the bitmap as [1].

Table 8.3.14.1-1: Test Parameters

Parameter	Test
Number of UCI information bits	1
Number of PRBs	1
Number of PUCCH symbols (<i>nrofSymbols</i>)	2
Number of sub-slot PUCCH repetitions (<i>nrofSlots</i>)	2
Number of Sub-slot symbols (<i>subslotLengthForPUCCH-r16</i>)	7
First symbol of sub-slot (<i>startingSymbolIndex</i>)	5
First PRB prior to frequency hopping	0
First PRB after frequency hopping	The largest PRB index – (Number of PRBs – 1)
Intra-slot frequency hopping	disabled
Inter-slot frequency hopping	enabled
Group and sequence hopping	neither
Hopping ID	0
Initial cyclic shift	0

The transient period as specified in TS 38.101-1 [17] clause 6.3.3.1 is not taken into account for performance requirement testing, where the RB hopping is symmetric to the CC centre, i.e., inter-slot frequency hopping is enabled.

8.3.14.2 Minimum requirements

The ACK missed detection probability shall not exceed 1% at the SNR given in table 8.3.14.2-1

Table 8.3. 14.2-1: Minimum requirements for sub-slot repetition PUCCH format 0 with 30 kHz SCS, 10MHz channel bandwidth

Number of Tx antennas	Number of RX antennas	Cyclic Prefix	Propagation conditions and correlation matrix (Annex G)	SNR (dB)
1	2	Normal	TDLC300-100 Low	1.5

8.4 Performance requirements for PRACH

8.4.1 PRACH False alarm probability

8.4.1.1 General

The false alarm requirement is valid for any number of receive antennas, for any channel bandwidth.

The false alarm probability is the conditional total probability of erroneous detection of the preamble (i.e. erroneous detection from any detector) when input is only noise.

8.4.1.2 Minimum requirement

The false alarm probability shall be less than or equal to 0.1%.

8.4.2 PRACH detection requirements

8.4.2.1 General

The probability of detection is the conditional probability of correct detection of the preamble when the signal is present. There are several error cases – detecting different preamble than the one that was sent, not detecting a preamble at all or correct preamble detection but with the wrong timing estimation. For AWGN, TDLC300-100 and TDLA30-10, a timing estimation error occurs if the estimation error of the timing of the strongest path is larger than the time error tolerance given in Table 8.4.2.1-1.

The performance requirements for high speed train (table 8.4.23-1 to 8.4.2.3-4) are optional.

Table 8.4.2.1-1: Time error tolerance for AWGN, TDLC300-100 and TDLA30-10

PRACH preamble	PRACH SCS (kHz)	Time error tolerance		
		AWGN	TDLC300-100	TDLA30-10
0	1.25	1.04 us	2.55 us	N/A
A1, A2, A3, B4, C0, C2	15	0.52 us	2.03 us	0.67 us
	30	0.26 us	1.77 us	0.41 us

The test preambles for normal mode are listed in table A.6-1 and the test parameter *msg1-FrequencyStart* is set to 0. The test preambles for high speed train restricted set type A are listed in A.6-3, the test preambles for high speed train restricted set type B are listed in A.6-4, and the test preambles for high speed train short formats are listed in A.6-5. The test parameter *msg1-FrequencyStart* for high speed train is set to 0.

The test preambles for PRACH with LRA=1151 and LRA=571 are listed in table A.6-6.

8.4.2.2 Minimum requirements for Normal Mode

The probability of detection shall be equal to or exceed 99% for the SNR levels listed in Tables 8.4.2.2-1 to 8.4.2.2-3.

Table 8.4.2.2-1: PRACH missed detection requirements for Normal Mode, 1.25 kHz SCS

Number of TX antennas	Number of RX antennas	Propagation conditions and correlation matrix (Annex G)	Frequency offset	SNR (dB)
				Burst format 0
1	2	AWGN	0	-14.5
		TDLC300-100 Low	400 Hz	-6.6
	4	AWGN	0	-16.7
		TDLC300-100 Low	400 Hz	-11.9
	8	AWGN	0	-18.9
		TDLC300-100 Low	400 Hz	-15.8

Table 8.4.2.2-2: PRACH missed detection requirements for Normal Mode, 15 kHz SCS

Number of TX antennas	Number of RX antennas	Propagation conditions and correlation matrix (Annex G)	Frequency offset	SNR (dB)					
				Burst format A1	Burst format A2	Burst format A3	Burst format B4	Burst format C0	Burst format C2
1	2	AWGN	0	-9.3	-12.6	-14.2	-16.8	-6.3	-12.5
		TDLC300-100 Low	400 Hz	-2.1	-4.8	-6.6	-8.8	0.8	-4.9
	4	AWGN	0	-11.6	-14.3	-16.0	-19.0	-8.7	-14.1
		TDLC300-100 Low	400 Hz	-7.3	-10.3	-11.7	-13.8	-4.3	-10.2
	8	AWGN	0	-13.8	-16.7	-18.2	-21.2	-11.1	-16.6
		TDLC300-100 Low	400 Hz	-11.0	-13.9	-15.2	-17.3	-8.1	-13.9

Table 8.4.2.2-3: PRACH missed detection requirements for Normal Mode, 30 kHz SCS

Number of TX antennas	Number of RX antennas	Propagation conditions and correlation matrix (Annex G)	Frequency offset	SNR (dB)					
				Burst format A1	Burst format A2	Burst format A3	Burst format B4	Burst format C0	Burst format C2
1	2	AWGN	0	-9.1	-12.0	-13.8	-16.5	-6.1	-11.9
		TDLC300-100 Low	400 Hz	-2.8	-5.7	-7.4	-9.9	0.1	-5.6
	4	AWGN	0	-11.4	-14.2	-15.9	-19.0	-8.6	-14.1
		TDLC300-100 Low	400 Hz	-7.2	-10.4	-12.0	-14.5	-4.5	-10.4
	8	AWGN	0	-13.7	-16.6	-18.1	-21.1	-11.0	-16.5
		TDLC300-100 Low	400 Hz	-10.7	-13.7	-15.1	-17.6	-7.8	-13.7

Table 8.4.2.2-4: Void

Table 8.4.2.2-5: Void

8.4.2.3 Minimum requirements for high speed train

The probability of detection shall be equal to or exceed 99% for the SNR levels listed in Tables 8.4.2.3-1 to 8.4.2.3-4

Table 8.4.2.3-1: PRACH missed detection requirements for high speed train, burst format 0, restricted set type A, 1.25 kHz SCS

Number of TX antennas	Number of RX antennas	Propagation conditions and correlation matrix (Annex G)	Frequency offset	SNR (dB)
				Burst format 0
1	2	AWGN	625 Hz	-12.0
		AWGN	1340 Hz	-13.8
		TDLC300-100 Low	0 Hz	-6.3
	4	AWGN	625 Hz	-14.5
		AWGN	1340 Hz	-16.2
		TDLC300-100 Low	0 Hz	-11.8
	8	AWGN	625 Hz	-16.5
		AWGN	1340 Hz	-18.4
		TDLC300-100 Low	0 Hz	-16.2

Table 8.4.2.3-2: PRACH missed detection requirements for high speed train, burst format 0, restricted set type B, 1.25 kHz SCS

Number of TX antennas	Number of RX antennas	Propagation conditions and correlation matrix (Annex G)	Frequency offset	SNR (dB)
				Burst format 0
1	2	AWGN	625 Hz	-11.6
		AWGN	2334 Hz	-13.1
		TDLC300-100 Low	0 Hz	-6.0
	4	AWGN	625 Hz	-14.0
		AWGN	2334 Hz	-15.4
		TDLC300-100 Low	0 Hz	-11.7
	8	AWGN	625 Hz	-16.3
		AWGN	2334 Hz	-17.4
		TDLC300-100 Low	0 Hz	-16.0

Table 8.4.2.3-3: PRACH missed detection requirements for high speed train, 15 kHz SCS

Number of TX antennas	Number of RX antennas	Propagation conditions and correlation matrix (Annex G)	Frequency offset	SNR (dB)		
				Burst format A2	Burst format B4	Burst format C2
1	2	AWGN	1740 Hz	-11.3	-14.3	-11.1
	4	AWGN	1740 Hz	-13.5	-16.7	-13.4
	8	AWGN	1740 Hz	-15.6	-18.2	-15.5

Table 8.4.2.3-4: PRACH missed detection requirements for high speed train, 30 kHz SCS

Number of TX antennas	Number of RX antennas	Propagation conditions and correlation matrix (Annex G)	Frequency offset	SNR (dB)		
				Burst format A2	Burst format B4	Burst format C2
1	2	AWGN	3334 Hz	-11.2	-14.6	-11.0
	4	AWGN	3334 Hz	-13.4	-16.7	-13.4
	8	AWGN	3334 Hz	-15.4	-18.4	-15.4

8.4.2.4 Minimum requirements for PRACH with $L_{RA}=1151$ and $L_{RA}=571$

The probability of detection shall be equal to or exceed 99% for the SNR levels listed in Tables 8.4.2.4-1 to 8.4.2.4-2.

Table 8.4.2.4-1: Missed detection requirements for PRACH with $L_{RA}=1151$, 15 kHz SCS

Number of TX antennas	Number of RX antennas	Propagation conditions and correlation matrix (Annex G)	Frequency offset	SNR (dB)		
				Burst format A2	Burst format B4	Burst format C2
1	2	AWGN	0	-21.4	-25.4	-21.4
		TDLA30-10 Low	400 Hz	-15.1	-18.3	-15.2

Table 8.4.2.4-2: Missed detection requirements for PRACH with $L_{RA}=571$, 30 kHz SCS

Number of TX antennas	Number of RX antennas	Propagation conditions and correlation matrix (Annex G)	Frequency offset	SNR (dB)		
				Burst format A2	Burst format B4	Burst format C2
1	2	AWGN	0	-18.4	-22.3	-18.4
		TDLA30-10 Low	400 Hz	-12.1	-15.8	-12.1

9 Radiated transmitter characteristics

9.1 General

Radiated transmitter characteristics requirements apply on the *BS type 1-H*, *BS type 1-O*, or *BS type 2-O* including all its functional components active and for all foreseen modes of operation of the BS unless otherwise stated.

9.2 Radiated transmit power

9.2.1 General

BS type 1-H, *BS type 1-O* and *BS type 2-O* are declared to support one or more beams, as per manufacturer's declarations specified in TS 38.141-2 [6]. Radiated transmit power is defined as the EIRP level for a declared beam at a specific *beam peak direction*.

For each beam, the requirement is based on declaration of a beam identity, *reference beam direction pair*, beamwidth, *rated beam EIRP*, *OTA peak directions set*, the *beam direction pairs* at the maximum steering directions and their associated *rated beam EIRP* and beamwidth(s).

For a declared beam and *beam direction pair*, the *rated beam EIRP* level is the maximum power that the base station is declared to radiate at the associated *beam peak direction* during the *transmitter ON period*.

For each *beam peak direction* associated with a *beam direction pair* within the *OTA peak directions set*, a specific *rated beam EIRP* level may be claimed. Any claimed value shall be met within the accuracy requirement as described below. *Rated beam EIRP* is only required to be declared for the *beam direction pairs* subject to conformance testing as detailed in TS 38.141-2 [6].

NOTE 1: *OTA peak directions set* is set of *beam peak directions* for which the EIRP accuracy requirement is intended to be met. The *beam peak directions* are related to a corresponding contiguous range or discrete list of *beam centre directions* by the *beam direction pairs* included in the set.

NOTE 2: A *beam direction pair* is data set consisting of the *beam centre direction* and the related *beam peak direction*.

NOTE 3: A declared EIRP value is a value provided by the manufacturer for verification according to the conformance specification declaration requirements, whereas a claimed EIRP value is provided by the manufacturer to the equipment user for normal operation of the equipment and is not subject to formal conformance testing.

For *operating bands* where the supported *fractional bandwidth (FBW)* is larger than 6%, two rated carrier EIRP may be declared by manufacturer:

- $P_{\text{rated,c,FBWlow}}$ for lower supported frequency range, and
- $P_{\text{rated,c,FBWhigh}}$ for higher supported frequency range.

For frequencies in between F_{FBWlow} and F_{FBWhigh} the rated carrier EIRP is:

- $P_{\text{rated,c,FBWlow}}$, for the carrier whose carrier frequency is within frequency range $F_{\text{FBWlow}} \leq f < (F_{\text{FBWlow}} + F_{\text{FBWhigh}}) / 2$,
- $P_{\text{rated,c,FBWhigh}}$, for the carrier whose carrier frequency is within frequency range $(F_{\text{FBWlow}} + F_{\text{FBWhigh}}) / 2 \leq f \leq F_{\text{FBWhigh}}$.

For *BS type 1-O* there is no requirement specified for bands n46, n96, n100 and n101 and n102.

9.2.2 Minimum requirement for *BS type 1-H* and *BS type 1-O*

For each declared beam, in normal conditions, for any specific *beam peak direction* associated with a *beam direction pair* within the *OTA peak directions set*, a manufacturer claimed EIRP level in the corresponding *beam peak direction* shall be achievable to within ± 2.2 dB of the claimed value.

For *BS type 1-O* only, for each declared beam, in extreme conditions, for any specific *beam peak direction* associated with a *beam direction pair* within the *OTA peak directions set*, a manufacturer claimed EIRP level in the corresponding *beam peak direction* shall be achievable to within ± 2.7 dB of the claimed value.

Normal and extreme conditions are defined in TS 38.141-2, annex B [6].

In certain regions, the minimum requirement for normal conditions may apply also for some conditions outside the range of conditions defined as normal.

9.2.3 Minimum requirement for *BS type 2-O*

For each declared beam, in normal conditions, for any specific *beam peak direction* associated with a *beam direction pair* within the *OTA peak directions set*, a manufacturer claimed EIRP level in the corresponding *beam peak direction* shall be achievable to within ± 3.4 dB of the claimed value.

For each declared beam, in extreme conditions, for any specific *beam peak direction* associated with a *beam direction pair* within the *OTA peak directions set*, a manufacturer claimed EIRP level in the corresponding *beam peak direction* shall be achievable to within ± 4.5 dB of the claimed value.

Normal and extreme conditions are defined in TS 38.141-2, annex B [6].

In certain regions, the minimum requirement for normal conditions may apply also for some conditions outside the range of conditions defined as normal.

9.3 OTA base station output power

9.3.1 General

OTA BS output power is declared as the TRP radiated requirement, with the output power accuracy requirement defined at the RIB during the *transmitter ON period*. TRP does not change with beamforming settings as long as the *beam peak direction* is within the *OTA peak directions set*. Thus the TRP accuracy requirement must be met for any beamforming setting for which the *beam peak direction* is within the *OTA peak directions set*.

The BS *rated carrier TRP output power* for *BS type 1-O* shall be within limits as specified in table 9.3.1-1.

Table 9.3.1-1: BS rated carrier TRP output power limits for *BS type 1-O*

BS class	$P_{\text{rated,c,TRP}}$
Wide Area BS	(note)
Medium Range BS	$\leq + 47$ dBm
Local Area BS	$\leq + 33$ dBm
NOTE: There is no upper limit for the $P_{\text{rated,c,TRP}}$ of the Wide Area Base Station.	

There is no upper limit for the *rated carrier TRP output power* of *BS type 2-O*.

For Band n41 and n90 operation in Japan, the rated output power, $P_{\text{rated,c,TRP}}$, declared by the manufacturer shall be equal to or less than 20 W per 10 MHz bandwidth.

Despite the general requirements for the BS output power described in clauses 9.3.2 – 9.3.3, additional regional requirements might be applicable.

NOTE: In certain regions, power limits corresponding to BS classes may apply for *BS type 2-O*.

9.3.2 Minimum requirement for *BS type 1-O*

In normal conditions, the *BS type 1-O maximum carrier TRP output power*, $P_{\max,c,TRP}$ measured at the RIB shall remain within ± 2 dB of the *rated carrier TRP output power* $P_{\text{rated},c,TRP}$, as declared by the manufacturer.

Normal conditions are defined in TS 38.141-1, annex B [6].

9.3.3 Minimum requirement for *BS type 2-O*

In normal conditions, the *BS type 2-O maximum carrier TRP output power*, $P_{\max,c,TRP}$ measured at the RIB shall remain within ± 3 dB of the *rated carrier TRP output power* $P_{\text{rated},c,TRP}$, as declared by the manufacturer.

Normal conditions are defined in TS 38.141-2, annex B [6].

9.3.4 Additional requirements (regional)

In certain regions, additional regional requirements may apply.

9.4 OTA output power dynamics

9.4.1 General

The requirements in clause 9.4 apply during the *transmitter ON period*. Transmit signal quality (as specified in clause 9.6) shall be maintained for the output power dynamics requirements.

The OTA output power requirements are *directional requirements* and apply to the *beam peak directions* over the *OTA peak directions set*.

9.4.2 OTA RE power control dynamic range

9.4.2.1 General

The OTA RE power control dynamic range is the difference between the power of an RE and the average RE power for a BS at maximum output power ($P_{\max,c,EIRP}$) for a specified reference condition.

This requirement shall apply at each RIB supporting transmission in the *operating band*.

9.4.2.2 Minimum requirement for *BS type 1-O*

The OTA RE power control dynamic range is specified the same as the conducted RE power control dynamic range requirement for *BS type 1-C* and *BS type 1-H* in table 6.3.2.2-1.

9.4.3 OTA total power dynamic range

9.4.3.1 General

The OTA total power dynamic range is the difference between the maximum and the minimum transmit power of an OFDM symbol for a specified reference condition.

This requirement shall apply at each RIB supporting transmission in the *operating band*.

NOTE 1: The upper limit of the OTA total power dynamic range is the BS maximum carrier EIRP ($P_{\max,c,EIRP}$) when transmitting on all RBs. The lower limit of the OTA total power dynamic range is the average EIRP for single RB transmission in the same direction using the same beam. The OFDM symbol carries PDSCH and not contain RS or SSB.

9.4.3.2 Minimum requirement for *BS type 1-O*

OTA total power dynamic range minimum requirement for *BS type 1-O* is specified such as for each NR carrier it shall be larger than or equal to the levels specified for the conducted requirement for *BS type 1-C* and *BS type 1-H* in table 6.3.3.2-1.

9.4.3.3 Minimum requirement for *BS type 2-O*

OTA total power dynamic range minimum requirement for *BS type 2-O* is specified such as for each NR carrier it shall be larger than or equal to the levels specified in table 9.4.3.3-1 in FR2-1 and table 9.4.3.3-2 in FR2-2.

Table 9.4.3.3-1: Minimum requirement for *BS type 2-O* total power dynamic range in FR2-1

SCS (kHz)	OTA total power dynamic range (dB)			
	50 MHz	100 MHz	200 MHz	400 MHz
60	18.1	21.2	24.2	N/A
120	15.0	18.1	21.2	24.2

Table 9.4.3.3-2: Minimum requirement for *BS type 2-O* total power dynamic range in FR2-2

SCS (kHz)	OTA total power dynamic range (dB)				
	100 MHz	400 MHz	800 MHz	1600 MHz	2000 MHz
120	18.1	24.2	N/A	N/A	N/A
480	N/A	18.1	20.9	23.9	N/A
960	N/A	15.1	17.9	20.9	21.7

9.5 OTA transmit ON/OFF power

9.5.1 General

OTA transmit ON/OFF power requirements apply only to TDD operation of NR BS.

9.5.2 OTA transmitter OFF power

9.5.2.1 General

OTA transmitter OFF power is defined as the mean power measured over $70/N$ μ s filtered with a square filter of bandwidth equal to the *transmission bandwidth configuration* of the BS (BW_{config}) centred on the assigned channel frequency during the *transmitter OFF period*. $N = \text{SCS}/15$, where SCS is Sub Carrier Spacing in kHz.

For BS supporting intra-band contiguous CA, the OTA transmitter OFF power is defined as the mean power measured over $70/N$ μ s filtered with a square filter of bandwidth equal to the *Aggregated BS Channel Bandwidth* $BW_{\text{Channel_CA}}$ centred on $(F_{\text{edge,high}} + F_{\text{edge,low}})/2$ during the *transmitter OFF period*. $N = \text{SCS}/15$, where SCS is the smallest supported Sub Carrier Spacing in kHz in the *Aggregated BS Channel Bandwidth*.

For *BS type 1-O*, the transmitter OFF power is defined as the output power at the *co-location reference antenna* conducted output(s). For *BS type 2-O* the transmitter OFF power is defined as TRP.

For *multi-band RIBs* and *single band RIBs* supporting transmission in multiple bands, the requirement is only applicable during the *transmitter OFF period* in all supported *operating bands*.

9.5.2.2 Minimum requirement for *BS type 1-O*

The total power from all *co-location reference antenna* conducted output(s) shall be less than -106 dBm/MHz.

9.5.2.3 Minimum requirement for *BS type 2-O*

The OTA transmitter OFF TRP spectral density for *BS type 2-O* shall be less than -36 dBm/MHz.

9.5.3 OTA transient period

9.5.3.1 General

The *OTA transmitter transient period* is the time period during which the transmitter is changing from the *transmitter OFF period* to the *transmitter ON period* or vice versa. The *transmitter transient period* is illustrated in figure 6.4.2.1-1.

This requirement shall be applied at each RIB supporting transmission in the *operating band*.

9.5.3.2 Minimum requirement for *BS type 1-O*

For *BS type 1-O*, the *OTA transmitter transient period* shall be shorter than the values listed in the minimum requirement table 9.5.3.2-1.

Table 9.5.3.2-1: Minimum requirement for the *OTA transmitter transient period* for *BS type 1-O*

Transition	Transient period length (µs)
OFF to ON	10
ON to OFF	10

9.5.3.3 Minimum requirement for *BS type 2-O*

For *BS type 2-O*, the *OTA transmitter transient period* shall be shorter than the values listed in the minimum requirement table 9.5.3.3-1.

Table 9.5.3.3-1: Minimum requirement for the *OTA transmitter transient period* for *BS type 2-O*

Transition	Transient period length (µs)
OFF to ON	3
ON to OFF	3

9.6 OTA transmitted signal quality

9.6.1 OTA frequency error

9.6.1.1 General

The requirements in clause 9.6.1 apply to the *transmitter ON period*.

OTA frequency error is the measure of the difference between the actual BS transmit frequency and the assigned frequency. The same source shall be used for RF frequency and data clock generation.

OTA frequency error requirement is defined as a *directional requirement* at the RIB and shall be met within the *OTA coverage range*.

9.6.1.2 Minimum requirement for *BS type 1-O*

For *BS type 1-O*, the modulated carrier frequency of each NR carrier configured by the BS shall be accurate to within the accuracy range given in table 6.5.1.2-1 observed over 1 ms.

9.6.1.3 Minimum requirement for *BS type 2-O*

For *BS type 2-O*, the modulated carrier frequency of each NR carrier configured by the BS shall be accurate to within the accuracy range given in table 9.6.1.3-1 observed over 1 ms.

Table 9.6.1.3-1: OTA frequency error minimum requirement

BS class	Accuracy
Wide Area BS	±0.05 ppm
Medium Range BS	±0.1 ppm
Local Area BS	±0.1 ppm

9.6.2 OTA modulation quality

9.6.2.1 General

Modulation quality is defined by the difference between the measured carrier signal and an ideal signal. Modulation quality can e.g. be expressed as Error Vector Magnitude (EVM). Details about how the EVM is determined are specified in Annex B for FR1 and Annex C for FR2.

OTA modulation quality requirement is defined as a *directional requirement* at the RIB and shall be met within the *OTA coverage range*.

9.6.2.2 Minimum Requirement for *BS type 1-O*

For *BS type 1-O*, the EVM levels of each NR carrier for different modulation schemes on PDSCH outlined in table 6.5.2.2-1 shall be met. Requirements shall be the same as clause 6.5.2.2 and follow EVM frame structure from clause 6.5.2.3.

9.6.2.3 Minimum Requirement for *BS type 2-O*

For *BS type 2-O*, the EVM levels of each NR carrier for different modulation schemes on PDSCH outlined in table 9.6.2.3-1 shall be met, following the EVM frame structure described in clause 9.6.2.3.1.

Table 9.6.2.3-1: EVM requirements for *BS type 2-O* carrier

Applicability	Modulation scheme for PDSCH	Required EVM (%)
FR2	QPSK	17.5
FR2	16QAM	12.5
FR2	64QAM	8
FR2-1	256QAM	3.5

9.6.2.3.1 EVM frame structure for measurement

EVM requirements shall apply for each NR carrier over all allocated resource blocks. Different modulation schemes listed in table 9.6.2.3-1 shall be considered for rank 1.

For NR, for all bandwidths, the EVM measurement shall be performed for each NR carrier over all allocated resource blocks and downlink subframes within 10 ms measurement periods. The boundaries of the EVM measurement periods need not be aligned with radio frame boundaries.

9.6.3 OTA time alignment error

9.6.3.1 General

This requirement shall apply to frame timing in MIMO transmission, *carrier aggregation* and their combinations.

Frames of the NR signals present in the radiated domain are not perfectly aligned in time. In relation to each other, the RF signals present in the radiated domain may experience certain timing differences.

The TAE is specified for a specific set of signals/transmitter configuration/transmission mode.

For a specific set of signals/transmitter configuration/transmission mode, the OTA Time Alignment Error (OTA TAE) is defined as the largest timing difference between any two different NR signals. The OTA time alignment error requirement is defined as a *directional requirement* at the RIB and shall be met within the *OTA coverage range*.

9.6.3.2 Minimum requirement for *BS type 1-0*

For MIMO transmission, at each carrier frequency, OTA TAE shall not exceed 65 ns.

For *intra-band contiguous carrier aggregation*, with or without MIMO, OTA TAE shall not exceed 260 ns.

For *intra-band non-contiguous carrier aggregation*, with or without MIMO, OTA TAE shall not exceed 3 μ s.

For inter-band *carrier aggregation*, with or without MIMO, OTA TAE shall not exceed 3 μ s.

Table 9.6.3.2-1: Void

Table 9.6.3.2-2: Void

Table 9.6.3.2-3: Void

9.6.3.3 Minimum requirement for *BS type 2-0*

The minimum requirement for TAE is given in Table 9.6.3.3-4.

Table 9.6.3.3-1: Void

Table 9.6.3.3-2: Void

Table 9.6.3.3-3: Void

Table 9.6.3.3-4: TAE requirements for *BS type 2-0*

Requirement	TAE		
	60, 120 kHz SCS (ns)	480 kHz SCS (ns)	960 kHz SCS (ns)
MIMO transmission	65	32.5	32.5
<i>intra-band contiguous carrier aggregation</i> , with or without MIMO	130	32.5	32.5
<i>intra-band non-contiguous carrier aggregation</i> , with or without MIMO (Note)	260	N/A	N/A
<i>inter-band carrier aggregation</i> , with or without MIMO	3000	3000	3000
NOTE: <i>intra-band non-contiguous carrier aggregation</i> is not supported for FR2-2 in this release.			

9.7 OTA unwanted emissions

9.7.1 General

Unwanted emissions consist of so-called out-of-band emissions and spurious emissions according to ITU definitions ITU-R SM.329 [2]. In ITU terminology, out of band emissions are unwanted emissions immediately outside the *BS channel bandwidth* resulting from the modulation process and non-linearity in the transmitter but excluding spurious emissions. Spurious emissions are emissions which are caused by unwanted transmitter effects such as harmonics

emission, parasitic emission, intermodulation products and frequency conversion products, but exclude out of band emissions.

The OTA out-of-band emissions requirement for the *BS type 1-O* and *BS type 2-O* transmitter is specified both in terms of Adjacent Channel Leakage power Ratio (ACLR) and operating band unwanted emissions (OBUE). The OTA Operating band unwanted emissions define all unwanted emissions in each supported downlink *operating band* plus the frequency ranges Δf_{OBUE} above and Δf_{OBUE} below each band. OTA Unwanted emissions outside of this frequency range are limited by an OTA spurious emissions requirement.

The maximum offset of the operating band unwanted emissions mask from the *operating band* edge is Δf_{OBUE} . The value of Δf_{OBUE} is defined in table 9.7.1-1 for *BS type 1-O* and *BS type 2-O* for the NR *operating bands*.

Table 9.7.1-1: Maximum offset Δf_{OBUE} outside the downlink *operating band*

BS type	Operating band characteristics (MHz)	Δf_{OBUE} (MHz)
BS type 1-O	$F_{\text{DL,high}} - F_{\text{DL,low}} < 100$	10
	$100 \text{ MHz} \leq F_{\text{DL,high}} - F_{\text{DL,low}} \leq 900$	40
BS type 2-O	$F_{\text{DL,high}} - F_{\text{DL,low}} \leq 4000$	1500
	$4000 < F_{\text{DL,high}} - F_{\text{DL,low}} \leq 14000$	3500

The unwanted emission requirements are applied per cell for all the configurations. Requirements for OTA unwanted emissions are captured using TRP, *directional requirements* or co-location requirements as described per requirement.

There is in addition a requirement for occupied bandwidth.

For band n104, the values of Δf_{OBUE} are defined in table 9.7.1-1a.

Table 9.7.1-1a: Maximum offset of OBUE outside the downlink *operating band* for band n104

BS type	Operating band	Δf_{OBUE} (MHz)
<i>BS type 1-O</i>	n104	100

9.7.2 OTA occupied bandwidth

9.7.2.1 General

The OTA occupied bandwidth is the width of a frequency band such that, below the lower and above the upper frequency limits, the mean powers emitted are each equal to a specified percentage $\beta/2$ of the total mean transmitted power. See also recommendation ITU-R SM.328 [3].

The value of $\beta/2$ shall be taken as 0.5%.

The OTA occupied bandwidth requirement shall apply during the *transmitter ON period* for a single transmitted carrier. The minimum requirement below may be applied regionally. There may also be regional requirements to declare the OTA occupied bandwidth according to the definition in the present clause.

The OTA occupied bandwidth is defined as a *directional requirement* and shall be met in the manufacturer's declared *OTA coverage range* at the RIB.

9.7.2.2 Minimum requirement for *BS type 1-O* and *BS type 2-O*

The OTA occupied bandwidth for each NR carrier shall be less than the *BS channel bandwidth*. For intra-band contiguous CA, the OTA occupied bandwidth shall be less than or equal to the *Aggregated BS Channel Bandwidth*.

9.7.3 OTA Adjacent Channel Leakage Power Ratio (ACLR)

9.7.3.1 General

OTA Adjacent Channel Leakage power Ratio (ACLR) is the ratio of the filtered mean power centred on the assigned channel frequency to the filtered mean power centred on an adjacent channel frequency. The measured power is TRP.

The requirement shall be applied per RIB during the *transmitter ON period*.

9.7.3.2 Minimum requirement for *BS type 1-0*

The ACLR (CACLR) absolute *basic limits* in table 6.6.3.2-2 + X, 6.6.3.2-3a + X (where X = 9 dB) or the ACLR (CACLR) *basic limit* in table 6.6.3.2-1, 6.6.3.2-2a or 6.6.3.2-3, whichever is less stringent, shall apply.

For a *RIB* operating in multi-carrier or contiguous CA, the ACLR requirements in clause 6.6.3.2 shall apply to *BS channel bandwidths* of the outermost carrier for the frequency ranges defined in table 6.6.3.2-1. For a *RIB* operating in *non-contiguous spectrum*, the ACLR requirement in clause 6.6.3.2 shall apply in *sub-block gaps* for the frequency ranges defined in table 6.6.3.2-2a, while the CACLR requirement in clause 6.6.3.2 shall apply in *sub-block gaps* for the frequency ranges defined in table 6.6.3.2-3.

For a *multi-band RIB*, the ACLR requirement in clause 6.6.3.2 shall apply in *Inter RF Bandwidth gaps* for the frequency ranges defined in table 6.6.3.2-2a, while the CACLR requirement in clause 6.6.3.2 shall apply in *Inter RF Bandwidth gaps* for the frequency ranges defined in table 6.6.3.2-3.

9.7.3.3 Minimum requirement for *BS type 2-0*

The OTA ACLR limit is specified in table 9.7.3.3-1.

The OTA ACLR absolute limit is specified in table 9.7.3.3-2.

The OTA ACLR (CACLR) absolute limit in table 9.7.3.3-2 or 9.7.3.3-4a or the ACLR (CACLR) limit in table 9.7.3.3-1, 9.7.3.3-3 or 9.7.3.3-4, whichever is less stringent, shall apply.

For a *RIB* operating in multi-carrier or contiguous CA, the OTA ACLR requirements in table 9.7.3.3-1 shall apply to *BS channel bandwidths* of the outermost carrier for the frequency ranges defined in the table. For a *RIB* operating in *non-contiguous spectrum*, the OTA ACLR requirement in table 9.7.3.3-3 shall apply in *sub-block gaps* for the frequency ranges defined in the table, while the OTA CACLR requirement in table 9.7.3.3-4 shall apply in *sub-block gaps* for the frequency ranges defined in the table.

The CACLR in a *sub-block gap* is the ratio of:

- a) the sum of the filtered mean power centred on the assigned channel frequencies for the two carriers adjacent to each side of the *sub-block gap*, and
- b) the filtered mean power centred on a frequency channel adjacent to one of the respective *sub-block* edges.

The assumed filter for the adjacent channel frequency is defined in table 9.7.3.3-4 and the filters on the assigned channels are defined in table 9.7.3.3-5.

For operation in *non-contiguous spectrum*, the CACLR for NR carriers located on either side of the *sub-block gap* shall be higher than the value specified in table 9.7.3.3-4.

Table 9.7.3.3-1: *BS type 2-O ACLR limit*

<i>BS channel bandwidth of lowest/highest carrier transmitted</i> BW_{Channel} (MHz)	<i>BS adjacent channel centre frequency offset below the lowest or above the highest carrier centre frequency transmitted</i>	<i>Assumed adjacent channel carrier</i>	<i>Filter on the adjacent channel frequency and corresponding filter bandwidth</i>	<i>ACLR limit (dB)</i>
50, 100, 200, 400, 800, 1600, 2000	BW_{Channel}	NR of same BW (Note 2)	Square (BW_{Config})	28 (Note 3) 26 (Note 4) 24 (Note 5)
NOTE 1: BW_{Channel} and BW_{Config} are the <i>BS channel bandwidth</i> and <i>transmission bandwidth configuration</i> of the <i>lowest/highest carrier</i> transmitted on the assigned channel frequency.				
NOTE 2: With SCS that provides largest <i>transmission bandwidth configuration</i> (BW_{Config}).				
NOTE 3: Applicable to bands defined within the frequency spectrum range of 24.25 – 33.4 GHz				
NOTE 4: Applicable to bands defined within the frequency spectrum range of 37 – 52.6 GHz				
NOTE 5: Applicable to bands defined within the frequency spectrum range of 52.6 – 71 GHz.				

Table 9.7.3.3-2: *BS type 2-O ACLR absolute limit*

BS class	ACLR absolute limit
Wide area BS	-13 dBm/MHz
Medium range BS	-20 dBm/MHz
Local area BS	-20 dBm/MHz

Table 9.7.3.3-3: *BS type 2-O ACLR limit in non-contiguous spectrum*

<i>BS channel bandwidth of carrier transmitted adjacent to sub-block gap</i> (MHz)	<i>Sub-block gap size (W_{gap}) where the limit applies</i> (MHz)	<i>BS adjacent channel centre frequency offset below or above the sub-block edge (inside the gap)</i>	<i>Assumed adjacent channel carrier</i>	<i>Filter on the adjacent channel frequency and corresponding filter bandwidth</i>	<i>ACLR limit</i>
50, 100	$W_{\text{gap}} \geq 100$ (Note 5) $W_{\text{gap}} \geq 250$ (Note 6)	25 MHz	50 MHz NR (Note 2)	Square (BW_{Config})	28 (Note 3) 26 (Note 4)
200, 400	$W_{\text{gap}} \geq 400$ (Note 6) $W_{\text{gap}} \geq 250$ (Note 5)	100 MHz	200 MHz NR (Note 2)	Square (BW_{Config})	28 (Note 3) 26 (Note 4)
NOTE 1: BW_{Config} is the <i>transmission bandwidth configuration</i> of the assumed adjacent channel carrier.					
NOTE 2: With SCS that provides largest <i>transmission bandwidth configuration</i> (BW_{Config}).					
NOTE 3: Applicable to bands defined within the frequency spectrum range of 24.25 – 33.4 GHz.					
NOTE 4: Applicable to bands defined within the frequency spectrum range of 37 – 52.6 GHz.					
NOTE 5: Applicable in case the <i>BS channel bandwidth</i> of the NR carrier transmitted at the other edge of the gap is 50 or 100 MHz.					
NOTE 6: Applicable in case the <i>BS channel bandwidth</i> of the NR carrier transmitted at the other edge of the gap is 200 or 400 MHz.					

Table 9.7.3.3-4: *BS type 2-O* CACLR limit in non-contiguous spectrum

<i>BS channel bandwidth of carrier transmitted adjacent to sub-block gap (MHz)</i>	<i>Sub-block gap size (W_{gap}) where the limit applies (MHz)</i>	<i>BS adjacent channel centre frequency offset below or above the sub-block edge (inside the gap)</i>	<i>Assumed adjacent channel carrier</i>	<i>Filter on the adjacent channel frequency and corresponding filter bandwidth</i>	<i>CACLR limit</i>
50, 100	$50 \leq W_{gap} < 100$ (Note 5)	25 MHz	50 MHz NR (Note 2)	Square (BW_{Config})	28 (Note 3)
	$50 \leq W_{gap} < 250$ (Note 6)				26 (Note 4)
200, 400	$200 \leq W_{gap} < 400$ (Note 6)	100 MHz	200 MHz NR (Note 2)	Square (BW_{Config})	28 (Note 3)
	$200 \leq W_{gap} < 250$ (Note 5)				26 (Note 4)

NOTE 1: BW_{Config} is the transmission bandwidth configuration of the assumed adjacent channel carrier.
NOTE 2: With SCS that provides largest transmission bandwidth configuration (BW_{Config}).
NOTE 3: Applicable to bands defined within the frequency spectrum range of 24.25 – 33.4 GHz.
NOTE 4: Applicable to bands defined within the frequency spectrum range of 37 – 52.6 GHz.
NOTE 5: Applicable in case the *BS channel bandwidth* of the NR carrier transmitted at the other edge of the gap is 50 or 100 MHz.
NOTE 6: Applicable in case the *BS channel bandwidth* of the NR carrier transmitted at the other edge of the gap is 200 or 400 MHz.

Table 9.7.3.3-4a: *BS type 2-O* CACLR absolute limit

BS class	CACLR absolute limit
Wide area BS	-13 dBm/MHz
Medium range BS	-20 dBm/MHz
Local area BS	-20 dBm/MHz

Table 9.7.3.3-5: Filter parameters for the assigned channel

RAT of the carrier adjacent to the sub-block gap	Filter on the assigned channel frequency and corresponding filter bandwidth
NR	NR of same BW with SCS that provides largest <i>transmission bandwidth configuration</i>

9.7.4 OTA operating band unwanted emissions

9.7.4.1 General

The OTA limits for operating band unwanted emissions are specified as TRP per RIB unless otherwise stated.

9.7.4.2 Minimum requirement for *BS type 1-O*

Out-of-band emissions in FR1 are limited by OTA operating band unwanted emission limits. Unless otherwise stated, the operating band unwanted emission limits in FR1 are defined from Δf_{OBUE} below the lowest frequency of each supported downlink *operating band* up to Δf_{OBUE} above the highest frequency of each supported downlink *operating band*. The values of Δf_{OBUE} are defined in table 9.7.1-1 for the NR *operating bands*.

The requirements shall apply whatever the type of transmitter considered and for all transmission modes foreseen by the manufacturer's specification. For a *RIB* operating in multi-carrier or contiguous CA, the requirements apply to *BS channel bandwidths* of the outermost carrier for the frequency ranges defined in clause 6.6.4.1.

For a *RIB* operating in *non-contiguous spectrum*, the requirements shall apply inside any *sub-block gap* for the frequency ranges defined in clause 6.6.4.1.

For a *multi-band RIB*, the requirements shall apply inside any *Inter RF Bandwidth gap* for the frequency ranges defined in clause 6.6.4.1.

The OTA operating band unwanted emission requirement for *BS type 1-O* is that for each applicable *basic limit* for *BS type 1-H* in clause 6.6.4.2, the power of any unwanted emission shall not exceed an OTA limit specified as the *basic limit* + X, where X = 9 dB.

9.7.4.2.1 Additional requirements

9.7.4.2.1.1 Protection of DTT

In certain regions the following requirement may apply for protection of DTT. For *BS type 1-O* operating in Band n20, the level of emissions in the band 470-790 MHz, measured in an 8 MHz filter bandwidth on centre frequencies F_{filter} according to table 9.7.4.2.1.1-1, shall not exceed the maximum emission TRP level shown in the table. This requirement applies in the frequency range 470-790 MHz even though part of the range falls in the spurious domain.

Table 9.7.4.2.1.1-1: Declared emissions levels for protection of DTT

Case	Measurement filter centre frequency	Condition on BS maximum aggregate TRP / 10 MHz, $P_{\text{TRP_10MHz}}$ (NOTE)	Maximum level $P_{\text{TRP,N,MAX}}$	Measurement bandwidth
A: for DTT frequencies where broadcasting is protected	$N*8 + 306$ MHz, $21 \leq N \leq 60$	$P_{\text{TRP_10MHz}} \geq 59$ dBm	0 dBm	8 MHz
	$N*8 + 306$ MHz, $21 \leq N \leq 60$	$36 \leq P_{\text{TRP_10MHz}} < 59$ dBm	$P_{\text{TRP_10MHz}} - 59$ dBm	8 MHz
	$N*8 + 306$ MHz, $21 \leq N \leq 60$	$P_{\text{TRP_10MHz}} < 36$ dBm	-23 dBm	8 MHz
B: for DTT frequencies where broadcasting is subject to an intermediate level of protection	$N*8 + 306$ MHz, $21 \leq N \leq 60$	$P_{\text{TRP_10MHz}} \geq 59$ dBm	10 dBm	8 MHz
	$N*8 + 306$ MHz, $21 \leq N \leq 60$	$36 \leq P_{\text{TRP_10MHz}} < 59$ dBm	$P_{\text{TRP_10MHz}} - 49$ dBm	8 MHz
	$N*8 + 306$ MHz, $21 \leq N \leq 60$	$P_{\text{TRP_10MHz}} < 36$ dBm	-13 dBm	8 MHz
C: for DTT frequencies where broadcasting is not protected	$N*8 + 306$ MHz, $21 \leq N \leq 60$	N/A	22 dBm	8 MHz
NOTE: $P_{\text{TRP_10MHz}}$ (dBm) is defined by $P_{\text{TRP_10MHz}} = P_{10\text{MHz}} + G_{\text{ant}} + 9\text{dB}$, where G_{ant} is 17 dBi.				

9.7.4.2.1.2 Limits in FCC Title 47

The BS may have to comply with the applicable emission limits established by FCC Title 47 [8], when deployed in regions where those limits are applied, and under the conditions declared by the manufacturer.

9.7.4.3 Minimum requirement for *BS type 2-O*

9.7.4.3.1 General

The requirements of either clause 9.7.4.3.2 (Category A limits) or clause 9.7.4.3.3 (Category B limits) shall apply. The application of either Category A or Category B limits shall be the same as for General OTA transmitter spurious emissions requirements (*BS type 2-O*) in clause 9.7.5.3.2. In addition, the limits in clause 9.7.4.3.4 may also apply.

Out-of-band emissions in FR2 are limited by OTA operating band unwanted emission limits. Unless otherwise stated, the OTA operating band unwanted emission limits in FR2 are defined from Δf_{OBUE} below the lowest frequency of each supported downlink *operating band* up to Δf_{OBUE} above the highest frequency of each supported downlink *operating band*. The values of Δf_{OBUE} are defined in table 9.7.1-1 for the NR *operating bands*.

The requirements shall apply whatever the type of transmitter considered and for all transmission modes foreseen by the manufacturer's specification. For a *RIB* operating in multi-carrier or contiguous CA, the requirements apply to the

frequencies (Δf_{OBUE}) starting from the edge of the *contiguous transmission bandwidth*. In addition, for a *RIB* operating in *non-contiguous spectrum*, the requirements apply inside any *sub-block gap*.

Emissions shall not exceed the maximum levels specified in the tables below, where:

- Δf is the separation between the *contiguous transmission bandwidth* edge frequency and the nominal -3dB point of the measuring filter closest to the *contiguous transmission bandwidth* edge.
- f_{offset} is the separation between the *contiguous transmission bandwidth* edge frequency and the centre of the measuring filter.
- $f_{\text{offset}_{\text{max}}}$ is the offset to the frequency Δf_{OBUE} outside the downlink *operating band*, where Δf_{OBUE} is defined in table 9.7.1-1.
- Δf_{max} is equal to $f_{\text{offset}_{\text{max}}}$ minus half of the bandwidth of the measuring filter.

In addition, inside any *sub-block gap* for a *RIB* operating in *non-contiguous spectrum*, emissions shall not exceed the cumulative sum of the limits specified for the adjacent *sub-blocks* on each side of the *sub-block gap*. The limit for each *sub-block* is specified in clauses 9.7.4.3.2 and 9.7.4.3.3 below, where in this case:

- Δf is the separation between the *sub-block* edge frequency and the nominal -3 dB point of the measuring filter closest to the *sub-block* edge.
- f_{offset} is the separation between the *sub-block* edge frequency and the centre of the measuring filter.
- $f_{\text{offset}_{\text{max}}}$ is equal to the *sub-block gap* bandwidth minus half of the bandwidth of the measuring filter.
- Δf_{max} is equal to $f_{\text{offset}_{\text{max}}}$ minus half of the bandwidth of the measuring filter.

9.7.4.3.2 OTA operating band unwanted emission limits (Category A)

BS unwanted emissions shall not exceed the maximum levels specified in table 9.7.4.3.2-1, 9.7.4.3.2-2, and 9.7.4.3.2-4.

Table 9.7.4.3.2-1: OBUE limits applicable in the frequency range 24.25 – 33.4 GHz

Frequency offset of measurement filter -3B point, Δf	Frequency offset of measurement filter centre frequency, f_{offset}	Limit	Measurement bandwidth
$0 \text{ MHz} \leq \Delta f < 0.1 * \text{BW}_{\text{contiguous}}$	$0.5 \text{ MHz} \leq f_{\text{offset}} < 0.1 * \text{BW}_{\text{contiguous}} + 0.5 \text{ MHz}$	Min(-5 dBm, Max($P_{\text{rated,t,TRP}} - 35 \text{ dB}$, -12 dBm))	1 MHz
$0.1 * \text{BW}_{\text{contiguous}} \leq \Delta f < \Delta f_{\text{max}}$	$0.1 * \text{BW}_{\text{contiguous}} + 0.5 \text{ MHz} \leq f_{\text{offset}} < f_{\text{offset}_{\text{max}}}$	Min(-13 dBm, Max($P_{\text{rated,t,TRP}} - 43 \text{ dB}$, -20 dBm))	1 MHz
NOTE 1: For <i>non-contiguous spectrum</i> operation within any <i>operating band</i> the limit within <i>sub-block gaps</i> is calculated as a cumulative sum of contributions from adjacent <i>sub-blocks</i> on each side of the <i>sub-block gap</i> .			

Table 9.7.4.3.2-2: OBUE limits applicable in the frequency range 37 – 52.6 GHz

Frequency offset of measurement filter -3B point, Δf	Frequency offset of measurement filter centre frequency, f_{offset}	Limit	Measurement bandwidth
$0 \text{ MHz} \leq \Delta f < 0.1 * \text{BW}_{\text{contiguous}}$	$0.5 \text{ MHz} \leq f_{\text{offset}} < 0.1 * \text{BW}_{\text{contiguous}} + 0.5 \text{ MHz}$	Min(-5 dBm, Max($P_{\text{rated,t,TRP}} - 33 \text{ dB}$, -12 dBm))	1 MHz
$0.1 * \text{BW}_{\text{contiguous}} \leq \Delta f < \Delta f_{\text{max}}$	$0.1 * \text{BW}_{\text{contiguous}} + 0.5 \text{ MHz} \leq f_{\text{offset}} < f_{\text{offset}_{\text{max}}}$	Min(-13 dBm, Max($P_{\text{rated,t,TRP}} - 41 \text{ dB}$, -20 dBm))	1 MHz
NOTE 1: For <i>non-contiguous spectrum</i> operation within any <i>operating band</i> the limit within <i>sub-block gaps</i> is calculated as a cumulative sum of contributions from adjacent <i>sub-blocks</i> on each side of the <i>sub-block gap</i> .			

Table 9.7.4.3.2-3: Void

Table 9.7.4.3.2-4: OBUE limits applicable in the frequency range 52.6 – 71 GHz

Frequency offset of measurement filter -3B point, Δf	Frequency offset of measurement filter centre frequency, f_{offset}	Limit	Measurement bandwidth
$0 \text{ MHz} \leq \Delta f < 0.1 * \text{BW}_{\text{contiguous}}$	$0.5 \text{ MHz} \leq f_{\text{offset}} < 0.1 * \text{BW}_{\text{contiguous}} + 0.5 \text{ MHz}$	Min(-5 dBm, Max($P_{\text{rated,t,TRP}} - 31 \text{ dB}$, -12 dBm))	1 MHz
$0.1 * \text{BW}_{\text{contiguous}} \leq \Delta f < \Delta f_{\text{max}}$	$0.1 * \text{BW}_{\text{contiguous}} + 0.5 \text{ MHz} \leq f_{\text{offset}} < f_{\text{offset}_{\text{max}}}$	Min(-13 dBm, Max($P_{\text{rated,t,TRP}} - 39 \text{ dB}$, -20 dBm))	1 MHz
NOTE 1: For <i>non-contiguous spectrum</i> operation within any <i>operating band</i> the limit within <i>sub-block gaps</i> is calculated as a cumulative sum of contributions from adjacent <i>sub-blocks</i> on each side of the <i>sub-block gap</i> .			

9.7.4.3.3 OTA operating band unwanted emission limits (Category B)

BS unwanted emissions shall not exceed the maximum levels specified in table 9.7.4.3.3-1, 9.7.4.3.3-2, and 9.7.4.3.3-3.

Table 9.7.4.3.3-1: OBUE limits applicable in the frequency range 24.25 – 33.4 GHz

Frequency offset of measurement filter -3 dB point, Δf	Frequency offset of measurement filter centre frequency, f_{offset}	Limit	Measurement bandwidth
$0 \text{ MHz} \leq \Delta f < 0.1 * \text{BW}_{\text{contiguous}}$	$0.5 \text{ MHz} \leq f_{\text{offset}} < 0.1 * \text{BW}_{\text{contiguous}} + 0.5 \text{ MHz}$	Min(-5 dBm, Max($P_{\text{rated,t,TRP}} - 35 \text{ dB}$, -12 dBm))	1 MHz
$0.1 * \text{BW}_{\text{contiguous}} \leq \Delta f < \Delta f_{\text{B}}$	$0.1 * \text{BW}_{\text{contiguous}} + 0.5 \text{ MHz} \leq f_{\text{offset}} < \Delta f_{\text{B}} + 0.5 \text{ MHz}$	Min(-13 dBm, Max($P_{\text{rated,t,TRP}} - 43 \text{ dB}$, -20 dBm))	1 MHz
$\Delta f_{\text{B}} \leq \Delta f < \Delta f_{\text{max}}$	$\Delta f_{\text{B}} + 5 \text{ MHz} \leq f_{\text{offset}} < f_{\text{offset}_{\text{max}}}$	Min(-5 dBm, Max($P_{\text{rated,t,TRP}} - 33 \text{ dB}$, -10 dBm))	10 MHz
NOTE 1: For non-contiguous spectrum operation within any <i>operating band</i> the limit within sub-block gaps is calculated as a cumulative sum of contributions from adjacent sub-blocks on each side of the sub-block gap, where the contribution from the far-end sub-block shall be scaled according to the measurement bandwidth of the near-end sub-block.			
NOTE 2: $\Delta f_{\text{B}} = 2 * \text{BW}_{\text{contiguous}}$ when $\text{BW}_{\text{contiguous}} \leq 500 \text{ MHz}$, otherwise $\Delta f_{\text{B}} = \text{BW}_{\text{contiguous}} + 500 \text{ MHz}$.			

Table 9.7.4.3.3-2: OBUE limits applicable in the frequency range 37 – 52.6 GHz

Frequency offset of measurement filter -3 dB point, Δf	Frequency offset of measurement filter centre frequency, f_{offset}	Limit	Measurement bandwidth
$0 \text{ MHz} \leq \Delta f < 0.1 * \text{BW}_{\text{contiguous}}$	$0.5 \text{ MHz} \leq f_{\text{offset}} < 0.1 * \text{BW}_{\text{contiguous}} + 0.5 \text{ MHz}$	Min(-5 dBm, Max($P_{\text{rated,t,TRP}} - 33 \text{ dB}$, -12 dBm))	1 MHz
$0.1 * \text{BW}_{\text{contiguous}} \leq \Delta f < \Delta f_{\text{B}}$	$0.1 * \text{BW}_{\text{contiguous}} + 0.5 \text{ MHz} \leq f_{\text{offset}} < \Delta f_{\text{B}} + 0.5 \text{ MHz}$	Min(-13 dBm, Max($P_{\text{rated,t,TRP}} - 41 \text{ dB}$, -20 dBm))	1 MHz
$\Delta f_{\text{B}} \leq \Delta f < \Delta f_{\text{max}}$	$\Delta f_{\text{B}} + 5 \text{ MHz} \leq f_{\text{offset}} < f_{\text{offset}_{\text{max}}}$	Min(-5 dBm, Max($P_{\text{rated,t,TRP}} - 31 \text{ dB}$, -10 dBm))	10 MHz
NOTE 1: For non-contiguous spectrum operation within any <i>operating band</i> the limit within sub-block gaps is calculated as a cumulative sum of contributions from adjacent sub-blocks on each side of the sub-block gap, where the contribution from the far-end sub-block shall be scaled according to the measurement bandwidth of the near-end sub-block.			
NOTE 2: $\Delta f_{\text{B}} = 2 * \text{BW}_{\text{contiguous}}$ when $\text{BW}_{\text{contiguous}} \leq 500 \text{ MHz}$, otherwise $\Delta f_{\text{B}} = \text{BW}_{\text{contiguous}} + 500 \text{ MHz}$.			

Table 9.7.4.3.3-3: OBUE limits applicable in the frequency range 52.6 – 71 GHz

Frequency offset of measurement filter -3 dB point, Δf	Frequency offset of measurement filter centre frequency, f_{offset}	Limit	Measurement bandwidth
$0 \text{ MHz} \leq \Delta f < 0.1 * BW_{\text{contiguous}}$	$0.5 \text{ MHz} \leq f_{\text{offset}} < 0.1 * BW_{\text{contiguous}} + 0.5 \text{ MHz}$	Min(-5 dBm, Max($P_{\text{rated,t,TRP}} - 31 \text{ dB}$, -12 dBm))	1 MHz
$0.1 * BW_{\text{contiguous}} \leq \Delta f < \Delta f_{\text{B}}$	$0.1 * BW_{\text{contiguous}} + 0.5 \text{ MHz} \leq f_{\text{offset}} < \Delta f_{\text{B}} + 0.5 \text{ MHz}$	Min(-13 dBm, Max($P_{\text{rated,t,TRP}} - 39 \text{ dB}$, -20 dBm))	1 MHz
$\Delta f_{\text{B}} \leq \Delta f < \Delta f_{\text{max}}$	$\Delta f_{\text{B}} + 5 \text{ MHz} \leq f_{\text{offset}} < f_{\text{offset,max}}$	Min(-5 dBm, Max($P_{\text{rated,t,TRP}} - 29 \text{ dB}$, -10 dBm))	10 MHz
NOTE 1: For non-contiguous spectrum operation within any <i>operating band</i> the limit within sub-block gaps is calculated as a cumulative sum of contributions from adjacent sub-blocks on each side of the sub-block gap, where the contribution from the far-end sub-block shall be scaled according to the measurement bandwidth of the near-end sub-block.			
NOTE 2: $\Delta f_{\text{B}} = 2 * BW_{\text{contiguous}}$ when $BW_{\text{contiguous}} \leq 500 \text{ MHz}$, otherwise $\Delta f_{\text{B}} = BW_{\text{contiguous}} + 500 \text{ MHz}$.			

9.7.4.3.4 Additional OTA operating band unwanted emission requirements

9.7.4.3.4.1 Protection of Earth Exploration Satellite Service

For BS operating in the frequency range 24.25 – 27.5 GHz, the power of unwanted emission shall not exceed the limits in table 9.7.4.3.4.1-1.

Table 9.7.4.3.4.1-1: OBUE limits for protection of Earth Exploration Satellite Service

Frequency range	Limit	Measurement Bandwidth
23.6 – 24 GHz	-3 dBm (Note 1)	200 MHz
23.6 – 24 GHz	-9 dBm (Note 2)	200 MHz
NOTE 1: This limit applies to BS brought into use on or before 1 September 2027.		
NOTE 2: This limit applies to BS brought into use after 1 September 2027.		

9.7.5 OTA transmitter spurious emissions

9.7.5.1 General

Unless otherwise stated, all requirements are measured as mean power.

The OTA spurious emissions limits are specified as TRP per RIB unless otherwise stated.

9.7.5.2 Minimum requirement for *BS type 1-0*

9.7.5.2.1 General

The OTA transmitter spurious emission limits for FR1 shall apply from 30 MHz to 12.75 GHz, excluding the frequency range from Δf_{OBUE} below the lowest frequency of each supported downlink *operating band*, up to Δf_{OBUE} above the highest frequency of each supported downlink *operating band*, where the Δf_{OBUE} is defined in table 9.7.1-1. For some FR1 *operating bands*, the upper limit is higher than 12.75 GHz in order to comply with the 5th harmonic limit of the downlink *operating band*, as specified in ITU-R recommendation SM.329 [2].

For *multi-band RIB* each supported *operating band* and Δf_{OBUE} MHz around each band are excluded from the OTA transmitter spurious emissions requirements.

The requirements shall apply whatever the type of transmitter considered (single carrier or multi-carrier). It applies for all transmission modes foreseen by the manufacturer's specification.

BS type 1-0 requirements consists of OTA transmitter spurious emission requirements based on TRP and co-location requirements not based on TRP.

9.7.5.2.2 General OTA transmitter spurious emissions requirements

The Tx spurious emissions requirements for *BS type 1-O* are that for each applicable *basic limit* above 30 MHz in clause 6.6.5.2.1, the TRP of any spurious emission shall not exceed an OTA limit specified as the *basic limit* + X, where X = 9 dB, unless stated differently in regional regulation.

9.7.5.2.3 Protection of the BS receiver of own or different BS

This requirement shall be applied for NR FDD operation in order to prevent the receivers of own or a different BS of the same band being desensitised by emissions from a type 1-O BS.

This requirement is a co-location requirement as defined in clause 4.9, the power levels are specified at the *co-location reference antenna* output.

The total power of any spurious emission from both polarizations of the *co-location reference antenna* connector output shall not exceed the *basic limits* in clause 6.6.5.2.2 + X dB, where X = -21 dB.

9.7.5.2.4 Additional spurious emissions requirements

These requirements may be applied for the protection of systems operating in frequency ranges other than the BS downlink *operating band*. The limits may apply as an optional protection of such systems that are deployed in the same geographical area as the BS, or they may be set by local or regional regulation as a mandatory requirement for an NR *operating band*. It is in some cases not stated in the present document whether a requirement is mandatory or under what exact circumstances that a limit applies, since this is set by local or regional regulation. An overview of regional requirements in the present document is given in clause 4.5.

Some requirements may apply for the protection of specific equipment (UE, MS and/or BS) or equipment operating in specific systems (GSM, CDMA, UTRA, E-UTRA, NR, etc.). The Tx additional spurious emissions requirements for *BS type 1-O* are that for each applicable *basic limit* in clause 6.6.5.2.3, the TRP of any spurious emission shall not exceed an OTA limit specified as the *basic limit* + X, where X = 9 dB.

9.7.5.2.5 Co-location with other base stations

These requirements may be applied for the protection of other BS receivers when GSM900, DCS1800, PCS1900, GSM850, CDMA850, UTRA FDD, UTRA TDD, E-UTRA and/or NR BS are co-located with a BS.

The requirements assume co-location with base stations of the same class.

NOTE: For co-location with UTRA, the requirements are based on co-location with UTRA FDD or TDD base stations.

This requirement is a co-location requirement as defined in clause 4.9, the power levels are specified at the *co-location reference antenna* output(s).

The power sum of any spurious emission is specified over all supported polarizations at the output(s) of the *co-location reference antenna* and shall not exceed the *basic limits* in clause 6.6.5.2.4 + X dB, where X = -21 dB.

For a *multi-band RIB*, the exclusions and conditions in the notes column of table 6.6.5.2.4-1 apply for each supported *operating band*.

9.7.5.3 Minimum requirement for *BS type 2-O*

9.7.5.3.1 General

In FR2, the OTA transmitter spurious emission limits apply from 30 MHz to 2nd harmonic of the upper frequency edge of the downlink *operating band*, excluding the frequency range from Δf_{OBUE} below the lowest frequency of the downlink *operating band*, up to Δf_{OBUE} above the highest frequency of the downlink *operating band*, where the Δf_{OBUE} is defined in table 9.7.1-1.

9.7.5.3.2 General OTA transmitter spurious emissions requirements

9.7.5.3.2.1 General

The requirements of either clause 9.7.5.3.2.2 (Category A limits) or clause 9.7.5.3.2.3 (Category B limits) shall apply. The application of either Category A or Category B limits shall be the same as for Operating band unwanted emissions in clause 9.7.4.3.

Table 9.7.5.3.2-1: Void

NOTE: Table 9.7.5.3.2-1 is moved to clause 9.7.5.3.2.2 as Table 9.7.5.3.2.2-1.

9.7.5.3.2.2 OTA transmitter spurious emissions (Category A)

The power of any spurious emission shall not exceed the limits in table 9.7.5.3.2-1

Table 9.7.5.3.2.2-1: BS radiated Tx spurious emission limits in FR2

Frequency range	Limit	Measurement Bandwidth	Note
30 MHz – 1 GHz	-13 dBm	100 kHz	Note 1
1 GHz – 2 nd harmonic of the upper frequency edge of the DL <i>operating band</i>		1 MHz	Note 1, Note 2
NOTE 1: Bandwidth as in ITU-R SM.329 [2], s4.1			
NOTE 2: Upper frequency as in ITU-R SM.329 [2], s2.5 table 1.			

9.7.5.3.2.3 OTA transmitter spurious emissions (Category B)

The power of any spurious emission shall not exceed the limits in table 9.7.5.3.2.3-1.

Table 9.7.5.3.2.3-1: BS radiated Tx spurious emission limits in FR2 (Category B)

Frequency range (Note 4)	Limit	Measurement Bandwidth	Note
30 MHz ↔ 1 GHz	-36 dBm	100 kHz	Note 1
1 GHz ↔ 18 GHz	-30 dBm	1 MHz	Note 1
18 GHz ↔ $F_{\text{step},1}$	-20 dBm	10 MHz	Note 2
$F_{\text{step},1}$ ↔ $F_{\text{step},2}$	-15 dBm	10 MHz	Note 2
$F_{\text{step},2}$ ↔ $F_{\text{step},3}$	-10 dBm	10 MHz	Note 2
$F_{\text{step},4}$ ↔ $F_{\text{step},5}$	-10 dBm	10 MHz	Note 2
$F_{\text{step},5}$ ↔ $F_{\text{step},6}$	-15 dBm	10 MHz	Note 2
$F_{\text{step},6}$ ↔ 2 nd harmonic of the upper frequency edge of the DL <i>operating band</i>	-20 dBm	10 MHz	Note 2, Note 3
NOTE 1: Bandwidth as in ITU-R SM.329 [2], s4.1			
NOTE 2: Limit and bandwidth as in ERC Recommendation 74-01 [19], Annex 2.			
NOTE 3: Upper frequency as in ITU-R SM.329 [2], s2.5 table 1.			
NOTE 4: The step frequencies $F_{\text{step},X}$ are defined in Table 9.7.5.3.2.3-2.			

Table 9.7.5.3.2.3-2: Step frequencies for defining the BS radiated Tx spurious emission limits in FR2 (Category B)

Operating band	F _{step,1} (GHz)	F _{step,2} (GHz)	F _{step,3} (GHz) (Note 2)	F _{step,4} (GHz) (Note 2)	F _{step,5} (GHz)	F _{step,6} (GHz)
n257	18	23.5	25	31	32.5	41.5
n258	18	21	22.75	29	30.75	40.5
n259	23.5	35.5	38	45	47.5	59.5
n263	18	43	53.5	74.5	85	127

NOTE 1: F_{step,X} are based on ERC Recommendation 74-01 [19], Annex 2.
NOTE 2: F_{step,3} and F_{step,4} are aligned with the values for Δf_{oBUE} in Table 9.7.1-1.

9.7.5.3.3 Additional OTA transmitter spurious emissions requirements

These requirements may be applied for the protection of systems operating in frequency ranges other than the BS downlink operating band. The limits may apply as an optional protection of such systems that are deployed in the same geographical area as the BS, or they may be set by local or regional regulation as a mandatory requirement for an NR operating band. It is in some cases not stated in the present document whether a requirement is mandatory or under what exact circumstances that a limit applies, since this is set by local or regional regulation. An overview of regional requirements in the present document is given in clause 4.5.

9.7.5.3.3.1 Limits for protection of Earth Exploration Satellite Service

For BS operating in the frequency range 24.25 – 27.5 GHz, the power of any spurious emissions shall not exceed the limits in Table 9.7.5.3.3.1-1.

Table 9.7.5.3.3.1-1: Limits for protection of Earth Exploration Satellite Service

Frequency range	Limit	Measurement Bandwidth	Note
23.6 – 24 GHz	-3 dBm	200 MHz	Note 1
23.6 – 24 GHz	-9 dBm	200 MHz	Note 2

NOTE 1: This limit applies to BS brought into use on or before 1 September 2027.
NOTE 2: This limit applies to BS brought into use after 1 September 2027.

9.8 OTA transmitter intermodulation

9.8.1 General

The OTA transmitter intermodulation requirement is a measure of the capability of the transmitter unit to inhibit the generation of signals in its non-linear elements caused by presence of the wanted signal and an interfering signal reaching the transmitter unit via the RDN and antenna array from a co-located base station. The requirement shall apply during the *transmitter ON period* and the *transmitter transient period*.

The requirement shall apply at each RIB supporting transmission in the *operating band*.

The transmitter intermodulation level is the *total radiated power* of the intermodulation products when an interfering signal is injected into the *co-location reference antenna*.

The OTA transmitter intermodulation requirement is not applicable for *BS type 2-0*.

9.8.2 Minimum requirement for *BS type 1-0*

For *BS type 1-0* the transmitter intermodulation level shall not exceed the TRP unwanted emission limits specified for OTA transmitter spurious emission in clause 9.7.5.2 (except clause 9.7.5.2.3 and clause 9.7.5.2.5), OTA operating band unwanted emissions in clause 9.7.4.2 and OTA ACLR in clause 9.7.3.2 in the presence of a wanted signal and an interfering signal, defined in table 9.8.2-1.

The requirement is applicable outside the *Base Station RF Bandwidth edges*. The interfering signal offset is defined relative to the *Base Station RF Bandwidth edges* or *Radio Bandwidth edges*.

For RIBs supporting operation in *non-contiguous spectrum*, the requirement is also applicable inside a *sub-block gap* for interfering signal offsets where the interfering signal falls completely within the *sub-block gap*. The interfering signal offset is defined relative to the *sub-block edges*.

For RIBs supporting operation in multiple *operating bands*, the requirement shall apply relative to the *Base Station RF Bandwidth edges* of each *operating band*. In case the *inter RF Bandwidth gap* is less than $3 \cdot BW_{\text{Channel}}$ (where BW_{Channel} is the minimal *BS channel bandwidth* of the band), the requirement in the gap shall apply only for interfering signal offsets where the interfering signal falls completely within the *inter RF Bandwidth gap*.

Table 9.8.2-1: Interfering and wanted signals for the OTA transmitter intermodulation requirement

Parameter	Value
Wanted signal	NR signal or multi-carrier, or multiple intra-band contiguously or non-contiguously aggregated carriers
Interfering signal type	NR signal the minimum <i>BS channel bandwidth</i> (BW_{Channel}) with 15 kHz SCS of the band defined in clause 5.3.5
Interfering signal power level	$\min(46 \text{ dBm}, P_{\text{rated,t,TRP}})$
Interfering signal centre frequency offset from the lower (upper) edge of the wanted signal or edge of <i>sub-block</i> inside a gap	$f_{\text{offset}} = \pm BW_{\text{Channel}} \left(n - \frac{1}{2} \right)$, for $n=1, 2$ and 3
NOTE 1: Interfering signal positions that are partially or completely outside of any downlink <i>operating band</i> of the RIB are excluded from the requirement, unless the interfering signal positions fall within the frequency range of adjacent downlink <i>operating bands</i> in the same geographical area. In case that none of the interfering signal positions fall completely within the frequency range of the downlink <i>operating band</i> , TS 38.141-2 [6] provides further guidance regarding appropriate test requirements.	
NOTE 2: In Japan, NOTE 1 is not applied in Band n77, n78, n79.	
NOTE 3: For <i>BS type 1-O</i> with dual polarization, the interfering signal power shall be equally divided between the supported polarizations at the <i>co-location reference antenna</i> .	

9.8.3 Additional requirements (regional)

Table 9.8.3-1: Void

For Band n79 operation in Japan, the transmitter intermodulation level shall not exceed the TRP unwanted emission limits specified for OTA transmitter spurious emission in clause 9.7.5.2 (except clause 9.7.5.2.3 and clause 9.7.5.2.5), OTA operating band unwanted emissions in clause 9.7.4.2 and OTA ACLR in clause 9.7.3.2 in the presence of a wanted signal and an interfering signal, defined in table 9.8.3-2.

Table 9.8.3-2: Interfering and wanted signals for the OTA transmitter intermodulation requirement for n79

Parameter	Value
Wanted signal	NR single carrier
Interfering signal type	NR signal of 40 MHz <i>channel bandwidth</i>
Interfering signal power level	$\min(46 \text{ dBm}, P_{\text{rated,t,TRP}})$
Interfering signal centre frequency offset from the lower (upper) edge of the wanted signal	$\pm 20 \text{ MHz}$ $\pm 60 \text{ MHz}$ $\pm 100 \text{ MHz}$

10 Radiated receiver characteristics

10.1 General

Radiated receiver characteristics are specified at RIB for *BS type 1-H*, *BS type 1-O*, or *BS type 2-O*, with full complement of transceivers for the configuration in normal operating condition.

Unless otherwise stated, the following arrangements apply for the radiated receiver characteristics requirements in clause 10:

- Requirements apply during the BS receive period.
- Requirements shall be met for any transmitter setting.
- For FDD operation the requirements shall be met with the transmitter unit(s) ON.
- Throughput requirements defined for the radiated receiver characteristics do not assume HARQ retransmissions.
- When BS is configured to receive multiple carriers, all the throughput requirements are applicable for each received carrier.
- For ACS, blocking and intermodulation characteristics, the negative offsets of the interfering signal apply relative to the lower *Base Station RF Bandwidth* edge or *sub-block* edge inside a *sub-block gap*, and the positive offsets of the interfering signal apply relative to the upper *Base Station RF Bandwidth* edge or *sub-block* edge inside a *sub-block gap*.
- Each requirement shall be met over the RoAoA specified.

NOTE 1: In normal operating condition the BS in FDD operation is configured to transmit and receive at the same time.

NOTE 2: In normal operating condition the BS in TDD operation is configured to TX OFF power during *receive period*.

For FR1 requirements which are to be met over the *OTA REFSENS RoAoA* absolute requirement values are offset by the following term:

$$\Delta_{\text{OTAREFSENS}} = 44.1 - 10 \cdot \log_{10}(\text{Be}W_{\theta, \text{REFSENS}} \cdot \text{Be}W_{\phi, \text{REFSENS}}) \text{ dB for the reference direction}$$

and

$$\Delta_{\text{OTAREFSENS}} = 41.1 - 10 \cdot \log_{10}(\text{Be}W_{\theta, \text{REFSENS}} \cdot \text{Be}W_{\phi, \text{REFSENS}}) \text{ dB for all other directions}$$

For requirements which are to be met over the *minSENS RoAoA* absolute requirement values are offset by the following term:

$$\Delta_{\text{minSENS}} = P_{\text{REFSENS}} - \text{EIS}_{\text{minSENS}} \text{ (dB)}$$

For FR2 requirements which are to be met over the *OTA REFSENS RoAoA* absolute requirement values are offset by the following term:

$$\Delta_{\text{FR2_REFSENS}} = -3 \text{ dB for the reference direction}$$

and

$$\Delta_{\text{FR2_REFSENS}} = 0 \text{ dB for all other directions}$$

10.2 OTA sensitivity

10.2.1 BS type 1-H and BS type 1-O

10.2.1.1 General

The OTA sensitivity requirement is a *directional requirement* based upon the declaration of one or more *OTA sensitivity direction declarations* (OSDD), related to a *BS type 1-H* and *BS type 1-O* receiver.

The *BS type 1-H* and *BS type 1-O* may optionally be capable of redirecting/changing the *receiver target* by means of adjusting BS settings resulting in multiple *sensitivity RoAoA*. The *sensitivity RoAoA* resulting from the current BS settings is the active *sensitivity RoAoA*.

If the BS is capable of redirecting the *receiver target* related to the OSDD then the OSDD shall include:

- *BS channel bandwidth* and declared minimum EIS level applicable to any active *sensitivity RoAoA* inside the *receiver target redirection range* in the OSDD.
- A declared *receiver target redirection range*, describing all the angles of arrival that can be addressed for the OSDD through alternative settings in the BS.
- Five declared *sensitivity RoAoA* comprising the conformance testing directions as detailed in TS 38.141-2 [6].
- The *receiver target reference direction*.

NOTE 1: Some of the declared *sensitivity RoAoA* may coincide depending on the redirection capability.

NOTE 2: In addition to the declared *sensitivity RoAoA*, several *sensitivity RoAoA* may be implicitly defined by the *receiver target redirection range* without being explicitly declared in the OSDD.

NOTE 3: (Void)

If the BS is not capable of redirecting the *receiver target* related to the OSDD, then the OSDD includes only:

- The set(s) of RAT, *BS channel bandwidth* and declared minimum EIS level applicable to the *sensitivity RoAoA* in the OSDD.
- One declared active *sensitivity RoAoA*.
- The *receiver target reference direction*.

NOTE 4: For BS without target redirection capability, the declared (fixed) *sensitivity RoAoA* is always the active *sensitivity RoAoA*.

The OTA sensitivity EIS level declaration shall apply to each supported polarization, under the assumption of *polarization match*.

10.2.1.2 Minimum requirement

For a received signal whose AoA of the incident wave is within the active *sensitivity RoAoA* of an OSDD, the error rate criterion as described in clause 7.2 shall be met when the level of the arriving signal is equal to the minimum EIS level in the respective declared set of EIS level and *BS channel bandwidth*.

10.2.2 BS type 2-O

There is no OTA sensitivity requirement for FR2, the OTA sensitivity is the same as the OTA reference sensitivity in clause 10.3.

10.3 OTA reference sensitivity level

10.3.1 General

The OTA REFSENS requirement is a *directional requirement* and is intended to ensure the minimum OTA reference sensitivity level for a declared *OTA REFSENS RoAoA*. The OTA reference sensitivity power level $EIS_{REFSENS}$ is the minimum mean power received at the RIB at which a reference performance requirement shall be met for a specified reference measurement channel.

The OTA REFSENS requirement shall apply to each supported polarization, under the assumption of *polarization match*.

10.3.2 Minimum requirement for BS type 1-O

The throughput shall be $\geq 95\%$ of the maximum throughput of the reference measurement channel as specified in the corresponding table and annex A.1 when the OTA test signal is at the corresponding $EIS_{REFSENS}$ level and arrives from any direction within the *OTA REFSENS RoAoA*.

Table 10.3.2-1: Wide Area BS reference sensitivity levels

BS channel bandwidth (MHz)	Sub-carrier spacing (kHz)	Reference measurement channel	OTA reference sensitivity level, $EIS_{REFSENS}$ (dBm)
5, 10, 15	15	G-FR1-A1-1	$-101.7 - \Delta_{OTAREFSNS}$
10, 15	30	G-FR1-A1-2	$-101.8 - \Delta_{OTAREFSNS}$
10, 15	60	G-FR1-A1-3	$-98.9 - \Delta_{OTAREFSNS}$
20, 25, 30, 35, 40, 45, 50	15	G-FR1-A1-4	$-95.3 - \Delta_{OTAREFSNS}$
20, 25, 30, 35, 40, 45, 50, 60, 70, 80, 90, 100	30	G-FR1-A1-5	$-95.6 - \Delta_{OTAREFSNS}$
20, 25, 30, 35, 40, 45, 50, 60, 70, 80, 90, 100	60	G-FR1-A1-6	$-95.7 - \Delta_{OTAREFSNS}$
NOTE: $EIS_{REFSENS}$ is the power level of a single instance of the reference measurement channel. This requirement shall be met for each consecutive application of a single instance of the reference measurement channel mapped to disjoint frequency ranges with a width corresponding to the number of resource blocks of the reference measurement channel each, except for one instance that might overlap one other instance to cover the full <i>BS channel bandwidth</i> .			

Table 10.3.2-1a: Wide Area BS reference sensitivity levels for n104

BS channel bandwidth (MHz)	Sub-carrier spacing (kHz)	Reference measurement channel	Reference sensitivity power level, $P_{REFSENS}$ (dBm) (Note 6)
20, 30, 40, 50	15	G-FR1-A1-4 (Note 1)	$-94.3 - \Delta_{OTAREFSNS}$
20, 30, 40, 50, 60, 70, 80, 90, 100	30	G-FR1-A1-5 (Note 1)	$-94.6 - \Delta_{OTAREFSNS}$
20, 30, 40, 50, 60, 70, 80, 90, 100	60	G-FR1-A1-6 (Note 1)	$-94.7 - \Delta_{OTAREFSNS}$
Note 1: $P_{REFSENS}$ is the power level of a single instance of the reference measurement channel. This requirement shall be met for each consecutive application of a single instance of the reference measurement channel mapped to disjoint frequency ranges with a width corresponding to the number of resource blocks of the reference measurement channel each, except for one instance that might overlap one other instance to cover the full <i>BS channel bandwidth</i> .			

Table 10.3.2-2: Medium Range BS reference sensitivity levels

BS channel bandwidth (MHz)	Sub-carrier spacing (kHz)	Reference measurement channel	OTA reference sensitivity level, $E_{IS_{REFSENS}}$ (dBm)
5, 10, 15	15	G-FR1-A1-1	-96.7 - $\Delta_{OTAREFSENS}$
10, 15	30	G-FR1-A1-2	-96.8 - $\Delta_{OTAREFSENS}$
10, 15	60	G-FR1-A1-3	-93.9 - $\Delta_{OTAREFSENS}$
20, 25, 30, 35, 40, 45, 50	15	G-FR1-A1-4	-90.3 - $\Delta_{OTAREFSENS}$
20, 25, 30, 35, 40, 45, 50, 60, 70, 80, 90, 100	30	G-FR1-A1-5	-90.6 - $\Delta_{OTAREFSENS}$
20, 25, 30, 35, 40, 45, 50, 60, 70, 80, 90, 100	60	G-FR1-A1-6	-90.7 - $\Delta_{OTAREFSENS}$
NOTE: $E_{IS_{REFSENS}}$ is the power level of a single instance of the reference measurement channel. This requirement shall be met for each consecutive application of a single instance of the reference measurement channel mapped to disjoint frequency ranges with a width corresponding to the number of resource blocks of the reference measurement channel each, except for one instance that might overlap one other instance to cover the full <i>BS channel bandwidth</i> .			

Table 10.3.2-2a: Medium Range BS reference sensitivity levels for n104

BS channel bandwidth (MHz)	Sub-carrier spacing (kHz)	Reference measurement channel (Note 5)	Reference sensitivity power level, $P_{REFSENS}$ (dBm)
20, 30, 40, 50	15	G-FR1-A1-4 (Note 1)	-89.3 - $\Delta_{OTAREFSENS}$
20, 30, 40, 50, 60, 70, 80, 90, 100	30	G-FR1-A1-5 (Note 1)	-89.6 - $\Delta_{OTAREFSENS}$
20, 30, 40, 50, 60, 70, 80, 90, 100	60	G-FR1-A1-6 (Note 1)	-89.7 - $\Delta_{OTAREFSENS}$
Note 1: $P_{REFSENS}$ is the power level of a single instance of the reference measurement channel. This requirement shall be met for each consecutive application of a single instance of the reference measurement channel mapped to disjoint frequency ranges with a width corresponding to the number of resource blocks of the reference measurement channel each, except for one instance that might overlap one other instance to cover the full <i>BS channel bandwidth</i> .			

Table 10.3.2-3: Local Area BS reference sensitivity levels

BS channel bandwidth (MHz)	Sub-carrier spacing (kHz)	Reference measurement channel	OTA reference sensitivity level, $E_{IS_{REFSENS}}$ (dBm)
5, 10, 15	15	G-FR1-A1-1	-93.7 - $\Delta_{OTAREFSENS}$
10, 15	30	G-FR1-A1-2	-93.8 - $\Delta_{OTAREFSENS}$
10, 15	60	G-FR1-A1-3	-90.9 - $\Delta_{OTAREFSENS}$
20, 25, 30, 35, 40, 45, 50	15	G-FR1-A1-4	-87.3 - $\Delta_{OTAREFSENS}$
20, 25, 30, 35, 40, 45, 50, 60, 70, 80, 90, 100	30	G-FR1-A1-5	-87.6 - $\Delta_{OTAREFSENS}$
20, 25, 30, 35, 40, 45, 50, 60, 70, 80, 90, 100	60	G-FR1-A1-6	-87.7 - $\Delta_{OTAREFSENS}$
NOTE: $E_{IS_{REFSENS}}$ is the power level of a single instance of the reference measurement channel. This requirement shall be met for each consecutive application of a single instance of the reference measurement channel mapped to disjoint frequency ranges with a width corresponding to the number of resource blocks of the reference measurement channel each, except for one instance that might overlap one other instance to cover the full <i>BS channel bandwidth</i> .			

Table 10.3.2-3a: Local Area BS reference sensitivity levels for n104

BS channel bandwidth (MHz)	Sub-carrier spacing (kHz)	Reference measurement channel (Note 5)	Reference sensitivity power level, P_{REFSENS} (dBm)
20, 30, 40, 50	15	G-FR1-A1-4 (Note 1)	$-86.3 - \Delta_{\text{OTAREFSSENS}}$
20, 30, 40, 50, 60, 70, 80, 90, 100	30	G-FR1-A1-5 (Note 1)	$-86.6 - \Delta_{\text{OTAREFSSENS}}$
20, 30, 40, 50, 60, 70, 80, 90, 100	60	G-FR1-A1-6 (Note 1)	$-86.7 - \Delta_{\text{OTAREFSSENS}}$
Note 1: P_{REFSENS} is the power level of a single instance of the reference measurement channel. This requirement shall be met for each consecutive application of a single instance of the reference measurement channel mapped to disjoint frequency ranges with a width corresponding to the number of resource blocks of the reference measurement channel each, except for one instance that might overlap one other instance to cover the full <i>BS channel bandwidth</i> .			

10.3.3 Minimum requirement for BS type 2-O

The throughput shall be $\geq 95\%$ of the maximum throughput of the reference measurement channel as specified in the corresponding table and annex A.1 when the OTA test signal is at the corresponding EIS_{REFSENS} level and arrives from any direction within the *OTA REFSSENS RoAoA*.

EIS_{REFSENS} levels are derived from a single declared basis level $EIS_{\text{REFSENS}_50\text{M}}$, which is based on a reference measurement channel with 50 MHz *BS channel bandwidth*. $EIS_{\text{REFSENS}_50\text{M}}$ itself is not a requirement and although it is based on a reference measurement channel with 50 MHz *BS channel bandwidth* it does not imply that BS has to support 50 MHz *BS channel bandwidth*.

For Wide Area BS, $EIS_{\text{REFSENS}_50\text{M}}$ is an integer value in the range -96 to -119 dBm. The specific value is declared by the vendor.

For Medium Range BS, $EIS_{\text{REFSENS}_50\text{M}}$ is an integer value in the range -91 to -114 dBm. The specific value is declared by the vendor.

For Local Area BS, $EIS_{\text{REFSENS}_50\text{M}}$ is an integer value in the range -86 to -109 dBm. The specific value is declared by the vendor.

Table 10.3.3-1: FR2 OTA reference sensitivity requirement

Frequency Range	BS channel Bandwidth (MHz)	Sub-carrier spacing (kHz)	Reference measurement channel	OTA reference sensitivity level, EIS_{REFSENS} (dBm)
FR2-1	50, 100, 200	60	G-FR2-A1-1	$EIS_{\text{REFSENS}_50\text{M}} + \Delta_{\text{FR2_REFSENS}}$
	50	120	G-FR2-A1-2	$EIS_{\text{REFSENS}_50\text{M}} + \Delta_{\text{FR2_REFSENS}}$
	100, 200, 400	120	G-FR2-A1-3	$EIS_{\text{REFSENS}_50\text{M}} + 3 + \Delta_{\text{FR2_REFSENS}}$
FR2-2	100,400	120	G-FR2-A1-3	$EIS_{\text{REFSENS}_50\text{M}} + 3 + \Delta_{\text{FR2_REFSENS}}$
	400, 800, 1600	480	G-FR2-A1-6	$EIS_{\text{REFSENS}_50\text{M}} + 9 + \Delta_{\text{FR2_REFSENS}}$
	400, 800, 1600, 2000	960	G-FR2-A1-7	$EIS_{\text{REFSENS}_50\text{M}} + 9 + \Delta_{\text{FR2_REFSENS}}$
NOTE 1: EIS_{REFSENS} is the power level of a single instance of the reference measurement channel. This requirement shall be met for each consecutive application of a single instance of the reference measurement channel mapped to disjoint frequency ranges with a width corresponding to the number of resource blocks of the reference measurement channel each, except for one instance that might overlap one other instance to cover the full <i>BS channel bandwidth</i> .				
NOTE 2: The declared $EIS_{\text{REFSENS}_50\text{M}}$ shall be within the range specified above.				

10.4 OTA dynamic range

10.4.1 General

The OTA dynamic range is a measure of the capability of the receiver unit to receive a wanted signal in the presence of an interfering signal inside the received *BS channel bandwidth*.

The requirement shall apply at the RIB when the AoA of the incident wave of a received signal and the interfering signal are from the same direction and are within the *OTA REFSENS RoAoA*.

The wanted and interfering signals apply to each supported polarization, under the assumption of *polarization match*.

10.4.2 Minimum requirement for *BS type 1-0*

For NR, the throughput shall be $\geq 95\%$ of the maximum throughput of the reference measurement channel.

Table 10.4.2-1: Wide Area BS OTA dynamic range for NR carrier

BS channel bandwidth (MHz)	Subcarrier spacing (kHz)	Reference measurement channel	Wanted signal mean power (dBm)	Interfering signal mean power (dBm) / BW_{Config}	Type of interfering signal
5	15	G-FR1-A2-1	-70.7- $\Delta_{OTAREFSENS}$	-82.5- $\Delta_{OTAREFSENS}$	AWGN
	30	G-FR1-A2-2	-71.4- $\Delta_{OTAREFSENS}$		
10	15	G-FR1-A2-1	-70.7- $\Delta_{OTAREFSENS}$	-79.3- $\Delta_{OTAREFSENS}$	AWGN
	30	G-FR1-A2-2	-71.4- $\Delta_{OTAREFSENS}$		
	60	G-FR1-A2-3	-68.4- $\Delta_{OTAREFSENS}$		
15	15	G-FR1-A2-1	-70.7- $\Delta_{OTAREFSENS}$	-77.5- $\Delta_{OTAREFSENS}$	AWGN
	30	G-FR1-A2-2	-71.4- $\Delta_{OTAREFSENS}$		
	60	G-FR1-A2-3	-68.4- $\Delta_{OTAREFSENS}$		
20	15	G-FR1-A2-4	-64.5- $\Delta_{OTAREFSENS}$	-76.2- $\Delta_{OTAREFSENS}$	AWGN
	30	G-FR1-A2-5	-64.5- $\Delta_{OTAREFSENS}$		
	60	G-FR1-A2-6	-64.8- $\Delta_{OTAREFSENS}$		
25	15	G-FR1-A2-4	-64.5- $\Delta_{OTAREFSENS}$	-75.2- $\Delta_{OTAREFSENS}$	AWGN
	30	G-FR1-A2-5	-64.5- $\Delta_{OTAREFSENS}$		
	60	G-FR1-A2-6	-64.8- $\Delta_{OTAREFSENS}$		
30	15	G-FR1-A2-4	-64.5- $\Delta_{OTAREFSENS}$	-74.4- $\Delta_{OTAREFSENS}$	AWGN
	30	G-FR1-A2-5	-64.5- $\Delta_{OTAREFSENS}$		
	60	G-FR1-A2-6	-64.8- $\Delta_{OTAREFSENS}$		
35	15	G-FR1-A2-4	-64.5- $\Delta_{OTAREFSENS}$	-73.7- $\Delta_{OTAREFSENS}$	AWGN
	30	G-FR1-A2-5	-64.5- $\Delta_{OTAREFSENS}$		
	60	G-FR1-A2-6	-64.8- $\Delta_{OTAREFSENS}$		
40	15	G-FR1-A2-4	-64.5- $\Delta_{OTAREFSENS}$	-73.1- $\Delta_{OTAREFSENS}$	AWGN
	30	G-FR1-A2-5	-64.5- $\Delta_{OTAREFSENS}$		
	60	G-FR1-A2-6	-64.8- $\Delta_{OTAREFSENS}$		
45	15	G-FR1-A2-4	-64.5- $\Delta_{OTAREFSENS}$	-72.6- $\Delta_{OTAREFSENS}$	AWGN
	30	G-FR1-A2-5	-64.5- $\Delta_{OTAREFSENS}$		
	60	G-FR1-A2-6	-64.8- $\Delta_{OTAREFSENS}$		
50	15	G-FR1-A2-4	-64.5- $\Delta_{OTAREFSENS}$	-72.1- $\Delta_{OTAREFSENS}$	AWGN
	30	G-FR1-A2-5	-64.5- $\Delta_{OTAREFSENS}$		
	60	G-FR1-A2-6	-64.8- $\Delta_{OTAREFSENS}$		
60	30	G-FR1-A2-5	-64.5- $\Delta_{OTAREFSENS}$	-71.3- $\Delta_{OTAREFSENS}$	AWGN
	60	G-FR1-A2-6	-64.8- $\Delta_{OTAREFSENS}$		
70	30	G-FR1-A2-5	-64.5- $\Delta_{OTAREFSENS}$	-70.7- $\Delta_{OTAREFSENS}$	AWGN

	60	G-FR1-A2-6	-64.8- $\Delta_{OTAREFSENS}$		
80	30	G-FR1-A2-5	-64.5- $\Delta_{OTAREFSENS}$	-70.1- $\Delta_{OTAREFSENS}$	AWGN
	60	G-FR1-A2-6	-64.8- $\Delta_{OTAREFSENS}$		
90	30	G-FR1-A2-5	-64.5- $\Delta_{OTAREFSENS}$	-69.5- $\Delta_{OTAREFSENS}$	AWGN
	60	G-FR1-A2-6	-64.8- $\Delta_{OTAREFSENS}$		
100	30	G-FR1-A2-5	-64.5- $\Delta_{OTAREFSENS}$	-69.1- $\Delta_{OTAREFSENS}$	AWGN
	60	G-FR1-A2-6	-64.8- $\Delta_{OTAREFSENS}$		

NOTE: The wanted signal mean power is the power level of a single instance of the corresponding reference measurement channel. This requirement shall be met for each consecutive application of a single instance of the reference measurement channel mapped to disjoint frequency ranges with a width corresponding to the number of resource blocks of the reference measurement channel each, except for one instance that might overlap one other instance to cover the full *BS channel bandwidth*.

Table 10.4.2-1a: Wide Area BS OTA dynamic range for NR carrier of band n104

BS channel bandwidth (MHz)	Subcarrier spacing (kHz)	Reference measurement channel	Wanted signal mean power (dBm)	Interfering signal mean power (dBm) / BW_{Config}	Type of interfering signal
20	15	G-FR1-A2-4	-63.5- $\Delta_{OTAREFSENS}$	-75.2- $\Delta_{OTAREFSENS}$	AWGN
	30	G-FR1-A2-5	-63.5- $\Delta_{OTAREFSENS}$		
	60	G-FR1-A2-6	-63.8- $\Delta_{OTAREFSENS}$		
30	15	G-FR1-A2-4	-63.5- $\Delta_{OTAREFSENS}$	-73.4- $\Delta_{OTAREFSENS}$	AWGN
	30	G-FR1-A2-5	-63.5- $\Delta_{OTAREFSENS}$		
	60	G-FR1-A2-6	-63.8- $\Delta_{OTAREFSENS}$		
40	15	G-FR1-A2-4	-63.5- $\Delta_{OTAREFSENS}$	-72.1- $\Delta_{OTAREFSENS}$	AWGN
	30	G-FR1-A2-5	-63.5- $\Delta_{OTAREFSENS}$		
	60	G-FR1-A2-6	-63.8- $\Delta_{OTAREFSENS}$		
50	15	G-FR1-A2-4	-63.5- $\Delta_{OTAREFSENS}$	-71.1- $\Delta_{OTAREFSENS}$	AWGN
	30	G-FR1-A2-5	-63.5- $\Delta_{OTAREFSENS}$		
	60	G-FR1-A2-6	-63.8- $\Delta_{OTAREFSENS}$		
60	30	G-FR1-A2-5	-63.5- $\Delta_{OTAREFSENS}$	-70.3- $\Delta_{OTAREFSENS}$	AWGN
	60	G-FR1-A2-6	-63.8- $\Delta_{OTAREFSENS}$		
70	30	G-FR1-A2-5	-63.5- $\Delta_{OTAREFSENS}$	-69.7- $\Delta_{OTAREFSENS}$	AWGN
	60	G-FR1-A2-6	-63.8- $\Delta_{OTAREFSENS}$		
80	30	G-FR1-A2-5	-63.5- $\Delta_{OTAREFSENS}$	-69.1- $\Delta_{OTAREFSENS}$	AWGN
	60	G-FR1-A2-6	-63.8- $\Delta_{OTAREFSENS}$		
90	30	G-FR1-A2-5	-63.5- $\Delta_{OTAREFSENS}$	-68.5- $\Delta_{OTAREFSENS}$	AWGN
	60	G-FR1-A2-6	-63.8- $\Delta_{OTAREFSENS}$		
100	30	G-FR1-A2-5	-63.5- $\Delta_{OTAREFSENS}$	-68.1- $\Delta_{OTAREFSENS}$	AWGN
	60	G-FR1-A2-6	-63.8- $\Delta_{OTAREFSENS}$		
NOTE 1: The wanted signal mean power is the power level of a single instance of the corresponding reference measurement channel. This requirement shall be met for each consecutive application of a single instance of the reference measurement channel mapped to disjoint frequency ranges with a width corresponding to the number of resource blocks of the reference measurement channel each, except for one instance that might overlap one other instance to cover the full <i>BS channel bandwidth</i> .					

Table 10.4.2-2: Medium Range BS OTA dynamic range for NR carrier

BS channel bandwidth (MHz)	Subcarrier spacing (kHz)	Reference measurement channel	Wanted signal mean power (dBm)	Interfering signal mean power (dBm) / BW _{Config}	Type of interfering signal
5	15	G-FR1-A2-1	-65.7- Δ _{OTAREFSSENS}	-77.5- Δ _{OTAREFSSENS}	AWGN
	30	G-FR1-A2-2	-66.4- Δ _{OTAREFSSENS}		
10	15	G-FR1-A2-1	-65.7- Δ _{OTAREFSSENS}	-74.3- Δ _{OTAREFSSENS}	AWGN
	30	G-FR1-A2-2	-66.4- Δ _{OTAREFSSENS}		
	60	G-FR1-A2-3	-63.4- Δ _{OTAREFSSENS}		
15	15	G-FR1-A2-1	-65.7- Δ _{OTAREFSSENS}	-72.5- Δ _{OTAREFSSENS}	AWGN
	30	G-FR1-A2-2	-66.4- Δ _{OTAREFSSENS}		
	60	G-FR1-A2-3	-63.4- Δ _{OTAREFSSENS}		
20	15	G-FR1-A2-4	-59.5- Δ _{OTAREFSSENS}	-71.2- Δ _{OTAREFSSENS}	AWGN
	30	G-FR1-A2-5	-59.5- Δ _{OTAREFSSENS}		
	60	G-FR1-A2-6	-59.8- Δ _{OTAREFSSENS}		
25	15	G-FR1-A2-4	-59.5- Δ _{OTAREFSSENS}	-70.2- Δ _{OTAREFSSENS}	AWGN
	30	G-FR1-A2-5	-59.5- Δ _{OTAREFSSENS}		
	60	G-FR1-A2-6	-59.8- Δ _{OTAREFSSENS}		
30	15	G-FR1-A2-4	-59.5- Δ _{OTAREFSSENS}	-69.4- Δ _{OTAREFSSENS}	AWGN
	30	G-FR1-A2-5	-59.5- Δ _{OTAREFSSENS}		
	60	G-FR1-A2-6	-59.8- Δ _{OTAREFSSENS}		
35	15	G-FR1-A2-4	-59.5- Δ _{OTAREFSSENS}	-68.7- Δ _{OTAREFSSENS}	AWGN
	30	G-FR1-A2-5	-59.5- Δ _{OTAREFSSENS}		
	60	G-FR1-A2-6	-59.8- Δ _{OTAREFSSENS}		
40	15	G-FR1-A2-4	-59.5- Δ _{OTAREFSSENS}	-68.1- Δ _{OTAREFSSENS}	AWGN
	30	G-FR1-A2-5	-59.5- Δ _{OTAREFSSENS}		
	60	G-FR1-A2-6	-59.8- Δ _{OTAREFSSENS}		
45	15	G-FR1-A2-4	-59.5- Δ _{OTAREFSSENS}	-67.6- Δ _{OTAREFSSENS}	AWGN
	30	G-FR1-A2-5	-59.5- Δ _{OTAREFSSENS}		
	60	G-FR1-A2-6	-59.8- Δ _{OTAREFSSENS}		
50	15	G-FR1-A2-4	-59.5- Δ _{OTAREFSSENS}	-67.1- Δ _{OTAREFSSENS}	AWGN
	30	G-FR1-A2-5	-59.5- Δ _{OTAREFSSENS}		
	60	G-FR1-A2-6	-59.8- Δ _{OTAREFSSENS}		
60	30	G-FR1-A2-5	-59.5- Δ _{OTAREFSSENS}	-66.3- Δ _{OTAREFSSENS}	AWGN
	60	G-FR1-A2-6	-59.8- Δ _{OTAREFSSENS}		
70	30	G-FR1-A2-5	-59.5- Δ _{OTAREFSSENS}	-65.7- Δ _{OTAREFSSENS}	AWGN

	60	G-FR1-A2-6	-59.8- $\Delta_{OTAREFSENS}$		
80	30	G-FR1-A2-5	-59.5- $\Delta_{OTAREFSENS}$	-65.1- $\Delta_{OTAREFSENS}$	AWGN
	60	G-FR1-A2-6	-59.8- $\Delta_{OTAREFSENS}$		
90	30	G-FR1-A2-5	-59.5- $\Delta_{OTAREFSENS}$	-64.5- $\Delta_{OTAREFSENS}$	AWGN
	60	G-FR1-A2-6	-59.8- $\Delta_{OTAREFSENS}$		
100	30	G-FR1-A2-5	-59.5- $\Delta_{OTAREFSENS}$	-64.1- $\Delta_{OTAREFSENS}$	AWGN
	60	G-FR1-A2-6	-59.8- $\Delta_{OTAREFSENS}$		

NOTE: The wanted signal mean power is the power level of a single instance of the corresponding reference measurement channel. This requirement shall be met for each consecutive application of a single instance of the reference measurement channel mapped to disjoint frequency ranges with a width corresponding to the number of resource blocks of the reference measurement channel each, except for one instance that might overlap one other instance to cover the full *BS channel bandwidth*.

Table 10.4.2-2a: Medium Range BS OTA dynamic range for NR carrier of band n104

BS channel bandwidth (MHz)	Subcarrier spacing (kHz)	Reference measurement channel (Note 2)	Wanted signal mean power (dBm)	Interfering signal mean power (dBm) / BW_{Config}	Type of interfering signal
20	15	G-FR1-A2-4	-58.5- $\Delta_{OTAREFSENS}$	-70.2- $\Delta_{OTAREFSENS}$	AWGN
	30	G-FR1-A2-5	-58.5- $\Delta_{OTAREFSENS}$		
	60	G-FR1-A2-6	-58.8- $\Delta_{OTAREFSENS}$		
30	15	G-FR1-A2-4	-58.5- $\Delta_{OTAREFSENS}$	-68.4- $\Delta_{OTAREFSENS}$	AWGN
	30	G-FR1-A2-5	-58.5- $\Delta_{OTAREFSENS}$		
	60	G-FR1-A2-6	-58.8- $\Delta_{OTAREFSENS}$		
40	15	G-FR1-A2-4	-58.5- $\Delta_{OTAREFSENS}$	-67.1- $\Delta_{OTAREFSENS}$	AWGN
	30	G-FR1-A2-5	-58.5- $\Delta_{OTAREFSENS}$		
	60	G-FR1-A2-6	-58.8- $\Delta_{OTAREFSENS}$		
50	15	G-FR1-A2-4	-58.5- $\Delta_{OTAREFSENS}$	-66.1- $\Delta_{OTAREFSENS}$	AWGN
	30	G-FR1-A2-5	-58.5- $\Delta_{OTAREFSENS}$		
	60	G-FR1-A2-6	-58.8- $\Delta_{OTAREFSENS}$		
60	30	G-FR1-A2-5	-58.5- $\Delta_{OTAREFSENS}$	-65.3- $\Delta_{OTAREFSENS}$	AWGN
	60	G-FR1-A2-6	-58.8- $\Delta_{OTAREFSENS}$		
70	30	G-FR1-A2-5	-58.5- $\Delta_{OTAREFSENS}$	-64.7- $\Delta_{OTAREFSENS}$	AWGN
	60	G-FR1-A2-6	-58.8- $\Delta_{OTAREFSENS}$		
80	30	G-FR1-A2-5	-58.5- $\Delta_{OTAREFSENS}$	-64.1- $\Delta_{OTAREFSENS}$	AWGN
	60	G-FR1-A2-6	-58.8- $\Delta_{OTAREFSENS}$		
90	30	G-FR1-A2-5	-58.5- $\Delta_{OTAREFSENS}$	-63.5- $\Delta_{OTAREFSENS}$	AWGN
	60	G-FR1-A2-6	-58.8- $\Delta_{OTAREFSENS}$		
100	30	G-FR1-A2-5	-58.5- $\Delta_{OTAREFSENS}$	-63.1- $\Delta_{OTAREFSENS}$	AWGN
	60	G-FR1-A2-6	-58.8- $\Delta_{OTAREFSENS}$		

NOTE 1: The wanted signal mean power is the power level of a single instance of the corresponding reference measurement channel. This requirement shall be met for each consecutive application of a single instance of the reference measurement channel mapped to disjoint frequency ranges with a width corresponding to the number of resource blocks of the reference measurement channel each, except for one instance that might overlap one other instance to cover the full BS channel bandwidth.

Table 10.4.2-3: Local Area BS OTA dynamic range for NR carrier

BS channel bandwidth (MHz)	Subcarrier spacing (kHz)	Reference measurement channel	Wanted signal mean power (dBm)	Interfering signal mean power (dBm) / BW_{Config}	Type of interfering signal
5	15	G-FR1-A2-1	-62.7- $\Delta_{OTAREFSENS}$	-74.5- $\Delta_{OTAREFSENS}$	AWGN
	30	G-FR1-A2-2	-64.4- $\Delta_{OTAREFSENS}$		
10	15	G-FR1-A2-1	-62.7- $\Delta_{OTAREFSENS}$	-71.3- $\Delta_{OTAREFSENS}$	AWGN
	30	G-FR1-A2-2	-64.4- $\Delta_{OTAREFSENS}$		
	60	G-FR1-A2-3	-60.4- $\Delta_{OTAREFSENS}$		
15	15	G-FR1-A2-1	-62.7- $\Delta_{OTAREFSENS}$	-69.5- $\Delta_{OTAREFSENS}$	AWGN
	30	G-FR1-A2-2	-64.4- $\Delta_{OTAREFSENS}$		
	60	G-FR1-A2-3	-60.4- $\Delta_{OTAREFSENS}$		
20	15	G-FR1-A2-4	-56.5- $\Delta_{OTAREFSENS}$	-68.2- $\Delta_{OTAREFSENS}$	AWGN
	30	G-FR1-A2-5	-56.5- $\Delta_{OTAREFSENS}$		
	60	G-FR1-A2-6	-56.8- $\Delta_{OTAREFSENS}$		
25	15	G-FR1-A2-4	-56.5- $\Delta_{OTAREFSENS}$	-67.2- $\Delta_{OTAREFSENS}$	AWGN
	30	G-FR1-A2-5	-56.5- $\Delta_{OTAREFSENS}$		
	60	G-FR1-A2-6	-56.8- $\Delta_{OTAREFSENS}$		
30	15	G-FR1-A2-4	-56.5- $\Delta_{OTAREFSENS}$	-66.4- $\Delta_{OTAREFSENS}$	AWGN
	30	G-FR1-A2-5	-56.5- $\Delta_{OTAREFSENS}$		
	60	G-FR1-A2-6	-56.8- $\Delta_{OTAREFSENS}$		
35	15	G-FR1-A2-4	-56.5- $\Delta_{OTAREFSENS}$	-65.7- $\Delta_{OTAREFSENS}$	AWGN
	30	G-FR1-A2-5	-56.5- $\Delta_{OTAREFSENS}$		
	60	G-FR1-A2-6	-56.8- $\Delta_{OTAREFSENS}$		
40	15	G-FR1-A2-4	-56.5- $\Delta_{OTAREFSENS}$	-65.1- $\Delta_{OTAREFSENS}$	AWGN
	30	G-FR1-A2-5	-56.5- $\Delta_{OTAREFSENS}$		
	60	G-FR1-A2-6	-56.8- $\Delta_{OTAREFSENS}$		
45	15	G-FR1-A2-4	-56.5- $\Delta_{OTAREFSENS}$	-64.6- $\Delta_{OTAREFSENS}$	AWGN
	30	G-FR1-A2-5	-56.5- $\Delta_{OTAREFSENS}$		
	60	G-FR1-A2-6	-56.8- $\Delta_{OTAREFSENS}$		
50	15	G-FR1-A2-4	-56.5- $\Delta_{OTAREFSENS}$	-64.1- $\Delta_{OTAREFSENS}$	AWGN
	30	G-FR1-A2-5	-56.5- $\Delta_{OTAREFSENS}$		
	60	G-FR1-A2-6	-56.8- $\Delta_{OTAREFSENS}$		
60	30	G-FR1-A2-5	-56.5- $\Delta_{OTAREFSENS}$	-63.3- $\Delta_{OTAREFSENS}$	AWGN
	60	G-FR1-A2-6	-56.8- $\Delta_{OTAREFSENS}$		
70	30	G-FR1-A2-5	-56.5- $\Delta_{OTAREFSENS}$	-62.7- $\Delta_{OTAREFSENS}$	AWGN

	60	G-FR1-A2-6	-56.8- $\Delta_{\text{OTAREFSENS}}$		
80	30	G-FR1-A2-5	-56.5- $\Delta_{\text{OTAREFSENS}}$	-62.1- $\Delta_{\text{OTAREFSENS}}$	AWGN
	60	G-FR1-A2-6	-56.8- $\Delta_{\text{OTAREFSENS}}$		
90	30	G-FR1-A2-5	-56.5- $\Delta_{\text{OTAREFSENS}}$	-61.5- $\Delta_{\text{OTAREFSENS}}$	AWGN
	60	G-FR1-A2-6	-56.8- $\Delta_{\text{OTAREFSENS}}$		
100	30	G-FR1-A2-5	-56.5- $\Delta_{\text{OTAREFSENS}}$	-61.1- $\Delta_{\text{OTAREFSENS}}$	AWGN
	60	G-FR1-A2-6	-56.8- $\Delta_{\text{OTAREFSENS}}$		

NOTE: The wanted signal mean power is the power level of a single instance of the corresponding reference measurement channel. This requirement shall be met for each consecutive application of a single instance of the reference measurement channel mapped to disjoint frequency ranges with a width corresponding to the number of resource blocks of the reference measurement channel each, except for one instance that might overlap one other instance to cover the full *BS channel bandwidth*.

Table 10.4.2-3a: Local Area BS OTA dynamic range for NR carrier of band n104

BS channel bandwidth (MHz)	Subcarrier spacing (kHz)	Reference measurement channel	Wanted signal mean power (dBm)	Interfering signal mean power (dBm) / BW_{Config}	Type of interfering signal
20	15	G-FR1-A2-4	-55.5- $\Delta_{OTAREFSENS}$	-67.2- $\Delta_{OTAREFSENS}$	AWGN
	30	G-FR1-A2-5	-55.5- $\Delta_{OTAREFSENS}$		
	60	G-FR1-A2-6	-55.8- $\Delta_{OTAREFSENS}$		
30	15	G-FR1-A2-4	-55.5- $\Delta_{OTAREFSENS}$	-65.4- $\Delta_{OTAREFSENS}$	AWGN
	30	G-FR1-A2-5	-55.5- $\Delta_{OTAREFSENS}$		
	60	G-FR1-A2-6	-55.8- $\Delta_{OTAREFSENS}$		
40	15	G-FR1-A2-4	-55.5- $\Delta_{OTAREFSENS}$	-64.1- $\Delta_{OTAREFSENS}$	AWGN
	30	G-FR1-A2-5	-55.5- $\Delta_{OTAREFSENS}$		
	60	G-FR1-A2-6	-55.8- $\Delta_{OTAREFSENS}$		
50	15	G-FR1-A2-4	-55.5- $\Delta_{OTAREFSENS}$	-63.1- $\Delta_{OTAREFSENS}$	AWGN
	30	G-FR1-A2-5	-55.5- $\Delta_{OTAREFSENS}$		
	60	G-FR1-A2-6	-55.8- $\Delta_{OTAREFSENS}$		
60	30	G-FR1-A2-5	-55.5- $\Delta_{OTAREFSENS}$	-62.3- $\Delta_{OTAREFSENS}$	AWGN
	60	G-FR1-A2-6	-55.8- $\Delta_{OTAREFSENS}$		
70	30	G-FR1-A2-5	-55.5- $\Delta_{OTAREFSENS}$	-61.7- $\Delta_{OTAREFSENS}$	AWGN
	60	G-FR1-A2-6	-55.8- $\Delta_{OTAREFSENS}$		
80	30	G-FR1-A2-5	-55.5- $\Delta_{OTAREFSENS}$	-61.1- $\Delta_{OTAREFSENS}$	AWGN
	60	G-FR1-A2-6	-55.8- $\Delta_{OTAREFSENS}$		
90	30	G-FR1-A2-5	-55.5- $\Delta_{OTAREFSENS}$	-60.5- $\Delta_{OTAREFSENS}$	AWGN
	60	G-FR1-A2-6	-55.8- $\Delta_{OTAREFSENS}$		
100	30	G-FR1-A2-5	-55.5- $\Delta_{OTAREFSENS}$	-60.1- $\Delta_{OTAREFSENS}$	AWGN
	60	G-FR1-A2-6	-55.8- $\Delta_{OTAREFSENS}$		

NOTE 1: The wanted signal mean power is the power level of a single instance of the corresponding reference measurement channel. This requirement shall be met for each consecutive application of a single instance of the reference measurement channel mapped to disjoint frequency ranges with a width corresponding to the number of resource blocks of the reference measurement channel each, except for one instance that might overlap one other instance to cover the full BS channel bandwidth.

10.5 OTA in-band selectivity and blocking

10.5.1 OTA adjacent channel selectivity

10.5.1.1 General

OTA Adjacent channel selectivity (ACS) is a measure of the receiver's ability to receive an OTA wanted signal at its assigned channel frequency in the presence of an OTA adjacent channel signal with a specified centre frequency offset of the interfering signal to the band edge of a victim system.

10.5.1.2 Minimum requirement for *BS type 1-0*

The requirement shall apply at the RIB when the AoA of the incident wave of a received signal and the interfering signal are from the same direction and are within the *minSENS RoAoA*.

The wanted and interfering signals apply to each supported polarization, under the assumption of *polarization match*.

The throughput shall be $\geq 95\%$ of the maximum throughput of the reference measurement channel.

For FR1 except for band n104, the OTA wanted and the interfering signal are specified in table 10.5.1.2-1 and table 10.5.1.2-2 for OTA ACS. For band n104, the OTA wanted and the interfering signal are specified in table 10.5.1.2-1a and table 10.5.1.2-2 for OTA ACS. The reference measurement channel for the OTA wanted signal is further specified in annex A.1. The characteristics of the interfering signal is further specified in annex D.

The OTA ACS requirement is applicable outside the *Base Station RF Bandwidth* or *Radio Bandwidth*. The OTA interfering signal offset is defined relative to the *Base station RF Bandwidth edges* or *Radio Bandwidth edges*.

For RIBs supporting operation in *non-contiguous spectrum* within any *operating band*, the OTA ACS requirement shall apply in addition inside any *sub-block gap*, in case the *sub-block gap* size is at least as wide as the NR interfering signal in table 10.5.1.2-2. The OTA interfering signal offset is defined relative to the *sub-block* edges inside the *sub-block gap*.

For *multi-band RIBs*, the OTA ACS requirement shall apply in addition inside any *Inter RF Bandwidth gap*, in case the *Inter RF Bandwidth gap* size is at least as wide as the NR interfering signal in table 10.5.1.2-2. The interfering signal offset is defined relative to the *Base Station RF Bandwidth edges* inside the *Inter RF Bandwidth gap*.

Table 10.5.1.2-1: OTA ACS requirement for *BS type 1-0*

<i>BS channel bandwidth of the lowest/highest carrier received (MHz)</i>	<i>Wanted signal mean power (dBm) (Note 2)</i>	<i>Interfering signal mean power (dBm)</i>
5, 10, 15, 20, 25, 30, 35, 40, 45, 50, 60, 70, 80,90, 100 (Note 1)	EIS _{minSENS} + 6 dB	Wide Area BS: -52 – Δ _{minSENS} Medium Range BS: -47– Δ _{minSENS} Local Area BS: -44– Δ _{minSENS}
NOTE 1: The SCS for the <i>lowest/highest carrier</i> received is the lowest SCS supported by the BS for that bandwidth		
NOTE 2: EIS _{minSENS} depends on the <i>BS channel bandwidth</i>		

Table 10.5.1.2-1a: OTA ACS requirement for BS type 1-O for band n104

BS channel bandwidth of the lowest/highest carrier received (MHz)	Wanted signal mean power (dBm) (Note 2)	Interfering signal mean power (dBm)
20, 30, 40, 50, 60, 70, 80,90, 100 (Note 1)	$EIS_{\min SENS} + 6 \text{ dB}$	Wide Area BS: $-55 - \Delta_{\min SENS}$ Medium Range BS: $-50 - \Delta_{\min SENS}$ Local Area BS: $-47 - \Delta_{\min SENS}$
NOTE 1: The SCS for the <i>lowest/highest carrier</i> received is the lowest SCS supported by the BS for that bandwidth		
NOTE 2: $EIS_{\min SENS}$ depends on the <i>BS channel bandwidth</i>		

Table 10.5.1.2-2: OTA ACS interferer frequency offset for BS type 1-O

BS channel bandwidth of the lowest/highest carrier received (MHz)	Interfering signal centre frequency offset from the lower/upper Base Station RF Bandwidth edge or sub-block edge inside a sub-block gap (MHz)	Type of interfering signal
5	± 2.5025	5 MHz DFT-s-OFDM NR signal, 15 kHz SCS, 25 RBs
10	± 2.5075	
15	± 2.5125	
20	± 2.5025	
25	± 9.4675	
30	± 9.4725	20 MHz DFT-s-OFDM NR signal, 15 kHz SCS, 100 RBs
35	± 9.4625	
40	± 9.4675	
45	± 9.4725	
50	± 9.4625	
60	± 9.4725	
70	± 9.4675	
80	± 9.4625	
90	± 9.4725	
100	± 9.4675	

10.5.1.3 Minimum requirement for BS type 2-O

The requirement shall apply at the RIB when the AoA of the incident wave of a received signal and the interfering signal are from the same direction and are within the *OTA REFSENS RoAoA*.

The wanted and interfering signals apply to each supported polarization, under the assumption of *polarization match*.

The throughput shall be $\geq 95\%$ of the maximum throughput of the reference measurement channel.

For FR2, the OTA wanted and the interfering signal are specified in table 10.5.1.3-1 and table 10.5.1.3-2 for OTA ACS. The reference measurement channel for the OTA wanted signal is further specified in annex A.1. The characteristics of the interfering signal is further specified in annex D.

The OTA ACS requirement is applicable outside the *Base Station RF Bandwidth*. The OTA interfering signal offset is defined relative to the Base station *RF Bandwidth edges*.

For RIBs supporting operation in *non-contiguous spectrum* within any *operating band*, the OTA ACS requirement shall apply in addition inside any *sub-block gap*, in case the *sub-block gap* size is at least as wide as the NR interfering signal in table 10.5.1.3-2. The OTA interfering signal offset is defined relative to the *sub-block edges* inside the *sub-block gap*.

Table 10.5.1.3-1: OTA ACS requirement for *BS type 2-0*

Frequency Range	BS channel bandwidth of the lowest/highest carrier received (MHz)	Wanted signal mean power (dBm)	Interfering signal mean power (dBm)
FR2-1	50, 100, 200, 400	$EIS_{REFSENS} + 6$ dB (Note 3)	$EIS_{REFSENS_50M} + 27.7 + \Delta_{FR2_REFSENS}$ (Note 1) $EIS_{REFSENS_50M} + 26.7 + \Delta_{FR2_REFSENS}$ (Note 2)
FR2-2	100, 400, 800, 1600, 2000	$EIS_{REFSENS} + 6$ dB (Note 3)	$EIS_{REFSENS_50M} + 28.7 + \Delta_{FR2_REFSENS}$ (Note 4)
NOTE 1: Applicable to bands defined within the frequency spectrum range of 24.25 – 33.4 GHz			
NOTE 2: Applicable to bands defined within the frequency spectrum range of 37 – 52.6 GHz			
NOTE 3: $EIS_{REFSENS}$ is given in clause 10.3.3			
NOTE 4: Applicable to bands defined within the frequency spectrum range of 57 – 71 GHz			

Table 10.5.1.3-2: OTA ACS interferer frequency offset for *BS type 2-0*

Frequency Range	BS channel bandwidth of the lowest/highest carrier received (MHz)	Interfering signal centre frequency offset from the lower/upper Base Station RF Bandwidth edge or sub-block edge inside a sub-block gap (MHz)	Type of interfering signal
FR2-1	50	± 24.29	50 MHz DFT-s-OFDM NR signal, 60 kHz SCS, 64 RBs
	100	± 24.31	
	200	± 24.29	
	400	± 24.31	
FR2-2	100	± 48.58	100 MHz DFT-s-OFDM NR signal, 120 kHz SCS, 64 RBs
	400	± 48.58	
	800	± 48.62	
	1600	± 48.58	
	2000	± 48.62	

10.5.2 OTA in-band blocking

10.5.2.1 General

The OTA in-band blocking characteristics is a measure of the receiver's ability to receive a OTA wanted signal at its assigned channel in the presence of an unwanted OTA interferer, which is an NR signal for general blocking or an NR signal with one RB for narrowband blocking.

10.5.2.2 Minimum requirement for *BS type 1-0*

The requirement shall apply at the RIB when the AoA of the incident wave of a received signal and the interfering signal are from the same direction, and:

- when the wanted signal is based on $EIS_{REFSENS}$: the AoA of the incident wave of a received signal and the interfering signal are within the *OTA REFSENS RoAoA*.
- when the wanted signal is based on $EIS_{minSENS}$: the AoA of the incident wave of a received signal and the interfering signal are within the *minSENS RoAoA*.

The wanted and interfering signals apply to each supported polarization, under the assumption of *polarization match*.

The throughput shall be $\geq 95\%$ of the maximum throughput of the reference measurement channel, with OTA wanted and OTA interfering signal specified in tables 10.5.2.2-1, table 10.5.2.2-2 and table 10.5.2.2-3 for general OTA and narrowband OTA blocking requirements. Narrowband blocking requirements are not applied for band n104. The reference measurement channel for the OTA wanted signal is identified in clause 10.3.2 and are further specified in annex A.1. The characteristics of the interfering signal is further specified in annex D.

The OTA in-band blocking requirements apply outside the *Base Station RF Bandwidth* or *Radio Bandwidth*. The interfering signal offset is defined relative to the *Base Station RF Bandwidth edges* or *Radio Bandwidth edges*.

For *BS type 1-O* the OTA in-band blocking requirement shall apply in the in-band blocking frequency range, which is from $F_{UL,low} - \Delta f_{OOB}$ to $F_{UL,high} + \Delta f_{OOB}$, excluding the downlink frequency range of the *FDD operating band*. The Δf_{OOB} for *BS type 1-O* is defined in table 10.5.2.2-0 except for band n104 and 10.5.2.2-0a for band n104.

Table 10.5.2.2-0: Δf_{OOB} offset for NR operating bands in FR1

BS type	Operating band characteristics	Δf_{OOB} (MHz)
BS type 1-O	$F_{UL,high} - F_{UL,low} < 100$ MHz	20
	$100 \text{ MHz} \leq F_{UL,high} - F_{UL,low} \leq 900$ MHz	60

For band n104, Δf_{OOB} for *BS type 1-O* is defined in table 10.5.2.2-0a.

Table 10.5.2.2-0a: Δf_{OOB} offset for NR operating bands for band n104

BS type	Operating band	Δf_{OOB} (MHz)
BS type 1-O	n104	100

For RIBs supporting operation in *non-contiguous spectrum* within any *operating band*, the OTA in-band blocking requirements apply in addition inside any *sub-block gap*, in case the *sub-block gap* size is at least as wide as twice the interfering signal minimum offset in table 10.5.2.2-1. The interfering signal offset is defined relative to the *sub-block edges* inside the *sub-block gap*.

For *multi-band RIBs*, the OTA in-band blocking requirements apply in the in-band blocking frequency ranges for each supported *operating band*. The requirement shall apply in addition inside any *Inter RF Bandwidth gap*, in case the *Inter RF Bandwidth gap* size is at least as wide as twice the interfering signal minimum offset in tables 10.5.2.2-1 and 10.5.2.2-3.

For a RIBs supporting operation in *non-contiguous spectrum* within any *operating band*, the OTA narrowband blocking requirements apply in addition inside any *sub-block gap*, in case the *sub-block gap* size is at least as wide as the interfering signal minimum offset in table 10.5.2.2-3. The interfering signal offset is defined relative to the *sub-block edges* inside the *sub-block gap*.

For a *multi-band RIBs*, the OTA narrowband blocking requirements apply in the narrowband blocking frequency ranges for each supported *operating band*. The requirement shall apply in addition inside any *Inter RF Bandwidth gap*, in case the *Inter RF Bandwidth gap* size is at least as wide as the interfering signal minimum offset in table 10.5.2.2-3.

Table 10.5.2.2-1: General OTA blocking requirement for BS type 1-O

BS channel bandwidth of the lowest/highest carrier received (MHz)	Wanted signal mean power (dBm) (Note 1)	Interfering signal mean power (dBm)	Interfering signal centre frequency minimum offset from the lower/upper Base Station RF Bandwidth edge or sub-block edge inside a sub-block gap (MHz)	Type of interfering signal
5, 10, 15, 20	$EIS_{REFSENS} + x \text{ dB}$	Wide Area BS: $-43 - \Delta_{OTAREFSENS}$ Medium Range BS: $-38 - \Delta_{OTAREFSENS}$ Local Area BS: $-35 - \Delta_{OTAREFSENS}$	± 7.5	5 MHz DFT-s-OFDM NR signal, 15 kHz SCS, 25 RBs
	$EIS_{minSENS} + x \text{ dB}$	Wide Area BS: $-43 - \Delta_{minSENS}$ Medium Range BS: $-38 - \Delta_{minSENS}$ Local Area BS: $-35 - \Delta_{minSENS}$	± 7.5	
25, 30, 35, 40, 45, 50, 60, 70, 80, 90, 100	$EIS_{REFSENS} + x \text{ dB}$	Wide Area BS: $-43 - \Delta_{OTAREFSENS}$ Medium Range BS: $-38 - \Delta_{OTAREFSENS}$ Local Area BS: $-35 - \Delta_{OTAREFSENS}$	± 30	20 MHz DFT-s-OFDM NR signal, 15 kHz SCS, 100 RBs
	$EIS_{minSENS} + x \text{ dB}$	Wide Area BS: $-43 - \Delta_{minSENS}$ Medium Range BS: $-38 - \Delta_{minSENS}$ Local Area BS: $-35 - \Delta_{minSENS}$	± 30	
NOTE 1: For a BS capable of single band operation only, "x" is equal to 6 dB. For a BS capable of multi-band operation, "x" is equal to 6 dB in case of interfering signals that are in the in-band blocking frequency range of the operating band where the wanted signal is present or in the in-band blocking frequency range of an adjacent or overlapping operating band. For other in-band blocking frequency ranges of the interfering signal for the supported operating bands, "x" is equal to 1.4 dB.				

Table 10.5.2.2-2: OTA narrowband blocking requirement for BS type 1-O

BS channel bandwidth of the lowest/highest carrier received (MHz)	OTA Wanted signal mean power (dBm)	OTA Interfering signal mean power (dBm)
5, 10, 15, 20	$EIS_{REFSENS} + 6 \text{ dB}$	Wide Area BS: $-49 - \Delta_{OTAREFSENS}$ Medium Range BS: $-44 - \Delta_{OTAREFSENS}$ Local Area BS: $-41 - \Delta_{OTAREFSENS}$
	$EIS_{minSENS} + 6 \text{ dB}$	Wide Area BS: $-49 - \Delta_{minSENS}$ Medium Range BS: $-44 - \Delta_{minSENS}$ Local Area BS: $-41 - \Delta_{minSENS}$
25, 30, 35, 40, 45, 50, 60, 70, 80, 90, 100	$EIS_{REFSENS} + 6 \text{ dB}$	Wide Area BS: $-49 - \Delta_{OTAREFSENS}$ Medium Range BS: $-44 - \Delta_{OTAREFSENS}$ Local Area BS: $-41 - \Delta_{OTAREFSENS}$
	$EIS_{minSENS} + 6 \text{ dB}$	Wide Area BS: $-49 - \Delta_{minSENS}$ Medium Range BS: $-44 - \Delta_{minSENS}$ Local Area BS: $-41 - \Delta_{minSENS}$
NOTE 1: The SCS for the lowest/highest carrier received is the lowest SCS supported by the BS for that bandwidth.		
NOTE 2: 7.5 kHz shift is not applied to the wanted signal.		

Table 10.5.2.2-3: OTA narrowband blocking interferer frequency offsets for *BS type 1-O*

<i>BS channel bandwidth of the lowest/highest carrier received (MHz)</i>	<i>Interfering RB centre frequency offset to the lower/upper Base Station RF Bandwidth edge or sub-block edge inside a sub-block gap (kHz) (Note 2)</i>	<i>Type of interfering signal</i>
5	$\pm(350 + m \cdot 180)$, m=0, 1, 2, 3, 4, 9, 14, 19, 24	5 MHz DFT-s-OFDM NR signal, 15 kHz SCS, 1 RB
10	$\pm(355 + m \cdot 180)$, m=0, 1, 2, 3, 4, 9, 14, 19, 24	
15	$\pm(360 + m \cdot 180)$, m=0, 1, 2, 3, 4, 9, 14, 19, 24	
20	$\pm(350 + m \cdot 180)$, m=0, 1, 2, 3, 4, 9, 14, 19, 24	
25	$\pm(565 + m \cdot 180)$, m=0, 1, 2, 3, 4, 29, 54, 79, 99	20 MHz DFT-s-OFDM NR signal, 15 kHz SCS, 1 RB
30	$\pm(570 + m \cdot 180)$, m=0, 1, 2, 3, 4, 29, 54, 79, 99	
35	$\pm(560 + m \cdot 180)$, m=0, 1, 2, 3, 4, 29, 54, 79, 99	
40	$\pm(565 + m \cdot 180)$, m=0, 1, 2, 3, 4, 29, 54, 79, 99	
45	$\pm(570 + m \cdot 180)$, m=0, 1, 2, 3, 4, 29, 54, 79, 99	
50	$\pm(560 + m \cdot 180)$, m=0, 1, 2, 3, 4, 29, 54, 79, 99	
60	$\pm(570 + m \cdot 180)$, m=0, 1, 2, 3, 4, 29, 54, 79, 99	
70	$\pm(565 + m \cdot 180)$, m=0, 1, 2, 3, 4, 29, 54, 79, 99	
80	$\pm(560 + m \cdot 180)$, m=0, 1, 2, 3, 4, 29, 54, 79, 99	
90	$\pm(570 + m \cdot 180)$, m=0, 1, 2, 3, 4, 29, 54, 79, 99	
100	$\pm(565 + m \cdot 180)$, m=0, 1, 2, 3, 4, 29, 54, 79, 99	
NOTE 1: Interfering signal consisting of one resource block is positioned at the stated offset, the channel bandwidth of the interfering signal is located adjacently to the lower/upper <i>Base Station RF Bandwidth</i> edge or <i>sub-block</i> edge inside a <i>sub-block gap</i> .		
NOTE 2: The centre of the interfering RB refers to the frequency location between the two central subcarriers.		

10.5.2.3 Minimum requirement for *BS type 2-O*

The requirement shall apply at the RIB when the AoA of the incident wave of a received signal and the interfering signal are from the same direction and are within the *OTA REFSENS RoAoA*.

The wanted and interfering signals apply to each supported polarization, under the assumption of *polarization match*.

The throughput shall be $\geq 95\%$ of the maximum throughput of the reference measurement channel.

For *BS type 2-O*, the OTA wanted and OTA interfering signals are provided at RIB using the parameters in table 10.5.2.3-1 for general OTA blocking requirements. The reference measurement channel for the wanted signal is further specified in annex A.1. The characteristics of the interfering signal is further specified in annex D.

The OTA blocking requirements are applicable outside the *Base Station RF Bandwidth*. The interfering signal offset is defined relative to the *Base Station RF Bandwidth* edges.

For *BS type 2-O* the OTA in-band blocking requirement shall apply from $F_{UL_low} - \Delta f_{OOB}$ to $F_{UL_high} + \Delta f_{OOB}$. The Δf_{OOB} for *BS type 2-O* is defined in table 10.5.2.3-0.

Table 10.5.2.3-0: Δf_{OoB} offset for NR operating bands in FR2

BS type	Frequency Range	Operating band characteristics (MHz)	Δf_{OoB} (MHz)
BS type 2-O	FR2-1	$F_{\text{UL_high}} - F_{\text{UL_low}} \leq 4000$	1500
	FR2-2	$4000 < F_{\text{UL_high}} - F_{\text{UL_low}} \leq 14000$	3500

For a RIBs supporting operation in *non-contiguous spectrum* within any *operating band*, the OTA blocking requirements apply in addition inside any *sub-block gap*, in case the *sub-block gap* size is at least as wide as twice the interfering signal minimum offset in table 10.5.2.3-1. The interfering signal offset is defined relative to the *sub-block* edges inside the *sub-block gap*.

Table 10.5.2.3-1: General OTA blocking requirement for BS type 2-O

Frequency Range	BS channel bandwidth of the lowest/highest carrier received (MHz)	OTA wanted signal mean power (dBm)	OTA interfering signal mean power (dBm)	OTA interfering signal centre frequency offset from the lower/upper Base Station RF Bandwidth edge or sub-block edge inside a sub-block gap (MHz)	Type of OTA interfering signal
FR2-1	50, 100, 200, 400	$E_{\text{ISREFSENS}} + 6$ dB	$E_{\text{ISREFSENS}_{50\text{M}}} + 33 + \Delta_{\text{FR2_REFSENS}}$	± 75	50 MHz DFT-s-OFDM NR signal, 60 kHz SCS, 64 RBs
FR2-2	100, 400, 800, 1600, 2000	$E_{\text{ISREFSENS}} + 6$ dB	$E_{\text{ISREFSENS}_{50\text{M}}} + 36 + \Delta_{\text{FR2_REFSENS}}$	± 150	100 MHz DFT-s-OFDM NR signal, 120 kHz SCS, 64 RBs

NOTE: $E_{\text{ISREFSENS}}$ and $E_{\text{ISREFSENS}_{50\text{M}}}$ are given in clause 10.3.3.

10.6 OTA out-of-band blocking

10.6.1 General

The OTA out-of-band blocking characteristics are a measure of the receiver unit ability to receive a wanted signal at the RIB at its assigned channel in the presence of an unwanted interferer.

10.6.2 Minimum requirement for BS type 1-O

10.6.2.1 General minimum requirement

The requirement shall apply at the RIB when the AoA of the incident wave of the received signal and the interfering signal are from the same direction and are within the *minSENS RoAoA*.

The wanted signal applies to each supported polarization, under the assumption of *polarization match*. The interferer shall be *polarization matched* in-band and the polarization maintained for out-of-band frequencies.

For OTA wanted and OTA interfering signals provided at the RIB using the parameters in table 10.6.2.1-1, the following requirements shall be met:

- The throughput shall be $\geq 95\%$ of the maximum throughput of the reference measurement channel. The reference measurement channel for the OTA wanted signal is identified in clause 10.3.2 for each *BS channel bandwidth* and further specified in annex A.1.

For a *multi-band RIB*, the OTA out-of-band requirement shall apply for each supported *operating band*, with the exception that the in-band blocking frequency ranges of all supported *operating bands* according to clause 7.4.2.2 shall be excluded from the OTA out-of-band blocking requirement.

For *BS type 1-O* the OTA out-of-band blocking requirement apply from 30 MHz to $F_{UL,low} - \Delta f_{OOB}$ and from $F_{UL,high} + \Delta f_{OOB}$ up to 12750 MHz, including the downlink frequency range of the FDD *operating band* for BS supporting FDD. The Δf_{OOB} for *BS type 1-O* is defined in table 10.5.2.2-0.

Table 10.6.2.1-1: OTA out-of-band blocking performance requirement

Wanted signal mean power (dBm)	Interfering signal RMS field-strength (V/m)	Type of interfering Signal
EIS _{minSENS} + 6 dB (Note 1)	0.36	CW carrier
NOTE 1: EIS _{minSENS} depends on the <i>channel bandwidth</i> as specified in clause 10.2. NOTE 2: The RMS field-strength level in V/m is related to the interferer EIRP level at a distance described as $E = \frac{\sqrt{30EIRP}}{r}$, where EIRP is in W and r is in m; for example, 0.36 V/m is equivalent to 36 dBm at fixed distance of 30 m.		

10.6.2.2 Co-location minimum requirement

This additional OTA out-of-band blocking requirement may be applied for the protection of BS receivers when NR, E-UTRA BS, UTRA BS, CDMA BS or GSM/EDGE BS operating in a different frequency band are co-located with a BS.

The requirement is a co-location requirement. The interferer power levels are specified at the *co-location reference antenna* conducted input. The interfering signal power is specified per supported polarization.

The requirement is valid over the *minSENS RoAoA*.

For OTA wanted and OTA interfering signal provided at the RIB using the parameters in table 10.6.2.1-1, the following requirements shall be met:

- The throughput shall be $\geq 95\%$ of the maximum throughput of the reference measurement channel. The reference measurement channel for the OTA wanted signal is identified in clause 10.3.2 for each *BS channel bandwidth* and further specified in annex A.1.

For *BS type 1-O* the OTA blocking requirement for co-location with BS in other frequency bands is applied for all *operating bands* for which co-location protection is provided.

Table 10.6.2.2-1: OTA blocking requirement for co-location with BS in other frequency bands

Frequency range of interfering signal	Wanted signal mean power (dBm)	Interfering signal mean power for WA BS (dBm)	Interfering signal mean power for MR BS (dBm)	Interfering signal mean power for LA BS (dBm)	Type of interfering signal
Frequency range of co-located downlink <i>operating band</i>	EIS _{minSENS} + 6 dB (Note 1)	+46	+38	+24	CW carrier
NOTE 1: EIS _{minSENS} depends on the BS class and on the <i>BS channel bandwidth</i> , see clause 10.2. NOTE 2: The requirement does not apply when the interfering signal falls within any of the supported uplink <i>operating band(s)</i> or in Δf_{OOB} immediately outside any of the supported uplink <i>operating band(s)</i> .					

10.6.3 Minimum requirement for *BS type 2-O*

10.6.3.1 General minimum requirement

The requirement shall apply at the RIB when the AoA of the incident wave of the received signal and the interfering signal are from the same direction and are within the *OTA REFSENS RoAoA*.

The wanted signal applies to each supported polarization, under the assumption of *polarization match*. The interferer shall be *polarization matched* in-band and the polarization maintained for out-of-band frequencies.

For *BS type 2-O* operating in FR2-1, the OTA out-of-band blocking requirement apply from 30 MHz to $F_{UL,low} - 1500$ MHz and from $F_{UL,high} + 1500$ MHz up to 2nd harmonic of the upper frequency edge of the *operating band*.

For *BS type 2-O* operating in FR2-2, the OTA out-of-band blocking requirement apply from 30 MHz to $F_{UL,low} - 3500$ MHz and from $F_{UL,high} + 3500$ MHz up to 2nd harmonic of the upper frequency edge of the *operating band*.

For OTA wanted and OTA interfering signals provided at the RIB using the parameters in table 10.6.3.1-1, the following requirements shall be met:

- The throughput shall be $\geq 95\%$ of the maximum throughput of the reference measurement channel. The reference measurement channel for the OTA wanted signal is identified in clause 10.3.3 for each *BS channel bandwidth* and further specified in annex A.1.

Table 10.6.3.1-1: OTA out-of-band blocking performance requirement

Frequency Range	Frequency range of interfering signal (MHz)	Wanted signal mean power (dBm)	Interferer RMS field-strength (V/m)	Type of interfering signal
FR2-1	30 to 12750	$EIS_{REFSENS} + 6$ dB	0.36	CW
	12750 to $F_{UL,low} - 1500$	$EIS_{REFSENS} + 6$ dB	0.1	CW
	$F_{UL,high} + 1500$ to 2 nd harmonic of the upper frequency edge of the <i>operating band</i>	$EIS_{REFSENS} + 6$ dB	0.1	CW
FR2-2	30 to 12750	$EIS_{REFSENS} + 6$ dB	0.36	CW
	12750 to $F_{UL,low} - 3500$	$EIS_{REFSENS} + 6$ dB	0.1	CW
	$F_{UL,high} + 3500$ to 2 nd harmonic of the upper frequency edge of the <i>operating band</i>	$EIS_{REFSENS} + 6$ dB	0.1	CW

10.7 OTA receiver spurious emissions

10.7.1 General

The OTA RX spurious emission is the power of the emissions radiated from the antenna array from a receiver unit.

The metric used to capture OTA receiver spurious emissions for *BS type 1-O* and *BS type 2-O* is *total radiated power* (TRP), with the requirement defined at the RIB.

10.7.2 Minimum requirement for *BS type 1-O*

For a BS operating in FDD, OTA RX spurious emissions requirement do not apply as they are superseded by the OTA TX spurious emissions requirement. This is due to the fact that TX and RX spurious emissions cannot be distinguished in OTA domain.

For a BS operating in TDD, the OTA RX spurious emissions requirement shall apply during the *transmitter OFF period* only.

For RX only *multi-band RIB*, the OTA RX spurious emissions requirements are subject to exclusion zones in each supported *operating band*.

The OTA RX spurious emissions requirement for *BS type 1-O* is that for each *basic limit* specified in table 10.7.2-1, the power sum of emissions at the RIB shall not exceed limits specified as the *basic limit* + X, where X = 9 dB, unless stated differently in regional regulation.

Table 10.7.2-1: General BS receiver spurious emission basic limits for BS type 1-O

Spurious frequency range	Basic limit (Note 4)	Measurement bandwidth	Notes
30 MHz – 1 GHz	-36 dBm	100 kHz	Note 1
1 GHz – 12.75 GHz	-30 dBm	1 MHz	Note 1, Note 2
12.75 GHz – 5 th harmonic of the upper frequency edge of the UL <i>operating band</i> in GHz		1 MHz	Note 1, Note 2, Note 3
12.75 GHz - 26 GHz	-30 dBm	1 MHz	Note 1, Note 2, Note 6
NOTE 1: Measurement bandwidths as in ITU-R SM.329 [2], s4.1.			
NOTE 2: Upper frequency as in ITU-R SM.329 [2], s2.5 table 1.			
NOTE 3: Applies for Band for which the upper frequency edge of the UL <i>operating band</i> is greater than 2.55 GHz and less than or equal to 5.2 GHz.			
NOTE 4: Additional limits may apply regionally.			
NOTE 5: The frequency range from Δf_{OBUE} below the lowest frequency of the BS transmitter <i>operating band</i> to Δf_{OBUE} above the highest frequency of the BS transmitter <i>operating band</i> may be excluded from the requirement. Δf_{OBUE} is defined in clause 9.7.1. For <i>multi-band RIB</i> , the exclusion applies for all supported <i>operating bands</i> .			
NOTE 6: Applies for Band for which the upper frequency edge of the UL <i>operating band</i> is greater than 5.2 GHz.			

10.7.3 Minimum requirement for BS type 2-O

The OTA RX spurious emissions requirement shall apply during the *transmitter OFF period* only.

For the BS type 2-O, the power of any RX spurious emission shall not exceed the limits in table 10.7.3-1.

10.7.3-1: Radiated Rx spurious emission limits for BS type 2-O

Spurious frequency range (Note 4)	Limit (Note 5)	Measurement Bandwidth	Note
30 MHz ↔ 1 GHz	-36 dBm	100 kHz	Note 1
1 GHz ↔ 18 GHz	-30 dBm	1 MHz	Note 1
18 GHz ↔ $F_{\text{step},1}$	-20 dBm	10 MHz	Note 2
$F_{\text{step},1}$ ↔ $F_{\text{step},2}$	-15 dBm	10 MHz	Note 2
$F_{\text{step},2}$ ↔ $F_{\text{step},3}$	-10 dBm	10 MHz	Note 2
$F_{\text{step},4}$ ↔ $F_{\text{step},5}$	-10 dBm	10 MHz	Note 2
$F_{\text{step},5}$ ↔ $F_{\text{step},6}$	-15 dBm	10 MHz	Note 2
$F_{\text{step},6}$ ↔ 2 nd harmonic of the upper frequency edge of the UL <i>operating band</i>	-20 dBm	10 MHz	Note 2, Note 3
NOTE 1: Bandwidth as in ITU-R SM.329 [2], s4.1.			
NOTE 2: Limit and bandwidth as in ERC Recommendation 74-01 [19], Annex 2.			
NOTE 3: Upper frequency as in ITU-R SM.329 [2], s2.5 table 1.			
NOTE 4: The step frequencies $F_{\text{step},X}$ are defined in table 10.7.3-2.			
NOTE 5: Additional limits may apply regionally.			

Table 10.7.3-2: Step frequencies for defining the radiated Rx spurious emission limits for BS type 2-O

Operating band	$F_{\text{step},1}$ (GHz)	$F_{\text{step},2}$ (GHz)	$F_{\text{step},3}$ (GHz)	$F_{\text{step},4}$ (GHz)	$F_{\text{step},5}$ (GHz)	$F_{\text{step},6}$ (GHz)
n257	18	23.5	25	31	32.5	41.5
n258	18	21	22.75	29	30.75	40.5
n259	23.5	35.5	38	45	47.5	59.5
n260	25	34	35.5	41.5	43	52
n261	18	25.5	26.0	29.85	30.35	38.35
n262	37.2	45.2	45.7	49.7	50.2	58.2
n263	18	43	53.5	74.5	85	127

In addition to the requirements in Table 10.7.3-1, the requirement for protection of EESS for BS operating in frequency range 24.25 - 27.5 GHz in clause 9.7.5.3.3 may be applied.

10.8 OTA receiver intermodulation

10.8.1 General

Third and higher order mixing of the two interfering RF signals can produce an interfering signal in the band of the desired channel. Intermodulation response rejection is a measure of the capability of the receiver unit to receive a wanted signal on its assigned channel frequency in the presence of two interfering signals which have a specific frequency relationship to the wanted signal. The requirement is defined as a *directional requirement* at the *RIB*.

10.8.2 Minimum requirement for *BS type 1-0*

The requirement shall apply at the RIB when the AoA of the incident wave of a received signal and the interfering signal are from the same direction, and:

- when the wanted signal is based on $EIS_{REFSENS}$: the AoA of the incident wave of a received signal and the interfering signal are within the *OTA REFSENS RoAoA*.
- when the wanted signal is based on $EIS_{minSENS}$: the AoA of the incident wave of a received signal and the interfering signal are within the *minSENS RoAoA*.

The wanted and interfering signals apply to each supported polarization, under the assumption of *polarization match*.

The throughput shall be $\geq 95\%$ of the maximum throughput of the reference measurement channel, with a wanted signal at the assigned channel frequency and two interfering signals at the RIB with the conditions specified in tables 10.8.2-1 and 10.8.2-2 for intermodulation performance and in tables 10.8.2-3 and 10.8.2-4 for narrowband intermodulation performance. Narrowband intermodulation requirements are not applied for band n104.

The reference measurement channel for the wanted signal is identified in table 10.3.2-1, table 10.3.2-2 and table 10.3.2-3 for each *BS channel bandwidth* and further specified in annex A.1. The characteristics of the interfering signal is further specified in annex D.

The subcarrier spacing for the modulated interfering signal shall be the same as the subcarrier spacing for the wanted signal, except for the case of wanted signal subcarrier spacing 60kHz and *BS channel bandwidth* ≤ 20 MHz, for which the subcarrier spacing of the interfering signal shall be 30kHz.

The receiver intermodulation requirement is applicable outside the *Base Station RF Bandwidth* or *Radio Bandwidth edges*. The interfering signal offset is defined relative to the *Base Station RF Bandwidth edges* or *Radio Bandwidth edges*.

For a RIBs supporting operation in non-contiguous spectrum within any *operating band*, the narrowband intermodulation requirement shall apply in addition inside any *sub-block gap* in case the *sub-block gap* is at least as wide as the *BS channel bandwidth* of the NR interfering signal in tables 10.8.2-2 and 10.8.2-4. The interfering signal offset is defined relative to the *sub-block edges* inside the *sub-block gap*.

For *multi-band RIBs*, the intermodulation requirement shall apply in addition inside any *Inter RF Bandwidth gap*, in case the gap size is at least twice as wide as the NR interfering signal centre frequency offset from the *Base Station RF Bandwidth edge*.

For *multi-band RIBs*, the narrowband intermodulation requirement shall apply in addition inside any *Inter RF Bandwidth gap* in case the gap size is at least as wide as the NR interfering signal in tables 10.8.2-2 and 10.8.2-4. The interfering signal offset is defined relative to the *Base Station RF Bandwidth edges* inside the *Inter RF Bandwidth gap*.

Table 10.8.2-1: General intermodulation requirement

BS class	Wanted Signal mean power (dBm)	Mean power of the interfering signals (dBm)	Type of interfering signals
Wide Area BS	$EIS_{REFSENS} + 6$ dB	$-52 - \Delta_{OTAREFSSENS}$	See Table 10.8.2-2
	$EIS_{minSENS} + 6$ dB	$-52 - \Delta_{minSENS}$	
Medium Range BS	$EIS_{REFSENS} + 6$ dB	$-47 - \Delta_{OTAREFSSENS}$	
	$EIS_{minSENS} + 6$ dB	$-47 - \Delta_{minSENS}$	
Local Area BS	$EIS_{REFSENS} + 6$ dB	$-44 - \Delta_{OTAREFSSENS}$	
	$EIS_{minSENS} + 6$ dB	$-44 - \Delta_{minSENS}$	
NOTE 1: $EIS_{REFSENS}$ and $EIS_{minSENS}$ depend on the BS class and on the <i>BS channel bandwidth</i> , see clause 10.3 and 10.2.			

Table 10.8.2-2: Interfering signals for intermodulation requirement

BS channel bandwidth of the lowest/highest carrier received (MHz)	Interfering signal centre frequency offset from the lower/upper base station RF Bandwidth edge (MHz)	Type of interfering signal (Note 3)
5	± 7.5	CW
	± 17.5	5 MHz DFT-s-OFDM NR signal (Note 1)
10	± 7.465	CW
	± 17.5	5 MHz DFT-s-OFDM NR signal (Note 1)
15	± 7.43	CW
	± 17.5	5 MHz DFT-s-OFDM NR signal (Note 1)
20	± 7.395	CW
	± 17.5	5 MHz DFT-s-OFDM NR signal (Note 1)
25	± 7.465	CW
	± 25	20 MHz DFT-s-OFDM NR signal (Note 2)
30	± 7.43	CW
	± 25	20 MHz DFT-s-OFDM NR signal (Note 2)
35	± 7.44	CW
	± 25	20 MHz DFT-s-OFDM NR signal (Note 2)
40	± 7.45	CW
	± 25	20 MHz DFT-s-OFDM NR signal (Note 2)
45	± 7.37	CW
	± 25	20 MHz DFT-s-OFDM NR signal (Note 2)
50	± 7.35	CW
	± 25	20 MHz DFT-s-OFDM NR signal (Note 2)
60	± 7.49	CW
	± 25	20 MHz DFT-s-OFDM NR signal (Note 2)
70	± 7.42	CW
	± 25	20 MHz DFT-s-OFDM NR signal (Note 2)
80	± 7.44	CW
	± 25	20 MHz DFT-s-OFDM NR signal (Note 2)
90	± 7.46	CW
	± 25	20 MHz DFT-s-OFDM NR signal (Note 2)
100	± 7.48	CW
	± 25	20 MHz DFT-s-OFDM NR signal (Note 2)
NOTE 1: Number of RBs is 25 for 15 kHz subcarrier spacing and 10 for 30 kHz subcarrier spacing.		
NOTE 2: Number of RBs is 100 for 15 kHz subcarrier spacing, 50 for 30 kHz subcarrier spacing and 24 for 60 kHz subcarrier spacing.		
NOTE 3: The RBs shall be placed adjacent to the transmission bandwidth configuration edge which is closer to the <i>Base Station RF Bandwidth edge</i> .		

Table 10.8.2-3: Narrowband intermodulation performance requirement in FR1

BS class	Wanted signal mean power (dBm)	Interfering signal mean power (dBm)	Type of interfering signals
Wide Area BS	$EIS_{REFSENS} + 6$ dB (Note 1)	$-52 - \Delta_{OTAREFSENS}$	See Table 10.8.2-4
	$EIS_{minSENS} + 6$ dB (Note 1)	$-52 - \Delta_{minSENS}$	
Medium Range BS	$EIS_{REFSENS} + 6$ dB (Note 1)	$-47 - \Delta_{OTAREFSENS}$	
	$EIS_{minSENS} + 6$ dB (Note 1)	$-47 - \Delta_{minSENS}$	
Local Area BS	$EIS_{REFSENS} + 6$ dB (Note 1)	$-44 - \Delta_{OTAREFSENS}$	
	$EIS_{minSENS} + 6$ dB (Note 1)	$-44 - \Delta_{minSENS}$	

NOTE 1: $EIS_{REFSENS} / EIS_{minSENS}$ depends on the *BS channel bandwidth*, see clause 10.3 and 10.2.

Table 10.8.2-4: Interfering signals for narrowband intermodulation requirement in FR1

<i>BS channel bandwidth of the lowest/highest carrier received (MHz)</i>	<i>Interfering RB centre frequency offset from the lower/upper Base Station RF Bandwidth edge or sub-block edge inside a sub-block gap (kHz) (Note 3)</i>	<i>Type of interfering signal</i>
5	±360	CW
	±1420	5 MHz DFT-s-OFDM NR signal, 1 RB (NOTE 1)
10	±370	CW
	±1960	5 MHz DFT-s-OFDM NR signal, 1 RB (NOTE 1)
15 (NOTE 2)	±380	CW
	±1960	5 MHz DFT-s-OFDM NR signal, 1 RB (NOTE 1)
20 (NOTE 2)	±390	CW
	±2320	5 MHz DFT-s-OFDM NR signal, 1 RB (NOTE 1)
25 (NOTE 2)	±325	CW
	±2350	20 MHz DFT-s-OFDM NR signal, 1 RB (NOTE 1)
30 (NOTE 2)	±335	CW
	±2350	20 MHz DFT-s-OFDM NR signal, 1 RB (NOTE 1)
35 (NOTE 2)	±345	CW
	±2710	20 MHz DFT-s-OFDM NR signal, 1 RB (NOTE 1)
40 (NOTE 2)	±355	CW
	±2710	20 MHz DFT-s-OFDM NR signal, 1 RB (NOTE 1)
45 (NOTE 2)	±365	CW
	±2710	20 MHz DFT-s-OFDM NR signal, 1 RB (NOTE 1)
50 (NOTE 2)	±375	CW
	±2710	20 MHz DFT-s-OFDM NR signal, 1 RB (NOTE 1)
60 (NOTE 2)	±395	CW
	±2710	20 MHz DFT-s-OFDM NR signal, 1 RB (NOTE 1)
70 (NOTE 2)	±415	CW
	±2710	20 MHz DFT-s-OFDM NR signal, 1 RB (NOTE 1)
80 (NOTE 2)	±435	CW
	±2710	20 MHz DFT-s-OFDM NR signal, 1 RB (NOTE 1)
90 (NOTE 2)	±365	CW
	±2530	20 MHz DFT-s-OFDM NR signal, 1 RB (NOTE 1)
100 (NOTE 2)	±385	CW
	±2530	20 MHz DFT-s-OFDM NR signal, 1 RB (NOTE 1)
<p>NOTE 1: Interfering signal consisting of one resource block positioned at the stated offset, the <i>BS channel bandwidth</i> of the interfering signal is located adjacently to the lower/upper <i>Base Station RF Bandwidth edge</i> or <i>sub-block edge</i> inside a <i>sub-block gap</i>.</p> <p>NOTE 2: This requirement shall apply only for a G-FRC mapped to the frequency range at the <i>channel edge</i> adjacent to the interfering signals.</p> <p>NOTE 3: The centre of the interfering RB refers to the frequency location between the two central subcarriers.</p>		

10.8.3 Minimum requirement for *BS type 2-O*

The requirement shall apply at the RIB when the AoA of the incident wave of the received signal and the interfering signal are from the same direction and are within the *OTA REFSENS RoAoA*.

The wanted and interfering signals applies to each supported polarization, under the assumption of *polarization match*.

Throughput shall be $\geq 95\%$ of the maximum throughput of the reference measurement channel, with OTA wanted signal at the assigned channel frequency and two OTA interfering signals provided at the RIB using the parameters in tables 10.8.3-1 and 10.8.3-2. All of the OTA test signals arrive from the same direction, and the requirement is valid if the signals arrive from any direction within the *OTA REFSENS RoAoA*. The reference measurement channel for the wanted signal is identified in table 10.3.3-1 for each *BS channel bandwidth* and further specified in annex A.1. The characteristics of the interfering signal is further specified in annex D.

The subcarrier spacing for the modulated interfering signal shall be the same as the subcarrier spacing for the wanted signal except for FR2-2 with 400MHz, 800MHz, 1600MHz and 2000MHz case.

The receiver intermodulation requirement is applicable outside the *Base Station RF Bandwidth*. The interfering signal offset is defined relative to the *Base Station RF Bandwidth edges*.

Table 10.8.3-1: General intermodulation requirement

BS channel bandwidth of the lowest/highest carrier received (MHz)	Wanted signal mean power (dBm)	Interfering signal mean power (dBm)	Type of interfering signals
50, 100, 200, 400, 800, 1600, 2000	$EIS_{REFSENS} + 6$	$EIS_{REFSENS_50M} + 25 + \Delta_{FR2_REFSENS}$ (Note 2), $EIS_{REFSENS_50M} + 28 + \Delta_{FR2_REFSENS}$ (Note 3)	See Table 10.8.3-2
NOTE 1: $EIS_{REFSENS}$ and $EIS_{REFSENS_50M}$ are given in clause 10.3.3.			
NOTE 2: Applicable to bands defined within the frequency spectrum range of FR2-1.			
NOTE 3: Applicable to bands defined within the frequency spectrum range of FR2-2.			

Table 10.8.3-2: Interfering signals for intermodulation requirement

Frequency Range	BS channel bandwidth of the lowest/highest carrier received (MHz)	Interfering signal centre frequency offset from the lower/upper Base Station RF Bandwidth edge (MHz)	Type of interfering signal
FR2-1	50	± 7.5	CW
		± 40	50MHz DFT-s-OFDM NR signal (Note 1)
	100	± 6.88	CW
		± 40	50MHz DFT-s-OFDM NR signal (Note 1)
	200	± 5.64	CW
		± 40	50MHz DFT-s-OFDM NR signal (Note 1)
	400	± 6.02	CW
		± 45	50MHz DFT-s-OFDM NR signal (Note 1)
FR2-2	100	± 7.5	CW
		± 65	100MHz DFT-s-OFDM NR signal (Note 2)
	400	± 6.28	CW
		± 70	100MHz DFT-s-OFDM NR signal (Note 2)
	800	$[\pm 7.3]$	CW
		$[\pm 105]$	100MHz DFT-s-OFDM NR signal (Note 2)
	1600	$[\pm 5.86]$	CW
		$[\pm 145]$	100MHz DFT-s-OFDM NR signal (Note 2)
	2000	± 7.48	CW
		± 210	100MHz DFT-s-OFDM NR signal (Note 2)
NOTE 1: Number of RBs is 64 for the 60 kHz subcarrier spacing, 32 for the 120 kHz subcarrier spacing			
NOTE 2: Number of RBs is 64 with 120 kHz subcarrier spacing.			

10.9 OTA in-channel selectivity

10.9.1 General

In-channel selectivity (ICS) is a measure of the receiver ability to receive a wanted signal at its assigned resource block locations in the presence of an interfering signal received at a larger power spectral density. In this condition a throughput requirement shall be met for a specified reference measurement channel. The interfering signal shall be an NR signal as specified in annex A.1 and shall be time aligned with the wanted signal.

10.9.2 Minimum requirement for *BS type 1-0*

The requirement shall apply at the RIB when the AoA of the incident wave of the received signal and the interfering signal are the same direction and are within the *minSENS RoAoA*

The wanted and interfering signals applies to each supported polarization, under the assumption of *polarization match*.

For *BS type 1-0*, the throughput shall be $\geq 95\%$ of the maximum throughput of the reference measurement channel as specified in annex A.1 with parameters specified:

- In table 10.9.2-1 for Wide Area BS, in table 10.9.2-2 for Medium Range BS and in table 10.9.2-3 for Local Area BS except in operating band n104.
- In table 10.9.2-1a for Wide Area BS, in table 10.9.2-2a for Medium Range BS and in table 10.9.2-3a for Local Area BS in operating band n104.

The characteristics of the interfering signal is further specified in annex D.

Table 10.9.2-1: Wide Area BS in-channel selectivity

<i>BS channel bandwidth</i> (MHz)	<i>Subcarrier spacing</i> (kHz)	<i>Reference measurement channel</i>	<i>Wanted signal mean power</i> (dBm)	<i>Interfering signal mean power</i> (dBm)	<i>Type of interfering signal</i>
5	15	G-FR1-A1-7	$-100.6 - \Delta_{\min\text{SENS}}$	$-81.4 - \Delta_{\min\text{SENS}}$	DFT-s-OFDM NR signal, 15 kHz SCS, 10 RBs
10, 15, 20, 25, 30, 35	15	G-FR1-A1-1	$-98.7 - \Delta_{\min\text{SENS}}$	$-77.4 - \Delta_{\min\text{SENS}}$	DFT-s-OFDM NR signal, 15 kHz SCS, 25 RBs
40, 45, 50	15	G-FR1-A1-4	$-92.3 - \Delta_{\min\text{SENS}}$	$-71.4 - \Delta_{\min\text{SENS}}$	DFT-s-OFDM NR signal, 15 kHz SCS, 100 RBs
5	30	G-FR1-A1-8	$-101.3 - \Delta_{\min\text{SENS}}$	$-81.4 - \Delta_{\min\text{SENS}}$	DFT-s-OFDM NR signal, 30 kHz SCS, 5 RBs
10, 15, 20, 25, 30, 35	30	G-FR1-A1-2	$-98.8 - \Delta_{\min\text{SENS}}$	$-78.4 - \Delta_{\min\text{SENS}}$	DFT-s-OFDM NR signal, 30 kHz SCS, 10 RBs
40, 45, 50, 60, 70, 80, 90, 100	30	G-FR1-A1-5	$-92.6 - \Delta_{\min\text{SENS}}$	$-71.4 - \Delta_{\min\text{SENS}}$	DFT-s-OFDM NR signal, 30 kHz SCS, 50 RBs
10, 15, 20, 25, 30, 35	60	G-FR1-A1-9	$-98.2 - \Delta_{\min\text{SENS}}$	$-78.4 - \Delta_{\min\text{SENS}}$	DFT-s-OFDM NR signal, 60 kHz SCS, 5 RBs
40, 45, 50, 60, 70, 80, 90, 100	60	G-FR1-A1-6	$-92.7 - \Delta_{\min\text{SENS}}$	$-71.6 - \Delta_{\min\text{SENS}}$	DFT-s-OFDM NR signal, 60 kHz SCS, 24 RBs
NOTE: Wanted and interfering signal are placed adjacently around F_c , where the F_c is defined for <i>BS channel bandwidth</i> of the wanted signal according to the table 5.4.2.2-1 . The aggregated wanted and interferer signal shall be centred in the <i>BS channel bandwidth</i> of the wanted signal.					

Table 10.9.2-1a: Wide Area BS in-channel selectivity for band n104

BS channel bandwidth (MHz)	Subcarrier spacing (kHz)	Reference measurement channel	Wanted signal mean power (dBm)	Interfering signal mean power (dBm)	Type of interfering signal
20, 30	15	G-FR1-A1-1	$-97.7-\Delta_{\min\text{SENS}}$	$-76.4-\Delta_{\min\text{SENS}}$	DFT-s-OFDM NR signal, 15 kHz SCS, 25 RBs
40, 50	15	G-FR1-A1-4	$-91.3-\Delta_{\min\text{SENS}}$	$-70.4-\Delta_{\min\text{SENS}}$	DFT-s-OFDM NR signal, 15 kHz SCS, 100 RBs
20, 30	30	G-FR1-A1-2	$-97.8-\Delta_{\min\text{SENS}}$	$-77.4-\Delta_{\min\text{SENS}}$	DFT-s-OFDM NR signal, 30 kHz SCS, 10 RBs
40, 50, 60, 70, 80, 90, 100	30	G-FR1-A1-5	$-91.6-\Delta_{\min\text{SENS}}$	$-70.4-\Delta_{\min\text{SENS}}$	DFT-s-OFDM NR signal, 30 kHz SCS, 50 RBs
20, 30	60	G-FR1-A1-9	$-97.2-\Delta_{\min\text{SENS}}$	$-77.4-\Delta_{\min\text{SENS}}$	DFT-s-OFDM NR signal, 60 kHz SCS, 5 RBs
40, 50, 60, 70, 80, 90, 100	60	G-FR1-A1-6	$-91.7-\Delta_{\min\text{SENS}}$	$-70.6-\Delta_{\min\text{SENS}}$	DFT-s-OFDM NR signal, 60 kHz SCS, 24 RBs
NOTE 1: Wanted and interfering signal are placed adjacently around F_c , where the F_c is defined for <i>BS channel bandwidth</i> of the wanted signal according to the table 5.4.2.2-1. The aggregated wanted and interferer signal shall be centred in the <i>BS channel bandwidth</i> of the wanted signal.					

Table 10.9.2-2: Medium Range BS in-channel selectivity

BS channel bandwidth (MHz)	Subcarrier spacing (kHz)	Reference measurement channel	Wanted signal mean power (dBm)	Interfering signal mean power (dBm)	Type of interfering signal
5	15	G-FR1-A1-7	$-95.6-\Delta_{\min\text{SENS}}$	$-76.4 - \Delta_{\min\text{SENS}}$	DFT-s-OFDM NR signal, 15 kHz SCS, 10 RBs
10, 15, 20, 25, 30, 35	15	G-FR1-A1-1	$-93.7-\Delta_{\min\text{SENS}}$	$-72.4 - \Delta_{\min\text{SENS}}$	DFT-s-OFDM NR signal, 15 kHz SCS, 25 RBs
40, 45, 50	15	G-FR1-A1-4	$-87.3-\Delta_{\min\text{SENS}}$	$-66.4 - \Delta_{\min\text{SENS}}$	DFT-s-OFDM NR signal, 15 kHz SCS, 100 RBs
5	30	G-FR1-A1-8	$-96.3-\Delta_{\min\text{SENS}}$	$-76.4 - \Delta_{\min\text{SENS}}$	DFT-s-OFDM NR signal, 30 kHz SCS, 5 RBs
10, 15, 20, 25, 30, 35	30	G-FR1-A1-2	$-93.8-\Delta_{\min\text{SENS}}$	$-73.4 - \Delta_{\min\text{SENS}}$	DFT-s-OFDM NR signal, 30 kHz SCS, 10 RBs
40, 45, 50, 60, 70, 80, 90, 100	30	G-FR1-A1-5	$-87.6-\Delta_{\min\text{SENS}}$	$-66.4 - \Delta_{\min\text{SENS}}$	DFT-s-OFDM NR signal, 30 kHz SCS, 50 RBs
10, 15, 20, 25, 30, 35	60	G-FR1-A1-9	$-93.2-\Delta_{\min\text{SENS}}$	$-73.4 - \Delta_{\min\text{SENS}}$	DFT-s-OFDM NR signal, 60 kHz SCS, 5 RBs
40, 45, 50, 60, 70, 80, 90, 100	60	G-FR1-A1-6	$-87.7-\Delta_{\min\text{SENS}}$	$-66.6 - \Delta_{\min\text{SENS}}$	DFT-s-OFDM NR signal, 60 kHz SCS, 24 RBs
NOTE: Wanted and interfering signal are placed adjacently around F_c , where the F_c is defined for <i>BS channel bandwidth</i> of the wanted signal according to the table 5.4.2.2-1. The aggregated wanted and interferer signal shall be centred in the <i>BS channel bandwidth</i> of the wanted signal.					

Table 10.9.2-2a: Medium Range BS in-channel selectivity for band n104

BS channel bandwidth (MHz)	Subcarrier spacing (kHz)	Reference measurement channel	Wanted signal mean power (dBm)	Interfering signal mean power (dBm)	Type of interfering signal
20, 30	15	G-FR1-A1-1	$-92.7-\Delta_{\min\text{SENS}}$	$-71.4-\Delta_{\min\text{SENS}}$	DFT-s-OFDM NR signal, 15 kHz SCS, 25 RBs
40, 50	15	G-FR1-A1-4	$-86.3-\Delta_{\min\text{SENS}}$	$-65.4-\Delta_{\min\text{SENS}}$	DFT-s-OFDM NR signal, 15 kHz SCS, 100 RBs
20, 30	30	G-FR1-A1-2	$-92.8-\Delta_{\min\text{SENS}}$	$-72.4-\Delta_{\min\text{SENS}}$	DFT-s-OFDM NR signal, 30 kHz SCS, 10 RBs
40, 50, 60, 70, 80, 90, 100	30	G-FR1-A1-5	$-86.6-\Delta_{\min\text{SENS}}$	$-65.4-\Delta_{\min\text{SENS}}$	DFT-s-OFDM NR signal, 30 kHz SCS, 50 RBs
20, 30	60	G-FR1-A1-9	$-92.2-\Delta_{\min\text{SENS}}$	$-72.4-\Delta_{\min\text{SENS}}$	DFT-s-OFDM NR signal, 60 kHz SCS, 5 RBs
40, 50, 60, 70, 80, 90, 100	60	G-FR1-A1-6	$-86.7-\Delta_{\min\text{SENS}}$	$-65.6-\Delta_{\min\text{SENS}}$	DFT-s-OFDM NR signal, 60 kHz SCS, 24 RBs
NOTE: Wanted and interfering signal are placed adjacently around F_c , where the F_c is defined for <i>BS channel bandwidth</i> of the wanted signal according to the table 5.4.2.2-1. The aggregated wanted and interferer signal shall be centred in the <i>BS channel bandwidth</i> of the wanted signal.					

Table 10.9.2-3: Local area BS in-channel selectivity

BS channel bandwidth (MHz)	Subcarrier spacing (kHz)	Reference measurement channel	Wanted signal mean power (dBm)	Interfering signal mean power (dBm)	Type of interfering signal
5	15	G-FR1-A1-7	$-92.6-\Delta_{\min\text{SENS}}$	$-73.4 - \Delta_{\min\text{SENS}}$	DFT-s-OFDM NR signal, 15 kHz SCS, 10 RBs
10, 15, 20, 25, 30, 35	15	G-FR1-A1-1	$-90.7-\Delta_{\min\text{SENS}}$	$-69.4 - \Delta_{\min\text{SENS}}$	DFT-s-OFDM NR signal, 15 kHz SCS, 25 RBs
40, 45, 50	15	G-FR1-A1-4	$-84.3-\Delta_{\min\text{SENS}}$	$-63.4 - \Delta_{\min\text{SENS}}$	DFT-s-OFDM NR signal, 15 kHz SCS, 100 RBs
5	30	G-FR1-A1-8	$-93.3-\Delta_{\min\text{SENS}}$	$-73.4 - \Delta_{\min\text{SENS}}$	DFT-s-OFDM NR signal, 30 kHz SCS, 5 RBs
10, 15, 20, 25, 30, 35	30	G-FR1-A1-2	$-90.8-\Delta_{\min\text{SENS}}$	$-70.4 - \Delta_{\min\text{SENS}}$	DFT-s-OFDM NR signal, 30 kHz SCS, 10 RBs
40, 45, 50, 60, 70, 80, 90, 100	30	G-FR1-A1-5	$-84.6-\Delta_{\min\text{SENS}}$	$-63.4 - \Delta_{\min\text{SENS}}$	DFT-s-OFDM NR signal, 30 kHz SCS, 50 RBs
10, 15, 20, 25, 30, 35	60	G-FR1-A1-9	$-90.2-\Delta_{\min\text{SENS}}$	$-70.4 - \Delta_{\min\text{SENS}}$	DFT-s-OFDM NR signal, 60 kHz SCS, 5 RBs
40, 45, 50, 60, 70, 80, 90, 100	60	G-FR1-A1-6	$-84.7-\Delta_{\min\text{SENS}}$	$-63.6 - \Delta_{\min\text{SENS}}$	DFT-s-OFDM NR signal, 60 kHz SCS, 24 RBs
NOTE: Wanted and interfering signal are placed adjacently around F_c , where the F_c is defined for <i>BS channel bandwidth</i> of the wanted signal according to the table 5.4.2.2-1. The aggregated wanted and interferer signal shall be centred in the <i>BS channel bandwidth</i> of the wanted signal.					

Table 10.9.2-3a: Local area BS in-channel selectivity for band n104

BS channel bandwidth (MHz)	Subcarrier spacing (kHz)	Reference measurement channel	Wanted signal mean power (dBm)	Interfering signal mean power (dBm)	Type of interfering signal
20, 30	15	G-FR1-A1-1	$-89.7-\Delta_{\text{minSENS}}$	$-68.4-\Delta_{\text{minSENS}}$	DFT-s-OFDM NR signal, 15 kHz SCS, 25 RBs
40, 50	15	G-FR1-A1-4	$-83.3-\Delta_{\text{minSENS}}$	$-62.4-\Delta_{\text{minSENS}}$	DFT-s-OFDM NR signal, 15 kHz SCS, 100 RBs
20, 30	30	G-FR1-A1-2	$-89.8-\Delta_{\text{minSENS}}$	$-69.4-\Delta_{\text{minSENS}}$	DFT-s-OFDM NR signal, 30 kHz SCS, 10 RBs
40, 50, 60, 70, 80, 90, 100	30	G-FR1-A1-5	$-83.6-\Delta_{\text{minSENS}}$	$-62.4-\Delta_{\text{minSENS}}$	DFT-s-OFDM NR signal, 30 kHz SCS, 50 RBs
20, 30	60	G-FR1-A1-9	$-89.2-\Delta_{\text{minSENS}}$	$-69.4-\Delta_{\text{minSENS}}$	DFT-s-OFDM NR signal, 60 kHz SCS, 5 RBs
40, 50, 60, 70, 80, 90, 100	60	G-FR1-A1-6	$-83.7-\Delta_{\text{minSENS}}$	$-62.6-\Delta_{\text{minSENS}}$	DFT-s-OFDM NR signal, 60 kHz SCS, 24 RBs
NOTE: Wanted and interfering signal are placed adjacently around F_c , where the F_c is defined for <i>BS channel bandwidth</i> of the wanted signal according to the table 5.4.2.2-1. The aggregated wanted and interferer signal shall be centred in the <i>BS channel bandwidth</i> of the wanted signal.					

10.9.3 Minimum requirement for *BS type 2-O*

The requirement shall apply at the RIB when the AoA of the incident wave of the received signal and the interfering signal are from the same direction and are within the *OTA REFSENS RoAoA*.

The wanted and interfering signals applies to each supported polarization, under the assumption of *polarization match*.

For *BS type 2-O*, the throughput shall be $\geq 95\%$ of the maximum throughput of the reference measurement channel as specified in annex A.1 with parameters specified in table 10.9.3-1. The characteristics of the interfering signal is further specified in annex D.

Table 10.9.3-1: OTA in-channel selectivity requirement for *BS type 2-O*

Frequency Range	BS channel bandwidth (MHz)	Subcarrier spacing (kHz)	Reference measurement channel	Wanted signal mean power (dBm) (Note 2)	Interfering signal mean power (dBm) (Note 2)	Type of interfering signal
FR2-1	50	60	G-FR2-A1-4	$EIS_{REFSENS_50M} + \Delta_{FR2_REFSENS}$	$EIS_{REFSENS_50M} + 10 + \Delta_{FR2_REFSENS}$	DFT-s-OFDM NR signal, 60 kHz SCS, 32 RB
	100,200	60	G-FR2-A1-1	$EIS_{REFSENS_50M} + 3 + \Delta_{FR2_REFSENS}$	$EIS_{REFSENS_50M} + 13 + \Delta_{FR2_REFSENS}$	DFT-s-OFDM NR signal, 60 kHz SCS, 64 RB
	50	120	G-FR2-A1-5	$EIS_{REFSENS_50M} + \Delta_{FR2_REFSENS}$	$EIS_{REFSENS_50M} + 10 + \Delta_{FR2_REFSENS}$	DFT-s-OFDM NR signal, 120 kHz SCS, 16 RB
	100,200,400	120	G-FR2-A1-2	$EIS_{REFSENS_50M} + 3 + \Delta_{FR2_REFSENS}$	$EIS_{REFSENS_50M} + 13 + \Delta_{FR2_REFSENS}$	DFT-s-OFDM NR signal, 120 kHz SCS, 32 RB
FR2-2	100,400	120	G-FR2-A1-2	$EIS_{REFSENS_50M} + 3 + \Delta_{FR2_REFSENS}$	$EIS_{REFSENS_50M} + 13 + \Delta_{FR2_REFSENS}$	DFT-s-OFDM NR signal, 120 kHz SCS, 32 RB
	400	480	G-FR2-A1-8	$EIS_{REFSENS_50M} + 9 + \Delta_{FR2_REFSENS}$	$EIS_{REFSENS_50M} + 19 + \Delta_{FR2_REFSENS}$	DFT-s-OFDM NR signal, 480 kHz SCS, 32 RB
	800, 1600	480	G-FR2-A1-6	$EIS_{REFSENS_50M} + 12 + \Delta_{FR2_REFSENS}$	$EIS_{REFSENS_50M} + 22 + \Delta_{FR2_REFSENS}$	DFT-s-OFDM NR signal, 480 kHz SCS, 54 RB
	400	960	G-FR2-A1-9	$EIS_{REFSENS_50M} + 9 + \Delta_{FR2_REFSENS}$	$EIS_{REFSENS_50M} + 19 + \Delta_{FR2_REFSENS}$	DFT-s-OFDM NR signal, 960 kHz SCS, 16 RB
	800, 1600, 2000	960	G-FR2-A1-7	$EIS_{REFSENS_50M} + 12 + \Delta_{FR2_REFSENS}$	$EIS_{REFSENS_50M} + 22 + \Delta_{FR2_REFSENS}$	DFT-s-OFDM NR signal, 960 kHz SCS, 27 RB

NOTE 1: Wanted and interfering signal are placed adjacently around F_c , where the F_c is defined for *BS channel bandwidth* of the wanted signal according to the table 5.4.2.2-1. The aggregated wanted and interferer signal shall be centred in the *BS channel bandwidth* of the wanted signal.

NOTE 2: $EIS_{REFSENS_50M}$ is defined in clause 10.3.3.

Table 10.9.3-2: (Void)

Table 10.9.3-3: (Void)

11 Radiated performance requirements

11.1 General

11.1.1 Scope and definitions

Radiated performance requirements specify the ability of the *BS type 1-O* or *BS type 2-O* to correctly demodulate radiated signals in various conditions and configurations. Radiated performance requirements are specified at the RIB.

Radiated performance requirements for the BS are specified for the fixed reference channels defined in annex A and the propagation conditions in annex G. The requirements only apply to those FRCs that are supported by the BS.

The radiated performance requirements for *BS type 1-O* and for the *BS type 2-O* are limited to two OTA *demodulation branches* as described in clause 11.1.2. Conformance requirements can only be tested for 1 or 2 *demodulation branches* depending on the number of polarizations supported by the BS, with the required SNR applied separately per polarization.

NOTE 1: The BS can support more than 2 *demodulation branches*, however OTA conformance testing can only be performed for 1 or 2 *demodulation branches*.

Unless stated otherwise, radiated performance requirements apply for a single carrier only. Radiated performance requirements for a BS supporting CA are defined in terms of single carrier requirements.

For *BS type 1-O* in FDD operation the requirements in clause 8 shall be met with the transmitter units associated with the RIB in the *operating band* turned ON.

NOTE 2: *BS type 1-O* in normal operating conditions in FDD operation is configured to transmit and receive at the same time. The transmitter unit(s) associated with the RIB may be OFF for some of the tests.

In tests performed with signal generators a synchronization signal may be provided from the BS to the signal generator, to enable correct timing of the wanted signal.

Whenever the "RX antennas" term is used for the radiated performance requirements description, it shall refer to the *demodulation branches* (i.e. not physical antennas of the antenna array).

The SNR used in this clause is specified based on a single carrier and defined as:

$$\text{SNR} = S / N$$

Where:

S is the total signal energy in a slot on a RIB.

N is the noise energy in a bandwidth corresponding to the *transmission bandwidth* over the duration where signal energy exists on a RIB.

11.1.2 OTA demodulation branches

Radiated performance requirements are only specified for up to 2 *demodulation branches*.

If the *BS type 1-O*, or the *BS type 2-O* uses polarization diversity and has the ability to maintain isolation between the signals for each of the *demodulation branches*, then radiated performance requirements can be tested for up to two *demodulation branches* (i.e. 1RX or 2RX test setups). When tested for two *demodulation branches*, each demodulation branch maps to one polarization.

If the *BS type 1-O*, or the *BS type 2-O* does not use polarization diversity then radiated performance requirements can only be tested for a single *demodulation branch* (i.e. 1RX test setup).

11.1.3 Void

11.2 Performance requirements for PUSCH

11.2.1 Requirements for *BS type 1-0*

11.2.1.1 Requirements for PUSCH with transform precoding disabled

Apply the requirements defined in clause 8.2.1 for 2Rx.

11.2.1.2 Requirements for PUSCH with transform precoding enabled

Apply the requirements defined in clause 8.2.2 for 2Rx.

11.2.1.3 Requirements for UCI multiplexed on PUSCH

Apply the requirements defined in clause 8.2.3 for 2Rx.

11.2.1.4 Requirements for PUSCH for high speed train

Apply the requirements defined in clause 8.2.4 for 2Rx.

11.2.1.5 Requirements for UL timing adjustment

Apply the requirements defined in clause 8.2.5 for 2Rx.

11.2.1.6 Requirements for PUSCH 0.001% BLER

Apply the requirements defined in clause 8.2.6 for 2Rx.

11.2.1.7 Requirements for PUSCH repetition Type A

Apply the requirements defined in clause 8.2.7 for 2Rx.

11.2.1.8 Requirements for PUSCH mapping Type B with non-slot transmission

Apply the requirements defined in clause 8.2.8 for 2Rx.

11.2.1.9 Requirements for PUSCH for 2-step RA type

Apply the requirements defined in clause 8.2.9 for 2Rx.

11.2.1.10 Requirements for interlaced PUSCH

Apply the requirements defined in clause 8.2.10 for 2Rx.

11.2.1.11 Requirements for CG-UCI multiplexed on interlaced PUSCH

Apply the requirements defined in clause 8.2.11 for 2Rx.

11.2.1.12 Requirements for TB processing over multi-slot PUSCH (TBoMS)

Apply the requirements defined in clause 8.2.12 for 2Rx.

11.2.1.13 Requirements for PUSCH with DM-RS bundling

Apply the requirements for 2Rx defined in clause 8.2.13 for 2Rx.

11.2.2 Requirements for *BS type 2-O*

11.2.2.1 Requirements for PUSCH with transform precoding disabled

11.2.2.1.1 General

The performance requirement of PUSCH is determined by a minimum required throughput for a given SNR. The required throughput is expressed as a fraction of maximum throughput for the FRCs listed in annex A. The performance requirements assume HARQ retransmissions.

Table 11.2.2.1.1-1: Test parameters for testing PUSCH

Parameter		Value
Transform precoding		Disabled
Default TDD UL-DL pattern (Note 1)		60 kHz and 120kHz SCS: 3D1S1U, S=10D:2G:2U 480kHz SCS:14D2S4U, S1=12D:2G0U, S2=0D:6G:8U
HARQ	Maximum number of HARQ transmissions	4
	RV sequence	0, 2, 3, 1
DM-RS	DM-RS configuration type	1
	DM-RS duration	single-symbol DM-RS
	Additional DM-RS symbols	pos0, pos1
	Number of DM-RS CDM group(s) without data	2
	Ratio of PUSCH EPRE to DM-RS EPRE	-3 dB
	DM-RS port(s)	{0}, {0, 1}
DM-RS sequence generation		$N_{ID}=0, n_{SCID}=0$
Time domain resource	PUSCH mapping type	B
	Start symbol index	0
	Allocation length	10
Frequency domain resource	RB assignment	Full applicable test bandwidth
	Frequency hopping	Disabled
TPMI index for 2Tx two-layer spatial multiplexing transmission		0
Code block group based PUSCH transmission		Disabled
PT-RS configuration	Frequency density (K_{PT-RS})	2, Disabled
	Time density (L_{PT-RS})	1, Disabled
NOTE 1: The same requirements are applicable to TDD with different UL-DL patterns		

11.2.2.1.2 Minimum requirements

The throughput shall be equal to or larger than the fraction of maximum throughput stated in the tables 11.2.2.1.2-1 to 11.2.2.1.2-10 at the given SNR for 1Tx and for 2Tx two-layer spatial multiplexing transmission.

Table 11.2.2.1.2-1: Minimum requirements for PUSCH with 70% of maximum throughput, 50 MHz channel bandwidth, 60 kHz SCS in FR2-1

Number of TX antennas	Number of demodulation branches	Cyclic prefix	Propagation conditions and correlation matrix (Annex G)	Fraction of maximum throughput	FRC (Annex A)	Additional DM-RS position	PT-RS	SNR (dB)
1	2	Normal	TDLA30-300 Low	70 %	G-FR2-A3-1	pos0	No	-2.0
					G-FR2-A3-13	pos1	No	-2.2
		Normal	TDLA30-300 Low	70 %	G-FR2-A4-1	pos0	Yes	12.0
							No	11.5
					G-FR2-A4-11	pos1	Yes	10.7
							No	10.7
	Normal	TDLA30-75 Low	70 %	G-FR2-A5-1	pos0	Yes	13.7	
						No	13.1	
				G-FR2-A5-6	pos1	Yes	13.4	
No	12.9							
2		Normal	TDLA30-300 Low	70 %	G-FR2-A3-6	pos0	No	1.5
					G-FR2-A3-18	pos1	No	1.2
		Normal	TDLA30-300 Low	70 %	G-FR2-A7-1	pos0	Yes	15.2
							No	14.3
					G-FR2-A7-6	pos1	Yes	13.8
							No	13.0

Table 11.2.2.1.2-2: Minimum requirements for PUSCH with 70% of maximum throughput, 100 MHz channel bandwidth, 60 kHz SCS in FR2-1

Number of TX antennas	Number of demodulation branches	Cyclic prefix	Propagation conditions and correlation matrix (Annex G)	Fraction of maximum throughput	FRC (Annex A)	Additional DM-RS position	PT-RS	SNR (dB)
1	2	Normal	TDLA30-300 Low	70 %	G-FR2-A3-2	pos0	No	-2.1
					G-FR2-A3-14	pos1	No	-2.4
		Normal	TDLA30-300 Low	70 %	G-FR2-A4-2	pos0	Yes	12.2
							No	11.2
					G-FR2-A4-12	pos1	Yes	11.2
							No	10.6
	Normal	TDLA30-75 Low	70 %	G-FR2-A5-2	pos0	Yes	14.2	
						No	13.3	
				G-FR2-A5-7	pos1	Yes	13.7	
No	13.1							
2		Normal	TDLA30-300 Low	70 %	G-FR2-A3-7	pos0	No	1.5
					G-FR2-A3-19	pos1	No	1.2
		Normal	TDLA30-300 Low	70 %	G-FR2-A7-2	pos0	Yes	16.0
							No	14.9
					G-FR2-A7-7	pos1	Yes	13.8
							No	13.1

Table 11.2.2.1.2-3: Minimum requirements for PUSCH with 70% of maximum throughput, 50 MHz channel bandwidth, 120 kHz SCS in FR2-1

Number of TX antennas	Number of demodulation branches	Cyclic prefix	Propagation conditions and correlation matrix (Annex G)	Fraction of maximum throughput	FRC (Annex A)	Additional DM-RS position	PT-RS	SNR (dB)
1	2	Normal	TDLA30-300 Low	70 %	G-FR2-A3-3	pos0	No	-1.8
					G-FR2-A3-15	pos1	No	-2.1
		Normal	TDLA30-300 Low	70 %	G-FR2-A4-3	pos0	Yes	11.6
							No	10.9
		Normal	TDLA30-75 Low	70 %	G-FR2-A5-3	pos0	Yes	13.7
							No	13.1
Normal	TDLA30-300 Low	70 %	G-FR2-A4-13	pos1	Yes	10.9		
					No	10.5		
2	Normal	TDLA30-300 Low	70 %	G-FR2-A3-8	pos0	No	1.4	
					pos1	No	1.3	
2	Normal	TDLA30-300 Low	70 %	G-FR2-A7-3	pos0	Yes	14.2	
					No	13.6		
				G-FR2-A7-8	pos1	Yes	13.9	
					No	13.1		

Table 11.2.2.1.2-4: Minimum requirements for PUSCH with 70% of maximum throughput, 100 MHz channel bandwidth, 120 kHz SCS in FR2-1

Number of TX antennas	Number of demodulation branches	Cyclic prefix	Propagation conditions and correlation matrix (Annex G)	Fraction of maximum throughput	FRC (Annex A)	Additional DM-RS position	PT-RS	SNR (dB)
1	2	Normal	TDLA30-300 Low	70 %	G-FR2-A3-4	pos0	No	-2.4
					G-FR2-A3-16	pos1	No	-2.5
		Normal	TDLA30-300 Low	70 %	G-FR2-A4-4	pos0	Yes	11.9
							No	10.5
		Normal	TDLA30-75 Low	70 %	G-FR2-A5-4	pos0	Yes	13.5
							No	12.9
Normal	TDLA30-300 Low	70 %	G-FR2-A4-14	pos1	Yes	11.1		
					No	10.5		
2	Normal	TDLA30-300 Low	70 %	G-FR2-A5-9	pos1	Yes	13.4	
					No	12.8		
2	Normal	TDLA30-300 Low	70 %	G-FR2-A3-9	pos0	No	1.4	
					pos1	No	1.2	
				G-FR2-A7-4	pos0	Yes	13.9	
					No	13.2		
G-FR2-A7-9	pos1	Yes	13.5					
	No	12.9						

Table 11.2.2.1.2-5: Minimum requirements for PUSCH with 70% of maximum throughput, 200 MHz channel bandwidth, 120 kHz SCS in FR2-1

Number of TX antennas	Number of demodulation branches	Cyclic prefix	Propagation conditions and correlation matrix (Annex G)	Fraction of maximum throughput	FRC (Annex A)	Additional DM-RS position	PT-RS	SNR (dB)
1	2	Normal	TDLA30-300 Low	70 %	G-FR2-A3-5	pos0	No	-2.1
					G-FR2-A3-17	pos1	No	-2.4
		Normal	TDLA30-300 Low	70 %	G-FR2-A4-5	pos0	Yes	11.3
							No	10.9
		Normal	TDLA30-75 Low	70 %	G-FR2-A4-15	pos1	Yes	11.2
							No	10.7
		Normal	TDLA30-75 Low	70 %	G-FR2-A5-5	pos0	Yes	14.1
							No	13.4
Normal	TDLA30-75 Low	70 %	G-FR2-A5-10	pos1	Yes	13.7		
					No	13.3		
2	2	Normal	TDLA30-300 Low	70 %	G-FR2-A3-10	pos0	No	1.4
					G-FR2-A3-22	pos1	No	1.1
		Normal	TDLA30-300 Low	70 %	G-FR2-A7-5	pos0	Yes	14.0
							No	13.3
Normal	TDLA30-300 Low	70 %	G-FR2-A7-10	pos1	Yes	13.6		
					No	13.0		

Table 11.2.2.1.2-6: Minimum requirements for PUSCH with 30% of maximum throughput, 50 MHz channel bandwidth, 60 kHz SCS in FR2-1

Number of TX antennas	Number of demodulation branches	Cyclic prefix	Propagation conditions and correlation matrix (Annex G)	Fraction of maximum throughput	FRC (Annex A)	Additional DM-RS position	PT-RS	SNR (dB)
1	2	Normal	TDLA30-300 Low	30 %	G-FR2-A4-1	pos0	Yes	4.0
							No	3.5
					G-FR2-A4-11	pos1	Yes	3.7
							No	3.1

Table 11.2.2.1.2-7: Minimum requirements for PUSCH with 30% of maximum throughput, 50 MHz channel bandwidth, 120 kHz SCS in FR2-1

Number of TX antennas	Number of demodulation branches	Cyclic prefix	Propagation conditions and correlation matrix (Annex G)	Fraction of maximum throughput	FRC (Annex A)	Additional DM-RS position	PT-RS	SNR (dB)
1	2	Normal	TDLA30-300 Low	30 %	G-FR2-A4-3	pos0	Yes	4.0
							No	3.6
					G-FR2-A4-13	pos1	Yes	3.7
							No	3.2

Table 11.2.2.1.2-8: Test requirements for PUSCH with 70% of maximum throughput, 100 MHz Channel Bandwidth, 120 kHz SCS in FR2-2

Number of TX antennas	Number of demodulation branches	Cyclic prefix	Propagation conditions and correlation matrix (annex G)	Fraction of maximum throughput	FRC (annex A)	Additional DM-RS position	PT-RS	SNR (dB)
1	2	Normal	TDLA30-650	70 %	G-FR2-A3B-3	pos1	No	-0.2
		Normal	TDLA30-650	70 %	G-FR2-A4-21	pos1	Yes	11.2
		Normal	TDLD30-200	70 %	G-FR2-A5-11	pos1	Yes	12.5
2	2	Normal	TDLA30-650	70 %	G-FR2-A3B-8	pos1	No	3.9
		Normal	TDLA30-650	70 %	G-FR2-A7-11	pos1	Yes	13.6

Table 11.2.2.1.2-9: Test requirements for PUSCH with 70% of maximum throughput, 400 MHz Channel Bandwidth, 120 kHz SCS in FR2-2

Number of TX antennas	Number of demodulation branches	Cyclic prefix	Propagation conditions and correlation matrix (annex G)	Fraction of maximum throughput	FRC (annex A)	Additional DM-RS position	PT-RS	SNR (dB)
1	2	Normal	TDLA10-650	70 %	G-FR2-A3B-4	pos1	No	-0.2
		Normal	TDLA10-650	70 %	G-FR2-A4-22	pos1	Yes	11.2
		Normal	TDLD10-200	70 %	G-FR2-A5-12	pos1	Yes	12.6
2	2	Normal	TDLA10-650	70 %	G-FR2-A3B-9	pos1	No	4
		Normal	TDLA10-650	70 %	G-FR2-A7-12	pos1	Yes	14

Table 11.2.2.1.2-10: Test requirements for PUSCH with 70% of maximum throughput, 400 MHz Channel Bandwidth, 480 kHz SCS in FR2-2

Number of TX antennas	Number of demodulation branches	Cyclic prefix	Propagation conditions and correlation matrix (annex G)	Fraction of maximum throughput	FRC (annex A)	Additional DM-RS position	PT-RS	SNR (dB)
1	2	Normal	TDLA10-650	70 %	G-FR2-A3B-5	pos1	No	-0.5
		Normal	TDLA10-650	70 %	G-FR2-A4-23	pos1	Yes	10.8
		Normal	TDLD10-200	70 %	G-FR2-A5-13	pos1	Yes	12.8
2	2	Normal	TDLA10-650	70 %	G-FR2-A3B-10	pos1	No	3.5
		Normal	TDLA10-650	70 %	G-FR2-A7-13	pos1	Yes	13.8

11.2.2.2 Requirements for PUSCH with transform precoding enabled

11.2.2.2.1 General

The performance requirement of PUSCH is determined by a minimum required throughput for a given SNR. The required throughput is expressed as a fraction of maximum throughput for the FRCs listed in Annex A. The performance requirements assume HARQ retransmissions.

Table 11.2.2.2.1-1: Test parameters for testing PUSCH

Parameter		Value
Transform precoding		Enabled
Default TDD UL-DL pattern (Note 1)		60 kHz and 120kHz SCS: 3D1S1U, S=10D:2G:2U 480kHz SCS:14D2S4U, S1=12D:2G0U, S2=0D:6G:8U
HARQ	Maximum number of HARQ transmissions	4
	RV sequence	0, 2, 3, 1
DM-RS	DM-RS configuration type	1
	DM-RS duration	single-symbol DM-RS
	Additional DM-RS position	pos0, pos1
	Number of DM-RS CDM group(s) without data	2
	Ratio of PUSCH EPRE to DM-RS EPRE	-3 dB
	DM-RS port(s)	0
	DM-RS sequence generation	$N_{ID}^0=0$, group hopping and sequence hopping are disabled
Time domain resource assignment	PUSCH mapping type	B
	Start symbol	0
	Allocation length	10
Frequency domain resource assignment	RB assignment	FR2-1: 30 PRBs in the middle of the test bandwidth FR2-2: 64 PRBs in the middle of the test bandwidth
	Frequency hopping	Disabled
Code block group based PUSCH transmission		Disabled
PT-RS		Not configured
NOTE 1: The same requirements are applicable to TDD with different UL-DL patterns.		

11.2.2.2.2 Minimum requirements

The throughput shall be equal to or larger than the fraction of maximum throughput stated in the tables 11.2.2.2.2-1 to 11.2.2.2.2-4 at the given SNR.

Table 11.2.2.2.2-1: Minimum requirements for PUSCH with 70% of maximum throughput, Type B, 50 MHz Channel Bandwidth, 60 kHz SCS in FR2-1

Number of TX antennas	Number of demodulation branches	Cyclic prefix	Propagation conditions and correlation matrix (Annex G)	Fraction of maximum throughput	FRC (Annex A)	Additional DM-RS position	SNR (dB)
1	2	Normal	TDLA30-300 Low	70 %	G-FR2-A3-11	pos0	-1.8
					G-FR2-A3-23	pos1	-1.9

Table 11.2.2.2-2: Minimum requirements for PUSCH with 70% of maximum throughput, Type B, 50 MHz Channel Bandwidth, 120 kHz SCS in FR2-1

Number of TX antennas	Number of demodulation branches	Cyclic prefix	Propagation conditions and correlation matrix (Annex G)	Fraction of maximum throughput	FRC (Annex A)	Additional DM-RS position	SNR (dB)
1	2	Normal	TDLA30-300 Low	70 %	G-FR2-A3-12	pos0	-1.8
					G-FR2-A3-24	pos1	-1.9

Table 11.2.2.2-3: Minimum requirements for PUSCH with 70% of maximum throughput, Type B, 100 MHz Channel Bandwidth, 120 kHz SCS in FR2-2

Number of TX antennas	Number of demodulation branches	Cyclic prefix	Propagation conditions and correlation matrix (Annex G)	Fraction of maximum throughput	FRC (Annex A)	Additional DM-RS position	SNR (dB)
1	2	Normal	TDLA30-650	70 %	G-FR2-A3B-6	pos1	0.1

Table 11.2.2.2-4: Minimum requirements for PUSCH with 70% of maximum throughput, Type B, 400 MHz Channel Bandwidth, 480 kHz SCS in FR2-2

Number of TX antennas	Number of demodulation branches	Cyclic prefix	Propagation conditions and correlation matrix (Annex G)	Fraction of maximum throughput	FRC (Annex A)	Additional DM-RS position	SNR (dB)
1	2	Normal	TDLA10-650	70 %	G-FR2-A3B-7	pos1	0.2

11.2.2.3 Requirements for UCI multiplexed on PUSCH

11.2.2.3.1 General

In the tests for UCI multiplexed on PUSCH, the UCI information only contains CSI part 1 and CSI part 2 information, and there is no HACK/ACK information transmitted.

The CSI part 1 block error probability (BLER) is defined as the probability of incorrectly decoding the CSI part 1 information when the CSI part 1 information is sent as follow:

$$BLER_{CSI\ part\ 1} = \frac{\#(\text{false CSI part 1})}{\#(\text{CSI part 1})}$$

where:

- #(false CSI part 1) denotes the number of incorrectly decoded CSI part 1 information transmitted occasions
- #(CSI part 1) denotes the number of CSI part 1 information transmitted occasions.

The CSI part 2 block error probability is defined as the probability of incorrectly decoding the CSI part 2 information when the CSI part 2 information is sent as follows:

$$BLER_{CSI\ part\ 2} = \frac{\#(\text{false CSI part 2})}{\#(\text{CSI part 2})}$$

where:

- #(false CSI part 2) denotes the number of incorrectly decoded CSI part 2 information transmitted occasions
- #(CSI part 2) denotes the number of CSI part 2 information transmitted occasions.

The number of UCI information bit payload per slot is defined for two cases as follows:

- 5 bits in CSI part 1, 2 bits in CSI part 2
- 20 bits in CSI part 1, 20 bits in CSI part 2

The 7bits UCI case is further defined with the bitmap [c0 c1 c2 c3 c4] = [0 1 0 1 0] for CSI part 1 information, where c0 is mapping to the RI information, and with the bitmap [c0 c1] = [1 0] for CSI part2 information.

The 40bits UCI information case is assumed random information bits selection.

In both tests, PUSCH data, CSI part 1 and CSI part 2 information are transmitted simultaneously.

Table 11.2.2.3.1-1: Test parameters for testing UCI multiplexed on PUSCH

Parameter		Value	
Transform precoding		Disabled	
Default TDD UL-DL pattern (Note 1)		120 kHz SCS: 3D1S1U, S=10D:2G:2U	
HARQ	Maximum number of HARQ transmissions	1	
	RV sequence	0	
DM-RS	DM-RS configuration type	1	
	DM-RS duration	single-symbol DM-RS	
	Additional DM-RS position	pos0,pos1	
	Number of DM-RS CDM group(s) without data	2	
	Ratio of PUSCH EPRE to DM-RS EPRE	-3 dB	
	DM-RS port(s)	{0}	
	DM-RS sequence generation	$N_{ID}^0=0, n_{SCID}=0$	
Time domain resource assignment	PUSCH mapping type	B	
	Start symbol	0	
	Allocation length	10	
Frequency domain resource assignment	RB assignment	Full applicable test bandwidth	
	Frequency hopping	Disabled	
Code block group based PUSCH transmission		Disabled	
PT-RS configuration	PT-RS	Disabled,	Enabled
	Frequency density (K_{PT-RS})	N/A.	2
	Time density (L_{PT-RS})	N/A.	1
UCI	Number of CSI part 1 and CSI part 2 information bit payload	{5,2},{20,20}	
	scaling	1	
	$\beta_{OffsetACK-Index1}$	11	
	$\beta_{OffsetCSI-Part1-Index1}$ and $\beta_{OffsetCSI-Part1-Index2}$	13	
	$\beta_{OffsetCSI-Part2-Index1}$ and $\beta_{OffsetCSI-Part2-Index2}$	13	
UCI partition for frequency hopping		Disabled	
NOTE 1: The same requirements are applicable to TDD with different UL-DL patterns.			

11.2.2.3.2 Minimum requirements

The CSI part 1 block error probability shall not exceed 0.1% at the SNR given in table 11.2.2.3.2-1 and table 11.2.2.3.2-2. The CSI part 2 block error probability shall not exceed 1% at the SNR given in table 11.2.2.3.2-3 and table 11.2.2.3.2-4.

Table 11.2.2.3.2-1: Minimum requirements for UCI multiplexed on PUSCH, Type B, with PT-RS, CSI part 1, 50 MHz Channel Bandwidth, 120 kHz SCS

Number of TX antennas	Number of demodulation branches	Cyclic prefix	Propagation conditions and correlation matrix (Annex G)	UCI bits (CSI part 1, CSI part 2)	Additional DM-RS position	FRC (Annex A)	SNR (dB)
1	2	Normal	TDLA30-300 Low	7(5,2)	pos0	G-FR2-A4-3	7.2
	2	Normal	TDLA30-300 Low	40(20,20)	pos0	G-FR2-A4-3	5.8
	2	Normal	TDLA30-300 Low	7(5,2)	pos1	G-FR2-A4-13	7.8
	2	Normal	TDLA30-300 Low	40(20,20)	pos1	G-FR2-A4-13	5.9

Table 11.2.2.3.2-2: Minimum requirements for UCI multiplexed on PUSCH, Type B, Without PTRS, CSI part 1, 50 MHz Channel Bandwidth, 120 kHz SCS

Number of TX antennas	Number of demodulation branches	Cyclic prefix	Propagation conditions and correlation matrix (Annex G)	UCI bits (CSI part 1, CSI part 2)	Additional DM-RS position	FRC (Annex A)	SNR (dB)
1	2	Normal	TDLA30-300 LOW	7(5,2)	pos0	G-FR2-A4-3	7.1
	2	Normal	TDLA30-300 LOW	40(20,20)	pos0	G-FR2-A4-3	5.8
	2	Normal	TDLA30-300 LOW	7(5,2)	pos1	G-FR2-A4-13	7.3
	2	Normal	TDLA30-300 LOW	40(20,20)	pos1	G-FR2-A4-13	5.5

Table 11.2.2.3.2-3: Minimum requirements for UCI multiplexed on PUSCH, Type B, with PTRS, CSI part 2, 50 MHz Channel Bandwidth, 120 kHz SCS

Number of TX antennas	Number of demodulation branches	Cyclic prefix	Propagation conditions and correlation matrix (Annex G)	UCI bits (CSI part 1, CSI part 2)	Additional DM-RS position	FRC (Annex A)	SNR (dB)
1	2	Normal	TDLA30-300 Low	7(5,2)	pos0	G-FR2-A4-3	1.1
	2	Normal	TDLA30-300 Low	40(20,20)	pos0	G-FR2-A4-3	4.0
	2	Normal	TDLA30-300 Low	7(5,2)	pos1	G-FR2-A4-13	1.3
	2	Normal	TDLA30-300 Low	40(20,20)	pos1	G-FR2-A4-13	4.0

Table 11.2.2.3.2-3: Minimum requirements for UCI multiplexed on PUSCH, Type B, with PTRS, CSI part 2, 50 MHz Channel Bandwidth, 120 kHz SCS

Number of TX antennas	Number of demodulation branches	Cyclic prefix	Propagation conditions and correlation matrix (Annex G)	UCI bits (CSI part 1, CSI part 2)	Additional DM-RS position	FRC (Annex A)	SNR (dB)
1	2	Normal	TDLA30-300 Low	7(5,2)	pos0	G-FR2-A4-3	1.1
	2	Normal	TDLA30-300 Low	40(20,20)	pos0	G-FR2-A4-3	4.0
	2	Normal	TDLA30-300 Low	7(5,2)	pos1	G-FR2-A4-13	1.3
	2	Normal	TDLA30-300 Low	40(20,20)	pos1	G-FR2-A4-13	4.0

Table 11.2.2.3.2-4: Minimum requirements for UCI multiplexed on PUSCH, Type B, Without PTRS, CSI part 2, 50 MHz Channel Bandwidth, 120 kHz SCS

Number of TX antennas	Number of demodulation branches	Cyclic prefix	Propagation conditions and correlation matrix (Annex G)	UCI bits (CSI part 1, CSI part 2)	Additional DM-RS position	FRC (Annex A)	SNR (dB)
1	2	Normal	TDLA30-300 Low	7(5,2)	pos0	G-FR2-A4-3	1.1
	2	Normal	TDLA30-300 Low	40(20,20)	pos0	G-FR2-A4-3	3.9
	2	Normal	TDLA30-300 Low	7(5,2)	pos1	G-FR2-A4-13	1.2
	2	Normal	TDLA30-300 Low	40(20,20)	pos1	G-FR2-A4-13	3.7

11.2.2.4 Requirements for PUSCH for 2-step RA type

11.2.2.4.1 General

The performance requirement of PUSCH for 2-step RA type is determined by a minimum required block error rate of MsgA for a given SNR for the FRCs listed in annex A. The performance requirements assume that the precedent preamble of MsgA is correctly detected in a 2-step RA type procedure and no HARQ retransmissions.

The performance requirements are applicable for wide area and medium range BS that support 2-step RA type. The performance requirements are not applied for a local area BS that supports 2-step RA type.

Table 11.2.2.4.1-1: Test parameters for testing PUSCH for 2-step RA type

Parameter		Value
Transform precoding		Disabled
Channel bandwidth		60 kHz SCS: 50 MHz 120 kHz SCS: 100 MHz
MCS		2
DM-RS	DM-RS configuration type	1
	DM-RS duration	single-symbol DM-RS
	Additional DM-RS symbols	pos1
	Number of DM-RS CDM group(s) without data	2
	Ratio of PUSCH EPRE to DM-RS EPRE	-3 dB
	DM-RS port(s)	{0}
	DM-RS sequence generation	$N_{ID}=0, n_{SCID}=0$
Time domain resource	PUSCH mapping type	B
	Start symbol	0
	Allocation length	10

Frequency domain resource	RB assignment	2 PRB
	Starting PRB index	0
	Frequency hopping	Disabled
Time Offset (TO)		60 kHz SCS: 0 to 0.6 120kHz SCS: 0 to 0.5
Note1: The power ratio between preamble and msgA is assumed to be sufficient to achieve 100% preamble detection. The SNR for the requirement is defined on the msgA PUSCH.		

11.2.2.4.2 Minimum requirements

The block error rate of MsgA shall be equal to or smaller than 1% at the given SNR.

Table 11.2.2.4.2-1 Minimum requirements of PUSCH for 2-step RA type with mapping type B

Number of TX antennas	Number of RX antennas	Cyclic prefix	Channel Bandwidth [MHz]	SCS [kHz]	Propagation conditions and correlation matrix (Annex G)	FRC (Annex A)	SNR [dB]
1	2	Normal	50	60	TDLA30-300 low	G-FR2-A3-25	8.7
			100	120	TDLA30-300 low	G-FR2-A3-26	8.3

11.2.2.5 Requirements for PUSCH repetition Type A

11.2.2.5.1 General

The performance requirement of PUSCH is determined by a maximum block error rate (BLER) for a given SNR. The BLER is defined as the probability of incorrectly decoding the PUSCH information when the PUSCH information is sent. The performance requirements assume HARQ retransmissions.

Table 11.2.2.5.1-1: Test parameters for testing PUSCH repetition Type A

Parameter		Value
Transform precoding		Disabled
Default TDD UL-DL pattern (Note 1)		60 kHz and 120kHz SCS: 3D1S1U, S=10D:2G:2U
HARQ	Maximum number of HARQ transmissions	4
	RV sequence	0, 3, 0,3
DM-RS	DM-RS configuration type	1
	DM-RS duration	single-symbol DM-RS
	Additional DM-RS symbols	Pos1
	Number of DM-RS CDM group(s) without data	2
	Ratio of PUSCH EPRE to DM-RS EPRE	-3 dB
	DM-RS port(s)	0
DM-RS sequence generation		$N_{ID}=0, n_{SCID}=0$
Time domain resource	PUSCH mapping type	B
	Start symbol index	0
	Allocation length	10
	PUSCH aggregation factor (Note 2)	n8
Frequency domain resource	RB assignment	Full applicable test bandwidth
	Frequency hopping	Disabled
Code block group based PUSCH transmission		Disabled
PT-RS configuration	Frequency density (K_{PT-RS})	Disabled
	Time density (L_{PT-RS})	Disabled
NOTE 1: The effective RV sequence is {0,2,3,1} with slot aggregation		
NOTE 2: The intention of this configuration is to have two effective transmissions of the transport block. To achieve this for the standard TDD pattern captured in this table, a value of n8 is necessary		

11.2.2.5.2 Minimum requirements

The BLER shall be equal to or smaller than the required target BLER for the FRCs stated in tables 11.2.2.5.2-1 to 11.2.2.5.2-4 at the given SNR for 1Tx. FRCs are defined in annex A. Unless stated otherwise, the MIMO correlation matrices for the gNB are defined in annex G for low correlation.

Table 11.2.2.5.2-1: Minimum requirements for PUSCH, TypeB, 50 MHz channel bandwidth, 60 kHz SCS

Number of TX antennas	Number of demodulation branches	Cyclic prefix	Propagation conditions and correlation matrix (Annex G)	Target BLER	FRC (Annex A)	Additional DM-RS position	SNR (dB)
1	2	Normal	TDLA30-300	1% (Note1)	G-FR2-A3A-5	Pos1	-11.9
NOTE 1: BLER is defined as residual BLER, i.e. ratio of incorrectly received transport blocks/sent transport blocks, independently of the number of HARQ transmission(s) for each transport block							

Table 11.2.2.5.2-2: Minimum requirements for PUSCH, TypeB, 100 MHz channel bandwidth, 60 kHz SCS

Number of TX antennas	Number of demodulation branches	Cyclic prefix	Propagation conditions and correlation matrix (Annex G)	Target BLER	FRC (Annex A)	Additional DM-RS position	SNR (dB)
1	2	Normal	TDLA30-300	1% (Note1)	G-FR2-A3A-6	Pos1	-12.2
NOTE 1: BLER is defined as residual BLER, i.e. ratio of incorrectly received transport blocks/sent transport blocks, independently of the number of HARQ transmission(s) for each transport block							

Table 11.2.2.5.2-3: Minimum requirements for PUSCH, TypeB, 50 MHz channel bandwidth, 120 kHz SCS

Number of TX antennas	Number of demodulation branches	Cyclic prefix	Propagation conditions and correlation matrix (Annex G)	Target BLER	FRC (Annex A)	Additional DM-RS position	SNR (dB)
1	2	Normal	TDLA30-300	1% (Note1)	G-FR2-A3A-7	Pos1	-11.2
NOTE 1: BLER is defined as residual BLER, i.e. ratio of incorrectly received transport blocks/sent transport blocks, independently of the number of HARQ transmission(s) for each transport block							

Table 11.2.2.5.2-4: Minimum requirements for PUSCH, TypeB, 100 MHz channel bandwidth, 120 kHz SCS

Number of TX antennas	Number of demodulation branches	Cyclic prefix	Propagation conditions and correlation matrix (Annex G)	Target BLER	FRC (Annex A)	Additional DM-RS position	SNR (dB)
1	2	Normal	TDLA30-300	1% (Note1)	G-FR2-A3A-8	Pos1	-11.7
NOTE 1: BLER is defined as residual BLER, i.e. ratio of incorrectly received transport blocks/sent transport blocks, independently of the number of HARQ transmission(s) for each transport block							

11.2.2.6 Requirements for PUSCH mapping Type B with non-slot transmission

11.2.2.6.1 General

The performance requirement of PUSCH is determined by a minimum required throughput for a given SNR. The required throughput is expressed as a fraction of maximum throughput for the FRCs listed in annex A. The performance requirements do not assume HARQ retransmissions.

Table 11.2.2.6.1-1: Test parameters for testing PUSCH mapping Type B with non-slot transmission

Parameter		Value
Transform precoding		Disabled
Default TDD UL-DL pattern (Note 1)		60 kHz and 120kHz SCS: 3D1S1U, S=10D:2G:2U
HARQ	Maximum number of HARQ transmissions	1
	RV sequence	0
DM-RS	DM-RS configuration type	1
	DM-RS duration	single-symbol DM-RS
	Additional DM-RS symbols	Pos0
	Number of DM-RS CDM group(s) without data	2
	Ratio of PUSCH EPRE to DM-RS EPRE	-3 dB
	DM-RS port(s)	0
DM-RS sequence generation		$N_{ID}=0, n_{SCID}=0$
Time domain resource	PUSCH mapping type	B
	Start symbol index	0
	Allocation length	4
Frequency domain resource	RB assignment	Full applicable test bandwidth
	Frequency hopping	Disabled
Code block group based PUSCH transmission		Disabled
PT-RS configuration	Frequency density (K_{PT-RS})	Disabled
	Time density (L_{PT-RS})	Disabled
NOTE 1: The same requirements are applicable to TDD with different UL-DL patterns		

11.2.2.6.2 Minimum requirements

The throughput shall be equal to or larger than the fraction of maximum throughput for the FRCs stated in tables 11.2.2.6.2-1 to 11.2.2.6.2-4 at the given SNR for 1Tx. FRCs are defined in an annex A. Unless stated otherwise, the MIMO correlation matrices for the gNB are defined in annex G for low correlation.

Table 11.2.2.6.2-1: Minimum requirements for PUSCH, Type B, 50 MHz channel bandwidth, 60 kHz SCS

Number of TX antennas	Number of demodulation branches	Cyclic prefix	Propagation conditions and correlation matrix (Annex G)	Fraction of maximum throughput	FRC (Annex A)	Additional DM-RS position	SNR (dB)
1	2	Normal	TDLA30-300	70%	G-FR2-A3A-1	Pos0	-4.4

Table 11.2.2.6.2-2: Minimum requirements for PUSCH, Type B, 100 MHz channel bandwidth, 60 kHz SCS

Number of TX antennas	Number of demodulation branches	Cyclic prefix	Propagation conditions and correlation matrix (Annex G)	Fraction of maximum throughput	FRC (Annex A)	Additional DM-RS position	SNR (dB)
1	2	Normal	TDLA30-300	70%	G-FR2-A3A-2	Pos0	-5.0

Table 11.2.2.6.2-3: Minimum requirements for PUSCH, Type B, 50 MHz channel bandwidth, 120 kHz SCS

Number of TX antennas	Number of demodulation branches	Cyclic prefix	Propagation conditions and correlation matrix (Annex G)	Fraction of maximum throughput	FRC (Annex A)	Additional DM-RS position	SNR (dB)
1	2	Normal	TDLA30-300	70%	G-FR2-A3A-3	Pos0	-4.1

Table 11.2.2.6.2-4: Minimum requirements for PUSCH, Type B, 100 MHz channel bandwidth, 120 kHz SCS

Number of TX antennas	Number of demodulation branches	Cyclic prefix	Propagation conditions and correlation matrix (Annex G)	Fraction of maximum throughput	FRC (Annex A)	Additional DM-RS position	SNR (dB)
1	2	Normal	TDLA30-300	70%	G-FR2-A3A-4	Pos0	-5.1

11.2.2.7 Requirements for PUSCH for high speed train

11.2.2.7.1 General

The performance requirement of PUSCH is determined by a minimum required throughput for a given SNR. The required throughput is expressed as a fraction of maximum throughput for the FRCs listed in annex A. The performance requirements assume HARQ retransmissions. The performance requirements for high speed train are optional and only applicable for FR2-1 below 30GHz.

The performance requirements for PUSCH high speed train apply to Wide Area Base Stations and Medium Range Base Stations (subject to declaration).

Table 11.2.2.7.1-1: Test parameters for testing high speed train

Parameter		Value
Transform precoding		Disabled
Default TDD UL-DL pattern (Note 1)		3D1S1U, S=10D:2G:2U
HARQ	Maximum number of HARQ transmissions	4
	RV sequence	0, 2, 3, 1
DM-RS	DM-RS configuration type	1
	DM-RS duration	single-symbol DM-RS
	Additional DM-RS symbols	Pos0 or Pos1 or Pos2
	Number of DM-RS CDM group(s) without data	2
	Ratio of PUSCH EPRE to DM-RS EPRE	-3 dB
	DM-RS port(s)	0
Time domain resource	DM-RS sequence generation	$N_{ID}=0, n_{SCID}=0$
	PUSCH mapping type	B
	Start symbol index	0
	Allocation length	10
Frequency domain resource	RB assignment	Full applicable test bandwidth
	Frequency hopping	Disabled
Code block group based PUSCH transmission		Disabled
PT-RS configuration	Frequency density (K_{PT-RS})	2
	Time density (L_{PT-RS})	1
NOTE 1: The same requirements are applicable to TDD with different UL-DL patterns		

11.2.2.7.2 Minimum requirements

The throughput shall be equal to or larger than the fraction of maximum throughput for the FRCs stated in tables 11.2.2.7.2-1 to 11.2.2.7.2-4 at the given SNR for 1Tx. FRCs are defined in an annex A. Unless stated otherwise, the MIMO correlation matrices for the gNB are defined in annex G for low correlation.

Table 11.2.2.7.2-1: Minimum requirements for PUSCH, Type B, 50 MHz channel bandwidth, 120 kHz SCS

Number of TX antennas	Number of demodulation branches	Cyclic prefix	Propagation conditions and correlation matrix (Annex G)	Fraction of maximum throughput	FRC (Annex A)	Additional DM-RS position	SNR (dB)
1	2	Normal	Scenario 4-BI-NR350, FR2	70%	G-FR2-A10-1	pos0	12.9
1	2	Normal	Scenario 4-BI-NR350, FR2	70%	G-FR2-A10-3, G-FR2-A10-5	pos1, pos2	12.5

Table 11.2.2.7.2-2: Minimum requirements for PUSCH, Type B, 200 MHz channel bandwidth, 120 kHz SCS

Number of TX antennas	Number of demodulation branches	Cyclic prefix	Propagation conditions and correlation matrix (Annex G)	Fraction of maximum throughput	FRC (Annex A)	Additional DM-RS position	SNR (dB)
1	2	Normal	Scenario 4-BI-NR350, FR2	70%	G-FR2-A10-2	pos0	12.8
1	2	Normal	Scenario 4-BI-NR350, FR2	70%	G-FR2-A10-4, G-FR2-A10-6	pos1, pos2	12.3

11.2.2.8 Requirements for UL timing adjustment

11.2.2.8.1 General

The performance requirement of UL timing adjustment is determined by a minimum required throughput for the moving UE at given SNR. The performance requirements assume HARQ retransmissions. The performance requirements for UL timing adjustment scenario Y defined in Annex G.4 are optional and only applicable for FR2-1 below 30GHz.

In the tests for UL timing adjustment, two signals are configured, one being transmitted by a moving UE and the other being transmitted by a stationary UE. The transmission of SRS from UE is optional. FRC parameters in Tables A.10-4, A.10-5, and A.10-6 are applied for both UEs. The received power for both UEs is the same. The resource blocks allocated for both UEs are consecutive. In scenario Y, Doppler shift is not taken into account.

Table 11.2.2.8.1-1 Test parameters for testing UL timing adjustment

Parameter		Value
Transform precoding		Disabled
Uplink-downlink allocation for TDD		120 kHz SCS: 3D1S1U, S=10D:2G:2U
Channel bandwidth		120 kHz SCS: 50MHz, 200 MHz
HARQ	Maximum number of HARQ transmissions	4
	RV sequence	0, 2, 3, 1
DM-RS	DM-RS configuration type	1
	DM-RS duration	single-symbol DM-RS
	DM-RS position (l_0)	2
	Additional DM-RS position	pos0, pos1, pos2
	Number of DM-RS CDM group(s) without data	2
	Ratio of PUSCH EPRE to DM-RS EPRE	-3 dB
	DM-RS port	{0}
Time domain resource assignment	DM-RS sequence generation	$N_{ID}^0=0, n_{SCID}=0$ for moving UE $N_{ID}^0=1, n_{SCID}=1$ for stationary UE
	PUSCH mapping type	B
	Allocation length	10
Frequency domain resource assignment	RB assignment	50 MHz CBW/120kHz SCS: 16 RB for each UE 200MHz CBW/120kHz SCS: 66 RB for each UE
	Starting PRB index	Moving UE: 0 Stationary UE: 16 for 50MHz CBW, 66 for 200MHz CBW for SCS 120kHz
	Frequency hopping	Disabled
SRS resource allocation	Slots in which sounding RS is transmitted (Note 1)	For TDD: - last symbol in slot #3 in radio frames for 120KHz
	SRS resource allocation	120 kHz SCS: - $C_{SRS} = 9, B_{SRS} = 0$, for 32 RB - $C_{SRS} = 33, B_{SRS} = 0$, for 132 RB
NOTE 1. The transmission of SRS is optional. And the transmission comb and SRS periodic are configured as $K_{TC} = 2$, and $T_{SRS} = 80$ respectively.		

11.2.2.8.2 Minimum requirements for high speed train

The throughput shall be $\geq 70\%$ of the maximum throughput of the reference measurement channel as specified in Annex A for the moving UE at the SNR given in table 11.2.2.8.2-1 for mapping type B.

Annex A for the moving UE at the SNR given in table 11.2.2.8.2-1 for mapping type B.

Table 11.2.2.8.2-1 Minimum requirements for UL timing adjustment with mapping type B for high speed train

Number of TX antennas	Number of RX antennas	Cyclic prefix	Channel Bandwidth [MHz]	SCS [kHz]	Moving propagation conditions and correlation matrix (Annex G)	FRC (Annex A)	SNR [dB]
1	2	Normal	50	120	Scenario Y	G-FR2-A10-7	9.1
					Scenario Y	G-FR2-A10-9, G-FR2-A10-11	8.8
			200	120	Scenario Y	G-FR2-A10-8	9.0
					Scenario Y	G-FR2-A10-10, G-FR2-A10-12	8.9

11.2.2.9 Requirements for TB processing over multi-slot PUSCH (TBoMS)

11.2.2.9.1 General

The performance requirement of PUSCH TBoMS is determined by a minimum required throughput for a given SNR. The required throughput is expressed as a fraction of maximum throughput for the FRCs listed in annex A. The performance requirements assume HARQ retransmissions.

Table 11.2.2.9.1-1: Test parameters for testing PUSCH TBoMS

Parameter		Value
Transform precoding		Disabled
Default TDD UL-DL pattern (Note 1)		60 kHz and 120kHz SCS: 3D1S1U, S=10D:2G:2U
HARQ	Maximum number of HARQ transmissions	4
	RV sequence	0, 2, 3, 1
DM-RS	DM-RS configuration type	1
	DM-RS duration	single-symbol DM-RS
	Additional DM-RS position	pos1
	Number of DM-RS CDM group(s) without data	2
	Ratio of PUSCH EPRE to DM-RS EPRE	-3 dB
	DM-RS port	0
	DM-RS sequence generation	$N_{ID}^0=0, n_{SCID}=0$
Time domain resource assignment	PUSCH mapping type	B
	Start symbol	0
	Allocation length	10
	Number of slots allocated for TBoMS PUSCH	2
	Number of repetitions of a single TBoMS	1
Frequency domain resource assignment	RB assignment	5 RBs in the middle of the test bandwidth
	Frequency hopping	Disabled
Code block group based PUSCH transmission		Disabled
PT-RS configuration	Frequency density (K_{PT-RS})	Disabled
	Time density (L_{PT-RS})	Disabled
Note 1: The same requirements are applicable to TDD with different UL-DL pattern.		

11.2.2.9.2 Minimum requirements

The throughput shall be equal to or larger than the fraction of maximum throughput for the FRCs stated in tables 11.2.2.9.2-1 to 11.2.2.9.2-2 at the given SNR. FRCs are defined in annex A.

Table 11.2.2.9.2-1: Minimum requirements for PUSCH TBoMS, Type B, 50 MHz channel bandwidth, 60 kHz SCS

Number of TX antennas	Number of RX antennas	Cyclic prefix	Duplex	Propagation conditions and correlation matrix (Annex G)	Fraction of maximum throughput	FRC (Annex A)	Additional DM-RS position	SNR (dB)
1	2	Normal	TDD	TDLA30-300 Low	70%	G-FR2-A3-27	pos1	-2.6

Table 11.2.2.9.2-2: Minimum requirements for PUSCH TBoMS, Type B, 50 MHz channel bandwidth, 120 kHz SCS

Number of TX antennas	Number of RX antennas	Cyclic prefix	Duplex	Propagation conditions and correlation matrix (Annex G)	Fraction of maximum throughput	FRC (Annex A)	Additional DM-RS position	SNR (dB)
1	2	Normal	TDD	TDLA30-300 Low	70%	G-FR2-A3-28	pos1	-2.4

11.2.2.10 Requirements for PUSCH with DM-RS bundling

11.2.2.10.1 General

The performance requirement of PUSCH is determined by a minimum required throughput for a given SNR. The required throughput is expressed as a fraction of maximum throughput for the FRCs listed in annex A. The performance requirements assume HARQ retransmissions.

Table 11.2.2.10.1-1: Test parameters for testing PUSCH with DM-RS bundling

Parameter		Value
Transform precoding		Disabled
Example TDD UL-DL pattern (Note 1)		60 kHz and 120kHz SCS: DDSUU or DSUUU, S=10D:2G:2U
HARQ	Maximum number of HARQ transmissions	4
	RV sequence	0, 3, 0,3 (Note 2)
DM-RS	DM-RS configuration type	1
	DM-RS duration	single-symbol DM-RS
	Additional DM-RS symbols	pos1
	Number of DM-RS CDM group(s) without data	2
	Ratio of PUSCH EPRE to DM-RS EPRE	-3 dB
	DM-RS port(s)	0
	DM-RS sequence generation	$N_{ID}=0, n_{SCID}=0$
Time domain resource	PUSCH mapping type	B
	Start symbol index	0
	Allocation length	14
	PUSCH aggregation factor	n2
pusch-TimeDomainWindowLength		2 slots
Frequency domain resource	RB assignment	Full applicable test bandwidth
	Frequency hopping	Disabled
Code block group based PUSCH transmission		Disabled
PT-RS configuration	Frequency density (K_{PT-RS})	Disabled
	Time density (L_{PT-RS})	Disabled
NOTE 1: The same TDD requirements are applicable to different UL-DL patterns with more than one consecutive UL slots when both pusch-TimeDomainWindowLength and PUSCH aggregation factor are configured as 2 slots. The UL (re)transmission of PUSCH is only scheduled for the actual TDW including 2 consecutive UL slots.		
NOTE 2: The effective RV sequence is {0,2,3,1} with slot aggregation.		

11.2.2.10.2 Minimum requirements

The throughput shall be equal to or larger than the fraction of maximum throughput stated in the tables 11.2.2.10.2-1 and 11.2.2.10.2-2 at the given SNR for 1Tx. FRCs are defined in annex A. Unless stated otherwise, the MIMO correlation matrices for the gNB are defined in annex G for low correlation.

Table 11.2.2.10.2-1: Minimum requirements for PUSCH, TypeB, 50 MHz channel bandwidth, 60 kHz SCS

Number of TX antennas	Number of demodulation branches	Cyclic prefix	Propagation conditions and correlation matrix (Annex G)	Fraction of maximum throughput	FRC (Annex A)	Additional DM-RS position	SNR (dB)
1	2	Normal	TDLA30-75	70%	G-FR2-A3B-1	pos1	-3.9

Table 11.2.2.10.2-2: Minimum requirements for PUSCH, TypeB, 50 MHz channel bandwidth, 120 kHz SCS

Number of TX antennas	Number of demodulation branches	Cyclic prefix	Propagation conditions and correlation matrix (Annex G)	Fraction of maximum throughput	FRC (Annex A)	Additional DM-RS position	SNR (dB)
1	2	Normal	TDLA30-75	70%	G-FR2-A3B-2	pos1	-3.5

11.3 Performance requirements for PUCCH

11.3.1 Requirements for *BS type 1-0*

11.3.1.1 DTX to ACK probability

Apply the requirements defined in clause 8.3.1

11.3.1.2 Performance requirements for PUCCH format 0

Apply the requirements defined in clause 8.3.2 for 2 Rx.

11.3.1.3 Performance requirements for PUCCH format 1

Apply the requirements defined in sub-clause 8.3.3 for 2Rx.

11.3.1.4 Performance requirements for PUCCH format 2

Apply the requirements defined in clause 8.3.4 for 2Rx.

11.3.1.5 Performance requirements for PUCCH format 3

Apply the requirements defined in clause 8.3.5 for 2Rx.

11.3.1.6 Performance requirements for PUCCH format 4

Apply the requirements defined in clause 8.3.6 for 2Rx.

11.3.1.7 Performance requirements for multi-slot PUCCH

Apply the requirements defined in clause 8.3.7 for 2Rx.

11.3.1.8 Performance requirements for PUCCH format 1 with DMRS bundling

Apply the requirements defined in clause 8.3.12 for 2Rx.

11.3.1.9 Performance requirements for PUCCH format 3 with DMRS bundling

Apply the requirements defined in clause 8.3.13 for 2Rx.

11.3.1.10 Performance requirements for sub-slot repetition PUCCH format 0

Apply the requirements defined in clause 8.3.14 for 2Rx.

11.3.2 Requirements for *BS type 2-0*

11.3.2.1 DTX to ACK probability

Apply the requirements defined in clause 8.3.1.

11.3.2.2 Performance requirements for PUCCH format 0

11.3.2.2.1 General

The ACK missed detection probability is the probability of not detecting an ACK when an ACK was sent.

Table 11.3.2.2.1-1: Test Parameters

Parameter	Test
Number of UCI information bits	1
Number of PRBs	FR2-1: 1. FR2-2:1,16
First PRB prior to frequency hopping	0
Intra-slot frequency hopping	N/A for 1 symbol Enabled for 2 symbols
First PRB after frequency hopping	The largest PRB index – (Number of PRBs - 1)
Group and sequence hopping	neither
Hopping ID	0
Initial cyclic shift	0
First symbol	13 for 1 symbol 12 for 2 symbols

The transient period as specified in TS 38.101-1 [17] clause 6.3.3.1 and TS 38.101-2 [18] clause 6.3.3.1 is not taken into account for performance requirement testing, where the RB hopping is symmetric to the CC centre, i.e. intra-slot frequency hopping is enabled.

11.3.2.2.2 Minimum requirements

The ACK missed detection probability shall not exceed 1% at the SNR given in table 11.3.2.2.2-1 to 11.3.2.2.2-4.

Table 11.3.2.2.2-1: Minimum requirements for PUCCH format 0 and 60 kHz SCS in FR2-1

Number of TX antennas	Number of demodulation branches	Propagation conditions and correlation matrix (Annex G)	Number of OFDM symbols	Channel bandwidth / SNR (dB)	
				50 MHz	100 MHz
1	2	TDLA30-300 Low	1	9.3	9.0
			2	4.2	4.0

Table 11.3.2.2.2-2: Minimum requirements for PUCCH format 0 and 120 kHz SCS in FR2-1

Number of TX antennas	Number of demodulation branches	Propagation conditions and correlation matrix (Annex G)	Number of OFDM symbols	Channel bandwidth / SNR (dB)		
				50 MHz	100 MHz	200 MHz
1	2	TDLA30-300 Low	1	9.5	9.2	9.7
			2	4.1	3.8	4.0

Table 11.3.2.2.2-3: Minimum requirements for PUCCH format 0 and 120 kHz SCS in FR2-2

Number of TX antennas	Number of demodulation branches	Propagation conditions and correlation matrix (Annex G)	Number of OFDM symbols	Number of PRBs	Channel bandwidth / SNR (dB)
					100 MHz
1	2	TDLA30-650 Low	1	1	9.6
			2	16	-5.8

Table 11.3.2.2.2-4: Minimum requirements for PUCCH format 0 and 480 kHz SCS in FR2-2

Number of TX antennas	Number of demodulation branches	Propagation conditions and correlation matrix (Annex G)	Number of OFDM symbols	Number of PRBs	Channel bandwidth / SNR (dB)
					400 MHz
1	2	TDLA10-650 Low	1	1	9.6
			2	16	-4.8

11.3.2.3 Performance requirements for PUCCH format 1

11.3.2.3.1 NACK to ACK requirements

11.3.2.3.1.1 General

The NACK to ACK detection probability is the probability that an ACK bit is falsely detected when a NACK bit was sent on the particular bit position, where the NACK to ACK detection probability is defined as follows:

$$\text{Prob}(\text{PUCCHNACK} \rightarrow \text{ACK bits}) = \frac{\#(\text{NACK bits decoded as ACK bits})}{\#(\text{Total NACK bits})}$$

where:

- $\#(\text{Total NACK bits})$ denotes the total number of NACK bits transmitted
- $\#(\text{NACK bits decoded as ACK bits})$ denotes the number of NACK bits decoded as ACK bits at the receiver, i.e. the number of received ACK bits
- NACK bits in the definition do not contain the NACK bits which are mapped from DTX, i.e. NACK bits received when DTX is sent should not be considered.

Random codeword selection is assumed.

Table 11.3.2.3.1.1-1: Test Parameters

Parameter	Test
Number of information bits	2
Number of PRBs	FR2-1:1 FR2-2:1,16
Number of symbols	14
First PRB prior to frequency hopping	0
Intra-slot frequency hopping	enabled
First PRB after frequency hopping	The largest PRB index – (nrofPRBs – 1)
Group and sequence hopping	neither
Hopping ID	0
Initial cyclic shift	0
First symbol	0
Index of orthogonal cover code (<i>timeDomainOCC</i>)	0

The transient period as specified in TS 38.101-1 [17] and TS 38.101-2 [18] clause 6.3.3.1 is not taken into account for performance requirement testing, where the RB hopping is symmetric to the CC centre, i.e. intra-slot frequency hopping is enabled.

11.3.2.3.1.2 Minimum requirements

The NACK to ACK probability shall not exceed 0.1% at the SNR given in Table 11.3.2.3.1.2-1 and Table 11.3.2.3.1.2-2.

Table 11.3.2.3.1.2-1: Minimum requirements for PUCCH format 1 with 60 kHz SCS in FR2-1

Number of TX antennas	Number of Demodulation Branches	Cyclic Prefix	Propagation conditions and correlation matrix (Annex G)	Channel bandwidth / SNR (dB)	
				50 MHz	100 MHz
1	2	Normal	TDLA30-300 Low	-1.2	-4.2

Table 11.3.2.3.1.2-2: Minimum requirements for PUCCH format 1 with 120 kHz SCS in FR2-1

Number of TX antennas	Number of Demodulation Branches	Cyclic Prefix	Propagation conditions and correlation matrix (Annex G)	Channel bandwidth / SNR (dB)		
				50 MHz	100 MHz	200 MHz
1	2	Normal	TDLA30-300 Low	-3.9	-3.9	-3.0

Table 11.3.2.3.1.2-3: Minimum requirements for PUCCH format 1 and 120 kHz SCS in FR2-2

Number of TX antennas	Number of demodulation branches	Cyclic Prefix	Propagation conditions and correlation matrix (Annex G)	Number of RBs	Channel bandwidth / SNR (dB)
					100 MHz
1	2	Normal	TDLA30-650 Low	1	-2.7
				16	-13.1

Table 11.3.2.3.1.2-4: Minimum requirements for PUCCH format 1 and 480 kHz SCS in FR2-2

Number of TX antennas	Number of demodulation branches	Cyclic Prefix	Propagation conditions and correlation matrix (Annex G)	Number of RBs	Channel bandwidth / SNR (dB)
					400 MHz
1	2	Normal	TDLA10-650 Low	1	-2.9
				16	-13.8

11.3.2.3.2 ACK missed detection requirements

11.3.2.3.2.1 General

The ACK missed detection probability is the probability of not detecting an ACK when an ACK was sent. The test parameters in Table 11.3.2.3.1.1-1 are configured.

The transient period as specified in TS 38.101-1 [17] and TS 38.101-2 [18] clause 6.3.3.1 is not taken into account for performance requirement testing, where the RB hopping is symmetric to the CC centre, i.e. intra-slot frequency hopping is enabled.

11.3.2.3.2.2 Minimum requirements

The ACK missed detection probability shall not exceed 1% at the SNR given in Table 11.3.2.3.2.2-1 to Table 11.3.2.3.2.2-4.

Table 11.3.2.3.2.2-1: Minimum requirements for PUCCH format 1 with 60 kHz SCS in FR2-1

Number of TX antennas	Number of Demodulation Branches	Cyclic Prefix	Propagation conditions and correlation matrix (Annex G)	Channel bandwidth / SNR (dB)	
				50 MHz	100 MHz
1	2	Normal	TDLA30-300 Low	-3.9	-4.2

Table 11.3.2.3.2.2-2: Minimum requirements for PUCCH format 1 with 120 kHz SCS in FR2-1

Number of TX antennas	Number of Demodulation Branches	Cyclic Prefix	Propagation conditions and correlation matrix (Annex G)	Channel bandwidth / SNR (dB)		
				50 MHz	100 MHz	200 MHz
1	2	Normal	TDLA30-300 Low	-4.7	-4.6	-4.6

Table 11.3.2.3.2.2-3: Minimum requirements for PUCCH format 1 and 120 kHz SCS in FR2-2

Number of TX antennas	Number of demodulation branches	Cyclic Prefix	Propagation conditions and correlation matrix (Annex G)	Number of RBs	Channel bandwidth / SNR (dB)
					100 MHz
1	2	Normal	TDLA30-650 Low	1	-4.1
				16	-14.8

Table 11.3.2.3.2.2-4: Minimum requirements for PUCCH format 1 and 480 kHz SCS in FR2-2

Number of TX antennas	Number of demodulation branches	Cyclic Prefix	Propagation conditions and correlation matrix (Annex G)	Number of RBs	Channel bandwidth / SNR (dB)
					400 MHz
1	2	Normal	TDLA10-650 Low	1	-4.2
				16	-14.4

11.3.2.4 Performance requirements for PUCCH format 2

11.3.2.4.1 ACK missed detection requirements

11.3.2.4.1.1 General

The ACK missed detection probability is the probability of not detecting an ACK when an ACK was sent.

The ACK missed detection requirement only applies to the PUCCH format 2 with 4 UCI bits.

Table 11.3.2.4.1.1-1: Test Parameters

Parameter	Value
Modulation order	QSPK
Starting RB location	0
Intra-slot frequency hopping	N/A
Number of PRBs	4
Number of symbols	1
The number of UCI information bits	4
First symbol	13
DM-RS sequence generation	$N_{ID}^0=0$

11.3.2.4.1.2 Minimum requirements

The ACK missed detection probability shall not exceed 1% at the SNR given in table 11.3.2.4.1.2-1 to 11.3.2.4.1.2-4 for 4UCI bits.

Table 11.3.2.4.1.2-1: Minimum requirements for PUCCH format 2 with 60 kHz SCS in FR2-1

Number of TX antennas	Number of Demodulation Branches	Cyclic Prefix	Propagation conditions and correlation matrix (Annex G)	Channel bandwidth / SNR (dB)	
				50 MHz	100 MHz
1	2	Normal	TDLA30-300 Low	6.7	7.2

Table 11.3.2.4.1.2-2: Minimum requirements for PUCCH format 2 with 120 kHz SCS in FR2-1

Number of TX antennas	Number of Demodulation Branches	Cyclic Prefix	Propagation conditions and correlation matrix (Annex G)	Channel bandwidth / SNR (dB)		
				50 MHz	100 MHz	200 MHz
1	2	Normal	TDLA30-300 Low	6.6	6.3	6.6

Table 11.3.2.4.1.2-3: Minimum requirements for PUCCH format 2 and 120 kHz SCS in FR2-2

Number of TX antennas	Number of demodulation branches	Cyclic Prefix	Propagation conditions and correlation matrix (Annex G)	Channel bandwidth / SNR (dB)
				100 MHz
1	2	Normal	TDLA30-650 Low	5.4

Table 11.3.2.4.1.2-4: Minimum requirements for PUCCH format 2 and 480 kHz SCS in FR2-2

Number of TX antennas	Number of demodulation branches	Cyclic Prefix	Propagation conditions and correlation matrix (Annex G)	Channel bandwidth / SNR (dB)
				400 MHz
1	2	Normal	TDLA10-650 Low	5.4

11.3.2.4.2 UCI BLER performance requirements

11.3.2.4.2.1 General

The UCI block error probability (BLER) is defined as the probability of incorrectly decoding the UCI information when the UCI information is sent. The UCI information does not contain CSI part 2.

The transient period as specified in TS 38.101-1 [17] and TS 38.101-2 [18] clause 6.3.3.1 is not taken into account for performance requirement testing, where the RB hopping is symmetric to the CC centre, i.e. intra-slot frequency hopping is enabled.

The UCI performance only applies to the PUCCH format 2 with 22 UCI bits.

Table 11.3.2.4.2.1-1: Test Parameters

Parameter	Value
Modulation order	QSPK
First PRB prior to frequency hopping	0
Intra-slot frequency hopping	enabled
First PRB after frequency hopping	The largest PRB index – (Number of PRBs – 1)
Number of PRBs	9
Number of symbols	2
The number of UCI information bits	22
First symbol	12
DM-RS sequence generation	$N_{ID}^0=0$

11.3.2.4.2.2 Minimum requirements

The UCI block error probability shall not exceed 1% at the SNR given in table 11.3.2.4.2.2-1 to 11.3.2.4.2.2-4 for 22 UCI bits.

Table 11.3.2.4.2.2-1: Minimum requirements for PUCCH format 2 with 60 kHz SCS in FR2-1

Number of TX antennas	Number of Demodulation Branches	Cyclic Prefix	Propagation conditions and correlation matrix (Annex G)	Channel bandwidth / SNR (dB)	
				50 MHz	100 MHz
1	2	Normal	TDLA30-300 Low	2.6	1.1

Table 11.3.2.4.2.2-2: Minimum requirements for PUCCH format 2 with 120 kHz SCS in FR2-1

Number of TX antennas	Number of Demodulation Branches	Cyclic Prefix	Propagation conditions and correlation matrix (Annex G)	Channel bandwidth / SNR (dB)		
				50 MHz	100 MHz	200 MHz
1	2	Normal	TDLA30-300 Low	1.2	1.2	1.1

Table 11.3.2.4.2.2-3: Minimum requirements for PUCCH format 2 and 120 kHz SCS in FR2-2

Number of TX antennas	Number of demodulation branches	Cyclic Prefix	Propagation conditions and correlation matrix (Annex G)	Channel bandwidth / SNR (dB)
				100 MHz
1	2	Normal	TDLA30-650 Low	2.1

Table 11.3.2.4.2.2-4: Minimum requirements for PUCCH format 2 and 480 kHz SCS in FR2-2

Number of TX antennas	Number of demodulation branches	Cyclic Prefix	Propagation conditions and correlation matrix (Annex G)	Channel bandwidth / SNR (dB)
				400 MHz
1	2	Normal	TDLA10-650 Low	2.6

11.3.2.5 Performance requirements for PUCCH format 3

11.3.2.5.1 General

The performance is measured by the required SNR at UCI block error probability not exceeding 1%.

The UCI block error probability is defined as the conditional probability of incorrectly decoding the UCI information when the UCI information is sent. The UCI information does not contain CSI part 2.

The transient period as specified in TS 38.101-2 [18] clause 6.3.3.1 is not taken into account for performance requirement testing, where the RB hopping is symmetric to the CC centre, i.e. intra-slot frequency hopping is enabled.

Table 11.3.2.5.1-1: Test parameters

Parameter	Test 1	Test 2
Modulation order	QPSK	
First PRB prior to frequency hopping	0	
Intra-slot frequency hopping	enabled	
First PRB after frequency hopping	The largest PRB index – (Number of PRBs - 1)	
Group and sequence hopping	neither	
Hopping ID	0	
Number of PRBs	1	3
Number of symbols	14	4
The number of UCI information bits	16	16
First symbol	0	0

11.3.2.5.2 Minimum requirements

The UCI block error probability shall not exceed 1% at the SNR given in Table 11.3.2.5.2-1 to 11.3.2.5.2-4.

Table 11.3.2.5.2-1: Required SNR for PUCCH format 3 with 60kHz SCS in FR2-1

Test Number	Number of TX antennas	Number of demodulation branches	Cyclic Prefix	Propagation conditions and correlation matrix (Annex G)	Additional DM-RS configuration	Channel Bandwidth / SNR (dB)	
						50 MHz	100 MHz
1	1	2	Normal	TDLA30-300 Low	No additional DM-RS	1.6	0.7
					Additional DM-RS	1.3	0.9
2	1	2	Normal	TDLA30-300 Low	No additional DM-RS	3.0	2.4

Table 11.3.2.5.2-2: Required SNR for PUCCH format 3 with 120kHz SCS in FR2-1

Test Number	Number of TX antennas	Number of demodulation branches	Cyclic Prefix	Propagation conditions and correlation matrix (Annex G)	Additional DM-RS configuration	Channel Bandwidth / SNR (dB)		
						50 MHz	100 MHz	200 MHz
1	1	2	Normal	TDLA30-300 Low	No additional DM-RS	1.4	0.7	0.7
					Additional DM-RS	1.3	1.4	0.9
2	1	2	Normal	TDLA30-300 Low	No additional DM-RS	1.1	2.9	1.4

Table 11.3.2.5.2-3: Minimum requirements for PUCCH format 3 and 120 kHz SCS in FR2-2

Test Number	Number of TX antennas	Number of Demodulation branches	Cyclic Prefix	Propagation conditions and correlation matrix (Annex G)	Additional DM-RS configuration	Channel bandwidth / SNR (dB)
						100
1	1	2	Normal	TDLA30-650 Low	No additional DM-RS	0.6
					Additional DM-RS	0.7
2	1	2	Normal	TDLA30-650 Low	No additional DM-RS	1.8

Table 11.3.2.5.2-4: Minimum requirements for PUCCH format 3 and 480 kHz SCS in FR2-2

Test Number	Number of TX antennas	Number of Demodulation branches	Cyclic Prefix	Propagation conditions and correlation matrix (Annex G)	Additional DM-RS configuration	Channel bandwidth / SNR (dB)
						400
1	1	2	Normal	TDLA10-650 Low	No additional DM-RS	0.5
					Additional DM-RS	0.5
2	1	2	Normal	TDLA10-650 Low	No additional DM-RS	2

11.3.2.6 Performance requirements for PUCCH format 4

11.3.2.6.1 General

The performance is measured by the required SNR at UCI block error probability not exceeding 1%.

The UCI block error probability is defined as the conditional probability of incorrectly decoding the UCI information when the UCI information is sent. The UCI information does not contain CSI part 2.

The transient period as specified in TS 38.101-2 [18] clause 6.3.3.1 is not taken into account for performance requirement testing, where the RB hopping is symmetric to the CC centre, i.e. intra-slot frequency hopping is enabled.

Table 11.3.2.6.1-1: Test parameters

Parameter	Value
Modulation order	QPSK
First PRB prior to frequency hopping starting PRB	0
Number of PRBs	For tests with FR2-1 : 1. For tests 2 with FR2-2:16
Intra-slot frequency hopping	enabled
First PRB after frequency hopping	The largest PRB index – (Number of PRBs – 1)
Group and sequence hopping	neither
Hopping ID	0
Number of symbols	14
The number of UCI information bits	22
First symbol	0
Length of the orthogonal cover code	n2
Index of the orthogonal cover code	n0

11.3.2.6.2 Minimum requirements

The UCI block error probability shall not exceed 1% at the SNR given in Table 11.3.2.6.2-1 to 11.3.2.6.2-4.

Table 11.3.2.6.2-1: Required SNR for PUCCH format 4 with 60 kHz SCS in FR2-1

Number of TX antennas	Number of demodulation branches	Cyclic Prefix	Propagation conditions and correlation matrix (Annex G)	Additional DM-RS configuration	Channel Bandwidth / SNR (dB)	
					50 MHz	100 MHz
1	2	Normal	TDLA30-300 Low	No additional DM-RS	3.0	2.7
				Additional DM-RS	3.1	3.5

Table 11.3.2.6.2-2: Required SNR for PUCCH format 4 with 120 kHz SCS in FR2-1

Number of TX antennas	Number of demodulation branches	Cyclic Prefix	Propagation conditions and correlation matrix (Annex G)	Additional DM-RS configuration	Channel Bandwidth / SNR (dB)		
					50 MHz	100 MHz	200 MHz
1	2	Normal	TDLA30-300 Low	No additional DM-RS	2.8	2.8	3.5
				Additional DM-RS	3.6	3.8	3.2

Table 11.3.2.6.2-3: Minimum requirements for PUCCH format 4 and 120 kHz SCS in FR2-2

Number of TX antennas	Number of demodulation branches	Cyclic Prefix	Propagation conditions and correlation matrix (annex G)	Number of PRBs	Additional DM-RS configuration	Channel bandwidth / SNR (dB)
						100 MHz
1	2	Normal	TDLA30-650 Low	1	No additional DM-RS	3.0
					Additional DM-RS	3.0
1	2	Normal	TDLA30-650 Low	16	No additional DM-RS	-9.0
					Additional DM-RS	-8.9

Table 11.3.2.6.2-4: Minimum requirements for PUCCH format 4 and 480 kHz SCS in FR2-2

Number of TX antennas	Number of demodulation branches	Cyclic Prefix	Propagation conditions and correlation matrix (annex G)	Number of PRBs	Additional DM-RS configuration	Channel bandwidth / SNR (dB)
						400 MHz
1	2	Normal	TDLA10-650 Low	1	No additional DM-RS	3.6
					Additional DM-RS	[-3.4]
1	2	Normal	TDLA10-650 Low	16	No additional DM-RS	-9.1
					Additional DM-RS	[-9.0]

11.3.2.7 Performance requirements for PUCCH format 1 with DMRS bundling

11.3.2.7.1 NACK to ACK requirements

11.3.2.7.1.1 General

The NACK to ACK detection probability is the probability that an ACK bit is falsely detected when an NACK bit was sent on the particular bit position, where the NACK to ACK detection probability is defined as follows:

$$\text{Prob}(\text{PUCCH NACK} \rightarrow \text{ACK bits}) = \frac{\#(\text{NACK bits decoded as ACK bits})}{\#(\text{Total NACK bits})},$$

where:

- $\#(\text{Total NACK bits})$ denotes the total number of NACK bits transmitted
- $\#(\text{NACK bits decoded as ACK bits})$ denotes the number of NACK bits decoded as ACK bits at the receiver, i.e. the number of received ACK bits
- NACK bits in the definition do not contain the NACK bits which are mapped from DTX, i.e. NACK bits received when DTX is sent should not be considered.

The NACK to ACK detection probability performance requirement only apply to PUCCH format 1 with 2 UCI bits. The UCI information only contain ACK/NACK information.

The 2bits UCI information is further defined with bitmap as [0 1].

Table 11.3.2.7.1.1-1: Test Parameters

Parameter	Test
Example TDD UL-DL pattern (Note1)	60 kHz SCS: DDSUU, S=10D:2G:2U or DSUUU 120 kHz SCS: DDSUU, S=10D:2G:2U, DSUUU or DSUUU
Number of information bits	2
Number of PRBs	1
Number of symbols	14
First PRB prior to frequency hopping	0
Intra-slot frequency hopping	disabled
Group and sequence hopping	neither
Hopping ID	0
Initial cyclic shift	0
First symbol	0
Index of orthogonal cover code (<i>timeDomainOCC</i>)	0
Number of slots for PUCCH repetition	2
PUCCH-TimeDomainWindowLength	2
Note 1:	The same TDD requirements are applicable to different UL-DL patterns with more than one consecutive UL slots when both <i>pucch-TimeDomainWindowLength</i> and PUCCH aggregation factor are configured as 2 slots. The UL (re)transmission of PUCCH is only scheduled for the actual TDW including 2 consecutive UL slots.

11.3.2.7.1.2 Minimum requirements

The NACK to ACK probability shall not exceed 0.1% at the SNR given in table 11.3.2.7.1.2-1 and table 11.3.2.7.1.2-2

Table 11.3.2.7.1.2-1: Minimum requirements for PUCCH format 1 with DMRS bundling, 60 kHz SCS, 50MHz channel bandwidth

Number of Tx antennas	Number of demodulation branches	Cyclic-Prefix	Propagation conditions and correlation matrix (Annex G)	SNR (dB)
1	2	Normal	TDLA30-75 Low	-3.3

Table 11.3.2.7.1.2-2: Minimum requirements for PUCCH format 1 with DMRS bundling, 120 kHz SCS, 50MHz channel bandwidth

Number of Tx antennas	Number of demodulation branches	Cyclic-Prefix	Propagation conditions and correlation matrix (Annex G)	SNR (dB)
1	2	Normal	TDLA30-75 Low	-3.2

11.3.2.7.2 ACK missed detection requirements

11.3.2.7.2.1 General

The ACK missed detection probability is the probability of not detecting an ACK when an ACK was sent. The test parameters in table 11.3.2.7.2.1-1 are configured.

The ACK missed detection probability performance requirement only apply to PUCCH format 1 with 2 UCI bits. The UCI information only contain ACK/NACK information.

The 2bits UCI information is further defined with bitmap as [0 1].

11.3.2.7.2.2 Minimum requirements

The ACK missed detection probability shall not exceed 1% at the SNR given in table 11.3.2.7.2.2-1 to table 11.3.2.7.2.2-2

Table 11.3.2.7.2.2-1: Minimum requirements for PUCCH format 1 with JCE, 60 kHz SCS, 50MHz channel bandwidth

Test Number	Number of Tx antennas	Number of demodulation branches	Cyclic-Prefix	Propagation conditions and correlation matrix (Annex G)	SNR (dB)
1	1	2	Normal	TDLA30-75 Low	-4.8

Table 11.3.2.7.2.2-1: Minimum requirements for PUCCH format 1 with JCE, 120 kHz SCS, 100MHz channel bandwidth

Test Number	Number of Tx antennas	Number of demodulation branches	Cyclic-Prefix	Propagation conditions and correlation matrix (Annex G)	SNR (dB)
1	1	2	Normal	TDLA30-75 Low	-4.9

11.3.2.8 Performance requirements for PUCCH format 3 with DMRS bundling

11.3.2.8.1 General

The performance is measured by the required SNR at UCI block error probability not exceeding 1%.

The UCI block error probability is defined as the conditional probability of incorrectly decoding the UCI information when the UCI information is sent. The UCI information does not contain CSI part 2.

Table 11.3.2.8.1-1: Test Parameters

Parameter	Test
Example TDD UL-DL pattern (Note 1)	60 kHz SCS: DDSUU, S=10D:2G:2U or DSUUU 120 kHz SCS: DDSUU, S=10D:2G:2U or DSUUU
Modulation order	QPSK
First PRB prior to frequency hopping	0
Intra-slot frequency hopping	disabled
Group and sequence hopping	neither
Hopping ID	0
Number of PRBs	1
Number of symbols	14
The number of UCI information bits	16
First symbol	0
Number of slots for PUCCH repetition	2
PUCCH-TimeDomainWindowLength	2
Note 1:	The same TDD requirements are applicable to different UL-DL patterns with more than one consecutive UL slots when both pucch-TimeDomainWindowLength and PUCCH aggregation factor are configured as 2 slots. The UL (re)transmission of PUCCH is only scheduled for the actual TDW including 2 consecutive UL slots.

11.3.2.8.2 Minimum requirements

The UCI block error probability shall not exceed 1% at the SNR given in Table 11.3.2.8.2-1 and Table 11.3.2.8.2-2.

Table 11.3.2.8.2-1: Minimum requirements for PUCCH format 3 with JCE, 60 kHz SCS, 50MHz channel bandwidth

Test Number	Number of TX antennas	Number of demodulation branches	Cyclic Prefix	Propagation conditions and correlation matrix (Annex G)	Additional DM-RS configuration	Channel bandwidth / SNR (dB)
						50 MHz
1	1	2	Normal	TDLA30-75 Low	No additional DM-RS	0.1
					Additional DM-RS	-0.2

Table 11.3.2.8.2-2: Minimum requirements for PUCCH format 3 with JCE, 120 kHz SCS, 50MHz channel bandwidth

Test Number	Number of TX antennas	Number of demodulation branches	Cyclic Prefix	Propagation conditions and correlation matrix (Annex G)	Additional DM-RS configuration	Channel bandwidth / SNR (dB)
						50 MHz
1	1	2	Normal	TDLA30-75 Low	No additional DM-RS	0.7
					Additional DM-RS	-0.1

11.4 Performance requirements for PRACH

11.4.1 Requirements for *BS type 1-0*

11.4.1.1 PRACH False alarm probability

Apply the requirements defined in clause 8.4.1 for 2Rx.

11.4.1.2 PRACH detection requirements

Apply the requirements defined in clause 8.4.2 for 2Rx.

11.4.2 Requirements for *BS type 2-0*

11.4.2.1 PRACH False alarm probability

11.4.2.1.1 General

The false alarm requirement is valid for any number of receive antennas, for any channel bandwidth.

The false alarm probability is the conditional total probability of erroneous detection of the preamble (i.e. erroneous detection from any detector) when input is only noise.

11.4.2.1.2 Minimum requirement

The false alarm probability shall be less than or equal to 0.1%.

11.4.2.2 PRACH detection requirements

11.4.2.2.1 General

The probability of detection is the conditional probability of correct detection of the preamble when the signal is present. There are several error cases – detecting different preamble than the one that was sent, not detecting a preamble at all or correct preamble detection but with the wrong timing estimation. For AWGN and TDLA30-300, a timing estimation error occurs if the estimation error of the timing of the strongest path is larger than the time error tolerance given in Table 11.4.2.2-1.

The performance requirements for high speed train (table 11.4.2.2.3-1) are optional and only applicable for FR2-1 below 30GHz.

Table 11.4.2.2-1: Time error tolerance for AWGN, TDLA30-300, and TDLA10-650

PRACH preamble	PRACH SCS (kHz)	Time error tolerance		
		AWGN	TDLA30-300	TDLA10-650
A1, A2, A3, B4, C0, C2	60	0.13 us	0.28 us	N/A
	120	0.07 us	0.22 us	N/A
	480	18 ns	N/A	68 ns

The test preambles for normal mode are listed in table A.6-2 and the test parameter *msg1-FrequencyStart* is set to 0. The test preambles for high speed train short formats are listed in table A.6-7 and the test parameter *msg1-FrequencyStart* for high speed train is set to 0.

11.4.2.2.2 Minimum requirements for Normal mode

The probability of detection shall be equal to or exceed 99% for the SNR levels listed in Tables 11.4.2.2.2-1 to 11.4.2.2.2-4.

Table 11.4.2.2.2-1: PRACH missed detection requirements for Normal Mode, 60 kHz SCS in FR2-1

Number of TX antennas	Number of demodulation branches	Propagation conditions and correlation matrix (Annex G)	Frequency offset	SNR (dB)					
				Burst format A1	Burst format A2	Burst format A3	Burst format B4	Burst format C0	Burst format C2
1	2	AWGN	0	-8.9	-11.9	-13.5	-15.8	-6.0	-11.8
		TDLA30-300 Low	4000 Hz	-1.6	-3.8	-4.8	-6.9	1.1	-3.9

Table 11.4.2.2.2-2: PRACH missed detection requirements for Normal Mode, 120 kHz SCS in FR2-1

Number of TX antennas	Number of demodulation branches	Propagation conditions and correlation matrix (Annex G)	Frequency offset	SNR (dB)					
				Burst format A1	Burst format A2	Burst format A3	Burst format B4	Burst format C0	Burst format C2
1	2	AWGN	0	-8.7	-11.5	-13.3	-15.8	-5.8	-11.4
		TDLA30-300 Low	4000 Hz	-1.7	-4.4	-5.8	-7.5	1.2	-4.2

Table 11.4.2.2.2-3: PRACH missed detection test requirements for Normal Mode, 120 kHz SCS in FR2-2

Number of TX antennas	Number of demodulation branches	Propagation conditions and correlation matrix (Annex G)	Frequency offset	SNR (dB)		
				Burst format A2	Burst format B4	Burst format C2
1	2	AWGN	0	-11.8	-16	-11.8
		TDLA30-650 Low	7100 Hz	-4.3	-7.3	-4.2

Table 11.4.2.2.22-4: PRACH missed detection test requirements for Normal Mode, 480 kHz SCS in FR2-2

Number of TX antennas	Number of demodulation branches	Propagation conditions and correlation matrix (Annex G)	Frequency offset	SNR (dB)		
				Burst format A2	Burst format B4	Burst format C2
1	2	AWGN	0	-11.7	-15.9	-11.8
		TDLA10-650 Low	7100 Hz	-4.5	-9.3	-4.5

11.4.2.2.3 Minimum requirements for high speed train

The probability of detection shall be equal to or exceed 99% for the SNR levels listed in Table 11.4.2.2.3-1.

Table 11.4.2.2.3-1: PRACH missed detection requirements for high speed train, 120 kHz SCS

Number of TX antennas	Number of RX antennas	Propagation conditions (Annex G)	Frequency offset	SNR (dB)
				Burst format C2
1	2	AWGN	19444 Hz	-10.4

11.4.2.2.4 Minimum requirements for PRACH with $L_{RA}=1151$ and $L_{RA}=571$

The probability of detection shall be equal to or exceed 99% for the SNR levels listed in Tables 11.4.2.2.4-1 to 11.4.2.2.4-3.

Table 11.4.2.2.4-1: Missed detection requirements for PRACH with $L_{RA}=571$, 120 kHz SCS in FR2-2

Number of TX antennas	Number of demodulation branches	Propagation conditions and correlation matrix (Annex G)	Frequency offset	SNR (dB)		
				Burst format A2	Burst format B4	Burst format C2
1	2	AWGN	0	-17.9	-22.1	-17.9
		TDLA30-650 Low	7100 Hz	-10.9	-13.8	-10.7

Table 11.4.2.2.4-2: Missed detection requirements for PRACH with $L_{RA}=1151$, 120 kHz SCS in FR2-2

Number of TX antennas	Number of demodulation branches	Propagation conditions and correlation matrix (Annex G)	Frequency offset	SNR (dB)		
				Burst format A2	Burst format B4	Burst format C2
1	2	AWGN	0	-20.9	-25.0	-20.8
		TDLA10-650	7100 Hz	-14.0	-16.9	-14.0

Table 11.4.2.2.4-3: Missed detection requirements for PRACH with $L_{RA}=571$, 480 kHz SCS in FR2-2

Number of TX antennas	Number of demodulation branches	Propagation conditions and correlation matrix (Annex G)	Frequency offset	SNR (dB)		
				Burst format A2	Burst format B4	Burst format C2
1	2	AWGN	0	-17.9	-22.0	-17.9
		TDLA10-650	7100 Hz	-11.1	-15.0	-11.1

Annex A (normative): Reference measurement channels

A.1 Fixed Reference Channels for reference sensitivity level, ACS, in-band blocking, out-of-band blocking, receiver intermodulation and in-channel selectivity (QPSK, R=1/3)

The parameters for the reference measurement channels are specified in table A.1-1 for FR1 reference sensitivity level, ACS, in-band blocking, out-of-band blocking, receiver intermodulation, in-channel selectivity, OTA sensitivity, OTA reference sensitivity level, OTA ACS, OTA in-band blocking, OTA out-of-band blocking, OTA receiver intermodulation and OTA in-channel selectivity. The parameters for the band n46, n96 and n102 reference measurement channels are specified in table A.1-1a and A.1-1b for reference sensitivity level, ACS, in-band blocking, out-of-band blocking, receiver intermodulation, in-channel selectivity.

The parameters for the reference measurement channels are specified in table A.1-2 for FR2 OTA reference sensitivity level, OTA ACS, OTA in-band blocking, OTA out-of-band blocking, OTA receiver intermodulation and OTA in-channel selectivity.

Reference measurement channels G-FR2-A1-1 to G-FR2-A1-5 are used for FR2-1 requirements. Reference measurement channels G-FR2-A1-2, G-FR2-A1-3, G-FR2-A1-6 to G-FR2-A1-9 are used for FR2-2 requirements.

Table A.1-1: FRC parameters for FR1 reference sensitivity level, ACS, in-band blocking, out-of-band blocking, receiver intermodulation, in-channel selectivity, OTA sensitivity, OTA reference sensitivity level, OTA ACS, OTA in-band blocking, OTA out-of-band blocking, OTA receiver intermodulation and OTA in-channel selectivity

Reference channel	G-FR1-A1-1	G-FR1-A1-2	G-FR1-A1-3	G-FR1-A1-4	G-FR1-A1-5	G-FR1-A1-6	G-FR1-A1-7	G-FR1-A1-8	G-FR1-A1-9	G-FR1-A1-10	G-FR1-A1-11
Subcarrier spacing (kHz)	15	30	60	15	30	60	15	30	60	15	15
Allocated resource blocks	25	11	11	106	51	24	15	6	6	24	105
CP-OFDM Symbols per slot (Note 1)	12	12	12	12	12	12	12	12	12	12	12
Modulation	QPSK	QPSK	QPSK	QPSK	QPSK	QPSK	QPSK	QPSK	QPSK	QPSK	QPSK
Code rate (Note 2)	1/3	1/3	1/3	1/3	1/3	1/3	1/3	1/3	1/3	1/3	1/3
Payload size (bits)	2152	984	984	9224	4352	2088	1320	528	528	[2088]	[8968]
Transport block CRC (bits)	16	16	16	24	24	16	16	16	16	16	24
Code block CRC size (bits)	-	-	-	24	-	-	-	-	-	-	24
Number of code blocks - C	1	1	1	2	1	1	1	1	1	1	2
Code block size including CRC (bits) (Note 3)	2168	1000	1000	4648	4376	2104	1336	544	544	[2104]	[4520]
Total number of bits per slot	7200	3168	3168	30528	14688	6912	4320	1728	1728	[6912]	[30240]
Total symbols per slot	3600	1584	1584	15264	7344	3456	2160	864	864	[3456]	[15120]

NOTE 1: $UL-DMRS-config-type = 1$ with $UL-DMRS-max-len = 1$, $UL-DMRS-add-pos = 1$ with $l_0 = 2$, $l = 11$ as per table 6.4.1.1.3-3 of TS 38.211 [9].

NOTE 2: MCS index 4 and target coding rate = 308/1024 are adopted to calculate payload size for receiver sensitivity and in-channel selectivity

NOTE 3: Code block size including CRC (bits) equals to K' in sub-clause 5.2.2 of TS 38.212 [15]. NOTE 2: MCS index 4 and target coding rate = 308/1024 are adopted to calculate payload size for receiver sensitivity and in-channel selectivity

NOTE 3: Code block size including CRC (bits) equals to K' in sub-clause 5.2.2 of TS 38.212 [15].

Table A.1-1a: FRC parameters for band n46, n96 and n102 reference sensitivity level, ACS, in-band blocking, out-of-band blocking, receiver intermodulation, in-channel selectivity

Reference channel	G-FR1-A1-12	G-FR1-A1-13	G-FR1-A1-14	G-FR1-A1-15	G-FR1-A1-16	G-FR1-A1-17	G-FR1-A1-18	G-FR1-A1-19
Channel bandwidth (MHz)	10	10	20	20	40	40	60	80
Subcarrier spacing (kHz)	15	30	15	30	15	30	30	30
Allocated resource blocks	5	4	10	10	21	21	32	43
CP-OFDM Symbols per slot (Note 1)	12	12	12	12	12	12	12	12
Modulation	QPSK	QPSK	QPSK	QPSK	QPSK	QPSK	QPSK	QPSK
Code rate (Note 2)	1/3	1/3	1/3	1/3	1/3	1/3	1/3	1/3
Payload size (bits)	432	352	888	888	1864	1864	2792	3752
Transport block CRC (bits)	16	16	16	16	16	16	16	16
Code block CRC size (bits)	-	-	-	-	-	-	-	-
Number of code blocks - C	1	1	1	1	1	1	1	1
Code block size including CRC (bits) (Note 3)	448	368	904	904	1880	1880	2808	3768
Total number of bits per slot	1440	1152	2880	2880	6048	6048	9216	12384
Total symbols per slot	720	576	1440	1440	3024	3024	4608	6192

NOTE 1: *UL-DMRS-config-type* = 1 with *UL-DMRS-max-len* = 1, *UL-DMRS-add-pos* = 1 with $l_0 = 2$, $l = 11$ as per table 6.4.1.1.3-3 of TS 38.211 [9].

NOTE 2: MCS index 4 and target coding rate = 308/1024 are adopted to calculate payload size for receiver sensitivity and in-channel selectivity

NOTE 3: Code block size including CRC (bits) equals to K' in sub-clause 5.2.2 of TS 38.212 [15].

NOTE 4: For reference channel A1-12, the allocated RB's are uniformly spaced over the channel bandwidth at RB index N , $N+10$, $N+20$, $N+30$, $N+40$ where $N=\{0,1,2,3,4,\dots,9\}$.

NOTE 5: For reference channel A1-13, the allocated RB's are uniformly spaced over the channel bandwidth at RB index N , $N+5$, $N+10$, $N+15$ where $N=\{0,1,2,3,4\}$.

NOTE 7: For reference channel A1-14, the allocated RB's are uniformly spaced over the channel bandwidth at RB index N , $N+10$, $N+20$, ..., $N+90$ where $N=\{0,1,2,3,\dots,9\}$.

NOTE 8: For reference channel A1-15, the allocated RB's are uniformly spaced over the channel bandwidth at RB index N , $N+5$, $N+10$, ..., $N+45$ where $N=\{0,1,2,3,4\}$.

NOTE 10: For reference channel A1-16, the allocated RB's are uniformly spaced over the channel bandwidth at RB index N , $N+10$, $N+20$, ..., $N+200$ where $N=\{0,1,2,3,4,\dots,9\}$.

NOTE 11: For reference channel A1-17, the allocated RB's are uniformly spaced over the channel bandwidth at RB index N , $N+5$, $N+10$, ..., $N+100$ where $N=\{0,1,2,3,4\}$.

NOTE 12: For reference channel A1-18, the allocated RB's are uniformly spaced over the channel bandwidth at RB index N , $N+5$, $N+10$, ..., $N+155$ where $N=\{0,1,2,3,4\}$.

NOTE 13: For reference channel A1-19, the allocated RB's are uniformly spaced over the channel bandwidth at RB index N , $N+5$, $N+10$, ..., $N+210$ where $N=\{0,1,2,3,4\}$.

Table A.1-2: FRC parameters for FR2 OTA reference sensitivity level, OTA ACS, OTA in-band blocking, OTA out-of-band blocking, OTA receiver intermodulation and OTA in-channel selectivity

Reference channel	G-FR2-A1-1	G-FR2-A1-2	G-FR2-A1-3	G-FR2-A1-4	G-FR2-A1-5	G-FR2-A1-6	G-FR2-A1-7	G-FR2-A1-8	G-FR2-A1-9
Subcarrier spacing (kHz)	60	120	120	60	120	480	960	480	960
Allocated resource blocks	66	32	66	33	16	66	33	33	17
CP-OFDM Symbols per slot (Note 1)	12	12	12	12	12	12	12	12	12
Modulation	QPSK	QPSK	QPSK	QPSK	QPSK	QPSK	QPSK	QPSK	QPSK
Code rate (Note 2)	1/3	1/3	1/3	1/3	1/3	1/3	1/3	1/3	1/3
Payload size (bits)	5632	2792	5632	2856	1416	5632	2856	2856	1480
Transport block CRC (bits)	24	16	24	16	16	24	16	16	16
Code block CRC size (bits)	-	-	-	-	-	-	-	-	-
Number of code blocks - C	1	1	1	1	1	1	1	1	1
Code block size including CRC (bits) (Note 3)	5656	2808	5656	2872	1432	5656	2872	2872	1496
Total number of bits per slot	19008	9216	19008	9504	4608	19008	9504	9504	4896
Total symbols per slot	9504	4608	9504	4752	2304	9504	4752	4752	2448
NOTE 1: DM-RS configuration type = 1 with DM-RS duration = single-symbol DM-RS, additional DM-RS position = pos1 with $l_0 = 2$, $l = 11$ as per table 6.4.1.1.3-3 of TS 38.211 [9].									
NOTE 2: MCS index 4 and target coding rate = 308/1024 are adopted to calculate payload size.									
NOTE 3: Code block size including CRC (bits) equals to K' in sub-clause 5.2.2 of TS 38.212 [15].									

A.2 Fixed Reference Channels for dynamic range (16QAM, R=2/3)

The parameters for the reference measurement channels are specified in table A.2-1 for FR1 dynamic range and OTA dynamic range. The parameters for the band n46, n96 and n102 reference measurement channels are specified in table A.2-1a and A.2-1b for band n46, n96 and n102 dynamic range.

Table A.2-1: FRC parameters for FR1 dynamic range and OTA dynamic range

Reference channel	G-FR1-A2-1	G-FR1-A2-2	G-FR1-A2-3	G-FR1-A2-4	G-FR1-A2-5	G-FR1-A2-6
Subcarrier spacing (kHz)	15	30	60	15	30	60
Allocated resource blocks	25	11	11	106	51	24
CP-OFDM Symbols per slot (Note 1)	12	12	12	12	12	12
Modulation	16QAM	16QAM	16QAM	16QAM	16QAM	16QAM
Code rate (Note 2)	2/3	2/3	2/3	2/3	2/3	2/3
Payload size (bits)	9224	4032	4032	38936	18960	8968
Transport block CRC (bits)	24	24	24	24	24	24
Code block CRC size (bits)	24	-	-	24	24	24
Number of code blocks - C	2	1	1	5	3	2
Code block size including CRC (bits) (Note 3)	4648	4056	4056	7816	6352	4520
Total number of bits per slot	14400	6336	6336	61056	29376	13824
Total symbols per slot	3600	1584	1584	15264	7344	3456
NOTE 1: DM-RS configuration type = 1 with DM-RS duration = single-symbol DM-RS, additional DM-RS position = pos1 with $l=2$, $l=11$ as per table 6.4.1.1.3-3 of TS 38.211 [9].						
NOTE 2: MCS index 16 and target coding rate = 658/1024 are adopted to calculate payload size.						
NOTE 3: Code block size including CRC (bits) equals to K' in sub-clause 5.2.2 of TS 38.212 [15].						

Table A.2-1a: FRC parameters for dynamic range for band n46, n96 and n102

Reference channel	G-FR1-A2-7	G-FR1-A2-8	G-FR1-A2-9	G-FR1-A2-10	G-FR1-A2-11	G-FR1-A2-12	G-FR1-A2-13	G-FR1-A2-14
Channel bandwidth (MHz)	10	10	20	20	40	40	60	80
Subcarrier spacing (kHz)	15	30	15	30	15	30	30	30
Allocated resource blocks	5	4	10	10	21	21	32	43
CP-OFDM Symbols per slot (Note 1)	12	12	12	12	12	12	12	12
Modulation	16QAM	16QAM	16QAM	16QAM	16QAM	16QAM	16QAM	16QAM
Code rate (Note 2)	2/3	2/3	2/3	2/3	2/3	2/3	2/3	2/3
Payload size (bits)	1864	1480	3752	3752	7808	7808	11784	15880
Transport block CRC (bits)	16	16	16	16	24	24	24	24
Code block CRC size (bits)	-	-	-	-	-	-	24	24
Number of code blocks - C	1	1	1	1	1	1	2	2
Code block size including CRC (bits) (Note 3)	1880	1496	3768	3768	7832	7832	5928	7976
Total number of bits per slot	2880	2304	5760	5760	12096	12096	18432	24768
Total symbols per slot	720	576	1440	1440	3024	3024	4608	6192
NOTE 1: DM-RS configuration type = 1 with DM-RS duration = single-symbol DM-RS, additional DM-RS position = pos1 with $l=2$, $l=11$ as per table 6.4.1.1.3-3 of TS 38.211 [9].								
NOTE 2: MCS index 16 and target coding rate = 658/1024 are adopted to calculate payload size.								
NOTE 3: Code block size including CRC (bits) equals to K' in sub-clause 5.2.2 of TS 38.212 [15].								
NOTE 4: For reference channel A2-7, the allocated RB's are uniformly spaced over the channel bandwidth at RB index N , $N+10$, $N+20$, $N+30$, $N+40$ where $N=\{0,1,2,3,4,5,6,7,8,9\}$.								
NOTE 5: For reference channel A2-8, the allocated RB's are uniformly spaced over the channel bandwidth at RB index N , $N+5$, $N+10$, $N+15$ where $N=\{0,1,2,3,4\}$.								
NOTE 6: For reference channel A2-9, the allocated RB's are uniformly spaced over the channel bandwidth at RB index N , $N+10$, $N+20$, ..., $N+90$ where $N=\{0,1,2,3,4,5,6,7,8,9\}$.								
NOTE 7: For reference channel A2-10, the allocated RB's are uniformly spaced over the channel bandwidth at RB index N , $N+5$, $N+10$, ..., $N+45$ where $N=\{0,1,2,3,4\}$.								
NOTE 8: For reference channel A2-11, the allocated RB's are uniformly spaced over the channel bandwidth at RB index N , $N+10$, $N+20$, ..., $N+200$ where $N=\{0,1,2,3,4,5,6,7,8,9\}$.								
NOTE 9: For reference channel A2-12, the allocated RB's are uniformly spaced over the channel bandwidth at RB index N , $N+5$, $N+10$, ..., $N+100$ where $N=\{0,1,2,3,4\}$.								
NOTE 10: For reference channel A2-13, the allocated RB's are uniformly spaced over the channel bandwidth at RB index N , $N+5$, $N+10$, ..., $N+155$ where $N=\{0,1,2,3,4\}$.								
NOTE 11: For reference channel A2-14, the allocated RB's are uniformly spaced over the channel bandwidth at RB index N , $N+5$, $N+10$, ..., $N+210$ where $N=\{0,1,2,3,4\}$.								

A.3 Fixed Reference Channels for performance requirements (QPSK, R=193/1024)

The parameters for the reference measurement channels are specified in table A.3-2, table A.3-2A, table A.3-4, and table A.3-6 for FR1 PUSCH performance requirements:

- FRC parameters are specified in table A.3-2 for FR1 PUSCH with transform precoding disabled, *Additional DM-RS position* = *pos1* and 1 transmission layer.
- FRC parameters are specified in table A.3-2A for FR1 PUSCH with transform precoding disabled, *Additional DM-RS position* = *pos2* and 1 transmission layer.
- FRC parameters are specified in table A.3-4 for FR1 PUSCH with transform precoding disabled, *Additional DM-RS position* = *pos1* and 2 transmission layers.
- FRC parameters are specified in table A.3-6 for FR1 PUSCH with transform precoding enabled, *Additional DM-RS position* = *pos1* and 1 transmission layer.

The parameters for the reference measurement channels are specified in table A.3-14 for FR1 PUSCH performance requirements for TB processing over multi-slot PUSCH:

- FRC parameters are specified in table A.3-14 for FR1 PUSCH with transform precoding disabled, *Additional DM-RS position* = *pos1* and 1 transmission layer.

The parameters for the reference measurement channels are specified in table A.3-7 to table A.3-12 for FR2 PUSCH performance requirements:

- FRC parameters are specified in table A.3-7 for FR2 PUSCH with transform precoding disabled, *Additional DM-RS position* = *pos0* and 1 transmission layer.
- FRC parameters are specified in table A.3-8 for FR2 PUSCH with transform precoding disabled, *Additional DM-RS position* = *pos0* and 2 transmission layers.
- FRC parameters are specified in table A.3-9 for FR2 PUSCH with transform precoding enabled, *Additional DM-RS position* = *pos0* and 1 transmission layer.
- FRC parameters are specified in table A.3-10 for FR2 PUSCH with transform precoding disabled, *Additional DM-RS position* = *pos1* and 1 transmission layer.
- FRC parameters are specified in table A.3-11 for FR2 PUSCH with transform precoding disabled, *Additional DM-RS position* = *pos1* and 2 transmission layers.
- FRC parameters are specified in table A.3-12 for FR2 PUSCH with transform precoding enabled, *Additional DM-RS position* = *pos1* and 1 transmission layer.

The parameters for the reference measurement channels are specified in table A.3-13 for FR2 PUSCH performance requirements for 2-step RA type:

- FRC parameters are specified in table A.3-13 for FR2 PUSCH with transform precoding disabled, *Additional DM-RS position* = *pos1* and 1 transmission layer.

The parameters for the reference measurement channels are specified in table A.3-15 for FR2 PUSCH performance requirements for TBoMS:

- FRC parameters are specified in table A.3-15 for FR2 PUSCH with transform precoding disabled, *Additional DM-RS position* = *pos1* and 1 transmission layer.

Table A.3-1: Void

Table A.3-2: FRC parameters for FR1 PUSCH performance requirements, transform precoding disabled, *Additional DM-RS position = pos1* and 1 transmission layer (QPSK, R=193/1024)

Reference channel	G-FR1-A3-8	G-FR1-A3-9	G-FR1-A3-10	G-FR1-A3-11	G-FR1-A3-12	G-FR1-A3-13	G-FR1-A3-14
Subcarrier spacing [kHz]	15	15	15	30	30	30	30
Allocated resource blocks	25	52	106	24	51	106	273
CP-OFDM Symbols per slot (Note 1)	12	12	12	12	12	12	12
Modulation	QPSK	QPSK	QPSK	QPSK	QPSK	QPSK	QPSK
Code rate (Note 2)	193/1024	193/1024	193/1024	193/1024	193/1024	193/1024	193/1024
Payload size (bits)	1352	2856	5768	1320	2792	5768	14856
Transport block CRC (bits)	16	16	24	16	16	24	24
Code block CRC size (bits)	-	-	24	-	-	24	24
Number of code blocks - C	1	1	2	1	1	2	4
Code block size including CRC (bits) (Note 2)	1368	2872	2920	1336	2808	2920	3744
Total number of bits per slot	7200	14976	30528	6912	14688	30528	78624
Total symbols per slot	3600	7488	15264	3456	7344	15264	39312
NOTE 1: <i>DM-RS configuration type = 1</i> with <i>DM-RS duration = single-symbol DM-RS</i> and the number of DM-RS CDM groups without data is 2, <i>Additional DM-RS position = pos1</i> , $l_0 = 2$ and $l = 11$ for PUSCH mapping type A, $l_0 = 0$ and $l = 10$ for PUSCH mapping type B as per table 6.4.1.1.3-3 of TS 38.211 [9].							
NOTE 2: Code block size including CRC (bits) equals to K' in clause 5.2.2 of TS 38.212 [15].							

Table A.3-2A: FRC parameters for FR1 PUSCH performance requirements, transform precoding disabled, *Additional DM-RS position = pos2* and 1 transmission layer (QPSK, R=193/1024)

Reference channel	G-FR1-A3-33	G-FR1-A3-33A	G-FR1-A3-34	G-FR1-A3-34A
Subcarrier spacing [kHz]	15	15	30	30
Allocated resource blocks	52	25	106	24
Data bearing CP-OFDM Symbols per slot (Note 1)	11	11	11	11
Modulation	QPSK	QPSK	QPSK	QPSK
Code rate (Note 2)	193/1024	193/1024	193/1024	193/1024
Payload size (bits)	2600	1256	5256	1192
Transport block CRC (bits)	16	16	24	16
Code block CRC size (bits)	-	-	24	-
Number of code blocks - C	1	1	2	1
Code block size including CRC (bits) (Note 2)	2616	1272	2664	1208
Total number of bits per slot	13728	6600	27984	6336
Total resource elements per slot	6846	3300	13992	3168
NOTE 1: <i>DM-RS configuration type = 1</i> with <i>DM-RS duration = single-symbol DM-RS</i> and the number of DM-RS CDM groups without data is 2, <i>Additional DM-RS position = pos2</i> , and $l_0 = 2$ or 3 for PUSCH mapping type A, as per table 6.4.1.1.3-3 of TS 38.211 [5].				
NOTE 2: Code block size including CRC (bits) equals to K' in clause 5.2.2 of TS 38.212 [15].				

Table A.3-3: Void

Table A.3-4: FRC parameters for FR1 PUSCH performance requirements, transform precoding disabled, Additional DM-RS position = pos1 and 2 transmission layers (QPSK, R=193/1024)

Reference channel	G-FR1-A3-22	G-FR1-A3-23	G-FR1-A3-24	G-FR1-A3-25	G-FR1-A3-26	G-FR1-A3-27	G-FR1-A3-28
Subcarrier spacing [kHz]	15	15	15	30	30	30	30
Allocated resource blocks	25	52	106	24	51	106	273
CP-OFDM Symbols per slot (Note 1)	12	12	12	12	12	12	12
Modulation	QPSK	QPSK	QPSK	QPSK	QPSK	QPSK	QPSK
Code rate (Note 2)	193/1024	193/1024	193/1024	193/1024	193/1024	193/1024	193/1024
Payload size (bits)	2728	5640	11528	2600	5512	11528	29736
Transport block CRC (bits)	16	24	24	16	24	24	24
Code block CRC size (bits)	-	24	24	-	24	24	24
Number of code blocks - C	1	2	4	1	2	4	8
Code block size including CRC (bits) (Note 2)	2744	2856	2912	2616	2792	2912	3744
Total number of bits per slot	14400	29952	61056	13824	29376	61056	157248
Total symbols per slot	7200	14976	30528	6912	14688	30528	78624
NOTE 1: DM-RS configuration type = 1 with DM-RS duration = single-symbol DM-RS and the number of DM-RS CDM groups without data is 2, Additional DM-RS position = pos1, $l_0 = 2$ and $l = 11$ for PUSCH mapping type A, $l_0 = 0$ and $l = 10$ for PUSCH mapping type B as per table 6.4.1.1.3-3 of TS 38.211 [9].							
NOTE 2: Code block size including CRC (bits) equals to K' in clause 5.2.2 of TS 38.212 [15].							

Table A.3-5: Void**Table A.3-6: FRC parameters for FR1 PUSCH performance requirements, transform precoding enabled, Additional DM-RS position = pos1 and 1 transmission layer (QPSK, R=193/1024)**

Reference channel	G-FR1-A3-31	G-FR1-A3-32
Subcarrier spacing [kHz]	15	30
Allocated resource blocks	25	24
DFT-s-OFDM Symbols per slot (Note 1)	12	12
Modulation	QPSK	QPSK
Code rate (Note 2)	193/1024	193/1024
Payload size (bits)	1352	1320
Transport block CRC (bits)	16	16
Code block CRC size (bits)	-	-
Number of code blocks - C	1	1
Code block size including CRC (bits) (Note 2)	1368	1336
Total number of bits per slot	7200	6912
Total symbols per slot	3600	3456
NOTE 1: DM-RS configuration type = 1 with DM-RS duration = single-symbol DM-RS and the number of DM-RS CDM groups without data is 2, Additional DM-RS position = pos1, $l_0 = 2$ and $l = 11$ for PUSCH mapping type A, $l_0 = 0$ and $l = 10$ for PUSCH mapping type B as per Table 6.4.1.1.3-3 of TS 38.211 [9].		
NOTE 2: Code block size including CRC (bits) equals to K' in sub-clause 5.2.2 of TS 38.212 [15].		

Table A.3-7: FRC parameters for FR2 PUSCH performance requirements, transform precoding disabled, Additional DM-RS position = pos0 and 1 transmission layer (QPSK, R=193/1024)

Reference channel	G-FR2-A3-1	G-FR2-A3-2	G-FR2-A3-3	G-FR2-A3-4	G-FR2-A3-5
Subcarrier spacing [kHz]	60	60	120	120	120
Allocated resource blocks	66	132	32	66	132
CP-OFDM Symbols per slot (Note 1)	9	9	9	9	9
Modulation	QPSK	QPSK	QPSK	QPSK	QPSK
Code rate (Note 2)	193/1024	193/1024	193/1024	193/1024	193/1024
Payload size (bits)	2664	5384	1320	2664	5384
Transport block CRC (bits)	16	24	16	16	24
Code block CRC size (bits)	-	24	-	-	24
Number of code blocks - C	1	2	1	1	2
Code block size including CRC (bits) (Note 2)	2680	2728	1336	2680	2728
Total number of bits per slot	14256	28512	6912	14256	28512
Total symbols per slot	7128	14256	3456	7128	14256
NOTE 1: DM-RS configuration type = 1 with DM-RS duration = single-symbol DM-RS and the number of DM-RS CDM groups without data is 2, Additional DM-RS position = pos0 with $l_0 = 0$ as per Table 6.4.1.1.3-3 of TS 38.211 [9].					
NOTE 2: Code block size including CRC (bits) equals to K' in sub-clause 5.2.2 of TS 38.212 [15].					

Table A.3-8: FRC parameters for FR2 PUSCH performance requirements, transform precoding disabled, Additional DM-RS position = pos0 and 2 transmission layers (QPSK, R=193/1024)

Reference channel	G-FR2-A3-6	G-FR2-A3-7	G-FR2-A3-8	G-FR2-A3-9	G-FR2-A3-10
Subcarrier spacing [kHz]	60	60	120	120	120
Allocated resource blocks	66	132	32	66	132
CP-OFDM Symbols per slot (Note 1)	9	9	9	9	9
Modulation	QPSK	QPSK	QPSK	QPSK	QPSK
Code rate (Note 2)	193/1024	193/1024	193/1024	193/1024	193/1024
Payload size (bits)	5384	10752	2600	5384	10752
Transport block CRC (bits)	24	24	16	24	24
Code block CRC size (bits)	24	24	-	24	24
Number of code blocks - C	2	3	1	2	3
Code block size including CRC (bits) (Note 2)	2728	3616	2616	2728	3616
Total number of bits per slot	28512	57024	13824	28512	57024
Total symbols per slot	14256	28512	6912	14256	28512
NOTE 1: DM-RS configuration type = 1 with DM-RS duration = single-symbol DM-RS and the number of DM-RS CDM groups without data is 2, Additional DM-RS position = pos0 with $l_0 = 0$ as per Table 6.4.1.1.3-3 of TS 38.211 [9].					
NOTE 2: Code block size including CRC (bits) equals to K' in sub-clause 5.2.2 of TS 38.212 [15].					

Table A.3-9: FRC parameters for FR2 PUSCH performance requirements, transform precoding enabled, *Additional DM-RS position = pos0* and 1 transmission layer (QPSK, R=193/1024)

Reference channel	G-FR2-A3-11	G-FR2-A3-12
Subcarrier spacing [kHz]	60	120
Allocated resource blocks	30	30
DFT-s-OFDM Symbols per slot (Note 1)	9	9
Modulation	QPSK	QPSK
Code rate (Note 2)	193/1024	193/1024
Payload size (bits)	1224	1224
Transport block CRC (bits)	16	16
Code block CRC size (bits)	-	-
Number of code blocks - C	1	1
Code block size including CRC (bits) (Note 2)	1240	1240
Total number of bits per slot	6480	6480
Total symbols per slot	3240	3240
NOTE 1: <i>DM-RS configuration type = 1</i> with <i>DM-RS duration = single-symbol DM-RS</i> and the number of DM-RS CDM groups without data is 2, <i>Additional DM-RS position = pos0</i> with $l_0 = 0$ as per Table 6.4.1.1.3-3 of TS 38.211 [9].		
NOTE 2: Code block size including CRC (bits) equals to K' in sub-clause 5.2.2 of TS 38.212 [15].		

Table A.3-10: FRC parameters for FR2 PUSCH performance requirements, transform precoding disabled, *Additional DM-RS position = pos1* and 1 transmission layer (QPSK, R=193/1024)

Reference channel	G-FR2-A3-13	G-FR2-A3-14	G-FR2-A3-15	G-FR2-A3-16	G-FR2-A3-17
Subcarrier spacing [kHz]	60	60	120	120	120
Allocated resource blocks	66	132	32	66	132
CP-OFDM Symbols per slot (Note 1)	8	8	8	8	8
Modulation	QPSK	QPSK	QPSK	QPSK	QPSK
Code rate (Note 2)	193/1024	193/1024	193/1024	193/1024	193/1024
Payload size (bits)	2408	4744	1160	2408	4744
Transport block CRC (bits)	16	24	16	16	24
Code block CRC size (bits)	-	24	-	-	24
Number of code blocks - C	1	2	1	1	2
Code block size including CRC (bits) (Note 2)	2424	2408	1176	2424	2408
Total number of bits per slot	12672	25344	6144	12672	25344
Total symbols per slot	6336	12672	3072	6336	12672
NOTE 1: <i>DM-RS configuration type = 1</i> with <i>DM-RS duration = single-symbol DM-RS</i> and the number of DM-RS CDM groups without data is 2, <i>Additional DM-RS position = pos1</i> with $l_0 = 0$ and $l = 8$ as per Table 6.4.1.1.3-3 of TS 38.211 [9].					
NOTE 2: Code block size including CRC (bits) equals to K' in sub-clause 5.2.2 of TS 38.212 [15].					

Table A.3-11: FRC parameters for FR2 PUSCH performance requirements, transform precoding disabled, Additional DM-RS position = pos1 and 2 transmission layers (QPSK, R=193/1024)

Reference channel	G-FR2-A3-18	G-FR2-A3-19	G-FR2-A3-20	G-FR2-A3-21	G-FR2-A3-22
Subcarrier spacing [kHz]	60	60	120	120	120
Allocated resource blocks	66	132	32	66	132
CP-OFDM Symbols per slot (Note 1)	8	8	8	8	8
Modulation	QPSK	QPSK	QPSK	QPSK	QPSK
Code rate (Note 2)	193/1024	193/1024	193/1024	193/1024	193/1024
Payload size (bits)	4744	9480	2408	4744	9480
Transport block CRC (bits)	24	24	16	24	24
Code block CRC size (bits)	24	24	-	24	24
Number of code blocks - C	2	3	1	2	3
Code block size including CRC (bits) (Note 2)	2408	3192	2424	2408	3192
Total number of bits per slot	25344	50688	12288	25344	50688
Total symbols per slot	12672	25344	6144	12672	25344
NOTE 1: DM-RS configuration type = 1 with DM-RS duration = single-symbol DM-RS and the number of DM-RS CDM groups without data is 2, Additional DM-RS position = pos1 with $l_0 = 0$ and $l = 8$ as per Table 6.4.1.1.3-3 of TS 38.211 [9].					
NOTE 2: Code block size including CRC (bits) equals to K' in sub-clause 5.2.2 of TS 38.212 [15].					

Table A.3-12: FRC parameters for FR2 PUSCH performance requirements, transform precoding enabled, Additional DM-RS position = pos1 and 1 transmission layer (QPSK, R=193/1024)

Reference channel	G-FR2-A3-23	G-FR2-A3-24
Subcarrier spacing [kHz]	60	120
Allocated resource blocks	30	30
DFT-s-OFDM Symbols per slot (Note 1)	8	8
Modulation	QPSK	QPSK
Code rate (Note 2)	193/1024	193/1024
Payload size (bits)	1128	1128
Transport block CRC (bits)	16	16
Code block CRC size (bits)	-	-
Number of code blocks - C	1	1
Code block size including CRC (bits) (Note 2)	1144	1144
Total number of bits per slot	5760	5760
Total symbols per slot	2880	2880
NOTE 1: DM-RS configuration type = 1 with DM-RS duration = single-symbol DM-RS and the number of DM-RS CDM groups without data is 2, Additional DM-RS position = pos1 with $l_0 = 0$ and $l = 8$ as per Table 6.4.1.1.3-3 of TS 38.211 [9].		
NOTE 2: Code block size including CRC (bits) equals to K' in sub-clause 5.2.2 of TS 38.212 [15].		

Table A.3-13: FRC parameters for FR2 PUSCH performance requirements, transform precoding disabled, Additional DM-RS position = pos1 and 1 transmission layer (QPSK, R=193/1024)

Reference channel	G-FR2-A3-25	G-FR2-A3-26
Subcarrier spacing [kHz]	60	120
Allocated resource blocks	2	2
CP-OFDM Symbols per slot (Note 1)	8	8
Modulation	QPSK	QPSK
Code rate (Note 2)	193/1024	193/1024
Payload size (bits)	72	72
Transport block CRC (bits)	16	16
Code block CRC size (bits)	0	0
Number of code blocks - C	1	1
Code block size including CRC (bits) (Note 2)	88	88
Total number of bits per slot	384	384
Total number of symbols per slot	192	192
NOTE 1: DM-RS configuration type = 1 with DM-RS duration = single-symbol DM-RS and the number of DM-RS CDM groups without data is 2, Additional DM-RS position = pos1 with l0= 2 as per Table 6.4.1.1.3-3 of TS 38.211 [9].		
NOTE 2: Code block size including CRC (bits) equals to K' in sub-clause 5.2.2 of TS 38.212 [15].		

Table A.3-14: FRC parameters for FR1 PUSCH performance requirements, transform precoding disabled, Additional DM-RS position = pos1 and 1 transmission layer (QPSK, R=193/1024)

Reference channel	G-FR1-A3-35	G-FR1-A3-36	G-FR1-A3-37	G-FR1-A3-38
Number of TBoMS slots	2	4	2	4
Subcarrier spacing [kHz]	15	15	30	30
Allocated resource blocks per slot	5	5	5	5
Data bearing CP-OFDM Symbols per slot (Note 1)	12	12	12	12
Modulation	QPSK	QPSK	QPSK	QPSK
Code rate (Note 2)	193/1024	193/1024	193/1024	193/1024
Payload size (bits)	552	1128	552	1128
Transport block CRC (bits)	16	16	16	16
Code block CRC size (bits)	-	-	-	-
Number of code blocks - C	1	1	1	1
Code block size including CRC (bits) (Note 2)	568	1144	568	1144
Total number of bits over all TBoMS slots	2880	5760	2880	5760
Total resource elements over all TBoMS slots	1440	2880	1440	2880
NOTE 1: DM-RS configuration type = 1 with DM-RS duration = single-symbol DM-RS and the number of DM-RS CDM groups without data is 2, Additional DM-RS position = pos1 with l0= 2 as per Table 6.4.1.1.3-3 of TS 38.211 [9].				
NOTE 2: Code block size including CRC (bits) equals to K' in sub-clause 5.2.2 of TS 38.212 [15].				

Table A.3-15: FRC parameters for FR2 PUSCH performance requirements, transform precoding disabled, Additional DM-RS position = pos1 and 1 transmission layer (QPSK, R=193/1024)

Reference channel	G-FR2-A3-27	G-FR2-A3-28
Number of TBoMS slots	2	2
Subcarrier spacing [kHz]	60	120
Allocated resource blocks per slot	5	5
Data bearing CP-OFDM Symbols per slot (Note 1)	8	8
Modulation	QPSK	QPSK
Code rate (Note 2)	193/1024	193/1024
Payload size (bits)	368	368
Transport block CRC (bits)	16	16
Code block CRC size (bits)	-	-
Number of code blocks - C	1	1
Code block size including CRC (bits) (Note 2)	384	384
Total number of bits over all TBoMS slots	1920	1920
Total resource elements over all TBoMS slots	960	960
NOTE 1: DM-RS configuration type = 1 with DM-RS duration = single-symbol DM-RS and the number of DM-RS CDM groups without data is 2, Additional DM-RS position = pos1 with , l0 = 0 and l = 8 for PUSCH mapping type B as per table 6.4.1.1.3-3 of TS 38.211 [9].		
NOTE 2: Code block size including CRC (bits) equals to 'K' in sub-clause 5.2.2 of TS 38.212 [15].		

A.3A Fixed Reference Channels for performance requirements (QPSK, R=99/1024)

The parameters for the reference measurement channel are specified in table A.3A-1 for FR1 PUSCH performance requirements:

- FRC parameters are specified in table A.3A-1 for FR1 PUSCH with transform precoding disabled, additional DM-RS position = pos1 and 1 transmission layer.

The parameters for the reference measurement channels are specified in table A.3A-2 to A.3A-3 for FR2 PUSCH performance requirements:

- FRC parameters are specified in table A.3A-2 for FR2 PUSCH with transform precoding disabled, additional DM-RS position = pos0 and 1 transmission layer.
- FRC parameters are specified in table A.3A-3 for FR2 PUSCH with transform precoding disabled, additional DM-RS position = pos1 and 1 transmission layer.

Table A.3A-1: FRC parameters for FR1 PUSCH performance requirements, transform precoding disabled, additional DM-RS position = pos1 and 1 transmission layer (QPSK, R=99/1024)

Reference channel	G-FR1-A3A-1	G-FR1-A3A-2	G-FR1-A3A-3	G-FR1-A3A-4
Subcarrier spacing (kHz)	15	15	30	30
Allocated resource blocks	25	52	24	106
Data bearing CP-OFDM Symbols per slot (Note 1)	12	12	12	12
Modulation	QPSK	QPSK	QPSK	QPSK
Code rate (Note 2)	99/1024	99/1024	99/1024	99/1024
Payload size (bits)	704	1480	672	2976
Transport block CRC (bits)	16	16	16	16
Code block CRC size (bits)	-	-	-	-
Number of code blocks - C	1	1	1	1
Code block size including CRC (bits) (Note 2)	720	1496	688	2992
Total number of bits per slot	7200	14976	6912	30528
Total resource elements per slot	3600	7488	3456	15264
NOTE 1: DM-RS configuration type = 1 with DM-RS duration = single-symbol DM-RS and the number of DM-RS CDM groups without data is 2, additional DM-RS position = pos1, $l_0 = 2$ and $l = 11$ for PUSCH mapping type A, $l_0 = 0$ and $l = 10$ for PUSCH mapping type B as per table 6.4.1.1.3-3 of TS 38.211 [9].				
NOTE 2: Code block size including CRC (bits) equals to K' in clause 5.2.2 of TS 38.212 [15].				

Table A.3A-2: FRC parameters for FR2 PUSCH performance requirements, transform precoding disabled, additional DM-RS position = pos0 and 1 transmission layer (QPSK, R=99/1024)

Reference channel	G-FR2-A3A-1	G-FR2-A3A-2	G-FR2-A3A-3	G-FR2-A3A-4
Subcarrier spacing [kHz]	60	60	120	120
Allocated resource blocks	66	132	32	66
Data bearing CP-OFDM Symbols per slot (Note 1)	3	3	3	3
Modulation	QPSK	QPSK	QPSK	QPSK
Code rate (Note 2)	99/1024	99/1024	99/1024	99/1024
Payload size (bits)	456	928	224	456
Transport block CRC (bits)	16	16	16	16
Code block CRC size (bits)	-	-	-	-
Number of code blocks - C	1	1	1	1
Code block size including CRC (bits) (Note 2)	472	944	240	472
Total number of bits per slot	4752	9504	2304	4752
Total symbols per slot	2376	4752	1152	2376
NOTE 1: DM-RS configuration type = 1 with DM-RS duration = single-symbol DM-RS and the number of DM-RS CDM groups without data is 2, additional DM-RS position = pos0, $l_0 = 0$ as per table 6.4.1.1.3-3 of TS 38.211 [9].				
NOTE 2: Code block size including CRC (bits) equals to K' in clause 5.2.2 of TS 38.212 [15].				

Table A.3A-3: FRC parameters for FR2 PUSCH performance requirements, transform precoding disabled, additional DM-RS position = pos1 and 1 transmission layer (QPSK, R=99/1024)

Reference channel	G-FR2-A3A-5	G-FR2-A3A-6	G-FR2-A3A-7	G-FR2-A3A-8
Subcarrier spacing [kHz]	60	60	120	120
Allocated resource blocks	66	132	32	66
Data bearing CP-OFDM Symbols per slot (Note 1)	8	8	8	8
Modulation	QPSK	QPSK	QPSK	QPSK
Code rate (Note 2)	99/1024	99/1024	99/1024	99/1024
Payload size (bits)	1224	2472	608	1224
Transport block CRC (bits)	16	16	16	16
Code block CRC size (bits)	-	-	-	-
Number of code blocks - C	1	1	1	1
Code block size including CRC (bits) (Note 2)	1240	2488	624	1240
Total number of bits per slot	12672	25344	6144	12672
Total symbols per slot	6336	12672	3072	6336
NOTE 1: DM-RS configuration type = 1 with DM-RS duration = single-symbol DM-RS and the number of DM-RS CDM groups without data is 2, additional DM-RS position = pos1, l0= 0 and l = 8 as per table 6.4.1.1.3-3 of TS 38.211 [9].				
NOTE 2: Code block size including CRC (bits) equals to K' in clause 5.2.2 of TS 38.212 [15].				

A.3B Fixed Reference Channels for performance requirements (QPSK, R=308/1024)

The parameters for the reference measurement channel are specified in table A.3B-1 for FR1 PUSCH performance requirements:

- FRC parameters are specified in table A.3B-1 for FR1 PUSCH with transform precoding disabled, additional DM-RS position = pos0 and 1 transmission layer.

The parameters for the reference measurement channel are specified in table A.3B-2 and table A.3B-3 for FR1 PUSCH performance requirements with DM-RS bundling:

- FRC parameters are specified in table A.3B-2 for FR1 PUSCH with transform precoding disabled, additional DM-RS position = pos1 and 1 transmission layer.
- FRC parameters are specified in table A.3B-3 for FR1 PUSCH with transform precoding disabled, additional DM-RS position = pos0 and 1 transmission layer.

The parameters for the reference measurement channel are specified in table A.3B-4 for FR2-1 PUSCH performance requirements with DM-RS bundling:

- FRC parameters are specified in table A.3B-4 for FR2-1 PUSCH with transform precoding disabled, additional DM-RS position = pos1 and 1 transmission layer.

The parameters for the reference measurement channel are specified in table A.3B-5 to table A.3B-7 for FR2-2 PUSCH performance requirements:

- FRC parameters are specified in table A.3B-5 for FR2-2 PUSCH with transform precoding disabled, *Additional DM-RS position = pos1* and 1 transmission layer.
- FRC parameters are specified in table A.3B-6 for FR2-2 PUSCH with transform precoding enabled, *Additional DM-RS position = pos1* and 1 transmission layer.
- FRC parameters are specified in table A.3B-7 for FR2-2 PUSCH with transform precoding disabled, *Additional DM-RS position = pos1* and 2 transmission layers.

Table A.3B-1: FRC parameters for FR1 PUSCH performance requirements, transform precoding disabled, additional DM-RS position = pos0 and 1 transmission layer (QPSK, R=308/1024)

Reference channel	G-FR1-A3B-1	G-FR1-A3B-2	G-FR1-A3B-3	G-FR1-A3B-4
Subcarrier spacing (kHz)	15	15	30	30
Allocated resource blocks	25	52	24	106
Data bearing CP-OFDM Symbols per slot (Note 1)	1	1	1	1
Modulation	QPSK	QPSK	QPSK	QPSK
Code rate (Note 2)	308/1024	308/1024	308/1024	308/1024
Payload size (bits)	176	368	168	768
Transport block CRC (bits)	16	16	16	16
Code block CRC size (bits)	-	-	-	-
Number of code blocks - C	1	1	1	1
Code block size including CRC (bits) (Note 2)	192	384	184	784
Total number of bits per slot	600	1248	576	2544
Total resource elements per slot	300	624	288	1272
NOTE 1: DM-RS configuration type = 1 with DM-RS duration = single-symbol DM-RS and the number of DM-RS CDM groups without data is 2, additional DM-RS position = pos0, $l_0 = 0$ for PUSCH mapping type B as per table 6.4.1.1.3-3 of TS 38.211 [9].				
NOTE 2: Code block size including CRC (bits) equals to K' in clause 5.2.2 of TS 38.212 [15].				

Table A.3B-2: FRC parameters for FR1 PUSCH performance requirements, transform precoding disabled, Additional DM-RS position = pos1 and 1 transmission layer (QPSK, R=308/1024)

Reference channel	G-FR1-A3B-5	G-FR1-A3B-6
Subcarrier spacing [kHz]	15	30
Allocated resource blocks	25	24
CP-OFDM Symbols per slot (Note 1)	12	12
Modulation	QPSK	QPSK
Code rate (Note 2)	308/1024	308/1024
Payload size (bits)	2152	2088
Transport block CRC (bits)	16	16
Code block CRC size (bits)	-	-
Number of code blocks - C	1	1
Code block size including CRC (bits) (Note 2)	2168	2104
Total number of bits per slot	7200	6912
Total resource elements per slot	3600	3456
NOTE 1: DM-RS configuration type = 1 with DM-RS duration = single-symbol DM-RS and the number of DM-RS CDM groups without data is 2, Additional DM-RS position = pos1, $l_0 = 2$ and $l = 11$ for PUSCH mapping type A, $l_0 = 0$ and $l = 10$ for PUSCH mapping type B as per Table 6.4.1.1.3-3 of TS 38.211 [9].		
NOTE 2: Code block size including CRC (bits) equals to K' in sub-clause 5.2.2 of TS 38.212 [15].		

Table A.3B-3: FRC parameters for FR1 PUSCH performance requirements, transform precoding disabled, *Additional DM-RS position = pos0* and 1 transmission layer (QPSK, R=308/1024)

Reference channel	G-FR1-A3B-7	G-FR1-A3B-8
Subcarrier spacing [kHz]	15	30
Allocated resource blocks	25	24
CP-OFDM Symbols per slot (Note 1)	13	13
Modulation	QPSK	QPSK
Code rate (Note 2)	308/1024	308/1024
Payload size (bits)	2408	2280
Transport block CRC (bits)	16	16
Code block CRC size (bits)	-	-
Number of code blocks - C	1	1
Code block size including CRC (bits) (Note 2)	2424	2296
Total number of bits per slot	7800	7488
Total resource elements per slot	3900	3744
NOTE 1: <i>DM-RS configuration type = 1</i> with <i>DM-RS duration = single-symbol DM-RS</i> and the number of DM-RS CDM groups without data is 2, <i>Additional DM-RS position = pos0</i> $l_0 = 2$ and $l = 11$ for PUSCH mapping type A, $l_0 = 0$ and $l = 10$ for PUSCH mapping type B as per table 6.4.1.1.3-3 of TS 38.211 [9].		
NOTE 2: Code block size including CRC (bits) equals to K' in sub-clause 5.2.2 of TS 38.212 [15].		

Table A.3B-4: FRC parameters for FR2-1 PUSCH performance requirements, transform precoding disabled, *Additional DM-RS position = pos1* and 1 transmission layer (QPSK, R=308/1024)

Reference channel	G-FR2-A3B-1	G-FR2-A3B-2
Subcarrier spacing [kHz]	60	120
Allocated resource blocks	66	32
CP-OFDM Symbols per slot (Note 1)	12	12
Modulation	QPSK	QPSK
Code rate (Note 2)	308/1024	308/1024
Payload size (bits)	5632	2792
Transport block CRC (bits)	24	16
Code block CRC size (bits)	-	-
Number of code blocks - C	1	1
Code block size including CRC (bits) (Note 2)	5656	2808
Total number of bits per slot	19008	9216
Total resource elements per slot	9504	4608
NOTE 1: <i>DM-RS configuration type = 1</i> with <i>DM-RS duration = single-symbol DM-RS</i> and the number of DM-RS CDM groups without data is 2, <i>Additional DM-RS position = pos1</i> with $l_0 = 0$ and $l = 10$ as per Table 6.4.1.1.3-3 of TS 38.211 [9].		
NOTE 2: Code block size including CRC (bits) equals to K' in sub-clause 5.2.2 of TS 38.212 [15].		

Table A.3B-5: FRC parameters for FR2-2 PUSCH performance requirements, transform precoding disabled, *Additional DM-RS position = pos1* and 1 transmission layer (QPSK, R=308/1024)

Reference channel	G-FR2-A3B-3	G-FR2-A3B-4	G-FR2-A3B-5
Subcarrier spacing [kHz]	120	120	480
Allocated resource blocks	66	264	66
CP-OFDM Symbols per slot (Note 1)	8	8	8
Modulation	QPSK	QPSK	QPSK
Code rate (Note 2)	308/1024	308/1024	308/1024
Payload size (bits)	3824	15112	3824
Transport block CRC (bits)	16	24	16
Code block CRC size (bits)	-	24	-
Number of code blocks - C	1	2	1
Code block size including CRC (bits) (Note 2)	3840	7592	3840
Total number of bits per slot without PT-RS	12672	50688	12672
Total symbols per slot without PT-RS	6336	25344	6336
NOTE 1: <i>DM-RS configuration type = 1</i> with <i>DM-RS duration = single-symbol DM-RS</i> and the number of DM-RS CDM groups without data is 2, <i>Additional DM-RS position = pos1</i> with $l_0 = 0$ and $l = 8$ as per Table 6.4.1.1.3-3 of TS 38.211 [9].			
NOTE 2: Code block size including CRC (bits) equals to K' in sub-clause 5.2.2 of TS 38.212 [15].			
NOTE 3: The calculation of the "Total number of bits per slot" and "Total symbols per slot" fields include the REs taken up by CSI part 1 and CSI part 2, if present.			

Table A.3B-6: FRC parameters for FR2-2 PUSCH performance requirements, transform precoding enabled, *Additional DM-RS position = pos1* and 1 transmission layer (QPSK, R=308/1024)

Reference channel	G-FR2-A3B-6	G-FR2-A3B-7
Subcarrier spacing [kHz]	120	480
Allocated resource blocks	64	64
DFT-s-OFDM Symbols per slot (Note 1)	8	8
Modulation	QPSK	QPSK
Code rate (Note 2)	308/1024	308/1024
Payload size (bits)	3624	3624
Transport block CRC (bits)	16	16
Code block CRC size (bits)	-	-
Number of code blocks - C	1	1
Code block size including CRC (bits) (Note 2)	3640	3640
Total number of bits per slot without PT-RS	12288	12288
Total symbols per slot without PT-RS	6144	6144
NOTE 1: <i>DM-RS configuration type = 1</i> with <i>DM-RS duration = single-symbol DM-RS</i> and the number of DM-RS CDM groups without data is 2, <i>Additional DM-RS position = pos1</i> with $l_0 = 0$ and $l = 8$ as per Table 6.4.1.1.3-3 of TS 38.211 [9].		
NOTE 2: Code block size including CRC (bits) equals to K' in sub-clause 5.2.2 of TS 38.212 [15].		
NOTE 3: The calculation of the "Total number of bits per slot" and "Total symbols per slot" fields include the REs taken up by CSI part 1 and CSI part 2, if present.		

Table A.3B-7: FRC parameters for FR2-2 PUSCH performance requirements, transform precoding disabled, *Additional DM-RS position = pos1 and 2* transmission layers (QPSK, R=308/1024)

Reference channel	G-FR2-A3B-8	G-FR2-A3B-9	G-FR2-A3B-10
Subcarrier spacing [kHz]	120	120	480
Allocated resource blocks	66	264	66
CP-OFDM Symbols per slot (Note 1)	8	8	8
Modulation	QPSK	QPSK	QPSK
Code rate (Note 2)	308/1024	308/1024	308/1024
Payload size (bits)	7552	30728	7552
Transport block CRC (bits)	24	24	24
Code block CRC size (bits)	-	24	-
Number of code blocks - C	1	4	1
Code block size including CRC (bits) (Note 2)	7576	7712	7576
Total number of bits per slot without PT-RS	25344	101376	25344
Total symbols per slot without PT-RS	12672	50688	12672
NOTE 1: <i>DM-RS configuration type = 1</i> with <i>DM-RS duration = single-symbol DM-RS</i> and the number of DM-RS CDM groups without data is 2, <i>Additional DM-RS position = pos1</i> with $l_0 = 0$ and $l = 8$ as per Table 6.4.1.1.3-3 of TS 38.211 [9].			
NOTE 2: Code block size including CRC (bits) equals to K' in sub-clause 5.2.2 of TS 38.212 [15].			
NOTE 3: The calculation of the "Total number of bits per slot" and "Total symbols per slot" fields include the REs taken up by CSI part 1 and CSI part 2, if present.			

A.4 Fixed Reference Channels for performance requirements (16QAM, R=658/1024)

The parameters for the reference measurement channels are specified in table A.4-2, table A.4-2A, table A.4-2B and table A.4-4 for FR1 PUSCH performance requirements:

- FRC parameters are specified in table A.4-2 for FR1 PUSCH with transform precoding disabled, *Additional DM-RS position = pos1* and 1 transmission layer.
- FRC parameters are specified in table A.4-2A for FR1 PUSCH with transform precoding disabled, additional DM-RS position = pos 2 and 1 transmission layer.
- FRC parameters are specified in table A.4-2B for FR1 PUSCH with transform-precoding disabled, *Additional DM-RS position = pos2* and 1 transmission layer
- FRC parameters are specified in table A.4-4 for FR1 PUSCH with transform precoding disabled, *Additional DM-RS position = pos1* and 2 transmission layers.

The parameters for the reference measurement channels are specified in table A.4-5 to table A.4-8 for FR2-1 PUSCH performance requirements:

- FRC parameters are specified in table A.4-5 for FR2-1 PUSCH with transform precoding disabled, *Additional DM-RS position = pos0* and 1 transmission layer.
- FRC parameters are specified in table A.4-6 for FR2-1 PUSCH with transform precoding disabled, *Additional DM-RS position = pos0* and 2 transmission layers.
- FRC parameters are specified in table A.4-7 for FR2-1 PUSCH with transform precoding disabled, *Additional DM-RS position = pos1* and 1 transmission layer.
- FRC parameters are specified in table A.4-8 for FR2-1 PUSCH with transform precoding disabled, *Additional DM-RS position = pos1* and 2 transmission layers.

The parameters for the reference measurement channels are specified in table A.4-7A for FR2-2 PUSCH performance requirements:

- FRC parameters are specified in table A.4-7A for FR2-2 PUSCH with transform precoding disabled, *Additional DM-RS position = pos1* and 1 transmission layer.

Table A.4-1: Void

Table A.4-2: FRC parameters for FR1 PUSCH performance requirements, transform precoding disabled, *Additional DM-RS position = pos1* and 1 transmission layer (16QAM, R=658/1024)

Reference channel	G-FR1-A4-8	G-FR1-A4-9	G-FR1-A4-10	G-FR1-A4-11 (Note 3)	G-FR1-A4-12	G-FR1-A4-13	G-FR1-A4-14
Subcarrier spacing [kHz]	15	15	15	30	30	30	30
Allocated resource blocks	25	52	106	24	51	106	273
CP-OFDM Symbols per slot (Note 1)	12	12	12	12	12	12	12
Modulation	16QAM	16QAM	16QAM	16QAM	16QAM	16QAM	16QAM
Code rate (Note 2)	658/1024	658/1024	658/1024	658/1024	658/1024	658/1024	658/1024
Payload size (bits)	9224	19464	38936	8968	18960	38936	100392
Transport block CRC (bits)	24	24	24	24	24	24	24
Code block CRC size (bits)	24	24	24	24	24	24	24
Number of code blocks - C	2	3	5	2	3	5	12
Code block size including CRC (bits) (Note 2)	4648	6520	7816	4520	6352	7816	8392
Total number of bits per slot	14400	29952	61056	13824	29376	61056	157248
Total symbols per slot	3600	7488	15264	3456	7344	15264	39312
NOTE 1: <i>DM-RS configuration type = 1</i> with <i>DM-RS duration = single-symbol DM-RS</i> and the number of DM-RS CDM groups without data is 2, <i>Additional DM-RS position = pos1</i> , $l_0 = 2$ and $l = 11$ for PUSCH mapping type A, $l_0 = 0$ and $l = 10$ for PUSCH mapping type B as per table 6.4.1.1.3-3 of TS 38.211 [9].							
NOTE 2: Code block size including CRC (bits) equals to K' in clause 5.2.2 of TS 38.212 [15].							
NOTE 3: The calculation of the "Total number of bits per slot" and "Total symbols per slot" fields include the REs taken up by CSI part 1 and CSI part 2, if present.							

Table A.4-2A: FRC parameters for FR1 PUSCH performance requirements, transform precoding disabled, *Additional DM-RS position = pos2* and 1 transmission layer (16QAM, R=658/1024)

Reference channel	G-FR1-A4-29	G-FR1-A4-29A	G-FR1-A4-30	G-FR1-A4-30A
Subcarrier spacing [kHz]	15	15	30	30
Allocated resource blocks	52	25	106	24
Data bearing CP-OFDM Symbols per slot (Note 1)	11	11	11	11
Modulation	16QAM	16QAM	16QAM	16QAM
Code rate (Note 2)	658/1024	658/1024	658/1024	658/1024
Payload size (bits)	17424	8456	35856	8064
Transport block CRC (bits)	24	24	24	24
Code block CRC size (bits)	24	24	24	-
Number of code blocks - C	3	2	5	1
Code block size including CRC (bits) (Note 2)	5840	4264	7200	8088
Total number of bits per slot	27456	13200	55968	12672
Total resource elements per slot	6846	3300	13992	3168
NOTE 1: <i>DM-RS configuration type = 1</i> with <i>DM-RS duration = single-symbol DM-RS</i> and the number of DM-RS CDM groups without data is 2, <i>Additional DM-RS position = pos2</i> , and $l_0 = 2$ or 3 for PUSCH mapping type A, as per table 6.4.1.1.3-3 of TS 38.211 [9].				
NOTE 2: Code block size including CRC (bits) equals to K' in clause 5.2.2 of TS 38.212 [15].				

Table A.4-2B: FRC parameters for FR1 PUSCH performance requirements, transform precoding disabled, Additional DM-RS position = pos2 and 1 transmission layer (16QAM, R=658/1024)

Reference channel	G-FR1-A4-31A	G-FR1-A4-31	G-FR1-A4-32A	G-FR1-A4-32
Subcarrier spacing [kHz]	15	15	30	30
Allocated resource blocks	12	25	12	50
CP-OFDM Symbols per slot (Note 1)	11	11	11	11
Modulation	16QAM	16QAM	16QAM	16QAM
Code rate (Note 2)	658/1024	658/1024	658/1024	658/1024
Payload size (bits)	4032	8456	4032	16896
Transport block CRC (bits)	24	24	24	24
Code block CRC size (bits)	-	24	-	24
Number of code blocks - C	1	2	1	3
Code block size including CRC (bits) (Note 2)	4056	4264	4056	5664
Total number of bits per slot	6336	13200	6336	26400
Total symbols per slot	1584	3300	1584	6600
NOTE 1: DM-RS configuration type = 1 with DM-RS duration = single-symbol DM-RS and the number of DM-RS CDM groups without data is 2, Additional DM-RS position = pos2, $l_0 = 2$ for PUSCH mapping type A, $l_0 = 2$ for PUSCH mapping type B, as per table 6.4.1.1.3-3 of TS 38.211 [9].				
NOTE 2: Code block size including CRC (bits) equals to K' in clause 5.2.2 of TS 38.212 [15].				

Table A.4-3: Void**Table A.4-4: FRC parameters for FR1 PUSCH performance requirements, transform precoding disabled, Additional DM-RS position = pos1 and 2 transmission layers (16QAM, R=658/1024)**

Reference channel	G-FR1-A4-22	G-FR1-A4-23	G-FR1-A4-24	G-FR1-A4-25	G-FR1-A4-26	G-FR1-A4-27	G-FR1-A4-28
Subcarrier spacing [kHz]	15	15	15	30	30	30	30
Allocated resource blocks	25	52	106	24	51	106	273
CP-OFDM Symbols per slot (Note 1)	12	12	12	12	12	12	12
Modulation	16QAM	16QAM	16QAM	16QAM	16QAM	16QAM	16QAM
Code rate (Note 2)	658/1024	658/1024	658/1024	658/1024	658/1024	658/1024	658/1024
Payload size (bits)	18432	38936	77896	17928	37896	77896	200808
Transport block CRC (bits)	24	24	24	24	24	24	24
Code block CRC size (bits)	24	24	24	24	24	24	24
Number of code blocks - C	3	5	10	3	5	10	24
Code block size including CRC (bits) (Note 2)	6176	7816	7816	6008	7608	7816	8392
Total number of bits per slot	28800	59904	122112	27648	58752	122112	314496
Total symbols per slot	7200	14976	30528	6912	14688	30528	78624
NOTE 1: DM-RS configuration type = 1 with DM-RS duration = single-symbol DM-RS and the number of DM-RS CDM groups without data is 2, Additional DM-RS position = pos1, $l_0 = 2$ and $l = 11$ for PUSCH mapping type A, $l_0 = 0$ and $l = 10$ for PUSCH mapping type B as per table 6.4.1.1.3-3 of TS 38.211 [9].							
NOTE 2: Code block size including CRC (bits) equals to K' in clause 5.2.2 of TS 38.212 [15].							

Table A.4-5: FRC parameters for FR2-1 PUSCH performance requirements, transform precoding disabled, Additional DM-RS position = pos0 and 1 transmission layer (16QAM, R=658/1024)

Reference channel	G-FR2-A4-1	G-FR2-A4-2	G-FR2-A4-3 (Note 3)	G-FR2-A4-4	G-FR2-A4-5
Subcarrier spacing [kHz]	60	60	120	120	120
Allocated resource blocks	66	132	32	66	132
CP-OFDM Symbols per slot (Note 1)	9	9	9	9	9
Modulation	16QAM	16QAM	16QAM	16QAM	16QAM
Code rate (Note 2)	658/1024	658/1024	658/1024	658/1024	658/1024
Payload size (bits)	18432	36896	8968	18432	36896
Transport block CRC (bits)	24	24	24	24	24
Code block CRC size (bits)	24	24	24	24	24
Number of code blocks - C	3	5	2	3	5
Code block size including CRC (bits) (Note 2)	6176	7408	4520	6176	7408
Total number of bits per slot without PT-RS	28512	57024	13824	28512	57024
Total number of bits per slot with PT-RS (Note 4)	27324	54648	13248	27324	54648
Total symbols per slot without PT-RS	7128	14256	3456	7128	14256
Total symbols per slot with PT-RS (Note 4)	6831	13662	3312	6831	13662
NOTE 1: DM-RS configuration type = 1 with DM-RS duration = single-symbol DM-RS and the number of DM-RS CDM groups without data is 2, Additional DM-RS position = pos0 with $l_0 = 0$ as per Table 6.4.1.1.3-3 of TS 38.211 [9].					
NOTE 2: Code block size including CRC (bits) equals to K' in sub-clause 5.2.2 of TS 38.212 [15].					
NOTE 3: The calculation of the "Total number of bits per slot" and "Total symbols per slot" fields include the REs taken up by CSI part 1 and CSI part 2, if present.					
NOTE 4: PT-RS configuration $K_{PT-RS} = 2$, $L_{PT-RS} = 1$.					

Table A.4-6: FRC parameters for FR2-1 PUSCH performance requirements, transform precoding disabled, Additional DM-RS position = pos0 and 2 transmission layers (16QAM, R=658/1024)

Reference channel	G-FR2-A4-6	G-FR2-A4-7	G-FR2-A4-8	G-FR2-A4-9	G-FR2-A4-10
Subcarrier spacing [kHz]	60	60	120	120	120
Allocated resource blocks	66	132	32	66	132
CP-OFDM Symbols per slot (Note 1)	9	9	9	9	9
Modulation	16QAM	16QAM	16QAM	16QAM	16QAM
Code rate (Note 2)	658/1024	658/1024	658/1024	658/1024	658/1024
Payload size (bits)	36896	73776	17928	36896	73776
Transport block CRC (bits)	24	24	24	24	24
Code block CRC size (bits)	24	24	24	24	24
Number of code blocks - C	5	9	3	5	9
Code block size including CRC (bits) (Note 2)	7408	8224	6008	7408	8224
Total number of bits per slot without PT-RS	57024	114048	27648	57024	114048
Total number of bits per slot with PT-RS (Note 3)	54648	109296	26496	54648	109296
Total symbols per slot without PT-RS	14256	28512	6912	14256	28512
Total symbols per slot with PT-RS (Note 3)	13662	27324	6624	13662	27324
NOTE 1: DM-RS configuration type = 1 with DM-RS duration = single-symbol DM-RS and the number of DM-RS CDM groups without data is 2, Additional DM-RS position = pos0 with $l_0 = 0$ as per Table 6.4.1.1.3-3 of TS 38.211 [9].					
NOTE 2: Code block size including CRC (bits) equals to K' in sub-clause 5.2.2 of TS 38.212 [15].					
NOTE 3: PT-RS configuration $K_{PT-RS} = 2$, $L_{PT-RS} = 1$.					

Table A.4-7: FRC parameters for FR2-1 PUSCH performance requirements, transform precoding disabled, Additional DM-RS position = pos1 and 1 transmission layer (16QAM, R=658/1024)

Reference channel	G-FR2-A4-11	G-FR2-A4-12	G-FR2-A4-13 (Note 3)	G-FR2-A4-14	G-FR2-A4-15
Subcarrier spacing [kHz]	60	60	120	120	120
Allocated resource blocks	66	132	32	66	132
CP-OFDM Symbols per slot (Note 1)	8	8	8	8	8
Modulation	16QAM	16QAM	16QAM	16QAM	16QAM
Code rate (Note 2)	658/1024	658/1024	658/1024	658/1024	658/1024
Payload size (bits)	16392	32776	7936	16392	32776
Transport block CRC (bits)	24	24	24	24	24
Code block CRC size (bits)	24	24	-	24	24
Number of code blocks - C	2	4	1	2	4
Code block size including CRC (bits) (Note 2)	8232	8224	7960	8232	8224
Total number of bits per slot without PT-RS	25344	50688	12288	25344	50688
Total number of bits per slot with PT-RS (Note 4)	24288	48576	11776	24288	48576
Total symbols per slot without PT-RS	6336	12672	3072	6336	12672
Total symbols per slot with PT-RS (Note 4)	6072	12144	2944	6072	12144
NOTE 1: DM-RS configuration type = 1 with DM-RS duration = single-symbol DM-RS and the number of DM-RS CDM groups without data is 2, Additional DM-RS position = pos1 with $l_0 = 0$ and $l = 8$ as per Table 6.4.1.1.3-3 of TS 38.211 [9].					
NOTE 2: Code block size including CRC (bits) equals to K' in sub-clause 5.2.2 of TS 38.212 [15].					
NOTE 3: The calculation of the "Total number of bits per slot" and "Total symbols per slot" fields include the REs taken up by CSI part 1 and CSI part 2, if present.					
NOTE 4: PT-RS configuration $K_{PT-RS} = 2$, $L_{PT-RS} = 1$.					

Table A.4-7A: FRC parameters for FR2-2 PUSCH performance requirements, transform precoding disabled, Additional DM-RS position = pos1 and 1 transmission layer (16QAM, R=658/1024)

Reference channel	G-FR2-A4-21	G-FR2-A4-22	G-FR2-A4-23
Subcarrier spacing [kHz]	120	120	480
Allocated resource blocks	66	264	66
CP-OFDM Symbols per slot (Note 1)	8	8	8
Modulation	16QAM	16QAM	16QAM
Code rate (Note 2)	658/1024	658/1024	658/1024
Payload size (bits)	16392	65576	16392
Transport block CRC (bits)	24	24	24
Code block CRC size (bits)	24	24	24
Number of code blocks - C	2	8	2
Code block size including CRC (bits) (Note 2)	8232	8224	8232
Total number of bits per slot without PT-RS	25344	101376	25344
Total number of bits per slot with PT-RS (Note 4)	24288	97152	24288
Total symbols per slot without PT-RS	6336	25344	6336
Total symbols per slot with PT-RS (Note 4)	6072	24288	6072
NOTE 1: DM-RS configuration type = 1 with DM-RS duration = single-symbol DM-RS and the number of DM-RS CDM groups without data is 2, Additional DM-RS position = pos1 with $l_0 = 0$ and $l = 8$ as per Table 6.4.1.1.3-3 of TS 38.211 [9].			
NOTE 2: Code block size including CRC (bits) equals to K' in sub-clause 5.2.2 of TS 38.212 [15].			
NOTE 3: The calculation of the "Total number of bits per slot" and "Total symbols per slot" fields include the REs taken up by CSI part 1 and CSI part 2, if present.			
NOTE 4: PT-RS configuration $K_{PT-RS} = 2$, $L_{PT-RS} = 1$.			

Table A.4-8: FRC parameters for FR2-1 PUSCH performance requirements, transform precoding disabled, *Additional DM-RS position = pos1* and 2 transmission layers (16QAM, R=658/1024)

Reference channel	G-FR2-A4-16	G-FR2-A4-17	G-FR2-A4-18	G-FR2-A4-19	G-FR2-A4-20
Subcarrier spacing [kHz]	60	60	120	120	120
Allocated resource blocks	66	132	32	66	132
CP-OFDM Symbols per slot (Note 1)	8	8	8	8	8
Modulation	16QAM	16QAM	16QAM	16QAM	16QAM
Code rate (Note 2)	658/1024	658/1024	658/1024	658/1024	658/1024
Payload size (bits)	32776	65576	15880	32776	65576
Transport block CRC (bits)	24	24	24	24	24
Code block CRC size (bits)	24	24	24	24	24
Number of code blocks - C	4	8	2	4	8
Code block size including CRC (bits) (Note 2)	8224	8224	7976	8224	8224
Total number of bits per slot without PT-RS	50688	101376	24576	50688	101376
Total number of bits per slot with PT-RS (Note 3)	48576	97152	23552	48576	97152
Total symbols per slot without PT-RS	12672	25344	6144	12672	25344
Total symbols per slot with PT-RS (Note 3)	12144	24288	5888	12144	24288
NOTE 1: <i>DM-RS configuration type = 1</i> with <i>DM-RS duration = single-symbol DM-RS</i> and the number of DM-RS CDM groups without data is 2, <i>Additional DM-RS position = pos1</i> with $l=0$ and $l=8$ as per Table 6.4.1.1.3-3 of TS 38.211 [9].					
NOTE 2: Code block size including CRC (bits) equals to K' in sub-clause 5.2.2 of TS 38.212 [15].					
NOTE 3: PT-RS configuration $K_{PT-RS}=2$, $L_{PT-RS}=1$.					

Table A.4-8A: Void

A.5 Fixed Reference Channels for performance requirements (64QAM, R=567/1024)

The parameters for the reference measurement channels are specified in table A.5-2 and table A.5-5 for FR1 PUSCH performance requirements:

- FRC parameters are specified in table A.5-2 for FR1 PUSCH with transform precoding disabled, *Additional DM-RS position = pos1* and 1 transmission layer.
- FRC parameters are specified in table A.5-5 for FR1 interlaced PUSCH with transform precoding disabled, *Additional DM-RS position = pos1* and 1 transmission layer.

The parameters for the reference measurement channels are specified in table A.5-3 to table A.5-4 for FR2-1 PUSCH performance requirements:

- FRC parameters are specified in table A.5-3 for FR2-1 PUSCH with transform precoding disabled, *Additional DM-RS position = pos0* and 1 transmission layer.
- FRC parameters are specified in table A.5-4 for FR2-1 PUSCH with transform precoding disabled, *Additional DM-RS position = pos1* and 1 transmission layer.

The parameters for the reference measurement channels are specified in table A.5-4A for FR2-2 PUSCH performance requirements:

- FRC parameters are specified in table A.5-4A for FR2-2 PUSCH with transform precoding disabled, *Additional DM-RS position = pos1* and 1 transmission layer.

Table A.5-1: Void

Table A.5-2: FRC parameters for FR1 PUSCH performance requirements, transform precoding disabled, Additional DM-RS position = pos1 and 1 transmission layer (64QAM, R=567/1024)

Reference channel	G-FR1-A5-8	G-FR1-A5-9	G-FR1-A5-10	G-FR1-A5-11	G-FR1-A5-12	G-FR1-A5-13	G-FR1-A5-14
Subcarrier spacing [kHz]	15	15	15	30	30	30	30
Allocated resource blocks	25	52	106	24	51	106	273
CP-OFDM Symbols per slot (Note 1)	12	12	12	12	12	12	12
Modulation	64QAM	64QAM	64QAM	64QAM	64QAM	64QAM	64QAM
Code rate (Note 2)	567/1024	567/1024	567/1024	567/1024	567/1024	567/1024	567/1024
Payload size (bits)	12040	25104	50184	11528	24576	50184	131176
Transport block CRC (bits)	24	24	24	24	24	24	24
Code block CRC size (bits)	24	24	24	24	24	24	24
Number of code blocks - C	2	3	6	2	3	6	16
Code block size including CRC (bits) (Note 2)	6056	8400	8392	5800	8224	8392	8224
Total number of bits per slot	21600	44928	91584	20736	44064	91584	235872
Total symbols per slot	3600	7488	15264	3456	7344	15264	39312
NOTE 1: DM-RS configuration type = 1 with DM-RS duration = single-symbol DM-RS and the number of DM-RS CDM groups without data is 2, Additional DM-RS position = pos1, $l_0 = 2$ and $l = 11$ for PUSCH mapping type A, $l_0 = 0$ and $l = 10$ for PUSCH mapping type B as per table 6.4.1.1.3-3 of TS 38.211 [9].							
NOTE 2: Code block size including CRC (bits) equals to K' in clause 5.2.2 of TS 38.212 [15].							

Table A.5-3: FRC parameters for FR2-1 PUSCH performance requirements, transform precoding disabled, Additional DM-RS position = pos0 and 1 transmission layer (64QAM, R=567/1024)

Reference channel	G-FR2-A5-1	G-FR2-A5-2	G-FR2-A5-3	G-FR2-A5-4	G-FR2-A5-5
Subcarrier spacing [kHz]	60	60	120	120	120
Allocated resource blocks	66	132	32	66	132
CP-OFDM Symbols per slot (Note 1)	9	9	9	9	9
Modulation	64QAM	64QAM	64QAM	64QAM	64QAM
Code rate (Note 2)	567/1024	567/1024	567/1024	567/1024	567/1024
Payload size (bits)	23568	47112	11528	23568	47112
Transport block CRC (bits)	24	24	24	24	24
Code block CRC size (bits)	24	24	24	24	24
Number of code blocks - C	3	6	2	3	6
Code block size including CRC (bits) (Note 2)	7888	7880	5800	7888	7880
Total number of bits per slot without PT-RS	42768	85536	20736	42768	85536
Total number of bits per slot with PT-RS (Note 3)	40986	81972	19872	40986	81972
Total symbols per slot without PT-RS	7128	14256	3456	7128	14256
Total symbols per slot with PT-RS (Note 3)	6831	13662	3312	6831	13662
NOTE 1: DM-RS configuration type = 1 with DM-RS duration = single-symbol DM-RS and the number of DM-RS CDM groups without data is 2, Additional DM-RS position = pos0 with $l_0 = 0$ as per Table 6.4.1.1.3-3 of TS 38.211 [9].					
NOTE 2: Code block size including CRC (bits) equals to K' in sub-clause 5.2.2 of TS 38.212 [15].					
NOTE 3: PT-RS configuration $K_{PT-RS} = 2$, $L_{PT-RS} = 1$.					

Table A.5-4: FRC parameters for FR2-1 PUSCH performance requirements, transform precoding disabled, Additional DM-RS position = pos1 and 1 transmission layer (64QAM, R=567/1024)

Reference channel	G-FR2-A5-6	G-FR2-A5-7	G-FR2-A5-8	G-FR2-A5-9	G-FR2-A5-10
Subcarrier spacing [kHz]	60	60	120	120	120
Allocated resource blocks	66	132	32	66	132
CP-OFDM Symbols per slot (Note 1)	8	8	8	8	8
Modulation	64QAM	64QAM	64QAM	64QAM	64QAM
Code rate (Note 2)	567/1024	567/1024	567/1024	567/1024	567/1024
Payload size (bits)	21000	42016	10248	21000	42016
Transport block CRC (bits)	24	24	24	24	24
Code block CRC size (bits)	24	24	24	24	24
Number of code blocks - C	3	5	2	3	5
Code block size including CRC (bits) (Note 2)	7032	8432	5160	7032	8432
Total number of bits per slot without PT-RS	38016	76032	18432	38016	76032
Total number of bits per slot with PT-RS (Note 3)	36432	72864	17664	36432	72864
Total symbols per slot without PT-RS	6336	12672	3072	6336	12672
Total symbols per slot with PT-RS (Note 3)	6072	12144	2944	6072	12144
NOTE 1: DM-RS configuration type = 1 with DM-RS duration = single-symbol DM-RS and the number of DM-RS CDM groups without data is 2, Additional DM-RS position = pos1 with $l_0 = 0$ and $l = 8$ as per Table 6.4.1.1.3-3 of TS 38.211 [9].					
NOTE 2: Code block size including CRC (bits) equals to K' in sub-clause 5.2.2 of TS 38.212 [15].					
NOTE 3: PT-RS configuration $K_{PT-RS} = 2$, $L_{PT-RS} = 1$.					

Table A.5-4A: FRC parameters for FR2-2 PUSCH performance requirements, transform precoding disabled, Additional DM-RS position = pos1 and 1 transmission layer (64QAM, R=567/1024)

Reference channel	G-FR2-A5-11	G-FR2-A5-12	G-FR2-A5-13
Subcarrier spacing [kHz]	120	120	480
Allocated resource blocks	66	264	66
CP-OFDM Symbols per slot (Note 1)	8	8	8
Modulation	64QAM	64QAM	64QAM
Code rate (Note 2)	567/1024	567/1024	567/1024
Payload size (bits)	21000	83976	21000
Transport block CRC (bits)	24	24	24
Code block CRC size (bits)	24	24	24
Number of code blocks - C	3	10	3
Code block size including CRC (bits) (Note 2)	7032	8424	7032
Total number of bits per slot without PT-RS	38016	152064	38016
Total number of bits per slot with PT-RS (Note 3)	36432	145728	36432
Total symbols per slot without PT-RS	6336	25344	6336
Total symbols per slot with PT-RS (Note 3)	6072	24288	6072
NOTE 1: DM-RS configuration type = 1 with DM-RS duration = single-symbol DM-RS and the number of DM-RS CDM groups without data is 2, Additional DM-RS position = pos1 with $l_0 = 0$ and $l = 8$ as per Table 6.4.1.1.3-3 of TS 38.211 [9].			
NOTE 2: Code block size including CRC (bits) equals to K' in sub-clause 5.2.2 of TS 38.212 [15].			
NOTE 3: PT-RS configuration $K_{PT-RS} = 2$, $L_{PT-RS} = 1$.			

Table A.5-5: FRC parameters for FR1 interlaced PUSCH performance requirements, transform precoding disabled, *additional DM-RS position = pos1* and 1 transmission layer (64QAM, R=567/1024)

Reference channel	G-FR1-A5-15	G-FR1-A5-16
Subcarrier spacing [kHz]	15	30
Allocated resource blocks	11	11
CP-OFDM Symbols per slot (Note 1)	12	12
Modulation	64QAM	64QAM
Code rate	567/1024	567/1024
Payload size (bits)	5248	5248
Transport block CRC (bits)	24	24
Code block CRC size (bits)	24	24
Number of code blocks - C	1	1
Code block size including CRC (bits) (Note 2)	5272	5272
Total number of bits per slot (Note 3)	9504	9504
Total symbols per slot (Note 3)	1584	1584
NOTE 1: <i>DM-RS configuration type = 1</i> with <i>DM-RS duration = single-symbol DM-RS</i> and the number of DM-RS CDM groups without data is 2, <i>Additional DM-RS position = pos1</i> , $l_0 = 2$ and $l = 11$ for PUSCH mapping type A, $l_0 = 0$ and $l = 10$ for PUSCH mapping type B as per table 6.4.1.1.3-3 of TS 38.211 [9]. NOTE 2: Code block size including CRC (bits) equals to K' in clause 5.2.2 of TS 38.212 [15]. NOTE 3: The calculation of the "Total number of bits per slot" and "Total symbols per slot" fields include the REs taken up by CG-UCI, if present.		

A.6 PRACH Test preambles

Table A.6-1: Test preambles for Normal Mode in FR1

Burst format	SCS (kHz)	Ncs	Logical sequence index	v
0	1.25	13	22	32
A1, A2, A3,	15	23	0	0
B4, C0, C2	30	46	0	0

Table A.6-2: Test preambles for Normal Mode in FR2

Burst format	SCS (kHz)	Ncs	Logical sequence index	v
A1, A2, A3,	60	69	0	0
B4, C0, C2	120	69	0	0

Table A.6-3: Test preambles for high speed train restricted set type A

Burst format	SCS (kHz)	Ncs	Logical sequence index	v
0	1.25	15	384	0

Table A.6-4: Test preambles for high speed train restricted set type B

Burst format	SCS (kHz)	Ncs	Logical sequence index	v
0	1.25	15	30	30

Table A.6-5: Test preambles for high speed train short formats in FR1

Burst format	SCS (kHz)	Ncs	Logical sequence index	v
A2, B4, C2	15	23	0	0
	30	46	0	0

Table A.6-6: Test preambles for PRACH with $L_{RA}=1151$ and $L_{RA}=571$

Burst format	SCS (kHz)	Ncs	Logical sequence index	v
A2, B4, C2	15	164	0	0
	30	190	0	0

Table A.6-7: Test preambles for high speed train short formats in FR2

Burst format	SCS (kHz)	Ncs	Logical sequence index	v
C2	120	0	0	0

Table A.6-8: Test preambles for PRACH with $L_{RA}=139$, $L_{RA}=571$ and $L_{RA}=1151$ for 120 kHz and 480 kHz SCS

Burst format	SCS (kHz)	L_{RA}	Ncs	Logical sequence index	v
A2 B4, C2	120	571	285	0	0
	120	1151	575	0	0
	480	139	69	0	0
	480	571	285	0	0

A.7 Fixed Reference Channels for performance requirements (16QAM, R=434/1024)

The parameters for the reference measurement channels are specified in table A.7-1 for FR2-1 PUSCH performance requirements with transform precoding disabled, additional DM-RS position = pos0 and 2 transmission layers.

The parameters for the reference measurement channels are specified in table A.7-2 for FR2-1 PUSCH performance requirements with transform precoding disabled, additional DM-RS position = pos1 and 2 transmission layers.

The parameters for the reference measurement channels are specified in table A.7-3 for FR2-2 PUSCH performance requirements with transform precoding disabled, additional DM-RS position = pos1 and 2 transmission layers.

Table A.7-1: FRC parameters for FR2-1 PUSCH performance requirements, transform precoding disabled, Additional DM-RS position = pos0 and 2 transmission layers (16QAM, R=434/1024)

Reference channel	G-FR2-A7-1	G-FR2-A7-2	G-FR2-A7-3	G-FR2-A7-4	G-FR2-A7-5
Subcarrier spacing [kHz]	60	60	120	120	120
Allocated resource blocks	66	132	32	66	132
CP-OFDM Symbols per slot (Note 1)	9	9	9	9	9
Modulation	16QAM	16QAM	16QAM	16QAM	16QAM
Code rate (Note 2)	434/1024	434/1024	434/1024	434/1024	434/1024
Payload size (bits)	24072	48168	11784	24072	48168
Transport block CRC (bits)	24	24	24	24	24
Code block CRC size (bits)	24	24	24	24	24
Number of code blocks - C	3	6	2	3	6
Code block size including CRC (bits) (Note 2)	8056	8056	5928	8056	8056
Total number of bits per slot without PT-RS	57024	114048	27648	57024	114048
Total number of bits per slot with PT-RS (Note 3)	54648	109296	26496	54648	109296
Total symbols per slot without PT-RS	14256	28512	6912	14256	28512
Total symbols per slot with PT-RS (Note 3)	13662	27324	6624	13662	27324
NOTE 1: <i>DM-RS configuration type</i> = 1 with <i>DM-RS duration</i> = <i>single-symbol DM-RS</i> and the number of DM-RS CDM groups without data is 2, <i>Additional DM-RS position</i> = <i>pos0</i> with $l_0 = 0$ as per Table 6.4.1.1.3-3 of TS 38.211 [9].					
NOTE 2: Code block size including CRC (bits) equals to K' in sub-clause 5.2.2 of TS 38.212 [15].					
NOTE 3: PT-RS configuration $K_{PT-RS} = 2$, $L_{PT-RS} = 1$.					

Table A.7-2: FRC parameters for FR2-1 PUSCH performance requirements, transform precoding disabled, Additional DM-RS position = pos1 and 2 transmission layers (16QAM, R=434/1024)

Reference channel	G-FR2-A7-6	G-FR2-A7-7	G-FR2-A7-8	G-FR2-A7-9	G-FR2-A7-10
Subcarrier spacing [kHz]	60	60	120	120	120
Allocated resource blocks	66	132	32	66	132
CP-OFDM Symbols per slot (Note 1)	8	8	8	8	8
Modulation	16QAM	16QAM	16QAM	16QAM	16QAM
Code rate (Note 2)	434/1024	434/1024	434/1024	434/1024	434/1024
Payload size (bits)	21504	43032	10504	21504	43032
Transport block CRC (bits)	24	24	24	24	24
Code block CRC size (bits)	24	24	24	24	24
Number of code blocks - C	3	6	2	3	6
Code block size including CRC (bits) (Note 2)	7200	7200	5288	7200	7200
Total number of bits per slot without PT-RS	50688	101376	24576	50688	101376
Total number of bits per slot with PT-RS (Note 3)	48576	97152	23552	48576	97152
Total symbols per slot without PT-RS	12672	25344	6144	12672	25344
Total symbols per slot with PT-RS (Note 3)	12144	24288	5888	12144	24288
NOTE 1: <i>DM-RS configuration type</i> = 1 with <i>DM-RS duration</i> = <i>single-symbol DM-RS</i> and the number of DM-RS CDM groups without data is 2, <i>Additional DM-RS position</i> = <i>pos1</i> with $l_0 = 0$ and $l = 8$ as per Table 6.4.1.1.3-3 of TS 38.211 [9].					
NOTE 2: Code block size including CRC (bits) equals to K' in clause 5.2.2 of TS 38.212 [15].					
NOTE 3: PT-RS configuration $K_{PT-RS} = 2$, $L_{PT-RS} = 1$.					

Table A.7-3: FRC parameters for FR2-2 PUSCH performance requirements, transform precoding disabled, Additional DM-RS position = pos1 and 2 transmission layers (16QAM, R=434/1024)

Reference channel	G-FR2-A7-11	G-FR2-A7-12	G-FR2-A7-13
Subcarrier spacing [kHz]	120	120	480
Allocated resource blocks	66	264	66
CP-OFDM Symbols per slot (Note 1)	8	8	8
Modulation	16QAM	16QAM	16QAM
Code rate (Note 2)	434/1024	434/1024	434/1024
Payload size (bits)	21504	86040	21504
Transport block CRC (bits)	24	24	24
Code block CRC size (bits)	24	24	24
Number of code blocks - C	3	11	3
Code block size including CRC (bits) (Note 2)	7200	7848	7200
Total number of bits per slot without PT-RS	50688	202752	50688
Total number of bits per slot with PT-RS (Note 4)	48576	194304	48576
Total symbols per slot without PT-RS	12672	50688	12672
Total symbols per slot with PT-RS (Note 4)	12144	48576	12144
NOTE 1: DM-RS configuration type = 1 with DM-RS duration = single-symbol DM-RS and the number of DM-RS CDM groups without data is 2, Additional DM-RS position = pos1 with $l_0=0$ and $l_1=8$ as per Table 6.4.1.1.3-3 of TS 38.211 [9].			
NOTE 2: Code block size including CRC (bits) equals to K' in sub-clause 5.2.2 of TS 38.212 [15].			
NOTE 3: The calculation of the "Total number of bits per slot" and "Total symbols per slot" fields include the REs taken up by CSI part 1 and CSI part 2, if present.			
NOTE 4: PT-RS configuration $K_{PT-RS}=2$, $L_{PT-RS}=1$.			

A.8 Fixed Reference Channels for performance requirements (QPSK, R=157/1024)

Note: Different FRC numbers are assigned in TS 38.141-1 [5] for the FRCs in this annex.

The parameters for the reference measurement channels are specified in table A.8-1 and A.8-2 for FR1 PUSCH performance requirements for 2-step RA type with Additional DM-RS position equals to pos2 and pos1 respectively.

Table A.8-1: FRC parameters for FR1 PUSCH performance requirements, transform precoding disabled, Additional DM-RS position = pos2 and 1 transmission layer (QPSK, R=157/1024)

Reference channel	G-FR1-A8-1	G-FR1-A8-2
Subcarrier spacing [kHz]	15	30
Allocated resource blocks	2	2
CP-OFDM Symbols per slot (Note 1)	11	11
Modulation	QPSK	QPSK
Code rate (Note 2)	157/1024	157/1024
Payload size (bits)	80	80
Transport block CRC (bits)	16	16
Code block CRC size (bits)	0	0
Number of code blocks - C	1	1
Code block size including CRC (bits) (Note 2)	96	96
Total number of bits per slot	528	528
Total symbols per slot	264	264
NOTE 1: DM-RS configuration type = 1 with DM-RS duration = single-symbol DM-RS and the number of DM-RS CDM groups without data is 2, Additional DM-RS position = pos2 with $l_0=2$ as per Table 6.4.1.1.3-3 of TS 38.211 [9].		
NOTE 2: Code block size including CRC (bits) equals to K' in clause 5.2.2 of TS 38.212 [15].		

Table A.8-2: FRC parameters for FR1 PUSCH performance requirements, transform precoding disabled, Additional DM-RS position = pos1 and 1 transmission layer (QPSK, R=157/1024)

Reference channel	G-FR1-A8-3	G-FR1-A8-4
Subcarrier spacing [kHz]	15	30
Allocated resource blocks	2	2
CP-OFDM Symbols per slot (Note 1)	12	12
Modulation	QPSK	QPSK
Code rate (Note 2)	157/1024	157/1024
Payload size (bits)	88	88
Transport block CRC (bits)	16	16
Code block CRC size (bits)	0	0
Number of code blocks - C	1	1
Code block size including CRC (bits) (Note 2)	104	104
Total number of bits per slot	576	576
Total symbols per slot	288	288
NOTE 1: DM-RS configuration type = 1 with DM-RS duration = single-symbol DM-RS and the number of DM-RS CDM groups without data is 2, Additional DM-RS position = pos1 with $l_0=2$ as per Table 6.4.1.1.3-3 of TS 38.211 [9].		
NOTE 2: Code block size including CRC (bits) equals to K' in clause 5.2.2 of TS 38.212 [15].		

A.9 Fixed Reference Channels for performance requirements (256QAM, R=682.5/1024)

Note: Different FRC numbers are assigned in TS 38.141-1 [5] for the FRCs in this annex.

The parameters for the reference measurement channels are specified in table A.9-1 for FR1 PUSCH performance requirements:

- FRC parameters are specified in table A.9-1 for FR1 PUSCH with transform precoding disabled, *Additional DM-RS position = pos1* and 1 transmission layer.

Table A.9-1: FRC parameters for FR1 PUSCH performance requirements, transform precoding disabled, Additional DM-RS position = pos1 and 1 transmission layer (256QAM, R=682.5/1024)

Reference channel	G-FR1-A9-1	G-FR1-A9-2	G-FR1-A9-3	G-FR1-A9-4	G-FR1-A9-5
Subcarrier spacing [kHz]	15	15	30	30	30
Allocated resource blocks	25	52	24	106	273
CP-OFDM Symbols per slot (Note 1)	12	12	12	12	12
Modulation	256QAM	256QAM	256QAM	256QAM	256QAM
Code rate (Note 2)	682/1024	682/1024	682/1024	682/1024	682/1024
Payload size (bits)	18960	39936	18432	81976	208976
Transport block CRC (bits)	24	24	24	24	24
Code block CRC size (bits)	24	24	24	24	24
Number of code blocks - C	3	5	3	10	25
Code block size including CRC (bits) (Note 2)	6352	8016	6176	8224	8384
Total number of bits per slot	28800	59904	27648	122112	314496
Total symbols per slot	3600	7488	3456	15264	39312
NOTE 1: DM-RS configuration type = 1 with DM-RS duration = single-symbol DM-RS and the number of DM-RS CDM groups without data is 2, Additional DM-RS position = pos1, $l_0=2$ and $l=11$ for PUSCH mapping type A, $l_0=0$ and $l=10$ for PUSCH mapping type B as per table 6.4.1.1.3-3 of TS 38.211 [5].					
NOTE 2: Code block size including CRC (bits) equals to K' in clause 5.2.2 of TS 38.212 [15].					

A.10 Fixed Reference Channels for performance requirements (64QAM, R=517/1024)

The parameters for the reference measurement channels are specified in table A.10-1, A.10-2 and A.10-3 for FR2 PUSCH performance requirements:

- FRC parameters are specified in table A.10-1 for FR2 PUSCH with transform precoding disabled, *Additional DM-RS position = pos0* and 1 transmission layer.
- FRC parameters are specified in table A.10-2 for FR2 PUSCH with transform precoding disabled, *Additional DM-RS position = pos1* and 1 transmission layer.
- FRC parameters are specified in table A.10-3 for FR2 PUSCH with transform precoding disabled, *Additional DM-RS position = pos2* and 1 transmission layer.

The parameters for the reference measurement channels are specified in table A.10-4, table A.10-5 and table A.10-6 for FR2 PUSCH UL timing adjustment performance requirements:

- FRC parameters are specified in table A.10-4 for FR2 UL timing adjustment requirements, PUSCH with transform precoding disabled, *Additional DM-RS position = pos0* and 1 transmission layer.
- FRC parameters are specified in table A.10-5 for FR2 UL timing adjustment requirements, PUSCH with transform precoding disabled, *DM-RS position = pos1* and 1 transmission layer.
- FRC parameters are specified in table A.10-6 for FR2 UL timing adjustment requirements, PUSCH with transform precoding disabled, *Additional Additional DM-RS position = pos2* and 1 transmission layer.

Table A.10-1: FRC parameters for FR2 PUSCH performance requirements, transform precoding disabled, Additional DM-RS position = pos0 and 1 transmission layer (64QAM, R=517/1024)

Reference channel	G-FR2-A10-1	G-FR2-A10-2
Subcarrier spacing [kHz]	120	120
Allocated resource blocks	32	132
Data bearing CP-OFDM Symbols per slot (Note 1)	9	9
Modulation	64QAM	64QAM
Code rate (Note 2)	517/1024	517/1024
Payload size (bits)	10504	43032
Transport block CRC (bits)	24	24
Code block CRC size (bits)	24	24
Number of code blocks - C	2	6
Code block size including CRC (bits) (Note 2)	5288	7200
Total number of bits per slot without PT-RS	20736	85536
Total number of bits per slot with PT-RS (Note 3)	19872	81972
Total resource elements per slot without PT-RS	3456	14256
Total resource elements per slot with PT-RS (Note 3)	3312	13662
NOTE 1: <i>DM-RS configuration type = 1 with DM-RS duration = single-symbol DM-RS and the number of DM-RS CDM groups without data is 2, Additional DM-RS position = pos0 with $l_0 = 0$ as per Table 6.4.1.1.3-3 of TS 38.211 [9].</i>		
NOTE 2: Code block size including CRC (bits) equals to K' in sub-clause 5.2.2 of TS 38.212 [15].		
NOTE 3: PT-RS configuration $K_{PT-RS} = 2, L_{PT-RS} = 1$.		

Table A.10-2: FRC parameters for FR2 PUSCH performance requirements, transform precoding disabled, Additional DM-RS position = pos1 and 1 transmission layer (64QAM, R=517/1024)

Reference channel	G-FR2-A10-3	G-FR2-A10-4
Subcarrier spacing [kHz]	120	120
Allocated resource blocks	32	132
Data bearing CP-OFDM Symbols per slot (Note 1)	8	8
Modulation	64QAM	64QAM
Code rate (Note 2)	517/1024	517/1024
Payload size (bits)	9224	37896
Transport block CRC (bits)	24	24
Code block CRC size (bits)	24	24
Number of code blocks - C	2	5
Code block size including CRC (bits) (Note 2)	4648	7608
Total number of bits per slot without PT-RS	18432	76032
Total number of bits per slot with PT-RS (Note 3)	17664	72864
Total resource elements per slot without PT-RS	3072	12672
Total resource elements per slot with PT-RS (Note 3)	2944	12144
NOTE 1: <i>DM-RS configuration type = 1 with DM-RS duration = single-symbol DM-RS and the number of DM-RS CDM groups without data is 2, Additional DM-RS position = pos1 with $l_0 = 0$ and $l = 8$ as per Table 6.4.1.1.3-3 of TS 38.211 [9].</i>		
NOTE 2: Code block size including CRC (bits) equals to K' in sub-clause 5.2.2 of TS 38.212 [15].		
NOTE 3: PT-RS configuration $K_{PT-RS} = 2, L_{PT-RS} = 1$.		

Table A.10-3: FRC parameters for FR2 PUSCH performance requirements, transform precoding disabled, Additional DM-RS position = pos2 and 1 transmission layer (64QAM, R=517/1024)

Reference channel	G-FR2-A10-5	G-FR2-A10-6
Subcarrier spacing [kHz]	120	120
Allocated resource blocks	32	132
Data bearing CP-OFDM Symbols per slot (Note 1)	7	7
Modulation	64QAM	64QAM
Code rate (Note 2)	517/1024	517/1024
Payload size (bits)	8064	33816
Transport block CRC (bits)	24	24
Code block CRC size (bits)	-	24
Number of code blocks - C	1	5
Code block size including CRC (bits) (Note 2)	8088	6792
Total number of bits per slot without PT-RS	16128	66528
Total number of bits per slot with PT-RS (Note 3)	15456	63756
Total resource elements per slot without PT-RS	2688	11088
Total resource elements per slot with PT-RS (Note 3)	2576	10626
NOTE 1: <i>DM-RS configuration type = 1 with DM-RS duration = single-symbol DM-RS and the number of DM-RS CDM groups without data is 2, Additional DM-RS position = pos2 with $l_0 = 0$ and $l = 4,8$ as per Table 6.4.1.1.3-3 of TS 38.211 [9].</i>		
NOTE 2: Code block size including CRC (bits) equals to K' in sub-clause 5.2.2 of TS 38.212 [15].		
NOTE 3: PT-RS configuration $K_{PT-RS} = 2, L_{PT-RS} = 1$.		

Table A.10-4: FRC parameters for FR2 UL timing adjustment requirements, PUSCH with transform precoding disabled, Additional DM-RS position = pos0 and 1 transmission layer (64QAM, R=517/1024)

Reference channel	G-FR2-A10-7	G-FR2-A10-8
Subcarrier spacing [kHz]	120	120
Allocated resource blocks	16	66
Data bearing CP-OFDM Symbols per slot (Note 1)	9	9
Modulation	64QAM	64QAM
Code rate (Note 2)	517/1024	517/1024
Payload size (bits)	5248	21504
Transport block CRC (bits)	24	24
Code block CRC size (bits)	-	24
Number of code blocks - C	1	3
Code block size including CRC (bits) (Note 2)	5272	7200
Total number of bits per slot without PT-RS	10368	42768
Total number of bits per slot with PT-RS (Note 3)	9936	40986
Total resource elements per slot without PT-RS	1728	7128
Total resource elements per slot with PT-RS (Note 3)	1656	6831
NOTE 1: <i>DM-RS configuration type = 1 with DM-RS duration = single-symbol DM-RS and the number of DM-RS CDM groups without data is 2, Additional DM-RS position = pos0 with $l_0 = 0$ as per Table 6.4.1.1.3-3 of TS 38.211 [9].</i>		
NOTE 2: Code block size including CRC (bits) equals to K' in sub-clause 5.2.2 of TS 38.212 [15].		
NOTE 3: PT-RS configuration $K_{PT-RS} = 2, L_{PT-RS} = 1$.		

Table A.10-5: FRC parameters for FR2 UL timing adjustment requirements, PUSCH with transform precoding disabled, Additional DM-RS position = pos1 and 1 transmission layer (64QAM, R=517/1024)

Reference channel	G-FR2-A10-9	G-FR2-A10-10
Subcarrier spacing [kHz]	120	120
Allocated resource blocks	16	66
Data bearing CP-OFDM Symbols per slot (Note 1)	8	8
Modulation	64QAM	64QAM
Code rate (Note 2)	517/1024	517/1024
Payload size (bits)	4608	18960
Transport block CRC (bits)	24	24
Code block CRC size (bits)	-	24
Number of code blocks - C	1	3
Code block size including CRC (bits) (Note 2)	4632	6352
Total number of bits per slot without PT-RS	9216	38016
Total number of bits per slot with PT-RS (Note 3)	8832	36432
Total resource elements per slot without PT-RS	1536	6336
Total resource elements per slot with PT-RS (Note 3)	1472	6072
NOTE 1: DM-RS configuration type = 1 with DM-RS duration = single-symbol DM-RS and the number of DM-RS CDM groups without data is 2, Additional DM-RS position = pos1 with $l_0=0$ and $l=8$ as per Table 6.4.1.1.3-3 of TS 38.211 [9].		
NOTE 2: Code block size including CRC (bits) equals to K' in sub-clause 5.2.2 of TS 38.212 [15].		
NOTE 3: PT-RS configuration $K_{PT-RS}=2$, $L_{PT-RS}=1$.		

Table A.10-6: FRC parameters for FR2 UL timing adjustment requirements, PUSCH with transform precoding disabled, Additional DM-RS position = pos2 and 1 transmission layer (64QAM, R=517/1024)

Reference channel	G-FR2-A10-11	G-FR2-A10-12
Subcarrier spacing [kHz]	120	120
Allocated resource blocks	16	66
Data bearing CP-OFDM Symbols per slot (Note 1)	7	7
Modulation	64QAM	64QAM
Code rate (Note 2)	517/1024	517/1024
Payload size (bits)	4032	16896
Transport block CRC (bits)	24	24
Code block CRC size (bits)	-	24
Number of code blocks - C	1	3
Code block size including CRC (bits) (Note 2)	4056	5664
Total number of bits per slot without PT-RS	8064	33264
Total number of bits per slot with PT-RS (Note 3)	7728	31878
Total resource elements per slot without PT-RS	1344	5544
Total resource elements per slot with PT-RS (Note 3)	1288	5313
NOTE 1: DM-RS configuration type = 1 with DM-RS duration = single-symbol DM-RS and the number of DM-RS CDM groups without data is 2, Additional DM-RS position = pos2 with $l_0=0$ and $l=4,8$ as per Table 6.4.1.1.3-3 of TS 38.211 [9].		
NOTE 2: Code block size including CRC (bits) equals to K' in sub-clause 5.2.2 of TS 38.212 [15].		
NOTE 3: PT-RS configuration $K_{PT-RS}=2$, $L_{PT-RS}=1$.		

Annex B (normative): Error Vector Magnitude (FR1)

B.1 Reference point for measurement

The EVM shall be measured at the point after the FFT and a zero-forcing (ZF) equalizer in the receiver, as depicted in figure B.1-1 below.

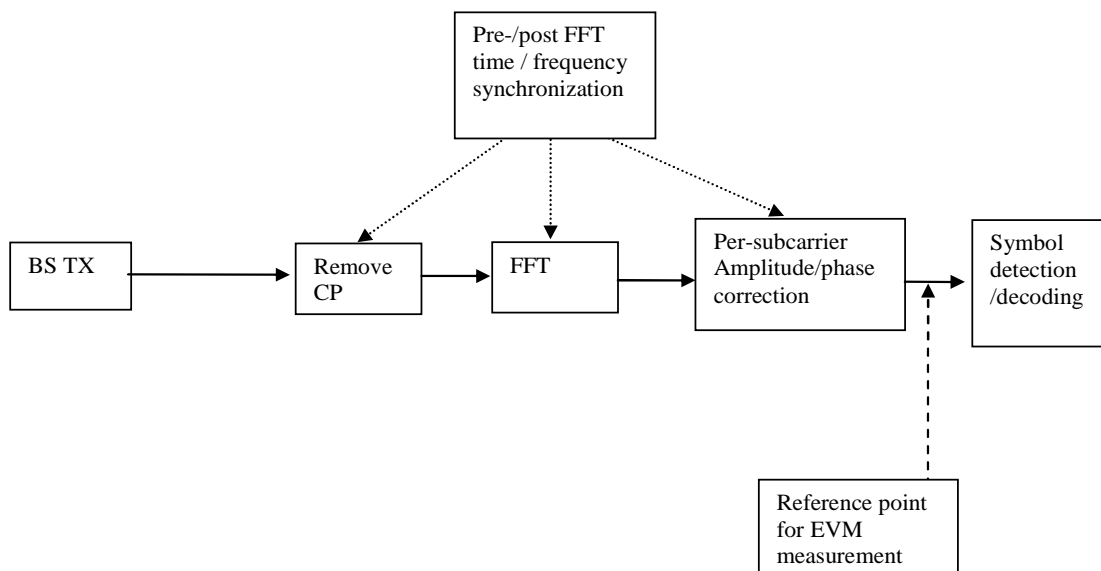

Figure B.1-1: Reference point for EVM measurement

B.2 Basic unit of measurement

The basic unit of EVM measurement is defined over one slot in the time domain and N_{BW}^{RB} subcarriers in the frequency domain:

$$EVM = \sqrt{\frac{\sum_{t \in T} \sum_{f \in F(t)} |Z'(t, f) - I(t, f)|^2}{\sum_{t \in T} \sum_{f \in F(t)} |I(t, f)|^2}}$$

where

T is the set of symbols with the considered modulation scheme being active within the slot,

$F(t)$ is the set of subcarriers within the N_{BW}^{RB} subcarriers with the considered modulation scheme being active in symbol t ,

$I(t, f)$ is the ideal signal reconstructed by the measurement equipment in accordance with relevant Tx models,

$Z'(t, f)$ is the modified signal under test defined in annex B.3.

NOTE: Although the basic unit of measurement is one slot, the equalizer is calculated over 10 ms measurement interval to reduce the impact of noise in the reference signals. The boundaries of the 10 ms measurement intervals need not be aligned with radio frame boundaries.

B.3 Modified signal under test

Implicit in the definition of EVM is an assumption that the receiver is able to compensate a number of transmitter impairments. The signal under test is equalized and decoded according to:

$$Z'(t, f) = \frac{FFT\{z(v - \Delta\tilde{t}) \cdot e^{-j2\pi\Delta\tilde{f}v}\} e^{j2\pi f\Delta\tilde{t}}}{\tilde{a}(f) \cdot e^{j\tilde{\varphi}(f)}}$$

where

$z(v)$ is the time domain samples of the signal under test.

$\Delta\tilde{t}$ is the sample timing difference between the FFT processing window in relation to nominal timing of the ideal signal. Note that two timing offsets are determined, the corresponding EVM is measured and the maximum used as described in annex B.7.

$\Delta\tilde{f}$ is the RF frequency offset.

$\tilde{\varphi}(f)$ is the phase response of the TX chain.

$\tilde{a}(f)$ is the amplitude response of the TX chain.

B.4 Estimation of frequency offset

The observation period for determining the frequency offset $\Delta\tilde{f}$ shall be 1 slot.

B.5 Estimation of time offset

B.5.1 General

The observation period for determining the sample timing difference $\Delta\tilde{t}$ shall be 1 slot.

In the following $\Delta\tilde{c}$ represents the middle sample of the EVM window of length W (defined in annex B.5.2) or the last sample of the first window half if W is even.

$\Delta\tilde{c}$ is estimated so that the EVM window of length W is centred on the measured cyclic prefix of the considered OFDM symbol. To minimize the estimation error the timing shall be based on demodulation reference signals. To limit time distortion of any transmit filter the reference signals in the 1 outer RBs are not taken into account in the timing estimation

Two values for $\Delta\tilde{t}$ are determined:

$$\Delta\tilde{t}_l = \Delta\tilde{c} + \alpha - \left\lfloor \frac{W}{2} \right\rfloor \text{ and}$$

$$\Delta\tilde{t}_h = \Delta\tilde{c} + \left\lfloor \frac{W}{2} \right\rfloor \text{ where } \alpha = 0 \text{ if } W \text{ is odd and } \alpha = 1 \text{ if } W \text{ is even.}$$

When the cyclic prefix length varies from symbol to symbol then T shall be further restricted to the subset of symbols with the considered modulation scheme being active and with the considered cyclic prefix length type.

B.5.2 Window length

Table B.5.2-1, B.5.2-2, B.5.2-3 specify the EVM window length (W) for normal CP.

Table B.5.2-1: EVM window length for normal CP, FR1, 15 kHz SCS

Channel bandwidth (MHz)	FFT size	CP length for symbols 1-6 and 8-13 in FFT samples	EVM window length W	Ratio of W to total CP length for symbols 1-6 and 8-13 (Note) (%)
5	512	36	14	40
10	1024	72	28	40
15	1536	108	44	40
20	2048	144	58	40
25	2048	144	72	50
30	3072	216	108	50
35	3072	216	108	50
40	4096	288	144	50
45	4096	288	144	50
50	4096	288	144	50

NOTE: These percentages are informative and apply to a slot's symbols 1 to 6 and 8 to 13. Symbols 0 and 7 have a longer CP and therefore a lower percentage.

Table B.5.2-2: EVM window length for normal CP, FR1, 30 kHz SCS

Channel bandwidth (MHz)	FFT size	CP length for symbols 1-13 in FFT samples	EVM window length W	Ratio of W to total CP length for symbols 1-13 (Note) (%)
5	256	18	8	40
10	512	36	14	40
15	768	54	22	40
20	1024	72	28	40
25	1024	72	36	50
30	1536	108	54	50
35	1536	108	54	50
40	2048	144	72	50
45	2048	144	72	50
50	2048	144	72	50
60	3072	216	130	60
70	3072	216	130	60
80	4096	288	172	60
90	4096	288	172	60
100	4096	288	172	60

NOTE: These percentages are informative and apply to a slot's symbols 1 through 13. Symbol 0 has a longer CP and therefore a lower percentage.

Table B.5.2-3: EVM window length for normal CP, FR1, 60 kHz SCS

Channel bandwidth (MHz)	FFT size	CP length in FFT samples	EVM window length W	Ratio of W to total CP length (Note) (%)
10	256	18	8	40
15	384	27	11	40
20	512	36	14	40
25	512	36	18	50
30	768	54	26	50
35	768	54	26	50
40	1024	72	36	50
45	1024	72	36	50
50	1024	72	36	50
60	1536	108	64	60
70	1536	108	64	60
80	2048	144	86	60
90	2048	144	86	60
100	2048	144	86	60

NOTE: These percentages are informative and apply to all OFDM symbols within subframe except for symbol 0 of slot 0 and slot 2. Symbol 0 of slot 0 and slot 2 may have a longer CP and therefore a lower percentage.

Table B.5.2-4 below specifies the EVM window length (W) for extended CP. The number of CP samples excluded from the EVM window is the same as for normal CP length.

Table B.5.2-4: EVM window length for extended CP, FR1, 60 kHz SCS

Channel bandwidth (MHz)	FFT size	CP length in FFT samples	EVM window length W	Ratio of W to total CP length (Note) (%)
10	256	64	54	84
15	384	96	80	83
20	512	128	106	83
25	512	128	110	85.9
30	768	192	164	85.9
35	768	192	164	85.9
40	1024	256	220	85.9
45	1024	256	220	85.9
50	1024	256	220	85.9
60	1536	384	340	88.6
70	1536	384	340	88.7
80	2048	512	454	88.7
90	2048	512	454	88.7
100	2048	512	454	88.7

NOTE: These percentages are informative.

B.6 Estimation of TX chain amplitude and frequency response parameters

The equalizer coefficients $\tilde{a}(f)$ and $\tilde{\varphi}(f)$ are determined as follows:

1. Calculate the complex ratios (amplitude and phase) of the post-FFT acquired signal $Z'(t, f)$ and the post-FFT ideal signal $I_2(t, f)$, for each reference signal, over 10ms measurement interval. This process creates a set of complex ratios:

$$a(t, f).e^{j\varphi(t, f)} = \frac{Z'(t, f)}{I_2(t, f)}$$

Where the post-FFT ideal signal $I_2(t, f)$ is constructed by the measuring equipment according to the relevant TX specifications, using the following parameters: i.e. nominal demodulation reference signals, (all other modulation symbols are set to 0 V), nominal carrier frequency, nominal amplitude and phase for each applicable subcarrier, nominal timing.

2. Perform time averaging at each reference signal subcarrier of the complex ratios, the time-averaging length is 10ms measurement interval. Prior to the averaging of the phases $\varphi(t_i, f)$ an unwrap operation must be performed according to the following definition: The unwrap operation corrects the radian phase angles of $\varphi(t_i, f)$ by adding multiples of 2π when absolute phase jumps between consecutive time instances t_i are greater than or equal to the jump tolerance of π radians. This process creates an average amplitude and phase for each reference signal subcarrier (i.e. every second subcarrier).

$$a(f) = \frac{\sum_{i=1}^N a(t_i, f)}{N}$$

$$\varphi(f) = \frac{\sum_{i=1}^N \varphi(t_i, f)}{N}$$

Where N is the number of reference signal; time-domain locations t_i from $Z'(t, f)$ for each reference signal subcarrier f .

3. The equalizer coefficients for amplitude and phase $\hat{a}(f)$ and $\hat{\varphi}(f)$ at the reference signal subcarriers are obtained by computing the moving average in the frequency domain of the time-averaged reference signal subcarriers, i.e. every second subcarrier. The moving average window size is 19 and averaging is over the DM-RS subcarriers in the allocated RBs. For DM-RS subcarriers at or near the edge of the channel, or when the number of available DM-RS subcarriers within a set of contiguously allocated RBs is smaller than the moving average window size, the window size is reduced accordingly as per figure B.6-1.
4. Perform linear interpolation from the equalizer coefficients $\hat{a}(f)$ and $\hat{\varphi}(f)$ to compute coefficients $\tilde{a}(f)$, $\tilde{\varphi}(f)$ for each subcarrier.

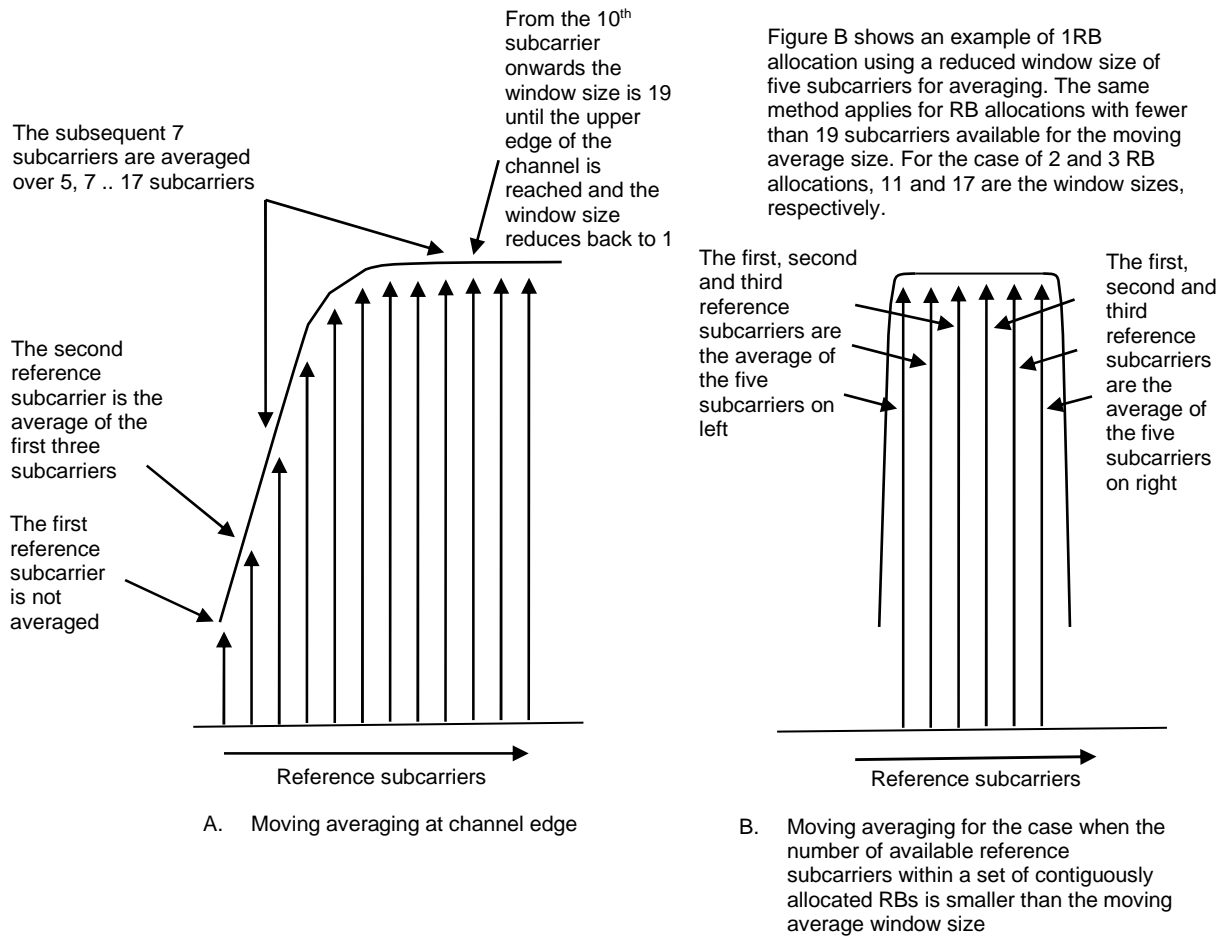

Figure B.6-1: Reference subcarrier smoothing in the frequency domain

B.7 Averaged EVM

EVM is averaged over all allocated downlink resource blocks with the considered modulation scheme in the frequency domain, and a minimum of N_{dl} slots where N_{dl} is the number of slots in a 10 ms measurement interval.

For FDD the averaging in the time domain equals the N_{dl} slot duration of the 10 ms measurement interval from the equalizer estimation step.

$$\overline{EVM}_{frame} = \sqrt{\frac{1}{\sum_{i=1}^{N_{dl}} Ni} \sum_{i=1}^{N_{dl}} \sum_{j=1}^{Ni} EVM_{i,j}^2}$$

- Where Ni is the number of resource blocks with the considered modulation scheme in slot i .
- The EVM requirements shall be tested against the maximum of the RMS average at the window W extremities of the EVM measurements:
- Thus $\overline{EVM}_{frame,l}$ is calculated using $\Delta\tilde{t} = \Delta\tilde{t}_l$ in the expressions above and $\overline{EVM}_{frame,h}$ is calculated using $\Delta\tilde{t} = \Delta\tilde{t}_h$ in the \overline{EVM}_{frame} calculation.
- Thus we get:

$$\overline{EVM} = \max(\overline{EVM}_{frame,l}, \overline{EVM}_{frame,h})$$

For TDD, let N_{dl}^{TDD} be the number of slots with downlink symbols within a 10 ms measurement interval, the averaging in the time domain can be calculated from N_{dl}^{TDD} slots of different 10 ms measurement intervals and should have a minimum of N_{dl} slots averaging length where N_{dl} is the number of slots in a 10 ms measurement interval.

- \overline{EVM}_{frame} is derived by: Square the EVM results in each 10 ms measurement interval. Sum the squares, divide the sum by the number of EVM relevant locations, square-root the quotient (RMS).

$$\overline{EVM}_{frame} = \sqrt{\frac{1}{\sum_{i=1}^{N_{dl}^{TDD}} N_i} \sum_{i=1}^{N_{dl}^{TDD}} \sum_{j=1}^{N_i} EVM_{i,j}^2}$$

- Where N_i is the number of resource blocks with the considered modulation scheme in slot i .
- The \overline{EVM}_{frame} is calculated, using the maximum of \overline{EVM}_{frame} at the window W extremities. Thus $\overline{EVM}_{frame,l}$ is calculated using $\tilde{t} = \Delta\tilde{t}_l$ and $\overline{EVM}_{frame,h}$ is calculated using $\tilde{t} = \Delta\tilde{t}_h$ (l and h , low and high; where low is the timing $(\Delta c - W/2)$ and high is the timing $(\Delta c + W/2)$).

$$EVM_{frame} = \max(\overline{EVM}_{frame,l}, \overline{EVM}_{frame,h})$$

- In order to unite at least N_{dl} slots, consider the minimum integer number of 10 ms measurement intervals, where N_{frame} is determined by.

$$N_{frame} = \left\lceil \frac{10 \times N_{slot}}{N_{dl}^{TDD}} \right\rceil$$

and $N_{slot} = 1$ for 15 kHz SCS, $N_{slot} = 2$ for 30 kHz SCS and $N_{slot} = 4$ for 60 kHz SCS normal CP.

- Unite by RMS.

$$\overline{EVM} = \sqrt{\frac{1}{N_{frame}} \sum_{k=1}^{N_{frame}} EVM_{frame,k}^2}$$

Annex C (normative): Error Vector Magnitude (FR2)

C.1 Reference point for measurement

The EVM shall be measured at the point after the FFT and a zero-forcing (ZF) equalizer in the receiver, as depicted in figure C.1-1 below.

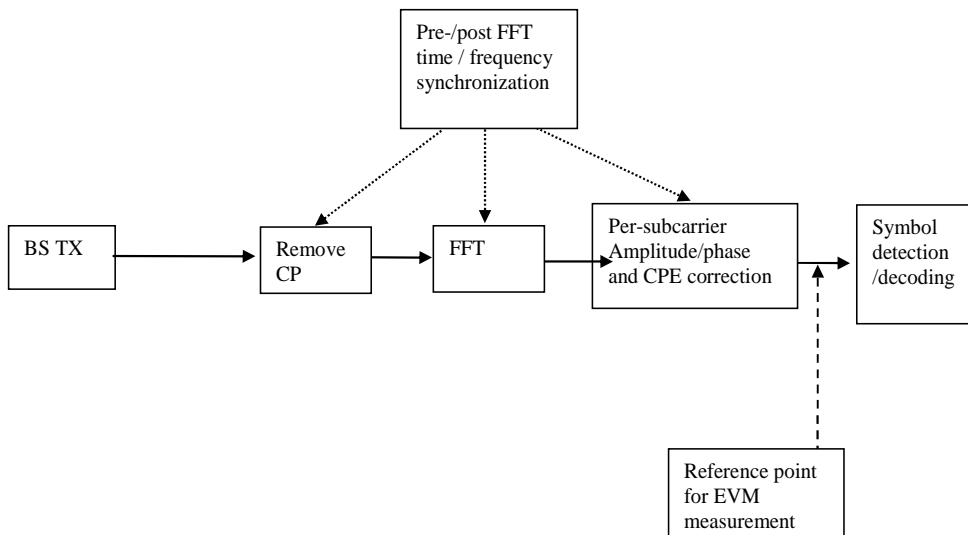

Figure C.1-1: Reference point for EVM measurement

C.2 Basic unit of measurement

The basic unit of EVM measurement is defined over one slot in the time domain and N_{BW}^{RB} subcarriers in the frequency domain:

$$EVM = \sqrt{\frac{\sum_{t \in T} \sum_{f \in F(t)} |Z'(t, f) - I(t, f)|^2}{\sum_{t \in T} \sum_{f \in F(t)} |I(t, f)|^2}}$$

where

T is the set of symbols with the considered modulation scheme being active within the slot,

$F(t)$ is the set of subcarriers within the N_{BW}^{RB} subcarriers with the considered modulation scheme being active in symbol t ,

$I(t, f)$ is the ideal signal reconstructed by the measurement equipment in accordance with relevant Tx models,

$Z'(t, f)$ is the modified signal under test defined in C.3.

NOTE: Although the basic unit of measurement is one slot, the equalizer is calculated over 10 ms measurement intervals to reduce the impact of noise in the reference signals. The boundaries of the 10 ms measurement intervals need not be aligned with radio frame boundaries.

C.3 Modified signal under test

Implicit in the definition of EVM is an assumption that the receiver is able to compensate a number of transmitter impairments. The signal under test is equalized and decoded according to:

$$Z'(t, f) = \frac{FFT\{z(v - \Delta\tilde{t}) \cdot e^{-j2\pi\Delta\tilde{f}v}\} e^{j2\pi f\Delta\tilde{t}}}{\tilde{a}(f) \cdot e^{j\tilde{\varphi}(f)}}$$

where

$z(v)$ is the time domain samples of the signal under test.

$\Delta\tilde{t}$ is the sample timing difference between the FFT processing window in relation to nominal timing of the ideal signal. Note that two timing offsets are determined, the corresponding EVM is measured and the maximum used as described in C.7.

$\Delta\tilde{f}$ is the RF frequency offset.

$\tilde{\varphi}(f)$ is the phase response of the TX chain.

$\tilde{a}(f)$ is the amplitude response of the TX chain.

C.4 Estimation of frequency offset

The observation period for determining the frequency offset $\Delta\tilde{f}$ shall be 1 slot.

C.5 Estimation of time offset

C.5.1 General

The observation period for determining the sample timing difference $\Delta\tilde{t}$ shall be 1 slot.

In the following $\Delta\tilde{c}$ represents the middle sample of the EVM window of length W (defined in C.5.2) or the last sample of the first window half if W is even.

$\Delta\tilde{c}$ is estimated so that the EVM window of length W is centred on the measured cyclic prefix of the considered OFDM symbol. To minimize the estimation error the timing shall be based on the reference signals. To limit time distortion of any transmit filter the reference signals in the 1 outer RBs are not taken into account in the timing estimation

Two values for $\Delta\tilde{t}$ are determined:

$$\Delta\tilde{t}_l = \Delta\tilde{c} + \alpha - \left\lfloor \frac{W}{2} \right\rfloor \text{ and}$$

$$\Delta\tilde{t}_h = \Delta\tilde{c} + \left\lfloor \frac{W}{2} \right\rfloor \text{ where } \alpha = 0 \text{ if } W \text{ is odd and } \alpha = 1 \text{ if } W \text{ is even.}$$

When the cyclic prefix length varies from symbol to symbol then T shall be further restricted to the subset of symbols with the considered modulation scheme being active and with the considered cyclic prefix length type.

C.5.2 Window length

Table C.5.2-1, Table C.5.2-2, Table C.5.2-2a and Table C.5.2-2b specify the EVM window length (W) for normal CP for FR2.

Table C.5.2-1: EVM window length for normal CP, FR2, 60 kHz SCS

Channel bandwidth (MHz)	FFT size	CP length in FFT samples	EVM window length W	Ratio of W to total CP length (Note) (%)
50	1024	72	36	50
100	2048	144	72	50
200	4096	288	144	50

NOTE: These percentages are informative and apply to all OFDM symbols within subframe except for symbol 0 of slot 0 and slot 2. Symbol 0 of slot 0 and slot 2 may have a longer CP and therefore a lower percentage.

Table C.5.2-2: EVM window length for normal CP, FR2, 120 kHz SCS

Channel bandwidth (MHz)	FFT size	CP length in FFT samples	EVM window length W	Ratio of W to total CP length (Note) (%)
50	512	36	18	50
100	1024	72	36	50
200	2048	144	72	50
400	4096	288	144	50

NOTE 1: These percentages are informative and apply to all OFDM symbols within subframe except for symbol 0 of slot 0 and slot 4. Symbol 0 of slot 0 and slot 4 may have a longer CP and therefore a lower percentage.

Table C.5.2-2a: EVM window length for normal CP, FR2-2, 480 kHz SCS

Channel bandwidth (MHz)	FFT size	CP length in FFT samples	EVM window length W	Ratio of W to total CP length (Note) (%)
400	1024	72	[36]	[50]
800	2048	144	[72]	[50]
1600	4096	288	[144]	[50]

NOTE 1: These percentages are informative and apply to all OFDM symbols within subframe except for symbol 0 of slot 0 and slot 4. Symbol 0 of slot 0 and slot 4 may have a longer CP and therefore a lower percentage.

Table C.5.2-2b: EVM window length for normal CP, FR2-2, 960 kHz SCS

Channel bandwidth (MHz)	FFT size	CP length in FFT samples	EVM window length W	Ratio of W to total CP length (Note) (%)
400	512	36	[18]	[50]
800	1024	72	[36]	[50]
1600	2048	144	[72]	[50]
2000	[2048]	[144]	[72]	[50]

NOTE 1: These percentages are informative and apply to all OFDM symbols within subframe except for symbol 0 of slot 0 and slot 4. Symbol 0 of slot 0 and slot 4 may have a longer CP and therefore a lower percentage.

Table C.5.2-3 below specifies the EVM window length (W) for extended CP. The number of CP samples excluded from the EVM window is the same as for normal CP length.

Table C.5.2-3: EVM window length for extended CP, FR2, 60 kHz SCS

Channel bandwidth (MHz)	FFT size	CP length in FFT samples	EVM window length W	Ratio of W to total CP length (Note) (%)
50	1024	256	220	85.9
100	2048	512	440	85.9
200	4096	1024	880	85.9
NOTE: These percentages are informative.				

C.6 Estimation of TX chain amplitude and frequency response parameters

The equalizer coefficients $\tilde{a}(f)$ and $\tilde{\varphi}(f)$ are determined as follows:

1. Calculate the complex ratios (amplitude and phase) of the post-FFT acquired signal $Z'(t, f)$ and the post-FFT ideal signal $I_2(t, f)$, for each reference signal, over 10ms measurement intervals. This process creates a set of complex ratios:

$$a(t, f).e^{j\varphi(t, f)} = \frac{Z'(t, f)}{I_2(t, f)}$$

Where the post-FFT ideal signal $I_2(t, f)$ is constructed by the measuring equipment according to the relevant TX specifications, using the following parameters:

- nominal demodulation reference signals and nominal PT-RS if present (all other modulation symbols are set to 0 V),
 - nominal carrier frequency,
 - nominal amplitude and phase for each applicable subcarrier,
 - nominal timing.
2. Perform time averaging at each reference signal subcarrier of the complex ratios, the time-averaging length is 10ms measurement interval. Prior to the averaging of the phases $\varphi(t_i, f)$ an unwrap operation must be performed according to the following definition: The unwrap operation corrects the radian phase angles of $\varphi(t_i, f)$ by adding multiples of $2*\text{PI}$ when absolute phase jumps between consecutive time instances t_i are greater than or equal to the jump tolerance of PI radians. This process creates an average amplitude and phase for each reference signal subcarrier (i.e. every second subcarrier).

$$a(f) = \frac{\sum_{i=1}^N a(t_i, f)}{N}$$

$$\varphi(f) = \frac{\sum_{i=1}^N \varphi(t_i, f)}{N}$$

Where N is the number of reference signal time-domain locations t_i from $Z'(t, f)$ for each reference signal subcarrier f .

3. The equalizer coefficients for amplitude and phase $\hat{a}(f)$ and $\hat{\varphi}(f)$ at the reference signal subcarriers are obtained by computing the moving average in the frequency domain of the time-averaged reference signal subcarriers, i.e. every second subcarrier. The moving average window size is 19 and averaging is over the DM-RS subcarriers in allocated RBs. For DM-RS subcarriers at or near the edge of the channel, or when the number

of available DM-RS subcarriers within a set of contiguously allocated RBs is smaller than the moving average window size, the window size is reduced accordingly as per figure C.6-1.

4. Perform linear interpolation from the equalizer coefficients $\hat{a}(f)$ and $\hat{\varphi}(f)$ to compute coefficients $\tilde{a}(f)$, $\tilde{\varphi}(f)$ for each subcarrier. To account for the common phase error (CPE) experienced in millimetre wave frequencies, $\bar{\varphi}(f)$, in the estimated coefficients contain phase rotation due to the CPE, θ , in addition to the phase of the equalizer coefficient $\tilde{\varphi}(f)$, that is

$$\bar{\varphi}(f) = \tilde{\varphi}(f) + \theta(t)$$

For OFDM symbols where PT-RS does not exist, $\theta(t)$ can be estimated by performing linear interpolation from neighboring symbols where PT-RS is present.

In order to separate component of the CPE, θ , contained in, $\bar{\varphi}(f)$, estimation and compensation of the CPE needs to follow. $\theta(t)$ is the common phase error (CPE), that rotates all the subcarriers of the OFDM symbol at time t .

Estimate of the CPE, $\theta(t)$, at OFDM symbol time, t , can then be obtained from using the PT-RS employing the expression

$$\tilde{\theta}(t) = \arg \left\{ \sum_{f \in f^{ptrs}} \left(\frac{Z'(t, f)}{I_{ptrs}(t, f)} \right) (\tilde{a}(f) e^{-j\bar{\varphi}(f)}) \right\}$$

In the above equation, f^{ptrs} is the set of subcarriers where PT-RS are mapped, $t \in t^{ptrs}$ where t^{ptrs} is the set of OFDM symbols where PT-RS are mapped while $Z'(t, f)$ and $I_{ptrs}(t, f)$ are the post-FFT acquired signal and the ideal PT-RS signal respectively. That is, estimate of the CPE at a given OFDM symbol is obtained from frequency correlation of the complex ratios at the PT-RS positions with the conjugate of the estimated equalizer complex coefficients. The estimated CPE can be subtracted from $\bar{\varphi}(f)$ to remove influence of the CPE, and obtain estimate of the complex coefficient's phase

$$\tilde{\varphi}(f) = \bar{\varphi}(f) - \tilde{\theta}(t)$$

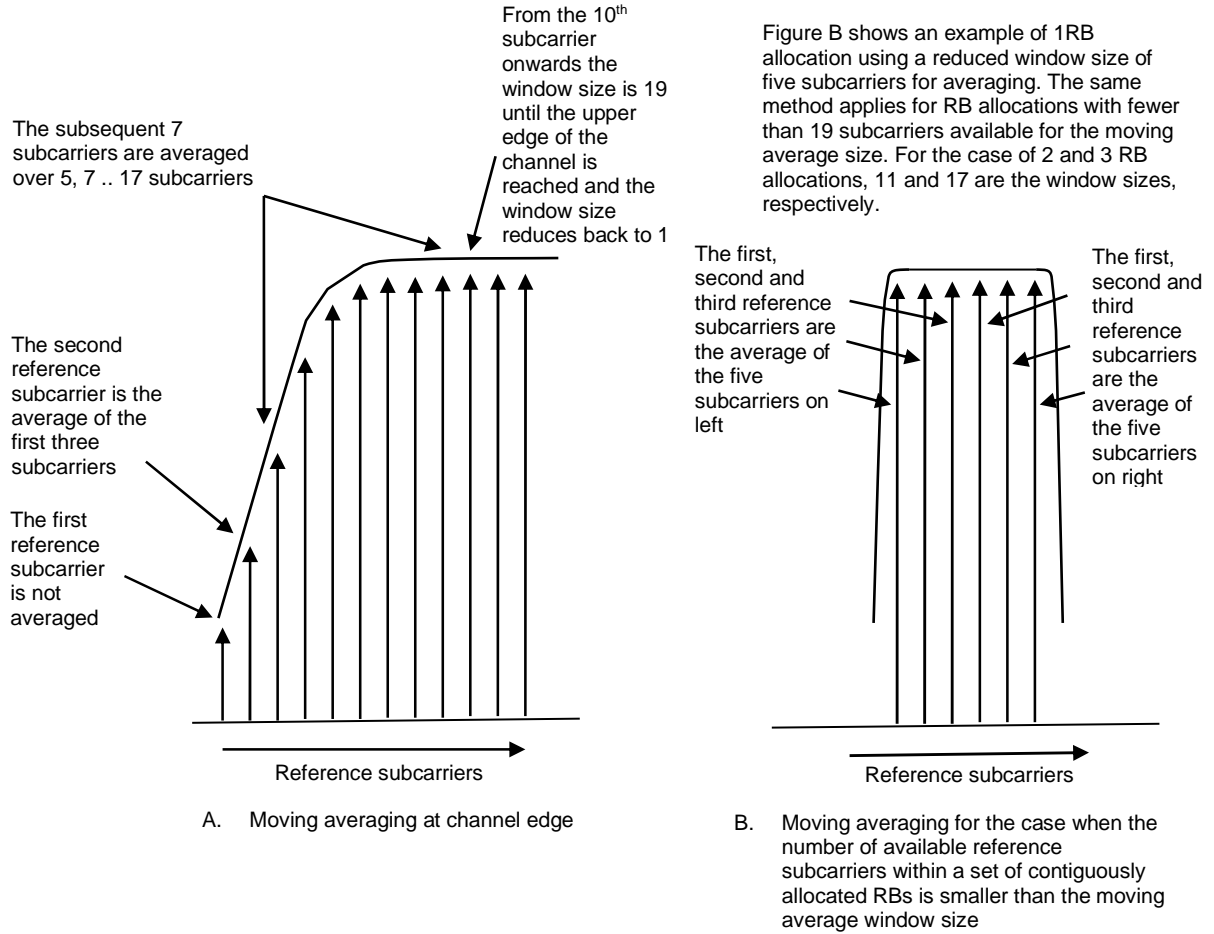

Figure C.6-1: Reference subcarrier smoothing in the frequency domain

C.7 Averaged EVM

EVM is averaged over all allocated downlink resource blocks with the considered modulation scheme in the frequency domain, and a minimum of N_{dl} slots where N_{dl} is the number of slots in a 10 ms measurement interval.

For TDD, let N_{dl}^{TDD} be the number of slots with downlink symbols within a 10 ms measurement interval, the averaging in the time domain can be calculated from N_{dl}^{TDD} slots of different 10 ms measurement intervals and should have a minimum of N_{dl} slots averaging length where N_{dl} is the number of slots in a 10 ms measurement interval.

- \overline{EVM}_{frame} is derived by: Square the EVM results in each 10 ms measurement intervals. Sum the squares, divide the sum by the number of EVM relevant locations, square-root the quotient (RMS).

$$\overline{EVM}_{frame} = \sqrt{\frac{1}{\sum_{i=1}^{N_{dl}^{TDD}} N_i} \sum_{i=1}^{N_{dl}^{TDD}} \sum_{j=1}^{N_i} EVM_{i,j}^2}$$

- Where N_i is the number of resource blocks with the considered modulation scheme in slot i .
- The \overline{EVM}_{frame} is calculated, using the maximum of \overline{EVM}_{frame} at the window W extremities. Thus $\overline{EVM}_{frame,l}$ is calculated using $\tilde{t} = \Delta\tilde{t}_l$ and $\overline{EVM}_{frame,h}$ is calculated using $\tilde{t} = \Delta\tilde{t}_h$ (l and h , low and high; where low is the timing $(\Delta c - W/2)$ and high is the timing $(\Delta c + W/2)$).

$$EVM_{frame} = \max(\overline{EVM}_{frame,l}, \overline{EVM}_{frame,h})$$

- In order to unite at least N_{dl} slots, consider the minimum integer number of 10 ms measurement intervals, where N_{frame} is determined by.

$$N_{frame} = \left\lceil \frac{10 \times N_{slot}}{N_{dl}^{TDD}} \right\rceil$$

and $N_{slot} = 4$ for 60 kHz SCS and $N_{slot} = 8$ for 120 kHz SCS.

- Unite by RMS.

$$\overline{EVM} = \sqrt{\frac{1}{N_{frame}} \sum_{k=1}^{N_{frame}} EVM_{frame,k}^2}$$

Annex D (normative): Characteristics of the interfering signals

The interfering signal shall be a PUSCH containing data and DM-RS symbols. Normal cyclic prefix is used. The data content shall be uncorrelated to the wanted signal and modulated according to clause 6 of TS38.211 [9]. Mapping of PUSCH modulation to receiver requirement are specified in table D-1.

Table D-1: Modulation of the interfering signal

Receiver requirement	Modulation
In-channel selectivity	16QAM
Adjacent channel selectivity and narrow-band blocking	QPSK
General blocking	QPSK
Receiver intermodulation	QPSK

Annex E:
Void

Annex F (normative): Relationship between EIRP based regulatory requirements and 3GPP requirements

F.1 General

This annex applies to FR1 *BS type 1-C*, *BS type 1-H* and *BS type 1-O*.

Some regional requirements are defined per effective isotropic radiated power (EIRP), which is a combination of the transmitted power (or in some cases spectral density) and the effective antenna gain which is a site-specific condition. Such requirements may be applied per antenna, per cell, or per base station. It shall be noted that the definition of BS or cell may differ between regulations.

The regulations are based on the assumption on *BS type 1-C* conducted requirements and a passive antenna and must be interpreted for active antenna systems that have active beamforming. This annex describes how the power per connector and sum power over *TAB connectors* can be related to such requirements.

Where the regulator prescribes a method for EIRP calculation, that method supersedes the proposed assessment in this annex.

F.2 Relationship between EIRP based regulatory requirements and conducted requirements

When 3GPP specifications mandate manufacturer declarations of the (conducted) output power or power spectral density per connector for the base station under the reference conditions stated as a way to accommodate the referred regional requirements without putting requirements on the local site conditions.

For the case when the base station manufacturer maximum output power or unwanted emission declarations apply per connector, the maximum EIRP can be estimated using the following formulas:

EIRP per antenna (applicable for *BS type 1-C*): $P_{\text{EIRP}} = P_{\text{Tx}} + G_{\text{Ant}}$

EIRP per cell or per BS (applicable for *BS type 1-H*): $P_{\text{EIRPcell}} = 10 * \log(\sum 10^{P_{\text{EIRPn}}/10})$

In case the EIRP requirement is set per polarization, the summation shall be made per polarization.

- " P_{EIRP} " is the resulting effective isotropic radiated power (or radiated power spectral density) resulting from the power (or power spectral density) declared by the manufacturer in dBm (or dBm/measurement BW).
- " P_{Tx} " is the conducted power or power spectral density declared by the manufacturer in dBm (or dBm/measurement BW).
- " G_{Ant} " is the effective antenna gain, calculated as the antenna gain (dBi) minus the loss of the site infrastructure connecting the BS antenna connector with the antenna (dB) for the applied frequency. The antenna nominal gain is only applicable within a certain frequency range. For *BS type 1-H*, G_{Ant} shall be an assumption on the gain of a passive antenna system in order to provide a total power emissions level comparable to the level obtained when a *BS type 1-C* is connected to a passive antenna. A typical example of a passive antenna gain, as used for *BS type 1-O*, is 17 dBi.
- "n" is the index number of the co-located antennas illuminating the same cell. P_{EIRPn} is the P_{EIRP} of the n th antenna.
- "Cell" is in this annex used in the sense that it is the limited geographical area covered by the carrier transmitted from one site.

F.3 Relationship between EIRP based regulatory requirements and OTA requirements

The regulations set an EIRP limit considering a passive antenna BS. Although the gain of passive antennas may vary somewhat, the variation is in the order of a few dBs. The gain variation of a *BS type I-O* may be much larger. However, *BS type I-O* unwanted emissions requirements are defined as TRP, since TRP impacts co-existence properties.

In order to relate the EIRP values in the specifications to TRP, a fixed assumption has been made on the gain of a typical passive BS antenna.

Thus, the maximum TRP can be estimated using the following formulas:

$$\text{TRP limit per antenna: } P_{\text{TRP, antenna}} = P_{\text{EIRP}} - G_{\text{Ant}}$$

$$\text{TRP limit per cell or per BS: } P_{\text{TRP}} = P_{\text{TRP, antenna}} + 9 \text{ dB}$$

It is noted that the *BS type I-O* architecture assumes that a BS subject to OTA requirements will have at least 8 antennas.

In case the TRP requirement is set per polarization, the summation shall be made per polarization.

- " P_{EIRP} " is the effective isotropic radiated power (or radiated power spectral density) set in the regulation (assuming a passive BS antenna) in dBm (or dBm/measurement BW).
- " G_{Ant} " is the effective antenna gain, the antenna gain (dBi) is a fixed reference value of 17 dBi. Directivity value should be used in above equations, however with all antenna losses are assumed zero then we can use effective antenna gain.

Annex G (Normative): Propagation conditions

G.1 Static propagation condition

The propagation for the static performance measurement is an Additive White Gaussian Noise (AWGN) environment. No fading or multi-paths exist for this propagation model.

G.2 Multi-path fading propagation conditions

The multipath propagation conditions consist of several parts:

- A delay profile in the form of a "tapped delay-line", characterized by a number of taps at fixed positions on a sampling grid. The profile can be further characterized by the r.m.s. delay spread and the maximum delay spanned by the taps.
- A combination of channel model parameters that include the Delay profile and the Doppler spectrum that is characterized by a classical spectrum shape and a maximum Doppler frequency.
- Different models are used for FR1, FR2(24.25 GHz – 71 GHz).

G.2.1 Delay profiles

The delay profiles are simplified from the TR 38.901 [16] TDL models. The simplification steps are shown below for information. These steps are only used when new delay profiles are created. Otherwise, the delay profiles specified in G.2.1.1, G.2.1.2 and G.2.1.3 can be used as such.

Step 1: Use the original TDL model from TR 38.901 [16].

Step 2: Re-order the taps in ascending delays.

Step 3: Perform delay scaling according to the procedure described in clause 7.7.3 in TR 38.901 [16].

Step 4: Apply the quantization to the delay resolution 5 ns. This is done simply by rounding the tap delays to the nearest multiple of the delay resolution.

Step 5: If multiple taps are rounded to the same delay bin, merge them by calculating their linear power sum.

Step 6: If there are more than 12 taps in the quantized model, merge the taps as follows

- Find the weakest tap from all taps (both merged and unmerged taps are considered)
 - If there are two or more taps having the same value and are the weakest, select the tap with the smallest delay as the weakest tap.
- When the weakest tap is the first delay tap, merge taps as follows
 - Update the power of the first delay tap as the linear power sum of the weakest tap and the second delay tap.
 - Remove the second delay tap.
- When the weakest tap is the last delay tap, merge taps as follows
 - Update the power of the last delay tap as the linear power sum of the second-to-last tap and the last tap.
 - Remove the second-to-last tap.

- Otherwise
 - For each side of the weakest tap, identify the neighbour tap that has the smaller delay difference to the weakest tap.
 - When the delay difference between the weakest tap and the identified neighbour tap on one side equals the delay difference between the weakest tap and the identified neighbour tap on the other side.
 - Select the neighbour tap that is weaker in power for merging.
 - Otherwise, select the neighbour tap that has smaller delay difference for merging.
 - To merge, the power of the merged tap is the linear sum of the power of the weakest tap and the selected tap.
 - When the selected tap is the first tap, the location of the merged tap is the location of the first tap. The weakest tap is removed.
 - When the selected tap is the last tap, the location of the merged tap is the location of the last tap. The weakest tap is removed.
 - Otherwise, the location of the merged tap is based on the average delay of the weakest tap and selected tap. If the average delay is on the sampling grid, the location of the merged tap is the average delay. Otherwise, the location of the merged tap is rounded towards the direction of the selected tap (e.g. 10 ns & 20 ns → 15 ns, 10 ns & 25 ns → 20 ns, if 25 ns had higher or equal power; 15 ns, if 10 ns had higher power) . The weakest tap and the selected tap are removed.
- Repeat step 6 until the final number of taps is 12.

Step 7: Round the amplitudes of taps to one decimal (e.g. -8.78 dB → -8.8 dB)

Step 8: If the delay spread has slightly changed due to the tap merge, adjust the final delay spread by increasing or decreasing the power of the last tap so that the delay spread is corrected.

Step 9: Re-normalize the highest tap to 0 dB.

Note 1: Some values of the delay profile created by the simplification steps may differ from the values in tables G.2.1.1-2, G.2.1.1-3, G.2.1.1-4, G.2.1.2-2, G.2.1.2-3, G.2.1.2-4 and G.2.1.2-5 for the corresponding model.

Note 2: For Step 5 and Step 6, the power values are expressed in the linear domain using 6 digits of precision. The operations are in the linear domain.

G.2.1.1 Delay profiles for FR1

The delay profiles for FR1 are selected to be representative of low, medium and high delay spread environment. The resulting model parameters are specified in table G.2.1.1-1 and the tapped delay line models are specified in tables G.2.1.1-2 ~ G.2.1.1-4.

Table G.2.1.1-1: Delay profiles for NR channel models

Model	Number of channel taps	Delay spread (r.m.s.)	Maximum excess tap delay (span)	Delay resolution
TDLA30	12	30 ns	290 ns	5 ns
TDLB100	12	100 ns	480 ns	5 ns
TDLC300	12	300 ns	2595 ns	5 ns

Table G.2.1.1-2: TDLA30 (DS = 30 ns)

Tap #	Delay (ns)	Power (dB)	Fading distribution
1	0	-15.5	Rayleigh
2	10	0	Rayleigh
3	15	-5.1	Rayleigh
4	20	-5.1	Rayleigh
5	25	-9.6	Rayleigh
6	50	-8.2	Rayleigh
7	65	-13.1	Rayleigh
8	75	-11.5	Rayleigh
9	105	-11.0	Rayleigh
10	135	-16.2	Rayleigh
11	150	-16.6	Rayleigh
12	290	-26.2	Rayleigh

Table G.2.1.1-3: TDLB100 (DS = 100 ns)

Tap #	Delay (ns)	Power (dB)	Fading distribution
1	0	0	Rayleigh
2	10	-2.2	Rayleigh
3	20	-0.6	Rayleigh
4	30	-0.6	Rayleigh
5	35	-0.3	Rayleigh
6	45	-1.2	Rayleigh
7	55	-5.9	Rayleigh
8	120	-2.2	Rayleigh
9	170	-0.8	Rayleigh
10	245	-6.3	Rayleigh
11	330	-7.5	Rayleigh
12	480	-7.1	Rayleigh

Table G.2.1.1-4: TDLC300 (DS = 300 ns)

Tap #	Delay (ns)	Power (dB)	Fading distribution
1	0	-6.9	Rayleigh
2	65	0	Rayleigh
3	70	-7.7	Rayleigh
4	190	-2.5	Rayleigh
5	195	-2.4	Rayleigh
6	200	-9.9	Rayleigh
7	240	-8.0	Rayleigh
8	325	-6.6	Rayleigh
9	520	-7.1	Rayleigh
10	1045	-13.0	Rayleigh
11	1510	-14.2	Rayleigh
12	2595	-16.0	Rayleigh

G.2.1.2 Delay profiles for FR2

The delay profiles for FR2 are specified in table G.2.1.2-1 and the tapped delay line models are specified in table G.2.1.2-2 - G.2.1.2-5.

Table G.2.1.2-1: Delay profiles for NR channel models

Model	Number of channel taps	Delay spread (r.m.s.)	Maximum excess tap delay (span)	Delay resolution
TDLA30	12	30 ns	290 ns	5 ns
TDLA10	16	10 ns	96 ns	2 ns
TDL10	10	10 ns	126 ns	2 ns
TDL30	10	30 ns	375 ns	5 ns

Table G.2.1.2-2: TDLA30 (DS = 30 ns)

Tap #	Delay (ns)	Power (dB)	Fading distribution
1	0	-15.5	Rayleigh
2	10	0	Rayleigh
3	15	-5.1	Rayleigh
4	20	-5.1	Rayleigh
5	25	-9.6	Rayleigh
6	50	-8.2	Rayleigh
7	65	-13.1	Rayleigh
8	75	-11.5	Rayleigh
9	105	-11.0	Rayleigh
10	135	-16.2	Rayleigh
11	150	-16.6	Rayleigh
12	290	-26.2	Rayleigh

Table G.2.1.2-3: TDLA10 (DS = 10 ns)

Tap #	Delay (ns)	Power (dB)	Fading distribution
1	0	-16.1	Rayleigh
2	4	0	
3	6	-4	
4	8	-10.2	
5	16	-18.6	
6	18	-9.3	
7	22	-13.7	
8	24	-17.9	
9	26	-13.5	
10	30	-14	
11	40	-15.4	
12	44	-18.9	
13	46	-21.0	
14	48	-21.6	
15	50	-19.3	
16	96	-25.9	

Table G.2.1.2-4: TDL10 (DS = 10 ns)

Tap #	Delay (ns)	Power (dB)	Fading distribution
1	0	-15.5	LOS
	0	0	Rayleigh
2	6	-5.1	Rayleigh
3	14	-5.1	
4	18	-9.6	
5	26	-8.2	
6	40	-13.1	
7	80	-11.5	
8	94	-11.0	
9	98	-16.2	
10	126	-16.6	

Note 1: Tap #1 follows a Ricean distribution.

Table G.2.1.2-5: TDLD30 (DS = 30 ns)

Tap #	Delay (ns)	Power (dB)	Fading distribution
1	0	-0.2	LOS Rayleigh
	0	-12.4	
2	20	-21	
3	40	-16.7	
4	55	-18.3	
5	80	-21.9	
6	120	-27.8	
7	240	-23.6	
8	285	-24.8	
9	290	-30.0	
10	375	-27.6	
Note 1: Tap #1 follows a Ricean distribution.			

G.2.2 Combinations of channel model parameters

The propagation conditions used for the performance measurements in multi-path fading environment are indicated as a combination of a channel model name and a maximum Doppler frequency, i.e., TDLA<DS>-<Doppler>, TDLB<DS>-<Doppler> or TDLC<DS>-<Doppler> where '<DS>' indicates the desired delay spread and '<Doppler>' indicates the maximum Doppler frequency (Hz).

Table G.2.2-1 and G.2.2-2 show the propagation conditions that are used for the performance measurements in multi-path fading environment for low, medium and high Doppler frequencies for FR1 and FR2 (24.25 GHz – 71 GHz), respectively.

Table G.2.2-1: Channel model parameters for FR1

Combination name	Tapped delay line model	Maximum Doppler frequency
TDLA30-5	TDLA30	5 Hz
TDLA30-10	TDLA30	10 Hz
TDLB100-400	TDLB100	400 Hz
TDLC300-100	TDLC300	100 Hz
TDLC300-600	TDLC300	600 Hz
TDLC300-1200	TDLC300	1200 Hz

Table G.2.2-2: Channel model parameters for FR2

Combination name	Tapped delay line model	Maximum Doppler frequency
TDLA30-75	TDLA30	75 Hz
TDLA30-300	TDLA30	300 Hz
TDLA10-650	TDLA10	650 Hz
TDLA30-650	TDLA30	650 Hz
TDLD10-200	TDLD10	200 Hz
TDLD30-200	TDLD30	200 Hz

G.2.3 MIMO Channel Correlation Matrices

The MIMO channel correlation matrices defined in G.2.3 apply for the antenna configuration using uniform linear arrays at both gNB and UE and for the antenna configuration using cross polarized antennas.

G.2.3.1 MIMO Correlation Matrices using Uniform Linear Array (ULA)

The MIMO channel correlation matrices defined in G.2.3.1 apply for the antenna configuration using uniform linear array (ULA) at both gNB and UE.

G.2.3.1.1 Definition of MIMO Correlation Matrices

Table G.2.3.1.1-1 defines the correlation matrix for the gNB:

Table G.2.3.1.1-1: gNB correlation matrix

	One antenna	Two antennas	Four antennas	Eight antennas
gNode B Correlation	$R_{gNB} = 1$	$R_{gNB} = \begin{pmatrix} 1 & \alpha \\ \alpha^* & 1 \end{pmatrix}$	$R_{gNB} = \begin{pmatrix} 1 & \alpha^{1/9} & \alpha^{4/9} & \alpha \\ \alpha^{1/9*} & 1 & \alpha^{1/9} & \alpha^{4/9} \\ \alpha^{4/9*} & \alpha^{1/9*} & 1 & \alpha^{1/9} \\ \alpha^* & \alpha^{4/9*} & \alpha^{1/9*} & 1 \end{pmatrix}$	$R_{gNB} = \begin{pmatrix} 1 & \alpha^{1/49} & \alpha^{4/49} & \alpha^{9/49} & \alpha^{16/49} & \alpha^{25/49} & \alpha^{36/49} & \alpha \\ \alpha^{1/49*} & 1 & \alpha^{1/49} & \alpha^{4/49} & \alpha^{9/49} & \alpha^{16/49} & \alpha^{25/49} & \alpha^{36/49} \\ \alpha^{4/49*} & \alpha^{1/49*} & 1 & \alpha^{1/49} & \alpha^{4/49} & \alpha^{9/49} & \alpha^{16/49} & \alpha^{25/49} \\ \alpha^{9/49*} & \alpha^{4/49*} & \alpha^{1/49*} & 1 & \alpha^{1/49} & \alpha^{4/49} & \alpha^{9/49} & \alpha^{16/49} \\ \alpha^{16/49*} & \alpha^{9/49*} & \alpha^{4/49*} & \alpha^{1/49*} & 1 & \alpha^{1/49} & \alpha^{4/49} & \alpha^{9/49} \\ \alpha^{25/49*} & \alpha^{16/49*} & \alpha^{9/49*} & \alpha^{4/49*} & \alpha^{1/49*} & 1 & \alpha^{1/49} & \alpha^{4/49} \\ \alpha^{36/49*} & \alpha^{25/49*} & \alpha^{16/49*} & \alpha^{9/49*} & \alpha^{4/49*} & \alpha^{1/49*} & 1 & \alpha^{1/49} \\ \alpha^* & \alpha^{36/49*} & \alpha^{25/49*} & \alpha^{16/49*} & \alpha^{9/49*} & \alpha^{4/49*} & \alpha^{1/49*} & 1 \end{pmatrix}$

Table G.2.3.1.1-2 defines the correlation matrix for the UE:

Table G.2.3.1.1-2: UE correlation matrix

	One antenna	Two antennas	Four antennas
UE Correlation	$R_{UE} = 1$	$R_{UE} = \begin{pmatrix} 1 & \beta \\ \beta^* & \mathbf{1} \end{pmatrix}$	$R_{UE} = \begin{pmatrix} 1 & \beta^{1/9} & \beta^{4/9} & \beta \\ \beta^{1/9*} & 1 & \beta^{1/9} & \beta^{4/9} \\ \beta^{4/9*} & \beta^{1/9*} & 1 & \beta^{1/9} \\ \beta^* & \beta^{4/9*} & \beta^{1/9*} & 1 \end{pmatrix}$

Table G.2.3.1.1-3 defines the channel spatial correlation matrix R_{spat} . The parameters α and β in Table G.2.3.1.1-3 defines the spatial correlation between the antennas at the gNB and UE respectively.

Table G.2.3.1.1-3: R_{spat} correlation matrices

<p>1x2 case</p>	$R_{spat} = R_{gNB} = \begin{pmatrix} 1 & \alpha \\ \alpha^* & 1 \end{pmatrix}$
<p>1x4 case</p>	$R_{spat} = R_{gNB} = \begin{pmatrix} 1 & \alpha^{1/9} & \alpha^{4/9} & \alpha \\ \alpha^{1/9*} & 1 & \alpha^{1/9} & \alpha^{4/9} \\ \alpha^{4/9*} & \alpha^{1/9*} & 1 & \alpha^{1/9} \\ \alpha^* & \alpha^{4/9*} & \alpha^{1/9*} & 1 \end{pmatrix}$
<p>1x8 case</p>	$R_{spat} = R_{gNB} = \begin{pmatrix} 1 & \alpha^{1/49} & \alpha^{4/49} & \alpha^{9/49} & \alpha^{16/49} & \alpha^{25/49} & \alpha^{36/49} & \alpha \\ \alpha^{1/49*} & 1 & \alpha^{1/49} & \alpha^{4/49} & \alpha^{9/49} & \alpha^{16/49} & \alpha^{25/49} & \alpha^{36/49} \\ \alpha^{4/49*} & \alpha^{1/49*} & 1 & \alpha^{1/49} & \alpha^{4/49} & \alpha^{9/49} & \alpha^{16/49} & \alpha^{25/49} \\ \alpha^{9/49*} & \alpha^{4/49*} & \alpha^{1/49*} & 1 & \alpha^{1/49} & \alpha^{4/49} & \alpha^{9/49} & \alpha^{16/49} \\ \alpha^{16/49*} & \alpha^{9/49*} & \alpha^{4/49*} & \alpha^{1/49*} & 1 & \alpha^{1/49} & \alpha^{4/49} & \alpha^{9/49} \\ \alpha^{25/49*} & \alpha^{16/49*} & \alpha^{9/49*} & \alpha^{4/49*} & \alpha^{1/49*} & 1 & \alpha^{1/49} & \alpha^{4/49} \\ \alpha^{36/49*} & \alpha^{25/49*} & \alpha^{16/49*} & \alpha^{9/49*} & \alpha^{4/49*} & \alpha^{1/49*} & 1 & \alpha^{1/49} \\ \alpha^* & \alpha^{36/49*} & \alpha^{25/49*} & \alpha^{16/49*} & \alpha^{9/49*} & \alpha^{4/49*} & \alpha^{1/49*} & 1 \end{pmatrix}$
<p>2x2 case</p>	$R_{spat} = R_{UE} \otimes R_{gNB} = \begin{bmatrix} 1 & \beta \\ \beta^* & 1 \end{bmatrix} \otimes \begin{bmatrix} 1 & \alpha \\ \alpha^* & 1 \end{bmatrix} = \begin{bmatrix} 1 & \alpha & \beta & \beta\alpha \\ \alpha^* & 1 & \beta\alpha^* & \beta \\ \beta^* & \beta^*\alpha & 1 & \alpha \\ \beta^*\alpha^* & \beta^* & \alpha^* & 1 \end{bmatrix}$
<p>2x4 case</p>	$R_{spat} = R_{UE} \otimes R_{gNB} = \begin{bmatrix} 1 & \beta \\ \beta^* & 1 \end{bmatrix} \otimes \begin{bmatrix} 1 & \alpha^{1/9} & \alpha^{4/9} & \alpha \\ \alpha^{1/9*} & 1 & \alpha^{1/9} & \alpha^{4/9} \\ \alpha^{4/9*} & \alpha^{1/9*} & 1 & \alpha^{1/9} \\ \alpha^* & \alpha^{4/9*} & \alpha^{1/9*} & 1 \end{bmatrix}$
<p>2x8 case</p>	$R_{spat} = R_{UE} \otimes R_{gNB} = \begin{bmatrix} 1 & \beta \\ \beta^* & 1 \end{bmatrix} \otimes \begin{pmatrix} 1 & \alpha^{1/49} & \alpha^{4/49} & \alpha^{9/49} & \alpha^{16/49} & \alpha^{25/49} & \alpha^{36/49} & \alpha \\ \alpha^{1/49*} & 1 & \alpha^{1/49} & \alpha^{4/49} & \alpha^{9/49} & \alpha^{16/49} & \alpha^{25/49} & \alpha^{36/49} \\ \alpha^{4/49*} & \alpha^{1/49*} & 1 & \alpha^{1/49} & \alpha^{4/49} & \alpha^{9/49} & \alpha^{16/49} & \alpha^{25/49} \\ \alpha^{9/49*} & \alpha^{4/49*} & \alpha^{1/49*} & 1 & \alpha^{1/49} & \alpha^{4/49} & \alpha^{9/49} & \alpha^{16/49} \\ \alpha^{16/49*} & \alpha^{9/49*} & \alpha^{4/49*} & \alpha^{1/49*} & 1 & \alpha^{1/49} & \alpha^{4/49} & \alpha^{9/49} \\ \alpha^{25/49*} & \alpha^{16/49*} & \alpha^{9/49*} & \alpha^{4/49*} & \alpha^{1/49*} & 1 & \alpha^{1/49} & \alpha^{4/49} \\ \alpha^{36/49*} & \alpha^{25/49*} & \alpha^{16/49*} & \alpha^{9/49*} & \alpha^{4/49*} & \alpha^{1/49*} & 1 & \alpha^{1/49} \\ \alpha^* & \alpha^{36/49*} & \alpha^{25/49*} & \alpha^{16/49*} & \alpha^{9/49*} & \alpha^{4/49*} & \alpha^{1/49*} & 1 \end{pmatrix}$

4x4 case	$R_{spat} = R_{UE} \otimes R_{gNB} = \begin{pmatrix} 1 & \beta^{1/9} & \beta^{4/9} & \beta \\ \beta^{1/9*} & 1 & \beta^{1/9} & \beta^{4/9} \\ \beta^{4/9*} & \beta^{1/9*} & 1 & \beta^{1/9} \\ \beta^* & \beta^{4/9*} & \beta^{1/9*} & 1 \end{pmatrix} \otimes \begin{pmatrix} 1 & \alpha^{1/9} & \alpha^{4/9} & \alpha \\ \alpha^{1/9*} & 1 & \alpha^{1/9} & \alpha^{4/9} \\ \alpha^{4/9*} & \alpha^{1/9*} & 1 & \alpha^{1/9} \\ \alpha^* & \alpha^{4/9*} & \alpha^{1/9*} & 1 \end{pmatrix}$
-----------------	---

For cases with more antennas at either gNB or UE or both, the channel spatial correlation matrix can still be expressed as the Kronecker product of R_{UE} and R_{gNB} according to $R_{spat} = R_{UE} \otimes R_{gNB}$.

G.2.3.1.2 MIMO Correlation Matrices at High, Medium and Low Level

The α and β for different correlation types are given in Table G.2.3.1.2-1.

Table G.2.3.1.2-1: Correlation for High Medium and Low Level

Low correlation		Medium Correlation		High Correlation	
α	β	α	β	α	β
0	0	0.9	0.3	0.9	0.9

The correlation matrices for high, medium and low correlation are defined in Table G.2.3.1.2-2, G.2.3.1.2-3 and G.2.3.1.2-4 as below.

The values in Table G.2.3.1.2-2 have been adjusted for the 2x4 and 4x4 high correlation cases to insure the correlation matrix is positive semi-definite after round-off to 4-digit precision. This is done using the equation:

$$\mathbf{R}_{high} = [\mathbf{R}_{spatial} + a\mathbf{I}_n] / (1 + a)$$

Where the value "a" is a scaling factor such that the smallest value is used to obtain a positive semi-definite result. For the 2x4 high correlation case, a=0.00010. For the 4x4 high correlation case, a=0.00012.

The same method is used to adjust the 4x4 medium correlation matrix in Table G.2.3.1.2-3 to insure the correlation matrix is positive semi-definite after round-off to 4-digit precision with a =0.00012.

Table G.2.3.1.2-2: MIMO correlation matrices for high correlation

1x2 case	$R_{high} = \begin{pmatrix} 1 & 0.9 \\ 0.9 & 1 \end{pmatrix}$
2x2 case	$R_{high} = \begin{pmatrix} 1 & 0.9 & 0.9 & 0.81 \\ 0.9 & 1 & 0.81 & 0.9 \\ 0.9 & 0.81 & 1 & 0.9 \\ 0.81 & 0.9 & 0.9 & 1 \end{pmatrix}$
2x4 case	$R_{high} = \begin{bmatrix} 1.0000 & 0.9883 & 0.9542 & 0.8999 & 0.8999 & 0.8894 & 0.8587 & 0.8099 \\ 0.9883 & 1.0000 & 0.9883 & 0.9542 & 0.8894 & 0.8999 & 0.8894 & 0.8587 \\ 0.9542 & 0.9883 & 1.0000 & 0.9883 & 0.8587 & 0.8894 & 0.8999 & 0.8894 \\ 0.8999 & 0.9542 & 0.9883 & 1.0000 & 0.8099 & 0.8587 & 0.8894 & 0.8999 \\ 0.8999 & 0.8894 & 0.8587 & 0.8099 & 1.0000 & 0.9883 & 0.9542 & 0.8999 \\ 0.8894 & 0.8999 & 0.8894 & 0.8587 & 0.9883 & 1.0000 & 0.9883 & 0.9542 \\ 0.8587 & 0.8894 & 0.8999 & 0.8894 & 0.9542 & 0.9883 & 1.0000 & 0.9883 \\ 0.8099 & 0.8587 & 0.8894 & 0.8999 & 0.8999 & 0.9542 & 0.9883 & 1.0000 \end{bmatrix}$
4x4 case	$R_{high} = \begin{bmatrix} 1.0000 & 0.9882 & 0.9541 & 0.8999 & 0.9882 & 0.9767 & 0.9430 & 0.8894 & 0.9541 & 0.9430 & 0.9105 & 0.8587 & 0.8999 & 0.8894 & 0.8587 & 0.8099 \\ 0.9882 & 1.0000 & 0.9882 & 0.9541 & 0.9767 & 0.9882 & 0.9767 & 0.9430 & 0.9430 & 0.9541 & 0.9430 & 0.9105 & 0.8894 & 0.8999 & 0.8894 & 0.8587 \\ 0.9541 & 0.9882 & 1.0000 & 0.9882 & 0.9430 & 0.9767 & 0.9882 & 0.9767 & 0.9105 & 0.9430 & 0.9541 & 0.9430 & 0.8587 & 0.8894 & 0.8999 & 0.8894 \\ 0.8999 & 0.9541 & 0.9882 & 1.0000 & 0.8894 & 0.9430 & 0.9767 & 0.9882 & 0.8587 & 0.9105 & 0.9430 & 0.9541 & 0.8099 & 0.8587 & 0.8894 & 0.8999 \\ 0.9882 & 0.9767 & 0.9430 & 0.8894 & 1.0000 & 0.9882 & 0.9541 & 0.8999 & 0.9882 & 0.9767 & 0.9430 & 0.8894 & 0.9541 & 0.9430 & 0.9105 & 0.8587 \\ 0.9767 & 0.9882 & 0.9767 & 0.9430 & 0.9882 & 1.0000 & 0.9882 & 0.9541 & 0.9767 & 0.9882 & 0.9767 & 0.9430 & 0.9430 & 0.9541 & 0.9430 & 0.9105 \\ 0.9430 & 0.9767 & 0.9882 & 0.9767 & 0.9541 & 0.9882 & 1.0000 & 0.9882 & 0.9430 & 0.9767 & 0.9882 & 0.9767 & 0.9105 & 0.9430 & 0.9541 & 0.9430 \\ 0.8894 & 0.9430 & 0.9767 & 0.9882 & 0.8999 & 0.9541 & 0.9882 & 1.0000 & 0.8894 & 0.9430 & 0.9767 & 0.9882 & 0.8587 & 0.9105 & 0.9430 & 0.9541 \\ 0.9541 & 0.9430 & 0.9105 & 0.8587 & 0.9882 & 0.9767 & 0.9430 & 0.8894 & 1.0000 & 0.9882 & 0.9541 & 0.8999 & 0.9882 & 0.9767 & 0.9430 & 0.8894 \\ 0.9430 & 0.9541 & 0.9430 & 0.9105 & 0.9767 & 0.9882 & 0.9767 & 0.9430 & 0.9882 & 1.0000 & 0.9882 & 0.9541 & 0.9767 & 0.9882 & 0.9767 & 0.9430 \\ 0.9105 & 0.9430 & 0.9541 & 0.9430 & 0.9430 & 0.9767 & 0.9882 & 0.9767 & 0.9541 & 0.9882 & 1.0000 & 0.9882 & 0.9430 & 0.9767 & 0.9882 & 0.9767 \\ 0.8587 & 0.9105 & 0.9430 & 0.9541 & 0.8894 & 0.9430 & 0.9767 & 0.9882 & 0.8999 & 0.9541 & 0.9882 & 1.0000 & 0.8894 & 0.9430 & 0.9767 & 0.9882 \\ 0.8999 & 0.8894 & 0.8587 & 0.8099 & 0.9541 & 0.9430 & 0.9105 & 0.8587 & 0.9882 & 0.9767 & 0.9430 & 0.8894 & 1.0000 & 0.9882 & 0.9541 & 0.8999 \\ 0.8894 & 0.8999 & 0.8894 & 0.8587 & 0.9430 & 0.9541 & 0.9430 & 0.9105 & 0.9767 & 0.9882 & 0.9767 & 0.9430 & 0.9882 & 1.0000 & 0.9882 & 0.9541 \\ 0.8587 & 0.8894 & 0.8999 & 0.8894 & 0.9105 & 0.9430 & 0.9541 & 0.9430 & 0.9430 & 0.9767 & 0.9882 & 0.9767 & 0.9541 & 0.9882 & 1.0000 & 0.9882 \\ 0.8099 & 0.8587 & 0.8894 & 0.8999 & 0.8587 & 0.9105 & 0.9430 & 0.9541 & 0.8894 & 0.9430 & 0.9767 & 0.9882 & 0.8999 & 0.9541 & 0.9882 & 1.0000 \end{bmatrix}$

Table G.2.3.1.2-3: MIMO correlation matrices for medium correlation

1x2 case	[N/A]
2x2 case	$R_{medium} = \begin{pmatrix} 1.0000 & 0.9000 & 0.3000 & 0.2700 \\ 0.9000 & 1.0000 & 0.2700 & 0.3000 \\ 0.3000 & 0.2700 & 1.0000 & 0.9000 \\ 0.2700 & 0.3000 & 0.9000 & 1.0000 \end{pmatrix}$
2x4 case	$R_{medium} = \begin{pmatrix} 1.0000 & 0.9884 & 0.9543 & 0.9000 & 0.3000 & 0.2965 & 0.2863 & 0.2700 \\ 0.9884 & 1.0000 & 0.9884 & 0.9543 & 0.2965 & 0.3000 & 0.2965 & 0.2863 \\ 0.9543 & 0.9884 & 1.0000 & 0.9884 & 0.2863 & 0.2965 & 0.3000 & 0.2965 \\ 0.9000 & 0.9543 & 0.9884 & 1.0000 & 0.2700 & 0.2863 & 0.2965 & 0.3000 \\ 0.3000 & 0.2965 & 0.2863 & 0.2700 & 1.0000 & 0.9884 & 0.9543 & 0.9000 \\ 0.2965 & 0.3000 & 0.2965 & 0.2863 & 0.9884 & 1.0000 & 0.9884 & 0.9543 \\ 0.2863 & 0.2965 & 0.3000 & 0.2965 & 0.9543 & 0.9884 & 1.0000 & 0.9884 \\ 0.2700 & 0.2863 & 0.2965 & 0.3000 & 0.9000 & 0.9543 & 0.9884 & 1.0000 \end{pmatrix}$
4x4 case	$R_{medium} = \begin{pmatrix} 1.0000 & 0.9882 & 0.9541 & 0.8999 & 0.8747 & 0.8645 & 0.8347 & 0.7872 & 0.5855 & 0.5787 & 0.5588 & 0.5270 & 0.3000 & 0.2965 & 0.2862 & 0.2700 \\ 0.9882 & 1.0000 & 0.9882 & 0.9541 & 0.8645 & 0.8747 & 0.8645 & 0.8347 & 0.5787 & 0.5855 & 0.5787 & 0.5588 & 0.2965 & 0.3000 & 0.2965 & 0.2862 \\ 0.9541 & 0.9882 & 1.0000 & 0.9882 & 0.8347 & 0.8645 & 0.8747 & 0.8645 & 0.5588 & 0.5787 & 0.5855 & 0.5787 & 0.2862 & 0.2965 & 0.3000 & 0.2965 \\ 0.8999 & 0.9541 & 0.9882 & 1.0000 & 0.7872 & 0.8347 & 0.8645 & 0.8747 & 0.5270 & 0.5588 & 0.5787 & 0.5855 & 0.2700 & 0.2862 & 0.2965 & 0.3000 \\ 0.8747 & 0.8645 & 0.8347 & 0.7872 & 1.0000 & 0.9882 & 0.9541 & 0.8999 & 0.8747 & 0.8645 & 0.8347 & 0.7872 & 0.5855 & 0.5787 & 0.5588 & 0.5270 \\ 0.8645 & 0.8747 & 0.8645 & 0.8347 & 0.9882 & 1.0000 & 0.9882 & 0.9541 & 0.8645 & 0.8747 & 0.8645 & 0.8347 & 0.5787 & 0.5855 & 0.5787 & 0.5588 \\ 0.8347 & 0.8645 & 0.8747 & 0.8645 & 0.9541 & 0.9882 & 1.0000 & 0.9882 & 0.8347 & 0.8645 & 0.8747 & 0.8645 & 0.5588 & 0.5787 & 0.5855 & 0.5787 \\ 0.7872 & 0.8347 & 0.8645 & 0.8747 & 0.8999 & 0.9541 & 0.9882 & 1.0000 & 0.7872 & 0.8347 & 0.8645 & 0.8747 & 0.5270 & 0.5588 & 0.5787 & 0.5855 \\ 0.5855 & 0.5787 & 0.5588 & 0.5270 & 0.8747 & 0.8645 & 0.8347 & 0.7872 & 1.0000 & 0.9882 & 0.9541 & 0.8999 & 0.8747 & 0.8645 & 0.8347 & 0.7872 \\ 0.5787 & 0.5855 & 0.5787 & 0.5588 & 0.8645 & 0.8747 & 0.8645 & 0.8347 & 0.9882 & 1.0000 & 0.9882 & 0.9541 & 0.8645 & 0.8747 & 0.8645 & 0.8347 \\ 0.5588 & 0.5787 & 0.5855 & 0.5787 & 0.8347 & 0.8645 & 0.8747 & 0.8645 & 0.9541 & 0.9882 & 1.0000 & 0.9882 & 0.8347 & 0.8645 & 0.8747 & 0.8645 \\ 0.5270 & 0.5588 & 0.5787 & 0.5855 & 0.7872 & 0.8347 & 0.8645 & 0.8747 & 0.8999 & 0.9541 & 0.9882 & 1.0000 & 0.7872 & 0.8347 & 0.8645 & 0.8747 \\ 0.3000 & 0.2965 & 0.2862 & 0.2700 & 0.5855 & 0.5787 & 0.5588 & 0.5270 & 0.8747 & 0.8645 & 0.8347 & 0.7872 & 1.0000 & 0.9882 & 0.9541 & 0.8999 \\ 0.2965 & 0.3000 & 0.2965 & 0.2862 & 0.5787 & 0.5855 & 0.5787 & 0.5588 & 0.8645 & 0.8747 & 0.8645 & 0.8347 & 0.9882 & 1.0000 & 0.9882 & 0.9541 \\ 0.2862 & 0.2965 & 0.3000 & 0.2965 & 0.5588 & 0.5787 & 0.5855 & 0.5787 & 0.8347 & 0.8645 & 0.8747 & 0.8645 & 0.9541 & 0.9882 & 1.0000 & 0.9882 \\ 0.2700 & 0.2862 & 0.2965 & 0.3000 & 0.5270 & 0.5588 & 0.5787 & 0.5855 & 0.7872 & 0.8347 & 0.8645 & 0.8747 & 0.8999 & 0.9541 & 0.9882 & 1.0000 \end{pmatrix}$

Table G.2.3.1.2-4: MIMO correlation matrices for low correlation

1x2 case	$R_{low} = \mathbf{I}_2$
1x4 case	$R_{low} = \mathbf{I}_4$
1x8 case	$R_{low} = \mathbf{I}_8$
2x2 case	$R_{low} = \mathbf{I}_4$
2x4 case	$R_{low} = \mathbf{I}_8$
2x8 case	$R_{low} = \mathbf{I}_{16}$
4x4 case	$R_{low} = \mathbf{I}_{16}$

In Table G.2.3.1.2-4, \mathbf{I}_d is a $d \times d$ identity matrix.

NOTE: For completeness, the correlation matrices were defined for high, medium and low correlation but performance requirements exist only for low correlation.

G.2.3.2 Multi-Antenna channel models using cross polarized antennas

The MIMO channel correlation matrices defined in G.2.3.2 apply to two cases as presented below:

- One TX antenna and multiple RX antennas case, with cross polarized antennas used at gNB
- Multiple TX antennas and multiple RX antennas case, with cross polarized antennas used at both UE and gNB

The cross-polarized antenna elements with +/-45 degrees polarization slant angles are deployed at gNB. For one TX antenna case, antenna element with +90 degree polarization slant angle is deployed at UE. For multiple TX antennas case, cross-polarized antenna elements with +90/0 degrees polarization slant angles are deployed at UE.

For the cross-polarized antennas, the N antennas are labelled such that antennas for one polarization are listed from 1 to N/2 and antennas for the other polarization are listed from N/2+1 to N, where N is the number of TX or RX antennas.

G.2.3.2.1 Definition of MIMO Correlation Matrices using cross polarized antennas

For the channel spatial correlation matrix, the following is used:

$$R_{Spat} = P_{UL} (R_{UE} \otimes \Gamma_{UL} \otimes R_{gNB}) P_{UL}^T$$

Where

- R_{UE} is the spatial correlation matrix at the UE with same polarization,
- R_{gNB} is the spatial correlation matrix at the gNB with same polarization,
- Γ_{UL} is a polarization correlation matrix,
- P_{UL} is a permutation matrix, and
- $(\bullet)^T$ denotes transpose.

Table G.2.3.2.1-1 defines the polarization correlation matrix.

Table G.2.3.2.1-1: Polarization correlation matrix

	One TX antenna	Multiple TX antennas
Polarization correlation matrix	$\Gamma_{UL} = \begin{bmatrix} 1 & -\gamma \\ -\gamma & 1 \end{bmatrix}$	$\Gamma_{UL} = \begin{bmatrix} 1 & -\gamma & 0 & 0 \\ -\gamma & 1 & 0 & 0 \\ 0 & 0 & 1 & \gamma \\ 0 & 0 & \gamma & 1 \end{bmatrix}$

The matrix P_{UL} is defined as

$$P_{UL}(a,b) = \begin{cases} 1 & \text{for } a = (j-1)Nr + i \text{ and } b = 2(j-1)Nr + i, \quad i = 1, \dots, Nr, j = 1, \dots, \lceil Nt/2 \rceil \\ 1 & \text{for } a = (j-1)Nr + i \text{ and } b = 2(j - Nt/2)Nr - Nr + i, \quad i = 1, \dots, Nr, j = \lceil Nt/2 \rceil + 1, \dots, Nt \\ 0 & \text{otherwise} \end{cases}$$

where Nt and Nr is the number of TX and RX antennas respectively, and $\lceil \bullet \rceil$ is the ceiling operator.

The matrix P_{UL} is used to map the spatial correlation coefficients in accordance with the antenna element labelling system described in G.2.3.2.

G.2.3.2.2 Spatial Correlation Matrices at UE and gNB sides

G.2.3.2.2.1 Spatial Correlation Matrices at UE side

For 1-antenna transmitter, $R_{UE} = 1$.

For 2-antenna transmitter using one pair of cross-polarized antenna elements, $R_{UE} = 1$.

For 4-antenna transmitter using two pairs of cross-polarized antenna elements, $R_{UE} = \begin{pmatrix} 1 & \beta \\ \beta^* & 1 \end{pmatrix}$.

G.2.3.2.2.2 Spatial Correlation Matrices at gNB side

For 2-antenna receiver using one pair of cross-polarized antenna elements, $R_{gNB} = 1$.

For 4-antenna receiver using two pairs of cross-polarized antenna elements, $R_{gNB} = \begin{pmatrix} 1 & \alpha \\ \alpha^* & 1 \end{pmatrix}$.

For 8-antenna receiver using four pairs of cross-polarized antenna elements, $R_{gNB} = \begin{pmatrix} 1 & \alpha^{1/9} & \alpha^{4/9} & \alpha \\ \alpha^{1/9*} & 1 & \alpha^{1/9} & \alpha^{4/9} \\ \alpha^{4/9*} & \alpha^{1/9*} & 1 & \alpha^{1/9} \\ \alpha^* & \alpha^{4/9*} & \alpha^{1/9*} & 1 \end{pmatrix}$.

G.2.3.2.3 MIMO Correlation Matrices using cross polarized antennas

The values for parameters α , β and γ for low spatial correlation are given in Table G.2.3.2.3-1.

Table G.2.3.2.3-1: Values for parameters α , β and γ

Low spatial correlation		
α	β	γ
0	0	0
Note 1: Value of α applies when more than one pair of cross-polarized antenna elements at gNB side.		
Note 2: Value of β applies when more than one pair of cross-polarized antenna elements at UE side.		

The correlation matrices for low spatial correlation are defined in Table G.2.3.2.3-2 as below.

Table G.2.3.2.3-2: MIMO correlation matrices for low spatial correlation

1x8 case	$R_{low} = \mathbf{I}_8$
2x8 case	$R_{low} = \mathbf{I}_{16}$

In Table G.2.3.2.3-2, \mathbf{I}_d is a $d \times d$ identity matrix.

G.3 High speed train condition

High speed train conditions are as follows:

- Scenario 1-NR350 / Scenario 1-NR500: Open space
- Scenario 3-NR350 / Scenario 3-NR500: Tunnel
- Scenario 4-BI-NR350, FR2: Open space

The high speed train conditions for the test of the baseband performance are three non-fading propagation channels. For BS with Rx diversity, the Doppler shift time variation is the same for each antenna at each time instant.

Doppler shift for all three scenarios is given by:

$$f_s(t) = f_d \cos\theta(t) \quad (\text{G.3.1})$$

where $f_s(t)$ is the Doppler shift and f_d is the maximum Doppler frequency.

For Scenario 1 and Scenario 3, the cosine of angle $\theta(t)$ is given by:

$$\cos\theta(t) = \frac{D_s/2 - vt}{\sqrt{D_{\min}^2 + (D_s/2 - vt)^2}}, \quad 0 \leq t \leq D_s/v \quad (\text{G.3.2})$$

$$\cos\theta(t) = \frac{-1.5D_s + vt}{\sqrt{D_{\min}^2 + (-1.5D_s + vt)^2}}, \quad D_s/v < t \leq 2D_s/v \quad (\text{G.3.3})$$

$$\cos\theta(t) = \cos\theta(t \bmod (2D_s/v)), \quad t > 2D_s/v \quad (\text{G.3.4})$$

where $D_s/2$ is the initial distance of the train from BS, and D_{\min} is BS-Railway track distance, both in meters; v is the velocity of the train in m/s, t is time in seconds.

For Scenario 4, the cosine of angle $\theta(t)$ is given by:

$$\cos\theta(t) = \frac{D_s - vt}{\sqrt{D_{\min}^2 + (D_s - vt)^2}}, \quad 0 < t \leq (0.5 * D_s)/v \quad (\text{G.3.5})$$

$$\cos\theta(t) = -\frac{vt}{\sqrt{D_{\min}^2 + (vt)^2}}, \quad (0.5 * D_s)/v < t \leq D_s/v \quad (\text{G.3.6})$$

$$\cos\theta(t) = \cos\theta\left(t \bmod \left(\frac{D_s}{v}\right)\right), \quad t > D_s/v \quad (\text{G.3.7})$$

where D_s is the initial distance of the train from BS, and D_{\min} is BS-Railway track distance, both in meters; v is the velocity of the train in m/s; t is time in seconds.

The required input parameters are listed in table G.3-1 and G.3-2. The resulting time varying Doppler shift is shown in Figure G.3-1, G.3-2, G.3-3, G.3-4 and G.3-9 for 350km/h scenarios, and in Figure G.3-5, G.3-6, G.3-7 and G.3-8 for 500km/h scenarios. For 350km/h scenarios, the Doppler shift was derived such that it corresponds to a velocity of around 350km/h for band n1 for the 15kHz SCS, for band n77 for the 30kHz SCS, and for band n257 for the 120kHz SCS. For 500km/h scenarios, the Doppler shift was derived such that it corresponds to a velocity of around 500km/h for band n3 for the 15kHz SCS and for band n77 for the 30kHz SCS. However, the same Doppler shift requirement shall be applied regardless of the frequency of operation of the basestation and thus for lower frequencies, the supported speed is higher.

Table G.3-1: Parameters for high speed train conditions for UE velocity 350 km/h

Parameter	Value		
	Scenario 1-NR350	Scenario 3-NR350	Scenario 4-BI-NR350, FR2
D_s	700 m	300 m	700 m
D_{\min}	150 m	2 m	150 m
v	350 km/h	350 km/h	350 km/h
f_d	1340 Hz for 15kHz SCS 2334 Hz for 30kHz SCS	1340 Hz for 15kHz SCS 2334 Hz for 30kHz SCS	19444 Hz for 120kHz SCS

Table G.3-2: Parameters for high speed train conditions for UE velocity 500 km/h

Parameter	Value	
	Scenario 1-NR500	Scenario 3-NR500
D_s	700 m	300 m
D_{min}	150 m	2 m
v	500 km/h	500 km/h
f_d	1740 Hz for 15kHz SCS 3334 Hz for 30kHz SCS	1740 Hz for 15kHz SCS 3334 Hz for 30kHz SCS

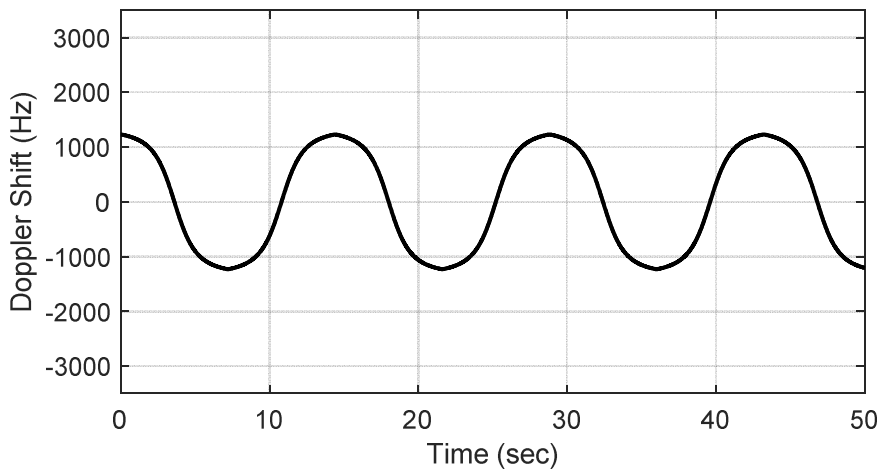

Figure G.3-1: Doppler shift trajectory for scenario 1-NR350 (15 kHz SCS)

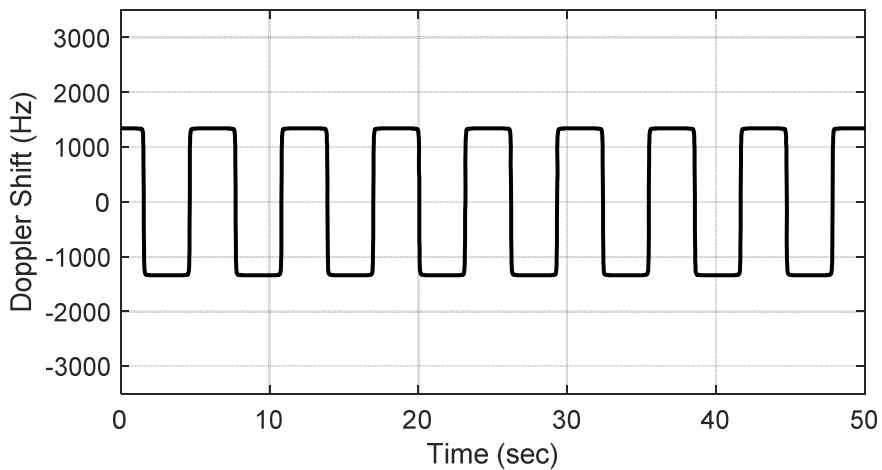

Figure G.3-2: Doppler shift trajectory for scenario 3-NR350 (15 kHz SCS)

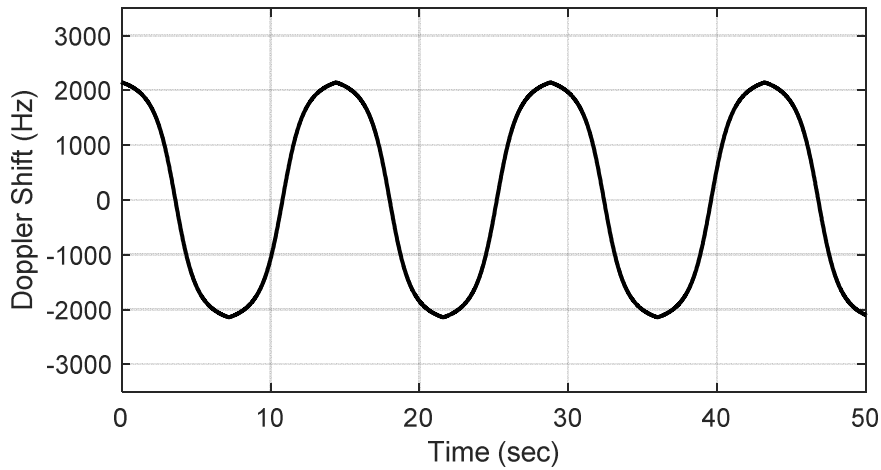

Figure G.3-3: Doppler shift trajectory for scenario 1-NR350 (30 kHz SCS)

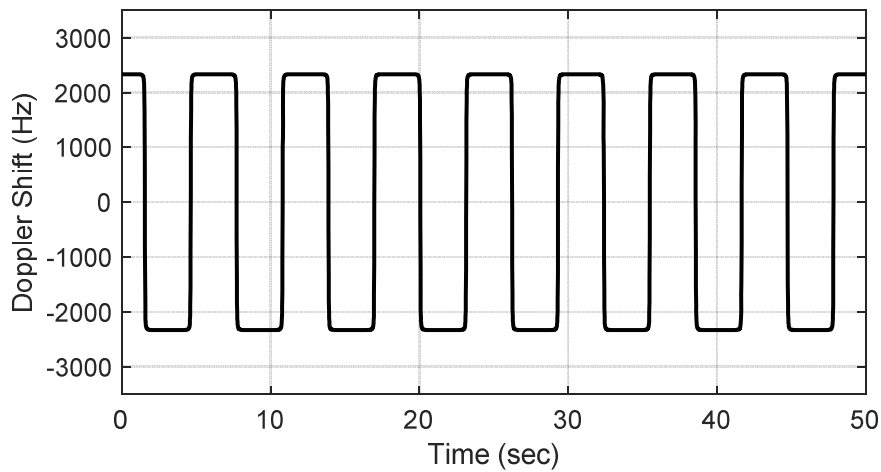

Figure G.3-4: Doppler shift trajectory for scenario 3-NR350 (30 kHz SCS)

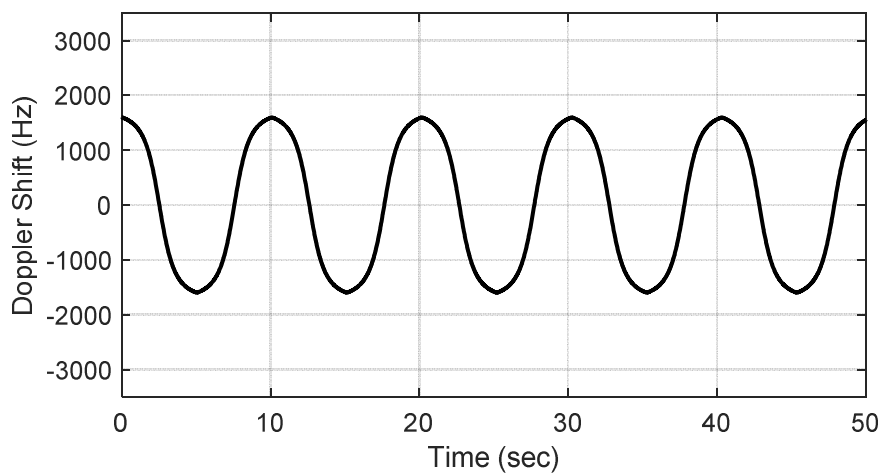

Figure G.3-5: Doppler shift trajectory for scenario 1-NR500 (15 kHz SCS)

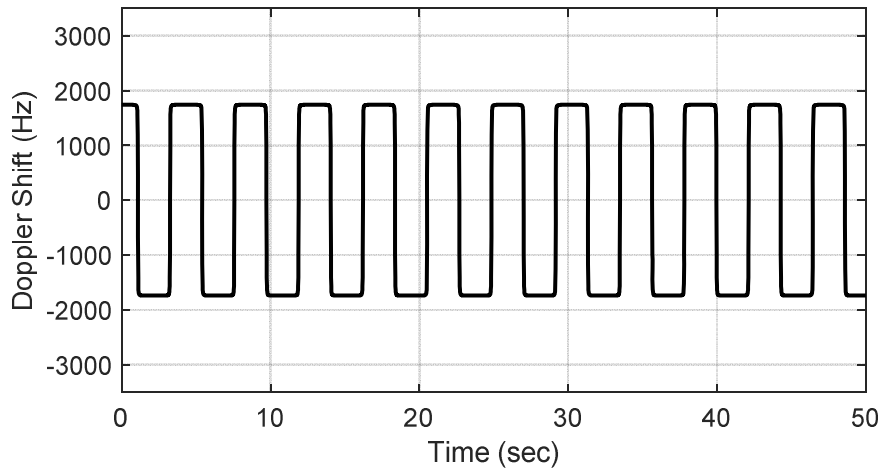

Figure G.3-6: Doppler shift trajectory for scenario 3-NR500 (15 kHz SCS)

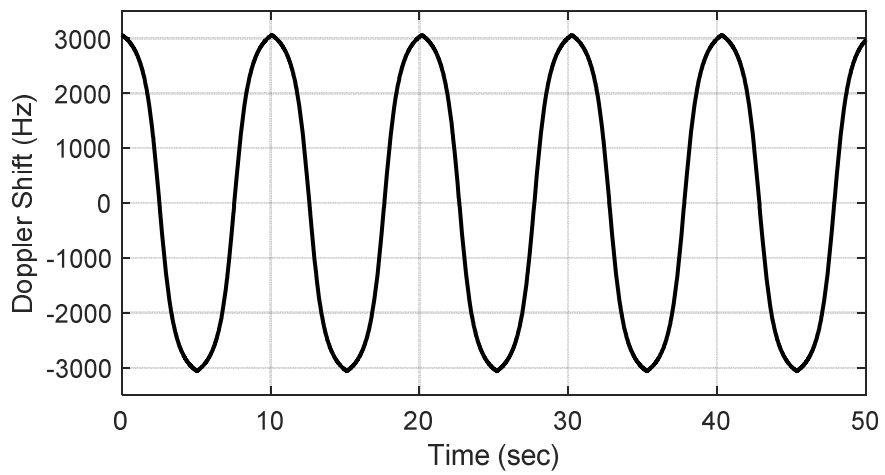

Figure G.3-7: Doppler shift trajectory for scenario 1-NR500 (30 kHz SCS)

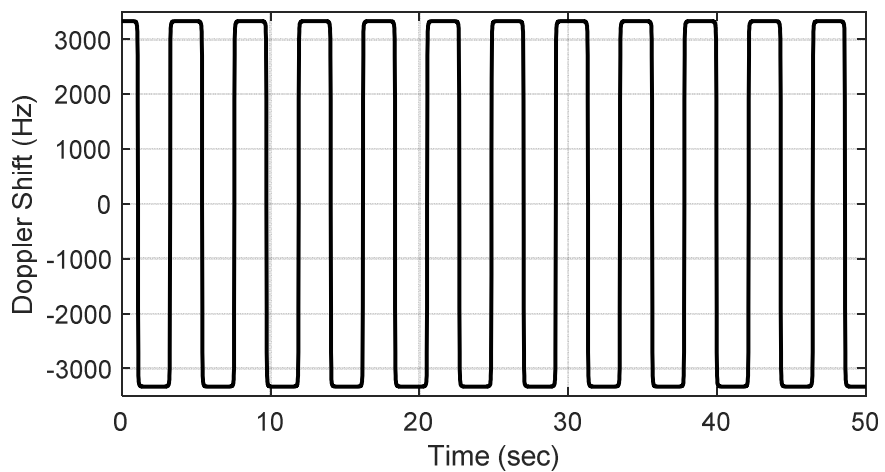

Figure G.3-8: Doppler shift trajectory for scenario 3-NR500 (30 kHz SCS)

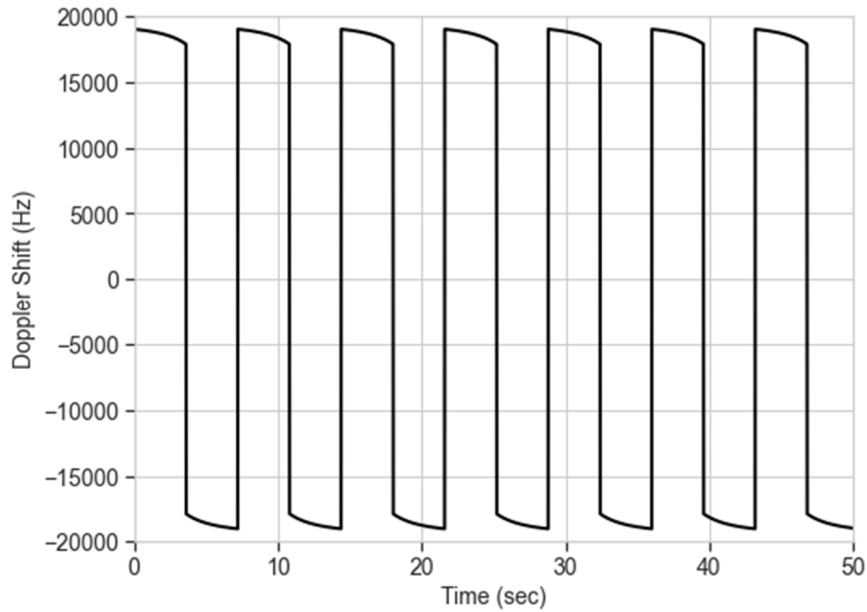

Figure G.3-9: Doppler shift trajectory for scenario 4-BI-NR350, FR2 (120 kHz SCS)

G.4 Moving propagation conditions

Figure G.4-1 illustrates the moving propagation conditions for the test of the UL timing adjustment performance. The time difference between the reference timing and the first tap is according Equation (G.4-1). The timing difference between moving UE and stationary UE is equal to $\Delta\tau - (T_A - 31) \times 16 \times 64 T_c$ for 15kHz SCS, $\Delta\tau - (T_A - 31) \times 16 \times 32 T_c$ for 30kHz SCS and $\Delta\tau - (T_A - 31) \times 16 \times 8 T_c$ for 120kHz SCS. The relative timing among all taps is fixed. The parameters for the moving propagation conditions are shown in Table G.4-1.

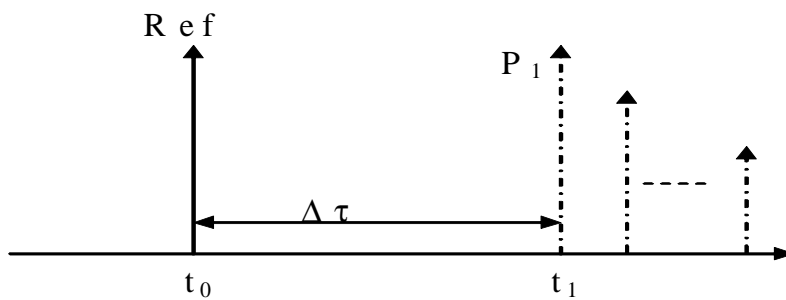

Figure G.4-1: Moving propagation conditions

$$\Delta\tau = \frac{A}{2} \cdot \sin(\Delta\omega \cdot t) \tag{G.4-1}$$

Table G.4-1: Parameters for UL timing adjustment

Parameter	Scenario X	Scenario Y	Scenario Z
Channel model	Stationary UE: AWGN Moving UE: TDLC300-400	Stationary UE: AWGN Moving UE: AWGN	Stationary UE: AWGN Moving UE: AWGN
UE speed	120 km/h	350 km/h	500 km/h
CP length	Normal	Normal	Normal
A	15 kHz: 10 μ s 30 kHz: 5 μ s	15 kHz: 10 μ s 30 kHz: 5 μ s 120 kHz: 1.25 μ s	15 kHz: 10 μ s 30 kHz: 5 μ s
$\Delta\omega$	15 kHz: 0.04 s ⁻¹ 30 kHz: 0.08 s ⁻¹	15 kHz: 0.13 s ⁻¹ 30 kHz: 0.26 s ⁻¹ 120 kHz: 1.04 s ⁻¹	15 kHz: 0.18 s ⁻¹ 30 kHz: 0.36 s ⁻¹

NOTE 1: Doppler shift is not taken into account in UL TA scenario Y and Z.

Annex H (informative): Change history

Change history							
Date	Meeting	TDoc	CR	Rev	Cat	Subject/Comment	New version
2017-05	RAN4#83	R4-1704619				Specification skeleton	0.0.1
2017-05	RAN4#83	R4-1705332				Specification skeleton (revised)	0.0.2
2017-05	RAN4#83	R4-1706228				Specification skeleton (revised)	0.0.3
2017-07	RAN4-NR AH #2	R4-1706983				Agreed Text Proposal in RAN4 NR AH #2: R4-1706955 , "TP to TS 38.104: BS classification for NR BS"	0.1.0
2018-08	RAN4#84	R4-1709212				Agreed Text Proposal in RAN4 #84: R4-1708872 , "TP to TS 38.104 BS transmitter transient period"	0.2.0
2018-10	RAN4#84 bis	R4-1711970				Agreed Text Proposal in RAN4 #84bis: R4-1710199 , "TP for TS 38.104: out of band blocking (10.4)" R4-1710587 , "TP for TS 38.104: Relationship with other core specifications (4.1)" R4-1710588 , "TP for TS 38.104: Relationship between minimum requirements and test requirements (4.2)" R4-1710589 , "TP for TS 38.104: Regional requirements (4.5)" R4-1710591 , "TP for TS 38.104: Conducted transmitter characteristics (general) (6.1)" R4-1710593 , "TP for TS 38.104: Operating band unwanted emissions (conducted) (6.6.4)" R4-1710594 , "TP for TS 38.104: Conducted receiver characteristics (General) (7.1)" R4-1710595 , "TP for TS 38.104: Radiated transmitter characteristics (General) (9.1)" R4-1710598 , "TP for TS 38.104: Radiated receiver characteristics (General) (10.1)" R4-1711325 , "TP to TS38.104: OTA Output power dynamics (9.4)" R4-1711363 , "TP to TS 38.104 - Occupied bandwidth (6.6.2)" R4-1711745 , "TP to TS 38.104 - Conducted and radiated requirement reference points (4.3)" R4-1711746 , "TP for TS 38.104: Adding applicability table to clause 4.6" R4-1711747 , "TP for TS 38.104: Operating bands and channel arrangements. (5)" R4-1711748 , "TP to TS38.104: conducted NR BS output power (6.2)" R4-1711750 , "TP for TS 38.104: Transmit ON/OFF power (6.4)" R4-1711753 , "TP for TS 38.104: Time alignment error requirements (6.5)" R4-1711754 , "TP for TS 38.104: Unwanted emissions, General (Conducted) (6.6.1)" R4-1711755 , "TP to TS 38.104: Occupied bandwidth for FR1 and FR2 NR BS (9.7)" R4-1711756 , "TP to TS 38.104: Transmitter spurious emissions (conducted) (6.6.5)" R4-1711757 , "TP for TS 38.104:Conducted BS transmitter intermodulation for FR1 (section 6.7)" R4-1711758 , "TP to TS 38.104: Reference Sensitivity (conducted) (7.2)" R4-1711759 , "TP to TS 38.104: NR BS conducted ACLR requirement in FR1 (6.6.3)" R4-1711760 , "TP to TS38.104: conducted NR BS receiver spurious emissions (7.6)" R4-1711761 , "TP to TS38.104: Radiated NR BS transmit power; FR1 (9.2)" R4-1711762 , "TP to TS38.104: OTA base station output power, FR1 (9.3)" R4-1711763 , "TP for TS 38.104: OTA Transmit ON/OFF power (9.5)" R4-1711764 , "TP to TS 38.104 - OTA ACLR" R4-1711765 , "TP for TS 38.104: OTA Operating band unwanted emissions and Spectrum emissions mask (9.7.4)" R4-1711766 , "TP for TS 38.104: OTA Spurious emission (9.7.5)" R4-1711767 , "TP for TS 38.104: Adding specification text for OTA TX IMD requirement in clause 9.8" R4-1711768 , "TP to TS 38.104: OTA Sensitivity (10.2)" R4-1711771 , "TP to TS38.104: OTA receiver spurious emissions, FR1 (10.7)" R4-1711772 , "TP to TS 38.104: Receiver Intermodulation (10.8)" R4-1711811 , "TP to TS 38.104: NR BS conducted in-band selectivity and blocking requirements in FR1 (7.4)" R4-1711950 , "TP to TS 38.104: Modulation Quality Skeleton (6.5)" R4-1711951 , "TP to TS38.104: frequency error for FR1 NR BS (6.5&9.6)" R4-1711952 , "TP to TS 38.104: OTA reference sensitivity (10.3)"	0.3.0

2017-11	RAN4#84 bis	R4-1711971			Alignment of structure, terminology, and definitions between clauses.	0.4.0
2017-12	RAN4#85	R4-1714544			<p>Agreed Text Proposal in RAN4 #85:</p> <p>R4-1712614, "TP to TS 38.104 - OTA sensitivity (10.2)"</p> <p>R4-1712648, "TP to TS 38.104: corrections for the applicability of "BS type" and "requirement set" definitions"</p> <p>R4-1712964, "TP for TS 38.104: out of band blocking (7.5)"</p> <p>R4-1713631, "TP to 38.104 on introduction of n71"</p> <p>R4-1713632, "TP to 38.104, clause 4.7 (Requirements for contiguous and non-contiguous spectrum)"</p> <p>R4-1713633, "TP to 38.104, clause 4.8 (Requirements for BS capable of multi-band operation)"</p> <p>R4-1713634, "TP to 38.104, clause 6.6.4.2.6 (basic limits for additional requirements for operating band unwanted emissions)"</p> <p>R4-1714116, "TP to TS 38.104: Revision of the TRP definition"</p> <p>R4-1714117, "TP to TS 38.104: Radiated NR BS transmit power; 2-O (9.2.3)"</p> <p>R4-1714121, "TP to TS 38.104: OTA Output power dynamics (9.4)"</p> <p>R4-1714125, "TP to TS 38.104 v0.4.0: OTA TDD Off power"</p> <p>R4-1714127, "TP for TS 38.104: OTA frequency error (9.6.1)"</p> <p>R4-1714129, "TP to TS 38.104: NR BS conducted ACLR requirements in FR1 (6.6.3)"</p> <p>R4-1714134, "TP to TS 38.104v0.4.0: Absolute levels for FR2 ACLR absolute levels for NR BS"</p> <p>R4-1714136, "TP for TS 38.104: Update of OTA TX IM requirement for sub-clause 4.9 and sub-clause 9.8"</p> <p>R4-1714141, "TP to TS 38.104: Reference Sensitivity (conducted) (7.2)"</p> <p>R4-1714142, "TP to TS 38.104: NR BS FRCs for receiver requirements"</p> <p>R4-1714150, "TP to TS 38.104 - OTA out of band blocking FR1 (10.6)"</p> <p>R4-1714306, "TP for TS 38.104: Adding of TRP in terminology in clause 3"</p> <p>R4-1714307, "TP to TS 38.104 - Conducted and radiated requirement reference points (4.3)"</p> <p>R4-1714308, "TP for TS 38.104: Base station classes (4.4)"</p> <p>R4-1714310, "TP to TS 38.104: Directional and TRP requirements identification (directional vs. TRP)"</p> <p>R4-1714312, "TP for TS 38.104: Update of applicability table in sub-clause 4.6"</p> <p>R4-1714313, "TP to TS 38.104: Operating bands (5.1-5.3)"</p> <p>R4-1714315, "TP to TS38.104: frequency error for NR BS (6.5&9.6)"</p> <p>R4-1714316, "TP for TS 38.104: Adding text for clause 6.5.2 Modulation quality"</p> <p>R4-1714317, "TP to TS 38.104: Dynamic Range for FR1 (conducted)"</p> <p>R4-1714318, "TP to TS38.104: ICS requirement (7.8&10.9)"</p> <p>R4-1714319, "TP for TS 38.104: Adding text for clause 9.6.4 Modulation quality"</p> <p>R4-1714320, "TP for TS 38.104: OTA Spurious emission (9.7.5)"</p> <p>R4-1714321, "TP for TS 38.104: OTA Dynamic range (10.4)"</p> <p>R4-1714390, "TP to TS 38.104: FR2 RX IM OTA, 10.8.3"</p> <p>R4-1714428, "TP to TS 38.104 v0.4.0: Time alignment for CA"</p> <p>R4-1714430, "TP to TS 38.104: Transmitter spurious emissions (conducted) (6.6.5)"</p> <p>R4-1714432, "TP to TS 38.104: Output Power Dynamics for FR1 (conducted)"</p> <p>R4-1714433, "TP to TS 38.104: OTA Rx spurious emissions for BS type O 2 (10.7.3)"</p> <p>R4-1714435, "TP to TS 38.104: FR2 REFSENS"</p> <p>R4-1714437, "TP for TS 38.104: Conducted Adjacent Channel Leakage Power Ratio (ACLR) (6.6.3)"</p> <p>R4-1714439, "TP for TS 38.104: Receiver spurious emission (7.6)"</p> <p>R4-1714476, "TP to TR 38.104: Channel arrangement (5.4)"</p> <p>R4-1714493, "TP for TS 38.104: Operating band unwanted emissions (6.6.4)"</p> <p>R4-1714515, "TP for TS 38.104: OTA Out-of-band emissions (9.7.4)"</p> <p>R4-1714517, "TP to TS 38.104: OTA base station output power, 2-O (9.3.3)"</p> <p>R4-1714518, "TP to TS 38.104: ACS and blocking update"</p> <p>R4-1714520, "Draft TP to TS 38.104: OTA In-band selectivity and blocking (10.5)"</p> <p>R4-1714525, "TP to TS 38.104: FR1 RX IM conducted 7.7"</p> <p>R4-1714526, "TP to TS 38.104: FR1 RX IM OTA 10.8.2"</p>	0.5.0
2017-12	RAN#78	RP-172268			Presented to TSG RAN for approval.	1.0.0
2017-12	RAN#78				Approved by plenary – Rel-15 spec under change control	15.0.0

2018-03	RAN#79	RP-180264	0004		F	TS 38.104 Combined updates (NSA) from RAN4 #86 and AH-1801	15.1.0
2018-06	RAN#80	RP-181076	0005		F	TS 38.104 Combined updates (NSA) from RAN4 #86bis and RAN4 #87	15.2.0
2018-09	RAN#81	RP-181896	0008		F	TS 38.104 Combined updates from RAN4 #88	15.3.0
2018-12	RAN#82	RP-182837	0016	1	F	CR to TS 38.104 on Combined updates from RAN4 #88bis and #89 (including 7.5 kHz carrier shift in UL for remaining bands)	15.4.0
2018-12	RAN#82	RP-182362	0017		B	CR to 38.104 on Combined CRs for BS Demodulation performance	15.4.0
2019-03	RAN#83	RP-190403	0019		F	<p>CR to TS 38.104 on Combined updates from RAN4 #90</p> <p>This document combines the proposed changes in the following Draft CRs from RAN4 #90:</p> <ul style="list-style-type: none"> - R4-1900284, "Draft CR on NR PUCCH format2 performance requirements for TS 38.104" - R4-1900763, "Draft CR to TS 38.104: Update of performance requirement numbers for DFT-s-OFDM based PUSCH" - R4-1900876, "Draft CR to TS 38.104: On RX spurious emissions requirement" - R4-1900968, "Draft CR for 38.104: Performance requirements for NR PUCCH format 1" - R4-1901329, "Draft CR to 38.104: Annex C.6 correction" - R4-1901330, "Draft CR to 38.104: Abbreviations addition" - R4-1901387, "Draft CR to TS 38.104 BS demodulation PUCCH format 0 requirements" - R4-1901474, "Draft CR to TS 38.104: Corrections on transmitter co-existence and co-location requirements" - R4-1901483, "Draft CR to TS 38.104: Corrections on general intermodulation requirement" - R4-1902239, "Draft CR to TS 38.104: Addition of missing EIRP/EIS definitions in terminology in clause 3.1" - R4-1902241, "Draft CR to 38.104; clarification of BS power limits" - R4-1902245, "Draft CR to 38.104: Correction to FR2 OTA Interfering signal mean power units" - R4-1902246, "Draft CR to 38.104; Correction to definition of OTA reference sensitivity" - R4-1902260, "draft CR to TS 38.104 - update emissions scaling" - R4-1902338, "Draft CR: Update on FR1 range extension for TS38.104" - R4-1902389, "draftCR for 38.104 on PUSCH requirements with CP-OFDM and FR1" - R4-1902394, "Draft CR to TS 38.104 – PUSCH requirements with CP-OFDM for FR2" - R4-1902396, "CR: Updates to PUCCH formats 3 and 4 performance requirements in TS 38.104" - R4-1902444, "Draft CR to TS 38.104: Editorial CR for BS demodulation requirements" - R4-1902561, "Draft CR for updating PRACH performance requirements in TS38.104" - R4-1902571, "Corrections to 38.104 Delay profile calculation" - R4-1902642, "Draft CR to TS 38.104: Correction on multi-band operation related requirements" 	15.5.0

2019-06	RAN#84	RP-191240	0029		<p>CR to TS 38.104 Combined updates from RAN4 #90bis and RAN4#91</p> <p>From RAN4 #90bis:</p> <ul style="list-style-type: none"> - R4-1903105, "Draft CR to TS 38.104: Corrections on terminologies and editorial errors" - R4-1903319, "Draft CR to TS 38.104: removal of unused definition: "minimum EIRP level under extreme condition" - R4-1903320, "Draft CR to TS 38.104: OSDD information correction" - R4-1903457, "Draft CR to TS 38.104: Removal of FFS for FR2 TDD OFF power level requirement in clause 9.5" - R4-1903499, "Draft CR to 38.104: Correction to unwanted emissions mask for bands n7 and n38" - R4-1903836, "Draft CR to TS 38.104: Correction on description on multi-band operation in section 4.8" - R4-1904024, "Draft CR to TS 38.104 Applicability rules for BS demodulation" - R4-1904234, "draftCR: Correlation matrix for 8Rx in TS 38.104" - R4-1904723, "Draft CR to TS 38.104: Update of performance requirements for DFT-s-OFDM based PUSCH" - R4-1904726, "draftCR for 38.104 on PUSCH requirements with CP-OFDM and FR1" - R4-1904729, "Draft CR on PRACH performance requirements in TS38.104" - R4-1904734, "Draft CR on TS 38.104 Performance requirement for PUCCH format 1" - R4-1904735, "Draft CR on NR PUCCH format2 performance requirements for TS 38.104" - R4-1904739, "Draft CR to TS 38.104 BS demodulation PUCCH format 0 requirements" - R4-1904745, "draftCR: Updates to PUCCH formats 3 and 4 performance requirements in TS 38.104" - R4-1904799, "Draft CR to TS 38.104: FRC update for PUSCH FR1 mapping type B and FR2 DMRS 1+1" - R4-1904816, "Draft CR : Clarification on step 5 and step 6 for delay profiles calculation (38.104)" - R4-1904842, "Draft CR to TS 38.104 BS demodulation CP-OFDM PUSCH FR2 requirements" - R4-1905126, "draft CR to 38.104 for TAE requirements" - R4-1905139, "draft CR to TS 38.104 on EVM measurement (Annex B and C)" - R4-1905140, "Draft CR: editorial correction on FR1 spurious emission requirement in TS38.104" - R4-1905143, "Draft CR for TS 38.104: Addition of NOTE for transmitter intermodulation requirements in certain regions" - R4-1905144, "Draft CR to TS 38.104: FRC reference corrections for the Rx requirements" - R4-1905145, "Draft CR to TS 38.104: Clarification on application of interfering signal offsets for ACS, blocking and intermodulation requirements" - R4-1905148, "Draft CR to TS 38.104: Corrections on out-of-band blocking requirement" <p>From RAN4 #91:</p> <ul style="list-style-type: none"> - R4-1906002, "Draft CR to 38.104: Subclause 6.7 and 9.8 transmitter intermodulation – correction of interfering signal type" - R4-1906096, "Draft CR to 38.104: Correction of frequency range for OTA spurious emissions" - R4-1906311, "Draft CR to 38.104: Correction on FRC (Annex A)" - R4-1906346, "Removal of n65 in Rel-15 38.104" - R4-1906915, "Draft CR to TS 38.104: Clarification on application of interfering signal offsets for OTA ACS, blocking and intermodulation requirements" - R4-1906918, "Draft CR to TS 38.104: Clarification on type of interfering signal for ACS, in-band blocking and ICS requirements" - R4-1907110, "Draft CR to TS 38.104: correction of the fundamental frequency limit of 2.55GHz for the spurious emissions" - R4-1907246, "Draft CR to TS 38.104: Update of performance requirements for DFT-s-OFDM based PUSCH" - R4-1907249, "Draft CR to TS 38.104: Correction on the terminology in PUSCH FRC tables" - R4-1907252, "Draft CR to TS38.104: Updates of PRACH performance requirements" - R4-1907255, "Draft CR on NR PUCCH format2 performance requirements for TS 38.104" 	15.6.0
---------	--------	-----------	------	--	--	--------

						<ul style="list-style-type: none"> - R4-1907258, "Draft CR on NR UCI on PUSCH performance requirements for TS 38.104" - R4-1907261, "draftCR: Updates to PUCCH formats 3 and 4 performance requirements in TS 38.104" - R4-1907266, "Draft CR on TS 38.104 Performance requirement for PUCCH format 1" - R4-1907267, "Draft CR on TS 38.104 Performance requirement for multi-slot PUCCH format 1" - R4-1907272, "Draft CR to TS 38.104 BS demodulation PUCCH format 0 requirements" - R4-1907275, "Draft CR to TS 38.104 BS demodulation CP-OFDM PUSCH FR2 requirements" - R4-1907277, "draftCR for 38.104 on PUSCH requirements with CP-OFDM and FR1" - R4-1907629, "Draft CR to 38.104: Term "reference signal" replacing by term "ideal signal" in EVM context" - R4-1907634, "Draft CR to 38.104: corrections to the EVM annex" - R4-1907659, "Draft CR to TS 38.104 on Spurious emission Category B in FR2" - R4-1907661, "Draft CR to 38.104 Definition of contiguous transmission bandwidth" - R4-1907662, "Draft CR to 38.104: BS TAE requirements" - R4-1907664, "Draft CR to 38.104: Clarification of interferer RB frequency for narrowband blocking" - R4-1907672, "Draft CR for TS 38.104: Correction on EVM" - R4-1907689, "Correction to CA carrier spacing" 	
2019-06	RAN#84	RP-191252	0024	1	B	CR to TS38.104 to introducing spectrum sharing on band n41	16.0.0
2019-06	RAN#84	RP-191242	0025		B	Introduction of band n14 - CR to TS 38.104	16.0.0
2019-06	RAN#84	RP-191246	0026		B	Introduction of band n30 - CR to TS 38.104	16.0.0
2019-06	RAN#84	RP-191244	0028		B	introduce n18 into TS38.104	16.0.0
2019-06	RAN#84	RP-191250	0030	1	B	n65 introduction to 38.104	16.0.0
2019-06	RAN#84	RP-191251	0031		B	Addition channel bandwidth of 30MHz for n50 in TS 38.104	16.0.0
2019-06	RAN#84	RP-191248	0032		B	CR to 38.104: Introduction of n48	16.0.0

2019-09	RAN#85	RP-192049	0034		A	CR to T 38.104: Implementation of endorsed draft CRs from RAN4#92 (Rel-16) (Mirrors changes in R4-1908440 for Rel-15 TS 38.104) - R4-1907940, "Draft CR to TS 38.104: Correction on the terminology in FRC tables in A.1 and A.2" - R4-1908307, "Draft CR to TS 38.104: Clarification on application of OTA receiver requirements for BS supporting polarization" - R4-1908387, "Draft CR for TS38.104: editorial correction for reference measurement channel" - R4-1908619, "Draft CR to TS38.104: Correction on interferer frequency offset values for ACS" - R4-1908629, "Draft CR to TS38.104: Corrections on EVM window length (Annex B.5.2, C.5.2)" - R4-1908774, "DraftCR to 38.104: Editorial Corrections to redundant units in clause 10.8.3" - R4-1908805, "Draft CR to 38.104: Limits in FCC title 47 for OTA operating band unwanted emissions (9.7)" - R4-1909270, "Draft CR to TS 38.104: Receiver spurious emissions frequency correction" - R4-1909309, "DraftCR to TS 38.104: text corrections, Rel-15" - R4-1909310, "DraftCR to 38.104: correction of TAB connectors mapping to TAB connector TX min cell group, Rel-15" - R4-1909416, "draft CR 38.104 - correct reference to annex F" - R4-1910066, "Draft CR to TS 38.104: Update of performance requirements for DFT-s-OFDM based PUSCH" - R4-1910069, "Draft CR on NR PUCCH format2 performance requirements for TS 38.104" - R4-1910072, "Draft CR on NR UCI on PUSCH performance requirements for TS 38.104" - R4-1910075, "draftCR for 38.104 on PUSCH requirements with CP-OFDM and FR1" - R4-1910078, "Draft CR to TS38.104: Updates to NR PRACH performance requirements" - R4-1910081, "Draft CR to TS 38.104 BS demodulation PUCCH format 0 requirements" - R4-1910084, "Draft CR to TS 38.104 BS demodulation CP-OFDM PUSCH FR2 requirements" - R4-1910088, "Draft CR for 38.104: Performance requirements for NR PUCCH format 1" - R4-1910089, "Draft CR for 38.104: Performance requirements for NR multi-slot PUCCH" - R4-1910094, "draftCR: Updates to PUCCH formats 3 and 4 performance requirements in TS 38.104" - R4-1910431, "Corrections to EVM calculations in 38.141-1 annex B" - R4-1910462, "Draft CR to 38.104: Correction on regional requirements (4.5)" - R4-1910493, "Draft CR to TS 38.104 correction to Annex C.7" - R4-1910606, "Draft CR for TS 38.104: Channel spacing for adjacent NR carriers"	16.1.0
2019-09	RAN#85	RP-192032	0035	1	B	CR to introduce 30MHz bandwidth of n41 to TS 38.104	16.1.0
2019-09	RAN#85	RP-192029	0036		B	CR on Introduction and Protection of SUL band n89 into TS 38.104	16.1.0
2019-09	RAN#85	RP-192031	0037		B	CR for TS 38.104: adding wider channel bandwidths in Band n7	16.1.0
2019-09	RAN#85	RP-192034	0039		B	n29 introduction to 38.104	16.1.0
2019-12	RAN#86	RP-192999	0049	1	A	CR to TS 38.104: Update of performance requirements for DFT-s-OFDM based PUSCH (Rel-16)	16.2.0
2019-12	RAN#86	RP-193013	0050	1	B	Introduction of 2010-2025MHz SUL band into Rel-16 TS 38.104	16.2.0
2019-12	RAN#86	RP-193034	0055		A	Sync raster to SSB resource element mapping	16.2.0
2019-12	RAN#86	RP-192999	0057		A	CR on correction of NR PUCCH format2 performance requirements (Rel-16) for TS 38.104	16.2.0
2019-12	RAN#86	RP-192999	0059	1	A	CR on correction of NR UCI on PUSCH performance requirements (Rel-16) for TS 38.104	16.2.0
2019-12	RAN#86	RP-192999	0061		A	CR on correction on FRC table for FR1 PUSCH performance requirements (Rel-16) for TS 38.104	16.2.0
2019-12	RAN#86	RP-192999	0063	1	A	CR for 38.104 on PUSCH requirements with CP-OFDM and FR1	16.2.0
2019-12	RAN#86	RP-193034	0065		A	CR for TS38.104: Corrections on channel bandwidth for band n34	16.2.0
2019-12	RAN#86	RP-193035	0067		A	CR to TS38.104: Editorial corrections	16.2.0
2019-12	RAN#86	RP-193035	0070	1	A	CR to 38.104 on Editorial corrections (Rel-16)	16.2.0
2019-12	RAN#86	RP-193034	0074		A	CR to 38.104 on Receiver spurious emission requirements	16.2.0
2019-12	RAN#86	RP-193021	0075	1	F	CR to remove square brackets for n90 in TS38.104	16.2.0
2019-12	RAN#86	RP-192999	0077		A	Updates to PRACH requirements in TS 38.104 for Rel-16	16.2.0
2019-12	RAN#86	RP-193034	0081		A	CR to TS 38.104: Correction on interference level of receiver dynamic range requirement	16.2.0
2019-12	RAN#86	RP-193034	0083		A	CR to TS 38.104: Finalization of interfering RB centre frequency offsets in receiver narrowband blocking requirement	16.2.0

2019-12	RAN#86	RP-193034	0085		A	CR to TR 38.104: Correction of table reference of interfering signal for ACS requirement	16.2.0
2019-12	RAN#86	RP-193034	0087		A	CR to TS 38.104: Correction on interfering signal frequency offsets for receiver intermodulation requirements	16.2.0
2019-12	RAN#86	RP-193034	0089		A	CR to TS 38.104 on corrections to channel raster entries for NR band (Rel-16)	16.2.0
2019-12	RAN#86	RP-193035	0097		A	CR to TS38.104: further updates on the abbreviations (section 3.3)-R16	16.2.0
2019-12	RAN#86	RP-193023	0098	1	B	CR to TS 38.104 - NB-IoT introduction	16.2.0
2019-12	RAN#86	RP-192999	0100		F	CR to TS 38.104 BS demodulation PUCCH format 0 requirements	16.2.0
2019-12	RAN#86	RP-192999	0102	1	F	CR to TS 38.104 BS demodulation CP-OFDM PUSCH FR2 requirements	16.2.0
2019-12	RAN#86	RP-193017	0103		B	CR to 38.104 - Band n75 - wider CBW	16.2.0
2019-12	RAN#86	RP-193018	0105		B	CR for TS 38.104: adding wider channel bandwidths in Band n77/n78	16.2.0
2019-12	RAN#86	RP-193016	0106		B	CR for TS 38.104: Addition channel bandwidth of 40MHz for n38	16.2.0
2019-12	RAN#86	RP-193035	0108		A	CR to 38.104: Correction on FR2 Category B OBUE mask	16.2.0
2019-12	RAN#86	RP-193002	0110		A	CR Frame averaging for EVM Annex B and C in TS 38.104	16.2.0
2019-12	RAN#86	RP-193035	0112		A	CR to TS 38.104: OTA TAE correction, Rel-16	16.2.0
2019-12	RAN#86	RP-193035	0114		A	CR to TS 38.104: MR BS class terminology correction, Rel-16	16.2.0
2019-12	RAN#86	RP-192999	0116	1	F	CR: Updates for PUCCH formats 3 and 4 performance requirements in TS 38.104 (Rel-16)	16.2.0
2019-12	RAN#86	RP-193035	0118		A	Correction of limit for TX spurious BS type 1-H	16.2.0
2019-12	RAN#86	RP-192999	0119		A	CR for 38.104: Performance requirements for NR PUCCH format 1	16.2.0
2019-12	RAN#86	RP-192999	0120		A	CR for 38.104: Performance requirements for NR multi-slot PUCCH	16.2.0
2019-12	RAN#86	RP-193035	0122		A	CR to TS 38.104: Editorial corrections	16.2.0
2019-12	RAN#86	RP-193035	0124		A	CR to TS 38.104: Clarification for the number of interfering signals	16.2.0
2020-03	RAN#87	RP-200381	0126		B	Introduction of n26	16.3.0
2020-03	RAN#87	RP-200382	0127	1	B	Introduction of n53	16.3.0
2020-03	RAN#87	RP-200384	0131		B	Introducing new channel bandwidth for band n28	16.3.0
2020-03	RAN#87	RP-200410	0132		F	CR to TS 38.104: Corrections on NB-IoT operation in NR channel bandwidth	16.3.0
2020-03	RAN#87	RP-200398	0134	1	A	CR to TS 38.104: Corrections on rated carrier output power symbols	16.3.0
2020-03	RAN#87	RP-200379	0136	1	C	CR for 38.104: new FRC tables for FR2 PUSCH 2T2R MCS12	16.3.0
2020-03	RAN#87	RP-200407	0137	2	B	CR for 38.104: introduction of UL timing adjustment	16.3.0
2020-03	RAN#87	RP-200407	0138	2	B	CR for 38.104: Appendix for UL timing adjustment	16.3.0
2020-03	RAN#87	RP-200386	0139		B	CR for TS 38.104: adding wider channel bandwidths for n66	16.3.0
2020-03	RAN#87	RP-200398	0142		A	CR to TS 38.104: Regional requirements	16.3.0
2020-03	RAN#87	RP-200392	0143		F	Maintenance on the BS BW for n92 and n94	16.3.0
2020-03	RAN#87	RP-200398	0145		A	IntraSlot frequency hopping applicability in the one OFDM symbol test case	16.3.0
2020-03	RAN#87	RP-200383	0146	1	B	CR to 38.104 Band n1 - wider CBW - Additional Channel BW	16.3.0
2020-03	RAN#87	RP-200385	0148		B	CR to 38.104 Band n38 - wider CBW - Additional Channel BW	16.3.0
2020-03	RAN#87	RP-200398	0149		A	CR to TS 38.104 editorial correction R16 catA	16.3.0
2020-03	RAN#87	RP-200407	0156	1	B	CR for TS 38.104: Introduction of PRACH demodulation requirements for NR HST	16.3.0
2020-03	RAN#87	RP-200407	0157	2	B	CR for 38.104: HST PUSCH demodulation requirements introduction	16.3.0
2020-03	RAN#87	RP-200407	0158	2	B	CR for 38.104: HST PUSCH demodulation Annex including both FRC and channel model	16.3.0
2020-03	RAN#87	RP-200379	0159	1	C	CR for 38.104: Performance requirements for FR2 PUSCH 2T2R 16QAM	16.3.0
2020-06	RAN#88	RP-200986	0164		A	CR for 38.104: Performance requirements clarification of PUSCH BS Type O-2 PT-RS configuration for MCS 2	16.4.0
2020-06	RAN#88	RP-201043	0167		F	CR for 38.104: Performance requirements for FR2 PUSCH 2T2R 16QAM	16.4.0
2020-06	RAN#88	RP-200986	0176		A	CR to TS 38.104: Correction to out-of-band blocking requirements in subclause 7.5 and subclause 10.6	16.4.0
2020-06	RAN#88	RP-200986	0178		A	CR to TS 38.104: Correction on the CA nominal channel spacing	16.4.0
2020-06	RAN#88	RP-200986	0180		A	30k SSB SCS for n50	16.4.0
2020-06	RAN#88	RP-200986	0182		A	Addition of 30k SSB SCS for Band n38	16.4.0
2020-06	RAN#88	RP-200972	0185		B	CR to TS 38.104: Introduction of FR2 DL 256QAM	16.4.0
2020-06	RAN#88	RP-200977	0190		B	CR for TS 38.104: adding 50 MHz CBW for n1	16.4.0
2020-06	RAN#88	RP-200986	0195		A	CR to 38.104: Adding missing clause on Radiated Performance requirements for multi-slot PUCCH (11.3.1)	16.4.0
2020-06	RAN#88	RP-200980	0198		B	CR to TS 38.104 - Add 40 MHz CBW in band n3	16.4.0
2020-06	RAN#88	RP-200982	0199		B	CR to TS 38.104 - Add 50 MHz CBW in band n65	16.4.0
2020-06	RAN#88	RP-200986	0209		A	CR to 38.104 on Receiver spurious emissions exclusion band (Rel-16)	16.4.0
2020-06	RAN#88	RP-200986	0211		A	CR to 38.104 on EESS protection for bands n257 and n258 (Rel-16)	16.4.0
2020-06	RAN#88	RP-200986	0213		A	TS38.104 draft CR on 30KHz SSB SCS for n40 (Rel-16)	16.4.0
2020-06	RAN#88	RP-200986	0207	1	A	CR to 38.104 on Removal of brackets and TBD (Rel-16)	16.4.0
2020-06	RAN#88	RP-200975	0165	1	B	CR for 38.104: HST PUSCH demodulation requirements	16.4.0

2020-06	RAN#88	RP-200975	0166	1	B	CR for 38.104: HST PUSCH demodulation FRC and channel model annexes	16.4.0
2020-06	RAN#88	RP-200975	0186	1	F	CR for 38.104 Introduction of PRACH demodulation requirements for NR HST	16.4.0
2020-06	RAN#88	RP-200975	0187	1	B	CR for 38.104: Performance requirements for UL timing adjustment	16.4.0
2020-06	RAN#88	RP-201043	0168	1	B	CR for TS 38.104: Introduce PUSCH performance requirements at 30% throughput test point	16.4.0
2020-06	RAN#88	RP-200986	0172	1	F	UCI multiplexed on PUSCH requirement	16.4.0
2020-06	RAN#88	RP-200978	0205	1	B	CR to 38.104 for Introduction of band n259	16.4.0
2020-09	RAN#89	RP-201497	0218	1	B	CR for 38.104: HST PUSCH demodulation requirements	16.5.0
2020-09	RAN#89	RP-201497	0219	1	B	CR for 38.104: HST PUSCH demodulation FRC and channel model annexes	16.5.0
2020-09	RAN#89	RP-201502	0220	1	B	Introduction of LTE/NR spectrum sharing in band 48/n48 frequency range	16.5.0
2020-09	RAN#89	RP-201512	0222		A	CR to TS 38.104: Correction of co-location requirement in subclause 7.5.3	16.5.0
2020-09	RAN#89	RP-201512	0224		A	CR to TS38.104: Add 30k SSB SCS for Band n34 and n39	16.5.0
2020-09	RAN#89	RP-201512	0227	1	A	CR to TS 38.104: OTA receiver spurious requirements for EESS protection (rel-16)	16.5.0
2020-09	RAN#89	RP-201499	0228		F	CR for 38.104: Performance requirements for UL timing adjustment	16.5.0
2020-09	RAN#89	RP-201507	0229		F	Correction to NB-IoT Bands with n26	16.5.0
2020-09	RAN#89	RP-201512	0233	1	A	CR to 38.104: Annex B and C clarification on equalisation calculation (B.6, C.6)	16.5.0
2020-09	RAN#89	RP-202101	0238	1	C	7.5 kHz UL shift for LTE/NR spectrum sharing in Band 38/n38	16.5.0
2020-09	RAN#89	RP-202113	0239	1	B	CR to TS 38.104: Introduction of NR-U into BS core specification	16.5.0
2020-12	RAN#90	RP-202422	0242	1	F	CR for 38.104: HST PUSCH demodulation requirements	16.6.0
2020-12	RAN#90	RP-202416	0243	1	B	CR for 38.104: Ultra high reliability BS demodulation requirements	16.6.0
2020-12	RAN#90	RP-202416	0244	1	B	CR for 38.104: Low latency BS demodulation requirements	16.6.0
2020-12	RAN#90	RP-202415	0245	2	B	CR to TS 38.104 BS demodulation requirements for 2-step RACH	16.6.0
2020-12	RAN#90	RP-202414	0247	1	F	CR to TS 38.104 with NR-U remaining open issues updates	16.6.0
2020-12	RAN#90	RP-202415	0248	1	B	CR on BS demodulation requirements for 2-step RACH for FR2	16.6.0
2020-12	RAN#90	RP-202416	0249	1	B	CR to TS 38.104: Addition of BS performance requirements for URLLC PUSCH repetition Type A	16.6.0
2020-12	RAN#90	RP-202422	0250	1	B	CR for 38.104: Introduction of performance requirements for NR HST PRACH under fading channel	16.6.0
2020-12	RAN#90	RP-202423	0257	1	F	Adding FRC table description in Annex in TS38.104 v16.5.0	16.6.0
2020-12	RAN#90	RP-202488	0261		A	CR to 38.104 on Category B OTA spurious emissions for and n257	16.6.0
2020-12	RAN#90	RP-202451	0240		B	Introduction of 1880-1920MHz SUL band into Rel-17 TS 38.104	17.0.0
2020-12	RAN#90	RP-202452	0241		B	Introduction of 2300-2400MHz SUL band into Rel-17 TS 38.104	17.0.0
2020-12	RAN#90	RP-202448	0253		B	CR to TS 38.104: introduction of NR band n13	17.0.0
2020-12	RAN#90	RP-202453	0258	1	B	Big CR to 38.104 - Additional Channel BW	17.0.0
2020-12	RAN#90	RP-202456	0214	3	B	LTE/NR spectrum sharing in Band 40/n40	17.0.0
2021-03	RAN#91e	RP-210096	0262	2	B	CR for TS 38.104 Introduction of SUL for UL of NR band n24	17.1.0
2021-03	RAN#91e	RP-210078	0264		A	CR for 38.104: HST PUSCH demodulation requirements	17.1.0
2021-03	RAN#91e	RP-210068	0266		A	CR for 38.104: Low latency FR1 BS demodulation requirements	17.1.0
2021-03	RAN#91e	RP-210068	0268		A	CR for 38.104: Ultra high reliability BS demodulation requirements	17.1.0
2021-03	RAN#91e	RP-210068	0270		A	CR on PUSCH repetition type A and PUSCH mapping type B radiated performance requirement for TS 38.104	17.1.0
2021-03	RAN#91e	RP-210117	0273		A	CR to TS 38.104: Additions of regional requirements for n41 and n90 in Japan, Rel-17	17.1.0
2021-03	RAN#91e	RP-210073	0275		A	CR on correction 2-step RACH performance requirements for FR2 in 38.104 (Rel-17)	17.1.0
2021-03	RAN#91e	RP-210078	0277		A	CR for 38.104: Cleanup for performance requirements of NR HST PRACH under	17.1.0
2021-03	RAN#91e	RP-210068	0279		A	CR to TS 38.104: Correction of BS performance requirements for URLLC PUSCH repetition Type A	17.1.0
2021-03	RAN#91e	RP-210084	0282		A	CR to TS 38.104: system parameters maintenance for NR-U	17.1.0
2021-03	RAN#91e	RP-210084	0284		A	CR to TS 38.104: corrections of NR-U BS Tx requirements	17.1.0
2021-03	RAN#91e	RP-210084	0286		A	CR to TS 38.104: corrections of NR-U BS Rx requirements	17.1.0
2021-03	RAN#91e	RP-210117	0289		A	CR to TS 38.104: EESS protection requirement correction	17.1.0
2021-03	RAN#91e	RP-210189	0291		B	Big CR to 38.104 - Additional Channel BW	17.1.0
2021-03	RAN#91e	RP-210117	0294		A	CR to TS38.104: Correction on the Aggregated Channel Bandwidth	17.1.0
2021-03	RAN#91e	RP-210097	0295		B	CR to 38.104: Introduction of n24	17.1.0
2021-03	RAN#91e	RP-210084	0297		A	CR to TS 38.104 corrections to NR-U BS RF Tx requirements	17.1.0
2021-03	RAN#91e	RP-210084	0299		A	CR to TS 38.104 corrections to NR-U BS RF Rx requirements	17.1.0
2021-06	RAN#92	RP-211117	0305		A	Correction of the channel raster of n259 for TS 38.104	17.2.0
2021-06	RAN#92	RP-211095	0307		A	CR to TS 38.104: Corrections on frequency offset symbols for spectrum emission mask for non-transmitted channels	17.2.0
2021-06	RAN#92	RP-211079	0310		F	CR to TS 38.104 on BS channel bandwidth per operating band	17.2.0
2021-06	RAN#92	RP-211105	0314		A	CR on correction of PUSCH repetition type A and PUSCH mapping type B radiated performance requirements for TS 38.104	17.2.0
2021-06	RAN#92	RP-211121	0318	1	B	CR to TS 38.104: Introduction of band n262	17.2.0

2021-06	RAN#92	RP-211115	0319		B	Big CR to TS 38.104: Adding channel BW support in existing NR bands	17.2.0
2021-06	RAN#92	RP-211116	0320	1	B	CR to TS 38.104: Introduction of band n67	17.2.0
2021-06	RAN#92	RP-211116	0321	1	B	CR to TS 38.104: Introduction of band n85	17.2.0
2021-06	RAN#92	RP-211095	0323		A	CR to 38.104 with correction of NR-U 60 MHz and 80 MHz channels	17.2.0
2021-06	RAN#92	RP-211094	0325		A	Big CR for NR-U BS demodulation requirements in TS 38.104 (Rel-17)	17.2.0
2021-06	RAN#92	RP-211108	0329		A	CR for 38.104: HST PUSCH demodulation requirements and spec maintenance	17.2.0
2021-06	RAN#92	RP-211108	0331		A	CR for 38.104: Low latency and ultra-low BLER FR1 BS demodulation requirements	17.2.0
2021-06	RAN#92	RP-211090	0333		A	CR to 38.104: In-band blocking for multi-band Base Stations	17.2.0
2021-09	RAN#93	RP-211907	0343		B	Big CR to TS 38.104: Adding channel BW support in existing NR bands	17.3.0
2021-09	RAN#93	RP-211909	0341		B	CR for TS 38.104: introduction of channel bandwidths 35MHz and 45MHz NOTE The CR is not implemented	17.3.0
2021-09	RAN#93	RP-211910	0348		B	Introduction of the UL 7.5kHz shift for NR TDD band n34 and n39 in 38.104 R17	17.3.0
2021-09	RAN#93	RP-211926	0351		F	Big CR for TS 38.104 Maintenance Demod part (Rel-17, CAT F)	17.3.0
2021-09	RAN#93	RP-211926	0354		A	Big CR for TS 38.104 Maintenance RF part (Rel-17, CAT A)	17.3.0
2021-12	RAN#94	RP-212835	0356		B	Big CR to TS 38.104: Adding channel BW support in existing NR bands	17.4.0
2021-12	RAN#94	RP-212836	0357		F	CR to TS 38.104 - Fix to band n85 introduction	17.4.0
2021-12	RAN#94	RP-212825	0355	2	B	CR for TS 38.104: 1024QAM	17.4.0
2021-12	RAN#94	RP-212824	0360		F	Big CR for TS 38.104 Maintenance RF part (Rel-17, CAT F)	17.4.0
2021-12	RAN#94	RP-212850	0362		F	Big CR for TS 38.104 Maintenance Demod part (Rel-17, CAT F)	17.4.0
2021-12	RAN#94	RP-213147	0363		B	CR for TS 38.104: introduction of channel bandwidths 35MHz and 45MHz NOTE The CR is a resubmission of CR R4-2114918 of RP-211909	17.4.0
2022-03	RAN#95-e	RP-220377	0364	1	B	CR for TS 38.104: capturing HAPS requirements	17.5.0
2022-03	RAN#95-e	RP-220347	0365	1	B	CR to TS38.104 on introduction of upper 700MHz A block	17.5.0
2022-03	RAN#95-e	RP-220357	0369	1	B	CR for 38.104 to introduce n102	17.5.0
2022-03	RAN#95-e	RP-220361	0372		B	BigCR for TS38.104: Introduction of conformance testing requirements for FR1 PUSCH 256QAM	17.5.0
2022-03	RAN#95-e	RP-220334	0374		F	Big CR for TS 38.104 Maintenance RF part (Rel-17, CAT F)	17.5.0
2022-03	RAN#95-e	RP-220334	0376		A	Big CR for TS 38.104 Maintenance Demod part (Rel-17, CAT A)	17.5.0
2022-03	RAN#95-e	RP-220376	0378		B	Big CR to 38.104: RMR 1900MHz band n101 introduction	17.5.0
2022-06	RAN#96	RP-221680	0379		B	Big CR on FR2 HST BS demodulation requirement for TS 38.104	17.6.0
2022-06	RAN#96	RP-221684	0380	1	B	CR to TS 38.104 - Tx requirements: RMR 900MHz band introduction	17.6.0
2022-06	RAN#96	RP-221671	0381		B	Big CR to TS 38.104: Adding channel BW support in existing NR bands	17.6.0
2022-06	RAN#96	RP-221684	0382	1	B	CR to 38.104 on introduction of n100 (system parameters)	17.6.0
2022-06	RAN#96	RP-221673	0383	1	B	CR to TS38.104 the introduction of 6425-7125MHz	17.6.0
2022-06	RAN#96	RP-221676	0384		B	Big CR to 38.104 for Rel-17 NR extension up to 71 GHz introduction	17.6.0
2022-06	RAN#96	RP-221684	0385		B	CR to TS 38.104: RMR900 Rx requirements for band n100, Rel-17	17.6.0
2022-06	RAN#96	RP-221676	0386		B	Big CR on extending NR to 71GHz for TS 38.104	17.6.0
2022-06	RAN#96	RP-221655	0389		F	Big CR for TS 38.104 Maintenance RF part (Rel-17, CAT F)	17.6.0
2022-06	RAN#96	RP-221659	0391		A	Big CR for TS 38.104 Maintenance Demod part (Rel-17, CAT A)	17.6.0
2022-09	RAN#97	RP-222038	0394	1	F	CR to 38.104 on n100 corrections	17.7.0
2022-09	RAN#97	RP-222041	0395		F	Big CR on FR2 HST BS demodulation requirement for TS 38.104	17.7.0
2022-09	RAN#97	RP-222050	0401	1	B	CR for 38.104: Add 5 MHz channel BW for n41	17.7.0
2022-09	RAN#97	RP-222026	0404		F	Big CR for TS 38.104 Maintenance RF part (Rel-17, CAT F)	17.7.0
2022-09	RAN#97	RP-222026	0407		F	Big CR for TS 38.104 Maintenance Demod part (Rel-17, CAT F)	17.7.0
2022-09	RAN#97	RP-222051	0408		F	Big CR to 38.104 for Rel-17 NR extension up to 71 GHz maintenance (Rel-17, CAT F)	17.7.0
2022-09	RAN#97	RP-222051	0410		B	Big CR of TS38.104 on system parameter updates for FR2-2	17.7.0
2022-12	RAN#98-e	RP-223307	0411		F	CR to TS 38.104 on reference to FRCs	17.8.0
2022-12	RAN#98-e	RP-223307	0412		F	CR to TS 38.104: Correction of guardband for FR2-2 in sub-clause 5.3.3	17.8.0
2022-12	RAN#98-e	RP-223300	0413		B	Big CR for coverage enhancement performance requirements for TS38.104	17.8.0
2022-12	RAN#98-e	RP-223308	0414	1	B	Corrections for 100MHz CBW inclusion for n46 n96 and n102	17.8.0
2022-12	RAN#98-e	RP-223309	0415		F	CR to TS 38.104 on tables for BS channel bandwidths	17.8.0
2022-12	RAN#98-e	RP-223297	0419		F	CR for TS38.104 correction on normal PUSCH requirements (Rel-17)	17.8.0
2022-12	RAN#98-e	RP-223309	0424	2	F	CR to 38.104: Spurious emission requirements, Rel-17	17.8.0
2022-12	RAN#98-e	RP-223302	0426		B	Big CR for TS 38.104 Demodulation requirements for Enhanced IIOT and URLLC support (Rel-17, CAT B)	17.8.0
2022-12	RAN#98-e	RP-223298	0429		F	CR for 38.104: define home class as one kind of LA BS	17.8.0

2022-12	RAN#98-e	RP-223524	0432	1	A	CR on R17 TS 38.104 to add channel raster exception for band n28 [n28_BS40MHz_raster]	17.8.0
2023-03	RAN#99	RP-230513	0434		F	Correction of coverage enhancement BS demodulation requirement in 38.104 (R17 F)	17.9.0
2023-03	RAN#99	RP-230510	0438		B	Big CR to 38.104: demodulation requirements introduction for FR2-2	17.9.0
2023-03	RAN#99	RP-230515	0440		F	CR for TS 38.104 Demodulation requirements for Enhanced IIOT and URLLC support (Rel-17, CAT F)	17.9.0
2023-03	RAN#99	RP-230506	0448	1	F	CR to 38.104: FRC number corrections (Rel-17)	17.9.0
2023-03	RAN#99	RP-230513	0451		F	CR to 38.104: BS Conformance, OBUE correction for 6G licensed band	17.9.0
2023-03	RAN#99	RP-230514	0458		F	CR to TS 38.104 on table references for OTA operating band unwanted emission limits	17.9.0
2023-03	RAN#99	RP-230514	0459		D	CR to TS 38.104: NR-ARFCN table reference correction for band n263, Rel-17	17.9.0
2023-03	RAN#99	RP-230514	0463		F	CR to 38.104: Correction on Rx intermodulation requirements for FR2-2 (Rel-17)	17.9.0
2023-06	RAN#100	RP-231347	0465	3	F	CR 38.104: PUSCH requirements for FR2-2	17.10.0
2023-06	RAN#100	RP-231347	0467	1	F	CR to TS 38.104 on corrections of table references for extending current NR operation to 71GHz	17.10.0
2023-06	RAN#100	RP-231348	0469		F	CR to TS 38.104 on corrections and clarifications of operating band unwanted emission limits for band n104	17.10.0
2023-06	RAN#100	RP-231347	0476		F	CR for TS38.104 FRC tables for FR2-2 PUSCH demodulation_Rel-17	17.10.0
2023-06	RAN#100	RP-231350	0478	1	F	CR for TS38.104 on FRC table for PUSCH TBoMS_Rel-17	17.10.0
2023-06	RAN#100	RP-231352	0481	1	A	CR for TS 38.104: Operating band unwanted emissions for Single RAT BS supporting multi-band operation	17.10.0
2023-06	RAN#100	RP-231339	0484		F	CR to TS 38.104 - Maintenance related to bands n100 and n101	17.10.0
2023-06	RAN#100	RP-231352	0487		A	CR on 38.104: Updates to FRC of PUSCH requirements(Rel-17)	17.10.0
2023-06	RAN#100	RP-231342	0489		F	CR on 38.104 Updates to the requirements for the PF0 requirements with sub-slot repetition	17.10.0
2023-06	RAN#100	RP-231356	0493	1	F	CR to 38.104: Correction to ACLR and CA CLR requirement	17.10.0
2023-06	RAN#100	RP-231356	0495		A	CR to 38.104: Correction to ACLR and CA CLR requirement	17.10.0
2023-09	RAN#101	RP-232488	0504		F	[CR for configuration of FR1 PUSCH TBoMS demodulation requirement	17.11.0
2023-09	RAN#101	RP-232504	0507		A	CR to 38.104: Correction to ACLR and CA CLR requirement	17.11.0
2023-09	RAN#101	RP-232490	0513		F	[NR_ext_to_71GHz-Perf] CR on 38.104: Clean up the brackets for FR2-2 PUSCH requirements	17.11.0
2023-09	RAN#101	RP-232505	0502	1	F	Update to table format for enabling automated data scraping	17.11.0
2023-09	RAN#101	RP-232496	0517	1	F	[NR_RAIL_EU_900MHz-Core, NR_RAIL_EU_1900MHz_TDD-Core] CR to TS 38.104: corrections of RMR-specific BS requirements for band n100 and n101, Rel-17	17.11.0
2023-09	RAN#101	RP-232486	0509	1	F	[NR_6GHz-Core] CR to 38.104: applicability note for n104	17.11.0
2023-12	RAN#102	RP-233342	0520		A	[NR_unlic] CR for 38.104: Removal of applicability rule (Rel-17, Cat A)	17.12.0
2023-12	RAN#102	RP-233340	0523		A	[NR_RF_FR1-Core] CR to TS 38.141-1 on correction of transmitter spurious emissions for protection of Band n20	17.12.0
2023-12	RAN#102	RP-233345	0529		F	Removing 20MHz channel raster points for 5925-5945MHz in the lower 6GHz bands	17.12.0
2023-12	RAN#102	RP-233339	0535		A	Addition of 30 KHz SCS for Sync Raster for Band n53	17.12.0
2023-12	RAN#102	RP-233345	0548		F	Removing 20MHz channel raster points for 5925-5945MHz in the lower 6GHz bands	17.12.0
2024-03	RAN#103	RP-240552	0589		F	(TEI17) CR to TS 38.104: Clean up of operating band definitions tables in subclause 5.2	17.13.0
2024-03	RAN#103	RP-240553	0587	1	F	(TEI17) CR to TS 38.104 - BS spurious receiver protection note generalization R17	17.13.0
2024-03	RAN#103	RP-240556	0571		A	(MB_MSR_RF) CR to 38.104: clarification on requirements for BS capable of multi-band operation	17.13.0
2024-03	RAN#103	RP-240557	0550		F	(NR_6GHz-Core) CR for TS 38.104, Correction on reference of PREFSENS for in-band blocking and out-of-band blocking for band n104	17.13.0
2024-03	RAN#103	RP-240563	0557		F	CR to TS 38.104 for editorial corrections of operating bands (Rel-17)	17.13.0
2024-03	RAN#103	RP-240565	0582		A	CR to 38.104: Correction on transmitter intermodulation additional requirements (Rel-17)	17.13.0
2024-03	RAN#103	RP-240565	0554	1	F	(NR_newRAT-Core) Correction for TS 38.104 R17	17.13.0
2024-03	RAN#103	RP-240567	0560		A	CR to TS 38.104 on correction of radiated performance requirement (Rel-17)	17.13.0
2024-03	RAN#103	RP-240572	0562		F	(NR_RAIL_EU_900MHz-Core) CR to TS 38.104 on additional unwanted emission limits for band n100	17.13.0
2024-03	RAN#103	RP-240572	0595	1	F	(NR_RAIL_EU_900MHz-Core, NR_RAIL_EU_1900MHz_TDD-Core) CR to TS 38.104: correction on n100/n101 deployment aspects and additional n100 OBUE requirement, Rel-17	17.13.0
2024-03	RAN#103	RP-240574	0574		A	(NR_RF_FR1) CR to TS 38.104: Channel raster to resource element mapping	17.13.0

2024-06	RAN#104	RP-241384	0609		F	[NR_newRAT-Perf] CR to TS 38.104 (Corrections on Clause 8.3.4.1.1 and 11.3.2.6.2) (rel 17)	17.14.0
2024-06	RAN#104	RP-241396	0619		F	CR for 38.104 on FR2-2 PUSCH demodulation requirements	17.14.0
2024-06	RAN#104	RP-241492	0628		A	(NR_unlic_enh-Core) CR to TS 38.104 NR-U Nominal channel spacing	17.14.0
2024-06	RAN#104	RP-241383	0603	1	F	(NR_newRAT-Core) CR for Total power dynamic range (TPDR)	17.14.0
2024-06	RAN#104	RP-241398	0633	1	F	CR to TS 38.104: Clarification on multiple carrier operation for n100/n101, Rel 17	17.14.0
2024-06	RAN#104	RP-241398	0636	1	F	CR to TS 38.104: Clarifications on RMR terminology and related operating bands	17.14.0
2024-06	RAN#104	RP-241393	0643	1	F	(NR_bands_R17_BWs-Core) CR for Tx intermodulation core requirements in certain region	17.14.0
2024-06	RAN#104	RP-241383	0639	2	F	CR to TS 38.104: Alignment with UE specification for n30 and n77 notes in Table 5.2-1	17.14.0
2024-09	RAN#105	RP-242155	0649	1	F	(NR_6GHz_unlic_EU-Core) CR to 38.104 on ACLR and CACLR in non-contiguous spectrum	17.15.0
2024-09	RAN#105	RP-242183	0654		F	(NR_RAIL_EU_900MHz-Core, NR_RAIL_EU_1900MHz_TDD-Core) CR to TS 38.104 on clarification on multiple carrier operation for bands n100 and n101	17.15.0
2024-09	RAN#105	RP-242189	0658		F	(NR_SUL_UL_n24-Core) Missing reference to FCC Order DA 20-48	17.15.0
2024-09	RAN#105	RP-242174	0660		D	(NR_newRAT-Core) Fixing notes numbering in Table 5.2-1	17.15.0
2024-09	RAN#105	RP-242193	0662	1	B	(TEI17) CR to TS 38.104 - BS spurious receiver protection note [MSR_BSRF_RX]	17.15.0

History

Document history		
V17.5.0	April 2022	Publication
V17.6.0	August 2022	Publication
V17.7.0	October 2022	Publication
V17.8.0	January 2023	Publication
V17.9.0	May 2023	Publication
V17.10.0	July 2023	Publication
V17.11.0	October 2023	Publication
V17.12.0	February 2024	Publication
V17.13.0	May 2024	Publication
V17.14.0	August 2024	Publication
V17.15.0	October 2024	Publication