

# ETSI TS 138 106 V17.10.0 (2024-10)



**5G;**  
**NR repeater radio transmission and reception**  
**(3GPP TS 38.106 version 17.10.0 Release 17)**



---

**Reference**

RTS/TSGR-0438106vha0

---

**Keywords**

5G

**ETSI**

---

650 Route des Lucioles  
F-06921 Sophia Antipolis Cedex - FRANCE

Tel.: +33 4 92 94 42 00 Fax: +33 4 93 65 47 16

Siret N° 348 623 562 00017 - APE 7112B  
Association à but non lucratif enregistrée à la  
Sous-Préfecture de Grasse (06) N° w061004871

---

**Important notice**

The present document can be downloaded from the  
ETSI [Search & Browse Standards application](#).

The present document may be made available in electronic versions and/or in print. The content of any electronic and/or print versions of the present document shall not be modified without the prior written authorization of ETSI. In case of any existing or perceived difference in contents between such versions and/or in print, the prevailing version of an ETSI deliverable is the one made publicly available in PDF format on [ETSI deliver](#).

Users should be aware that the present document may be revised or have its status changed,  
this information is available in the [Milestones listing](#).

If you find errors in the present document, please send your comments to  
the relevant service listed under [Committee Support Staff](#).

If you find a security vulnerability in the present document, please report it through our  
[Coordinated Vulnerability Disclosure \(CVD\)](#) program.

---

**Notice of disclaimer & limitation of liability**

The information provided in the present deliverable is directed solely to professionals who have the appropriate degree of experience to understand and interpret its content in accordance with generally accepted engineering or other professional standard and applicable regulations.

No recommendation as to products and services or vendors is made or should be implied.

No representation or warranty is made that this deliverable is technically accurate or sufficient or conforms to any law and/or governmental rule and/or regulation and further, no representation or warranty is made of merchantability or fitness for any particular purpose or against infringement of intellectual property rights.

In no event shall ETSI be held liable for loss of profits or any other incidental or consequential damages.

Any software contained in this deliverable is provided "AS IS" with no warranties, express or implied, including but not limited to, the warranties of merchantability, fitness for a particular purpose and non-infringement of intellectual property rights and ETSI shall not be held liable in any event for any damages whatsoever (including, without limitation, damages for loss of profits, business interruption, loss of information, or any other pecuniary loss) arising out of or related to the use of or inability to use the software.

---

**Copyright Notification**

No part may be reproduced or utilized in any form or by any means, electronic or mechanical, including photocopying and microfilm except as authorized by written permission of ETSI.

The content of the PDF version shall not be modified without the written authorization of ETSI.

The copyright and the foregoing restriction extend to reproduction in all media.

© ETSI 2024.  
All rights reserved.

---

# Intellectual Property Rights

## Essential patents

IPRs essential or potentially essential to normative deliverables may have been declared to ETSI. The declarations pertaining to these essential IPRs, if any, are publicly available for **ETSI members and non-members**, and can be found in ETSI SR 000 314: "*Intellectual Property Rights (IPRs); Essential, or potentially Essential, IPRs notified to ETSI in respect of ETSI standards*", which is available from the ETSI Secretariat. Latest updates are available on the ETSI Web server (<https://ipr.etsi.org/>).

Pursuant to the ETSI Directives including the ETSI IPR Policy, no investigation regarding the essentiality of IPRs, including IPR searches, has been carried out by ETSI. No guarantee can be given as to the existence of other IPRs not referenced in ETSI SR 000 314 (or the updates on the ETSI Web server) which are, or may be, or may become, essential to the present document.

## Trademarks

The present document may include trademarks and/or tradenames which are asserted and/or registered by their owners. ETSI claims no ownership of these except for any which are indicated as being the property of ETSI, and conveys no right to use or reproduce any trademark and/or tradename. Mention of those trademarks in the present document does not constitute an endorsement by ETSI of products, services or organizations associated with those trademarks.

**DECT™**, **PLUGTESTS™**, **UMTS™** and the ETSI logo are trademarks of ETSI registered for the benefit of its Members. **3GPP™** and **LTE™** are trademarks of ETSI registered for the benefit of its Members and of the 3GPP Organizational Partners. **oneM2M™** logo is a trademark of ETSI registered for the benefit of its Members and of the oneM2M Partners. **GSM®** and the GSM logo are trademarks registered and owned by the GSM Association.

---

# Legal Notice

This Technical Specification (TS) has been produced by ETSI 3rd Generation Partnership Project (3GPP).

The present document may refer to technical specifications or reports using their 3GPP identities. These shall be interpreted as being references to the corresponding ETSI deliverables.

The cross reference between 3GPP and ETSI identities can be found under <https://webapp.etsi.org/key/queryform.asp>.

---

# Modal verbs terminology

In the present document "**shall**", "**shall not**", "**should**", "**should not**", "**may**", "**need not**", "**will**", "**will not**", "**can**" and "**cannot**" are to be interpreted as described in clause 3.2 of the [ETSI Drafting Rules](#) (Verbal forms for the expression of provisions).

"**must**" and "**must not**" are **NOT** allowed in ETSI deliverables except when used in direct citation.

# Contents

Intellectual Property Rights .....	2
Legal Notice .....	2
Modal verbs terminology.....	2
Foreword.....	6
1 Scope .....	8
2 References .....	8
3 Definitions of terms, symbols and abbreviations .....	9
3.1 Terms.....	9
3.2 Symbols.....	10
3.3 Abbreviations .....	11
4 General .....	12
4.1 Relationship between Minimum Requirements and Test Requirements .....	12
4.2 Conducted and radiated requirement reference points .....	12
4.2.1 Repeater type 1-C .....	12
4.2.2 Repeater type 2-O .....	13
4.3 Repeater classes.....	13
4.3.1 Repeater class for downlink.....	13
4.3.2 Repeater class for uplink.....	13
4.4 Regional requirements.....	14
4.5 Applicability of requirements.....	14
4.6 Requirements for contiguous and <i>non-contiguous spectrum</i> .....	15
4.7 Requirements for repeater capable of multi-band operation .....	15
5 Operating bands.....	15
5.1 General .....	15
5.2 Operating bands.....	16
5.3 Channel arrangement.....	16
5.3.1 Channel raster .....	16
5.3.1.1 NR-ARFCN and channel raster.....	16
5.3.1.2 Channel raster entries for each <i>operating band</i> .....	16
5.3.2 Synchronization raster .....	16
5.3.2.1 Synchronization raster and numbering.....	16
5.3.2.2 Synchronization raster entries for each operating band.....	16
6 Conducted characteristics .....	16
6.1 General .....	16
6.2 Repeater output power.....	17
6.2.1 General.....	17
6.2.2 Minimum requirement .....	17
6.3 Frequency stability .....	17
6.3.1 General.....	17
6.3.2 Minimum requirement .....	18
6.4 Out of band gain.....	18
6.4.1 General.....	18
6.4.2 Minimum requirement .....	18
6.5 Unwanted emissions.....	18
6.5.1 General.....	18
6.5.2 Adjacent Channel Leakage Power Ratio .....	19
6.5.2.1 General .....	19
6.5.2.2 Minimum requirements .....	19
6.5.3 Operating band unwanted emissions .....	23
6.5.3.1 General .....	23
6.5.3.2 Minimum requirements .....	25
6.5.3.2.1 Minimum requirements for Wide Area repeater type 1-C (Category A).....	25

6.5.3.2.2	Minimum requirements for Wide Area <i>repeater type 1-C</i> (Category B).....	26
6.5.3.2.3	Minimum requirements for Medium Range <i>repeater type 1-C</i> (Category A and B) for DL.....	28
6.5.3.2.4	Minimum requirements for Local Area <i>repeater type 1-C</i> (Category A and B).....	29
6.5.3.2.5	Minimum requirements for additional requirements.....	30
6.5.3.2.6	Minimum requirements inside passband with no UL input signal .....	31
6.5.4	Transmitter spurious emissions.....	32
6.5.4.1	General .....	32
6.5.4.2	Minimum requirements.....	32
6.5.4.2.1	General transmitter spurious emissions requirements .....	32
6.5.4.2.2	Additional spurious emissions requirements .....	33
6.5.4.2.3	Co-location with base stations and <i>repeater type 1-C</i> Nodes .....	43
6.5.5	Receiver spurious emissions .....	48
6.5.5.1	General .....	48
6.5.5.2	Minimum requirements .....	48
6.6	Repeater Error Vector Magnitude .....	49
6.6.1	Downlink repeater error vector magnitude .....	49
6.6.1.1	General .....	49
6.6.1.2	Minimum requirement .....	49
6.6.1.3	Repeater EVM frame structure for measurement.....	50
6.6.2	Uplink repeater error vector magnitude .....	50
6.6.2.1	General .....	50
6.6.2.2	Minimum requirement .....	50
6.7	Input intermodulation .....	50
6.7.1	General requirement .....	50
6.7.1.1	General .....	50
6.7.1.2	Minimum requirement .....	51
6.7.2	Co-location with BS/repeater in other systems.....	51
6.7.2.1	General .....	51
6.7.2.2	Minimum requirement .....	51
6.7.3	Co-existence with other systems.....	52
6.7.3.1	General .....	52
6.7.3.2	Minimum requirement .....	52
6.8	Output intermodulation .....	53
6.8.1	General.....	53
6.8.2	Minimum requirements for <i>repeater type 1-C</i> .....	53
6.8.2.1	Minimum requirements.....	53
6.8.2.2	Additional requirements.....	53
6.9	Adjacent Channel Rejection Ratio (ACRR).....	54
6.9.1	General.....	54
6.9.2	Minimum Requirements .....	54
6.10	Transmit ON/OFF power .....	55
6.10.1	Transmitter OFF power .....	55
6.10.1.1	General .....	55
6.10.1.2	Minimum requirement for <i>repeater type 1-C</i> .....	55
6.10.2	Transmitter transient period.....	55
6.10.2.1	General .....	55
6.10.2.2	Minimum requirement for <i>repeater type 1-C</i> .....	56
7	Radiated characteristics.....	56
7.1	General .....	56
7.2	OTA output power.....	56
7.2.1	General.....	56
7.2.2	Minimum requirement .....	57
7.3	OTA frequency stability .....	58
7.3.1	General.....	58
7.3.2	Minimum requirement .....	58
7.4	OTA out of band gain.....	58
7.4.1	General.....	58
7.4.2	Minimum requirement .....	58
7.5	OTA unwanted emissions .....	59
7.5.1	General.....	59
7.5.2	OTA Adjacent Channel Leakage Power Ratio (ACLR) .....	59

7.5.2.1	General .....	59
7.5.2.2	Minimum requirement for <i>repeater type 2-O</i> .....	59
7.5.3	OTA operating band unwanted emissions .....	63
7.5.3.1	General .....	63
7.5.3.2	Minimum requirement for <i>repeater type 2-O</i> .....	63
7.5.3.2.1	General .....	63
7.5.3.2.2	OTA operating band unwanted emission limits (Category A) .....	63
7.5.3.2.3	OTA operating band unwanted emission limits (Category B).....	64
7.5.3.2.4	Additional OTA operating band unwanted emission requirements.....	65
7.5.4	OTA transmitter spurious emissions.....	65
7.5.4.1	General .....	65
7.5.4.2	Minimum requirement for <i>repeater type 2-O</i> .....	65
7.5.4.2.1	General .....	65
7.5.4.2.2	General OTA transmitter spurious emissions requirements .....	66
7.5.4.2.3	Additional OTA transmitter spurious emissions requirements.....	67
7.6	OTA Repeater Error Vector Magnitude .....	67
7.6.1	Downlink repeater error vector magnitude .....	67
7.6.1.1	General .....	67
7.6.1.2	Minimum requirement .....	68
7.6.1.3	Repeater EVM frame structure for measurement.....	68
7.6.2	Uplink repeater error vector magnitude .....	68
7.6.2.1	General .....	68
7.6.2.2	Minimum requirement .....	69
7.7	OTA input intermodulation .....	69
7.7.1	General.....	69
7.7.2	Minimum requirement .....	69
7.8	OTA Adjacent Channel Rejection Ratio (ACRR).....	70
7.8.1	General.....	70
7.8.2	Minimum Requirements .....	70
7.9	OTA transmit ON/OFF power.....	71
7.9.1	General.....	71
7.9.2	OTA transmitter OFF power.....	71
7.9.2.1	General .....	71
7.9.2.2	Minimum requirement for <i>repeater type 2-O</i> .....	71
7.9.3	OTA transient period .....	71
7.9.3.1	General .....	71
7.9.3.2	Minimum requirement for <i>repeater type 2-O</i> .....	71
<b>Annex A:</b>	<b>Void .....</b>	<b>73</b>
<b>Annex B (informative):</b>	<b>Change history .....</b>	<b>74</b>
History .....		75

---

# Foreword

This Technical Specification has been produced by the 3rd Generation Partnership Project (3GPP).

The contents of the present document are subject to continuing work within the TSG and may change following formal TSG approval. Should the TSG modify the contents of the present document, it will be re-released by the TSG with an identifying change of release date and an increase in version number as follows:

Version x.y.z

where:

- x the first digit:
  - 1 presented to TSG for information;
  - 2 presented to TSG for approval;
  - 3 or greater indicates TSG approved document under change control.
- y the second digit is incremented for all changes of substance, i.e. technical enhancements, corrections, updates, etc.
- z the third digit is incremented when editorial only changes have been incorporated in the document.

In the present document, modal verbs have the following meanings:

- shall** indicates a mandatory requirement to do something
- shall not** indicates an interdiction (prohibition) to do something

The constructions "shall" and "shall not" are confined to the context of normative provisions, and do not appear in Technical Reports.

The constructions "must" and "must not" are not used as substitutes for "shall" and "shall not". Their use is avoided insofar as possible, and they are not used in a normative context except in a direct citation from an external, referenced, non-3GPP document, or so as to maintain continuity of style when extending or modifying the provisions of such a referenced document.

- should** indicates a recommendation to do something
- should not** indicates a recommendation not to do something
- may** indicates permission to do something
- need not** indicates permission not to do something

The construction "may not" is ambiguous and is not used in normative elements. The unambiguous constructions "might not" or "shall not" are used instead, depending upon the meaning intended.

- can** indicates that something is possible
- cannot** indicates that something is impossible

The constructions "can" and "cannot" are not substitutes for "may" and "need not".

- will** indicates that something is certain or expected to happen as a result of action taken by an agency the behaviour of which is outside the scope of the present document
- will not** indicates that something is certain or expected not to happen as a result of action taken by an agency the behaviour of which is outside the scope of the present document
- might** indicates a likelihood that something will happen as a result of action taken by some agency the behaviour of which is outside the scope of the present document

**might not** indicates a likelihood that something will not happen as a result of action taken by some agency the behaviour of which is outside the scope of the present document

In addition:

**is** (or any other verb in the indicative mood) indicates a statement of fact

**is not** (or any other negative verb in the indicative mood) indicates a statement of fact

The constructions "is" and "is not" do not indicate requirements.



---

# 1 Scope

The present document establishes the minimum RF characteristics of NR Repeater.

---

# 2 References

The following documents contain provisions which, through reference in this text, constitute provisions of the present document.

- References are either specific (identified by date of publication, edition number, version number, etc.) or non-specific.
- For a specific reference, subsequent revisions do not apply.
- For a non-specific reference, the latest version applies. In the case of a reference to a 3GPP document (including a GSM document), a non-specific reference implicitly refers to the latest version of that document *in the same Release as the present document*.

- [1] 3GPP TR 21.905: "Vocabulary for 3GPP Specifications".
- [2] 3GPP TS 38.104: "NR; Base Station (BS) radio transmission and reception".
- [3] 3GPP TR 25.942: "RF system scenarios".
- [4] Recommendation ITU-R SM.328: "Spectra and bandwidth of emissions".
- [5] ITU-R Recommendation SM.329: "Unwanted emissions in the spurious domain".
- [6] ITU-R Recommendation M.1545: "Measurement uncertainty as it applies to test limits for the terrestrial component of International Mobile Telecommunications – 2000".
- [7] 3GPP TS 38.115-1: "NR; Repeater conformance testing - Part 1: Conducted conformance testing".
- [8] 3GPP TS 38.115-2: "NR; Repeater conformance testing - Part 2: Radiated conformance testing".
- [9] ERC Recommendation 74-01: "Unwanted emissions in the spurious domain".
- [10] "Title 47 of the Code of Federal Regulations (CFR)", Federal Communications Commission.
- [11] Void
- [12] Void
- [13] 3GPP TS 38.101-1: "NR User Equipment (UE) radio transmission and reception; Part 1: Range 1 Standalone".
- [14] 3GPP TS 38.101-2: "NR User Equipment (UE) radio transmission and reception: Part 2: Range 2 Standalone".
- [15] Void
- [16] Void
- [17] Void
- [18] Void
- [19] 3GPP TS 38.213: "NR; Physical layer procedures for control".
- [20] 3GPP TS 36.104: "Evolved Universal Terrestrial Radio Access (E-UTRA); Base Station (BS) radio transmission and reception"

## 3 Definitions of terms, symbols and abbreviations

### 3.1 Terms

For the purposes of the present document, the terms given in 3GPP TR 21.905 [1] and the following apply. A term defined in the present document takes precedence over the definition of the same term, if any, in 3GPP TR 21.905 [1].

**Antenna connector:** connector at the conducted interface of the *repeater type 1-C*

**Beam:** beam (of the antenna) is the main lobe of the radiation pattern of an *antenna array*

**Beam centre direction:** direction equal to the geometric centre of the half-power contour of the beam

**Beam direction pair:** data set consisting of the *beam centre direction* and the related *beam peak direction*

**Beam peak direction:** direction where the maximum EIRP is found

**Beamwidth:** beam which has a half-power contour that is essentially elliptical, the half-power beamwidths in the two pattern cuts that respectively contain the major and minor axis of the ellipse

**directional requirement:** requirement which is applied in a specific direction within the *OTA coverage range*.

**Equivalent isotropic radiated power:** equivalent power radiated from an isotropic directivity device producing the same field intensity at a point of observation as the field intensity radiated in the direction of the same point of observation by the discussed device

**Fractional bandwidth:** *fractional bandwidth* FBW is defined as  $FBW = 200 \cdot \frac{F_{FBW\ high} - F_{FBW\ low}}{F_{FBW\ high} + F_{FBW\ low}} \%$

**gap between passbands:** frequency gap between two consecutive passbands that belong to the same *operating band*, where the RF requirements in the gap are based on co-existence for un-coordinated operation

**Inter-passband gap:** The frequency gap between two supported consecutive *passbands* that belong to different operating bands.

**Maximum passband output power:** mean power level measured per *passband* at the *antenna connector*, during the *transmitter ON state* in a specified reference condition

**Maximum passband TRP output power:** mean power level measured per passband during the *transmitter ON state* in a specified reference condition and corresponding to the declared *rated passband TRP output power* ( $P_{\text{rated,p,TRP}}$ )

**Measurement bandwidth:** RF bandwidth in which an emission level is specified

**multi-band connector:** *Antenna Connector* for a *Multi-band repeater*.

**Multi-band repeater:** *Repeater Type 1-C* whose *antenna connector* is associated with a transmitter and/or receiver that is characterized by the ability to process two or more *passband(s)* in common active RF components simultaneously, where at least one *passband* is configured at a different operating band than the other *passband(s)* and where this different operating band is not a sub-band or superseding-band of another supported operating band

**Nominal channel bandwidth:** Bandwidth calculated as  $\min(100\text{MHz}, BW_{\text{passband}})$  in FR1 or  $\min(400\text{MHz}, BW_{\text{passband}})$  in FR2. If this bandwidth is not defined for BS channel bandwidth for the operating band, *nominal channel bandwidth* shall be defined as the widest BS channel bandwidth for the operating band which is narrower than  $BW_{\text{passband}}$ .

**Non-contiguous spectrum:** spectrum consisting of two or more *passbands* separated by *inter-passband gap(s)*.

**Operating band:** frequency range in which NR operates (paired or unpaired), that is defined with a specific set of technical requirements

**OTA coverage range:** a common range of directions within which OTA requirements that are neither specified in the *OTA peak directions sets* nor as *TRP requirement* are intended to be met

**OTA peak directions set:** set(s) of *beam peak directions* within which certain OTA requirements are intended to be met, where all *OTA peak directions set(s)* are subsets of the *OTA coverage range*

**Passband:** The frequency range in which the repeater operates in with operational configuration, this frequency range can correspond to one or several consecutive nominal channels, if they are not consecutive each subset of channels shall be considered as an individual *passband*, a repeater can have one or several *passbands*, all channels within the *passband(s)* shall belong to a single operator or collaborating operators.

**passband edge:** Frequency at the edge of the passband

**Radiated interface boundary:** *operating band* specific radiated requirements reference where the radiated requirements apply

**Rated beam EIRP:** For a declared beam and *beam direction pair*, the *rated beam EIRP* level is the maximum power that the repeater is declared to radiate at the associated *beam peak direction* during the *transmitter ON state*

**Rated passband output power:** mean power level associated with a *passband* the manufacturer has declared to be available at the *antenna connector*, during the *transmitter ON state* in a specified reference condition

**Rated passband TRP output power:** mean power level declared by the manufacturer per passband, that the manufacturer has declared to be available at the RIB during the *transmitter ON state*

**Rated total output power:** mean power level associated with a particular *operating band* the manufacturer has declared to be available at the *antenna connector*, during the *transmitter ON state* in a specified reference condition

**Rated total TRP output power:** mean power level associated with a particular *operating band*, that the manufacturer has declared to be available at the RIB during the *transmitter ON state* in a specified reference condition

**Reference beam direction pair:** Beam direction pair in the reference direction declared by the manufacturer.

**Repeater type 1-C:** Repeater operating at FR1 with a requirement set consisting only of conducted requirements defined at individual *antenna connectors*.

**Repeater type 2-O:** Repeater operating at FR2 with a requirement set consisting only of OTA requirements defined at the RIB

**Requirement set:** one of the NR requirements set as defined for *NR repeater*

**single-band connector:** *Repeater type 1-C antenna connector* supporting operation either in a single *operating band* only, or in multiple *operating bands* but does not meet the conditions for a *multi-band connector*.

**Sub-band:** A *sub-band* of an operating band contains a part of the uplink and downlink frequency range of the operating band.

**sub-block:** one contiguous allocated block of spectrum for transmission and reception by the repeater.

**Superseding-band:** A *superseding-band* of an operating band includes the whole of the uplink and downlink frequency range of the operating band.

**Total radiated power:** is the total power radiated by the antenna

NOTE: The *total radiated power* is the power radiating in all direction for two orthogonal polarizations. *Total radiated power* is defined in both the near-field region and the far-field region

**Transmitter OFF state:** Time period during which the repeater downlink or uplink is not allowed to transmit in the corresponding direction.

**Transmitter ON state:** Time period during which the repeater is transmitting downlink or uplink signals in the corresponding direction.

**Transmitter transient period:** Time period during which the repeater is changing from the OFF state to the ON state or vice versa.

## 3.2 Symbols

For the purposes of the present document, the following symbols apply:

$BW_{\text{Config}}$       *Transmission bandwidth configuration*, where  $BW_{\text{Config}} = N_{\text{RB}} \times \text{SCS} \times 12$

$BW_{\text{Nominal}}$	Nominal channel bandwidth
$BW_{\text{Passband}}$	<i>Passband</i> bandwidth
$\Delta f$	Separation between the <i>passband edge</i> frequency and the nominal -3 dB point of the measuring filter closest to the carrier frequency
$\Delta f_{\text{max}}$	$f_{\text{offset,max}}$ minus half of the bandwidth of the measuring filter
$\Delta f_{\text{OBUE}}$	Maximum offset of the <i>operating band</i> unwanted emissions mask from the <i>operating band edge</i>
$F_{\text{DL,low}}$	The lowest frequency of the downlink <i>operating band</i>
$F_{\text{DL,high}}$	The highest frequency of the downlink <i>operating band</i>
$F_{\text{FBWhigh}}$	Highest supported frequency within supported operating band, for which <i>fractional bandwidth</i> support was declared
$F_{\text{FBWlow}}$	Lowest supported frequency within supported operating band, for which <i>fractional bandwidth</i> support was declared
$F_{\text{filter}}$	Filter centre frequency
$F_{\text{offset,high}}$	Frequency offset from $F_{\text{C,high}}$ to the upper <i>passband edge</i>
$F_{\text{offset,low}}$	Frequency offset from $F_{\text{C,low}}$ to the lower <i>passband edge</i>
$f_{\text{offset}}$	Separation between the <i>passband edge</i> frequency and the centre of the measuring
$f_{\text{offset,max}}$	The offset to the frequency $\Delta f_{\text{OBUE}}$ outside the <i>operating band</i>
$F_{\text{step,X}}$	Frequency steps for the OTA transmitter spurious emissions (Category B)
$F_{\text{UL,low}}$	The lowest frequency of the uplink <i>operating band</i>
$F_{\text{UL,high}}$	The highest frequency of the uplink <i>operating band</i>
$P_{\text{EM,n50/n75,ind}}$	Declared emission level for Band n50/n75; ind = a, b
$P_{\text{rated,p,AC}}$	Rated passband output power per antenna connector
$P_{\text{rated,t,AC}}$	Rated total output power declared per antenna connector
$P_{\text{rated,p,EIRP}}$	Rated passband EIRP output power
$P_{\text{rated,p,TRP}}$	Rated passband TRP output power declared per RIB
$P_{\text{rated,t,TRP}}$	Rated total TRP output power declared per RIB
$P_{\text{in,p,AC}}$	Input power intended to produce the maximum rated output power ( $P_{\text{rated,p,AC}}$ ) at the <i>antenna connector</i>
$P_{\text{in,p,EIRP}}$	Input power intended to produce the maximum rated output power ( $P_{\text{rated,p,TRP}}$ ) at the RIB
$P_{\text{rated,out,FBWhigh}}$	The rated output EIRP for the higher supported frequency range within supported <i>operating band</i> , for which <i>fractional bandwidth</i> support was declared
$P_{\text{rated,out,FBWlow}}$	The rated output EIRP for the lower supported frequency range within supported <i>operating band</i> , for which <i>fractional bandwidth</i> support was declared
$P_{\text{max,p,AC}}$	<i>Maximum passband output power</i> measured per <i>antenna connector</i>
$P_{\text{max,p,EIRP}}$	<i>Maximum passband EIRP output power</i> when repeater is configured at the rated passband TRP output power ( $P_{\text{rated,p,TRP}}$ )
$P_{\text{max,p,TRP}}$	<i>Maximum passband TRP output power</i> measured per RIB
$W_{\text{gap}}$	<i>Inter passband Bandwidth gap size</i>

### 3.3 Abbreviations

For the purposes of the present document, the abbreviations given in 3GPP TR 21.905 [1] and the following apply. An abbreviation defined in the present document takes precedence over the definition of the same abbreviation, if any, in 3GPP TR 21.905 [1].

ACLR	Adjacent Channel Leakage Ratio
AoA	Angle of Arrival
BW	Bandwidth
CACLR	Cumulative ACLR
CP-OFDM	Cyclic Prefix-OFDM
DFT-s-OFDM	Discrete Fourier Transform-spread-OFDM
DL	Downlink
EIRP	Effective Isotropic Radiated Power
EVM	Error Vector Magnitude
FBW	Fractional Bandwidth
FR	Frequency Range
ITU-R	Radiocommunication Sector of the International Telecommunication Union
LA	Local Area
MR	Medium Range
NR	New Radio
OBUE	Operating Band Unwanted Emissions
OOB	Out-of-band

OTA	Over-The-Air
QAM	Quadrature Amplitude Modulation
RF	Radio Frequency
RIB	Radiated Interface Boundary
RX	Receiver
SCS	Sub-Carrier Spacing
TX	Transmitter
TRP	Total Radiated Power
UL	Uplink
WA	Wide Area

## 4 General

### 4.1 Relationship between Minimum Requirements and Test Requirements

Conformance to the present specification is demonstrated by fulfilling the test requirements specified in the conformance specification TS 38.115-1 [7] or TS 38.115-2 [8].

The minimum requirements given in this specification make no allowance for measurement uncertainty. The test specifications TS 38.115-1 [7] and TS 38.115-2 [8] define test tolerances. These test tolerances are individually calculated for each test. The test tolerances are used to relax the minimum requirements in this specification to create test requirements. For some requirements, including regulatory requirements, the test tolerance is set to zero.

The measurement results returned by the test system are compared - without any modification - against the test requirements as defined by the shared risk principle.

The shared risk principle is defined in recommendation ITU-R M.1545 [6].

### 4.2 Conducted and radiated requirement reference points

#### 4.2.1 Repeater type 1-C

For *repeater type 1-C*, the requirements are applied at the repeater *antenna connector* (BS-side connector or UE-side connector) for downlink or uplink for the configuration in normal operating conditions.

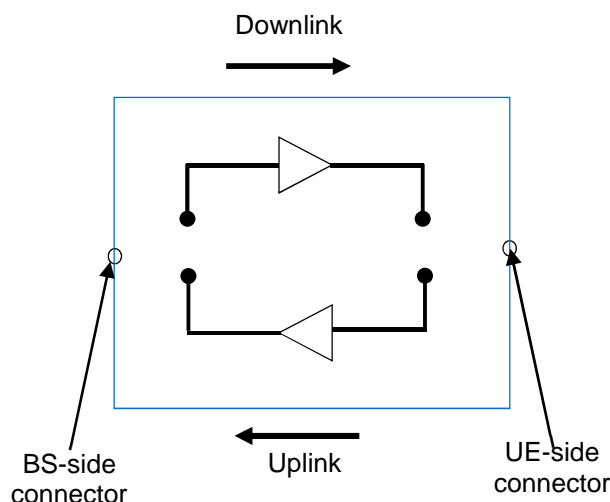

Figure 4.2.1-1: *Repeater type 1-C* downlink and uplink interface

## 4.2.2 Repeater type 2-O

For *repeater type 2-O*, the radiated characteristics are defined over the air (OTA), where the operating band specific radiated interface is referred to as the Radiated Interface Boundary (RIB). Radiated requirements are also referred to as OTA requirements. The (spatial) characteristics in which the OTA requirements apply are detailed for each requirement.

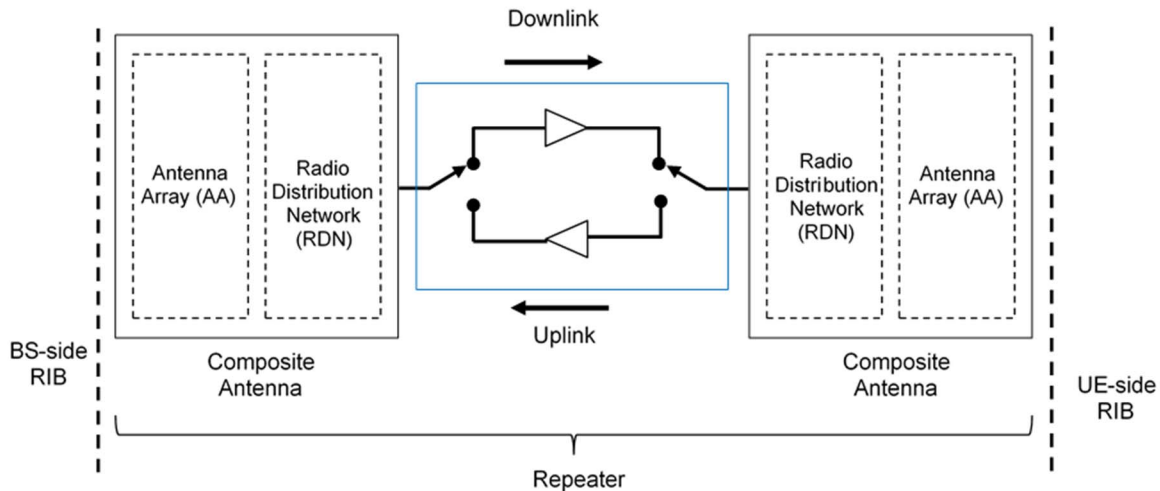

Figure 4.2.2-1: Radiated reference points for *repeater type 2-O*

## 4.3 Repeater classes

### 4.3.1 Repeater class for downlink

The requirements in this specification apply to downlink Wide Area repeaters, downlink Medium Range repeaters and downlink Local Area repeaters unless otherwise stated. The associated deployment scenarios for each class are exactly the same for repeater with and without connectors.

For *repeater type 1-C* and *type 2-O*, repeater downlink classes are defined as indicated below:

- Wide Area repeaters are characterised by requirements derived from Macro Cell scenarios with a repeater to UE minimum distance along the ground equal to 35 m.
- Medium Range repeaters are characterised by requirements derived from Micro Cell scenarios with a repeater to UE minimum distance along the ground equal to 5 m.
- Local Area repeaters are characterised by requirements derived from Pico Cell scenarios with a repeater to UE minimum distance along the ground equal to 2 m or from Femto Cell scenarios.
- Note: The requirements in this specification for LA 1-C repeaters apply to 1-C repeaters with declared output power less than or equal to LA rated output power limits as in table 6.2.1-1.

### 4.3.2 Repeater class for uplink

The requirements in this specification apply to uplink Wide Area repeaters and uplink Local Area repeaters unless otherwise stated. The associated deployment scenarios for each class are exactly the same for repeater with and without connectors.

For *repeater type 1-C* and *type 2-O*, repeater uplink classes are defined as indicated below:

- Wide Area repeaters are characterised by requirements derived from Macro Cell and/or Micro Cell scenarios.
- Local Area repeaters are characterised by requirements derived from Pico Cell and/or Micro Cell scenarios.

## 4.4 Regional requirements

Some requirements in the present document may only apply in certain regions either as optional requirements, or as mandatory requirements set by local and regional regulation. It is normally not stated in the 3GPP specifications under what exact circumstances the regional requirements apply, since this is defined by local or regional regulation.

Table 4.4-1 lists all requirements in the present specification that may be applied differently in different regions.

**Table 4.4-1: List of regional requirements**

Clause number	Requirement	Comments
5.2	<i>Operating bands</i>	Some NR <i>operating bands</i> may be applied regionally.
6.2	Repeater output power	For Band n41 and n90 operation in Japan, additional output power limits shall be applied.
6.2.4, 7.3.4	Repeater output power, OTA repeater output power: Additional requirements	These requirements may be applied regionally as additional repeater output power requirements.
6.5.2	Adjacent Channel Leakage Power Ratio	For Band n41 and n90 operation in Japan, absolute ACLR limits shall be applied to the sum of the absolute ACLR power over all <i>antenna connectors</i> for <i>repeater type 1-C</i> .
6.5.3.2, 7.5.3.2	Operating band unwanted emission, OTA operating band unwanted emissions	Category A or Category B operating band unwanted emissions limits may be applied regionally.
6.5.3.2.5.1	Operating band unwanted emission	The repeater may have to comply with the additional requirements, when deployed in regions where those limits are applied, and under the conditions declared by the manufacturer.
6.5.3.2.5.2	Operating band unwanted emission	The repeater operating in Band n20 may have to comply with the additional requirements for protection of DTT, when deployed in certain regions.
6.5.3.2	Operating band unwanted emissions	For Band n41 and n90 operation in Japan, the operating band unwanted emissions limits shall be applied to the sum of the emission power over all <i>antenna connectors</i> for <i>repeater type 1-C</i> .
6.5.4.2.1, 7.5.4.2	Tx spurious emissions, OTA Tx spurious emissions	Category A or Category B spurious emission limits, as defined in ITU-R Recommendation SM.329 [5], may apply regionally.
6.5.4.2.2, 7.5.4.2.3	Tx spurious emissions: additional requirements, OTA Tx spurious emissions: additional requirements	These requirements may be applied for the protection of system operating in frequency ranges other than the repeater <i>operating band</i> .
6.5.4.2	Transmitter spurious emissions	For Band n41 and n90 operation in Japan, the sum of the spurious emissions over all <i>antenna connectors</i> for <i>repeater type 1-C</i> shall not exceed the <i>basic limits</i> .
6.5.5.1	Receiver spurious emissions	For Band n41 and n90 operation in Japan, the sum of receiver spurious emissions requirements over all <i>antenna connectors</i> for <i>repeater type 1-C</i> shall not exceed <i>minimum requirements</i> defined in clause 6.5.5.2.
6.7.2	Input intermodulation	Interfering signal positions that are partially or completely outside of any downlink <i>operating band</i> of the repeater are not excluded from the requirement in Japan in Band n77, n78, n79.
6.8	Output intermodulation	For Band n41 and n90 operation in Japan, the repeater may have to comply with the additional requirements, when deployed in certain regions.

## 4.5 Applicability of requirements

In table 4.5-1, the requirement applicability for each requirement set is defined. For each requirement, the applicable requirement clause in the specification is identified. Requirements not included in a requirement set is marked not applicable (NA).

Table 4.5-1: Requirement set applicability

Requirement	Requirement set		
	Repeater type 1-C	Repeater type 2-O	
Repeater output power	6.2	NA	
Frequency stability	6.3		
Out of band gain	6.4		
Unwanted emissions	6.5		
Error Vector Magnitude	6.6		
Input intermodulation	6.7		
Output intermodulation	6.8		
Adjacent Channel Rejection Ratio (ACRR)	6.9		
Transmit ON/OFF power	6.10		
Repeater output power	NA		7.2
OTA frequency stability		7.3	
OTA out of band gain		7.4	
OTA unwanted emissions		7.5	
OTA Error Vector Magnitude		7.6	
OTA input intermodulation		7.7	
OTA Adjacent Channel Rejection Ratio (ACRR)		7.8	
OTA transmit ON/OFF power		7.9	

## 4.6 Requirements for contiguous and *non-contiguous spectrum*

A spectrum allocation where a repeater operates can either be contiguous or non-contiguous. Unless otherwise stated, the requirements in the present specification apply for repeater configured for both contiguous spectrum operation and non-contiguous spectrum operation.

For repeater operation in non-contiguous spectrum, some requirements apply at the repeater *passband* edges. For each such requirement, it is stated how the limits apply relative to the repeater *gap between passbands* and the *Inter-passband gap* respectively.

## 4.7 Requirements for repeater capable of multi-band operation

For multi-band connector or multi-band RIB, the RF requirements in clauses 6 and 7 apply separately to each supported operating band unless otherwise stated. For some requirements, it is explicitly stated that specific additions or exclusions to the requirement apply at multi-band connector(s), and multi-band RIB(s) as detailed in the requirement clause. For repeater capable of multi-band operation, various structures in terms of combinations of different downlink and uplink implementations (multi-band or single band) with mapping to one or more *antenna connectors for repeater type 1-C* in different ways are possible. For multi-band connector(s) the exclusions or provisions for multi-band apply. For single-band connector(s), the following applies:

- Single-band transmitter spurious emissions, *operating band* unwanted emissions, ACLR, output intermodulation, ACRR and receiver spurious emissions requirements apply to this *connector* that is mapped to single-band.
- If the repeater is configured for single-band operation, single-band requirements shall apply to this *antenna connector* configured for single-band operation and no exclusions or provisions for multi-band capable repeater are applicable. Single-band requirements are tested separately at the *antenna connector* configured for single-band operation, with all other *antenna connectors* terminated.

# 5 Operating bands

## 5.1 General

The channel arrangements presented in this clause are based on the *operating bands* defined in the present release of specifications.



NOTE: Other *operating bands* may be considered in future releases.

Requirements throughout the RF specifications are in many cases defined separately for different frequency ranges (FR). The frequency ranges in which NR can operate according to the present version of the specification are identified as described in table 5.1-1.

**Table 5.1-1: Definition of frequency ranges**

Frequency range designation		Corresponding frequency range
FR1		410 MHz – 7125 MHz
FR2	FR2-1	24250 MHz – 52600 MHz
	FR2-2	52600 MHz – 71000 MHz

Whenever FR2 is referred, both FR2-1 and FR2-2 frequency sub-ranges shall be applied, unless otherwise stated.

## 5.2 Operating bands

NR repeater is designed to operate in the *operating bands* in FR1 and FR2-1 defined in TS 38.104 [2] except the operating bands n46, n96 and n102.

## 5.3 Channel arrangement

### 5.3.1 Channel raster

#### 5.3.1.1 NR-ARFCN and channel raster

The NR-ARFCN and channel raster is the same as specified for BS in TS 38.104 [2], subclause 5.4.2.1.

#### 5.3.1.2 Channel raster entries for each *operating band*

The channel raster entries for NR bands for FR1 and FR2-1 defined in TS 38.104 [2] are the same as specified for BS in TS 38.104 [2], clause 5.4.2.3.

### 5.3.2 Synchronization raster

#### 5.3.2.1 Synchronization raster and numbering

The synchronization raster and numbering are the same as specified for BS in TS 38.104 [2], clause 5.4.3.1.

#### 5.3.2.2 Synchronization raster entries for each operating band

The synchronization raster entries for NR bands for FR1 and FR2-1 defined in TS 38.104 [2] are the same as specified for BS in TS 38.104 [2], clause 5.4.3.3.

---

## 6 Conducted characteristics

### 6.1 General

Unless otherwise stated, the conducted transmitter characteristics are specified at the *antenna connector* for *repeater type I-C* configuration in normal operating conditions.

Requirements apply in both DL and UL unless otherwise stated or declared.

For the DL the *antenna connector* on the BS side is the input and the *antenna connector* on the UE side is the output.

For the UL the *antenna connector* on the UE side is the input and the *antenna connector* on the BS side is the output.  
All requirements are defined for normal conditions, unless otherwise stated.

## 6.2 Repeater output power

### 6.2.1 General

The repeater conducted output power requirement is at the *antenna connector*.

The *rated passband output power* of the *repeater type 1-C* shall be as specified in table 6.2.1-1 and table 6.2.1-2.

**Table 6.2.1-1: Repeater type 1-C DL transmission classes rated output power limits for repeater classes**

Repeater class	$P_{\text{rated,p,AC}}$
Wide Area repeater	Note 1
Medium Range repeater	$\leq 38 \text{ dBm} + X$ , Note 2
Local Area repeater	$\leq 24 \text{ dBm} + X$ , Note 2
NOTE 1: There is no upper limit for the $P_{\text{rated,p,AC}}$ <i>rated passband output power</i> of the Wide Area repeater	
NOTE 2: $X = 10 \cdot \log(\text{ceil}(\text{passband bandwidth}/20\text{MHz}))$	

**Table 6.2.1-2: Repeater type 1-C UL transmission classes rated output power limits for repeater classes**

Repeater class	$P_{\text{rated,p,AC}}$
Wide Area repeater	Note 1
Local Area repeater	$\leq 24 \text{ dBm} + X$ , Note 2
NOTE 1: There is no upper limit for the $P_{\text{rated,p,AC}}$ <i>rated passband output power</i> of the Wide Area repeater.	
NOTE 2: $X = 10 \cdot \log(\text{ceil}(\text{passband bandwidth}/20\text{MHz}))$	

### 6.2.2 Minimum requirement

The requirements shall apply with NR signals in the *passband* of the repeater at:

The lowest input power ( $P_{\text{in,p,AC}}$ ) that produces the *rated passband output power* ( $P_{\text{rated,p,AC}}$ ).

Up to:

The lowest input power ( $P_{\text{in,p,AC}}$ ) that produces the *rated passband output power* ( $P_{\text{rated,p,AC}}$ ), plus 10dB

In normal conditions, the measured output power,  $P_{\text{max,p,AC}}$  shall remain within +2 dB and -2 dB of the *rated passband output power*  $P_{\text{rated,p,AC}}$ , declared by the manufacturer.

In extreme conditions, the measured output power,  $P_{\text{max,p,AC}}$  shall remain within +2.5 dB and -2.5 dB of the *rated passband output power*  $P_{\text{rated,p,AC}}$ , declared by the manufacturer.

## 6.3 Frequency stability

### 6.3.1 General

Frequency stability is the ability to maintain the same frequency on the output signal with respect to the input signal.

## 6.3.2 Minimum requirement

The frequency deviation of the output signal with respect to the input signal shall be no more than  $\pm 0,01$  PPM.

## 6.4 Out of band gain

### 6.4.1 General

Out of band gain refers to the gain of the repeater outside the *passband*.

The intended use of a repeater in a system is to amplify the in-band signals and not to amplify signals outside of the *passband*.

In the intended application of the repeater, the out of band gain is less than lowest expected the coupling loss to the nearest source of emissions.

### 6.4.2 Minimum requirement

The gain outside the *passband* shall not exceed the maximum level specified in table 6.4.2-1 or table 6.4.2-2, where:

- $f\_offset\_CW$  is the offset between the outer channel edge frequency of the outer channel in the *passband* and a CW signal.

**Table 6.4.2-1: Out of band gain limits 1 for bands below 2496 MHz**

Frequency offset, $f\_offset\_CW$	Maximum gain
$0,2 \leq f\_offset\_CW < 1,0$ MHz	60 dB
$1,0 \leq f\_offset\_CW < 5,0$ MHz	45 dB
$5,0 \leq f\_offset\_CW < 10,0$ MHz	45 dB
$10,0$ MHz $\leq f\_offset\_CW$	35 dB

**Table 6.4.2-2: Out of band gain limits 1 for bands above 2496 MHz**

Frequency offset, $f\_offset\_CW$	Maximum gain
$[0,2] < f\_offset\_CW < 4,0$ MHz	60 dB
$4,0 < f\_offset\_CW < 15,0$ MHz	45 dB
$15,0$ MHz $< f\_offset\_CW$	35 dB

## 6.5 Unwanted emissions

### 6.5.1 General

Unwanted emissions consist of out-of-band emissions and spurious emissions according to ITU definitions [5]. In ITU terminology, out of band emissions are unwanted emissions immediately outside the channel bandwidth resulting from the modulation process and non-linearity in the transmitter but excluding spurious emissions. Spurious emissions are emissions which are caused by unwanted transmitter effects such as harmonics emission, parasitic emission, intermodulation products and frequency conversion products, but exclude out of band emissions.

The out-of-band emissions requirement for the Repeater transmitter is specified both in terms of Adjacent Channel Leakage power Ratio (ACLR) and *operating band* unwanted emissions (OBUE).

The maximum offset of the *operating band* unwanted emissions mask from the *operating band* edge is  $\Delta f_{OBUE}$ . The Operating band unwanted emissions define all unwanted emissions in each supported downlink *operating band* of *repeater type 1-C* DL and uplink *operating band* of *repeater type 1-C* UL, plus the frequency ranges  $\Delta f_{OBUE}$  above and  $\Delta f_{OBUE}$  below each band. Unwanted emissions outside of this frequency range are limited by a spurious emissions requirement.

The values of  $\Delta f_{OBUE}$  are defined in tables 6.5.1-1 and 6.5.1-2 for the NR *operating bands*.

**Table 6.5.1-1: Maximum offset of OBUE outside the downlink operating band of repeater type 1-C DL**

Repeater type	Operating band characteristics	$\Delta f_{\text{OBUE}}$ (MHz)
Repeater type 1-C	$F_{\text{DL,high}} - F_{\text{DL,low}} < 200$ MHz	10
	$200 \text{ MHz} \leq F_{\text{DL,high}} - F_{\text{DL,low}} \leq 900$ MHz	40

**Table 6.5.1-2: Maximum offset of OBUE outside the uplink operating band of repeater 1-C UL**

Repeater type	Operating band characteristics	$\Delta f_{\text{OBUE}}$ (MHz)
Repeater type 1-C	$F_{\text{UL,high}} - F_{\text{UL,low}} < 200$ MHz	10
	$200 \text{ MHz} \leq F_{\text{UL,high}} - F_{\text{UL,low}} \leq 900$ MHz	40
	$200 \text{ MHz} \leq F_{\text{UL,high}} - F_{\text{UL,low}} \leq 900$ MHz	40

There is no co-location unwanted emission requirement for LA 1-C repeaters deployed in Femto cell scenario.

## 6.5.2 Adjacent Channel Leakage Power Ratio

### 6.5.2.1 General

Adjacent Channel Leakage power Ratio (ACLR) is the ratio of the filtered mean power centred on the assigned channel frequency to the filtered mean power centred on an adjacent channel frequency.

The requirements shall apply outside the *repeater type 1-C passband* whatever the type of transmitter considered (single carrier or multi-carrier) and for all transmission modes foreseen by the manufacturer's specification.

For a *repeater* operating in *non-contiguous spectrum*, the ACLR requirement in clause 6.5.2.2 shall apply in *Gaps between passbands* for the frequency ranges defined in table 6.5.2.2-3, while the CACLR requirement in clause 6.5.2.2 shall apply in *gaps between passbands* for the frequency ranges defined in table 6.5.2.2-4.

For a *multi-band connector*, the ACLR requirement in clause 6.5.2.2 shall apply in *inter-passband gaps* for the frequency ranges defined in table 6.5.2.2-3, while the CACLR requirement in clause 6.5.2.2 shall apply in *inter-passband gaps* for the frequency ranges defined in table 6.5.2.2-4.

The requirement shall apply during the *transmitter ON state*.

### 6.5.2.2 Minimum requirements

The ACLR is defined with a square filter of bandwidth equal to the transmission bandwidth configuration of the transmitted signal ( $BW_{\text{Config}}$ ) centred on the assigned channel frequency and a filter centred on the adjacent channel frequency according to the tables below.

For *repeater type 1-C*, for DL (all repeater classes), and for UL for WA class, either the ACLR (CACLR) absolute *minimum requirements* in table 6.5.2.2-2, 6.5.2.2-5 or else the relevant the ACLR (CACLR) *limits* in table 6.5.2.2-1, 6.5.2.2-3 or 6.5.2.2-4, whichever is less stringent, shall apply for each *antenna connector*. For UL for LA class, the ACLR (CACLR) limits in table 6.5.2.2-1a, 6.5.2.2-3 or 6.5.2.2-4a shall apply.

For Band n41 and n90 operation in Japan, absolute ACLR limits shall be applied to the sum of the absolute ACLR power over all *antenna connectors* for *repeater type 1-C*.

**Table 6.5.2.2-1: Repeater type 1-C ACLR limit for DL (all repeater classes) and for UL for Wide Area class**

Repeater type 1-C nominal channel bandwidth $BW_{Nominal}$ (MHz)	Repeater type 1-C adjacent channel centre frequency offset below or above the passband edge	Assumed adjacent channel carrier (informative)	Filter on the adjacent channel frequency and corresponding filter bandwidth	ACLR limit
5, 10, 15, 20, 25, 30, 35, 40, 45, 50, 60, 70, 80, 90, 100	$BW_{Nominal}/2$	NR of same BW (Note 2)	Square ( $BW_{Config}$ )	45 dB 38 dB (Note 4)
	$1.5 \times BW_{Nominal}$	NR of same BW (Note 2)	Square ( $BW_{Config}$ )	45 dB 38 dB (Note 4)
	2.5 MHz	5 MHz E-UTRA	Square (4.5 MHz)	45 dB (Note 3)
	7.5 MHz	5 MHz E-UTRA	Square (4.5 MHz)	45 dB (Note 3)

NOTE 1:  $BW_{Nominal}$  is the *nominal channel bandwidth*.  $BW_{Config}$  is the *transmission bandwidth configuration* assumed for the adjacent channel.  
NOTE 2: With SCS that provides largest *transmission bandwidth configuration* ( $BW_{Config}$ ).  
NOTE 3: The requirements are applicable when the band is also defined for E-UTRA or UTRA.  
NOTE 4: For repeater operating in band n104, ACLR requirement 38 dB applies. For repeater operating in other bands, ACLR requirement 45 dB applies.

**Table 6.5.2.2-1a: Repeater type 1-C ACLR limit for UL for Local Area**

Repeater type 1-C nominal channel bandwidth $BW_{Nominal}$ (MHz)	Repeater type 1-C adjacent channel centre frequency offset below or above the passband edge	Assumed adjacent channel carrier (informative)	Filter on the adjacent channel frequency and corresponding filter bandwidth	ACLR limit
5, 10, 15, 20, 25, 30, 35, 40, 45, 50, 60, 70, 80, 90, 100	$BW_{Nominal}/2$	NR of same BW (Note 2)	Square ( $BW_{Config}$ )	31 dB
	$1.5 \times BW_{Nominal}$	NR of same BW (Note 2)	Square ( $BW_{Config}$ )	31 dB
	2.5 MHz	5 MHz E-UTRA	Square (4.5 MHz)	31 dB
	7.5 MHz	5 MHz E-UTRA	Square (4.5 MHz)	31 dB

NOTE 1:  $BW_{Nominal}$  is the *nominal channel bandwidth*.  $BW_{Config}$  is the *transmission bandwidth configuration* assumed for the adjacent channel.  
NOTE 2: With SCS that provides the largest *transmission bandwidth configuration* ( $BW_{Config}$ ).  
NOTE 3: The requirements are applicable when the band is also defined for E-UTRA or UTRA.

The ACLR absolute *minimum requirement* is specified in table 6.5.2.2-2 and is applicable for both contiguous spectrum, non-contiguous spectrum and multiple bands

**Table 6.5.2.2-2: Repeater type 1-C ACLR absolute limit for DL and UL for WA class, for DL for MR class and for DL for LA class**

Repeater category / class	ACLR absolute limit
Category A Wide Area DL and UL	-13 dBm/MHz
Category B Wide Area DL and UL	-15 dBm/MHz
Medium Range DL	-25 dBm/MHz
Local Area DL	-32 dBm/MHz

**Table 6.5.2.2-3: Repeater type 1-C ACLR limit in non-contiguous spectrum or multiple bands for DL (all repeater classes) and for UL for Wide Area class**

Repeater type 1-C nominal channel bandwidth $BW_{\text{Nominal}}$ (MHz)	Gap between passbands or inter-passband gap size ( $W_{\text{gap}}$ ) where the limit applies (MHz)	Repeater type 1-C adjacent channel centre frequency offset below or above the passband edge (inside the gap)	Assumed adjacent channel carrier	Filter on the adjacent channel frequency and corresponding filter bandwidth	ACLR limit
5, 10, 15, 20	$W_{\text{gap}} \geq 15$ (Note 3) $W_{\text{gap}} \geq 45$ (Note 4)	2.5 MHz	5 MHz NR (Note 2)	Square ( $BW_{\text{Config}}$ )	45 dB 38 dB (Note 5)
	$W_{\text{gap}} \geq 20$ (Note 3) $W_{\text{gap}} \geq 50$ (Note 4)	7.5 MHz	5 MHz NR (Note 2)	Square ( $BW_{\text{Config}}$ )	45 dB 38 dB (Note 5)
25, 30, 35, 40, 45, 50, 60, 70, 80, 90, 100	$W_{\text{gap}} \geq 60$ (Note 4) $W_{\text{gap}} \geq 30$ (Note 3)	10 MHz	20 MHz NR (Note 2)	Square ( $BW_{\text{Config}}$ )	45 dB 38 dB (Note 5)
	$W_{\text{gap}} \geq 80$ (Note 4) $W_{\text{gap}} \geq 50$ (Note 3)	30 MHz	20 MHz NR (Note 2)	Square ( $BW_{\text{Config}}$ )	45 dB 38 dB (Note 5)

NOTE 1:  $BW_{\text{Nominal}}$  is the *nominal channel bandwidth*.  $BW_{\text{Config}}$  is the *transmission bandwidth configuration* assumed for the adjacent channel.

NOTE 2: With SCS that provides the largest *transmission bandwidth configuration* ( $BW_{\text{Config}}$ ).

NOTE 3: Applicable in case the *repeater type 1-C nominal channel bandwidth* at the other edge of the gap is  $\leq 20$  MHz.

NOTE 4: Applicable in case the *repeater type 1-C nominal channel bandwidth* at the other edge of the gap is  $> 20$  MHz.

NOTE 5: For repeater operating in band n104, ACLR requirement 38 dB applies. For repeater operating in other bands, ACLR requirement 45 dB applies.

**Table 6.5.2.2-3a: Repeater type 1-C ACLR limit in non-contiguous spectrum or multiple bands for UL for Local Area class**

Repeater type 1-C nominal channel bandwidth $BW_{\text{Nominal}}$ (MHz)	Sub-block or inter-passband gap size ( $W_{\text{gap}}$ ) where the limit applies (MHz)	Repeater type 1-C adjacent channel centre frequency offset below or above the passband edge (inside the gap)	Assumed adjacent channel carrier	Filter on the adjacent channel frequency and corresponding filter bandwidth	ACLR limit
5, 10, 15, 20	$W_{\text{gap}} \geq 15$ (Note 3) $W_{\text{gap}} \geq 45$ (Note 4)	2.5 MHz	5 MHz NR (Note 2)	Square ( $BW_{\text{Config}}$ )	31 dB
	$W_{\text{gap}} \geq 20$ (Note 3) $W_{\text{gap}} \geq 50$ (Note 4)	7.5 MHz	5 MHz NR (Note 2)	Square ( $BW_{\text{Config}}$ )	31 dB
25, 30, 35, 40, 45, 50, 60, 70, 80, 90, 100	$W_{\text{gap}} \geq 60$ (Note 4) $W_{\text{gap}} \geq 30$ (Note 3)	10 MHz	20 MHz NR (Note 2)	Square ( $BW_{\text{Config}}$ )	31 dB
	$W_{\text{gap}} \geq 80$ (Note 4) $W_{\text{gap}} \geq 50$ (Note 3)	30 MHz	20 MHz NR (Note 2)	Square ( $BW_{\text{Config}}$ )	31 dB

NOTE 1:  $BW_{\text{Config}}$  is the *transmission bandwidth configuration* assumed for the adjacent channel.

NOTE 2: With SCS that provides the largest *transmission bandwidth configuration* ( $BW_{\text{Config}}$ ).

NOTE 3: Applicable in case the *repeater type 1-C nominal channel bandwidth* at the other edge of the gap is  $\leq 20$  MHz.

NOTE 4: Applicable in case the *repeater type 1-C nominal channel bandwidth* at the other edge of the gap is  $> 20$  MHz.

The Cumulative Adjacent Channel Leakage power Ratio (CACLR) in a *gap between passbands* or the *inter-passband gap* is the ratio of:

- the sum of the filtered mean power centred on the assigned channel frequencies for the two carriers adjacent to each side of the *gap between passbands* or the *inter-passband gap*, and
- the filtered mean power centred on a frequency channel adjacent to one of the respective *repeater type 1-C passband edges*.

The assumed filter for the adjacent channel frequency is defined in table 6.5.3.2-4 and the filters on the assigned channels are defined in table 6.5.2.2-6.

For operation in *non-contiguous spectrum* or multiple bands, the ACLR for NR carriers located on either side of the *gap between passbands* or the *inter-passband gap* shall be higher than the value specified in table 6.5.2.2-4.

**Table 6.5.2.2-4: Repeater type 1-C ACLR limit for DL (all repeater classes) and for UL for Wide Area class**

Repeater type 1-C nominal channel bandwidth $BW_{\text{Nominal}}$ (MHz)	Gap between passbands or inter-passband gap size ( $W_{\text{gap}}$ ) where the limit applies (MHz)	Repeater type 1-C adjacent channel centre frequency offset below or above the passband edge (inside the gap)	Assumed adjacent channel carrier	Filter on the adjacent channel frequency and corresponding filter bandwidth	ACLR limit
5, 10, 15, 20	$5 \leq W_{\text{gap}} < 15$ (Note 3) $5 \leq W_{\text{gap}} < 45$ (Note 4)	2.5 MHz	5 MHz NR (Note 2)	Square ( $BW_{\text{Config}}$ )	45 dB 38 dB (Note 5)
	$10 < W_{\text{gap}} < 20$ (Note 3) $10 \leq W_{\text{gap}} < 50$ (Note 4)	7.5 MHz	5 MHz NR (Note 2)	Square ( $BW_{\text{Config}}$ )	45 dB 38 dB (Note 5)
25, 30, 35, 40, 45, 50, 60, 70, 80, 90, 100	$20 \leq W_{\text{gap}} < 60$ (Note 4) $20 \leq W_{\text{gap}} < 30$ (Note 3)	10 MHz	20 MHz NR (Note 2)	Square ( $BW_{\text{Config}}$ )	45 dB 38 dB (Note 5)
	$40 < W_{\text{gap}} < 80$ (Note 4) $40 \leq W_{\text{gap}} < 50$ (Note 3)	30 MHz	20 MHz NR (Note 2)	Square ( $BW_{\text{Config}}$ )	45 dB 38 dB (Note 5)

NOTE 1:  $BW_{\text{Config}}$  is the *transmission bandwidth configuration* assumed for the adjacent channel.  
NOTE 2: With SCS that provides the largest *transmission bandwidth configuration* ( $BW_{\text{Config}}$ ).  
NOTE 3: Applicable in case the *repeater type 1-C nominal channel bandwidth* at the other edge of the gap is  $\leq 20$  MHz.  
NOTE 4: Applicable in case the *repeater type 1-C nominal channel bandwidth* at the other edge of the gap is  $> 20$  MHz.  
NOTE 5: For repeater operating in band n104, ACLR requirement 38 dB applies. For repeater operating in other bands, ACLR requirement 45 dB applies.

The ACLR shall be higher than the value specified in table 6.5.2.2-4a for *repeater type 1-C* for UL Local Area.

**Table 6.5.2.2-4a: Repeater type 1-C ACLR limit for UL for Local Area**

Repeater type 1-C nominal channel bandwidth $BW_{\text{Nominal}}$ (MHz)	Gap between passbands or inter-passband gap size ( $W_{\text{gap}}$ ) where the limit applies (MHz)	Repeater type 1-C adjacent channel centre frequency offset below or above the passband edge (inside the gap)	Assumed adjacent channel carrier	Filter on the adjacent channel frequency and corresponding filter bandwidth	ACLR limit
5, 10, 15, 20	$5 \leq W_{\text{gap}} < 15$ (Note 3) $5 \leq W_{\text{gap}} < 45$ (Note 4)	2.5 MHz	5 MHz NR (Note 2)	Square ( $BW_{\text{Config}}$ )	31 dB
	$10 < W_{\text{gap}} < 20$ (Note 3) $10 \leq W_{\text{gap}} < 50$ (Note 4)	7.5 MHz	5 MHz NR (Note 2)	Square ( $BW_{\text{Config}}$ )	31 dB
25, 30, 35, 40, 45, 50, 60, 70, 80, 90, 100	$20 \leq W_{\text{gap}} < 60$ (Note 4) $20 \leq W_{\text{gap}} < 30$ (Note 3)	10 MHz	20 MHz NR (Note 2)	Square ( $BW_{\text{Config}}$ )	31 dB
	$40 < W_{\text{gap}} < 80$ (Note 4) $40 \leq W_{\text{gap}} < 50$ (Note 3)	30 MHz	20 MHz NR (Note 2)	Square ( $BW_{\text{Config}}$ )	31 dB

NOTE 1:  $BW_{\text{Config}}$  is the *transmission bandwidth configuration* assumed for the adjacent channel.  
NOTE 2: With SCS that provides the largest *transmission bandwidth configuration* ( $BW_{\text{Config}}$ ).  
NOTE 3: Applicable in case the *repeater type 1-C nominal channel bandwidth* at the other edge of the gap is  $\leq 20$  MHz.  
NOTE 4: Applicable in case the *repeater type 1-C nominal channel bandwidth* at the other edge of the gap is  $> 20$  MHz.

The ACLR absolute *minimum requirement* is specified in table 6.5.2.2-5.

**Table 6.5.2.2-5: Repeater type 1-C CACLR absolute limit for DL and UL for WA class, for DL for MR class and for DL for LA class**

Repeater type 1-C category / class	CACLR absolute limit
Category A Wide Area DL and UL	-13 dBm/MHz
Category B Wide Area DL and UL	-15 dBm/MHz
Medium Range DL	-25 dBm/MHz
Local Area DL	-32 dBm/MHz

**Table 6.5.2.2-6: Filter parameters for the assigned channel**

RAT of the carrier adjacent to the gap between passbands or inter-passband gap	Filter on the assigned channel frequency and corresponding filter bandwidth
NR	NR of same BW with SCS that provides largest transmission bandwidth configuration

## 6.5.3 Operating band unwanted emissions

### 6.5.3.1 General

Unless otherwise stated, the Operating Band Unwanted Emission (OBUE) limits for *repeater type 1-C* DL are defined from  $\Delta f_{\text{OBUE}}$  below the lowest frequency of each supported downlink *operating band* up to  $\Delta f_{\text{OBUE}}$  above the highest frequency of each supported downlink *operating band*. The values of  $\Delta f_{\text{OBUE}}$  are defined in table 6.5.1-1 for the NR *operating bands*.

Unless otherwise stated, the Operating Band Unwanted Emission (OBUE) limits for *repeater type 1-C* UL are defined from  $\Delta f_{\text{OBUE}}$  below the lowest frequency of each supported uplink *operating band* up to  $\Delta f_{\text{OBUE}}$  above the highest frequency of each supported uplink *operating band*. The values of  $\Delta f_{\text{OBUE}}$  are defined in table 6.5.1-2 for the NR *operating bands*.

The requirements shall apply whatever the type of transmitter considered and for all transmission modes foreseen by the manufacturer's specification. In addition, for *repeater type 1-C* operating in *non-contiguous spectrum*, the requirements apply inside any *gap between passbands*. In addition, for a *repeater type 1-C* operating in multiple bands, the requirements apply inside any *inter-passband gap*.

Limits are specified in the tables below, where:

- $\Delta f$  is the separation between the *passband edge* frequency and the nominal -3dB point of the measuring filter closest to the carrier frequency.
- $f_{\text{offset}}$  is the separation between the *passband edge* frequency and the centre of the measuring filter.
- $f_{\text{offset}_{\text{max}}}$  is the offset to the frequency  $\Delta f_{\text{OBUE}}$  outside the downlink *operating band* of *repeater type 1-C* DL and uplink *operating band* of *repeater type 1-C* UL, where  $\Delta f_{\text{OBUE}}$  is defined in tables 6.5.1-1 and 6.5.1-2.
- $\Delta f_{\text{max}}$  is equal to  $f_{\text{offset}_{\text{max}}}$  minus half of the bandwidth of the measuring filter.

For a *multi-band connector* inside any *inter-passband gaps* with  $W_{\text{gap}} < 2 * \Delta f_{\text{OBUE}}$ , a combined minimum requirement shall be applied which is the cumulative sum of the minimum requirement specified at the *repeater type 1-C passband edges* on each side of the *inter-passband gap*. The minimum requirement for *repeater type 1-C Bandwidth edge* is specified in clauses 6.5.3.2.1 to 6.5.3.2.4 below, where in this case:

- $\Delta f$  is the separation between the *repeater type 1-C passband edge* frequency and the nominal -3 dB point of the measuring filter closest to the *repeater type 1-C passband edge*.
- $f_{\text{offset}}$  is the separation from the *repeater type 1-C passband edge* frequency to the centre of the measuring filter.
- $f_{\text{offset}_{\text{max}}}$  is equal to the *inter-passband gap* minus half of the bandwidth of the measuring filter.



- $\Delta f_{\max}$  is equal to  $f_{\text{offset}_{\max}}$  minus half of the bandwidth of the measuring filter.

For a *multi-band connector of repeater type 1-C DL*, the operating band unwanted emission limits apply also in a supported downlink *operating band* without any carrier transmitted, in the case where there are carrier(s) transmitted in another supported downlink *operating band*. In this case, no cumulative minimum requirement is applied in the *inter-band gap* between a supported downlink *operating band* with carrier(s) transmitted and a supported downlink *operating band* without any carrier transmitted and

- In case the *inter-band gap* between a supported downlink *operating band* with carrier(s) transmitted and a supported downlink *operating band* without any carrier transmitted is less than  $2 * \Delta f_{\text{OBUE}}$ ,  $f_{\text{offset}_{\max}}$  shall be the offset to the frequency  $\Delta f_{\text{OBUE}}$  MHz outside the outermost edges of the two supported downlink *operating bands* and the operating band unwanted emission minimum requirement of the band where there are carriers transmitted, as defined in the tables of the present clause, shall apply across both downlink bands.
- In other cases, the operating band unwanted emission minimum requirement of the band where there are carriers transmitted, as defined in the tables of the present clause for the largest frequency offset ( $\Delta f_{\max}$ ), shall apply from  $\Delta f_{\text{OBUE}}$  MHz below the lowest frequency, up to  $\Delta f_{\text{OBUE}}$  MHz above the highest frequency of the supported downlink *operating band* without any carrier transmitted.

For a *multi-band connector of repeater type 1-C UL*, the operating band unwanted emission limits apply also in a supported uplink *operating band* without any carrier transmitted, in the case where there are carrier(s) transmitted in another supported uplink *operating band*. In this case, no cumulative minimum requirement is applied in the *inter-band gap* between a supported uplink *operating band* with carrier(s) transmitted and a supported uplink *operating band* without any carrier transmitted and

- In case the *inter-band gap* between a supported uplink *operating band* with carrier(s) transmitted and a supported uplink *operating band* without any carrier transmitted is less than  $2 * \Delta f_{\text{OBUE}}$ ,  $f_{\text{offset}_{\max}}$  shall be the offset to the frequency  $\Delta f_{\text{OBUE}}$  MHz outside the outermost edges of the two supported uplink *operating bands* and the operating band unwanted emission minimum requirement of the band where there are carriers transmitted, as defined in the tables of the present clause, shall apply across both uplink bands.
- In other cases, the operating band unwanted emission minimum requirements of the band where there are carriers transmitted, as defined in the tables of the present clause for the largest frequency offset ( $\Delta f_{\max}$ ), shall apply from  $\Delta f_{\text{OBUE}}$  MHz below the lowest frequency, up to  $\Delta f_{\text{OBUE}}$  MHz above the highest frequency of the supported uplink *operating band* without any carrier transmitted.

In addition, inside any *gap between passbands* for a *single-band connector* operating in *non-contiguous spectrum*, a combined minimum requirement shall be applied which is the cumulative sum of the minimum requirement specified for the adjacent *sub-blocks* on each side of the *gap between passbands*. The minimum requirement for each *sub-block* is specified in clauses 6.5.3.2.1 to 6.5.3.2.4 below, where in this case:

- $\Delta f$  is the separation between the *sub-block* edge frequency and the nominal -3 dB point of the measuring filter closest to the *sub-block* edge.
- $f_{\text{offset}}$  is the separation between the *sub-block* edge frequency and the centre of the measuring filter.
- $f_{\text{offset}_{\max}}$  is equal to the *gap between passbands* bandwidth minus half of the bandwidth of the measuring filter.
- $\Delta f_{\max}$  is equal to  $f_{\text{offset}_{\max}}$  minus half of the bandwidth of the measuring filter.

For Wide Area *repeater type 1-C*, the requirements of either clause 6.5.3.2.1 (Category A limits) or clause 6.5.3.2.2 (Category B limits) shall apply.

For Medium Range *repeater type 1-C*, the requirements in clause 6.5.3.2.3 shall apply (Category A and B).

For Local Area *repeater type 1-C*, the requirements of clause 6.5.3.2.4 shall apply (Category A and B).

The application of either Category A or Category B minimum requirements shall be the same as for Transmitter spurious emissions in clause 6.5.4.

For Band n41 and n90 operation in Japan, the operating band unwanted emissions limits shall be applied to the sum of the emission power over all *antenna connectors* for *repeater type 1-C*.

In addition to, for the part of passband where there is no input signal at DL input port, the requirements in table 6.5.2.2-2 shall apply. In addition to, for the part of passband where there is no input signal at UL input port, the requirements in clause 6.5.3.2.6 shall apply.

### 6.5.3.2 Minimum requirements

#### 6.5.3.2.1 Minimum requirements for Wide Area repeater type 1-C (Category A)

For repeater operating in Bands n5, n8, n12, n13, n14, n18, n26, n28, n29, n71, n85, minimum requirements are specified in table 6.5.3.2.1-1.

**Table 6.5.3.2.1-1: Wide Area repeater type 1-C operating band unwanted emission minimum requirements (NR bands below 1 GHz) for Category A**

Frequency offset of measurement filter -3dB point, $\Delta f$	Frequency offset of measurement filter centre frequency, $f_{\text{offset}}$	Minimum requirements (Notes 1, 2)	Measurement bandwidth
$0 \text{ MHz} \leq \Delta f < 5 \text{ MHz}$	$0.05 \text{ MHz} \leq f_{\text{offset}} < 5.05 \text{ MHz}$	$-7 \text{ dBm} - \frac{7}{5} \cdot \left( \frac{f_{\text{offset}}}{\text{MHz}} - 0.05 \right) \text{ dB}$	100 kHz
$5 \text{ MHz} \leq \Delta f < \min(10 \text{ MHz}, \Delta f_{\text{max}})$	$5.05 \text{ MHz} \leq f_{\text{offset}} < \min(10.05 \text{ MHz}, f_{\text{offset}_{\text{max}}})$	-14 dBm	100 kHz
$10 \text{ MHz} \leq \Delta f \leq \Delta f_{\text{max}}$	$10.05 \text{ MHz} \leq f_{\text{offset}} < f_{\text{offset}_{\text{max}}}$	-13 dBm (Note 3)	100 kHz
NOTE 1: For a <i>repeater type 1-C</i> supporting <i>non-contiguous spectrum</i> operation within any <i>operating band</i> , the emission limits within <i>gaps between passbands</i> is calculated as a cumulative sum of contributions from adjacent <i>sub-blocks</i> on each side of the <i>gap between passbands</i> . Exception is $\Delta f \geq 10 \text{ MHz}$ from both adjacent <i>sub-blocks</i> on each side of the <i>gap between passbands</i> , where the emission limits within <i>gaps between passbands</i> shall be -13 dBm/1 MHz.			
NOTE 2: For a <i>multi-band connector</i> with <i>inter-passband gap</i> $< 2 \cdot \Delta f_{\text{OBUE}}$ the emission limits within the <i>inter-passband gaps</i> is calculated as a cumulative sum of contributions from adjacent <i>sub-blocks</i> or <i>passband</i> on each side of the <i>inter-passband gap</i> , where the contribution from the far-end <i>sub-block</i> or <i>passband</i> shall be scaled according to the <i>measurement bandwidth</i> of the near-end <i>sub-block</i> or <i>passband</i> .			
NOTE 3: The requirement is not applicable when $\Delta f_{\text{max}} < 10 \text{ MHz}$ .			

For repeater operating in Bands n1, n2, n3, n7, n24, n25, n30, n34, n38, n39, n40, n41, n48, n50, n65, n66, n70, n74, n75, n77, n78, n79, n90, n92, n94, minimum requirements are specified in table 6.5.3.2.1-2.

**Table 6.5.3.2.1-2: Wide Area repeater type 1-C operating band unwanted emission minimum requirements (NR bands above 1 GHz) for Category A**

Frequency offset of measurement filter -3dB point, $\Delta f$	Frequency offset of measurement filter centre frequency, $f_{\text{offset}}$	Minimum requirement (Notes 1, 2)	Measurement bandwidth
$0 \text{ MHz} \leq \Delta f < 5 \text{ MHz}$	$0.05 \text{ MHz} \leq f_{\text{offset}} < 5.05 \text{ MHz}$	$-7 \text{ dBm} - \frac{7}{5} \cdot \left( \frac{f_{\text{offset}}}{\text{MHz}} - 0.05 \right) \text{ dB}$	100 kHz
$5 \text{ MHz} \leq \Delta f < \min(10 \text{ MHz}, \Delta f_{\text{max}})$	$5.05 \text{ MHz} \leq f_{\text{offset}} < \min(10.05 \text{ MHz}, f_{\text{offset}_{\text{max}}})$	-14 dBm	100 kHz
$10 \text{ MHz} \leq \Delta f \leq \Delta f_{\text{max}}$	$10.05 \text{ MHz} \leq f_{\text{offset}} < f_{\text{offset}_{\text{max}}}$	-13 dBm (Note 3)	1MHz
NOTE 1: For a <i>repeater type 1-C</i> supporting <i>non-contiguous spectrum</i> operation within any <i>operating band</i> , the emission limits within <i>gaps between passbands</i> is calculated as a cumulative sum of contributions from adjacent <i>sub-blocks</i> on each side of the <i>gap between passbands</i> , where the contribution from the far-end <i>sub-block</i> shall be scaled according to the <i>measurement bandwidth</i> of the near-end <i>sub-block</i> . Exception is $\Delta f \geq 10 \text{ MHz}$ from both adjacent <i>sub-blocks</i> on each side of the <i>gap between passbands</i> , where the emission limits within <i>gaps between passbands</i> shall be -13 dBm/1 MHz.			
NOTE 2: For a <i>multi-band connector</i> with <i>inter-passband gap</i> $< 2 \cdot \Delta f_{\text{OBUE}}$ the emission limits within the <i>inter-passband gaps</i> is calculated as a cumulative sum of contributions from adjacent <i>sub-blocks</i> or <i>passband</i> on each side of the <i>inter-passband gap</i> , where the contribution from the far-end <i>sub-block</i> or <i>passband</i> shall be scaled according to the <i>measurement bandwidth</i> of the near-end <i>sub-block</i> or <i>passband</i> .			
NOTE 3: The requirement is not applicable when $\Delta f_{\text{max}} < 10 \text{ MHz}$ .			

### 6.5.3.2.2 Minimum requirements for Wide Area *repeater type 1-C* (Category B)

For Category B Operating band unwanted emissions, there are two options for the *minimum requirements* that may be applied regionally. Either the *minimum requirements* in clause 6.5.3.2.2.1 or clause 6.5.3.2.2.2 shall be applied.

#### 6.5.3.2.2.1 Category B requirements (Option 1)

For *repeater type 1-C* operating in Bands n5, n8, n12, n20, n26, n28, n29, n67, n71, n85, the minimum requirements are specified in table 6.5.3.2.2.1-1:

**Table 6.5.3.2.2.1-1: Wide Area *repeater type 1-C* operating band unwanted emission minimum requirements (NR bands below 1 GHz) for Category B**

Frequency offset of measurement filter -3dB point, $\Delta f$	Frequency offset of measurement filter centre frequency, $f_{\text{offset}}$	Minimum requirement (Notes 1, 2)	Measurement bandwidth
$0 \text{ MHz} \leq \Delta f < 5 \text{ MHz}$	$0.05 \text{ MHz} \leq f_{\text{offset}} < 5.05 \text{ MHz}$	$-7 \text{ dBm} - \frac{7}{5} \cdot \left( \frac{f_{\text{offset}}}{\text{MHz}} - 0.05 \right) \text{ dB}$	100 kHz
$5 \text{ MHz} \leq \Delta f < \min(10 \text{ MHz}, \Delta f_{\text{max}})$	$5.05 \text{ MHz} \leq f_{\text{offset}} < \min(10.05 \text{ MHz}, f_{\text{offset}_{\text{max}}})$	-14 dBm	100 kHz
$10 \text{ MHz} \leq \Delta f \leq \Delta f_{\text{max}}$	$10.05 \text{ MHz} \leq f_{\text{offset}} < f_{\text{offset}_{\text{max}}}$	-16 dBm (Note 3)	100 kHz
NOTE 1: For a <i>repeater type 1-C</i> supporting <i>non-contiguous spectrum</i> operation within any <i>operating band</i> , the emission limits within <i>gaps between passbands</i> is calculated as a cumulative sum of contributions from adjacent <i>sub-blocks</i> on each side of the <i>gap between passbands</i> . Exception is $\Delta f \geq 10 \text{ MHz}$ from both adjacent <i>sub-blocks</i> on each side of the <i>gap between passbands</i> , where the emission limits within <i>gaps between passbands</i> shall be -15 dBm/1 MHz.			
NOTE 2: For a <i>multi-band connector</i> with <i>inter-passband gap</i> $< 2 \cdot \Delta f_{\text{OBUe}}$ the emission limits within the <i>inter-passband gaps</i> is calculated as a cumulative sum of contributions from adjacent <i>sub-blocks</i> or <i>passband</i> on each side of the <i>inter-passband gap</i> .			
NOTE 3: The requirement is not applicable when $\Delta f_{\text{max}} < 10 \text{ MHz}$ .			

For *repeater* operating in Bands n1, n2, n3, n7, n25, n34, n38, n39, n40, n41, n48, n50, n65, n66, n70, n75, n77, n78, n79, n90, n92, n94, minimum requirements are specified in table 6.5.3.2.2.1-2.

**Table 6.5.3.2.2.1-2: Wide Area *repeater type 1-C* operating band unwanted emission minimum requirements for Category B**

Frequency offset of measurement filter -3dB point, $\Delta f$	Frequency offset of measurement filter centre frequency, $f_{\text{offset}}$	Minimum requirements (Notes 1, 2)	Measurement bandwidth
$0 \text{ MHz} \leq \Delta f < 5 \text{ MHz}$	$0.05 \text{ MHz} \leq f_{\text{offset}} < 5.05 \text{ MHz}$	$-7 \text{ dBm} - \frac{7}{5} \cdot \left( \frac{f_{\text{offset}}}{\text{MHz}} - 0.05 \right) \text{ dB}$	100 kHz
$5 \text{ MHz} \leq \Delta f < \min(10 \text{ MHz}, \Delta f_{\text{max}})$	$5.05 \text{ MHz} \leq f_{\text{offset}} < \min(10.05 \text{ MHz}, f_{\text{offset}_{\text{max}}})$	-14 dBm	100 kHz
$10 \text{ MHz} \leq \Delta f \leq \Delta f_{\text{max}}$	$10.5 \text{ MHz} \leq f_{\text{offset}} < f_{\text{offset}_{\text{max}}}$	-15 dBm (Note 3)	1MHz
NOTE 1: For a <i>repeater type 1-C</i> supporting <i>non-contiguous spectrum</i> operation within any <i>operating band</i> , the emission limits within <i>gaps between passbands</i> is calculated as a cumulative sum of contributions from adjacent <i>sub-blocks</i> on each side of the <i>gap between passbands</i> , where the contribution from the far-end <i>sub-block</i> shall be scaled according to the <i>measurement bandwidth</i> of the near-end <i>sub-block</i> . Exception is $\Delta f \geq 10 \text{ MHz}$ from both adjacent <i>sub-blocks</i> on each side of the <i>gap between passbands</i> , where the emission limits within <i>gaps between passbands</i> shall be -15 dBm/1 MHz.			
NOTE 2: For a <i>multi-band connector</i> with <i>inter-passband gap</i> $< 2 \cdot \Delta f_{\text{OBUe}}$ the emission limits within the <i>inter-passband gaps</i> is calculated as a cumulative sum of contributions from adjacent <i>sub-blocks</i> or <i>passband</i> on each side of the <i>inter-passband gap</i> , where the contribution from the far-end <i>sub-block</i> or <i>passband</i> shall be scaled according to the <i>measurement bandwidth</i> of the near-end <i>sub-block</i> or <i>passband</i> .			
NOTE 3: The requirement is not applicable when $\Delta f_{\text{max}} < 10 \text{ MHz}$ .			

For *repeater type 1-C* operating in Band n104, the limits are specified in tables 6.5.3.2.2.1-2a:

**Table 6.5.3.2.2.1-2a: Wide Area repeater type 1-C operating band unwanted emission limits for band n104 for Category B**

Frequency offset of measurement filter -3dB point, $\Delta f$	Frequency offset of measurement filter centre frequency, $f_{\text{offset}}$	Basic limits	Measurement bandwidth
$0 \text{ MHz} \leq \Delta f < 20 \text{ MHz}$	$0.05 \text{ MHz} \leq f_{\text{offset}} < 20.05 \text{ MHz}$	$-7\text{dBm} - \frac{7}{20} \left( \frac{f_{\text{offset}}}{\text{MHz}} - 0.05 \right)$	100 kHz
$20 \text{ MHz} \leq \Delta f < \min(40 \text{ MHz}, \Delta f_{\text{max}})$	$20.05 \text{ MHz} \leq f_{\text{offset}} < \min(40.05 \text{ MHz}, f_{\text{offset}_{\text{max}}})$	-14 dBm	100 kHz
$40 \text{ MHz} \leq \Delta f \leq \Delta f_{\text{max}}$	$40.5 \text{ MHz} \leq f_{\text{offset}} < f_{\text{offset}_{\text{max}}}$	-15 dBm (Note 3)	1MHz
NOTE 1: For a <i>repeater type 1-C</i> supporting <i>non-contiguous spectrum</i> operation within any <i>operating band</i> , the emission limits within <i>gaps between passbands</i> is calculated as a cumulative sum of contributions from adjacent <i>sub-blocks</i> on each side of the <i>gap between passband</i> , where the contribution from the far-end <i>sub-block</i> shall be scaled according to the <i>measurement bandwidth</i> of the near-end <i>sub-block</i> . Exception is $\Delta f \geq 40\text{MHz}$ from both adjacent <i>sub-blocks</i> on each side of the <i>gap between passband</i> , where the emission limits within <i>gaps between passbands</i> shall be -15 dBm/1 MHz.			
NOTE 2: For a <i>multi-band connector</i> with <i>inter-passband gap</i> $< 2 \cdot \Delta f_{\text{OBUE}}$ the emission limits within the <i>inter-passband gaps</i> is calculated as a cumulative sum of contributions from adjacent <i>sub-blocks</i> or <i>passband</i> on each side of the <i>inter-passband gap</i> , where the contribution from the far-end <i>sub-block</i> or <i>passband</i> shall be scaled according to the <i>measurement bandwidth</i> of the near-end <i>sub-block</i> or <i>passband</i> .			
NOTE 3: The requirement is not applicable when $\Delta f_{\text{max}} < 40 \text{ MHz}$ .			

## 6.5.3.2.2.2 Category B requirements (Option 2)

The limits in this clause are intended for Europe and may be applied regionally for *repeater type 1-C* operating in bands n1, n3, n7, n8, n38, n65.

For a *repeater type 1-C* operating in bands n1, n3, n7, n8, n38 or n65, minimum requirements are specified in table 6.5.3.2.2.2-1:

**Table 6.5.3.2.2.2-1: Regional Wide Area repeater type 1-C operating band unwanted emission minimum requirements for Category B**

Frequency offset of measurement filter -3dB point, $\Delta f$	Frequency offset of measurement filter centre frequency, $f_{\text{offset}}$	Minimum requirements (Notes 1, 2)	Measurement bandwidth
$0 \text{ MHz} \leq \Delta f < 0.2 \text{ MHz}$	$0.015 \text{ MHz} \leq f_{\text{offset}} < 0.215 \text{ MHz}$	-14 dBm	30 kHz
$0.2 \text{ MHz} \leq \Delta f < 1 \text{ MHz}$	$0.215 \text{ MHz} \leq f_{\text{offset}} < 1.015 \text{ MHz}$	$-14\text{dBm} - 15 \cdot \left( \frac{f_{\text{offset}}}{\text{MHz}} - 0.215 \right) \text{dB}$	30 kHz
(Note 4)	$1.015 \text{ MHz} \leq f_{\text{offset}} < 1.5 \text{ MHz}$	-26 dBm	30 kHz
$1 \text{ MHz} \leq \Delta f \leq \min(10 \text{ MHz}, \Delta f_{\text{max}})$	$1.5 \text{ MHz} \leq f_{\text{offset}} < \min(10.5 \text{ MHz}, f_{\text{offset}_{\text{max}}})$	-13 dBm	1 MHz
$10 \text{ MHz} \leq \Delta f \leq \Delta f_{\text{max}}$	$10.5 \text{ MHz} \leq f_{\text{offset}} < f_{\text{offset}_{\text{max}}}$	-15 dBm (Note 3)	1 MHz
NOTE 1: For a <i>repeater type 1-C</i> supporting <i>non-contiguous spectrum</i> operation within any <i>operating band</i> , the emission limits within <i>gaps between passbands</i> is calculated as a cumulative sum of contributions from adjacent <i>sub-blocks</i> on each side of the <i>gap between passbands</i> , where the contribution from the far-end <i>sub-block</i> shall be scaled according to the <i>measurement bandwidth</i> of the near-end <i>sub-block</i> . Exception is $\Delta f \geq 10\text{MHz}$ from both adjacent <i>sub-blocks</i> on each side of the <i>gap between passbands</i> , where the emission limits within <i>gaps between passbands</i> shall be -15 dBm/1 MHz.			
NOTE 2: For a <i>multi-band connector</i> with <i>inter-passband gap</i> $< 2 \cdot \Delta f_{\text{OBUE}}$ the emission limits within the <i>inter-passband gaps</i> is calculated as a cumulative sum of contributions from adjacent <i>sub-blocks</i> or <i>passband</i> on each side of the <i>inter-passband gap</i> , where the contribution from the far-end <i>sub-block</i> or <i>passband</i> shall be scaled according to the <i>measurement bandwidth</i> of the near-end <i>sub-block</i> or <i>passband</i> .			
NOTE 3: The requirement is not applicable when $\Delta f_{\text{max}} < 10 \text{ MHz}$ .			
NOTE 4: This frequency range ensures that the range of values of $f_{\text{offset}}$ is continuous.			

### 6.5.3.2.3 Minimum requirements for Medium Range *repeater type 1-C* (Category A and B) for DL

For Medium Range *repeater type 1-C* for DL, minimum requirements are specified in table 6.5.3.2.3-1 and table 6.5.3.2.3-2.

For the tables in this clause for *repeater type 1-C*,  $P_{\text{rated},x} = P_{\text{rated},p,AC} - 10 \cdot \log(\text{ceil}(BW_{\text{Passband}}/20\text{MHz}))$

**Table 6.5.3.2.3-1: Medium Range *repeater type 1-C* operating band unwanted emission minimum requirements,  $31 < P_{\text{rated},x} \leq 38$  dBm**

Frequency offset of measurement filter -3dB point, $\Delta f$	Frequency offset of measurement filter centre frequency, $f_{\text{offset}}$	Minimum requirements (Notes 1, 2)	Measurement bandwidth
$0 \text{ MHz} \leq \Delta f < 5 \text{ MHz}$	$0.05 \text{ MHz} \leq f_{\text{offset}} < 5.05 \text{ MHz}$	$P_{\text{rated},x} - 53 \text{ dB} - \frac{7}{5} \left( \frac{f_{\text{offset}}}{\text{MHz}} - 0.05 \right) \text{ dB}$	100 kHz
$5 \text{ MHz} \leq \Delta f < \min(10 \text{ MHz}, \Delta f_{\text{max}})$	$5.05 \text{ MHz} \leq f_{\text{offset}} < \min(10.05 \text{ MHz}, f_{\text{offset}_{\text{max}}})$	$P_{\text{rated},x} - 60 \text{ dB}$	100 kHz
$10 \text{ MHz} \leq \Delta f \leq \Delta f_{\text{max}}$	$10.05 \text{ MHz} \leq f_{\text{offset}} < f_{\text{offset}_{\text{max}}}$	$\text{Min}(P_{\text{rated},x} - 60 \text{ dB}, -25 \text{ dBm})$ (Note 3)	100 kHz
NOTE 1: For a <i>repeater type 1-C</i> DL supporting <i>non-contiguous spectrum</i> operation within any <i>operating band</i> the emission limits within <i>gaps between passbands</i> is calculated as a cumulative sum of contributions from adjacent <i>sub-blocks</i> on each side of the <i>gap between passbands</i> . Exception is $\Delta f \geq 10 \text{ MHz}$ from both adjacent <i>sub-blocks</i> on each side of the <i>gap between passbands</i> , where the emission limits within <i>gaps between passbands</i> shall be $\text{Min}(P_{\text{rated},x} - 60 \text{ dB}, -25 \text{ dBm})/100 \text{ kHz}$ .			
NOTE 2: For a <i>multi-band connector</i> with <i>inter-passband gap</i> $< 2 \cdot \Delta f_{\text{OBUE}}$ the emission limits within the <i>inter-passband gaps</i> is calculated as a cumulative sum of contributions from adjacent <i>sub-blocks</i> or <i>passband</i> on each side of the <i>inter-passband gap</i> .			
NOTE 3: The requirement is not applicable when $\Delta f_{\text{max}} < 10 \text{ MHz}$ .			

For *repeater type 1-C* operating in Band n104, the limits are specified in table 6.5.3.2.3-1a and table 6.5.3.2.3-2a.

**Table 6.5.3.2.3-1a. Medium Range *repeater type 1-C* operating band unwanted emission limits for band n104,  $31 < P_{\text{rated},x} \leq 38$  dBm**

Frequency offset of measurement filter -3dB point, $\Delta f$	Frequency offset of measurement filter centre frequency, $f_{\text{offset}}$	Minimum requirements (Notes 1, 2)	Measurement bandwidth
$0 \text{ MHz} \leq \Delta f < 20 \text{ MHz}$	$0.05 \text{ MHz} \leq f_{\text{offset}} < 20.05 \text{ MHz}$	$P_{\text{rated},x} - 53 \text{ dB} - \frac{7}{20} \left( \frac{f_{\text{offset}}}{\text{MHz}} - 0.05 \right)$	100 kHz
$20 \text{ MHz} \leq \Delta f < \min(40 \text{ MHz}, \Delta f_{\text{max}})$	$20.05 \text{ MHz} \leq f_{\text{offset}} < \min(40.05 \text{ MHz}, f_{\text{offset}_{\text{max}}})$	$P_{\text{rated},x} - 60 \text{ dB}$	100 kHz
$40 \text{ MHz} \leq \Delta f \leq \Delta f_{\text{max}}$	$40.05 \text{ MHz} \leq f_{\text{offset}} < f_{\text{offset}_{\text{max}}}$	$\text{Min}(P_{\text{rated},x} - 60 \text{ dB}, -25 \text{ dBm})$ (Note 3)	100 kHz
NOTE 1: For a <i>repeater type 1-C</i> DL supporting <i>non-contiguous spectrum</i> operation within any <i>operating band</i> the emission limits within <i>gaps between passbands</i> is calculated as a cumulative sum of contributions from adjacent <i>sub-blocks</i> on each side of the <i>gap between passband</i> . Exception is $\Delta f \geq 40 \text{ MHz}$ from both adjacent <i>sub-blocks</i> on each side of the <i>gap between passband</i> , where the emission limits within <i>gaps between passbands</i> shall be $\text{Min}(P_{\text{rated},x} - 60 \text{ dB}, -25 \text{ dBm})/100 \text{ kHz}$ .			
NOTE 2: For a <i>multi-band connector</i> with <i>inter-passband gap</i> $< 2 \cdot \Delta f_{\text{OBUE}}$ the emission limits within the <i>inter-passband gaps</i> is calculated as a cumulative sum of contributions from adjacent <i>sub-blocks</i> or <i>passband</i> on each side of the <i>inter-passband gap</i> .			
NOTE 3: The requirement is not applicable when $\Delta f_{\text{max}} < 40 \text{ MHz}$ .			

**Table 6.5.3.2.3-2: Medium Range repeater type 1-C operating band unwanted emission minimum requirements,  $P_{\text{rated},x} \leq 31$  dBm**

Frequency offset of measurement filter -3dB point, $\Delta f$	Frequency offset of measurement filter centre frequency, $f_{\text{offset}}$	Minimum requirements (Notes 1, 2)	Measurement bandwidth
$0 \text{ MHz} \leq \Delta f < 5 \text{ MHz}$	$0.05 \text{ MHz} \leq f_{\text{offset}} < 5.05 \text{ MHz}$	$-22 \text{ dBm} - \frac{7}{5} \left( \frac{f_{\text{offset}}}{\text{MHz}} - 0.05 \right) \text{ dB}$	100 kHz
$5 \text{ MHz} \leq \Delta f < \min(10 \text{ MHz}, \Delta f_{\text{max}})$	$5.05 \text{ MHz} \leq f_{\text{offset}} < \min(10.05 \text{ MHz}, f_{\text{offset}_{\text{max}}})$	-29 dBm	100 kHz
$10 \text{ MHz} \leq \Delta f \leq \Delta f_{\text{max}}$	$10.05 \text{ MHz} \leq f_{\text{offset}} < f_{\text{offset}_{\text{max}}}$	-29 dBm (Note 3)	100 kHz

NOTE 1: For a *repeater type 1-C* DL supporting *non-contiguous spectrum* operation within any *operating band* the emission limits within *gaps between passbands* is calculated as a cumulative sum of contributions from adjacent *sub-blocks* on each side of the *gap between passbands*. Exception is  $f \geq 10 \text{ MHz}$  from both adjacent *sub-blocks* on each side of the *gap between passbands*, where the emission limits within *gaps between passbands* shall be -29dBm/100kHz.

NOTE 2: For a *multi-band connector* with *inter-passband gap*  $< 2 * \Delta f_{\text{OBUe}}$  the emission limits within the *inter-passband gaps* is calculated as a cumulative sum of contributions from adjacent *sub-blocks* or *passband* on each side of the *inter-passband gap*.

NOTE 3: The requirement is not applicable when  $\Delta f_{\text{max}} < 10 \text{ MHz}$ .

**Table 6.5.3.2.3-2a. Medium Range repeater type 1-C operating band unwanted emission limits for band 104,  $P_{\text{rated},x} \leq 31$  dBm**

Frequency offset of measurement filter -3dB point, $\Delta f$	Frequency offset of measurement filter centre frequency, $f_{\text{offset}}$	Minimum requirements (Notes 1, 2)	Measurement bandwidth
$0 \text{ MHz} \leq \Delta f < 20 \text{ MHz}$	$0.05 \text{ MHz} \leq f_{\text{offset}} < 20.05 \text{ MHz}$	$-22 \text{ dBm} - \frac{7}{20} \left( \frac{f_{\text{offset}}}{\text{MHz}} - 0.05 \right)$	100 kHz
$20 \text{ MHz} \leq \Delta f < \min(40 \text{ MHz}, \Delta f_{\text{max}})$	$20.05 \text{ MHz} \leq f_{\text{offset}} < \min(40.05 \text{ MHz}, f_{\text{offset}_{\text{max}}})$	-29 dBm	100 kHz
$40 \text{ MHz} \leq \Delta f \leq \Delta f_{\text{max}}$	$40.05 \text{ MHz} \leq f_{\text{offset}} < f_{\text{offset}_{\text{max}}}$	-29 dBm	100 kHz

NOTE 1: For a *repeater type 1-C* DL supporting *non-contiguous spectrum* operation within any *operating band* the emission limits within *gaps between passbands* is calculated as a cumulative sum of contributions from adjacent *sub-blocks* on each side of the *gap between passband*. Exception is  $f \geq 40 \text{ MHz}$  from both adjacent *sub-blocks* on each side of the *gap between passband*, where the emission limits within *gaps between passbands* shall be -29dBm/100kHz.

NOTE 2: For a *multi-band connector* with *inter-passband gap*  $< 2 * \Delta f_{\text{OBUe}}$  the emission limits within the *inter-passband gaps* is calculated as a cumulative sum of contributions from adjacent *sub-blocks* or *passband* on each side of the *inter-passband gap*.

NOTE 3: The requirement is not applicable when  $\Delta f_{\text{max}} < 40 \text{ MHz}$ .

#### 6.5.3.2.4 Minimum requirements for Local Area *repeater type 1-C* (Category A and B)

For Local Area *repeater type 1-C*, *minimum requirements* are specified in table 6.5.3.2.4-1.

Table 6.5.3.2.4-1: Local Area repeater type 1-C operating band unwanted emission limits

Frequency offset of measurement filter -3dB point, $\Delta f$	Frequency offset of measurement filter centre frequency, $f_{\text{offset}}$	Minimum requirements (Notes 1, 2)	Measurement bandwidth
$0 \text{ MHz} \leq \Delta f < 5 \text{ MHz}$	$0.05 \text{ MHz} \leq f_{\text{offset}} < 5.05 \text{ MHz}$	$-30\text{dBm} - \frac{7}{5} \left( \frac{f_{\text{offset}}}{\text{MHz}} - 0.05 \right) \text{dB}$	100 kHz
$5 \text{ MHz} \leq \Delta f < \min(10 \text{ MHz}, \Delta f_{\text{max}})$	$5.05 \text{ MHz} \leq f_{\text{offset}} < \min(10.05 \text{ MHz}, f_{\text{offset}_{\text{max}}})$	-37 dBm	100 kHz
$10 \text{ MHz} \leq \Delta f \leq \Delta f_{\text{max}}$	$10.05 \text{ MHz} \leq f_{\text{offset}} < f_{\text{offset}_{\text{max}}}$	-37 dBm (Note 10)	100 kHz
NOTE 1: For a <i>repeater type 1-C</i> supporting <i>non-contiguous spectrum</i> operation within any <i>operating band</i> the emission limits within <i>gaps between passbands</i> is calculated as a cumulative sum of contributions from adjacent <i>sub-blocks</i> on each side of the <i>gap between passbands</i> . Exception is $\Delta f \geq 10\text{MHz}$ from both adjacent <i>sub-blocks</i> on each side of the <i>gap between passbands</i> , where the emission limits within <i>gaps between passbands</i> shall be -37dBm/100kHz.			
NOTE 2: For a <i>multi-band connector</i> with <i>inter-passband gap</i> $< 2^* \Delta f_{\text{OBUe}}$ the emission limits within the <i>inter-passband gaps</i> is calculated as a cumulative sum of contributions from adjacent <i>sub-blocks</i> or <i>passband</i> on each side of the <i>inter-passband gap</i>			
NOTE 3: The requirement is not applicable when $\Delta f_{\text{max}} < 10 \text{ MHz}$ .			

For *repeater type 1-C* operating in Band n104, *minimum requirements* are specified in table 6.5.3.2.4-1a.

Table 6.5.3.2.4-1a. Local Area repeater type 1-C operating band unwanted emission limits for band n104

Frequency offset of measurement filter -3dB point, $\Delta f$	Frequency offset of measurement filter centre frequency, $f_{\text{offset}}$	Minimum requirements(Notes 1, 2)	Measurement bandwidth
$0 \text{ MHz} \leq \Delta f < 20 \text{ MHz}$	$0.05 \text{ MHz} \leq f_{\text{offset}} < 20.05 \text{ MHz}$	$-30\text{dBm} - \frac{7}{20} \left( \frac{f_{\text{offset}}}{\text{MHz}} - 0.05 \right)$	100 kHz
$20 \text{ MHz} \leq \Delta f < \min(40 \text{ MHz}, \Delta f_{\text{max}})$	$20.05 \text{ MHz} \leq f_{\text{offset}} < \min(40.05 \text{ MHz}, f_{\text{offset}_{\text{max}}})$	-37 dBm	100 kHz
$40 \text{ MHz} \leq \Delta f \leq \Delta f_{\text{max}}$	$40.05 \text{ MHz} \leq f_{\text{offset}} < f_{\text{offset}_{\text{max}}}$	-37 dBm	100 kHz
NOTE 1: For a <i>repeater</i> supporting <i>non-contiguous spectrum</i> operation within any <i>operating band</i> the emission limits within <i>sub-block gaps</i> is calculated as a cumulative sum of contributions from adjacent <i>sub-blocks</i> on each side of the <i>sub-block gap</i> . Exception is $\Delta f \geq 40\text{MHz}$ from both adjacent <i>sub-blocks</i> on each side of the <i>sub-block gap</i> , where the emission limits within <i>sub-block gaps</i> shall be -37dBm/100kHz.			
NOTE 2: For a <i>multi-band connector</i> with <i>Inter RF Bandwidth gap</i> $< 2^* \Delta f_{\text{OBUe}}$ the emission limits within the <i>Inter RF Bandwidth gaps</i> is calculated as a cumulative sum of contributions from adjacent <i>sub-blocks</i> or <i>RF Bandwidth</i> on each side of the <i>Inter RF Bandwidth gap</i>			
NOTE 3: The requirement is not applicable when $\Delta f_{\text{max}} < 40 \text{ MHz}$ .			

### 6.5.3.2.5 Minimum requirements for additional requirements

#### 6.5.3.2.5.1 Limits in FCC Title 47

In addition to the requirements in clauses 6.5.3.2.1, 6.5.3.2.2, 6.5.3.2.3 and 6.5.3.2.4, the *repeater type 1-C* may have to comply with the applicable emission limits established by FCC Title 47 [10], when deployed in regions where those limits are applied, and under the conditions declared by the manufacturer.

#### 6.5.3.2.5.2 Protection of DTT

In certain regions the following requirement may apply for protection of DTT. For *repeater type 1-C* operating in Band n20, the level of emissions in the band 470-790 MHz, measured in an 8 MHz filter bandwidth on centre frequencies  $F_{\text{filter}}$  according to table 6.5.3.2.5.2-1, a minimum requirements  $P_{\text{EM,N}}$  is declared by the manufacturer. This requirement applies in the frequency range 470-790 MHz even though part of the range falls in the spurious domain.

**Table 6.5.3.2.5.2-1: Declared emissions *minimum requirement* for protection of DTT**

Filter centre frequency, $F_{\text{filter}}$	Measurement bandwidth	Declared emission <i>minimum requirement</i> (dBm)
$F_{\text{filter}} = 8 \cdot N + 306$ (MHz); $21 \leq N \leq 60$	8 MHz	$P_{\text{EM,N}}$

NOTE: The regional requirement is defined in terms of EIRP (effective isotropic radiated power), which is dependent on both the repeater emissions at the *antenna connector* and the deployment (including antenna gain and feeder loss). The requirement defined above provides the characteristics of the repeater needed to verify compliance with the regional requirement. Compliance with the regional requirement can be determined using the method outlined in TS 36.104 [20], annex F.

6.5.3.2.6 Minimum requirements inside passband with no UL input signal

The requirement is defined as a function of frequency offset from the edge of some part of passband with non-zero input signal. The requirement is measured as the ratio of the repeater output power in a zero-input basic unit to the repeater output power in a non-zero input basic unit. Basic unit equal to 360 KHz.

The average of the basic requirements over 10 sub-frames shall not exceed the values specified in table 6.5.3.2.6-1.

**Table 6.5.3.2.6-1: Minimum requirements inside passband with no UL input signal**

Parameter description	Unit	Limit (NOTE 1)		Applicable Frequencies
General	dB	$\max\{-25 - 10 \cdot \log_{10}(N_{RB}/L_{CRB}),$ $20 \cdot \log_{10} EVM - 3 - 5 \cdot ( \Delta_{RB}  - 1)/L_{CRB},$ $-57 \text{ dBm} + 10 \log_{10}(SCS/15 \text{ kHz}) - \overline{P_{RB}}\}$		Any zero-input basic unit (NOTE 2)
IQ Image	dB	-28	Image frequencies when output power > 10 dBm	Image frequencies (NOTES 2, 3)
		-25	Image frequencies when output power ≤ 10 dBm	
Carrier leakage	dBc	-28	Output power > 10 dBm	Carrier leakage frequency (NOTES 4, 5)
		-25	0 dBm ≤ Output power ≤ 10 dBm	
		-20	-30 dBm ≤ Output power < 0 dBm	
		-10	-40 dBm ≤ Output power < -30 dBm	

NOTE 1: requirement is evaluated in each zero-input basic unit. For each such basic unit, the minimum requirement is calculated as the higher of  $\overline{P_{RB}} - 30$  dB and the power sum of all limit values (General, IQ Image or Carrier leakage) that apply.  $\overline{P_{RB}}$  is defined in NOTE 10.

NOTE 2: The measurement bandwidth is one basic unit and the limit is expressed as a ratio of measured power in one zero-input basic unit to the measured average power per non-zero input basic unit, where the averaging is done across all non-zero input parts of the passband.

NOTE 3: The applicable frequencies for this limit are those that are enclosed in the reflection of the non-zero input part of passband, based on symmetry with respect to the carrier leakage frequency, but excluding any non-zero input basic units.

NOTE 4: The measurement bandwidth is 1 basic unit and the limit is expressed as a ratio of measured power in one zero-input basic unit to the measured total power in all non-zero input basic units

NOTE 5: The applicable frequencies are those that are enclosed either in the basic unit containing the carrier leakage frequency, or in the two basic units immediately adjacent to the carrier leakage frequency but excluding any non-zero input basic units.

NOTE 6:  $L_{CRB}$  is the  $\text{floor}\left(\frac{BW_{\text{passband}}}{\text{basic unit}}\right)$ .

NOTE 7:  $N_{RB}$  is the  $\text{floor}\left(\frac{\text{bandwidth of non-zero input signal}}{\text{basic unit}}\right)$ .

NOTE 8:  $EVM$  is the limit specified in table 6.6.2.2-1 for the modulation format used in the non-zero input basic units..

NOTE 9:  $\Delta_{RB}$  is the starting frequency offset between the end of nearest non-zero input basic unit and the measured zero-input basic unit (e.g.  $\Delta_{RB} = 1$  or  $\Delta_{RB} = -1$  for the first zero-input basic unit outside of the non-zero input part of passband).

NOTE 10:  $\overline{P_{RB}}$  is an average of the transmitted power over 10 sub-frames normalized by the number of non-zero input basic units, measured in dBm.



## 6.5.4 Transmitter spurious emissions

### 6.5.4.1 General

For *repeater type 1-C*, the transmitter spurious emission limits shall apply from 9 kHz to 12.75 GHz, excluding

- the frequency range from  $\Delta f_{\text{OBUE}}$  below the lowest frequency of each supported downlink *operating band*, up to  $\Delta f_{\text{OBUE}}$  above the highest frequency of each supported downlink *operating band*, where the  $\Delta f_{\text{OBUE}}$  is defined in table 6.5.1-1 for downlink, or
- the frequency range from  $\Delta f_{\text{OBUE}}$  below the lowest frequency of each supported uplink *operating band*, up to  $\Delta f_{\text{OBUE}}$  above the highest frequency of each supported uplink *operating band*, where the  $\Delta f_{\text{OBUE}}$  is defined in table 6.5.1-2 for uplink

For some *operating bands*, the upper limit is higher than 12.75 GHz in order to comply with the 5<sup>th</sup> harmonic limit of the downlink *operating band*, as specified in ITU-R recommendation SM.329 [5].

For a *multi-band connector*, for each supported *operating band* together with  $\Delta f_{\text{OBUE}}$  around the band is excluded from the transmitter spurious emissions requirement.

The requirements shall apply whatever the type of transmitter considered (single carrier or multi-carrier). It applies for all transmission modes foreseen by the manufacturer's specification.

Unless otherwise stated, all requirements are measured as mean power (RMS).

For Band n41 and n90 operation in Japan, the sum of the spurious emissions over all *antenna connectors* for *Repeater type 1-C* shall not exceed the *minimum requirements* defined in clause 6.5.5.2.

### 6.5.4.2 Minimum requirements

#### 6.5.4.2.1 General transmitter spurious emissions requirements

The *minimum requirements* of either table 6.5.4.2.1-1, table 6.5.4.2.1-2 (Category A limits) or table 6.5.4.2.1-3 (Category B limits) shall apply. The application of either Category A or Category B limits shall be the same as for operating band unwanted emissions in clause 6.5.3.

**Table 6.5.4.2.1-1: General *repeater type 1-C* transmitter spurious emission minimum requirements for DL in FR1, Category A**

Spurious frequency range	Minimum requirements	Measurement bandwidth	Notes
9 kHz – 150 kHz	-13 dBm	1 kHz	Note 1
150 kHz – 30 MHz		10 kHz	Note 1
30 MHz – 1 GHz		100 kHz	Note 1
1 GHz – 12.75 GHz		1 MHz	Note 1, Note 2
12.75 GHz – 5 <sup>th</sup> harmonic of the upper frequency edge of the DL <i>operating band</i> in GHz		1 MHz	Note 1, Note 2, Note 3
NOTE 1: <i>Measurement bandwidths</i> as in ITU-R SM.329 [5], s4.1.			
NOTE 2: Upper frequency as in ITU-R SM.329 [5], s2.5 table 1.			
NOTE 3: For <i>repeater type 1-C</i> DL, this spurious frequency range applies only for <i>operating bands</i> for which the 5 <sup>th</sup> harmonic of the upper frequency edge of the DL <i>operating band</i> is reaching beyond 12.75 GHz.			

**Table 6.5.4.2.1-2: General repeater type 1-C transmitter spurious emission minimum requirements for UL in FR1, Category A**

Spurious frequency range	Minimum requirements	Measurement bandwidth	Notes
9 kHz – 150 kHz	-36 dBm	1 kHz	Note 1
150 kHz – 30 MHz		10 kHz	Note 1
30 MHz – 1 GHz		100 kHz	Note 1
1 GHz – 12.75 GHz	-30 dBm	1 MHz	Note 1, Note 2
12.75 GHz – 5 <sup>th</sup> harmonic of the upper frequency edge of the UL <i>operating band</i> in GHz		1 MHz	Note 1, Note 2, Note 3

NOTE 1: *Measurement bandwidths* as in ITU-R SM.329 [5], s4.1.  
NOTE 2: Upper frequency as in ITU-R SM.329 [5], s2.5 table 1.  
NOTE 3: For *repeater type 1-C UL*, this spurious frequency range applies only for *operating bands* for which the 5<sup>th</sup> harmonic of the upper frequency edge of the UL *operating band* is reaching beyond 12.75 GHz.

**Table 6.5.4.2.1-3: General repeater type 1-C transmitter spurious emission minimum requirements in FR1, Category B**

Spurious frequency range	minimum requirements	Measurement bandwidth	Notes
9 kHz – 150 kHz	-36 dBm	1 kHz	Note 1
150 kHz – 30 MHz		10 kHz	Note 1
30 MHz – 1 GHz		100 kHz	Note 1
1 GHz – 12.75 GHz	-30 dBm	1 MHz	Note 1, Note 2
12.75 GHz – 5 <sup>th</sup> harmonic of the upper frequency edge of the <i>operating band</i> in GHz		1 MHz	Note 1, Note 2, Note 3

NOTE 1: *Measurement bandwidths* as in ITU-R SM.329 [5], s4.1.  
NOTE 2: Upper frequency as in ITU-R SM.329 [5], s2.5 table 1.  
NOTE 3: For *repeater type 1-C DL*, this spurious frequency range applies only for *operating bands* for which the 5<sup>th</sup> harmonic of the upper frequency edge of the DL *operating band* is reaching beyond 12.75 GHz.  
For *repeater type 1-C UL*, this spurious frequency range applies only for *operating bands* for which the 5<sup>th</sup> harmonic of the upper frequency edge of the UL *operating band* is reaching beyond 12.75 GHz.

#### 6.5.4.2.2 Additional spurious emissions requirements

These requirements may be applied for the protection of system operating in other frequency ranges. The limits may apply as an optional protection of such systems that are deployed in the same geographical area as the repeater-Node, or they may be set by local or regional regulation as a mandatory requirement for an NR *operating band*. It is in some cases not stated in the present document whether a requirement is mandatory or under what exact circumstances that a limit applies, since this is set by local or regional regulation. An overview of regional requirements in the present document is given in clause 4.5.

Some requirements may apply for the protection of specific equipment (UE, MS and/or BS) or equipment operating in specific systems (GSM, CDMA, UTRA, E-UTRA, NR, etc.) as listed below.

The spurious emission *minimum requirements* are provided in table 6.5.4.2.2-1 where requirements for co-existence with the system listed in the first column apply for *repeater type 1-C*. For a *multi-band connector*, the exclusions and conditions in the Note column of table 6.5.4.2.2-1 apply for each supported *operating band*.

**Table 6.5.4.2.2-1: Repeater type 1-C spurious emissions minimum requirements for co-existence with systems operating in other frequency bands**

System type to co-exist with	Frequency range for co-existence requirement	Minimum requirements	Measurement bandwidth	Note
GSM900	921 – 960 MHz	-57 dBm	100 kHz	This requirement does not apply to repeater operating in band n8
	876 – 915 MHz	-61 dBm	100 kHz	For the frequency range 880-915 MHz, this requirement does not apply to repeater operating in band n8, since it is already covered by the requirement in clause 6.5.5.2.2.
DCS1800	1805 – 1880 MHz	-47 dBm	100 kHz	This requirement does not apply to repeater operating in band n3.
	1710 – 1785 MHz	-61 dBm	100 kHz	This requirement does not apply to repeater operating in band n3, since it is already covered by the requirement in clause 6.5.5.2.2.
PCS1900	1930 – 1990 MHz	-47 dBm	100 kHz	This requirement does not apply to repeater operating in band n2, n25 or band n70.
	1850 – 1910 MHz	-61 dBm	100 kHz	This requirement does not apply to repeater operating in band n2 or n25 since it is already covered by the requirement in clause 6.6.5.2.2.
GSM850 or CDMA850	869 – 894 MHz	-57 dBm	100 kHz	This requirement does not apply to repeater operating in band n5 or n26.
	824 – 849 MHz	-61 dBm	100 kHz	This requirement does not apply to repeater operating in band n5 or n26, since it is already covered by the requirement in clause 6.6.5.2.2.
UTRA FDD Band I or E-UTRA Band 1 or NR Band n1	2110 – 2170 MHz	-52 dBm	1 MHz	This requirement does not apply to repeater operating in band n1 or n65
	1920 – 1980 MHz	-49 dBm	1 MHz	This requirement does not apply to repeater operating in band n1 or n65, since it is already covered by the requirement in clause 6.6.5.2.2.
UTRA FDD Band II or E-UTRA Band 2 or NR Band n2	1930 – 1990 MHz	-52 dBm	1 MHz	This requirement does not apply to repeater operating in band n2 or n70.
	1850 – 1910 MHz	-49 dBm	1 MHz	This requirement does not apply to repeater operating in band n2, since it is already covered by the requirement in clause 6.6.5.2.2.
UTRA FDD Band III or E-UTRA Band 3 or NR Band n3	1805 – 1880 MHz	-52 dBm	1 MHz	This requirement does not apply to repeater operating in band n3.
	1710 – 1785 MHz	-49 dBm	1 MHz	This requirement does not apply to repeater operating in band n3, since it is already covered by the requirement in clause 6.6.5.2.2.
UTRA FDD Band IV or E-UTRA Band 4	2110 – 2155 MHz	-52 dBm	1 MHz	This requirement does not apply to repeater operating in band n66
	1710 – 1755 MHz	-49 dBm	1 MHz	This requirement does not apply to repeater operating in band n66, since it is already covered by the requirement in clause 6.6.5.2.2.
UTRA FDD Band V or E-UTRA Band 5 or NR Band n5	869 – 894 MHz	-52 dBm	1 MHz	This requirement does not apply to repeater operating in band n5 or n26.
	824 – 849 MHz	-49 dBm	1 MHz	This requirement does not apply to repeater operating in band n5 or n26, since it is already covered by the requirement in clause 6.6.5.2.2.

System type to co-exist with	Frequency range for co-existence requirement	Minimum requirements	Measurement bandwidth	Note
UTRA FDD	860 – 890 MHz	-52 dBm	1 MHz	This requirement does not apply to repeater operating in band n18.
Band VI, XIX or	815 – 830 MHz	-49 dBm	1 MHz	This requirement does not apply to repeater operating in band n18, since it is already covered by the requirement in clause 6.6.5.2.2.
E-UTRA Band 6, 18, 19 or NR Band n18	830 – 845 MHz	-49 dBm	1 MHz	
UTRA FDD Band VII or E-UTRA Band 7 or NR Band n7	2620 – 2690 MHz	-52 dBm	1 MHz	This requirement does not apply to repeater operating in band n7.
	2500 – 2570 MHz	-49 dBm	1 MHz	This requirement does not apply to repeater operating in band n7, since it is already covered by the requirement in clause 6.6.5.2.2.
UTRA FDD Band VIII or E-UTRA Band 8 or NR Band n8	925 – 960 MHz	-52 dBm	1 MHz	This requirement does not apply to repeater operating in band n8.
	880 – 915 MHz	-49 dBm	1 MHz	This requirement does not apply to repeater operating in band n8, since it is already covered by the requirement in clause 6.6.5.2.2.
UTRA FDD Band IX or E-UTRA Band 9	1844.9 – 1879.9 MHz	-52 dBm	1 MHz	This requirement does not apply to repeater operating in band n3.
	1749.9 – 1784.9 MHz	-49 dBm	1 MHz	This requirement does not apply to repeater operating in band n3, since it is already covered by the requirement in clause 6.6.5.2.2.
UTRA FDD Band X or E-UTRA Band 10	2110 – 2170 MHz	-52 dBm	1 MHz	This requirement does not apply to repeater operating in band n66
	1710 – 1770 MHz	-49 dBm	1 MHz	This requirement does not apply to repeater operating in band n66, since it is already covered by the requirement in clause 6.6.5.2.2.
UTRA FDD Band XI or XXI or E-UTRA Band 11 or 21	1475.9 – 1510.9 MHz	-52 dBm	1 MHz	This requirement does not apply to repeater operating in band n50, n74, n75, n92 or n94.
	1427.9 – 1447.9 MHz	-49 dBm	1 MHz	This requirement does not apply to repeater operating in band n50, n51, n74, n75, n76, n91, n92, n93 or n94.
	1447.9 – 1462.9 MHz	-49 dBm	1 MHz	This requirement does not apply to repeater operating in band n50, n74, n75, n92 or n94.
UTRA FDD Band XII or E-UTRA Band 12 or NR Band n12	729 – 746 MHz	-52 dBm	1 MHz	This requirement does not apply to repeater operating in band n12 or n85.
	699 – 716 MHz	-49 dBm	1 MHz	This requirement does not apply to repeater operating in band n12 or n85, since it is already covered by the requirement in clause 6.6.5.2.2. For NR repeater operating in n29, it applies 1 MHz below the Band n29 downlink operating band (Note 5).

System type to co-exist with	Frequency range for co-existence requirement	Minimum requirements	Measurement bandwidth	Note
UTRA FDD Band XIII or E-UTRA Band 13	746 – 756 MHz	-52 dBm	1 MHz	This requirement does not apply to repeater operating in band n13.
	777 – 787 MHz	-49 dBm	1 MHz	This requirement does not apply to repeater operating in band n13, since it is already covered by the requirement in clause 6.6.5.2.2.
UTRA FDD Band XIV or E-UTRA Band 14 or NR band n14	758 – 768 MHz	-52 dBm	1 MHz	This requirement does not apply to repeater operating in band n14.
	788 – 798 MHz	-49 dBm	1 MHz	This requirement does not apply to repeater operating in band n14, since it is already covered by the requirement in clause 6.6.5.2.2.
E-UTRA Band 17	734 – 746 MHz	-52 dBm	1 MHz	
	704 – 716 MHz	-49 dBm	1 MHz	For NR repeater operating in n29, it applies 1 MHz below the Band n29 downlink operating band (Note 5).
UTRA FDD Band XX or E-UTRA Band 20 or NR Band n20	791 – 821 MHz	-52 dBm	1 MHz	This requirement does not apply to repeater operating in band n20 or n28.
	832 – 862 MHz	-49 dBm	1 MHz	This requirement does not apply to repeater operating in band n20, since it is already covered by the requirement in clause 6.6.5.2.2.
UTRA FDD Band XXII or E-UTRA Band 22	3510 – 3590 MHz	-52 dBm	1 MHz	This requirement does not apply to repeater operating in band n48, n77 or n78.
	3410 – 3490 MHz	-49 dBm	1 MHz	This requirement does not apply to repeater operating in band n77 or n78.
E-UTRA Band 24	1525 – 1559 MHz	-52 dBm	1 MHz	This requirement does not apply to repeater operating in band n24.
	1626.5 – 1660.5 MHz	-49 dBm	1 MHz	This requirement does not apply to repeater operating in band n24, since it is already covered by the requirement in clause 6.6.5.2.2.
UTRA FDD Band XXV or E-UTRA Band 25 or NR band n25	1930 – 1995 MHz	-52 dBm	1 MHz	This requirement does not apply to repeater operating in band n2, n25 or n70.
	1850 – 1915 MHz	-49 dBm	1 MHz	This requirement does not apply to repeater operating in band n25 since it is already covered by the requirement in clause 6.6.5.2.2. For repeater operating in Band n2, it applies for 1910 MHz to 1915 MHz, while the rest is covered in clause 6.6.5.2.2.
UTRA FDD Band XXVI or E-UTRA Band 26 or NR Band n26	859 – 894 MHz	-52 dBm	1 MHz	This requirement does not apply to repeater operating in band n5 or n26.
	814 – 849 MHz	-49 dBm	1 MHz	This requirement does not apply to repeater operating in band n26 since it is already covered by the requirement in clause 6.6.5.2.2. For repeater operating in Band n5, it applies for 814 MHz to 824 MHz, while the rest is covered in clause 6.6.5.2.2.
E-UTRA Band 27	852 – 869 MHz	-52 dBm	1 MHz	This requirement does not apply to repeater operating in Band n5.
	807 – 824 MHz	-49 dBm	1 MHz	This requirement also applies to repeater operating in Band n28, starting 4 MHz above the Band n28 downlink operating band (Note 5).

System type to co-exist with	Frequency range for co-existence requirement	Minimum requirements	Measurement bandwidth	Note
E-UTRA Band 28 or NR Band n28	758 – 803 MHz	-52 dBm	1 MHz	This requirement does not apply to repeater operating in band n20, n67 or n28.
	703 – 748 MHz	-49 dBm	1 MHz	This requirement does not apply to repeater operating in band n28, since it is already covered by the requirement in clause 6.6.5.2.2. For repeater operating in band n67, it applies for 703 MHz to 736 MHz.
E-UTRA Band 29 or NR Band n29	717 – 728 MHz	-52 dBm	1 MHz	This requirement does not apply to repeater operating in Band n29 or n85
E-UTRA Band 30 or NR Band n30	2350 – 2360 MHz	-52 dBm	1 MHz	This requirement does not apply to repeater operating in band n30
	2305 – 2315 MHz	-49 dBm	1 MHz	This requirement does not apply to repeater operating in band n30, since it is already covered by the requirement in clause 6.6.5.2.2.
E-UTRA Band 31	462.5 – 467.5 MHz	-52 dBm	1 MHz	
	452.5 – 457.5 MHz	-49 dBm	1 MHz	
UTRA FDD band XXXII or E-UTRA band 32	1452 – 1496 MHz	-52 dBm	1 MHz	This requirement does not apply to repeater operating in band n50, n74, n75, n92 or n94.
UTRA TDD Band a) or E-UTRA Band 33	1900 – 1920 MHz	-52 dBm	1 MHz	
UTRA TDD Band a) or E-UTRA Band 34 or NR band n34	2010 – 2025 MHz	-52 dBm	1 MHz	This requirement does not apply to repeater operating in Band n34.
UTRA TDD Band b) or E-UTRA Band 35	1850 – 1910 MHz	-52 dBm	1 MHz	
UTRA TDD Band b) or E-UTRA Band 36	1930 – 1990 MHz	-52 dBm	1 MHz	This requirement does not apply to repeater operating in Band n2 or n25.
UTRA TDD Band c) or E-UTRA Band 37	1910 – 1930 MHz	-52 dBm	1 MHz	
UTRA TDD Band d) or E-UTRA Band 38 or NR Band n38	2570 – 2620 MHz	-52 dBm	1 MHz	This requirement does not apply to repeater operating in Band n38.
UTRA TDD Band f) or E-UTRA Band 39 or NR band n39	1880 – 1920MHz	-52 dBm	1 MHz	This requirement does not apply to repeater operating in Band n39.
UTRA TDD Band e) or E-UTRA Band 40 or NR Band n40	2300 – 2400MHz	-52 dBm	1 MHz	This requirement does not apply to repeater operating in Band n30 or n40.
E-UTRA Band 41 or NR Band n41, n90	2496 – 2690 MHz	-52 dBm	1 MHz	This is not applicable to repeater operating in Band n41, n53 or [n90].

System type to co-exist with	Frequency range for co-existence requirement	Minimum requirements	Measurement bandwidth	Note
E-UTRA Band 42	3400 – 3600 MHz	-52 dBm	1 MHz	This is not applicable to repeater operating in Band n48, n77 or n78.
E-UTRA Band 43	3600 – 3800 MHz	-52 dBm	1 MHz	This is not applicable to repeater operating in Band n48, n77 or n78.
E-UTRA Band 44	703 – 803 MHz	-52 dBm	1 MHz	This is not applicable to repeater operating in Band n28.
E-UTRA Band 45	1447 – 1467 MHz	-52 dBm	1 MHz	
E-UTRA Band 46	5150 – 5925 MHz	-52 dBm	1 MHz	
E-UTRA Band 47	5855 – 5925 MHz	-52 dBm	1 MHz	
E-UTRA Band 48 or NR Band n48	3550 – 3700 MHz	-52 dBm	1 MHz	This is not applicable to repeater operating in Band n48, n77 or n78.
E-UTRA Band 50 or NR band n50	1432 – 1517 MHz	-52 dBm	1 MHz	This requirement does not apply to repeater operating in Band n50, n51, n74, n75, n76, n91, n92, n93 or n94.
E-UTRA Band 51 or NR Band n51	1427 – 1432 MHz	-52 dBm	1 MHz	This requirement does not apply to repeater operating in Band n50, n51, n75, n76, n91, n92, n93 or n94.
E-UTRA Band 53 or NR Band n53	2483.5 - 2495 MHz	-52 dBm	1 MHz	This requirement does not apply to repeater operating in Band n41, n53 or n90.
E-UTRA Band 65 or NR Band n65	2110 – 2200 MHz	-52 dBm	1 MHz	This requirement does not apply to repeater operating in band n1 or n65.
	1920 – 2010 MHz	-49 dBm	1 MHz	For repeater operating in Band n1, it applies for 1980 MHz to 2010 MHz, while the rest is covered in clause 6.6.5.2.2. This requirement does not apply to repeater operating in band n65, since it is already covered by the requirement in clause 6.6.5.2.2.
E-UTRA Band 66 or NR Band n66	2110 – 2200 MHz	-52 dBm	1 MHz	This requirement does not apply to repeater operating in band n66.
	1710 – 1780 MHz	-49 dBm	1 MHz	This requirement does not apply to repeater operating in band n66, since it is already covered by the requirement in clause 6.6.5.2.2.
E-UTRA Band 67	738 – 758 MHz	-52 dBm	1 MHz	This requirement does not apply to repeater operating in Band n28 or n67.
E-UTRA Band 68	753 -783 MHz	-52 dBm	1 MHz	This requirement does not apply to repeater operating in band n28.
	698-728 MHz	-49 dBm	1 MHz	For repeater operating in Band n28, this requirement applies between 698 MHz and 703 MHz, while the rest is covered in clause 6.6.5.2.2.
E-UTRA Band 69	2570 – 2620 MHz	-52 dBm	1 MHz	This requirement does not apply to repeater operating in Band n38.
E-UTRA Band 70 or NR Band n70	1995 – 2020 MHz	-52 dBm	1 MHz	This requirement does not apply to repeater operating in band n2, n25 or n70
	1695 – 1710 MHz	-49 dBm	1 MHz	This requirement does not apply to repeater operating in band n70, since it is already covered by the requirement in clause 6.6.5.2.2.
E-UTRA Band 71 or NR Band n71	617 – 652 MHz	-52 dBm	1 MHz	This requirement does not apply to repeater operating in band n71
	663 – 698 MHz	-49 dBm	1 MHz	This requirement does not apply to repeater operating in band n71, since it is already covered by the requirement in clause 6.6.5.2.2.
E-UTRA Band 72	461 – 466 MHz	-52 dBm	1 MHz	
	451 – 456 MHz	-49 dBm	1 MHz	

System type to co-exist with	Frequency range for co-existence requirement	Minimum requirements	Measurement bandwidth	Note
E-UTRA Band 74 or NR Band n74	1475 – 1518 MHz	-52 dBm	1 MHz	This requirement does not apply to repeater operating in band n50, n74, n75, n92 or n94.
	1427 – 1470 MHz	-49 dBm	1MHz	This requirement does not apply to repeater operating in band n50, n51, n74, n75, n76, n91, n92, n93 or n94.
E-UTRA Band 75 or NR Band n75	1432 – 1517 MHz	-52 dBm	1 MHz	This requirement does not apply to repeater operating in Band n50, n51, n74, n75, n76, n91, n92, n93 or n94.
E-UTRA Band 76 or NR Band n76	1427 – 1432 MHz	-52 dBm	1 MHz	This requirement does not apply to repeater operating in Band n50, n51, n75, n76, n91, n92, n93 or n94.
NR Band n77	3.3 – 4.2 GHz	-52 dBm	1 MHz	This requirement does not apply to repeater operating in Band n48, n77 or n78
NR Band n78	3.3 – 3.8 GHz	-52 dBm	1 MHz	This requirement does not apply to repeater operating in Band n48, n77 or n78
NR Band n79	4.4 – 5.0 GHz	-52 dBm	1 MHz	This requirement does not apply to repeater operating in Band n79
NR Band n80	1710 – 1785 MHz	-49 dBm	1 MHz	This requirement does not apply to repeater operating in band n3, since it is already covered by the requirement in clause 6.6.5.2.2.
NR Band n81	880 – 915 MHz	-49 dBm	1 MHz	This requirement does not apply to repeater operating in band n8, since it is already covered by the requirement in clause 6.6.5.2.2.
NR Band n82	832 – 862 MHz	-49 dBm	1 MHz	This requirement does not apply to repeater operating in band n20, since it is already covered by the requirement in clause 6.6.5.2.2.
NR Band n83	703 – 748 MHz	-49 dBm	1 MHz	This requirement does not apply to repeater operating in band n28, since it is already covered by the requirement in clause 6.6.5.2.2. For repeater operating in Band n67, it applies for 703 MHz to 736 MHz.
NR Band n84	1920 – 1980 MHz	-49 dBm	1 MHz	This requirement does not apply to repeater operating in band n1, since it is already covered by the requirement in clause 6.6.5.2.2.
E-UTRA Band 85 or NR Band n85	728 – 746 MHz	-52 dBm	1 MHz	This requirement does not apply to repeater operating in band n12 or n85. For NR repeater operating in n29, it applies 1 MHz below the Band n29 downlink operating band (Note 5).
	698 – 716 MHz	-49 dBm	1 MHz	This requirement does not apply to repeater operating in band n12 or n85, since it is already covered by the requirement in clause 6.6.5.2.2.
NR Band n86	1710 – 1780 MHz	-49 dBm	1 MHz	This requirement does not apply to repeater operating in band n66, since it is already covered by the requirement in clause 6.6.5.2.2.
NR Band n89	824 – 849 MHz	-49 dBm	1 MHz	This requirement does not apply to repeater operating in band n5, since it is already covered by the requirement in clause 6.6.5.2.2.
NR Band n91	1427 – 1432 MHz	-52 dBm	1 MHz	This requirement does not apply to repeater operating in Band n50, n51, n75 or n76.
	832 – 862 MHz	-49 dBm	1 MHz	This requirement does not apply to repeater operating in band n20, since it is already covered by the requirement in clause 6.6.5.5.1.2.
NR Band n92	1432 – 1517 MHz	-52 dBm	1 MHz	This requirement does not apply to repeater operating in Band n50, n51, n74, n75 or n76.
	832 – 862 MHz	-49 dBm	1 MHz	This requirement does not apply to repeater operating in band n20, since it is already covered by the requirement in clause 6.6.5.5.1.2.
NR Band n93	1427 – 1432 MHz	-52 dBm	1 MHz	This requirement does not apply to repeater operating in Band n50, n51, n75 or n76.
	880 – 915 MHz	-49 dBm	1 MHz	This requirement does not apply to repeater operating in band n8, since it is already covered by the requirement in clause 6.6.5.5.1.2.



System type to co-exist with	Frequency range for co-existence requirement	Minimum requirements	Measurement bandwidth	Note
NR Band n94	1432 – 1517 MHz	-52 dBm	1 MHz	This requirement does not apply to repeater operating in Band n50, n51, n74, n75 or n76.
	880 – 915 MHz	-49 dBm	1 MHz	This requirement does not apply to repeater operating in band n8, since it is already covered by the requirement in clause 6.6.5.5.1.2.
NR Band n95	2010 – 2025 MHz	-52 dBm	1 MHz	
NR Band n96	5925 – 7125 MHz	-52 dBm	1 MHz	
NR Band n97	2300 – 2400MHz	-52 dBm	1 MHz	
NR Band n98	1880 – 1920MHz	-52 dBm	1 MHz	
NR Band n99	1626.5 – 1660.5 MHz	-49 dBm	1 MHz	This requirement does not apply to repeater operating in band n24, since it is already covered by the requirement in clause 6.5.5.2.2.
NR band n101	1900 – 1910 MHz	-52 dBm	1 MHz	This requirement does not apply to repeater operating in Band n101.
NR Band n102	5925 – 6425 MHz	-52 dBm	1 MHz	
E-UTRA Band 103	757 – 758 MHz	-52 dBm	1 MHz	
	787 – 788 MHz	-49 dBm	1 MHz	
NR Band n104	6425 – 7125 MHz	-52 dBm	1 MHz	This requirement does not apply to repeater operating in Band n104

NOTE 1: As defined in the scope for spurious emissions in this clause, except for the cases where the noted requirements apply to a repeater operating in Band n28, the co-existence requirements in table 6.5.4.2.3 - 1 do not apply for the  $\Delta f_{\text{OBUE}}$  frequency range immediately outside the downlink *operating band* (see table 5.2-1). Emission limits for this excluded frequency range may be covered by local or regional requirements.

NOTE 2: Table 6.5.5.2.3 -1 assumes that two *operating bands*, where the frequency ranges in table 5.2-1 would be overlapping, are not deployed in the same geographical area. For such a case of operation with overlapping frequency arrangements in the same geographical area, special co-existence requirements may apply that are not covered by the 3GPP specifications.

NOTE 3: For unsynchronized operation, special co-existence requirements may apply that are not covered by the 3GPP specifications.

NOTE 4: For NR Band n28 repeater, specific solutions may be required to fulfil the spurious emissions limits for repeater for co-existence with E-UTRA Band 27 UL *operating band*.

NOTE 5: For NR Band n29 repeater, specific solutions may be required to fulfil the spurious emissions limits for NR repeater for co-existence with UTRA Band XII, E-UTRA Band 12 or NR Band n12 UL operating band, E-UTRA Band 17 UL operating band or E-UTRA Band 85 UL or NR Band n85 UL operating band.

The following requirement may be applied for the protection of PHS. This requirement is also applicable at specified frequencies falling between  $\Delta f_{\text{OBUE}}$  below the lowest repeater transmitter frequency of the downlink *operating band* and  $\Delta f_{\text{OBUE}}$  above the highest repeater transmitter frequency of the downlink *operating band*.  $\Delta f_{\text{OBUE}}$  is defined in clause 6.5.1.

The spurious emission *minimum requirements* for this requirement are:

**Table 6.5.4.2.3-2: Repeater spurious emissions minimum requirements for repeater for co-existence with PHS for DL**

Frequency range	minimum requirements	Measurement Bandwidth	Note
1884.5 – 1915.7 MHz	-41 dBm	300 kHz	Applicable when co-existence with PHS system operating in 1884.5 – 1915.7 MHz

In certain regions, the following requirement may apply to NR repeater operating in Band n50 and n75 within the 1432 – 1452 MHz, and in Band n51 and Band n76. The *minimum requirements* are specified in table 6.5.4.2.3-4. This requirement is also applicable at the frequency range from  $\Delta f_{\text{OBUE}}$  below the lowest frequency of the repeater downlink *operating band* up to  $\Delta f_{\text{OBUE}}$  above the highest frequency of the repeater downlink *operating band*.

**Table 6.5.4.2.3-4: Additional operating band unwanted emission minimum requirement for NR repeater operating in Band n50 and n75 within 1432 – 1452 MHz, and in Band n51 and n76**

Filter centre frequency, $F_{\text{filter}}$	Minimum requirements	Measurement Bandwidth
$F_{\text{filter}} = 1413.5 \text{ MHz}$	-42 dBm	27 MHz

In certain regions, the following requirement may apply to repeater operating in NR Band n50 and n75 within 1492-1517 MHz and in Band n74 within 1492-1518 MHz. The maximum level of emissions, measured on centre frequencies  $F_{\text{filter}}$  with filter bandwidth according to table 6.5.4.2.3-5, shall be defined according to the *minimum requirements*  $P_{\text{EM},n50/n75,a}$  nor  $P_{\text{EM},n50/n75,b}$  declared by the manufacturer.

**Table 6.5.4.2.3-5: Operating band n50, n74 and n75 declared emission above 1518 MHz**

Filter centre frequency, $F_{\text{filter}}$	Declared minimum requirements (dBm)	Measurement bandwidth
$1518.5 \text{ MHz} \leq F_{\text{filter}} \leq 1519.5 \text{ MHz}$	$P_{\text{EM},n50/n75,a}$	1 MHz
$1520.5 \text{ MHz} \leq F_{\text{filter}} \leq 1558.5 \text{ MHz}$	$P_{\text{EM},n50/n75,b}$	1 MHz

In certain regions, the following requirement shall be applied to repeater operating in Band n13 and n14 to ensure that appropriate interference protection is provided to 700 MHz public safety operations. This requirement is also applicable at the frequency range from 10 MHz below the lowest frequency of the repeater downlink operating band up to 10 MHz above the highest frequency of the repeater downlink operating band.

The power of any spurious emission shall not exceed:

**Table 6.5.4.2.3-6: Repeater spurious emissions limits for protection of 700 MHz public safety operations**

Operating Band	Frequency range	Maximum Level	Measurement Bandwidth
n13	763 - 775 MHz	-46 dBm	6.25 kHz
n13	793 - 805 MHz	-46 dBm	6.25 kHz
n14	769 - 775 MHz	-46 dBm	6.25 kHz
n14	799 - 805 MHz	-46 dBm	6.25 kHz

In certain regions, the following requirement may apply to NR repeater operating in Band n30. This requirement is also applicable at the frequency range from 10 MHz below the lowest frequency of the repeater downlink operating band up to 10 MHz above the highest frequency of the repeater downlink operating band.

The power of any spurious emission shall not exceed:

**Table 6.5.4.2.3-7: Additional NR repeater spurious emissions minimum requirements for Band n30**

Frequency range	Minimum requirements	Measurement Bandwidth	Note
2200 – 2345 MHz	-45 dBm	1 MHz	
2362.5 – 2365 MHz	-25 dBm	1 MHz	
2365 – 2367.5 MHz	-40 dBm	1 MHz	
2367.5 – 2370 MHz	-42 dBm	1 MHz	
2370 – 2395 MHz	-45 dBm	1 MHz	

The following requirement may apply to repeater operating in Band n48 in certain regions. The power of any spurious emission shall not exceed:

**Table 6.5.4.2.3-8: Additional repeater spurious emissions limits for Band n48**

Frequency range	Maximum Level	Measurement Bandwidth (NOTE)	Note
3530 MHz – 3720 MHz	-25 dBm	1 MHz	Applicable 10 MHz from the assigned <i>passband edge</i>
3100 MHz – 3530 MHz 3720 MHz – 4200 MHz	-40 dBm	1 MHz	

NOTE: The resolution bandwidth of the measuring equipment should be equal to the measurement bandwidth. However, to improve measurement accuracy, sensitivity and efficiency, the resolution bandwidth may be smaller than the measurement bandwidth. When the resolution bandwidth is smaller than the measurement bandwidth, the result should be integrated over the measurement bandwidth in order to obtain the equivalent noise bandwidth of the measurement bandwidth.

NOTE: The regional requirement, included in [12], is defined in terms of EIRP, which is dependent on both the repeater emissions at the *antenna connector* and the deployment (including antenna gain and feeder loss). The requirement defined above provides the characteristics of the base station needed to verify compliance with the regional requirement. The assessment of the EIRP level is described in Annex F.

The following requirement shall be applied to repeater operating in Band n26 to ensure that appropriate interference protection is provided to 800 MHz public safety operations. This requirement is also applicable at the frequency range from 10 MHz below the lowest frequency of the repeater downlink operating band up to 10 MHz above the highest frequency of the repeater downlink operating band.

The power of any spurious emission shall not exceed:

**Table 6.5.4.2.3-9: Repeater spurious emissions limits for protection of 800 MHz public safety operations**

Operating Band	Frequency range	Maximum Level	Measurement Bandwidth	Note
n26	851 - 859 MHz	-13 dBm	100 kHz	Applicable for offsets > 37.5kHz from the <i>passband edge</i>

The following requirement may apply to Repeater for Band n41 and n90 operation in Japan. This requirement is also applicable at the frequency range from  $\Delta f_{\text{OBUE}}$  below the lowest frequency of the Repeater downlink operating band up to  $\Delta f_{\text{OBUE}}$  above the highest frequency of the Repeater downlink operating band.

The power of any spurious emission shall not exceed:

**Table 6.5.4.2.3-10: Additional repeater spurious emissions minimum requirements for Band n41 and n90**

Frequency range	Minimum requirement	Measurement Bandwidth
2505 MHz – 2535 MHz	-42 dBm	1 MHz
NOTE: This requirement applies for carriers allocated within 2545-2645 MHz.		

The following requirement may apply to repeater operating in 3.45-3.55 GHz in Band n77 in certain regions. Emissions shall not exceed the maximum levels specified in table 6.5.4.2.3-11.

Table 6.5.4.2.3-11: Additional repeater spurious emissions limits for Band n77

Channel bandwidth [MHz]	Frequency range [MHz]	Filter centre frequency, $F_{\text{filter}}$ [MHz]	Minimum requirement [dBm]	Measurement bandwidth [MHz]
All	3430 – 3440 3560 – 3570	$3430.5 \leq F_{\text{filter}} < 3439.5$ $3560.5 \leq F_{\text{filter}} < 3569.5$	-25	1
All	$\leq 3430$ $> 3570$	$F_{\text{filter}} < 3429.5$ $3570.5 \leq F_{\text{filter}}$	-40	1

NOTE: The resolution bandwidth of the measuring equipment should be equal to the measurement bandwidth. However, to improve measurement accuracy, sensitivity and efficiency, the resolution bandwidth may be smaller than the measurement bandwidth. When the resolution bandwidth is smaller than the measurement bandwidth, the result should be integrated over the measurement bandwidth in order to obtain the equivalent noise bandwidth of the measurement bandwidth.

#### 6.5.4.2.3 Co-location with base stations and *repeater type 1-C* Nodes

These requirements may be applied for the protection of other BS, IAB-DU, IAB-MT and *repeater type 1-C* receivers when GSM900, DCS1800, PCS1900, GSM850, CDMA850, UTRA FDD, UTRA TDD, E-UTRA, NR BS, IAB-DU, IAB-MT, or *repeater type 1-C* are co-located with *repeater type 1-C*.

The requirements assume a 30 dB coupling loss between transmitter and receiver and are based on co-location with same class.

The *minimum requirements* are in table 6.5.4.2.3-1 for a *repeater type 1-C*. Requirements for co-location with a system listed in the first column apply, depending on the declared *repeater type 1-C* class. For a *multi-band connector*, the exclusions and conditions in the Note column of table 6.5.4.2.3-1 shall apply for each supported *operating band*.

**Table 6.5.4.2.3-1: Repeater type 1-C spurious emissions minimum requirements for co-location with BS, IAB-Node or repeater-Node**

Type of co-located BS	Frequency range for co-location requirement	Minimum requirements			Measurement bandwidth	Note
		WA repeater	MR repeater	LA repeater		
GSM900	876 – 915 MHz	-98 dBm	-91 dBm	-70 dBm	100 kHz	
DCS1800	1710 – 1785 MHz	-98 dBm	-91 dBm	-80 dBm	100 kHz	
PCS1900	1850 – 1910 MHz	-98 dBm	-91 dBm	-80 dBm	100 kHz	
GSM850 or CDMA850	824 – 849 MHz	-98 dBm	-91 dBm	-70 dBm	100 kHz	
UTRA FDD Band I or E-UTRA Band 1 or NR Band n1	1920 – 1980 MHz	-96 dBm	-91 dBm	-88 dBm	100 kHz	
UTRA FDD Band II or E-UTRA Band 2 or NR Band n2	1850 – 1910 MHz	-96 dBm	-91 dBm	-88 dBm	100 kHz	
UTRA FDD Band III or E-UTRA Band 3 or NR Band n3	1710 – 1785 MHz	-96 dBm	-91 dBm	-88 dBm	100 kHz	
UTRA FDD Band IV or E-UTRA Band 4	1710 – 1755 MHz	-96 dBm	-91 dBm	-88 dBm	100 kHz	
UTRA FDD Band V or E-UTRA Band 5 or NR Band n5	824 – 849 MHz	-96 dBm	-91 dBm	-88 dBm	100 kHz	
UTRA FDD Band VI, XIX or E-UTRA Band 6, 19	830 – 845 MHz	-96 dBm	-91 dBm	-88 dBm	100 kHz	
UTRA FDD Band VII or E-UTRA Band 7 or NR Band n7	2500 – 2570 MHz	-96 dBm	-91 dBm	-88 dBm	100 kHz	
UTRA FDD Band VIII or E-UTRA Band 8 or NR Band n8	880 – 915 MHz	-96 dBm	-91 dBm	-88 dBm	100 kHz	
UTRA FDD Band IX or E-UTRA Band 9	1749.9 – 1784.9 MHz	-96 dBm	-91 dBm	-88 dBm	100 kHz	
UTRA FDD Band X or E-UTRA Band 10	1710 – 1770 MHz	-96 dBm	-91 dBm	-88 dBm	100 kHz	
UTRA FDD Band XI or E-UTRA Band 11	1427.9 – 1447.9 MHz	-96 dBm	-91 dBm	-88 dBm	100 kHz	This is not applicable to repeater operating in Band n50, n75, n91, n92, n93 or n94
UTRA FDD Band XII or E-UTRA Band 12 or NR Band n12	699 – 716 MHz	-96 dBm	-91 dBm	-88 dBm	100 kHz	
UTRA FDD Band XIII or E-UTRA Band 13 or NR Band n13	777 – 787 MHz	-96 dBm	-91 dBm	-88 dBm	100 kHz	
UTRA FDD Band XIV or E-UTRA Band 14 or NR Band n14	788 – 798 MHz	-96 dBm	-91 dBm	-88 dBm	100 kHz	
E-UTRA Band 17	704 – 716 MHz	-96 dBm	-91 dBm	-88 dBm	100 kHz	
E-UTRA Band 18 or NR Band n18	815 – 830 MHz	-96 dBm	-91 dBm	-88 dBm	100 kHz	
UTRA FDD Band XX or E-UTRA Band 20 or NR Band n20	832 – 862 MHz	-96 dBm	-91 dBm	-88 dBm	100 kHz	
UTRA FDD Band XXI or E-UTRA Band 21	1447.9 – 1462.9 MHz	-96 dBm	-91 dBm	-88 dBm	100 kHz	This is not applicable to repeater operating in Band n50, n75, n92 or n94
UTRA FDD Band XXII or E-UTRA Band 22	3410 – 3490 MHz	-96 dBm	-91 dBm	-88 dBm	100 kHz	This is not applicable to repeater operating in Band n48, n77 or n78
E-UTRA Band 24 or NR Band n24	1626.5 – 1660.5 MHz	-96 dBm	-91 dBm	-88 dBm	100 kHz	

Type of co-located BS	Frequency range for co-location requirement	Minimum requirements			Measurement bandwidth	Note
		WA repeater	MR repeater	LA repeater		
UTRA FDD Band XXV or E-UTRA Band 25 or NR Band n25	1850 – 1915 MHz	-96 dBm	-91 dBm	-88 dBm	100 kHz	
UTRA FDD Band XXVI or E-UTRA Band 26 or NR Band n26	814 – 849 MHz	-96 dBm	-91 dBm	-88 dBm	100 kHz	
E-UTRA Band 27	807 – 824 MHz	-96 dBm	-91 dBm	-88 dBm	100 kHz	
E-UTRA Band 28 or NR Band n28	703 – 748 MHz	-96 dBm	-91 dBm	-88 dBm	100 kHz	
E-UTRA Band 30 or NR Band n30	2305 – 2315 MHz	-96 dBm	-91 dBm	-88 dBm	100 kHz	
E-UTRA Band 31	452.5 – 457.5 MHz	-96 dBm	-91 dBm	-88 dBm	100 kHz	
UTRA TDD Band a) or E-UTRA Band 33	1900 – 1920 MHz	-96 dBm	-91 dBm	-88 dBm	100 kHz	
UTRA TDD Band a) or E-UTRA Band 34 or NR band n34	2010 – 2025 MHz	-96 dBm	-91 dBm	-88 dBm	100 kHz	This is not applicable to repeater operating in Band n34
UTRA TDD Band b) or E-UTRA Band 35	1850 – 1910 MHz	-96 dBm	-91 dBm	-88 dBm	100 kHz	
UTRA TDD Band b) or E-UTRA Band 36	1930 – 1990 MHz	-96 dBm	-91 dBm	-88 dBm	100 kHz	This is not applicable to repeater operating in Band n2 or band n25
UTRA TDD Band c) or E-UTRA Band 37	1910 – 1930 MHz	-96 dBm	-91 dBm	-88 dBm	100 kHz	
UTRA TDD Band d) or E-UTRA Band 38 or NR Band n38	2570 – 2620 MHz	-96 dBm	-91 dBm	-88 dBm	100 kHz	This is not applicable to repeater operating in Band n38.
UTRA TDD Band f) or E-UTRA Band 39 or NR band n39	1880 – 1920MHz	-96 dBm	-91 dBm	-88 dBm	100 kHz	This is not applicable to repeater operating in Band n39
UTRA TDD Band e) or E-UTRA Band 40 or NR Band n40	2300 – 2400MHz	-96 dBm	-91 dBm	-88 dBm	100 kHz	This is not applicable to repeater operating in Band n30 or n40.
E-UTRA Band 41 or NR Band n41, n90	2496 – 2690 MHz	-96 dBm	-91 dBm	-88 dBm	100 kHz	This is not applicable to repeater operating in Band n41, n53 or [n90]
E-UTRA Band 42	3400 – 3600 MHz	-96 dBm	-91 dBm	-88 dBm	100 kHz	This is not applicable to repeater operating in Band n48, n77 or n78
E-UTRA Band 43	3600 – 3800 MHz	-96 dBm	-91 dBm	-88 dBm	100 kHz	This is not applicable to repeater operating in Band n48, n77 or n78
E-UTRA Band 44	703 – 803 MHz	-96 dBm	-91 dBm	-88 dBm	100 kHz	This is not applicable to repeater operating in Band n28
E-UTRA Band 45	1447 – 1467 MHz	-96 dBm	-91 dBm	-88 dBm	100 kHz	

Type of co-located BS	Frequency range for co-location requirement	Minimum requirements			Measurement bandwidth	Note
		WA repeater	MR repeater	LA repeater		
E-UTRA Band 46 or NR Band n46	5150 – 5925 MHz	N/A	-91 dBm	-88 dBm	100 kHz	
E-UTRA Band 48 or NR Band n48	3550 – 3700 MHz	-96 dBm	-91 dBm	-88 dBm	100 kHz	This is not applicable to repeater operating in Band n48, n77 or n78
E-UTRA Band 50 or NR Band n50	1432 – 1517 MHz	-96 dBm	-91 dBm	-88 dBm	100 kHz	This is not applicable to repeater operating in Band n51, n74, n75, n91, n92, n93 or n94
E-UTRA Band 51 or NR Band n51	1427 – 1432 MHz	N/A	N/A	-88 dBm	100 kHz	This is not applicable to repeater operating in Band n50, n74, n75, n76, n91, n92, n93 or n94
E-UTRA Band 53 or NR Band n53	2483.5 – 2495 MHz	N/A	-91 dBm	-88 dBm	100 kHz	This is not applicable to repeater operating in Band n41, n53 or n90
E-UTRA Band 65 or NR Band n65	1920 – 2010 MHz	-96 dBm	-91 dBm	-88 dBm	100 kHz	
E-UTRA Band 66 or NR Band n66	1710 – 1780 MHz	-96 dBm	-91 dBm	-88 dBm	100 kHz	
E-UTRA Band 68	698 – 728 MHz	-96 dBm	-91 dBm	-88 dBm	100 kHz	
E-UTRA Band 70 or NR Band n70	1695 – 1710 MHz	-96 dBm	-91 dBm	-88 dBm	100 kHz	
E-UTRA Band 71 or NR Band n71	663 – 698 MHz	-96 dBm	-91 dBm	-88 dBm	100 kHz	
E-UTRA Band 72	451 – 456 MHz	-96 dBm	-91 dBm	-88 dBm	100 kHz	
E-UTRA Band 74 or NR Band n74	1427 – 1470 MHz	-96 dBm	-91 dBm	-88 dBm	100 kHz	This is not applicable to repeater operating in Band n50, n51, n91, n92, n93 or n94
NR Band n77	3.3 – 4.2 GHz	-96 dBm	-91 dBm	-88 dBm	100 kHz	This is not applicable to repeater operating in Band n48, n77 or n78
NR Band n78	3.3 – 3.8 GHz	-96 dBm	-91 dBm	-88 dBm	100 kHz	This is not applicable to repeater operating in Band n48, n77 or n78
NR Band n79	4.4 – 5.0 GHz	-96 dBm	-91 dBm	-88 dBm	100 kHz	
NR Band n80	1710 – 1785 MHz	-96 dBm	-91 dBm	-88 dBm	100 kHz	
NR Band n81	880 – 915 MHz	-96 dBm	-91 dBm	-88 dBm	100 kHz	
NR Band n82	832 – 862 MHz	-96 dBm	-91 dBm	-88 dBm	100 kHz	
NR Band n83	703 – 748 MHz	-96 dBm	-91 dBm	-88 dBm	100 kHz	
NR Band n84	1920 – 1980 MHz	-96 dBm	-91 dBm	-88 dBm	100 kHz	
E-UTRA Band 85 or NR Band n85	698 – 716 MHz	-96 dBm	-91 dBm	-88 dBm	100 kHz	
NR Band n86	1710 – 1780 MHz	-96 dBm	-91 dBm	-88 dBm	100 kHz	
NR Band n89	824 – 849 MHz	-96 dBm	-91 dBm	-88 dBm	100 kHz	
NR Band n91	832 – 862 MHz	N/A	N/A	-88 dBm	100 kHz	
NR Band n92	832 – 862 MHz	-96 dBm	-91 dBm	-88 dBm	100 kHz	



Type of co-located BS	Frequency range for co-location requirement	Minimum requirements			Measurement bandwidth	Note
		WA repeater	MR repeater	LA repeater		
NR Band n93	880 – 915 MHz	N/A	N/A	-88 dBm	100 kHz	
NR Band n94	880 – 915 MHz	-96 dBm	-91 dBm	-88 dBm	100 kHz	
NR Band n95	2010 – 2025 MHz	-96 dBm	-91 dBm	-88 dBm	100 kHz	
NR Band n96	5925 – 7125 MHz	N/A	-90 dBm	-87 dBm	100 kHz	
NR Band n97	2300 – 2400MHz	-96 dBm	-91 dBm	-88 dBm	100 kHz	
NR Band n98	1880 – 1920MHz	-96 dBm	-91 dBm	-88 dBm	100 kHz	
NR Band n99	1626.5 – 1660.5 MHz	-96 dBm	-91 dBm	-88 dBm	100 kHz	
NR Band n101	1900 – 1910 MHz	-96 dBm	NA	NA	100 kHz	
NR Band n102	5925 – 6425 MHz	N/A	-90 dBm	-87 dBm	100 kHz	
E-UTRA Band 103	787 – 788 MHz	-96 dBm	-91 dBm	-88 dBm	100 kHz	
NR Band n104	6425 – 7125 MHz	-95 dBm	-90 dBm	-87 dBm	100 kHz	This requirement does not apply to repeater operating in Band n104.

NOTE 1: As defined in the scope for spurious emissions in this clause, the co-location requirements in table 6.5.4.2.4-1 do not apply for the frequency range extending  $\Delta f_{\text{OBUE}}$  immediately outside the transmit frequency range of a *repeater type 1-C*. The current state-of-the-art technology does not allow a single generic solution for co-location with other system on adjacent frequencies for 30dB antenna to antenna minimum coupling loss. However, there are certain site-engineering solutions that can be used. These techniques are addressed in TR 25.942 [3].

NOTE 2: Table 6.5.4.2.3-1 assumes that two *operating bands*, where the corresponding transmit and receive frequency ranges in table 5.2-1 would be overlapping, are not deployed in the same geographical area. For such a case of operation with overlapping frequency arrangements in the same geographical area, special co-location requirements may apply that are not covered by the 3GPP specifications.

## 6.5.5 Receiver spurious emissions

### 6.5.5.1 General

The receiver spurious emissions power is the power of emissions generated or amplified in a receiver unit that appear at the *antenna connector*. The requirements only apply to *repeater type 1-C* for TDD operation.

For each *antenna connectors* on BS-side and UE-side supporting both RX and TX in TDD, the requirements apply during the *transmitter OFF state*. For *antenna connectors* both BS-side and UE-side in FDD, the RX spurious emissions requirements are superseded by the TX spurious emissions requirements, as specified in clause 6.5.4.

For *multi-band connectors* that both transmit and receive in *operating band* supporting TDD, RX spurious emissions requirements are applicable during the *TX OFF state*, and are subject to exclusion zones in each supported *operating band*.

For Band n41 and n90 operation in Japan, the sum of receiver spurious emissions requirements over all *antenna connectors* for *repeater type 1-C* shall not exceed *minimum requirements* defined in clause 6.5.5.2.

### 6.5.5.2 Minimum requirements

The receiver spurious emissions requirements for *repeater type 1-C* are that for each *antenna connector*, the power of emissions shall not exceed the value specified in table 6.5.5.2-1.

**Table 6.5.5.2-1: Repeater type 1-C receiver spurious emissions minimum requirements**

Spurious frequency range	Minimum requirements	Measurement bandwidth	Note
30 MHz – 1 GHz	-57 dBm	100 kHz	Note 1
1 GHz – 12.75 GHz	-47 dBm	1 MHz	Note 1, Note 2
12.75 GHz – 5 <sup>th</sup> harmonic of the upper frequency edge of the UL <i>operating band</i> in GHz	-47 dBm	1 MHz	Note 1, Note 2, Note 3, Note 5
12.75 GHz - 26 GHz	-47 dBm	1 MHz	Note 1, Note 2, Note 6
NOTE 1: <i>Measurement bandwidths</i> as in ITU-R SM.329 [5], s4.1.			
NOTE 2: Upper frequency as in ITU-R SM.329 [5], s2.5 table 1.			
NOTE 3: This spurious frequency range applies only for <i>operating bands</i> for which the 5 <sup>th</sup> harmonic of the upper frequency edge of the UL <i>operating band</i> is reaching beyond 12.75 GHz.			
NOTE 4: The frequency range from $\Delta f_{\text{OBUE}}$ below the lowest frequency of the repeater transmitter <i>operating band</i> to $\Delta f_{\text{OBUE}}$ above the highest frequency of the repeater transmitter <i>operating band</i> may be excluded from the requirement. $\Delta f_{\text{OBUE}}$ is defined in clause 6.5.1. For <i>multi-band connectors</i> , the exclusion applies for all supported <i>operating bands</i> .			
NOTE 5: Does not apply for band n104.			
NOTE 6: Applies only for band n104.			

## 6.6 Repeater Error Vector Magnitude

### 6.6.1 Downlink repeater error vector magnitude

#### 6.6.1.1 General

The Repeater Error Vector Magnitude (EVM) is a measure of the difference between the symbols provided at the input of repeater and the measured signal symbols at the output of the repeater after the equalization by the measurement equipment. This difference is called the error vector. Details about how the repeater EVM is determined are the same as specified in TS 38.104 [2] Annex B for FR1. The repeater EVM result is defined as the square root of the ratio of the mean error vector power to the mean reference power expressed in percent.

The repeater EVM requirement is applicable for a repeater operating at an input power in the range from what is required to reach the maximum output power to the minimum power level in table 6.6.1.1-1.

**Table 6.6.1.1-1: Minimum input power for repeater EVM**

Repeater DL class	Minimum input power spectral density (dBm/MHz)	
	QPSK, 16 QAM, 64QAM	256QAM <sup>1</sup>
WA	-82	-75
MR	-77	-70
LA	-74	-67

Note 1: support of 256QAM is based on the declaration

#### 6.6.1.2 Minimum requirement

The repeater EVM levels for different modulation schemes outlined in table 6.6.1.2-1 shall be met using the frame structure described in clause 6.6.1.3.

**Table 6.6.1.2-1: Repeater EVM requirements**

Parameter	Required repeater EVM
QPSK, 16QAM, 64QAM	8 %
256QAM	3.5 % <sup>1</sup>

Note 1: support of 256QAM is based on the declaration.

### 6.6.1.3 Repeater EVM frame structure for measurement

The input signals for the repeater EVM requirement shall have the same frame structure as defined for the BS in TS 38.104 [2].

## 6.6.2 Uplink repeater error vector magnitude

### 6.6.2.1 General

The Repeater Error Vector Magnitude is a measure of the difference between the reference waveform provided at the input of repeater and the measured waveform at the output of the repeater. This difference is called the error vector. Details about how the repeater EVM is determined are the same as specified in TS 38.101-1 [13] Annex F for FR1. Before calculating the repeater EVM the measured waveform is corrected by the sample timing offset and RF frequency offset. Then the carrier leakage shall be removed from the measured waveform before calculating the repeater EVM.

The measured waveform is further equalised using the channel estimates subjected to the repeater EVM equaliser spectrum flatness requirement specified in TS 38.101-1 [13] clause 6.4.2.4. For DFT-s-OFDM waveforms, the repeater EVM result is defined after the front-end FFT and IDFT as the square root of the ratio of the mean error vector power to the mean reference power expressed as a %. For CP-OFDM waveforms, the repeater EVM result is defined after the front-end FFT as the square root of the ratio of the mean error vector power to the mean reference power expressed as a %.

The basic repeater EVM measurement interval in one slot in the time domain. The repeater EVM measurement interval is reduced by any symbols that contains an allowable power transient in the measurement interval, as defined in TS 38.101-1 [13] clause 6.3.3 for EVM for UE.

The repeater EVM requirement is applicable for a repeater operating at an input power in the range from what is required to reach the maximum output power to the minimum power level in table 6.6.2.1-1.

**Table 6.6.2.1-1: Minimum input power for repeater EVM**

Repeater UL class	Minimum input power spectral density (dBm/MHz)	
	QPSK, 16 QAM, 64QAM	256QAM <sup>1</sup>
WA	-82	-75
LA	-74	-67

Note 1: support of 256QAM is based on the declaration

### 6.6.2.2 Minimum requirement

The RMS average of the basic repeater EVM measurements over 10 subframes for the average repeater EVM case for the different modulation schemes shall not exceed the values specified in table 6.6.2.2-1.

**Table 6.6.2.2-1: Requirements for Repeater Error Vector Magnitude**

Parameter	Unit	Average Repeater EVM Level
QPSK, 16 QAM, 64QAM	%	8
256 QAM	%	3.5 <sup>1</sup>

Note 1: support of 256QAM is based on the declaration.

## 6.7 Input intermodulation

### 6.7.1 General requirement

#### 6.7.1.1 General

The input intermodulation is a measure of the capability of the repeater to inhibit the generation of interference in the *passband*, in the presence of interfering signals on frequencies other than the *passband*.

The following requirement applies for interfering signals depending on the repeaters *passband*.

This requirement applies to the uplink and downlink of the repeater during the *transmitter ON state*.

There is no co-location input intermodulation requirement for LA 1-C repeaters deployed in Femto cell scenario.

### 6.7.1.2 Minimum requirement

For the parameters specified in table 6.7.1.2-1, the power in the *passband* shall not increase with more than 10 dB at the output of the repeater as measured with 1 MHz measurement bandwidth, compared to the level obtained without interfering signals applied.

The core requirement is applicable for all frequency separation possibilities between the two interfering signals that cause the 3rd order intermodulation product to fall into the *passband*.

Table 6.7.1.2-1 specifies the parameters for two interfering signals, where:

- $f_1$  offset is the offset from the channel edge frequency of the first or last channel in the *passband* of the closer carrier.

**Table 6.7.1.2-1: Input intermodulation requirement**

$f_1$ offset	Interfering Signal Levels	Type of signals	Measurement bandwidth
1 MHz	-40 dBm	2 CW carriers	1 MHz

## 6.7.2 Co-location with BS/repeater in other systems

### 6.7.2.1 General

This additional input intermodulation requirement may be applied for the protection of NR repeater receivers when GSM, CDMA, UTRA, E-UTRA, NR BS or repeater operating in a different frequency band are co-located with a NR repeater.

The following requirement applies for interfering signals depending on the repeaters *passband*.

This requirement applies to the uplink and downlink of the repeater. If the BS side is declared to meet co-location requirements, then it should meet input intermodulation co-location requirements for the downlink. If the UE side is declared to meet co-location requirements, then it should meet input intermodulation co-location requirements for the uplink.

### 6.7.2.2 Minimum requirement

For the parameters specified in table 6.7.2.2-1 for DL and 6.7.2.2-2 for UL, the power in the *passband* shall not increase with more than 10 dB at the output of the repeater as measured with 1MHz measurement bandwidth, compared to the level obtained without interfering signals applied.

The core requirement is applicable for all frequency separation possibilities between the two interfering signals that cause the 3rd order intermodulation product to fall into the *passband*.

**Table 6.7.2.2-1: input intermodulation requirement for NR repeater DL when co-located with BS/repeater in other frequency bands.**

Frequency range of interfering signal	Interfering signal mean power for repeater with WA UE side (dBm)	Interfering signal mean power for repeater with MR UE side(dBm)	Interfering signal mean power for repeater with LA UE side(dBm)	Type of interfering signals
Frequency range of co-located BS's downlink operating band or located repeater's <i>passband</i>	+16	+8	x (Note 1)	2 CW carriers
NOTE 1: x = -7 dBm for NR repeater co-located with Pico GSM850 or Pico CDMA850 x = -4 dBm for NR repeater co-located with Pico DCS1800 or Pico PCS1900 x = -6 dBm for NR repeater co-located with UTRA bands or E-UTRA bands or NR bands NOTE 2: The requirement does not apply when the interfering signal falls within the <i>passband</i> . NOTE 3: For unsynchronized base stations (except in band n46, n96, and n102) or repeaters, special co-location requirements may apply that are not covered by the 3GPP specifications.				

**Table 6.7.2.2-2: input intermodulation requirement for NR repeater UL when co-located with BS/repeater in other frequency bands.**

Frequency range of interfering signal	Interfering signal mean power for repeater with WA BS side(dBm)	Interfering signal mean power for repeater with LA BS side(dBm)	Type of interfering signals
Frequency range of co-located BS's downlink operating band or located repeater's <i>passband</i>	+16	$P_{\text{rated,p,AC}} - 30$	2 CW carriers
NOTE 1: The requirement does not apply when the interfering signal falls within the <i>passband</i> . NOTE 2: For unsynchronized base stations (except in band n46, n96, and n102) or repeaters, special co-location requirements may apply that are not covered by the 3GPP specifications.			

## 6.7.3 Co-existence with other systems

### 6.7.3.1 General

This input intermodulation existence requirement may be applied for the protection of NR repeater receivers when GSM, CDMA, UTRA, E-UTRA, NR BS or repeater operating in another frequency band co-exist with a NR repeater.

### 6.7.3.2 Minimum requirement

For the parameters specified in table 6.7.3.2-1, the power in the *passband* shall not increase with more than 10 dB at the output of the repeater as measured with 1MHz measurement bandwidth, compared to the level obtained without interfering signals applied.

The core requirement is applicable for all frequency separation possibilities between the two interfering signals that cause the 3rd order intermodulation product to fall into the *passband*.

**Table 6.7.3.2-1: input intermodulation requirement for NR repeater when co-exist with BS/repeater in other non-overlapping frequency bands**

Frequency range of interfering signal	Interfering signal mean power (dBm)	Type of interfering signals	Measurement bandwidth
Frequency range of co-existence system operating band	-15	2 CW carriers	1MHz
NOTE 1: All the interfering signals should be limited into the frequency ranges that are either X MHz higher than $F_{\text{UL,high}}$ or X MHz lower than $F_{\text{UL,low}}$ , where X equals to 20MHz when $F_{\text{UL,high}} - F_{\text{UL,low}}$ is not larger than 200MHz, otherwise X equals to 60MHz			

## 6.8 Output intermodulation

### 6.8.1 General

The output intermodulation requirement is a measure of the capability of the repeater to inhibit the generation of signals in its non-linear elements caused by presence of the wanted signal and an interfering signal reaching the repeater via the output port. The requirement shall apply during the *transmitter ON state* and the *transmitter transient period*.

The requirement shall apply to the uplink and downlink of the Repeater.

For *repeater type 1-C*, the output intermodulation level is the power of the intermodulation products when an interfering signal is injected into the *antenna connector*.

### 6.8.2 Minimum requirements for *repeater type 1-C*

#### 6.8.2.1 Minimum requirements

The output intermodulation level is the power of the intermodulation products when an interfering signal is injected into the output port. The wanted signal *passband* shall be the maximum bandwidth supported by the repeater.

For *repeater type 1-C*, the wanted signal and interfering signal centre frequency is specified in table 6.8.2.1-1, where interfering signal level is *rated total output power* ( $P_{\text{rated,t,AC}}$ ) at *antenna connector* in the *passband* – 30 dB.

The unwanted emission with output intermodulation applied shall not exceed the corresponding uplink and downlink unwanted emission limits in clause 6.5 in the presence of an interfering signal according to table 6.8.2.1-1. The measurement may be limited to frequencies on which third and fifth order intermodulation products appear, considering the width of these products.

**Table 6.8.2.1-1: Interfering and wanted signals for the output intermodulation requirement**

Parameter	Value
Wanted signal type	NR signal, filling all supported <i>passbands</i> in the operating band and with sufficient carriers to fill each <i>passband</i> . Minimum defined SCS for the operating band
Interfering signal type	NR signal, with the minimum SCS and channel bandwidth defined in the operating band in [2]
Interfering signal level	<i>Rated total output power</i> ( $P_{\text{rated,t,AC}}$ ) in the <i>passband</i> – 30 dB
Interfering signal centre frequency offset from the lower/upper edge of the wanted signal or edge of <i>sub-block</i> inside a <i>sub-block gap</i>	$f_{\text{offset}} = \pm \text{minimum pass band} \left( n - \frac{1}{2} \right)$ , for n=1, 2 and 3
NOTE 1: Interfering signal positions that are partially or completely outside of any downlink operating band of the repeater are excluded from the requirement, unless the interfering signal positions fall within the frequency range of adjacent downlink operating bands in the same geographical area. In case that none of the interfering signal positions fall completely within the frequency range of the downlink operating band, TS 38.115-1 [7] provides further guidance regarding appropriate test requirements.	
NOTE 2: In Japan, NOTE 1 is not applied in Band n77, n78, n79.	

#### 6.8.2.2 Additional requirements

For repeater supporting Band n41 and n90 operation in Japan, the sum of output intermodulation level over all *antenna connectors* shall not exceed the unwanted emission limits in clauses 6.5 in the presence of an NR interfering signal according to table 6.8.2.2-1.

**Table 6.8.2-1 Interfering and wanted signals for the additional output intermodulation requirement for Band n41 and n90**

Parameter	Value
Wanted signal	NR single (NOTE)
Interfering signal type	NR signal of 10 MHz <i>passband bandwidth</i>
Interfering signal level	<i>Rated total output power</i> ( $P_{\text{rated,t,AC}}$ ) in the <i>passband</i> – 30 dB
Interfering signal centre frequency offset from the lower/upper <i>passband</i> centre frequency of the wanted signal	$\pm 5$ MHz $\pm 15$ MHz $\pm 25$ MHz
NOTE: This requirement applies for <i>passband</i> allocated within 2545-2645 MHz.	

## 6.9 Adjacent Channel Rejection Ratio (ACRR)

### 6.9.1 General

Adjacent Channel Rejection Ratio (ACRR) is the ratio of the average gain over a carrier of the repeater in the *passband* to the average gain of the repeater over an adjacent channel outside the repeater *passband*. The carrier in the *passband* and in the adjacent channel shall be of the same type (reference carrier) with bandwidths as defined by *nominal channel bandwidth*.

The requirement shall apply to the uplink and downlink of the Repeater, where the donor link is maintained via antennas (wireless Repeater).

The requirement is differentiated between uplink and downlink.

The requirement shall apply during the *transmitter ON state*.

### 6.9.2 Minimum Requirements

For a repeater operating at *passband* below 2496 MHz, the ACRR requirements in table 6.9.2-1 shall apply in downlink. ACRR for downlink shall be higher than the value specified in the table 6.9.2-1.

**Table 6.9.2-1: Repeater Downlink ACRR below 2496MHz**

Co-existence with other systems	Repeater Class	Channel offset from frequency edge of <i>passband</i> (MHz)	ACRR limit
UTRA, E-UTRA, NR	Wide Area repeater	$BW_{\text{Nominal}}/2$	45
	Medium Range repeater	$BW_{\text{Nominal}}/2$	45
	Local Area repeater	$BW_{\text{Nominal}}/2$	33 (Note 1)
NOTE 1: This requirement does not applicable if the <i>passband</i> occupies the entire <i>operating band</i> .			

For a repeater operating at *passband* above 2496 MHz, the ACRR requirements in table 6.9.2-1a shall apply in downlink. ACRR for downlink shall be higher than the value specified in the table 6.9.2-1a.

**Table 6.9.2-1a: Repeater Downlink ACRR above 2496 MHz**

Co-existence with other systems	Repeater Class	Channel offset from frequency edge of <i>passband</i> (MHz)	ACRR limit
UTRA, E-UTRA, NR	Wide Area repeater	$BW_{\text{Nominal}}/2$	33dB
	Medium Range repeater	$BW_{\text{Nominal}}/2$	33dB
	Local Area repeater	$BW_{\text{Nominal}}/2$	33dB (Note 1)
NOTE 1: This requirement does not applicable if the <i>passband</i> occupies the entire <i>operating band</i> .			

For a repeater operating at *passband* below 2496 MHz, the ACRR requirements in table 6.9.2-2 shall apply in uplink. ACRR for uplink shall be higher than the value specified in the table 6.9.2-2.

**Table 6.9.2-2: Repeater Uplink ACRR below 2496 MHz**

Co-existence with other systems	Repeater Class	Channel offset from frequency edge of <i>passband</i> (MHz)	ACRR limit
UTRA, E-UTRA, NR	Wide Area repeater	$BW_{Nominal}/2$	33dB
	Local Area repeater	$BW_{Nominal}/2$	33dB (Note 1)
NOTE 1: This requirement does not applicable if the <i>passband</i> occupies the entire <i>operating band</i> .			

For a repeater operating at *passband* above 2496 MHz, the ACRR requirements in table 6.9.2-2a shall apply in uplink. ACRR for uplink shall be higher than the value specified in the table 6.9.2-2a.

**Table 6.9.2-2a: Repeater Uplink ACRR above 2496 MHz**

Co-existence with other systems	Repeater Class	Channel offset from frequency edge of <i>passband</i> (MHz)	ACRR limit
UTRA, E-UTRA, NR	Wide Area repeater	$BW_{Nominal}/2$	33dB
	Local Area repeater	5MHz	20dBc (Note 1, Note 2)
		$BW_{Nominal}/2$	33dBc (Note 1)
NOTE 1: This requirement does not applicable if the <i>passband</i> occupies the entire <i>operating band</i> .			
NOTE 2: In this case, the channel within the <i>passband</i> and the adjacent channel are assumed to have a bandwidth of 10 MHz			

## 6.10 Transmit ON/OFF power

### 6.10.1 Transmitter OFF power

#### 6.10.1.1 General

Transmit OFF power requirements apply only to TDD operation of the repeater. The requirement applies to both downlink and uplink of the repeater.

Transmitter OFF power is defined as the mean power measured over  $70/N$  us filtered with a square filter of bandwidth equal to the *passband bandwidth* of the repeater ( $BW_{passband}$ ) centred on the assigned channel frequency during the *transmitter OFF state*.  $N = SCS/15$ , where SCS is Sub Carrier Spacing in kHz of the input signal.

For *multi-band connectors* and for *single band connectors* supporting transmission in multiple *operating bands*, the requirement is only applicable during the *transmitter OFF state* in all supported *operating bands*.

#### 6.10.1.2 Minimum requirement for *repeater type 1-C*

For *repeater type 1-C downlink*, the requirements for transmitter OFF power spectral density shall be less than -85 dBm/MHz per *antenna connector*.

For *repeater type 1-C uplink*, the requirements for transmitter OFF power spectral density shall be less than  $-50dBm / (SCS \cdot (12 \cdot N_{RB} + 1) / 1000)$  MHz per *antenna connector*, where SCS is Sub Carrier Spacing in kHz.

### 6.10.2 Transmitter transient period

#### 6.10.2.1 General

*Transmitter transient period* requirements apply only to TDD operation of the repeater. The requirement applies to both downlink and uplink of the repeater.

The *transmitter transient period* is the time period during which the transmitter is changing from the *transmitter OFF state* to the *transmitter ON state* or vice versa. The *transmitter transient period* is illustrated in figure 6.10.2.1-1.



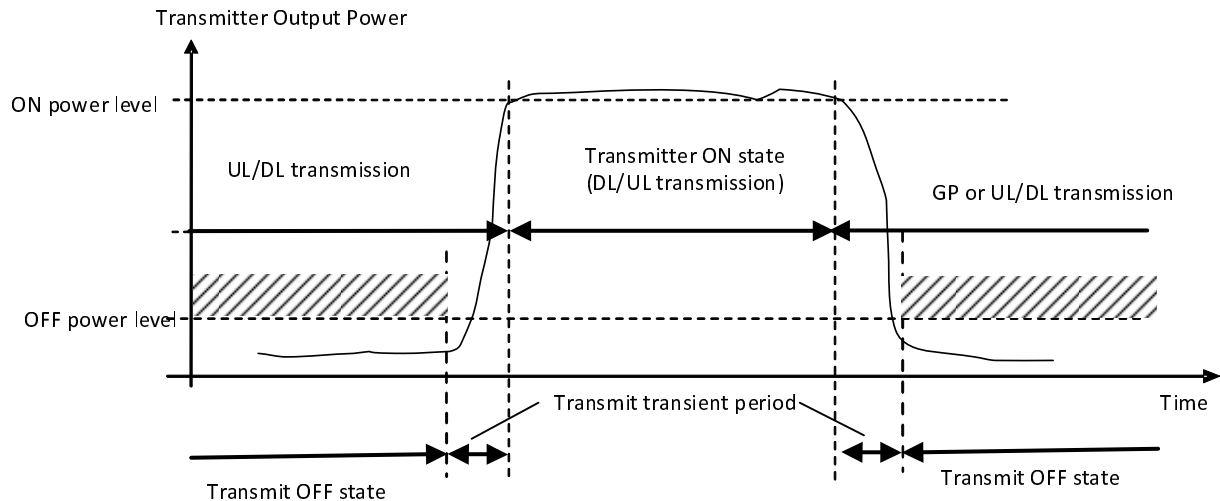

**Figure 6.10.2.1-1: Example of relations between *transmitter ON state*, *transmitter OFF state* and *transmitter transient period***

For *repeater type 1-C* this requirement shall be applied at the *antenna connector* supporting transmission in the *operating band*. The beginning and end point of downlink and uplink bursts are referenced to the slot timing at the input.

**6.10.2.2 Minimum requirement for *repeater type 1-C***

For *repeater type 1-C*, the *transmitter transient period* shall be shorter than the values listed in the minimum requirement table 6.10.2.2-1.

**Table 6.10.2.2-1: Minimum requirement for the *transmitter transient period* for *repeater type 1-C***

Transition	Transient period length (µs)
OFF to ON	10
ON to OFF	10

## 7 Radiated characteristics

### 7.1 General

Radiated characteristics are specified at RIB for *repeater type 2-O*. Requirements apply in both DL and UL unless otherwise stated or declared.

All requirements are defined for normal conditions, unless otherwise stated.

### 7.2 OTA output power

#### 7.2.1 General

*Repeater type 2-O* are declared to support one or more beams, as per manufacturer's declarations specified in TS 38.115-2 [8]. Radiated transmit power is defined as the EIRP level for a declared beam at a specific *beam peak direction*.

For each beam, the requirement is based on declaration of a beam identity, *reference beam direction pair*, beamwidth, *rated beam EIRP*, *OTA peak directions set*, the *beam direction pairs* at the maximum steering directions and their associated *rated beam EIRP* and beamwidth(s).

For a declared beam and *beam direction pair*, the *rated beam EIRP* level is the maximum power that the repeater is declared to radiate at the associated *beam peak direction*.

For each *beam peak direction* associated with a *beam direction pair* within the *OTA peak directions set*, a specific *rated beam EIRP* level may be claimed. Any claimed value shall be met within the accuracy requirement as described below. *Rated beam EIRP* is only required to be declared for the *beam direction pairs* subject to conformance testing as detailed in TS 38.115-2 [8].

NOTE 1: *OTA peak directions set* is set of *beam peak directions* for which the EIRP accuracy requirement is intended to be met. The *beam peak directions* are related to a corresponding contiguous range or discrete list of *beam centre directions* by the *beam direction pairs* included in the set.

NOTE 2: A *beam direction pair* is data set consisting of the *beam centre direction* and the related *beam peak direction*.

NOTE 3: A declared EIRP value is a value provided by the manufacturer for verification according to the conformance specification declaration requirements, whereas a claimed EIRP value is provided by the manufacturer to the equipment user for normal operation of the equipment and is not subject to formal conformance testing.

For *pass bands* where the supported *fractional bandwidth* (FBW) is larger than 6%, two rated beam EIRP may be declared by manufacturer:

- $P_{\text{rated,out,FBWlow}}$  for lower supported frequency range, and
- $P_{\text{rated,out,FBWhigh}}$  for higher supported frequency range.

For frequencies in between  $F_{\text{FBWlow}}$  and  $F_{\text{FBWhigh}}$  the rated beam EIRP is:

- $P_{\text{rated,out,FBWlow}}$ , for the output whose frequency is within frequency range  $F_{\text{FBWlow}} \leq f < (F_{\text{FBWlow}} + F_{\text{FBWhigh}}) / 2$ ,
- $P_{\text{rated,out,FBWhigh}}$ , for the output whose frequency is within frequency range  $(F_{\text{FBWlow}} + F_{\text{FBWhigh}}) / 2 \leq f \leq F_{\text{FBWhigh}}$ .

OTA repeater output power is also declared as a TRP radiated requirement, with the output power accuracy requirement defined at the RIB. TRP does not change with beamforming settings as long as the *beam peak direction* is within the *OTA peak directions set*. Thus, the TRP accuracy requirement shall be met for any beamforming setting for which the *beam peak direction* is within the *OTA peak directions set*.

There is no upper limit for the *rated TRP output power* and the *rated beam EIRP output power* of repeater type 2-O DL transmission.

The *repeater rated TRP output power* and the *rated beam EIRP output power* for repeater type 2-O UL transmission shall be within limits as specified in table 9.2.1-1.

**Table 7.2.1-1: Repeater *rated TRP output power* limits for repeater type 2-O UL transmission**

Repeater class	$P_{\text{rated,p,TRP}}$	$P_{\text{rated,p,EIRP}}$
Wide Area	(note 1)	(note 1)
Local Area	$\leq + 35 + X$ dBm (Note 2)	$\leq + 55 + X$ dBm (Note 2)
NOTE1: There is no upper limit for the $P_{\text{rated,p,TRP}}$ or $P_{\text{rated,p,EIRP}}$ of the <i>repeater type</i> 2-O UL transmission.		
NOTE2: $X = 10 \cdot \log(\text{ceil}(\text{passband bandwidth}/100\text{MHz}))$		

## 7.2.2 Minimum requirement

The AoA of the input signal shall be the same as the reference direction for the *OTA peak directions set* when operating in the opposite DL/UL direction.

The requirements shall apply with NR signals in the *passband* of the repeater at:

The lowest input power ( $P_{\text{p,in,EIRP}}$ ) that produces the *rated passband TRP output power* ( $P_{\text{rated,p,TRP}}$ )

Up to:

The lowest input power ( $P_{p,in,EIRP}$ ) that produces the *rated passband TRP output power* ( $P_{rated,p,TRP}$ ), plus 10dB.

In normal conditions, the measured output power,  $P_{max,p,EIRP}$  shall remain within +3.4 dB and -3.4 dB of the *rated beam EIRP output power*  $P_{rated,p,EIRP}$ , declared by the manufacturer.

In extreme conditions, the measured output power,  $P_{max,p,EIRP}$  shall remain within +4.5 dB and -4.5 dB of the *rated beam EIRP output power*  $P_{rated,p,EIRP}$ , declared by the manufacturer.

In normal conditions, the *repeater type 2-O maximum passband TRP output power*,  $P_{max,p,TRP}$  measured at the RIB shall remain within  $\pm 3$  dB of the *rated passband TRP output power*  $P_{rated,p,TRP}$ , as declared by the manufacturer.

## 7.3 OTA frequency stability

### 7.3.1 General

Frequency stability is the ability to maintain the same frequency on the output signal with respect to the input signal.

OTA frequency stability requirement is defined as a *directional requirement* at the RIB and shall be met within the *OTA coverage range*.

### 7.3.2 Minimum requirement

The frequency deviation of the output signal with respect to the input signal shall be no more than  $\pm 0,01$  PPM.

## 7.4 OTA out of band gain

### 7.4.1 General

Out of band gain refers to the gain of the repeater outside the *passband*.

The requirement is based on the ratio of TRP output power to directional input power.

The intended use of a repeater in a system is to amplify the in-band signals and not to amplify signals outside of the *passband*.

In the intended application of the repeater, the out of band gain is less than lowest expected the coupling loss to the nearest source of emissions.

### 7.4.2 Minimum requirement

The gain outside the *passband* shall not exceed the maximum level specified in table 7.4.2-1, where:

- $f_{offset\_CW}$  is the offset between the outer channel edge frequency of the outer channel in the *passband* and a CW signal.

**Table 7.4.2-1: Out of band gain limits 1**

Frequency offset, $f_{offset\_CW}$	Maximum gain
$0.1 * \text{Minimum} \{400\text{MHz}, \text{passband BW}\} \leq f_{offset\_CW} < 150$ MHz	68 dB
$150 \text{ MHz} \leq f_{offset\_CW} < 400 \text{ MHz}$	55 dB
$400 \text{ MHz} \leq f_{offset\_CW} < f_{offset\_max}$	35 dB

## 7.5 OTA unwanted emissions

### 7.5.1 General

Unwanted emissions consist of so-called out-of-band emissions and spurious emissions according to ITU definitions ITU-R SM.329 [5]. In ITU terminology, out of band emissions are unwanted emissions immediately outside the *passband* resulting from the modulation process and non-linearity in the transmitter but excluding spurious emissions. Spurious emissions are emissions which are caused by unwanted transmitter effects such as harmonics emission, parasitic emission, intermodulation products and frequency conversion products, but exclude out of band emissions.

The OTA out-of-band emissions requirement for the *repeater type 2-O* transmitter is specified both in terms of Adjacent Channel Leakage power Ratio (ACLR) and Operating Band Unwanted Emissions (OBUE). OTA Unwanted emissions outside of this frequency range are limited by an OTA spurious emissions requirement.

The maximum offset of the operating band unwanted emissions mask from the *operating band* edge is  $\Delta f_{\text{OBUE}}$ . The value of  $\Delta f_{\text{OBUE}}$  is defined in table 7.5.1-1 for *repeater type 2-O* for NR *operating bands*.

**Table 7.5.1-1: Maximum offset  $\Delta f_{\text{OBUE}}$  outside the downlink *operating band* for *repeater type 2-O***

Repeater type	Operating band characteristics	$\Delta f_{\text{OBUE}}$ (MHz)
Repeater type 2-O	$F_{\text{DL,high}} - F_{\text{DL,low}} \leq 4000$ MHz	1500

The unwanted emission requirements are applied per cell for all the configurations. Requirements for OTA unwanted emissions are captured using TRP, *directional requirements* or co-location requirements as described per requirement.

### 7.5.2 OTA Adjacent Channel Leakage Power Ratio (ACLR)

#### 7.5.2.1 General

OTA Adjacent Channel Leakage power Ratio (ACLR) is the ratio of the filtered mean power centred on the assigned channel frequency to the filtered mean power centred on an adjacent channel frequency. The measured power is TRP.

The requirement shall be applied per RIB during the *transmitter ON state*.

#### 7.5.2.2 Minimum requirement for *repeater type 2-O*

The OTA ACLR limit is specified in table 7.5.2.2-1 for DL and UL for Wide Area class and DL for Local Area class.

The OTA ACLR limit is specified in table 7.5.2.2-1a for UL for Local Area class.

The OTA ACLR absolute limit is specified in table 7.5.2.2-2.

Either the OTA ACLR (CACLR) absolute limit in table 7.5.2.2-2 or 7.5.2.2-5 or the relevant ACLR (CACLR) limit in table 7.5.2.2-1, 7.5.2.2-1a, 7.5.2.2-3, 7.5.5.2-3a, 7.5.2.2-4 or 7.5.2.2-4a, whichever is less stringent, shall apply.

For a RIB operating in *non-contiguous spectrum*, the OTA ACLR requirement in table 7.5.2.2-3 shall apply in *gaps between passbands* for the frequency ranges defined in the table, while the OTA CACLR requirement in table 7.5.2.2-4 shall apply in *gaps between passbands* for the frequency ranges defined in the table.

The CACLR in a *gap between passbands* is the ratio of:

- the sum of the filtered mean power centred on the assigned channel frequencies for the two carriers adjacent to each side of the *gap between passbands*, and
- the filtered mean power centred on a frequency channel adjacent to one of the respective *passband* edges.

The assumed filter for the adjacent channel frequency is defined in table 7.5.2.2-4 and the filters on the assigned channels are defined in table 7.5.2.2-6.

For operation in *non-contiguous spectrum*, the CACLR for NR carriers located on either side of the *gap between passbands* shall be higher than the value specified in table 7.5.2.2-4.

**Table 7.5.2.2-1: Repeater type 2-O ACLR limit for DL and UL for WA class and DL for LA class**

Repeater nominal channel bandwidth $BW_{\text{Nominal}}$ (MHz)	Repeater adjacent channel centre frequency offset below or above the passband edge	Assumed adjacent channel carrier	Filter on the adjacent channel frequency and corresponding filter bandwidth	ACLR limit (dB)
50, 100, 200, 400	$BW_{\text{Nominal}}/2$	NR of same BW (Note 2)	Square ( $BW_{\text{Config}}$ )	28 (Note 3) 26 (Note 4)
NOTE 1: $BW_{\text{Nominal}}$ is the <i>nominal channel bandwidth</i> . $BW_{\text{Config}}$ is the <i>transmission bandwidth configuration</i> assumed for the adjacent channel.				
NOTE 2: With SCS that provides the largest <i>transmission bandwidth configuration</i> ( $BW_{\text{Config}}$ ).				
NOTE 3: Applicable to bands defined within the frequency spectrum range of 24.25 – 33.4 GHz				
NOTE 4: Applicable to bands defined within the frequency spectrum range of 37 – 52.6 GHz				

**Table 7.5.2.2-1a: Repeater type 2-O ACLR limit for UL LA class**

Repeater nominal channel bandwidth $BW_{\text{Nominal}}$ (MHz)	Repeater adjacent channel centre frequency offset below or above the passband edge	Assumed adjacent channel carrier	Filter on the adjacent channel frequency and corresponding filter bandwidth	ACLR limit (dB)
50, 100, 200, 400	$BW_{\text{Nominal}}/2$	NR of same BW (Note 2)	Square ( $BW_{\text{Config}}$ )	17 (Note 3) 16 (Note 4)
NOTE 1: $BW_{\text{Nominal}}$ is the <i>nominal channel bandwidth</i> . $BW_{\text{Config}}$ is the <i>transmission bandwidth configuration</i> assumed for the adjacent channel.				
NOTE 2: With SCS that provides the largest <i>transmission bandwidth configuration</i> ( $BW_{\text{Config}}$ ).				
NOTE 3: Applicable to bands defined within the frequency spectrum range of 24.25 – 33.4 GHz				
NOTE 4: Applicable to bands defined within the frequency spectrum range of 37 – 52.6 GHz				

**Table 7.5.2.2-2: Repeater type 2-O ACLR absolute limit**

Repeater class	ACLR absolute limit
Wide area DL and UL	-13 dBm/MHz
Medium range DL	-20 dBm/MHz
Local area DL	-20 dBm/MHz

**Table 7.5.2.2-3: Repeater type 2-O ACLR limit in non-contiguous spectrum for DL and UL for WA class and DL for LA class**

Repeater nominal channel bandwidth $BW_{\text{Nominal}}$ (MHz)	Gap between passbands size ( $W_{\text{gap}}$ ) where the limit applies (MHz)	Repeater adjacent channel centre frequency offset below or above the passband edge (inside the gap)	Assumed adjacent channel carrier	Filter on the adjacent channel frequency and corresponding filter bandwidth	ACLR limit
50, 100, 200, 400	$W_{\text{gap}} \geq 100$ (Note 5) $W_{\text{gap}} \geq 250$ (Note 6)	25 MHz	50 MHz NR (Note 2)	Square ( $BW_{\text{Config}}$ )	28 (Note 3) 26 (Note 4)
50, 100, 200, 400	$W_{\text{gap}} \geq 400$ (Note 6) $W_{\text{gap}} \geq 250$ (Note 5)	100 MHz	200 MHz NR (Note 2)	Square ( $BW_{\text{Config}}$ )	28 (Note 3) 26 (Note 4)

NOTE 1:  $BW_{\text{Nominal}}$  is the *nominal channel bandwidth*.  $BW_{\text{Config}}$  is the *transmission bandwidth configuration* assumed for the adjacent channel.  
NOTE 2: With SCS that provides the largest *transmission bandwidth configuration* ( $BW_{\text{Config}}$ ).  
NOTE 3: Applicable to bands defined within the frequency spectrum range of 24.25 – 33.4 GHz.  
NOTE 4: Applicable to bands defined within the frequency spectrum range of 37 – 52.6 GHz.  
NOTE 5: Applicable in case the *repeater type 2-O nominal channel bandwidth* at the other edge of the gap is  $\leq 100$  MHz.  
NOTE 6: Applicable in case the *repeater type 2-O nominal channel bandwidth* at the other edge of the gap is  $> 100$  MHz.

**Table 7.5.2.2-3a: Repeater type 2-O ACLR limit in non-contiguous spectrum for UL for LA class**

Repeater nominal channel bandwidth $BW_{\text{Nominal}}$ (MHz)	Gap between passbands size ( $W_{\text{gap}}$ ) where the limit applies (MHz)	Repeater adjacent channel centre frequency offset below or above the passband edge (inside the gap)	Assumed adjacent channel carrier	Filter on the adjacent channel frequency and corresponding filter bandwidth	ACLR limit
50, 100, 200, 400	$W_{\text{gap}} \geq 100$ (Note 5) $W_{\text{gap}} \geq 250$ (Note 6)	25 MHz	50 MHz NR (Note 2)	Square ( $BW_{\text{Config}}$ )	17 (Note 3) 16 (Note 4)
50, 100, 200, 400	$W_{\text{gap}} \geq 400$ (Note 6) $W_{\text{gap}} \geq 250$ (Note 5)	100 MHz	200 MHz NR (Note 2)	Square ( $BW_{\text{Config}}$ )	17 (Note 3) 16 (Note 4)

NOTE 1:  $BW_{\text{Config}}$  is the *transmission bandwidth configuration* assumed for the adjacent channel.  
NOTE 2: With SCS that provides the largest *transmission bandwidth configuration* ( $BW_{\text{Config}}$ ).  
NOTE 3: Applicable to bands defined within the frequency spectrum range of 24.25 – 33.4 GHz.  
NOTE 4: Applicable to bands defined within the frequency spectrum range of 37 – 52.6 GHz.  
NOTE 5: Applicable in case the *repeater type 2-O nominal channel bandwidth* at the other edge of the gap is  $\leq 100$  MHz.  
NOTE 6: Applicable in case the *repeater type 2-O nominal channel bandwidth* at the other edge of the gap is  $> 100$  MHz.

**Table 7.5.2.2-4: Repeater type 2-O CACLR limit in non-contiguous spectrum for DL and UL for WA class and DL for LA class**

Repeater nominal channel bandwidth $BW_{Nominal}$ (MHz)	Gap between passbands size ( $W_{gap}$ ) where the limit applies (MHz)	Repeater adjacent channel centre frequency offset below or above the passband edge (inside the gap)	Assumed adjacent channel carrier	Filter on the adjacent channel frequency and corresponding filter bandwidth	CACLR limit
50, 100, 200, 400	$50 \leq W_{gap} < 100$ (Note 5) $50 \leq W_{gap} < 250$ (Note 6)	25 MHz	50 MHz NR (Note 2)	Square ( $BW_{Config}$ )	28 (Note 3) 26 (Note 4)
50, 100, 200, 400	$200 \leq W_{gap} < 400$ (Note 6) $200 \leq W_{gap} < 250$ (Note 5)	100 MHz	200 MHz NR (Note 2)	Square ( $BW_{Config}$ )	28 (Note 3) 26 (Note 4)

NOTE 1:  $BW_{Config}$  is the *transmission bandwidth configuration* assumed for the adjacent channel.

NOTE 2: With SCS that provides the largest *transmission bandwidth configuration* ( $BW_{Config}$ ).

NOTE 3: Applicable to bands defined within the frequency spectrum range of 24.25 – 33.4 GHz.

NOTE 4: Applicable to bands defined within the frequency spectrum range of 37 – 52.6 GHz.

NOTE 5: Applicable in case the *repeater type 2-O nominal channel bandwidth* at the other edge of the gap is  $\leq 100$  MHz.

NOTE 6: Applicable in case the *repeater type 2-O nominal channel bandwidth* at the other edge of the gap is  $> 100$  MHz.

**Table 7.5.2.2-4a: Repeater type 2-O CACLR limit in non-contiguous spectrum for UL for LA class**

Repeater nominal channel bandwidth $BW_{Nominal}$ (MHz)	Gap between passbands size ( $W_{gap}$ ) where the limit applies (MHz)	Repeater adjacent channel centre frequency offset below or above the passband edge (inside the gap)	Assumed adjacent channel carrier	Filter on the adjacent channel frequency and corresponding filter bandwidth	CACLR limit
50, 100, 200, 400	$50 \leq W_{gap} < 100$ (Note 5) $50 \leq W_{gap} < 250$ (Note 6)	25 MHz	50 MHz NR (Note 2)	Square ( $BW_{Config}$ )	17 (Note 3) 16 (Note 4)
50, 100, 200, 400	$200 \leq W_{gap} < 400$ (Note 6) $200 \leq W_{gap} < 250$ (Note 5)	100 MHz	200 MHz NR (Note 2)	Square ( $BW_{Config}$ )	17 (Note 3) 16 (Note 4)

NOTE 1:  $BW_{Config}$  is the *transmission bandwidth configuration* assumed for the adjacent channel.

NOTE 2: With SCS that provides the largest *transmission bandwidth configuration* ( $BW_{Config}$ ).

NOTE 3: Applicable to bands defined within the frequency spectrum range of 24.25 – 33.4 GHz.

NOTE 4: Applicable to bands defined within the frequency spectrum range of 37 – 52.6 GHz.

NOTE 5: Applicable in case the *repeater type 2-O nominal channel bandwidth* at the other edge of the gap is  $\leq 100$  MHz.

NOTE 6: Applicable in case the *repeater type 2-O nominal channel bandwidth* at the other edge of the gap is  $> 100$  MHz.

**Table 7.5.2.2-5: Repeater type 2-O CACLR absolute limit**

Repeater class	CACLR absolute limit
Wide area DL and UL	-13 dBm/MHz
Medium range DL	-20 dBm/MHz
Local area DL	-20 dBm/MHz

**Table 7.5.2.2-6: Filter parameters for the assigned channel**

RAT of the carrier adjacent to the gap between passbands	Filter on the assigned channel frequency and corresponding filter bandwidth
NR	NR of same BW with SCS that provides largest <i>transmission bandwidth configuration</i>

## 7.5.3 OTA operating band unwanted emissions

### 7.5.3.1 General

The OTA limits for operating band unwanted emissions are specified as TRP per RIB unless otherwise stated.

In addition to, for the part of passband where there is no input signal, -13dBm/MHz shall apply for all classes DL and UL.

### 7.5.3.2 Minimum requirement for *repeater type 2-O*

#### 7.5.3.2.1 General

The requirements of either clause 7.5.3.2.2 (Category A limits) or clause 7.5.3.2.3 (Category B limits) shall apply. The application of either Category A or Category B limits shall be the same as for General OTA transmitter spurious emissions requirements (*repeater type 2-O*) in clause 7.5.3.3.2. In addition, the limits in clause 7.5.3.2.4 may also apply.

Out-of-band emissions in FR2 are limited by OTA operating band unwanted emission limits.

For *repeater type 2-O*, unless otherwise stated, the OTA operating band unwanted emission limits in FR2 are defined from  $\Delta f_{\text{OBUE}}$  below the lowest frequency of each supported downlink *operating band* up to  $\Delta f_{\text{OBUE}}$  above the highest frequency of each supported downlink *operating band*.

The values of  $\Delta f_{\text{OBUE}}$  are defined in table 7.5.1-1 for the NR *operating bands*.

The requirements shall apply whatever the type of transmitter considered and for all transmission modes foreseen by the manufacturer's specification. For a *RIB* operating in contiguous CA, the requirements apply to the frequencies ( $\Delta f_{\text{OBUE}}$ ) starting from the edge of the *passband*. In addition, for a *RIB* operating in *non-contiguous spectrum*, the requirements apply inside any *gap between passbands*.

Emissions shall not exceed the maximum levels specified in the tables below, where:

- $\Delta f$  is the separation between the *passband* edge frequency and the nominal -3dB point of the measuring filter closest to the *passband* edge.
- $f_{\text{offset}}$  is the separation between the *passband* edge frequency and the centre of the measuring filter.
- $f_{\text{offset}_{\text{max}}}$  is the offset to the frequency  $\Delta f_{\text{OBUE}}$  outside the downlink *operating band*, where  $\Delta f_{\text{OBUE}}$  is defined in table 7.5.1-1.
- $\Delta f_{\text{max}}$  is equal to  $f_{\text{offset}_{\text{max}}}$  minus half of the bandwidth of the measuring filter.

In addition, inside any *gap between passbands* for a *RIB* operating in *non-contiguous spectrum*, emissions shall not exceed the cumulative sum of the limits specified for the adjacent *sub-blocks* on each side of the *gap between passbands*. The limit for each *sub-block* is specified in clauses 7.5.3.2.2 and 7.5.3.2.3 below, where in this case:

- $\Delta f$  is the separation between the *sub-block* edge frequency and the nominal -3 dB point of the measuring filter closest to the *sub-block* edge.
- $f_{\text{offset}}$  is the separation between the *sub-block* edge frequency and the centre of the measuring filter.
- $f_{\text{offset}_{\text{max}}}$  is equal to the *gap between passbands* bandwidth minus half of the bandwidth of the measuring filter.
- $\Delta f_{\text{max}}$  is equal to  $f_{\text{offset}_{\text{max}}}$  minus half of the bandwidth of the measuring filter.

#### 7.5.3.2.2 OTA operating band unwanted emission limits (Category A)

*Repeater type 2-O* unwanted emissions shall not exceed the maximum levels specified in tables 7.5.3.2.2-1 and 7.5.3.5.2-2.



Table 7.5.3.2.2-1: OBUE limits applicable in the frequency range 24.25 – 33.4 GHz

Frequency offset of measurement filter -3B point, $\Delta f$	Frequency offset of measurement filter centre frequency, $f_{\text{offset}}$	Limit	Measurement bandwidth
$0 \text{ MHz} \leq \Delta f < 0.1 * \text{BW}_{\text{contiguous}}$	$0.5 \text{ MHz} \leq f_{\text{offset}} < 0.1 * \text{BW}_{\text{contiguous}} + 0.5 \text{ MHz}$	Min(-5 dBm, Max( $P_{\text{rated,t,TRP}} - 35 \text{ dB}$ , -12 dBm))	1 MHz
$0.1 * \text{BW}_{\text{contiguous}} \leq \Delta f < \Delta f_{\text{max}}$	$0.1 * \text{BW}_{\text{contiguous}} + 0.5 \text{ MHz} \leq f_{\text{offset}} < f_{\text{offset}_{\text{max}}}$	Min(-13 dBm, Max( $P_{\text{rated,t,TRP}} - 43 \text{ dB}$ , -20 dBm))	1 MHz

NOTE 1: For *non-contiguous spectrum* operation within any *operating band* the limit within *gaps between passbands* is calculated as a cumulative sum of contributions from adjacent *sub-blocks* on each side of the *gap between passbands*.

Table 7.5.3.2.2-2: OBUE limits applicable in the frequency range 37 – 52.6 GHz

Frequency offset of measurement filter -3B point, $\Delta f$	Frequency offset of measurement filter centre frequency, $f_{\text{offset}}$	Limit	Measurement bandwidth
$0 \text{ MHz} \leq \Delta f < 0.1 * \text{BW}_{\text{contiguous}}$	$0.5 \text{ MHz} \leq f_{\text{offset}} < 0.1 * \text{BW}_{\text{contiguous}} + 0.5 \text{ MHz}$	Min(-5 dBm, Max( $P_{\text{rated,t,TRP}} - 33 \text{ dB}$ , -12 dBm))	1 MHz
$0.1 * \text{BW}_{\text{contiguous}} \leq \Delta f < \Delta f_{\text{max}}$	$0.1 * \text{BW}_{\text{contiguous}} + 0.5 \text{ MHz} \leq f_{\text{offset}} < f_{\text{offset}_{\text{max}}}$	Min(-13 dBm, Max( $P_{\text{rated,t,TRP}} - 41 \text{ dB}$ , -20 dBm))	1 MHz

NOTE 1: For *non-contiguous spectrum* operation within any *operating band* the limit within *gaps between passbands* is calculated as a cumulative sum of contributions from adjacent *sub-blocks* on each side of the *gap between passbands*.

### 7.5.3.2.3 OTA operating band unwanted emission limits (Category B)

Repeater type 2-O unwanted emissions shall not exceed the maximum levels specified in table 7.5.3.2.3-1 or 7.5.3.2.3-2.

Table 7.5.3.2.3-1: OBUE limits applicable in the frequency range 24.25 – 33.4 GHz

Frequency offset of measurement filter -3 dB point, $\Delta f$	Frequency offset of measurement filter centre frequency, $f_{\text{offset}}$	Limit	Measurement bandwidth
$0 \text{ MHz} \leq \Delta f < 0.1 * \text{BW}_{\text{contiguous}}$	$0.5 \text{ MHz} \leq f_{\text{offset}} < 0.1 * \text{BW}_{\text{contiguous}} + 0.5 \text{ MHz}$	Min(-5 dBm, Max( $P_{\text{rated,t,TRP}} - 35 \text{ dB}$ , -12 dBm))	1 MHz
$0.1 * \text{BW}_{\text{contiguous}} \leq \Delta f < \Delta f_{\text{B}}$	$0.1 * \text{BW}_{\text{contiguous}} + 0.5 \text{ MHz} \leq f_{\text{offset}} < \Delta f_{\text{B}} + 0.5 \text{ MHz}$	Min(-13 dBm, Max( $P_{\text{rated,t,TRP}} - 43 \text{ dB}$ , -20 dBm))	1 MHz
$\Delta f_{\text{B}} \leq \Delta f < \Delta f_{\text{max}}$	$\Delta f_{\text{B}} + 5 \text{ MHz} \leq f_{\text{offset}} < f_{\text{offset}_{\text{max}}}$	Min(-5 dBm, Max( $P_{\text{rated,t,TRP}} - 33 \text{ dB}$ , -10 dBm))	10 MHz

NOTE 1: For *non-contiguous spectrum* operation within any *operating band* the limit within *gaps between passbands* is calculated as a cumulative sum of contributions from adjacent *sub-blocks* on each side of the *gap between passbands*.

NOTE 2:  $\Delta f_{\text{B}} = 2 * \text{BW}_{\text{contiguous}}$  when  $\text{BW}_{\text{contiguous}} \leq 500 \text{ MHz}$ , otherwise  $\Delta f_{\text{B}} = \text{BW}_{\text{contiguous}} + 500 \text{ MHz}$ .

**Table 7.5.3.2.3-2: OBUE limits applicable in the frequency range 37 – 52.6 GHz**

Frequency offset of measurement filter -3 dB point, $\Delta f$	Frequency offset of measurement filter centre frequency, $f_{\text{offset}}$	Limit	Measurement bandwidth
$0 \text{ MHz} \leq \Delta f < 0.1 * \text{BW}_{\text{contiguous}}$	$0.5 \text{ MHz} \leq f_{\text{offset}} < 0.1 * \text{BW}_{\text{contiguous}} + 0.5 \text{ MHz}$	Min(-5 dBm, Max( $P_{\text{rated,t,TRP}} - 33 \text{ dB}$ , -12 dBm))	1 MHz
$0.1 * \text{BW}_{\text{contiguous}} \leq \Delta f < \Delta f_{\text{B}}$	$0.1 * \text{BW}_{\text{contiguous}} + 0.5 \text{ MHz} \leq f_{\text{offset}} < \Delta f_{\text{B}} + 0.5 \text{ MHz}$	Min(-13 dBm, Max( $P_{\text{rated,t,TRP}} - 41 \text{ dB}$ , -20 dBm))	1 MHz
$\Delta f_{\text{B}} \leq \Delta f < \Delta f_{\text{max}}$	$\Delta f_{\text{B}} + 5 \text{ MHz} \leq f_{\text{offset}} < f_{\text{offset}_{\text{max}}}$	Min(-5 dBm, Max( $P_{\text{rated,t,TRP}} - 31 \text{ dB}$ , -10 dBm))	10 MHz
NOTE 1: For non-contiguous spectrum operation within any <i>operating band</i> the limit within gaps between <i>passbands</i> is calculated as a cumulative sum of contributions from adjacent sub-blocks on each side of the gap between <i>passbands</i> .			
NOTE 2: $\Delta f_{\text{B}} = 2 * \text{BW}_{\text{contiguous}}$ when $\text{BW}_{\text{contiguous}} \leq 500 \text{ MHz}$ , otherwise $\Delta f_{\text{B}} = \text{BW}_{\text{contiguous}} + 500 \text{ MHz}$ .			

### 7.5.3.2.4 Additional OTA operating band unwanted emission requirements

#### 7.5.3.2.4.1 Protection of Earth Exploration Satellite Service

For repeater operating in the frequency range 24.25 – 27.5 GHz, the power of unwanted emission shall not exceed the limits in table 7.5.3.2.4.1-1 for DL and in table 7.5.3.2.4.1-2.

**Table 7.5.3.2.4.1-1: OBUE limits for protection of Earth Exploration Satellite Service for DL**

Frequency range	Limit	Measurement Bandwidth
23.6 – 24 GHz	-3 dBm (Note 1)	200 MHz
23.6 – 24 GHz	-9 dBm (Note 2)	200 MHz
NOTE 1: This limit applies to repeater brought into use on or before 1 September 2027.		
NOTE 2: This limit applies to repeater brought into use after 1 September 2027.		

**Table 7.5.3.2.4.1-2: OBUE limits for protection of Earth Exploration Satellite Service for UL**

Frequency range	Limit	Measurement Bandwidth
23.6 – 24 GHz	1 dBm	200 MHz

## 7.5.4 OTA transmitter spurious emissions

### 7.5.4.1 General

Unless otherwise stated, all requirements are measured as mean power.

The OTA spurious emissions limits are specified as TRP per RIB unless otherwise stated.

### 7.5.4.2 Minimum requirement for *repeater type 2-0*

#### 7.5.4.2.1 General

For *repeater type 2-0*, the OTA transmitter spurious emission limits apply from 30 MHz to 2<sup>nd</sup> harmonic of the upper frequency edge of the downlink *operating band*, excluding the frequency range from  $\Delta f_{\text{OBUE}}$  below the lowest frequency of the downlink *operating band*, up to  $\Delta f_{\text{OBUE}}$  above the highest frequency of the downlink *operating band*, where the  $\Delta f_{\text{OBUE}}$  is defined in table 7.5.1-1.

### 7.5.4.2.2 General OTA transmitter spurious emissions requirements

#### 7.5.4.2.2.1 General

The requirements of either clause 7.5.4.2.2.2 (Category A limits) or clause 7.5.4.2.2.3 (Category B limits) shall apply. The application of either Category A or Category B limits shall be the same as for Operating band unwanted emissions in clause 7.5.4.

#### 7.5.4.2.2.2 OTA transmitter spurious emissions (Category A)

The power of any spurious emission shall not exceed the limits in table 7.5.4.2.2.2-1.

**Table 7.5.4.2.2.2-1: Repeater radiated Tx spurious emission limits in FR2**

Frequency range	Limit	Measurement Bandwidth	Note
30 MHz – 1 GHz	-13 dBm	100 kHz	Note 1
1 GHz – 2 <sup>nd</sup> harmonic of the upper frequency edge of the <i>operating band</i>		1 MHz	Note 1, Note 2

NOTE 1: Bandwidth as in ITU-R SM.329 [5], s4.1  
NOTE 2: Upper frequency as in ITU-R SM.329 [5], s2.5 table 1.

#### 7.5.4.2.2.3 OTA transmitter spurious emissions (Category B)

The power of any spurious emission shall not exceed the limits in table 7.5.4.2.2.3-1.

**Table 7.5.4.2.2.3-1: Repeater radiated Tx spurious emission limits in FR2 (Category B)**

Frequency range (Note 4)	Limit	Measurement Bandwidth	Note
30 MHz ↔ 1 GHz	-36 dBm	100 kHz	Note 1
1 GHz ↔ 18 GHz	-30 dBm	1 MHz	Note 1
18 GHz ↔ $F_{\text{step},1}$	-20 dBm	10 MHz	Note 2
$F_{\text{step},1}$ ↔ $F_{\text{step},2}$	-15 dBm	10 MHz	Note 2
$F_{\text{step},2}$ ↔ $F_{\text{step},3}$	-10 dBm	10 MHz	Note 2
$F_{\text{step},4}$ ↔ $F_{\text{step},5}$	-10 dBm	10 MHz	Note 2
$F_{\text{step},5}$ ↔ $F_{\text{step},6}$	-15 dBm	10 MHz	Note 2
$F_{\text{step},6}$ ↔ 2 <sup>nd</sup> harmonic of the upper frequency edge of the <i>operating band</i>	-20 dBm	10 MHz	Note 2, Note 3

NOTE 1: Bandwidth as in ITU-R SM.329 [5], s4.1  
NOTE 2: Limit and bandwidth as in ERC Recommendation 74-01 [9], Annex 2.  
NOTE 3: Upper frequency as in ITU-R SM.329 [5], s2.5 table 1.  
NOTE 4: The step frequencies  $F_{\text{step},x}$  are defined in table 7.5.4.2.2.3-2.

**Table 7.5.4.2.2.3-2: Step frequencies for defining the Repeater radiated Tx spurious emission limits in FR2 (Category B)**

Operating band	$F_{\text{step},1}$ (GHz)	$F_{\text{step},2}$ (GHz)	$F_{\text{step},3}$ (GHz) (Note 2)	$F_{\text{step},4}$ (GHz) (Note 2)	$F_{\text{step},5}$ (GHz)	$F_{\text{step},6}$ (GHz)
n257	18	23.5	25	31	32.5	41.5
n258	18	21	22.75	29	30.75	40.5
n259	23.5	35.5	38	45	47.5	59.5
n263	18	43	53.5	74.5	85	127

NOTE 1:  $F_{\text{step},x}$  are based on ERC Recommendation 74-01 [9], Annex 2.  
NOTE 2:  $F_{\text{step},3}$  and  $F_{\text{step},4}$  are aligned with the values for  $\Delta f_{\text{OBUE}}$  in table 7.5.1-1.

### 7.5.4.2.3 Additional OTA transmitter spurious emissions requirements

These requirements may be applied for the protection of systems operating in frequency ranges other than the repeater-Node. The limits may apply as an optional protection of such systems that are deployed in the same geographical area as the repeater-Node, or they may be set by local or regional regulation as a mandatory requirement for an NR *operating band*. It is in some cases not stated in the present document whether a requirement is mandatory or under what exact circumstances that a limit applies, since this is set by local or regional regulation. An overview of regional requirements in the present document is given in clause 4.4.

#### 7.5.4.2.3.1 Limits for protection of Earth Exploration Satellite Service

For repeater operating in the frequency range 24.25 – 27.5 GHz, the power of any spurious emissions shall not exceed the limits in table 7.5.4.2.3.1-1 and table 7.5.4.2.3.1-2.

**Table 7.5.4.2.3.1-1: Limits for protection of Earth Exploration Satellite Service for DL**

Frequency range	Limit	Measurement Bandwidth	Note
23.6 – 24 GHz	-3 dBm	200 MHz	Note 1
23.6 – 24 GHz	-9 dBm	200 MHz	Note 2
NOTE 1: This limit applies to Repeater brought into use on or before 1 September 2027.			
NOTE 2: This limit applies to Repeater brought into use after 1 September 2027.			

**Table 7.5.4.2.3.1-2: OBUE limits for protection of Earth Exploration Satellite Service for UL**

Frequency range	Limit	Measurement Bandwidth
23.6 – 24 GHz	1 dBm	200 MHz

## 7.6 OTA Repeater Error Vector Magnitude

### 7.6.1 Downlink repeater error vector magnitude

#### 7.6.1.1 General

The Repeater Error Vector Magnitude (EVM) is a measure of the difference between the symbols provided at the input of the repeater and the measured signal symbols at the output of the repeater after the equalization by the measurement equipment. This difference is called the error vector. Details about how the repeater EVM is determined are same as specified in TS 38.104 [2] Annex C for FR2. The repeater EVM result is defined as the square root of the ratio of the mean error vector power to the mean reference power expressed in percent.

OTA modulation quality requirement is defined as a *directional requirement* at the RIB and shall be met within the *OTA coverage range* on the transmit side and the AoA of the incident wave of the received signal is in the reference direction at the receive side.

The repeater EVM requirement is applicable when the repeater is operating with an input power level within the range from what is required to reach the rated beam EIRP output power ( $P_{\text{rated,p,EIRP}}$ ) to the minimum power levels in table 7.6.1.1-1.

**Table 7.6.1.1-1: Minimum input power for repeater EVM**

BS class	Minimum input power (dBm/MHz)					
	24.25 – 33.4 GHz			37 – 52.6 GHz		
	Up to 16 QAM	64QAM <sup>1</sup>	256QAM <sup>2</sup>	Up to 16 QAM	64QAM <sup>1</sup>	256QAM <sup>2</sup>
WA, MR, LA	-77- G <sub>RX_ANT</sub>	-73- G <sub>RX_ANT</sub>	-66- G <sub>RX_ANT</sub>	-75- G <sub>RX_ANT</sub>	-71- G <sub>RX_ANT</sub>	-64- G <sub>RX_ANT</sub>
Note 1: support of 64QAM is based on the declaration						
Note 2: support of 256QAM is based on the declaration						

Where  $G_{RX\_ANT}$  is the gain of the receive side antennas and is based on EIRP and TRP declaration.

### 7.6.1.2 Minimum requirement

The repeater EVM levels for different modulation schemes outlined in table 7.6.1.2-1 shall be met using the frame structure described in clause 7.6.1.3.

**Table 7.6.1.2-1: Repeater EVM requirements**

Parameter	Required repeater EVM
Up to 16QAM	12.5%
64QAM	8 % <sup>1</sup>
256QAM	3.5 % <sup>2</sup>
Note 1: support of 64QAM is based on the declaration	
Note 2: support of 256QAM is based on the declaration.	

### 7.6.1.3 Repeater EVM frame structure for measurement

The input signals for the repeater EVM requirement shall have the same frame structure as defined for the BS in TS 38.104 [2].

## 7.6.2 Uplink repeater error vector magnitude

### 7.6.2.1 General

The Repeater Error Vector Magnitude is a measure of the difference between the reference waveform provided at the input of repeater and the measured waveform at the output of the repeater. This difference is called the error vector. Details about how the repeater EVM is determined are the same as specified in TS 38.101-2 [14] Annex F for FR2. Before calculating the repeater EVM, the measured waveform is corrected by the sample timing offset and RF frequency offset. Then the carrier leakage shall be removed from the measured waveform before calculating the repeater EVM.

The measured waveform is further equalised using the channel estimates subjected to the EVM equaliser spectrum flatness requirement specified in TS 38.101-2 [14] clauses 6.4.2.4 and 6.4.2.5. For DFT-s-OFDM waveforms, the repeater EVM result is defined after the front-end FFT and IDFT as the square root of the ratio of the mean error vector power to the mean reference power expressed as a %. For CP-OFDM waveforms, the repeater EVM result is defined after the front-end FFT as the square root of the ratio of the mean error vector power to the mean reference power expressed as a %.

The basic repeater EVM measurement interval is one slot in the time domain. The repeater EVM measurement interval is reduced by any symbols that contains an allowable power transient in the measurement interval as defined in TS 38.101-2 [14] clause 6.3.3.

All the parameters defined in clause 7.6.2 are defined using the measurement methodology specified in TS 38.101-2 [14] Annex F.

OTA modulation quality requirement is defined as a *directional requirement* at the RIB and shall be met within the *OTA coverage range* on the transmit side and the AoA of the incident wave of the received signal is in the reference direction at the receive side.

The repeater EVM requirement is applicable when the repeater is operating with an input power level within the range from what is required to reach the rated beam EIRP output power ( $P_{rated,p,EIRP}$ ) to the minimum input power levels in table 7.6.2.1-1.

**Table 7.6.2.1-1: Minimum input power for repeater EVM**

BS class	Minimum input power (dBm/MHz)			
	24.25 – 33.4 GHz		37 – 52.6 GHz	
	Up to 16 QAM	64QAM <sup>1</sup>	Up to 16 QAM	64QAM <sup>1</sup>
WA, MR, LA	-77- $G_{RX\_ANT}$	-73- $G_{RX\_ANT}$	-75- $G_{RX\_ANT}$	-71- $G_{RX\_ANT}$

Note 1: support of 64QAM is based on the declaration

Where  $G_{RX\_ANT}$  is the gain of the receive side antennas and is calculated from EIRP and TRP declaration.

## 7.6.2.2 Minimum requirement

The RMS average of the basic repeater EVM measurements over 10 subframes for the average repeater EVM case, for the different modulation schemes shall not exceed the values specified in table 7.6.2.1-1.

**Table 7.6.2.2-1: Minimum requirements for repeater error vector magnitude**

Parameter	Unit	Average repeater EVM level
Up to 16 QAM	%	12.5
64 QAM	%	8 <sup>1</sup>

Note 1: support of 64QAM is based on the declaration

## 7.7 OTA input intermodulation

### 7.7.1 General

The input intermodulation is a measure of the capability of the repeater to inhibit the generation of interference in the *passband*, in the presence of interfering signals on frequencies other than the *passband*. The requirement is defined as a directional requirement.

The requirement shall apply at the RIB when the AoA of the incident wave of a received signal and the interfering signal are from the same direction:

The interfering signals apply to each supported polarization, under the assumption of polarization match.

The following requirement applies for interfering signals depending on the repeaters *passband*.

This requirement applies to the uplink and downlink of the repeater during the *transmitter ON state*.

### 7.7.2 Minimum requirement

For the parameters specified in table 7.7.2-1, the power in the *passband* shall not increase with more than 10 dB at the output of the repeater as measured with 1 MHz measurement bandwidth, compared to the level obtained without interfering signals applied.

The core requirement is applicable for all frequency separation possibilities between the two interfering signals that cause the 3rd order intermodulation product to fall into the whole *passband*.

Table 7.7.2-1 specifies the parameters for two interfering signals, where:

- $f_1$  offset is the offset from the channel edge frequency of the first or last channel in the *passband* of the closer carrier.
- $G_{RX\_ANT}$  is the gain of the receive side antennas and is calculated from EIRP and TRP declaration.

Table 7.7.2-1: Input intermodulation requirement

$f_1$ offset	Interfering Signal Levels	Type of signals	Measurement bandwidth
1 MHz	-53dBm – $G_{RX\_ANT}$	2 CW carriers	1 MHz

## 7.8 OTA Adjacent Channel Rejection Ratio (ACRR)

### 7.8.1 General

OTA Adjacent Channel Rejection Ratio (ACRR) is the ratio of the average gain over a carrier of the repeater in the *passband* to the average gain of the repeater over an adjacent channel outside the repeater *passband*. The requirement shall apply to the uplink and downlink of the Repeater. The bandwidth of the channel inside the *passband* and the adjacent channel shall be of the same type (reference carrier) with bandwidths as defined by *nominal channel bandwidth*.

The requirement is differentiated between downlink and uplink.

The requirement shall apply during the *transmitter ON state*.

The ACRR is a ratio of gain in the adjacent channel to gain in the wanted channel. The gain in each case is defined as the ratio of TRP output power to directional input power.

### 7.8.2 Minimum Requirements

The requirement shall apply at the RIB when the AoA of the incident wave of a received signal in the *passband* and a received signal on an adjacent channel outside repeater *passband* is from the same direction and are the same as the TX reference direction for the opposite DL/UL setting.

For a repeater operating at *passband* operating in FR2, the ACRR requirements in table 7.8.2-1 shall apply in downlink. ACRR for downlink shall be higher than the value specified in the table 7.8.2-1.

Table 7.8.2-1: Repeater Downlink ACRR

Co-existence with other systems	Repeater Class	Channel offset from frequency edge of <i>passband</i> (MHz)	ACRR limit
NR	Wide Area repeater	$BW_{Nominal}/2$	28 (Note 2) 26 (Note 3)
	Medium Range repeater	$BW_{Nominal}/2$	28 (Note 2) 26 (Note 3)
	Local Area repeater	$BW_{Nominal}/2$	28 (Notes 1, 2) 26 (Note 1, 3)
NOTE 1: This requirement does not applicable if the <i>passband</i> occupies the entire <i>operating band</i> .			
NOTE 2: Applicable to bands defined within the frequency spectrum range of 24.25 – 33.4 GHz.			
NOTE 3: Applicable to bands defined within the frequency spectrum range of 37 – 52.6 GHz			

For a repeater operating at *passband* operating in FR2, the ACRR requirements in table 7.8.2-2 shall apply in uplink. In ACRR for uplink shall be higher than the value specified in the table 7.8.2-2.

Table 7.8.2-2: Repeater Uplink ACRR

Co-existence with other systems	Repeater Class	Channel offset from frequency edge of <i>passband</i> (MHz)	ACRR limit
NR	Wide Area repeater	$BW_{Nominal}/2$	28 (Note 2) 26 (Note 3)
	Local Area repeater	$BW_{Nominal}/2$	17 (Notes 1, 2) 16 (Note 1, 3)
NOTE 1: This requirement does not applicable if the <i>passband</i> occupies the entire <i>operating band</i> .			
NOTE 2: Applicable to bands defined within the frequency spectrum range of 24.25 – 33.4 GHz.			
NOTE 3: Applicable to bands defined within the frequency spectrum range of 37 – 52.6 GHz.			

## 7.9 OTA transmit ON/OFF power

### 7.9.1 General

OTA transmit ON/OFF power requirements apply only to TDD operation of repeater. The requirements apply to both downlink and uplink of the repeater.

### 7.9.2 OTA transmitter OFF power

#### 7.9.2.1 General

OTA transmitter OFF power is defined as the mean power measured over  $70/N$   $\mu$ s filtered with a square filter of bandwidth equal to the *passband bandwidth* of the repeater ( $BW_{\text{passband}}$ ) centred on the assigned channel frequency during the *transmitter OFF state*.  $N = \text{SCS}/15$ , where SCS is Sub Carrier Spacing in kHz of the input signal. The OTA transmitter OFF power is defined as TRP.

#### 7.9.2.2 Minimum requirement for *repeater type 2-O*

The OTA transmitter OFF TRP spectral density for *repeater type 2-O* shall be less than -36 dBm/MHz.

### 7.9.3 OTA transient period

#### 7.9.3.1 General

The OTA *transmitter transient period* is the time period during which the transmitter is changing from the *transmitter OFF state* to the *transmitter ON state* or vice versa. The *transmitter transient period* is illustrated in figure 7.9.3.1-1.

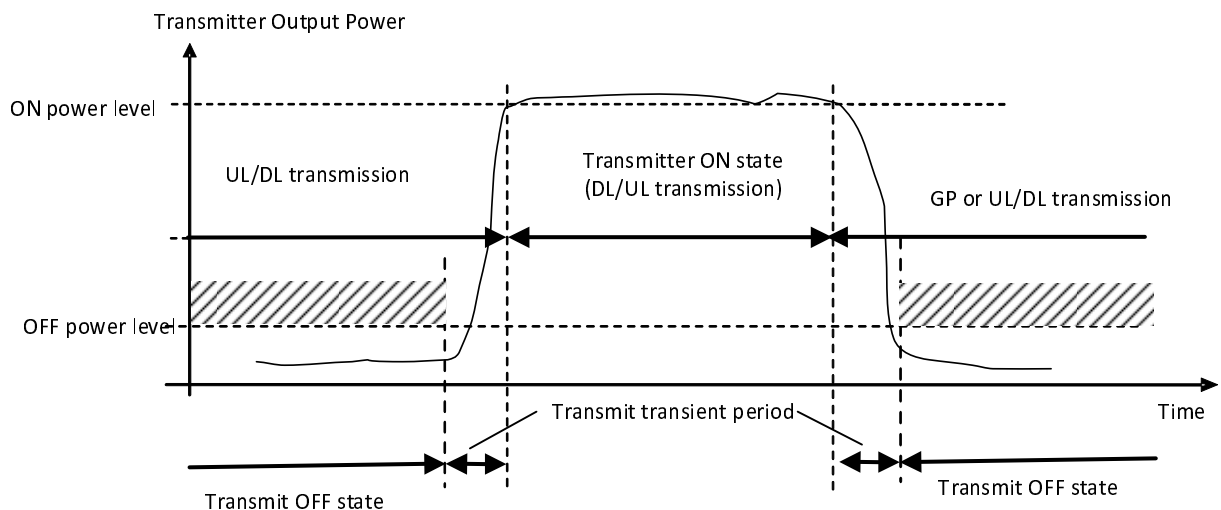

**Figure 7.9.3.1-1: Example of relations between *transmitter ON state*, *transmitter OFF state* and *transmitter transient period***

This requirement shall be applied at each RIB supporting transmission in the *operating band*. The beginning and end point of downlink and uplink bursts are referenced to the slot timing at the input.

#### 7.9.3.2 Minimum requirement for *repeater type 2-O*

For *repeater type 2-O*, the OTA *transmitter transient period* shall be shorter than the values listed in the minimum requirement table 7.9.3.2-1.



**Table 7.9.3.2-1: Minimum requirement for the OTA *transmitter transient period* for repeater type 2-O**

<b>Transition</b>	<b>Transient period length (<math>\mu\text{s}</math>)</b>
OFF to ON	3
ON to OFF	3

## Annex A: Void

## Annex B (informative): Change history

Change history							
Date	TSG #	TSG Doc.	CR	Rev	Subject/Comment	Old	New
2022-03	RAN#95e	RP-220790			NR Repeater Radio Transmission and Reception		1.0.0

Change history							
Date	Meeting	TDoc	CR	Rev	Cat	Subject/Comment	New version
2022-03	RAN#95					Approved by plenary – Rel-17 spec under change control	17.0.0
2022-06	RAN#96	RP-221681	0002	1	F	CR to 38.106: TDD off power radiated requirement correction	17.1.0
2022-06	RAN#96	RP-221681	0003	1	F	CR to 38.106: Corections to definitons, symbols and abbreviations	17.1.0
2022-06	RAN#96	RP-221681	0004	1	F	CR to 38.106: Output power definitions for NR repeaters	17.1.0
2022-06	RAN#96	RP-221681	0006	1	F	CR for TS 38.106 R17: clean up of clause 4	17.1.0
2022-06	RAN#96	RP-221681	0007	1	F	CR for TS 38.106 R17: clean up of clause 6	17.1.0
2022-06	RAN#96	RP-221681	0008	1	F	CR for TS 38.106 R17: clean up of clause 7	17.1.0
2022-06	RAN#96	RP-221681	0009	1	F	CR to TS 38.106: clarification on the supported operating bands for NR repeater	17.1.0
2022-06	RAN#96	RP-221681	0011	1	F	CR to TS 38.106 with corrections to repeater core specification	17.1.0
2022-06	RAN#96	RP-221681	0012		F	BIG CR to 38.106 maintenance	17.1.0
2022-09	RAN#97	RP-222034	0013		F	CR to 38.106: NR repeater ACLR requirements	17.2.0
2022-09	RAN#97	RP-222034	0015	1	F	CR to 38.106: NR repeater receiver spurious emissions requirements	17.2.0
2022-09	RAN#97	RP-222034	0016		F	CR to 38.106: Removal of unlicensed bands for NR repeaters	17.2.0
2022-09	RAN#97	RP-222034	0017	1	F	CR to 38.106: Correction of LA ACLR requirements	17.2.0
2022-09	RAN#97	RP-222034	0018		F	CR to 38.106: Correction of LA ACLR requirements	17.2.0
2022-09	RAN#97	RP-222034	0019	1	F	CR to TS 38.106 with updates and corrections for conductive part	17.2.0
2022-09	RAN#97	RP-222034	0020		F	CR to TS 38.106 with updates and corrections for radiated part	17.2.0
2022-09	RAN#97	RP-222034	0021		F	Big CR for TS 38.106 Maintenance (Rel-17, CAT F)	17.2.0
2022-12	RAN#98-e	RP-223310	0026	1	F	CR to 38.106: ACLR requirements	17.3.0
2022-12	RAN#98-e	RP-223310	0027	1	F	CR to 38.106: EVM requirements	17.3.0
2022-12	RAN#98-e	RP-223310	0028	1	F	CR to 38.106: ACRR requirements	17.3.0
2023-03	RAN#99	RP-230518	0029	1	F	CR for TS 38.106: Correction of some errors in 3.2	17.4.0
2023-06	RAN#100	RP-231339	0035		F	CR to 38.106: Corrections on repeater OTA output power requirements (Rel-17)	17.5.0
2023-09	RAN#101	RP-232496	0038	1	F	[NR_repeater] CR to 38.106: Input intermodulation	17.6.0
2023-12	RAN#102	RP-233350	0043	1	F	CR to 38.106: Correction of terminologies for NR repeaters (Rel-17)	17.7.0
2023-12	RAN#102	RP-233350	0046		F	CR to TS 38.106 with correction of co-existence and co-location requirements	17.7.0
2024-03	RAN#103	RP-240574	0063	1	F	CR to 38.106: NR repeater transmitter spurious emissions requirements (rel-17)	17.8.0
2024-06	RAN#104	RP-241468	0079		F	CR to TS 38.106: removal of environmental annex	17.9.0
2024-09	RAN#105	RP-242186	0092	1	F	Clarification on extreme conditions	17.10.0

---

# History

<b>Document history</b>		
V17.0.0	April 2022	Publication
V17.1.0	August 2022	Publication
V17.2.0	October 2022	Publication
V17.3.0	January 2023	Publication
V17.4.0	May 2023	Publication
V17.5.0	July 2023	Publication
V17.6.0	October 2023	Publication
V17.7.0	January 2024	Publication
V17.8.0	May 2024	Publication
V17.9.0	August 2024	Publication
V17.10.0	October 2024	Publication