

ETSI TS 138 115-1 V17.5.0 (2024-05)



**5G;
NR;
Repeater conformance testing -
Part 1: Conducted conformance testing
(3GPP TS 38.115-1 version 17.5.0 Release 17)**



Reference

RTS/TSGR-0438115-1vh50

Keywords

5G

ETSI

650 Route des Lucioles
F-06921 Sophia Antipolis Cedex - FRANCE

Tel.: +33 4 92 94 42 00 Fax: +33 4 93 65 47 16

Siret N° 348 623 562 00017 - APE 7112B
Association à but non lucratif enregistrée à la
Sous-Préfecture de Grasse (06) N° w061004871

Important notice

The present document can be downloaded from:

<https://www.etsi.org/standards-search>

The present document may be made available in electronic versions and/or in print. The content of any electronic and/or print versions of the present document shall not be modified without the prior written authorization of ETSI. In case of any existing or perceived difference in contents between such versions and/or in print, the prevailing version of an ETSI deliverable is the one made publicly available in PDF format at www.etsi.org/deliver.

Users of the present document should be aware that the document may be subject to revision or change of status.

Information on the current status of this and other ETSI documents is available at

<https://portal.etsi.org/TB/ETSIDeliverableStatus.aspx>

If you find errors in the present document, please send your comment to one of the following services:

<https://portal.etsi.org/People/CommitteeSupportStaff.aspx>

If you find a security vulnerability in the present document, please report it through our
Coordinated Vulnerability Disclosure Program:

<https://www.etsi.org/standards/coordinated-vulnerability-disclosure>

Notice of disclaimer & limitation of liability

The information provided in the present deliverable is directed solely to professionals who have the appropriate degree of experience to understand and interpret its content in accordance with generally accepted engineering or other professional standard and applicable regulations.

No recommendation as to products and services or vendors is made or should be implied.

No representation or warranty is made that this deliverable is technically accurate or sufficient or conforms to any law and/or governmental rule and/or regulation and further, no representation or warranty is made of merchantability or fitness for any particular purpose or against infringement of intellectual property rights.

In no event shall ETSI be held liable for loss of profits or any other incidental or consequential damages.

Any software contained in this deliverable is provided "AS IS" with no warranties, express or implied, including but not limited to, the warranties of merchantability, fitness for a particular purpose and non-infringement of intellectual property rights and ETSI shall not be held liable in any event for any damages whatsoever (including, without limitation, damages for loss of profits, business interruption, loss of information, or any other pecuniary loss) arising out of or related to the use of or inability to use the software.

Copyright Notification

No part may be reproduced or utilized in any form or by any means, electronic or mechanical, including photocopying and microfilm except as authorized by written permission of ETSI.

The content of the PDF version shall not be modified without the written authorization of ETSI.

The copyright and the foregoing restriction extend to reproduction in all media.

© ETSI 2024.
All rights reserved.

Intellectual Property Rights

Essential patents

IPRs essential or potentially essential to normative deliverables may have been declared to ETSI. The declarations pertaining to these essential IPRs, if any, are publicly available for **ETSI members and non-members**, and can be found in ETSI SR 000 314: "*Intellectual Property Rights (IPRs); Essential, or potentially Essential, IPRs notified to ETSI in respect of ETSI standards*", which is available from the ETSI Secretariat. Latest updates are available on the ETSI Web server (<https://ipr.etsi.org/>).

Pursuant to the ETSI Directives including the ETSI IPR Policy, no investigation regarding the essentiality of IPRs, including IPR searches, has been carried out by ETSI. No guarantee can be given as to the existence of other IPRs not referenced in ETSI SR 000 314 (or the updates on the ETSI Web server) which are, or may be, or may become, essential to the present document.

Trademarks

The present document may include trademarks and/or tradenames which are asserted and/or registered by their owners. ETSI claims no ownership of these except for any which are indicated as being the property of ETSI, and conveys no right to use or reproduce any trademark and/or tradename. Mention of those trademarks in the present document does not constitute an endorsement by ETSI of products, services or organizations associated with those trademarks.

DECT™, **PLUGTESTS™**, **UMTS™** and the ETSI logo are trademarks of ETSI registered for the benefit of its Members. **3GPP™** and **LTE™** are trademarks of ETSI registered for the benefit of its Members and of the 3GPP Organizational Partners. **oneM2M™** logo is a trademark of ETSI registered for the benefit of its Members and of the oneM2M Partners. **GSM®** and the GSM logo are trademarks registered and owned by the GSM Association.

Legal Notice

This Technical Specification (TS) has been produced by ETSI 3rd Generation Partnership Project (3GPP).

The present document may refer to technical specifications or reports using their 3GPP identities. These shall be interpreted as being references to the corresponding ETSI deliverables.

The cross reference between 3GPP and ETSI identities can be found under <https://webapp.etsi.org/key/queryform.asp>.

Modal verbs terminology

In the present document "**shall**", "**shall not**", "**should**", "**should not**", "**may**", "**need not**", "**will**", "**will not**", "**can**" and "**cannot**" are to be interpreted as described in clause 3.2 of the [ETSI Drafting Rules](#) (Verbal forms for the expression of provisions).

"**must**" and "**must not**" are **NOT** allowed in ETSI deliverables except when used in direct citation.

Contents

Intellectual Property Rights	2
Legal Notice	2
Modal verbs terminology.....	2
Foreword.....	8
1 Scope	10
2 References	10
3 Definitions of terms, symbols and abbreviations	11
3.1 Terms.....	11
3.2 Symbols.....	12
3.3 Abbreviations	12
4 General conducted test conditions and declarations.....	13
4.1 Measurement uncertainties and test requirements	13
4.1.1 General.....	13
4.1.2 Acceptable uncertainty of Test System.....	13
4.1.2.1 General	13
4.1.2.2 Conducted characteristics measurements	14
4.1.3 Interpretation of measurement results	16
4.2 Conducted requirement reference points	16
4.3 Repeater classes.....	16
4.3.1 Repeater class for downlink.....	16
4.3.2 Repeater class for uplink.....	17
4.4 Regional requirements.....	17
4.5 Repeater configurations.....	17
4.5.1 General configurations.....	17
4.5.2 Transmission with multiple BS-side antenna connectors	17
4.5.3 Transmission with multiple UE-side antenna connectors	18
4.5.4 Duplexers.....	18
4.5.5 Power supply options.....	18
4.5.6 Ancillary RF amplifiers	18
4.5.7 Combining of repeaters.....	19
4.6 Manufacturer declarations	19
4.7 Test configurations	22
4.7.1 General.....	22
4.7.2 Test signal used to build Test Configurations.....	22
4.7.3 RTC1: Contiguous spectrum operation.....	22
4.7.3.1 RTC1 generation	22
4.7.3.2 RTC1 power allocation	23
4.7.5 RTC2: Non-contiguous spectrum operation	23
4.7.5.1 RTC2 generation	23
4.7.5.2 RTC2 power allocation	23
4.7.6 RTC3: Multi-band test configuration for full carrier allocation.....	23
4.7.6.1 RTC3 generation	23
4.7.6.2 RTC3 power allocation	24
4.7.7 RTC4: Multi-band test configuration with high PSD per carrier.....	24
4.7.7.1 RTC4 generation	24
4.7.7.2 RTC4 power allocation	24
4.8 Applicability of requirements.....	24
4.8.1 General.....	24
4.8.2 Applicability of test configurations for single-band operation	24
4.8.4 Applicability of test configurations for multi-band operation	25
4.9 RF channels and test models	26
4.9.1 RF channels	26
4.9.2 Test models	27
4.9.2.1 General	27

4.9.2.2	FR1 test models for repeater type 1-C for DL.....	27
4.9.2.3 FR1 test models for repeater type 1-C for UL	27
4.9.2.3.1	General	27
4.9.2.3.2	FR1 test model 1.1 (RUL-FR1-TM1.1).....	28
4.9.2.3.3	FR1 test model 2 (RUL-FR1-TM2).....	29
4.9.2.3.3a	FR1 test model 2a (RUL-FR1-TM2a)	29
4.9.2.3.4	FR1 test model 3.1 (RUL-FR1-TM3.1).....	29
4.9.2.3.5	FR1 test model 3.1a (RUL-FR1-TM3.1a)	29
4.9.2.4	Data content of Physical channels and Signals for RUL-FR1-TM	30
4.9.2.4.1	General	30
4.9.2.4.2	PUSCH	30
4.10	Requirements for contiguous and non-contiguous spectrum.....	30
4.11	Requirements for repeater capable of multi-band operation	31
4.12	Format and interpretation of tests.....	31
5	Operating bands and channel arrangement.....	32
6	Conducted characteristics.....	32
6.1	General	32
6.2	Repeater output power.....	32
6.2.1	Definition and applicability	32
6.2.2	Minimum requirement	33
6.2.3	Test purpose.....	33
6.2.4	Method of test	33
6.2.4.1	<i>Initial conditions</i>	33
6.2.4.2	<i>Procedure</i>	34
6.2.5	Test requirement	34
6.3	Frequency stability	34
6.3.1	Definition and applicability	34
6.3.2	Minimum Requirement.....	34
6.3.3	Test purpose.....	35
6.3.4	Method of test	35
6.3.5	Test Requirements	35
6.4	Out of band gain.....	35
6.4.1	Definition and applicability	35
6.4.2	Minimum Requirement.....	35
6.4.3	Test purpose.....	35
6.4.4	Method of test	35
6.4.4.1	Initial conditions	35
6.4.4.2	Procedure	35
6.4.5	Test Requirements	35
6.5	Unwanted emissions.....	36
6.5.1	General.....	36
6.5.2	Adjacent Channel Leakage Power Ratio (ACLR)	37
6.5.2.1	Definition and applicability.....	37
6.5.2.2	Minimum requirement	37
6.5.2.3	Test purpose	37
6.5.2.4	Method of test	37
6.5.2.4.1	Initial conditions	37
6.5.2.4.2	Procedure.....	37
6.5.2.5	Test requirements	38
6.5.3	Operating band unwanted emissions	42
6.5.3.1	Definition and applicability.....	42
6.5.3.2	Minimum requirement	44
6.5.3.3	Test purpose	44
6.5.3.4	Method of test	44
6.5.3.4.1	Initial conditions.....	44
6.5.3.4.2	Procedure.....	44
6.5.3.4	Test requirements.....	45
6.5.3.4.1	Minimum requirements for Wide Area repeater type 1-C (Category A).....	45
6.5.3.4.2	Minimum requirements for Wide Area <i>repeater type 1-C</i> (Category B).....	46

6.5.3.4.2.1	Category B requirements (Option 1)	46
6.5.3.4.2.2	Category B requirements (Option 2)	48
6.5.3.4.3	Minimum requirements for Medium Range <i>repeater type I-C</i> (Category A and B) for DL.....	49
6.5.3.4.4	Minimum requirements for Local Area <i>repeater type I-C</i> (Category A and B).....	50
6.5.3.4.5	Minimum requirements for additional requirements	51
6.5.4	Transmitter spurious emissions.....	52
6.5.4.1	Definition and applicability.....	52
6.5.4.2	Minimum requirement	52
6.5.4.3	Test purpose	52
6.5.4.4	Method of test	52
6.5.4.4.1	Initial conditions	52
6.5.4.4.2	Procedure.....	53
6.5.4.5	Test requirements	53
6.5.4.5.1	General transmitter spurious emissions requirements	53
6.5.4.5.2	Additional spurious emissions requirements	54
6.5.4.5.3	Co-location with base stations and <i>repeater type I-C</i> Nodes	64
6.5.5	Receiver spurious emissions	70
6.5.5.1	Definition and applicability.....	70
6.5.5.2	Minimum requirement	70
6.5.5.3	Test purpose	70
6.5.5.4	Method of test	70
6.5.5.4.1	Initial conditions	70
6.5.5.4.2	Procedure.....	70
6.5.5.5	Test requirements	70
6.6	Repeater Error Vector Magnitude	71
6.6.1	Downlink repeater error vector magnitude	71
6.6.1.1	General	71
6.6.1.2	Minimum requirements	71
6.6.1.3	Test purpose	71
6.6.1.4	Method of test	72
6.6.1.4.1	Initial conditions	72
6.6.1.4.2	Procedure.....	72
6.6.1.5	Test requirement	73
6.6.2	Uplink repeater error vector magnitude	73
6.6.2.1	General	73
6.6.2.2	Minimum requirement	73
6.6.2.3	Test purpose	73
6.6.2.3	Method of test	73
6.6.2.3.1	Initial conditions	73
6.6.2.3.2	Procedure.....	74
6.6.2.4	Test requirement	74
6.7	Input intermodulation	75
6.7.1	Definition and applicability	75
6.7.1.1	General	75
6.7.1.2	Minimum requirements	75
6.7.1.3	Test purpose	75
6.7.1.4	Method of test	75
6.7.1.4.1	Initial conditions	75
6.7.1.4.2	Procedure.....	75
6.7.1.5	Test requirements	75
6.7.1.5.1	General requirement	75
6.7.1.5.2	Co-location with BS/Repeater in other systems	76
6.7.1.5.3	Co-existence with other systems	77
6.8	Output intermodulation	77
6.8.1	Definition and applicability	77
6.8.1.1	General	77
6.8.1.2	Minimum requirements	78
6.8.1.3	Test purpose	78
6.8.1.4	Method of test	78
6.8.1.4.1	Initial conditions	78
6.8.1.4.2	Procedure.....	78
6.8.1.5	Test requirements	78

6.8.1.5.1	General requirements.....	78
6.8.1.5.2	Additional requirements	79
6.9	Adjacent Channel Rejection Ratio (ACRR).....	79
6.9.1	Definitions and applicability.....	79
6.9.2	Co-existence with UTRA, E-UTRA and NR.....	80
6.9.2.1	Minimum requirements.....	80
6.9.2.2	Test purpose	80
6.9.2.3	Method of test	80
6.9.2.3.1	Initial conditions.....	80
6.9.2.3.2	Procedure.....	80
6.9.2.3.3	Test Requirements.....	80
6.10	Transmit ON/OFF power	82
6.10.1	Transmitter OFF power	82
6.10.1.1	Definition and applicability.....	82
6.10.1.2	Minimum requirement	82
6.10.1.3	Test purpose	82
6.10.1.4	Method of test	82
6.10.1.5	Test requirements.....	82
6.10.2	Transmitter transient period.....	82
6.10.2.1	Definition and applicability.....	82
6.10.2.2	Minimum requirement	83
6.10.2.3	Test purpose	83
6.10.2.4	Method of test	83
6.10.2.4.1	Initial conditions.....	83
6.10.2.4.2	Procedure.....	83
Annex A (normative): Repeater stimulus signals.....		85
A.1	Repeater stimulus signal 1.....	85
A.2	Repeater stimulus signal 2.....	85
A.3	Repeater stimulus signal spectral purity requirements.....	85
Annex B (normative): Environmental requirements for the repeater		86
B.1	General	86
B.2	Normal test environment.....	86
B.3	Extreme test environment.....	87
B.3.1	Extreme temperature	87
B.4	Vibration.....	87
B.5	Power supply	88
B.6	Measurement of test environments.....	88
Annex C (informative): Test tolerances and derivation of test requirements.....		88
C.1	Measurement of conducted characteristics.....	89
Annex D (informative): Measurement system set-up.....		89
D.1	Repeater output power and transmit ON/OFF power.....	90
D.2	Out of band gain.....	90
D.3	Unwanted emission: Operating band unwanted emission, transmitter spurious emission, and ACLR	91
D.4	Modulation Accuracy: Repeater Error Vector Magnitude and Frequency Stability	91
D.5	Input intermodulation.....	92
D.6	Output Intermodulation	92

D.7	Adjacent Channel Rejection Ratio	93
D.8	Rx spurious emission requirement	93
Annex E (normative): In-channel TX tests		93
E.1	General	94
E.2	Basic principles	94
E.2.1	Output signal of the repeater under test	94
E.2.2	Ideal signal	94
E.2.3	Measurement results	95
E.2.4	Measurement points	95
E.3	Pre-FFT minimization process	96
E.4	Timing of the FFT window	96
E.5	Resource element TX power	97
E.6	Post-FFT equalisation	97
E.7	EVM	99
E.7.0	General	99
E.7.1	Averaged EVM (FDD)	99
E.7.2	Averaged EVM (TDD)	100
Annex F (informative): Change history		101
History		102

Foreword

This Technical Specification has been produced by the 3rd Generation Partnership Project (3GPP).

The contents of the present document are subject to continuing work within the TSG and may change following formal TSG approval. Should the TSG modify the contents of the present document, it will be re-released by the TSG with an identifying change of release date and an increase in version number as follows:

Version x.y.z

where:

- x the first digit:
 - 1 presented to TSG for information;
 - 2 presented to TSG for approval;
 - 3 or greater indicates TSG approved document under change control.
- y the second digit is incremented for all changes of substance, i.e. technical enhancements, corrections, updates, etc.
- z the third digit is incremented when editorial only changes have been incorporated in the document.

In the present document, modal verbs have the following meanings:

- shall** indicates a mandatory requirement to do something
- shall not** indicates an interdiction (prohibition) to do something

The constructions "shall" and "shall not" are confined to the context of normative provisions, and do not appear in Technical Reports.

The constructions "must" and "must not" are not used as substitutes for "shall" and "shall not". Their use is avoided insofar as possible, and they are not used in a normative context except in a direct citation from an external, referenced, non-3GPP document, or so as to maintain continuity of style when extending or modifying the provisions of such a referenced document.

- should** indicates a recommendation to do something
- should not** indicates a recommendation not to do something
- may** indicates permission to do something
- need not** indicates permission not to do something

The construction "may not" is ambiguous and is not used in normative elements. The unambiguous constructions "might not" or "shall not" are used instead, depending upon the meaning intended.

- can** indicates that something is possible
- cannot** indicates that something is impossible

The constructions "can" and "cannot" are not substitutes for "may" and "need not".

- will** indicates that something is certain or expected to happen as a result of action taken by an agency the behaviour of which is outside the scope of the present document
- will not** indicates that something is certain or expected not to happen as a result of action taken by an agency the behaviour of which is outside the scope of the present document
- might** indicates a likelihood that something will happen as a result of action taken by some agency the behaviour of which is outside the scope of the present document

might not indicates a likelihood that something will not happen as a result of action taken by some agency the behaviour of which is outside the scope of the present document

In addition:

is (or any other verb in the indicative mood) indicates a statement of fact

is not (or any other negative verb in the indicative mood) indicates a statement of fact

The constructions "is" and "is not" do not indicate requirements.

1 Scope

The present document specifies the Radio Frequency (RF) test methods and conformance requirements for NR repeater *type 1-C*. These have been derived from, and are consistent with the conducted requirements for *repeater type 1-C* in NR repeater specification defined in TS 38.106 [2].

A *repeater type 1-C* only has conducted requirements so it requires compliance to this specification only.

A *repeater type 2-O* has only radiated requirements so it requires compliance to TS 38.115-2 [3] only.

2 References

The following documents contain provisions which, through reference in this text, constitute provisions of the present document.

- References are either specific (identified by date of publication, edition number, version number, etc.) or non-specific.
- For a specific reference, subsequent revisions do not apply.
- For a non-specific reference, the latest version applies. In the case of a reference to a 3GPP document (including a GSM document), a non-specific reference implicitly refers to the latest version of that document *in the same Release as the present document*.

- [1] 3GPP TR 21.905: "Vocabulary for 3GPP Specifications".
- [2] 3GPP TS 38.106: "NR; Repeater Radio Transmission and Reception"
- [3] 3GPP TS 38.115-2: "NR; Repeater conformance testing, Part 2: Radiated conformance testing"
- [4] ITU-R Recommendation SM.329: "Unwanted emissions in the spurious domain"
- [5] 3GPP TS 38.104: "NR; Base Station (BS) radio transmission and reception"
- [6] 3GPP TS 36.104: "Evolved Universal Terrestrial Radio Access (E-UTRA); Base Station (BS) radio transmission and reception"
- [7] 3GPP TS 38.141-1: "NR; Base Station (BS) conformance testing, Part 1: Conducted conformance testing"
- [8] 3GPP TS 38.211: "NR; Physical channels and modulation"
- [9] 3GPP TS 38.101-1: "NR; User Equipment (UE) radio transmission and reception; Part 1: Range 1 Standalone"
- [10] 3GPP TS 38.331: "NR; Radio Resource Control (RRC) protocol specification"
- [11] ITU-R Recommendation M.1545: "Measurement uncertainty as it applies to test limits for the terrestrial component of International Mobile Telecommunications – 2000"
- [12] ITU-T Recommendation O.150, "Equipment for the measurement of digital and analogue/digital parameters"
- [13] Federal Communications Commission: "Title 47 of the Code of Federal Regulations (CFR) "
- [14] ECC/DEC/(17)06: "The harmonised use of the frequency bands 1427-1452 MHz and 1492-1518 MHz for Mobile/Fixed Communications Networks Supplemental Downlink (MFCN SDL)"
- [15] 3GPP TR 25.942: "RF system scenarios"
- [16] IEC 60 721-3-3: "Classification of environmental conditions - Part 3-3: Classification of groups of environmental parameters and their severities - Stationary use at weather protected locations"

- [17] IEC 60 721-3-4: "Classification of environmental conditions - Part 3: Classification of groups of environmental parameters and their severities - Clause 4: Stationary use at non-weather protected locations"
- [18] IEC 60 721: "Classification of environmental conditions"
- [19] IEC 60 068-2-1 (2007): "Environmental testing - Part 2: Tests. Tests A: Cold"
- [20] IEC 60 068-2-2: (2007): "Environmental testing - Part 2: Tests. Tests B: Dry heat"
- [21] IEC 60 068-2-6: (2007): "Environmental testing - Part 2: Tests - Test Fc: Vibration (sinusoidal)"

3 Definitions of terms, symbols and abbreviations

3.1 Terms

For the purposes of the present document, the terms given in 3GPP TR 21.905 [1] and the following apply. A term defined in the present document takes precedence over the definition of the same term, if any, in 3GPP TR 21.905 [1].

Antenna connector: connector at the conducted interface of the *repeater type 1-C*

Fractional bandwidth: *fractional bandwidth* FBW is defined as $FBW = 200 \cdot \frac{F_{FBW_{high}} - F_{FBW_{low}}}{F_{FBW_{high}} + F_{FBW_{low}}} \%$

gap between passbands: frequency gap between two consecutive passbands that belong to the same *operating band*, where the RF requirements in the gap are based on co-existence for un-coordinated operation

Inter-passband gap: The frequency gap between two supported consecutive *passbands* that belong to different operating bands.

Maximum passband output power: mean power level measured per *passband* at the *antenna connector*, during the *transmitter ON state* in a specified reference condition.

multi-band connector: *Antenna Connector* for a *Multi-band repeater*.

Multi-band repeater: *Repeater Type 1-C* whose *antenna connector* is associated with a transmitter and/or receiver that is characterized by the ability to process two or more *passband(s)* in common active RF components simultaneously, where at least one *passband* is configured at a different operating band than the other *passband(s)* and where this different operating band is not a sub-band or superseding-band of another supported operating band

Nominal channel bandwidth: Bandwidth calculated as $\min(100\text{MHz}, BW_{\text{passband}})$ in FR1 or $\min(400\text{MHz}, BW_{\text{passband}})$ in FR2. If this bandwidth is not defined for BS channel bandwidth for the operating band, *nominal channel bandwidth* shall be defined as the widest BS channel bandwidth for the operating band which is narrower than BW_{passband} .

Non-contiguous spectrum: spectrum consisting of two or more *passbands* separated by *inter-passband gap(s)*.

Operating band: frequency range in which NR operates (paired or unpaired), that is defined with a specific set of technical requirements

passband edge: Frequency at the edge of the passband

Repeater RF Bandwidth: RF bandwidth in which a repeater transmits and/or receives single or multiple *passband(s)* within a supported operating band

NOTE: In single passband operation, the Repeater RF Bandwidth is equal to the passband bandwidth.

Repeater type 1-C: Repeater operating at FR1 with a requirement set consisting only of conducted requirements defined at individual *antenna connectors*.

Requirement set: one of the NR requirements set as defined for *NR repeater*

single-band connector: Repeater type 1-C antenna connector supporting operation either in a single *operating band* only, or in multiple *operating bands* but does not meet the conditions for a *multi-band connector*.

Sub-band: A *sub-band* of an operating band contains a part of the uplink and downlink frequency range of the operating band.

sub-block: one contiguous allocated block of spectrum for transmission and reception by the repeater.

Superseding-band: A *superseding-band* of an operating band includes the whole of the uplink and downlink frequency range of the operating band.

Transmitter OFF state: Time period during which the repeater downlink or uplink is not allowed to transmit in the corresponding direction.

Transmitter ON state: Time period during which the repeater is transmitting downlink or uplink signals in the corresponding direction.

Transmitter transient period: Time period during which the repeater is changing from the OFF state to the ON state or vice versa.

3.2 Symbols

For the purposes of the present document, the following symbols apply:

BW_{Config}	Transmission bandwidth configuration, where $BW_{\text{Config}} = N_{\text{RB}} \times \text{SCS} \times 12$
BW_{Nominal}	Nominal channel bandwidth
BW_{Passband}	<i>Passband</i> bandwidth
Δf	Separation between the <i>passband edge</i> frequency and the nominal -3 dB point of the measuring filter closest to the carrier frequency
Δf_{max}	$f_{\text{offsetmax}}$ minus half of the bandwidth of the measuring filter
Δf_{OBUE}	Maximum offset of the <i>operating band</i> unwanted emissions mask from the <i>operating band edge</i>
$F_{\text{DL,low}}$	The lowest frequency of the downlink <i>operating band</i>
$F_{\text{DL,high}}$	The highest frequency of the downlink <i>operating band</i>
F_{FBWhigh}	Highest supported frequency within supported operating band, for which <i>fractional bandwidth</i> support was declared
F_{FBWlow}	Lowest supported frequency within supported operating band, for which <i>fractional bandwidth</i> support was declared
F_{filter}	Filter centre frequency
$F_{\text{offset,high}}$	Frequency offset from $F_{\text{C,high}}$ to the upper <i>passband edge</i>
$F_{\text{offset,low}}$	Frequency offset from $F_{\text{C,low}}$ to the lower <i>passband edge</i>
f_{offset}	Separation between the <i>passband edge</i> frequency and the centre of the measuring filter
$f_{\text{offsetmax}}$	The offset to the frequency Δf_{OBUE} outside the <i>operating band</i>
$F_{\text{UL,low}}$	The lowest frequency of the uplink <i>operating band</i>
$F_{\text{UL,high}}$	The highest frequency of the uplink <i>operating band</i>
$P_{\text{EM,n50/n75,ind}}$	Declared emission level for Band n50/n75; ind = a, $bP_{\text{max,p,AC}}$ <i>Maximum passband output power</i> measured per <i>antenna connector</i>
$P_{\text{rated,in}}$	Rated pass band input power to the repeater for the test per antenna connector
$P_{\text{rated,p,AC}}$	Rated passband output power per antenna connector
$P_{\text{rated,t,AC}}$	Rated total output power declared per antenna connector W_{gap} <i>Inter passband Bandwidth gap size</i>

3.3 Abbreviations

For the purposes of the present document, the abbreviations given in 3GPP TR 21.905 [1] and the following apply. An abbreviation defined in the present document takes precedence over the definition of the same abbreviation, if any, in 3GPP TR 21.905 [1].

ACLR	Adjacent Channel Leakage Ratio
BW	Bandwidth
CACLR	Cumulative ACLR
CP-OFDM	Cyclic Prefix-OFDM

DFT-s-OFDM	Discrete Fourier Transform-spread-OFDM
DL	Downlink
EVM	Error Vector Magnitude
FBW	Fractional Bandwidth
FR	Frequency Range
ITU-R	Radiocommunication Sector of the International Telecommunication Union
LA	Local Area
MR	Medium Range
NR	New Radio
OBUE	Operating Band Unwanted Emissions
OOB	Out-of-band
QAM	Quadrature Amplitude Modulation
RF	Radio Frequency
RX	Receiver
SCS	Sub-Carrier Spacing
TX	Transmitter
UL	Uplink
WA	Wide Area

4 General conducted test conditions and declarations

4.1 Measurement uncertainties and test requirements

4.1.1 General

The requirements of this clause apply to all applicable tests in part 1 of this specification, i.e. to all conducted tests defined for FR1. The frequency ranges FR1 and FR2 are defined in clause 5.1 of TS 38.106 [2].

The minimum requirements are given in TS 38.106 [2]. Test Tolerances for the conducted test requirements explicitly stated in the present document are given in annex C of the present document.

Test Tolerances are individually calculated for each test. The Test Tolerances are used to relax the minimum requirements to create test requirements.

When a test requirement differs from the corresponding minimum requirement, then the Test Tolerance applied for the test is non-zero. The Test Tolerance for the test and the explanation of how the minimum requirement has been relaxed by the Test Tolerance are given in annex C.

4.1.2 Acceptable uncertainty of Test System

4.1.2.1 General

The maximum acceptable uncertainty of the Test System is specified below for each test defined explicitly in the present specification, where appropriate. The maximum acceptable uncertainty of the Test System for test requirements included by reference is defined in the respective referred test specification.

The Test System shall enable the stimulus signals in the test case to be adjusted to within the specified tolerance and the equipment under test to be measured with an uncertainty not exceeding the specified values. All tolerances and uncertainties are absolute values, and are valid for a confidence level of 95 %, unless otherwise stated.

A confidence level of 95 % is the measurement uncertainty tolerance interval for a specific measurement that contains 95 % of the performance of a population of test equipment.

For RF tests, it should be noted that the uncertainties in clause 4.1.2 apply to the Test System operating into a nominal 50 ohm load and do not include system effects due to mismatch between the DUT and the Test System.

4.1.2.2 Conducted characteristics measurements

Table 4.1.2.2-1: Maximum Test System uncertainty for conducted characteristics tests

Clause	Maximum Test System Uncertainty	Derivation of Test System Uncertainty
6.2 Repeater output power	± 0.7 dB, $f \leq 3$ GHz ± 1.0 dB, 3 GHz $< f \leq 7.125$ GHz	
6.3 Frequency stability	± 12 Hz Measurement results of ± 500 Hz	
6.4 Out of band gain	± 0.5 dB, $f \leq 3.0$ GHz ± 0.8 dB, 3.0 GHz $< f \leq 4.2$ GHz Calibration of test set-up shall be made without DUT in order to achieve the accuracy	
6.5.2 ACLR/ CACLR	BW ≤ 20 MHz: ± 0.8 dB BW > 20 MHz: ± 1.2 dB Absolute power ± 2.0 dB, $f \leq 3$ GHz Absolute power ± 2.5 dB, 3 GHz $< f \leq 7.125$ GHz	
6.5.3 Operating band unwanted emission	± 1.5 dB, $f \leq 3.0$ GHz ± 1.8 dB, 3.0 GHz $< f \leq 4.2$ GHz The interference from the signal generator ACLR shall be minimum 10 dB below that of a NR repeater according to clause 6.5.2.	
6.5.4 Spurious emissions	In NR and coexistence receive bands: for results > -60 dBm ± 2.0 dB for results < -60 dBm ± 3.0 dB Outside above range: emission power; 9 kHz $< f \leq 4$ GHz ± 2.0 dB 4 GHz $< f \leq 19$ GHz ± 4.0 dB. The interference from the signal generator ACLR shall be minimum 10 dB below that of a NR repeater according to clause 6.5.2.	
6.6 EVM	1% signal analyser 2% stimulus signal	
6.7 Input intermodulation	± 1.2 dB	Formula: RSS CW1 level error, 2 x CW2 level error, and measurement error (using all errors = ± 0.5 dB)
6.8 Output intermodulation	For operating band unwanted emission: ± 2.1 dB The interference from the signal generator ACLR shall be minimum 10 dB below that of a NR repeater according to clause 6.5.2. For spurious emission: In NR and coexistence receive bands: for results > -60 dBm ± 2.0 dB for results < -60 dBm ± 3.0 dB Outside above range: emission power; 9 kHz $< f \leq 4$ GHz ± 2.0 dB; 4 GHz $< f \leq 19$ GHz ± 4.0 dB. The interference signal must have a spurious emission level at least 10 dB below the spurious levels required in 6.5.4 and 6.5.5.	Formula: RSS 2x Interference signal level error and operating band unwanted emission measurement level error. (1 dB interference signal level error is assumed).
6.9 ACRR	± 0.7 dB	
6.10.1 Transmit ON/OFF power	± 2.0 dB, $f \leq 3$ GHz ± 2.5 dB, 3 GHz $< f \leq 7.125$ GHz	
6.10.1 Transmit OFF power	N/A	

4.1.3 Interpretation of measurement results

The measurement results returned by the Test System are compared - without any modification - against the test requirements as defined by the Shared Risk principle.

The Shared Risk principle is defined in Recommendation ITU-R M.1545 [11].

The actual measurement uncertainty of the Test System for the measurement of each parameter shall be included in the test report.

The recorded value for the Test System uncertainty shall be, for each measurement, equal to or lower than the appropriate figure in clause 4.1.2 of the present document.

If the Test System for a test is known to have a measurement uncertainty greater than that specified in clause 4.1.2, it is still permitted to use this apparatus provided that an adjustment is made as follows.

Any additional uncertainty in the Test System over and above that specified in clause 4.1.2 shall be used to tighten the test requirement, making the test harder to pass. For some tests e.g. receiver tests, this may require modification of stimulus signals. This procedure will ensure that a Test System not compliant with clause 4.1.2 does not increase the chance of passing a device under test where that device would otherwise have failed the test if a Test System compliant with clause 4.1.2 had been used.

4.2 Conducted requirement reference points

For *repeater type 1-C*, the requirements are applied at the repeater *antenna connector* (BS-side connector or UE-side connector) for downlink or uplink for the configuration in normal operating conditions.

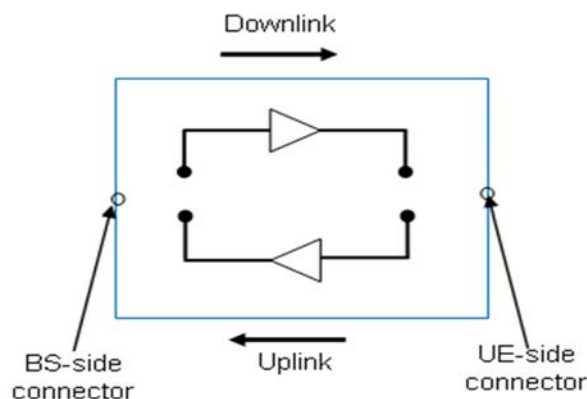

Figure 4.2-1: *Repeater type 1-C* downlink and uplink interface

4.3 Repeater classes

4.3.1 Repeater class for downlink

The requirements in this specification apply to downlink Wide Area repeaters, downlink Medium Range repeaters and downlink Local Area repeaters unless otherwise stated. The associated deployment scenarios for each class are exactly the same for repeater with and without connectors.

For *repeater type 1-C*, repeater downlink classes are defined as indicated below:

- Wide Area repeaters are characterised by requirements derived from Macro Cell scenarios with a repeater to UE minimum distance along the ground equal to 35 m.
- Medium Range repeaters are characterised by requirements derived from Micro Cell scenarios with a repeater to UE minimum distance along the ground equal to 5 m.

- Local Area repeaters are characterised by requirements derived from Pico Cell scenarios with a repeater to UE minimum distance along the ground equal to 2 m.

4.3.2 Repeater class for uplink

The requirements in this specification apply to uplink Wide Area repeaters and uplink Local Area repeaters unless otherwise stated. The associated deployment scenarios for each class are exactly the same for repeater with and without connectors.

For *repeater type 1-C*, repeater uplink classes are defined as indicated below:

- Wide Area repeaters are characterised by requirements derived from Macro Cell and/or Micro Cell scenarios.
- Local Area repeaters are characterised by requirements derived from Pico Cell and/or Micro Cell scenarios.

4.4 Regional requirements

Some requirements in the present document may only apply in certain regions either as optional requirements, or as mandatory requirements set by local and regional regulation. It is normally not stated in the 3GPP specifications under what exact circumstances the regional requirements apply, since this is defined by local or regional regulation.

Table 4.4-1 lists all requirements in the present specification that may be applied differently in different regions.

4.5 Repeater configurations

4.5.1 General configurations

For *repeater type 1-C*, the requirements are applied at the repeater *antenna connector* (BS-side connector or UE-side connector) for downlink or uplink for the configuration in normal operating conditions.

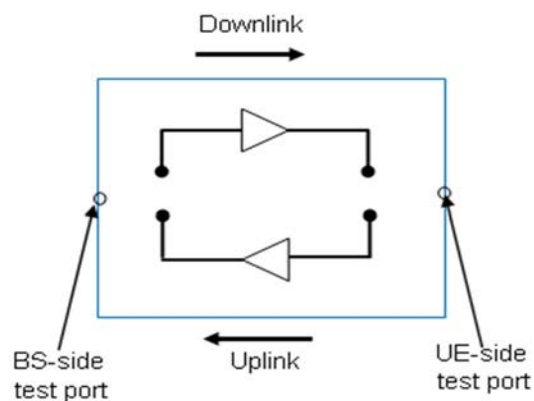

Figure 4.5.1-1: *Repeater type 1-C* test ports

4.5.2 Transmission with multiple BS-side antenna connectors

Unless otherwise stated, for the tests in clause 6 of the present document, the requirement applies for each BS-side *antenna connector* in the case of transmission with multiple BS-side *antenna connectors*.

Requirements are tested at the *antenna connector*, with the remaining *antenna connector(s)* being terminated. If the manufacturer has declared the antenna connectors to be equivalent (D.13), it is sufficient to measure the signal at any one of the BS-side *antenna connectors*.

4.5.3 Transmission with multiple UE-side antenna connectors

Unless otherwise stated, for the tests in clause 6 of the present document, the requirement applies for each UE-side *antenna connector* in the case of transmission with multiple UE-side *antenna connectors*.

Requirements are tested at the *antenna connector*, with the remaining *antenna connector(s)* being terminated. If the manufacturer has declared the antenna connectors to be equivalent (D.13), it is sufficient to measure the signal at any one of the UE-side *antenna connectors*.

4.5.4 Duplexers

The requirements of the present document shall be met with a duplexer fitted, if a duplexer is supplied as part of the repeater. If the duplexer is supplied as an option by the manufacturer, sufficient tests should be repeated with and without the duplexer fitted to verify that the repeater meets the requirements of the present document in both cases.

The following tests shall be performed with the duplexer fitted, and without it fitted if this is an option:

- 1) clause 6.2, repeater output power, for the highest static power step only, if this is measured at the antenna connector;
- 2) clause 6.4, out of band gain; outside the repeater downlink or uplink band;
- 3) clause 6.5, unwanted emissions; outside the repeater downlink or uplink band;
- 4) clause 6.7, output intermodulation; for the testing of conformance, the carrier frequencies should be selected to minimize intermodulation products from the transmitters falling in receive channels.
- 5) clause 6.9, Adjacent Channel Rejection Ratio; outside the repeater downlink or uplink band.

The remaining tests may be performed with or without the duplexer fitted.

NOTE 1: When performing receiver tests with a duplexer fitted, it is important to ensure that the output from the transmitters does not affect the test apparatus. This can be achieved using a combination of attenuators, isolators and filters.

NOTE 2: When duplexers are used, intermodulation products will be generated, not only in the duplexer but also in the antenna system. The intermodulation products generated in the antenna system are not controlled by 3GPP specifications, and may degrade during operation (e.g. due to moisture ingress). Therefore, to ensure continued satisfactory operation of a repeater, an operator will normally select NR-ARFCNs to minimize intermodulation products falling on receive channels. For testing of complete conformance, an operator may specify the NR-ARFCNs to be used.

4.5.5 Power supply options

If the repeater is supplied with a number of different power supply configurations, it may not be necessary to test RF parameters for each of the power supply options, provided that it can be demonstrated that the range of conditions over which the equipment is tested is at least as great as the range of conditions due to any of the power supply configurations.

4.5.6 Ancillary RF amplifiers

The *repeater type 1-C* requirements of the present document shall be met with the ancillary RF amplifier fitted. At tests, the ancillary amplifier is connected to the repeater by a connecting network (including any cable(s), attenuator(s), etc.) with applicable loss to make sure the appropriate operating conditions of the ancillary amplifier and the repeater. The applicable connecting network loss range is declared by the manufacturer (D.14). Other characteristics and the temperature dependence of the attenuation of the connecting network are neglected. The actual attenuation value of the connecting network is chosen for each test as one of the applicable extreme values. The lowest value is used unless otherwise stated.

Sufficient tests should be repeated with the ancillary amplifier fitted and, if it is optional, without the ancillary RF amplifier to verify that the repeater meets the requirements of the present document in both cases.

When testing, the following tests shall be repeated with the optional ancillary amplifier fitted according to the table below, where "x" denotes that the test is applicable:

Table 4.5.6-1: Tests applicable to ancillary RF amplifiers

Clause	Ancillary RF amplifier needed
6.2	x
6.4	x
6.5	x
6.7	x
6.8	x
6.9	x

In repeater output power test (clause 6.2) highest applicable attenuation value is applied.

4.5.7 Combining of repeaters

If the repeater is intended for combination with additional apparatus connected to a repeater port and this combination is supplied as a system, the combination of repeater together with the additional apparatus shall also fulfil the repeater requirements. E.g. if the repeater is intended for combination such that multiple repeaters amplify the same signals into the same ports the combination shall also fulfil the repeater requirements.

An example of such a configuration is shown in figure 4.5.7-1.

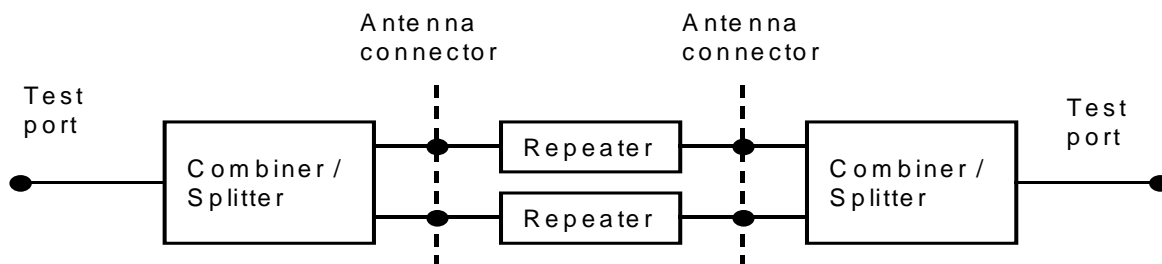

Figure 4.5.7-1: Example of repeater configuration

4.6 Manufacturer declarations

The following repeater declarations listed in table 4.6-1, when applicable to the repeater under test, are required to be provided by the manufacturer for the conducted requirements testing of the *repeater type 1-C*. Declarations can be made independently for UL and DL.

Table 4.6-1: Manufacturer declarations for *repeater type 1-C* conducted test requirements

Declaration identifier	Declaration	Description
D.1	Repeater class	Repeater class of the repeater, declared as Wide Area repeater, Medium Range repeater, or Local Area repeater.
D.2	<i>Operating bands</i> and passband frequency ranges	List of NR <i>operating band(s)</i> supported by <i>single-band connector(s)</i> and/or <i>multi-band connector(s)</i> of the repeater and passband frequency range(s) within the <i>operating band(s)</i> that the repeater can operate in. Declarations shall be made per <i>antenna connector</i> .
D.3	Spurious emission category	Declare the repeater spurious emission category as either category A or B with respect to the limits for spurious emissions, as defined in Recommendation ITU-R SM.329 [4].
D.4	Additional operating band unwanted emissions	The manufacturer shall declare whether the repeater under test is intended to operate in geographic areas where the additional operating band unwanted emission limits defined in clause 6.6.4.5.6 apply. (Note 2, Note 3).
D.5	Co-existence with other systems	The manufacturer shall declare whether the repeater under test is intended to operate in geographic areas where one or more of the systems GSM850, GSM900, DCS1800, PCS1900, UTRA FDD, UTRA TDD, E-UTRA, PHS and/or NR operating in another band are deployed.
D.6	Co-location with other base stations, repeaters and IABs	The manufacturer shall declare whether the repeater under test is intended to operate co-located with Base Stations, repeaters and IABs of one or more of the systems GSM850, GSM900, DCS1800, PCS1900, UTRA FDD, UTRA TDD, E-UTRA and/or NR operating in another band.
D.7	<i>Single band connector</i> or <i>multi-band connector</i>	Declaration of the single band or multi-band capability of <i>single band connector(s)</i> or <i>multi-band connector(s)</i> , declared for every connector.
D.8	Other band combination multi-band restrictions	Declare any other limitations under simultaneous operation in the declared band combinations (D.12) for each <i>multi-band connector</i> which have any impact on the test configuration generation. Declared for every <i>multi-band connector</i> .
D.9	Rated output power per passband ($P_{\text{rated,p,AC}}$)	Conducted rated output power per passband, per <i>single band connector</i> or <i>multi-band connector</i> . Declared per supported <i>passband</i> , per <i>antenna connector</i> . (Note 1)
D.10	Rated total output power ($P_{\text{rated,t,AC}}$)	Conducted total rated output power. Declared per supported <i>operating band</i> , per <i>antenna connector</i> . For <i>multi-band connectors</i> declared for each supported <i>operating band</i> in each supported band combination. (Note 1)
D.11	Rated multi-band total output power, $P_{\text{rated,MB,AC}}$	Conducted multi-band rated total output power. Declared per supported operating band combinations, per <i>multi-band connector</i> . (Note 1)
D.12	Operating band combination support	List of operating bands combinations supported by <i>single-band connector(s)</i> and/or <i>multi-band connector(s)</i> of the repeater. Declared per <i>antenna connector</i> .
D.13	Equivalent connectors	List of <i>antenna connectors</i> which have been declared equivalent. Equivalent connectors imply that the <i>antenna connector</i> are expected to behave in the same way when presented with identical signals under the same operating conditions. All declarations made for the <i>antenna connector</i> are identical and the transmitter unit and/or receiver unit driving the <i>antenna connector</i> are of identical design.
D.14	Connecting network loss range for repeater testing with ancillary RF amplifiers	Declaration of the range of connecting network losses (in dB) for <i>repeater type 1-C</i> testing with ancillary Tx RF amplifier only, or with Rx RF amplifier only, or with combined Tx/Rx RF amplifiers. (Note 4)
D.15	Long delay repeater	Declared only if the repeater internal delay between the input and output for this repeater does not fit within the TDD transient time. The repeater is intended for situations in which it will not cause interference to other nodes. This is achieved by RF isolation or by reservation of longer guard periods, which degrades frame utilization. The length of repeaters internal delay is declared using this declaration.
D.16	Input signal power level for maximum output power	Declaration of input signal power level required to reach maximum output power. Declared per passband.
D.17	Repeater radiating direction	Declaration on whether the repeater is intended to radiate in DL, UL or both. Testing shall be performed only for the direction(s) in which the repeater radiates.
D.18	Maximum repeater RF Bandwidth	Maximum <i>repeater RF Bandwidth</i> in the <i>operating band</i> for single-band operation. Declared per supported <i>operating band</i> , per <i>antenna connector</i> for <i>repeater type 1-C</i> . (Note 5)
D.19	Maximum repeater RF Bandwidth for multi-band operation	Maximum <i>repeater RF Bandwidth</i> for multi-band operation. Declared per supported <i>operating band</i> , per <i>antenna connector</i> for <i>repeater type 1-C</i> .

NOTE 1:	If a repeater is capable of 256QAM operation then up to two rated output power declarations may be made. One declaration is applicable when configured for 256QAM operation, and the other declaration is applicable when not configured for 256QAM operation. If a repeater is not capable of 256QAM operation, only one declaration can be made.
NOTE 2:	If repeater is declared to support Band n20 (D.2), the manufacturer shall declare if the repeater may operate in geographical areas allocated to broadcasting (DTT). Additionally, related declarations of the emission levels and maximum output power shall be declared.
NOTE 3:	If repeater is declared to support Band n24 (D.2), the manufacturer shall declare if the repeater may operate in geographical areas where FCC regulations apply. Additionally, related declarations of the emission levels and maximum output power shall be declared.
NOTE 4:	This manufacturer declaration is optional.
NOTE 5:	Parameters for contiguous or non-contiguous spectrum operation in the operating band are assumed to be the same unless they are separately declared. When separately declared, they shall still use the same declaration identifier.

4.7 Test configurations

4.7.1 General

Test configurations in this specification refer to the configuration of test signals from test equipment that are provided to the repeater input.

The test configurations shall be constructed using the methods defined below, subject to the parameters declared by the manufacturer for the supported RF configurations as listed in clause 4.6. The test configurations to use for conformance testing are defined for each supported RF configuration in clauses 4.8.3 and 4.8.4.

The applicable test models for generation of the carrier transmit test signal are defined in clause 4.9.

NOTE: If required, carriers are shifted to align with the channel raster.

4.7.2 Test signal used to build Test Configurations

The signal's channel bandwidth and subcarrier spacing used to build NR Test Configurations shall be selected according to table 4.7.2-1.

Table 4.7.2-1: Signal to be used to build NR repeater TCs

Operating Band characteristics		$F_{DL_high} - F_{DL_low}$ or $F_{UL_high} - F_{UL_low}$ <100 MHz (Note 2)	$F_{DL_high} - F_{DL_low}$ or $F_{UL_high} - F_{UL_low}$ ≥ 100 MHz (Note 2)
TC signal characteristics	$BW_{channel}$	5 MHz (Note 1)	20 MHz (Note 1)
	Subcarrier spacing	Smallest supported subcarrier spacing of the operating band	
NOTE 1: If this channel bandwidth is not supported for the operating band, the narrowest supported channel bandwidth shall be used.			
NOTE 2: Either the DL operating band characteristics or the UL operating band characteristics should be considered (if different) depending on the tested transmission direction.			

4.7.3 RTC1: Contiguous spectrum operation

The purpose of test configuration RTC1 is to test all repeater requirements that need an input signal in the *passband* when there is only one *passband* per *operating band*.

4.7.3.1 RTC1 generation

RTC1 shall be constructed on a per band basis using the following method:

- Declared maximum repeater RF Bandwidth supported shall be used (D.18);

- Select the carrier to be tested according to 4.7.2 and place it adjacent to the lower *passband* edge. If the width of the *passband* is at least twice the bandwidth of the signal to be tested then place a second signal adjacent to the upper *passband* edge. Otherwise reposition the carrier to be tested according to the single carrier test frequencies described in section 4.9.1.

The test configuration should be constructed sequentially on a per band basis using the same *antenna connector*. All configured component carriers are transmitted simultaneously in the tests where the repeater should be ON.

4.7.3.2 RTC1 power allocation

Set the power spectral density of each carrier to the same level so that the sum of the carrier powers equals the expected input power to the repeater for the test (i.e., either $P_{\text{rated,in}}$ or $P_{\text{rated,in}} + 10\text{dB}$) according to the manufacturer's declaration in clause 4.6.

4.7.5 RTC2: Non-contiguous spectrum operation

The purpose of RTC2 is to test all repeater requirements that need an input signal in the *passband* when there is more than one *passband* per *operating band*.

4.7.5.1 RTC2 generation

RTC2 is constructed on a per band basis using the following method:

- The repeater *passband* bandwidths shall be the declared maximum repeater RF Bandwidth supported for multiple *passbands* (D.18). The repeater RF Bandwidth consists of one sub-block gap and the two highest and lowest declared *passbands*.
- For each *passband*, select the carrier to be tested according to 4.7.2. If the the width of the *passband* is at least twice that of the carrier to be tested then place a carrier adjacent to the upper *passband* edge and another carrier (as described in 4.7.2) adjacent to the lower *passband* edge. Otherwise, tests shall be applied with one carrier adjacent to the lower sub-block edge and one carrier adjacent to the upper sub-block edge for each sub-block gap.
- The sub-block edges adjacent to the sub-block gap shall be determined using the specified $F_{\text{offset_high}}$ and $F_{\text{offset_low}}$ for the carriers adjacent to the sub-block gap.

4.7.5.2 RTC2 power allocation

Set the power of each carrier to the same level so that the sum of the carrier powers equals the expected input power to the repeater for the test (i.e., either $P_{\text{rated,in}}$ or $P_{\text{rated,in}} + 10\text{dB}$) according to the manufacturer's declaration in clause 4.6.

4.7.6 RTC3: Multi-band test configuration for full carrier allocation

The purpose of RTC3 is to test multi-band operation aspects.

4.7.6.1 RTC3 generation

RTC3 is based on re-using the previously specified test configurations applicable per band involved in multi-band operation. It is constructed using the following method:

- The repeater RF Bandwidth of each supported operating band shall be the declared maximum repeater RF Bandwidth in multi-band operation (D.19).
- The number of carriers of each supported *operating band* shall be sufficient to fill all of the *passbands* with one or two carriers (depending on the *passband* bandwidth). Carriers shall be selected according to 4.7.2 and shall first be placed at the outermost edges of the declared repeater Radio Bandwidth. Additional carriers shall next be placed at the repeater RF Bandwidths edges, if possible.
- Each concerned band shall be considered as an independent band and the carrier placement in each band shall be according to RTC1, where the declared parameters for multi-band operation shall apply. The mirror image of the single-band test configuration shall be used in each alternate band(s) and in the highest band.

- If the bandwidth of any *passband* is insufficient to accommodate two carriers then tests shall be repeated with the test carriers positioned such that there is a carrier adjacent to the lower edge of a sub-block gap or inter-band gap and a carrier adjacent to the upper edge of the sub-block gap or inter-band gap, for each sub-block gap or inter-block gap.

4.7.6.2 RTC3 power allocation

Unless otherwise stated, set the power of each carrier in all supported *operating bands* to the same level so that the sum of the carrier powers equals the expected input power to the repeater for the test (i.e., either $P_{\text{rated,in}}$ or $P_{\text{rated,in}} + 10\text{dB}$) according to the manufacturer's declaration in clause 4.6.

4.7.7 RTC4: Multi-band test configuration with high PSD per carrier

The purpose of RTC4 is to test multi-band operation aspects considering higher PSD cases with reduced number of carriers and non-contiguous operation (if supported) in multi-band mode.

4.7.7.1 RTC4 generation

RTC4 is based on re-using the existing test configuration applicable per band involved in multi-band operation. It is constructed using the following method:

- The repeater RF Bandwidth of each supported *operating band* shall be the declared maximum repeater RF Bandwidth in multi-band operation (D.19).
- The allocated repeater RF Bandwidth of the outermost bands shall be located at the outermost edges of the declared Maximum Radio Bandwidth.
- The maximum number of carriers is limited to two per band. Carriers shall be selected according to 4.7.2 and shall first be placed at the outermost edges of the declared Maximum Radio Bandwidth for outermost bands and at the Repeater RF Bandwidths edges for middle band(s) if any. Additional carriers shall next be placed at the Repeater RF Bandwidths edges, if possible.
- Each concerned band shall be considered as an independent band and the carrier placement in each band shall be according to RTC3, where the declared parameters for multi-band operation shall apply. Narrowest supported NR channel bandwidth and smallest subcarrier spacing shall be used in the test configuration.
- If only one carrier can be placed for the concerned band(s), the carrier(s) shall be placed at the outermost edges of the declared maximum radio bandwidth for outermost band(s) and at one of the outermost edges of the supported frequency range within the Base Station RF Bandwidths for middle band(s) if any.

4.7.7.2 RTC4 power allocation

Unless otherwise stated, set the power of each carrier in all supported *operating bands* to the same level so that the sum of the carrier powers equals the expected input power to the repeater for the test (i.e., either $P_{\text{rated,in}}$ or $P_{\text{rated,in}} + 10\text{dB}$) according to the manufacturer's declaration in clause 4.6.

4.8 Applicability of requirements

4.8.1 General

4.8.2 Applicability of test configurations for single-band operation

The applicable test configurations are specified in the tables below for each the supported RF configuration, which shall be declared according to clause 4.6. The generation and power allocation for each test configuration is defined in clause 4.7. This clause contains the test configurations for a repeater capable of single carrier, and/or multi-carrier operation in both contiguous and non-contiguous spectrum in single band.

For a repeater declared to support a single *passband* within a single band (D.2), the test configurations in the second column of table 4.8.3-1 shall be used for testing.

For a repeater declared to support more than one *passband* within a single band (D.2) and where the parameters in the manufacture's declaration according to clause 4.6 are identical for all passbands, the test configurations in the third column of table 4.8.3-1 shall be used for testing.

For a repeater declared to support more than one *passband* within a single band (D.2) and where the parameters in the manufacture's declaration according to clause 4.6 are not identical for all passbands, the test configurations in the fourth column of table 4.8.3-1 shall be used for testing.

Table 4.8.3-1: Test configurations for a repeater capable of single or multiple *passbands* in a single band

Test case	Single passband repeater	Multiple passband capable repeater with identical parameters per passband	Multiple passband capable repeater with different parameters per passband
Repeater output power	RTC1	RTC1	RTC1, RTC2
Frequency stability	Tested with Error Vector Magnitude	Tested with Error Vector Magnitude	Tested with Error Vector Magnitude
Out of band gain	N/A	N/A	N/A
Transmit ON/OFF power (only applied for NR TDD repeater)	RTC1	RTC1	RTC1, RTC2
Error Vector Magnitude	RTC1	RTC1	RTC1, RTC2
Adjacent Channel Leakage power Ratio (ACLR)	RTC1	RTC1, RTC2	RTC1, RTC2
Cumulative ACLR requirement in non-contiguous spectrum	-	RTC2	RTC2
Operating band unwanted emissions	RTC1	RTC1, RTC2	RTC1, RTC2
Transmitter spurious emissions	RTC1	RTC1, RTC2	RTC1, RTC2
Output intermodulation	RTC1	RTC1, RTC2	RTC1, RTC2
Input intermodulation	N/A	N/A	N/A
Adjacent Channel Rejection Ratio (ACRR)	RTC1	RTC2	RTC1, RTC2
Receiver spurious emissions	RTC1	RTC1, RTC2	RTC1, RTC2

4.8.4 Applicability of test configurations for multi-band operation

For a repeater declared to be capable of multi-band operation, the test configuration in table 4.8.4-1 and/or table 4.8.3-1 shall be used for testing. In the case where multiple bands are mapped on common *multi-band connector*, the test configuration in the second column of table 4.8.4-1 shall be used. In the case where multiple bands are mapped on common *single-band connector*, the test configuration in table 4.8.3-1 shall be used. In the case where multiple bands are mapped on separate *single-band connector* or *multi-band connector*, the test configuration in the third column of table 4.8.4-1 shall be used.

Table 4.8.4-1: Test configuration for a Repeater capable of multi-band operation

Repeater test case	Test configuration	
	Common connector	Separate connectors
Repeater output power	RTC1/2 (Note 1), RTC3	RTC1/2 (Note 1), RTC3
Frequency stability	Tested with Error Vector Magnitude	Tested with Error Vector Magnitude
Out of band gain	N/A	N/A
Transmit ON/OFF power (only applied for NR TDD Repeater)	RTC3	RTC3
Frequency error	Tested with Error Vector Magnitude	Tested with Error Vector Magnitude
Error Vector Magnitude (Note 8)	RTC1/2 (Note 1), RTC3	RTC1/2 (Note 1), RTC3
Adjacent Channel Leakage power Ratio (ACLR)	RTC1/2 (Note 1), RTC4 (Note 2)	RTC1/2 (Note 1, 3), RTC4 (Note 2, 3)
Cumulative ACLR requirement in non-contiguous spectrum	RTC2 (Note 1), RTC4 (Note 2)	RTC2 (Note 1, 3)
Operating band unwanted emissions	RTC1/2 (Note 1), RTC4	RTC1/2 (Note 1, 3), RTC4 (Note 3)
Transmitter spurious emissions	RTC1/2 (Note 1), RTC4	RTC1/2 (Note 1, 3), RTC4 (Note 3)
Output intermodulation	RTC1/2 (Note 1)	RTC1/2 (Note 1, 3)
Input Intermodulation	N/A	N/A
Adjacent Channel Rejection Ratio	RTC1/2 (Note 1), RTC4 (Note 2)	RTC1/2 (Note 1, 3), RTC4 (Note 2, 3)
Receiver spurious emissions	RTC1/2 (Note 1), RTC4	RTC1/2 (Note 1, 3), RTC4 (Note 3)
Note 1: RTC1 and/or RTC2 shall be applied in each supported operating band. Note 2: RTC4 may be applied for Inter RF Bandwidth gap only. Note 3: For single-band operation test, other antenna connector(s) is (are) terminated.		

4.9 RF channels and test models

4.9.1 RF channels

For the single passband testing many tests in this TS are performed with appropriate frequencies in the bottom, middle and top channels of the supported frequency range of the repeater. These are denoted as RF channels B (bottom), M (middle) and T (top).

Unless otherwise stated, the test shall be performed with a single passband at each of the RF channels B, M and T.

Many tests in this TS are performed with the maximum repeater RF Bandwidth located at the bottom, middle and top of the supported frequency range in the operating band. These are denoted as B_{RFBW} (bottom), M_{RFBW} (middle) and T_{RFBW} (top).

Unless otherwise stated, the test shall be performed at B_{RFBW} , M_{RFBW} and T_{RFBW} defined as following:

- B_{RFBW} : maximum repeater RF Bandwidth located at the bottom of the supported frequency range in the operating band.
- M_{RFBW} : maximum repeater RF Bandwidth located in the middle of the supported frequency range in the operating band.
- T_{RFBW} : maximum repeater RF Bandwidth located at the top of the supported frequency range in the operating band.

For repeater capable of multi-band operation, unless otherwise stated, the test shall be performed at $B_{\text{RFBW_T'RFBW}}$ and $B'_{\text{RFBW_T'RFBW}}$ defined as following:

- $B_{\text{RFBW_T'RFBW}}$: the *repeater RF Bandwidths* located at the bottom of the supported frequency range in the lowest operating band and at the highest possible simultaneous frequency position, within the Maximum Radio Bandwidth, in the highest operating band.

- $B'_{\text{RFBW_T_RFBW}}$: the *repeater RF Bandwidths* located at the top of the supported frequency range in the highest operating band and at the lowest possible simultaneous frequency position, within the Maximum Radio Bandwidth, in the lowest operating band.

NOTE: $B_{\text{RFBW_T_RFBW}} = B'_{\text{RFBW_T_RFBW}} = B_{\text{RFBW_T_RFBW}}$ when the declared Maximum Radio Bandwidth spans all operating bands. $B_{\text{RFBW_T_RFBW}}$ means the *repeater RF Bandwidths* are located at the bottom of the supported frequency range in the lower operating band and at the top of the supported frequency range in the upper operating band.

When a test is performed by a test laboratory, the position of B, M and T for single passband, B_{RFBW} , M_{RFBW} and T_{RFBW} for single band operation, the position of $B_{\text{RFBW_T_RFBW}}$ and $B'_{\text{RFBW_T_RFBW}}$ in the supported operating band combinations shall be specified by the laboratory. The laboratory may consult with operators, the manufacturer or other bodies.

4.9.2 Test models

4.9.2.1 General

The following clauses will describe the FR1 test models needed for *repeater type 1-C*.

4.9.2.2 FR1 test models for repeater type 1-C for DL

FR1 test model in clause 4.9.2.2 in TS 38.141-1[7] applies to *repeater type 1-C* as below:

- NR-FR1-TM1.1 applies to RDL-FR1-TM1.1
- NR-FR1-TM1.2 applies to RDL-FR1-TM1.2
- NR-FR1-TM2 applies to RDL-FR1-TM2
- NR-FR1-TM2a applies to RDL-FR1-TM2a
- NR-FR1-TM3.1 applies to RDL-FR1-TM3.1
- NR-FR1-TM3.1a applies to RDL-FR1-TM3.1a
- NR-FR1-TM3.2 applies to RDL-FR1-TM3.2
- NR-FR1-TM3.3 applies to RDL-FR1-TM3.3

Testing models applying to NB-IoT operation in clause 4.9.2.2 in TS 38.141-1[7] are not applicable to repeaters.

4.9.2.3 FR1 test models for repeater type 1-C for UL

4.9.2.3.1 General

The set-up of physical channels for transmitter tests shall be according to one of the FR1 test models (R-TMs) below. A reference to the applicable test model is made within each test.

The following general parameters are used by all repeater test models:

- Duration is 2 radio frames for TDD (20 ms)
- The slots are numbered 0 to $10 \times 2^\mu - 1$ where μ is the numerology corresponding to the subcarrier spacing
- N_{RB} is the maximum transmission bandwidth configuration seen in clause 5.3.2 in TS 38.106 [2].
- Normal CP
- Virtual resource blocks of localized type

Repeater test models are derived based on the uplink/downlink configuration as shown in the table 4.9.2.2.1-1 using information element *TDD-UL-DL-ConfigCommon* as defined in TS 38.331 [10].

Table 4.9.2.3.1-1: Configurations of TDD for repeater type 1-C test models

Field name	Value		
referenceSubcarrierSpacing (kHz)	15	30	60
Periodicity (ms) for dl-UL-TransmissionPeriodicity	5	5	5
nrofDownlinkSlots	3	7	14
nrofDownlinkSymbols	10	6	12
nrofUplinkSlots	1	2	4
nrofUplinkSymbols	2	4	8

Common physical channel parameters for all repeater FR1 test models are specified in table 4.9.2.3.1-2 and table 4.9.2.3.1-3 for PUSCH. Specific physical channel parameters for repeater FR1 test models are described in clauses 4.9.2.3.2 to 4.9.2.3.5.

Table 4.9.2.3.1-2: Common physical channel parameters for PUSCH for repeater type 1-C test models

Parameter	Value
Mapping type	PUSCH mapping type A
<i>dmrs-TypeA-Position</i> for the first DM-RS symbol	pos2
<i>dmrs-AdditionalPosition</i> for additional DM-RS symbol(s)	Pos1
<i>dmrs-Type</i> for comb pattern	Configuration type 1
<i>maxLength</i>	1
Ratio of PUSCH EPRE to DM-RS EPRE	0 dB

Table 4.9.2.3.1-3: Common physical channel parameters for PUSCH by RNTI for repeater type 1-C test models

Parameter	Value
	PUSCH $n_{RNTI} = 0$

4.9.2.3.2 FR1 test model 1.1 (RUL-FR1-TM1.1)

This model shall be used for tests on:

- Repeater output power
- Out of band gain
- Unwanted emissions
 - ACLR
 - Operating band unwanted emissions
 - Transmitter spurious emissions
 - Receiver spurious emissions
- Transmitter intermodulation
-
- Input intermodulation
- Output intermodulation
- ACRR
- Transmitter ON/OFF power

Common physical channel parameters are defined in clause 4.9.2.3.1. Specific physical channel parameters for RUL-FR1-TM1.1 are defined in table 4.9.2.3.2-1.

Table 4.9.2.2-1: Specific physical channel parameters of RUL-FR1-TM1.1

Parameter	Value
# of PRBs PUSCH	N_{RB}
Modulation PUSCH	QPSK

4.9.2.3.3 FR1 test model 2 (RUL-FR1-TM2)

This model shall be used for tests on:

- Transmitted signal quality
- Uplink repeater EVM of single 64QAM PRB allocation (at lower PSD TX power limit at min power)-
Frequency stability (at min power)

Common physical channel parameters are defined in clause 4.9.2.3.1. Specific physical channel parameters for RUL-FR1-TM2 are defined in table 4.9.2.3.3-1.

Table 4.9.2.3.3-1: Specific physical channel parameters of RUL-FR1-TM2

Parameter	Value												
# of 64QAM PUSCH PRBs	1												
Level of boosting (dB)	0												
Location of 64QAM PRB	<table border="1"> <thead> <tr> <th>Slot</th> <th>RB</th> <th>n</th> </tr> </thead> <tbody> <tr> <td>$3n$</td> <td>0</td> <td>$n = 0, \dots, \left\lfloor \frac{10 \times 2^\mu}{3} \right\rfloor - 1$</td> </tr> <tr> <td>$3n+1$</td> <td>$\left\lfloor \frac{N_{RB}}{2} \right\rfloor$</td> <td>$n = 0, \dots, \left\lfloor \frac{10 \times 2^\mu - 1}{3} \right\rfloor - 1$</td> </tr> <tr> <td>$3n+2$</td> <td>$N_{RB} - 1$</td> <td>$n = 0, \dots, \left\lfloor \frac{10 \times 2^\mu - 2}{3} \right\rfloor - 1$</td> </tr> </tbody> </table>	Slot	RB	n	$3n$	0	$n = 0, \dots, \left\lfloor \frac{10 \times 2^\mu}{3} \right\rfloor - 1$	$3n+1$	$\left\lfloor \frac{N_{RB}}{2} \right\rfloor$	$n = 0, \dots, \left\lfloor \frac{10 \times 2^\mu - 1}{3} \right\rfloor - 1$	$3n+2$	$N_{RB} - 1$	$n = 0, \dots, \left\lfloor \frac{10 \times 2^\mu - 2}{3} \right\rfloor - 1$
Slot	RB	n											
$3n$	0	$n = 0, \dots, \left\lfloor \frac{10 \times 2^\mu}{3} \right\rfloor - 1$											
$3n+1$	$\left\lfloor \frac{N_{RB}}{2} \right\rfloor$	$n = 0, \dots, \left\lfloor \frac{10 \times 2^\mu - 1}{3} \right\rfloor - 1$											
$3n+2$	$N_{RB} - 1$	$n = 0, \dots, \left\lfloor \frac{10 \times 2^\mu - 2}{3} \right\rfloor - 1$											
# of PUSCH PRBs which are not allocated	$N_{RB} - 1$												

4.9.2.3.3a FR1 test model 2a (RUL-FR1-TM2a)

This model shall be used for tests on:

- Uplink repeater EVM of single 256QAM PRB allocation (at min power)
- Frequency stability (at min power)

Common physical channel parameters are defined in clause 4.9.2.3.3. Physical channel parameters and numbers of the allocated PRB are defined in table 4.9.2.3.3-1 with all 64QAM PUSCH PRBs replaced by 256QAM PUSCH PRBs.

4.9.2.3.4 FR1 test model 3.1 (RUL-FR1-TM3.1)

This model shall be used for tests on:

- Transmitted signal quality
- Frequency stability (at max power)
- Uplink repeater EVM for modulation (at max power)

Common physical channel parameters are defined in clause 4.9.2.3.1. Physical channel parameters are defined in table 4.9.2.3.2-1 with all QPSK PUSCH PRBs replaced with selected modulation order PUSCH PRBs according to the corresponding test procedure.

4.9.2.3.5 FR1 test model 3.1a (RUL-FR1-TM3.1a)

This model shall be used for tests on:

- Transmitted signal quality
- Frequency stability (at max power)
- Uplink repeater EVM for 256QAM modulation (at max power)

Common physical channel parameters are defined in clause 4.9.2.3.1. Physical channel parameters are defined in table 4.9.2.3.2-1 with all QPSK PUSCH PRBs replaced by 256QAM PUSCH PRBs.

4.9.2.4 Data content of Physical channels and Signals for RUL-FR1-TM

4.9.2.4.1 General

Randomisation of the data content is obtained by utilizing a PN sequence generator and the length-31 Gold sequence scrambling of TS 38.211 [8], clause 5.2.1 which is invoked by all physical channels prior to modulation and mapping to the RE grid.

Initialization of the scrambler and RE-mappers as defined in TS 38.211 [8] use the following additional parameters:

- N_{ID}^{cell} , Physical layer cell identity = 1 is used as the default physical layer cell identity
- $q = 0$ (single code word)
- Rank 1, single layer

4.9.2.4.2 PUSCH

- Generate the required amount of bits from the output of the PN23 sequence generator [12]. The PN sequence generator is initialized with a starting seed of "all ones" in the first allocated slot of each frame. The PN sequence is continuous over the slot boundaries.
- Perform user specific scrambling according to TS 38.211 [8], clause 6.3.1.1.
- Perform modulation of the scrambled bits with the modulation scheme defined for each user according to TS 38.211 [8], clause 6.3.1.2
- $n_{ID} = N_{ID}^{cell}$
- Perform mapping of the complex-valued symbols to layer according to TS 38.211 [8], clause 6.3.1.3.
- Perform PUSCH mapping according to TS 38.211 [8] using parameters listed in table 4.9.2.3-2.
- DM-RS sequence generation according to TS 38.211 [8], clause 6.4.1.1.1 where l is the OFDM symbol number within the slot with the symbols indicated by table 4.9.2.2-3.
- $N_{ID}^{scID} = N_{ID}^{cell}$
- $n_{scID} = 0$
- DM-RS mapping according to TS 38.211 [8], clause 6.4.1.1.3 using parameters listed in table 4.9.2.2-3.

4.10 Requirements for contiguous and non-contiguous spectrum

A spectrum allocation where a repeater operates can either be contiguous or non-contiguous. Unless otherwise stated, the requirements in the present specification apply for repeater configured for both contiguous spectrum operation and non-contiguous spectrum operation.

For repeater operation in non-contiguous spectrum, some requirements apply both at the repeater *passband* edges and inside the sub-block gaps. For each such requirement, it is stated how the limits apply relative to the repeater *passband* edges and the sub-block edges respectively.

4.11 Requirements for repeater capable of multi-band operation

For *multi-band connector* the conducted test requirements in clause 6 and 7 apply separately to each supported *operating band* unless otherwise stated. For some conducted test requirements, it is explicitly stated that specific additions or exclusions to the requirement apply at *multi-band connector(s)* as detailed in the requirement clause. For repeater capable of multi-band operation, various structures in terms of combinations of different transceivers in downlink and transceivers in uplink implementations (multi-band or single band) with mapping of transceivers to one or more *antenna connectors* for *repeater type 1-C* in different ways are possible. For *multi-band connector(s)* the exclusions or provisions for multi-band apply. For *single-band connector(s)*, the following applies:

- Single-band transmitter spurious emissions, *operating band* unwanted emissions, ACLR, output intermodulation, ACRR and receiver spurious emissions requirements apply to this *connector* that is mapped to single-band.
- If the repeater is configured for single-band operation, *single-band requirements* shall apply to this connector configured for single-band operation and no exclusions or provisions for multi-band capable repeater are applicable. *Single-band requirements* are tested separately at the connector configured for single-band operation, with all other connectors terminated.

For *multi-band connectors* supporting the bands for TDD, the RF requirements in the present specification assume no simultaneous uplink and downlink occur between the bands.

NOTE 1: The conducted test requirements for multi-band connectors supporting bands for both FDD and TDD are not covered by the present release of this specification.

4.12 Format and interpretation of tests

Each test has a standard format:

X Title

All tests are applicable to all equipment within the scope of the present document, unless otherwise stated.

X.1 Definition and applicability

This clause gives the general definition of the parameter under consideration and specifies whether the test is applicable to all equipment or only to a certain subset. Required manufacturer declarations may be included here.

X.2 Minimum requirement

This clause contains the reference to the clause to the 3GPP reference (or core) specification which defines the minimum requirement.

X.3 Test purpose

This clause defines the purpose of the test.

X.4 Method of test

X.4.1 General

In some cases there are alternative test procedures or initial conditions. In such cases, guidance for which initial conditions and test procedures can be applied are stated here. In the case only one test procedure is applicable, that is stated here.

X.4.2y First test method

X.4.2y.1 Initial conditions

This clause defines the initial conditions for each test, including the test environment, the RF channels to be tested and the basic measurement set-up.

X.4.2y.2 Procedure

This clause describes the steps necessary to perform the test and provides further details of the test definition like domain (e.g. frequency-span), range, weighting (e.g. bandwidth), and algorithms (e.g. averaging). The procedure may

comprise data processing of the measurement result before comparison with the test requirement (e.g. average result from several measurement positions).

X.4.3y Alternative test method (if any)

If there are alternative test methods, each is described with its initial conditions and procedures.

X.5 Test requirement

This clause defines the pass/fail criteria for the equipment under test, see clause 4.1.3 (Interpretation of measurement results). Test requirements for every minimum requirement referred in clause X.2 are listed here. Cases where minimum requirements do not apply need not be mentioned.

5 Operating bands and channel arrangement

For the NR operation in NR operating bands specification, their channel bandwidth configurations, channel spacing and raster, as well as synchronization raster specification, refer to TS 38.106 [2], clause 5 and its relevant clauses.

For the conducted testing purposes in this specification, only FR1 operating bands are considered.

6 Conducted characteristics

6.1 General

Unless otherwise stated, the conducted transmitter characteristics are specified at the *antenna connector* for *repeater type 1-C* configuration in normal operating conditions.

Requirements apply in both DL and UL.

For the DL the *antenna connector* on the BS side is the input and the *antenna connector* on the UE side is the output.

For the UL the *antenna connector* on the UE side is the input and the *antenna connector* on the BS side is the output.

General test conditions for conducted tests of the *repeater type 1-C* are given in clause 4, including interpretation of measurement results and configurations for testing. Repeater configurations for the tests are defined in clause 4.5.

If a number of *single-band connectors*, or *multi-band connectors* have been declared equivalent (D.13), only a representative one is necessary to be tested to demonstrate conformance.

6.2 Repeater output power

6.2.1 Definition and applicability

The repeater conducted output power requirements are specified at *single-band connector*, or at *multi-band connector*.

The *rated passband output power* $P_{\text{rated,p,AC}}$ of the *repeater type 1-C* shall be as specified in table 6.2.1-1 and table 6.2.1-2.

Table 6.2.1-1: Repeater type 1-C DL transmission classes rated output power limits for repeater classes

Repeater class	$P_{\text{rated,p,AC}}$
Wide Area repeater	Note 1
Medium Range repeater	$\leq 38 \text{ dBm} + X$, Note 2
Local Area repeater	$\leq 24 \text{ dBm} + X$, Note 2
NOTE 1: There is no upper limit for the $P_{\text{rated,p,AC}}$ <i>rated passband output power</i> of the Wide Area repeater.	
NOTE 2: $X = 10 \cdot \log(\text{ceil}(\text{passband bandwidth}/20\text{MHz}))$	

Table 6.2.1-2: Repeater type 1-C UL transmission classes rated output power limits for repeater classes

Repeater class	$P_{\text{rated,p,AC}}$
Wide Area repeater	Note 1
Local Area repeater	$\leq 24 \text{ dBm} + X$, Note 2
NOTE 1: There is no upper limit for the $P_{\text{rated,p,AC}}$ <i>rated passband output power</i> of the Wide Area repeater.	
NOTE 2: $X = 10 \cdot \log(\text{ceil}(\text{passband bandwidth}/20\text{MHz}))$	

The output power limit for the respective repeater classes in tables 6.2.1-1 and 6.2.1-2 shall be compared to the rated output power and the declared repeater class. It is not subject to testing.

6.2.2 Minimum requirement

The minimum requirement applies per *single-band connector*, or per *multi-band connector* supporting transmission in the *passband*.

The minimum requirement for *repeater type 1-C* is defined for normal and extreme conditions in TS 38.106 [2], clause 6.2.2.

6.2.3 Test purpose

The test purpose is to verify that the repeater output power accuracy of the *rated passband output power* across the frequency range and under normal and extreme conditions is within the limit specified by the minimum requirement in 6.2.2.

6.2.4 Method of test

6.2.4.1 Initial conditions

Test environment:

- Normal, see annex B.2,
- Extreme, see annexes B.3 and B.5.

A measurement system set-up is shown in annex x.

RF channels to be tested for single carrier: B, M and T; see clause 4.9.1.

RF channels positions to be tested for multi-carrier and/or CA:

- B_{RFBW} , M_{RFBW} and T_{RFBW} for *single-band connector(s)*, see clause 4.9.1.
- B'_{RFBW} , T'_{RFBW} and B'_{RFBW}_T for *multi-band connector(s)*, see clause 4.9.1.

Under extreme test environment, it is sufficient to test on one NR-ARFCN or one RF bandwidth position, and with one applicable test configuration defined in clauses 4.7 and 4.8. Testing shall be performed under extreme power supply conditions, as defined in annex B.5.

NOTE: Tests under extreme power supply conditions also test extreme temperatures.

Power levels to be tested:

- The lowest input power ($P_{in,p,AC}$) that produces the *rated passband output power* ($P_{rated,p,AC}$).
- The lowest input power ($P_{in,p,AC}$) that produces the *rated passband output power* ($P_{rated,p,AC}$), plus 10 dB.

6.2.4.2 Procedure

- 1) Connect the power measuring equipment to the output *single-band connector(s)* or to *multi-band connector(s)* and the signal generator equipment to the input *single-band connector(s)* or to *multi-band connector(s)* under test as shown in annex D.1.1. All connectors not under test shall be terminated.
- 2) For single carrier set the signal generator to transmit according to the applicable test configuration in clause 4.8 using the corresponding test models or set of physical channels in clause 4.9.2 at power levels to be tested, as in clause 6.2.4.1.

For a connector under test declared to be capable of multi-carrier and/or CA operation set the connector under test to transmit on all carriers configured using the applicable test configuration and corresponding power setting specified in clauses 4.7 and 4.8 using the corresponding test models or set of physical channels in clause 4.9.2.

- 3) Measure the *maximum passband output power measured per antenna connector* ($P_{max,p,AC}$) for each carrier at each connector under test.

In addition, for *multi-band connectors*, the following steps shall apply:

- 4) For a *multi-band connectors* and single band tests, repeat the steps above per involved *operating band* where single band test configurations and test models shall apply with no carrier activated in the other *operating band*.

6.2.5 Test requirement

For each *single-band connector* or *multi-band connector* under test, the power measured in clause 6.2.4.2 in step 3 ($P_{max,p,AC}$) shall remain within the values provided in table 6.2.5-1 for normal and extreme test environments, relative to the manufacturer's declared $P_{rated,p,AC}$ for *repeater type 1-C* (D.9):

Table 6.2.5-1: Test requirements for conducted repeater output power accuracy

Normal test environment	Extreme test environment
$f \leq 3.0$ GHz: ± 2.7 dB	$f \leq 3.0$ GHz: ± 3.2 dB
3.0 GHz < $f \leq 7.125$ GHz: ± 3.0 dB	3.0 GHz < $f \leq 7.125$ GHz: ± 3.5 dB

6.3 Frequency stability

6.3.1 Definition and applicability

Frequency stability is the ability to maintain the same frequency on the output signal with respect to the input signal.

6.3.2 Minimum Requirement

The minimum requirement is in TS 38.106 [2], clause 6.3.2.

6.3.3 Test purpose

The test purpose is to verify that frequency stability is within the limit specified by the minimum requirement.

6.3.4 Method of test

Requirement is tested together with modulation quality test, as described in clause 6.6.

6.3.5 Test Requirements

The frequency deviation of the output signal with respect to the input signal shall be accurate to within $\pm(0.01 \text{ ppm} + 12 \text{ Hz})$ observed over 1 ms.

6.4 Out of band gain

6.4.1 Definition and applicability

Out of band gain refers to the gain of the repeater outside the *passband*.

6.4.2 Minimum Requirement

The minimum requirement is in TS 38.106 [2], clause 6.4.2.

6.4.3 Test purpose

The test purpose is to verify that out of band gain is within the limit specified by the minimum requirement.

6.4.4 Method of test

6.4.4.1 Initial conditions

Test environment:

- Normal, see annex B.2,

6.4.4.2 Procedure

- 1) Connect the CW generator to the input and power measuring equipment to the output *single-band connector(s)* or to *multi-band connector(s)* under test as shown in annex D.1.1. All connectors not under test shall be terminated.
- 2) Set the CW generator to generate a test signal with an input power equivalent to $P_{\text{in,p,AC}}$.
- 3) Measure the for each carrier at each connector under test. The out of band gain at the frequency under test is given by the difference in dB between the measured output power and the power of the input signal.
- 4) Repeat steps 2-3, shifting the offset frequency of the CW from the edge of the *passband* from 200kHz to 10MHz in steps of 200kHz for each *passband* and, for the case of multi-band connectors each operating band.

6.4.5 Test Requirements

The gain outside the *passband* shall not exceed the maximum level specified in table 6.4.5-1 or table 6.4.5-2 or table 6.4.5-3, where:

- $f_{\text{offset_CW}}$ is the offset between the outer channel edge frequency of the outer channel in the *passband* and a CW signal.

Table 6.4.5-1: Out of band gain limits 1 for bands below 2496 MHz

Frequency offset, $f_{\text{offset_CW}}$	Maximum gain
$0,2 \leq f_{\text{offset_CW}} < 1,0$ MHz	60.5 dB
$1,0 \leq f_{\text{offset_CW}} < 5,0$ MHz	45.5 dB
$5,0 \leq f_{\text{offset_CW}} < 10,0$ MHz	45.5 dB
$10,0 \text{ MHz} \leq f_{\text{offset_CW}}$	35.5 dB

Table 6.4.5-2: Out of band gain limits 1 for bands above 2496 MHz and below 3000 MHz

Frequency offset, $f_{\text{offset_CW}}$	Maximum gain
$[0,2] < f_{\text{offset_CW}} < 4,0$ MHz	60.5 dB
$4,0 < f_{\text{offset_CW}} < 15,0$ MHz	45.5 dB
$15,0 \text{ MHz} < f_{\text{offset_CW}}$	35.5 dB

Table 6.4.5-3: Out of band gain limits 1 for bands above above 3000 MHz

Frequency offset, $f_{\text{offset_CW}}$	Maximum gain
$[0,2] < f_{\text{offset_CW}} < 4,0$ MHz	60.8 dB
$4,0 < f_{\text{offset_CW}} < 15,0$ MHz	45.8 dB
$15,0 \text{ MHz} < f_{\text{offset_CW}}$	35.8 dB

6.5 Unwanted emissions

6.5.1 General

Unwanted emissions consist of out-of-band emissions and spurious emissions according to ITU definitions [4]. In ITU terminology, out of band emissions are unwanted emissions immediately outside the channel bandwidth resulting from the modulation process and non-linearity in the transmitter but excluding spurious emissions. Spurious emissions are emissions which are caused by unwanted transmitter effects such as harmonics emission, parasitic emission, intermodulation products and frequency conversion products, but exclude out of band emissions.

The out-of-band emissions requirement for the Repeater transmitter is specified both in terms of Adjacent Channel Leakage power Ratio (ACLR) and *operating band* unwanted emissions (OBUE).

The maximum offset of the *operating band* unwanted emissions mask from the *operating band* edge is Δf_{OBUE} . The *operating band* unwanted emissions define all unwanted emissions in each supported downlink *operating band* of *repeater type 1-C* DL and uplink *operating band* of *repeater type 1-C* UL, plus the frequency ranges Δf_{OBUE} above and Δf_{OBUE} below each band. Unwanted emissions outside of this frequency range are limited by a spurious emissions requirement.

The values of Δf_{OBUE} are defined in tables 6.5.1-1 and 6.5.1-2 for the NR *operating bands*.

Table 6.5.1-1: Maximum offset of OBUE outside the downlink *operating band* of *repeater type 1-C* DL

Repeater type	<i>Operating band</i> characteristics	Δf_{OBUE} (MHz)
Repeater type 1-C	$F_{\text{DL,high}} - F_{\text{DL,low}} < 200$ MHz	10
	$200 \text{ MHz} \leq F_{\text{DL,high}} - F_{\text{DL,low}} \leq 900$ MHz	40

Table 6.5.1-2: Maximum offset of OBUE outside the uplink *operating band* of *repeater 1-C* UL

Repeater type	<i>Operating band</i> characteristics	Δf_{OBUE} (MHz)
Repeater type 1-C	$F_{\text{UL,high}} - F_{\text{UL,low}} < 200$ MHz	10
	$200 \text{ MHz} \leq F_{\text{UL,high}} - F_{\text{UL,low}} \leq 900$ MHz	40

6.5.2 Adjacent Channel Leakage Power Ratio (ACLR)

6.5.2.1 Definition and applicability

Adjacent Channel Leakage power Ratio (ACLR) is the ratio of the filtered mean power centred on the assigned channel frequency to the filtered mean power centred on an adjacent channel frequency.

The requirements shall apply outside the *repeater type 1-C passband* whatever the type of transmitter considered (single carrier or multi-carrier) and for all transmission modes foreseen by the manufacturer's specification.

For a *repeater* operating in *non-contiguous spectrum*, the ACLR requirement in clause 6.5.2.5 shall apply in *gaps between passbands* for the frequency ranges defined in table 6.5.2.5-3 or 6.5.2.5-3a, while the CACLR requirement in clause 6.5.2.5 shall apply in *gaps between passbands* for the frequency ranges defined in table 6.5.2.5-4 or 6.5.2.5-4a.

For a *multi-band connector*, the ACLR requirement in clause 6.5.2.5 shall apply in *inter-passband gaps* for the frequency ranges defined in table 6.5.2.5-3 or 6.5.2.5-3a, while the CACLR requirement in clause 6.5.2.5 shall apply in *inter-passband gaps* for the frequency ranges defined in table 6.5.2.5-4 or 6.5.2.5-4a.

The requirement shall apply during the *transmitter ON state*.

6.5.2.2 Minimum requirement

The minimum requirement applies per *single-band connector*, or per *multi-band connector* supporting transmission in the *operating band*.

The minimum requirement in TS 38.106 [2], clause 6.5.2.2.

6.5.2.3 Test purpose

To verify that the adjacent channel leakage power ratio requirement shall be met as specified by the minimum requirement.

6.5.2.4 Method of test

6.5.2.4.1 Initial conditions

Test environment: Normal; see annex B.2.

RF channels to be tested for single carrier: B, M and T; see clause 4.9.1.

6.5.2.4.2 Procedure

- 1) Connect the *single-band connector* or *multi-band connector* under test to measurement equipment as shown in annex D.3. All connectors not under test shall be terminated.

The measurement device characteristics shall be:

- Measurement filter bandwidth: defined in clause 6.5.2.5.
- Detection mode: true RMS voltage or true average power.

- 2) Set the input signal to the representative connectors under test according to the applicable test configuration in clause 4.7 using the corresponding test models RDL-FR1-TM1.1 and RUL-FR1-TM1.1 in clause 4.9.2 at the input power intended to produce the maximum rated output power, $P_{in,p,AC} + 10dB$.
- 3) Measure ACLR for the frequency offsets both side of the passband edge as specified in clause 6.5.2.5. In multiple carrier case only offset frequencies below the lowest and above the highest carrier frequency used shall be measured.
- 4) For the ACLR requirement applied inside *gap between passbands*, or inside *Inter passband gap* for multi-band operation:

- a) Measure ACLR inside *gap between passbands* or *Inter passband gap* as specified in clause 6.5.2.5, if applicable.
 - b) Measure CACLR inside *gap between passbands* or *Inter passband gap* as specified in clause 6.5.2.5, if applicable.
- 5) Repeat the test with the channel set-up according to RDL-FR1-TM1.2 for DL and RUL-FR1-TM1.2 for UL in clause 4.9.2.

In addition, for *multi-band connectors*, the following steps shall apply:

- 6) For a *multi-band connectors* and single band tests, repeat the steps above per involved *operating band* where single band test configurations and test models shall apply with no carrier activated in the other *operating band*.

6.5.2.5 Test requirements

The ACLR is defined with a square filter of bandwidth equal to the transmission bandwidth configuration of the transmitted signal (BW_{Config}) centred on the assigned channel frequency and a filter centred on the adjacent channel frequency according to the tables below.

The ACLR shall be higher than the value specified in table 6.5.2.5-1 for *repeater type 1-C* for DL and UL for Wide Area class.

For *repeater type 1-C* for DL and for UL for WA class, the ACLR (CACLR) absolute limits in table 6.5.2.5-2, 6.5.2.5-5 or the ACLR (CACLR) *limits* in table 6.5.2.5-1, 6.5.2.5-3 or 6.5.2.5-4, whichever is less stringent, shall apply for each *antenna connector*.

For Band n41 and n90 operation in Japan, absolute ACLR limits shall be applied to the sum of the absolute ACLR power over all *antenna connectors* for *repeater type 1-C*.

Table 6.5.2.5-1: Repeater type 1-C ACLR limit for DL and for UL for Wide Area class

Repeater type 1-C nominal channel bandwidth BW_{Nominal} (MHz)	Repeater type 1-C adjacent channel centre frequency offset below or above the passband edge	Assumed adjacent channel carrier (informative)	Filter on the adjacent channel frequency and corresponding filter bandwidth	ACLR limit
5, 10, 15, 20	$BW_{\text{Nominal}}/2$	NR of same BW (Note 2)	Square (BW_{Config})	44.2 dB (Note 4) 37.2 dB (Note 5)
	$1.5 \times BW_{\text{Nominal}}$	NR of same BW (Note 2)	Square (BW_{Config})	44.2 dB (Note 4) 37.2 dB (Note 5)
	2.5 MHz	5 MHz E-UTRA	Square (4.5 MHz)	44.2 dB (Note 3)
	7.5 MHz	5 MHz E-UTRA	Square (4.5 MHz)	44.2 dB (Note 3)
25, 30, 35, 40, 45, 50, 60, 70, 80, 90, 100	$BW_{\text{Nominal}}/2$	NR of same BW (Note 2)	Square (BW_{Config})	43.8 dB (Note 4) 36.8 dB (Note 5)
	$1.5 \times BW_{\text{Nominal}}$	NR of same BW (Note 2)	Square (BW_{Config})	43.8 dB (Note 4) 36.8 dB (Note 5)
	2.5 MHz	5 MHz E-UTRA	Square (4.5 MHz)	43.8 dB (Note 3)
	7.5 MHz	5 MHz E-UTRA	Square (4.5 MHz)	43.8 dB (Note 3)
NOTE 1: BW_{Nominal} is the <i>nominal channel bandwidth</i> . BW_{Config} is the <i>transmission bandwidth configuration</i> assumed for the adjacent channel.				
NOTE 2: With SCS that provides largest transmission bandwidth configuration (BW_{Config}).				
NOTE 3: The requirements are applicable when the band is also defined for E-UTRA or UTRA.				
NOTE 4: Applicable to bands other than n104.				
NOTE 5: Applicable to band n104.				

The ACLR absolute limit is specified in table 6.5.2.5-2.

The ACLR shall be higher than the value specified in table 6.5.2.5-1a for *repeater type 1-C* for UL Local Area.

Table 6.5.2.5-1a: Repeater type 1-C ACLR limit for UL for Local Area

Repeater type 1-C nominal channel bandwidth $BW_{Nominal}$ (MHz)	Repeater type 1-C adjacent channel centre frequency offset below above the passband edge	Assumed adjacent channel carrier (informative)	Filter on the adjacent channel frequency and corresponding filter bandwidth	ACLR limit
5, 10, 15, 20	$BW_{Nominal}/2$	NR of same BW (Note 2)	Square (BW_{Config})	30.2 dB
	$1.5 \times BW_{Nominal}$	NR of same BW (Note 2)	Square (BW_{Config})	30.2 dB
	2.5 MHz	5 MHz E-UTRA	Square (4.5 MHz)	30.2 dB
	7.5 MHz	5 MHz E-UTRA	Square (4.5 MHz)	30.2 dB
25, 30, 35, 40, 45, 50, 60, 70, 80, 90, 100	$BW_{Nominal}/2$	NR of same BW (Note 2)	Square (BW_{Config})	29.8 dB
	$1.5 \times BW_{Nominal}$	NR of same BW (Note 2)	Square (BW_{Config})	29.8 dB
	2.5 MHz	5 MHz E-UTRA	Square (4.5 MHz)	29.8 dB
	7.5 MHz	5 MHz E-UTRA	Square (4.5 MHz)	29.8 dB

NOTE 1: $BW_{Nominal}$ is the nominal channel bandwidth. BW_{Config} is the transmission bandwidth configuration assumed for the adjacent channel.
 NOTE 2: With SCS that provides the largest transmission bandwidth configuration (BW_{Config}).
 NOTE 3: The requirements are applicable when the band is also defined for E-UTRA or UTRA.

Table 6.5.2.5-2: Repeater type 1-C ACLR absolute limit for DL and UL for WA class, for DL for MR class and for DL for LA class

Repeater category / class	ACLR absolute limit
Category A Wide Area DL and UL	-13 dBm/MHz
Category B Wide Area DL and UL	-15 dBm/MHz
Medium Range DL	-25 dBm/MHz
Local Area DL	-32 dBm/MHz

For operation in non-contiguous spectrum or multiple bands, the ACLR shall be higher than the value specified in Table 6.5.2.5-3 or Table 6.5.2.5-3a.

Table 6.5.2.5-3: Repeater type 1-C ACLR limit in non-contiguous spectrum or multiple bands for DL (all repeater classes) and for UL for Wide Area class

Repeater type 1-C nominal channel bandwidth $BW_{Nominal}$ (MHz)	Gap between passbands or inter-passband gap size (W_{gap}) where the limit applies (MHz)	Repeater type 1-C adjacent channel centre frequency offset below or above the passband edge (inside the gap)	Assumed adjacent channel carrier	Filter on the adjacent channel frequency and corresponding filter bandwidth	ACLR limit
5, 10, 15, 20	$W_{gap} \geq 15$ (Note 3)	2.5 MHz	5 MHz NR (Note 2)	Square (BW_{Config})	44.2 dB (Note 5)
	$W_{gap} \geq 45$ (Note 4)				37.2 dB (Note 6)
	$W_{gap} \geq 20$ (Note 3)	7.5 MHz	5 MHz NR (Note 2)	Square (BW_{Config})	44.2 dB (Note 5)
	$W_{gap} \geq 50$ (Note 4)				37.2 dB (Note 6)
25, 30, 35, 40, 45, 50, 60, 70, 80, 90, 100	$W_{gap} \geq 60$ (Note 4)	10 MHz	20 MHz NR (Note 2)	Square (BW_{Config})	43.8 dB (Note 5)
	$W_{gap} \geq 30$ (Note 3)				36.8 dB (Note 6)
	$W_{gap} \geq 80$ (Note 4)	30 MHz	20 MHz NR (Note 2)	Square (BW_{Config})	43.8 dB (Note 5)
	$W_{gap} \geq 50$ (Note 3)				36.8 dB (Note 6)

NOTE 1: $BW_{Nominal}$ is the nominal channel bandwidth. BW_{Config} is the transmission bandwidth configuration assumed for the adjacent channel.
 NOTE 2: With SCS that provides the largest transmission bandwidth configuration (BW_{Config}).
 NOTE 3: Applicable in case the repeater type 1-C nominal channel bandwidth at the other edge of the gap is ≤ 20 MHz.
 NOTE 4: Applicable in case the repeater type 1-C nominal channel bandwidth at the other edge of the gap is > 20 MHz.
 NOTE 5: Applicable to bands other than n104.
 NOTE 6: Applicable to band n104.

Table 6.5.2.5-3a: Repeater type 1-C ACLR limit in non-contiguous spectrum or multiple bands for UL for Local Area class

Repeater type 1-C nominal channel bandwidth BW_{Nominal} (MHz)	Gap between passbands or inter-passband gap size (W_{gap}) where the limit applies (MHz)	Repeater type 1-C adjacent channel centre frequency offset below or above the passband edge (inside the gap)	Assumed adjacent channel carrier	Filter on the adjacent channel frequency and corresponding filter bandwidth	ACLR limit
5, 10, 15, 20	$W_{\text{gap}} \geq 15$ (Note 3) $W_{\text{gap}} \geq 45$ (Note 4)	2.5 MHz	5 MHz NR (Note 2)	Square (BW_{Config})	30.2 dB
	$W_{\text{gap}} \geq 20$ (Note 3) $W_{\text{gap}} \geq 50$ (Note 4)	7.5 MHz	5 MHz NR (Note 2)	Square (BW_{Config})	30.2 dB
25, 30, 35, 40, 45, 50, 60, 70, 80, 90, 100	$W_{\text{gap}} \geq 60$ (Note 4) $W_{\text{gap}} \geq 30$ (Note 3)	10 MHz	20 MHz NR (Note 2)	Square (BW_{Config})	29.8 dB
	$W_{\text{gap}} \geq 80$ (Note 4) $W_{\text{gap}} \geq 50$ (Note 3)	30 MHz	20 MHz NR (Note 2)	Square (BW_{Config})	29.8 dB
NOTE 1: BW_{Nominal} is the <i>nominal channel bandwidth</i> . BW_{Config} is the <i>transmission bandwidth configuration</i> assumed for the adjacent channel.					
NOTE 2: With SCS that provides the largest <i>transmission bandwidth configuration</i> (BW_{Config}).					
NOTE 3: Applicable in case the <i>repeater type 1-C nominal channel bandwidth</i> at the other edge of the gap is ≤ 20 MHz.					
NOTE 4: Applicable in case the <i>repeater type 1-C nominal channel bandwidth</i> at the other edge of the gap is > 20 MHz.					

The Cumulative Adjacent Channel Leakage power Ratio (CACLR) in a *gap between passband* or the *inter-passband gap* is the ratio of:

- the sum of the filtered mean power centred on the assigned channel frequencies for the two carriers adjacent to each side of the *gap between passband* or the *inter-passband gap*, and
- the filtered mean power centred on a frequency channel adjacent to one of the respective *repeater type 1-C passband edges*.

The assumed filter for the adjacent channel frequency is defined in table 6.5.2.5-4 and 6.5.2.5-4a and the filters on the assigned channels are defined in table 6.5.2.5-6.

For operation in *non-contiguous spectrum* or multiple bands, the CACLR for *repeater type 1-C* for DL and for UL for WA class for NR carriers located on either side of the *gap between passband* or the *inter-passband gap* shall be higher than the value specified in table 6.5.2.5-4.

Table 6.5.2.5-4: Repeater type 1-C CACLR limit for DL and for UL for Wide Area class

Repeater type 1-C nominal channel bandwidth BW_{Nominal} (MHz)	Gap between passbands or inter-passband gap size (W_{gap}) where the limit applies (MHz)	Repeater type 1-C adjacent channel centre frequency offset below or above the passband edge (inside the gap)	Assumed adjacent channel carrier	Filter on the adjacent channel frequency and corresponding filter bandwidth	CACLR limit
5, 10, 15, 20	$5 \leq W_{\text{gap}} < 15$ (Note 3) $5 \leq W_{\text{gap}} < 45$ (Note 4)	2.5 MHz	5 MHz NR (Note 2)	Square (BW_{Config})	44.2 dB
	$10 < W_{\text{gap}} < 20$ (Note 3) $10 \leq W_{\text{gap}} < 50$ (Note 4)	7.5 MHz	5 MHz NR (Note 2)	Square (BW_{Config})	44.2 dB
25, 30, 35, 40, 45, 50, 60, 70, 80, 90, 100	$20 \leq W_{\text{gap}} < 60$ (Note 4) $20 \leq W_{\text{gap}} < 30$ (Note 3)	10 MHz	20 MHz NR (Note 2)	Square (BW_{Config})	43.8 dB
	$40 < W_{\text{gap}} < 80$ (Note 4) $40 \leq W_{\text{gap}} < 50$ (Note 3)	30 MHz	20 MHz NR (Note 2)	Square (BW_{Config})	43.8 dB
NOTE 1: BW_{Nominal} is the nominal channel bandwidth. BW_{Config} is the transmission bandwidth configuration assumed for the adjacent channel.					
NOTE 2: With SCS that provides the largest transmission bandwidth configuration (BW_{Config}).					
NOTE 3: Applicable in case the repeater type 1-C nominal channel bandwidth at the other edge of the gap is ≤ 20 MHz.					
NOTE 4: Applicable in case the repeater type 1-C nominal channel bandwidth at the other edge of the gap is > 20 MHz.					

The CACLR shall be higher than the value specified in table 6.5.2.5-4a for repeater type 1-C for UL Local Area.

Table 6.5.2.5-4a: Repeater type 1-C CACLR limit for UL for Local Area

Repeater type 1-C nominal channel bandwidth BW_{Nominal} (MHz)	Gap between passbands or inter-passband gap size (W_{gap}) where the limit applies (MHz)	Repeater type 1-C adjacent channel centre frequency offset below or above the passband edge (inside the gap)	Assumed adjacent channel carrier	Filter on the adjacent channel frequency and corresponding filter bandwidth	CACLR limit
5, 10, 15, 20	$5 \leq W_{\text{gap}} < 15$ (Note 3)	2.5 MHz	5 MHz NR (Note 2)	Square (BW_{Config})	30.2 dB
	$5 \leq W_{\text{gap}} < 45$ (Note 4)				
	$10 < W_{\text{gap}} < 20$ (Note 3)	7.5 MHz	5 MHz NR (Note 2)	Square (BW_{Config})	30.2 dB
	$10 \leq W_{\text{gap}} < 50$ (Note 4)				
25, 30, 35, 40, 45, 50, 60, 70, 80, 90, 100	$20 \leq W_{\text{gap}} < 60$ (Note 4)	10 MHz	20 MHz NR (Note 2)	Square (BW_{Config})	29.8 dB
	$20 \leq W_{\text{gap}} < 30$ (Note 3)				
	$40 < W_{\text{gap}} < 80$ (Note 4)	30 MHz	20 MHz NR (Note 2)	Square (BW_{Config})	29.8 dB
	$40 \leq W_{\text{gap}} < 50$ (Note 3)				
NOTE 1: BW_{Nominal} is the nominal channel bandwidth. BW_{Config} is the transmission bandwidth configuration assumed for the adjacent channel.					
NOTE 2: With SCS that provides the largest transmission bandwidth configuration (BW_{Config}).					
NOTE 3: Applicable in case the repeater type 1-C nominal channel bandwidth at the other edge of the gap is ≤ 20 MHz.					
NOTE 4: Applicable in case the repeater type 1-C nominal channel bandwidth at the other edge of the gap is > 20 MHz.					

The CACLR absolute limit is specified in table 6.5.2.5-5.

Table 6.5.2.5-5: Repeater type 1-C CACLR absolute limit for DL and UL for WA class, for DL for MR class and for DL for LA class

Repeater type 1-C category / class	CACLR absolute limit
Category A Wide Area DL and UL	-13 dBm/MHz
Category B Wide Area DL and UL	-15 dBm/MHz
Medium Range DL	-25 dBm/MHz
Local Area DL	-32 dBm/MHz

Table 6.5.2.5-6: Filter parameters for the assigned channel

RAT of the carrier adjacent to the gap between passbands or inter-passband gap	Filter on the assigned channel frequency and corresponding filter bandwidth
NR	NR of same BW with SCS that provides largest transmission bandwidth configuration

6.5.3 Operating band unwanted emissions

6.5.3.1 Definition and applicability

Unless otherwise stated, the operating band unwanted emission (OBUE) limits for repeater type 1-C DL are defined from Δf_{OBUE} below the lowest frequency of each supported downlink operating band up to Δf_{OBUE} above the highest

frequency of each supported downlink *operating band*. The values of Δf_{OBUE} are defined in table 6.5.1-1 for the NR *operating bands*.

Unless otherwise stated, the operating band unwanted emission (OBUE) limits for *repeater type 1-C UL* are defined from Δf_{OBUE} below the lowest frequency of each supported uplink *operating band* up to Δf_{OBUE} above the highest frequency of each supported uplink *operating band*. The values of Δf_{OBUE} are defined in table 6.5.1-2 for the NR *operating bands*.

The requirements shall apply whatever the type of transmitter considered and for all transmission modes foreseen by the manufacturer's specification. In addition, for *repeater type 1-C* operating in *non-contiguous spectrum*, the requirements apply inside any *gap between passband*. In addition, for a *repeater type 1-C* operating in multiple bands, the requirements apply inside any *inter-passband gap*.

Limits are specified in the tables below, where:

- Δf is the separation between the *passband edge* frequency and the nominal -3dB point of the measuring filter closest to the carrier frequency.
- f_{offset} is the separation between the *passband edge* frequency and the centre of the measuring filter.
- $f_{\text{offset}_{\text{max}}}$ is the offset to the frequency Δf_{OBUE} outside the downlink *operating band* of *repeater type 1-C DL* and uplink *operating band* of *repeater type 1-C UL*, where Δf_{OBUE} is defined in tables 6.5.1-1 and 6.5.1-2.
- Δf_{max} is equal to $f_{\text{offset}_{\text{max}}}$ minus half of the bandwidth of the measuring filter.

For a *multi-band connector* inside any *inter-passband gaps* with $W_{\text{gap}} < 2 * \Delta f_{\text{OBUE}}$, a combined minimum requirement shall be applied which is the cumulative sum of the minimum requirement specified at the *repeater type 1-C passband edges* on each side of the *inter-passband gap*.

- Δf is the separation between the *repeater type 1-C passband edge* frequency and the nominal -3 dB point of the measuring filter closest to the *repeater type 1-C passband edge*.
- f_{offset} is the separation from the *repeater type 1-C passband edge* frequency to the centre of the measuring filter.
- $f_{\text{offset}_{\text{max}}}$ is equal to the *inter-passband gap* minus half of the bandwidth of the measuring filter.
- Δf_{max} is equal to $f_{\text{offset}_{\text{max}}}$ minus half of the bandwidth of the measuring filter.

For a *multi-band connector* of *repeater type 1-C DL*, the operating band unwanted emission limits apply also in a supported downlink *operating band* without any carrier transmitted, in the case where there are carrier(s) transmitted in another supported downlink *operating band*. In this case, no cumulative minimum requirement is applied in the *inter-band gap* between a supported downlink *operating band* with carrier(s) transmitted and a supported downlink *operating band* without any carrier transmitted and

- In case the *inter-band gap* between a supported downlink *operating band* with carrier(s) transmitted and a supported downlink *operating band* without any carrier transmitted is less than $2 * \Delta f_{\text{OBUE}}$, $f_{\text{offset}_{\text{max}}}$ shall be the offset to the frequency Δf_{OBUE} MHz outside the outermost edges of the two supported downlink *operating bands* and the operating band unwanted emission minimum requirement of the band where there are carriers transmitted, as defined in the tables of the present clause, shall apply across both downlink bands.
- In other cases, the operating band unwanted emission minimum requirement of the band where there are carriers transmitted, as defined in the tables of the present clause for the largest frequency offset (Δf_{max}), shall apply from Δf_{OBUE} MHz below the lowest frequency, up to Δf_{OBUE} MHz above the highest frequency of the supported downlink *operating band* without any carrier transmitted.

For a *multi-band connector* of *repeater type 1-C UL*, the operating band unwanted emission limits apply also in a supported uplink *operating band* without any carrier transmitted, in the case where there are carrier(s) transmitted in another supported uplink *operating band*. In this case, no cumulative minimum requirement is applied in the *inter-band gap* between a supported uplink *operating band* with carrier(s) transmitted and a supported uplink *operating band* without any carrier transmitted and

- In case the *inter-band gap* between a supported uplink *operating band* with carrier(s) transmitted and a supported uplink *operating band* without any carrier transmitted is less than $2 * \Delta f_{\text{OBUE}}$, $f_{\text{offset}_{\text{max}}}$ shall be the offset to the frequency Δf_{OBUE} MHz outside the outermost edges of the two supported uplink *operating bands* and the

operating band unwanted emission minimum requirement of the band where there are carriers transmitted, as defined in the tables of the present clause, shall apply across both uplink bands.

- In other cases, the operating band unwanted emission minimum requirements of the band where there are carriers transmitted, as defined in the tables of the present clause for the largest frequency offset (Δf_{\max}), shall apply from Δf_{OBUE} MHz below the lowest frequency, up to Δf_{OBUE} MHz above the highest frequency of the supported uplink operating band without any carrier transmitted.

In addition, inside any *gap between passband* for a *single-band connector* operating in *non-contiguous spectrum*, a combined minimum requirement shall be applied which is the cumulative sum of the minimum requirement specified for the adjacent *sub-blocks* on each side of the *gap between passband*.

- Δf is the separation between the *sub-block* edge frequency and the nominal -3 dB point of the measuring filter closest to the *sub-block* edge.
- f_{offset} is the separation between the *sub-block* edge frequency and the centre of the measuring filter.
- $f_{\text{offset}_{\max}}$ is equal to the *gap between passband* bandwidth minus half of the bandwidth of the measuring filter.
- Δf_{\max} is equal to $f_{\text{offset}_{\max}}$ minus half of the bandwidth of the measuring filter.

6.5.3.2 Minimum requirement

The minimum requirement applies per *single-band connector*, or per *multi-band connector* supporting transmission in the *operating band*.

The minimum requirement is defined in TS 38.106 [2], clause 6.5.3.2

6.5.3.3 Test purpose

This test measures the emissions close to the assigned channel bandwidth of the wanted signal, while the transmitter is in operation.

6.5.3.4 Method of test

6.5.3.4.1 Initial conditions

Test environment: Normal; see annex B.2.

RF channels to be tested for single carrier: B, M and T; see clause 4.9.1.

6.5.3.4.2 Procedure

- 1) Connect the *single-band connector* or *multi-band connector* under test to measurement equipment as shown in annex D.1.1. All connectors not under test shall be terminated.

As a general rule, the resolution bandwidth of the measuring equipment should be equal to the measurement bandwidth. However, to improve measurement accuracy, sensitivity, efficiency and avoiding e.g. carrier leakage, the resolution bandwidth may be smaller than the measurement bandwidth. When the resolution bandwidth is smaller than the measurement bandwidth, the result should be integrated over the measurement bandwidth in order to obtain the equivalent noise bandwidth of the measurement bandwidth.

The measurement device characteristics shall be:

Detection mode: True RMS.

- 2) Set the input signal to the representative connectors under test according to the applicable test configuration in clause 4.8 using the corresponding test models NR-FR1-TM 1.1 in clause 4.9.2 at the input power intended to produce the maximum rated output power, $P_{\text{in,p,AC}} + 10\text{dB}$.
- 3) Step the centre frequency of the measurement filter in contiguous steps and measure the emission within the specified frequency ranges with the specified measurement bandwidth. For connector under test declared to operate in multiple bands or non-contiguous spectrum, the emission within the *Inter passband Bandwidth* or *sub-*

block gap shall be measured using the specified measurement bandwidth from the closest RF Bandwidth or sub block edge.

- 4) Repeat the test for the remaining test cases, with the channel set-up according to NR-FR1-TM 1.2.

In addition, for *multi-band connectors*, the following steps shall apply:

- 5) For a *multi-band connectors* and single band tests, repeat the steps above per involved *operating band* where single band test configurations and test models shall apply with no carrier activated in the other *operating band*.

6.5.3.4 Test requirements

6.5.3.4.1 Minimum requirements for Wide Area repeater type 1-C (Category A)

For repeater operating in Bands n5, n8, n12, n13, n14, n18, n26, n28, n29, n71, n85, minimum requirements are specified in table 6.5.3.4.1-1.

Table 6.5.3.4.1-1: Wide Area repeater type 1-C operating band unwanted emission minimum requirements (NR bands below 1 GHz) for Category A

Frequency offset of measurement filter -3dB point, Δf	Frequency offset of measurement filter centre frequency, f_{offset}	Minimum requirements (Note 1, 2)	Measurement bandwidth
$0 \text{ MHz} \leq \Delta f < 5 \text{ MHz}$	$0.05 \text{ MHz} \leq f_{\text{offset}} < 5.05 \text{ MHz}$	$-5.5 \text{ dBm} - \frac{7}{5} \cdot \left(\frac{f_{\text{offset}}}{\text{MHz}} - 0.05 \right) \text{ dB}$	100 kHz
$5 \text{ MHz} \leq \Delta f < \min(10 \text{ MHz}, \Delta f_{\text{max}})$	$5.05 \text{ MHz} \leq f_{\text{offset}} < \min(10.05 \text{ MHz}, f_{\text{offset}_{\text{max}}})$	-12.5 dBm	100 kHz
$10 \text{ MHz} \leq \Delta f \leq \Delta f_{\text{max}}$	$10.05 \text{ MHz} \leq f_{\text{offset}} < f_{\text{offset}_{\text{max}}}$	-13 dBm (Note 3)	100 kHz
<p>NOTE 1: For a <i>repeater type 1-C</i> supporting <i>non-contiguous spectrum</i> operation within any <i>operating band</i>, the emission limits within <i>gaps between passbands</i> is calculated as a cumulative sum of contributions from adjacent <i>sub-blocks</i> on each side of the <i>gap between passband</i>. Exception is $\Delta f \geq 10 \text{ MHz}$ from both adjacent <i>sub-blocks</i> on each side of the <i>gap between passband</i>, where the emission limits within <i>gaps between passbands</i> shall be -13 dBm/1 MHz.</p> <p>NOTE 2: For a <i>multi-band connector</i> with <i>inter-passband gap</i> $< 2 \cdot \Delta f_{\text{OBUe}}$ the emission limits within the <i>inter-passband gaps</i> is calculated as a cumulative sum of contributions from adjacent <i>sub-blocks</i> or <i>passband</i> on each side of the <i>inter-passband gap</i>, where the contribution from the far-end <i>sub-block</i> or <i>passband</i> shall be scaled according to the <i>measurement bandwidth</i> of the near-end <i>sub-block</i> or <i>passband</i>.</p> <p>NOTE 3: The requirement is not applicable when $\Delta f_{\text{max}} < 10 \text{ MHz}$.</p>			

For *repeater type 1-C* operating in Bands n1, n2, n3, n7, n24, n25, n30, n34, n38, n39, n40, n41, n50, n65, n66, n70, n74, n75, n92, n94 minimum requirements are specified in table 6.5.3.4.1-2:

Table 6.5.3.4.1-2: Wide Area repeater type 1-C operating band unwanted emission minimum requirements (1GHz < NR bands ≤ 3GHz) for Category A

Frequency offset of measurement filter -3dB point, Δf	Frequency offset of measurement filter centre frequency, f_{offset}	Minimum requirement (Note 1, 2)	Measurement bandwidth
$0 \text{ MHz} \leq \Delta f < 5 \text{ MHz}$	$0.05 \text{ MHz} \leq f_{\text{offset}} < 5.05 \text{ MHz}$	$-5.5 \text{ dBm} - \frac{7}{5} \cdot \left(\frac{f_{\text{offset}}}{\text{MHz}} - 0.05 \right) \text{ dB}$	100 kHz
$5 \text{ MHz} \leq \Delta f < \min(10 \text{ MHz}, \Delta f_{\text{max}})$	$5.05 \text{ MHz} \leq f_{\text{offset}} < \min(10.05 \text{ MHz}, f_{\text{offset}_{\text{max}}})$	-12.5 dBm	100 kHz
$10 \text{ MHz} \leq \Delta f \leq \Delta f_{\text{max}}$	$10.5 \text{ MHz} \leq f_{\text{offset}} < f_{\text{offset}_{\text{max}}}$	-13 dBm (Note 3)	1MHz
<p>NOTE 1: For a repeater supporting non-contiguous spectrum operation within any <i>operating band</i>, the emission limits within sub-block gaps is calculated as a cumulative sum of contributions from adjacent sub blocks on each side of the sub block gap, where the contribution from the far-end sub-block shall be scaled according to the measurement bandwidth of the near-end sub-block. Exception is $\Delta f \geq 10\text{MHz}$ from both adjacent sub blocks on each side of the sub-block gap, where the emission limits within sub-block gaps shall be -13 dBm/1 MHz.</p> <p>NOTE 2: For a <i>multi-band connector</i> with Inter RF Bandwidth gap < $2 \cdot \Delta f_{\text{OBUe}}$ the emission limits within the Inter RF Bandwidth gaps is calculated as a cumulative sum of contributions from adjacent sub-blocks or RF Bandwidth on each side of the Inter RF Bandwidth gap, where the contribution from the far-end sub-block or RF Bandwidth shall be scaled according to the measurement bandwidth of the near-end sub-block or RF Bandwidth.</p> <p>NOTE 3: The requirement is not applicable when $\Delta f_{\text{max}} < 10 \text{ MHz}$.</p>			

For *repeater type 1-C* operating in Bands n48, n77, n78, n79, *minimum requirements* are specified in table 6.5.3.4.1-3:

Table 6.5.3.4.1-3: Wide Area repeater type 1-C operating band unwanted emission limits (NR bands >3GHz) for Category A

Frequency offset of measurement filter -3dB point, Δf	Frequency offset of measurement filter centre frequency, f_{offset}	Minimum requirement (Note 1, 2)	Measurement bandwidth
$0 \text{ MHz} \leq \Delta f < 5 \text{ MHz}$	$0.05 \text{ MHz} \leq f_{\text{offset}} < 5.05 \text{ MHz}$	$-5.2 \text{ dBm} - \frac{7}{5} \cdot \left(\frac{f_{\text{offset}}}{\text{MHz}} - 0.05 \right) \text{ dB}$	100 kHz
$5 \text{ MHz} \leq \Delta f < \min(10 \text{ MHz}, \Delta f_{\text{max}})$	$5.05 \text{ MHz} \leq f_{\text{offset}} < \min(10.05 \text{ MHz}, f_{\text{offset}_{\text{max}}})$	-12.2 dBm	100 kHz
$10 \text{ MHz} \leq \Delta f \leq \Delta f_{\text{max}}$	$10.5 \text{ MHz} \leq f_{\text{offset}} < f_{\text{offset}_{\text{max}}}$	-13 dBm (Note 3)	1MHz
<p>NOTE 1: For a repeater supporting non-contiguous spectrum operation within any <i>operating band</i>, the emission limits within sub-block gaps is calculated as a cumulative sum of contributions from adjacent sub blocks on each side of the sub block gap, where the contribution from the far-end sub-block shall be scaled according to the measurement bandwidth of the near-end sub-block. Exception is $\Delta f \geq 10\text{MHz}$ from both adjacent sub blocks on each side of the sub-block gap, where the emission limits within sub-block gaps shall be -13 dBm/1 MHz.</p> <p>NOTE 2: For a <i>multi-band connector</i> with Inter RF Bandwidth gap < $2 \cdot \Delta f_{\text{OBUe}}$ the emission limits within the Inter RF Bandwidth gaps is calculated as a cumulative sum of contributions from adjacent sub-blocks or RF Bandwidth on each side of the Inter RF Bandwidth gap, where the contribution from the far-end sub-block or RF Bandwidth shall be scaled according to the measurement bandwidth of the near-end sub-block or RF Bandwidth.</p> <p>NOTE 3: The requirement is not applicable when $\Delta f_{\text{max}} < 10 \text{ MHz}$.</p>			

6.5.3.4.2 Minimum requirements for Wide Area *repeater type 1-C* (Category B)

For Category B Operating band unwanted emissions, there are two options for the *minimum requirements* that may be applied regionally. Either the *minimum requirements* in clause 6.5.3.4.2.1 or clause 6.5.3.4.2.2 shall be applied.

6.5.3.4.2.1 Category B requirements (Option 1)

For *repeater type 1-C* operating in Bands n5, n8, n12, n20, n26, n28, n29, n67, n71, n85, the minimum requirements are specified in table 6.5.3.4.2.1-1:

Table 6.5.3.4.2.1-1: Wide Area repeater type 1-C operating band unwanted emission minimum requirements (NR bands below 1 GHz) for Category B

Frequency offset of measurement filter -3dB point, Δf	Frequency offset of measurement filter centre frequency, f_{offset}	Minimum requirement (Note 1, 2)	Measurement bandwidth
$0 \text{ MHz} \leq \Delta f < 5 \text{ MHz}$	$0.05 \text{ MHz} \leq f_{\text{offset}} < 5.05 \text{ MHz}$	$-5.5 \text{ dBm} - \frac{7}{5} \cdot \left(\frac{f_{\text{offset}}}{\text{MHz}} - 0.05 \right) \text{ dB}$	100 kHz
$5 \text{ MHz} \leq \Delta f < \min(10 \text{ MHz}, \Delta f_{\text{max}})$	$5.05 \text{ MHz} \leq f_{\text{offset}} < \min(10.05 \text{ MHz}, f_{\text{offset}_{\text{max}}})$	-12.5 dBm	100 kHz
$10 \text{ MHz} \leq \Delta f \leq \Delta f_{\text{max}}$	$10.05 \text{ MHz} \leq f_{\text{offset}} < f_{\text{offset}_{\text{max}}}$	-16 dBm (Note 3)	100 kHz
<p>NOTE 1: For a <i>repeater type 1-C</i> supporting <i>non-contiguous spectrum</i> operation within any <i>operating band</i>, the emission limits within <i>gaps between passbands</i> is calculated as a cumulative sum of contributions from adjacent <i>sub-blocks</i> on each side of the <i>gap between passband</i>. Exception is $\Delta f \geq 10 \text{ MHz}$ from both adjacent <i>sub-blocks</i> on each side of the <i>gap between passband</i>, where the emission limits within <i>gaps between passbands</i> shall be -15 dBm/1 MHz.</p> <p>NOTE 2: For a <i>multi-band connector</i> with <i>inter-passband gap</i> $< 2 \cdot \Delta f_{\text{OBUe}}$ the emission limits within the <i>inter-passband gaps</i> is calculated as a cumulative sum of contributions from adjacent <i>sub-blocks</i> or <i>passband</i> on each side of the <i>inter-passband gap</i>.</p> <p>NOTE 3: The requirement is not applicable when $\Delta f_{\text{max}} < 10 \text{ MHz}$.</p>			

For *repeater type 1-C* operating in Bands n1, n2, n3, n7, n25, n34, n38, n39, n40, n41, n48, n50, n65, n66, n70, n75, n92, n94, minimum requirements are specified in table 6.5.3.4.2.1-2:

Table 6.5.3.4.2.1-2: Wide Area repeater type 1-C operating band unwanted emission limits (1GHz < NR bands ≤ 3GHz) for Category B

Frequency offset of measurement filter -3dB point, Δf	Frequency offset of measurement filter centre frequency, f_{offset}	Minimum requirements (Note 1, 2)	Measurement bandwidth
$0 \text{ MHz} \leq \Delta f < 5 \text{ MHz}$	$0.05 \text{ MHz} \leq f_{\text{offset}} < 5.05 \text{ MHz}$	$-5.5 \text{ dBm} - \frac{7}{5} \cdot \left(\frac{f_{\text{offset}}}{\text{MHz}} - 0.05 \right) \text{ dB}$	100 kHz
$5 \text{ MHz} \leq \Delta f < \min(10 \text{ MHz}, \Delta f_{\text{max}})$	$5.05 \text{ MHz} \leq f_{\text{offset}} < \min(10.05 \text{ MHz}, f_{\text{offset}_{\text{max}}})$	-12.5 dBm	100 kHz
$10 \text{ MHz} \leq \Delta f \leq \Delta f_{\text{max}}$	$10.5 \text{ MHz} \leq f_{\text{offset}} < f_{\text{offset}_{\text{max}}}$	-15 dBm (Note 3)	1MHz
<p>NOTE 1: For a <i>repeater type 1-C</i> supporting <i>non-contiguous spectrum</i> operation within any <i>operating band</i>, the emission limits within <i>gaps between passbands</i> is calculated as a cumulative sum of contributions from adjacent <i>sub-blocks</i> on each side of the <i>gap between passband</i>, where the contribution from the far-end <i>sub-block</i> shall be scaled according to the <i>measurement bandwidth</i> of the near-end <i>sub-block</i>. Exception is $\Delta f \geq 10 \text{ MHz}$ from both adjacent <i>sub-blocks</i> on each side of the <i>gap between passband</i>, where the emission limits within <i>gaps between passbands</i> shall be -15 dBm/1 MHz.</p> <p>NOTE 2: For a <i>multi-band connector</i> with <i>inter-passband gap</i> $< 2 \cdot \Delta f_{\text{OBUe}}$ the emission limits within the <i>inter-passband gaps</i> is calculated as a cumulative sum of contributions from adjacent <i>sub-blocks</i> or <i>passband</i> on each side of the <i>inter-passband gap</i>, where the contribution from the far-end <i>sub-block</i> or <i>passband</i> shall be scaled according to the <i>measurement bandwidth</i> of the near-end <i>sub-block</i> or <i>passband</i>.</p> <p>NOTE 3: The requirement is not applicable when $\Delta f_{\text{max}} < 10 \text{ MHz}$.</p>			

For *repeater type 1-C* operating in Bands n48, n77, n78, n79, *minimum requirements* are specified in tables 6.5.3.4.2.1-3:

Table 6.5.3.4.2.1-3: Wide Area repeater operating band unwanted emission limits (NR bands >3GHz) for Category B

Frequency offset of measurement filter -3dB point, Δf	Frequency offset of measurement filter centre frequency, f_{offset}	Minimum requirement (Note 1, 2)	Measurement bandwidth
$0 \text{ MHz} \leq \Delta f < 5 \text{ MHz}$	$0.05 \text{ MHz} \leq f_{\text{offset}} < 5.05 \text{ MHz}$	$-5.2 \text{ dBm} - \frac{7}{5} \cdot \left(\frac{f_{\text{offset}}}{\text{MHz}} - 0.05 \right) \text{ dB}$	100 kHz
$5 \text{ MHz} \leq \Delta f < \min(10 \text{ MHz}, \Delta f_{\text{max}})$	$5.05 \text{ MHz} \leq f_{\text{offset}} < \min(10.05 \text{ MHz}, f_{\text{offset}_{\text{max}}})$	-12.2 dBm	100 kHz
$10 \text{ MHz} \leq \Delta f \leq \Delta f_{\text{max}}$	$10.5 \text{ MHz} \leq f_{\text{offset}} < f_{\text{offset}_{\text{max}}}$	-15 dBm (Note 3)	1 MHz
<p>NOTE 1: For a repeater supporting non-contiguous spectrum operation within any <i>operating band</i>, the emission limits within sub-block gaps is calculated as a cumulative sum of contributions from adjacent sub blocks on each side of the sub block gap, where the contribution from the far-end sub-block shall be scaled according to the measurement bandwidth of the near-end sub-block. Exception is $\Delta f \geq 10 \text{ MHz}$ from both adjacent sub blocks on each side of the sub-block gap, where the emission limits within sub-block gaps shall be -15 dBm/1 MHz.</p> <p>NOTE 2: For a <i>multi-band connector</i> with Inter RF Bandwidth gap $< 2 \cdot \Delta f_{\text{OBUe}}$ the emission limits within the Inter RF Bandwidth gaps is calculated as a cumulative sum of contributions from adjacent sub-blocks or RF Bandwidth on each side of the Inter RF Bandwidth gap, where the contribution from the far-end sub-block or RF Bandwidth shall be scaled according to the measurement bandwidth of the near-end sub-block or RF Bandwidth.</p> <p>NOTE 3: The requirement is not applicable when $\Delta f_{\text{max}} < 10 \text{ MHz}$.</p>			

6.5.3.4.2.2 Category B requirements (Option 2)

The limits in this clause are intended for Europe and may be applied regionally for *repeater type 1-C* operating in bands n1, n3, n7, n8, n38, n65.

For a *repeater type 1-C* operating in bands n1, n3, n7, n8, n38 or n65, minimum requirements are specified in Table 6.5.3.4.2.2-1:

Table 6.5.3.4.2.2-1: Regional Wide Area *repeater type 1-C* operating band unwanted emission minimum requirements for Category B

Frequency offset of measurement filter -3dB point, Δf	Frequency offset of measurement filter centre frequency, f_{offset}	Minimum requirements (Note 1, 2)	Measurement bandwidth
$0 \text{ MHz} \leq \Delta f < 0.2 \text{ MHz}$	$0.015 \text{ MHz} \leq f_{\text{offset}} < 0.215 \text{ MHz}$	-12.5 dBm	30 kHz
$0.2 \text{ MHz} \leq \Delta f < 1 \text{ MHz}$	$0.215 \text{ MHz} \leq f_{\text{offset}} < 1.015 \text{ MHz}$	$-12.5 \text{ dBm} - 15 \cdot \left(\frac{f_{\text{offset}}}{\text{MHz}} - 0.215 \right) \text{ dB}$	30 kHz
(Note 4)	$1.015 \text{ MHz} \leq f_{\text{offset}} < 1.5 \text{ MHz}$	-24.5 dBm	30 kHz
$1 \text{ MHz} \leq \Delta f \leq \min(10 \text{ MHz}, \Delta f_{\text{max}})$	$1.5 \text{ MHz} \leq f_{\text{offset}} < \min(10.5 \text{ MHz}, f_{\text{offset}_{\text{max}}})$	-11.5 dBm	1 MHz
$10 \text{ MHz} \leq \Delta f \leq \Delta f_{\text{max}}$	$10.5 \text{ MHz} \leq f_{\text{offset}} < f_{\text{offset}_{\text{max}}}$	-15 dBm (Note 3)	1 MHz
<p>NOTE 1: For a <i>repeater type 1-C</i> supporting <i>non-contiguous spectrum</i> operation within any <i>operating band</i>, the emission limits within <i>gaps between passbands</i> is calculated as a cumulative sum of contributions from adjacent <i>sub-blocks</i> on each side of the <i>gap between passband</i>, where the contribution from the far-end <i>sub-block</i> shall be scaled according to the <i>measurement bandwidth</i> of the near-end <i>sub-block</i>. Exception is $\Delta f \geq 10 \text{ MHz}$ from both adjacent <i>sub-blocks</i> on each side of the <i>gap between passband</i>, where the emission limits within <i>gaps between passbands</i> shall be -15 dBm/1 MHz.</p> <p>NOTE 2: For a <i>multi-band connector</i> with <i>inter-passband gap</i> $< 2 \cdot \Delta f_{\text{OBUe}}$ the emission limits within the <i>inter-passband gaps</i> is calculated as a cumulative sum of contributions from adjacent <i>sub-blocks</i> or <i>passband</i> on each side of the <i>inter-passband gap</i>, where the contribution from the far-end <i>sub-block</i> or <i>passband</i> shall be scaled according to the <i>measurement bandwidth</i> of the near-end <i>sub-block</i> or <i>passband</i>.</p> <p>NOTE 3: The requirement is not applicable when $\Delta f_{\text{max}} < 10 \text{ MHz}$.</p> <p>NOTE 4: This frequency range ensures that the range of values of f_{offset} is continuous.</p>			

6.5.3.4.3 Minimum requirements for Medium Range *repeater type 1-C* (Category A and B) for DL

For Medium Range *repeater type 1-C* for DL, minimum requirements are specified in table 6.5.3.4.3-1 to table 6.5.3.4.3-4.

For the tables in this clause for *repeater type 1-C*, $P_{\text{rated},x} = P_{\text{rated},p,AC} - 10 \cdot \log(\text{ceil}(BW_{\text{Passband}}/20\text{MHz}))$

Table 6.5.3.4.3-1: Medium Range *repeater type 1-C* operating band unwanted emission minimum requirements, $31 < P_{\text{rated},x} \leq 38$ dBm (NR bands ≤ 3 GHz)

Frequency offset of measurement filter -3dB point, Δf	Frequency offset of measurement filter centre frequency, f_{offset}	Minimum requirements (Note 1, 2)	Measurement bandwidth
$0 \text{ MHz} \leq \Delta f < 5 \text{ MHz}$	$0.05 \text{ MHz} \leq f_{\text{offset}} < 5.05 \text{ MHz}$	$P_{\text{rated},x} - 51.5 \text{ dB} - \frac{7}{5} \left(\frac{f_{\text{offset}}}{\text{MHz}} - 0.05 \right) \text{ dB}$	100 kHz
$5 \text{ MHz} \leq \Delta f < \min(10 \text{ MHz}, \Delta f_{\text{max}})$	$5.05 \text{ MHz} \leq f_{\text{offset}} < \min(10.05 \text{ MHz}, f_{\text{offset}_{\text{max}}})$	$P_{\text{rated},x} - 58.5 \text{ dB}$	100 kHz
$10 \text{ MHz} \leq \Delta f \leq \Delta f_{\text{max}}$	$10.05 \text{ MHz} \leq f_{\text{offset}} < f_{\text{offset}_{\text{max}}}$	$\text{Min}(P_{\text{rated},x} - 60 \text{ dB}, -25 \text{ dBm})$ (Note 3)	100 kHz
NOTE 1: For a <i>repeater type 1-C</i> DL supporting <i>non-contiguous spectrum</i> operation within any <i>operating band</i> the emission limits within <i>gaps between passbands</i> is calculated as a cumulative sum of contributions from adjacent <i>sub-blocks</i> on each side of the <i>gap between passband</i> . Exception is $\Delta f \geq 10 \text{ MHz}$ from both adjacent <i>sub-blocks</i> on each side of the <i>gap between passband</i> , where the emission limits within <i>gaps between passbands</i> shall be $\text{Min}(P_{\text{rated},x} - 60 \text{ dB}, -25 \text{ dBm})/100 \text{ kHz}$.			
NOTE 2: For a <i>multi-band connector</i> with <i>inter-passband gap</i> $< 2 \cdot \Delta f_{\text{OBUe}}$ the emission limits within the <i>inter-passband gaps</i> is calculated as a cumulative sum of contributions from adjacent <i>sub-blocks</i> or <i>passband</i> on each side of the <i>inter-passband gap</i> .			
NOTE 3: The requirement is not applicable when $\Delta f_{\text{max}} < 10 \text{ MHz}$.			

Table 6.5.3.4.3-2: Medium Range *repeater type 1-C* operating band unwanted emission minimum requirements, $P_{\text{rated},x} \leq 31$ dBm (NR bands ≤ 3 GHz)

Frequency offset of measurement filter -3dB point, Δf	Frequency offset of measurement filter centre frequency, f_{offset}	Minimum requirements (Note 1, 2)	Measurement bandwidth
$0 \text{ MHz} \leq \Delta f < 5 \text{ MHz}$	$0.05 \text{ MHz} \leq f_{\text{offset}} < 5.05 \text{ MHz}$	$-20.5 \text{ dBm} - \frac{7}{5} \left(\frac{f_{\text{offset}}}{\text{MHz}} - 0.05 \right) \text{ dB}$	100 kHz
$5 \text{ MHz} \leq \Delta f < \min(10 \text{ MHz}, \Delta f_{\text{max}})$	$5.05 \text{ MHz} \leq f_{\text{offset}} < \min(10.05 \text{ MHz}, f_{\text{offset}_{\text{max}}})$	-27.5 dBm	100 kHz
$10 \text{ MHz} \leq \Delta f \leq \Delta f_{\text{max}}$	$10.05 \text{ MHz} \leq f_{\text{offset}} < f_{\text{offset}_{\text{max}}}$	-29 dBm (Note 3)	100 kHz
NOTE 1: For a <i>repeater type 1-C</i> DL supporting <i>non-contiguous spectrum</i> operation within any <i>operating band</i> the emission limits within <i>gaps between passbands</i> is calculated as a cumulative sum of contributions from adjacent <i>sub-blocks</i> on each side of the <i>gap between passband</i> . Exception is $\Delta f \geq 10 \text{ MHz}$ from both adjacent <i>sub-blocks</i> on each side of the <i>gap between passband</i> , where the emission limits within <i>gaps between passbands</i> shall be $-29 \text{ dBm}/100 \text{ kHz}$.			
NOTE 2: For a <i>multi-band connector</i> with <i>inter-passband gap</i> $< 2 \cdot \Delta f_{\text{OBUe}}$ the emission limits within the <i>inter-passband gaps</i> is calculated as a cumulative sum of contributions from adjacent <i>sub-blocks</i> or <i>passband</i> on each side of the <i>inter-passband gap</i> .			
NOTE 3: The requirement is not applicable when $\Delta f_{\text{max}} < 10 \text{ MHz}$.			

Table 6.5.3.4.3-3: Medium Range repeater *operating band* unwanted emission limits, $31 < P_{\text{rated},x} \leq 38$ dBm (NR bands >3GHz)

Frequency offset of measurement filter -3dB point, Δf	Frequency offset of measurement filter centre frequency, f_{offset}	Minimum requirements (Note 1, 2)	Measurement bandwidth
$0 \text{ MHz} \leq \Delta f < 5 \text{ MHz}$	$0.05 \text{ MHz} \leq f_{\text{offset}} < 5.05 \text{ MHz}$	$P_{\text{rated},x} - 51.2 \text{ dB} - \frac{7}{5} \left(\frac{f_{\text{offset}}}{\text{MHz}} - 0.05 \right) \text{ dB}$	100 kHz
$5 \text{ MHz} \leq \Delta f < \min(10 \text{ MHz}, \Delta f_{\text{max}})$	$5.05 \text{ MHz} \leq f_{\text{offset}} < \min(10.05 \text{ MHz}, f_{\text{offset,max}})$	$P_{\text{rated},x} - 58.2 \text{ dB}$	100 kHz
$10 \text{ MHz} \leq \Delta f \leq \Delta f_{\text{max}}$	$10.05 \text{ MHz} \leq f_{\text{offset}} < f_{\text{offset,max}}$	$\text{Min}(P_{\text{rated},x} - 60 \text{ dB}, -25 \text{ dBm})$ (Note 3)	100 kHz
<p>NOTE 1: For a repeater supporting non-contiguous spectrum operation within any <i>operating band</i> the emission limits within sub-block gaps is calculated as a cumulative sum of contributions from adjacent sub blocks on each side of the sub block gap. Exception is $\Delta f \geq 10 \text{ MHz}$ from both adjacent sub blocks on each side of the sub-block gap, where the emission limits within sub-block gaps shall be $\text{Min}(P_{\text{rated},x} - 60 \text{ dB}, -25 \text{ dBm})/100 \text{ kHz}$.</p> <p>NOTE 2: For a <i>multi-band connector</i> with Inter RF Bandwidth gap $< 2 \cdot \Delta f_{\text{OBUE}}$ the emission limits within the Inter RF Bandwidth gaps is calculated as a cumulative sum of contributions from adjacent sub-blocks or RF Bandwidth on each side of the Inter RF Bandwidth gap.</p> <p>NOTE 3: The requirement is not applicable when $\Delta f_{\text{max}} < 10 \text{ MHz}$.</p>			

Table 6.5.3.4.3-4: Medium Range repeater *operating band* unwanted emission limits, $P_{\text{rated},x} \leq 31$ dBm (NR bands >3GHz)

Frequency offset of measurement filter -3dB point, Δf	Frequency offset of measurement filter centre frequency, f_{offset}	Minimum requirements (Note 1, 2)	Measurement bandwidth
$0 \text{ MHz} \leq \Delta f < 5 \text{ MHz}$	$0.05 \text{ MHz} \leq f_{\text{offset}} < 5.05 \text{ MHz}$	$-20.2 \text{ dBm} - \frac{7}{5} \left(\frac{f_{\text{offset}}}{\text{MHz}} - 0.05 \right) \text{ dB}$	100 kHz
$5 \text{ MHz} \leq \Delta f < \min(10 \text{ MHz}, \Delta f_{\text{max}})$	$5.05 \text{ MHz} \leq f_{\text{offset}} < \min(10.05 \text{ MHz}, f_{\text{offset,max}})$	-27.2 dBm	100 kHz
$10 \text{ MHz} \leq \Delta f \leq \Delta f_{\text{max}}$	$10.05 \text{ MHz} \leq f_{\text{offset}} < f_{\text{offset,max}}$	-29 dBm (Note 3)	100 kHz
<p>NOTE 1: For a repeater supporting non-contiguous spectrum operation within any <i>operating band</i> the emission limits within sub-block gaps is calculated as a cumulative sum of contributions from adjacent sub blocks on each side of the sub block gap. Exception is $\Delta f \geq 10 \text{ MHz}$ from both adjacent sub blocks on each side of the sub-block gap, where the emission limits within sub-block gaps shall be $-29 \text{ dBm}/100 \text{ kHz}$.</p> <p>NOTE 2: For a <i>multi-band connector</i> with Inter RF Bandwidth gap $< 2 \cdot \Delta f_{\text{OBUE}}$ the emission limits within the Inter RF Bandwidth gaps is calculated as a cumulative sum of contributions from adjacent sub-blocks or RF Bandwidth on each side of the Inter RF Bandwidth gap.</p> <p>NOTE 3: The requirement is not applicable when $\Delta f_{\text{max}} < 10 \text{ MHz}$.</p>			

6.5.3.4.4 Minimum requirements for Local Area *repeater type 1-C* (Category A and B)

For Local Area *repeater type 1-C* in NR bands $\leq 3 \text{ GHz}$, *minimum requirements* are specified in table 6.5.3.4.4-1.

For Local Area *repeater type 1-C* in NR bands $> 3 \text{ GHz}$, *minimum requirements* are specified in table 6.5.3.4.4-2.

Table 6.5.3.4.4-1: Local Area repeater type 1-C operating band unwanted emission limits (NR bands ≤3GHz)

Frequency offset of measurement filter -3dB point, Δf	Frequency offset of measurement filter centre frequency, f_{offset}	Minimum requirements (Note 1, 2)	Measurement bandwidth
$0 \text{ MHz} \leq \Delta f < 5 \text{ MHz}$	$0.05 \text{ MHz} \leq f_{\text{offset}} < 5.05 \text{ MHz}$	$-28.5 \text{ dBm} - \frac{7}{5} \left(\frac{f_{\text{offset}}}{\text{MHz}} - 0.05 \right) \text{ dB}$	100 kHz
$5 \text{ MHz} \leq \Delta f < \min(10 \text{ MHz}, \Delta f_{\text{max}})$	$5.05 \text{ MHz} \leq f_{\text{offset}} < \min(10.05 \text{ MHz}, f_{\text{offset}_{\text{max}}})$	-35.5 dBm	100 kHz
$10 \text{ MHz} \leq \Delta f \leq \Delta f_{\text{max}}$	$10.05 \text{ MHz} \leq f_{\text{offset}} < f_{\text{offset}_{\text{max}}}$	-37 dBm (Note 10)	100 kHz
NOTE 1: For a <i>repeater type 1-C</i> supporting <i>non-contiguous spectrum</i> operation within any <i>operating band</i> the emission limits within <i>gaps between passbands</i> is calculated as a cumulative sum of contributions from adjacent <i>sub-blocks</i> on each side of the <i>gap between passband</i> . Exception is $\Delta f \geq 10 \text{ MHz}$ from both adjacent <i>sub-blocks</i> on each side of the <i>gap between passband</i> , where the emission limits within <i>gaps between passbands</i> shall be -37dBm/100kHz.			
NOTE 2: For a <i>multi-band connector</i> with <i>inter-passband gap</i> $< 2 \cdot \Delta f_{\text{OBUe}}$ the emission limits within the <i>inter-passband gaps</i> is calculated as a cumulative sum of contributions from adjacent <i>sub-blocks</i> or <i>passband</i> on each side of the <i>inter-passband gap</i>			
NOTE 3: The requirement is not applicable when $\Delta f_{\text{max}} < 10 \text{ MHz}$.			

Table 6.5.3.4.4-2: Local Area repeater operating band unwanted emission limits (NR bands >3GHz)

Frequency offset of measurement filter -3dB point, Δf	Frequency offset of measurement filter centre frequency, f_{offset}	Minimum requirements (Note 1, 2)	Measurement bandwidth
$0 \text{ MHz} \leq \Delta f < 5 \text{ MHz}$	$0.05 \text{ MHz} \leq f_{\text{offset}} < 5.05 \text{ MHz}$	$-28.2 \text{ dBm} - \frac{7}{5} \left(\frac{f_{\text{offset}}}{\text{MHz}} - 0.05 \right) \text{ dB}$	100 kHz
$5 \text{ MHz} \leq \Delta f < \min(10 \text{ MHz}, \Delta f_{\text{max}})$	$5.05 \text{ MHz} \leq f_{\text{offset}} < \min(10.05 \text{ MHz}, f_{\text{offset}_{\text{max}}})$	-35.2 dBm	
$10 \text{ MHz} \leq \Delta f \leq \Delta f_{\text{max}}$	$10.05 \text{ MHz} \leq f_{\text{offset}} < f_{\text{offset}_{\text{max}}}$	-37 dBm (Note 3)	
NOTE 1: For a repeater supporting non-contiguous spectrum operation within any <i>operating band</i> the emission limits within sub-block gaps is calculated as a cumulative sum of contributions from adjacent sub blocks on each side of the sub block gap. Exception is $\Delta f \geq 10 \text{ MHz}$ from both adjacent sub blocks on each side of the sub-block gap, where the emission limits within sub-block gaps shall be -37dBm/100kHz.			
NOTE 2: For a <i>multi-band connector</i> with Inter RF Bandwidth gap $< 2 \cdot \Delta f_{\text{OBUe}}$ the emission limits within the Inter RF Bandwidth gaps is calculated as a cumulative sum of contributions from adjacent sub-blocks or RF Bandwidth on each side of the Inter RF Bandwidth gap			
NOTE 3: The requirement is not applicable when $\Delta f_{\text{max}} < 10 \text{ MHz}$.			

6.5.3.4.5 Minimum requirements for additional requirements

6.5.3.4.5.1 Limits in FCC Title 47

In addition to the requirements in clauses 6.5.3.4.1, 6.5.3.4.2, 6.5.3.4.3 and 6.5.3.4.4, the *repeater type 1-C* may have to comply with the applicable emission limits established by FCC Title 47 [13], when deployed in regions where those limits are applied, and under the conditions declared by the manufacturer.

6.5.3.4.5.2 Protection of DTT

In certain regions the following requirement may apply for protection of DTT. For *repeater type 1-C* operating in Band n20, the level of emissions in the band 470-790 MHz, measured in an 8 MHz filter bandwidth on centre frequencies F_{filter} according to table 6.5.3.4.5.2-1, a minimum requirements $P_{\text{EM,N}}$ is declared by the manufacturer. This requirement applies in the frequency range 470-790 MHz even though part of the range falls in the spurious domain.

Table 6.5.3.4.5.2-1: Declared emissions *minimum requirement* for protection of DTT

Filter centre frequency, F_{filter}	Measurement bandwidth	Declared emission minimum requirement (dBm)
$F_{\text{filter}} = 8 \cdot N + 306$ (MHz); $21 \leq N \leq 60$	8 MHz	$P_{\text{EM,N}}$

Note: The regional requirement is defined in terms of EIRP (effective isotropic radiated power), which is dependent on both the repeater emissions at the *antenna connector* and the deployment (including antenna gain and feeder loss). The requirement defined above provides the characteristics of the repeater needed to verify compliance with the regional requirement. Compliance with the regional requirement can be determined using the method outlined in TS 36.104 [5], annex E.

6.5.4 Transmitter spurious emissions

6.5.4.1 Definition and applicability

For *repeater type 1-C*, the transmitter spurious emission limits shall apply from 9 kHz to 12.75 GHz, excluding

- the frequency range from Δf_{OBUE} below the lowest frequency of each supported downlink *operating band*, up to Δf_{OBUE} above the highest frequency of each supported downlink *operating band*, where the Δf_{OBUE} is defined in table 6.5.1-1 for downlink, or
- the frequency range from Δf_{OBUE} below the lowest frequency of each supported uplink *operating band*, up to Δf_{OBUE} above the highest frequency of each supported uplink *operating band*, where the Δf_{OBUE} is defined in table 6.5.1-2 for uplink

. For some *operating bands*, the upper limit is higher than 12.75 GHz in order to comply with the 5th harmonic limit of the downlink *operating band*, as specified in ITU-R recommendation SM.329 [4].

For a *multi-band connector*, for each supported *operating band* together with Δf_{OBUE} around the band is excluded from the transmitter spurious emissions requirement.

The requirements shall apply whatever the type of transmitter considered (single carrier or multi-carrier). It applies for all transmission modes foreseen by the manufacturer's specification.

Unless otherwise stated, all requirements are measured as mean power (RMS).

For Band n41 and n90 operation in Japan, the sum of the spurious emissions over all *antenna connectors* for *Repeater type 1-C* shall not exceed the *minimum requirements* defined in clause 6.5.4.5.

6.5.4.2 Minimum requirement

The minimum requirement applies per *single-band connector*, or per *multi-band connector* supporting transmission in the *operating band*.

The minimum requirement is defined in TS 38.106 [2], clause 6.5.4.2.

6.5.4.3 Test purpose

This test measures conducted spurious emissions while the transmitter is in operation.

6.5.4.4 Method of test

6.5.4.4.1 Initial conditions

Test environment: Normal; see annex B.2.

RF channels to be tested for single carrier:

- B when testing the spurious emissions below $F_{DL_low} - \Delta f_{OBUE}$,
- T when testing the spurious emissions above $F_{DL_high} + \Delta f_{OBUE}$; see clause 4.9.1.

6.5.4.4.2 Procedure

- 1) Connect the *single-band connector* or *multi-band connector* under test to measurement equipment as shown in annex D.1.1. All connectors not under test shall be terminated.
- 2) Measurements shall use a measurement bandwidth in accordance to the conditions in clause 6.5.4.5.

The measurement device characteristics shall be:

- Detection mode: True RMS.
- 3) Set the input signal to the representative connectors under test according to the applicable test configuration in clause 4.8 using the corresponding test models NR-FR1-TM 1.1 in clause 4.9.2 at the input power intended to produce the maximum rated output power, $P_{in,p,AC} + 10dB$.
 - 4) Measure the emission at the specified frequencies with specified measurement bandwidth.

In addition, for *multi-band connectors*, the following steps shall apply:

- 5) For a *multi-band connectors* and single band tests, repeat the steps above per involved *operating band* where single band test configurations and test models shall apply with no carrier activated in the other *operating band*.

6.5.4.5 Test requirements

6.5.4.5.1 General transmitter spurious emissions requirements

The *minimum requirements* of either table 6.5.4.5.1-1, table 6.5.4.5.1-2 (Category A limits) or table 6.5.4.5.1-3 (Category B limits) shall apply. The application of either Category A or Category B limits shall be the same as for operating band unwanted emissions in clause 6.5.3.

Table 6.5.4.5.1-1: General *repeater type 1-C* transmitter spurious emission minimum requirements for DL in FR1, Category A

Spurious frequency range	Minimum requirements	Measurement bandwidth	Notes
9 kHz – 150 kHz	-13 dBm	1 kHz	Note 1
150 kHz – 30 MHz		10 kHz	Note 1
30 MHz – 1 GHz		100 kHz	Note 1
1 GHz – 12.75 GHz		1 MHz	Note 1, Note 2
12.75 GHz – 5 th harmonic of the upper frequency edge of the DL <i>operating band</i> in GHz		1 MHz	Note 1, Note 2, Note 3
NOTE 1: <i>Measurement bandwidths</i> as in ITU-R SM.329 [4], s4.1.			
NOTE 2: Upper frequency as in ITU-R SM.329 [4], s2.5 table 1.			
NOTE 3: For <i>repeater type 1-C</i> DL, this spurious frequency range applies only for <i>operating bands</i> for which the 5 th harmonic of the upper frequency edge of the DL <i>operating band</i> is reaching beyond 12.75 GHz.			

Table 6.5.4.5.1-2: General *repeater type 1-C* transmitter spurious emission minimum requirements for UL in FR1, Category A

Spurious frequency range	Minimum requirements	Measurement bandwidth	Notes
9 kHz – 150 kHz	-36 dBm	1 kHz	Note 1
150 kHz – 30 MHz		10 kHz	Note 1
30 MHz – 1 GHz		100 kHz	Note 1
1 GHz – 12.75 GHz	-30 dBm	1 MHz	Note 1, Note 2
12.75 GHz – 5 th harmonic of the upper frequency edge of the UL <i>operating band</i> in GHz		1 MHz	Note 1, Note 2, Note 3
NOTE 1: <i>Measurement bandwidths</i> as in ITU-R SM.329 [4], s4.1. NOTE 2: Upper frequency as in ITU-R SM.329 [4], s2.5 table 1. NOTE 3: For <i>repeater type 1-C</i> UL, this spurious frequency range applies only for <i>operating bands</i> for which the 5 th harmonic of the upper frequency edge of the UL <i>operating band</i> is reaching beyond 12.75 GHz.			

Table 6.5.4.5.1-3: General *repeater type 1-C* transmitter spurious emission minimum requirements in FR1, Category B

Spurious frequency range	minimum requirements	Measurement bandwidth	Notes
9 kHz – 150 kHz	-36 dBm	1 kHz	Note 1
150 kHz – 30 MHz		10 kHz	Note 1
30 MHz – 1 GHz		100 kHz	Note 1
1 GHz – 12.75 GHz	-30 dBm	1 MHz	Note 1, Note 2
12.75 GHz – 5 th harmonic of the upper frequency edge of the <i>operating band</i> in GHz		1 MHz	Note 1, Note 2, Note 3
NOTE 1: <i>Measurement bandwidths</i> as in ITU-R SM.329 [4], s4.1. NOTE 2: Upper frequency as in ITU-R SM.329 [4], s2.5 table 1. NOTE 3: For <i>repeater type 1-C</i> DL, this spurious frequency range applies only for <i>operating bands</i> for which the 5 th harmonic of the upper frequency edge of the DL <i>operating band</i> is reaching beyond 12.75 GHz. For <i>repeater type 1-C</i> UL, this spurious frequency range applies only for <i>operating bands</i> for which the 5 th harmonic of the upper frequency edge of the UL <i>operating band</i> is reaching beyond 12.75 GHz.			

6.5.4.5.2 Additional spurious emissions requirements

These requirements may be applied for the protection of system operating in other frequency ranges. The limits may apply as an optional protection of such systems that are deployed in the same geographical area as the repeater-Node, or they may be set by local or regional regulation as a mandatory requirement for an NR *operating band*. It is in some cases not stated in the present document whether a requirement is mandatory or under what exact circumstances that a limit applies, since this is set by local or regional regulation.

Some requirements may apply for the protection of specific equipment (UE, MS and/or BS) or equipment operating in specific systems (GSM, CDMA, UTRA, E-UTRA, NR, etc.) as listed below.

The spurious emission *minimum requirements* are provided in table 6.5.4.5.2-1 where requirements for co-existence with the system listed in the first column apply for *repeater type 1-C*. For a *multi-band connector*, the exclusions and conditions in the Note column of table 6.5.4.5.2-1 apply for each supported *operating band*.

Table 6.5.4.5.2-1: Repeater type 1-C spurious emissions minimum requirements for co-existence with systems operating in other frequency bands

System type to co-exist with	Frequency range for co-existence requirement	Minimum requirements	Measurement bandwidth	Note
GSM900	921 – 960 MHz	-57 dBm	100 kHz	This requirement does not apply to repeater operating in band n8
	876 – 915 MHz	-61 dBm	100 kHz	For the frequency range 880-915 MHz, this requirement does not apply to repeater operating in band n8.
DCS1800	1805 – 1880 MHz	-47 dBm	100 kHz	This requirement does not apply to repeater operating in band n3.
	1710 – 1785 MHz	-61 dBm	100 kHz	This requirement does not apply to repeater operating in band n3.
PCS1900	1930 – 1990 MHz	-47 dBm	100 kHz	This requirement does not apply to repeater operating in band n2, n25 or band n70.
	1850 – 1910 MHz	-61 dBm	100 kHz	This requirement does not apply to repeater operating in band n2 or n25.
GSM850 or CDMA850	869 – 894 MHz	-57 dBm	100 kHz	This requirement does not apply to repeater operating in band n5 or n26.
	824 – 849 MHz	-61 dBm	100 kHz	This requirement does not apply to repeater operating in band n5 or n26.
UTRA FDD Band I or E-UTRA Band 1 or NR Band n1	2110 – 2170 MHz	-52 dBm	1 MHz	This requirement does not apply to repeater operating in band n1 or n65
	1920 – 1980 MHz	-49 dBm	1 MHz	This requirement does not apply to repeater operating in band n1 or n65.
UTRA FDD Band II or E-UTRA Band 2 or NR Band n2	1930 – 1990 MHz	-52 dBm	1 MHz	This requirement does not apply to repeater operating in band n2 or n70.
	1850 – 1910 MHz	-49 dBm	1 MHz	This requirement does not apply to repeater operating in band n2.
UTRA FDD Band III or E-UTRA Band 3 or NR Band n3	1805 – 1880 MHz	-52 dBm	1 MHz	This requirement does not apply to repeater operating in band n3.
	1710 – 1785 MHz	-49 dBm	1 MHz	This requirement does not apply to repeater operating in band n3.
UTRA FDD Band IV or E-UTRA Band 4	2110 – 2155 MHz	-52 dBm	1 MHz	This requirement does not apply to repeater operating in band n66
	1710 – 1755 MHz	-49 dBm	1 MHz	This requirement does not apply to repeater operating in band n66.
UTRA FDD Band V or E-UTRA Band 5 or NR Band n5	869 – 894 MHz	-52 dBm	1 MHz	This requirement does not apply to repeater operating in band n5 or n26.
	824 – 849 MHz	-49 dBm	1 MHz	This requirement does not apply to repeater operating in band n5 or n26.
UTRA FDD	860 – 890 MHz	-52 dBm	1 MHz	This requirement does not apply to repeater operating in band n18.
Band VI, XIX or E-UTRA Band 6, 18, 19 or NR Band n18	815 – 830 MHz	-49 dBm	1 MHz	This requirement does not apply to repeater operating in band n18.
	830 – 845 MHz	-49 dBm	1 MHz	
UTRA FDD Band VII or E-UTRA Band 7 or NR Band n7	2620 – 2690 MHz	-52 dBm	1 MHz	This requirement does not apply to repeater operating in band n7.
	2500 – 2570 MHz	-49 dBm	1 MHz	This requirement does not apply to repeater operating in band n7.

UTRA FDD Band VIII or E-UTRA Band 8 or NR Band n8	925 – 960 MHz	-52 dBm	1 MHz	This requirement does not apply to repeater operating in band n8.
	880 – 915 MHz	-49 dBm	1 MHz	This requirement does not apply to repeater operating in band n8.
UTRA FDD Band IX or E-UTRA Band 9	1844.9 – 1879.9 MHz	-52 dBm	1 MHz	This requirement does not apply to repeater operating in band n3.
	1749.9 – 1784.9 MHz	-49 dBm	1 MHz	This requirement does not apply to repeater operating in band n3.
UTRA FDD Band X or E-UTRA Band 10	2110 – 2170 MHz	-52 dBm	1 MHz	This requirement does not apply to repeater operating in band n66
	1710 – 1770 MHz	-49 dBm	1 MHz	This requirement does not apply to repeater operating in band n66.
UTRA FDD Band XI or XXI or E-UTRA Band 11 or 21	1475.9 – 1510.9 MHz	-52 dBm	1 MHz	This requirement does not apply to repeater operating in band n50, n74, n75, n92 or n94.
	1427.9 – 1447.9 MHz	-49 dBm	1 MHz	This requirement does not apply to repeater operating in band n50, n51, n74, n75, n76, n91, n92, n93 or n94.
	1447.9 – 1462.9 MHz	-49 dBm	1 MHz	This requirement does not apply to repeater operating in band n50, n74, n75, n92 or n94.
UTRA FDD Band XII or E-UTRA Band 12 or NR Band n12	729 – 746 MHz	-52 dBm	1 MHz	This requirement does not apply to repeater operating in band n12 or n85.
	699 – 716 MHz	-49 dBm	1 MHz	This requirement does not apply to repeater operating in band n12 or n85. For NR repeater operating in n29, it applies 1 MHz below the Band n29 downlink operating band (Note 5).
UTRA FDD Band XIII or E-UTRA Band 13	746 – 756 MHz	-52 dBm	1 MHz	This requirement does not apply to repeater operating in band n13.
	777 – 787 MHz	-49 dBm	1 MHz	This requirement does not apply to repeater operating in band n13.
UTRA FDD Band XIV or E-UTRA Band 14 or NR band n14	758 – 768 MHz	-52 dBm	1 MHz	This requirement does not apply to repeater operating in band n14.
	788 – 798 MHz	-49 dBm	1 MHz	This requirement does not apply to repeater operating in band n14.
E-UTRA Band 17	734 – 746 MHz	-52 dBm	1 MHz	
	704 – 716 MHz	-49 dBm	1 MHz	For NR repeater operating in n29, it applies 1 MHz below the Band n29 downlink operating band (Note 5).
UTRA FDD Band XX or E- UTRA Band 20 or NR Band n20	791 – 821 MHz	-52 dBm	1 MHz	This requirement does not apply to repeater operating in band n20 or n28.
	832 – 862 MHz	-49 dBm	1 MHz	This requirement does not apply to repeater operating in band n20.
UTRA FDD Band XXII or E-UTRA Band 22	3510 – 3590 MHz	-52 dBm	1 MHz	This requirement does not apply to repeater operating in band n48, n77 or n78.
	3410 – 3490 MHz	-49 dBm	1 MHz	This requirement does not apply to repeater operating in band n77 or n78.

E-UTRA Band 24	1525 – 1559 MHz	-52 dBm	1 MHz	This requirement does not apply to repeater operating in band n24.
	1626.5 – 1660.5 MHz	-49 dBm	1 MHz	This requirement does not apply to repeater operating in band n24.
UTRA FDD Band XXV or E-UTRA Band 25 or NR band n25	1930 – 1995 MHz	-52 dBm	1 MHz	This requirement does not apply to repeater operating in band n2, n25 or n70.
	1850 – 1915 MHz	-49 dBm	1 MHz	This requirement does not apply to repeater operating in band n25 since it is already covered by the requirement in clause 6.5.4.5.2. For repeater operating in Band n2, it applies for 1910 MHz to 1915 MHz, while the rest is covered in clause 6.5.4.5.2.
UTRA FDD Band XXVI or E-UTRA Band 26 or NR Band n26	859 – 894 MHz	-52 dBm	1 MHz	This requirement does not apply to repeater operating in band n5 or n26.
	814 – 849 MHz	-49 dBm	1 MHz	This requirement does not apply to repeater operating in band n26 since it is already covered by the requirement in clause 6.5.4.5.2. For repeater operating in Band n5, it applies for 814 MHz to 824 MHz, while the rest is covered in clause 6.5.4.5.2.
E-UTRA Band 27	852 – 869 MHz	-52 dBm	1 MHz	This requirement does not apply to repeater operating in Band n5.
	807 – 824 MHz	-49 dBm	1 MHz	This requirement also applies to repeater operating in Band n28, starting 4 MHz above the Band n28 downlink operating band (Note 5).
E-UTRA Band 28 or NR Band n28	758 – 803 MHz	-52 dBm	1 MHz	This requirement does not apply to repeater operating in band n20, n67 or n28.
	703 – 748 MHz	-49 dBm	1 MHz	This requirement does not apply to repeater operating in band n28.. For repeater operating in band n67, it applies for 703 MHz to 736 MHz.
E-UTRA Band 29 or NR Band n29	717 – 728 MHz	-52 dBm	1 MHz	This requirement does not apply to repeater operating in Band n29 or n85
E-UTRA Band 30 or NR Band n30	2350 – 2360 MHz	-52 dBm	1 MHz	This requirement does not apply to repeater operating in band n30
	2305 – 2315 MHz	-49 dBm	1 MHz	This requirement does not apply to repeater operating in band n30.
E-UTRA Band 31	462.5 – 467.5 MHz	-52 dBm	1 MHz	
	452.5 – 457.5 MHz	-49 dBm	1 MHz	
UTRA FDD band XXXII or E-UTRA band 32	1452 – 1496 MHz	-52 dBm	1 MHz	This requirement does not apply to repeater operating in band n50, n74, n75, n92 or n94.
UTRA TDD Band a) or E-UTRA Band 33	1900 – 1920 MHz	-52 dBm	1 MHz	
UTRA TDD Band a) or E-UTRA Band 34 or NR band n34	2010 – 2025 MHz	-52 dBm	1 MHz	This requirement does not apply to repeater operating in Band n34.
UTRA TDD Band b) or E-UTRA Band 35	1850 – 1910 MHz	-52 dBm	1 MHz	
UTRA TDD Band b) or E-UTRA Band 36	1930 – 1990 MHz	-52 dBm	1 MHz	This requirement does not apply to repeater operating in Band n2 or n25.
UTRA TDD Band c) or E-UTRA Band 37	1910 – 1930 MHz	-52 dBm	1 MHz	

UTRA TDD Band d) or E-UTRA Band 38 or NR Band n38	2570 – 2620 MHz	-52 dBm	1 MHz	This requirement does not apply to repeater operating in Band n38.
UTRA TDD Band f) or E-UTRA Band 39 or NR band n39	1880 – 1920MHz	-52 dBm	1 MHz	This requirement does not apply to repeater operating in Band n39.
UTRA TDD Band e) or E-UTRA Band 40 or NR Band n40	2300 – 2400MHz	-52 dBm	1 MHz	This requirement does not apply to repeater operating in Band n30 or n40.
E-UTRA Band 41 or NR Band n41, n90	2496 – 2690 MHz	-52 dBm	1 MHz	This is not applicable to repeater operating in Band n41, n53 or [n90].
E-UTRA Band 42	3400 – 3600 MHz	-52 dBm	1 MHz	This is not applicable to repeater operating in Band n48, n77 or n78.
E-UTRA Band 43	3600 – 3800 MHz	-52 dBm	1 MHz	This is not applicable to repeater operating in Band n48, n77 or n78.
E-UTRA Band 44	703 – 803 MHz	-52 dBm	1 MHz	This is not applicable to repeater operating in Band n28.
E-UTRA Band 45	1447 – 1467 MHz	-52 dBm	1 MHz	
E-UTRA Band 46	5150 – 5925 MHz	-52 dBm	1 MHz	
E-UTRA Band 47	5855 – 5925 MHz	-52 dBm	1 MHz	
E-UTRA Band 48 or NR Band n48	3550 – 3700 MHz	-52 dBm	1 MHz	This is not applicable to repeater operating in Band n48, n77 or n78.
E-UTRA Band 50 or NR band n50	1432 – 1517 MHz	-52 dBm	1 MHz	This requirement does not apply to repeater operating in Band n50, n51, n74, n75, n76, n91, n92, n93 or n94.
E-UTRA Band 51 or NR Band n51	1427 – 1432 MHz	-52 dBm	1 MHz	This requirement does not apply to repeater operating in Band n50, n51, n75, n76, n91, n92, n93 or n94.
E-UTRA Band 53 or NR Band n53	2483.5 - 2495 MHz	-52 dBm	1 MHz	This requirement does not apply to repeater operating in Band n41, n53 or n90.
E-UTRA Band 65 or NR Band n65	2110 – 2200 MHz	-52 dBm	1 MHz	This requirement does not apply to repeater operating in band n1 or n65.
	1920 – 2010 MHz	-49 dBm	1 MHz	For repeater operating in Band n1, it applies for 1980 MHz to 2010 MHz, while the rest is covered in clause 6.5.4.5.2. This requirement does not apply to repeater operating in band n65.
E-UTRA Band 66 or NR Band n66	2110 – 2200 MHz	-52 dBm	1 MHz	This requirement does not apply to repeater operating in band n66.
	1710 – 1780 MHz	-49 dBm	1 MHz	This requirement does not apply to repeater operating in band n66.
E-UTRA Band 67 or NR Band n67	738 – 758 MHz	-52 dBm	1 MHz	This requirement does not apply to repeater operating in Band n28 or n67.
E-UTRA Band 68	753 -783 MHz	-52 dBm	1 MHz	This requirement does not apply to repeater operating in band n28.
	698-728 MHz	-49 dBm	1 MHz	For repeater operating in Band n28, this requirement applies between 698 MHz and 703 MHz, while the rest is covered in clause 6.5.4.5.2.
E-UTRA Band 69	2570 – 2620 MHz	-52 dBm	1 MHz	This requirement does not apply to repeater operating in Band n38.
E-UTRA Band 70 or NR Band n70	1995 – 2020 MHz	-52 dBm	1 MHz	This requirement does not apply to repeater operating in band n2, n25 or n70

	1695 – 1710 MHz	-49 dBm	1 MHz	This requirement does not apply to repeater operating in band n70..
E-UTRA Band 71 or NR Band n71	617 – 652 MHz	-52 dBm	1 MHz	This requirement does not apply to repeater operating in band n71
	663 – 698 MHz	-49 dBm	1 MHz	This requirement does not apply to repeater operating in band n71.
E-UTRA Band 72	461 – 466 MHz	-52 dBm	1 MHz	
	451 – 456 MHz	-49 dBm	1 MHz	
E-UTRA Band 74 or NR Band n74	1475 – 1518 MHz	-52 dBm	1 MHz	This requirement does not apply to repeater operating in band n50, n74, n75, n92 or n94.
	1427 – 1470 MHz	-49 dBm	1MHz	This requirement does not apply to repeater operating in band n50, n51, n74, n75, n76, n91, n92, n93 or n94.
E-UTRA Band 75 or NR Band n75	1432 – 1517 MHz	-52 dBm	1 MHz	This requirement does not apply to repeater operating in Band n50, n51, n74, n75, n76, n91, n92, n93 or n94.
E-UTRA Band 76 or NR Band n76	1427 – 1432 MHz	-52 dBm	1 MHz	This requirement does not apply to repeater operating in Band n50, n51, n75, n76, n91, n92, n93 or n94.
NR Band n77	3.3 – 4.2 GHz	-52 dBm	1 MHz	This requirement does not apply to repeater operating in Band n48, n77 or n78
NR Band n78	3.3 – 3.8 GHz	-52 dBm	1 MHz	This requirement does not apply to repeater operating in Band n48, n77 or n78
NR Band n79	4.4 – 5.0 GHz	-52 dBm	1 MHz	This requirement does not apply to repeater operating in Band n79
NR Band n80	1710 – 1785 MHz	-49 dBm	1 MHz	This requirement does not apply to repeater operating in band n3.
NR Band n81	880 – 915 MHz	-49 dBm	1 MHz	This requirement does not apply to repeater operating in band n8.
NR Band n82	832 – 862 MHz	-49 dBm	1 MHz	This requirement does not apply to repeater operating in band n20.
NR Band n83	703 – 748 MHz	-49 dBm	1 MHz	This requirement does not apply to repeater operating in band n28. For repeater operating in Band n67, it applies for 703 MHz to 736 MHz.
NR Band n84	1920 – 1980 MHz	-49 dBm	1 MHz	This requirement does not apply to repeater operating in band n1.
E-UTRA Band 85 and NR Band n85	728 – 746 MHz	-52 dBm	1 MHz	This requirement does not apply to repeater operating in band n12 or n85. For NR repeater operating in n29, it applies 1 MHz below the Band n29 downlink operating band (Note 5).
	698 – 716 MHz	-49 dBm	1 MHz	This requirement does not apply to repeater operating in band n12 or n85.
NR Band n86	1710 – 1780 MHz	-49 dBm	1 MHz	This requirement does not apply to repeater operating in band n66.
NR Band n89	824 – 849 MHz	-49 dBm	1 MHz	This requirement does not apply to repeater operating in band n5.
NR Band n91	1427 – 1432 MHz	-52 dBm	1 MHz	This requirement does not apply to repeater operating in Band n50, n51, n75 or n76.
	832 – 862 MHz	-49 dBm	1 MHz	This requirement does not apply to repeater operating in band n20, since it is already covered by the requirement in clause 6.5.4.5.2.
NR Band n92	1432 – 1517 MHz	-52 dBm	1 MHz	This requirement does not apply to repeater operating in Band n50, n51, n74, n75 or n76.
	832 – 862 MHz	-49 dBm	1 MHz	This requirement does not apply to repeater operating in band n20, since it is already covered by the requirement in clause 6.5.4.5.2.
NR Band n93	1427 – 1432 MHz	-52 dBm	1 MHz	This requirement does not apply to repeater operating in Band n50, n51, n75 or n76.
	880 – 915 MHz	-49 dBm	1 MHz	This requirement does not apply to repeater operating in band n8, since it is already covered by the requirement in clause 6.5.4.5.2.
NR Band n94	1432 – 1517 MHz	-52 dBm	1 MHz	This requirement does not apply to repeater operating in Band n50, n51, n74, n75 or n76.

	880 – 915 MHz	-49 dBm	1 MHz	This requirement does not apply to repeater operating in band n8, since it is already covered by the requirement in clause 6.5.4.5.2.
NR Band n95	2010 – 2025 MHz	-52 dBm	1 MHz	
NR Band n96	5925 – 7125 MHz	-52 dBm	1 MHz	
NR Band n97	2300 – 2400MHz	-52 dBm	1 MHz	
NR Band n98	1880 – 1920MHz	-52 dBm	1 MHz	
NR Band n99	1626.5 – 1660.5 MHz	-49 dBm	1 MHz	This requirement does not apply to repeater operating in band n24.
NR Band n100	919.4 – 925 MHz	-52 dBm	1 MHz	This requirement does not apply to repeater operating in Band n8 or n100.
	874.4 – 880 MHz	-49 dBm	1 MHz	This requirement does not apply to repeater operating in band n100.
NR band n101	1900 – 1910 MHz	-52 dBm	1 MHz	This requirement does not apply to repeater operating in Band n101.
NR Band n102	5925 – 6425 MHz	-52 dBm	1 MHz	
E-UTRA Band 103	757 – 758 MHz	-52 dBm	1 MHz	
	787 – 788 MHz	-49 dBm	1 MHz	
NR Band n104	6425 – 7125 MHz	-52 dBm	1 MHz	This requirement does not apply to repeater operating in Band n104

NOTE 1: As defined in the scope for spurious emissions in this clause, except for the cases where the noted requirements apply to a repeater operating in Band n28, the co-existence requirements in table 6.5.4.5.2 - 1 do not apply for the Δf_{OBUE} frequency range immediately outside the downlink *operating band*. Emission limits for this excluded frequency range may be covered by local or regional requirements.

NOTE 2: Table 6.5.4.5.2 -1 assumes that two *operating bands*, where the frequency ranges would be overlapping, are not deployed in the same geographical area. For such a case of operation with overlapping frequency arrangements in the same geographical area, special co-existence requirements may apply that are not covered by the 3GPP specifications.

NOTE 3: For unsynchronized operation, special co-existence requirements may apply that are not covered by the 3GPP specifications.

NOTE 4: For NR Band n28 repeater, specific solutions may be required to fulfil the spurious emissions limits for repeater for co-existence with E-UTRA Band 27 UL *operating band*.

NOTE 5: For NR Band n29 repeater, specific solutions may be required to fulfil the spurious emissions limits for NR repeater for co-existence with UTRA Band XII, E-UTRA Band 12 or NR Band n12 UL *operating band*, E-UTRA Band 17 UL *operating band* or E-UTRA Band 85 UL or NR Band n85 UL *operating band*.

The following requirement may be applied for the protection of PHS. This requirement is also applicable at specified frequencies falling between Δf_{OBUE} below the lowest repeater transmitter frequency of the downlink *operating band* and Δf_{OBUE} above the highest repeater transmitter frequency of the downlink *operating band*. Δf_{OBUE} is defined in clause 6.5.1.

The spurious emission *minimum requirements* for this requirement are:

Table 6.5.4.5.2-2: Repeater spurious emissions minimum requirements for repeater for co-existence with PHS for DL

Frequency range	<i>minimum requirements</i>	<i>Measurement Bandwidth</i>	Note
1884.5 – 1915.7 MHz	-41 dBm	300 kHz	Applicable when co-existence with PHS system operating in 1884.5 – 1915.7 MHz

In certain regions, the following requirement may apply to NR repeater operating in Band n50 and n75 within the 1432 – 1452 MHz, and in Band n51 and Band n76. The *minimum requirements* are specified in Table 6.5.4.5.2-3. This requirement is also applicable at the frequency range from Δf_{OBUE} below the lowest frequency of the repeater downlink *operating band* up to Δf_{OBUE} above the highest frequency of the repeater downlink *operating band*.

Table 6.5.4.5.2-3: Additional operating band unwanted emission minimum requirement for NR repeater operating in Band n50 and n75 within 1432 – 1452 MHz, and in Band n51 and n76

Filter centre frequency, F_{filter}	Minimum requirements	Measurement Bandwidth
$F_{\text{filter}} = 1413.5 \text{ MHz}$	-42 dBm	27 MHz

In certain regions, the following requirement may apply to repeater operating in NR Band n50 and n75 within 1492-1517 MHz and in Band n74 within 1492-1518 MHz. The maximum level of emissions, measured on centre frequencies F_{filter} with filter bandwidth according to Table 6.5.4.5.2-4, shall be defined according to the *minimum requirements* $P_{\text{EM},n50/n75,a}$ nor $P_{\text{EM},n50/n75,b}$ declared by the manufacturer.

Table 6.5.4.5.2-4: Operating band n50, n74 and n75 declared emission above 1518 MHz

Filter centre frequency, F_{filter}	Declared <i>minimum requirements</i> (dBm)	Measurement bandwidth
$1518.5 \text{ MHz} \leq F_{\text{filter}} \leq 1519.5 \text{ MHz}$	$P_{\text{EM},n50/n75,a}$	1 MHz
$1520.5 \text{ MHz} \leq F_{\text{filter}} \leq 1558.5 \text{ MHz}$	$P_{\text{EM},n50/n75,b}$	1 MHz

In certain regions, the following requirement shall be applied to repeater operating in Band n13 and n14 to ensure that appropriate interference protection is provided to 700 MHz public safety operations. This requirement is also applicable at the frequency range from 10 MHz below the lowest frequency of the repeater downlink operating band up to 10 MHz above the highest frequency of the repeater downlink operating band.

The power of any spurious emission shall not exceed:

Table 6.5.4.5.2-5: Repeater spurious emissions limits for protection of 700 MHz public safety operations

Operating Band	Frequency range	Maximum Level	Measurement Bandwidth
n13	763 - 775 MHz	-46 dBm	6.25 kHz
n13	793 - 805 MHz	-46 dBm	6.25 kHz
n14	769 - 775 MHz	-46 dBm	6.25 kHz
n14	799 - 805 MHz	-46 dBm	6.25 kHz

In certain regions, the following requirement may apply to NR repeater operating in Band n30. This requirement is also applicable at the frequency range from 10 MHz below the lowest frequency of the repeater downlink operating band up to 10 MHz above the highest frequency of the repeater downlink operating band.

The power of any spurious emission shall not exceed:

Table 6.5.4.5.2-6: Additional NR repeater spurious emissions minimum requirements for Band n30

Frequency range	Minimum requirements	Measurement Bandwidth	Note
2200 – 2345 MHz	-45 dBm	1 MHz	
2362.5 – 2365 MHz	-25 dBm	1 MHz	
2365 – 2367.5 MHz	-40 dBm	1 MHz	
2367.5 – 2370 MHz	-42 dBm	1 MHz	
2370 – 2395 MHz	-45 dBm	1 MHz	

The following requirement may apply to repeater operating in Band n48 in certain regions. The power of any spurious emission shall not exceed:

Table 6.5.4.5.2-7: Additional repeater spurious emissions limits for Band n48

Frequency range	Maximum Level	Measurement Bandwidth (NOTE)	Note
3530 MHz – 3720 MHz	-25 dBm	1 MHz	Applicable 10 MHz from the assigned passband edge
3100 MHz – 3530 MHz 3720 MHz – 4200 MHz	-40 dBm	1 MHz	

NOTE: The resolution bandwidth of the measuring equipment should be equal to the measurement bandwidth. However, to improve measurement accuracy, sensitivity and efficiency, the resolution bandwidth may be smaller than the measurement bandwidth. When the resolution bandwidth is smaller than the measurement bandwidth, the result should be integrated over the measurement bandwidth in order to obtain the equivalent noise bandwidth of the measurement bandwidth.

NOTE: The regional requirement, included in [14], is defined in terms of EIRP, which is dependent on both the repeater emissions at the *antenna connector* and the deployment (including antenna gain and feeder loss). The requirement defined above provides the characteristics of the base station needed to verify compliance with the regional requirement. The assessment of the EIRP level is described in Annex F.

The following requirement shall be applied to repeater operating in Band n26 to ensure that appropriate interference protection is provided to 800 MHz public safety operations. This requirement is also applicable at the frequency range from 10 MHz below the lowest frequency of the repeater downlink operating band up to 10 MHz above the highest frequency of the repeater downlink operating band.

The power of any spurious emission shall not exceed:

Table 6.5.4.5.2-8: Repeater spurious emissions limits for protection of 800 MHz public safety operations

Operating Band	Frequency range	Maximum Level	Measurement Bandwidth	Note
n26	851 - 859 MHz	-13 dBm	100 kHz	Applicable for offsets > 37.5kHz from the passband edge

The following requirement may apply to Repeater for Band n41 and n90 operation in Japan. This requirement is also applicable at the frequency range from Δf_{OBUE} below the lowest frequency of the Repeater downlink operating band up to Δf_{OBUE} above the highest frequency of the Repeater downlink operating band.

The power of any spurious emission shall not exceed:

Table 6.5.4.5.2-9: Additional repeater spurious emissions minimum requirements for Band n41 and n90

Frequency range	Minimum requirement	Measurement Bandwidth
2505 MHz – 2535 MHz	-42 dBm	1 MHz
NOTE: This requirement applies for carriers allocated within 2545-2645 MHz.		

The following requirement may apply to repeater operating in 3.45-3.55 GHz in Band n77 in certain regions. Emissions shall not exceed the maximum levels specified in table 6.5.4.2.3-11.

Table 6.5.4.5.2-10: Additional repeater spurious emissions limits for Band n77

Channel bandwidth [MHz]	Frequency range [MHz]	Filter centre frequency, F_{filter} [MHz]	Minimum requirement [dBm]	Measurement bandwidth [MHz]
All	3430 – 3440 3560 – 3570	$3430.5 \leq F_{\text{filter}} < 3439.5$ $3560.5 \leq F_{\text{filter}} < 3569.5$	-25	1
All	≤ 3430 > 3570	$F_{\text{filter}} < 3429.5$ $3570.5 \leq F_{\text{filter}}$	-40	1

NOTE: The resolution bandwidth of the measuring equipment should be equal to the measurement bandwidth. However, to improve measurement accuracy, sensitivity and efficiency, the resolution bandwidth may be smaller than the measurement bandwidth. When the resolution bandwidth is smaller than the measurement bandwidth, the result should be integrated over the measurement bandwidth in order to obtain the equivalent noise bandwidth of the measurement bandwidth.

6.5.4.5.3 Co-location with base stations and *repeater type 1-C* Nodes

These requirements may be applied for the protection of other BS, IAB-DU, IAB-MT and *repeater type 1-C* receivers when GSM900, DCS1800, PCS1900, GSM850, CDMA850, UTRA FDD, UTRA TDD, E-UTRA, NR BS, IAB-DU, IAB-MT, or *repeater type 1-C* are co-located with *repeater type 1-C*.

The requirements assume a 30 dB coupling loss between transmitter and receiver and are based on co-location with same class.

The *minimum requirements* are in table 6.5.4.5.3-1 for a *repeater type 1-C*. Requirements for co-location with a system listed in the first column apply, depending on the declared *repeater type 1-C* class. For a *multi-band connector*, the exclusions and conditions in the Note column of table 6.5.4.5.3-1 shall apply for each supported *operating band*.

Table 6.5.4.5.3-1: Repeater type 1-C spurious emissions minimum requirements for co-location with BS, IAB-Node or repeater-Node

Type of co-located BS	Frequency range for co-location requirement	Minimum requirements			Measurement bandwidth	Note
		WA repeater	MR repeater	LA repeater		
GSM900	876 – 915 MHz	-98 dBm	-91 dBm	-70 dBm	100 kHz	
DCS1800	1710 – 1785 MHz	-98 dBm	-91 dBm	-80 dBm	100 kHz	
PCS1900	1850 – 1910 MHz	-98 dBm	-91 dBm	-80 dBm	100 kHz	
GSM850 or CDMA850	824 – 849 MHz	-98 dBm	-91 dBm	-70 dBm	100 kHz	
UTRA FDD Band I or E-UTRA Band 1 or NR Band n1	1920 – 1980 MHz	-96 dBm	-91 dBm	-88 dBm	100 kHz	
UTRA FDD Band II or E-UTRA Band 2 or NR Band n2	1850 – 1910 MHz	-96 dBm	-91 dBm	-88 dBm	100 kHz	
UTRA FDD Band III or E-UTRA Band 3 or NR Band n3	1710 – 1785 MHz	-96 dBm	-91 dBm	-88 dBm	100 kHz	
UTRA FDD Band IV or E-UTRA Band 4	1710 – 1755 MHz	-96 dBm	-91 dBm	-88 dBm	100 kHz	
UTRA FDD Band V or E-UTRA Band 5 or NR Band n5	824 – 849 MHz	-96 dBm	-91 dBm	-88 dBm	100 kHz	
UTRA FDD Band VI, XIX or E-UTRA Band 6, 19	830 – 845 MHz	-96 dBm	-91 dBm	-88 dBm	100 kHz	
UTRA FDD Band VII or E-UTRA Band 7 or NR Band n7	2500 – 2570 MHz	-96 dBm	-91 dBm	-88 dBm	100 kHz	
UTRA FDD Band VIII or E-UTRA Band 8 or NR Band n8	880 – 915 MHz	-96 dBm	-91 dBm	-88 dBm	100 kHz	
UTRA FDD Band IX or E-UTRA Band 9	1749.9 – 1784.9 MHz	-96 dBm	-91 dBm	-88 dBm	100 kHz	
UTRA FDD Band X or E-UTRA Band 10	1710 – 1770 MHz	-96 dBm	-91 dBm	-88 dBm	100 kHz	
UTRA FDD Band XI or E-UTRA Band 11	1427.9 – 1447.9 MHz	-96 dBm	-91 dBm	-88 dBm	100 kHz	This is not applicable to repeater operating in Band n50, n75, n91, n92, n93 or n94
UTRA FDD Band XII or E-UTRA Band 12 or NR Band n12	699 – 716 MHz	-96 dBm	-91 dBm	-88 dBm	100 kHz	
UTRA FDD Band XIII or E-UTRA Band 13 or NR Band n13	777 – 787 MHz	-96 dBm	-91 dBm	-88 dBm	100 kHz	
UTRA FDD Band XIV or E-UTRA Band 14 or NR Band n14	788 – 798 MHz	-96 dBm	-91 dBm	-88 dBm	100 kHz	
E-UTRA Band 17	704 – 716 MHz	-96 dBm	-91 dBm	-88 dBm	100 kHz	
E-UTRA Band 18 or NR Band n18	815 – 830 MHz	-96 dBm	-91 dBm	-88 dBm	100 kHz	
UTRA FDD Band XX or E-UTRA Band 20 or NR Band n20	832 – 862 MHz	-96 dBm	-91 dBm	-88 dBm	100 kHz	
UTRA FDD Band XXI or E-UTRA Band 21	1447.9 – 1462.9 MHz	-96 dBm	-91 dBm	-88 dBm	100 kHz	This is not applicable to repeater operating in Band n50, n75, n92 or n94

UTRA FDD Band XXII or E-UTRA Band 22	3410 – 3490 MHz	-96 dBm	-91 dBm	-88 dBm	100 kHz	This is not applicable to repeater operating in Band n48, n77 or n78
E-UTRA Band 24 or NR Band n24	1626.5 – 1660.5 MHz	-96 dBm	-91 dBm	-88 dBm	100 kHz	
UTRA FDD Band XXV or E-UTRA Band 25 or NR Band n25	1850 – 1915 MHz	-96 dBm	-91 dBm	-88 dBm	100 kHz	
UTRA FDD Band XXVI or E-UTRA Band 26 or NR Band n26	814 – 849 MHz	-96 dBm	-91 dBm	-88 dBm	100 kHz	
E-UTRA Band 27	807 – 824 MHz	-96 dBm	-91 dBm	-88 dBm	100 kHz	
E-UTRA Band 28 or NR Band n28	703 – 748 MHz	-96 dBm	-91 dBm	-88 dBm	100 kHz	
E-UTRA Band 30 or NR Band n30	2305 – 2315 MHz	-96 dBm	-91 dBm	-88 dBm	100 kHz	
E-UTRA Band 31	452.5 – 457.5 MHz	-96 dBm	-91 dBm	-88 dBm	100 kHz	
UTRA TDD Band a) or E-UTRA Band 33	1900 – 1920 MHz	-96 dBm	-91 dBm	-88 dBm	100 kHz	
UTRA TDD Band a) or E-UTRA Band 34 or NR band n34	2010 – 2025 MHz	-96 dBm	-91 dBm	-88 dBm	100 kHz	This is not applicable to repeater operating in Band n34
UTRA TDD Band b) or E-UTRA Band 35	1850 – 1910 MHz	-96 dBm	-91 dBm	-88 dBm	100 kHz	
UTRA TDD Band b) or E-UTRA Band 36	1930 – 1990 MHz	-96 dBm	-91 dBm	-88 dBm	100 kHz	This is not applicable to repeater operating in Band n2 or band n25
UTRA TDD Band c) or E-UTRA Band 37	1910 – 1930 MHz	-96 dBm	-91 dBm	-88 dBm	100 kHz	
UTRA TDD Band d) or E-UTRA Band 38 or NR Band n38	2570 – 2620 MHz	-96 dBm	-91 dBm	-88 dBm	100 kHz	This is not applicable to repeater operating in Band n38.
UTRA TDD Band f) or E-UTRA Band 39 or NR band n39	1880 – 1920MHz	-96 dBm	-91 dBm	-88 dBm	100 kHz	This is not applicable to repeater operating in Band n39
UTRA TDD Band e) or E-UTRA Band 40 or NR Band n40	2300 – 2400MHz	-96 dBm	-91 dBm	-88 dBm	100 kHz	This is not applicable to repeater operating in Band n30 or n40.
E-UTRA Band 41 or NR Band n41, n90	2496 – 2690 MHz	-96 dBm	-91 dBm	-88 dBm	100 kHz	This is not applicable to repeater operating in Band n41, n53 or [n90]
E-UTRA Band 42	3400 – 3600 MHz	-96 dBm	-91 dBm	-88 dBm	100 kHz	This is not applicable to repeater operating in Band n48, n77 or n78

E-UTRA Band 43	3600 – 3800 MHz	-96 dBm	-91 dBm	-88 dBm	100 kHz	This is not applicable to repeater operating in Band n48, n77 or n78
E-UTRA Band 44	703 – 803 MHz	-96 dBm	-91 dBm	-88 dBm	100 kHz	This is not applicable to repeater operating in Band n28
E-UTRA Band 45	1447 – 1467 MHz	-96 dBm	-91 dBm	-88 dBm	100 kHz	
E-UTRA Band 46 or NR Band n46	5150 – 5925 MHz	N/A	-91 dBm	-88 dBm	100 kHz	This is not applicable to repeater operating in Band n46 or n96
E-UTRA Band 48 or NR Band n48	3550 – 3700 MHz	-96 dBm	-91 dBm	-88 dBm	100 kHz	This is not applicable to repeater operating in Band n48, n77 or n78
E-UTRA Band 50 or NR Band n50	1432 – 1517 MHz	-96 dBm	-91 dBm	-88 dBm	100 kHz	This is not applicable to repeater operating in Band n51, n74, n75, n91, n92, n93 or n94
E-UTRA Band 51 or NR Band n51	1427 – 1432 MHz	N/A	N/A	-88 dBm	100 kHz	This is not applicable to repeater operating in Band n50, n74, n75, n76, n91, n92, n93 or n94
E-UTRA Band 53 or NR Band n53	2483.5 – 2495 MHz	N/A	-91 dBm	-88 dBm	100 kHz	This is not applicable to repeater operating in Band n41, n53 or n90
E-UTRA Band 65 or NR Band n65	1920 – 2010 MHz	-96 dBm	-91 dBm	-88 dBm	100 kHz	
E-UTRA Band 66 or NR Band n66	1710 – 1780 MHz	-96 dBm	-91 dBm	-88 dBm	100 kHz	
E-UTRA Band 68	698 – 728 MHz	-96 dBm	-91 dBm	-88 dBm	100 kHz	
E-UTRA Band 70 or NR Band n70	1695 – 1710 MHz	-96 dBm	-91 dBm	-88 dBm	100 kHz	
E-UTRA Band 71 or NR Band n71	663 – 698 MHz	-96 dBm	-91 dBm	-88 dBm	100 kHz	
E-UTRA Band 72	451 – 456 MHz	-96 dBm	-91 dBm	-88 dBm	100 kHz	
E-UTRA Band 74 or NR Band n74	1427 – 1470 MHz	-96 dBm	-91 dBm	-88 dBm	100 kHz	This is not applicable to repeater operating in Band n50, n51, n91, n92, n93 or n94

NR Band n77	3.3 – 4.2 GHz	-96 dBm	-91 dBm	-88 dBm	100 kHz	This is not applicable to repeater operating in Band n48, n77 or n78
NR Band n78	3.3 – 3.8 GHz	-96 dBm	-91 dBm	-88 dBm	100 kHz	This is not applicable to repeater operating in Band n48, n77 or n78
NR Band n79	4.4 – 5.0 GHz	-96 dBm	-91 dBm	-88 dBm	100 kHz	
NR Band n80	1710 – 1785 MHz	-96 dBm	-91 dBm	-88 dBm	100 kHz	
NR Band n81	880 – 915 MHz	-96 dBm	-91 dBm	-88 dBm	100 kHz	
NR Band n82	832 – 862 MHz	-96 dBm	-91 dBm	-88 dBm	100 kHz	
NR Band n83	703 – 748 MHz	-96 dBm	-91 dBm	-88 dBm	100 kHz	
NR Band n84	1920 – 1980 MHz	-96 dBm	-91 dBm	-88 dBm	100 kHz	
E-UTRA Band 85 or NR Band n85	698 – 716 MHz	-96 dBm	-91 dBm	-88 dBm	100 kHz	
NR Band n86	1710 – 1780 MHz	-96 dBm	-91 dBm	-88 dBm	100 kHz	
NR Band n89	824 – 849 MHz	-96 dBm	-91 dBm	-88 dBm	100 kHz	
NR Band n91	832 – 862 MHz	N/A	N/A	-88 dBm	100 kHz	
NR Band n92	832 – 862 MHz	-96 dBm	-91 dBm	-88 dBm	100 kHz	
NR Band n93	880 – 915 MHz	N/A	N/A	-88 dBm	100 kHz	
NR Band n94	880 – 915 MHz	-96 dBm	-91 dBm	-88 dBm	100 kHz	
NR Band n95	2010 – 2025 MHz	-96 dBm	-91 dBm	-88 dBm	100 kHz	
NR Band n96	5925 – 7125 MHz	N/A	-90 dBm	-87 dBm	100 kHz	
NR Band n97	2300 – 2400MHz	-96 dBm	-91 dBm	-88 dBm	100 kHz	
NR Band n98	1880 – 1920MHz	-96 dBm	-91 dBm	-88 dBm	100 kHz	
NR Band n99	1626.5 – 1660.5 MHz	-96 dBm	-91 dBm	-88 dBm	100 kHz	
NR Band n102	5925 – 6425 MHz	N/A	-90 dBm	-87 dBm	100 kHz	
E-UTRA Band 103	787 – 788 MHz	-96 dBm	-91 dBm	-88 dBm	100 kHz	
NR Band n104	6425 – 7125 MHz	-95 dBm	-90 dBm	-87 dBm	100 kHz	This requirement does not apply to repeater operating in Band n104.

NOTE 1: As defined in the scope for spurious emissions in this clause, the co-location requirements in table 6.5.4.5.3-1 do not apply for the frequency range extending Δf_{OBUE} immediately outside the transmit frequency range of a *repeater type 1-C*. The current state-of-the-art technology does not allow a single generic solution for co-location with other system on adjacent frequencies for 30dB antenna to antenna minimum coupling loss. However, there are certain site-engineering solutions that can be used. These techniques are addressed in TR 25.942 [15].

NOTE 2: Table 6.5.4.5.3-1 assumes that two *operating bands*, where the corresponding transmit and receive frequency ranges would be overlapping, are not deployed in the same geographical area. For such a case of operation with overlapping frequency arrangements in the same geographical area, special co-location requirements may apply that are not covered by the 3GPP specifications.

6.5.5 Receiver spurious emissions

6.5.5.1 Definition and applicability

The receiver spurious emissions power is the power of emissions generated or amplified in a receiver unit that appear at the *antenna connector*. The requirements only apply to *repeater type 1-C* for TDD operation.

For each *antenna connectors* on BS-side and UE-side supporting both RX and TX in TDD, the requirements apply during the *transmitter OFF state*. For *antenna connectors* both BS-side and UE-side in FDD, the RX spurious emissions requirements are superseded by the TX spurious emissions requirements, as specified in clause 6.5.4.5.

For *multi-band connectors* that both transmit and receive in *operating band* supporting TDD, RX spurious emissions requirements are applicable during the *TX OFF state*, and are subject to exclusion zones in each supported *operating band*.

For Band n41 and n90 operation in Japan, the sum of receiver spurious emissions requirements over all *antenna connectors* for *repeater type 1-C* shall not exceed *minimum requirements* defined in clause 6.5.5.5.

6.5.5.2 Minimum requirement

The minimum requirements are in TS 38.106 [2], clause 6.5.5.2.

6.5.5.3 Test purpose

The test purpose is to verify the ability of the repeater to limit the interference caused by receiver spurious emissions to other systems.

6.5.5.4 Method of test

6.5.5.4.1 Initial conditions

Test environment: Normal; see annex B.2.

RF channels to be tested for single carrier: M; see clause 4.9.1.

6.5.5.4.2 Procedure

The minimum requirement is applied to all connectors under test,

- 1) Connect the connector under test to measurement equipment as shown in annex D.9.
- 2) Ensure the transmitter is OFF.
- 3) Set the measurement equipment parameters as specified in table 6.5.5.5-1.
- 4) Measure the spurious emissions over each frequency range described in table 6.5.5.5-1.

In addition, for a *multi-band connector*, the following steps shall apply:

- 5) For *multi-band connector* and single band tests, repeat the steps above per involved band where single band test configurations and test models shall apply with no carrier activated in the other band.

6.5.5.5 Test requirements

The receiver spurious emissions requirements for *repeater type 1-C* are that for each *antenna connector*, the power of emissions shall not exceed the value specified in table 6.5.5.5-1.

Table 6.5.5.5-1: Repeater type 1-C receiver spurious emissions limits

Spurious frequency range	Basic limits	Measurement bandwidth	Note
30 MHz – 1 GHz	-57 dBm	100 kHz	Note 1
1 GHz – 12.75 GHz	-47 dBm	1 MHz	Note 1, Note 2
12.75 GHz – 5 th harmonic of the upper frequency edge of the UL <i>operating band</i> in GHz	-47 dBm	1 MHz	Note 1, Note 2, Note 3
12.75 GHz - 26 GHz	-47 dBm	1 MHz	Note 1, Note 2
NOTE 1: <i>Measurement bandwidths</i> as in ITU-R SM.329 [4], s4.1.			
NOTE 2: Upper frequency as in ITU-R SM.329 [4], s2.5 table 1.			
NOTE 3: This spurious frequency range applies only for <i>operating bands</i> for which the 5 th harmonic of the upper frequency edge of the UL <i>operating band</i> is reaching beyond 12.75 GHz.			
NOTE 4: The frequency range from Δf_{OBUE} below the lowest frequency of the repeater transmitter <i>operating band</i> to Δf_{OBUE} above the highest frequency of the repeater transmitter <i>operating band</i> may be excluded from the requirement. Δf_{OBUE} is defined in clause 6.5.1. For <i>multi-band connectors</i> , the exclusion applies for all supported <i>operating bands</i> .			

6.6 Repeater Error Vector Magnitude

6.6.1 Downlink repeater error vector magnitude

6.6.1.1 General

The Repeater Error Vector Magnitude (EVM) is a measure of the difference between the symbols provided at the input of repeater and the measured signal symbols at the output of the repeater after the equalization by the measurement equipment. This difference is called the error vector. Details about how the repeater EVM is determined are the same as specified in TS 38.104 Annex B for FR1. The repeater EVM result is defined as the square root of the ratio of the mean error vector power to the mean reference power expressed in percent. The accuracy of the input symbols is counted in the measurement uncertainty.

The repeater EVM requirement is applicable for a repeater operating at an input power in the range from what is required to reach the maximum output power to the minimum power level in table 6.6.1.1-1.

Table 6.6.1.1-1: Minimum input power for repeater EVM

Repeater DL class	Minimum input power spectral density (dBm/MHz)	
	QPSK, 16 QAM, 64QAM	256QAM ¹
WA	-82	-75
MR	-77	-70
LA	-74	-67
Note 1: support of 256QAM is based on the declaration		

6.6.1.2 Minimum requirements

The minimum requirement is in TS 38.106 [2] clause 6.6.1.2.

6.6.1.3 Test purpose

To verify that the downlink repeater EVM deterioration is within the limit specified by the minimum requirements after the signal passed through the Repeater.

6.6.1.4 Method of test

6.6.1.4.1 Initial conditions

Test environment: Normal; see annex B.2.

RF channels to be tested for single carrier: B, M and T; see clause 4.9.1.

RF bandwidth positions to be tested for multi-carrier and/or CA:

- B_{RFBW} , M_{RFBW} and T_{RFBW} in single-band operation, see clause 4.9.1;
- $B_{RFBW_T'_{RFBW}}$ and $B'_{RFBW_T_{RFBW}}$ in multi-band operation, see clause 4.9.1.

6.6.1.4.2 Procedure

The minimum requirement is applied to all *antenna connectors*, they may be tested one at a time or multiple *antenna connectors* may be tested in parallel as shown in annex D.1.1 for *repeater type 1-C*. Whichever method is used the procedure is repeated until all *antenna connectors* necessary to demonstrate conformance have been tested.

- 1) For an *antenna connector* declared to be capable of single carrier operation only (D.16), set the *antenna connector* under test to transmit a signal according to the applicable test configuration in clause 4.8 using the corresponding test models:
 - RDL-FR1-TM3.1a if 256QAM is supported by repeater without power back off, or
 - RDL-FR1-TM3.1a at manufacturer's declared rated output power if 256QAM is supported by repeater with power back off, and RDL-FR1-TM3.1 at maximum power, or
 - RDL-FR1-TM3.1 if highest modulation order supported by repeater is 64QAM, or
 - RDL-FR1-TM3.2 if highest modulation order supported by repeater is 16QAM, or
 - RDL-FR1-TM3.3 if highest modulation order supported by repeater is QPSK.

For an *antenna connector* declared to be capable of multi-carrier operation (D.15-D.16), set the *antenna connector* under test to transmit according to the applicable test configuration and corresponding power setting specified in clauses 4.7 and 4.8 using the corresponding test models on all carriers configured:

- RDL-FR1-TM3.1a if 256QAM is supported by repeater without power back off, or
- RDL-FR1-TM3.1a at manufacturer's declared rated output power if 256QAM is supported by repeater with power back off, and RDL-FR1-TM3.1 at maximum power, or
- RDL-FR1-TM3.1 if highest modulation order supported by repeater is 64QAM, or
- RDL-FR1-TM3.2 if highest modulation order supported by repeater is 16QAM, or
- RDL-FR1-TM3.3 if highest modulation order supported by repeater is QPSK.

For RDL-FR1-TM3.1a, power back-off shall be applied if it is declared.

- 2) Measure the repeater EVM and frequency error as defined in annex H.
- 3) Repeat steps 1 and 2 for RDL-FR1-TM2 if 256QAM is not supported by repeater or for RDL-FR1-TM2a if 256QAM is supported by repeater. For RDL-FR1-TM2 and RDL-FR1-TM2a, the OFDM symbol TX power (OSTP) shall be at the lower limit of the dynamic range according to the test procedure in clause 6.3.3.4 and test requirements in clause 6.3.3.5.

In addition, for *multi-band connector(s)*, the following steps shall apply:

- 4) For *multi-band connectors* and single band tests, repeat the steps above per involved band where single band test configurations and test models shall apply with no carrier activated in the other band.

6.6.1.5 Test requirement

The downlink of the Repeater EVM levels for different modulation schemes shall not exceed values in table 6.6.1.5-1.

Table 6.6.1.5-1: Repeater EVM test requirements

Parameter	Required test repeater EVM
QPSK, 16QAM, 64QAM	[9.25 %]
256QAM	[4.75 %] ¹
Note 1: support of 256QAM is based on the declaration.	

6.6.2 Uplink repeater error vector magnitude

6.6.2.1 General

The Repeater Error Vector Magnitude is a measure of the difference between the reference waveform provided at the input of the repeater and the measured waveform at the output of the repeater. This difference is called the error vector. Details about how the repeater EVM is determined are the same as specified in TS 38.101-1[9] Annex F. Before calculating the repeater EVM the measured waveform is corrected by the sample timing offset and RF frequency offset. Then the carrier leakage shall be removed from the measured waveform before calculating the repeater EVM.

The measured waveform is further equalised using the channel estimates subjected to the repeater EVM equaliser spectrum flatness requirement specified in TS 38.101-1[9] clause 6.4.2.4. For DFT-s-OFDM waveforms, the repeater EVM result is defined after the front-end FFT and IDFT as the square root of the ratio of the mean error vector power to the mean reference power expressed as a %. For CP-OFDM waveforms, the repeater EVM result is defined after the front-end FFT as the square root of the ratio of the mean error vector power to the mean reference power expressed as a %. The accuracy of the input waveform is counted in the measurement uncertainty.

The basic repeater EVM measurement interval in one slot in the time domain. The repeater EVM measurement interval is reduced by any symbols that contains an allowable power transient in the measurement interval, as defined in TS 38.101-1 [9] clause 6.3.3 for EVM for UE.

The repeater EVM requirement is applicable for a repeater operating at an input power in the range from what is required to reach the maximum output power to the minimum power level in table 6.6.2.1-1.

Table 6.6.2.1-1: Minimum input power for repeater EVM

Repeater UL class	Minimum input power spectral density (dBm/MHz)	
	QPSK, 16 QAM, 64QAM	256QAM ¹
WA	-82	-75
LA	-74	-67
Note 1: support of 256QAM is based on the declaration		

6.6.2.2 Minimum requirement

The minimum requirement is in TS 38.106 [9] clause 6.6.2.2.

6.6.2.3 Test purpose

To verify that the uplink repeater EVM deterioration is within the limit specified by the minimum requirements after the signal passed through the Repeater.

6.6.2.3 Method of test

6.6.2.3.1 Initial conditions

Test environment: Normal; see annex B.2.

RF channels to be tested for single carrier: B, M and T; see clause 4.9.1.

RF bandwidth positions to be tested for multi-carrier and/or CA:

- B_{RFBW} , M_{RFBW} and T_{RFBW} in single-band operation, see clause 4.9.1;
- $B_{\text{RFBW}}T_{\text{RFBW}}$ and $B'_{\text{RFBW}}T_{\text{RFBW}}$ in multi-band operation, see clause 4.9.1.

6.6.2.3.2 Procedure

For repeater, the minimum requirement is applied to all *antenna connectors*, they may be tested one at a time or multiple *antenna connectors* may be tested in parallel as shown in annex D.1.1 for *repeater type I-C*. Whichever method is used the procedure is repeated until all *antenna connectors* necessary to demonstrate conformance have been tested.

- 1) For an *antenna connector* declared to be capable of single carrier operation only (D.16), set the *antenna connector* under test to transmit a signal according to the applicable test configuration in clause 4.8 using the corresponding test models:
 - RUL-TM3.1a if 256QAM is supported by repeater without power back off, or
 - RUL-FR1-TM3.1a at manufacturer's declared rated output power if 256QAM is supported by repeater with power back off, and RUL-FR1-TM3.1 at maximum power, or
 - RUL-FR1-TM3.1 with highest modulation order supported by repeater.

For an *antenna connector* declared to be capable of multi-carrier operation (D.15-D.16), set the *antenna connector* under test to transmit according to the applicable test configuration and corresponding power setting specified in clauses 4.7 and 4.8 using the corresponding test models on all carriers configured:

- RUL-FR1-TM3.1a if 256QAM is supported by repeater without power back off, or
- RUL-FR1-TM3.1a at manufacturer's declared rated output power if 256QAM is supported by repeater with power back off, and RUL-FR1-TM3.1 at maximum power, or
- RUL-FR1-TM3.1 with highest modulation order supported by repeater.

For RUL-FR1-TM3.1a, power back-off shall be applied if it is declared.

- 2) Measure the repeater EVM and frequency error as defined in annex H.
- 3) Repeat steps 1 and 2 for RUL-FR1-TM2 if 256QAM is not supported by repeater or for RUL-FR1-TM2a if 256QAM is supported by repeater. For RUL-FR1-TM2 and RUL-FR1-TM2a the OFDM symbol TX power (OSTP) shall be at the lower limit of the dynamic range according to the test procedure in clause 6.3.3.4 and test requirements in clause 6.3.3.5.

In addition, for *multi-band connector(s)*, the following steps shall apply:

- 4) For *multi-band connectors* and single band tests, repeat the steps above per involved band where single band test configurations and test models shall apply with no carrier activated in the other band.

6.6.2.4 Test requirement

The uplink of the Repeater EVM levels for different modulation schemes shall not exceed values in table 6.6.2.4-1.

Table 6.6.2.4-1: Repeater EVM test requirements

Parameter	Required test repeater EVM
QPSK, 16QAM, 64QAM	[9.25 %]
256QAM	[4.75 %] ¹
Note 1: support of 256QAM is based on the declaration.	

6.7 Input intermodulation

6.7.1 Definition and applicability

6.7.1.1 General

The input intermodulation is a measure of the capability of the Repeater to inhibit the generation of interference in the passband, in the presence of interfering signals on frequencies other than the passband.

Third and higher order mixing of the two interfering RF signals can produce an interfering signal in the band of the desired channel. Intermodulation response rejection is a measure of the capability of the Repeater to maintain the wanted frequency free of internally created interference.

The measurements shall apply to both uplink and downlink paths of the Repeater, during the *transmitter ON state* at maximum gain.

6.7.1.2 Minimum requirements

The minimum requirement is in TS 38.106 [2] clauses 6.7.1.2, 6.7.2.2 and 6.7.3.2.

6.7.1.3 Test purpose

The purpose of this test is to verify that the Repeater meets the intermodulation characteristics requirements as specified by the minimum requirements.

6.7.1.4 Method of test

6.7.1.4.1 Initial conditions

Test environment: normal; see Annex A.2

A measurement system set-up is shown in Annex D.

- 1) Set the Repeater to maximum gain.
- 2) Connect two signal generators with a combining circuit or one signal generator with the ability to generate several CW carriers to the input.
- 3) Connect a spectrum analyser to the output of the Repeater.

6.7.1.4.2 Procedure

- 1) Adjust the frequency of the input signals, either below or above the passband, so that one carrier, f_1 , is 1 MHz outside the channel edge frequency of the first or last channel in the passband, and the lowest order intermodulation product from the two carriers is positioned in the centre of the passband.
- 2) Measure the increase in output power in the passband when the interferer is applied.
- 3) Repeat the measurement for the opposite path of the Repeater.

6.7.1.5 Test requirements

6.7.1.5.1 General requirement

The intermodulation performance should be met when the following signals are applied to the NR Repeater:

Table 6.7.1.5.1-1: Input intermodulation requirement

f₁ offset	Interfering Signal Levels	Type of signals	Measurement bandwidth
1,0 MHz	-40 dBm	2 CW carriers	1 MHz

f₁ offset is the offset from the channel edge frequency of the first or last channel in the passband of the closer carrier.

For the parameters specified in Table 6.7.1.5.1-1, the power in the pass band shall not increase by more than [10+TT] dB at the output of the Repeater as measured in the centre of the pass band, compared to the level obtained without interfering signals applied.

6.7.1.5.2 Co-location with BS/Repeater in other systems

This additional input intermodulation requirement may be applied for the protection of NR repeater receivers when GSM, CDMA, UTRA, E-UTRA, NR BS or repeater operating in a different frequency band are co-located with a NR repeater.

The following requirement applies for interfering signals depending on the repeaters *passband*.

This requirement applies to the uplink and downlink of the repeater. If the BS side is declared to meet co-location requirements, then it should meet input intermodulation co-location requirements for the downlink. If the UE side is declared to meet co-location requirements, then it should meet input intermodulation co-location requirements for the uplink.

Table 6.7.1.5.2-1: input intermodulation requirement for NR repeater DL when co-located with BS/repeater in other frequency bands.

Frequency range of interfering signal	Interfering signal mean power for repeater with WA UE side (dBm)	Interfering signal mean power for repeater with MR UE side(dBm)	Interfering signal mean power for repeater with LA UE side(dBm)	Type of interfering signals
Frequency range of co-located BS's downlink operating band or located repeater's <i>passband</i>	+16	+8	x (Note 1)	2 CW carriers
NOTE 1: x = -7 dBm for NR repeater co-located with Pico GSM850 or Pico CDMA850 x = -4 dBm for NR repeater co-located with Pico DCS1800 or Pico PCS1900 x = -6 dBm for NR repeater co-located with UTRA bands or E-UTRA bands or NR bands NOTE 2: The requirement does not apply when the interfering signal falls within the <i>passband</i> . NOTE 3: For unsynchronized base stations or repeaters (except in band n46 and n96), special co-location requirements may apply that are not covered by the 3GPP specifications.				

Table 6.7.1.5.2-2: input intermodulation requirement for NR repeater UL when co-located with BS/repeater in other frequency bands.

Frequency range of interfering signal	Interfering signal mean power for repeater with WA BS side(dBm)	Interfering signal mean power for repeater with LA BS side(dBm)	Type of interfering signals
Frequency range of co-located BS's downlink operating band or located repeater's <i>passband</i>	+16	P _{rated,p,AC} -30	2 CW carriers
NOTE 1: The requirement does not apply when the interfering signal falls within the <i>passband</i> . NOTE 2: For unsynchronized base stations or repeaters (except in band n46 and n96), special co-location requirements may apply that are not covered by the 3GPP specifications.			

NOTE 1: The co-location requirements in Table 6.7.1.5.2-1 and 6.7.1.5.2-2 do not apply when the Repeaters passband frequency range is adjacent to the frequency range of the co-location requirement in the Table 6.7.1.5.2-1 or Table 6.7.1.5.2-2. The current state-of-the-art technology does not allow a single generic solution for co-location with other system on adjacent frequencies for 30dB Repeater-BS minimum coupling loss. However, there are certain site-engineering solutions that can be used. These techniques are addressed in TR 25.942 [15].

NOTE 2: The Table 6.7.1.5.2-1 and Table 6.7.1.5.2-2 assumes that two operating bands, where the corresponding BS or Repeater transmit and receive frequency ranges would be overlapping, are not deployed in the same geographical area. For such a case of operation with overlapping frequency arrangements in the same geographical area, special co-location requirements may apply that are not covered by the 3GPP specifications.

For the parameters specified in table Table 6.7.1.5.2-1 and 6.7.1.5.2-2, the power in the passband shall not increase with more than $[10 + TT]$ dB B at the output of the repeater as measured in the centre of the passband, compared to the level obtained without interfering signals applied.

6.7.1.5.3 Co-existence with other systems

This input intermodulation existence requirement may be applied for the protection of NR repeater receivers when GSM, CDMA, UTRA, E-UTRA, NR BS or repeater operating in another frequency band co-exist with a NR repeater.

The intermodulation performance should be met when the signals in Table 6.7.1.5.3-1 are applied to the Repeater:

Table 6.7.1.5.3-1: input intermodulation requirement for NR repeater when co-exist with BS/repeater in other non-overlapping frequency bands

Frequency range of interfering signal	Interfering signal mean power (dBm)	Type of interfering signals	Measurement bandwidth
Frequency range of co-existence system operating band	-15	2 CW carriers	1MHz
NOTE 1: All the interfering signals should be limited into the frequency ranges that are either X MHz higher than $F_{UL,high}$ or X MHz lower than $F_{UL,low}$, where X equals to 20MHz when $F_{UL,high} - F_{UL,low}$ is not larger than 200MHz, otherwise X equals to 60MHz			

NOTE 1: The co-existence requirements in Table 6.7.1.5.3-1 do not apply when the repeaters pass band frequency range is adjacent to the frequency range of the co-existence requirement in the Table 6.7.1.5.3-1. The current state-of-the-art technology does not allow a single generic solution for co-existence.

NOTE 2: The Table 6.7.1.5.3-1 assumes that two operating bands, where the frequency ranges would be overlapping, are not deployed in the same geographical area. For such a case of operation with overlapping frequency arrangements in the same geographical area, special co-existence requirements may apply that are not covered by the 3GPP specifications.

For the parameters specified in Table 6.7.1.5.3-1, the power in the pass band shall not increase with more than $[10 + TT]$ dB at the output of the repeater as measured in the centre of the pass band, compared to the level obtained without interfering signals applied.

6.8 Output intermodulation

6.8.1 Definition and applicability

6.8.1.1 General

The output intermodulation requirement is a measure of the capability of the repeater to inhibit the generation of signals in its non-linear elements caused by presence of the wanted signal and an interfering signal reaching the repeater via the output port. The requirement shall apply during the *transmitter ON state* and the *transmitter transient period*.

The requirement shall apply to the uplink and downlink of the Repeater.

For *repeater type 1-C*, the output intermodulation level is the power of the intermodulation products when an interfering signal is injected into the *antenna connector*.

6.8.1.2 Minimum requirements

The minimum requirement is in TS 38.106 [2] clause 6.8.2.

6.8.1.3 Test purpose

The test purpose is to verify the ability of the repeater to restrict the generation of intermodulation products in the presence of a subject signal on the repeater input and output ports, and an interfering signal applied at the repeater output port.

6.8.1.4 Method of test

6.8.1.4.1 Initial conditions

Test environment: normal; see Annex A.2

A measurement system set-up is shown in Annex D.

- 1) Connect a signal generator to the input port of the Repeater (wanted signal). Connect a signal generator to the output port (interfering signal) and make sure the signal generator power is directed to the repeater output port.
- 2) Detection mode: True RMS.

6.8.1.4.2 Procedure

- 1) Set the Repeater to maximum gain.
- 2) Set the signal generator at the repeater input port (wanted signal) to generate a signal in accordance to test model R-FR1-TM1.1, with a bandwidth as defined in Table 6.8.1.5.1-1, at the level which produce the manufacturer specified maximum output power at maximum gain.
- 3) Set the signal generator at the repeater output port (interference signal) to generate a signal in accordance to test model R-FR1-TM1.1, with a bandwidth, level and frequency offset as defined in Table 6.8.1.5.1-1.
- 4) Measure the emission at the specified frequencies with specified measurement bandwidth as described in the test requirements and note that the measured value does not exceed the specified value. Measurements in the band of the interfering signal shall be excluded. The measurements can be limited to the power of all third and fifth order intermodulation products.
- 5) Repeat the test from step 3 on until all interfering signal centre frequency offsets in Table 6.8.1.5.1-1 has been tested, but exclude interfering signal frequencies that are outside of the allocated frequency band for NR downlink.
- 6) For repeater supporting Band n41 and n90 operation in Japan, repeat the test using wanted and interfering signal parameters as defined in Table 6.8.1.5.2-1.

NOTE: As a general rule the resolution bandwidth of the measuring equipment should be equal to the measurement bandwidth. However, to improve measurement accuracy, sensitivity and efficiency, the resolution bandwidth can be smaller than the measurement bandwidth. When the resolution bandwidth is smaller than the measurement bandwidth, the result should be integrated over the measurement bandwidth in order to obtain the equivalent noise bandwidth of the measurement bandwidth.

6.8.1.5 Test requirements

6.8.1.5.1 General requirements

Test requirement shall be met using interfering and wanted signal parameters according to Table 6.8.1.5.1-1

Table 6.8.1.5.1-1: Interfering and wanted signals for the output intermodulation requirement

Parameter	Value
Wanted signal type	NR signal, filling all supported <i>passbands</i> in the operating band and with sufficient carriers to fill each <i>passband</i> . Minimum defined SCS for the operating band
Interfering signal type	NR signal, with the minimum SCS and channel bandwidth defined in the operating band in [2]
Interfering signal level	<i>Rated total output power</i> ($P_{\text{rated,t,AC}}$) in the <i>passband</i> – 30 dB
Interfering signal centre frequency offset from the lower/upper edge of the wanted signal or edge of <i>sub-block</i> inside a <i>sub-block gap</i>	$f_{\text{offset}} = \pm \text{minimum passband} \left(n - \frac{1}{2} \right)$, for n=1, 2 and 3
NOTE 1: Interfering signal positions that are partially or completely outside of any downlink operating band of the repeater are excluded from the requirement, unless the interfering signal positions fall within the frequency range of adjacent downlink operating bands in the same geographical area. In case that none of the interfering signal positions fall completely within the frequency range of the downlink operating band, TS 38.115-1 [7] provides further guidance regarding appropriate test requirements.	
NOTE 2: In Japan, NOTE 1 is not applied in Band n77, n78, n79.	

In all measurements, the requirements according to either clause [6.5.3] Operating band unwanted emission (Category A) and the downlink requirements of [6.5.4] Spurious emission (Category A) or [6.5.3] Operating band unwanted emissions (Category B) and the downlink requirements of [6.5.4] Spurious emission (Category B) shall be fulfilled.

6.8.1.5.2 Additional requirements

For repeater supporting Band n41 and n90 operation in Japan, the sum of output intermodulation level over all *antenna connectors* shall not exceed the unwanted emission limits in clauses 6.5 in the presence of an NR interfering signal according to table 6.8.1.5.2-1.

Table 6.8.1.5.2-1: Interfering and wanted signals for the additional output intermodulation requirement for Band n41 and n90

Parameter	Value
Wanted signal	NR signal (NOTE)
Interfering signal type	NR signal of 10 MHz <i>passband bandwidth</i>
Interfering signal level	<i>Rated total output power</i> ($P_{\text{rated,t,AC}}$) in the <i>passband</i> – 30 dB
Interfering signal centre frequency offset from the lower/upper <i>passband</i> centre frequency of the wanted signal	± 5 MHz ± 15 MHz ± 25 MHz
NOTE: This requirement applies for <i>passband</i> allocated within 2545-2645 MHz.	

6.9 Adjacent Channel Rejection Ratio (ACRR)

6.9.1 Definitions and applicability

Adjacent Channel Rejection Ratio (ACRR) is the ratio of the average gain over a carrier of the repeater in the *passband* to the average gain of the repeater over an adjacent channel outside the repeater *passband*. The carrier in the *passband* and in the adjacent channel shall be of the same type (reference carrier) with bandwidths as defined by *nominal channel bandwidth*. In case of Local Area repeater above 2496 MHz, the channel within the *passband* and the adjacent channel are assumed to have a bandwidth of 10 MHz

The requirement is differentiated between uplink and downlink.

The requirement shall apply during the *transmitter ON state*.

6.9.2 Co-existence with UTRA, E-UTRA and NR

This requirement shall be applied for the protection of UTRA, E-UTRA and NR signals in geographic areas in which NR Repeater, NR BS, E-UTRA BS and UTRA BS are deployed so that they serve adjacent channels. The reference carrier is a NR carrier.

6.9.2.1 Minimum requirements

The minimum requirement is in TS 38.106 [2] sub-clause 6.9.2.

6.9.2.2 Test purpose

To verify that the Repeater ACRR requirement is met as specified in sub-clause 6.9.2.1.

6.9.2.3 Method of test

6.9.2.3.1 Initial conditions

Test environment: normal; see Annex A2. [RF channels to be updated]

RF channels to be tested for single carrier: B, T; see clause 4.9.1.

Repeater RF Bandwidth positions to be tested for multi-carrier:

- B_{RFBW} and T_{RFBW} in single-band operation, see clause 4.9.1;
- B'_{RFBW} , T'_{RFBW} and B_{RFBW} , T_{RFBW} in multi-band operation, see clause 4.9.1.

6.9.2.3.2 Procedure

- 1) Set the signal generator to transmit a signal modulated with test model XX for downlink and test model XX for uplink as defined in section 4.9 at the first or last channel with channel offset from frequency range of passband defined in section 6.9.2.3.3 within the pass band.
- 2) Adjust the input power to the Repeater to create the maximum nominal Repeater output power at maximum gain
- 3) Measure the RRC filtered mean power at the RF output port over a certain slot.
- 4) Set the signal generator to transmit the same signal and the same input power at one of the channel offsets outside the repeater pass band according to Tables in section 6.9.2.3.3.
- 5) Measure the filtered mean power at the RF output port over a certain slot.
- 6) Calculate the ratio of the measured power in the pass band to the measured power at the channel offset.
- 7) Repeat step 4) to 6) until all channel offsets in Tables in section 6.9.2.3.3 are measured.

6.9.2.3.3 Test Requirements

For a repeater operating at *passband* below 2496 MHz, the ACRR requirements in table 6.9.2.3.3-1 shall apply in downlink. In normal conditions the ACRR for downlink shall be higher than the value specified in the Table 6.9.2.3.3-1.

Table 6.9.2.3.3-1: Repeater Downlink ACRR below 2496MHz

Co-existence with other systems	Repeater Class	Channel offset from frequency edge of passband (MHz)	Filter on the adjacent channel frequency and corresponding filter bandwidth	ACRR limit
UTRA, E-UTRA, NR	Wide Area repeater	$BW_{Nominal}/2$	Square (BW_{Config})	44.3dB
	Medium Range repeater	$BW_{Nominal}/2$	Square (BW_{Config})	44.3dB
	Local Area repeater	$BW_{Nominal}/2$	Square (BW_{Config})	32.3dB (Note 1)
NOTE 1: This requirement does not applicable if the <i>passband</i> occupies the entire <i>operating band</i> .				
NOTE 2: $BW_{Nominal}$ is the <i>nominal channel bandwidth</i> . BW_{Config} is the <i>transmission bandwidth configuration</i> assumed for the adjacent channel.				
NOTE 3: With SCS that provides largest <i>transmission bandwidth configuration</i> (BW_{Config}).				

For a repeater operating at passband above 2496 MHz, the ACRR requirements in table 6.9.2.3.3-1a shall apply in downlink. In normal conditions the ACRR for downlink shall be higher than the value specified in the Table 6.9.2.3.3-1a.

Table 6.9.2.3.3-1a: Repeater Downlink ACRR above 2496 MHz

Co-existence with other systems	Repeater Class	Channel offset from frequency edge of passband (MHz)	Filter on the adjacent channel frequency and corresponding filter bandwidth	ACRR limit
UTRA, E-UTRA, NR	Wide Area repeater	$BW_{Nominal}/2$	Square (BW_{Config})	32.3dB
	Medium Range repeater	$BW_{Nominal}/2$	Square (BW_{Config})	32.3dB
	Local Area repeater	$BW_{Nominal}/2$	Square (BW_{Config})	32.3dB (Note 1)
NOTE 1: This requirement does not applicable if the <i>passband</i> occupies the entire <i>operating band</i> .				
NOTE 2: $BW_{Nominal}$ is the <i>nominal channel bandwidth</i> . BW_{Config} is the <i>transmission bandwidth configuration</i> assumed for the adjacent channel.				
NOTE 3: With SCS that provides largest <i>transmission bandwidth configuration</i> (BW_{Config}).				

For a repeater operating at *passband* below 2496 MHz, the ACRR requirements in table 6.9.2.3.3-2 shall apply in uplink. In normal conditions the ACRR for uplink shall be higher than the value specified in the Table 6.9.2.3.3-2.

Table 6.9.2.3.3-2: Repeater Uplink ACRR below 2496 MHz

Co-existence with other systems	Repeater Class	Channel offset from frequency edge of passband (MHz)	Filter on the adjacent channel frequency and corresponding filter bandwidth	ACRR limit
UTRA, E-UTRA, NR	Wide Area repeater	$BW_{Nominal}/2$	Square (BW_{Config})	32.3dB
	Local Area repeater	$BW_{Nominal}/2$	Square (BW_{Config})	32.3dB (Note 1)
NOTE 1: This requirement does not applicable if the <i>passband</i> occupies the entire <i>operating band</i> .				
NOTE 2: $BW_{Nominal}$ is the <i>nominal channel bandwidth</i> . BW_{Config} is the <i>transmission bandwidth configuration</i> assumed for the adjacent channel.				
NOTE 3: With SCS that provides largest <i>transmission bandwidth configuration</i> (BW_{Config}).				

For a repeater operating at *passband* above 2496 MHz, the ACRR requirements in table 6.9.2.3.3-2a shall apply in uplink. In normal conditions the ACRR for uplink shall be higher than the value specified in the Table 6.9.2.3.3-2a.

Table 6.9.2.3.3-2a: Repeater Uplink ACRR above 2496 MHz

Co-existence with other systems	Repeater Class	Channel offset from frequency edge of <i>passband</i> (MHz)	Filter on the adjacent channel frequency and corresponding filter bandwidth	ACRR limit
UTRA, E-UTRA, NR	Wide Area repeater	$BW_{Nominal}/2$	Square (BW_{Config})	32.3dB
	Local Area repeater	5MHz	9 MHz	19.3dB (Note 1, Note 2)
		$BW_{Nominal}/2$	Square (BW_{Config})	32.3dB (Note 1)

NOTE 1: This requirement does not applicable if the *passband* occupies the entire *operating band*.
NOTE 2: In this case, the channel within the *passband* and the adjacent channel are assumed to have a bandwidth of 10 MHz
NOTE 3: $BW_{Nominal}$ is the *nominal channel bandwidth*. BW_{Config} is the *transmission bandwidth configuration* assumed for the adjacent channel.
NOTE 4: With SCS that provides largest *transmission bandwidth configuration* (BW_{Config}).

6.10 Transmit ON/OFF power

6.10.1 Transmitter OFF power

6.10.1.1 Definition and applicability

Transmit OFF power requirements apply only to TDD operation of the repeater. The requirement applies to both downlink and uplink of the repeater.

Transmitter OFF power is defined as the mean power measured over $70/N$ us filtered with a square filter of bandwidth equal to the *passband bandwidth* of the repeater ($BW_{passband}$) centred on the assigned channel frequency during the *transmitter OFF state*. $N = SCS/15$, where SCS is Sub Carrier Spacing in kHz of the input signal.

For *multi-band connectors* and for *single band connectors* supporting transmission in multiple *operating bands*, the requirement is only applicable during the *transmitter OFF state* in all supported *operating bands*.

6.10.1.2 Minimum requirement

The minimum requirement for *repeater type 1-C* is in TS 38.106 [2], clause 6.10.1.2.

6.10.1.3 Test purpose

The purpose of this test is to verify the transmitter OFF power is within the limits of the minimum requirements.

6.10.1.4 Method of test

Requirement is tested together with transmitter transient period, as described in clause 6.10.2.4.

6.10.1.5 Test requirements

The conformance testing of transmit OFF power is included in the conformance testing of transmitter transient period; therefore, see clause 6.10.2.5 for test requirements.

6.10.2 Transmitter transient period

6.10.2.1 Definition and applicability

Transmitter transient period requirements apply only to TDD operation of the repeater. The requirement applies to both downlink and uplink of the repeater.

The *transmitter transient period* is the time period during which the transmitter is changing from the *transmitter OFF state* to the *transmitter ON state* or vice versa. The *transmitter transient period* is illustrated in figure 6.10.2.1-1.

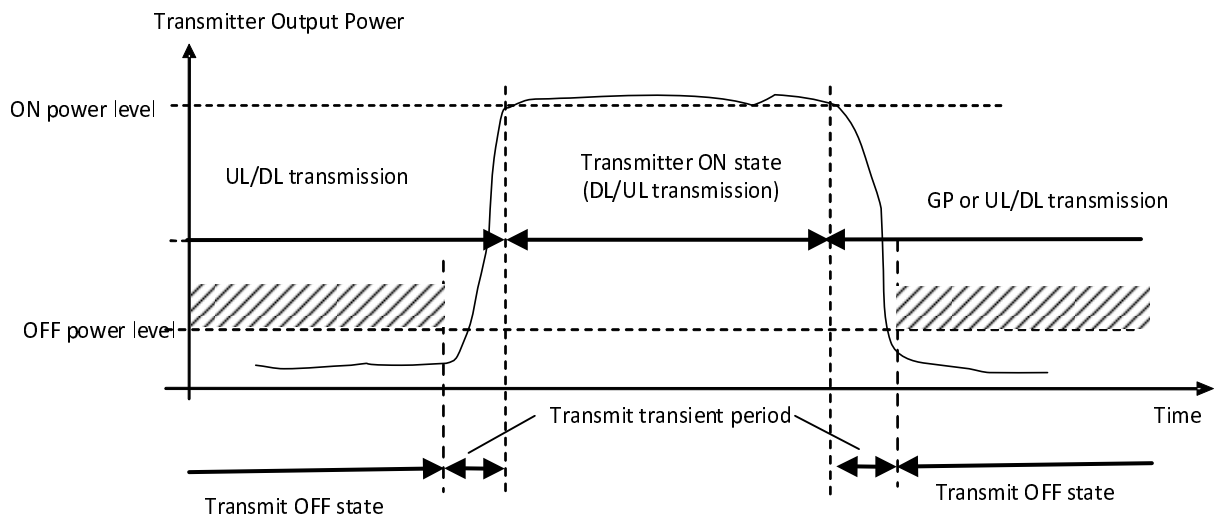

Figure 6.10.2.1-1: Example of relations between transmitter *ON state*, transmitter *OFF state* and *transmitter transient period*

For *repeater type 1-C* this requirement shall be applied at the *antenna connector* supporting transmission in the *operating band*.

For a repeater that is not declared to be a long delay repeater (D.15), the beginning and end point of downlink and uplink bursts are referenced to the slot timing at the input.

For a repeater that is declared to be a long delay repeater (D.15), the beginning and end point of downlink and uplink bursts are referenced to the slot timing at the input plus the declared repeater delay.

6.10.2.2 Minimum requirement

The minimum requirement for *repeater type 1-C* is in TS 38.106 [2], clause 6.10.2.2.

6.10.2.3 Test purpose

The purpose of this test is to verify the transmitter transient periods are within the limits of the minimum requirements.

6.10.2.4 Method of test

6.10.2.4.1 Initial conditions

Test environment:

- normal; see annex B.2.

RF channels to be tested for single carrier:

- M; see clause 4.9.1.

6.10.2.4.2 Procedure

The minimum requirement is applied to all *antenna connectors*, they may be tested one at a time or multiple *antenna connectors* may be tested in parallel as shown in annex D.1.1. Whichever method is used the procedure is repeated until all *antenna connectors* necessary to demonstrate conformance have been tested.

- 1) Connect *antenna connector* for input and output signals to measurement equipment as shown in annex D.1.1. All *antenna connectors* not under test shall be terminated.

As a general rule, the resolution bandwidth of the measuring equipment should be equal to the measurement bandwidth. However, to improve measurement accuracy, sensitivity, efficiency and avoiding e.g. carrier leakage, the resolution bandwidth may be smaller than the measurement bandwidth. When the resolution bandwidth is smaller than the measurement bandwidth, the result should be integrated over the measurement bandwidth in order to obtain the equivalent noise bandwidth of the measurement bandwidth.

- 2) Set the input signal to the representative connectors under test according to the applicable test configuration in clause 4.8 using the corresponding test models in clause 4.9.2 at the input power intended to produce the maximum rated output power, $P_{\text{rated,in, AC}} + 10\text{dB}$.
- 3) Measure the mean power spectral density over $70/N \mu\text{s}$ filtered with a square filter of bandwidth equal to the RF bandwidth of the *antenna connector* centred on the central frequency of the RF bandwidth. $70/N \mu\text{s}$ average window centre is set from $35/N \mu\text{s}$ after end of one transmitter ON state + $10 \mu\text{s}$ to $35/N \mu\text{s}$ before start of next transmitter ON state – $10 \mu\text{s}$. $N = \text{SCS}/15$, where SCS is Sub Carrier Spacing in kHz.

In addition, for *multi-band connector(s)*, the following steps shall apply:

- 4) For *multi-band connectors* and single band tests, repeat the steps above per involved band where single band test configurations and test models shall apply with no carrier activated in the other band.

6.10.2.5 Test requirements

For *repeater type 1-C downlink*, the requirements for transmitter OFF power spectral density shall be less than -83 dBm/MHz per *antenna connector* for carrier frequency $f \leq 3.0 \text{ GHz}$.

For *repeater type 1-C downlink*, the requirements for transmitter OFF power spectral density shall be less than -82.5 dBm/MHz per *antenna connector* for carrier frequency $3.0 \text{ GHz} < f \leq 6.0 \text{ GHz}$.

For *repeater type 1-C uplink*, the requirements for transmitter OFF power spectral density shall be less than $-48 \text{ dBm} / (\text{SCS} * (12 * N_{\text{RB}} + 1) / 1000) \text{ MHz}$ per *antenna connector*, where SCS is Sub Carrier Spacing in kHz for carrier frequency $f \leq 3.0 \text{ GHz}$.

For *repeater type 1-C uplink*, the requirements for transmitter OFF power spectral density shall be less than $-47.5 \text{ dBm} / (\text{SCS} * (12 * N_{\text{RB}} + 1) / 1000) \text{ MHz}$ per *antenna connector*, where SCS is Sub Carrier Spacing in kHz for carrier frequency $3.0 \text{ GHz} < f \leq 6.0 \text{ GHz}$.

For *multi-band connector*, the requirement is only applicable during the transmitter OFF state in all supported operating bands.

Annex A (normative): Repeater stimulus signals

A.1 Repeater stimulus signal 1

This repeater stimulus signal shall be used for the following tests:

- Uplink maximum output power
- Uplink operating band unwanted emissions
- Uplink spurious emissions

Two uplink fixed reference channels for performance requirements (16QAM $\frac{3}{4}$) for FDD according to the TS38.141-1 [7], [A.4 table A.4-1, channel reference AX-X of 5] MHz bandwidth generated on separate centre frequencies with equal power and combined with a time difference of 266,7 μ s (4 OFDM symbols)

The PUSCH data payload shall contain only zeroes (0000 0000).

Each reference channel shall be subjected to time windowing and filtering so that it fulfils the spectral purity requirements defined in A.3.

A.2 Repeater stimulus signal 2

This repeater stimulus signal shall be used for the following tests:

- Downlink operating band unwanted emissions
- Downlink spurious emissions

Two NR-FR1-TM1.1 channels according to the TS38.141-1 [7] of 5 MHz bandwidth generated on separate centre frequencies with equal power and combined with a time difference of [1400 μ s (21 OFDM symbols)].

Each NR-FR1-TM1.1 channel shall be subjected to time windowing and filtering so that it fulfils the spectral purity requirements defined in A.3.

A.3 Repeater stimulus signal spectral purity requirements

The reference channels or test models constituting the repeater stimulus signal shall fulfil the spectral purity requirements defined in table A.3-1 and A.3-2, where:

- the minimum spectral density suppression is related to the reference spectral density.

Table A.3-1: Repeater stimulus signal spectral purity requirements for nominal channel bandwidth of passband ≤ 20 MHz

Center frequency of measurement filter	Minimum requirements	Measurement filter type and filter bandwidth	Integration bandwidth
50.0 kHz outside from channel edge	46.8 dBc (Note 1)	Square (100 kHz)	100 kHz
Center of adjacent channel frequency with same nominal channel BW	46.8 dBc (Note 2)	Square (nominal channel BW)	Nominal channel BW
NOTE 1: the reference spectral density shall be taken at the carrier center frequency with an integration bandwidth of 100 kHz. NOTE 2: the reference spectral density shall be taken at the carrier center frequency with an integration bandwidth of nominal carrier BW			

Table A.3-2: Repeater stimulus signal spectral purity requirements for nominal channel bandwidth of passband > 20 MHz

Center frequency of measurement filter	Minimum requirements	Measurement filter type and filter bandwidth	Integration bandwidth
50.0 kHz outside from channel edge	47.2 dBc (Note 1)	Square (100 kHz)	100 kHz
Center of adjacent channel frequency with same nominal channel BW	47.2 dBc (Note 2)	Square (nominal channel BW)	Nominal channel BW
NOTE 1: the reference spectral density shall be taken at the carrier center frequency with an integration bandwidth of 100 kHz. NOTE 2: the reference spectral density shall be taken at the carrier center frequency with an integration bandwidth of nominal carrier BW			

Annex B (normative): Environmental requirements for the repeater

B.1 General

For each test in the present document, the environmental conditions under which the repeater is to be tested are defined.

B.2 Normal test environment

When a normal test environment is specified for a test, the test should be performed within the minimum and maximum limits of the conditions stated in table B.1.

Table B.1: Limits of conditions for normal test environment

Condition	Minimum	Maximum
Barometric pressure	86 kPa	106 kPa
Temperature	15 °C	30 °C
Relative humidity	20 %	85 %
Power supply	Nominal, as declared by the manufacturer	
Vibration	Negligible	

The ranges of barometric pressure, temperature and humidity represent the maximum variation expected in the uncontrolled environment of a test laboratory. If it is not possible to maintain these parameters within the specified limits, the actual values shall be recorded in the test report.

NOTE: This may, for instance, be the case for measurements of radiated emissions performed on an open field test site.

B.3 Extreme test environment

The manufacturer shall declare one of the following:

- 1) The equipment class for the equipment under test, as defined in the IEC 60 721-3-3 [16];
- 2) The equipment class for the equipment under test, as defined in the IEC 60 721-3-4 [17];
- 3) The equipment that does not comply with the mentioned classes, the relevant classes from IEC 60 721 [18] documentation for temperature, humidity and vibration shall be declared.

NOTE: Reduced functionality for conditions that fall outside of the standard operational conditions is not tested in the present document. These may be stated and tested separately.

B.3.1 Extreme temperature

When an extreme temperature test environment is specified for a test, the test shall be performed at the standard minimum and maximum operating temperatures defined by the manufacturer's declaration for the equipment under test.

Minimum temperature:

The test shall be performed with the environment test equipment and methods including the required environmental phenomena into the equipment, conforming to the test procedure of IEC 60 068-2-1 [19].

Maximum temperature:

The test shall be performed with the environmental test equipment and methods including the required environmental phenomena into the equipment, conforming to the test procedure of IEC 60 068-2-2 [20].

NOTE: It is recommended that the equipment is made fully operational prior to the equipment being taken to its lower operating temperature.

B.4 Vibration

When vibration conditions are specified for a test, the test shall be performed while the equipment is subjected to a vibration sequence as defined by the manufacturer's declaration for the equipment under test. This shall use the environmental test equipment and methods of inducing the required environmental phenomena in to the equipment, conforming to the test procedure of IEC 60 068-2-6 [21]. Other environmental conditions shall be within the ranges specified in annex B.2.

NOTE: The higher levels of vibration may induce undue physical stress in to equipment after a prolonged series of tests. The testing body should only vibrate the equipment during the RF measurement process.

B.5 Power supply

When extreme power supply conditions are specified for a test, the test shall be performed at the standard upper and lower limits of operating voltage defined by manufacturer's declaration for the equipment under test.

Upper voltage limit:

The equipment shall be supplied with a voltage equal to the upper limit declared by the manufacturer (as measured at the input terminals to the equipment). The tests shall be carried out at the steady state minimum and maximum temperature limits declared by the manufacturer for the equipment, to the methods described in IEC 60 068-2-1 [19] Test Ab/Ad and IEC 60 068-2-2 [20] Test Bb/Bd: Dry heat.

Lower voltage limit:

The equipment shall be supplied with a voltage equal to the lower limit declared by the manufacturer (as measured at the input terminals to the equipment). The tests shall be carried out at the steady state minimum and maximum temperature limits declared by the manufacturer for the equipment, to the methods described in IEC 60 068-2-1 [19] Test Ab/Ad and IEC 60 068-2-2 [20] Test Bb/Bd: Dry heat.

B.6 Measurement of test environments

The measurement accuracy of the repeater test environments defined in annex B shall be:

Pressure: ± 5 kPa

Temperature: ± 2 degrees

Relative humidity: ± 5 %

DC voltage: ± 1.0 %

AC voltage: ± 1.5 %

Vibration: 10 %

Vibration frequency: 0.1 Hz

The above values shall apply unless the test environment is otherwise controlled and the specification for the control of the test environment specifies the uncertainty for the parameter.

Annex C (informative): Test tolerances and derivation of test requirements

C.1 Measurement of conducted characteristics

Table C.1-1: Derivation of test requirements (conducted tests)

Test	Minimum requirement in TS 38.106 [2]	Test Tolerance (TT)	Test requirement in the present document
6.2 Repeater output power	See TS 38.106 [2], clause 6.2	Normal and extreme conditions: 0.7 dB, $f \leq 3.0$ GHz 1.0 dB, $3.0 \text{ GHz} < f \leq 7.125\text{GHz}$	Formula: Upper limit + TT, Lower limit – TT
6.3 Frequency stability	See TS 38.106 [2], clause 6.3	12 Hz	Formula: Frequency Error limit + TT
6.4 Out of band gain	See TS 38.106 [2], clause 6.4	0.5 dB, $f \leq 3.0$ GHz 0.8 dB, $3.0 \text{ GHz} < f \leq 7.125\text{GHz}$	Formula: Minimum Requirement + TT
6.5.2 ACLR/ CACLR	See TS 38.106 [2], clause 6.5.2	Relative ACLR/CACLR: BW $\leq 20\text{MHz}$: 0.8 dB BW $> 20\text{MHz}$: 1.2 dB Absolute ACLR/CACLR: 0 dB	Formula: ACLR Minimum Requirement - TT Absolute limit +TT
6.5.3 Operating band unwanted emission	See TS 38.106 [2], clause 6.5.3	Offsets $< 10\text{MHz}$: 1.5 dB, $f \leq 3.0\text{GHz}$ 1.8 dB, $3.0\text{GHz} < f \leq 7.125 \text{ GHz}$ Offsets $\geq 10\text{MHz}$: 0 dB	Formula: Minimum Requirement + TT
6.5.4 Spurious emissions	See TS 38.106 [2], clause 6.5.4	0 dB	Formula: Minimum Requirement + TT
6.6 EVM	See TS 38.106 [2], clause 6.6	1.25%	Formula: EVM limit + TT
6.7 Input intermodulation	See TS 38.106 [2], clause 6.7	0 dB	Formula: Minimum Requirement + TT
6.8 Output intermodulation	See TS 38.106 [2], clause 6.8	0 dB	Formula: Minimum Requirement + TT
6.9 ACRR	See TS 38.106 [2], clause 6.9	0.7 dB	Formula: Minimum Requirement – TT
6.10.1 Transmit ON/OFF power	See TS 38.106 [2], clause 6.10.1	2.0 dB, $f \leq 3.0$ GHz 2.5 dB, $3.0 \text{ GHz} < f \leq 7.125 \text{ GHz}$	Formula: Minimum Requirement + TT
6.10.2 Transmitter transient period	See TS 38.106 [2], clause 6.10.2	N/A	
NOTE: TT values are applicable for normal condition unless otherwise stated.			

Annex D (informative): Measurement system set-up

Example of measurement system set-ups are attached below as an informative annex.

D.1 Repeater output power and transmit ON/OFF power

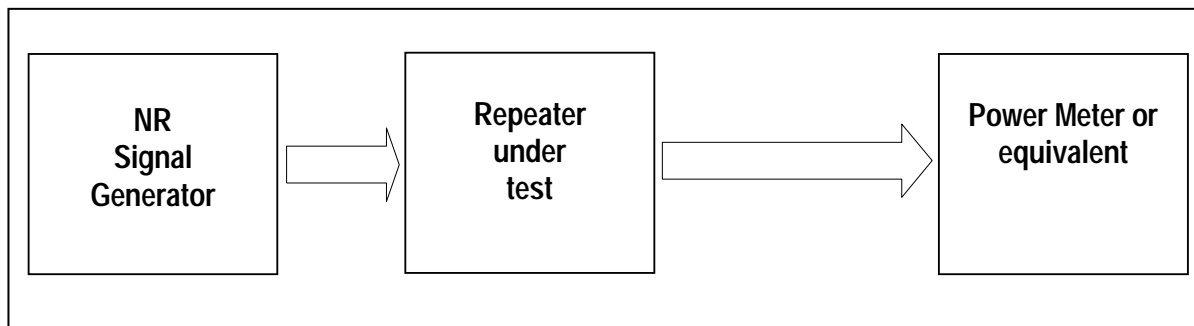

Figure D.1-1: Measuring system set-up for repeater output power and transmit ON/OFF power

Note 1: The repeater is a bi-directional device. The signal generator may need protection.

Note 2: UL/DL timing can be provided to the repeater.

D.2 Out of band gain

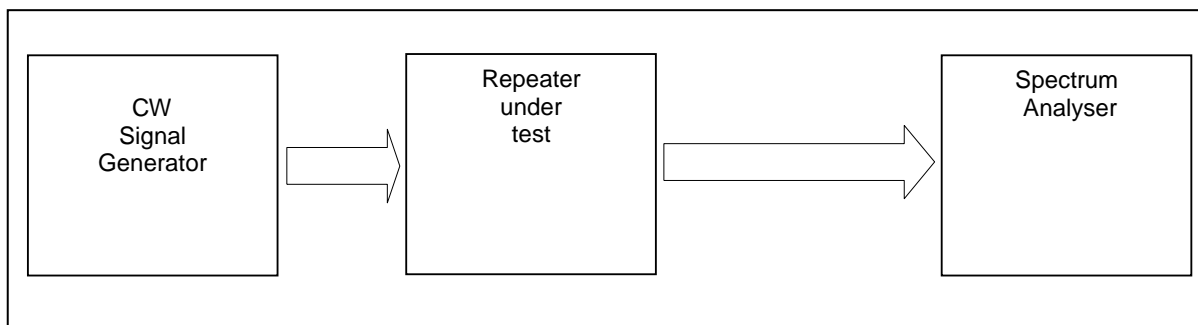

Figure D.2-1: Measuring system set-up for out of band gain

Note: The repeater is a bi-directional device. The signal generator may need protection.

D.3 Unwanted emission: Operating band unwanted emission, transmitter spurious emission, and ACLR

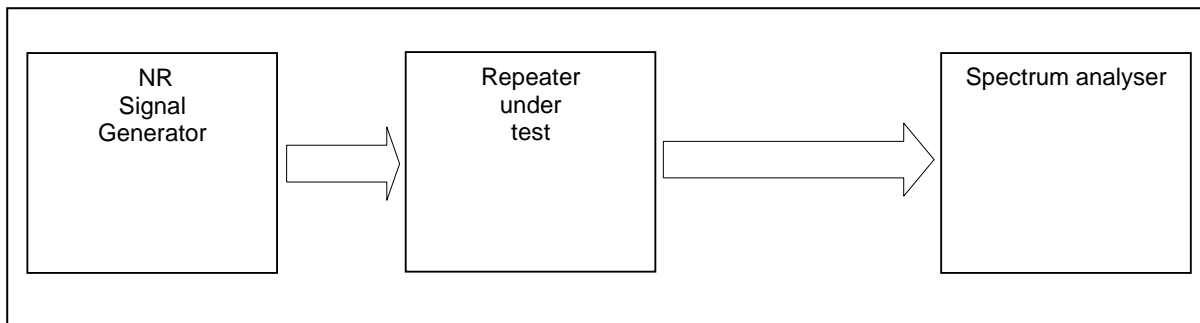

Figure D.3-1: Measuring system set-up for unwanted emission: Operating band unwanted emission, transmitter spurious emission, and ACLR

Note 1: The repeater is a bi-directional device. The signal generator may need protection.

Note 2: UL/DL timing can be provided to the repeater.

D.4 Modulation Accuracy: Repeater Error Vector Magnitude and Frequency Stability

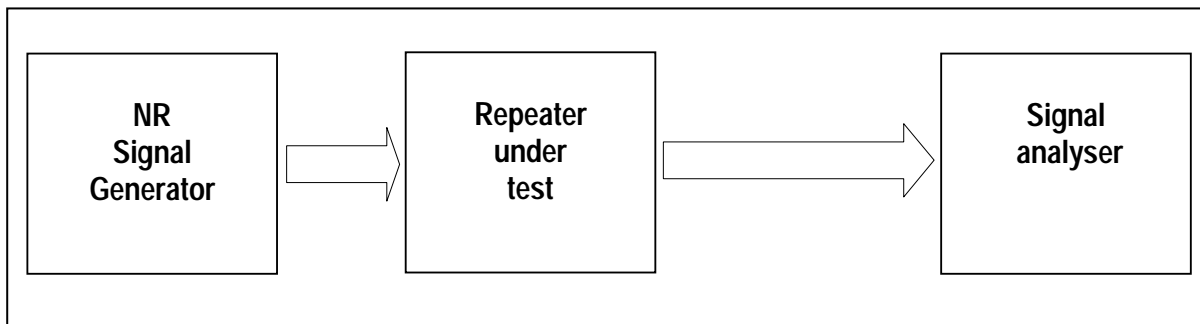

Figure D.4-1: Measuring system set-up for repeater error vector magnitude and frequency stability

Note 1: The repeater is a bi-directional device. The signal generator may need protection.

Note 2: UL/DL timing can be provided to the repeater.

D.5 Input intermodulation

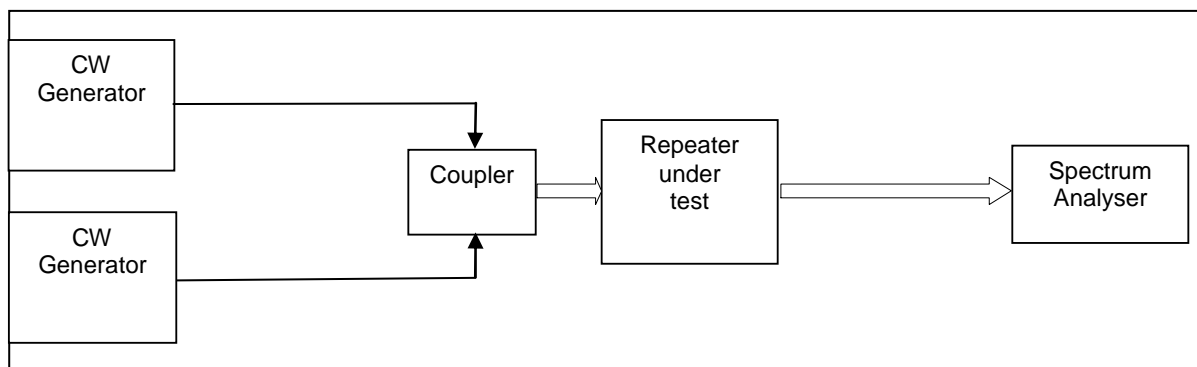

Figure D.5-1: Measuring system set-up for input intermodulation.

Note: The repeater is a bi-directional device. The signal generator may need protection.

D.6 Output Intermodulation

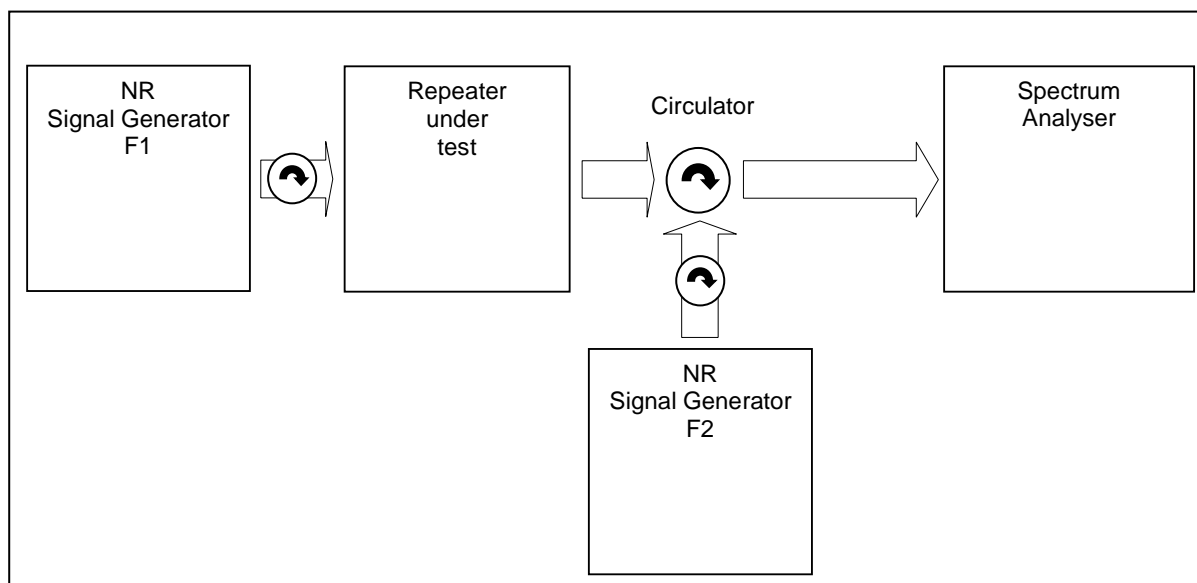

Figure D.6-1: Measuring system set-up for output intermodulation.

Note 1: The repeater is a bi-directional device. The signal generator may need protection.

Note 2: UL/DL timing can be provided to the repeater.

D.7 Adjacent Channel Rejection Ratio

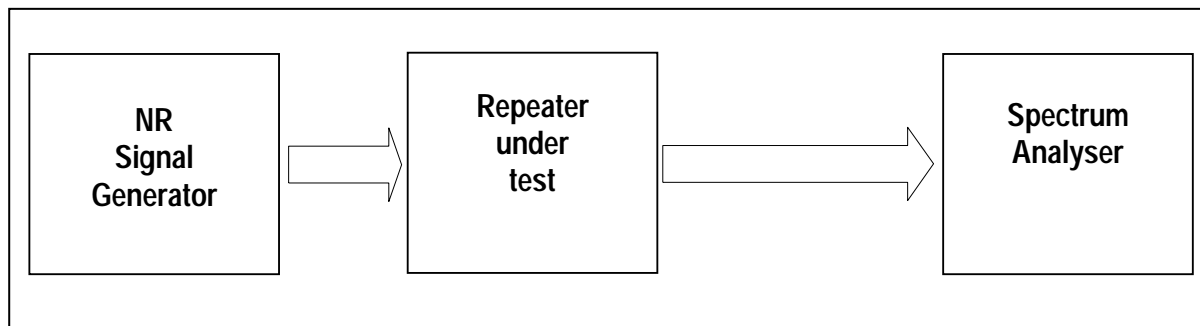

Figure D.7-1: Measuring system set-up for Adjacent Channel Rejection Ratio

Note 1: The repeater is a bi-directional device. The signal generator may need protection.

Note 2: UL/DL timing can be provided to the repeater.

D.8 Rx spurious emission requirement

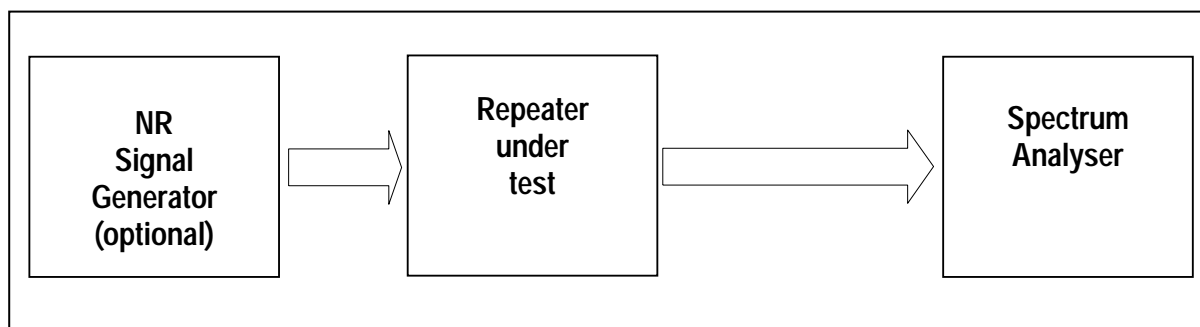

Figure D.8-1: Measuring system set-up for receiver spurious emission

Note 1: The repeater is a bi-directional device. The signal generator may need protection.

Note 2: UL/DL timing can be provided to the repeater.

Annex E (normative): In-channel TX tests

E.1 General

The in-channel TX test enables the measurement of all relevant parameters that describe the in-channel quality of the output signal of the repeater under test in a single measurement process.

The parameters describing the in-channel quality of a transmitter, however, are not necessarily independent. The algorithm chosen for description inside this annex places particular emphasis on the exclusion of all interdependencies among the parameters.

E.2 Basic principles

The process is based on the comparison of the actual output signal of the repeater under test, received by an ideal receiver, with an ideal signal, that is generated by the measuring equipment and represents an ideal error free received signal. All signals are represented as equivalent (generally complex) baseband signals.

The description below uses numbers and illustrations as examples only. These numbers are taken from a FDD frame structure with normal CP length, 30 kHz SCS and a transmission bandwidth configuration of 100 MHz ($N_{RB} = 273$). The application of the text below, however, is not restricted to this parameter set.

E.2.1 Output signal of the repeater under test

The output signal of the repeater under test is acquired by the measuring equipment and stored for further processing. It is sampled at a sampling rate which is the product of the SCS and the *FFT size*, and it is named $\tilde{z}(v)$. The *FFT size* is determined by the transmission bandwidth in table 6.6.3.5-2 for 15 kHz SCS, table 6.6.3.5-3 for 30 kHz SCS and table 6.5.3.5-4 for 60 kHz SCS in [6]. In the time domain, it comprises at least 10 ms. It is modelled as a signal with the following parameters:

- demodulated data content,
- carrier frequency,
- amplitude and phase for each subcarrier.

For the example in the annex, the *FFT size* is 4096 based on table 6.6.3.5-3 in [6]. The sampling rate of 122.88 Msps is the product of the *FFT size* and SCS.

E.2.2 Ideal signal

Two types of ideal signals are defined:

The first ideal signal $\tilde{z}_1(v)$ is constructed by the measuring equipment according to the relevant TX specifications, using the following parameters:

- demodulated data content,
- nominal carrier frequency,
- nominal amplitude and phase for each subcarrier.

It is represented as a sequence of samples at the sampling rate determined from annex E.2.1 in the time domain. The structure of the signal is described in the test models.

The second ideal signal $\tilde{z}_2(v)$ is constructed by the measuring equipment according to the relevant TX specifications, using the following parameters:

- nominal demodulation reference signals (all other modulation symbols are set to 0 V),
- nominal carrier frequency,
- nominal amplitude and phase for each applicable subcarrier,

- nominal timing.

It is represented as a sequence of samples at the sampling rate determined from annex E.2.1 in the time domain.

E.2.3 Measurement results

The measurement results, achieved by the in-channel TX test are the following:

- Carrier frequency stability
- EVM

E.2.4 Measurement points

The EVM shall be measured at the point after the FFT and a zero-forcing (ZF) equalizer in the receiver, as depicted for FR1 in figure F.2.4-1. The FFT window of *FFT size* samples out of (*FFT size* + cyclic prefix length) samples in the time domain is selected in the "Remove CP" box. The *FFT size* and the cyclic prefix length are obtained from table 6.6.3.5-2 for 15 kHz SCS, table 6.6.3.5-3 for 30 kHz SCS and table 6.6.3.5-4 for 60 kHz SCS in [6].

In one subframe, there are two symbols with the length of the cyclic prefix larger than the values listed in tables 6.6.3.5-2, 6.6.3.5-3 and 6.6.3.5-4 in [6]. Table F.2.4-1 lists the slot number and the symbol number and the formula how to compute the length of cyclic prefix for those two symbols according to the sampling rate.

Table E.2.4-1: Slot number and symbol number identifying the longer CP length for normal CP

SCS (kHz)	# slots in subframe	Symbol # and slot # with longer CP	Longer CP length
15	1	(symbol 0, slot 0) (symbol 7, slot 0)	CP length + $FFT\ size / 128$
30	2	(symbol 0, slot 0) (symbol 0, slot 1)	CP length + $FFT\ size / 64$
60	4	(symbol 0, slot 0) (symbol 0, slot 2)	CP length + $FFT\ size / 32$

For the example used in the annex, the "Remove CP" box selects 4096 samples out of 4384 samples. Symbol 0 has 64 more samples in the cyclic prefix than the other 13 symbols in the slot (the longer CP length = 352).

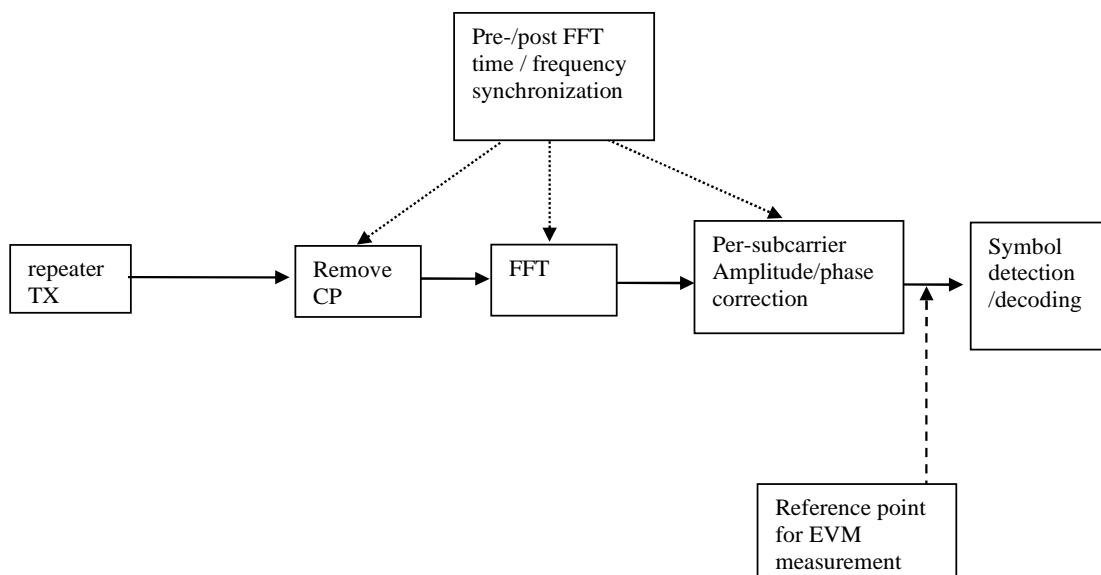

Figure E.2.4-1: Reference point for FR1 EVM measurements

E.3 Pre-FFT minimization process

Sample Timing, Carrier Frequency in $\mathbf{z}(v)$ are varied in order to minimise the difference between $\mathbf{z}(v)$ and $\mathbf{r}_1(v)$, after the amplitude ratio of $\mathbf{z}(v)$ and $\mathbf{r}_1(v)$ has been scaled. Best fit (minimum difference) is achieved when the RMS difference value between $\mathbf{z}(v)$ and $\mathbf{r}_1(v)$ is an absolute minimum.

The carrier frequency variation is the measurement result: carrier frequency stability.

From the acquired samples, one value of carrier frequency stability can be derived.

NOTE 1: The minimisation process, to derive the RF error can be supported by post-FFT operations. However the minimisation process defined in the pre-FFT domain comprises all acquired samples (i.e. it does not exclude the samples inbetween the FFT widths and it does not exclude the bandwidth outside the transmission bandwidth configuration).

NOTE 2: The algorithm would allow to derive carrier frequency error and sample frequency error of the TX under test separately. However there are no requirements for sample frequency error. Hence the algorithm models the RF and the sample frequency commonly (not independently). It returns one error and does not distinguish between both.

After this process, the samples $\mathbf{z}(v)$ are called $\mathbf{z}^p(v)$.

E.4 Timing of the FFT window

The FFT window length is *FFT size* samples per OFDM symbol. For FDD, there are $14N_{dt}$ FFTs performed where N_{dt} is the number of slots in a 10 ms measurement interval, and the number of symbols in a slot for normal CP is 14.

The position in time for the FFT shall be determined.

For the example used in the annex, the FFT window length is 4096 samples per OFDM symbol. 280 FFTs (i.e. 1,146,880 samples) cover less than the acquired number of samples (i.e. 1,228,800 samples in 10 ms).

In an ideal signal, the FFT may start at any instant within the cyclic prefix without causing an error. The TX filter, however, reduces the window. The EVM requirements shall be met within a window $W < CP$. There are three different instants for FFT:

- Centre of the reduced window, called Δf ,
- $\Delta c - W/2$, and
- $\Delta c + W/2$.

The value of EVM window length W is obtained from tables 6.6.3.5-2 for 15 kHz SCS, 6.6.3.5-3 for 30 kHz SCS and 6.6.3.5-4 for 60 kHz SCS in [6] and the transmission bandwidth.

The repeater shall transmit a signal according to the test models intended for EVM. The demodulation reference signal of the second ideal signal shall be used to find the centre of the FFT window.

The timing of the measured signal is determined in the pre-FFT domain as follows, using $\mathbf{z}^p(v)$ and $\mathbf{r}_2(v)$:

1. The measured signal is delay spread by the TX filter. Hence the distinct borders between the OFDM symbols and between data and CP are also spread and the timing is not obvious.
2. In the ideal signal $\mathbf{r}_2(v)$, the timing is known.

Correlation between bullet (1) and (2) will result in a correlation peak. The meaning of the correlation peak is approximately the "impulse response" of the TX filter.

3. The meaning of "impulse response" assumes that the autocorrelation of the ideal signal $\mathbf{r}_2(v)$ is a Dirac peak and that the correlation between the ideal signal $\mathbf{r}_2(v)$ and the data in the measured signal is 0. The correlation peak, (the highest, or in case of more than one highest, the earliest) indicates the timing in the measured signal.

The number of samples used for FFT is reduced compared to $\mathbf{z}^p(v)$. This subset of samples is called $\mathbf{z}'(v)$.

From the acquired samples one timing can be derived.

The timing of the centre Δt is determined according to the cyclic prefix length of the OFDM symbols. For normal CP, there are two values for Δt in a 1 ms period:

- $\Delta t = \text{length of cyclic prefix} / 2$,
- $\Delta t = \text{Longer CP length} - \text{length of cyclic prefix} / 2$,

Where the length of cyclic prefix is obtained from table 6.6.3.5-2 for 15 kHz SCS, table 6.6.3.5-3 for 30 kHz SCS and table 6.6.3.5-4 for 60 kHz SCS in [6], and the longer CP length is obtained from table F.2.4-1.

As per the example values:

- $\Delta t = 144$ within the CP of length 288 for OFDM symbols 1 to 13 of a slot,
- $\Delta t = 208 = 352 - 144$ within the CP of length 352 for OFDM symbol 0 of a slot.

E.5 Resource element TX power

Perform FFT on $z'(t)$ with the FFT window timing Δt . The result is called $Z'(t, f)$. The RE TX power (RETP) is then defined as:

$$RETP = |Z'(t, f)|^2 \cdot f_{SCS}$$

Where SCS is the subcarrier spacing in Hz.

From RETP the OFDM Symbol TX power (OSTP) is derived as follows:

$$OSTP = \frac{1}{N_{SYM}} \sum RETP$$

Where the summation accumulates $N_{RB} \cdot N_{SC}^{CP}$ RETP values of all N_{SYM} OFDM symbols that carry PDSCH and not containing PDCCH, RS or SSB within a slot.

From the acquired samples, N_{dt} values for each OSTP can be obtained and averaged where N_{dt} is the number of slots in a 10 ms measurement interval for FDD. For TDD, N_{dt} is the number of slots with downlink symbols in a 10 ms measurement interval and is computed according to the values in table 4.9.2.2-1 in [6].

For the example used in the annex, $N_{dt} = 20$ and $N_{RB} = 273$.

E.6 Post-FFT equalisation

Perform $14N_{dt}$ FFTs on $z'(t)$, one for each OFDM symbol within 10 ms measurement interval with the FFT window timing to produce an array of samples, $14N_{dt}$ in the time axis t by *FFT size* in the frequency axis f .

For the example in the annex, 280 FFTs are performed on $z'(t)$. The result is an array of samples, 280 in the time axis by 4096 in the frequency axis.

The equalizer coefficients $a(f)$ and $\varphi(f)$ are determined as follows:

1. Calculate the complex ratios (amplitude and phase) of the post-FFT acquired signal $Z'(t, f)$ and the post-FFT ideal signal $I_2(t, f)$ for each demodulation reference signal, over 10 ms measurement interval. This process creates a set of complex ratios:

$$a(t, f)e^{j\varphi(t, f)} = \frac{Z'(t, f)}{I_2(t, f)}$$

2. Perform time averaging at each demodulation reference signal subcarrier of the complex ratios, the time-averaging length is 10 ms measurement interval. Prior to the averaging of the phases $\varphi(t, f)$ an unwrap operation must be performed according to the following definition:

- The unwrap operation corrects the radian phase angles of $\varphi(t_i, f)$ by adding multiples of $2 * \pi$ when absolute phase jumps between consecutive time instances t_i are greater than or equal to the jump tolerance of π radians.
- This process creates an average amplitude and phase for each demodulation reference signal subcarrier (i.e. every second subcarrier).

$$a(f) = \frac{\sum_{i=1}^N a(t_i, f)}{N}$$

and

$$\varphi(f) = \frac{\sum_{i=1}^N \varphi(t_i, f)}{N}$$

Where N is the number of demodulation reference signals time-domain locations t_i from $Z'(t, f)$ for each demodulation reference signal subcarrier f .

- The equalizer coefficients for amplitude and phase $\hat{a}(f)$ and $\hat{\varphi}(f)$ at the demodulation reference signal subcarriers are obtained by computing the moving average in the frequency domain of the time-averaged demodulation reference signal subcarriers. The moving average window size is 19 and averaging is over the DM-RS subcarriers in the allocated RBs. For DM-RS subcarriers at or near the edge of the channel, or when the number of available DM-RS subcarriers within a set of contiguously allocated RBs is smaller than the moving average window size, the window size is reduced accordingly as per figure F.6-1.
- Perform linear interpolation from the equalizer coefficients $\hat{a}(f)$ and $\hat{\varphi}(f)$ to compute coefficients $a(f)$, $\varphi(f)$ for each subcarrier.

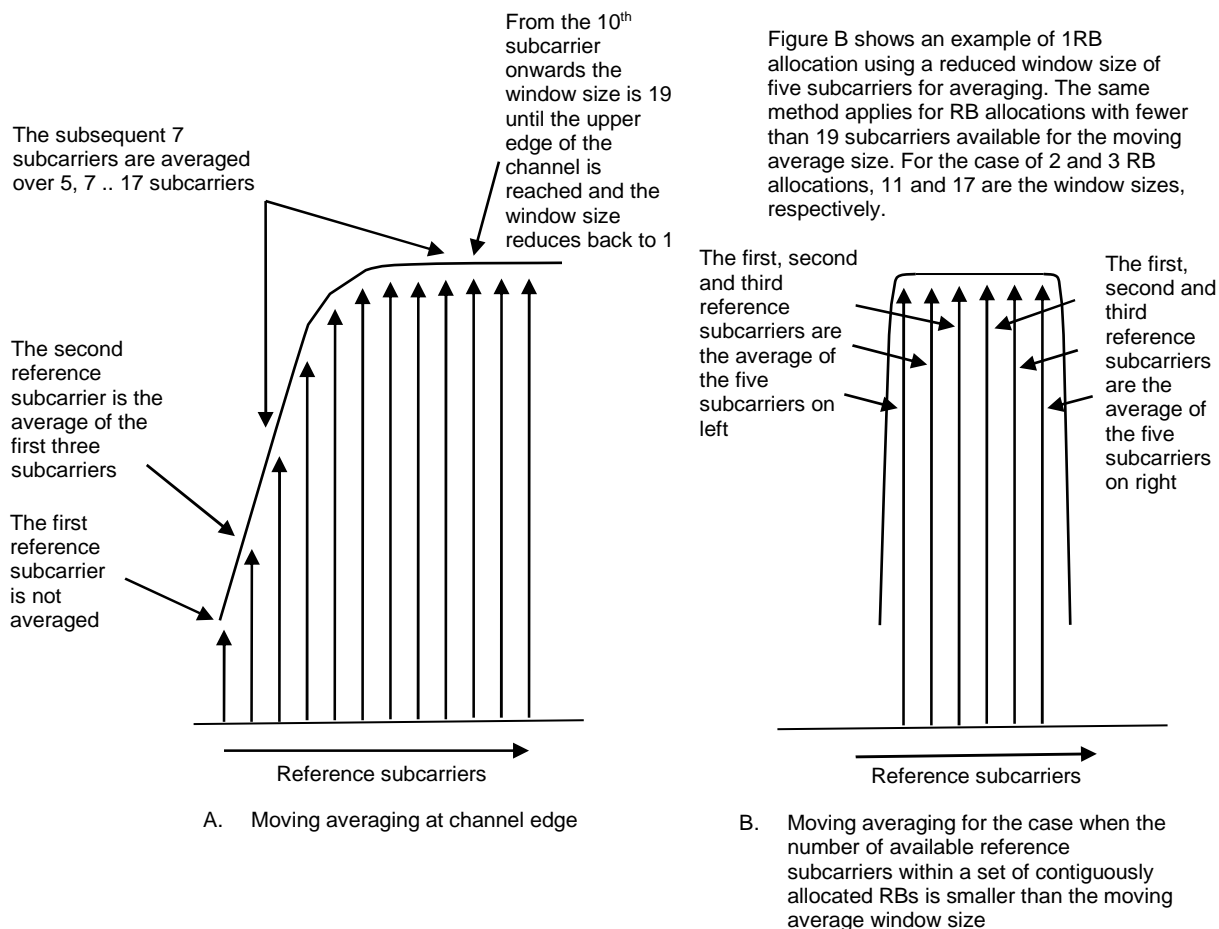

Figure E.6-1: Reference subcarrier smoothing in the frequency domain

E.7 EVM

E.7.0 General

For EVM create two sets of $Z_{eq}^i(t, f)$, according to the timing $(\Delta c - W/2)$ and $(\Delta c + W/2)$, using the equalizer coefficients from F.6.

The equivalent ideal samples are calculated from $t_1(v)$ (annex E.2.2) and are called $I(t, f)$.

The EVM is the difference between the ideal signal and the equalized measured signal.

$$EVM = \sqrt{\frac{\sum_{t \in T} \sum_{f \in F(t)} |Z_{eq}^i(t, f) - I(t, f)|^2}{\sum_{t \in T} \sum_{f \in F(t)} |I(t, f)|^2}}$$

Where:

- T is the set of symbols with the considered modulation scheme being active within the slot,
- $F(t)$ is the set of subcarriers within the resource blocks with the considered modulation scheme being active in symbol t ,
- $I(t, f)$ is the ideal signal reconstructed by the measurement equipment in accordance with relevant test models,
- $Z_{eq}^i(t, f)$ is the equalized signal under test.

NOTE: Although the basic unit of measurement is one slot, the equalizer is calculated over the entire 10 ms measurement interval to reduce the impact of noise in the reference signals.

E.7.1 Averaged EVM (FDD)

EVM is averaged over all allocated downlink resource blocks with the considered modulation scheme in the frequency domain, and a minimum of N_{dl} slots where N_{dl} is the number of slots in a 10 ms measurement interval. The averaging in the time domain equals the N_{dl} slot duration of the 10 ms measurement interval from the equalizer estimation step.

$$EVM_{frame} = \sqrt{\frac{1}{\sum_{i=1}^{N_{dl}} N_i} \sum_{i=1}^{N_{dl}} \sum_{j=1}^{N_i} EVM_{i,j}^2}$$

Where N_i is the number of resource blocks with the considered modulation scheme in slot i .

The EVM requirements shall be tested against the maximum of the RMS average at the window W extremities of the EVM measurements:

Thus $EVM_{frame,l}$ is calculated using $t = \Delta t_l$ in the expressions above and $EVM_{frame,h}$ is calculated using $t = \Delta t_h$ in the EVM_{frame} calculation where l and h , low and high; where low is the timing $(\Delta c - W/2)$ and high is the timing $(\Delta c + W/2)$.

Thus:

$$EVM = \max(EVM_{frame,l}, EVM_{frame,h})$$

The resulting EVM is compared against the limit.

E.7.2 Averaged EVM (TDD)

Let N_{dl}^{TDD} be the number of slots with downlink symbols within a 10 ms measurement interval. For TDD, the averaging in the time domain can be calculated from N_{dl}^{TDD} slots of different 10 ms measurement intervals and should have a minimum of N_{dl} slots averaging length where N_{dl} is the number of slots in a 10 ms measurement interval.

EVM_{frame} is derived by: Square the EVM results in each 10 ms measurement interval. Sum the squares, divide the sum by the number of EVM relevant locations, square-root the quotient (RMS).

$$EVM_{frame} = \sqrt{\frac{1}{\sum_{k=1}^{N_{dl}^{TDD}} N_i} \sum_{i=1}^{N_{dl}^{TDD}} \sum_{j=1}^{N_i} EVM_{i,j}^2}$$

Where N_i is the number of resource blocks with the considered modulation scheme in slot i .

The EVM_{frame} is calculated, using the maximum of EVM_{frame} at the window W extremities. Thus $EVM_{frame,l}$ is calculated using $t = \Delta t_l$ and $EVM_{frame,h}$ is calculated using $t = \Delta t_h$ (l and h , low and high; where low is the timing $(\Delta c - W/2)$ and high is the timing $(\Delta c + W/2)$).

$$EVM_{frame} = \max(EVM_{frame,l}, EVM_{frame,h})$$

In order to unite at least N_{dl} slots, consider the minimum integer number of 10 ms measurement intervals, where N_{frame} is determined by.

$$N_{frame} = \left\lceil \frac{10 \times N_{dl}}{N_{dl}^{TDD}} \right\rceil$$

and $N_{slot} = 1$ for 15 kHz SCS, $N_{slot} = 2$ for 30 kHz SCS and $N_{slot} = 4$ for 60 kHz SCS normal CP.

Unite by RMS.

$$EVM = \sqrt{\frac{1}{N_{frame}} \sum_{R=1}^{N_{frame}} EVM_{frame,R}^2}$$

The resulting EVM is compared against the limit.

Annex F (informative): Change history

Change history							
Date	Meeting	TDoc	CR	Rev	Cat	Subject/Comment	New version
2022-05	RAN4#103e					TS skeleton	0.0.1
2022-08	RAN4#104e	R4-2211701				TP for TS 38.115-1: Clause 5 operating bands	0.1.0
2022-08	RAN4#104e	R4-2212840				TP to TS 38.115-1 clause 6.8 Output intermodulation - conducted	0.1.0
2022-08	RAN4#104e	R4-2213719				TP for TS 38.115-1: section 4.10-4.12	0.1.0
2022-08	RAN4#104e	R4-2213976				TP to TS 38.115-1 Annex A Repeater stimulus signals	0.1.0
2022-08	RAN4#104e	R4-2214740				TP for TS 38.115-1: Clause 3 definitions	0.1.0
2022-08	RAN4#104e	R4-2214741				TP for TS 38.115-1: Clause 4.2-4.5	0.1.0
2022-08	RAN4#104e	R4-2214785				TP to TS 38.115-1: Test Configurations and Requirement applicability	0.1.0
2022-08	RAN4#104e	R4-2214787				TP to TS 38.115-1: Frequency Stability, Out of band gain, unwanted emissions	0.1.0
2022-08	RAN4#104e	R4-2214789				TP to TS 38.115-1: In-band measurements Annex	0.1.0
2022-08	RAN4#104e	R4-2214791				TP to TS 38.115-1: TDD Switching	0.1.0
2022-08	RAN4#104e	R4-2214801				TP to TS 38.115-1: Manufacturer declarations for NR FR1 repeaters	0.1.0
2022-08	RAN4#104e	R4-2214803				TP to TS 38.115-1 clause 6.7 Input intermodulation - conducted	0.1.0
2022-08	RAN4#104e	R4-2214840				TP for TS 38.115-1: Section 6.9	0.1.0
2022-08	RAN4#104e	R4-2214841				TP for TS 38.115-1: Annex D	0.1.0
2022-08	RAN4#104e	R4-2214865				TP to TS 38.115-1 clause 4.9 RF channels and test models	0.1.0
2022-08	RAN4#104e	R4-2214867				TP to TS 38.115-1 clause 6.6 EVM - conducted	0.1.0
2022-10	RAN4#104be	R4-2216839				TP to TS 38.115-1: Annex B: Environmental requirements for the repeater	0.2.0
2022-10	RAN4#104be	R4-2216840				TP to TS 38.115-1: Annex C: Test tolerances and derivation of test requirements	0.2.0
2022-10	RAN4#104be	R4-2216841				TP to TS 38.115-1: Annex E: Characteristics of interfering signals	0.2.0
2022-10	RAN4#104be	R4-2217293				TP to TS 38.115-1: Repeater output power (6.1, 6.2)	0.2.0
2022-10	RAN4#104be	R4-2217296				TP for TS 38.115-1: scope and reference	0.2.0
2022-10	RAN4#104be	R4-2217297				TP to TS 38.115-1: Measurement uncertainties and test requirements (4.1)	0.2.0
2022-11	RAN4#105	R4-2218486				Correction TP for TS 38.115-1	0.3.0
2022-11	RAN4#105	R4-2220214				TP to 38.115-1: ACLR requirement	0.3.0
2022-11	RAN4#105	R4-2220217				TP to 38.115-1: EVM requirement	0.3.0
2022-11	RAN4#105	R4-2220226				Draft CR to 38.115-1: Spectrum purity	0.3.0
2022-11	RAN4#105	R4-2220270				TP to 38.115-1: ACRR requirement	0.3.0
2022-12	RAN#98e	RP-222843				Editorial update for 1.0.0 version	1.0.0

Change history							
Date	Meeting	TDoc	CR	Rev	Cat	Subject/Comment	New version
2022-12	RAN#98-e					Approved by plenary – Rel-17 spec under change control	17.0.0
2023-03	RAN#99	RP-230518	0001	1	F	CR for TS 38.115-1: Correction of some errors	17.1.0
2023-03	RAN#99	RP-230518	0003	1	B	CR to TS38.106 the introduction of band n104	17.1.0
2023-03	RAN#99	RP-230518	0005		F	CR to 38.115-1: Correction on repeater EVM test procedure	17.1.0
2023-03	RAN#99	RP-230518	0006		F	CR to 38.115-1: Correction on repeater ACLR requirement	17.1.0
2023-03	RAN#99	RP-230518	0007		F	CR to 38.115-1: NR repeater measurement system set-up	17.1.0
2023-06	RAN#100	RP-231339	0008	1	F	CR for TS 38.115-1, Add manufacturer declarations for test configurations and RF channels	17.2.0
2023-06	RAN#100	RP-231339	0010		F	CR to 38.115-1: Corrections on repeater transient period requirements (Rel-17)	17.2.0
2023-06	RAN#100	RP-231339	0012	1	F	CR to TS 38.115-1: Addition of missing bands for repeater co-existence and co-location requirements	17.2.0
2023-06	RAN#100	RP-231339	0014	1	F	CR to TS 38.115-1: Clarifications for repeater test models	17.2.0
2023-09	RAN#101	RP-232496	0016	1	F	[NR_repeater] CR to 38.115-1: Input intermodulation	17.3.0
2023-12	RAN#102	RP-233350	0021	1	F	CR to 38.115-1: Correction of terminologies for NR repeaters (Rel-17)	17.4.0
2023-12	RAN#102	RP-233350	0023		F	CR to TS 38.115-1 with correction of co-existence and co-location requirements	17.4.0
2024-03	RAN#102	RP-240574	0025		F	(NR_repeater-Perf) CR for TS 38.115-1, Correction on manufacturer declarations	17.5.0
2024-03	RAN#102	RP-240574	0027	1	F	CR to 38.115-1: NR repeater transmitter spurious emissions requirements (rel-17)	17.5.0

History

Document history		
V17.0.0	January 2023	Publication
V17.1.0	May 2023	Publication
V17.2.0	July 2023	Publication
V17.3.0	October 2023	Publication
V17.4.0	January 2024	Publication
V17.5.0	May 2024	Publication