

ETSI TS 138 401 V15.6.0 (2019-07)



**5G;  
NG-RAN;  
Architecture description  
(3GPP TS 38.401 version 15.6.0 Release 15)**



---

Reference

RTS/TSGR-0338401vf60

---

Keywords

5G

**ETSI**

650 Route des Lucioles  
F-06921 Sophia Antipolis Cedex - FRANCE

Tel.: +33 4 92 94 42 00 Fax: +33 4 93 65 47 16

Siret N° 348 623 562 00017 - NAF 742 C  
Association à but non lucratif enregistrée à la  
Sous-Préfecture de Grasse (06) N° 7803/88

---

**Important notice**

The present document can be downloaded from:

<http://www.etsi.org/standards-search>

The present document may be made available in electronic versions and/or in print. The content of any electronic and/or print versions of the present document shall not be modified without the prior written authorization of ETSI. In case of any existing or perceived difference in contents between such versions and/or in print, the prevailing version of an ETSI deliverable is the one made publicly available in PDF format at [www.etsi.org/deliver](http://www.etsi.org/deliver).

Users of the present document should be aware that the document may be subject to revision or change of status.

Information on the current status of this and other ETSI documents is available at

<https://portal.etsi.org/TB/ETSIDeliverableStatus.aspx>

If you find errors in the present document, please send your comment to one of the following services:

<https://portal.etsi.org/People/CommitteeSupportStaff.aspx>

---

**Copyright Notification**

No part may be reproduced or utilized in any form or by any means, electronic or mechanical, including photocopying and microfilm except as authorized by written permission of ETSI.

The content of the PDF version shall not be modified without the written authorization of ETSI.

The copyright and the foregoing restriction extend to reproduction in all media.

© ETSI 2019.

All rights reserved.

**DECT™**, **PLUGTESTS™**, **UMTS™** and the ETSI logo are trademarks of ETSI registered for the benefit of its Members.

**3GPP™** and **LTE™** are trademarks of ETSI registered for the benefit of its Members and of the 3GPP Organizational Partners.

**oneM2M™** logo is a trademark of ETSI registered for the benefit of its Members and of the oneM2M Partners.

**GSM®** and the GSM logo are trademarks registered and owned by the GSM Association.

---

## Intellectual Property Rights

### Essential patents

IPRs essential or potentially essential to normative deliverables may have been declared to ETSI. The information pertaining to these essential IPRs, if any, is publicly available for **ETSI members and non-members**, and can be found in ETSI SR 000 314: "*Intellectual Property Rights (IPRs); Essential, or potentially Essential, IPRs notified to ETSI in respect of ETSI standards*", which is available from the ETSI Secretariat. Latest updates are available on the ETSI Web server (<https://ipr.etsi.org/>).

Pursuant to the ETSI IPR Policy, no investigation, including IPR searches, has been carried out by ETSI. No guarantee can be given as to the existence of other IPRs not referenced in ETSI SR 000 314 (or the updates on the ETSI Web server) which are, or may be, or may become, essential to the present document.

### Trademarks

The present document may include trademarks and/or tradenames which are asserted and/or registered by their owners. ETSI claims no ownership of these except for any which are indicated as being the property of ETSI, and conveys no right to use or reproduce any trademark and/or tradename. Mention of those trademarks in the present document does not constitute an endorsement by ETSI of products, services or organizations associated with those trademarks.

---

## Legal Notice

This Technical Specification (TS) has been produced by ETSI 3rd Generation Partnership Project (3GPP).

The present document may refer to technical specifications or reports using their 3GPP identities. These shall be interpreted as being references to the corresponding ETSI deliverables.

The cross reference between 3GPP and ETSI identities can be found under <http://webapp.etsi.org/key/queryform.asp>.

---

## Modal verbs terminology

In the present document "**shall**", "**shall not**", "**should**", "**should not**", "**may**", "**need not**", "**will**", "**will not**", "**can**" and "**cannot**" are to be interpreted as described in clause 3.2 of the [ETSI Drafting Rules](#) (Verbal forms for the expression of provisions).

"**must**" and "**must not**" are **NOT** allowed in ETSI deliverables except when used in direct citation.

# Contents

Intellectual Property Rights .....	2
Legal Notice .....	2
Modal verbs terminology.....	2
Foreword.....	5
1 Scope .....	6
2 References .....	6
3 Definitions and abbreviations.....	7
3.1 Definitions .....	7
3.2 Abbreviations .....	7
4 General principles .....	8
5 General architecture .....	8
5.1 General .....	8
5.2 User plane.....	8
5.3 Control plane.....	9
6 NG-RAN architecture.....	10
6.1 Overview .....	10
6.1.1 Overall Architecture of NG-RAN.....	10
6.1.2 Overall architecture for separation of gNB-CU-CP and gNB-CU-UP .....	11
6.2 NG-RAN identifiers .....	12
6.2.1 Principle of handling Application Protocol Identities.....	12
6.2.2 gNB-DU ID .....	13
6.3 Transport addresses .....	13
6.4 UE associations in NG-RAN Node .....	13
7 NG-RAN functions description.....	14
7.0 General .....	14
7.1 NG-RAN sharing.....	14
8 Overall procedures in gNB-CU/gNB-DU Architecture .....	15
8.1 UE Initial Access.....	15
8.2 Intra-gNB-CU Mobility.....	16
8.2.1 Intra-NR Mobility .....	16
8.2.1.1 Inter-gNB-DU Mobility .....	16
8.2.1.2 Intra-gNB-DU handover .....	18
8.2.2 EN-DC Mobility .....	18
8.2.2.1 Inter-gNB-DU Mobility using MCG SRB .....	18
8.2.2.2 Inter-gNB-DU Mobility using SCG SRB (SRB3) .....	19
8.3 Mechanism of centralized retransmission of lost PDUs.....	19
8.3.1 Centralized Retransmission in Intra gNB-CU Cases .....	19
8.4 Multi-Connectivity operation .....	21
8.4.1 Secondary Node Addition.....	21
8.4.1.1 EN-DC .....	21
8.4.2 Secondary Node Release (MN/SN initiated) .....	21
8.4.2.1 EN-DC .....	21
8.5 F1 Startup and cells activation .....	23
8.6 RRC state transition.....	24
8.6.1 RRC connected to RRC inactive.....	24
8.6.2 RRC inactive to other states.....	25
8.7 RRC connection reestablishment .....	26
8.8 Multiple TNLAs for F1-C .....	28
8.9 Overall procedures involving E1 and F1 .....	29
8.9.1 UE Initial Access .....	29
8.9.2 Bearer context setup over F1-U .....	30

8.9.3	Bearer context release over F1-U .....	31
8.9.3.1	gNB-CU-CP initiated bearer context release .....	31
8.9.3.2	gNB-CU-UP initiated bearer context release .....	32
8.9.4	Inter-gNB handover involving gNB-CU-UP change .....	33
8.9.5	Change of gNB-CU-UP .....	34
8.9.6	RRC State transition .....	35
8.9.6.1	RRC Connected to RRC Inactive .....	35
8.9.6.2	RRC Inactive to other states .....	36
8.10	Multiple TNLAs for E1 .....	38
8.11	Support of Network Sharing with multiple cell-ID broadcast .....	39
8.11.1	General .....	39
8.11.2	Initial Registration – separate PLMN signalling .....	39
8.11.3	RRC Connection Reestablishment – separate PLMN signalling .....	40
8.11.4	Support of shared signalling transport .....	40
9	Synchronization .....	41
9.1	gNB Synchronization .....	41
10	NG-RAN interfaces .....	41
10.1	NG interface .....	41
10.2	Xn interface .....	42
10.3	F1 interface .....	42
10.4	E1 interface .....	42
10.5	Antenna interface - general principles .....	42
11	Overall procedures in NG-RAN Architecture .....	42
11.1	Multiple TNLAs for Xn-C .....	42
<b>Annex A (informative):</b>	<b>Deployment scenarios of gNB/en-gNB .....</b>	<b>44</b>
<b>Annex B:</b>	<b>NG-RAN Architecture for Radio Access Network Sharing with multiple cell ID broadcast (informative).....</b>	<b>45</b>
<b>Annex C (informative):</b>	<b>Change History .....</b>	<b>46</b>
History .....		47

---

# Foreword

This Technical Specification has been produced by the 3<sup>rd</sup> Generation Partnership Project (3GPP).

The contents of the present document are subject to continuing work within the TSG and may change following formal TSG approval. Should the TSG modify the contents of the present document, it will be re-released by the TSG with an identifying change of release date and an increase in version number as follows:

Version x.y.z

where:

- x the first digit:
  - 1 presented to TSG for information;
  - 2 presented to TSG for approval;
  - 3 or greater indicates TSG approved document under change control.
- y the second digit is incremented for all changes of substance, i.e. technical enhancements, corrections, updates, etc.
- z the third digit is incremented when editorial only changes have been incorporated in the document.

---

# 1 Scope

The present document describes the overall architecture of the NG-RAN, including interfaces NG, Xn and F1 interfaces and their interaction with the radio interface.

---

# 2 References

The following documents contain provisions which, through reference in this text, constitute provisions of the present document.

- References are either specific (identified by date of publication, edition number, version number, etc.) or non-specific.
- For a specific reference, subsequent revisions do not apply.
- For a non-specific reference, the latest version applies. In the case of a reference to a 3GPP document (including a GSM document), a non-specific reference implicitly refers to the latest version of that document *in the same Release as the present document*.

- [1] 3GPP TR 21.905: "Vocabulary for 3GPP Specifications".
- [2] 3GPP TS 38.300: "NR; Overall description; Stage-2".
- [3] 3GPP TS 23.501: "System Architecture for the 5G System".
- [4] 3GPP TS 38.473: "NG-RAN; F1 application protocol (F1AP)".
- [5] 3GPP TS 38.414: "NG-RAN; NG data transport".
- [6] 3GPP TS 38.424: "NG-RAN; Xn data transport".
- [7] 3GPP TS 38.474: "NG-RAN; F1 data transport".
- [8] ITU-T Recommendation G.823 (2000-03): "The control of jitter and wander within digital networks which are based on the 2048 kbit/s hierarchy".
- [9] ITU-T Recommendation G.824 (2000-03): "The control of jitter and wander within digital networks which are based on the 1544 kbit/s hierarchy".
- [10] ITU-T Recommendation G.825 (2001-08): "The control of jitter and wander within digital networks which are based on the synchronous digital hierarchy (SDH)".
- [11] ITU-T Recommendation G.8261/Y.1361 (2008-04): "Timing and Synchronization aspects in Packet networks".
- [12] 3GPP TS 37.340: "NR; Multi-connectivity; Overall description; Stage-2".
- [13] 3GPP TS 33.501: "Security Architecture and Procedures for 5G System".
- [14] 3GPP TS 38.410: "NG-RAN; NG general aspect and principles".
- [15] 3GPP TS 38.420: "NG-RAN; Xn general aspects and principles".
- [16] 3GPP TS 38.470: "NG-RAN; F1 general aspects and principles".
- [17] 3GPP TS 38.460: "NG-RAN; E1 general aspects and principles".
- [18] 3GPP TS 33.210: "3G security; Network Domain Security (NDS); IP Network Layer Security".
- [19] 3GPP TS 36.300: "Evolved Universal Terrestrial Radio Access (E-UTRA), Evolved Universal Terrestrial Radio Access Network (E-UTRAN); Overall description; Stage 2".

## 3 Definitions and abbreviations

### 3.1 Definitions

For the purposes of the present document, the terms and definitions given in TR 21.905 [1] and the following apply. A term defined in the present document takes precedence over the definition of the same term, if any, in TR 21.905 [1].

**en-gNB:** as defined in TS 37.340 [12].

**gNB:** as defined in TS 38.300 [2].

**gNB Central Unit (gNB-CU):** a logical node hosting RRC, SDAP and PDCP protocols of the gNB or RRC and PDCP protocols of the en-gNB that controls the operation of one or more gNB-DUs. The gNB-CU terminates the F1 interface connected with the gNB-DU.

**gNB Distributed Unit (gNB-DU):** a logical node hosting RLC, MAC and PHY layers of the gNB or en-gNB, and its operation is partly controlled by gNB-CU. One gNB-DU supports one or multiple cells. One cell is supported by only one gNB-DU. The gNB-DU terminates the F1 interface connected with the gNB-CU.

**gNB-CU-Control Plane (gNB-CU-CP):** a logical node hosting the RRC and the control plane part of the PDCP protocol of the gNB-CU for an en-gNB or a gNB. The gNB-CU-CP terminates the E1 interface connected with the gNB-CU-UP and the F1-C interface connected with the gNB-DU.

**gNB-CU-User Plane (gNB-CU-UP):** a logical node hosting the user plane part of the PDCP protocol of the gNB-CU for an en-gNB, and the user plane part of the PDCP protocol and the SDAP protocol of the gNB-CU for a gNB. The gNB-CU-UP terminates the E1 interface connected with the gNB-CU-CP and the F1-U interface connected with the gNB-DU.

**NG-RAN node:** as defined in TS 38.300 [2].

**PDU Session Resource:** This term is used for specification of NG, Xn, and E1 interfaces. It denotes NG-RAN interface and radio resources provided to support a PDU Session.

### 3.2 Abbreviations

For the purposes of the present document, the terms and definitions given in TR 21.905 [1] and the following apply. A term defined in the present document takes precedence over the definition of the same term, if any, in TR 21.905 [1].

5GC	5G Core Network
AMF	Access and Mobility Management Function
AP	Application Protocol
AS	Access Stratum
CM	Connection Management
CMAS	Commercial Mobile Alert Service
ETWS	Earthquake and Tsunami Warning System
F1-U	F1 User plane interface
F1-C	F1 Control plane interface
F1AP	F1 Application Protocol
FDD	Frequency Division Duplex
GTP-U	GPRS Tunnelling Protocol
IP	Internet Protocol
NAS	Non-Access Stratum
O&M	Operation and Maintenance
PWS	Public Warning System
QoS	Quality of Service
RET	Remote Electrical Tilting
RNL	Radio Network Layer
RRC	Radio Resource Control
SAP	Service Access Point
SCTP	Stream Control Transmission Protocol



SFN	System Frame Number
SM	Session Management
SMF	Session Management Function
TDD	Time Division Duplex
TDM	Time Division Multiplexing
TMA	Tower Mounted Amplifier
TNL	Transport Network Layer

---

## 4 General principles

The general principles guiding the definition of NG-RAN architecture as well as the NG-RAN interfaces are the following:

- Logical separation of signalling and data transport networks.
- NG-RAN and 5GC functions are fully separated from transport functions. Addressing scheme used in NG-RAN and 5GC shall not be tied to the addressing schemes of transport functions. The fact that some NG-RAN or 5GC functions reside in the same equipment as some transport functions does not make the transport functions part of the NG-RAN or the 5GC.
- Mobility for an RRC connection is fully controlled by the NG-RAN.
- The NG-RAN interfaces are defined along the following principles:
  - The functional division across the interfaces have as few options as possible.
  - Interfaces are based on a logical model of the entity controlled through this interface.
  - One physical network element can implement multiple logical nodes.

---

## 5 General architecture

### 5.1 General

The protocols over Uu and NG interfaces are divided into two structures:

- **User plane protocols**

These are the protocols implementing the actual PDU Session service, i.e. carrying user data through the access stratum.

- **Control plane protocols**

These are the protocols for controlling the PDU Sessions and the connection between the UE and the network from different aspects (including requesting the service, controlling different transmission resources, handover etc.). Also a mechanism for transparent transfer of NAS messages is included.

### 5.2 User plane

The PDU Session Resource service is offered from SAP to SAP by the Access Stratum. Figure 5.2-1 shows the protocols on the Uu and the NG interfaces that linked together provide this PDU Session Resource service.

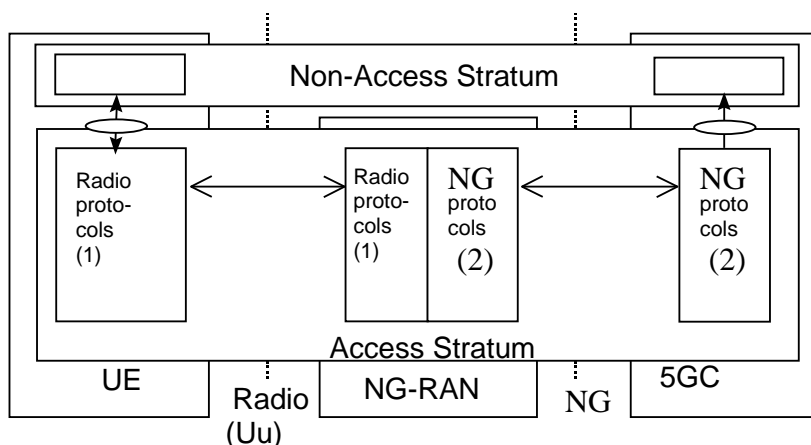

NOTE 1: The radio interface protocols are defined in 3GPP TS 38.2xx and TS 38.3xx.  
 NOTE 2: The NG interface protocols are defined in 3GPP TS 38.41x.

Figure 5.2-1: NG and Uu user plane

### 5.3 Control plane

Figure 5.3-1 shows the control plane (signalling) protocol stacks on NG and Uu interfaces.

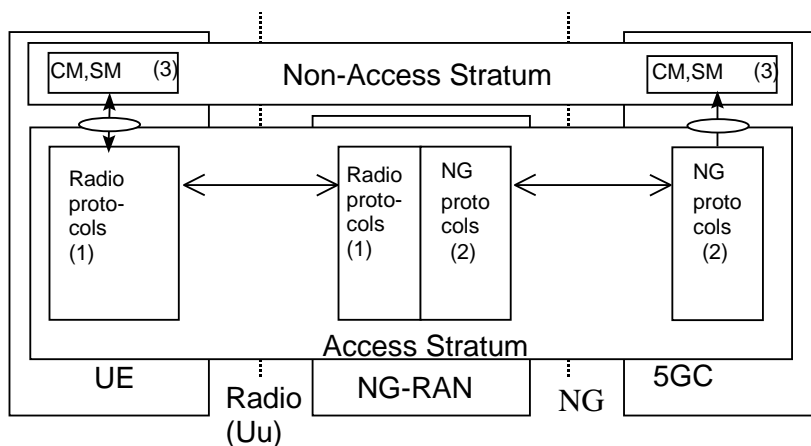

NOTE 1: The radio interface protocols are defined in 3GPP TS 38.2xx and TS 38.3xx.  
 NOTE 2: The protocol is defined in 3GPP TS 38.41x. (Description of NG interface).  
 NOTE 3: CM, SM: This exemplifies a set of NAS control protocols between UE and 5GC. The evolution of the protocol architecture for these protocols is outside the scope of the present document.

Figure 5.3-1: NG and Uu control plane

NOTE: Both the Radio protocols and the NG protocols contain a mechanism to transparently transfer NAS messages.

## 6 NG-RAN architecture

### 6.1 Overview

#### 6.1.1 Overall Architecture of NG-RAN

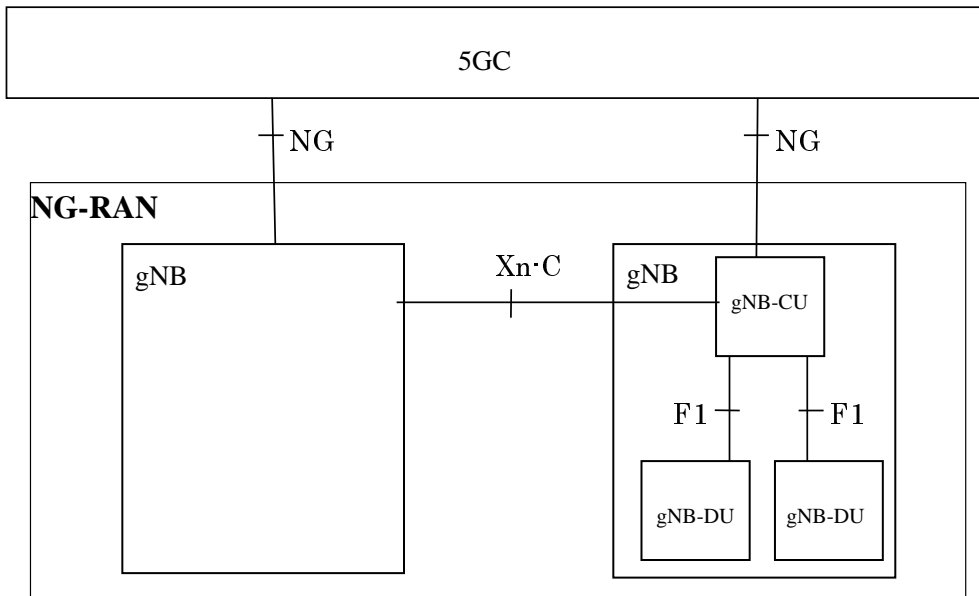

**Figure 6.1-1: Overall architecture**

The NG-RAN consists of a set of gNBs connected to the 5GC through the NG interface.

An gNB can support FDD mode, TDD mode or dual mode operation.

gNBs can be interconnected through the Xn interface.

A gNB may consist of a gNB-CU and one or more gNB-DU(s). A gNB-CU and a gNB-DU is connected via F1 interface.

One gNB-DU is connected to only one gNB-CU.

**NOTE:** In case of network sharing with multiple cell ID broadcast, each Cell Identity associated with a subset of PLMNs corresponds to a gNB-DU and the gNB-CU it is connected to, i.e. the corresponding gNB-DUs share the same physical layer cell resources.

**NOTE:** For resiliency, a gNB-DU may be connected to multiple gNB-CUs by appropriate implementation.

NG, Xn and F1 are logical interfaces.

For NG-RAN, the NG and Xn-C interfaces for a gNB consisting of a gNB-CU and gNB-DUs, terminate in the gNB-CU. For EN-DC, the S1-U and X2-C interfaces for a gNB consisting of a gNB-CU and gNB-DUs, terminate in the gNB-CU. The gNB-CU and connected gNB-DUs are only visible to other gNBs and the 5GC as a gNB. A possible deployment scenario is described in Annex A.

The node hosting user plane part of NR PDCP (e.g. gNB-CU, gNB-CU-UP, and for EN-DC, MeNB or SgNB depending on the bearer split) shall perform user inactivity monitoring and further informs its inactivity or (re)activation to the node having C-plane connection towards the core network (e.g. over E1, X2). The node hosting NR RLC (e.g. gNB-DU) may perform user inactivity monitoring and further inform its inactivity or (re)activation to the node hosting control plane, e.g. gNB-CU or gNB-CU-CP.

UL PDCP configuration (i.e. how the UE uses the UL at the assisting node) is indicated via X2-C (for EN-DC), Xn-C (for NG-RAN) and F1-C. Radio Link Outage/Resume for DL and/or UL is indicated via X2-U (for EN-DC), Xn-U (for NG-RAN) and F1-U.

The NG-RAN is layered into a Radio Network Layer (RNL) and a Transport Network Layer (TNL).

The NG-RAN architecture, i.e. the NG-RAN logical nodes and interfaces between them, is defined as part of the RNL.

For each NG-RAN interface (NG, Xn, F1) the related TNL protocol and the functionality are specified. The TNL provides services for user plane transport, signalling transport.

In NG-Flex configuration, each NG-RAN node is connected to all AMFs of AMF Sets within an AMF Region supporting at least one slice also supported by the NG-RAN node. The AMF Set and the AMF Region are defined in 3GPP TS 23.501 [3].

If security protection for control plane and user plane data on TNL of NG-RAN interfaces has to be supported, NDS/IP 3GPP TS 33.501 [13] shall be applied.

## 6.1.2 Overall architecture for separation of gNB-CU-CP and gNB-CU-UP

The overall architecture for separation of gNB-CU-CP and gNB-CU-UP is depicted in Figure 6.1.2-1.

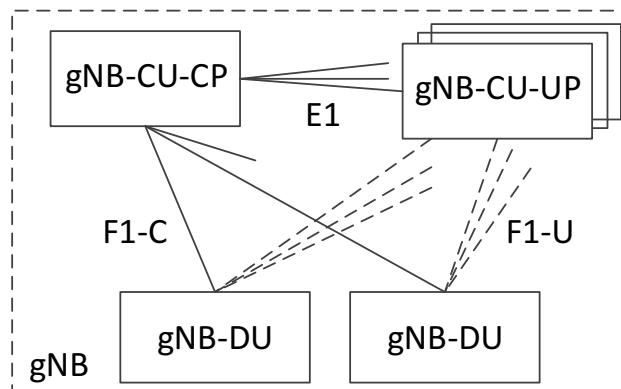

**Figure 6.1.2-1. Overall architecture for separation of gNB-CU-CP and gNB-CU-UP**

- A gNB may consist of a gNB-CU-CP, multiple gNB-CU-UPs and multiple gNB-DUs;
- The gNB-CU-CP is connected to the gNB-DU through the F1-C interface;
- The gNB-CU-UP is connected to the gNB-DU through the F1-U interface;
- The gNB-CU-UP is connected to the gNB-CU-CP through the E1 interface;
- One gNB-DU is connected to only one gNB-CU-CP;
- One gNB-CU-UP is connected to only one gNB-CU-CP;

NOTE 1: For resiliency, a gNB-DU and/or a gNB-CU-UP may be connected to multiple gNB-CU-CPs by appropriate implementation.

- One gNB-DU can be connected to multiple gNB-CU-UPs under the control of the same gNB-CU-CP;
- One gNB-CU-UP can be connected to multiple DUs under the control of the same gNB-CU-CP;

NOTE 2: The connectivity between a gNB-CU-UP and a gNB-DU is established by the gNB-CU-CP using Bearer Context Management functions.

NOTE 3: The gNB-CU-CP selects the appropriate gNB-CU-UP(s) for the requested services for the UE. In case of multiple CU-UPs they belong to same security domain as defined in TS 33.210 [18].

NOTE 4: Data forwarding between gNB-CU-UPs during intra-gNB-CU-CP handover within a gNB may be supported by Xn-U.

## 6.2 NG-RAN identifiers

### 6.2.1 Principle of handling Application Protocol Identities

An Application Protocol Identity (AP ID) is allocated when a new UE-associated logical connection is created in either an NG-RAN node or an AMF. An AP ID shall uniquely identify a logical connection associated to a UE over the NG interface or Xn interface within a node (NG-RAN node or AMF) or over the F1 interface or over the E1 interface. Upon receipt of a message that has a new AP ID from the sending node, the receiving node shall store the AP ID of the sending node for the duration of the logical connection. The receiving node shall assign the AP ID to be used to identify the logical connection associated to the UE and include it as well as the previously received new AP ID from the sending node, in the first returned message to the sending node. In all subsequent messages to and from sending node, both AP IDs of sending node and receiving node shall be included.

The definitions of AP IDs as used on NG interface or Xn interface or F1 interface or E1 interface are shown below:

#### **RAN UE NGAP ID:**

A RAN UE NGAP ID shall be allocated so as to uniquely identify the UE over the NG interface within a gNB. When an AMF receives a RAN UE NGAP ID it shall store it for the duration of the UE-associated logical NG-connection for this UE. Once known to an AMF this is included in all UE associated NGAP signalling.

The RAN UE NGAP ID shall be unique within the logical NG-RAN node.

#### **AMF UE NGAP ID:**

An AMF UE NGAP ID shall be allocated so as to uniquely identify the UE over the NG interface within the AMF. When a NG-RAN node receives an AMF UE NGAP ID it shall store it for the duration of the UE-associated logical NG-connection for this UE. Once known to a NG-RAN node this ID is included in all UE associated NGAP signalling.

The AMF UE NGAP ID shall be unique within an AMF Set as specified in 3GPP TS 23.501 [3].

#### **Old NG-RAN node UE XnAP ID:**

An Old NG-RAN node UE XnAP ID shall be allocated so as to uniquely identify the UE over the Xn interface within a source NG-RAN node. When a target NG-RAN node receives an Old NG-RAN node UE XnAP ID it shall store it for the duration of the UE-associated logical Xn-connection for this UE. Once known to a target NG-RAN node this ID is included in all UE associated XnAP signalling. The Old NG-RAN node UE XnAP ID shall be unique within the logical NG-RAN node.

#### **New NG-RAN node UE XnAP ID:**

A New NG-RAN node UE XnAP ID shall be allocated so as to uniquely identify the UE over the Xn interface within a target NG-RAN node. When a source NG-RAN node receives a New NG-RAN node UE XnAP ID it shall store it for the duration of the UE-associated logical Xn-connection for this UE. Once known to a source NG-RAN node this ID is included in all UE associated XnAP signalling. The New NG-RAN node UE XnAP ID shall be unique within the logical NG-RAN node.

#### **M-NG-RAN node UE XnAP ID:**

An M-NG-RAN node UE XnAP ID shall be allocated so as to uniquely identify the UE over the Xn interface within an M-NG-RAN node for dual connectivity. When an S-NG-RAN node receives an M-NG-RAN node UE XnAP ID it shall store it for the duration of the UE-associated logical Xn-connection for this UE. Once known to an S-NG-RAN node this ID is included in all UE associated XnAP signalling. The M-NG-RAN node UE XnAP ID shall be unique within the logical NG-RAN node.

#### **S-NG-RAN node UE XnAP ID:**

A S-NG-RAN node UE XnAP ID shall be allocated so as to uniquely identify the UE over the Xn interface within an S-NG-RAN node for dual connectivity. When an M-NG-RAN node receives a S-NG-RAN node UE

XnAP ID it shall store it for the duration of the UE-associated logical Xn-connection for this UE. Once known to an M-NG-RAN node this ID is included in all UE associated XnAP signalling. The S-NG-RAN node UE XnAP ID shall be unique within the logical NG-RAN node.

**gNB-CU UE F1AP ID:**

A gNB-CU UE F1AP ID shall be allocated so as to uniquely identify the UE over the F1 interface within a gNB-CU. When a gNB-DU receives a gNB-CU UE F1AP ID it shall store it for the duration of the UE-associated logical F1-connection for this UE. The gNB-CU UE F1AP ID shall be unique within the gNB-CU logical node.

**gNB-DU UE F1AP ID:**

A gNB-DU UE F1AP ID shall be allocated so as to uniquely identify the UE over the F1 interface within a gNB-DU. When a gNB-CU receives a gNB-DU UE F1AP ID it shall store it for the duration of the UE-associated logical F1-connection for this UE. The gNB-DU UE F1AP ID shall be unique within the gNB-DU logical node.

**gNB-CU-CP UE E1AP ID:**

A gNB-CU-CP UE E1AP ID shall be allocated so as to uniquely identify the UE over the E1 interface within a gNB-CU-CP. When a gNB-CU-UP receives a gNB-CU-CP UE E1AP ID it shall store it for the duration of the UE-associated logical E1-connection for this UE. The gNB-CU-CP UE E1AP ID shall be unique within the gNB-CU-CP logical node.

**gNB-CU-UP UE E1AP ID:**

A gNB-CU-UP UE E1AP ID shall be allocated so as to uniquely identify the UE over the E1 interface within a gNB-CU-UP. When a gNB-CU-CP receives a gNB-CU-UP UE E1AP ID it shall store it for the duration of the UE-associated logical E1-connection for this UE. The gNB-CU-UP UE E1AP ID shall be unique within the gNB-CU-UP logical node.

## 6.2.2 gNB-DU ID

The gNB-DU ID is configured at the gNB-DU and used to uniquely identify the gNB-DU at least within a gNB-CU. The gNB-DU provides its gNB-DU ID to the gNB-CU during the F1 Setup procedure. The gNB-DU ID is used only within F1AP procedures.

## 6.3 Transport addresses

The transport layer address parameter is transported in the radio network application signalling procedures that result in establishment of transport bearer connections.

The transport layer address parameter shall not be interpreted in the radio network application protocols and reveal the addressing format used in the transport layer.

The formats of the transport layer addresses are further described in 3GPP TS 38.414 [5], 3GPP TS 38.424 [6] and 3GPP TS 38.474 [7].

## 6.4 UE associations in NG-RAN Node

There are several types of UE associations needed in the NG-RAN node: the "NG-RAN node UE context" used to store all information needed for a UE and the associations between the UE and the logical NG and Xn connections used for NG/XnAP UE associated messages. An "NG-RAN node UE context" exists for a UE in CM\_CONNECTED.

**Definitions:****NG-RAN node UE context:**

An NG-RAN node UE context is a block of information in an NG-RAN node associated to one UE. The block of information contains the necessary information required to maintain the NG-RAN services towards the active UE. An NG-RAN node UE context is established when the transition to RRC\_CONNECTED for a UE is completed or in the target NG-RAN node after completion of handover resource allocation during handover preparation, in which case at

least UE state information, security information, UE capability information and the identities of the UE-associated logical NG-connection shall be included in the NG-RAN node UE context.

For Dual Connectivity an NG-RAN node UE context is also established in the S-NG-RAN node after completion of S-NG-RAN node Addition Preparation procedure.

If radio bearers are requested to be setup during a UE Context setup or modification procedure, the UE capabilities are signalled to the receiving node as part of the UE context setup or modification procedures.

#### **Bearer context:**

A bearer context is a block of information in a gNB-CU-UP node associated to one UE that is used for the sake of communication over the E1 interface. It may include the information about data radio bearers, PDU sessions and QoS-flows associated to the UE. The block of information contains the necessary information required to maintain user-plane services toward the UE.

#### **UE-associated logical NG/Xn/F1/E1 -connection:**

NGAP, XnAP, F1AP and E1AP provide means to exchange control plane messages associated with the UE over the respectively NG-C, Xn-C, F1-C or E1 interface.

A UE-associated logical connection is established during the first NGAP/XnAP/F1AP message exchange between the NG/Xn/F1 peer nodes.

The connection is maintained as long as UE associated NG/XnAP/F1AP messages need to be exchanged over the NG/Xn/F1 interface.

The UE-associated logical NG-connection uses the identities AMF UE NGAP ID and RAN UE NGAP ID.

The UE-associated logical Xn-connection uses the identities Old NG-RAN node UE XnAP ID and New NG-RAN node UE XnAP ID, or M-NG-RAN node UE XnAP ID and S-NG-RAN node UE XnAP ID.

The UE-associated logical F1-connection uses the identities gNB-CU UE F1AP ID and gNB-DU UE F1AP ID.

When a node (AMF or gNB) receives a UE associated NGAP/XnAP/F1AP message the node retrieves the associated UE based on the NGAP/XnAP/F1AP ID.

#### **UE-associated signalling:**

UE-associated signalling is an exchange of NGAP/XnAP/F1AP messages associated with one UE over the UE-associated logical NG/Xn/F1-connection.

NOTE1: The UE-associated logical NG-connection may exist before the NG-RAN node UE context is setup in the NG-RAN node.

NOTE2: The UE-associated logical F1-connection may exist before the UE context is setup in the gNB-DU.

---

## 7 NG-RAN functions description

### 7.0 General

For the list of functions refer to TS 38.300 [2].

### 7.1 NG-RAN sharing

NG-RAN supports radio access network sharing as specified in TS 23.501 [3] and TS 38.300 [2] and TS 36.300 [19].

## 8 Overall procedures in gNB-CU/gNB-DU Architecture

### 8.1 UE Initial Access

The signalling flow for UE Initial access is shown in Figure 8.1-1.

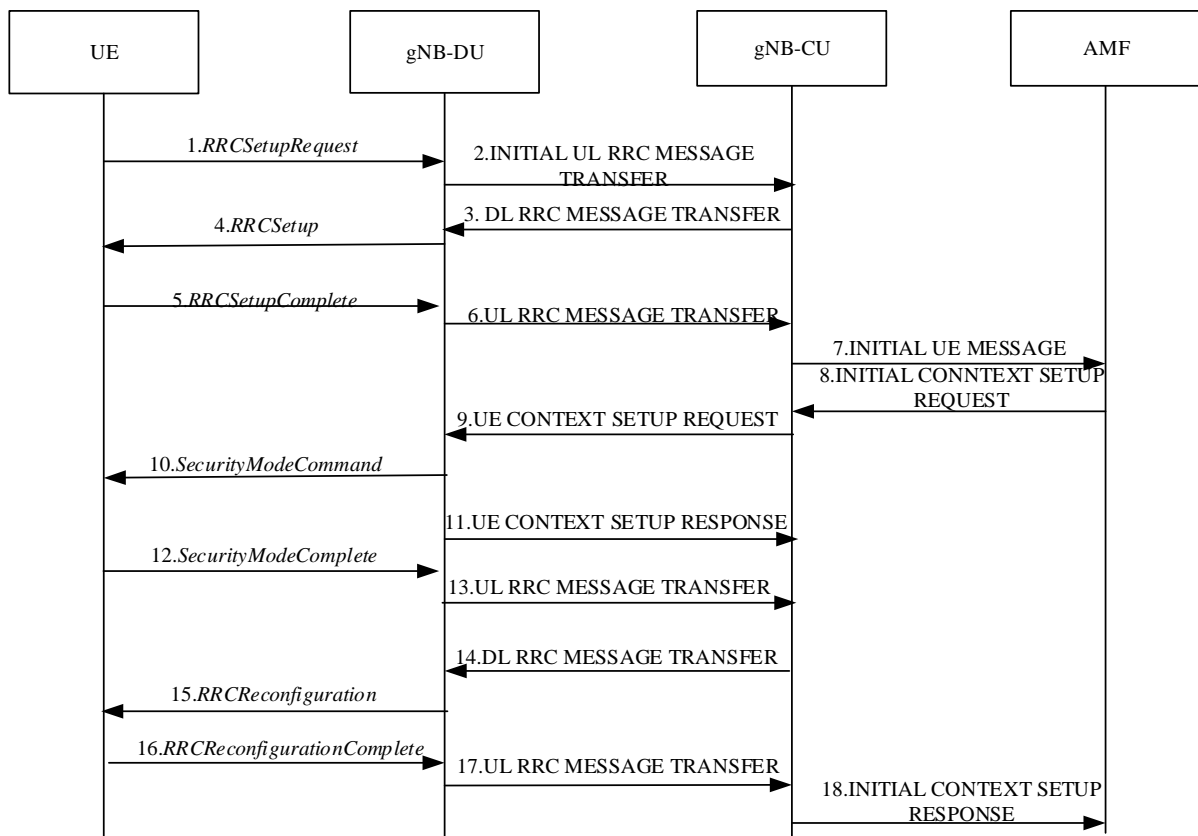

**Figure 8.1-1: UE Initial Access procedure**

1. The UE sends an *RRCSetupRequest* message to the gNB-DU.
2. The gNB-DU includes the RRC message and, if the UE is admitted, the corresponding low layer configuration for the UE in the INITIAL UL RRC MESSAGE TRANSFER message and transfers to the gNB-CU. The INITIAL UL RRC MESSAGE TRANSFER message includes the C-RNTI allocated by the gNB-DU.
3. The gNB-CU allocates a gNB-CU UE F1AP ID for the UE and generates a *RRCSetup* message towards UE. The RRC message is encapsulated in -the DL RRC MESSAGE TRANSFER message.
4. The gNB-DU sends the *RRCSetup* message to the UE.
5. The UE sends the RRC CONNECTION SETUP COMPLETE message to the gNB-DU.
6. The gNB-DU encapsulates the RRC message in the UL RRC MESSAGE TRANSFER message and sends it to the gNB-CU.
7. The gNB-CU sends the INITIAL UE MESSAGE message to the AMF.
8. The AMF sends the INITIAL CONTEXT SETUP REQUEST message to the gNB-CU.
9. The gNB-CU sends the UE CONTEXT SETUP REQUEST message to establish the UE context in the gNB-DU. In this message, it may also encapsulate the *SecurityModeCommand* message.



10. The gNB-DU sends the *SecurityModeCommand* message to the UE.
11. The gNB-DU sends the UE CONTEXT SETUP RESPONSE message to the gNB-CU.
12. The UE responds with the *SecurityModeComplete* message
13. The gNB-DU encapsulates the RRC message in the UL RRC MESSAGE TRANSFER message and sends it to the gNB-CU.
14. The gNB-CU generates the *RRCReconfiguration* message and encapsulates it in the DL RRC MESSAGE TRANSFER message
15. The gNB-DU sends *RRCReconfiguration* message to the UE.
16. The UE sends *RRCReconfigurationComplete* message to the gNB-DU.
17. The gNB-DU encapsulates the RRC message in the UL RRC MESSAGE TRANSFER message and send it to the gNB-CU.
18. The gNB-CU sends the INITIAL CONTEXT SETUP RESPONSE message to the AMF.

## 8.2 Intra-gNB-CU Mobility

### 8.2.1 Intra-NR Mobility

#### 8.2.1.1 Inter-gNB-DU Mobility

This procedure is used for the case when the UE moves from one gNB-DU to another gNB-DU within the same gNB-CU during NR operation. Figure 8.2.1.1-1 shows the inter-gNB-DU mobility procedure for intra-NR.

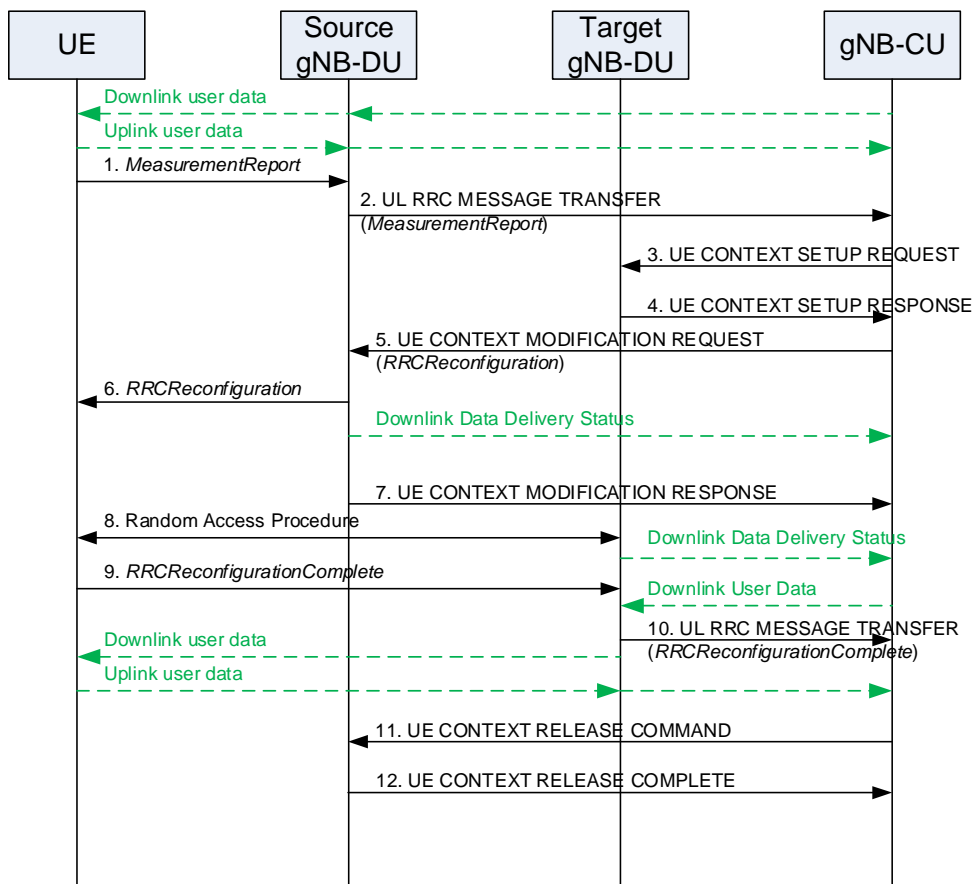

**Figure 8.2.1.1-1: Inter-gNB-DU Mobility for intra-NR**

1. The UE sends a *MeasurementReport* message to the source gNB-DU.
2. The source gNB-DU sends an UL RRC MESSAGE TRANSFER message to the gNB-CU to convey the received *MeasurementReport* message.
3. The gNB-CU sends an UE CONTEXT SETUP REQUEST message to the target gNB-DU to create an UE context and setup one or more data bearers. The UE CONTEXT SETUP REQUEST message includes a *HandoverPreparationInformation*.
4. The target gNB-DU responds to the gNB-CU with an UE CONTEXT SETUP RESPONSE message.
5. The gNB-CU sends a UE CONTEXT MODIFICATION REQUEST message to the source gNB-DU, which includes a generated *RRCReconfiguration* message and indicates to stop the data transmission for the UE. The source gNB-DU also sends a Downlink Data Delivery Status frame to inform the gNB-CU about the unsuccessfully transmitted downlink data to the UE.
6. The source gNB-DU forwards the received *RRCReconfiguration* message to the UE.
7. The source gNB-DU responds to the gNB-CU with the UE CONTEXT MODIFICATION RESPONSE message.
8. A Random Access procedure is performed at the target gNB-DU. The target gNB-DU sends a Downlink Data Delivery Status frame to inform the gNB-CU. Downlink packets, which may include PDCP PDUs not successfully transmitted in the source gNB-DU, are sent from the gNB-CU to the target gNB-DU.

NOTE: It is up to gNB-CU implementation whether to start sending DL User Data to gNB-DU before or after reception of the Downlink Data Delivery Status.

9. The UE responds to the target gNB-DU with an *RRCReconfigurationComplete* message.

10. The target gNB-DU sends an UL RRC MESSAGE TRANSFER message to the gNB-CU to convey the received *RRCReconfigurationComplete* message. Downlink packets are sent to the UE. Also, uplink packets are sent from the UE, which are forwarded to the gNB-CU through the target gNB-DU.
11. The gNB-CU sends an UE CONTEXT RELEASE COMMAND message to the source gNB-DU.
12. The source gNB-DU releases the UE context and responds the gNB-CU with an UE CONTEXT RELEASE COMPLETE message.

### 8.2.1.2 Intra-gNB-DU handover

This procedure is used for the case that UE moves from one cell to another cell within the same gNB-DU or for the case that intra-cell handover is performed during NR operation, and supported by UE Context Modification (gNB-CU initiated) procedure as specified in TS 38.473 [4]. When the intra-cell handover is performed, the gNB-CU provides new UL GTP TEID to the gNB-DU and gNB-DU provides new DL GTP TEID to the gNB-CU. The gNB-DU shall continue sending UL PDCP PDUs to the gNB-CU with the previous UL GTP TEID until it re-establishes the RLC, and use the new UL GTP TEID after RLC re-establishment. The gNB-CU shall continue sending DL PDCP PDUs to the gNB-DU with the previous DL GTP TEID until it performs PDCP re-establishment or PDCP data recovery, and use the new DL GTP TEID starting with the PDCP re-establishment or data recovery.

## 8.2.2 EN-DC Mobility

### 8.2.2.1 Inter-gNB-DU Mobility using MCG SRB

This procedure is used for the case the UE moves from one gNB-DU to another gNB-DU within the same gNB-CU when only MCG SRB is available during EN-DC operation. Figure 8.2.2.1-1 shows the inter-gNB-DU mobility procedure using MCG SRB in EN-DC.

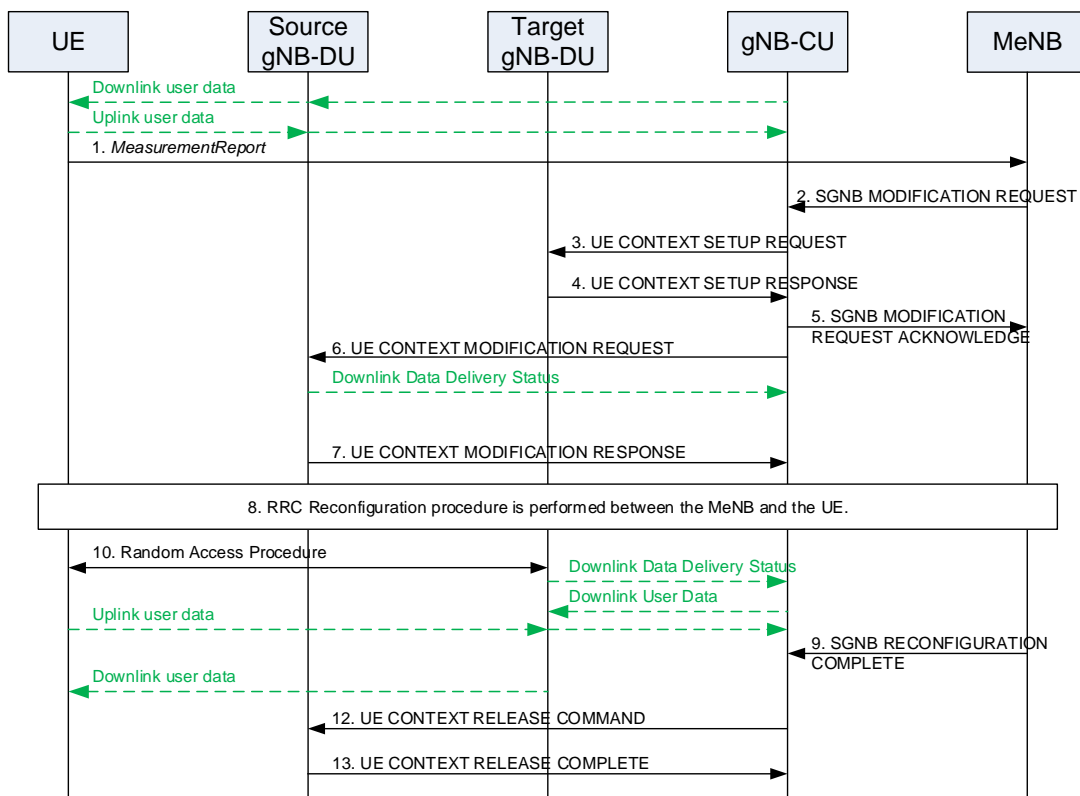

Figure 8.2.2.1-1: Inter-gNB-DU Mobility using MCG SRB in EN-DC

1. The UE sends a *MeasurementReport* message to the MeNB.
2. The MeNB sends an SGNB MODIFICATION REQUEST message.
3. The gNB-CU sends an UE CONTEXT SETUP REQUEST message to the target gNB-DU to create an UE context and setup one or more data bearers. The UE CONTEXT SETUP REQUEST message includes a CG-ConfigInfo.
4. The target gNB-DU responds the gNB-CU with an UE CONTEXT SETUP RESPONSE message.
5. The gNB-CU responds the MeNB with an SGNB MODIFICATION REQUEST ACKNOWLEDGE message.
6. The gNB-CU sends a UE CONTEXT MODIFICATION REQUEST message to the source gNB-DU indicating to stop the data transmission to the UE. The source gNB-DU also sends a Downlink Data Delivery Status frame to inform the gNB-CU about the unsuccessfully transmitted downlink data to the UE.
7. The source gNB-DU responds the gNB-CU with an UE CONTEXT MODIFICATION RESPONSE message.
8. The MeNB and the UE perform RRC Reconfiguration procedure.
9. The MeNB sends an SGNB RECONFIGURATION COMPLETE message to the gNB-CU.
10. Random Access procedure is performed at the target gNB-DU. The target gNB-DU sends a Downlink Data Delivery Status frame to inform the gNB-CU. Downlink packets, which may include PDCP PDUs not successfully transmitted in the source gNB-DU, are sent from the gNB-CU to the target gNB-DU. Downlink packets are sent to the UE. Also, uplink packets are sent from the UE, which are forwarded to the gNB-CU through the target gNB-DU.

NOTE: It is up to gNB-CU implementation whether to start sending DL User Data to gNB-DU before or after reception of the Downlink Data Delivery Status.

11. The gNB-CU sends an UE CONTEXT RELEASE COMMAND message to the source gNB-DU.
12. The source gNB-DU releases the UE context and responds the gNB-CU with an UE CONTEXT RELEASE COMPLETE message.

### 8.2.2.2 Inter-gNB-DU Mobility using SCG SRB (SRB3)

This procedure is used for the case the UE moves from one gNB-DU to another gNB-DU when SCG SRB (SRB3) is available during EN-DC operation. The procedure is the same as inter-gNB-DU Mobility for intra-NR as defined in clause 8.2.1.1 but the UE CONTEXT SETUP REQUEST message includes a CG-ConfigInfo.

## 8.3 Mechanism of centralized retransmission of lost PDUs

### 8.3.1 Centralized Retransmission in Intra gNB-CU Cases

This mechanism allows to perform the retransmission of the PDCP PDUs that are not delivered by a gNB-DU (gNB-DU1) because the corresponding radio links toward the UE are subject to outage. When such outage occurs, the gNB-DU affected by outage informs the gNB-CU of such event. The gNB-CU can switch transmission of data traffic, as well as perform retransmission of undelivered PDCP PDUs, from the gNB-DU affected by outage to other available gNB-DUs (e.g. gNB-DU2 in Figure 8.3.1-1) with a well-functioning radio link toward the UE. The mechanism is also applicable in EN-DC and MR-DC with 5GC, refer to TS 37.340 [12].

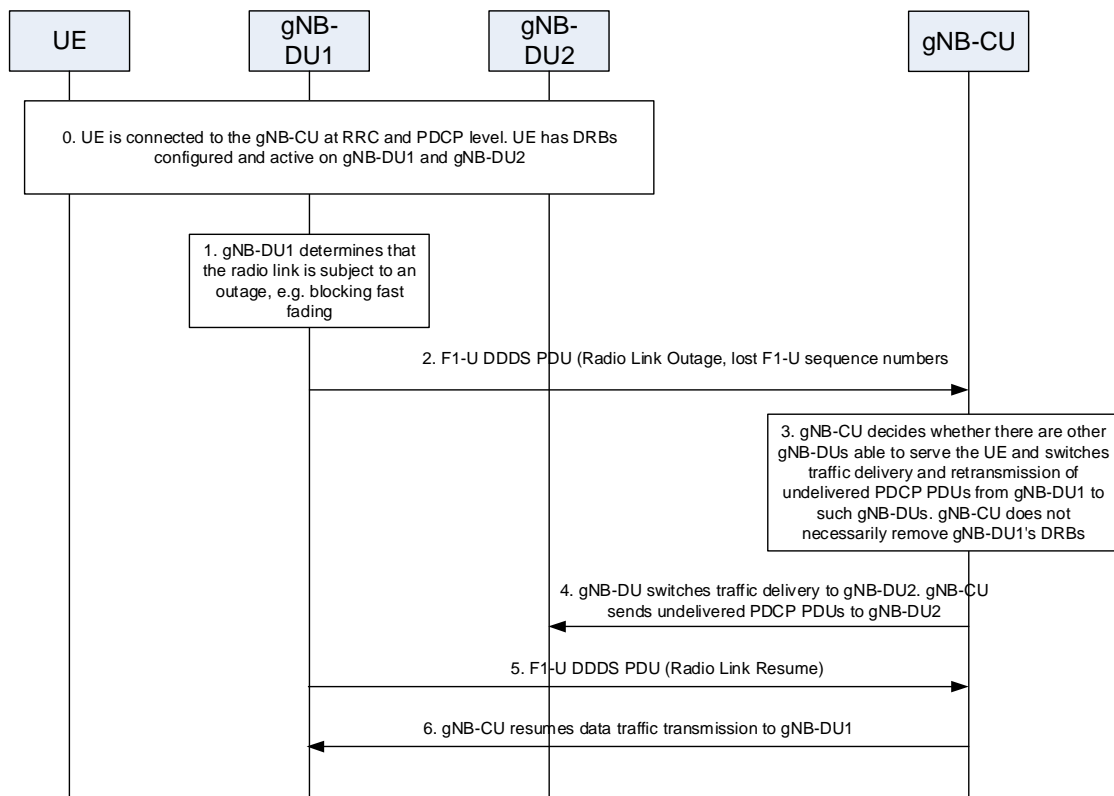

**Figure 8.3.1-1: Procedure for centralized retransmission in intra gNB-CU scenarios**

The mechanism is shown in Figure 8.3.1-1 and targets the multi-connectivity scenario, where a UE is served by multiple data radio bearers established at least on two gNB-DUs, and it includes the following steps:

0. The UE is connected and can transmit/receive data to/from gNB-DU1 and gNB-DU2.
1. gNB-DU1 realizes that the radio link towards the UE is experiencing outage.
2. gNB-DU1 sends the "Radio Link Outage" notification message to the gNB-CU over the F1-U interface, as part of the DDDS PDU of the concerned data radio bearer. The message may include information to be used by the gNB-CU to perform retransmission of the PDCP PDUs that were not delivered by the gNB-DU1 (e.g. the highest transmitted NR PDCP Sequence Number, the highest successfully delivered NR PDCP Sequence Number and the lost NR-U Sequence Numbers).
3. gNB-CU decides to switch data traffic transmission and retransmission of PDCP PDUs that were undelivered in gNB-DU1 via gNB-DU2. gNB-CU stops sending downlink traffic to gNB-DU1. The radio leg between gNB-DU1 and the UE is not necessarily removed.
4. gNB-CU starts sending traffic (namely new PDUs and potentially retransmitted PDUs) to gNB-DU2.
5. If gNB-DU1 realizes that the radio link of the concerned data radio bearer is back in normal operation, it may send a "Radio Link Resume" notification message as part of the DDDS PDU over the F1-U interface to inform the gNB-CU that the radio link can be used again for the concerned data radio bearer.
6. gNB-CU may start sending traffic (namely new PDUs and potentially retransmitted PDUs) of the concerned data radio bearer via gNB-DU1 again.

## 8.4 Multi-Connectivity operation

### 8.4.1 Secondary Node Addition

#### 8.4.1.1 EN-DC

This clause gives the SgNB addition procedure in EN-DC given that en-gNB consists of gNB-CU and gNB-DU(s), as shown in Figure 8.4.1.1-1.

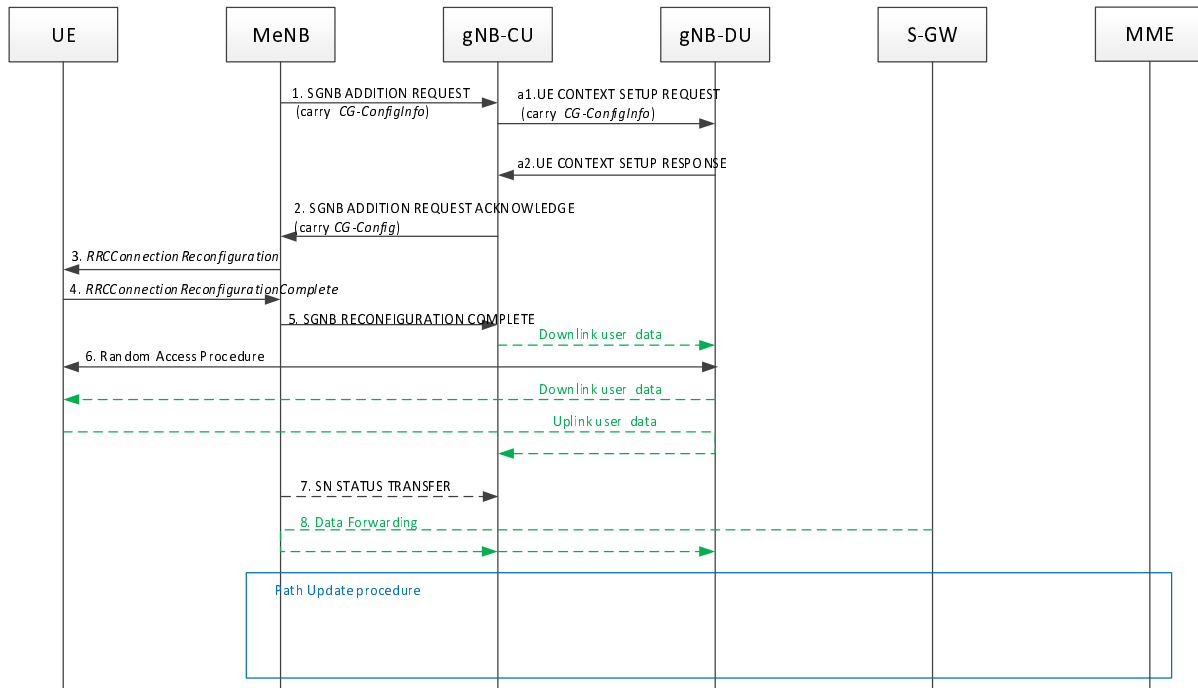

Figure 8.4.1.1-1: SgNB addition procedure in EN-DC

1~8: refer to TS 37.340 [12]

a1. After receiving the SgNB ADDITION REQUEST message from MeNB, the gNB-CU sends the UE CONTEXT SETUP REQUEST message to the gNB-DU to create a UE context. As specified in 37.340 [12], in the course of a Secondary Node Change, the UE CONTEXT SETUP REQUEST message may contain source cell group configuration to allow gNB-DU to perform delta configuration.

a2. The gNB-DU responds to the gNB-CU with the UE CONTEXT SETUP RESPONSE message. In case the gNB-DU receives the UE CONTEXT SETUP REQUEST message without the source cell group configuration or in the course of a Secondary Node Change as specified in 37.340 [12] or if the gNB-DU decides to perform full configuration after receiving the source cell group configuration, it shall perform full configuration and indicate that it has applied full configuration in the UE CONTEXT SETUP RESPONSE message.

NOTE: On Inter-gNB-CU Mobility, same method is performed to achieve full configuration and delta configuration.

### 8.4.2 Secondary Node Release (MN/SN initiated)

#### 8.4.2.1 EN-DC

This clause gives the SgNB release procedure in EN-DC given that the en-gNB consists of a gNB-CU and gNB-DU(s).

##### MN initiated SN Release

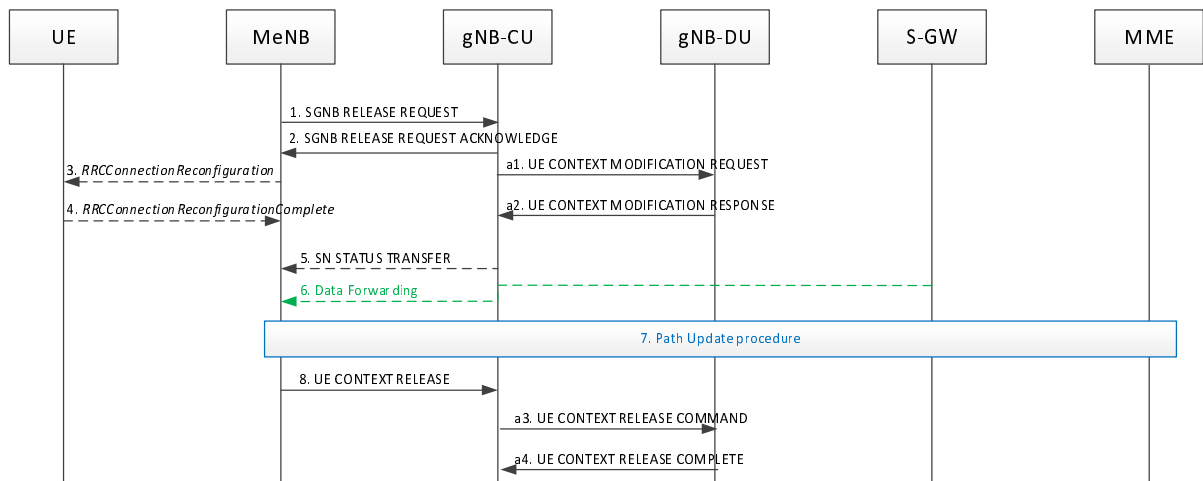

Figure 8.4.2.1-1 SgNB release procedure in EN-DC (MN initiated)

1~8: refer to TS 37.340 [12]

NOTE: The timing of sending the Step 2 SgNB RELEASE REQUEST ACKNOWLEDGE message is an example, it may be sent e.g. after step a1 or after a2 and it is up to implementation.

- a1. After receiving SgNB RELEASE REQUEST message from MeNB, gNB-CU sends the UE CONTEXT MODIFICATION REQUEST message to gNB-DU to stop the data transmission for the UE. It is up to gNB-DU implementation when to stop the UE scheduling.
- a2. gNB-DU responds to gNB-CU with UE CONTEXT MODIFICATION RESPONSE message.
- a3. After receiving the UE CONTEXT RELEASE message from MeNB, the gNB-CU sends the UE CONTEXT RELEASE COMMAND message to the gNB-DU to release the UE context.
- a4. The gNB-DU responds to the gNB-CU with the UE CONTEXT RELEASE COMPLETE message.

**SN initiated SN Release**

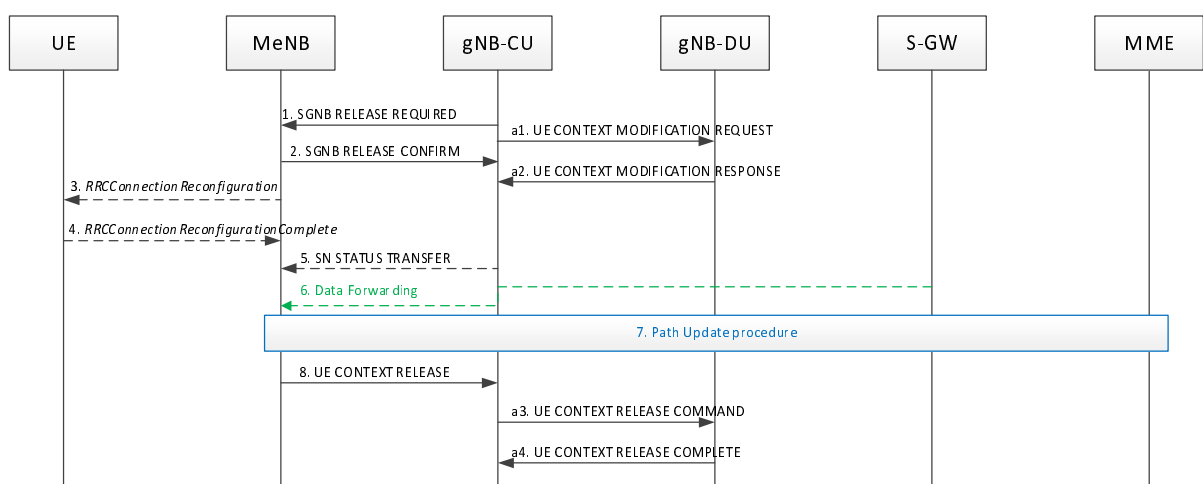

Figure 8.4.2.1-2 SgNB release procedure in EN-DC (SN initiated)

1~8: refer to TS 37.340 [12]

- a1. gNB-CU sends the UE CONTEXT MODIFICATION REQUEST message to gNB-DU to stop the data transmission for the UE. It is up to gNB-DU implementation when to stop the UE scheduling. This step may occur before step 1.

- a2. gNB-DU responds to gNB-CU with UE CONTEXT MODIFICATION RESPONSE message.
- a3. After receiving the UE CONTEXT RELEASE message from MeNB, the gNB-CU sends the UE CONTEXT RELEASE COMMAND message to the gNB-DU to release the UE context.
- a4. The gNB-DU responds to the gNB-CU with the UE CONTEXT RELEASE COMPLETE message.

## 8.5 F1 Startup and cells activation

This function allows to setup the F1 interface between a gNB-DU and a gNB-CU and it allows to activate the gNB-DU cells.

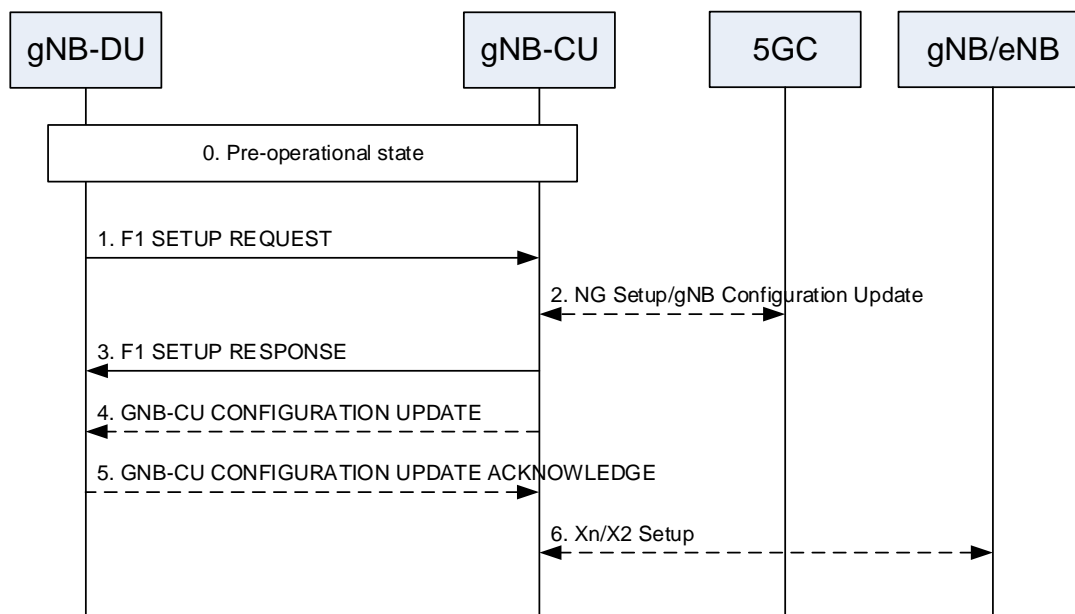

**Figure 8.5-1: F1 startup and cell activation**

0. The gNB-DU and its cells are configured by OAM in the F1 pre-operational state. The gNB-DU has TNL connectivity toward the gNB-CU.
1. The gNB-DU sends an F1 SETUP REQUEST message to the gNB-CU including a list of cells that are configured and ready to be activated.
2. In NG-RAN, the gNB-CU ensures the connectivity toward the core network. For this reason, the gNB-CU may initiate either the NG Setup or the gNB Configuration Update procedure towards 5GC.
3. The gNB-CU sends an F1 SETUP RESPONSE message to the gNB-DU that optionally includes a list of cells to be activated. The cells in the list of cells to be activated in F1 SETUP RESPONSE message become active, while the cells not in the list are inactive. The cells that are active are *Out-of-Service* until the gNB-DU indicates that they are *In-Service*. The gNB-DU will initiate the gNB-DU Configuration Update procedure towards the gNB-CU and includes the cell(s) that are *In-Service* and/or the cell(s) that are *Out-Of-Service*. The gNB-DU may also indicate cell(s) to be deleted, in which case the gNB-CU removes the corresponding cell(s) information.
4. The gNB-CU may send a GNB CU CONFIGURATION UPDATE message to the gNB-DU that optionally includes a list of cells to be activated, e.g., in case that these cells were not activated using the F1 SETUP RESPONSE message.
5. The gNB-DU replies with a GNB CU CONFIGURATION UPDATE ACKNOWLEDGE message that optionally includes a list of cells that failed to be activated. The gNB-CU regards all Active cells as *Out-Of-Service* until the gNB-DU indicates that they are *In-Service*.



6. The gNB-CU may initiate either the Xn Setup towards a neighbour NG-RAN node or the EN-DC X2 Setup procedure towards a neighbour eNB.

NOTE 1: For NG-RAN in case that the F1 SETUP RESPONSE message is not used to activate any cell, step 2 may be performed after step 3.

Over the F1 interface between a gNB-CU and a gNB-DU pair, the following two Cell States are possible:

- *Inactive*: the cell is known by both the gNB-DU and the gNB-CU. The cell shall not serve UEs;
- *Active*: the cell is known by both the gNB-DU and the gNB-CU. The cell should try to provide services to the UEs.

The gNB-CU decides whether the Cell State should be "Inactive" or "Active". The gNB-CU can request the gNB-DU to change the Cell State using the F1 SETUP RESPONSE, the GNB DU CONFIGURATION UPDATE ACKNOWLEDGE, or the GNB CU CONFIGURATION UPDATE messages.

The gNB-DU reports to the gNB-CU the *Service Status*. The *Service Status* is the state of the radio transmission over the air. The *Service Status* is reported by the gNB-DU for cells for which the Cell State is "Active". The following *Service Status* are defined:

- *In-Service*: the cell is operational and able to serve UEs.
- *Out-Of-Service*: the cell is not operational, and it is not able to serve UEs. The gNB-DU is trying to make the cell operational.

The gNB-DU reports the *Service Status* using the GNB DU CONFIGURATION UPDATE message.

NOTE 2: If gNB-DU regards that one or more cells cannot become operational, the gNB-DU deletes them and reports them using the GNB DU CONFIGURATION UPDATE message.

## 8.6 RRC state transition

### 8.6.1 RRC connected to RRC inactive

This section gives the RRC connected to RRC inactive state transition given that gNB consists of gNB-CU and gNB-DU(s), as shown in Figure 8.6.1-1.

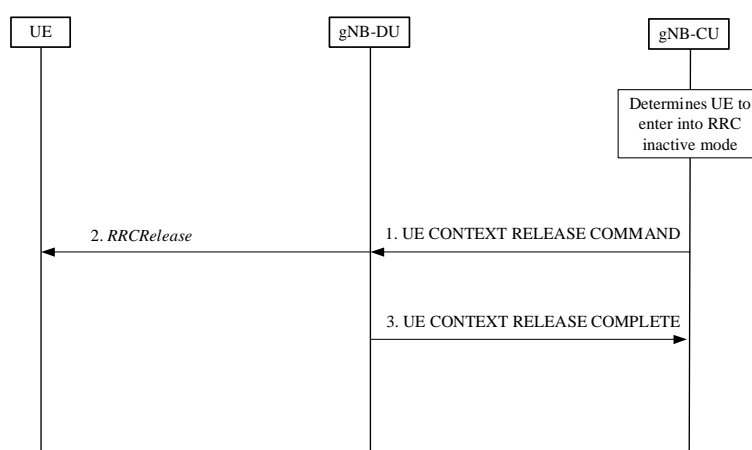

**Figure 8.6.1-1: RRC connected to RRC inactive state transition procedure**

0. At first, the gNB-CU determines the UE to enter into RRC inactive mode from connected mode.
1. The gNB-CU generates *RRCRelease* message towards UE. The RRC message is encapsulated in UE CONTEXT RELEASE COMMAND message to the gNB-DU.

2. The gNB-DU forwards *RRRelease* message to UE.
3. gNB-DU responds with UE CONTEXT RELEASE COMPLETE message.

## 8.6.2 RRC inactive to other states

This section gives the RRC inactive to other RRC states transition given that gNB consists of gNB-CU and gNB-DU(s), as shown in Figure 8.6.2-1.

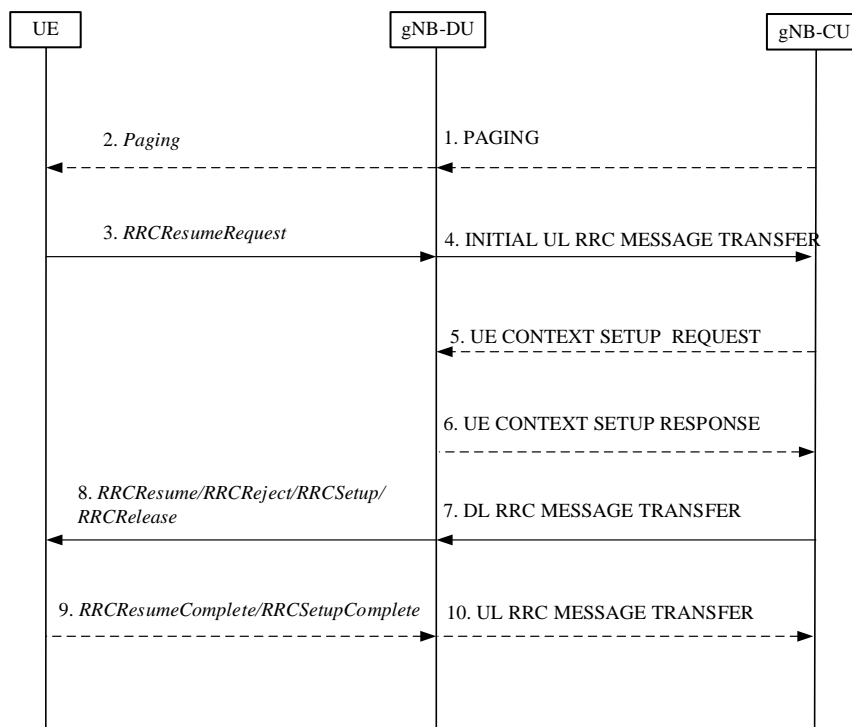

**Figure 8.6.2-1: RRC inactive to other RRC states transition procedure**

1. If data is received from 5GC, the gNB-CU sends PAGING message to gNB-DU.
  2. The gNB-DU sends *Paging* message to UE.
- NOTE: step 1 and 2 only exist in case of DL data arrival.
3. UE sends *RRCResumeRequest* message either upon RAN-based paging, UL data arrival or RNA update.
  4. The gNB-DU includes *RRCResumeRequest* in a non-UE associated INITIAL UL RRC MESSAGE TRANSFER message and transfer to the gNB-CU.
  5. For UE Inactive to UE Active transitions, excluding transitions due to signalling exchange only, the gNB-CU allocates gNB-CU UE F1AP ID and sends UE CONTEXT SETUP REQUEST message to gNB-DU, which may include SRB ID(s) and DRB ID(s) to be setup, CellGroupConfig stored in gNB-CU or retrieved from the old NG-RAN node may also be included.
  6. The gNB-DU responds with UE CONTEXT SETUP RESPONSE message, which contains RLC/MAC/PHY configuration of SRB and DRBs provided by the gNB-DU.

NOTE: step 5 and 6 exist for inactive to active transitions, excluding transitions due to signalling exchange only. When gNB-CU successfully retrieves and verifies the UE context, it may decide to let the UE enter into RRC active mode. gNB-CU shall trigger UE context setup procedure between gNB-CU and gNB-DU, during which both SRB1, SRB2 and DRB(s) can be setup. For signalling exchange only transitions, gNB-CU does not trigger UE Context Setup procedure. For inactive to Idle transitions the gNB-CU does not trigger the UE Context Setup procedure.

7. The gNB-CU generates *RRCResume/RRCSetup/RRCReject/RRCRelease* message towards UE. The RRC message is encapsulated in DL RRC MESSAGE TRANSFER message together with SRB ID.
8. The gNB-DU forwards RRC message to UE either over SRB0 or SRB1 as indicated by the SRB ID.

NOTE: in step 7, it is expected that gNB-CU takes appropriate action, e.g. generates RRC resume message for inactive to active state transition (for both cases of signaling exchange only, and UP data exchange), generates RRC setup message for fallback to establish a new RRC connection, and generates either RRC release message without suspend configuration for inactive to idle state transition, or RRC release message with suspend configuration to remain in inactive state.  
If step 5 and 6 are not performed, the gNB-DU deduces the SRB on which to deliver the RRC message in step 7 from the SRB ID, i.e. SRB ID "0" corresponds to SRB0, SRB ID "1" corresponds to SRB1.

9. UE sends *RRCResumeComplete/RRCSetupComplete* message to the gNB-DU.

10. The gNB-DU encapsulates RRC in UL RRC MESSAGE TRANSFER message and send to the gNB-CU.

NOTE: step 9 and step 10 exist for inactive to active state transition (for both cases of signaling exchange only, and UP data exchange). UE generates *RRCResumeComplete/RRCSetupComplete* message for resume the existing RRC connection or fallback to a new RRC connection respectively.

## 8.7 RRC connection reestablishment

This procedure is used for the case that UE tries to reestablish the RRC connection, as shown in Figure 8.7-1.

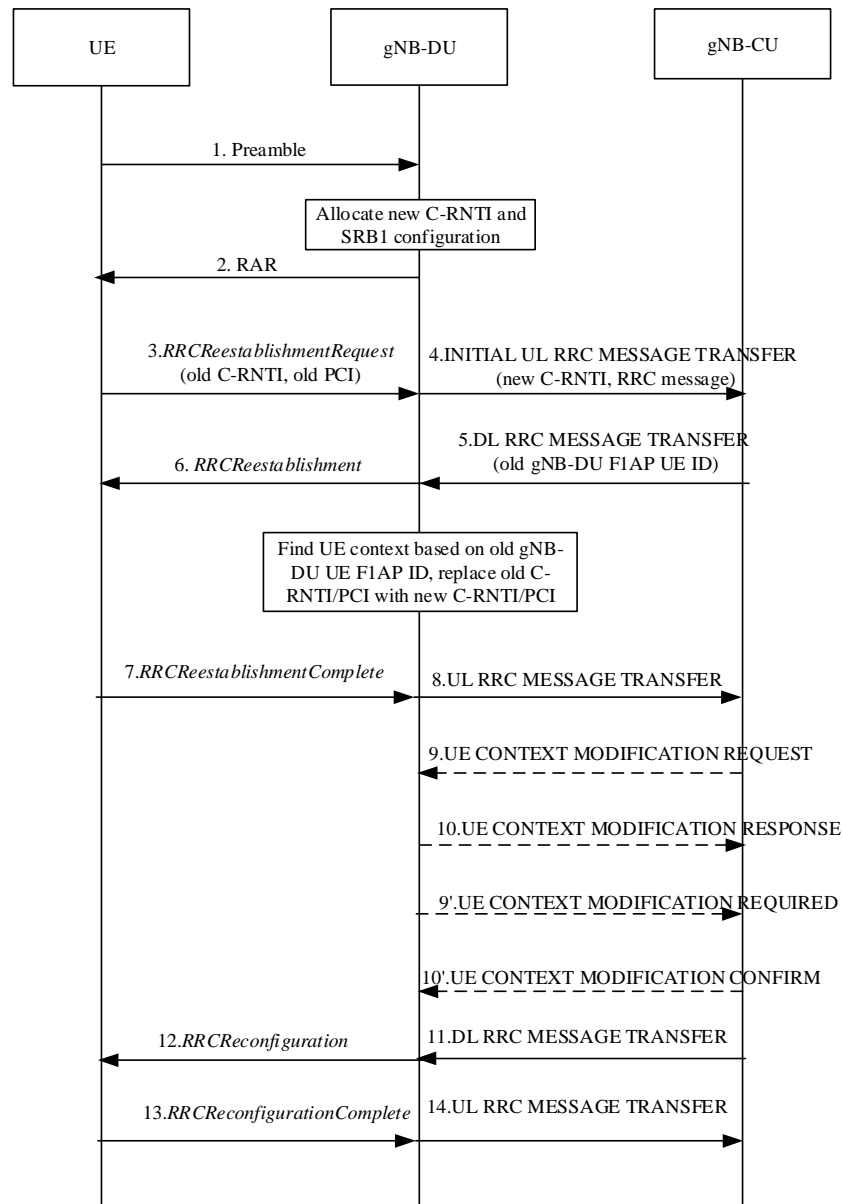

**Figure 8.7-1: RRC connection reestablishment procedure**

1. UE sends preamble to the gNB-DU.
2. The gNB-DU allocates new C-RNTI and responds UE with RAR.
3. The UE sends *RRCReestablishmentRequest* message to the gNB-DU, which contains old C-RNTI and old PCI.
4. The gNB-DU includes the RRC message and, if the UE is admitted, the corresponding low layer configuration for the UE in the INITIAL UL RRC MESSAGE TRANSFER message and transfers to the gNB-CU. The INITIAL UL RRC MESSAGE TRANSFER message should include C-RNTI.
5. The gNB-CU includes *RRCReestablishment* message and transfers to the gNB-DU. If the UE requests to re-establish RRC connection in the last serving gNB-DU, the DL RRC MESSAGE TRANSFER message shall include old gNB-DU UE F1AP ID.
6. The gNB-DU retrieves UE context based on old gNB-DU UE F1AP ID, replaces old C-RNTI/PCI with new C-RNTI/PCI. It sends *RRCReestablishment* message to UE.
- 7-8. The UE sends *RRCReestablishmentComplete* message to the gNB-DU. The gNB-DU encapsulates the RRC message in UL RRC MESSAGE TRANSFER message and sends to gNB-CU.

9-10. The gNB-CU triggers UE context modification procedure by sending UE CONTEXT MODIFICIATION REQUEST, which may include DRBs to be modified and released list. The gNB-DU responses with UE CONTEXT MODIFICATION RESPONSE message.

9'-10'. The gNB-DU triggers UE context modification procedure by sending UE CONTEXT MODIFICIATION REQUIRED, which may include DRBs to be modified and released list. The gNB-CU responses with UE CONTEXT MODIFICATION CONFIRM message.

NOTE: Here it is assumed that UE accesses from the original gNB-DU where the UE contexts are available for that UE, and either step 9-10 or step 9' and 10' may exist or both could be skipped.

NOTE: If UE accesses from a gNB-DU other than the original one, gNB-CU should trigger UE Context Setup procedure towards this new gNB-DU.

11-12. The gNB-CU includes *RRCReconfiguration* message into DL RRC MESSAGE TRANSFER message and transfers to the gNB-DU. The gNB-DU forwards it to the UE.

13-14. The UE sends *RRCReconfigurationComplete* message to the gNB-DU, and gNB-DU forwards it to the gNB-CU.

## 8.8 Multiple TNLAs for F1-C

In the following, the procedure for managing multiple TNLAs for F1-C is described.

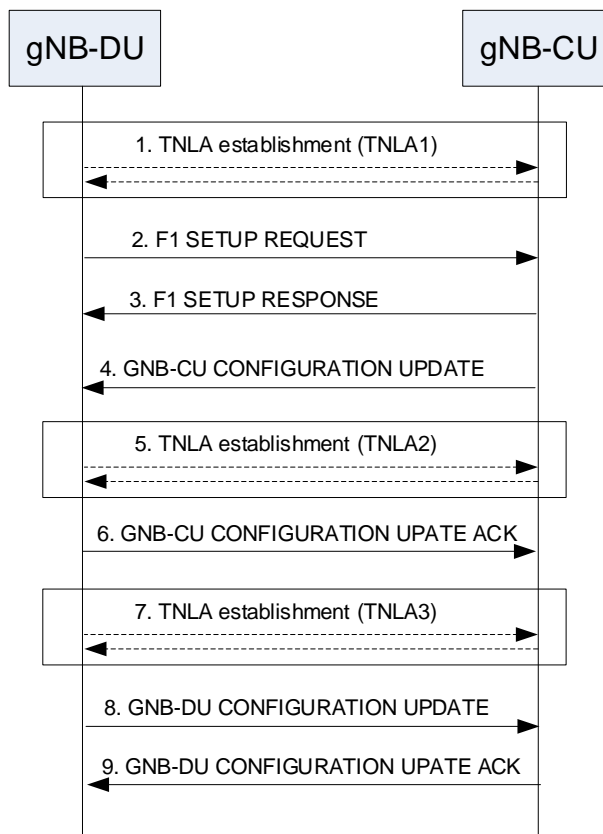

Figure 8.8-1: Managing multiple TNLAs for F1-C.

1. The gNB-DU establishes the first TNLA with the gNB-CU using a configured TNL address.

NOTE: The gNB-DU may use different source and/or destination IP end point(s) if the TNL establishment towards one IP end point fails. How the gNB-DU gets the remote IP end point(s) and its own IP address are outside the scope of this specification.

- 2-3. Once the TNLA has been established, the gNB-DU initiates the F1 Setup procedure to exchange application level configuration data
- 4-6. The gNB-CU may add additional TNL Endpoint(s) to be used for F1-C signalling between the gNB-CU and the gNB-DU pair using the gNB-CU Configuration Update procedure. The gNB-CU Configuration Update procedure also allows the gNB-CU to request the gNB-DU to modify or release TNLA(s).
- 7-9. The gNB-DU may add additional TNL association(s) to be used for F1-C signalling using a gNB-CU endpoint already in use for existing TNL associations between the gNB-CU and the gNB-DU pair. The gNB-DU CONFIGURATION UPDATE message including the gNB-DU ID shall be the first F1AP message sent on an additional TNLA of an already setup F1-C interface instance after the TNL association has become operational.

The F1AP UE TNLA binding is a binding between a F1AP UE association and a specific TNL association for a given UE. After the F1AP UE TNLA binding is created, the gNB-CU can update the UE TNLA binding by sending the F1AP message for the UE to the gNB-DU via a different TNLA. The gNB-DU shall update the F1AP UE TNLA binding with the new TNLA. The gNB-DU Configuration Update procedure also allows the gNB-DU to inform the gNB-CU that the indicated TNLA(s) will be removed by the gNB-DU.

## 8.9 Overall procedures involving E1 and F1

The following clauses describe the overall procedures involving E1 and F1.

### 8.9.1 UE Initial Access

The signalling flow for UE Initial access involving E1 and F1 is shown in Figure 8.9.1-1.

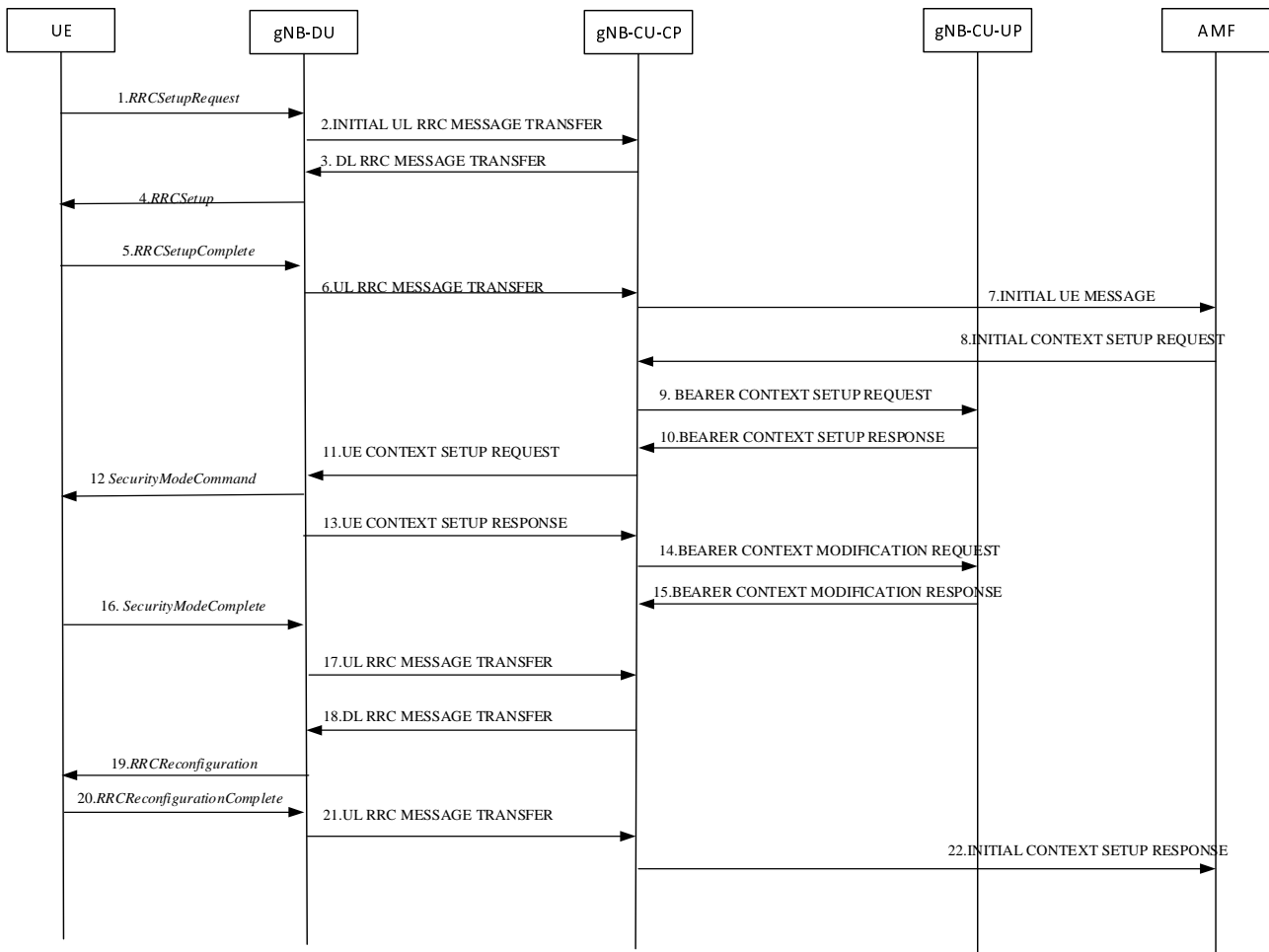

**Figure 8.9.1-1: UE Initial Access procedure involving E1 and F1**

Steps 1-8 are defined in clause 8.1.

9. The gNB-CU-CP sends the BEARER CONTEXT SETUP REQUEST message to establish the bearer context in the gNB-CU-UP.

10 The gNB-CU-UP sends the BEARER CONTEXT SETUP RESPONSE message to gNB-CU-CP, including F1-U UL TEID and transport layer address allocated by gNB-CU-UP.

Steps 11-13 are defined in clause 8.1.

14. The gNB-CU-CP sends the BEARER CONTEXT MODIFICATION REQUEST message to the gNB-CU-UP, including F1-U DL TEID and transport layer address allocated by gNB-DU.

15. The gNB-CU-UP sends the BEARER CONTEXT MODIFICATION RESPONSE message to the gNB-CU-CP.

Steps 16-22 are defined in clause 8.1.

NOTE: 14-15 and 16-17 can happen in parallel, but both are before 18.

## 8.9.2 Bearer context setup over F1-U

Figure 8.9.2-1 shows the procedure used to setup the bearer context in the gNB-CU-UP.

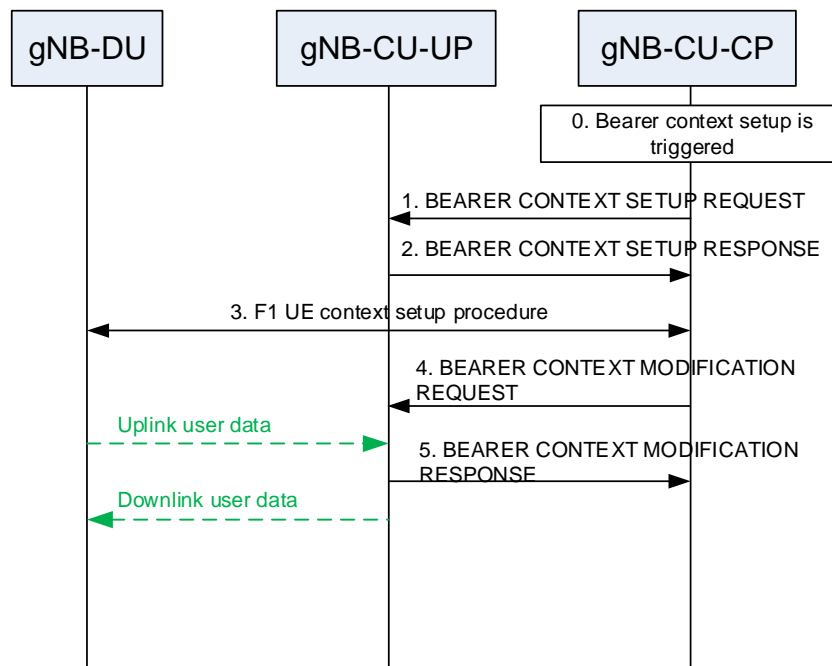

**Figure 8.9.2-1: Bearer context setup over F1-U**

0. Bearer context setup (e.g., following an SGNB ADDITION REQUEST message from the MeNB) is triggered in gNB-CU-CP.
  1. The gNB-CU-CP sends a BEARER CONTEXT SETUP REQUEST message containing UL TNL address information for S1-U or NG-U, and if required, DL TNL address information for X2-U or Xn-U to setup the bearer context in the gNB-CU-UP. For NG-RAN, the gNB-CU-CP decides flow-to-DRB mapping and sends the generated SDAP and PDCP configuration to the gNB-CU-UP.
  2. The gNB-CU-UP responds with a BEARER CONTEXT SETUP RESPONSE message containing the UL TNL address information for F1-U, and DL TNL address information for S1-U or NG-U, and if required, UL TNL address information for X2-U or Xn-U.
- NOTE: The indirect data transmission for split bearer through the gNB-CU-UP is not precluded.
3. F1 UE context setup procedure is performed to setup one or more bearers in the gNB-DU.
  4. The gNB-CU-CP sends a BEARER CONTEXT MODIFICATION REQUEST message containing the DL TNL address information for F1-U and PDCP status.
  5. The gNB-CU-UP responds with a BEARER CONTEXT MODIFICATION RESPONSE message.

## 8.9.3 Bearer context release over F1-U

### 8.9.3.1 gNB-CU-CP initiated bearer context release

Figure 8.9.3.1-1 shows the procedure used to release the bearer context in the gNB-CU-UP initiated by the gNB-CU-CP.



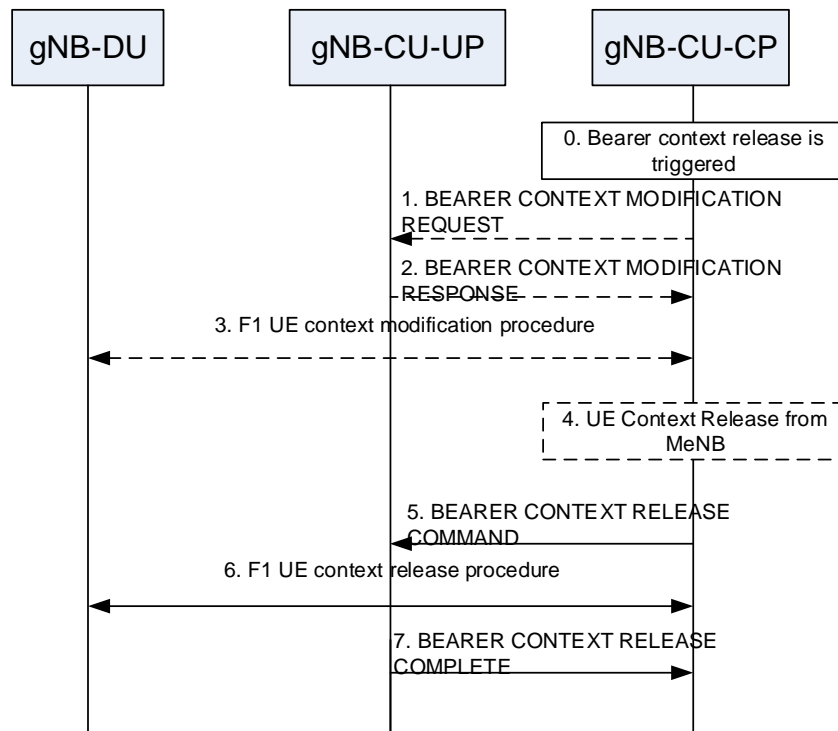
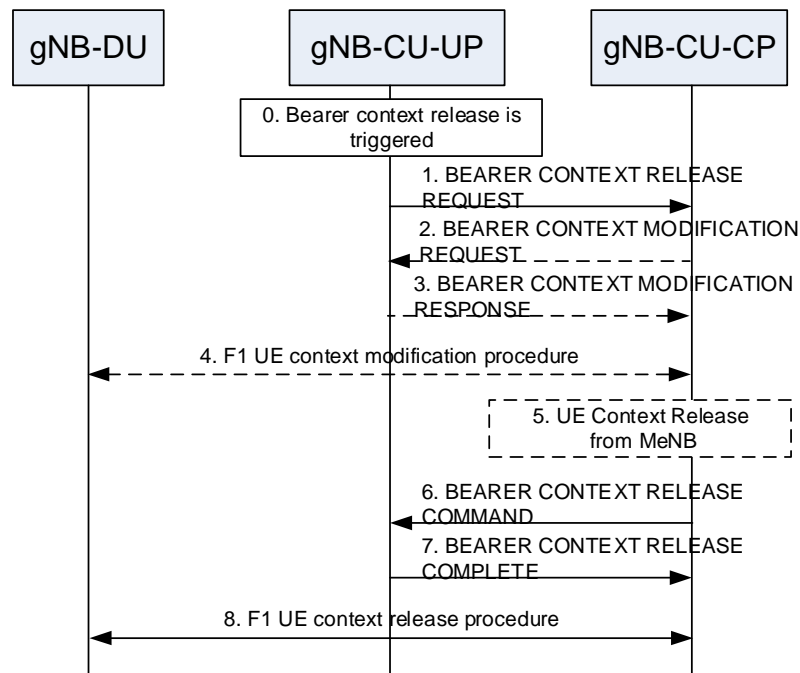

**Figure 8.9.3.1-1: Bearer context release over F1-U – gNB-CU-CP initiated**

- 0. Bearer context release (e.g., following an SGNB RELEASE REQUEST message from the MeNB) is triggered in gNB-CU-CP.
  - 1. The gNB-CU-CP sends a BEARER CONTEXT MODIFICATION REQUEST message to the gNB-CU-UP.
  - 2. The gNB-CU-UP responds with a BEARER CONTEXT MODIFICATION RESPONSE carrying the PDCP UL/DL status.
  - 3. F1 UE context modification procedure is performed to stop the data transmission for the UE. It is up to gNB-DU implementation when to stop the UE scheduling.
- NOTE: step 1-3 are performed only if the PDCP status of the bearer(s) needs to be preserved e.g., for bearer type change.
- 4. The gNB-CU-CP may receive the UE CONTEXT RELEASE message from the MeNB in EN-DC operation as described in Section 8.4.2.1.
  - 5. and 7. Bearer context release procedure is performed.
  - 6. F1 UE context release procedure is performed to release the UE context in the gNB-DU.

### 8.9.3.2 gNB-CU-UP initiated bearer context release

Figure 8.9.3.2-1 shows the procedure used to release the bearer context in the gNB-CU-UP initiated by the gNB-CU-UP.

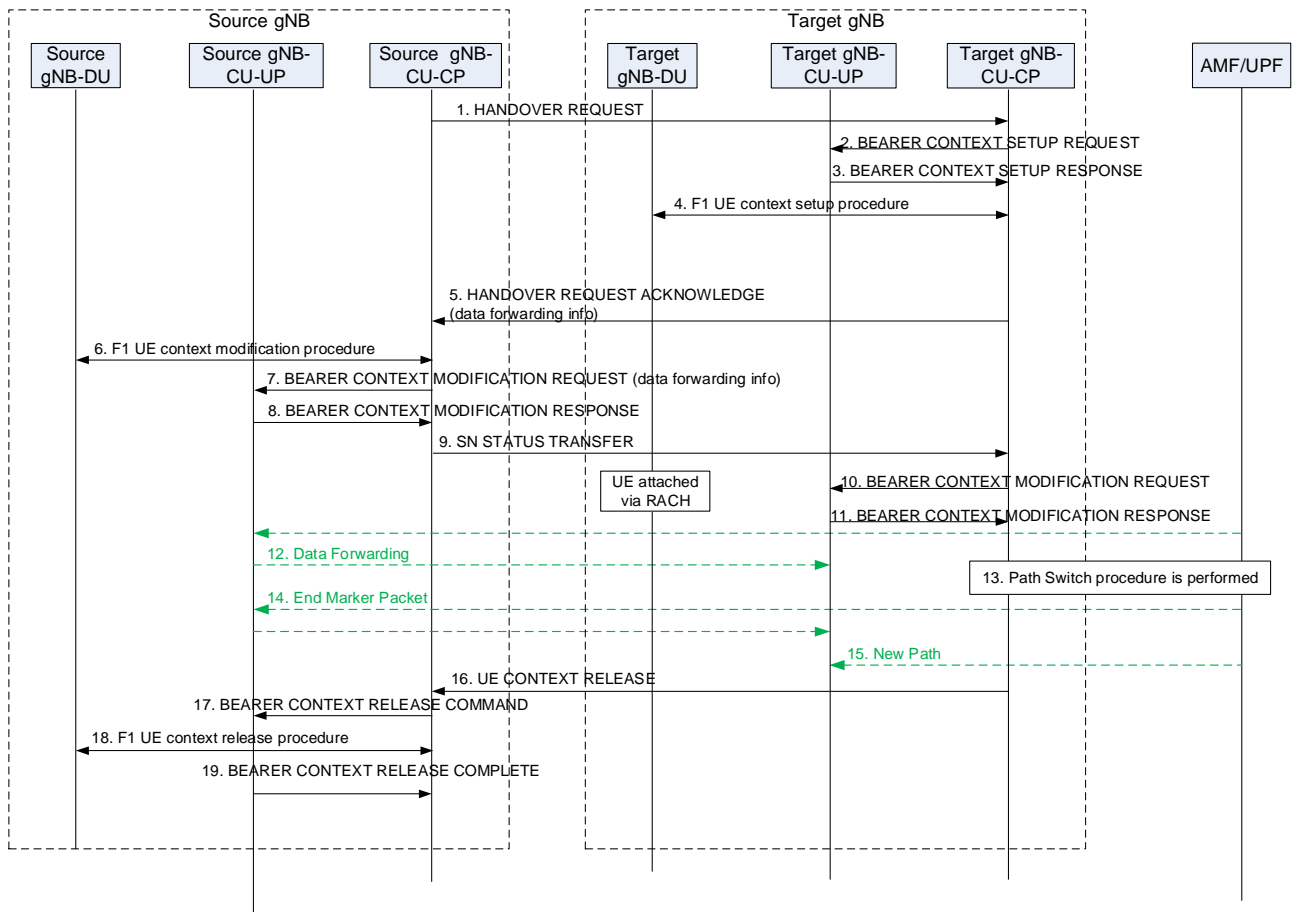

**Figure 8.9.3.2-1: Bearer context release over F1-U – gNB-CU-UP initiated**

0. Bearer context release is triggered in gNB-CU-UP e.g., due to local failure.
1. The gNB-CU-UP sends a BEARER CONTEXT RELEASE REQUEST message to request the release of the bearer context in the gNB-CU-UP. This message may contain the PDCP status.
- 2.- 5. If the PDCP status needs to be preserved, the E1 Bearer Context Modification and the F1 UE Context Modification procedures are performed. The E1 Bearer Context Modification procedure is used to convey data forwarding information to the gNB-CU-UP. The gNB-CU-CP may receive the UE Context Release from the MeNB.
6. The gNB-CU-CP sends a BEARER CONTEXT RELEASE COMMAND message to release the bearer context in the gNB-CU-UP.
7. The gNB-CU-UP responds with a BEARER CONTEXT RELEASE COMPLETE to confirm the release of the bearer context including also data forwarding information.
8. F1 UE context release procedure may be performed to release the UE context in the gNB-DU.

## 8.9.4 Inter-gNB handover involving gNB-CU-UP change

Figure 8.9.4-1 shows the procedure used for inter-gNB handover involving gNB-CU-UP change. Overall inter-gNB handover procedure is specified in TS 37.340 [12].

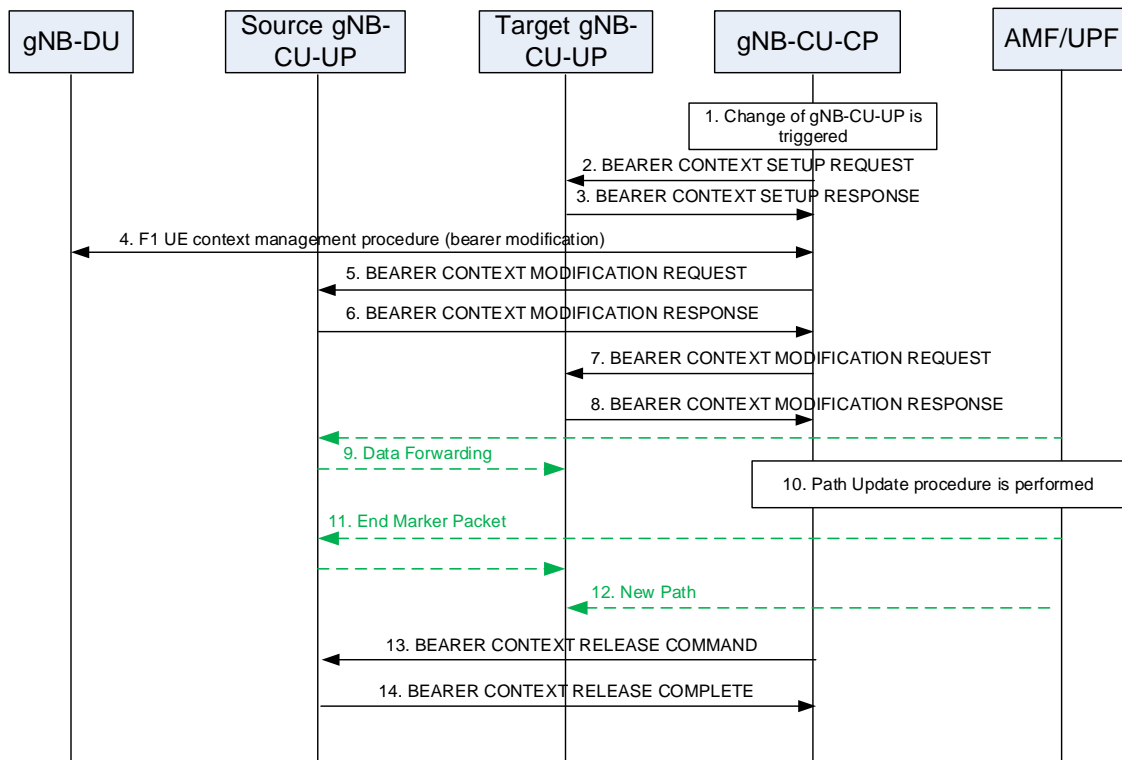

**Figure 8.9.4-1: Inter-gNB handover involving gNB-CU-UP change**

1. The source gNB-CU-CP sends HANOVER REQUEST message to the target gNB-CU-CP.
- 2-4. Bearer context setup procedure is performed as described in Section 8.9.2.
5. The target gNB-CU-CP responds the source gNB-CU-CP with an HANOVER REQUEST ACKNOWLEDGE message.
6. The F1 UE Context Modification procedure is performed to stop UL data transmission at the gNB-DU and to send the handover command to the UE.
- 7-8. Bearer context modification procedure (gNB-CU-CP initiated) is performed to enable the gNB-CU-CP to retrieve the PDCP UL/DL status and to exchange data forwarding information for the bearer.
9. The source gNB-CU-CP sends an SN STATUS TRANSFER message to the target gNB-CU-CP.
- 10-11. Bearer context modification procedure is performed as described in Section 8.9.2.
12. Data Forwarding may be performed from the source gNB-CU-UP to the target gNB-CU-UP.
- 13-15. Path Switch procedure is performed to update the DL TNL address information for the NG-U towards the core network.
16. The target gNB-CU-CP sends an UE CONTEXT RELEASE message to the source gNB-CU-CP.
17. and 19. Bearer context release procedure is performed.
18. F1 UE context release procedure is performed to release the UE context in the source gNB-DU.

### 8.9.5 Change of gNB-CU-UP

Figure 8.9.5-1 shows the procedure used for the change of gNB-CU-UP within a gNB.



**Figure 8.9.5-1: Change of gNB-CU-UP**

- Change of gNB-CU-UP is triggered in gNB-CU-CP based on e.g., measurement report from the UE.
3. Bearer Context Setup procedure is performed as described in Section 8.9.2.
4. F1 UE Context Modification procedure is performed to change the UL TNL address information for F1-U for one or more bearers in the gNB-DU.
- 5-6. Bearer Context Modification procedure (gNB-CU-CP initiated) is performed to enable the gNB-CU-CP to retrieve the PDCP UL/DL status and to exchange data forwarding information for the bearer.
- 7-8. Bearer Context Modification procedure is performed as described in Section 8.9.2.
9. Data Forwarding may be performed from the source gNB-CU-UP to the target gNB-CU-UP.
- 10-12. Path Switch procedure is performed to update the DL TNL address information for the NG-U towards the core network.
- 13-14. Bearer Context Release procedure (gNB-CU-CP initiated) is performed as described in Section 8.9.3.

## 8.9.6 RRC State transition

### 8.9.6.1 RRC Connected to RRC Inactive

The procedure for changing the UE state from RRC-connected to RRC-inactive is shown in Figure 8.9.6.1-1.

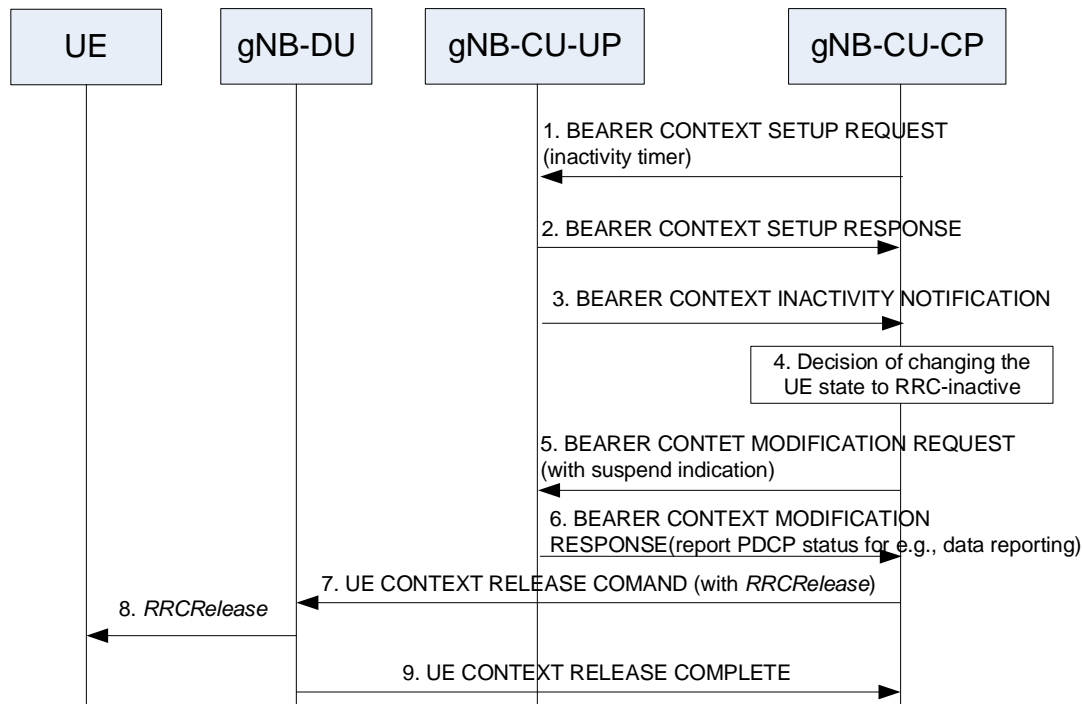

**Figure 8.9.6.1-1: RRC Connected to RRC Inactive state transition.**

1. The gNB-CU-CP sends BEARER CONTEXT SETUP REQUEST message with UE/PDU session/DRB level inactivity timer.
2. The gNB-CU-UP sends BEARER CONTEXT SETUP RESPONSE message.
3. The gNB-CU-UP sends BEARER CONTEXT INACTIVITY NOTIFICATION message with inactivity monitoring results.
4. The gNB-CU-CP determines that the UE should enter RRC-inactive (e.g., after receiving E1 Bearer Context Inactivity Notification procedure).
5. The gNB-CU-CP sends BEARER CONTEXT MODIFICATION REQUEST message with a RRC Suspend indication to the gNB-CU-UP, which indicates that the UE is entering RRC-inactive state. The gNB-CU-CP keeps the F1 UL TEIDs.
6. The gNB-CU-UP sends the BEARER CONTEXT MODIFICATION RESPONSE message including the PDCP UL and DL status that may be needed for e.g., data volume reporting. The gNB-CU-UP keeps the Bearer Context, the UE-associated logical E1-connection, the NG-U related resource (e.g., NG-U DL TEIDs) and the F1 UL TEIDs.
7. The gNB-CU-CP sends the UE CONTEXT RELEASE COMMAND message to the gNB-DU serving the UE, together with the *RRCRelease* message to be sent to the UE.

NOTE: step 5 and 7 can be performed at the same time.

8. The gNB-DU sends the *RRCRelease* message to the UE.
9. The gNB-DU sends the UE CONTEXT RELEASE COMPLETE message to the gNB-CU-CP.

### 8.9.6.2 RRC Inactive to other states

The procedure for changing the UE state from RRC-inactive to RRC-connected is shown in Figure 8.9.6.2-1.

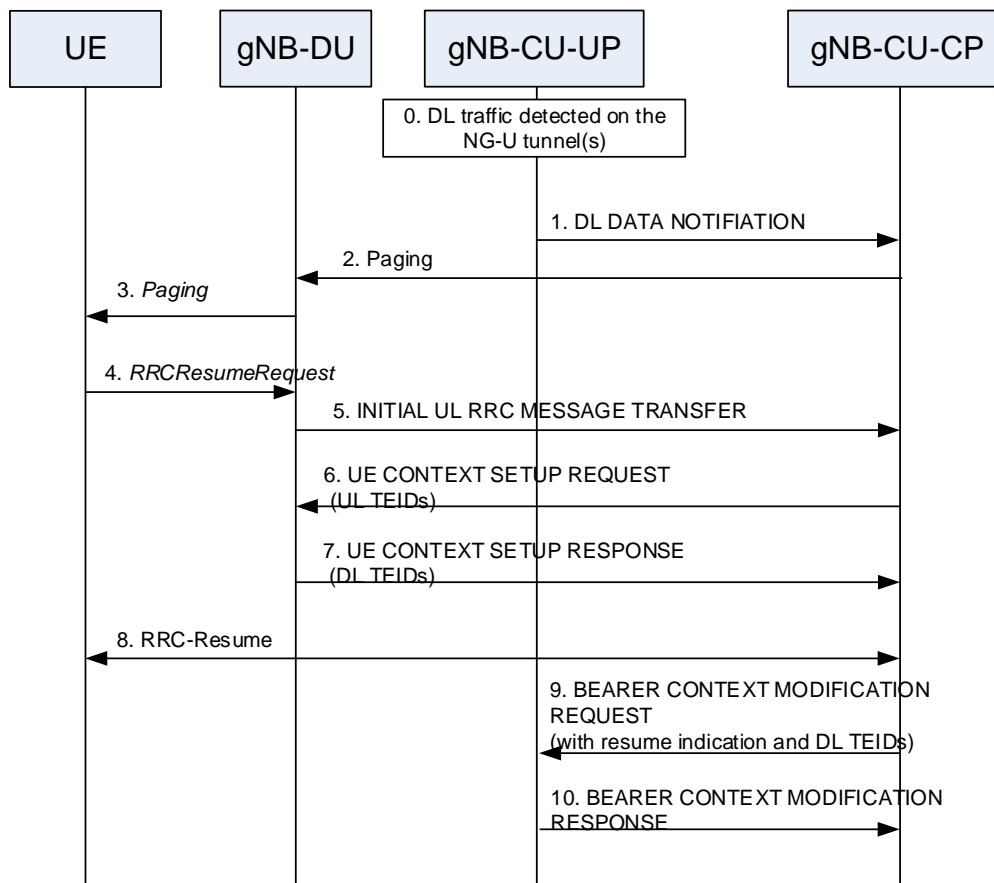

**Figure 8.9.6.2-1: RRC Inactive to RRC Connected state transition.**

0. The gNB-CU-UP receives DL data on NG-U interface.
  1. The gNB-CU-UP sends DL DATA NOTIFICATION message to the gNB-CU-CP.
  2. The gNB-CU-CP initiates PAGING procedure.
  3. The gNB-DU sends the *Paging* message to the UE.
- NOTE: step 0-3 are needed only in case of DL data.
4. The UE sends *RRCResumeRequest* message either upon RAN paging or UL data arrival.
  5. The gNB-DU sends the INITIAL UL RRC MESSAGE TRANSFER message to the gNB-CU-CP.
  6. The gNB-CU-CP sends UE CONTEXT SETUP REQUEST message including the stored F1 UL TEIDs to create the UE context in the gNB-DU.
  7. The gNB-DU responds with the UE CONTEXT SETUP RESPONSE message including the F1 DL TEIDs allocated for the DRBs.
  8. The gNB-CU-CP and the UE perform the RRC-Resume procedure via the gNB-DU.
  9. The gNB-CU-CP sends BEARER CONTEXT MODIFICATION REQUEST message with a RRC Resume indication, which indicates that the UE is resuming from RRC-inactive state. The gNB-CU-CP also includes the F1 DL TEIDs received from the gNB-DU in step 7.
  10. The gNB-CU-UP responds with the BEARER CONTEXT MODIFICATION RESPONSE message.

NOTE steps 8 and 9 can be performed in parallel.

## 8.10 Multiple TNLAs for E1

In the following, the procedure for managing multiple TNLAs for E1 is described.

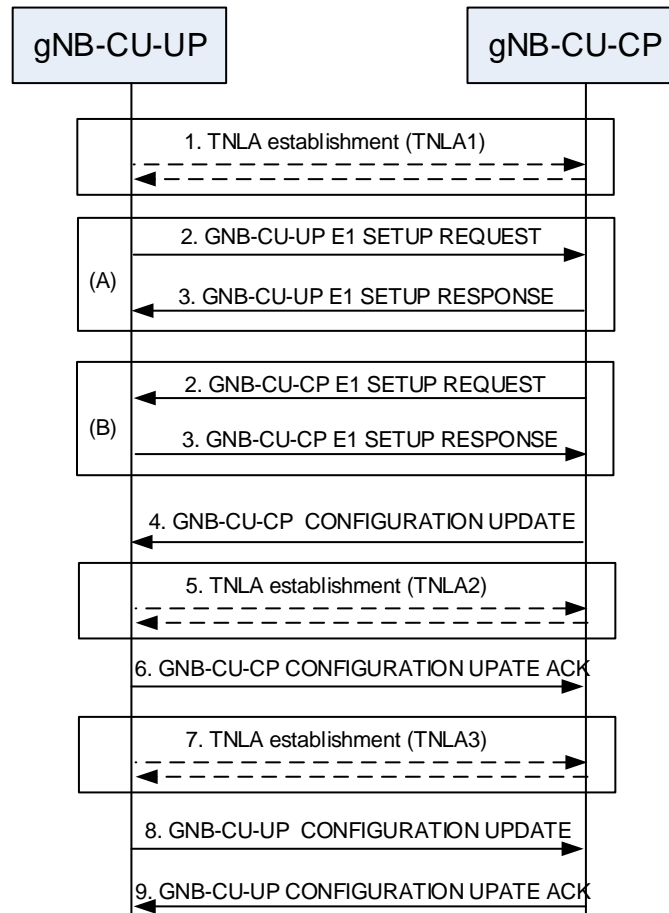

**Figure 8.10-1: Managing multiple TNLAs for E1.**

1. Either the gNB-CU-CP or gNB-CU-UP establishes the first SCTP association with the gNB-CU-UP or gNB-CU-CP respectively using a configured TNL address.

**NOTE:** The gNB-CU-UP/gNB-CU-CP may use different source and/or destination IP end point(s) if the TNL establishment towards one IP end point fails. How the gNB-CU-UP/gNB-CU-CP gets the remote IP end point(s) and its own IP address are outside the scope of this specification.

- 2-3 (A). Once the TNLA (gNB-CU-UP initiated) has been established, the gNB-CU-UP initiates the E1 Setup procedure to exchange application level configuration data

- 2-3 (B). Once the TNLA (gNB-CU-CP initiated) has been established, the gNB-CU-CP initiates the E1 Setup procedure to exchange application level configuration data

- 4-6. The gNB-CU-CP may add additional SCTP Endpoint(s) to be used for E1 signalling between the gNB-CU-CP and the gNB-CU-UP pair using the gNB-CU-CP Configuration Update procedure. The gNB-CU-CP Configuration Update procedure also allows the gNB-CU-CP to request the gNB-CU-UP to modify or release TNLA(s).

- 7-9. The gNB-CU-UP may add additional TNL association(s) to be used for E1 signalling using a gNB-CU-CP endpoint already in use for existing TNL associations between the gNB-CU-CP and the gNB-CU-UP pair. The gNB-CU-UP CONFIGURATION UPDATE message including the gNB-CU-UP ID shall be the first E1AP message sent on an additional TNLA of an already setup E1 interface instance after the TNL association has become operational. The E1AP UE TNLA binding is a binding between a E1AP UE association and a specific TNL association for a given UE. After the E1AP UE TNLA binding is created, the gNB-CU-CP can update the UE TNLA binding by sending the E1AP message for the UE to the gNB-CU-UP via a different TNLA. The

gNB-CU-UP shall update the E1AP UE TNLA binding with the new TNLA. The gNB-CU-UP Configuration Update procedure also allows the gNB-CU-UP to inform the gNB-CU-CP that the indicated TNLA(s) will be removed by the gNB-CU-UP.

## 8.11 Support of Network Sharing with multiple cell-ID broadcast

### 8.11.1 General

This section describes necessary additions as compared to the case where network sharing with multiple cell-ID broadcast is not applied.

The signalling flows in the subsequent sections assuming 2 sharing operators, A and B. The F1-C signalling transport deployment used is indicated within the subsequent sections.

### 8.11.2 Initial Registration – separate PLMN signalling

The signalling flow for Initial Registration for network sharing with multiple cell-ID broadcast with separate per-PLMN signalling is shown in Figure 8.11.2-1.

In this example message flow

- the UE is assumed to not provide an ue-Identity from which the DU is able to deduce the PLMN ID.
- each F1-C interface instance uses a separate signalling transport or share signalling transport with other F1-C interface instances.- the gNB-DU<sub>A/B</sub> entity shown in Figure 8.11.2-1 is a simplified representation of the gNB-DU<sub>A</sub> of PLMN A, the gNB DU<sub>B</sub> of PLMN B and respective radio resources of the shared cell.

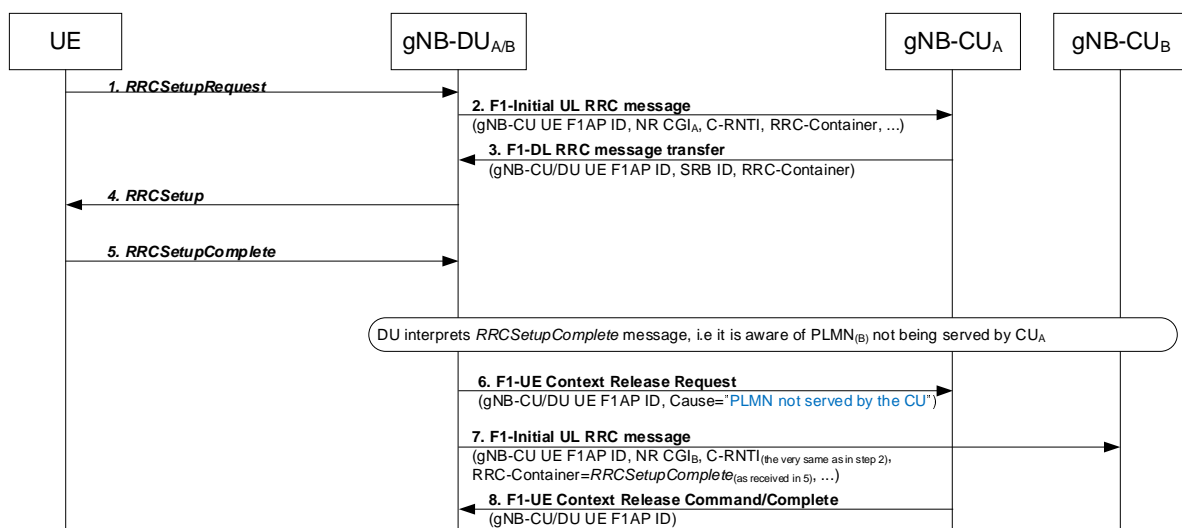

**Figure 8.11.2-1: UE Initial Access procedure and network sharing with multiple cell-ID broadcast**

NOTE: Steps 1-5 are defined in clause 8.1. Note, that the selectedPLMN-Identity is provided in step 5.

- The gNB-DU<sub>A</sub> sends the F1AP UE CONTEXT RELEASE REQUEST message to the gNB-CU<sub>A</sub>, including a Cause set to “PLMN not served by the CU”.
- The gNB-DU<sub>B</sub> sends the F1AP INITIAL UL RRC MESSAGE to the gNB-CU<sub>B</sub>, including the NR CGI associated with PLMN<sub>B</sub>, the C-RNTI indicated by the gNB-DU<sub>A</sub> at step 2, and the RRC-Container with the RRC message received in step 5.
- The gNB-CU<sub>A</sub> triggers the F1AP UE Context Release procedure.

NOTE: Initiating procedures from gNB-DU<sub>A</sub> towards gNB-CU<sub>A</sub> and from gNB-DU<sub>B</sub> to gNB-CU<sub>B</sub> in parallel is not precluded.



### 8.11.3 RRC Connection Reestablishment – separate PLMN signalling

The signalling flow for RRC Connection Reestablishment for network sharing with multiple cell-ID broadcast with separate per-PLMN signalling is shown in Figure 8.11.3-1.

In this example message flow

- each F1-C/Xn-C interface instance uses either a separate signalling transport or share signalling transport with other interface instances.
- the New gNB-DU<sub>A/B</sub> entity shown in Figure 8.11.3-1 is a simplified representation of the New gNB-DU<sub>A</sub> of PLMN A, the New gNB DU<sub>B</sub> of PLMN B and respective radio resources of the shared cell.

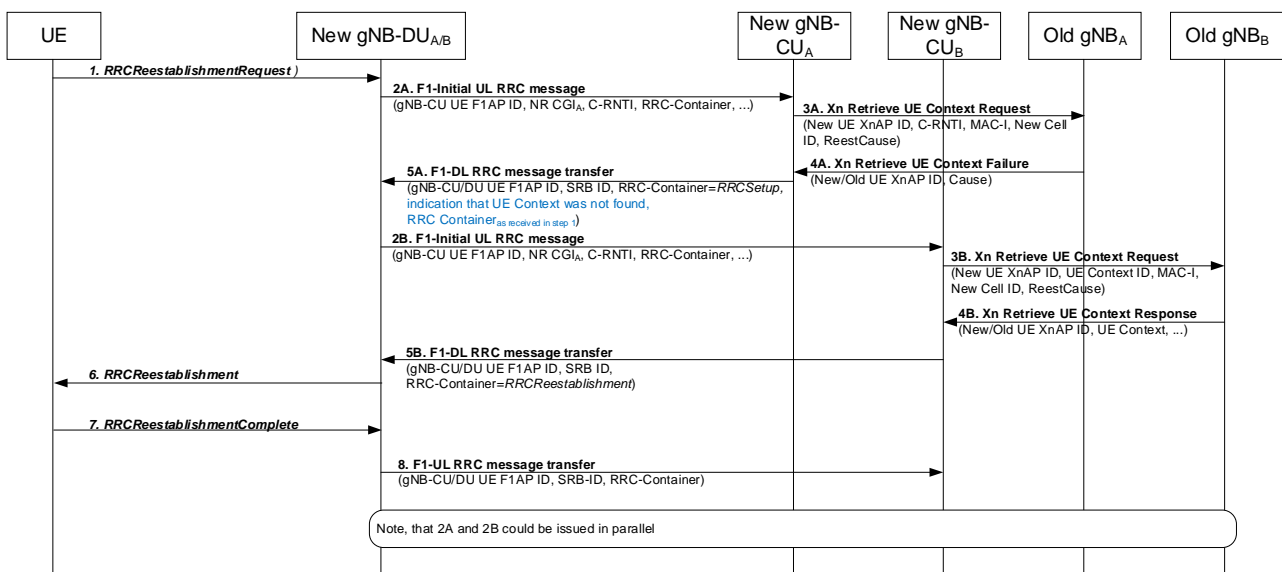

**Figure 8.11.3-1: RRC Connection Reestablishment and network sharing with multiple cell-ID broadcast**

1. The UE sends the RRCReestablishmentRequest.

2A-5A. Depicts the case where the UE context could not be retrieved by the new gNB-CU<sub>A</sub>. In step 2A, the NR CGI associated to PLMN<sub>A</sub> is indicated. In step 5A, the gNB-CU<sub>A</sub> would prepare the possibility to revert back to normal RRC Connection Establishment, indicating that the UE Context was not retrievable and may include the re-directed RRC message as received in step 1. If the New gNB-DU<sub>A/B</sub> was not able to deduce the RRC message from step 1, this indicator triggers step 2B. The New gNB-DU<sub>A</sub> is supposed to trigger the release the UE-associated signalling connection (not shown).

2B-5B. Depicts the case where the UE context was retrievable by the new gNB-CU<sub>B</sub>. In step 2B, the NR CGI associated to PLMN<sub>B</sub> is indicated. 2B also includes the C-RNTI allocated at reception of step 1.

6-8. The RRC Connection Reestablishment continues with the New gNB-CU<sub>B</sub>.

NOTE: If all gNB-CUs indicate that the UE context is not retrievable, the RRC connection reestablishment falls back to RRC Connection setup, as described in section 8.11.2.

### 8.11.4 Support of shared signalling transport

This section specifies for F1-C, Xn-C and, in case of EN-DC, for X2-C, how an interface instance is identified in case of network sharing with multiple cell ID broadcast with shared signalling transport.

For UE associated signalling, the interface instance is identified by assigning on F1-C appropriate UE F1AP IDs, on Xn-C appropriate UE XnAP IDs and on X2-C appropriate UE X2AP IDs.

For non-UE associated signalling, the interface instance is identified on F1-C by the assigning an appropriate value to the Transaction ID, on Xn-C and X2-C by including the Interface Instance Indication in the respective message and assigning an appropriate value to it.

---

## 9 Synchronization

### 9.1 gNB Synchronization

The gNB shall support a logical synchronization port for phase-, time- and/or frequency synchronization.

Logical synchronization port for phase- and time-synchronization shall provide:

- 1) accuracy that allows to meet the gNB requirements on maximum relative phase difference for all gNBs in synchronized TDD-unicast area;
- 2) continuous time without leap seconds traceable to common time reference for all gNBs in synchronized TDD-unicast area.

A logical synchronization port for phase- and time-synchronization may also be provided for e.g., all gNBs in FDD time domain inter-cell interference coordination synchronization area.

Furthermore common SFN initialization time shall be provided for all gNBs in synchronized TDD-unicast area.

Based on this information, the gNB may derive the SFN according to the following formula:

$$SFN = \{time\} \bmod \{period(SFN)\},$$

where:

time	time adjusted by the common SFN initialization time, in units of 10 ms to match the length of radio frame and accuracy accordingly;
period(SFN)	SFN period.

In case gNB is connected via TDM interface, it may be used to frequency synchronize the gNB. The characteristics of the clock in the gNB shall be designed taking into account that the jitter and wander performance requirements on the interface are in accordance with network limits for output wander at traffic interfaces of either ITU-T Recommendation G.823 [8], ITU-T Recommendation G.824 [9] or network limits for the maximum output jitter and wander at any hierarchical interface of ITU-T Recommendation G.825 [10], whichever is applicable.

In case gNB is connected via Ethernet interface and the network supports Synchronous Ethernet, the gNB may use this interface to get frequency synchronization. In this case the design of the gNB clock should be done considering the jitter and wander performance requirements on the interface are as specified for output jitter and wander at EEC interfaces of ITU-T Recommendation G.8261/Y.1361 [11], defined in clause 9.2.1. Further considerations on Synchronous Ethernet recommendations and architectural aspects are defined in clause 12.2.1 and Annex A of ITU-T Recommendation G.8261/Y.1361 [11].

A configurable LTE TDD-offset of start frame shall be supported by all gNBs in synchronized TDD-unicast areas in order to achieve interoperability in coexistence scenarios.

---

## 10 NG-RAN interfaces

### 10.1 NG interface

3GPP TS 38.410 [14] specifies NG interface general aspects and principles.

## 10.2 Xn interface

3GPP TS 38.420 [15] specifies Xn interface general aspects and principles.

## 10.3 F1 interface

3GPP TS 38.470 [16] specifies F1 interface general aspects and principles.

## 10.4 E1 interface

3GPP TS 38.460 [17] specifies E1 interface general aspects and principles.

## 10.5 Antenna interface - general principles

The Iuant interface for the control of RET antennas or TMAs is a logical part of the NG-RAN.

The support of any standardised antenna interface technique shall not be prevented; e.g. AISG (Antenna interface standards group) specifications may be used.

# 11 Overall procedures in NG-RAN Architecture

## 11.1 Multiple TNLAs for Xn-C

In the following, the procedure for managing multiple TNLAs for Xn-C is described.

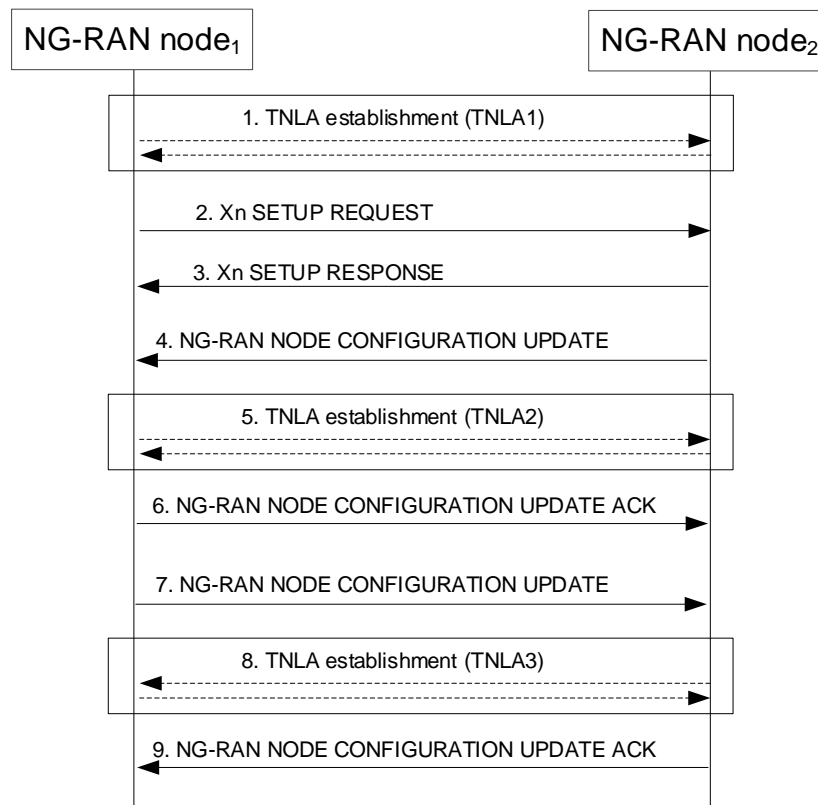

**Figure 11.1-1: Managing multiple TNLAs for Xn-C.**

1. The NG-RAN node<sub>1</sub> establishes the first TNLA with the NG-RAN node<sub>2</sub> using a configured TNL address.

NOTE: The NG-RAN node<sub>1</sub> may use different source and/or destination IP end point(s) if the TNL establishment towards one IP end point fails. How the NG-RAN node<sub>1</sub> gets the remote IP end point(s) and its own IP address are outside the scope of this specification.

- 2-3. Once the TNLA has been established, the NG-RAN node<sub>1</sub> initiates the Xn Setup procedure to exchange application level configuration data
- 4-6. The NG-RAN node<sub>2</sub> may add additional TNL Endpoint(s) to be used for Xn-C signalling between the NG-RAN node<sub>1</sub> and the NG-RAN node<sub>2</sub> pair using the NG-RAN node Configuration Update procedure. NG-RAN node Configuration Update procedure also allows the NG-RAN node<sub>2</sub> to request the NG-RAN node<sub>1</sub> to modify or release TNLA(s).
- 7-9. The NG-RAN node<sub>1</sub> may add additional TNL Endpoint(s) to be used for Xn-C signalling between the NG-RAN node<sub>1</sub> and the NG-RAN node<sub>2</sub> pair using the NG-RAN node Configuration Update procedure. NG-RAN node Configuration Update procedure also allows the NG-RAN node<sub>1</sub> to request the NG-RAN node<sub>2</sub> to modify or release TNLA(s).

## Annex A (informative): Deployment scenarios of gNB/en-gNB

Figure A-1 shows logical nodes (CU-C, CU-U and DU), internal to a logical gNB/en-gNB. Protocol terminations of the NG and Xn interfaces are depicted as ellipses in Figure A-1. The terms "Central Entity" and "Distributed Entity" shown in Figure A-1 refer to physical network nodes.

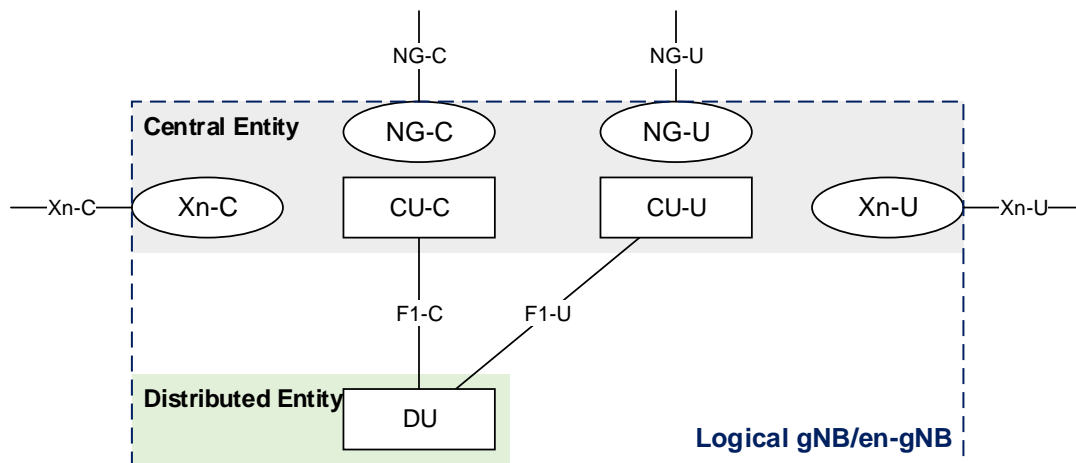

Figure A-1: Example deployment of an Logical gNB/en-gNB

---

## Annex B: NG-RAN Architecture for Radio Access Network Sharing with multiple cell ID broadcast (informative)

Each gNB-DU serving a cell identified by a Cell Identity associated with a subset of PLMNs is connected to a gNB-CU via a single F1-C interface instance.

Each F1-C interface instance is setup individually.

F1-C interface instances terminating at gNB-DUs which share the same physical radio resources may share the same F1-C signalling transport resources. If this option is applied,

- non-UE associated signalling is associated to an F1-C interface instance by allocating the corresponding Transaction ID from a value range associated to that F1-C interface instance.
- node related, non-UE associated F1-C interface signalling may provide information destined for multiple logical nodes in a single F1AP procedure instance once the F1-C interface instance is setup.

NOTE 1: If the Interface Instance Indication corresponds to more than one interface instance, the respective F1AP message carries information destined for multiple logical nodes.

- a UE associated signalling connection is associated to an F1-C interface instance by allocating values for the corresponding gNB-DU UE F1AP ID and gNB-CU UE F1AP ID so that they can be mapped to that interface instance.

NOTE 2: One possible implementation is to partition the value ranges of the gNB-DU UE F1AP ID and gNB-CU UE F1AP ID and associate each value range with an F1-C interface instance.

Interpreting the content of RRC MSG3 and other unciphered RRC message by the gNB-DU is supported.

Content for System Information Broadcast is assumed to be coordinated among the sharing PLMNs. PLMN specific SIB1 content is controlled by the respective PLMN owner. Non PLMN specific content needs coordination to avoid contradicting indication by PLMN specific gNB-CUs. For Warning messages (SIB6, SIB7 and SIB8), if provided by more than one gNB-CU, warning message duplicates are identified by provision of the Message Number and the Serial Number by the gNB-CU and don't trigger new broadcast or replace existing broadcast. Other coordination between gNB-CUs is ensured by appropriate implementation.

## Annex C (informative): Change History

Change history							
Date	Meeting	TDoc	CR	Rev	Cat	Subject/Comment	New version
2017-04	RAN3#95bis	R3-171307				First Draft	0.0.1
2017-05	RAN3#96	R3-171962				Reflected agreed TP in RAN3#96. Added new Clause 8 for overall procedure for gNB-CU/DU architecture	0.1.0
2017-06	RAN3#NR Ad Hoc	R3-172634				Reflected agreed TP in RAN3#NR Ad Hoc in 2017-06 (Qingdao)	0.2.0
2017-08	RAN3#97	R3-173449				Reflected agreed TP in RAN3#97	0.3.0
2017-10	RAN3#97bis	R3-174237				Reflected agreed TP in RAN3#97bis	0.4.0
2017-10	RAN3#97bis	R3-174258				Removed subclauses under 10.3 (moved to 38.470)	0.4.1
2017-11	RAN3#98	R3-175054				Reflected agreed TP in RAN3#98	0.5.0
2017-12	RP-78	RP-172545				Submit to RAN Plenary#78 for approval	1.0.0
2017-12	RP-78					TR Approved by RAN plenary	15.0.0
2018-03	RP-79	RP-180468	0007	1	-	Correction on intra-gNB-DU handover	15.1.0
2018-06	RP-80	RP-181237	0001	5	B	Introduction of SA NR (38.401 Baseline CR covering RAN3 agreements)	15.2.0
2018-06	RP-80	RP-181240	0008	4	B	Introduction of Separation of CP and UP for Split Option 2 (38.401 Baseline CR covering RAN3 agreements)	15.2.0
2018-06	RP-80	RP-181238	0012	1	F	CR to TS38.401 on UL blockage	15.2.0
2018-06	RP-80	RP-181238	0014	1	F	CR to 38.401 on DL User Data to DU	15.2.0
2018-06	RP-80	RP-181238	0016	-	F	TP for 38.401 in supporting full configuration	15.2.0
2018-09	RP-81	RP-181922	0022	2	F	NR Corrections (38.401 Baseline CR covering RAN3-101 agreements)	15.3.0
2018-12	RP-82	RP-182707	0023	3	F	NR Corrections (TS 38.401 Baseline CR covering RAN3-101Bis and RAN3-102 agreements)	15.4.0
2019-03	RP-83	RP-190554	0025	-	F	Correction to Intra-gNB-CU mobility	15.5.0
2019-03	RP-83	RP-190560	0026	1	F	Correction from Rapporteur for 38.401	15.5.0
2019-03	RP-83	RP-190554	0037	1	F	About Cells Failed to be Activated IE	15.5.0
2019-07	RP-84	RP-191394	0039	3	F	Correction of AMF set related statements	15.6.0
2019-07	RP-84	RP-191395	0063	1	F	CR to 38.401 on Multiple TNLAs for F1-C and E1	15.6.0
2019-07	RP-84	RP-191395	0065		F	Multiple TNLAs for Xn-C	15.6.0
2019-07	RP-84	RP-191502	0043	2	F	Clarify the support for multiple TNLAs for F1-C	15.6.0
2019-07	RP-84	RP-191397	0067	1	F	RAN sharing with multiple Cell ID broadcast	15.6.0
2019-07	RP-84	RP-191396	0068	1	F	Procedure description on optional IEs in CU to DU RRC information IE.	15.6.0

---

# History

<b>Document history</b>		
V15.2.0	July 2018	Publication
V15.3.0	September 2018	Publication
V15.4.0	April 2019	Publication
V15.5.0	May 2019	Publication
V15.6.0	July 2019	Publication