

ETSI TS 138 401 V16.2.0 (2020-07)



**5G;
NG-RAN;
Architecture description
(3GPP TS 38.401 version 16.2.0 Release 16)**



Reference

RTS/TSGR-0338401vg20

Keywords

5G

ETSI

650 Route des Lucioles
F-06921 Sophia Antipolis Cedex - FRANCE

Tel.: +33 4 92 94 42 00 Fax: +33 4 93 65 47 16

Siret N° 348 623 562 00017 - NAF 742 C
Association à but non lucratif enregistrée à la
Sous-Préfecture de Grasse (06) N° 7803/88

Important notice

The present document can be downloaded from:

<http://www.etsi.org/standards-search>

The present document may be made available in electronic versions and/or in print. The content of any electronic and/or print versions of the present document shall not be modified without the prior written authorization of ETSI. In case of any existing or perceived difference in contents between such versions and/or in print, the prevailing version of an ETSI deliverable is the one made publicly available in PDF format at www.etsi.org/deliver.

Users of the present document should be aware that the document may be subject to revision or change of status.

Information on the current status of this and other ETSI documents is available at

<https://portal.etsi.org/TB/ETSIDeliverableStatus.aspx>

If you find errors in the present document, please send your comment to one of the following services:

<https://portal.etsi.org/People/CommitteeSupportStaff.aspx>

Copyright Notification

No part may be reproduced or utilized in any form or by any means, electronic or mechanical, including photocopying and microfilm except as authorized by written permission of ETSI.

The content of the PDF version shall not be modified without the written authorization of ETSI.

The copyright and the foregoing restriction extend to reproduction in all media.

© ETSI 2020.

All rights reserved.

DECT™, **PLUGTESTS™**, **UMTS™** and the ETSI logo are trademarks of ETSI registered for the benefit of its Members.

3GPP™ and **LTE™** are trademarks of ETSI registered for the benefit of its Members and of the 3GPP Organizational Partners.

oneM2M™ logo is a trademark of ETSI registered for the benefit of its Members and of the oneM2M Partners.

GSM® and the GSM logo are trademarks registered and owned by the GSM Association.

Intellectual Property Rights

Essential patents

IPRs essential or potentially essential to normative deliverables may have been declared to ETSI. The information pertaining to these essential IPRs, if any, is publicly available for **ETSI members and non-members**, and can be found in ETSI SR 000 314: "*Intellectual Property Rights (IPRs); Essential, or potentially Essential, IPRs notified to ETSI in respect of ETSI standards*", which is available from the ETSI Secretariat. Latest updates are available on the ETSI Web server (<https://ipr.etsi.org/>).

Pursuant to the ETSI IPR Policy, no investigation, including IPR searches, has been carried out by ETSI. No guarantee can be given as to the existence of other IPRs not referenced in ETSI SR 000 314 (or the updates on the ETSI Web server) which are, or may be, or may become, essential to the present document.

Trademarks

The present document may include trademarks and/or tradenames which are asserted and/or registered by their owners. ETSI claims no ownership of these except for any which are indicated as being the property of ETSI, and conveys no right to use or reproduce any trademark and/or tradename. Mention of those trademarks in the present document does not constitute an endorsement by ETSI of products, services or organizations associated with those trademarks.

Legal Notice

This Technical Specification (TS) has been produced by ETSI 3rd Generation Partnership Project (3GPP).

The present document may refer to technical specifications or reports using their 3GPP identities. These shall be interpreted as being references to the corresponding ETSI deliverables.

The cross reference between 3GPP and ETSI identities can be found under <http://webapp.etsi.org/key/queryform.asp>.

Modal verbs terminology

In the present document "**shall**", "**shall not**", "**should**", "**should not**", "**may**", "**need not**", "**will**", "**will not**", "**can**" and "**cannot**" are to be interpreted as described in clause 3.2 of the [ETSI Drafting Rules](#) (Verbal forms for the expression of provisions).

"**must**" and "**must not**" are **NOT** allowed in ETSI deliverables except when used in direct citation.

Contents

Intellectual Property Rights	2
Legal Notice	2
Modal verbs terminology.....	2
Foreword.....	6
1 Scope	7
2 References	7
3 Definitions and abbreviations.....	8
3.1 Definitions	8
3.2 Abbreviations	9
4 General principles	9
5 General architecture	10
5.1 General	10
5.2 User plane.....	10
5.3 Control plane.....	11
6 NG-RAN architecture.....	12
6.1 Overview	12
6.1.1 Overall Architecture of NG-RAN.....	12
6.1.2 Overall architecture for separation of gNB-CU-CP and gNB-CU-UP	13
6.1.3 Overall Architecture of IAB	14
6.1.4 Protocol stacks of IAB	15
6.2 NG-RAN identifiers	16
6.2.1 Principle of handling Application Protocol Identities.....	16
6.2.2 gNB-DU ID	18
6.2.3 ng-eNB-DU ID	18
6.3 Transport addresses	18
6.4 UE associations in NG-RAN Node	18
7 NG-RAN functions description.....	19
7.0 General	19
7.1 NG-RAN sharing.....	19
7.2 Remote Interference Management	19
7.3 Cross-Link Interference Management.....	19
7.4 Support for Non-Public Networks.....	20
7.5 RACH Optimisation Function.....	20
8 Overall procedures in gNB-CU/gNB-DU Architecture	20
8.1 UE Initial Access.....	20
8.2 Intra-gNB-CU Mobility.....	21
8.2.1 Intra-NR Mobility.....	21
8.2.1.1 Inter-gNB-DU Mobility	21
8.2.1.2 Intra-gNB-DU handover	23
8.2.2 EN-DC Mobility	25
8.2.2.1 Inter-gNB-DU Mobility using MCG SRB	25
8.2.2.2 Inter-gNB-DU Mobility using SCG SRB (SRB3)	27
8.2.2.3 Inter-gNB-DU Conditional PSCell Change using MCG SRB without MN negotiation.....	27
8.2.3 Intra-CU topology adaptation procedure	29
8.2.3.1 Intra-CU topology adaptation procedure in SA.....	29
8.2.3.2 Intra-CU topology adaptation procedure in NSA using MCG SRB.....	32
8.2.3.3 Intra-CU topology adaptation procedure in NSA using SCG SRB (SRB3).....	33
8.2.4 Intra-CU topological redundancy procedure.....	33
8.2.5 Intra-CU Backhaul RLF recovery for IAB-nodes in SA mode.....	36
8.3 Mechanism of centralized retransmission of lost PDUs.....	36
8.3.1 Centralized Retransmission in Intra gNB-CU Cases	36

8.4	Multi-Connectivity operation	38
8.4.1	Secondary Node Addition.....	38
8.4.1.1	EN-DC	38
8.4.2	Secondary Node Release (MN/SN initiated)	38
8.4.2.1	EN-DC	38
8.4.3	SCG suspend/resume in RRC_INACTIVE	40
8.5	F1 Startup and cells activation	41
8.6	RRC state transition.....	42
8.6.1	RRC connected to RRC inactive.....	42
8.6.2	RRC inactive to other states.....	43
8.7	RRC connection reestablishment	44
8.8	Multiple TNLAs for F1-C	46
8.9	Overall procedures involving E1 and F1	47
8.9.1	UE Initial Access	47
8.9.2	Bearer context setup over F1-U	48
8.9.3	Bearer context release over F1-U	49
8.9.3.1	gNB-CU-CP initiated bearer context release	49
8.9.3.2	gNB-CU-UP initiated bearer context release	50
8.9.4	Inter-gNB handover involving gNB-CU-UP change.....	51
8.9.5	Change of gNB-CU-UP	53
8.9.6	RRC State transition	54
8.9.6.1	RRC Connected to RRC Inactive.....	54
8.9.6.2	RRC Inactive to other states.....	55
8.9.7	Trace activation/deactivation over F1 and E1.....	57
8.9.8	BH RLC channel establishment procedure.....	57
8.9.9	Traffic Mapping	59
8.9.9.1	Traffic Mapping from IP-layer to Layer-2	59
8.9.9.2	BH RLC Channel Mapping on BAP Layer.....	59
8.9.10	IAB-node release	59
8.9.10.1	IAB-node orderly release	59
8.9.10.2	IAB-node disorderly release.....	60
8.9.11	IAB-node OAM	60
8.9.12	Handling of IAB-MTs in INACTIVE State.....	60
8.9.13	IP Address Allocation for IAB-nodes.....	60
8.10	Multiple TNLAs for E1	61
8.11	Support of Network Sharing with multiple cell-ID broadcast.....	62
8.11.1	General.....	62
8.11.2	Initial Registration – separate PLMN signalling.....	62
8.11.3	RRC Connection Reestablishment – separate PLMN signalling	63
8.11.4	Support of shared signalling transport	65
8.12	IAB-node Integration Procedure	65
8.12.1	Standalone IAB integration	65
8.12.2	NSA IAB Integration procedure	66
8.13	Overall procedures for MDT	67
8.13.1	Signalling based MDT activation	67
8.13.2	Management based MDT activation	68
8.14	Self-optimisation	71
8.14.1	Overall procedures for MRO	71
8.14.1.1	Signalling of RLF information from gNB-CU to gNB-DU	71
9	Synchronization.....	72
9.1	gNB Synchronization	72
10	NG-RAN interfaces.....	73
10.1	NG interface	73
10.2	Xn interface	73
10.3	F1 interface.....	73
10.4	E1 interface	73
10.5	Antenna interface - general principles.....	73
11	Overall procedures in NG-RAN Architecture	73
11.1	Multiple TNLAs for Xn-C	73

Annex A (informative): **Deployment scenarios of gNB/en-gNB75**

Annex B: **NG-RAN Architecture for Radio Access Network Sharing with
multiple cell ID broadcast (informative).....76**

Annex C (informative): **Change History77**

History78

Foreword

This Technical Specification has been produced by the 3rd Generation Partnership Project (3GPP).

The contents of the present document are subject to continuing work within the TSG and may change following formal TSG approval. Should the TSG modify the contents of the present document, it will be re-released by the TSG with an identifying change of release date and an increase in version number as follows:

Version x.y.z

where:

- x the first digit:
 - 1 presented to TSG for information;
 - 2 presented to TSG for approval;
 - 3 or greater indicates TSG approved document under change control.
- y the second digit is incremented for all changes of substance, i.e. technical enhancements, corrections, updates, etc.
- z the third digit is incremented when editorial only changes have been incorporated in the document.

1 Scope

The present document describes the overall architecture of the NG-RAN, including interfaces NG, Xn and F1 interfaces and their interaction with the radio interface.

2 References

The following documents contain provisions which, through reference in this text, constitute provisions of the present document.

- References are either specific (identified by date of publication, edition number, version number, etc.) or non-specific.
- For a specific reference, subsequent revisions do not apply.
- For a non-specific reference, the latest version applies. In the case of a reference to a 3GPP document (including a GSM document), a non-specific reference implicitly refers to the latest version of that document *in the same Release as the present document*.

- [1] 3GPP TR 21.905: "Vocabulary for 3GPP Specifications".
- [2] 3GPP TS 38.300: "NR; Overall description; Stage-2".
- [3] 3GPP TS 23.501: "System Architecture for the 5G System".
- [4] 3GPP TS 38.473: "NG-RAN; F1 application protocol (F1AP)".
- [5] 3GPP TS 38.414: "NG-RAN; NG data transport".
- [6] 3GPP TS 38.424: "NG-RAN; Xn data transport".
- [7] 3GPP TS 38.474: "NG-RAN; F1 data transport".
- [8] ITU-T Recommendation G.823 (2000-03): "The control of jitter and wander within digital networks which are based on the 2048 kbit/s hierarchy".
- [9] ITU-T Recommendation G.824 (2000-03): "The control of jitter and wander within digital networks which are based on the 1544 kbit/s hierarchy".
- [10] ITU-T Recommendation G.825 (2001-08): "The control of jitter and wander within digital networks which are based on the synchronous digital hierarchy (SDH)".
- [11] ITU-T Recommendation G.8261/Y.1361 (2008-04): "Timing and Synchronization aspects in Packet networks".
- [12] 3GPP TS 37.340: "NR; Multi-connectivity; Overall description; Stage-2".
- [13] 3GPP TS 33.501: "Security Architecture and Procedures for 5G System".
- [14] 3GPP TS 38.410: "NG-RAN; NG general aspect and principles".
- [15] 3GPP TS 38.420: "NG-RAN; Xn general aspects and principles".
- [16] 3GPP TS 38.470: "NG-RAN; F1 general aspects and principles".
- [17] 3GPP TS 38.460: "NG-RAN; E1 general aspects and principles".
- [18] 3GPP TS 33.210: "3G security; Network Domain Security (NDS); IP Network Layer Security".
- [19] 3GPP TS 36.300: "Evolved Universal Terrestrial Radio Access (E-UTRA), Evolved Universal Terrestrial Radio Access Network (E-UTRAN); Overall description; Stage 2".
- [20] 3GPP TS 32.422: "Trace control and configuration management".

- [21] 3GPP TS 37.470: "Evolved Universal Terrestrial Radio Access Network (E-UTRAN) and NG-RAN; W1 general aspects and principles; Stage-2".
- [22] 3GPP TS 38.340: "NR; Backhaul Adaptation Protocol (BAP) specification".
- [23] 3GPP TS 38.331: "NR; Radio Resource Control (RRC) protocol specification".
- [24] 3GPP TS 38.425: "NG-RAN; NR user plane Protocol".

3 Definitions and abbreviations

3.1 Definitions

For the purposes of the present document, the terms and definitions given in TR 21.905 [1] and the following apply. A term defined in the present document takes precedence over the definition of the same term, if any, in TR 21.905 [1].

Conditional Handover: as defined in TS 38.300 [2].

Conditional PSCell Change: as defined in TS 37.340 [12].

DAPS Handover: as defined in TS 38.300 [2].

en-gNB: as defined in TS 37.340 [12].

Early Data Forwarding: as defined in TS 38.300 [2].

gNB: as defined in TS 38.300 [2].

gNB Central Unit (gNB-CU): a logical node hosting RRC, SDAP and PDCP protocols of the gNB or RRC and PDCP protocols of the en-gNB that controls the operation of one or more gNB-DUs. The gNB-CU terminates the F1 interface connected with the gNB-DU.

gNB Distributed Unit (gNB-DU): a logical node hosting RLC, MAC and PHY layers of the gNB or en-gNB, and its operation is partly controlled by gNB-CU. One gNB-DU supports one or multiple cells. One cell is supported by only one gNB-DU. The gNB-DU terminates the F1 interface connected with the gNB-CU.

gNB-CU-Control Plane (gNB-CU-CP): a logical node hosting the RRC and the control plane part of the PDCP protocol of the gNB-CU for an en-gNB or a gNB. The gNB-CU-CP terminates the E1 interface connected with the gNB-CU-UP and the F1-C interface connected with the gNB-DU.

gNB-CU-User Plane (gNB-CU-UP): a logical node hosting the user plane part of the PDCP protocol of the gNB-CU for an en-gNB, and the user plane part of the PDCP protocol and the SDAP protocol of the gNB-CU for a gNB. The gNB-CU-UP terminates the E1 interface connected with the gNB-CU-CP and the F1-U interface connected with the gNB-DU.

IAB-node: as defined in TS 38.300 [2].

IAB-donor: as defined in TS 38.300 [2].

IAB-donor-CU: the gNB-CU of an IAB-donor, terminating the F1 interface towards IAB-nodes and IAB-donor-DU.

IAB-donor-DU: the gNB-DU of an IAB-donor, hosting the IAB BAP sublayer (as defined in TS 38.340 [22]), providing wireless backhaul to IAB-nodes.

IAB-DU: as defined in TS 38.300 [2].

IAB-MT: as defined in TS 38.300 [2].

ng-eNB: as defined in TS 38.300 [2].

ng-eNB Central Unit (ng-eNB-CU): as defined in TS 37.470 [21].

ng-eNB Distributed Unit (ng-eNB-DU): as defined in TS 37.470 [21].

NG-RAN node: as defined in TS 38.300 [2].

PDU Session Resource: This term is used for specification of NG, Xn, and E1 interfaces. It denotes NG-RAN interface and radio resources provided to support a PDU Session.

Public Network Integrated NPN: as defined in TS 23.501 [3].

Stand-alone Non-Public Network: as defined in TS 23.501 [3].

3.2 Abbreviations

For the purposes of the present document, the terms and definitions given in TR 21.905 [1] and the following apply. A term defined in the present document takes precedence over the definition of the same term, if any, in TR 21.905 [1].

5GC	5G Core Network
AMF	Access and Mobility Management Function
AP	Application Protocol
AS	Access Stratum
BH	Backhaul
CAG	Closed Access Group
CHO	Conditional Handover
CLI	Cross-Link Interference
CM	Connection Management
CMAS	Commercial Mobile Alert Service
DAPS	Dual Active Protocol Stack
ETWS	Earthquake and Tsunami Warning System
F1-U	F1 User plane interface
F1-C	F1 Control plane interface
F1AP	F1 Application Protocol
FDD	Frequency Division Duplex
GTP-U	GPRS Tunnelling Protocol
IAB	Integrated Access and Backhaul
IP	Internet Protocol
NAS	Non-Access Stratum
NID	Network identifier
NPN	Non-Public Network
PNI-NPN	Public Network Integrated Non-Public Network
O&M	Operation and Maintenance
PWS	Public Warning System
QoS	Quality of Service
RET	Remote Electrical Tilting
RIM	Remote Interference Management
RIM-RS	Remote Interference Management Reference Signal
RNL	Radio Network Layer
RRC	Radio Resource Control
SAP	Service Access Point
SCTP	Stream Control Transmission Protocol
SFN	System Frame Number
SM	Session Management
SMF	Session Management Function
SNPN	Stand-alone Non-Public Network
TDD	Time Division Duplex
TDM	Time Division Multiplexing
TMA	Tower Mounted Amplifier
TNL	Transport Network Layer

4 General principles

The general principles guiding the definition of NG-RAN architecture as well as the NG-RAN interfaces are the following:

- Logical separation of signalling and data transport networks.
- NG-RAN and 5GC functions are fully separated from transport functions. Addressing scheme used in NG-RAN and 5GC shall not be tied to the addressing schemes of transport functions. The fact that some NG-RAN or 5GC functions reside in the same equipment as some transport functions does not make the transport functions part of the NG-RAN or the 5GC.
- Mobility for an RRC connection is fully controlled by the NG-RAN.
- The NG-RAN interfaces are defined along the following principles:
 - The functional division across the interfaces have as few options as possible.
 - Interfaces are based on a logical model of the entity controlled through this interface.
 - One physical network element can implement multiple logical nodes.

5 General architecture

5.1 General

The protocols over Uu and NG interfaces are divided into two structures:

- **User plane protocols**

These are the protocols implementing the actual PDU Session service, i.e. carrying user data through the access stratum.

- **Control plane protocols**

These are the protocols for controlling the PDU Sessions and the connection between the UE and the network from different aspects (including requesting the service, controlling different transmission resources, handover etc.). Also a mechanism for transparent transfer of NAS messages is included.

5.2 User plane

The PDU Session Resource service is offered from SAP to SAP by the Access Stratum. Figure 5.2-1 shows the protocols on the Uu and the NG interfaces that linked together provide this PDU Session Resource service.

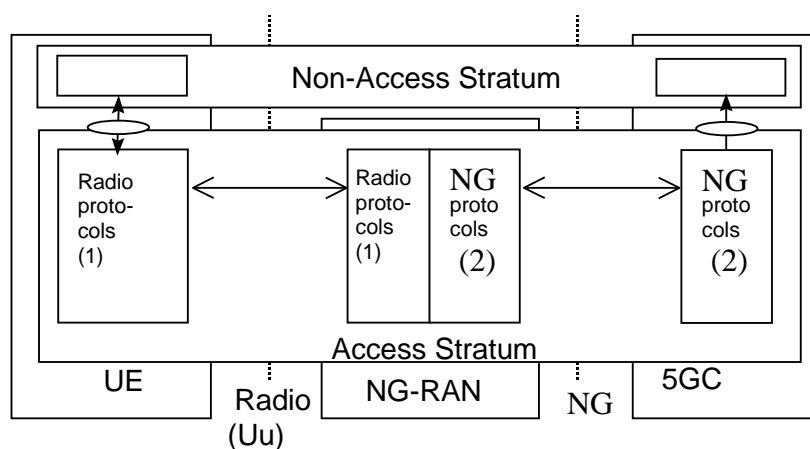

NOTE 1: The radio interface protocols are defined in TS 38.2xx and TS 38.3xx.

NOTE 2: The NG interface protocols are defined in TS 38.41x.

Figure 5.2-1: NG and Uu user plane

5.3 Control plane

Figure 5.3-1 shows the control plane (signalling) protocol stacks on NG and Uu interfaces.

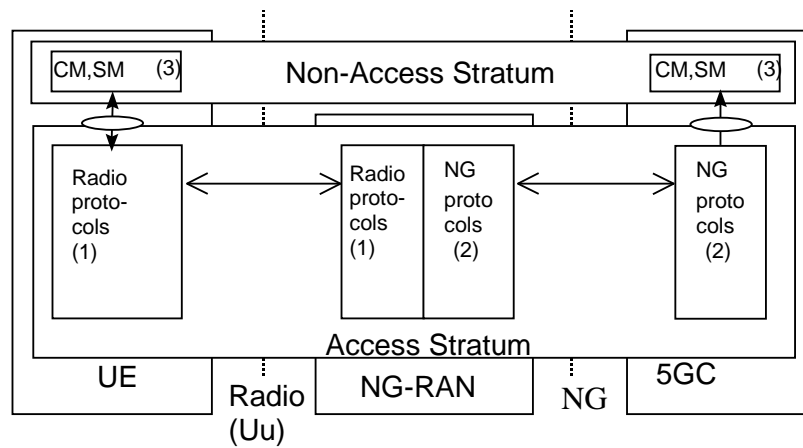

NOTE 1: The radio interface protocols are defined in TS 38.2xx and TS 38.3xx.

NOTE 2: The protocol is defined in TS 38.41x. (Description of NG interface).

NOTE 3: CM, SM: This exemplifies a set of NAS control protocols between UE and 5GC. The evolution of the protocol architecture for these protocols is outside the scope of the present document.

Figure 5.3-1: NG and Uu control plane

NOTE: Both the Radio protocols and the NG protocols contain a mechanism to transparently transfer NAS messages.

6 NG-RAN architecture

6.1 Overview

6.1.1 Overall Architecture of NG-RAN

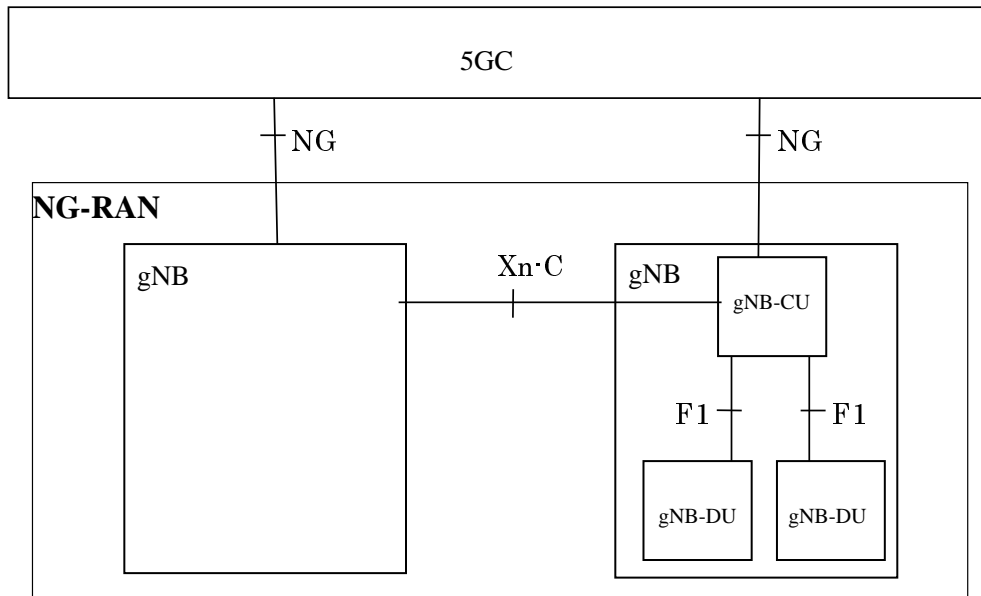

Figure 6.1-1: Overall architecture

The NG-RAN consists of a set of gNBs connected to the 5GC through the NG interface.

NOTE: As specified in TS 38.300 [2], NG-RAN could also consist of a set of ng-eNBs, an ng-eNB may consist of an ng-eNB-CU and one or more ng-eNB-DU(s). An ng-eNB-CU and an ng-eNB-DU is connected via W1 interface. The general principle described in this section also applies to ng-eNB and W1 interface, if not explicitly specified otherwise.

An gNB can support FDD mode, TDD mode or dual mode operation.

gNBs can be interconnected through the Xn interface.

A gNB may consist of a gNB-CU and one or more gNB-DU(s). A gNB-CU and a gNB-DU is connected via F1 interface.

One gNB-DU is connected to only one gNB-CU.

NOTE: In case of network sharing with multiple cell ID broadcast, each Cell Identity associated with a subset of PLMNs corresponds to a gNB-DU and the gNB-CU it is connected to, i.e. the corresponding gNB-DUs share the same physical layer cell resources.

NOTE: For resiliency, a gNB-DU may be connected to multiple gNB-CUs by appropriate implementation.

NG, Xn and F1 are logical interfaces.

For NG-RAN, the NG and Xn-C interfaces for a gNB consisting of a gNB-CU and gNB-DUs, terminate in the gNB-CU. For EN-DC, the S1-U and X2-C interfaces for a gNB consisting of a gNB-CU and gNB-DUs, terminate in the gNB-CU. The gNB-CU and connected gNB-DUs are only visible to other gNBs and the 5GC as a gNB. A possible deployment scenario is described in Annex A.

The node hosting user plane part of NR PDCP (e.g. gNB-CU, gNB-CU-UP, and for EN-DC, MeNB or SgNB depending on the bearer split) shall perform user inactivity monitoring and further informs its inactivity or (re)activation to the node having C-plane connection towards the core network (e.g. over E1, X2). The node hosting NR RLC (e.g.

gNB-DU) may perform user inactivity monitoring and further inform its inactivity or (re)activation to the node hosting control plane, e.g. gNB-CU or gNB-CU-CP.

UL PDCP configuration (i.e. how the UE uses the UL at the assisting node) is indicated via X2-C (for EN-DC), Xn-C (for NG-RAN) and F1-C. Radio Link Outage/Resume for DL and/or UL is indicated via X2-U (for EN-DC), Xn-U (for NG-RAN) and F1-U.

The NG-RAN is layered into a Radio Network Layer (RNL) and a Transport Network Layer (TNL).

The NG-RAN architecture, i.e. the NG-RAN logical nodes and interfaces between them, is defined as part of the RNL.

For each NG-RAN interface (NG, Xn, F1) the related TNL protocol and the functionality are specified. The TNL provides services for user plane transport, signalling transport.

In NG-Flex configuration, each NG-RAN node is connected to all AMFs of AMF Sets within an AMF Region supporting at least one slice also supported by the NG-RAN node. The AMF Set and the AMF Region are defined in TS 23.501 [3].

If security protection for control plane and user plane data on TNL of NG-RAN interfaces has to be supported, NDS/IP TS 33.501 [13] shall be applied.

6.1.2 Overall architecture for separation of gNB-CU-CP and gNB-CU-UP

The overall architecture for separation of gNB-CU-CP and gNB-CU-UP is depicted in Figure 6.1.2-1.

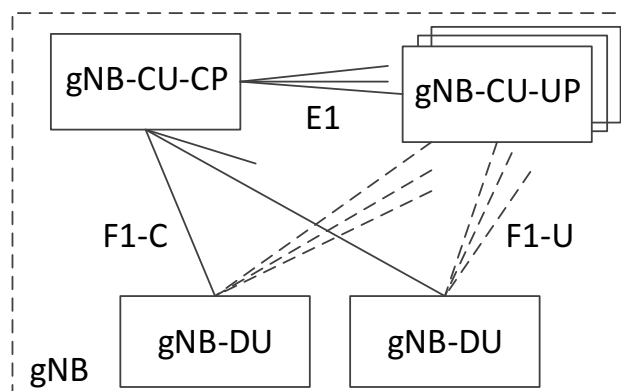

Figure 6.1.2-1. Overall architecture for separation of gNB-CU-CP and gNB-CU-UP

- A gNB may consist of a gNB-CU-CP, multiple gNB-CU-UPs and multiple gNB-DUs;
- The gNB-CU-CP is connected to the gNB-DU through the F1-C interface;
- The gNB-CU-UP is connected to the gNB-DU through the F1-U interface;
- The gNB-CU-UP is connected to the gNB-CU-CP through the E1 interface;
- One gNB-DU is connected to only one gNB-CU-CP;
- One gNB-CU-UP is connected to only one gNB-CU-CP;

NOTE 1: For resiliency, a gNB-DU and/or a gNB-CU-UP may be connected to multiple gNB-CU-CPs by appropriate implementation.

- One gNB-DU can be connected to multiple gNB-CU-UPs under the control of the same gNB-CU-CP;
- One gNB-CU-UP can be connected to multiple DUs under the control of the same gNB-CU-CP;

NOTE 2: The connectivity between a gNB-CU-UP and a gNB-DU is established by the gNB-CU-CP using Bearer Context Management functions.

NOTE 3: The gNB-CU-CP selects the appropriate gNB-CU-UP(s) for the requested services for the UE. In case of multiple CU-UPs they belong to same security domain as defined in TS 33.210 [18].

NOTE 4: Data forwarding between gNB-CU-UPs during intra-gNB-CU-CP handover within a gNB may be supported by Xn-U.

6.1.3 Overall Architecture of IAB

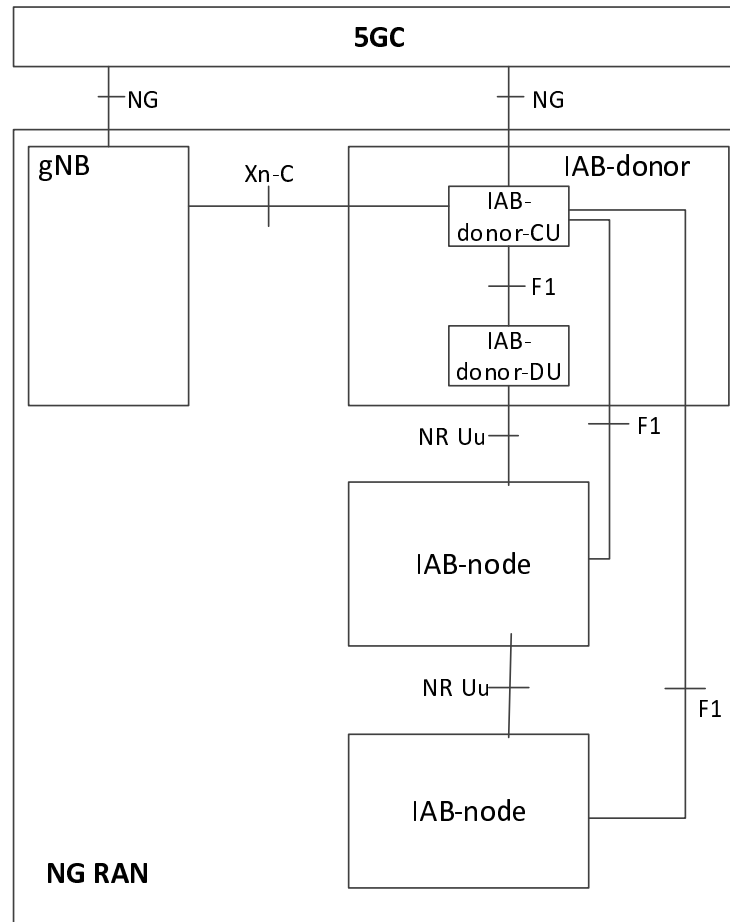

Figure 6.1.3-1: Overall architecture of IAB

The NG-RAN supports IAB by the IAB-node wirelessly connecting to the gNB capable of serving the IAB-nodes, named IAB-donor.

The IAB-donor consists of an IAB-donor-CU and one or more IAB-donor-DU(s). In case of separation of gNB-CU-CP and gNB-CU-UP, the IAB-donor may consist of an IAB-donor-CU-CP, multiple IAB-donor-CU-UPs and multiple IAB-donor-DUs.

The IAB-node connects to an upstream IAB-node or an IAB-donor-DU via a subset of the UE functionalities of the NR Uu interface (named IAB-MT function of IAB-node). The IAB-node provides wireless backhaul to the downstream IAB-nodes and UEs via the network functionalities of the NR Uu interface (named IAB-DU function of IAB-node).

The F1-C traffic between an IAB-node and IAB-donor-CU is backhauled via the IAB-donor-DU and the optional intermediate hop IAB-node(s).

The F1-U traffic between an IAB-node and IAB-donor-CU is backhauled via the IAB-donor-DU and the optional intermediate hop IAB-node(s).

All functions specified for a gNB-DU are equally applicable for an IAB-DU and IAB-donor-DU, unless otherwise stated, and all functions specified for a gNB-CU are equally applicable for an IAB-donor-CU, unless otherwise stated. All functions specified for the UE context are equally applicable for managing the context of IAB-MT, unless otherwise stated.

6.1.4 Protocol stacks of IAB

Figure 6.1.4-1 shows the protocol stack for F1-U between IAB-DU and the IAB-donor-CU-UP, and Figure 6.1.4-2 shows the protocol stack for F1-C between IAB-DU and the IAB-donor-CU-CP. In these example figures, F1-U and F1-C traffic are carried over two backhaul hops.

NOTE: F1 needs to be security-protected as described in TS 33.501. The security layer is not shown in the Figures 6.1.4-1/2/3.

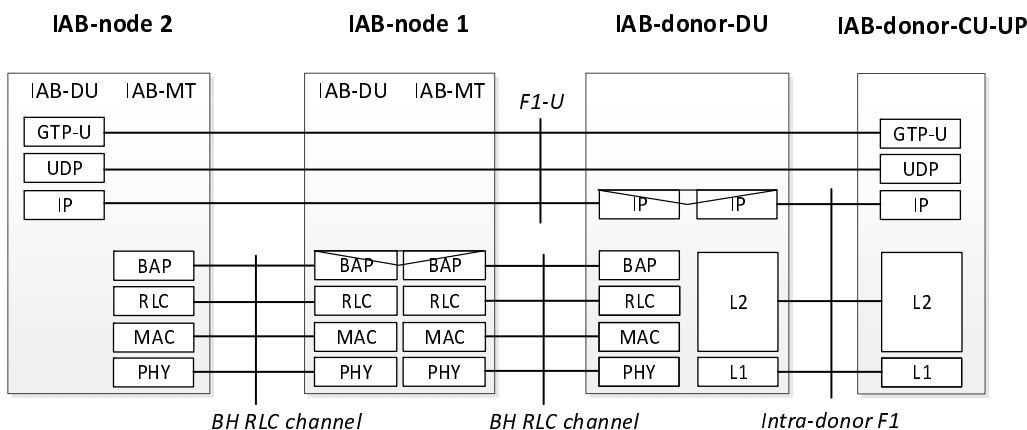

Figure 6.1.4-1: Protocol stack for F1-U of IAB

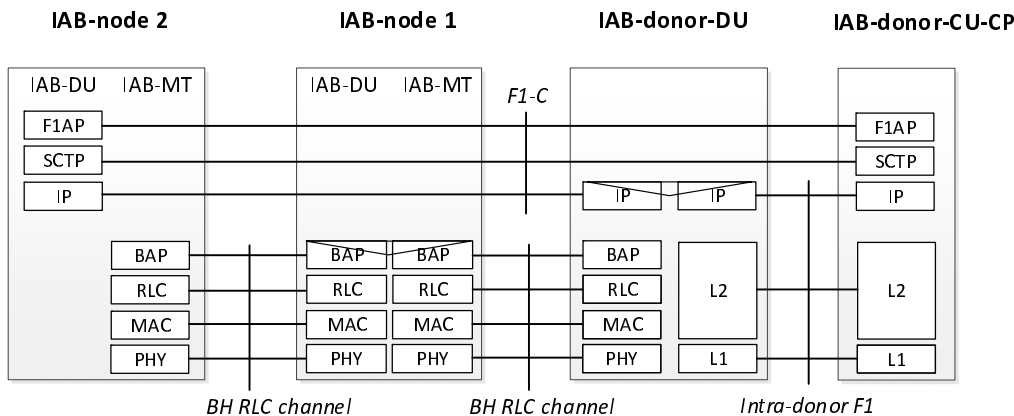

Figure. 6.1.4-2: Protocol stack for F1-C of IAB

Figure 6.1.4-3 shows the protocol stack for F1-C between IAB-DU and the IAB-donor-CU-CP, when the F1-C traffic is transmitted via the MeNB.

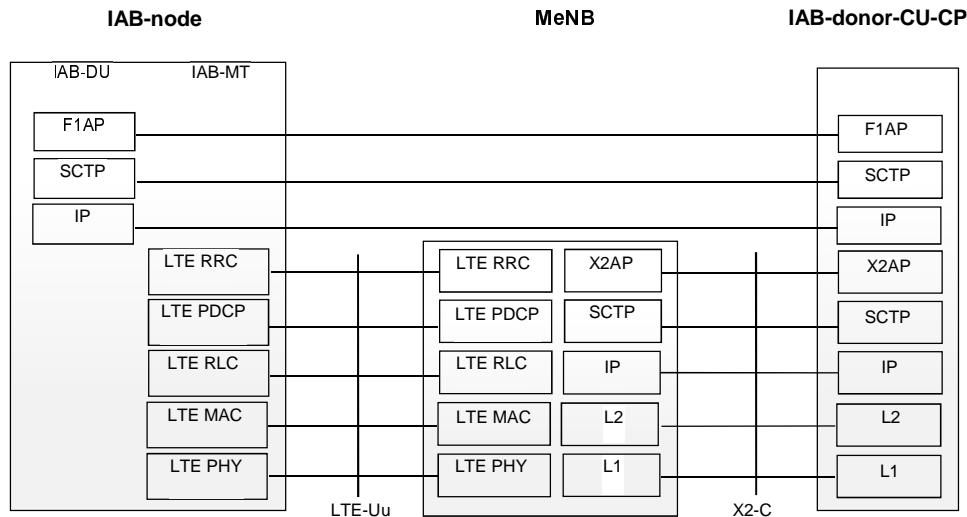

Fig. 6.1.4-3: Protocol stack for IAB F1-C traffic delivered via the MeNB

6.2 NG-RAN identifiers

6.2.1 Principle of handling Application Protocol Identities

An Application Protocol Identity (AP ID) is allocated when a new UE-associated logical connection is created in either an NG-RAN node or an AMF. An AP ID shall uniquely identify a logical connection associated to a UE over the NG interface or Xn interface within a node (NG-RAN node or AMF) or over the F1 interface or over the E1 interface or over the W1 interface. Upon receipt of a message that has a new AP ID from the sending node, the receiving node shall store the AP ID of the sending node for the duration of the logical connection. The receiving node shall assign the AP ID to be used to identify the logical connection associated to the UE and include it as well as the previously received new AP ID from the sending node, in the first returned message to the sending node. In all subsequent messages to and from sending node, both AP IDs of sending node and receiving node shall be included.

The definitions of AP IDs as used on NG interface or Xn interface or F1 interface or E1 interface are shown below:

RAN UE NGAP ID:

A RAN UE NGAP ID shall be allocated so as to uniquely identify the UE over the NG interface within a gNB. When an AMF receives a RAN UE NGAP ID it shall store it for the duration of the UE-associated logical NG-connection for this UE. Once known to an AMF this is included in all UE associated NGAP signalling.

The RAN UE NGAP ID shall be unique within the logical NG-RAN node.

AMF UE NGAP ID:

An AMF UE NGAP ID shall be allocated so as to uniquely identify the UE over the NG interface within the AMF. When a NG-RAN node receives an AMF UE NGAP ID it shall store it for the duration of the UE-associated logical NG-connection for this UE. Once known to a NG-RAN node this ID is included in all UE associated NGAP signalling.

The AMF UE NGAP ID shall be unique within an AMF Set as specified in TS 23.501 [3].

Old NG-RAN node UE XnAP ID:

An Old NG-RAN node UE XnAP ID shall be allocated so as to uniquely identify the UE over the Xn interface within a source NG-RAN node. When a target NG-RAN node receives an Old NG-RAN node UE XnAP ID it shall store it for the duration of the UE-associated logical Xn-connection for this UE. Once known to a target NG-RAN node this ID is included in all UE associated XnAP signalling. The Old NG-RAN node UE XnAP ID shall be unique within the logical NG-RAN node.

New NG-RAN node UE XnAP ID:

A New NG-RAN node UE XnAP ID shall be allocated so as to uniquely identify the UE over the Xn interface within a target NG-RAN node. When a source NG-RAN node receives a New NG-RAN node UE XnAP ID it shall store it for the duration of the UE-associated logical Xn-connection for this UE. Once known to a source NG-RAN node this ID is included in all UE associated XnAP signalling. The New NG-RAN node UE XnAP ID shall be unique within the logical NG-RAN node.

M-NG-RAN node UE XnAP ID:

An M-NG-RAN node UE XnAP ID shall be allocated so as to uniquely identify the UE over the Xn interface within an M-NG-RAN node for dual connectivity. When an S-NG-RAN node receives an M-NG-RAN node UE XnAP ID it shall store it for the duration of the UE-associated logical Xn-connection for this UE. Once known to an S-NG-RAN node this ID is included in all UE associated XnAP signalling. The M-NG-RAN node UE XnAP ID shall be unique within the logical NG-RAN node.

S-NG-RAN node UE XnAP ID:

A S-NG-RAN node UE XnAP ID shall be allocated so as to uniquely identify the UE over the Xn interface within an S-NG-RAN node for dual connectivity. When an M-NG-RAN node receives a S-NG-RAN node UE XnAP ID it shall store it for the duration of the UE-associated logical Xn-connection for this UE. Once known to an M-NG-RAN node this ID is included in all UE associated XnAP signalling. The S-NG-RAN node UE XnAP ID shall be unique within the logical NG-RAN node.

gNB-CU UE F1AP ID:

A gNB-CU UE F1AP ID shall be allocated so as to uniquely identify the UE over the F1 interface within a gNB-CU. When a gNB-DU receives a gNB-CU UE F1AP ID it shall store it for the duration of the UE-associated logical F1-connection for this UE. The gNB-CU UE F1AP ID shall be unique within the gNB-CU logical node.

gNB-DU UE F1AP ID:

A gNB-DU UE F1AP ID shall be allocated so as to uniquely identify the UE over the F1 interface within a gNB-DU. When a gNB-CU receives a gNB-DU UE F1AP ID it shall store it for the duration of the UE-associated logical F1-connection for this UE. The gNB-DU UE F1AP ID shall be unique within the gNB-DU logical node.

gNB-CU-CP UE E1AP ID:

A gNB-CU-CP UE E1AP ID shall be allocated so as to uniquely identify the UE over the E1 interface within a gNB-CU-CP. When a gNB-CU-UP receives a gNB-CU-CP UE E1AP ID it shall store it for the duration of the UE-associated logical E1-connection for this UE. The gNB-CU-CP UE E1AP ID shall be unique within the gNB-CU-CP logical node.

gNB-CU-UP UE E1AP ID:

A gNB-CU-UP UE E1AP ID shall be allocated so as to uniquely identify the UE over the E1 interface within a gNB-CU-UP. When a gNB-CU-CP receives a gNB-CU-UP UE E1AP ID it shall store it for the duration of the UE-associated logical E1-connection for this UE. The gNB-CU-UP UE E1AP ID shall be unique within the gNB-CU-UP logical node.

ng-eNB-CU UE W1AP ID:

An ng-eNB-CU UE W1AP ID shall be allocated so as to uniquely identify the UE over the W1 interface within an ng-eNB-CU. When an ng-eNB-DU receives an ng-eNB-CU UE W1AP ID it shall store it for the duration of the UE-associated logical W1-connection for this UE. The ng-eNB-CU UE W1AP ID shall be unique within the ng-eNB-CU logical node.

ng-eNB-DU UE W1AP ID:

An ng-eNB-DU UE W1AP ID shall be allocated so as to uniquely identify the UE over the W1 interface within an ng-eNB-DU. When an ng-eNB-CU receives an ng-eNB-DU UE W1AP ID it shall store it for the duration of the UE-associated logical W1-connection for this UE. The ng-eNB-DU UE W1AP ID shall be unique within the ng-eNB-DU logical node.

6.2.2 gNB-DU ID

The gNB-DU ID is configured at the gNB-DU and used to uniquely identify the gNB-DU at least within a gNB-CU. The gNB-DU provides its gNB-DU ID to the gNB-CU during the F1 Setup procedure. The gNB-DU ID is used only within F1AP procedures.

6.2.3 ng-eNB-DU ID

The ng-eNB-DU ID is configured at the ng-eNB-DU and used to uniquely identify the ng-eNB-DU at least within an ng-eNB-CU. The ng-eNB-DU provides its ng-eNB-DU ID to the ng-eNB-CU during the W1 Setup procedure. The ng-eNB-DU ID is used only within W1AP procedures.

6.3 Transport addresses

The transport layer address parameter is transported in the radio network application signalling procedures that result in establishment of transport bearer connections.

The transport layer address parameter shall not be interpreted in the radio network application protocols and reveal the addressing format used in the transport layer.

The formats of the transport layer addresses are further described in TS 38.414 [5], TS 38.424 [6] and TS 38.474 [7].

6.4 UE associations in NG-RAN Node

There are several types of UE associations needed in the NG-RAN node: the "NG-RAN node UE context" used to store all information needed for a UE and the associations between the UE and the logical NG and Xn connections used for NG/XnAP UE associated messages. An "NG-RAN node UE context" exists for a UE in CM_CONNECTED.

Definitions:

NG-RAN node UE context:

An NG-RAN node UE context is a block of information in an NG-RAN node associated to one UE. The block of information contains the necessary information required to maintain the NG-RAN services towards the active UE. An NG-RAN node UE context is established when the transition to RRC CONNECTED for a UE is completed or in the target NG-RAN node after completion of handover resource allocation during handover preparation, in which case at least UE state information, security information, UE capability information and the identities of the UE-associated logical NG-connection shall be included in the NG-RAN node UE context.

For Dual Connectivity an NG-RAN node UE context is also established in the S-NG-RAN node after completion of S-NG-RAN node Addition Preparation procedure.

If radio bearers are requested to be setup during a UE Context setup or modification procedure, the UE capabilities are signalled to the receiving node as part of the UE context setup or modification procedures.

Bearer context:

A bearer context is a block of information in a gNB-CU-UP node associated to one UE that is used for the sake of communication over the E1 interface. It may include the information about data radio bearers, PDU sessions and QoS-flows associated to the UE. The block of information contains the necessary information required to maintain user-plane services toward the UE.

UE-associated logical NG/Xn/F1/E1 -connection:

NGAP, XnAP, F1AP and E1AP provide means to exchange control plane messages associated with the UE over the respectively NG-C, Xn-C, F1-C or E1 interface.

A UE-associated logical connection is established during the first NGAP/XnAP/F1AP message exchange between the NG/Xn/F1 peer nodes.

The connection is maintained as long as UE associated NG/XnAP/F1AP messages need to be exchanged over the NG/Xn/F1 interface.

The UE-associated logical NG-connection uses the identities AMF UE NGAP ID and RAN UE NGAP ID.

The UE-associated logical Xn-connection uses the identities Old NG-RAN node UE XnAP ID and New NG-RAN node UE XnAP ID, or M-NG-RAN node UE XnAP ID and S-NG-RAN node UE XnAP ID.

The UE-associated logical F1-connection uses the identities gNB-CU UE F1AP ID and gNB-DU UE F1AP ID.

When a node (AMF or gNB) receives a UE associated NGAP/XnAP/F1AP message the node retrieves the associated UE based on the NGAP/XnAP/F1AP ID.

UE-associated signalling:

UE-associated signalling is an exchange of NGAP/XnAP/F1AP messages associated with one UE over the UE-associated logical NG/Xn/F1-connection.

NOTE1: The UE-associated logical NG-connection may exist before the NG-RAN node UE context is setup in the NG-RAN node.

NOTE2: The UE-associated logical F1-connection may exist before the UE context is setup in the gNB-DU.

NOTE3: The general principle described in this section also applies to ng-eNB and W1 interface, if not explicitly specified otherwise.

7 NG-RAN functions description

7.0 General

For the list of functions refer to TS 38.300 [2].

7.1 NG-RAN sharing

NG-RAN supports radio access network sharing as specified in TS 23.501 [3] and TS 38.300 [2] and TS 36.300 [19].

7.2 Remote Interference Management

The Remote Interference Management function in non-split gNB case is specified in TS 38.300 [2].

In case of split gNB architecture, in the victim set, a gNB-DU detects the remote interference. If remote interference is detected, the gNB-DU can send out the RIM-RS. In the aggressor set, if a gNB-DU detects the RIM-RS sent by the victim gNB(s), it sends to the gNB-CU the RIM-RS detection status and the victim Set ID. The gNB-CU acts as a coordinator on behalf of its affiliated gNB-DUs, where the gNB-CU merges the outgoing RIM information received from its gNB-DUs in the aggressor set and forwards the merged information to all the gNBs in the victim set.

Similarly, in the victim set, the gNB-CU distributes the incoming RIM information to all the gNB-DUs in the set, as indicated in the RIM information received from the aggressor set.

In addition, to facilitate consolidation of RIM information, the gNB-DU provides the associated aggressor set ID and the victim set ID of each serving cell to the gNB-CU.

7.3 Cross-Link Interference Management

The Cross-Link Interference Management function in non-split gNB case is specified in TS 38.300 [2].

In case of split gNB architecture, the gNB-CU forwards the TDD DL/UL patterns received from neighboring nodes to each concerned gNB-DU. The gNB-DU reports the TDD DL/UL patterns of its serving cells to the gNB-CU if Cross-Link Interference is detected.

7.4 Support for Non-Public Networks

NG-RAN supports NPN as specified in TS 23.501 [3] and TS 38.300 [2].

7.5 RACH Optimisation Function

The RACH Optimization Function in non-split gNB case is specified in TS 38.300 [2].

In case of split gNB architecture, RACH configuration conflict detection and resolution function is located at the gNB-DU. To perform RACH optimisation at gNB-DU, gNB-CU sends the RACH report reported by the UE to gNB-DU via F1AP signalling. The gNB-DU signals the PRACH configuration per-cell to gNB-CU. The gNB-CU may forward a limited set of neighbour cell's PRACH configurations received from neighbour gNB-CU to the gNB-DU to resolve the configuration conflict.

8 Overall procedures in gNB-CU/gNB-DU Architecture

8.1 UE Initial Access

The signalling flow for UE Initial access is shown in Figure 8.1-1.

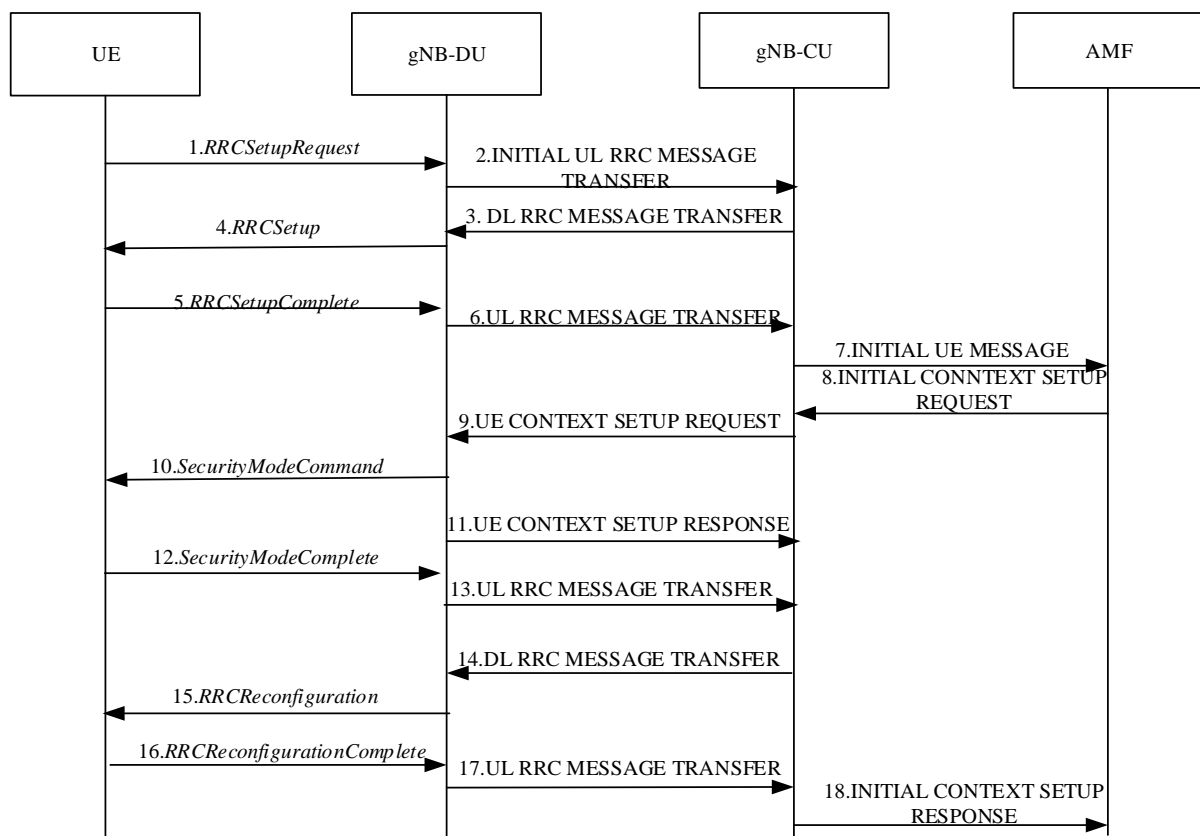

Figure 8.1-1: UE Initial Access procedure

1. The UE sends an *RRCSetupRequest* message to the gNB-DU.

2. The gNB-DU includes the RRC message and, if the UE is admitted, the corresponding low layer configuration for the UE in the INITIAL UL RRC MESSAGE TRANSFER message and transfers to the gNB-CU. The INITIAL UL RRC MESSAGE TRANSFER message includes the C-RNTI allocated by the gNB-DU.
3. The gNB-CU allocates a gNB-CU UE F1AP ID for the UE and generates a *RRCSetup* message towards UE. The RRC message is encapsulated in -the DL RRC MESSAGE TRANSFER message.
4. The gNB-DU sends the *RRCSetup* message to the UE.
5. The UE sends the RRC CONNECTION SETUP COMPLETE message to the gNB-DU.
6. The gNB-DU encapsulates the RRC message in the UL RRC MESSAGE TRANSFER message and sends it to the gNB-CU.
7. The gNB-CU sends the INITIAL UE MESSAGE message to the AMF.
8. The AMF sends the INITIAL CONTEXT SETUP REQUEST message to the gNB-CU.
9. The gNB-CU sends the UE CONTEXT SETUP REQUEST message to establish the UE context in the gNB-DU. In this message, it may also encapsulate the *SecurityModeCommand* message. In case of NG-RAN sharing, the gNB-CU includes the serving PLMN ID (for SNPNs the serving SNPN ID).
10. The gNB-DU sends the *SecurityModeCommand* message to the UE.
11. The gNB-DU sends the UE CONTEXT SETUP RESPONSE message to the gNB-CU.
12. The UE responds with the *SecurityModeComplete* message
13. The gNB-DU encapsulates the RRC message in the UL RRC MESSAGE TRANSFER message and sends it to the gNB-CU.
14. The gNB-CU generates the *RRCReconfiguration* message and encapsulates it in the DL RRC MESSAGE TRANSFER message
15. The gNB-DU sends *RRCReconfiguration* message to the UE.
16. The UE sends *RRCReconfigurationComplete* message to the gNB-DU.
17. The gNB-DU encapsulates the RRC message in the UL RRC MESSAGE TRANSFER message and send it to the gNB-CU.
18. The gNB-CU sends the INITIAL CONTEXT SETUP RESPONSE message to the AMF.

8.2 Intra-gNB-CU Mobility

8.2.1 Intra-NR Mobility

8.2.1.1 Inter-gNB-DU Mobility

This procedure is used for the case when the UE moves from one gNB-DU to another gNB-DU within the same gNB-CU during NR operation. Figure 8.2.1.1-1 shows the inter-gNB-DU mobility procedure for intra-NR.

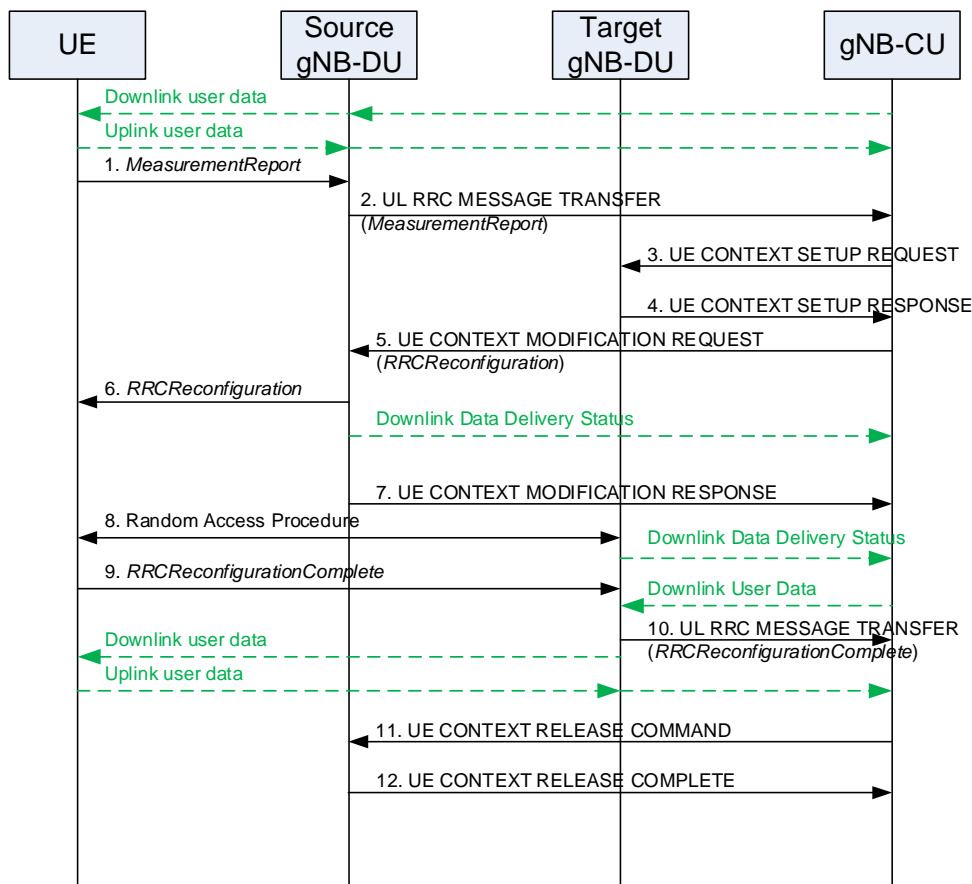

Figure 8.2.1.1-1: Inter-gNB-DU Mobility for intra-NR

1. The UE sends a *MeasurementReport* message to the source gNB-DU.
2. The source gNB-DU sends an UL RRC MESSAGE TRANSFER message to the gNB-CU to convey the received *MeasurementReport* message.
3. The gNB-CU sends an UE CONTEXT SETUP REQUEST message to the target gNB-DU to create an UE context and setup one or more data bearers. The UE CONTEXT SETUP REQUEST message includes a *HandoverPreparationInformation*. In case of NG-RAN sharing, the gNB-CU includes the serving PLMN ID (for SNPNs the serving SNPN ID).
4. The target gNB-DU responds to the gNB-CU with an UE CONTEXT SETUP RESPONSE message.
5. The gNB-CU sends a UE CONTEXT MODIFICATION REQUEST message to the source gNB-DU, which includes a generated *RRCReconfiguration* message and indicates to stop the data transmission for the UE. The source gNB-DU also sends a Downlink Data Delivery Status frame to inform the gNB-CU about the unsuccessfully transmitted downlink data to the UE.

NOTE: In case of DAPS Handover, the UE CONTEXT MODIFICATION REQUEST message in step 5 does not indicate to stop the data transmission for the UE. Instead, the DL RRC Message Transfer procedure can be used which carries the handover command to the UE. The UE CONTEXT MODIFICATION REQUEST message that indicates to stop the data transmission for the UE is sent to the source gNB-DU once the gNB-CU knows that the UE has successfully accessed the target gNB-DU, for which the source gNB-DU sends a DDDS frame about the unsuccessfully transmitted downlink data to the gNB-CU.

6. The source gNB-DU forwards the received *RRCReconfiguration* message to the UE.
7. The source gNB-DU responds to the gNB-CU with the UE CONTEXT MODIFICATION RESPONSE message.

8. A Random Access procedure is performed at the target gNB-DU. The target gNB-DU sends a Downlink Data Delivery Status frame to inform the gNB-CU. Downlink packets, which may include PDCP PDUs not successfully transmitted in the source gNB-DU, are sent from the gNB-CU to the target gNB-DU.

NOTE: It is up to gNB-CU implementation whether to start sending DL User Data to gNB-DU before or after reception of the Downlink Data Delivery Status.

9. The UE responds to the target gNB-DU with an *RRCReconfigurationComplete* message.
10. The target gNB-DU sends an UL RRC MESSAGE TRANSFER message to the gNB-CU to convey the received *RRCReconfigurationComplete* message. Downlink packets are sent to the UE. Also, uplink packets are sent from the UE, which are forwarded to the gNB-CU through the target gNB-DU.
11. The gNB-CU sends an UE CONTEXT RELEASE COMMAND message to the source gNB-DU.
12. The source gNB-DU releases the UE context and responds the gNB-CU with an UE CONTEXT RELEASE COMPLETE message.

8.2.1.2 Intra-gNB-DU handover

This procedure is used for the case that UE moves from one cell to another cell within the same gNB-DU or for the case that intra-cell handover is performed during NR operation, and supported by UE Context Modification (gNB-CU initiated) procedure as specified in TS 38.473 [4]. When the intra-cell handover is performed, the gNB-CU provides new UL GTP TEID to the gNB-DU and gNB-DU provides new DL GTP TEID to the gNB-CU. The gNB-DU shall continue sending UL PDCP PDUs to the gNB-CU with the previous UL GTP TEID until it re-establishes the RLC, and use the new UL GTP TEID after RLC re-establishment. The gNB-CU shall continue sending DL PDCP PDUs to the gNB-DU with the previous DL GTP TEID until it performs PDCP re-establishment or PDCP data recovery, and use the new DL GTP TEID starting with the PDCP re-establishment or data recovery.

8.2.1.3 Inter-gNB-DU Conditional Handover or Conditional PSCell Change

This procedure is used for the case when the UE moves from one gNB-DU to another gNB-DU within the same gNB-CU during NR operation for conditional handover or conditional PSCell change. Figure 8.2.1.3-1 shows the inter-gNB-DU conditional mobility procedure for intra-NR.

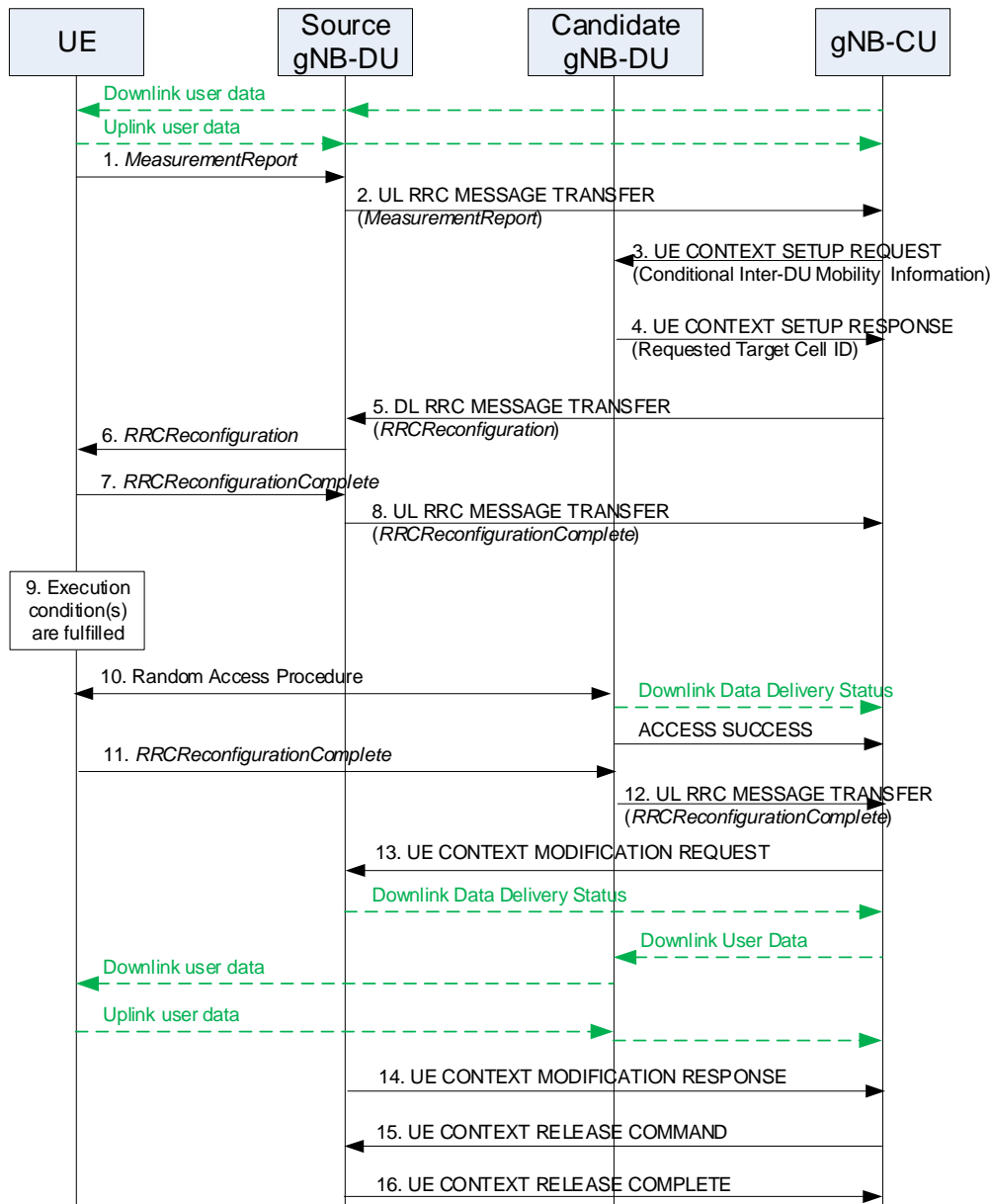

Figure 8.2.1.3-1: Inter-gNB-DU Conditional Handover or Conditional PSCell Change for intra-NR

- 1-2. The steps 1-2 are as defined in clause 8.2.1.1.
- 3. The gNB-CU sends an UE CONTEXT SETUP REQUEST message to the candidate gNB-DU to create an UE context and setup one or more data bearers. The UE CONTEXT SETUP REQUEST message is sent for each candidate cell and includes a HandoverPreparationInformation (conditional handover) or a CG-ConfigInfo (conditional PSCell change).
- 4. The candidate gNB-DU responds to the gNB-CU with an UE CONTEXT SETUP RESPONSE message including the target cell ID that was requested from the gNB-CU. The response message is sent for each requested candidate cell.
- 5. The gNB-CU sends a DL RRC MESSAGE TRANSFER message to the source gNB-DU, which includes a generated RRCReconfiguration message.
- 6. The step 6 is as defined in clause 8.2.1.1.
- 7-8. The UE responds to the source gNB-DU with an RRCReconfigurationComplete message, for which the source gNB-DU forwards to the gNB-CU via an UL RRC MESSAGE TRANSFER message.

9. An execution condition to trigger initiation of conditional handover or conditional PSCell change is fulfilled.
 10. A Random Access procedure is performed at the candidate gNB-DU, which becomes the target gNB-DU if successful. The target gNB-DU sends a Downlink Data Delivery Status frame to inform the gNB-CU. The target gNB-DU also sends an ACCESS SUCCESS message to inform the gNB-CU of which cell the UE has successfully accessed.
 - 11-12. The steps 11-12 are as defined in steps 9-10 in clause 8.2.1.1.
 13. The gNB-CU sends a UE CONTEXT MODIFICATION REQUEST message to the source gNB-DU and indicates to stop the data transmission for the UE. The source gNB-DU also sends a Downlink Data Delivery Status frame to inform the gNB-CU about the unsuccessfully transmitted downlink data to the UE. Downlink packets, which may include PDCP PDUs not successfully transmitted in the source gNB-DU, are sent from the gNB-CU to the target gNB-DU.
- NOTE: The step 13 may happen before step 12, as soon as the gNB-CU knows which cell the UE has successfully accessed.
- NOTE: The gNB-CU may initiate UE Context Release procedure toward the other signalling connections or other candidate target gNB-DUs, if any, to cancel conditional handover or conditional PSCell change for the UE.
14. The source gNB-DU responds to the gNB-CU with the UE CONTEXT MODIFICATION RESPONSE message.
 - 15 -16. The steps 15-16 are as defined in steps 11-12 in clause 8.2.1.1.

8.2.2 EN-DC Mobility

8.2.2.1 Inter-gNB-DU Mobility using MCG SRB

This procedure is used for the case the UE moves from one gNB-DU to another gNB-DU within the same gNB-CU when only MCG SRB is available during EN-DC operation. Figure 8.2.2.1-1 shows the inter-gNB-DU mobility procedure using MCG SRB in EN-DC.

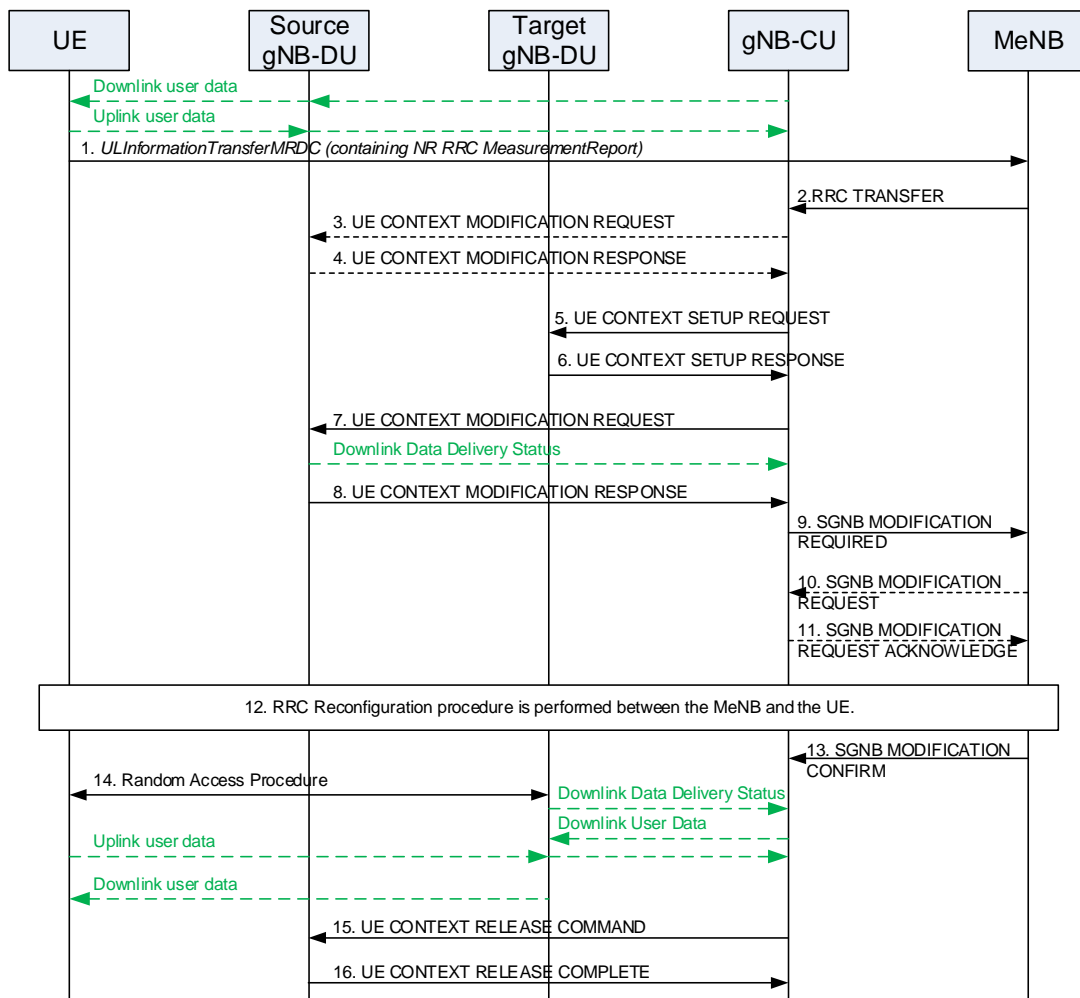

Figure 8.2.2.1-1: Inter-gNB-DU Mobility using MCG SRB in EN-DC

1. The UE sends an *ULInformationTransferMRDC* message to the MeNB
2. The MeNB sends RRC TRANSFER message to the gNB-CU.
3. The gNB-CU may send UE CONTEXT MODIFICATION REQUEST message to the source gNB-DU to query the latest SCG configuration.
4. The source gNB-DU responds with an UE CONTEXT MODIFICATION RESPONSE message that includes full configuration information.
5. The gNB-CU sends an UE CONTEXT SETUP REQUEST message to the target gNB-DU to create an UE context and setup one or more data bearers. The UE CONTEXT SETUP REQUEST message includes a CG ConfigInfo.
6. The target gNB-DU responds the gNB-CU with an UE CONTEXT SETUP RESPONSE message.
7. The gNB-CU sends a UE CONTEXT MODIFICATION REQUEST message to the source gNB-DU indicating to stop the data transmission to the UE. The source gNB-DU also sends a Downlink Data Delivery Status frame to inform the gNB-CU about the unsuccessfully transmitted downlink data to the UE.
8. The source gNB-DU responds the gNB-CU with an UE CONTEXT MODIFICATION RESPONSE message.
9. The gNB-CU sends an SGNB MODIFICATION REQUIRED message to the MeNB.

10/11. The MeNB Initiated SgNB Modification procedure may be triggered by the SgNB Initiated SgNB Modification procedure (e.g. to provide information such as data forwarding addresses, new SN security key, measurement gap, etc...).

12. The MeNB and the UE perform RRC Connection Reconfiguration procedure.

13. The MeNB sends an SGNB MODIFICATION CONFIRM message to the gNB-CU.

14. Random Access procedure is performed at the target gNB-DU. The target gNB-DU sends a Downlink Data Delivery Status frame to inform the gNB-CU. Downlink packets, which may include PDCP PDUs not successfully transmitted in the source gNB-DU, are sent from the gNB-CU to the target gNB-DU. Downlink packets are sent to the UE. Also, uplink packets are sent from the UE, which are forwarded to the gNB-CU through the target gNB-DU.

NOTE: It is up to gNB-CU implementation whether to start sending DL User Data to gNB-DU before or after reception of the Downlink Data Delivery Status.

15. The gNB-CU sends an UE CONTEXT RELEASE COMMAND message to the source gNB-DU.

16. The source gNB-DU releases the UE context and responds the gNB-CU with an UE CONTEXT RELEASE COMPLETE message.

8.2.2.2 Inter-gNB-DU Mobility using SCG SRB (SRB3)

This procedure is used for the case the UE moves from one gNB-DU to another gNB-DU when SCG SRB (SRB3) is available during EN-DC operation. The procedure is the same as inter-gNB-DU Mobility for intra-NR as defined in clause 8.2.1.1 but the UE CONTEXT SETUP REQUEST message includes a CG-ConfigInfo.

8.2.2.3 Inter-gNB-DU Conditional PSCell Change using MCG SRB without MN negotiation

This procedure is used for the case where the UE moves from one gNB-DU to another gNB-DU within the same gNB-CU when only MCG SRB is available and the MN's configuration is not changed during EN-DC operation for conditional PSCell change. Figure 8.2.2.3-1 shows the inter-gNB-DU conditional PSCell change procedure using MCG SRB in EN-DC.

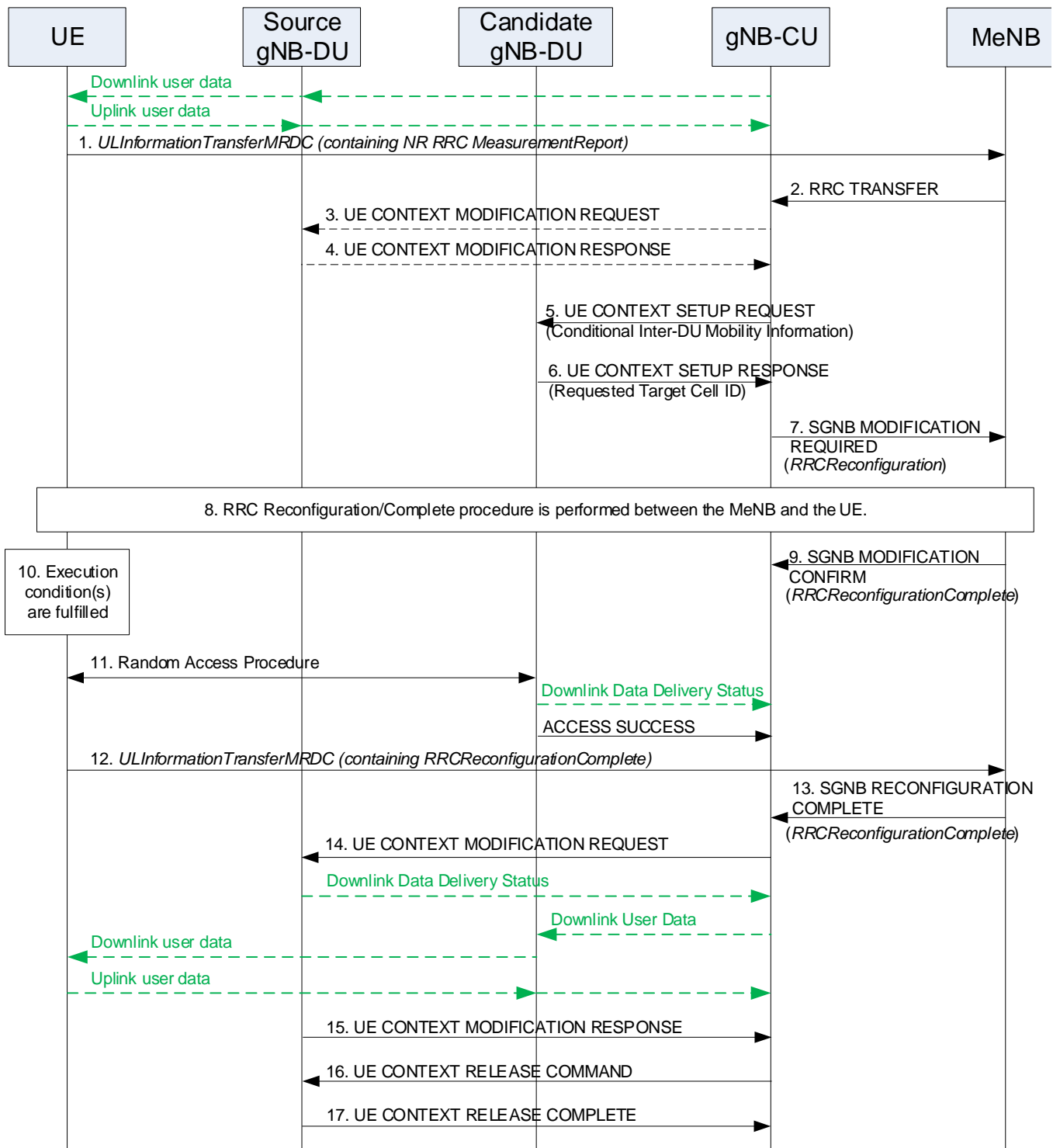

Figure 8.2.2.3-1: Inter-gNB-DU Conditional PSCell Change using MCG SRB without MN negotiation in EN-DC

1-4. The steps 1-4 are as defined in clause 8.2.2.1.

5. The gNB-CU sends an UE CONTEXT SETUP REQUEST message to the candidate gNB-DU to create an UE context and setup one or more data bearers. The UE CONTEXT SETUP REQUEST message is sent for each candidate cell and includes a CG-ConfigInfo.

6. The candidate gNB-DU responds the gNB-CU with an UE CONTEXT SETUP RESPONSE message including the target cell ID that was requested from the gNB-CU. The response message is sent for each requested candidate cell.
 7. The gNB-CU sends an SGNB MODIFICATION REQUIRED message to the MeNB, which includes a generated *RRCReconfiguration* message.
 8. The MeNB and the UE perform RRC Connection Reconfiguration/Complete procedure.
 9. The MeNB sends an SGNB MODIFICATION CONFIRM message to the gNB-CU, to convey the received *RRCReconfigurationComplete* message at step 8.
 10. An execution condition to trigger initiation of conditional PSCell change is fulfilled.
 11. Random Access procedure is performed at the candidate gNB-DU, which becomes the target gNB-DU if successful. The target gNB-DU sends a Downlink Data Delivery Status frame to inform the gNB-CU. The target gNB-DU also sends an ACCESS SUCCESS message to inform the gNB-CU of which cell the UE has successfully accessed.
 - 12-13. The UE responds with an *RRCReconfigurationComplete* message (embedded in an *ULInformationTransferMRDC* message), which the MeNB forwards to the gNB-CU via an SGNB RECONFIGURATION COMPLETE message.
 14. The gNB-CU sends a UE CONTEXT MODIFICATION REQUEST message to the source gNB-DU and indicates to stop the data transmission for the UE. The source gNB-DU sends a Downlink Data Delivery Status frame to inform the gNB-CU about the unsuccessfully transmitted downlink data to the UE. Downlink packets, which may include PDCP PDUs not successfully transmitted in the source gNB-DU, are sent from the gNB-CU to the target gNB-DU. Downlink packets are sent to the UE. Also, uplink packets are sent from the UE, which are forwarded to the gNB-CU through the target gNB-DU.
- NOTE: The step 14 may happen before step 13, as soon as the gNB-CU knows which cell the UE has successfully accessed.
- NOTE: The gNB-CU may initiate UE Context Release procedure toward the other signalling connections or other candidate target gNB-DUs, if any, to cancel conditional PSCell change for the UE.
15. The source gNB-DU responds to the gNB-CU with the UE CONTEXT MODIFICATION RESPONSE message.
 - 16-17. The steps 16-17 are as defined in steps 11-12 in clause 8.2.1.1.

8.2.3 Intra-CU topology adaptation procedure

8.2.3.1 Intra-CU topology adaptation procedure in SA

During the intra-CU topology adaptation in SA, both the source and the target parent node are served by the same IAB-donor-CU. The target parent node may use a different IAB-donor-DU than the source parent node. The source path may have common nodes with the target path. Figure 8.2.3.1-1 shows an example of the topology adaptation procedure, where the target parent node uses a different IAB-donor-DU than the one used by the source parent node.

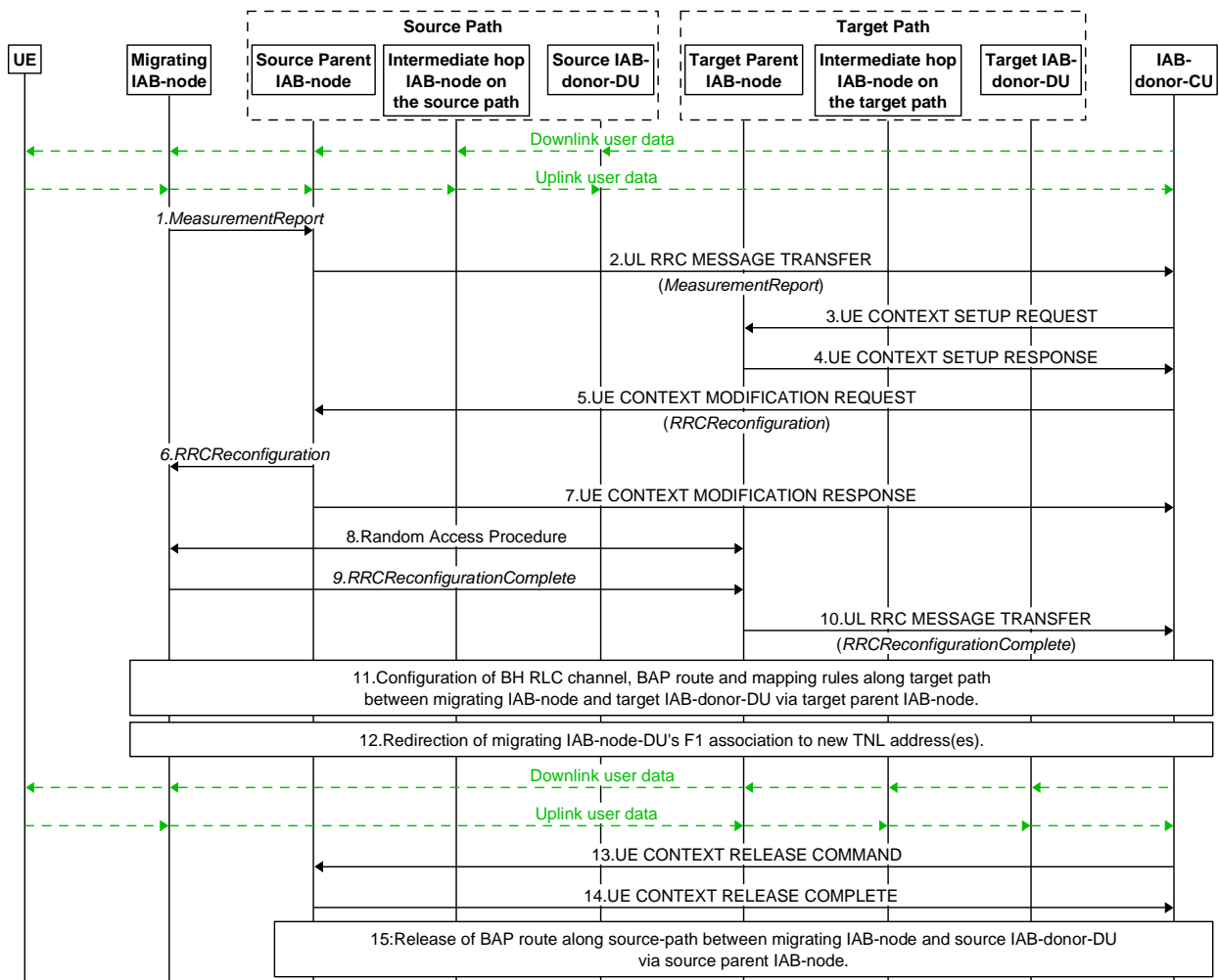

Figure 8.2.3.1-1: IAB intra-CU topology adaptation procedure

1. The migrating IAB-MT sends a *MeasurementReport* message to the source parent node IAB-DU. This report is based on a Measurement Configuration the migrating IAB-MT received from the IAB-donor-CU before.
2. The source parent node IAB-DU sends an UL RRC MESSAGE TRANSFER message to the IAB-donor-CU to convey the received *MeasurementReport*.
3. The IAB-donor-CU sends a UE CONTEXT SETUP REQUEST message to the target parent node IAB-DU to create the UE context for the migrating IAB-MT and set up one or more bearers. These bearers can be used by the migrating IAB-MT for its own signalling, and, optionally, data traffic.
4. The target parent node IAB-DU responds to the IAB-donor-CU with a UE CONTEXT SETUP RESPONSE message.
5. The IAB-donor-CU sends a UE CONTEXT MODIFICATION REQUEST message to the source parent node IAB-DU, which includes a generated *RRCReconfiguration* message. The *RRCReconfiguration* message includes a default BH RLC channel and a default BAP Routing ID configuration for UL F1-C/non-F1 traffic mapping on the target path. It may include additional BH RLC channels. This step may also include allocation of TNL address(es) that is (are) routable via the target IAB-donor-DU. The new TNL address(es) may be included in the *RRCReconfiguration* message as a replacement for the TNL address(es) that is (are) routable via the source IAB-donor-DU. In case IPsec tunnel mode is used to protect the F1 and non-F1 traffic, the allocated TNL address is outer IP address. The TNL address replacement is not necessary if the source and target paths use the same IAB-donor-DU. The *Transmission Action Indicator* in the UE CONTEXT MODIFICATION REQUEST message indicates to stop the data transmission to the migrating IAB-node.
6. The source parent node IAB-DU forwards the received *RRCReconfiguration* message to the migrating IAB-MT.
7. The source parent node IAB-DU responds to the IAB-donor-CU with the UE CONTEXT MODIFICATION RESPONSE message.

8. A Random Access procedure is performed at the target parent node IAB-DU.
9. The migrating IAB-MT responds to the target parent node IAB-DU with an *RRCReconfigurationComplete* message.
10. The target parent node IAB-DU sends an UL RRC MESSAGE TRANSFER message to the IAB-donor-CU to convey the received *RRCReconfigurationComplete* message. Also, uplink packets can be sent from the migrating IAB-MT, which are forwarded to the IAB-donor-CU through the target parent node IAB-DU. These UL packets belong to the IAB-MT's own signalling and, optionally, data traffic.
11. The IAB-donor-CU configures BH RLC channels and BAP-sublayer routing entries on the target path between the target parent IAB-node and target IAB-donor-DU as well as DL mappings on the target IAB-donor-DU for the migrating IAB-node's target path. These configurations may be performed at an earlier stage, e.g. immediately after step 3. The IAB-donor-CU may establish additional BH RLC channels to the migrating IAB-MT via RRC message.
12. The F1-C connections are switched to use the migrating IAB-node's new TNL address(es), IAB-donor-CU updates the UL BH information associated to each GTP-tunnel to migrating IAB-node. This step may also update UL FTEID and DL FTEID associated to each GTP-tunnel. All F1-U tunnels are switched to use the migrating IAB-node's new TNL address(es). This step may use non-UE associated signaling in E1 and/or F1 interface to provide updated UP configuration for F1-U tunnels of multiple connected UEs or child IAB-MTs. The IAB-donor-CU may also update the UL BH information associated with non-UP traffic. Implementation must ensure the avoidance of potential race conditions, i.e. no conflicting configurations are concurrently performed using UE-associated and non-UE-associated procedures.
13. The IAB-donor-CU sends a UE CONTEXT RELEASE COMMAND message to the source parent node IAB-DU.
14. The source parent node IAB-DU releases the migrating IAB-MT's context and responds to the IAB-donor-CU with a UE CONTEXT RELEASE COMPLETE message.
15. The IAB-donor-CU releases BH RLC channels and BAP-sublayer routing entries on the source path between source parent IAB-node and source IAB-donor-DU.

NOTE: In case that the source path and target path have common nodes, the BH RLC channels and BAP-sublayer routing entries of those nodes may not need to be released in Step 15.

Steps 11, 12 and 15 should also be performed for the migrating IAB-node's descendant nodes, as follows:

The IAB-donor-CU may allocate new TNL address(es) that is (are) routable via the target IAB-donor-DU to the descendent nodes via *RRCReconfiguration* message.

If needed, the IAB-donor-CU may also provide a new default UL mapping which includes a default BH RLC channel and a default BAP Routing ID for UL F1-C/non-F1 traffic on the target path, to the descendant nodes via *RRCReconfiguration* message.

If needed, the IAB-donor-CU configures BH RLC channels, BAP-sublayer routing entries on the target path for the descendant nodes and the BH RLC channel mappings on the descendant nodes in the same manner as described for the migrating IAB-node in step 11.

The descendant nodes switch their F1-C connections and F1-U tunnels to new TNL addresses that are anchored at the new IAB-donor-DU, in the same manner as described for the migrating IAB-node in step 12.

Based on implementation, these steps can be performed after or in parallel with the handover of the migrating IAB-node.

NOTE: In upstream direction, in-flight packets between the source parent node and the IAB-donor-CU can be delivered even after the target path is established.

NOTE: In-flight downlink data in the source path may be discarded, up to implementation via the NR user plane protocol (TS 38.425 [24]).

NOTE: The IAB-donor-CU can determine the unsuccessfully transmitted downlink data over the backhaul link by implementation.

8.2.3.2 Intra-CU topology adaptation procedure in NSA using MCG SRB

This procedure is used when the migrating IAB-MT moves from source parent node to target parent node within the same IAB-donor-CU while only MCG SRB is available for IAB-node during EN-DC operation. The target parent node may use a different IAB-donor-DU than the one used by the source parent node. The source path may have common nodes with the target path. Figure 8.2.3.2-1 shows the topology adaptation procedure using MCG SRB of IAB-MT in EN-DC, where the target parent node uses a different IAB-donor-DU than the source parent node.

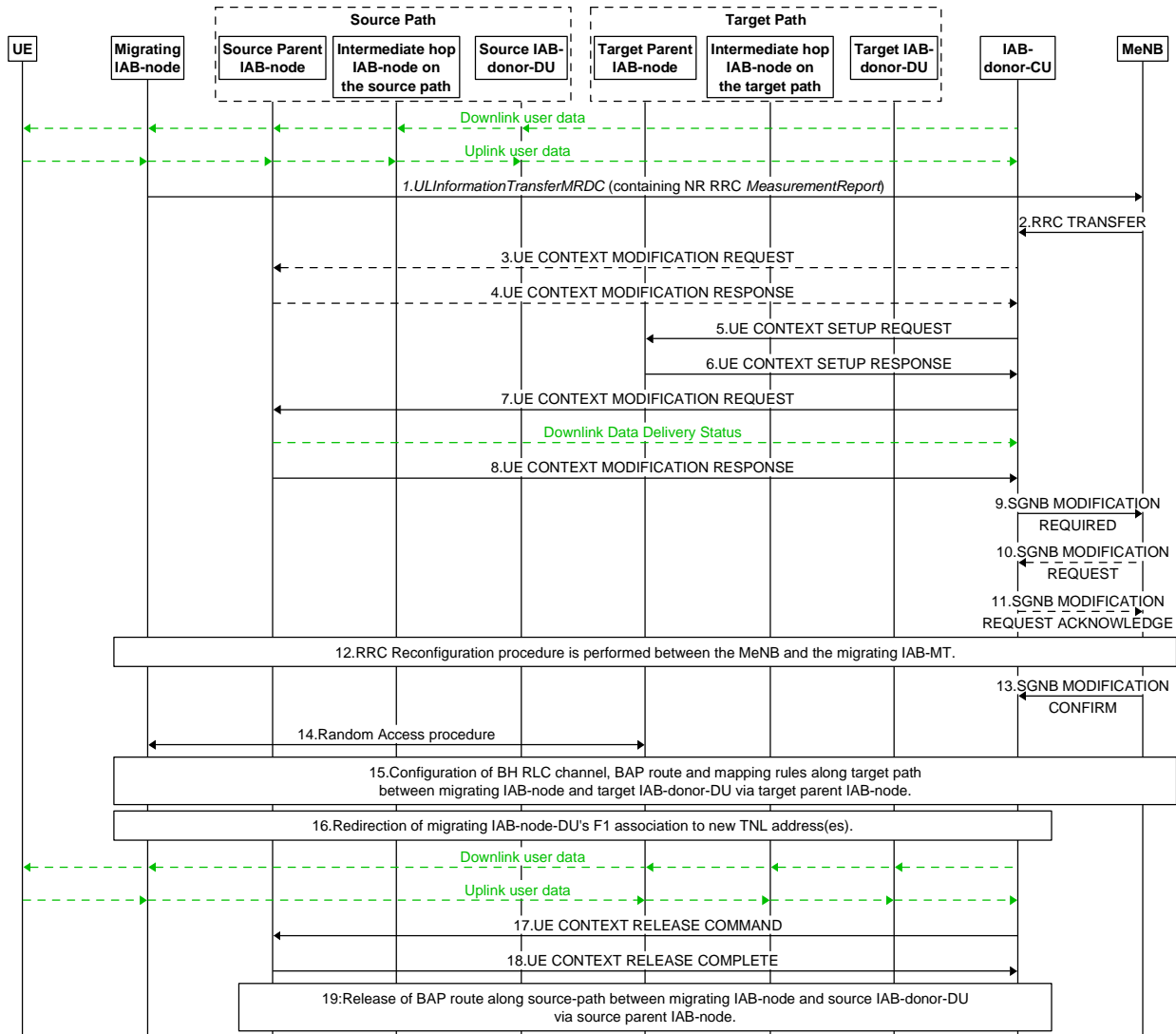

Figure 8.2.3.2-1: IAB intra-CU topology adaptation procedure using MCG SRB in EN-DC

1. The migrating IAB-MT sends an *ULInformationTransferMRDC* message to the MeNB
2. The MeNB sends RRC TRANSFER message to the IAB-donor-CU.
3. The IAB-donor-CU may send UE CONTEXT MODIFICATION REQUEST message to the source parent node IAB-DU, to query the latest SCG configuration.
4. The source parent node IAB-DU responds with a UE CONTEXT MODIFICATION RESPONSE message that includes full configuration information.
5. The IAB-donor-CU sends a UE CONTEXT SETUP REQUEST message to the target parent node IAB-DU, to create a UE context for migrating IAB-MT and set up one or more bearers. These bearers can be used by the migrating IAB-MT for its own signalling, and, optionally, data traffic. The UE CONTEXT SETUP REQUEST message includes *CG-ConfigInfo*.

6. The target parent node IAB-DU responds to the IAB-donor-CU with a UE CONTEXT SETUP RESPONSE message.
7. The IAB-donor-CU sends a UE CONTEXT MODIFICATION REQUEST message to the source parent node IAB-DU, this message includes the *Transmission Action Indicator* IE, which instructs the source parent node IAB-DU to stop the data transmission to the migrating IAB-node. The source parent node IAB-DU also sends a Downlink Data Delivery Status frame to inform the IAB-donor-CU about the unsuccessfully transmitted downlink data to the migrating IAB-node.
8. The source parent node IAB-DU responds to the IAB-donor-CU with a UE CONTEXT MODIFICATION RESPONSE message.
9. The IAB-donor-CU sends an SGNB MODIFICATION REQUIRED message to the MeNB.
- 10/11. The MeNB initiated SgNB Modification procedure may be triggered by the SgNB initiated SgNB Modification procedure (e.g. to provide information such as data forwarding addresses, new SN security key, measurement gap, etc.).
12. The MeNB and the migrating IAB-MT perform RRC Connection Reconfiguration procedure. The *RRCConnectionReconfiguration* message includes information as described for the intra-CU topology adaptation procedure in SA in section 8.2.3.1.
13. The MeNB sends an SGNB MODIFICATION CONFIRM message to the IAB-donor-CU.
14. The migrating IAB-MT performs Random Access procedure at the target parent node IAB-DU.
- 15-19. The remaining steps of the procedure follow the steps 11-15 of the intra-CU topology adaptation procedure in SA scenario, as defined in clause 8.2.3.1. The main difference is that the RRC message for the migrating IAB-node, if involved, will be transmitted using the MCG SRB.

8.2.3.3 Intra-CU topology adaptation procedure in NSA using SCG SRB (SRB3)

This procedure is used when the migrating IAB-MT moves from source parent node to target parent node within the same IAB-donor-CU, when SCG SRB (SRB3) is available for IAB-node during EN-DC operation. The target parent node may use a different IAB-donor-DU than the source parent node. The source path may have common nodes with the target path. The procedure is the same as intra-CU topology adaptation procedure in SA scenario as defined in clause 8.2.3.1 but the UE CONTEXT SETUP REQUEST message includes *CG-ConfigInfo* in step 3.

8.2.4 Intra-CU topological redundancy procedure

The intra-CU topological redundancy procedure enables the establishment and release of redundant paths in the IAB-topology underneath the same IAB-donor-CU. The redundant paths may use different IAB-donor-DUs. They may also have common intermediate nodes. Since topological redundancy uses NR-DC for the IAB-MT, it is only supported for IAB-nodes operating in SA mode.

Figure 8.2.4-1 shows an example for an IAB topology, where one IAB-node, referred to as the dual-connecting IAB-node, has two paths towards the IAB-donor via different IAB-donor-DUs.

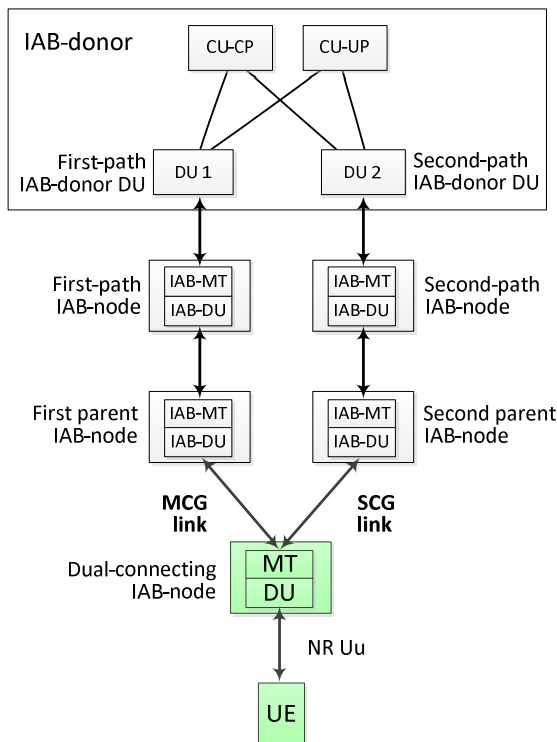

Figure 8.2.4-1: Example for IAB topology with two redundant paths

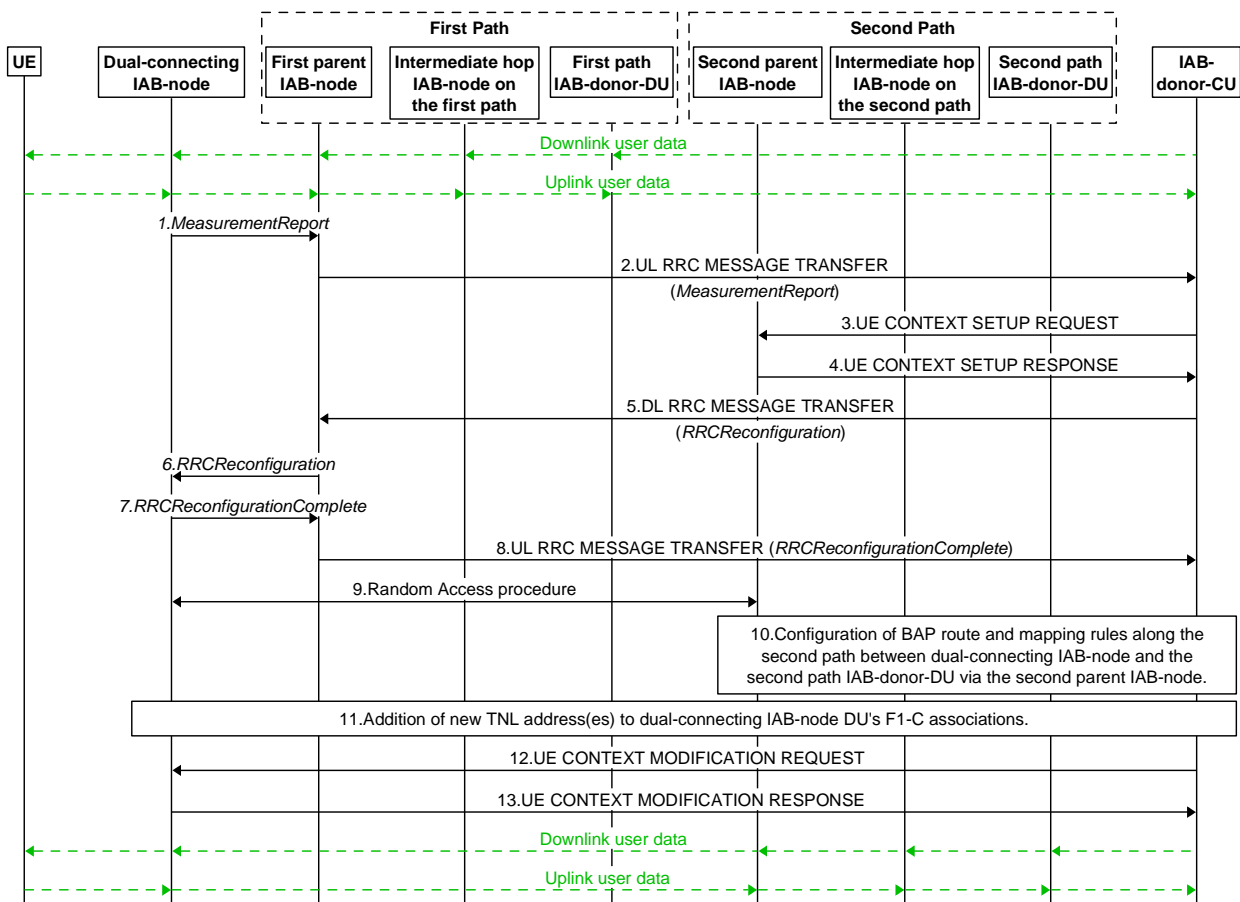

Figure 8.2.4-2: Procedure for establishment of redundant path in IAB topology

Figure 8.2.4-2 shows the procedure for the establishment of the second path. This procedure has the following steps:

1. The dual-connecting IAB-MT sends a *MeasurementReport* message to the first parent node IAB-DU. This report is based on a Measurement Configuration the dual-connecting IAB-MT received from the IAB-donor-CU before.
2. The first parent node IAB-DU sends an UL RRC MESSAGE TRANSFER message to the IAB-donor-CU to convey the received *MeasurementReport*.
3. The IAB-donor-CU sends the UE CONTEXT SETUP REQUEST message to the second parent node IAB-DU, to create the UE context for the dual-connecting IAB-MT and to set up one or more bearers. These bearers can be used by the dual-connecting IAB-MT for its own signalling, and, optionally, data traffic.
4. The second parent node IAB-DU responds to the IAB-donor-CU with a UE CONTEXT SETUP RESPONSE message.
5. The IAB-donor-CU sends a DL RRC MESSAGE TRANSFER message to the first parent node IAB-DU, which includes a generated *RRCReconfiguration* message. The *RRCReconfiguration* message may contain one or more TNL address(es) for the dual-connecting IAB-DU, which are anchored at the second-path IAB-donor-DU. The IAB-donor-CU can proactively obtain these TNL addresses from the second-path IAB-donor-DU. In case IPsec tunnel mode is used to protect the F1 and non-F1 traffic, the allocated TNL address is the outer IP address. The TNL address allocation is not necessary if the first and second paths use the same IAB-donor-DU.
6. The first parent node IAB-DU forwards the received *RRCReconfiguration* message to the dual-connecting IAB-MT.
7. The dual-connecting IAB-MT responds to the first parent node IAB-DU with an *RRCReconfigurationComplete* message.
8. The first parent node IAB-DU sends an UL RRC MESSAGE TRANSFER message to the IAB-donor-CU, to convey the received *RRCReconfigurationComplete* message.
9. A Random Access procedure is performed at the second parent node IAB-DU.
10. The IAB-donor-CU configures BH RLC channels and BAP-layer route entries on the second path between dual-connecting IAB-node and second-path IAB-donor-DU. These configurations may be performed at an earlier stage, e.g. immediately after step 3.
11. The new TNL addresses allocated in step 5 (if any) are added to the dual-connecting IAB-DU's F1-C association(s) with the IAB-donor-CU. The IAB-donor-CU may configure new UL BH information on the second path for F1AP messages.
12. The IAB-donor-CU may migrate the F1-U tunnels it has with the dual-connecting IAB-DU from the first path to the second path via the UE CONTEXT MODIFICATION REQUEST message.
13. The dual-connectivity IAB-DU replies with a UE CONTEXT MODIFICATION RESPONSE message.

Steps 12 and 13 can be performed for a subset of UE bearers, e.g., to balance the load between the first and the second path.

In case the second path is used for the dual-connecting IAB-node's descendant node(s), Steps 10 and 11 are also performed for the descendant node(s), as follows:

When the second path uses a different IAB-donor-DU, the IAB-donor-CU shall configure the descendant IAB-DU(s) with one or more new TNL addresses, which are anchored on the IAB-donor-DU of the second path.

If needed, the IAB-donor-CU configures BH RLC channels, BAP-layer route entries on the target path for the descendant nodes and the BH RLC channel mappings on the descendant nodes in the same manner as described for the dual-connecting IAB-node in step 10.

The descendant nodes' new TNL addresses (if any) are added to the descendant node IAB-DU's F1-C association(s) with the IAB-donor-CU. The IAB-donor-CU may configure UL BH information for the second path to carry F1AP messages.

The IAB-donor-CU may migrate the F1-U tunnels it has with the dual-connecting IAB-node's descendant node(s) from the first path to the second path, as described for step 12.

Based on implementation, these steps can be performed after or in parallel with the redundant path addition of the dual connecting IAB-node.

The IAB-donor-CU may initiate the release of the redundant path by releasing the BAP routing entries and modifying/releasing the BH RLC channels on that path.

8.2.5 Intra-CU Backhaul RLF recovery for IAB-nodes in SA mode

The intra-CU backhaul RLF recovery procedure for IAB-nodes in SA mode enables migration of an IAB-node to another parent node underneath the same IAB-donor-CU, when the IAB-MT declares a backhaul RLF. The declaration of backhaul RLF is described in TS 38.331 [23].

NOTE: Determination of whether the recovery occurs at the same or at a different IAB-donor-CU is up to implementation.

Figure 8.2.5-1 shows an example of the BH RLF recovery procedure for an IAB-node in SA mode. In this example, the IAB-node changes from its initial parent node to a new parent node, where the new parent node is served by an IAB-donor-DU different than the one serving its initial parent node.

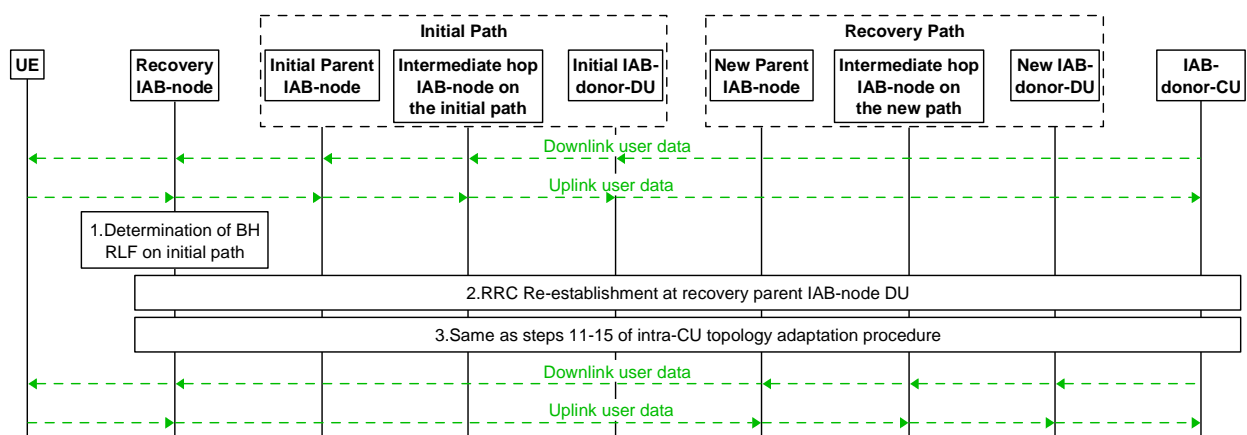

Figure 8.2.5-1: IAB intra-CU backhaul RLF recovery procedure for an IAB-node in SA mode

1. The IAB-MT declares BH RLF for the MCG as described in TS 38.331 [23], clause 5.3.10.3.
2. The IAB-MT undergoing recovery from RLF conducts the RRC re-establishment procedure at the new parent node, as defined in clause 8.7. In this procedure, the IAB-donor-CU may provide new TNL address(es), which is(are) anchored at the new IAB-donor-DU, to the IAB-MT via RRC signalling. Furthermore, the IAB-donor-CU may also provide a new default UL mapping which includes a default BH RLC channel and a default BAP Routing ID for UL F1-C/non-F1 traffic on the target path, to the IAB-node undergoing recovery from RLF via *RRCReconfiguration* message in this procedure.
3. The remaining part of the procedure follows the steps 11-15 of the intra-CU topology adaptation procedure defined in clause 8.2.3.

Descendant node(s) of the IAB-node undergoing recovery from RLF may also need to switch to new TNL address(es) anchored in the target-path IAB-donor-DU following the same mechanism as described for IAB intra-CU topology adaptation procedure in clause 8.2.3. The descendant node(s) may also be provided with new default UL mapping via RRC, after the IAB-node undergoing recovery from RLF connects the IAB-donor-CU via the recovery path.

8.3 Mechanism of centralized retransmission of lost PDUs

8.3.1 Centralized Retransmission in Intra gNB-CU Cases

This mechanism allows to perform the retransmission of the PDCP PDUs that are not delivered by a gNB-DU (gNB-DU1) because the corresponding radio links toward the UE are subject to outage. When such outage occurs, the gNB-

DU affected by outage informs the gNB-CU of such event. The gNB-CU can switch transmission of data traffic, as well as perform retransmission of undelivered PDCP PDUs, from the gNB-DU affected by outage to other available gNB-DUs (e.g. gNB-DU2 in Figure 8.3.1-1) with a well-functioning radio link toward the UE. The mechanism is also applicable in EN-DC and MR-DC with 5GC, refer to TS 37.340 [12].

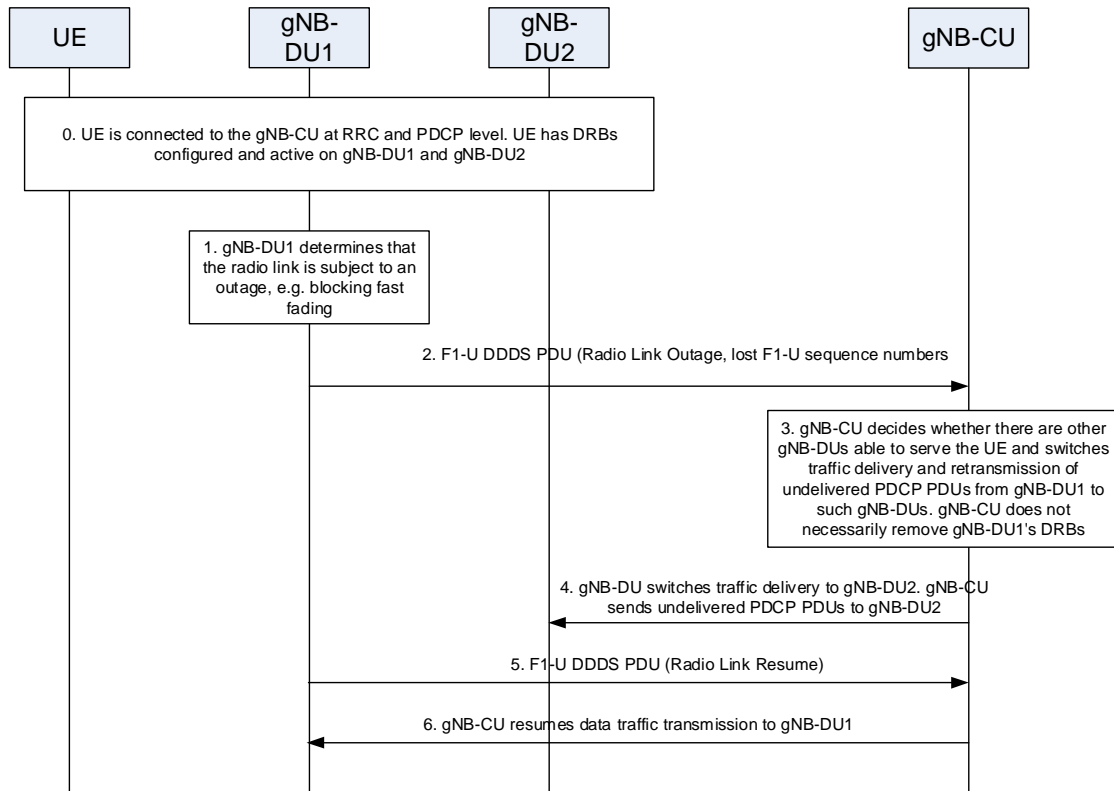

Figure 8.3.1-1: Procedure for centralized retransmission in intra gNB-CU scenarios

The mechanism is shown in Figure 8.3.1-1 and targets the multi-connectivity scenario, where a UE is served by multiple data radio bearers established at least on two gNB-DUs, and it includes the following steps:

0. The UE is connected and can transmit/receive data to/from gNB-DU1 and gNB-DU2.
1. gNB-DU1 realizes that the radio link towards the UE is experiencing outage.
2. gNB-DU1 sends the "Radio Link Outage" notification message to the gNB-CU over the F1-U interface, as part of the DDDS PDU of the concerned data radio bearer. The message may include information to be used by the gNB-CU to perform retransmission of the PDCP PDUs that were not delivered by the gNB-DU1 (e.g. the highest transmitted NR PDCP Sequence Number, the highest successfully delivered NR PDCP Sequence Number and the lost NR-U Sequence Numbers).
3. gNB-CU decides to switch data traffic transmission and retransmission of PDCP PDUs that were undelivered in gNB-DU1 via gNB-DU2. gNB-CU stops sending downlink traffic to gNB-DU1. The radio leg between gNB-DU1 and the UE is not necessarily removed.
4. gNB-CU starts sending traffic (namely new PDUs and potentially retransmitted PDUs) to gNB-DU2.
5. If gNB-DU1 realizes that the radio link of the concerned data radio bearer is back in normal operation, it may send a "Radio Link Resume" notification message as part of the DDDS PDU over the F1-U interface to inform the gNB-CU that the radio link can be used again for the concerned data radio bearer.
6. gNB-CU may start sending traffic (namely new PDUs and potentially retransmitted PDUs) of the concerned data radio bearer via gNB-DU1 again.

8.4 Multi-Connectivity operation

8.4.1 Secondary Node Addition

8.4.1.1 EN-DC

This clause gives the SgNB addition procedure in EN-DC given that en-gNB consists of gNB-CU and gNB-DU(s), as shown in Figure 8.4.1.1-1.

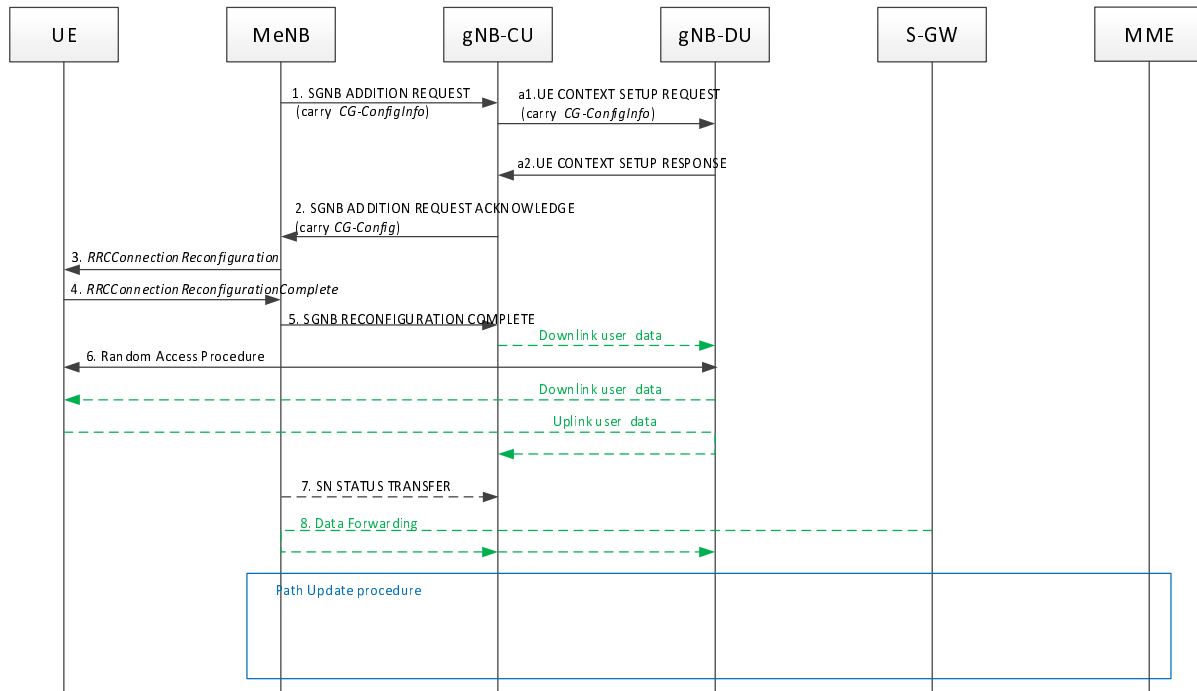

Figure 8.4.1.1-1: SgNB addition procedure in EN-DC

1~8: refer to TS 37.340 [12]

a1. After receiving the SgNB ADDITION REQUEST message from MeNB, the gNB-CU sends the UE CONTEXT SETUP REQUEST message to the gNB-DU to create a UE context. As specified in TS 37.340 [12], in the course of a Secondary Node Change, the UE CONTEXT SETUP REQUEST message may contain source cell group configuration to allow gNB-DU to perform delta configuration.

a2. The gNB-DU responds to the gNB-CU with the UE CONTEXT SETUP RESPONSE message. In case the gNB-DU receives the UE CONTEXT SETUP REQUEST message without the source cell group configuration or in the course of a Secondary Node Change as specified in TS 37.340 [12] or if the gNB-DU decides to perform full configuration after receiving the source cell group configuration, it shall perform full configuration and indicate that it has applied full configuration in the UE CONTEXT SETUP RESPONSE message.

NOTE: On Inter-gNB-CU Mobility, same method is performed to achieve full configuration and delta configuration.

8.4.2 Secondary Node Release (MN/SN initiated)

8.4.2.1 EN-DC

This clause gives the SgNB release procedure in EN-DC given that the en-gNB consists of a gNB-CU and gNB-DU(s).

MN initiated SN Release

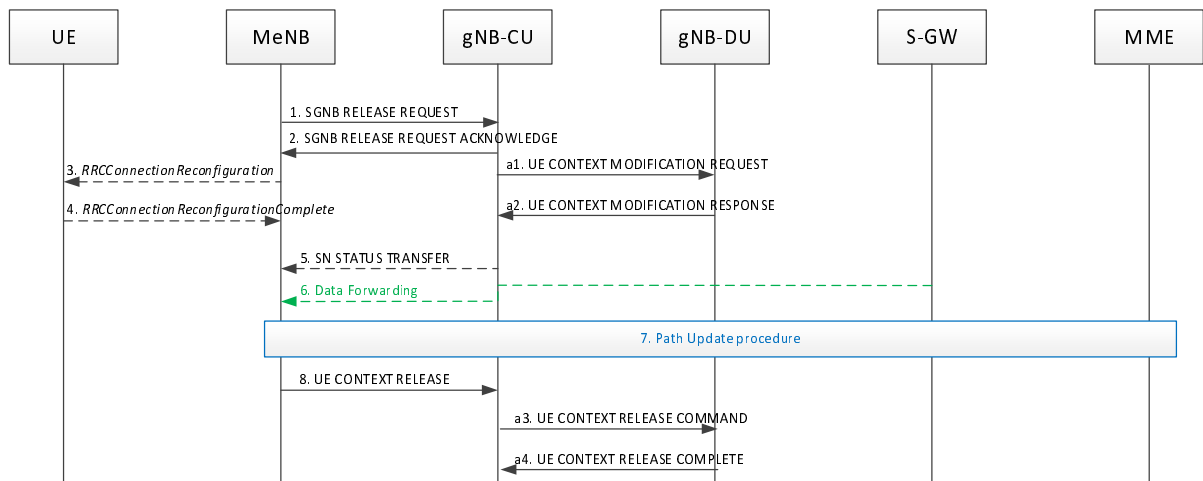

Figure 8.4.2.1-1 SgNB release procedure in EN-DC (MN initiated)

1~8: refer to TS 37.340 [12]

NOTE: The timing of sending the Step 2 SgNB RELEASE REQUEST ACKNOWLEDGE message is an example, it may be sent e.g. after step a1 or after a2 and it is up to implementation.

- a1. After receiving SgNB RELEASE REQUEST message from MeNB, gNB-CU sends the UE CONTEXT MODIFICATION REQUEST message to gNB-DU to stop the data transmission for the UE. It is up to gNB-DU implementation when to stop the UE scheduling.
- a2. gNB-DU responds to gNB-CU with UE CONTEXT MODIFICATION RESPONSE message.
- a3. After receiving the UE CONTEXT RELEASE message from MeNB, the gNB-CU sends the UE CONTEXT RELEASE COMMAND message to the gNB-DU to release the UE context.
- a4. The gNB-DU responds to the gNB-CU with the UE CONTEXT RELEASE COMPLETE message.

SN initiated SN Release

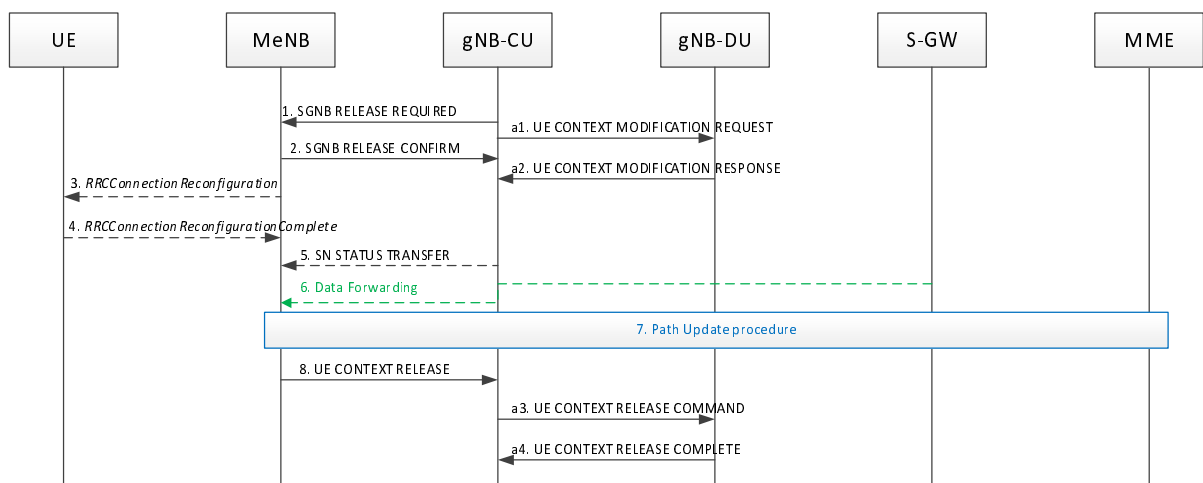

Figure 8.4.2.1-2 SgNB release procedure in EN-DC (SN initiated)

1~8: refer to TS 37.340 [12]

- a1. gNB-CU sends the UE CONTEXT MODIFICATION REQUEST message to gNB-DU to stop the data transmission for the UE. It is up to gNB-DU implementation when to stop the UE scheduling. This step may occur before step 1.

- a2. gNB-DU responds to gNB-CU with UE CONTEXT MODIFICATION RESPONSE message.
- a3. After receiving the UE CONTEXT RELEASE message from MeNB, the gNB-CU sends the UE CONTEXT RELEASE COMMAND message to the gNB-DU to release the UE context.
- a4. The gNB-DU responds to the gNB-CU with the UE CONTEXT RELEASE COMPLETE message.

8.4.3 SCG suspend/resume in RRC_INACTIVE

In the following, the procedure for SCG resume in RRC_INACTIVE is described.

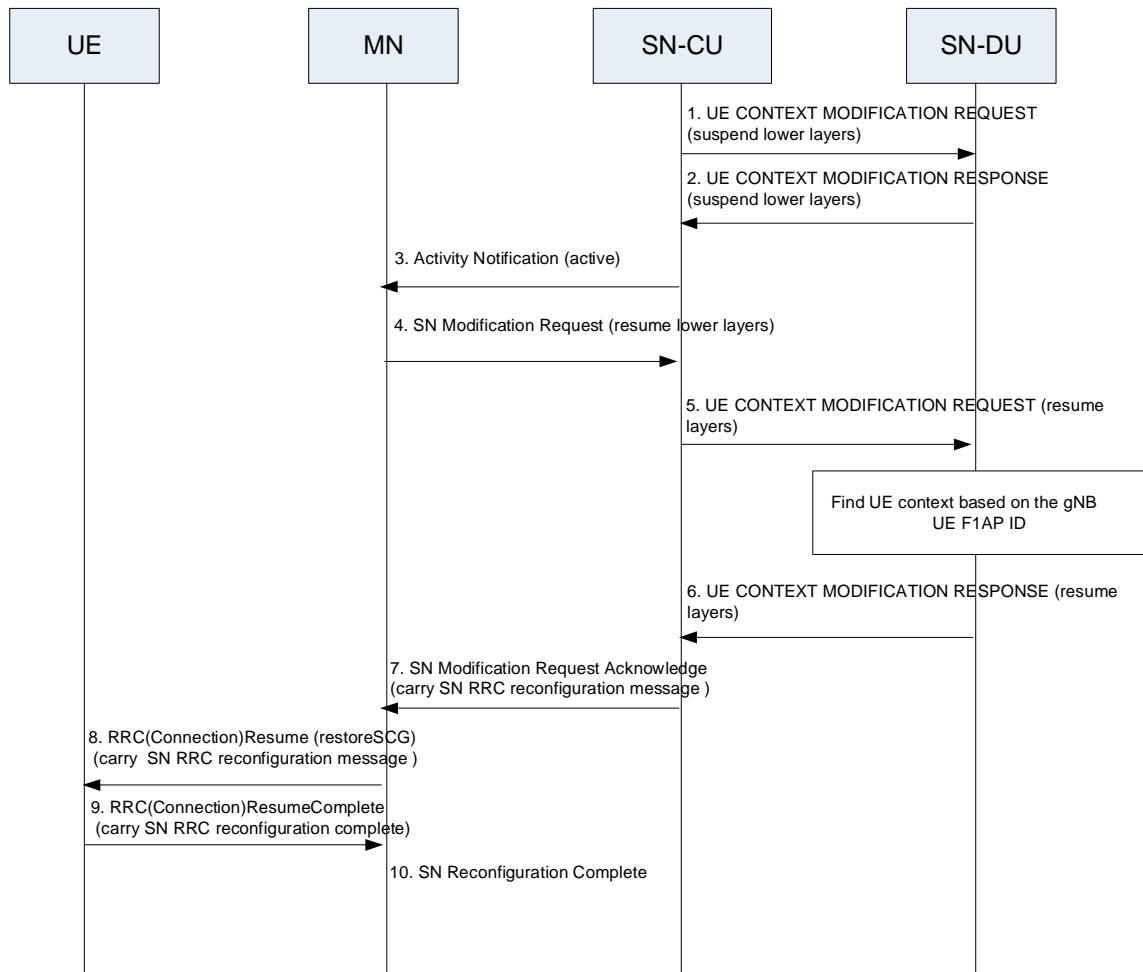

Figure 8.4.3-1: SCG Suspend/Resume in RRC_INACTIVE

1. The CU of SN sends the UE CONTEXT MODIFICATION REQUEST message to the DU of SN to suspend the SCG of the UE before the UE enters into RRC_INACTIVE state from RRC_CONNECTED state.
2. The DU of SN sends the UE CONTEXT MODIFICATION RESPONSE to the CU of SN, and keeps all lower layer configuration for UEs without transmitting or receiving data from UE.
- 3~4: refer to TS 37.340 [12].
5. The CU of SN sends the UE CONTEXT MODIFICATION REQUEST message to the DU of SN to resume the SCG of the UE before the UE enters into RRC_CONNECTED state from RRC_INACTIVE state.
6. The DU of SN sends the UE CONTEXT MODIFICATION RESPONSE message to the CU of SN, and uses the previously stored lower layer configuration for the UE.
- 7~10: refer to TS 37.340 [12].

8.5 F1 Startup and cells activation

This function allows to setup the F1 interface between a gNB-DU and a gNB-CU and it allows to activate the gNB-DU cells.

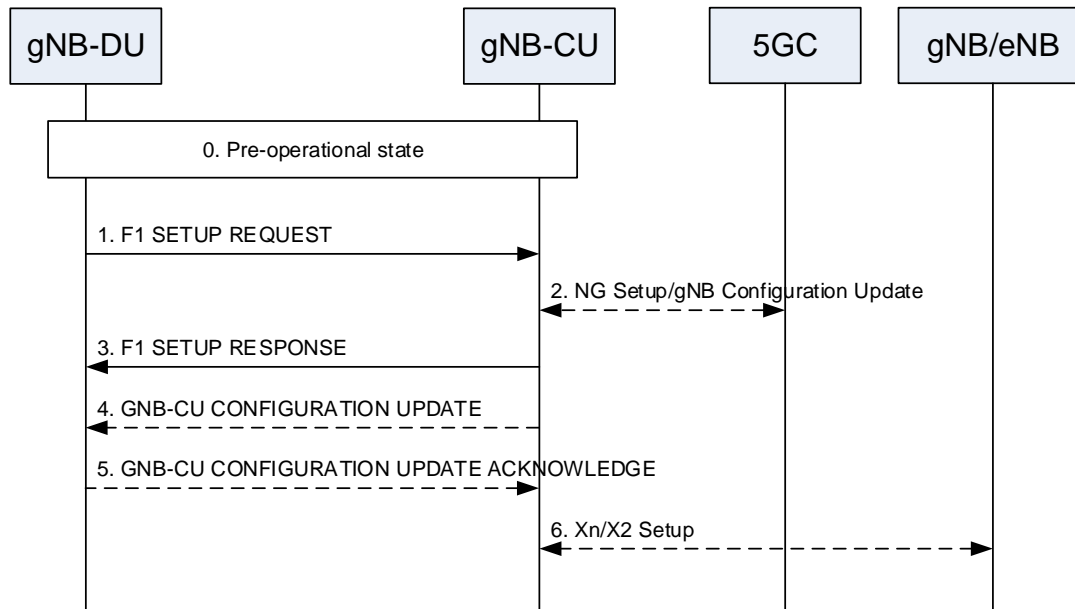

Figure 8.5-1: F1 startup and cell activation

0. The gNB-DU and its cells are configured by OAM in the F1 pre-operational state. The gNB-DU has TNL connectivity toward the gNB-CU.
1. The gNB-DU sends an F1 SETUP REQUEST message to the gNB-CU including a list of cells that are configured and ready to be activated. For each cell supporting NPN the gNB-DU includes NPN specific information.
2. In NG-RAN, the gNB-CU ensures the connectivity toward the core network. For this reason, the gNB-CU may initiate either the NG Setup or the gNB Configuration Update procedure towards 5GC.
3. The gNB-CU sends an F1 SETUP RESPONSE message to the gNB-DU that optionally includes a list of cells to be activated. The cells in the list of cells to be activated in F1 SETUP RESPONSE message become active, while the cells not in the list are inactive. The cells that are active are *Out-of-Service* until the gNB-DU indicates that they are *In-Service*. The gNB-DU will initiate the gNB-DU Configuration Update procedure towards the gNB-CU and includes the cell(s) that are *In-Service* and/or the cell(s) that are *Out-Of-Service*. The gNB-DU may also indicate cell(s) to be deleted, in which case the gNB-CU removes the corresponding cell(s) information.
4. The gNB-CU may send a GNB CU CONFIGURATION UPDATE message to the gNB-DU that optionally includes a list of cells to be activated, e.g., in case that these cells were not activated using the F1 SETUP RESPONSE message.
5. The gNB-DU replies with a GNB CU CONFIGURATION UPDATE ACKNOWLEDGE message that optionally includes a list of cells that failed to be activated. The gNB-CU regards all Active cells as *Out-Of-Service* until the gNB-DU indicates that they are *In-Service*.
6. The gNB-CU may initiate either the Xn Setup towards a neighbour NG-RAN node or the EN-DC X2 Setup procedure towards a neighbour eNB.

NOTE 1: For NG-RAN in case that the F1 SETUP RESPONSE message is not used to activate any cell, step 2 may be performed after step 3.

Over the F1 interface between a gNB-CU and a gNB-DU pair, the following two Cell States are possible:

- *Inactive*: the cell is known by both the gNB-DU and the gNB-CU. The cell shall not serve UEs;
- *Active*: the cell is known by both the gNB-DU and the gNB-CU. The cell should try to provide services to the UEs.

The gNB-CU decides whether the Cell State should be “Inactive” or “Active”. The gNB-CU can request the gNB-DU to change the Cell State using the F1 SETUP RESPONSE, the GNB DU CONFIGURATION UPDATE ACKNOWLEDGE, or the GNB CU CONFIGURATION UPDATE messages.

The gNB-DU reports to the gNB-CU the *Service Status*. The *Service Status* is the state of the radio transmission over the air. The *Service Status* is reported by the gNB-DU for cells for which the Cell State is “Active”. The following *Service Status* are defined:

- *In-Service*: the cell is operational and able to serve UEs.
- *Out-Of-Service*: the cell is not operational, and it is not able to serve UEs. The gNB-DU is trying to make the cell operational.

The gNB-DU reports the *Service Status* using the GNB DU CONFIGURATION UPDATE message.

NOTE 2: If gNB-DU regards that one or more cells cannot become operational, the gNB-DU deletes them and reports them using the GNB DU CONFIGURATION UPDATE message.

8.6 RRC state transition

8.6.1 RRC connected to RRC inactive

This section gives the RRC connected to RRC inactive state transition given that gNB consists of gNB-CU and gNB-DU(s), as shown in Figure 8.6.1-1.

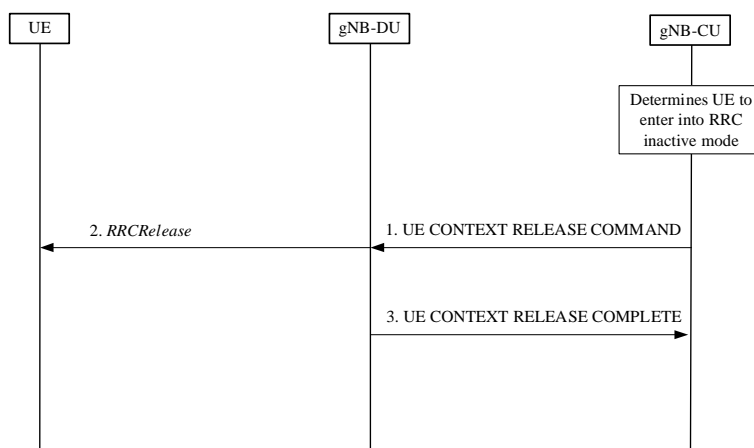

Figure 8.6.1-1: RRC connected to RRC inactive state transition procedure

0. At first, the gNB-CU determines the UE to enter into RRC inactive mode from connected mode.
1. The gNB-CU generates *RRCRelease* message towards UE. The RRC message is encapsulated in UE CONTEXT RELEASE COMMAND message to the gNB-DU.
2. The gNB-DU forwards *RRCRelease* message to UE.
3. The gNB-DU responds with UE CONTEXT RELEASE COMPLETE message.

8.6.2 RRC inactive to other states

This section gives the RRC inactive to other RRC states transition given that gNB consists of gNB-CU and gNB-DU(s), as shown in Figure 8.6.2-1.

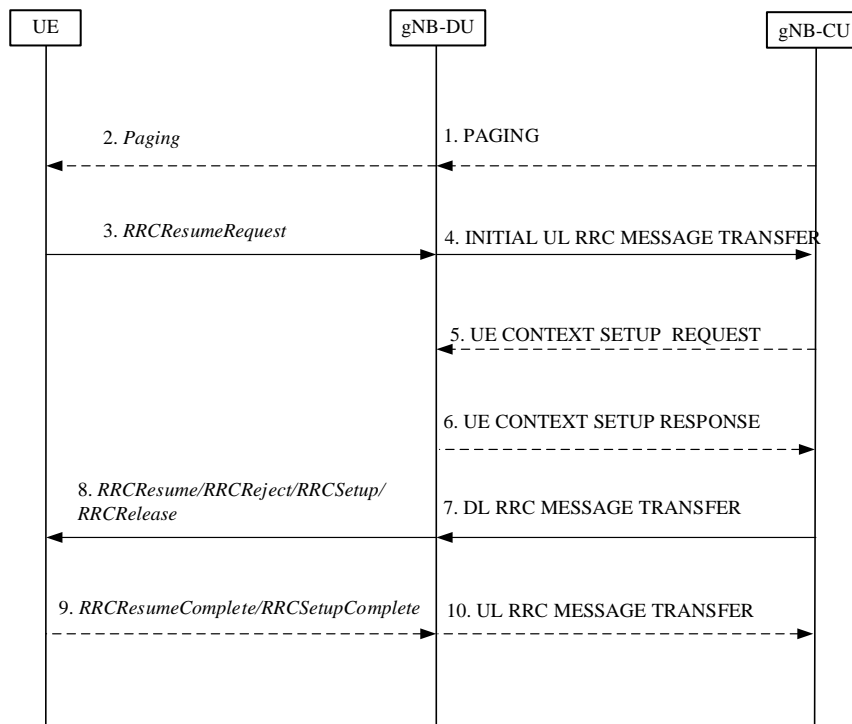

Figure 8.6.2-1: RRC inactive to other RRC states transition procedure

1. If data is received from 5GC, the gNB-CU sends PAGING message to the gNB-DU.
2. The gNB-DU sends *Paging* message to UE.

NOTE: step 1 and 2 only exist in case of DL data arrival.

3. The UE sends *RRCResumeRequest* message either upon RAN-based paging, UL data arrival or RNA update.
4. The gNB-DU includes *RRCResumeRequest* in a non-UE associated INITIAL UL RRC MESSAGE TRANSFER message and transfer to the gNB-CU.
5. For UE Inactive to UE Active transitions, excluding transitions due to signalling exchange only, the gNB-CU allocates gNB-CU UE F1AP ID and sends UE CONTEXT SETUP REQUEST message to gNB-DU, which may include SRB ID(s) and DRB ID(s) to be setup, CellGroupConfig stored in gNB-CU or retrieved from the old NG-RAN node may also be included. In case of NG-RAN sharing, the gNB-CU includes the serving PLMN ID (in case of SNPNs the serving NID).
6. The gNB-DU responds with UE CONTEXT SETUP RESPONSE message, which contains RLC/MAC/PHY configuration of SRB and DRBs provided by the gNB-DU.

NOTE: step 5 and step 6 exist for inactive to active transitions, excluding transitions due to signalling exchange only. When gNB-CU successfully retrieves and verifies the UE context, it may decide to let the UE enter into RRC active mode. gNB-CU shall trigger UE context setup procedure between gNB-CU and gNB-DU, during which both SRB1, SRB2 and DRB(s) can be setup. For signalling exchange only transitions, gNB-CU does not trigger UE Context Setup procedure. For inactive to Idle transitions the gNB-CU does not trigger the UE Context Setup procedure.

7. The gNB-CU generates *RRCResume/RRCSetup/RRCReject/RRCRelease* message or receives *RRCRelease* message from the old NG-RAN node towards the UE. The RRC message is encapsulated in DL RRC MESSAGE TRANSFER message together with SRB ID.
8. The gNB-DU forwards RRC message to the UE either over SRB0 or SRB1 as indicated by the SRB ID.

NOTE: in step 7, it is expected that gNB-CU takes appropriate action, e.g. generates RRC resume message for inactive to active state transition (for both cases of signaling exchange only, and UP data exchange), generates *RRCSetup* message for fallback to establish a new RRC connection, and generates or receives from the old NG-RAN node either *RRCRelease* message without suspend configuration for inactive to idle state transition, or *RRCRelease* message with suspend configuration to remain in inactive state. If step 5 and 6 are not performed, the gNB-DU deduces the SRB on which to deliver the RRC message in step 7 from the SRB ID, i.e. SRB ID "0" corresponds to SRB0, SRB ID "1" corresponds to SRB1.

9. The UE sends *RRCResumeComplete/RRCSetupComplete* message to the gNB-DU.

10. The gNB-DU encapsulates RRC in UL RRC MESSAGE TRANSFER message and send to the gNB-CU.

NOTE: step 9 and step 10 exist for inactive to active state transition (for both cases of signaling exchange only, and UP data exchange). UE generates *RRCResumeComplete/RRCSetupComplete* message for resume the existing RRC connection or fallback to a new RRC connection respectively.

8.7 RRC connection reestablishment

This procedure is used for the case that UE tries to reestablish the RRC connection, as shown in Figure 8.7-1.

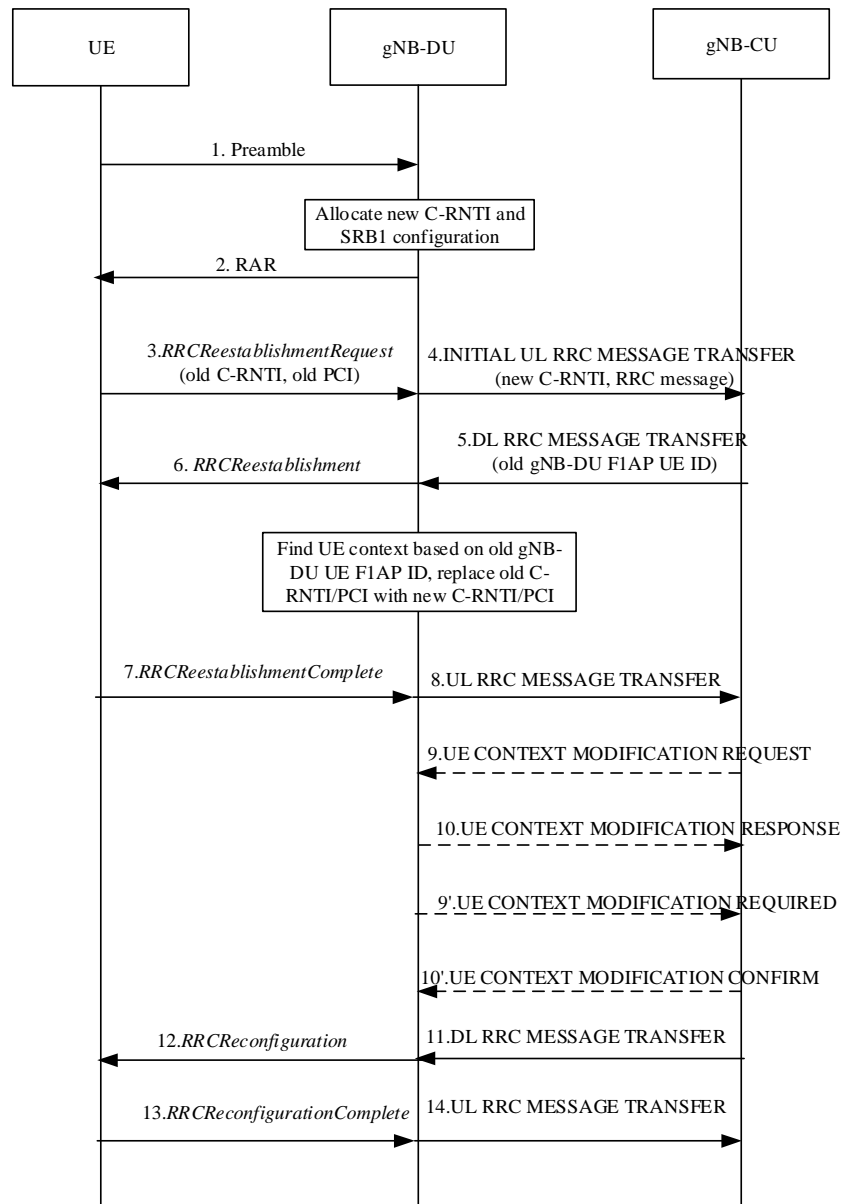

Figure 8.7-1: RRC connection reestablishment procedure

1. The UE sends a preamble to the gNB-DU.
2. The gNB-DU allocates new C-RNTI and responds with RAR.
3. The UE sends an *RRCReestablishmentRequest* message to the gNB-DU, which contains old C-RNTI and old PCI.
4. The gNB-DU includes the RRC message and, if the UE is admitted, the corresponding low layer configuration for the UE in the INITIAL UL RRC MESSAGE TRANSFER message and transfers to the gNB-CU. The INITIAL UL RRC MESSAGE TRANSFER message includes the new C-RNTI.
5. The gNB-CU includes an *RRCReestablishment* message and transfers to the gNB-DU. If the UE requests to re-establish RRC connection in the last serving gNB-DU, the DL RRC MESSAGE TRANSFER message shall include old gNB-DU UE F1AP ID.
6. The gNB-DU retrieves the UE context based on the old gNB-DU UE F1AP ID, and replaces old C-RNTI/PCI with new C-RNTI/PCI. It sends the *RRCReestablishment* message to UE.

- 7-8. The UE sends an *RRCReestablishmentComplete* message to the gNB-DU. The gNB-DU encapsulates the RRC message in the UL RRC MESSAGE TRANSFER message and sends to the gNB-CU.
 - 9-10. The gNB-CU triggers an UE Context Modification procedure by sending UE CONTEXT MODIFICIATION REQUEST message, which may include DRBs to be modified and released list. The gNB-DU responses with the UE CONTEXT MODIFICATION RESPONSE message.
 - 9'-10'. The gNB-DU triggers an UE Context Modification procedure by sending UE CONTEXT MODIFICIATION REQUIRED message, which may include DRBs to be modified and released list. The gNB-CU responses with UE CONTEXT MODIFICATION CONFIRM message.
- NOTE: Here it is assumed that the UE accessed the original gNB-DU where the UE context is available for that UE, and either steps 9-10 or steps 9'-10' may be executed or both could be skipped.
- NOTE: If the UE accessed from a gNB-DU other than the original one, the gNB-CU should trigger the UE Context Setup procedure toward this new gNB-DU.
- 11-12. The gNB-CU includes an *RRCReconfiguration* message into the DL RRC MESSAGE TRANSFER message and transfers to the gNB-DU. The gNB-DU forwards it to the UE.
 - 13-14. The UE sends an *RRCReconfigurationComplete* message to the gNB-DU, and the gNB-DU forwards it to the gNB-CU.

8.8 Multiple TNLAs for F1-C

In the following, the procedure for managing multiple TNLAs for F1-C is described.

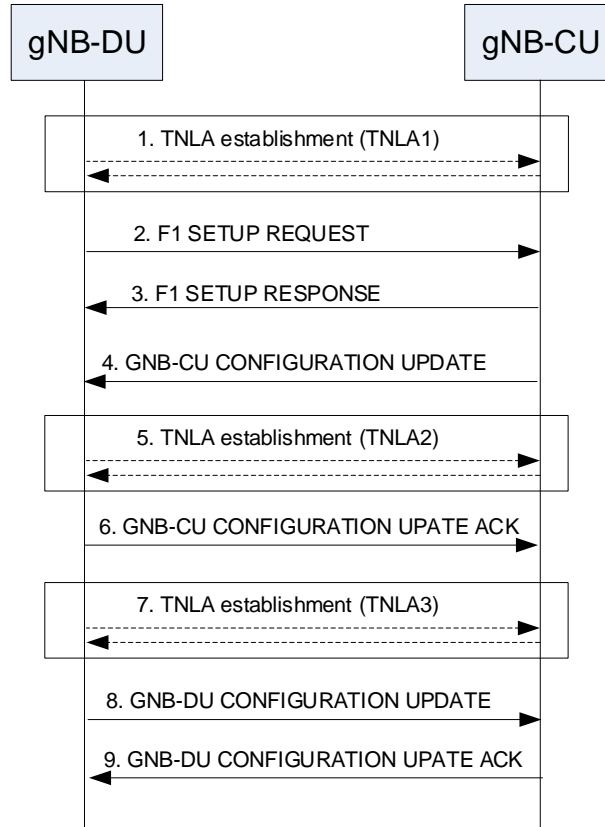

Figure 8.8-1: Managing multiple TNLAs for F1-C.

- 1. The gNB-DU establishes the first TNLA with the gNB-CU using a configured TNL address.

NOTE: The gNB-DU may use different source and/or destination IP end point(s) if the TNL establishment towards one IP end point fails. How the gNB-DU gets the remote IP end point(s) and its own IP address are outside the scope of this specification.

- 2-3. Once the TNLA has been established, the gNB-DU initiates the F1 Setup procedure to exchange application level configuration data
- 4-6. The gNB-CU may add additional TNL Endpoint(s) to be used for F1-C signalling between the gNB-CU and the gNB-DU pair using the gNB-CU Configuration Update procedure. The gNB-CU Configuration Update procedure also allows the gNB-CU to request the gNB-DU to modify or release TNLA(s).
- 7-9. The gNB-DU may add additional TNL association(s) to be used for F1-C signalling using a gNB-CU endpoint already in use for existing TNL associations between the gNB-CU and the gNB-DU pair. The gNB-DU CONFIGURATION UPDATE message including the gNB-DU ID shall be the first F1AP message sent on an additional TNLA of an already setup F1-C interface instance after the TNL association has become operational.

The F1AP UE TNLA binding is a binding between a F1AP UE association and a specific TNL association for a given UE. After the F1AP UE TNLA binding is created, the gNB-CU can update the UE TNLA binding by sending the F1AP message for the UE to the gNB-DU via a different TNLA. The gNB-DU shall update the F1AP UE TNLA binding with the new TNLA. The gNB-DU Configuration Update procedure also allows the gNB-DU to inform the gNB-CU that the indicated TNLA(s) will be removed by the gNB-DU.

8.9 Overall procedures involving E1 and F1

The following clauses describe the overall procedures involving E1 and F1.

8.9.1 UE Initial Access

The signalling flow for UE Initial access involving E1 and F1 is shown in Figure 8.9.1-1.

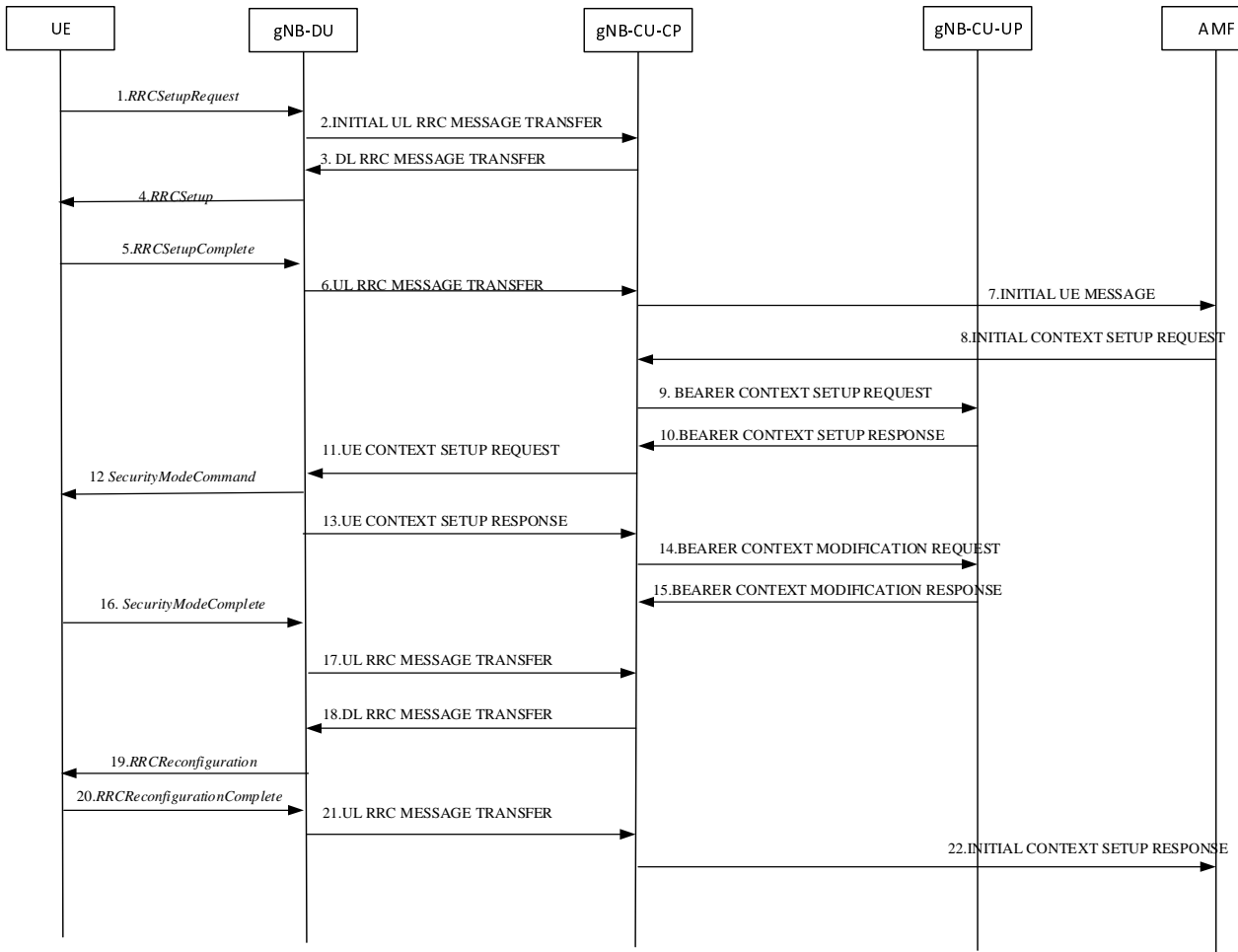

Figure 8.9.1-1: UE Initial Access procedure involving E1 and F1

Steps 1-8 are defined in clause 8.1.

9. The gNB-CU-CP sends the BEARER CONTEXT SETUP REQUEST message to establish the bearer context in the gNB-CU-UP.

10 The gNB-CU-UP sends the BEARER CONTEXT SETUP RESPONSE message to the gNB-CU-CP, including F1-U UL TEID and transport layer address allocated by the gNB-CU-UP.

Steps 11-13 are defined in clause 8.1.

14. The gNB-CU-CP sends the BEARER CONTEXT MODIFICATION REQUEST message to the gNB-CU-UP, including F1-U DL TEID and transport layer address allocated by the gNB-DU.

15. The gNB-CU-UP sends the BEARER CONTEXT MODIFICATION RESPONSE message to the gNB-CU-CP.

Steps 16-22 are defined in clause 8.1.

NOTE: Steps 14-15 and steps 16-17 can happen in parallel, but both are before step 18.

8.9.2 Bearer context setup over F1-U

Figure 8.9.2-1 shows the procedure used to setup the bearer context in the gNB-CU-UP.

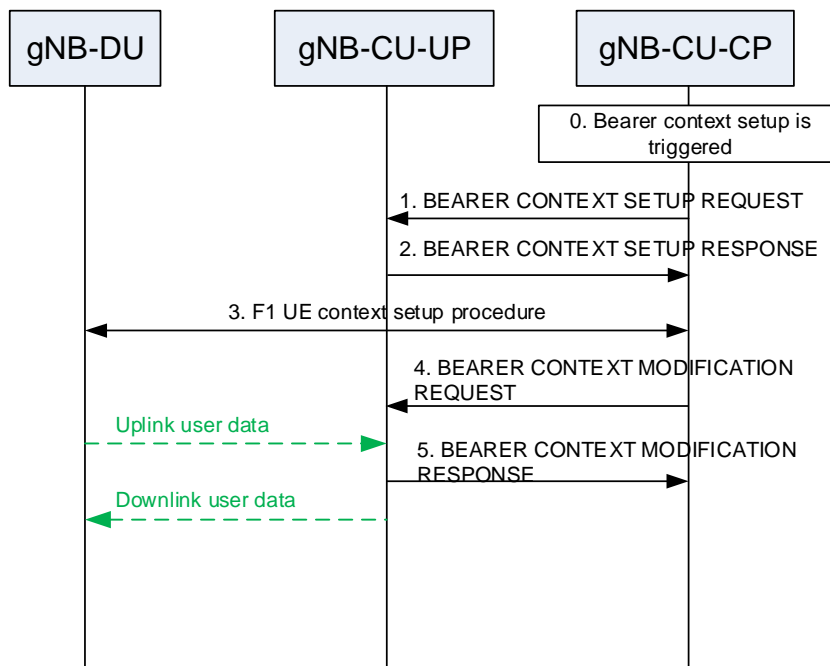

Figure 8.9.2-1: Bearer context setup over F1-U

0. Bearer context setup (e.g., following an SGNB ADDITION REQUEST message from the MeNB) is triggered in gNB-CU-CP.
1. The gNB-CU-CP sends a BEARER CONTEXT SETUP REQUEST message containing UL TNL address information for S1-U or NG-U, and if required, DL TNL address information for X2-U or Xn-U to setup the bearer context in the gNB-CU-UP. For NG-RAN, the gNB-CU-CP decides flow-to-DRB mapping and sends the generated SDAP and PDCP configuration to the gNB-CU-UP.

NOTE: In case of Conditional Handover, the BEARER CONTEXT SETUP REQUEST message indicates to ignore the included security context and not to initiate sending downlink packets until the UE successfully accesses. Up to implementation, the gNB-CU-CP may request to establish bearer context as if a regular HO was requested.

2. The gNB-CU-UP responds with a BEARER CONTEXT SETUP RESPONSE message containing the UL TNL address information for F1-U, and DL TNL address information for S1-U or NG-U, and if required, UL TNL address information for X2-U or Xn-U.

NOTE: The indirect data transmission for split bearer through the gNB-CU-UP is not precluded.

3. F1 UE context setup procedure is performed to setup one or more bearers in the gNB-DU.
4. The gNB-CU-CP sends a BEARER CONTEXT MODIFICATION REQUEST message containing the DL TNL address information for F1-U and PDCP status.
5. The gNB-CU-UP responds with a BEARER CONTEXT MODIFICATION RESPONSE message.

8.9.3 Bearer context release over F1-U

8.9.3.1 gNB-CU-CP initiated bearer context release

Figure 8.9.3.1-1 shows the procedure used to release the bearer context in the gNB-CU-UP initiated by the gNB-CU-CP.

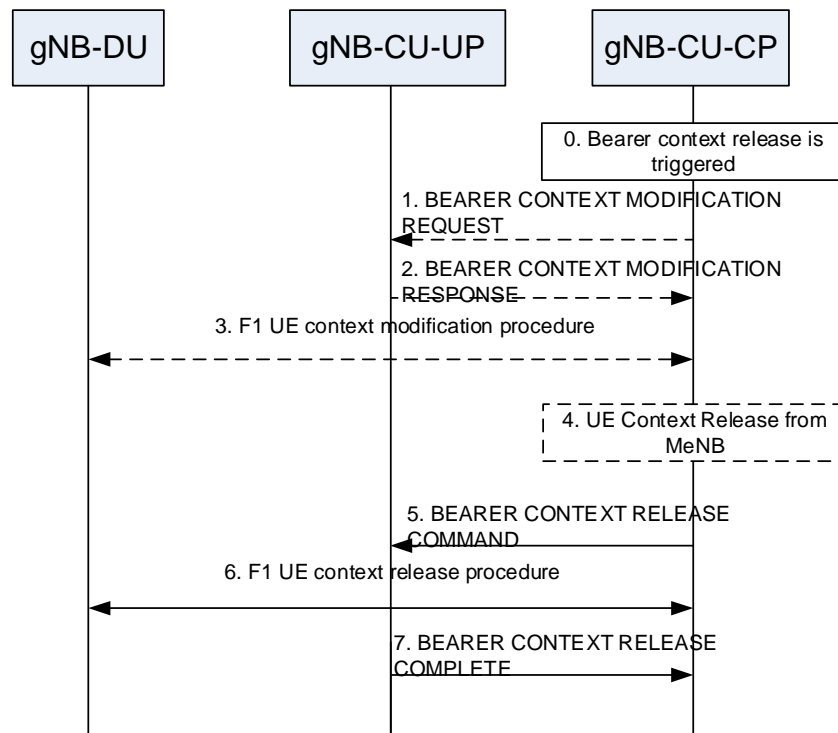

Figure 8.9.3.1-1: Bearer context release over F1-U – gNB-CU-CP initiated

- 0. Bearer context release (e.g., following an SGNB RELEASE REQUEST message from the MeNB) is triggered in gNB-CU-CP.
 - 1. The gNB-CU-CP sends a BEARER CONTEXT MODIFICATION REQUEST message to the gNB-CU-UP.
 - 2. The gNB-CU-UP responds with a BEARER CONTEXT MODIFICATION RESPONSE carrying the PDCP UL/DL status.
 - 3. F1 UE context modification procedure is performed to stop the data transmission for the UE. It is up to gNB-DU implementation when to stop the UE scheduling.
- NOTE: step 1-3 are performed only if the PDCP status of the bearer(s) needs to be preserved e.g., for bearer type change.
- 4. The gNB-CU-CP may receive the UE CONTEXT RELEASE message from the MeNB in EN-DC operation as described in Section 8.4.2.1.
 - 5. and 7. Bearer context release procedure is performed.
 - 6. F1 UE context release procedure is performed to release the UE context in the gNB-DU.

8.9.3.2 gNB-CU-UP initiated bearer context release

Figure 8.9.3.2-1 shows the procedure used to release the bearer context in the gNB-CU-UP initiated by the gNB-CU-UP.

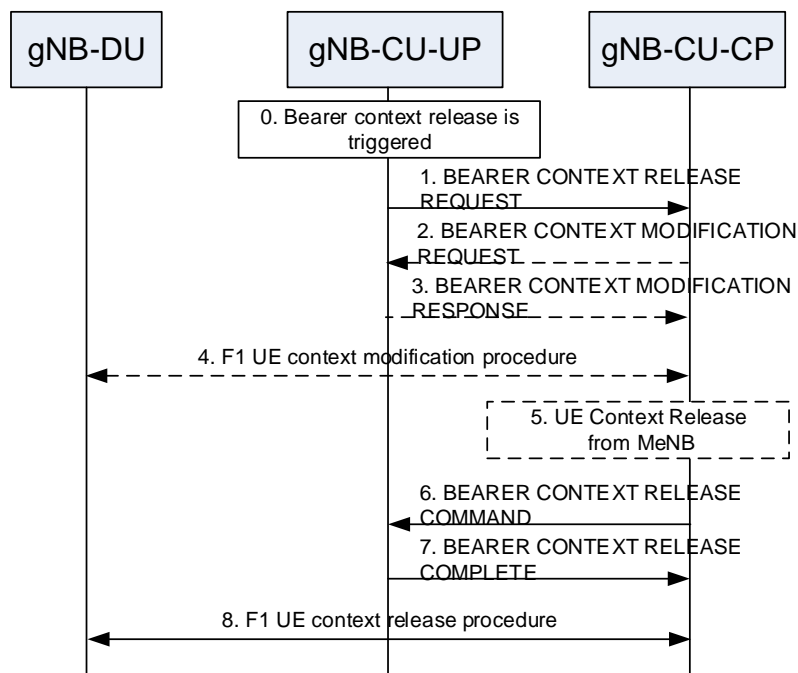

Figure 8.9.3.2-1: Bearer context release over F1-U – gNB-CU-UP initiated

0. Bearer context release is triggered in gNB-CU-UP e.g., due to local failure.
1. The gNB-CU-UP sends a BEARER CONTEXT RELEASE REQUEST message to request the release of the bearer context in the gNB-CU-UP. This message may contain the PDCP status.
- 2.- 5. If the PDCP status needs to be preserved, the E1 Bearer Context Modification and the F1 UE Context Modification procedures are performed. The E1 Bearer Context Modification procedure is used to convey data forwarding information to the gNB-CU-UP. The gNB-CU-CP may receive the UE Context Release from the MeNB.
6. The gNB-CU-CP sends a BEARER CONTEXT RELEASE COMMAND message to release the bearer context in the gNB-CU-UP.
7. The gNB-CU-UP responds with a BEARER CONTEXT RELEASE COMPLETE to confirm the release of the bearer context including also data forwarding information.
8. F1 UE context release procedure may be performed to release the UE context in the gNB-DU.

8.9.4 Inter-gNB handover involving gNB-CU-UP change

Figure 8.9.4-1 shows the procedure used for inter-gNB handover involving gNB-CU-UP change. Overall inter-gNB handover procedure is specified in TS 37.340 [12].

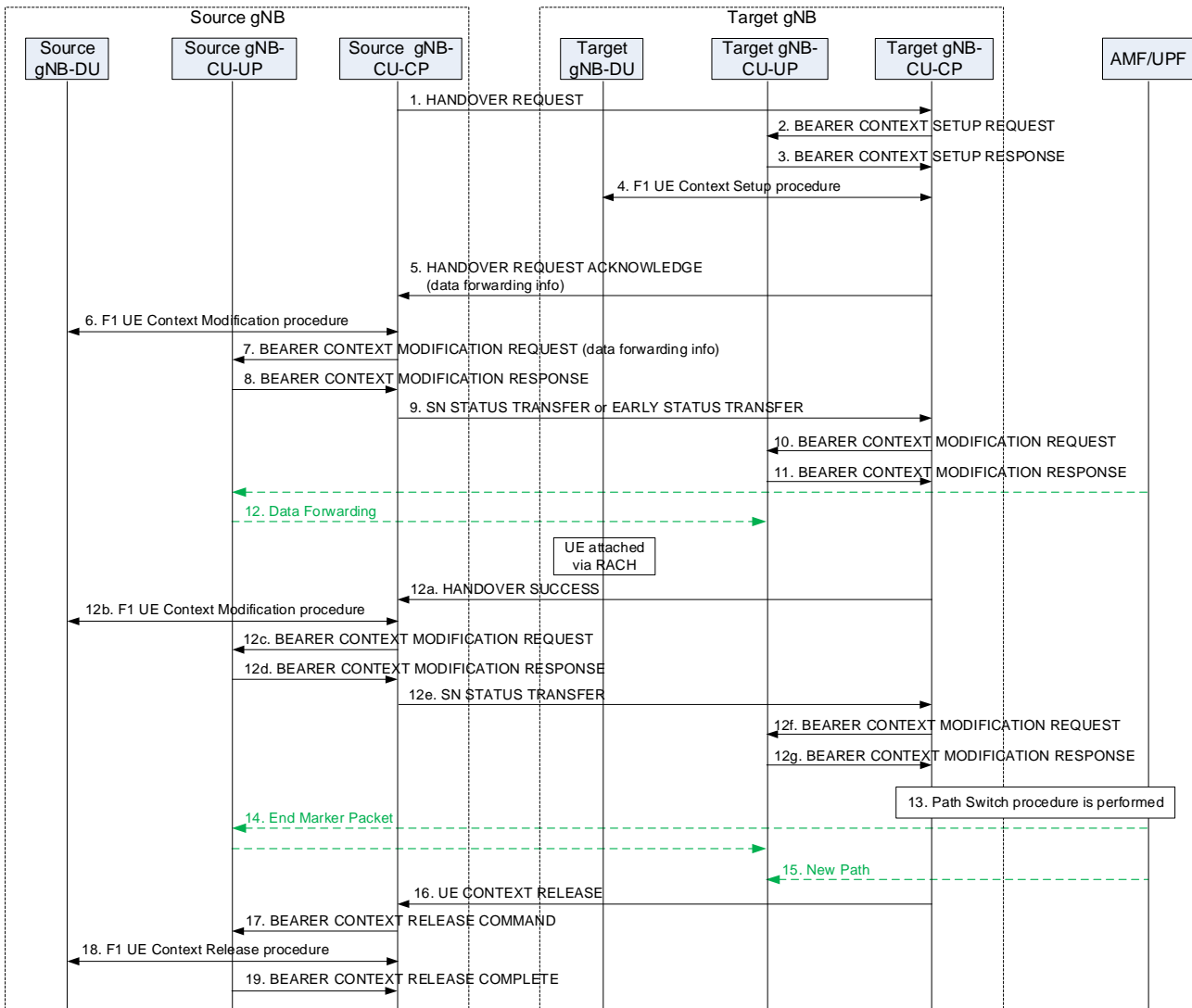

Figure 8.9.4-1: Inter-gNB handover involving gNB-CU-UP change

1. The source gNB-CU-CP sends HANDOVER REQUEST message to the target gNB-CU-CP. In case of Conditional Handover, the target gNB is regarded as a candidate gNB which is only accessed by the UE when the CHO condition(s) are fulfilled.
 - 2-4. Bearer Context Setup procedure is performed as described in Section 8.9.2.
 5. The target gNB-CU-CP responds the source gNB-CU-CP with an HANDOVER REQUEST ACKNOWLEDGE message.
- NOTE: In case of Conditional Handover, it is up to target gNB-CU-CP implementation to make sure that the EARLY STATUS TRANSFER information is forwarded to the right gNB-CU-UP (e.g. separate UE-associated signalling connection over Xn interface for each gNB-CU-UP).
6. The F1 UE Context Modification procedure is performed to send the handover command to the UE, and to indicate to stop the data transmission for the UE.
- NOTE: In case of DAPS Handover or Conditional Handover, the F1 UE Context Modification procedure in step 6 does not indicate to stop the data transmission for the UE. Instead, the F1 DL RRC Message Transfer procedure can be used which carries the handover command to the UE.
- 7-8. Bearer Context Modification procedure (gNB-CU-CP initiated) is performed to enable the gNB-CU-CP to retrieve the PDCP UL/DL status and to exchange data forwarding information for the bearer.
 9. The source gNB-CU-CP sends an SN STATUS TRANSFER message to the target gNB-CU-CP.

- NOTE: In case of DAPS Handover, the EARLY STATUS TRANSFER message is sent for DRBs configured with DAPS instead of the SN STATUS TRANSFER message.
- NOTE: In case of Conditional Handover, the EARLY STATUS TRANSFER message is sent only if early data forwarding is applied.
- NOTE: The COUNT related info for the EARLY STATUS TRANSFER message is retrieved from the source gNB-CU-UP via the steps 7/8.
- 10-11. Bearer Context Modification procedure is performed as described in Section 8.9.2. The COUNT related info carried by the EARLY STATUS TRANSFER message is also provided to the target gNB-CU-UP.
12. Data Forwarding may be performed from the source gNB-CU-UP to the target gNB-CU-UP.
- NOTE: In case of Conditional Handover, the UE performs RACH when the CHO condition(s) are fulfilled. Once successfully accessed, the target gNB-DU sends an ACCESS SUCCESS message to inform the target gNB-CU-CP of which cell the UE has accessed through. The target gNB-CU-CP may forward to the target gNB-CU-UP, necessary information for sending downlink packets (i.e. DL TNL address information for F1-U and UP security information corresponding to the accessed cell), via a Bearer context modification procedure. The target gNB-CU-CP may initiate Bearer context release procedure toward the other signalling connections or other candidate target gNB-CU-UPs, if any, to release the prepared conditional handover resources for the UE.
- 12a. In case of DAPS Handover or Conditional Handover, the target gNB-CU-CP sends the HANDOVER SUCCESS message to the source gNB-CU-CP to inform that the UE has successfully accessed the target cell.
- 12b In case of DAPS Handover or Conditional Handover, the F1 UE Context Modification procedure is performed to indicate to stop the data transmission for the UE.
- 12c-12d. In case of DAPS Handover or Conditional Handover, the Bearer context modification procedure (gNB-CU-CP initiated) is performed to indicate the source gNB-CU-UP to stop packet delivery and also to retrieve the PDCP UL/DL status.
- 12e. In case of DAPS Handover or Conditional Handover, the source gNB-CU-CP sends the SN STATUS TRANSFER message to the target gNB-CU-CP.
- 12f-12g. In case of DAPS Handover or Conditional Handover, the Bearer context modification procedure is performed to provide the PDCP UL/DL status to the target gNB-CU-UP.
- NOTE: In case of Conditional Handover, inactivity monitoring is performed after step 12g.
- 13-15. Path Switch procedure is performed to update the DL TNL address information for the NG-U towards the core network.
16. The target gNB-CU-CP sends an UE CONTEXT RELEASE message to the source gNB-CU-CP.
17. and 19. Bearer Context Release procedure is performed.
18. F1 UE Context Release procedure is performed to release the UE context in the source gNB-DU.

8.9.5 Change of gNB-CU-UP

Figure 8.9.5-1 shows the procedure used for the change of gNB-CU-UP within a gNB.

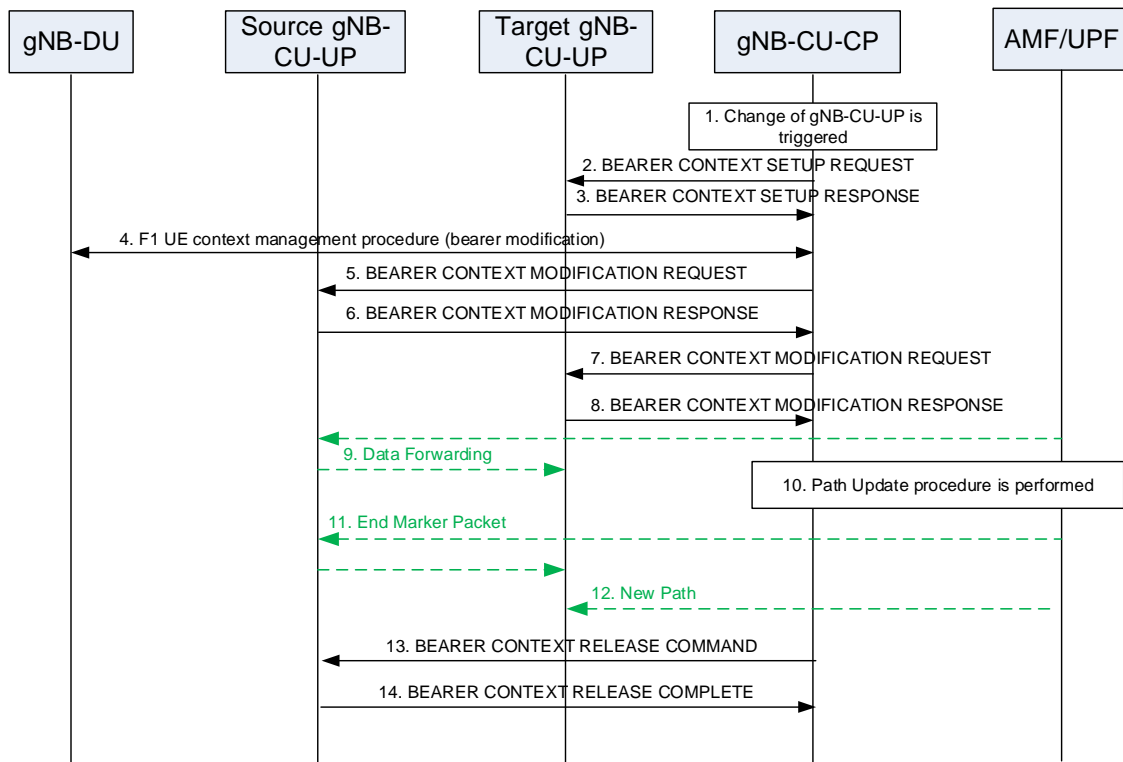

Figure 8.9.5-1: Change of gNB-CU-UP

1. Change of gNB-CU-UP is triggered in gNB-CU-CP based on e.g., measurement report from the UE.
- 2-3. Bearer Context Setup procedure is performed as described in Section 8.9.2.
4. F1 UE Context Modification procedure is performed to change the UL TNL address information for F1-U for one or more bearers in the gNB-DU.
- 5-6. Bearer Context Modification procedure (gNB-CU-CP initiated) is performed to enable the gNB-CU-CP to retrieve the PDCP UL/DL status and to exchange data forwarding information for the bearer.
- 7-8. Bearer Context Modification procedure is performed as described in Section 8.9.2.
9. Data Forwarding may be performed from the source gNB-CU-UP to the target gNB-CU-UP.
- 10-12. Path Switch procedure is performed to update the DL TNL address information for the NG-U towards the core network.
- 13-14. Bearer Context Release procedure (gNB-CU-CP initiated) is performed as described in Section 8.9.3.

8.9.6 RRC State transition

8.9.6.1 RRC Connected to RRC Inactive

The procedure for changing the UE state from RRC-connected to RRC-inactive is shown in Figure 8.9.6.1-1.

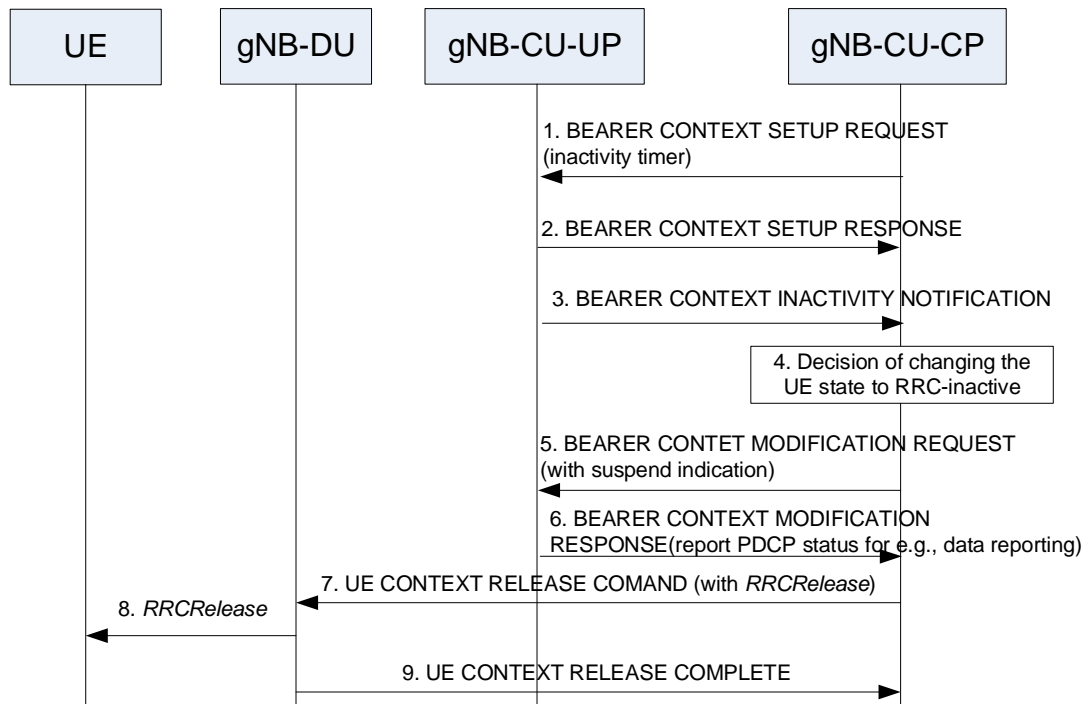

Figure 8.9.6.1-1: RRC Connected to RRC Inactive state transition.

1. The gNB-CU-CP sends BEARER CONTEXT SETUP REQUEST message with UE/PDU session/DRB level inactivity timer.
2. The gNB-CU-UP sends BEARER CONTEXT SETUP RESPONSE message.
3. The gNB-CU-UP sends BEARER CONTEXT INACTIVITY NOTIFICATION message with inactivity monitoring results.
4. The gNB-CU-CP determines that the UE should enter RRC-inactive (e.g., after receiving Bearer Context Inactivity Notification procedure).
5. The gNB-CU-CP sends BEARER CONTEXT MODIFICATION REQUEST message with a Bearer Context Status Change to the gNB-CU-UP, which indicates that the UE is entering RRC-inactive state. The gNB-CU-CP keeps the F1 UL TEIDs.
6. The gNB-CU-UP sends the BEARER CONTEXT MODIFICATION RESPONSE message including the PDCP UL and DL status that may be needed for e.g., data volume reporting. The gNB-CU-UP keeps the Bearer Context, the UE-associated logical E1-connection, the NG-U related resource (e.g., NG-U DL TEIDs) and the F1 UL TEIDs.
7. The gNB-CU-CP sends the UE CONTEXT RELEASE COMMAND message to the gNB-DU serving the UE, together with the *RRCRelease* message to be sent to the UE.

NOTE: step 5 and step 7 can be performed at the same time.

8. The gNB-DU sends the *RRCRelease* message to the UE.
9. The gNB-DU sends the UE CONTEXT RELEASE COMPLETE message to the gNB-CU-CP.

8.9.6.2 RRC Inactive to other states

The procedure for changing the UE state from RRC-inactive to RRC-connected is shown in Figure 8.9.6.2-1.

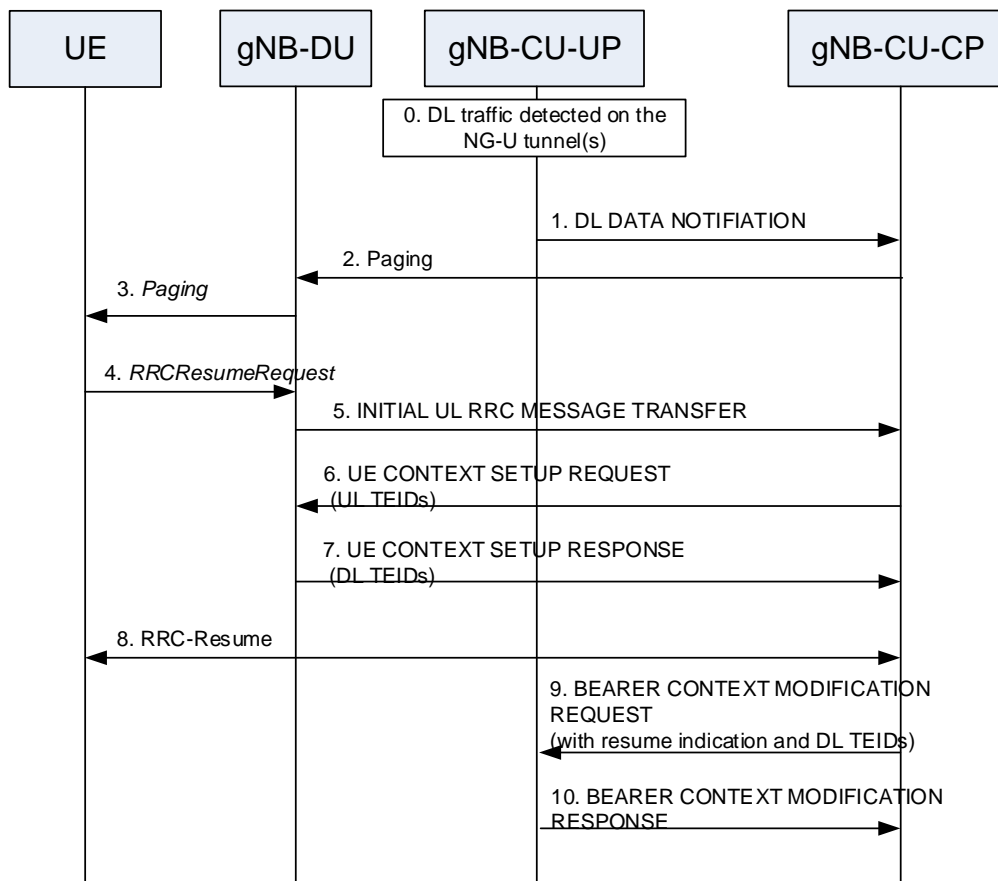

Figure 8.9.6.2-1: RRC Inactive to RRC Connected state transition.

0. The gNB-CU-UP receives DL data on NG-U interface.
 1. The gNB-CU-UP sends DL DATA NOTIFICATION message to the gNB-CU-CP.
 2. The gNB-CU-CP initiates PAGING procedure.
 3. The gNB-DU sends the *Paging* message to the UE.
- NOTE: steps 0-3 are needed only in case of DL data.
4. The UE sends *RRCResumeRequest* message either upon RAN paging or UL data arrival.
 5. The gNB-DU sends the INITIAL UL RRC MESSAGE TRANSFER message to the gNB-CU-CP.
 6. The gNB-CU-CP sends UE CONTEXT SETUP REQUEST message including the stored F1 UL TEIDs to create the UE context in the gNB-DU.
 7. The gNB-DU responds with the UE CONTEXT SETUP RESPONSE message including the F1 DL TEIDs allocated for the DRBs.
 8. The gNB-CU-CP and the UE perform the RRC-Resume procedure via the gNB-DU.
 9. The gNB-CU-CP sends BEARER CONTEXT MODIFICATION REQUEST message with a RRC Resume indication, which indicates that the UE is resuming from RRC-inactive state. The gNB-CU-CP also includes the F1 DL TEIDs received from the gNB-DU in step 7.
 10. The gNB-CU-UP responds with the BEARER CONTEXT MODIFICATION RESPONSE message.

NOTE steps 8 and 9 can be performed in parallel.

8.9.7 Trace activation/deactivation over F1 and E1

Figure 8.9.6-1 shows the procedure used for the activation and the deactivation of UE traces in the gNB-DU, the gNB-CU-UP or both.

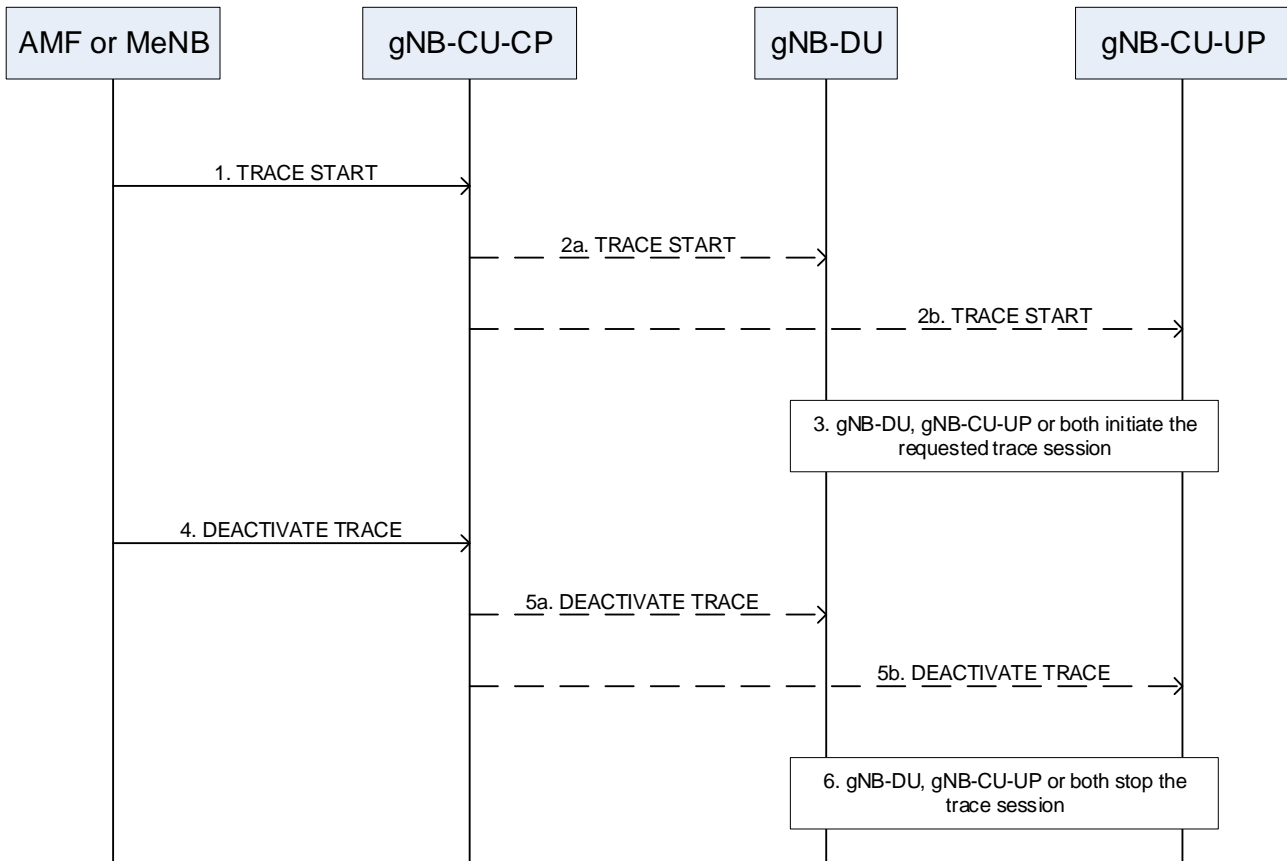

Figure 8.9.6-1: Trace activation/deactivation over F1 and E1

1. The gNB-CU-CP receives a TRACE START message from the AMF or the MeNB (in case of EN-DC).
2. The gNB-CU-CP initiates the Trace Start procedure by sending a TRACE START message to the gNB-DU, the gNB-CU-UP or both.
3. Upon reception of the TRACE START message, the gNB-DU, the gNB-CU-UP or both initiate the requested trace session and report it as described in TS 32.422 [20].
4. The gNB-CU-CP receives a DEACTIVATE TRACE message from the AMF or the MeNB (in case of EN-DC).
5. The gNB-CU-CP initiates the Deactivate Trace procedure by sending a DEACTIVATE TRACE message to the gNB-DU, the gNB-CU-UP or both.
6. Upon reception of the DEACTIVATE TRACE message, the gNB-DU, the gNB-CU-UP or both stop the trace session for the indicated trace reference.

8.9.8 BH RLC channel establishment procedure

The BH RLC channel is an RLC channel used for backhauling between IAB-node and IAB-donor-DU, or between different IAB-nodes. The BH RLC channel establishment may be triggered by a UE accessing the network and establishing a DRB.

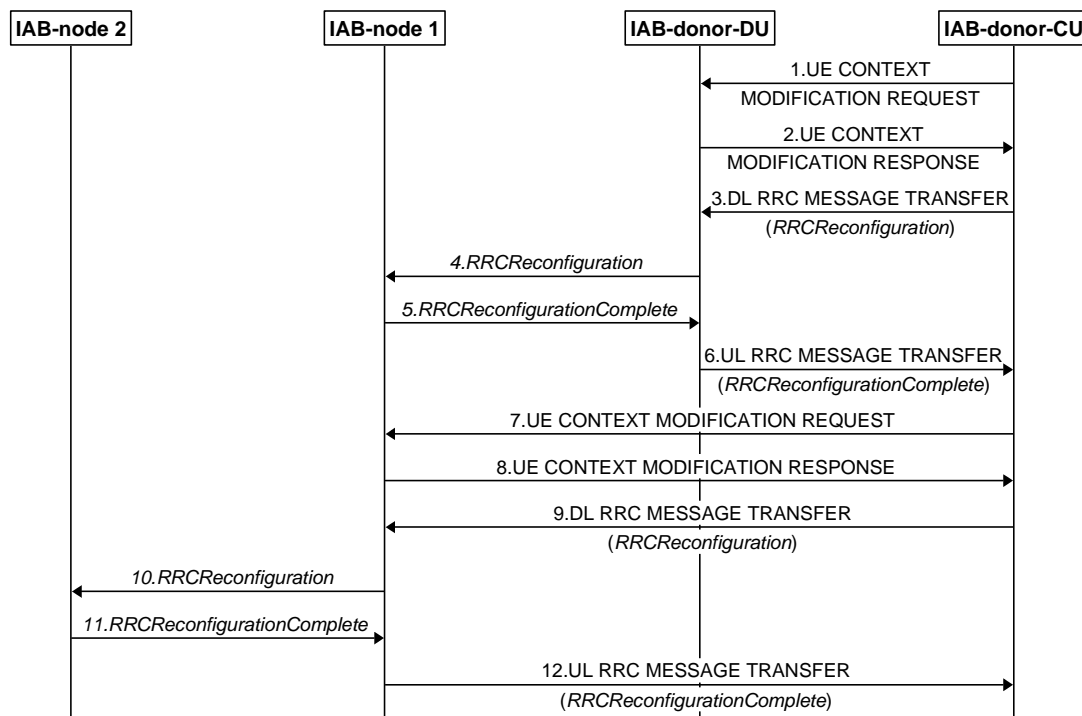

Figure 8.9.8-1: Signalling flow for IAB BH RLC channel establishment procedure

1. The IAB-donor-CU sends to the IAB-donor-DU a UE CONTEXT MODIFICATION REQUEST message for setting up the parent-node IAB-DU side of the BH link between IAB-donor-DU and IAB-node 1. This step is optional and is required only when a new BH RLC channel needs to be established on the BH link between IAB-donor-DU and IAB-node 1.
2. The IAB-donor-DU sends the UE CONTEXT MODIFICATION RESPONSE message to the IAB-donor-CU.
3. The IAB-donor-CU sends to the IAB-donor-DU a DL RRC MESSAGE TRANSFER message encapsulating the *RRCReconfiguration* message for configuring the IAB-MT of IAB-node 1. This step is optional and is required only when a new BH RLC channel needs to be established on the BH link between IAB-donor-DU and IAB-node 1.
4. The IAB-donor-DU decapsulates and forwards the *RRCReconfiguration* message to the IAB-MT of IAB-node 1. This step is optional and is required only when a new BH RLC channel needs to be established on the BH link between IAB-donor-DU and IAB-node 1.
5. The IAB-MT of IAB-node 1 sends to the IAB-donor-DU an *RRCReconfigurationComplete* message destined to the IAB-donor-CU. This step is optional and is required only when a new BH RLC channel needs to be established on the BH link between IAB-donor-DU and IAB-node 1.
6. The IAB-donor-DU sends the UL RRC MESSAGE TRANSFER message encapsulating the *RRCReconfigurationComplete* message to the IAB-donor-CU. This step is optional and is required only when a new BH RLC channel needs to be established on the BH link between IAB-donor-DU and IAB-node 1.
7. The IAB-donor-CU sends to the IAB-DU of IAB-node 1 a UE CONTEXT MODIFICATION REQUEST message for setting up the parent node IAB-DU side of the BH link between IAB-node 1 and IAB-node 2. This step is optional and is required only when a new BH RLC channel needs to be established on the BH link between IAB-node 1 and IAB-node 2.
8. The IAB-node 1 sends the UE CONTEXT MODIFICATION RESPONSE message to the IAB-donor-CU.
9. The IAB-donor-CU sends to the IAB-DU of IAB-node 1 a DL RRC MESSAGE TRANSFER message encapsulating the *RRCReconfiguration* message for configuring the IAB-MT of IAB-node 2. This step is optional and is required only when a new BH RLC channel needs to be established on the BH link between IAB-node 1 and IAB-node 2.

10. The IAB-DU of IAB-node 1 decapsulates and forwards the *RRCReconfiguration* message to the IAB-MT of IAB-node 2. This step is optional and is required only when a new BH RLC channel needs to be established on the BH link between IAB-node 1 and IAB-node 2.
11. The IAB-MT of IAB-node 2 sends to IAB-node 1 an *RRCReconfigurationComplete* message destined to the IAB-donor-CU. This step is optional and is required only when a new BH RLC channel needs to be established on the BH link between IAB-node 1 and IAB-node 2.
12. IAB-node 1 sends the UL RRC MESSAGE TRANSFER message encapsulating the *RRCReconfigurationComplete* message to the IAB-donor-CU. This step is optional and is required only when a new BH RLC channel needs to be established on the BH link between IAB-node 1 and IAB-node 2.

The IAB-donor-CU uses the existing CU-DU split principles and the UE Context Setup procedure or UE Context Modification procedure to configure the parent IAB-DU side of the BH RLC channel. The IAB-donor-CU uses RRC signaling (which is encapsulated in the DL RRC MESSAGE TRANSFER message terminating at the parent node IAB-DU side of the BH RLC channel) to configure the child node IAB-MT side of the BH RLC channel.

The IAB-donor-CU configures the IAB-DU with a mapping to the BH RLC channel to be used for a specific UL F1-U tunnel during the UE Context Setup procedure or the F1-AP UE Context Modification procedure for the UE.

8.9.9 Traffic Mapping

8.9.9.1 Traffic Mapping from IP-layer to Layer-2

When forwarding IP packets, the IAB-donor-DU performs the traffic mapping from IP-layer to layer-2 as defined in TS 38.340 [22]. The traffic mapping information is configured by the IAB-donor-CU, which contains the IP header information, and the BH information including the BAP routing ID and a list of egress link and BH RLC channel pairs.

Multiple traffic mappings can contain the same BAP routing ID and/or list of egress link and BH RLC channel pairs.

The traffic mappings can be configured as part of the UE Context Setup or UE Context Modification procedures. They may also be configured via the non-UE-associated BAP Mapping Configuration procedure.

NOTE: Implementation must ensure the avoidance of potential race conditions, i.e. no conflicting configurations are concurrently performed using UE-associated and non-UE-associated procedures.

8.9.9.2 BH RLC Channel Mapping on BAP Layer

When traffic is forwarded on BAP layer as described in TS 38.300 [2], the IAB-node performs the BH RLC channel mapping as defined in TS 38.340 [22]. The BH RLC channel mapping information is configured by the IAB-donor-CU.

The BH RLC channel mappings can be configured as part of the UE Context Setup or UE Context Modification procedures. They may also be configured via the non-UE-associated BAP Configuration procedure.

NOTE: Implementation must ensure the avoidance of potential race conditions, i.e. that no conflicting configurations are concurrently performed using UE-associated and non-UE-associated procedures.

8.9.10 IAB-node release

An IAB-node may depart the network either in an orderly fashion, which implies that both the network and the IAB-node are aware in advance, or in a disorderly fashion (e.g. due to an RLF with failed recovery).

8.9.10.1 IAB-node orderly release

For orderly release, the IAB-donor-CU can remove the F1 interface connection to the IAB-DU without releasing the IAB-MT. If the IAB-MT needs to be released, IAB-MT will perform the deregistration procedure. If both F1 interface and IAB-MT need to be released, the IAB-donor-CU should remove the F1 interface to the IAB-DU before it releases the collocated IAB-MT. The deregistration procedure is the same as the UE deregistration procedure. The IAB-donor-CU hands over the UEs or child IAB-nodes currently connected to the IAB-node's cell(s) to another cell(s), or releases the UEs and may stop accepting incoming handovers or connections to the IAB-node that is about to be released. The IAB-donor-CU may also update/release the BH RLC channels in the intermediate hops. At this point, the F1 interface will be released and the corresponding SCTP associations will be removed.

8.9.10.2 IAB-node disorderly release

For the disorderly release case, how to remove the IAB-node context is up to network implementation.

8.9.11 IAB-node OAM

The IAB-node receives commands, configuration data and software downloads (e.g. for equipment software upgrades) from its OAM system. The IAB-node can also send alarms and traffic counter information to its OAM system. The transport connection between the IAB-node and its OAM, using IP, is provided by the IAB-MT's PDU session via 5G network, or the IAB-MT's PDN connection via LTE network when IAB-MT uses EN-DC.

NOTE: The transport connection between the IAB-node and its OAM may also be provided using the Backhaul IP layer by implementation.

Alarms in the IAB generate bursts of high-priority traffic, to be transported in real time. Traffic counters generate bursts of traffic, but their transport need not be real-time. Configuration messages from OAM to the IAB will also generate small bursts of traffic, possibly with lower priority than alarms but still delay-sensitive: when a configuration is committed on the OAM, the time interval between the commitment and the effect on the equipment shall be small. Alarm messages and commands should be transported on a high-priority bearer, while counters may be transported on a lower priority bearer.

OAM software download to the IAB may generate larger amounts of data, but both the required data rate and the priority of this kind of traffic are much lower than in the case of alarms, commands and counters.

For different types of OAM traffic, it is necessary to use different DRBs between the IAB-MT and the serving DU, and different BH RLC channels for intermediate hops, with different QoS parameters. Aggregation of F1-U traffic for OAM with other F1-U traffic on the same BH RLC channels is not precluded. The QoS parameters are provided to the IAB-donor during the IAB-MT's PDU session establishment, or the IAB-MT's PDN connection establishment when IAB-MT uses EN-DC.

NOTE: When the transport connection between the IAB-node and its OAM is provided by the Backhaul IP layer, the OAM traffic may be aggregated with other traffic types on the same BH RLC channel. The QoS for OAM is ensured by implementation.

8.9.12 Handling of IAB-MTs in INACTIVE State

The IAB-MT optionally supports the RRC INACTIVE state. Upon the IAB-MT entering the RRC INACTIVE state, it is up to implementation to keep or release the F1 connection of the collocated IAB-DU.

8.9.13 IP Address Allocation for IAB-nodes

An IAB-node may obtain IP address(es) either from the IAB-donor or from the OAM system. The IP address(es) is(are) used by the IAB-node for F1 and non-F1 traffic exchange via the backhaul. In case IPsec tunnel mode is used to protect this F1 and non-F1 traffic, the IP address(es) refer to the outer tunnel addresses. The allocation of the inner tunnel IP address(es) is outside of 3GPP scope.

In case of IAB-donor-based IP address allocation, the IP address(es) is(are) allocated by the IAB-donor-CU or IAB-donor-DU. In both cases, the IAB-node requests the IP address(es) via RRC from the IAB-donor-CU. It includes a separate IP address request for each usage, where the usages defined are all traffic, F1-U, F1-C and non-F1. The IAB-donor-CU may initiate the IAB TNL Address Allocation procedure to obtain IP addresses from the IAB-donor-DU. The IAB-donor-CU sends the IP addresses allocated for each usage to the IAB-node via RRC.

The IAB-node may be allocated one or multiple IPv6 addresses or one 64-bit IPv6 prefix for each usage and/or one or multiple IPv4 addresses for each usage. Each allocated IP address/IPv6 prefix is unique within the IAB network and routable from the wireline network.

In case of OAM-based IP address allocation, the IAB-node informs the IAB-donor-CU via an UL RRC message about the IP address(es) it received for each purpose. This occurs before the IAB node uses the IP address(es) for UL and/or DL traffic.

The IAB-donor-CU configures the IAB-donor-DU with mappings between IP header fields and L2 parameters (BAP Routing ID, BH RLC channels) used for DL traffic. Each mapping configuration may hold an IPv4 address, IPv6

address or a 64-bit IPv6 prefix. In case of two mapping entries matching the same IP header where one holds an IPv6 prefix and the other holds a full IPv6 address, the one with full IPv6 address takes precedence at the IAB-donor-DU.

In case of IAB-donor-allocated IP addresses, the IAB-node's IP address(es) can be updated using DL RRC signalling.

For F1-C traffic transfer for NSA IAB, the LTE leg and NR leg should use separate IP address pairs {IAB-DU's IP address, IAB-donor-CU's IP address}. How the IAB-DU gets the remote IP end point(s) and its own IP address for LTE leg is not specified in this release.

8.10 Multiple TNLAs for E1

In the following, the procedure for managing multiple TNLAs for E1 is described.

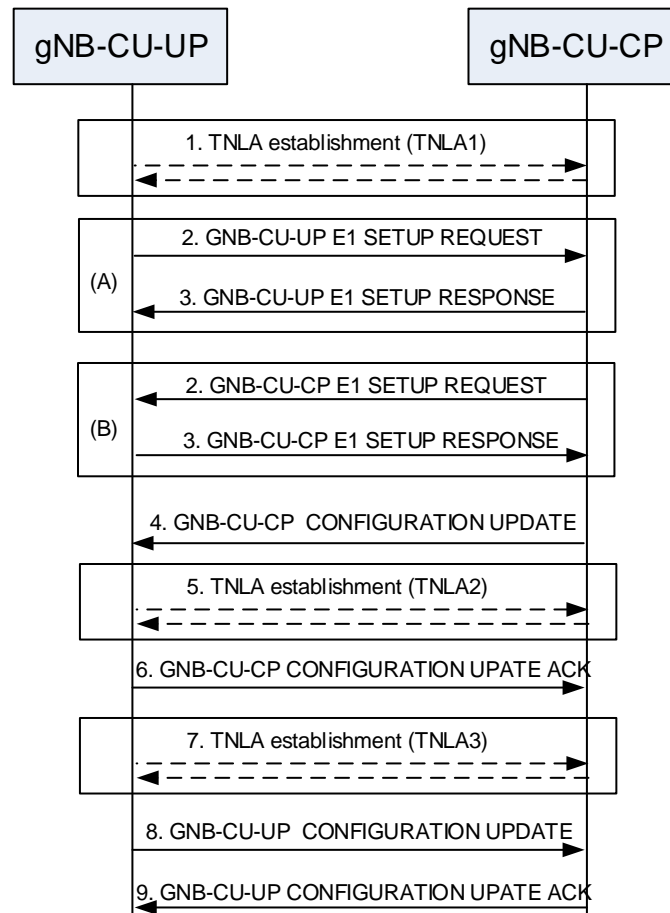

Figure 8.10-1: Managing multiple TNLAs for E1.

1. Either the gNB-CU-CP or gNB-CU-UP establishes the first SCTP association with the gNB-CU-UP or gNB-CU-CP respectively using a configured TNL address.

NOTE: The gNB-CU-UP/gNB-CU-CP may use different source and/or destination IP end point(s) if the TNL establishment towards one IP end point fails. How the gNB-CU-UP/gNB-CU-CP gets the remote IP end point(s) and its own IP address are outside the scope of this specification.

- 2-3 (A). Once the TNLA (gNB-CU-UP initiated) has been established, the gNB-CU-UP initiates the E1 Setup procedure to exchange application level configuration data

- 2-3 (B). Once the TNLA (gNB-CU-CP initiated) has been established, the gNB-CU-CP initiates the E1 Setup procedure to exchange application level configuration data

- 4-6. The gNB-CU-CP may add additional SCTP Endpoint(s) to be used for E1 signalling between the gNB-CU-CP and the gNB-CU-UP pair using the gNB-CU-CP Configuration Update procedure. The gNB-CU-CP

Configuration Update procedure also allows the gNB-CU-CP to request the gNB-CU-UP to modify or release TNLA(s).

- 7-9. The gNB-CU-UP may add additional TNL association(s) to be used for E1 signalling using a gNB-CU-CP endpoint already in use for existing TNL associations between the gNB-CU-CP and the gNB-CU-UP pair. The gNB-CU-UP CONFIGURATION UPDATE message including the gNB-CU-UP ID shall be the first E1AP message sent on an additional TNLA of an already setup E1 interface instance after the TNL association has become operational. The E1AP UE TNLA binding is a binding between a E1AP UE association and a specific TNL association for a given UE. After the E1AP UE TNLA binding is created, the gNB-CU-CP can update the UE TNLA binding by sending the E1AP message for the UE to the gNB-CU-UP via a different TNLA. The gNB-CU-UP shall update the E1AP UE TNLA binding with the new TNLA. The gNB-CU-UP Configuration Update procedure also allows the gNB-CU-UP to inform the gNB-CU-CP that the indicated TNLA(s) will be removed by the gNB-CU-UP.

8.11 Support of Network Sharing with multiple cell-ID broadcast

8.11.1 General

This section describes necessary additions as compared to the case where network sharing with multiple cell-ID broadcast is not applied.

The signalling flows in the subsequent sections assuming 2 sharing operators, A and B. The F1-C signalling transport deployment used is indicated within the subsequent sections.

8.11.2 Initial Registration – separate PLMN signalling

The signalling flow for Initial Registration for network sharing with multiple cell-ID broadcast with separate per-PLMN signalling is shown in Figure 8.11.2-1.

In this example message flow

- the UE is assumed to not provide an ue-Identity from which the DU is able to deduce the PLMN ID.
- each F1-C interface instance uses a separate signalling transport or share signalling transport with other F1-C interface instances.
- the gNB-DU_{A/B} entity shown in Figure 8.11.2-1 is a simplified representation of the gNB-DU_A of PLMN A, the gNB DU_B of PLMN B and respective radio resources of the shared cell.

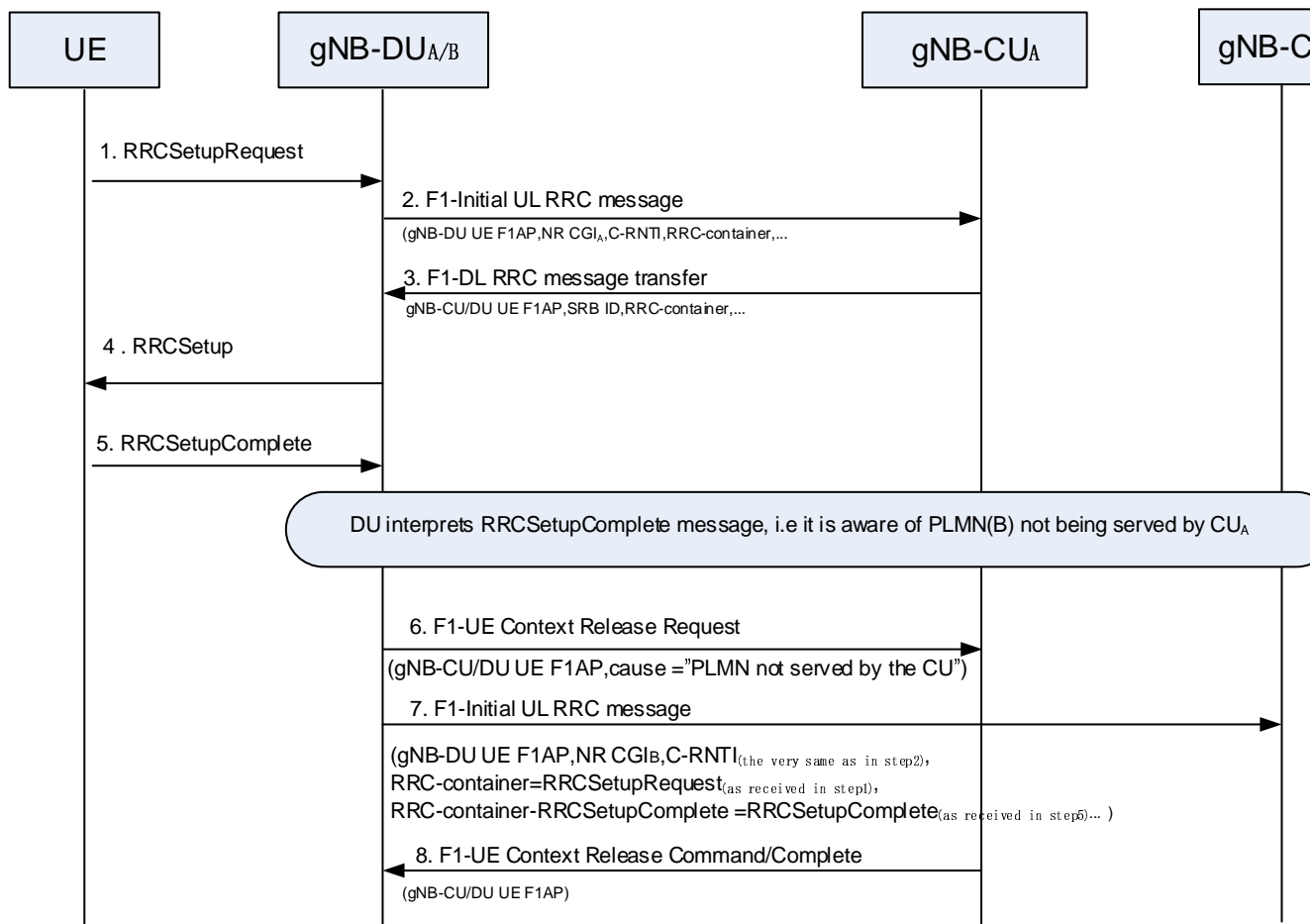

Figure 8.11.2-1: UE Initial Access procedure and network sharing with multiple cell-ID broadcast

NOTE: Steps 1-5 are defined in clause 8.1. Note, that the selectedPLMN-Identity is provided in step 5.

6. The gNB-DU_A sends the F1AP UE CONTEXT RELEASE REQUEST message to the gNB-CU_A, including a Cause set to "PLMN not served by the CU".
7. The gNB-DU_B sends the F1AP INITIAL UL RRC MESSAGE to the gNB-CU_B, including the NR CGI associated with PLMN_B, the C-RNTI indicated by the gNB-DU_A at step 2, and the RRC-Container IE and the *RRC-Container-RRCSetupComplete* IE with the RRC message received in step1 and step 5 respectively. The *RRC-Container-RRCSetupComplete* IE are included in the INITIAL UL RRC MESSAGE TRANSFER for the case of network sharing and shall contain the RRC messages received via the RRC *UL-DCCH-Message* IE from the UE, but never previously sent to the gNB-CU_B.
8. The gNB-CU_A triggers the F1AP UE Context Release procedure.

NOTE: Initiating procedures from gNB-DU_A towards gNB-CU_A and from gNB-DU_B to gNB-CU_B in parallel is not precluded.

8.11.3 RRC Connection Reestablishment – separate PLMN signalling

The signalling flow for RRC Connection Reestablishment for network sharing with multiple cell-ID broadcast with separate per-PLMN signalling is shown in Figure 8.11.3-1.

In this example message flow

- each F1-C/Xn-C interface instance uses either a separate signalling transport or a share signalling transport with other interface instances.
- the New gNB-DU_{A/B} entity shown in Figure 8.11.3-1 is a simplified representation of the New gNB-DU_A of PLMN A, the New gNB DU_B of PLMN B and respective radio resources of the shared cell.

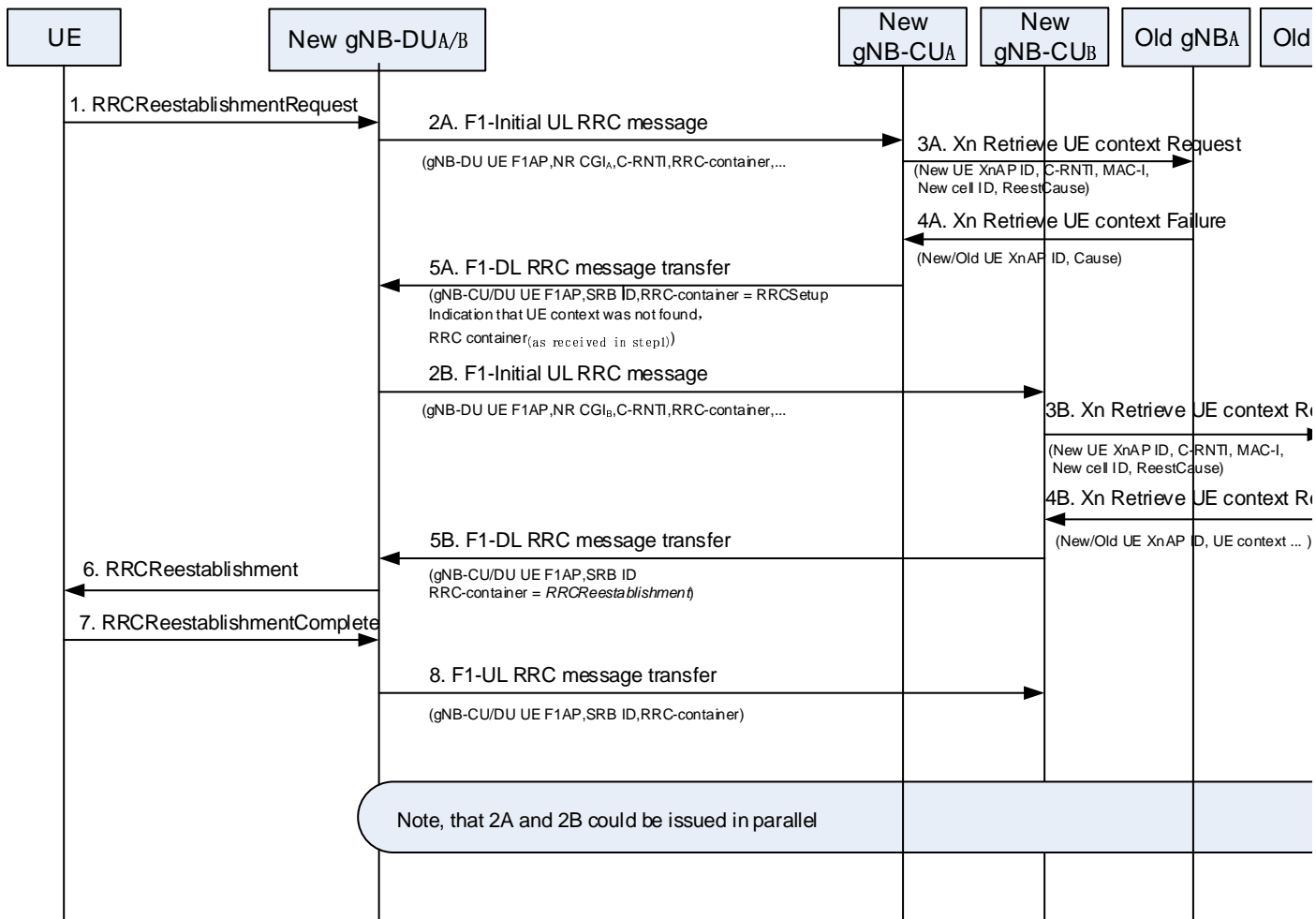

Figure 8.11.3-1: RRC Connection Reestablishment and network sharing with multiple cell-ID broadcast

- The UE sends the RRCReestablishmentRequest.
- 2A-5A. Depicts the case where the UE context could not be retrieved by the new gNB-CU_A. In step 2A, the NR CGI associated to PLMN_A is indicated. In step 5A, the gNB-CU_A would prepare the possibility to revert back to normal RRC Connection Establishment, indicating that the UE Context was not retrievable and may include the re-directed RRC message as received in step 1. After step 5A, the gNB-DU_A may redirect the UE towards the PLMN indicated in DL RRC message transfer, if the PLMN assistance information is provided by the gNB-CU_A. If the New gNB-DU_{A/B} was not able to deduce the RRC message from step 1, this indicator triggers step 2B. The New gNB-DU_A is supposed to trigger the release the UE-associated signalling connection (not shown).
- 2B-5B. Depicts the case where the UE context was retrievable by the New gNB-CU_B. In step 2B, the NR CGI associated to PLMN_B is indicated. Step 2B also includes the C-RNTI allocated at reception of step 1.
- 6-8. The RRC Connection Reestablishment continues with the New gNB-CU_B.

NOTE: If all gNB-CUs indicate that the UE context is not retrievable, the RRC connection reestablishment falls back to RRC Connection setup, as described in section 8.11.2.

NOTE: Initiating procedures from gNB-DU_A towards gNB-CU_A and from gNB-DU_B to gNB-CU_B in parallel is not precluded.

8.11.4 Support of shared signalling transport

This section specifies for F1-C, Xn-C and, in case of EN-DC, for X2-C, how an interface instance is identified in case of network sharing with multiple cell ID broadcast with shared signalling transport.

For UE associated signalling, the interface instance is identified by assigning on F1-C appropriate UE F1AP IDs, on Xn-C appropriate UE XnAP IDs and on X2-C appropriate UE X2AP IDs.

For non-UE associated signalling, the interface instance is identified on F1-C by the assigning an appropriate value to the Transaction ID, on Xn-C and X2-C by including the Interface Instance Indication in the respective message and assigning an appropriate value to it.

8.12 IAB-node Integration Procedure

8.12.1 Standalone IAB integration

A high-level flow chart for SA-based IAB integration is shown in the Figure 8.12-1:

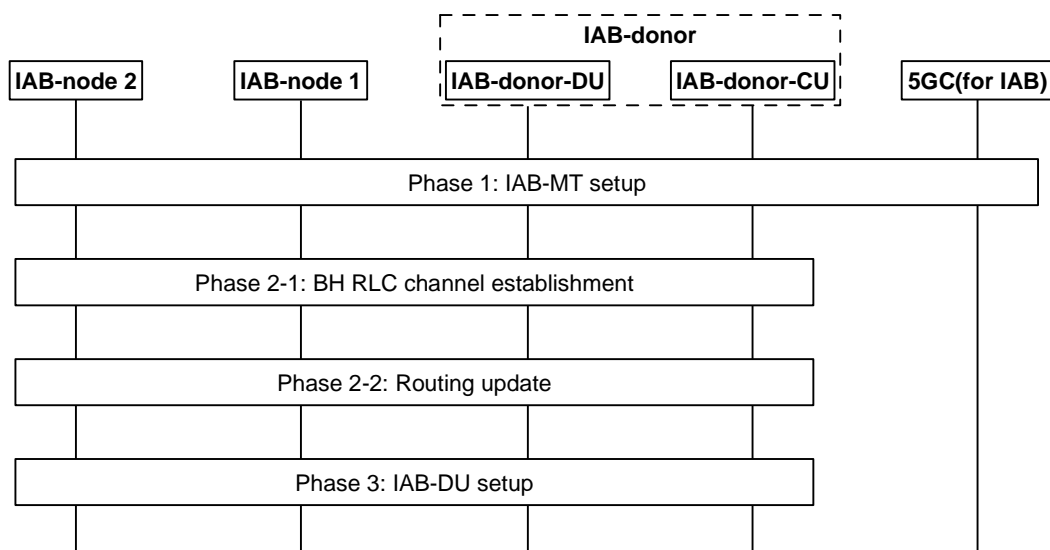

Figure 8.12.1-1: The integration procedure for IAB-node in SA

Phase 1: IAB-MT setup. In this phase, the IAB-MT of the new IAB-node (e.g. IAB-node 2 in Figure 8.12.1-1) connects to the network in the same way as a UE, by performing RRC connection setup procedure with IAB-donor-CU, authentication with the core network, IAB-node 2-related context management, IAB-node 2's access traffic-related radio bearer configuration at the RAN side (SRBs and optionally DRBs), and, optionally, OAM connectivity establishment by using the IAB-MT's PDU session. The IAB-node can select the parent node for access based on an over-the-air indication from potential parent node IAB-DU (transmitted in SIB1). To indicate its IAB capability, the IAB-MT includes the IAB-node indication in *RRCSetupComplete* message, to assist the IAB-donor to select an AMF supporting IAB.

NOTE: The signalling flow for UE initial access procedure as shown in Figure 8.1-1/Figure 8.9.1-1 is used for the setup of the IAB-MT.

Phase 2-1: BH RLC channel establishment. During the bootstrapping procedure, one default BH RLC channel for non-UP traffic e.g. carrying F1-C traffic/non-F1 traffic to and from the IAB-node 2 in the integration phase, is established. This may require the setup of a new BH RLC channel or modification of an existing BH RLC channel between IAB-node 1 and IAB-donor-DU. The IAB-donor-CU may establish additional (non-default) BH RLC

channels. This phase also includes configuring the BAP Address of the IAB-node 2 and default BAP Routing ID for the upstream direction.

NOTE: If the OAM connectivity is supported via backhaul IP layer by implementation, one or more BH RLC channels used for OAM traffic can also be established.

Phase 2-2: Routing update. In this phase, the BAP sublayer is updated to support routing between the new IAB-node 2 and the IAB-donor-DU. For the downstream direction, the IAB-donor-CU initiates F1AP procedure to configure the IAB-donor-DU with the mapping from IP header field(s) to the BAP Routing ID related to IAB-node 2. The routing tables are updated on all ancestor IAB-nodes (e.g. IAB-node 1 in Figure 8.12.1-1) and on the IAB-donor-DU, with routing entries for the new BAP Routing ID(s). This phase may also include the IP address allocation procedure for IAB-node 2. IAB-node 2 may request one or more IP addresses from the IAB-donor-CU via RRC. The IAB-donor-CU may send the IP address(es) to the IAB-node 2 via RRC. The IAB-donor-CU may obtain the IP address(es) from the IAB-donor-DU via F1-AP or by other means (e.g. OAM, DHCP). IP address allocation procedure may occur at any time after RRC connection has been established.

Phase 3: IAB-DU part setup. In this phase, the IAB-DU of IAB-node 2 is configured via OAM. The IAB-DU of IAB-node 2 initiates the TNL establishment, and F1 setup (as defined in clause 8.5) with the IAB-donor-CU using the allocated IP address(es). The IAB-donor-CU discovers collocation of IAB-MT and IAB-DU from the IAB-node's BAP Address included in the F1 SETUP REQUEST message. After the F1 is set up, the IAB-node 2 can start serving the UEs.

NOTE: The IAB-DU can discover the IAB-donor-CU's IP address in the same manner as a non-IAB gNB-DU.

8.12.2 NSA IAB Integration procedure

The IAB integration procedure for NSA is shown in Figure 8.12.2-1.

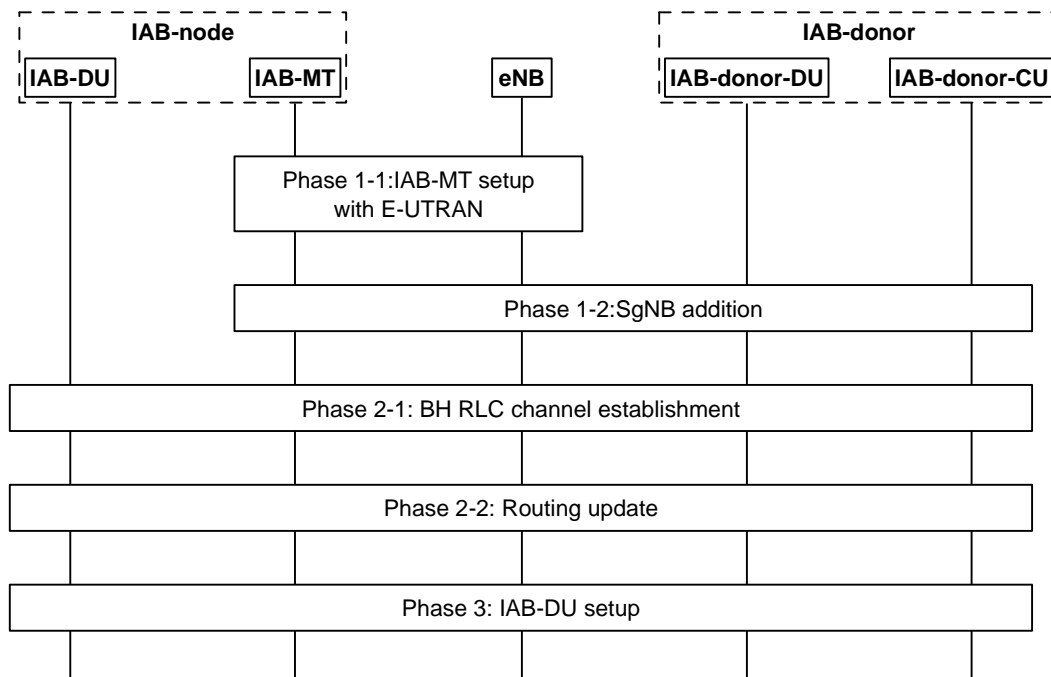

Figure 8.12.2-1: Signalling flow for IAB integration procedure in NSA

Phase 1-1. IAB-MT part setup with E-UTRAN. In this phase, the IAB-MT part connects to the LTE network as a UE, by performing RRC connection setup procedure with an eNB, authentication with the EPC, IAB-node's access traffic-related radio bearer configuration at the E-UTRAN side, and optionally, OAM connectivity establishment by using the IAB-MT's PDN connection. The IAB-node can select the IAB-supporting eNB based on an over-the-air indication from eNB (transmitted in SIB1). To indicate its IAB capability, the IAB-MT includes the IAB-node indication in *RRCConnectionSetupComplete* message, to assist the eNB to select an MME supporting IAB. The eNB then configures the IAB-MT part with an NR measurement configuration in order to perform discovery, measurement and measurement reporting of candidate gNBs. To enable the eNB choose an en-gNB which supports IAB function, the IAB capability of neighbour gNBs can be pre-configured in the eNB (e.g. by OAM).

NOTE: Other ways to enable the eNB know the IAB capability of neighbour gNBs are not precluded.

Phase 1-2. SgNB addition. In this phase, the IAB-MT part connects to the parent node IAB-DU and IAB-donor-CU via the EN-DC SgNB Addition procedure. The procedure defined in section 8.4.1 is reused. The eNB includes “*IAB Node Indication*” in SGNB ADDITION REQUEST message to inform the IAB-donor-CU that the request is for an IAB-node. In addition, SRB3 can be set up for the IAB-MT, to transmit RRC message between the IAB-MT and the IAB-donor-CU via the NR links directly.

Phase 2-1: BH RLC channel establishment. This phase is the same as Phase 2-1 in the standalone IAB integration procedure (refer to the Phase 2-1 in clause 8.12.1). This step may occur in Phase 1-2.

Phase 2-2: Routing update. This phase is the same as Phase 2-2 in the standalone IAB integration procedure (refer to the Phase 2-2 in clause 8.12.1), except that the IP traffic on the F1-C interface may be transmitted via the MeNB.

Phase 3. IAB-DU part setup. This phase is the same as Phase 3 in the standalone IAB integration procedure (refer to the Phase 3 in clause 8.12.1), except that the IP traffic on the F1-C interface may be transmitted via the MeNB.

The IAB-donor-CU decides to only configure LTE leg, or only to configure NR leg, or to configure both LTE leg and NR leg, to be used for F1-C traffic transfer. The configuration may be performed before IAB-DU part setup. IAB-donor-CU may also change the configuration after IAB-DU part setup. In case the configuration is not performed before IAB-DU part setup, the IAB node uses the NR leg as the default one. When both LTE leg and NR leg are configured, it is up to the implementation to select the leg for F1-C traffic transfer.

8.13 Overall procedures for MDT

The following clauses describe the overall procedures for MDT measurement involving E1 and F1.

8.13.1 Signalling based MDT activation

The signalling flow for Signalling based MDT activation involving E1 and F1 is shown in Figure 8.13.1-1.

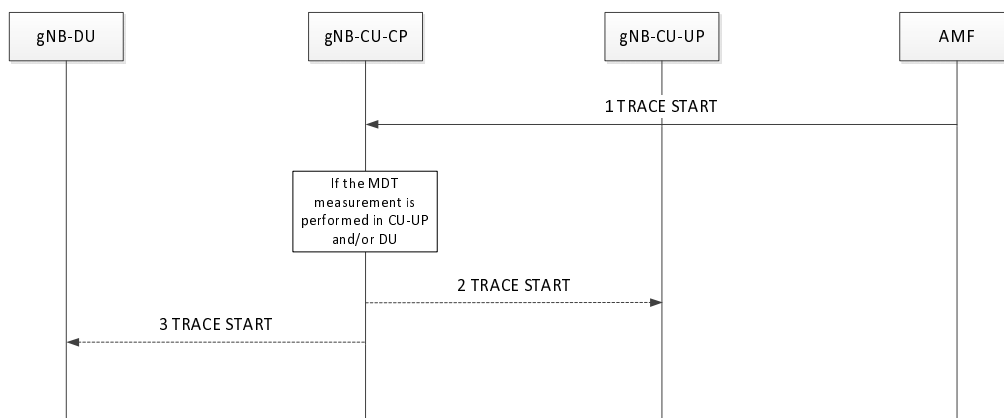

Figure 8.13.1-1 Signalling based MDT Activation

1. The AMF starts a trace session and sends a TRACE START message to the gNB. The AMF shall consider the MDT user consent information when activating an MDT trace session for the UE as defined in TS32.422 [20]. TRACE START message includes the parameters for configuring MDT measurements.
2. The gNB-CU-CP decides if the gNB-CU-UP, or the gNB-DU, or both, should be involved in the MDT measurement. If the gNB-CU-UP should be involved in the MDT measurement, the gNB-CU-CP sends TRACE START message to the gNB-CU-UP, including MDT configuration parameters.
3. If the gNB-DU should be involved in the MDT measurement, the gNB-CU-CP sends TRACE START message to the gNB-DU, including MDT configuration parameters.

8.13.2 Management based MDT activation

In Management Based Trace Activation towards a gNB-CU-CP, gNB-CU-UP or a gNB-DU can be fulfilled with the Cell Traffic trace functionality defined in TS32.422 [20]. The configuration parameters of the Trace Session that are received by a node in split RAN architecture are defined in TS32.422 [20].

The following description is valid for both an en-gNB and a gNB.

If the MDT measurement is initiated by the EM towards the gNB-CU-CP, and if the activation involves measurements collected by multiple nodes under the same gNB-CU-CP control in a split RAN architecture, the EM sends MDT measurement activation to the gNB-CU-CP and the gNB-CU-CP may further decide which gNB-DU(s) or which gNB-CU-UP(s) to perform the MDT measurement.

When gNB-CU-CP or a gNB-DU receive the Trace Session Activation message from the management system for a given cell or a list of cell(s) under its control, the gNB-CU-CP or gNB-DU shall start a Trace Session for the given cell or list of cell(s). For Management Based MDT sent directly to a gNB-CU-UP, no MDT Area Configuration (apart from PLMN IDs) is to be included in the MDT activation indication.

Each node receiving an MDT activation indication reports the measurements collected according to such activation directly to the TCE the node has been configured with.

The signalling flow for management based MDT in gNB-CU-CP, gNB-DU and gNB-CU-UP is shown in Figure 8.13.2-1, Figure 8.13.2-2 and in Figure 8.13.2-3 respectively.

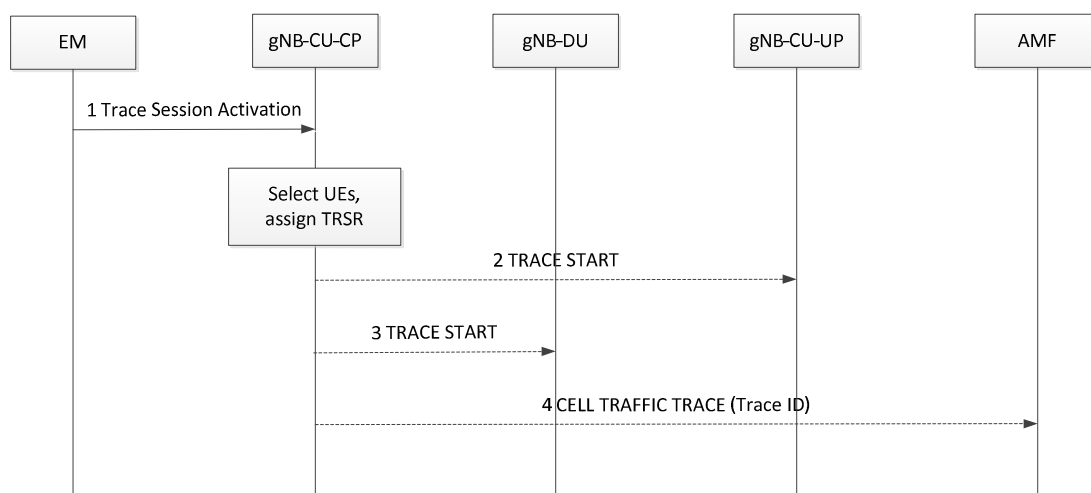

Figure 8.13.2-1 Management based MDT Activation in gNB-CU-CP

1. The EM sends a Trace Session activation request to the gNB-CU-CP. This request includes the parameters for configuring UE measurements.
2. The gNB-CU-CP shall select the suitable UEs for MDT data collection. If the UE is not in the specified area or if the serving PLMN is not within the Management Based MDT PLMN List the UE shall not be selected by the gNB-CU-CP for MDT data collection as defined in TS32.422 [20].

For each selected UE, if the gNB-CU-UP should perform MDT measurement, the gNB-CU-CP sends TRACE START message to the gNB-CU-UP, including MDT configuration parameters.

3. For each selected UE, if the gNB-DU should perform MDT measurement, the gNB-CU-CP sends TRACE START message to the gNB-DU, including MDT configuration parameters.
4. The gNB-CU-CP may send CELL TRAFFIC TRACE message to the AMF for the selected UE, including Trace ID for MDT. The AMF forwards Trace ID and UE identity to the TCE.

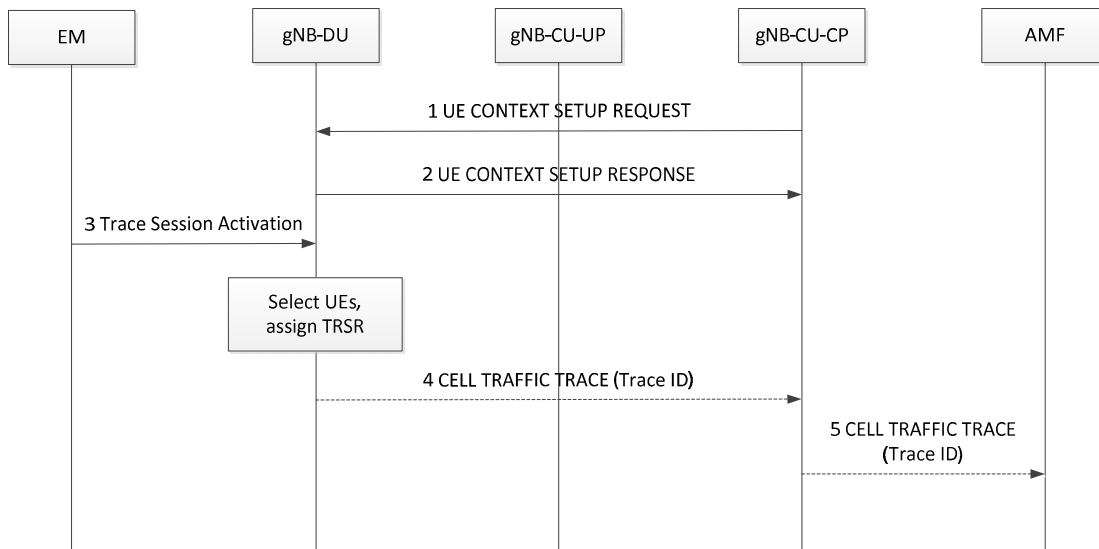

Figure 8.13.2-2 Management based MDT Activation in gNB-DU

1. The gNB-CU-CP sends UE CONTEXT SETUP REQUEST message to the gNB-DU, including Management based MDT PLMN List.
2. The gNB-DU sends UE CONTEXT SETUP RESPONSE message to the gNB-CU-CP.
3. The EM sends a Trace Session activation request to the gNB-DU. This request includes the parameters for configuring UE measurements.
4. The gNB-DU shall select the suitable UEs for MDT data collection. If the UE is not in the specified area or if the serving PLMN is not within the Management Based MDT PLMN List the UE shall not be selected by the gNB-DU for MDT data collection as defined in TS32.422 [20].

For each selected UE, the gNB-DU may send CELL TRAFFIC TRACE message to the gNB-CU-CP in the F1 UE associated signalling, including Trace ID for MDT.

5. Upon reception of a CELL TRAFFIC TRACE message from F1, the gNB-CU-CP shall send CELL TRAFFIC TRACE message to the AMF for this UE, including Trace ID for MDT. The AMF forwards Trace ID and UE identity to the TCE.

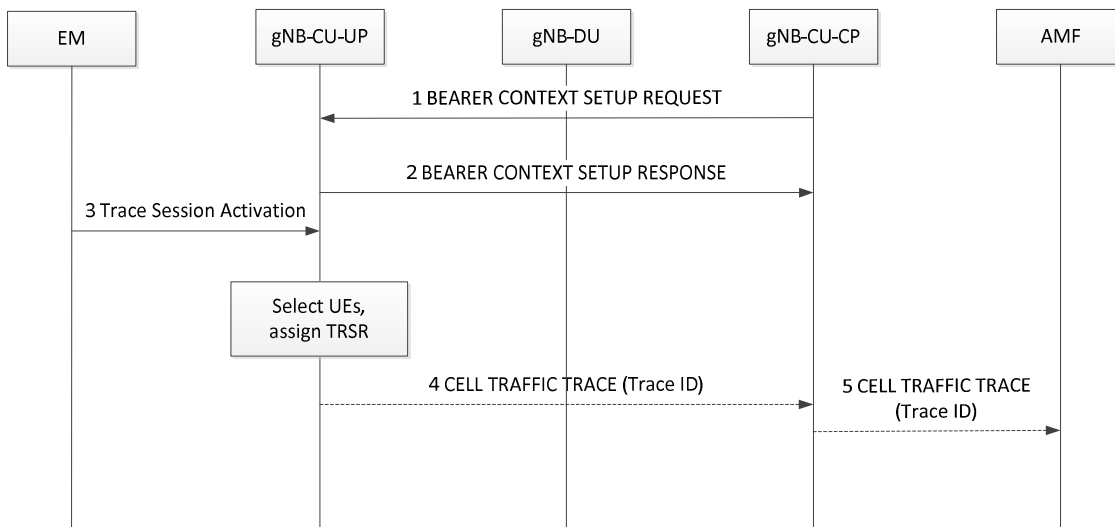

Figure 8.13.2-3 Management based MDT Activation in gNB-CU-UP

1. The gNB-CU-CP sends BEARER CONTEXT SETUP REQUEST message to the gNB-CU-UP, including Management based MDT PLMN List.
2. The gNB-CU-UP sends BEARER CONTEXT SETUP RESPONSE message to the gNB-CU-CP.
3. The EM sends a Trace Session activation request to the gNB-CU-UP. This request includes the parameters for configuring UE measurements.
4. The gNB-CU-UP shall select the suitable UEs for MDT data collection. If the serving PLMN is not within the Management Based MDT PLMN List the UE shall not be selected by the gNB-CU-UP for MDT data collection as defined in TS32.422 [20].

For each selected UE, the gNB-CU-UP may send CELL TRAFFIC TRACE message to the gNB-CU-CP in the E1 UE associated signalling, including Trace ID for MDT

5. Upon reception of a CELL TRAFFIC TRACE message from E1, the gNB-CU-CP shall send CELL TRAFFIC TRACE message to the AMF for this UE, including Trace ID for MDT. The AMF forwards Trace ID and UE identity to the TCE.

In the EN-DC case, the EM provides the MDT configuration to both MeNB and en-gNB independently.

As specified in TS32.422 [20] in Management based MDT getting user consent is required before activating the MDT functionality because of privacy and legal obligations. In the case of EN-DC user consent gets communicated to the MeNB at the UE context setup procedure using the INITIAL CONTEXT SETUP REQUEST message. In particular when the Management Based MDT Allowed IE is contained in the INITIAL CONTEXT SETUP REQUEST message, the MeNB stores it in the UE context and uses it, together with information in the Management Based MDT PLMN List IE, if available, to allow subsequent selection of the UE for management based MDT as specified in TS 32.422 [20]. The MeNB will forward the MDT user consent to the SgNB at EN-DC setup. In particular, if available in the UE context, the MeNB will include the Management Based MDT Allowed IE and the Management Based MDT PLMN List IE in the SGNB ADDITION REQUEST message to the SgNB. Furthermore, the user consent will be forwarded to the relevant gNB-CU-UP at the bearer context setup or to the gNB-DU by including the Management Based MDT PLMN List IE in the BEARER CONTEXT SETUP REQUEST or UE CONTEXT SETUP REQUEST.

The following shows a flow chart summarizing the functionality.

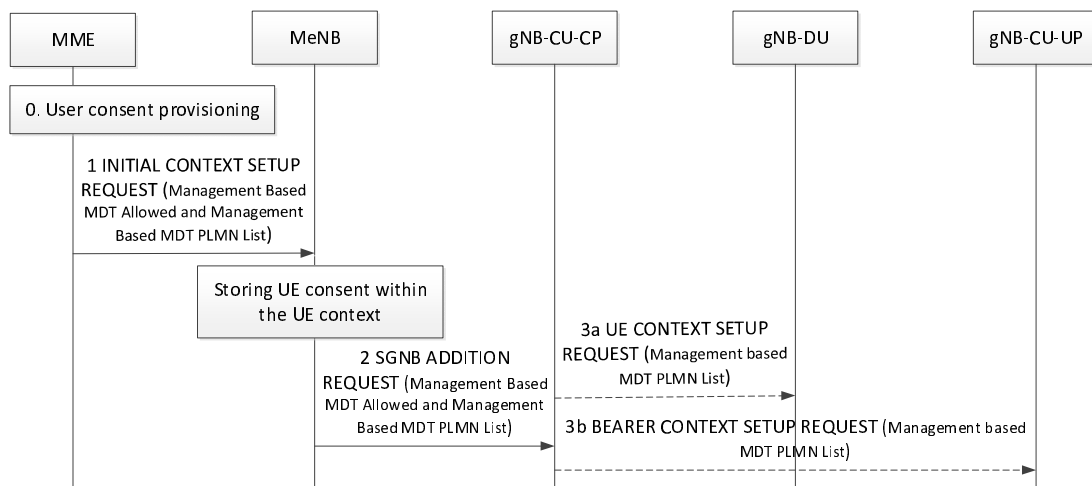

Figure 8.13.2-4 User consent propagation in EN-DC

0. User Context information are made available at the MME.
1. The MME sends INITIAL CONTEXT SETUP REQUEST message to the MeNB, including Management Based MDT Allowed IE and the Management based MDT PLMN List IE to communicate user consent to the eNB.
2. The MeNB sends SGNB ADDITION REQUEST to the gNB-CU-CP at EN-DC setup. This request includes Management Based MDT Allowed IE and, optionally, the Management based MDT PLMN List IE, if available.

- 3a. The user consent is communicated to the gNB-DU at the UE context setup by including the Management based MDT PLMN List IE in the UE CONTEXT SETUP REQUEST.
- 3b. The user consent is communicated to the gNB-CU-UP at the bearer context setup by including the Management based MDT PLMN List IE in the BEARER CONTEXT SETUP REQUEST.

8.14 Self-optimisation

8.14.1 Overall procedures for MRO

The following clauses describe the overall procedures for MRO involving F1.

8.14.1.1 Signalling of RLF information from gNB-CU to gNB-DU

The signalling flow for signalling of RLF information from gNB-CU to gNB-DU is shown in Figure 8.14.1.1-1, where the example where NG-RAN nodes exchange the RLF Report via the Xn: FAILURE INDICATION message has been considered.

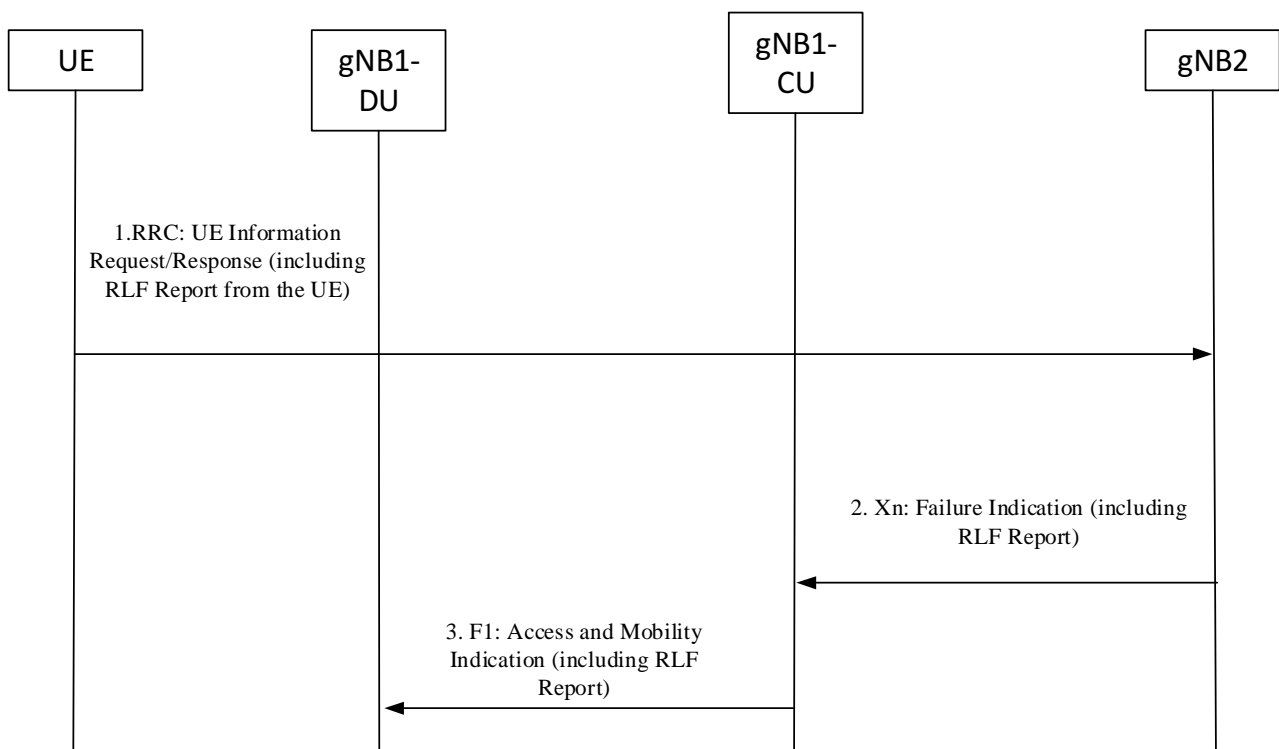

Figure 8.14.1.1-1 Example of signalling of RLF information from gNB-CU to gNB-DU in NG RAN

1. A UE with a logged RLF Report connects to a cell in gNB2 and it signals the RLF Report to gNB2 by means of the RRC UE Information Request/Response procedures.
2. The gNB2 sends an Xn: Failure Indication to gNB1-CU where the UE may have previously been connected prior to the connection failure. This includes also the RLF Report.
3. The gNB1-CU sends the F1: Access and Mobility Indication message to the gNB1-DU, including the RLF Report.

It is also possible for the gNB-CU receiving the RLF Report from the UE to signal it directly to the gNB-DU by means of the F1: Access and Mobility Indication procedure.

9 Synchronization

9.1 gNB Synchronization

The gNB shall support a logical synchronization port for phase-, time- and/or frequency synchronization.

Logical synchronization port for phase- and time-synchronization shall provide:

- 1) accuracy that allows to meet the gNB requirements on maximum relative phase difference for all gNBs in synchronized TDD-unicast area;
- 2) continuous time without leap seconds traceable to common time reference for all gNBs in synchronized TDD-unicast area. In the case the TDD-unicast area is not isolated, the common time reference shall be traceable to the Coordinated Universal Time (UTC).

A logical synchronization port for phase- and time-synchronization may also be provided for e.g., all gNBs in FDD time domain inter-cell interference coordination synchronization area.

Furthermore common SFN initialization time shall be provided for all gNBs in synchronized TDD-unicast area.

In case of non isolated networks, the start of the radio frame on the output shall be synchronous with the input time reference, i.e., when an UTC traceable reference is required, the start of the radio frame shall be aligned with the start time of the UTC second.

Unless otherwise mutually agreed by the operators of the cells in non isolated networks and/or unless different SFN initialization offset settings do not affect operators' networks in the same area, the common SFN initialization time should be 1980-01-06T00:00:19 International Atomic Time (TAI).

Based on this information, the gNB may derive the SFN according to the following formula:

$$SFN = \{time\} \bmod \{period(SFN)\},$$

where:

- | | |
|-------------|---|
| time | time adjusted by the common SFN initialization time, in units of 10 ms to match the length of radio frame and accuracy accordingly; |
| period(SFN) | SFN period. |

In case gNB is connected via TDM interface, it may be used to frequency synchronize the gNB. The characteristics of the clock in the gNB shall be designed taking into account that the jitter and wander performance requirements on the interface are in accordance with network limits for output wander at traffic interfaces of either ITU-T Recommendation G.823 [8], ITU-T Recommendation G.824 [9] or network limits for the maximum output jitter and wander at any hierarchical interface of ITU-T Recommendation G.825 [10], whichever is applicable.

In case gNB is connected via Ethernet interface and the network supports Synchronous Ethernet, the gNB may use this interface to get frequency synchronization. In this case the design of the gNB clock should be done considering the jitter and wander performance requirements on the interface are as specified for output jitter and wander at EEC interfaces of ITU-T Recommendation G.8261/Y.1361 [11], defined in clause 9.2.1. Further considerations on Synchronous Ethernet recommendations and architectural aspects are defined in clause 12.2.1 and Annex A of ITU-T Recommendation G.8261/Y.1361 [11].

A configurable LTE TDD-offset of start frame shall be supported by all gNBs in synchronized TDD-unicast areas in order to achieve interoperability in coexistence scenarios.

10 NG-RAN interfaces

10.1 NG interface

TS 38.410 [14] specifies NG interface general aspects and principles.

10.2 Xn interface

TS 38.420 [15] specifies Xn interface general aspects and principles.

10.3 F1 interface

TS 38.470 [16] specifies F1 interface general aspects and principles.

10.4 E1 interface

TS 38.460 [17] specifies E1 interface general aspects and principles.

10.5 Antenna interface - general principles

The Iuant interface for the control of RET antennas or TMAs is a logical part of the NG-RAN.

The support of any standardised antenna interface technique shall not be prevented; e.g. AISG (Antenna interface standards group) specifications may be used.

11 Overall procedures in NG-RAN Architecture

11.1 Multiple TNLAs for Xn-C

In the following, the procedure for managing multiple TNLAs for Xn-C is described.

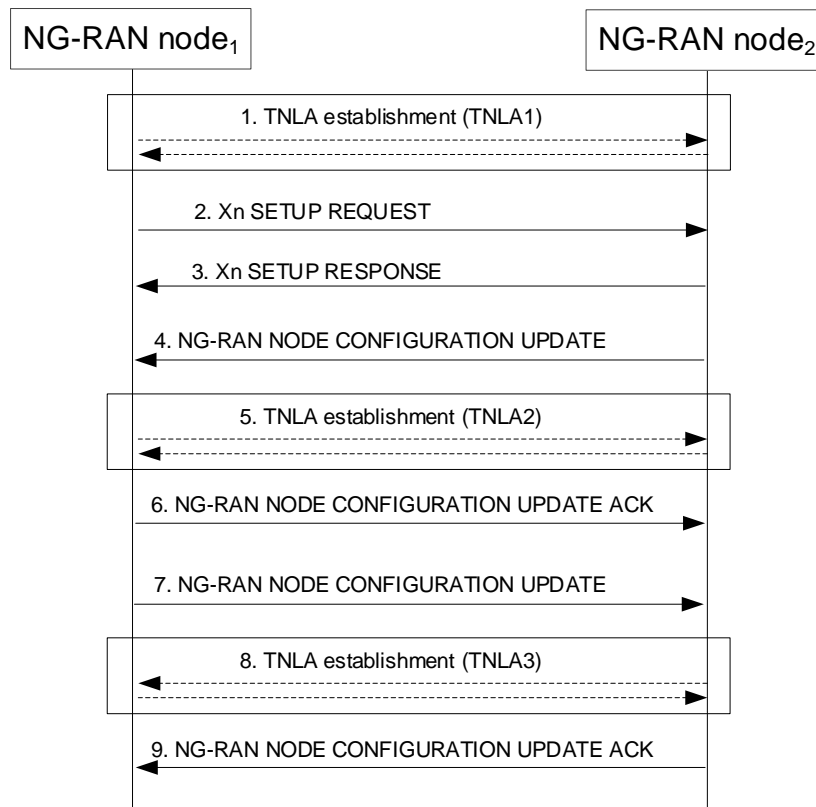

Figure 11.1-1: Managing multiple TNLAs for Xn-C.

1. The NG-RAN node₁ establishes the first TNLA with the NG-RAN node₂ using a configured TNL address.

NOTE: The NG-RAN node₁ may use different source and/or destination IP end point(s) if the TNL establishment towards one IP end point fails. How the NG-RAN node₁ gets the remote IP end point(s) and its own IP address are outside the scope of this specification.

2-3. Once the TNLA has been established, the NG-RAN node₁ initiates the Xn Setup procedure to exchange application level configuration data

4-6. The NG-RAN node₂ may add additional TNL Endpoint(s) to be used for Xn-C signalling between the NG-RAN node₁ and the NG-RAN node₂ pair using the NG-RAN node Configuration Update procedure. NG-RAN node Configuration Update procedure also allows the NG-RAN node₂ to request the NG-RAN node₁ to modify or release TNLA(s).

7-9. The NG-RAN node₁ may add additional TNL Endpoint(s) to be used for Xn-C signalling between the NG-RAN node₁ and the NG-RAN node₂ pair using the NG-RAN node Configuration Update procedure. NG-RAN node Configuration Update procedure also allows the NG-RAN node₁ to request the NG-RAN node₂ to modify or release TNLA(s).

Annex A (informative): Deployment scenarios of gNB/en-gNB

Figure A-1 shows logical nodes (CU-C, CU-U and DU), internal to a logical gNB/en-gNB. Protocol terminations of the NG and Xn interfaces are depicted as ellipses in Figure A-1. The terms "Central Entity" and "Distributed Entity" shown in Figure A-1 refer to physical network nodes.

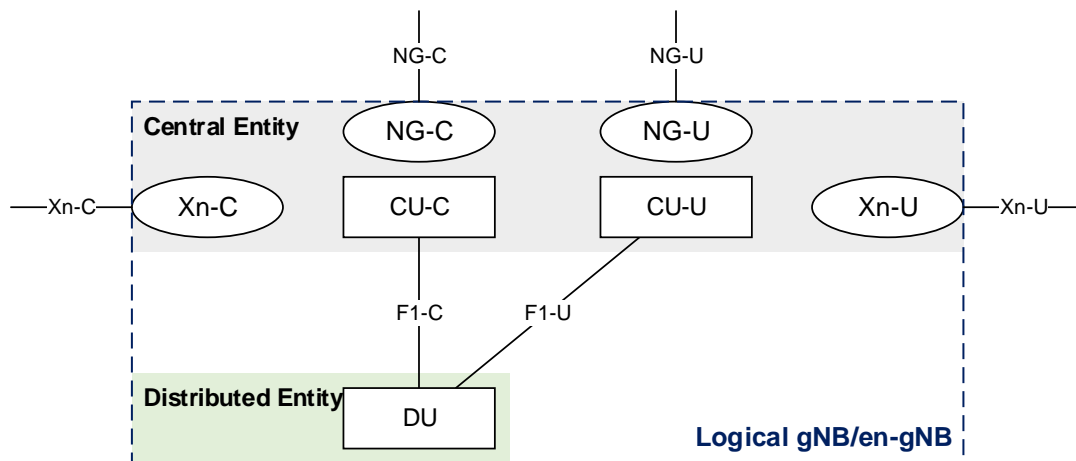

Figure A-1: Example deployment of an Logical gNB/en-gNB

Annex B: NG-RAN Architecture for Radio Access Network Sharing with multiple cell ID broadcast (informative)

Each gNB-DU serving a cell identified by a Cell Identity associated with a subset of PLMNs is connected to a gNB-CU via a single F1-C interface instance.

Each F1-C interface instance is setup individually.

F1-C interface instances terminating at gNB-DUs which share the same physical radio resources may share the same F1-C signalling transport resources. If this option is applied,

- non-UE associated signalling is associated to an F1-C interface instance by allocating the corresponding Transaction ID from a value range associated to that F1-C interface instance.
- node related, non-UE associated F1-C interface signalling may provide information destined for multiple logical nodes in a single F1AP procedure instance once the F1-C interface instance is setup.

NOTE 1: If the Interface Instance Indication corresponds to more than one interface instance, the respective F1AP message carries information destined for multiple logical nodes.

- a UE associated signalling connection is associated to an F1-C interface instance by allocating values for the corresponding gNB-DU UE F1AP ID and gNB-CU UE F1AP ID so that they can be mapped to that interface instance.

NOTE 2: One possible implementation is to partition the value ranges of the gNB-DU UE F1AP ID and gNB-CU UE F1AP ID and associate each value range with an F1-C interface instance.

Interpreting the content of RRC MSG3 and other unciphered RRC message by the gNB-DU is supported.

Content for System Information Broadcast is assumed to be coordinated among the sharing PLMNs. PLMN specific SIB1 content is controlled by the respective PLMN owner. Non PLMN specific content needs coordination to avoid contradicting indication by PLMN specific gNB-CUs. For Warning messages (SIB6, SIB7 and SIB8), if provided by more than one gNB-CU, warning message duplicates are identified by provision of the Message Number and the Serial Number by the gNB-CU and don't trigger new broadcast or replace existing broadcast. Other coordination between gNB-CUs is ensured by appropriate implementation.

Annex C (informative): Change History

Change history							
Date	Meeting	TDoc	CR	Rev	Cat	Subject/Comment	New version
2017-04	RAN3#95bis	R3-171307				First Draft	0.0.1
2017-05	RAN3#96	R3-171962				Reflected agreed TP in RAN3#96. Added new Clause 8 for overall procedure for gNB-CU/DU architecture	0.1.0
2017-06	RAN3#NR Ad Hoc	R3-172634				Reflected agreed TP in RAN3#NR Ad Hoc in 2017-06 (Qingdao)	0.2.0
2017-08	RAN3#97	R3-173449				Reflected agreed TP in RAN3#97	0.3.0
2017-10	RAN3#97bis	R3-174237				Reflected agreed TP in RAN3#97bis	0.4.0
2017-10	RAN3#97bis	R3-174258				Removed subclauses under 10.3 (moved to 38.470)	0.4.1
2017-11	RAN3#98	R3-175054				Reflected agreed TP in RAN3#98	0.5.0
2017-12	RP-78	RP-172545				Submit to RAN Plenary#78 for approval	1.0.0
2017-12	RP-78					TR Approved by RAN plenary	15.0.0
2018-03	RP-79	RP-180468	0007	1	-	Correction on intra-gNB-DU handover	15.1.0
2018-06	RP-80	RP-181237	0001	5	B	Introduction of SA NR (38.401 Baseline CR covering RAN3 agreements)	15.2.0
2018-06	RP-80	RP-181240	0008	4	B	Introduction of Separation of CP and UP for Split Option 2 (38.401 Baseline CR covering RAN3 agreements)	15.2.0
2018-06	RP-80	RP-181238	0012	1	F	CR to TS38.401 on UL blockage	15.2.0
2018-06	RP-80	RP-181238	0014	1	F	CR to 38.401 on DL User Data to DU	15.2.0
2018-06	RP-80	RP-181238	0016	-	F	TP for 38.401 in supporting full configuration	15.2.0
2018-09	RP-81	RP-181922	0022	2	F	NR Corrections (38.401 Baseline CR covering RAN3-101 agreements)	15.3.0
2018-12	RP-82	RP-182707	0023	3	F	NR Corrections (TS 38.401 Baseline CR covering RAN3-101Bis and RAN3-102 agreements)	15.4.0
2019-03	RP-83	RP-190554	0025	-	F	Correction to Intra-gNB-CU mobility	15.5.0
2019-03	RP-83	RP-190560	0026	1	F	Correction from Rapporteur for 38.401	15.5.0
2019-03	RP-83	RP-190554	0037	1	F	About Cells Failed to be Activated IE	15.5.0
2019-07	RP-84	RP-191394	0039	3	F	Correction of AMF set related statements	15.6.0
2019-07	RP-84	RP-191395	0063	1	F	CR to 38.401 on Multiple TNLAs for F1-C and E1	15.6.0
2019-07	RP-84	RP-191395	0065	-	F	Multiple TNLAs for Xn-C	15.6.0
2019-07	RP-84	RP-191502	0043	2	F	Clarify the support for multiple TNLAs for F1-C	15.6.0
2019-07	RP-84	RP-191397	0067	1	F	RAN sharing with multiple Cell ID broadcast	15.6.0
2019-07	RP-84	RP-191396	0068	1	F	Procedure description on optional IEs in CU to DU RRC information IE.	15.6.0
2019-12	RP-86	RP-192916	0045	4	F	Correction to RRC Inactive transition	15.7.0
2019-12	RP-86	RP-192916	0104	-	F	Inter-gNB-DU mobility using MCG SRB procedure	15.7.0
2019-12	RP-86	RP-192754	0105	2	F	CR for RRC Container IE in Initial UL RRC Message Transfer procedure	15.7.0
2019-12	RP-86	RP-192908	0060	4	B	Introduction of RIM in TS 38.401	16.0.0
2019-12	RP-86	RP-192913	0075	1	F	Trace function support stage-2	16.0.0
2019-12	RP-86	RP-192913	0097	2	F	Introduction of common time standard source	16.0.0
2019-12	RP-86	RP-192911	0107	2	F	CR to 38.401 on corrections to ng-eNB deployment	16.0.0
2019-12	RP-86	RP-192908	0109	-	B	Introduction of Cross-link Interference Management	16.0.0
2019-12	RP-86	RP-192910	0112	-	B	Support of SN Resume during the RRCResume procedure	16.0.0
2020-03	RP-87-e	RP-200425	0114	-	D	Rapporteur updating of specification 38.401	16.1.0
2020-07	RP-88-e	RP-201077	0033	21	B	BL CR to 38.401 Support for IAB	16.2.0
2020-07	RP-88-e	RP-201082	0099	7	B	Addition of MDT features	16.2.0
2020-07	RP-88-e	RP-201080	0102	6	B	BL CR NPN for TS 38.401	16.2.0
2020-07	RP-88-e	RP-201075	0110	6	B	Baseline CR for introducing Rel-16 NR mobility enhancement	16.2.0
2020-07	RP-88-e	RP-201082	0116	4	B	Addition of SON features	16.2.0
2020-07	RP-88-e	RP-201091	0122	1	A	Correction for gNB-DU transmission stop descriptoin in the inter-gNB HO involving gNB-CU-UP change	16.2.0
2020-07	RP-88-e	RP-201085	0130	-	F	Rapporteur Corrections to 38.401	16.2.0

History

Document history		
V16.2.0	July 2020	Publication