

ETSI TS 138 521-3 V16.7.0 (2021-05)



**5G;
NR;
User Equipment (UE) conformance specification;
Radio transmission and reception;
Part 3: Range 1 and Range 2 Interworking operation
with other radios
(3GPP TS 38.521-3 version 16.7.0 Release 16)**



Reference

RTS/TSGR-0538521-3vg70

Keywords

5G

ETSI

650 Route des Lucioles
F-06921 Sophia Antipolis Cedex - FRANCE

Tel.: +33 4 92 94 42 00 Fax: +33 4 93 65 47 16

Siret N° 348 623 562 00017 - APE 7112B
Association à but non lucratif enregistrée à la
Sous-Préfecture de Grasse (06) N° w061004871

Important notice

The present document can be downloaded from:

<http://www.etsi.org/standards-search>

The present document may be made available in electronic versions and/or in print. The content of any electronic and/or print versions of the present document shall not be modified without the prior written authorization of ETSI. In case of any existing or perceived difference in contents between such versions and/or in print, the prevailing version of an ETSI deliverable is the one made publicly available in PDF format at www.etsi.org/deliver.

Users of the present document should be aware that the document may be subject to revision or change of status.

Information on the current status of this and other ETSI documents is available at

<https://portal.etsi.org/TB/ETSIDeliverableStatus.aspx>

If you find errors in the present document, please send your comment to one of the following services:

<https://portal.etsi.org/People/CommitteeSupportStaff.aspx>

Notice of disclaimer & limitation of liability

The information provided in the present deliverable is directed solely to professionals who have the appropriate degree of experience to understand and interpret its content in accordance with generally accepted engineering or other professional standard and applicable regulations.

No recommendation as to products and services or vendors is made or should be implied.

No representation or warranty is made that this deliverable is technically accurate or sufficient or conforms to any law and/or governmental rule and/or regulation and further, no representation or warranty is made of merchantability or fitness for any particular purpose or against infringement of intellectual property rights.

In no event shall ETSI be held liable for loss of profits or any other incidental or consequential damages.

Any software contained in this deliverable is provided "AS IS" with no warranties, express or implied, including but not limited to, the warranties of merchantability, fitness for a particular purpose and non-infringement of intellectual property rights and ETSI shall not be held liable in any event for any damages whatsoever (including, without limitation, damages for loss of profits, business interruption, loss of information, or any other pecuniary loss) arising out of or related to the use of or inability to use the software.

Copyright Notification

No part may be reproduced or utilized in any form or by any means, electronic or mechanical, including photocopying and microfilm except as authorized by written permission of ETSI.

The content of the PDF version shall not be modified without the written authorization of ETSI.

The copyright and the foregoing restriction extend to reproduction in all media.

© ETSI 2021.
All rights reserved.

Intellectual Property Rights

Essential patents

IPRs essential or potentially essential to normative deliverables may have been declared to ETSI. The declarations pertaining to these essential IPRs, if any, are publicly available for **ETSI members and non-members**, and can be found in ETSI SR 000 314: "*Intellectual Property Rights (IPRs); Essential, or potentially Essential, IPRs notified to ETSI in respect of ETSI standards*", which is available from the ETSI Secretariat. Latest updates are available on the ETSI Web server (<https://ipr.etsi.org/>).

Pursuant to the ETSI Directives including the ETSI IPR Policy, no investigation regarding the essentiality of IPRs, including IPR searches, has been carried out by ETSI. No guarantee can be given as to the existence of other IPRs not referenced in ETSI SR 000 314 (or the updates on the ETSI Web server) which are, or may be, or may become, essential to the present document.

Trademarks

The present document may include trademarks and/or tradenames which are asserted and/or registered by their owners. ETSI claims no ownership of these except for any which are indicated as being the property of ETSI, and conveys no right to use or reproduce any trademark and/or tradename. Mention of those trademarks in the present document does not constitute an endorsement by ETSI of products, services or organizations associated with those trademarks.

DECT™, **PLUGTESTS™**, **UMTS™** and the ETSI logo are trademarks of ETSI registered for the benefit of its Members. **3GPP™** and **LTE™** are trademarks of ETSI registered for the benefit of its Members and of the 3GPP Organizational Partners. **oneM2M™** logo is a trademark of ETSI registered for the benefit of its Members and of the oneM2M Partners. **GSM®** and the GSM logo are trademarks registered and owned by the GSM Association.

Legal Notice

This Technical Specification (TS) has been produced by ETSI 3rd Generation Partnership Project (3GPP).

The present document may refer to technical specifications or reports using their 3GPP identities. These shall be interpreted as being references to the corresponding ETSI deliverables.

The cross reference between 3GPP and ETSI identities can be found under <http://webapp.etsi.org/key/queryform.asp>.

Modal verbs terminology

In the present document "**shall**", "**shall not**", "**should**", "**should not**", "**may**", "**need not**", "**will**", "**will not**", "**can**" and "**cannot**" are to be interpreted as described in clause 3.2 of the [ETSI Drafting Rules](#) (Verbal forms for the expression of provisions).

"**must**" and "**must not**" are **NOT** allowed in ETSI deliverables except when used in direct citation.

Contents

Intellectual Property Rights	2
Legal Notice	2
Modal verbs terminology.....	2
Foreword.....	14
1 Scope	15
2 References	15
3 Definitions, symbols and abbreviations	16
3.1 Definitions	16
3.2 Symbols.....	16
3.3 Abbreviations	17
4 General	18
4.1 Relationship between minimum requirements and test requirements	18
4.2 Applicability of minimum requirements	18
4.3 Specification suffix information.....	19
4.4 Test points analysis	19
4.5 Applicability and test coverage rules.....	19
4.5.1 Test coverage across 5G NR architecture options	20
4.6 E-UTRA configuration for EN-DC FR1 tests applying the E-UTRA anchor-agnostic approach	21
4.7 E-UTRA configuration for EN-DC FR2 tests applying the E-UTRA anchor-agnostic approach	22
4.8 E-UTRA configuration for EN-DC FR1 tests not applying the E-UTRA anchor-agnostic approach.....	24
5 Operating bands and channel arrangement.....	25
5.1 General	25
5.2 Operating bands.....	25
5.2A Operating bands for CA	25
5.2A.1 Inter-band CA between FR1 and FR2.....	25
5.2B Operating bands for DC	26
5.2B.1 General.....	26
5.2B.2 to 5.2B.7 Void	26
5.2E Operating bands for V2X	26
5.2E.1 Intra-band V2X bands.....	26
5.2E.2 Inter-band V2X bands.....	26
5.3 UE Channel bandwidth	27
5.3A UE Channel bandwidth for CA	27
5.3A.1 Inter-band CA between FR1 and FR2.....	27
5.3B UE Channel bandwidth for EN-DC.....	27
5.3B.0 General.....	27
5.3B.1 Intra-band EN-DC in FR1.....	27
5.3B.1.1 General	27
5.3B.1.2 BCS for Intra-band contiguous EN-DC	28
5.3B.1.3 BCS for Intra-band non-contiguous EN-DC.....	28
5.3E UE Channel bandwidth for V2X	29
5.3E.1 Intra-band contiguous V2X in FR1.....	29
5.3E.2 Intra-band non-contiguous V2X in FR1	30
5.3E.3 Inter-band V2X in FR1	30
5.4 Void.....	30
5.4A Channel arrangement for CA.....	30
5.4B Channel arrangement for DC.....	30
5.4B.1 Channel spacing for intra-band EN-DC carriers.....	30
5.5 Configuration	31
5.5A Configuration for CA	31
5.5A.1 Inter-band CA configurations between FR1 and FR2.....	31
5.5B Configuration for DC	32
5.5B.1 General.....	32

5.5B.2	Intra-band contiguous EN-DC	33
5.5B.3	Intra-band non-contiguous EN-DC	33
5.5B.4	Inter-band EN-DC within FR1	34
5.5B.4.1	Inter-band EN-DC configurations within FR1 (two bands)	35
5.5B.4.2	Inter-band EN-DC configurations within FR1 (three bands)	39
5.5B.4.3	Inter-band EN-DC configurations within FR1 (four bands)	46
5.5B.4.4	Inter-band EN-DC configurations within FR1 (five bands)	52
5.5B.4.5	Inter-band EN-DC configurations within FR1 (six bands)	55
5.5B.4a	Inter-band NE-DC within FR1	55
5.5B.4a.1	Inter-band NE-DC configurations within FR1 (two bands)	55
5.5B.5	Inter-band EN-DC including FR2	55
5.5B.5.1	Inter-band EN-DC configurations including FR2 (two bands)	56
5.5B.5.2	Inter-band EN-DC configurations including FR2 (three bands)	62
5.5B.5.3	Inter-band EN-DC configurations including FR2 (four bands)	67
5.5B.5.4	Inter-band EN-DC configurations including FR2 (five bands)	71
5.5B.5.5	Void	73
5.5B.6	Inter-band EN-DC including FR1 and FR2	73
5.5B.6.1	Void	74
5.5B.6.2	Inter-band EN-DC configurations including FR1 and FR2 (three bands)	74
5.5B.6.3	Inter-band EN-DC configurations including FR1 and FR2 (four bands)	77
5.5B.6.4	Inter-band EN-DC configurations including FR1 and FR2 (five bands)	78
5.5B.6.5	Inter-band EN-DC configurations including FR1 and FR2 (six bands)	79
5.5B.7	Inter-band NR-DC between FR1 and FR2	79
5.5B.7.1	Inter-band NR-DC configurations between FR1 and FR2 (two bands)	80
5.5E	Configuration for V2X operation	80
5.5E.1	General	80
5.5E.2	Intra-band contiguous V2X operation in FR1	81
5.5E.3	Intra-band non-contiguous V2X operation in FR1	81
5.5E.4	Inter-band V2X operation in FR1	81
5.5E.4.1	Inter-band V2X configurations within FR1 (two bands)	81
6	Transmitter characteristics	81
6.1	General	81
6.2	Transmitter power	82
6.2A	Transmitter power for CA without EN-DC	82
6.2A.1	UE maximum output power for CA	82
6.2A.1.1	UE maximum output power for inter-band NR CA between FR 1 and FR 2 without EN-DC	82
6.2A.2	UE maximum output power reduction for CA	83
6.2A.2.1	UE maximum output power reduction for inter-band NR CA between FR 1 and FR 2 without EN-DC	83
6.2A.3	UE additional maximum output power reduction for CA	83
6.2A.3.1	UE additional maximum output power reduction for inter-band NR CA between FR 1 and FR 2 without EN-DC	83
6.2A.4	Configured output power level for CA	83
6.2A.4.1	Configured output power level for inter-band NR CA between FR 1 and FR 2 without EN-DC	83
6.2A.4.2	$\Delta T_{IB,c}$ for CA	84
6.2A.4.2.1	$\Delta T_{IB,c}$ for inter-band CA between FR 1 and FR 2	84
6.2B	Transmitter power for DC	84
6.2B.1	UE Maximum Output Power for DC	84
6.2B.1.1	UE Maximum Output Power for Intra-Band Contiguous EN-DC	84
6.2B.1.1.5	Test requirements	87
6.2B.1.2	UE Maximum Output Power for Intra-Band Non-Contiguous EN-DC	89
6.2B.1.3	UE Maximum Output Power for Inter-Band EN-DC within FR1	93
6.2B.1.4	UE Maximum Output Power for Inter-Band EN-DC including FR2	109
6.2B.1.4.1	UE Maximum Output Power for Inter-Band EN-DC including FR2 - EIRP and TR	109
6.2B.1.4.2	UE Maximum Output Power for Inter-Band EN-DC including FR2 - Spherical Coverage	110
6.2B.1.4_1	UE Maximum Output Power for Inter-Band EN-DC including FR2 (>2 CCs)	111
6.2B.1.4_1.1	UE Maximum Output Power for Inter-Band EN-DC including FR2 (3 CCs)	111
6.2B.1.4_1.2	UE Maximum Output Power for Inter-Band EN-DC including FR2 (4 CCs)	113
6.2B.1.4_1.3	UE Maximum Output Power for Inter-Band EN-DC including FR2 (5 CCs)	115
6.2B.1.4D	UE Maximum Output Power for Inter-Band EN-DC including FR2 for UL-MIMO	116
6.2B.1.5	UE Maximum Output Power for Inter-Band EN-DC including both FR1 and FR2	117

6.2B.1.5D	UE Maximum Output Power for Inter-Band EN-DC including both FR1 and FR2 for UL-MIMO...	118
6.2B.2	UE Maximum Output Power reduction for EN-DC	118
6.2B.2.0	General	118
6.2B.2.1	UE Maximum Output Power reduction for Intra-Band Contiguous EN-DC	118
6.2B.2.2	UE Maximum Output Power reduction for Intra-Band Non-Contiguous EN-DC	130
6.2B.2.3	UE Maximum Output Power reduction for Inter-Band EN-DC within FR1	137
6.2B.2.4	UE Maximum Output Power reduction for Inter-Band EN-DC including FR2	138
6.2B.2.5	UE Maximum Output power reduction for inter-band EN-DC including both FR1 and FR2	139
6.2B.3	UE additional maximum output power reduction for EN-DC	139
6.2B.3.1	UE Additional Maximum Output Power reduction for Intra-band contiguous EN-DC	139
6.2B.3.2	UE Additional Maximum Output Power reduction for Intra-Band Non-Contiguous EN-DC	162
6.2B.3.3	UE Additional Maximum Output Power reduction for Inter-Band EN-DC within FR1	178
6.2B.3.4	UE Additional Maximum Output Power reduction for Inter-Band EN-DC including FR2	179
6.2B.3.5	UE Additional Maximum Output power reduction for inter-band EN-DC including both FR1 and FR2	180
6.2B.4	Configured Output Power for EN-DC	181
6.2B.4.1	Configured Output Power Level for EN-DC	181
6.2B.4.1.0	Minimum Conformance Requirements	181
6.2B.4.1.1	Configured Output Power Level for Intra-Band Contiguous EN-DC	190
6.2B.4.1.2	Configured Output Power for Intra-Band Non-Contiguous EN-DC	194
6.2B.4.1.3	Configured Output Power for Inter-Band EN-DC within FR1	198
6.2B.4.1.4	Configured Output Power for Inter-Band EN-DC including FR2	204
6.2B.4.1.5	Configured Output Power for Inter-Band EN-DC including both FR1 and FR2	205
6.2B.4.2	$\Delta T_{IB,c}$ for EN-DC	205
6.2B.4.2.1	Intra-Band Contiguous EN-DC	205
6.2B.4.2.2	Intra-Band non-Contiguous EN-DC	205
6.2B.4.2.3	Inter-Band EN-DC within FR1	206
6.2B.4.2.4	Inter-band EN-DC including FR2	226
6.2B.4.2.5	Inter-band EN-DC including both FR1 and FR2	227
6.2B.5	Configured Output Power for NR-DC	227
6.2B.5.1	Configured Output power Level	227
6.2B.5.1.1	Configured Output Power Level for Inter-band NR-DC between FR1 and FR2	227
6.3	Output power dynamics	228
6.3A	Output Power Dynamics for CA without EN-DC	228
6.3A.1	UE Output Power Dynamics for CA	228
6.3A.1.1	UE Output Power Dynamics for NR CA between FR 1 and FR 2 without EN-DC	228
6.3B	Output power dynamics for DC	228
6.3B.1	Minimum Output Power for EN-DC	228
6.3B.1.1	Minimum Output Power for intra-band contiguous EN-DC	228
6.3B.1.2	Minimum output power for intra-band non-contiguous EN-DC	229
6.3B.1.3	Minimum output power for inter-band EN-DC within FR1	230
6.3B.1.4	Minimum Output Power for EN-DC Interband including FR2	231
6.3B.1.4_1	Minimum output power for inter-band EN-DC including FR2 (>2 CCs)	232
6.3B.1.4D	Minimum output power for inter-band EN-DC including FR2 for UL-MIMO	234
6.3B.2	Transmit OFF Power for EN-DC	235
6.3B.2.1	Transmit OFF Power for intra-band contiguous EN-DC	235
6.3B.2.2	Transmit OFF Power for intra-band non-contiguous EN-DC	236
6.3B.2.3	Transmit OFF Power for inter-band EN-DC within FR1	236
6.3B.2.4	Transmit OFF Power for inter-band EN-DC including FR2	236
6.3B.2.4_1	Transmit OFF Power for Inter-band EN-DC including FR2 (>2 CCs)	237
6.3B.2.4_1.1	Transmit OFF Power for Inter-band EN-DC including FR2 (3 CCs)	237
6.3B.2.4_1.2	Transmit OFF Power for Inter-band EN-DC including FR2 (4 CCs)	238
6.3B.2.4_1.3	Transmit OFF Power for Inter-band EN-DC including FR2 (5 CCs)	239
6.3B.3	Tx ON/OFF time mask/PUCCH time mask for EN-DC	240
6.3B.3.1	Tx ON/OFF time mask for intra-band contiguous EN-DC	240
6.3B.3.2	Tx ON/OFF time mask for intra-band non-contiguous EN-DC	241
6.3B.3.3	Tx ON/OFF time mask for inter-band EN-DC within FR1	242
6.3B.3.4	Transmit ON/OFF time mask for inter-band EN-DC including FR2	243
6.3B.4	PRACH time mask for EN-DC	244
6.3B.4.1	PRACH time mask for intra-band contiguous EN-DC	244
6.3B.4.2	PRACH Time Mask for intra-band non-contiguous EN-DC	245
6.3B.4.3	PRACH Time Mask for inter-band EN-DC within FR1	245

6.3B.4.3.1	Test purpose	246
6.3B.5	Output power dynamics for EN-DC with UL sharing from UE perspective	247
6.3B.5.1	E-UTRA and NR switching time mask for TDM based UL sharing from UE perspective	247
6.3B.6	Output power dynamics for intra-band EN-DC without dual PA capability	247
6.3B.7	Output power dynamics for intra-band EN-DC with dual PA capability	247
6.3B.8	Power control for EN-DC	247
6.3B.8.1	Absolute power tolerance for EN-DC	247
6.3B.8.1.1	Absolute power tolerance for intra-band contiguous EN-DC	247
6.3B.8.1.2	Absolute power tolerance for intra-band non-contiguous EN-DC	248
6.3B.8.1.3	Absolute power tolerance for inter-band EN-DC within FR1	248
6.3B.8.1.4	Absolute power tolerance for inter-band EN-DC including FR2	249
6.3B.8.2	Relative power tolerance for EN-DC	250
6.3B.8.2.1	Relative power tolerance for intra-band contiguous EN-DC	250
6.3B.8.2.2	Relative power tolerance for intra-band non-contiguous EN-DC	250
6.3B.8.2.3	Relative power tolerance for inter-band EN-DC within FR1	251
6.3B.8.2.4	Relative power tolerance for inter-band EN-DC including FR2	252
6.3B.8.3	Aggregate power tolerance for EN-DC	253
6.3B.8.3.1	Aggregate power tolerance for intra-band contiguous EN-DC	253
6.3B.8.3.2	Aggregate power tolerance for intra-band non-contiguous EN-DC	253
6.3B.8.3.3	Aggregate power tolerance for inter-band EN-DC within FR1	254
6.3B.8.3.4	Aggregate power tolerance for inter-band EN-DC including FR2	254
6.4	Transmit signal quality	255
6.4A	Transmit Signal Quality for inter-band NR CA between FR and FR2 without EN-DC	255
6.4A.1	Frequency error for inter-band NR CA between FR 1 and FR 2 without EN-DC	255
6.4A.2	Transmit Modulation Quality for inter-band NR CA without EN-DC	256
6.4A.2.1	Error Vector Magnitude for inter-band NR CA between FR 1 and FR 2 without EN-DC	256
6.4A.2.2	Carrier Leakage for inter-band NR CA between FR 1 and FR 2 without EN-DC	256
6.4A.2.3	In-band Emissions for inter-band NR CA between FR 1 and FR 2 without EN-DC	256
6.4A.2.4	EVM Equalizer Spectral Flatness for inter-band NR CA between FR 1 and FR 2 without EN-DC	256
6.4B	Transmit Signal Quality for DC	257
6.4B.1	Frequency error	257
6.4B.1.1	Frequency error for Intra-band contiguous EN-DC	257
6.4B.1.2	Frequency error for Intra-band non-contiguous EN-DC	257
6.4B.1.3	Frequency error for Inter-band EN-DC within FR1	259
6.4B.1.4	Frequency Error for inter-band EN-DC including FR2	259
6.4B.1.4_1	Frequency Error for Inter-band EN-DC including FR2 (>2 CCs)	260
6.4B.1.4_1.1	Frequency Error for Inter-band EN-DC including FR2 (3 CCs)	260
6.4B.1.4_1.2	Frequency Error for Inter-band EN-DC including FR2 (4 CCs)	261
6.4B.1.4_1.3	Frequency Error for Inter-band EN-DC including FR2 (5 CCs)	262
6.4B.2	Transmit Modulation Quality for DC	263
6.4B.2.1	Transmit Modulation Quality for intra-band contiguous EN-DC	263
6.4B.2.1.1	Error Vector Magnitude for intra-band contiguous EN-DC	263
6.4B.2.1.2	Carrier Leakage for intra-band contiguous EN-DC	264
6.4B.2.1.3	In-band Emissions for intra-band contiguous EN-DC	265
6.4B.2.1.4	EVM Equalizer Flatness for intra-band contiguous EN-DC	271
6.4B.2.2	Transmit Modulation Quality for intra-band non-contiguous EN-DC	272
6.4B.2.2.1	Error Vector Magnitude for intra-band non-contiguous EN-DC	272
6.4B.2.2.2	Carrier Leakage for intra-band non-contiguous EN-DC	273
6.4B.2.2.3	In-band Emissions for intra-band non-contiguous EN-DC	274
6.4B.2.2.4	EVM Equalizer Flatness for intra-band non-contiguous EN-DC	279
6.4B.2.3	Transmit Modulation Quality for inter-band EN-DC within FR1	281
6.4B.2.3.1	Error Vector Magnitude for inter-band EN-DC within FR1	281
6.4B.2.3.2	Carrier Leakage for inter-band EN-DC within FR1	281
6.4B.2.3.3	In-band Emissions for inter-band EN-DC within FR1	282
6.4B.2.3.4	EVM Equalizer Flatness for inter-band EN-DC within FR1	283
6.4B.2.4	Transmit Modulation Quality for inter-band EN-DC including FR2	284
6.4B.2.4.1	Error Vector Magnitude for inter-band EN-DC including FR2	284
6.4B.2.4.1_1	Error Vector Magnitude for inter-band EN-DC including FR2 (>2 CCs)	285
6.4B.2.4.1D	Error Vector Magnitude for inter-band EN-DC including FR2 for UL-MIMO	287
6.4B.2.4.2_1	Carrier Leakage for inter-band EN-DC including FR2 (>2 CCs)	288
6.4B.2.4.2D	Carrier Leakage for inter-band EN-DC including FR2 for UL-MIMO	291
6.4B.2.4.3D	In-band Emissions for inter-band EN-DC including FR2 for UL-MIMO	292

6.4B.2.4.2	Carrier Leakage for inter-band EN-DC including FR2	294
6.4B.2.4.3	In-band Emissions for inter-band EN-DC including FR2	295
6.4B.2.4.3_1	In-band Emissions for inter-band EN-DC including FR2 (>2 CCs).....	296
6.4B.2.4.4	EVM Equalizer Flatness for inter-band EN-DC including FR2	298
6.5	Output RF spectrum emissions.....	299
6.5A	Output RF spectrum emissions for CA.....	299
6.5A.1	Occupied bandwidth for CA without EN-DC.....	299
6.5A.2	Out-of-band emissions for CA without EN-DC.....	300
6.5A.2.1	Spectrum emissions mask for CA without EN-DC.....	300
6.5A.2.2	Additional Spectrum emissions mask for CA without EN-DC.....	300
6.5A.2.3	Adjacent channel leakage ratio for CA without EN-DC.....	300
6.5A.3	Spurious emissions for CA without EN-DC.....	300
6.5A.3.1	Inter-band CA between FR1 and FR2.....	300
6.5B	Output RF spectrum emissions for DC.....	301
6.5B.1	Occupied bandwidth for EN-DC	301
6.5B.1.1	Occupied bandwidth for Intra-Band Contiguous EN-DC	301
6.5B.1.2	Occupied bandwidth for Intra-Band Non-Contiguous EN-DC	303
6.5B.1.3	Occupied bandwidth for Inter-Band EN-DC within FR1.....	304
6.5B.1.4	Occupied bandwidth for Inter-Band EN-DC including FR2 (2 CCs)	305
6.5B.1.4_1	Occupied bandwidth for Inter-band EN-DC including FR2 (>2 CCs).....	306
6.5B.1.4_1.1	Occupied bandwidth for Inter-band EN-DC including FR2 (3 CCs)	306
6.5B.1.4_1.2	Occupied bandwidth for Inter-band EN-DC including FR2 (4 CCs)	307
6.5B.1.4_1.3	Occupied bandwidth for Inter-band EN-DC including FR2 (5 CCs)	308
6.5B.1.4D	Occupied bandwidth for inter-band EN-DC including FR2 for UL-MIMO	309
6.5B.2	Out-of-band emissions for EN-DC	310
6.5B.2.1	Out-of-band emissions for Intra-band contiguous EN-DC.....	310
6.5B.2.1.1	Spectrum emissions mask for intra-band contiguous EN-DC	310
6.5B.2.1.2	Additional spectrum emissions mask for intra-band contiguous EN-DC.....	316
6.5B.2.1.3	Adjacent channel leakage ratio for intra-band contiguous EN-DC	320
6.5B.2.2	Out-of-band emissions for Intra-band non-contiguous EN-DC	327
6.5B.2.2.1	Spectrum emissions mask for intra-band non-contiguous EN-DC.....	327
6.5B.2.2.2	Spectrum emissions mask for intra-band non-contiguous EN-DC.....	329
6.5B.2.2.3	Adjacent channel leakage ratio for intra-band non-contiguous EN-DC	330
6.5B.2.3	Out-of-band emissions for Inter-band EN-DC within FR1	333
6.5B.2.3.1	Spectrum emissions mask for Inter-band EN-DC within FR1	333
6.5B.2.3.2	Additional Spectrum emissions mask for Inter-band EN-DC within FR1	334
6.5B.2.3.3	Adjacent channel leakage ratio for inter-band EN-DC within FR1	335
6.5B.2.4	Out-of-band emissions for Inter-band EN-DC including FR2	336
6.5B.2.4.1	Spectrum emissions mask for Inter-band EN-DC including FR2 (2 CCs).....	336
6.5B.2.4.1_1	Spectrum emissions mask for Inter-band EN-DC including FR2 (>2 CCs).....	337
6.5B.2.4.1_1.1	Spectrum emissions mask for Inter-band EN-DC including FR2 (3 CCs).....	337
6.5B.2.4.1_1.2	Spectrum emissions mask for Inter-band EN-DC including FR2 (4 CCs).....	338
6.5B.2.4.1_1.3	Spectrum emissions mask for Inter-band EN-DC including FR2 (5 CCs).....	339
6.5B.2.4.1D	Spectrum emissions mask for inter-band EN-DC including FR2 for UL-MIMO	340
6.5B.2.4.3	Adjacent channel leakage ratio for Inter-band EN-DC including FR2 (2 CCs)	340
6.5B.2.4.3_1	Adjacent channel leakage ratio for Inter-band EN-DC including FR2 (>2 CCs).....	341
6.5B.2.4D.3	Adjacent channel leakage ratio for inter-band EN-DC including FR2 for UL-MIMO.....	344
6.5B.3	Spurious emissions for EN-DC.....	345
6.5B.3.1	Spurious Emissions for intra-band contiguous EN-DC.....	345
6.5B.3.1.1	General spurious emissions for intra-band contiguous EN-DC.....	345
6.5B.3.1.2	Spurious emission band UE co-existence for intra-band contiguous EN-DC	347
6.5B.3.2	Spurious Emissions for intra-band non-contiguous EN-DC	350
6.5B.3.2.1	General spurious emissions for Intra-band non-contiguous EN-DC	350
6.5B.3.2.2	Spurious emission band UE co-existence for intra-band non-contiguous EN-DC	351
6.5B.3.3	Spurious Emissions for Inter-band EN-DC within FR1	354
6.5B.3.3.1	General spurious emissions for Inter-band EN-DC within FR1	354
6.5B.3.3.2	Spurious emission band UE co-existence for Inter-band within FR1	356
6.5B.3.4	Spurious Emissions for Inter-band including FR2	402
6.5B.3.4.1	General Spurious Emissions for Inter-band including FR2 (2 CCs)	403
6.5B.3.4.1_1	Transmitter Spurious emissions for Inter-band EN-DC including FR2 (>2 CCs).....	403
6.5B.3.4.1D	Spurious Emissions for inter-band EN-DC including FR2 for UL-MIMO	406
6.5B.3.4.2	Spurious emission band UE co-existence for Inter-band including FR2.....	407

6.5B.3.5	Spurious emissions for Inter-band including FR1 and FR2	408
6.5B.3.5.1	General Spurious Emissions for Inter-band including FR1 and FR2	408
6.5B.3.5.2	Spurious emission band UE co-existence for Inter-band including FR1 and FR2	408
6.5B.4	Additional Spurious Emissions for EN-DC	408
6.5B.4.1	Additional Spurious Emissions for Intra-band contiguous EN-DC	408
6.5B.4.2	Additional Spurious Emissions for Intra-band non-contiguous EN-DC	412
6.5B.4.3	Additional Spurious Emissions for Inter-band EN-DC within FR1	413
6.5B.5	Transmit intermodulation	414
6.5B.5.1	Intra-band contiguous EN-DC	414
6.5B.5.2	Intra-band non-contiguous EN-DC	414
6.5B.5.3	Inter-band EN-DC within FR1	414
6.5B.5.4	Inter-band EN-DC including FR2	415
6.5B.5.5	Inter-band EN-DC including both FR1 and FR2	415
7	Receiver characteristics	415
7.1	General	415
7.2	Void	416
7.3	Void	416
7.3A	Reference sensitivity for CA without EN-DC	416
7.3A.1	General	416
7.3A.2	Reference sensitivity power level for CA without EN-DC	416
7.3A.3	$\Delta R_{IB,c}$ for CA without EN-DC	416
7.3A.3.1	$\Delta R_{IB,c}$ for Inter-band CA between FR1 and FR2 without EN-DC	417
7.3A.4	Void	417
7.3B	Reference sensitivity level for DC	417
7.3B.1	General	417
7.3B.2	Reference sensitivity for EN-DC	417
7.3B.2.0	Minimum Conformance Requirements of Reference sensitivity for EN-DC	417
7.3B.2.0.1	Intra-band contiguous EN-DC	417
7.3B.2.0.2	Intra-band non-contiguous EN-DC	418
7.3B.2.0.3	Inter-band EN-DC within FR1	418
7.3B.2.0.3a	Inter-band NE-DC within FR1	442
7.3B.2.0.4	Inter-band EN-DC including FR2	442
7.3B.2.0.5	Inter-band EN-DC including both FR1 and FR2	442
7.3B.2.1	Reference sensitivity for Intra-band Contiguous EN-DC (2 CCs)	442
7.3B.2.2	Reference sensitivity for Intra-band non-contiguous EN-DC (2 CCs)	448
7.3B.2.3	Reference sensitivity for Inter-band EN-DC within FR1 (2 CCs)	452
7.3B.2.3.1	Test purpose	452
7.3B.2.3.2	Test applicability	453
7.3B.2.3.3	Minimum conformance requirements	453
7.3B.2.3.4	Test description	453
7.3B.2.3.5	Test requirement	486
7.3B.2.3_1.1	Reference sensitivity for EN-DC within FR1 (3 CCs)	497
7.3B.2.3_1.2	Reference sensitivity for EN-DC within FR1 (4 CCs)	514
7.3B.2.3_1.3	Reference sensitivity for EN-DC within FR1 (5 CCs)	520
7.3B.2.3_1.4	Reference sensitivity for EN-DC within FR1 (6 CCs)	523
7.3B.2.4	Reference sensitivity for Inter-band EN-DC including FR2	523
7.3B.2.4_1	Reference sensitivity for Inter-band EN-DC including FR2 (>2 CCs)	524
7.3B.2.4_1.1	Reference sensitivity for Inter-band EN-DC including FR2 (3 CCs)	524
7.3B.2.4_1.2	Reference sensitivity for Inter-band EN-DC including FR2 (4 CCs)	525
7.3B.2.4_1.3	Reference sensitivity for Inter-band EN-DC including FR2 (5 CCs)	525
7.3B.2.4_1.4	Reference sensitivity for Inter-band EN-DC including FR2 (6 CCs)	526
7.3B.2.4D	Reference sensitivity for inter-band EN-DC including FR2 for UL-MIMO	526
7.3B.2.5	Reference sensitivity for Inter-band EN-DC including FR1 and FR2 (3 CCs)	526
7.3B.2.5D	Reference sensitivity for inter-band EN-DC including FR1 and FR2 for UL-MIMO	526
7.3B.2.6	Void	527
7.3B.3	$\Delta R_{IB,c}$ ΔR_{IBNC} for EN-DC	527
7.3B.3.0	General	527
7.3B.3.1	Reference sensitivity $\Delta R_{IB,c}$ for Intra-band Contiguous EN-DC	527
7.3B.3.2	Reference sensitivity $\Delta R_{IB,c}$ for Intra-band non-contiguous EN-DC	528
7.3B.3.3	$\Delta R_{IB,c}$ for Inter-band EN-DC within FR1	529
7.3B.3.3.1	$\Delta R_{IB,c}$ for EN-DC in two bands	529

7.3B.3.3.2	$\Delta R_{IB,c}$ for EN-DC in three bands	532
7.3B.3.3.3	$\Delta R_{IB,c}$ for EN-DC in four bands.....	538
7.3B.3.3.4	$\Delta R_{IB,c}$ for EN-DC in five bands	544
7.3B.3.3.5	$\Delta R_{IB,c}$ for EN-DC six bands.....	547
7.3B.3.4	Reference sensitivity for $\Delta R_{IB,c}$ Inter-band EN-DC including FR2	547
7.3B.4	EIS Spherical Coverage for Inter-band EN-DC including FR2.....	547
7.4	Void.....	548
7.4A	Maximum Input Level for CA.....	548
7.4A.1	Test purpose.....	548
7.4A.2	Test applicability	548
7.4B	Maximum Input Level for DC.....	548
7.4B.0	Minimum conformance requirement	548
7.4B.0.1	Intra-band contiguous EN-DC in FR1.....	548
7.4B.0.2	Intra-band non-contiguous EN-DC in FR1	549
7.4B.0.3	Inter-band EN-DC within FR1	549
7.4B.0.4	Inter-band EN-DC including FR2	549
7.4B.0.5	Inter-band EN-DC including both FR1 and FR2	549
7.4B.1	Maximum Input Level for Intra-Band Contiguous EN-DC (2 CCs).....	549
7.4B.2	Maximum Input Level for Intra-Band Non-Contiguous EN-DC (2 CCs)	552
7.4B.3	Maximum Input Level for Inter-band EN-DC within FR1	554
7.4B.3_1	Maximum Input Level for EN-DC within FR1 (>2 CCs).....	555
7.4B.3_1.1	Maximum Input Level for EN-DC within FR1 (3 CCs)	555
7.4B.3_1.2	Maximum Input Level for EN-DC within FR1 (4 CCs)	555
7.4B.3_1.3	Maximum Input Level for EN-DC within FR1 (5 CCs)	556
7.4B.3_1.4	Maximum Input Level for EN-DC within FR1 (6 CCs)	557
7.4B.4	Maximum Input Level for inter-band EN-DC including FR2 (2CCs).....	558
7.4B.4_1	Maximum Input Level for inter-band EN-DC including FR2 (>2CCs).....	559
7.4B.4_1.1	Maximum Input Level for Inter-Band EN-DC including FR2 (3 CCs)	559
7.4B.4_1.2	Maximum Input Level for Inter-Band EN-DC including FR2 (4 CCs)	559
7.4B.4_1.3	Maximum Input Level for Inter-Band EN-DC including FR2 (5 CCs)	560
7.4B.4_1.4	Maximum Input Level for Inter-Band EN-DC including FR2 (6 CCs)	561
7.4B.4D	Maximum Input Level for inter-band EN-DC including FR2 for UL-MIMO.....	562
7.4B.5	Maximum Input Level for inter-band EN-DC including both FR1 and FR2.....	563
7.4B.5D	Maximum Input Level for inter-band EN-DC including FR1 and FR2 for UL-MIMO	563
7.5	Void.....	563
7.5A	Adjacent Channel Selectivity for CA	563
7.5B	Adjacent channel selectivity for DC.....	564
7.5B.0	Minimum Conformance Requirements.....	564
7.5B.0.1	Intra-band contiguous EN-DC in FR1.....	564
7.5B.0.2	Intra-band non-contiguous EN-DC in FR1	564
7.5B.0.3	Inter-band EN-DC within FR1	565
7.5B.0.3a	Inter-band NE-DC within FR1	565
7.5B.0.4	Inter-band EN-DC including FR2	565
7.5B.0.5	Inter-band EN-DC including both FR1 and FR2	565
7.5B.1	Adjacent Channel Selectivity for intra-band contiguous EN-DC (2 CCs).....	565
7.5B.1.5	Test requirement	567
7.5B.2	Adjacent Channel Selectivity for intra-band non-contiguous EN-DC (2 CCs)	567
7.5B.3	Adjacent Channel Selectivity for inter-band EN-DC within FR1 (2 CCs)	568
7.5B.3_1	Adjacent Channel Selectivity for EN-DC within FR1 (>2 CCs)	569
7.5B.3_1.1	Adjacent Channel Selectivity for EN-DC within FR1 (3 CCs).....	569
7.5B.3_1.2	Adjacent Channel Selectivity for EN-DC within FR1 (4 CCs).....	570
7.5B.4	Adjacent Channel Selectivity for inter-band EN-DC including FR2 (2CCs)	571
7.5B.4_1	Adjacent Channel Selectivity for inter-band EN-DC including FR2 (>2 CCs)	572
7.5B.4_1.1	Adjacent Channel Selectivity for inter-band EN-DC including FR2 (3 CCs).....	572
7.5B.4_1.2	Adjacent Channel Selectivity for inter-band EN-DC including FR2 (4 CCs).....	573
7.5B.4_1.3	Adjacent Channel Selectivity for inter-band EN-DC including FR2 (5 CCs).....	575
7.5B.4_1.4	Adjacent Channel Selectivity for inter-band EN-DC including FR2 (6 CCs).....	576
7.5B.4D	Adjacent Channel Selectivity for inter-band EN-DC including FR2 for UL-MIMO	578
7.5B.5	Adjacent Channel Selectivity for inter-band EN-DC including both FR1 and FR2	578
7.5B.5D	Adjacent Channel Selectivity for inter-band EN-DC including FR1 and FR2 for UL-MIMO.....	578
7.6	Void.....	579
7.6A	Blocking characteristics for CA	579

7.6B	Blocking characteristics for DC	579
7.6B.1	General.....	579
7.6B.2	Inband blocking for DC	579
7.6B.2.0	Minimum Conformance Requirements.....	579
7.6B.2.0.1	Intra-band contiguous EN-DC in FR1	579
7.6B.2.0.2	Intra-band non-contiguous EN-DC in FR1.....	580
7.6B.2.0.3	Inter-band EN-DC within FR1	580
7.6B.2.0.3A	Inter-band NE-DC within FR1	580
7.6B.2.0.4	Inter-band EN-DC including FR2	580
7.6B.2.0.5	Inter-band EN-DC including both FR1 and FR2.....	580
7.6B.2.1	Inband blocking for intra-band contiguous EN-DC in FR1 (2 CCs).....	580
7.6B.2.2	Inband blocking for intra-band non-contiguous EN-DC in FR1 (2 CCs)	583
7.6B.2.3	Inband blocking for inter-band EN-DC within FR1 (2 CCs)	585
7.6B.2.3_1	Inband blocking for EN-DC within FR1 (>2 CCs)	585
7.6B.2.3_1.1	Inband blocking for EN-DC within FR1 (3 CCs).....	585
7.6B.2.3_1.2	Inband blocking for EN-DC within FR1 (4 CCs).....	589
7.6B.2.3_1.3	Inband blocking for EN-DC within FR1 (5 CCs).....	592
7.6B.2.3_1.4	Void.....	592
7.6B.2.4	Inband blocking for inter-band EN-DC including FR2 (2 CCs)	592
7.6B.2.4_1	Inband blocking for inter-band EN-DC including FR2 (>2 CCs).....	593
7.6B.2.4_1.1	Inband blocking for inter-band EN-DC including FR2 (3 CCs).....	593
7.6B.2.4_1.2	Inband blocking for inter-band EN-DC including FR2 (4 CCs).....	594
7.6B.2.4_1.3	Inband blocking for inter-band EN-DC including FR2 (5 CCs).....	595
7.6B.2.4_1.4	Inband blocking for inter-band EN-DC including FR2 (6 CCs).....	596
7.6B.2.4D	Inband blocking for inter-band EN-DC including FR2 for UL-MIMO	596
7.6B.2.5	Inband blocking for inter-band EN-DC including both FR1 and FR2	597
7.6B.2.5D	Inband blocking for inter-band EN-DC including FR1 and FR2 for UL-MIMO.....	597
7.6B.3	Out-of-band blocking for DC.....	597
7.6B.3.0	Minimum Conformance Requirements.....	597
7.6B.3.0.1	Intra-band contiguous EN-DC in FR1	597
7.6B.3.0.2	Intra-band non-contiguous EN-DC in FR1.....	598
7.6B.3.0.3	Inter-band EN-DC within FR1	598
7.6B.3.0.3A	Inter-band NE-DC within FR1	599
7.6B.3.0.4	Inter-band EN-DC including FR2	599
7.6B.3.0.5	Inter-band EN-DC including both FR1 and FR2.....	599
7.6B.3.1	Out-of-band blocking for intra-band contiguous EN-DC in FR1 (2 CCs).....	599
7.6B.3.2	Out-of-band blocking for intra-band non-contiguous EN-DC in FR1 (2 CCs).....	603
7.6B.3.3	Out-of-band blocking for inter-band EN-DC within FR1 (2 CCs).....	604
7.6B.3.3_1	Out-of-band blocking for EN-DC within FR1 (>2 CCs).....	611
7.6B.3.3_1.1	Out-of-band blocking for EN-DC within FR1 (3 CCs)	611
7.6B.3.3_1.2	Out-of-band blocking for EN-DC within FR1 (4 CCs)	614
7.6B.4	Narrow band blocking for DC	617
7.6B.4.0	Minimum Conformance Requirements.....	617
7.6B.4.0.1	Intra-band contiguous EN-DC in FR1	617
7.6B.4.0.2	Intra-band non-contiguous EN-DC in FR1.....	617
7.6B.4.0.3	Inter-band EN-DC within FR1	617
7.6B.4.0.3A	Inter-band NE-DC within FR1	617
7.6B.4.0.4	Inter-band EN-DC including FR2	617
7.6B.4.0.5	Inter-band EN-DC including both FR1 and FR2.....	618
7.6B.4.1	Narrow band blocking for intra-band contiguous EN-DC in FR1 (2 CCs).....	618
7.6B.4.2	Narrow band blocking for intra-band non-contiguous EN-DC in FR1 (2 CCs).....	621
7.6B.4.3	Narrow band blocking for inter-band EN-DC within FR1 (2 CCs)	622
7.6B.4.3_1	Narrow band blocking for EN-DC within FR1 (>2 CCs)	623
7.6B.4.3_1.1	Narrow band blocking for EN-DC within FR1 (3 CCs).....	623
7.6B.4.3_1.2	Narrow band blocking for EN-DC within FR1 (4 CCs).....	626
7.6B.4.3_1.3	Narrow band blocking for EN-DC within FR1 (5 CCs).....	629
7.6B.4.3_1.4	Void.....	630
7.7	Void.....	630
7.7A	Spurious response for CA.....	630
7.7B	Spurious response for DC.....	630
7.7B.0	Minimum Conformance Requirements.....	630
7.7B.0.1	Intra-band contiguous EN-DC in FR1.....	630

7.7B.0.2	Intra-band non-contiguous EN-DC in FR1	630
7.7B.0.3	Inter-band EN-DC within FR1	630
7.7B.0.3A	Inter-band NE-DC within FR1	631
7.7B.0.4	Inter-band EN-DC including FR2	631
7.7B.0.5	Inter-band EN-DC including both FR1 and FR2	631
7.7B.1	Spurious Response for intra-band contiguous EN-DC in FR1 (2 CCs).....	631
7.7B.2	Spurious Response for intra-band non-contiguous EN-DC in FR1 (2 CCs).....	633
7.7B.3	Spurious Response for inter-band EN-DC within FR1 (2 CCs)	634
7.7B.3_1	Spurious Response for EN-DC within FR1 (>2 CCs)	637
7.7B.3_1.1	Spurious Response for EN-DC within FR1 (3 CCs).....	637
7.7B.3_1.2	Spurious Response for EN-DC within FR1 (4 CCs).....	639
7.8	Void.....	640
7.8B	Intermodulation characteristics for DC in FR1	640
7.8B.1	General.....	640
7.8B.2	Wide band Intermodulation	640
7.8B.2.0	Minimum Conformance Requirements.....	640
7.8B.2.0.1	Intra-band contiguous EN-DC in FR1	640
7.8B.2.0.2	Intra-band non-contiguous EN-DC in FR1.....	641
7.8B.2.0.3	Inter-band EN-DC within FR1	641
7.8B.2.0.4	Inter-band EN-DC including FR2	641
7.8B.2.0.5	Inter-band EN-DC including both FR1 and FR2.....	641
7.8B.2.1	Wideband Intermodulation for intra-band contiguous EN-DC in FR1	641
7.8B.2.2	Wideband Intermodulation for intra-band non-contiguous EN-DC in FR1	645
7.8B.2.3	Wideband Intermodulation for inter-band EN-DC in FR1 (2 CCs)	646
7.8B.2.3_1	Wideband Intermodulation for EN-DC within FR1 (>2 CCs)	646
7.8B.2.3_1.1	Wideband Intermodulation for EN-DC within FR1 (3 CCs).....	646
7.8B.2.3_1.2	Wideband Intermodulation for EN-DC within FR1 (4 CCs).....	650
7.8B.2.3_1.3	Wideband Intermodulation for EN-DC within FR1 (5 CCs).....	650
7.8B.2.3_1.4	Wideband Intermodulation for EN-DC within FR1 (6 CCs).....	650
7.8B.2.3A	Wideband Intermodulation for inter-band NE-DC within FR1 (2 CCs)	650
7.8B.2.4	Void.....	650
7.8B.2.5	Void.....	650
7.8B.2.6	Void.....	650
7.8B.2.7	Void.....	650
7.8B.2.8	Void.....	650
7.8B.2.9	Void.....	650
7.9	Void.....	650
7.9B	Spurious emissions for DC in FR1	650
7.9B.0	Minimum Conformance Requirements.....	650
7.9B.0.1	Intra-band contiguous EN-DC in FR1.....	650
7.9B.0.2	Intra-band non-contiguous EN-DC in FR1	650
7.9B.0.3	Inter-band EN-DC within FR1	651
7.9B.0.4	Inter-band EN-DC including FR2	651
7.9B.0.5	Inter-band EN-DC including both FR1 and FR2	651
7.9B.1	Spurious Emissions for intra-band contiguous EN-DC in FR1(2 CCs).....	651
7.9B.2	Spurious Emissions for intra-band non-contiguous EN-DC in FR1(2 CCs).....	652
7.9B.3	Spurious Emissions for inter-band EN-DC within FR1(2 CCs)	653
7.9B.4	Spurious Emissions for inter-band EN-DC including FR2 (2 CCs)	653
7.9B.4_1	Spurious Emissions for inter-band EN-DC including FR2 (>2 CCs)	654
7.9B.4_1.1	Spurious Emissions for inter-band EN-DC including FR2 (3 CCs).....	654
7.9B.4_1.2	Spurious Emissions for inter-band EN-DC including FR2 (4 CCs).....	654
7.9B.4_1.3	Spurious Emissions for inter-band EN-DC including FR2 (5 CCs).....	654
7.9B.4_1.4	Spurious Emissions for inter-band EN-DC including FR2 (5 CCs).....	655
7.9B.5	Spurious Emissions for inter-band EN-DC including both FR1 and FR2 (3 CCs).....	655
7.9B.3_1	Spurious Emissions for EN-DC within FR1 (>2 CCs)	655
7.9B.3_1.1	Spurious Emissions for EN-DC within FR1 (3 CCs).....	655
Annex A (normative):	Measurement Channels.....	657
A.1	General	657
A.2	UL reference measurement channels for E-UTRA TDD Config 2.....	657
A.2.1	General	657

A.2.2	Reference measurement channels for E-UTRA	658
A.2.2.1	Full RB allocation.....	658
A.2.2.1.1	QPSK	658
A.2.2.1.2	16-QAM.....	658
A.2.2.1.3	64-QAM.....	659
A.2.2.1.4	256 QAM	660
A.2.2.2	Partial RB allocation.....	661
A.2.2.2.1	QPSK	661
A.2.2.2.2	16-QAM.....	663
A.2.2.2.3	64-QAM.....	666
A.2.2.2.4	256 QAM	669
A.3	DL reference measurement channels for E-UTRA	670
A.3.1	General	670
Annex B (normative):	Propagation Conditions.....	674
Annex C (normative):	Downlink Physical Channels.....	675
Annex D (normative):	Characteristics of the Interfering Signal	676
Annex E (normative):	Global In-Channel Tx Test	677
Annex F (informative):	Measurement uncertainties and Test Tolerances	678
F.1	Acceptable uncertainty of Test System (normative)	678
F.1.1	Measurement of test environments.....	678
F.1.2	Measurement of transmitter.....	679
F.1.3	Measurement of receiver	686
F.2	Interpretation of measurement results (normative)	689
F.3	Test Tolerance and Derivation of Test Requirements (informative).....	690
F.3.1	Measurement of test environments.....	690
F.3.2	Measurement of transmitter.....	691
F.3.3	Measurement of receiver	697
F.4	Uplink power window	700
F.4.1	Introduction	700
F.4.2	Setting the power window above a requirement.....	700
F.4.2.1	NR FR1	700
F.4.2.2	NR FR2.....	701
F.4.2.3	E-UTRA.....	701
F.4.3	Setting the power window below a requirement	703
F.4.3.1	NR FR1	703
F.4.3.2	NR FR2.....	704
F.4.3.3	E-UTRA.....	704
F.4.4	Setting the power window centred on a target value	706
F.4.4.1	NR FR1	706
F.4.4.2	NR FR2.....	707
F.4.4.3	E-UTRA.....	707
Annex G (normative):	Uplink Physical Channels	709
Annex H (normative):	Statistical Testing.....	710
H.1	General	710
H.2	Statistical testing of receiver characteristics.....	710
H.2.1	General.....	710
H.2.2	Mapping throughput to error ratio	710
H.2.3	Design of the test	711
H.2.4	Numerical definition of the pass fail limits.....	712
H.2.5	Pass fail decision rules	713
Annex I (normative):	Void	714

Annex J (normative):	Test applicability per permitted test method	715
Annex K (normative):	EIRP, TRP, and EIS measurement procedures.....	716
Annex L (normative):	Void	717
Annex M (normative):	Dual uplink interferer	718
Annex N (normative):	Modified MPR behaviour	719
N.1	Indication of modified MPR behaviour.....	719
Annex O (informative):	Change history	720
History		741

Foreword

This Technical Specification has been produced by the 3rd Generation Partnership Project (3GPP).

The contents of the present document are subject to continuing work within the TSG and may change following formal TSG approval. Should the TSG modify the contents of the present document, it will be re-released by the TSG with an identifying change of release date and an increase in version number as follows:

Version x.y.z

where:

- x the first digit:
 - 1 presented to TSG for information;
 - 2 presented to TSG for approval;
 - 3 or greater indicates TSG approved document under change control.
- y the second digit is incremented for all changes of substance, i.e. technical enhancements, corrections, updates, etc.
- z the third digit is incremented when editorial only changes have been incorporated in the document.

The present document is part 3 of a multi-part Technical Specification (TS) covering the New Radio (NR) User Equipment (UE) conformance specification, which is divided in the following parts:

- TS 38.521-1 [8]: "NR; User Equipment (UE) conformance specification; Radio transmission and reception; Part 1: Range 1 Standalone" (the present document).
- TS 38.521-2 [9]: "NR; User Equipment (UE) conformance specification; Radio transmission and reception; Part 2: Range 2 Standalone".
- TS 38.521-3: "NR; User Equipment (UE) conformance specification; Radio transmission and reception; Part 3: Range 1 and Range 2 Interworking operation with other radios".
- TS 38.521-4 [22]: "NR; User Equipment (UE) conformance specification; Radio transmission and reception; Part 4: Performance".
- TS 38.522 [14]: "NR; User Equipment (UE) conformance specification; Applicability of RF and RRM test cases".
- TS 38.533 [23]: "NR; User Equipment (UE) conformance specification; Radio resource management (RRM)".

1 Scope

The present document specifies the measurement procedures for the conformance test of the user equipment (UE) that contain RF characteristics for carrier aggregation between Range 1 and Range 2 and additional requirements due to NR non-standalone (NSA) operation mode with E-UTRA.

The requirements are listed in different clauses only if the corresponding parameters deviate. More generally, tests are only applicable to those mobiles that are intended to support the appropriate functionality. To indicate the circumstances in which tests apply, this is noted in the "*definition and applicability*" part of the test.

For example only Release 15 and later UE declared to support 5G-NR shall be tested for this functionality. In the event that for some tests different conditions apply for different releases, this is indicated within the text of the test itself.

2 References

The following documents contain provisions which, through reference in this text, constitute provisions of the present document.

- References are either specific (identified by date of publication, edition number, version number, etc.) or non-specific.
- For a specific reference, subsequent revisions do not apply.
- For a non-specific reference, the latest version applies. In the case of a reference to a 3GPP document (including a GSM document), a non-specific reference implicitly refers to the latest version of that document *in the same Release as the present document*.

- [1] 3GPP TR 21.905: "Vocabulary for 3GPP Specifications"
- [2] 3GPP TS 38.101-1: "NR; User Equipment (UE) radio transmission and reception; Part 1: Range 1 Standalone".
- [3] 3GPP TS 38.101-2: "NR; User Equipment (UE) radio transmission and reception; Part 2: Range 2 Standalone".
- [4] 3GPP TS 38.101-3: "NR; User Equipment (UE) radio transmission and reception; Part 3: Range 1 and Range 2 Interworking operation with other radios".
- [5] 3GPP TS 36.101: "Evolved Universal Terrestrial Radio Access (E-UTRA); User Equipment (UE) radio transmission and reception".
- [6] 3GPP TS 38.508-1: "5GS; User Equipment (UE) conformance specification; Part 1: Common test environment".
- [7] 3GPP TR 38.905: "NR; Derivation of test points for radio transmission and reception conformance test cases".
- [8] 3GPP TS 38.521-1: "User Equipment (UE) conformance specification; Radio transmission and reception; Part 1: Range 1 Standalone".
- [9] 3GPP TS 38.521-2: "NR; User Equipment (UE) conformance specification; Radio transmission and reception; Part 2: Range 2 Standalone".
- [10] 3GPP TS 36.521-1: "Evolved Universal Terrestrial Radio Access (E-UTRA); User Equipment (UE) conformance specification; Radio transmission and reception; Part 1: Conformance testing"
- [11] 3GPP TS 36.508: "Evolved Universal Terrestrial Radio Access (E-UTRA) and Evolved Packet Core (EPC); Common test environments for User Equipment (UE) conformance testing".
- [12] 3GPP TS 36.133: "Evolved Universal Terrestrial Radio Access (E-UTRA); Requirements for support of radio resource management".
- [13] 3GPP TS 36.211: "E-UTRA; Physical channels and modulation".

- [14] 3GPP TS 38.522: "NR; User Equipment (UE) conformance specification; Applicability of radio transmission, radio reception and radio resource management test cases".
- [15] Void.
- [16] 3GPP TS 38.306: "NR: User Equipment (UE) radio access capabilities".
- [17] 3GPP TS 36.331: "Evolved Universal Terrestrial Radio Access (E-UTRA); Radio Resource Control (RRC); Protocol specification".
- [18] 3GPP TS 38.331: "NR; Radio Resource Control (RRC) protocol specification".
- [19] 3GPP TS 38.213: "NR; Physical layer procedures for control".
- [20] 3GPP TS 36.213: "E-UTRA Physical layer procedures".
- [21] Recommendation ITU-R M.1545: "Measurement uncertainty as it applies to test limits for the terrestrial component of International Mobile Telecommunications-2000".
- [22] 3GPP TS 38.521-4: "NR; User Equipment (UE) conformance specification; Radio transmission and reception; Part 4: Performance".
- [23] 3GPP TS 38.533: "NR; User Equipment (UE) conformance specification; Radio resource management (RRM)".
- [24] 3GPP TS 36.214: "E-UTRA; Physical layer; Measurements".

3 Definitions, symbols and abbreviations

3.1 Definitions

For the purposes of the present document, the terms and definitions given in TR 21.905 [1] and the following apply. A term defined in the present document takes precedence over the definition of the same term, if any, in TR 21.905 [1].

Con-current operation: The simultaneous transmission and reception of sidelink and Uu interfaces while operation is agnostic of the service used on each interface.

3.2 Symbols

For the purposes of the present document, the following symbols apply:

$\Delta R_{IB,c}$	Allowed reference sensitivity relaxation due to support for CA or DC operation, for serving cell c .
$\Delta T_{IB,c}$	Allowed maximum configured output power relaxation due to support for CA or DC operation, for serving cell c
$BW_{E-UTRA_Channel}$	Channel bandwidth of E-UTRA carrier
$BW_{E-UTRA_Channel_CA}$	Channel bandwidth of E-UTRA sub-block which is composed of intra-band contiguous CA E-UTRA carriers
$BW_{NR_Channel}$	Channel bandwidth of NR carrier
$BW_{NR_Channel_CA}$	Channel bandwidth of NR sub-block which is composed of intra-band contiguous CA NR carriers
$Ceil(x)$	Rounding upwards; $ceil(x)$ is the smallest integer such that $ceil(x) \geq x$
$EN-DC_{ACLR}$	The ratio of the filtered mean power centred on the aggregated sub-block bandwidth ENBW to the filtered mean power centred on an adjacent bandwidth of the same size ENBW
$E-UTRA_{ACLR}$	E-UTRA ACLR
F_C	<i>RF reference frequency</i> for the carrier centre on the channel raster
F_{DL_low}	The lowest frequency of the downlink <i>operating band</i>
F_{DL_high}	The highest frequency of the downlink <i>operating band</i>
F_{UL_low}	The lowest frequency of the uplink <i>operating band</i>
F_{UL_high}	The highest frequency of the uplink <i>operating band</i>
F_{OOB}	The boundary between the NR out of band emission and spurious emission domains
L_{CRB}	Transmission bandwidth which represents the length of a contiguous resource block allocation

	expressed in units of resources blocks
Max()	The largest of given numbers
Min()	The smallest of given numbers
NR _{ACLR}	NR ACLR
N _{RB}	Transmission bandwidth configuration, expressed in units of resource blocks
P _{CMAX}	The configured maximum UE output power
RB _{start}	Indicates the lowest RB index of transmitted resource blocks
W _{gap}	The sub-block gap between the two sub-blocks

3.3 Abbreviations

For the purposes of the present document, the abbreviations given in TR 21.905 [1] and the following apply. An abbreviation defined in the present document takes precedence over the definition of the same abbreviation, if any, in TR 21.905 [1].

ACLR	Adjacent Channel Leakage Ratio
ACS	Adjacent Channel Selectivity
A-MPR	Additional Maximum Power Reduction
BCS	Bandwidth Combination Set
CA	Carrier Aggregation
CC	Component Carrier
DC	Dual Connectivity
EN-DC	E-UTRA/NR DC
EIRP	Equivalent Isotropically Radiated Power
EVM	Error Vector Magnitude
FR	Frequency Range
ENBW	The aggregated bandwidth of an E-UTRA sub-block and an adjacent NR sub-block
ITS	Intelligent Transportation System
ITU-R	Radio communication Sector of the International Telecommunication Union
MBW	Measurement bandwidth defined for the protected band
MPR	Allowed maximum power reduction
MSD	Maximum Sensitivity Degradation
MCG	Master Cell Group
NR	New Radio
NS	Network Signalling
NSA	Non-Standalone, a mode of operation where operation of another radio is assisted with another radio
OOB	Out-of-band
OOBE	Out-of-band emission
OTA	Over The Air
PRB	Physical Resource Block
PSCCH	Physical Sidelink Control CHannel
PSSCH	Physical Sidelink Shared CHannel
RE	Resource Element
REFSENS	Reference Sensitivity
RF	Radio Frequency
Rx	Receiver
SCG	Secondary Cell Group
SCS	Subcarrier spacing
SEM	Spectrum Emission Mask
SL	Sidelink
SUL	Supplementary uplink
TDM	Time Division Multiplex
Tx	Transmitter
UE	User Equipment
UL-MIMO	Up Link Multiple Antenna transmission
ULSUP	Uplink sharing from UE perspective
V2X	Vehicle to Everything

4 General

4.1 Relationship between minimum requirements and test requirements

TS 38.101-3 [4] is interwork specification for NR UE, covering RF characteristics and minimum performance requirements. Conformance to TS 38.101-3 [4] is demonstrated by fulfilling the test requirements specified in the present document.

The Minimum Requirements given in this specification make no allowance for measurement uncertainty (MU). The present document defines test tolerances (TT). These test tolerances are individually calculated for each test. The test tolerances are used to relax the minimum requirements in TS 38.101-3 [4] to create test requirements. For some requirements, including regulatory requirements, the test tolerance is set to zero.

The measurement results returned by the test system are compared - without any modification - against the test requirements as defined by various levels of "Shared Risk" principle as described below. a) Core specification value is not relaxed by any relaxation value ($TT=0$). For each single measurement, the probability of a borderline good UE being judged as FAIL equals the probability of a borderline bad UE being judged as PASS.

- Test tolerances equal to 0 ($TT=0$) are considered in this specification.

b) Core specification value is relaxed by a relaxation value ($TT>0$). For each single measurement, the probability of a borderline bad UE being judged as PASS is greater than the probability of a borderline good UE being judged as FAIL.

- Test tolerances lower than measurement uncertainty and greater than 0 ($0 < TT < MU$) are considered in this specification.

- Test tolerances high up to measurement uncertainty ($TT = MU$) are considered in this specification which is also known as "Never fail a good DUT" principle.

c) Core specification value is tightened by a stringent value ($TT<0$). For each single measurement, the probability of a borderline good UE being judged as FAIL is greater than the probability of a borderline bad UE being judged as PASS.

- Test tolerances lower than 0 ($TT<0$) are not considered in this specification.

The "Never fail a good DUT" and the "Shared Risk" principles are defined in Recommendation ITU-R M.1545 [21].

4.2 Applicability of minimum requirements

- a) In TS 38.101-3 [4] the Minimum Requirements are specified as general requirements and additional requirements. Where the Requirement is specified as a general requirement, the requirement is mandated to be met in all scenarios
- b) For specific scenarios for which an additional requirement is specified, in addition to meeting the general requirement, the UE is mandated to meet the additional requirements.
- c) The spurious emissions power requirements are for the long-term average of the power. For the purpose of reducing measurement uncertainty, it is acceptable to average the measured power over a period of time sufficient to reduce the uncertainty due to the statistical nature of the signal.
- d) Terminal that supports EN-DC configuration shall meet E-UTRA requirements as specified in TS 36.101 [5] and NR requirements as in TS 38.101-1 [2] and TS 38.101-2 [3] unless otherwise specified in TS 38.101-3 [4].
- e) All the requirements for intra-band contiguous and non-contiguous EN-DC apply under the assumption of the same uplink-downlink and special subframe configurations in the E-UTRA and slot format indicated by UL-DL-configurationCommon and UL-DL-configurationDedicated in the NR for the EN-DC.
- f) For EN-DC combinations with CA configurations for E-UTRA and/or NR, all the requirements for E-UTRA and/or NR all the requirements for E-UTRA and/or NR intra-band contiguous and non-contiguous CA apply

under the assumption of the same slot format indicated by UL-DL-configurationCommon and UL-DL-configurationDedicated in the PSCell and SCells for NR and the same uplink-downlink and special subframe configurations in PCell and SCells for E-UTRA.

A terminal which supports an EN-DC configuration shall support:

- If any subsets of the EN-DC configuration do not specify its own bandwidth combination sets in 5.3B, then the terminal shall support the same E-UTRA bandwidth combination sets it signals the support for in E-UTRA CA configuration part of E-UTRA – NR DC and shall support the same NR bandwidth combination sets it signals the support for in NR CA configuration part of E-UTRA – NR DC.
- Else if one of the subsets of the EN-DC configuration specify its own bandwidth combination sets in 5.3B, then the terminal shall support a product set of channel bandwidth for each band specified by E-UTRA bandwidth combination sets, NR bandwidth combination sets, and EN-DC bandwidth combination sets it signals the support.

A terminal which supports an inter-band EN-DC configuration with a certain UL configuration shall support the all lower order DL configurations of the lower order EN-DC combinations, which have this certain UL configuration and the fallbacks of this UL configuration.

A terminal which supports CA or DC configurations, which include FR2 intra-band CA combinations with multiple subblocks, where at least one of the subblocks consists of a contiguous CA combination, is not required to support all possible fallback combinations but can directly fall back to a single FR2 carrier. Deactivating carriers within the CA or DC combination is still possible.

Terminal that supports inter-band NR-DC between FR1 and FR2 configuration shall meet the requirements for corresponding CA configuration (suffix A), unless otherwise specified.

4.3 Specification suffix information

Unless stated otherwise the following suffixes are used for indicating at 2nd level clause, shown in Table 4.3-1.

Table 4.3-1: Definition of suffixes

Clause suffix	Variant
None	Single Carrier
A	Carrier Aggregation (CA) between FR1 and FR2
B	Dual-Connectivity (DC) with and without SUL including UL sharing from UE perspective, inter-band NR DC between FR1 and FR2
D	UL MIMO
E	V2X

4.4 Test points analysis

The information on test point analysis and test point selection including number of test points for each test case is shown in TR 38.905 [7] clause 4.3.

4.5 Applicability and test coverage rules

- (1) The applicability and test coverage rules for Non-Standalone (NSA) only capable devices shall include the following:
 - (a) For each NR band in a device; test all the EN-DC exception test requirements as per test procedures in TS 38.521-3.
 - (b) Test all the EN-DC FR2 non-exception test requirements in TS 38.521-3 with test procedures which refer appropriately back to TS 38.521-2 [9] for each NR band. Test only one EN-DC combination per FR2 band

for each EN-DC configuration as defined in clause 5.5B of TS 38.101-3 [4] using LTE anchor agnostic approach.

- (c) Test all the EN-DC FR1 non-exception test requirements in TS 38.521-3 with test procedures which refer appropriately back to TS 38.521-1 [8] for each NR band. Test only one EN-DC combination per FR1 band for each EN-DC configuration as defined in clause 5.5B of 38.101-3 [4] using LTE anchor agnostic approach.
- (2) The applicability and test coverage rules for Standalone (SA) and NSA capable devices shall include the following:
- (a) For each NR band in a device, test all the EN-DC exception test requirements as per test procedures in TS 38.521-3.
 - (b) Test all the Standalone FR2 test requirements as per test procedures in TS 38.521-2 [9] for each NR band. This also fulfils coverage for all non-exception EN-DC FR2 test requirements for that NR band and need not be retested. If Standalone FR2 cannot be tested (due to test case not being complete), then test in EN-DC mode following (1)(b) above.
 - (c) Test all the Standalone FR1 test requirements as per test procedures in TS 38.521-1 [8] for each NR band. This also fulfils coverage for all non-exception EN-DC FR1 test requirements for that NR band and need not be retested. If Standalone FR1 cannot be tested (due to test case not being complete), then test in EN-DC mode following (1)(c) above.

4.5.1 Test coverage across 5G NR architecture options

The test cases in this specification cover both Standalone (FR1+FR2 CA without DC) as well as Non-Standalone FR1 and FR2 (E-UTRA and 5G NR interworking) testing. Below shall be the understanding with respect to coverage across 5G NR architecture options:

- 1) Unless otherwise stated within the test case, it shall be understood that test requirements are agnostic of the NSA architecture option configured within the test. The test coverage across NSA options shall be considered fulfilled by execution of the NSA test case in one NSA option. Subsequently the test execution and test results can be leveraged to other NSA options.
- 2) Only one SA or NSA architecture option type is identified and utilized in the definition of each test case within this test specification. NSA test cases are configured using *Connectivity EN-DC* i.e. NSA Option 3 and Standalone (SA) test cases are configured using *Connectivity NR* i.e. SA Option 2 which shall be the default architecture options used for NSA and SA test execution respectively.
- 3) If a UE does not support NSA Option 3, any other supported NSA option can be configured to execute the test. This is accomplished by appropriately picking the generic procedure parameter from Table 4.5.1-2. The leverage rule detailed in (1) would apply.

Table 4.5.1-1: Generic procedure parameter summary for SA

Generic Procedure Parameter to use in Initial Conditions		Description	5G NR SA Architecture Option supported by UE
Connectivity	NR	NG-RAN NR Radio Access	SA Option 2
	E-UTRA	NG-RAN E-UTRA Radio Access	SA Option 5

Editor's note: Any additional test config details needed for SA Option 5 is FFS.

Table 4.5.1-2: Generic procedure parameter summary for NSA

Generic Procedure Parameter to use in Initial Conditions		Description	5G NR NSA Architecture Option supported by UE
Connectivity	NSA		
	EN-DC	E-UTRA-NR Dual Connectivity	NSA Option 3
	NE-DC	NR-E-UTRA Dual Connectivity	NSA Option 4
	NGEN-DC	NG-RAN E-UTRA-NR Dual Connectivity	NSA Option 7

Editor's note: Any additional test config details needed for NSA Options 4 and 7 are FFS.

4.6 E-UTRA configuration for EN-DC FR1 tests applying the E-UTRA anchor-agnostic approach

This clause applies to EN-DC test cases where E-UTRA anchor needs to be configured as per the anchor-agnostic approach outlined in clauses 6.1 and 7.1 of TS 38.101-3 [4]. The LTE anchor-agnostic approach is defined as measurements on the NR carrier under conditions where the LTE anchor resources do not interfere with NR operation. The configuration defined in this clause ensures establishment of such conditions.

For baseline configuration, the E-UTRA carrier will be configured for each test case in clauses 6 and 7 as defined in the equivalent standalone E-UTRA test in TS 36.521-1 [10]. However, the below exceptions defined in Table 4.6-1, 4.6-2, 4.6-3, 4.6-4 and 4.6-5 are applied to ensure that the E-UTRA anchor resources do not interfere with NR operation.

For EN-DC within FR1 band combinations with multiple E-UTRA component carriers, it is sufficient to configure any one E-UTRA carrier from the carrier group whenever it is determined that anchor agnostic approach can be applied. Unless otherwise stated, the number of component carriers (CCs) listed in the test case titles of Clause 6 and clause 7 shall refer to the number of component carriers configured within the test case.

Table 4.6-1: E-UTRA configuration for EN-DC FR1 tests applying anchor agnostic approach

Parameter	Value	Comments
Test Frequency during and after connection setup	Mid (See Table 4.6-2)	As defined in TS 36.508 for the LTE band under test
Bandwidth during and after connection setup	5 MHz (See Table 4.6-2)	Supported by all LTE bands.
DL signal levels during connection setup	RS EPRE -85.0 dBm/15kHz	DL physical channels as defined in Annex C0, C.1, C.2 and Annex C.3 of TS 36.521-1 [10]. TS 36.521-1 [10] annex C.0 defines the default DL power level of RS EPRE to be -85dBm/15kHz.
UL Signal levels during connection setup	PUSCH Power	Attained by enabling open loop power control and setting up UL signal levels according to Annex H.0, H.2 and H.3 of TS 36.521-1 [10].
DL/UL RMC after connection setup	0 RB allocation on both DL and UL (see Table 4.6-2)	Once the LTE link is established, then LTE Tx can be restricted by configuring 0 RB allocation on DL and UL. <i>TimeAlignmentTimerDedicated</i> IE to be set to infinity to ensure UE doesn't look for TA adjustments (See Table 4.6-5)
CQI Reports and SRS after connection setup	Disabled (See Table 4.6-3 and 4.6-4)	Disable periodic and aperiodic CQI reports to ensure none of these transmissions occur on the LTE uplink. Since LTE transmissions could easily exceed spurious emissions limits, tests that are intended to measure RF parameters on the NR should simply avoid LTE transmit altogether.

Table 4.6-2: E-UTRA Test Configuration Table

E-UTRA Test Parameters					
E-UTRA Channel Bandwidth	E-UTRA Test Frequency	Downlink		Uplink	
		Modulation	RB allocation	Modulation	RB allocation
5 MHz ²	MidRange ¹	N/A	0	N/A	0
NOTE 1: E-UTRA Test Frequency as specified in TS 36.508 [11] clause 4.3.1.					
NOTE 2: For EN-DC Intra-band tests that need to apply E-UTRA anchor agnostic approach, refer to and pick applicable E-UTRA channel bandwidth from clause 5.3B.1 and indicate within test case if it is different than 5 MHz.					

Table 4.6-3: *CQI-ReportConfig-DEFAULT*: Additional E-UTRA Anchor Configuration

Derivation Path: TS 36.508 [7] clause 4.6.3, Table 4.6.3-2 CQI-ReportConfig-DEFAULT			
Information Element	Value/remark	Comment	Condition
CQI-ReportConfig-DEFAULT ::= SEQUENCE {			
cqi-ReportModeAperiodic	NOT PRESENT		
cqi-ReportPeriodic	NOT PRESENT		
}			

Table 4.6-4: *PhysicalConfigDedicated-DEFAULT*: Additional E-UTRA Anchor Configuration

Derivation Path: TS 36.508 [7] clause 4.8.2, Table 4.8.2.1.6-1 PhysicalConfigDedicated-DEFAULT			
Information Element	Value/remark	Comment	Condition
PhysicalConfigDedicated-DEFAULT ::= SEQUENCE {			
soundingRS-UL-ConfigDedicated	Not present		RBC
}			

Table 4.6-5: *MAC-MainConfig-RBC*: Additional E-UTRA Anchor Configuration

Derivation Path: TS 36.508 [7] clause 4.8.2.1.5, Table 4.8.2.1.5-1 MAC-MainConfig-RBC			
Information Element	Value/remark	Comment	Condition
<i>timeAlignmentTimerDedicated</i>	Infinity		

4.7 E-UTRA configuration for EN-DC FR2 tests applying the E-UTRA anchor-agnostic approach

This clause applies to EN-DC test cases where E-UTRA anchor needs to be configured as per the anchor-agnostic approach outlined in clauses 6.1 and 7.1 of TS 38.101-3 [4]. The LTE anchor-agnostic approach is defined as measurements on the NR carrier under conditions where the LTE anchor resources do not interfere with NR operation. The configuration defined in this clause ensures establishment of such conditions.

For baseline configuration, the E-UTRA carrier will be configured for each test case in clauses 6 and 7 as defined in the equivalent standalone E-UTRA test in TS 36.521-1 [10]. However, the below exceptions defined in Table 4.7-1 to 4.7-7 are applied to ensure that the E-UTRA anchor resources do not interfere with NR operation.

Since the E-UTRA link is always a functional link when testing EN-DC including FR2 band combinations, it is sufficient to configure any one E-UTRA carrier from the carrier group, irrespective of the number of E-UTRA carriers in the EN-DC combination under test. Unless otherwise stated, the number of component carriers (CCs) listed in the test case titles of Clause 6 and clause 7 shall refer to the number of component carriers configured within the test case.

Table 4.7-1: E-UTRA configuration for EN-DC FR2 tests applying anchor agnostic approach

Parameter	Value	Comments
Test Frequency during and after connection setup	Mid (See Table 4.7-2)	As defined in TS 36.508 for the LTE band under test
Bandwidth during and after connection setup	5 MHz (See Table 4.7-2)	Supported by all LTE bands.
DL signal levels	See table 4.7-3	DL physical channels as defined in Annex C0, C.1, C.2 and Annex C.3 of TS 36.521-1 [10].
UL Signal levels for connection setup and UBF transmission	PUSCH Power	Attained by enabling open loop power control and setting up UL signal levels according to Annex H.0, H.2 and H.3 of TS 36.521-1 [10] with the exception for power control message exception defined in Table 4.7-5
DL/UL RMC after connection setup except for UBF transmission	0 RB allocation on both DL and UL (see Table 4.7-2)	Once the LTE link is established, then LTE Tx can be restricted by configuring 0 RB allocation on DL and UL. <i>TimeAlignmentTimerDedicated</i> IE to be set to infinity to ensure UE doesn't look for TA adjustments (See Table 4.7-7)
CQI Reports and SRS after connection setup	Disabled (See Table 4.7-4 and 4.7-6)	Disable periodic and aperiodic CQI reports to ensure none of these transmissions occur on the LTE uplink. Since LTE transmissions could easily exceed spurious emissions limits, tests that are intended to measure RF parametrics on the NR should simply avoid LTE transmit altogether.

Table 4.7-2: E-UTRA Test Configuration Table

E-UTRA Test Parameters					
E-UTRA Channel Bandwidth	E-UTRA Test Frequency	Downlink		Uplink	
		Modulation	RB allocation	Modulation	RB allocation
5 MHz ²	MidRange ¹	N/A	0	N/A	0
NOTE 1: E-UTRA Test Frequency as specified in TS 36.508 [11] clause 4.3.1					
NOTE 2: For EN-DC Intra-band tests that need to apply E-UTRA anchor agnostic approach, refer to and pick applicable E-UTRA channel bandwidth from clause 5.3B.1 and indicate within test case if it is different than 5 MHz.					

Table 4.7-3: Default Downlink power levels for E-UTRA anchor

	Unit	Band Group	Channel Bandwidth					
			1.4 MHz	3 MHz	5MHz	10MHz	15 MHz	20 MHz
RS EPRE	dBm/15kHz	FDD_A, TDD_A	N/A	N/A	≥ -120.0	N/A	N/A	N/A
		FDD_B1, TDD_B1	N/A	N/A	≥ -119.5	N/A	N/A	N/A
		FDD_C, TDD_C	N/A	N/A	≥ -119.0	N/A	N/A	N/A
		FDD_D, TDD_D	N/A	N/A	≥ -118.5	N/A	N/A	N/A
		FDD_E, TDD_E	N/A	N/A	≥ -118.0	N/A	N/A	N/A
		FDD_G, TDD_G	N/A	N/A	≥ -117.0	N/A	N/A	N/A
		FDD_H, TDD_H	N/A	N/A	≥ -116.5	N/A	N/A	N/A
		FDD_N, TDD_N	N/A	N/A	≥ -113.5	N/A	N/A	N/A
NOTE 1: The power level is specified at RSRP reference point as defined in TS 36.214 [24]								
NOTE 2: E-UTRA Band groups are defined in TS 36.133 [12] clause 3.5.1.								

Table 4.7-4: CQI-ReportConfig-DEFAULT: Additional E-UTRA Anchor Configuration

Derivation Path: TS 36.508 [7] clause 4.6.3, Table 4.6.3-2 CQI-ReportConfig-DEFAULT			
Information Element	Value/remark	Comment	Condition
CQI-ReportConfig-DEFAULT ::= SEQUENCE {			
cqi-ReportModeAperiodic	NOT PRESENT		
cqi-ReportPeriodic	NOT PRESENT		
}			

Table 4.7-5: UplinkPowerControlCommon-DEFAULT : Additional E-UTRA Anchor Configuration

Derivation Path: TS 36.508 [7] clause 4.6.3, UplinkPowerControlCommon-DEFAULT			
Information Element	Value/remark	Comment	Condition
UplinkPowerControlCommon-DEFAULT ::= SEQUENCE {			
p0-NominalPUSCH	-60 (-60 dBm)	To attain maximum power from the DUT	
}			

Table 4.7-6: PhysicalConfigDedicated-DEFAULT: Additional E-UTRA Anchor Configuration

Derivation Path: TS 36.508 [7] clause 4.8.2, Table 4.8.2.1.6-1 PhysicalConfigDedicated-DEFAULT			
Information Element	Value/remark	Comment	Condition
PhysicalConfigDedicated-DEFAULT ::= SEQUENCE {			
soundingRS-UL-ConfigDedicated	Not present		RBC
}			

Table 4.7-7: MAC-MainConfig-RBC: Additional E-UTRA Anchor Configuration

Derivation Path: TS 36.508 [7] clause 4.8.2.1.5, Table 4.8.2.1.5-1 MAC-MainConfig-RBC			
Information Element	Value/remark	Comment	Condition
timeAlignmentTimerDedicated	Infinity		

4.8 E-UTRA configuration for EN-DC FR1 tests not applying the E-UTRA anchor-agnostic approach

Unless otherwise stated, the following message exception defined in tables 4.8-1, 4.8-2 and 4.8-3 apply for EN-DC FR1 tests not applying the E-UTRA anchor-agnostic approach.

Table 4.8-1: CQI-ReportConfig-DEFAULT: Additional E-UTRA Anchor Configuration

Derivation Path: TS 36.508 [7] clause 4.6.3, Table 4.6.3-2 CQI-ReportConfig-DEFAULT			
Information Element	Value/remark	Comment	Condition
CQI-ReportConfig-DEFAULT ::= SEQUENCE {			
cqi-ReportModeAperiodic	NOT PRESENT		
cqi-ReportPeriodic	NOT PRESENT		
}			

Table 4.8-2: PhysicalConfigDedicated-DEFAULT: Additional E-UTRA Anchor Configuration

Derivation Path: TS 36.508 [7] clause 4.8.2, Table 4.8.2.1.6-1 PhysicalConfigDedicated-DEFAULT			
Information Element	Value/remark	Comment	Condition
PhysicalConfigDedicated-DEFAULT ::= SEQUENCE {			
soundingRS-UL-ConfigDedicated	Not present		RBC
}			

Table 4.8-3: MAC-MainConfig-RBC: Additional E-UTRA Anchor Configuration

Derivation Path: TS 36.508 [7] clause 4.8.2.1.5, Table 4.8.2.1.5-1 MAC-MainConfig-RBC			
Information Element	Value/remark	Comment	Condition
<i>timeAlignmentTimerDedicated</i>	Infinity		

5 Operating bands and channel arrangement

5.1 General

The channel arrangements presented in this clause are based on the operating bands and channel bandwidths defined in the present release of specifications.

NOTE: Other operating bands and channel bandwidths may be considered in future releases.

Requirements throughout the RF specifications are in many cases defined separately for different frequency ranges (FR). The frequency ranges in which NR can operate according to this version of the specifications are identified as described in Table 5.1-1.

Table 5.1-1: Definition of frequency ranges

Frequency range designation	Corresponding frequency range
FR1	410 MHz – 7125 MHz
FR2	24250 MHz – 52600 MHz

The present specification covers band combinations including

- at least one FR1 operating band and one FR2 operating band for carrier aggregation and dual connectivity operations;
- at least one E-UTRA operating band for dual connectivity operations.

5.2 Operating bands

NR is designed to operate in FR1 operating bands defined in TS 38.101-1 [2] and FR2 operating bands defined in TS 38.101-2 [3]. E-UTRA is designed to operate in operating bands defined in TS 36.101 [4].

5.2A Operating bands for CA

5.2A.1 Inter-band CA between FR1 and FR2

NR carrier aggregation is designed to operate in the operating bands defined in Table 5.2A.1-1. The band combinations include at least one FR1 operating band and one FR2 operating band.

Table 5.2A.1-1: Band combinations for inter-band NR CA between FR1 and FR2

NR CA Band	NR Band
CA_n8-n258	n8, n258
CA_n71-n257 ¹	n71, n257
CA_n77-n257 ¹	n77, n257
CA_n78-n257 ¹	n78, n257
CA_n79-n257 ¹	n79, n257
NOTE 1: Applicable for UE supporting inter-band carrier aggregation with mandatory simultaneous Rx/Tx capability.	

5.2B Operating bands for DC

5.2B.1 General

The operating bands are specified in clause 5.5B for operation with EN-DC, NGEN-DC, NE-DC or NR-DC configured.

5.2B.2 to 5.2B.7 Void

5.2E Operating bands for V2X

5.2E.1 Intra-band V2X bands

NR V2X operation is designed to operate concurrent with E-UTRA uplink/downlink or sidelink on the operating bands combinations listed in Table 5.2E.1-1.

Table 5.2E.1-1: Intra-band V2X operating bands

V2X con-current operating band	E-UTRA or NR Band	Interface
V2X_47_n47 ¹	47	PC5
	n47	PC5
NOTE 1: Only single switched SL is supported.		

5.2E.2 Inter-band V2X bands

NR V2X operation is designed to operate concurrent with E-UTRA uplink/downlink on the operating bands combinations listed in Table 5.2E.2-1.

Table 5.2E.2-1: Inter-band con-current V2X operating bands

E-UTRA-NR V2X Band Combination	E-UTRA or NR Band	Interface
V2X_20_n38	20	Uu
	n38	PC5
V2X_n71_47	47	PC5
	n71	Uu
V2X_n71_(n) 47 ¹	47	PC5
	n47	PC5
	n71	Uu
NOTE 1: Only single switched SL in ITS band is supported.		

5.3 UE Channel bandwidth

5.3A UE Channel bandwidth for CA

5.3A.1 Inter-band CA between FR1 and FR2

For inter-band NR CA between FR1 and FR2, a carrier aggregation configuration is a combination of operating bands, each supporting a carrier aggregation bandwidth class as specified in clause 5.3A.5 of TS 38.101-1 [2] and clause 5.3A.4 of TS 38.101-2 [3] independently.

5.3B UE Channel bandwidth for EN-DC

5.3B.0 General

For intra-band contiguous EN-DC, the aggregated channel bandwidth is sum of the individual NR and E-UTRA channel bandwidths assuming nominal EN-DC channel with 0 kHz offset spacing as specified in clause 5.4.

$$\text{ENBW} = \text{BW}_{\text{NR_Channel}} + \text{BW}_{\text{E-UTRA_Channel}}$$

In the case where the NR sub-block and/or the E-UTRA sub-block itself is composed of intra-band contiguous CA carriers, the EN-DC aggregated channel bandwidth is the sum of the aggregated channel bandwidths of the NR and E-UTRA sub-blocks assuming nominal EN-DC channel spacing between the NR sub-block and E-UTRA sub-block.

$$\text{ENBW} = \text{BW}_{\text{NR_Channel_CA}} + \text{BW}_{\text{E-UTRA_Channel_CA}}$$

For NR inter-band dual connectivity specified in 5.5B.7, the corresponding NR CA configurations in 5.5A.1, i.e., dual uplink inter-band carrier aggregation between FR1 and FR2 with uplink assigned to two NR bands, are applicable to Dual Connectivity.

NOTE: Requirements for the dual connectivity configurations are defined in the clause corresponding NR uplink CA between FR1 and FR2 configurations, unless otherwise specified.

Intra-band contiguous EN-DC configurations are defined using intra-band contiguous EN-DC bandwidth class notation DC_(n)XYZ where the first EN-DC bandwidth class letter indicates the number of contiguous E-UTRA carriers and the second EN-DC bandwidth class letter indicates the number of contiguous NR carriers for the EN-DC combination of E-UTRA Band X and NR Band nX. Applicable contiguous intraband EN-DC bandwidth classes are listed in Table 5.3B.0-1

Table 5.3B.0-1: Intra-band contiguous EN-DC bandwidth classes

Intra-band contiguous EN-DC bandwidth class	Number of contiguous CC	
	E-UTRA	NR
AA	1	1
AB	1	2
CA	2	1
DA	3	1

5.3B.1 Intra-band EN-DC in FR1

5.3B.1.1 General

The requirements for intra-band EN-DC in this specification are defined for EN-DC configurations with associated bandwidth combination sets.

For each EN-DC configuration, requirements are specified for all bandwidth combinations contained in a *bandwidth combination set*, which is indicated per supported band combination in the UE radio access capability. A UE can indicate support of several bandwidth combination sets per band combination.

5.3B.1.2 BCS for Intra-band contiguous EN-DC

For intra-band contiguous EN-DC, an EN-DC configuration is a single operating band supporting an intra-band contiguous EN-DC bandwidth class.

Bandwidth combination sets for intra-band contiguous EN-DC are specified in Table 5.3B.1.2-1.

Table 5.3B.1.2-1: EN-DC configurations and bandwidth combination sets defined for intra-band contiguous EN-DC

E-UTRA – NR configuration / Bandwidth combination set						
Downlink EN-DC configuration	Uplink EN-DC configurations	Component carriers in order of increasing carrier frequency			Maximum aggregated bandwidth (MHz)	Bandwidth combination set
		Channel bandwidths for E-UTRA carrier (MHz)	Channel bandwidths for NR carrier (MHz)	Channel bandwidths for E-UTRA carrier (MHz)		
DC_(n)41AA	DC_(n)41AA	20	40, 60, 80,100		120	0
			40, 60, 80,100	20		
		20	40, 50, 60, 80,100		120	1
			40, 50, 60, 80,100	20		
DC_(n)41CA	DC_(n)41AA, DC_41A_n41A	20+20	40, 60, 80,100		140	0
			40, 60, 80,100	20+20		
		20+20	40, 50, 60, 80,100		140	1
			40, 50, 60, 80,100	20+20		
DC_(n)41DA	DC_(n)41AA, DC_41A_n41A	20+20+20	40, 60, 80,100		160	0
			40, 60, 80,100	20+20+20		
		20+20+20	40, 50, 60, 80,100		160	1
			40, 50, 60, 80,100	20+20+20		
DC_(n)71AA	DC_(n)71AA	15	5		20	0
		10	5, 10			
		5	5, 10, 15			
			5	15		
			5, 10	10		
			5, 10, 15	5		

NOTE 1: Void
NOTE 2: Void
NOTE 3: Void
NOTE 4: The channel bandwidths for E-UTRA or NR carrier should be at least supported in one of the BCS indicated in E-UTRA bandwidth combination sets or NR bandwidth combination sets if reported.

5.3B.1.3 BCS for Intra-band non-contiguous EN-DC

For intra-band non-contiguous EN-DC, an EN-DC configuration is a single operating band supporting E-UTRA and NR carriers, where E-UTRA configuration is indicated by using E-UTRA CA bandwidth class as defined in TS 36.101 [5] and NR configuration is indicated by using NR CA bandwidth class as defined in TS 38.101-1 [2].

Requirements for intra-band non-contiguous EN-DC are defined for the EN-DC configurations and bandwidth combination sets specified in Table 5.3B.1.3-1.

Table 5.3B.1.3-1: EN-DC configurations and bandwidth combination sets defined for intra-band non-contiguous EN-DC

E-UTRA – NR configuration / Bandwidth combination set						
Downlink EN-DC configuration	Uplink EN-DC configurations	Component carriers in order of increasing carrier frequency			Maximum aggregated bandwidth (MHz)	Bandwidth combination set
		Channel bandwidths for E-UTRA carrier (MHz)	Channel bandwidths for NR carrier (MHz)	Channel bandwidths for E-UTRA carrier (MHz)		
DC_3A_n3A	DC_3A_n3A ⁽¹⁾		5, 10, 15, 20, 25, 30	5, 10, 15, 20	50	0
DC_41A_n41A	DC_41A_n41A	20	40, 60, 80,100		120	0
			40, 60, 80,100	20		
		20	40, 50, 60, 80,100		120	1
	40, 50, 60, 80,100	20				
DC_41C_n41A	DC_41A_n41A	20+20	40, 60, 80,100		140	0
			40, 60, 80,100	20+20		
		20+20	40, 50, 60, 80,100		140	1
	40, 50, 60, 80,100	20+20				
DC_41D_n41A	DC_41A_n41A	20+20+20	40, 60, 80,100		160	0
			40, 60, 80,100	20+20+20		
		20+20+20	40, 50, 60, 80,100		160	1
	40, 50, 60, 80,100	20+20+20				

NOTE 1: Only single switched UL is supported in Rel-15.

5.3E UE Channel bandwidth for V2X

The requirements specified in clause 5.3B are applicable to NR V2X UE.

5.3E.1 Intra-band contiguous V2X in FR1

For intra-band contiguous E-UTRA NR V2X UE, an EN-DC bandwidth class in Table 5.3.B-1 are considered to specify the V2X transmission/reception configurations.

Bandwidth combination sets and V2X transmission/reception configurations for intra-band contiguous V2X UE are specified in Table 5.3E.1-1.

Table 5.3E.1-1: E-UTRA-NR V2X configurations and bandwidth combination sets for intra-band contiguous V2X UE

V2X configuration	SL transmission band	Channel bandwidths for E-UTRA carrier (MHz)	Channel bandwidths for NR carrier (MHz)	Maximum aggregated bandwidth (MHz)	Bandwidth combination set
V2X_(n)47AA	E-UTRA Band 47 or NR band n47	10	10,20,30,40	60	0
		20	10,20,30,40		

5.3E.2 Intra-band non-contiguous V2X in FR1

For intra-band non-contiguous E-UTRA NR V2X UE, an EN-DC bandwidth class in Table 5.3.B-1 are considered to specify the V2X transmission/reception configurations.

Bandwidth combination sets and SL transmission/reception configurations for intra-band non-contiguous V2X are specified in Table 5.3E.2-1.

Table 5.3E.2-1: E-UTRA-NR V2X configurations and bandwidth combination sets for intra-band non-contiguous V2X UE

V2X configuration	SL transmission band	Channel bandwidths for E-UTRA carrier (MHz)	Channel bandwidths for NR carrier (MHz)	Maximum aggregated bandwidth (MHz)	Bandwidth combination set
V2X_47A_n47A	E-UTRA Band 47 or NR band n47	10	10,20,30,40	60	0
		20	10,20,30,40		

5.3E.3 Inter-band V2X in FR1

For inter-band E-UTRA NR V2X UE, the each channel bandwidth for inter-band V2X operations in FR1 is specified in TS 36.101 [4] and TS 38.101-1 [2], respectively.

5.4 Void

5.4A Channel arrangement for CA

The channel arrangement for CA operations in FR1 and FR2 as specified in TS 38.101-1 [2] and TS 38.101-2 [3], respectively.

5.4B Channel arrangement for DC

The channel arrangement for intra-band EN-DC operations in FR1 is specified in TS 36.101 [5] and TS 38.101-1 [2], respectively.

5.4B.1 Channel spacing for intra-band EN-DC carriers

The spacing between carriers will depend on the deployment scenario, the size of the frequency block available and the channel bandwidths. The nominal channel spacing between and E-UTRA carrier and an adjacent NR carrier for intra-band contiguous EN-DC is defined as following:

- For NR operating bands with 100 kHz channel raster,

$$\text{Nominal Channel spacing} = (BW_{E-UTRA_Channel} + BW_{NR_Channel})/2$$

- For NR operating bands with 15 kHz channel raster,

$$\text{Nominal Channel spacing} = (BW_{E-UTRA_Channel} + BW_{NR_Channel})/2 + \{-5\text{kHz}, 0\text{kHz}, 5\text{kHz}\}$$

- For NR operating bands with 30 kHz channel raster,

$$\text{Nominal Channel spacing} = (BW_{E-UTRA_Channel} + BW_{NR_Channel})/2 + \{-10\text{kHz}, 0\text{kHz}, 10\text{kHz}\}$$

where $BW_{E-UTRA_Channel}$ and $BW_{NR_Channel}$ are the channel bandwidths of the E-UTRA and NR carriers. The channel spacing can be adjusted depending on the channel raster to optimize performance in a particular deployment scenario.

For intra-band non-contiguous EN-DC the channel spacing between E-UTRA and NR carriers shall be larger than the nominal channel spacing defined in this clause.

5.5 Configuration

5.5A Configuration for CA

5.5A.1 Inter-band CA configurations between FR1 and FR2

Table 5.5A.1-1: Inter-band CA configurations and bandwidth combinations sets between FR1 and FR2 (two bands)

NR CA configuration	Uplink CA configuration	NR Band	SCS (kHz)	5 MHz	10 MHz	15 MHz	20 MHz	40 MHz	50 MHz	60 MHz	80 MHz	100 MHz	200 MHz	400 MHz	Bandwidth combination set
CA_n8A-n258A	CA_n8A-n258A	n8	15	Yes	Yes	Yes	Yes								0
			30		Yes	Yes	Yes								
			60												
		n258	60					Yes			Yes	Yes			
			120					Yes			Yes	Yes	Yes		
CA_n71A-n257A	-	n71	15	Yes	Yes	Yes	Yes								0
			30		Yes	Yes	Yes								
			60												
		n257	60					Yes			Yes	Yes			
			120					Yes			Yes	Yes	Yes		
CA_n77A-n257A	CA_n77A-n257A	n77	15		Yes	Yes	Yes	Yes	Yes						0
			30		Yes	Yes	Yes	Yes	Yes	Yes	Yes	Yes			
			60		Yes	Yes	Yes	Yes	Yes	Yes	Yes	Yes			
		n257	60					Yes			Yes	Yes			
			120					Yes			Yes	Yes	Yes		
CA_n77A-n257D	CA_n77A-n257A	n77	15		Yes	Yes	Yes	Yes	Yes						0
			30		Yes	Yes	Yes	Yes	Yes	Yes	Yes	Yes			
			60		Yes	Yes	Yes	Yes	Yes	Yes	Yes	Yes			
		n257	See CA_n257D in Table 5.5A.1-2 in TS 38.101-2												
CA_n77A-n257E	CA_n77A-n257A	n77	15		Yes	Yes	Yes	Yes	Yes						0
			30		Yes	Yes	Yes	Yes	Yes	Yes	Yes	Yes			
			60		Yes	Yes	Yes	Yes	Yes	Yes	Yes	Yes			
		n257	See CA_n257E in Table 5.5A.1-2 in TS 38.101-2												
CA_n77A-n257F	CA_n77A-n257A	n77	15		Yes	Yes	Yes	Yes	Yes						0
			30		Yes	Yes	Yes	Yes	Yes	Yes	Yes	Yes			
			60		Yes	Yes	Yes	Yes	Yes	Yes	Yes	Yes			
		n257	See CA_n257F in Table 5.5A.1-2 in TS 38.101-2												
CA_n77C-n257A	CA_n77A-n257A	n77	See CA_n77C in Table 5.5A.1-1 in TS 38.101-1												
		n257	60						Yes			Yes	Yes		
			120					Yes			Yes	Yes	Yes		
CA_n77C-n257D	CA_n77A-n257A	n77	See CA_n77C in Table 5.5A.1-1 in TS 38.101-1												
		n257	See CA_n257D in Table 5.5A.1-2 in TS 38.101-2												
CA_n77C-n257E	CA_n77A-n257A	n77	See CA_n77C in Table 5.5A.1-1 in TS 38.101-1												
		n257	See CA_n257E in Table 5.5A.1-2 in TS 38.101-2												
CA_n77C-n257F	CA_n77A-n257A	n77	See CA_n77C in Table 5.5A.1-1 in TS 38.101-1												
		n257	See CA_n257F in Table 5.5A.1-2 in TS 38.101-2												
CA_n78A-n257A	CA_n78A-n257A	n78	15		Yes	Yes	Yes	Yes	Yes						0
			30		Yes	Yes	Yes	Yes	Yes	Yes	Yes	Yes			
			60		Yes	Yes	Yes	Yes	Yes	Yes	Yes	Yes			
		n257	60					Yes			Yes	Yes			
			120					Yes			Yes	Yes	Yes		
CA_n78A-n257D	CA_n78A-n257A	n78	15		Yes	Yes	Yes	Yes	Yes						0
			30		Yes	Yes	Yes	Yes	Yes	Yes	Yes	Yes			
			60		Yes	Yes	Yes	Yes	Yes	Yes	Yes	Yes			
		n257	See CA_n257D in Table 5.5A.1-2 in TS 38.101-2												
CA_n78A-n257E	CA_n78A-n257A	n78	15		Yes	Yes	Yes	Yes	Yes						0
			30		Yes	Yes	Yes	Yes	Yes	Yes	Yes	Yes			
			60		Yes	Yes	Yes	Yes	Yes	Yes	Yes	Yes			

NR CA configuration	Uplink CA configuration	NR Band	SCS (kHz)	5 MHz	10 MHz	15 MHz	20 MHz	40 MHz	50 MHz	60 MHz	80 MHz	100 MHz	200 MHz	400 MHz	Bandwidth combination set
		n257	See CA_n257E in Table 5.5A.1-2 in TS 38.101-2												
CA_n7 8A-n257F	CA_n78A-n257A	n78	15		Yes	Yes	Yes	Yes	Yes						0
			30		Yes	Yes	Yes	Yes	Yes	Yes	Yes				
			60		Yes	Yes	Yes	Yes	Yes	Yes	Yes	Yes			
		n257	See CA_n257F in Table 5.5A.1-2 in TS 38.101-2												
CA_n7 8C-n257A	CA_n78A-n257A	n78	See CA_n78C in Table 5.5A.1-1 in TS 38.101-1												0
		n257	60						Yes			Yes	Yes		
			120					Yes				Yes	Yes	Yes	
CA_n7 8C-n257D	CA_n78A-n257A	n78	See CA_n78C in Table 5.5A.1-1 in TS 38.101-1												0
		n257	See CA_n257D in Table 5.5A.1-2 in TS 38.101-2												
CA_n7 8C-n257E	CA_n78A-n257A	n78	See CA_n78C in Table 5.5A.1-1 in TS 38.101-1												0
		n257	See CA_n257E in Table 5.5A.1-2 in TS 38.101-2												
CA_n7 8C-n257F	CA_n78A-n257A	n78	See CA_n78C in Table 5.5A.1-1 in TS 38.101-1												0
		n257	See CA_n257F in Table 5.5A.1-2 in TS 38.101-2												
CA_n7 9A-n257A	CA_n79A-n257A	n79	15					Yes	Yes						0
			30					Yes	Yes	Yes	Yes	Yes			
			60					Yes	Yes	Yes	Yes	Yes			
		n257	60					Yes				Yes	Yes		
			120					Yes					Yes	Yes	Yes
CA_n7 9A-n257D	CA_n79A-n257A	n79	15					Yes	Yes						0
			30					Yes	Yes	Yes	Yes	Yes			
			60					Yes	Yes	Yes	Yes	Yes			
		n257	See CA_n257D in Table 5.5A.1-2 in TS 38.101-2												
CA_n7 9A-n257E	CA_n79A-n257A	n79	15					Yes	Yes						0
			30					Yes	Yes	Yes	Yes	Yes			
			60					Yes	Yes	Yes	Yes	Yes			
		n257	See CA_n257E in Table 5.5A.1-2 in TS 38.101-2												
CA_n7 9A-n257F	CA_n79A-n257A	n79	15					Yes	Yes						0
			30					Yes	Yes	Yes	Yes	Yes			
			60					Yes	Yes	Yes	Yes	Yes			
		n257	See CA_n257F in Table 5.5A.1-2 in TS 38.101-2												
CA_n7 9C-n257A	CA_n79A-n257A	n79	See CA_n79C in Table 5.5A.1-1 in TS 38.101-1												0
		n257	60						Yes			Yes	Yes		
			120					Yes				Yes	Yes	Yes	
CA_n7 9C-n257D	CA_n79A-n257A	n79	See CA_n79C in Table 5.5A.1-1 in TS 38.101-1												0
		n257	See CA_n257D in Table 5.5A.1-2 in TS 38.101-2												
CA_n7 9C-n257E	CA_n79A-n257A	n79	See CA_n79C in Table 5.5A.1-1 in TS 38.101-1												0
		n257	See CA_n257E in Table 5.5A.1-2 in TS 38.101-2												
CA_n7 9C-n257F	CA_n79A-n257A	n79	See CA_n79C in Table 5.5A.1-1 in TS 38.101-1												0
		n257	See CA_n257F in Table 5.5A.1-2 in TS 38.101-2												

5.5B Configuration for DC

5.5B.1 General

The operating bands and bandwidth classes are specified for operation with EN-DC, NGEN-DC, NE-DC or NR-DC configured. The EN-DC, NE-DC or NGEN-DC band combinations include at least one E-UTRA operating band.

For EN-DC or NE-DC configurations indicated by column "Single Uplink allowed" (e.g., problematic band combinations as defined in TS 38.306 [16]) in tables in this clause the UE may indicate capability of not supporting simultaneous dual and triple uplink operation due to possible intermodulation interference to its own primary downlink channel bandwidth of PCell or PSCell if the intermodulation order is 2 or if the intermodulation order is 3 for the combinations when both operating bands are between 450 MHz – 960 MHz or between 1427 MHz – 2690 MHz.

In the case for EN-DC or NE-DC configurations listed in tables in this clause for which the intermodulation products caused by the dual and triple uplink operation fall into the receive band but do not interfere with its own primary downlink channel bandwidth of PCell or PSCell as defined in Annex I the UE is mandated to operate in dual and triple

uplink mode. Single Uplink is also allowed for certain band combinations where intermodulation or reverse intermodulation products could create difficulty for meeting emission requirements.

For EN-DC combinations of order 3 or higher, "Single Uplink allowed" UL configurations captured in Table 5.5B.2-1, Table 5.5B.3-1, and Table 5.5B.4-1 apply.

Non-contiguous resource allocation and almost contiguous allocation are not applicable for E-UTRA or NR carrier part of intra-band EN-DC configuration.

If multiple UL DC configurations are listed for multiple DL DC configurations, valid uplink configurations are such that uplink does not have more carriers than downlink.

Non-contiguous resource allocation and almost contiguous allocation are not applicable for E-UTRA or NR carrier part of intra-band EN-DC configuration.

5.5B.2 Intra-band contiguous EN-DC

Supported channel bandwidths for E-UTRA operating bands are defined in TS 36.521-1 [10] and for NR operating bands in TS 38.521-1 [8].

Table 5.5B.2-1: Intra-band contiguous EN-DC configurations

EN-DC Configuration	Uplink EN-DC configuration (NOTE 1)	Single UL allowed
DC_(n)41AA ⁵ DC_(n)41CA ⁵ DC_(n)41DA ⁵	DC_(n)41AA	Yes ³
DC_(n)41CA ⁵ DC_(n)41DA ⁵	DC_41A_n41A	Yes ³
DC_(n)71AA ²	DC_(n)71AA	No ⁴
NOTE 1: Uplink EN-DC configurations are the configurations supported by the present release of specifications.		
NOTE 2: Requirements in this specification apply for NR SCS of 15 kHz only.		
NOTE 3: Single UL allowed due to potential emission issues, not self-interference.		
NOTE 4: For UE(s) supporting dynamic power sharing it is mandatory to do dual simultaneous UL. For UE(s) not supporting dynamic power sharing single UL is allowed.		
NOTE 5: The minimum requirements only apply for non-simultaneous Tx/Rx between all carriers.		

5.5B.3 Intra-band non-contiguous EN-DC

Supported channel bandwidths for E-UTRA operating bands are defined in TS 36.521-1 [10] and for NR operating bands in TS 38.521-1 [8].

Table 5.5B.3-1: Intra-band non-contiguous EN-DC configurations

EN-DC Configuration	Uplink EN-DC configuration (NOTE 1)	Single UL allowed
DC_3A_n3A	DC_3A_n3A ²	Yes ²
DC_41A_n41A ³ DC_41C_n41A ³ DC_41D_n41A ³	DC_41A_n41A	Yes ⁴
DC_66A_n66A	DC_66A_n66A ⁵	Yes ⁵
NOTE 1: Uplink EN-DC configurations are the configurations supported by the present release of specifications.		
NOTE 2: Only single switched UL is supported in Rel-15		
NOTE 3: The minimum requirements only apply for non-simultaneous Tx/Rx between all carriers.		
NOTE 4: Single UL allowed due to potential emission issues, not self-interference.		
NOTE 5: Only single switched UL is supported.		

5.5B.4 Inter-band EN-DC within FR1

Supported channel bandwidths for E-UTRA operating bands and CA configurations are defined in TS 36.521-1 [10] and for NR operating bands and CA configurations in TS 38.521-1 [8] and present document.

5.5B.4.1 Inter-band EN-DC configurations within FR1 (two bands)

Table 5.5B.4.1-1: Inter-band EN-DC configurations within FR1 (two bands)

EN-DC configuration	Uplink EN-DC configuration (NOTE 1)	Single UL allowed
DC_1A_n3A	DC_1A_n3A	DC_1_n3
DC_1A_n28A	DC_1A_n28A	No
DC_1A_n40A	DC_1A_n40A	No
DC_1A_n51A	DC_1A_n51A	No
DC_1A_n77A ⁷ DC_1A_n77C ⁷	DC_1A_n77A	DC_1_n77
DC_1A_n78A ⁷ DC_1A_n78C ⁷	DC_1A_n78A	No
DC_1A_n79A ⁷ DC_1A_n79C ⁷	DC_1A_n79A	No
DC_2A_n5A	DC_2A_n5A	No
DC_2A_n41A DC_2C_n41A	DC_2A_n41A DC_2C_n41A	No
DC_2A_n66A	DC_2A_n66A	DC_2_n66
DC_2A_n71A	DC_2A_n71A	No
DC_2A_n78A	DC_2A_n78A	DC_2_n78
DC_3A_n1A	DC_3A_n1A	DC_3_n1
DC_3A_n7A	DC_3A_n7A	No
DC_3A_n28A	DC_3A_n28A	No
DC_3A_n40A	DC_3A_n40A	No
DC_3A_n41A DC_3C_n41A	DC_3A_n41A DC_3C_n41A	DC_3_n41
DC_3A_n51A	DC_3A_n51A	No
DC_3A_n77A ⁷ DC_3A_n77C ⁷	DC_3A_n77A	DC_3_n77
DC_3A_n78A ⁷ DC_3A_n78C ⁷ DC_3C_n78A ⁷	DC_3A_n78A	DC_3_n78
DC_3A_n79A ⁷ DC_3A_n79C ⁷	DC_3A_n79A	No
DC_5A_n2A	DC_5A_n2A	No
DC_5A_n40A	DC_5A_n40A	No
DC_5A_n66A	DC_5A_n66A	DC_5_n66
DC_5A_n78A ⁷	DC_5A_n78A	No
DC_7A_n1A	DC_7A_n1A	No
DC_7A_n3A	DC_7A_n3A	No
DC_7A_n28A	DC_7A_n28A	No
DC_7A_n51A	DC_7A_n51A	No
DC_7A_n66A DC_7C_n66A	DC_7A_n66A	No
DC_7A_n78A ⁷	DC_7A_n78A	No
DC_7C_n78A ⁷	DC_7A_n78A	No
DC_7A-7A_n78A ⁷	DC_7A_n78A	No
DC_8A_n1A	DC_8A_n1A	No
DC_8A_n3A	DC_8A_n3A	No
DC_8A_n40A ⁷	DC_8A_n40A	No
DC_8A_n41A DC_8A_n41C DC_8A_n41(2A)	DC_8A_n41A	No
DC_8A_n77A ⁷	DC_8A_n77A	No
DC_8A_n78A ⁷	DC_8A_n78A	No
DC_8A_n79A ⁷	DC_8A_n79A	No
DC_11A_n77A ⁷	DC_11A_n77A	No
DC_11A_n78A ⁷	DC_11A_n78A	No
DC_11A_n79A ⁷	DC_11A_n79A	No
DC_12A_n5A	DC_12A_n5A	No
DC_12A_n66A	DC_12A_n66A	No
DC_12A_n78A	DC_12A_n78A	DC_12_n78
DC_13A_n2A	DC_13A_n2A	No
DC_13A_n66A	DC_13A_n66A	No

EN-DC configuration	Uplink EN-DC configuration (NOTE 1)	Single UL allowed
DC_14A_n2A	DC_14A_n2A	No
DC_14A_n66A	DC_14A_n66A	No
DC_18A_n77A ⁷	DC_18A_n77A	No
DC_18A_n78A ⁷	DC_18A_n78A	No
DC_18A_n79A ⁷	DC_18A_n79A	No
DC_19A_n77A ⁷ DC_19A_n77C ⁷	DC_19A_n77A	No
DC_19A_n78A ⁷ DC_19A_n78C ⁷	DC_19A_n78A	No
DC_19A_n79A ⁷ DC_19A_n79C ⁷	DC_19A_n79A	No
DC_20A_n1A	DC_20A_n1A	No
DC_20A_n3A	DC_20A_n3A	No
DC_20A_n8A	DC_20A_n8A	DC_20_n8
DC_20A_n28A ^{8,10}	DC_20A_n28A	No
DC_20A_n51A	DC_20A_n51A	No
DC_20A_n77A ⁷	DC_20A_n77A	No
DC_20A_n78A ⁷	DC_20A_n78A	No
DC_21A_n77A ⁷ DC_21A_n77C ⁷	DC_21A_n77A	No
DC_21A_n78A ⁷ DC_21A_n78C ⁷	DC_21A_n78A	No
DC_21A_n79A ⁷ DC_21A_n79C ⁷	DC_21A_n79A	No
DC_25A_n41A	DC_25A_n41A	No
DC_26A_n41A	DC_26A_n41A	No
DC_26A_n77A ⁷	DC_26A_n77A	No
DC_26A_n78A ⁷	DC_26A_n78A	No
DC_26A_n79A ⁷	DC_26A_n79A	No
DC_28A_n3A	DC_28A_n3A	No
DC_28A_n51A	DC_28A_n51A	No
DC_28A_n77A ⁷ DC_28A_n77C ⁷	DC_28A_n77A	No
DC_28A_n78A ⁷ DC_28A_n78C ⁷	DC_28A_n78A	No
DC_28A_n79A ⁷ DC_28A_n79C ⁷	DC_28A_n79A	No
DC_30A_n5A	DC_30A_n5A	No
DC_30A_n66A	DC_30A_n66A	No
DC_38A_n78A ⁷	N/A	No
DC_39A_n41A DC_39C_n41A	DC_39A_n41A DC_39C_n41A	No
DC_39A_n78A ^{6,7}	DC_39A_n78A	No
DC_39A_n79A ⁷	DC_39A_n79A	No
DC_40A_n1A	DC_40A_n1A	No
DC_40A_n41A	DC_40A_n41A	No
DC_40A_n77A	N/A	No
DC_40A_n78A DC_40C_n78A	DC_40A_n78A DC_40C_n78A	No
DC_41A_n77A DC_41C_n77A	DC_41A_n77A	No
DC_41A_n78A DC_41C_n78A	DC_41A_n78A	No
DC_41A_n79A ^{6,7} DC_41C_n79A ^{6,7}	DC_41A_n79A	No
DC_42A_n51A	DC_42A_n51A	No

EN-DC configuration	Uplink EN-DC configuration (NOTE 1)	Single UL allowed
DC_42A_n77A ^{3,4,9,11} DC_42A_n77C ^{3,4,9} DC_42C_n77A ^{3,4,9} DC_42C_n77C ^{3,4,9} DC_42D_n77A ^{3,4,9} DC_42E_n77A ^{3,4,9}	N/A	N/A
DC_42A_n78A ^{3,4,9} DC_42A_n78C ^{3,4,9} DC_42C_n78A ^{3,4,9} DC_42C_n78C ^{3,4,9} DC_42D_n78A ^{3,4,9} DC_42E_n78A ^{3,4,9}	N/A	N/A
DC_42A_n79A ⁹ DC_42A_n79C ⁹ DC_42C_n79A ⁹ DC_42C_n79C ⁹ DC_42D_n79A ⁹ DC_42E_n79A ⁹	N/A	N/A
DC_46A_n78A ² DC_46C_n78A ² DC_46D_n78A ² DC_46E_n78A ²	N/A	N/A
DC_48A_n5A	DC_48A_n5A	No
DC_48A_n66A	DC_48A_n66A	No
DC_66A_n2A	DC_66A_n2A	DC_66_n2
DC_66A_n5A	DC_66A_n5A	DC_66_n5
DC_66A_n41A	DC_66A_n41A	No
DC_66A_n71A	DC_66A_n71A	No
DC_66A_n78A	DC_66A_n78A	No
<p>NOTE 1: Uplink EN-DC configurations are the configurations supported by the present release of specifications.</p> <p>NOTE 2: Restricted to E-UTRA operation when inter-band carrier aggregation is configured. The downlink operating band for Band 46 is paired with the uplink operating band (external E-UTRA band) of the carrier aggregation configuration that is supporting the configured PCell.</p> <p>NOTE 3: The minimum requirements apply only when there is non-simultaneous Tx/Rx operation between E-UTRA and NR carriers. This restriction applies also for these carriers when applicable EN-DC configuration is part of a higher order EN-DC configuration.</p> <p>NOTE 4: The minimum requirements for intra-band contiguous or non-contiguous EN-DC apply. The intra-band requirements also apply for these carriers when applicable EN-DC configuration is a subset of a higher order EN-DC configuration.</p> <p>NOTE 5: The frequency range above 3600 MHz for Band n78 is not used in this combination.</p> <p>NOTE 6: The frequency range below 2506 MHz for Band 41 is not used in this combination.</p> <p>NOTE 7: Applicable for UE supporting inter-band EN-DC with mandatory simultaneous Rx/Tx capability.</p> <p>NOTE 8: The frequency range in band n28 is restricted for this band combination to 703-733 MHz for the UL and 758-788 MHz for the DL.</p> <p>NOTE 9: The combination is not used alone as fall back mode of other band combinations in which UL in Band 42 is not used.</p> <p>NOTE 10: The maximum power spectral density imbalance between downlink carriers is within [6] dB. The power spectral density imbalance condition also applies for these carriers when applicable EN-DC configuration is a subset of a higher order EN-DC configuration.</p> <p>NOTE 11: The minimum requirements for inter-band EN-DC apply when the maximum power spectral density imbalance between downlink carriers is within 6 dB. The power spectral density imbalance condition also applies for these carriers when applicable EN-DC configuration is a subset of a higher order EN-DC configuration.</p>		

5.5B.4.2 Inter-band EN-DC configurations within FR1 (three bands)

Table 5.5B.4.2-1: Inter-band EN-DC configurations within FR1 (three bands)

EN-DC configuration	Uplink EN-DC configuration (NOTE 1)
DC_1A-3A_n28A	DC_1A_n28A DC_3A_n28A
DC_1A-3A_n77A ⁵ DC_1A-3A_n77C ⁵	DC_1A_n77A DC_3A_n77A
DC_1A-3A_n78A ⁵ DC_1A-3A_n78C ⁵ DC_1A-3C_n78A ⁵	DC_1A_n78A DC_3A_n78A
DC_1A-3A_n79A ⁵ DC_1A-3A_n79C ⁵	DC_1A_n79A DC_3A_n79A
DC_1A-5A_n78A ⁵	DC_1A_n78A DC_5A_n78A
DC_1A-7A_n3A	DC_1A_n3A DC_7A_n3A
DC_1A-7A_n28A ⁵	DC_1A_n28A DC_7A_n28A
DC_1A-7A_n78A ⁵	DC_1A_n78A DC_7A_n78A
DC_1A-7A-7A_n78A ⁵	DC_1A_n78A DC_7A_n78A
DC_1A-8A_n3A	DC_1A_n3A DC_8A_n3A
DC_1A-8A_n78A ⁵	DC_1A_n78A DC_8A_n78A
DC_1A-18A_n77A ⁵	DC_1A_n77A DC_18A_n77A
DC_1A-18A_n78A ⁵	DC_1A_n78A DC_18A_n78A
DC_1A-18A_n79A	DC_1A_n79A DC_18A_n79A
DC_1A-19A_n77A ⁵ DC_1A-19A_n77C ⁵	DC_1A_n77A DC_19A_n77A
DC_1A-19A_n78A ⁵ DC_1A-19A_n78C ⁵	DC_1A_n78A DC_19A_n78A
DC_1A-19A_n79A ⁵ DC_1A-19A_n79C ⁵	DC_1A_n79A DC_19A_n79A
DC_1A-20A_n3A	DC_1A_n3A DC_20A_n3A
DC_1A-20A_n28A ⁶	DC_1A_n28A DC_20A_n28A
DC_1A-20A_n78A ⁵	DC_1A_n78A DC_20A_n78A
DC_1A-21A_n77A ⁵ DC_1A-21A_n77C ⁵	DC_1A_n77A DC_21A_n77A
DC_1A-21A_n78A ⁵ DC_1A-21A_n78C ⁵	DC_1A_n78A DC_21A_n78A
DC_1A-21A_n79A ⁵ DC_1A-21A_n79C ⁵	DC_1A_n79A DC_21A_n79A
DC_1A-28A_n3A	DC_1A_n3A DC_28A_n3A
DC_1A-28A_n77A ⁵ DC_1A-28A_n77C ⁵	DC_1A_n77A DC_28A_n77A
DC_1A-28A_n78A ⁵ DC_1A-28A_n78C ⁵	DC_1A_n78A DC_28A_n78A
DC_1A_n28A-n78A ⁵	DC_1A_n28A, DC_1A_n78A
DC_1A-28A_n79A DC_1A-28A_n79C	DC_1A_n79A DC_28A_n79A

EN-DC configuration	Uplink EN-DC configuration (NOTE 1)
DC_1A-41A_n77A DC_1A-41C_n77A	DC_1A_n77A DC_41A_n77A
DC_1A-41A_n78A DC_1A-41C_n78A	DC_1A_n78A DC_41A_n78A
DC_1A-41C_n79A	DC_1A_n79A
DC_1A-42A_n77A DC_1A-42A_n77C DC_1A-42C_n77A DC_1A-42C_n77C DC_1A-42D_n77A DC_1A-42E_n77A	DC_1A_n77A
DC_1A-42A_n78A DC_1A-42A_n78C DC_1A-42C_n78A DC_1A-42C_n78C DC_1A-42D_n78A DC_1A-42E_n78A	DC_1A_n78A
DC_1A-42A_n79A DC_1A-42A_n79C DC_1A-42C_n79A DC_1A-42C_n79C DC_1A-42D_n79A DC_1A-42E_n79A	DC_1A_n79A
DC_1A_n77A-n79A	DC_1A_n77A DC_1A_n79A
DC_1A_n78A-n79A	DC_1A_n78A DC_1A_n79A
DC_1A_SUL_n78A-n84A ⁵	DC_1A_n78A DC_1A_n84A_ULSUP-TDM_n78A DC_1A_n84A_ULSUP-FDM_n78A
DC_2A-5A_n66A	DC_2A_n66A DC_5A_n66A
DC_2A-12A_n66A	DC_2A_n66A DC_12A_n66A
DC_2A-14A_n2A	DC_2A_n2A ² DC_14A_n2A
DC_2A-14A_n66A	DC_2A_n66A DC_14A_n66A
DC_2A-2A-14A_n66A	DC_2A_n66A DC_14A_n66A
DC_2A-30A_n66A	DC_2A_n66A DC_30A_n66A
DC_2A-66A_n5A	DC_2A_n5A DC_66A_n5A
DC_2A-66A_n41A	DC_2A_n41A DC_66A_n41A
DC_2A-66A_n71A	DC_2A_n71A DC_66A_n71A
DC_2A-(n)71AA	DC_2A_n71A DC_(n)71AA
DC_3A_n3A-n77A	DC_3A_n77A DC_3A_n3A ²
DC_3A_n3A-n78A	DC_3A_n78A DC_3A_n3A ²
DC_3A-5A_n78A ⁵	DC_3A_n78A DC_5A_n78A
DC_3A-7A_n28A	DC_3A_n28A DC_7A_n28A

EN-DC configuration	Uplink EN-DC configuration (NOTE 1)
DC_3A-7A_n78A ⁵ DC_3C-7A_n78A ⁵	DC_3A_n78A DC_7A_n78A
DC_3A-7C_n78A ⁵ DC_3C-7C_n78A ⁵	DC_3A_n78A DC_7A_n78A
DC_3A-7A-7A_n78A ⁵	DC_3A_n78A DC_7A_n78A
DC_3A-8A_n1A	DC_3A_n1A DC_8A_n1A
DC_3A-8A_n78A	DC_3A_n78A DC_8A_n78A
DC_3A-18A_n78A	DC_3A_n78A DC_18A_n78A
DC_3A-19A_n77A ⁵ DC_3A-19A_n77C ⁵	DC_3A_n77A DC_19A_n77A
DC_3A-19A_n78A ⁵ DC_3A-19A_n78C ⁵	DC_3A_n78A DC_19A_n78A
DC_3A-19A_n79A ⁵ DC_3A-19A_n79C ⁵	DC_3A_n79A DC_19A_n79A
DC_3A-20A_n1A	DC_3A_n1A DC_20A_n1A
DC_3A-20A_n28A ^{5,6}	DC_3A_n28A DC_20A_n28A
DC_3A-20A_n78A ⁵ DC_3C-20A_n78A ⁵	DC_3A_n78A DC_20A_n78A
DC_3A-21A_n77A ⁵ DC_3A-21A_n77C ⁵	DC_3A_n77A DC_21A_n77A
DC_3A-21A_n78A ⁵ DC_3A-21A_n78C ⁵	DC_3A_n78A DC_21A_n78A
DC_3A-21A_n79A ⁵ DC_3A-21A_n79C ⁵	DC_3A_n79A DC_21A_n79A
DC_3A-28A_n77A DC_3A-28A_n77C	DC_3A_n77A DC_28A_n77A
DC_3A-28A_n78A ⁵ DC_3A-28A_n78C ⁵	DC_3A_n78A DC_28A_n78A
DC_3A_n28A-n78A ⁵	DC_3A_n28A, DC_3A_n78A
DC_3A-28A_n79A DC_3A-28A_n79C	DC_3A_n79A DC_28A_n79A
DC_3A-38A_n78A	DC_3A_n78A
DC_3A-40A_n1A	DC_3A_n1A DC_40A_n1A
DC_3A-41A_n78A	DC_3A_n78A DC_41A_n78A
DC_3A-42A_n77A DC_3A-42A_n77C DC_3A-42C_n77A DC_3A-42C_n77C DC_3A-42D_n77A DC_3A-42E_n77A	DC_3A_n77A
DC_3A-42A_n78A DC_3A-42A_n78C DC_3A-42C_n78A DC_3A-42C_n78C DC_3A-42D_n78A DC_3A-42E_n78A	DC_3A_n78A

EN-DC configuration	Uplink EN-DC configuration (NOTE 1)
DC_3A-42A_n79A DC_3A-42A_n79C DC_3A-42C_n79A DC_3A-42C_n79C DC_3A-42D_n79A DC_3A-42E_n79A	DC_3A_n79A
DC_3A_n77A-n79A	DC_3A_n77A DC_3A_n79A
DC_3A_n78A-n79A	DC_3A_n78A DC_3A_n79A
DC_3A_SUL_n78A-n80A ⁵	DC_3A_n78A DC_3A_n80A_ULSUP-TDM_n78A DC_3A_n80A_ULSUP-FDM_n78A
DC_3A_SUL_n78A-n82A ⁵	DC_3A_n78A DC_3A_n82A
DC_3A_SUL_n79A-n80A ⁵	DC_3A_n79A DC_3A_n80A_ULSUP-TDM_n79A DC_3A_n80A_ULSUP-FDM_n79A
DC_5A-7A_n78A	DC_5A_n78A DC_7A_n78A
DC_5A-7A-7A_n78A	DC_5A_n78A DC_7A_n78A
DC_5A-30A_n66A	DC_5A_n66A DC_30A_n66A
DC_7A-8A_n1A	DC_7A_n1A DC_8A_n1A
DC_7A-20A_n1A	DC_7A_n1A DC_20A_n1A
DC_7A-20A_n3A	DC_7A_n3A DC_20A_n3A
DC_7A-20A_n28A ⁶	DC_7A_n28A DC_20A_n28A
DC_7A-20A_n78A ⁵	DC_7A_n78A DC_20A_n78A
DC_7A-28A_n3A	DC_7A_n3A DC_28A_n3A
DC_7A-28A_n78A ⁵	DC_7A_n78A DC_28A_n78A
DC_7C-28A_n78A ⁵	DC_7A_n78A DC_28A_n78A
DC_7A_n28A-n78A ⁵	DC_7A_n28A, DC_7A_n78A
DC_7A-46A_n78A ³ DC_7A-46C_n78A ³ DC_7A-46D_n78A ³ DC_7A-46E_n78A ³	DC_7A_n78A
DC_8A_SUL_n78A-n81A ⁵	DC_8A_n78A DC_8A_n81A_ULSUP-TDM_n78A DC_8A_n81A_ULSUP-FDM_n78A
DC_8A_SUL_n79A-n81A ⁵	DC_8A_n79A DC_8A_n81A_ULSUP-TDM_n79A DC_8A_n81A_ULSUP-FDM_n79A
DC_12A-30A_n66A	DC_12A_n66A DC_30A_n66A
DC_18A-28A_n77A ⁵	DC_18A_n77A DC_28A_n77A
DC_18A-28A_n78A ⁵	DC_18A_n78A DC_28A_n78A

EN-DC configuration	Uplink EN-DC configuration (NOTE 1)
DC_18A-28A_n79A ⁵	DC_18A_n79A DC_28A_n79A
DC_19A-21A_n77A ⁵ DC_19A-21A_n77C ⁵	DC_19A_n77A DC_21A_n77A
DC_19A-21A_n78A ⁵ DC_19A-21A_n78C ⁵	DC_19A_n78A DC_21A_n78A
DC_19A-21A_n79A ⁵ DC_19A-21A_n79C ⁵	DC_19A_n79A DC_21A_n79A
DC_19A-42A_n77A DC_19A-42A_n77C	DC_19A_n77A
DC_19A-42A_n78A DC_19A-42A_n78C	DC_19A_n78A
DC_19A-42A_n79A DC_19A-42A_n79C	DC_19A_n79A
DC_19A-42C_n77A DC_19A-42C_n77C	DC_19A_n77A
DC_19A-42C_n78A DC_19A-42C_n78C	DC_19A_n78A
DC_19A-42C_n79A DC_19A-42C_n79C	DC_19A_n79A
DC_19A_n77A-n79A	DC_19A_n77A DC_19A_n79A
DC_19A_n78A-n79A	DC_19A_n78A DC_19A_n79A
DC_20A_n8A-n75A ⁶	DC_20A_n8A
DC_20A_n28A-n75A ⁶	DC_20A_n28A
DC_20A_n28A-n78A ^{5,6}	DC_20A_n28A DC_20A_n78A
DC_20A_n75A-n78A ⁵	DC_20A_n78A
DC_20A_n76A-n78A ⁵	DC_20A_n78A
DC_20A_SUL_n78A-n82A ⁵	DC_20A_n78A DC_20A_n82A_ULSUP-TDM_n78A DC_20A_n82A_ULSUP-FDM_n78A
DC_20A_SUL_n78A-n83A ⁵	DC_20A_n78A DC_20A_n83A
DC_21A-28A_n77A DC_21A-28A_n77C	DC_21A_n77A DC_28A_n77A
DC_21A-28A_n78A DC_21A-28A_n78C	DC_21A_n78A DC_28A_n78A
DC_21A-28A_n79A DC_21A-28A_n79C	DC_21A_n79A DC_28A_n79A
DC_21A-42A_n77A DC_21A-42A_n77C DC_21A-42C_n77A DC_21A-42C_n77C	DC_21A_n77A
DC_21A-42A_n78A DC_21A-42A_n78C DC_21A-42C_n78A DC_21A-42C_n78C	DC_21A_n78A
DC_21A-42A_n79A DC_21A-42A_n79C DC_21A-42C_n79A DC_21A-42C_n79C	DC_21A_n79A
DC_21A_n77A-n79A	DC_21A_n77A DC_21A_n79A
DC_21A_n78A-n79A	DC_21A_n78A DC_21A_n79A

EN-DC configuration	Uplink EN-DC configuration (NOTE 1)
DC_28A-42A_n77A DC_28A-42A_n77C DC_28A-42C_n77A	DC_28A_n77A
DC_28A-42A_n78A DC_28A-42A_n78C DC_28A-42C_n78A	DC_28A_n78A
DC_28A-42A_n79A DC_28A-42A_n79C DC_28A-42C_n79A	DC_28A_n79A
DC_28A_SUL_n78A-n83A ⁵	DC_28A_n78A DC_28A_n83A_ULSUP-TDM_n78A DC_28A_n83A_ULSUP-FDM_n78A
DC_41A-42A_n77A DC_41A-42C_n77A DC_41C-42A_n77A DC_41C-42C_n77A	DC_41A_n77A
DC_41A-42A_n78A DC_41A-42C_n78A DC_41C-42A_n78A DC_41C-42C_n78A	DC_41A_n78A
DC_41A-42A_n79A DC_41A-42C_n79A DC_41C-42A_n79A DC_41C-42C_n79A	DC_41A_n79A
DC_66A_(n)71AA	DC_66A_n71A DC_(n)71AA
DC_66A_SUL_n78A-n86A ⁵	DC_66A_n78A DC_66A_n86A_ULSUP-TDM_n78A DC_66A_n86A_ULSUP-FDM_n78A
<p>NOTE 1: Uplink EN-DC configurations are the configurations supported by the present release of specifications.</p> <p>NOTE 2: Only single switched UL is supported.</p> <p>NOTE 3: Restricted to E-UTRA operation when inter-band carrier aggregation is configured. The downlink operating band for Band 46 is paired with the uplink operating band (external E-UTRA band) of the carrier aggregation configuration that is supporting the configured PCell.</p> <p>NOTE 4: If a UE is configured with both NR UL and NR SUL carriers in a cell, the switching time between NR UL carrier and NR SUL carrier can be up to 140us and placed in SUL resources.</p> <p>NOTE 5: Applicable for UE supporting inter-band EN-DC with mandatory simultaneous Rx/Tx capability</p> <p>NOTE 6: The frequency range in band n28 is restricted for this band combination to 703-733 MHz for the UL and 758-788 MHz for the DL.</p>	

5.5B.4.3 Inter-band EN-DC configurations within FR1 (four bands)

Table 5.5B.4.3-1: Inter-band EN-DC configurations within FR1 (four bands)

EN-DC configuration	Uplink EN-DC configuration (NOTE 1)
DC_1A-3A-5A_n78A ²	DC_1A_n78A DC_3A_n78A DC_5A_n78A
DC_1A-3A-7A_n28A	DC_1A_n28A DC_3A_n28A DC_7A_n28A
DC_1A-3A-7A_n78A ² DC_1A-3C-7A_n78A ²	DC_1A_n78A DC_3A_n78A DC_7A_n78A
DC_1A-3A-7A-7A_n78A ²	DC_1A_n78A DC_3A_n78A DC_7A_n78A
DC_1A-3A-8A_n78A ²	DC_1A_n78A DC_3A_n78A DC_8A_n78A
DC_1A-3A-19A_n77A ² DC_1A-3A-19A_n77C ²	DC_1A_n77A DC_3A_n77A DC_19A_n77A
DC_1A-3A-19A_n78A ² DC_1A-3A-19A_n78C ²	DC_1A_n78A DC_3A_n78A DC_19A_n78A
DC_1A-3A-19A_n79A ² DC_1A-3A-19A_n79C ²	DC_1A_n79A DC_3A_n79A DC_19A_n79A
DC_1A-3A-20A_n28A ³	DC_1A_n28A DC_3A_n28A DC_20A_n28A
DC_1A-3A-20A_n78A ²	DC_1A_n78A DC_3A_n78A DC_20A_n78A
DC_1A-3A-21A_n77A ² DC_1A-3A-21A_n77C ²	DC_1A_n77A DC_3A_n77A DC_21A_n77A
DC_1A-3A-21A_n78A ² DC_1A-3A-21A_n78C ²	DC_1A_n78A DC_3A_n78A DC_21A_n78A
DC_1A-3A-21A_n79A ² DC_1A-3A-21A_n79C ²	DC_1A_n79A DC_3A_n79A DC_21A_n79A
DC_1A-3A-28A_n77A ²	DC_1A_n77A DC_3A_n77A DC_28A_n77A
DC_1A-3A-28A_n78A ²	DC_1A_n78A DC_3A_n78A DC_28A_n78A
DC_1A-3A-28A_n79A ²	DC_1A_n79A DC_3A_n79A DC_28A_n79A
DC_1A-3A_n28A-n78A ²	DC_1A_n28A DC_1A_n78A DC_3A_n28A DC_3A_n78A
DC_1A-3A-42A_n77A DC_1A-3A-42A_n77C DC_1A-3A-42C_n77A DC_1A-3A-42C_n77C	DC_1A_n77A DC_3A_n77A
DC_1A-3A-42A_n78A DC_1A-3A-42A_n78C DC_1A-3A-42C_n78A DC_1A-3A-42C_n78C DC_1A-3A-42D_n78A	DC_1A_n78A DC_3A_n78A

EN-DC configuration	Uplink EN-DC configuration (NOTE 1)
DC_1A-3A-42A_n79A DC_1A-3A-42A_n79C DC_1A-3A-42C_n79A DC_1A-3A-42C_n79C DC_1A-3A-42D_n79A	DC_1A_n79A DC_3A_n79A
DC_1A-5A-7A_n78A	DC_1A_n78A DC_5A_n78A DC_7A_n78A
DC_1A-5A-7A-7A_n78A	DC_1A_n78A DC_5A_n78A DC_7A_n78A
DC_1A-7A-20A_n28A ³	DC_1A_n28A DC_7A_n28A DC_20A_n28A
DC_1A-7A-20A_n78A ²	DC_1A_n78A DC_7A_n78A DC_20A_n78A
DC_1A-7A_n28A-n78A ²	DC_1A_n28A DC_1A_n78A DC_7A_n28A DC_7A_n78A
DC_1A-18A-28A_n77A	DC_1A_n77A DC_18A_n77A DC_28A_n77A
DC_1A-18A-28A_n78A	DC_1A_n78A DC_18A_n78A DC_28A_n78A
DC_1A-18A-28A_n79A ²	DC_1A_n79A DC_18A_n79A DC_28A_n79A
DC_1A-19A-21A_n77A DC_1A-19A-21A_n77C	DC_1A_n77A DC_19A_n77A DC_21A_n77A
DC_1A-19A-21A_n78A DC_1A-19A-21A_n78C	DC_1A_n78A DC_19A_n78A DC_21A_n78A
DC_1A-19A-21A_n79A DC_1A-19A-21A_n79C	DC_1A_n79A DC_19A_n79A DC_21A_n79A
DC_1A-19A-42A_n77A DC_1A-19A-42A_n77C DC_1A-19A-42C_n77A DC_1A-19A-42C_n77C	DC_1A_n77A DC_19A_n77A
DC_1A-19A-42A_n78A DC_1A-19A-42A_n78C DC_1A-19A-42C_n78A DC_1A-19A-42C_n78C	DC_1A_n78A DC_19A_n78A
DC_1A-19A-42A_n79A DC_1A-19A-42A_n79C DC_1A-19A-42C_n79A DC_1A-19A-42C_n79C	DC_1A_n79A DC_19A_n79A
DC_1A-20A_n28A-n78A ^{2,3}	DC_1A_n28A DC_1A_n78A DC_20A_n28A DC_20A_n78A
DC_1A-21A-28A_n77A ²	DC_1A_n77A DC_21A_n77A DC_28A_n77A
DC_1A-21A-28A_n78A ²	DC_1A_n78A DC_21A_n78A DC_28A_n78A

EN-DC configuration	Uplink EN-DC configuration (NOTE 1)
DC_1A-21A-28A_n79A ²	DC_1A_n79A DC_21A_n79A DC_28A_n79A
DC_1A-21A-42A_n77A DC_1A-21A-42A_n77C DC_1A-21A-42C_n77A DC_1A-21A-42C_n77C	DC_1A_n77A DC_21A_n77A
DC_1A-21A-42A_n78A DC_1A-21A-42A_n78C DC_1A-21A-42C_n78A DC_1A-21A-42C_n78C	DC_1A_n78A DC_21A_n78A
DC_1A-21A-42A_n79A DC_1A-21A-42A_n79C DC_1A-21A-42C_n79A DC_1A-21A-42C_n79C	DC_1A_n79A DC_21A_n79A
DC_1A-28A-42A_n77A DC_1A-28A-42C_n77A	DC_1A_n77A DC_28A_n77A
DC_1A-28A-42A_n78A DC_1A-28A-42C_n78A	DC_1A_n78A DC_28A_n78A
DC_1A-28A-42A_n79A DC_1A-28A-42C_n79A	DC_1A_n79A DC_28A_n79A
DC_1A-41A-42A_n77A DC_1A-41A-42C_n77A DC_1A-41C-42A_n77A DC_1A-41C-42C_n77A	DC_1A_n77A DC_41A_n77A
DC_1A-41A-42A_n78A DC_1A-41A-42C_n78A DC_1A-41C-42A_n78A DC_1A-41C-42C_n78A	DC_1A_n78A DC_41A_n78A
DC_1A-41A-42A_n79A DC_1A-41A-42C_n79A DC_1A-41C-42A_n79A DC_1A-41C-42C_n79A	DC_1A_n79A DC_41A_n79A
DC_2A-7A-7A-13A_n66A DC_2A-7C-13A_n66A	DC_2A_n66A DC_7A_n66A DC_13A_n66A
DC_2A-7C-66A_n66A DC_2A-7A-7A-66A_n66A	DC_2A_n66A DC_7A_n66A DC_66A_n66A ⁴
DC_2A-7A-7A-66A_n78A DC_2A-7C-66A_n78A	DC_2A_n78A DC_7A_n78A DC_66A_n78A
DC_2A-7A-13A_n66A	DC_2A_n66A DC_7A_n66A DC_13A_n66A
DC_2A-7A-66A_n66A	DC_2A_n66A DC_7A_n66A DC_66A_n66A ⁴
DC_2A-14A-66A_n2A	DC_2A_n2A ⁴ DC_14A_n2A DC_66A_n2A
DC_2A-14A-66A-66A_n2A	DC_2A_n2A ⁴ DC_14A_n2A DC_66A_n2A
DC_2A-14A-66A_n66A	DC_2A_n66A DC_14A_n66A DC_66A_n66A ⁴
DC_2A-2A-14A-66A_n66A	DC_2A_n66A DC_14A_n66A DC_66A_n66A ⁴

EN-DC configuration	Uplink EN-DC configuration (NOTE 1)
DC_2A-66A-(n)71AA	DC_2A_n71A DC_66A_n71A DC_(n)71AA
DC_3A-5A-7A_n78A	DC_3A_n78A DC_5A_n78A DC_7A_n78A
DC_3A-5A-7A-7A_n78A	DC_3A_n78A DC_5A_n78A DC_7A_n78A
DC_3A-7A-20A_n28A ³	DC_3A_n28A DC_7A_n28A DC_20A_n28A
DC_3A-7A-20A_n78A ²	DC_3A_n78A DC_7A_n78A DC_20A_n78A
DC_3A-7A-28A_n78A ² DC_3A-7C-28A_n78A ²	DC_3A_n78A DC_7A_n78A DC_28A_n78A
DC_3A-7A_n28A-n78A ²	DC_3A_n28A DC_3A_n78A DC_7A_n28A DC_7A_n78A
DC_3A-19A-21A_n77A ² DC_3A-19A-21A_n77C ²	DC_3A_n77A DC_19A_n77A DC_21A_n77A
DC_3A-19A-21A_n78A ² DC_3A-19A-21A_n78C ²	DC_3A_n78A DC_19A_n78A DC_21A_n78A
DC_3A-19A-21A_n79A ² DC_3A-19A-21A_n79C ²	DC_3A_n79A DC_19A_n79A DC_21A_n79A
DC_3A-19A-42A_n77A DC_3A-19A-42A_n77C DC_3A-19A-42C_n77A DC_3A-19A-42C_n77C	DC_3A_n77A DC_19A_n77A
DC_3A-19A-42A_n78A DC_3A-19A-42A_n78C DC_3A-19A-42C_n78A DC_3A-19A-42C_n78C	DC_3A_n78A DC_19A_n78A
DC_3A-19A-42A_n79A ² DC_3A-19A-42A_n79C ² DC_3A-19A-42C_n79A ² DC_3A-19A-42C_n79C ²	DC_3A_n79A DC_19A_n79A
DC_3A-20A_n28A-n78A ^{2,3}	DC_3A_n28A DC_3A_n78A DC_20A_n28A DC_20A_n78A
DC_3A-21A-42A_n77A DC_3A-21A-42A_n77C DC_3A-21A-42C_n77A DC_3A-21A-42C_n77C	DC_3A_n77A DC_21A_n77A
DC_3A-21A-42A_n78A DC_3A-21A-42A_n78C DC_3A-21A-42C_n78A DC_3A-21A-42C_n78C	DC_3A_n78A DC_21A_n78A
DC_3A-21A-42A_n79A DC_3A-21A-42A_n79C DC_3A-21A-42C_n79A DC_3A-21A-42C_n79C	DC_3A_n79A DC_21A_n79A
DC_3A-28A-42A_n77A DC_3A-28A-42C_n77A	DC_3A_n77A DC_28A_n77A

EN-DC configuration	Uplink EN-DC configuration (NOTE 1)
DC_3A-28A-42A_n78A DC_3A-28A-42C_n78A	DC_3A_n78A DC_28A_n78A
DC_3A-28A-42A_n79A DC_3A-28A-42C_n79A	DC_3A_n79A DC_28A_n79A
DC_7A-20A_n28A-n78A ^{2,3}	DC_7A_n28A DC_7A_n78A DC_20A_n28A DC_20A_n78A
DC_19A-21A-42A_n77A DC_19A-21A-42A_n77C DC_19A-21A-42C_n77A DC_19A-21A-42C_n77C	DC_19A_n77A DC_21A_n77A
DC_19A-21A-42A_n78A DC_19A-21A-42A_n78C DC_19A-21A-42C_n78A DC_19A-21A-42C_n78C	DC_19A_n78A DC_21A_n78A
DC_19A-21A-42A_n79A DC_19A-21A-42A_n79C DC_19A-21A-42C_n79A DC_19A-21A-42C_n79C	DC_19A_n79A DC_21A_n79A
DC_21A-28A-42A_n77A DC_21A-28A-42C_n77A	DC_21A_n77A DC_28A_n77A
DC_21A-28A-42A_n78A DC_21A-28A-42C_n78A	DC_21A_n78A DC_28A_n78A
DC_21A-28A-42A_n79A DC_21A-28A-42C_n79A	DC_21A_n79A DC_28A_n79A
NOTE 1: Uplink EN-DC configurations are the configurations supported by the present release of specifications.	
NOTE 2: Applicable for UE supporting inter-band EN-DC with mandatory simultaneous Rx/Tx capability	
NOTE 3: The frequency range in band n28 is restricted for this band combination to 703-733 MHz for the UL and 758-788 MHz for the DL.	
NOTE 4: Only single switched UL is supported.	

5.5B.4.4 Inter-band EN-DC configurations within FR1 (five bands)

Table 5.5B.4.4-1: Inter-band EN-DC configurations within FR1 (five bands)

EN-DC configuration	Uplink EN-DC configuration (NOTE 1)
DC_1A-3A-5A-7A_n78A	DC_1A_n78A DC_3A_n78A DC_5A_n78A DC_7A_n78A
DC_1A-3A-5A-7A-7A_n78A	DC_1A_n78A DC_3A_n78A DC_5A_n78A DC_7A_n78A
DC_1A-3A-5A-41A_n79A	DC_1A_n79A DC_3A_n79A DC_5A_n79A DC_41A_n79A
DC_1A-3A-7A-20A_n28A ³	DC_1A_n28A DC_3A_n28A DC_7A_n28A DC_20A_n28A
DC_1A-3A-7A-20A_n78A ²	DC_1A_n78A DC_3A_n78A DC_7A_n78A DC_20A_n78A
DC_1A-3A-7A_n28A-n78A ²	DC_1A_n28A DC_1A_n78A DC_3A_n28A DC_3A_n78A DC_7A_n28A DC_7A_n78A
DC_1A-3A-19A-21A_n77A ² DC_1A-3A-19A-21A_n77C ²	DC_1A_n77A DC_3A_n77A DC_19A_n77A DC_21A_n77A
DC_1A-3A-19A-21A_n78A ² DC_1A-3A-19A-21A_n78C ²	DC_1A_n78A DC_3A_n78A DC_19A_n78A DC_21A_n78A
DC_1A-3A-19A-21A_n79A ² DC_1A-3A-19A-21A_n79C ²	DC_1A_n79A DC_3A_n79A DC_19A_n79A DC_21A_n79A
DC_1A-3A-19A-42A_n77A DC_1A-3A-19A-42A_n77C DC_1A-3A-19A-42C_n77A DC_1A-3A-19A-42C_n77C	DC_1A_n77A DC_3A_n77A DC_19A_n77A
DC_1A-3A-19A-42A_n78A DC_1A-3A-19A-42A_n78C DC_1A-3A-19A-42C_n78A DC_1A-3A-19A-42C_n78C	DC_1A_n78A DC_3A_n78A DC_19A_n78A
DC_1A-3A-19A-42A_n79A DC_1A-3A-19A-42A_n79C DC_1A-3A-19A-42C_n79A DC_1A-3A-19A-42C_n79C	DC_1A_n79A DC_3A_n79A DC_19A_n79A
DC_1A-3A-20A_n28A-n78A ^{2,3}	DC_1A_n28A DC_1A_n78A DC_3A_n28A DC_3A_n78A DC_20A_n28A DC_20A_n78A
DC_1A-3A-21A-42A_n77A DC_1A-3A-21A-42A_n77C DC_1A-3A-21A-42C_n77A DC_1A-3A-21A-42C_n77C	DC_1A_n77A DC_3A_n77A DC_21A_n77A

EN-DC configuration	Uplink EN-DC configuration (NOTE 1)
DC_1A-3A-21A-42A_n78A DC_1A-3A-21A-42A_n78C DC_1A-3A-21A-42C_n78A DC_1A-3A-21A-42C_n78C	DC_1A_n78A DC_3A_n78A DC_21A_n78A
DC_1A-3A-21A-42A_n79A DC_1A-3A-21A-42A_n79C DC_1A-3A-21A-42C_n79A DC_1A-3A-21A-42C_n79C	DC_1A_n79A DC_3A_n79A DC_21A_n79A
DC_1A-3A-28A-42A_n77A DC_1A-3A-28A-42C_n77A	DC_1A_n77A DC_3A_n77A DC_28A_n77A
DC_1A-3A-28A-42A_n78A DC_1A-3A-28A-42C_n78A	DC_1A_n78A DC_3A_n78A DC_28A_n78A
DC_1A-3A-28A-42A_n79A DC_1A-3A-28A-42C_n79A	DC_1A_n79A DC_3A_n79A DC_28A_n79A
DC_1A-7A-20A_n28A-n78A ^{2,3}	DC_1A_n28A DC_1A_n78A DC_7A_n28A DC_7A_n78A DC_20A_n28A DC_20A_n78A
DC_1A-19A-21A-42A_n77A DC_1A-19A-21A-42A_n77C DC_1A-19A-21A-42C_n77A DC_1A-19A-21A-42C_n77C	DC_1A_n77A DC_19A_n77A DC_21A_n77A
DC_1A-19A-21A-42A_n78A DC_1A-19A-21A-42A_n78C DC_1A-19A-21A-42C_n78A DC_1A-19A-21A-42C_n78C	DC_1A_n78A DC_19A_n78A DC_21A_n78A
DC_1A-19A-21A-42A_n79A DC_1A-19A-21A-42A_n79C DC_1A-19A-21A-42C_n79A DC_1A-19A-21A-42C_n79C	DC_1A_n79A DC_19A_n79A DC_21A_n79A
DC_1A-21A-28A-42A_n77A DC_1A-21A-28A-42C_n77A	DC_1A_n77A DC_21A_n77A DC_28A_n77A
DC_1A-21A-28A-42A_n78A DC_1A-21A-28A-42C_n78A	DC_1A_n78A DC_21A_n78A DC_28A_n78A
DC_1A-21A-28A-42A_n79A DC_1A-21A-28A-42C_n79A	DC_1A_n79A DC_21A_n79A DC_28A_n79A
DC_3A-7A-20A_n28A-n78A ^{2,3}	DC_3A_n28A DC_3A_n78A DC_7A_n28A DC_7A_n78A DC_20A_n28A DC_20A_n78A
DC_3A-19A-21A-42A_n78A DC_3A-19A-21A-42C_n78A	DC_3A_n78A DC_19A_n78A DC_21A_n78A
DC_3A-19A-21A-42A_n79A DC_3A-19A-21A-42C_n79A	DC_3A_n79A DC_19A_n79A DC_21A_n79A

NOTE 1: Uplink EN-DC configurations are the configurations supported by the present release of specifications.
NOTE 2: Applicable for UE supporting inter-band EN-DC with mandatory simultaneous Rx/Tx capability
NOTE 3: The frequency range in band n28 is restricted for this band combination to 703-733 MHz for the UL and 758-788 MHz for the DL

5.5B.4.5 Inter-band EN-DC configurations within FR1 (six bands)

Table 5.5B.4.5-1: Inter-band EN-DC configurations within FR1 (six bands)

EN-DC configuration	Uplink EN-DC configuration (NOTE 1)
DC_1A-3A-7A-20A_n28A-n78A ^{2,3}	DC_1A_n28A DC_1A_n78A DC_3A_n28A DC_3A_n78A DC_7A_n28A DC_7A_n78A DC_20A_n28A DC_20A_n78A
NOTE 1: Uplink EN-DC configurations are the configurations supported by the present release of specifications.	
NOTE 2: Applicable for UE supporting inter-band EN-DC with mandatory simultaneous Rx/Tx capability	
NOTE 3: The frequency range in band n28 is restricted for this band combination to 703-733 MHz for the UL and 758-788 MHz for the DL	

5.5B.4a Inter-band NE-DC within FR1

5.5B.4a.1 Inter-band NE-DC configurations within FR1 (two bands)

Table 5.5B.4a.1-1: Inter-band NE-DC configurations within FR1 (two bands)

NE-DC configuration	Uplink NE-DC configuration (NOTE 1)	Single UL allowed
DC_n1A_28A	DC_n1A_28A	No
NOTE 1: Uplink EN-DC configurations are the configurations supported by the present release of specifications.		

5.5B.5 Inter-band EN-DC including FR2

Supported channel bandwidths for E-UTRA operating bands and CA configurations are defined in TS 36.521-1 [10] and for NR operating bands and CA configurations in TS 38.521-1 [8], TS 38.521-2 [9] and present document.

5.5B.5.1 Inter-band EN-DC configurations including FR2 (two bands)

Table 5.5B.5.1-1: Inter-band EN-DC configurations including FR2 (two bands)

EN-DC configuration	Uplink EN-DC configuration (NOTE 1)
DC_1A_n257A DC_1A_n257D DC_1A_n257E DC_1A_n257F DC_1A_n257G DC_1A_n257H DC_1A_n257I DC_1A_n257J DC_1A_n257K DC_1A_n257L DC_1A_n257M	DC_1A_n257A DC_1A_n257D DC_1A_n257G DC_1A_n257H DC_1A_n257I DC_1A_n257J DC_1A_n257K DC_1A_n257L DC_1A_n257M
DC_2A_n257A DC_2C_n257A	DC_2A_n257A
DC_2A_n257(2A)	DC_2A_n257A
DC_2A-2A_n257A	DC_2A_n257A
DC_2A_n260A DC_2A_n260G DC_2A_n260H DC_2A_n260I DC_2A_n260J DC_2A_n260K DC_2A_n260L DC_2A_n260M DC_2C_n260A	DC_2A_n260A
DC_2A_n260(2A)	DC_2A_n260A
DC_2A-2A_n260A DC_2A-2A_n260G DC_2A-2A_n260H DC_2A-2A_n260I DC_2A-2A_n260J DC_2A-2A_n260K DC_2A-2A_n260L DC_2A-2A_n260M	DC_2A_n260A
DC_3A_n257A DC_3A_n257D DC_3A_n257E DC_3A_n257F DC_3A_n257G DC_3A_n257H DC_3A_n257I	DC_3A_n257A DC_3A_n257B DC_3A_n257D DC_3A_n257G DC_3A_n257H DC_3A_n257I
DC_3A_n258A	DC_3A_n258A
DC_5A_n257A DC_5B_n257A	DC_5A_n257A DC_5B_n257A
DC_5A-5A_n257A	DC_5A_n257A
DC_5A_n260A DC_5A_n260B DC_5A_n260C DC_5A_n260D DC_5A_n260E DC_5A_n260F DC_5A_n260G DC_5A_n260H DC_5A_n260I DC_5A_n260J DC_5A_n260K DC_5A_n260L DC_5A_n260M DC_5A_n260O DC_5A_n260P DC_5A_n260Q DC_5B_n260A	DC_5A_n260A DC_5B_n260A

EN-DC configuration	Uplink EN-DC configuration (NOTE 1)
DC_5A_n260(2A) DC_5A_n260(3A) DC_5A_n260(4A) DC_5A_n260(A-I) DC_5A_n260(D-G) DC_5A_n260(D-H) DC_5A_n260(D-I) DC_5A_n260(D-O) DC_5A_n260(D-P) DC_5A_n260(D-Q) DC_5A_n260(E-O) DC_5A_n260(E-P) DC_5A_n260(E-Q) DC_5A_n260(G-I)	DC_5A_n260A
DC_5A-5A_n260A	DC_5A_n260A
DC_5A_n261A DC_5A_n261B DC_5A_n261C DC_5A_n261D DC_5A_n261E DC_5A_n261F DC_5A_n261G DC_5A_n261H DC_5A_n261I DC_5A_n261J DC_5A_n261K DC_5A_n261L DC_5A_n261M DC_5A_n261O DC_5A_n261P DC_5A_n261Q	DC_5A_n261A
DC_5A_n261(2A) DC_5A_n261(3A) DC_5A_n261(4A) DC_5A_n261(D-G) DC_5A_n261(D-H) DC_5A_n261(D-I) DC_5A_n261(D-O) DC_5A_n261(D-P) DC_5A_n261(D-Q) DC_5A_n261(E-O) DC_5A_n261(E-P) DC_5A_n261(E-Q)	DC_5A_n261A
DC_7A_n257A	DC_7A_n257A
DC_7A-7A_n257A	DC_7A_n257A
DC_7A_n258A	DC_7A_n258A
DC_8A_n257A	DC_8A_n257A
DC_8A_n258A	DC_8A_n258A
DC_11A_n257A	DC_11A_n257A
DC_12A_n260A DC_12A_n260G DC_12A_n260H DC_12A_n260I DC_12A_n260J DC_12A_n260K DC_12A_n260L DC_12A_n260M	DC_12A_n260A
DC_12A_n260(A-I) DC_12A_n260(G-I)	DC_12A_n260A
DC_13A_n257A	DC_13A_n257A
DC_13A_n260A	DC_13A_n260A

EN-DC configuration	Uplink EN-DC configuration (NOTE 1)
DC_18A_n257A	DC_18A_n257A
DC_19A_n257A DC_19A_n257D DC_19A_n257E DC_19A_n257F DC_19A_n257G DC_19A_n257H DC_19A_n257I	DC_19A_n257A DC_19A_n257G DC_19A_n257H DC_19A_n257I
DC_20A_n258A	DC_20A_n258A
DC_21A_n257A DC_21A_n257D DC_21A_n257E DC_21A_n257F DC_21A_n257G DC_21A_n257H DC_21A_n257I	DC_21A_n257A DC_21A_n257G DC_21A_n257H DC_21A_n257I
DC_26A_n257A	DC_26A_n257A
DC_28A_n257A DC_28A_n257D DC_28A_n257E DC_28A_n257F	DC_28A_n257A
DC_28A_n258A	DC_28A_n258A
DC_30A_n260A DC_30A_n260G DC_30A_n260H DC_30A_n260I DC_30A_n260J DC_30A_n260K DC_30A_n260L DC_30A_n260M	DC_30A_n260A
DC_30A_n260(A-I) DC_30A_n260(G-I)	DC_30A_n260A
DC_39A_n258A	DC_39A_n258A
DC_41A_n257A DC_41C_n257A	DC_41A_n257A DC_41C_n257A
DC_41A_n258A	DC_41A_n258A
DC_42A_n257A DC_42A_n257D DC_42A_n257E DC_42A_n257F DC_42C_n257A DC_42C_n257D DC_42C_n257E DC_42C_n257F DC_42D_n257A DC_42E_n257A	DC_42A_n257A DC_42C_n257A
DC_48A_n257A DC_48C_n257A	DC_48A_n257A DC_48C_n257A
DC_48A-48A_n257A	DC_48A_n257A
DC_48A_n260A DC_48C_n260A	DC_48A_n260A DC_48C_n260A
DC_48A-48A_n260A	DC_48A_n260A

EN-DC configuration	Uplink EN-DC configuration (NOTE 1)
DC_66A_n257A DC_66A_n257(2A) DC_66A_n257G DC_66A_n257H DC_66A_n257I DC_66A_n257J DC_66A_n257K DC_66A_n257L DC_66A_n257M DC_66C_n257A	DC_66A_n257A
DC_66A-66A_n257A	DC_66A_n257A
DC_66A_n260A DC_66A_n260D DC_66A_n260E DC_66A_n260F DC_66A_n260G DC_66A_n260H DC_66A_n260I DC_66A_n260J DC_66A_n260K DC_66A_n260L DC_66A_n260M DC_66A_n260O DC_66A_n260P DC_66A_n260Q	DC_66A_n260A
DC_66A_n260(2A) DC_66A_n260(3A) DC_66A_n260(4A) DC_66A_n260(A-I) DC_66A_n260(D-G) DC_66A_n260(D-H) DC_66A_n260(D-I) DC_66A_n260(D-O) DC_66A_n260(D-P) DC_66A_n260(D-Q) DC_66A_n260(E-O) DC_66A_n260(E-P) DC_66A_n260(E-Q) DC_66A_n260(G-I)	DC_66A_n260A
DC_66A-66A_n260A DC_66A-66A_n260G DC_66A-66A_n260H DC_66A-66A_n260I DC_66A-66A_n260J DC_66A-66A_n260K DC_66A-66A_n260L DC_66A-66A_n260M	DC_66A_n260A
DC_66A_n261A DC_66A_n261D DC_66A_n261E DC_66A_n261F DC_66A_n261G DC_66A_n261H DC_66A_n261I DC_66A_n261J DC_66A_n261K DC_66A_n261L DC_66A_n261M DC_66A_n261O DC_66A_n261P DC_66A_n261Q	DC_66A_n261A

EN-DC configuration	Uplink EN-DC configuration (NOTE 1)
DC_66A_n261(2A) DC_66A_n261(3A) DC_66A_n261(4A) DC_66A_n261(D-G) DC_66A_n261(D-H) DC_66A_n261(D-I) DC_66A_n261(D-O) DC_66A_n261(D-P) DC_66A_n261(D-Q) DC_66A_n261(E-O) DC_66A_n261(E-P) DC_66A_n261(E-Q)	DC_66A_n261A
NOTE 1: Uplink EN-DC configurations are the configurations supported by the present release of specifications. NOTE 2: Applicable for UE supporting inter-band EN-DC with mandatory simultaneous Rx/Tx capability for all of the above combinations	

5.5B.5.2 Inter-band EN-DC configurations including FR2 (three bands)

Table 5.5B.5.2-1: Inter-band EN-DC configurations including FR2 (three bands)

EN-DC configuration	Uplink EN-DC configuration (NOTE 1)
DC_1A-3A_n257A ² DC_1A-3A_n257D ² DC_1A-3A_n257E ² DC_1A-3A_n257F ² DC_1A-3A_n257G DC_1A-3A_n257H DC_1A-3A_n257I	DC_1A_n257A DC_1A_n257D DC_3A_n257A DC_3A_n257D DC_3A_n257G DC_3A_n257H DC_3A_n257I
DC_1A-5A_n257A ²	DC_1A_n257A DC_5A_n257A
DC_1A-7A_n257A ²	DC_1A_n257A DC_7A_n257A
DC_1A-7A-7A_n257A ²	DC_1A_n257A DC_7A_n257A
DC_1A-8A_n257A ²	DC_1A_n257A DC_8A_n257A
DC_1A-18A_n257A ²	DC_1A_n257A DC_18A_n257A
DC_1A-19A_n257A ² DC_1A-19A_n257D ² DC_1A-19A_n257E ² DC_1A-19A_n257F ² DC_1A-19A_n257G DC_1A-19A_n257H DC_1A-19A_n257I	DC_1A_n257A DC_1A_n257D DC_1A_n257G DC_1A_n257H DC_1A_n257I DC_19A_n257A DC_19A_n257D
DC_1A-21A_n257A ² DC_1A-21A_n257D ² DC_1A-21A_n257E ² DC_1A-21A_n257F ² DC_1A-21A_n257G DC_1A-21A_n257H DC_1A-21A_n257I	DC_1A_n257A DC_1A_n257G DC_1A_n257H DC_1A_n257I DC_21A_n257A DC_21A_n257G DC_21A_n257H DC_21A_n257I
DC_1A-28A_n257A ² DC_1A-28A_n257D ² DC_1A-28A_n257E ² DC_1A-28A_n257F ²	DC_1A_n257A DC_28A_n257A
DC_1A-41A_n257A DC_1A-41C_n257A	DC_1A_n257A DC_41A_n257A DC_41C_n257A
DC_1A-42A_n257A DC_1A-42A_n257D DC_1A-42A_n257E DC_1A-42A_n257F DC_1A-42A_n257G DC_1A-42A_n257H DC_1A-42A_n257I DC_1A-42C_n257A DC_1A-42C_n257D DC_1A-42C_n257E DC_1A-42C_n257F DC_1A-42D_n257A DC_1A-42D_n257G DC_1A-42D_n257H DC_1A-42D_n257I DC_1A-42E_n257A DC_1A-42E_n257G DC_1A-42E_n257H DC_1A-42E_n257I	DC_1A_n257A DC_1A_n257D DC_1A_n257G DC_1A_n257H DC_1A_n257I DC_42A_n257A DC_42A_n257D
DC_2A-5A_n257A ²	DC_2A_n257A DC_5A_n257A

EN-DC configuration	Uplink EN-DC configuration (NOTE 1)
DC_2A-5A_n260A DC_2A-5A_n260G DC_2A-5A_n260H DC_2A-5A_n260I DC_2A-5A_n260J DC_2A-5A_n260K DC_2A-5A_n260L DC_2A-5A_n260M	DC_2A_n260A DC_5A_n260A
DC_2A-12A_n260A DC_2A-12A_n260G DC_2A-12A_n260H DC_2A-12A_n260I DC_2A-12A_n260J DC_2A-12A_n260K DC_2A-12A_n260L DC_2A-12A_n260M	DC_2A_n260A DC_12A_n260A
DC_2A-13A_n257A ²	DC_2A_n257A DC_13A_n257A
DC_2A-13A_n260A ²	DC_2A_n260A DC_13A_n260A
DC_2A-30A_n260A DC_2A-30A_n260G DC_2A-30A_n260H DC_2A-30A_n260I DC_2A-30A_n260J DC_2A-30A_n260K DC_2A-30A_n260L DC_2A-30A_n260M	DC_2A_n260A DC_30A_n260A
DC_2A-66A_n257A ²	DC_2A_n257A DC_66A_n257A
DC_2A-66A_n260A DC_2A-66A_n260G DC_2A-66A_n260H DC_2A-66A_n260I DC_2A-66A_n260J DC_2A-66A_n260K DC_2A-66A_n260L DC_2A-66A_n260M	DC_2A_n260A DC_66A_n260A
DC_3A-5A_n257A ²	DC_3A_n257A DC_5A_n257A
DC_3A-7A_n257A ²	DC_3A_n257A DC_7A_n257A
DC_3A-7A-7A_n257A ²	DC_3A_n257A DC_7A_n257A
DC_3A-19A_n257A ² DC_3A-19A_n257D ² DC_3A-19A_n257E ² DC_3A-19A_n257F ² DC_3A-19A_n257G DC_3A-19A_n257H DC_3A-19A_n257I	DC_3A_n257A DC_3A_n257D DC_3A_n257G DC_3A_n257H DC_3A_n257I DC_19A_n257A DC_19A_n257D
DC_3A-21A_n257A ² DC_3A-21A_n257D ² DC_3A-21A_n257E ² DC_3A-21A_n257F ² DC_3A-21A_n257G DC_3A-21A_n257H DC_3A-21A_n257I	DC_3A_n257A DC_3A_n257D DC_3A_n257G DC_3A_n257H DC_3A_n257I DC_21A_n257A DC_21A_n257D
DC_3A-28A_n257A ² DC_3A-28A_n257D ² DC_3A-28A_n257E ² DC_3A-28A_n257F ²	DC_3A_n257A DC_28A_n257A

EN-DC configuration	Uplink EN-DC configuration (NOTE 1)
DC_3A-41A_n257A	DC_3A_n257A DC_41A_n257A
DC_3A-42A_n257A ² DC_3A-42A_n257D ² DC_3A-42A_n257E ² DC_3A-42A_n257F ² DC_3A-42A_n257G DC_3A-42A_n257H DC_3A-42A_n257I DC_3A-42C_n257A ² DC_3A-42C_n257D ² DC_3A-42C_n257E ² DC_3A-42C_n257F ² DC_3A-42C_n257G DC_3A-42C_n257H DC_3A-42C_n257I DC_3A-42D_n257A ² DC_3A-42D_n257G DC_3A-42D_n257H DC_3A-42D_n257I DC_3A-42E_n257A ² DC_3A-42E_n257G DC_3A-42E_n257H DC_3A-42E_n257I	DC_3A_n257A DC_3A_n257D DC_3A_n257G DC_3A_n257H DC_3A_n257I DC_42A_n257A DC_42A_n257D
DC_5A-7A_n257A ²	DC_5A_n257A DC_7A_n257A
DC_5A-7A-7A_n257A	DC_5A_n257A DC_7A_n257A
DC_5A-30A_n260A DC_5A-30A_n260G DC_5A-30A_n260H DC_5A-30A_n260I DC_5A-30A_n260J DC_5A-30A_n260K DC_5A-30A_n260L DC_5A-30A_n260M	DC_5A_n260A DC_30A_n260A
DC_5A-66A_n257A	DC_5A_n257A DC_66A_n257A
DC_5A-66A_n260A DC_5A-66A_n260G DC_5A-66A_n260H DC_5A-66A_n260I DC_5A-66A_n260J DC_5A-66A_n260K DC_5A-66A_n260L DC_5A-66A_n260M	DC_5A_n260A DC_66A_n260A
DC_12A-30A_n260A DC_12A-30A_n260G DC_12A-30A_n260H DC_12A-30A_n260I DC_12A-30A_n260J DC_12A-30A_n260K DC_12A-30A_n260L DC_12A-30A_n260M	DC_12A_n260A DC_30A_n260A
DC_12A-66A_n260A DC_12A-66A_n260G DC_12A-66A_n260H DC_12A-66A_n260I DC_12A-66A_n260J DC_12A-66A_n260K DC_12A-66A_n260L DC_12A-66A_n260M	DC_12A_n260A DC_66A_n260A
DC_13A-66A_n257A ²	DC_13A_n257A DC_66A_n257A

EN-DC configuration	Uplink EN-DC configuration (NOTE 1)
DC_13A-66A_n260A ²	DC_13A_n260A DC_66A_n260A
DC_18A-28A_n257A ²	DC_18A_n257A DC_28A_n257A
DC_19A-21A_n257A ² DC_19A-21A_n257D ² DC_19A-21A_n257E ² DC_19A-21A_n257F ² DC_19A-21A_n257G DC_19A-21A_n257H DC_19A-21A_n257I	DC_19A_n257A DC_19A_n257D DC_21A_n257A DC_21A_n257D DC_21A_n257G
DC_19A-42A_n257A ² DC_19A-42A_n257D ² DC_19A-42A_n257E ² DC_19A-42A_n257F ² DC_19A-42A_n257G ² DC_19A-42A_n257H ² DC_19A-42A_n257I ² DC_19A-42C_n257A ² DC_19A-42C_n257G ² DC_19A-42C_n257H ² DC_19A-42C_n257I ²	DC_19A_n257A DC_19A_n257D DC_19A_n257G DC_19A_n257H DC_19A_n257I DC_42A_n257A DC_42A_n257D DC_42A_n257G DC_42A_n257H DC_42A_n257I
DC_21A-28A_n257A ² DC_21A-28A_n257D ² DC_21A-28A_n257E ² DC_21A-28A_n257F ²	DC_21A_n257A DC_28A_n257A
DC_21A-42A_n257A ² DC_21A-42A_n257D ² DC_21A-42A_n257E ² DC_21A-42A_n257F ² DC_21A-42A_n257G DC_21A-42A_n257H DC_21A-42A_n257I DC_21A-42C_n257A ² DC_21A-42C_n257G DC_21A-42C_n257H DC_21A-42C_n257I	DC_21A_n257A DC_21A_n257D DC_21A_n257G DC_21A_n257H DC_21A_n257I DC_42A_n257A DC_42A_n257D
DC_28A-42C_n257A ² DC_28A-42A_n257A ²	DC_28A_n257A DC_42A_n257A
DC_30A-66A_n260A DC_30A-66A_n260G DC_30A-66A_n260H DC_30A-66A_n260I DC_30A-66A_n260J DC_30A-66A_n260K DC_30A-66A_n260L DC_30A-66A_n260M	DC_30A_n260A DC_66A_n260A
DC_41A-42A_n257A DC_41A-42C_n257A DC_41C-42A_n257A DC_41C-42C_n257A	DC_41A_n257A DC_42A_n257A
NOTE 1: Uplink EN-DC configurations are the configurations supported by the present release of specifications.	
NOTE 2: Applicable for UE supporting inter-band EN-DC with mandatory simultaneous Rx/Tx capability	

5.5B.5.3 Inter-band EN-DC configurations including FR2 (four bands)

Table 5.5B.5.3-1: Inter-band EN-DC configurations including FR2 (four bands)

EN-DC configuration	Uplink EN-DC configuration (NOTE 1)
DC_1A-3A-5A_n257A ²	DC_1A_n257A DC_3A_n257A DC_5A_n257A
DC_1A-3A-7A_n257A ²	DC_1A_n257A DC_3A_n257A DC_7A_n257A
DC_1A-3A-7A-7A_n257A	DC_1A_n257A DC_3A_n257A DC_7A_n257A
DC_1A-3A-19A_n257A ² DC_1A-3A-19A_n257G DC_1A-3A-19A_n257H DC_1A-3A-19A_n257I	DC_1A_n257A DC_3A_n257A DC_3A_n257G DC_3A_n257H DC_3A_n257I DC_19A_n257A
DC_1A-3A-21A_n257A ² DC_1A-3A-21A_n257G DC_1A-3A-21A_n257H DC_1A-3A-21A_n257I	DC_1A_n257A DC_3A_n257A DC_3A_n257G DC_3A_n257H DC_3A_n257I DC_21A_n257A
DC_1A-3A-28A_n257A ²	DC_1A_n257A DC_3A_n257A DC_28A_n257A
DC_1A-3A-42A_n257A DC_1A-3A-42A_n257G DC_1A-3A-42A_n257H DC_1A-3A-42A_n257I DC_1A-3A-42C_n257A DC_1A-3A-42C_n257D DC_1A-3A-42C_n257E DC_1A-3A-42C_n257F DC_1A-3A-42C_n257G DC_1A-3A-42C_n257H DC_1A-3A-42C_n257I DC_1A-3A-42D_n257G DC_1A-3A-42D_n257H DC_1A-3A-42D_n257I	DC_1A_n257A DC_1A_n257G DC_1A_n257H DC_1A_n257I DC_3A_n257ADC_3A_n257G DC_3A_n257H DC_3A_n257I
DC_1A-5A-7A_n257A ²	DC_1A_n257A DC_5A_n257A DC_7A_n257A
DC_1A-5A-7A-7A_n257A	DC_1A_n257A DC_5A_n257A DC_7A_n257A
DC_1A-18A-28A_n257A ²	DC_1A_n257A DC_18A_n257A DC_28A_n257A
DC_1A-19A-21A_n257A DC_1A-19A-21A_n257D DC_1A-19A-21A_n257E DC_1A-19A-21A_n257F DC_1A-19A-21A_n257G DC_1A-19A-21A_n257H DC_1A-19A-21A_n257I	DC_1A_n257A DC_1A_n257G DC_1A_n257H DC_1A_n257I DC_19A_n257A DC_21A_n257A DC_21A_n257G DC_21A_n257H DC_21A_n257I

EN-DC configuration	Uplink EN-DC configuration (NOTE 1)
DC_1A-19A-42A_n257A DC_1A-19A-42A_n257G DC_1A-19A-42A_n257H DC_1A-19A-42A_n257I DC_1A-19A-42C_n257A DC_1A-19A-42C_n257D DC_1A-19A-42C_n257E DC_1A-19A-42C_n257F DC_1A-19A-42C_n257G DC_1A-19A-42C_n257H DC_1A-19A-42C_n257I	DC_1A_n257A DC_1A_n257G DC_1A_n257H DC_1A_n257I DC_19A_n257A DC_42A_n257A
DC_1A-21A-28A_n257A ²	DC_1A_n257A DC_21A_n257A DC_28A_n257A
DC_1A-21A-42A_n257A DC_1A-21A-42A_n257G DC_1A-21A-42A_n257H DC_1A-21A-42A_n257I DC_1A-21A-42C_n257A DC_1A-21A-42C_n257D DC_1A-21A-42C_n257E DC_1A-21A-42C_n257F DC_1A-21A-42C_n257G DC_1A-21A-42C_n257H DC_1A-21A-42C_n257I	DC_1A_n257A DC_1A_n257G DC_1A_n257H DC_1A_n257I DC_21A_n257A DC_21A_n257G DC_21A_n257H DC_21A_n257I DC_42A_n257A DC_42A_n257D
DC_1A-28A-42A_n257A DC_1A-28A-42C_n257A	DC_1A_n257A DC_28A_n257A DC_42A_n257A
DC_1A-41A-42A_n257A DC_1A-41A-42C_n257A DC_1A-41C-42A_n257A DC_1A-41C-42C_n257A	DC_1A_n257A DC_41A_n257A DC_42A_n257A
DC_3A-5A-7A_n257A ²	DC_3A_n257A DC_5A_n257A DC_7A_n257A
DC_3A-5A-7A-7A_n257A ²	DC_3A_n257A DC_5A_n257A DC_7A_n257A
DC_3A-19A-21A_n257A ²	DC_3A_n257A DC_19A_n257A DC_21A_n257A
DC_3A-19A-42A_n257A DC_3A-19A-42A_n257G DC_3A-19A-42A_n257H DC_3A-19A-42A_n257I DC_3A-19A-42C_n257A DC_3A-19A-42C_n257D DC_3A-19A-42C_n257E DC_3A-19A-42C_n257F DC_3A-19A-42C_n257G DC_3A-19A-42C_n257H DC_3A-19A-42C_n257I	DC_3A_n257A DC_3A_n257D DC_3A_n257G DC_3A_n257H DC_3A_n257I DC_19A_n257A DC_19A_n257D DC_19A_n257G DC_19A_n257H DC_19A_n257I DC_42A_n257A DC_42A_n257D DC_42A_n257G DC_42A_n257H DC_42A_n257I

EN-DC configuration	Uplink EN-DC configuration (NOTE 1)
DC_3A-21A-42A_n257A DC_3A-21A-42A_n257G DC_3A-21A-42A_n257H DC_3A-21A-42A_n257I DC_3A-21A-42C_n257A DC_3A-21A-42C_n257D DC_3A-21A-42C_n257E DC_3A-21A-42C_n257F DC_3A-21A-42C_n257G DC_3A-21A-42C_n257H DC_3A-21A-42C_n257I	DC_3A_n257A DC_3A_n257D DC_3A_n257G DC_3A_n257H DC_3A_n257I DC_21A_n257A DC_21A_n257D DC_21A_n257G DC_21A_n257H DC_21A_n257I DC_42A_n257A DC_42A_n257D DC_42A_n257G DC_42A_n257H DC_42A_n257I
DC_3A-28A-42A_n257A DC_3A-28A-42C_n257A	DC_3A_n257A DC_28A_n257A DC_42A_n257A
DC_19A-21A-42A_n257A ² DC_19A-21A-42A_n257G ² DC_19A-21A-42A_n257H ² DC_19A-21A-42A_n257I ² DC_19A-21A-42C_n257A ² DC_19A-21A-42C_n257D ² DC_19A-21A-42C_n257E ² DC_19A-21A-42C_n257F ² DC_19A-21A-42C_n257G ² DC_19A-21A-42C_n257H ² DC_19A-21A-42C_n257I ²	DC_19A_n257A DC_19A_n257D DC_19A_n257G DC_19A_n257H DC_19A_n257I DC_21A_n257A DC_21A_n257D DC_21A_n257G DC_21A_n257H DC_21A_n257I DC_42A_n257A DC_42A_n257D DC_42A_n257G DC_42A_n257H DC_42A_n257I
DC_21A-28A-42A_n257A ² DC_21A-28A-42C_n257A ²	DC_21A_n257A DC_28A_n257A DC_42A_n257A
NOTE 1: Uplink EN-DC configurations are the configurations supported by the present release of specifications. NOTE 2: Applicable for UE supporting inter-band EN-DC with mandatory simultaneous Rx/Tx capability	

5.5B.5.4 Inter-band EN-DC configurations including FR2 (five bands)

Table 5.5B.5.4-1: Inter-band EN-DC configurations including FR2 (five bands)

EN-DC configuration	Uplink EN-DC configuration (NOTE 1)
DC_1A-3A-5A-7A_n257A	DC_1A_n257A DC_3A_n257A DC_5A_n257A DC_7A_n257A
DC_1A-3A-5A-7A-7A_n257A	DC_1A_n257A DC_3A_n257A DC_5A_n257A DC_7A_n257A
DC_1A-3A-19A-21A_n257A DC_1A-3A-19A-21A_n257D DC_1A-3A-19A-21A_n257E DC_1A-3A-19A-21A_n257F	DC_1A_n257A DC_3A_n257A DC_19A_n257A DC_21A_n257A
DC_1A-3A-19A-42A_n257A DC_1A-3A-19A-42A_n257D DC_1A-3A-19A-42A_n257E DC_1A-3A-19A-42A_n257F DC_1A-3A-19A-42A_n257G DC_1A-3A-19A-42A_n257H DC_1A-3A-19A-42A_n257I DC_1A-3A-19A-42C_n257A DC_1A-3A-19A-42C_n257D DC_1A-3A-19A-42C_n257E DC_1A-3A-19A-42C_n257F DC_1A-3A-19A-42C_n257G DC_1A-3A-19A-42C_n257H DC_1A-3A-19A-42C_n257I	DC_1A_n257A DC_3A_n257A DC_3A_n257G DC_3A_n257H DC_3A_n257I DC_19A_n257A DC_42A_n257A
DC_1A-3A-21A-42A_n257A DC_1A-3A-21A-42C_n257A DC_1A-3A-21A-42C_n257D DC_1A-3A-21A-42C_n257E DC_1A-3A-21A-42C_n257F DC_1A-3A-21A-42C_n257G DC_1A-3A-21A-42C_n257H DC_1A-3A-21A-42C_n257I	DC_1A_n257A DC_3A_n257A DC_3A_n257G DC_3A_n257H DC_3A_n257I DC_3A_n257J DC_21A_n257A DC_42A_n257A
DC_1A-3A-28A-42A_n257A DC_1A-3A-28A-42C_n257A	DC_1A_n257A DC_3A_n257A DC_28A_n257A DC_42A_n257A
DC_1A-19A-21A-42A_n257A DC_1A-19A-21A-42A_n257D DC_1A-19A-21A-42A_n257E DC_1A-19A-21A-42A_n257F DC_1A-19A-21A-42A_n257G DC_1A-19A-21A-42A_n257H DC_1A-19A-21A-42A_n257I DC_1A-19A-21A-42C_n257A DC_1A-19A-21A-42C_n257D DC_1A-19A-21A-42C_n257E DC_1A-19A-21A-42C_n257F DC_1A-19A-21A-42C_n257G DC_1A-19A-21A-42C_n257H DC_1A-19A-21A-42C_n257I	DC_1A_n257A DC_1A_n257G DC_1A_n257H DC_1A_n257I DC_19A_n257A DC_21A_n257A DC_21A_n257G DC_21A_n257H DC_21A_n257I DC_42A_n257A
DC_1A-19A-28A-42C_n257A	DC_1A_n257A DC_19A_n257A DC_28A_n257A DC_42A_n257A
DC_1A-21A-28A-42A_n257A	DC_1A_n257A DC_21A_n257A DC_28A_n257A DC_42A_n257A

NOTE 1: Uplink EN-DC configurations are the configurations supported by the present release of specifications.

5.5B.5.5 Void

5.5B.6 Inter-band EN-DC including FR1 and FR2

Supported channel bandwidths for E-UTRA operating bands and CA configurations are defined in TS 36.521-1 [10] and for NR operating bands and CA configurations in TS 38.521-1 [8], TS 38.521-2 [9] and present document.

5.5B.6.1 Void

5.5B.6.2 Inter-band EN-DC configurations including FR1 and FR2 (three bands)

Table 5.5B.6.2-1: Inter-band EN-DC configurations including FR1 and FR2_(three bands)

EN-DC configuration	Uplink EN-DC configuration (NOTE 1)
DC_1A_n77A-n257A DC_1A_n77A-n257D DC_1A_n77A-n257E DC_1A_n77A-n257F DC_1A_n77C-n257A DC_1A_n77C-n257D DC_1A_n77C-n257E DC_1A_n77C-n257F	DC_1A_n77A DC_1A_n257A DC_1A_n77A-n257A
DC_1A_n78A-n257A DC_1A_n78A-n257D DC_1A_n78A-n257E DC_1A_n78A-n257F DC_1A_n78C-n257A DC_1A_n78C-n257D DC_1A_n78C-n257E DC_1A_n78C-n257F	DC_1A_n78A DC_1A_n257A DC_1A_n78A-n257A
DC_1A_n79A-n257A DC_1A_n79A-n257D DC_1A_n79A-n257E DC_1A_n79A-n257F DC_1A_n79C-n257A DC_1A_n79C-n257D DC_1A_n79C-n257E DC_1A_n79C-n257F	DC_1A_n79A DC_1A_n257A DC_1A_n79A-n257A
DC_3A_n77A-n257A DC_3A_n77A-n257D DC_3A_n77A-n257E DC_3A_n77A-n257F DC_3A_n77C-n257A DC_3A_n77C-n257D DC_3A_n77C-n257E DC_3A_n77C-n257F	DC_3A_n77A DC_3A_n257A DC_3A_n77A-n257A
DC_3A_n78A-n257A DC_3A_n78A-n257D DC_3A_n78A-n257E DC_3A_n78A-n257F DC_3A_n78C-n257A DC_3A_n78C-n257D DC_3A_n78C-n257E DC_3A_n78C-n257F	DC_3A_n78A DC_3A_n257A DC_3A_n78A-n257A
DC_3A_n79A-n257A DC_3A_n79A-n257D DC_3A_n79A-n257E DC_3A_n79A-n257F DC_3A_n79C-n257A DC_3A_n79C-n257D DC_3A_n79C-n257E DC_3A_n79C-n257F	DC_3A_n79A DC_3A_n257A DC_3A_n79A-n257A
DC_5A_n78A-n257A ²	DC_5A_n78A DC_5A_n257A
DC_7A_n78A-n257A	DC_7A_n78A DC_7A_n257A
DC_7A-7A_n78A-n257A	DC_7A_n78A DC_7A_n257A DC_7A_n78A-n257A
DC_19A_n77A-n257A DC_19A_n77A-n257D DC_19A_n77A-n257E DC_19A_n77A-n257F DC_19A_n77C-n257A DC_19A_n77C-n257D DC_19A_n77C-n257E DC_19A_n77C-n257F	DC_19A_n77A DC_19A_n257A DC_19A_n77A-n257A

EN-DC configuration	Uplink EN-DC configuration (NOTE 1)
DC_19A_n78A-n257A DC_19A_n78A-n257D DC_19A_n78A-n257E DC_19A_n78A-n257F DC_19A_n78C-n257A DC_19A_n78C-n257D DC_19A_n78C-n257E DC_19A_n78C-n257F	DC_19A_n78A DC_19A_n257A DC_19A_n78A-n257A
DC_19A_n79A-n257A DC_19A_n79A-n257D DC_19A_n79A-n257E DC_19A_n79A-n257F DC_19A_n79C-n257A DC_19A_n79C-n257D DC_19A_n79C-n257E DC_19A_n79C-n257F	DC_19A_n79A DC_19A_n257A DC_19A_n79A-n257A
DC_21A_n77A-n257A	DC_21A_n77A DC_21A_n257A
DC_21A_n78A-n257A	DC_21A_n78A DC_21A_n257A
DC_21A_n79A-n257A	DC_21A_n79A DC_21A_n257A
NOTE 1: Uplink EN-DC configurations are the configurations supported by the present release of specifications. NOTE 2: Applicable for UE supporting inter-band EN-DC with mandatory simultaneous Rx/Tx capability	

5.5B.6.3 Inter-band EN-DC configurations including FR1 and FR2 (four bands)

Table 5.5B.6.3-1: Inter-band EN-DC configurations including FR1 and FR2 (four bands)

EN-DC configuration	Uplink EN-DC configuration (NOTE 1)
DC_1A-3A_n78A-n257A DC_1A-3A_n78A-n257G DC_1A-3A_n78A-n257H DC_1A-3A_n78A-n257I	DC_1A_n78A DC_1A_n257A DC_1A_n257D DC_1A_n257G DC_1A_n257H DC_1A_n257I DC_3A_n78A DC_3A_n257A DC_3A_n257D DC_3A_n257G DC_3A_n257H DC_3A_n257I
DC_1A-5A_n78A-n257A	DC_1A_n78A DC_1A_n257A DC_5A_n78A DC_5A_n257A
DC_1A-7A_n78A-n257A	DC_1A_n78A DC_1A_n257A DC_7A_n78A DC_7A_n257A
DC_1A-7A-7A_n78A-n257A	DC_1A_n78A DC_1A_n257A DC_7A_n78A DC_7A_n257A
DC_3A-5A_n78A-n257A	DC_3A_n78A DC_3A_n257A DC_5A_n78A DC_5A_n257A
DC_3A-7A_n78A-n257A	DC_3A_n78A DC_3A_n257A DC_7A_n78A DC_7A_n257A
DC_3A-7A-7A_n78A-n257A	DC_3A_n78A DC_3A_n257A DC_7A_n78A DC_7A_n257A
DC_5A-7A_n78A-n257A	DC_5A_n78A DC_5A_n257A DC_7A_n78A DC_7A_n257A
DC_5A-7A-7A_n78A-n257A	DC_5A_n78A DC_5A_n257A DC_7A_n78A DC_7A_n257A
NOTE 1: Uplink EN-DC configurations are the configurations supported by the present release of specifications.	

5.5B.6.4 Inter-band EN-DC configurations including FR1 and FR2 (five bands)

Table 5.5B.6.4-1: Inter-band EN-DC configurations including FR1 and FR2 (five bands)

EN-DC configuration	Uplink EN-DC configuration (NOTE 1)
DC_1A-3A-5A_n78A-n257A	DC_1A_n78A DC_1A_n257A DC_3A_n78A DC_3A_n257A DC_5A_n78A DC_5A_n257A
DC_1A-3A-7A_n78A-n257A	DC_1A_n78A DC_1A_n257A DC_3A_n78A DC_3A_n257A DC_7A_n78A DC_7A_n257A
DC_1A-3A-7A-7A_n78A-n257A	DC_1A_n78A DC_1A_n257A DC_3A_n78A DC_3A_n257A DC_7A_n78A DC_7A_n257A
DC_1A-5A-7A_n78A-n257A	DC_1A_n78A DC_1A_n257A DC_5A_n78A DC_5A_n257A DC_7A_n78A DC_7A_n257A
DC_1A-5A-7A-7A_n78A-n257A	DC_1A_n78A DC_1A_n257A DC_5A_n78A DC_5A_n257A DC_7A_n78A DC_7A_n257A
DC_3A-5A-7A_n78A-n257A	DC_3A_n78A DC_3A_n257A DC_5A_n78A DC_5A_n257A DC_7A_n78A DC_7A_n257A
DC_3A-5A-7A-7A_n78A-n257A	DC_3A_n78A DC_3A_n257A DC_5A_n78A DC_5A_n257A DC_7A_n78A DC_7A_n257A

NOTE 1: Uplink EN-DC configurations are the configurations supported by the present release of specifications.

5.5B.6.5 Inter-band EN-DC configurations including FR1 and FR2 (six bands)

Table 5.5B.6.5-1: Inter-band EN-DC configurations including FR1 and FR2 (six bands)

EN-DC configuration	Uplink EN-DC configuration (NOTE 1)
DC_1A-3A-5A-7A_n78A-n257A	DC_1A_n78A DC_1A_n257A DC_3A_n78A DC_3A_n257A DC_5A_n78A DC_5A_n257A DC_7A_n78A DC_7A_n257A
NOTE 1: Uplink EN-DC configurations are the configurations supported by the present release of specifications.	

5.5B.7 Inter-band NR-DC between FR1 and FR2

Supported channel bandwidths for E-UTRA operating bands and CA configurations are defined in TS 36.521-1 [10] and for NR operating bands and CA configurations in TS 38.521-1 [8], TS 38.521-2 [9] and present document.

5.5B.7.1 Inter-band NR-DC configurations between FR1 and FR2 (two bands)

Table 5.5B.7-1: Inter-band NR-DC configurations between FR1 and FR2 (two bands)

Downlink NR-DC configuration	Uplink NR-DC configuration
DC_n77A-n257A DC_n77A-n257D DC_n77A-n257E DC_n77A-n257F DC_n77A-n257G DC_n77A-n257H DC_n77A-n257I DC_n77A-n257J DC_n77A-n257K DC_n77A-n257L DC_n77A-n257M DC_n77C-n257A DC_n77C-n257D DC_n77C-n257E DC_n77C-n257F	DC_n77A-n257A
DC_n78A-n257A DC_n78A-n257D DC_n78A-n257E DC_n78A-n257F DC_n78A-n257G DC_n78A-n257H DC_n78A-n257I DC_n78A-n257J DC_n78A-n257K DC_n78A-n257L DC_n78A-n257M DC_n78C-n257A DC_n78C-n257D DC_n78C-n257E DC_n78C-n257F	DC_n78A-n257A
DC_n79A-n257A DC_n79A-n257D DC_n79A-n257E DC_n79A-n257F DC_n79A-n257G DC_n79A-n257H DC_n79A-n257I DC_n79A-n257J DC_n79A-n257K DC_n79A-n257L DC_n79A-n257M DC_n79C-n257A DC_n79C-n257D DC_n79C-n257E DC_n79C-n257F	DC_n79A-n257A
NOTE 1: NR configuration for FR1 and FR2 are defined in TS 38.521-1 [8] and TS 38.521-2 [9] respectively.	

5.5E Configuration for V2X operation

5.5E.1 General

The operating bands and bandwidth classes are specified for V2X operation.

5.5E.2 Intra-band contiguous V2X operation in FR1

Table 5.5E.2-1: Intra-band contiguous V2X configurations

V2X configuration	SL transmission
V2X_(n)47AA	E-UTRA Band 47 or NR band n47
NOTE 1: Only single switched SL is supported.	

5.5E.3 Intra-band non-contiguous V2X operation in FR1

Table 5.5E.3-1: Intra-band non-contiguous V2X configurations

V2X configuration	SL transmission
V2X_47A_n47A	E-UTRA Band 47 or NR band n47
NOTE 1: Only single switched SL is supported.	

5.5E.4 Inter-band V2X operation in FR1

5.5E.4.1 Inter-band V2X configurations within FR1 (two bands)

Table 5.5E.4.1-1: Inter-band V2X configurations

V2X configuration	V2X transmission configuration
V2X_20A_n38A	V2X_20A_n38A
V2X_n71A_47A	V2X_n71A_47A
NOTE 1: V2X transmission configurations are the configurations supported by the present release of specifications.	

6 Transmitter characteristics

6.1 General

Editor's note: Test configurations/environments that require new spherical scan shall be included in test procedure clause and identifying such scenarios is currently FFS and owned by RAN5.

Unless otherwise stated the transmitter, characteristics are specified at the antenna connector(s) of the UE for the bands operating on frequency range 1 and over the air of the UE for the bands operating on frequency range 2. The requirements for frequency range 1 and frequency range 2 can be verified separately. For the carrier in frequency range 1, requirements can be verified with NR FR2 link disabled. For the carrier in frequency range 2, requirements can be verified in OTA mode with E-UTRA connecting to the network by OTA without calibration.

For NR FR2 Tx test cases the identified beam peak direction can be stored and reused for a device under test in various configurations/environments for the full duration of device testing as long as beam peak direction is the same.

Unless otherwise stated, requirements for NR transmitter written in TS 38.521-1 [8] and TS 38.521-2 [9] apply and are assumed anchor agnostic. Requirements are verified under conditions where anchor resources do not interfere NR operation. For Rel-15, unless otherwise stated, if UE indicates IE `maxNumberSRS-Ports-PerResource = n2` in NR standalone operation mode, the said UE shall meet the NR requirements for either power class 2 or power class 3 in EN-DC within FR1 if UE indicates IE `maxNumberSRS-Ports-PerResource = n1` for EN-DC on this NR band. For Rel-16 and forward, if UE indicates IE `powerClassNRPart-r16` as defined in TS 38.331 [18] in EN-DC, UE shall meet NR requirements according to this power class.

Unless otherwise stated, Channel Bandwidth shall be prioritized in the selecting of test points. Subcarrier spacing shall be selected after Test Channel Bandwidth is selected.

For conformance testing involving FR2 test cases in this specification, the UE under test shall be pre-configured with UL Tx diversity schemes disabled to account for single polarization System Simulator (SS) in the test environment. The UE under test may transmit with dual polarization.

Uplink RB allocations for E-UTRA carrier given in Table 6.1-1 are used throughout this clause, unless otherwise stated by the test case.

Table 6.1-1: Common uplink configuration for E-UTRA carrier

Channel Bandwidth	RB allocation			
	Full_Allocation	Partial_Allocation	1RB_Left	1RB_Right
1.4MHz	6@0	5@0	1@0	1@5
3MHz	15@0	4@0	1@0	1@14
5MHz	25@0	8@0	1@0	1@24
10MHz	50@0	12@0	1@0	1@49
15MHz	75@0	16@0	1@0	1@74
20MHz	100@0	18@0	1@0	1@99
NOTE: Partial_Allocation corresponds to the test points with 0dB $MPR_{single,E-UTRA}$ for QPSK modulation type included in TS 36.521-1 Table 6.2.2.4.1-1.				

6.2 Transmitter power

6.2A Transmitter power for CA without EN-DC

6.2A.1 UE maximum output power for CA

6.2A.1.1 UE maximum output power for inter-band NR CA between FR 1 and FR 2 without EN-DC

6.2A.1.1.1 Test purpose

Same test purpose as in clause 6.2.1 in TS 38.521-1 [8] for NR FR1 carrier(s) and clause 6.2.1 in TS 38.521-2 [9] for NR FR2 carrier(s).

6.2A.1.1.2 Test applicability

The requirements in this test are not testable due to issues with combined testing of NR FR1 conducted mode with NR FR2 in radiated mode. Therefore, the conducted and radiated requirements are tested separately.

No test case details are specified. The SA requirements for maximum output power apply and are tested in TS 38.521-1 [8] clauses 6.2 and 6.2A and TS 38.521-2 [9] clauses 6.2 and 6.2A

6.2A.2 UE maximum output power reduction for CA

6.2A.2.1 UE maximum output power reduction for inter-band NR CA between FR 1 and FR 2 without EN-DC

6.2A.2.1.1 Test purpose

Same test purpose as in clause 6.2.2 in TS 38.521-1 [8] for NR FR1 carrier(s) and clause 6.2.2 in TS 38.521-2 [9] for NR FR2 carrier(s).

6.2A.2.1.2 Test applicability

The requirements in this test are not testable due to issues with combined testing of NR FR1 conducted mode with NR FR2 in radiated mode. Therefore, the conducted and radiated requirements are tested separately.

No test case details are specified. The SA requirements for additional spectrum emissions mask apply and are tested in TS 38.521-1 [8] clauses 6.2 and 6.2A and TS 38.521-2 [9] clauses 6.2 and 6.2A

6.2A.3 UE additional maximum output power reduction for CA

6.2A.3.1 UE additional maximum output power reduction for inter-band NR CA between FR 1 and FR 2 without EN-DC

6.2A.3.1.1 Test purpose

Same test purpose as in clause 6.2.3.1 in TS 38.521-1 [8] for NR FR1 carrier and clause 6.2.3.1 in TS 38.521-2 [9] for NR FR2 carrier.

6.2A.3.1.2 Test applicability

The requirements in this test are not testable due to issues with combined testing of NR FR1 and E-UTRA in conducted mode with NR FR2 in radiated mode. Therefore, the conducted and radiated requirements are tested separately.

No test case details are specified. The single carrier requirements for Additional Maximum Output Power apply and are tested as part of clause 6.2.3 in TS 38.521-1 [8] for NR FR1 carrier and clause 6.2.3 in TS 38.521-2 [9] for NR FR2 carrier.

6.2A.4 Configured output power level for CA

6.2A.4.1 Configured output power level for inter-band NR CA between FR 1 and FR 2 without EN-DC

6.2A.4.1.1 Test purpose

Same test purpose as in clause 6.2.4 in TS 38.521-1 [8] for NR FR1 carrier(s) and clause 6.2.4 in TS 38.521-2 [9] for NR FR2 carrier(s).

6.2A.4.1.2 Test applicability

The requirements in this test are not testable due to issues with combined testing of NR FR1 conducted mode with NR FR2 in radiated mode. Therefore, the conducted and radiated requirements are tested separately.

No test case details are specified. The SA requirements for configured output power level apply and are tested in TS 38.521-1 [8] clauses 6.2 and 6.2A and TS 38.521-2 [9] clauses 6.2 and 6.2A.

6.2A.4.2 $\Delta T_{IB,c}$ for CA

6.2A.4.2.1 $\Delta T_{IB,c}$ for inter-band CA between FR 1 and FR 2

For the UE which supports inter-band NR CA configuration, $\Delta T_{IB,c}$ in Table 6.2A.4.2.1-1 applies. Unless otherwise stated, $\Delta T_{IB,c}$ is set to zero.

Table 6.2A.4.2.1-1: Void

6.2B Transmitter power for DC

6.2B.1 UE Maximum Output Power for DC

6.2B.1.1 UE Maximum Output Power for Intra-Band Contiguous EN-DC

Editor's note:

- For overlapping transmission there is no test point satisfying 0dB MPR according to RAN4 specification.
- Test requirements for Power Class 2 of Rel-15 is FFS due to ongoing RAN4 discussion on minimum requirement

6.2B.1.1.1 Test purpose

To verify that the error of the UE maximum output power does not exceed the range prescribed by the specified nominal maximum output power and tolerance.

An excess maximum output power has the possibility to interfere to other channels or other systems. A small maximum output power decreases the coverage area.

6.2B.1.1.2 Test applicability

This test applies to all types of E-UTRA UE release 15 and forward, supporting intra-band contiguous EN-DC operation on FR1.

6.2B.1.1.3 Minimum conformance requirements

The following UE Power Classes define the total maximum output power for any transmission bandwidth(s) of the CG(s) configured.

The maximum output power is measured as the total maximum output power across the UE antenna connector(s). The period of measurement shall be at least one sub frame.

Table 6.2B.1.1.3-1: Maximum output power for EN-DC (continuous sub-blocks)

DC configuration	Power class 2 (dBm)	Tolerance (dB)	Power class 3 (dBm)	Tolerance (dB)
EN-DC_(n)71AA			23	+2/-3
DC_(n)41AA	26	+2/-2 ¹	23	+2/-2 ¹
NOTE 1: If all transmitted resource blocks over all component carriers are confined within F_{UL_low} and $F_{UL_low} + 4$ MHz or/and $F_{UL_high} - 4$ MHz and F_{UL_high} , the maximum output power requirement is relaxed by reducing the lower tolerance limit by 1.5 dB				
NOTE 2: Power Class 3 is the default power class unless otherwise stated.				

If UE supports a different power class than the default UE power class for EN-DC band combination, and the supported power class enables higher maximum output power than that of the default power class:

- if the E-UTRA UL/DL configuration is 0 or 6; or

- if the E-UTRA UL/DL configuration is 1 and special subframe configuration is 0 or 5; or
- if the IE $p\text{-maxUE-FRI-r15}$ as defined in TS 36.331 [17] is provided and set to the maximum output power of the default power class or lower;
 - apply all requirements for the default power class, and set the configured transmitted power as specified in clause 6.2B.4;
- else
 - apply all requirements for the supported power class, and set the configured transmitted power class as specified in subclause 6.2B.4;

The normative reference for this requirement is TS 38.101-3 [4] clause 6.2B.1.

LTE anchor agnostic approach is not applied. E-UTRA test point analysis is included and E-UTRA measurements are performed.

6.2B.1.1.4 Test description

6.2B.1.1.4.1 Initial condition

Initial conditions are a set of test configurations the UE needs to be tested in and the steps for the SS to take with the UE to reach the correct measurement state.

The initial test configurations consist of environmental conditions, test frequencies and channel bandwidths based on EN-DC operating bands specified in clause 5.3B.1.2, channel bandwidths and sub-carrier spacings for the NR cell specified in TS 38.521-1 [8] clause 5.3 and channel bandwidth for the E-UTRA cell are specified in TS 36.521-1 [10] clause 5.4.2. All of these configurations shall be tested with applicable test parameters for each EN-DC configuration specified in clause 5.3B.1.2, and are shown in table 6.2B.1.1.4.1-1. The details of the uplink reference measurement channels (RMCs) are specified in TS 36.521-1 [10] Annex A, clause A.2.3 for E-UTRA RMC for TDD, TS 36.521-1 [10] Annex A, clause A.2.2 for E-UTRA RMC for FDD, and TS 38.521-1 [8] Annex A, clause A.2 for NR RMC. Configurations of PDSCH and PDCCH before measurement are specified in TS 36.521-1 [10] Annex C, clause C.2 and in TS 38.521-1 [8] Annex C, clause C.2 for E-UTRA CG and NR CG respectively.

Table 6.2B.1.1.4.1-1: Test configuration table for

Initial Conditions					
Test Environment as specified in TS 38.508-1 [5] clause 4.1		Normal, TL/VL, TL/VH, TH/VL, TH/VH			
NR Test Frequencies as specified in TS 38.508-1 [5] clause 4.3.1		Mid range			
E-UTRA Test Frequencies as specified in TS 36.508-1 [11] clause 4.3.1					
Test EN-DC bandwidth combination as specified in TS 38.508-1 [5] clause 4.3.1		Highest N_{RB_agg}			
NR Test SCS as specified in Table 5.3.5-1 in TS 38.521-1 [8]		Highest supported SCS			
NR/E-UTRA Test Parameters					
Test ID	Downlink Configuration	EN-DC Uplink Configuration			
		E-UTRA Cell		NR Cell	
		Modulation	RB allocation (NOTE 2)	Modulation	RB allocation (NOTE 1)

1	N/A	QPSK	Partial_Allocation	N/A	N/A
2	N/A	QPSK	1RB_Left	N/A	N/A
3	N/A	N/A	N/A	DFT-s-OFDM QPSK	Inner Full
4	N/A	N/A	N/A	DFT-s-OFDM QPSK	Inner_1RB_LEFT
NOTE 1: The specific configuration of each RB allocation is defined in Table 6.1-1 in TS 38.521-1 [8].					
NOTE 2: The specific configuration of each RB allocation is defined in Table 6.1-1 in current specification.					

Table 6.2B.1.1.4.1-2: Void

1. Connect the SS to the UE antenna connectors as shown in TS 38.508-1 [6] clause A.3.1.1 for SS diagram and clause A.3.2.1 for UE diagram.
2. The parameter settings for the E-UTRA cell are set up according to TS 36.508 [11] clause 4.4.3, and the parameter settings for the NR cell are set up according to TS 38.508-1 [6] clause 4.4.3.
3. Downlink signals are initially set up according to TS 36.521-1 [10] Annex C, clause C.0 and TS 38.521-1 [8] Annex C, clause C.0 for E-UTRA CG and NR CG respectively, and uplink signals according to TS 36.521-1 [10] Annex H and TS 38.521-1 [8] Annex G for E-UTRA CG and NR CG respectively.
4. The UL Reference Measurement channels are TS 36.521-1 [10] Annex A, clause A.2 and TS 38.521-1 [8] Annex A, clause A.2 for E-UTRA CG and NR CG respectively.
5. Propagation conditions are set according to TS 36.521-1 [10] Annex B.0 and TS 38.521-1 [8] Annex B, clause B.0 for E-UTRA CG and NR CG respectively.
6. Ensure the UE is in state RRC_CONNECTED with generic procedure parameters Connectivity EN-DC, DC bearer MCG and SCG, Connected without release *On* according to TS 38.508-1 [6] clause 4.5. Message contents are defined in clause 6.2B.1.1.4.3.
7. For the case of testing overlapping E-UTRA and NR UL transmission scenario when both bands are TDD, ensure E-UTRA UL transmission overlaps with NR UL transmission in time by giving SCG a delay of 3 E-UTRA subframes, or by giving MCG a delay of 2 subframes.

6.2B.1.1.4.2 Test procedure

1. SS sends uplink scheduling information for each UL HARQ process via PDCCH DCI format 0 and DCI format 0_1 for C_RNTI to schedule the UL RMC according to table 6.2B.1.1.4.1-1 on E-UTRA CC and NR CC respectively. Since the UL has no payload and no loopback data to send, the UE sends uplink MAC padding bits on the UL RMC.
2. Send continuously uplink power control "up" commands to the UE for NR and E-UTRA carrier until the UE transmits at its P_{UMAX} level; allow at least 200 ms from the first TPC command for the UE to reach P_{UMAX} level.
3. Measure the mean transmitted power over all EN-DC component carriers in the EN-DC, which shall meet the requirements described in table 6.2B.1.1.5-1 and the period of the measurement shall be at least the continuous duration of one active sub-frame.
4. For UEs supporting Power Class 2, repeat steps 1~3 on the applicable bands with message exception defined in Table 6.2B.1.1.4.3-5.

6.2B.1.1.4.3 Message contents

Message contents are according to TS 36.508 [11] clause 4.6.1 and TS 38.508-1 [6] clause 4.6.1 with the following exceptions.

6.2B.1.1.4.3-1: PhysicalCellGroupConfig

Derivation Path: TS 38.508-1 [6], Table 4.6.3-106			
Information Element	Value/remark	Comment	Condition
p-NR-FR1	23		Power Class 3 UE
	26		Power Class 2 UE

6.2B.1.1.4.3-2: RRCConnectionReconfiguration: nr-Config-r15

Derivation Path: TS 36.508 [11], Table 4.6.1-8			
Information Element	Value/remark	Comment	Condition
p-MaxEUTRA-r15	23		Power Class 3 UE
	26		Power Class 2 UE

6.2B.1.1.4.3-3: RRCConnectionReconfiguration: tdm-PatternConfig if operating on FDD band

Derivation Path: TS 36.508 [11], Table 4.6.1-8			
Information Element	Value/remark	Comment	Condition
tdm-PatternConfig-r15 ::= CHOICE { setup ::= SEQUENCE {			
subframeAssignment-r15	sa2	Apply if operating on FDD band for a UE NOT indicating support of dynamicPowerSharing in the UE-MRDC-Capability IE according to TS 38.213 [x] clause 7.6.1	
harq-Offset-r15	0		
}			
}			

6.2B.1.1.4.3-4: SystemInformationBlockType1: tdd-Config if operating on TDD band

Derivation Path: TS 36.508 [11], Table 4.6.3-23			
Information Element	Value/remark	Comment	Condition
TDD-Config-DEFAULT ::= SEQUENCE {			
subframeAssignment	sa2	Operating on TDD band	
specialSubframePatterns	ssp7		
}			

6.2B.1.1.4.3-5: RRCConnectionReconfiguration: p-MaxUE-FR1-r15 (step 4 in 6.2B.1.1.4.2)

Derivation Path: TS 36.508 [11], Table 4.6.1-8			
Information Element	Value/remark	Comment	Condition
nonCriticalExtension SEQUENCE {		RRCConnectionReconfiguration-v1530-IEs	
p-MaxUE-FR1-r15	23		Power Class 2 UE
}			

6.2B.1.1.5 Test requirements

The maximum output power for the DC configuration, derived in step 3 shall be within the range prescribed by the DC UE Power Class and tolerance in Table 6.2B.1.1.5-1 for power class 3 UE and Table 6.2B.1.1.5-2 for power class 2 UE.

The corresponding requirements is specified in table 6.2.2.5-1, 6.2.2_1.5-1 in TS 36.521-1 [10] or table 6.2.1.5-1, 6.2.1.5-2 in TS 38.521-1 [8].

The maximum output power for the DC configuration, derived in step 4 shall be within the range prescribed in Table 6.2B.1.1.5-1.

Table 6.2B.1.1.5-1: Maximum output power for EN-DC (continuous sub-blocks) for power class 3

DC configuration	Power class2	Tolerance (dB)	Power class 3 (dBm)	Tolerance (dB)
DC_(n)71AA			23	+2+TT/-2.5-TT
DC_(n)41AA			23	+2+TT/-2 ¹ +TT

NOTE 1: If all transmitted resource blocks over all component carriers are confined within F_{UL_low} and $F_{UL_low} + 4$ MHz or/and $F_{UL_high} - 4$ MHz and F_{UL_high} , the maximum output power requirement is relaxed by reducing the lower tolerance limit by 1.5 dB

NOTE 2: TT for each frequency and channel bandwidth is specified in Table 6.2B.1.1.5-3.

Table 6.2B.1.1.5-2: Maximum output power for EN-DC (continuous sub-blocks) for Power Class 2 for Rel-15

DC configuration	Carrier	Power class2	Tolerance (dB)	Condition	Comment
DC_(n)41AA	NR carrier	FFS	FFS	UE indicates PC2 on NR band	FFS
		FFS	FFS	UE indicates PC3 on NR band	FFS
	E-UTRA carrier	26	+2+TT/-2 ¹ -TT	UE indicates PC2 ON E-UTRA band	UE meets power class 2 requirements
		23	+2+TT/-2 ¹ -TT	UE indicates PC3 on E-UTRA band	UE meets power class 3 requirements

NOTE 1: If all transmitted resource blocks over all component carriers are confined within F_{UL_low} and $F_{UL_low} + 4$ MHz or/and $F_{UL_high} - 4$ MHz and F_{UL_high} , the maximum output power requirement is relaxed by reducing the lower tolerance limit by 1.5 dB

NOTE 2: TT for each frequency and channel bandwidth is specified in Table 6.2B.1.1.5-3

Table 6.2B.1.1.5-2a: Maximum output power for EN-DC (continuous sub-blocks) for Power Class 2 for Rel-16 and forward

DC configuration	Carrier	Power class2	Tolerance (dB)	Condition	Comment
DC_(n)41AA	NR carrier	26	+2+TT/-3 ¹ -TT	UE reporting (PC2 by $P_{PowerClass,NR}$, and PC2 or Not present by <i>powerClassNRPart-r16</i>)	UE meets power class 2 requirements
		23	+2+TT/-2 ¹ -TT	UE reporting (PC2 by $P_{PowerClass,NR}$, and PC3 by <i>powerClassNRPart-r16</i>) or UE reporting (PC3 by $P_{PowerClass,NR}$)	UE meets power class 3 requirements
	E-UTRA carrier	26	+2+TT/-2 ¹ -TT	UE indicates PC2 ON E-UTRA band	UE meets power class 2 requirements
		23	+2+TT/-2 ¹ -TT	UE indicates PC3 on E-UTRA band	UE meets power class 3 requirements

NOTE 1: If all transmitted resource blocks over all component carriers are confined within F_{UL_low} and $F_{UL_low} + 4$ MHz or/and $F_{UL_high} - 4$ MHz and F_{UL_high} , the maximum output power requirement is relaxed by reducing the lower tolerance limit by 1.5 dB

NOTE 2: TT for each frequency and channel bandwidth is specified in Table 6.2B.1.1.5-3

Table 6.2B.1.1.5-3: Test Tolerance

	$f \leq 3.0\text{GHz}$	$3.0\text{GHz} < f \leq 6\text{GHz}$
$\text{BW} \leq 40\text{MHz}$	0.7 dB	1.0 dB
$40\text{MHz} < \text{BW} \leq 100\text{MHz}$	1.0 dB	1.0 dB

6.2B.1.2 UE Maximum Output Power for Intra-Band Non-Contiguous EN-DC

Editor's note:

- For overlapping transmission there is no test point satisfying 0dB MPR according to RAN4 specification.
- Test requirements for Power Class 2 of Rel-15 is FFS due to ongoing RAN4 discussion on minimum requirement

6.2B.1.2.1 Test purpose

To verify that the error of the UE maximum output power does not exceed the range prescribed by the specified nominal maximum output power and tolerance.

An excess maximum output power has the possibility to interfere to other channels or other systems. A small maximum output power decreases the coverage area.

6.2B.1.2.2 Test applicability

This test applies to all types of E-UTRA UE release 15 and forward, supporting intra-band non-contiguous EN-DC operation on FR1.

6.2B.1.2.3 Minimum conformance requirements

The following UE Power Classes define the total maximum output power for any transmission bandwidth(s) of the CG(s) configured.

The maximum output power is measured as the total maximum output power across the UE antenna connector(s). The period of measurement shall be at least one sub frame.

Table 6.2B.1.2.3-1: Maximum output power for EN-DC (non-continuous sub-blocks)

DC configuration	Power class 2 (dBm)	Tolerance (dB)	Power class 3 (dBm)	Tolerance (dB)
DC_2A_n2A ⁴			23	+2/-3
EN-DC_3A_n3A ⁽²⁾			23	+2/-3
DC_41A_n41A	26	+2/-2 ¹	23	+2/-2 ¹
DC_66A_n66A ⁴			23	+2/-3

NOTE 1: If all transmitted resource blocks over all component carriers are confined within F_{UL_low} and $F_{UL_low} + 4$ MHz or/and $F_{UL_high} - 4$ MHz and F_{UL_high} , the maximum output power requirement is relaxed by reducing the lower tolerance limit by 1.5 dB

NOTE 2: Only single switched UL is supported in Rel.15

NOTE 3: Power Class 3 is the default power class unless otherwise stated.

NOTE 4: Only single switched UL is supported.

If UE supports a different power class than the default UE power class for EN-DC band combination, and the supported power class enables higher maximum output power than that of the default power class:

- if the E-UTRA UL/DL configuration is 0 or 6; or
- if the E-UTRA UL/DL configuration is 1 and special subframe configuration is 0 or 5; or
- if the IE *p-maxUE-FR1-r15* as defined in TS 36.331 [17] is provided and set to the maximum output power of the default power class or lower:

- apply all requirements for the default power class, and set the configured transmitted power as specified in subclause 6.2B.4;
- else
- apply all requirements for the supported power class, and set the configured transmitted power class as specified in subclause 6.2B.4.

The normative reference for this requirement is TS 38.101-3 [4] clause 6.2B.1.

LTE anchor agnostic approach is not applied. E-UTRA test point analysis is included and E-UTRA measurements are performed.

6.2B.1.2.4 Test description

6.2B.1.2.4.1 Initial condition

Initial conditions are a set of test configurations the UE needs to be tested in and the steps for the SS to take with the UE to reach the correct measurement state.

The initial test configurations consist of environmental conditions, test frequencies and channel bandwidths based on EN-DC operating bands specified in Table 5.3B.1.3-1, channel bandwidths and sub-carrier spacings for the NR cell are specified in TS 38.521-1 [8] clause 5.3 and channel bandwidth for the E-UTRA cell are specified in TS 36.521-1 [10] clause 5.4.2. All of these configurations shall be tested with applicable test parameters for each EN-DC configuration specified in Table 5.3B.1.3-1, and are shown in table 6.2B.1.2.4.1-1. The details of the uplink reference measurement channels (RMCs) are specified in TS 36.521-1 [10] Annex A, clause A.2.3 for E-UTRA RMC for TDD, TS 36.521-1 [10] Annex A, clause A.2.2 for E-UTRA RMC for FDD, and TS 38.521-1 [8] Annex A, clause A.2 for NR RMC Configurations of PDSCH and PDCCH before measurement are specified in TS 36.521-1 [10] Annex C, clause C.2 and in TS 38.521-1 [8] Annex C, clause C.2 for E-UTRA CG and NR CG respectively.

Table 6.2B.1.2.4.1-1: Test configuration table for intra-band non-contiguous EN-DC

Initial Conditions					
Test Environment as specified in TS 38.508-1 [5] clause 4.1		Normal, TL/VL, TL/VH, TH/VL, TH/VH			
NR Test Frequencies as specified in TS 38.508-1 [5] clause 4.3.1 E-UTRA Test Frequencies as specified in TS 36.508-1 [11] clause 4.3.1		Minimum Wgap, Maximum Wgap			
Test EN-DC bandwidth combination as specified in TS 38.508-1 [5] clause 4.3.1		Highest N_{RB_agg}			
NR Test SCS as specified in Table 5.3.5-1 in TS 38.521-1 [8]		Highest supported SCS			
NR/E-UTRA Test Parameters					
Test ID	Downlink Configuration	EN-DC Uplink Configuration			
		E-UTRA Cell		NR Cell	
		Modulation	RB allocation (NOTE 2)	Modulation	RB allocation (NOTE 1)
1	N/A	QPSK	Partial_Allocation	N/A	N/A
2	N/A	QPSK	1RB_Left	N/A	N/A
3	N/A	N/A	N/A	DFT-s-OFDM QPSK	Inner Full
4	N/A	N/A	N/A	DFT-s-OFDM QPSK	Inner_1RB_LEFT
NOTE 1: The specific configuration of each RB allocation is defined in Table 6.1-1 in TS 38.521-1 [8].					
NOTE 2: The specific configuration of each RB allocation is defined in Table 6.1-1 in current specification.					

1. Connect the SS to the UE antenna connectors as shown in TS 38.508-1 [6] A.3.1.1 for SS diagram and A.3.2.1 for UE diagram.

2. The parameter settings for the cell are set up according to TS 38.508-1 [6] clause 4.4.3.
3. Downlink signals are initially set up according to TS 36.521-1 [10] Annex C.0 and TS 38.521-1 [8] Annex C.0 for E-UTRA CG and NR CG respectively, and uplink signals according to TS 36.521-1 [10] Annex H and TS 38.521-1 [8] Annex G for E-UTRA CG and NR CG respectively.
4. The UL Reference Measurement channels are TS 36.521-1 [10] Annex A.2 and TS 38.521-1 [8] Annex A.2 for E-UTRA CG and NR CG respectively.
5. Propagation conditions are set according to TS 36.521-1 [10] Annex B.0 and TS 38.521-1 [8] Annex B.0 for E-UTRA CG and NR CG respectively.
6. Ensure the UE is in state RRC_CONNECTED with generic procedure parameters Connectivity EN-DC, DC bearer MCG and SCG, Connected without release *On* according to TS 38.508-1 [6] clause 4.5. Message contents are defined in clause 6.2B.1.2.4.3.
7. For the case of testing overlapping E-UTRA and NR UL transmission scenario when both bands are TDD, ensure E-UTRA UL transmission overlaps with NR UL transmission in time by giving SCG a delay of 3 E-UTRA subframes, or by giving MCG a delay of 2 subframes.

6.2B.1.2.4.2 Test procedure

1. SS sends uplink scheduling information for each UL HARQ process via PDCCH DCI format 0 and DCI format 0_1 for C_RNTI to schedule the UL RMC according to table 6.2B.1.2.4.1-1 on E-UTRA CC and NR CC respectively. Since the UL has no payload and no loopback data to send the UE sends uplink MAC padding bits on the UL RMC.
2. Send continuously uplink power control "up" commands to the UE for NR and E-UTRA carrier until the UE transmits at its P_{UMAX} level; allow at least 200 ms from the first TPC command for the UE to reach P_{UMAX} level for Power class 3.
3. Measure the mean transmitted power over all EN-DC component carriers in the EN-DC, which shall meet the requirements described in table 6.2B.1.2.5-1 and the period of the measurement shall be at least the continuous duration of one active sub-frame.
4. For UEs supporting Power Class 2, repeat steps 1~3 on the applicable bands with message exception defined in Table 6.2B.1.1.4.3-5.

6.2B.1.2.4.3 Message contents

Same message contents as specified in 6.2B.1.1.4.3.

6.2B.1.2.5 Test requirements

The maximum output power for the DC configuration, derived in step 3 shall be within the range prescribed by the DC UE Power Class and tolerance in Table 6.2B.1.2.5-1 for power class 3 UE and Table 6.2B.1.2.5-2 for power class 2 UE. The corresponding requirements is specified in table 6.2.2.5-1, 6.2.2_1.5-1 in TS 36.521-1 [10] or table 6.2.1.5-1, 6.2.1.5-2 in TS 38.521-1 [8].

The maximum output power for the DC configuration, derived in step 4 shall be within the range prescribed in Table 6.2B.1.2.5-1.

Table 6.2B.1.2.5-1: Maximum output power for EN-DC (non-continuous sub-blocks) for power class 3

DC configuration	Power class 2 (dBm)	Tolerance (dB)	Power class 3 (dBm)	Tolerance (dB)
DC_2A_n2A ⁴			23	+2+TT/-2 ¹ -TT
DC_3A_n3A ⁽²⁾			23	+2+TT/-2 ¹ -TT
DC_41A_n41A			23	+2+TT/-2 ¹ -TT
DC_66A_n66A ⁴			23	+2+TT/-2 ¹ -TT

NOTE 1: If all transmitted resource blocks over all component carriers are confined within F_{UL_low} and $F_{UL_low} + 4$ MHz or/and $F_{UL_high} - 4$ MHz and F_{UL_high} , the maximum output power requirement is relaxed by reducing the lower tolerance limit by 1.5 dB

NOTE 2: Only single switched UL is supported in Rel.15

NOTE 3: TT for each frequency and channel bandwidth is specified in Table 6.2B.1.2.5-3

NOTE 4: Only single switched UL is supported.

Table 6.2B.1.2.5-2: Maximum output power for EN-DC (non-continuous sub-blocks) for power class 2 for Rel-15

DC configuration	Carrier	Power class2	Tolerance (dB)	Condition	Comment
DC_41A_n41A	NR carrier	FFS	FFS	UE indicates PC2 on NR band	FFS
		FFS	FFS	UE indicates PC3 on NR band	FFS
	E-UTRA carrier	26	+2+TT/-3 ¹ -TT	UE indicates PC3 on E-UTRA carrier of this DC_Configuration	UE meets power class 2 requirements
		23	+2+TT/-2 ¹ -TT	UE indicates PC3 on E-UTRA carrier of this DC_Configuration	UE meets power class 3 requirements

NOTE 1: If all transmitted resource blocks over all component carriers are confined within F_{UL_low} and $F_{UL_low} + 4$ MHz or/and $F_{UL_high} - 4$ MHz and F_{UL_high} , the maximum output power requirement is relaxed by reducing the lower tolerance limit by 1.5 dB

NOTE 2: TT for each frequency and channel bandwidth is specified in Table 6.2B.1.1.5-3

Table 6.2B.1.2.5-2a: Maximum output power for EN-DC (non-continuous sub-blocks) for power class 2 for Rel-16 and forward

DC configuration	Carrier	Power class2	Tolerance (dB)	Condition	Comment
DC_41A_n41A	NR carrier	26	+2+TT/-3 ¹ -TT	UE reporting (PC2 by $P_{PowerClass,NR}$, and PC2 or Not present by <i>powerClassNRPart-r16</i>)	UE meets power class 2 requirements
		23	+2+TT/-2 ¹ -TT	UE reporting (PC2 by $P_{PowerClass,NR}$, and PC3 by <i>powerClassNRPart-r16</i>) or UE reporting (PC3 by $P_{PowerClass,NR}$)	UE meets power class 3 requirements
	E-UTRA carrier	26	+2+TT/-2 ¹ -TT	UE indicates PC2 ON E-UTRA carrier of this DC_Configuration	UE meets power class 2 requirements
		23	+2+TT/-2 ¹ -TT	UE indicates PC3 on E-UTRA carrier of this DC_Configuration	UE meets power class 3 requirements
NOTE 1: If all transmitted resource blocks over all component carriers are confined within FUL_low and FUL_low + 4 MHz or/and FUL_high – 4 MHz and FUL_high, the maximum output power requirement is relaxed by reducing the lower tolerance limit by 1.5 dB					
NOTE 2: TT for each frequency and channel bandwidth is specified in Table 6.2B.1.1.5-3					

Table 6.2B.1.2.5-3: Test Tolerance

	$f \leq 3.0\text{GHz}$	$3.0\text{GHz} < f \leq 6\text{GHz}$
BW \leq 40MHz	0.7 dB	1.0 dB
40MHz < BW \leq 100MHz	1.0 dB	1.0 dB

6.2B.1.3 UE Maximum Output Power for Inter-Band EN-DC within FR1

6.2B.1.3.1 Test purpose

To verify that the error of the UE maximum output power does not exceed the range prescribed by the specified nominal maximum output power and tolerance.

An excess maximum output power has the possibility to interfere to other channels or other systems. A small maximum output power decreases the coverage area.

6.2B.1.3.2 Test applicability

This test applies to all types of E-UTRA UE release 15 and forward, supporting inter-band EN-DC operating on FR1.

6.2B.1.3.3 Minimum conformance requirements

For inter-band EN-DC of E-UTRA and NR in FR1, the following UE Power Classes define the maximum output power for any transmission bandwidth within the aggregated channel bandwidth. The maximum output power is measured as the sum of the maximum output power at each UE antenna connector. The period of measurement shall be at least one sub frame (1ms). UE maximum output power shall be measured over all component carriers from different bands. If each band has separate antenna connectors, maximum output power is measured as the sum of maximum output power at each UE antenna connector.

Table 6.2B.1.3.3-1: Maximum output power for inter-band EN-DC (two bands)

EN-DC configuration	Power class 2 (dBm)	Tolerance (dB)	Power class 3 (dBm)	Tolerance (dB)
DC_1A_n3A			23	+2/-3
DC_1A_n28A			23	+2/-3
DC_1A_n40A			23	+2/-3
DC_1A_n51A			23	+2/-3
DC_1A_n77A			23	+2/-3
DC_1A_n78A DC_1A_n84A_ULSUP- TDM_n78A DC_1A_n84A_ULSUP- FDM_n78A			23	+2/-3
DC_1A_n79A			23	+2/-3
DC_2A_n5A			23	+2/-3 ¹
DC_2A_n41A			23	+2/-3
DC_2A_n66A			23	+2/-3 ¹
DC_2A_n71A			23	+2/-3
DC_2A_n78A			23	+2/-3
DC_3A_n7A			23	+2/-3 ¹
DC_3A_n28A			23	+2/-3 ¹
DC_3A_n40A			23	+2/-3 ¹
DC_3A_n41A, DC_3C_n41A	26 ⁶	+2/-3	23	+2/-3
DC_3A_n51A			23	+2/-3 ¹
DC_3A_n77A			23	+2/-3 ¹
DC_3A_n78A	26 ⁶	+2/-3 ¹	23	+2/-3 ¹
DC_3A_n79A DC_3A_n80A_ULSUP- TDM_n79A, DC_3A_n80A_ULSUP- FDM_n79A			23	+2/-3 ¹
DC_3A_n82A			23	+2/-3 ¹
DC_5A_n2A			23	+2/-3
DC_5A_n40A			23	+2/-3 ¹
DC_5A_n66A			23	+2/-3 ¹
DC_5A_n78A			23	+2/-3
DC_7A_n1A			23	+2/-3
DC_7A_n3A			23	+2/-3
DC_7A_n28A			23	+2/-3 ¹
DC_7A_n51A			23	+2/-3 ¹
DC_7A_n66A			23	+2/-3 ¹
DC_7A_n78A DC_7C_n78A			23	+2/-3
DC_8A_n1A			23	+2/-3
DC_8A_n3A			23	+2/-3
DC_8A_n40A			23	+2/-3 ¹
DC_8A_n41A, DC_8A_n81A_ULSUP- TDM, DC_8A_n81A_ULSUP- FDM			23	+2/-3
DC_8A_n77A			23	+2/-3

EN-DC configuration	Power class 2 (dBm)	Tolerance (dB)	Power class 3 (dBm)	Tolerance (dB)
DC_8A_n78A DC_8A_n81A_ULSUP- TDM_n78A, DC_8A_n81A_ULSUP- FDM_n78A			23	+2/-3
DC_8A_n79A DC_8A_n81A_ULSUP- TDM_n79A, DC_8A_n81A_ULSUP- FDM_n79A			23	+2/-3
DC_11A_n77A			23	+2/-3
DC_11A_n78A			23	+2/-3
DC_11A_n79A			23	+2/-3
DC_12A_n5A			23	+2/-3
DC_12A_n66A			23	+2/-3
DC_12A_n78A			23	+2/-3
DC_13A_n2A			23	+2/-3
DC_13A_n66A			23	+2/-3
DC_14A_n2A			23	+2/-3
DC_14A_n66A			23	+2/-3
DC_18A_n77A			23	+2/-3
DC_18A_n78A			23	+2/-3
DC_18A_n79A			23	+2/-3
DC_19A_n77A			23	+2/-3
DC_19A_n78A			23	+2/-3
DC_19A_n79A			23	+2/-3
DC_20A_n1A			23	+2/-3
DC_20A_n3A			23	+2/-3
DC_20A_n8A			23	+2/-3
DC_20A_n28A DC_20A_n83A			23	+2/-3
DC_20A_n51A			23	+2/-3
DC_20A_n77A			23	+2/-3
DC_20A_n78A DC_20A_n82A_ULSUP -TDM_n78A, DC_20A_n82A_ULSUP -FDM_n78A			23	+2/-3
DC_21A_n77A			23	+2/-3
DC_21A_n78A			23	+2/-3
DC_21A_n79A			23	+2/-3
DC_25A_n41A			23	+2/-3
DC_26A_n41A			23	+2/-3
DC_26A_n77A			23	+2/-3
DC_26A_n78A			23	+2/-3
DC_26A_n79A			23	+2/-3
DC_28A_n3A			23	+2/-3
DC_28A_n51A			23	+2/-3
DC_28A_n77A			23	+2/-3

EN-DC configuration	Power class 2 (dBm)	Tolerance (dB)	Power class 3 (dBm)	Tolerance (dB)
DC_28A_n78A DC_28A_n83A_ULSUP -TDM_n78A, DC_28A_n83A_ULSUP -FDM_n78A			23	+2/-3
DC_28A_n79A			23	+2/-3
DC_30A_n5A			23	+2/-3
DC_30A_n66A			23	+2/-3
DC_38A_n78A			N/A	N/A
DC_39A_n41A	26	+2/-3 ¹	23	+2/-2
DC_39A_n78A			23	+2/-3 ¹
DC_39A_n79A	26	+2/-3	23	+2/-3 ¹
DC_40A_n1A			23	+2/-3
DC_40A_n41A			23	+2/-3
DC_40A_n77A			N/A	N/A
DC_40A_n78A			23	+2/-3
DC_41A_n77A DC_41C_n77A			23	+2/-3 ¹
DC_41A_n78A DC_41C_n78A			23	+2/-3 ¹
DC_41A_n79A DC_41C_n79A	26	+2/-3 ¹	23	+2/-3 ¹
DC_42A_n51A			23	+2/-3
DC_42A_n77A			N/A	N/A
DC_42A_n78A			N/A	N/A
DC_42A_n79A			N/A	N/A
DC_48A_n5A			23	+2/-3
DC_48A_n66A			23	+2/-3
DC_66A_n2A			23	+2/-3
DC_66A_n5A			23	+2/-3 ¹
DC_66A_n41A			23	+2/-3
DC_66A_n71A			23	+2/-3
DC_66A_n78A, DC_66A_n86A_ULSUP -TDM_n78A, DC_66A_n86A_ULSUP -FDM_n78A			23	+2/-3

NOTE 1: For the transmission bandwidths confined within F_{UL_low} and $F_{UL_low} + 4$ MHz or $F_{UL_high} - 4$ MHz and F_{UL_high} , the maximum output power requirement is relaxed by reducing the lower tolerance limit by 1.5 dB.

NOTE 2: $P_{PowerClass, EN-DC}$ is the maximum UE power specified without taking into account the tolerance.

NOTE 3: For inter-band EN-DC the maximum power requirement should apply to the total transmitted power over all component carriers (per UE).

NOTE 4: Power Class 3 is the default power class unless otherwise stated.

NOTE 5: The UE is not required to support PC2 within each individual cell group. Power class support within each individual cell group is signaled separately by the UE.

NOTE 6: The UE supports PC3 within E-UTRA cell group, and supports either PC3 or PC2 within NR cell group. Power class support within each individual cell group is signaled separately by the UE.

If a UE supports a different power class than the default UE power class for an EN-DC band combination and the supported power class enables higher maximum output power than that of the default power class:

- if the field of UE capability *maxUplinkDutyCycle-EN-DC* is absent and the percentage of NR uplink symbols transmitted in a certain evaluation period is larger than 30% (The exact evaluation period is no less than one radio frame); or

- if the field of UE capability *maxUplinkDutyCycle-EN-DC* is not absent and the percentage of NR uplink symbols transmitted in a certain evaluation period is larger than *maxUplinkDutyCycle-EN-DC* as defined in TS38.331 (The exact evaluation period is no less than one radio frame); or
- if the IE *p-maxUE-FRI* as defined in TS 38.331 is provided and set to the maximum output power of the default power class or lower;
 - shall apply all requirements for the default power class to the supported power class and set the configured transmitted power as specified clause 6.2B.4;
- Else if the IE *p-maxUE-FRI* as defined in TS 38.331 is not provided or set to the higher value than the maximum output power of the default power class and the percentage of uplink symbols transmitted in a certain evaluation period is less than or equal to *maxUplinkDutyCycle-EN-DC* as defined in TS 38.331; or
- if the IE *p-maxUE-FRI* as defined in TS 38.331 is not provided or set to the higher value than the maximum output power of the default power class and the percentage of NR uplink symbols transmitted in a certain evaluation period is less than or equal to 30% when *maxUplinkDutyCycle-EN-DC* is absent. (The exact evaluation period is no less than one radio frame):
 - shall apply all requirements for the supported power class and set the configured transmitted power class as specified in clause 6.2B.4.

If a UE supports a different power class than the default UE power class for an E-UTRA FDD and NR TDD EN-DC band combination and the supported power class enables higher maximum output power than that of the default power class:

If UE indicating the two capabilities *maxUplinkDutyCycle-EN-DC_FDDTDD_1* and *maxUplinkDutyCycle-EN-DC_FDDTDD_2*:

- if the IE *p-maxUE-FRI* as defined in TS 38.331 is not provided or set to the higher value than the maximum output power of the default power class, and the percentage of EUTRA uplink symbols transmitted in a certain evaluation period is between 40% and 70%, and the percentage of NR uplink symbols transmitted in a certain evaluation period is less than or equal to *maxUplinkDutyCycle-EN-DC_FDDTDD_1* as defined in TS 38.331 (The exact evaluation period is no less than one radio frame); or
 - if the IE *p-maxUE-FRI* as defined in TS 38.331 is not provided or set to the higher value than the maximum output power of the default power class, and the percentage of EUTRA uplink symbols transmitted in a certain evaluation period is no larger than 40%, and the percentage of NR uplink symbols transmitted in a certain evaluation period is less than or equal to *maxUplinkDutyCycle-EN-DC_FDDTDD_2* as defined in TS 38.331 (The exact evaluation period is no less than one radio frame)
 - shall apply all requirements for the supported power class and set the configured transmitted power class as specified in sub-clause 6.2B.4.
 - else
 - shall apply all requirements for the default power class and set the configured transmitted power as specified sub-clause 6.2B.4;
- else
- shall apply all requirements for the supported power class and set the configured transmitted power as specified sub-clause 6.2B.4;

The normative reference for this requirement is TS 38.101-3 [4] clause 6.2B.1.

LTE anchor agnostic approach is not applied. E-UTRA test point analysis is included and E-UTRA measurements are performed.

6.2B.1.3.4 Test description

6.2B.1.3.4.1 Initial condition

Initial conditions are a set of test configurations the UE needs to be tested in and the steps for the SS to take with the UE to reach the correct measurement state.

The initial test configurations consist of environmental conditions, test frequencies, DC configuration specified in clause 5.5B.4 and test channel bandwidths specified in TS 36.508 [11] clause 4.3.1 and TS 38.508-1 [6] clause 4.3.1, and sub-carrier spacing based on NR operating bands specified in TS 38.521-1 [8] clause 5.3. All of these configurations shall be tested with applicable test parameters for each EN-DC configuration, and are shown in table 6.2B.1.3.4.1-1. The details of the uplink reference measurement channels (RMCs) are specified in TS 36.521-1 [10] Annex A, clause A.2.3 for E-UTRA RMC for TDD, TS 36.521-1 [10] Annex A, clause A.2.2 for E-UTRA RMC for FDD, and TS 38.521-1 [8] Annex A, clause A.2 for NR RMC. Configurations of PDSCH and PDCCH before measurement are specified in TS 36.521-1 [10] Annex C, clause C.2 and in TS 38.521-1 [8] Annex C, clause C.2 for E-UTRA CG and NR CG respectively.

Table 6.2B.1.3.4.1-1: Test configuration table

Default Conditions								
Test Environment as specified in TS 38.508-1 [6] clause 4.1					Normal, TL/VL, TL/VH, TH/VL, TH/VH			
Test Frequencies as specified in TS 38.508-1 [6] clause 4.3.1 and TS 36.508 [6]					Low range for E-UTRA CC1 and NR CC1, Mid range for E-UTRA CC1 and NR CC1, High range for E-UTRA CC1 and NR CC1 (NOTE 4)			
Test EN-DC channel bandwidth as specified in TS 36.508 [6] clause 4.3.1 and TS 38.508-1 clause 4.3.1					5MHz for E-UTRA CC1 and Lowest for NR CC1, Highest for E-UTRA CC1 and Highest for NR CC1			
Test SCS for the NR cell as specified in TS 38.521-1 [8] Table 5.3.5-1					Lowest, Highest			
Test Parameters								
Test ID	Test Freq	E-UTRA BW	NR BW	Downlink Configuration	EN-DC Uplink Configuration			
					E-UTRA Cell		NR Cell	
					Modulation	RB allocation (NOTE 1)	Modulation (NOTE 3)	RB allocation (NOTE 2)
1	High	Default	Default	N/A	QPSK	1RB_Right	DFT-s-OFDM PI/2 BPSK	Inner_1RB_Right
2	Low	Default	Default		QPSK	1RB_Left	DFT-s-OFDM PI/2 BPSK	Inner_1RB_Left
3	Default	Default	Default		QPSK	Partial_Allocation	DFT-s-OFDM PI/2 BPSK	Inner_Full
4	High	Default	Default		QPSK	1RB_Right	DFT-s-OFDM QPSK	Inner_1RB_Right
5	Low	Default	Default		QPSK	1RB_Left	DFT-s-OFDM QPSK	Inner_1RB_Left
6	Default	Default	Default		QPSK	Partial_Allocation	DFT-s-OFDM QPSK	Inner_Full
7	High	5MHz, Highest	Lowest		QPSK	1RB_Right	N/A	N/A
8	Low	5MHz, Highest	Lowest		QPSK	1RB_Left	N/A	N/A
9	Default	5MHz, Highest	Lowest		QPSK	Partial_Allocation	N/A	N/A
10	High	5MHz	Lowest, Highest		N/A	N/A	DFT-s-OFDM PI/2 BPSK	Inner_1RB_Right
11	Low	5MHz	Lowest, Highest		N/A	N/A	DFT-s-OFDM PI/2 BPSK	Inner_1RB_Left
12	Default	5MHz	Lowest, Highest		N/A	N/A	DFT-s-OFDM PI/2 BPSK	Inner_Full
13	High	5MHz	Lowest, Highest		N/A	N/A	DFT-s-OFDM QPSK	Inner_1RB_Right
14	Low	5MHz	Lowest, Highest		N/A	N/A	DFT-s-OFDM QPSK	Inner_1RB_Left
15	Default	5MHz	Lowest, Highest		N/A	N/A	DFT-s-OFDM QPSK	Inner_Full

NOTE 1: The specific configuration of each RB allocation is defined in Table 6.1-1 in current specification.
 NOTE 2: The specific configuration of each RB allocation is defined in Table 6.1-1 in TS 38.521-1 [8].
 NOTE 3: DFT-s-OFDM Pi/2 BPSK test applies only for UEs which supports Pi/2 BPSK in NR FR1.
 NOTE 4: For NR band n28, 30MHz test channel bandwidth is tested with Low range and High range test frequencies.

1. Connect the SS to the UE antenna connectors as shown in TS 38.508-1 [6] clause A.3.1.1 for SS and clause A.3.2.1 for UE.
2. The parameter settings for the cell are set up according to TS 38.508-1 [6] clause 4.4.3.
3. Downlink signals are initially set up according to TS 36.521-1 [10] Annex C.0 and TS 38.521-1 [8] Annex C.0 for E-UTRA CG and NR CG respectively, and uplink signals according to TS 36.521-1 [10] Annex H and TS 38.521-1 [8] Annex G for E-UTRA CG and NR CG respectively.
4. The UL Reference Measurement channels are TS 36.521-1 [10] Annex A.2 and TS 38.521-1 [8] Annex A.2 for E-UTRA CG and NR CG respectively.
5. Propagation conditions are set according to TS 36.521-1 [10] and TS 38.521-1 [8] Annex B.0 for E-UTRA CG and NR CG respectively.
6. Ensure the UE is in state RRC_CONNECTED with generic procedure parameters Connectivity EN-DC, DC bearer *MCG* and *SCG*, Connected without release *On* according to TS 38.508-1 [6] clause 4.5. Message contents are defined in clause 6.2B.1.3.4.3.
7. For the case of testing overlapping E-UTRA and NR UL transmission scenario when both bands are TDD, ensure E-UTRA UL transmission overlaps with NR UL transmission in time by giving SCG a delay of 3 E-UTRA subframes, or by giving MCG a delay of 2 subframes.

6.2B.1.3.4.2 Test procedure

1. SS sends uplink scheduling information for each UL HARQ process via PDCCH DCI format 0 and DCI format 0_1 for C_RNTI to schedule the UL RMC according to table 6.2B.1.3.4.1-1 on E-UTRA CC and NR CC respectively. Since the UL has no payload and no loopback data to send the UE sends uplink MAC padding bits on the UL RMC. For an E-UTRA FDD and NR TDD EN-DC band combination, if UE supports PC2, the percentage of EUTRA uplink symbols transmitted in each radio frame shall be less than 40%.
2. Send continuously uplink power control "up" commands to the UE for NR and E-UTRA carrier according to table 6.2B.1.3.4.1-1 until the UE transmits at its P_{UMAX} level; allow at least 200 ms from the first TPC command for the UE to reach P_{UMAX} level.
3. For test ID 1~6 measure the sum of mean transmitted power over all EN-DC component carriers in the EN-DC, which shall meet the requirements described in table 6.2B.1.3.5-1 and the period of the measurement shall be at least the continuous duration of one active sub-frame.

For test ID 7~15 measure the mean transmitted power over E-UTRA carrier or NR carrier, which shall meet the requirements described in table 6.2.2.5-1 in TS 36.521-1 [10] or table 6.2.1.5-1 in TS 38.521-1 [8] respectively. The period of the measurement shall be at least the continuous duration of one active sub-frame.

4. For UEs supporting Power Class 2, repeat steps 1~3 on the applicable bands with message exception defined in Table 6.2B.1.3.4.3-5.

6.2B.1.3.4.3 Message contents

Message contents are according to TS 36.508 [11] clause 4.6.1 and TS 38.508-1 [6] clause 4.6.1 with the following exceptions.

6.2B.1.3.4.3-1: PhysicalCellGroupConfig

Derivation Path: TS 38.508-1 [6], Table 4.6.3-106			
Information Element	Value/remark	Comment	Condition
PhysicalCellGroupConfig ::= SEQUENCE {			
p-NR-FR1	20	For simultaneous E-UTRA and NR transmission	Power Class 3 UE Test IDs 1-6
	23	For Test IDs 7~9 NR carrier is configured but not measured.	Power Class 3 UE Test IDs 7-15
	23	For simultaneous E-UTRA and NR transmission	Power Class 2 UE Test IDs 1-6
	26	For Test IDs 7~9 NR carrier is configured but not measured.	Power Class 2 UE Test IDs 7-15
}			

6.2B.1.3.4.3-2: RRCConnectionReconfiguration: nr-Config-r15

Derivation Path: TS 36.508 [11], Table 4.6.1-8			
Information Element	Value/remark	Comment	Condition
p-MaxEUTRA-r15	20	For simultaneous E-UTRA and NR transmission	Power Class 3 UE Test IDs 1-6
	23	For Test IDs 10~15 E-UTRA carrier is configured but not measured.	Power Class 3 UE Test IDs 7-15
	23	For simultaneous E-UTRA and NR transmission	Power Class 2 UE Test IDs 1-6
	26	For Test IDs 10~15 E-UTRA carrier is configured but not measured.	Power Class 2 UE Test IDs 7-15

6.2B.1.3.4.3-3: RRCConnectionReconfiguration: tdm-PatternConfig if E-UTRA on FDD band and UE does not support dynamic power sharing

Derivation Path: TS 36.508 [11], Table 4.6.1-8			
Information Element	Value/remark	Comment	Condition
tdm-PatternConfig-r15 CHOICE{			
setup SEQUENCE {			
subframeAssignment-r15	sa2		
harq-Offset-r15	0		
}			
}			

6.2B.1.3.4.3-4: SystemInformationBlockType1: tdd-Config if E-UTRA on TDD band

Derivation Path: TS 36.508 [11], Table 4.6.3-23			
Information Element	Value/remark	Comment	Condition
TDD-Config-DEFAULT ::= SEQUENCE {		Operating on TDD band	
subframeAssignment	Sa2		
specialSubframePatterns	Ssp7		
}			

6.2B.1.3.4.3-5: RRCConnectionReconfiguration: p-MaxUE-FR1-r15 (step 4 in 6.2B.1.3.4.2)

Derivation Path: TS 36.508 [11], Table 4.6.1-8			
Information Element	Value/remark	Comment	Condition
nonCriticalExtension SEQUENCE {		RRCConnectionReconfiguration-v1530-IEs	
p-MaxUE-FR1-r15	23		Power Class 2 UE
}			

6.2B.1.3.5 Test requirements

For test ID 1~6 the maximum output power for the DC configuration, derived in step 3 shall be within the range prescribed by the UE Power Class and tolerance in Table 6.2B.1.3.5-1.

For test ID 7~15 the maximum output power for the DC configuration, derived in step 3 shall be within the range prescribed by the UE Power Class and tolerance in table 6.2.2.5-1 in TS 36.521-1 [10] or table 6.2.1.5-1 in TS 38.521-1 [8] for E-UTRA carrier and NR carrier respectively for Power class 3, and in Table 6.2B.1.3.5-2a for Power class 2.

For test ID 1~6 the maximum output power for the DC configuration, derived in step 4 shall be within the range prescribed by Power Class 3 and tolerance in Table 6.2B.1.3.5-1.

For test ID 7~15 the maximum output power for the DC configuration, derived in step 4 shall be within the range prescribed by Power Class 3 and tolerance in table 6.2.2.5-1 in TS 36.521-1 [10] or table 6.2.1.5-1 in TS 38.521-1 [8] for E-UTRA carrier and NR carrier respectively.

Table 6.2B.1.3.5-1: Maximum output power for inter-band EN-DC (two bands), for overlapping UL transmission

EN-DC configuration	Power class 2 (dBm)	Tolerance (dB)	Power class 3 (dBm)	Tolerance (dB)
DC_1A_n3A			23	+2 +TT/-3-TT
DC_1A_n28A			23	+2 +TT/-3-TT
DC_1A_n40A			23	+2 +TT/-3-TT
DC_1A_n51A			23	+2 +TT/-3-TT
DC_1A_n77A			23	+2 +TT/-3-TT
DC_1A_n78A DC_1A_n84A_ULSUP- TDM_n78A DC_1A_n84A_ULSUP- FDM_n78A			23	+2 +TT/-3-TT
DC_1A_n79A			23	+2 +TT/-3-TT
DC_2A_n5A			23	+2 +TT/-3-TT ³
DC_2A_n41A			23	+2 +TT/-3-TT
DC_2A_n66A			23	+2 +TT/-3-TT ³
DC_2A_n71A			23	+2 +TT/-3-TT
DC_2A_n78A			23	+2 +TT/-3-TT
DC_3A_n7A			23	+2 +TT/-3-TT ³
DC_3A_n28A			23	+2 +TT/-3-TT ³
DC_3A_n40A			23	+2 +TT/-3-TT ³
DC_3A_n41A, DC_3C_n41A	26 ⁸	+2+TT/-3-TT ³	23	+2+TT/-3-TT ³
DC_3A_n51A			23	+2 +TT/-3-TT ³
DC_3A_n77A			23	+2 +TT/-3-TT ³
DC_3A_n78A	26 ⁸	+2+TT/-3-TT ³	23	+2 +TT/-3-TT ³
DC_3A_n79A DC_3A_n80A_ULSUP- TDM_n79A, DC_3A_n80A_ULSUP- FDM_n79A			23	+2 +TT/-3-TT ³
DC_3A_n82A			23	+2 +TT/-3-TT ³
DC_5A_n2A			23	+2 +TT/-3-TT
DC_5A_n40A			23	+2 +TT/-3-TT ³
DC_5A_n66A			23	+2 +TT/-3-TT ³
DC_5A_n78A			23	+2 +TT/-3-TT
DC_7A_n1A			23	+2 +TT/-3-TT
DC_7A_n3A			23	+2 +TT/-3-TT
DC_7A_n28A			23	+2 +TT/-3-TT ³
DC_7A_n51A			23	+2 +TT/-3-TT ³
DC_7A_n66A			23	+2 +TT/-3-TT ³
DC_7A_n78A DC_7C_n78A			23	+2 +TT/-3-TT
DC_8A_n1A				+2 +TT/-3-TT
DC_8A_n3A				+2 +TT/-3-TT
DC_8A_n40A			23	+2 +TT/-3-TT ³
DC_8A_n41A, DC_8A_n81A_ULSUP- TDM, DC_8A_n81A_ULSUP- FDM			23	+2 +TT/-3-TT
DC_8A_n77A			23	+2 +TT/-3-TT

EN-DC configuration	Power class 2 (dBm)	Tolerance (dB)	Power class 3 (dBm)	Tolerance (dB)
DC_8A_n78A DC_8A_n81A_ULSUP- TDM_n78A, DC_8A_n81A_ULSUP- FDM_n78A			23	+2 +TT/-3-TT
DC_8A_n79A DC_8A_n81A_ULSUP- TDM_n79A, DC_8A_n81A_ULSUP- FDM_n79A			23	+2 +TT/-3-TT
DC_11A_n77A			23	+2 +TT/-3-TT
DC_11A_n78A			23	+2 +TT/-3-TT
DC_11A_n79A			23	+2 +TT/-3-TT
DC_12A_n5A			23	+2 +TT/-3-TT
DC_12A_n66A			23	+2 +TT/-3-TT
DC_12A_n78A			23	+2 +TT/-3-TT
DC_13A_n2A			23	+2 +TT/-3-TT
DC_13A_n66A			23	+2 +TT/-3-TT
DC_14A_n2A			23	+2 +TT/-3-TT
DC_14A_n66A			23	+2 +TT/-3-TT
DC_18A_n77A			23	+2 +TT/-3-TT
DC_18A_n78A			23	+2 +TT/-3-TT
DC_18A_n79A			23	+2 +TT/-3-TT
DC_19A_n77A			23	+2 +TT/-3-TT
DC_19A_n78A			23	+2 +TT/-3-TT
DC_19A_n79A			23	+2 +TT/-3-TT
DC_20A_n1A			23	+2 +TT/-3-TT
DC_20A_n3A			23	+2 +TT/-3-TT
DC_20A_n8A			23	+2 +TT/-3-TT
DC_20A_n28A DC_20A_n83A			23	+2 +TT/-3-TT
DC_20A_n51A			23	+2 +TT/-3-TT
DC_20A_n77A			23	+2 +TT/-3-TT
DC_20A_n78A DC_20A_n82A_ULSUP -TDM_n78A, DC_20A_n82A_ULSUP -FDM_n78A			23	+2 +TT/-3-TT
DC_21A_n77A			23	+2 +TT/-3-TT
DC_21A_n78A			23	+2 +TT/-3-TT
DC_21A_n79A			23	+2 +TT/-3-TT
DC_25A_n41A			23	+2 +TT/-3-TT
DC_26A_n41A			23	+2 +TT/-3-TT
DC_26A_n77A			23	+2 +TT/-3-TT
DC_26A_n78A			23	+2 +TT/-3-TT
DC_26A_n79A			23	+2 +TT/-3-TT
DC_28A_n3A			23	+2 +TT/-3-TT
DC_28A_n51A			23	+2 +TT/-3-TT
DC_28A_n77A			23	+2 +TT/-3-TT

EN-DC configuration	Power class 2 (dBm)	Tolerance (dB)	Power class 3 (dBm)	Tolerance (dB)
DC_28A_n78A DC_28A_n83A_ULSUP -TDM_n78A, DC_28A_n83A_ULSUP -FDM_n78A			23	+2 +TT/-3-TT
DC_28A_n79A			23	+2 +TT/-3-TT
DC_30A_n5A			23	+2 +TT/-3-TT
DC_30A_n66A			23	+2 +TT/-3-TT
DC_38A_n78A			N/A	N/A
DC_39A_n41A	26	+2/-3 ¹	23	+2 +TT/-3-TT ³
DC_39A_n78A			23	+2 +TT/-3-TT ³
DC_39A_n79A	26	+2/-3	23	+2 +TT/-3-TT ³
DC_40A_n1A			23	+2 +TT/-3-TT
DC_40A_n41A			23	+2 +TT/-3-TT
DC_40A_n77A			N/A	N/A
DC_40A_n78A			23	+2 +TT/-3-TT
DC_41A_n77A DC_41C_n77A			23	+2 +TT/-3-TT ³
DC_41A_n78A DC_41C_n78A			23	+2 +TT/-3-TT ³
DC_41A_n79A DC_41C_n79A	26	+2/-3 ¹	23	+2 +TT/-3-TT ³
DC_42A_n51A			23	+2 +TT/-3-TT
DC_42A_n77A			N/A	N/A
DC_42A_n78A			N/A	N/A
DC_42A_n79A			N/A	N/A
DC_48A_n5A			23	+2 +TT/-3-TT
DC_48A_n66A			23	+2 +TT/-3-TT
DC_66A_n2A			23	+2 +TT/-3-TT
DC_66A_n5A			23	+2 +TT/-3-TT ³
DC_66A_n41A			23	+2 +TT/-3-TT
DC_66A_n71A			23	+2 +TT/-3-TT
DC_66A_n78A, DC_66A_n86A_ULSUP -TDM_n78A, DC_66A_n86A_ULSUP -FDM_n78A			23	+2 +TT/-3-TT

- NOTE 1: TT applies to output power in each UL carrier with E-UTRA UL transmission not overlapping with NR UL transmission in time, and its value is the same as TT of standalone E-UTRA or NR transmission. For detailed values refer to Table 6.2B.1.3.5-2.
- NOTE 2: TT applies to overall output power with E-UTRA UL transmission overlapping with NR UL transmission in time, and its value is the maximum TT among all E-UTRA and NR UL carriers. For detailed values refer to Table 6.2B.1.3.5-3.
- NOTE 3: For the transmission bandwidths confined within F_{UL_low} and $F_{UL_low} + 4$ MHz or $F_{UL_high} - 4$ MHz and F_{UL_high} , the maximum output power requirement is relaxed by reducing the lower tolerance limit by 1.5 dB.
- NOTE 4: $P_{PowerClass, EN-DC}$ is the maximum UE power specified without taking into account the tolerance.
- NOTE 5: For inter-band EN-DC the maximum power requirement should apply to the total transmitted power over all component carriers (per UE).
- NOTE 6: Power Class 3 is the default power class unless otherwise stated.
- NOTE 7: The UE is not required to support PC2 within each individual cell group. Power class support within each individual cell group is signaled separately by the UE.
- NOTE 8: The UE supports PC3 within E-UTRA cell group, and supports either PC3 or PC2 within NR cell group. Power class support within each individual cell group is signaled separately by the UE.

Table 6.2B.1.3.5-2: Void

Table 6.2B.1.3.5-2a: Maximum output power for inter-band EN-DC (two bands), for non-overlapping UL transmission for power class 2 (Rel-16 and forward)

EN-DC configuration	Carrier	Power class 2 (dBm)	Tolerance (dB)	Condition	Comment
DC_3A_n41A	NR carrier	26	+2+TT/-3 ² -TT	UE reporting (PC2 by $P_{\text{PowerClass,NR}}$, and PC2 or Not present by <i>powerClassNRPart-r16</i>)	UE meets power class 2 requirements
		23	+2+TT/-2 ² -TT	UE reporting (PC2 by $P_{\text{PowerClass,NR}}$, and PC3 by <i>powerClassNRPart-r16</i>) or UE reporting (PC3 by $P_{\text{PowerClass,NR}}$)	UE meets power class 3 requirements
	E-UTRA carrier	23	+2+TT/-2 ² -TT	UE indicates PC3 on E-UTRA band	UE meets power class 3 requirements
DC_3A_n78A	NR carrier	26	+2+TT/-3-TT	UE reporting (PC2 by $P_{\text{PowerClass,NR}}$, and PC2 or Not present by <i>powerClassNRPart-r16</i>)	UE meets power class 2 requirements
		23	+2+TT/-3-TT	UE reporting (PC2 by $P_{\text{PowerClass,NR}}$, and PC3 by <i>powerClassNRPart-r16</i>) or UE reporting (PC3 by $P_{\text{PowerClass,NR}}$)	UE meets power class 3 requirements
	E-UTRA carrier	23	+2+TT/-2 ² -TT	UE indicates PC3 on E-UTRA band	UE meets power class 3 requirements
DC_39A_n41A	NR carrier	26	+2+TT/-3 ² -TT	UE reporting (PC2 by $P_{\text{PowerClass,NR}}$, and PC2 or Not present by <i>powerClassNRPart-r16</i>)	UE meets power class 2 requirements
		23	+2+TT/-2 ² -TT	UE reporting (PC2 by $P_{\text{PowerClass,NR}}$, and PC3 by <i>powerClassNRPart-r16</i>) or UE reporting (PC3 by $P_{\text{PowerClass,NR}}$)	UE meets power class 3 requirements
	E-UTRA carrier	23	+2+TT/-2 ² -TT	UE indicates PC3 on E-UTRA band	UE meets power class 3 requirements
DC_39A_n79A	NR carrier	26	+2+TT/-3-TT	UE reporting (PC2 by $P_{\text{PowerClass,NR}}$, and PC2 or Not present by <i>powerClassNRPart-r16</i>)	UE meets power class 2 requirements
		23	+2+TT/-3-TT	UE reporting (PC2 by $P_{\text{PowerClass,NR}}$, and PC3 by <i>powerClassNRPart-r16</i>) or UE reporting (PC3 by $P_{\text{PowerClass,NR}}$)	UE meets power class 3 requirements
	E-UTRA carrier	23	+2+TT/-2 ² -TT	UE indicates PC3 on E-UTRA band	UE meets power class 3 requirements

DC_41A_n79A DC_41C_n79A	NR carrier	26	+2+TT/-3-TT	UE reporting (PC2 by $P_{\text{PowerClass,NR}}$, and PC2 or Not present by $\text{powerClassNRPart-r16}$)	UE meets power class 2 requirements
		23	+2+TT/-3-TT	UE reporting (PC2 by $P_{\text{PowerClass,NR}}$, and PC3 by $\text{powerClassNRPart-r16}$) or UE reporting (PC3 by $P_{\text{PowerClass,NR}}$)	UE meets power class 3 requirements
	E-UTRA carrier	26	+2+TT/-2 ² -TT	UE indicates PC2 on E-UTRA band	UE meets power class 2 requirements
		23	+2+TT/-2 ² -TT	UE indicates PC3 on E-UTRA band	UE meets power class 3 requirements

NOTE 1: TT applies to output power in each UL carrier with E-UTRA UL transmission not overlapping with NR UL transmission in time, and its value is the same as TT of standalone E-UTRA or NR transmission. For detailed values refer to Table 6.2B.1.3.5-3.

NOTE 2: For the transmission bandwidths confined within $F_{\text{UL,low}}$ and $F_{\text{UL,low}} + 4 \text{ MHz}$ or $F_{\text{UL,high}} - 4 \text{ MHz}$ and $F_{\text{UL,high}}$, the maximum output power requirement is relaxed by reducing the lower tolerance limit by 1.5 dB.

NOTE 3: $P_{\text{PowerClass,EN-DC}}$ is the maximum UE power specified without taking into account the tolerance.

Table 6.2B.1.3.5-3: Test Tolerance for UE maximum output power (Overlapping UL transmission)

TT for overall output power											
			NR								
			BW ≤ 20MHz			20 MHz < BW ≤ 40MHz			40MHz < BW ≤ 100MHz		
			$f \leq 3.0\text{GHz}$	$3.0\text{GHz} < f \leq 4.2\text{GHz}$	$4.2\text{GHz} < f \leq 6.0\text{GHz}$	$f \leq 3.0\text{GHz}$	$3.0\text{GHz} < f \leq 4.2\text{GHz}$	$4.2\text{GHz} < f \leq 6.0\text{GHz}$	$f \leq 3.0\text{GHz}$	$3.0\text{GHz} < f \leq 4.2\text{GHz}$	$4.2\text{GHz} < f \leq 6.0\text{GHz}$
E-UTRA	BW ≤ 20MHz	$f \leq 3.0\text{GHz}$	0.7 dB	1.0 dB	1.0 dB	0.7 dB	1.0 dB	1.0 dB	1.0 dB	1.0 dB	1.0 dB
		$3.0\text{GHz} < f \leq 4.2\text{GHz}$	1.0 dB	1.0 dB	1.0 dB	1.0 dB	1.0 dB	1.0 dB	1.0 dB	1.0 dB	1.0 dB

6.2B.1.4 UE Maximum Output Power for Inter-Band EN-DC including FR2

6.2B.1.4.1 UE Maximum Output Power for Inter-Band EN-DC including FR2 - EIRP and TR

Editor's note: The following aspects are either missing or not yet determined:

- The referred test case 6.2.1.1 in TS 38.521-2 is incomplete for power class 1, 2 and 4.
- The following aspects of the clause are for future consideration:
- Test Procedures for EIRP beam peak Extreme Conditions are FFS

6.2B.1.4.1.1 Test purpose

Same test purpose as in clause 6.2.1.1.1 in TS 38.521-2 [9] for the NR carrier.

6.2B.1.4.1.2 Test applicability

This test case applies to all types of E-UTRA UE release 15 and forward, supporting inter-band EN-DC including FR2 with 2CCs.

6.2B.1.4.1.3 Minimum conformance requirements

UE maximum output power requirement for E-UTRA single carrier and CA operation specified in subclauses 6.2.2 and 6.2.2A of TS 36.101 [10] and for NR single carrier and CA operation specified in subclause 6.2.1, 6.2A.1, and 6.2D.1 of TS 38.101-2 [9] apply.

No exception requirements applicable to NR or LTE. LTE anchor agnostic approach is applied.

The normative reference for this requirement is TS 38.101-3 [4] clause 6.2B.1.4.

6.2B.1.4.1.4 Test description

Same test description as in clause 6.2.1.1.4 in TS 38.521-2 [9] for the *NR* carrier with the following exception:

The initial test configurations for E-UTRA band consist of environmental conditions, test frequencies, and channel bandwidths based on E-UTRA bands specified in Table 4.7-1.

For initial conditions as in clause 6.2.1.1.4.1 in TS 38.521-2 [9], the following steps will be added to configure E-UTRA component:

2.1 The parameter settings for E-UTRA cell are set up according to TS 36.508 [11] clause 4.4.3.

3.1 The E-UTRA downlink signal level, uplink signal level are set according to Table 4.7-1 and propagation conditions are set according to Annex B.0 of TS 36.521-1 [10].

Step 6 of Initial conditions as in clause 6.2.1.1.4.1 in TS 38.521-2 [9] is replaced by:

6. Ensure the UE is in state RRC_CONNECTED with generic procedure parameters Connectivity EN-DC, DC bearer MCG and SCG, Connected without release On according to TS 38.508-1 [6] clause 4.5.

Same test procedure as in clause 6.2.1.1.4.2 in TS 38.521-2 [9] with the following steps added for E-UTRA component:

1.1 On the E-UTRA carrier, disable periodic and aperiodic CQI reports, disable SRS, set *TimeAlignmentTimerDedicated* IE to infinity and disable downlink and uplink scheduling, all as per Table 4.7-1 under clause 4.7.

6.2B.1.4.1.5 Test requirement

Same test requirement as in clause 6.2.1.1.5 in TS 38.521-2 [9] for the *NR* carrier.

6.2B.1.4.2 UE Maximum Output Power for Inter-Band EN-DC including FR2 - Spherical Coverage

Editor's note: The following aspects are either missing or not yet determined:

- **Measurement Uncertainties and Test Tolerances are FFS for power class 1, 2 and 4.**

6.2B.1.4.2.1 Test purpose

Same test purpose as in clause 6.2.1.2.1 in TS 38.521-2 [9] for the *NR* carrier.

6.2B.1.4.2.2 Test applicability

This test case applies to all types of E-UTRA UE release 15 and forward, supporting inter-band EN-DC including FR2 with 2 UL CCs.

6.2B.1.4.2.3 Minimum conformance requirements

UE maximum output power requirement for E-UTRA single carrier and CA operation specified in subclauses 6.2.2 and 6.2.2A of TS 36.101 [10] and for NR single carrier and CA operation specified in subclause 6.2.1, 6.2A.1, and 6.2D.1 of TS 38.101-2 [9] apply.

No exception requirements applicable to NR or LTE. LTE anchor agnostic approach is applied.

The normative reference for this requirement is TS 38.101-3 [4] clause 6.2B.1.4.

6.2B.1.4.2.4 Test description

Same test description as in clause 6.2.1.2.4 in TS 38.521-2 [9] for the *NR* carrier with the following exception:

The initial test configurations for E-UTRA band consist of environmental conditions, test frequencies, and channel bandwidths based on E-UTRA bands specified in Table 4.7-1.

For initial conditions as in clause 6.2.1.2.4.1 in TS 38.521-2 [9], the following steps will be added to configure E-UTRA component:

- 2.1 The parameter settings for E-UTRA cell are set up according to TS 36.508 [11] clause 4.4.3.
- 3.1 The E-UTRA downlink signal level, uplink signal level are set according to Table 4.7-1 and propagation conditions are set according to Annex B.0 of TS 36.521-1 [10].

Step 6 of initial conditions as in clause 6.2.1.2.4.1 in TS 38.521-2 [9] is replaced by:

- 6. Ensure the UE is in state RRC_CONNECTED with generic procedure parameters Connectivity EN-DC, DC bearer MCG and SCG, Connected without release On according to TS 38.508-1 [6] clause 4.5.

Same test procedure as in clause 6.2.1.2.4.2 in TS 38.521-2 [9] with the following steps added for E-UTRA component:

1.1 On the E-UTRA carrier, disable periodic and aperiodic CQI reports, disable SRS, set *TimeAlignmentTimerDedicated* IE to infinity and disable downlink and uplink scheduling, all as per Table 4.7-1 under clause 4.7.

6.2B.1.4.2.5 Test requirement

Same test requirement as in clause 6.2.1.2.5 in TS 38.521-2 [9] for the *NR* carrier.

6.2B.1.4_1 UE Maximum Output Power for Inter-Band EN-DC including FR2 (>2 CCs)

6.2B.1.4_1.1 UE Maximum Output Power for Inter-Band EN-DC including FR2 (3 CCs)

6.2B.1.4_1.1.1 UE Maximum Output Power for Inter-Band EN-DC including FR2 (3 CCs) - EIRP and TRP

Editor's note: The following aspects are either missing or not yet determined:

- The referred test case 6.2A.1.1.1 in TS 38.521-2 [9] is incomplete for aggregated BW > 400MHz.
- The referred test case 6.2A.1.1.1 in TS 38.521-2 [9] is incomplete for power class 1, 2 and 4.
- Test Procedures for EIRP beam peak Extreme Conditions are FFS.

6.2B.1.4_1.1.1.1 Test purpose

Same test purpose as in clause 6.2.1.1.1 in TS 38.521-2 [9] for the *NR* carrier.

6.2B.1.4_1.1.1.2 Test applicability

This test case applies to all types of E-UTRA UE release 15 and forward, supporting inter-band EN-DC including FR2 with 3 UL CCs (2NR UL CCs).

6.2B.1.4_1.1.1.3 Minimum conformance requirements

Same minimum conformance requirements as in clause 6.2B.1.4.1.3

6.2B.1.4_1.1.1.4 Test description

6.2B.1.4_1.1.1.4.1 Initial condition

Same test description as in clause 6.2A.1.1.1.4 in TS 38.521-2 [9] for the *NR* carriers with the following exception:

The initial test configurations for E-UTRA band consist of environmental conditions, test frequencies, and channel bandwidths based on E-UTRA bands specified in Table 4.7-1.

For Initial conditions as in clause 6.2A.1.1.1.4.1 in TS 38.521-2 [9], the following steps will be added to configure E-UTRA component:

- 2.1. The parameter settings for E-UTRA cell are set up according to TS 36.508 [11] clause 4.4.3.
- 3.1. The E-UTRA downlink signal level, uplink signal level are set according to Table 4.7-1 and propagation conditions are set according to Annex B.0 of TS 36.521-1 [10].

Step 6 of Initial conditions as in clause 6.2A.1.1.1.4.1 in TS 38.521-2 [9] is replaced by:

6. Ensure the UE is in state RRC_CONNECTED with generic procedure parameters Connectivity EN-DC, DC bearer MCG and SCG, Connected without release On according to TS 38.508-1 [6] clause 4.5.

Same test procedure as in clause 6.2A.1.1.1.4.2 in TS 38.521-2 [9] with the following steps added for E-UTRA component:

- 1.1 On the E-UTRA carrier, disable periodic and aperiodic CQI reports, disable SRS, set *TimeAlignmentTimerDedicated* IE to infinity and disable downlink and uplink scheduling, all as per Table 4.7-1 under clause 4.7.

6.2B.1.4_1.1.1.5 Test Requirements

Same test requirement as in clause 6.2A.1.1.1.5 in TS 38.521-2 [9] for the *NR* carriers.

6.2B.1.4_1.1.2 UE Maximum Output Power for Inter-Band EN-DC including FR2 (3 CCs) - Spherical Coverage

Editor's note: The following aspects are either missing or not yet determined:

- The referred test case 6.2A.1.2.1 in TS 38.521-2 is incomplete for aggregated BW > 400MHz.
- The referred test case 6.2A.1.2.1 in TS 38.521-2 is incomplete for power class 1, 2 and 4.

6.2B.1.4_1.1.2.1 Test purpose

Same test purpose as in clause 6.2.1.2.1 in TS 38.521-2 [9] for the *NR* carrier.

6.2B.1.4_1.1.2.2 Test applicability

This test case applies to all types of E-UTRA UE release 15 and forward, supporting inter-band EN-DC including FR2 with 3 UL CCs (2NR UL CCs).

6.2B.1.4_1.1.2.3 Minimum conformance requirements

Same minimum conformance requirements as in clause 6.2B.1.4.2.3.

6.2B.1.4_1.1.2.4 Test description

6.2B.1.4_1.1.2.4.1 Initial condition

Same test description as in clause 6.2A.1.2.1.4 in TS 38.521-2 [9] for the *NR* carriers with the following exception:

The initial test configurations for E-UTRA band consist of environmental conditions, test frequencies, and channel bandwidths based on E-UTRA bands specified in Table 4.7-1.

For Initial conditions as in clause 6.2A.1.2.1.4.1 in TS 38.521-2 [9], the following steps will be added to configure E-UTRA component:

- 2.1. The parameter settings for E-UTRA cell are set up according to TS 36.508 [11] subclause 4.4.3.
- 3.1. The E-UTRA downlink signal level, uplink signal level are set according to Table 4.7-1 and propagation conditions are set according to Annex B.0 of TS 36.521-1 [10].

Step 6 of Initial conditions as in clause 6.2A.1.2.1.4.1 in TS 38.521-2 [9] is replaced by:

6. Ensure the UE is in state RRC_CONNECTED with generic procedure parameters Connectivity EN-DC, DC bearer MCG and SCG, Connected without release On according to TS 38.508-1 [6] clause 4.5.

Same test procedure as in clause 6.2A.1.2.1.4.2 in TS 38.521-2 [9] with the following steps added for E-UTRA component:

- 1.1 On the E-UTRA carrier, disable periodic and aperiodic CQI reports, disable SRS, set TimeAlignmentTimerDedicated IE to infinity and disable downlink and uplink scheduling, all as per Table 4.7-1 under clause 4.7.

6.2B.1.4_1.1.2.5 Test Requirements

Same test requirement as in clause 6.2A.1.2.1.5 in TS 38.521-2 [9] for the NR carriers.

6.2B.1.4_1.2 UE Maximum Output Power for Inter-Band EN-DC including FR2 (4 CCs)

6.2B.1.4_1.2.1 UE Maximum Output Power for Inter-Band EN-DC including FR2 (4 CCs) - EIRP and TRP

Editor's note: The following aspects are either missing or not yet determined:

- - The referred test case 6.2A.1.1.2 in TS 38.521-2 is incomplete for aggregated BW > 400MHz.
- The referred test case 6.2A.1.1.2 in TS 38.521-2 is incomplete for power class 1, 2 and 4.

6.2B.1.4_1.2.1.1 Test purpose

Same test purpose as in clause 6.2.1.1.1 in TS 38.521-2 [9] for the NR carriers.

6.2B.1.4_1.2.1.2 Test applicability

This test case applies to all types of E-UTRA UE release 15 and forward, supporting inter-band EN-DC including FR2 with 4 UL CCs (3NR UL CCs).

6.2B.1.4_1.2.1.3 Minimum conformance requirements

Same minimum conformance requirements as in clause 6.2B.1.4.1.3.

6.2B.1.4_1.2.1.4 Test description

6.2B.1.4_1.2.1.4.1 Initial condition

Same test description as in clause 6.2A.1.1.2.4 in TS 38.521-2 [9] for the NR carriers with the following exception:

The initial test configurations for E-UTRA band consist of environmental conditions, test frequencies, and channel bandwidths based on E-UTRA bands specified in Table 4.7-1.

For Initial conditions as in clause 6.2A.1.1.2.4.1 in TS 38.521-2 [9], the following steps will be added to configure E-UTRA component:

- 2.1. The parameter settings for E-UTRA cell are set up according to TS 36.508 [11] clause 4.4.3.

- 3.1. The E-UTRA downlink signal level, uplink signal level are set according to Table 4.7-1 and propagation conditions are set according to Annex B.0 of TS 36.521-1 [10].

Step 6 of Initial conditions as in clause 6.2A.1.1.2.4.1 in TS 38.521-2 [9] is replaced by:

6. Ensure the UE is in state RRC_CONNECTED with generic procedure parameters Connectivity EN-DC, DC bearer MCG and SCG, Connected without release On according to TS 38.508-1 [6] clause 4.5.

Same test procedure as in clause 6.2A.1.1.2.4.2 in TS 38.521-2 [9] with the following steps added for E-UTRA component:

- 1.1 On the E-UTRA carrier, disable periodic and aperiodic CQI reports, disable SRS, set *TimeAlignmentTimerDedicated* IE to infinity and disable downlink and uplink scheduling, all as per Table 4.7-1 under clause 4.7.

6.2B.1.4_1.2.1.5 Test Requirements

Same test requirement as in clause 6.2A.1.1.2.5 in TS 38.521-2 [9] for the NR carrier.

6.2B.1.4_1.2.2 UE Maximum Output Power for Inter-Band EN-DC including FR2 (4 CCs) - Spherical Coverage

Editor's note: The following aspects are either missing or not yet determined:

- The referred test case 6.2A.1.2.2 in TS 38.521-2 is incomplete for aggregated BW > 400MHz.
- The referred test case 6.2A.1.2.2 in TS 38.521-2 is incomplete for power class 1, 2 and 4.

6.2B.1.4_1.2.2.1 Test purpose

Same test purpose as in clause 6.2.1.2.1 in TS 38.521-2 [9] for the NR carriers.

6.2B.1.4_1.2.2.2 Test applicability

This test case applies to all types of E-UTRA UE release 15 and forward, supporting inter-band EN-DC including FR2 with 4 UL CCs (3NR UL CCs).

6.2B.1.4_1.2.2.3 Minimum conformance requirements

Same minimum conformance requirements as in clause 6.2B.1.4.2.3.

6.2B.1.4_1.2.2.4 Test description

6.2B.1.4_1.2.2.4.1 Initial condition

Same test description as in clause 6.2A.1.2.2.4 in TS 38.521-2 [9] for the NR carriers with the following exception:

The initial test configurations for E-UTRA band consist of environmental conditions, test frequencies, and channel bandwidths based on E-UTRA bands specified in Table 4.7-1.

For Initial conditions as in clause 6.2A.1.2.2.4.1 in TS 38.521-2 [9], the following steps will be added to configure E-UTRA component:

- 2.1. The parameter settings for E-UTRA cell are set up according to TS 36.508 [11] subclause 4.4.3.
- 3.1. The E-UTRA downlink signal level, uplink signal level are set according to Table 4.7-1 and propagation conditions are set according to Annex B.0 of TS 36.521-1 [10].

Step 6 of Initial conditions as in clause 6.2A.1.2.2.4.1 in TS 38.521-2 [9] is replaced by:

6. Ensure the UE is in state RRC_CONNECTED with generic procedure parameters Connectivity EN-DC, DC bearer MCG and SCG, Connected without release On according to TS 38.508-1 [6] clause 4.5.

Same test procedure as in clause 6.2A.1.2.2.4.2 in TS 38.521-2 [9] with the following steps added for E-UTRA component:

- 1.1 On the E-UTRA carrier, disable periodic and aperiodic CQI reports, disable SRS, set *TimeAlignmentTimerDedicated* IE to infinity and disable downlink and uplink scheduling, all as per Table 4.7-1 under clause 4.7.

6.2B.1.4_1.2.2.5 Test Requirements

Same test requirement as in clause 6.2A.1.2.2.5 in TS 38.521-2 [9] for the *NR* carriers.

6.2B.1.4_1.3 UE Maximum Output Power for Inter-Band EN-DC including FR2 (5 CCs)

6.2B.1.4_1.3.1 UE Maximum Output Power for Inter-Band EN-DC including FR2 (5 CCs) - EIRP and TRP

Editor's note: The following aspects are either missing or not yet determined:

- The referred test case 6.2A.1.1.3 in TS 38.521-2 is incomplete for aggregated BW > 400MHz.
- The referred test case 6.2A.1.1.3 in TS 38.521-2 is incomplete for power class 1, 2 and 4.

6.2B.1.4_1.3.1.1 Test purpose

Same test purpose as in clause 6.2.1.1.1 in TS 38.521-2 [9] for the *NR* carriers.

6.2B.1.4_1.3.1.2 Test applicability

This test case applies to all types of E-UTRA UE release 15 and forward, supporting inter-band EN-DC including FR2 with 5 UL CCs (4NR UL CCs).

6.2B.1.4_1.3.1.3 Minimum conformance requirements

Same minimum conformance requirements as in clause 6.2B.1.4.1.3.

6.2B.1.4_1.3.1.4 Test description

6.2B.1.4_1.3.1.4.1 Initial condition

Same test description as in clause 6.2A.1.1.3.4 in TS 38.521-2 [9] for the *NR* carriers with the following exception:

The initial test configurations for E-UTRA band consist of environmental conditions, test frequencies, and channel bandwidths based on E-UTRA bands specified in Table 4.7-1.

For Initial conditions as in clause 6.2A.1.1.3.4.1 in TS 38.521-2 [9], the following steps will be added to configure E-UTRA component:

- 2.1. The parameter settings for E-UTRA cell are set up according to TS 36.508 [11] clause 4.4.3.
- 3.1. The E-UTRA downlink signal level, uplink signal level are set according to Table 4.7-1 and propagation conditions are set according to Annex B.0 of TS 36.521-1 [10].

Step 6 of Initial conditions as in clause 6.2A.1.1.3.4.1 in TS 38.521-2 [9] is replaced by:

6. Ensure the UE is in state *RRC_CONNECTED* with generic procedure parameters *Connectivity EN-DC*, *DC bearer MCG* and *SCG*, *Connected without release On* according to TS 38.508-1 [6] clause 4.5.

Same test procedure as in clause 6.2A.1.1.3.4.2 in TS 38.521-2 [9] with the following steps added for E-UTRA component:

- 1.1 On the E-UTRA carrier, disable periodic and aperiodic CQI reports, disable SRS, set *TimeAlignmentTimerDedicated* IE to infinity and disable downlink and uplink scheduling, all as per Table 4.7-1 under clause 4.7.

6.2B.1.4_1.3.1.5 Test Requirements

Same test requirement as in clause 6.2A.1.1.3.5 in TS 38.521-2 [9] for the *NR* carriers.

6.2B.1.4_1.3.2 UE Maximum Output Power for Inter-Band EN-DC including FR2 (5 CCs) – Spherical Coverage

Editor's note: The following aspects are either missing or not yet determined:

- The referred test case 6.2A.1.2.3 in TS 38.521-2 is incomplete for aggregated BW > 400MHz.
- The referred test case 6.2A.1.2.3 in TS 38.521-2 is incomplete for power class 1, 2 and 4.

6.2B.1.4_1.3.2.1 Test purpose

Same test purpose as in clause 6.2.1.2.1 in TS 38.521-2 [9] for the *NR* carriers.

6.2B.1.4_1.3.2.2 Test applicability

This test case applies to all types of E-UTRA UE release 15 and forward, supporting inter-band EN-DC including FR2 with 5 UL CCs (4NR UL CCs).

6.2B.1.4_1.3.2.3 Minimum conformance requirements

Same minimum conformance requirements as in clause 6.2B.1.4.2.3.

6.2B.1.4_1.3.2.4 Test description

6.2B.1.4_1.3.2.4.1 Initial condition

Same test description as in clause 6.2A.1.2.3.4 in TS 38.521-2 [9] for the *NR* carriers with the following exception:

The initial test configurations for E-UTRA band consist of environmental conditions, test frequencies, and channel bandwidths based on E-UTRA bands specified in Table 4.7-1.

For Initial conditions as in clause 6.2A.1.2.3.4.1 in TS 38.521-2 [9], the following steps will be added to configure E-UTRA component:

- 2.1. The parameter settings for E-UTRA cell are set up according to TS 36.508 [11] subclause 4.4.3.
- 3.1. The E-UTRA downlink signal level, uplink signal level are set according to Table 4.7-1 and propagation conditions are set according to Annex B.0 of TS 36.521-1 [10].

Step 6 of Initial conditions as in clause 6.2A.1.2.3.4.1 in TS 38.521-2 [9] is replaced by:

6. Ensure the UE is in state RRC_CONNECTED with generic procedure parameters Connectivity EN-DC, DC bearer MCG and SCG, Connected without release On according to TS 38.508-1 [6] clause 4.5.

Same test procedure as in clause 6.2A.1.2.3.4.2 in TS 38.521-2 [9] with the following steps added for E-UTRA component:

- 1.1 On the E-UTRA carrier, disable periodic and aperiodic CQI reports, disable SRS, set TimeAlignmentTimerDedicated IE to infinity and disable downlink and uplink scheduling, all as per Table 4.7-1 under clause 4.7.

6.2B.1.4_1.3.2.5 Test Requirements

Same test requirement as in clause 6.2A.1.2.3.5 in TS 38.521-2 [9] for the *NR* carriers.

6.2B.1.4D UE Maximum Output Power for Inter-Band EN-DC including FR2 for UL-MIMO

Editor's note: This clause is incomplete. The following aspects are either missing or not yet determined:

- The referred test case 6.2D.1 in TS 38.521-2 [9] is incomplete

6.2B.1.4D.1 Test purpose

Same test purpose as in clause 6.2D.1 in TS 38.521-2 [9] for the NR carrier.

6.2B.1.4D.2 Test applicability

This test case applies to all types of E-UTRA UE release 15 and forward, supporting inter-band EN-DC including FR2 with UL-MIMO.

6.2B.1.4D.3 Minimum conformance requirements

Same minimum conformance requirements as in clause 6.2D.1 in TS 38.521-2 [9] for the NR carrier.

No exception requirements applicable to NR or LTE. LTE anchor agnostic approach is applied.

The normative reference for this measurement is TS 38.101-3 [4] clause 6.2B.1.4.

6.2B.1.4D.4 Test description

Same test description as in clause [6.2D.1] in TS 38.521-2 [9] for the NR carrier with the following exception:

The initial test configurations for E-UTRA band consist of environmental conditions, test frequencies, and channel bandwidths based on E-UTRA bands specified in Table 4.6-1. For Initial conditions as in clause [6.2D.1] in TS 38.521-2 [9], the following steps will be added to configure E-UTRA component:

- 2.1. The parameter settings for E-UTRA cell are set up according to TS 36.508 [11] clause 4.4.3.
- 3.1. The E-UTRA downlink signal level, uplink signal level are set according to Table 4.7-1 and propagation conditions are set according to Annex B.0 of TS 36.521-1 [10].

[Step 6] of Initial conditions as in clause 6.2D.1 in TS 38.521-2 [9] is replaced by:

6. Ensure the UE is in state RRC_CONNECTED with generic procedure parameters Connectivity EN-DC, DC bearer MCG and SCG according to TS 38.508 [6] clause 4.5.

6.2B.1.4D.5 Test Requirement

Same test requirement as in clause 6.2D.1 of TS 38.521-2 [9] for the NR carrier.

6.2B.1.5 UE Maximum Output Power for Inter-Band EN-DC including both FR1 and FR2

6.2B.1.5.1 Test purpose

Same test purpose as in clause 6.2.1.1 in TS 38.521-1 [8] for NR FR1 carrier and 6.2.1.1 in TS 38.521-2 [9] for NR FR2 carrier.

6.2B.1.5.2 Test applicability

The requirements in this test are not testable due to issues with combined testing of NR FR1 and E-UTRA in conducted mode with NR FR2 in radiated mode. Therefore, the conducted and radiated requirements are tested separately.

No test case details are specified. The NSA requirements for maximum output power apply and are tested as part of the EN-DC within FR1 and EN-DC including FR2 test cases in clause 6.2B.

6.2B.1.5D UE Maximum Output Power for Inter-Band EN-DC including both FR1 and FR2 for UL-MIMO

6.2B.1.5D.1 Test purpose

Same test purpose as in clause 6.2.1.1 in TS 38.521-1 [8] for NR FR1 carrier and 6.2.1.1 in TS 38.521-2 [9] for NR FR2 carrier.

6.2B.1.5D.2 Test applicability

The requirements in this test are not testable due to issues with combined testing of NR FR1 and E-UTRA in conducted mode with NR FR2 in radiated mode. Therefore, the conducted and radiated requirements are tested separately.

No test case details are specified. The NSA requirements for maximum output power apply and are tested as part of the EN-DC within FR1 as in clause 6.2.1 in TS 38.521-1 [8] and EN-DC within FR2 as in clause 6.2.1 in TS 38.521-2 [9].

6.2B.2 UE Maximum Output Power reduction for EN-DC

6.2B.2.0 General

The UE maximum output power reduction (MPR) specified in this clause is applicable for UEs configured with EN-DC when NS_01 is indicated in the MCG and the SCG. The MPR applies subject to indication in the field *modifiedMPRbehavior* for the SCG [2].

6.2B.2.1 UE Maximum Output Power reduction for Intra-Band Contiguous EN-DC

6.2B.2.1.1 Test purpose

Same test purpose as in clause 6.2.2.1 in TS 38.521-1 [8] for the NR carrier.

6.2B.2.1.2 Test applicability

This test case applies to all types of E-UTRA power class 3 and power class 2 UE release 15 and forward, supporting intra-band contiguous EN-DC.

6.2B.2.1.3 Minimum conformance requirements

When the UE is configured for intra-band contiguous EN-DC, the UE determines the total allowed maximum output power reduction as specified in this clause.

For UE supporting dynamic power sharing the following:

- for the MCG, MPR_c in accordance with TS 36.101 [5]
- for the SCG,

$$MPR'_c = MPR_{NR} = \text{MAX}(MPR_{\text{single,NR}}, MPR_{\text{ENDC}})$$

- for the total configured transmission power,

$$MPR_{\text{tot}} = P_{\text{PowerClass,EN-DC}} - \min(P_{\text{PowerClass,EN-DC}}, 10 * \log_{10}(10^{((P_{\text{PowerClass,E-UTRA}} - MPR_{\text{E-UTRA}})/10)} + 10^{((P_{\text{PowerClass,NR}} - MPR_{\text{NR}})/10)}))$$

where

$$MPR_{\text{E-UTRA}} = \text{MAX}(MPR_{\text{single,E-UTRA}}, MPR_{\text{ENDC}})$$

with

- $MPR_{\text{single,E-UTRA}}$ is the MPR defined for the E-UTRA transmission in TS 36.101 [5]
- $MPR_{\text{single,NR}}$ is the MPR defined for the NR transmission in TS 38.101-1 [2]

For UEs not supporting dynamic power sharing the following

- for the MCG,

$$MPR_c = \text{MAX}(MPR_{\text{single,E-UTRA}}, MPR_{\text{ENDC}})$$

- for the SCG,

$$MPR'_c = \text{MAX}(MPR_{\text{single,NR}}, MPR_{\text{ENDC}})$$

where

- $MPR_{\text{single,NR}}$ is the MPR defined for the NR transmission in TS 38.101-1 [2]
- $MPR_{\text{single,E-UTRA}}$ is the MPR defined for the E-UTRA transmission in TS 36.101 [5]

MPR in this subclause is applicable for power class 3 and power class 2 UEs indicating IE *dualPA-Architecture* supported with ENDC power class being the same as the E-UTRA and NR power class, otherwise the UE can use as much MPR as needed to fulfil emissions requirements when scheduled with dual uplink transmission. For UEs scheduled with single uplink transmission, MPR in subclause 6.2.4 of TS 36.101 [5] and 6.2.2 of TS 38.101-1 [2] apply. For a UE supporting dynamic power sharing for DC_(n)71AA for which dual simultaneous uplink transmissions are mandatory and A-MPR defined in subclause 6.2B.3.1.1 is applied as MPR. The allowed maximum output power reduction for IM3 related emissions applied to transmission on the MCG and the SCG is defined as follows:

$$MPR_{\text{ENDC}} = M_A$$

Where M_A is defined as follows

$$M_A = \begin{cases} 15; & 0 \leq B < 0.5 \\ 10; & 0.5 \leq B < 1.0 \\ 8; & 1.0 \leq B < 2.0 \\ 6; & 2.0 < B \end{cases}$$

Where:

For UEs supporting dynamic power sharing,

$$B = (L_{\text{CRB_alloc, E-UTRA}} * 12 * \text{SCS}_{\text{E-UTRA}} + L_{\text{CRB_alloc,NR}} * 12 * \text{SCS}_{\text{NR}}) / 1,000,000$$

For UEs not supporting dynamic power sharing,

For E-UTRA

$$B = (L_{\text{CRB_alloc, E-UTRA}} * 12 * \text{SCS}_{\text{E-UTRA}} + 12 * \text{SCS}_{\text{NR}}) / 1,000,000$$

Where $\text{SCS}_{\text{NR}} = 15$ kHz is assumed in calculation of B.

For NR

$$B = (12 * \text{SCS}_{\text{E-UTRA}} + L_{\text{CRB_alloc,NR}} * 12 * \text{SCS}_{\text{NR}}) / 1,000,000$$

Where $\text{SCS}_{\text{E-UTRA}} = 15$ kHz is assumed in calculation of B.

and M_A is reduced by 1 dB for $B < 2$.

The normative reference for this requirement is TS 38.101-3 [4] clause 6.2B.2.1.

Exception requirements for both NR and E-UTRA are defined for this test when transmission on E-UTRA overlap in time with NR. LTE anchor agnostic approach is not applied for this case. E-UTRA test point analysis is included and E-UTRA measurements are performed.

Exception requirements for both NR and E-UTRA are defined for this test when transmission on E-UTRA doesn't overlap in time with NR, for a UE that doesn't support dynamic power sharing. LTE anchor agnostic approach is not applied for this case. E-UTRA test point analysis is included and E-UTRA measurements are performed.

No exception requirements for NR or E-UTRA are defined for this test when transmission on E-UTRA doesn't overlap in time with NR, for a UE that supports dynamic power sharing. LTE anchor agnostic approach is not applied for this case based on the test point analysis in TS 38.905 [7].

6.2B.2.1.4 Test description

6.2B.2.1.4.1 Initial conditions

Initial conditions are a set of test configurations the UE needs to be tested in and the steps for the SS to take with the UE to reach the correct measurement state.

The initial test configurations consist of environmental conditions, test frequencies and test channel bandwidths based on NR operating bands specified in clause 5.3B.1.2, channel bandwidths and sub-carrier spacings for the NR cell specified in TS 38.521-1 [8] clause 5.3 and channel bandwidth for the E-UTRA cell are specified in TS 36.521-1 [10] clause 5.4.2. All of these configurations shall be tested with applicable test parameters for each EN-DC combination of test channel bandwidth and sub-carrier spacing, and are shown in table 6.4B.2.1.3.4.1-1. The details of the uplink reference measurement channels (RMCs) are specified in Annexes A.2. Configurations of PDSCH and PDCCH before measurement are specified in TS 36.521.1 [10] Annex C.2 and in TS 38.521-1 [8] Annex C.2 for E-UTRA CG and NR CG respectively.

Table 6.2B.2.1.4.1-1: Test configuration table

Initial Conditions									
Test Environment as specified in TS 38.508-1 [6] clause 4.1.				Normal, TL/VL, TL/VH, TH/VL, TH/VH					
Test Frequencies as specified in TS 38.508-1 [6] clause 4.3.1.				Low range, High range					
Test EN-DC bandwidth combination as specified in Table 5.3B.1.2-1.				Lowest N_{RB_agg} , Highest N_{RB_agg} (Note 2)					
Test SCS for the NR cell as specified in TS 38.521-1 [8] Table 5.3.5-1.				Lowest, Highest					
Test Parameters									
Test ID	Freq	ChBw	SCS	Downlink Configuration	EN-DC Uplink Configuration				
					E-UTRA Cell		NR Cell		Common
					Modulation	RB allocation (Note 5)	Modulation	RB allocation (NOTE 1)	
1	Default	Default	Default	N/A	16QAM	Outer_Full	DFT-s-OFDM Pi/2 BPSK	Outer_Full	B
2 (Note 3)	Default				16QAM	Outer_1RB_Left	DFT-s-OFDM Pi/2 BPSK	Edge_1RB_Right	B
3 (Note 3)	Low				16QAM	Outer_1RB_Left	DFT-s-OFDM Pi/2 BPSK	N/A	A
4 (Note 3)	High				16QAM	N/A	DFT-s-OFDM Pi/2 BPSK	Edge_1RB_Right	A
5 (Note 4)	Default				16QAM	Outer_1RB_Right	DFT-s-OFDM Pi/2 BPSK	Edge_1RB_Left	B
6 (Note 4)	Low				16QAM	N/A	DFT-s-OFDM Pi/2 BPSK	Edge_1RB_Left	A
7 (Note 4)	High				16QAM	Outer_1RB_Right	DFT-s-OFDM Pi/2 BPSK	N/A	A
8	Default				16QAM	Outer_Full	DFT-s-OFDM QPSK	Outer_Full	B
9 (Note 3)	Default				16QAM	Outer_1RB_Left	DFT-s-OFDM QPSK	Edge_1RB_Right	B
10 (Note 3)	Low				16QAM	Outer_1RB_Left	DFT-s-OFDM QPSK	N/A	A
11 (Note 3)	High				16QAM	N/A	DFT-s-OFDM QPSK	Edge_1RB_Right	A
12 (Note 4)	Default				16QAM	Outer_1RB_Right	DFT-s-OFDM QPSK	Edge_1RB_Left	B
13 (Note 4)	Low				16QAM	N/A	DFT-s-OFDM QPSK	Edge_1RB_Left	A
14 (Note 4)	High				16QAM	Outer_1RB_Right	DFT-s-OFDM QPSK	N/A	A
15	Default				16QAM	Outer_Full	DFT-s-OFDM 16QAM	Outer_Full	B
16 (Note 3)	Default				16QAM	Outer_1RB_Left	DFT-s-OFDM 16QAM	Edge_1RB_Right	B

17 (Note 3)	Low				16QAM	Outer_1RB_Left	DFT-s-OFDM 16QAM	N/A	A
18 (Note 3)	High				16QAM	N/A	DFT-s-OFDM 16QAM	Edge_1RB_Right	A
19 (Note 4)	Default				16QAM	Outer_1RB_Right	DFT-s-OFDM 16QAM	Edge_1RB_Left	B
20 (Note 4)	Low				16QAM	N/A	DFT-s-OFDM 16QAM	Edge_1RB_Left	A
21 (Note 4)	High				16QAM	Outer_1RB_Right	DFT-s-OFDM 16QAM	N/A	A
22	Default				16QAM	Outer_Full	DFT-s-OFDM 64QAM	Outer_Full	B
23 (Note 3)	Low				16QAM	Outer_1RB_Left	DFT-s-OFDM 64QAM	Edge_1RB_Right	B
24 (Note 4)	High				16QAM	Outer_1RB_Right	DFT-s-OFDM 64QAM	Edge_1RB_Left	B
25	Default				16QAM	Outer_Full	DFT-s-OFDM 256QAM	Outer_Full	B
26 (Note 3)	Low				16QAM	Outer_1RB_Left	DFT-s-OFDM 256QAM	Edge_1RB_Right	B
27 (Note 4)	High				16QAM	Outer_1RB_Right	DFT-s-OFDM 256QAM	Edge_1RB_Left	B
28	Default				16QAM	Outer_Full	CP-OFDM QPSK	Outer_Full	B
29 (Note 3)	Default				16QAM	Outer_1RB_Left	CP-OFDM QPSK	Edge_1RB_Right	B
30 (Note 3)	Low				16QAM	Outer_1RB_Left	CP-OFDM QPSK	N/A	A
31 (Note 3)	High				16QAM	N/A	CP-OFDM QPSK	Edge_1RB_Right	A
32 (Note 4)	Default				16QAM	Outer_1RB_Right	CP-OFDM QPSK	Edge_1RB_Left	B
33 (Note 4)	Low				16QAM	N/A	CP-OFDM QPSK	Edge_1RB_Left	A
34 (Note 4)	High				16QAM	Outer_1RB_Right	CP-OFDM QPSK	N/A	A
35	Default				16QAM	Outer_Full	CP-OFDM 16QAM	Outer_Full	B
36 (Note 3)	Default				16QAM	Outer_1RB_Left	CP-OFDM 16QAM	Edge_1RB_Right	B
37 (Note 3)	Low				16QAM	Outer_1RB_Left	CP-OFDM 16QAM	N/A	A
38 (Note 3)	High				16QAM	N/A	CP-OFDM 16QAM	Edge_1RB_Right	A
39 (Note 4)	Default				16QAM	Outer_1RB_Right	CP-OFDM 16QAM	Edge_1RB_Left	B

40 (Note 4)	Low				16QAM	N/A	CP-OFDM 16QAM	Edge_1RB_Left	A
41 (Note 4)	High				16QAM	Outer_1RB_Right	CP-OFDM 16QAM	N/A	A
42	Default				16QAM	Outer_Full	CP-OFDM 64QAM	Outer_Full	B
43 (Note 3)	Low				16QAM	Outer_1RB_Left	CP-OFDM 64QAM	Edge_1RB_Right	B
44 (Note 4)	High				16QAM	Outer_1RB_Right	CP-OFDM 64QAM	Edge_1RB_Left	B
45	Default				16QAM	Outer_Full	CP-OFDM 256QAM	Outer_Full	B
46 (Note 3)	Low				16QAM	Outer_1RB_Left	CP-OFDM 256QAM	Edge_1RB_Right	B
47 (Note 4)	High				16QAM	Outer_1RB_Right	CP-OFDM 256QAM	Edge_1RB_Left	B
48 (Note 4)	Default				16QAM	Edge_Full_Right	CP-OFDM 256QAM	Edge_Full_Left	B

NOTE 1: The specific configuration of each RB allocation is defined in Table 6.1-1 in TS 38.521-1 [8].

NOTE 2: If the UE supports multiple CC combinations in the EN-DC configuration with the same $N_{RB,agg}$, select the combination to test as follows:

- Lowest ENBW: NR component with lowest N_{RB} is tested.
- Highest ENBW: NR component with highest N_{RB} is tested.

NOTE 3: Applicable when E-UTRA cell carrier frequency is lower than NR cell carrier.

NOTE 4: Applicable when NR cell carrier frequency is lower than E-UTRA cell carrier.

NOTE 5: Outer_Full defined as the transmission bandwidth configuration N_{RB} per channel bandwidth for the E-UTRA component as indicated in TS 36.521 [10] Table 5.4.2-1. Outer_1RB_Left defined as 1 RB allocated at the left edge of the E-UTRA component. Edge_Full_Right is defined as 2 RBs allocated at the right edge of the E-UTRA component. Outer_1RB_Right defined as 1 RB allocated at the right edge of the E-UTRA component.

NOTE 6: DFT-s-OFDM Pi/2 BPSK test applies only for UEs which supports Pi/2 BPSK in FR1

NOTE 7: Test IDs with simultaneous E-UTRA and NR UL transmission only apply for UEs indicating dualPA-Architecture.

NOTE 8: Power config as specified in Table 6.2B.2.1.4.3-4 (PC3) or Table 6.2B.2.1.4.3-5 (PC2).

NOTE 9: Test IDs with simultaneous E-UTRA and NR UL transmission don't apply to DC_(n)71AA for a UE supporting dynamic power sharing (A-MPR is applied as MPR and covered by 6.2B.3.1.1).

1. Connect the SS to the UE antenna connectors as shown in TS 38.508-1 [6] Annex A, Figure A.3.1.1 for TE diagram and clause A.3.2.1 for UE diagram.
2. The parameter settings for the E-UTRA cell are set up according to TS 36.508 [11] clause 4.4.3, and the parameter settings for the NR cell are set up according to TS 38.508-1 [6] clause 4.4.3.
3. Downlink signals are initially set up according to TS 36.521-1 [10] Annex C.0 and TS 38.521-1 [8] Annex C.0 for E-UTRA CG and NR CG respectively, and uplink signals according to TS 36.521-1 [10] Annex H and TS 38.521-1 [8] Annex G for E-UTRA CG and NR CG respectively.
4. NR downlink signals are initially set up according to Annex C.0, C.1, and C.2 and uplink signals according to Annex G.0, G.1, G.2, and G.3.0 of TS 38.521-1 [8].
5. The UL Reference Measurement channels are TS 36.521-1 [10] Annex A.2 and TS 38.521-1 [8] Annex A.2 for E-UTRA CG and NR CG respectively.
6. Propagation conditions are set according to TS 36.521-1 [10] Annex B.0 and TS 38.521-1 [8] Annex B.0 for E-UTRA CG and NR CG respectively.
7. Ensure the UE is in state RRC_CONNECTED with generic procedure parameters Connectivity EN-DC, DC bearer MCG and SCG, Connected without release *On* according to TS 38.508-1 [6] clause 4.5. Message contents are defined in clause 6.2B.2.1.4.3.

8. For the case of testing overlapping E-UTRA and NR UL transmission scenario when both bands are TDD, ensure E-UTRA UL transmission overlaps with NR UL transmission in time by giving SCG a delay of 3 E-UTRA subframes, or by giving MCG a delay of 2 subframes.

6.2B.2.1.4.2 Test procedure

1. SS sends uplink scheduling information for each UL HARQ process via PDCCH DCI format 0 and DCI format 0_1 for C_RNTI to schedule the UL RMC according to Table 6.2B.2.1.4.1-1 on E-UTRA CC and NR CC respectively. For test points configured with message in Table 6.2B.2.1.4.3-7, NR SS only schedules UL RMC on NR slots that does not overlap with E-UTRA uplink subframe. Since the UL has no payload and no loopback data to send, the UE transmits uplink MAC padding bits on the UL RMC.
2. Send continuously uplink power control "up" commands to the UE for NR and E-UTRA carrier until the UE transmits at its P_{UMAX} level; allow at least 200 ms from the first TPC command starting in this step for the UE to reach P_{UMAX} level.
3. Measure the mean power over all component carriers for the EN-DC configuration, which shall meet the requirements described in clause 6.2B.2.1.5. The period of the measurement shall be at least the continuous duration of one active sub-frame (1ms). For TDD slots with transient periods are not under test.
4. For UEs supporting Power Class 2, repeat steps 1~3 for Test ID 25 and 45 in Table 6.2B.2.1.4.1-1 on the applicable bands with message exception defined in Table 6.2B.2.1.4.3-7.

NOTE 1: When switching to DFT-s-OFDM waveform, as specified in the test configuration table 6.2B.2.1.4.1-1, send an NR RRCReconfiguration message according to TS 38.508-1 [6] clause 4.6.3 Table 4.6.3-118 PUSCH-Config with TRANSFORM_PRECODER_ENABLED condition.

6.2B.2.1.4.3 Message contents

Message contents are according to TS 38.508-1 [6] clause 4.6.1 with the following exceptions:

Table 6.2B.2.1.4.3-1: AdditionalSpectrumEmission for MCG

Derivation Path: 36.508 [11] clause 4.6.3, Table 4.4.3.3-1			
Information Element	Value/remark	Comment	Condition
AdditionalSpectrumEmission	0 (NS_01)		

Table 6.2B.2.1.4.3-2: AdditionalSpectrumEmission for SCG

Derivation Path: 38.508-1 [5] clause 4.6.3, Table 4.6.3-1			
Information Element	Value/remark	Comment	Condition
AdditionalSpectrumEmission	0 (NS_01)		

Table 6.2B.2.1.4.3-3: PhysicalCellGroupConfig for PC3

Derivation Path: TS 38.508-1 [6], Table 4.6.3-106			
Information Element	Value/remark	Comment	Condition
p-NR-FR1	23	Power config A (NOTE 1)	
	20	Power config B (NOTE 2)	
NOTE 1: Applies when E-UTRA UL transmission not overlapping with NR UL transmission in time.			
NOTE 2: Applies when E-UTRA UL transmission overlapping with NR UL transmission in time.			

Table 6.2B.2.1.4.3-4: RRCConnectionReconfiguration: nr-Config-r15 for PC3

Derivation Path: TS 36.508 [11], Table 4.6.1-8			
Information Element	Value/remark	Comment	Condition
p-MaxEUTRA-r15	23	Power config A (NOTE 1)	
	20	Power config B (NOTE 2)	
NOTE 1: Applies when E-UTRA UL transmission not overlapping with NR UL transmission in time.			
NOTE 2: Applies when E-UTRA UL transmission overlapping with NR UL transmission in time.			

Table 6.2B.2.1.4.3-5: PhysicalCellGroupConfig for PC2

Derivation Path: TS 38.508-1 [6], Table 4.6.3-106			
Information Element	Value/remark	Comment	Condition
p-NR-FR1	26	Power config A (NOTE 1)	
	23	Power config B (NOTE 2)	
NOTE 1: Applies when E-UTRA UL transmission not overlapping with NR UL transmission in time.			
NOTE 2: Applies when E-UTRA UL transmission overlapping with NR UL transmission in time.			

Table 6.2B.2.1.4.3-6: RRCConnectionReconfiguration: nr-Config-r15 for PC2

Derivation Path: TS 36.508 [11], Table 4.6.1-8			
Information Element	Value/remark	Comment	Condition
p-MaxEUTRA-r15	26	Power config A (NOTE 1)	
	23	Power config B (NOTE 2)	
NOTE 1: Applies when E-UTRA UL transmission not overlapping with NR UL transmission in time.			
NOTE 2: Applies when E-UTRA UL transmission overlapping with NR UL transmission in time.			

6.2B.2.1.4.3-7: RRCConnectionReconfiguration: p-MaxUE-FR1-r15 (step 4 in 6.2B.2.1.4.2)

Derivation Path: TS 36.508 [11], Table 4.6.1-8			
Information Element	Value/remark	Comment	Condition
nonCriticalExtension SEQUENCE {		RRCConnectionReconfiguration-v1530-IEs	
p-MaxUE-FR1-r15	23		Power Class 2 UE
}			

Table 6.2B.2.1.4.3-8: RRCConnectionReconfiguration: tdm-PatternConfig if operating on FDD band

Derivation Path: TS 36.508 [11], Table 4.6.1-8			
Information Element	Value/remark	Comment	Condition
tdm-PatternConfig-r15 ::= CHOICE{			Power config A (NOTE 1)
setup ::= SEQUENCE {		Apply if operating on FDD band for a UE NOT indicating support of dynamicPowerSharing in the <i>UE-MRDC-Capability</i> IE according to TS 38.213 [x] clause 7.6.1	
subframeAssignment-r15	sa2		
harq-Offset-r15	0		
}			
}			
NOTE 1: Applies when E-UTRA UL transmission not overlapping with NR UL transmission in time.			

6.2B.2.1.5 Test requirement

The maximum output power, derived in step 3 shall be within the range prescribed by the UE Power Class, the nominal maximum output power and tolerance in table 6.2B.2.1.5-1/table 6.2B.2.1.5-2/ table 6.2B.2.1.5-5/ table 6.2B.2.1.5-6 for UE supporting dynamic power sharing and table 6.2B.2.1.5-3/table 6.2B.2.1.5-4/ table 6.2B.2.1.5-7/ table 6.2B.2.1.5-8 for UE not supporting dynamic power sharing.

The maximum output power, derived in step 4 shall be within the range prescribed by Power Class 3, the nominal maximum output power and tolerance in table 6.2B.2.1.5-1/table 6.2B.2.1.5-2/ table 6.2B.2.1.5-5/ table 6.2B.2.1.5-6 for UE supporting dynamic power sharing and table 6.2B.2.1.5-3/table 6.2B.2.1.5-4/ table 6.2B.2.1.5-7/ table 6.2B.2.1.5-8 for UE not supporting dynamic power sharing.

Table 6.2B.2.1.5-1: UE Power Class 3 test requirements, E-UTRA UL transmission overlapping with NR UL transmission

Configuration ID	Test SCS (kHz)	MPR _{tot} (dB)	P _{EN-DC, tot_L} (dBm)	P _{EN-DC, tot_H} (dBm)	T _{LOW} (P _{CMAX_L}) (dB)	T _{HIGH} (P _{CMAX_H}) (dB)	Upper limit (dBm)	Lower limit (dBm)
1, 8, 15, 22, 25, 28, 35, 42, 45 (NOTE 1)	15, 30, 60	3.0	20.0	23.0	6.0	2.0	25.0 + TT	14.0 - TT
2, 5, 9, 12, 16, 19, 23, 24, 26, 27, 29, 32, 36, 39, 43, 44, 46, 47 (NOTE 2)	15	11.0	12.0	23.0	6.0	2.0	25.0 + TT	6.0 - TT
	30, 60	6.0	17.0	23.0	5.0	2.0	25.0 + TT	12.0 - TT
48 (NOTE 3)	15	7.0	16.0	23.0	5.0	2.0	25.0 + TT	11.0 - TT
	30, 60	5.0	18.0	23.0	5.0	2.0	25.0 + TT	13.0 - TT

NOTE 1: Test configuration IDs with transmission overlap with full RB allocation, requirements in TS 38.101-3 [4] apply.
NOTE 2: Test configuration IDs with transmission overlap with 1RB allocation, requirements in TS 38.101-3 [4] apply.
NOTE 3: Test configuration IDs with transmission overlap with edge full RB allocation, requirements in TS 38.101-3 [4] apply.

Table 6.2B.2.1.5-2: UE Power Class 3 test requirements, UE supporting dynamic power sharing, E-UTRA UL transmission not overlapping with NR UL transmission

Configuration ID	Test SCS (kHz)	MPR (dB)	P _{CMAX, L} (dBm)	P _{CMAX, H} (dBm)	T _{LOW} (P _{CMAX_L}) (dB)	T _{HIGH} (P _{CMAX_H}) (dB)	Upper limit (dBm)	Lower limit (dBm)
3, 7, 10, 14, 17, 21, 30, 34, 37, 41 (NOTE 1)	15, 30, 60	1.0	22.0	23.0	2.0	2.0	25.0 + TT	20.0 - TT
4, 6 (NOTE 2)	15, 30, 60	3.5	19.5	23.0	2.0	2.0	25.0 + TT	17.5 - TT
11, 13 (NOTE 2)	15, 30, 60	1	22.0	23.0	2.0	2.0	25.0 + TT	20.0 - TT
18, 20 (NOTE 2)	15, 30, 60	2	21.0	23.0	2.0	2.0	25.0 + TT	19.0 - TT
31, 33, 38, 40 (NOTE 2)	15, 30, 60	3	20.0	23.0	2.0	2.0	25.0 + TT	18.0 - TT

NOTE 1: Test configuration IDs without transmission overlap with E-UTRA allocation, MPR requirements in TS 36.101 [4] apply.
NOTE 2: Test configuration IDs without transmission overlap with NR allocation, MPR requirements in TS 38.101-1 [2] apply.

Table 6.2B.2.1.5-3: UE Power Class 3 test requirements, UE not supporting dynamic power sharing, E-UTRA UL transmission overlapping with NR UL transmission

Configuration ID	Test SCS (kHz)	MPR _{tot} (dB)	P _{EN-DC, tot_L} (dBm)	P _{EN-DC, tot_H} (dBm)	T _{LOW} (P _{CMAX_L}) (dB)	T _{HIGH} (P _{CMAX_H}) (dB)	Upper limit (dBm)	Lower limit (dBm)
1, 8, 15, 22, 25, 28, 35, 42, 45 (NOTE 1)	15, 30, 60	6.0	17.0	23.0	5.0	2.0	25.0 + TT	12.0 - TT
2, 5, 9, 12, 16, 19, 23, 24, 26, 27, 29, 32, 36, 39, 43, 44, 46, 47 (NOTE 2)	15	14.0	9.0	23.0	7.0	2.0	25.0 + TT	2.0 - TT
	30, 60	9.0	14.0	23.0	6.0	2.0	25.0 + TT	8.0 - TT
48 (NOTE 3)	15, 30	9.0	14.0	23.0	6.0	2.0	25.0 + TT	8.0 - TT
	60	7.0	16.0	23.0	5.0	2.0	25.0 + TT	11.0 - TT

NOTE 1: Test configuration IDs with transmission overlap with full RB allocation, requirements in TS 38.101-3 [4] apply.
NOTE 2: Test configuration IDs with transmission overlap with 1RB allocation, requirements in TS 38.101-3 [4] apply.
NOTE 3: Test configuration IDs with transmission overlap with edge full RB allocation, requirements in TS 38.101-3 [4] apply.

Table 6.2B.2.1.5-4: UE Power Class 2 test requirements, UE supporting dynamic power sharing, E-UTRA UL transmission overlapping with NR UL transmission

Configuration ID	Test SCS (kHz)	MPR _{tot} (dB)	P _{EN-DC, tot_L} (dBm)	P _{EN-DC, tot_H} (dBm)	T _{LOW} (P _{CMAX_L}) (dB)	T _{HIGH} (P _{CMAX_H}) (dB)	Upper limit (dBm)	Lower limit (dBm)
1, 8, 15, 22, 25, 28, 35, 42, 45 (NOTE 1)	15, 30, 60	3.0	23.0	26.0	3.0	2.0	28.0 + TT	20.0 - TT
2, 5, 9, 12, 16, 19, 23, 24, 26, 27, 29, 32, 36, 39, 43, 44, 46, 47 (NOTE 2)	15	11.0	15.0	26.0	6.0	2.0	28.0 + TT	9.0 - TT
	30, 60	6.0	20.0	26.0	6.0	2.0	28.0 + TT	14.0 - TT
48 (NOTE 3)	15	7.0	19.0	26.0	5.0	2.0	28.0 + TT	14.0 - TT
	30, 60	5.0	21.0	26.0	5.0	2.0	28.0 + TT	16.0 - TT

NOTE 1: Test configuration IDs with transmission overlap with full RB allocation, requirements in TS 38.101-3 [4] apply.
NOTE 2: Test configuration IDs with transmission overlap with 1RB allocation, requirements in TS 38.101-3 [4] apply.
NOTE 3: Test configuration IDs with transmission overlap with edge full RB allocation, requirements in TS 38.101-3 [4] apply.

Table 6.2B.2.1.5-5: UE Power Class 2 test requirements, UE supporting dynamic power sharing, E-UTRA UL transmission not overlapping with NR UL transmission (Rel-15 UE or Rel-16 UE reporting (PC2 by $P_{PowerClass,NR}$, and PC2 or Not present by *powerClassNRPart-r16*))

Configuration ID	Test SCS (kHz)	MPR (dB)	$P_{CMAX,L}$ (dBm)	$P_{CMAX,H}$ (dBm)	T_{LOW} ($P_{CMAX,L}$) (dB)	T_{HIGH} ($P_{CMAX,H}$) (dB)	Upper limit (dBm)	Lower limit (dBm)
3, 7, 10, 14, 17, 21, 30, 34, 37, 41 (NOTE 1)	15, 30, 60	1.0	25.0	26.0	2.0	2.0	28.0 + TT	23.0 - TT
4, 6 (NOTE 2)	15, 30, 60	3.5	22.5	26.0	2.0	2.0	28.0 + TT	20.5 - TT
11, 13 (NOTE 2)	15, 30, 60	3.5	22.5	26.0	2.0	2.0	28.0 + TT	20.5 - TT
18, 20 (NOTE 2)	15, 30, 60	3.5	22.5	26.0	2.0	2.0	28.0 + TT	20.5 - TT
31,33, 38, 40 (NOTE 2)	15, 30, 60	3.5	22.5	26.0	2.0	2.0	28.0 + TT	20.5 - TT

NOTE 1: Test configuration IDs without transmission overlap with E-UTRA allocation, MPR requirements in TS 36.101 [4] apply.
NOTE 2: Test configuration IDs without transmission overlap with NR allocation, MPR requirements in TS 38.101-1 [2] apply.

Table 6.2B.2.1.5-5a: UE Power Class 2 test requirements, UE supporting dynamic power sharing, E-UTRA UL transmission not overlapping with NR UL transmission (Rel-16 UE reporting (PC2 by $P_{PowerClass,NR}$, and PC3 by *powerClassNRPart-r16*) or Rel-16 UE reporting (PC3 by $P_{PowerClass,NR}$))

Configuration ID	Test SCS (kHz)	MPR (dB)	$P_{CMAX,L}$ (dBm)	$P_{CMAX,H}$ (dBm)	T_{LOW} ($P_{CMAX,L}$) (dB)	T_{HIGH} ($P_{CMAX,H}$) (dB)	Upper limit (dBm)	Lower limit (dBm)
3, 7, 10, 14, 17, 21, 30, 34, 37, 41 (NOTE 1)	15, 30, 60	1.0	25.0	26.0	2.0	2.0	28.0 + TT	23.0 - TT
4, 6 (NOTE 2)	15, 30, 60	0.5	22.5	23.0	2.0	2.0	25.0 + TT	20.5 - TT
11, 13 (NOTE 2)	15, 30, 60	1.0	22.0	23.0	2.0	2.0	25.0 + TT	20.0 - TT
18, 20 (NOTE 2)	15, 30, 60	2.0	21.0	23.0	2.0	2.0	25.0 + TT	19.0 - TT
31,33, 38, 40 (NOTE 2)	15, 30, 60	3.0	20.0	23.0	2.5	2.0	25.0 + TT	17.5 - TT

NOTE 1: Test configuration IDs without transmission overlap with NR allocation, MPR requirements in TS 36.101 [4] apply.
NOTE 2: Test configuration IDs without transmission overlap with E-UTRA allocation, MPR requirements in TS 38.101-1 [2] apply.

Table 6.2B.2.1.5-6: UE Power Class 2 test requirements, UE not supporting dynamic power sharing, E-UTRA UL transmission overlapping with NR UL transmission

Configuration ID	Test SCS (kHz)	MPR _{tot} (dB)	P _{EN-DC, tot_L} (dBm)	P _{EN-DC, tot_H} (dBm)	T _{LOW} (P _{CMAX_L}) (dB)	T _{HIGH} (P _{CMAX_H}) (dB)	Upper limit (dBm)	Lower limit (dBm)
1, 8, 15, 22, 25, 28, 35, 42, 45 (NOTE 1)	15, 30, 60	6.0	20.0	26.0	6.0	2.0	28.0 + TT	14.0 - TT
2, 5, 9, 12, 16, 19, 23, 24, 26, 27, 29, 32, 36, 39, 43, 44, 46, 47 (NOTE 2)	15	14.0	12.0	26.0	6.0	2.0	28.0 + TT	6.0 - TT
	30, 60	9.0	17.0	26.0	5.0	2.0	28.0 + TT	12.0 - TT
48 (NOTE 3)	15, 30	9.0	17.0	26.0	5.0	2.0	28.0 + TT	12.0 - TT
	60	7.0	19.0	26.0	5.0	2.0	28.0 + TT	14.0 - TT

NOTE 1: Test configuration IDs with transmission overlap with full RB allocation, requirements in TS 38.101-3 [4] apply.
NOTE 2: Test configuration IDs with transmission overlap with 1RB allocation, requirements in TS 38.101-3 [4] apply.
NOTE 3: Test configuration IDs with transmission overlap with edge full RB allocation, requirements in TS 38.101-3 [4] apply.

Table 6.2B.2.1.5-7: Test Tolerance

	f ≤ 3.0GHz	3.0GHz < f ≤ 6GHz
BW ≤ 40MHz	0.7	1.0
40MHz < BW ≤ 100MHz	1.0	1.0

6.2B.2.2 UE Maximum Output Power reduction for Intra-Band Non-Contiguous EN-DC

6.2B.2.2.1 Test purpose

Same test purpose as in clause 6.2B.2.1.1.

6.2B.2.2.2 Test applicability

This test case applies to all types of E-UTRA UE release 15 and forward, supporting intra-band non-contiguous EN-DC.

6.2B.2.2.3 Minimum conformance requirements

When the UE is configured for intra-band non-contiguous EN-DC, the UE determines the total allowed maximum output power reduction as specified in this subclause.

For UE supporting dynamic power sharing the following:

- for the MCG, MPR_c in accordance with TS 36.101 [4]
- for the SCG,

$$MPR'_c = MPR_{NR} = \text{MAX}(MPR_{\text{single,NR}}, MPR_{\text{ENDC}})$$

- for the total configured transmission power,

$$MPR_{\text{tot}} = P_{\text{PowerClass,EN-DC}} - \min(P_{\text{PowerClass,EN-DC}}, 10 \cdot \log_{10}(10^{(P_{\text{PowerClass,E-UTRA}} - MPR_{\text{E-UTRA}})/10}) + 10^{(P_{\text{PowerClass,NR}} - MPR_{\text{NR}})/10}))$$

where

$$MPR_{\text{E-UTRA}} = \text{MAX}(MPR_{\text{single,E-UTRA}}, MPR_{\text{ENDC}})$$

with

- $MPR_{single, E-UTRA}$ is the MPR defined for the E-UTRA transmission in TS 36.101 [4]
- $MPR_{single, NR}$ is the MPR defined for the NR transmission in TS 38.101-1 [2]

For UEs not supporting dynamic power sharing the following

- for the MCG,

$$MPR_c = \text{MAX}(MPR_{single, E-UTRA}, MPR_{ENDC})$$

- for the SCG,

$$MPR'_c = \text{MAX}(MPR_{single, NR}, MPR_{ENDC})$$

where

- $MPR_{single, NR}$ is the MPR defined for the NR transmission in TS 38.101-1 [2]
- $MPR_{single, E-UTRA}$ is the MPR defined for the E-UTRA transmission in TS 36.101 [4]

MPR in this subclause is applicable for power class 3 and power class 2 UEs indicating IE *dualPA-Architecture* supported with ENDC power class being the same as the E-UTRA and NR power class, otherwise the UE can use as much MPR as needed to fulfil emissions requirements when scheduled with dual uplink transmission. For UEs scheduled with single uplink transmission, MPR in subclause 6.2.4 of TS 36.101 [5] and 6.2.3 of TS 38.101-1 [2] apply. The allowed maximum output power reduction for IM3 related emissions applied to transmission on the MCG and the SCG is defined as follows:

$$MPR_{ENDC} = M_A$$

Where M_A is defined as follows

$$M_A = \begin{array}{ll} 18 ; & 0 \leq B < 1.0 \\ 17 ; & 1.0 \leq B < 2.0 \\ 16 ; & 2.0 \leq B < 5.0 \\ 15 ; & 5.0 \leq B \end{array}$$

Where:

For UEs supporting dynamic power sharing,

$$B = (L_{CRB_alloc, E-UTRA} * 12 * SCS_{E-UTRA} + L_{CRB_alloc, NR} * 12 * SCS_{NR}) / 1,000.000$$

For UEs not supporting dynamic power sharing,

For E-UTRA

$$B = (L_{CRB_alloc, E-UTRA} * 12 * SCS_{E-UTRA} + 12 * SCS_{NR}) / 1,000.000$$

Where $SCS_{NR} = 15$ kHz is assumed in calculation of B.

For NR

$$B = (12 * SCS_{E-UTRA} + L_{CRB_alloc, NR} * 12 * SCS_{NR}) / 1,000.000$$

Where $SCS_{E-UTRA} = 15$ kHz is assumed in calculation of B.

and M_A is reduced by 1 dB for $B < 2$.

The normative reference for this requirement is TS 38.101-3 [4] clause 6.2B.2.2.

Exception requirements for both NR and E-UTRA are defined for this test when transmission on E-UTRA overlap in time with NR. LTE anchor agnostic approach is not applied for this case. E-UTRA test point analysis is included and E-UTRA measurements are performed.

Exception requirements for both NR and E-UTRA are defined for this test when transmission on E-UTRA doesn't overlap in time with NR, for a UE that doesn't support dynamic power sharing. LTE anchor agnostic approach is not applied for this case. E-UTRA test point analysis is included and E-UTRA measurements are performed.

No exception requirements for NR or E-UTRA are defined for this test when transmission on E-UTRA doesn't overlap in time with NR, for a UE that supports dynamic power sharing. LTE anchor agnostic approach is not applied for this case based on the test point analysis in TS 38.905 [7].

6.2B.2.2.4 Test description

6.2B.2.2.4.1 Initial conditions

Same initial conditions as described in clause 6.2B.2.1.4.1 for both E-UTRA and NR carriers with the following exception:

Table 6.2B.2.2.4.1-1: Test Configuration Table

Initial Conditions	
Test Frequencies as specified in TS 38.508 [7] clause 4.3.1 for different DC bandwidth classes	Low range, High range with MaxWGap

6.2B.2.2.4.2 Test procedure

Same test procedure as described in clause 6.2B.2.1.4.2.

6.2B.2.2.4.3 Message contents

Same message contents as in clause 6.2B.2.1.4.3. with the following exceptions:

- Instead of Table 6.2B.2.1.4.3-4 --> use Table 6.2B.2.2.4.3-1
- Instead of Table 6.2B.2.1.4.3-5 --> use Table 6.2B.2.2.4.3-2

6.2B.2.2.4.3-1: RRCConnectionReconfiguration: nr-Config-r15 for PC3

Derivation Path: TS 36.508 [11], Table 4.6.1-8			
Information Element	Value/remark	Comment	Condition
p-MaxEUTRA-r15	23	Power config A (NOTE 1)	
	20	Power config B (NOTE 2)	
	7	Power config C (NOTE 3)	
	4	Power config D (NOTE 3)	
	5	Power config E (NOTE 3)	SCS_15KHz
	6	Power config E (NOTE 3)	SCS_30kHz OR SCS_60kHz
P-Max	23	Power config A (NOTE 1)	
	20	Power config B (NOTE 2)	
	8	Power config C (NOTE 3)	
	5	Power config D (NOTE 3)	
	6	Power config E (NOTE 3)	SCS_15KHz
	7	Power config E (NOTE 3)	SCS_30kHz OR SCS_60kHz
NOTE 1: Applies when E-UTRA UL transmission not overlapping with NR UL transmission in time. NOTE 2: Applies when E-UTRA UL transmission overlapping with NR UL transmission in time and UE doesn't support dynamic power sharing. NOTE 3: Applies when E-UTRA UL transmission overlapping with NR UL transmission and UE supports dynamic power sharing.			

6.2B.2.2.4.3-2: RRCConnectionReconfiguration: nr-Config-r15 for PC2

Derivation Path: TS 36.508 [11], Table 4.6.1-8			
Information Element	Value/remark	Comment	Condition
p-MaxEUTRA-r15	26	Power config A (NOTE 1)	
	23	Power config B (NOTE 2)	
	10	Power config C (NOTE 3)	
	7	Power config D (NOTE 3)	
	8	Power config E (NOTE 3)	SCS_15KHz
	9	Power config E (NOTE 3)	SCS_30kHz OR SCS_60kHz
P-Max	26	Power config A (NOTE 1)	
	23	Power config B (NOTE 2)	
	11	Power config C (NOTE 3)	
	8	Power config D (NOTE 3)	
	9	Power config E (NOTE 3)	SCS_15KHz
	10	Power config E (NOTE 3)	SCS_30kHz OR SCS_60kHz
NOTE 1: Applies when E-UTRA UL transmission not overlapping with NR UL transmission in time.			
NOTE 2: Applies when E-UTRA UL transmission overlapping with NR UL transmission in time and UE doesn't support dynamic power sharing.			
NOTE 3: Applies when E-UTRA UL transmission overlapping with NR UL transmission and UE supports dynamic power sharing.			

6.2B.2.2.5 Test requirement

The maximum output power, derived in step 3 shall be within the range prescribed by the nominal maximum output power and tolerance in table 6.2B.2.2.5-1/table 6.2B.2.2.5-2/table 6.2B.2.2.5-5/table 6.2B.2.2.5-6 for UE supporting dynamic power sharing and table 6.2B.2.2.5-3/table 6.2B.2.2.5-4/table 6.2B.2.2.5-7/table 6.2B.2.2.5-8 for UE not supporting dynamic power sharing.

Table 6.2B.2.2.5-1: UE Power Class 3 test requirements, UE supporting dynamic power sharing, E-UTRA UL transmission overlapping with NR UL transmission

Configuration ID	Test SCS (kHz)	MPR _{tot} (dB)	P _{EN-DC, tot_L} (dBm)	P _{EN-DC, tot_H} (dBm)	T _{LOW} (P _{CMAX_L}) (dB)	T _{HIGH} (P _{CMAX_H}) (dB)	Upper limit (dBm)	Lower limit (dBm)
1, 8, 15, 22, 25, 28, 35, 42, 45 (NOTE 1)	15, 30, 60	12.0	11.0	23.0	6.0	4.0	27.0 + TT	5.0 - TT
2, 5, 9, 12, 16, 19, 23, 24, 26, 27, 29, 32, 36, 39, 43, 44, 46, 47 (NOTE 2)	15, 30, 60	15.0	8.0	23.0	7.0	4.0	27.0 + TT	1.0 - TT
48 (NOTE 3)	15	14.0	9.0	23.0	7.0	4.0	27.0 + TT	2.0 - TT
	30, 60	13.0	10.0	23.0	7.0	4.0	27.0 + TT	3.0 - TT
NOTE 1: Test configuration IDs with transmission overlap with full RB allocation, requirements in TS 38.101-3 [4] apply.								
NOTE 2: Test configuration IDs with transmission overlap with 1RB allocation, requirements in TS 38.101-3 [4] apply.								
NOTE 3: Test configuration IDs with transmission overlap with edge full RB allocation, requirements in TS 38.101-3 [4] apply.								

Table 6.2B.2.2.5-2: UE Power Class 3 test requirements, UE supporting dynamic power sharing, E-UTRA UL transmission not overlapping with NR UL transmission

Configuration ID	Test SCS (kHz)	MPR (dB)	$P_{\text{CMAX, L}}$ (dBm)	$P_{\text{CMAX, H}}$ (dBm)	$T_{\text{LOW}} (P_{\text{CMAX, L}})$ (dB)	$T_{\text{HIGH}} (P_{\text{CMAX, H}})$ (dB)	Upper limit (dBm)	Lower limit (dBm)
3, 7, 10, 14, 17, 21, 30, 34, 37, 41 (NOTE 1)	15, 30, 60	1.0	22.0	23.0	2.0	2.0	25.0 + TT	20.0 - TT
4, 6 (NOTE 2)	15, 30, 60	3.5	19.5	23.0	2.0	2.0	25.0 + TT	17.5 - TT
11, 13 (NOTE 2)	15, 30, 60	1	22.0	23.0	2.0	2.0	25.0 + TT	20.0 - TT
18, 20 (NOTE 2)	15, 30, 60	2	21.0	23.0	2.0	2.0	25.0 + TT	19.0 - TT
31, 33, 38, 40 (NOTE 2)	15, 30, 60	3	20.0	23.0	2.0	2.0	25.0 + TT	18.0 - TT

NOTE 1: Test configuration IDs without transmission overlap with E-UTRA allocation, MPR requirements in TS 36.101 [4] apply.
NOTE 2: Test configuration IDs without transmission overlap with NR allocation, MPR requirements in TS 38.101-1 [2] apply.

Table 6.2B.2.2.5-3: UE Power Class 3 test requirements, UE not supporting dynamic power sharing, E-UTRA UL transmission overlapping with NR UL transmission

Configuration ID	Test SCS (kHz)	MPR_{tot} (dB)	$P_{\text{EN-DC, tot, L}}$ (dBm)	$P_{\text{EN-DC, tot, H}}$ (dBm)	$T_{\text{LOW}} (P_{\text{CMAX, L}})$ (dB)	$T_{\text{HIGH}} (P_{\text{CMAX, H}})$ (dB)	Upper limit (dBm)	Lower limit (dBm)
1, 8, 15, 22, 25, 28, 35, 42, 45 (NOTE 1)	15, 30, 60	15.0	8.0	23.0	7.0	4.0	27.0 + TT	1.0 - TT
2, 5, 9, 12, 16, 19, 23, 24, 26, 27, 29, 32, 36, 39, 43, 44, 46, 47 (NOTE 2)	15, 30, 60	17.0	6.0	23.0	7.0	4.0	27.0 + TT	-1.0 - TT
48 (NOTE 3)	15, 30	17.0	6.0	23.0	7.0	4.0	27.0 + TT	-1.0 - TT
	60	16.5	6.5	23.0	7.0	4.0	27.0 + TT	-0.5 - TT

NOTE 1: Test configuration IDs with transmission overlap with full RB allocation, requirements in TS 38.101-3 [4] apply.
NOTE 2: Test configuration IDs with transmission overlap with 1RB allocation, requirements in TS 38.101-3 [4] apply.
NOTE 3: Test configuration IDs with transmission overlap with edge full RB allocation, requirements in TS 38.101-3 [4] apply.

Table 6.2B.2.2.5-4: UE Power Class 3 test requirements, UE not supporting dynamic power sharing, E-UTRA UL transmission not overlapping with NR UL transmission

Configuration ID	Test SCS (kHz)	MPR (dB)	$P_{\text{CMAX, L}}$ (dBm)	$P_{\text{CMAX, H}}$ (dBm)	$T_{\text{LOW}} (P_{\text{CMAX, L}})$ (dB)	$T_{\text{HIGH}} (P_{\text{CMAX, H}})$ (dB)	Upper limit (dBm)	Lower limit (dBm)
3, 4, 6, 7, 10, 11, 13, 14, 17, 18, 20, 21, 30, 31, 34, 37, 38, 40, 41	15, 30, 60	17.0	6.0	23.0	7.0	4.0	27.0 + TT	-1.0 - TT

NOTE: Test configuration IDs without transmission overlap with 1RB allocation, requirements in TS 38.101-3 [4] apply.

Table 6.2B.2.2.5-5: UE Power Class 2 test requirements, UE supporting dynamic power sharing, E-UTRA UL transmission overlapping with NR UL transmission

Configuration ID	Test SCS (kHz)	MPR _{tot} (dB)	P _{EN-DC, tot_L} (dBm)	P _{EN-DC, tot_H} (dBm)	T _{LOW} (P _{CMAX_L}) (dB)	T _{HIGH} (P _{CMAX_H}) (dB)	Upper limit (dBm)	Lower limit (dBm)
1, 8, 15, 22, 25, 28, 35, 42, 45 (NOTE 1)	15, 30, 60	12.0	14.0	26.0	6.0	4.0	30.0 + TT	8.0 - TT
2, 5, 9, 12, 16, 19, 23, 24, 26, 27, 29, 32, 36, 39, 43, 44, 46, 47 (NOTE 2)	15, 30, 60	15.0	11.0	26.0	6.0	4.0	30.0 + TT	5.0 - TT
48 (NOTE 3)	15	14.0	12.0	26.0	6.0	4.0	30.0 + TT	6.0 - TT
	30, 60	13.0	13.0	26.0	6.0	4.0	30.0 + TT	7.0 - TT

NOTE 1: Test configuration IDs with transmission overlap with full RB allocation, requirements in TS 38.101-3 [4] apply.
NOTE 2: Test configuration IDs with transmission overlap with 1RB allocation, requirements in TS 38.101-3 [4] apply.
NOTE 3: Test configuration IDs with transmission overlap with edge full RB allocation, requirements in TS 38.101-3 [4] apply.

Table 6.2B.2.2.5-6: UE Power Class 2 test requirements, UE supporting dynamic power sharing, E-UTRA UL transmission not overlapping with NR UL transmission (Rel-15 UE or Rel-16 UE reporting (PC2 by P_{PowerClass,NR}, and PC2 or Not present by powerClassNRPart-r16))

Configuration ID	Test SCS (kHz)	MPR (dB)	P _{CMAX, L} (dBm)	P _{CMAX, H} (dBm)	T _{LOW} (P _{CMAX_L}) (dB)	T _{HIGH} (P _{CMAX_H}) (dB)	Upper limit (dBm)	Lower limit (dBm)
3, 7, 10, 14, 17, 21, 30, 34, 37, 41 (NOTE 1)	15, 30, 60	1.0	25.0	26.0	2.0	2.0	28.0 + TT	23.0 - TT
4, 6 (NOTE 2)	15, 30, 60	3.5	22.5	26.0	2.0	2.0	28.0 + TT	20.5 - TT
11, 13 (NOTE 2)	15, 30, 60	3.5	22.5	26.0	2.0	2.0	28.0 + TT	20.5 - TT
18, 20 (NOTE 2)	15, 30, 60	3.5	22.5	26.0	2.0	2.0	28.0 + TT	20.5 - TT
31, 33, 38, 40 (NOTE 2)	15, 30, 60	3.5	22.5	26.0	2.0	2.0	28.0 + TT	20.5 - TT

NOTE 1: Test configuration IDs without transmission overlap with E-UTRA allocation, MPR requirements in TS 36.101 [4] apply.
NOTE 2: Test configuration IDs without transmission overlap with NR allocation, MPR requirements in TS 38.101-1 [2] apply.

Table 6.2B.2.2.5-6a: UE Power Class 2 test requirements, UE supporting dynamic power sharing, E-UTRA UL transmission not overlapping with NR UL transmission (Rel-16 UE reporting (PC2 by $P_{PowerClass,NR}$, and PC3 by $powerClassNRPart-r16$) or Rel-16 UE reporting (PC3 by $P_{PowerClass,NR}$))

Configuration ID	Test SCS (kHz)	MPR (dB)	$P_{CMAX,L}$ (dBm)	$P_{CMAX,H}$ (dBm)	T_{LOW} ($P_{CMAX,L}$) (dB)	T_{HIGH} ($P_{CMAX,H}$) (dB)	Upper limit (dBm)	Lower limit (dBm)
3, 7, 10, 14, 17, 21, 30, 34, 37, 41 (NOTE 1)	15, 30, 60	1.0	25.0	26.0	2.0	2.0	28.0 + TT	23.0 - TT
4, 6 (NOTE 2)	15, 30, 60	0.5	22.5	23.0	2.0	2.0	25.0 + TT	20.5 - TT
11, 13 (NOTE 2)	15, 30, 60	1.0	22.0	23.0	2.0	2.0	25.0 + TT	20.0 - TT
18, 20 (NOTE 2)	15, 30, 60	2.0	21.0	23.0	2.0	2.0	25.0 + TT	19.0 - TT
31, 33, 38, 40 (NOTE 2)	15, 30, 60	3.0	20.0	23.0	2.0	2.0	25.0 + TT	17.5 - TT

NOTE 1: Test configuration IDs without transmission overlap with E-UTRA allocation, MPR requirements in TS 36.101 [4] apply.
NOTE 2: Test configuration IDs without transmission overlap with NR allocation, MPR requirements in TS 38.101-1 [2] apply.

Table 6.2B.2.2.5-7: UE Power Class 2 test requirements, UE not supporting dynamic power sharing, E-UTRA UL transmission overlapping with NR UL transmission

Configuration ID	Test SCS (kHz)	MPR_{tot} (dB)	$P_{EN-DC,tot,L}$ (dBm)	$P_{EN-DC,tot,H}$ (dBm)	T_{LOW} ($P_{CMAX,L}$) (dB)	T_{HIGH} ($P_{CMAX,H}$) (dB)	Upper limit (dBm)	Lower limit (dBm)
1, 8, 15, 22, 25, 28, 35, 42, 45 (NOTE 1)	15, 30, 60	15.0	11.0	26.0	6.0	4.0	30.0 + TT	5.0 - TT
2, 5, 9, 12, 16, 19, 23, 24, 26, 27, 29, 32, 36, 39, 43, 44, 46, 47 (NOTE 2)	15, 30, 60	17.0	9.0	26.0	7.0	4.0	30.0 + TT	2.0 - TT
48 (NOTE 3)	15, 30	17.0	9.0	26.0	7.0	4.0	30.0 + TT	2.0 - TT
	60	16.0	10.0	26.0	7.0	4.0	30.0 + TT	3.0 - TT

NOTE 1: Test configuration IDs with transmission overlap with full RB allocation, requirements in TS 38.101-3 [4] apply.
NOTE 2: Test configuration IDs with transmission overlap with 1RB allocation, requirements in TS 38.101-3 [4] apply.
NOTE 3: Test configuration IDs with transmission overlap with edge full RB allocation, requirements in TS 38.101-3 [4] apply.

Table 6.2B.2.2.5-8: UE Power Class 2 test requirements, UE not supporting dynamic power sharing, E-UTRA UL transmission not overlapping with NR UL transmission (Rel-15 UE or Rel-16 UE reporting (PC2 by $P_{PowerClass,NR}$, and PC2 or Not present by $powerClassNRPart-r16$))

Configuration ID	Test SCS (kHz)	MPR (dB)	$P_{CMAX,L}$ (dBm)	$P_{CMAX,H}$ (dBm)	T_{LOW} ($P_{CMAX,L}$) (dB)	T_{HIGH} ($P_{CMAX,H}$) (dB)	Upper limit (dBm)	Lower limit (dBm)
3, 4, 6, 7, 10, 11, 13, 14, 17, 18, 20, 21, 30, 31, 34, 37, 38, 40, 41	15, 30, 60	17.0	9.0	26.0	7.0	4.0	30.0 + TT	2.0 - TT

NOTE: Test configuration IDs without transmission overlap with 1RB allocation, requirements in TS 38.101-3 [4] apply.

Table 6.2B.2.2.5-8a: UE Power Class 2 test requirements, UE not supporting dynamic power sharing, E-UTRA UL transmission not overlapping with NR UL transmission (Rel-16 UE reporting (PC2 by $P_{PowerClass,NR}$, and PC3 by *powerClassNRPart-r16*) or Rel-16 UE reporting (PC3 by $P_{PowerClass,NR}$))

Configuration ID	Test SCS (kHz)	MPR (dB)	$P_{CMAX,L}$ (dBm)	$P_{CMAX,H}$ (dBm)	T_{LOW} ($P_{CMAX,L}$) (dB)	T_{HIGH} ($P_{CMAX,H}$) (dB)	Upper limit (dBm)	Lower limit (dBm)
3, 7, 10, 14, 17, 21, 30, 34, 37, 41 (NOTE 1)	15, 30, 60	17.0	9.0	26.0	7.0	4.0	30.0 + TT	2.0 - TT
4, 6, 11, 13, 18, 20, 31, 33, 38, 40 (NOTE 2)	15, 30, 60	17.0	6.0	23.0	7.0	2.0	25.0 + TT	-1.0 - TT

NOTE 1: Test configuration IDs without transmission overlap with NR allocation, MPR requirements in TS 38.101-3 [4] apply.
NOTE 2: Test configuration IDs without transmission overlap with E-UTRA allocation, MPR requirements in TS 38.101-3 [4] apply.

Table 6.2B.2.2.5-9: Test Tolerance

	$f \leq 3.0\text{GHz}$	$3.0\text{GHz} < f \leq 6\text{GHz}$
$BW \leq 40\text{MHz}$	0.7	1.0
$40\text{MHz} < BW \leq 100\text{MHz}$	1.0	1.0

6.2B.2.3 UE Maximum Output Power reduction for Inter-Band EN-DC within FR1

6.2B.2.3.1 Test purpose

Same test purpose as in clause 6.2.2.1 in TS 38.521-1 [8] for the NR carrier.

6.2B.2.3.2 Test applicability

The requirements of this test apply to all types of E-UTRA UE release 15 and forward, supporting inter-band EN-DC within FR1.

6.2B.2.3.3 Minimum conformance requirements

For inter-band EN-DC between E-UTRA and FR1 NR, UE maximum output power reduction specified in TS 36.101 [5] and TS 38.101-1 [2] apply for E-UTRA and NR respectively.

The normative reference for this requirement is TS 38.101-3 [4] clause 6.2B.2.3.

No exception requirements applicable to NR or LTE. LTE anchor agnostic approach is applied.

6.2B.2.3.4 Test description

Same test description as in clause 6.2.2.4 in TS 38.521-1 [8] for the NR carrier with the following exceptions:

The initial test configurations for E-UTRA band consist of environmental conditions, test frequencies, and channel bandwidths based on E-UTRA bands specified in Table 4.6-1.

For Initial conditions as in clause 6.2.2.4.1 in TS 38.521-1 [8], the following steps will be added to configure E-UTRA component:

- 2.1. The parameter settings for the E-UTRA cell are set up according to TS 36.508 [11] clause 4.4.3 with E-UTRA channel bandwidth and test frequencies defined in Table 4.6-1.
- 3.1. Downlink E-UTRA signals are initially set up according to TS 36.521-1 [10] Annex C0, C.1 and C.3.0, and uplink signals according to Annex H.1 and H.3.0.

4.1. The E-UTRA UL Reference Measurement channels are set according to Table 4.6-1.

Step 6 of Initial conditions as in clause 6.2.2.4.1 in TS 38.521-1 [8] is replaced by:

6. Ensure the UE is in state RRC_CONNECTED with generic procedure parameters Connectivity EN-DC, DC bearer MCG and SCG according to TS 38.508 [6] clause 4.5.

Same test procedure as in clause 6.2.2.4.2 in TS 38.521-1 [8].

6.2B.2.3.5 Test requirement

For Rel-15 UE or Rel-16 PC3 UE, same test requirement as in clause 6.2.2.5 in TS 38.521-1 [8].

For Rel-16 PC2 UE reporting (PC2 by $P_{\text{PowerClass,NR}}$, and PC2 or Not present by *powerClassNRPart-r16*), same test requirement for PC2 UE as in clause 6.2.2.5 in TS 38.521-1 [8]. For Rel-16 PC2 UE reporting (PC2 by $P_{\text{PowerClass,NR}}$, and PC3 by *powerClassNRPart-r16*) or Rel-16 PC2 UE reporting (PC3 by $P_{\text{PowerClass,NR}}$), same test requirement for PC3 UE as in clause 6.2.2.5 in TS 38.521-1 [8].

6.2B.2.4 UE Maximum Output Power reduction for Inter-Band EN-DC including FR2

Editor's note: Following aspects are missing or under discussion

- **The referred test case 6.2.2 in TS 38.521-2 [9] is incomplete for PC1, PC2 and PC4.**

6.2B.2.4.1 Test purpose

To verify that the error of the UE maximum output power does not exceed the range prescribed by the specified maximum output power with MPR and tolerance.

An excess maximum output power has the possibility to interfere to other channels or other systems. A small maximum output power decreases the coverage area.

6.2B.2.4.2 Test applicability

This test case applies to all types of E-UTRA UE release 15 and forward, supporting inter-band EN-DC including FR2.

6.2B.2.4.3 Minimum conformance requirements

UE maximum output power reduction requirement for E-UTRA single carrier and CA operation specified in clauses 6.2.3 and 6.2.3A of TS 36.101[5] and for NR single carrier and CA operation specified in clauses 6.2.2, 6.2A.2, and 6.2D.2 of TS 38.101-2 [3] apply.

The normative reference for this requirement is TS 38.101-3 [4] clause 6.2B.2.4.

No exception requirements applicable to NR or LTE. LTE anchor agnostic approach is applied.

6.2B.2.4.4 Test description

6.2B.2.4.4.1 Initial conditions

Same test description as in clause 6.2.2.4 in TS 38.521-2 [9] for the NR carrier with the following exceptions:

The initial test configurations for E-UTRA band consist of environmental conditions, test frequencies, and channel bandwidths based on E-UTRA bands specified in Table 4.6-1.

For Initial conditions as in clause 6.2.2.4.1 in TS 38.521-2 [9], the following steps will be added to configure E-UTRA component:

- 2.1. The parameter settings for the E-UTRA cell are set up according to TS 36.508 [11] clause 4.4.3 with E-UTRA channel bandwidth and test frequencies defined in Table 4.6-1.
- 3.1. Downlink E-UTRA signals are initially set up according to TS 36.521-1 [10] Annex C, clauses C.0, C.1 and C.3.0, and uplink signals according to Annex H, clauses H.1 and H.3.0.

4.1. The E-UTRA UL Reference Measurement channels are set according to Table 4.6-1.

Step 6 of Initial conditions as in clause 6.2.2.4.1 in TS 38.521-2 [9] is replaced by:

6. Ensure the UE is in state RRC_CONNECTED with generic procedure parameters Connectivity EN-DC, DC bearer MCG and SCG according to TS 38.508 [6] clause 4.5.

Same test procedure as in clause 6.2.2.4.2 in TS 38.521-2 [9] with the following steps added for E-UTRA component:

- 1.1 On the E-UTRA carrier, disable periodic and aperiodic CQI reports, disable SRS, set *TimeAlignmentTimerDedicated* IE to infinity and disable downlink and uplink scheduling, all as per Table 4.7-1 under clause 4.7.

6.2B.2.4.5 Test requirement

Same test requirement as in clause 6.2.2.5 in TS 38.521-2 [9] for the NR carrier.

6.2B.2.5 UE Maximum Output power reduction for inter-band EN-DC including both FR1 and FR2

6.2B.2.5.1 Test purpose

Same test purpose as in clause 6.2B.2.3.1 in TS 38.521-1 [8] for NR FR1 carrier(s) and clause 6.2B.2.4.1 in TS 38.521-2 [9] for NR FR2 carrier(s).

6.2B.2.5.2 Test applicability

The requirements in this test are not testable due to issues with combined testing of NR FR1 and E-UTRA in conducted mode with NR FR2 in radiated mode. Therefore, the conducted and radiated requirements are tested separately.

No test case details are specified. The NSA requirements for maximum output power apply and are tested as part of the EN-DC within FR1 and EN-DC including FR2 test cases in clause 6.2B.

6.2B.3 UE additional maximum output power reduction for EN-DC

6.2B.3.1 UE Additional Maximum Output Power reduction for Intra-band contiguous EN-DC

Editor's note:

- **Test requirements for non-overlapping transmission of non-DPS UE need further investigation**

6.2B.3.1.1 Test purpose

Additional emission requirements can be signalled by the network with network signalling value indicated by the field *additionalSpectrumEmission*. To meet these additional requirements, additional maximum power reduction (A-MPR) is allowed for the maximum output power as specified in Table 6.2B.1.1.3-1. Unless stated otherwise, an A-MPR of 0 dB shall be used.

6.2B.3.1.2 Test applicability

The requirements of this test apply in test case 6.5B.2.1.2 Additional spectrum emission mask for network signalled values NS_04 and NS_35 to all types of E-UTRA power class 3 and power class 2 UE release 15 and forward, supporting intra-band contiguous EN-DC.

6.2B.3.1.3 Minimum conformance requirements

For intra-band contiguous EN-DC band combinations with additional requirements the allowed A-MPR is specified in table 6.2B.3.1.3-1 for UEs configured with EN-DC and combinations of network signalling values indicated in the E-UTRA and NR cell groups.

Unless otherwise stated the A-MPR specified in subclause 6.2B.3.1 for intra-band contiguous EN-DC configurations is the total power reduction allowed including MPR.

Table 6.2B.3.1.3-1: Additional maximum power reduction for Intra-band contiguous EN-DC

DC configuration	Requirement (subclause)	E-UTRA network signalling value	NR network signalling value	A-MPR (clause)
DC_(n)71AA	6.5B.2.1.2.3.1	NS_35	NS_35	6.2B.3.1.3.1 ³
DC_(n)41AA ¹	6.5B.2.1.2.3.2	NS_01 or NS_04	NS_04	6.2B.3.1.3.2 ⁴
NOTE 1: Only applies to UEs that support dual UL transmission for this EN-DC combination.				
NOTE 2: The additional emission requirement is indicated when the combination of network signalling values in the two CGs is set (only for UEs configured with EN-DC).				
NOTE 3: The A-MPR is applied as MPR if NS_35 is not signalled.				
NOTE 4: Void.				

The normative reference for this requirement is TS 38.101-3 [4] clause 6.2B.3.1.

Exception requirements for both NR and E-UTRA are defined for this test when transmission on E-UTRA overlap in time with NR. LTE anchor agnostic approach is not applied for this case. E-UTRA test point analysis is included and E-UTRA measurements are performed.

Exception requirements for both NR and E-UTRA are defined for this test when transmission on E-UTRA doesn't overlap in time with NR, for a UE that doesn't support dynamic power sharing. LTE anchor agnostic approach is not applied for this case. E-UTRA test point analysis is included and E-UTRA measurements are performed.

No exception requirements for NR or E-UTRA are defined for this test when transmission on E-UTRA doesn't overlap in time with NR, for a UE that supports dynamic power sharing. LTE anchor agnostic approach is not applied for this case.

6.2B.3.1.3.1 A-MPR for DC_(n)71AA

For UE supporting dynamic power sharing the following:

- for the MCG, A-MPR_c in accordance with TS 36.101 [5]
- for the SCG, A-MPR'_c = [A-MPR_{DC}]
- for the total configured transmission power, A-MPR_{tot} = A-MPR_{DC}

with A-MPR_{DC} as defined in this subclause.

For UEs not supporting dynamic power sharing the following

- for the MCG,
A-MPR_c = A-MPR_{E-UTRA}
- for the SCG,
A-MPR'_c = A-MPR_{NR}

with A-MPR_{E-UTRA} and A-MPR_{NR} as defined in this subclause.

For DC_(n)71AA with configured with network signaling values as per Table 6.2B.3.1.0-1 the allowed A-MPR is defined by

- for UE indicating support of dynamicPowerSharing in the *UE-MRDC-Capability* IE

$$A\text{-MPR}_{DC} = \text{CEIL}\{ M_{A,DC}(A), 0.5 \}$$

where A-MPR_{DC} is the total power reduction allowed (dB),

- for OFDM:

$$M_{A,DC} = 11.00 - 11.67 * A; \quad 0.00 < A \leq 0.30$$

$$8.10 - 2.00 * A; \quad 0.30 < A \leq 0.80$$

$$6.50; \quad 0.80 < A \leq 1.00$$

- for DFT-S-OFDM:

$$M_{A,DC} = 11.00 - 13.33 * A; \quad 0.00 < A \leq 0.30$$

$$8.00 - 3.33 * A; \quad 0.30 < A \leq 0.60$$

$$6.00; \quad 0.60 < A \leq 1.00$$

where:

$$A = \frac{L_{CRB,E-UTRA} + L_{CRB,NR}}{N_{RB,E-UTRA} + N_{RB,NR}}$$

with $L_{CRB,E-UTRA}$ and $N_{RB,E-UTRA}$ the number of allocated PRB and transmission bandwidth for MCG, $L_{CRB,NR}$ and $N_{RB,NR}$ the number of allocated PRB and transmission bandwidth for SCG with SCS = 15 kHz.

- for UE not indicating support of dynamicPowerSharing

$$A\text{-MPR}_{E-UTRA} = \text{CEIL}\{ M_{A,E-UTRA}, 0.5 \}$$

$$A\text{-MPR}_{NR} = \text{CEIL}\{ M_{A,NR}, 0.5 \}$$

where A-MPR is the total power reduction allowed per CG with

$$M_{A,E-UTRA} = M_{A,DC}(A_{E-UTRA,wc}) - 1 - \Delta_{E-UTRA}$$

$$M_{A,NR} = M_{A,DC}(A_{NR,wc}) - 1 - \Delta_{NR}$$

$$A_{E-UTRA,wc} = \frac{L_{CRB,E-UTRA} + 1}{N_{RB,E-UTRA} + N_{RB,NR}}$$

$$A_{NR,wc} = \frac{1 + L_{CRB,NR}}{N_{RB,E-UTRA} + N_{RB,NR}}$$

$$\Delta_{E-UTRA} = 10 \log_{10} \frac{N_{RB,E-UTRA}}{N_{RB,E-UTRA} + N_{RB,NR}}$$

$$\Delta_{NR} = 10 \log_{10} \frac{N_{RB,NR}}{N_{RB,E-UTRA} + N_{RB,NR}}$$

Where $L_{CRB,NR}$ and $N_{RB,NR}$ the number of allocated PRB and transmission bandwidth for SCG with SCS = 15 kHz.

6.2B.3.1.3.2 A-MPR for NS_04

6.2B.3.1.3.2.0 General

When the UE is configured for B41/n41 intra-band contiguous EN-DC and it receives IE NS_04, the UE determines the total allowed maximum output power reduction as specified in this clause. The A-MPR for EN-DC defined in this clause is used instead of MPR defined in 6.2B.2.2, not additively, so EN-DC MPR = 0 when NS_04 is signaled. For UEs scheduled with single uplink transmission, AMPR in subclause 6.2.4 of [5] and 6.2.3 of [2] apply.

For UE supporting dynamic power sharing the following:

- for the MCG, A-MPR_c in accordance with 36.101 [5]
- for the SCG,

$$A\text{-MPR}'_c = A\text{-MPR}_{NR} = \text{MAX}(A\text{-MPR}_{\text{single,NR}}, A\text{-MPR}_{IM3})$$

- for the total configured transmission power,

$$A\text{-MPR}_{\text{tot}} = P_{\text{PowerClass,EN-DC}} - \min(P_{\text{PowerClass,EN-DC}}, 10 * \log_{10}(10^{(P_{\text{PowerClass,E-UTRA}} - A\text{-MPR}_{E-UTRA})/10}) + 10^{(P_{\text{PowerClass,NR}} - A\text{-MPR}_{NR})/10}))$$

where

$$A\text{-MPR}_{E\text{-UTRA}} = \text{MAX}(A\text{-MPR}_{\text{single},E\text{-UTRA}} + \text{MPR}_{\text{single},E\text{-UTRA}}, A\text{-MPR}_{\text{IM3}})$$

with

- $A\text{-MPR}_{\text{single}, E\text{-UTRA}}$ is the A-MPR defined for the E-UTRA transmission in TS 36.101 [5]
- $A\text{-MPR}_{\text{single},\text{NR}}$ is the A-MPR defined for the NR transmission in TS 38.101-1 [2]
- $\text{MPR}_{\text{single},E\text{-UTRA}}$ is the MPR defined for the E-UTRA transmission in TS 36.101 [5]

For UEs not supporting dynamic power sharing the following

- for the MCG,

$$A\text{-MPR}'_c = \text{MAX}(A\text{-MPR}_{\text{single}, E\text{-UTRA}} + \text{MPR}_{\text{single},E\text{-UTRA}}, A\text{-MPR}_{\text{IM3}})$$

- for the SCG,

$$A\text{-MPR}'_c = \text{MAX}(A\text{-MPR}_{\text{single},\text{NR}}, A\text{-MPR}_{\text{IM3}})$$

where

- $A\text{-MPR}_{\text{single}, E\text{-UTRA}}$ is the A-MPR defined for the E-UTRA transmission in TS 36.101 [5]
- $A\text{-MPR}_{\text{single},\text{NR}}$ is the A-MPR defined for the NR transmission in TS 38.101-1 [2]
- $\text{MPR}_{\text{single},E\text{-UTRA}}$ is the MPR defined for the E-UTRA transmission in TS 36.101 [5]

The UE determines the Channel Configuration Case and the value of $A\text{-MPR}_{\text{IM3}}$ as follows:

If $F_{\text{IM3},\text{low_block},\text{low}} < 2490.5$ MHz

Channel Configuration Case B. $A\text{-MPR}_{\text{IM3}}$ defined in clause 6.2B.3.1.3.2.2.

Else

Channel Configuration Case A. $A\text{-MPR}_{\text{IM3}}$ defined in clause 6.2B.3.1.3.2.1.

where

- $F_{\text{IM3},\text{low_block},\text{low}} = (2 * F_{\text{low_channel},\text{low_edge}}) - F_{\text{high_channel},\text{high_edge}}$
- $F_{\text{low_channel},\text{low_edge}}$ is the lowermost frequency of lower transmission bandwidth configuration.
- $F_{\text{high_channel},\text{high_edge}}$ is the uppermost frequency of upper transmission bandwidth configuration.

Where the transmission bandwidth configuration for NR is the maximum frequency span covering all the configured SCSSpecificCarrier for scenarios that carrier bandwidths with different SCS can be fully overlapped.

6.2B.3.1.3.2.1 $A\text{-MPR}_{\text{IM3}}$ for NS_04 to meet -13 dBm / 1MHz for 26dBm UE power

$A\text{-MPR}$ in this subclause is relative to 26 dBm for a power class 2 Cell Group. The same $A\text{-MPR}$ is used relative to 23 dBm for a power class 3 Cell Group. For the UE is configured with channel configurations Case A or Case C (defined in Clause 6.2B.3.2.3.1), the allowed maximum output power reduction for IM3s applied to transmission on the MCG and the SCG with non-contiguous resource allocation is defined as follows:

$$A\text{-MPR}_{\text{IM3}} = M_A$$

Where M_A is defined as follows

$$M_A = 15 ; 0 \leq B < 0.5$$

$$10 ; 0.5 \leq B < 1.0$$

$$8 ; 1.0 \leq B < 2.0$$

$$6 ; 2.0 \leq B$$

Where:

For UEs supporting dynamic power sharing,

$$B = (L_{CRB_alloc, E-UTRA} * 12 * SCS_{E-UTRA} + L_{CRB_alloc, NR} * 12 * SCS_{NR}) / 1,000,000$$

For UEs not supporting dynamic power sharing,

For E-UTRA

$$B = (L_{CRB_alloc, E-UTRA} * 12 * SCS_{E-UTRA} + 12 * SCS_{NR}) / 1,000,000$$

Where $SCS_{NR} = 15$ kHz is assumed in calculation of B.

For NR

$$B = (12 * SCS_{E-UTRA} + L_{CRB_alloc, NR} * 12 * SCS_{NR}) / 1,000,000$$

Where $SCS_{E-UTRA} = 15$ kHz is assumed in calculation of B

and M_A is reduced by 1 dB for $B < 2.0$.

6.2B.3.1.3.2.2 A-MPR for NS_04 to meet -25 dBm / 1MHz for 26 dBm UE power

A-MPR in this subclause is relative to 26 dBm for a power class 2 Cell Group. The same A-MPR is used relative to 23 dBm for a power class 3 Cell Group. For the UE is configured with channel configurations Case B or Case D (defined in clause 6.2B.3.2.1), the allowed maximum output power reduction for IM3s applied to transmission on the MCG and the SCG with non-contiguous resource allocation is defined as follows:

$$A-MPR_{IM3} = M_A$$

Where M_A is defined as follows

$$M_A = 15 ; 0 \leq B < 1.0$$

$$14 ; 1.0 \leq B < 2.0$$

$$13 ; 2.0 \leq B < 5.0$$

$$12 ; 5.0 \leq B$$

Where:

For UEs supporting dynamic power sharing,

$$B = (L_{CRB_alloc, E-UTRA} * 12 * SCS_{E-UTRA} + L_{CRB_alloc, NR} * 12 * SCS_{NR}) / 1,000,000$$

For UEs not supporting dynamic power sharing,

For E-UTRA

$$B = (L_{CRB_alloc, E-UTRA} * 12 * SCS_{E-UTRA} + 12 * SCS_{NR}) / 1,000,000$$

Where $SCS_{NR} = 15$ kHz is assumed in calculation of B.

For NR

$$B = (12 * SCS_{E-UTRA} + L_{CRB_alloc, NR} * 12 * SCS_{NR}) / 1,000,000$$

Where $SCS_{E-UTRA} = 15$ kHz is assumed in calculation of B

and M_A is reduced by 1 dB.

6.2B.3.1.4 Test description

6.2B.3.1.4.1 Initial conditions

Initial conditions are a set of test configurations the UE needs to be tested in and the steps for the SS to take with the UE to reach the correct measurement state.

The initial test configurations consist of environmental conditions, test frequencies and channel bandwidths based on NR operating bands specified in clause 5.3B.1.2, channel bandwidths and sub-carrier spacings for the NR cell specified in TS 38.521-1 [8] clause 5.3 and channel bandwidth for the E-UTRA cell are specified in TS 36.521-1 [10] clause 5.4.2. All these configurations shall be tested with applicable test parameters for each EN-DC configuration specified in clause 5.3B.1.2 and are shown in table 6.2B.3.1.4.1-1 through 6.2B.3.1.4.1-2. The details of the uplink reference measurement channels (RMCs) are specified in Annex A.2. Configurations of PDSCH and PDCCH before measurement are specified in TS 36.521-1 [10] Annex C.2 and in TS 38.521-1 [8] Annex C.2 for E-UTRA CG and NR CG respectively.

Table 6.2B.3.1.4.1-0: Void

Table 6.2B.3.1.4.1-1: Test configuration table (network signalled value "NS_35")

Initial Conditions							
Test Environment as specified in TS 38.508-1 [6] clause 4.1				Normal			
Test Frequencies as specified in TS 38.508-1 [6] clause 4.3.1				Low range, High range			
Test EN-DC bandwidth combination as specified in Table 5.3B.1.2-1				Lowest N _{RB_agg} , Highest N _{RB_agg} (Note 2)			
Test SCS for the NR cell as specified in TS 38.521-1 [8] Table 5.3.5-1				Lowest, Highest			
Test Parameters							
Test ID	Freq	Downlink Configuration	EN-DC Uplink Configuration				
			E-UTRA Cell		NR Cell		Common Power config (Note 8)
			Modulation	RB allocation (Note 5)	Modulation	RB allocation (Note 1)	
1	Default	N/A	16QAM	Outer_Full	DFT-s-OFDM Pi/2 BPSK	Outer_Full	B
2 (Note 3)	Default		16QAM	Outer_1RB_Left	DFT-s-OFDM Pi/2 BPSK	Edge_1RB_Right	B
3 (Note 3)	Low		16QAM	Outer_1RB_Left	DFT-s-OFDM Pi/2 BPSK	N/A	A
4 (Note 3)	High		16QAM	N/A	DFT-s-OFDM Pi/2 BPSK	Edge_1RB_Right	A
5 (Note 4)	Default		16QAM	Outer_1RB_Right	DFT-s-OFDM Pi/2 BPSK	Edge_1RB_Left	B
6 (Note 4)	Low		16QAM	N/A	DFT-s-OFDM Pi/2 BPSK	Edge_1RB_Left	A
7 (Note 4)	High		16QAM	Outer_1RB_Right	DFT-s-OFDM Pi/2 BPSK	N/A	A
8	Default		16QAM	Outer_Full	DFT-s-OFDM QPSK	Outer_Full	B
9 (Note 3)	Default		16QAM	Outer_1RB_Left	DFT-s-OFDM QPSK	Edge_1RB_Right	B
10 (Note 3)	Low		16QAM	Outer_1RB_Left	DFT-s-OFDM QPSK	N/A	A
11 (Note 3)	High		16QAM	N/A	DFT-s-OFDM QPSK	Edge_1RB_Right	A
12 (Note 4)	Default		16QAM	Outer_1RB_Right	DFT-s-OFDM QPSK	Edge_1RB_Left	B
13 (Note 4)	Low		16QAM	N/A	DFT-s-OFDM QPSK	Edge_1RB_Left	A
14 (Note 4)	High		16QAM	Outer_1RB_Right	DFT-s-OFDM QPSK	N/A	A
15	Default		16QAM	Outer_Full	DFT-s-OFDM 16QAM	Outer_Full	B
16 (Note 3)	Default		16QAM	Outer_1RB_Left	DFT-s-OFDM 16QAM	Edge_1RB_Right	B
17 (Note 3)	Low		16QAM	Outer_1RB_Left	DFT-s-OFDM 16QAM	N/A	A
18 (Note 3)	High		16QAM	N/A	DFT-s-OFDM 16QAM	Edge_1RB_Right	A
19 (Note 4)	Default		16QAM	Outer_1RB_Right	DFT-s-OFDM 16QAM	Edge_1RB_Left	B
20 (Note 4)	Low		16QAM	N/A	DFT-s-OFDM 16QAM	Edge_1RB_Left	A
21 (Note 4)	High		16QAM	Outer_1RB_Right	DFT-s-OFDM 16QAM	N/A	A
22	Default		16QAM	Outer_Full	DFT-s-OFDM 64QAM	Outer_Full	B
23 (Note 3)	Low		16QAM	Outer_1RB_Left	DFT-s-OFDM 64QAM	Edge_1RB_Right	B
24 (Note 4)	High		16QAM	Outer_1RB_Right	DFT-s-OFDM 64QAM	Edge_1RB_Left	B
25	Default		16QAM	Outer_Full	DFT-s-OFDM 256QAM	Outer_Full	B
26 (Note 3)	Low		16QAM	Outer_1RB_Left	DFT-s-OFDM 256QAM	Edge_1RB_Right	B

27 (Note 4)	High		16QAM	Outer_1RB_Right	DFT-s-OFDM 256QAM	Edge_1RB_Left	B
28	Default		16QAM	Outer_Full	CP-OFDM QPSK	Outer_Full	B
29 (Note 3)	Default		16QAM	Outer_1RB_Left	CP-OFDM QPSK	Edge_1RB_Right	B
30 (Note 3)	Low		16QAM	Outer_1RB_Left	CP-OFDM QPSK	N/A	A
31 (Note 3)	High		16QAM	N/A	CP-OFDM QPSK	Edge_1RB_Right	A
32 (Note 4)	Default		16QAM	Outer_1RB_Right	CP-OFDM QPSK	Edge_1RB_Left	B
33 (Note 4)	Low		16QAM	N/A	CP-OFDM QPSK	Edge_1RB_Left	A
34 (Note 4)	High		16QAM	Outer_1RB_Right	CP-OFDM QPSK	N/A	A
35	Default		16QAM	Outer_Full	CP-OFDM 16QAM	Outer_Full	B
36 (Note 3)	Default		16QAM	Outer_1RB_Left	CP-OFDM 16QAM	Edge_1RB_Right	B
37 (Note 3)	Low		16QAM	Outer_1RB_Left	CP-OFDM 16QAM	N/A	A
38 (Note 3)	High		16QAM	N/A	CP-OFDM 16QAM	Edge_1RB_Right	A
39 (Note 4)	Default		16QAM	Outer_1RB_Right	CP-OFDM 16QAM	Edge_1RB_Left	B
40 (Note 4)	Low		16QAM	N/A	CP-OFDM 16QAM	Edge_1RB_Left	A
41 (Note 4)	High		16QAM	Outer_1RB_Right	CP-OFDM 16QAM	N/A	A
42	Default		16QAM	Outer_Full	CP-OFDM 64QAM	Outer_Full	B
43 (Note 3)	Low		16QAM	Outer_1RB_Left	CP-OFDM 64QAM	Edge_1RB_Right	B
44 (Note 4)	High		16QAM	Outer_1RB_Right	CP-OFDM 64QAM	Edge_1RB_Left	B
45	Default		16QAM	Outer_Full	CP-OFDM 256QAM	Outer_Full	B
46 (Note 3)	Low		16QAM	Outer_1RB_Left	CP-OFDM 256QAM	Edge_1RB_Right	B
47 (Note 4)	High		16QAM	Outer_1RB_Right	CP-OFDM 256QAM	Edge_1RB_Left	B
48 (Note 4)	Default		16QAM	Edge_Full_Right	CP-OFDM 256QAM	Edge_Full_Left	B

NOTE 1: The specific configuration of each RB allocation is defined in Table 6.1-1 in TS 38.521-1 [8].

NOTE 2: If the UE supports multiple CC combinations in the EN-DC configuration with the same N_{RB_agg} , select the combination to test as follows:

- Lowest ENBW: NR component with lowest N_{RB} is tested.
- Highest ENBW: NR component with highest N_{RB} is tested.

NOTE 3: Applicable when E-UTRA cell carrier frequency is lower than NR cell carrier.

NOTE 4: Applicable when NR cell carrier frequency is lower than E-UTRA cell carrier.

NOTE 5: Outer_Full defined as the transmission bandwidth configuration N_{RB} per channel bandwidth for the E-UTRA component as indicated in TS 36.521 [10] Table 5.4.2-1. Outer_1RB_Left defined as 1 RB allocated at the left edge of the E-UTRA component. Edge_Full_Right is defined as 2 RBs allocated at the right edge of the E-UTRA component. Outer_1RB_Right defined as 1 RB allocated at the right edge of the E-UTRA component.

NOTE 6: DFT-s-OFDM Pi/2 BPSK test applies only for UEs which supports Pi/2 BPSK in FR1.

NOTE 7: Test IDs with simultaneous E-UTRA and NR UL transmission only apply for UEs indicating dualPA-Architecture.

NOTE 8: Power config as specified in Table 6.2B.3.1.4.3-1-1 to 6.2B.3.1.4.3-2 (PC3) or Table 6.2B.3.1.4.3-3 to 6.2B.3.1.4.3-4 (PC2).

Table 6.2B.3.1.4.1-2: NR test configuration table for NS_04

Initial Conditions							
Test Environment as specified in TS 38.508-1 [6] clause 4.1			Normal				
Test Frequencies as specified in TS 38.508-1 [6] clause 4.3.1			Low range, High range (Note 7)				
Test EN-DC bandwidth combination as specified in Table 5.3B.1.2-1			Lowest N_{RB_agg} , Highest N_{RB_agg} (Note 2)				
Test SCS for the NR cell as specified in TS 38.521-1 [8] Table 5.3.5-1			Lowest, Highest				
Test Parameters							
Test ID	Freq	Downlink Configuration	EN-DC Uplink Configuration				
			E-UTRA Cell		NR Cell		Common Power config (Note 8)
			Modulation	RB allocation (Note 5)	Modulation	RB allocation (Note 1)	
1	Default	N/A	16QAM	Outer_Full	DFT-s-OFDM Pi/2 BPSK	Outer_Full	B
2 (Note 3)	Default		16QAM	Outer_1RB_Left	DFT-s-OFDM Pi/2 BPSK	Edge_1RB_Right	B
3 (Note 3)	Low		16QAM	Outer_1RB_Left	DFT-s-OFDM Pi/2 BPSK	N/A	A
4 (Note 3)	High		16QAM	N/A	DFT-s-OFDM Pi/2 BPSK	Edge_1RB_Right	A
5 (Note 4)	Default		16QAM	Outer_1RB_Right	DFT-s-OFDM Pi/2 BPSK	Edge_1RB_Left	B
6 (Note 4)	Low		16QAM	N/A	DFT-s-OFDM Pi/2 BPSK	Edge_1RB_Left	A
7 (Note 4)	High		16QAM	Outer_1RB_Right	DFT-s-OFDM Pi/2 BPSK	N/A	A
8	Default		16QAM	Outer_Full	DFT-s-OFDM QPSK	Outer_Full	B
9 (Note 3)	Default		16QAM	Outer_1RB_Left	DFT-s-OFDM QPSK	Edge_1RB_Right	B
10 (Note 3)	Low		16QAM	Outer_1RB_Left	DFT-s-OFDM QPSK	N/A	A
11 (Note 3)	High		16QAM	N/A	DFT-s-OFDM QPSK	Edge_1RB_Right	A
12 (Note 4)	Default		16QAM	Outer_1RB_Right	DFT-s-OFDM QPSK	Edge_1RB_Left	B
13 (Note 4)	Low		16QAM	N/A	DFT-s-OFDM QPSK	Edge_1RB_Left	A
14 (Note 4)	High		16QAM	Outer_1RB_Right	DFT-s-OFDM QPSK	N/A	A
15	Default		16QAM	Outer_Full	DFT-s-OFDM 16QAM	Outer_Full	B
16 (Note 3)	Default		16QAM	Outer_1RB_Left	DFT-s-OFDM 16QAM	Edge_1RB_Right	B
17 (Note 3)	Low		16QAM	Outer_1RB_Left	DFT-s-OFDM 16QAM	N/A	A
18 (Note 3)	High		16QAM	N/A	DFT-s-OFDM 16QAM	Edge_1RB_Right	A
19 (Note 4)	Default		16QAM	Outer_1RB_Right	DFT-s-OFDM 16QAM	Edge_1RB_Left	B
20 (Note 4)	Low		16QAM	N/A	DFT-s-OFDM 16QAM	Edge_1RB_Left	A
21 (Note 4)	High		16QAM	Outer_1RB_Right	DFT-s-OFDM 16QAM	N/A	A
22	Default		16QAM	Outer_Full	DFT-s-OFDM 64QAM	Outer_Full	B
23 (Note 3)	Low		16QAM	Outer_1RB_Left	DFT-s-OFDM 64QAM	Edge_1RB_Right	B
24 (Note 4)	High		16QAM	Outer_1RB_Right	DFT-s-OFDM 64QAM	Edge_1RB_Left	B
25	Default		16QAM	Outer_Full	DFT-s-OFDM 256QAM	Outer_Full	B
26 (Note 3)	Low		16QAM	Outer_1RB_Left	DFT-s-OFDM 256QAM	Edge_1RB_Right	B

27 (Note 4)	High		16QAM	Outer_1RB_Right	DFT-s-OFDM 256QAM	Edge_1RB_Left	B
28	Default		16QAM	Outer_Full	CP-OFDM QPSK	Outer_Full	B
29 (Note 3)	Default		16QAM	Outer_1RB_Left	CP-OFDM QPSK	Edge_1RB_Right	B
30 (Note 3)	Low		16QAM	Outer_1RB_Left	CP-OFDM QPSK	N/A	A
31 (Note 3)	High		16QAM	N/A	CP-OFDM QPSK	Edge_1RB_Right	A
32 (Note 4)	Default		16QAM	Outer_1RB_Right	CP-OFDM QPSK	Edge_1RB_Left	B
33 (Note 4)	Low		16QAM	N/A	CP-OFDM QPSK	Edge_1RB_Left	A
34 (Note 4)	High		16QAM	Outer_1RB_Right	CP-OFDM QPSK	N/A	A
35	Default		16QAM	Outer_Full	CP-OFDM 16QAM	Outer_Full	B
36 (Note 3)	Default		16QAM	Outer_1RB_Left	CP-OFDM 16QAM	Edge_1RB_Right	B
37 (Note 3)	Low		16QAM	Outer_1RB_Left	CP-OFDM 16QAM	N/A	A
38 (Note 3)	High		16QAM	N/A	CP-OFDM 16QAM	Edge_1RB_Right	A
39 (Note 4)	Default		16QAM	Outer_1RB_Right	CP-OFDM 16QAM	Edge_1RB_Left	B
40 (Note 4)	Low		16QAM	N/A	CP-OFDM 16QAM	Edge_1RB_Left	A
41 (Note 4)	High		16QAM	Outer_1RB_Right	CP-OFDM 16QAM	N/A	A
42	Default		16QAM	Outer_Full	CP-OFDM 64QAM	Outer_Full	B
43 (Note 3)	Low		16QAM	Outer_1RB_Left	CP-OFDM 64QAM	Edge_1RB_Right	B
44 (Note 4)	High		16QAM	Outer_1RB_Right	CP-OFDM 64QAM	Edge_1RB_Left	B
45	Default		16QAM	Outer_Full	CP-OFDM 256QAM	Outer_Full	B
46 (Note 3)	Low		16QAM	Outer_1RB_Left	CP-OFDM 256QAM	Edge_1RB_Right	B
47 (Note 4)	High		16QAM	Outer_1RB_Right	CP-OFDM 256QAM	Edge_1RB_Left	B
48 (Note 4)	Default		16QAM	Edge_Full_Right	CP-OFDM 256QAM	Edge_Full_Left	B

NOTE 1: The specific configuration of each RB allocation is defined in Table 6.1-1 in TS 38.521-1 [8].
 NOTE 2: If the UE supports multiple CC combinations in the EN-DC configuration with the same $N_{RB,agg}$, select the combination to test as follows:
 - Lowest ENBW: NR component with lowest N_{RB} is tested.
 - Highest ENBW: NR component with highest N_{RB} is tested.
 NOTE 3: Applicable when E-UTRA cell carrier frequency is lower than NR cell carrier.
 NOTE 4: Applicable when NR cell carrier frequency is lower than E-UTRA cell carrier.
 NOTE 5: Outer_Full defined as the transmission bandwidth configuration N_{RB} per channel bandwidth for the E-UTRA component as indicated in TS 36.521 [10] Table 5.4.2-1. Outer_1RB_Left defined as 1 RB allocated at the left edge of the E-UTRA component. Edge_Full_Right is defined as 2 RBs allocated at the right edge of the E-UTRA component. Outer_1RB_Right defined as 1 RB allocated at the right edge of the E-UTRA component.
 NOTE 6: DFT-s-OFDM Pi/2 BPSK test applies only for UEs which supports Pi/2 BPSK in FR1.
 NOTE 7: Additional IM3 test frequencies may apply.
 NOTE 8: Power config as specified in Table 6.2B.3.1.4.3-1 to 6.2B.3.1.4.3-2 (PC3) or Table 6.2B.3.1.4.3-3 to 6.2B.3.1.4.3-4 (PC2).
 NOTE 9: Test IDs with simultaneous E-UTRA and NR UL transmission only apply for UEs indicating dualPA-Architecture.

Table 6.2B.3.1.4.1-3: Additional IM3 Test Frequencies for NS_04 intra-band contiguous EN-DC

Additional Initial Condition	
Additional IM3 Test Frequencies	if SCS 15 kHz, 15 kHz NR raster, and NR ChBw 40 MHz or 50 MHz then IM3 test frequencies as specified in Table 6.2B.3.1.4.1-4. if SCS 30 kHz, 30 kHz NR raster, and NR ChBw 40 MHz, 50 MHz or 60 MHz then IM3 test frequencies as specified in Table 6.2B.3.1.4.1-5. if SCS 60 kHz, 15 kHz NR raster, and NR ChBw 40 MHz, 50 MHz or 60 MHz then IM3 test frequencies as specified in Table 6.2B.3.1.4.1-6.

Table 6.2B.3.1.4.1-4: EN-DC combination DC_(n)41AA, intra-band contiguous, SCS 15 kHz, 15 kHz NR raster, IM3 test frequencies

EN-DC channel bandwidth combination	CC	Bandwidth [MHz]	carrier Bandwidth [PRBs]	Range		Carrier centre [MHz] Note 2	Carrier centre [ARFCN]	point A [MHz]	absolute Frequency Point A [ARFCN]	offset ToCarrier [Carrier PRBs]	SS block SCS [kHz]	GSCN	absoluteFrequencySSB [ARFCN]
				Downlink & Uplink	IM3								
E-UTRA: 20MHz + NR: 40MHz	E-UTRA CC1	20	100	Downlink & Uplink	IM3	2600.400	40694	-	-	-	-	-	-
	NR CC1	40	216	Downlink & Uplink	IM3	2570.400	514080	2550.96	510192	0	15	6384	514080
E-UTRA: 20MHz + NR: 50MHz	E-UTRA CC1	20	100	Downlink & Uplink	IM3	2620.400	40894	-	-	-	-	-	-
	NR CC1	50	270	Downlink & Uplink	IM3	2585.400	517080	2561.1	512220	0	15	6408	517080

Table 6.2B.3.1.4.1-5: EN-DC combination DC_(n)41AA, intra-band contiguous, SCS 30 kHz, 30 kHz NR raster, IM3 test frequencies

EN-DC channel bandwidth combination	CC	Bandwidth [MHz]	carrier Bandwidth [PRBs]	Range		Carrier centre [MHz] Note 2	Carrier centre [ARFCN]	point A [MHz]	absolute Frequency Point A [ARFCN]	offset ToCarrier [Carrier PRBs]	SS block SCS [kHz]	GSCN	absoluteFrequencySSB [ARFCN]
				Downlink & Uplink	IM3								
E-UTRA: 20MHz + NR: 40MHz	E-UTRA CC1	20	100	Downlink & Uplink	IM3	2600.400	40694	-	-	-	-	-	-
	NR CC1	40	216	Downlink & Uplink	IM3	2570.400	514080	2550.96	510192	0	15	6384	514080
E-UTRA: 20MHz + NR: 50MHz	E-UTRA CC1	20	100	Downlink & Uplink	IM3	2620.400	40894	-	-	-	-	-	-
	NR CC1	50	270	Downlink & Uplink	IM3	2585.400	517080	2561.1	512220	0	15	6408	517080
E-UTRA: 20MHz + NR: 60MHz	E-UTRA CC1	20	100	Downlink & Uplink	IM3	2640.500	41095	-	-	-	-	-	-
	NR CC1	60	162	Downlink & Uplink	IM3	2600.500	520100	2571.34	514268	0	30	6438	520100

Table 6.2B.3.1.4.1-6: EN-DC combination DC_(n)41AA, intra-band contiguous, SCS 60 kHz, 15 kHz NR raster, IM3 test frequencies

EN-DC channel bandwidth combination	CC	Bandwidth [MHz]	carrier Bandwidth [PRBs]	Range		Carrier centre [MHz] Note 2	Carrier centre [ARFCN]	point A [MHz]	absolute FrequencyPointA [ARFCN]	offset ToCarrier [Carrier PRBs]	SS block SCS [kHz]	GSCN	absoluteFrequencySSB [ARFCN]
E-UTRA: 20MHz + NR: 40MHz	E-UTRA CC1	20	100	Downlink & Uplink	IM3	2600.400	40694	-	-	-	-	-	-
	NR CC1	40	51	Downlink & Uplink	IM3	2570.400	514080	2552.04	510408	0	15	6387	514080
E-UTRA: 20MHz + NR: 50MHz	E-UTRA CC1	20	100	Downlink & Uplink	IM3	2620.400	40894	-	-	-	-	-	-
	NR CC1	50	65	Downlink & Uplink	IM3	2585.400	517080	2562	512400	0	15	6411	517080
E-UTRA: 20MHz + NR: 60MHz	E-UTRA CC1	20	100	Downlink & Uplink	IM3	2640.500	41095	-	-	-	-	-	-
	NR CC1	60	79	Downlink & Uplink	IM3	2600.500	520100	2572.06	514412	0	15	6435	520100

Editor's note: The following lines belong at the end of clause 6.2B.3.1.4.1. As new tables are added to this clause, these lines should always follow the tables.

The initial test configurations for E-UTRA consist of test frequency based on E-UTRA operating band and test channel bandwidth as specified in Table 4.6-1.

1. Connect the SS to the UE antenna connectors as shown in TS 38.508-1 [6] Annex A, Figure A.3.1.1 for TE diagram and clause A.3.2.1 for UE diagram.
2. The parameter settings for E-UTRA the cell are set up according to TS 36.508 [11] clause 4.4.3, and the parameter settings for the NR cell are set up according to TS 38.508-1 [6] clause 4.4.3.
3. Downlink signals are initially set up according to TS 36.521-1 [10] Annex C.0 and TS 38.521-1 [8] Annex C.0 for E-UTRA CG and NR CG respectively, and uplink signals according to TS 36.521-1 [10] Annex H and TS 38.521-1 [8] Annex G for E-UTRA CG and NR CG respectively.
4. NR downlink signals are initially set up according to Annex C.0, C.1, and C.2 and uplink signals according to Annex G.0, G.1, G.2, and G.3.0 of TS 38.521-1 [8].
5. The UL Reference Measurement channels are set according to TS 36.521-1 [10] Annex A.2 and TS 38.521-1 [8] Annex A.2 for E-UTRA CG and NR CG link respectively.
6. Propagation conditions are set according to TS 36.521-1 [10] Annex B.0 and TS 38.521-1 [8] Annex B.0 for E-UTRA CG and NR CG respectively.
7. Ensure the UE is in state RRC_CONNECTED with generic procedure parameters Connectivity EN-DC, DC bearer *MCG* and *SCG*, Connected without release *On* according to TS 38.508-1 [6] clause 4.5. Message contents are defined in clause 6.2B.3.1.4.3.
8. For the case of testing overlapping E-UTRA and NR UL transmission scenario when both bands are TDD, ensure E-UTRA UL transmission overlaps with NR UL transmission in time by giving SCG a delay of 3 E-UTRA subframes, or by giving MCG a delay of 2 subframes.

6.2B.3.1.4.2 Test procedure

1. SS sends uplink scheduling information for each UL HARQ process via PDCCH DCI format 0 and DCI format 0_1 for C_RNTI to schedule the UL RMC according to table 6.2B.3.1.4.1-1 or 6.2B.3.1.4.1-2 on both EN-DC component carriers. Since the UL has no payload and no loopback data to send the UE sends uplink MAC padding bits on the UL RMC.
2. Send continuously uplink power control "up" commands to the UE for NR and E-UTRA carrier until the UE transmits at its P_{UMAX} level; allow at least 200 ms starting from the first TPC command in this step for the UE to reach P_{UMAX} level.
3. Measure the mean power over all component carriers for the EN-DC configuration, which shall meet the requirements described in table 6.2B.3.1.5.1-1 through to 6.2B.3.1.5.2-6. The period of the measurement shall be at least the continuous duration of one active sub-frame (1ms). For TDD, only slots consisting of only UL symbols are under test.

NOTE 1: When switching to DFT-s-OFDM waveform, as specified in the test configuration table 6.2B.3.1.4.1-1 or 6.2B.3.1.4.1-2, send an NR RRCReconfiguration message according to TS 38.508-1 [6] clause 4.6.3 Table 4.6.3-118 PUSCH-Config with TRANSFORM_PRECODER_ENABLED condition.

6.2B.3.1.4.3 Message contents

Message contents are according to TS 38.508-1 [6] clause 4.6.1, with the following exceptions.

Table 6.2B.3.1.4.3-1: RRCConnectionReconfiguration: nr-Config-r15 for PC3

Derivation Path: TS 36.508 [11], Table 4.6.1-8			
Information Element	Value/remark	Comment	Condition
p-MaxEUTRA-r15	23	Power config A (NOTE 1)	
	20	Power config B (NOTE 2)	
NOTE 1: Applies when E-UTRA UL transmission not overlapping with NR UL transmission in time.			
NOTE 2: Applies when E-UTRA UL transmission overlapping with NR UL transmission in time.			

Table 6.2B.3.1.4.3-2: PhysicalCellGroupConfig for PC3

Derivation Path: TS 38.508-1 [6], Table 4.6.3-106			
Information Element	Value/remark	Comment	Condition
p-NR-FR1	23	Power config A (NOTE 1)	
	20	Power config B (NOTE 2)	
NOTE 1: Applies when E-UTRA UL transmission not overlapping with NR UL transmission in time.			
NOTE 2: Applies when E-UTRA UL transmission overlapping with NR UL transmission in time.			

Table 6.2B.3.1.4.3-3: RRCConnectionReconfiguration: nr-Config-r15 for PC2

Derivation Path: TS 36.508 [11], Table 4.6.1-8			
Information Element	Value/remark	Comment	Condition
p-MaxEUTRA-r15	26	Power config A (NOTE 1)	
	23	Power config B (NOTE 2)	
NOTE 1: Applies when E-UTRA UL transmission not overlapping with NR UL transmission in time.			
NOTE 2: Applies when E-UTRA UL transmission overlapping with NR UL transmission in time.			

Table 6.2B.3.1.4.3-4: PhysicalCellGroupConfig for PC2

Derivation Path: TS 38.508-1 [6], Table 4.6.3-106			
Information Element	Value/remark	Comment	Condition
p-NR-FR1	26	Power config A (NOTE 1)	
	23	Power config B (NOTE 2)	
NOTE 1: Applies when E-UTRA UL transmission not overlapping with NR UL transmission in time.			
NOTE 2: Applies when E-UTRA UL transmission overlapping with NR UL transmission in time.			

6.2B.3.1.4.3.1 Message contents exceptions (network signalled value "NS_04")

Message contents are according to TS 38.508-1 [6] clause 4.6.1 with the following exceptions for NS_04:

Table 6.2B.3.1.4.3.1-1: AdditionalSpectrumEmission for MCG and "NS_04"

Derivation Path: 36.508 [11] clause 4.6.3, Table 4.4.3.3-1			
Information Element	Value/remark	Comment	Condition
AdditionalSpectrumEmission	1 (NS_04)		

Table 6.2B.3.1.4.3.1-2: AdditionalSpectrumEmission for SCG and "NS_04"

Derivation Path: TS 38.508-1 [6] clause 4.6.3, Table 4.6.3-1			
Information Element	Value/remark	Comment	Condition
AdditionalSpectrumEmission	1 (NS_04)		

6.2B.3.1.4.3.2 Message contents exceptions (network signalled value "NS_35")

Message contents are according to TS 38.508-1 [6] clause 4.6.1 with the following exceptions for NS_35:

Table 6.2B.3.1.4.3.2-1: Additional Spectrum Emission for MCG and "NS_35"

Derivation Path: 36.508 [11] clause 4.6.3, Table 4.4.3.3-1			
Information Element	Value/remark	Comment	Condition
AdditionalSpectrumEmission	1 (NS_35)		

Table 6.2B.3.1.4.3.2-2: Additional Spectrum Emission for for SCG "NS_35"

Derivation Path: TS 38.508-1 [5] clause 4.6.3, Table 4.6.3-1			
Information Element	Value/remark	Comment	Condition
AdditionalSpectrumEmission	1 (NS_35)		

6.2B.3.1.5 Test requirement

Table: 6.2B.3.1.5-1: Test Tolerance for UE maximum output power (LTE, NR TX separately)

Uplink TX		$f \leq 3.0\text{GHz}$	$3.0\text{GHz} < f \leq 4.2\text{GHz}$	$4.2\text{GHz} < f \leq 6\text{GHz}$
LTE	$BW \leq 20\text{MHz}$	0.7	1.0	1.3
NR	$BW \leq 40\text{MHz}$	0.7 dB	1.0 dB	1.0
	$40\text{MHz} < BW \leq 100\text{MHz}$	1.0 dB	1.0 dB	1.0

6.2B.3.1.5.1 Test requirement for network signalled value "NS_35"

The maximum output power, derived in step 3 shall be within the range prescribed by the nominal maximum output power and tolerance in table 6.2B.3.1.5.1-1. The allowed A-MPR values specified in table 6.2B.3.1.3-1 are in addition to the allowed MPR requirements specified in clause 6.2B.1.1.3. For the UE maximum output power modified by MPR and/or A-MPR, the power limits specified in table 6.2B.1.1.3-1 apply.

Table 6.2B.3.1.5.1-1: UE Power Class test requirements for network signalled value "NS_35" for UEs not supporting dynamic power sharing

Test ID	Test frequency	E-UTRA BW	NR BW	Modulation	$P_{PowerClass}$ (dBm)	$\Delta P_{PowerClass}$ (dB)	A-MPR _c (dB)	ΔTC_{c} (dB) Note 7	$P_{CMAX,c}$ (dBm)	$T(P_{CMAX_{L,f,c}})$ (dB)	$T_{L,c}$ (dB)	Upper limit	Lower limit
1, 8, 15, 22, 25	Low	5	5	E-UTRA/NR	23	0	6.0	0	17.0	5	+2/-3	25+TT	12-TT
1, 8, 15, 22, 25	Low	5	15	E-UTRA/NR	23	0	6.0	0	17.0	5	+2/-3	25+TT	12-TT
1, 8, 15, 22, 25	High	5	5	E-UTRA/NR	23	0	6.0	0	17.0	5	+2/-3	25+TT	12-TT
1, 8, 15, 22, 25	High	15	5	E-UTRA/NR	23	0	6.0	0	17.0	5	+2/-3	25+TT	12-TT
2, 5, 9, 12, 16, 19, 23, 24, 2, 26, 27	Low	5	5	E-UTRA/NR	23	0	10.5	0	12.5	6	+2/-3	25+TT	6.5-TT
2, 5, 9, 12, 16, 19, 23, 24, 2, 26, 27	Low	5	15	E-UTRA/NR	23	0	11.0	0	12.0	6	+2/-3	25+TT	6-TT
2, 5, 9, 12, 16, 19, 23, 24, 2, 26, 27	High	5	5	E-UTRA/NR	23	0	10.5	0	12.5	6	+2/-3	25+TT	6.5-TT
2, 5, 9, 12, 16, 19, 23, 24, 2, 26, 27	High	15	5	E-UTRA/NR	23	0	11.0	0	12.0	6	+2/-3	25+TT	6-TT
3, 10, 17	Low	5	5	E-UTRA/NR	23	0	12.5	0	10.5	6	+2/-3	25+TT	4.5-TT
3, 14, 17	Low	5	15	E-UTRA/NR	23	0	16.0	0	7.0	7	+2/-3	25+TT	0-TT
4, 11, 18	High	5	5	E-UTRA/NR	23	0	12.5	0	10.5	12.5	+2/-3	25+TT	4.5-TT
4, 11, 18	High	15	5	E-UTRA/NR	23	0	16.0	0	7.0	16.0	+2/-3	25+TT	0-TT
6, 13, 20	Low	5	5	E-UTRA/NR	23	0	11.0	0	12.0	6	+2/-3	25+TT	6-TT
6, 13, 20	Low	5	15	E-UTRA/NR	23	0	11.0	0	12.0	6	+2/-3	25+TT	6-TT
7, 14, 21	High	5	5	E-UTRA/NR	23	0	11.0	0	12.0	6	+2/-3	25+TT	6-TT
7, 14, 21	High	15	5	E-UTRA/NR	23	0	11.0	0	12.0	6	+2/-3	25+TT	6-TT
28, 35, 42, 45	Low	5	5	E-UTRA/NR	23	0	6.5	0	16.5	5	+2/-3	25+TT	11.5-TT
28, 35, 42, 45	Low	5	15	E-UTRA/NR	23	0	6.5	0	16.5	5	+2/-3	25+TT	11.5-TT
28, 35, 42, 45	High	5	5	E-UTRA/NR	23	0	6.5	0	16.5	5	+2/-3	25+TT	11.5-TT
28, 35, 42, 45	High	15	5	E-UTRA/NR	23	0	6.5	0	16.5	5	+2/-3	25+TT	11.5-TT
29, 35, 42, 45	Low	5	5	E-UTRA/NR	23	0	11.0	0	12.0	6	+2/-3	25+TT	6.5-TT
29, 35, 42, 45	Low	5	15	E-UTRA/NR	23	0	11.0	0	12.0	6	+2/-3	25+TT	6-TT
29, 35, 42, 45	High	5	5	E-UTRA/NR	23	0	11.0	0	12.0	6	+2/-3	25+TT	6.5-TT
29, 35, 42, 45	High	15	5	E-UTRA/NR	23	0	11.0	0	12.0	6	+2/-3	25+TT	6-TT
30, 34, 37, 41	Low	5	5	E-UTRA/NR	23	0	11.0	0	12.0	6	+2/-3	25+TT	6-TT
30, 34, 37, 41	Low	5	15	E-UTRA/NR	23	0	11.0	0	12.0	6	+2/-3	25+TT	6-TT
31, 33, 38, 40	High	5	5	E-UTRA/NR	23	0	11.0	0	12.0	6	+2/-3	25+TT	6-TT
31, 33, 38, 40	High	15	5	E-UTRA/NR	23	0	11.0	0	12.0	6	+2/-3	25+TT	6-TT

Table 6.2B.3.1.5.1-1A: UE Power Class test requirements for network signalled value "NS_35" for UEs supporting dynamic power sharing

Test ID	Test freq. range	E-UTRA BW	NR BW	Modulation	$P_{\text{PowerClass}}$ (dBm)	$\Delta P_{\text{PowerClass}}$ (dB)	A-MPR _c (dB)	ΔTC_{c} (dB) Note 7	$P_{\text{CMAX}_{x,c}}$ (dBm)	$T(P_{\text{CMAX}_{L,f,c}})$ (dB)	$T_{L,c}$ (dB)	Upper limit	Lower limit
---------	------------------	-----------	-------	------------	-------------------------------	-------------------------------------	-------------------------	--------------------------------	-------------------------------	-----------------------------------	----------------	-------------	-------------

1, 8, 15, 22, 25	Low	5	5	E-UTRA	23	0	8.5	0	14.5	5	+2/-3	25+TT	9.5-TT
1, 8, 15, 22, 25	Low	5	5	NR	23	0	8.5	0	14.5	5	+2/-3	25+TT	9.5-TT
1, 8, 15, 22, 25	Low	5	15	E-UTRA	23	0	13.0	0	10.0	6	+2/-3	25+TT	4-TT
1, 8, 15, 22, 25	Low	5	15	NR	23	0	6.5	0	16.5	5	+2/-3	25+TT	11.5-TT
1, 8, 15, 22, 25	High	5	5	E-UTRA	23	0	8.5	0	14.5	5	+2/-3	25+TT	9.5-TT
1, 8, 15, 22, 25	High	5	5	NR	23	0	8.5	0	14.5	5	+2/-3	25+TT	9.5-TT
1, 8, 15, 22, 25	High	15	5	E-UTRA	23	0	6.5	0	16.5	5	+2/-3	25+TT	11.5-TT
1, 8, 15, 22, 25	High	15	5	NR	23	0	13.0	0	10.0	6	+2/-3	25+TT	4-TT
2, 5, 9, 12, 16, 19, 23, 24, 2, 26, 27	Low	5	5	E-UTRA	23	0	13.0	0	10.0	6	+2/-3	25+TT	4-TT
2, 5, 9, 12, 16, 19, 23, 24, 2, 26, 27	Low	5	5	NR	23	0	13.0	0	10.0	6	+2/-3	25+TT	4-TT
2, 5, 9, 12, 16, 19, 23, 24, 2, 26, 27	Low	5	15	E-UTRA	23	0	16.0	0	7.0	7	+2/-3	25+TT	0-TT
2, 5, 9, 12, 16, 19, 23, 24, 2, 26, 27	Low	5	15	NR	23	0	11.0	0	12.0	6	+2/-3	25+TT	6-TT
2, 5, 9, 12, 16, 19, 23, 24, 2, 26, 27	High	5	5	E-UTRA	23	0	13.0	0	10.0	6	+2/-3	25+TT	4-TT
2, 5, 9, 12, 16, 19, 23, 24, 2, 26, 27	High	5	5	NR	23	0	13.0	0	10.0	6	+2/-3	25+TT	4-TT
2, 5, 9, 12, 16, 19, 23, 24, 2, 26, 27	High	15	5	E-UTRA	23	0	11.5	0	11.5	6	+2/-3	25+TT	5.5-TT
2, 5, 9, 12, 16, 19, 23, 24, 2, 26, 27	High	15	5	NR	23	0	16.0	0	7.0	7	+2/-3	25+TT	0-TT
3, 10, 17	Low	5	5	E-UTRA/	23	0	12.5	0	10.5	6	+2/-3	25+TT	4.5-TT
3, 10, 17	Low	5	15	E-UTRA	23	0	16.0	0	7.0	7	+2/-3	25+TT	0-TT
4, 11, 18	High	5	5	NR	23	0	13.0	0	10.0	6	+2/-3	25+TT	4-TT
4, 11, 18	High	15	5	NR	23	0	16.0	0	7.0	7	+2/-3	25+TT	0-TT
6, 17, 20	Low	5	5	E-UTRA/	23	0	13.0	0	10.0	6	+2/-3	25+TT	4-TT
6, 17, 20	Low	5	15	E-UTRA	23	0	16.5	0	6.5	7	+2/-3	25+TT	-0.5-TT
7, 14, 21	High	5	5	NR	23	0	13.0	0	10.0	6	+2/-3	25+TT	4-TT
7, 14, 21	High	15	5	NR	23	0	16.0	0	7.0	7	+2/-3	25+TT	0-TT
28, 35, 42, 45	Low	5	5	E-UTRA	23	0	9.5	0	13.5	5	+2/-3	25+TT	8.5-TT
28, 35, 42, 45	Low	5	5	NR	23	0	9.5	0	13.5	5	+2/-3	25+TT	8.5-TT
28, 35, 42, 45	Low	5	15	E-UTRA	23	0	13.5	0	9.5	6	+2/-3	25+TT	3.5-TT
28, 35, 42, 45	Low	5	15	NR	23	0	7.0	0	16.0	5	+2/-3	25+TT	11-TT
28, 35, 42, 45	High	5	5	E-UTRA	23	0	9.5	0	13.5	5	+2/-3	25+TT	8.5-TT

28, 35, 42, 45	High	5	5	NR	23	0	9.5	0	13.5	5	+2/-3	25+TT	8.5-TT
28, 35, 42, 45	High	15	5	E-UTRA	23	0	7.0	0	16.0	5	+2/-3	25+TT	11-TT
28, 35, 42, 45	High	15	5	NR	23	0	13.0	0	10.0	6	+2/-3	25+TT	4-TT
29, 36, 43, 46	Low	5	5	E-UTRA	23	0	13.0	0	10.0	6	+2/-3	25+TT	4-TT
29, 36, 43, 46	Low	5	5	NR	23	0	13.0	0	10.0	6	+2/-3	25+TT	4-TT
29, 36, 43, 46	Low	5	15	E-UTRA	23	0	16.0	0	7.0	7	+2/-3	25+TT	0-TT
29, 36, 43, 46	Low	5	15	NR	23	0	11.0	0	12.0	6	+2/-3	25+TT	6-TT
29, 36, 43, 46	High	5	5	E-UTRA	23	0	13.0	0	10.0	6	+2/-3	25+TT	4-TT
29, 36, 43, 46	High	5	5	NR	23	0	13.0	0	10.0	6	+2/-3	25+TT	4-TT
29, 36, 43, 46	High	15	5	E-UTRA	23	0	11.5	0	11.5	6	+2/-3	25+TT	0-TT
29, 36, 43, 46	High	15	5	NR	23	0	16.0	0	7.0	7	+2/-3	25+TT	5.5-TT
30, 37	Low	5	5	E-UTRA/	23	0	13.0	0	10.0	6		25+TT	4-TT
30, 37	Low	5	15	E-UTRA	23	0	16.0	0	7.0	7		25+TT	0-TT
31, 38	High	5	5	NR	23	0	13.0	0	10.0	6		25+TT	4-TT
31, 38	High	15	5	NR	23	0	16.0	0	7.0	7		25+TT	0-TT
34, 41	High	5	5	NR	23	0	13.0	0	10.0	6		25+TT	4-TT
34, 41	High	15	5	NR	23	0	16.0	0	7.0	7		25+TT	0-TT
33, 40	Low	5	5	E-UTRA/	23	0	13.0	0	10.0	6		25+TT	4-TT
33, 40	Low	5	15	E-UTRA	23	0	16.5	0	6.5	7		25+TT	-0.5-TT

NOTE 8: TT for each frequency and channel bandwidth is specified in Table 6.2B.3.1.5-1.

6.2B.3.1.5.2 Test requirement for network signalled value "NS_04"

Table 6.2B.3.1.5.2-1: UE Power Class 3 test requirements for NS_04, supporting dynamic power sharing and E-UTRA UL transmission overlapping with NR UL transmission

Test ID	Test SCS (kHz)	A-MPR _{tot} (dB)	P _{EN-DC, tot_L} (dBm)	P _{EN-DC, tot_H} (dBm)	T _{LOW} (P _{C_{MAX,L}}) (dB)	T _{HIGH} (P _{C_{MAX,H}}) (dB)	Upper limit (dBm)	Lower limit (dBm)
1, 8, 15, 22, 25, 28, 35, 42, 45 (Note 1, 4)	15, 30, 60	3	20	23	6	2	25+TT	14-TT
1, 8, 15, 22, 25, 28, 35, 42, 45 (Note 1, 5)	15, 30, 60	9	14	23	6	2	25+TT	8-TT
2, 5, 9, 12, 16, 19, 23, 24, 26, 27, 29, 32, 36, 39, 43, 44, 46, 47 (Note 2, 4, 5)	15	11	12	23	6	2	25+TT	6-TT
2, 5, 9, 12, 16, 19, 23, 24, 26, 27, 29, 32, 36, 39, 43, 44, 46, 47 (Note 2, 4)	30, 60	6	17	23	5	2	25+TT	12-TT
2, 5, 9, 12, 16, 19, 23, 24, 26, 27, 29, 32, 36, 39, 43, 44, 46, 47 (Note 2, 5)	30, 60	11	12	23	6	2	25+TT	6-TT
48 (Note 3, 4)	15	7	16	23	5	2	25+TT	11-TT
48 (Note 3, 4)	30, 60	12	11	23	6	2	25+TT	5-TT
48 (Note 3, 5)	15, 30, 60	7	16	23	5	2	25+TT	11-TT

NOTE 1: Test configuration IDs with transmission overlap with full RB allocation, requirements in TS 38.101-3 [4] apply.

NOTE 2: Test configuration IDs with transmission overlap with 1RB allocation, requirements in TS 38.101-3 [4] apply.

NOTE 3: Test configuration IDs with transmission overlap with edge full RB allocation, requirements in TS 38.101-3 [4] apply.

NOTE 4: When $F_{IM3,low_block,low} \geq 2490.5$ MHz (Case A)

NOTE 5: When $F_{IM3,low_block,low} < 2490.5$ MHz (Case B)

NOTE 6: TT for each frequency and channel bandwidth is specified in Table 6.2B.3.1.5-1.

Table 6.2B.3.1.5.2-2: UE Power Class 3 test requirements for NS_04, supporting dynamic power sharing and E-UTRA UL transmission not overlapping with NR UL transmission

Test ID	Test SCS (kHz)	MPR (dB)	A-MPR (dB)	P _{EN-DC, tot_L} (dBm)	P _{EN-DC, tot_H} (dBm)	T _{LOW} (P _{C_{MAX_L}}) (dB)	T _{HIGH} (P _{C_{MAX_H}}) (dB)	Upper limit (dBm)	Lower limit (dBm)
3, 7, 10, 14, 17, 21, 30, 34, 37, 41 (Note 1)	15, 30, 60	0	3	20	23	4	2	25+TT	16-TT
4 (Note 2)	15, 30, 60	0.5	0	22.5	23	2	2	25+TT	20.5-TT
6 (Note 2)	15, 30, 60	0	3.5	19.5	23	3.5	2	25+TT	16-TT
11 (Note 2)	15, 30, 60	1	0	22	23	2	2	25+TT	20-TT
13 (Note 2)	15, 30, 60	0	4	19	23	3.5	2	25+TT	15.5-TT
18 (Note 2)	15, 30, 60	2	0	21	23	2	2	25+TT	19-TT
20 (Note 2)	15, 30, 60	0	4	19	23	3.5	2	25+TT	15.5-TT
31 (Note 2)	15, 30, 60	3	0	20	23	2.5	2	25+TT	17.5-TT
33 (Note 2)	15, 30, 60	0	5.5	17.5	23	5	2	25+TT	12-TT
38 (Note 2)	15, 30, 60	3	0	20	23	2.5	2	25+TT	17.5-TT
40 (Note 2)	15, 30, 60	0	5.5	17.5	23	5	2	25+TT	12-TT

NOTE 1: Test configuration IDs without transmission overlap, 1RB E-UTRA allocation, A-MPR requirements in TS 36.101 [5] apply.
NOTE 2: Test configuration IDs without transmission overlap, 1RB NR allocation, A-MPR requirements in TS 38.101-1 [2] apply.
NOTE 3: Void.
NOTE 4: Void.
NOTE 5: Void.
NOTE 6: TT for each frequency and channel bandwidth is specified in Table 6.2B.3.1.5-1.

Table 6.2B.3.1.5.2-3: UE Power Class 3 test requirements for NS_04, not supporting dynamic power sharing and E-UTRA UL transmission overlapping with NR UL transmission

Test ID	Test SCS (kHz)	A-MPR _{tot} (dB)	P _{EN-DC, tot_L} (dBm)	P _{EN-DC, tot_H} (dBm)	T _{LOW} (P _{C_{MAX_L}}) (dB)	T _{HIGH} (P _{C_{MAX_H}}) (dB)	Upper limit (dBm)	Lower limit (dBm)
1, 8, 15, 22, 25, 28, 35, 42, 45 (Note 1, 4)	15, 30, 60	6	17	23	5	2	25+TT	12-TT
1, 8, 15, 22, 25, 28, 35, 42, 45 (Note 1, 5)	15, 30, 60	12	11	23	6	2	25+TT	5-TT
2, 5, 9, 12, 16, 19, 23, 24, 26, 27, 29, 32, 36, 39, 43, 44, 46, 47 (Note 2, 4, 5)	15	14	9	23	7	2	25+TT	2-TT
2, 5, 9, 12, 16, 19, 23, 24, 26, 27, 29, 32, 36, 39, 43, 44, 46, 47 (Note 2, 4)	30, 60	9	14	23	6	2	25+TT	8-TT
2, 5, 9, 12, 16, 19, 23, 24, 26, 27, 29, 32, 36, 39, 43, 44, 46, 47 (Note 2, 5)	30, 60	14	9	23	7	2	25+TT	2-TT
48 (Note 3, 4)	15	10	13	23	6	2	25+TT	7-TT
48 (Note 3, 4)	30, 60	15	8	23	7	2	25+TT	1-TT
48 (Note 3, 5)	15, 30, 60	10	13	23	6	2	25+TT	7-TT

NOTE 1: Test configuration IDs with transmission overlap with full RB allocation, requirements in TS 38.101-3 [4] apply.
NOTE 2: Test configuration IDs with transmission overlap with 1RB allocation, requirements in TS 38.101-3 [4] apply.
NOTE 3: Test configuration IDs with transmission overlap with edge full RB allocation, requirements in TS 38.101-3 [4] apply.
NOTE 4: When $F_{IM3,low_block,low} \geq 2490.5$ MHz (Case A)
NOTE 5: When $F_{IM3,low_block,low} < 2490.5$ MHz (Case B)
NOTE 6: TT for each frequency and channel bandwidth is specified in Table 6.2B.3.1.5-1.

Table 6.2B.3.1.5.2-4: UE Power Class 2 test requirements for NS_04, supporting dynamic power sharing and E-UTRA UL transmission overlapping with NR UL transmission

Test ID	Test SCS (kHz)	A-MPR _{tot} (dB)	P _{EN-DC, tot_L} (dBm)	P _{EN-DC, tot_H} (dBm)	T _{LOW} (P _{CMAX_L}) (dB)	T _{HIGH} (P _{CMAX_H}) (dB)	Upper limit (dBm)	Lower limit (dBm)
1, 8, 15, 22, 25, 28, 35, 42, 45 (Note 1, 4)	15, 30, 60	3	23	26	3	2	28+TT	20-TT
1, 8, 15, 22, 25, 28, 35, 42, 45 (Note 1, 5)	15, 30, 60	9	17	26	5	2	28+TT	12-TT
2, 5, 9, 12, 16, 19, 23, 24, 26, 27, 29, 32, 36, 39, 43, 44, 46, 47 (Note 2, 4, 5)	15	11	15	26	6	2	28+TT	9-TT
2, 5, 9, 12, 16, 19, 23, 24, 26, 27, 29, 32, 36, 39, 43, 44, 46, 47 (Note 2, 4)	30, 60	6	20	26	6	2	28+TT	14-TT
2, 5, 9, 12, 16, 19, 23, 24, 26, 27, 29, 32, 36, 39, 43, 44, 46, 47 (Note 2, 5)	30, 60	11	15	26	6	2	28+TT	9-TT
48 (Note 3, 4)	15	7	19	26	5	2	28+TT	14-TT
48 (Note 3, 4)	30, 60	12	14	26	6	2	28+TT	8-TT
48 (Note 3, 5)	15, 30, 60	7	19	26	5	2	28+TT	14-TT

NOTE 1: Test configuration IDs with transmission overlap with full RB allocation, requirements in TS 38.101-3 [4] apply.
NOTE 2: Test configuration IDs with transmission overlap with 1RB allocation, requirements in TS 38.101-3 [4] apply.
NOTE 3: Test configuration IDs with transmission overlap with edge full RB allocation, requirements in TS 38.101-3 [4] apply.
NOTE 4: When $F_{IM3,low_block,low} \geq 2490.5$ MHz (Case A)
NOTE 5: When $F_{IM3,low_block,low} < 2490.5$ MHz (Case B)
NOTE 6: TT for each frequency and channel bandwidth is specified in Table 6.2B.3.1.5-1.

Table 6.2B.3.1.5.2-5: UE Power Class 2 test requirements for NS_04, supporting dynamic power sharing and E-UTRA UL transmission not overlapping with NR UL transmission (Rel-15 UE or Rel-16 UE reporting (PC2 by P_{PowerClass,NR}, and PC2 or Not present by powerClassNRPart-r16))

Test ID	Test SCS (kHz)	MPR (dB)	A-MPR (dB)	P _{EN-DC, tot_L} (dBm)	P _{EN-DC, tot_H} (dBm)	T _{LOW} (P _{CMAX_L}) (dB)	T _{HIGH} (P _{CMAX_H}) (dB)	Upper limit (dBm)	Lower limit (dBm)
3, 7, 10, 14, 17, 21, 30, 34, 37, 41 (Note 1)	15, 30, 60	0	3	23	26	2	2	28+TT	21-TT
4 (Note 2)	15, 30, 60	3.5	0	22.5	26	2	2	28+TT	20.5-TT
6 (Note 2)	15, 30, 60	0	5.5	20.5	26	2.5	2	28+TT	18-TT
11 (Note 2)	15, 30, 60	3.5	0	22.5	26	2	2	28+TT	20.5-TT
13 (Note 2)	15, 30, 60	0	6	20	26	2.5	2	28+TT	17.5-TT
18 (Note 2)	15, 30, 60	3.5	0	22.5	26	2	2	28+TT	20.5-TT
20 (Note 2)	15, 30, 60	0	6	20	26	2.5	2	28+TT	17.5-TT
31 (Note 2)	15, 30, 60	3.5	0	22.5	26	2	2	28+TT	20.5-TT
33 (Note 2)	15, 30, 60	0	7.5	18.5	26	4	2	28+TT	14.5-TT
38 (Note 2)	15, 30, 60	3.5	0	22.5	26	2	2	28+TT	20.5-TT
40 (Note 2)	15, 30, 60	0	7.5	18.5	26	4	2	28+TT	14.5-TT

NOTE 1: Test configuration IDs without transmission overlap, 1RB E-UTRA allocation, A-MPR requirements in TS 36.101 [5] apply.
NOTE 2: Test configuration IDs without transmission overlap, 1RB NR allocation, A-MPR requirements in TS 38.101-1 [2] apply.
NOTE 3: Void.
NOTE 4: Void.
NOTE 5: Void.
NOTE 6: TT for each frequency and channel bandwidth is specified in Table 6.2B.3.1.5-1.

Table 6.2B.3.1.5.2-5a: UE Power Class 2 test requirements for NS_04, E-UTRA UL transmission not overlapping with NR UL transmission (Rel-16 UE reporting (PC2 by $P_{PowerClass,NR}$, and PC3 by $powerClassNRPart-r16$) or Rel-16 UE reporting (PC3 by $P_{PowerClass,NR}$))

Test ID	Test SCS (kHz)	MPR (dB)	A-MPR (dB)	P_{EN-DC, tot_L} (dBm)	P_{EN-DC, tot_H} (dBm)	T_{LOW} ($P_{C_{MAX_L}}$) (dB)	T_{HIGH} ($P_{C_{MAX_H}}$) (dB)	Upper limit (dBm)	Lower limit (dBm)
3, 7, 10, 14, 17, 21, 30, 34, 37, 41 (Note 1)	15, 30, 60	0	3	23	26	2	2	28+TT	21+TT
4 (Note 2)	15, 30, 60	0.5	0	22.5	23	2	2	25+TT	20.5+TT
6 (Note 2)	15, 30, 60	0	3.5	19.5	23	3.5	2	25+TT	16+TT
11 (Note 2)	15, 30, 60	1	0	22	23	2	2	25+TT	20+TT
13 (Note 2)	15, 30, 60	0	4	19	23	3.5	2	25+TT	15.5+TT
18 (Note 2)	15, 30, 60	2	0	21	23	2	2	25+TT	19+TT
20 (Note 2)	15, 30, 60	0	4	19	23	3.5	2	25+TT	15.5+TT
31 (Note 2)	15, 30, 60	3	0	20	23	2.5	2	25+TT	17.5+TT
33 (Note 2)	15, 30, 60	0	5.5	17.5	23	5	2	25+TT	12.5+TT
38 (Note 2)	15, 30, 60	3	0	20	23	2.5	2	25+TT	17.5+TT
40 (Note 2)	15, 30, 60	0	5.5	17.5	23	5	2	25+TT	12.5+TT

NOTE 1: Test configuration IDs without transmission overlap, 1RB E-UTRA allocation, A-MPR requirements in TS 36.101 [5] apply.
NOTE 2: Test configuration IDs without transmission overlap, 1RB NR allocation, A-MPR requirements in TS 38.101- [2] apply.
NOTE 3: TT for each frequency and channel bandwidth is specified in Table 6.2B.3.1.5-1.

Table 6.2B.3.1.5.2-6: UE Power Class 2 test requirements for NS_04, not supporting dynamic power sharing and E-UTRA UL transmission overlapping with NR UL transmission

Test ID	Test SCS (kHz)	A-MPR _{tot} (dB)	P_{EN-DC, tot_L} (dBm)	P_{EN-DC, tot_H} (dBm)	T_{LOW} ($P_{C_{MAX_L}}$) (dB)	T_{HIGH} ($P_{C_{MAX_H}}$) (dB)	Upper limit (dBm)	Lower limit (dBm)
1, 8, 15, 22, 25, 28, 35, 42, 45 (Note 1, 4)	15, 30, 60	6	20	26	6	2	28+TT	14-TT
1, 8, 15, 22, 25, 28, 35, 42, 45 (Note 1, 5)	15, 30, 60	12	14	26	6	2	28+TT	8-TT
2, 5, 9, 12, 16, 19, 23, 24, 26, 27, 29, 32, 36, 39, 43, 44, 46, 47 (Note 2, 4, 5)	15	14	12	26	6	2	28+TT	6-TT
2, 5, 9, 12, 16, 19, 23, 24, 26, 27, 29, 32, 36, 39, 43, 44, 46, 47 (Note 2, 4)	30, 60	9	17	26	5	2	28+TT	12-TT
2, 5, 9, 12, 16, 19, 23, 24, 26, 27, 29, 32, 36, 39, 43, 44, 46, 47 (Note 2, 5)	30, 60	14	12	26	6	2	28+TT	6-TT
48 (Note 3, 4)	15	10	16	26	5	2	28+TT	11-TT
48 (Note 3, 4)	30, 60	15	11	26	6	2	28+TT	5-TT
48 (Note 3, 5)	15, 30, 60	10	16	26	5	2	28+TT	11-TT

NOTE 1: Test configuration IDs with transmission overlap with full RB allocation, requirements in TS 38.101-3 [4] apply.
NOTE 2: Test configuration IDs with transmission overlap with 1RB allocation, requirements in TS 38.101-3 [4] apply.
NOTE 3: Test configuration IDs with transmission overlap with edge full RB allocation, requirements in TS 38.101-3 [4] apply.
NOTE 4: When $F_{IM3,low_block,low} \geq 2490.5$ MHz (Case A)
NOTE 5: When $F_{IM3,low_block,low} < 2490.5$ MHz (Case B)
NOTE 6: TT for each frequency and channel bandwidth is specified in Table 6.2B.3.1.5-1.

6.2B.3.2 UE Additional Maximum Output Power reduction for Intra-Band Non-Contiguous EN-DC

Editor's note: This test case is incomplete. The following aspects are either missing or not yet determined:

- Test frequencies for the Minimum W_{GAP}
- Test requirements for non-overlapping transmission of non-DPS UE need further investigation

6.2B.3.2.1 Test purpose

Additional emission requirements can be signalled by the network with network signalling value indicated by the field *additionalSpectrumEmission*. To meet these additional requirements, additional maximum power reduction (A-MPR) is allowed for the maximum output power as specified in Table 6.2B.1.1.3-1. Unless stated otherwise, an A-MPR of 0 dB shall be used.

6.2B.3.2.2 Test applicability

The requirements of this test apply in test case 6.5B.2.2.2 Additional spectrum emission mask for network signalled values NS_04 to all types of E-UTRA UE release 15 and forward, supporting intra-band non-contiguous EN-DC.

6.2B.3.2.3 Minimum conformance requirements

For intra-band non-contiguous EN-DC band combinations with additional requirements the A-MPR allowed are specified in table 6.2B.3.2.3-1 for UEs configured with EN-DC and combinations of network signalling values indicated in the E-UTRA and NR cell group(s). Unless otherwise stated the A-MPR specified in subclause 6.2B.3.2 for intra-band non-contiguous EN-DC configurations is the total power reduction allowed including MPR. For UEs scheduled with single uplink transmission, AMPR in subclause 6.2.4 of [4] and 6.2.3 of [2] apply.

Table 6.2B.3.2.3-1: Allowed power reduction for intra-band non-contiguous EN-DC

DC configuration	Requirement (clause)	E-UTRA network signalling value	NR network signalling value	A-MPR (clause)
DC_41A_n41A ¹	6.6.3.3.19 and 6.6.2.2.2 of TS 36.101 [5] and 6.5.2.3.2 and 6.5.3.3.1 of TS 38.101-1 [2]	NS_01 or NS_04	NS_04	6.2B.3.2.3.1
NOTE 1: Only applies to UEs that support dual UL transmission for this EN-DC combination. NOTE 2: The requirement applies when the combination of network signalling values in the two CGs is set (only for UEs configured with EN-DC).				

The normative reference for this requirement is TS 38.101-3 [4] clause 6.2B.3.2.

Exception requirements for both NR and E-UTRA are defined for this test when transmission on E-UTRA overlap in time with NR.LTE anchor agnostic approach is not applied for this case and referred to as sub-test 1. E-UTRA test point analysis is included and E-UTRA measurements are performed.

Exception requirements for both NR and E-UTRA are defined for this test when transmission on E-UTRA doesn't overlap in time with NR, for a UE that doesn't support dynamic power sharing. LTE anchor agnostic approach is not applied for this case. E-UTRA test point analysis is included and E-UTRA measurements are performed.

No exception requirements for NR or E-UTRA are defined for this test when transmission on E-UTRA doesn't overlap in time with NR, for a UE that supports dynamic power sharing. LTE anchor agnostic approach is not applied for this case.

6.2B.3.2.3.1 A-MPR for NS_04

When the UE is configured for B41/n41 intra-band non-contiguous EN-DC and it receives IE NS_04, the UE determines the total allowed maximum output power reduction as specified in this clause. The A-MPR for EN-DC defined in this clause is used instead of MPR defined in 6.2B.2.2, not additively, so EN-DC MPR=0 when NS_04 is signalled.

For UE supporting dynamic power sharing the following:

- for the MCG, A-MPR_c in accordance with TS 36.101 [5]
- for the SCG,

$$A-MPR'_c = A-MPR_{NR} = \text{MAX}(A-MPR_{\text{single,NR}}, A-MPR_{\text{EN-DC}})$$

- for the total configured transmission power,

$$A-MPR_{tot} = P_{PowerClass,EN-DC} - \min(P_{PowerClass,EN-DC}, 10 \cdot \log_{10}(10^{(P_{PowerClass,E-UTRA} - A-MPR_{E-UTRA})/10}) + 10^{(P_{PowerClass,NR} - A-MPR_{NR})/10}))$$

where

$$A-MPR_{E-UTRA} = \text{MAX}(A-MPR_{single,E-UTRA} + MPR_{single,E-UTRA}, A-MPR_{EN-DC})$$

$$A-MPR_{EN-DC} = \text{MAX}(A-MPR_{IM3}, A-MPR_{ACLROverlap})$$

with

- $A-MPR_{single,E-UTRA}$ is the A-MPR defined for the E-UTRA transmission in TS 38.101-3 [4]
- $A-MPR_{single,NR}$ is the A-MPR defined for the NR transmission in TS 38.101-1 [2]
- $MPR_{single,E-UTRA}$ is the MPR defined for the E-UTRA transmission in TS 38.101-3 [4]

For UEs not supporting dynamic power sharing the following

- for the MCG,

$$A-MPR_c = \text{MAX}(A-MPR_{single,E-UTRA} + MPR_{single,E-UTRA}, A-MPR_{IM3}, A-MPR_{ACLROverlap})$$

- for the SCG,

$$A-MPR'_c = \text{MAX}(A-MPR_{single,NR}, A-MPR_{IM3}, A-MPR_{ACLROverlap})$$

where

- $A-MPR_{single,E-UTRA}$ is the A-MPR defined for the E-UTRA transmission in TS 36.101 [5]
- $A-MPR_{single,NR}$ is the A-MPR defined for the NR transmission in TS 38.101-1 [2]
- $MPR_{single,E-UTRA}$ is the MPR defined for the E-UTRA transmission in TS 36.101 [5]

The UE determines the Channel Configuration Case and the value of $A-MPR_{IM3}$ as follows:

$$\text{If } \text{AND}(F_{IM3,low_block,high} < F_{filter,low}, \text{MAX}(SEM_{-13,high}, F_{IM3,high_block,low}) > F_{filter,high})$$

Channel Configuration Case C. $A-MPR_{IM3}$ defined in Clause 6.2B.3.1.3.2.1

Else

Channel Configuration Case D. $A-MPR_{IM3}$ defined in Clause 6.2B.3.1.3.2.2

where

- $F_{IM3,low_block,high} = (2 * F_{low_channel,high_edge}) - F_{high_channel,low_edge}$
- $F_{IM3,high_block,low} = (2 * F_{high_channel,low_edge}) - F_{low_channel,high_edge}$
- $F_{low_channel,low_edge}$ is the lowermost frequency of lower transmission bandwidth configuration.
- $F_{low_channel,high_edge}$ is the uppermost frequency of lower transmission bandwidth configuration.
- $F_{high_channel,low_edge}$ is the lowermost frequency of upper transmission bandwidth configuration.
- $F_{high_channel,high_edge}$ is the uppermost frequency of upper transmission bandwidth configuration.
- $F_{filter,low} = 2480$ MHz
- $F_{filter,high} = 2745$ MHz
- $SEM_{-13,high}$ = Threshold frequency where upper spectral emission mask for upper channel drops from -13 dBm / 1MHz to -25 dBm / 1MHz, as specified in Clause 6.6.2.2.2 in [5] and Subclause 6.5.2.3.2 in [2] respectively.

Where the transmission bandwidth configuration for NR is the maximum frequency span covering all the configured SCSSpecificCarrier for scenarios that carrier bandwidths with different SCS can be fully overlapped.

The UE determines the value of $A\text{-MPR}_{\text{ACLROverlap}}$ as specified in Table 6.2B.3.2.3.1-1:

Table 6.2B.3.2.3.1-1: $A\text{-MPR}_{\text{ACLROverlap}}$

W_{gap}	$A\text{-MPR}_{\text{ACLROverlap}}$
$< BW_{\text{channel,E-UTRA}} + BW_{\text{channel,NR}}$	4 dB
$\geq BW_{\text{channel,E-UTRA}} + BW_{\text{channel,NR}}$	0 dB
NOTE 1: $W_{\text{gap}} = F_{\text{high_channel,low_edge}} - F_{\text{low_channel,high_edge}}$	

6.2B.3.2.4 Test description

6.2B.3.2.4.1 Initial conditions

Initial conditions are a set of test configurations the UE needs to be tested in and the steps for the SS to take with the UE to reach the correct measurement state.

The initial test configurations consist of environmental conditions, test frequencies, test channel bandwidths and sub-carrier spacing based on NR operating bands specified in table 5.2B.3.1-1. All of these configurations shall be tested with applicable test parameters for each combination of test channel bandwidth and sub-carrier spacing, and are shown in test configuration table 6.2B.3.1.4.1-1 through 6.2B.3.1.4.1-2 with additional IM3 test frequencies for NS_04 in 6.2B.3.2.4.1-1. The details of the uplink reference measurement channels (RMCs) are specified in Annex A2. Configurations of PDSCH and PDCCH before measurement are specified in Annex TS 36.521-1 [10] Annex C and in Annex C2 for LTE link and NR link respectively.

Table 6.2B.3.2.4.1-0: E-UTRA test configuration table

E-UTRA Test Parameters				
E-UTRA Channel Bandwidth	E-UTRA Test Frequency (Note 1)	Downlink	Uplink	
		N/A for A-MPR testing	Modulation	RB allocation
20 MHz	Low range and High range (Note 2)		QPSK	100
NOTE 1: E-UTRA Test Frequency as specified in TS 36.508 [6] clause 4.3.1				
NOTE 2: NR carrier shall be the outermost carrier during test.				

Table 6.2B.3.2.4.1-1: Additional IM3 Test Frequencies for NS_04 intra-band non-contiguous EN-DC

Additional Initial Condition	
Additional IM3 Test Frequencies	if maximum $W_{\text{GAP}} > 88.4$ MHz, and SCS 15 kHz, 15 kHz NR raster then IM3 test frequencies as specified in Table 6.2B.3.2.4.1-2. if maximum $W_{\text{GAP}} > 88.4$ MHz, and SCS 15 kHz, 30 kHz NR raster then IM3 test frequencies as specified in Table 6.2B.3.2.4.1-3. if maximum $W_{\text{GAP}} > 88.4$ MHz, and SCS 15 kHz, 60 kHz NR raster then IM3 test frequencies as specified in Table 6.2B.3.2.4.1-4.

Table 6.2B.3.2.4.1-2: EN-DC combination DC_41A_n41A, intra-band non-contiguous, SCS 15 kHz, 15 kHz NR raster, IM3 test frequencies

EN-DC channel bandwidth combination	CC	Bandwidth [MHz]	carrierBandwidth [PRBs]	Range		Carrier centre [MHz] Note 2	Carrier centre [ARFCN]	point A [MHz]	absolute FrequencyPoint A [ARFCN]	offsetTo Carrier [Carrier PRBs]	SS block SCS [kHz]	GSC N	absoluteFrequencySSB [ARFCN]
				Downlink & Uplink	IM3								
E-UTRA: 20MHz + NR: 40MHz	E-UTRA CC1	20	100	Downlink & Uplink	IM3	2666.700	41357	-	-	-	-	-	-
	NR CC1	40	216	Downlink & Uplink	IM3	2548.300	509660	2528.86	505772	0	15	6327	509660
NR: 40MHz + E-UTRA: 20MHz	E-UTRA CC1	20	100	Downlink & Uplink	IM3	2558.300	40273	-	-	-	-	-	-
	NR CC1	40	216	Downlink & Uplink	IM3	2676.700	535340	2657.26	531452	0	15	6648	535340
E-UTRA: 20MHz + NR: 50MHz	E-UTRA CC1	20	100	Downlink & Uplink	IM3	2524.900	39939	-	-	-	-	-	-
	NR CC1	50	270	Downlink & Uplink	IM3	2665.000	533000	2640.7	528140	0	15	6606	533000
NR: 50MHz + E-UTRA: 20MHz	E-UTRA CC1	20	100	Downlink & Uplink	IM3	2666.700	41357	-	-	-	-	-	-
	NR CC1	50	270	Downlink & Uplink	IM3	2543.300	508660	2519	503800	0	15	6303	508660

Table 6.2B.3.2.4.1-3: EN-DC combination DC_41A_n41A, intra-band non-contiguous, SCS 30 kHz, 30 kHz NR raster, IM3 test frequencies

EN-DC channel bandwidth combination	CC	Bandwidth [MHz]	carrierBandwidth [PRBs]	Range	Carrier centre [MHz] Note 2	Carrier centre [ARFCN]	point A [MHz]	absolute FrequencyPoint A [ARFCN]	offsetTo Carrier [Carrier PRBs]	SS block SCS [kHz]	GSC N	absoluteFrequencySSB [ARFCN]
-------------------------------------	----	-----------------	-------------------------	-------	-----------------------------	------------------------	---------------	-----------------------------------	---------------------------------	--------------------	-------	------------------------------

E-UTRA: 20MHz + NR: 40MHz	E-UTRA CC1	20	100	Downlink & Uplink	IM3	2666.700	41357	-	-	-	-	-	-
	NR CC1	40	106	Downlink & Uplink	IM3	2548.300	509660	2529.22	505844	0	30	6333	509660
NR: 40MHz + E-UTRA: 20MHz	E-UTRA CC1	20	100	Downlink & Uplink	IM3	2558.300	40273	-	-	-	-	-	-
	NR CC1	40	106	Downlink & Uplink	IM3	2676.700	535340	2657.62	531524	0	30	6654	535340
E-UTRA: 20MHz + NR: 50MHz	E-UTRA CC1	20	100	Downlink & Uplink	IM3	2524.900	39939	-	-	-	-	-	-
	NR CC1	50	133	Downlink & Uplink	IM3	2665.000	533000	2641.06	528212	0	30	6612	533000
NR: 50MHz + E-UTRA: 20MHz	E-UTRA CC1	20	100	Downlink & Uplink	IM3	2666.700	41357	-	-	-	-	-	-
	NR CC1	50	133	Downlink & Uplink	IM3	2543.300	508660	2519.36	503872	0	30	6309	508660

Table 6.2B.3.2.4.1-4: EN-DC combination DC_41A_n41A, intra-band non-contiguous, SCS 60 kHz, 15 kHz NR raster, IM3 test frequencies

EN-DC channel bandwidth combination	CC	Bandwidth [MHz]	carrierBandwidth [PRBs]	Range		Carrier centre [MHz] Note 2	Carrier centre [ARFCN]	point A [MHz]	absolute Frequen cyPoint A [ARFCN]	offsetTo Carrier [Carrier PRBs]	SS block SCS [kHz]	GSC N	absoluteF requery SSB [ARFCN]
E-UTRA: 20MHz + NR: 40MHz	E-UTRA CC1	20	100	Downlink & Uplink	IM3	2666.700	41357	-	-	-	-	-	-
	NR CC1	40	51	Downlink & Uplink	IM3	2548.300	509660	2529.94	505988	0	15	6330	509660
NR: 40MHz + E-UTRA: 20MHz	E-UTRA CC1	20	100	Downlink & Uplink	IM3	2558.300	40273	-	-	-	-	-	-
	NR CC1	40	51	Downlink & Uplink	IM3	2676.700	535340	2658.34	531668	0	15	6651	535340
E-UTRA: 20MHz + NR: 50MHz	E-UTRA CC1	20	100	Downlink & Uplink	IM3	2524.900	39939	-	-	-	-	-	-
	NR CC1	50	65	Downlink & Uplink	IM3	2665.000	535340	2653.3	530660	0	15	6639	535340
NR: 50MHz + E-UTRA: 20MHz	E-UTRA CC1	20	100	Downlink & Uplink	IM3	2666.700	41357	-	-	-	-	-	-
	NR CC1	50	65	Downlink & Uplink	IM3	2543.300	508660	2519.9	503980	0	15	6306	508660

Editor's note: The following lines belong at the end of clause 6.2B.3.2.4.1. As new tables are added to this clause, these lines should always follow the tables.

1. Connect the SS to the UE antenna connectors as shown in TS 38.508-1 [6] Annex A, Figure A.3.1.1.1 for TE diagram and clause A.3.2.1 for UE diagram.
2. The parameter settings for the cell are set up according to TS 38.508-1 [6] clause 4.4.3.
3. Downlink signals are initially set up according to TS 36.521-1 [10] Annex C.0 and TS 38.521-1 [8] Annex C.0 for E-UTRA CG and NR CG respectively, and uplink signals according to TS 36.521-1 [10] Annex H and TS 38.521-1 [8] Annex G for E-UTRA CG and NR CG respectively.
4. NR downlink signals are initially set up according to Annex C.0, C.1, and C.2 and uplink signals according to Annex G.0, G.1, G.2, and G.3.0 of TS 38.521-1 [8].
5. The UL Reference Measurement channels are set according to TS 36.521-1 [10] Annex A.2 and Annex A for LTE link and NR link respectively.
6. Propagation conditions are set according to TS 36.521-1 [10] Annex B.0 and TS 38.521-1 [8] Annex B.0 for E-UTRA CG and NR CG respectively.
7. Ensure the UE is in state RRC_CONNECTED with generic procedure parameters Connectivity EN-DC, DC bearer *MCG* and *SCG*, Connected without release *On* according to TS 38.508-1 [6] clause 4.5. Message contents are defined in clause 6.2B.3.2.4.3.
8. For the case of testing overlapping E-UTRA and NR UL transmission scenario when both bands are TDD, ensure E-UTRA UL transmission overlaps with NR UL transmission in time by giving SCG a delay of 3 E-UTRA subframes, or by giving MCG a delay of 2 subframes.

6.2B.3.2.4.2 Test procedure

1. SS sends uplink scheduling information for each UL HARQ process via PDCCH DCI format 0 and DCI format [0_1] for C_RNTI to schedule the UL RMC according to table 6.2B.3.2.4.1-1 on both EN-DC component carriers. Since the UL has no payload and no loopback data to send the UE sends uplink MAC padding bits on the UL RMC.
2. Send continuously uplink power control "up" commands to the UE for NR and E-UTRA carrier until the UE transmits at its P_{UMAX} level; allow at least 200 ms starting from the first TPC command in this step for the UE to reach P_{UMAX} level.
3. Measure the mean power over all component carriers for the EN-DC configuration, which shall meet the requirements described in table 6.2B.3.2.5-1. The period of the measurement shall be at least the continuous duration of one sub-frame (1ms).

NOTE 1: When switching to DFT-s-OFDM waveform, as specified in the test configuration table 6.2B.3.1.4.1-2, send an NR RRCReconfiguration message according to TS 38.508-1 [6] clause 4.6.3 Table 4.6.3-118 PUSCH-Config with TRANSFORM_PRECODER_ENABLED condition.

6.2B.3.2.4.3 Message contents

Message contents are according to TS 38.508-1 [6] clause 4.6.1, with the following exceptions.

Table 6.2B.3.2.4.3-1: RRCConnectionReconfiguration: nr-Config-r15

Derivation Path: TS 36.508 [11], Table 4.6.1-8			
Information Element	Value/remark	Comment	Condition
p-MaxEUTRA-r15	23	Apply if run test points with E-UTRA UL transmission not overlapping with NR UL transmission in time for PC3 UE	
	20	Apply if run test points with E-UTRA UL transmission overlapping with NR UL transmission in time for PC3 UE, and UE doesn't support dynamic power sharing.	
P-Max	23	Apply if run test points with E-UTRA UL transmission not overlapping with NR UL transmission in time for PC3 UE	
	20	Apply if run test points with E-UTRA UL transmission overlapping with NR UL transmission in time for PC3 UE, and UE doesn't support dynamic power sharing.	

6.2B.3.2.4.3.1 Message contents exceptions (network signalled value "NS_04")

For "NS_04" see A-MPR test case in table 6.2B.3.1.4.3.1-1 and table 6.2B.3.1.4.3.1-2.

6.2B.3.2.5 Test requirement

The maximum output power, derived in step 3 shall be within the range prescribed by the nominal maximum output power and tolerance in table 6.2B.3.2.5-1. The allowed A-MPR values specified in table 6.2B.3.2.3-1 are in addition to the allowed MPR requirements specified in clause 6.2B.1.1.3. For the UE maximum output power modified by MPR and/or A-MPR, the power limits specified in table 6.2B.1.1.3-1 apply.

Table 6.2B.3.2.5-0: Test Tolerance for UE maximum output power (LTE, NR TX separately)

Uplink TX		$f \leq 3.0\text{GHz}$	$3.0\text{GHz} < f \leq 4.2\text{GHz}$	$4.2\text{GHz} < f \leq 6\text{GHz}$
LTE	$\text{BW} \leq 20\text{MHz}$	0.7	1.0	1.3
NR	$\text{BW} \leq 40\text{MHz}$	0.7 dB	1.0 dB	1.0
	$40\text{MHz} < \text{BW} \leq 100\text{MHz}$	1.0 dB	1.0 dB	1.0

Table 6.2B.3.2.5-1: UE Power Class 3 test requirements for network signalled value "NS_04"

Test ID	Modulation	$\Delta P_{\text{PowerClass}}$ (dB)	MPR (dB)	A-MPR (dB)	A-MPR _{EN-DC} (dB)	A-MPR _c (dB)	$\Delta T_{C,c}$ (dB) Note 7	$P_{\text{CMAX},c}$ (dBm)	$T(P_{\text{CMAX},L,f,c})$ (dB)	$T_{L,c}$ (dB)	Upper limit	Lower limit
1, 8, 15, 22, 25, 28, 35, 42 and 45	E-UTRA Note 1	0	2	0	6	6	0 (1.5)	17 (15.5)	5 (5)	2 (3.5)	25+TT	12-TT (10.5-TT)
1, 8, 15, 22, 25, 28, 35, 42 and 45	E-UTRA Note 2	0	2	0	11	11	0 (1.5)	12 (10.5)	6 (6)	2 (3.5)	25+TT	6-TT (4.5-TT)
1, 8, 15, 22, 25, 28, 35, 42 and 45	NR, Note 1	0	-	Note 5	6	6	0 (1.5)	17 (15.5)	5 (5)	2 (3.5)	25+TT	12-TT (10.5-TT)
1, 8, 15, 22, 25, 28, 35, 42 and 45	NR, Note 2	0	-	Note 5	11	11	0 (1.5)	12 (10.5)	6 (6)	2 (3.5)	25+TT	6-TT (4.5-TT)
2, 5, 9, 16, 19, 23, 24, 26, 27, 29, 32, 36, 39, 43, 44, 46, and 47	E-UTRA Note 1, 3	0	1	Note 6	14	14	0 (1.5)	9 (7.5)	6 (7)	2 (3.5)	25+TT	3-TT (0.5-TT)
2, 5, 9, 16, 19, 23, 24, 26, 27, 29, 32, 36, 39, 43, 44, 46, and 47	E-UTRA Note 1, 4	0	1	Note 6	9	9	0 (1.5)	14 (12.5)	5 (6)	2 (3.5)	25+TT	9-TT (6.5-TT)
2, 5, 9, 16, 19, 23, 24, 26, 27, 29, 32, 36, 39, 43, 44, 46, and 47	E-UTRA Note 2	0	1	Note 6	14	14	0 (1.5)	9 (7.5)	6	2 (3.5)	25+TT	3-TT (0.5-TT)
2, 5, 9, 16, 19, 23, 24, 26, 27, 29, 32, 36, 39, 43, 44, 46, and 47	NR Note 1, 3	0	-	Note 5	14	14	0 (1.5)	9 (7.5)	6 (7)	2 (3.5)	25+TT	3-TT (0.5-TT)
2, 5, 9, 16, 19, 23, 24, 26, 27, 29, 32, 36, 39, 43, 44, 46, and 47	NR Note 1, 4	0	-	Note 5	9	9	0 (1.5)	14 (12.5)	5 (6)	2 (3.5)	25+TT	9-TT (6.5-TT)

2, 5, 9, 16, 19, 23, 24, 26, 27, 29, 32, 36, 39, 43, 44, 46, and 47	NR Note 2	0	-	Note 5	11	11	0 (1.5)	9 (7.5)	6 (6)	2 (3.5)	25+TT	3-TT (0.5-TT)
3, 7, 10, 14, 17, 21, 30, 34, 37, 41	E-UTRA Note 1	0	1	Note 6	14	14	0 (1.5)	9 (7.5)	6 (7)	2 (3.5)	25+TT	3-TT (0.5-TT)
3, 7, 10, 14, 17, 21, 30, 34, 37 and 41	E-UTRA Note 2	0	1	Note 6	14	14	0 (1.5)	9 (7.5)	6 (7)	2 (3.5)	25+TT	3-TT (0.5-TT)
4	NR	0	0.5	Note 9	0	0	0 (1.5)	22.5 (21)	2 (2)	2 (3.5)	25+TT	20.5-TT (19-TT)
6	NR	0	0	Note 9	3.5	3.5	0 (1.5)	19.5 (18)	3.5 (4)	2 (3.5)	25+TT	16-TT (14-TT)
11	NR	0	1	Note 9	0	0	0 (1.5)	22 (20.5)	2 (2.5)	2 (3.5)	25+TT	20-TT (18-TT)
13	NR	0	0	Note 9	4	4	0 (1.5)	19 (17.5)	3.5 (5)	2 (3.5)	25+TT	15.5-TT (12.5-TT)
18	NR	0	2	Note 9	0	0	0 (1.5)	21 (19.5)	2 (3.5)	2 (3.5)	25+TT	19-TT (16-TT)
20	NR	0	0	Note 9	4	4	0 (1.5)	19 (17.5)	3.5 (5)	2 (3.5)	25+TT	15.5-TT (12.5-TT)
31	NR	0	3	Note 9	0	0	0 (1.5)	20 (18.5)	2.5 (4)	2 (3.5)	25+TT	17.5-TT (14.5-TT)
33	NR	0	0	Note 9	5.5	5.5	0 (1.5)	17.5 (16)	5 (5)	2 (3.5)	25+TT	12-TT (11-TT)
38	NR	0	3	Note 9	0	0	0 (1.5)	20 (18.5)	2.5 (4)	2 (3.5)	25+TT	17.5-TT (14.5-TT)
40	NR	0	0	Note 9	5.5	5.5	0 (1.5)	17.5 (16)	5 (5)	2 (3.5)	25+TT	12-TT (11-TT)

NOTE 1: When $F_{IM3,low_block,low} \geq 2490.5$ MHz (Case A)
 NOTE 2: When $F_{IM3,low_block,low} < 2490.5$ MHz (Case B)
 NOTE 3: When NR SCS = 15kHz.
 NOTE 4: When NR SCS = 30 kHz or 60 kHz.
 NOTE 5: NR A-MPR values for NS_04 are defined in Table 6.2.3.3.2-1.
 NOTE 6: E-UTRA A-MPR= 3 dB for 1 RB and $f_c < 2517.5$ MHz, otherwise 0 dB.
 NOTE 7: $\Delta T_{C,c} = 1.5$ dB for transmission bandwidths confined within F_{UL_low} and $F_{UL_low} + 4$ MHz or $F_{UL_high} - 4$ MHz and F_{UL_high} , otherwise 0 dB.
 NOTE 8: TT for each frequency and channel bandwidth is specified in Table 6.2B.3.2.5-0.
 NOTE 9: Apply for UE supporting dynamic power sharing. NR A-MPR values for NS_04 are defined in TS 38.101-1 [2].

Table 6.2B.3.2.5-2: UE Power Class 2 test requirements for network signalled value "NS_04" (Rel-15 UE or Rel-16 UE reporting (PC2 by $P_{\text{PowerClass, NR}}$, and PC2 or Not present by *powerClassNRPart-r16*))

Test ID	Modulation	$\Delta P_{\text{PowerClass}}$ (dB)	MPR (dB)	A-MPR (dB)	A-MPR _{EN-DC} (dB)	A-MPR _c (dB)	$\Delta T_{C,c}$ (dB) Note 7	$P_{\text{CMAX},c}$ (dBm)	$T(P_{\text{CMAX},L,f,c})$ (dB)	$T_{L,c}$ (dB)	Upper limit	Lower limit
1, 8, 15, 22, 25, 28, 35, 42 and 45	E-UTRA Note 1	3	2	0	6	6	0 (1.5)	17 (15.5)	5 (5)	2 (3.5)	28+TT	12-TT (10.5- TT)
1, 8, 15, 22, 25, 28, 35, 42 and 45	E-UTRA Note 2	3	2	0	11	11	0 (1.5)	12 (10.5)	6 (6)	2 (3.5)	28+TT	6-TT (4.5-TT)
1, 8, 15, 22, 25, 28, 35, 42 and 45	NR, Note 1	3	-	Note 5	6	6	0 (1.5)	17 (15.5)	5 (5)	2 (3.5)	28+TT	12-TT (10.5- TT)
1, 8, 15, 22, 25, 28, 35, 42 and 45	NR, Note 2	3	-	Note 5	11	11	0 (1.5)	12 (10.5)	6 (6)	2 (3.5)	28+TT	6-TT (4.5-TT)
2, 5, 9, 16, 19, 23, 24, 26, 27, 29, 32, 36, 39, 43, 44, 46, and 47	E-UTRA Note 1, 3	3	1	Note 6	14	14	0 (1.5)	9 (7.5)	6 (7)	2 (3.5)	28+TT	3-TT (0.5-TT)
2, 5, 9, 16, 19, 23, 24, 26, 27, 29, 32, 36, 39, 43, 44, 46, and 47	E-UTRA Note 1, 4	3	1	Note 6	9	9	0 (1.5)	14 (12.5)	5 (6)	2 (3.5)	28+TT	9-TT (6.5-TT)
2, 5, 9, 16, 19, 23, 24, 26, 27, 29, 32, 36, 39, 43, 44, 46, and 47	E-UTRA Note 2	3	1	Note 6	14	14	0 (1.5)	9 (7.5)	6	2 (3.5)	28+TT	3-TT (0.5-TT)
2, 5, 9, 16, 19, 23, 24, 26, 27, 29, 32, 36, 39, 43, 44, 46, and 47	NR Note 1, 3	3	-	Note 5	14	14	0 (1.5)	9 (7.5)	6 (7)	2 (3.5)	28+TT	3-TT (0.5-TT)
2, 5, 9, 16, 19, 23, 24, 26, 27, 29, 32, 36, 39, 43, 44, 46, and 47	NR Note 1, 4	3	-	Note 5	9	9	0 (1.5)	14 (12.5)	5 (6)	2 (3.5)	28+TT	9-TT (6.5-TT)

2, 5, 9, 16, 19, 23, 24, 26, 27, 29, 32, 36, 39, 43, 44, 46, and 47	NR Note 2	3	-	Note 5	11	11	0 (1.5)	9 (7.5)	6 (6)	2 (3.5)	28+TT	3-TT (0.5-TT)
3, 7, 10, 14, 17, 21, 30, 34, 37, 41	E-UTRA Note 1	0	1	Note 6	14	14	0 (1.5)	9 (7.5)	6 (7)	2 (3.5)	28+TT	3-TT (0.5-TT)
3, 7, 10, 14, 17, 21, 30, 34, 37 and 41	E-UTRA Note 2	0	1	Note 6	14	14	0 (1.5)	9 (7.5)	6 (7)	2 (3.5)	28+TT	3-TT (0.5-TT)
4	NR	0	3.5	Note 9	0	0	0 (1.5)	22.5 (21)	2 (2)	2 (3.5)	28+TT	20.5-TT (19-TT)
6	NR	0	0	Note 9	5.5	5.5	0 (1.5)	20.5 (19)	2.5 (3.5)	2 (3.5)	28+TT	18-TT (15.5-TT)
11	NR	0	3.5	Note 9	0	0	0 (1.5)	22.5 (21)	2 (2)	2 (3.5)	28+TT	20.5-TT (19-TT)
13	NR	0	0	Note 9	6	6	0 (1.5)	20 (18.5)	2.5 (4)	2 (3.5)	28+TT	17.5-TT (14.5-TT)
18	NR	0	3.5	Note 9	0	0	0 (1.5)	22.5 (21)	2 (2)	2 (3.5)	28+TT	20.5-TT (19-TT)
20	NR	0	0	Note 9	6	6	0 (1.5)	20 (18.5)	2.5 (4)	2 (3.5)	28+TT	17.5-TT (14.5-TT)
31	NR	0	3.5	Note 9	0	0	0 (1.5)	22.5 (21)	2 (2)	2 (3.5)	28+TT	20.5-TT (19-TT)
33	NR	0	0	Note 9	7.5	7.5	0 (1.5)	18.5 (17)	4 (5)	2 (3.5)	28+TT	14.5-TT (12-TT)
38	NR	0	3.5	Note 9	0	0	0 (1.5)	22.5 (21)	2 (2)	2 (3.5)	28+TT	20.5-TT (19-TT)
40	NR	0	0	Note 9	7.5	7.5	0 (1.5)	18.5 (17)	4 (5)	2 (3.5)	28+TT	14.5-TT (12-TT)

NOTE 1: When $F_{IM3,low_block,low} \geq 2490.5$ MHz (Case A).

NOTE 2: When $F_{IM3,low_block,low} < 2490.5$ MHz (Case B).

NOTE 3: When NR SCS = 15kHz.

NOTE 4: When NR SCS = 30 kHz or 60 kHz.

NOTE 5: NR A-MPR values for NS_04 are defined in Table 6.2.3.3.2-1.

NOTE 6: E-UTRA A-MPR= 3 dB for 1 RB and $f_c < 2517.5$ MHz, otherwise 0 dB.

NOTE 7: $\Delta T_{C,c} = 1.5$ dB for transmission bandwidths confined within $F_{UL,low}$ and $F_{UL,low} + 4$ MHz or $F_{UL,high} - 4$ MHz and $F_{UL,high}$, otherwise 0 dB.

NOTE 8: TT for each frequency and channel bandwidth is specified in Table 6.2B.3.2.5-0.

NOTE 9: Apply for UE supporting dynamic power sharing. NR A-MPR values for NS_04 are defined in TS 38.101-1 [24].

Table 6.2B.3.2.5-2a: UE Power Class 2 test requirements for network signalled value "NS_04" (Rel-16 UE reporting (PC2 by $P_{\text{PowerClass,NR}}$, and PC3 by *powerClassNRPart-r16*) or Rel-16 UE reporting (PC3 by $P_{\text{PowerClass,NR}}$))

Test ID	Modulation	$\Delta P_{\text{PowerClass}}$ (dB)	MPR (dB)	A-MPR (dB)	A-MPR _{EN-DC} (dB)	A-MPR _c (dB)	$\Delta T_{C,c}$ (dB) Note 7	$P_{\text{CMAX},c}$ (dBm)	$T(P_{\text{CMAX},L,f,c})$ (dB)	$T_{L,c}$ (dB)	Upper limit	Lower limit
1, 8, 15, 22, 25, 28, 35, 42 and 45	E-UTRA Note 1	3	2	0	6	6	0 (1.5)	17 (15.5)	5 (5)	2 (3.5)	28+TT	12-TT (10.5-TT)
1, 8, 15, 22, 25, 28, 35, 42 and 45	E-UTRA Note 2	3	2	0	11	11	0 (1.5)	12 (10.5)	6 (6)	2 (3.5)	28+TT	6-TT (4.5-TT)
1, 8, 15, 22, 25, 28, 35, 42 and 45	NR, Note 1	3	-	Note 5	6	6	0 (1.5)	17 (15.5)	5 (5)	2 (3.5)	28+TT	12-TT (10.5-TT)
1, 8, 15, 22, 25, 28, 35, 42 and 45	NR, Note 2	3	-	Note 5	11	11	0 (1.5)	12 (10.5)	6 (6)	2 (3.5)	28+TT	6-TT (4.5-TT)
2, 5, 9, 16, 19, 23, 24, 26, 27, 29, 32, 36, 39, 43, 44, 46, and 47	E-UTRA Note 1, 3	3	1	Note 6	14	14	0 (1.5)	9 (7.5)	6 (7)	2 (3.5)	28+TT	3-TT (0.5-TT)
2, 5, 9, 16, 19, 23, 24, 26, 27, 29, 32, 36, 39, 43, 44, 46, and 47	E-UTRA Note 1, 4	3	1	Note 6	9	9	0 (1.5)	14 (12.5)	5 (6)	2 (3.5)	28+TT	9-TT (6.5-TT)
2, 5, 9, 16, 19, 23, 24, 26, 27, 29, 32, 36, 39, 43, 44, 46, and 47	E-UTRA Note 2	3	1	Note 6	14	14	0 (1.5)	9 (7.5)	6	2 (3.5)	28+TT	3-TT (0.5-TT)
2, 5, 9, 16, 19, 23, 24, 26, 27, 29, 32, 36, 39, 43, 44, 46, and 47	NR Note 1, 3	3	-	Note 5	14	14	0 (1.5)	9 (7.5)	6 (7)	2 (3.5)	28+TT	3-TT (0.5-TT)
2, 5, 9, 16, 19, 23, 24, 26, 27, 29, 32, 36, 39, 43, 44, 46, and 47	NR Note 1, 4	3	-	Note 5	9	9	0 (1.5)	14 (12.5)	5 (6)	2 (3.5)	28+TT	9-TT (6.5-TT)

2, 5, 9, 16, 19, 23, 24, 26, 27, 29, 32, 36, 39, 43, 44, 46, and 47	NR Note 2	3	-	Note 5	11	11	0 (1.5)	9 (7.5)	6 (6)	2 (3.5)	28+TT	3-TT (0.5-TT)
3, 7, 10, 14, 17, 21, 30, 34, 37, 41	E-UTRA Note 1	3	1	Note 6	14	14	0 (1.5)	9 (7.5)	6 (7)	2 (3.5)	28+TT	3-TT (0.5-TT)
3, 7, 10, 14, 17, 21, 30, 34, 37 and 41	E-UTRA Note 2	3	1	Note 6	14	14	0 (1.5)	9 (7.5)	6 (7)	2 (3.5)	28+TT	3-TT (0.5-TT)
4	NR	0	0.5	Note 9	0	0	0 (1.5)	22.5 (21)	2 (2)	2 (3.5)	25+TT	20.5-TT (19-TT)
6	NR	0	0	Note 9	3.5	3.5	0 (1.5)	19.5 (18)	3.5 (4)	2 (3.5)	25+TT	16-TT (14-TT)
11	NR	0	1	Note 9	0	0	0 (1.5)	22 (20.5)	2 (2.5)	2 (3.5)	25+TT	20-TT (18-TT)
13	NR	0	0	Note 9	4	4	0 (1.5)	19 (17.5)	3.5 (5)	2 (3.5)	25+TT	15.5-TT (12.5-TT)
18	NR	0	2	Note 9	0	0	0 (1.5)	21 (19.5)	2 (3.5)	2 (3.5)	25+TT	19-TT (16-TT)
20	NR	0	0	Note 9	4	4	0 (1.5)	19 (17.5)	3.5 (5)	2 (3.5)	25+TT	15.5-TT (12.5-TT)
31	NR	0	3	Note 9	0	0	0 (1.5)	20 (18.5)	2.5 (4)	2 (3.5)	25+TT	17.5-TT (14.5-TT)
33	NR	0	0	Note 9	5.5	5.5	0 (1.5)	17.5 (16)	5 (5)	2 (3.5)	25+TT	12-TT (11-TT)
38	NR	0	3	Note 9	0	0	0 (1.5)	20 (18.5)	2.5 (4)	2 (3.5)	25+TT	17.5-TT (14.5-TT)
40	NR	0	0	Note 9	5.5	5.5	0 (1.5)	17.5 (16)	5 (5)	2 (3.5)	25+TT	12-TT (11-TT)

NOTE 1: When $F_{IM3,low_block,low} \geq 2490.5$ MHz (Case A).

NOTE 2: When $F_{IM3,low_block,low} < 2490.5$ MHz (Case B).

NOTE 3: When NR SCS = 15kHz.

NOTE 4: When NR SCS = 30 kHz or 60 kHz.

NOTE 5: NR A-MPR values for NS_04 are defined in Table 6.2.3.3.2-1.

NOTE 6: E-UTRA A-MPR= 3 dB for 1 RB and $f_c < 2517.5$ MHz, otherwise 0 dB.

NOTE 7: $\Delta T_{C,c} = 1.5$ dB for transmission bandwidths confined within $F_{UL,low}$ and $F_{UL,low} + 4$ MHz or $F_{UL,high} - 4$ MHz and $F_{UL,high}$, otherwise 0 dB.

NOTE 8: TT for each frequency and channel bandwidth is specified in Table 6.2B.3.2.5-0.

NOTE 9: Apply for UE supporting dynamic power sharing. NR A-MPR values for NS_04 are defined in TS 38.101-1 [2].

6.2B.3.3 UE Additional Maximum Output Power reduction for Inter-Band EN-DC within FR1

6.2B.3.3.1 Test purpose

Same test purpose as in clause 6.2.3.1 in TS 38.521-1 [8] for the NR carrier.

6.2B.3.3.2 Test applicability

The requirements of this test apply to all types of E-UTRA UE release 15 and forward, supporting inter-band EN-DC.

6.2B.3.3.3 Minimum conformance requirements

For inter-band EN-DC between E-UTRA and FR1 NR, UE additional maximum output power reduction specified in TS 36.101 [5] and TS 38.101-1 [2] apply for E-UTRA and NR respectively.

The normative reference for this requirement is TS 38.101-3 [4] clause 6.2B.3.3.

No exception requirements applicable to NR or LTE. LTE anchor agnostic approach is applied

6.2B.3.3.4 Test description

Same test description as in clause 6.2.3.4 in TS 38.521-1 [8] for the NR carrier with the following exceptions:

The initial test configurations for E-UTRA band consist of environmental conditions, test frequencies, and channel bandwidths based on E-UTRA bands specified in Table 4.6-1.

For Initial conditions as in clause 6.2.3.4.1 in TS 38.521-1 [8], the following steps will be added to configure E-UTRA component:

- 2.1. The parameter settings for the E-UTRA cell are set up according to TS 36.508 [11] clause 4.4.3 with E-UTRA channel bandwidth and test frequencies defined in Table 6.2B.3.3.4-1.
- 3.1. Downlink E-UTRA signals are initially set up according to TS 36.521-1 [10] Annex C0, C.1 and C.3.0, and uplink signals according to Annex H.1 and H.3.0.
- 4.1. The E-UTRA UL Reference Measurement channels are set according to Table 6.2B.3.3.4-1.

Step 6 of Initial conditions as in clause 6.2.3.4.1 in TS 38.521-1 [8] is replaced by:

6. Ensure the UE is in state RRC_CONNECTED with generic procedure parameters Connectivity EN-DC, DC bearer MCG and SCG according to TS 38.508 [6] clause 4.5.

Same test procedure as in clause 6.2.3.4.2 in TS 38.521-1 [8].

6.2B.3.3.5 Test requirement

For Rel-15 UE or Rel-16 PC3 UE, same test requirement as in clause 6.2.2.5 in TS 38.521-1 [8].

For Rel-16 PC2 UE reporting (PC2 by $P_{\text{PowerClass,NR}}$, and PC2 or Not present by *powerClassNRPart-r16*), same test requirement for PC2 UE as in clause 6.2.3.5 in TS 38.521-1 [8]. For Rel-16 PC2 UE reporting (PC2 by $P_{\text{PowerClass,NR}}$, and PC3 by *powerClassNRPart-r16*) or Rel-16 PC2 UE reporting (PC3 by $P_{\text{PowerClass,NR}}$), same test requirement for PC3 UE as in clause 6.2.3.5 in TS 38.521-1 [8].

6.2B.3.4 UE Additional Maximum Output Power reduction for Inter-Band EN-DC including FR2

Editor's note: This test case is incomplete. Following aspects are missing or under discussion:

- **Test requirements in referenced TS 38.521-2 [9] test case is incomplete due to missing Test Tolerance**

6.2B.3.4.1 Test purpose

Same test purpose as in clause 6.2.3.1 in TS 38.521-2 [9] for the NR carrier.

6.2B.3.4.2 Test applicability

This test case applies to all types of E-UTRA UE release 15 and forward, supporting inter-band EN-DC including FR2.

6.2B.3.4.3 Minimum conformance requirements

Same minimum conformance requirements as in clause 6.2.2.3 in TS 38.521-2 [9] for the NR carrier.

No exception requirements applicable to NR or LTE. LTE anchor agnostic approach is applied.

6.2B.3.4.4 Test description

6.2B.3.4.4.1 Initial conditions

Same test description as in clause 6.2.3.4 in TS 38.521-2 [9] for the NR carrier with the following exception:

The initial test configurations for E-UTRA band consist of environmental conditions, test frequencies, and channel bandwidths based on E-UTRA bands specified in Table 4.7-1. For Initial conditions as in clause 6.2.3.4.1 in TS 38.521-2 [9], the following steps will be added to configure E-UTRA component:

- 2.1. The parameter settings for E-UTRA cell are set up according to TS 36.508 [11] clause 4.4.3.
- 3.1. The E-UTRA downlink signal level, uplink signal level are set according to Table 4.7-1 and propagation conditions are set according to Annex B.0 of TS 36.521-1 [10].

Step 6 of Initial conditions as in clause 6.2.3.4.1 in TS 38.521-2 [9] is replaced by:

6. Ensure the UE is in state RRC_CONNECTED with generic procedure parameters Connectivity EN-DC, DC bearer MCG and SCG, Connected without release On according to TS 38.508-1 [6] clause 4.5.

6.2B.3.4.4.2 Test procedure

Same test procedure as in clause 6.2.3.4.2 in TS 38.521-2 [9] with the following steps added for E-UTRA component:

- 1.1 On the E-UTRA carrier, disable periodic and aperiodic CQI reports, disable SRS, set *TimeAlignmentTimerDedicated* IE to infinity and disable downlink and uplink scheduling, all as per Table 4.7-1 under clause 4.7.

6.2B.3.4.4.3 Message contents

Message contents are according to TS 38.508-1 [5] clause 4.6 with the following exceptions for each network signalled value.

1. Information element *AdditionalSpectrumEmission* for NR can be set in *nr-SecondaryCellGroupConfig* according to TS 38.331 [15]. This exception indicates that the UE shall meet the additional spurious emission requirement for a specific deployment scenario.

Table 6.2B.3.4.4.3-1: *AdditionalSpectrumEmission*: Additional spurious emissions test requirement

Derivation Path: TS 38.508-1 [5] clause 4.6.3, Table 4.6.3-1			
Information Element	Value/remark	Comment	Condition
AdditionalSpectrumEmission	1 (NS_201)	for band n258	

6.2B.3.4.5 Test requirement

Same test requirement as in clause 6.2.2.5 in TS 38.521-2 [9] for the NR carrier.

6.2B.3.5 UE Additional Maximum Output power reduction for inter-band EN-DC including both FR1 and FR2

6.2B.3.5.1 Test purpose

Same test purpose as in clause 6.2.3.1 in TS 38.521-1 [8] for NR FR1 carrier and clause 6.2.3.1 in TS 38.521-2 [9] for NR FR2 carrier.

6.2B.3.5.2 Test applicability

The requirements in this test are not testable due to issues with combined testing of NR FR1 and E-UTRA in conducted mode with NR FR2 in radiated mode. Therefore, the conducted and radiated requirements are tested separately.

No test case details are specified. The NSA requirements for Additional Maximum Output Power apply and are tested as part of the EN-DC within FR1 and EN-DC including FR2 test cases in clause 6.2B.3.

6.2B.4 Configured Output Power for EN-DC

6.2B.4.1 Configured Output Power Level for EN-DC

6.2B.4.1.0 Minimum Conformance Requirements

6.2B.4.1.0.1 Configured output power level

6.2B.4.1.0.1.1 Intra-band contiguous EN-DC

The following requirements apply for one component carrier per CG configured for synchronous DC.

For intra-band dual connectivity with one uplink serving cell per CG on E-UTRA and NR respectively, the UE is allowed to set its configured maximum output power $P_{\text{CMAX},c(i),i}$ for serving cell $c(i)$ of CG i , $i = 1, 2$, and its total configured maximum transmission power for EN-DC operation $\hat{P}_{\text{total}}^{\text{EN-DC}} = 10 \log_{10}(\hat{P}_{\text{total}}^{\text{EN-DC}})$ with $\hat{P}_{\text{total}}^{\text{EN-DC}}$ as specified in clause 7.6 of TS 38.213 [19].

The configured maximum output power $P_{\text{CMAX,E-UTRA},c}(p)$ in sub-frame p for the configured E-UTRA uplink carrier shall be set within the bounds:

$$P_{\text{CMAX,L,E-UTRA},c}(p) \leq P_{\text{CMAX,E-UTRA},c}(p) \leq P_{\text{CMAX,H,E-UTRA},c}(p)$$

where $P_{\text{CMAX,L,E-UTRA},c}$ and $P_{\text{CMAX,H,E-UTRA},c}$ are the limits for a serving cell c as specified in TS 36.101 [5] clause 6.2.5 modified by P_{LTE} as follows:

$$P_{\text{CMAX,L,E-UTRA},c} = \text{MIN} \{ \text{MIN}(P_{\text{EMAX},c}, P_{\text{EMAX,EN-DC}}, P_{\text{LTE}}) - \Delta t_{\text{C,E-UTRA},c}, (P_{\text{PowerClass,EN-DC}} - \Delta P_{\text{PowerClass,EN-DC}}), (P_{\text{PowerClass}} - \Delta P_{\text{PowerClass}}) - \text{MAX}(M\text{PR}_c + A\text{-M}\text{PR}_c + \Delta T_{\text{IB},c} + \Delta T_{\text{C,E-UTRA},c} + \Delta T_{\text{ProSe}}, P\text{-M}\text{PR}_c) \}$$

$$P_{\text{CMAX,H,E-UTRA},c} = \text{MIN} \{ P_{\text{EMAX},c}, P_{\text{EMAX,EN-DC}}, P_{\text{LTE}}, P_{\text{PowerClass,EN-DC}}, P_{\text{PowerClass}} - \Delta P_{\text{PowerClass}} \}$$

where

- $P_{\text{EMAX,EN-DC}}$ is the value given by the field *p-maxUE-FR1* of the *RRCCONNECTIONRECONFIGURATION-v1530* IE as defined in TS 36.331 [17];
- P_{LTE} is the value given by the field *p-maxEUTRA-r15* of the *RRCCONNECTIONRECONFIGURATION-v1510* IE as defined in TS 36.331 [17] which is the same as P_{LTE} in TS 38.213 [19];
- $\Delta t_{\text{C,E-UTRA},c} = 1.5$ dB when NOTE 2 in Table 6.2.2-1 of TS 36.101 [5] applies; $\Delta t_{\text{C,E-UTRA},c} = 0$ dB otherwise;

and whenever NS_01 is not indicated within CG 1:

- for a UE indicating support of dynamicPowerSharing, the $M\text{PR}_c$ and the $A\text{-M}\text{PR}_c$ are determined in accordance with the DCI of serving cell c of the CG 1 and the specification in clause 6.2.4 of TS 36.101 [5];
- for a UE not indicating support of dynamicPowerSharing, the $A\text{-M}\text{PR}_c$ is determined in accordance with clause 6.2B.3.1 with parameters applicable for UEs not indicating support of dynamicPowerSharing and $M\text{PR}_c = 0$ dB;

and whenever NS_01 is indicated in CG 1:

- for a UE indicating support of dynamicPowerSharing, the $M\text{PR}_c$ is determined in accordance with the DCI of serving cell c of the CG 1 and the specification in clause 6.2.4 of TS 36.101 [5];
- for a UE not indicating support of dynamicPowerSharing, the $M\text{PR}_c$ is determined in accordance with clause 6.2B.2.1 with parameters applicable for UEs not indicating support of dynamicPowerSharing and $A\text{-M}\text{PR}_c = 0$ dB;

The configured maximum output power $P_{\text{CMAX,NR},c}(q)$ in physical channel q for the configured NR carrier shall be set within the bounds:

$$P_{\text{CMAX,L,f,c},NR}(q) \leq P_{\text{CMAX,f,c},NR}(q) \leq P_{\text{CMAX,H,f,c},NR}(q)$$

where $P_{\text{CMAX_L_NR},c}$ and $P_{\text{CMAX_H_NR},c}$ are the limits for a serving cell c as specified in clause 6.2.4 of TS 38.101-1 [2] modified as follows:

$$P_{\text{CMAX_L},f,c, NR} = \text{MIN} \{ \text{MIN}(P_{\text{EMAX},c}, P_{\text{EMAX, EN-DC}}, P_{\text{NR}}) - \Delta T_{\text{C_NR},c}, (P_{\text{PowerClass, EN-DC}} - \Delta P_{\text{PowerClass, EN-DC}}), (P_{\text{PowerClass}} - \Delta P_{\text{PowerClass}}) - \text{MAX}(\text{MAX}(\text{MPR}_c, \text{A-MPR}_c) + \Delta T_{\text{IB},c} + \Delta T_{\text{C_NR},c} + \Delta T_{\text{RxsRS}}, P - \text{MPR}_c) \}$$

$$P_{\text{CMAX_H},f,c, NR} = \text{MIN} \{ P_{\text{EMAX},c}, P_{\text{EMAX, EN-DC}}, P_{\text{NR}}, P_{\text{PowerClass, EN-DC}}, P_{\text{PowerClass}} - \Delta P_{\text{PowerClass}} \}$$

where

- $P_{\text{EMAX, EN-DC}}$ is the value given by the field *p-maxUE-FRI* of the *RRConnectionReconfiguration-v1530* IE as defined in TS 36.331 [17];
- P_{LTE} signalled by RRC as *p-MaxEUTRA-r15* in TS 36.331 [17]
- P_{NR} is the value given by the field *p-NR-FRI* of the *PhysicalCellGroupConfig* IE as defined in [18] and signalled by RRC;
- $\Delta T_{\text{C_E-UTRA},c} = 1.5\text{dB}$ when NOTE 2 in Table 6.2.2-1 in TS 36.101 [4] applies for a serving cell c , otherwise $\Delta T_{\text{C_E-UTRA},c} = 0\text{dB}$;
- $\Delta T_{\text{C_NR},c} = 1.5\text{dB}$ when NOTE 3 in Table 6.2.1-1 in TS 38.101-1 [2] applies for a serving cell c , otherwise $\Delta T_{\text{C_NR},c} = 0\text{dB}$;
- $\Delta T_{\text{IB},c}$ specified in clause 6.2B.4.2.1 for EN-DC, the individual Power Class defined in table 6.2B.1.1 and any other additional power reductions parameters specified in clauses 6.2B.2 and 6.2B.3 for EN-DC are applicable to $P_{\text{CMAX_E-UTRA},c}$ and $P_{\text{CMAX},f,c, NR}$ evaluations.

$P_{\text{PowerClass, EN-DC}}$ is defined in clause 6.2B.1.1 for intra-band contiguous EN-DC;

- $P_{\text{PowerClass, NR}}$ is the nominal UE power of the power class that the UE supports for the NR band of the EN-DC combination as defined in clause 6.2.1 of 38.101-1 [2]; in case IE [*powerClassNRPart*] as defined in TS 38.331 [18] is indicated, $P_{\text{PowerClass, NR}}$ should use that value instead.
- $P_{\text{PowerClass, E-UTRA}}$ is the nominal UE power of the power class that the UE supports for the E-UTRA band of the EN-DC combination as defined in clause 6.2.2 of 36.101 [5];-

$\Delta P_{\text{PowerClass, EN-DC}}$ is 3 dB for a power class 2 capable EN-DC UE when LTE UL/DL configuration is 0 or 6; or LTE UL/DL configuration is 1 and special subframe configuration is 0 or 5; $\Delta P_{\text{PowerClass, EN-DC}} = 3\text{ dB}$ when the IE *p-maxUE-FRI* as defined in TS 36.331 [17] is provided and set to the maximum output power of the default power class or lower; $\Delta P_{\text{PowerClass, EN-DC}}$ is 6 dB for a power class 1.5 capable EN-DC UE when the LTE UL duty cycle is greater than $\text{max}(50\%, \text{maxUplinkDutyCycle})$; $\Delta P_{\text{PowerClass, EN-DC}}$ is 3 dB for a power class 1.5 capable EN-DC UE when the LTE UL duty cycle is between $\text{max}(50\%, \text{maxUplinkDutyCycle})$ and $\text{max}(25\%, \text{maxUplinkDutyCycle}/2)$; otherwise $\Delta P_{\text{PowerClass, EN-DC}} = 0\text{ dB}$;

and whenever NS_01 is not indicated within CG 2:

- for a UE indicating support of dynamicPowerSharing, $\text{A-MPR}_c = \text{A-MPR}'_c$ with $\text{A-MPR}'_c$ determined in accordance with clause 6.2B.3.1 and $\text{MPR}_c = 0\text{ dB}$ if transmission(s) in subframe p on CG 1 overlap in time with physical channel q on CG 2;
- for a UE indicating support of dynamicPowerSharing, A-MPR_c is determined in accordance with TS 38.101-1 [2] if transmission(s) in subframe p on CG 1 does not overlap in time with physical channel q on CG 2;
- for a UE not indicating support of dynamicPowerSharing, the A-MPR_c is determined in accordance with clause 6.2B.3.1 with parameters applicable for UEs not indicating support of dynamicPowerSharing and $\text{MPR}_c = 0\text{ dB}$;

and whenever NS_01 is indicated in CG 2.

- for a UE indicating support of dynamicPowerSharing, $\text{MPR}_c = \text{MPR}'_c$ with MPR'_c determined in accordance with clause 6.2B.2.1 and $\text{A-MPR}_c = 0\text{ dB}$ if transmission(s) in subframe p on CG 1 overlap in time with physical channel q on CG 2;
- for a UE indicating support of dynamicPowerSharing, MPR_c is determined in accordance with TS 38.101-1 [2] if transmission(s) in subframe p on CG 1 does not overlap in time with physical channel q on CG 2;

- for a UE not indicating support of dynamicPowerSharing, the MPRc is determined in accordance with clause 6.2B.2.1 with parameters applicable for UEs not indicating support of dynamicPowerSharing and A-MPRc = 0 dB;

If the transmissions from NR and E-UTRA do not overlap, then the complete clauses for configured transmitted power for E-UTRA and NR respectively from their own specifications apply with the modifications specified above. The lower value between $P_{\text{PowerClass, EN-DC}}$ or $P_{\text{EMAX, EN-DC}}$ shall not be exceeded at any time by UE.

If the EN-DC UE is not supporting dynamic power sharing, then the complete clauses for configured transmitted power for E-UTRA and NR respectively from their own specifications TS 36.101 [5] and TS 38.101-1 [2] respectively apply with the modifications specified above.

If the UE does not support dynamic power sharing,

$$P_{\text{Total}}^{\text{EN-DC}} = \text{MIN} \{ P_{\text{EMAX, EN-DC}}, P_{\text{PowerClass, EN-DC}} - \Delta P_{\text{PowerClass, EN-DC}} \} + 0.3 \text{ dB}$$

For UEs indicating support of dynamicPowerSharing in the *UE-MRDC-Capability* IE the UE can configure the total maximum transmission power $P_{\text{Total}}^{\text{EN-DC}}$ within the range

$$P_{\text{EN-DC, tot_L}} \leq P_{\text{Total}}^{\text{EN-DC}} \leq P_{\text{EN-DC, tot_H}}$$

where

$$P_{\text{EN-DC, tot_L}}(p, q) = \text{MIN} \{ P_{\text{PowerClass, EN-DC}} - \Delta P_{\text{PowerClass, EN-DC}} - \text{MAX} \{ \text{MPR}_{\text{tot}}, \text{A-MPR}_{\text{tot}} \}, P_{\text{EMAX, EN-DC}} \}$$

$$P_{\text{EN-DC, tot_H}}(p, q) = \text{MIN} \{ P_{\text{PowerClass, EN-DC}}, P_{\text{EMAX, EN-DC}} \}$$

for sub-frame p on CG 1 overlapping with physical channel q on CG 2 and with MPR_{tot} and $\text{A-MPR}_{\text{tot}}$ in accordance with 6.2B.2.1 and clause 6.2B.3.1, respectively.

The measured total maximum output power P_{UMAX} over both CGs/RATs, measured over the transmission reference time duration is

$$P_{\text{UMAX}} = 10 \log_{10} [p_{\text{UMAX, c, E-UTRA}} + p_{\text{UMAX, f, c, NR}}],$$

where $p_{\text{UMAX, c, E-UTRA}}$ and $p_{\text{UMAX, c, NR}}$ denotes the measured output power of serving cell c for *E-UTRA* and *NR* respectively, expressed in linear scale.

For UEs indicating support of dynamicPowerSharing, the measured total configured maximum output power P_{UMAX} shall be within the following bounds:

$$P_{\text{CMAX_L}} - T_{\text{LOW}}(P_{\text{CMAX_L}}) \leq P_{\text{UMAX}} \leq P_{\text{CMAX_H}} + T_{\text{HIGH}}(P_{\text{CMAX_H}})$$

with the tolerances $T_{\text{LOW}}(P_{\text{CMAX_L}})$ and $T_{\text{HIGH}}(P_{\text{CMAX_H}})$ for applicable values of $P_{\text{CMAX_L}}$ and $P_{\text{CMAX_H}}$ specified in Table 6.2B.4.1.0.1.1-2.

When an UL subframe transmission p from E-UTRA overlap with a physical channel q from the NR, then for P_{UMAX} evaluation, the E-UTRA subframe p is taken as reference period T_{REF} and always considered as the reference measurement duration and the following rules are applicable.

T_{REF} and T_{eval} are specified in Table 6.2B.4.1.0.1.1-1 when same or different subframes and physical channel durations are used in aggregated carriers. $P_{\text{PowerClass, EN-DC}}$ shall not be exceeded by the UE during any evaluation period of time.

Table 6.2B.4.1.0.1.1-1: P_{CMAX} evaluation window

transmission duration	T_{REF}	T_{eval}
Different transmission duration in different RAT carriers	E-UTRA Subframe	$\text{Min}(T_{\text{no_hopping}}, \text{Physical Channel Length})$

For each T_{REF} , the $P_{\text{CMAX_H}}$ is evaluated per T_{eval} and given by the maximum value over the transmission(s) within the T_{eval} as follows:

$$P_{\text{CMAX_H}} = \text{MAX} \{ P_{\text{CMAX_EN-DC_H}}(p, q), P_{\text{CMAX_EN-DC_H}}(p, q+1), \dots, P_{\text{CMAX_EN-DC_H}}(p, q+n) \}$$

where $P_{\text{CMAX_EN-DC_H}}$ are the applicable upper limits for each overlapping scheduling unit pairs (p,q) , $(p, q+1)$, up to $(p, q+n)$ for each applicable T_{eval} duration, where $q+n$ is the last NR UL physical channel overlapping with LTE subframe p .

While $P_{\text{CMAX_L}}$ is computed as follows:

$$P_{\text{CMAX_L}} = \text{MIN} \{ P_{\text{CMAX_EN-DC_L}}(p,q), P_{\text{CMAX_EN-DC_L}}(p,q+1), \dots, P_{\text{CMAX_EN-DC_L}}(p,q+n) \}$$

where $P_{\text{CMAX_EN-DC_L}}$ are the applicable lower limits for each overlapping scheduling unit pairs (p,q) , $(p, q+1)$, up to $(p, q+n)$ for each applicable T_{eval} duration, where $q+n$ is the last NR UL physical channel overlapping with E-UTRA subframe p ,

With

$$P_{\text{CMAX_EN-DC_H}}(p,q) = \text{MIN} \{ 10 \log_{10} [p_{\text{CMAX_H-E-UTRA,c}}(p) + p_{\text{CMAX_H,f,c,NR,c}}(q)], P_{\text{EMAX, EN-DC}}, P_{\text{PowerClass, EN-DC}} \}$$

And:

$$a = 10 \log_{10} [p_{\text{CMAX_E-UTRA,c}}(p) + p_{\text{CMAX_f,c,NR}}(q)] > P_{\text{EN-DC,tot_L}}$$

$$b = 10 \log_{10} [p_{\text{CMAX_E-UTRA,c}}(p) + p_{\text{CMAX_f,c,NR}}(q) / X_{\text{scale}}] > P_{\text{EN-DC,tot_L}}$$

If $a = \text{FALSE}$ and the configured transmission power spectral density between the MCG and SCG differs by less than 6 dB

$$P_{\text{CMAX_EN-DC_L}}(p,q) = \text{MIN} \{ 10 \log_{10} [p_{\text{CMAX_L-E-UTRA,c}}(p) + p_{\text{CMAX_L,f,c,NR,c}}(q)], P_{\text{EMAX, EN-DC}}, P_{\text{PowerClass, EN-DC}} - \Delta P_{\text{PowerClass, EN-DC}} \}$$

ELSE If $(a = \text{TRUE})$ AND $(b = \text{FALSE})$ and the configured transmission power spectral density between the MCG and SCG differs by less than 6 dB

$$P_{\text{CMAX_EN-DC_L}}(p,q) = \text{MIN} \{ 10 \log_{10} [p_{\text{CMAX_L-E-UTRA,c}}(p) + p_{\text{CMAX_L,f,c,NR,c}}(q) / X_{\text{scale}}], P_{\text{EMAX, EN-DC}}, P_{\text{PowerClass, EN-DC}} - \Delta P_{\text{PowerClass, EN-DC}} \}$$

ELSE If $b = \text{TRUE}$ or the transmission power after power scaling spectral density between the MCG and SCG differs by more than 6 dB

$$P_{\text{CMAX_EN-DC_L}}(p,q) = \text{MIN} \{ 10 \log_{10} [p_{\text{CMAX_L-E-UTRA,c}}(p)], P_{\text{EMAX, EN-DC}}, P_{\text{PowerClass, EN-DC}} - \Delta P_{\text{PowerClass, EN-DC}} \}$$

where

- $p_{\text{CMAX_H-E-UTRA,c}}(p)$ is the E-UTRA higher limit of the maximum configured power expressed in linear scale;
- $p_{\text{CMAX_H-NR,c}}(q)$ is the NR higher limit of the maximum configured power expressed in linear scale;
- $p_{\text{CMAX_L-E-UTRA,c}}(p)$ is the E-UTRA lower limit of the maximum configured power expressed in linear scale;
- $p_{\text{CMAX_L-NR,c}}(q)$ is the NR lower limit of the maximum configured power expressed in linear scale;
- $P_{\text{PowerClass, EN-DC}}$ is defined in clause 6.2B.1.1.3-1 for intra-band EN-DC;
- X_{scale} is the linear value of X dB which is configured by RRC and can only take values [0, 6] dB
- $p_{\text{CMAX_E-UTRA,c}}(p)$ is the linear value of $P_{\text{CMAX_E-UTRA,c}}(p)$, the real configured max power for E-UTRA
- $p_{\text{CMAX_f,c,NR}}(q)$ is the linear value of $P_{\text{CMAX_f,c,NR}}(q)$, the real configured max power of NR

Table 6.2B.4.1.0.1.1-2: P_{CMAX} tolerance for Dual Connectivity E-UTRANR

P _{CMAX} (dBm)	Tolerance T _{LOW} (P _{CMAX_L}) (dB)	Tolerance T _{HIGH} (P _{CMAX_H}) (dB)
23 ≤ P _{CMAX} ≤ 33	3.0	2.0
22 ≤ P _{CMAX} < 23	5.0	2.0
21 ≤ P _{CMAX} < 22	5.0	3.0
20 ≤ P _{CMAX} < 21	6.0	4.0
16 ≤ P _{CMAX} < 20	5.0	
11 ≤ P _{CMAX} < 16	6.0	
-40 ≤ P _{CMAX} < 11	7.0	

If the UE supports dynamic power sharing, and when LTE and NR transmissions overlap and the condition (If (a=TRUE) AND (b=FALSE)) is met, SCG shall be transmitted and the following supplementary minimum requirement apply for the measured SCG power, P_{UMAX,f,c,NR}(q), under nominal conditions and unless otherwise stated.

$$10\log(p_{\text{CMAX}_{L,f,c,NR}}(q)/X_{\text{scale}}) - T_{\text{LOW}}(10\log(p_{\text{CMAX}_{L,f,c,NR}}(q)/X_{\text{scale}})) \leq P_{\text{UMAX},f,c,NR}(q) \leq 10\log(p_{\text{CMAX}_{H,f,c,NR}}(q)) + T_{\text{HIGH}}(10\log(p_{\text{CMAX}_{H,f,c,NR}}(q))).$$

with the tolerances T_{LOW} and T_{HIGH} for applicable values of P_{CMAX} specified in Table 6.2B.4.1.0.1.1-2.

If the UE supports dynamic power sharing, the measured maximum output power in subframe *p* on CG 1, p_{UMAX,c,E-UTRA}, shall meet the requirements in clause 6.2.5 in TS 36.101 [5] with the limits P_{CMAX_L,c} and P_{CMAX_H,c} replaced by P_{CMAX_L,E-UTRA,c} and P_{CMAX_H,E-UTRA,c} as specified above, respectively.

If the configured transmission power spectral density between the MCG and SCG differs by more than 6 dB, then

$$P_{\text{UMAX},f,c,NR}(q) \leq 10\log(p_{\text{CMAX}_{H,f,c,NR}}(q)) + T_{\text{HIGH}}(10\log(p_{\text{CMAX}_{H,f,c,NR}}(q))).$$

6.2B.4.1.0.1.2 Intra-band non-contiguous EN-DC

The following requirements apply for one component carrier per CG configured for synchronous DC. The CG(s) are indexed by *j* = 1 for MCG and *j* = 2 for SCG.

The configured maximum output power P_{CMAX,E-UTRA,c}(*p*) in sub-frame *p* for the configured E-UTRA uplink carrier shall be set in accordance with clause 6.2B.4.1.0.1.1 but where

- for a UE not indicating support of dynamicPowerSharing, the A-MPR_c determined in accordance with clause 6.2B.3.2 with parameters applicable for UEs not indicating support of dynamicPowerSharing and MPR_c = 0 dB;

whenever NS_01 is not indicated within CG 1 while

- for a UE not indicating support of dynamicPowerSharing, the MPR_c determined in accordance with clause 6.2B.2.2 with parameters applicable for UEs not indicating support of dynamicPowerSharing and A-MPR_c = 0 dB;

whenever NS_01 is indicated in CG 1.

The configured maximum output power P_{CMAX,NR,c}(*q*) in physical channel *q* for the configured NR carrier shall be set in accordance with clause 6.2B.4.1.0.1.1 but where

- for a UE indicating support of dynamicPowerSharing, A-MPR_c = A-MPR'_c with A-MPR'_c determined in accordance with clause 6.2B.3.2 and MPR_c = 0 dB if transmission(s) in subframe *p* on CG 1 overlap in time with physical channel *q* on CG 2;
- for a UE indicating support of dynamicPowerSharing, A-MPR_c is determined in accordance with [2] if transmission(s) in subframe *p* on CG 1 does not overlap in time with physical channel *q* on CG 2;
- for a UE not indicating support of dynamicPowerSharing, the A-MPR_c is determined in accordance with clause 6.2B.3.2 with parameters applicable for UEs not indicating support of dynamicPowerSharing and MPR_c = 0 dB;

For UEs indicating support of dynamicPowerSharing in the *UE-MRDC-Capability IE*, the UE can configure the total transmission power in accordance with clause 6.2B.4.1.0.1.1 but with $P_{\text{powerclass,EN-DC}}$ the EN-DC power class of the intra-band non-contiguous band combination configured and A-MPR determined in accordance with clause 6.2B.3.2.

whenever NS_01 is not indicated in CG 2 while

- for a UE indicating support of dynamicPowerSharing, $\text{MPR}_c = \text{MPR}'_c$ with MPR'_c determined in accordance with clause 6.2B.2.2 and $\text{A-MPR}_c = 0$ dB if transmission(s) in subframe p on CG 1 overlap in time with physical channel q on CG 2;
- for a UE indicating support of dynamicPowerSharing, MPR_c is determined in accordance with TS 38.101-1 [2] if transmission(s) in subframe p on CG 1 does not overlap in time with physical channel q on CG 2;
- for a UE not indicating support of dynamicPowerSharing, the MPR_c is determined in accordance with clause 6.2B.2.2 with parameters applicable for UEs not indicating support of dynamicPowerSharing and $\text{A-MPR}_c = 0$ dB;

whenever NS_01 is indicated in CG 2.

For UEs indicating support of dynamicPowerSharing in the *UE-MRDC-Capability IE*, the UE can configure the total transmission power in accordance with clause 6.2B.4.1.1 but with $P_{\text{powerclass,EN-DC}}$ the EN-DC power class of the intra-band non-contiguous band combination configured and A-MPR determined in accordance with clause 6.2B.3.2.

The total maximum output power P_{UMAX} over both CGs is measured in accordance with clause 6.2B.4.1.0.1.1 and shall be within the limits specified in clause 6.2B.4.1.0.1.1 but with parameters applicable for the non-contiguous band combination configured.

The maximum output power levels $p_{\text{UMAX},c,E\text{-UTRA}}$ and $p_{\text{UMAX},f,c,NR}$ for the CGs are measured in accordance with clause 6.2B.4.1.0.1.1 and shall be within the limits specified in clause 6.2B.4.1.0.1.1 but with parameters applicable for the non-contiguous band combination configured.

6.2B.4.1.0.1.3 Inter-band EN-DC within FR1

For inter-band dual connectivity with one uplink serving cell per CG on E-UTRA and NR respectively, the UE is allowed to set its configured maximum output power $P_{\text{CMAX},c(i),i}$ for serving cell $c(i)$ of CG i , $i = 1, 2$, and its total configured maximum transmission power for EN-DC operation, $P_{\text{Total}}^{\text{EN-DC}} = 10\log_{10}(\hat{P}_{\text{total}}^{\text{EN-DC}})$ with $\hat{P}_{\text{total}}^{\text{EN-DC}}$ as specified in clause 7.6 of TS 38.213 [19].

The configured maximum output power $P_{\text{CMAX}_E\text{-UTRA},c}(p)$ in sub-frame p for the configured E-UTRA uplink carrier shall be set within the bounds:

$$P_{\text{CMAX}_L E\text{-UTRA},c}(p) \leq P_{\text{CMAX}_E\text{-UTRA},c}(p) \leq P_{\text{CMAX}_H E\text{-UTRA},c}(p)$$

where $P_{\text{CMAX}_L E\text{-UTRA},c}$ and $P_{\text{CMAX}_H E\text{-UTRA},c}$ are the limits for a serving cell c as specified in TS 36.101 [5] clause 6.2.5 modified by P_{LTE} as follows:

$$P_{\text{CMAX}_L E\text{-UTRA},c} = \text{MIN} \{ P_{\text{EMAX,EN-DC}}, (P_{\text{PowerClass,EN-DC}} - \Delta P_{\text{PowerClass}}), \text{MIN}(P_{\text{EMAX},c}, P_{\text{LTE}}) - \Delta T_{C_E\text{-UTRA},c}, (P_{\text{PowerClass}} - \Delta P_{\text{PowerClass}}) - \text{MAX}(\text{MPR}_c + \text{A-MPR}_c + \Delta T_{\text{IB},c} + \Delta T_{C_E\text{-UTRA},c} + \Delta T_{\text{ProSe}}, P\text{-MPR}_c) \}$$

$$P_{\text{CMAX}_H E\text{-UTRA},c} = \text{MIN} \{ P_{\text{EMAX},c}, P_{\text{EMAX,EN-DC}}, (P_{\text{PowerClass,EN-DC}} - \Delta P_{\text{PowerClass}}), P_{\text{LTE}}, P_{\text{PowerClass}} - \Delta P_{\text{PowerClass}} \}$$

The configured maximum output power $P_{\text{CMAX}_NR,c}(q)$ in physical-channel q for the configured NR carrier shall be set within the bounds:

$$P_{\text{CMAX}_L f,c,NR}(q) \leq P_{\text{CMAX}_f,c,NR}(q) \leq P_{\text{CMAX}_H f,c,NR}(q)$$

where $P_{\text{CMAX}_L NR,c}$ and $P_{\text{CMAX}_H NR,c}$ are the limits for a serving cell c as specified in clause 6.2.4 of TS 38.101-1 [2] modified as follows:

$$P_{\text{CMAX}_L f,c,NR} = \text{MIN} \{ P_{\text{EMAX,EN-DC}}, (P_{\text{PowerClass,EN-DC}} - \Delta P_{\text{PowerClass}}), \text{MIN}(P_{\text{EMAX},c}, P_{\text{NR}}) - \Delta T_{C_{NR},c}, (P_{\text{PowerClass}} - \Delta P_{\text{PowerClass}}) - \text{MAX}(\text{MAX}(\text{MPR}_c, \text{A-MPR}_c) + \Delta T_{\text{IB},c} + \Delta T_{C_{NR},c} + \Delta T_{\text{RxsRS}}, P\text{-MPR}_c) \}$$

$$P_{\text{CMAX}_H f,c,NR} = \text{MIN} \{ P_{\text{EMAX},c}, P_{\text{EMAX,EN-DC}}, (P_{\text{PowerClass,EN-DC}} - \Delta P_{\text{PowerClass}}), P_{\text{NR}}, P_{\text{PowerClass}} - \Delta P_{\text{PowerClass}} \}$$

where

- $P_{EMAX,EN-DC}$ is the value given by the field $p-maxUE-FR1$ of the *RRConnectionReconfiguration-v1530* IE as defined in TS 36.331 [17];
- P_{LTE} is the value given by the field $p-maxEUTRA-r15$ of the *RRConnectionReconfiguration-v1510* IE as defined in TS 36.331 [17];
- P_{NR} is the value given by the field $p-NR-FR1$ of the *PhysicalCellGroupConfig* IE as defined TS 38.331 [18];
- $\Delta T_{c,E-UTRA,c} = 1.5$ dB when NOTE 2 in Table 6.2.2-1 in TS 36.101 [5] applies for a serving cell c , otherwise $\Delta T_{c,E-UTRA,c} = 0$ dB;
- $\Delta T_{C,NR,c} = 1.5$ dB when NOTE 3 in Table 6.2.1-1 in TS 38.101-1 [2] applies for a serving cell c , otherwise $\Delta T_{C,NR,c} = 0$ dB;
- $\Delta T_{IB,c}$ specified in clause 6.2B.4.2.3 for EN-DC, the individual Power Class defined in table 6.2B.1.3 and any other additional power reductions parameters specified in clauses 6.2B.2 and 6.2B.3 for EN-DC are applicable to $P_{CMAX_E-UTRA,c}$ and $P_{CMAX_E,c,NR}$ evaluations.
- $P_{PowerClass, EN-DC}$ is defined in clause 6.2B.1.3 for inter-band EN-DC;
- $P_{PowerClass,NR}$ is the nominal UE power of the power class that the UE supports for the NR band of the EN-DC combination as defined in clause 6.2.1 of 38.101-1 [2]; in case IE [*powerClassNRPart*] as defined in TS 38.331 [18] is indicated, $P_{PowerClass,NR}$ should use that value instead.
- $P_{PowerClass,E-UTRA}$ is the nominal UE power of the power class that the UE supports for the E-UTRA band of the EN-DC combination as defined in clause 6.2.2 of 36.101 [5];
- $\Delta P_{PowerClass,EN-DC} = 3$ dB for a power class 2 capable EN-DC UE when requirements of default power class had been applied as specified in sub-clause 6.2B.1; otherwise $\Delta P_{PowerClass,EN-DC} = 0$ dB;

If the transmissions from NR and E-UTRA do not overlap, then the complete clauses for configured transmitted power for E-UTRA and NR respectively from their own specifications apply with the modifications specified above. The lower value between $P_{PowerClass, EN-DC}$ or $P_{EMAX, EN-DC}$ shall not be exceeded at any time by UE.

$P_{Total}^{EN-DC} = 10 \log_{10}(\hat{P}_{total}^{EN-DC})$ with P_{Total}^{EN-DC} the configured maximum transmission power for EN-DC operation as specified in clause 7.6 of TS 38.213 [19].

The total configured maximum transmission power for both synchronous and non-synchronous operation is

$$P_{Total}^{EN-DC} = \text{MIN} \{ P_{EMAX, EN-DC}, P_{PowerClass, EN-DC} - \Delta P_{PowerClass} \}$$

If the UE does not support dynamic power sharing,

$$P_{Total}^{EN-DC} = \text{MIN} \{ P_{EMAX, EN-DC}, P_{PowerClass, EN-DC} - \Delta P_{PowerClass, EN-DC} \} + 0.3 \text{ dB}$$

If the EN-DC UE does not support dynamic power sharing, then the complete clauses for configured transmitted power for E-UTRA and NR respectively from their own specifications TS 36.101 [5] and TS 38.101-1 [2] respectively apply with the modifications specified above and P_{Total}^{EN-DC} applies.

When a UE supporting dynamic sharing is configured for overlapping E-UTRA uplink and NR uplink transmissions, the UE can set its configured maximum output power $P_{CMAX_E-UTRA,c}$ and $P_{CMAX_NR,c}$ for the configured E-UTRA and NR uplink carriers, respectively, and its configured maximum transmission power for EN-DC operation, \hat{P}_{Total}^{EN-DC} , as specified above.

The measured total maximum output power P_{UMAX} over both CGs/RATs, measured over the transmission reference time duration is

$$P_{UMAX} = 10 \log_{10} [p_{UMAX,c,E-UTRA} + p_{UMAX,c,NR}],$$

where $p_{UMAX,c,E-UTRA}$ and $p_{UMAX,c,NR}$ denotes the measured output power of serving cell c for E-UTRA and NR respectively, expressed in linear scale.

The measured total configured maximum output power P_{UMAX} shall be within the following bounds:

$$P_{CMAX_L} - T_{LOW}(P_{CMAX_L}) \leq P_{UMAX} \leq P_{CMAX_H} + T_{HIGH}(P_{CMAX_H})$$

with the tolerances $T_{LOW}(P_{CMAX_H})$ and $T_{HIGH}(P_{CMAX_H})$ for applicable values of P_{CMAX} specified in Table 6.2B.4.1.0.1.3-2.

When an UL subframe transmission p from E-UTRA overlap with a physical-channel q from the NR, then for P_{UMAX} evaluation, the E-UTRA subframe p is taken as reference period T_{REF} and always considered as the reference measurement duration and the following rules are applicable.

T_{REF} and T_{eval} are specified in Table 6.2B.4.1.0.1.3-1 when same or different subframe and physical-channel durations are used in aggregated carriers. $P_{PowerClass_EN-DC}$ shall not be exceeded by the UE during any evaluation period of time.

Table 6.2B.4.1.0.1.3-1: P_{CMAX} evaluation window

transmission duration	T_{REF}	T_{eval}
Different transmission duration in different RAT carriers	E-UTRA Subframe	Min($T_{no_hopping}$, Physical Channel Length)

For each T_{REF} , the P_{CMAX_H} is evaluated per T_{eval} and given by the maximum value over the transmission(s) within the T_{eval} as follows:

$$P_{CMAX_H} = \text{MAX} \{ P_{CMAX_EN-DC_H}(p,q), P_{CMAX_EN-DC_H}(p,q+1), \dots, P_{CMAX_EN-DC_H}(p,q+n) \}$$

where $P_{CMAX_EN-DC_H}$ are the applicable upper limits for each overlapping scheduling unit pairs (p,q) , $(p,q+1)$, up to $(p,q+n)$ for each applicable T_{eval} duration, where $q+n$ is the last NR UL physical-channel overlapping with E-UTRA subframe p .

While P_{CMAX_L} is computed as follows:

$$P_{CMAX_L} = \text{MIN} \{ P_{CMAX_EN-DC_L}(p,q), P_{CMAX_EN-DC_L}(p,q+1), \dots, P_{CMAX_EN-DC_L}(p,q+n) \}$$

where $P_{CMAX_EN-DC_L}$ are the applicable lower limits for each overlapping scheduling unit pairs (p,q) , $(p,q+1)$, up to $(p,q+n)$ for each applicable T_{eval} duration, where $q+n$ is the last NR UL physical-channel overlapping with E-UTRA subframe p ,

With

$$P_{CMAX_EN-DC_H}(p,q) = \text{MIN} \{ 10 \log_{10} [p_{CMAX_H_E-UTRA,c}(p) + p_{CMAX_H,f,c,NR,c}(q)], P_{EMAX, EN-DC}, P_{PowerClass, EN-DC} \}$$

And:

$$a = 10 \log_{10} [p_{CMAX_E-UTRA,c}(p) + p_{CMAX,f,c,NR}(q)] > P_{Total}^{EN-DC}$$

$$b = 10 \log_{10} [p_{CMAX_E-UTRA,c}(p) + p_{CMAX,f,c,NR}(q) / X_{scale}] > P_{Total}^{EN-DC}$$

If a= FALSE

$$P_{CMAX_EN-DC_L}(p,q) = \text{MIN} \{ 10 \log_{10} [p_{CMAX_L_E-UTRA,c}(p) + p_{CMAX_L,f,c,NR,c}(q)], P_{EMAX, EN-DC}, P_{PowerClass, EN-DC} \}$$

ELSE If (a=TRUE) AND (b=FALSE)

$$P_{CMAX_EN-DC_L}(p,q) = \text{MIN} \{ 10 \log_{10} [p_{CMAX_L_E-UTRA,c}(p) + p_{CMAX_L,f,c,NR,c}(q) / X_{scale}], P_{EMAX, EN-DC}, P_{PowerClass, EN-DC} \}$$

ELSE If b= TRUE

$$P_{CMAX_EN-DC_L}(p,q) = \text{MIN} \{ 10 \log_{10} [p_{CMAX_L_E-UTRA,c}(p)], P_{EMAX, EN-DC}, P_{PowerClass, EN-DC} \}$$

where

- $p_{CMAX_H_E-UTRA,c}(p)$ is the E-UTRA higher limit of the maximum configured power expressed in linear scale;
- $p_{CMAX_H_NR,c}(q)$ is the NR higher limit of the maximum configured power expressed in linear scale;
- $p_{CMAX_L_E-UTRA,c}(p)$ is the E-UTRA lower limit of the maximum configured power expressed in linear scale;
- $p_{CMAX_L_NR,c}(q)$ is the NR lower limit of the maximum configured power expressed in linear scale;

- $P_{\text{PowerClass, EN-DC}}$ is defined in clause 6.2B.1.3-1 for inter-band EN-DC;
- X_{scale} is the linear value of X dB which is configured by RRC and can only take values [0, 6]
- $P_{\text{CMAX_E-UTRA,c}}(p)$ is the linear value of $P_{\text{CMAX_E-UTRA,c}}(p)$, the real configured max power for LTE
- $P_{\text{CMAX_f,c,NR}}(q)$ is the linear value of $P_{\text{CMAX_f,c,NR}}(q)$, the real configured max power of NR

Table 6.2B.4.1.0.1.3-2: P_{CMAX} tolerance for Dual Connectivity E-UTRANR

$P_{\text{CMAX}}(\text{dBm})$	Tolerance $T_{\text{LOW}}(P_{\text{CMAX_L}})$ (dB)	Tolerance $T_{\text{HIGH}}(P_{\text{CMAX_H}})$ (dB)
$23 \leq P_{\text{CMAX}} \leq 33$	3.0	2.0
$22 \leq P_{\text{CMAX}} < 23$	5.0	2.0
$21 \leq P_{\text{CMAX}} < 22$	5.0	3.0
$20 \leq P_{\text{CMAX}} < 21$	6.0	4.0
$16 \leq P_{\text{CMAX}} < 20$	5.0	
$11 \leq P_{\text{CMAX}} < 16$	6.0	
$-40 \leq P_{\text{CMAX}} < 11$	7.0	
NOTE 1: For UEs not indicating support of dynamic power sharing, the upper tolerance T_{high} shall be reduced by 0.3 dB for $P \geq 20$ dBm.		

When E-UTRA and NR transmissions overlap and the condition (If (a=TRUE) AND (b=FALSE)) is met, SCG shall be transmitted and the following supplementary minimum requirement apply for the measured SCG power, $P_{\text{UMAX,f,c,NR}}(q)$, under nominal conditions.

$$10\log(p_{\text{CMAX_L,f,c,NR}}(q)/X_{\text{scale}}) - T_{\text{LOW}}(10\log(p_{\text{CMAX_L,f,c,NR}}(q)/X_{\text{scale}})) \leq P_{\text{UMAX,f,c,NR}}(q) \leq 10\log(p_{\text{CMAX_H,f,c,NR}}(q)) + T_{\text{HIGH}}(10\log(p_{\text{CMAX_H,f,c,NR}}(q)))$$

with the tolerances T_{LOW} and T_{HIGH} for applicable values of P_{CMAX} specified in Table 6.2B.4.1.0.1.3-2.

6.2B.4.1.0.1.4 Inter-band EN-DC including FR2

For inter-band dual connectivity with one uplink serving cell per CG on E-UTRA and NR respectively, with NR configured in FR2, the UE is allowed to set its configured maximum output power $P_{\text{CMAX,c(i),i}}$ for serving cell c(i) of CG i, $i = 1,2$.

The UE maximum configured power $P_{\text{CMAX,c(i),i}}$, on E-UTRA for the subframe i shall be set according to clause 6.2.5 from TS 36.101 [5]. Applicable inter-band $\Delta T_{\text{IB,c}}$ parameters shall be used according to the clauses 6.2B.4.2.4 or 6.2B.4.2.5.

The UE maximum configured power $P_{\text{CMAX,c(j),i}}$, on NR for the slot j shall be set according to clause 6.2.4 from TS 38.101-2 [3].

For the configured power measurements TS 36.101 [5] clause 6.2.5 and TS 38.101-2 [3] clause 6.2.4 are applicable.

6.2B.4.1.0.1.5 Inter-band EN-DC including both FR1 and FR2

For inter-band dual connectivity with one uplink serving cell per CG on E-UTRA and NR respectively, with both CGs configured in FR1, the requirements specified in clause 6.2B.4.1.0.1.3 apply.

For inter-band dual connectivity with one uplink serving cell per CG on E-UTRA and NR respectively, with NR configured in FR2, the requirements specified in clause 6.2B.4.1.0.1.4 apply.

For inter-band dual connectivity with one uplink serving cell in first CG on E-UTRA and two uplink serving cells in second CG on NR FR1 and NR FR2 respectively, the UE is allowed to set its configured maximum output power $P_{\text{CMAX,c(i),i}}$ for serving cell c(i), $i = 1,2,3$ with $i=1$ for E-UTRA, $i=2$ for NR FR1 and $i=3$ for NR FR2.

- For serving cell on FR2, the requirements specified in clause 6.2.4 in TS 38.101-2 [3] apply to the UE maximum configured power $P_{\text{CMAX,c(3),3}}$ and the measured maximum configured power.
- For remaining inter-band dual connectivity involving CG1 and CG2, the requirements specified in clause 6.2B.4.1.0.1.3 apply.

6.2B.4.1.1 Configured Output Power Level for Intra-Band Contiguous EN-DC

6.2B.4.1.1.1 Test purpose

To verify the UE does not exceed the power bounds defined by P_{CMAX_L} and P_{CMAX_H}

6.2B.4.1.1.2 Test applicability

This test case applies to all types of E-UTRA UE release 15 and forward, supporting intra-band contiguous EN-DC.

6.2B.4.1.1.3 Minimum conformance requirements

The minimum conformance requirements are defined in clause 6.2B.4.1.0.1.1.

Exception requirements for both NR and E-UTRA are defined for this test and therefore LTE anchor agnostic approach is not applied. E-UTRA test point analysis is included and E-UTRA measurements are performed.

6.2B.4.1.1.4 Test description

6.2B.4.1.1.4.1 Initial conditions

Initial conditions are a set of test configurations the UE needs to be tested in and the steps for the SS to take with the UE to reach the correct measurement state.

The initial test configurations consist of environmental conditions, test frequencies and channel bandwidths based on EN-DC operating bands specified in clause 5.3B.1.2, channel bandwidths and sub-carrier spacings for the NR cell specified in TS 38.521-1 [8] clause 5.3 and channel bandwidth for the E-UTRA cell are specified in TS 36.521-1 [10] clause 5.4.2. All of these configurations shall be tested with applicable test parameters for each EN-DC configuration specified in clause 5.3B.1.2 and are shown in table 6.2B.4.1.1.4.1-1. The details of the uplink reference measurement channels (RMCs) are specified in Annex A.2. Configurations of PDSCH and PDCCH before measurement are specified in TS 36.521-1 [10] Annex C.2 and in TS 38.521-1 [8] Annex C.2 for E-UTRA CG and NR CG respectively.

Table 6.2B.4.1.1.4.1-1: Test configurations table for intra-band contiguous EN-DC

Initial Conditions							
Test Environment as specified in TS 38.508-1 [5] clause 4.1			Normal, TL/VL, TL/VH, TH/VL, TH/VH				
NR and E-UTRA Test Frequencies as specified in TS 38.508-1 [5] clause 4.3.1			Mid range				
Test EN-DC bandwidth combination as specified in TS 38.508-1 [5] clause 4.3.1			Lowest N_{RB_agg} , Highest N_{RB_agg}				
NR Test SCS as specified in Table 5.3.5-1 in TS 38.521-1 [8]			Highest supported SCS				
NR/E-UTRA Test Parameters for UE supporting DPS							
Test ID (NOTE 3)	Downlink Configuration	EN-DC Uplink Configuration					
		E-UTRA Cell			NR Cell		
		Modulation	RB allocation (NOTE 2)	P_{LTE}	Modulation	RB allocation (NOTE 1)	P_{NR}
1a-1f	N/A	QPSK	Full_Allocation	{-13, 7, 12, 15, 19, 23} for PC3 UE {-13, 7, 12, 15, 21, 26} for PC2 UE	CP-OFDM QPSK	Outer_Full	{-13, 7, 12, 15, 18, 23} for PC3 UE {-13, 7, 12, 15, 21, 26} for PC2 UE
2a-2c		QPSK	Partial_Allocation	{-10, 10, 15}	N/A	N/A	{-10, 10, 15}
3a-3c		N/A	N/A	{-10, 10, 15}	DFT-s-OFDM QPSK	Inner Full	{-10, 10, 15}
NR/E-UTRA Test Parameters for UE not supporting DPS							
Test ID (NOTE 3)	Downlink Configuration	EN-DC Uplink Configuration					
		E-UTRA Cell			NR Cell		
		Modulation	RB allocation (NOTE 2)	P_{LTE}	Modulation	RB allocation (NOTE 1)	P_{NR}
1a-1d	N/A	QPSK	Full_Allocation	{-10, 10, 15, 23} for PC3 UE {-10, 10, 15, 26} for PC2 UE	CP-OFDM QPSK	Outer_Full	{-10, 10, 15, 23} for PC3 UE {-10, 10, 15, 26} for PC2 UE
2a-2c		QPSK	Partial_Allocation	{-10, 10, 15}	N/A	N/A	{-10, 10, 15}
3a-3c		N/A	N/A	{-10, 10, 15}	DFT-s-OFDM QPSK	Inner Full	{-10, 10, 15}
NOTE 1: The specific configuration of each RB allocation is defined in Table 6.1-1 in TS 38.521-1 [8].							
NOTE 2: The specific configuration of each RB allocation is defined in Table 6.1-1 in current specification.							
NOTE 3: The suffix in Test ID identifies the configured power level being tested from the P_{LTE} and P_{NR} lists							

Table 6.2B.4.1.1.4.1-2: Void

1. Connect the SS to the UE antenna connectors as shown in [6] TS 38.508-1 A.3.1.2.1 for SS diagram and A.3.2.1 for UE diagram.
2. The parameter settings for the E-UTRA cell are set up according to TS 36.508 [11] clause 4.4.3, and the parameter settings for the NR cell are set up according to TS 38.508-1 [6] clause 4.4.3.
3. Downlink signals are initially set up according to TS 36.521-1 [10] Annex C.0 and TS 38.521-1 [8] Annex C.0 for E-UTRA CG and NR CG respectively, and uplink signals according to TS 36.521-1 [10] Annex H and TS 38.521-1 [8] Annex G for E-UTRA CG and NR CG respectively.
4. The UL Reference Measurement channels are TS 36.521-1 [10] Annex A.2 and TS 38.521-1 [8] Annex A.2 for E-UTRA CG and NR CG respectively.

5. Propagation conditions are set according to TS 36.521-1 [10] Annex B.0 and TS 38.521-1 [8] Annex B.0 for E-UTRA CG and NR CG respectively.
6. Ensure the UE is in state RRC_CONNECTED with generic procedure parameters Connectivity EN-DC, DC bearer *MCG* and *SCG*, Connected without release *On* according to TS 38.508-1 [6] clause 4.5. Message contents are defined in clause 6.2B.4.1.1.4.3.
7. For the case of testing overlapping E-UTRA and NR UL transmission scenario when both bands are TDD, ensure E-UTRA UL transmission overlaps with NR UL transmission in time by giving SCG a delay of 3 E-UTRA subframes, or by giving MCG a delay of 2 subframes.

6.2B.4.1.1.4.2 Test procedure

1. SS sends uplink scheduling information for each UL HARQ process via PDCCH DCI format 0 and DCI format 0_1 for C_RNTI to schedule the UL RMC according table 6.2B.4.1.1.4.1-1 on E-UTRA CC and NR CC respectively. For test points configured with message in Table 6.2B.4.1.1.4.3-1, NR SS only schedules UL RMC on NR slots that does not overlap with E-UTRA uplink subframe. Since the UE has no payload and no loopback data to send the UE sends uplink MAC padding bits on the UL RMC.
2. Send continuously uplink power control "up" commands to the UE for NR and E-UTRA carrier until the UE transmits at its P_{UMAX} level; allow at least 200 ms from the first TPC command for the UE to reach P_{UMAX} level.
3. Measure the mean transmitted power over E-UTRA component carrier and NR component carrier respectively, or/and measure the sum of mean transmitted power over E-UTRA and NR component carriers according to Table 6.2B.4.1.1.5-1 and Table 6.2B.4.1.1.5-2. The period of the measurement shall be at least the continuous duration of one active sub-frame. For TDD, only slots consisting of only UL symbols are under test.

6.2B.4.1.1.4.3 Message contents

Message contents are according to TS 36.508 [11] clause 4.6.1 and TS 38.508-1 [6] clause 4.6.1 with the following exceptions.

Table 6.2B.4.1.1.4.3-1: RRCConnectionReconfiguration: tdm-PatternConfig if E-UTRA on FDD band and UE doesn't support dynamic power sharing

Derivation Path: TS 36.508 [11], Table 4.6.1-8			
Information Element	Value/remark	Comment	Condition
tdm-PatternConfig-r15 CHOICE{			Test ID 1d
setup SEQUENCE {			
subframeAssignment-r15	sa2		
harq-Offset-r15	0		
}			
}			

Table 6.2B.4.1.1.4.3-2: SystemInformationBlockType1: tdd-Config if E-UTRA on TDD band

Derivation Path: TS 36.508 [11], Table 4.6.3-23			
Information Element	Value/remark	Comment	Condition
TDD-Config-DEFAULT ::= SEQUENCE {		Operating on TDD band	
subframeAssignment	sa2		
specialSubframePatterns	ssp7		
}			

Table 6.2B.4.1.1.4.3-3: RRCConnectionReconfiguration: nr-Config-r15

Derivation Path: TS 36.508 [11], Table 4.6.1-8			
Information Element	Value/remark	Comment	Condition
p-MaxEUTRA-r15	Defined as P_{LTE} in Table 6.2B.4.1.1.4.1-1		

Table 6.2B.4.1.1.4.3-4: PhysicalCellGroupConfig

Derivation Path: TS 38.508-1 [6], Table 4.6.3-106			
Information Element	Value/remark	Comment	Condition
PhysicalCellGroupConfig ::= SEQUENCE {			
p-NR-FR1	Defined as P _{NR} in Table 6.2B.4.1.1.4.1-1		
}			

Table 6.2B.4.1.1.4.3-5: RRCConnectionReconfiguration: p-MaxUE-FR1-r15

Derivation Path: TS 36.508 [11], Table 4.6.1-8			
Information Element	Value/remark	Comment	Condition
nonCriticalExtension SEQUENCE {		RRCConnectionReconfiguration-v1530-IEs	
p-MaxUE-FR1-r15	23		
}			

6.2B.4.1.1.5 Test requirement

For UE supporting DPS, the output power measured shall not exceed the values specified in Table 6.2B.4.1.1.5-1.

Table 6.2B.4.1.1.5-1: P_{C_{MAX}} configured UE output power for UE supporting DPS

	E-UTRA component carrier	NR component carrier	Total power measured over E-UTRA and NR component carriers
Test ID 1a	Not measured	Not measured	-10dBm ± (7+TT)
Test ID 1b	Not measured	Not measured	10dBm ± (7+TT)
Test ID 1c	Not measured	Not measured	15 ± (6+TT)
Test ID 1d	Not measured	Not measured	18 ± (5+TT)
Test ID 1e	Not measured	18 + (5+TT) / 11 - (6+TT) for PC3 UE	21.54dBm + (3+TT) / 19.64 - (5+TT) for PC3 UE
		21 + (3+TT) / 14 - (6+TT) for PC2 UE (Rel-15 UE or Rel-16 UE reporting (PC2 by P _{PowerClass,NR} , and PC2 or Not present by <i>powerClassNRPart-r16</i>))	24 + (2+TT) / 21.8 - (5+TT) for PC2 UE (Rel-15 UE or Rel-16 UE reporting (PC2 by P _{PowerClass,NR} , and PC2 or Not present by <i>powerClassNRPart-r16</i>))
		21 + (3+TT) / 11 - (6+TT) for PC2 UE (Rel-16 UE reporting (PC2 by P _{PowerClass,NR} , and PC3 by <i>powerClassNRPart-r16</i>), or Rel-16 UE reporting (PC3 by P _{PowerClass,NR}))	24 + (2+TT) / 21.4 - (5+TT) for PC2 UE (Rel-16 UE reporting (PC2 by P _{PowerClass,NR} , and PC3 by <i>powerClassNRPart-r16</i>), or Rel-16 UE reporting (PC3 by P _{PowerClass,NR}))
Test ID 1f	Maximum output power with reduction as defined in Table 6.2.3.5-1 of TS 36.521-1 [10]	N/A	Maximum output power with reduction as defined in Table 6.2.3-1 of TS 36.521-1 [10]
Test ID 2a	-10dBm ± (7+TT)	N/A-	Not measured
Test ID 2b	10dBm ± (6+TT)	N/A-	Not measured
Test ID 2c	15dBm ± (5+TT)	N/A-	Not measured
Test ID 3a	N/A	-10dBm ± (7+TT)	Not measured
Test ID 3b	N/A	10dBm ± (6+TT)	Not measured
Test ID 3c	N/A	15dBm ± (5+TT)	Not measured
NOTE 1: In addition NOTE 2 in Table 6.2.2-1 in TS 36.101 [5] and/or NOTE 3 in Table 6.2.1-1 in TS 38.101-1 [2] shall apply to the tolerances.			
NOTE 2: TT for each frequency and channel bandwidth is specified in Table 6.2B.4.1.1.5-3			

For UE not supporting DPS, the output power measured shall not exceed the values specified in Table 6.2B.4.1.1.5-2.

Table 6.2B.4.1.1.5-2: P_{CMAX} configured UE output power for UE not supporting DPS

	E-UTRA component carrier	NR component carrier	Total power measured over E-UTRA and NR component carriers
Test ID 1a	-10 dBm ± (7+TT)	-10 dBm ± (7+TT)	Not measured
Test ID 1b	10 dBm ± (6+TT)	10 dBm ± (6+TT)	Not measured
Test ID 1c	15 dBm ± (5+TT)	15 dBm ± (5+TT)	Not measured
Test ID 1d	Maximum output power with reduction as defined in Table 6.2.3.5-1 of TS 36.521-1 [10]	N/A	Not measured
Test ID 2a	-10dBm ± (7+TT)	N/A	Not measured
Test ID 2b	10dBm ± (6+TT)	N/A	Not measured
Test ID 2c	15dBm ± (5+TT)	N/A	Not measured
Test ID 3a	N/A	-10dBm ± (7+TT)	Not measured
Test ID 3b	N/A	10dBm ± (6+TT)	Not measured
Test ID 3c	N/A	15dBm ± (5+TT)	Not measured
NOTE 1: In addition NOTE 2 in Table 6.2.2-1 in TS 36.101 [5] and/or NOTE 3 in Table 6.2.1-1 in TS 38.101-1 [2] shall apply to the tolerances.			
NOTE 2: TT for each frequency and channel bandwidth is specified in Table 6.2B.4.1.1.5-3			

Table 6.2B.4.1.1.5-3: Test Tolerance (UE configured UE output power)

	f ≤ 3.0GHz	3.0GHz < f ≤ 4.2GHz	4.2GHz < f ≤ 6.0GHz
BW ≤ 40MHz	0.7 dB	1.0 dB	1.0 dB
40MHz < BW ≤ 100MHz	1.0 dB	1.0 dB	1.0 dB

6.2B.4.1.2 Configured Output Power for Intra-Band Non-Contiguous EN-DC

6.2B.4.1.2.1 Test purpose

To verify the UE does not exceed the power bounds defined by P_{CMAX,L} and P_{CMAX,H}.

6.2B.4.1.2.2 Test applicability

This test case applies to all types of E-UTRA UE release 15 and forward, supporting intra-band non-contiguous EN-DC.

6.2B.4.1.2.3 Minimum conformance requirements

The minimum conformance requirements are defined in clause 6.2B.4.1.0.1.2.

Exception requirements for both NR and E-UTRA are defined for this test and therefore LTE anchor agnostic approach is not applied. E-UTRA test point analysis is included and E-UTRA measurements are performed.

6.2B.4.1.2.4 Test description

6.2B.4.1.2.4.1 Initial conditions

Initial conditions are a set of test configurations the UE needs to be tested in and the steps for the SS to take with the UE to reach the correct measurement state.

The initial test configurations consist of environmental conditions, test frequencies and channel bandwidths based on EN-DC operating bands specified in clause 5.3B.1.2, channel bandwidths and sub-carrier spacings for the NR cell specified in TS 38.521-1 [8] clause 5.3 and channel bandwidth for the E-UTRA cell are specified in TS 36.521-1 [10] clause 5.4.2. All of these configurations shall be tested with applicable test parameters for each EN-DC configuration specified in clause 5.3B.1.2 and are shown in table 6.2B.4.1.2.4.1-1. The details of the uplink reference measurement channels (RMCs) are specified in Annex A.2. Configurations of PDSCH and PDCCH before measurement are specified in TS 36.521-1 [10] Annex C.2 and in TS 38.521-1 [8] Annex C.2 for E-UTRA CG and NR CG respectively.

Table 6.2B.4.1.2.4.1-1: Test configurations table for intra-band non-contiguous EN-DC

Initial Conditions							
Test Environment as specified in TS 38.508-1 [5] clause 4.1			Normal, TL/VL, TL/VH, TH/VL, TH/VH				
NR and E-UTRA Test Frequencies as specified in TS 38.508-1 [5] clause 4.3.1			Maximum Wgap				
Test EN-DC bandwidth combination as specified in TS 38.508-1 [5] clause 4.3.1			Lowest N_{RB_agg} , Highest N_{RB_agg}				
NR Test SCS as specified in Table 5.3.5-1 in TS 38.521-1 [8]			Highest supported SCS				
NR/E-UTRA Test Parameters for UE supporting DPS							
Test ID (NOTE 3)	Downlink Configuration	EN-DC Uplink Configuration					
		E-UTRA Cell			NR Cell		
		Modulation	RB allocation (NOTE 2)	P_{LTE}	Modulation	RB allocation (NOTE 1)	P_{NR}
1a-1d	N/A	QPSK	Full_Allocation	{-13, 7, 10, 23} for PC3 UE {-13, 7, 12, 26} for PC2 UE	CP-OFDM QPSK	Outer_Full	{-13, 7, 10, 23} for PC3 UE {-13, 7, 13, 26} for PC2 UE
2a-2c		QPSK	Partial_Allocation	{-10, 10, 15}	N/A	N/A	{-10, 10, 15}
3a-3c		N/A	N/A	{-10, 10, 15}	DFT-s-OFDM QPSK	Inner Full	{-10, 10, 15}
NR/E-UTRA Test Parameters for UE not supporting DPS							
Test ID (NOTE 3)	Downlink Configuration	EN-DC Uplink Configuration					
		E-UTRA Cell			NR Cell		
		Modulation	RB allocation (NOTE 2)	P_{LTE}	Modulation	RB allocation (NOTE 1)	P_{NR}
1a-1b	N/A	QPSK	Full_Allocation	{-10, 23} for PC3 UE {-10, 26} for PC2 UE	CP-OFDM QPSK	Outer_Full	{-10, 23} for PC3 UE {-10, 26} for PC2 UE
2a-2c		QPSK	Partial_Allocation	{-10, 10, 15}	N/A	N/A	{-10, 10, 15}
3a-3c		N/A	N/A	{-10, 10, 15}	DFT-s-OFDM QPSK	Inner Full	{-10, 10, 15}
NOTE 1: The specific configuration of each RB allocation is defined in Table 6.1-1 in TS 38.521-1 [8].							
NOTE 2: The specific configuration of each RB allocation is defined in Table 6.1-1 in current specification.							
NOTE 3: The suffix in Test ID identifies the configured power level being tested from the P_{LTE} and P_{NR} lists							

Table 6.2B.4.1.2.4.1-2: Void

1. Connect the SS to the UE antenna connectors as shown in [6] TS 38.508-1 A.3.1.2.1 for SS diagram and A.3.2.1 for UE diagram.
2. The parameter settings for the E-UTRA cell are set up according to TS 36.508 [11] clause 4.4.3, and the parameter settings for the NR cell are set up according to TS 38.508-1 [6] clause 4.4.3.
3. Downlink signals are initially set up according to TS 36.521-1 [10] Annex C.0 and TS 38.521-1 [8] Annex C.0 for E-UTRA CG and NR CG respectively, and uplink signals according to TS 36.521-1 [10] Annex H and TS 38.521-1 [8] Annex G for E-UTRA CG and NR CG respectively.
4. The UL Reference Measurement channels are TS 36.521-1 [10] Annex A.2 and TS 38.521-1 [8] Annex A.2 for E-UTRA CG and NR CG respectively.
5. Propagation conditions are set according to TS 36.521-1 [10] Annex B.0 and TS 38.521-1 [8] Annex B.0 for E-UTRA CG and NR CG respectively.

6. Ensure the UE is in state RRC_CONNECTED with generic procedure parameters Connectivity EN-DC, DC bearer MCG and SCG, Connected without release On according to TS 38.508-1 [6] clause 4.5. Message contents are defined in clause 6.2B.4.1.2.4.3.
7. For the case of testing overlapping E-UTRA and NR UL transmission scenario when both bands are TDD, ensure E-UTRA UL transmission overlaps with NR UL transmission in time by giving SCG a delay of 3 E-UTRA subframes, or by giving MCG a delay of 2 subframes.

6.2B.4.1.2.4.2 Test procedure

1. SS sends uplink scheduling information for each UL HARQ process via PDCCH DCI format 0 and DCI format 0_1 for C_RNTI to schedule the UL RMC according table 6.2B.4.1.2.4.1-1 on E-UTRA CC and NR CC respectively. Since the UE has no payload and no loopback data to send the UE sends uplink MAC padding bits on the UL RMC.
2. Send continuously uplink power control "up" commands to the UE for NR and E-UTRA carrier until the UE transmits at its P_{UMAX} level; allow at least 200 ms from the first TPC command for the UE to reach P_{UMAX} level.
3. Measure the mean transmitted power over E-UTRA component carrier and NR component carrier respectively, or/and measure the sum of mean transmitted power over E-UTRA and NR component carriers according to Table 6.2B.4.1.2.5-1 and Table 6.2B.4.1.2.5-2. The period of the measurement shall be at least the continuous duration of one active sub-frame. For TDD, only slots consisting of only UL symbols are under test.

6.2B.4.1.2.4.3 Message contents

Message contents are according to TS 36.508 [11] clause 4.6.1 and TS 38.508-1 [6] clause 4.6.1 with the following exceptions.

Table 6.2B.4.1.2.4.3-1: RRCConnectionReconfiguration: tdm-PatternConfig if E-UTRA on FDD band and UE doesn't support dynamic power sharing

Derivation Path: TS 36.508 [11], Table 4.6.1-8			
Information Element	Value/remark	Comment	Condition
tdm-PatternConfig-r15 CHOICE{			
setup SEQUENCE {			
subframeAssignment-r15	sa2		
harq-Offset-r15	0		
}			
}			

Table 6.2B.4.1.2.4.3-2: SystemInformationBlockType1: tdd-Config if E-UTRA on TDD band

Derivation Path: TS 36.508 [11], Table 4.6.3-23			
Information Element	Value/remark	Comment	Condition
TDD-Config-DEFAULT ::= SEQUENCE {		Operating on TDD band	
subframeAssignment	sa2		
specialSubframePatterns	ssp7		
}			

Table 6.2B.4.1.2.4.3-3: RRCConnectionReconfiguration: nr-Config-r15

Derivation Path: TS 36.508 [11], Table 4.6.1-8			
Information Element	Value/remark	Comment	Condition
p-MaxEUTRA-r15	Defined as P _{LTE} in Table 6.2B.4.1.2.4.1-1		

Table 6.2B.4.1.2.4.3-4: PhysicalCellGroupConfig

Derivation Path: TS 38.508-1 [6], Table 4.6.3-106			
Information Element	Value/remark	Comment	Condition
PhysicalCellGroupConfig ::= SEQUENCE {			
p-NR-FR1	Defined as P _{NR} in Table 6.2B.4.1.2.4.1-1		
}			

Table 6.2B.4.1.2.4.3-5: RRCConnectionReconfiguration: p-MaxUE-FR1-r15

Derivation Path: TS 36.508 [11], Table 4.6.1-8			
Information Element	Value/remark	Comment	Condition
nonCriticalExtension ::= SEQUENCE {		RRCConnectionReconfiguration-v1530-IEs	
p-MaxUE-FR1-r15	23		
}			

6.2B.4.1.2.5 Test requirement

For UE supporting DPS, the output power measured shall not exceed the values specified in Table 6.2B.4.1.2.5-1.

Table 6.2B.4.1.2.5-1: P_{CMAX} configured UE output power for UE supporting DPS

	E-UTRA component carrier	NR component carrier	Total power measured over E-UTRA and NR component carriers
Test ID 1a	Not measured	Not measured	-10dBm ± (7+TT)
Test ID 1b	Not measured	Not measured	10dBm ± (7+TT)
Test ID 1c	Not measured	10 + (7+TT) / 2 – (7+TT) for PC3 UE	13.0 + (6+TT) / 10.64 – (7+TT) for PC3 UE
		13 + (6+TT) / 5 - (7+TT) for PC2 UE (Rel-15 UE or Rel-16 UE reporting (PC2 by P _{PowerClass,NR} , and PC2 or Not present by <i>powerClassNRPart-r16</i>))	15.5 + (6+TT) / 12.8 - (6+TT) for PC2 UE (Rel-15 UE or Rel-16 UE reporting (PC2 by P _{PowerClass,NR} , and PC2 or Not present by <i>powerClassNRPart-r16</i>))
		13 + (6+TT) / 2 - (7+TT) for PC2 UE (Rel-16 UE reporting (PC2 by P _{PowerClass,NR} , and PC3 by <i>powerClassNRPart-r16</i>), or Rel-16 UE reporting (PC3 by P _{PowerClass,NR}))	15.5 + (6+TT) / 12.4 - (6+TT) for PC2 UE (Rel-16 UE reporting (PC2 by P _{PowerClass,NR} , and PC3 by <i>powerClassNRPart-r16</i>), or Rel-16 UE reporting (PC3 by P _{PowerClass,NR}))
Test ID 1d	Maximum output power with reduction as defined in Table 6.2.3.5-1 of TS 36.521-1 [10]	N/A	Maximum output power with reduction as defined in Table 6.2.3-1 of TS 36.521-1 [10]
Test ID 2a	-10dBm ± (7+TT)	N/A	Not measured
Test ID 2b	10dBm ± (6+TT)	N/A	Not measured
Test ID 2c	15dBm ± (5+TT)	N/A	Not measured
Test ID 3a	N/A	-10dBm ± (7+TT)	Not measured
Test ID 3b	N/A	10dBm ± (6+TT)	Not measured
Test ID 3c	N/A	15dBm ± (5+TT)	Not measured
NOTE 1: In addition NOTE 2 in Table 6.2.2-1 in TS 36.101 [5] and/or NOTE 3 in Table 6.2.1-1 in TS 38.101-1 [2] shall apply to the tolerances.			
NOTE 2: TT for each frequency and channel bandwidth is specified in Table 6.2B.4.1.1.5-3			

For UE not supporting DPS, the output power measured shall not exceed the values specified in Table 6.2B.4.1.1.5-2.

Table 6.2B.4.1.2.5-2: P_{CMAX} configured UE output power for UE not supporting DPS

	E-UTRA component carrier	NR component carrier	Total power measured over E-UTRA and NR component carriers
Test ID 1a	-10 dBm \pm (7+TT)	-10 dBm \pm (7+TT)	Not measured
Test ID 1b	Maximum output power with reduction as defined in Table 6.2.3.5-1 of TS 36.521-1 [10]	N/A	Not measured
Test ID 2a	-10dBm \pm (7+TT)	N/A	Not measured
Test ID 2b	10dBm \pm (6+TT)	N/A	Not measured
Test ID 2c	15dBm \pm (5+TT)	N/A	Not measured
Test ID 3a	N/A	-10dBm \pm (7+TT)	Not measured
Test ID 3b	N/A	10dBm \pm (6+TT)	Not measured
Test ID 3c	N/A	15dBm \pm (5+TT)	Not measured
NOTE 1: In addition NOTE 2 in Table 6.2.2-1 in TS 36.101 [5] and/or NOTE 3 in Table 6.2.1-1 in TS 38.101-1 [2] shall apply to the tolerances.			
NOTE 2: TT for each frequency and channel bandwidth is specified in Table 6.2B.4.1.1.5-3			

Table 6.2B.4.1.2.5-3: Test Tolerance for UE configured UE output power (Separate measurements over E-UTRA and NR CCs)

Uplink TX		$f \leq 3.0\text{GHz}$	$3.0\text{GHz} < f \leq 4.2\text{GHz}$	$4.2\text{GHz} < f \leq 6\text{GHz}$
E-UTRA	$\text{BW} \leq 20\text{MHz}$	0.7 dB	1.0 dB	1.3 dB
NR	$\text{BW} \leq 40\text{MHz}$	0.7 dB	1.0 dB	1.0 dB
	$40\text{MHz} < \text{BW} \leq 100\text{MHz}$	1.0 dB	1.0 dB	1.0 dB

Table 6.2B.4.1.2.5-4: Test Tolerance for UE configured UE output power (Combined measurements of E-UTRA and NR CCs)

TT for overall output power											
			NR								
			$\text{BW} \leq 20\text{MHz}$			$20\text{MHz} < \text{BW} \leq 40\text{MHz}$			$40\text{MHz} < \text{BW} \leq 100\text{MHz}$		
			$f \leq 3.0\text{GHz}$	$3.0\text{GHz} < f \leq 4.2\text{GHz}$	$4.2\text{GHz} < f \leq 6.0\text{GHz}$	$f \leq 3.0\text{GHz}$	$3.0\text{GHz} < f \leq 4.2\text{GHz}$	$4.2\text{GHz} < f \leq 6.0\text{GHz}$	$f \leq 3.0\text{GHz}$	$3.0\text{GHz} < f \leq 4.2\text{GHz}$	$4.2\text{GHz} < f \leq 6.0\text{GHz}$
E-UTRA	$\text{BW} \leq 20\text{MHz}$	$f \leq 3.0\text{GHz}$	0.7 dB	1.0 dB	1.0 dB	0.7 dB	1.0 dB	1.0 dB	1.0 dB	1.0 dB	1.0 dB
		$3.0\text{GHz} < f \leq 4.2\text{GHz}$	1.0 dB	1.0 dB	1.0 dB	1.0 dB	1.0 dB	1.0 dB	1.0 dB	1.0 dB	1.0 dB

6.2B.4.1.3 Configured Output Power for Inter-Band EN-DC within FR1

6.2B.4.1.3.1 Test purpose

To verify the UE does not exceed the power bounds defined by P_{CMAX} and P_{CMAX_H} .

6.2B.4.1.3.2 Test applicability

This test case applies to all types of E-UTRA UE release 15 and forward, supporting inter-band EN-DC within FR1.

6.2B.4.1.3.3 Minimum conformance requirements

The minimum conformance requirements are defined in clause 6.2B.4.1.0.1.3.

Exception requirements for both NR and E-UTRA are defined for this test and therefore LTE anchor agnostic approach is not applied. E-UTRA test point analysis is included and E-UTRA measurements are performed.

6.2B.4.1.3.4 Test description

6.2B.4.1.3.4.1 Initial conditions

Initial conditions are a set of test configurations the UE needs to be tested in and the steps for the SS to take with the UE to reach the correct measurement state.

The initial test configurations consist of environmental conditions, test frequencies and channel bandwidths based on EN-DC operating bands specified in clause 5.3B.1.2, channel bandwidths and sub-carrier spacings for the NR cell specified in TS 38.521-1 [8] clause 5.3 and channel bandwidth for the E-UTRA cell are specified in TS 36.521-1 [10] clause 5.4.2. All of these configurations shall be tested with applicable test parameters for each EN-DC configuration specified in clause 5.3B.1.2 and are shown in table 6.2B.4.1.3.4.1-1. The details of the uplink reference measurement channels (RMCs) are specified in Annex A.2. Configurations of PDSCH and PDCCH before measurement are specified in TS 36.521-1 [10] Annex C.2 and in TS 38.521-1 [8] Annex C.2 for E-UTRA CG and NR CG respectively.

Table 6.2B.4.1.3.4.1-1: Test configurations table for inter-band contiguous EN-DC

Initial Conditions							
Test Environment as specified in TS 38.508-1 [5] clause 4.1			Normal, TL/VL, TL/VH, TH/VL, TH/VH				
NR Test Frequencies as specified in TS 38.508-1 [5] clause 4.3.1 E-UTRA Test Frequencies as specified in TS 36.508-1 [11] clause 4.3.1			Mid range				
Test EN-DC bandwidth combination as specified in TS 38.508-1 [5] clause 4.3.1			5MHz for E-UTRA CC1 and Lowest for NR CC1, Highest for E-UTRA CC1 and Highest for NR CC1				
NR Test SCS as specified in Table 5.3.5-1 in TS 38.521-1 [8]			Highest supported SCS				
NR/E-UTRA Test Parameters for UE supporting DPS							
Test ID (NOTE 3)	Downlink Configuration	EN-DC Uplink Configuration					
		E-UTRA Cell			NR Cell		
		Modulation	RB allocation (NOTE 2)	P _{LTE}	Modulation	RB allocation (NOTE 1)	P _{NR}
1a-1h	N/A	QPSK	Partial_Allocation	{-13, 12, 14, 17, 18, 19, 20, 23} for PC3 UE {-13, 12, 14, 17, 18, 19, 23, 26} for PC2 UE	DFT-s-OFDM QPSK	Inner Full	{-13, 12, 14, 17, 18, 19, 23, 23} for PC3 UE {-13, 12, 14, 17, 18, 19, 26, 26} for PC2 UE
2a-2c		QPSK	Partial_Allocation	{-10, 10, 15}	N/A	N/A	{-10, 10, 15}
3a-3c		N/A	N/A	{-10, 10, 15}	DFT-s-OFDM QPSK	Inner Full	{-10, 10, 15}
NR/E-UTRA Test Parameters for UE not supporting DPS							
Test ID (NOTE 3)	Downlink Configuration	EN-DC Uplink Configuration					
		E-UTRA Cell			NR Cell		
		Modulation	RB allocation (NOTE 2)	P _{LTE}	Modulation	RB allocation (NOTE 1)	P _{NR}
1-1d	N/A	QPSK	Full_Allocation	{-10, 10, 15, 23} for PC3 UE {-10, 10, 15, 26} for PC2 UE	CP-OFDM QPSK	Outer_Full	{-10, 10, 15, 23} for PC3 UE {-10, 10, 15, 26} for PC2 UE
2a-2c		QPSK	Partial_Allocation	{-10, 10, 15}	N/A	N/A	{-10, 10, 15}
3a-3c		N/A	N/A	{-10, 10, 15}	DFT-s-OFDM QPSK	Inner Full	{-10, 10, 15}
NOTE 1: The specific configuration of each RB allocation is defined in Table 6.1-1 in TS 38.521-1 [8].							
NOTE 2: The specific configuration of each RB allocation is defined in Table 6.1-1 in current specification.							
NOTE 3: The suffix in Test ID identifies the configured power level being tested from the P _{LTE} and P _{NR} lists							

Table 6.2B.4.1.3.4.1-2: Void

1. Connect the SS to the UE antenna connectors as shown in [6] TS 38.508-1 A.3.1.2.1 for SS diagram and A.3.2.1 for UE diagram.
2. The parameter settings for the E-UTRA cell are set up according to TS 36.508 [11] clause 4.4.3, and the parameter settings for the NR cell are set up according to TS 38.508-1 [6] clause 4.4.3.
3. Downlink signals are initially set up according to TS 36.521-1 [10] Annex C.0 and TS 38.521-1 [8] Annex C.0 for E-UTRA CG and NR CG respectively, and uplink signals according to TS 36.521-1 [10] Annex H and TS 38.521-1 [8] Annex G for E-UTRA CG and NR CG respectively.

4. The UL Reference Measurement channels are TS 36.521-1 [10] Annex A.2 and TS 38.521-1 [8] Annex A.2 for E-UTRA CG and NR CG respectively.
5. Propagation conditions are set according to TS 36.521-1 [10] Annex B.0 and TS 38.521-1 [8] Annex B.0 for E-UTRA CG and NR CG respectively.
6. Ensure the UE is in state RRC_CONNECTED with generic procedure parameters Connectivity EN-DC, DC bearer MCG and SCG, Connected without release *On* according to TS 38.508-1 [6] clause 4.5. Message contents are defined in clause 6.2B.4.1.3.4.3.
7. For the case of testing overlapping E-UTRA and NR UL transmission scenario when both bands are TDD, ensure E-UTRA UL transmission overlaps with NR UL transmission in time by giving SCG a delay of 3 E-UTRA subframes, or by giving MCG a delay of 2 subframes.

6.2B.4.1.3.4.2 Test procedure

1. SS sends uplink scheduling information for each UL HARQ process via PDCCH DCI format 0 and DCI format 0_1 for C_RNTI to schedule the UL RMC according table 6.2B.4.1.3.4.1-1 on E-UTRA CC and NR CC respectively. Since the UE has no payload and no loopback data to send the UE sends uplink MAC padding bits on the UL RMC.
2. Send continuously uplink power control "up" commands to the UE for NR and E-UTRA carrier until the UE transmits at its P_{UMAX} level; allow at least 200 ms from the first TPC command for the UE to reach P_{UMAX} level.
3. Measure the mean transmitted power over E-UTRA component carrier and NR component carrier respectively, or/and measure the sum of mean transmitted power over E-UTRA and NR component carriers according to Table 6.2B.4.1.3.5-1 and Table 6.2B.4.1.3.5-2. The period of the measurement shall be at least the continuous duration of one active sub-frame. For TDD, only slots consisting of only UL symbols are under test.

6.2B.4.1.3.4.3 Message contents

Message contents are according to TS 36.508 [11] clause 4.6.1 and TS 38.508-1 [6] clause 4.6.1 with the following exceptions.

Table 6.2B.4.1.3.4.3-1: RRCConnectionReconfiguration: tdm-PatternConfig if E-UTRA on FDD band and UE doesn't support dynamic power sharing

Derivation Path: TS 36.508 [11], Table 4.6.1-8			
Information Element	Value/remark	Comment	Condition
tdm-PatternConfig-r15 CHOICE{			
setup SEQUENCE {			
subframeAssignment-r15	sa2		
harq-Offset-r15	0		
}			
}			

Table 6.2B.4.1.3.4.3-2: SystemInformationBlockType1: tdd-Config if E-UTRA on TDD band

Derivation Path: TS 36.508 [11], Table 4.6.3-23			
Information Element	Value/remark	Comment	Condition
TDD-Config-DEFAULT ::= SEQUENCE {		Operating on TDD band	
subframeAssignment	sa2		
specialSubframePatterns	ssp7		
}			

Table 6.2B.4.1.3.4.3-3: RRCConnectionReconfiguration: nr-Config-r15

Derivation Path: TS 36.508 [11], Table 4.6.1-8			
Information Element	Value/remark	Comment	Condition
p-MaxEUTRA-r15	Defined as PLTE in Table 6.2B.4.1.3.4.1-1		

Table 6.2B.4.1.3.4.3-4: PhysicalCellGroupConfig

Derivation Path: TS 38.508-1 [6], Table 4.6.3-106			
Information Element	Value/remark	Comment	Condition
PhysicalCellGroupConfig ::= SEQUENCE {			
p-NR-FR1	Defined as P _{NR} in Table 6.2B.4.1.3.4.1-1		
}			

Table 6.2B.4.1.3.4.3-5: RRCConnectionReconfiguration: p-MaxUE-FR1-r15

Derivation Path: TS 36.508 [11], Table 4.6.1-8			
Information Element	Value/remark	Comment	Condition
nonCriticalExtension		RRCCONNECTION RECONFIGURATION-v1530-IEs	
SEQUENCE {			
p-MaxUE-FR1-r15	23		
}			

6.2B.4.1.3.5 Test requirement

For UE supporting DPS, the output power measured shall not exceed the values specified in Table 6.2B.4.1.3.5-1.

Table 6.2B.4.1.3.5-1: P_{CMAX} configured UE output power for UE supporting DPS

	E-UTRA component carrier	NR component carrier	Total power measured over E-UTRA and NR component carriers

Test ID 1a	Not measured	Not measured	-10dBm ± (7+TT)
Test ID 1b	Not measured	Not measured	15dBm ± (6+TT)
Test ID 1c	Not measured	Not measured	17 ± (5+TT)
Test ID 1d	Not measured	Not measured	20 + (4+TT)/ - (6+TT)
Test ID 1e	Not measured	Not measured	21 + (3+TT)/ - (5+TT)
Test ID 1f	Not measured	Not measured	22+ (2+TT)/ - (5+TT)
Test ID 1g	Not measured	23 + (2+TT) / 17 - (5+TT) for PC3 UE	23 + (2+TT) / 21.8 - (5+TT) for PC3 UE
		26 + (2+TT) / 20 - (6+TT) for PC2 UE (Rel-15 UE or Rel-16 UE reporting (PC2 by P _{PowerClass,NR} , and PC2 or Not present by <i>powerClassNRPart-r16</i>))	26 + (2+TT) / 24.8 - (3+TT) for PC2 UE (Rel-15 UE or Rel-16 UE reporting (PC2 by P _{PowerClass,NR} , and PC2 or Not present by <i>powerClassNRPart-r16</i>))
		23 + (2+TT) / 17 - (5+TT) for PC2 UE (Rel-16 UE reporting (PC2 by P _{PowerClass,NR} , and PC3 by <i>powerClassNRPart-r16</i>), or Rel-16 UE reporting (PC3 by P _{PowerClass,NR}))	26 + (2+TT) / 24.0 - (3+TT) for PC2 UE (Rel-16 UE reporting (PC2 by P _{PowerClass,NR} , and PC3 by <i>powerClassNRPart-r16</i>), or Rel-16 UE reporting (PC3 by P _{PowerClass,NR}))
Test ID 1h	Maximum output power with reduction as defined in Table 6.2.3.5-1 of TS 36.521-1 [10]	N/A	Maximum output power with reduction as defined in Table 6.2.3-1 of TS 36.521-1 [10]
Test ID 2a	-10dBm ± (7+TT)	N/A	Not measured
Test ID 2b	10dBm ± (6+TT)	N/A	Not measured
Test ID 2c	15dBm ± (5+TT)	N/A	Not measured
Test ID 3a	N/A	-10dBm ± (7+TT)	Not measured
Test ID 3b	N/A	10dBm ± (6+TT)	Not measured
Test ID 3c	N/A	15dBm ± (5+TT)	Not measured
NOTE 1: In addition NOTE 2 in Table 6.2.2-1 in TS 36.101 [5] and/or NOTE 3 in Table 6.2.1-1 in TS 38.101-1 [2] shall apply to the tolerances.			
NOTE 2: TT for each frequency and channel bandwidth is specified in Table 6.2B.4.1.3.5-3 and Table 6.2B.4.1.3.5-4.			

For UE not supporting DPS, the output power measured shall not exceed the values specified in Table 6.2B.4.1.3.5-2.

Table 6.2B.4.1.3.5-2: P_CMAX configured UE output power for UE not supporting DPS

	E-UTRA component carrier	NR component carrier	Total power measured over E-UTRA and NR component carriers
Test ID 1a	-10 dBm ± (7+TT)	-10 dBm ± (7+TT)	Not measured
Test ID 1b	10 dBm ± (6+TT)	10 dBm ± (6+TT)	Not measured
Test ID 1c	15 dBm ± (5+TT)	15 dBm ± (5+TT)	Not measured
Test ID 1d	Maximum output power with reduction as defined in Table 6.2.3.5-1 of TS 36.521-1 [10]	N/A	Not measured
Test ID 2a	-10dBm ± (7+TT)	N/A	Not measured
Test ID 2b	10dBm ± (6+TT)	N/A	Not measured
Test ID 2c	15dBm ± (5+TT)	N/A	Not measured
Test ID 3a	N/A	-10dBm ± (7+TT)	Not measured
Test ID 3b	N/A	10dBm ± (6+TT)	Not measured
Test ID 3c	N/A	15dBm ± (5+TT)	Not measured
NOTE 1: In addition NOTE 2 in Table 6.2.2-1 in TS 36.101 [5] and/or NOTE 3 in Table 6.2.1-1 in TS 38.101-1 [2] shall apply to the tolerances.			
NOTE 2: TT for each frequency and channel bandwidth is specified in Table 6.2B.4.1.3.5-3 and Table 6.2B.4.1.3.5-4.			

Table 6.2B.4.1.3.5-3: Test Tolerance for UE maximum output power (Separate measurements over E-UTRA and NR CCs)

Uplink TX		$f \leq 3.0\text{GHz}$	$3.0\text{GHz} < f \leq 4.2\text{GHz}$	$4.2\text{GHz} < f \leq 6\text{GHz}$
E-UTRA	$\text{BW} \leq 20\text{MHz}$	0.7 dB	1.0 dB	1.3 dB
NR	$\text{BW} \leq 40\text{MHz}$	0.7 dB	1.0 dB	1.0 dB
	$40\text{MHz} < \text{BW} \leq 100\text{MHz}$	1.0 dB	1.0 dB	1.0 dB

Table 6.2B.4.1.3.5-4: Test Tolerance for UE maximum output power (Combined measurements of E-UTRA and NR CCs)

TT for overall output power											
			NR								
			$\text{BW} \leq 20\text{MHz}$			$20\text{MHz} < \text{BW} \leq 40\text{MHz}$			$40\text{MHz} < \text{BW} \leq 100\text{MHz}$		
			$f \leq 3.0\text{GHz}$	$3.0\text{GHz} < f \leq 4.2\text{GHz}$	$4.2\text{GHz} < f \leq 6.0\text{GHz}$	$f \leq 3.0\text{GHz}$	$3.0\text{GHz} < f \leq 4.2\text{GHz}$	$4.2\text{GHz} < f \leq 6.0\text{GHz}$	$f \leq 3.0\text{GHz}$	$3.0\text{GHz} < f \leq 4.2\text{GHz}$	$4.2\text{GHz} < f \leq 6.0\text{GHz}$
E-UTRA	$\text{BW} \leq 20\text{MHz}$	$f \leq 3.0\text{GHz}$	0.7 dB	1.0 dB	1.0 dB	0.7 dB	1.0 dB	1.0 dB	1.0 dB	1.0 dB	1.0 dB
		$3.0\text{GHz} < f \leq 4.2\text{GHz}$	1.0 dB	1.0 dB	1.0 dB	1.0 dB	1.0 dB	1.0 dB	1.0 dB	1.0 dB	1.0 dB

For the UE which supports inter-band EN-DC configuration, $\Delta T_{\text{IB},c}$ in 6.2B.4.2 applies where unless otherwise stated, the same $\Delta T_{\text{IB},c}$ is applicable to NR band(s) part for DC configurations which have the same NR operating band combination. Unless otherwise stated, $\Delta T_{\text{IB},c}$ is set to zero.

6.2B.4.1.4 Configured Output Power for Inter-Band EN-DC including FR2

6.2B.4.1.4.1 Test purpose

Same test purpose as in clause 6.2.4.1 in TS 38.521-2 [9] for the NR carrier.

6.2B.4.1.4.2 Test applicability

This test case applies to all types of E-UTRA UE release 15 and forward, supporting inter-band EN-DC including FR2 with 2CCs.

The requirements of this test for NR carrier are covered in test cases 6.2B.1.1 Maximum output power for Inter-Band EN-DC including FR2, 6.2B.2.1 Maximum output power reduction for Inter-Band EN-DC including FR2 and 6.2B.3.1 UE maximum output power with additional requirements for Inter-Band EN-DC including FR2 to all types of NR UE release 15 and forward.

6.2B.4.1.4.3 Minimum conformance requirements

UE configured output power requirement for E-UTRA single carrier and CA operation specified in subclauses 6.2.5 and 6.2.5A of [10] and for NR single carrier and CA operation specified in subclause 6.2.4, 6.2A.4 and 6.2D.4 of [9] apply.

No exception requirements applicable to NR or LTE. LTE anchor agnostic approach is applied.

The normative reference for this requirement is TS 38.101-3 [4] clause 6.2B.4.1.4.

6.2B.4.1.4.4 Test description

This test is covered by clause 6.2B.1.1 Maximum output power for Inter-Band EN-DC including FR2, 6.2B.2.1 Maximum output power reduction for Inter-Band EN-DC including FR2 and 6.2B.3.1 UE maximum output power with additional requirements for Inter-Band EN-DC including FR2.

6.2B.4.1.4.5 Test requirement

This test is covered by clause 6.2B.1.1 Maximum output power for Inter-Band EN-DC including FR2, 6.2B.2.1 Maximum output power reduction for Inter-Band EN-DC including FR2 and 6.2B.3.1 UE maximum output power with additional requirements for Inter-Band EN-DC including FR2.

6.2B.4.1.5 Configured Output Power for Inter-Band EN-DC including both FR1 and FR2

6.2B.4.1.5.1 Test purpose

Same test purpose as in clause 6.2.4.1 in TS 38.521-1 [8] for NR FR1 carrier and 6.2.4.1 in TS 38.521-2 [9] for NR FR2 carrier.

6.2B.4.1.5.2 Test applicability

The requirements in this test are not testable due to issues with combined testing of NR FR1 and E-UTRA in conducted mode with NR FR2 in radiated mode. Therefore, the conducted and radiated requirements are tested separately.

No test case details are specified. The NSA requirements for maximum output power apply and are tested as part of the EN-DC within FR1 and EN-DC including FR2 test cases in clause 6.2B.

6.2B.4.2 $\Delta T_{IB,c}$ for EN-DC

For the UE which supports inter-band EN-DC configuration, $\Delta T_{IB,c}$ in Tables below applies where unless otherwise stated, the same $\Delta T_{IB,c}$ is applicable to NR band(s) part for DC configurations which have the same NR operating band combination. Unless otherwise stated, $\Delta T_{IB,c}$ is set to zero.

Unless $\Delta T_{IB,c}$ is specified for the NE-DC configuration, the specified $\Delta T_{IB,c}$ for the EN-DC configuration including same bands as the corresponding NE-DC configuration is applicable for the NE-DC configuration.

6.2B.4.2.1 Intra-Band Contiguous EN-DC

$\Delta T_{IB,c}$ is not applicable for intra-band contiguous EN-DC.

6.2B.4.2.2 Intra-Band non-Contiguous EN-DC

$\Delta T_{IB,c}$ is not applicable for intra-band non-contiguous EN-DC.

6.2B.4.2.3 Inter-Band EN-DC within FR1

6.2B.4.2.3.1 $\Delta T_{IB,c}$ for EN-DC two bands

Table 6.2B.4.2.3.1-1: $\Delta T_{IB,c}$ due to EN-DC(two bands)

Inter-band EN-DC configuration	E-UTRA or NR Band	$\Delta T_{B,c}$ (dB)
DC_1_n3	1	0.3
	n3	0.3
DC_1_n28	1	0.3
	n28	0.6
DC_1_n40	1	0.5
	n40	0.5
DC_1_n51	1	0.6
	n51	0.6
DC_1_n77	1	0.6
	n77	0.8
DC_1_n78	1	0.3
	n78	0.8
DC_2_n5	2	0.3
	n5	0.3
DC_2_n41	2	0.5
	n41	0.4 ¹
		0.9 ²
DC_2_n66	2	0.5
	n66	0.5
DC_2_n71	2	0.3
	n71	0.3
DC_2_n78	2	0.6
	n78	0.8
DC_3_n1	3	0.3
	n1	0.3
DC_3_n7	3	0.5
	n7	0.5
DC_3_n28	3	0.3
	n28	0.3
DC_3_n40	3	0.5
	n40	0.5
DC_3_n41	3	0.5
	n41	0.3 ³
		0.8 ⁴
DC_3_n51	3	0.3
	n51	0.3
DC_3_n77	3	0.6
	n77	0.8
DC_3_n78	3	0.6
	n78	0.8
DC_5_n2, DC_5-5_n2	5	0.3
	n2	0.3
DC_5_n40	5	0.3
	n40	0.3
DC_5_n66	5	0.3
	n66	0.3
DC_5_n78	5	0.6
	n78	0.8
DC_7_n1	7	0.6
	n1	0.5
DC_7_n3	7	0.5
	n3	0.5
DC_7_n28	7	0.3
	n28	0.3
DC_7_n51	7	0.3
	n51	0.3
DC_7_n66, DC_7-7_n66	7	0.5
	n66	0.5
DC_7_n78, DC_7-7_n78	7	0.5
	n78	0.8
DC_8_n1	8	0.3
	n1	0.3
DC_8_n3	8	0.3

Inter-band EN-DC configuration	E-UTRA or NR Band	$\Delta T_{B,c}$ (dB)
DC_1_n3	1	0.3
	n3	0.3
	n3	0.3
DC_8_n40	8	0.3
	n40	0.3
DC_8_n41	8	0.3
	n41	0.3
DC_8_n77	8	0.6
	n77	0.8
DC_8_n78	8	0.6
	n78	0.8
DC_11_n77	11	0.4
	n77	0.8
DC_11_n78	11	0.4
	n78	0.8
DC_12_n5	12	0.4
	n5	0.8
DC_12_n66	12	0.8
	n66	0.3
DC_12_n78	12	0.5
	n78	0.8
DC_13_n2	13	0.3
	n2	0.3
DC_13_n66	13	0.3
	n66	0.3
DC_14_n2	14	0.3
	n2	0.3
DC_14_n66	14	0.3
	n66	0.3
DC_18_n77	18	0.3
	n77	0.8
DC_18_n78	18	0.3
	n78	0.8
DC_19_n77	19	0.3
	n77	0.8
DC_19_n78	19	0.3
	n78	0.8
DC_20_n1	20	0.3
	n1	0.3
DC_20_n3	20	0.3
	n3	0.3
DC_20_n8	20	0.4
	n8	0.4
DC_20_n28	20	0.5
	n28	0.5
DC_20_n51	20	0.5
	n51	0.5
DC_20_n77	20	0.6
	n77	0.8
DC_20_n78	20	0.6
	n78	0.8
DC_21_n77	21	0.4
	n77	0.8
DC_21_n78	21	0.4
	n78	0.8
DC_25_n41	25	0.5
	n41	0.4 ¹ 0.9 ²
DC_26_n41	26	0.3
	n41	0.3
DC_26_n77	26	0.3
	n77	0.8
DC_26_n78	26	0.3

Inter-band EN-DC configuration	E-UTRA or NR Band	$\Delta T_{B,c}$ (dB)
DC_1_n3	1	0.3
	n3	0.3
	n78	0.8
DC_28_n51	28	0.5
	n51	0.5
DC_28_n77	28	0.5
	n77	0.8
DC_28_n78	28	0.5
	n78	0.8
DC_30_n5	30	0.3
	n5	0.3
DC_30_n66	30	0.5
	n66	0.8
DC_38_n78	n78	0.5
	39	0.5
DC_39_n41	n41	0.5
	39	0.3
DC_39_n78	n78	0.8
	39	0.3
DC_39_n79	n79	0.8
	n1	0.5
DC_40_n1	40	0.5
	n41 ⁵	0.5
DC_40_n41 ⁵	n41	0.5
	n77	0.5
DC_40_n77	n77	0.5
DC_40_n78	n78	0.5 ⁶
DC_41_n77	41	0.3
	n77	0.8
DC_41_n78	41	0.3
	n78	0.8
DC_41_n79	41	0.3
	n79	0.8
DC_42_n51	42	0.6
	n51	0.8
DC_48_n5	48	0.3
	n5	0.3
DC_48_n66	48	0.8
	n66	0.6
DC_66_n2	66	0.5
	n2	0.5
DC_66_n5	66	0.3
	n5	0.3
DC_66_n41	66	0.5
	n41	0.8 ¹
		1.3 ²
DC_66_n71	66	0.3
	n71	0.3
DC_66_n78	66	0.6
	n78	0.8

NOTE 1: The requirement is applied for UE transmitting on the frequency range of 2545-2690 MHz.
NOTE 2: The requirement is applied for UE transmitting on the frequency range of 2496-2545 MHz.
NOTE 3: Applicable for the frequency range of 2515 - 2690 MHz.
NOTE 4: Applicable for the frequency range of 2496 - 2515 MHz.
NOTE 5: Applicable for UE supporting inter-band EN-DC without simultaneous Rx/Tx.
NOTE 6: Only applicable for UE supporting inter-band carrier aggregation with uplink in one E-UTRA band and without simultaneous Rx/Tx.

6.2B.4.2.3.2 $\Delta T_{IB,c}$ for EN-DC three bands

Table 6.2B.4.2.3.2-1: $\Delta T_{IB,c}$ due to EN-DC (three bands)

Inter-band EN-DC configuration	E-UTRA or NR Band	$\Delta T_{IB,c}$ (dB)
DC_1-3_n28	1	0.3
	3	0.3
	n28	0.6
DC_1-3_n77	1	0.6
	3	0.6
	n77	0.8
DC_1-3_n78	1	0.6
	3	0.6
	n78	0.8
DC_1-3_n79	1	0.3
	3	0.3
DC_1-5_n78	1	0.3
	5	0.6
	n78	0.8
DC_1-7_n3	1	0.6
	7	0.6
	n3	0.6
DC_1-7_n28	1	0.5
	7	0.6
	n28	0.6
DC_1-7_n78 DC_1-7-7_n78	1	0.6
	7	0.6
	n78	0.8
DC_1-8_n3	1	0.3
	8	0.3
	n3	0.3
DC_1-8_n78	1	0.3
	8	0.6
	n78	0.8
DC_1-18_n77	1	0.3
	18	0.3
	n77	0.8
DC_1-18_n78	1	0.3
	18	0.3
	n78	0.8
DC_1-19_n77	1	0.3
	19	0.3
	n77	0.8
DC_1-19_n78	1	0.3
	19	0.3
	n78	0.8
DC_1-19_n79	1	0.3
	19	0.3
DC_1-20_n3	1	0.3
	20	0.3
	n3	0.3
DC_1-20_n28	1	0.3
	20	0.6
	n28	0.6
DC_1-20_n78	1	0.3
	20	0.3
	n78	0.8
DC_1-21_n77	1	0.3
	21	0.3
	n77	0.8
DC_1-21_n78	1	0.6
	21	0.4
	n78	0.8
DC_1-21_n79	1	0.3
	21	0.3
DC_1-28_n3	1	0.3
	28	0.6
	n3	0.3

Inter-band EN-DC configuration	E-UTRA or NR Band	$\Delta T_{IB,c}$ (dB)
DC_1-28_n77	1	0.3
	28	0.6
	n77	0.8
DC_1-28_n78 DC_1_n28-n78	1	0.3
	28 or n28	0.6
	n78	0.8
DC_1_n28-n79	1	0.3
	n28	0.3
DC_1-41_n77	1	0.5
	41	0.5
	n77	0.8
DC_1-41_n78	1	0.5
	41	0.5
	n78	0.8
DC_1-41_n79	1	0.5
	41	0.5
DC_1-42_n77	1	0.6
	42	0.8
	n77	0.8
DC_1-42_n78	1	0.3
	42	0.8
	n78	0.8
DC_1-42_n79	1	0.3
	42	0.8
DC_1_n77-n79	1	0.6
	n77	0.8
DC_1_SUL_n78-n84	1	0.3
	n78	0.8
	n84	0.3
DC_1_n78-n79	1	0.3
	n78	0.8
	n79	0.5
DC_2-5_n66	2	0.5
	5	0.3
	n66	0.5
DC_2-14_n2	2	0.3
	14	0.3
	n2	0.3
DC_2-14_n66 DC_2-2-14_n66	2	0.5
	14	0.3
	n66	0.5
DC_2-30_n66	2	0.5
	30	0.3
	n66	0.5
DC_2-66_n5	2	0.5
	66	0.5
	n5	0.3
DC_2-66_n41	2	0.5
	66	0.5
	n41	0.8 ¹ 1.3 ²
DC_2-66_n71	2	0.5
	66	0.5
	n71	0.3
DC_2-(n)71	2	0.3
	71	0.3
	n71	
DC_3_n3-n77	3	0.6
	n3	0.6
	n77	0.8
DC_3_n3-n78	3	0.6
	n3	0.6
	n78	0.8

Inter-band EN-DC configuration	E-UTRA or NR Band	$\Delta T_{IB,c}$ (dB)
DC_3-5_n78	3	0.6
	5	0.6
	n78	0.8
DC_3-7_n28	3	0.5
	7	0.5
	n28	0.3
DC_3-7_n78, DC_3-7-7_n78	3	0.6
	7	0.6
	n78	0.8
DC_3-8_n78	3	0.6
	8	0.6
	n78	0.8
DC_3-19_n77	3	0.6
	19	0.3
	n77	0.8
DC_3-19_n78	3	0.6
	19	0.3
	n78	0.8
DC_3-19_n79	3	0.3
	19	0.3
DC_3-20_n1	3	0.3
	20	0.3
	n1	0.3
DC_3-20_n28	3	0.3
	20	0.5
	n28	0.5
DC_3-20_n78	3	0.5
	20	0.3
	n78	0.8
DC_3-21_n77	3	0.8
	21	0.9
	n77	0.8
DC_3-21_n78	3	0.8
	21	0.9
	n78	0.8
DC_3-21_n79	3	0.8
	21	0.9
DC_3-28_n78	3	0.5
	28	0.3
	n78	0.8
DC_3_n28-n78	3	0.5
	n28	0.3
	n78	0.8
DC_3-38_n78	3	0.6
	n78	0.8
DC_3-40_n1	3	0.5
	40	0.5
	n1	0.5
DC_3-41_n78	3	0.6
	41	0.3 ¹
	n78	0.8 ²
DC_3-42_n77	3	0.6
	42	0.8
	n77	0.8
DC_3-42_n78	3	0.6
	42	0.8
	n78	0.8
DC_3-42_n79	3	0.6
	42	0.8
DC_3_n77-n79	3	0.6
	n77	0.8
DC_3_n78-n79	3	0.6

Inter-band EN-DC configuration	E-UTRA or NR Band	$\Delta T_{IB,c}$ (dB)
	n78	0.8
	n79	0.5
DC_3_SUL_n78-n80	3	0.6
	n78	0.8
	n80	0.6
DC_3_SUL_n78-n82	3	0.5
	n78	0.8
	n82	0.3
DC_5-7_n78, DC_5-7-7_n78	5	0.6
	7	0.6
	n78	0.8
DC_5-30_n66	5	0.3
	30	0.3
	n66	0.5
DC_7-20_n28	7	0.3
	20	0.6
	n28	0.6
DC_7-20_n1	7	0.6
	20	0.3
	n1	0.5
DC_7-20_n3	7	0.5
	20	0.3
	n3	0.5
DC_7-20_n78	7	0.3
	20	0.3
	n78	0.8
DC_7-28_n3	7	0.5
	28	0.3
	n3	0.5
DC_7-28_n78	7	0.3
	28	0.3
	n78	0.8
DC_7_n28-n78	7	0.3
	n28	0.3
	n78	0.8
DC_7-46_n78	7	0.5
	n78	0.8
DC_8_SUL_n78- n81	8	0.6
	n78	0.8
	n81	0.6
DC_14-66_n2 DC_14-66-66_n2	14	0.3
	66	0.5
	n2	0.5
DC_14-66_n66	14	0.3
	66	0.3
	n66	0.3
DC_18-28_n77	18	0.5
	28	0.5
	n77	0.8
DC_18-28_n78	18	0.5
	28	0.5
	n78	0.8
DC_18-28_n79	18	0.5
	28	0.5
DC_19-21_n77	19	0.3
	21	0.4
	n77	0.8
DC_19-21_n78	19	0.3
	21	0.4
	n78	0.8
DC_19-21_n79	19	0.3
	21	0.4
DC_19-42_n77	19	0.3

Inter-band EN-DC configuration	E-UTRA or NR Band	$\Delta T_{IB,c}$ (dB)
	42	0.8
	n77	0.8
DC_19-42_n78	19	0.3
	42	0.8
	n78	0.8
DC_19-42_n79	19	0.3
	42	0.8
DC_19_n77-n79	19	0.3
	n77	0.8
DC_19_n78-n79	19	0.3
	n78	0.8
	n79	0.5
DC_20_n8-n75	20	0.4
	n8	0.4
DC_20_n28-n75	20	0.5
	n28	0.7
DC_20_n28-n78	20	0.6
	n28	0.6
	n78	0.8
DC_20_n75-n78	20	0.5
	n78	0.8
DC_20_n76-n78	20	0.5
	n78	0.8
DC_20_SUL_n78-n82	20	0.6
	n78	0.8
	n82	0.6
DC_20_SUL_n78-n83	20	0.8
	n78	0.8
	n83	0.8
DC_21-42_n77	21	0.4
	42	0.8
	n77	0.8
DC_21-42_n78	21	0.4
	42	0.8
	n78	0.8
DC_21-42_n79	21	0.4
	42	0.8
DC_21_n77-n79	21	0.4
	n77	0.8
DC_21_n78-n79	21	0.4
	n78	0.8
	n79	0.5
DC_28-42_n77	28	0.5
	42	0.8
	n77	0.8
DC_28-42_n78	28	0.5
	42	0.8
	n78	0.8
DC_28-42_n79	28	0.5
	42	0.8
DC_28_SUL_n78-n83	28	0.5
	n78	0.8
	n83	0.5
DC_41-42_n77	41	0.5
	42	0.8
	n77	0.8
DC_41-42_n78	41	0.5
	42	0.8
	n78	0.8
DC_41-42_n79	41	0.3
	42	0.8
DC_66_(n)71	66	0.3
	71	0.3

Inter-band EN-DC configuration	E-UTRA or NR Band	$\Delta T_{IB,c}$ (dB)
	n71	
	66	0.6
DC_66_SUL_n78-n86	n78	0.8
	n86	0.6
NOTE 1: The requirement is applied for UE transmitting on the frequency range of 2545-2690 MHz.		
NOTE 2: The requirement is applied for UE transmitting on the frequency range of 2496-2545 MHz.		

6.2B.4.2.3.3 $\Delta T_{IB,c}$ for EN-DC four bands

Table 6.2B.4.2.3.3-1: $\Delta T_{IB,c}$ due to EN-DC(four bands)

Inter-band EN-DC configuration	E-UTRA or NR Band	$\Delta T_{IB,c}$ (dB)
DC_1-3-5_n78	1	0.6
	3	0.6
	5	0.3
	n78	0.8
DC_1-3-7_n28	1	0.6
	3	0.6
	7	0.6
	n28	0.6
DC_1-3-7_n78 DC_1-3-7-7_n78	1	0.7
	3	0.7
	7	0.7
	n78	0.8
DC_1-3-8_n78	1	0.6
	3	0.6
	8	0.6
	n78	0.8
DC_1-3-19_n78	1	0.6
	3	0.6
	19	0.3
	n78	0.8
DC_1-3-19_n79	1	0.3
	3	0.3
	19	0.3
DC_1-3-20_n28	1	0.3
	3	0.3
	20	0.6
	n28	0.6
DC_1-3-20_n78	1	0.6
	3	0.6
	20	0.3
	n78	0.8
DC_1-3-21_n77	1	0.6
	3	0.8
	21	0.9
	n77	0.8
DC_1-3-21_n78	1	0.6
	3	0.8
	21	0.9
	n78	0.8
DC_1-3-21_n79	1	0.3
	3	0.8
	21	0.9
DC_1-3-28_n77	1	0.6
	3	0.6
	28	0.6
	n77	0.8
DC_1-3-28_n78 DC_1-3_n28-n78	1	0.6
	3	0.6
	28 or n28	0.6
	n78	0.8
DC_1-3-28_n79	1	0.6
	3	0.6
	28	0.6
DC_1-3-42_n77	1	0.6
	3	0.6
	42	0.8
	n77	0.8
DC_1-3-42_n78	1	0.6
	3	0.6
	42	0.8
	n78	0.8
DC_1-3-42_n79	1	0.6
	3	0.6

Inter-band EN-DC configuration	E-UTRA or NR Band	$\Delta T_{IB,c}$ (dB)
	42	0.8
	1	0.6
DC_1-5-7_n78	5	0.6
DC_1-5-7-7_n78	7	0.6
	n78	0.8
DC_1-7-20_n28	1	0.5
	7	0.6
	20	0.6
	n28	0.6
DC_1-7-20_n78	1	0.6
	7	0.7
	20	0.4
	n78	0.8
DC_1-7_n28-n78	1	0.6
	7	0.6
	n28	0.6
	n78	0.8
DC_1-18-28_n77	1	0.3
	18	0.5
	28	0.5
	n77	0.8
DC_1-18-28_n78	1	0.3
	18	0.5
	28	0.5
	n78	0.8
DC_1-18-28_n79	1	0.3
	18	0.5
	28	0.5
DC_1-19-42_n77	1	0.6
	19	0.3
	42	0.8
	n77	0.8
DC_1-19-42_n78	1	0.3
	19	0.3
	42	0.8
	n78	0.8
DC_1-19-42_n79	1	0.3
	19	0.3
	42	0.8
DC_1-20_n28-n78	1	0.3
	20	0.6
	n28	0.6
	n78	0.8
DC_1-21-28_n77	1	0.6
	21	0.4
	28	0.6
	n77	0.8
DC_1-21-28_n78	1	0.3
	21	0.4
	28	0.6
	n78	0.8
DC_1-21-28_n79	1	0.3
	21	0.4
	28	0.6
DC_1-21-42_n77	1	0.6
	21	0.4
	42	0.8
	n77	0.8
DC_1-21-42_n78	1	0.3
	21	0.4
	42	0.8
	n78	0.8
DC_1-21-42_n79	1	0.3

Inter-band EN-DC configuration	E-UTRA or NR Band	$\Delta T_{IB,c}$ (dB)
	21	0.4
	42	0.8
DC_1-28-42_n77	1	0.6
	28	0.6
	42	0.8
	n77	0.8
DC_1-28-42_n78	1	0.3
	28	0.6
	42	0.8
	n78	0.8
DC_1-28-42_n79	1	0.3
	28	0.6
	42	0.8
DC_1-41-42_n77	1	0.5
	41	0.5
	42	0.8
	n77	0.8
DC_1-41-42_n78	1	0.5
	41	0.5
	42	0.8
	n78	0.8
DC_1-41-42_n79	1	0.5
	41	0.5
	42	0.8
DC_2-7-13_n66 DC_2-7-7-13_n66	2	0.5
	7	0.5
	13	0.3
	n66	0.5
DC_2-7-66_n66 DC_2-7-7-66_n66	2	0.5
	7	0.5
	66	0.5
	n66	
DC_2-7-66_n78 DC_2-7-7-66_n78	2	0.6
	7	0.5
	66	0.6
	n78	0.8
DC_2-14-66_n2 DC_2-14-66-66_n2	2	0.5
	14	0.3
	66	0.5
	n2	0.5
DC_2-14-66_n66 DC_2-2-14-66_n66	2	0.5
	14	0.3
	66	0.5
	n66	0.5
DC_2-66-(n)71	2	0.5
	66	0.5
	71	0.3
	n71	
DC_3-5-7_n78 DC_3-5-7-7_n78	3	0.6
	5	0.6
	7	0.6
	n78	0.8
DC_3-7-20_n28	3	0.5
	7	0.5
	20	0.6
	n28	0.5
DC_3-7-20_n78	3	0.6
	7	0.6
	20	0.3
	n78	0.8
DC_3-7-28_n78	3	0.6
	7	0.6
	28	0.6

Inter-band EN-DC configuration	E-UTRA or NR Band	$\Delta T_{IB,c}$ (dB)
	n78	0.8
DC_3-7_n28-n78	3	0.6
	7	0.6
	n28	0.6
	n78	0.8
DC_3-19-21_n77	3	0.8
	19	0.3
	21	0.9
	n77	0.8
DC_3-19-21_n78	3	0.8
	19	0.3
	21	0.9
	n78	0.8
DC_3-19-21_n79	3	0.8
	19	0.3
	21	0.9
DC_3-19-42_n77	3	0.6
	19	0.3
	42	0.8
	n77	0.8
DC_3-19-42_n78	3	0.6
	19	0.3
	42	0.8
	n78	0.8
DC_3-19-42_n79	3	0.6
	19	0.3
	42	0.8
DC_3-20_n28-n78	3	0.6
	20	0.6
	n28	0.6
	n78	0.8
DC_3-21-42_n77	3	0.8
	21	0.9
	42	0.8
	n77	0.8
DC_3-21-42_n78	3	0.8
	21	0.9
	42	0.8
	n78	0.8
DC_3-21-42_n79	3	0.8
	21	0.9
	42	0.8
DC_3-28-42_n77	3	0.6
	28	0.5
	42	0.8
	n77	0.8
DC_3-28-42_n78	3	0.6
	28	0.5
	42	0.8
	n78	0.8
DC_3-28-42_n79	3	0.6
	28	0.5
	42	0.8
DC_7-20_n28-n78	7	0.3
	20	0.6
	n28	0.6
	n78	0.8
DC_19-21-42_n77	19	0.3
	21	0.4
	42	0.8
	n77	0.8
DC_19-21-42_n78	19	0.3
	21	0.4

Inter-band EN-DC configuration	E-UTRA or NR Band	$\Delta T_{IB,c}$ (dB)
	42	0.8
	n78	0.8
DC_19-21-42_n79	19	0.3
	21	0.4
	42	0.8
DC_21-28-42_n77	21	0.4
	28	0.5
	42	0.8
	n77	0.8
DC_21-28-42_n78	21	0.4
	28	0.5
	42	0.8
	n78	0.8
DC_21-28-42_n79	21	0.4
	28	0.5
	42	0.8

6.2B.4.2.3.4 $\Delta T_{IB,c}$ for EN-DC five bands

Table 6.2B.4.2.3.4-1: $\Delta T_{IB,c}$ due to EN-DC (five bands)

Inter-band EN-DC configuration	E-UTRA or NR Band	$\Delta T_{IB,c}$ (dB)
DC_1-3-5-7_n78, DC_1-3-5-7-7_n78	1	0.6
	3	0.6
	5	0.6
	7	0.6
	n78	0.8
DC_1-3-7-20_n28	1	0.6
	3	0.6
	7	0.6
	20	0.6
	n28	0.6
DC_1-3-7-20_n78	1	0.6
	3	0.6
	7	0.6
	20	0.6
	n78	0.6
DC_1-3-7_n28-n78	1	0.7
	3	0.7
	7	0.7
	n28	0.6
	n78	0.8
DC_1-3-19-21_n77	1	0.6
	3	0.8
	19	0.3
	21	0.9
	n77	0.8
DC_1-3-19-21_n78	1	0.6
	3	0.8
	19	0.3
	21	0.9
	n78	0.8
DC_1-3-19-21_n79	1	0.3
	3	0.8
	19	0.3
	21	0.9
DC_1-3-19-42_n77	1	0.6
	3	0.6
	19	0.3
	42	0.8
	n77	0.8
DC_1-3-19-42_n78	1	0.6
	3	0.6
	19	0.3
	42	0.8
	n78	0.8
DC_1-3-19-42_n79	1	0.6
	3	0.6
	19	0.3
	42	0.8
DC_1-3-20_n28-n78	1	0.6
	3	0.6
	20	0.6
	n28	0.6
	n78	0.8
DC_1-3-21-42_n77	1	0.6
	3	0.8
	21	0.9
	42	0.8
	n77	0.6

Inter-band EN-DC configuration	E-UTRA or NR Band	$\Delta T_{IB,c}$ (dB)
DC_1-3-21-42_n78	1	0.6
	3	0.8
	21	0.9
	42	0.8
	n78	0.6
DC_1-3-21-42_n79	1	0.6
	3	0.8
	21	0.9
	42	0.8
DC_1-3-28-42_n77	1	0.6
	3	0.6
	28	0.6
	42	0.8
	n77	0.8
DC_1-3-28-42_n78	1	0.6
	3	0.6
	28	0.6
	42	0.8
	n78	0.8
DC_1-3-28-42_n79	1	0.6
	3	0.6
	28	0.6
	42	0.8
DC_1-7-20_n28-n78	1	0.6
	7	0.7
	20	0.6
	n28	0.6
	n78	0.8
DC_1-19-21-42_n77	1	0.3
	19	0.3
	21	0.4
	42	0.8
	n77	0.8
DC_1-19-21-42_n78	1	0.3
	19	0.3
	21	0.4
	42	0.8
	n78	0.8
DC_1-19-21-42_n79	1	0.3
	19	0.3
	21	0.4
	42	0.8
DC_1-21-28-42_n77	1	0.6
	21	0.4
	28	0.6
	42	0.8
	n77	0.8
DC_1-21-28-42_n78	1	0.3
	21	0.4
	28	0.6
	42	0.8
	n78	0.8
DC_1-21-28-42_n79	1	0.3
	21	0.4
	28	0.6
	42	0.8
DC_3-7-20_n28-n78	3	0.6
	7	0.6

Inter-band EN-DC configuration	E-UTRA or NR Band	$\Delta T_{IB,c}$ (dB)
	20	0.6
	n28	0.6
	n78	0.8

6.2B.4.2.3.5 $\Delta T_{IB,c}$ for EN-DC six bands

Table 6.2B.4.2.3.5-1: $\Delta T_{IB,c}$ due to EN-DC (six bands)

Inter-band EN-DC configuration	E-UTRA or NR Band	$\Delta T_{IB,c}$ (dB)
DC_1-3-7-20_n28-n78	1	0.7
	3	0.7
	7	0.7
	20	0.6
	n28	0.6
	n78	0.8

6.2B.4.2.4 Inter-band EN-DC including FR2

6.2B.4.2.4.1 $\Delta T_{IB,c}$ for EN-DC two bands

Unless otherwise stated, $\Delta T_{IB,c}$ for E-UTRA and FR2 NR bands of inter-band EN-DC combinations defined in table 5.2B.5.1-1 is set to zero.

Table 6.2B.4.2.4.1-1: Void

6.2B.4.2.4.2 $\Delta T_{IB,c}$ for EN-DC three bands

Unless otherwise stated, $\Delta T_{IB,c}$ for FR2 NR bands is set to zero, and $\Delta T_{IB,c}$ for constituent E-UTRA bands for inter-band EN-DC defined in table 5.2B.5.2-1 is the same as those for the corresponding E-UTRA CA configuration specified in TS 36.101 [4], without the FR2 NR bands.

Table 6.2B.4.2.4.2-1: Void

6.2B.4.2.4.3 $\Delta T_{IB,c}$ for EN-DC four bands

Unless otherwise stated, $\Delta T_{IB,c}$ for FR2 NR bands is set to zero, and $\Delta T_{IB,c}$ for constituent E-UTRA bands for inter-band EN-DC defined in table 5.2B.5.3-1 is the same as those for the corresponding E-UTRA CA configuration specified in TS 36.101 [4], without the FR2 NR bands.

Table 6.2B.4.2.4.3-1: Void

6.2B.4.2.4.4 $\Delta T_{IB,c}$ for EN-DC five bands

Unless otherwise stated, $\Delta T_{IB,c}$ for FR2 NR bands is set to zero, and $\Delta T_{IB,c}$ for constituent E-UTRA bands for inter-band EN-DC defined in table 5.2B.5.4-1 is the same as those for the corresponding E-UTRA CA configuration specified in TS 36.101 [4], without the FR2 NR bands.

Table 6.2B.4.2.4.4-1: Void

6.2B.4.2.4.5	Void
6.2B.4.2.5	Inter-band EN-DC including both FR1 and FR2
6.2B.4.2.5.1	$\Delta T_{IB,c}$ for EN-DC three bands

Unless otherwise stated, for inter-band EN-DC configurations defined in table 5.2B.6.2-1, $\Delta T_{IB,c}$ for constituent FR2 NR bands is set to zero, and $\Delta T_{IB,c}$ for constituent E-UTRA and FR1 NR bands is the same as those for the corresponding inter band EN-DC configuration without the FR2 bands specified in 6.2B.4.2.3.

Table 6.2B.4.2.5.1-1: Void

6.2B.4.2.5.2	$\Delta T_{IB,c}$ for EN-DC four bands
--------------	--

Unless otherwise stated, for inter-band EN-DC configurations defined in table 5.2B.6.3-1, $\Delta T_{IB,c}$ for constituent FR2 NR bands is set to zero, and $\Delta T_{IB,c}$ for constituent E-UTRA and FR1 NR bands is the same as those for the corresponding inter band EN-DC configuration without the FR2 bands specified in 6.2B.4.2.3.

6.2B.4.2.5.3	$\Delta T_{IB,c}$ for EN-DC five bands
--------------	--

Unless otherwise stated, for inter-band EN-DC configurations defined in table 5.2B.6.4-1, $\Delta T_{IB,c}$ for constituent FR2 NR bands is set to zero, and $\Delta T_{IB,c}$ for constituent E-UTRA and FR1 NR bands is the same as those for the corresponding inter band EN-DC configuration without the FR2 bands specified in 6.2B.4.2.3.

6.2B.4.2.5.4	$\Delta T_{IB,c}$ for EN-DC six bands
--------------	---------------------------------------

Unless otherwise stated, for inter-band EN-DC configurations defined in table 5.2B.6.5-1, $\Delta T_{IB,c}$ for constituent FR2 NR bands is set to zero, and $\Delta T_{IB,c}$ for constituent E-UTRA and FR1 NR bands is the same as those for the corresponding inter band EN-DC configuration without the FR2 bands specified in 6.2B.4.2.3.

6.2B.5 Configured Output Power for NR-DC

6.2B.5.1 Configured Output power Level

6.2B.5.1.1 Configured Output Power Level for Inter-band NR-DC between FR1 and FR2

6.2B.5.1.1.1 Test purpose

Same test purpose as in clause 6.2.4.1 in TS 38.521-1 [8] for NR FR1 carrier and 6.2.4.1 in TS 38.521-2 [9] for NR FR2 carrier.

6.2B.5.1.1.2 Test applicability

The requirements in this test are not testable due to issues with combined testing of NR FR1 in conducted mode with NR FR2 in radiated mode. Therefore, the conducted and radiated requirements are tested separately.

No test case details are specified. The SA requirements for configured output power apply and are tested as part of the standalone NR within FR1 in clause 6.2.4 in TS 38.521-1 [8] and standalone NR within FR2 in clause 6.2.4 in TS 38.521-2 [9].

6.3 Output power dynamics

6.3A Output Power Dynamics for CA without EN-DC

6.3A.1 UE Output Power Dynamics for CA

6.3A.1.1 UE Output Power Dynamics for NR CA between FR 1 and FR 2 without EN-DC

6.3A.1.1.1 Test purpose

Same test purpose as in clause 6.3 in TS 38.521-1 [8] for NR FR1 carrier(s) and clause 6.3 in TS 38.521-2 [9] for NR FR2 carrier(s).

6.3A.1.1.2 Test applicability

The requirements in this test are not testable due to issues with combined testing of NR FR1 conducted mode with NR FR2 in radiated mode. Therefore, the conducted and radiated requirements are tested separately.

No test case details are specified. The SA requirements for maximum output power apply and are tested in TS 38.521-1 [8] clauses 6.3 and 6.2A and TS 38.521-2 [9] clauses 6.3 and 6.3A

6.3B Output power dynamics for DC

6.3B.1 Minimum Output Power for EN-DC

6.3B.1.1 Minimum Output Power for intra-band contiguous EN-DC

6.3B.1.1.1 Test purpose

Same test purpose as in clause 6.3.1.1 in TS 38.521-1 [8] for the NR carrier.

6.3B.1.1.2 Test applicability

This test applies to all types of E-UTRA UE release 15 and forward, supporting intra-band contiguous EN-DC.

6.3B.1.1.3 Minimum conformance requirements

Same minimum conformance requirements as in clause 6.3.1.3 in TS 38.521-1 [8] for the NR carrier.

Exception requirements for both NR and E-UTRA are defined for this test and therefore LTE anchor agnostic approach is not applied.

The normative reference for this requirement is TS 38.101-3 [4] clause 6.3.

6.3B.1.1.4 Test description

Same test descriptions as in clause 6.3.1.4 in TS 38.521-1 [8] for the NR carrier with the following exceptions:

Table 6.3B.1.1.4-1: Test configuration table

E-UTRA Test Parameters					
E-UTRA Channel Bandwidth	E-UTRA Test Frequency	Downlink		Uplink	
		N/A for min output power test		Modulation	RB allocation
5 MHz	MidRange			QPSK	25
NOTE 1: E-UTRA Test Frequency as specified in TS 36.508 [11] clause 4.3.1.					

For Initial conditions as in clause 6.3.1.4.1 in TS 38.521-1 [8], the following steps will be added to configure E-UTRA component:

- 2.1. The parameter settings for the E-UTRA cell are set up according to TS 36.508 [11] clause 4.4.3 with E-UTRA channel bandwidth and test frequencies defined in Table 6.3B.1.1.4-1.
- 3.1. Downlink signals are initially set up according to TS 36.521-1 [10] Annex C.0, C.1 and C.3.0, and uplink signals according to Annex H.1 and H.3.0.
- 4.1. The UL Reference Measurement channels are set according to Table 6.3B.1.1.4-1.

Step 6 of Initial conditions as in clause 6.3.1.4.1 in TS 38.521-1 [8] is replaced by:

6. Ensure the UE is in state RRC_CONNECTED with generic procedure parameters Connectivity EN-DC, DC bearer *MCG* and *SCG*, Connected without release *On* according to TS 38.508-1 [6] clause 4.5.

Same test procedure as in clause 6.3.1.4.2 in TS 38.521-1 [8] with the following steps added for E-UTRA component:

- 1.1. For E-UTRA component, SS sends uplink scheduling information for each UL HARQ process via PDCCH DCI format 0 for C_RNTI to schedule the UL RMC according to table 6.3B.1.1.4-1. Since the UE has no payload and no loopback data to send the UE sends uplink MAC padding bits on the UL RMC.
- 2.1. For E-UTRA component, send continuously uplink power control "down" commands in every uplink scheduling information to the UE.

6.3B.1.1.5 Test requirements

Same test requirement as in clause 6.3.1.5 in TS 38.521-1 [8] for the NR carrier.

6.3B.1.2 Minimum output power for intra-band non-contiguous EN-DC

6.3B.1.2.1 Test purpose

Same test purpose as in clause 6.3.1.1 in TS 38.521-1 [8] for the NR carrier.

6.3B.1.2.2 Test applicability

This test applies to all types of E-UTRA UE release 15 and forward, supporting intra-band non-contiguous EN-DC.

6.3B.1.2.3 Minimum conformance requirements

Same minimum conformance requirements as in clause 6.3.1.3 in TS 38.521-1 [8] for the NR carrier.

No exception requirements applicable to NR or LTE. LTE anchor agnostic approach is applied.

The normative reference for this requirement is TS 38.101-1 [2] clause 6.3.

6.3B.1.2.4 Test description

Same test descriptions as in clause 6.3.1.4 in TS 38.521-1 [8] for the NR carrier with the following exceptions:

Table 6.3B.1.2.4-1: Test Configuration Table

Initial Conditions	
Test Frequencies as specified in TS 38.508-1 [6] clause 4.3.1 for different EN-DC bandwidth classes	Low with maxWGap, High with maxWGap
Test EN-DC bandwidth combination as specified in Table 5.3B.1.2-1 across bandwidth combination sets supported by the UE	Lowest N_{RB_agg} , Highest N_{RB_agg} (NOTE1)
NOTE 1: If the UE supports multiple CC Combinations in the EN-DC Configuration with the same N_{RB_agg} , only the combination with the lowest N_{RB_SCG} and highest N_{RB_SCG} are tested for Lowest N_{RB_agg} , and Highest N_{RB_agg} , respectively.	

The initial test configurations for E-UTRA as specified in Table 4.6-1 except for the parameters specified in Table 6.3B.1.2.4-1.

For Initial conditions as in clause 6.3.1.4.1 in TS 38.521-1 [8], the following steps will be added to configure E-UTRA component:

- 2.1. The parameter settings for the E-UTRA cell are set up according to TS 36.508 [11] clause 4.4.3 with E-UTRA channel bandwidth and test frequencies defined in Table 6.3B.1.2.4-1.
- 3.1. Downlink signals are initially set up according to TS 36.521-1 [10] Annex C, clauses C.0, C.1 and C.3.0, and uplink signals according to Annex H, clauses H.1 and H.3.0.
- 4.1. The UL Reference Measurement channels are set according to Table 6.3B.1.2.4-1.

Step 6 of Initial conditions as in clause 6.3.1.4.1 in TS 38.521-1 [8] is replaced by:

6. Ensure the UE is in state RRC_CONNECTED with generic procedure parameters Connectivity EN-DC, DC bearer MCG and SCG, Connected without release On according to TS 38.508-1 [6] clause 4.5.

6.3B.1.2.5 Test requirements

Same test requirement as in clause 6.3.1.5 in TS 38.521-1 [8] for the NR carrier.

6.3B.1.3 Minimum output power for inter-band EN-DC within FR1

6.3B.1.3.1 Test purpose

Same test purpose as in clause 6.3.1.1 in TS 38.521-1 [8] for the NR carrier.

6.3B.1.3.2 Test applicability

This test case applies to all types of E-UTRA UE release 15 and forward, supporting inter-band EN-DC.

6.3B.1.3.3 Minimum conformance requirements

Same minimum conformance requirements as in clause 6.3.1.3 in TS 38.521-1 [8] for the NR carrier.

No exception requirements applicable to NR or LTE. LTE anchor agnostic approach is applied.

The normative reference for this requirement is TS 38.101-3 [4] clause 6.3.

6.3B.1.3.4 Test description

Same test descriptions as in clause 6.3.1.4 in TS 38.521-1 [8] for the NR carrier with the following exceptions:

The initial test configurations for E-UTRA band consist of environmental conditions, test frequencies, and channel bandwidths based on E-UTRA bands specified in Table 4.6-1. For Initial conditions as in clause 6.3.1.4.1 in TS 38.521-1 [8], the following steps will be added to configure E-UTRA component:

- 2.1. The parameter settings for E-UTRA cell are set up according to TS 36.508 [11] clause 4.4.3.

- 3.1. The E-UTRA downlink signal level, uplink signal level are set according to Table 4.6-1 and propagation conditions are set according to Annex B.0 of TS 36.521-1 [10].

Step 6 of Initial conditions as in clause 6.3.1.4.1 in TS 38.521-1 [8] is replaced by:

6. Ensure the UE is in state RRC_CONNECTED with generic procedure parameters Connectivity EN-DC, DC bearer MCG and SCG, Connected without release *On* according to TS 38.508-1 [6] clause 4.5.

6.3B.1.3.5 Test requirements

Same test requirement as in clause 6.3.1.5 in TS 38.521-1 [8] for the NR carrier.

6.3B.1.4 Minimum Output Power for EN-DC Interband including FR2

Editor's note: The following aspects of the clause are for future consideration:

- Testing of extreme conditions for FR2 is FFS.

6.3B.1.4.1 Test purpose

Same test purpose as in clause 6.3.1.1 in TS 38.521-2 [9] for the NR carrier.

6.3B.1.4.2 Test applicability

This test case applies to all types of E-UTRA UE release 15 and forward, supporting inter-band EN-DC including FR2.

6.3B.1.4.3 Minimum conformance requirements

Same minimum conformance requirements as in clause 6.3.1.3 in TS 38.521-2 [9] for the NR carrier.

No exception requirements applicable to NR or LTE. LTE anchor agnostic approach is applied.

The normative reference for this requirement is TS 38.101-3 [4] clause 6.3B.1.

6.3B.1.4.4 Test description

Same test description as in clause 6.3.1.4 in TS 38.521-2 [9] for the NR carrier with the following exception:

The initial test configurations for E-UTRA band consist of environmental conditions, test frequencies, and channel bandwidths based on E-UTRA bands specified in Table 4.7-1.

For initial conditions as in clause 6.3.1.4.1 in TS 38.521-2 [9], the following steps will be added to configure E-UTRA component:

- 2.1. The parameter settings for E-UTRA cell are set up according to TS 36.508 [11] clause 4.4.3.
- 3.1. The E-UTRA downlink signal level, uplink signal level are set according to Table 4.7-1 and propagation conditions are set according to Annex B.0 of TS 36.521-1 [10].

Step 6 of initial conditions as in clause 6.3.1.4.1 in TS 38.521-2 [9] is replaced by:

6. Ensure the UE is in state RRC_CONNECTED with generic procedure parameters Connectivity EN-DC, DC bearer MCG and SCG, Connected without release *On* according to TS 38.508-1 [6] clause 4.5.

Same test procedure as in clause 6.3.1.4.2 in TS 38.521-2 [9] with the following steps added for E-UTRA component:

- 1.1 On the E-UTRA carrier, disable periodic and aperiodic CQI reports, disable SRS, set *TimeAlignmentTimerDedicated* IE to infinity and disable downlink and uplink scheduling, all as per Table 4.7-1 under clause 4.7.

6.3B.1.4.5 Test requirements

Same test requirement as in clause 6.3.1.5 in TS 38.521-2 [9] for the NR carrier.

6.3B.1.4_1 Minimum output power for inter-band EN-DC including FR2 (>2 CCs)

6.3B.1.4_1.1 Minimum output power for inter-band EN-DC including FR2 (3 CCs)

Editor's note: This clause is incomplete. The following aspects are either missing or not yet determined:

- The referred test case 6.3A.1.1 in TS 38.521-2 [9] is incomplete.

6.3B.1.4_1.1.1 Test purpose

Same test purpose as in clause 6.3.1.1 in TS 38.521-2 [9] for the NR carrier.

6.3B.1.4_1.1.2 Test applicability

This test case applies to all types of E-UTRA UE release 15 and forward, supporting inter-band EN-DC including FR2 with 3 UL CCs (2NR UL CCs).

6.3B.1.4_1.1.3 Minimum conformance requirements

Same minimum conformance requirements as in clause 6.3.1.3 in TS 38.521-2 [9] for the NR carrier.

No exception requirements applicable to NR or LTE. LTE anchor agnostic approach is applied.

The normative reference for this requirement is TS 38.101-3 [4] clause 6.3B.

6.3B.1.4_1.1.4 Test description

6.3B.1.4_1.1.4.1 Initial condition

Same test description as in clause 6.3A.1.1.4 in TS 38.521-2 [9] for the NR carrier with the following exception:

The initial test configurations for E-UTRA band consist of environmental conditions, test frequencies, and channel bandwidths based on E-UTRA bands specified in Table 4.7-1.

For Initial conditions as in clause 6.3A.1.1.4.1 in TS 38.521-2 [9], the following steps will be added to configure E-UTRA component:

- 2.1. The parameter settings for E-UTRA cell are set up according to TS 36.508 [11] clause 4.4.3.
- 3.1. The E-UTRA downlink signal level, uplink signal level are set according to Table 4.7-1 and propagation conditions are set according to Annex B.0 of TS 36.521-1 [10].

Step 6 of Initial conditions as in clause 6.3A.1.1.4.1 in TS 38.521-2 [9] is replaced by:

6. Ensure the UE is in state RRC_CONNECTED with generic procedure parameters Connectivity EN-DC, DC bearer MCG and SCG, Connected without release On according to TS 38.508-1 [6] clause 4.5.

Same test procedure as in clause 6.3A.1.1.4.2 in TS 38.521-2 [9] with the following steps added for E-UTRA component:

- 1.1 On the E-UTRA carrier, disable periodic and aperiodic CQI reports, disable SRS, set *TimeAlignmentTimerDedicated* IE to infinity and disable downlink and uplink scheduling, all as per Table 4.7-1 under clause 4.7.

6.3B.1.4_1.1.5 Test Requirements

Same test requirement as in clause 6.3A.1.1.5 in TS 38.521-2 [9] for the NR carrier.

6.3B.1.4_1.2 Minimum output power for inter-band EN-DC including FR2 (4 CCs)

Editor's note: This clause is incomplete. The following aspects are either missing or not yet determined:

- The referred test case 6.3A.1.2 in TS 38.521-2 [9] is incomplete.

6.3B.1.4_1.2.1 Test purpose

Same test purpose as in clause 6.3.1.1 in TS 38.521-2 [9] for the NR carrier.

6.3B.1.4_1.2.2 Test applicability

This test case applies to all types of E-UTRA UE release 15 and forward, supporting inter-band EN-DC including FR2 with 4 UL CCs (3NR UL CCs).

6.3B.1.4_1.2.3 Minimum conformance requirements

Same minimum conformance requirements as in clause 6.3.1.3 in TS 38.521-2 [9] for the NR carrier.

No exception requirements applicable to NR or LTE. LTE anchor agnostic approach is applied.

The normative reference for this requirement is TS 38.101-3 [4] clause 6.3B.

6.3B.1.4_1.2.4 Test description

6.3B.1.4_1.2.4.1 Initial condition

Same test description as in clause 6.3A.1.2.4 in TS 38.521-2 [9] for the NR carrier with the following exception:

The initial test configurations for E-UTRA band consist of environmental conditions, test frequencies, and channel bandwidths based on E-UTRA bands specified in Table 4.7-1.

For Initial conditions as in clause 6.3A.1.2.4.1 in TS 38.521-2 [9], the following steps will be added to configure E-UTRA component:

- 2.1. The parameter settings for E-UTRA cell are set up according to TS 36.508 [11] clause 4.4.3.
- 3.1. The E-UTRA downlink signal level, uplink signal level are set according to Table 4.7-1 and propagation conditions are set according to Annex B.0 of TS 36.521-1 [10].

Step 6 of Initial conditions as in clause 6.3A.1.2.4.1 in TS 38.521-2 [9] is replaced by:

6. Ensure the UE is in state RRC_CONNECTED with generic procedure parameters Connectivity EN-DC, DC bearer MCG and SCG, Connected without release On according to TS 38.508-1 [6] clause 4.5.

Same test procedure as in clause 6.3A.1.2.4.2 in TS 38.521-2 [9] with the following steps added for E-UTRA component:

- 1.1 On the E-UTRA carrier, disable periodic and aperiodic CQI reports, disable SRS, set *TimeAlignmentTimerDedicated* IE to infinity and disable downlink and uplink scheduling, all as per Table 4.7-1 under clause 4.7.

6.3B.1.4_1.2.5 Test Requirements

Same test requirement as in clause 6.3A.1.2.5 in TS 38.521-2 [9] for the NR carrier.

6.3B.1.4_1.3 Minimum output power for inter-band EN-DC including FR2 (5 CCs)

Editor's note: This clause is incomplete. The following aspects are either missing or not yet determined:

- **The referred test case 6.3A.1.3 in TS 38.521-2 [9] is incomplete.**

6.3B.1.4_1.3.1 Test purpose

Same test purpose as in clause 6.3.1.1 in TS 38.521-2 [9] for the NR carrier.

6.3B.1.4_1.3.2 Test applicability

This test case applies to all types of E-UTRA UE release 15 and forward, supporting inter-band EN-DC including FR2 with 5 UL CCs (4NR UL CCs).

6.3B.1.4_1.3.3 Minimum conformance requirements

Same minimum conformance requirements as in clause 6.3.1.3 in TS 38.521-2 [9] for the NR carrier.

No exception requirements applicable to NR or LTE. LTE anchor agnostic approach is applied.

The normative reference for this requirement is TS 38.101-3 [4] clause 6.3B.

6.3B.1.4_1.3.4 Test description

6.3B.1.4_1.3.4.1 Initial condition

Same test description as in clause 6.3A.1.3.4 in TS 38.521-2 [9] for the NR carrier with the following exception:

The initial test configurations for E-UTRA band consist of environmental conditions, test frequencies, and channel bandwidths based on E-UTRA bands specified in Table 4.7-1.

For Initial conditions as in clause 6.3A.1.3.4.1 in TS 38.521-2 [9], the following steps will be added to configure E-UTRA component:

- 2.1. The parameter settings for E-UTRA cell are set up according to TS 36.508 [11] clause 4.4.3.
- 3.1. The E-UTRA downlink signal level, uplink signal level are set according to Table 4.7-1 and propagation conditions are set according to Annex B.0 of TS 36.521-1 [10].

Step 6 of Initial conditions as in clause 6.3A.1.3.4.1 in TS 38.521-2 [9] is replaced by:

6. Ensure the UE is in state RRC_CONNECTED with generic procedure parameters Connectivity EN-DC, DC bearer MCG and SCG, Connected without release On according to TS 38.508-1 [6] clause 4.5.

Same test procedure as in clause 6.3A.1.3.4.2 in TS 38.521-2 [9] with the following steps added for E-UTRA component:

- 1.1 On the E-UTRA carrier, disable periodic and aperiodic CQI reports, disable SRS, set *TimeAlignmentTimerDedicated* IE to infinity and disable downlink and uplink scheduling, all as per Table 4.7-1 under clause 4.7.

6.3B.1.4_1.3.5 Test Requirements

Same test requirement as in clause 6.3A.1.3.5 in TS 38.521-2 [9] for the NR carrier.

6.3B.1.4D Minimum output power for inter-band EN-DC including FR2 for UL-MIMO

Editor's note: This clause is incomplete. The following aspects are either missing or not yet determined:

- The referred test case 6.3D.1 in TS 38.521-2 [9] is incomplete

6.3B.1.4D.1 Test purpose

Same test purpose as in clause 6.3D.1.1 in TS 38.521-2 [9] for the NR carrier.

6.3B.1.4D.2 Test applicability

This test case applies to all types of E-UTRA UE release 15 and forward, supporting inter-band EN-DC FR2.

6.3B.1.4D.3 Minimum conformance requirements

Same minimum conformance requirements as in clause 6.3D.1.3 in TS 38.521-2 [9] for the NR carrier.

No exception requirements applicable to NR or LTE. LTE anchor agnostic approach is applied.

The normative reference for this measurement is TS 38.101-3 [4] clause 6.3B.

6.3B.1.4D.4 Test Description

Same test description as in clause 6.3D.1.4 in TS 38.521-2 [9] for the NR carrier with the following exceptions:

The initial test configurations for E-UTRA consist of test frequency based on E-UTRA operating band and test channel bandwidth as specified in Table 4.7-1.

For Initial conditions as in clause 6.3D.1.4.1 in TS 38.521-2 [9], the following steps will be added to configure E-UTRA component:

- 2.1. The parameter settings for the cell are set up according to TS 36.508 [11] subclause 4.4.3.
- 3.1. The E-UTRA downlink signal level, uplink signal level are set according to Table 4.7-1 and propagation conditions are set according to Annex B.0 of TS 36.521-1 [10].

Step 6 of Initial conditions as in clause 6.3D.1.4.1 in TS 38.521-2 [9] is replaced by:

6. Ensure the UE is in state RRC_CONNECTED with generic procedure parameters Connectivity EN-DC, DC bearer MCG and SCG, Connected without release *On* according to TS 38.508-1 [6] clause 4.5.

Same Test procedure as in clause 6.3D.1.4.2 in TS 38.521-2 [9] with the following steps added for E-UTRA component:

- 1.1. On the E-UTRA carrier, disable periodic and aperiodic CQI reports, disable SRS, set TimeAlignmentTimerDedicated IE to infinity and disable downlink and uplink scheduling, all as per Table 4.7-1 under clause 4.7.

6.3B.1.4D.5 Test Requirement

Same test requirement as specified in TS 38.521-2 [9] clause 6.3D.1.5 for the NR carrier(s).

6.3B.2 Transmit OFF Power for EN-DC

6.3B.2.1 Transmit OFF Power for intra-band contiguous EN-DC

6.3B.2.1.1 Test purpose

Same test purpose as in clause 6.3.2.1 in TS 38.521-1 [8] for the NR carrier.

6.3B.2.1.2 Test applicability

The requirements of this test apply in Clause 6.3B.3 Tx ON/OFF time mask/PUCCH time mask to all types of E-UTRA UE release 15 and forward, supporting intra-band contiguous EN-DC.

6.3B.2.1.3 Minimum conformance requirements

Same minimum conformance requirements as in clause 6.3.2.3 in TS 38.521-1 [8] for the NR carrier.

The normative reference for this requirement is TS 38.101-3 [4] clause 6.3.

6.3B.2.1.4 Test description

This test is covered by Clause 6.3B.3 Tx ON/OFF time mask/PUCCH time mask for EN-DC.

6.3B.2.1.5 Test requirements

Same test requirement as in clause 6.3.2.5 in TS 38.521-1 [8] for the NR carrier.

6.3B.2.2 Transmit OFF Power for intra-band non-contiguous EN-DC

6.3B.2.2.1 Test purpose

Same test purpose as in clause 6.3.2.1 in TS 38.521-1 [8] for the NR carrier.

6.3B.2.2.2 Test applicability

The requirements of this test apply in clause 6.3B.3 Tx ON/OFF time mask/PUCCH time mask to all types of E-UTRA UE Release 15 and forward, supporting intra-band non-contiguous EN-DC.

6.3B.2.2.3 Minimum conformance requirements

Same minimum conformance requirements as in clause 6.3.2.3 in TS 38.521-1 [8] for the NR carrier.

The normative reference for this requirement is TS 38.101-3 [4] clause 6.3.

6.3B.2.2.4 Test description

This test is covered by Clause 6.3B.3 Tx ON/OFF time mask/PUCCH time mask for EN-DC.

6.3B.2.2.5 Test requirements

Same test requirement as in clause 6.3.2.5 in TS 38.521-1 [8] for the NR carrier.

6.3B.2.3 Transmit OFF Power for inter-band EN-DC within FR1

6.3B.2.3.1 Test purpose

Same test purpose as in clause 6.3.2.1 in TS 38.521-1 [8] for the NR carrier.

6.3B.2.3.2 Test applicability

The requirements of this test apply in Clause 6.3B.3 Tx ON/OFF time mask/PUCCH time mask to all types of E-UTRA UE release 15 and forward, supporting inter-band EN-DC.

6.3B.2.3.3 Minimum conformance requirements

Same minimum conformance requirements as in clause 6.3.2.3 in TS 38.521-1 [8] for the NR carrier.

No exception requirements applicable to NR or LTE. LTE anchor agnostic approach is applied.

The normative reference for this requirement is TS 38.101-3 [4] clause 6.3.

6.3B.2.3.4 Test description

This test is covered by Clause 6.3B.3 Tx ON/OFF time mask/PUCCH time mask for EN-DC.

6.3B.2.3.5 Test requirements

Same test requirement as in clause 6.3.2.5 in TS 38.521-1 [8] for the NR carrier.

6.3B.2.4 Transmit OFF Power for inter-band EN-DC including FR2

Editor's note: This test case is complete for Band n257. Following aspects are either missing or not yet determined:

- The referred test case 6.3.2 in TS 38.521-2 [9] is incomplete for other than band n257.

6.3B.2.4.1 Test purpose

Same test purpose as in clause 6.3.2.1 in TS 38.521-2 [9] for the NR carrier.

6.3B.2.4.2 Test applicability

This test case applies to all types of E-UTRA UE release 15 and forward, supporting inter-band EN-DC including FR2 with 2CCs.

6.3B.2.4.3 Minimum conformance requirements

Same minimum conformance requirements as in clause 6.3.2.3 in TS 38.521-2 [9] for the NR carrier.

No exception requirements applicable to NR or LTE. LTE anchor agnostic approach is applied.

The normative reference for this requirement is TS 38.101-3 [4] clause 6.3.

6.3B.2.4.4 Test description

Same test description as in clause 6.3.2.4 in TS 38.521-2 [9] for the NR carrier with the following exception:

The initial test configurations for E-UTRA band consist of environmental conditions, test frequencies, and channel bandwidths based on E-UTRA bands specified in Table 4.7-1.

For Initial conditions as in clause 6.3.2.4.1 in TS 38.521-2 [9], the following steps will be added to configure E-UTRA component:

- 2.1. The parameter settings for E-UTRA cell are set up according to TS 36.508 [11] clause 4.4.3.
- 3.1. The E-UTRA downlink signal level, uplink signal level are set according to Table 4.7-1 and propagation conditions are set according to Annex B.0 of TS 36.521-1 [10].

Step 6 of Initial conditions as in clause 6.3.2.4.1 in TS 38.521-2 [9] is replaced by:

6. Ensure the UE is in state RRC_CONNECTED with generic procedure parameters Connectivity EN-DC, DC bearer MCG and SCG, Connected without release On according to TS 38.508-1 [6] clause 4.5.

Same test procedure as in clause 6.3.2.4.2 in TS 38.521-2 [9] with the following steps added for E-UTRA component:

- 1.1 On the E-UTRA carrier, disable periodic and aperiodic CQI reports, disable SRS, set *TimeAlignmentTimerDedicated* IE to infinity and disable downlink and uplink scheduling, all as per Table 4.7-1 under clause 4.7.

6.3B.2.4.5 Test requirements

Same test requirement as in clause 6.3.2.5 in TS 38.521-2 [8] for the NR carrier.

6.3B.2.4_1 Transmit OFF Power for Inter-band EN-DC including FR2 (>2 CCs)

6.3B.2.4_1.1 Transmit OFF Power for Inter-band EN-DC including FR2 (3 CCs)

Editor's note: The following aspects are either missing or not yet determined in the referred test case 6.3A.2.1 in TS 38.521-2 [9]:

- For PC3, The testability of this test case is pending further analysis on relaxation of the requirement for other than Band n257.
- For PC3, Measurement Uncertainties and Test Tolerances for intra-band contiguous CA supporting aggregated BW > 400MHz is TBD.
- Measurement Uncertainties, Test Tolerances and testability limit analysis is TBD for PC1/2/4.

6.3B.2.4_1.1.1 Test purpose

Same test purpose as in clause 6.3.2.1 in TS 38.521-2 [9] for the NR carrier.

6.3B.2.4_1.1.2 Test applicability

This test case applies to all types of E-UTRA UE release 15 and forward, supporting inter-band EN-DC including FR2 with 3 UL CCs (2NR UL CCs).

6.3B.2.4_1.1.3 Minimum conformance requirements

Same minimum conformance requirements as in clause 6.3.2.3 in TS 38.521-2 [9] for the NR carrier.

No exception requirements applicable to NR or LTE. LTE anchor agnostic approach is applied.

The normative reference for this requirement is TS 38.101-3 [4] clause 6.3.

6.3B.2.4_1.1.4 Test description

6.3B.2.4_1.1.4.1 Initial condition

Same test description as in clause 6.3A.2.1.4 in TS 38.521-2 [9] for the NR carrier with the following exception:

The initial test configurations for E-UTRA band consist of environmental conditions, test frequencies, and channel bandwidths based on E-UTRA bands specified in Table 4.7-1.

For Initial conditions as in clause 6.3A.2.1.4.1 in TS 38.521-2 [9], the following steps will be added to configure E-UTRA component:

- 2.1. The parameter settings for E-UTRA cell are set up according to TS 36.508 [11] clause 4.4.3.
- 3.1. The E-UTRA downlink signal level, uplink signal level are set according to Table 4.7-1 and propagation conditions are set according to Annex B.0 of TS 36.521-1 [10].

Step 6 of Initial conditions as in clause 6.3A.2.1.4.1 in TS 38.521-2 [9] is replaced by:

6. Ensure the UE is in state RRC_CONNECTED with generic procedure parameters Connectivity EN-DC, DC bearer MCG and SCG, Connected without release On according to TS 38.508-1 [6] clause 4.5.

Same test procedure as in clause 6.3A.2.1.4.2 in TS 38.521-2 [9] with the following steps added for E-UTRA component:

- 1.1 On the E-UTRA carrier, disable periodic and aperiodic CQI reports, disable SRS, set *TimeAlignmentTimerDedicated* IE to infinity and disable downlink and uplink scheduling, all as per Table 4.7-1 under clause 4.7.

6.3B.2.4_1.1.5 Test Requirements

Same test requirement as in clause 6.3A.2.1.5 in TS 38.521-2 [9] for the NR carrier.

6.3B.2.4_1.2 Transmit OFF Power for Inter-band EN-DC including FR2 (4 CCs)

Editor's note: The following aspects are either missing or not yet determined in the referred test case 6.3A.2.1 in TS 38.521-2 [9]:

- For PC3, The testability of this test case is pending further analysis on relaxation of the requirement for other than Band n257.
- For PC3, Measurement Uncertainties and Test Tolerances for intra-band contiguous CA supporting aggregated BW > 400MHz is TBD.
- Measurement Uncertainties, Test Tolerances and testability limit analysis is TBD for PC1/2/4.

6.3B.2.4_1.2.1 Test purpose

Same test purpose as in clause 6.3.2.1 in TS 38.521-2 [9] for the NR carrier.

6.3B.2.4_1.2.2 Test applicability

This test case applies to all types of E-UTRA UE release 15 and forward, supporting inter-band EN-DC including FR2 with 4 UL CCs (3NR UL CCs).

6.3B.2.4_1.2.3 Minimum conformance requirements

Same minimum conformance requirements as in clause 6.3.2.3 in TS 38.521-2 [9] for the NR carrier.

No exception requirements applicable to NR or LTE. LTE anchor agnostic approach is applied.

The normative reference for this requirement is TS 38.101-3 [4] clause 6.3.

6.3B.2.4_1.2.4 Test description

6.3B.2.4_1.2.4.1 Initial condition

Same test description as in clause 6.3A.2.2.4 in TS 38.521-2 [9] for the NR carrier with the following exception:

The initial test configurations for E-UTRA band consist of environmental conditions, test frequencies, and channel bandwidths based on E-UTRA bands specified in Table 4.7-1.

For Initial conditions as in clause 6.3A.2.2.4.1 in TS 38.521-2 [9], the following steps will be added to configure E-UTRA component:

- 2.1. The parameter settings for E-UTRA cell are set up according to TS 36.508 [11] clause 4.4.3.
- 3.1. The E-UTRA downlink signal level, uplink signal level are set according to Table 4.7-1 and propagation conditions are set according to Annex B.0 of TS 36.521-1 [10].

Step 6 of Initial conditions as in clause 6.3A.2.2.4.1 in TS 38.521-2 [9] is replaced by:

6. Ensure the UE is in state RRC_CONNECTED with generic procedure parameters Connectivity EN-DC, DC bearer MCG and SCG, Connected without release On according to TS 38.508-1 [6] clause 4.5.

Same test procedure as in clause 6.3A.2.2.4.2 in TS 38.521-2 [9] with the following steps added for E-UTRA component:

- 1.1 On the E-UTRA carrier, disable periodic and aperiodic CQI reports, disable SRS, set *TimeAlignmentTimerDedicated* IE to infinity and disable downlink and uplink scheduling, all as per Table 4.7-1 under clause 4.7.

6.3B.2.4_1.2.5 Test Requirements

Same test requirement as in clause 6.3A.2.2.5 in TS 38.521-2 [9] for the NR carrier.

6.3B.2.4_1.3 Transmit OFF Power for Inter-band EN-DC including FR2 (5 CCs)

Editor's note: The following aspects are either missing or not yet determined in the referred test case 6.3A.2.1 in TS 38.521-2 [9]

- **For PC3, The testability of this test case is pending further analysis on relaxation of the requirement for other than Band n257.**
- **For PC3, Measurement Uncertainties and Test Tolerances for intra-band contiguous CA supporting aggregated BW > 400MHz is TBD.**
- **Measurement Uncertainties, Test Tolerances and testability limit analysis is TBD for PC1/2/4.**

6.3B.2.4_1.3.1 Test purpose

Same test purpose as in clause 6.3.2.1 in TS 38.521-2 [9] for the NR carrier.

6.3B.2.4_1.3.2 Test applicability

This test case applies to all types of E-UTRA UE release 15 and forward, supporting inter-band EN-DC including FR2 with 5 UL CCs (4NR UL CCs).

6.3B.2.4_1.3.3 Minimum conformance requirements

Same minimum conformance requirements as in clause 6.3.2.3 in TS 38.521-2 [9] for the NR carrier.

No exception requirements applicable to NR or LTE. LTE anchor agnostic approach is applied.

The normative reference for this requirement is TS 38.101-3 [4] clause 6.3.

6.3B.2.4_1.3.4 Test description

6.3B.2.4_1.3.4.1 Initial condition

Same test description as in clause 6.3A.2.3.4 in TS 38.521-2 [9] for the NR carrier with the following exception:

The initial test configurations for E-UTRA band consist of environmental conditions, test frequencies, and channel bandwidths based on E-UTRA bands specified in Table 4.7-1.

For Initial conditions as in clause 6.3A.2.3.4.1 in TS 38.521-2 [9], the following steps will be added to configure E-UTRA component:

- 2.1. The parameter settings for E-UTRA cell are set up according to TS 36.508 [11] clause 4.4.3.
- 3.1. The E-UTRA downlink signal level, uplink signal level are set according to Table 4.7-1 and propagation conditions are set according to Annex B.0 of TS 36.521-1 [10].

Step 6 of Initial conditions as in clause 6.3A.2.3.4.1 in TS 38.521-2 [9] is replaced by:

6. Ensure the UE is in state RRC_CONNECTED with generic procedure parameters Connectivity EN-DC, DC bearer MCG and SCG, Connected without release On according to TS 38.508-1 [6] clause 4.5.

Same test procedure as in clause 6.3A.2.3.4.2 in TS 38.521-2 [9] with the following steps added for E-UTRA component:

- 1.1 On the E-UTRA carrier, disable periodic and aperiodic CQI reports, disable SRS, set *TimeAlignmentTimerDedicated* IE to infinity and disable downlink and uplink scheduling, all as per Table 4.7-1 under clause 4.7.

6.3B.2.4_1.3.5 Test Requirements

Same test requirement as in clause 6.3A.2.3.5 in TS 38.521-2 [9] for the NR carrier.

6.3B.3 Tx ON/OFF time mask/PUCCH time mask for EN-DC

6.3B.3.1 Tx ON/OFF time mask for intra-band contiguous EN-DC

6.3B.3.1.1 Test purpose

Same test purpose as in clause 6.3.3.2.1 in TS 38.521-1 [8] for the NR carrier.

6.3B.3.1.2 Test applicability

This test applies to all types of E-UTRA UE release 15 and forward, supporting intra-band contiguous EN-DC.

6.3B.3.1.3 Minimum conformance requirements

Same minimum conformance requirements as in clause 6.3.3.2.3 in TS 38.521-1 [8] for the NR carrier.

No exception requirements applicable to NR or LTE. LTE anchor agnostic approach is applied.

The normative reference for this requirement is TS 38.101-3 [4] clause 6.3.

6.3B.3.1.4 Test description

Same test descriptions as in clause 6.3.3.2.4 in TS 38.521-1 [8] for the NR carrier with the following exceptions:

The initial test configurations for E-UTRA band consist of environmental conditions, test frequencies, and channel bandwidths based on E-UTRA bands specified in Table 4.6-1.

For Initial conditions as in clause 6.3.3.2.4.1 in TS 38.521-1 [8], the following steps will be added to configure E-UTRA component:

- 2.1. The parameter settings for the E-UTRA cell are set up according to TS 36.508 [11] clause 4.4.3.
- 3.1. The E-UTRA Downlink signal level, uplink signal level are set according to Table 4.6-1 and propagation conditions are set according to Annex B.0 of TS 36.521-1 [10].

Step 6 of Initial conditions as in clause 6.3.3.2.4.1 in TS 38.521-1 [8] is replaced by:

6. Ensure the UE is in state RRC_CONNECTED with generic procedure parameters Connectivity EN-DC, DC bearer *MCG* and *SCG*, *Connected without release On* according to TS 38.508-1 [6] clause 4.5.

Same test procedure as in clause 6.3.3.2.4.2 in TS 38.521-1 [8] with the following steps added for E-UTRA component:

- 1.1. On the E-UTRA carrier, disable periodic and aperiodic CQI reports, disable SRS, set *TimeAlignmentTimerDedicated* IE to infinity and disable downlink and uplink scheduling, all as per Table 4.6-1 under clause 4.6.

6.3B.3.1.5 Test requirements

Same test requirement as in clause 6.3.3.2.5 in TS 38.521-1 [8] for the NR carrier.

6.3B.3.2 Tx ON/OFF time mask for intra-band non-contiguous EN-DC

6.3B.3.2.1 Test purpose

Same test purpose as in clause 6.3.3.2.1 in TS 38.521-1 [8] for the NR carrier.

6.3B.3.2.2 Test applicability

This test applies to all types of E-UTRA UE release 15 and forward, supporting intra-band non-contiguous EN-DC.

6.3B.3.2.3 Minimum conformance requirements

Same minimum conformance requirements as in clause 6.3.3.2.3 in TS 38.521-1 [8] for the NR carrier.

No exception requirements applicable to NR or LTE. LTE anchor agnostic approach is applied.

The normative reference for this requirement is TS 38.101-3 [4] clause 6.3.

6.3B.3.2.4 Test description

Same test descriptions as in clause 6.3.3.2.4 in TS 38.521-1 [8] for the NR carrier with the following exceptions:

The initial test configurations for E-UTRA band consist of environmental conditions, test frequencies, and channel bandwidths based on E-UTRA bands specified in Table 4.6-1.

For Initial conditions as in clause 6.3.3.2.4.1 in TS 38.521-1 [8], the following steps will be added to configure E-UTRA component:

- 2.1. The parameter settings for the E-UTRA cell are set up according to TS 36.508 [11] clause 4.4.3.

- 3.1. The E-UTRA Downlink signal level, uplink signal level are set according to Table 4.6-1 and propagation conditions are set according to Annex B.0 of TS 36.521-1 [10].

Step 6 of Initial conditions as in clause 6.3.3.2.4.1 in TS 38.521-1 [8] is replaced by:

6. Ensure the UE is in state RRC_CONNECTED with generic procedure parameters Connectivity EN-DC, DC bearer *MCG* and *SCG*, *Connected without release On* according to TS 38.508-1 [6] clause 4.5.

Same test procedure as in clause 6.3.3.2.4.2 in TS 38.521-1 [8] with the following steps added for E-UTRA component:

- 1.1. On the E-UTRA carrier, disable periodic and aperiodic CQI reports, disable SRS, set *TimeAlignmentTimerDedicated* IE to infinity and disable downlink and uplink scheduling, all as per Table 4.6-1 under clause 4.6.

6.3B.3.2.5 Test requirements

Same test requirement as in clause 6.3.3.2.5 in TS 38.521-1 [8] for the NR carrier.

6.3B.3.3 Tx ON/OFF time mask for inter-band EN-DC within FR1

6.3B.3.3.1 Test purpose

Same test purpose as in clause 6.3.3.2.1 in TS 38.521-1 [8] for the NR carrier.

6.3B.3.3.2 Test applicability

This test applies to all types of E-UTRA UE release 15 and forward, supporting inter-band EN-DC.

6.3B.3.3.3 Minimum conformance requirements

Same minimum conformance requirements as in clause 6.3.3.2.3 in TS 38.521-1 [8] for the NR carrier.

No exception requirements applicable to NR or LTE.LTE anchor agnostic approach is applied.

The normative reference for this requirement is TS 38.101-3 [4] clause 6.3.

6.3B.3.3.4 Test description

Same test descriptions as in clause 6.3.3.2.4 in TS 38.521-1 [8] for the NR carrier with the following exceptions:

The initial test configurations for E-UTRA band consist of environmental conditions, test frequencies, and channel bandwidths based on E-UTRA bands specified in Table 4.6-1.

For Initial conditions as in clause 6.3.3.2.4.1 in TS 38.521-1 [8], the following steps will be added to configure E-UTRA component:

- 2.1. The parameter settings for the E-UTRA cell are set up according to TS 36.508 [11] clause 4.4.3.
- 3.1. The E-UTRA Downlink signal level, uplink signal level are set according to Table 4.6-1 and propagation conditions are set according to Annex B.0 of TS 36.521-1 [10].

Step 6 of Initial conditions as in clause 6.3.3.2.4.1 in TS 38.521-1 [8] is replaced by:

6. Ensure the UE is in state RRC_CONNECTED with generic procedure parameters Connectivity EN-DC, DC bearer *MCG* and *SCG*, *Connected without release On* according to TS 38.508-1 [6] clause 4.5.

Same test procedure as in clause 6.3.3.2.4.2 in TS 38.521-1 [8] with the following steps added for E-UTRA component:

- 1.1. On the E-UTRA carrier, disable periodic and aperiodic CQI reports, disable SRS, set *TimeAlignmentTimerDedicated* IE to infinity and disable downlink and uplink scheduling, all as per Table 4.6-1 under clause 4.6.

6.3B.3.3.5 Test requirements

Same test requirement as in clause 6.3.3.2.5 in TS 38.521-1 [8] for the NR carrier.

6.3B.3.4 Transmit ON/OFF time mask for inter-band EN-DC including FR2

Editor's note: This clause is incomplete. The following aspects are either missing or not yet determined:

- **The referred test case 6.3.3.2 in TS 38.521-2 [9] is incomplete**

6.3B.3.4.1 Test purpose

Same test purpose as in clause 6.3.3.2.1 in TS 38.521-2 [9] for the NR carrier.

6.3B.3.4.2 Test applicability

This test case applies to all types of E-UTRA UE release 15 and forward, supporting inter-band EN-DC FR2.

6.3B.3.4.3 Minimum conformance requirements

Same minimum conformance requirements as in clause 6.3.3.2.3 in TS 38.521-2 [9] for the NR carrier.

No exception requirements applicable to NR or LTE. LTE anchor agnostic approach is applied.

The normative reference for this measurement is TS 38.101-3 [4] clause 6.3B.

6.3B.3.4.4 Test Description

Same test description as in clause 6.3.3.2.4 in TS 38.521-2 [9] for the NR carrier with the following exceptions:

The initial test configurations for E-UTRA consist of test frequency based on E-UTRA operating band and test channel bandwidth as specified in Table 4.7-1.

For Initial conditions as in clause 6.3.3.2.4.1 in TS 38.521-2 [9], the following steps will be added to configure E-UTRA component:

- 2.1. The parameter settings for the cell are set up according to TS 36.508 [11] subclause 4.4.3.
- 3.1. The E-UTRA downlink signal level, uplink signal level are set according to Table 4.7-1 and propagation conditions are set according to Annex B.0 of TS 36.521-1 [10].

Step 6 of Initial conditions as in clause 6.3.3.2.4.1 in TS 38.521-2 [9] is replaced by:

6. Ensure the UE is in state RRC_CONNECTED with generic procedure parameters Connectivity EN-DC, DC bearer MCG and SCG, Connected without release *On* according to TS 38.508-1 [6] clause 4.5.

Same Test procedure as in clause 6.3.3.2.4.2 in TS 38.521-2 [9] with the following steps added for E-UTRA component:

- 1.1 On the E-UTRA carrier, disable periodic and aperiodic CQI reports, disable SRS, set *TimeAlignmentTimerDedicated* IE to infinity and disable downlink and uplink scheduling, all as per Table 4.7-1 under clause 4.7.

6.3B.3.4.5 Test Requirement

Same test requirement as specified in TS 38.521-2 [9] clause 6.3.3.2.5 for the NR carrier(s).

6.3B.4 PRACH time mask for EN-DC

6.3B.4.1 PRACH time mask for intra-band contiguous EN-DC

6.3B.4.1.1 Test purpose

Same test purpose as in clause 6.3.3.4.1 in TS 38.521-1 [8] for the NR carrier.

6.3B.4.1.2 Test applicability

This test applies to all types of E-UTRA UE release 15 and forward, supporting intra-band contiguous EN-DC.

6.3B.4.1.3 Minimum conformance requirements

Same minimum conformance requirements as in clause 6.3.3.4.3 in TS 38.521-1 [8] for the NR carrier.

The normative reference for this requirement is TS 38.101-3 [4] clause 6.3.

No exception requirements applicable to NR or LTE. LTE anchor agnostic approach is applied.

6.3B.4.1.4 Test description

Same test description as in clause 6.3.3.4.4 in TS 38.521-1 [8] with the following exception:

Table 6.3B.4.1.4-1: Test Configuration Table

Initial Conditions	
Test Frequencies as specified in TS 38.508-1 [6] clause 4.3.1 for different DC bandwidth classes.	Mid range
Test EN-DC bandwidth combination as specified in Table 5.3B.1.2-1 across bandwidth combination sets supported by the UE	Highest NRB_agg (NOTE 1)
NOTE 1: If the UE supports multiple CC Combinations in the EN-DC Configuration with the same NRB_agg , only the combination with the highest NRB_SCG is tested	

The initial test configurations for E-UTRA as specified in Table 4.6-1 except for the parameters specified in Table 6.3B.4.1.4-1.

For Initial conditions as in clause 6.3.3.4.4.1 in TS 38.521-1 [8], the following steps will be added to configure E-UTRA component:

- 2.1. The parameter settings for E-UTRA cell are set up according to TS 36.508 [11] clause 4.4.3.
- 3.1. The E-UTRA downlink signal level, uplink signal level are set according to Table 4.6-1 and propagation conditions are set according to Annex B.0 of TS 36.521-1 [10].

Step 5 of Initial conditions as in clause 6.3.3.4.4.1 in TS 38.521-1 [8] is replaced by:

5. Ensure the UE is in state RRC_CONNECTED with generic procedure parameters Connectivity EN-DC, DC bearer MCG and SCG, Connected without release *On* according to TS 38.508 [6] clause 4.5.

For Message contents as in clause 6.3.3.4.4.3 in TS 38.521-1 [8], the following exception:

Table 6.3B.4.1.4-2: RACH-ConfigGeneric: PRACH measurement

Derivation Path: TS 38.508-1[5], Table 4.6.3-130			
Information Element	Value/remark	Comment	Condition
RACH-ConfigGeneric ::= SEQUENCE {			
prach-ConfigurationIndex	14	Unpaired Spectrum	PRACH Format 0
	128	Unpaired Spectrum	PRACH Format A3

6.3B.4.1.5 Test requirements

Same test requirement as in clause 6.3.3.4.5 in TS 38.521-1 [8].

6.3B.4.2 PRACH Time Mask for intra-band non-contiguous EN-DC

6.3B.4.2.1 Test purpose

Same test purpose as in clause 6.3.3.4.1 in TS 38.521-1 [8] for the NR carrier.

6.3B.4.2.2 Test applicability

This test applies to all types of E-UTRA UE release 15 and forward, supporting intra-band non-contiguous EN-DC.

6.3B.4.2.3 Minimum conformance requirements

Same minimum conformance requirements as in clause 6.3.3.4.3 in TS 38.521-1 [8] for the NR carrier.

The normative reference for this requirement is TS 38.101-3 [4] clause 6.3.

No exception requirements applicable to NR or LTE. LTE anchor agnostic approach is applied.

6.3B.4.2.4 Test description

Same test description as in clause 6.3.3.4.4 in TS 38.521-1 [8] with the following exception:

Table 6.3B.4.2.4-1: Test Configuration Table

Initial Conditions	
Test Frequencies as specified in TS 36TS 38.508-1 [76] clause 4.3.1 for different EN-DC bandwidth classes	MaxWGap
Test EN-DC bandwidth combination as specified in Table 5.3B.1.2-1 across bandwidth combination sets supported by the UE	Highest NRB_agg (NOTE1)
NOTE 1: If the UE supports multiple CC Combinations in the EN-DC Configuration with the same NRB_agg , only the combination with the highest NRB_SCG is tested	

The initial test configurations for E-UTRA as specified in Table 4.6-1 except for the parameters specified in Table 6.3B.4.2.4-1.

For Initial conditions as in clause 6.3.3.4.4.1 in TS 38.521-1 [8], the following steps will be added to configure E-UTRA component:

- 2.1. The parameter settings for E-UTRA cell are set up according to TS 36.508 [11] clause 4.4.3.
- 3.1. The E-UTRA downlink signal level, uplink signal level are set according to Table 4.6-1 and propagation conditions are set according to Annex B.0 of TS 36.521-1 [10].

Step 5 of Initial conditions as in clause 6.3.3.4.4.1 in TS 38.521-1 [8] is replaced by:

5. Ensure the UE is in state RRC_CONNECTED with generic procedure parameters Connectivity EN-DC, DC bearer MCG and SCG, Connected without release *On* according to TS 38.508 [6] clause 4.5.

For Message contents as in clause 6.3.3.4.4.3 in TS 38.521-1 [8], the following exception:

Table 6.3B.4.2.4-2: RACH-ConfigGeneric: PRACH measurement

Derivation Path: TS 38.508-1[5], Table 4.6.3-130			
Information Element	Value/remark	Comment	Condition
RACH-ConfigGeneric ::= SEQUENCE {			
prach-ConfigurationIndex	14	Unpaired Spectrum	PRACH Format 0
	128	Unpaired Spectrum	PRACH Format A3

6.3B.4.2.5 Test requirements

Same test requirement as in clause 6.3.3.4.5 in TS 38.521-1 [8].

6.3B.4.3 PRACH Time Mask for inter-band EN-DC within FR16.3B.4.3.1 Test purpose

6.3B.4.3.1 Test purpose

Same test purpose as in clause 6.3.3.4.1 in TS 38.521-1 [8] for the NR carrier.

6.3B.4.3.2 Test applicability

This test applies to all types of E-UTRA UE release 15 and forward, supporting inter-band EN-DC.

6.3B.4.3.3 Minimum conformance requirements

Same minimum conformance requirements as in clause 6.3.3.4.3 in TS 38.521-1 [8] for the NR carrier.

The normative reference for this requirement is TS 38.101-3 [4] clause 6.3.

No exception requirements applicable to NR or LTE. LTE anchor agnostic approach is applied.

6.3B.4.3.4 Test description

Same test description as in clause 6.3.3.4.4 in TS 38.521-1 [8] for the NR carrier with the following exception:

The initial test configurations for E-UTRA band consist of environmental conditions, test frequencies, and channel bandwidths based on E-UTRA bands specified in Table 4.6-1. For Initial conditions as in clause 6.3.3.4.4.1 in TS 38.521-1 [8], the following steps will be added to configure E-UTRA component:

- 2.1. The parameter settings for E-UTRA cell are set up according to TS 36.508 [11] clause 4.4.3.
- 3.1. The E-UTRA downlink signal level, uplink signal level are set according to Table 4.6-1 and propagation conditions are set according to Annex B.0 of TS 36.521-1 [10].

Step 5 of Initial conditions as in clause 6.3.3.4.4.1 in TS 38.521-1 [8] is replaced by:

5. Ensure the UE is in state RRC_CONNECTED with generic procedure parameters Connectivity EN-DC, DC bearer MCG and SCG, Connected without release *On* according to TS 38.508 [6] clause 4.5.

6.3B.4.3.5 Test requirements

Same test requirement as in clause 6.3.3.4.5 in TS 38.521-1 [8].

6.3B.5 Output power dynamics for EN-DC with UL sharing from UE perspective

6.3B.5.1 E-UTRA and NR switching time mask for TDM based UL sharing from UE perspective

No test case details are specified. Current test procedures for time masks are based on power measurement in relatively long period compared with transient period. For time masks between 2 active time slots with different power level, the test procedure can't provide enough resolution to identify non-conformant UEs. Therefore the minimum requirement is not testable.

6.3B.6 Output power dynamics for intra-band EN-DC without dual PA capability

No test case details are specified. Current test procedures for time masks are based on power measurement in relatively long period compared with transient period. For time masks between 2 active time slots with different power level, the test procedure can't provide enough resolution to identify non-conformant UEs. Therefore the minimum requirement is not testable.

6.3B.7 Output power dynamics for intra-band EN-DC with dual PA capability

No test case details are specified. Current test procedures for time masks are based on power measurement in relatively long period compared with transient period. For time masks between 2 active time slots with different power level, the test procedure can't provide enough resolution to identify non-conformant UEs. Therefore the minimum requirement is not testable.

6.3B.8 Power control for EN-DC

6.3B.8.1 Absolute power tolerance for EN-DC

6.3B.8.1.1 Absolute power tolerance for intra-band contiguous EN-DC

6.3B.8.1.1.1 Test purpose

Same test purpose as in clause 6.3.4 in TS 38.521-1 [8] for the NR FR1 carrier(s),

6.3B.8.1.1.2 Test applicability

This test case applies to all types of E-UTRA UE release 15 and forward, supporting intra-band contiguous EN-DC.

6.3B.8.1.1.3 Minimum conformance requirements

Same minimum conformance requirements as in clause 6.3.4 in TS 38.521-1 [8] for the *NR* carrier.

No exception requirements applicable to NR or LTE. LTE anchor agnostic approach is applied.

6.3B.8.1.1.4 Test description

Same test description as in clause 6.3.4.2.4 in TS 38.521-1 [8] for the NR carrier with the following exception:

Notes defined in Table 6.3.4.2.4.1-1 will be updated as below.

The initial test configurations for E-UTRA band consist of environmental conditions, test frequencies, and channel bandwidths based on E-UTRA bands specified in Table 4.6-1. For Initial conditions as in clause 6.3.4.2.4.1 in TS 38.521-1 [8], the following steps will be added to configure E-UTRA component:

2.1. The parameter settings for E-UTRA cell are set up according to TS 36.508 [11] clause 4.4.3.

3.1. The E-UTRA downlink signal level, uplink signal level are set according to Table 4.6-1 and propagation conditions are set according to Annex B, clause B.0 of TS 36.521-1 [10].

Step 6 of Initial conditions as in clause 6.3.4.2.4.1 in TS 38.521-1 [8] is replaced by:

6. Ensure the UE is in state RRC_CONNECTED with generic procedure parameters Connectivity EN-DC, DC bearer MCG and SCG according to TS 38.508 [6] clause 4.5.

6.3B.8.1.1.5 Test Requirement

Same test requirement as in clause 6.3.4.2.5 in TS 38.521-1 [8] for the NR carrier.

6.3B.8.1.2 Absolute power tolerance for intra-band non-contiguous EN-DC

6.3B.8.1.2.1 Test purpose

Same test purpose as in clause 6.3.4 in TS 38.521-1 [8] for the NR FR1 carrier(s).

6.3B.8.1.2.2 Test applicability

This test case applies to all types of E-UTRA UE release 15 and forward, supporting intra-band non-contiguous EN-DC.

6.3B.8.1.2.3 Minimum conformance requirements

Same minimum conformance requirements as in clause 6.3.4 in TS 38.521-1 [8] for the NR carrier.

No exception requirements applicable to NR or LTE. LTE anchor agnostic approach is applied.

6.3B.8.1.2.4 Test description

Same test description as in clause 6.3.4.2.4 in TS 38.521-1 [8] for the NR carrier with the following exception:

Notes defined in Table 6.3.4.2.4.1-1 will be updated as below.

The initial test configurations for E-UTRA band consist of environmental conditions, test frequencies, and channel bandwidths based on E-UTRA bands specified in Table 4.6-1. For Initial conditions as in clause 6.3.4.2.4.1 in TS 38.521-1 [8], the following steps will be added to configure E-UTRA component:

2.1. The parameter settings for E-UTRA cell are set up according to TS 36.508 [11] clause 4.4.3.

3.1. The E-UTRA downlink signal level, uplink signal level are set according to Table 4.6-1 and propagation conditions are set according to Annex B, clause B.0 of TS 36.521-1 [10].

Step 6 of Initial conditions as in clause 6.3.4.2.4.1 in TS 38.521-1 [8] is replaced by:

6. Ensure the UE is in state RRC_CONNECTED with generic procedure parameters Connectivity EN-DC, DC bearer MCG and SCG according to TS 38.508 [6] clause 4.5.

6.3B.8.1.2.5 Test Requirement

Same test requirement as in clause 6.3.4.2.5 in TS 38.521-1 [8] for the NR carrier.

6.3B.8.1.3 Absolute power tolerance for inter-band EN-DC within FR1

6.3B.8.1.3.1 Test purpose

Same test purpose as in clause 6.3.4 in TS 38.521-1 [8] for the NR FR1 carrier(s).

6.3B.8.1.3.2 Test applicability

This test case applies to all types of E-UTRA UE release 15 and forward, supporting inter-band EN-DC within FR1.

6.3B.8.1.3.3 Minimum conformance requirements

Same minimum conformance requirements as in clause 6.3.4 in TS 38.521-1 [8] for the NR carrier.

No exception requirements applicable to NR or LTE. LTE anchor agnostic approach is applied.

6.3B.8.1.3.4 Test description

Same test description as in clause 6.3.4.2.4 in TS 38.521-1 [8] for the NR carrier with the following exception:

Notes defined in Table 6.3.4.2.4.1-1 will be updated as below.

The initial test configurations for E-UTRA band consist of environmental conditions, test frequencies, and channel bandwidths based on E-UTRA bands specified in Table 4.6-1. For Initial conditions as in clause 6.3.4.2.4.1 in TS 38.521-1 [8], the following steps will be added to configure E-UTRA component:

- 2.1. The parameter settings for E-UTRA cell are set up according to TS 36.508 [11] clause 4.4.3.
- 3.1. The E-UTRA downlink signal level, uplink signal level are set according to Table 4.6-1 and propagation conditions are set according to Annex B, clause B.0 of TS 36.521-1 [10].

Step 6 of Initial conditions as in clause 6.3.4.2.4.1 in TS 38.521-1 [8] is replaced by:

6. Ensure the UE is in state RRC_CONNECTED with generic procedure parameters Connectivity EN-DC, DC bearer MCG and SCG according to TS 38.508 [6] clause 4.5.

6.3B.8.1.3.5 Test Requirement

Same test requirement as in clause 6.3.4.2.5 in TS 38.521-1 [8] for the NR carrier.

6.3B.8.1.4 Absolute power tolerance for inter-band EN-DC including FR2

Editor's note: This clause is incomplete. The following aspects are either missing or not yet determined:

- **The referred test case 6.3.4.2 in TS 38.521-2 [9] is incomplete**

6.3B.8.1.4.1 Test purpose

Same test purpose as in clause 6.3.4.2.1 in TS 38.521-2 [9] for NR FR2 carrier(s).

6.3B.8.1.4.2 Test applicability

This test case applies to all types of E-UTRA UE release 15 and forward, supporting inter-band EN-DC including FR2.

6.3B.8.1.4.3 Minimum conformance requirements

Same minimum conformance requirements as in clause 6.3.4.2.3 in TS 38.521-2 [9] for the NR carrier.

No exception requirements applicable to NR or LTE. LTE anchor agnostic approach is applied.

6.3B.8.1.4.4 Test description

Same test description as in clause 6.3.4.2.4 in TS 38.521-2 [9] for the NR carrier with the following exception:

Notes defined in Table 6.3.4.2.4.1-1 will be updated as below.

The initial test configurations for E-UTRA band consist of environmental conditions, test frequencies, and channel bandwidths based on E-UTRA bands specified in Table 4.6-1. For Initial conditions as in clause 6.3.4.2.4.1 in TS 38.521-2 [9], the following steps will be added to configure E-UTRA component:

2.1. The parameter settings for E-UTRA cell are set up according to TS 36.508 [11] clause 4.4.3.

3.1. The E-UTRA downlink signal level, uplink signal level are set according to Table 4.6-1 and propagation conditions are set according to Annex B, clause B.0 of TS 36.521-1 [10].

Step 6 of Initial conditions as in clause 6.3.4.2.4.1 in TS 38.521-2 [9] is replaced by:

6. Ensure the UE is in state RRC_CONNECTED with generic procedure parameters Connectivity EN-DC, DC bearer MCG and SCG according to TS 38.508 [6] clause 4.5.

6.3B.8.1.4.5 Test Requirement

Same test requirement as in clause 6.3.4.2.5 in TS 38.521-2 [9] for the NR carrier.

6.3B.8.2 Relative power tolerance for EN-DC

6.3B.8.2.1 Relative power tolerance for intra-band contiguous EN-DC

6.3B.8.2.1.1 Test purpose

Same test purpose as in clause 6.3.4 in TS 38.521-1 [8] for the NR FR1 carrier(s).

6.3B.8.2.1.2 Test applicability

This test case applies to all types of E-UTRA UE release 15 and forward, supporting intra-band contiguous EN-DC.

6.3B.8.2.1.3 Minimum conformance requirements

Same minimum conformance requirements as in clause 6.3.4 in TS 38.521-1 [8] for the NR carrier.

No exception requirements applicable to NR or LTE. LTE anchor agnostic approach is applied.

6.3B.8.2.1.4 Test description

Same test description as in clause 6.3.4.3.4 in TS 38.521-1 [8] for the NR carrier with the following exception:

Notes defined in Table 6.3.4.3.4.1-1 will be updated as below.

The initial test configurations for E-UTRA band consist of environmental conditions, test frequencies, and channel bandwidths based on E-UTRA bands specified in Table 4.6-1. For Initial conditions as in clause 6.3.4.3.4.1 in TS 38.521-1 [8], the following steps will be added to configure E-UTRA component:

2.1. The parameter settings for E-UTRA cell are set up according to TS 36.508 [11] clause 4.4.3.

3.1. The E-UTRA downlink signal level, uplink signal level are set according to Table 4.6-1 and propagation conditions are set according to Annex B, clause B.0 of TS 36.521-1 [10].

Step 6 of Initial conditions as in clause 6.3.4.3.4.1 in TS 38.521-1 [8] is replaced by:

6. Ensure the UE is in state RRC_CONNECTED with generic procedure parameters Connectivity EN-DC, DC bearer MCG and SCG according to TS 38.508 [6] clause 4.5.

6.3B.8.2.1.5 Test Requirement

Same test requirement as in clause 6.3.4.3.5 in TS 38.521-1 [8] for the NR carrier.

6.3B.8.2.2 Relative power tolerance for intra-band non-contiguous EN-DC

6.3B.8.2.2.1 Test purpose

Same test purpose as in clause 6.3.4 in TS 38.521-1 [8] for the NR FR1 carrier(s).

6.3B.8.2.2.2 Test applicability

This test case applies to all types of E-UTRA UE release 15 and forward, supporting intra-band non-contiguous EN-DC.

6.3B.8.2.2.3 Minimum conformance requirements

Same minimum conformance requirements as in clause 6.3.4 in TS 38.521-1 [8] for the NR carrier.

No exception requirements applicable to NR or LTE. LTE anchor agnostic approach is applied.

6.3B.8.2.2.4 Test description

Same test description as in clause 6.3.4.3.4 in TS 38.521-1 [8] for the NR carrier with the following exception:

Notes defined in Table 6.3.4.3.4.1-1 will be updated as below.

The initial test configurations for E-UTRA band consist of environmental conditions, test frequencies, and channel bandwidths based on E-UTRA bands specified in Table 4.6-1. For Initial conditions as in clause 6.3.4.3.4.1 in TS 38.521-1 [8], the following steps will be added to configure E-UTRA component:

- 2.1. The parameter settings for E-UTRA cell are set up according to TS 36.508 [11] clause 4.4.3.
- 3.1. The E-UTRA downlink signal level, uplink signal level are set according to Table 4.6-1 and propagation conditions are set according to Annex B, clause B.0 of TS 36.521-1 [10].

Step 6 of Initial conditions as in clause 6.3.4.3.4.1 in TS 38.521-1 [8] is replaced by:

6. Ensure the UE is in state RRC_CONNECTED with generic procedure parameters Connectivity EN-DC, DC bearer MCG and SCG according to TS 38.508 [6] clause 4.5.

6.3B.8.1.2.5 Test Requirement

Same test requirement as in clause 6.3.4.3.5 in TS 38.521-1 [8] for the NR carrier.

6.3B.8.2.3 Relative power tolerance for inter-band EN-DC within FR1

6.3B.8.2.3.1 Test purpose

Same test purpose as in clause 6.3.4 in TS 38.521-1 [8] for the NR FR1 carrier(s).

6.3B.8.2.3.2 Test applicability

This test case applies to all types of E-UTRA UE release 15 and forward, supporting inter-band EN-DC within FR1.

6.3B.8.2.3.3 Minimum conformance requirements

Same minimum conformance requirements as in clause 6.3.4 in TS 38.521-1 [8] for the NR carrier.

No exception requirements applicable to NR or LTE. LTE anchor agnostic approach is applied.

6.3B.8.2.3.4 Test description

Same test description as in clause 6.3.4.3.4 in TS 38.521-1 [8] for the NR carrier with the following exception:

Notes defined in Table 6.3.4.3.4.1-1 will be updated as below.

The initial test configurations for E-UTRA band consist of environmental conditions, test frequencies, and channel bandwidths based on E-UTRA bands specified in Table 4.6-1. For Initial conditions as in clause 6.3.4.3.4.1 in TS 38.521-1 [8], the following steps will be added to configure E-UTRA component:

- 2.1. The parameter settings for E-UTRA cell are set up according to TS 36.508 [11] clause 4.4.3.

- 3.1. The E-UTRA downlink signal level, uplink signal level are set according to Table 4.6-1 and propagation conditions are set according to Annex B, clause B.0 of TS 36.521-1 [10].

Step 6 of Initial conditions as in clause 6.3.4.3.4.1 in TS 38.521-1 [8] is replaced by:

6. Ensure the UE is in state RRC_CONNECTED with generic procedure parameters Connectivity EN-DC, DC bearer MCG and SCG according to TS 38.508 [6] clause 4.5.

6.3B.8.2.3.5 Test Requirement

Same test requirement as in clause 6.3.4.3.5 in TS 38.521-1 [8] for the NR carrier.

6.3B.8.2.4 Relative power tolerance for inter-band EN-DC including FR2

Editor's note: This clause is incomplete. The following aspects are either missing or not yet determined:

- **The referred test case 6.3.4.3 in TS 38.521-2 [9] is incomplete**

6.3B.8.2.4.1 Test purpose

Same test purpose as in clause 6.3.4.3.1 in TS 38.521-2 [9] for NR FR2 carrier(s).

6.3B.8.2.4.2 Test applicability

This test case applies to all types of E-UTRA UE release 15 and forward, supporting inter-band EN-DC including FR2.

6.3B.8.2.4.3 Minimum conformance requirements

Same minimum conformance requirements as in clause 6.3.4.3.3 in TS 38.521-2 [9] for the NR carrier.

No exception requirements applicable to NR or LTE. LTE anchor agnostic approach is applied.

6.3B.8.2.4.4 Test description

Same test description as in clause 6.3.4.3.4 in TS 38.521-2 [9] for the NR carrier with the following exception:

Notes defined in Table 6.3.4.3.4.1-1 will be updated as below.

The initial test configurations for E-UTRA band consist of environmental conditions, test frequencies, and channel bandwidths based on E-UTRA bands specified in Table 4.6-1. For Initial conditions as in clause 6.3.4.3.4.1 in TS 38.521-2 [9], the following steps will be added to configure E-UTRA component:

- 2.1. The parameter settings for E-UTRA cell are set up according to TS 36.508 [11] clause 4.4.3.
- 3.1. The E-UTRA downlink signal level, uplink signal level are set according to Table 4.6-1 and propagation conditions are set according to Annex B, clause B.0 of TS 36.521-1 [10].

Step 6 of Initial conditions as in clause 6.3.4.3.4.1 in TS 38.521-2 [9] is replaced by:

6. Ensure the UE is in state RRC_CONNECTED with generic procedure parameters Connectivity EN-DC, DC bearer MCG and SCG according to TS 38.508 [6] clause 4.5.

6.3B.8.2.4.5 Test Requirement

Same test requirement as in clause 6.3.4.3.5 in TS 38.521-2 [9] for the NR carrier.

6.3B.8.3 Aggregate power tolerance for EN-DC

6.3B.8.3.1 Aggregate power tolerance for intra-band contiguous EN-DC

6.3B.8.3.1.1 Test purpose

Same test purpose as in clause 6.3.4 in TS 38.521-1 [8] for the NR FR1 carrier(s).

6.3B.8.3.1.2 Test applicability

This test case applies to all types of E-UTRA UE release 15 and forward, supporting intra-band contiguous EN-DC.

6.3B.8.3.1.3 Minimum conformance requirements

Same minimum conformance requirements as in clause 6.3.4 in TS 38.521-1 [8] for the *NR* carrier.

No exception requirements applicable to NR or LTE. LTE anchor agnostic approach is applied.

6.3B.8.3.1.4 Test description

Same test description as in clause 6.3.4.4.4 in TS 38.521-1 [8] for the NR carrier with the following exception:

Notes defined in Table 6.3.4.4.4.1-1 will be updated as below.

The initial test configurations for E-UTRA band consist of environmental conditions, test frequencies, and channel bandwidths based on E-UTRA bands specified in Table 4.6-1. For Initial conditions as in clause 6.3.4.4.4.1 in TS 38.521-1 [8], the following steps will be added to configure E-UTRA component:

- 2.1. The parameter settings for E-UTRA cell are set up according to TS 36.508 [11] clause 4.4.3.
- 3.1. The E-UTRA downlink signal level, uplink signal level are set according to Table 4.6-1 and propagation conditions are set according to Annex B, clause B.0 of TS 36.521-1 [10].

Step 6 of Initial conditions as in clause 6.3.4.3.4.1 in TS 38.521-1 [8] is replaced by:

6. Ensure the UE is in state RRC_CONNECTED with generic procedure parameters Connectivity EN-DC, DC bearer MCG and SCG according to TS 38.508 [6] clause 4.5.

6.3B.8.3.1.5 Test Requirement

Same test requirement as in clause 6.3.4.4.5 in TS 38.521-1 [8] for the NR carrier.

6.3B.8.3.2 Aggregate power tolerance for intra-band non-contiguous EN-DC

6.3B.8.3.2.1 Test purpose

Same test purpose as in clause 6.3.4 in TS 38.521-1 [8] for the NR FR1 carrier(s).

6.3B.8.3.2.2 Test applicability

This test case applies to all types of E-UTRA UE release 15 and forward, supporting intra-band non-contiguous EN-DC.

6.3B.8.3.2.3 Minimum conformance requirements

Same minimum conformance requirements as in clause 6.3.4 in TS 38.521-1 [8] for the *NR* carrier.

No exception requirements applicable to NR or LTE. LTE anchor agnostic approach is applied.

6.3B.8.3.2.4 Test description

Same test description as in clause 6.3.4.4.4 in TS 38.521-1 [8] for the NR carrier with the following exception:

Notes defined in Table 6.3.4.4.4.1-1 will be updated as below.

The initial test configurations for E-UTRA band consist of environmental conditions, test frequencies, and channel bandwidths based on E-UTRA bands specified in Table 4.6-1. For Initial conditions as in clause 6.3.4.4.4.1 in TS 38.521-1 [8], the following steps will be added to configure E-UTRA component:

- 2.1. The parameter settings for E-UTRA cell are set up according to TS 36.508 [11] clause 4.4.3.
- 3.1. The E-UTRA downlink signal level, uplink signal level are set according to Table 4.6-1 and propagation conditions are set according to Annex B, clause B.0 of TS 36.521-1 [10].

Step 6 of Initial conditions as in clause 6.3.4.4.4.1 in TS 38.521-1 [8] is replaced by:

6. Ensure the UE is in state RRC_CONNECTED with generic procedure parameters Connectivity EN-DC, DC bearer MCG and SCG according to TS 38.508 [6] clause 4.5.

6.3B.8.3.2.5 Test Requirement

Same test requirement as in clause 6.3.4.4.5 in TS 38.521-1 [8] for the NR carrier.

6.3B.8.3.3 Aggregate power tolerance for inter-band EN-DC within FR1

6.3B.8.3.3.1 Test purpose

Same test purpose as in clause 6.3.4 in TS 38.521-1 [8] for the NR FR1 carrier(s).

6.3B.8.3.3.2 Test applicability

This test case applies to all types of E-UTRA UE release 15 and forward, supporting inter-band EN-DC within FR1.

6.3B.8.3.3.3 Minimum conformance requirements

Same minimum conformance requirements as in clause 6.3.4 in TS 38.521-1 [8] for the NR carrier.

No exception requirements applicable to NR or LTE. LTE anchor agnostic approach is applied.

6.3B.8.3.3.4 Test description

Same test description as in clause 6.3.4.4.4 in TS 38.521-1 [8] for the NR carrier with the following exception:

Notes defined in Table 6.3.4.4.4.1-1 will be updated as below.

The initial test configurations for E-UTRA band consist of environmental conditions, test frequencies, and channel bandwidths based on E-UTRA bands specified in Table 4.6-1. For Initial conditions as in clause 6.3.4.4.4.1 in TS 38.521-1 [8], the following steps will be added to configure E-UTRA component:

- 2.1. The parameter settings for E-UTRA cell are set up according to TS 36.508 [11] clause 4.4.3.
- 3.1. The E-UTRA downlink signal level, uplink signal level are set according to Table 4.6-1 and propagation conditions are set according to Annex B, clause B.0 of TS 36.521-1 [10].

Step 6 of Initial conditions as in clause 6.3.4.4.4.1 in TS 38.521-1 [8] is replaced by:

6. Ensure the UE is in state RRC_CONNECTED with generic procedure parameters Connectivity EN-DC, DC bearer MCG and SCG according to TS 38.508 [6] clause 4.5.

6.3B.8.3.3.5 Test Requirement

Same test requirement as in clause 6.3.4.4.5 in TS 38.521-1 [8] for the NR carrier.

6.3B.8.3.4 Aggregate power tolerance for inter-band EN-DC including FR2

Editor's note: This clause is incomplete. The following aspects are either missing or not yet determined:

- The referred test case 6.3.4.4 in TS 38.521-2 [9] is incomplete

6.3B.8.3.4.1 Test purpose

Same test purpose as in clause 6.3.4.4.1 in TS 38.521-2 [9] for NR FR2 carrier(s).

6.3B.8.3.4.2 Test applicability

This test case applies to all types of E-UTRA UE release 15 and forward, supporting inter-band EN-DC including FR2.

6.3B.8.3.4.3 Minimum conformance requirements

Same minimum conformance requirements as in clause 6.3.4.4.3 in TS 38.521-2 [9] for the NR carrier.

No exception requirements applicable to NR or LTE. LTE anchor agnostic approach is applied.

6.3B.8.3.4.4 Test description

Same test description as in clause 6.3.4.4.4 in TS 38.521-2 [9] for the NR carrier with the following exception:

Notes defined in Table 6.3.4.4.4.1-1 will be updated as below.

The initial test configurations for E-UTRA band consist of environmental conditions, test frequencies, and channel bandwidths based on E-UTRA bands specified in Table 4.6-1. For Initial conditions as in clause 6.3.4.4.4.1 in TS 38.521-2 [9], the following steps will be added to configure E-UTRA component:

- 2.1. The parameter settings for E-UTRA cell are set up according to TS 36.508 [11] clause 4.4.3.
- 3.1. The E-UTRA downlink signal level, uplink signal level are set according to Table 4.6-1 and propagation conditions are set according to Annex B, clause B.0 of TS 36.521-1 [10].

Step 6 of Initial conditions as in clause 6.3.4.4.4.1 in TS 38.521-2 [9] is replaced by:

6. Ensure the UE is in state RRC_CONNECTED with generic procedure parameters Connectivity EN-DC, DC bearer MCG and SCG according to TS 38.508 [6] clause 4.5.

6.3B.8.3.4.5 Test Requirement

Same test requirement as in clause 6.3.4.4.5 in TS 38.521-2 [9] for the NR carrier.

6.4 Transmit signal quality

6.4A Transmit Signal Quality for inter-band NR CA between FR and FR2 without EN-DC

6.4A.1 Frequency error for inter-band NR CA between FR 1 and FR 2 without EN-DC

6.4A.1.1 Test purpose

Same test purpose as in clause 6.4.1 in TS 38.521-1 [8] for NR FR1 carrier(s) and clause 6.4.1 in TS 38.521-2 [9] for NR FR2 carrier(s).

6.4A.1.2 Test applicability

The requirements in this test are not testable due to issues with combined testing of NR FR1 conducted mode with NR FR2 in radiated mode. Therefore, the conducted and radiated requirements are tested separately.

No test case details are specified. The SA requirements for frequency error apply and are tested in TS 38.521-1 [8] clauses 6.4 and 6.4A and TS 38.521-2 [9] clauses 6.4 and 6.4A

6.4A.2 Transmit Modulation Quality for inter-band NR CA without EN-DC

6.4A.2.1 Error Vector Magnitude for inter-band NR CA between FR 1 and FR 2 without EN-DC

6.4A.2.1.1 Test purpose

Same test purpose as in clause 6.4.2.1 in TS 38.521-1 [8] for NR FR1 carrier(s) and clause 6.4.2.1 in TS 38.521-2 [9] for NR FR2 carrier(s).

6.4A.2.1.2 Test applicability

The requirements in this test are not testable due to issues with combined testing of NR FR1 conducted mode with NR FR2 in radiated mode. Therefore, the conducted and radiated requirements are tested separately.

No test case details are specified. The SA requirements for error vector magnitude apply and are tested in TS 38.521-1 [8] clauses 6.4 and 6.4A and TS 38.521-2 [9] clauses 6.4 and 6.4A

6.4A.2.2 Carrier Leakage for inter-band NR CA between FR 1 and FR 2 without EN-DC

6.4A.2.2.1 Test purpose

Same test purpose as in clause 6.4.2.2 in TS 38.521-1 [8] for NR FR1 carrier(s) and clause 6.4.2.2 in TS 38.521-2 [9] for NR FR2 carrier(s).

6.4A.2.2.2 Test applicability

The requirements in this test are not testable due to issues with combined testing of NR FR1 conducted mode with NR FR2 in radiated mode. Therefore, the conducted and radiated requirements are tested separately.

No test case details are specified. The SA requirements for carrier leakage apply and are tested in TS 38.521-1 [8] clauses 6.4 and 6.4A and TS 38.521-2 [9] clauses 6.4 and 6.4A

6.4A.2.3 In-band Emissions for inter-band NR CA between FR 1 and FR 2 without EN-DC

6.4A.2.3.1 Test purpose

Same test purpose as in clause 6.4.2.3 in TS 38.521-1 [8] for NR FR1 carrier(s) and clause 6.4.2.3 in TS 38.521-2 [9] for NR FR2 carrier(s).

6.4A.2.3.1 Test applicability

The requirements in this test are not testable due to issues with combined testing of NR FR1 conducted mode with NR FR2 in radiated mode. Therefore, the conducted and radiated requirements are tested separately.

No test case details are specified. The SA requirements for in-band emissions apply and are tested in TS 38.521-1 [8] clauses 6.4 and 6.4A and TS 38.521-2 [9] clauses 6.4 and 6.4A

6.4A.2.4 EVM Equalizer Spectral Flatness for inter-band NR CA between FR 1 and FR 2 without EN-DC

6.4A.2.4.1 Test purpose

Same test purpose as in clause 6.4.2.4 in TS 38.521-1 [8] for NR FR1 carrier(s) and clause 6.4.2.4 in TS 38.521-2 [9] for NR FR2 carrier(s).

6.4A.2.4.1 Test applicability

The requirements in this test are not testable due to issues with combined testing of NR FR1 conducted mode with NR FR2 in radiated mode. Therefore, the conducted and radiated requirements are tested separately.

No test case details are specified. The SA requirements for EVM equalizer spectral flatness apply and are tested in TS 38.521-1 [8] clauses 6.4 and 6.4A and TS 38.521-2 [9] clauses 6.4 and 6.4A

6.4B Transmit Signal Quality for DC

6.4B.1 Frequency error

6.4B.1.1 Frequency error for Intra-band contiguous EN-DC

6.4B.1.1.1 Test purpose

Same test purpose as in clause 6.4.1 in TS 38.521-1 [8] for the NR carrier.

6.4B.1.1.2 Test applicability

This test case applies to all types of E-UTRA UE release 15 and forward, supporting intra-band contiguous EN-DC.

6.4B.1.1.3 Minimum conformance requirements

For intra-band contiguous EN-DC, the requirement shall apply on each component carrier as defined in clause 6.5.1 in TS 38.101-3 [4] and in clause 6.4.1 in TS 38.101-1 [2], respectively.

No exception requirements applicable to NR or LTE. LTE anchor agnostic approach is applied.

The normative reference for this measurement is TS 38.101-3 [4] clause 6.4B.1.1.

6.4B.1.1.4 Test description

Same test description as in clause 6.4.1.4 in TS 38.521-1 [8] for the NR carrier with the following exception:

Notes defined in Table 6.4.1.4.1-1 will be updated as below.

The initial test configurations for E-UTRA band consist of environmental conditions, test frequencies, and channel bandwidths based on E-UTRA bands specified in Table 4.6-1. For Initial conditions as in clause 6.4.1.4.1 in TS 38.521-1 [8], the following steps will be added to configure E-UTRA component:

- 2.1. The parameter settings for E-UTRA cell are set up according to TS 36.508 [11] clause 4.4.3.
- 3.1. The E-UTRA downlink signal level, uplink signal level are set according to Table 4.6-1 and propagation conditions are set according to Annex B, clause B.0 of TS 36.521-1 [10].

Step 6 of Initial conditions as in clause 6.4.1.4.1 in TS 38.521-1 [8] is replaced by:

6. Ensure the UE is in state RRC_CONNECTED with generic procedure parameters Connectivity EN-DC, DC bearer MCG and SCG according to TS 38.508 [6] clause 4.5.

6.4B.1.1.5 Test Requirement

The 10 frequency error Δf results must fulfil the test requirement defined in clause 6.4.1.5 TS 38.521-1 [8].

6.4B.1.2 Frequency error for Intra-band non-contiguous EN-DC

6.4B.1.2.1 Test purpose

Same test purpose as in clause 6.4.1 in TS 38.521-1 [8] for the NR carrier.

6.4B.1.2.2 Test applicability

This test case applies to all types of E-UTRA UE release 15 and forward, supporting intra-band non-contiguous EN-DC.

6.4B.1.2.3 Minimum conformance requirements

For intra-band non-contiguous EN-DC, the requirement shall apply on each component carrier as defined in clause 6.5.1 in TS 38.101-3 [4] and in clause 6.4.1 in TS 38.101-1 [2], respectively.

No exception requirements applicable to NR or LTE. LTE anchor agnostic approach is applied.

The normative reference for this measurement is TS 38.101-3 [4] clause 6.4B.1.2.

6.4B.1.2.4 Test description

Same test description as in clause 6.4.1.4 in TS 38.521-1 [8] for the NR carrier with the following exception:

The initial test configurations consist of environmental conditions, test frequencies and channel bandwidths based on EN-DC operating bands specified in clause 5.2B.3, all of these configurations shall be tested with applicable test parameters for each intra-band non-contiguous EN-DC configuration specified in clause 5.3B.1.3, and are shown in table 6.4B.1.2.4-1.

Table 6.4B.1.2.4-1: Test Configuration Table

Initial Conditions				
Test Environment as specified in TS 38.508-1 [6] clause 4.1		Normal, TL/VL, TL/VH, TH/VL, TH/VH		
Test Frequencies as specified in TS 38.508-1 [6] clause 4.3.1 for different EN-DC bandwidth classes		MinWgap , MaxWgap		
Test Channel Bandwidths as specified in TS 38.508-1 [6] clause 4.3.1		Highest NRB_agg (NOTE3)		
Test SCS as specified in Table 5.3.5-1		Lowest		
Test Parameters				
Test ID	Downlink Configuration		Uplink Configuration	
	Modulation	RB allocation	Modulation	RB allocation
1	CP-OFDM QPSK	Full RB (NOTE 1)	DFT-s-OFDM QPSK	REFSENS (NOTE 2)
NOTE 1: Full RB allocation shall be used per each SCS and channel BW as specified in Table 7.3.2.4.1-2.				
NOTE 2: REFSENS refers to Table 7.3.2.4.1-3 which defines uplink RB configuration and start RB location for each SCS, channel BW and NR band.				
NOTE 3: If the UE supports multiple CC Combinations in the EN-DC Configuration with the same NRB_agg , only the combination with the highest NRB_SCG is tested.				

The initial test configurations for E-UTRA band consist of environmental conditions, test frequencies, and channel bandwidths based on E-UTRA bands specified in Table 4.6-1 with the exception that E-UTRA test frequency are specified in Table 7.4B.2.4.1-1 based on intra-band non-contiguous EN-DC configuration specified in clause 5.3B.1.3.

For Initial conditions as in clause 6.4.1.4.1 in TS 38.521-1 [8], the following steps will be added to configure E-UTRA component:

- 2.1. The parameter settings for E-UTRA cell are set up according to TS 36.508 [11] clause 4.4.3.
- 3.1. The E-UTRA downlink signal level, uplink signal level are set according to Table 4.6-1 and propagation conditions are set according to Annex B, clause B.0 of TS 36.521-1 [10].

Steps 4 and 6 of Initial conditions as in clause 6.4.1.4.1 in TS 38.521-1 [8] is replaced by:

4. The DL and UL Reference Measurement frequencies are set according to Table 6.4B.1.2.4-1.

6. Ensure the UE is in state RRC_CONNECTED with generic procedure parameters Connectivity EN-DC, DC bearer MCG and SCG according to TS 38.508 [6] clause 4.5.

6.4B.1.2.5 Test Requirement

The 10 frequency error Δf results must fulfil the test requirement defined in TS 38.521-1 [8], clause 6.4.1.5.

6.4B.1.3 Frequency error for Inter-band EN-DC within FR1

6.4B.1.3.1 Test purpose

Same test purpose as in clause 6.4.1 in TS 38.521-1 [8] for the NR carrier.

6.4B.1.3.2 Test applicability

This test case applies to all types of E-UTRA UE release 15 and forward, supporting inter-band EN-DC.

6.4B.1.3.3 Minimum conformance requirements

For inter-band EN-DC with uplink assigned to one E-UTRA band and one NR band, the requirements shall apply on each component carrier as defined in clause 6.5.1 in TS 36.101 [5] and in clause 6.4.1 in TS 38.101-1 [2], respectively, with all component carriers active. If multiple component carriers are assigned to one E-UTRA band, the requirements in clauses 6.5.1A in TS 36.101 [5] apply for those component carriers, and if multiple component carriers are assigned to one NR band, the requirements in clauses 6.4A.1 in TS 38.101-1 [2] apply for those component carriers.

No exception requirements applicable to NR or LTE. LTE anchor agnostic approach is applied.

The normative reference for this measurement is TS 38.101-3 [4] clause 6.4B.1.3.

6.4B.1.3.4 Test description

Same test description as in clause 6.4.1.4 in TS 38.521-1 [8] for the NR carrier with the following exception:

The initial test configurations for E-UTRA band consist of environmental conditions, test frequencies, and channel bandwidths based on E-UTRA bands specified in Table 4.6-1. For Initial conditions as in clause 6.4.1.4.1 in TS 38.521-1 [8], the following steps will be added to configure E-UTRA component:

- 2.1. The parameter settings for E-UTRA cell are set up according to TS 36.508 [11] clause 4.4.3.
- 3.1. The E-UTRA downlink signal level, uplink signal level are set according to Table 4.6-1 and propagation conditions are set according to Annex B.0 of TS 36.521-1 [10].

Step 6 of Initial conditions as in clause 6.4.1.4.1 in TS 38.521-1 [8] is replaced by:

6. Ensure the UE is in state RRC_CONNECTED with generic procedure parameters Connectivity EN-DC, DC bearer MCG and SCG according to TS 38.508 [6] clause 4.5.

6.4B.1.3.5 Test Requirement

The 10 frequency error Δf results must fulfil the test requirement defined in 6.4.1.5 TS 38.521-1 [8].

6.4B.1.4 Frequency Error for inter-band EN-DC including FR2

Editor's note:

- **The following aspects of the clause are for future consideration:**
 - **Testing of extreme conditions for FR2 is FFS.**

6.4B.1.4.1 Test purpose

Same test purpose as in clause 6.4.1.1 in TS 38.521-2 [9] for the NR carrier.

6.4B.1.4.2 Test applicability

This test applies to all types of E-UTRA UE release 15 and forward, supporting intra-band EN-DC including FR2.

6.4B.1.4.3 Minimum conformance requirements

Same minimum conformance requirements as in clause 6.4.1.3 in TS 38.521-2 [9] for the NR carrier.

No exception requirements applicable to NR or LTE. LTE anchor agnostic approach is applied.

The normative reference for this requirement is TS 38.101-3 [4] clause 6.4B.

6.4B.1.4.4 Test description

Same test description as in clause 6.4.1.4 in TS 38.521-2 [9] for the NR carrier with the following exception:

The initial test configurations for E-UTRA band consist of environmental conditions, test frequencies, and channel bandwidths based on E-UTRA bands specified in Table 4.7-1.

For initial conditions as in clause 6.4.1.4.1 in TS 38.521-2 [9], the following steps will be added to configure E-UTRA component:

- 2.1. The parameter settings for E-UTRA cell are set up according to TS 36.508 [11] clause 4.4.3.
- 3.1. The E-UTRA downlink signal level, uplink signal level are set according to Table 4.7-1 and propagation conditions are set according to Annex B.0 of TS 36.521-1 [10].

Step 6 of Initial conditions as in clause 6.4.1.4.1 in TS 38.521-2 [9] is replaced by:

6. Ensure the UE is in state RRC_CONNECTED with generic procedure parameters Connectivity EN-DC, DC bearer MCG and SCG, Connected without release On according to TS 38.508-1 [6] clause 4.5.

Same test procedure as in clause 6.4.1.4.2 in TS 38.521-2 [9] with the following steps added for E-UTRA component:

- 1.1 On the E-UTRA carrier, disable periodic and aperiodic CQI reports, disable SRS, set *TimeAlignmentTimerDedicated* IE to infinity and disable downlink and uplink scheduling, all as per Table 4.7-1 under clause 4.7.

6.4B.1.4.5 Test requirements

Same test requirement as in clause 6.4.1.5 in TS 38.521-2 [9] for the NR carrier.

6.4B.1.4_1 Frequency Error for Inter-band EN-DC including FR2 (>2 CCs)

Editor's note: Test applicability, Test Description in below sub-clauses requires updates to clarify number of E-UTRA carriers that will be configured during the test that will be limited to only 1 E-UTRA CC

6.4B.1.4_1.1 Frequency Error for Inter-band EN-DC including FR2 (3 CCs)

6.4B.1.4_1.1.1 Test purpose

Same test purpose as in clause 6.4.1.1 in TS 38.521-2 [9] for the NR carrier.

6.4B.1.4_1.1.2 Test applicability

This test case applies to all types of E-UTRA UE release 15 and forward, supporting inter-band EN-DC including FR2 with 3 UL CCs (2NR UL CCs).

6.4B.1.4_1.1.3 Minimum conformance requirements

Same minimum conformance requirements as in clause 6.4.1.3 in TS 38.521-2 [9] for the NR carrier.

No exception requirements applicable to NR or LTE. LTE anchor agnostic approach is applied.

The normative reference for this requirement is TS 38.101-3 [4] clause 6.4B.1.4.

6.4B.1.4_1.1.4 Test description

6.4B.1.4_1.1.4.1 Initial condition

Same test description as in clause 6.4A.1.1.4 in TS 38.521-2 [9] for the *NR* carrier with the following exception:

The initial test configurations for E-UTRA band consist of environmental conditions, test frequencies, and channel bandwidths based on E-UTRA bands specified in Table 4.7-1.

For Initial conditions as in clause 6.4A.1.1.4.1 in TS 38.521-2 [9], the following steps will be added to configure E-UTRA component:

- 2.1. The parameter settings for E-UTRA cell are set up according to TS 36.508 [11] clause 4.4.3.
- 3.1. The E-UTRA downlink signal level, uplink signal level are set according to Table 4.7-1 and propagation conditions are set according to Annex B.0 of TS 36.521-1 [10].

Step 6 of Initial conditions as in clause 6.4A.1.1.4.1 in TS 38.521-2 [9] is replaced by:

6. Ensure the UE is in state *RRC_CONNECTED* with generic procedure parameters Connectivity EN-DC, DC bearer MCG and SCG, Connected without release On according to TS 38.508-1 [6] clause 4.5.

Same test procedure as in clause 6.4A.1.1.4.2 in TS 38.521-2 [9] with the following steps added for E-UTRA component:

- 1.1 On the E-UTRA carrier, disable periodic and aperiodic CQI reports, disable SRS, set *TimeAlignmentTimerDedicated* IE to infinity and disable downlink and uplink scheduling, all as per Table 4.7-1 under clause 4.7.

6.4B.1.4_1.1.5 Test Requirements

Same test requirement as in clause 6.4A.1.1.5 in TS 38.521-2 [9] for the *NR* carrier.

6.4B.1.4_1.2 Frequency Error for Inter-band EN-DC including FR2 (4 CCs)

6.4B.1.4_1.2.1 Test purpose

Same test purpose as in clause 6.4.1.1 in TS 38.521-2 [9] for the *NR* carrier.

6.4B.1.4_1.2.2 Test applicability

This test case applies to all types of E-UTRA UE release 15 and forward, supporting inter-band EN-DC including FR2 with 4 UL CCs (3NR UL CCs).

6.4B.1.4_1.2.3 Minimum conformance requirements

Same minimum conformance requirements as in clause 6.4.1.3 in TS 38.521-2 [9] for the *NR* carrier.

No exception requirements applicable to *NR* or *LTE*. *LTE* anchor agnostic approach is applied.

The normative reference for this requirement is TS 38.101-3 [4] clause 6.4B.1.4.

6.4B.1.4_1.2.4 Test description

6.4B.1.5.4_1.2.1 Initial condition

Same test description as in clause 6.4A.1.2.4 in TS 38.521-2 [9] for the *NR* carrier with the following exception:

The initial test configurations for E-UTRA band consist of environmental conditions, test frequencies, and channel bandwidths based on E-UTRA bands specified in Table 4.7-1.

For Initial conditions as in clause 6.4A.1.2.4.1 in TS 38.521-2 [9], the following steps will be added to configure E-UTRA component:

- 2.1. The parameter settings for E-UTRA cell are set up according to TS 36.508 [11] clause 4.4.3.
- 3.1. The E-UTRA downlink signal level, uplink signal level are set according to Table 4.7-1 and propagation conditions are set according to Annex B.0 of TS 36.521-1 [10].

Step 6 of Initial conditions as in clause 6.4A.1.2.4.1 in TS 38.521-2 [9] is replaced by:

6. Ensure the UE is in state RRC_CONNECTED with generic procedure parameters Connectivity EN-DC, DC bearer MCG and SCG, Connected without release On according to TS 38.508-1 [6] clause 4.5.

Same test procedure as in clause 6.4A.1.2.4.2 in TS 38.521-2 [9] with the following steps added for E-UTRA component:

- 1.1 On the E-UTRA carrier, disable periodic and aperiodic CQI reports, disable SRS, set *TimeAlignmentTimerDedicated* IE to infinity and disable downlink and uplink scheduling, all as per Table 4.7-1 under clause 4.7.

6.4B.1.4_1.2.5 Test Requirements

Same test requirement as in clause 6.4A.1.2.5 in TS 38.521-2 [9] for the NR carrier.

6.4B.1.4_1.3 Frequency Error for Inter-band EN-DC including FR2 (5 CCs)

6.4B.1.4_1.3.1 Test purpose

Same test purpose as in clause 6.4.1.1 in TS 38.521-2 [9] for the NR carrier.

6.4B.1.4_1.3.2 Test applicability

This test case applies to all types of E-UTRA UE release 15 and forward, supporting inter-band EN-DC including FR2 with 5 UL CCs (4NR UL CCs).

6.4B.1.4_1.3.3 Minimum conformance requirements

Same minimum conformance requirements as in clause 6.4.1.3 in TS 38.521-2 [9] for the NR carrier.

No exception requirements applicable to NR or LTE. LTE anchor agnostic approach is applied.

The normative reference for this requirement is TS 38.101-3 [4] clause 6.4B.1.4.

6.4B.1.4_1.3.4 Test description

6.4B.1.4_1.3.4.1 Initial condition

Same test description as in clause 6.4A.1.3.4 in TS 38.521-2 [9] for the NR carrier with the following exception:

The initial test configurations for E-UTRA band consist of environmental conditions, test frequencies, and channel bandwidths based on E-UTRA bands specified in Table 4.7-1.

For Initial conditions as in clause 6.4A.1.3.4.1 in TS 38.521-2 [9], the following steps will be added to configure E-UTRA component:

- 2.1. The parameter settings for E-UTRA cell are set up according to TS 36.508 [11] clause 4.4.3.
- 3.1. The E-UTRA downlink signal level, uplink signal level are set according to Table 4.7-1 and propagation conditions are set according to Annex B.0 of TS 36.521-1 [10].

Step 6 of Initial conditions as in clause 6.4A.1.3.4.1 in TS 38.521-2 [9] is replaced by:

6. Ensure the UE is in state RRC_CONNECTED with generic procedure parameters Connectivity EN-DC, DC bearer MCG and SCG, Connected without release On according to TS 38.508-1 [6] clause 4.5.

Same test procedure as in clause 6.4A.1.3.4.2 in TS 38.521-2 [9] with the following steps added for E-UTRA component:

- 1.1 On the E-UTRA carrier, disable periodic and aperiodic CQI reports, disable SRS, set *TimeAlignmentTimerDedicated* IE to infinity and disable downlink and uplink scheduling, all as per Table 4.7-1 under clause 4.7.

6.4B.1.4_1.3.5 Test Requirements

Same test requirement as in clause 6.4A.1.3.5 in TS 38.521-2 [9] for the NR carrier.

6.4B.2 Transmit Modulation Quality for DC

6.4B.2.1 Transmit Modulation Quality for intra-band contiguous EN-DC

6.4B.2.1.1 Error Vector Magnitude for intra-band contiguous EN-DC

6.4B.2.1.1.1 Test purpose

The Error Vector Magnitude is a measure of the difference between the reference waveform and the measured waveform. This difference is called the error vector. Before calculating the EVM the measured waveform is corrected by the sample timing offset and RF frequency offset. Then the carrier leakage shall be removed from the measured waveform before calculating the EVM.

The measured waveform is further equalised using the channel estimates subjected to the EVM equaliser spectrum flatness requirement specified in clause 6.4B.2.1.4.3. For DFT-s-OFDM waveforms, the EVM result is defined after the front-end FFT and IDFT as the square root of the ratio of the mean error vector power to the mean reference power expressed as a %. For CP-OFDM waveforms, the EVM result is defined after the front-end FFT as the square root of the ratio of the mean error vector power to the mean reference power expressed as a %.

The basic EVM measurement interval in the time domain is one preamble sequence for the PRACH and the duration of PUCCH/PUSCH channel, or one hop, if frequency hopping is enabled for PUCCH and PUSCH in the time domain. The EVM measurement interval is reduced by any symbols that contains an allowable power transient as defined in clause 6.3.3.3 of TS 38.521-1 [8].

6.4B.2.1.1.2 Test applicability

This test case applies to all types of E-UTRA UE release 15 and forward, supporting intra-band EN-DC.

6.4B.2.1.1.3 Minimum conformance requirements

For the intra-band contiguous EN-DC with one component carrier per CG the EVM requirement applies with PRB allocation in one of the CG and the other CG unallocated.

The EVM requirements for each CG are according to clause 6.5.2 of TS 36.101 [5] for the MCG and clause 6.4.2 of TS 38.101-1 [2] for the SCG with EN-DC configured.

The normative reference for this requirement is TS 38.101-3 [4] clause 6.4B.2.1.1.

No exception requirements applicable to NR or LTE. LTE anchor agnostic approach is applied.

6.4B.2.1.1.4 Test description

Same test description as in clause 6.4.2.1.4 in TS 38.521-1 [8] for the NR carrier with the following exception:

Table 6.4B.2.1.1.4-1: Test Configuration Table

Initial Conditions	
Test Frequencies as specified in TS 38.508-1 [6] clause 4.3.1	Mid range
Test EN-DC bandwidth combination as specified in Table 5.3B.1.2-1	Highest NRB_agg (NOTE 1)
NOTE 1: If the UE supports multiple CC Combinations in the EN-DC Configuration with the same NRB_agg , only the combination with the highest NRB_SCG is tested.	

The initial test configurations for E-UTRA as specified in Table 4.6-1 except for the parameters specified in Table 6.4B.2.1.1.4-1.

For Initial conditions as in clause 6.4.2.1.4.1 in TS 38.521-1 [8], the following steps are added to configure E-UTRA component:

- 2.1. The parameter settings for E-UTRA cell are set up according to TS 36.508 [11] clause 4.4.3.
- 3.1. The E-UTRA downlink signal level, uplink signal level are set according to Table 4.6-1 and propagation conditions are set according to Annex B.0 of TS 36.521-1 [10].

Step 6 of Initial conditions as in clause 6.4.2.1.4.1 in TS 38.521-1 [8] is replaced by:

6. Ensure the UE is in state RRC_CONNECTED with generic procedure parameters Connectivity EN-DC, DC bearer MCG and SCG, Connected without release *On* according to TS 38.508 [6] clause 4.5.

Same test procedure as in clause 6.4.2.1.4.2 in TS 38.521-1 [8].

For Message contents as in clause 6.4.2.1.4.3 in TS 38.521-1 [8], the following exception:

Table 6.4B.2.1.1.4-2: RACH-ConfigGeneric: PRACH measurement

Derivation Path: TS 38.508-1[5], Table 4.6.3-130			
Information Element	Value/remark	Comment	Condition
RACH-ConfigGeneric ::= SEQUENCE {			
prach-ConfigurationIndex	14	Unpaired Spectrum	PRACH Format 0

6.4B.2.1.1.5 Test requirements

Same test requirement as in clause 6.4.2.1.5 in TS 38.521-1 [8] for the NR carrier.

6.4B.2.1.2 Carrier Leakage for intra-band contiguous EN-DC

6.4B.2.1.2.1 Test purpose

Carrier leakage expresses itself as unmodulated sine wave with the carrier frequency or centre frequency of aggregated transmission bandwidth configuration. It is an interference of approximately constant amplitude and independent of the amplitude of the wanted signal. Carrier leakage interferes with the centre sub carriers of the UE under test (if allocated), especially, when their amplitude is small. The measurement interval is defined over one slot in the time domain.

The purpose of this test is to exercise the UE transmitter to verify its modulation quality in terms of carrier leakage.

6.4B.2.1.2.2 Test applicability

This test case applies to all types of E-UTRA UE release 15 and forward, supporting intra-band EN-DC.

6.4B.2.1.2.3 Minimum conformance requirements

The carrier leakage requirements for each CG are according to clause 6.5.2 of TS 36.101 [5] for the MCG and clause 6.4.2 of TS 38.101-1 [2] for the SCG with EN-DC configured.

The normative reference for this requirement is TS 38.101-3 [4] clause 6.4B.2.1.2.

No exception requirements applicable to NR or LTE. LTE anchor agnostic approach is applied.

6.4B.2.1.2.4 Test description

Same test description as in clause 6.4.2.2.4 in TS 38.521-1 [8] for the NR carrier with the following exception:

Table 6.4B.2.1.2.4-1: Test Configuration

Initial Conditions	
Test Frequencies as specified in TS 38.508-1 [6] clause 4.3.1	Mid range
Test EN-DC bandwidth combination as specified in Table 5.3B.1.2-1	Highest NRB_agg (NOTE 1)
NOTE 1: If the UE supports multiple CC Combinations in the EN-DC Configuration with the same NRB_agg , only the combination with the highest NRB_SCG is tested.	

The initial test configurations for E-UTRA as specified in Table 4.6-1 except for the parameters specified in Table 6.4B.2.1.2.4-1 For Initial conditions as in clause 6.4.2.2.4.1 in TS 38.521-1 [8], the following steps will be added to configure E-UTRA component:

- 2.1. The parameter settings for E-UTRA cell are set up according to TS 36.508 [11] clause 4.4.3.
- 3.1. The E-UTRA downlink signal level, uplink signal level are set according to Table 4.6-1 and propagation conditions are set according to Annex B.0 of TS 36.521-1 [10].

Step 6 of Initial conditions as in clause 6.4.2.2.4.1 in TS 38.521-1 [8] is replaced by:

6. Ensure the UE is in state RRC_CONNECTED with generic procedure parameters Connectivity EN-DC, DC bearer MCG and SCG, Connected without release *On* according to TS 38.508 [6] clause 4.5.

6.4B.2.1.2.5 Test requirements

Same test requirement as in clause 6.4.2.2.5 in TS 38.521-1 [8] for the NR carrier.

6.4B.2.1.3 In-band Emissions for intra-band contiguous EN-DC

6.4B.2.1.3.1 Test purpose

The in-band emissions are a measure of the interference falling into the non-allocated resources blocks.

The in-band emission is defined as the average emission across 12 sub-carriers and as a function of the RB offset from the edge of the allocated UL transmission bandwidth. The in-band emission is measured as the ratio of the UE output power in a non-allocated RB to the UE output power in an allocated RB.

The basic in-band emissions measurement interval is defined over one slot in the time domain, however, the minimum requirement applies when the in-band emission measurement is averaged over 10 sub-frames. When the PUSCH or PUCCH transmission slot is shortened due to multiplexing with SRS, the in-band emissions measurement interval is reduced by one or more symbols, accordingly.

The purpose of this test is to exercise the UE transmitter to verify its modulation quality in terms of in-band emissions.

6.4B.2.1.3.2 Test applicability

This test applies to all types of E-UTRA UE release 15 and forward, supporting intra-band contiguous EN-DC.

6.4B.2.1.3.3 Minimum conformance requirements

For the MCG the in-band emission requirements in Table 6.5.2A.3.1-1 and Table 6.5.2A.3.1-2 in TS 36.101 [5] apply within the aggregated transmission bandwidth configuration of the EN-DC bandwidth with the carriers of both CGs

active and one single contiguous PRB allocation of bandwidth L_{CRB} within the MCG at the edge of the said aggregated transmission bandwidth configuration.

For the SCG the in-band emission requirements in Table 6.5.2A.3.1-1 and Table 6.5.2A.3.1-2 in TS 36.101 [5] apply within the aggregated transmission bandwidth configuration of the EN-DC bandwidth with the carriers of both CGs active and one single contiguous PRB allocation of bandwidth L_{CRB} within the SCG at the edge of the aggregated transmission bandwidth configuration.

The normative reference for this requirement is TS 38.101-3 [4] clause 6.4B.2.1.3

Exception requirements for both NR and E-UTRA are defined for this test and therefore LTE anchor agnostic approach is not applied. E-UTRA test point analysis is included and E-UTRA measurements are performed.

6.4B.2.1.3.4 Test description

6.4B.2.1.3.4.1 Initial condition

Initial conditions are a set of test configurations the UE needs to be tested in and the steps for the SS to take with the UE to reach the correct measurement state.

The initial test configurations consist of environmental conditions, test frequencies and test channel bandwidths based on NR operating bands specified in clause 5.3B.1.2, channel bandwidths and sub-carrier spacings for the NR cell specified in TS 38.521-1 [8] clause 5.3 and channel bandwidth for the E-UTRA cell are specified in TS 36.521-1 [10] clause 5.4.2. All of these configurations shall be tested with applicable test parameters for each EN-DC combination of test channel bandwidth and sub-carrier spacing, and are shown in table 6.4B.2.1.3.4.1-1. The details of the uplink reference measurement channels (RMCs) are specified in Annexes A.2. Configurations of PDSCH and PDCCH before measurement are specified in TS 36.521.1 [10] Annex C.2 and in TS 38.521-1 [8] Annex C.2 for E-UTRA CG and NR CG respectively.

Table 6.4B.2.1.3.4.1-1: Test configuration table

Initial Conditions					
Test Environment as specified in TS 38.508-1 [6] clause 4.1		Normal			
Test Frequencies as specified in TS 38.508-1 [6] clause 4.3.1		Low range, Mid range, High range			
Test EN-DC bandwidth combination as specified in Table 5.3B.1.2-1		Lowest NRB_agg, Highest NRB_agg (Note 2)			
Test SCS for the NR cell as specified in TS 38.521-1 [8] Table 5.3.5-1		Lowest			
Test Parameters					
Test ID	Downlink Configuration	EN-DC Uplink Configuration			
		E-UTRA Cell		NR Cell	
		Modulation	RB allocation	Modulation	RB allocation (Note 1)
1 (Note3)	N/A for In-band emission test	QPSK	0	DFT-s-OFDM QPSK	Inner_1RB_Left
2 (Note 4)		QPSK	0	DFT-s-OFDM QPSK	Inner_1RB_Right
3 (Note3)		QPSK	0	CP-OFDM QPSK	Inner_1RB_Left
4 (Note 4)		QPSK	0	CP-OFDM QPSK	Inner_1RB_Right
5 (Note3)		QPSK	Outer_1RB_Right	DFT-s-OFDM QPSK	0
6 (Note 4)		QPSK	Outer_1RB_Left	DFT-s-OFDM QPSK	0
NOTE 1: The specific configuration of each RB allocation is defined in Table 6.1-1 in TS 38.521-1 [8].					
NOTE 2: If the UE supports multiple CC combinations in the EN-DC configuration with the same NRB_agg, select the combination to test as follows: - Lowest ENBW: NR component with lowest NRB is tested. - Highest ENBW: NR component with highest NRB is tested.					
NOTE 3: Applicable when E-UTRA cell carrier frequency is lower than NR cell carrier.					
NOTE 4: Applicable when NR cell carrier frequency is lower than E-UTRA cell carrier.					
NOTE 5: Outer_1RB_Left defined as 1 RB allocated at the left edge of the E-UTRA component. Outer_1RB_Right defined as 1 RB allocated at the right edge of the E-UTRA component.					

The initial test configurations for E-UTRA consist of test frequency based on E-UTRA operation band and test channel bandwidth as specified in Table 4.6-1.

1. Connect the SS to the UE antenna connectors as shown in TS 38.508-1 [6] Annex A, Figure A.3.1.1 for TE diagram and clause A.3.2.1 for UE diagram.
2. The parameter settings for the E-UTRA cell are set up according to TS 36.508 [11] clause 4.4.3, and the parameter settings for the NR cell are set up according to TS 38.508-1 [6] clause 4.4.3.
3. Downlink signals are initially set up according to TS 36.521-1 [10] Annex C.0 and TS 38.521-1 [8] Annex C.0 for E-UTRA CG and NR CG respectively, and uplink signals according to TS 36.521-1 [10] Annex H and TS 38.521-1 [8] Annex G for E-UTRA CG and NR CG respectively.
4. NR downlink signals are initially set up according to Annex C.0, C.1, and C.2 and uplink signals according to Annex G.0, G.1, G.2, and G.3.0 of TS 38.521-1 [8].
5. The UL Reference Measurement channels are TS 36.521-1 [10] Annex A.2 and TS 38.521-1 [8] Annex A.2 for E-UTRA CG and NR CG respectively.
6. Propagation conditions are set according to TS 36.521-1 [10] Annex B.0 and TS 38.521-1 [8] Annex B.0 for E-UTRA CG and NR CG respectively.
7. Ensure the UE is in state RRC_CONNECTED with generic procedure parameters Connectivity EN-DC, DC bearer MCG and SCG, Connected without release *On* according to TS 38.508-1 [6] clause 4.5. Message contents are defined in clause 6.4B.2.1.3.4.3.

8. On the E-UTRA carrier, disable periodic and aperiodic CQI reports, disable SRS, set *TimeAlignmentTimerDedicated* IE to infinity and disable downlink and uplink scheduling, all as per Table 4.6-1 under clause 4.6.

6.4B.2.1.3.4.2 Test procedure

1. SS sends uplink scheduling information for each UL HARQ process via PDCCH DCI format 0 and DCI format 0_1 for C_RNTI to schedule the UL RMC according to Table 6.4B.2.1.3.4.1-1 on E-UTRA CC and NR CC respectively. Since the UL has no payload and no loopback data to send, the UE transmits uplink MAC padding bits on the UL RMC.
2. For NR CC, send uplink power control commands to the UE using 1dB power step size to ensure that the UE output power measured by the test system is within the Uplink power control window, defined as +MU to +(MU + Uplink power control window size) dB of the target power level 0dBm, where:
 - MU is the test system uplink power measurement uncertainty and is specified in Table F.1.2-1 for the carrier frequency f and the channel bandwidth BW.
 - Uplink power control window size = 1dB (UE power step size) + 0.7dB (UE power step tolerance) + (Test system relative power measurement uncertainty), where, the UE power step tolerance is specified in TS 38.101-1 [2], Table 6.3.4.3-1 and is 0.7dB for 1dB power step size, and the Test system relative power measurement uncertainty is specified in Table F.1.2-1.
3. Measure In-band emission on NR CC using Global In-Channel Tx-Test (Annex E). Measure power spectral density on E-UTRA CC. For TDD slots with transient periods are not under test.
4. For NR CC, send uplink power control commands to the UE using 1dB power step size to ensure that the UE output power measured by the test system is within the Uplink power control window, defined as +MU to +(MU + Uplink power control window size) dB of the target power level -30dBm, where MU and Uplink power control window size are defined above.
5. Measure In-band emission on NR CC using Global In-Channel Tx-Test (Annex E). Measure power spectral density on E-UTRA CC. For TDD slots with transient periods are not under test.
6. For NR CC, send uplink power control commands to the UE using 1dB power step size to ensure that the UE output power measured by the test system is within the Uplink power control window, defined as +MU to +(MU + Uplink power control window size) dB of the target power level -40dBm, where MU and Uplink power control window size are defined above.
7. Measure In-band emission on NR CC using Global In-Channel Tx-Test (Annex E). Measure power spectral density on E-UTRA CC. For TDD slots with transient periods are not under test.
8. For E-UTRA CC, send uplink power control commands to the UE using 1dB power step size to ensure that the UE output power measured by the test system is within the Uplink power control window, defined as +MU to +(MU + Uplink power control window size) dB of the target power level 0dBm, where:
 - MU is the test system uplink power measurement uncertainty and is specified in Table F.1.2-1 for the carrier frequency f and the channel bandwidth BW.
 - Uplink power control window size = 1dB (UE power step size) + 1.0dB (UE power step tolerance) + (Test system relative power measurement uncertainty), where, the UE power step tolerance is specified in TS 36.101 [5], Table 6.3.5.2.1-1 and is 1.0dB for 1dB power step size, and the Test system relative power measurement uncertainty is specified in Table F.1.2-1.
9. Measure In-band emission on E-UTRA CC using Global In-Channel Tx-Test (Annex E). Measure power spectral density on NR CC. For TDD slots with transient periods are not under test.
10. For E-UTRA CC, send uplink power control commands to the UE using 1dB power step size to ensure that the UE output power measured by the test system is within the Uplink power control window, defined as +MU to +(MU + Uplink power control window size) dB of the target power level -30dBm, where MU and Uplink power control window size are defined above.
11. Measure In-band emission on E-UTRA CC using Global In-Channel Tx-Test (Annex E). Measure power spectral density on NR CC. For TDD slots with transient periods are not under test.

12. For E-UTRA CC, send uplink power control commands to the UE using 1dB power step size to ensure that the UE output power measured by the test system is within the Uplink power control window, defined as +MU to +(MU + Uplink power control window size) dB of the target power level -40dBm, where MU and Uplink power control window size are defined above.

13. Measure In-band emission on E-UTRA CC using Global In-Channel Tx-Test (Annex E). Measure power spectral density on NR CC. For TDD slots with transient periods are not under test.

NOTE 1: When switching to DFT-s-OFDM waveform, as specified in the test configuration table 6.4B.2.1.3.4.1-1, send an NR RRCReconfiguration message according to TS 38.508-1 [6] clause 4.6.3 Table 4.6.3-118 PUSCH-Config with TRANSFORM_PRECODER_ENABLED condition.

NOTE 2: The purpose of the Uplink power control window is to ensure that the actual UE output power is no less than the target power level, and as close as possible to the target power level. The relationship between the Uplink power control window, the target power level and the corresponding possible actual UE Uplink power window is illustrated in Annex F, clause F.4.

Table 6.4B.2.1.3.4.2-1: Void

Table 6.4B.2.1.3.4.2-2: Void

6.4B.2.1.3.4.3 Message contents

Message contents are according to TS 38.508-1 [6] clause 4.6.1.

6.4B.2.1.3.5 Test requirements

Each of the [20] In-band emissions results, derived in Annex E.4.3 shall not exceed the corresponding values in Table 6.4B.2.1.3.5-1.

Table 6.4B.2.1.3.5-1: Test requirements for in-band emissions (allocated component carrier)

Parameter	Unit	Limit	Applicable Frequencies
General	dB	$\max \left\{ -25 - 10 \cdot \log_{10} (N_{RB} / L_{CRB}), \right.$ $20 \cdot \log_{10} EVM - 3 - 5 \cdot (\Delta_{RB} - 1) / L_{CRB},$ $\left. -57 \text{ dBm} / 180 \text{ kHz} - P_{RB} \right\} + TT$	Any non-allocated (NOTE 2)
IQ Image	dB	-25	Exception for IQ image (NOTE 3)
Carrier leakage	dBc	25 + TT	Exception for Carrier frequency (NOTE 4)
		20 + TT	
		10 + TT	
<p>NOTE 1: An in-band emissions combined limit is evaluated in each non-allocated RB. For each such RB, the minimum requirement is calculated as the higher of $P_{RB} - 30$ dB and the power sum of all limit values (General, IQ Image or Carrier leakage) that apply. P_{RB} is defined in NOTE 9. The limit is evaluated in each non-allocated RB.</p> <p>NOTE 2: The measurement bandwidth is 1 RB and the limit is expressed as a ratio of measured power in one non-allocated RB to the measured average power per allocated RB, where the averaging is done across all allocated RBs</p> <p>NOTE 3: Exceptions to the general limit are allowed for up to $L_{CRBs} + 1$ RBs within a contiguous width of $L_{CRBs} + 1$ non-allocated RBs. The measurement bandwidth is 1 RB.</p> <p>NOTE 4: Exceptions to the general limit are allowed for up to two contiguous non-allocated RBs. The measurement bandwidth is 1 RB and the limit is expressed as a ratio of measured power in the non-allocated RB to the measured total power in all allocated RBs.</p> <p>NOTE 5: L_{CRB} is the Transmission Bandwidth (see Figure 5.6-1) not exceeding $\lfloor N_{RB} / 2 - 1 \rfloor$</p> <p>NOTE 6: N_{RB} is the Transmission Bandwidth Configuration (see Figure 5.6-1) of the component carrier with RBs allocated.</p> <p>NOTE 7: EVM is the limit specified in Table 6.5.2.1.1-1 for the modulation format used in the allocated RBs.</p> <p>NOTE 8: Δ_{RB} is the starting frequency offset between the allocated RB and the measured non-allocated RB (e.g. $\Delta_{RB} = 1$ or $\Delta_{RB} = -1$ for the first adjacent RB outside of the allocated bandwidth).</p> <p>NOTE 9: P_{RB} is the transmitted power per 180 kHz in allocated RBs, measured in dBm.</p> <p>NOTE 10: Test tolerance TT = 0.8 dB.</p>			

The in-band emissions results, measured with the spectral test shall not exceed the corresponding values in Table 6.4B.2.1.3.5-2.

Table 6.4B.2.1.3.5-2: Test requirements for in-band emissions (not allocated component carrier)

Parameter	Unit	Meas BW NOTE 1	Limit	remark	Applicable Frequencies	
General	dB	BW of 1 RB (180KHz rectangular)	$\max \left\{ -25 - 10 \cdot \log_{10} (N_{RB} / L_{CRB}), \right.$ $20 \cdot \log_{10} EVM - 3 - 5 \cdot (\Delta_{RB} - 1) / L_{CRB},$ $\left. -57 \text{ dBm} / 180 \text{ kHz} - P_{RB} \right\}$	The reference value is the average power per allocated RB in the allocated component carrier	Any RB in the non-allocated component carrier. The frequency raster of the RBs is derived when this component carrier is allocated with RBs	
IQ Image	dB	BW of 1 RB (180KHz rectangular)	-25 + TT	The reference value is the average power per allocated RB in the allocated component carrier	The frequencies of the L_{CRB} contiguous non-allocated RBs are unknown. The frequency raster of the RBs is derived when this component carrier is allocated with RBs	
			NOTE 2			
Carrier leakage	dBc	BW of 1 RB (180KHz rectangular)	NOTE 3		The reference value is the total power of the allocated RBs in the allocated component carrier	The frequencies of the up to 2 non-allocated RBs are unknown. The frequency raster of the RBs is derived when this component carrier is allocated with RBs
			-25 + TT	Output power > 0 dBm		
			-20 + TT	-30 dBm ≤ Output power ≤ 0 dBm		
			-10 + TT	-40 dBm ≤ Output power < -30 dBm		
NOTE 1: Resolution BWs smaller than the measurement BW may be integrated to achieve the measurement bandwidth.						
NOTE 2: Exceptions to the general limit is are allowed for up to $L_{CRB} + 1$ RBs within a contiguous width of $L_{CRB} + 1$ non-allocated RBs.						
NOTE 3: Two Exceptions to the general limit are allowed for up to two contiguous non-allocated RBs						
NOTE 4: NOTES 1, 5, 6, 7, 8, 9 from Table 6.5.2A.3.1-1 apply for Table 6.5.2A.3.1-2 as well.						
NOTE 5: Δ_{RB} for measured non-allocated RB in the non-allocated component carrier may take non-integer values when the carrier spacing between the CCs is not a multiple of RB.						
NOTE 6: Test tolerance TT = 0.8 dB.						

6.4B.2.1.4 EVM Equalizer Flatness for intra-band contiguous EN-DC

6.4B.2.1.4.1 Test purpose

Same test purpose as in clause 6.4.2.4 in TS 38.521-1 [8] for the NR carrier.

6.4B.2.1.4.2 Test applicability

This test case applies to all types of E-UTRA UE release 15 and forward, supporting intra-band contiguous EN-DC.

6.4B.2.1.4.3 Minimum conformance requirements

Same minimum conformance requirements as in clause 6.4.2.4.3 in TS 38.521-1 [8] for the NR carrier.

No exception requirements applicable to NR or LTE. LTE anchor agnostic approach is applied.

6.4B.2.1.4.4 Test description

Same test description as in clause 6.4.2.4.4 in TS 38.521-1 [8] for the NR carrier with the following exception:

Table 6.4B.2.1.4.4-1: Test Configuration Table

Initial Conditions	
Test Frequencies as specified in TS 38.508-1 [6] clause 4.3.1	Mid range
Test EN-DC bandwidth combination as specified in Table 5.3B.1.2-1	Highest NRB_agg (NOTE 1)
NOTE 1: If the UE supports multiple CC Combinations in the EN-DC Configuration with the same NRB_agg, only the combination with the highest NRB_SCG is tested.	

The initial test configurations for E-UTRA band consist of environmental conditions, test frequencies, and channel bandwidths based on E-UTRA bands specified in Table 4.6-1.

For Initial conditions as in clause 6.4.2.4.4.1 in TS 38.521-1 [8], the following steps will be added to configure E-UTRA component:

- 2.1. The parameter settings for E-UTRA cell are set up according to TS 36.508 [11] clause 4.4.3.
- 3.1. The E-UTRA downlink signal level, uplink signal level are set according to Table 4.6-1 and propagation conditions are set according to Annex B.0 of TS 36.521-1 [10].

Step 6 of Initial conditions as in clause 6.4.2.4.4.1 in TS 38.521-1 [8] is replaced by:

6. Ensure the UE is in state RRC_CONNECTED with generic procedure parameters Connectivity EN-DC, DC bearer MCG and SCG, Connected without release On according to TS 38.508-1 [6] clause 4.5.

Same test procedure as in clause 6.4.2.4.4.2 in TS 38.521-1 [8] with the following steps added for E-UTRA component:

- 1.1. On the E-UTRA carrier, disable periodic and aperiodic CQI reports, disable SRS, set *TimeAlignmentTimerDedicated* IE to infinity and disable downlink and uplink scheduling, all as per Table 4.6-1 under clause 4.6.

6.4B.2.1.4.5 Test requirement

Same test requirement as in clause 6.4.2.4.5 in TS 38.521-1 [8] for the NR carrier.

6.4B.2.2 Transmit Modulation Quality for intra-band non-contiguous EN-DC

6.4B.2.2.1 Error Vector Magnitude for intra-band non-contiguous EN-DC

6.4B.2.2.1.1 Test purpose

Same test purpose as in clause 6.4.2.1.1 in TS 38.521-1 [8] for the NR carrier.

6.4B.2.2.1.2 Test applicability

This test case applies to all types of E-UTRA UE release 15 and forward, supporting intra-band non-contiguous EN-DC.

6.4B.2.2.1.3 Minimum conformance requirements

For the intra-band non-contiguous EN-DC with one component carrier per CG the EVM requirement applies with PRB allocation in one of the CG and the other CG unallocated.

The EVM requirements for each CG are according to clause 6.5.2.1 of TS 36.101 [5] for the MCG and clause 6.4.2.1.3 of TS 38.521-1 [8] for the SCG with EN-DC configured.

The normative reference for this requirement is TS 38.101-3 [4] clause 6.4B.2.2.1.

No exception requirements applicable to NR or LTE. LTE anchor agnostic approach is applied.

6.4B.2.2.1.4 Test description

Same test description as in clause 6.4.2.1.4 in TS 38.521-1 [8] for the NR carrier with the following exception:

The initial test configurations for E-UTRA band consist of environmental conditions, test frequencies, and channel bandwidths based on E-UTRA bands specified in Table 4.6-1. For Initial conditions as in clause 6.4.2.1.4.1 in TS 38.521-1 [8], the following steps will be added to configure E-UTRA component:

- 2.1. The parameter settings for E-UTRA cell are set up according to TS 36.508 [11] clause 4.4.3.
- 3.1. The E-UTRA downlink signal level, uplink signal level are set according to Table 4.6-1 and propagation conditions are set according to Annex B.0 of TS 36.521-1 [10].

Step 6 of Initial conditions as in clause 6.4.2.1.4.1 in TS 38.521-1 [8] is replaced by:

6. Ensure the UE is in state RRC_CONNECTED with generic procedure parameters Connectivity EN-DC, DC bearer MCG and SCG, Connected without release *On* according to TS 38.508 [6] clause 4.5.

Same test procedure as in clause 6.4.2.1.4.2 in TS 38.521-1 [8].

For Message contents as in clause 6.4.2.1.4.3 in TS 38.521-1 [8], the following exception:

Table 6.4B.2.2.1.4-1: RACH-ConfigGeneric: PRACH measurement

Derivation Path: TS 38.508-1[5], Table 4.6.3-130			
Information Element	Value/remark	Comment	Condition
RACH-ConfigGeneric ::= SEQUENCE {			
prach-ConfigurationIndex	14	Unpaired Spectrum	PRACH Format 0

6.4B.2.2.1.5 Test requirement

Same test requirement as in clause 6.4.2.1.5 in TS 38.521-1 [8] for the NR carrier.

6.4B.2.2.2 Carrier Leakage for intra-band non-contiguous EN-DC

6.4B.2.2.2.1 Test purpose

Same test purpose as in clause 6.4.2.2.1 in TS 38.521-1 [8] for the NR carrier.

6.4B.2.2.2.2 Test applicability

This test case applies to all types of E-UTRA UE release 15 and forward, supporting intra-band non-contiguous EN-DC.

6.4B.2.2.2.3 Minimum conformance requirements

The carrier leakage requirements for each CG are according to clause 6.5.2.2 of TS 36.101 [5] for the MCG and clause 6.4.2.2.3 of TS 38.521-1 [8] for the SCG with EN-DC configured and PRB allocation only in the CG being measured.

The normative reference for this requirement is TS 38.101-3 [4] clause 6.4B.2.2.2.

No exception requirements applicable to NR or LTE. LTE anchor agnostic approach is applied.

6.4B.2.2.2.4 Test description

Same test description as in clause 6.4.2.2.4 in TS 38.521-1 [8] for the NR carrier with the following exception:

The initial test configurations for E-UTRA band consist of environmental conditions, test frequencies, and channel bandwidths based on E-UTRA bands specified in Table 4.6-1.

For Initial conditions as in clause 6.4.2.2.4.1 in TS 38.521-1 [8], the following steps will be added to configure E-UTRA component:

- 2.1. The parameter settings for E-UTRA cell are set up according to TS 36.508 [11] clause 4.4.3.
- 3.1. The E-UTRA downlink signal level, uplink signal level are set according to Table 4.6-1 and propagation conditions are set according to Annex B.0 of TS 36.521-1 [10].

Step 6 of Initial conditions as in clause 6.4.2.2.4.1 in TS 38.521-1 [8] is replaced by the following two steps:

6. Ensure the UE is in state RRC_CONNECTED with generic procedure parameters Connectivity EN-DC, DC bearer MCG and SCG, Connected without release *On* according to TS 38.508 [6] clause 4.5.
7. On the E-UTRA carrier, disable periodic and aperiodic CQI reports, disable SRS, set *TimeAlignmentTimerDedicated* IE to infinity and disable downlink and uplink scheduling, all as per Table 4.6-1 under clause 4.6.

6.4B.2.2.2.5 Test requirement

Same test requirement as in clause 6.4.2.2.5 in TS 38.521-1 [8] for the NR carrier.

6.4B.2.2.3 In-band Emissions for intra-band non-contiguous EN-DC

6.4B.2.2.3.1 Test purpose

Same test purpose as in clause 6.4.2.3.1 in TS 38.521-1 [8] for the NR carrier.

6.4B.2.2.3.2 Test applicability

This test case applies to all types of E-UTRA UE release 15 and forward, supporting intra-band non-contiguous EN-DC.

6.4B.2.2.3.3 Minimum conformance requirements

For the MCG the in-band emission requirements in Table 6.5.2A.3.1-1 and Table 6.5.2A.3.1-2 in TS 36.101 [5] apply within the transmission bandwidth configuration of the MCG with the carriers of both CGs active and one single contiguous PRB allocation of bandwidth L_{CRB} within the MCG at the edge of the transmission bandwidth configuration.

For the SCG the in-band emission requirements in Table 6.5.2A.3.1-1 and Table 6.5.2A.3.1-2 in TS 36.101 [5] apply within the transmission bandwidth configuration of the SCG with the carriers of both CGs active and one single contiguous PRB allocation of bandwidth L_{CRB} within the SCG at the edge of the transmission bandwidth configuration.

The normative reference for this requirement is TS 38.101-3 [4] clause 6.4B.2.2.3.

No exception requirements applicable to NR or LTE.

6.4B.2.2.3.4 Test description

6.4B.2.2.3.4.1 Initial conditions

Initial conditions are a set of test configurations the UE needs to be tested in and the steps for the SS to take with the UE to reach the correct measurement state.

The initial test configurations consist of environmental conditions, test frequencies and test channel bandwidths based on NR operating bands specified in clause 5.3B.1.2, channel bandwidths and sub-carrier spacings for the NR cell specified in TS 38.521-1 [8] clause 5.3 and channel bandwidth for the E-UTRA cell are specified in TS 36.521-1 [10] clause 5.4.2. All of these configurations shall be tested with applicable test parameters for each EN-DC combination of test channel bandwidth and sub-carrier spacing, and are shown in table 6.4B.2.2.3.4.1-1. The details of the uplink reference measurement channels (RMCs) are specified in Annexes A.2. Configurations of PDSCH and PDCCH before measurement are specified in TS 36.521.1 [10] Annex C.2 and in TS 38.521-1 [8] Annex C.2 for E-UTRA CG and NR CG respectively.

Table 6.4B.2.2.3.4-1: Test Configuration Table

Initial Conditions					
Test Environment as specified in TS 38.508-1 [6] clause 4.1		Normal			
Test Frequencies as specified in TS 38.508-1 [6] clause 4.3.1		MaxWGap			
Test EN-DC bandwidth combination as specified in Table 5.3B.1.3-1		Lowest N_{RB_agg} , Highest N_{RB_agg} (NOTE 4)			
Test SCS for the NR cell as specified in TS 38.521-1 [8] Table 5.3.5-1		Lowest			
Test Parameters					
Test ID	Downlink Configuration	EN-DC Uplink Configuration			
		E-UTRA Cell		NR Cell	
		Modulation	RB allocation (NOTE 3)	Modulation	RB allocation (NOTE 1,2)
1	N/A for carrier leakage testing	QPSK	0	DFT-s-OFDM QPSK	Inner_1RB_Left
2		QPSK	0	DFT-s-OFDM QPSK	Inner_1RB_Right
3		QPSK	0	CP-OFDM QPSK	Inner_1RB_Left
4		QPSK	0	CP-OFDM QPSK	Inner_1RB_Right
5		QPSK	Outer_1RB_Left	DFT-s-OFDM QPSK	0
6		QPSK	Outer_1RB_Right	DFT-s-OFDM QPSK	0
NOTE 1: The specific configuration of each RB allocation is defined in Table 6.1-1 in TS 38.521-1 [8].					
NOTE 2: When the signalled DC carrier position is at Inner_1RB_Left, use Inner_1RB_Right for UL RB allocation.					
NOTE 3: Outer_1RB_Left defined as 1 RB allocated at the left edge of the E-UTRA component. Outer_1RB_Right defined as 1 RB allocated at the right edge of the E-UTRA component.					
NOTE 4: If the UE supports multiple CC combinations in the EN-DC configuration with the same N_{RB_agg} , select the combination to test as follows: - Lowest ENBW: NR component with lowest NRB is tested. - Highest ENBW: NR component with highest NRB is tested.					

The initial test configurations for E-UTRA consist of test frequency based on E-UTRA operating band and test channel bandwidth as specified in Table 4.6-1.

1. Connect the SS to the UE antenna connectors as shown in TS 38.508-1 [6] Annex A, in Figure A.3.1.1.1 for TE diagram and clause A.3.2.1 for UE diagram.
2. The parameter settings for NR cell are set up according to TS 38.508-1 [6] clause 4.4.3.
3. The parameter settings for E-UTRA cell are set up according to TS 36.508 [11] clause 4.4.3. The E-UTRA downlink signal level, uplink signal level are set according to Table 4.6-1 and propagation conditions are set according to Annex B.0 of TS 36.521-1 [10].
4. NR downlink signals are initially set up according to Annex C.0, C.1, and C.2 and uplink signals according to Annex G.0, G.1, G.2, and G.3.0 of TS 38.521-1 [8].

5. E-UTRA downlink signals are initially set up according to Annex C.0, C.1 and C.3.0, and uplink signals according to Annex H.1 and H.3.0 of TS 36.521-1 [10].
6. The UL Reference Measurement channels are TS 36.521-1 [10] Annex A.2 and TS 38.521-1 [8] Annex A.2 for E-UTRA CG and NR CG respectively.
7. Propagation conditions are set according to TS 36.521-1 [10] Annex B.0 and TS 38.521-1 [8] Annex B.0 for E-UTRA CG and NR CG respectively.
8. Ensure the UE is in state RRC_CONNECTED with generic procedure parameters Connectivity EN-DC, DC bearer *MCG* and *SCG*, Connected without release *On* according to TS 38.508-1 [6] clause 4.5. Message contents are defined in clause 6.4B.2.2.3.4.3.
9. On the E-UTRA carrier, disable periodic and aperiodic CQI reports, disable SRS, set *TimeAlignmentTimerDedicated* IE to infinity and disable downlink and uplink scheduling, all as per Table 4.6-1 under clause 4.6.

6.4B.2.2.3.4.2 Test procedure

1. SS sends uplink scheduling information for each UL HARQ process via PDCCH DCI format 0 and DCI format 0_1 for C_RNTI to schedule the UL RMC according to Table 6.4B.2.2.3.4.1-1 on E-UTRA CC and NR CC respectively. Since the UL has no payload and no loopback data to send, the UE transmits uplink MAC padding bits on the UL RMC.
2. For NR CC, send uplink power control commands to the UE using 1dB power step size to ensure that the UE output power measured by the test system is within the Uplink power control window, defined as +MU to +(MU + Uplink power control window size) dB of the target power level 0dBm, where:
 - MU is the test system uplink power measurement uncertainty and is specified in Table F.1.2-1 for the carrier frequency *f* and the channel bandwidth *BW*.
 - Uplink power control window size = 1dB (UE power step size) + 0.7dB (UE power step tolerance) + (Test system relative power measurement uncertainty) + (Test system relative power measurement uncertainty), where, the UE power step tolerance is specified in TS 38.101-1 [2], Table 6.3.4.3-1 and is 0.7dB for 1dB power step size, and the Test system relative power measurement uncertainty is specified in Table F.1.2-1.
3. Measure In-band emission on NR CC using Global In-Channel Tx-Test (Annex E). Measure power spectral density on E-UTRA CC. For TDD slots with transient periods are not under test.
4. For NR CC, send uplink power control commands to the UE using 1dB power step size to ensure that the UE output power measured by the test system is within the Uplink power control window, defined as +MU to +(MU + Uplink power control window size) dB of the target power level -30dBm, where MU and Uplink power control window size are defined above.
5. Measure In-band emission on NR CC using Global In-Channel Tx-Test (Annex E). Measure power spectral density on E-UTRA CC. For TDD slots with transient periods are not under test.
6. For NR CC, send uplink power control commands to the UE using 1dB power step size to ensure that the UE output power measured by the test system is within the Uplink power control window, defined as +MU to +(MU + Uplink power control window size) dB of the target power level -40dBm, where MU and Uplink power control window size are defined above.
7. Measure In-band emission on NR CC using Global In-Channel Tx-Test (Annex E). Measure power spectral density on E-UTRA CC. For TDD slots with transient periods are not under test.
8. For E-UTRA CC, send uplink power control commands to the UE using 1dB power step size to ensure that the UE output power measured by the test system is within the Uplink power control window, defined as +MU to +(MU + Uplink power control window size) dB of the target power level 0dBm, where:
 - MU is the test system uplink power measurement uncertainty and is specified in Table F.1.2-1 for the carrier frequency *f* and the channel bandwidth *BW*.
 - Uplink power control window size = 1dB (UE power step size) + 1.0dB (UE power step tolerance) , where, the UE power step tolerance is specified in TS 36.101 [5], Table 6.3.5.2.1-1 and is 1.0dB for 1dB power step size, and the Test system relative power measurement uncertainty is specified in Table F.1.2-1.

9. Measure In-band emission on E-UTRA CC using Global In-Channel Tx-Test (Annex E). Measure power spectral density on NR CC. For TDD slots with transient periods are not under test.
 10. For E-UTRA CC, send uplink power control commands to the UE using 1dB power step size to ensure that the UE output power measured by the test system is within the Uplink power control window, defined as +MU to +(MU + Uplink power control window size) dB of the target power level -30dBm, where MU and Uplink power control window size are defined above.
 11. Measure In-band emission on E-UTRA CC using Global In-Channel Tx-Test (Annex E). Measure power spectral density on NR CC. For TDD slots with transient periods are not under test
 12. For E-UTRA CC, send uplink power control commands to the UE using 1dB power step size to ensure that the UE output power measured by the test system is within the Uplink power control window, defined as +MU to +(MU + Uplink power control window size) dB of the target power level -40dBm, where MU and Uplink power control window size are defined above.
 13. Measure In-band emission on E-UTRA CC using Global In-Channel Tx-Test (Annex E). Measure power spectral density on NR CC. For TDD slots with transient periods are not under test.
- NOTE 1: When switching to DFT-s-OFDM waveform, as specified in the test configuration table 6.4B.2.2.3.4.1-1, send an NR RRCReconfiguration message according to TS 38.508-1 [6] clause 4.6.3 Table 4.6.3-118 PUSCH-Config with TRANSFORM_PRECODER_ENABLED condition.
- NOTE 2: The purpose of the Uplink power control window is to ensure that the actual UE output power is no less than the target power level, and as close as possible to the target power level. The relationship between the Uplink power control window, the target power level and the corresponding possible actual UE Uplink power window is illustrated in Annex F, clause F.4.

Table 6.4B.2.2.3.4.2-1: Void

Table 6.4B.2.2.3.4.2-2: Void

6.4B.2.2.3.4.3 Message contents

Message contents are according to TS 38.508-1 [5] clause 4.6.

6.4B.2.2.3.5 Test requirement

Each of the [20] In-band emissions results, derived in Annex E.4.3 shall not exceed the corresponding values in Tables 6.4B.2.2.3.5-1.

Table 6.4B.2.2.3.5-1: Minimum requirements for in-band emissions (allocated component carrier)

Parameter	Unit	Limit	Applicable Frequencies
General	dB	$\max \left\{ -25 - 10 \cdot \log_{10} (N_{RB} / L_{CRB}), \right.$ $20 \cdot \log_{10} EVM - 3 - 5 \cdot (\Delta_{RB} - 1) / L_{CRB},$ $\left. -57 \text{ dBm} / 180 \text{ kHz} - P_{RB} \right\}$	Any non-allocated (NOTE 2)
IQ Image	dB	-25	Exception for IQ image (NOTE 3)
Carrier leakage	dBc	-25	Exception for Carrier frequency (NOTE 4)
		-20	
		-10	
<p>NOTE 1: An in-band emissions combined limit is evaluated in each non-allocated RB. For each such RB, the minimum requirement is calculated as the higher of $P_{RB} - 30$ dB and the power sum of all limit values (General, IQ Image or Carrier leakage) that apply. P_{RB} is defined in NOTE 9. The limit is evaluated in each non-allocated RB.</p> <p>NOTE 2: The measurement bandwidth is 1 RB and the limit is expressed as a ratio of measured power in one non-allocated RB to the measured average power per allocated RB, where the averaging is done across all allocated RBs.</p> <p>NOTE 3: Exceptions to the general limit are allowed for up to $L_{CRBs} + 1$ RBs within a contiguous width of $L_{CRBs} + 1$ non-allocated RBs. The measurement bandwidth is 1 RB.</p> <p>NOTE 4: Exceptions to the general limit are allowed for up to two contiguous non-allocated RBs. The measurement bandwidth is 1 RB and the limit is expressed as a ratio of measured power in the non-allocated RB to the measured total power in all allocated RBs.</p> <p>NOTE 5: L_{CRB} is the Transmission Bandwidth (see Figure [5.6-1]) not exceeding $\lfloor N_{RB} / 2 - 1 \rfloor$</p> <p>NOTE 6: N_{RB} is the Transmission Bandwidth Configuration (see Figure [5.6-1]) of the component carrier with RBs allocated.</p> <p>NOTE 7: EVM is the limit specified in Table 6.4.2.1.3-1 for the modulation format used in the allocated RBs.</p> <p>NOTE 8: Δ_{RB} is the starting frequency offset between the allocated RB and the measured non-allocated RB (e.g. $\Delta_{RB} = 1$ or $\Delta_{RB} = -1$ for the first adjacent RB outside of the allocated bandwidth).</p> <p>NOTE 9: P_{RB} is the transmitted power per 180 kHz in allocated RBs, measured in dBm.</p>			

Table 6.4B.2.2.3.5-2: Minimum requirements for in-band emissions (not allocated component carrier)

Parameter	Unit	Meas BW NOTE 1	Limit	remark	Applicable Frequencies	
General	dB	BW of 1 RB (180KHz rectangular)	$\max \left\{ -25 - 10 \cdot \log_{10} (N_{RB} / L_{CRB}), \right.$ $20 \cdot \log_{10} EVM - 3 - 5 \cdot (\Delta_{RB} - 1) / L_{CRB},$ $\left. -57 \text{ dBm} / 180 \text{ kHz} - P_{RB} \right\}$	The reference value is the average power per allocated RB in the allocated component carrier	Any RB in the non-allocated component carrier. The frequency raster of the RBs is derived when this component carrier is allocated with RBs	
IQ Image	dB	BW of 1 RB (180KHz rectangular)	-25 NOTE 2	The reference value is the average power per allocated RB in the allocated component carrier	The frequencies of the L_{CRB} contiguous non-allocated RBs are unknown. The frequency raster of the RBs is derived when this component carrier is allocated with RBs	
Carrier leakage	dBc	BW of 1 RB (180KHz rectangular)	NOTE 3		The reference value is the total power of the allocated RBs in the allocated component carrier	The frequencies of the up to 2 non-allocated RBs are unknown. The frequency raster of the RBs is derived when this component carrier is allocated with RBs
			-25	Output power > 0 dBm		
			-20	-30 dBm ≤ Output power ≤ 0 dBm		
			-10	-40 dBm ≤ Output power < -30 dBm		
<p>NOTE 1: Resolution BWs smaller than the measurement BW may be integrated to achieve the measurement bandwidth.</p> <p>NOTE 2: Exceptions to the general limit is are allowed for up to $L_{CRB} + 1$ RBs within a contiguous width of $L_{CRB} + 1$ non-allocated RBs.</p> <p>NOTE 3: Two Exceptions to the general limit are allowed for up to two contiguous non-allocated RBs</p> <p>NOTE 4: NOTES 1, 5, 6, 7, 8, 9 from Table 6.4B.2.2.3.5-1 apply for Table 6.4B.2.2.3.5-2 as well.</p> <p>NOTE 5: Δ_{RB} for measured non-allocated RB in the non-allocated component carrier may take non-integer values when the carrier spacing between the CCs is not a multiple of RB.</p>						

6.4B.2.2.4 EVM Equalizer Flatness for intra-band non-contiguous EN-DC

6.4B.2.2.4.1 Test purpose

Same test purpose as in clause 6.4.2.4 in TS 38.521-1 [8] for the NR carrier.

6.4B.2.2.4.2 Test applicability

This test case applies to all types of E-UTRA UE release 15 and forward, supporting intra-band non-contiguous EN-DC.

6.4B.2.2.4.3 Minimum conformance requirements

Same minimum conformance requirements as in clause 6.4.2.4.3 in TS 38.521-1 [8] for the NR carrier.

No exception requirements applicable to NR or LTE. LTE anchor agnostic approach is applied.

6.4B.2.2.4.4 Test description

Same test description as in clause 6.4.2.4.4 in TS 38.521-1 [8] for the NR carrier with the following exception:

Table 6.4B.2.2.4.4-1: Test Configuration Table

Initial Conditions			
Test Environment as specified in TS 38.508-1 [6] clause 4.1		Normal, TL/VL, TL/VH, TH/VL, TH/VH	
Test Frequencies as specified in TS 38.508-1 [6] clause 4.3.1		MaxWGap	
Test Channel Bandwidths as specified in TS 38.508-1 [6] clause 4.3.1		Highest N _{RB_agg} (NOTE 1, 2)	
Test SCS as specified in Table 5.3.5-1		Lowest	
Test parameters			
Test ID	Downlink Configuration	Uplink Configuration	
	N/A for EVM equalizer flatness testing	Modulation	NR RB allocation (NOTE 3)
1		DFT-s-OFDM QPSK	Outer Full
2		CP-OFDM QPSK	Outer Full
NOTE 1: Test Channel Bandwidths are checked separately for each NR band, which applicable channel bandwidths are specified in Table 5.3.5-1 of 38.521-1 [8].			
NOTE 2: Lowest and highest allowed NR channel BW as specified in Table 5.3B.1.3-1. If the UE supports multiple CC Combinations in the EN-DC Configuration with the same N _{RB_agg} , only the combination with the highest N _{RB_SCG} is tested.			
NOTE 3: The specific configuration of each RB allocation is defined in Table 6.1-1 of 38.521-1 [8].			

The initial test configurations for E-UTRA band consist of environmental conditions, test frequencies, and channel bandwidths based on E-UTRA bands specified in Table 4.6-1.

For Initial conditions as in clause 6.4.2.4.4.1 in TS 38.521-1 [8], the following steps will be added to configure E-UTRA component:

- 2.1. The parameter settings for E-UTRA cell are set up according to TS 36.508 [11] clause 4.4.3.
- 3.1. The E-UTRA downlink signal level, uplink signal level are set according to Table 4.6-1 and propagation conditions are set according to Annex B.0 of TS 36.521-1 [10].

Step 6 of Initial conditions as in clause 6.4.2.4.4.1 in TS 38.521-1 [8] is replaced by:

6. Ensure the UE is in state RRC_CONNECTED with generic procedure parameters Connectivity EN-DC, DC bearer MCG and SCG, Connected without release On according to TS 38.508-1 [6] clause 4.5.

Same test procedure as in clause 6.4.2.4.4.2 in TS 38.521-1 [8] with the following steps added for E-UTRA component:

- 1.1 On the E-UTRA carrier, disable periodic and aperiodic CQI reports, disable SRS, set *TimeAlignmentTimerDedicated* IE to infinity and disable downlink and uplink scheduling, all as per Table 4.6-1 under clause 4.6.

6.4B.2.2.4.5 Test requirement

Same test requirement as in clause 6.4.2.4.5 in TS 38.521-1 [8] for the NR carrier.

6.4B.2.3 Transmit Modulation Quality for inter-band EN-DC within FR1

6.4B.2.3.1 Error Vector Magnitude for inter-band EN-DC within FR1

6.4B.2.3.1.1 Test purpose

Same test purpose as in clause 6.4.2.1.1 in TS 38.521-1 [8] for the NR carrier.

6.4B.2.3.1.2 Test applicability

This test case applies to all types of E-UTRA UE release 15 and forward, supporting inter-band EN-DC.

6.4B.2.3.1.3 Minimum conformance requirements

Same minimum conformance requirements as in clause 6.4.2.1.3 in TS 38.521-1 [8] for the NR carrier.

The normative reference for this requirement is TS 38.101-3 [4] clause 6.4B.2.

No exception requirements applicable to NR or LTE. LTE anchor agnostic approach is applied.

6.4B.2.3.1.4 Test description

Same test description as in clause 6.4.2.1.4 in TS 38.521-1 [8] for the NR carrier with the following exception:

The initial test configurations for E-UTRA band consist of environmental conditions, test frequencies, and channel bandwidths based on E-UTRA bands specified in Table 4.6-1. For Initial conditions as in clause 6.4.2.1.4.1 in TS 38.521-1 [8], the following steps will be added to configure E-UTRA component:

- 2.1. The parameter settings for E-UTRA cell are set up according to TS 36.508 [11] clause 4.4.3.
- 3.1. The E-UTRA downlink signal level, uplink signal level are set according to Table 4.6-1 and propagation conditions are set according to Annex B.0 of TS 36.521-1 [10].

Step 6 of Initial conditions as in clause 6.4.2.1.4.1 in TS 38.521-1 [8] is replaced by the following two steps:

6. Ensure the UE is in state RRC_CONNECTED with generic procedure parameters Connectivity EN-DC, DC bearer MCG and SCG, Connected without release *On* according to TS 38.508 [6] clause 4.5.
7. On the E-UTRA carrier, disable periodic and aperiodic CQI reports, disable SRS, set *TimeAlignmentTimerDedicated* IE to infinity and disable downlink and uplink scheduling, all as per Table 4.6-1 under clause 4.6.

Same test procedure as in clause 6.4.2.1.4.2 in TS 38.521-1 [8].

6.4B.2.3.1.5 Test requirement

Same test requirement as in clause 6.4.2.1.5 in TS 38.521-1 [8] for the NR carrier.

6.4B.2.3.2 Carrier Leakage for inter-band EN-DC within FR1

6.4B.2.3.2.1 Test purpose

Same test purpose as in clause 6.4.2.2.1 in TS 38.521-1 [8] for the NR carrier.

6.4B.2.3.2.2 Test applicability

This test case applies to all types of E-UTRA UE release 15 and forward, supporting inter-band EN-DC.

6.4B.2.3.2.3 Minimum conformance requirements

Same minimum conformance requirements as in clause 6.4.2.2.3 in TS 38.521-1 [8] for the NR carrier.

The normative reference for this requirement is TS 38.101-3 [4] clause 6.4B.2.

No exception requirements applicable to NR or LTE. LTE anchor agnostic approach is applied.

6.4B.2.3.2.4 Test description

Same test description as in clause 6.4.2.2.4 in TS 38.521-1 [8] for the NR carrier with the following exception:

The initial test configurations for E-UTRA band consist of environmental conditions, test frequencies, and channel bandwidths based on E-UTRA bands specified in Table 4.6-1.

For Initial conditions as in clause 6.4.2.2.4.1 in TS 38.521-1 [8], the following steps will be added to configure E-UTRA component:

- 2.1. The parameter settings for E-UTRA cell are set up according to TS 36.508 [11] clause 4.4.3.
- 3.1. The E-UTRA downlink signal level, uplink signal level are set according to Table 4.6-1 and propagation conditions are set according to Annex B.0 of TS 36.521-1 [10].

Step 6 of Initial conditions as in clause 6.5.2.2.4.1 in TS 38.521-1 [8] is replaced by the following two steps:

6. Ensure the UE is in state RRC_CONNECTED with generic procedure parameters Connectivity EN-DC, DC bearer MCG and SCG, Connected without release *On* according to TS 38.508 [6] clause 4.5.
7. On the E-UTRA carrier, disable periodic and aperiodic CQI reports, disable SRS, set *TimeAlignmentTimerDedicated* IE to infinity and disable downlink and uplink scheduling, all as per Table 4.6-1 under clause 4.6.

6.4B.2.3.2.5 Test requirement

Same test requirement as in clause 6.4.2.2.5 in TS 38.521-1 [8] for the NR carrier.

6.4B.2.3.3 In-band Emissions for inter-band EN-DC within FR1

6.4B.2.3.3.1 Test purpose

Same test purpose as in clause 6.4.2.3.1 in TS 38.521-1 [8] for the NR carrier.

6.4B.2.3.3.2 Test applicability

This test case applies to all types of E-UTRA UE release 15 and forward, supporting inter-band EN-DC.

6.4B.2.3.3.3 Minimum conformance requirements

Same minimum conformance requirements as in clause 6.4.2.3.3 in TS 38.521-1 [8] for the NR carrier.

The normative reference for this requirement is TS 38.101-3 [4] clause 6.4B.2.

No exception requirements applicable to NR or LTE. LTE anchor agnostic approach is applied.

6.4B.2.3.3.4 Test description

Same test description as in clause 6.4.2.3.4 in TS 38.521-1 [8] for the NR carrier with the following exception:

The initial test configurations for E-UTRA band consist of environmental conditions, test frequencies, and channel bandwidths based on E-UTRA bands specified in Table 4.6-1. For Initial conditions as in clause 6.4.2.3.4.1 in TS 38.521-1 [8], the following steps will be added to configure E-UTRA component:

- 2.1. The parameter settings for E-UTRA cell are set up according to TS 36.508 [11] clause 4.4.3.
- 3.1. The E-UTRA downlink signal level, uplink signal level are set according to Table 4.6-1 and propagation conditions are set according to Annex B.0 of TS 36.521-1 [10].

Step 6 of Initial conditions as in clause 6.4.2.3.4.1 in TS 38.521-1 [8] is replaced by:

6. Ensure the UE is in state RRC_CONNECTED with generic procedure parameters Connectivity EN-DC, DC bearer MCG and SCG, Connected without release *On* according to TS 38.508 [6] clause 4.5.
7. On the E-UTRA carrier, disable periodic and aperiodic CQI reports, disable SRS, set *TimeAlignmentTimerDedicated* IE to infinity and disable downlink and uplink scheduling, all as per Table 4.6-1 under clause 4.6.

Same test procedure as in clause 6.4.2.3.4.2 in TS 38.521-1 [8].

6.4B.2.3.3.5 Test requirement

Same test requirement as in clause 6.4.2.3.5 in TS 38.521-1 [8] for the NR carrier.

6.4B.2.3.4 EVM Equalizer Flatness for inter-band EN-DC within FR1

6.4B.2.3.4.1 Test purpose

Same test purpose as in clause 6.4.2.4 in TS 38.521-1 [8] for the NR carrier.

6.4B.2.3.4.2 Test applicability

This test case applies to all types of E-UTRA UE release 15 and forward, supporting inter-band EN-DC.

6.4B.2.3.4.3 Minimum conformance requirements

Same minimum conformance requirements as in clause 6.4.2.4.3 in TS 38.521-1 [8] for the NR carrier.

No exception requirements applicable to NR or LTE. LTE anchor agnostic approach is applied.

6.4B.2.3.4.4 Test description

6.4B.2.3.4.4.1 Initial conditions

Same test description as in clause 6.4.2.4.4 in TS 38.521-1 [8] for the NR carrier with the following exception:

The initial test configurations for E-UTRA band consist of environmental conditions, test frequencies, and channel bandwidths based on E-UTRA bands specified in Table 4.6-1.

For Initial conditions as in clause 6.4.2.4.4.1 in TS 38.521-1 [8], the following steps will be added to configure E-UTRA component:

- 2.1. The parameter settings for E-UTRA cell are set up according to TS 36.508 [11] clause 4.4.3.
- 3.1. The E-UTRA downlink signal level, uplink signal level are set according to Table 4.6-1 and propagation conditions are set according to Annex B.0 of TS 36.521-1 [10].

Step 6 of Initial conditions as in clause 6.4.2.4.4.1 in TS 38.521-1 [8] is replaced by:

6. Ensure the UE is in state RRC_CONNECTED with generic procedure parameters Connectivity EN-DC, DC bearer MCG and SCG, Connected without release *On* according to TS 38.508-1 [6] clause 4.5.

Same test procedure as in clause 6.4.2.4.4.2 in TS 38.521-1 [8] with the following steps added for E-UTRA component:

- 1.1 On the E-UTRA carrier, disable periodic and aperiodic CQI reports, disable SRS, set *TimeAlignmentTimerDedicated* IE to infinity and disable downlink and uplink scheduling, all as per Table 4.6-1 under clause 4.6.

6.4B.2.3.4.5 Test requirement

Same test requirement as in clause 6.4.2.4.5 in TS 38.521-1 [8] for the NR carrier.

6.4B.2.4 Transmit Modulation Quality for inter-band EN-DC including FR2

6.4B.2.4.1 Error Vector Magnitude for inter-band EN-DC including FR2

Editor's note: This clause is incomplete. The following aspects are either missing or not yet determined:

- The referred test case 6.4.2.1 in TS 38.521-2 [9] is incomplete.
- Measurement Uncertainty and Test Tolerance are FFS.
- TS 38.101-2 [3] clause 6.3.4.3: Relative power tolerances are in square brackets.

6.4B.2.4.1.1 Test purpose

Same test purpose as in clause 6.4.2.1 in TS 38.521-2 [9] for the NR carrier.

6.4B.2.4.1.2 Test applicability

This test case applies to all types of E-UTRA UE release 15 and forward, supporting inter-band EN-DC including FR2 with 2 UL CCs.

6.4B.2.4.1.3 Minimum conformance requirements

For inter-band EN-DC including FR2 or both FR1 and FR2, transmit modulation quality for EN-DC operations in FR1 and FR2 as specified in TS 36.101 [5], 38.101-1 [2] and 38.101-2 [3] apply for E-UTRA, NR FR1 and NR FR2 respectively.

The normative reference for this requirement is TS 38.101-3 [4] clause 6.4B.2.4.

Same minimum conformance requirements as in clause 6.4.2.1.3 in TS 38.521-2 [9] for the NR carrier.

No exception requirements applicable to NR or LTE. LTE anchor agnostic approach is applied.

6.4B.2.4.1.4 Test description

6.4B.2.4.1.4.1 Initial conditions

Same test description as in clause 6.4.2.1.4 in TS 38.521-2 [9] for the NR carrier with the following exception:

The initial test configurations for E-UTRA band consist of environmental conditions, test frequencies, and channel bandwidths based on E-UTRA bands specified in Table 4.7-1. For Initial conditions as in clause 6.4.2.1.4.1 in TS 38.521-2 [9], the following steps will be added to configure E-UTRA component:

- 2.1. The parameter settings for E-UTRA cell are set up according to TS 36.508 [11] clause 4.4.3.
- 3.1. The E-UTRA downlink signal level, uplink signal level are set according to Table 4.7-1 and propagation conditions are set according to Annex B.0 of TS 36.521-1 [10].

Step 6 of Initial conditions as in clause 6.4.2.4.1 in TS 38.521-2 [9] is replaced by:

6. Ensure the UE is in state RRC_CONNECTED with generic procedure parameters Connectivity EN-DC, DC bearer MCG and SCG, Connected without release On according to TS 38.508-1 [6] clause 4.5.

Same test procedure as in clause 6.4.2.1.4.1 in TS 38.521-2 [9] with the following steps added for E-UTRA component:

- 1.1 On the E-UTRA carrier, disable periodic and aperiodic CQI reports, disable SRS, set *TimeAlignmentTimerDedicated* IE to infinity and disable downlink and uplink scheduling, all as per Table 4.7-1 under clause 4.7.

6.4B.2.4.1.5 Test requirement

Same test requirement as in clause 6.4.2.1.5 in TS 38.521-2 [9] for the NR carrier.

6.4B.2.4.1_1 Error Vector Magnitude for inter-band EN-DC including FR2 (>2 CCs)

6.4B.2.4.1_1.1 Error Vector Magnitude for inter-band EN-DC including FR2 (3 CCs)

Editor's note: This clause is incomplete. The following aspects are either missing or not yet determined:

- The referred test case 6.4A.2.1.1 in TS 38.521-2 [9] is incomplete.
- Test configuration table is FFS.

6.4B.2.4.1_1.1.1 Test purpose

Same test purpose as in clause 6.4.2.1.1 in TS 38.521-2 [9] for the NR carrier.

6.4B.2.4.1_1.1.2 Test applicability

This test case applies to all types of E-UTRA UE release 15 and forward, supporting inter-band EN-DC including FR2 with 3 UL CCs (2NR UL CCs).

6.4B.2.4.1_1.1.3 Minimum conformance requirements

Same minimum conformance requirements as in clause 6.4.2.1.3 in TS 38.521-2 [9] for the NR carrier.

No exception requirements applicable to NR or LTE. LTE anchor agnostic approach is applied.

The normative reference for this requirement is TS 38.101-3 [4] clause 6.4B.2.4.

6.4B.2.4.1_1.1.4 Test description

6.4B.2.4.1_1.1.4.1 Initial condition

Same test description as in clause 6.4A.2.1.1.4 in TS 38.521-2 [9] for the NR carrier with the following exception:

The initial test configurations for E-UTRA band consist of environmental conditions, test frequencies, and channel bandwidths based on E-UTRA bands specified in Table 4.7-1.

For Initial conditions as in clause 6.4A.2.1.1.4.1 in TS 38.521-2 [9], the following steps will be added to configure E-UTRA component:

- 2.1. The parameter settings for E-UTRA cell are set up according to TS 36.508 [11] clause 4.4.3.
- 3.1. The E-UTRA downlink signal level, uplink signal level are set according to Table 4.7-1 and propagation conditions are set according to Annex B.0 of TS 36.521-1 [10].

Step 6 of Initial conditions as in clause 6.4A.2.1.1.4.1 in TS 38.521-2 [9] is replaced by:

6. Ensure the UE is in state RRC_CONNECTED with generic procedure parameters Connectivity EN-DC, DC bearer MCG and SCG, Connected without release On according to TS 38.508-1 [6] clause 4.5.

Same test procedure as in clause 6.4A.2.1.1.4.2 in TS 38.521-2 [9] with the following steps added for E-UTRA component:

- 1.1 On the E-UTRA carrier, disable periodic and aperiodic CQI reports, disable SRS, set *TimeAlignmentTimerDedicated* IE to infinity and disable downlink and uplink scheduling, all as per Table 4.7-1 under clause 4.7.

6.4B.2.4.1_1.1.5 Test Requirements

Same test requirement as in clause 6.4A.2.1.1.5 in TS 38.521-2 [9] for the NR carrier.

6.4B.2.4.1_1.2 Error Vector Magnitude for inter-band EN-DC including FR2 (4 CCs)

Editor's note: This clause is incomplete. The following aspects are either missing or not yet determined:

- The referred test case 6.4A.2.1.2 in TS 38.521-2 [9] is incomplete.
- Test configuration table is FFS.

6.4B.2.4.1_1.2.1 Test purpose

Same test purpose as in clause 6.4.2.1.1 in TS 38.521-2 [9] for the NR carrier.

6.4B.2.4.1_1.2.2 Test applicability

This test case applies to all types of E-UTRA UE release 15 and forward, supporting inter-band EN-DC including FR2 with 4 UL CCs (3NR UL CCs).

6.4B.2.4.1_1.2.3 Minimum conformance requirements

Same minimum conformance requirements as in clause 6.4.2.1.3 in TS 38.521-2 [9] for the NR carrier.

No exception requirements applicable to NR or LTE. LTE anchor agnostic approach is applied.

The normative reference for this requirement is TS 38.101-3 [4] clause 6.4B.2.4.

6.4B.2.4.1_1.2.4 Test description

6.4B.2.4.1_1.2.4.1 Initial condition

Same test description as in clause 6.4A.2.1.2.4 in TS 38.521-2 [9] for the NR carrier with the following exception:

The initial test configurations for E-UTRA band consist of environmental conditions, test frequencies, and channel bandwidths based on E-UTRA bands specified in Table 4.7-1.

For Initial conditions as in clause 6.4A.2.1.2.4.1 in TS 38.521-2 [9], the following steps will be added to configure E-UTRA component:

- 2.1. The parameter settings for E-UTRA cell are set up according to TS 36.508 [11] clause 4.4.3.
- 3.1. The E-UTRA downlink signal level, uplink signal level are set according to Table 4.7-1 and propagation conditions are set according to Annex B.0 of TS 36.521-1 [10].

Step 6 of Initial conditions as in clause 6.4A.2.1.2.4.1 in TS 38.521-2 [9] is replaced by:

6. Ensure the UE is in state RRC_CONNECTED with generic procedure parameters Connectivity EN-DC, DC bearer MCG and SCG, Connected without release On according to TS 38.508-1 [6] clause 4.5.

Same test procedure as in clause 6.4A.2.1.2.4.2 in TS 38.521-2 [9] with the following steps added for E-UTRA component:

- 1.1 On the E-UTRA carrier, disable periodic and aperiodic CQI reports, disable SRS, set *TimeAlignmentTimerDedicated* IE to infinity and disable downlink and uplink scheduling, all as per Table 4.7-1 under clause 4.7.

6.4B.2.4.1_1.2.5 Test Requirements

Same test requirement as in clause 6.4A.2.1.2.5 in TS 38.521-2 [9] for the NR carrier.

6.4B.2.4.1_1.3 Error Vector Magnitude for inter-band EN-DC including FR2 (5 CCs)

Editor's note: This clause is incomplete. The following aspects are either missing or not yet determined:

- The referred test case 6.4A.2.1.3 in TS 38.521-2 [9] is incomplete.
- Test configuration table is FFS.

6.4B.2.4.1_1.3.1 Test purpose

Same test purpose as in clause 6.4.2.1.1 in TS 38.521-2 [9] for the NR carrier.

6.4B.2.4.1_1.3.2 Test applicability

This test case applies to all types of E-UTRA UE release 15 and forward, supporting inter-band EN-DC including FR2 with 5 UL CCs (4NR UL CCs).

6.4B.2.4.1_1.3.3 Minimum conformance requirements

Same minimum conformance requirements as in clause 6.4.2.1.3 in TS 38.521-2 [9] for the NR carrier.

No exception requirements applicable to NR or LTE. LTE anchor agnostic approach is applied.

The normative reference for this requirement is TS 38.101-3 [4] clause 6.4B.2.4.

6.4B.2.4.1_1.3.4 Test description

6.4B.2.4.1_1.3.4.1 Initial condition

Same test description as in clause 6.4A.2.1.3.4 in TS 38.521-2 [9] for the NR carrier with the following exception:

The initial test configurations for E-UTRA band consist of environmental conditions, test frequencies, and channel bandwidths based on E-UTRA bands specified in Table 4.7-1.

For Initial conditions as in clause 6.4A.2.1.3.4.1 in TS 38.521-2 [9], the following steps will be added to configure E-UTRA component:

- 2.1. The parameter settings for E-UTRA cell are set up according to TS 36.508 [11] clause 4.4.3.
- 3.1. The E-UTRA downlink signal level, uplink signal level are set according to Table 4.7-1 and propagation conditions are set according to Annex B.0 of TS 36.521-1 [10].

Step 6 of Initial conditions as in clause 6.4A.2.1.3.4.1 in TS 38.521-2 [9] is replaced by:

6. Ensure the UE is in state RRC_CONNECTED with generic procedure parameters Connectivity EN-DC, DC bearer MCG and SCG, Connected without release On according to TS 38.508-1 [6] clause 4.5.

Same test procedure as in clause 6.4A.2.1.3.4.2 in TS 38.521-2 [9] with the following steps added for E-UTRA component:

- 1.1 On the E-UTRA carrier, disable periodic and aperiodic CQI reports, disable SRS, set *TimeAlignmentTimerDedicated* IE to infinity and disable downlink and uplink scheduling, all as per Table 4.7-1 under clause 4.7.

6.4B.2.4.1_1.3.5 Test Requirements

Same test requirement as in clause 6.4A.2.1.3.5 in TS 38.521-2 [9] for the NR carrier.

6.4B.2.4.1D Error Vector Magnitude for inter-band EN-DC including FR2 for UL-MIMO

Editor's note: This clause is incomplete. The following aspects are either missing or not yet determined:

- The referred test case 6.4D.2.1 in TS 38.521-2 [9] is incomplete.
- Measurement Uncertainty and Test Tolerance are FFS and Annex F needs to be updated.

6.4B.2.4.1D.1 Test purpose

Same test purpose as in clause 6.4D.2.1.1 in TS 38.521-2 [9] for the NR carrier.

6.4B.2.4.1D.2 Test applicability

This test case applies to all types of E-UTRA UE release 15 and forward, supporting inter-band EN-DC including FR2 and UL-MIMO.

6.4B.2.4.1D.3 Minimum conformance requirements

For inter-band EN-DC including FR2 or both FR1 and FR2, transmit modulation quality for EN-DC operations in FR1 and FR2 as specified in TS 36.101 [5], 38.101-1 [2] and 38.101-2 [3] apply for E-UTRA, NR FR1 and NR FR2 respectively.

The normative reference for this requirement is TS 38.101-3 [4] clause 6.4B.2.4.

Same minimum conformance requirements as in clause 6.4D.2.1.3 in TS 38.521-2 [9] for the NR carrier.

No exception requirements applicable to NR or LTE. LTE anchor agnostic approach is applied.

6.4B.2.4.1D.4 Test description

6.4B.2.4.1D.4.1 Initial conditions

Same test description as in clause 6.4D.2.1.4 in TS 38.521-2 [9] for the NR carrier with the following exception:

The initial test configurations for E-UTRA band consist of environmental conditions, test frequencies, and channel bandwidths based on E-UTRA bands specified in Table 4.7-1. For Initial conditions as in clause 6.4D.2.1.4.1 in TS 38.521-2 [9], the following steps will be added to configure E-UTRA component:

- 2.1. The parameter settings for E-UTRA cell are set up according to TS 36.508 [11] clause 4.4.3.
- 3.1. The E-UTRA downlink signal level, uplink signal level are set according to Table 4.7-1 and propagation conditions are set according to Annex B.0 of TS 36.521-1 [10].

Step 6 of Initial conditions as in clause 6.4D.2.4.1 in TS 38.521-2 [9] is replaced by:

6. Ensure the UE is in state RRC_CONNECTED with generic procedure parameters Connectivity EN-DC, DC bearer MCG and SCG, Connected without release On according to TS 38.508-1 [6] clause 4.5.

Same test procedure as in clause 6.4D.2.1.4.1 in TS 38.521-2 [9] with the following steps added for E-UTRA component:

- 1.1 On the E-UTRA carrier, disable periodic and aperiodic CQI reports, disable SRS, set *TimeAlignmentTimerDedicated* IE to infinity and disable downlink and uplink scheduling, all as per Table 4.7-1 under clause 4.7.

6.4B.2.4.1D.5 Test requirement

Same test requirement as in clause 6.4D.2.1.5 in TS 38.521-2 [9] for the NR carrier.

6.4B.2.4.2_1 Carrier Leakage for inter-band EN-DC including FR2 (>2 CCs)

6.4B.2.4.2_1.1 Carrier Leakage for inter-band EN-DC including FR2 (3 CCs)

Editor's note: This clause is incomplete. The following aspects are either missing or not yet determined:

- The referred test case 6.4A.2.2.1 in TS 38.521-2 [9] is incomplete.
- Measurement Uncertainty and Test Tolerance are FFS.

6.4B.2.4.2_1.1.1 Test purpose

Same test purpose as in clause 6.4.2.2 in TS 38.521-2 [9] for the NR carrier.

6.4B.2.4.2_1.1.2 Test applicability

This test case applies to all types of E-UTRA UE release 15 and forward, supporting inter-band EN-DC including FR2 with 3 CCs(2NR CCs).

6.4B.2.4.2_1.1.3 Minimum conformance requirements

Same minimum conformance requirements as in clause 6.4B.2.4.2.3.

6.4B.2.4.2_1.1.4 Test Description

6.4B.2.4.2_1.1.4.1 Initial conditions

Same test description as in clause 6.4A.2.2.1.4 in TS 38.521-2 [9] for the NR carrier with the following exception:

The initial test configurations for E-UTRA band consist of environmental conditions, test frequencies, and channel bandwidths based on E-UTRA bands specified in Table 4.7-1.

For Initial conditions as in clause 6.4A.2.2.1.4.1 in TS 38.521-2 [9], the following steps will be added to configure E-UTRA component:

- 2.1. The parameter settings for E-UTRA cell are set up according to TS 36.508 [11] clause 4.4.3.
- 3.1. The E-UTRA downlink signal level, uplink signal level are set according to Table 4.7-1 and propagation conditions are set according to Annex B.0 of TS 36.521-1 [10].

Step 6 of Initial conditions as in clause 6.4A.2.2.1.4.1 in TS 38.521-2 [9] is replaced by:

6. Ensure the UE is in state RRC_CONNECTED with generic procedure parameters Connectivity EN-DC, DC bearer MCG and SCG, Connected without release On according to TS 38.508-1 [6] clause 4.5.

Same test procedure as in clause 6.4A.2.2.1.4.2 in TS 38.521-2 [9] with the following steps added for E-UTRA component:

- 1.1 On the E-UTRA carrier, disable periodic and aperiodic CQI reports, disable SRS, set *TimeAlignmentTimerDedicated* IE to infinity and disable downlink and uplink scheduling, all as per Table 4.7-1 under clause 4.7.

6.4B.2.4.2_1.1.5 Test Requirement

Same test requirement as in clause 6.4A.2.2.1.5 in TS 38.521-2 [9] for the NR carrier.

6.4B.2.4.2_1.2 Carrier Leakage for inter-band EN-DC including FR2 (4 CCs)

Editor's note: This clause is incomplete. The following aspects are either missing or not yet determined:

- The referred test case 6.4A.2.2.2 in TS 38.521-2 [9] is incomplete.
- Measurement Uncertainty and Test Tolerance are FFS.

6.4B.2.4.2_1.2.1 Test purpose

Same test purpose as in clause 6.4.2.2 in TS 38.521-2 [9] for the NR carrier.

6.4B.2.4.2_1.2.2 Test applicability

This test case applies to all types of E-UTRA UE release 15 and forward, supporting inter-band EN-DC including FR2 with 4 CCs(3NR CCs).

6.4B.2.4.2_1.2.3 Minimum conformance requirements

Same minimum conformance requirements as in clause 6.4B.2.4.2.3.

6.4B.2.4.2_1.2.4 Test Description

6.4B.2.4.2_1.2.4.1 Initial conditions

Same test description as in clause 6.4A.2.2.2.4 in TS 38.521-2 [9] for the NR carrier with the following exception:

The initial test configurations for E-UTRA band consist of environmental conditions, test frequencies, and channel bandwidths based on E-UTRA bands specified in Table 4.7-1.

For Initial conditions as in clause 6.4A.2.2.2.4.1 in TS 38.521-2 [9], the following steps will be added to configure E-UTRA component:

- 2.1. The parameter settings for E-UTRA cell are set up according to TS 36.508 [11] clause 4.4.3.
- 3.1. The E-UTRA downlink signal level, uplink signal level are set according to Table 4.7-1 and propagation conditions are set according to Annex B.0 of TS 36.521-1 [10].

Step 6 of Initial conditions as in clause 6.4A.2.2.2.4.1 in TS 38.521-2 [9] is replaced by:

6. Ensure the UE is in state RRC_CONNECTED with generic procedure parameters Connectivity EN-DC, DC bearer MCG and SCG, Connected without release On according to TS 38.508-1 [6] clause 4.5.

Same test procedure as in clause 6.4A.2.2.2.4.2 in TS 38.521-2 [9] with the following steps added for E-UTRA component:

- 1.1 On the E-UTRA carrier, disable periodic and aperiodic CQI reports, disable SRS, set *TimeAlignmentTimerDedicated* IE to infinity and disable downlink and uplink scheduling, all as per Table 4.7-1 under clause 4.7.

6.4B.2.4.2_1.2.5 Test Requirement

Same test requirement as in clause 6.4A.2.2.2.5 in TS 38.521-2 [9] for the NR carrier.

6.4B.2.4.2_1.3 Carrier Leakage for inter-band EN-DC including FR2 (5 CCs)

Editor's note: This clause is incomplete. The following aspects are either missing or not yet determined:

- The referred test case 6.4A.2.2.3 in TS 38.521-2 [9] is incomplete.
- Measurement Uncertainty and Test Tolerance are FFS.

6.4B.2.4.2_1.3.1 Test purpose

Same test purpose as in clause 6.4.2.2 in TS 38.521-2 [9] for the NR carrier.

6.4B.2.4.2_1.3.2 Test applicability

This test case applies to all types of E-UTRA UE release 15 and forward, supporting inter-band EN-DC including FR2 with 5 CCs(4NR CCs).

6.4B.2.4.2_1.3.3 Minimum conformance requirements

Same minimum conformance requirements as in clause 6.4B.2.4.2.3.

6.4B.2.4.2_1.3.4 Test Description

6.4B.2.4.2_1.3.4.1 Initial conditions

Same test description as in clause 6.4A.2.2.3.4 in TS 38.521-2 [9] for the NR carrier with the following exception:

The initial test configurations for E-UTRA band consist of environmental conditions, test frequencies, and channel bandwidths based on E-UTRA bands specified in Table 4.7-1.

For Initial conditions as in clause 6.4A.2.2.3.4.1 in TS 38.521-2 [9], the following steps will be added to configure E-UTRA component:

- 2.1. The parameter settings for E-UTRA cell are set up according to TS 36.508 [11] clause 4.4.3.
- 3.1. The E-UTRA downlink signal level, uplink signal level are set according to Table 4.7-1 and propagation conditions are set according to Annex B.0 of TS 36.521-1 [10].

Step 6 of Initial conditions as in clause 6.4A.2.2.3.4.1 in TS 38.521-2 [9] is replaced by:

6. Ensure the UE is in state RRC_CONNECTED with generic procedure parameters Connectivity EN-DC, DC bearer MCG and SCG, Connected without release On according to TS 38.508-1 [6] clause 4.5.

Same test procedure as in clause 6.4A.2.2.3.4.2 in TS 38.521-2 [9] with the following steps added for E-UTRA component:

- 1.1 On the E-UTRA carrier, disable periodic and aperiodic CQI reports, disable SRS, set *TimeAlignmentTimerDedicated* IE to infinity and disable downlink and uplink scheduling, all as per Table 4.7-1 under clause 4.7.

6.4B.2.4.2_1.3.5 Test Requirement

Same test requirement as in clause 6.4A.2.2.3.5 in TS 38.521-2 [9] for the NR carrier.

6.4B.2.4.2D Carrier Leakage for inter-band EN-DC including FR2 for UL-MIMO

Editor's note: This clause is incomplete. The following aspects are either missing or not yet determined:

- **The referred test case 6.4D.2.2 in TS 38.521-2 [9] is incomplete.**
- **Measurement Uncertainty and Test Tolerance are FFS and Annex F needs to be updated.**

6.4B.2.4.2D.1 Test purpose

Same test purpose as in clause 6.4D.2.2.1 in TS 38.521-2 [9] for the NR carrier.

6.4B.2.4.2D.2 Test applicability

This test case applies to all types of E-UTRA UE release 15 and forward, supporting inter-band EN-DC including FR2 and UL-MIMO.

6.4B.2.4.2D.3 Minimum conformance requirements

For inter-band EN-DC including FR2 or both FR1 and FR2, transmit modulation quality for EN-DC operations in FR1 and FR2 as specified in TS 36.101 [5], 38.101-1 [2] and 38.101-2 [3] apply for E-UTRA, NR FR1 and NR FR2 respectively.

The normative reference for this requirement is TS 38.101-3 [4] clause 6.4B.2.4.

Same minimum conformance requirements as in clause 6.4D.2.2.3 in TS 38.521-2 [9] for the NR carrier.

No exception requirements applicable to NR or LTE. LTE anchor agnostic approach is applied

6.4B.2.4.2D.4 Test description

6.4B.2.4.2D.4.1 Initial conditions

Same test description as in clause 6.4D.2.2.4 in TS 38.521-2 [9] for the NR carrier with the following exception:

The initial test configurations for E-UTRA band consist of environmental conditions, test frequencies, and channel bandwidths based on E-UTRA bands specified in Table 4.7-1. For Initial conditions as in clause 6.4D.2.2.4.1 in TS 38.521-2 [9], the following steps will be added to configure E-UTRA component:

- 2.1. The parameter settings for E-UTRA cell are set up according to TS 36.508 [11] clause 4.4.3.

- 3.1. The E-UTRA downlink signal level, uplink signal level are set according to Table 4.7-1 and propagation conditions are set according to Annex B.0 of TS 36.521-1 [10].

Step 6 of Initial conditions as in clause 6.4D.2.4.1 in TS 38.521-2 [9] is replaced by:

6. Ensure the UE is in state RRC_CONNECTED with generic procedure parameters Connectivity EN-DC, DC bearer MCG and SCG, Connected without release On according to TS 38.508-1 [6] clause 4.5.

Same test procedure as in clause 6.4D.2.2.4.1 in TS 38.521-2 [9] with the following steps added for E-UTRA component:

- 1.1 On the E-UTRA carrier, disable periodic and aperiodic CQI reports, disable SRS, set *TimeAlignmentTimerDedicated* IE to infinity and disable downlink and uplink scheduling, all as per Table 4.7-1 under clause 4.7.

6.4B.2.4.2D.5 Test requirement

Same test requirement as in clause 6.4D.2.2.5 in TS 38.521-2 [9] for the NR carrier.

6.4B.2.4.3D In-band Emissions for inter-band EN-DC including FR2 for UL-MIMO

Editor's note: This clause is incomplete. The following aspects are either missing or not yet determined:

- The referred test case 6.4D.2.3 in TS 38.521-2 [9] is incomplete.
- Measurement Uncertainty and Test Tolerance are FFS and Annex F needs to be updated.

6.4B.2.4.3D.1 Test purpose

Same test purpose as in clause 6.4D.2.3.1 in TS 38.521-2 [9] for the NR carrier.

6.4B.2.4.3D.2 Test applicability

This test case applies to all types of E-UTRA UE release 15 and forward, supporting inter-band EN-DC including FR2 and UL-MIMO.

6.4B.2.4.3D.3 Minimum conformance requirements

For inter-band EN-DC including FR2 or both FR1 and FR2, transmit modulation quality for EN-DC operations in FR1 and FR2 as specified in TS 36.101 [5], TS 38.101-1 [2] and TS 38.101-2 [3] apply for E-UTRA, NR FR1 and NR FR2 respectively.

The normative reference for this requirement is TS 38.101-3 [4] clause 6.4B.2.4.

Same minimum conformance requirements as in clause 6.4D.2.3.3 in TS 38.521-2 [9] for the NR carrier.

No exception requirements applicable to NR or LTE. LTE anchor agnostic approach is applied.

6.4B.2.4.3D.4 Test description

6.4B.2.4.3D.4.1 Initial conditions

Same test description as in clause 6.4D.2.3.4 in TS 38.521-2 [9] for the NR carrier with the following exception:

The initial test configurations for E-UTRA band consist of environmental conditions, test frequencies, and channel bandwidths based on E-UTRA bands specified in Table 4.7-1. For Initial conditions as in clause 6.4D.2.3.4.1 in TS 38.521-2 [9], the following steps will be added to configure E-UTRA component:

- 2.1. The parameter settings for E-UTRA cell are set up according to TS 36.508 [11] clause 4.4.3.
- 3.1. The E-UTRA downlink signal level, uplink signal level are set according to Table 4.7-1 and propagation conditions are set according to Annex B.0 of TS 36.521-1 [10].

Step 6 of Initial conditions as in clause 6.4D.2.3.4.1 in TS 38.521-2 [9] is replaced by:

6. Ensure the UE is in state RRC_CONNECTED with generic procedure parameters Connectivity EN-DC, DC bearer MCG and SCG, Connected without release On according to TS 38.508-1 [6] clause 4.5.

Same test procedure as in clause 6.4D.2.3.4.1 in TS 38.521-2 [9] with the following steps added for E-UTRA component:

- 1.1 On the E-UTRA carrier, disable periodic and aperiodic CQI reports, disable SRS, set *TimeAlignmentTimerDedicated* IE to infinity and disable downlink and uplink scheduling, all as per Table 4.7-1 under clause 4.7.

6.4B.2.4.3D.5 Test requirement

Same test requirement as in clause 6.4D.2.3.5 in TS 38.521-2 [9] for the NR carrier.

6.4B.2.4.4D EVM Equalizer Flatness for inter-band EN-DC including FR2 for UL-MIMO

Editor's note: This clause is incomplete. The following aspects are either missing or not yet determined:

- **The referred test case 6.4D.2.4 in TS 38.521-2 [9] is incomplete.**
- **Measurement Uncertainty and Test Tolerance are FFS and Annex F needs to be updated.**

6.4B.2.4.4D.1 Test purpose

Same test purpose as in clause 6.4D.2.4.1 in TS 38.521-2 [9] for the NR carrier.

6.4B.2.4.4D.2 Test applicability

This test case applies to all types of E-UTRA UE release 15 and forward, supporting inter-band EN-DC including FR2 and UL-MIMO.

6.4B.2.4.4D.3 Minimum conformance requirements

For inter-band EN-DC including FR2 or both FR1 and FR2, transmit modulation quality for EN-DC operations in FR1 and FR2 as specified in TS 36.101 [5], TS 38.101-1 [2] and TS 38.101-2 [3] apply for E-UTRA, NR FR1 and NR FR2 respectively.

The normative reference for this requirement is TS 38.101-3 [4] clause 6.4B.2.4.

Same minimum conformance requirements as in clause 6.4D.2.4.3 in TS 38.521-2 [9] for the NR carrier.

No exception requirements applicable to NR or LTE. LTE anchor agnostic approach is applied.

6.4B.2.4.4D.4 Test description

6.4B.2.4.4D.4.1 Initial conditions

Same test description as in clause 6.4D.2.4.4 in TS 38.521-2 [9] for the NR carrier with the following exception:

The initial test configurations for E-UTRA band consist of environmental conditions, test frequencies, and channel bandwidths based on E-UTRA bands specified in Table 4.7-1. For Initial conditions as in clause 6.4D.2.4.4.1 in TS 38.521-2 [9], the following steps will be added to configure E-UTRA component:

- 2.1. The parameter settings for E-UTRA cell are set up according to TS 36.508 [11] clause 4.4.3.
- 3.1. The E-UTRA downlink signal level, uplink signal level are set according to Table 4.7-1 and propagation conditions are set according to Annex B.0 of TS 36.521-1 [10].

Step 6 of Initial conditions as in clause 6.4D.2.4.1 in TS 38.521-2 [9] is replaced by:

6. Ensure the UE is in state RRC_CONNECTED with generic procedure parameters Connectivity EN-DC, DC bearer MCG and SCG, Connected without release On according to TS 38.508-1 [6] clause 4.5.

Same test procedure as in clause 6.4D.2.4.4.1 in TS 38.521-2 [9] with the following steps added for E-UTRA component:

- 1.1 On the E-UTRA carrier, disable periodic and aperiodic CQI reports, disable SRS, set *TimeAlignmentTimerDedicated* IE to infinity and disable downlink and uplink scheduling, all as per Table 4.7-1 under clause 4.7.

6.4B.2.4.4D.5 Test requirement

Same test requirement as in clause 6.4D.2.4.5 in TS 38.521-2 [9] for the NR carrier.

6.4B.2.4.2 Carrier Leakage for inter-band EN-DC including FR2

Editor's note: This clause is incomplete. The following aspects are either missing or not yet determined:

- The referred test case 6.4.2.2 in TS 38.521-2 [9] is incomplete.
- Measurement Uncertainty and Test Tolerance are FFS.
- TS 38.101-2 [3] clause 6.3.4.3: Relative power tolerances are in square brackets.

6.4B.2.4.2.1 Test purpose

Same test purpose as in clause 6.4.2.2 in TS 38.521-2 [9] for the NR carrier.

6.4B.2.4.2.2 Test applicability

This test case applies to all types of E-UTRA UE release 15 and forward, supporting inter-band EN-DC including FR2 with 2 UL CCs.

6.4B.2.4.2.3 Minimum conformance requirements

For inter-band EN-DC including FR2 or both FR1 and FR2, transmit modulation quality for EN-DC operations in FR1 and FR2 as specified in TS 36.101 [5], 38.101-1 [2] and 38.101-2 [3] apply for E-UTRA, NR FR1 and NR FR2 respectively.

The normative reference for this requirement is TS 38.101-3 [4] clause 6.4B.2.4.

Same minimum conformance requirements as in clause 6.4.2.2.3 in TS 38.521-2 [9] for the NR carrier.

No exception requirements applicable to NR or LTE. LTE anchor agnostic approach is applied

6.4B.2.4.2.4 Test description

6.4B.2.4.2.4.1 Initial conditions

Same test description as in clause 6.4.2.2.4 in TS 38.521-2 [9] for the NR carrier with the following exception:

The initial test configurations for E-UTRA band consist of environmental conditions, test frequencies, and channel bandwidths based on E-UTRA bands specified in Table 4.7-1. For Initial conditions as in clause 6.4.2.2.4.1 in TS 38.521-2 [9], the following steps will be added to configure E-UTRA component:

- 2.1. The parameter settings for E-UTRA cell are set up according to TS 36.508 [11] clause 4.4.3.
- 3.1. The E-UTRA downlink signal level, uplink signal level are set according to Table 4.7-1 and propagation conditions are set according to Annex B.0 of TS 36.521-1 [10].

Step 6 of Initial conditions as in clause 6.4.2.4.1 in TS 38.521-2 [9] is replaced by:

6. Ensure the UE is in state RRC_CONNECTED with generic procedure parameters Connectivity EN-DC, DC bearer MCG and SCG, Connected without release On according to TS 38.508-1 [6] clause 4.5.

Same test procedure as in clause 6.4.2.2.4.1 in TS 38.521-2 [9] with the following steps added for E-UTRA component:

1.1 On the E-UTRA carrier, disable periodic and aperiodic CQI reports, disable SRS, set *TimeAlignmentTimerDedicated* IE to infinity and disable downlink and uplink scheduling, all as per Table 4.7-1 under clause 4.7.

6.4B.2.4.2.5 Test requirement

Same test requirement as in clause 6.4.2.2.5 in TS 38.521-2 [9] for the NR carrier.

6.4B.2.4.3 In-band Emissions for inter-band EN-DC including FR2

Editor's note: This clause is incomplete. The following aspects are either missing or not yet determined:

- The referred test case 6.4.2.3 in TS 38.521-2 [9] is incomplete.
- Measurement Uncertainty and Test Tolerance are FFS.
- 38.101-2 [3] clause 6.3.4.3: Relative power tolerances are in square brackets.

6.4B.2.4.3.1 Test purpose

Same test purpose as in clause 6.4.2.3 in TS 38.521-2 [9] for the NR carrier.

6.4B.2.4.3.2 Test applicability

This test case applies to all types of E-UTRA UE release 15 and forward, supporting inter-band EN-DC including FR2 with 2 UL CCs.

6.4B.2.4.3.3 Minimum conformance requirements

For inter-band EN-DC including FR2 or both FR1 and FR2, transmit modulation quality for EN-DC operations in FR1 and FR2 as specified in TS 36.101 [5], TS 38.101-1 [2] and TS 38.101-2 [3] apply for E-UTRA, NR FR1 and NR FR2 respectively.

The normative reference for this requirement is TS 38.101-3 [4] clause 6.4B.2.4.

Same minimum conformance requirements as in clause 6.4.2.3.3 in TS 38.521-2 [9] for the NR carrier.

No exception requirements applicable to NR or LTE. LTE anchor agnostic approach is applied.

6.4B.2.4.3.4 Test description

6.4B.2.4.3.4.1 Initial conditions

Same test description as in clause 6.4.2.3.4 in TS 38.521-2 [9] for the NR carrier with the following exception:

The initial test configurations for E-UTRA band consist of environmental conditions, test frequencies, and channel bandwidths based on E-UTRA bands specified in Table 4.7-1. For Initial conditions as in clause 6.4.2.3.4.1 in TS 38.521-2 [9], the following steps will be added to configure E-UTRA component:

- 2.1. The parameter settings for E-UTRA cell are set up according to TS 36.508 [11] clause 4.4.3.
- 3.1. The E-UTRA downlink signal level, uplink signal level are set according to Table 4.7-1 and propagation conditions are set according to Annex B.0 of TS 36.521-1 [10].

Step 6 of Initial conditions as in clause 6.4.2.4.1 in TS 38.521-2 [9] is replaced by:

6. Ensure the UE is in state RRC_CONNECTED with generic procedure parameters Connectivity EN-DC, DC bearer MCG and SCG, Connected without release On according to TS 38.508-1 [6] clause 4.5.

Same test procedure as in clause 6.4.2.3.4.1 in TS 38.521-2 [9] with the following steps added for E-UTRA component:

- 1.1 On the E-UTRA carrier, disable periodic and aperiodic CQI reports, disable SRS, set *TimeAlignmentTimerDedicated* IE to infinity and disable downlink and uplink scheduling, all as per Table 4.7-1 under clause 4.7.

6.4B.2.4.3.5 Test requirement

Same test requirement as in clause 6.4.2.3.5 in TS 38.521-2 [9] for the NR carrier.

6.4B.2.4.3_1 In-band Emissions for inter-band EN-DC including FR2 (>2 CCs)

6.4B.2.4.3_1.1 In-band Emissions for inter-band EN-DC including FR2 (3 CCs)

Editor's note: This clause is incomplete. The following aspects are either missing or not yet determined:

- The referred test case 6.4A.2.3.1 in TS 38.521-2 [9] is incomplete.
- Measurement Uncertainty and Test Tolerance are FFS.

6.4B.2.4.3_1.1.1 Test purpose

Same test purpose as in clause 6.4.2.3 in TS 38.521-2 [9] for the NR carrier.

6.4B.2.4.3_1.1.2 Test applicability

This test case applies to all types of E-UTRA UE release 15 and forward, supporting inter-band EN-DC including FR2 with 3 CCs(2NR CCs).

6.4B.2.4.3_1.1.3 Minimum conformance requirements

Same minimum conformance requirements as in clause 6.4B.2.4.3.3.

6.4B.2.4.3_1.1.4 Test description

6.4B.2.4.3_1.1.4.1 Initial conditions

Same test description as in clause 6.4A.2.3.1.4 in TS 38.521-2 [9] for the NR carrier with the following exception:

The initial test configurations for E-UTRA band consist of environmental conditions, test frequencies, and channel bandwidths based on E-UTRA bands specified in Table 4.7-1. For Initial conditions as in clause 6.4A.2.3.1.4.1 in TS 38.521-2 [9], the following steps will be added to configure E-UTRA component:

- 2.1. The parameter settings for E-UTRA cell are set up according to TS 36.508 [11] clause 4.4.3.
- 3.1. The E-UTRA downlink signal level, uplink signal level are set according to Table 4.7-1 and propagation conditions are set according to Annex B.0 of TS 36.521-1 [10].

Step 6 of Initial conditions as in clause 6.4A.2.3.1.4.1 in TS 38.521-2 [9] is replaced by:

6. Ensure the UE is in state RRC_CONNECTED with generic procedure parameters Connectivity EN-DC, DC bearer MCG and SCG, Connected without release On according to TS 38.508-1 [6] clause 4.5.

Same test procedure as in clause 6.4A.2.3.1.4.2 in TS 38.521-2 [9] with the following steps added for E-UTRA component:

- 1.1 On the E-UTRA carrier, disable periodic and aperiodic CQI reports, disable SRS, set *TimeAlignmentTimerDedicated* IE to infinity and disable downlink and uplink scheduling, all as per Table 4.7-1 under clause 4.7.

6.4B.2.4.3_1.1.5 Test requirement

Same test requirement as in clause 6.4A.2.3.1.5 in TS 38.521-2 [9] for the NR carrier.

6.4B.2.4.3_1.2 In-band Emissions for inter-band EN-DC including FR2 (4 CCs)

Editor's note: This clause is incomplete. The following aspects are either missing or not yet determined:

- The referred test case 6.4A.2.3.2 in TS 38.521-2 [9] is incomplete.

- Measurement Uncertainty and Test Tolerance are FFS.

6.4B.2.4.3_1.2.1 Test purpose

Same test purpose as in clause 6.4.2.3 in TS 38.521-2 [9] for the NR carrier.

6.4B.2.4.3_1.2.2 Test applicability

This test case applies to all types of E-UTRA UE release 15 and forward, supporting inter-band EN-DC including FR2 with 4 CCs(3NR CCs).

6.4B.2.4.3_1.2.3 Minimum conformance requirements

Same minimum conformance requirements as in clause 6.4B.2.4.3.3.

6.4B.2.4.3_1.2.4 Test description

6.4B.2.4.3_1.2.4.1 Initial conditions

Same test description as in clause 6.4A.2.3.2.4 in TS 38.521-2 [9] for the NR carrier with the following exception:

The initial test configurations for E-UTRA band consist of environmental conditions, test frequencies, and channel bandwidths based on E-UTRA bands specified in Table 4.7-1. For Initial conditions as in clause 6.4A.2.3.2.4.1 in TS 38.521-2 [9], the following steps will be added to configure E-UTRA component:

- 2.1. The parameter settings for E-UTRA cell are set up according to TS 36.508 [11] clause 4.4.3.
- 3.1. The E-UTRA downlink signal level, uplink signal level are set according to Table 4.7-1 and propagation conditions are set according to Annex B.0 of TS 36.521-1 [10].

Step 6 of Initial conditions as in clause 6.4A.2.3.2.4.1 in TS 38.521-2 [9] is replaced by:

6. Ensure the UE is in state RRC_CONNECTED with generic procedure parameters Connectivity EN-DC, DC bearer MCG and SCG, Connected without release On according to TS 38.508-1 [6] clause 4.5.

Same test procedure as in clause 6.4A.2.3.2.4.2 in TS 38.521-2 [9] with the following steps added for E-UTRA component:

- 1.1 On the E-UTRA carrier, disable periodic and aperiodic CQI reports, disable SRS, set *TimeAlignmentTimerDedicated* IE to infinity and disable downlink and uplink scheduling, all as per Table 4.7-1 under clause 4.7.

6.4B.2.4.3_1.2.5 Test requirement

Same test requirement as in clause 6.4A.2.3.2.5 in TS 38.521-2 [9] for the NR carrier.

6.4B.2.4.3_1.3 In-band Emissions for inter-band EN-DC including FR2 (5 CCs)

Editor's note: This clause is incomplete. The following aspects are either missing or not yet determined:

- The referred test case 6.4A.2.3.3 in TS 38.521-2 [9] is incomplete.
- Measurement Uncertainty and Test Tolerance are FFS.

6.4B.2.4.3_1.3.1 Test purpose

Same test purpose as in clause 6.4.2.3 in TS 38.521-2 [9] for the NR carrier.

6.4B.2.4.3_1.3.2 Test applicability

This test case applies to all types of E-UTRA UE release 15 and forward, supporting inter-band EN-DC including FR2 with 5 CCs(4NR CCs).

6.4B.2.4.3_1.3.3 Minimum conformance requirements

Same minimum conformance requirements as in clause 6.4B.2.4.3.3.

6.4B.2.4.3_1.3.4 Test description

6.4B.2.4.3_1.3.4.1 Initial conditions

Same test description as in clause 6.4A.2.3.3.4 in TS 38.521-2 [9] for the NR carrier with the following exception:

The initial test configurations for E-UTRA band consist of environmental conditions, test frequencies, and channel bandwidths based on E-UTRA bands specified in Table 4.7-1. For Initial conditions as in clause 6.4A.2.3.3.4.1 in TS 38.521-2 [9], the following steps will be added to configure E-UTRA component:

- 2.1. The parameter settings for E-UTRA cell are set up according to TS 36.508 [11] clause 4.4.3.
- 3.1. The E-UTRA downlink signal level, uplink signal level are set according to Table 4.7-1 and propagation conditions are set according to Annex B.0 of TS 36.521-1 [10].

Step 6 of Initial conditions as in clause 6.4A.2.3.3.4.1 in TS 38.521-2 [9] is replaced by:

6. Ensure the UE is in state RRC_CONNECTED with generic procedure parameters Connectivity EN-DC, DC bearer MCG and SCG, Connected without release On according to TS 38.508-1 [6] clause 4.5.

Same test procedure as in clause 6.4A.2.3.3.4.2 in TS 38.521-2 [9] with the following steps added for E-UTRA component:

- 1.1 On the E-UTRA carrier, disable periodic and aperiodic CQI reports, disable SRS, set *TimeAlignmentTimerDedicated* IE to infinity and disable downlink and uplink scheduling, all as per Table 4.7-1 under clause 4.7.

6.4B.2.4.3_1.3.5 Test requirement

Same test requirement as in clause 6.4A.2.3.3.5 in TS 38.521-2 [9] for the NR carrier.

6.4B.2.4.4 EVM Equalizer Flatness for inter-band EN-DC including FR2

Editor's note: This clause is incomplete. The following aspects are either missing or not yet determined:

- The referred test case 6.4.2.4 in TS 38.521-2 [9] is incomplete.
- Measurement Uncertainty and Test Tolerance are FFS.
- 38.101-2 [3] clause 6.3.4.3: Relative power tolerances are in square brackets.

6.4B.2.4.4.1 Test purpose

Same test purpose as in clause 6.4.2.4 in TS 38.521-2 [9] for the NR carrier.

6.4B.2.4.4.2 Test applicability

This test case applies to all types of E-UTRA UE release 15 and forward, supporting inter-band EN-DC including FR2 with 2 UL CCs.

6.4B.2.4.4.3 Minimum conformance requirements

For inter-band EN-DC including FR2 or both FR1 and FR2, transmit modulation quality for EN-DC operations in FR1 and FR2 as specified in TS 36.101 [5], TS 38.101-1 [2] and TS 38.101-2 [3] apply for E-UTRA, NR FR1 and NR FR2 respectively.

The normative reference for this requirement is TS 38.101-3 [4] clause 6.4B.2.4.

Same minimum conformance requirements as in clause 6.4.2.4.3 in TS 38.521-2 [9] for the NR carrier.

No exception requirements applicable to NR or LTE. LTE anchor agnostic approach is applied.

6.4B.2.4.4.4 Test description

6.4B.2.4.4.4.1 Initial conditions

Same test description as in clause 6.4.2.4.4 in TS 38.521-2 [9] for the NR carrier with the following exception:

The initial test configurations for E-UTRA band consist of environmental conditions, test frequencies, and channel bandwidths based on E-UTRA bands specified in Table 4.7-1. For Initial conditions as in clause 6.4.2.4.4.1 in TS 38.521-2 [9], the following steps will be added to configure E-UTRA component:

- 2.1. The parameter settings for E-UTRA cell are set up according to TS 36.508 [11] clause 4.4.3.
- 3.1. The E-UTRA downlink signal level, uplink signal level are set according to Table 4.7-1 and propagation conditions are set according to Annex B.0 of TS 36.521-1 [10].

Step 6 of Initial conditions as in clause 6.4.2.4.4.1 in TS 38.521-2 [9] is replaced by:

6. Ensure the UE is in state RRC_CONNECTED with generic procedure parameters Connectivity EN-DC, DC bearer MCG and SCG, Connected without release On according to TS 38.508-1 [6] clause 4.5.

Same test procedure as in clause 6.4.2.4.4.1 in TS 38.521-2 [9] with the following steps added for E-UTRA component:

- 1.1 On the E-UTRA carrier, disable periodic and aperiodic CQI reports, disable SRS, set *TimeAlignmentTimerDedicated* IE to infinity and disable downlink and uplink scheduling, all as per Table 4.7-1 under clause 4.7.

6.4B.2.4.4.5 Test requirement

Same test requirement as in clause 6.4.2.4.5 in TS 38.521-2 [9] for the NR carrier.

6.5 Output RF spectrum emissions

6.5A Output RF spectrum emissions for CA

6.5A.1 Occupied bandwidth for CA without EN-DC

6.5A.1.1 Test purpose

Same test purpose as in clause 6.5.1 in TS 38.521-1 [8] for NR FR1 carrier(s) and clause 6.5.1 in TS 38.521-2 [9] for NR FR2 carrier(s).

6.5A.1.2 Test applicability

The requirements in this test are not testable due to issues with combined testing of NR FR1 conducted mode with NR FR2 in radiated mode. Therefore, the conducted and radiated requirements are tested separately.

No test case details are specified. The SA requirements for occupied bandwidth apply and are tested in TS 38.521-1 [8] clauses 6.5 and 6.5A and TS 38.521-2 [9] clauses 6.5 and 6.5A.

6.5A.2 Out-of-band emissions for CA without EN-DC

6.5.A.2.1 Spectrum emissions mask for CA without EN-DC

6.5A.2.1.1 Test purpose

Same test purpose as in clause 6.5.2.2 in TS 38.521-1 [8] for NR FR1 carrier(s) and clause 6.5.2.1 in TS 38.521-2 [9] for NR FR2 carrier(s).

6.5A.2.1.2 Test applicability

The requirements in this test are not testable due to issues with combined testing of NR FR1 conducted mode with NR FR2 in radiated mode. Therefore, the conducted and radiated requirements are tested separately.

No test case details are specified. The SA requirements for additional spectrum emissions mask apply and are tested in TS 38.521-1 [8] clauses 6.5 and 6.5A and TS 38.521-2 [9] clauses 6.5 and 6.5A.

6.5A.2.2 Additional Spectrum emissions mask for CA without EN-DC

6.5A.2.2.1 Test purpose

Same test purpose as in clause 6.5.2.3 in TS 38.521-1 [8] for NR FR1 carrier(s) and clause 6.5.2.2 in TS 38.521-2 [9] for NR FR2 carrier(s).

6.5A.2.2.2 Test applicability

The requirements in this test are not testable due to issues with combined testing of NR FR1 conducted mode with NR FR2 in radiated mode. Therefore, the conducted and radiated requirements are tested separately.

No test case details are specified. The SA requirements for additional spectrum emissions mask apply and are tested in TS 38.521-1 [8] clauses 6.5 and 6.5A and TS 38.521-2 [9] clauses 6.5 and 6.5A.

6.5A.2.3 Adjacent channel leakage ratio for CA without EN-DC

No test case details specified as there are no exception requirements applicable to NR FR1 or NR FR2 as per TS 38.101-3 [4], clause 6.5A.2. The SA requirement for ACLR applies and is tested in TS 38.521-1 [8] and TS 38.521-2 [9] for FR1 and FR2 respectively.

6.5A.3 Spurious emissions for CA without EN-DC

6.5A.3.1 Inter-band CA between FR1 and FR2

6.5A.3.1.1 Test purpose

Same test purpose as in clause 6.5.3 in TS 38.521-1 [8] for NR FR1 carrier(s) and clause 6.5.3 in TS 38.521-2 [9] for NR FR2 carrier(s).

6.5A.3.1.2 Test applicability

The requirements in this test are not testable due to issues with combined testing of NR FR1 conducted mode with NR FR2 in radiated mode. Therefore, the conducted and radiated requirements are tested separately.

No test case details are specified. The SA requirements for spurious emission for inter-band CA between FR1 and FR2 and UE co-existence requirements apply for each component carrier and are tested in TS 38.521-1 [8] clauses 6.5 and 6.5A and TS 38.521-2 [9] clauses 6.5 and 6.5A.

6.5B Output RF spectrum emissions for DC

6.5B.1 Occupied bandwidth for EN-DC

6.5B.1.1 Occupied bandwidth for Intra-Band Contiguous EN-DC

Editor's note: This clause is incomplete. The following aspects are either missing or not yet determined:

- measurement uncertainty for ENBW > 100 MHz is FFS.

6.5B.1.1.1 Test purpose

To verify that the UE occupied bandwidth for intra-band contiguous EN-DC for all transmission bandwidth configurations supported by the UE are less than their specific limits.

6.5B.1.1.2 Test applicability

This test case applies to all types of E-UTRA UE release 15 and forward, supporting intra-band contiguous EN-DC.

6.5B.1.1.3 Minimum conformance requirements

For intra-band contiguous EN-DC, the occupied bandwidth is a measure of the bandwidth containing the 99% of the total integrated power of the transmitted spectrum. The OBW shall be less than the aggregated channel bandwidth for EN-DC, denoted as EN-BW in clause 5.3B.

The normative reference for this measurement is TS 38.101-3 [4] clause 6.5B.1.

Exception requirements for both NR and E-UTRA are defined for this test and therefore LTE anchor agnostic approach is not applied. E-UTRA test point analysis is included and E-UTRA measurements are performed.

6.5B.1.1.4 Test description

6.5B.1.1.4.1 Initial condition

Initial conditions are a set of test configurations the UE needs to be tested in and the steps for the SS to take with the UE to reach the correct measurement state.

The initial test configurations consist of environmental conditions, test frequencies and channel bandwidths based on EN-DC operating bands specified in clause 5.3B.1.2, channel bandwidths and sub-carrier spacings for the NR cell specified in TS 38.521-1 [8] clause 5.3 and channel bandwidth for the E-UTRA cell are specified in TS 36.521-1 [10] clause 5.4.2. All of these configurations shall be tested with applicable test parameters for each EN-DC configuration specified in clause 5.3B.1.2 and are shown in table 6.5B.1.1.4.1-1. The details of the uplink reference measurement channels (RMCs) are specified in Annex A.2. Configurations of PDSCH and PDCCH before measurement are specified in TS 36.521-1 [10] Annex C.2 and in TS 38.521-1 [8] Annex C.2 for E-UTRA CG and NR CG respectively.

Table 6.5B.1.1.4.1-1: Test configuration table

Initial Conditions					
Test Environment as specified in TS 38.508-1 [6] clause 4.1		Normal			
Test Frequencies as specified in TS 38.508-1 [6] clause 4.3.1		Mid range			
Test EN-DC bandwidth combination as specified in Table 5.3B.1.2-1		All			
Test SCS for the NR cell as specified in TS 38.521-1 [8] Table 5.3.5-1		Lowest SCS per Channel Bandwidth			
Test Parameters					
Test ID	Downlink Configuration	EN-DC Uplink Configuration			
		E-UTRA Cell		NR Cell	
		Modulation	RB allocation (NOTE 2)	Modulation	RB allocation (NOTE 1)
1	N/A for OBW testing.	QPSK	Outer_Full	CP-OFDM QPSK	Outer_Full
NOTE 1: The specific configuration of each RB allocation is defined in Table 6.1-1 in TS 38.521-1 [8].					
NOTE 2: Outer_Full defined as the transmission bandwidth configuration N_{RB} per channel bandwidth for the E-UTRA component as indicated in TS 36.521-1 [10] Table 5.4.2-1.					

1. Connect the SS to the UE antenna connectors as shown in [6] TS 38.508-1 A.3.1.2.1 for SS diagram and A.3.2.1 for UE diagram.
2. The parameter settings for the E-UTRA cell are set up according to TS 36.508 [11] clause 4.4.3, and the parameter settings for the NR cell are set up according to TS 38.508-1 [6] clause 4.4.3.
3. Downlink signals are initially set up according to TS 36.521-1 [10] Annex C.0 and TS 38.521-1 [8] Annex C.0 for E-UTRA CG and NR CG respectively, and uplink signals according to TS 36.521-1 [10] Annex H and TS 38.521-1 [8] Annex G for E-UTRA CG and NR CG respectively.
4. The UL Reference Measurement channels are TS 36.521-1 [10] Annex A.2 and TS 38.521-1 [8] Annex A.2 for E-UTRA CG and NR CG respectively.
5. Propagation conditions are set according to TS 36.521-1 [10] Annex B.0 and TS 38.521-1 [8] Annex B.0 for E-UTRA CG and NR CG respectively.
6. Ensure the UE is in state RRC_CONNECTED with generic procedure parameters Connectivity EN-DC, DC bearer MCG and SCG, Connected without release On according to TS 38.508-1 [6] clause 4.5. Message contents are defined in clause 6.2B.1.1.4.3.
7. For the case of testing overlapping E-UTRA and NR UL transmission scenario when both bands are TDD, ensure E-UTRA UL transmission overlaps with NR UL transmission in time by giving SCG a delay of 3 E-UTRA subframes, or by giving MCG a delay of 2 subframes.

6.5B.1.1.4.2 Test procedure

1. SS sends uplink scheduling information for each UL HARQ process via PDCCH DCI format 0 and DCI format 0_1 for C_RNTI to schedule the UL RMC according to table 6.5B.1.1.4.1-1 on E-UTRA CC and NR CC respectively. Since the UL has no payload and no loopback data to send the UE sends uplink MAC padding bits on the UL RMC.
2. Send continuously uplink power control "up" commands to the UE for NR and E-UTRA carrier until the UE transmits at its P_{UMAX} level; allow at least 200 ms from the first TPC command for the UE to reach P_{UMAX} level.
3. Measure the power spectrum distribution over all EN-DC component carriers in the EN-DC within two times or more range over the requirement for Occupied Bandwidth specification for intra-band contiguous EN-DC centring on the current carrier frequency in the EN-DC configuration. The characteristics of the filter shall be approximately Gaussian (typical spectrum analyser filter). Other methods to measure the power spectrum distribution are allowed. The measuring duration is at least 1ms over consecutive active uplink slots.

4. Calculate the total power within the range of all frequencies measured in step 3 and save this value as "Total power".
5. Sum up the power upward from the lower boundary of the measured frequency range in step 3 and seek the limit frequency point by which this sum becomes 0.5% of "Total power" and save this point as "Lower Frequency".
6. Sum up the power downward from the upper boundary of the measured frequency range in step 3 and seek the limit frequency point by which this sum becomes 0.5% of "Total power" and save this point as "Upper Frequency".
7. Calculate the difference "Upper Frequency" – "Lower Frequency" = "Occupied Bandwidth" between the two limit frequencies obtained in step 5 and step 6.

6.5B.1.1.4.3 Message contents

Message contents are according to TS 36.508 [11] clause 4.6.1 and TS 38.508-1 [6] clause 4.6.1 with the following exceptions.

Table 6.5B.1.1.4.3-1: RRCConnectionReconfiguration: nr-Config-r15

Derivation Path: TS 36.508 [11], Table 4.6.1-8			
Information Element	Value/remark	Comment	Condition
p-MaxEUTRA-r15	23		Power Class 2 UE AND simultaneous E-UTRA and NR transmission
	20		Power Class 3 UE AND simultaneous E-UTRA and NR transmission

Table 6.5B.1.1.4.3-2: PhysicalCellGroupConfig

Derivation Path: TS 38.508-1 [6] Table 4.6.3-106			
Information Element	Value/remark	Comment	Condition
p-NR-FR1	23		Power Class 2 UE AND simultaneous E-UTRA and NR transmission
	20		Power Class 3 UE AND simultaneous E-UTRA and NR transmission

Table 6.5B.1.1.4.3-4: SystemInformationBlockType1: tdd-Config if operating on TDD band

Derivation Path: TS 36.508 [11], Table 4.6.3-23			
Information Element	Value/remark	Comment	Condition
TDD-Config-DEFAULT ::= SEQUENCE {		Operating on TDD band	
subframeAssignment	sa2		
specialSubframePatterns	ssp7		
}			

6.5B.1.1.5 Test requirements

The measured Occupied Bandwidth shall not exceed values of aggregated channel bandwidth as defined in clause 5.3B.1.2 for intra-band contiguous EN-DC.

6.5B.1.2 Occupied bandwidth for Intra-Band Non-Contiguous EN-DC

6.5B.1.2.1 Test purpose

Same test purpose as in clause 6.5.1.1 in TS 38.521-1 [8] for the NR carrier.

6.5B.1.2.2 Test applicability

This test case applies to all types of E-UTRA UE release 15 and forward, supporting intra-band non-contiguous EN-DC.

6.5B.1.2.3 Minimum conformance requirements

Same minimum conformance requirements as in clause 6.5.1.3 in TS 38.521-1 [8] for the NR carrier.

The normative reference for this requirement is TS 38.101-3 [4] clause 6.5B.1.

No exception requirements applicable to NR or LTE. LTE anchor agnostic approach is applied.

6.5B.1.2.4 Test description

Same test description as in clause 6.5.1.4 in TS 38.521-1 [8] for the NR carrier with the following exceptions:

Table 6.5B.1.2.4-1: Test Configuration Table

Initial Conditions	
Test Frequencies as specified in TS 38.508-1 [6] clause 4.3.1.4.3 for cases with single E-UTRA carrier	Low with maxWgap (NR low – E-UTRA high)
Test Channel Bandwidths as specified in TS 38.508-1 [6] subclause 4.3.1.4.3	All for NR; Lowest for E-UTRA

For Initial conditions as in clause 6.5.1.4.1 in TS 38.521-1 [8], the following steps will be added to configure E-UTRA component:

- 2.1. The parameter settings for E-UTRA cell are set up according to TS 36.508 [11] clause 4.4.3.
- 3.1. The E-UTRA downlink signal level, uplink signal level are set according to Table 4.6-1 and propagation conditions are set according to Annex B.0 of TS 36.521-1 [10].

Step 6 of Initial conditions as in clause 6.5.1.4.1 in TS 38.521-1 [8] is replaced by:

6. Ensure the UE is in state RRC_CONNECTED with generic procedure parameters Connectivity EN-DC, DC bearer MCG and SCG, Connected without release *On* according to TS 38.508 [6] clause 4.5.
7. On the E-UTRA carrier, disable periodic and aperiodic CQI reports, disable SRS, set *TimeAlignmentTimerDedicated* IE to infinity and disable downlink and uplink scheduling, all as per Table 4.6-1 under clause 4.6.

Same test procedure as in clause 6.5.1.4.2 in TS 38.521-1 [8].

6.5B.1.2.5 Test requirement

Same test requirement as in clause 6.5.1.5 in TS 38.521-1 [8] for the NR carrier.

6.5B.1.3 Occupied bandwidth for Inter-Band EN-DC within FR1

6.5B.1.3.1 Test purpose

Same test purpose as in clause 6.5.1.1 in TS 38.521-1 [8] for the NR carrier.

6.5B.1.3.2 Test applicability

This test case applies to all types of E-UTRA UE release 15 and forward, supporting inter-band EN-DC.

6.5B.1.3.3 Minimum conformance requirements

Same minimum conformance requirements as in clause 6.5.1.3 in TS 38.521-1 [8] for the NR carrier.

The normative reference for this requirement is TS 38.101-3 [4] clause 6.5B.1.

No exception requirements applicable to NR or LTE. LTE anchor agnostic approach is applied.

6.5B.1.3.4 Test description

Same test description as in clause 6.5.1.4 in TS 38.521-1 [8] for the NR carrier with the following exceptions:

The initial test configurations for E-UTRA consist of test frequency based on E-UTRA operating band and test channel bandwidth as specified in Table 4.6-1.

For Initial conditions as in clause 6.5.1.4.1 in TS 38.521-1 [8], the following steps will be added to configure E-UTRA component:

- 2.1. The parameter settings for the cell are set up according to TS 36.508 [11] clause 4.4.3.
- 3.1. The E-UTRA downlink signal level, uplink signal level are set according to Table 4.6-1 and propagation conditions are set according to Annex B.0 of TS 36.521-1 [10].

Step 6 of Initial conditions as in clause 6.5.1.4.1 in TS 38.521-1 [8] is replaced by:

6. Ensure the UE is in state RRC_CONNECTED with generic procedure parameters Connectivity EN-DC, DC bearer MCG and SCG, Connected without release *On* according to TS 38.508 [6] clause 4.5.
7. On the E-UTRA carrier, disable periodic and aperiodic CQI reports, disable SRS, set *TimeAlignmentTimerDedicated* IE to infinity and disable downlink and uplink scheduling, all as per Table 4.6-1 under clause 4.6.

6.5B.1.3.5 Test requirement

Same test requirement as in clause 6.5.1.5 in TS 38.521-1 [8] for the NR carrier.

6.5B.1.4 Occupied bandwidth for Inter-Band EN-DC including FR2 (2 CCs)

Editor's note: The following aspects are either missing or not yet determined:

- The referred test case 6.5.1 in TS 38.521-2 [9] is incomplete for some scenarios (band, bandwidth, power class etc...) as indicated in its editor's note.

6.5B.1.4.1 Test purpose

Same test purpose as in clause 6.5.1.1 in TS 38.521-2 [9] for the NR carrier.

6.5B.1.4.2 Test applicability

This test case applies to all types of E-UTRA UE release 15 and forward, supporting inter-band EN-DC including FR2 with 2 UL CCs.

6.5B.1.4.3 Minimum conformance requirements

Same minimum conformance requirements as in clause 6.5.1.3 in TS 38.521-2 [9] for the NR carrier.

No exception requirements applicable to NR or LTE. LTE anchor agnostic approach is applied.

6.5B.1.4.4 Test description

6.5B.1.4.4.1 Initial conditions

Same test description as in clause 6.5.1.4 in TS 38.521-2 [9] for the NR carrier with the following exception:

The initial test configurations for E-UTRA band consist of environmental conditions, test frequencies, and channel bandwidths based on E-UTRA bands specified in Table 4.7-1. For Initial conditions as in clause 6.5.1.4.1 in TS 38.521-2 [9], the following steps will be added to configure E-UTRA component:

- 2.1. The parameter settings for E-UTRA cell are set up according to TS 36.508 [11] clause 4.4.3.

- 3.1. The E-UTRA downlink signal level, uplink signal level are set according to Table 4.7-1 and propagation conditions are set according to Annex B.0 of TS 36.521-1 [10].

Step 6 of Initial conditions as in clause 6.5.1.4.1 in TS 38.521-2 [9] is replaced by:

6. Ensure the UE is in state RRC_CONNECTED with generic procedure parameters Connectivity EN-DC, DC bearer MCG and SCG, Connected without release On according to TS 38.508-1 [6] clause 4.5.

Same test procedure as in clause 6.5.1.4.2 in TS 38.521-2 [9] with the following steps added for E-UTRA component:

- 1.1 On the E-UTRA carrier, disable periodic and aperiodic CQI reports, disable SRS, set *TimeAlignmentTimerDedicated* IE to infinity and disable downlink and uplink scheduling, all as per Table 4.7-1 under clause 4.7.

6.5B.1.4.5 Test requirement

Same test requirement as in clause 6.5.1.5 in TS 38.521-2 [9] for the NR carrier.

6.5B.1.4_1 Occupied bandwidth for Inter-band EN-DC including FR2 (>2 CCs)

Editor's note: Test applicability, Test Description in below sub-clauses requires updates to clarify number of E-UTRA carriers that will be configured during the test that will be limited to only 1 E-UTRA CC

6.5B.1.4_1.1 Occupied bandwidth for Inter-band EN-DC including FR2 (3 CCs)

Editor's note: This clause is incomplete. The following aspects are either missing or not yet determined:

- **The referred test case 6.5A.1.1 in TS 38.521-2 [9] is incomplete for some scenarios (band, aggregated bandwidth, CA configuration, power class etc...) as indicated in its editor's note.**

6.5B.1.4_1.1.1 Test purpose

Same test purpose as in clause 6.5.1.1 in TS 38.521-2 [9] for the NR carrier.

6.5B.1.4_1.1.2 Test applicability

This test case applies to all types of E-UTRA UE release 15 and forward, supporting inter-band EN-DC including FR2 with 3 UL CCs (2NR UL CCs).

6.5B.1.4_1.1.3 Minimum conformance requirements

Same minimum conformance requirements as in clause 6.5.1.3 in TS 38.521-2 [9] for the NR carrier.

No exception requirements applicable to NR or LTE. LTE anchor agnostic approach is applied.

The normative reference for this requirement is TS 38.101-3 [4] clause 6.5B.1.

6.5B.1.4_1.1.4 Test description

6.5B.1.4_1.1.4.1 Initial condition

Same test description as in clause 6.5A.1.1.4 in TS 38.521-2 [9] for the NR carrier with the following exception:

The initial test configurations for E-UTRA band consist of environmental conditions, test frequencies, and channel bandwidths based on E-UTRA bands specified in Table 4.7-1.

For Initial conditions as in clause 6.5A.1.1.4.1 in TS 38.521-2 [9], the following steps will be added to configure E-UTRA component:

- 2.1. The parameter settings for E-UTRA cell are set up according to TS 36.508 [11] clause 4.4.3.
- 3.1. The E-UTRA downlink signal level, uplink signal level are set according to Table 4.7-1 and propagation conditions are set according to Annex B.0 of TS 36.521-1 [10].

Step 6 of Initial conditions as in clause 6.5A.1.1.4.1 in TS 38.521-2 [9] is replaced by:

6. Ensure the UE is in state RRC_CONNECTED with generic procedure parameters Connectivity EN-DC, DC bearer MCG and SCG, Connected without release On according to TS 38.508-1 [6] clause 4.5.

Same test procedure as in clause 6.5A.1.1.4.2 in TS 38.521-2 [9] with the following steps added for E-UTRA component:

- 1.1 On the E-UTRA carrier, disable periodic and aperiodic CQI reports, disable SRS, set *TimeAlignmentTimerDedicated* IE to infinity and disable downlink and uplink scheduling, all as per Table 4.7-1 under clause 4.7.

6.5B.1.4_1.1.5 Test Requirements

Same test requirement as in clause 6.5A.1.1.5 in TS 38.521-2 [9] for the NR carrier.

6.5B.1.4_1.2 Occupied bandwidth for Inter-band EN-DC including FR2 (4 CCs)

Editor's note: This clause is incomplete. The following aspects are either missing or not yet determined:

- **The referred test case 6.5A.1.2 in TS 38.521-2 [9] is incomplete for some scenarios (band, aggregated bandwidth, CA configuration, power class etc...) as indicated in its editor's note.**

6.5B.1.4_1.2.1 Test purpose

Same test purpose as in clause 6.5.1.1 in TS 38.521-2 [9] for the NR carrier.

6.5B.1.4_1.2.2 Test applicability

This test case applies to all types of E-UTRA UE release 15 and forward, supporting inter-band EN-DC including FR2 with 4 UL CCs (3NR UL CCs).

6.5B.1.4_1.2.3 Minimum conformance requirements

Same minimum conformance requirements as in clause 6.5.1.3 in TS 38.521-2 [9] for the NR carrier.

No exception requirements applicable to NR or LTE. LTE anchor agnostic approach is applied.

The normative reference for this requirement is TS 38.101-3 [4] clause 6.5B.1.

6.5B.1.4_1.2.4 Test description

6.5B.1.4_1.2.4.1 Initial condition

Same test description as in clause 6.5A.1.2.4 in TS 38.521-2 [9] for the NR carrier with the following exception:

The initial test configurations for E-UTRA band consist of environmental conditions, test frequencies, and channel bandwidths based on E-UTRA bands specified in Table 4.7-1.

For Initial conditions as in clause 6.5A.1.2.4.1 in TS 38.521-2 [9], the following steps will be added to configure E-UTRA component:

- 2.1. The parameter settings for E-UTRA cell are set up according to TS 36.508 [11] clause 4.4.3.
- 3.1. The E-UTRA downlink signal level, uplink signal level are set according to Table 4.7-1 and propagation conditions are set according to Annex B.0 of TS 36.521-1 [10].

Step 6 of Initial conditions as in clause 6.5A.1.2.4.1 in TS 38.521-2 [9] is replaced by:

6. Ensure the UE is in state RRC_CONNECTED with generic procedure parameters Connectivity EN-DC, DC bearer MCG and SCG, Connected without release On according to TS 38.508-1 [6] clause 4.5.

Same test procedure as in clause 6.5A.1.2.4.2 in TS 38.521-2 [9] with the following steps added for E-UTRA component:

1.1 On the E-UTRA carrier, disable periodic and aperiodic CQI reports, disable SRS, set *TimeAlignmentTimerDedicated* IE to infinity and disable downlink and uplink scheduling, all as per Table 4.7-1 under clause 4.7.

6.5B.1.4_1.2.5 Test Requirements

Same test requirement as in clause 6.5A.1.2.5 in TS 38.521-2 [9] for the NR carrier.

6.5B.1.4_1.3 Occupied bandwidth for Inter-band EN-DC including FR2 (5 CCs)

Editor's note: This clause is incomplete. The following aspects are either missing or not yet determined:

- **The referred test case 6.5A.1.1 in TS 38.521-2 [9] is incomplete for some scenarios (band, aggregated bandwidth, CA configuration, power class etc...) as indicated in its editor's note.**

6.5B.1.4_1.3.1 Test purpose

Same test purpose as in clause 6.5.1.1 in TS 38.521-2 [9] for the NR carrier.

6.5B.1.4_1.3.2 Test applicability

This test case applies to all types of E-UTRA UE release 15 and forward, supporting inter-band EN-DC including FR2 with 5 UL CCs (4NR UL CCs).

6.5B.1.4_1.3.3 Minimum conformance requirements

Same minimum conformance requirements as in clause 6.5.1.3 in TS 38.521-2 [9] for the NR carrier.

No exception requirements applicable to NR or LTE. LTE anchor agnostic approach is applied.

The normative reference for this requirement is TS 38.101-3 [4] clause 6.5B.1.

6.5B.1.4_1.3.4 Test description

6.5B.1.4_1.3.4.1 Initial condition

Same test description as in clause 6.5A.1.3.4 in TS 38.521-2 [9] for the NR carrier with the following exception:

The initial test configurations for E-UTRA band consist of environmental conditions, test frequencies, and channel bandwidths based on E-UTRA bands specified in Table 4.7-1.

For Initial conditions as in clause 6.5A.1.3.4.1 in TS 38.521-2 [9], the following steps will be added to configure E-UTRA component:

- 2.1. The parameter settings for E-UTRA cell are set up according to TS 36.508 [11] clause 4.4.3.
- 3.1. The E-UTRA downlink signal level, uplink signal level are set according to Table 4.7-1 and propagation conditions are set according to Annex B.0 of TS 36.521-1 [10].

Step 6 of Initial conditions as in clause 6.5A.1.3.4.1 in TS 38.521-2 [9] is replaced by:

6. Ensure the UE is in state RRC_CONNECTED with generic procedure parameters Connectivity EN-DC, DC bearer MCG and SCG, Connected without release On according to TS 38.508-1 [6] clause 4.5.

Same test procedure as in clause 6.5A.1.3.4.2 in TS 38.521-2 [9] with the following steps added for E-UTRA component:

- 1.1 On the E-UTRA carrier, disable periodic and aperiodic CQI reports, disable SRS, set *TimeAlignmentTimerDedicated* IE to infinity and disable downlink and uplink scheduling, all as per Table 4.7-1 under clause 4.7.

6.5B.1.4_1.3.5 Test Requirements

Same test requirement as in clause 6.5A.1.3.5 in TS 38.521-2 [9] for the NR carrier.

6.5B.1.4D Occupied bandwidth for inter-band EN-DC including FR2 for UL-MIMO

Editor's note: This clause is incomplete. The following aspects are either missing or not yet determined:

- The referred test case 6.5D.1 in TS 38.521-2 [9] is incomplete

6.5B.1.4D.1 Test purpose

Same test purpose as in clause 6.5D.1.1 in TS 38.521-2 [9] for the NR carrier.

6.5B.1.4D.2 Test applicability

This test case applies to all types of E-UTRA UE release 15 and forward, supporting inter-band EN-DC including FR2 with 2 UL CCs.

6.5B.1.4D.3 Minimum conformance requirements

Same minimum conformance requirements as in clause 6.5D.1.3 in TS 38.521-2 [9] for the NR carrier.

No exception requirements applicable to NR or LTE. LTE anchor agnostic approach is applied.

6.5B.1.4D.4 Test description

6.5B.1.4D.4.1 Initial conditions

Same test description as in clause 6.5D.1.4 in TS 38.521-2 [9] for the NR carrier with the following exception:

The initial test configurations for E-UTRA band consist of environmental conditions, test frequencies, and channel bandwidths based on E-UTRA bands specified in Table 4.7-1. For Initial conditions as in clause 6.5D.1.4.1 in TS 38.521-2 [9], the following steps will be added to configure E-UTRA component:

- 2.1. The parameter settings for E-UTRA cell are set up according to TS 36.508 [11] clause 4.4.3.
- 3.1. The E-UTRA downlink signal level, uplink signal level are set according to Table 4.7-1 and propagation conditions are set according to Annex B.0 of TS 36.521-1 [10].

Step 6 of Initial conditions as in clause 6.5D.1.4.1 in TS 38.521-2 [9] is replaced by:

6. Ensure the UE is in state RRC_CONNECTED with generic procedure parameters Connectivity EN-DC, DC bearer MCG and SCG, Connected without release On according to TS 38.508-1 [6] clause 4.5.

Same test procedure as in clause 6.5D.1.4.2 in TS 38.521-2 [9] with the following steps added for E-UTRA component:

- 1.1 On the E-UTRA carrier, disable periodic and aperiodic CQI reports, disable SRS, set *TimeAlignmentTimerDedicated* IE to infinity and disable downlink and uplink scheduling, all as per Table 4.7-1 under clause 4.7.

6.5B.1.4D.5 Test requirement

Same test requirement as in clause 6.5D.1.5 in TS 38.521-2 [9] for the NR carrier.

6.5B.2 Out-of-band emissions for EN-DC

6.5B.2.1 Out-of-band emissions for Intra-band contiguous EN-DC

6.5B.2.1.1 Spectrum emissions mask for intra-band contiguous EN-DC

6.5B.2.1.1.1 Test purpose

To verify that the power of any UE emissions shall not exceed specified level for the specified aggregated bandwidth for the EN-DC intra-band contiguous.

6.5B.2.1.1.2 Test applicability

This test case applies to all types of E-UTRA UE release 15 and forward, supporting intra-band contiguous EN-DC.

6.5B.2.1.1.3 Minimum conformance requirements

The general spectrum emission for intra-band contiguous EN-DC is specified in Table 6.5B.2.1.1.3-1.

Table 6.5B.2.1.1.3-1: General spectrum emission mask for intra-band contiguous EN-DC

Δf_{oob} (MHz)	Spectrum emission limit (dBm)	Measurement bandwidth
$\pm 0 - 1$	$\text{Max}(\text{Round}(10 \cdot \log(0.15/\text{ENBW})), -24)$	30 kHz
$\pm 1 - 5$	-10	1 MHz
$\pm 5 - \text{ENBW}$	-13	1 MHz
$\pm \text{ENBW} - (\text{ENBW} + 5)$	-25	1 MHz
NOTE: ENBW refers to the aggregated channel bandwidth in MHz as defined in clause 5.3B.		

The normative reference for this measurement is TS 38.101-3 [4] clause 6.5B.2.1.1.

Exception requirements for both NR and E-UTRA are defined for this test and therefore LTE anchor agnostic approach is not applied. E-UTRA test point analysis is included and E-UTRA measurements are performed.

6.5B.2.1.1.4 Test description

6.5B.2.1.1.4.1 Initial conditions

Initial conditions are a set of test configurations the UE needs to be tested in and the steps for the SS to take with the UE to reach the correct measurement state.

The initial test configurations consist of environmental conditions, test frequencies and channel bandwidths based on EN-DC operating bands specified in clause 5.3B.1.2, channel bandwidths and sub-carrier spacings for the NR cell specified in TS 38.521-1 [8] clause 5.3 and channel bandwidth for the E-UTRA cell are specified in TS 36.521-1 [10] clause 5.4.2. All of these configurations shall be tested with applicable test parameters for each EN-DC configuration specified in clause 5.3B.1.2 and are shown in table 6.5B.2.1.1.4.1-1. The details of the uplink reference measurement channels (RMCs) are specified in Annex A.2. Configurations of PDSCH and PDCCH before measurement are specified in TS 36.521-1 [10] Annex C.2 and in TS 38.521-1 [8] Annex C.2 for E-UTRA CG and NR CG respectively.

Table 6.5B.2.1.1.4.1-1: Test configuration table

Initial Conditions									
Test Environment as specified in TS 38.508-1 [6] clause 4.1					Normal, TL/VL, TL/VH, TH/VL, TH/VH				
Test Frequencies as specified in TS 38.508-1 [6] clause 4.3.1					Low range, High range				
Test EN-DC bandwidth combination as specified in Table 5.3B.1.2-1					Lowest N_{RB_agg} , Highest N_{RB_agg} (Note 2)				
Test SCS for the NR cell as specified in TS 38.521-1 [8] Table 5.3.5-1					Lowest, Highest				
Test Parameters									
Test ID	Freq	ChBw	SCS	Downlink Configuration	EN-DC Uplink Configuration				
					E-UTRA Cell		NR Cell		Common Power config (NOTE 8)
					Modulation	RB allocation (Note 5)	Modulation	RB allocation (NOTE 1)	
1	Default	Default	Default	N/A	16QAM	Outer_Full	DFT-s-OFDM Pi/2 BPSK	Outer_Full	B
2 (Note 3)	Default				16QAM	Outer_1RB_Left	DFT-s-OFDM Pi/2 BPSK	Edge_1RB_Right	B
3 (Note 3)	Low				16QAM	Outer_1RB_Left	DFT-s-OFDM Pi/2 BPSK	N/A	A
4 (Note 3)	High				16QAM	N/A	DFT-s-OFDM Pi/2 BPSK	Edge_1RB_Right	A
5 (Note 4)	Default				16QAM	Outer_1RB_Right	DFT-s-OFDM Pi/2 BPSK	Edge_1RB_Left	B
6 (Note 4)	Low				16QAM	N/A	DFT-s-OFDM Pi/2 BPSK	Edge_1RB_Left	A
7 (Note 4)	High				16QAM	Outer_1RB_Right	DFT-s-OFDM Pi/2 BPSK	N/A	A
8	Default				16QAM	Outer_Full	DFT-s-OFDM QPSK	Outer_Full	B
9 (Note 3)	Default				16QAM	Outer_1RB_Left	DFT-s-OFDM QPSK	Edge_1RB_Right	B
10 (Note 3)	Low				16QAM	Outer_1RB_Left	DFT-s-OFDM QPSK	N/A	A
11 (Note 3)	High				16QAM	N/A	DFT-s-OFDM QPSK	Edge_1RB_Right	A
12 (Note 4)	Default				16QAM	Outer_1RB_Right	DFT-s-OFDM QPSK	Edge_1RB_Left	B
13 (Note 4)	Low				16QAM	N/A	DFT-s-OFDM QPSK	Edge_1RB_Left	A
14 (Note 4)	High				16QAM	Outer_1RB_Right	DFT-s-OFDM QPSK	N/A	A
15	Default				16QAM	Outer_Full	DFT-s-OFDM 16QAM	Outer_Full	B
16 (Note 3)	Default				16QAM	Outer_1RB_Left	DFT-s-OFDM 16QAM	Edge_1RB_Right	B
17 (Note 3)	Low				16QAM	Outer_1RB_Left	DFT-s-OFDM 16QAM	N/A	A

18 (Note 3)	High				16QAM	N/A	DFT-s-OFDM 16QAM	Edge_1RB_Right	A
19 (Note 4)	Default				16QAM	Outer_1RB_Right	DFT-s-OFDM 16QAM	Edge_1RB_Left	B
20 (Note 4)	Low				16QAM	N/A	DFT-s-OFDM 16QAM	Edge_1RB_Left	A
21 (Note 4)	High				16QAM	Outer_1RB_Right	DFT-s-OFDM 16QAM	N/A	A
22	Default				16QAM	Outer_Full	DFT-s-OFDM 64QAM	Outer_Full	B
23 (Note 3)	Low				16QAM	Outer_1RB_Left	DFT-s-OFDM 64QAM	Edge_1RB_Right	B
24 (Note 4)	High				16QAM	Outer_1RB_Right	DFT-s-OFDM 64QAM	Edge_1RB_Left	B
25	Default				16QAM	Outer_Full	DFT-s-OFDM 256QAM	Outer_Full	B
26 (Note 3)	Low				16QAM	Outer_1RB_Left	DFT-s-OFDM 256QAM	Edge_1RB_Right	B
27 (Note 4)	High				16QAM	Outer_1RB_Right	DFT-s-OFDM 256QAM	Edge_1RB_Left	B
28	Default				16QAM	Outer_Full	CP-OFDM QPSK	Outer_Full	B
29 (Note 3)	Default				16QAM	Outer_1RB_Left	CP-OFDM QPSK	Edge_1RB_Right	B
30 (Note 3)	Low				16QAM	Outer_1RB_Left	CP-OFDM QPSK	N/A	A
31 (Note 3)	High				16QAM	N/A	CP-OFDM QPSK	Edge_1RB_Right	A
32 (Note 4)	Default				16QAM	Outer_1RB_Right	CP-OFDM QPSK	Edge_1RB_Left	B
33 (Note 4)	Low				16QAM	N/A	CP-OFDM QPSK	Edge_1RB_Left	A
34 (Note 4)	High				16QAM	Outer_1RB_Right	CP-OFDM QPSK	N/A	A
35	Default				16QAM	Outer_Full	CP-OFDM 16QAM	Outer_Full	B
36 (Note 3)	Default				16QAM	Outer_1RB_Left	CP-OFDM 16QAM	Edge_1RB_Right	B
37 (Note 3)	Low				16QAM	Outer_1RB_Left	CP-OFDM 16QAM	N/A	A
38 (Note 3)	High				16QAM	N/A	CP-OFDM 16QAM	Edge_1RB_Right	A
39 (Note 4)	Default				16QAM	Outer_1RB_Right	CP-OFDM 16QAM	Edge_1RB_Left	B
40 (Note 4)	Low				16QAM	N/A	CP-OFDM 16QAM	Edge_1RB_Left	A

41 (Note 4)	High				16QAM	Outer_1RB_Right	CP-OFDM 16QAM	N/A	A
42	Default				16QAM	Outer_Full	CP-OFDM 64QAM	Outer_Full	B
43 (Note 3)	Low				16QAM	Outer_1RB_Left	CP-OFDM 64QAM	Edge_1RB_Right	B
44 (Note 4)	High				16QAM	Outer_1RB_Right	CP-OFDM 64QAM	Edge_1RB_Left	B
45	Default				16QAM	Outer_Full	CP-OFDM 256QAM	Outer_Full	B
46 (Note 3)	Low				16QAM	Outer_1RB_Left	CP-OFDM 256QAM	Edge_1RB_Right	B
47 (Note 4)	High				16QAM	Outer_1RB_Right	CP-OFDM 256QAM	Edge_1RB_Left	B
48 (Note 4)	Default				16QAM	Edge_Full_Right	CP-OFDM 256QAM	Edge_Full_Left	B

NOTE 1: The specific configuration of each RB allocation is defined in Table 6.1-1 in TS 38.521-1 [8].

NOTE 2: If the UE supports multiple CC combinations in the EN-DC configuration with the same $N_{RB,agg}$, select the combination to test as follows:

- Lowest ENBW: NR component with lowest N_{RB} is tested.
- Highest ENBW: NR component with highest N_{RB} is tested.

NOTE 3: Applicable when E-UTRA cell carrier frequency is lower than NR cell carrier.

NOTE 4: Applicable when NR cell carrier frequency is lower than E-UTRA cell carrier.

NOTE 5: Outer_Full defined as the transmission bandwidth configuration N_{RB} per channel bandwidth for the E-UTRA component as indicated in TS 36.521 [10] Table 5.4.2-1. Outer_1RB_Left defined as 1 RB allocated at the left edge of the E-UTRA component. Outer_1RB_Right defined as 1 RB allocated at the right edge of the E-UTRA component. Edge_Full_Right is defined as 2 RBs allocated at the right edge of the E-UTRA component.

NOTE 6: DFT-s-OFDM Pi/2 BPSK test applies only for UEs which supports Pi/2 BPSK in FR1

NOTE 7: Power config as specified in Table 6.5B.2.1.2.4.3-3 (PC3) or 6.5B.2.1.2.4.3-4 (PC2).

NOTE 8: All test points in this table must also exist in table 6.2B.2.1.4.1-1 (MPR).

NOTE 9: Test IDs with simultaneous E-UTRA and NR UL transmission only apply for UEs indicating dualPA-Architecture.

1. Connect the SS to the UE antenna connectors as shown in [6] TS 38.508-1 A.3.1.2.1 for SS diagram and A.3.2.1 for UE diagram.
2. The parameter settings for the E-UTRA cell are set up according to TS 36.508 [11] clause 4.4.3, and the parameter settings for the NR cell are set up according to TS 38.508-1 [6] clause 4.4.3.
3. Downlink signals are initially set up according to TS 36.521-1 [10] Annex C.0 and TS 38.521-1 [8] Annex C.0 for E-UTRA CG and NR CG respectively, and uplink signals according to TS 36.521-1 [10] Annex H and TS 38.521-1 [8] Annex G for E-UTRA CG and NR CG respectively.
4. The UL Reference Measurement channels are TS 36.521-1 [10] Annex A.2 and TS 38.521-1 [8] Annex A.2 for E-UTRA CG and NR CG respectively.
5. Propagation conditions are set according to TS 36.521-1 [10] Annex B.0 and TS 38.521-1 [8] Annex B.0 for E-UTRA CG and NR CG respectively.
6. Ensure the UE is in state RRC_CONNECTED with generic procedure parameters Connectivity EN-DC, DC bearer MCG and SCG, Connected without release *On* according to TS 38.508-1 [6] clause 4.5. Message contents are defined in clause 6.2B.1.1.4.3.

6.5B.2.1.1.4.2 Test procedure

1. SS sends uplink scheduling information for each UL HARQ process via PDCCH DCI format 0 and DCI format 0_1 for C_RNTI to schedule the UL RMC according to table 6.5B.1.1.4.1-1 on E-UTRA CC and NR CC respectively. Since the UL has no payload and no loopback data to send the UE sends uplink MAC padding bits on the UL RMC.

2. Send continuously uplink power control "up" commands to the UE for NR and E-UTRA carrier until the UE transmits at its P_{UMAX} level; allow at least 200 ms from the first TPC command for the UE to reach P_{UMAX} level.
3. Measure the mean power over all component carriers for the EN-DC configuration. The period of measurement shall be at least the continuous duration of 1ms over consecutive active uplink slots For TDD, only slots consisting of only UL symbols are under test.
4. Measure the power of the transmitted signal with a measurement filter of bandwidths according to table 6.5B.2.1.1.5-1. The centre frequency of the filter shall be stepped in continuous steps according to the same table. The measured power shall be recorded for each step. The measurement period shall capture the active TSs.

NOTE 1: When switching to DFT-s-OFDM waveform, as specified in the test configuration table 6.5B.2.1.1.4.1-1, send an NR RRCReconfiguration message according to TS 38.508-1 [6] clause 4.6.3 Table 4.6.3-118 PUSCH-Config with TRANSFORM_PRECODER_ENABLED condition.

6.5B.2.1.2.4.3 Message contents

Message contents are according to TS 38.508-1 [6] clause 4.6.1 with the following exceptions:

Table 6.5B.2.1.2.4.3-1: AdditionalSpectrumEmission for MCG

Derivation Path: 36.508 [11] clause 4.6.3, Table 4.4.3.3-1			
Information Element	Value/remark	Comment	Condition
AdditionalSpectrumEmission	0 (NS_01)		

Table 6.5B.2.1.2.4.3-2: AdditionalSpectrumEmission for SCG

Derivation Path: 38.508-1 [5] clause 4.6.3, Table 4.6.3-1			
Information Element	Value/remark	Comment	Condition
AdditionalSpectrumEmission	0 (NS_01)		

Table 6.5B.2.1.2.4.3-3: PhysicalCellGroupConfig for PC3

Derivation Path: TS 38.508-1 [6], Table 4.6.3-106			
Information Element	Value/remark	Comment	Condition
p-NR-FR1	23	Power config A (NOTE 1)	
	20	Power config B (NOTE 2)	
NOTE 1: Applies when E-UTRA UL transmission not overlapping with NR UL transmission in time.			
NOTE 2: Applies when E-UTRA UL transmission overlapping with NR UL transmission in time.			

Table 6.5B.2.1.2.4.3-4: RRCConnectionReconfiguration: nr-Config-r15 for PC3

Derivation Path: TS 36.508 [11], Table 4.6.1-8			
Information Element	Value/remark	Comment	Condition
p-MaxEUTRA-r15	23	Power config A (NOTE 1)	
	20	Power config B (NOTE 2)	
NOTE 1: Applies when E-UTRA UL transmission not overlapping with NR UL transmission in time.			
NOTE 2: Applies when E-UTRA UL transmission overlapping with NR UL transmission in time.			

Table 6.5B.2.1.2.4.3-5: PhysicalCellGroupConfig for PC2

Derivation Path: TS 38.508-1 [6], Table 4.6.3-106			
Information Element	Value/remark	Comment	Condition
p-NR-FR1	26	Power config A (NOTE 1)	
	23	Power config B (NOTE 2)	
NOTE 1: Applies when E-UTRA UL transmission not overlapping with NR UL transmission in time.			
NOTE 2: Applies when E-UTRA UL transmission overlapping with NR UL transmission in time.			

Table 6.5B.2.1.2.4.3-6: RRCConnectionReconfiguration: nr-Config-r15 for PC2

Derivation Path: TS 36.508 [11], Table 4.6.1-8			
Information Element	Value/remark	Comment	Condition
p-MaxEUTRA-r15	26	Power config A (NOTE 1)	
	23	Power config B (NOTE 2)	
NOTE 1: Applies when E-UTRA UL transmission not overlapping with NR UL transmission in time.			
NOTE 2: Applies when E-UTRA UL transmission overlapping with NR UL transmission in time.			

6.5B.2.1.2.5 Test requirements

The power of any UE emissions shall fulfil requirements in Table 6.5B.2.1.2.5-1.

Table 6.5B.2.1.1.5-1: General spectrum emission mask for intra-band contiguous EN-DC

Δf_{foob} (MHz)	Spectrum emission limit (dBm)	Measurement bandwidth
$\pm 0 - 1$	$\text{Max}(\text{Round}(10 \cdot \log(0.15/\text{ENBW})), -24)$	30 kHz
$\pm 1 - 5$	$-10 + \text{TT}$	1 MHz
$\pm 5 - \text{ENBW}$	$-13 + \text{TT}$	1 MHz
$\pm \text{ENBW} - (\text{ENBW} + 5)$	$-25 + \text{TT}$	1 MHz
NOTE: ENBW refers to the aggregated channel bandwidth in MHz as defined in clause 5.3B.		

Table 6.5B.2.1.1.5-2: Test Tolerance (Spectrum Emission Mask)

$f \leq 3.0\text{GHz}$	$3.0\text{GHz} < f \leq 4.2\text{GHz}$	$4.2\text{GHz} < f \leq 6.0\text{GHz}$
1.5 dB	1.8 dB	1.8 dB

6.5B.2.1.2 Additional spectrum emissions mask for intra-band contiguous EN-DC

6.5B.2.1.2.1 Test purpose

To verify that UE transmitter does not cause unacceptable interference to other channels or other systems in terms of transmitter spurious emissions under the deployment scenarios where additional requirements are specified.

6.5B.2.1.2.2 Test applicability

This test case applies to all types of E-UTRA power class 3 and power class 2 UE release 15 and forward, supporting intra-band contiguous EN-DC.

6.5B.2.1.2.3 Minimum conformance requirements

6.5B.2.1.2.3.1 Minimum requirement for network signalled value "NS_35"

For contiguous intra-band EN-DC configuration of DC_(n)71AA when NS_35 is indicated for the UE the requirements in table 6.5B.2.1.2.3-1 apply in the frequency ranges immediately adjacent and outside the aggregation of the said sub-blocks

When NS_35 is indicated in the MCG and NS_35 is indicated in the SCG the requirements in table 6.5B.2.1.2.3.1-1 apply in the frequency ranges immediately adjacent and outside the aggregated sub-blocks of the EN-DC configuration for DC_(n)71AA.

Table 6.5B.2.1.2.3.1-1: Additional requirements

	Frequency offset of measurement filter centre frequency, f_{offset}	Minimum requirement (dBm)	Measurement bandwidth
$0 \text{ MHz} \leq \Delta f < 0.1 \text{ MHz}$	$0.015 \text{ MHz} \leq f_{\text{offset}} < 0.085 \text{ MHz}$	-13	30 kHz
$0.1 \text{ MHz} \leq \Delta f < \text{ENBW}$	$0.15 \text{ MHz} \leq f_{\text{offset}} < \text{ENBW} - 0.05 \text{ MHz}$	-13	100 kHz
$\text{ENBW} \leq \Delta f < \text{ENBW} + 5 \text{ MHz}$	$\text{ENBW} + 0.5 \text{ MHz} \leq f_{\text{offset}} < \text{ENBW} + 4.5 \text{ MHz}$	-25	1 MHz
NOTE: ENBW is the aggregated bandwidth of an E-UTRA sub-block and an adjacent NR sub-block; there is no frequency separation between the said sub-blocks. The sub-block bandwidths include any internal guard bands.			

The normative reference for this requirement is TS 38.101-3 [4] clause 6.5B.2.1.2.1.

Exception requirements for both NR and E-UTRA are defined for this test when transmission on E-UTRA overlap in time with NR.LTE and therefore LTE anchor agnostic approach is not applied. E-UTRA test point analysis is included and E-UTRA measurements are performed.

Exception requirements for both NR and E-UTRA are defined for this test when transmission on E-UTRA doesn't overlap in time with NR, for a UE that doesn't support dynamic power sharing. LTE anchor agnostic approach is not applied for this case. E-UTRA test point analysis is included and E-UTRA measurements are performed.

No exception requirements for NR or E-UTRA are defined for this test when transmission on E-UTRA doesn't overlap in time with NR, for a UE that supports dynamic power sharing. LTE anchor agnostic approach is not applied for this case.

6.5B.2.1.2.3.2 Minimum requirement for network signalled value "NS_04"

Additional spectrum emission requirements are signalled by the network to indicate that the UE shall meet an additional requirement for a specific deployment scenario as part of the cell handover/broadcast message.

The Band 41/n41 SEM transition point from -13 dBm/MHz to -25 dBm/MHz is based on the emission bandwidth. The emission bandwidth is defined as the width of the signal between two points, one below the carrier centre frequency and one above the carrier centre frequency, outside of which all emissions are attenuated at least 26 dB below the transmitter power. Since the 26 dB emission bandwidth is implementation dependent, the transmission bandwidths occupied by RBs is used for the SEM. The emission bandwidth for LTE carriers is document in TS 36.101 [5], and the emission bandwidth for NR carriers is documented in TS 38.101-1 [2]. The total emission bandwidth for contiguous intra-band EN-DC is the sum of the emission bandwidth for each CC plus the guard band between contiguous CCs.

When "NS_04" is indicated in the cell, the power of any UE emission shall not exceed the levels specified in Table 6.5B.2.1.2.3.2-1.

Table 6.5B.2.1.2.3.2-1: n41 SEM with NS_04

Δf_{OOB} MHz	Spectrum emission limit (dBm)/ measurement bandwidth for each channel bandwidth						Measurement bandwidth
	10 MHz	15 MHz	20 MHz	40 MHz	50 MHz	> 50 MHz	
$\pm 0 - 1$	-18	-20	-21	-24	-25		30 kHz
$\pm 1 - 5$	-10						1 MHz
$\pm 5 - X$	-13						
$\pm X - (\text{BW}_{\text{Channel}} + 5 \text{ MHz})$	-25						
NOTE 1: X is defined as the sum of the emission bandwidth of the component carriers plus the guard band between contiguous CCs.							

The normative reference for this requirement is TS 38.101-3 [4] clause 6.5B.2.1.2.2.

Exception requirements for both NR and E-UTRA are defined for this test and therefore LTE anchor agnostic approach is not applied. E-UTRA test point analysis is included and E-UTRA measurements are performed.

6.5B.2.1.2.4 Test description

6.5B.2.1.2.4.1 Initial conditions

Initial conditions are a set of test configurations the UE needs to be tested in and the steps for the SS to take with the UE to reach the correct measurement state.

The initial test configurations consist of environmental conditions, test frequencies and channel bandwidths based on EN-DC operating bands specified in clause 5.3B.1.2, channel bandwidths and sub-carrier spacings for the NR cell specified in TS 38.521-1 [8] clause 5.3 and channel bandwidth for the E-UTRA cell are specified in TS 36.521-1 [10] clause 5.4.2. All these configurations shall be tested with applicable test parameters for each EN-DC configuration specified in clause 5.3B.1.2 and are shown in test configuration table 6.2B.3.1.4.1-1 through 6.2B.3.1.4.1-26. The details of the uplink reference measurement channels (RMCs) are specified in Annex A.2. Configurations of PDSCH and PDCCH before measurement are specified in TS 36.521-1 [10] Annex C.2 and in TS 38.521-1 [8] Annex C.2 for E-UTRA CG and NR CG respectively.

Table 6.5B.2.1.2.4.1-0: E-UTRA test configuration table

E-UTRA Test Parameters				
E-UTRA Channel Bandwidth	E-UTRA Test Frequency (Note 1)	Downlink	Uplink	
		N/A for A-MPR testing.	Modulation	RB allocation
20 MHz	Low range and High range (Note 2)		QPSK	100
NOTE 1: E-UTRA Test Frequency as specified in TS 36.508 [6] clause 4.3.1				
NOTE 2: NR carrier shall be the outermost carrier during test.				

The initial test configurations for E-UTRA consist of test frequency based on E-UTRA operating band and test channel bandwidth as specified in Table 4.6-1.

1. Connect the SS to the UE antenna connectors as shown in TS 38.508-1 [6] Annex A, Figure A.3.1.2.1 for SS diagram and clause A.3.2.1 for UE diagram.
2. The parameter settings for the E-UTRA cell are set up according to TS 36.508 [11] clause 4.4.3, and the parameter settings for the NR cell are set up according to TS 38.508-1 [6] clause 4.4.3.
3. Downlink signals are initially set up according to TS 36.521-1 [10] Annex C.0 and TS 38.521-1 [8] Annex C.0 for E-UTRA CG and NR CG respectively, and uplink signals according to TS 36.521-1 [10] Annex H and TS 38.521-1 [8] Annex G for E-UTRA CG and NR CG respectively.
4. NR downlink signals are initially set up according to Annex C.0, C.1, and C.2 and uplink signals according to Annex G.0, G.1, G.2, and G.3.0 of TS 38.521-1 [8].
5. The UL Reference Measurement channels are set according to TS 36.521-1 [10] Annex A.2 and TS 38.521-1 [8] Annex A.2 for E-UTRA CG link and NR CG link respectively.
6. Propagation conditions are set according to TS 36.521-1 [10] Annex B.0 and TS 38.521-1 [8] Annex B.0 for E-UTRA CG link and NR CG link respectively.
7. Ensure the UE is in state RRC_CONNECTED with generic procedure parameters Connectivity EN-DC, DC bearer MCG and SCG, Connected without release *On* according to TS 38.508-1 [6] clause 4.5. Message contents are defined in clause 6.5B.2.1.2.4.3.
8. For the case of testing overlapping E-UTRA and NR UL transmission scenario when both bands are TDD, ensure E-UTRA UL transmission overlaps with NR UL transmission in time by giving SCG a delay of 3 E-UTRA subframes, or by giving MCG a delay of 2 subframes.

6.5B.2.1.2.4.2 Test procedure

1. SS sends uplink scheduling information for each UL HARQ process via PDCCH DCI format 0 and DCI format [0_1] for C_RNTI to schedule the UL RMC according to table 6.2B.3.1.4.1-1 on both EN-DC component carriers. Since the UL has no payload and no loopback data to send the UE sends uplink MAC padding bits on the UL RMC.

2. Send continuously uplink power control "up" commands to the UE for NR and E-UTRA carrier until the UE transmits at its P_{UMAX} level; allow at least 200 ms from the first TPC command starting from the first TPC command in this step for the UE to reach P_{UMAX} level.
3. Measure the mean power over all component carriers for the EN-DC configuration, which shall meet the requirements described in table 6.5B.2.1.2.5.1-1 through to 6.5B.2.1.2.5.2-1. The period of the measurement shall be at least the continuous duration of one active sub-frame (1ms).
4. Measure the power of the transmitted signal with a measurement filter of bandwidths according to table 6.5B.2.1.2.5-1 through to 6.5B.2.1.2.5.2-1. The centre frequency of the filter shall be stepped in contiguous steps according to the same table. The measured power shall be recorded for each step. The measurement period shall capture the active time slots.

NOTE 1: When switching to DFT-s-OFDM waveform, as specified in the test configuration table 6.2B.3.1.4.1-2, send an NR RRCReconfiguration message according to TS 38.508-1 [6] clause 4.6.3 Table 4.6.3-118 PUSCH-Config with TRANSFORM_PRECODER_ENABLED condition.

6.5B.2.1.2.4.3 Message contents

Message contents are according to TS 38.508-1 [6] clause 4.6.1, with the following exceptions.

Table 6.5B.2.1.2.4.3-1: RRCConnectionReconfiguration: nr-Config-r15

Derivation Path: TS 36.508 [11], Table 4.6.1-8			
Information Element	Value/remark	Comment	Condition
p-MaxEUTRA-r15	23	Apply if run test points with E-UTRA UL transmission not overlapping with NR UL transmission in time for PC3 UE	
	20	Apply if run test points with E-UTRA UL transmission overlapping with NR UL transmission in time for PC3 UE, and UE doesn't support dynamic power sharing.	
P-Max	23	Apply if run test points with E-UTRA UL transmission not overlapping with NR UL transmission in time for PC3 UE	
	20	Apply if run test points with E-UTRA UL transmission overlapping with NR UL transmission in time for PC3 UE, and UE doesn't support dynamic power sharing.	

6.5B.2.1.2.4.3.1 Message contents exceptions for network signalled value "NS_35"

For "NS_35" see A-MPR test case in table 6.2B.3.1.4.3.2-1 and table 6.2B.3.1.4.3.2-2.

6.5B.2.1.2.4.3.2 Message contents exceptions for network signalled value "NS_04"

For "NS_04" see A-MPR test case in table 6.2B.3.1.4.3.1-1 and table 6.2B.3.1.4.3.1-2.

6.5B.2.1.2.5 Test requirement

6.5B.2.1.2.5-1: Test Tolerance (Additional Spectrum Emission Mask)

f ≤ 3.0GHz	3.0GHz < f ≤ 4.2GHz	4.2GHz < f ≤ 6.0GHz
1.5 dB	1.8 dB	1.8 dB

6.5B.2.1.2.5.1 Test requirement for network signalled value "NS_35"

When "NS_35" is indicated in the cell measured UE mean power in the channel bandwidth, derived in step 3, shall fulfil requirements in table 6.2B.3.1.5.1-1, and the power of any UE shall not exceed the described values in table 6.5B.2.1.2.5.1-1. The requirements in the table apply in the frequency ranges immediately adjacent and outside the aggregation of the sub-blocks.

Table 6.5B.2.1.2.5.1-1: Additional requirements for "NS_35"

Δf_{OoB}	Frequency offset of measurement filter centre frequency, f_{offset}	Minimum requirement [dBm]	Measurement bandwidth
$0 \text{ MHz} \leq \Delta f < 0.1 \text{ MHz}$	$0.015 \text{ MHz} \leq f_{\text{offset}} < 0.085 \text{ MHz}$	-13+TT	30 kHz
$0.1 \text{ MHz} \leq \Delta f < \text{ENBW}$	$0.15 \text{ MHz} \leq f_{\text{offset}} < \text{ENBW} - 0.05 \text{ MHz}$	-13+TT	100 kHz
$\text{ENBW} \leq \Delta f < \text{ENBW} + 5 \text{ MHz}$	$\text{ENBW} + 0.5 \text{ MHz} \leq f_{\text{offset}} < \text{ENBW} + 4.5 \text{ MHz}$	-25+TT	1 MHz
NOTE: ENBW is the aggregated bandwidth of an E-UTRA sub-block and an adjacent NR sub-block; there is no frequency separation between the said sub-blocks. The sub-block bandwidths include any internal guard bands.			

6.5B.2.1.2.5.2 Test requirement for network signalled value "NS_04"

When "NS_04" is indicated in the cell measured UE mean power in the channel bandwidth, derived in step 3, shall fulfil requirements in tables 6.2B.3.1.5.2-1, and the power of any UE shall not exceed the described values in table 6.5B.2.1.2.5.2-1. The requirements in the table apply in the frequency ranges immediately adjacent and outside the aggregation of the sub-blocks.

Table 6.5B.2.1.2.5.2-1: Additional requirements for n41 SEM with NS_04

Δf_{OoB} MHz	Spectrum emission limit (dBm)/ measurement bandwidth for each channel bandwidth						Measurement bandwidth
	10 MHz	15 MHz	20 MHz	40 MHz	50 MHz	> 50 MHz	
$\pm 0 - 1$	-18+TT	-20+TT	-21+TT	-24+TT	-25+TT		30 kHz
$\pm 1 - 5$	-10+TT						1 MHz
$\pm 5 - X$	-13+TT						
$\pm X - (\text{BW}_{\text{Channel}} + 5 \text{ MHz})$	-25+TT						
NOTE 1: X is defined as the sum of the emission bandwidth of the component carriers plus the guard band between contiguous CCs.							

6.5B.2.1.3 Adjacent channel leakage ratio for intra-band contiguous EN-DC

6.5B.2.1.3.1 Test purpose

To verify that UE transmitter does not cause unacceptable interference to adjacent channels in terms of Adjacent Channel Leakage Power Ratio (ACLR).

6.5B.2.1.3.2 Test applicability

This test case applies to all types of E-UTRA UE release 15 and forward, supporting intra-band EN-DC.

6.5B.2.1.3.3 Minimum conformance requirements

For EN-DC operation with an E-UTRA sub-block immediately adjacent to an NR sub-block, the ACLR is defined as the ratio of the filtered mean power centred on the aggregated sub-block bandwidth ENBW to the filtered mean power centred on an adjacent bandwidth of the same size ENBW at nominal channel spacing. The UE shall meet the ACLR minimum requirement $\text{EN-DC}_{\text{ACLR}}$ specified in Table 6.5B.2.1.3-1 with ENBW the sum of the sub-block bandwidths.

The assigned channel power and adjacent channel power are measured with rectangular filters with measurement bandwidths specified in 6.5B.2.1.3-1.

Table 6.5B.2.1.3-1: ACLR for intra-band EN-DC (contiguous sub-blocks)

Parameter	Unit	Value
EN-DC _{ACLR}	dBc	30
Measurement bandwidth of EN-DC channel		1.00*ENBW
Measurement bandwidth of adjacent channel		0.95*ENBW
Frequency offset of adjacent channel		ENBW / -ENBW
NOTE 1: ENBW is the aggregated bandwidth in MHz as defined in clause 5.3B.		
NOTE 2: The frequency offset is that in between the centre frequencies of the measurement filters		

The normative reference for this requirement is TS 38.101-3 [4] clause 6.5B.2.1.3.

Exception requirements for both NR and E-UTRA are defined for this test and therefore LTE anchor agnostic approach is not applied. E-UTRA test point analysis is included and E-UTRA measurements are performed.

6.5B.2.1.3.4 Test description

6.5B.2.1.3.4.1 Initial conditions

Initial conditions are a set of test configurations the UE needs to be tested in and the steps for the SS to take with the UE to reach the correct measurement state.

The initial test configurations consist of environmental conditions, test frequencies and channel bandwidths based on EN-DC operating bands specified in clause 5.3B.1.2, channel bandwidths and sub-carrier spacings for the NR cell specified in TS 38.521-1 [8] clause 5.3 and channel bandwidth for the E-UTRA cell are specified in TS 36.521-1 [10] clause 5.4.2. All of these configurations shall be tested with applicable test parameters for each EN-DC configuration specified in clause 5.3B.1.2 and are shown in table 6.5B.2.1.1.4.1-1. The details of the uplink reference measurement channels (RMCs) are specified in Annex A.2. Configurations of PDSCH and PDCCH before measurement are specified in TS 36.521-1 [10] Annex C.2 and in TS 38.521-1 [8] Annex C.2 for E-UTRA CG and NR CG respectively.

Table 6.5B.2.1.3.4.1-1: Test Configuration Table

Initial Conditions									
Test Environment as specified in TS 38.508-1 [6] clause 4.1					Normal, TL/ML, TL/VH, TH/VL, TH/VH				
Test Frequencies as specified in TS 38.508-1 [6] clause 4.3.1					Low range, High range				
Test EN-DC bandwidth combination as specified in Table 5.3B.1.2-1					Lowest N _{RB_agg} , Highest N _{RB_agg} (Note 2)				
Test SCS for the NR cell as specified in TS 38.521-1 [8] Table 5.3.5-1					Lowest, Highest				
Test Parameters									
Test ID	Freq	ChBw	SCS	Downlink Configuration	EN-DC Uplink Configuration				
					E-UTRA Cell		NR Cell		Common Power config (NOTE 8)
					Modulation	RB allocation (Note 5)	Modulation	RB allocation (NOTE 1)	
1	Default	Default	Default	N/A	16QAM	Outer_Full	DFT-s-OFDM Pi/2 BPSK	Outer_Full	B
2 (Note 3)	Default				16QAM	Outer_1RB_Left	DFT-s-OFDM Pi/2 BPSK	Edge_1RB_Right	B
3 (Note 3)	Low				16QAM	Outer_1RB_Left	DFT-s-OFDM Pi/2 BPSK	N/A	A
4 (Note 3)	High				16QAM	N/A	DFT-s-OFDM Pi/2 BPSK	Edge_1RB_Right	A
5 (Note 4)	Default				16QAM	Outer_1RB_Right	DFT-s-OFDM Pi/2 BPSK	Edge_1RB_Left	B
6 (Note 4)	Low				16QAM	N/A	DFT-s-OFDM Pi/2 BPSK	Edge_1RB_Left	A
7 (Note 4)	High				16QAM	Outer_1RB_Right	DFT-s-OFDM Pi/2 BPSK	N/A	A
8	Default				16QAM	Outer_Full	DFT-s-OFDM QPSK	Outer_Full	B
9 (Note 3)	Default				16QAM	Outer_1RB_Left	DFT-s-OFDM QPSK	Edge_1RB_Right	B
10 (Note 3)	Low				16QAM	Outer_1RB_Left	DFT-s-OFDM QPSK	N/A	A
11 (Note 3)	High				16QAM	N/A	DFT-s-OFDM QPSK	Edge_1RB_Right	A
12 (Note 4)	Default				16QAM	Outer_1RB_Right	DFT-s-OFDM QPSK	Edge_1RB_Left	B
13 (Note 4)	Low				16QAM	N/A	DFT-s-OFDM QPSK	Edge_1RB_Left	A
14 (Note 4)	High				16QAM	Outer_1RB_Right	DFT-s-OFDM QPSK	N/A	A
15	Default				16QAM	Outer_Full	DFT-s-OFDM 16QAM	Outer_Full	B
16 (Note 3)	Default				16QAM	Outer_1RB_Left	DFT-s-OFDM 16QAM	Edge_1RB_Right	B
17 (Note 3)	Low				16QAM	Outer_1RB_Left	DFT-s-OFDM 16QAM	N/A	A

18 (Note 3)	High				16QAM	N/A	DFT-s-OFDM 16QAM	Edge_1RB_Right	A
19 (Note 4)	Default				16QAM	Outer_1RB_Right	DFT-s-OFDM 16QAM	Edge_1RB_Left	B
20 (Note 4)	Low				16QAM	N/A	DFT-s-OFDM 16QAM	Edge_1RB_Left	A
21 (Note 4)	High				16QAM	Outer_1RB_Right	DFT-s-OFDM 16QAM	N/A	A
22	Default				16QAM	Outer_Full	DFT-s-OFDM 64QAM	Outer_Full	B
23 (Note 3)	Low				16QAM	Outer_1RB_Left	DFT-s-OFDM 64QAM	Edge_1RB_Right	B
24 (Note 4)	High				16QAM	Outer_1RB_Right	DFT-s-OFDM 64QAM	Edge_1RB_Left	B
25	Default				16QAM	Outer_Full	DFT-s-OFDM 256QAM	Outer_Full	B
26 (Note 3)	Low				16QAM	Outer_1RB_Left	DFT-s-OFDM 256QAM	Edge_1RB_Right	B
27 (Note 4)	High				16QAM	Outer_1RB_Right	DFT-s-OFDM 256QAM	Edge_1RB_Left	B
28	Default				16QAM	Outer_Full	CP-OFDM QPSK	Outer_Full	B
29 (Note 3)	Default				16QAM	Outer_1RB_Left	CP-OFDM QPSK	Edge_1RB_Right	B
30 (Note 3)	Low				16QAM	Outer_1RB_Left	CP-OFDM QPSK	N/A	A
31 (Note 3)	High				16QAM	N/A	CP-OFDM QPSK	Edge_1RB_Right	A
32 (Note 4)	Default				16QAM	Outer_1RB_Right	CP-OFDM QPSK	Edge_1RB_Left	B
33 (Note 4)	Low				16QAM	N/A	CP-OFDM QPSK	Edge_1RB_Left	A
34 (Note 4)	High				16QAM	Outer_1RB_Right	CP-OFDM QPSK	N/A	A
35	Default				16QAM	Outer_Full	CP-OFDM 16QAM	Outer_Full	B
36 (Note 3)	Default				16QAM	Outer_1RB_Left	CP-OFDM 16QAM	Edge_1RB_Right	B
37 (Note 3)	Low				16QAM	Outer_1RB_Left	CP-OFDM 16QAM	N/A	A
38 (Note 3)	High				16QAM	N/A	CP-OFDM 16QAM	Edge_1RB_Right	A
39 (Note 4)	Default				16QAM	Outer_1RB_Right	CP-OFDM 16QAM	Edge_1RB_Left	B
40 (Note 4)	Low				16QAM	N/A	CP-OFDM 16QAM	Edge_1RB_Left	A

41 (Note 4)	High				16QAM	Outer_1RB_Right	CP-OFDM 16QAM	N/A	A
42	Default				16QAM	Outer_Full	CP-OFDM 64QAM	Outer_Full	B
43 (Note 3)	Low				16QAM	Outer_1RB_Left	CP-OFDM 64QAM	Edge_1RB_Right	B
44 (Note 4)	High				16QAM	Outer_1RB_Right	CP-OFDM 64QAM	Edge_1RB_Left	B
45	Default				16QAM	Outer_Full	CP-OFDM 256QAM	Outer_Full	B
46 (Note 3)	Low				16QAM	Outer_1RB_Left	CP-OFDM 256QAM	Edge_1RB_Right	B
47 (Note 4)	High				16QAM	Outer_1RB_Right	CP-OFDM 256QAM	Edge_1RB_Left	B
48 (Note 4)	Default				16QAM	Edge_Full_Right	CP-OFDM 256QAM	Edge_Full_Left	B

NOTE 1: The specific configuration of each RB allocation is defined in Table 6.1-1 in TS 38.521-1 [8].

NOTE 2: If the UE supports multiple CC combinations in the EN-DC configuration with the same N_{RB_agg} , select the combination to test as follows:

- Lowest ENBW: NR component with lowest N_{RB} is tested.
- Highest ENBW: NR component with highest N_{RB} is tested.

NOTE 3: Applicable when E-UTRA cell carrier frequency is lower than NR cell carrier.

NOTE 4: Applicable when NR cell carrier frequency is lower than E-UTRA cell carrier.

NOTE 5: Outer_Full defined as the transmission bandwidth configuration N_{RB} per channel bandwidth for the E-UTRA component as indicated in TS 36.521 [10] Table 5.4.2-1. Outer_1RB_Left defined as 1 RB allocated at the left edge of the E-UTRA component. Edge_Full_Right is defined as 2 RBs allocated at the right edge of the E-UTRA component. Outer_1RB_Right defined as 1 RB allocated at the right edge of the E-UTRA component.

NOTE 6: DFT-s-OFDM Pi/2 BPSK test applies only for UEs which supports Pi/2 BPSK in FR1

NOTE 7: Power config as specified in Table 6.5B.2.1.3.4.3-3 (PC3) or Table 6.5B.2.1.3.4.3-4 (PC2).

NOTE 9: All test points in this table must also exist in table 6.2B.2.1.4.1-1 (MPR).

NOTE 10: Test IDs with simultaneous E-UTRA and NR UL transmission only apply for UEs indicating dualPA-Architecture.

1. Connect the SS to the UE antenna connectors as shown in [6] TS 38.508-1 A.3.1.2.1 for SS diagram and A.3.2.1 for UE diagram.
2. The parameter settings for the E-UTRA cell are set up according to TS 36.508 [11] clause 4.4.3, and the parameter settings for the NR cell are set up according to TS 38.508-1 [6] clause 4.4.3.
3. Downlink signals are initially set up according to TS 36.521-1 [10] Annex C.0 and TS 38.521-1 [8] Annex C.0 for E-UTRA CG and NR CG respectively, and uplink signals according to TS 36.521-1 [10] Annex H and TS 38.521-1 [8] Annex G for E-UTRA CG and NR CG respectively.
4. The UL Reference Measurement channels are TS 36.521-1 [10] Annex A.2 and TS 38.521-1 [8] Annex A.2 for E-UTRA CG and NR CG respectively.
5. Propagation conditions are set according to TS 36.521-1 [10] Annex B.0 and TS 38.521-1 [8] Annex B.0 for E-UTRA CG and NR CG respectively.
6. Ensure the UE is in state RRC_CONNECTED with generic procedure parameters Connectivity EN-DC, DC bearer MCG and SCG, Connected without release *On* according to TS 38.508-1 [6] clause 4.5. Message contents are defined in clause 6.2B.1.1.4.3.

6.5B.2.1.3.4.2 Test procedure

1. SS sends uplink scheduling information for each UL HARQ process via PDCCH DCI format 0 and DCI format [0_1] for C_RNTI to schedule the UL RMC according to Table 6.5B.2.1.3.4.1-1 on both EN-DC component carriers. Since the UL has no payload and no loopback data to send the UE sends uplink MAC padding bits on the UL RMC.

2. Send continuously uplink power control "up" commands to the UE for NR and E-UTRA carrier until the UE transmits at its P_{UMAX} level; allow at least 200ms for the UE to reach P_{UMAX} level.
3. Measure the filtered mean power of the transmitted signal centred on the aggregated sub-block ENBW with a measurement filter of bandwidth according to Table 6.5B.2.1.3-1. The period of the measurement shall be at least the continuous duration of 1ms over consecutive active uplink slots. For TDD, only slots consisting of only UL symbols are under test.
4. Measure the filtered mean power of the first adjacent channel on both lower and upper side of the assigned NR + E-UTRA channel, respectively with a frequency offset and measurement filter of bandwidth according to Table 6.5B.2.1.3-1.
5. Calculate the ratios of the power between the values measured in step 3 over step 4 for lower and upper side respectively.

NOTE 1: When switching to DFT-s-OFDM waveform, as specified in the test configuration table 6.5B.2.1.1.4.1-1, send an NR RRCReconfiguration message according to TS 38.508-1 [6] clause 4.6.3 Table 4.6.3-118 PUSCH-Config with TRANSFORM_PRECODER_ENABLED condition.

6.5B.2.1.3.4.3 Message contents

Message contents are according to TS 38.508-1 [5] clause 4.6.1 with the following exceptions:

Table 6.5B.2.1.3.4.3-1: AdditionalSpectrumEmission for MCG

Derivation Path: 36.508 [11] clause 4.6.3, Table 4.4.3.3-1			
Information Element	Value/remark	Comment	Condition
AdditionalSpectrumEmission	0 (NS_01)		

Table 6.5B.2.1.3.4.3-2: AdditionalSpectrumEmission for SCG

Derivation Path: 38.508-1 [5] clause 4.6.3, Table 4.6.3-1			
Information Element	Value/remark	Comment	Condition
AdditionalSpectrumEmission	0 (NS_01)		

Table 6.5B.2.1.3.4.3-3: PhysicalCellGroupConfig for PC3

Derivation Path: TS 38.508-1 [6], Table 4.6.3-106			
Information Element	Value/remark	Comment	Condition
p-NR-FR1	23	Power config A (NOTE 1)	
	20	Power config B (NOTE 2)	
NOTE 1: Applies when E-UTRA UL transmission not overlapping with NR UL transmission in time.			
NOTE 2: Applies when E-UTRA UL transmission overlapping with NR UL transmission in time.			

Table 6.5B.2.1.3.4.3-4: RRCConnectionReconfiguration: nr-Config-r15 for PC3

Derivation Path: TS 36.508 [11], Table 4.6.1-8			
Information Element	Value/remark	Comment	Condition
p-MaxEUTRA-r15	23	Power config A (NOTE 1)	
	20	Power config B (NOTE 2)	
NOTE 1: Applies when E-UTRA UL transmission not overlapping with NR UL transmission in time.			
NOTE 2: Applies when E-UTRA UL transmission overlapping with NR UL transmission in time			

6.5B.2.1.3.5 Test requirement

The measured adjacent channel power ratio, derived in step 5, shall be less than or equal to $30 + TT$ dBc, where

- $TT = 0.8$ dB for $f \leq 4.0$ GHz, $TT = 1.0$ dB for 4.0 GHz $< f \leq 6.0$ GHz,

6.5B.2.2 Out-of-band emissions for Intra-band non-contiguous EN-DC

6.5B.2.2.1 Spectrum emissions mask for intra-band non-contiguous EN-DC

Editor's note: The following aspects are either missing or not yet determined:

- **Testing of none simultaneous LTE-NR transmission is FFS.**

6.5B.2.2.1.1 Test purpose

Same test purpose as in clause 6.5.2.2 in TS 38.521-1 [8] for the NR carrier.

6.5B.2.2.1.2 Test applicability

This test case applies to all types of E-UTRA UE release 15 and forward, supporting intra-band non-contiguous EN-DC.

6.5B.2.2.1.3 Minimum conformance requirements

The spectral emission mask for intra-band non-contiguous EN-DC is a composite of the emission mask for each CC with the level set to the maximum value from each mask for each frequency outside of the transmission bandwidth of either carrier. A composite spectrum emission mask is a combination of individual CC spectrum emissions masks. Where two masks overlap the most relaxed limit is used. Composite spectrum emission mask applies to frequencies up to $\pm \Delta f_{\text{OoB}}$ starting from the edges of the sub-blocks. If for some frequency an individual CC spectrum emission mask overlaps with the bandwidth of another CC then the emission mask does not apply for that frequency.

The normative reference for this requirement is TS 38.101-3 [4] clause 6.5B.2.2.1.

The spectral emission mask for intra-band non-contiguous EN-DC is a composite of the emission mask for each CC with the level set to the maximum value from each mask and therefore LTE anchor agnostic approach is not applied.

6.5B.2.2.1.4 Test description

6.5B.2.2.1.4.1 Initial conditions

Initial conditions are a set of test configurations the UE needs to be tested in and the steps for the SS to take with the UE to reach the correct measurement state.

The initial test configurations consist of environmental conditions, test frequencies and channel bandwidths based on EN-DC operating bands specified in TS 38.508-1 [6] clause 4.3.1.4.3, channel bandwidths and sub-carrier spacings for the NR cell specified in TS 38.521-1 [8] clause 5.3 and channel bandwidth for the E-UTRA cell are specified in TS 36.521-1 [10] clause 5.4.2. All of these configurations shall be tested with applicable test parameters for each EN-DC configuration specified in TS 38.508-1 [6] clause 4.3.1.4.3 and are shown in table 6.5B.2.2.1.4.1-1. The details of the uplink reference measurement channels (RMCs) are specified in Annex A.2. Configurations of PDSCH and PDCCH before measurement are specified in TS 36.521-1 [10] Annex C.2 and in TS 38.521-1 [8] Annex C.2 for E-UTRA CG and NR CG respectively.

Table 6.5B.2.2.1.4.1-1: Test Configuration Table

Initial Conditions						
Test Environment as specified in TS 38.508-1 [5] subclause 4.1		Normal				
Test Frequencies as specified in TS 38.508-1 [6] clause 4.3.1.4.3 for cases with single E-UTRA carrier		Low with maxWgap (NR low – E-UTRA high); High with maxWgap (E-UTRA low – NR high)				
Test Channel Bandwidths as specified in TS 38.508-1 [6] subclause 4.3.1.4.3		Lowest for E-UTRA, lowest for NR; Highest for E-UTRA, highest for NR				
Test SCS as specified as specified in TS 38.508-1 [6] subclause 4.3.1.4.3		Lowest, Highest				
Test Parameters for Channel Bandwidths						
Test ID	Freq	Downlink Configuration	NR Uplink Configuration		E-UTRA Uplink Configuration	
			Modulation (NOTE 2)	RB allocation (NOTE 1)	Modulation	RB allocation (NOTE 3)
		N/A				
1	Low		DFT-s-OFDM Pi/2 BPSK	Edge_1RB_Left	QPSK	Edge_1_RB_Right
2	High		DFT-s-OFDM Pi/2 BPSK	Edge_1RB_Right	QPSK	Edge_1_RB_Left
3	Default		DFT-s-OFDM Pi/2 BPSK	Outer Full	QPSK	Full
4	Low		DFT-s-OFDM QPSK	Edge_1RB_Left	QPSK	Edge_1_RB_Right
5	High		DFT-s-OFDM QPSK	Edge_1RB_Right	QPSK	Edge_1_RB_Left
6	Default		DFT-s-OFDM QPSK	Outer Full	QPSK	Full
7	Low		DFT-s-OFDM 16 QAM	Edge_1RB_Left	16QAM	Edge_1_RB_Right
8	High		DFT-s-OFDM 16 QAM	Edge_1RB_Right	16QAM	Edge_1_RB_Left
9	Default		DFT-s-OFDM 16 QAM	Outer Full	16QAM	Full
10	Low		DFT-s-OFDM 64 QAM	Edge_1RB_Left	16QAM	Edge_1_RB_Right
11	High		DFT-s-OFDM 64 QAM	Edge_1RB_Right	16QAM	Edge_1_RB_Left
12	Default		DFT-s-OFDM 64 QAM	Outer Full	16QAM	Full
13	Low		DFT-s-OFDM 256 QAM	Edge_1RB_Left	16QAM	Edge_1_RB_Right
14	High		DFT-s-OFDM 256 QAM	Edge_1RB_Right	16QAM	Edge_1_RB_Left
15	Default		DFT-s-OFDM 256 QAM	Outer Full	16QAM	Full
16	Low		CP-OFDM QPSK	Edge_1RB_Left	QPSK	Edge_1_RB_Right
17	High		CP-OFDM QPSK	Edge_1RB_Right	QPSK	Edge_1_RB_Left
18	Default		CP-OFDM QPSK	Outer Full	QPSK	Full
19	Low		CP-OFDM 16 QAM	Edge_1RB_Left	16QAM	Edge_1_RB_Right
20	High		CP-OFDM 16 QAM	Edge_1RB_Right	16QAM	Edge_1_RB_Left
21	Default		CP-OFDM 16 QAM	Outer Full	16QAM	Full
22	Low		CP-OFDM 64 QAM	Edge_1RB_Left	16QAM	Edge_1_RB_Right
23	High		CP-OFDM 64 QAM	Edge_1RB_Right	16QAM	Edge_1_RB_Left
24	Default		CP-OFDM 64 QAM	Outer Full	16QAM	Full
25	Low		CP-OFDM 256 QAM	Edge_1RB_Left	16QAM	Edge_1_RB_Right
26	High		CP-OFDM 256 QAM	Edge_1RB_Right	16QAM	Edge_1_RB_Left
27	Default		CP-OFDM 256 QAM	Outer Full	16QAM	Full
NOTE 1: The specific configuration of each RB allocation is defined in Table 6.1-1.						
NOTE 2: DFT-s-OFDM Pi/2 BPSK test applies only for UEs which supports half Pi BPSK in FR1.						
NOTE 3: For a given E-UTRA channel BW and modulation, Full allocation refers to the higher allocation defined in table 6.6.2.1.4.1-1 in 36.521-1 [10].						

For Initial conditions as in clause 6.5.2.2.4.1 in TS 38.521-1 [8], the following steps will be added to configure E-UTRA component:

- 2.1. The parameter settings for E-UTRA cell are set up according to TS 36.508 [11] clause 4.4.3.
- 3.1. The E-UTRA downlink signal level, uplink signal level are set according to Table 4.6-1 and propagation conditions are set according to Annex B.0 of TS 36.521-1 [10].

Step 6 of Initial conditions as in clause 6.5.2.2.4.1 in TS 38.521-1 [8] is replaced by the following two steps:

6. Ensure the UE is in state RRC_CONNECTED with generic procedure parameters Connectivity EN-DC, DC bearer MCG and SCG according to TS 38.508 [6] clause 4.5.

7. On the E-UTRA carrier, disable periodic and aperiodic CQI reports, disable SRS, set *TimeAlignmentTimerDedicated* IE to infinity and disable downlink and uplink scheduling, all as per Table 4.6-1 under clause 4.6.

6.5B.2.2.1.4.2 Test Procedure

1. For NR carrier, SS sends uplink scheduling information for each UL HARQ process via PDCCH DCI format 0_1 for C_RNTI to schedule the UL RMC according to Table 6.5B.2.2.1.4.1-1. Since the UL has no payload and no loopback data to send the UE sends uplink MAC padding bits on the UL RMC.
2. For E-UTRA carrier, SS sends uplink scheduling information via PDCCH DCI format 0 for C_RNTI to schedule the UL RMC according to Table 6.5B.2.2.1.4.1-1. Since the UE has no payload data to send, the UE transmits uplink MAC padding bits on the UL RMC.
3. Send continuously uplink power control "up" commands to the UE for NR and E-UTRA carrier until the UE transmits at its P_{UMAX} level; allow at least 200 ms from the first TPC command starting in this step for the UE to reach P_{UMAX} level.
4. For E-UTRA carrier, measure the power of the transmitted signal with a measurement filter of bandwidths according to table 6.6.2.1.5-1 or 6.6.2.1.5-2 in TS 36.521-1 [10], as applicable. The centre frequency of the filter shall be stepped in continuous steps according to the same table. The measured power shall be recorded for each step. The measurement period shall capture the active TSs. If for some frequency an individual spectrum emission mask overlaps with the bandwidth of the NR carrier then the emission mask does not apply for that frequency.
5. For NR carrier, measure the power of the transmitted signal with a measurement filter of bandwidths according to table 6.5.2.2.5-1 in TS 38.521-1 [8]. The centre frequency of the filter shall be stepped in continuous steps according to the same table. The measured power shall be recorded for each step. The measurement period shall capture the active TSs. If for some frequency an individual spectrum emission mask overlaps with the bandwidth of the E-UTRA carrier then the emission mask does not apply for that frequency.

NOTE 1: When switching to DFT-s-OFDM waveform, send an NR RRCReconfiguration message according to TS 38.508-1 [6] clause 4.6.3 Table 4.6.3-118 PUSCH-Config with TRANSFORM_PRECODER_ENABLED condition.

6.5B.2.2.1.5 Test requirement

-For NR carrier frequency masks not overlapping with E-UTRA carrier frequency masks, Power of any UE emission shall fulfil requirements in Table 6.5.2.2.5-1 defined in TS 38.521-1 [8].

-For E-UTRA carrier frequency masks not overlapping with NR carrier frequency masks, Power of any UE emission shall fulfil requirements in Table 6.6.2.1.5-1 or 6.6.2.1.5-2 in TS 36.521-1 [10], as applicable.

-For NR carrier frequency masks overlapping with E-UTRA carrier frequency masks, the most relaxed limit is used between requirements in Table 6.5.2.2.5-1 defined in TS 38.521-1 [8] and Table 6.6.2.1.5-1 or 6.6.2.1.5-2 in TS 36.521-1 [10], as applicable.

6.5B.2.2.2 Spectrum emissions mask for intra-band non-contiguous EN-DC

Editor's note: This clause is incomplete. The following aspects are either missing or not yet determined:

- **For $W_{gap} < NR \Delta f_{OOB} + E-UTRA \Delta f_{OOB}$, test description and test requirements are FFS.**

6.5B.2.2.2.1 Test purpose

Same test purpose as in clause 6.5.2.3 in TS 38.521-1 [8] for the NR carrier.

6.5B.2.2.2.2 Test applicability

This test case applies to all types of E-UTRA UE release 15 and forward, supporting intra-band non-contiguous EN-DC.

6.5B.2.2.2.3 Minimum conformance requirements

The spectral emission mask for intra-band non-contiguous EN-DC is a composite of the emission mask for each CC with the level set to the maximum value from each mask for each frequency outside of the transmission bandwidth of either carrier. A composite spectrum emission mask is a combination of individual CC spectrum emissions masks. Where two masks overlap the most relaxed limit is used. Composite spectrum emission mask applies to frequencies up to $\pm \Delta f_{\text{OOB}}$ starting from the edges of the sub-blocks. If for some frequency an individual CC spectrum emission mask overlaps with the bandwidth of another CC then the emission mask does not apply for that frequency.

The normative reference for this requirement is TS 38.101-3 [4] clause 6.5B.2.2.2.

No exception requirements applicable to NR or LTE when $W_{\text{gap}} > \text{NR } \Delta f_{\text{OOB}} + \text{E-UTRA } \Delta f_{\text{OOB}}$. LTE anchor agnostic approach is applied when $W_{\text{gap}} > \text{NR } \Delta f_{\text{OOB}} + \text{E-UTRA } \Delta f_{\text{OOB}}$.

Exception requirements for both NR and E-UTRA are defined for this test when $W_{\text{gap}} < \text{NR } \Delta f_{\text{OOB}} + \text{E-UTRA } \Delta f_{\text{OOB}}$ and therefore LTE anchor agnostic approach is not applied when $W_{\text{gap}} < \text{NR } \Delta f_{\text{OOB}} + \text{E-UTRA } \Delta f_{\text{OOB}}$.

6.5B.2.2.2.4 Test description

For $W_{\text{gap}} > \text{NR } \Delta f_{\text{OOB}} + \text{E-UTRA } \Delta f_{\text{OOB}}$:

Same test description as in clause 6.5.2.3.4 in TS 38.521-1 [8] for the NR carrier with the following exception:

The initial test configurations for E-UTRA band consist of environmental conditions, test frequencies, and channel bandwidths based on E-UTRA bands specified in Table 4.6-1. For Initial conditions as in clause 6.5.2.3.4.1 in TS 38.521-1 [8], the following steps will be added to configure E-UTRA component:

- 2.1. The parameter settings for E-UTRA cell are set up according to TS 36.508 [11] clause 4.4.3.
- 3.1. The E-UTRA downlink signal level, uplink signal level are set according to Table 4.6-1 and propagation conditions are set according to Annex B.0 of TS 36.521-1 [10].

Step 6 of Initial conditions as in clause 6.5.2.2.4.1 in TS 38.521-1 [8] is replaced by the following two steps:

6. Ensure the UE is in state RRC_CONNECTED with generic procedure parameters Connectivity EN-DC, DC bearer MCG and SCG according to TS 38.508 [6] clause 4.5.
7. On the E-UTRA carrier, disable periodic and aperiodic CQI reports, disable SRS, set *TimeAlignmentTimerDedicated* IE to infinity and disable downlink and uplink scheduling, all as per Table 4.6-1 under clause 4.6.

Same test procedure as in clause 6.5.2.3.4.2 in TS 38.521-1 [8] with the following steps exception:

3. Measure the mean power of the UE in the channel bandwidth of the radio access mode according to the test configuration. The period of the measurement shall be at least the continuous duration of 1ms over consecutive active uplink slots. For TDD, only slots consisting of only UL symbols are under test.

For $W_{\text{gap}} < \text{NR } \Delta f_{\text{OOB}} + \text{E-UTRA } \Delta f_{\text{OOB}}$:

FFS.

6.5B.2.2.2.5 Test requirement

For $W_{\text{gap}} > \text{NR } \Delta f_{\text{OOB}} + \text{E-UTRA } \Delta f_{\text{OOB}}$:

Power of any UE emission shall fulfil requirements in Table 6.5.2.3.5-1 defined in TS 38.521-1 [8] for the NR carrier.

For $W_{\text{gap}} < \text{NR } \Delta f_{\text{OOB}} + \text{E-UTRA } \Delta f_{\text{OOB}}$:

FFS.

6.5B.2.2.3 Adjacent channel leakage ratio for intra-band non-contiguous EN-DC

Editor's note: The following aspects are either missing or not yet determined:

- Testing of none simultaneous LTE-NR transmission is FFS.

6.5B.2.2.3.1 Test purpose

Same test purpose as in clause 6.5.2.4.1.1 in TS 38.521-1 [8] for the NR carrier.

6.5B.2.2.3.2 Test applicability

This test case applies to all types of E-UTRA UE release 15 and forward, supporting intra-band non-contiguous EN-DC.

6.5B.2.2.3.3 Minimum conformance requirements

For intra-band non-contiguous EN-DC, the EN-DC Adjacent Channel Leakage power Ratio ($EN-DC_{ACLR}$) is the ratio of the sum of the filtered mean powers centred on the assigned E-UTRA and NR sub-block frequencies to the filtered mean power centred on an adjacent channel frequency at nominal channel spacing. In case the sub-block gap bandwidth W_{gap} is smaller than a E-UTRA or NR sub-block bandwidth, no $EN-DC_{ACLR}$ requirement is set for the corresponding sub-block for the gap. The assigned EN-DC sub-block power and adjacent channel power are measured with rectangular filters with measurement bandwidths specified in TS 38.101-3 [4] for the E-UTRA sub-block, and [2],[3] for the NR sub-block. If the measured adjacent channel power is greater than -50dBm then the $EN-DC_{ACLR}$ shall be higher than the value specified in for $E-UTRA_{ACLR}$ and NR_{ACLR} .

The normative reference for this requirement is TS 38.101-3 [4] clause 6.5B.2.2.3.

Adjacent Channel Leakage power Ratio must be measured for both NR and E-UTRA and therefore LTE anchor agnostic approach is not applied.

6.5B.2.2.3.4 Test description

6.5B.2.2.3.4.1 Initial conditions

Initial conditions are a set of test configurations the UE needs to be tested in and the steps for the SS to take with the UE to reach the correct measurement state.

The initial test configurations consist of environmental conditions, test frequencies and channel bandwidths based on EN-DC operating bands specified in TS 38.508-1 [6] clause 4.3.1.4.3, channel bandwidths and sub-carrier spacings for the NR cell specified in TS 38.521-1 [8] clause 5.3 and channel bandwidth for the E-UTRA cell are specified in TS 36.521-1 [10] clause 5.4.2. All of these configurations shall be tested with applicable test parameters for each EN-DC configuration specified in TS 38.508-1 [6] clause 4.3.1.4.3 and are shown in table 6.5B.2.2.3.4.1-1. The details of the uplink reference measurement channels (RMCs) are specified in Annex A.2. Configurations of PDSCH and PDCCH before measurement are specified in TS 36.521-1 [10] Annex C.2 and in TS 38.521-1 [8] Annex C.2 for E-UTRA CG and NR CG respectively.

Table 6.5B.2.3.4.1-1: Test Configuration Table

Initial Conditions						
Test Environment as specified in TS 38.508-1 [5] subclause 4.1		Normal, TL/VL, TL/VH, TH/VL, TH/VH				
Test Frequencies as specified in TS 38.508-1 [6] clause 4.3.1.4.3 for cases with single E-UTRA carrier		Low with maxWgap (NR low – E-UTRA high); High with maxWgap (E-UTRA low – NR high)				
Test Channel Bandwidths as specified in TS 38.508-1 [6] subclause 4.3.1.4.3		Lowest for E-UTRA, lowest for NR; Highest for E-UTRA, highest for NR				
Test SCS as specified as specified in TS 38.508-1 [6] subclause 4.3.1.4.3		Lowest, Highest				
Test Parameters for Channel Bandwidths						
Test ID	Freq	Downlink Configuration	NR Uplink Configuration		E-UTRA Uplink Configuration	
			Modulation (NOTE 2)	RB allocation (NOTE 1)	Modulation	RB allocation (NOTE 3)
		N/A				
1	Low		DFT-s-OFDM Pi/2 BPSK	Edge_1RB_Left	QPSK	Edge_1_RB_Right
2	High		DFT-s-OFDM Pi/2 BPSK	Edge_1RB_Right	QPSK	Edge_1_RB_Left
3	Default		DFT-s-OFDM Pi/2 BPSK	Outer Full	QPSK	Full
4	Low		DFT-s-OFDM QPSK	Edge_1RB_Left	QPSK	Edge_1_RB_Right
5	High		DFT-s-OFDM QPSK	Edge_1RB_Right	QPSK	Edge_1_RB_Left
6	Default		DFT-s-OFDM QPSK	Outer Full	QPSK	Full
7	Low		DFT-s-OFDM 16 QAM	Edge_1RB_Left	16QAM	Edge_1_RB_Right
8	High		DFT-s-OFDM 16 QAM	Edge_1RB_Right	16QAM	Edge_1_RB_Left
9	Default		DFT-s-OFDM 16 QAM	Outer Full	16QAM	Full
10	Low		DFT-s-OFDM 64 QAM	Edge_1RB_Left	16QAM	Edge_1_RB_Right
11	High		DFT-s-OFDM 64 QAM	Edge_1RB_Right	16QAM	Edge_1_RB_Left
12	Default		DFT-s-OFDM 64 QAM	Outer Full	16QAM	Full
13	Low		DFT-s-OFDM 256 QAM	Edge_1RB_Left	16QAM	Edge_1_RB_Right
14	High		DFT-s-OFDM 256 QAM	Edge_1RB_Right	16QAM	Edge_1_RB_Left
15	Default		DFT-s-OFDM 256 QAM	Outer Full	16QAM	Full
16	Low		CP-OFDM QPSK	Edge_1RB_Left	QPSK	Edge_1_RB_Right
17	High		CP-OFDM QPSK	Edge_1RB_Right	QPSK	Edge_1_RB_Left
18	Default		CP-OFDM QPSK	Outer Full	QPSK	Full
19	Low		CP-OFDM 16 QAM	Edge_1RB_Left	16QAM	Edge_1_RB_Right
20	High		CP-OFDM 16 QAM	Edge_1RB_Right	16QAM	Edge_1_RB_Left
21	Default		CP-OFDM 16 QAM	Outer Full	16QAM	Full
22	Low		CP-OFDM 64 QAM	Edge_1RB_Left	16QAM	Edge_1_RB_Right
23	High		CP-OFDM 64 QAM	Edge_1RB_Right	16QAM	Edge_1_RB_Left
24	Default		CP-OFDM 64 QAM	Outer Full	16QAM	Full
25	Low		CP-OFDM 256 QAM	Edge_1RB_Left	16QAM	Edge_1_RB_Right
26	High		CP-OFDM 256 QAM	Edge_1RB_Right	16QAM	Edge_1_RB_Left
27	Default		CP-OFDM 256 QAM	Outer Full	16QAM	Full
NOTE 1: The specific configuration of each RB allocation is defined in Table 6.1-1.						
NOTE 2: DFT-s-OFDM Pi/2 BPSK test applies only for UEs which supports half Pi BPSK in FR1.						
NOTE 3: For a given E-UTRA channel BW and modulation, Full allocation refers to the higher allocation defined in table 6.6.2.3.4.1-1 in 36.521-1 [10].						

For Initial conditions as in clause 6.5.2.4.1.4.1 in TS 38.521-1 [8], the following steps will be added to configure E-UTRA component:

- 2.1. The parameter settings for E-UTRA cell are set up according to TS 36.508 [11] clause 4.4.3.

- 3.1. The E-UTRA downlink signal level, uplink signal level are set according to Table 4.6-1 and propagation conditions are set according to Annex B.0 of TS 36.521-1 [10].

Step 6 of Initial conditions as in clause 6.5.2.4.1.4.1 in TS 38.521-1 [8] is replaced by the following two steps:

6. Ensure the UE is in state RRC_CONNECTED with generic procedure parameters Connectivity EN-DC, DC bearer MCG and SCG according to TS 38.508 [6] clause 4.5.
7. On the E-UTRA carrier, disable periodic and aperiodic CQI reports, disable SRS, set *TimeAlignmentTimerDedicated* IE to infinity and disable downlink and uplink scheduling, all as per Table 4.6-1 under clause 4.6.

6.5B.2.2.3.4.2 Test Procedure

1. For NR carrier, SS sends uplink scheduling information for each UL HARQ process via PDCCH DCI format 0_1 for C_RNTI to schedule the UL RMC according to Table 6.5B.2.2.3.4.1-1. Since the UL has no payload and no loopback data to send the UE sends uplink MAC padding bits on the UL RMC.
2. For E-UTRA carrier, SS sends uplink scheduling information for each UL HARQ process via PDCCH DCI format 0 for C_RNTI to schedule the UL RMC according to Table 6.5B.2.2.3.4.1-1. Since the UE has no payload data to send, the UE transmits uplink MAC padding bits on the UL RMC.
3. Send continuously power control “up” commands to the UE for NR and E-UTRA until the UE transmits at P_{UMAX} level. Allow at least 200ms for the UE to reach P_{UMAX} level.
4. Measure the rectangular filtered mean power for the assigned NR channel.
5. Measure the rectangular filtered mean power of the first NR adjacent channel on both lower and upper side of the assigned NR channel, respectively. Skip the measurement within the W_{gap} in case $W_{gap} < NR$ sub-block bandwidth.
6. Calculate the ratios of the power between the values measured in step 4 over step 5 for lower and upper NR ACLR, respectively.
7. Measure the rectangular filtered mean power for E-UTRA channel.
8. Measure the rectangular filtered mean power of the first E-UTRA adjacent channel on both lower and upper side of the E-UTRA channel, respectively. Skip the measurement within the W_{gap} in case $W_{gap} < E-UTRA$ sub-block bandwidth.
9. Calculate the ratios of the power between the values measured in step 7 over step 8 for lower and upper E-UTRA_{ACLR}, respectively.

6.5B.2.2.3.5 Test requirement

For NR ACLR, if the measured adjacent channel power is greater than -50 dBm then the measured NR ACLR shall be higher than the limits in table 6.5.2.4.1.5-2 defined in clause 6.5.2.4.1.5 in TS 38.521-1 [8] for the NR carrier.

For E-UTRA ACLR, if the measured adjacent channel power is greater than -50 dBm then the measured E-UTRA ACLR shall be higher than the limits in table 6.6.2.3.5.1-1 defined in clause 6.6.2.3.5 in TS 36.521-1 [10] for the E-UTRA carrier.

6.5B.2.3 Out-of-band emissions for Inter-band EN-DC within FR1

6.5B.2.3.1 Spectrum emissions mask for Inter-band EN-DC within FR1

6.5B.2.3.1.1 Test purpose

Same test purpose as in clause 6.5.2.2 in TS 38.521-1 [8] for the NR carrier.

6.5B.2.3.1.2 Test applicability

This test case applies to all types of E-UTRA UE release 15 and forward, supporting inter-band EN-DC.

6.5B.2.3.1.3 Minimum conformance requirements

Same minimum conformance requirements as in clause 6.5.2.2.3 in TS 38.521-1 [8] for the NR carrier.

The normative reference for this requirement is TS 38.101-3 [4] clause 6.5B.2.3.

No exception requirements applicable to NR or LTE. LTE anchor agnostic approach is applied.

6.5B.2.3.1.4 Test description

Same test description as in clause 6.5.2.2.4 in TS 38.521-1 [8] for the NR carrier with the following exception:

The initial test configurations for E-UTRA band consist of environmental conditions, test frequencies, and channel bandwidths based on E-UTRA bands specified in Table 4.6-1. For Initial conditions as in clause 6.5.2.2.4.1 in TS 38.521-1 [8], the following steps will be added to configure E-UTRA component:

- 2.1. The parameter settings for E-UTRA cell are set up according to TS 36.508 [11] clause 4.4.3.
- 3.1. The E-UTRA downlink signal level, uplink signal level are set according to Table 4.6-1 and propagation conditions are set according to Annex B.0 of TS 36.521-1 [10].

Step 6 of Initial conditions as in clause 6.5.2.2.4.1 in TS 38.521-1 [8] is replaced by the following two steps:

6. Ensure the UE is in state RRC_CONNECTED with generic procedure parameters Connectivity EN-DC, DC bearer MCG and SCG according to TS 38.508 [6] clause 4.5.
7. On the E-UTRA carrier, disable periodic and aperiodic CQI reports, disable SRS, set *TimeAlignmentTimerDedicated* IE to infinity and disable downlink and uplink scheduling, all as per Table 4.6-1 under clause 4.6.

Same test procedure as in clause 6.5.2.2.4.2 in TS 38.521-1 [8] with the following steps exception:

3. Measure the mean power of the UE in the channel bandwidth of the radio access mode according to the test configuration. The period of the measurement shall be at least the continuous duration of one active sub-frame (1ms) and in the uplink symbols. For TDD slots with transient periods are not under test.

6.5B.2.3.1.5 Test requirement

Power of any UE emission shall fulfil requirements in Table 6.5.2.2.5-1 defined in TS 38.521-1 [8] for the NR carrier. 6.5B.2.3.2.

6.5B.2.3.2 Additional Spectrum emissions mask for Inter-band EN-DC within FR1

6.5B.2.3.2.1 Test purpose

Same test purpose as in clause 6.5.2.3.1 in TS 38.521-1 [8] for the NR carrier.

6.5B.2.3.2.2 Test applicability

This test case applies to all types of E-UTRA UE release 15 and forward, supporting inter-band EN-DC.

6.5B.2.3.2.3 Minimum conformance requirements

Same minimum conformance requirements as in clause 6.5.2.3.3 in TS 38.521-1 [8] for the NR carrier.

The normative reference for this requirement is TS 38.101-3 [4] clause 6.5B.2.3.

No exception requirements applicable to NR or LTE. LTE anchor agnostic approach is applied.

6.5B.2.3.2.4 Test description

Same test description as in clause 6.5.2.3.4 in TS 38.521-1 [8] for the NR carrier with the following exception:

The initial test configurations for E-UTRA band consist of environmental conditions, test frequencies, and channel bandwidths based on E-UTRA bands specified in Table 4.6-1. For Initial conditions as in clause 6.5.2.3.4.1 in TS 38.521-1 [8], the following steps will be added to configure E-UTRA component:

- 2.1. The parameter settings for E-UTRA cell are set up according to TS 36.508 [11] clause 4.4.3.
- 3.1. The E-UTRA downlink signal level, uplink signal level are set according to Table 4.6-1 and propagation conditions are set according to Annex B.0 of TS 36.521-1 [10].

Step 6 of Initial conditions as in clause 6.5.2.3.4.1 in TS 38.521-1 [8] is replaced by the following two steps:

6. Ensure the UE is in state RRC_CONNECTED with generic procedure parameters Connectivity EN-DC, DC bearer MCG and SCG according to TS 38.508 [6] clause 4.5.
7. On the E-UTRA carrier, disable periodic and aperiodic CQI reports, disable SRS, set *TimeAlignmentTimerDedicated* IE to infinity and disable downlink and uplink scheduling, all as per Table 4.6-1 under clause 4.6.

Same test procedure as in clause 6.5.2.3.4.2 in TS 38.521-1 [8] with the following steps exception:

3. Measure the mean power of the UE in the channel bandwidth of the radio access mode according to the test configuration. The period of the measurement shall be at least the continuous duration of one active sub-frame (1ms) and in the uplink symbols. For TDD slots with transient periods are not under test.

6.5B.2.3.2.5 Test requirement

Power of any UE emission shall fulfil requirements in applicable table from Table 6.5.2.3.5-1 to Table 6.5.2.3.5.2-1 defined in TS 38.521-1 [8] for the NR carrier.

6.5B.2.3.3 Adjacent channel leakage ratio for inter-band EN-DC within FR1

6.5B.2.3.3.1 Test purpose

Same test purpose as in clause 6.5.2.4.1.1 in TS 38.521-1 [8].

6.5B.2.3.3.2 Test applicability

This test case applies to all types of E-UTRA UE release 15 and forward, supporting inter-band EN-DC.

6.5B.2.3.3.3 Minimum conformance requirements

Same minimum conformance requirements as in clause 6.5.2.4.1.3 in TS 38.521-1 [8] for the NR carrier.

The normative reference for this requirement is TS 38.101-3 [4] clause 6.5B.2.3.

No exception requirements applicable to NR or LTE. LTE anchor agnostic approach is applied

6.5B.2.3.3.4 Test description

Same test description as in clause 6.5.2.4.1.4 in TS 38.521-1 [8] for the NR carrier with the following exception:

The initial test configurations for E-UTRA band consist of environmental conditions, test frequencies, and channel bandwidths based on E-UTRA bands specified in Table 4.6-1.

For Initial conditions as in clause 6.5.2.4.1.4.1 in TS 38.521-1 [8], the following steps will be added to configure E-UTRA component:

- 2.1. The parameter settings for E-UTRA cell are set up according to TS 36.508 [11] clause 4.4.3.

- 3.1. The E-UTRA downlink signal level, uplink signal level are set according to Table 4.6-1 and propagation conditions are set according to Annex B.0 of TS 36.521-1 [10].

Step 6 of Initial conditions as in clause 6.5.2.4.1.4.1 in TS 38.521-1 [8] is replaced by the following two steps:

6. Ensure the UE is in state RRC_CONNECTED with generic procedure parameters Connectivity EN-DC, DC bearer MCG and SCG, Connected without release *On* according to TS 38.508 [6] clause 4.5.
7. On the E-UTRA carrier, disable periodic and aperiodic CQI reports, disable SRS, set *TimeAlignmentTimerDedicated* IE to infinity and disable downlink and uplink scheduling, all as per Table 4.6-1 under clause 4.6.

Same test procedure as in clause 6.5.2.4.1.4.2 in TS 38.521-1 [8] with the following steps exception:

3. Measure the mean power of the UE in the channel bandwidth of the radio access mode according to the test configuration. The period of the measurement shall be at least the continuous duration of one active sub-frame (1ms) and in the uplink symbols. For TDD slots with transient periods are not under test.

6.5B.2.3.3.5 Test requirement

If the measured adjacent channel power is greater than -50 dBm then the measured NR ACLR shall be higher than the limits in table 6.5.2.4.1.5-2 defined in clause 6.5.2.4.1.5 in TS 38.521-1 [8] for the NR carrier.

6.5B.2.4 Out-of-band emissions for Inter-band EN-DC including FR2

6.5B.2.4.1 Spectrum emissions mask for Inter-band EN-DC including FR2 (2 CCs)

6.5B.2.4.1.1 Test purpose

Same test purpose as in clause 6.5.2.1.1 in TS 38.521-2 [9] for the NR carrier.

6.5B.2.4.1.2 Test applicability

This test case applies to all types of E-UTRA UE release 15 and forward, supporting inter-band EN-DC including FR2 with 2 UL CCs.

6.5B.2.4.1.3 Minimum conformance requirements

Same minimum conformance requirements as in clause 6.5.2.1.3 in TS 38.521-2 [9] for the NR carrier.

No exception requirements applicable to NR or LTE. LTE anchor agnostic approach is applied.

6.5B.2.4.1.4 Test description

6.5B.2.4.1.4.1 Initial conditions

Same test description as in clause 6.5.2.1.4 in TS 38.521-2 [9] for the NR carrier with the following exception:

The initial test configurations for E-UTRA band consist of environmental conditions, test frequencies, and channel bandwidths based on E-UTRA bands specified in Table 4.7-1. For Initial conditions as in clause 6.5.2.1.4.1 in TS 38.521-2 [9], the following steps will be added to configure E-UTRA component:

- 2.1. The parameter settings for E-UTRA cell are set up according to TS 36.508 [11] clause 4.4.3.
- 3.1. The E-UTRA downlink signal level, uplink signal level are set according to Table 4.7-1 and propagation conditions are set according to Annex B.0 of TS 36.521-1 [10].

Step 6 of Initial conditions as in clause 6.5.2.1.4.1 in TS 38.521-2 [9] is replaced by:

6. Ensure the UE is in state RRC_CONNECTED with generic procedure parameters Connectivity EN-DC, DC bearer MCG and SCG, Connected without release *On* according to TS 38.508-1 [6] clause 4.5.

Same test procedure as in clause 6.5.2.1.4.2 in TS 38.521-2 [9] with the following steps added for E-UTRA component:

1.1 On the E-UTRA carrier, disable periodic and aperiodic CQI reports, disable SRS, set *TimeAlignmentTimerDedicated* IE to infinity and disable downlink and uplink scheduling, all as per Table 4.7-1 under clause 4.7.

6.5B.2.4.1.5 Test requirement

Same test requirement as in clause 6.5.2.1.5 in TS 38.521-2 [9] for the NR carrier.

6.5B.2.4.1_1 Spectrum emissions mask for Inter-band EN-DC including FR2 (>2 CCs)

Editor's note: Test applicability, Test Description in below sub-clauses requires updates to clarify number of E-UTRA carriers that will be configured during the test

6.5B.2.4.1_1.1 Spectrum emissions mask for Inter-band EN-DC including FR2 (3 CCs)

Editor's note: The following aspects are either missing or not yet determined:

- **The referred test case 6.5A.2.1.1 in TS 38.521-2 [9] is incomplete for intra-band contiguous CA supporting aggregated BW > 400MHz are TBD.**

6.5B.2.4.1_1.1.1 Test purpose

Same test purpose as in clause 6.5.2.1.1 in TS 38.521-2 [9] for the NR carrier.

6.5B.2.4.1_1.1.2 Test applicability

This test case applies to all types of E-UTRA UE release 15 and forward, supporting inter-band EN-DC including FR2 with 3 UL CCs (2NR UL CCs).

6.5B.2.4.1_1.1.3 Minimum conformance requirements

Same minimum conformance requirements as in clause 6.5.2.1.3 in TS 38.521-2 [9] for the NR carrier.

No exception requirements applicable to NR or LTE. LTE anchor agnostic approach is applied.

The normative reference for this requirement is TS 38.101-3 [4] clause 6.4B.1.4.

6.5B.2.4.1_1.1.4 Test description

6.5B.2.4.1_1.1.4.1 Initial condition

Same test description as in clause 6.5A.2.1.1.4 in TS 38.521-2 [9] for the NR carrier with the following exception:

The initial test configurations for E-UTRA band consist of environmental conditions, test frequencies, and channel bandwidths based on E-UTRA bands specified in Table 4.7-1.

For Initial conditions as in clause 6.5A.2.1.1.4.1 in TS 38.521-2 [9], the following steps will be added to configure E-UTRA component:

- 2.1. The parameter settings for E-UTRA cell are set up according to TS 36.508 [11] clause 4.4.3.
- 3.1. The E-UTRA downlink signal level, uplink signal level are set according to Table 4.7-1 and propagation conditions are set according to Annex B.0 of TS 36.521-1 [10].

Step 6 of Initial conditions as in clause 6.5A.2.1.1.4.1 in TS 38.521-2 [9] is replaced by:

6. Ensure the UE is in state RRC_CONNECTED with generic procedure parameters Connectivity EN-DC, DC bearer MCG and SCG, Connected without release On according to TS 38.508-1 [6] clause 4.5.

Same test procedure as in clause 6.5A.2.1.1.4.2 in TS 38.521-2 [9] with the following steps added for E-UTRA component:

1.1 On the E-UTRA carrier, disable periodic and aperiodic CQI reports, disable SRS, set *TimeAlignmentTimerDedicated* IE to infinity and disable downlink and uplink scheduling, all as per Table 4.7-1 under clause 4.7.

6.5B.2.4.1_1.1.5 Test Requirements

Same test requirement as in clause 6.5A.2.1.1.5 in TS 38.521-2 [9] for the NR carrier.

6.5B.2.4.1_1.2 Spectrum emissions mask for Inter-band EN-DC including FR2 (4 CCs)

Editor's note: This clause is incomplete. The following aspects are either missing or not yet determined:

- The referred test case 6.5A.2.1.2 in TS 38.521-2 [9] is incomplete for intra-band contiguous CA supporting aggregated BW > 400MHz are TBD.

6.5B.2.4.1_1.2.1 Test purpose

Same test purpose as in clause 6.5.2.1.1 in TS 38.521-2 [9] for the NR carrier.

6.5B.2.4.1_1.2.2 Test applicability

This test case applies to all types of E-UTRA UE release 15 and forward, supporting inter-band EN-DC including FR2 with 4 UL CCs (3NR UL CCs).

6.5B.2.4.1_1.2.3 Minimum conformance requirements

Same minimum conformance requirements as in clause 6.5.2.1.3 in TS 38.521-2 [9] for the NR carrier.

No exception requirements applicable to NR or LTE. LTE anchor agnostic approach is applied.

The normative reference for this requirement is TS 38.101-3 [4] clause 6.4B.1.4.

6.5B.2.4.1_1.2.4 Test description

6.5B.2.4.1_1.2.4.1 Initial condition

Same test description as in clause 6.5A.2.1.2.4 in TS 38.521-2 [9] for the NR carrier with the following exception:

The initial test configurations for E-UTRA band consist of environmental conditions, test frequencies, and channel bandwidths based on E-UTRA bands specified in Table 4.7-1.

For Initial conditions as in clause 6.5A.2.1.2.4.1 in TS 38.521-2 [9], the following steps will be added to configure E-UTRA component:

- 2.1. The parameter settings for E-UTRA cell are set up according to TS 36.508 [11] clause 4.4.3.
- 3.1. The E-UTRA downlink signal level, uplink signal level are set according to Table 4.7-1 and propagation conditions are set according to Annex B.0 of TS 36.521-1 [10].

Step 6 of Initial conditions as in clause 6.5A.2.1.2.4.1 in TS 38.521-2 [9] is replaced by:

6. Ensure the UE is in state RRC_CONNECTED with generic procedure parameters Connectivity EN-DC, DC bearer MCG and SCG, Connected without release On according to TS 38.508-1 [6] clause 4.5.

Same test procedure as in clause 6.5A.2.1.2.4.2 in TS 38.521-2 [9] with the following steps added for E-UTRA component:

- 1.1 On the E-UTRA carrier, disable periodic and aperiodic CQI reports, disable SRS, set *TimeAlignmentTimerDedicated* IE to infinity and disable downlink and uplink scheduling, all as per Table 4.7-1 under clause 4.7.

6.5B.2.4.1_1.2.5 Test Requirements

Same test requirement as in clause 6.5A.2.1.2.5 in TS 38.521-2 [9] for the *NR* carrier.

6.5B.2.4.1_1.3 Spectrum emissions mask for Inter-band EN-DC including FR2 (5 CCs)

Editor's note: This clause is incomplete. The following aspects are either missing or not yet determined:

- **The referred test case 6.5A.2.1.3 in TS 38.521-2 [9] is incomplete for intra-band contiguous CA supporting aggregated BW > 400MHz are TBD.**

6.5B.2.4.1_1.3.1 Test purpose

Same test purpose as in clause 6.5.2.1.1 in TS 38.521-2 [9] for the *NR* carrier.

6.5B.2.4.1_1.3.2 Test applicability

This test case applies to all types of E-UTRA UE release 15 and forward, supporting inter-band EN-DC including FR2 with 5 UL CCs (4NR UL CCs).

6.5B.2.4.1_1.3.3 Minimum conformance requirements

Same minimum conformance requirements as in clause 6.5.2.1.3 in TS 38.521-2 [9] for the *NR* carrier.

No exception requirements applicable to *NR* or *LTE*. *LTE* anchor agnostic approach is applied.

The normative reference for this requirement is TS 38.101-3 [4] clause 6.4B.1.4.

6.5B.2.4.1_1.3.4 Test description

6.5B.2.4.1_1.3.4.1 Initial condition

Same test description as in clause 6.5A.2.1.3.4 in TS 38.521-2 [9] for the *NR* carrier with the following exception:

The initial test configurations for E-UTRA band consist of environmental conditions, test frequencies, and channel bandwidths based on E-UTRA bands specified in Table 4.7-1.

For Initial conditions as in clause 6.5A.2.1.3.4.1 in TS 38.521-2 [9], the following steps will be added to configure E-UTRA component:

- 2.1. The parameter settings for E-UTRA cell are set up according to TS 36.508 [11] clause 4.4.3.
- 3.1. The E-UTRA downlink signal level, uplink signal level are set according to Table 4.7-1 and propagation conditions are set according to Annex B.0 of TS 36.521-1 [10].

Step 6 of Initial conditions as in clause 6.5A.2.1.3.4.1 in TS 38.521-2 [9] is replaced by:

6. Ensure the UE is in state *RRC_CONNECTED* with generic procedure parameters Connectivity EN-DC, DC bearer MCG and SCG, Connected without release On according to TS 38.508-1 [6] clause 4.5.

Same test procedure as in clause 6.5A.2.1.3.4.2 in TS 38.521-2 [9] with the following steps added for E-UTRA component:

- 1.1 On the E-UTRA carrier, disable periodic and aperiodic CQI reports, disable SRS, set *TimeAlignmentTimerDedicated* IE to infinity and disable downlink and uplink scheduling, all as per Table 4.7-1 under clause 4.7.

6.5B.2.4.1_1.3.5 Test Requirements

Same test requirement as in clause 6.5A.2.1.3.5 in TS 38.521-2 [9] for the *NR* carrier.

6.5B.2.4.1D Spectrum emissions mask for inter-band EN-DC including FR2 for UL-MIMO

Editor's note: This clause is incomplete. The following aspects are either missing or not yet determined:

- The referred test case 6.5D.2.1 in TS 38.521-2 [9] is incomplete

6.5B.2.4.1D.1 Test purpose

Same test purpose as in clause 6.5D.2.1 in TS 38.521-2 [9] for the NR carrier.

6.5B.2.4.1D.2 Test applicability

This test case applies to all types of E-UTRA UE release 15 and forward, supporting inter-band EN-DC FR2.

6.5B.2.4.1D.3 Minimum conformance requirements

Same minimum conformance requirements as in clause 6.5D.2.1 in TS 38.521-2 [9] for the NR carrier.

No exception requirements applicable to NR or LTE. LTE anchor agnostic approach is applied.

The normative reference for this measurement is TS 38.101-3 [4] clause 6.2B.2.4.

6.5B.2.4.1D.4 Test description

Same test description as in clause [6.5D.2.1] in TS 38.521-2 [9] for the NR carrier with the following exception:

The initial test configurations for E-UTRA band consist of environmental conditions, test frequencies, and channel bandwidths based on E-UTRA bands specified in Table 4.6-1. For Initial conditions as in clause [6.5D.2.1] in TS 38.521-2 [9], the following steps will be added to configure E-UTRA component:

- 2.1. The parameter settings for E-UTRA cell are set up according to TS 36.508 [11] clause 4.4.3.
- 3.1. The E-UTRA downlink signal level, uplink signal level are set according to Table 4.7-1 and propagation conditions are set according to Annex B.0 of TS 36.521-1 [10].

[Step 6] of Initial conditions as in clause [6.5D.2.1] in TS 38.521-2 [9] is replaced by:

6. Ensure the UE is in state RRC_CONNECTED with generic procedure parameters Connectivity EN-DC, DC bearer MCG and SCG according to TS 38.508 [6] clause 4.5.

6.5B.2.4.1D.5 Test Requirement

Same test requirement as in clause 6.5D.2.1 of TS 38.521-2 [9] for the NR carrier.

6.5B.2.4.3 Adjacent channel leakage ratio for Inter-band EN-DC including FR2 (2 CCs)

Editor's note: The following aspects are either missing or not yet determined:

- The referred test case 6.5.2.3 in TS 38.521-2 [9] is incomplete for PC1, 2 and 4.
- The referred test case 6.5.2.3 in TS 38.521-2 [9] is incomplete for aggregated BW > 400MHz.

6.5B.2.4.3.1 Test purpose

Same test purpose as in clause 6.5.2.3.1 in TS 38.521-2 [9] for the NR carrier.

6.5B.2.4.3.2 Test applicability

This test case applies to all types of E-UTRA UE release 15 and forward, supporting inter-band EN-DC including FR2 with 2 UL CCs.

6.5B.2.4.3.3 Minimum conformance requirements

Same minimum conformance requirements as in clause 6.5.2.3.3 in TS 38.521-2 [9] for the NR carrier.

No exception requirements applicable to NR or LTE. LTE anchor agnostic approach is applied.

6.5B.2.4.3.4 Test description

6.5B.2.4.3.4.1 Initial conditions

Same test description as in clause 6.5.2.3.4 in TS 38.521-2 [9] for the NR carrier with the following exception:

The initial test configurations for E-UTRA band consist of environmental conditions, test frequencies, and channel bandwidths based on E-UTRA bands specified in Table 4.7-1. For Initial conditions as in clause 6.5.2.3.4.1 in TS 38.521-2 [9], the following steps will be added to configure E-UTRA component:

- 2.1. The parameter settings for E-UTRA cell are set up according to TS 36.508 [11] clause 4.4.3.
- 3.1. The E-UTRA downlink signal level, uplink signal level are set according to Table 4.7-1 and propagation conditions are set according to Annex B.0 of TS 36.521-1 [10].

Step 6 of Initial conditions as in clause 6.5.2.3.4.1 in TS 38.521-2 [9] is replaced by:

6. Ensure the UE is in state RRC_CONNECTED with generic procedure parameters Connectivity EN-DC, DC bearer MCG and SCG, Connected without release On according to TS 38.508-1 [6] clause 4.5.

Same test procedure as in clause 6.5.2.3.4.2 in TS 38.521-2 [9] with the following steps added for E-UTRA component:

- 1.1 On the E-UTRA carrier, disable periodic and aperiodic CQI reports, disable SRS, set *TimeAlignmentTimerDedicated* IE to infinity and disable downlink and uplink scheduling, all as per Table 4.7-1 under clause 4.7.

6.5B.2.4.3.5 Test requirement

Same test requirement as in clause 6.5.2.3.5 in TS 38.521-2 [9] for the NR carrier.

6.5B.2.4.3_1 Adjacent channel leakage ratio for Inter-band EN-DC including FR2 (>2 CCs)

Editor's note: Test applicability, Test Description in below sub-clauses requires updates to clarify number of E-UTRA carriers that will be configured during the test

6.5B.2.4.3_1.1 Adjacent channel leakage ratio for Inter-band EN-DC including FR2 (3 CCs)

Editor's note: The following aspects are either missing or not yet determined:

- **The referred test case 6.5A.2.2.1 in TS 38.521-2 [9] is incomplete for intra-band contiguous CA supporting aggregated BW > 400MHz are TBD.**

6.5B.2.4.3_1.1.1 Test purpose

Same test purpose as in clause 6.5.2.3.1 in TS 38.521-2 [9] for the NR carrier.

6.5B.2.4.3_1.1.2 Test applicability

This test case applies to all types of E-UTRA UE release 15 and forward, supporting inter-band EN-DC including FR2 with 3 UL CCs (2NR UL CCs).

6.5B.2.4.3_1.1.3 Minimum conformance requirements

Same minimum conformance requirements as in clause 6.5.2.3.3 in TS 38.521-2 [9] for the NR carrier.

No exception requirements applicable to NR or LTE. LTE anchor agnostic approach is applied.

The normative reference for this requirement is TS 38.101-3 [4] clause 6.4B.2.4.

6.5B.2.4.3_1.1.4 Test description

6.5B.2.4.3_1.1.4.1 Initial condition

Same test description as in clause 6.5A.2.2.1.4 in TS 38.521-2 [9] for the *NR* carrier with the following exception:

The initial test configurations for E-UTRA band consist of environmental conditions, test frequencies, and channel bandwidths based on E-UTRA bands specified in Table 4.7-1.

For Initial conditions as in clause 6.5A.2.2.1.4.1 in TS 38.521-2 [9], the following steps will be added to configure E-UTRA component:

- 2.1. The parameter settings for E-UTRA cell are set up according to TS 36.508 [11] clause 4.4.3.
- 3.1. The E-UTRA downlink signal level, uplink signal level are set according to Table 4.7-1 and propagation conditions are set according to Annex B.0 of TS 36.521-1 [10].

Step 6 of Initial conditions as in clause 6.5A.2.2.1.4.1 in TS 38.521-2 [9] is replaced by:

6. Ensure the UE is in state `RRC_CONNECTED` with generic procedure parameters Connectivity EN-DC, DC bearer MCG and SCG, Connected without release On according to TS 38.508-1 [6] clause 4.5.

Same test procedure as in clause 6.5A.2.2.1.4.2 in TS 38.521-2 [9] with the following steps added for E-UTRA component:

- 1.1 On the E-UTRA carrier, disable periodic and aperiodic CQI reports, disable SRS, set *TimeAlignmentTimerDedicated* IE to infinity and disable downlink and uplink scheduling, all as per Table 4.7-1 under clause 4.7.

6.5B.2.4.3_1.1.5 Test Requirements

Same test requirement as in clause 6.5A.2.2.1.5 in TS 38.521-2 [9] for the *NR* carrier.

6.5B.2.4.3_1.2 Adjacent channel leakage ratio for Inter-band EN-DC including FR2 (4 CCs)

Editor's note: The following aspects are either missing or not yet determined:

- The referred test case 6.5A.2.2.2 in TS 38.521-2 [9] is incomplete for intra-band contiguous CA supporting aggregated BW > 400MHz are TBD.

6.5B.2.4.3_1.2.1 Test purpose

Same test purpose as in clause 6.5.2.3.1 in TS 38.521-2 [9] for the *NR* carrier.

6.5B.2.4.3_1.2.2 Test applicability

This test case applies to all types of E-UTRA UE release 15 and forward, supporting inter-band EN-DC including FR2 with 4 UL CCs (3NR UL CCs).

6.5B.2.4.3_1.2.3 Minimum conformance requirements

Same minimum conformance requirements as in clause 6.5.2.3.3 in TS 38.521-2 [9] for the *NR* carrier.

No exception requirements applicable to *NR* or *LTE*. *LTE* anchor agnostic approach is applied.

The normative reference for this requirement is TS 38.101-3 [4] clause 6.4B.2.4.

6.5B.2.4.3_1.2.4 Test description

6.5B.2.4.3_1.2.4.1 Initial condition

Same test description as in clause 6.5A.2.2.2.4 in TS 38.521-2 [9] for the *NR* carrier with the following exception:

The initial test configurations for E-UTRA band consist of environmental conditions, test frequencies, and channel bandwidths based on E-UTRA bands specified in Table 4.7-1.

For Initial conditions as in clause 6.5A.2.2.2.4.1 in TS 38.521-2 [9], the following steps will be added to configure E-UTRA component:

- 2.1. The parameter settings for E-UTRA cell are set up according to TS 36.508 [11] clause 4.4.3.
- 3.1. The E-UTRA downlink signal level, uplink signal level are set according to Table 4.7-1 and propagation conditions are set according to Annex B.0 of TS 36.521-1 [10].

Step 6 of Initial conditions as in clause 6.5A.2.2.2.4.1 in TS 38.521-2 [9] is replaced by:

6. Ensure the UE is in state RRC_CONNECTED with generic procedure parameters Connectivity EN-DC, DC bearer MCG and SCG, Connected without release On according to TS 38.508-1 [6] clause 4.5.

Same test procedure as in clause 6.5A.2.2.2.4.2 in TS 38.521-2 [9] with the following steps added for E-UTRA component:

- 1.1 On the E-UTRA carrier, disable periodic and aperiodic CQI reports, disable SRS, set *TimeAlignmentTimerDedicated* IE to infinity and disable downlink and uplink scheduling, all as per Table 4.7-1 under clause 4.7.

6.5B.2.4.3_1.2.5 Test Requirements

Same test requirement as in clause 6.5A.2.2.2.5 in TS 38.521-2 [9] for the *NR* carrier.

6.5B.2.4.3_1.3 Adjacent channel leakage ratio for Inter-band EN-DC including FR2 (5 CCs)

Editor's note: The following aspects are either missing or not yet determined:

- The referred test case 6.5A.2.2.3 in TS 38.521-2 [9] is incomplete for intra-band contiguous CA supporting aggregated BW > 400MHz are TBD.

6.5B.2.4.3_1.3.1 Test purpose

Same test purpose as in clause 6.5.2.3.1 in TS 38.521-2 [9] for the *NR* carrier.

6.5B.2.4.3_1.3.2 Test applicability

This test case applies to all types of E-UTRA UE release 15 and forward, supporting inter-band EN-DC including FR2 with 5 UL CCs (4NR UL CCs).

6.5B.2.4.3_1.3.3 Minimum conformance requirements

Same minimum conformance requirements as in clause 6.5.2.3.3 in TS 38.521-2 [9] for the *NR* carrier.

No exception requirements applicable to *NR* or *LTE*. *LTE* anchor agnostic approach is applied.

The normative reference for this requirement is TS 38.101-3 [4] clause 6.4B.2.4.

6.5B.2.4.3_1.3.4 Test description

6.5B.2.4.3_1.3.4.1 Initial condition

Same test description as in clause 6.5A.2.2.3.4 in TS 38.521-2 [9] for the *NR* carrier with the following exception:

The initial test configurations for E-UTRA band consist of environmental conditions, test frequencies, and channel bandwidths based on E-UTRA bands specified in Table 4.7-1.

For Initial conditions as in clause 6.5A.2.2.3.4.1 in TS 38.521-2 [9], the following steps will be added to configure E-UTRA component:

- 2.1. The parameter settings for E-UTRA cell are set up according to TS 36.508 [11] clause 4.4.3.
- 3.1. The E-UTRA downlink signal level, uplink signal level are set according to Table 4.7-1 and propagation conditions are set according to Annex B.0 of TS 36.521-1 [10].

Step 6 of Initial conditions as in clause 6.5A.2.2.3.4.1 in TS 38.521-2 [9] is replaced by:

6. Ensure the UE is in state RRC_CONNECTED with generic procedure parameters Connectivity EN-DC, DC bearer MCG and SCG, Connected without release On according to TS 38.508-1 [6] clause 4.5.

Same test procedure as in clause 6.5A.2.2.3.4.2 in TS 38.521-2 [9] with the following steps added for E-UTRA component:

- 1.1 On the E-UTRA carrier, disable periodic and aperiodic CQI reports, disable SRS, set *TimeAlignmentTimerDedicated* IE to infinity and disable downlink and uplink scheduling, all as per Table 4.7-1 under clause 4.7.

6.5B.2.4.3_1.3.5 Test Requirements

Same test requirement as in clause 6.5A.2.2.3.5 in TS 38.521-2 [9] for the NR carrier.

6.5B.2.4D.3 Adjacent channel leakage ratio for inter-band EN-DC including FR2 for UL-MIMO

Editor's note: This clause is incomplete. The following aspects are either missing or not yet determined:

- **The referred test case 6.5D.2.2 in TS 38.521-2 [9] is incomplete**

6.5B.2.4D.3.1 Test purpose

Same test purpose as in clause 6.5D.2.2 in TS 38.521-2 [9] for the NR carrier.

6.5B.2.4D.3.2 Test applicability

This test case applies to all types of E-UTRA UE release 15 and forward, supporting inter-band EN-DC FR2.

No exception requirements applicable to NR or LTE. LTE anchor agnostic approach is applied.

6.5B.2.4D.3.3 Minimum conformance requirements

Same minimum conformance requirements as in clause 6.5D.2.2 in TS 38.521-2 [9] for the NR carrier.

No exception requirements applicable to NR or LTE. LTE anchor agnostic approach is applied.

The normative reference for this measurement is TS 38.101-3 [4] clause 6.2B.2.4.

6.5B.2.4D.3.4 Test description

Same test description as in clause 6.5D.2.2 in TS 38.521-2 [9] for the NR carrier with the following exception:

The initial test configurations for E-UTRA band consist of environmental conditions, test frequencies, and channel bandwidths based on E-UTRA bands specified in Table 4.6-1. For Initial conditions as in clause 6.5D.2.2 in TS 38.521-2 [9], the following steps will be added to configure E-UTRA component:

- 2.1. The parameter settings for E-UTRA cell are set up according to TS 36.508 [11] clause 4.4.3.
- 3.1. The E-UTRA downlink signal level, uplink signal level are set according to Table 4.7-1 and propagation conditions are set according to Annex B.0 of TS 36.521-1 [10].

[Step 6] of Initial conditions as in clause 6.5D.2.2 in TS 38.521-2 [9] is replaced by:

6. Ensure the UE is in state RRC_CONNECTED with generic procedure parameters Connectivity EN-DC, DC bearer MCG and SCG according to TS 38.508 [6] clause 4.5.

Same test procedure as in clause 6.5D.2.2 in TS 38.521-2 [9] with the following steps added for E-UTRA component:

- 1.1 On the E-UTRA carrier, disable periodic and aperiodic CQI reports, disable SRS, set TimeAlignmentTimerDedicated IE to infinity and disable downlink and uplink scheduling, all as per Table 4.7-1 under clause 4.7.

6.5B.2.4D.3.5 Test Requirement

Same test requirement as in clause 6.5D.2.2 of TS 38.521-2 [9] for the NR carrier.

6.5B.3 Spurious emissions for EN-DC

Spurious emissions are emissions which are caused by unwanted transmitter effects such as harmonics emission, parasitic emissions, intermodulation products and frequency conversion products, but exclude out of band emissions. The spurious emission limits are specified in terms of general requirements in line with SM.329 [3] and NR operating band requirement to address UE co-existence.

To improve measurement accuracy, sensitivity and efficiency, the resolution bandwidth may be smaller than the measurement bandwidth. When the resolution bandwidth is smaller than the measurement bandwidth, the result should be integrated over the measurement bandwidth in order to obtain the equivalent noise bandwidth of the measurement bandwidth.

6.5B.3.1 Spurious Emissions for intra-band contiguous EN-DC

6.5B.3.1.1 General spurious emissions for intra-band contiguous EN-DC

6.5B.3.1.1.1 Test purpose

To verify that UE transmitter does not cause unacceptable interference to other channels or other systems in terms of transmitter spurious emissions.

6.5B.3.1.1.2 Test applicability

This test case applies to all types of E-UTRA UE release 15 and forward, supporting intra-band EN-DC.

6.5B.3.1.1.3 Minimum conformance requirements

The general spurious emissions requirements specified in clause 6.6.3.1 of TS 36.521-1 [10] and clause 6.5.3.1 of TS 38.521-1 [8] apply beyond any frequencies for which the out-of-band emissions requirements in clause 6.5B.2.1 of TS 38.101-3 [4] apply.

The normative reference for this requirement is TS 38.101-3 [4] clause 6.5B.3.1.1.

No exception requirements applicable to NR or LTE. LTE anchor agnostic approach is applied.

6.5B.3.1.1.4 Test description

Same test description as in clause 6.5.3.1.4 in TS 38.521-1 [8] for the NR carrier with the following exceptions:

Table 6.5B.3.1.1.4-1: Test Configuration Table

Initial Conditions	
Test Frequencies as specified in TS 38.508-1 [6] clause 4.3.1 for different EN-DC bandwidth classes	Low range, Mid range, High range
Test EN-DC bandwidth combination as specified in Table 5.3B.1.2-1 across bandwidth combination sets supported by the UE	Lowest N_{RB_agg} , Highest N_{RB_agg} (NOTE1)
NOTE 1: If the UE supports multiple CC Combinations in the EN-DC Configuration with the same N_{RB_agg} , only the combination with the lowest N_{RB_SCG} , mid N_{RB_SCG} and highest N_{RB_SCG} are tested for Lowest N_{RB_agg} , Mid N_{RB_agg} and Highest N_{RB_agg} , respectively.	

The initial test configurations for E-UTRA band consist of environmental conditions, test frequencies, and channel bandwidths are specified in Table 4.6-1 except for the parameters specified in Table 6.5B.3.1.1.4-1.

For Initial conditions as in clause 6.5.3.1.4 in TS 38.521-1 [8], the following steps will be added to configure E-UTRA component:

- 2.1 The parameter settings for the E-UTRA cell are set up according to TS 36.508 [11] clause 4.4.3 with E-UTRA channel bandwidth and test frequencies defined in Table 6.5B.3.1.1.4-1.
- 3.1. The E-UTRA downlink signal level, uplink signal level are set according to Table 4.6-1 and propagation conditions are set according to Annex B.0 of TS 36.521-1 [10].
- 4.1. The UL Reference Measurement channels are set according to Table 6.5B.3.1.1.4-1.

Step 6 of Initial conditions as in clause 6.5.3.1.4 in TS 38.521-1 [8] is replaced by:

6. Ensure the UE is in state RRC_CONNECTED with generic procedure parameters Connectivity EN-DC, DC bearer MCG and SCG according to TS 38.508 [6] clause 4.5.

Same test procedure as in clause 6.5.3.1.4 in TS 38.521-1 [8].

6.5B.3.1.1.5 Test Requirement

The measured average power of spurious emission, derived in step 5, shall not exceed the described value in Table 6.5B.3.1.1.5-1.

Unless otherwise stated, the spurious emission limits apply for the frequency ranges that are more than Δf_{OOB} (MHz) from the edge of the channel bandwidth shown in Table 6.5.3.1.5-1 of TS 38.521-1 [8] for NR carrier, and Table 6.6.3.1.3-1 of TS 36.521-1[10] for E-UTRA carrier.

NOTE: For measurement conditions at the edge of each frequency range, the lowest frequency of the measurement position in each frequency range should be set at the lowest boundary of the frequency range plus MBW/2. The highest frequency of the measurement position in each frequency range should be set at the highest boundary of the frequency range minus MBW/2. MBW denotes the measurement bandwidth defined for the protected band.

Table 6.5B.3.1.1.5-1: General spurious emissions test requirements

Frequency Range	Maximum Level	Measurement bandwidth	NOTE
$9 \text{ kHz} \leq f < 150 \text{ kHz}$	-36 dBm	1 kHz	
$150 \text{ kHz} \leq f < 30 \text{ MHz}$	-36 dBm	10 kHz	
$30 \text{ MHz} \leq f < 1000 \text{ MHz}$	-36 dBm	100 kHz	
$1 \text{ GHz} \leq f < 12.75 \text{ GHz}$	-30 dBm	1 MHz	4
	-25 dBm	1 MHz	3
12.75 GHz $\leq f <$ 5th harmonic of the upper frequency edge of the UL operating band in GHz	-30 dBm	1 MHz	1
$12.75 \text{ GHz} < f < 26 \text{ GHz}$	-30 dBm	1 MHz	2
NOTE 1: Applies for Band that the upper frequency edge of the UL Band more than 2.69 GHz.			
NOTE 2: Applies for Band that the upper frequency edge of the UL Band more than 5.2 GHz.			
NOTE 3: Applies for Band n41, CA configurations including Band n41, and EN-DC configurations that include n41 specified in clause 5.2B of TS 36.101 [4] when NS_04 is signalled.			
NOTE 4: Does not apply for Band n41, CA configurations including Band n41, and EN-DC configurations that include n41 specified in subclause 5.2B of TS 38.101-3 [4] when NS_04 is signalled.			

6.5B.3.1.2 Spurious emission band UE co-existence for intra-band contiguous EN-DC**6.5B.3.1.2.1 Test purpose**

To verify that UE transmitter does not cause unacceptable interference to other channels or other systems in terms of transmitter spurious emissions for band UE co-existence for intra-band contiguous EN-DC.

6.5B.3.1.2.2 Test applicability

This test case applies to all types of NR UE release 15 and forward supporting intra-band contiguous EN-DC.

6.5B.3.1.2.3 Minimum conformance requirements

This clause specifies the requirements for the specified EN-DC configurations for coexistence with protected bands.

The requirements in Table 6.5B.3.1.2.3-1 apply on each component carrier with all component carriers are active.

Table 6.5B.3.1.2.3-1: Requirements for intra band contiguous EN-DC

EN-DC Configuration	Spurious emission						
	Protected band	Frequency range (MHz)			Maximum Level (dBm)	MBW (MHz)	NOTE
DC_(n)71	E-UTRA Band 4, 5, 12, 13, 14, 17, 24, 26, 30, 48, 66	F _{DL_low}	-	F _{DL_high}	-50	1	
	E-UTRA Band 2, 25, 41, 70 NR Band n77 ⁵	F _{DL_low}	-	F _{DL_high}	-50	1	2
	E-UTRA Band 29	F _{DL_low}	-	F _{DL_high}	-38	1	3
	E-UTRA Band 71	F _{DL_low}	-	F _{DL_high}	-50	1	3
DC_(n)41	E-UTRA Band 1, 2, 3, 4, 5, 8, 10, 11, 12, 13, 14, 17, 18, 19, 21, 24, 25, 26, 27, 28, 29, 30, 34, 39, 42, 44, 45, 48, 50, 51, 66, 70, 71, 73, 74 NR Band n77, n78	F _{DL_low}	-	F _{DL_high}	-50	1	
	Frequency range	1884.5	-	1915.7	-41	0.3	4
	NR Band n79	F _{DL_low}	-	F _{DL_high}	-50	1	2

NOTE 1:	F_{DL_low} and F_{DL_high} refer to each E-UTRA frequency band specified in Table 5.2-1 of TS 36.121-1 [10].
NOTE 2:	As exceptions, measurements with a level up to the applicable requirements defined in Table 6.5B.3.1.1.5-1 are permitted for each assigned E-UTRA carrier used in the measurement due to 2 nd , 3 rd , 4 th or 5 th harmonic spurious emissions. Due to spreading of the harmonic emission the exception is also allowed for the first 1 MHz frequency range immediately outside the harmonic emission on both sides of the harmonic emission. This results in an overall exception interval centred at the harmonic emission of $(2\text{MHz} + N \times L_{CRB} \times 180\text{kHz})$, where N is 2, 3, 4, 5 for the 2 nd , 3 rd , 4 th or 5 th harmonic respectively. The exception is allowed if the measurement bandwidth (MBW) totally or partially overlaps the overall exception interval.
NOTE 3:	These requirements also apply for the frequency ranges that are less than F_{OOB} (MHz) in Table 6.5.3.1-1 and Table 6.5A.3.1-1 of TS 38.101-1 [2] from the edge of the channel bandwidth.
NOTE 4:	Applicable when co-existence with PHS system operating in 1884.5 - 1915.7 MHz.
NOTE 5:	Only applies to NR UE release 16 and forward supporting intra-band contiguous EN-DC

NOTE: To simplify the above Table, E-UTRA band numbers are listed for bands which are specified only for E-UTRA operation or both E-UTRA and NR operation. NR band numbers are listed for bands which are specified only for NR operation.

The normative reference for this requirement is TS 38.101-3 [4] clause 6.5B.3.1.2.

Exception requirements for both NR and E-UTRA are defined for this test and therefore LTE anchor agnostic approach is not applied. E-UTRA test point analysis is included and E-UTRA measurements are performed.

6.5B.3.1.2.4 Test description

6.5B.3.1.2.4.1 Initial conditions

Initial conditions are a set of test configurations the UE needs to be tested in and the steps for the SS to take with the UE to reach the correct measurement state.

The initial test configurations consist of environmental conditions, test frequencies and channel bandwidths based on EN-DC operating bands specified in clause 5.2B.2.1, channel bandwidths and sub-carrier spacings for the NR cell specified in TS 38.521-1 [8] clause 5.3 and channel bandwidth for the E-UTRA cell are specified in TS 36.521-1 [10] clause 5.4.2. All of these configurations shall be tested with applicable test parameters for each EN-DC configuration specified in clause 5.3B.1.2 and are shown in table 6.5B.3.1.2.4.1-1. The details of the uplink reference measurement channels (RMCs) are specified in Annex A.2. Configurations of PDSCH and PDCCH before measurement are specified in TS 36.521-1 [10] Annex C.2 and in TS 38.521-1 [8] Annex C.2 for E-UTRA CG and NR CG respectively.

Table 6.5B.3.1.2.4.1-1: Test configuration table

Initial Conditions					
Test Environment as specified in TS 38.508-1 [6] clause 4.1		Normal			
Test Frequencies as specified in TS 38.508-1 [6] clause 4.3.1		Low range, High range			
Test EN-DC bandwidth combination as specified in Table 5.3B.1.2-1		Lowest and Highest N_{RB_agg} (Note 3)			
Test SCS for the NR cell as specified in TS 38.521-1 [8] Table 5.3.5-1		Lowest SCS per Channel Bandwidth			
Test Parameters					
Test ID	Downlink Configuration	EN-DC Uplink Configuration			
		E-UTRA Cell		NR Cell	
		Modulation	RB allocation (NOTE 2)	Modulation	RB allocation (NOTE 1)
1	N/A for Spurious emission.	QPSK	Outer_Full	CP-OFDM QPSK	Edge_1RB_Left
2		QPSK	Outer_Full	CP-OFDM QPSK	Edge_1RB_Right
3		QPSK	Outer_Full	CP-OFDM QPSK	Outer Full
Note 1: The specific configuration of each RB allocation is defined in Table 6.1-1 in TS 38.521-1 [8]. Note 2: Outer_Full defined as the transmission bandwidth configuration N_{RB} per channel bandwidth for the E-UTRA component as indicated in TS 36.521-1 [10] Table 5.4.2-1. Note 3: If the UE supports multiple CC Combinations in the EN-DC Configuration with the same aggregated channel BW, only the combination with the highest NR BW is tested.					

1. Connect the SS to the UE antenna connectors as shown in TS 38.508-1 [5] Annex A, Figure A.3.1.1.1 for TE diagram and clause A.3.2.1 for UE diagram.
2. The parameter settings for the E-UTRA cell are set up according to TS 36.508 [11] clause 4.4.3, and the parameter settings for the NR cell are set up according to TS 38.508-1 [6] clause 4.4.3.
3. E-UTRA downlink signals are initially set up according to Annex C0, C.1 and C.3.0, and uplink signals according to Annex H.1 and H.3.0 of TS 36.521-1 [10].
4. NR downlink signals are initially set up according to Annex C.0, C.1 and C.2, and uplink signals according to Annex G.0, G.1, G.2, G.3.0 of TS 38.521-1 [8].
5. The UL Reference Measurement channels are set up according to TS 36.521-1 [10] Annex A.2 and TS 38.521-1 [8] Annex A.2 for E-UTRA CG and NR CG respectively.
6. Propagation conditions are set according to TS 36.521-1 [10] Annex B.0 and TS 38.521-1 [8] Annex B.0 for E-UTRA CG and NR CG, respectively.
7. Ensure the UE is in state RRC_CONNECTED with generic procedure parameters Connectivity EN-DC, DC bearer MCG and SCG, Connected without release *On* according to TS 38.508-1 [6] clause 4.5. Message contents are defined in clause 6.5B.3.1.2.4.3.

6.5B.3.1.2.4.2 Test Procedure

1. E-UTRA SS sends uplink scheduling information for each UL HARQ process via PDCCH DCI format 0 for C_RNTI to schedule the UL RMC according to Table 6.5B.3.1.2.4.1-1. Since the UE has no payload data to send, the UE transmits uplink MAC padding bits on the UL RMC.
2. NR SS sends uplink scheduling information for each UL HARQ process via PDCCH DCI format 0_1 for C_RNTI to schedule the UL RMC according to Table 6.5B.3.1.2.4.1-1. Since the UE has no payload data to send, the UE transmits uplink MAC padding bits on the UL RMC.
3. Both NR and E-UTRA SS send continuously uplink power control "up" commands in the uplink scheduling information to the UE until the UE transmits at P_{UMAX} level.

4. Measure the power of the transmitted signal with a measurement filter of bandwidths according to Table 6.5B.3.1.2.3-1. The centre frequency of the filter shall be stepped in contiguous steps according to table 6.5B.3.1.2.3-1. The measured power shall be verified for each step. The measurement period shall capture the active time slots.

6.5B.3.2.1.4.3 Message Contents

Message contents are according to TS 38.508-1 [5] clause 4.6 and TS 38.508-1 [6] clause 4.6.1 with the following exceptions.

Table 6.5B.3.2.1.4.3-1: RRCConnectionReconfiguration: nr-Config-r15

Derivation Path: TS 36.508 [11], Table 4.6.1-8			
Information Element	Value/remark	Comment	Condition
p-MaxEUTRA-r15	23		Power Class 2 UE AND simultaneous E-UTRA and NR transmission
	20		Power Class 3 UE AND simultaneous E-UTRA and NR transmission

Table 6.5B.3.2.1.4.3-2: PhysicalCellGroupConfig

Derivation Path: TS 38.508-1 [6] Table 4.6.3-106			
Information Element	Value/remark	Comment	Condition
p-NR-FR1	23		Power Class 2 UE AND simultaneous E-UTRA and NR transmission
	20		Power Class 3 UE AND simultaneous E-UTRA and NR transmission

6.5B.3.1.2.5 Test Requirement

Test requirements for Spurious Emissions UE Co-existence for intra-band contiguous EN-DC are the same as described in minimum requirements and are not repeated in this clause.

6.5B.3.2 Spurious Emissions for intra-band non-contiguous EN-DC

6.5B.3.2.1 General spurious emissions for Intra-band non-contiguous EN-DC

6.5B.3.2.1.1 Test purpose

To verify that UE transmitter does not cause unacceptable interference to other channels or other systems in terms of transmitter spurious emissions.

6.5B.3.2.1.2 Test applicability

This test case applies to all types of E-UTRA UE release 15 and forward supporting intra-band non-contiguous EN-DC.

6.5B.3.2.1.3 Minimum conformance requirements

The general spurious emissions requirements specified in clause 6.6.3.1 of TS 36.521-1 [10] and clause 6.5.3.1 of TS 38.521-1 [8] apply beyond any frequencies for which the out-of-band emissions requirements in clause 6.5B.2.2 of TS 38.101-3 [4] apply.

The normative reference for this requirement is TS 38.101-3 [4] clause 6.5B.3.2.1.

No exception requirements applicable to NR or LTE. LTE anchor agnostic approach is applied.

6.5B.3.2.1.4 Test description

Same test description as in clause 6.5.3.1.4 in TS 38.521-1 [8] for the NR carrier with the following exceptions:

Table 6.5B.3.2.1.4-1: Test Configuration Table

Initial Conditions	
Test Frequencies as specified in TS 38.508-1 [6] clause 4.3.1 for different EN-DC bandwidth classes	MaxWGap (Low range, High range)
Test EN-DC bandwidth combination as specified in Table 5.3B.1.2-1 across bandwidth combination sets supported by the UE	Lowest N_{RB_agg} , Highest N_{RB_agg} (NOTE1)
NOTE 1: If the UE supports multiple CC Combinations in the EN-DC Configuration with the same N_{RB_agg} , only the combination with the lowest N_{RB_SCG} , mid N_{RB_SCG} and highest N_{RB_SCG} are tested for Lowest N_{RB_agg} , Mid N_{RB_agg} and Highest N_{RB_agg} , respectively.	

The initial test configurations for E-UTRA band consist of environmental conditions, test frequencies, and channel bandwidths are specified in Table 4.6-1 except for the parameters specified in Table 6.5B.3.2.1.4-1.

For Initial conditions as in clause 6.5.3.1.4 in TS 38.521-1 [8], the following steps will be added to configure E-UTRA component:

- 2.1. The parameter settings for the E-UTRA cell are set up according to TS 36.508 [11] clause 4.4.3 with E-UTRA channel bandwidth and test frequencies defined in Table 6.5B.3.1.1.4-1.
- 3.1. The E-UTRA downlink signal level, uplink signal level are set according to Table 4.6-1 and propagation conditions are set according to Annex B.0 of TS 36.521-1 [10].

Step 6 of Initial conditions as in clause 6.2.2.4.1 in TS 38.521-1 [8] is replaced by:

6. Ensure the UE is in state RRC_CONNECTED with generic procedure parameters Connectivity EN-DC, DC bearer MCG and SCG according to TS 38.508 [6] clause 4.5.

Same test procedure as in clause 6.5.3.1.4 in TS 38.521-1 [8].

6.5B.3.2.1.5 Test Requirement

Same test requirement as in clause 6.5B.3.1.1.5.

6.5B.3.2.2 Spurious emission band UE co-existence for intra-band non-contiguous EN-DC

6.5B.3.2.2.1 Test purpose

To verify that UE transmitter does not cause unacceptable interference to other channels or other systems in terms of transmitter spurious emissions for band UE co-existence for intra-band non-contiguous EN-DC.

6.5B.3.2.2.2 Test applicability

This test case applies to all types of E-UTRA UE release 15 and forward supporting intra-band non-contiguous EN-DC.

6.5B.3.2.2.3 Minimum conformance requirements

This clause specifies the requirements for the specified EN-DC configurations for co-existence with protected bands.

The requirements in Table 6.5B.3.2.2.3-1 apply with all component carriers are active.

Table 6.5B.3.2.2.3-1: Requirements for intra-band non-contiguous EN-DC

EN-DC Configuration	Spurious emission						
	Protected band	Frequency range (MHz)		Maximum Level (dBm)	MBW (MHz)	NOTE	
...							
DC_41A_n41A	E-UTRA Band 1, 2, 3, 4, 5, 8, 10, 11, 12, 13, 14, 17, 18, 19, 21, 24, 25, 26, 27, 28, 29, 34, 39, 42, 44, 45, 48, 50, 51, 66, 70, 71, 73, 74 NR Band n77, n78 and n79	F _{DL_low}	-	F _{DL_high}	-50	1	
	Frequency range	1884.5	-	1915.7	-41	0.3	3
	E-UTRA Band 30, 40	F _{DL_low}	-	F _{DL_high}	[-40]	1	
...							
<p>NOTE 1: F_{DL_low} and F_{DL_high} refer to each E-UTRA frequency band specified in Table 5.2-1 of TS 36.121-1 [10].</p> <p>NOTE 2: As exceptions, measurements with a level up to the applicable requirements defined in Table 6.5.3.1.3-2 of TS 38.521-1 [8] are permitted for each assigned E-UTRA carrier used in the measurement due to 2nd, 3rd, 4th or 5th harmonic spurious emissions. Due to spreading of the harmonic emission the exception is also allowed for the first 1 MHz frequency range immediately outside the harmonic emission on both sides of the harmonic emission. This results in an overall exception interval centred at the harmonic emission of (2MHz + N x L_{CRB} x 180kHz), where N is 2, 3, 4, 5 for the 2nd, 3rd, 4th or 5th harmonic respectively. The exception is allowed if the measurement bandwidth (MBW) totally or partially overlaps the overall exception interval.</p> <p>NOTE 3: Applicable when co-existence with PHS system operating in 1884.5 - 1915.7 MHz.</p>							

The normative reference for this requirement is TS 38.101-3 [4] clause 6.5B.3.2.2.

Exception requirements are applicable for NR but not for E-UTRA within this test. LTE anchor agnostic approach is not applied. E-UTRA configuration is included but E-UTRA measurements are not performed.

6.5B.3.2.2.4 Test description

6.5B.3.2.2.4.1 Initial conditions

Initial conditions are a set of test configurations the UE needs to be tested in and the steps for the SS to take with the UE to reach the correct measurement state.

The initial test configurations consist of environmental conditions, test frequencies, test channel bandwidths and sub-carrier spacing based on NR operating bands specified in table 5.2B.2.1-1. All of these configurations shall be tested with applicable test parameters for each combination of test channel bandwidth and sub-carrier spacing are shown in Table 6.5B.3.2.2.4.1-1 for E-UTRA and Table 6.5B.3.2.2.4.1-2 for NR. The details of the uplink reference measurement channels (RMCs) are specified in Annex A.2. Configurations of PDSCH and PDCCH before measurement are specified in Annex TS 36.521-1 [10] Annex C and in TS 38.521-1 [8] Annex C2 for LTE link and NR link respectively.

Table 6.5B.3.2.2.4.1-1: Test configuration table

Initial Conditions					
Test Environment as specified in TS 38.508-1 [6] clause 4.1		Normal			
Test Frequencies as specified in TS 38.508-1 [6] clause 4.3.1		MaxWgap (Low range, High range)			
Test EN-DC bandwidth combination as specified in Table 5.3B.1.2-1		Lowest and Highest N_{RB_agg} (Note 3)			
Test SCS for the NR cell as specified in TS 38.521-1 [8] Table 5.3.5-1		Lowest SCS per Channel Bandwidth			
Test Parameters					
Test ID	Downlink Configuration	EN-DC Uplink Configuration			
		E-UTRA Cell		NR Cell	
		Modulation	RB allocation (NOTE 2)	Modulation	RB allocation (NOTE 1)
1	N/A for Spurious emission.	QPSK	Outer_Full	CP-OFDM QPSK	Edge_1RB_Left
2		QPSK	Outer_Full	CP-OFDM QPSK	Edge_1RB_Right
3		QPSK	Outer_Full	CP-OFDM QPSK	Outer Full
NOTE 1: The specific configuration of each RB allocation is defined in Table 6.1-1 in TS 38.521-1 [8].					
NOTE 2: Outer_Full defined as the transmission bandwidth configuration N_{RB} per channel bandwidth for the E-UTRA component as indicated in TS 36.521-1 [10] Table 5.4.2-1.					
NOTE 3: If the UE supports multiple CC Combinations in the EN-DC Configuration with the same aggregated channel BW, only the combination with the highest NR BW is tested.					

1. Connect the SS to the UE antenna connectors as shown in TS 38.508-1 [6] Annex A, Figure A.3.1.1.1 for SS diagram and clause A.3.2.1 for UE diagram.
2. The parameter settings for the cell are set up according to TS 38.508-1 [6] clause 4.4.3.
3. E-UTRA downlink signals are initially set up according to Annex C0, C.1 and C.3.0, and uplink signals according to Annex H.1 and H.3.0 of TS 36.521-1 [10].
4. NR downlink signals are initially set up according to Annex C.0, C.1 and C.2, and uplink signals according to Annex G.0, G.1, G.2, G.3.0 of TS 38.521-1 [8].
5. The UL Reference Measurement channels are set according to TS 36.521-1 [10] Annex A.2 and TS 38.521-1 [8] Annex A.2 for E-UTRA CG and NR CG respectively.
6. For each EN-DC combination specified in Table 5.3B.1.3-1, channel spacing between NR and E-UTRA is specified according to clause 5.4B.1.
7. Propagation conditions are set according to TS 36.521-1 [10] Annex B and TS 38.521-1 [8] Annex B for E-UTRA link and NR link respectively.
8. Ensure the UE is in state RRC_CONNECTED with generic procedure parameters Connectivity EN-DC, DC bearer *MCG* and *SCG*, Connected without release *On* according to TS 38.508-1 [6] clause 4.5. Message contents are defined in clause 6.5B.3.2.2.4.3.

6.5B.3.2.2.4.2 Test Procedure

1. E-UTRA SS sends uplink scheduling information for each UL HARQ process via PDCCH DCI format 0 for C_RNTI to schedule the UL RMC according to Table 6.5B.3.2.2.4.1-1. Since the UE has no payload data to send, the UE transmits uplink MAC padding bits on the UL RMC.
2. NR SS sends uplink scheduling information for each UL HARQ process via PDCCH DCI format [0_1] for C_RNTI to schedule the UL RMC according to Table 6.5B.3.2.2.4.1-1. Since the UE has no payload data to send, the UE transmits uplink MAC padding bits on the UL RMC.

3. Send continuously uplink power control "up" commands to the UE for both NR and E-UTRA carriers until the UE transmits at its P_{UMAX} level; allow at least 200 ms starting from the first TPC command in this step for the UE to reach P_{UMAX} level.
4. Measure the power of the transmitted signal with a measurement filter of bandwidths according to table 6.5B.3.2.2.3-1. The centre frequency of the filter shall be stepped in contiguous steps according to the same table. The measured power shall be recorded for each step. The measurement period shall capture the active time slots.

6.5B.3.2.2.4.3 Message Contents

Message contents are according to TS 38.508-1 [5] clause 4.6 and TS 38.508-1 [6] clause 4.6.1 with the following exceptions.

Table 6.5B.3.2.2.4.3-1: RRCConnectionReconfiguration: nr-Config-r15.

Derivation Path: TS 36.508 [11], Table 4.6.1-8			
Information Element	Value/remark	Comment	Condition
p-MaxEUTRA-r15	23		Power Class 2 UE AND simultaneous E-UTRA and NR transmission
	20		Power Class 3 UE AND simultaneous E-UTRA and NR transmission

Table 6.5B.3.2.2.4.3-2: PhysicalCellGroupConfig

Derivation Path: TS 38.508-1 [6] Table 4.6.3-106			
Information Element	Value/remark	Comment	Condition
p-NR-FR1	23		Power Class 2 UE AND simultaneous E-UTRA and NR transmission
	20		Power Class 3 UE AND simultaneous E-UTRA and NR transmission

6.5B.3.2.2.5 Test Requirement

Test requirements for Spurious Emissions UE Co-existence for intra-band non-contiguous EN-DC are the same as the minimum requirements described in clause 6.5B.3.2.2.3 and are not repeated in this clause.

6.5B.3.3 Spurious Emissions for Inter-band EN-DC within FR1

6.5B.3.3.1 General spurious emissions for Inter-band EN-DC within FR1

6.5B.3.3.1.1 Test purpose

Same test purpose as in clause 6.5B.3.1.1.1.

6.5B.3.3.1.2 Test applicability

This test case applies to all types of NR UE release 15 and forward supporting inter-band EN-DC.

6.5B.3.3.1.3 Minimum conformance requirements

The general spurious emissions requirements specified in subclause 6.6.3.1 of TS 36.101 [5], subclause 6.5.3.1 of TS 38.101-1 [2] and TS 38.101-2 [3] apply for each component carrier. For the case of inter-band EN-DC with a single carrier per cell group, the general spurious emissions requirements also apply with both downlink carrier and both uplink carriers active. Limits on configured maximum output power for the uplink according to subclause 6.2B.4 apply.

NOTE: The general spurious emission requirements with both uplink carriers active are allowed to be verified for only a single inter-band EN-DC configuration per NR band. Furthermore, the requirements are allowed to be verified by measuring spurious emissions at the specific frequencies where second and third order intermodulation products generated by the two transmitted carriers can occur.

The normative reference for this requirement is TS 38.101-3 [4] clause 6.5B.3.3.1. Exception requirements applicable for both NR or LTE, therefore LTE anchor agnostic approach is not applied

6.5B.3.3.1.4 Test description

6.5B.3.3.1.4.1 Initial condition

Same initial conditions as in clause 6.5B.3.1.2.4.1 with the following exceptions:

Table 6.5B.3.3.1.4.1-1: Test configuration table

Initial Conditions	
Test EN-DC channel bandwidth as specified in TS 36.508 [6] clause 4.3.1 and TS 38.508-1 clause 4.3.1	5MHz for E-UTRA CC1 and Lowest for NR CC1, Highest for E-UTRA CC1 and Highest for NR CC1

and additional step 8 when both bands are TDD:

8. For both E-UTRA and NR UL uplink carriers active when both bands are TDD, ensure E-UTRA UL transmission overlaps with NR UL transmission in time by giving SCG a delay of 3 subframes, or by giving MCG a delay of 2 subframes.

6.5B.3.3.1.4.2 Test procedure

Same test procedure as in clause 6.5B.3.1.2.4.2 with the following exceptions in step 4:

- Instead of Table 6.5B.3.1.2.3.-1 -> use Table 6.5B.3.1.1.5-1.

Note: Measured spurious emissions at the specific frequencies of second and third order intermodulation products generated by the two transmitted carriers.

6.5B.3.3.1.4.3 Message Contents

Message contents are according to TS 36.508 [11] clause 4.6.1 and TS 38.508-1 [6] clause 4.6.1 with the following exceptions.

Table 6.5B.3.3.1.4.3-1: SystemInformationBlockType1: tdd-Config if E-UTRA on TDD band

Derivation Path: TS 36.508 [11], Table 4.6.3-23			
Information Element	Value/remark	Comment	Condition
TDD-Config-DEFAULT ::= SEQUENCE {		Operating on TDD band	
subframeAssignment	Sa2		
specialSubframePatterns	Ssp7		
}			

Table 6.5B3.3.1.4.3-1a: RRCConnectionReconfiguration: tdm-PatternConfig if E-UTRA on FDD band and UE does not support dynamic power sharing

Derivation Path: TS 36.508 [11], Table 4.6.1-8			
Information Element	Value/remark	Comment	Condition
tdm-PatternConfig-r15 CHOICE{			
setup SEQUENCE {			
subframeAssignment-r15	sa2		
harq-Offset-r15	0		
}			
}			

Table 6.5B.3.3.1.4.3-2: RRCConnectionReconfiguration: nr-Config-r15

Derivation Path: TS 36.508 [11], Table 4.6.1-8			
Information Element	Value/remark	Comment	Condition
p-MaxEUTRA-r15	23		Power Class 2 UE AND simultaneous E-UTRA and NR transmission
	20		Power Class 3 UE AND simultaneous E-UTRA and NR transmission

Table 6.5B.3.3.1.4.3-3: PhysicalCellGroupConfig

Derivation Path: TS 38.508-1 [6] Table 4.6.3-106			
Information Element	Value/remark	Comment	Condition
p-NR-FR1	23		Power Class 2 UE AND simultaneous E-UTRA and NR transmission
	20		Power Class 3 UE AND simultaneous E-UTRA and NR transmission

6.5B.3.3.1.5 Test Requirement

Same test requirement as in clause 6.5B.3.1.1.5.

6.5B.3.3.2 Spurious emission band UE co-existence for Inter-band within FR1

Editor's note: The default and additional test configuration is analysed based on the assumption that only intermodulation products need to be tested.

6.5B.3.3.2.1 Test purpose

To verify that UE transmitter does not cause unacceptable interference to other channels or other systems in terms of transmitter spurious emissions for band UE co-existence for inter-band EN-DC.

6.5B.3.3.2.2 Test applicability

This test case applies to all types of E-UTRA UE release 15 and forward supporting inter-band EN-DC.

6.5B.3.3.2.3 Minimum conformance requirements

This clause specifies the requirements for the specified EN-DC, for coexistence with protected bands. The requirements in Table 6.5B.3.3.2-1 apply on each component carrier with all component carriers are active.

NOTE: For inter-band EN_DC with the uplink assigned to one LTE band and one NR band, the requirements in Table 6.5B.3.3.2.3-1 could be verified by measuring spurious emissions at the specific frequencies where second and third order intermodulation products generated by the two transmitted carriers can occur.

Table 6.5B.3.3.2.3-1: Spurious emission band UE co-existence limits Rel-15

EN-DC Configuration	Spurious emission						
	Protected band	Frequency range (MHz)			Maximum Level (dBm)	MBW (MHz)	NOTE
DC_1_n28	E-UTRA Band 5, 7, 8, 18, 19, 20, 26, 27, 31, 38, 40, 41, 72, 73	F _{DL_low}	-	F _{DL_high}	-50	1	
	E-UTRA Band 1, 22, 32, 42, 43, 50, 51, 52, 65, 74, 75, 76 NR band n77, n78	F _{DL_low}	-	F _{DL_high}	-50	1	2
	E-UTRA band n3, n34	F _{DL_low}	-	F _{DL_high}	-50	1	5
	E-UTRA Band 11, 21	F _{DL_low}	-	F _{DL_high}	-50	1	9, 11
	E-UTRA Band 1, 65	F _{DL_low}	-	F _{DL_high}	-50	1	9, 10
	Frequency range	470	-	694	-42	8	5, 17
	Frequency range	470	-	710	-26.2	6	14
	Frequency range	758	-	773	-32	1	5
	Frequency range	773	-	803	-50	1	
	Frequency range	662	-	694	-26.2	6	5
	Frequency range	1880	-	1895	-40	1	5, 16
	Frequency range	1895	-	1915	-15.5	5	5, 7, 16
	Frequency range	1915	-	1920	+1.6	5	5, 7, 16
	Frequency range	1839.9	-	1879.9	-50	1	5
Frequency range	1884.5	-	1915.7	-41	0.3	9, 15	
DC_1_n40	Band 1, 5, 7, 8, 20, 22, 26, 27, 28, 31, 32, 38, 41, 42, 43, 44, 45, 50, 51, 52, 65, 67, 68, 69, 72, 73, 74, 75, 76	F _{DL_low}	-	F _{DL_high}	-50	1	
	Band 3, 34	F _{DL_low}	-	F _{DL_high}	-50	1	5
	Frequency range	1880	-	1895	-40	1	5, 17
	Frequency range	1895	-	1915	-15.5	5	5, 7, 17
	Frequency range	1915	-	1920	+1.6	5	5, 7, 17
DC_1_n51	E-UTRA Band 7, 12, 13, 17, 20, 22, 27, 28, 29, 31, 38, 44, 48, 67, 68, 69, 72, 73	F _{DL_low}	-	F _{DL_high}	-50	1	
	E-UTRA Band 3, 34	F _{DL_low}	-	F _{DL_high}	-50	1	5, 2
	Frequency range	1880	-	1895	-40	1	5, 16
	Frequency range	1895	-	1915	-15.5	5	5, 7, 16
	Frequency range	1915	-	1920	+1.6	5	5, 7, 16
	E-UTRA Band 5, 6, 8, 26, 30, 40, 41, 42, 43, 46 NR Band n77, n78, n79,	F _{DL_low}	-	F _{DL_high}	-50	1	2
DC_1_n77	E-UTRA Band 1, 3, 5, 7, 8, 11, 18, 19, 20, 21, 26, 28, 34, 40, 41, 65, 74	F _{DL_low}	-	F _{DL_high}	-50	1	
	Frequency range	1880	-	1895	-40	1	5, 8
	Frequency range	1895	-	1915	-15.5	5	5, 7, 8
	Frequency range	1915	-	1920	+1.6	5	5, 7, 8
DC_1_n78 DC_1_n84_ULS UP-TDM_n78	E-UTRA Band 1, 3, 5, 7, 8, 11, 18, 19, 20, 21, 26, 28, 34, 40, 41, 65, 74	F _{DL_low}	-	F _{DL_high}	-50	1	
	Frequency range	1880	-	1895	-40	1	5, 8
	Frequency range	1895	-	1915	-15.5	5	5, 7, 8
	Frequency range	1915	-	1920	+1.6	5	5, 7, 8
DC_1_n79	E-UTRA Band 1, 3, 5, 7, 8, 11, 18, 19, 21, 26, 28, 34, 40, 41, 42, 65, 74	F _{DL_low}	-	F _{DL_high}	-50	1	
	Frequency range	1880	-	1895	-40	1	5, 8
	Frequency range	1895	-	1915	-15.5	5	5, 7, 8
	Frequency range	1915	-	1920	+1.6	5	5, 7, 8
DC_2_n5	E-UTRA Bands 4, 5, 12, 13, 14, 17, 24, 26, 28, 29, 30, 42, 48, 50, 51, 53, 66, 70, 71, 74, 85	F _{DL_low}	-	F _{DL_high}	-50	1	
	E-UTRA Bands 2, 25	F _{DL_low}	-	F _{DL_high}	-50	1	2
	E-UTRA Band 41, 43	F _{DL_low}	-	F _{DL_high}	-50	1	
DC_2_n66	E-UTRA Bands 4, 5, 12, 13, 14, 17, 24, 26, 27, 28, 29, 30, 41, 50, 51, 66, 70, 71, 74, 85	F _{DL_low}	-	F _{DL_high}	-50	1	

	E-UTRA Bands 2, 25	F _{DL_low}	-	F _{DL_high}	-50	1	5
	E-UTRA Bands 42, 48	F _{DL_low}	-	F _{DL_high}	-50	1	2
DC_2_n71	E-UTRA Band 4, 5, 12, 13, 14, 17, 24, 26, 29, 30, 48, 66	F _{DL_low}	-	F _{DL_high}	-50	1	
	E-UTRA Band 2, 25, 41, 70	F _{DL_low}	-	F _{DL_high}	-50	1	2
	E-UTRA Band n71	F _{DL_low}	-	F _{DL_high}	-50	1	5
DC_2_n78	E-UTRA Band 4, 5, 12, 13, 14, 17, 24, 26, 27, 28, 29, 30, 41, 50, 51, 66, 70, 71, 74, 85	F _{DL_low}	-	F _{DL_high}	-50	1	
	E-UTRA Band 2, 25	F _{DL_low}	-	F _{DL_high}	-50	1	2
DC_3_n7	E-UTRA Band 1, 5, 7, 8, 20, 26, 27, 28, 31, 32, 33, 34, 40, 43, 44, 50, 51, 65, 67, 72, 74, 75, 76	F _{DL_low}	-	F _{DL_high}	-50	1	
	E-UTRA band 3	F _{DL_low}	-	F _{DL_high}	-50	1	5
	E-UTRA Band 22, 42	F _{DL_low}	-	F _{DL_high}	-50	1	2
	Frequency range	2570	-	2575	+1.6	5	5, 6, 7
	Frequency range	2575	-	2595	-15.5	5	5, 6, 7
DC_3_n28	E-UTRA Band 1, 42, 43, 50, 51, 65, 74, 75, 76 NR band n77, n78, n79	F _{DL_low}	-	F _{DL_high}	-50	1	2
	E-UTRA band 1	F _{DL_low}	-	F _{DL_high}	-50	1	9, 11
	E-UTRA band 3	F _{DL_low}	-	F _{DL_high}	-50	1	5
	E-UTRA Band 5, 7, 8, 18, 19, 20, 26, 27, 31, 34, 38, 40, 41, 72	F _{DL_low}	-	F _{DL_high}	-50	1	
	E-UTRA Band 11, 21	F _{DL_low}	-	F _{DL_high}	-50	1	9, 10
	Frequency range	1884.5	-	1915.7	-41	0.3	13
	Frequency range	470	-	710	-26.2	6	14
	Frequency range	758	-	773	-32	1	5
	Frequency range	773	-	803	-50	1	
	Frequency range	1884.5	-	1915.7	-41	0.3	3, 9
DC_3_n40	E-UTRA Band 1, 5, 7, 8, 20, 26, 27, 28, 31, 32, 33, 34, 38, 39, 41, 43, 44, 45, 50, 51, 65, 67, 68, 69, 72, 73, 75, 76	F _{DL_low}	-	F _{DL_high}	-50	1	
	E-UTRA Band 3	F _{DL_low}	-	F _{DL_high}	-50	1	5
	E-UTRA Band 22, 42, 52	F _{DL_low}	-	F _{DL_high}	-50	1	2
	Frequency range	1884.5	-	1915.7	-41	0.3	3
DC_3_n51	E-UTRA Band 7, 8, 12, 13, 17, 20, 27, 28, 31, 33, 38, 48, 67, 68, 69, 72, 73	F _{DL_low}	-	F _{DL_high}	-50	1	
	E-UTRA Band 3	F _{DL_low}	-	F _{DL_high}	-50	1	5
	E-UTRA Band 1, 5, 6, 22, 26, 30, 34, 36, 40, 41, 42, 43, 44, 46, 65, 71	F _{DL_low}	-	F _{DL_high}	-50	1	2
DC_3_n77	E-UTRA Band 1, 3, 5, 7, 8, 11, 18, 19, 20, 21, 26, 28, 34, 39, 40, 41, 65, 74	F _{DL_low}	-	F _{DL_high}	-50	1	
	Frequency range	1884.5	-	1915.7	-41	0.3	3
DC_3_n78 DC_3_n80_ULS UP-TDM_n78	E-UTRA Band 1, 3, 5, 7, 8, 11, 18, 19, 20, 21, 26, 28, 34, 39, 40, 41, 65, 74	F _{DL_low}	-	F _{DL_high}	-50	1	
	Frequency range	1884.5	-	1915.7	-41	0.3	3
DC_3_n79 DC_3_n80_ULS UP-TDM_n79	E-UTRA Band 1, 3, 5, 8, 11, 18, 19, 21, 28, 34, 39, 40, 41, 65, 74	F _{DL_low}	-	F _{DL_high}	-50	1	
	E-UTRA Band 42	F _{DL_low}	-	F _{DL_high}	-50	1	2
	Frequency range	1884.5	-	1915.7	-41	0.3	3
DC_3_n82	E-UTRA Band 1, 3, 7, 8, 20, 22, 31, 32, 33, 34, 38, 40, 43, 50, 51, 65, 67, 68, 69, 72, 74, 75, 76	F _{DL_low}	-	F _{DL_high}	-50	1	
	E-UTRA Band 42	F _{DL_low}	-	F _{DL_high}	-50	1	2
DC_5_n40	E-UTRA Band 1, 3, 5, 7, 8, 28, 31, 34, 38, 42, 43, 45, 65, 73	F _{DL_low}	-	F _{DL_high}	-50	1	
	E-UTRA Band 26	859	-	869	-27	1	
	E-UTRA Band 41, 52	F _{DL_low}	-	F _{DL_high}	-50	1	

DC_5_n66	E-UTRA Band 1, 2, 3, 4, 5, 6, 7, 8, 12, 13, 14, 17, 24, 25, 28, 29, 30, 34, 38, 40, 43, 45, 50, 51, 65, 66, 70, 71, 85	F _{DL_low}	-	F _{DL_high}	-50	1		
	E-UTRA Band 26	859	-	869	-27	1		
	E-UTRA Band 41, 42, 48, 52	F _{DL_low}	-	F _{DL_high}	-50	1	2	
DC_5_n78	E-UTRA Band 1, 2, 3, 4, 5, 7, 8, 12, 13, 14, 17, 24, 25, 28, 29, 30, 31, 34, 38, 40, 45, 65, 66, 70	F _{DL_low}	-	F _{DL_high}	-50	1		
	E-UTRA Band 26	859	-	869	-27	1		
	E-UTRA Band 41	F _{DL_low}	-	F _{DL_high}	-50	1	7	
DC_7_n28	E-UTRA Band 2, 3, 5, 7, 8, 20, 26, 27, 31, 34, 40, 72	F _{DL_low}	-	F _{DL_high}	-50	1		
	E-UTRA Band 1, 4, 42, 43, 50, 51, 65, 66, 74, 75, 76 NR band n78	F _{DL_low}	-	F _{DL_high}	-50	1	2	
	E-UTRA band 1	F _{DL_low}	-	F _{DL_high}	-50	1	9, 10	
	Frequency range	758	-	773	-32	1	5	
	Frequency range	773	-	803	-50	1		
	Frequency range	2570	-	2575	+1.6	5	5, 6, 7	
	Frequency range	2575	-	2595	-15.5	5	5, 6, 7	
DC_7_n51	E-UTRA Band 2, 3, 5, 8, 26, 30, 31, 32, 33, 34, 40, 48, 72	F _{DL_low}	-	F _{DL_high}	-50	1		
	Frequency range	2570	-	2575	+1.6	5	5, 7, 16	
	Frequency range	2575	-	2595	-15.5	5	5, 7, 16	
	Frequency range	2595	-	2620	-40	1	5, 6	
	E-UTRA Band 1, 4, 12, 13, 14, 17, 20, 22, 23, 27, 28, 29, 42, 43, 44, 46, 65, 66, 67, 68 NR Band n77, n78, n79,	F _{DL_low}	-	F _{DL_high}	-50	1	2	
	DC_7_n78	E-UTRA Band 1, 2, 3, 4, 5, 7, 8, 11, 18, 19, 20, 21, 26, 27, 28, 31, 32, 33, 34, 40, 50, 51, 65, 66, 67, 68, 72, 74, 75, 76	F _{DL_low}	-	F _{DL_high}	-50	1	
		Frequency range	2570	-	2575	+1.6	5	5, 6, 7
Frequency range		2575	-	2595	-15.5	5	5, 6, 7	
Frequency range		2595	-	2620	-40	1	5, 6	
DC_8_n40	E-UTRA Band 1, 20, 28, 31, 32, 33, 34, 38, 39, 40, 45, 50, 51, 65, 67, 68, 69, 72, 73, 74, 75, 76	F _{DL_low}	-	F _{DL_high}	-50	1		
	E-UTRA Band 3, 7, 22, 41, 42, 43, 52	F _{DL_low}	-	F _{DL_high}	-50	1	2	
	E-UTRA Band 8	F _{DL_low}	-	F _{DL_high}	-50	1	5	
DC_8_n77	E-UTRA Band 1, 20, 28, 31, 32, 33, 34, 38, 39, 40, 44, 45, 50, 51, 65, 67, 68, 69, 72, 73, 74, 75, 76	F _{DL_low}	-	F _{DL_high}	-50	1		
	E-UTRA band 3, 7, 41	F _{DL_low}	-	F _{DL_high}	-50	1	2	
	E-UTRA Band 8	F _{DL_low}	-	F _{DL_high}	-50	1	5	
	E-UTRA Band 11, 21	F _{DL_low}	-	F _{DL_high}	-50	1	12	
	Frequency range	860	-	890	-40	1	5, 12	
	Frequency range	1884.5	-	1915.7	-41	0.3	3, 12	
DC_8_n78 DC_8_n81_ULS UP-TDM_n78	E-UTRA Band 1, 20, 28, 34, 39, 40, 65	F _{DL_low}	-	F _{DL_high}	-50	1		
	E-UTRA Band 3, 7, 41	F _{DL_low}	-	F _{DL_high}	-50	1	2	
	E-UTRA Band 8	F _{DL_low}	-	F _{DL_high}	-50	1	5	
	E-UTRA Band 11, 21	F _{DL_low}	-	F _{DL_high}	-50	1	12	
	Frequency range	860	-	890	-40	1	5, 12	
	Frequency range	1884.5	-	1915.7	-41	0.3	3, 12	
DC_8_n79 DC_8_n81_ULS UP-TDM_n79	E-UTRA Band 1, 8, 28, 34, 39, 40, 65, 74	F _{DL_low}	-	F _{DL_high}	-50	1		
	E-UTRA Band 3, 41, 42	F _{DL_low}	-	F _{DL_high}	-50	1	2	
	E-UTRA Band 11, 21	F _{DL_low}	-	F _{DL_high}	-50	1	12	
	Frequency range	860	-	890	-40	1	5, 12	
	Frequency range	1884.5	-	1915.7	-41	0.3	3	

DC_11_n77	E-UTRA Band 1, 3, 18, 19, 28, 34, 65	F _{DL_low}	-	F _{DL_high}	-50	1	
	Frequency range	945	-	960	-50	1	
	Frequency range	1884.5	-	1915.7	-41	0.3	3
	Frequency range	2545	-	2575	-50	1	
	Frequency range	2595	-	2645	-50	1	
DC_11_n78	E-UTRA Band 1, 3, 18, 19, 28, 34, 65	F _{DL_low}	-	F _{DL_high}	-50	1	
	Frequency range	945	-	960	-50	1	
	Frequency range	1884.5	-	1915.7	-41	0.3	3
	Frequency range	2545	-	2575	-50	1	
	Frequency range	2595	-	2645	-50	1	
DC_11_n79	E-UTRA Band 1, 3, 18, 19, 28, 34, 42, 65	F _{DL_low}	-	F _{DL_high}	-50	1	
	Frequency range	945	-	960	-50	1	
	Frequency range	1884.5	-	1915.7	-41	0.3	3
	Frequency range	2545	-	2575	-50	1	
	Frequency range	2595	-	2645	-50	1	
DC_12_n5	E-UTRA Band 2, 5, 12, 13, 14, 17, 24, 25, 26, 30, 42, 43 50, 51, 71, 74	F _{DL_low}	-	F _{DL_high}	-50	1	
	E-UTRA Band 4, 41, 48, 66, 70	F _{DL_low}	-	F _{DL_high}	-50	1	2
	E-UTRA Band 12, 85	F _{DL_low}	-	F _{DL_high}	-50	1	
DC_12_n66	E-UTRA Band 2, 5, 13, 14, 17, 25, 26, 27, 30, 41, 71, 74	F _{DL_low}	-	F _{DL_high}	-50	1	
	E-UTRA Bands 4, 48, 50, 51, 66, 70	F _{DL_low}	-	F _{DL_high}	-50	1	2
	E-UTRA Band 12, 85	F _{DL_low}	-	F _{DL_high}	-50	1	5
DC_18_n77	E-UTRA Band 1, 3, 11, 21, 28, 34, 65, 74	F _{DL_low}	-	F _{DL_high}	-50	1	
	Frequency range	945	-	960	-50	1	
	Frequency range	1884.5	-	1915.7	-41	0.3	3
	Frequency range	2545	-	2575	-50	1	
	Frequency range	2595	-	2645	-50	1	
DC_18_n78	E-UTRA Band 1, 3, 11, 21, 28, 34, 65, 74	F _{DL_low}	-	F _{DL_high}	-50	1	
	Frequency range	945	-	960	-50	1	
	Frequency range	1884.5	-	1915.7	-41	0.3	3
	Frequency range	2545	-	2575	-50	1	
	Frequency range	2595	-	2645	-50	1	
DC_18_n79	E-UTRA Band 1, 3, 11, 21, 28, 34, 42, 65, 74	F _{DL_low}	-	F _{DL_high}	-50	1	
	Frequency range	945	-	960	-50	1	
	Frequency range	1884.5	-	1915.7	-41	0.3	3
	Frequency range	2545	-	2575	-50	1	
	Frequency range	2595	-	2645	-50	1	
DC_19_n77	E-UTRA Band 1, 3, 11, 21, 28, 34, 65, 74	F _{DL_low}	-	F _{DL_high}	-50	1	
	Frequency range	945	-	960	-50	1	
	Frequency range	1884.5	-	1915.7	-41	0.3	3
	Frequency range	2545	-	2575	-50	1	
	Frequency range	2595	-	2645	-50	1	
DC_19_n78	E-UTRA Band 1, 3, 11, 21, 28, 34, 65, 74	F _{DL_low}	-	F _{DL_high}	-50	1	
	Frequency range	945	-	960	-50	1	
	Frequency range	1884.5	-	1915.7	-41	0.3	3
	Frequency range	2545	-	2575	-50	1	
	Frequency range	2595	-	2645	-50	1	
DC_19_n79	E-UTRA Band 1, 3, 11, 21, 28, 34, 42, 65, 74	F _{DL_low}	-	F _{DL_high}	-50	1	
	Frequency range	945	-	960	-50	1	
	Frequency range	1884.5	-	1915.7	-41	0.3	3
	Frequency range	2545	-	2575	-50	1	
	Frequency range	2595	-	2645	-50	1	

DC_20_n8	E-UTRA Band 1, 3, 7, 22, 28, 31, 32, 34, 38, 42, 43, 65, 75, 76, NR band n78	F _{DL_low}	-	F _{DL_high}	-50	1	
DC_20_n28 DC_20_n83	E-UTRA Band 1, 3, 7, 8, 22, 31, 32, 34, 38, 42, 43, 65, 75, 76	F _{DL_low}	-	F _{DL_high}	-50	1	
DC_20_n51	E-UTRA Band 1, 3, 4, 8, 17, 22, 28, 29, 31, 40, 43, 48, 65, 66, 68, 72	F _{DL_low}	-	F _{DL_high}	-50	1	
	E-UTRA Band 20	F _{DL_low}	-	F _{DL_high}	-50	1	5
	Frequency range	758	-	788	-50	1	
	E-UTRA Band 2, 7, 25, 32, 33, 34, 35, 36, 37, 38, 39, 41, 42, 46, 69, 70 NR Band n77, n78, n79.	F _{DL_low}	-	F _{DL_high}	-50	1	2
DC_20_n77	E-UTRA Band 1, 3, 7, 8, 31, 32, 33, 34, 40, 50, 51, 65, 67, 68, 72, 74, 75, 76						
	E-UTRA Band 20	F _{DL_low}	-	F _{DL_high}	-50	1	5
	E-UTRA Band 38, 69	F _{DL_low}	-	F _{DL_high}	-50	1	2
DC_20_n78 DC_20_n82_UL SUP-TDM_n78	E-UTRA Band 1, 3, 7, 8, 31, 32, 33, 34, 40, 50, 51, 65, 67, 68, 72, 74, 75, 76						
	E-UTRA Band 20	F _{DL_low}	-	F _{DL_high}	-50	1	5
	E-UTRA Band 38, 69	F _{DL_low}	-	F _{DL_high}	-50	1	2
DC_21_n77	E-UTRA Band 1, 3, 18, 19, 21, 28, 34, 65	F _{DL_low}	-	F _{DL_high}	-50	1	
	Frequency range	945	-	960	-50	1	
	Frequency range	1884.5	-	1915.7	-41	0.3	3
	Frequency range	2545	-	2575	-50	1	
	Frequency range	2595	-	2645	-50	1	
DC_21_n78	E-UTRA Band 1, 3, 18, 19, 21, 28, 34, 65	F _{DL_low}	-	F _{DL_high}	-50	1	
	Frequency range	945	-	960	-50	1	
	Frequency range	1884.5	-	1915.7	-41	0.3	3
	Frequency range	2545	-	2575	-50	1	
	Frequency range	2595	-	2645	-50	1	
DC_21_n79	E-UTRA Band 1, 3, 18, 19, 21, 28, 34, 42, 65	F _{DL_low}	-	F _{DL_high}	-50	1	
	Frequency range	945	-	960	-50	1	
	Frequency range	1884.5	-	1915.7	-41	0.3	3
	Frequency range	2545	-	2575	-50	1	
	Frequency range	2595	-	2645	-50	1	
DC_25_n41	E-UTRA band 4, 5, 12, 13, 14, 17, 24, 26, 27, 28, 29, 30, 42, 45, 48, 66, 70,71	F _{DL_low}	-	F _{DL_high}	-50	1	
	E-UTRA/NR Band 2, 25	F _{DL_low}	-	F _{DL_high}	-50	1	5
DC_26_n41	E-UTRA/NR Band 1, 2, 3, 4, 5, 11, 12, 13, 14, 17, 18, 19, 21, 24, 25, 26, 29, 30, 31, 34, 39, 42, 43, 48, 50, 51, 65, 66, 70, 71, 74	F _{DL_low}	-	F _{DL_high}	-50	1	
	Frequency range	1884.5		1915.7	-41	0.3	3
	Frequency range	703	-	799	-50	1	
	Frequency range	799	-	803	-40	1	5
	Frequency range	945	-	960	-50	1	
DC_26_n77	E-UTRA Band 1, 3, 5, 11, 18, 19, 21, 26, 34, 39, 40, 41, 65, 74	F _{DL_low}	-	F _{DL_high}	-50	1	
	Frequency range	703	-	799	-50	1	
	Frequency range	799	-	803	-40	1	5
	Frequency range	945	-	960	-50	1	
	Frequency range	1884.5	-	1915.7	-41	0.3	3
	Frequency range	2545	-	2575	-50	1	
DC_26_n78	E-UTRA Band 1, 3, 5, 11, 18, 19, 21, 26, 34, 39, 40, 41, 65, 74	F _{DL_low}	-	F _{DL_high}	-50	1	
	Frequency range	703	-	799	-50	1	

	Frequency range	799	-	803	-40	1	5
	Frequency range	945	-	960	-50	1	
	Frequency range	1884.5	-	1915.7	-41	0.3	3
	Frequency range	2545	-	2575	-50	1	
	Frequency range	2595	-	2645	-50	1	
DC_26_n79	E-UTRA Band 1, 3, 5, 11, 18, 19, 21, 26, 34, 39, 40, 41, 42, 65, 79	F _{DL_low}	-	F _{DL_high}	-50	1	
	Frequency range	703	-	799	-50	1	
	Frequency range	799	-	803	-40	1	5
	Frequency range	945	-	960	-50	1	
	Frequency range	1884.5	-	1915.7	-41	0.3	3
	Frequency range	2545	-	2575	-50	1	
DC_28_n51	E-UTRA Band 2, 3, 5, 7, 8, 25, 26, 31, 34, 38, 40, 41, 72	F _{DL_low}	-	F _{DL_high}	-50	1	
	E-UTRA Band 4, 20, 22, 24, 32, 42, 43, 45, 46, 65, 66, 71, 73 NR band n78, n79	F _{DL_low}	-	F _{DL_high}	-50	1	2
	E-UTRA Band 1	F _{DL_low}	-	F _{DL_high}	-50	1	2, 9, 10
	Frequency range	470	-	694	-42	8	5, 17
	Frequency range	470	-	710	-26.2	6	14
	Frequency range	662	-	694	-26.2	6	5
	Frequency range	758	-	773	-32	1	5
	Frequency range	773	-	803	-50	1	
DC_28_n77	E-UTRA Band 3, 5, 7, 8, 18, 19, 20, 26, 34, 39, 40, 41, 74	F _{DL_low}	-	F _{DL_high}	-50	1	
	E-UTRA Band 1, 65	F _{DL_low}	-	F _{DL_high}	-50	1	2
	E-UTRA Band 1	F _{DL_low}	-	F _{DL_high}	-50	1	9, 10
	E-UTRA Band 11, 21	F _{DL_low}	-	F _{DL_high}	-50	1	9, 11
	Frequency range	758	-	773	-32	1	
	Frequency range	773	-	803	-50	1	
	Frequency range	1884.5	-	1915.7	-41	0.3	3
DC_28_n78 DC_28_n83_UL SUP-TDM_n78	E-UTRA Band 3, 5, 7, 8, 18, 19, 20, 26, 34, 39, 40, 41	F _{DL_low}	-	F _{DL_high}	-50	1	
	E-UTRA Band 1, 65, 74	F _{DL_low}	-	F _{DL_high}	-50	1	2
	E-UTRA Band 1	F _{DL_low}	-	F _{DL_high}	-50	1	9, 11
	E-UTRA Band 11, 21	F _{DL_low}	-	F _{DL_high}	-50	1	9, 10
	Frequency range	758	-	773	-32	1	
	Frequency range	773	-	803	-50	1	
	Frequency range	1884.5	-	1915.7	-41	0.3	3, 9
DC_28_n79	E-UTRA Band 3, 5, 8, 18, 19, 34, 39, 40, 41, 42	F _{DL_low}	-	F _{DL_high}	-50	1	
	E-UTRA Band 1, 65, 74	F _{DL_low}	-	F _{DL_high}	-50	1	2
	E-UTRA Band 1	F _{DL_low}	-	F _{DL_high}	-50	1	9, 11
	E-UTRA Band 11, 21	F _{DL_low}	-	F _{DL_high}	-50	1	9, 10
	Frequency range	758	-	773	-32	1	
	Frequency range	773	-	803	-50	1	
	Frequency range	1884.5	-	1915.7	-41	0.3	3, 9
DC_30_n5	E-UTRA Band 2, 4, 5, 7, 12, 13, 14, 17, 24, 25, 26, 29, 30, 38, 48, 66, 70, 71, 85	F _{DL_low}	-	F _{DL_high}	-50	1	
	E-UTRA Band 41, 48, 52	F _{DL_low}	-	F _{DL_high}	-50	1	2
DC_30_n66	E-UTRA Band 2, 4, 5, 12, 13, 14, 17, 24, 25, 26, 27, 29, 30, 38, 41, 66, 70, 71	F _{DL_low}	-	F _{DL_high}	-50	1	
	Band 48	F _{DL_low}	-	F _{DL_high}	-50	1	2
DC_38_n78	N/A						
DC_39_n78	E-UTRA Band 1, 8, 34, 40, 41, 44, 45	F _{DL_low}	-	F _{DL_high}	-50	1	
	Frequency range	1805	-	1855	-40	1	18
	Frequency range	1855	-	1880	-15.5	5	18
DC_39_n79	E-UTRA Band 1, 8, 34, 40, 41, 44, 45	F _{DL_low}	-	F _{DL_high}	-50	1	
	Frequency range	1805	-	1855	-40	1	18
	Frequency range	1855	-	1880	-15.5	5	18
DC_40_n77	N/A						

DC_41_n77	E-UTRA Band 1, 3, 5, 8, 11, 18, 19, 21, 26, 28, 33, 34, 39, 40, 44, 45, 73, 74	F _{DL_low}	-	F _{DL_high}	-50	1	
	Frequency range	1884.5		1915.7	-41	0.3	3
DC_41_n78	E-UTRA Band 1, 3, 5, 8, 11, 18, 19, 21, 26, 28, 34, 39, 40, 44, 45, 74	F _{DL_low}	-	F _{DL_high}	-50	1	
	Frequency range	1884.5		1915.7	-41	0.3	3
DC_41_n79	E-UTRA Band 1, 3, 5, 8, 11, 18, 19, 21, 26, 28, 34, 39, 40, 42, 44, 45, 65, 74	F _{DL_low}	-	F _{DL_high}	-50	1	
	Frequency range	1884.5	-	1915.7	-41	0.3	3
DC_42_n51	E-UTRA Band 3, 8, 20, 25, 30, 31, 34, 39, 41, 73	F _{DL_low}	-	F _{DL_high}	-50	1	
	E-UTRA Band 1, 2, 4, 5, 6, 7, 12, 13, 14, 17, 23, 24, 26, 27, 28, 29, 32, 38, 40, 44, 46, 65, 66, 67, 68, 70, 71	F _{DL_low}	-	F _{DL_high}	-50	1	2
DC_42_n77	N/A						
DC_42_n78	N/A						
DC_42_n79	N/A						
DC_66_n5	E-UTRA Band 1, 2, 3, 4, 5, 6, 7, 8, 12, 13, 14, 17, 24, 25, 26, 28, 29, 30, 34, 38, 40, 43, 45, 50, 51, 65, 66, 70, 71, 85	F _{DL_low}	-	F _{DL_high}	-50	1	
	E-UTRA Band 41, 42, 48, 52	F _{DL_low}	-	F _{DL_high}	-50	1	2
DC_66_n71	E-UTRA Band 4, 5, 7, 13, 14, 17, 22, 24, 26, 27, 29, 30, 43,-50, 51, 66, 74	F _{DL_low}	-	F _{DL_high}	-50	1	
	E-UTRA Band 2, 25, 41, 42, 48, 70	F _{DL_low}	-	F _{DL_high}	-50	1	2
	E-UTRA Band 71	F _{DL_low}	-	F _{DL_high}	-50	1	5
DC_66_n78, DC_66_n86_UL SUP-TDM_n78	E-UTRA Band 1, 3, 5, 7, 8, 20, 26, 28, 34, 39, 40, 41, 65	F _{DL_low}	-	F _{DL_high}	-50	1	

- NOTE 1: FDL_low and FDL_high refer to each E-UTRA frequency band specified in Table 5.2-1 of TS 36.121-1 [10].
- NOTE 2: As exceptions, measurements with a level up to the applicable requirements defined in Table 6.5B.3.1.1.5-1 are permitted for each assigned E-UTRA carrier used in the measurement due to 2nd, 3rd, 4th or 5th harmonic spurious emissions. Due to spreading of the harmonic emission the exception is also allowed for the first 1 MHz frequency range immediately outside the harmonic emission on both sides of the harmonic emission. This results in an overall exception interval centred at the harmonic emission of $(2\text{MHz} + N \times L_{\text{CRB}} \times 180\text{kHz})$, where N is 2, 3, 4, 5 for the 2nd, 3rd, 4th or 5th harmonic respectively. The exception is allowed if the measurement bandwidth (MBW) totally or partially overlaps the overall exception interval.
- NOTE 3: Applicable when co-existence with PHS system operating in 1884.5 -1915.7MHz.
- NOTE 4: Void.
- NOTE 5: These requirements also apply for the frequency ranges that are less than F_{OOB} (MHz) in Table 6.5.3.1-1 and Table 6.5A.3.1-1 of TS 38.101-1 [2] from the edge of the channel bandwidth.
- NOTE 6: This requirement is applicable for any channel bandwidths within the range 2500 - 2570 MHz with the following restriction: for carriers of 15 MHz bandwidth when carrier centre frequency is within the range 2560.5 - 2562.5 MHz and for carriers of 20 MHz bandwidth when carrier centre frequency is within the range 2552 - 2560 MHz the requirement is applicable only for an uplink transmission bandwidth less than or equal to 54 RB.
- NOTE 7: For these adjacent bands, the emission limit could imply risk of harmful interference to UE(s) operating in the protected operating band.
- NOTE 8: This requirement is applicable for any channel bandwidths within the range 1920 - 1980 MHz with the following restriction: for carriers of 15 MHz bandwidth when carrier centre frequency is within the range 1927.5 - 1929.5 MHz and for carriers of 20 MHz bandwidth when carrier centre frequency is within the range 1930 - 1938 MHz the requirement is applicable only for an uplink
- NOTE 9: Applicable when the assigned E-UTRA carrier is confined within 718 MHz and 748 MHz and when the channel bandwidth used is 5 or 10 MHz.
- NOTE 10: As exceptions, measurements with a level up to the applicable requirement of -36 dBm/MHz is permitted for each assigned E-UTRA carrier used in the measurement due to 2nd harmonic spurious emissions. An exception is allowed if there is at least one individual RB within the transmission bandwidth (see Figure 5.6-1) for which the 2nd harmonic totally or partially overlaps the measurement bandwidth (MBW).
- NOTE 11: As exceptions, measurements with a level up to the applicable requirement of -38 dBm/MHz is permitted for each assigned E-UTRA carrier used in the measurement due to 3rd harmonic spurious emissions. An exception is allowed if there is at least one individual RB within the transmission bandwidth (see Figure 5.6-1) for which the 3rd harmonic totally or partially overlaps the measurement bandwidth (MBW).
- NOTE 12: This requirement is applicable only for the following cases: - for carriers of 5 MHz channel bandwidth when carrier centre frequency (F_c) is within the range $902.5 \text{ MHz} \leq F_c < 907.5 \text{ MHz}$ with an uplink transmission bandwidth less than or equal to 20 RB - for carriers of 5 MHz channel bandwidth when carrier centre frequency (F_c) is within the range $907.5 \text{ MHz} \leq F_c \leq 912.5 \text{ MHz}$ without any restriction on uplink transmission bandwidth. - for carriers of 10 MHz channel bandwidth when carrier centre frequency (F_c) is $F_c = 910 \text{ MHz}$ with an uplink transmission bandwidth less than or equal to 32 RB with $\text{RB}_{\text{start}} > 3$.
- NOTE13: Void.
- NOTE 14: This requirement is applicable for 5 and 10 MHz E-UTRA channel bandwidth allocated within 718-728MHz. For carriers of 10 MHz bandwidth, this requirement applies for an uplink transmission bandwidth less than or equal to 30 RB with $\text{RB}_{\text{start}} > 1$ and $\text{RB}_{\text{start}} < 48$.
- NOTE 15: Void.
- NOTE 16: This requirement is applicable for any channel bandwidths within the range 1920 - 1980 MHz with the following restriction: for carriers of 15 MHz bandwidth when carrier centre frequency is within the range 1927.5 - 1929.5 MHz and for carriers of 20 MHz bandwidth when carrier centre frequency is within the range 1930 - 1938 MHz the requirement is applicable only for an uplink transmission bandwidth less than or equal to 54 RB.
- NOTE 17: This requirement is applicable in the case of a 10 MHz E-UTRA carrier confined within 703 MHz and 733 MHz, otherwise the requirement of -25 dBm with a measurement bandwidth of 8 MHz applies.
- NOTE 18: This requirement is only applicable for E-UTRA carriers with bandwidth confined within 1885-1920 MHz (requirement for carriers with at least 1RB confined within 1880 - 1885 MHz is not specified). This requirement applies for an uplink transmission bandwidth less than or equal to 54 RB for E-UTRA carriers of 15 MHz bandwidth when carrier centre frequency is within the range 1892.5 - 1894.5 MHz and for E-UTRA carriers of 20 MHz bandwidth when carrier centre frequency is within the range 1895 - 1903 MHz.
- NOTE 19: Void.

Table 6.5B.3.3.2.3-2: Spurious emission band UE co-existence limits Rel-16

EN-DC Configuration	Spurious emission						
	Protected band	Frequency range (MHz)			Maximum Level (dBm)	MBW (MHz)	NOTE
DC_1_n3	E-UTRA Band 1, 5, 7, 8, 11, 18, 19, 20, 21, 26, 27, 28, 31, 32, 38, 40, 41, 43, 44, 50, 51, 65, 67, 72, 73, 74, 75, 76 NR Band n79	F _{DL_low}	-	F _{DL_high}	-50	1	
	E-UTRA band 3, 34	F _{DL_low}	-	F _{DL_high}	-50	1	5
	E-UTRA band 22, 42, 52 NR Band n77, n78	F _{DL_low}	-	F _{DL_high}	-50	1	2
	Frequency range	1884.5	-	1915.7	-41	0.3	16
	Frequency range	1880	-	1895	-40	1	5, 17
	Frequency range	1895	-	1915	-15.5	5	5, 7, 17
	Frequency range	1915	-	1920	+1.6	5	5, 7, 17
DC_1_n5	E-UTRA Band 1, 5, 7, 8, 11, 18, 19, 21, 22, 28, 31, 38, 40, 42, 43, 50, 51, 65, 73, 74	F _{DL_low}	-	F _{DL_high}	-50	1	
	E-UTRA band 3,34	F _{DL_low}	-	F _{DL_high}	-50	1	5
	E-UTRA band 41, 52 NR Band n77, n78, n79	F _{DL_low}	-	F _{DL_high}	-50	1	2
DC_1_n7	E-UTRA Band 1, 5, 7, 8, 20, 22, 26, 27, 28, 31,32, 40, 42, 43, 50, 51, 52, 65, 67, 72, 74, 75, 76 NR Band n78, n79	F _{DL_low}	-	F _{DL_high}	-50	1	
	band n77	F _{DL_low}	-	F _{DL_high}	-50	1	2
	band 3, 34	F _{DL_low}	-	F _{DL_high}	-50	1	5
	Frequency range	1880	-	1895	-40	1	5, 16
	Frequency range	1895	-	1915	-15.5	5	5, 7, 16
	Frequency range	1915	-	1920	+1.6	5	5, 7, 16
	Frequency range	2570	-	2575	+1.6	5	5, 6, 7
	Frequency range	2575	-	2595	-15.5	5	5, 6, 7
Frequency range	2595	-	2620	-40	1	5, 6	
DC_1_n28	E-UTRA Band 5, 7, 8, 18, 19, 20, 26, 27, 31, 38, 40, 41, 72, 73 NR band n79	F _{DL_low}	-	F _{DL_high}	-50	1	
	E-UTRA Band 1, 22, 32, 42, 43, 50, 51, 52, 65, 74, 75, 76 NR band n77, n78	F _{DL_low}	-	F _{DL_high}	-50	1	2
	E-UTRA band 3, 34	F _{DL_low}	-	F _{DL_high}	-50	1	5
	E-UTRA Band 11, 21	F _{DL_low}	-	F _{DL_high}	-50	1	9, 11
	E-UTRA Band 1, 65	F _{DL_low}	-	F _{DL_high}	-50	1	9, 10
	Frequency range	470	-	694	-42	8	5, 17
	Frequency range	470	-	710	-26.2	6	14
	Frequency range	758	-	773	-32	1	5
	Frequency range	773	-	803	-50	1	
	Frequency range	662	-	694	-26.2	6	5
	Frequency range	1880	-	1895	-40	1	5, 16
	Frequency range	1895	-	1915	-15.5	5	5, 7, 16
Frequency range	1915	-	1920	+1.6	5	5, 7, 16	
DC_1_n38	E-UTRA Band 1, 3, 5, 8, 20, 22, 27, 28, 31, 32, 34, 40, 42, 43, 50, 51, 65, 67, 68, 72, 74, 75, 76	F _{DL_low}	-	F _{DL_high}	-50	1	
DC_1_n40	E-UTRA Band 1, 5, 7, 8, 20, 22, 26, 27, 28, 31, 32, 38, 40, 41, 42, 43, 44, 45, 50, 51, 52, 65, 67, 68, 69, 72, 73, 74, 75, 76	F _{DL_low}	-	F _{DL_high}	-50	1	
	Band 3, 34	F _{DL_low}	-	F _{DL_high}	-50	1	5
	Frequency range	1880	-	1895	-40	1	5, 17
	Frequency range	1895	-	1915	-15.5	5	5, 7, 17
Frequency range	1915	-	1920	+1.6	5	5, 7, 17	
DC_1_n51	E-UTRA Band 7, 12, 13, 17, 20, 22, 27, 28, 29, 31, 38, 44, 48, 67, 68, 69, 72, 73	F _{DL_low}	-	F _{DL_high}	-50	1	
	E-UTRA Band 3, 34	F _{DL_low}	-	F _{DL_high}	-50	1	5, 2
	Frequency range	1880	-	1895	-40	1	5, 16

	Frequency range	1895	-	1915	-15.5	5	5, 7, 16
	Frequency range	1915	-	1920	+1.6	5	5, 7, 16
	E-UTRA Band 5, 6, 8, 26, 30, 40, 41, 42, 43, 46 NR Band n77, n78, n79,	F _{DL_low}	-	F _{DL_high}	-50	1	2
DC_1_n77 DC_1_n84_ULS UP-TDM_n77	E-UTRA Band 1, 3, 5, 7, 8, 11, 18, 19, 20, 21, 26, 28, 34, 40, 41, 65, 74	F _{DL_low}	-	F _{DL_high}	-50	1	
	Frequency range	1880	-	1895	-40	1	5, 8
	Frequency range	1895	-	1915	-15.5	5	5, 7, 8
	Frequency range	1915	-	1920	+1.6	5	5, 7, 8
DC_1_n78 DC_1_n84_ULS UP-TDM_n78	E-UTRA Band 1, 3, 5, 7, 8, 11, 18, 19, 20, 21, 26, 28, 34, 40, 41, 65, 74	F _{DL_low}	-	F _{DL_high}	-50	1	
	Frequency range	1880	-	1895	-40	1	5, 8
	Frequency range	1895	-	1915	-15.5	5	5, 7, 8
	Frequency range	1915	-	1920	+1.6	5	5, 7, 8
DC_1_n79 DC_1_n84_ULS UP-TDM_n79	E-UTRA Band 1, 3, 5, 7, 8, 11, 18, 19, 21, 26, 28, 34, 40, 41, 42, 65, 74	F _{DL_low}	-	F _{DL_high}	-50	1	
	Frequency range	1880	-	1895	-40	1	5, 8
	Frequency range	1895	-	1915	-15.5	5	5, 7, 8
	Frequency range	1915	-	1920	+1.6	5	5, 7, 8
DC_1_n80	E-UTRA Band 1, 5, 7, 8, 11, 18, 19, 20, 21, 26, 27, 28, 31, 32, 38, 40, 41, 43, 44, 45, 50, 51, 65, 67, 68, 69, 72, 73, 74, 75, 76, NR Band n79	F _{DL_low}	-	F _{DL_high}	-50	1	
	E-UTRA Band 3, 34	F _{DL_low}	-	F _{DL_high}	-50	1	5
	E-UTRA Band 22, 42, NR Band n77, n78	F _{DL_low}	-	F _{DL_high}	-50	1	2
DC_2_n5	E-UTRA Bands 4, 5, 12, 13, 14, 17, 24, 26, 28, 29, 30, 42, 48, 50, 51, 53, 66, 70, 71, n71, 74, 85 NR Band n77	F _{DL_low}	-	F _{DL_high}	-50	1	
	NR Band n77	F _{DL_low}	-	F _{DL_high}	-50	1	2, 5
	E-UTRA Bands 2, 25	F _{DL_low}	-	F _{DL_high}	-50	1	5
	E-UTRA Band 41, 43	F _{DL_low}	-	F _{DL_high}	-50	1	2
DC_2_n41	E-UTRA Band 4, 5, 10, 12, 13, 14, 17, 24, 26, 27, 28, 29, 30, 42, 48, 50, 51, 66, 70, 71, 74, 85	F _{DL_low}	-	F _{DL_high}	-50	1	
	E-UTRA Bands 2, 25	F _{DL_low}	-	F _{DL_high}	-50	1	5
	E-UTRA Band 43 NR Band n77	F _{DL_low}	-	F _{DL_high}	-50	1	2
DC_2_n66	E-UTRA Bands 4, 5, 10, 12, 13, 14, 17, 24, 26, 27, 28, 29, 30, 41, 50, 51, 66, 70, 71, n71, 74, 85	F _{DL_low}	-	F _{DL_high}	-50	1	
	E-UTRA Bands 2, 25	F _{DL_low}	-	F _{DL_high}	-50	1	5
	E-UTRA Bands 42, 48 NR Band n77	F _{DL_low}	-	F _{DL_high}	-50	1	2
DC_2_n71	E-UTRA Band 4, 5, 12, 13, 14, 17, 24, 26, 29, 30, 48, 66	F _{DL_low}	-	F _{DL_high}	-50	1	
	E-UTRA Band 2, 25, 41, 70 NR Band n77	F _{DL_low}	-	F _{DL_high}	-50	1	2
	E-UTRA Band n71	F _{DL_low}	-	F _{DL_high}	-50	1	5
DC_2_n78	E-UTRA Band 4, 5, 12, 13, 14, 17, 24, 26, 27, 28, 29, 30, 41, 50, 51, 66, 70, 71, 74, 85	F _{DL_low}	-	F _{DL_high}	-50	1	
	E-UTRA Band 2, 25	F _{DL_low}	-	F _{DL_high}	-50	1	2
DC_3_n1	E-UTRA Band 1, 5, 7, 8, 11, 18, 19, 20, 21, 26, 27, 28, 31, 32, 38, 40, 41, 43, 44, 50, 51, 65, 67, 72, 73, 74, 75, 76 NR Band n79	F _{DL_low}	-	F _{DL_high}	-50	1	
	E-UTRA band 3, 34	F _{DL_low}	-	F _{DL_high}	-50	1	5

	E-UTRA band 22, 42, 52 NR Band n77, n78	F _{DL_low}	-	F _{DL_high}	-50	1	2
	Frequency range	1880		1895	-40	1	5,17
	Frequency range	1895		1915	-15.5	5	5, 7, 17
	Frequency range	1915		1920	+1.6	5	5, 7, 17
DC_3_n5	E-UTRA Band 1, 5, 7, 8, 11, 18, 19, 21, 22, 28, 31, 38, 40, 42, 43, 50, 51, 65, 73, 74 NR Band n79	F _{DL_low}	-	F _{DL_high}	-50	1	
	E-UTRA band 3,34	F _{DL_low}	-	F _{DL_high}	-50	1	5
	E-UTRA Band 52 Band n77, n78	F _{DL_low}	-	F _{DL_high}	-50	1	2
	Frequency range	1884.5	-	1915.7	-41	0.3	3
DC_3_n7	E-UTRA Band 1, 5, 7, 8, 20, 26, 27, 28, 31, 32, 33, 34, 40, 43, 44, 50, 51, 65, 67, 72, 74, 75, 76	F _{DL_low}	-	F _{DL_high}	-50	1	
	E-UTRA band 3	F _{DL_low}	-	F _{DL_high}	-50	1	5
	E-UTRA band 22, 42	F _{DL_low}	-	F _{DL_high}	-50	1	2
	Frequency range	2570	-	2575	+1.6	5	5, 6, 7
	Frequency range	2575	-	2595	-15.5	5	5, 6, 7
	Frequency range	2595	-	2620	-40	1	5, 6
DC_3_n28	E-UTRA Band 1, 42, 43, 50, 51, 65, 74, 75, 76 NR band n77, n78, n79	F _{DL_low}	-	F _{DL_high}	-50	1	2
	E-UTRA band 1	F _{DL_low}	-	F _{DL_high}	-50	1	9, 11
	E-UTRA band 3	F _{DL_low}	-	F _{DL_high}	-50	1	5
	E-UTRA Band 5, 7, 8, 18, 19, 20, 26, 27, 31, 34, 38, 40, 41, 72	F _{DL_low}	-	F _{DL_high}	-50	1	
	E-UTRA Band 11, 21	F _{DL_low}	-	F _{DL_high}	-50	1	9, 10
	Frequency range	1884.5	-	1915.7	-41	0.3	13
	Frequency range	470	-	710	-26.2	6	14
	Frequency range	758	-	773	-32	1	5
	Frequency range	773	-	803	-50	1	
	Frequency range	1884.5	-	1915.7	-41	0.3	3, 9
DC_3_n38	E-UTRA Band 1, 5, 8, 20, 27, 28, 31, 32, 33, 34, 40, 43, 50, 51, 65, 67, 68, 72, 74, 75, 76	F _{DL_low}	-	F _{DL_high}	-50	1	
	E-UTRA Band 22, 42	F _{DL_low}	-	F _{DL_high}	-50	1	2
DC_3_n40	E-UTRA Band 1, 5, 7, 8, 20, 26, 27, 28, 31, 32, 33, 34, 38, 39, 41, 43, 44, 45, 50, 51, 65, 67, 68, 69, 72, 73, 75, 76	F _{DL_low}	-	F _{DL_high}	-50	1	
	E-UTRA Band 3	F _{DL_low}	-	F _{DL_high}	-50	1	5
	E-UTRA Band 22, 42, 52	F _{DL_low}	-	F _{DL_high}	-50	1	2
DC_3_n41, DC_3_n80_ULS UP-TDM_n41	E-UTRA Band 1, 5, 8, 11, 18, 19, 21, 26, 27, 28, 34, 39, 40, 44, 45, 50, 51, 65, 73, 74	F _{DL_low}	-	F _{DL_high}	-50	1	
	E-UTRA Band 42, 52 NR Band n77, n78, n79	F _{DL_low}	-	F _{DL_high}	-50	1	
	Frequency range	1884.5	-	1915.7	-41	0.3	3
DC_3_n51	E-UTRA Band 7, 8, 12, 13, 17, 20, 27, 28, 31, 33, 38, 48, 67, 68, 69, 72, 73	F _{DL_low}	-	F _{DL_high}	-50	1	
	E-UTRA Band 3	F _{DL_low}	-	F _{DL_high}	-50	1	5
	E-UTRA Band 1, 5, 6, 22, 26, 30, 34, 36, 40, 41, 42, 43, 44, 46, 65, 71	F _{DL_low}	-	F _{DL_high}	-50	1	2
DC_3_n77 DC_3_n80_ULS UP-TDM_n77	E-UTRA Band 1, 3, 5, 7, 8, 11, 18, 19, 20, 21, 26, 28, 34, 39, 40, 41, 65, 74	F _{DL_low}	-	F _{DL_high}	-50	1	
	Frequency range	1884.5	-	1915.7	-41	0.3	3
DC_3_n78 DC_3_n80_ULS UP-TDM_n78	E-UTRA Band 1, 3, 5, 7, 8, 11, 18, 19, 20, 21, 26, 28, 34, 39, 40, 41, 65, 74	F _{DL_low}	-	F _{DL_high}	-50	1	
	Frequency range	1884.5	-	1915.7	-41	0.3	3
	E-UTRA Band 1, 3, 5, 8, 11, 18, 19, 21, 28, 34, 39, 40, 41, 65, 74	F _{DL_low}	-	F _{DL_high}	-50	1	

DC_3_n79 DC_3_n80_ULS UP-TDM_n79	E-UTRA Band 42	F _{DL_low}	-	F _{DL_high}	-50	1	2
	Frequency range	1884.5	-	1915.7	-41	0.3	3
DC_3_n82	E-UTRA Band 1, 3, 7, 8, 20, 22, 31, 32, 33, 34, 38, 40, 43, 50, 51, 65, 67, 68, 69, 72, 74, 75, 76	F _{DL_low}	-	F _{DL_high}	-50	1	
	E-UTRA Band 42	F _{DL_low}	-	F _{DL_high}	-50	1	2
DC_3_n84	E-UTRA Band 1, 5, 7, 8, 11, 18, 19, 20, 21, 26, 27, 28, 31, 32, 38, 40, 41, 43, 44, 45, 50, 51, 65, 67, 68, 69, 72, 73, 74, 75, 76 NR Band n79	F _{DL_low}	-	F _{DL_high}	-50	1	
	E-UTRA Band 3	F _{DL_low}	-	F _{DL_high}	-50	1	5
	NR Band n77, n78	F _{DL_low}	-	F _{DL_high}	-50	1	2
DC_5_n2	E-UTRA Band 4, 5, 12, 13, 14, 17, 24, 28, 29, 30, 42, 50, 51, 53, 66, 70, 71, 74, 85	F _{DL_low}	-	F _{DL_high}	-50	1	
	E-UTRA Band 25	F _{DL_low}	-	F _{DL_high}	-50	1	5
	NR Band n2	F _{DL_low}	-	F _{DL_high}	-50	1	5
	E-UTRA Band 26	859	-	869	-27	1	
	E-UTRA Band 41, 43 NR Band n77	F _{DL_low}	-	F _{DL_high}	-50	1	2
DC_5_n40	E-UTRA Band 1, 3, 5, 7, 8, 28, 31, 34, 38, 42, 43, 45, 65, 73	F _{DL_low}	-	F _{DL_high}	-50	1	
	E-UTRA Band 26	859	-	869	-27	1	
	E-UTRA Band 41, 52	F _{DL_low}	-	F _{DL_high}	-50	1	
DC_5_n66	E-UTRA Band 1, 2, 3, 4, 5, 6, 7, 8, 12, 13, 14, 17, 24, 25, 28, 29, 30, 34, 38, 40, 43, 45, 50, 51, 65, 66, 70, 71, 85	F _{DL_low}	-	F _{DL_high}	-50	1	
	E-UTRA Band 26	859	-	869	-27	1	
	E-UTRA Band 41, 42, 48, 52 NR Band n77	F _{DL_low}	-	F _{DL_high}	-50	1	2
DC_5_n71	E-UTRA Band 4, 5, 12, 13, 14, 17, 24, 26, 30, 48, 66, 85	F _{DL_low}	-	F _{DL_high}	-50	1	
	E-UTRA Band 2, 25, 41, 70 NR Band n77	F _{DL_low}	-	F _{DL_high}	-50	1	2
	E-UTRA Band 29	F _{DL_low}	-	F _{DL_high}	-38	1	5
	E-UTRA Band 71	F _{DL_low}	-	F _{DL_high}	-50	1	5
DC_5_n78	E-UTRA Band 1, 2, 3, 4, 5, 7, 8, 12, 13, 14, 17, 24, 25, 28, 29, 30, 31, 34, 38, 40, 45, 65, 66, 70	F _{DL_low}	-	F _{DL_high}	-50	1	
	E-UTRA Band 26	859	-	869	-27	1	
	E-UTRA Band 41	F _{DL_low}	-	F _{DL_high}	-50	1	7
DC_5_n79	Bands 1, 2, 3, 4, 5, 7, 8, 12, 13, 14, 17, 24, 25, 28, 29, 30, 31, 34, 38, 40, 42, 43, 45, 48, 50, 51, 65, 66, 70, 71, 73, 74, 85	F _{DL_low}	-	F _{DL_high}	-50	1	
	E-UTRA Band 26	859	-	869	-27	1	
	Bands 41, 52	F _{DL_low}	-	F _{DL_high}	-50	1	2
DC_7_n1	Band 1, 5, 7, 8, 20, 22, 26, 27, 28, 31, 32, 40, 42, 43, 50, 51, 52, 65, 67, 72, 74, 75, 76, n78, n79	F _{DL_low}	-	F _{DL_high}	-50	1	
	band n77	F _{DL_low}	-	F _{DL_high}	-50	1	2
	band 3, 34	F _{DL_low}	-	F _{DL_high}	-50	1	5
	Frequency range	1880		1895	-40	1	5, 16
	Frequency range	1895		1915	-15.5	5	5, 7, 16
	Frequency range	1915		1920	+1.6	5	5, 7, 16
	Frequency range	2570	-	2575	+1.6	5	5, 6, 7
	Frequency range	2575	-	2595	-15.5	5	5, 6, 7
Frequency range	2595	-	2620	-40	1	5, 6	
DC_7_n3	E-UTRA Band 1, 5, 7, 8, 20, 26, 27, 28, 31, 32, 33, 34, 40, 43, 50, 51, 65, 67, 68, 72, 74, 75, 76	F _{DL_low}	-	F _{DL_high}	-50	1	
	E-UTRA band 3	F _{DL_low}	-	F _{DL_high}	-50	1	5
	E-UTRA band 22, 42, 52 NR band n78, n77	F _{DL_low}	-	F _{DL_high}	-50	1	2

	Frequency range	2570	-	2575	+1.6	5	5, 6, 7
	Frequency range	2575	-	2595	-15.5	5	5, 6, 7
	Frequency range	2595	-	2620	-40	1	5, 6
DC_7_n5	E-UTRA Band 1, 2, 3, 4, 5, 7, 8, 12, 13, 14, 17, 22, 28, 29, 30, 31, 40, 42, 43, 50, 51, 65, 66, 74, 85	F _{DL_low}	-	F _{DL_high}	-50	1	
	E-UTRA Band 52 NR Band n77, n78	F _{DL_low}	-	F _{DL_high}	-50	1	2
	Frequency range	2570	-	2575	+1.6	5	5, 7, 6
	Frequency range	2575	-	2595	-15.5	5	5, 7, 6
	Frequency range	2595	-	2620	-40	1	5, 14
DC_7_n28	E-UTRA Band 2, 3, 5, 7, 8, 20, 26, 27, 31, 34, 40, 72	F _{DL_low}	-	F _{DL_high}	-50	1	
	E-UTRA Band 1, 4, 42, 43, 50, 51, 65, 66, 74, 75, 76 NR band n78	F _{DL_low}	-	F _{DL_high}	-50	1	2
	E-UTRA band 1	F _{DL_low}	-	F _{DL_high}	-50	1	9, 10
	Frequency range	758	-	773	-32	1	5
	Frequency range	773	-	803	-50	1	
	Frequency range	2570	-	2575	+1.6	5	5, 6, 7
	Frequency range	2575	-	2595	-15.5	5	5, 6, 7
	Frequency range	2595	-	2620	-40	1	5, 6
DC_7_n51	E-UTRA Band 2, 3, 5, 8, 26, 30, 31, 32, 33, 34, 40, 48, 72	F _{DL_low}	-	F _{DL_high}	-50	1	
	Frequency range	2570	-	2575	+1.6	5	5, 7, 16
	Frequency range	2575	-	2595	-15.5	5	5, 7, 16
	Frequency range	2595	-	2620	-40	1	5, 21
	E-UTRA Band 1, 4, 10, 12, 13, 14, 17, 20, 22, 23, 27, 28, 29, 42, 43, 44, 46, 65, 66, 67, 68 NR Band n77, n78, n79,	F _{DL_low}	-	F _{DL_high}	-50	1	2
DC_7_n66	E-UTRA Band 2, 4, 5, 7, 12, 13, 14, 17, 26, 27, 28, 29, 30, 43, 50, 51, 66, 74, 85	F _{DL_low}	-	F _{DL_high}	-50	1	
	E-UTRA Band 42	F _{DL_low}	-	F _{DL_high}	-50	1	2
	Frequency range	2570	-	2575	+1.6	5	5, 6, 7
	Frequency range	2575	-	2595	-15.5	5	5, 6, 7
	Frequency range	2595	-	2620	-40	1	5, 6
DC_7_n71	E-UTRA Band 4, 5, 12, 13, 14, 17, 26, 30, 66, 85	F _{DL_low}	-	F _{DL_high}	-50	1	
	E-UTRA Band 2, 70	F _{DL_low}	-	F _{DL_high}	-50	1	2
	E-UTRA Band 29	F _{DL_low}	-	F _{DL_high}	-38	1	5
	Frequency range	2570	-	2575	1.6	5	5, 6, 7
	Frequency range	2575	-	2595	-15.5	5	5, 6, 7
	Frequency range	2595	-	2620	-40	1	5, 6
DC_7_n77	E-UTRA Band 1, 2, 3, 4, 5, 7, 8, 11, 18, 19, 20, 21, 26, 27, 28, 31, 32, 33, 34, 40, 50, 51, 65, 66, 67, 68, 72, 74, 75, 76	F _{DL_low}	-	F _{DL_high}	-50	1	
	Frequency range	2570	-	2575	+1.6	5	5, 6, 7
	Frequency range	2575	-	2595	-15.5	5	5, 6, 7
	Frequency range	2595	-	2620	-40	1	5, 6
DC_7_n78	E-UTRA Band 1, 2, 3, 4, 5, 7, 8, 11, 18, 19, 20, 21, 26, 27, 28, 31, 32, 33, 34, 40, 50, 51, 65, 66, 67, 68, 72, 74, 75, 76	F _{DL_low}	-	F _{DL_high}	-50	1	
	Frequency range	2570	-	2575	+1.6	5	5, 6, 7
	Frequency range	2575	-	2595	-15.5	5	5, 6, 7
	Frequency range	2595	-	2620	-40	1	5, 6
DC_8_n1	E-UTRA Band 20, 28, 31, 32, 38, 40, 50, 51, 65, 67, 72, 73, 74, 75, 76	F _{DL_low}	-	F _{DL_high}	-50	1	
	E-UTRA band 3, 7, 22, 41, 42, 43, 52 NR Band n77, n78, n79	F _{DL_low}	-	F _{DL_high}	-50	1	2

	E-UTRA Band 1, 8, 34	F _{DL_low}	-	F _{DL_high}	-50	1	5
	E-UTRA band 11, 21	F _{DL_low}	-	F _{DL_high}	-50	1	12
	Frequency range	860	-	890	-40	1	5, 12
	Frequency range	1880	-	1895	-40	1	5, 16
	Frequency range	1895	-	1915	-15.5	5	5, 7, 16
	Frequency range	1915	-	1920	+1.6	5	5, 7, 16
DC_8_n3	E-UTRA Band 1, 20, 28, 31, 32, 33, 34, 38, 39, 40, 44, 50, 51, 65, 67, 72, 73, 74, 75, 76	F _{DL_low}	-	F _{DL_high}	-50	1	
	E-UTRA band 3, 8	F _{DL_low}	-	F _{DL_high}	-50	1	2, 5
	E-UTRA band 11, 21	F _{DL_low}	-	F _{DL_high}	-50	1	12
	E-UTRA band 7, 22, 41, 42, 43, 52				-50	1	2
	NR Band n77, n78, n79	F _{DL_low}	-	F _{DL_high}			
	Frequency range	1884.5	-	1915.7	-41	0.3	3.12
	Frequency range	860	-	890	-40	1	5.12
DC_7_n80	E-UTRA Band 1, 5, 7, 8, 20, 26, 27, 28, 31, 32, 33, 34, 40, 43, 50, 51, 65, 67, 68, 72, 74, 75, 76.	F _{DL_low}	-	F _{DL_high}	-50	1	
	NR Band n79						
	E-UTRA Band 3	F _{DL_low}	-	F _{DL_high}	-50	1	5
	E-UTRA Band 22, 42, NR Band n77, n78	F _{DL_low}	-	F _{DL_high}	-50	1	2
	Frequency range	2570	-	2575	+1.6	5	5, 6, 7
	Frequency range	2575	-	2595	-15.5	5	5, 6, 7
	Frequency range	2595	-	2620	-40	1	5, 6
DC_8_n40	E-UTRA Band 1, 20, 28, 31, 32, 33, 34, 38, 39, 40, 45, 50, 51, 65, 67, 68, 69, 72, 73, 74, 75, 76	F _{DL_low}	-	F _{DL_high}	-50	1	
	E-UTRA Band 3, 7, 22, 41, 42, 43, 52	F _{DL_low}	-	F _{DL_high}	-50	1	2
	E-UTRA Band 8	F _{DL_low}	-	F _{DL_high}	-50	1	5
DC_8_n41, DC_8_n81_ULS UP-TDM_n41	E-UTRA Band 1, 11, 21, 28, 34, 39, 40, 45, 50, 51, 65, 73, 74	F _{DL_low}	-	F _{DL_high}	-50	1	
	E-UTRA band 3, 42, 52	F _{DL_low}	-	F _{DL_high}	-50	1	2
	NR Band n77, n78, n79						
	E-UTRA Band 8	F _{DL_low}	-	F _{DL_high}	-50	1	5
	Frequency range	860	-	890	-40	1	5, 12
	Frequency range	1884.5	-	1915.7	-41	0.3	3
DC_8_n77	E-UTRA Band 1, 20, 28, 31, 32, 33, 34, 38, 39, 40, 44, 45, 50, 51, 65, 67, 68, 69, 72, 73, 74, 75, 76	F _{DL_low}	-	F _{DL_high}	-50	1	
	E-UTRA band 3, 7, 41	F _{DL_low}	-	F _{DL_high}	-50	1	2
	E-UTRA Band 8	F _{DL_low}	-	F _{DL_high}	-50	1	5
	E-UTRA Band 11, 21	F _{DL_low}	-	F _{DL_high}	-50	1	12
	Frequency range	860	-	890	-40	1	5, 12
	Frequency range	1884.5	-	1915.7	-41	0.3	3, 12
DC_8_n78 DC_8_n81_ULS UP-TDM_n78, DC_8_n81_ULS UP-FDM_n78	E-UTRA Band 1, 20, 28, 34, 39, 40, 65, 74	F _{DL_low}	-	F _{DL_high}	-50	1	
	E-UTRA Band 3, 7, 41	F _{DL_low}	-	F _{DL_high}	-50	1	2
	E-UTRA Band 8	F _{DL_low}	-	F _{DL_high}	-50	1	5
	E-UTRA Band 11, 21	F _{DL_low}	-	F _{DL_high}	-50	1	12
	Frequency range	860	-	890	-40	1	5, 12
	Frequency range	1884.5	-	1915.7	-41	0.3	3, 12
DC_8_n79 DC_8_n81_ULS UP-TDM_n79	E-UTRA Band 1, 8, 28, 34, 39, 40, 65	F _{DL_low}	-	F _{DL_high}	-50	1	
	E-UTRA Band 3, 41, 42	F _{DL_low}	-	F _{DL_high}	-50	1	2
	E-UTRA Band 11, 21	F _{DL_low}	-	F _{DL_high}	-50	1	12
	Frequency range	860	-	890	-40	1	5, 12
	Frequency range	1884.5	-	1915.7	-41	0.3	3
DC_8_n80	E-UTRA Band 1, 20, 28, 31, 32, 33, 34, 38, 39, 40, 45, 50, 51, 65, 67, 68, 69, 72, 73, 74, 75, 76	F _{DL_low}	-	F _{DL_high}	-50	1	
	NR Band n79						

	E-UTRA Band 3, 8	F _{DL_low}	-	F _{DL_high}	-50	1	5
	E-UTRA Band 3, 7, 22, 41, 42, 43, 52	F _{DL_low}	-	F _{DL_high}	-50	1	2
	NR Band n77, n78						
	E-UTRA Band 11, 21	F _{DL_low}	-	F _{DL_high}	-50	1	13
	Frequency range	1884.5	-	1915.7	-41	0.3	3
DC_11_n77	E-UTRA Band 1, 3, 18, 19, 28, 34, 65	F _{DL_low}	-	F _{DL_high}	-50	1	
	Frequency range	945	-	960	-50	1	
	Frequency range	1884.5	-	1915.7	-41	0.3	3
	Frequency range	2545	-	2575	-50	1	
	Frequency range	2595	-	2645	-50	1	
DC_11_n78	E-UTRA Band 1, 3, 18, 19, 28, 34, 65	F _{DL_low}	-	F _{DL_high}	-50	1	
	Frequency range	945	-	960	-50	1	
	Frequency range	1884.5	-	1915.7	-41	0.3	3
	Frequency range	2545	-	2575	-50	1	
	Frequency range	2595	-	2645	-50	1	
DC_11_n79	E-UTRA Band 1, 3, 18, 19, 28, 34, 42, 65	F _{DL_low}	-	F _{DL_high}	-50	1	
	Frequency range	945	-	960	-50	1	
	Frequency range	1884.5	-	1915.7	-41	0.3	3
	Frequency range	2545	-	2575	-50	1	
	Frequency range	2595	-	2645	-50	1	
DC_12_n2	E-UTRA Band 5, 13, 14, 17, 24, 26, 27, 30, 41, 50, 53, 71, 74	F _{DL_low}	-	F _{DL_high}	-50	1	
	E-UTRA Band 12, 25, 85	F _{DL_low}	-	F _{DL_high}	-50	1	3
	E-UTRANR Band n2	F _{DL_low}	-	F _{DL_high}	-50	1	5
	E-UTRA Band 4, 51, 66, 70, NR Band n77	F _{DL_low}	-	F _{DL_high}	-50	1	2
DC_12_n5	E-UTRA Band 2, 5, 12, 13, 14, 17, 24, 25, 26, 30, 42, 43 50, 51, 71, 74	F _{DL_low}	-	F _{DL_high}	-50	1	
	E-UTRA Band 4, 41, 48, 66, 70, NR Band n77	F _{DL_low}	-	F _{DL_high}	-50	1	2
	E-UTRA Band 12, 85	F _{DL_low}	-	F _{DL_high}	-50	1	
DC_12_n66	E-UTRA Band 2, 5, 13, 14, 17, 25, 26, 27, 30, 41, 53, 71, 74	F _{DL_low}	-	F _{DL_high}	-50	1	
	E-UTRA Bands 4, 48, 50, 51, 66, 70, NR Band n77	F _{DL_low}	-	F _{DL_high}	-50	1	2
	E-UTRA Band 12, 85	F _{DL_low}	-	F _{DL_high}	-50	1	5
DC_12_n71	E-UTRA Band 5, 13, 14, 17, 24, 26, 27, 30, 48, 50, 51, 74	F _{DL_low}	-	F _{DL_high}	-50	1	
	E-UTRA Band 2, 4, 25, 41, 66, 70	F _{DL_low}	-	F _{DL_high}	-50	1	2
	E-UTRA Band 12, 71, 85	F _{DL_low}	-	F _{DL_high}	-50	1	5
DC_12_n78	E-UTRA Band 2, 5, 7, 13, 17, 25, 26, 41, 71	F _{DL_low}	-	F _{DL_high}	-50	1	
	E-UTRA Band 4, 66	F _{DL_low}	-	F _{DL_high}	-50	1	2
	E-UTRA band 12	F _{DL_low}	-	F _{DL_high}	-50	1	5
	Frequency range	1884.5	-	1915.7	-41	0.3	3
DC_13_n2	E-UTRA Band 4, 5,12,13,17, 26, 29, 41, 48, 66, 70, 71	F _{DL_low}	-	F _{DL_high}	-50	1	
	E-UTRA Band 2,14, 25	F _{DL_low}	-	F _{DL_high}	-50	1	5
	E-UTRA Band 30	F _{DL_low}	-	F _{DL_high}	-50	1	2
	Frequency range	769	-	775	-35	0.006 25	5
	Frequency range	799	-	805	-35	0.006 25	5
DC_13_n66	E-UTRA Band 2, 4, 5, 12, 13, 17, 25, 26, 27, 29, 41, 50, 51, 53, 66, 70, 71, 74, 85	F _{DL_low}	-	F _{DL_high}	-50	1	
	E-UTRA Band 14	F _{DL_low}	-	F _{DL_high}	-50	1	5
	E-UTRA Band 30, 48, NR Band n77	F _{DL_low}	-	F _{DL_high}	-50	1	2

	Frequency range	769	-	775	-35	0.006 25	5
	Frequency range	799	-	803	-35	0.006 25	5
DC_18_n77	E-UTRA Band 1, 3, 11, 21, 28, 34, 65, 74	F _{DL_low}	-	F _{DL_high}	-50	1	
	Frequency range	945	-	960	-50	1	
	Frequency range	1884.5	-	1915.7	-41	0.3	3
	Frequency range	2545	-	2575	-50	1	
	Frequency range	2595	-	2645	-50	1	
DC_18_n78	E-UTRA Band 1, 3, 11, 21, 28, 34, 65, 74	F _{DL_low}	-	F _{DL_high}	-50	1	
	Frequency range	945	-	960	-50	1	
	Frequency range	1884.5	-	1915.7	-41	0.3	3
	Frequency range	2545	-	2575	-50	1	
	Frequency range	2595	-	2645	-50	1	
DC_18_n79	E-UTRA Band 1, 3, 11, 21, 28, 34, 42, 65, 74	F _{DL_low}	-	F _{DL_high}	-50	1	
	Frequency range	945	-	960	-50	1	
	Frequency range	1884.5	-	1915.7	-41	0.3	3
	Frequency range	2545	-	2575	-50	1	
	Frequency range	2595	-	2645	-50	1	
DC_19_n77	E-UTRA Band 1, 3, 11, 21, 28, 34, 65, 74	F _{DL_low}	-	F _{DL_high}	-50	1	
	Frequency range	945	-	960	-50	1	
	Frequency range	1884.5	-	1915.7	-41	0.3	3
	Frequency range	2545	-	2575	-50	1	
	Frequency range	2595	-	2645	-50	1	
DC_19_n78	E-UTRA Band 1, 3, 11, 21, 28, 34, 65, 74	F _{DL_low}	-	F _{DL_high}	-50	1	
	Frequency range	945	-	960	-50	1	
	Frequency range	1884.5	-	1915.7	-41	0.3	3
	Frequency range	2545	-	2575	-50	1	
	Frequency range	2595	-	2645	-50	1	
DC_19_n79	E-UTRA Band 1, 3, 11, 21, 28, 34, 42, 65, 74	F _{DL_low}	-	F _{DL_high}	-50	1	
	Frequency range	945	-	960	-50	1	
	Frequency range	1884.5	-	1915.7	-41	0.3	3
	Frequency range	2545	-	2575	-50	1	
	Frequency range	2595	-	2645	-50	1	
DC_20_n1	E-UTRA Band 1, 3, 7, 8, 20, 22, 31, 32, 40, 42, 43, 50, 51, 65, 67, 68, 72, 75, 76	F _{DL_low}	-	F _{DL_high}	-50	1	
	E-UTRANR Band 1	F _{DL_low}	-	F _{DL_high}	-50	1	5
	E-UTRA Band 38, 69 NR Band n77, n78	F _{DL_low}	-	F _{DL_high}	-50	1	2
	Frequency range	758	-	788	-50	1	
DC_20_n3	E-UTRA Band 1, 7, 8, 31, 32, 33, 34, 40, 43, 50, 51, 65, 67, 72, 74, 75, 76	F _{DL_low}	-	F _{DL_high}	-50	1	
	E-UTRA Band 20 E-UTRANR Band 3	F _{DL_low}	-	F _{DL_high}	-50	1	5
	E-UTRA Band 22, 38, 42, 52	F _{DL_low}	-	F _{DL_high}	-50	1	2
	Frequency range	758	-	788	-50	1	
DC_20_n8	E-UTRA Band 1, 3, 7, 22, 28, 31, 32, 34, 38, 42, 43, 65, 75, 76, NR band n78	F _{DL_low}	-	F _{DL_high}	-50	1	
DC_20_n28 DC_20_n83	E-UTRA Band 1, 3, 7, 8, 22, 31, 32, 34, 38, 42, 43, 65, 75, 76	F _{DL_low}	-	F _{DL_high}	-50	1	
DC_20_n51	E-UTRA Band 1, 3, 4, 8, 17, 22, 28, 29, 31, 40, 43, 48, 65, 66, 68, 72	F _{DL_low}	-	F _{DL_high}	-50	1	
	E-UTRA Band 20	F _{DL_low}	-	F _{DL_high}	-50	1	5
	Frequency range	758	-	788	-50	1	

	E-UTRA Band 2, 7, 25, 32, 33, 34, 35, 36, 37, 38, 39, 41, 42, 46, 69, 70 NR Band n77, n78, n79,	F _{DL_low}	-	F _{DL_high}	-50	1	2
DC_20_n77	E-UTRA Band 1, 3, 7, 8, 31, 32, 33, 34, 40, 50, 51, 65, 67, 68, 72, 74, 75, 76						
	E-UTRA Band 20	F _{DL_low}	-	F _{DL_high}	-50	1	5
	E-UTRA Band 38, 69	F _{DL_low}	-	F _{DL_high}	-50	1	2
DC_20_n78 DC_20_n82_ULS UP-TDM_n78	E-UTRA Band 1, 3, 7, 8, 31, 32, 33, 34, 40, 50, 51, 65, 67, 68, 72, 74, 75, 76						
	E-UTRA Band 20	F _{DL_low}	-	F _{DL_high}	-50	1	5
	E-UTRA Band 38, 69	F _{DL_low}	-	F _{DL_high}	-50	1	2
DC_20_n80	E-UTRA Band 1, 7, 8, 27, 28, 31, 32, 33, 34, 40, 43, 50, 51, 65, 67, 68, 72, 74, 75, 76. NR Band n79	F _{DL_low}	-	F _{DL_high}	-50	1	
	E-UTRA Band 3, 20	F _{DL_low}	-	F _{DL_high}	-50	1	5
	E-UTRA Band 22, 42, NR Band n77, n78	F _{DL_low}	-	F _{DL_high}	-50	1	2
DC_21_n77	E-UTRA Band 1, 3, 18, 19, 21, 28, 34, 65	F _{DL_low}	-	F _{DL_high}	-50	1	
	Frequency range	945	-	960	-50	1	
	Frequency range	1884.5	-	1915.7	-41	0.3	3
	Frequency range	2545	-	2575	-50	1	
	Frequency range	2595	-	2645	-50	1	
DC_21_n78	E-UTRA Band 1, 3, 18, 19, 21, 28, 34, 65	F _{DL_low}	-	F _{DL_high}	-50	1	
	Frequency range	945	-	960	-50	1	
	Frequency range	1884.5	-	1915.7	-41	0.3	3
	Frequency range	2545	-	2575	-50	1	
	Frequency range	2595	-	2645	-50	1	
DC_21_n79	E-UTRA Band 1, 3, 18, 19, 21, 28, 34, 42, 65	F _{DL_low}	-	F _{DL_high}	-50	1	
	Frequency range	945	-	960	-50	1	
	Frequency range	1884.5	-	1915.7	-41	0.3	3
	Frequency range	2545	-	2575	-50	1	
	Frequency range	2595	-	2645	-50	1	
DC_25_n41	E-UTRA band 4, 5, 12, 13, 14, 24, 26, 27, 28, 29, 30, 42, 45, 48, 66, 70,71	F _{DL_low}	-	F _{DL_high}	-50	1	
	E-UTRA Band 2, 25, NR Band n77	F _{DL_low}	-	F _{DL_high}	-50	1	5
DC_26_n41	E-UTRA/NR Band 1, 2, 3, 4, 5, 11, 12, 13, 14, 17, 18, 19, 21, 24, 25, 26, 29, 30, 31, 34, 39, 42, 43, 48, 50, 51, 65, 66, 70, 71, 74	F _{DL_low}	-	F _{DL_high}	-50	1	
	Frequency range	1884.5		1915.7	-41	0.3	3, 19
	Frequency range	703	-	799	-50	1	
	Frequency range	799	-	803	-40	1	5
	Frequency range	945	-	960	-50	1	
DC_26_n77	E-UTRA Band 1, 3, 5, 11, 18, 19, 21, 26, 34, 39, 40, 41, 65, 74	F _{DL_low}	-	F _{DL_high}	-50	1	
	Frequency range	703	-	799	-50	1	
	Frequency range	799	-	803	-40	1	5
	Frequency range	945	-	960	-50	1	
	Frequency range	1884.5	-	1915.7	-41	0.3	3
	Frequency range	2545	-	2575	-50	1	
	Frequency range	2595	-	2645	-50	1	
DC_26_n78	E-UTRA Band 1, 3, 5, 11, 18, 19, 21, 26, 34, 39, 40, 41, 65, 74	F _{DL_low}	-	F _{DL_high}	-50	1	
	Frequency range	703	-	799	-50	1	
	Frequency range	799	-	803	-40	1	5

	Frequency range	945	-	960	-50	1		
	Frequency range	1884.5	-	1915.7	-41	0.3	3	
	Frequency range	2545	-	2575	-50	1		
	Frequency range	2595	-	2645	-50	1		
DC_26_n79	E-UTRA Band 1, 3, 5, 11, 18, 19, 21, 26, 34, 39, 40, 41, 65, 74	F _{DL_low}	-	F _{DL_high}	-50	1		
	Frequency range	703	-	799	-50	1		
	Frequency range	799	-	803	-40	1	5	
	Frequency range	945	-	960	-50	1		
	Frequency range	1884.5	-	1915.7	-41	0.3	3	
	Frequency range	2545	-	2575	-50	1		
DC_28_n3	E-UTRA Band 1, 22, 42, 43, 50, 51, 65, 74, 75, 76, NR Band n77, n78	F _{DL_low}	-	F _{DL_high}	-50	1	2	
	E-UTRA Band 1	F _{DL_low}	-	F _{DL_high}	-50	1	9, 11	
	E-UTRA Band 3, 5, 7, 8, 18, 19, 20, 26, 27, 31, 34, 38, 40, 41, 72, 73 NR Band n79	F _{DL_low}	-	F _{DL_high}	-50	1		
	E-UTRA Band 11, 21	F _{DL_low}	-	F _{DL_high}	-50	1	9, 10	
	Frequency range	470	-	710	-26.2	6	14	
	Frequency range	758	-	773	-32	1	5	
	Frequency range	773	-	803	-50	1		
	Frequency range	1884.5	-	1915.7	-41	0.3	3, 9	
	DC_28_n5	E-UTRA Band 2, 3, 5, 7, 8, 14, 18, 19, 24, 25, 26, 28, 30, 31, 34, 38, 40, 45, 48, 70, 71	F _{DL_low}	-	F _{DL_high}	-50		
		E-UTRA Band 1, 4, 22, 32, 41, 42, 43, 50, 51, 52, 65, 66, 73, 74, 75, 76 NR Band n77, n78, n79	F _{DL_low}	-	F _{DL_high}	-50	1	2
E-UTRA Band 1		F _{DL_low}	-	F _{DL_high}	-50	1	9, 11	
E-UTRA Band 11, 21		F _{DL_low}	-	F _{DL_high}	-50	1	9, 10	
Frequency range		1884.5	-	1915.7	-41	0.3	3, 9	
Frequency range		470	-	694	-42	8	5, 17	
Frequency range		470	-	710	-26.2	6	14	
Frequency range		662	-	694	-26.2	6	5	
Frequency range		758	-	773	-32	1	5	
Frequency range		773	-	803	-50	1		
Frequency range		773	-	803	-50	1		
DC_28_n8		E-UTRA Band 20, 31, 34, 38, 40, 72	F _{DL_low}	-	F _{DL_high}	-50	1	
		E-UTRA band 3, 7, 22, 41, 42, 43, 50, 51, 52, 65, 73, 74, 75, 76 NR Band n77, n78, n79	F _{DL_low}	-	F _{DL_high}	-50	1	2
	E-UTRA Band 8	F _{DL_low}	-	F _{DL_high}	-50	1	5	
	E-UTRA Band 11, 21	F _{DL_low}	-	F _{DL_high}	-50	1	9, 10	
	E-UTRA Band 1	F _{DL_low}	-	F _{DL_high}	-50	1	9, 11	
	Frequency range	470	-	694	-42	8	5, 17	
	Frequency range	470	-	710	-26.2	6	14	
	Frequency range	662	-	694	-26.2	6	5	
	Frequency range	758	-	773	-32	1	5	
	Frequency range	773	-	803	-50	1		
	Frequency range	860	-	890	-40	1	5, 12	
	Frequency range	1884.5	-	1915.7	-41	0.3	3, 9	
	DC_28_n41	E-UTRA Band 4, 14, 18, 19, 20, 26, 27, 39, 42, 43, 50, 51, 52, 65, 66, 71, 73 NR Band n77, n78, n79	F _{DL_low}	-	F _{DL_high}	-50	1	2
E-UTRA Band 1		F _{DL_low}	-	F _{DL_high}	-50	1	9, 11	
E-UTRA Band 2, 3, 5, 8, 24, 25, 30, 31, 34, 40, 48, 70, 72		F _{DL_low}	-	F _{DL_high}	-50	1		
E-UTRA Band 11, 21, 74, 75, 76		F _{DL_low}	-	F _{DL_high}	-50	1	9, 10	
Frequency range		470	-	694	-42	8	5, 17	

	Frequency range	470	-	710	-26.2	6	14	
	Frequency range	662	-	694	-26.2	6	5	
	Frequency range	758	-	773	-32	1	5	
	Frequency range	773	-	803	-50	1		
	Frequency range	1884.5	-	1915.7	-41	0.3	3, 9	
DC_28_n50	E-UTRA Band 4, 40, 42, 43, 65, 66, 73 NR Band n77, n78, n79	F _{DL_low}	-	F _{DL_high}	-50	1	2	
	E-UTRA Band 1	F _{DL_low}	-	F _{DL_high}	-50	1	9, 10	
	E-UTRA Band 2, 3, 5, 7, 8, 18, 19, 25, 26, 27, 31, 34, 38, 39, 41, 48, 72	F _{DL_low}	-	F _{DL_high}	-50	1		
	Frequency range	470	-	694	-42	8	5, 17	
	Frequency range	470	-	710	-26.2	6	14	
	Frequency range	662	-	694	-26.2	6	5	
	Frequency range	758	-	773	-32	1	5	
	Frequency range	773	-	803	-50	1		
DC_28_n51	E-UTRA Band 2, 3, 5, 7, 8, 25, 26, 31, 34, 38, 40, 41, 72	F _{DL_low}	-	F _{DL_high}	-50	1		
	E-UTRA Band 4, 10, 22, 24, 32, 42, 43, 45, 46, 65, 66, 71, 73 NR band n78, n79	F _{DL_low}	-	F _{DL_high}	-50	1	2	
	E-UTRA Band 1	F _{DL_low}	-	F _{DL_high}	-50	1	2, 9, 10	
	Frequency range	470	-	694	-42	8	5, 17	
	Frequency range	470	-	710	-26.2	6	14	
	Frequency range	662	-	694	-26.2	6	5	
	Frequency range	758	-	773	-32	1	5	
	Frequency range	773	-	803	-50	1		
DC_28_n77	E-UTRA Band 3, 5, 7, 8, 18, 19, 20, 26, 34, 39, 40, 41	F _{DL_low}	-	F _{DL_high}	-50	1		
	E-UTRA Band 1, 65, 74	F _{DL_low}	-	F _{DL_high}	-50	1	2	
	E-UTRA Band 1	F _{DL_low}	-	F _{DL_high}	-50	1	9, 11	
	E-UTRA Band 11, 21	F _{DL_low}	-	F _{DL_high}	-50	1	9, 10	
	Frequency range	758	-	773	-32	1		
	Frequency range	773	-	803	-50	1		
	Frequency range	1884.5	-	1915.7	-41	0.3	3, 9	
DC_28_n78 DC_28_n83_ULS UP-TDM_n78	E-UTRA Band 3, 5, 7, 8, 18, 19, 20, 26, 34, 39, 40, 41	F _{DL_low}	-	F _{DL_high}	-50	1		
	E-UTRA Band 1, 65, 74	F _{DL_low}	-	F _{DL_high}	-50	1	2	
	E-UTRA Band 1	F _{DL_low}	-	F _{DL_high}	-50	1	9, 11	
	E-UTRA Band 11, 21	F _{DL_low}	-	F _{DL_high}	-50	1	9, 10	
	Frequency range	758	-	773	-32	1		
	Frequency range	773	-	803	-50	1		
	Frequency range	1884.5	-	1915.7	-41	0.3	3	
DC_28_n79	E-UTRA Band 3, 5, 8, 18, 19, 34, 39, 40, 41, 42	F _{DL_low}	-	F _{DL_high}	-50	1		
	E-UTRA Band 1, 65, 74	F _{DL_low}	-	F _{DL_high}	-50	1	2	
	E-UTRA Band 1	F _{DL_low}	-	F _{DL_high}	-50	1	9, 11	
	E-UTRA Band 11, 21	F _{DL_low}	-	F _{DL_high}	-50	1	9, 10	
	Frequency range	758	-	773	-32	1		
	Frequency range	773	-	803	-50	1		
	Frequency range	1884.5	-	1915.7	-41	0.3	3, 9	
DC_30_n5	E-UTRA Band 2, 4, 5, 7, 12, 13, 14, 17, 24, 25, 26, 29, 30, 38, 48, 53, 66, 70, 71, 85	F _{DL_low}	-	F _{DL_high}	-50	1		
	E-UTRA Band 41, NR Band n77	F _{DL_low}	-	F _{DL_high}	-50	1	2	
DC_30_n66	E-UTRA Band 2, 4, 5, 12, 13, 14, 17, 24, 25, 26, 27, 29, 30, 38, 41, 66, 70, 71	F _{DL_low}	-	F _{DL_high}	-50	1		
	E-UTRA Band 48, NR Band n77	F _{DL_low}	-	F _{DL_high}	-50	1	2	
DC_38_n78		N/A						

DC_39_n41	E-UTRA Band 1, 8, 26, 28, 34, 40, 42, 44, 45, 50, 51, 74	F _{DL_low}	-	F _{DL_high}	-50	1	
	NR Band n77, n78, n79	F _{DL_low}	-	F _{DL_high}	-50	1	2
	Frequency range	1805	-	1855	-40	1	5
	Frequency range	1855	-	1880	-15.5	5	5, 7, 19
DC_39_n78	E-UTRA Band 1, 8, 28, 34, 40, 41, 44, 45	F _{DL_low}	-	F _{DL_high}	-50	1	
	Frequency range	1805	-	1855	-40	1	18
	Frequency range	1855	-	1880	-15.5	5	18
DC_39_n79	E-UTRA Band 1, 8, 28, 34, 40, 41, 44, 45	F _{DL_low}	-	F _{DL_high}	-50	1	
	Frequency range	1805	-	1855	-40	1	18
	Frequency range	1855	-	1880	-15.5	5	18
DC_40_n1	E-UTRA Band 1, 3, 5, 7, 8, 20, 22, 26, 27, 28, 31, 32, 38, 41, 42, 43, 44, 45, 50, 51, 52, 65, 67, 68, 69, 72, 73, 74, 75, 76 NR Band n78	F _{DL_low}	-	F _{DL_high}	-50	1	
	E-UTRA Band 34	F _{DL_low}	-	F _{DL_high}	-50	1	5
	NR Band n77, n79	F _{DL_low}	-	F _{DL_high}	-50	1	2
DC_40_n41	Bands 1, 3, 5, 8, 26, 27, 28, 34, 39, 42, 44, 45, 50, 51, 65, 73, 74, NR Band n77, n78	F _{DL_low}	-	F _{DL_high}	-50	1	
	NR Band n79	F _{DL_low}	-	F _{DL_high}	-50	1	2
DC_40_n77	N/A						
DC_40_n78	E-UTRA Band 1, 3, 5, 7, 8, 20, 26, 27, 28, 31, 32, 33, 34, 38, 39, 41, 44, 45, 50, 51, 65, 67, 68, 69, 72, 73, 74, 75, 76	F _{DL_low}	-	F _{DL_high}	-50	1	
	NR Band n79	F _{DL_low}	-	F _{DL_high}	-50	1	2

DC_41_n77	E-UTRA Band 1, 3, 5, 8, 11, 18, 19, 21, 26, 28, 33, 34, 39, 40, 44, 45, 73, 74	F _{DL_low}	-	F _{DL_high}	-50	1	
	Frequency range	1884.5		1915.7	-41	0.3	3
DC_41_n78	E-UTRA Band 1, 3, 5, 8, 11, 18, 19, 21, 26, 28, 34, 39, 40, 44, 45, 74	F _{DL_low}	-	F _{DL_high}	-50	1	
	Frequency range	1884.5		1915.7	-41	0.3	3
DC_41_n79	E-UTRA Band 1, 3, 5, 8, 11, 18, 19, 21, 26, 28, 34, 40, 42, 44, 45, 65, 74	F _{DL_low}	-	F _{DL_high}	-50	1	
	Frequency range	1884.5	-	1915.7	-41	0.3	3
DC_42_n51	E-UTRA Band 3, 8, 20, 25, 30, 31, 34, 39, 41, 73	F _{DL_low}	-	F _{DL_high}	-50	1	
	E-UTRA Band 1, 2, 4, 5, 6, 7, 12, 13, 14, 17, 23, 24, 26, 27, 28, 29, 32, 38, 40, 44, 46, 65, 66, 67, 68, 70, 71	F _{DL_low}	-	F _{DL_high}	-50	1	2
DC_42_n77	N/A						
DC_42_n78	N/A						
DC_42_n79	N/A						
DC_48_n5	E-UTRA Band 2, 4, 5, 12, 13, 14, 17, 24, 25, 26, 29, 30, 41, 50, 51, 66, 70, 71, 74, 85	F _{DL_low}	-	F _{DL_high}	-50	1	
	Frequency range	1884.5	-	1915.7	-41	0.3	3
DC_48_n66	E-UTRA Band 2, 4, 5, 12, 13, 14, 17, 24, 25, 26, 29, 30, 41, 50, 51, 66, 70, 71, 74, 85	F _{DL_low}	-	F _{DL_high}	-50	1	
DC_66_n2	E-UTRA Band 4, 5, 12, 13, 14, 17, 22, 24, 26, 27, 28, 29, 30, 41, 50, 51, 53, 66, 70, 71, 74, 85	F _{DL_low}	-	F _{DL_high}	-50	1	
	E-UTRA Band 25	F _{DL_low}	-	F _{DL_high}	-50	1	5
	E-UTRANR Band n2	F _{DL_low}	-	F _{DL_high}	-50	1	5
	E-UTRA Band 42, 43, NR Band n77	F _{DL_low}	-	F _{DL_high}	-50	1	2
DC_66_n5	E-UTRA Band 1, 2, 3, 4, 5, 6, 7, 8, 12, 13, 14, 17, 24, 25, 26, 28, 29, 30, 34, 38, 40, 43, 45, 50, 51, 65, 66, 70, 71, 85	F _{DL_low}	-	F _{DL_high}	-50	1	
	E-UTRA Band 41, 42, 48, 52, NR Band n77	F _{DL_low}	-	F _{DL_high}	-50	1	2

DC_66_n25	E-UTRA Band 4, 5, 7, 12, 13, 14, 17, 24, 26, 27, 28, 29, 30, 38, 41, 50, 51, 53, 66, 70, 71, 74, 85	F _{DL_low}	-	F _{DL_high}	-50	1	
	E-UTRA Band 42, 48, NR Band n77	F _{DL_low}	-	F _{DL_high}	-50	1	2
	E-UTRA Band 2	F _{DL_low}	-	F _{DL_high}	-50	1	5
	E-UTRA Band 25	F _{DL_low}	-	F _{DL_high}	-50	1	5
	E-UTRA Band 43	F _{DL_low}	-	F _{DL_high}	-50	1	2
DC_66_n41	E-UTRA Band 2, 4, 5, 12, 13, 14, 17, 24, 25, 26, 27, 28, 29, 30, 43, 50, 51, 66, 70, 71, 74, 85	F _{DL_low}	-	F _{DL_high}	-50	1	
	E-UTRA Band 42, 48, NR Band n77	F _{DL_low}	-	F _{DL_high}	-50	1	2
DC_66_n71	E-UTRA Band 4, 5, 7, 13, 14, 17, 22, 24, 26, 27, 29, 30, 43,-50, 51, 66, 74	F _{DL_low}	-	F _{DL_high}	-50	1	
	E-UTRA Band 2, 25, 41, 42, 48, 70 NR Band n77	F _{DL_low}	-	F _{DL_high}	-50	1	2
	E-UTRA Band 71	F _{DL_low}	-	F _{DL_high}	-50	1	5
DC_66_n78, DC_66_n86_ULS UP-TDM_n78, DC_66_n86_ULS UP-FDM_n78	E-UTRA Band 1, 3, 5, 7, 8, 20, 26, 28, 34, 39, 40, 41, 65	F _{DL_low}	-	F _{DL_high}	-50	1	
DC_71_n5	E-UTRA Band 4, 12, 13, 14, 17, 24, 26, 30, 48, 66, 85 NR Band n5	F _{DL_low}	-	F _{DL_high}	-50	1	
	E-UTRA Band 2, 25, 41, 70, NR Band n77	F _{DL_low}	-	F _{DL_high}	-50	1	2
	E-UTRA Band 29	F _{DL_low}	-	F _{DL_high}	-38	1	5
	E-UTRA Band 71	F _{DL_low}	-	F _{DL_high}	-50	1	5

NOTE 1: F_{DL_low} and F_{DL_high} refer to each E-UTRA frequency band specified in Table 5.5-1 in TS 36.101 [10].

NOTE 2: As exceptions, measurements with a level up to the applicable requirements defined in Table 6.6.3.1-2 are permitted for each assigned E-UTRA carrier used in the measurement due to 2nd, 3rd, 4th or 5th harmonic spurious emissions. Due to spreading of the harmonic emission the exception is also allowed for the first 1 MHz frequency range immediately outside the harmonic emission on both sides of the harmonic emission. This results in an overall exception interval centred at the harmonic emission of (2 MHz + N x L_{CRB} x 180 kHz), where N is 2, 3, 4, 5 for the 2nd, 3rd, 4th or 5th harmonic respectively. The exception is allowed if the measurement bandwidth (MBW) totally or partially overlaps the overall exception interval.

NOTE 3: Applicable when co-existence with PHS system operating in 1884.5 - 1915.7 MHz

NOTE 4: Void.

NOTE 5: These requirements also apply for the frequency ranges that are less than F_{00B} (MHz) in Table 6.5.3.1-1 and Table 6.5A.3.1-1 of TS 38.101-1 [2] from the edge of the channel bandwidth.

NOTE 6: This requirement is applicable for any channel bandwidths within the range 2500 - 2570 MHz with the following restriction: for carriers of 15 MHz bandwidth when carrier centre frequency is within the range 2560.5 - 2562.5 MHz and for carriers of 20 MHz bandwidth when carrier centre frequency is within the range 2552 - 2560 MHz the requirement is applicable only for an uplink transmission bandwidth less than or equal to 54 RB.

NOTE 7: For these adjacent bands, the emission limit could imply risk of harmful interference to UE(s) operating in the protected operating band.

NOTE 8: This requirement is applicable for any channel bandwidths within the range 1920 - 1980 MHz with the following restriction: for carriers of 15 MHz bandwidth when carrier centre frequency is within the range 1927.5 - 1929.5 MHz and for carriers of 20 MHz bandwidth when carrier centre frequency is within the range 1930 - 1938 MHz the requirement is applicable only for an uplink

NOTE 9: Applicable when the assigned E-UTRA carrier is confined within 718 MHz and 748 MHz and when the channel bandwidth used is 5 or 10 MHz.

NOTE 10: As exceptions, measurements with a level up to the applicable requirement of -38 dBm/MHz is permitted for each assigned E-UTRA carrier used in the measurement due to 2nd harmonic spurious emissions. An exception is allowed if there is at least one individual RB within the transmission bandwidth (see Figure 5.6-1) for which the 2nd harmonic totally or partially overlaps the measurement bandwidth (MBW).

NOTE 11: As exceptions, measurements with a level up to the applicable requirement of -36 dBm/MHz is permitted for each assigned E-UTRA carrier used in the measurement due to 3rd harmonic spurious emissions. An exception is allowed if there is at least one individual RB within the transmission bandwidth (see Figure 5.6-1) for which the 3rd harmonic totally or partially overlaps the measurement bandwidth (MBW).

NOTE 12: This requirement is applicable only for the following cases: A: for carriers of 5 MHz channel bandwidth when carrier centre frequency (F_c) is within the range $902.5 \text{ MHz} \leq F_c < 907.5 \text{ MHz}$ with an uplink transmission bandwidth less than or equal to 20 RB; B: for carriers of 5 MHz channel bandwidth when carrier centre frequency (F_c) is within the range $907.5 \text{ MHz} \leq F_c \leq 912.5 \text{ MHz}$ without any restriction on uplink transmission bandwidth; C: for carriers of 10 MHz channel bandwidth when carrier centre frequency (F_c) is $F_c = 910 \text{ MHz}$ with an uplink transmission bandwidth less than or equal to 32 RB with $RB_{\text{start}} > 3$.

NOTE 13: Void.

NOTE 14: This requirement is applicable for 5 and 10 MHz E-UTRA channel bandwidth allocated within 718-728MHz. For carriers of 10 MHz bandwidth, this requirement applies for an uplink transmission bandwidth less than or equal to 30 RB with $RB_{\text{start}} > 1$ and $RB_{\text{start}} < 48$.

NOTE 15: Void.

NOTE 16: This requirement is applicable for any channel bandwidths within the range 1920 - 1980 MHz with the following restriction: for carriers of 15 MHz bandwidth when carrier centre frequency is within the range 1927.5 - 1929.5 MHz and for carriers of 20 MHz bandwidth when carrier centre frequency is within the range 1930 - 1938 MHz the requirement is applicable only for an uplink transmission bandwidth less than or equal to 54 RB.

NOTE 17: This requirement is applicable in the case of a 10 MHz E-UTRA carrier confined within 703 MHz and 733 MHz, otherwise the requirement of -25 dBm with a measurement bandwidth of 8 MHz applies.

NOTE 18: This requirement is only applicable for E-UTRA carriers with bandwidth confined within 1885 - 1920 MHz (requirement for carriers with at least 1RB confined within 1880 - 1885 MHz is not specified). This requirement applies for an uplink transmission bandwidth less than or equal to 54 RB for E-UTRA carriers of 15 MHz bandwidth when carrier centre frequency is within the range 1892.5 - 1894.5 MHz and for E-UTRA carriers of 20 MHz bandwidth when carrier centre frequency is within the range 1895 - 1903 MHz.

NOTE 19: Void.

NOTE 20: Void.

NOTE 21: Void.

NOTE 22: This requirement is applicable for power class 3 UE for any channel bandwidths within the range 2570 - 2615 MHz with the following restriction: for carriers of 15 MHz bandwidth when carrier centre frequency is within the range 2605.5 - 2607.5 MHz and for carriers of 20 MHz bandwidth when carrier centre frequency is within the range 2597 - 2605 MHz the requirement is applicable only for an uplink transmission bandwidth less than or equal to 54 RB.

NOTE: To simplify the above Table, E-UTRA band numbers are listed for bands which are specified only for E-UTRA operation or both E-UTRA and NR operation. NR band numbers are listed for bands which are specified only for NR operation.

The normative reference for this requirement is TS 38.101-3 [1] clause 6.5B.3.3.2, Table 6.5B.3.3.2-1.

Exception requirements for both NR and E-UTRA are defined for this test and therefore LTE anchor agnostic approach is not applied. E-UTRA test point analysis is included and E-UTRA measurements are performed.

6.5B.3.3.2.4 Test description

6.5B.3.3.2.4.1 Initial conditions

Same initial conditions as described in clause 6.5B.3.1.2.4.1 with the following exceptions:

- Instead of Table 6.5B.3.1.2.4.1-1 --> use Table 6.5B.3.3.2.4.1-1.

Table 6.5B.3.3.2.4.1-1: Test Configuration Table

Initial Conditions											
Test Environment as specified in TS 38.508-1 [6] clause 4.1						Normal					
Test Frequencies as specified in TS 38.508-1 [6] clause 4.3.1						For test frequencies refer to "Range" columns.					
Test EN-DC channel bandwidth as specified in TS 36.508 [6] clause 4.3.1 and TS 38.508-1 clause 4.3.1						Refer to "NR N _{RB} " and "E-UTRA N _{RB} " columns					
Test SCS for the NR cell as specified in TS 38.521-1 [8] Table 5.3.5-1						Lowest SCS per Channel Bandwidth					
Test Parameters for DC Configurations											
ID	DC Configuration / N _{RB,agg}					DL Allocation			UL Allocation (Note 1,2)		
	DC Configuration				E-UTRA Ch BW/N _{RB}	NR Ch BW/N _{RB}	CC MOD E-UTRA/NR	E-UTRA & NR RB allocation	CC MOD E-UTRA/NR	E-UTRA & NR allocations (L _{CRB} @ RB _{start})	
	E-UTRA		NR								
	Band	Range	Band	Range							
Default Test Settings for a DC_XA_nYA Configuration											
1	X	Low	Y	Low	Highest Ch BW / Highest N _{RB}	Highest Ch BW / Highest N _{RB}	QPSK/CP -OFDM QPSK	NA	QPSK / CP-OFDM QPSK	1@0	1@0
2	X	High	Y	High	Highest Ch BW / Highest N _{RB}	Highest Ch BW / Highest N _{RB}	QPSK/CP -OFDM QPSK	NA	QPSK / CP-OFDM QPSK	1@RB _{max}	1@RB _{max}
Test Setting for DC_1A_n3A Configuration											
1	1	Low	3	Low	10/50	30/160	QPSK/CP -OFDM QPSK	NA	QPSK / CP-OFDM QPSK	1@0	1@0
2	1	High	3	Mid	10/50	30/160	QPSK/CP -OFDM QPSK	NA	QPSK / CP-OFDM QPSK	1@49	1@0
Test Setting for DC_1A_n78A Configuration											
1	1	Low	78	Low	20/100	100/273	QPSK/CP -OFDM QPSK	NA	QPSK / CP-OFDM QPSK	1@0	1@272
2	1	Low	78	High	20/100	100/273	QPSK/CP -OFDM QPSK	NA	QPSK / CP-OFDM QPSK	1@0	1@272
3	1	Low	78	Note 8	20/100	100/273	QPSK/CP -OFDM QPSK	NA	QPSK / CP-OFDM QPSK	1@0	1@0
Test Setting for DC_2A_n41A Configuration											
1	2	Low	41	Low	20/100	100/273	QPSK/CP -OFDM QPSK	NA	QPSK / CP-OFDM QPSK	1@0	1@272
2	2	Low	41	High	20/100	100/273	QPSK/CP -OFDM QPSK	NA	QPSK / CP-OFDM QPSK	1@0	1@30
3	2	Low	41	High	20/100	100/273	QPSK/CP -OFDM QPSK	NA	QPSK / CP-OFDM QPSK	1@0	1@62
4	2	Low	41	Low	20/100	100/273	QPSK/CP -OFDM QPSK	NA	QPSK / CP-OFDM QPSK	1@0	1@209
5	2	High	41	High	20/100	100/273	QPSK/CP -OFDM QPSK	NA	QPSK / CP-OFDM QPSK	1@99	1@272
6	2	Low	41	Low	20/100	100/273	QPSK/CP -OFDM QPSK	NA	QPSK / CP-OFDM QPSK	1@0	1@0
Test Setting for DC_2A_n66A Configuration											

1	2	Low	66	Low	20/100	40/216	QPSK/CP -OFDM QPSK	NA	QPSK / CP-OFDM QPSK	1@0	1@0
2	2	High	66	High	20/100	40/216	QPSK/CP -OFDM QPSK	NA	QPSK / CP-OFDM QPSK	1@99	1@215
3	2	High	66	Low	20/100	40/216	QPSK/CP -OFDM QPSK	NA	QPSK / CP-OFDM QPSK	1@99	1@0
4	2	High	66	Low	20/100	40/216	QPSK/CP -OFDM QPSK	NA	QPSK / CP-OFDM QPSK	1@0	1@0
5	2	High	66	High	20/100	40/216	QPSK/CP -OFDM QPSK	NA	QPSK / CP-OFDM QPSK	1@0	1@215
Test Setting for DC_2A_n78A Configuration											
1	2	Low	78	Low	20/100	100/273	QPSK/CP -OFDM QPSK	NA	QPSK / CP-OFDM QPSK	1@0	1@272
2	2	Low	78	Low	20/100	100/273	QPSK/CP -OFDM QPSK	NA	QPSK / CP-OFDM QPSK	1@99	1@0
3	2	High	78	Low	20/100	100/273	QPSK/CP -OFDM QPSK	NA	QPSK / CP-OFDM QPSK	1@99	1@272
4	2	Low	78	High	20/100	100/273	QPSK/CP -OFDM QPSK	NA	QPSK / CP-OFDM QPSK	1@0	1@272
Test Settings for DC_3A_n1A Configuration											
1	3	Low	1	Low	20/100	20/106	QPSK/CP -OFDM QPSK	NA	QPSK / CP-OFDM QPSK	1@0	1@0
2	3	Low	1	High	20/100	20/106	QPSK/CP -OFDM QPSK	NA	QPSK / CP-OFDM QPSK	1@99	1@105
Test Setting for DC_3A_n7A Configuration											
1	3	Low	7	High	20/100	10/52	QPSK/CP -OFDM QPSK	NA	QPSK / CP-OFDM QPSK	1@47	1@51
2	3	Mid	7	High	20/100	10/52	QPSK/CP -OFDM QPSK	NA	QPSK / CP-OFDM QPSK	1@99	1@51
3	3	Low	7	Low	20/100	10/52	QPSK/CP -OFDM QPSK	NA	QPSK / CP-OFDM QPSK	1@0	1@51
4	3	Mid	7	Low	20/100	10/52	QPSK/CP -OFDM QPSK	NA	QPSK / CP-OFDM QPSK	1@99	1@0
5	3	Low	7	High	20/100	10/52	QPSK/CP -OFDM QPSK	NA	QPSK / CP-OFDM QPSK	1@0	1@51
Test Settings for DC_3A_n41A Configuration											
1	3	Low	41	Low	20/100	100/273	QPSK/CP -OFDM QPSK	NA	QPSK / CP-OFDM QPSK	1@0	1@0
2	3	High	41	High	20/100	100/273	QPSK/CP -OFDM QPSK	NA	QPSK / CP-OFDM QPSK	1@99	1@272
3	3	Mid	41	High	20/100	100/273	QPSK/CP -OFDM QPSK	NA	QPSK / CP-OFDM QPSK	1@0	1@272
4	3	Note 4	41	High	10/50	100/273	QPSK/CP -OFDM QPSK	NA	QPSK / CP-OFDM QPSK	1@49	1@272
Test Setting for DC_3A_n78A Configuration											

1	3	High	78	High	20/100	100/273	QPSK/CP -OFDM QPSK	NA	QPSK / CP-OFDM QPSK	1@99	1@272
2	3	High	78	Mid	20/100	100/273	QPSK/CP -OFDM QPSK	NA	QPSK / CP-OFDM QPSK	1@99	1@272
3	3	Low	78	Mid	20/100	100/273	QPSK/CP -OFDM QPSK	NA	QPSK / CP-OFDM QPSK	1@0	1@272
Test Settings for DC_3A_n79A Configuration											
1	3	Low	79	Low	20/100	100/273	QPSK/CP -OFDM QPSK	NA	QPSK / CP-OFDM QPSK	1@0	1@0
2	3	High	79	Note 3	20/100	100/273	QPSK/CP -OFDM QPSK	NA	QPSK / CP-OFDM QPSK	1@75	1@0
3	3	High	79	Low	20/100	100/273	QPSK/CP -OFDM QPSK	NA	QPSK / CP-OFDM QPSK	1@RB _{max}	1@136
4	3	High	79	Low	20/100	100/273	QPSK/CP -OFDM QPSK	NA	QPSK / CP-OFDM QPSK	1@75	1@RB _{max}
5	3	Low	79	Low	20/100	100/273	QPSK/CP -OFDM QPSK	NA	QPSK / CP-OFDM QPSK	1@RB _{max}	1@136
6	3	Low	79	Note 3	20/100	100/273	QPSK/CP -OFDM QPSK	NA	QPSK / CP-OFDM QPSK	1@RB _{max}	1@RB _{max}
Test Settings for DC_5A_n66A Configuration											
1	5	Low	66	Low	10/50	40/216	QPSK/CP -OFDM QPSK	NA	QPSK / CP-OFDM QPSK	1@0	1@0
2	5	High	66	High	10/50	40/216	QPSK/CP -OFDM QPSK	NA	QPSK / CP-OFDM QPSK	1@49	1@215
3	5	Low	66	Low	10/50	40/216	QPSK/CP -OFDM QPSK	NA	QPSK / CP-OFDM QPSK	1@49	1@0
4	5	High	66	Low	10/50	40/216	QPSK/CP -OFDM QPSK	NA	QPSK / CP-OFDM QPSK	1@49	1@0
Test Setting for DC_5A_n78A Configuration											
1	5	Low	78	High	10/50	100/273	QPSK/CP -OFDM QPSK	NA	QPSK / CP-OFDM QPSK	1@0	1@272
2	5	Low	78	Note 7	10/50	100/273	QPSK/CP -OFDM QPSK	NA	QPSK / CP-OFDM QPSK	1@0	1@0
3	5	High	78	Low	10/50	100/273	QPSK/CP -OFDM QPSK	NA	QPSK / CP-OFDM QPSK	1@49	1@272
4	5	High	78	High	10/50	100/273	QPSK/CP -OFDM QPSK	NA	QPSK / CP-OFDM QPSK	1@27	1@0
5	5	Low	78	Mid	10/50	100/273	QPSK/CP -OFDM QPSK	NA	QPSK / CP-OFDM QPSK	1@0	1@272
6	5	Low	78	Mid	10/50	100/273	QPSK/CP -OFDM QPSK	NA	QPSK / CP-OFDM QPSK	1@0	1@0
7	5	High	78	Mid	10/50	100/273	QPSK/CP -OFDM QPSK	NA	QPSK / CP-OFDM QPSK	1@49	1@272
Test Setting for DC_7A_n1A Configuration											

1	7	Low	1	Low	20/100	20/106	QPSK/CP -OFDM QPSK	NA	QPSK / CP-OFDM QPSK	1@0	1@0
2	7	Low	1	High	20/100	20/106	QPSK/CP -OFDM QPSK	NA	QPSK / CP-OFDM QPSK	1@0	1@105
3	7	Mid	1	High	20/100	20/106	QPSK/CP -OFDM QPSK	NA	QPSK / CP-OFDM QPSK	1@22	1@105
Test Setting for DC_7A_n3A Configuration											
1	7	High	3	Low	20/100	30/160	QPSK/CP -OFDM QPSK	NA	QPSK / CP-OFDM QPSK	1@99	1@77
2	7	Low	3	Low	20/100	30/160	QPSK/CP -OFDM QPSK	NA	QPSK / CP-OFDM QPSK	1@0	1@59
3	7	High	3	High	20/100	30/160	QPSK/CP -OFDM QPSK	NA	QPSK / CP-OFDM QPSK	1@99	1@86
4	7	High	3	Low	10/50	5/25	QPSK/CP -OFDM QPSK	NA	QPSK / CP-OFDM QPSK	1@49	1@0
5	7	High	3	Low	20/100	30/160	QPSK/CP -OFDM QPSK	NA	QPSK / CP-OFDM QPSK	1@99	1@0
6	7	Low	3	Mid	20/100	30/160	QPSK/CP -OFDM QPSK	NA	QPSK / CP-OFDM QPSK	1@0	1@66
Test Setting for DC_7A_n66A Configuration											
1	7	Low	66	High	20/100	40/216	QPSK/CP -OFDM QPSK	NA	QPSK / CP-OFDM QPSK	1@99	1@215
2	7	Low	66	High	20/100	40/216	QPSK/CP -OFDM QPSK	NA	QPSK / CP-OFDM QPSK	1@0	1@0
3	7	Mid	66	High	20/100	40/216	QPSK/CP -OFDM QPSK	NA	QPSK / CP-OFDM QPSK	1@50	1@215
4	7	Low	66	High	20/100	40/216	QPSK/CP -OFDM QPSK	NA	QPSK / CP-OFDM QPSK	1@0	1@215
5	7	Mid	66	Low	20/100	40/216	QPSK/CP -OFDM QPSK	NA	QPSK / CP-OFDM QPSK	1@99	1@0
6	7	High	66	Low	20/100	40/216	QPSK/CP -OFDM QPSK	NA	QPSK / CP-OFDM QPSK	1@99	1@0
Test Setting for DC_7A_n78A Configuration											
1	7	Low	78	Low	20/100	100/273	QPSK/CP -OFDM QPSK	NA	QPSK / CP-OFDM QPSK	1@0	1@0
2	7	Mid	78	Low	20/100	100/273	QPSK/CP -OFDM QPSK	NA	QPSK / CP-OFDM QPSK	1@99	1@0
3	7	Mid	78	Low	20/100	100/273	QPSK/CP -OFDM QPSK	NA	QPSK / CP-OFDM QPSK	1@27	1@272
4	7	Low	78	Low	20/100	100/273	QPSK/CP -OFDM QPSK	NA	QPSK / CP-OFDM QPSK	1@99	1@272
5	7	High	78	High	20/100	100/273	QPSK/CP -OFDM QPSK	NA	QPSK / CP-OFDM QPSK	1@77	1@0
6	7	Mid	78	Mid	20/100	100/273	QPSK/CP -OFDM QPSK	NA	QPSK / CP-OFDM QPSK	1@99	1@272

7	7	High	78	Mid	20/100	100/273	QPSK/CP -OFDM QPSK	NA	QPSK / CP-OFDM QPSK	1@0	1@272
8	7	High	78	Low	20/100	100/273	QPSK/CP -OFDM QPSK	NA	QPSK / CP-OFDM QPSK	1@99	1@0
9	7	High	78	Mid	20/100	100/273	QPSK/CP -OFDM QPSK	NA	QPSK / CP-OFDM QPSK	1@99	1@0
Test Settings for DC_8A_n1A Configuration											
1	8	Low	1	Low	10/50	20/106	QPSK/CP -OFDM QPSK	NA	QPSK / CP-OFDM QPSK	1@0	1@0
Test Settings for DC_8A_n3A Configuration											
1	8	High	3	Low	10/50	30/160	QPSK/CP -OFDM QPSK	NA	QPSK / CP-OFDM QPSK	1@49	1@0
2	8	Low	3	Low	10/50	30/160	QPSK/CP -OFDM QPSK	NA	QPSK / CP-OFDM QPSK	1@0	1@159
3	8	High	3	High	10/50	30/160	QPSK/CP -OFDM QPSK	NA	QPSK / CP-OFDM QPSK	1@49	1@159
Test Settings for DC_8A_n41A Configuration											
1	8	Low	41	Low	10/50	100/273	QPSK/CP -OFDM QPSK	NA	QPSK / CP-OFDM QPSK	1@0	1@0
2	8	High	41	High	10/50	100/273	QPSK/CP -OFDM QPSK	NA	QPSK / CP-OFDM QPSK	1@49	1@272
3	8	Mid	41	Mid	10/50	100/273	QPSK/CP -OFDM QPSK	NA	QPSK / CP-OFDM QPSK	1@49	1@136
4	8	Low	41	High	10/50	100/273	QPSK/CP -OFDM QPSK	NA	QPSK / CP-OFDM QPSK	1@0	1@272
Test Settings for DC_8A_n77A Configuration											
1	8	Low	77	Note 9	10/50	100/273	QPSK/CP -OFDM QPSK	NA	QPSK / CP-OFDM QPSK	1@0	1@0
2	8	High	77	Low	10/50	100/273	QPSK/CP -OFDM QPSK	NA	QPSK / CP-OFDM QPSK	1@49	1@37
3	8	High	77	Mid	10/50	100/273	QPSK/CP -OFDM QPSK	NA	QPSK / CP-OFDM QPSK	1@49	1@97
4	8	Low	77	Mid	10/50	100/273	QPSK/CP -OFDM QPSK	NA	QPSK / CP-OFDM QPSK	1@0	1@211
5	8	Low	77	Note 9	10/50	100/273	QPSK/CP -OFDM QPSK	NA	QPSK / CP-OFDM QPSK	1@0	1@0
6	8	High	77	High	10/50	100/273	QPSK/CP -OFDM QPSK	NA	QPSK / CP-OFDM QPSK	1@49	1@272
7	8	High	77	Mid	10/50	100/273	QPSK/CP -OFDM QPSK	NA	QPSK / CP-OFDM QPSK	1@49	1@0
8	8	Low	77	Note 9	10/50	100/273	QPSK/CP -OFDM QPSK	NA	QPSK / CP-OFDM QPSK	1@0	1@0
9	8	High	77	Low	10/50	100/273	QPSK/CP -OFDM QPSK	NA	QPSK / CP-OFDM QPSK	1@49	1@85
Test Settings for DC_8A_n78A Configuration											

1	8	High	78	Mid	10/50	100/273	QPSK/CP -OFDM QPSK	NA	QPSK / CP-OFDM QPSK	1@49	1@272
2	8	High	78	Low	10/50	100/273	QPSK/CP -OFDM QPSK	NA	QPSK / CP-OFDM QPSK	1@0	1@0
3	8	Low	78	High	10/50	100/273	QPSK/CP -OFDM QPSK	NA	QPSK / CP-OFDM QPSK	1@49	1@272
4	8	High	78	High	10/50	100/273	QPSK/CP -OFDM QPSK	NA	QPSK / CP-OFDM QPSK	1@0	1@0
5	8	High	78	High	10/50	100/273	QPSK/CP -OFDM QPSK	NA	QPSK / CP-OFDM QPSK	1@49	1@0
6	8	Mid	78	Low	10/50	100/273	QPSK/CP -OFDM QPSK	NA	QPSK / CP-OFDM QPSK	1@25	1@0
Test Settings for DC_11A_n77A Configuration											
1	11	Low	77	Note 10	10/50	100/273	QPSK/CP -OFDM QPSK	NA	QPSK / CP-OFDM QPSK	1@0	1@0
2	11	Low	77	Low	10/50	100/273	QPSK/CP -OFDM QPSK	NA	QPSK / CP-OFDM QPSK	1@0	1@0
3	11	Low	77	Mid	10/50	100/273	QPSK/CP -OFDM QPSK	NA	QPSK / CP-OFDM QPSK	1@0	1@63
4	11	Low	77	Mid	10/50	100/273	QPSK/CP -OFDM QPSK	NA	QPSK / CP-OFDM QPSK	1@0	1@104
5	11	Low	77	Note 10	10/50	100/273	QPSK/CP -OFDM QPSK	NA	QPSK / CP-OFDM QPSK	1@0	1@0
6	11	Low	77	Note 10	10/50	100/273	QPSK/CP -OFDM QPSK	NA	QPSK / CP-OFDM QPSK	1@0	1@0
7	11	Low	77	Note 10	10/50	100/273	QPSK/CP -OFDM QPSK	NA	QPSK / CP-OFDM QPSK	1@0	1@0
8	11	Low	77	Low	10/50	100/273	QPSK/CP -OFDM QPSK	NA	QPSK / CP-OFDM QPSK	1@0	1@75
9	11	Low	77	Note 10	10/50	100/273	QPSK/CP -OFDM QPSK	NA	QPSK / CP-OFDM QPSK	1@0	1@0
10	11	Low	77	Note 10	10/50	100/273	QPSK/CP -OFDM QPSK	NA	QPSK / CP-OFDM QPSK	1@0	1@0
Test Settings for DC_11A_n78A Configuration											
1	11	Low	78	Mid	10/50	100/273	QPSK/CP -OFDM QPSK	NA	QPSK / CP-OFDM QPSK	1@0	1@184
2	11	Low	78	Low	10/50	100/273	QPSK/CP -OFDM QPSK	NA	QPSK / CP-OFDM QPSK	1@0	1@0
3	11	Low	78	High	10/50	100/273	QPSK/CP -OFDM QPSK	NA	QPSK / CP-OFDM QPSK	1@0	1@63
4	11	Low	78	High	10/50	100/273	QPSK/CP -OFDM QPSK	NA	QPSK / CP-OFDM QPSK	1@0	1@104
5	11	Low	78	Note 11	10/50	100/273	QPSK/CP -OFDM QPSK	NA	QPSK / CP-OFDM QPSK	1@0	1@0

6	11	Low	78	Note 11	10/50	100/273	QPSK/CP -OFDM QPSK	NA	QPSK / CP-OFDM QPSK	1@0	1@0
7	11	Low	78	Low	10/50	100/273	QPSK/CP -OFDM QPSK	NA	QPSK / CP-OFDM QPSK	1@0	1@75
Test Settings for DC_11A_n79A Configuration											
1	11	Low	79	High	10/50	100/273	QPSK/CP -OFDM QPSK	NA	QPSK / CP-OFDM QPSK	1@0	1@272
2	11	Low	79	Mid	10/50	100/273	QPSK/CP -OFDM QPSK	NA	QPSK / CP-OFDM QPSK	1@0	1@132
3	11	High	79	High	10/50	100/273	QPSK/CP -OFDM QPSK	NA	QPSK / CP-OFDM QPSK	1@49	1@30
4	11	Low	79	Mid	10/50	100/273	QPSK/CP -OFDM QPSK	NA	QPSK / CP-OFDM QPSK	1@0	1@272
Test Setting for DC_12A_n66A Configuration											
1	12	Low	66	Low	10/50	40/216	QPSK/CP -OFDM QPSK	NA	QPSK / CP-OFDM QPSK	1@0	1@0
2	12	High	66	High	10/50	40/216	QPSK/CP -OFDM QPSK	NA	QPSK / CP-OFDM QPSK	1@49	1@215
3	12	Low	66	High	10/50	40/216	QPSK/CP -OFDM QPSK	NA	QPSK / CP-OFDM QPSK	1@49	1@215
Test Setting for DC_12A_n78A Configuration											
1	12	Low	78	Low	10/50	100/273	QPSK/CP -OFDM QPSK	NA	QPSK / CP-OFDM QPSK	1@0	1@0
2	12	High	78	Low	10/50	100/273	QPSK/CP -OFDM QPSK	NA	QPSK / CP-OFDM QPSK	1@49	1@272
3	12	Low	78	Mid	10/50	100/273	QPSK/CP -OFDM QPSK	NA	QPSK / CP-OFDM QPSK	1@0	1@136
Test Setting for DC_13A_n2A Configuration											
1	13	Low	2	Low	10/50	20/106	QPSK/CP -OFDM QPSK	NA	QPSK / CP-OFDM QPSK	1@0	1@0
Test Setting for DC_20A_n1A Configuration											
1	20	Low	1	Low	20/100	20/106	QPSK/CP -OFDM QPSK	NA	QPSK / CP-OFDM QPSK	1@0	1@0
2	20	High	1	High	20/100	20/106	QPSK/CP -OFDM QPSK	NA	QPSK / CP-OFDM QPSK	1@99	1@105
Test Setting for DC_20A_n3A Configuration											
1	20	Low	3	Low	20/100	30/160	QPSK/CP -OFDM QPSK	NA	QPSK / CP-OFDM QPSK	1@0	1@0
2	20	High	3	High	20/100	30/160	QPSK/CP -OFDM QPSK	NA	QPSK / CP-OFDM QPSK	1@99	1@159
3	20	Low	3	High	20/100	30/160	QPSK/CP -OFDM QPSK	NA	QPSK / CP-OFDM QPSK	1@0	1@159
Test Setting for DC_25A_n41A Configuration											
1	25	Low	41	Low	20/100	100/273	QPSK/CP -OFDM QPSK	NA	QPSK / CP-OFDM QPSK	1@0	1@272

2	25	Low	41	High	20/100	100/273	QPSK/CP -OFDM QPSK	NA	QPSK / CP-OFDM QPSK	1@0	1@30
3	25	Low	41	High	20/100	100/273	QPSK/CP -OFDM QPSK	NA	QPSK / CP-OFDM QPSK	1@0	1@62
4	25	Low	41	Low	20/100	100/273	QPSK/CP -OFDM QPSK	NA	QPSK / CP-OFDM QPSK	1@0	1@209
5	25	High	41	High	20/100	100/273	QPSK/CP -OFDM QPSK	NA	QPSK / CP-OFDM QPSK	1@99	1@272
6	25	Low	41	Low	20/100	100/273	QPSK/CP -OFDM QPSK	NA	QPSK / CP-OFDM QPSK	1@0	1@0
Test Setting for DC_26A_n41A Configuration											
1	26	High	41	High	15/75	100/273	QPSK/CP -OFDM QPSK	NA	QPSK / CP-OFDM QPSK	1@74	1@272
2	26	Low	41	Low	15/75	100/273	QPSK/CP -OFDM QPSK	NA	QPSK / CP-OFDM QPSK	1@0	1@12
3	26	Low	41	Low	15/75	100/273	QPSK/CP -OFDM QPSK	NA	QPSK / CP-OFDM QPSK	1@0	1@41
4	26	High	41	Low	15/75	100/273	QPSK/CP -OFDM QPSK	NA	QPSK / CP-OFDM QPSK	1@74	1@0
5	26	Low	41	Low	15/75	100/273	QPSK/CP -OFDM QPSK	NA	QPSK / CP-OFDM QPSK	1@0	1@232
Test Setting for DC_26A_n77A Configuration											
1	26	Low	77	Mid	15/75	100/273	QPSK/CP -OFDM QPSK	NA	QPSK / CP-OFDM QPSK	1@0	1@272
2	26	Low	77	3521,1 3	15/75	100/273	QPSK/CP -OFDM QPSK	NA	QPSK / CP-OFDM QPSK	1@0	1@0
3	26	High	77	Mid	15/75	100/273	QPSK/CP -OFDM QPSK	NA	QPSK / CP-OFDM QPSK	1@74	1@34
4	26	Low	77	3578,7 3	15/75	100/273	QPSK/CP -OFDM QPSK	NA	QPSK / CP-OFDM QPSK	1@0	1@0
5	26	Low	77	4028,6 4	15/75	100/273	QPSK/CP -OFDM QPSK	NA	QPSK / CP-OFDM QPSK	1@0	1@0
6	26	Low	77	Low	15/75	100/273	QPSK/CP -OFDM QPSK	NA	QPSK / CP-OFDM QPSK	1@0	1@201
7	26	Low	77	High	15/75	100/273	QPSK/CP -OFDM QPSK	NA	QPSK / CP-OFDM QPSK	1@0	1@272
8	26	Low	77	3483,7 8	15/75	100/273	QPSK/CP -OFDM QPSK	NA	QPSK / CP-OFDM QPSK	1@0	1@0
Test Setting for DC_26A_n78A Configuration											
1	26	Low	78	High	15/75	100/273	QPSK/CP -OFDM QPSK	NA	QPSK / CP-OFDM QPSK	1@0	1@272
2	26	Low	78	Mid	15/75	100/273	QPSK/CP -OFDM QPSK	NA	QPSK / CP-OFDM QPSK	1@0	1@0
3	26	High	78	High	15/75	100/273	QPSK/CP -OFDM QPSK	NA	QPSK / CP-OFDM QPSK	1@74	1@34

4	26	Low	78	Mid	15/75	100/273	QPSK/CP -OFDM QPSK	NA	QPSK / CP-OFDM QPSK	1@0	1@78
5	26	Low	78	Low	15/75	100/273	QPSK/CP -OFDM QPSK	NA	QPSK / CP-OFDM QPSK	1@0	1@201
6	26	Low	78	Note 13	15/75	100/273	QPSK/CP -OFDM QPSK	NA	QPSK / CP-OFDM QPSK	1@0	1@0
Test Setting for DC_26A_n79A Configuration											
N/A (Note 14)											
Test Setting for DC_28A_n3A Configuration											
1	28	Low	3	Low	20/100	30/160	QPSK/CP -OFDM QPSK	NA	QPSK / CP-OFDM QPSK	1@0	1@0
2	28	High	3	High	20/100	30/160	QPSK/CP -OFDM QPSK	NA	QPSK / CP-OFDM QPSK	1@99	1@159
3	28	High	3	Low	20/100	30/160	QPSK/CP -OFDM QPSK	NA	QPSK / CP-OFDM QPSK	1@99	1@0
Test Setting for DC_30A_n5A Configuration											
1	30	High	5	High	10/50	20/106	QPSK/CP -OFDM QPSK	NA	QPSK / CP-OFDM QPSK	1@49	1@105
Test Settings for DC_39A_n41A Configuration											
1	39	High	41	High	20/100	100/273	QPSK/CP -OFDM QPSK	NA	QPSK / CP-OFDM QPSK	1@99	1@272
Test Settings for DC_39A_n79A Configuration											
1	39	Low	79	Low	20/100	100/273	QPSK/CP -OFDM QPSK	NA	QPSK / CP-OFDM QPSK	1@0	1@0
2	39	High	79	High	20/100	100/273	QPSK/CP -OFDM QPSK	NA	QPSK / CP-OFDM QPSK	1@99	1@272
3	39	Mid	79	High	20/100	100/273	QPSK/CP -OFDM QPSK	NA	QPSK / CP-OFDM QPSK	1@0	1@136
4	39	Low	79	Note 5	20/100	100/273	QPSK/CP -OFDM QPSK	NA	QPSK / CP-OFDM QPSK	1@99	1@0
Test Settings for DC_40A_n1A Configuration											
1	40	Low	1	LOW	20/100	20/106	QPSK/CP -OFDM QPSK	NA	QPSK / CP-OFDM QPSK	1@0	1@0
2	40	High	1	LOW	20/100	20/106	QPSK/CP -OFDM QPSK	NA	QPSK / CP-OFDM QPSK	1@0	1@0
3	40	High	1	LOW	20/100	20/106	QPSK/CP -OFDM QPSK	NA	QPSK / CP-OFDM QPSK	1@99	1@81
4	40	Mid	1	LOW	20/100	20/106	QPSK/CP -OFDM QPSK	NA	QPSK / CP-OFDM QPSK	1@0	1@0
Test Settings for DC_40A_n41A Configuration											
1	40	Low	41	Low	20/100	100/273	QPSK/CP -OFDM QPSK	NA	QPSK / CP-OFDM QPSK	1@0	1@0
2	40	High	41	High	20/100	100/273	QPSK/CP -OFDM QPSK	NA	QPSK / CP-OFDM QPSK	1@99	1@272

3	40	Mid	41	High	20/100	100/273	QPSK/CP -OFDM QPSK	NA	QPSK / CP-OFDM QPSK	1@50	1@272
4	40	Low	41	High	20/100	100/273	QPSK/CP -OFDM QPSK	NA	QPSK / CP-OFDM QPSK	1@0	1@272
Test Settings for DC_40A_n78A Configuration											
1	40	Low	78	HIGH	20/100	100/273	QPSK/CP -OFDM QPSK	NA	QPSK / CP-OFDM QPSK	1@0	1@53
2	40	Low	78	HIGH	20/100	100/273	QPSK/CP -OFDM QPSK	NA	QPSK / CP-OFDM QPSK	1@99	1@0
3	40	Low	78	HIGH	20/100	50/270	QPSK/CP -OFDM QPSK	NA	QPSK / CP-OFDM QPSK	1@0	1@269
4	40	Low	78	HIGH	20/100	100/273	QPSK/CP -OFDM QPSK	NA	QPSK / CP-OFDM QPSK	1@0	1@110
5	40	High	78	LOW	20/100	100/273	QPSK/CP -OFDM QPSK	NA	QPSK / CP-OFDM QPSK	1@0	1@0
6	40	High	78	LOW	20/100	100/273	QPSK/CP -OFDM QPSK	NA	QPSK / CP-OFDM QPSK	1@0	1@86
7	40	High	78	LOW	20/100	100/273	QPSK/CP -OFDM QPSK	NA	QPSK / CP-OFDM QPSK	1@99	1@0
8	40	Low	78	LOW	20/100	100/273	QPSK/CP -OFDM QPSK	NA	QPSK / CP-OFDM QPSK	1@0	1@272
Test Settings for DC_41A_n77A Configuration											
1	41	Mid	77	Low	20/100	100/273	QPSK/CP -OFDM QPSK	NA	QPSK / CP-OFDM QPSK	1@0	1@0
2	41	Low	77	Low	20/100	100/273	QPSK/CP -OFDM QPSK	NA	QPSK / CP-OFDM QPSK	1@0	1@185
3	41	Low	77	High	20/100	100/273	QPSK/CP -OFDM QPSK	NA	QPSK / CP-OFDM QPSK	1@0	1@57
4	41	Low	77	Note 15	20/100	100/273	QPSK/CP -OFDM QPSK	NA	QPSK / CP-OFDM QPSK	1@0	1@0
5	41	Low	77	High	20/100	100/273	QPSK/CP -OFDM QPSK	NA	QPSK / CP-OFDM QPSK	1@99	1@0
6	41	High	77	High	20/100	100/273	QPSK/CP -OFDM QPSK	NA	QPSK / CP-OFDM QPSK	1@99	1@201
7	41	Mid	77	Mid	20/100	100/273	QPSK/CP -OFDM QPSK	NA	QPSK / CP-OFDM QPSK	1@99	1@46
8	41	Low	77	Low	20/100	100/273	QPSK/CP -OFDM QPSK	NA	QPSK / CP-OFDM QPSK	1@0	1@214
9	41	Low	77	High	20/100	100/273	QPSK/CP -OFDM QPSK	NA	QPSK / CP-OFDM QPSK	1@0	1@29
10	41	High	77	High	20/100	100/273	QPSK/CP -OFDM QPSK	NA	QPSK / CP-OFDM QPSK	1@99	1@272
11	41	Mid	77	Mid	20/100	100/273	QPSK/CP -OFDM QPSK	NA	QPSK / CP-OFDM QPSK	1@99	1@0

1 2	41	Low	77	Low	20/100	100/273	QPSK/CP -OFDM QPSK	NA	QPSK / CP-OFDM QPSK	1@99	1@0
1 3	41	Low	77	High	20/100	100/273	QPSK/CP -OFDM QPSK	NA	QPSK / CP-OFDM QPSK	1@0	1@272
1 4	41	Mid	77	Low	20/100	100/273	QPSK/CP -OFDM QPSK	NA	QPSK / CP-OFDM QPSK	1@99	1@0
1 5	41	High	77	Low	20/100	100/273	QPSK/CP -OFDM QPSK	NA	QPSK / CP-OFDM QPSK	1@99	1@161
1 6	41	High	77	High	20/100	100/273	QPSK/CP -OFDM QPSK	NA	QPSK / CP-OFDM QPSK	1@99	1@122
Test Settings for DC_41A_n78A Configuration											
1	41	High	78	Mid	20/100	100/273	QPSK/CP -OFDM QPSK	NA	QPSK / CP-OFDM QPSK	1@99	1@0
2	41	Low	78	Low	20/100	100/273	QPSK/CP -OFDM QPSK	NA	QPSK / CP-OFDM QPSK	1@0	1@185
3	41	High	78	Mid	20/100	100/273	QPSK/CP -OFDM QPSK	NA	QPSK / CP-OFDM QPSK	1@0	1@272
4	41	Low	78	Mid	20/100	100/273	QPSK/CP -OFDM QPSK	NA	QPSK / CP-OFDM QPSK	1@0	1@0
5	41	Low	78	Low	20/100	100/273	QPSK/CP -OFDM QPSK	NA	QPSK / CP-OFDM QPSK	1@0	1@214
6	41	Low	78	Mid	20/100	100/273	QPSK/CP -OFDM QPSK	NA	QPSK / CP-OFDM QPSK	1@99	1@69
7	41	Low	78	Low	20/100	100/273	QPSK/CP -OFDM QPSK	NA	QPSK / CP-OFDM QPSK	1@99	1@0
8	41	High	78	Low	20/100	100/273	QPSK/CP -OFDM QPSK	NA	QPSK / CP-OFDM QPSK	1@99	1@161
9	41	Mid	78	Low	20/100	100/273	QPSK/CP -OFDM QPSK	NA	QPSK / CP-OFDM QPSK	1@99	1@0
1 0	41	Low	78	Mid	20/100	100/273	QPSK/CP -OFDM QPSK	NA	QPSK / CP-OFDM QPSK	1@0	1@98
Test Settings for DC_41A_n79A Configuration											
1	41	Low	79	Low	20/100	100/273	QPSK/CP -OFDM QPSK	NA	QPSK / CP-OFDM QPSK	1@0	1@0
2	41	High	79	High	20/100	100/273	QPSK/CP -OFDM QPSK	NA	QPSK / CP-OFDM QPSK	1@99	1@272
3	41	High	79	Note 6	20/100	100/273	QPSK/CP -OFDM QPSK	NA	QPSK / CP-OFDM QPSK	1@0	1@0
4	41	Mid	79	Low	20/100	100/273	QPSK/CP -OFDM QPSK	NA	QPSK / CP-OFDM QPSK	1@0	1@136
5	41	High	79	Low	20/100	100/273	QPSK/CP -OFDM QPSK	NA	QPSK / CP-OFDM QPSK	1@75	1@272
6	41	High	79	Low	20/100	100/273	QPSK/CP -OFDM QPSK	NA	QPSK / CP-OFDM QPSK	1@99	1@136

7	41	High	79	Low	20/100	100/273	QPSK/CP -OFDM QPSK	NA	QPSK / CP-OFDM QPSK	1@99	1@272
8	41	Note 6	79	Low	20/100	100/273	QPSK/CP -OFDM QPSK	NA	QPSK / CP-OFDM QPSK	1@0	1@0
9	41	High	79	Note 6	20/100	100/273	QPSK/CP -OFDM QPSK	NA	QPSK / CP-OFDM QPSK	1@99	1@0
Test Settings for DC_48A_n5A Configuration											
1	48	High	5	High	20/100	20/106	QPSK/CP -OFDM QPSK	NA	QPSK / CP-OFDM QPSK	1@0	1@105
Test Settings for DC_48A_n66A Configuration											
1	48	High	66	Low	20/100	40/216	QPSK/CP -OFDM QPSK	NA	QPSK / CP-OFDM QPSK	1@0	1@0
Test Settings for DC_66A_n2A Configuration											
1	66	Low	2	Low	20/100	20/106	QPSK/CP -OFDM QPSK	NA	QPSK / CP-OFDM QPSK	1@0	1@0
2	66	High	2	High	20/100	20/106	QPSK/CP -OFDM QPSK	NA	QPSK / CP-OFDM QPSK	1@99	1@105
3	66	Low	2	High	20/100	20/106	QPSK/CP -OFDM QPSK	NA	QPSK / CP-OFDM QPSK	1@0	1@105
4	66	Low	2	Low	20/100	20/106	QPSK/CP -OFDM QPSK	NA	QPSK / CP-OFDM QPSK	1@0	1@105
5	66	Low	2	Low	20/100	20/106	QPSK/CP -OFDM QPSK	NA	QPSK / CP-OFDM QPSK	1@0	1@46
Test Settings for DC_66A_n41A Configuration											
1	66	Low	41	Low	20/100	100/273	QPSK/CP -OFDM QPSK	NA	QPSK / CP-OFDM QPSK	1@0	1@272
2	66	Low	41	Mid	20/100	100/273	QPSK/CP -OFDM QPSK	NA	QPSK / CP-OFDM QPSK	1@0	1@0
3	66	High	41	Low	20/100	100/273	QPSK/CP -OFDM QPSK	NA	QPSK / CP-OFDM QPSK	1@99	1@59
4	66	Low	41	High	20/100	100/273	QPSK/CP -OFDM QPSK	NA	QPSK / CP-OFDM QPSK	1@0	1@248
5	66	High	41	Low	20/100	100/273	QPSK/CP -OFDM QPSK	NA	QPSK / CP-OFDM QPSK	1@99	1@89
6	66	Low	41	High	20/100	100/273	QPSK/CP -OFDM QPSK	NA	QPSK / CP-OFDM QPSK	1@0	1@218
7	66	High	41	Mid	20/100	100/273	QPSK/CP -OFDM QPSK	NA	QPSK / CP-OFDM QPSK	1@99	1@0
8	66	Low	41	High	20/100	100/273	QPSK/CP -OFDM QPSK	NA	QPSK / CP-OFDM QPSK	1@0	1@186
9	66	Low	41	Low	20/100	100/273	QPSK/CP -OFDM QPSK	NA	QPSK / CP-OFDM QPSK	1@0	1@203
10	66	High	41	Low	20/100	100/273	QPSK/CP -OFDM QPSK	NA	QPSK / CP-OFDM QPSK	1@99	1@0
Test Settings for DC_66A_n78A Configuration											

1	66	High	78	High	20/100	100/273	QPSK/CP -OFDM QPSK	NA	QPSK / CP-OFDM QPSK	1@99	1@272
2	66	Low	78	Mid	20/100	100/273	QPSK/CP -OFDM QPSK	NA	QPSK / CP-OFDM QPSK	1@0	1@247
<p>Note 1: Use DC Configuration – specific test points if present in the table, otherwise use test points from matching Group Test Settings, if present in the table. Otherwise use the Default Test Settings test points.</p> <p>Note 2: X, Y correspond to the different bands in the DC Configuration. E.g. for DC_1A_n3A, X=1, Y=3.</p> <p>Note 3: Test Point ID 2 for DC_3A_n79A have the centre carrier frequency of 4480.5 MHz in Band 79 (NR ARFCN=698700). Test Point ID 6 for DC_3A_n79A have the centre carrier frequency of 4909.5 MHz in Band 79 (NR ARFCN=727300).</p> <p>Note 4: Test Point ID 4 for DC_3A_n41A have the centre carrier frequency of 1773 MHz in Band 3 (EARFCN=19830).</p> <p>Note 5: Test Point ID 4 for DC_39A_n79A have the centre carrier frequency of 4649.96 MHz in Band 79 (NR ARFCN=709998).</p> <p>Note 6: Test Point ID 3 for DC_41A_n79A have the centre carrier frequency of 4869.5 MHz in Band 79 (NR ARFCN=724634). Test Point ID 8 for DC_41A_n79A have the centre carrier frequency of 2600 MHz in Band 41 (EARFCN=40690). Test Point ID 9 for DC_41A_n79A have the centre carrier frequency of 4760 MHz in Band 79 (NR ARFCN=717334).</p> <p>Note 7: Test Point ID 2 for DC_5A_n78A have the centre carrier frequency of 3494 MHz in Band 78 (NR ARFCN=632932).</p> <p>Note 8: Test Point ID 3 for DC_1A_n78A have the centre carrier frequency of 3470 MHz in Band 78 (NR ARFCN=631332).</p> <p>Note 9: Test Point ID 1 for DC_8A_n77A have the centre carrier frequency of 3950,13 MHz in Band n77 (NR ARFCN=663342). Test Point ID 5 for have the centre carrier frequency of 3524,55 MHz in Band n77 (NR ARFCN=634970). Test Point ID 8 for have the centre carrier frequency of 3584,55 MHz in Band n77 (NR ARFCN=638970).</p> <p>Note 10: Test Point ID 1 for DC_11A_n77A have the centre carrier frequency of 3617,43 MHz in Band n77 (NR ARFCN=641162). Test Point ID 5 for have the centre carrier frequency of 3686,43 MHz in Band n77 (NR ARFCN=645762). Test Point ID 6 for have the centre carrier frequency of 3494,94 MHz in Band n77 (NR ARFCN=632996). Test Point ID 7 for have the centre carrier frequency of 3858,42 MHz in Band n77 (NR ARFCN=657228). Test Point ID 9 for have the centre carrier frequency of 4037,43 MHz in Band n77 (NR ARFCN=669162). Test Point ID 10 for have the centre carrier frequency of 4097,43 MHz in Band n77 (NR ARFCN=673162).</p> <p>Note 11: Test Point ID 5 for have the centre carrier frequency of 3686,43 MHz in Band n78 (NR ARFCN=645762). Test Point ID 6 for have the centre carrier frequency of 3494,94 MHz in Band n78 (NR ARFCN=632996).</p> <p>Note 12: Test Point ID 2 for have the centre carrier frequency of 3521,13 MHz in Band n77 (NR ARFCN=634742). Test Point ID 4 for have the centre carrier frequency of 3578,73 MHz in Band n77 (NR ARFCN=638582). Test Point ID 5 for have the centre carrier frequency of 4028,64 MHz in Band n77 (NR ARFCN=668576). Test Point ID 8 for have the centre carrier frequency of 3483,78 MHz in Band n77 (NR ARFCN=632252).</p> <p>Note 13: Test Point ID 6 for have the centre carrier frequency of 3483,78 MHz in Band n78 (NR ARFCN=632252).</p> <p>Note 14: Test case not applicable for the EN-DC configuration as no IM products occurs in the protected bands.</p> <p>Note 15: Test Point ID 4 for have the centre carrier frequency of 3488,55 MHz in Band n77 (NR ARFCN=632570).</p>											

Additional step 8 when both bands are TDD:

8. For both E-UTRA and NR UL uplink carriers active when both bands are TDD, ensure E-UTRA UL transmission overlaps with NR UL transmission in time by giving SCG a delay of 3 E-UTRA subframes, or by giving MCG a delay of 2 subframes.

6.5B.3.3.2.4.2 Test Procedure

Same test procedure as described in clause 6.5B.3.1.2.4.2 with the following exceptions:

Instead of Table 6.5B.3.1.2.3-1 --> use Table 6.5B.3.3.2.5-1 and 6.5B.3.3.2.5-2.

In addition to test configurations above, NSA only capable UEs needs to be tested according to LTE anchor agnostic approach below.

Same test description as in clause 6.5.3.2.4 in TS 38.521-1 [8] for the NR carrier with the following exceptions:

The initial test configurations for E-UTRA consist of test frequency based on E-UTRA operating band and test channel bandwidth as specified in Table 4.6-1.

For Initial conditions as in clause 6.5.3.2.4.1 in TS 38.521-1 [8], the following steps will be added to configure E-UTRA component:

- 2.1. The parameter settings for the cell are set up according to TS 36.508 [11] clause 4.4.3.
- 3.1. The E-UTRA downlink signal level, uplink signal level are set according to Table 4.6-1 and propagation conditions are set according to Annex B.0 of TS 36.521-1 [10].

Step 6 of Initial conditions as in clause 6.5.3.2.4.1 in TS 38.521-1 [8] is replaced by:

6. Ensure the UE is in state RRC_CONNECTED with generic procedure parameters Connectivity EN-DC, DC bearer MCG and SCG, Connected without release *On* according to TS 38.508 [6] clause 4.5.
7. On the E-UTRA carrier, disable periodic and aperiodic CQI reports, disable SRS, set *TimeAlignmentTimerDedicated* IE to infinity and disable downlink and uplink scheduling, all as per Table 4.6-1 under clause 4.6.

6.5B.3.3.2.4.3 Message Contents

Message contents are according to TS 36.508 [11] clause 4.6.1 and TS 38.508-1 [6] clause 4.6.1 with the following exceptions.

Table 6.5B.3.3.2.4.3-1: SystemInformationBlockType1: tdd-Config if E-UTRA on TDD band

Derivation Path: TS 36.508 [11], Table 4.6.3-23			
Information Element	Value/remark	Comment	Condition
TDD-Config-DEFAULT ::= SEQUENCE {		Operating on TDD band	
subframeAssignment	Sa2		
specialSubframePatterns	Ssp7		
}			

Table 6.5B3.3.2.4.3-1a: Void

Table 6.5B.3.3.2.4.3-2: RRCConnectionReconfiguration: nr-Config-r15

Derivation Path: TS 36.508 [11], Table 4.6.1-8			
Information Element	Value/remark	Comment	Condition
p-MaxEUTRA-r15	23		Power Class 2 UE AND simultaneous E-UTRA and NR transmission
	20		Power Class 3 UE AND simultaneous E-UTRA and NR transmission

Table 6.5B.3.3.2.4.3-3: PhysicalCellGroupConfig

Derivation Path: TS 38.508-1 [6] Table 4.6.3-106			
Information Element	Value/remark	Comment	Condition
p-NR-FR1	23		Power Class 2 UE AND simultaneous E-UTRA and NR transmission
	20		Power Class 3 UE AND simultaneous E-UTRA and NR transmission

6.5B.3.3.2.5 Test Requirement

The test requirements are in Table 6.5B.3.3.2.5-1 and Table 6.5B.3.3.2.5-2. For EN-DC only capable devices, in addition to Table 6.5B.3.3.2.5-1 and Table 6.5B.3.3.2.5-2, the test requirements as in clause 6.5.3.2.5 in TS 38.521-1 [8] are also needed.

Table 6.5B.3.3.2.5-1: Requirements for inter-band within FR1 for Rel-15

EN-DC Configuration	Spurious emission						
	Protected band	Frequency range (MHz)			Maximum Level (dBm)	MBW (MHz)	NOTE
DC_1_n78	E-UTRA Band 3, 11, 21	F _{DL_low}	-	F _{DL_high}	-50	1	
	Frequency range	1880	-	1895	-40	1	5, 8
DC_2_n5	E-UTRA Band 42, 48	F _{DL_low}	-	F _{DL_high}	-50	1	
	E-UTRA Band 41, 43	F _{DL_low}	-	F _{DL_high}	-50	1	2
DC_2_n66	E-UTRA Band 4, 10, 24, 50, 66, 70, 74	F _{DL_low}	-	F _{DL_high}	-50	1	
	E-UTRA Band 2, 25	F _{DL_low}	-	F _{DL_high}	-50	1	5
	E-UTRA Band 42, 48	F _{DL_low}	-	F _{DL_high}	-50	1	2
DC_2_n78	E-UTRA Band 24, 50, 51, 74	F _{DL_low}	-	F _{DL_high}	-50	1	
	E-UTRA Band 2, 25	F _{DL_low}	-	F _{DL_high}	-50	1	2
DC_3_n7	E-UTRA Band 5, 8, 20, 26, 27, 28, 44, 67	F _{DL_low}	-	F _{DL_high}	-50	1	
	E-UTRA Band 42	F _{DL_low}	-	F _{DL_high}	-50	1	2
DC_3_n41	E-UTRA Band 5, 8, 20, 26, 27, 28, 44	F _{DL_low}	-	F _{DL_high}	-50	1	
	E-UTRA Band 18, 19	F _{DL_low}	-	F _{DL_high}	-50	1	14, 20
	E-UTRA Band 42, NR Band n77, n78, n79	F _{DL_low}	-	F _{DL_high}	-50	1	2
DC_3_n78	E-UTRA Band 3, 34, 39	F _{DL_low}	-	F _{DL_high}	-50	1	
	Frequency range	1884.5	-	1915.7	-41	0.3	3
DC_3_n79	E-UTRA Band 5, 8, 11, 18, 19, 21, 41	F _{DL_low}	-	F _{DL_high}	-50	1	
DC_5_n66	E-UTRA Band 5, 6, 7, 8, 38	F _{DL_low}	-	F _{DL_high}	-50	1	
	E-UTRA Band 26	859	-	869	-27	1	
	E-UTRA Band 41, 42, 52	F _{DL_low}	-	F _{DL_high}	-50	1	2
	E-UTRA Band 18, 19	F _{DL_low}	-	F _{DL_high}	-40	1	
DC_5_n78	E-UTRA Band 1, 2, 3, 4, 7, 10, 25, 34, 38, 65, 66, 70	F _{DL_low}	-	F _{DL_high}	-50	1	
	Frequency range	1884.5	-	1915.7	-41	0.3	3, 4
	Frequency range	2545	-	2575	-50	1	
	Frequency range	2595	-	2645	-50	1	
	E-UTRA Band 41	F _{DL_low}	-	F _{DL_high}	-50	1	7
DC_7_n78	E-UTRA Band 3, 5, 8, 11, 18, 19, 20, 21, 26, 27, 28, 32, 50, 51, 67, 68, 74, 75, 76	F _{DL_low}	-	F _{DL_high}	-50	1	
DC_8_n41	E-UTRA Band 28,n77,78,79	F _{DL_low}	-	F _{DL_high}	-50	1	
	E-UTRA band 3, 42, 52	F _{DL_low}	-	F _{DL_high}	-50	1	2
DC_8_n77	E-UTRA Band 1, 32, 33, 34, 38, 39, 40,50, 65, 69, 74, 75	F _{DL_low}	-	F _{DL_high}	-50	1	
	E-UTRA band 3, 7, 41	F _{DL_low}	-	F _{DL_high}	-50	1	2
	E-UTRA Band 11, 21	F _{DL_low}	-	F _{DL_high}	-50	1	12
	Frequency range	1884.5	-	1915.7	-41	0.3	3, 12
DC_8_n78	E-UTRA band 34, 39, 40, 74	F _{DL_low}	-	F _{DL_high}	-50	1	
	E-UTRA Band 3, 7, 41	F _{DL_low}	-	F _{DL_high}	-50	1	2
	E-UTRA Band 11, 21	F _{DL_low}	-	F _{DL_high}	-50	1	12
	Frequency range	1884.5	-	1915.7	-41	0.3	3, 12
DC_11_n77	E-UTRA Band 1, 3, 18, 19, 28, 34, 65	F _{DL_low}	-	F _{DL_high}	-50	1	
	Frequency range	945	-	960	-50	1	
	Frequency range	1884.5	-	1915.7	-41	0.3	3
	Frequency range	2545	-	2575	-50	1	
	Frequency range	2595	-	2645	-50	1	
DC_11_n78	E-UTRA Band 1, 3, 18, 19, 28, 34, 65	F _{DL_low}	-	F _{DL_high}	-50	1	
	Frequency range	1884.5	-	1915.7	-41	0.3	3
DC_11_n79	E-UTRA Band 1, 3, 34, 42, 65	F _{DL_low}	-	F _{DL_high}	-50	1	
	Frequency range	1884.5	-	1915.7	-41	0.3	3
DC_12_n66	E-UTRA Band 41	F _{DL_low}	-	F _{DL_high}	-50	1	
DC_25_n41	E-UTRA Band 12, 13, 14, 17, 28, 29, 42, 71	F _{DL_low}	-	F _{DL_high}	-50	1	
	NR Band n77	F _{DL_low}	-	F _{DL_high}	-50	1	5
	E-UTRA Band 3, 5, 18, 19, 26, 42	F _{DL_low}	-	F _{DL_high}	-50	1	

DC_26_n41	Frequency range	799	-	803	-40	1	5
	Frequency range	945	-	960	-50	1	
DC_26_n77	E-UTRA Band 1, 3, 34, 39, 40, 41, 65	F _{DL_low}	-	F _{DL_high}	-50	1	
	Frequency range	1884.5	-	1915.7	-41	0.3	3
	Frequency range	2545	-	2575	-50	1	
	Frequency range	2595	-	2645	-50	1	
DC_26_n78	E-UTRA Band 1, 3, 34, 39, 41, 65	F _{DL_low}	-	F _{DL_high}	-50	1	
	Frequency range	1884.5	-	1915.7	-41	0.3	3
	Frequency range	2545	-	2575	-50	1	
	Frequency range	2595	-	2645	-50	1	
DC_30_n5	E-UTRA Band 71	F _{DL_low}	-	F _{DL_high}	-50	1	
DC_39_n41	E-UTRA Band 42, 44	F _{DL_low}	-	F _{DL_high}	-50	1	
	NR Band n77, n78, n79	F _{DL_low}	-	F _{DL_high}	-50	1	2
DC_39_n79	E-UTRA Band 8, 41, 44 or NR Band n8, n41	F _{DL_low}	-	F _{DL_high}	-50	1	
DC_40_n41	Bands 1, 34, 39, 65	F _{DL_low}	-	F _{DL_high}	-50	1	
	NR Band n79	F _{DL_low}	-	F _{DL_high}	-50	1	2
	Frequency range	1884.5	-	1915.7	-41	0.3	3, 19
DC_41_n77	E-UTRA Band 3, 5, 8, 11, 18, 19, 21, 26, 28, 33, 34, 39, 44, 45, 74	F _{DL_low}	-	F _{DL_high}	-50	1	
	Frequency range	1884.5	-	1915.7	-41	0.3	3
DC_41_n78	E-UTRA Band 3, 5, 8, 11, 18, 19, 21, 26, 28, 34, 39, 44, 45, 74	F _{DL_low}	-	F _{DL_high}	-50	1	
	Frequency range	1884.5	-	1915.7	-41	0.3	3
DC_41_n79	E-UTRA Band 1, 3, 5, 8, 9, 18, 19, 28, 34, 40, 44, 65 or NR Band n1, n3, n8, n28, n34, n40	F _{DL_low}	-	F _{DL_high}	-50	1	
	Frequency range	1884.5	-	1915.7	-41	0.3	3
DC_66_n2	E-UTRA Band 2, 22, 25, 42, 43 Band n7	F _{DL_low}	-	F _{DL_high}	-50	1	2, 5
	E-UTRA Band 4, 10, 66	F _{DL_low}	-	F _{DL_high}	-50	1	
	E-UTRA Band 50, 75	F _{DL_low}	-	F _{DL_high}	-50	1	
	E-UTRA Band 24	F _{DL_low}	-	F _{DL_high}	-50	1	
	E-UTRA Band 70	F _{DL_low}	-	F _{DL_high}	-50	1	
DC_66_n5	E-UTRA Band 43	F _{DL_low}	-	F _{DL_high}	-50	1	
	E-UTRA Band 42, 48, 52	F _{DL_low}	-	F _{DL_high}	-50	1	2

DC_66_n78	E-UTRA Band 3, 34, 39	F _{DL_low}	-	F _{DL_high}	-50	1	
NOTE 1:	F _{DL_low} and F _{DL_high} refer to each E-UTRA frequency band specified in Table 5.5-1 of TS 36.101 [5].						
NOTE 2:	As exceptions, measurements with a level up to the applicable requirements defined in Table 6.6.3.1-2 of TS 38.101-3 [1] are permitted for each assigned E-UTRA carrier used in the measurement due to 2 nd , 3 rd , 4 th or 5 th harmonic spurious emissions. Due to spreading of the harmonic emission the exception is also allowed for the first 1 MHz frequency range immediately outside the harmonic emission on both sides of the harmonic emission. This results in an overall exception interval centred at the harmonic emission of (2MHz + N x L _{CRB} x 180kHz), where N is 2, 3, 4, 5 for the 2 nd , 3 rd , 4 th or 5 th harmonic respectively. The exception is allowed if the measurement bandwidth (MBW) totally or partially overlaps the overall exception interval.						
NOTE 3:	Applicable when co-existence with PHS system operating in 1884.5 -1915.7MHz						
NOTE 4:	Void.						
NOTE 5:	These requirements also apply for the frequency ranges that are less than F _{OOB} (MHz) in Table 6.5.3.1-1 and Table 6.5A.3.1-1 of TS 38.101-1 [2] from the edge of the channel bandwidth.						
NOTE 6:	This requirement is applicable for any channel bandwidths within the range 2500 - 2570 MHz with the following restriction: for carriers of 15 MHz bandwidth when carrier centre frequency is within the range 2560.5 - 2562.5 MHz and for carriers of 20 MHz bandwidth when carrier centre frequency is within the range 2552 - 2560 MHz the requirement is applicable only for an uplink transmission bandwidth less than or equal to 54 RB.						
NOTE 7:	For these adjacent bands, the emission limit could imply risk of harmful interference to UE(s) operating in the protected operating band.						
NOTE 8:	This requirement is applicable for any channel bandwidths within the range 1920 - 1980 MHz with the following restriction: for carriers of 15 MHz bandwidth when carrier centre frequency is within the range 1927.5 - 1929.5 MHz and for carriers of 20 MHz bandwidth when carrier centre frequency is within the range 1930 - 1938 MHz the requirement is applicable only for an uplink.						
NOTE 9:	Applicable when the assigned E-UTRA carrier is confined within 718 MHz and 748 MHz and when the channel bandwidth used is 5 or 10 MHz.						
NOTE 10:	As exceptions, measurements with a level up to the applicable requirement of -36 dBm/MHz is permitted for each assigned E-UTRA carrier used in the measurement due to 2nd harmonic spurious emissions. An exception is allowed if there is at least one individual RB within the transmission bandwidth (see Figure 5.6-1) for which the 2nd harmonic totally or partially overlaps the measurement bandwidth (MBW).						
NOTE 11:	As exceptions, measurements with a level up to the applicable requirement of -38 dBm/MHz is permitted for each assigned E-UTRA carrier used in the measurement due to 3rd harmonic spurious emissions. An exception is allowed if there is at least one individual RB within the transmission bandwidth (see Figure 5.6-1) for which the 3rd harmonic totally or partially overlaps the measurement bandwidth (MBW).						
NOTE 12:	This requirement is applicable only for the following cases: - for carriers of 5 MHz channel bandwidth when carrier centre frequency (F _c) is within the range 902.5 MHz ≤ F _c < 907.5 MHz with an uplink transmission bandwidth less than or equal to 20 RB - for carriers of 5 MHz channel bandwidth when carrier centre frequency (F _c) is within the range 907.5 MHz ≤ F _c ≤ 912.5 MHz without any restriction on uplink transmission bandwidth. - for carriers of 10 MHz channel bandwidth when carrier centre frequency (F _c) is F _c = 910 MHz with an uplink transmission bandwidth less than or equal to 32 RB with RB _{start} > 3.						
NOTE13:	Void.						
NOTE 14:	This requirement is applicable for 5 and 10 MHz E-UTRA channel bandwidth allocated within 718-728MHz. For carriers of 10 MHz bandwidth, this requirement applies for an uplink transmission bandwidth less than or equal to 30 RB with RB _{start} > 1 and RB _{start} <48.						
NOTE 15:	Void.						
NOTE 16:	This requirement is applicable for any channel bandwidths within the range 1920 - 1980 MHz with the following restriction: for carriers of 15 MHz bandwidth when carrier centre frequency is within the range 1927.5 - 1929.5 MHz and for carriers of 20 MHz bandwidth when carrier centre frequency is within the range 1930 - 1938 MHz the requirement is applicable only for an uplink transmission bandwidth less than or equal to 54 RB.						
NOTE 17:	This requirement is applicable in the case of a 10 MHz E-UTRA carrier confined within 703 MHz and 733 MHz, otherwise the requirement of -25 dBm with a measurement bandwidth of 8 MHz applies.						
NOTE 18:	This requirement is only applicable for E-UTRA carriers with bandwidth confined within 1885-1920 MHz (requirement for carriers with at least 1RB confined within 1880 - 1885 MHz is not specified). This requirement applies for an uplink transmission bandwidth less than or equal to 54 RB for E-UTRA carriers of 15 MHz bandwidth when carrier centre frequency is within the range 1892.5 - 1894.5 MHz and for E-UTRA carriers of 20 MHz bandwidth when carrier centre frequency is within the range 1895 - 1903 MHz.						
NOTE 19:	Void.						

Table 6.5B.3.3.2.5-2: Requirements for inter-band within FR1 for Rel-16

EN-DC Configuration	Spurious emission						
	Protected band	Frequency range (MHz)			Maximum Level (dBm)	MBW (MHz)	NOTE
DC_1_n3	E-UTRA Band 1, 11, 21, 32, 43, 50, 65, 74, 75	F _{DL_low}	-	F _{DL_high}	-50	1	
	NR Band 77, 78	F _{DL_low}	-	F _{DL_high}	-50	1	2
DC_2_n5	E-UTRA Band 42, 48 NR band n77	F _{DL_low}	-	F _{DL_high}	-50	1	
	E-UTRA Band 41, 43	F _{DL_low}	-	F _{DL_high}	-50	1	2
DC_2_n41	E-UTRA Band 12, 13, 14, 17, 28, 29, 42, 71	F _{DL_low}	-	F _{DL_high}	-50	1	
	E-UTRA Bands 2	F _{DL_low}	-	F _{DL_high}	-50	1	5
DC_3_n1	E-UTRA Band 1, 11, 21, 32, 50, 65, 74, 75	F _{DL_low}	-	F _{DL_high}	-50	1	
DC_5_n2	E-UTRA Band 42	F _{DL_low}	-	F _{DL_high}	-50	1	
	E-UTRA Band 41, 43 NR Band n77	F _{DL_low}	-	F _{DL_high}	-50	1	2
DC_7_n1	E-UTRA Band 32, 50, 51, 75, 76 or NR Band n79	F _{DL_low}	-	F _{DL_high}	-50	1	
DC_7_n3	E-UTRA Band 5, 8, 20, 26, 27, 28, 67, 68, 42, 52	F _{DL_low}	-	F _{DL_high}	-50	1	
	NR Band 77, 78	F _{DL_low}	-	F _{DL_high}	-50	1	2
DC_8_n1	E-UTRA Band 43 or NR Band n77, n78, n79	F _{DL_low}	-	F _{DL_high}	-50	1	2
DC_8_n3	E-UTRA Band 20, 28, 38, 44	F _{DL_low}	-	F _{DL_high}	-50	1	
	E-UTRA Band 7, 22, 41, 42, 43 or NR Band n77, n78, n79	F _{DL_low}	-	F _{DL_high}	-50	1	2
	Frequency range	860	-	890	-40	1	5, 12
DC_7_n66	E-UTRA Band 5, 12, 13, 14, 17, 26, 27, 28, 29, 85	F _{DL_low}	-	F _{DL_high}	-50	1	
	E-UTRA band 42	F _{DL_low}	-	F _{DL_high}	-50	1	2
DC_12_n66	E-UTRA Band 41, 53	F _{DL_low}	-	F _{DL_high}	-50	1	
	NR band n77	F _{DL_low}	-	F _{DL_high}	-50	1	2
DC_12_n78	E-UTRA Band 2, 7, 25, 41	F _{DL_low}	-	F _{DL_high}	-50	1	
	E-UTRA Band 4, 66	F _{DL_low}	-	F _{DL_high}	-50	1	2
	Frequency range	1884.5	-	1915.7	-41	0.3	3
DC_13_n2	E-UTRA Band 41	F _{DL_low}	-	F _{DL_high}	-50	1	
DC_13_n66	E-UTRA Band 41, 53	F _{DL_low}	-	F _{DL_high}	-50	1	
	NR Band n77	F _{DL_low}	-	F _{DL_high}	-50	1	2
DC_20_n1	E-UTRA Band 22, 42, 43	F _{DL_low}	-	F _{DL_high}	-50	1	
	NR Band 77, 78	F _{DL_low}	-	F _{DL_high}	-50	1	2
DC_20_n3	E-UTRA Band 7, 8	F _{DL_low}	-	F _{DL_high}	-50	1	
	E-UTRA Band 38, 42, 52	F _{DL_low}	-	F _{DL_high}	-50	1	2
DC_28_n3	NR Band n77	F _{DL_low}	-	F _{DL_high}	-50	1	2
	E-UTRA Band 7, 41	F _{DL_low}	-	F _{DL_high}	-50	1	
DC_30_n5	E-UTRA Band 71	F _{DL_low}	-	F _{DL_high}	-50	1	
	NR band n77	F _{DL_low}	-	F _{DL_high}	-50	1	2
DC_40_n1	E-UTRA Band 7, 31, 32, 41, 45, 50, 72, 73, 74, 75	F _{DL_low}	-	F _{DL_high}	-50	1	
DC_40_n78	E-UTRA Band 5, 8, 20, 26, 27, 28, 32, 44, 45, 50, 51, 74, 75, 76	F _{DL_low}	-	F _{DL_high}	-50	1	
	NR Band n79	F _{DL_low}	-	F _{DL_high}	-50	1	2
DC_48_n5	E-UTRA Band 25, 70	F _{DL_low}	-	F _{DL_high}	-50	1	
	Frequency range	1884.5	-	1915.7	-41	0.3	3
DC_48_n66	E-UTRA Band 2, 25	F _{DL_low}	-	F _{DL_high}	-50	1	
DC_66_n41	E-UTRA Band 5, 12, 13, 14, 17, 26, 27, 28, 29, 43, 85	F _{DL_low}	-	F _{DL_high}	-50	1	
	E-UTRA Band 42, 48, NR band n77	F _{DL_low}	-	F _{DL_high}	-50	1	2

- NOTE 1: F_{DL_low} and F_{DL_high} refer to each E-UTRA frequency band specified in Table 5.5-1 in TS 36.101 [5].
- NOTE 2: As exceptions, measurements with a level up to the applicable requirements defined in Table 6.6.3.1-2 are permitted for each assigned E-UTRA carrier used in the measurement due to 2nd, 3rd, 4th or 5th harmonic spurious emissions. Due to spreading of the harmonic emission the exception is also allowed for the first 1 MHz frequency range immediately outside the harmonic emission on both sides of the harmonic emission. This results in an overall exception interval centred at the harmonic emission of $(2 \text{ MHz} + N \times L_{CRB} \times 180 \text{ kHz})$, where N is 2, 3, 4, 5 for the 2nd, 3rd, 4th or 5th harmonic respectively. The exception is allowed if the measurement bandwidth (MBW) totally or partially overlaps the overall exception interval.
- NOTE 3: Applicable when co-existence with PHS system operating in 1884.5 - 1915.7 MHz
- NOTE 4: Void.
- NOTE 5: These requirements also apply for the frequency ranges that are less than F_{OOB} (MHz) in Table 6.5.3.1-1 and Table 6.5A.3.1-1 of TS 38.101-1 [2] from the edge of the channel bandwidth.
- NOTE 6: This requirement is applicable for any channel bandwidths within the range 2500 - 2570 MHz with the following restriction: for carriers of 15 MHz bandwidth when carrier centre frequency is within the range 2560.5 - 2562.5 MHz and for carriers of 20 MHz bandwidth when carrier centre frequency is within the range 2552 - 2560 MHz the requirement is applicable only for an uplink transmission bandwidth less than or equal to 54 RB.
- NOTE 7: For these adjacent bands, the emission limit could imply risk of harmful interference to UE(s) operating in the protected operating band.
- NOTE 8: This requirement is applicable for any channel bandwidths within the range 1920 - 1980 MHz with the following restriction: for carriers of 15 MHz bandwidth when carrier centre frequency is within the range 1927.5 - 1929.5 MHz and for carriers of 20 MHz bandwidth when carrier centre frequency is within the range 1930 - 1938 MHz the requirement is applicable only for an uplink
- NOTE 9: Applicable when the assigned E-UTRA carrier is confined within 718 MHz and 748 MHz and when the channel bandwidth used is 5 or 10 MHz.
- NOTE 10: As exceptions, measurements with a level up to the applicable requirement of -38 dBm/MHz is permitted for each assigned E-UTRA carrier used in the measurement due to 2nd harmonic spurious emissions. An exception is allowed if there is at least one individual RB within the transmission bandwidth (see Figure 5.6-1) for which the 2nd harmonic totally or partially overlaps the measurement bandwidth (MBW).
- NOTE 11: As exceptions, measurements with a level up to the applicable requirement of -36 dBm/MHz is permitted for each assigned E-UTRA carrier used in the measurement due to 3rd harmonic spurious emissions. An exception is allowed if there is at least one individual RB within the transmission bandwidth (see Figure 5.6-1) for which the 3rd harmonic totally or partially overlaps the measurement bandwidth (MBW).
- NOTE 12: This requirement is applicable only for the following cases: A: for carriers of 5 MHz channel bandwidth when carrier centre frequency (F_c) is within the range $902.5 \text{ MHz} \leq F_c < 907.5 \text{ MHz}$ with an uplink transmission bandwidth less than or equal to 20 RB; B: for carriers of 5 MHz channel bandwidth when carrier centre frequency (F_c) is within the range $907.5 \text{ MHz} \leq F_c \leq 912.5 \text{ MHz}$ without any restriction on uplink transmission bandwidth; C: for carriers of 10 MHz channel bandwidth when carrier centre frequency (F_c) is $F_c = 910 \text{ MHz}$ with an uplink transmission bandwidth less than or equal to 32 RB with $RB_{start} > 3$.
- NOTE 13: Void.
- NOTE 14: This requirement is applicable for 5 and 10 MHz E-UTRA channel bandwidth allocated within 718-728MHz. For carriers of 10 MHz bandwidth, this requirement applies for an uplink transmission bandwidth less than or equal to 30 RB with $RB_{start} > 1$ and $RB_{start} < 48$.
- NOTE 15: Void.
- NOTE 16: This requirement is applicable for any channel bandwidths within the range 1920 - 1980 MHz with the following restriction: for carriers of 15 MHz bandwidth when carrier centre frequency is within the range 1927.5 - 1929.5 MHz and for carriers of 20 MHz bandwidth when carrier centre frequency is within the range 1930 - 1938 MHz the requirement is applicable only for an uplink transmission bandwidth less than or equal to 54 RB.
- NOTE 17: This requirement is applicable in the case of a 10 MHz E-UTRA carrier confined within 703 MHz and 733 MHz, otherwise the requirement of -25 dBm with a measurement bandwidth of 8 MHz applies.
- NOTE 18: This requirement is only applicable for E-UTRA carriers with bandwidth confined within 1885 - 1920 MHz (requirement for carriers with at least 1RB confined within 1880 - 1885 MHz is not specified). This requirement applies for an uplink transmission bandwidth less than or equal to 54 RB for E-UTRA carriers of 15 MHz bandwidth when carrier centre frequency is within the range 1892.5 - 1894.5 MHz and for E-UTRA carriers of 20 MHz bandwidth when carrier centre frequency is within the range 1895 - 1903 MHz.
- NOTE 19: Void.
- NOTE 20: Void.
- NOTE 21: Void.

6.5B.3.4 Spurious Emissions for Inter-band including FR2

Editor's note: This clause is complete for Band n257, n258, n260 and n261. The following aspects are either missing or not yet determined:

- The referred test case 6.5.3 in TS 38.521-2 [9] is incomplete for frequency above 80 GHz.

6.5B.3.4.1 General Spurious Emissions for Inter-band including FR2 (2 CCs)

6.5B.3.4.1.1 Test purpose

Same test purpose as in clause 6.5.3.1.1 in TS 38.521-2 [9] for the NR carrier.

6.5B.3.4.1.2 Test applicability

This test case applies to all types of E-UTRA UE release 15 and forward, supporting inter-band EN-DC including FR2 with 2 UL CCs.

6.5B.3.4.1.3 Minimum conformance requirements

Same minimum conformance requirements as in clause 6.5.3.1.3 in TS 38.521-2 [9] for the NR carrier.

No exception requirements applicable to NR or LTE. LTE anchor agnostic approach is applied.

The normative reference for this requirement is TS 38.101-3 [4] clause 6.5B.3.4.

6.5B.3.4.1.4 Test description

6.4B.3.4.1.4.1 Initial conditions

Same test description as in clause 6.5.3.1.4 in TS 38.521-2 [9] for the NR carrier with the following exception:

The initial test configurations for E-UTRA band consist of environmental conditions, test frequencies, and channel bandwidths based on E-UTRA bands specified in Table 4.6-1. For Initial conditions as in clause 6.5.3.1.4.1 in TS 38.521-2 [9], the following steps will be added to configure E-UTRA component:

2.1 The parameter settings for E-UTRA cell are set up according to TS 36.508 [11] clause 4.4.3.

3.1 The E-UTRA downlink signal level, uplink signal level are set according to Table 4.7-1 and propagation conditions are set according to Annex B.0 of TS 36.521-1 [10].

Step 6 of Initial conditions as in clause 6.5.3.1.4.1 in TS 38.521-2 [9] is replaced by:

6. Ensure the UE is in state RRC_CONNECTED with generic procedure parameters Connectivity EN-DC, DC bearer MCG and SCG, Connected without release On according to TS 38.508-1 [6] clause 4.5.

Same test procedure as in clause 6.5.3.1.4.1 in TS 38.521-2 [9] with the following steps added for E-UTRA component:

1.1 On the E-UTRA carrier, disable periodic and aperiodic CQI reports, disable SRS, set *TimeAlignmentTimerDedicated* IE to infinity and disable downlink and uplink scheduling, all as per Table 4.7-1 under clause 4.7.

6.5B.3.4.1.5 Test requirement

Same test requirement as in clause 6.5.3.1.5 in TS 38.521-2 [9] for the NR carrier.

6.5B.3.4.1_1 Transmitter Spurious emissions for Inter-band EN-DC including FR2 (>2 CCs)

Editor's note: Test applicability, Test Description in below sub-clauses requires updates to clarify number of E-UTRA carriers that will be configured during the test that will be limited to only 1 E-UTRA CC

6.5B.3.4.1_1.1 Transmitter Spurious emissions for Inter-band EN-DC including FR2 (3 CCs)

Editor's note: This clause is incomplete. The following aspects are either missing or not yet determined:

- **Test configuration table and Connection diagram in TS 38.521-2 [9] are TBD**
- **The referred test case 6.5A.3.1.1 in TS 38.521-2 [9] is incomplete.**

6.5B.3.4.1_1.1.1 Test purpose

Same test purpose as in clause 6.5.3.1 in TS 38.521-2 [9] for the NR carrier.

6.5B.3.4.1_1.1.2 Test applicability

This test case applies to all types of E-UTRA UE release 15 and forward, supporting inter-band EN-DC including FR2 with 3 UL CCs (2NR UL CCs).

6.5B.3.4.1_1.1.3 Minimum conformance requirements

Same minimum conformance requirements as in clause 6.5.3.3 in TS 38.521-2 [9] for the NR carrier.

No exception requirements applicable to NR or LTE. LTE anchor agnostic approach is applied.

The normative reference for this requirement is TS 38.101-3 [4] clause 6.4B.3.4.

6.5B.3.4.1_1.1.4 Test description

6.5B.3.4.1_1.1.4.1 Initial condition

Same test description as in clause 6.5A.3.1.1.4 in TS 38.521-2 [9] for the NR carrier with the following exception:

The initial test configurations for E-UTRA band consist of environmental conditions, test frequencies, and channel bandwidths based on E-UTRA bands specified in Table 4.7-1.

For Initial conditions as in clause 6.5A.3.1.1.4.1 in TS 38.521-2 [9], the following steps will be added to configure E-UTRA component:

- 2.1. The parameter settings for E-UTRA cell are set up according to TS 36.508 [11] clause 4.4.3.
- 3.1. The E-UTRA downlink signal level, uplink signal level are set according to Table 4.7-1 and propagation conditions are set according to Annex B.0 of TS 36.521-1 [10].

Step 6 of Initial conditions as in clause 6.5A.3.1.1.4.1 in TS 38.521-2 [9] is replaced by:

6. Ensure the UE is in state RRC_CONNECTED with generic procedure parameters Connectivity EN-DC, DC bearer MCG and SCG, Connected without release On according to TS 38.508-1 [6] clause 4.5.

Same test procedure as in clause 6.5A.3.1.1.4.2 in TS 38.521-2 [9] with the following steps added for E-UTRA component:

- 1.1 On the E-UTRA carrier, disable periodic and aperiodic CQI reports, disable SRS, set *TimeAlignmentTimerDedicated* IE to infinity and disable downlink and uplink scheduling, all as per Table 4.7-1 under clause 4.7.

6.5B.3.4.1_1.1.5 Test Requirements

Same test requirement as in clause 6.5A.3.1.1.5 in TS 38.521-2 [9] for the NR carrier.

6.5B.3.4.1_1.2 Transmitter Spurious emissions for Inter-band EN-DC including FR2 (4 CCs)

Editor's note: This clause is incomplete. The following aspects are either missing or not yet determined:

- Test configuration table and Connection diagram in TS 38.521-2 [9] are TBD
- The referred test case 6.5A.3.1.2 in TS 38.521-2 [9] is incomplete.

6.5B.3.4.1_1.2.1 Test purpose

Same test purpose as in clause 6.5.3.1 in TS 38.521-2 [9] for the NR carrier.

6.5B.3.4.1_1.2.2 Test applicability

This test case applies to all types of E-UTRA UE release 15 and forward, supporting inter-band EN-DC including FR2 with 4 UL CCs (3NR UL CCs).

6.5B.3.4.1_1.2.3 Minimum conformance requirements

Same minimum conformance requirements as in clause 6.5.3.3 in TS 38.521-2 [9] for the NR carrier.

No exception requirements applicable to NR or LTE. LTE anchor agnostic approach is applied.

The normative reference for this requirement is TS 38.101-3 [4] clause 6.4B.3.4.

6.5B.3.4.1_1.2.4 Test description

6.5B.3.4.1_1.2.4.1 Initial condition

Same test description as in clause 6.5A.3.1.2.4 in TS 38.521-2 [9] for the NR carrier with the following exception:

The initial test configurations for E-UTRA band consist of environmental conditions, test frequencies, and channel bandwidths based on E-UTRA bands specified in Table 4.7-1.

For Initial conditions as in clause 6.5A.3.1.2.4.1 in TS 38.521-2 [9], the following steps will be added to configure E-UTRA component:

- 2.1. The parameter settings for E-UTRA cell are set up according to TS 36.508 [11] clause 4.4.3.
- 3.1. The E-UTRA downlink signal level, uplink signal level are set according to Table 4.7-1 and propagation conditions are set according to Annex B.0 of TS 36.521-1 [10].

Step 6 of Initial conditions as in clause 6.5A.3.1.2.4.1 in TS 38.521-2 [9] is replaced by:

6. Ensure the UE is in state RRC_CONNECTED with generic procedure parameters Connectivity EN-DC, DC bearer MCG and SCG, Connected without release On according to TS 38.508-1 [6] clause 4.5.

Same test procedure as in clause 6.5A.3.1.2.4.2 in TS 38.521-2 [9] with the following steps added for E-UTRA component:

- 1.1 On the E-UTRA carrier, disable periodic and aperiodic CQI reports, disable SRS, set *TimeAlignmentTimerDedicated* IE to infinity and disable downlink and uplink scheduling, all as per Table 4.7-1 under clause 4.7.

6.5B.3.4.1_1.2.5 Test Requirements

Same test requirement as in clause 6.5A.3.1.2.5 in TS 38.521-2 [9] for the NR carrier.

6.5B.3.4.1_1.3 Transmitter Spurious emissions for Inter-band EN-DC including FR2 (5 CCs)

Editor's note: This clause is incomplete. The following aspects are either missing or not yet determined:

- **Test configuration table and Connection diagram in TS 38.521-2 [9] are TBD**
- **The referred test case 6.5A.3.1.3 in TS 38.521-2 [9] is incomplete.**

6.5B.3.4.1_1.3.1 Test purpose

Same test purpose as in clause 6.5.3.1 in TS 38.521-2 [9] for the NR carrier.

6.5B.3.4.1_1.3.2 Test applicability

This test case applies to all types of E-UTRA UE release 15 and forward, supporting inter-band EN-DC including FR2 with 5 UL CCs (4NR UL CCs).

6.5B.3.4.1_1.3.3 Minimum conformance requirements

Same minimum conformance requirements as in clause 6.5.3.3 in TS 38.521-2 [9] for the NR carrier.

No exception requirements applicable to NR or LTE. LTE anchor agnostic approach is applied.

The normative reference for this requirement is TS 38.101-3 [4] clause 6.4B.3.4.

6.5B.3.4.1_1.3.4 Test description

6.5B.3.4.1_1.3.4.1 Initial condition

Same test description as in clause 6.5A.3.1.3.4 in TS 38.521-2 [9] for the NR carrier with the following exception:

The initial test configurations for E-UTRA band consist of environmental conditions, test frequencies, and channel bandwidths based on E-UTRA bands specified in Table 4.7-1.

For Initial conditions as in clause 6.5A.3.1.3.4.1 in TS 38.521-2 [9], the following steps will be added to configure E-UTRA component:

- 2.1. The parameter settings for E-UTRA cell are set up according to TS 36.508 [11] clause 4.4.3.
- 3.1. The E-UTRA downlink signal level, uplink signal level are set according to Table 4.7-1 and propagation conditions are set according to Annex B.0 of TS 36.521-1 [10].

Step 6 of Initial conditions as in clause 6.5A.3.1.3.4.1 in TS 38.521-2 [9] is replaced by:

6. Ensure the UE is in state RRC_CONNECTED with generic procedure parameters Connectivity EN-DC, DC bearer MCG and SCG, Connected without release On according to TS 38.508-1 [6] clause 4.5.

Same test procedure as in clause 6.5A.3.1.3.4.2 in TS 38.521-2 [9] with the following steps added for E-UTRA component:

- 1.1 On the E-UTRA carrier, disable periodic and aperiodic CQI reports, disable SRS, set *TimeAlignmentTimerDedicated* IE to infinity and disable downlink and uplink scheduling, all as per Table 4.7-1 under clause 4.7.

6.5B.3.4.1_1.3.5 Test Requirements

Same test requirement as in clause 6.5A.3.1.3.5 in TS 38.521-2 [9] for the NR carrier.

6.5B.3.4.1D Spurious Emissions for inter-band EN-DC including FR2 for UL-MIMO

Editor's note: This clause is incomplete. The following aspects are either missing or not yet determined:

- **The referred test case 6.5D.3 in TS 38.521-2 [9] is incomplete**

6.5B.3.4.1D.1 Test purpose

Same test purpose as in clause 6.5D.3.1 in TS 38.521-2 [9] for the NR carrier.

6.5B.3.4.1D.2 Test applicability

This test case applies to all types of E-UTRA UE release 15 and forward, supporting inter-band EN-DC FR2.

6.5B.3.4.1D.3 Minimum conformance requirements

Same minimum conformance requirements as in clause 6.5D.3.1 in TS 38.521-2 [9] for the NR carrier.

No exception requirements applicable to NR or LTE. LTE anchor agnostic approach is applied.

The normative reference for this measurement is TS 38.101-3 [4] clause 6.5B.3.4.

6.5B.3.4.1D.4 Test Description

Same test description as in clause 6.5D.3.1 in TS 38.521-2 [9] for the NR carrier with the following exceptions:

The initial test configurations for E-UTRA consist of test frequency based on E-UTRA operating band and test channel bandwidth as specified in Table 4.6-1.

For Initial conditions as in clause 6.5D.3.1 in TS 38.521-2 [9], the following steps will be added to configure E-UTRA component:

- 2.1. The parameter settings for the cell are set up according to TS 36.508 [11] subclause 4.4.3.
- 3.1. The E-UTRA downlink signal level, uplink signal level are set according to Table 4.6-1 and propagation conditions are set according to Annex B.0 of TS 36.521-1 [10].

Step 6 of Initial conditions as in clause 6.5D.3.1 in TS 38.521-2 [9] is replaced by:

6. Ensure the UE is in state RRC_CONNECTED with generic procedure parameters Connectivity EN-DC, DC bearer MCG and SCG, Connected without release *On* according to TS 38.508 [6] clause 4.5.
7. On the E-UTRA carrier, disable periodic and aperiodic CQI reports, disable SRS, set TimeAlignmentTimerDedicated IE to infinity and disable downlink and uplink scheduling, all as per Table 4.6-1 under clause 4.6.

6.5B.3.4.1D.5 Test Requirement

Same test requirement as specified in TS 38.521-2 [9] clause 6.5D.3.1 for the NR carrier(s).

6.5B.3.4.2 Spurious emission band UE co-existence for Inter-band including FR2

Editor's note: The following aspects are either missing or not yet determined:

- **The referred test case 6.5.3.2 in TS 38.521-2 [9] is incomplete for PC1, PC2 and PC4.**

6.5B.3.4.2.1 Test purpose

Same test purpose as in clause 6.5.3.2.1 in TS 38.521-2 [9] for the NR carrier.

6.5B.3.4.2.2 Test applicability

This test case applies to all types of E-UTRA UE release 15 and forward, supporting inter-band EN-DC including FR2.

6.5B.3.4.2.3 Minimum conformance requirements

Same minimum conformance requirements as in clause 6.5.3.2.3 in TS 38.521-2 [9] for the NR carrier.

No exception requirements applicable to NR or LTE. LTE anchor agnostic approach is applied.

The normative reference for this requirement is TS 38.101-3 [4] clause 6.5B.3.4.1.

6.5B.3.4.2.4 Test description

Same Test description as in clause 6.5.3.2.4 in TS 38.521-2 [9] for the NR carrier with the following exception:

The initial test configurations for E-UTRA band consist of environmental conditions, test frequencies, and channel bandwidths based on E-UTRA bands specified in Table 4.7-1.

For initial conditions as in clause 6.5.3.2.4.1 in TS 38.521-2 [9], the following steps will be added to configure E-UTRA component:

- 2.1 The parameter settings for E-UTRA cell are set up according to TS 36.508 [11] clause 4.4.3.
- 3.1 The E-UTRA downlink signal level, uplink signal level are set according to Table 4.7-1 and propagation conditions are set according to Annex B.0 of TS 36.521-1 [10].

Step 6 of Initial conditions as in clause 6.5.3.2.4.1 in TS 38.521-2 [9] is replaced by:

6. Ensure the UE is in state RRC_CONNECTED with generic procedure parameters Connectivity EN-DC, DC bearer MCG and SCG, Connected without release On according to TS 38.508-1 [6] clause 4.5.

Same test procedure as in clause 6.5.3.2.4.1 in TS 38.521-2 [9] with the following steps added for E-UTRA component:

- 1.1 On the E-UTRA carrier, disable periodic and aperiodic CQI reports, disable SRS, set *TimeAlignmentTimerDedicated* IE to infinity and disable downlink and uplink scheduling, all as per Table 4.7-1 under clause 4.7.

6.5B.3.4.2.5 Test requirement

Same Test requirement as in clause 6.5.3.2.5 in TS 38.521-2 [9] for the NR carrier.

6.5B.3.5 Spurious emissions for Inter-band including FR1 and FR2

6.5B.3.5.1 General Spurious Emissions for Inter-band including FR1 and FR2

6.5B.3.5.1.1 Test purpose

Same test purpose as in clause 6.5.3 in TS 38.521-1 [8] for NR FR1 carrier(s) and clause 6.5.3 in TS 38.521-2 [9] for NR FR2 carrier(s).

6.5B.3.5.1.2 Test applicability

The requirements in this test are not testable due to issues with combined testing of NR FR1 and E-UTRA in conducted mode with NR FR2 in radiated mode. Therefore, the conducted and radiated requirements are tested separately.

No test case details are specified. The NSA requirements for spurious emissions apply and are tested as part of the EN-DC within FR1 and EN-DC including FR2 test cases in clause 6.5B.3.

6.5B.3.5.2 Spurious emission band UE co-existence for Inter-band including FR1 and FR2

6.5B.3.5.2.1 Test purpose

Same test purpose as in clause 6.5.3 in TS 38.521-1 [8] for NR FR1 carrier(s) and clause 6.5.3 in TS 38.521-2 [9] for NR FR2 carrier(s).

6.5B.3.5.2.2 Test applicability

The requirements in this test are not testable due to issues with combined testing of NR FR1 and E-UTRA in conducted mode with NR FR2 in radiated mode. Therefore, the conducted and radiated requirements are tested separately.

No test case details are specified. The NSA requirements for spurious emissions apply and are tested as part of the EN-DC within FR1 and EN-DC including FR2 test cases in clause 6.5B.3.

6.5B.4 Additional Spurious Emissions for EN-DC

6.5B.4.1 Additional Spurious Emissions for Intra-band contiguous EN-DC

6.5B.4.1.1 Test purpose

To verify that UE transmitter does not cause unacceptable interference to other channels or other systems in terms of transmitter spurious emissions under the deployment scenarios where additional requirements are specified.

6.5B.4.1.2 Test applicability

This test case applies to all types of E-UTRA UE release 15 and forward supporting intra-band contiguous EN-DC.

6.5B.4.1.3 Minimum conformance requirements

These requirements are specified in terms of an additional spectrum emission requirement. Additional spurious emission requirements are signalled by the network to indicate that the UE shall meet an additional requirement for a specific deployment scenario as part of the cell handover/broadcast message.

NOTE: For measurement conditions at the edge of each frequency range, the lowest frequency of the measurement position in each frequency range should be set at the lowest boundary of the frequency range plus MBW/2. The highest frequency of the measurement position in each frequency range should be set at the highest boundary of the frequency range minus MBW/2. MBW denotes the measurement bandwidth defined for the protected band.

6.5B.4.1.3.1 Minimum requirement (network signalled value "NS_04")

When "NS 04" is indicated in the cell, the power of any UE emission shall not exceed the levels specified in Table 6.5B.4.1.3.1-1. This requirement also applies for the frequency ranges that are less than F_{OOB} (MHz) in Table 6.6.3.1-1 of TS 38.521-1 [8] from the edge of the channel bandwidth.

Table 6.5B.4.1.3.1-1: Additional requirements

Frequency band (MHz)	Channel bandwidth / Spectrum emission limit (dBm)	Measurement bandwidth
$2495 \leq f < 2496$	-13	1% of Channel BW for contiguous BW up to 100 MHz, 1 MHz for contiguous BW > 100 MHz
$2490.5 \leq f < 2495$	-13	1 MHz
$0 < f < 2490.5$	-25	1 MHz

The normative reference for this requirement is TS 38.101-3 [4] clause 6.5B.4.1.1.

Exception requirements for both NR and E-UTRA are defined for this test. LTE anchor agnostic approach is not applied. E-UTRA test point analysis is included and E-UTRA measurements are performed.

6.5B.4.1.4 Test description

6.5B.4.1.4.1 Initial conditions

Initial conditions are a set of test configurations the UE needs to be tested in and the steps for the SS to take with the UE to reach the correct measurement state.

The initial test configurations consist of environmental conditions, test frequencies, test channel bandwidths and sub-carrier spacing based on NR operating bands specified in table 5.2B.2.1-1. All of these configurations shall be tested with applicable test parameters for each combination of test channel bandwidth and sub-carrier spacing are shown in Table 6.5B.4.1.4.1-1 for E-UTRA and Table 6.5B.4.1.4.1-2 for NR. The details of the uplink reference measurement channels (RMCs) are specified in Annex A.2. Configurations of PDSCH and PDCCH before measurement are specified in Annex TS 36.521-1 [10] Annex C and in TS 38.521-1 [8] Annex C2 for LTE link and NR link respectively.

Table 6.5B.4.1.4.1-1: EN-DC test configuration table for NS_04

Initial Conditions							
Test Environment as specified in TS 38.508-1 [6] clause 4.1		Normal					
Test Frequencies as specified in TS 38.508-1 [6] clause 4.3.1		Low range, High range					
Test EN-DC bandwidth combination as specified in Table 5.3B.1.2-1		Lowest N_{RB_agg} , Highest N_{RB_agg} (Note 2)					
Test SCS for the NR cell as specified in TS 38.521-1 [8] Table 5.3.5-1		Lowest SCS per Channel Bandwidth					
Test Parameters							
Test ID	Freq	Downlink Configuration	EN-DC Uplink Configuration				
			E-UTRA Cell		NR Cell	Common	
Modulation	RB allocation (Note 5)		Modulation	RB allocation (Note 1)	Power config (Note 6)		
1	Default		16QAM	Outer_Full	DFT-s-OFDM QPSK	Outer_Full	B or C
2 (Note 3)	Default		16QAM	Outer_1RB_Left	DFT-s-OFDM QPSK	Edge_1RB_Right	B or D
3 (Note 3)	Low		16QAM	Outer_1RB_Left	DFT-s-OFDM QPSK	N/A	A
4 (Note 3)	High		16QAM	N/A	DFT-s-OFDM QPSK	Edge_1RB_Right	A
5 (Note 4)	Default		16QAM	Outer_1RB_Right	DFT-s-OFDM QPSK	Edge_1RB_Left	B or D
6 (Note 4)	Low		16QAM	N/A	DFT-s-OFDM QPSK	Edge_1RB_Left	A
7 (Note 4)	High		16QAM	Outer_1RB_Right	DFT-s-OFDM QPSK	N/A	A
8	Default		16QAM	Outer_Full	CP-OFDM 256QAM	Outer_Full	B or C
9 (Note 3)	Low	16QAM	Outer_1RB_Left	CP-OFDM 256QAM	Edge_1RB_Right	B or D	
10 (Note 4)	High	16QAM	Outer_1RB_Right	CP-OFDM 256QAM	Edge_1RB_Left	B or D	
11 (Note 4)	Default	16QAM	Edge_Full_Right	CP-OFDM 256QAM	Edge_Full_Left	B or E	

NOTE 1: The specific configuration of each RB allocation is defined in Table 6.1-1 in TS 38.521-1 [8].
 NOTE 2: If the UE supports multiple CC combinations in the EN-DC configuration with the same N_{RB_agg} , select the combination to test as follows:
 - Lowest ENBW: NR component with lowest N_{RB} is tested.
 - Highest ENBW: NR component with highest N_{RB} is tested.
 NOTE 3: Applicable when E-UTRA cell carrier frequency is lower than NR cell carrier.
 NOTE 4: Applicable when NR cell carrier frequency is lower than E-UTRA cell carrier.
 NOTE 5: Outer_Full defined as the transmission bandwidth configuration N_{RB} per channel bandwidth for the E-UTRA component as indicated in TS 36.521 [10] Table 5.4.2-1. Outer_1RB_Left defined as 1 RB allocated at the left edge of the E-UTRA component. Outer_1RB_Right defined as 1 RB allocated at the right edge of the E-UTRA component.
 NOTE 6: Power config as specified in Table 6.2B.3.1.4.3-2.
 NOTE 7: Test IDs with simultaneous E-UTRA and NR UL transmission only apply for UEs indicating dualPA-Architecture.

1. Connect the SS to the UE antenna connectors as shown in TS 38.508-1 [6] Annex A, Figure A.3.1.1.1 for SS diagram and clause A.3.2.1 for UE diagram.
2. The parameter settings for NR cell are set up according to TS 38.508-1 [6] clause 4.4.3.
3. The parameter settings for E-UTRA cell are set up according to TS 36.508 [11] clause 4.4.3.
4. E-UTRA downlink signals are initially set up according to Annex C0, C.1 and C.3.0, and uplink signals according to Annex H.1 and H.3.0 of TS 36.521-1 [10].
5. NR downlink signals are initially set up according to Annex C.0, C.1 and C.2, and uplink signals according to Annex G.0, G.1, G.2, G.3.0 of TS 38.521-1 [8].
6. The UL Reference Measurement channels are set according to Table 6.5B.4.1.4.1-1.

7. NR propagation conditions are set according to B.0 of TS 38.521-1 [8]. E-UTRA propagation conditions are set according to B.0 of TS 36.521-1 [10].
8. Ensure the UE is in state RRC_CONNECTED with generic procedure parameters Connectivity EN-DC, DC bearer *MCG* and *SCG*, Connected without release *On* according to TS 38.508-1 [6] clause 4.5. Message contents are defined in clause 6.5B.4.1.4.3.

6.5B.4.1.4.2 Test Procedure

1. E-UTRA SS sends uplink scheduling information for each UL HARQ process via PDCCH DCI format 0 for C_RNTI to schedule the UL RMC according to Table 6.5B.4.1.4.1-1. Since the UE has no payload data to send, the UE transmits uplink MAC padding bits on the UL RMC.
2. NR SS sends uplink scheduling information for each UL HARQ process via PDCCH DCI format [0_1] for C_RNTI to schedule the UL RMC according to Table 6.5B.4.1.4.1-1. Since the UE has no payload data to send, the UE transmits uplink MAC padding bits on the UL RMC.
3. Send continuously uplink power control "up" commands to the UE for both NR and E-UTRA carriers until the UE transmits at its P_{UMAX} level; allow at least 200 ms starting from the first TPC command in this step for the UE to reach P_{UMAX} level.
4. Measure the mean power of each component carriers for the EN-DC configuration, which shall meet the requirements described in 6.2B.3.1.5.2 depending NS-values. The period of the measurement shall be at least the continuous duration of one sub-frame.
5. Measure the power of the transmitted signal with a measurement filter of bandwidths according to table 6.5B.4.1.3.1 -1. The centre frequency of the filter shall be stepped in contiguous steps according to the same table. The measured power shall be recorded for each step. The measurement period shall capture the active time slots.

6.5B.4.1.4.3 Message Contents

Message contents are according to TS 38.508-1 [5] clause 4.6 with the following exceptions for each network signalled value.

6.5B.4.1.4.3.1 Message contents exceptions for network signalled value "NS_04"

1. Information element `additionalSpectrumEmission` is set to NS_04. This can be set in *SIB1* as part of the cell broadcast message. This exception indicates that the UE shall meet the additional spurious emission requirement for a specific deployment scenario.

Table 6.5B.4.1.4.3.1-1: *AdditionalSpectrumEmission*: Additional spurious emissions test requirement for "NS_04"

Derivation Path: TS 38.508-1 [5] clause 4.6.3, Table 4.6.3-1			
Information Element	Value/remark	Comment	Condition
<code>additionalSpectrumEmission</code>	1 (NS_04)		

Table 6.5B.4.1.4.3.1-2: *RRCConnectionReconfiguration*: nr-Config-r15

Derivation Path: TS 36.508 [11], Table 4.6.1-8			
Information Element	Value/remark	Comment	Condition
<code>p-MaxEUTRA-r15</code>	23		Power Class 2 UE AND simultaneous E-UTRA and NR transmission
	20		Power Class 3 UE AND simultaneous E-UTRA and NR transmission

Table 6.5B.4.1.4.3.1-3: PhysicalCellGroupConfig

Derivation Path: TS 38.508-1 [6] Table 4.6.3-106			
Information Element	Value/remark	Comment	Condition
p-NR-FR1	23		Power Class 2 UE AND simultaneous E-UTRA and NR transmission
	20		Power Class 3 UE AND simultaneous E-UTRA and NR transmission

6.5B.4.1.5 Test Requirement

Test requirements for additional spurious emissions for intra-band contiguous EN-DC are the same as the minimum requirements described in clause 6.5B.4.1.3 and are not repeated in this clause.

6.5B.4.2 Additional Spurious Emissions for Intra-band non-contiguous EN-DC

Editor's note: Wgap for intra-band non-contiguous EN-DC is FFS in TS 38.508-1

6.5B.4.2.1 Test purpose

Same minimum conformance requirements as in clause 6.5B.4.1.1.

6.5B.4.2.2 Test applicability

This test case applies to all types of E-UTRA UE release 15 and forward, supporting intra-band non-contiguous EN-DC.

6.5B.4.2.3 Minimum conformance requirements

Same minimum conformance requirements as in clause 6.5B.4.1.3.

6.5B.4.2.4 Test description

6.5B.4.2.4.1 Initial conditions

Same initial conditions as described in clause 6.5B.4.1.4.1 for both E-UTRA and NR carriers with the following exception:

1. For each EN-DC combination specified in Table 5.3B.1.3-1, channel spacing between NR and E-UTRA is specified according to clause 5.4B.1.
2. Set up the NR and E-UTRA test frequencies so that NR carrier is located at the lower frequency side as specified in Table 5.3B.1.3-1. Repeat each testing with E-UTRA carrier frequency is located at the lower side as specified in Table 5.3B.1.3-1.

6.5B.4.2.4.2 Test Procedure

Same test procedure as described in clause 6.5B.4.1.4.2.

6.5B.4.2.4.3 Message Contents

Message contents are according to TS 38.508-1 [5] clause 4.6 with the following exceptions for each network signalled value.

6.5B.4.2.4.3.1 Message contents exceptions for network signalled value "NS_04"

1. Information element additionalSpectrumEmission is set to NS_04. This can be set in *SIB1* as part of the cell broadcast message. This exception indicates that the UE shall meet the additional spurious emission requirement for a specific deployment scenario.

Table 6.5B.4.2.4.3.1-1: Additional Spectrum Emission: Additional spurious emissions test requirement for "NS_04"

Derivation Path: TS 38.508-1 [5] clause 4.6.3, Table 4.6.3-1			
Information Element	Value/remark	Comment	Condition
additionalSpectrumEmission	1 (NS_04)		

6.5B.4.2.5 Test Requirement

Test requirements for Spurious Emissions for intra-band non-contiguous EN-DC are the same as the minimum requirements described in 6.5B.4.2.3 and are not repeated in this clause.

6.5B.4.3 Additional Spurious Emissions for Inter-band EN-DC within FR1

6.5B.4.3.1 Test purpose

Same test purpose as in clause 6.5.3.3.1 in TS 38.521-1 [8] for the NR carrier.

6.5B.4.3.2 Test applicability

This test case applies to all types of E-UTRA UE release 15 and forward supporting inter-band EN-DC

6.5B.4.3.3 Minimum conformance requirements

Same minimum conformance requirements as in clause 6.5.3.3.3 in TS 38.521-1 [8] for the NR carrier.

The normative reference for this requirement is TS 38.101-3 [4] clause 6.5B.4.

No exception requirements applicable to NR or LTE. LTE anchor agnostic approach is applied.

6.5B.4.3.4 Test description

Same test description as in clause 6.5.3.3.4 in TS 38.521-1 [8] for the NR carrier with the following exception:

The initial test configurations for E-UTRA band consist of environmental conditions, test frequencies, and channel bandwidths based on E-UTRA bands specified in Table 4.6-1. For Initial conditions as in clause 6.5.3.3.4.1 in TS 38.521-1 [8], the following steps will be added to configure E-UTRA component:

- 2.1. The parameter settings for E-UTRA cell are set up according to TS 36.508 [11] clause 4.4.3.
- 3.1. The E-UTRA downlink signal level, uplink signal level are set according to Table 4.6-1 and propagation conditions are set according to Annex B.0 of TS 36.521-1 [10].

Step 6 of Initial conditions as in clause 6.5.3.3.4.1 in TS 38.521-1 [8] is replaced by the following two steps:

6. Ensure the UE is in state RRC_CONNECTED with generic procedure parameters Connectivity EN-DC, DC bearer MCG and SCG, Connected without release *On* according to TS 38.508 [6] clause 4.5.
7. On the E-UTRA carrier, disable periodic and aperiodic CQI reports, disable SRS, set *TimeAlignmentTimerDedicated* IE to infinity and disable downlink and uplink scheduling, all as per Table 4.6-1 under clause 4.6.

Same test procedure as in clause 6.5.3.3.4.2 in TS 38.521-1 [8].

6.5B.4.3.5 Test Requirement

Same test requirement as in clause 6.5.3.3.5 in TS 38.521-1 [8] for the NR carrier.

6.5B.5 Transmit intermodulation

6.5B.5.1 Intra-band contiguous EN-DC

6.5B.5.2 Intra-band non-contiguous EN-DC

6.5B.5.3 Inter-band EN-DC within FR1

6.5B.5.3.1 Test purpose

Same test purpose as in clause 6.5.4 in TS 38.521-1 [8] for the NR carrier.

6.5B.5.3.2 Test applicability

This test applies to all types of E-UTRA UE release 15 and forward, supporting inter-band EN-DC within FR1.

6.5B.5.3.3 Minimum conformance requirements

The transmit intermodulation requirement specified in clauses 6.7.1 and 6.7.1A of TS 36.101 [5] and clauses 6.5.4 and 6.5A.4 of TS 38.101-1 [2] apply for each component carrier in E-UTRA bands and NR bands, respectively.

No exception requirements applicable to NR or LTE. LTE anchor agnostic approach is applied.

The normative reference for this measurement is TS 38.101-3 [4] clause 6.5B.5.3.

6.5B.5.3.4 Test description

Same test description as in clause 6.5.4.4 in TS 38.521-1 [8] for the NR carrier with the following exception:

The initial test configurations for E-UTRA band consist of environmental conditions, test frequencies, and channel bandwidths based on E-UTRA bands specified in Table 4.6-1. For Initial conditions as in clause 6.5.4.4.1 in TS 38.521-1 [8], the following steps will be added to configure E-UTRA component:

- 2.1. The parameter settings for E-UTRA cell are set up according to TS 36.508 [11] clause 4.4.3.
- 3.1. The E-UTRA downlink signal level, uplink signal level are set according to Table 4.6-1 and propagation conditions are set according to Annex B.0 of TS 36.521-1 [10].

Step 6 of Initial conditions as in clause 6.5.4.4.1 in TS 38.521-1 [8] is replaced by:

6. Ensure the UE is in state RRC_CONNECTED with generic procedure parameters Connectivity EN-DC, DC bearer MCG and SCG according to TS 38.508 [6] clause 4.5.

Same test procedure as in clause 6.5.4.4.2 in TS 38.521-1 [8].

6.5B.5.3.5 Test Requirement

The ratio derived in step 6 and 8, shall not exceed the described value in Table 6.5.4.5-1 defined in TS 38.521-1 [8].

6.5B.5.4 Inter-band EN-DC including FR2

6.5B.5.5 Inter-band EN-DC including both FR1 and FR2

7 Receiver characteristics

7.1 General

Editor's note: Test configurations/environments that require new spherical scan shall be included in test procedure clause and identifying such scenarios is currently FFS and owned by RAN5.

Unless otherwise stated the receiver characteristics are specified at the antenna connector(s) of the UE for the bands operating on frequency range 1 and over the air of the UE for the bands operating on frequency range 2. The requirements for frequency range 1 and frequency range 2 can be verified separately. For the carrier in frequency range 1, requirements can be verified with NR FR2 link disabled. For the carrier in frequency range 2, requirements can be verified in OTA mode with E-UTRA connecting to the network by OTA without calibration.

For NR FR2 Rx test cases the identified beam peak direction can be stored and reused for a device under test in various configurations/environments for the full duration of device testing as long as beam peak direction is the same.

The requirements defined in this clause are the extra requirements compared with the single carrier requirements defined in TS 38.521-1 [8] and TS 38.521-2 [9].

Unless otherwise stated, the UL and DL reference measurement channels are the same with the configurations specified in TS 38.521-1 [8] and TS 38.521-2 [9].

Unless otherwise stated, requirements for NR receiver written in TS 38.521-1 [8] and TS 38.521-2 [9] apply and are assumed anchor agnostic. Requirements are verified under conditions where anchor resources do not interfere NR operation.

For intra-band non-contiguous EN-DC, the output power is configured as follows:

- One E-UTRA uplink carrier with the output power set to 29dB below $P_{\text{CMAX_L,c}}$ and the NR band whose downlink is being tested has its uplink carrier output power set to 4dB below $P_{\text{CMAX_L,f,c}}$.
- One NR uplink carrier with the output power set to 29dB below $P_{\text{CMAX_L,f,c}}$ and the E-UTRA band whose downlink is being tested has its uplink carrier output power set to 4 dB below $P_{\text{CMAX_L,c}}$.

For the additional requirements for intra-band non-contiguous EN-DC of two sub-blocks, an in-gap test refers to the case when the interfering signal is located at a negative offset with respect to the assigned lowest channel frequency of the highest sub-block and located at a positive offset with respect to the assigned highest channel frequency of the lowest sub-block.

For the additional requirements for intra-band non-contiguous EN-DC of two sub-blocks, an out-of-gap test refers to the case when the interfering signal(s) is (are) located at a positive offset with respect to the assigned channel frequency of the highest carrier frequency or located at a negative offset with respect to the assigned channel frequency of the lowest carrier frequency.

For the additional requirements for intra-band non-contiguous EN-DC of two sub-blocks with channel bandwidth larger than or equal to 5 MHz, the existing adjacent channel selectivity requirements, in-band blocking requirements (for each case), and narrow band blocking requirements apply for in-gap tests only if the corresponding interferer frequency offsets with respect to the two measured carriers satisfy the following condition in relation to the sub-block gap size W_{gap} for at least one of the E-UTRA or NR sub-blocks, so that the interferer frequency position does not change the nature of the core requirement tested:

$$W_{\text{gap}} \geq 2 \cdot |F_{\text{Interferer (offset)}}| - BW_{\text{Channel}}$$

For the E-UTRA sub-block, the $F_{\text{Interferer (offset)}}$, for a sub-block with a single component carrier is the interferer frequency offset with respect to carrier as specified in clause 7.5.1, clause 7.6.1 and clause 7.6.3 for the respective requirement in TS 36.521 [10] and BW_{Channel} . $F_{\text{Interferer (offset)}}$ for the E-UTRA sub-block with two or more contiguous component carriers

is the interference frequency offset with respect to the carrier adjacent to the gap is specified in clause 7.5.1A, 7.6.1A and 7.6.3A in TS 38.521 [10].

For the NR sub-block, the $F_{\text{Interferer (offset)}}$ for a sub-block with a single component carrier is the interferer frequency offset with respect to carrier as specified in clause 7.5, clause 7.6.2 and clause 7.6.4 for the respective requirement in TS 38.521-1 [8] and BW_{Channel} .

The interferer frequency offsets for adjacent channel selectivity, each in-band blocking case and narrow-band blocking shall be tested separately with a single in-gap interferer at a time.

Unless otherwise stated, Channel Bandwidth shall be prioritized in the selecting of test points. Subcarrier spacing shall be selected after Test Channel Bandwidth is selected.

For conformance testing involving FR2 test cases in this specification, the UE under test shall be pre-configured with UL Tx diversity schemes disabled to account for single polarization System Simulator (SS) in the test environment. The UE under test may transmit with dual polarization.

7.2 Void

7.3 Void

7.3A Reference sensitivity for CA without EN-DC

7.3A.1 General

For NR CA operation NR single carrier REFSENS requirements defined in TS 38.101-1 [2] and TS 38.101-2 [3] apply to all downlink bands part of NR CA configurations listed in Table 5.2A.1-1 unless sensitivity degradation is allowed as defined in clause 7.3A in TS 38.101-3 [4].

7.3A.2 Reference sensitivity power level for CA without EN-DC

7.3A.2.1 Test purpose

Same test purpose as in clause 7.3.2 in TS 38.521-1 [8] for NR FR1 carrier(s) and clause 7.3.2 in TS 38.521-2 [9] for NR FR2 carrier(s).

7.3A.2.2 Test applicability

The requirements in this test are not testable due to issues with combined testing of NR FR1 conducted mode with NR FR2 in radiated mode. Therefore, the conducted and radiated requirements are tested separately.

No test case details are specified. The SA requirements for receiver sensitivity power level apply and are tested in TS 38.521-1 [8] clauses 7.3 and 7.3A and TS 38.521-2 [9] clauses 7.3 and 7.3A.

7.3A.3 $\Delta R_{\text{IB,c}}$ for CA without EN-DC

For the UE which supports inter-band NR CA configuration, the minimum requirement for reference sensitivity in clause 7.3.2 in TS 38.101-1 [2] and clause 7.3.2, 7.3A.2 in TS 38.101-2 [3] shall be increased by the amount given in $\Delta R_{\text{IB,c}}$ in Tables below. Unless otherwise stated, $\Delta R_{\text{IB,c}}$ is set to zero.

In case the UE supports more than one of band combinations for CA, SUL or DC, and an operating band belongs to more than one band combinations then

- When the operating band frequency range is $\leq 1\text{GHz}$, the applicable additional $\Delta R_{\text{IB,c}}$ shall be the average value for all band combinations defined in clause 7.3A, 7.3B, 7.3C in this specification and 7.3A, 7.3B in TS 38.101-3 [4], truncated to one decimal place that apply for that operating band among the supported band combinations. In case there is a harmonic relation between low band UL and high band DL, then the maximum $\Delta R_{\text{IB,c}}$ among the different supported band combinations involving such band shall be applied

- When the operating band frequency range is > 1 GHz, the applicable additional $\Delta R_{IB,c}$ shall be the maximum value for all band combinations defined in clause 7.3A, 7.3B, 7.3C in this specification and 7.3A, 7.3B in TS 38.101-3 [4] for the applicable operating bands.

7.3A.3.1 $\Delta R_{IB,c}$ for Inter-band CA between FR1 and FR2 without EN-DC

Unless otherwise stated, $\Delta R_{IB,c}$ for NR FR1 band and FR2 band of inter-band CA defined in table 5.5A.1-1 is set to zero.

7.3A.4 Void

7.3B Reference sensitivity level for DC

7.3B.1 General

For EN-DC, E-UTRA and NR single carrier, CA, and MIMO operation of REFSENS requirements defined in TS 38.101-1 [2], TS 38.101-2 [3] and TS 36.101 [5] apply to all downlink bands of EN-DC configurations listed in clause 5.5B, unless sensitivity degradation exception is allowed in this clause of this specification, clause 7.3 in TS 38.101-1 [2], clause 7.3 in TS 38.101-2 [3] or clause 7.3 in TS 36.101 [5]. Allowed exceptions specified in this clause also apply to any higher order EN-DC configuration combination containing one of the band combinations that exception is allowed for. Reference sensitivity exceptions are specified by applying maximum sensitivity degradation (MSD) into applicable REFSENS requirement. EN-DC REFSENS requirements shall be met for NR uplink transmissions using QPSK DFT-s-OFDM waveforms as defined in clause 7.3.2 in TS 38.101-1 [2]. Unless otherwise specified UL allocation uses the lowest SCS allowable for a given channel BW. Limits on configured maximum output power for the uplink according to subclause 6.2B.4 shall apply.

In case of interband EN-DC the receiver REFSENS requirements in this clause do not apply for 1.4 and 3 MHz E-UTRA carriers. For the case of inter-band EN-DC with a single carrier per cell group and multi-carrier per cell group, in addition to the E-UTRA and NR single carrier, CA, and MIMO operation of REFSENS requirements defined in TS 38.101-1 [2], TS 38.101-2 [3], and TS 36.101 [5], the REFSENS requirements specified therein also apply with both downlink carriers and both uplink carriers active unless sensitivity exceptions are allowed in this clause of this specification, clause 7.3 in TS 38.101-1 [2] or clause 7.3 in TS 36.101 [5].

NOTE: For inter-band EN-DC, the reference sensitivity requirement with both uplink carriers active is allowed to be verified for only a single inter-band EN-DC configuration per NR band.

7.3B.2 Reference sensitivity for EN-DC

7.3B.2.0 Minimum Conformance Requirements of Reference sensitivity for EN-DC

7.3B.2.0.1 Intra-band contiguous EN-DC

For intra-band contiguous EN-DC configurations, the reference sensitivity power level REFSENS is the minimum mean power applied to each one of the UE antenna ports at which the throughput for the carrier(s) of the E-UTRA and NR CGs shall meet or exceed the requirements for the specified E-UTRA and NR reference measurement channels. The reference sensitivity requirements apply with all uplink carriers and all downlink carriers active for EN-DC configuration and Uplink EN-DC configuration listed in Table 5.5B.2-1 and Table 5.5B.3-1, as supported by the UE. For EN-DC configurations where uplink is not available in either the MCG or the SCG or for EN-DC configurations where the UE only supports single uplink operation, reference sensitivity requirements apply with single uplink transmission. The downlink carrier(s) from the cell group with uplink shall be configured closer to the uplink operating band than any of the downlink carriers from the cell group without uplink.

Sensitivity degradation is allowed for Intra-band contiguous EN-DC configurations listed in Table 7.3B.2.0.1-1, the reference sensitivity is defined only for the specific uplink and downlink test points which are specified in Table 7.3B.2.0.1-1 and E-UTRA and NR single carrier requirements do not apply.

Table 7.3B.2.0.1-1: Reference sensitivity (MSD) for intra-band contiguous EN-DC

EN-DC configuration/channel allocations/MSD								
EN-DC configuration	E-UTRA/NR band	F _c (UL) (MHz)	Channel bandwidth (MHz)	UL allocation (L _{CRB})	F _c (DL) (MHz)	MSD (dB)	Duplex mode	
DC_(n)71AA	71	665.5	5	5 (RB _{end} = 24)	619.5	0	FDD	
	n71	675.5	15	15 (RB _{start} = 0)	629.5	1.8		
DC_(n)71AA	71	670.5	15	15 (RB _{end} = 74)	624.5	0		
	n71	680.5	5	5 (RB _{start} = 0)	634.5	1.6		
DC_(n)71AA	71	668	10	10 (RB _{end} = 49)	622	0		
	n71	678	10	10 (RB _{start} = 0)	632	1.7		
DC_(n)71AA	71	668	10	10 (RB _{start} = 0)	622	17.2		
	n71	678	10	10 (RB _{end} = 51)	632	29.4		
DC_(n)71AA	71	665.5	5	5 (RB _{end} = 24)	619.5	0		FDD
	n71	675.5	151	15 (RB _{start} = 0)	6321	2.5		
DC_(n)71AA	71	670.5	15	15 (RB _{end} = 74)	624.5	0		
	n71	680.5	51	5 (RB _{start} = 0)	6371	2.2		
DC_(n)71AA	71	668	10	10 (RB _{end} = 49)	622	0		
	n71	678	101	10 (RB _{start} = 0)	634.51	2.5		
DC_(n)71AA	71	668	10	10 (RB _{start} = 0)	622	17.2		
	n71	678	101	10 (RB _{end} = 51)	634.51	29.1		
NOTE 1: In accordance to BCS1, the NR uplink bandwidth is specified as in this table, but the corresponding NR downlink bandwidth is 5 MHz larger.								
NOTE 2: The transmitters powers shall be set to P _{UMAX} , as defined in TS 38.101-1 [2], TS 38.101-2 [3], and TS 36.101 [5], with additional limits on configured maximum output power for the uplink according to subclause 6.2B.4.								

7.3B.2.0.2 Intra-band non-contiguous EN-DC

For intra-band non-contiguous EN-DC configurations, the reference sensitivity power level REFSENS is the minimum mean power applied to each one of the UE antenna ports at which the throughput for the carrier(s) of the E-UTRA and NR CGs shall meet or exceed the requirements for the specified E-UTRA and NR reference measurement channels.

For DC_3A_n3A intra-band non-contiguous EN-DC combination, only single switched UL is supported in rel.15, therefore, no MSD is specified and E-UTRA and NR single carrier requirements apply.

7.3B.2.0.3 Inter-band EN-DC within FR1

Reference sensitivity exceptions are specified for the condition when there is uplink transmission only in the aggressor band.

7.3B.2.0.3.1 Reference sensitivity exceptions due to UL harmonic interference for EN-DC in NR FR1

Sensitivity degradation is allowed for a band if it is impacted by UL harmonic interference from another band part of the same EN-DC configuration. Reference sensitivity exceptions for the victim band (high) are specified in Table 7.3B.2.0.3.1-1 with uplink configuration of the aggressor band (low) specified in Table 7.3B.2.0.3.1-2.

Table 7.3B.2.0.3.1-1: Reference sensitivity exceptions (MSD) due to UL harmonic for EN-DC in NR FR1

E-UTRA or NR Band / Channel bandwidth of the affected DL band / MSD													
UL band	DL band	5 MHz (dB)	10 MHz (dB)	15 MHz (dB)	20 MHz (dB)	25 MHz (dB)	30 MHz (dB)	40 MHz (dB)	50 MHz (dB)	60 MHz (dB)	80 MHz (dB)	90 MHz (dB)	100 MHz (dB)
1, 3	n77 ^{2, 13}		23.9	22.1	20.9			17.9	16.8	16.0	14.8	14.3	13.8
	n77 ³		1.1	0.8	0.3								
2	n78 ^{2, 13}		23.9	22.1	20.9			17.9	16.8	16.0	14.8	14.3	13.8
	n78 ³		1.1	0.8	0.3								
3	n78 ^{2, 13}		23.9	22.1	20.9			17.9	16.8	16.0	14.8	14.3	13.8
	n78 ³		1.1	0.8	0.3								
5	n78 ^{6,7}		10.5	8.9	7.8			5.4	4.2	3.5	2.3	2.1	1.4
8	n41 ^{8,9}		13	11.3	10.1			7.0	6.1	5.5	4.3	3.9	3.5
8	n77 ^{6,7} n78 ^{6,7}		10.8	9.1	8			5.1	4.2	3.5	2.3	2.1	1.4
8	n79 ^{4,5}							6.8	6.2	5.6	4.9		4.4
12	n66 ^{8,9,10}	10	7.5	6.2	5.5			2.4					
12	n78 ^{4,5}		10.4	8.9	7.8			4.7	3.7	3	1.7	1.2	0.7
18, 19	n77 ^{4,5} n78 ^{4,5}		10.4	8.9	7.8			4.7	3.7	3	1.7	1.2	0.7
28	n51 ^{2,13}	27.8											
	n51 ³	1.9											
28	n77 ^{4,5} n78 ^{4,5}		10.4	8.9	7.8			4.7	3.7	3	1.7	1.2	0.7
20	n77 ^{6,7} n78 ^{6,7}		10.8	9.1	8			6	4.0	3.2	2.0	1.5	1.0
26	n41 ^{8,9}		10.3	8.4	7.4			5	4.3	3.9	3.1	2.7	
26	n77 ^{6,7} n78 ^{6,7}		10.8	9.1	8			6	4.0	3.2	2.0	1.5	1.0
n28	1 ^{8,9,10}	10.2	7.6	6.2	5.3								
n71	2 ¹¹	4.6	1.0	0.7	0.6								
	2 ¹²	1.7	1.0	0.7	0.6								
n71	7 ^{6,7}	14.6	11.7	10.1	9								
66	n78 ^{2, 13}		23.9	22.1	20.9			17.9	16.8	16.0	14.8	14.3	13.8
	n78 ³		1.1	0.8	0.3								
n66	48 ^{2,13}	27.3	24.4	22.4	21.2								
	48 ³	1.9	1.4	0.9	0.4								

- NOTE 1: Void.
- NOTE 2: The requirements should be verified for UL EARFCN or NR ARFCN of the aggressor (lower) band (superscript LB) such that $f_{UL}^{LB} = \lfloor f_{DL}^{HB} / 0.2 \rfloor \cdot 0.1$ in MHz and $F_{UL_low}^{LB} + BW_{Channel}^{LB} / 2 \leq f_{UL}^{LB} \leq F_{UL_high}^{LB} - BW_{Channel}^{LB} / 2$ with carrier frequency in the victim (higher) band in MHz and the channel bandwidth configured in the lower band.
- NOTE 3: The requirements are only applicable to channel bandwidths no larger than 20 MHz and with a carrier frequency at $\pm (20 + BW_{Channel}^{HB} / 2)$ MHz offset from $2f_{UL}^{LB}$ in the victim (higher) band) with $F_{UL_low}^{LB} + BW_{Channel}^{LB} / 2 \leq f_{UL}^{LB} \leq F_{UL_high}^{LB} - BW_{Channel}^{LB} / 2$, where $BW_{Channel}^{LB}$ and $BW_{Channel}^{HB}$ are the channel bandwidths configured in the aggressor (lower) and victim (higher) bands in MHz, respectively.
- NOTE 4: These requirements apply when there is at least one individual RE within the uplink transmission bandwidth of the aggressor (lower) band for which the 5th transmitter harmonic is within the downlink transmission bandwidth of a victim (higher) band.
- NOTE 5: The requirements should be verified for UL EARFCN of the aggressor (lower) band (superscript LB) such that $f_{UL}^{LB} = \lfloor f_{DL}^{HB} / 0.5 \rfloor \cdot 0.1$ in MHz and $F_{UL_low}^{LB} + BW_{Channel}^{LB} / 2 \leq f_{UL}^{LB} \leq F_{UL_high}^{LB} - BW_{Channel}^{LB} / 2$ with carrier frequency in the victim (higher) band in MHz and the channel bandwidth configured in the lower band.
- NOTE 6: These requirements apply when there is at least one individual RE within the uplink transmission bandwidth of the aggressor (lower) band for which the 4th transmitter harmonic is within the downlink transmission bandwidth of a victim (higher) band.
- NOTE 7: The requirements should be verified for UL EARFCN of the aggressor (lower) band (superscript LB) such that $f_{UL}^{LB} = \lfloor f_{DL}^{HB} / 0.4 \rfloor \cdot 0.1$ in MHz and $F_{UL_low}^{LB} + BW_{Channel}^{LB} / 2 \leq f_{UL}^{LB} \leq F_{UL_high}^{LB} - BW_{Channel}^{LB} / 2$ with carrier frequency in the victim (higher) band in MHz and the channel bandwidth configured in the lower band.
- NOTE 8: These requirements apply when there is at least one individual RE within the uplink transmission bandwidth of a low band for which the 3rd transmitter harmonic is within the downlink transmission bandwidth of a high band.
- NOTE 9: The requirements should be verified for UL EARFCN of the aggressor (lower) band (superscript LB) such that in MHz and $F_{UL_low}^{LB} + BW_{Channel}^{LB} / 2 \leq f_{UL}^{LB} \leq F_{UL_high}^{LB} - BW_{Channel}^{LB} / 2$ with the carrier frequency in the victim (higher) band in MHz and the channel bandwidth configured in the low band.
- NOTE 10: Applicable for the operations with 2 or 4 antenna ports supported in the band with carrier aggregation configured.
- NOTE 11: These requirements apply when the lower edge frequency of the 5 MHz uplink channel in Band 71 is located at or below 668 MHz and the downlink channel in Band 2 is located with its upper edge at 1990 MHz.
- NOTE 12: These requirements apply when the lower edge frequency of the 10 MHz, 15 MHz, or 20 MHz uplink channel in Band 71 is located at or below 668 MHz and the downlink channel in Band 2 is located with its upper edge at 1990 MHz.
- NOTE 13: These requirements apply when there is at least one individual RE within the uplink transmission bandwidth of the aggressor (lower) band for which the 2nd transmitter harmonic is within the downlink transmission bandwidth of a victim (higher) band and a range ΔF_{HD} above and below the edge of this downlink transmission bandwidth. The value ΔF_{HD} depends on the EN-DC band combination: $\Delta F_{HD} = 10$ MHz for DC_1_n77, DC_2_n77, DC_66_n77, DC_3_n77, DC_3_n78, DC_28_n51, DC_66_n78.
- NOTE 14: MSD test point can be chosen according to supported BW and lowest SCS supported by the UE

Table 7.3B.2.0.3.1-2: Uplink configuration for reference sensitivity exceptions due to UL harmonic interference for EN-DC in NR FR1

E-UTRA or NR Band / Channel bandwidth of the affected DL band / UL RB allocation of the aggressor band														
UL band	DL band	SCS of UL band (kHz)	5 MHz (LCRB)	10 MHz (LCRB)	15 MHz (LCRB)	20 MHz (LCRB)	25 MHz (LCRB)	30 MHz (LCRB)	40 MHz (LCRB)	50 MHz (LCRB)	60 MHz (LCRB)	80 MHz (LCRB)	90 MHz (LCRB)	100 MHz (LCRB)
1	n77	15		25	36	50			100	100	100	100	100	100
2	n78	15		25	36	50			50	50	50	50	50	50
3	n77	15		25	36	50			50	50	50	50	50	50
3	n78	15		25	36	50			50	50	50	50	50	50
5	n78	15	8	16	25	25			25					
8	n41	15		16	25	25			25	25	25	25	25	25
8	n77 n78	15		16	25	25			25	25	25	25	25	25
8	n79	15							25	25	25	25		25
12	n66	15	8	16	20	20			20					
12	n78	15		10	15	20			25	25	25	25	25	25
18	n77, n78	15		16	25	25			25	25	25	25	25	25
19	n77, n78	15		16	25	25			25	25	25	25		25
20	n77 n78	15		16	25	25 ¹ , 25 ²			25	25	25	25	25	25
26	n41	15		16	25	25			25	25				
26	n77 n78	15		16	25	25			25	25	25	25	25	25
n28	1	15	8	16	25	25								
28	n51	15	12											
28	n77 n78	15		10	-15	20			25	25	25	25	25	25
66	n78	15		25	36	50			100	100	100	100	100	100
n66	48	15	12	25	36	50								
n71	2	15	25 ⁴ / 8 ⁵	25 ⁴ / 8 ⁵	20 ⁴ / 8 ⁵	20 ⁴ / 8 ⁵								
n71	7	15	8	16	25	25								

NOTE 1: The UL configuration applies regardless of the channel bandwidth of the UL band unless the UL resource blocks exceed that specified in Table 7.3.1-2 in TS 36.101 [5] or Table 7.3.2-3 in TS 38.101-1 [2] for the uplink bandwidth in which case the allocation according to Table 7.3.1-2 in TS 36.101 [5] or Table 7.3.2-3 in TS 38.101-1 [2] applies.

NOTE 2: Void.

NOTE 3: Unless stated otherwise, UL resource blocks shall be centred within the transmission bandwidth configuration for the channel bandwidth.

NOTE 4: These requirements apply when the lower edge frequency of the 5 MHz uplink channel in Band 71 is located at or below 668 MHz and the downlink channel in Band 2 is located with its upper edge at 1990 MHz.

NOTE 5: These requirements apply when the lower edge frequency of the 10 MHz, 15 MHz, or 20 MHz uplink channel in Band 71 is located at or below 668 MHz and the downlink channel in Band 2 is located with its upper edge at 1990 MHz.

NOTE 6: If the aggressor band is NR band, the test SCS and UL RB can be adjusted according to supported BW and lowest SCS supported by the UE

7.3B.2.0.3.2 Reference sensitivity exceptions due to receiver harmonic mixing for EN-DC in NR FR1

Sensitivity degradation is allowed for a band if it is impacted by receiver harmonic mixing due to another band part of the same EN-DC configuration. Reference sensitivity exceptions for the victim band (low) are specified in Table 7.3B.2.0.3.2-1 with uplink configuration of the aggressor band (high) specified in Table 7.3B.2.0.3.2-2.

Table 7.3B.2.0.3.2-1: Reference sensitivity exceptions (MSD) due to receiver harmonic mixing for EN-DC in NR FR1

E-UTRA or NR Band / Channel bandwidth of the affected DL band / MSD												
UL band	DL band	5 MHz (dB)	10 MHz (dB)	15 MHz (dB)	20 MHz (dB)	25 MHz (dB)	40 MHz (dB)	50 MHz (dB)	60 MHz (dB)	80 MHz (dB)	90 MHz (dB)	100 MHz (dB)
2	n71 ⁴	26.8	23.6	21.2	15.6							
n41	26 ⁴	24.3	24.3	22.5	N/A							
n77	3	5.7	4.0	3.0	2.7							
n78	3	5.7	4.0	3.0	2.7							
n77	41 ⁸	10.4	10.4	10.4	10.4							
n77	28 ²	28	25	23.2	22							
n78	41 ⁸	10.4	10.4	10.4	10.4							
n79	11 ⁴	39.3	36.3	34.5								
n79	19 ²	29.5	26.5	24.7								
n79	21 ⁴	39.3	36.3	34.5								
n79	26 ²	27	24	22.2								

NOTE 1: These requirements apply when there is at least one individual RE within the uplink transmission bandwidth of the aggressor (higher) band for which the mixing product due to harmonic of victim (lower) band LO with leakage of aggressor (higher) band is within the downlink transmission bandwidth of a victim (lower) band.

NOTE 2: The requirements should be verified for DL EARFCN of the victim (lower) band (superscript LB) such that $f_{DL}^{LB} = \lfloor f_{UL}^{HB} / 0.5 \rfloor 0.1$ with f_{DL}^{LB} the DL carrier frequency in the lowerband and f_{UL}^{HB} the UL carrier frequency in the higher band, both in MHz.

NOTE 3: Void.

NOTE 4: The requirements should be verified for DL EARFCN or NR-ARFCN of the victim (lower) band (superscript LB) such that $f_{DL}^{LB} = \lfloor f_{UL}^{HB} / 0.3 \rfloor 0.1$ with f_{DL}^{LB} the DL carrier frequency in the lower band and in MHz and f_{UL}^{HB} the UL carrier frequency in the higher band, both in MHz.

NOTE 5: Void.

NOTE 6: Void.

NOTE 7: Void.

NOTE 8: The requirements should be verified for DL EARFCN of the victim (lower) band (superscript LB) such that $f_{DL}^{LB} = \lfloor f_{UL}^{HB} / 0.15 \rfloor 0.1$ with f_{DL}^{LB} the DL carrier frequency in the lower band and f_{UL}^{HB} the UL carrier frequency in the higher band, both in MHz.

NOTE 9: MSD test point can be chosen according to supported BW and lowest SCS supported by the UE.

Table 7.3B.2.0.3.2-2: Uplink configuration for reference sensitivity exceptions due to receiver harmonic mixing for EN-DC in NR FR1

E-UTRA or NR Band / SCS / Channel bandwidth of the affected DL band / UL RB allocation of the aggressor band													
UL band	DL band	SCS of UL band (kHz)	5 MHz (L _{CRB})	10 MHz (L _{CRB})	15 MHz (L _{CRB})	20 MHz (L _{CRB})	25 MHz (L _{CRB})	40 MHz (L _{CRB})	50 MHz (L _{CRB})	60 MHz (L _{CRB})	80 MHz (L _{CRB})	90 MHz (L _{CRB})	100 MHz (L _{CRB})
2	n71	15	25	50	50	50							
n41	26	15	25	50	75								
n77	3	15	25	50	75	100							
n78	3	15	25	50	75	100							
n77	28	15	25	50	75	100							
n77	41	15	12	25	36	50							
n78	41	15	12	25	36	50							
n79	11	15	25	50	75								
n79	19	15	25	50	75								
n79	21	15	25	50	75								
n79	26	15	25	50	75								

NOTE 1: Void.
 NOTE 2: Void.
 NOTE 3: The UL configuration applies regardless of the channel bandwidth of the UL band. UL resource blocks allocation in the table shall be further limited to that specified in Table 7.3.1-2 in TS 36.101 [5] or Table 7.3.2-3 in TS 38.101-1[2].
 NOTE 4: Unless otherwise stated, the UL resource blocks allocation is applied at the center of the channel bandwidth. The note applies to the entire table.
 NOTE 5: If the aggressor band is NR band, the test SCS and UL RB can be adjusted according to supported BW and lowest SCS supported by the UE.

7.3B.2.0.3.3 Void

7.3B.2.0.3.4 Reference sensitivity exceptions due to cross band isolation for EN-DC in NR FR1

Sensitivity degradation is allowed for a band if it is impacted by UL of another band part of the same EN-DC configuration due to cross band isolation issues. Reference sensitivity exceptions for the victim band are specified in Table 7.3B.2.0.3.4-1, Table 7.3B.2.0.3.4-1a with uplink configuration of the aggressor band specified in Table 7.3B.2.0.3.4-2.

Table 7.3B.2.0.3.4-1: Reference sensitivity exceptions (MSD) due to cross band isolation for PC3 EN-DC in NR FR1

E-UTRA or NR Band / Channel bandwidth of the affected DL band /MSD													
UL band	DL band	5 MHz (dBm)	10 MHz (dB)	15 MHz (dB)	20 MHz (dB)	25 MHz (dB)	30 MHz (dB)	40 MHz (dB)	50 MHz (dB)	60 MHz (dB)	80 MHz (dB)	90 MHz (dB)	100 MHz (dB)
n1 ³	3	[3]	2.3	2	1.8								
1 ⁴	n3	3	2.2	1.9	1.7	1.6	1.5	[1.4]					
1	n40	6.6	6.6	6.6	6.6	6.6	6.6	6.6	6.6	6.6	6.6		
n40	1	8.3	8.3	8.3	8.3								
n41	2	0.6	0.6	0.6	0.6								
n41	25	0.6	0.6	0.6	0.6								
n77	41 ¹	4.5	4.5	4.5	4.5								
n41	66 ¹	3.5	3.5	3.5	3.5								
41	n77		8.3	8.3	8.3			6.3	5.3	4.5	4.0	3.9	3.8
3	n51	6.4											
30	n66	8.3	8.3	8.3	8.3			8.3					
n78	7 ¹	4.5	4.5	4.5	4.5								
n78	38	3.3	3.3	3.3	3.3								
n78	41 ¹	4.5	4.5	4.5	4.5								
n78	46				7								
41	n78		8.3	8.3	8.3			6.3	5.3	4.5	4.0	3.9	3.8
n79	42 ⁴	2.8	2.8	2.8	2.8								

NOTE 1: Applicable only when harmonic mixing MSD for this combination is not applied.
 NOTE 2: The DL victim band should be configured using the lowest SCS that is compatible with the highest CBW for which an MSD is specified.
 NOTE 3: MSD test point can be chosen according to supported BW and lowest SCS supported by the UE.
 NOTE 4: The requirements only apply for UEs supporting inter-band DC_42_n79 ENDC with simultaneous Rx/Tx capability. Simultaneous Rx/Tx capability does not apply for UEs supporting band 42 with a n77 implementation only. These restrictions are applicable to related higher order configurations.
 NOTE 5: These requirements apply when the uplink is active in Band n1, n84 and the separation between the lower edge of the uplink channel in Band n1, n84 and the upper edge of the downlink channel in Band 3 is < 60 MHz. For each channel bandwidth in Band 3, the requirement applies regardless of channel bandwidth in Band n1, n84.

Table 7.3B.2.0.3.4-1a: Reference sensitivity exceptions (MSD) due to cross band isolation for PC2 EN-DC in NR FR1

E-UTRA or NR Band / Channel bandwidth of the affected DL band / MSD													
UL band	DL band	5 MHz (dB)	10 MHz (dB)	15 MHz (dB)	20 MHz (dB)	25 MHz (dB)	30 MHz (dB)	40 MHz (dB)	50 MHz (dB)	60 MHz (dB)	80 MHz (dB)	90 MHz (dB)	100 MHz (dB)
3	n41		0.7	0.7	0.7			0.7	0.7	0.7	0.7	0.7	0.7
n41	3	2.3	2.3	2.3	2.3								

Table 7.3B.2.0.3.4-2: Uplink configuration for reference sensitivity exceptions due to cross band isolation for PC3 EN-DC in NR FR1

E-UTRA or NR Band / SCS / Channel bandwidth of the affected DL band / UL RB allocation of the aggressor band														
UL band	DL band	SCS of UL band (kHz)	5 MHz (L _{CRB})	10 MHz (L _{CRB})	15 MHz (L _{CRB})	20 MHz (L _{CRB})	25 MHz (L _{CRB})	30 MHz (L _{CRB})	40 MHz (L _{CRB})	50 MHz (L _{CRB})	60 MHz (L _{CRB})	80 MHz (L _{CRB})	90 MHz (L _{CRB})	100 MHz (L _{CRB})
n1	3	15	25	25	25	25								
1	n3	15	25	25	25	25	25	25	[25]					
1	n40	15	25	50	75	100	100	100	100	100	100	100		
n40	1	15	25	50	75	100								
n41	2	30	160	160	160	160								
n41	25	30	160	160	160	160								
n77	41	30	270	270	270	270								
n41	66	30	128	128	128	128								
41	n77	15		100	100	100			100	100	100	100	100	100
3	n51	15	25											
30	n66	15	25	25	25	25			25					
n78	7	30	270	270	270	270								
n78	38	30	270	270	270	270								
n78	41	30	270	270	270	270								
n78	46	30				270								
41	n78	15		100	100	100			100	100	100	100	100	100
n79	42	30	270 ⁴	270 ⁴	270 ⁴	270 ⁴								

NOTE 1: The UL configuration applies regardless of the channel bandwidth of the UL band. UL resource blocks allocation in the table shall be further limited to that specified in Table 7.3.1-2 in TS 36.101 [5] or Table 7.3.2-3 in TS 38.101-1 [2].

NOTE 2: When the maximum UL RB allocation "L_{CRB}" value is less than the maximum transmission bandwidth configuration "N_{RB}" defined in Table 5.3.2-1 in 38.101-1 [2] for the specified UL band SCS, the UL band should be configured using the lowest CBW that is compatible with the maximum specified L_{CRB} value.

NOTE 3: If the aggressor band is NR band, the test SCS and UL RB can be adjusted according to supported BW and lowest SCS supported by the UE.

NOTE 4: The requirements only apply for UEs supporting inter-band ENDC with simultaneous Rx/Tx capability. Simultaneous Rx/Tx capability does not apply for UEs supporting band 42 with a n77 implementation only. These restrictions are applicable to related higher order configurations.

7.3B.2.0.3.5 MSD for intermodulation interference due to dual uplink operation for EN-DC in NR FR1

For EN-DC configurations in NR FR1 the UE may indicate capability of not supporting simultaneous dual uplink operation due to possible intermodulation interference overlapping in frequency to its own primary downlink channel bandwidth if

- the intermodulation order is 2;
- the intermodulation order is 3 when both operating bands are between 450 MHz – 960 MHz or between 1427 MHz – 2690 MHz

In the case for EN-DC configurations in NR FR1 for which the intermodulation products caused by dual uplink operation do not interfere with its own primary downlink channel bandwidth as defined in Annex M the UE is mandated to operate in dual and triple uplink mode.

For EN-DC configurations in NR FR1 with uplink and downlink assigned to E-UTRA and NR FR1 bands given in Table 7.3B.2.0.3.5.1-1, Table 7.3B.2.0.3.5.1-1a, Table 7.3B.2.0.3.5.2-0 and Table 7.3B.2.0.3.5.2-1 the reference sensitivity is defined only for the specific uplink and downlink test points specified in Table 7.3B.2.0.3.5.1-1, Table 7.3B.2.0.3.5.1-1a, Table 7.3B.2.0.3.5.2-0 and Table 7.3B.2.0.3.5.2-1. For these test points the reference sensitivity levels specified in clause 7.3.1 in TS 36.101 [5] and 7.3.2 of TS 38.101-1 [2] for the corresponding channel bandwidths

or in clause 7.3.1 of TS 36.101 [5] are relaxed by the amount of the parameter MSD given in Table 7.3B.2.0.3.5.1-1, Table 7.3B.2.0.3.5.1-1a, Table 7.3B.2.0.3.5.2-0 and Table 7.3B.2.0.3.5.2-1.

The throughput on each of the CGs shall be $\geq 95\%$ of the maximum throughput of the respective reference measurement channels as specified in Annex A of TS 38.101-1 [2] and Annex A of TS 36.101 [5], with parameters specified in Table 7.3B.2.0.3.5.1-1, Table 7.3B.2.0.3.5.1-1a, Table 7.3B.2.0.3.5.2-0 and Table 7.3B.2.0.3.5.2-1 with dual UL transmissions overlapping in time unless otherwise stated.

7.3B.2.0.3.5.1 MSD test points for intermodulation interference due to dual uplink operation for EN-DC in NR FR1 involving two bands

Table 7.3B.2.0.3.5.1-1: MSD test points for PCell due to dual uplink operation for EN-DC in NR FR1 (two bands)

NR or E-UTRA Band / Channel bandwidth / N _{RB} / MSD							
EN-DC Configuration	EUTRA or NR band	UL F _c (MHz)	UL/DL BW (MHz)	UL L _{CRB}	DL F _c (MHz)	MSD (dB)	IMD order
DC_1_n3	1	1950	5	25	2140	23	IMD3
	n3	1760	5	25	1855	N/A	N/A
DC_1A_n5A	1	1965	5	25	2155	6	IMD4
	n5	836.5	5	25	876.5	N/A	N/A
DC_1A_n77A DC_1A_SUL_n77A- n84A	1	1950	5	25	2140	29.8 32.5 ⁴	IMD2 ³
	n77, n78	4090	10	50	4090	N/A	N/A
DC_1A_n77A DC_1A-SUL_n77A- n84A DC_1A_n78A, DC_1A_SUL_n78A- n84A	1	1950	5	25	2140	8.0 10.7 ⁴	IMD4 ³
	n77, n78	3710	10	50	3710	N/A	N/A
DC_1A_n78A, DC_1A_SUL_n78A- n84A	1	1950	5	25	2140	8.0 10.7 ⁴	IMD4 ³
	n78	3710	10	25	3710	N/A	
DC_2A_n66A	2	1855	5	25	1935	20	IMD3
	n66	1775	5	25	2175	N/A	N/A
DC_2A_n66A	2	1883.3	5	25	1963.3	N/A	N/A
	n66	1750	5	25	2150	4	IMD5
DC_2A_n78A	2	1855	5	25	1935	26 28.7 ⁴	IMD2 ³
	n78	3790	10	50	3790	N/A	N/A
DC_2A_n78A	2	1885	5	25	1965	8.0 10.7 ⁴	IMD4 ³
	n78	3690	10	50	3700	N/A	N/A
DC_3_n1	3	1760	5	25	1855	N/A	N/A
	n1	1950	5	25	2140	23	IMD3
DC_3_n5	3	1771	10	50	1866	4	IMD4
	n5	838	5	25	883	N/A	N/A
	3	1721	10	50	1816	N/A	N/A
	n5	838	5	25	883	24	IMD2 ³
DC_3A_n7A DC_3C_n7A	3	1730	5	25	1825	N/A	N/A
	n7	2535	10	50	2655	10.2 ⁵	IMD4
DC_3A_n20A	3	1775	5	25	1870	4	IMD4
	n20	840	5	25	799	N/A	N/A
	3	1735	5	25	1830	N/A	N/A
	n20	847	5	25	806	9	IMD4
DC_3A_n41A DC_3C_n41A	3	1740	5	25	1835	8.2	IMD4
	n41	2657.5	10	50	2657.5	N/A	IMD4
DC_3A_SUL_n41A- n80A, DC_3C_SUL_n41A- n80A	3	1740	5	25	1835	8.2	IMD4
	n41	2657.5	10	52	2657.5	N/A	N/A
DC_3A_n77A DC_3A_SUL_n77A- n80A DC_3A_n78A DC_3A-SUL_n78A- n80A, DC_3C_n78A	3	1740	5	25	1835	26 28.7 ⁴	IMD2 ³
	n77, n78	3575	10	50	3575	N/A	N/A
DC_3A_n77A DC_3A_SUL_n77A- n80A, DC_3A_n78A DC_3A-SUL_n78A- n80A, DC_3C_n78A	3	1765	5	25	1860	8.0 10.7 ⁴	IMD4 ³
	n77, n78	3435	10	50	3435	N/A	N/A
DC_5A_n66A	5	838	5	25	883	30	IMD2 ³
	n66	1721	5	25	2121	N/A	N/A
DC_5A_n78A	5	844	5	25	889	8.3	IMD4
	n78	3421	10	50	3421	N/A	N/A

DC_7_n3	7	2535	10	50	2655	13	IMD4
	n3	1730	5	25	1825	N/A	N/A
DC_7_n5	7	2547	10	50	2667	N/A	N/A
	n5	834	5	25	879	12	IMD3 ³
DC_7A_n77A	7	2540	5	25	2660	7.1	IMD4
	n77	3870	10	50	3870	N/A	N/A
DC_7A_n66A	7	2535	10	50	2655	15	4 th IMD
DC_7A-7A_n66A DC_7C_n66A	n66	1730	5	25	2130	N/A	N/A
DC_8A_n1A	8	887.5	5	25	932.5	N/A	N/A
	n1	1965	5	25	2155	6	IMD4
DC_8A_n3A	8	900	5	25	945	8	IMD4 ³
	n3	1755	10	50	1850	N/A	N/A
	8	897.5	5	25	942.5	N/A	N/A
	n3	1747.5	10	50	1842.5	6.4	IMD5
DC_8A_n41A	8	882.5	5	25	927.5	12.1	IMD3 ³
	n41	2685	10	50	2685	N/A	N/A
DC_8A_SUL_n41A- n81A	8	882.5	5	25	927.5	12.1	IMD3 ³
	n41	2685	10	52	2685	N/A	N/A
DC_8A_n77A DC_8A_n78A DC_8A-n79C, DC_8A-SUL_n78A- n81A	8	897.5	5	25	942.5	8.3	IMD4
	n77, n78	3635	10	50	3635	N/A	H4
DC_12_n78	12	710	5	25	740	5.5	IMD5
	n78	3580	10	50	3580	N/A	N/A
DC_20A_n3A	20	840	5	25	799	N/A	N/A
	n3	1775	5	25	1870	4	IMD4
	20	847	5	25	806	9	IMD4
	n3	1735	5	25	1830	N/A	N/A
DC_8A_n79A DC_8A-SUL_n79A- n81A	8	897.5	5	25	942.5	4.8	IMD5
	n79	4532.5	40	216	4532.5	N/A	N/A
DC_18A_n77A DC_18A_n78A	18	N/A	N/A	N/A	N/A	N/A	IMD4
	n77, n78	N/A	N/A	N/A	N/A	N/A	N/A
DC_19A_n78A	19	N/A	N/A	N/A	N/A	N/A	IMD4
	n78	N/A	N/A	N/A	N/A	N/A	N/A
DC_20A_n8A	20	849.5	5	25	808.5	21	IMD3
	n8	892.5	5	25	937.5	21	IMD3
DC_20A_n77A DC_20A_n78A, DC_20A-SUL_n78A- n82A	20	850	5	25	809	11	IMD4
	n77, n78	3359	10	50	3359	N/A	N/A
DC_20A_n77A	20	840	5	25	799	6.5	IMD5 ⁴
	n77	4159	10	50	4159	N/A	N/A
DC_21A_n79A	21	1457.5	5	25	1505.5	18.4	IMD3
	n79	4420.5	40	216	4420.5	N/A	N/A
DC_26A_n41A	26	839	5	25	884	15.6	IMD3
	n41	2562	10	50	2562	N/A	N/A
DC_28A_n41A	28	723	105	25	768	12.7	IMD3
	n41	2225	105	25	2225	N/A	N/A
DC_28_n50	28	730	10	50	775	15.3	IMD 2
	n50	1500	10	50	1500	N/A	N/A
	28	740	10	50	785	6	IMD 4
	n50	1500	10	50	1500	N/A	N/A
	28	740	10	50	785	0.5	IMD 5
	n50	1500	10	50	1500	N/A	N/A
DC_28A_n51A	28	742.3	5	25	797.3	5	IMD 4
	n51	1429.5	5	25	1429.5	N/A	N/A
DC_26A_n77A, DC_26A_n78A	26	836.5	5	25	881.5	11.1	IMD4
	n77, n78	3391	10	50	3391	N/A	N/A
DC_28A_n77A,	28	705.5	5	25	760.5	5.5	IMD5

DC_28A_n78A, DC_28A-SUL_n78A- n83A	n77, n78	3582.5	10	50	3582.5	N/A	N/A
DC_48A_n66A	48	3630	20	100	3630	N/A	N/A
	n66	1715	5	25	2115	4	IMD5
DC_66A_n2A	66	1775	5	25	2175	N/A	N/A
	n2	1855	5	25	1935	20	IMD3
	66	1750	5	25	2150	4	IMD5
	n2	1883.3	5	25	1963.3	N/A	N/A
DC_66A_n5A	n5	838	5	25	883	30	IMD2 ³
	66	1721	5	25	2121	N/A	N/A
DC_66A_n25A	66	1775	5	25	2175	N/A	N/A
	n25	1855	5	25	1935	20	IMD3
	66	1712.5	5	25	2112.5	23	IMD3
	n25	1912.5	5	25	1992.5	N/A	N/A
	66	1750	5	25	2150	4	IMD5
DC_66A_n71A	n25	1883.3	5	25	1963.3	N/A	N/A
	66	1750	5	25	2150	5	IMD4
DC_66A_n78A	n71	675	5	25	629	N/A	N/A
	66	1730	5	25	2130	5.0	IMD5
	n78	3660	5	50	3660	N/A	N/A
NOTE 1: Both of the transmitters shall be set min(+20 dBm, P _{CMAX,L,c}) as defined in clause 6.2.5A.							
NOTE 2: RB _{START} = 0							
NOTE 3: This band is subject to IMD5 also which MSD is not specified.							
NOTE 4: Applicable only if operation with 4 antenna ports is supported in the band with EN-DC configured.							
NOTE 5: Void.							
NOTE 6: For NR band, UL/DL BW and UL L _{CRB} can be adjusted according to the supported BW and lowest SCS supported by the UE.							

Table 7.3B.2.0.3.5.1-1a: MSD test points for PCell due to dual uplink operation for PC2 EN-DC in NR FR1 (two bands)

NR or E-UTRA Band / Channel bandwidth / N _{RB} / MSD							
EN-DC Configuration	EUTRA or NR band	UL F _c (MHz)	UL/DL BW (MHz)	UL L _{CRB}	DL F _c (MHz)	MSD (dB)	IMD order
DC_3A_n41A	3	1740	5	25	1835	18.4	IMD4
	n41	2657.5	10	50	2657.5	N/A	N/A
DC_3A_n78A	3	1740	5	25	1835	31.9	IMD2
	n78	3575	10	50	3575	N/A	N/A
DC_3A_n78A	3	1765	5	25	1860	18.5	IMD4
	n78	3435	10	50	3435	N/A	N/A

Table 7.3B.2.0.3.5.1-1a: MSD test points for PCell due to dual uplink operation for PC2 EN-DC in NR FR1 (two bands)

NR or E-UTRA Band / Channel bandwidth / N _{RB} / MSD							
EN-DC Configuration	EUTRA or NR band	UL F _c (MHz)	UL/DL BW (MHz)	UL L _{CRB}	DL F _c (MHz)	MSD (dB)	IMD order
DC_3A_n78A	3	1740	5	25	1835	31.9	IMD2
	n78	3575	10	50	3575	N/A	N/A
DC_3A_n78A	3	1765	5	25	1860	18.5	IMD4
	n78	3435	10	50	3435	N/A	N/A

7.3B.2.0.3.5.2 MSD test points for intermodulation interference due to dual uplink operation for EN-DC in NR FR1 involving three bands

Table 7.3B.2.0.3.5.2-0: MSD test points for PCell due to dual uplink operation for EN-DC in NR FR1 (three bands)

NR or E-UTRA Band / Channel bandwidth / N _{RB} / MSD							
EN-DC Configuration	EUTRA/NR band	UL F _c (MHz)	UL/DL BW (MHz)	UL L _{CRB}	DL F _c (MHz)	MSD (dB)	IMD order
DC_66A_(n)71AA	66	1750	5	25	2150	5	IMD4
	n71	678	10	10 (RB _{start} =0)	632	N/A	N/A
NOTE 1: For NR band, UL/DL BW and UL L _{CRB} can be adjusted according to the supported BW and lowest SCS supported by the UE.							

Table 7.3B.2.0.3.5.2-1: MSD test points for Scell due to dual uplink operation for EN-DC in NR FR1 (three bands)

NR or E-UTRA Band / Channel bandwidth / NRB / MSD							
EN-DC Configuration	EUTRA/NR band	UL Fc (MHz)	UL/DL BW (MHz)	UL L _{CRB}	DL Fc (MHz)	MSD (dB)	IMD order
DC_1A-3A_n28A DC_1A-3C_n28A	1	1975	5	25	2165	N/A	N/A
	n28	710.5	5	25	765.5	N/A	N/A
	3	1723.5	5	25	1818.5	4.0	IMD5
DC_1A-3A_n28A DC_1A-3C_n28A	3	1780	5	25	1875	N/A	N/A
	n28	710.5	5	25	765.5	N/A	N/A
	1	1949	5	25	2139	11.0	IMD4
DC_1A-7A_n28A DC_1A-7C_n28A	1	1935	5	25	2125	N/A	N/A
	n28	718	5	25	773	N/A	N/A
	7	2533	10	50	2653	30.0	IMD2
DC_1A-3A_n77A	1	1950	5	25	2140	N/A	N/A
	3	1712.5	5	25	1807.5	31.5	IMD2
	n77	3757.5	10	50	3757.5	N/A	N/A
	1	1950	5	25	2140	N/A	N/A
	3	1775	5	25	1870	8.5	IMD4
	n77	3980	10	50	3980	N/A	N/A
	1	1950	5	25	2140	31.0	IMD2
	3	1775	5	25	1870	N/A	N/A
DC_1A-3A_n78A DC_1A-3C_n78A	n77	3915	10	50	3915	N/A	N/A
	1	1950	5	25	2140	N/A	N/A
	3	1712.5	5	25	1807.5	31.2	IMD2
	n78	3757.5	10	50	3757.5	N/A	N/A
	1	1935	5	25	2125	2.8	IMD5
	3	1775	5	25	1870	N/A	N/A
DC_1A-5A_n78A	n78	3725	10	50	3725	N/A	N/A
	1	1932	5	25	2122	18.1	IMD3
	5	829	5	25	874	N/A	N/A
	n78	3780	10	50	3780	N/A	N/A
	1	1975	5	25	2165	N/A	N/A
	5	840	5	25	885	3.1	IMD5
DC_1A-7A_n78A DC_1A-7C_n78A	n78	3405	10	50	3405	N/A	N/A
	1	1977.5	5	25	2167.5	N/A	N/A
	7	2507.5	5	25	2627.5	9.1	IMD4
	n78	3305	10	50	3305	N/A	N/A
	1	1950	5	25	2140	8.7	IMD4
	7	2510	10	50	2630	N/A	N/A
DC_1A_n7A-n78A	n78	3580	10	50	3580	N/A	N/A
	1	1977.5	5	25	2167.5	N/A	N/A
	n7	2507.5	5	25	2627.5	9.1	IMD4
	n78	3305	10	50	3305	N/A	N/A
	1	1970	5	25	2160	N/A	N/A
	n7	2520	5	25	2640	N/A	N/A
DC_1A-3A_n79A	n78	3390	10	52	3390	10.1	IMD4
	1	1950	5	25	2140	3.6	IMD5
	3	1750	5	25	1845	N/A	N/A
DC_1A-8A_n78A	n79	4860	40	216	4860	N/A	N/A
	1	N/A	N/A	N/A	N/A	N/A	N/A
	8	N/A	N/A	N/A	N/A	N/A	IMD5
DC_1A-8A_n78A	n78	N/A	N/A	N/A	N/A	N/A	N/A
	1	1945	5	25	2135	N/A	N/A
	8	900	5	25	945	N/A	N/A
	n78	3745	10	52	3745	14.9	IMD3
	1	1940	5	25	2130	N/A	N/A
	8	895	5	25	940	3.3	IMD5
DC_1A-18A_n77A	n78	3380	10	52	3330	N/A	N/A
	1	N/A	N/A	N/A	N/A	N/A	N/A
	18	N/A	N/A	N/A	N/A	N/A	IMD5
	n77	N/A	N/A	N/A	N/A	N/A	N/A
	1	1930	5	25	2120	16.4	IMD3
	18	825	5	25	870	N/A	N/A
DC_1A-18A_n78A	n77	3770	10	50	3770	N/A	N/A
DC_1A-18A_n78A	1	N/A	N/A	N/A	N/A	N/A	N/A

NR or E-UTRA Band / Channel bandwidth / NRB / MSD							
EN-DC Configuration	EUTRA/NR band	UL Fc (MHz)	UL/DL BW (MHz)	UL L _{CRB}	DL Fc (MHz)	MSD (dB)	IMD order
	18	N/A	N/A	N/A	N/A	N/A	IMD5
	n78	N/A	N/A	N/A	N/A	N/A	N/A
	1	1930	5	25	2120	16.4	IMD3
	18	819	5	25	864	N/A	N/A
	n78	3758	10	50	3758	N/A	N/A
DC_1A-18A_n79A	1	1935	5	25	2125	N/A	N/A
	18	822.5	5	25	867.5	18.3	IMD3
	n79	4737.5	40	216	4737.5	N/A	N/A
	1	1930	5	25	2120	N/A	N/A
	18	820	5	25	865	8.9	IMD4
	n79	4925	40	216	4925	N/A	N/A
	1	1935	5	25	2125	8.1	IMD4
	18	822.5	5	25	867.5	N/A	N/A
DC_1A-19A_n77A DC_1A-19A_n78A	n79	4592.5	40	216	4592.5	N/A	N/A
	1	1940	5	25	2130	17.8	IMD3
	19	832.5	5	25	877.5	N/A	N/A
	n77, n78	3795	10	50	3795	N/A	N/A
	1	N/A	N/A	N/A	N/A	N/A	N/A
DC_1A-19A_n79A	19	N/A	N/A	N/A	N/A	N/A	IMD5
	n78	N/A	N/A	N/A	N/A	N/A	N/A
	1	1950	5	25	2140	N/A	N/A
	19	837.5	5	25	882.5	18.3	IMD3
	n79	4782.5	40	216	4782.5	N/A	N/A
	1	1950	5	25	2140	8.1	IMD4
DC_1A-20A_n78A	19	837.5	5	25	882.5	N/A	N/A
	n79	4652.5	40	216	4652.5	N/A	N/A
	1	1930	5	25	2120	20.3	IMD3
DC_1A-20A_n78A	20	835	5	25	794	N/A	N/A
	n78	3790	10	50	3790	N/A	N/A
	1	1950	5	25	2140	N/A	N/A
DC_1A-21A_n77A DC_1A-21A_n78A	20	851	5	25	810	3.0	IMD5
	n78	3330	10	50	3330	N/A	N/A
	1	1964.6	5	25	2154.6	30.6	IMD2
	21	1450.4	5	25	1498.4	N/A	N/A
	n77, n78	3605	10	50	3605	N/A	N/A
	1	N/A	N/A	N/A	N/A	N/A	N/A
	21	N/A	N/A	N/A	N/A	N/A	IMD2
	n78	N/A	N/A	N/A	N/A	N/A	N/A
DC_1A-21A_n79A	1	1950	5	25	2140	N/A	N/A
	21	1452	5	25	1500	2.9	IMD5
	n77, n78	3675	10	50	3675	N/A	N/A
DC_1A-28A_n3A	1	N/A	N/A	N/A	N/A	N/A	N/A
	21	N/A	N/A	N/A	N/A	N/A	IMD4
	n79	N/A	N/A	N/A	N/A	N/A	N/A
DC_1A-28A_n77A	28	710.5	5	25	765.5	N/A	N/A
	n3	1780	5	25	1875	N/A	N/A
	1	1949	5	25	2139	11.0	IMD4
DC_1A-28A_n78A	1	1960	5	25	2150	15.8	IMD3
	28	740	5	25	795	N/A	N/A
	n77	3630	10	50	3630	N/A	N/A
DC_1A-28A_n78A	1	1960	5	25	2150	N/A	N/A
	28	725	5	25	780	4.3	IMD5
	n77	3330	10	50	3330	N/A	N/A
DC_1A-28A_n78A	1	1960	5	25	2150	15.7	IMD3
	28	740	5	25	795	N/A	N/A
	n78	3630	10	50	3630	N/A	N/A
DC_1A-28A_n78A	1	1970	5	25	2160	N/A	N/A
	28	739	5	25	794	4.2	IMD5
	n78	3352	10	50	3352	N/A	N/A
DC_1A_n28A-n78A	1	1950	5	25	2140	N/A	N/A
	n28	733	5	25	788	N/A	N/A

NR or E-UTRA Band / Channel bandwidth / NRB / MSD							
EN-DC Configuration	EUTRA/NR band	UL Fc (MHz)	UL/DL BW (MHz)	UL LCRB	DL Fc (MHz)	MSD (dB)	IMD order
	n78	3416	10	50	3416	15.7	IMD3
	1	1950	5	25	2140	N/A	N/A
	n78	3320	10	50	3320	N/A	N/A
	n28	735	5	25	790	3.3	IMD5
DC_1A-28A_n79A	1	1930	5	25	2120	N/A	N/A
	28	733	5	25	788	15.2	IMD3
	n79	4648	40	216	4648	N/A	N/A
	1	1925	5	25	2115	N/A	N/A
	28	740	5	25	795	10.0	IMD4
	n79	4980	40	216	4980	N/A	N/A
	1	1977.5	5	25	2167.5	1.2	IMD4
	28	745.5	5	25	800.5	N/A	N/A
	n79	4420	40	216	4420	N/A	N/A
	1	1935	5	25	2125	4.5	IMD5
	28	718	5	25	773	N/A	N/A
n79	4807	40	216	4807	N/A	N/A	
DC_1A_n40A-n78A	1	1930	5	25	2120	N/A	N/A
	n40	2340	5	25	2340	N/A	N/A
	n78	3450	10	50	3450	9.8	IMD4 3*fB1-fn40
	1	1960	5	25	2150	N/A	N/A
	n40	2360	5	25	2360	10.6	IMD4 3*fB1-fn78
	n78	3520	10	50	3520	N/A	N/A
DC_1A-41A_n28A	1	1935	5	25	2125	N/A	N/A
	n28	718	5	25	773	N/A	N/A
	41	2653	10	50	2653	30	IMD2
DC_1A-41A_n77A	1	1970	5	25	2160	N/A	N/A
	n77	3400	10	50	3400	N/A	N/A
	41	2510	5	25	2510	11.0	IMD4
	1	1950	5	25	2140	9.3	IMD4
	n77	3710	10	50	3710	N/A	N/A
	41	2640	5	25	2640	N/A	N/A
	1	1930	5	25	2120	N/A	N/A
	n77	4150	10	50	4150	N/A	N/A
DC_1A-41A_n78A	41	2510	5	25	2510	3.6	IMD5
	1	1950	5	25	2140	9.3	IMD4
	41	2640	5	25	2640	N/A	N/A
	n78	3710	10	50	3710	N/A	N/A
	1	1975	5	25	2165	N/A	N/A
	41	2515	5	25	2515	12	IMD4
DC_1A-41A_n78A	n78	3410	10	50	3410	N/A	N/A
	1	1955	5	25	2145	8.7	IMD4
	41	2507.5	10	50	2507.5	N/A	N/A
	n78	3580	10	50	3580	N/A	N/A
DC_1A-41A_n79A	1	1970	5	25	2160	N/A	N/A
	n79	4500	40	216	4500	N/A	N/A
	41	2530	5	25	2530	29.4	IMD2
DC_1A-42A_n79A	1	1977.5	5	25	2167.5	N/A	N/A
	n79	4420	40	216	4420	N/A	N/A
	42	3490	5	25	3490	4.8	IMD5
	42	3402.5	5	25	3402.5	N/A	N/A
	n79	4640	40	216	4640	N/A	N/A
	1	1975	5	25	2165	15.5	IMD3
	42	3450	5	25	3450	N/A	N/A
	n79	4520	40	216	4520	N/A	N/A
DC_1A-SUL_n77A-n80A	1	1950	5	25	2140	9.3	IMD4
	1	1950	5	25	2140	23	IMD3
	n80	1760	5	25		N/A	N/A

NR or E-UTRA Band / Channel bandwidth / NRB / MSD							
EN-DC Configuration	EUTRA/NR band	UL Fc (MHz)	UL/DL BW (MHz)	UL L _{CRB}	DL Fc (MHz)	MSD (dB)	IMD order
DC_1A-SUL_n77A-n80A	1	1922.5	5	25	2112.5	N/A	N/A
	n80	1782.5	5	25		N/A	N/A
	n78	3425	10	50	3425	13.0	IMD4
DC_1A_n78A-n79A	1	1950	5	25	2140	N/A	N/A
	n78	3410	10	50	3410	N/A	N/A
	n79	4870	40	216	4870	15.9	IMD3
	1	1950	5	25	2140	N/A	N/A
	n79	4670	40	216	4670	N/A	N/A
DC_2A-12A_n66A	n78	3490	10	50	3490	4.6	IMD5
	2	N/A	N/A	N/A	N/A	N/A	IMD4
	12	N/A	N/A	N/A	N/A	N/A	N/A
DC_2A-14A_n66A	n66	N/A	N/A	N/A	N/A	N/A	N/A
	2	1874	5	25	1954	7.2	IMD4
	14	793	5	25	763	N/A	N/A
DC_3A-5A_n78A	66	1770	5	25	2170	N/A	N/A
	3	N/A	N/A	N/A	N/A	N/A	IMD3
	5	N/A	N/A	N/A	N/A	N/A	N/A
DC_3A-7A_n28A DC_3A-7C_n28A DC_3C-7A_n28A DC_3C-7C_n28A	n78	N/A	N/A	N/A	N/A	N/A	N/A
	3	1712.5	5	25	1807.5	N/A	N/A
	n28	743	5	25	798	N/A	N/A
	7	2562	10	50	2682	16.9	IMD3
	7	2543	10	50	2663	N/A	N/A
DC_3A-7A_n78A DC_3C-7A_n78A DC_3C-7C_n78A DC_3A-3A-7A_n78A DC_3A-3A-7A-7A_n78A DC_3A-7A_SUL_n78A-n80A DC_3C-7A_SUL_n78A-n80A	n28	710.5	5	25	765.5	N/A	N/A
	3	1737.5	5	25	1832.5	26.0	IMD2
	3	1725	5	25	1820	17.6	IMD3
	7	2565	5	25	2685	N/A	N/A
	n78	3310	10	50	3310	N/A	N/A
DC_3A-8A_n77A	3	1725	5	25	1820	8.6	IMD4
	7	2565	5	25	2685	N/A	N/A
	n78	3475	10	50	3475	N/A	N/A
DC_3A-8A_n77A	3	1715	5	25	1810	N/A	N/A
	n77	4190	10	50	4190	N/A	N/A
	8	910	5	25	955	9.7	IMD4
DC_3A-8A_n77A	8	910	5	25	955	N/A	N/A
	n77	3640	10	50	3640	N/A	N/A
	3	1725	5	25	1820	16.5	IMD3
DC_3A-8A_n78A	8	910	5	25	955	N/A	N/A
	n78	3640	10	50	3640	N/A	N/A
	3	1725	5	25	1820	16.5	IMD3
DC_3A-8A_n79A	3	1755	5	25	1850	N/A	N/A
	n79	4465	40	216	4465	N/A	N/A
	8	910	5	25	955	15.3	IMD3
DC_3A-8A_n79A	8	910	5	25	955	N/A	N/A
	n79	4580	40	216	4580	N/A	N/A
	3	1755	5	25	1850	8.8	IMD4
DC_3A_n7A-n78A DC_3C_n7A-n78A	3	1730	5	25	1825	N/A	N/A
	n7	2560	5	25	2680	N/A	N/A
	n78	3390	10	52	3390	16.1	IMD3 2*fn7-fB3
DC_3A-8A_n78A	8	910	5	25	955	N/A	N/A
	n78	3640	10	50	3640	N/A	N/A
	3	1725	5	25	1820	16.5	IMD3
DC_3A-18A_n77A	3	N/A	N/A	N/A	N/A	N/A	IMD3

NR or E-UTRA Band / Channel bandwidth / NRB / MSD							
EN-DC Configuration	EUTRA/NR band	UL Fc (MHz)	UL/DL BW (MHz)	UL L _{CRB}	DL Fc (MHz)	MSD (dB)	IMD order
DC_3A-18A_n78A	18	N/A	N/A	N/A	N/A	N/A	N/A
	n77, n78	N/A	N/A	N/A	N/A	N/A	N/A
DC_3A-19A_n78A	3	N/A	N/A	N/A	N/A	N/A	IMD3
	19	N/A	N/A	N/A	N/A	N/A	N/A
DC_3A-19A_n79A	n78	N/A	N/A	N/A	N/A	N/A	N/A
	3	1775	5	25	1870	N/A	N/A
	19	840	5	25	885	[18.5]	IMD3
	n79	4435	40	216	4435	N/A	N/A
	3	1782.5	5	25	1877.5	0.2	IMD4
	19	842.5	5	25	887.5	N/A	N/A
DC_3A-20A_n28A DC_3C-20A_n28A	n79	4420	40	216	4420	N/A	N/A
	20	852	5	25	811	N/A	N/A
DC_3A_n20A-n78A	n28	738	5	25	793	N/A	N/A
	3	1723	5	25	1818	9.4	IMD4
	3	1730	5	25	1825	N/A	N/A
DC_3A-20A_n78A DC_3C-20A_n78A	n20	845	5	25	804	N/A	N/A
	n78	3420	10	52	3420	16.1	IMD3
	3	1725	5	25	1820	17.3	IMD3
DC_3A-21A_n77A DC_3A-21A_n78A	20	845	5	25	804	N/A	N/A
	n78	3510	10	50	3510	N/A	N/A
	3	1767.5	5	25	1862.5	N/A	N/A
	21	1459.5	5	25	1507.5	8.8	IMD4
	n77, n78	3795	10	50	3795	N/A	N/A
DC_3A-21A_n77A	3	N/A	N/A	N/A	N/A	N/A	IMD2
	21	N/A	N/A	N/A	N/A	N/A	N/A
	n78	N/A	N/A	N/A	N/A	N/A	N/A
DC_3A-21A_n79A	3	1771.6	5	25	1866.6	3.4	IMD5
	21	1450.4	5	25	1498.4	N/A	N/A
	n77	3935	10	50	3935	N/A	N/A
DC_3A-21A_n79A	3	N/A	N/A	N/A	N/A	N/A	N/A
	21	N/A	N/A	N/A	N/A	N/A	IMD3
	n79	N/A	N/A	N/A	N/A	N/A	N/A
	3	1774.2	5	25	1869.2	17.8	IMD3
	21	1450.4	5	25	1498.4	N/A	N/A
	n79	4770	40	216	4770	N/A	N/A
DC_3A-28A_n77A	3	1712.5	5	25	1807.5	N/A	N/A
	28	715	5	25	770	15.3	IMD3
	n77	4195	10	50	4195	N/A	N/A
	3	1755	5	25	1850	17.0	IMD3
	28	735	5	25	790	N/A	N/A
	n77	3320	10	50	3320	N/A	N/A
DC_3A-28A_n78A	3	1775	5	25	1870	17.3	IMD3
	28	740	5	25	760	N/A	N/A
	n78	3350	10	25	3350	N/A	N/A
DC_3A-28A_n79A	3	1770	5	25	1865	N/A	N/A
	28	725	5	25	780	10.3	IMD4
	n79	4530	40	216	4530	N/A	N/A
	3	1775	5	25	1870	5.7	IMD5
	28	725	5	25	780	N/A	N/A
	n79	4770	40	216	4770	N/A	N/A
DC_3A_n28A-n78A DC_3C_n28A-n78A	3	1750	5	25	1845	N/A	N/A
	n28	743	5	25	798	N/A	N/A
	n78	3764	10	50	3764	4.5	IMD5
DC_3A-41A_n28A DC_3A-41C_n28A	41	2543	10	50	2543	N/A	N/A
	n28	710.5	5	25	765.5	N/A	N/A
	3	1737.5	5	25	1832.5	26	IMD2
	3	1780	5	25	1875	N/A	N/A
	n28	738	5	25	793	N/A	N/A
	41	2518	5	25	2518	27.4	IMD2
	3	1715	5	25	1810	N/A	N/A
n28	743	5	25	798	N/A	N/A	

NR or E-UTRA Band / Channel bandwidth / NRB / MSD							
EN-DC Configuration	EUTRA/NR band	UL Fc (MHz)	UL/DL BW (MHz)	UL LCRB	DL Fc (MHz)	MSD (dB)	IMD order
	41	2687	5	25	2687	15.9	IMD3
DC_3A-41A_n77A DC_3A-41C_n77A	3	1720	5	25	1815	N/A	N/A
	n77	3900	10	50	3900	N/A	N/A
	41	2640	5	25	2640	5.3	IMD5
	41	2620	5	25	2620	N/A	N/A
	n77	3400	10	50	3400	N/A	N/A
	3	1745	5	25	1840	16.4	IMD3
DC_3A-41A_n78A	41	2620	5	25	2620	N/A	N/A
	n78	3400	10	52	3400	N/A	N/A
	3	1745	5	25	1840	16.4	IMD3
DC_3A_n78A-n79A	3	1770	5	25	1865	N/A	N/A
	n78	3340	10	50	3340	N/A	N/A
	n79	4910	40	216	4910	16.3	IMD3
	3	1770	5	25	1865	N/A	N/A
	n79	4510	40	216	4510	N/A	N/A
	n78	3710	10	50	3710	4.2	IMD5
DC_3A-SUL_n78A-n82A	3	1775	5	25	1870	4	IMD4
	n82	840	5	25		N/A	N/A
DC_3A-21A_n79A	3	1774.2	5	25	1869.2	17.8	IMD3
	21	1450.4	5	25	1498.4	N/A	N/A
	n79	4770	40	216	4770	N/A	N/A
DC_5A-7A_n78A	5	844	5	25	889	N/A	N/A
	7	2525	5	25	2645	30.1	IMD2
	n78	3489	10	50	3489	N/A	N/A
	5	834	5	25	879	30.2	IMD2
	7	2550	5	25	2670	N/A	N/A
	n78	3429	10	50	3429	N/A	N/A
	5	830	5	25	875	3.3	IMD5
	7	2525	5	25	2645	N/A	N/A
	n78	3350	10	50	3350	N/A	N/A
DC_5A_41A_n78A	5	860	5	25	885	30.2	IMD2
	41	2615	5	25	2615	N/A	N/A
	n78	3500	10	50	3500	N/A	N/A
	5	856.5	5	25	881.5	3.1	IMD5
	41	2620.5	5	25	2620.5	N/A	N/A
	n78	3490	10	50	3490	N/A	N/A
DC_5A-41A_n79A	5	835	5	25	880	23.9	IMD3
	41	2665	5	25	2665	N/A	N/A
	n79	4450	40	216	4450	N/A	N/A
	5	826.5	5	25	871.5	N/A	N/A
	41	2517.5	5	25	2517.5	1.8	IMD4
	n79	4980	40	216	4980	N/A	N/A
DC_7A-20A_n1A	7	2510	10	50	2630	N/A	N/A
	20	841	10	50	800	4.5	IMD5
	n1	1940	5	25	2130	N/A	N/A
DC_7A-20A_n3A	7	2543	10	50	2663	N/A	N/A
	20	847	10	20	806	10.5	IMD2
	n3	1737	5	25	1832	N/A	N/A
	7	2510	10	50	2630	26.0	IMD2 ¹
	20	855	5	25	896	N/A	N/A
	n3	1775	10	50	1870	N/A	N/A
DC_7A-20A_n28A	20	852	5	25	811	N/A	N/A
	n28	738	5	25	793	N/A	N/A
	7	2550	10	50	2670	5.9	IMD5
DC_7A-20A_n78A	7	2560	5	25	2680	N/A	N/A
	20	851	5	25	810	30.5	IMD2
	n78	3370	10	50	3370	N/A	N/A
DC_7A-20A_n78A	7	2560	5	25	2680	N/A	N/A
	20	851	5	25	810	3.0	IMD5
	n78	3435	10	50	3435	N/A	N/A
DC_7A-20A_n78A	7	2555	5	25	2675	30.8	IMD2

NR or E-UTRA Band / Channel bandwidth / NRB / MSD							
EN-DC Configuration	EUTRA/NR band	UL Fc (MHz)	UL/DL BW (MHz)	UL LCRB	DL Fc (MHz)	MSD (dB)	IMD order
	20	845	5	25	804	N/A	N/A
	n78	3520	10	50	3520	N/A	N/A
DC_7A-28A_n3A	7	2543	5	25	2663	N/A	N/A
	28	741	5	25	796.0	20.0	IMD2
	n3	1747	5	25	1842	N/A	N/A
	7	2540	5	25	2685	18	IMD3
	28	745	5	25	800	N/A	N/A
	n3	1715	5	25	1810	N/A	N/A
DC_7A-28A_n5A DC_7C-28A_n5A	7	2540	5	25	2725	N/A	N/A
	28	721	5	25	776	4.4	IMD5
	n5	829	5	25	854	N/A	N/A
	7	2510	5	25	2630	5.9	IMD5
	28	730	5	25	785	N/A	N/A
	n5	840	5	25	874	N/A	N/A
DC_7A-28A_n78A	7	2570	5	25	2670	N/A	N/A
	28	720	5	25	780	8.3	IMD2
	n78	3350	10	50	3421	N/A	N/A
	7	2570	5	25	2670	N/A	N/A
	28	720	5	25	790	3.0	IMD5
	n78	3460	10	50	3421	N/A	N/A
	7	2570	5	25	2650	30.5	IMD2
	28	740	5	25	768	N/A	N/A
DC_7A_n28A-n78A DC_7C_n28A-n78A	n78	3390	10	50	3421	N/A	N/A
	7	2565	5	25	2685	N/A	N/A
	n28	745	5	25	800	N/A	N/A
	n78	3310	10	50	3310	29.7	IMD2
	7	2565	5	25	2685	N/A	N/A
	n78	3365	10	50	3365	N/A	N/A
DC_7A-46A_n78A ⁶	n28	745	5	25	800	28.8	IMD2
	7	N/A	N/A	N/A	N/A	N/A	N/A
DC_14A-66A_n2A DC_14A-66A-66A_n2A	46	N/A	N/A	N/A	N/A	N/A	IMD2, IMD5
	n78	N/A	N/A	N/A	N/A	N/A	N/A
DC_14A-66A_n2A	14	793	5	25	763	N/A	N/A
	66	1762	5	25	2162	7.6	IMD4
	n2	1874	5	25	1954	N/A	N/A
DC_18A-28A_n77A	18	820	5	25	865	N/A	N/A
	28	723	5	25	778	4.4	IMD5
	n77	4058	10	50	4058	N/A	N/A
DC_18A-28A_n77A	18	820	5	25	865	3.9	IMD5
	28	723	5	25	778	N/A	N/A
	n77	3757	10	50	3757	N/A	N/A
DC_18A-28A_n78A	18	819	5	25	864	3.8	IMD5
	28	723	5	25	778	N/A	N/A
	n78	3756	10	50	3756	N/A	N/A
DC_18A-41A_n77A DC_18A-41C_n77A	18	820	5	25	865	3.4	IMD5
	n77	3527.5	10	50	3527.5	N/A	N/A
	41	2640	5	25	2640	N/A	N/A
DC_18A-41A_n78A DC_18A-41C_n78A	18	820	5	25	865	3.4	IMD5
	n78	3527.5	10	50	3527.5	N/A	N/A
	41	2640	5	25	2640	N/A	N/A
DC_19A-21A_n77A DC_19A-21A_n78A	19	837.5	5	25	882.5	18.7	IMD3
	21	1450.4	5	25	1498.4	N/A	N/A
	n77, n78	3783.3	10	50	3783.3	N/A	N/A
DC_19A-21A_n77A	19	837.5	5	25	882.5	N/A	N/A
	21	1454.5	5	25	1502.5	9.0	IMD4
	n77	4015	10	50	4015	N/A	N/A
DC_19A-21A_n79A	19	N/A	N/A	N/A	N/A	N/A	IMD5
	21	N/A	N/A	N/A	N/A	N/A	N/A
	n79	N/A	N/A	N/A	N/A	N/A	N/A
	19	837.5	5	25	882.2	N/A	N/A

NR or E-UTRA Band / Channel bandwidth / NRB / MSD							
EN-DC Configuration	EUTRA/NR band	UL Fc (MHz)	UL/DL BW (MHz)	UL L _{CRB}	DL Fc (MHz)	MSD (dB)	IMD order
	21	1452	5	25	1500	3.8	IMD5
	n79	4850	40	216	4850	N/A	N/A
DC_20A_n1A-n78A	20	845	5	25	804	N/A	N/A
	n1	1940	5	25	2130	N/A	N/A
	n78	3630	10	52	3630	16.0	IMD3
	20	835	5	25	794	N/A	N/A
	n1	1930	5	25	2120	15.3	IMD3
	n78	3790	10	52	3790	N/A	N/A
DC_20A_n3A-n78A	20	845	5	25	804	N/A	N/A
	n3	1730	5	25	1825	N/A	N/A
	n78	3420	10	52	3420	16.1	IMD3
	20	845	5	25	804	N/A	N/A
	n3	1765	5	25	1860	15.7	IMD3
DC_20A_SUL_n78A-n80A	20	847	5	25	806	9	IMD4
	n80	1735	5	25		N/A	N/A
DC_21A-28A_n77A	21	1452	5	25	1500	N/A	N/A
	28	730.5	5	25	785.5	16.9	IMD3
	n77	3689.5	10	50	3689.5	N/A	N/A
	21	1450.5	5	25	1498.5	9.9	IMD4
	28	730.5	5	25	785.5	N/A	N/A
DC_21A-28A_n79A	n77	3690	10	50	3690	N/A	N/A
	21	1450	5	25	1498	5.2	IMD5
	28	730.5	5	25	785.5	N/A	N/A
DC_28A-42A_79A	n79	4420	40	216	4420	N/A	N/A
	28	730	5	25	785	N/A	N/A
	42	3420	5	25	3420	15.3	IMD3
	n79	4880	40	216	4880	N/A	N/A
	28	745	5	25	800	16.2	IMD2
	42	3597.5	5	25	3597.5	N/A	N/A
DC_19A_n78A-n79A	n79	4420	40	216	4420	N/A	N/A
	19	835	5	25	880	N/A	N/A
	n78	3680	10	50	3680	N/A	N/A
	n79	4515	40	216	4515	29.3	IMD2
	19	835	5	25	880	N/A	N/A
	n79	4550	40	216	4550	N/A	N/A
DC_20A_n28A-n78A DC_20A_SUL_n78A-n83A	n78	3715	10	50	3715	28.8	IMD2
	20	857	5	25	816	N/A	N/A
	n28, n83	743	5	25	798	N/A	N/A
	n78	3314	10	50	3314	8.7	IMD4
	20	837	5	25	796	N/A	N/A
	n78	3310	10	50	3310	N/A	N/A
DC_21A_n78A-n79A	n28	744	5	25	799	9.4	IMD4
	21	1453	5	25	1501	N/A	N/A
	n78	3420	10	50	3420	N/A	N/A
	n79	4873	40	216	4873	30.1	IMD2
	21	1453	5	25	1501	N/A	N/A
	n79	4940	40	216	4940	N/A	N/A
DC_3A-40A_n1A	n78	3487	10	50	3487	29.8	IMD2
	n1	1950	5	25	2140	N/A	N/A
	3	1735	5	25	1830	N/A	N/A
	40	2380	5	25	2380	8.0	IMD5

NOTE 1: For NR band, UL/DL BW and UL L_{CRB} can be adjusted according to the supported BW and lowest SCS supported by the UE.

7.3B.2.0.3.5.3 Void

7.3B.2.0.3a Inter-band NE-DC within FR1

Reference sensitivity exceptions are specified for the condition when there is uplink transmission only in the aggressor band. This subclause addresses directly only NE-DC configurations that don't have a corresponding specified EN-DC configuration or specific NE-DC exceptions.

7.3B.2.0.3a.1 Reference sensitivity exceptions due to UL harmonic interference for NE-DC in NR FR1

Sensitivity degradation is allowed for a band if it is impacted by UL harmonic interference from another band part of the same NE-DC configuration. For the NE-DC configurations that have an EN-DC defined configuration, the reference sensitivity exceptions for the victim band (high) are specified in Table 7.3B.2.3.1-1 with uplink configuration of the aggressor band (low) specified in Table 7.3B.2.3.1-2 are applicable.

7.3B.2.0.4 Inter-band EN-DC including FR2

7.3B.2.0.4.1 Void

7.3B.2.0.5 Inter-band EN-DC including both FR1 and FR2

7.3B.2.0.5.1 Reference sensitivity exceptions due to UL harmonic interference for EN-DC including both FR1 and FR2

For inter-band EN-DC of E-UTRA and NR in both FR1 and FR2, the UE is allowed to apply each sensitivity degradation for EN-DC in FR1 specified in clause 7.3B.2.3 TS 38.101-3 and for EN-DC including FR2 specified in clause 7.3B.2.3 of TS 38.101-3 independently.

The normative reference for this requirement is TS 38.101-3 [4] clause 7.3B.2.

7.3B.2.1 Reference sensitivity for Intra-band Contiguous EN-DC (2 CCs)

Editor's note: MSD test point selection is based on core spec requirement and shall be added to TP analysis to TS 38.905 [7].

7.3B.2.1.1 Test purpose

To verify the ability of UE that support intra-band contiguous EN-DC configurations to receive data with a given average throughput for a specified reference measurement channel, under conditions of low signal level, ideal propagation and no added noise. A UE unable to meet the throughput requirement under these conditions will decrease the effective coverage area.

7.3B.2.1.2 Test applicability

This test applies to all types of NR UE release 15 and forward supporting intra-band EN-DC.

7.3B.2.1.3 Minimum conformance requirements

The minimum conformance requirements are defined in clause 7.3B.2.0.

Exception requirements for both NR and E-UTRA are defined for this test and therefore LTE anchor agnostic approach is not applied. E-UTRA test point analysis is included and E-UTRA measurements are performed.

7.3B.2.1.4 Test description

7.3B.2.1.4.1 Initial conditions

Initial conditions are a set of test configurations the UE needs to be tested in and the steps for the SS to take with the UE to reach the correct measurement state.

The initial test configurations consist of environmental conditions, test frequencies and channel bandwidths based on EN-DC operating bands specified in clause 5.2B, and the channel bandwidth combination for E-UTRA and NR component carriers shall follow the value specified in Table 5.3B.1.2-1. All of these configurations shall be tested with applicable test parameters for each EN-DC configuration are shown in Table 7.3B.2.1.4.1-1 for DC_(n)71AA and Table 7.3B.2.1.4.1-2 for intra-band contiguous EN-DC other than DC_(n)71AA.

The details of the uplink and downlink reference measurement channels (RMCs) are specified in Annex A.2 and A.3 for E-UTRA RMC respectively. The details of the uplink and downlink reference measurement channels (RMCs) are specified in TS 38.521-1 [8] Annex A.2 and A.3 for NR RMC respectively. The details of the OCNG patterns used are specified in TS 36.521-1 [10] Annex A.5 and in TS 38.521-1 [8] Annex A.5 for E-UTRA CG and NR CG respectively. Configurations of PDSCH and PDCCH before measurement are specified in TS 36.521-1 [10] Annex C.2 and in TS 38.521-1 [8] Annex C.2 for E-UTRA CG and NR CG respectively.

Table 7.3B.2.1.4.1-1: Test configurations table for EN-DC configurations affected by Reference sensitivity exceptions

Initial Conditions							
Test Environment as specified in TS 38.508-1 [5] clause 4.1				Normal, TL/VL, TL/VH, TH/VL, TH/VH			
NR Test Frequencies as specified in TS 38.508-1 [5] clause 4.3.1				Low, mid and high range			
E-UTRA Test Frequencies as specified in TS 36.508-1 [11] clause 4.3.1							
E-UTRA Test Channel Bandwidths as specified in TS 36.508 [11] clause 4.3.1				Specified below			
NR Test Channel Bandwidths as specified in TS 38.508-1 [5] clause 4.3.1				Specified below			
NR Test SCS as specified in Table 5.3.5-1 in TS 38.521-1 [8]				Lowest supported SCS			
NR/E-UTRA Test Parameters							
Downlink Configuration				Uplink Configuration			
NR Modulation	NR RB allocation	E-UTRA Modulation	E-UTRA RB allocation	NR Modulation	NR RB allocation	E-UTRA Modulation	E-UTRA RB allocation
CP-OFDM QPSK	Full RB (NOTE 1)	QPSK	Full RB	DFT-s-OFDM QPSK		QPSK	
Test Point configurations							
Test Settings for DC_(n)71AA for dual UL UE							
Test ID	E-UTRA/NR band	F _c (UL) (MHz) N _{UL}	UL Channel BW (MHz)	UL allocation (LCRB)	F _c (DL) (MHz) N _{DL}	Duplex mode	
1	71	665.5MHz, E _{UL} = 133147	5	5@19	619.5 MHz E _{DL} = 68611	FDD	
	n71	675.5 N _{UL} = 135100	15	15@0	629.5 N _{DL} = 125900		
2	71	670.5 E _{UL} = 133197	15	15@59	624.5 E _{DL} = 68661		
	n71	680.5 N _{UL} = 136100	5	5@0	634.5 N _{DL} = 126900		
3	71	668 E _{UL} = 133172	10	10@39	622 E _{DL} = 68636		
	n71	678 N _{UL} = 135600	10	10@0	632 N _{DL} = 126400		
4	71	668 E _{UL} = 133172	10	10@0	622 E _{DL} = 68636		
	n71	678 N _{UL} = 135600	10	10@41	632 N _{DL} = 126400		
5	71	665.5 E _{UL} = 133147	5	5@19	619.5 E _{DL} = 68611	FDD	
	n71	675.5 N _{UL} = 135100	15 ³	15@0	632 ³ N _{UL} = 126400		
6	71	670.5 E _{UL} = 133197	15	15@59	624.5 E _{DL} = 68661		
	n71	680.5 N _{UL} = 136100	5 ³	5@0	637 ³ N _{UL} = 127400		
7	71	668 E _{UL} = 133172	10	10@39	622 E _{DL} = 68636		
	n71	678 N _{UL} = 135600	10 ³	10@0	634.5 ³ N _{UL} = 126900		
8	71	668 E _{UL} = 133172	10	10@0	622 E _{DL} = 68636		
	n71	678 N _{UL} = 135600	10 ³	10@41	634.5 ³ N _{UL} = 126900		
Test Settings for DC_(n)71AA for single UL UE							
1	71	default	Highest	0	default	FDD	

	n71	default	Highest	REFSENS_NR	default
NOTE 1:	Full RB allocation shall be used per each SCS and channel BW as specified in Table 7.3.2.4.1-2 of TS 38.521-1 [8].				
NOTE 2:	Test Channel Bandwidths are checked separately for each E-UTRA band, which applicable channel bandwidths are specified in Table 5.3B.1.2-1.				
NOTE 3:	In accordance to BCS1, the NR uplink bandwidth is specified as in this table, but the corresponding NR downlink bandwidth is 5 MHz larger.				
NOTE 4:	In an E-UTRA band or FR1 band where UE supports 4Rx, the test shall be performed only with 4Rx antennas ports connected.				
NOTE 5:	REFSENS_NR refers to the single carrier Uplink RB allocation for reference sensitivity according to table 7.3.2.4.1-3 of TS 38.521-1 [8].				

Table 7.3B.2.1.4.1-2: Test configurations table for EN-DC configurations not affected by Reference sensitivity exceptions, EN-DC configuration other than DC_(n)71AA

Initial Conditions								
	Test Environment as specified in TS 38.508-1 [6] clause 4.1				Normal, TL/VL, TL/VH, TH/VL, TH/VH			
	NR Test Frequencies as specified in TS 38.508-1 [6] clause 4.3.1, E-UTRA Test Frequencies as specified in TS 36.508 [11] clause 4.3.1				Low range, High range			
	Test DC Combination setting (NRB_agg) as specified in clause [TBD] for the DC Configuration across bandwidth combination sets supported by the UE.				Refer to "NR NRB" and "E-UTRA NRB" columns			
	Network signalling value				NS_01 by default, exceptions listed in Table 7.3.3-3, dependent on PCC Band			
Test Parameters for DC Configurations								
ID	PCC – E-UTRA				SCG -NR			
	Band	Range	NRB		Band	Range	NRB	
	UL MOD	DL MOD	CH BW	DLalloc / UL alloc	UL MOD	DL MOD	UL/DL Ch BW	DLalloc / UL alloc
Test Settings for a DC_(n)XAA Configuration (Intra-band contiguous EN-DC) – Note 2								
1 (Note 4)	X	default			nX	default		
	QPSK	QPSK	Highest N _{RB}	All RBs / REFSENS_LTE	DFT-s-OFDM QPSK	CP-OFDM QPSK	Highest N _{RB}	All RBs / REFSENS_NR
2 (Note 5)	X	default			nX	default		
	N/A	QPSK	Highest N _{RB}	All RBs / 0	DFT-s-OFDM QPSK	CP-OFDM QPSK	Highest N _{RB}	All RBs / REFSENS_NR
Note 1:	REFSENS_NR refers to the single carrier Uplink RB allocation for reference sensitivity according to table 7.3.2.4.1-3 of TS 38.521-1 [8].							
Note 2:	Not LTE anchor agnostic configuration due to exception requirement for intra-band contiguous CA in clause 7.4B, 7.5B, 7.6B.2, 7.6B.3, 7.6B.4, 7.7B, 7.8B, 7.9B test cases							
Note 3:	In a FR1 band where UE supports 4Rx, the test shall be performed only with 4Rx antennas ports connected.							
Note 4:	Test point for UE supporting dual UL.							
Note 5:	Test point for UE supporting single UL.							

1. Connect the SS to the UE antenna connectors as shown in TS 38.508-1 [5] Annex A, Figure A.3.1.1.1 for TE diagram and clause A.3.2.1 for UE diagram.
2. The parameter settings for NR cell are set up according to TS 38.508-1 [5] clause 4.4.3.
3. The parameter settings for E-URA cell are set up according to TS 36.508 [11] clause 4.4.3.
4. NR downlink signals are initially set up according to Annex C.0, C.1, C.2, C.3.1, and uplink signals according to Annex G.0, G.1, G.2, and G.3.1 of TS 38.521-1 [8].

5. E-UTRA downlink signals are initially set up according to Annex C0, C.1 and C.3.0, and uplink signals according to Annex H.1 and H.3.0 of TS 36.521-1 [10].
6. The DL and UL Reference Measurement channels for NR are set according to Table 7.3B.2.1.4.1-1 and Table 7.3B.2.1.4.1-2.
7. The DL and UL Reference Measurement channels for E-UTRA are set according to Table 7.3B.2.1.4.1-1 and Table 7.3B.2.1.4.1-2.
8. NR propagation conditions are set according to Annex B.0 of TS 38.521-1 [8].
9. E-UTRA propagation conditions are set according to Annex B.0 of TS 36.521-1 [10].
10. Ensure the UE is in state RRC_CONNECTED with generic procedure parameters *Connectivity* EN-DC, DC bearer MCG and SCG, Connected without release *On* according to TS 38.508-1 [6] clause 4.5. Message contents are defined in clause 7.3B.2.1.4.3.

7.3B.2.1.4.2 Test procedure

1. SS transmits PDSCH via PDCCH DCI format 1A and PDCCH DCI format 1_1 for C_RNTI to transmit the DL RMC according to Table 7.3B.2.1.4.1-1 and Table 7.3B.2.1.4.1-2 on the E-UTRA CC and NR CC. The SS sends downlink MAC padding bits on the DL RMC.
2. SS sends uplink scheduling information for each UL HARQ process via PDCCH DCI format 0 and DCI format 0_1 for C_RNTI to schedule the UL RMC according to Table 7.3B.2.3.4.1-1 on both EN-DC component carriers. Since the UL has no payload and no loopback data to send the UE sends uplink MAC padding bits on the UL RMC.
3. For test points in Table 7.3B.2.1.4.1-1, set the Downlink signal level to the appropriate REFSSENS value defined in Table 7.3B.2.1.5-1. For test points in Table 7.3B.2.1.4.1-2, set the Downlink signal level to the appropriate REFSSENS value defined in TS 38.521-1 [8], Table 7.3.3-1 for NR band and TS 36.521-1 [10] Table 7.3.3-1 for E-UTRA band. Send continuously uplink power control "up" commands in the uplink scheduling information to both carriers to ensure the UE transmits PUMAX level for at least the duration of the Throughput measurement.
4. Measure the average throughput of both NR and E-UTRA for a duration sufficient to achieve statistical significance according to Annex H.2 of TS 38.521-1 [8] for NR band, and Annex G.2 of TS 36.521-1 [10] for EUTRA band.

7.3B.2.1.4.3 Message contents

Message contents are according to TS 38.508-1 [5] clause 4.6 for NR band. Message contents are according to TS 36.508 [7] clause 4.6 for EUTRA band.

7.3B.2.1.5 Test requirement

For intra-band contiguous EN-DC configurations DC_(n)71AA with dual UL, the throughput of each CG shall be \geq 95% of the maximum throughput of the reference measurement channels as specified in Annex A.3.2 with reference receive power level specified in Table 7.3B.2.1.5-1

Reference sensitivity test requirements for EN-DC configurations other than DC_(n)71AA with dual UL UE, are specified in Table 7.3.5-1 in TS 36.521-1 [10] for the LTE CC, and Table 7.3.2.5-1 in TS 38.521-1 [8] for the NR CC.

Table 7.3B.2.1.5-1: Reference sensitivity for intra-band DC_(n)71AA with dual UL

EN-DC	E-UTRA/ NR band	SCS (kHz)	Channel BW (MHz)	Ref sensitivity (dBm)	Note	Duplex mode
DC_(n)71AA	71	N/A	5	-96.5	Note 1	FDD
	n71	15	15	-89.8 +TT		
	71	N/A	15	-91.3	Note 2	
	n71	15	5	-95.6 +TT		
	71	N/A	10	-93.5	Note 3	
	n71	15	10	-92.3 +TT		
	71	N/A	10	-76.3	Note 4	
	n71	15	10	-64.6 +TT		
	71	N/A	5	-96.5	Note 5	
	n71	15	15 ⁹	-89.1 +TT		
	71	N/A	15	-91.3	Note 6	
	n71	15	5 ⁹	-95.0 +TT		
	71	N/A	10	-93.5	Note 7	
	n71	15	10 ⁹	-91.5 +TT		
	71	N/A	10	-76.3	Note 8	
	n71	15	10 ⁹	-64.9 +TT		

NOTE 1: For test configuration specified by Table 7.3B.2.1.4.1-1 Test ID 1.
NOTE 2: For test configuration specified by Table 7.3B.2.1.4.1-1 Test ID 2.
NOTE 3: For test configuration specified by Table 7.3B.2.1.4.1-1 Test ID 3.
NOTE 4: For test configuration specified by Table 7.3B.2.1.4.1-1 Test ID 4.
NOTE 5: For test configuration specified by Table 7.3B.2.1.4.1-1 Test ID 5.
NOTE 6: For test configuration specified by Table 7.3B.2.1.4.1-1 Test ID 6.
NOTE 7: For test configuration specified by Table 7.3B.2.1.4.1-1 Test ID 7.
NOTE 8: For test configuration specified by Table 7.3B.2.1.4.1-1 Test ID 8.
NOTE 9: In accordance to BCS1, the NR uplink bandwidth is specified as in this table, but the corresponding NR downlink bandwidth is 5 MHz larger.

Table 7.3B.2.1.5-2: Test Tolerance (TT) for NR RX sensitivity level

$f \leq 3.0\text{GHz}$	$3.0\text{GHz} < f \leq 6.0\text{ GHz}$
0.7 dB	1.0 dB

7.3B.2.2 Reference sensitivity for Intra-band non-contiguous EN-DC (2 CCs)

7.3B.2.2.1 Test purpose

Same as in clause 7.3B.2.1.1.

7.3B.2.2.2 Test applicability

This test applies to all types of E-UTRA UE release 15 and forward, supporting intra-band non-contiguous EN-DC.

7.3B.2.2.3 Minimum conformance requirements

The minimum conformance requirements are defined in clause 7.3B.2.0.

For DC_3A_n3A in Rel-16, exception requirements for both NR and E-UTRA are defined for this test and therefore LTE anchor agnostic approach is not applied. E-UTRA test point analysis is included and E-UTRA measurements are performed.

For DC_3A_n3A in Rel-15 and EN-DC configurations other than DC_3A_n3A, no exception requirements for NR or E-UTRA are defined. LTE anchor agnostic approach is applied.

7.3B.2.2.4 Test Description

7.3B.2.2.4.1 Initial Condition

Initial conditions are a set of **test configurations the UE needs to be tested in and the steps for the SS** to take with the UE to reach the correct measurement state.

The initial test configurations for E-UTRA consist of the test frequency based on E-UTRA operating band and test channel bandwidth as specified in Table 4.6-1, with the exception that the E-UTRA channel bandwidth is the lowest supported value in Table 5.3B.1.3-1 for the EN-DC non-contiguous configuration under test.

The initial test configurations consist of environmental conditions, test frequencies, test channel bandwidths and sub-carrier spacing based on NR operating bands specified in clause 5.2B. All of these configurations shall be tested with applicable test parameters for each combination of test channel bandwidth and sub-carrier spacing are shown in Table 7.3B.2.2.4.1-2 for NR band. The details of the uplink reference measurement channels (RMCs) are specified in Annex A.2. Configurations of PDSCH and PDCCH before measurement are specified in TS 38.521-1 [8] Annex C2.

Table 7.3B.2.2.4.1-1: Test Configuration Table for EN-DC configurations affected by Reference sensitivity exceptions

Initial Conditions							
Test Environment as specified in TS 38.508-1 [5] clause 4.1				Normal, TL/VL, TL/VH, TH/VL, TH/VH			
NR Test Frequencies as specified in TS 38.508-1 [5] clause 4.3.1 E-UTRA Test Frequencies as specified in TS 36.508-1 [11] clause 4.3.1				Low, mid and high range			
E-UTRA Test Channel Bandwidths as specified in TS 36.508 [11] clause 4.3.1				Specified below			
NR Test Channel Bandwidths as specified in TS 38.508-1 [5] clause 4.3.1				Specified below			
NR Test SCS as specified in Table 5.3.5-1 in TS 38.521-1 [8]				Lowest supported SCS			
NR/E-UTRA Test Parameters							
Downlink Configuration				Uplink Configuration			
NR Modulation	NR RB allocation	E-UTRA Modulation	E-UTRA RB allocation	NR Modulation	NR RB allocation	E-UTRA Modulation	E-UTRA RB allocation
CP-OFDM QPSK	Full RB (NOTE 1)	QPSK	Full RB	DFT-s-OFDM QPSK		QPSK	
Test Point configurations							
Test Settings for DC_3A_n3A dual UL UE							
Test ID	E-UTRA/NR band	F _c (UL) (MHz) N _{UL}	UL Channel BW (MHz)	UL allocation (L _{CRB})	F _c (DL) (MHz) N _{DL}	Duplex mode	
1	3	1782.5, N _{UL} = TBD	5	12@0	1877.5 N _{DL} = TBD	FDD	
	n3	1772.5 N _{UL} = TBD	5	12@13	1867.5 N _{DL} = TBD		
2	3	1782.5, N _{UL} = TBD	5	12@9	1877.5 N _{DL} = TBD		
	n3	1752.5 N _{UL} = TBD	5	12@0	1847.5 N _{DL} = TBD		
3	3	1782.5 N _{UL} = TBD	5	12@12	1877.5 N _{DL} = TBD		
	n3	1737.5 N _{UL} = TBD	5	12@0	1832.5 N _{DL} = TBD		
4	3	1737.5 N _{UL} = TBD	5	12@0	1832.5 N _{DL} = TBD		
	n3	1782.5 N _{UL} = TBD	5	12@12	1877.5 N _{DL} = TBD		
Test Settings for DC_3A_n3A for single UL UE							
1	3	default	Highest	0	default	FDD	
	n3	default	Highest	REFSENS_NR	default		
NOTE 1: Full RB allocation shall be used per each SCS and channel BW as specified in Table 7.3.2.4.1-2 of TS 38.521-1 [8].							
NOTE 2: In an E-UTRA band or FR1 band where UE supports 4Rx, the test shall be performed only with 4Rx antennas ports connected.							

Table 7.3B.2.2.4.1-2: Test configurations table for EN-DC configurations not affected by Reference sensitivity exceptions, EN-DC configuration other than DC_3A_n3A

Initial Conditions								
	Test Environment as specified in TS 38.508-1 [6] clause 4.1				Normal, TL/VL, TL/VH, TH/VL, TH/VH			
	NR Test Frequencies as specified in TS 38.508-1 [6] clause 4.3.1, E-UTRA Test Frequencies as specified in TS 36.508 [11] clause 4.3.1				TBD			
	Test DC Combination setting (NRB_agg) as specified in clause [TBD] for the DC Configuration across bandwidth combination sets supported by the UE.				Refer to "NR NRB" and "E-UTRA NRB" columns			
	Network signalling value				NS_01 by default, exceptions listed in Table 7.3.3-3, dependent on PCC Band			
Test Parameters for DC Configurations								
ID	PCC – E-UTRA				SCG -NR			
	Band	Range	NRB		Band	Range	NRB	
	UL MOD	DL MOD	CH BW	DLalloc / UL alloc	UL MOD	DL MOD	UL/DL Ch BW	DLalloc / UL allo
Test Settings for a DC_XA_nXA Configuration (Intra-band non-contiguous EN-DC) – Note 2								
1	X	default			nX	default		
	N/A	N/A	NOTE 4	N/A	DFT-s-OFDM QPSK	CP-OFDM QPSK	Highest N _{RB}	All RBs / REFSSENS_NR
<p>Note 1: REFSSENS_NR refers to the single carrier Uplink RB allocation for reference sensitivity according to table 7.3.2.4.1 3 of TS 38.521-1 [8].</p> <p>Note 2: LTE anchor agnostic configuration</p> <p>Note 3: In a FR1 band where UE supports 4Rx, the test shall be performed only with 4Rx antennas ports connected.</p> <p>Note 4: The E-UTRA channel bandwidth is the lowest supported value in Table 5.3B.1.3-1 for the EN-DC non-contiguous configuration.</p> <p>Note 5: Full RB allocation shall be used per each SCS and channel BW as specified in Table 7.3.2.4.1-2 of TS 38.521-1 [8].</p>								

1. Connect the SS to the UE antenna connectors as shown in TS 38.508-1 [5] Annex A, Figure A.3.1.1.1 for TE diagram and clause A.3.2 for UE diagram.
2. The parameter settings for NR cell are set up according to TS 38.508-1 [6] clause 4.4.3.
3. The parameter settings for E-UTRA cell are set up according to TS 36.508 [11] clause 4.4.3. E-UTRA downlink signal level, and uplink signal level are set according to Table 4.6-1.
4. NR downlink signals are initially set up according to Annex C.0, C.1, and C.2 and uplink signals according to Annex G.0, G.1, G.2, and G.3.0 of TS 38.521-1 [8].
5. The NR UL Reference Measurement channels for NR are set according to Table 7.3B.2.2.4.1-2.
6. Set up the NR and E-UTRA test frequencies so that NR carrier is located at the lower frequency side as specified in Table 5.3B.1.3-1. Repeat each testing with E-UTRA carrier frequency is located at the lower side as specified in Table 5.3B.1.3-1.
7. NR propagation conditions are set according to Annex B.0 of TS 38.521-1 [8]. E-UTRA propagation conditions are set according to Annex B.0 of TS 36.521-1 [10].
8. Ensure the UE is in state RRC_CONNECTED with generic procedure parameters Connectivity EN-DC, DC bearer MCG and SCG, Connected without release *On* according to TS 38.508-1 [6] clause 4.5. Message contents are defined in clause 7.3B.2.2.4.3.
9. On the E-UTRA carrier, disable periodic and aperiodic CQI reports, disable SRS, set *TimeAlignmentTimerDedicated* IE to infinity and disable downlink and uplink scheduling, all as per Table 4.6-1 under clause 4.6.

7.3B.2.2.4.2 Test Procedure

For test points in Table 7.3B.2.2.4.1-1,

FFS

For test points in Table 7.3B.2.2.4.1-2,

1. NR SS transmits PDSCH via PDCCH DCI format 1_1 for C_RNTI to transmit the DL RMC according to Table 7.3B.2.2.4.1-2 on the NR CC. The NR SS sends downlink MAC padding bits on the DL RMC.
2. NR SS sends uplink scheduling information for each UL HARQ process via PDCCH DCI format 0_1 for C_RNTI to schedule the UL RMC according to Table 7.3B.2.2.4.1-2. Since the UL has no payload and no loopback data to send the UE sends uplink MAC padding bits on the UL RMC.
3. Set the Downlink signal level to the appropriate REFSSENS value defined in TS 38.521-1 [8], Table 7.3.2.5-1 for NR band. Send continuously uplink power control "up" commands in the uplink scheduling information to NR carrier to ensure the UE transmits PUMAX level for at least the duration of the Throughput measurement.
4. Measure the average throughput of the NR carrier for a duration sufficient to achieve statistical significance according to Annex H.2 of TS 38.521-1 [8] for NR band.

7.3B.2.2.4.3 Message Contents

Message contents are according to TS 38.508-1 [6] clause 4.6.1.

7.3B.2.2.5 Test Requirement

For intra-band non-contiguous EN-DC configuration DC_3A_n3A, the measured throughput on the NR carrier shall be $\geq 95\%$ of the maximum throughput of the reference measurement channels as specified in Annex A with reference receive power level specified in Table 7.3B.2.2.5-1, and parameters specified Tables 7.3.2.4.1-1, Tables 7.3.2.4.1-2 and Tables 7.3.2.4.1-3 of TS 38.521-1 [8] for NR band.

Reference sensitivity test requirements for EN-DC configurations other than DC_3A_n3A, are specified in Table 7.3.2.5-1 in TS 38.521-1 [8] for the NR CC.

Table 7.3B.2.2.5-1: Reference sensitivity for intra-band Non-contiguous EN-DC

EN-DC	Test ID	E-UTRA/ NR band	SCS (kHz)	Channel BW (MHz)	Ref sensitivity (dBm)	Duplex mode
DC_3A_n3A	1	3	N/A	5	TBD	FDD
		n3	15	5		
	2	3	N/A	5		
		n3	15	10		
	3	3	N/A	5		
		n3	15	15		
	4	3	N/A	5		
		n3	15	20		

Note: NR band Test tolerance (TT) is specified in Table 7.3B.2.2.5-2

Table 7.3B.2.2.5-2: Test Tolerance (TT) for NR RX sensitivity level

$f \leq 3.0\text{GHz}$	$3.0\text{GHz} < f \leq 6.0\text{GHz}$
0.7 dB	1.0 dB

7.3B.2.3 Reference sensitivity for Inter-band EN-DC within FR1 (2 CCs)

7.3B.2.3.1 Test purpose

Same as in clause 7.3B.2.1.1.

7.3B.2.3.2 Test applicability

This test applies to all types of NR UE release 15 and forward supporting inter-band EN-DC.

7.3B.2.3.3 Minimum conformance requirements

The minimum conformance requirements are defined in clause 7.3B.2.0.

LTE anchor agnostic approach is not applied.

7.3B.2.3.4 Test description

7.3B.2.3.4.1 Void

7.3B.2.3.4.2 Test description

7.3B.2.3.4.2.1 Initial conditions

Initial conditions are a set of test configurations the UE needs to be tested in and the steps for the SS to take with the UE to reach the correct measurement state.

The initial test configurations consist of environmental conditions, test frequencies, test channel bandwidths based on EN-DC operating bands specified in clause 5.2B, channel bandwidths and sub-carrier spacings for the NR cell specified in TS 38.521-1 [8] clause 5.3 and channel bandwidth for the E-UTRA cell are specified in TS 36.521-1 [10] clause 5.4.2. All of these configurations shall be tested with applicable test parameters for each EN-DC configuration are shown in Table 7.3B.2.3.4.2.1-0 to Table 7.3B.2.3.4.2.1-6.

The details of the uplink and downlink reference measurement channels (RMCs) are specified in Annex A.2 and A.3 for E-UTRA RMC respectively. The details of the uplink and downlink reference measurement channels (RMCs) are specified in TS 38.521-1 [8] Annex A.2 and A.3 for NR RMC respectively. The details of the OCNG patterns used are specified in TS 36.521-1 [10] Annex A.5 and in TS 38.521-1 [8] Annex A.5 for E-UTRA CG and NR CG respectively. Configurations of PDSCH and PDCCH before measurement are specified in TS 36.521-1 [10] Annex C.2 and in TS 38.521-1 [8] Annex C.2 for E-UTRA CG and NR CG respectively.

For configurations without any reference sensitivity exception, in a FR1 band where UE supports 4Rx, the test shall be performed only with 4Rx antennas ports connected. For configurations with reference sensitivity exception, in an E-UTRA band or FR1 band where UE supports 4Rx, the test shall be performed only with 4Rx antennas ports connected.

Table 7.3B.2.3.4.2.1-0: Test configurations table for EN-DC configuration without any reference sensitivity exception

Initial Conditions								
	Test Environment as specified in TS 38.508-1 [6] clause 4.1				Normal, TL/VL, TL/VH, TH/VL, TH/VH			
	NR Test Frequencies as specified in TS 38.508-1 [6] clause 4.3.1, E-UTRA Test Frequencies as specified in TS 36.508 [11] clause 4.3.1				Mid range			
	Test DC Combination setting (NRB_agg) as specified in clause [TBD] for the DC Configuration across bandwidth combination sets supported by the UE.				Refer to "NR NRB" and "E-UTRA NRB" columns			
	Network signalling value				NS_01 by default Unless given by Table 7.3.3-3 in TS 36.521-1 [10] for the E-UTRA band and Table 7.3.2.3-4 in TS 38.521-1 [8] for the NR band.			
Test Parameters for DC Configurations								
ID	PCC – E-UTRA				SCG -NR			
	Band	Range	NRB		Band	Range	NRB	
	UL MOD	DL MOD	CH BW	DLalloc / UL alloc	UL MOD	DL MOD	UL/DL Ch BW	DLalloc / UL alloc
Test Settings for a DC_XA_nYA Configuration (Inter-band EN-DC) – Note 2								
1	X	default			nY	default		
	N/A	N/A	5 MHz	N/A	DFT-s-OFDM QPSK	CP-OFDM QPSK	Highest N _{RB}	All RBs / REFSSENS_NR
NOTE 1: REFSSENS_NR refers to the single carrier Uplink RB allocation for reference sensitivity according to table 7.3.2.4.1-3 of TS 38.521-1 [8].								
NOTE 2: LTE anchor agnostic configuration								
NOTE 3: In a FR1 band where UE supports 4Rx, the test shall be performed only with 4Rx antennas ports connected.								

Table 7.3B.2.3.4.2.1-1: Initial test conditions for reference sensitivity exceptions due to UL harmonic interference for EN-DC in NR FR1

Initial Conditions							
Test Environment as specified in TS 38.508-1 [6] clause 4.1				Normal, TL/VL, TL/VH, TH/VL, TH/VH			
NR Test Frequencies as specified in TS 38.508-1 [6] clause 4.3.1 E-UTRA Test Frequencies as specified in TS 38.508-1 [11] clause 4.3.1				Mid range for E-UTRA and NR, unless otherwise specified in Table 7.3B.2.3.4.2.1-2_1 to Table 7.3B.2.3.4.2.1-2_28			
NR Test Channel Bandwidths as specified in TS 38.508-1 [6] clause 4.3.1 E-UTRA Test Channel Bandwidths as specified in TS 36.508 [11] clause 4.3.1				Highest NRB_agg, unless otherwise specified in Table 7.3B.2.3.4.2.1-2_1 to Table 7.3B.2.3.4.2.1-2_28			
NR Test SCS as specified in Table 5.3.5-1				Lowest supported SCS otherwise specified			
Test Parameters							
Downlink Configuration				Uplink Configuration			
E-UTRA Cell		NR Cell		E-UTRA Cell		NR Cell	
Modulation	RB allocation	Modulation	RB allocation	Modulation	RB allocation	Modulation	RB allocation
QPSK	Full RB	CP-OFDM QPSK	Full RB (NOTE 1)	QPSK	Full RB	DFT-s-OFDM QPSK	Full RB (NOTE 1)
NOTE 1: Full RB allocation shall be used per each SCS and channel BW as specified in Table 7.3.2.4.1-2 of TS 38.521-1 [8].							

Table 7.3B.2.3.4.2.1-2_1: Test configurations table for exceptions due to UL harmonic interference for EN-DC 1_n77

E-UTRA Band 1				NR Band n77		
Test ID	Channel BW (MHz)	F _c (UL) (MHz) N _{UL}	UL allocation (L _{CRB})	NR F _c (DL) (MHz) N _{DL}	NR CBW (MHz)	UL allocation (L _{CRB})
1	10	1925 MHz / 18050	25@12	3850.02 MHz / 656668	Lowest	REFSENS (NOTE 2)
2		1925 MHz / 18050	50@0	3850.02 MHz / 656668	Mid Highest	REFSENS (NOTE 2)
3		1950 MHz / 18300	25@12	3900 MHz / 660000	Lowest	REFSENS (NOTE 2)
4		1950 MHz / 18300	50@0	3900 MHz / 660000	Mid Highest	REFSENS (NOTE 2)
5		1975 MHz / 18550	25@12	3950.01 MHz / 663334	Lowest	REFSENS (NOTE 2)
6		1975 MHz / 18550	50@0	3950.01 MHz / 663334	Mid Highest	REFSENS (NOTE 2)
NOTE 1: Test frequencies are selected to fulfil Note 2 and 13 in Table 7.3B.2.0.3.1-1.						
NOTE 2: REFSENS refers to Table 7.3.2.4.1-3 in TS 38.521-1 [8] which defines uplink RB configuration and start RB location for each SCS, channel BW and NR band.						

Table 7.3B.2.3.4.2.1-2_2: Test configurations table for exceptions due to UL harmonic interference for EN-DC 1_n77 (For Note 3 in Table 7.3B.2.0.3.1-1)

E-UTRA Band 1				NR Band n77			
Test ID	Channel BW (MHz)	F _c (UL) (MHz) / N _{UL}	UL allocation (L _{CRB})	NR F _c (DL) (MHz)	NR F _c (DL) N _{UL}	NR CBW (MHz)	UL allocation (L _{CRB})
1	10	1925MHz / 18050	25@12	3825.000	655000	10	REFSENS (NOTE 2)
			36@7	3822.495	654833	15	
			50@0	3820.005	654667	20	
2		1950 MHz / 18300	25@12	3874.995	658333	10	REFSENS (NOTE 2)
			36@7	3872.505	658167	15	
			50@0	3870.000	658000	20	
3	1975 MHz / 18550	25@12	3975.000	665000	10	REFSENS (NOTE 2)	
		36@7	3977.505	665167	15		
		50@0	3979.995	665333	20		
NOTE 1: Test frequencies are selected to fulfil Note 3 in Table 7.3B.2.0.3.1-1.							
NOTE 2: REFSENS refers to Table 7.3.2.4.1-3 which defines uplink RB configuration and start RB location for each SCS, channel BW and NR band.							
NOTE 3: Only NR channel bandwidths supported by the UE are tested.							

Table 7.3B.2.3.4.2.1-2_3: Test configurations table for exceptions due to UL harmonic interference for EN-DC 3_n77

E-UTRA Band 3				NR Band n77		
Test ID	Channel BW (MHz)	F _c (UL) (MHz) N _{UL}	UL allocation (L _{CRB})	NR F _c (DL) (MHz) N _{DL}	NR CBW (MHz)	UL allocation (L _{CRB})
1	10	1715 MHz / 19250	25@12	3430.02 MHz / 628668	Lowest	REFSENS (NOTE 2)
2		1715 MHz / 19250	50@0	3430.02 MHz / 628668	Mid Highest	REFSENS (NOTE 2)
3		1747.5 MHz / 19575	25@12	3495 MHz / 633000	Lowest	REFSENS (NOTE 2)
4		1747.5 MHz / 19575	50@12	3495 MHz / 633000	Mid Highest	REFSENS (NOTE 2)
5	10	1780 MHz / 19900	25@12	3560.01 MHz / 637334	Lowest	REFSENS (NOTE 2)
6		1780 MHz / 19900	50@12	3560.01 MHz / 637334	Mid Highest	REFSENS (NOTE 2)

NOTE 1: Test frequencies are selected to fulfil 13 in Table 7.3B.2.0.3.1-1.
NOTE 2: REFSENS refers to Table 7.3.2.4.1-3 in TS 38.521-1 [8] which defines uplink RB configuration and start RB location for each SCS, channel BW and NR band.

Table 7.3B.2.3.4.2.1-2_4: Test configurations table for exceptions due to UL harmonic interference for EN-DC 3_n77 (For Note 3 in Table 7.3B.2.0.3.1-1)

E-UTRA Band 3				NR Band n77			
Test ID	Channel BW (MHz)	F _c (UL) (MHz) / N _{UL}	UL allocation (L _{CRB})	NR F _c (DL) (MHz)	NR F _c (DL) N _{DL}	NR CBW (MHz)	UL allocation (L _{CRB})
1	10	1715 MHz / 19250	25@12	3405.000	627000	10	REFSENS (NOTE 2)
			36@7	3402.495	626833	15	
			50@0	3400.005	626667	20	
2		1747.5 MHz / 19575	25@12	3469.995	631333	10	REFSENS (NOTE 2)
			36@7	3467.505	631167	15	
			50@0	3465.000	631000	20	
3		1780 MHz / 19900	25@12	3585.000	639000	10	REFSENS (NOTE 2)
			36@7	3587.505	639167	15	
			50@0	3589.995	639333	20	

NOTE 1: Test frequencies are selected to fulfil Note 3 in Table 7.3B.2.0.3.1-1.
NOTE 2: REFSENS refers to Table 7.3.2.4.1-3 which defines uplink RB configuration and start RB location for each SCS, channel BW and NR band.
NOTE 3: Only NR channel bandwidths supported by the UE are tested.

Table 7.3B.2.3.4.2.1-2_5: Test configurations table for exceptions due to UL harmonic interference for EN-DC 2_n78

E-UTRA Band 2				NR Band n78		
Test ID	Channel BW (MHz)	F _c (UL) (MHz) N _{UL}	UL allocation (L _{CRB})	NR F _c (DL) (MHz) N _{DL}	NR CBW (MHz)	UL allocation (L _{CRB})
1	10	1855 MHz/ 18650	25@12	3710.01 MHz/ 647334	Lowest	REFSENS (NOTE 2)
2		1855 MHz/ 18650	50@0	3710.01 MHz/ 647334	Mid Highest	REFSENS (NOTE 2)
3		1865 MHz/ 18750	25@12	3730.02 MHz/ 648668	Lowest	REFSENS (NOTE 2)
4		1865 MHz/ 18750	50@0	3730.02 MHz/ 648668	Mid Highest	REFSENS (NOTE 2)
5		1875MHz/ 18850	25@12	3750 MHz/ 650000	Lowest	REFSENS (NOTE 2)
6		1875 MHz/ 18850	50@0	3750 MHz/ 650000	Mid Highest	REFSENS (NOTE 2)

NOTE 1: Test frequencies are selected to fulfil Note 2 and 13 in Table 7.3B.2.0.3.1-1.
 NOTE 2: REFSENS refers to Table 7.3.2.4.1-3 in TS 38.521-1 [8] which defines uplink RB configuration and start RB location for each SCS, channel BW and NR band.

Table 7.3B.2.3.4.2.1-2_6: Test configurations table for exceptions due to UL harmonic interference for EN-DC 2_n78 (for Note 3 in Table 7.3B.2.0.3.1-1)

E-UTRA Band 2					NR Band n78				
Test ID	Channel BW (MHz)	F _c (UL) (MHz)	F _c (UL) N _{UL}	UL allocation (L _{CRB})	NR F _c (DL) (MHz)	NR F _c (DL) N _{DL}	NR CBW (MHz)	UL allocation (L _{CRB})	
1	10	1855	18650	25@12	3685.005	645667	10	REFSENS (NOTE 2)	
				36@7	3682.500	645500	15		
				50@0	3679.995	645333	20		
2		1867.5	18775	18775	25@12	3709.995	647333	10	REFSENS (NOTE 2)
					36@7	3707.505	647167	15	
					50@0	3705.000	647000	20	
3		1885	18950	18925	25@12	3795.000	653000	10	REFSENS (NOTE 2)
					36@7	3792.495	652833	15	
					50@0	3789.795	652653	20	

NOTE 1: Test frequencies are selected to fulfil Note 3 in Table 7.3B.2.0.3.1-1.
 NOTE 2: REFSENS refers to Table 7.3.2.4.1-3 which defines uplink RB configuration and start RB location for each SCS, channel BW and NR band.
 NOTE 3: Only NR channel bandwidths supported by the UE are tested.

Table 7.3B.2.3.4.2.1-2_7: Test configurations table for exceptions due to UL harmonic interference for EN-DC 3_n78 (Test frequencies are selected to fulfil Requirement for Note 1 and 2 in Table 7.3B.2.0.3.1-1)

E-UTRA Band 3				NR Band n78		
Test ID	Channel BW (MHz)	F _c (UL) (MHz) N _{UL}	UL allocation (L _{CRB})	NR F _c (DL) (MHz) N _{DL}	NR CBW (MHz)	UL allocation (L _{CRB})
1	10	1715 MHz / 19250	25@12	3430.02 MHz / 628668	Lowest	REFSENS (NOTE 2)
2		1715 MHz / 19250	50@0	3430.02 MHz / 628668	Mid Highest	REFSENS (NOTE 2)
3		1747.5 MHz / 19575	25@12	3495 MHz / 633000	Lowest	REFSENS (NOTE 2)
4		1747.5 MHz / 19575	50@0	3495 MHz / 633000	Mid Highest	REFSENS (NOTE 2)
5		1780 MHz / 19900	25@12	3560.01 MHz / 637334	Lowest	REFSENS (NOTE 2)
6		1780 MHz / 19900	50@0	3560.01 MHz / 637334	Mid Highest	REFSENS (NOTE 2)
NOTE 1: Test frequencies are selected to fulfil Note 2 and 13 in Table 7.3B.2.0.3.1-1.						
NOTE 2: REFSENS refers to Table 7.3.2.4.1-3 in TS 38.521-1 [8] which defines uplink RB configuration and start RB location for each SCS, channel BW and NR band.						

Table 7.3B.2.3.4.2.1-2_8: Test configurations table for exceptions due to UL harmonic interference for EN-DC 3_n78 (Test frequencies are selected to fulfil Requirement for Note 3 in Table 7.3B.2.0.3.1-1)

E-UTRA Band 3				NR Band n78			
Test ID	Channel BW (MHz)	F _c (UL) (MHz) / N _{UL}	UL allocation (L _{CRB})	NR F _c (DL) (MHz)	NR F _c (DL) N _{UL}	NR CBW (MHz)	UL allocation (L _{CRB})
1	10	1715 MHz / 19250	25@12	3405.000	627000	10	REFSENS (NOTE 2)
			36@7	3402.495	626833	15	
			50@0	3400.005	626667	20	
2		1747.5 MHz / 19575	25@12	3469.995	631333	10	REFSENS (NOTE 2)
			36@7	3467.505	631167	15	
			50@0	3465.000	631000	20	
3	1780 MHz / 19900	25@12	3585.000	639000	10	REFSENS (NOTE 2)	
		36@7	3587.505	639167	15		
		50@0	3589.995	639333	20		
NOTE 1: Test frequencies are selected to fulfil Note 3 in Table 7.3B.2.0.3.1-1.							
NOTE 2: REFSENS refers to Table 7.3.2.4.1-3 which defines uplink RB configuration and start RB location for each SCS, channel BW and NR band.							
NOTE 3: Only NR channel bandwidths supported by the UE are tested.							

Table 7.3B.2.3.4.2.1-2_9: Test configurations table for exceptions due to UL harmonic interference for EN-DC 5_n78 (Test frequencies are selected to fulfil Requirement of Note 6 and 7 in Table 7.3B.2.0.3.1-1)

E-UTRA Band 5				NR Band n78		
Test ID	Channel BW (MHz)	F _c (UL) (MHz) N _{UL}	UL allocation (L _{CRB})	NR F _c (DL) (MHz) N _{DL}	NR CBW (MHz)	UL allocation (L _{CRB})
1	10	837.5 MHz/ 20535	16@17	3350.01 MHz/ 623334	Lowest	REFSENS (NOTE 2)
2		837.5 MHz/ 20535	25@12	3350.01 MHz/ 623334	40	REFSENS (NOTE 2)
3		840.7 MHz/ 20567	16@17	3362.82 MHz/ 624188	Lowest	REFSENS (NOTE 2)
4		840.7 MHz/ 20567	25@12	3362.82 MHz/ 624188	40	REFSENS (NOTE 2)
5		844 MHz/ 20600	16@17	3376.02 MHz/ 625068	Lowest	REFSENS (NOTE 2)
6		844 MHz/ 20600	25@12	3376.02 MHz/ 625068	40	REFSENS (NOTE 2)

NOTE 1: Test frequencies are selected to fulfil Note 6 and 7 in Table 7.3B.2.0.3.1-1.
NOTE 2: REFSENS refers to Table 7.3.2.4.1-3 in TS 38.521-1 [8] which defines uplink RB configuration and start RB location for each SCS, channel BW and NR band.
NOTE 3: For UEs with limited UE NR channel bandwidth capability, if the channel BW is not supported by the UE, skip the test point. This shall apply only for Rel 15 UEs.

Table 7.3B.2.3.4.2.1-2_10: Test configurations table for exceptions due to UL harmonic interference for EN-DC 8_n41 (Test frequencies are selected to fulfil Requirement of Note 8 and 9 in Table 7.3B.2.0.3.1-1)

E-UTRA Band 8				NR Band n41		
Test ID	Channel BW (MHz)	F _c (UL) (MHz) N _{UL}	UL allocation (L _{CRB})	NR F _c (DL) (MHz) N _{DL}	NR CBW (MHz)	UL allocation (L _{CRB})
1	10	885 MHz/ 21500	16@17	2655 MHz/ 531000	Lowest	REFSENS (NOTE 2)
2		885 MHz/ 21500	25@12	2655 MHz/ 531000	Mid	REFSENS (NOTE 2)
3		890 MHz/ 21550	16@17	2670 MHz/ 534000	Lowest	REFSENS (NOTE 2)

NOTE 1: Test frequencies are selected to fulfil Note 8 and 9 in Table 7.3B.2.0.3.1-1.
NOTE 2: REFSENS refers to Table 7.3.2.4.1-3 in TS 38.521-1 [8] which defines uplink RB configuration and start RB location for each SCS, channel BW and NR band.

Table 7.3B.2.3.4.2.1-2_11: Test configurations table for exceptions due to UL harmonic interference for EN-DC 8_n77 and 8_n78 (Test frequencies are selected to fulfil Requirement of Note 6 and 7 in Table 7.3B.2.0.3.1-1)

E-UTRA Band 8				NR Band n77/n78		
Test ID	Channel BW (MHz)	F _c (UL) (MHz) N _{UL}	UL allocation (L _{CRB})	NR F _c (DL) (MHz) N _{DL}	NR CBW (MHz)	UL allocation (L _{CRB})
1	10	885 MHz/ 21500	16@17	3540 MHz/ 636000	Lowest	REFSENS (NOTE 2)
2		885 MHz/ 21500	25@12	3540 MHz/ 636000	Mid Highest	REFSENS (NOTE 2)
3		897.5 MHz/ 21625	16@17	3590.01 MHz/ 639334	Lowest	REFSENS (NOTE 2)
4		897.5 MHz/ 21625	25@12	3590.01 MHz/ 639334	Mid Highest	REFSENS (NOTE 2)
5		910 MHz/ 21750	16@17	3640.02 MHz/ 642668	Lowest	REFSENS (NOTE 2)
6		910 MHz/ 21750	25@12	3640.02 MHz/ 642668	Mid Highest	REFSENS (NOTE 2)

NOTE 1: Test frequencies are selected to fulfil Note 6 and 7 in Table 7.3B.2.0.3.1-1.
NOTE 2: REFSENS refers to Table 7.3.2.4.1-3 in TS 38.521-1 [8] which defines uplink RB configuration and start RB location for each SCS, channel BW and NR band.

Table 7.3B.2.3.4.2.1-2_12: Test configurations table for exceptions due to UL harmonic interference for EN-DC 8_n79 (Requirement of Note 4 and 5)

E-UTRA Band 8				NR Band n79		
Test ID	Channel BW (MHz)	F _c (UL) (MHz) N _{UL}	UL allocation (L _{CRB})	NR F _c (DL) (MHz) N _{DL}	NR CBW (MHz)	UL allocation (L _{CRB})
1	10	890 MHz/ 21550	25@12	4450.02 MHz /696668	Lowest Mid Highest	REFSENS (NOTE 2)
2		897.5 MHz/ 21625	25@12	4487.52 MHz/ 699168	Lowest Mid Highest	REFSENS (NOTE 2)
3		910 MHz/ 21750	25@12	4550.01 MHz/ 703334	Lowest Mid Highest	REFSENS (NOTE 2)

NOTE 1: Test frequencies are selected to fulfil Note 4 and 5 in Table 7.3B.2.0.3.1-1.
NOTE 2: REFSENS refers to Table 7.3.2.4.1-3 in TS 38.521-1 [8] which defines uplink RB configuration and start RB location for each SCS, channel BW and NR band.

Table 7.3B.2.3.4.2.1-2_13: Test configurations table for exceptions due to UL harmonic interference for EN-DC 12_n66 (Requirement of Note 8 and 9)

E-UTRA Band 12				NR Band n66		
Test ID	Channel BW (MHz)	F _c (UL) (MHz) N _{UL}	UL allocation (L _{CRB})	NR F _c (DL) (MHz) N _{DL}	NR CBW (MHz)	UL allocation (L _{CRB})
1	10	704.1 MHz/ 23061	8@21	2112.5 MHz/ 422500	Lowest	REFSENS (NOTE 2)
2		707.5 MHz/ 23095	8@21	2122.5 MHz/ 424500	Lowest	REFSENS (NOTE 2)
		707.5 MHz/ 23095	20@15	2122.5 MHz/ 424500	Mid	REFSENS (NOTE 2)
3		711 MHz/ 23130	8@21	2133 MHz/ 426600	Lowest	REFSENS (NOTE 2)
		711 MHz/ 23130	20@15	2133 MHz/ 426600	Mid Highest	REFSENS (NOTE 2)

NOTE 1: Test frequencies are selected to fulfil Note 8 and 9 in Table 7.3B.2.0.3.1-1.
NOTE 2: REFSENS refers to Table 7.3.2.4.1-3 in TS 38.521-1 [8] which defines uplink RB configuration and start RB location for each SCS, channel BW and NR band.

Table 7.3B.2.3.4.2.1-2_14: Test configurations table for exceptions due to UL harmonic interference for EN-DC 18_n77 (Requirement of Note 4 and 5)

E-UTRA Band 18				NR Band n77		
Test ID	Channel BW (MHz)	F _c (UL) (MHz) N _{UL}	UL allocation (L _{CRB})	NR F _c (DL) (MHz) N _{DL}	NR CBW (MHz)	UL allocation (L _{CRB})
1	10	820 MHz/ 23900	16@17	4100.01 MHz/ 673334	Lowest	REFSENS (NOTE 2)
2		820 MHz/ 23900	25@12	4100.01 MHz/ 673334	Mid Highest	REFSENS (NOTE 2)
3		822.5 MHz/ 23925	16@17	4112.52 MHz/ 674168	Lowest	REFSENS (NOTE 2)
4		822.5 MHz/ 23925	25@12	4112.52 MHz/ 674168	Mid Highest	REFSENS (NOTE 2)
5		825 MHz/ 23950	16@17	4125 MHz/ 675000	Lowest	REFSENS (NOTE 2)
6		825 MHz/ 23950	25@12	4125 MHz/ 675000	Mid Highest	REFSENS (NOTE 2)

NOTE 1: Test frequencies are selected to fulfil Note 4 and 5 in Table 7.3B.2.0.3.1-1.
NOTE 2: REFSENS refers to Table 7.3.2.4.1-3 in TS 38.521-1 [8] which defines uplink RB configuration and start RB location for each SCS, channel BW and NR band.

Table 7.3B.2.3.4.2.1-2_15: Test configurations table for exceptions due to UL harmonic interference for EN-DC 19_n77 (Requirement of Note 4 and 5)

E-UTRA Band 19				NR Band n77		
Test ID	Channel BW (MHz)	F _c (UL) (MHz) N _{UL}	UL allocation (L _{CRB})	NR F _c (DL) (MHz) N _{DL}	NR CBW (MHz)	UL allocation (L _{CRB})
1	10	835 MHz/ 24050	16@17	4175.01 MHz/ 678334	Lowest	REFSENS (NOTE 2)
2		835 MHz/ 24050	25@12	4175.01 MHz/ 678334	40	REFSENS (NOTE 2)
3		838.9 MHz/ 24089	16@17	4194.99 MHz/ 679666	Lowest	REFSENS (NOTE 2)
NOTE 1: Test frequencies are selected to fulfil Note 4 and 5 in Table 7.3B.2.0.3.1-1.						
NOTE 2: REFSENS refers to Table 7.3.2.4.1-3 in TS 38.521-1 [8] which defines uplink RB configuration and start RB location for each SCS, channel BW and NR band.						
NOTE 3: For UEs with limited UE NR channel bandwidth capability, if the channel BW is not supported by the UE, skip the test point. This shall apply only for Rel 15 UEs.						

Table 7.3B.2.3.4.2.1-2_16: Test configurations table for exceptions due to UL harmonic interference for EN-DC 28_n77/n78 (Requirement of Note 4 and 5)

E-UTRA Band 28				NR Band n77/n78		
Test ID	Channel BW (MHz)	F _c (UL) (MHz) N _{UL}	UL allocation (L _{CRB})	NR F _c (DL) (MHz) N _{DL}	NR CBW (MHz)	UL allocation (L _{CRB})
1	10	708 MHz/ 27260	10@20	3540 MHz/ 636000	Lowest	REFSENS (NOTE 2)
2		708 MHz/ 27260	25@12	3540 MHz/ 636000	Mid Highest	REFSENS (NOTE 2)
3		723 MHz/ 27410	10@20	3615 MHz/ 641000	Lowest	REFSENS (NOTE 2)
4		723 MHz/ 27410	25@12	3615 MHz/ 641000	Mid Highest	REFSENS (NOTE 2)
5		743 MHz/ 27610	10@20	3715.02 MHz/ 647668	Lowest	REFSENS (NOTE 2)
6		743 MHz/ 27610	25@12	3715.02 MHz/ 647668	Mid Highest	REFSENS (NOTE 2)
NOTE 1: Test frequencies are selected to fulfil Note 4 and 5 in Table 7.3B.2.0.3.1-1.						
NOTE 2: REFSENS refers to Table 7.3.2.4.1-3 in TS 38.521-1 [8] which defines uplink RB configuration and start RB location for each SCS, channel BW and NR band.						

Table 7.3B.2.3.4.2.1-2_17: Void

Table 7.3B.2.3.4.2.1-2_18: Test configurations table for exceptions due to UL harmonic interference for EN-DC 26_n41 (Requirement of Note 8 and 9)

E-UTRA Band 26				NR Band n41		
Test ID	Channel BW (MHz)	F _c (UL) (MHz) N _{UL}	UL allocation (LCRB)	NR F _c (DL) (MHz) N _{DL}	NR CBW (MHz)	UL allocation (LCRB)
1		833.7 MHz/ 26887	16@17	2501.1 MHz/ 500220	Lowest	REFSENS (NOTE 2)
3		844 MHz/ 26990	16@17	2532 MHz/ 506400	Lowest	REFSENS (NOTE 2)
		844 MHz/ 26990	25@12	2532 MHz/ 506400	50	REFSENS (NOTE 2)
NOTE 1: Test frequencies are selected to fulfil Note 8 and 9 in Table 7.3B.2.0.3.1-1.						
NOTE 2: REFSENS refers to Table 7.3.2.4.1-3 in TS 38.521-1 [8] which defines uplink RB configuration and start RB location for each SCS, channel BW and NR band.						
NOTE 3: For UEs with limited UE NR channel bandwidth capability, if the channel BW is not supported by the UE, skip the test point. This shall apply only for Rel 15 UEs.						

Table 7.3B.2.3.4.2.1-2_19: Test configurations table for exceptions due to UL harmonic interference for EN-DC 26_n77/78 (Requirement of Note 6 and 7)

E-UTRA Band 26				NR Band n77/n78		
Test ID	Channel BW (MHz)	F _c (UL) (MHz) N _{UL}	UL allocation (LCRB)	NR F _c (DL) (MHz) N _{DL}	NR CBW (MHz)	UL allocation (LCRB)
1	10	825 MHz/ 26800	16@17	3300 MHz/ 620000	Lowest Mid Highest	REFSENS (NOTE 2)
2		831.5 MHz/ 26865	16@17	3326 MHz/ 621733	Lowest Mid Highest	REFSENS (NOTE 2)
3		844 MHz/ 226990	16@17	3376 MHz/ 625066	Lowest Mid Highest	REFSENS (NOTE 2)
NOTE 1: Test frequencies are selected to fulfil Note 6 and 7 in Table 7.3B.2.0.3.1-1.						
NOTE 2: REFSENS refers to Table 7.3.2.4.1-3 in TS 38.521-1 [8] which defines uplink RB configuration and start RB location for each SCS, channel BW and NR band.						

Table 7.3B.2.3.4.2.1-2_20: Test configurations table for exceptions due to UL harmonic interference for EN-DC 66_n77/78 (Requirement of Note 2 and 13)

E-UTRA Band 66				NR Band n77/n78		
Test ID	Channel BW (MHz)	F _c (UL) (MHz) N _{UL}	UL allocation (LCRB)	NR F _c (DL) (MHz) N _{DL}	NR CBW (MHz)	UL allocation (LCRB)
1	10	1715 MHz/ 132022	25@12	3430 MHz/ 628666	Lowest Mid Highest	REFSENS (NOTE 2)
2		1755 MHz/ 132422	25@12	3510 MHz/ 634000	Lowest Mid Highest	REFSENS (NOTE 2)
3		1775 MHz/ 132622	25@12	3550 MHz/ 636666	Lowest Mid Highest	REFSENS (NOTE 2)
NOTE 1: Test frequencies are selected to fulfil Note 2 and 13 in Table 7.3B.2.0.3.1-1.						
NOTE 2: REFSENS refers to Table 7.3.2.4.1-3 in TS 38.521-1 [8] which defines uplink RB configuration and start RB location for each SCS, channel BW and NR band.						

Table 7.3B.2.3.4.2.1-21: Test configurations table for exceptions due to UL harmonic interference for EN-DC 66_n78 (Requirement of Note 3)

E-UTRA Band 66				NR Band n78					
Test ID	Channel BW (MHz)	F _c (UL) (MHz) / N _{UL}	UL allocation (L _{CRB})	NR F _c (DL) (MHz)	NR F _c (DL) N _{UL}	NR CBW (MHz)	UL allocation (L _{CRB})		
1	10	1715 MHz / 132022	25@12	3405.000	627000	10	REFSENS (NOTE 2)		
				3402.495	626833	15			
3400.005				626667	20				
3454.995				630333	10				
3457.500				630500	15				
3460.005				630667	20				
2		1755 MHz / 132422		1755 MHz / 132422	25@12	3484.995	632333	10	REFSENS (NOTE 2)
						3482.505	632167	15	
3480.000						632000	20		
3535.005						635667	10		
3537.495						635833	15		
3540.000						636000	20		
3	1775 MHz / 132622	1775 MHz / 132622	25@12	3574.995		638333	10	REFSENS (NOTE 2)	
				3577.500		638500	15		
3580.005				638667		20			
3574.995				638333		10			
3577.500				638500		15			
3580.005				638667		20			
4	1775 MHz / 132622	1775 MHz / 132622		25@12	3574.995	638333	10	REFSENS (NOTE 2)	
3577.500					638500	15			
3580.005					638667	20			
3574.995					638333	10			
3577.500					638500	15			
3580.005					638667	20			
5	1775 MHz / 132622	1775 MHz / 132622	25@12		3574.995	638333	10	REFSENS (NOTE 2)	
3577.500					638500	15			
3580.005					638667	20			
3574.995					638333	10			
3577.500					638500	15			
3580.005					638667	20			
6	1775 MHz / 132622	1775 MHz / 132622		25@12	3574.995	638333	10	REFSENS (NOTE 2)	
3577.500					638500	15			
3580.005					638667	20			
3574.995					638333	10			
3577.500					638500	15			
3580.005					638667	20			

NOTE 1: Test frequencies are selected to fulfil Note 3 in Table 7.3B.2.0.3.1-1.
 NOTE 2: REFSENS refers to Table 7.3.2.4.1-3 which defines uplink RB configuration and start RB location for each SCS, channel BW and NR band.
 NOTE 3: Only NR channel bandwidths supported by the UE are tested.

Table 7.3B.2.3.4.2.1-22: Test configurations table for exceptions due to UL harmonic interference for EN-DC 1_n28

NR Band n28				E-UTRA Band 1		
Test ID	Channel BW (MHz)	F _c (UL) (MHz) / N _{UL}	UL allocation (L _{CRB})	E-UTRA F _c (DL) (MHz) N _{DL}	E-UTRA CBW (MHz)	UL allocation (L _{CRB})
1	10	715 MHz / 143000	8@21	2145 MHz / 350	5	REFSENS (NOTE 2)
2	10	715 MHz / 143000	16@17	2145 MHz / 350	10	REFSENS (NOTE 2)
3	10	715 MHz / 143000	25@12	2145 MHz / 350	15, 20	REFSENS (NOTE 2)

NOTE 1: Test frequencies are selected to fulfil Note 8, 9 and 10 in Table 7.3B.2.0.3.1-1.
 NOTE 2: REFSENS refers to Table 7.3.4.1-1 in TS 36.521-1 [10] which defines uplink RB configuration and start RB location for each channel BW.

Table 7.3B.2.3.4.2.1-23: Test configurations table for exceptions due to UL harmonic interference for EN-DC 7_n71 (Requirement of Note 6 and 7)

NR Band n71				E-UTRA Band 7		
Test ID	Channel BW (MHz)	F _c (UL) (MHz) / N _{UL}	UL allocation (L _{CRB})	F _c (DL) (MHz) N _{DL}	CBW (MHz)	UL allocation (L _{CRB})
1	10	668 MHz / 133600	16@17	2672 MHz / 3270	10	REFSENS (NOTE 2)
2			25@17		15	REFSENS (NOTE 2)
3			25@17		20	REFSENS (NOTE 2)

NOTE 1: Test frequencies are selected to fulfil Note 6 and 7 in Table 7.3B.2.0.3.1-1.
 NOTE 2: REFSENS refers to Table 7.3.4.1-1 in TS 36.521-1 [10] which defines uplink RB configuration and start RB location for each channel BW and E-UTRA band.

Table 7.3B.2.3.4.2.1-2_24: Test configurations table for exceptions due to UL harmonic interference for EN-DC 2_n71 (Requirement of Note 11 and 12)

NR Band n71				E-UTRA Band 2		
Test ID	Channel BW (MHz)	F _c (UL) (MHz) N _{UL}	UL allocation (L _{CRB})	F _c (DL) (MHz) N _{DL}	CBW (MHz)	UL allocation (L _{CRB})
1	5	665.5 MHz/ 133100	25@12	1985 MHz/ 1150	10	REFSENS (NOTE 2)
			20@15	1982.5 MHz/ 1125	15	REFSENS (NOTE 2)
			20@15	1980 MHz/ 1100	20	REFSENS (NOTE 2)
2	10	668 MHz/ 133600	8@21	1985 MHz/ 1150	10	REFSENS (NOTE 2)
				1982.5 MHz/ 1125	15	REFSENS (NOTE 2)
				1980 MHz/ 1100	20	REFSENS (NOTE 2)

NOTE 1: Test frequencies are selected to fulfil Note 11 and 12 in Table 7.3B.2.0.3.1-1.
NOTE 2: REFSENS refers to Table 7.3.4.1-1 in TS 36.521-1 [10] which defines uplink RB configuration and start RB location for each channel BW and E-UTRA band.

Table 7.3B.2.3.4.2.1-2_25: Test configurations table for exceptions due to UL harmonic interference for EN-DC 12_n78 (Test frequencies are selected to fulfil Requirement of Note 4 and 5 in Table 7.3B.2.0.3.1-1)

E-UTRA Band 12				NR Band 78		
Test ID	Channel BW (MHz)	F _c (UL) (MHz) / N _{UL}	UL allocation (L _{CRB})	NR F _c (DL) (MHz) / N _{DL}	NR CBW (MHz)	UL allocation (L _{CRB})
1	10	711 MHz / 23130	10@10	Mid	10	REFSENS (NOTE 2)
			15@22		15	
			20@15		20	
			25@12		>=40	

NOTE 1: Test frequencies are selected to fulfil Note 4 and 5 in Table 7.3B.2.0.3.1-1.
NOTE 2: REFSENS refers to Table 7.3.2.4.1-3 which defines uplink RB configuration and start RB location for each SCS, channel BW and NR band.
NOTE 3: Only Highest NR channel bandwidths supported by the UE are tested.

Table 7.3B.2.3.4.2.1-2_26: Test configurations table for exceptions due to UL harmonic interference for EN-DC 48_n66 (Victim LTE B48) (Requirement of Note 2 and 13)

NR Band n66				E-UTRA Band 48		
Test ID	Channel BW (MHz)	F _c (UL) (MHz) N _{UL}	UL allocation (L _{CRB})	F _c (DL) (MHz) N _{DL}	CBW (MHz)	UL allocation (L _{CRB})
1	5	1777.5 MHz/ 355500	12@6	3555.0 MHz/ 55290	5	REFSENS (NOTE 2)
				3555.0 MHz/ 55290	10	REFSENS (NOTE 2)
				3555.0 MHz/ 55290	15	REFSENS (NOTE 2)

NOTE 1: Test frequencies are selected to fulfil Note 2 and 13 in Table 7.3B.2.0.3.1-1.
NOTE 2: REFSENS refers to Table 7.3.4.1-1 in TS 36.521-1 [10] which defines uplink RB configuration and start RB location for each channel BW and E-UTRA band.

Table 7.3B.2.3.4.2.1-2_27: Test configurations table for exceptions due to UL harmonic interference for EN-DC 48_n66 (Victim LTE B48) (Requirement of Note 3)

NR Band n66				E-UTRA Band 48		
Test ID	Channel BW (MHz)	F _c (UL) (MHz) N _{UL}	UL allocation (LCRB)	F _c (DL) (MHz) N _{DL}	CBW (MHz)	UL allocation (LCRB)
1	5	1777.5 MHz/ 355500	12@6	3577.5 MHz/ 55515	5	REFSENS (NOTE 2)
				3580.0 MHz/ 55540	10	REFSENS (NOTE 2)
				3585.0 MHz/ 55590	20	REFSENS (NOTE 2)
NOTE 1: Test frequencies are selected to fulfil Note 3 in Table 7.3B.2.0.3.1-1.						
NOTE 2: REFSENS refers to Table 7.3.4.1-1 in TS 36.521-1 [10] which defines uplink RB configuration and start RB location for each channel BW and E-UTRA band.						

Table 7.3B.2.3.4.2.1-2_28: Test configurations table for exceptions due to UL harmonic interference for EN-DC 28_n51 (Victim n51) (Requirement of Note 2, 13)

E-UTRA Band B28				NR Band n51		
Test ID	Channel BW (MHz)	F _c (UL) (MHz) N _{UL}	UL allocation (LCRB)	F _c (DL) (MHz) N _{DL}	CBW (MHz)	UL allocation (LCRB)
1	5	710 MHz/ 27280	12@6	1420 MHz/ 284000	5	REFSENS (NOTE 2)
NOTE 1: Test frequencies are selected to fulfil Note 2 and 13 in Table 7.3B.2.0.3.1-1.						
NOTE 2: REFSENS refers to Table 7.3.2.4.1-3 which defines uplink RB configuration and start RB location for each SCS, channel BW and NR band.						

The initial test configurations for E-UTRA band and NR band consist of environmental conditions, test frequencies, and channel bandwidths and RB allocations for exceptional test scenarios due to receiver harmonic mixing for EN-DC in NR FR1 are specified in Table 7.3B.2.3.4.2.1-3, to Table 7.3B.2.3.4.2.1-3j.

Table 7.3B.2.3.4.2.1-3: Default test conditions for reference sensitivity exceptions due to receiver harmonic mixing for EN-DC in NR FR1

Default Conditions							
Test Environment as specified in TS 38.508-1 [6] clause 4.1				Normal, TL/VL, TL/VH, TH/VL, TH/VH			
NR Test Frequencies as specified in TS 38.508-1 [6] clause 4.3.1 E-UTRA Test Frequencies as specified in TS 38.508-1 [11] clause 4.3.1				Mid range for E-UTRA and NR, unless otherwise specified in Table 7.3B.2.3.4.2.1-3a to Table 7.3B.2.3.4.2.1-3k			
NR Test Channel Bandwidths as specified in TS 38.508-1 [6] clause 4.3.1 E-UTRA Test Channel Bandwidths as specified in TS 36.508 [11] clause 4.3.1				Highest NRB_agg, unless otherwise specified in Table 7.3B.2.3.4.2.1-3a to Table 7.3B.2.3.4.2.1-3k			
NR Test SCS as specified in Table 5.3.5-1				Lowest supported SCS			
Test Parameters							
Downlink Configuration				Uplink Configuration			
Higher Frequency Band		Lower Frequency Band		Higher Frequency Band		Lower Frequency Band	
Modulation	RB allocation	Modulation	RB allocation	Modulation	RB allocation	Modulation	RB allocation
(NOTE 1)	Full RB	(NOTE 1)	Full RB	(NOTE 2)	(NOTE 3)	(NOTE 2)	REFSENS (NOTE 4)
NOTE 1: QPSK for E-UTRA band or CP-OFDM QPSK for NR band. NOTE 2: QPSK for E-UTRA band or DFT-s-OFDM QPSK for NR band. NOTE 3: Uplink RB configuration as defined in Table 7.3B.2.0.3.2-1, unless otherwise specified in Table 7.3B.2.3.4.2.1-3a to Table 7.3B.2.3.4.2.1-3k. NOTE 4: REFSENS refers to Table 7.3.2.4.1-3 in TS 38.521-1 [8] if higher frequency band is NR band, which defines uplink RB configuration and start RB location for each SCS, channel BW and NR band; REFSENS refers to Table 7.3.4.1-1 in TS 36.521-1 [10] if higher frequency band is E-UTRA band, which defines uplink RB configuration and start RB location for each channel BW, unless otherwise specified in Table 7.3B.2.3.4.2.1-3a to Table 7.3B.2.3.4.2.1-3k.							

Table 7.3B.2.3.4.2.1-3a: Test configurations table for exceptions due to receiver harmonic mixing for EN-DC 2_n71

Test ID	NR Band n71			E-UTRA Band 2		
	NR Channel BW	NR F _c (UL)	UL allocation (L _{CRB})	Channel BW (MHz)	F _c (UL) (MHz) / N _{UL}	UL allocation (L _{CRB})
1	5	Low	REFSENS (NOTE 2)	5	1858.50 / 18685	25@0
2	5	Low	REFSENS (NOTE 2)	10	1858.50 / 18685	50@0
3	5	Mid	REFSENS (NOTE 2)	5	1903.50 / 19135	25@0
4	5	Mid	REFSENS (NOTE 2)	10	1903.50 / 19135	50@0
5	20	Low	REFSENS (NOTE 2)	5	1881.00 / 18910	25@0
6	20	Low	REFSENS (NOTE 2)	10	1881.00 / 18910	50@0
7	20	Low	REFSENS (NOTE 2)	15	1881.00 / 18910	50@13
8	20	Low	REFSENS (NOTE 2)	20	1881.00 / 18910	50@25
9	20	Mid	REFSENS (NOTE 2)	5	1903.50 / 19135	25@0
10	20	Mid	REFSENS (NOTE 2)	10	1903.50 / 19135	50@0
<p>NOTE 1: Test frequencies are selected to fulfil Note 4 in Table 7.3B.2.0.3.2-1.</p> <p>NOTE 2: REFSENS refers to Table 7.3.2.4.1-3 in TS 38.521-1 [8] which defines uplink RB configuration and start RB location for each SCS, channel BW and NR band.</p> <p>NOTE 3: For UEs with limited UE NR channel bandwidth capability, if the channel BW is not supported by the UE, skip the test point. This shall apply only for Rel 15 UEs.</p>						

Table 7.3B.2.3.4.2.1-3aa: Test configurations table for exceptions due to receiver harmonic mixing for EN-DC 3_n78

Test ID	NR Band n78			E-UTRA Band 3		
	NR Channel BW	NR F _c (UL)	UL allocation (L _{CRB})	Channel BW (MHz)	F _c (UL) (MHz) / N _{UL}	UL allocation (L _{CRB})
1	50	Mid	100@85	20	Mid	REFSENS (NOTE 3)
<p>NOTE 1: Test frequencies are selected to fulfil Note 4 in Table 7.3B.2.0.3.2-1.</p> <p>NOTE 2: For UEs with limited UE NR channel bandwidth capability, if the channel BW is not supported by the UE, skip the test point. This shall apply only for Rel 15 UEs.</p> <p>NOTE 3: REFSENS refers to Table 7.3.4.1-1 in TS 36.521-1 [10] which defines uplink RB configuration and start RB location for each channel BW.</p>						

Table 7.3B.2.3.4.2.1-3b: Test configurations table for exceptions due to receiver harmonic mixing for EN-DC 26_n41 (Victim band LTE)

NR Band n41				E-UTRA Band 26		
Test ID	Channel BW (MHz)	F _c (UL) (MHz) N _{UL}	UL allocation (LCRB)	F _c (DL) (MHz) N _{DL}	CBW (MHz)	UL allocation (LCRB)
1	10	2593 MHz/ 518601	50@0	864.3 MHz/ 8743	5, 10, 15, 20	REFSENS (NOTE 2)
2		2660 MHz/ 532000	50@0	886.6 MHz/ 8966	5, 10, 15, 20	REFSENS (NOTE 2)
NOTE 1: Test frequencies are selected to fulfil Note 4 in Table 7.3B.2.0.3.2-1.						
NOTE 2: REFSENS refers to Table 7.3.4.1-1 in TS 36.521-1 [10] which defines uplink RB configuration and start RB location for each channel BW.						

Table 7.3B.2.3.4.2.1-3c: Void**Table 7.3B.2.3.4.2.1-3d: Test configurations table for exceptions due to receiver harmonic mixing for EN-DC 41_n77 (Victim band LTE)**

NR Band n77				E-UTRA Band 41		
Test ID	Channel BW (MHz)	F _c (UL) (MHz) N _{UL}	UL allocation (LCRB)	E-UTRA F _c (DL) (MHz) N _{DL}	CBW (MHz)	UL allocation (LCRB)
1	20	3765 MHz/ 651000	50@28	2510 MHz/ 39790	5, 10, 15, 20	REFSENS (NOTE 2)
2		4005 MHz/ 667000	50@28	2670 MHz/ 41390	5, 10, 15, 20	REFSENS (NOTE 2)
NOTE 1: Test frequencies are selected to fulfil Note 8 in Table 7.3B.2.0.3.2-1.						
NOTE 2: REFSENS refers to Table 7.3.4.1-1 in TS 36.521-1 [10] which defines uplink RB configuration and start RB location for each channel BW.						

Table 7.3B.2.3.4.2.1-3e: Test configurations table for exceptions due to receiver harmonic mixing for EN-DC 41_n78 (Victim band LTE)

NR Band n78				E-UTRA Band 41		
Test ID	Channel BW (MHz)	F _c (UL) (MHz) N _{UL}	UL allocation (LCRB)	E-UTRA F _c (DL) (MHz) N _{DL}	CBW (MHz)	UL allocation (LCRB)
1	20	3789.7 MHz/ 652644	50@28	2526.4MHz/ 39954	5, 10, 15, 20	REFSENS (NOTE 2)
NOTE 1: Test frequencies are selected to fulfil Note 8 in Table 7.3B.2.0.3.2-1.						
NOTE 2: REFSENS refers to Table 7.3.4.1-1 in TS 36.521-1 [10] which defines uplink RB configuration and start RB location for each channel BW.						

Table 7.3B.2.3.4.2.1-3f: Test configurations table for exceptions due to receiver harmonic mixing for EN-DC 28_n77 (Victim band LTE)

NR Band n77				E-UTRA Band 41		
Test ID	Channel BW (MHz)	F _c (UL) (MHz) N _{UL}	UL allocation (LCRB)	E-UTRA F _c (DL) (MHz) N _{DL}	CBW (MHz)	UL allocation (LCRB)
1	20	3850 MHz/ 656666	100@3	770 MHz/ 9330	5, 10, 15, 20	REFSENS (NOTE 2)
2		3950 MHz/ 663333	100@3	790 MHz/ 9530	5, 10, 15, 20	REFSENS (NOTE 2)
NOTE 1: Test frequencies are selected to fulfil Note 2 in Table 7.3B.2.0.3.2-1.						
NOTE 2: REFSENS refers to Table 7.3.4.1-1 in TS 36.521-1 [10] which defines uplink RB configuration and start RB location for each channel BW.						

Table 7.3B.2.3.4.2.1-3g: Void**Table 7.3B.2.3.4.2.1-3h: Void****Table 7.3B.2.3.4.2.1-3i: Test configurations table for exceptions due to receiver harmonic mixing for EN-DC 21_n79**

Test ID	E-UTRA Band 21			NR Band n79	
	Channel BW	F _c (UL)	UL allocation (L _{CRB})	NR Channel BW (MHz)	NR F _c (UL) (MHz) / N _{UL}
1	5	Mid	REFSENS (NOTE 2)	40	4510.20 / 700680
2	10	Mid	REFSENS (NOTE 2)	40	4510.20 / 700680
3	15	Mid	REFSENS (NOTE 2)	40	4510.20 / 700680
NOTE 1: Test frequencies are selected to fulfil Note 3 in Table 7.3B.2.0.3.2-1. NOTE 2: Test point NR f _{UL/DL} = 4510.2 MHz (N _{DL} = 700680). NOTE 3: REFSENS refers to Table 7.3.4.1-1 in TS 36.521-1 [10] which defines uplink RB configuration and start RB location for each channel BW and E-UTRA band. NOTE 4: For UEs with limited UE NR channel bandwidth capability, if the channel BW is not supported by the UE, skip the test point. This shall apply only for Rel 15 UEs.					

Table 7.3B.2.3.4.2.1-3j: Test configurations table for exceptions due to receiver harmonic mixing for EN-DC 26_n79 (Victim band LTE)

Test ID	NR Band n79			E-UTRA Band 26		
	Channel BW (MHz)	F _c (UL) (MHz) N _{UL}	UL allocation (L _{CRB})	E-UTRA F _c (DL) (MHz) N _{DL}	CBW (MHz)	UL allocation (L _{CRB})
1	40	4427.4 MHz / 695160	216@0	885.4 MHz / 8954	5, 10, 15	REFSENS (NOTE 2)
NOTE 1: Test frequencies are selected to fulfil Note 2 in Table 7.3B.2.0.3.2-1. NOTE 2: REFSENS refers to Table 7.3.4.1-1 in TS 36.521-1 [10] which defines uplink RB configuration and start RB location for each channel BW.						

Table 7.3B.2.3.4.2.1-3k: Void

The initial test configurations for E-UTRA band and NR band consist of environmental conditions, test frequencies, and channel bandwidths and RB allocations for exceptional test scenarios due to cross band isolation for EN-DC in NR FR1 are specified in Table 7.3B.2.3.4.2.1-4, to Table 7.3B.2.3.4.2.1-4n.

Table 7.3B.2.3.4.2.1-4: Test configurations table for exceptions due to cross band isolation for EN-DC FR1

Initial Conditions							
Test Environment as specified in TS 38.508-1 [6] clause 4.1				Normal, TL/VL, TL/VH, TH/VL, TH/VH			
NR Test Frequencies as specified in TS 38.508-1 [6] clause 4.3.1 E-UTRA Test Frequencies as specified in TS 36.508 [11] clause 4.3.1				Specified in Table 7.3B.2.3.4.2.1-4a to Table 7.3B.2.3.4.2.1-4n.			
NR Test Channel Bandwidths as specified in TS 38.508-1 [6] clause 4.3.1 E-UTRA Test Channel Bandwidths as specified in TS 36.508 [11] clause 4.3.1				Specified in Table 7.3B.2.3.4.2.1-4a to Table 7.3B.2.3.4.2.1-4n.			
NR Test SCS as specified in Table 5.3.5-1				30 KHz			
NR Test Parameters							
Downlink Configuration				Uplink Configuration			
NR Modulation	NR RB allocation	E-UTRA Modulation	E-UTRA RB allocation	NR Modulation	NR RB allocation	E-UTRA Modulation	E-UTRA RB allocation
CP-OFDM QPSK	Full RB (NOTE 1)	QPSK	Full RB	DFT-s-OFDM QPSK	Specified in Table 7.3B.2.3.4.2.1-4a to Table 7.3B.2.3.4.2.1-4n	QPSK	Table 7.3.4.1-1 in TS 36.521-1 [10]
NOTE 1: Full RB allocation shall be used per each SCS and channel BW as specified in Table 7.3.2.4.1-2 of TS 38.521-1 [8].							

Table 7.3B.2.3.4.2.1-4a: Test configurations for exceptions due to cross band isolation for EN-DC 2_n41 (Victim band LTE)

Aggressor UL			E-UTRA B2		
CBW/RB allocation			Ch BW/Frequency range		
			10MHz	15 MHz	20MHz
			High range	High range	High range
NR	100 MHz 160@0	low range	X ¹ -	X ¹ -	X ¹
n41	100 MHz 160@0	mid range	-	-	X ¹
NOTE 1: The UL resource blocks shall be located as close as possible to the downlink operating band but confined within the transmission bandwidth configuration for the channel bandwidth.					
NOTE 2: NR UL RB configuration shall set per Table 7.3.2.4.1-3 in TS 38.521-1 [8].					

Table 7.3B.2.3.4.2.1-4b: Test configurations for exceptions due to cross band isolation for EN-DC 25_n41 (Victim band LTE)

Aggressor UL			E-UTRA B25		
CBW/RB allocation			Ch BW/Frequency range		
			10MHz	15 MHz	20MHz
			High range	High range	High range
NR	100 MHz 160@0	low range	X ¹ -	X ¹ -	X ¹
n41	100 MHz 160@0	mid range	-	-	X ¹
NOTE 1: The UL resource blocks shall be located as close as possible to the downlink operating band but confined within the transmission bandwidth configuration for the channel bandwidth.					
NOTE 2: NR UL RB configuration shall set per Table 7.3.2.4.1-3 in TS 38.521-1 [8].					

Table 7.3B.2.3.4.2.1-4c: Test configurations for exceptions due to cross band isolation for EN-DC 7_n78 (Victim band LTE)

Aggressor UL CBW/RB allocation			E-UTRA B7 DL CBM/RB allocation		
			10MHz	15 MHz	20MHz
			Low, Mid High range	Low, Mid High range	Low, Mid High range
NR Band n78	100 MHz 270@0	Low range	X	X	X
	100 MHz 270@0	High range	-	-	X

NOTE 1: The UL resource blocks shall be located as close as possible to the downlink operating band but confined within the transmission bandwidth configuration for the channel bandwidth.
NOTE 2: NR UL RB configuration shall be further limited to that specified per Table 7.3.2.4.1-3 in TS 38.521-1 [8].

Table 7.3B.2.3.4.2.1-4d: Test configurations for exceptions due to cross band isolation for EN-DC 38_n78 (Victim band LTE)

Aggressor UL CBW/RB allocation			E-UTRA B38 DL CBM/RB allocation		
			10MHz	15 MHz	20MHz
			Low, Mid High range	Low, Mid High range	Low, Mid High range
NR Band n78	100 MHz 270@0	Low range	X	X	X
	100 MHz 270@0	High range	-	-	X

NOTE 1: The UL resource blocks shall be located as close as possible to the downlink operating band but confined within the transmission bandwidth configuration for the channel bandwidth.
NOTE 2: NR UL RB configuration shall be further limited to that specified per Table 7.3.2.4.1-3 in TS 38.521-1 [8].

Table 7.3B.2.3.4.2.1-4e: Test configurations table for exceptions due to cross band isolation for EN-DC 41_n77 (Victim band LTE)

Aggressor UL CBW/RB allocation			E-UTRA B41 Ch BW/Frequency range		
			10MHz	15 MHz	20MHz
			High range	High range	High range
NR	100 MHz 270@0	Low range	X ¹	X ¹	X ¹
n77	100 MHz 270@0	Mid range	-	-	X ¹

NOTE 1: The UL resource blocks shall be located as close as possible to the downlink operating band but confined within the transmission bandwidth configuration for the channel bandwidth.
NOTE 2: NR UL RB configuration shall be further limited to that specified per Table 7.3.2.4.1-3 in TS 38.521-1 [8].
NOTE 3: Applicable only when harmonic mixing MSD for this combination is not applied.

Table 7.3B.2.3.4.2.1-4f: Test configurations table for exceptions due to cross band isolation for EN-DC 41_n77 (Victim band NR)

Aggressor UL CBW/RB allocation			n77 Ch BW/Frequency range		
			20MHz	50 MHz	100MHz
			Low range	Mid range	High range
E-UTRA B41	20 MHz 100@0	High range	X ¹	X ¹	X ¹
	20 MHz 100@0	Mid range	X ¹	-	-

NOTE 1: The UL resource blocks shall be located as close as possible to the downlink operating band but confined within the transmission bandwidth configuration for the channel bandwidth.
 NOTE 2: NR UL RB configuration shall be further limited to that specified per Table 7.3.2.4.1-3 in TS 38.521-1 [8].
 NOTE 3: Applicable only when harmonic mixing MSD for this combination is not applied.

Table 7.3B.2.3.4.2.1-4g: Test configurations table for exceptions due to cross band isolation for EN-DC 41_n78(Victim band LTE)

Aggressor UL CBW/RB allocation			E-UTRA B41 Ch BW/Frequency range		
			10MHz	15 MHz	20MHz
			High range	High range	High range
NR	100 MHz 270@0	low range	X ¹	X ¹	X ¹
n78	100 MHz 270@0	mid range	-	-	X ¹

NOTE 1: The UL resource blocks shall be located as close as possible to the downlink operating band but confined within the transmission bandwidth configuration for the channel bandwidth.
 NOTE 2: NR UL RB configuration shall be further limited to that specified per Table 7.3.2.4.1-3 in TS 38.521-1 [8].
 NOTE 3: Applicable only when harmonic mixing MSD for this combination is not applied.

Table 7.3B.2.3.4.2.1-4h: Test configurations table for exceptions due to cross band isolation for EN-DC 41_n78 (Victim band NR)

Aggressor UL CBW/RB allocation			n78 Ch BW/Frequency range		
			20MHz	50 MHz	100MHz
			Low range	Mid range	High range
E-UTRA B41	20 MHz 100@0	High range	X ¹	X ¹	X ¹
	20 MHz 100@0	Mid range	X ¹	-	-

NOTE 1: The UL resource blocks shall be located as close as possible to the downlink operating band but confined within the transmission bandwidth configuration for the channel bandwidth.
 NOTE 2: NR UL RB configuration shall be further limited to that specified per Table 7.3.2.4.1-3 in TS 38.521-1 [8].
 NOTE 3: Applicable only when harmonic mixing MSD for this combination is not applied.

Table 7.3B.2.3.4.2.1-4i: Test configurations table for exceptions due to cross band isolation for EN-DC 66_n41(Victim band LTE)

Aggressor UL CBW/RB allocation			E-UTRA B66 Ch BW/Frequency range		
			10MHz	15 MHz	20MHz
			High range	High range	High range
NR	100 MHz 128@0	low range	X ¹	X ¹	X ¹
n41	100 MHz 128@0	mid range	-	-	X ¹

NOTE 1: The UL resource blocks shall be located as close as possible to the downlink operating band but confined within the transmission bandwidth configuration for the channel bandwidth.
NOTE 2: NR UL RB configuration shall be further limited to that specified per Table 7.3.2.4.1-3 in TS 38.521-1 [8].
NOTE 3: Applicable only when harmonic mixing MSD for this combination is not applied.

Table 7.3B.2.3.4.2.1-4j: Test configurations table for exceptions due to cross band isolation for EN-DC 1_n40 (Victim band NR)

Aggressor UL CBW/RB allocation			NR n40 Ch BW/Frequency range		
			10MHz	30 MHz	80 MHz
			Low range	Low range	Low range
E-UTRA	20 MHz 100@0	Mid range	X ¹	X ¹	X ¹
B1	20 MHz 100@0	High range	-	-	X ¹

NOTE 1: The UL resource blocks shall be located as close as possible to the downlink operating band but confined within the transmission bandwidth configuration for the channel bandwidth.
NOTE 2: NR UL RB configuration shall be further limited to that specified per Table 7.3.2.4.1-3 in TS 38.521-1 [8].

Table 7.3B.2.3.4.2.1-4k: Test configurations table for exceptions due to cross band isolation for EN-DC 1_n40 (Victim band LTE)

Aggressor UL CBW/RB allocation			E-UTRA B1 Ch BW/Frequency range		
			10MHz	15 MHz	20MHz
			Low range	Mid range	High range
NR	20 MHz 100@0	low range	X ¹	X ¹	X ¹
n40	20 MHz 100@0	mid range	-	-	X ¹

NOTE 1: The UL resource blocks shall be located as close as possible to the downlink operating band but confined within the transmission bandwidth configuration for the channel bandwidth.
NOTE 2: NR UL RB configuration shall be further limited to that specified per Table 7.3.2.4.1-3 in TS 38.521-1 [8].

Table 7.3B.2.3.4.2.1-4l: Test configurations table for exceptions due to cross band isolation for EN-DC 3_n51 (Victim band NR)

Aggressor UL CBW/RB allocation			NR n51 Ch BW/Frequency range		
			5 MHz	5 MHz	5 MHz
			Low range	Mid range	High range
E-UTRA	5 MHz 25@0	low range	X ¹	-	-
B3	5 MHz 25@0	Mid range	X ¹	-	-

NOTE 1: The UL resource blocks shall be located as close as possible to the downlink operating band but confined within the transmission bandwidth configuration for the channel bandwidth.
NOTE 2: NR UL RB configuration shall be further limited to that specified per Table 7.3.2.4.1-3 in TS 38.521-1 [8].

Table 7.3B.2.3.4.2.1-4m: Test configurations table for exceptions due to cross band isolation for EN-DC 30_n66 (Victim band NR)

Aggressor UL CBW/RB allocation			NR n66		
			Ch BW/Frequency range		
			20 MHz Low range	20 MHz Mid range	20 MHz High range
E-UTRA B30	5 MHz 25@0	low range	X ¹	X ¹	X ¹
	5 MHz 25@0	Mid range	-	-	X ¹
NOTE 1: The UL resource blocks shall be located as close as possible to the downlink operating band but confined within the transmission bandwidth configuration for the channel bandwidth.					
NOTE 2: NR UL RB configuration shall be further limited to that specified per Table 7.3.2.4.1-3 in TS 38.521-1 [8].					

Table 7.3B.2.3.4.2.1-4n: Test configurations table for exceptions due to cross band isolation for EN-DC 46_n78 (Victim band LTE)

Aggressor UL CBW/RB allocation			E-UTRA B46		
			Ch BW/Frequency range		
			20 MHz Low range	20 MHz Mid range	20 MHz High range
NR	50 MHz 270@0	mid range	X ¹	X ¹	X ¹
N78	50 MHz 270@0	high range	X ¹	-	-
NOTE 1: The UL resource blocks shall be located as close as possible to the downlink operating band but confined within the transmission bandwidth configuration for the channel bandwidth.					
NOTE 2: NR UL RB configuration shall be further limited to that specified per Table 7.3.2.4.1-3 in TS 38.521-1 [8].					

The initial test configurations for E-UTRA band and NR band consist of environmental conditions, test frequencies, and channel bandwidths and RB allocations for exceptional test scenarios due to dual uplink operation for EN-DC in NR FR1 (two bands) are specified in Table 7.3B.2.3.4.2.1-5.

Table 7.3B.2.3.4.2.1-5: Test Configuration Table Reference sensitivity exceptions due to dual uplink operation for EN-DC in NR FR1 (two bands)

Initial Conditions												
Test Environment as specified in TS 38.508-1 [6] clause 4.1					Normal, TL/VL, TL/VH, TH/VL, TH/VH							
NR Test Frequencies as specified in TS 38.508-1 [6] clause 4.3.1					For test frequencies refer to "Range" columns.							
E-UTRA Test Frequencies as specified in TS 36.508 [11] clause 4.3.1												
Test DC Combination setting (N _{RB_agg}) as specified in clause [TBD] for the DC Configuration across bandwidth combination sets supported by the UE.					Refer to "NR N _{RB} " and "E-UTRA N _{RB} " columns							
Network signalling value					NS_01 Unless given by Table 7.3.3-3 in TS 36.521-1 [10] for the E-UTRA band and Table 7.3.2.3-4 in TS 38.521-1 [8] for the NR band.							
Test Parameters for DC Configurations												
ID	DC Configuration / N _{RB_agg}					DL Allocation			UL Allocation (Note 2,3)			
	DC Configuration				E-UTRA Ch BW	NR Ch BW	CC MOD E-UTRA/NR	E-UTRA & NR RB allocation		CC MOD E-UTRA/NR	E-UTRA & NR allocations (L _{CRB} @ RB _{start})	
	E-UTRA		NR					PCC	SCC			
	Band	Range	Band	Range								
Default Test Settings for a DC_XA-nYA Configuration												
1	X	Mid	Y	Mid	5	Mid	QPSK /CP-OFDM QPSK	All RBs	QPSK/DFT-s-OFDM QPSK	REFSENS	REFSENS	
Test Settings for DC_1A-n5A Configuration												
1	1	Note 5	5	Note 5	5	5	Note 7	All RBs	Note 7	25@0	25@0	
Test Settings for DC_1A-n77A Configuration												
1	1	Note 5	77	Note 5	5	10	Note 7	All RBs	Note 7	25@0	25@0	
Test Settings for DC_2A-n66A Configuration												
1	2	Note 5	66	Note 5	5	5	Note 7	All RBs	Note 7	25@0	25@0	
Test Settings for DC_2A-n78A Configuration												
1	2	Note 5	78	Note 5	5	10	Note 7	All RBs	Note 7	25@0	50@0	
Test Settings for DC_3A-n5A Configuration												
1	3	Note 5	5	Note 5	10	5	Note 7	All RBs	Note 7	50@0	25@0	
Test Settings for DC_3A-n7A Configuration												
1	3	Note 5	7	Note 5	5	10	Note 7	All RBs	Note 7	25@0	50@0	
Test Settings for DC_3A-n20A Configuration												
1	3	Note 5	20	Note 5	5	5	Note 7	All RBs	Note 7	25@0	25@0	
Test Settings for DC_3A-n77A Configuration												
1	3	Note 5	77/78	Note 5	5	10	Note 7	All RBs	Note 7	25@0	50@0	
Test Settings for DC_5A-n66A Configuration												
1	5	Note 5	66	Note 5	5	5	Note 7	All RBs	Note 7	25@0	25@0	
Test Settings for DC_5A-n78A Configuration												
1	5	Note 5	78	Note 5	5	10	Note 7	All RBs	Note 7	25@0	52@0	
Test Settings for DC_7A-n5A Configuration												
1	7	Low	5	High	10	5	Note 7	All RBs	Note 7	50@0	25@0	
Test Settings for DC_7A-n66A Configuration												
1	7	Note 5	66	Note 5	10	5	Note 7	All RBs	Note 7	50@0	25@0	

Test Settings for DC_7A-n77A Configuration											
1	7	Low	77	High	5	10	Note 7	All RBs	Note 7	25@0	50@0
Test Settings for DC_8A-n1A Configuration											
1	8	Low	1	High	5	5	Note 7	All RBs	Note 7	25@0	25@0
Test Settings for DC_8A-n3A Configuration											
1	8	Low	3	High	5	10	Note 7	All RBs	Note 7	25@0	50@0
Test Settings for DC_8A-n41A Configuration											
1	8	Low	41	High	5	10	Note 7	All RBs	Note 7	25@0	50@0
Test Settings for DC_8A-n77A/n78A Configuration											
1	8	Note 5	77	Note 5	5	10	Note 7	All RBs	Note 7	25@0	52@0
2	8	Note 5	78	Note 5	5	10	Note 7	All RBs	Note 7	25@0	52@0
Test Settings for DC_8A-n79A Configuration											
1	8	Note 5	79	Note 5	5	40	Note 7	All RBs	Note 7	25@0	216@0
Test Settings for DC_12A-n78A Configuration											
1	12	Note 5	78	Note 5	5	10	Note 7	All RBs	All RBs	25@0	50@0
Test Settings for DC_20A-n3A Configuration											
1	20	Note 5	3	Note 5	5	5	Note 7	All RBs	Note 7	25@0	25@0
Test Settings for DC_20A-n8A Configuration											
1	20	Note 5	8	Note 5	5	5	Note 7	All RBs	Note 7	25@0	25@0
Test Settings for DC_20A-n77A Configuration											
1	20	Note 5	77	Note 5	5	10	Note 7	All RBs	Note 7	25@0	50@0
2	20	Note 5	77	Note 5	5	10	Note 7	All RBs	Note 7	25@0	50@0
Test Settings for DC_21A- n79A Configuration											
1	21	Note 5	79	Note 5	5	40	Note 7	All RBs	Note 7	25@0	216@0
Test Settings for DC_26- n41A Configuration											
1	26	Note 5	41	Note 5	5	10	Note 7	All RBs	Note 7	25@0	50@0
Test Settings for DC_26A- n77/n78A Configuration											
1	26	Note 5	77	Note 5	5	10	Note 7	All RBs	Note 7	25@0	50@0
1	26	Note 5	78	Note 5	5	10	Note 7	All RBs	Note 7	25@0	50@0
Test Settings for DC_48A- n66A Configuration											
1	48	Note 5	66	Note 5	20	5	Note 7	All RBs	Note 7	100@0	25@0
Test Settings for DC_28A- n41A Configuration											
1	28	Note 5	41	Note 5	10	10	Note 7	All RBs	Note 7	50@0	50@0
Test Settings for DC_28A- n50A Configuration											
1	28	Note 5	50	Note 5	10	10	Note 7	All RBs	Note 7	50@0	50@0
Test Settings for DC_28A- n51A Configuration											
1	28	Note 5	51	Note 5	5	5	Note 7	All RBs	Note 7	25@0	25@0
Test Settings for DC_28A- n77/n78A Configuration											
1	28	Note 5	77	Note 5	5	10	Note 7	All RBs	Note 7	25@0	50@0
2	28	Note 5	78	Note 5	5	10	Note 7	All RBs	Note 7	25@0	50@0
Test Settings for DC_66A-n2A Configuration											
1	66	Note 5	2	Note 5	5	5	Note 7	All RBs	Note 7	25@0	25@0
Test Settings for DC_66A-n5A Configuration											
1	66	Note 5	5	Note 5	5	5	Note 7	All RBs	Note 7	25@0	25@0
Test Settings for DC_66A-n25A Configuration											
1	66	Note 5	5	Note 5	5	5	Note 7	All RBs	Note 7	25@0	25@0
Test Settings for DC_66A-n71A Configuration											

1	66	Note 5	71	Note 5	5	5	Note 7	All RBs	Note 7	25@0	25@0
Test Settings for CA_7A-20A Configuration											
1	7	Note 5	20	Note 5	10	5	QPSK	All RBs	QPSK	50@0	25@0
Note 1:	Both of the transmitters shall be set min(+20 dBm, $P_{\text{CMAX_L,c}}$) as defined in clause 6.2.5A. In case Single UL is allowed and the UE only indicates support of "Single UL" the output power of the active UL shall be set at $P_{\text{CMAX_L,c}}$ or set to the maximum output power according to the UE power scaling capability.										
Note 2:	Use DC Configuration – specific test points if present in the table, otherwise use test points from matching Group Test Settings, if present in the table. Otherwise use the Default Test Settings test points.										
Note 3:	X,Y correspond to the different bands in the DC Configuration. E.g. for DC_1A-n3A, X=1, Y=3.										
Note 4:	REFSENS refers to the E_UTRA bands and NR band N_{RB} 's single carrier Uplink RB allocation for reference sensitivity according to table 7.3.5-2 of TS 36.521-1 [10] and Table 7.3.2.4.1-3 of TS 38.521-1 [8], respectively										
Note 5:	Test frequency for each DC configuration shall follow Table 7.3B.2.0.3.5.1-1. If test configurations of each ID in a DC configuration are same, test frequency shall follow the order of Table 7.3B.2.0.3.5.1-1.										
Note 6:	Not applicable if the UE only supports Bandwidth Combination Set 1.										
Note 7:	Same as default.										
Note 8:	$\text{RB}_{\text{START}} = 0$										

Table 7.3B.2.3.4.2.1-6: Test Configuration Table for EN-DC configurations affected by Reference sensitivity exceptions (two bands)

Initial Conditions								
Test Environment as specified in TS 38.508-1 [6] clause 4.1				Normal, TL/VL, TL/VH, TH/VL, TH/VH				
NR Test Frequencies as specified in TS 38.508-1 [6] clause 4.3.1, E-UTRA Test Frequencies as specified in TS 36.508 [11] clause 4.3.1				For test frequencies refer to "Range" columns.				
Test DC Combination setting (NRB_agg) as specified in clause [TBD] for the DC Configuration across bandwidth combination sets supported by the UE.				Refer to "NR NRB" and "E-UTRA NRB " columns				
Network signalling value				NS_01 by default, exceptions listed in Table 7.3.3-3, dependent on PCC Band				
Test Parameters for DC Configurations								
ID	PCC – E-UTRA				SCG -NR			
	Band	Range	NRB		Band	Range	NRB	
	UL MOD	DL MOD	CH BW	DLalloc / UL alloc	UL MOD	DL MOD	UL/DL Ch BW	DLalloc / UL alloc
Test Settings for a DC_1A_n3A Configuration								
12, 11	1	Mid			n3	Mid		
	QPSK	QPSK	20 MHz	All RBs / REFSSENS_ENDC_3	N/A	QPSK	40 MHz	All RBs / 0
24, 10	1	UL 1950 / DL 2140			n3	UL 1760 / DL 1855		
	QPSK	QPSK	5 MHz	All RBs / REFSSENS_ENDC_4	DFT-s-OFDM QPSK	CP-OFDM QPSK	5 MHz	All RBs / REFSSENS_ENDC_4
36	1	Low			n3	High		
	N/A	QPSK	20 MHz	All RBs / REFSSENS_ENDC_3	DFT-s-OFDM QPSK	CP-OFDM QPSK	40 MHz	All RBs / 0
Test Settings for a DC_1A_n78A Configuration								
17	1	Mid			n78	Mid		
	N/A	N/A	5MHz	N/A	DFT-s-OFDM QPSK	CP-OFDM QPSK	100MHz	All RBs / REFSSENS_NR
24	1	UL 1950 / DL 2140			n78	3710		
	QPSK	QPSK	5 MHz	All RBs / REFSSENS_ENDC_4	DFT-s-OFDM QPSK	CP-OFDM QPSK	10 MHz	All RBs / REFSSENS_ENDC_4
Test Settings for a DC_3A_n1A Configuration								
12, 11	3	Mid			n1	Mid		
	N/A	QPSK	20 MHz	All RBs / 0	N/A	CP-OFDM QPSK	100 MHz	All RBs / REFSSENS_ENDC_3
26	3	High			n1	Low		
	N/A	QPSK	20 MHz	All RBs / 0	DFT-s-OFDM QPSK	CP-OFDM QPSK	20 MHz	All RBs / REFSSENS_ENDC_3
34	3	UL 1760 / DL 1855			n1	UL 1950 / DL 2140		
	QPSK	QPSK	5 MHz	All RBs / REFSSENS_ENDC_4	DFT-s-OFDM QPSK	CP-OFDM QPSK	5 MHz	All RBs / REFSSENS_ENDC_4
47	3	Mid			n1	Mid		
	N/A	N/A	5MHz	N/A	DFT-s-OFDM QPSK	CP-OFDM QPSK	100 MHz	All RBs / REFSSENS_NR
Test Settings for a DC_3A_n41A Configuration								
16	3	Low			n41	Low		

	QPSK	QPSK	20 MHz	All RBs / REFSENS_ENDC_ 3	N/A	CP-OFDM QPSK	20 MHz	All RBs / 0
2 ⁶	3	Mid			n41	Low		
	QPSK	QPSK	20 MHz	All RBs / REFSENS_ENDC_ 3	N/A	CP-OFDM QPSK	20 MHz	All RBs / 0
3 ⁶	3	High			n41	Low		
	N/A	QPSK	20 MHz	All RBs / 0	DFT-s- OFDM QPSK	CP-OFDM QPSK	100 MHz	All RBs / REFSENS_END C_3
4 ⁶	3	High			n41	Mid		
	N/A	QPSK	20 MHz	All RBs / 0	DFT-s- OFDM QPSK	CP-OFDM QPSK	100 MHz	All RBs / REFSENS_END C_3
5 ⁴ , 10	3	DL 1835			n41	2657.5		
	QPSK	QPSK	5 MHz	All RBs / REFSENS_ENDC_ 4	DFT-s- OFDM QPSK	CP-OFDM QPSK	10 MHz	All RBs / REFSENS_END C_4
Test Settings for a DC_3A_n78A Configuration								
1 ³	3	Mid			n78	3495		
	QPSK	QPSK	20 MHz	All RBs / REFSENS_ENDC_ 1	N/A	CP-OFDM QPSK	100 MHz	All RBs / 0
2 ³	3	Mid			n78	3525		
	QPSK	QPSK	20 MHz	All RBs / REFSENS_ENDC_ 1	N/A	CP-OFDM QPSK	20 MHz	All RBs / 0
3 ⁵	3	Mid			n78	3685		
	N/A	QPSK	20 MHz	All RBs / 0	DFT-s- OFDM QPSK	CP-OFDM QPSK	20 MHz	All RBs / REFSENS_END C_2
3a ⁹	3	Low			n78	High		
	QPSK	QPSK	20	All RBs/0	DFT-s- OFDM QPSK	CP-OFDM QPSK	20	All RBs / REFSENS_END C_2
4 ⁴	3	UL 1740 / DL 1835			n78	3575		
	QPSK	QPSK	5 MHz	All RBs / REFSENS_ENDC_ 4	DFT-s- OFDM QPSK	CP-OFDM QPSK	10 MHz	All RBs / REFSENS_END C_4
5 ⁴	3	UL 1765 / DL 1860			n78	3435		
	QPSK	QPSK	5 MHz	All RBs / REFSENS_ENDC_ 4	DFT-s- OFDM QPSK	CP-OFDM QPSK	10 MHz	All RBs / REFSENS_END C_4
Test Settings for a DC_7A_n3A Configuration								
1 ⁷	7	DL 2655			n3	DL 1825		
	QPSK	N/A	10 MHz	N/A	N/A	CP-OFDM QPSK	5 MHz	All RBs / REFSENS_END C_4
Test Settings for a DC_8A_n1A Configuration								
1 ⁷	8	DL 932.5			n1	DL 2155		
	QPSK	N/A	5 MHz	N/A	N/A	CP-OFDM QPSK	5 MHz	All RBs / REFSENS_END C_4
Test Settings for a DC_8A_n3A Configuration								
1 ⁷	8	DL 945			n3	DL 1850		
	QPSK	N/A	5 MHz	N/A	N/A	CP-OFDM QPSK	10 MHz	All RBs / REFSENS_END C_4
2 ⁷	8	DL 942.5			n3	DL 1842.5		
	QPSK	N/A	5 MHz	N/A	N/A	CP-OFDM QPSK	10 MHz	All RBs / REFSENS_END C_4

Test Settings for a DC_8A_n77A Configuration								
1 ³	8	Mid			n77	3590		
	QPSK	QPSK	10 MHz	All RBs / REFSSENS_ENDC_1	N/A	QPSK	100 MHz	All RBs / 0
2 ² , 8	8	Mid			n77	3520		
	QPSK	QPSK	10 MHz	All RBs / REFSSENS_ENDC_1	N/A	QPSK	100 MHz	All RBs / 0
3 ⁴	8	UL 897.5			n77	3635		
	QPSK	QPSK	5 MHz	All RBs / REFSSENS_ENDC_4	CP-OFDM QPSK	CP-OFDM QPSK	10 MHz	All RBs / REFSSENS_ENDC_4
Test Settings for a DC_11A_n79A Configuration								
1 ⁵	11	Mid			n79	4457.7		
	N/A	QPSK	10 MHz	All RBs / 0	DFT-s-OFDM QPSK	QPSK	100 MHz	All RBs / REFSSENS_ENDC_2
2 ² , 9	11	Mid			n79	4512.7		
	N/A	QPSK	10 MHz	All RBs / 0	DFT-s-OFDM QPSK	QPSK	100 MHz	All RBs / REFSSENS_ENDC_2
Test Settings for a DC_19_n79 Configuration								
1 ⁵	19	DL 884			n79	Low		
	N/A	QPSK	10 MHz	All RBs / 0	DFT-s-OFDM QPSK	CP-OFDM QPSK	40 MHz	All RBs / REFSSENS_ENDC_2
2 ² , 9	19	DL 884			n79	4445.02		
	N/A	QPSK	10 MHz	All RBs / 0	DFT-s-OFDM QPSK	CP-OFDM QPSK	40 MHz	All RBs / REFSSENS_ENDC_2
Test Settings for a DC_20A_n3A Configuration								
1 ⁷	20	Mid			n3	Mid		
	QPSK	N/A	5 MHz	N/A	DFT-s-OFDM QPSK	CP-OFDM QPSK	40 MHz	All RBs / REFSSENS_NR
2 ⁴	20	UL 840 / DL 799			n3	UL 1775 / DL 1870		
	QPSK	QPSK	5 MHz	All RBs / REFSSENS_ENDC_4	DFT-s-OFDM QPSK	CP-OFDM QPSK	5 MHz	All RBs / REFSSENS_ENDC_4
3 ⁴	20	UL 847 / DL 806			n3	UL 1735 / DL 1830		
	QPSK	QPSK	5 MHz	All RBs / REFSSENS_ENDC_4	DFT-s-OFDM QPSK	CP-OFDM QPSK	5 MHz	All RBs / REFSSENS_ENDC_4
Test Settings for a DC_20A_n78A Configuration								
1 ² , 8	20	Mid			n78	Mid		
	QPSK	QPSK	20 MHz	All RBs / REFSSENS_ENDC_1	N/A	QPSK	100 MHz	All RBs / 0
2 ³	20	Mid			n78	3388 MHz		
	QPSK	QPSK	20 MHz	All RBs / REFSSENS_ENDC_1	N/A	CP-OFDM QPSK	100 MHz	All RBs / 0
3 ⁴	20	UL 850 / DL 809 MHz			n78	3359 MHz		
	QPSK	QPSK	5 MHz	All RBs / REFSSENS_ENDC_4	DFT-s-OFDM QPSK	CP-OFDM QPSK	10 MHz	All RBs / REFSSENS_ENDC_4
Test Settings for a DC_26A_n41A Configuration								
1 ³	26	High			n41	2524.5		
	QPSK	QPSK	15 MHz	All RBs / REFSSENS_ENDC_1	N/A	QPSK	50 MHz	All RBs / 0

2 ² , 8	26	High			n41	2572		
	QPSK	QPSK	15 MHz	All RBs / REFSENS_ENDC_1	N/A	QPSK	50 MHz	All RBs / 0
3 ⁴	26	UL 839			n41	2562		
	QPSK	QPSK	5 MHz	All RBs / REFSENS_ENDC_4	CP- OFDM QPSK	CP-OFDM QPSK	10 MHz	All RBs / REFSENS_EN DC_4
Test Settings for a DC_26A_n77A/DC_26A_n78A Configuration								
1 ³	26	High			n77/n78	3366		
	QPSK	QPSK	15 MHz	All RBs / REFSENS_ENDC_1	N/A	QPSK	100 MHz	All RBs / 0
2 ² , 8	26	High			n77/n78	3446		
	QPSK	QPSK	15 MHz	All RBs / REFSENS_ENDC_1	N/A	QPSK	100 MHz	All RBs / 0
3 ⁴	26	UL 836.5			n77/n78	3391		
	QPSK	QPSK	5 MHz	All RBs / REFSENS_ENDC_4	CP- OFDM QPSK	CP-OFDM QPSK	10 MHz	All RBs / REFSENS_EN DC_4
Test Settings for a DC_26A_n79A Configuration								
1 ⁵	26	High			n79	4432.5		
	N/A	QPSK	15 MHz	All RBs / 0	CP- OFDM QPSK	CP-OFDM QPSK	60 MHz	All RBs / REFSENS_EN DC_2
2 ² , 9	26	High			n79	4470.5		
	N/A	QPSK	15 MHz	All RBs / 0	CP- OFDM QPSK	CP-OFDM QPSK	60 MHz	All RBs / REFSENS_EN DC_2
Test Settings for a DC_40_n78 Configuration								
1 ⁵	40	Mid			n78	3525		
	N/A	QPSK	20 MHz	All RBs / 0	DFT-s- OFDM QPSK	CP-OFDM QPSK	20 MHz	All RBs / REFSENS_EN DC_2
2 ² , 9	40	Low			n78	Mid		
	QPSKN /A	QPSK	20 MHz	All RBs / REFSENS_ENDC_20	DFT-s- OFDM QPSKN/ A	CP-OFDM QPSK	100 MHz	All RBs / REFSENS_EN DC_20
Test Settings for a DC_41A_n77A/DC_41A_n78A Configuration								
1 ⁵	41	Mid			n77/n78	3889.5		
	N/A	QPSK	20 MHz	All RBs / 0	CP- OFDM QPSK	CP-OFDM QPSK	100 MHz	All RBs / REFSENS_EN DC_2
2 ⁶	41	Mid			n77/n78	3974.5		
	N/A	QPSK	20 MHz	All RBs / 0	CP- OFDM QPSK	CP-OFDM QPSK	100 MHz	All RBs / REFSENS_EN DC_3

<p>NOTE 1: REFSSENS_LTE refers to the single carrier Uplink RB allocation for reference sensitivity according to table 7.3.3-2 of TS 36.521-1 [10]. REFSENS_NR refers to the single carrier Uplink RB allocation for reference sensitivity according to table 7.3.2.4.1-3 of TS 38.521-1 [8]. REFSENS_ENDC_1 refers to the Uplink RB allocation for reference sensitivity exceptions due to UL harmonic interference according to table 7.3B.2.0.3.1-2. REFSENS_ENDC_2 refers to the Uplink RB allocation for reference sensitivity exceptions due to receiver harmonic mixing according to table 7.3B.2.0.3.2-2. REFSENS_ENDC_3 refers to the Uplink RB allocation for reference sensitivity exceptions due to cross band isolation according to table 7.3B.2.0.3.4-2. REFSENS_ENDC_4 refers to the Uplink RB allocation for reference sensitivity exceptions due to dual uplink operation according to table 7.3B.2.0.3.5.1-1.</p> <p>NOTE 2: Test ID with no exception NOTE 3: Test ID with UL harmonic exception NOTE 4: Test ID with 2UL intermodulation exception NOTE 5: Test ID with UL receiver harmonic mixing NOTE 6: Test ID with UL cross band isolation NOTE 7: Test ID with LTE anchor agnostic, which applies to NSA only capable UEs NOTE 8: Test ID with UL harmonic exception avoided NOTE 9: Test ID with UL receiving harmonic exception avoided NOTE 10: Only applicable to UEs not supporting UE capability <i>singleUL-Transmission</i>. NOTE 11: Test ID with Cross band isolation exception avoided, which is only applicable to DC_1_n3, DC_3_n1 and DC_3_n84.. NOTE 12: In an E-UTRA band or FR1 band where UE supports 4Rx, the test shall be performed only with 4Rx antennas ports connected.</p>

1. Connect the SS to the UE antenna connectors as shown in TS 38.508-1 [5] Annex A, Figure A.3.1.1.1 for TE diagram and clause A.3.2 for UE diagram.
2. The parameter settings for NR cell are set up according to TS 38.508-1 [6] clause 4.4.3.
3. The parameter settings for E-UTRA cell are set up according to TS 36.508 [11] clause 4.4.3.
4. NR downlink signals are initially set up according to Annex C.0, C.1, C.2, C.3.1, and uplink signals according to Annex G.0, G.1, G.2, and G.3.1 of TS 38.521-1 [8].
5. E-UTRA downlink signals are initially set up according to Annex C.0, C.1 and C.3.0, and uplink signals according to Annex H.1 and H.3.0 of TS 36.521-1 [10].
6. The DL and UL Reference Measurement channels are set according to Tables 7.3B.2.3.4.2.1-0 to 7.3B.2.3.4.2.1-6 for E-UTRA CG and NR CG.
7. NR propagation conditions are set according to Annex B.0 of TS 38.521-1 [8]. E-UTRA propagation conditions are set according to Annex B.0 of TS 36.521-1 [10].
8. Ensure the UE is in state RRC_CONNECTED with generic procedure parameters Connectivity EN-DC, DC bearer MCG and SCG, Connected without release *On* according to TS 38.508-1 [6] clause 4.5. Message contents are defined in clause 7.3B.2.3.4.2.3.
9. On the E-UTRA carrier, disable periodic and aperiodic CQI reports, disable SRS, set *TimeAlignmentTimerDedicated* IE to infinity and disable downlink and uplink scheduling, all as per Table 4.6-1 under clause 4.6. Step 9 only applicable to the test configuration in Table 7.3B.2.3.4.2.1-0.

7.3B.2.3.4.2.2 Test procedure

For test points in Table 7.3B.2.3.4.2.1-0:

1. NR SS transmits PDSCH via PDCCH DCI format 1_1 for C_RNTI to transmit the DL RMC according to Table 7.3B.2.3.4.2.1-0 on the NR CC. The NR SS sends downlink MAC padding bits on the DL RMC.
2. NR SS sends uplink scheduling information for each UL HARQ process via PDCCH DCI format 0_1 for C_RNTI to schedule the UL RMC according to Table 7.3B.2.3.4.2.1-0. Since the UL has no payload and no loopback data to send the UE sends uplink MAC padding bits on the UL RMC.

3. Set the Downlink signal level to the appropriate REFSENS value defined in TS 38.521-1 [8], Table 7.3.2.5-1 for NR band. Send continuously uplink power control "up" commands in the uplink scheduling information to both carriers to ensure the UE transmits PUMAX level for at least the duration of the Throughput measurement.
4. Measure the average throughput of the NR carrier for a duration sufficient to achieve statistical significance according to Annex H.2 of TS 38.521-1 [8] for NR band.

For test points in Table 7.3B.2.3.4.2.1-6:

1. SS transmits PDSCH via PDCCH DCI format 1A and PDCCH DCI format 1_1 for C_RNTI to transmit the DL RMC according to Table 7.3B.2.3.4.2.1-6 on the E-UTRA CC and NR CC. The SS sends downlink MAC padding bits on the DL RMC.
2. SS sends uplink scheduling information for each UL HARQ process via PDCCH DCI format 0 and DCI format 0_1 for C_RNTI to schedule the UL RMC according to Table 7.3B.2.3.4.2.1-6 on the E-UTRA CC and NR CC. Since the UL has no payload and no loopback data to send the UE sends uplink MAC padding bits on the UL RMC.
3. Set the Downlink signal level for the E-UTRA CC and NR CC to the appropriate REFSENS value defined in Tables 7.3B.2.3.5-1 to 7.3B.2.3.5-4. Send continuously uplink power control "up" commands in the uplink scheduling information to both carriers to ensure the UE transmits PUMAX level for at least the duration of the Throughput measurement.
4. Measure the average throughput of both NR and E-UTRA for a duration sufficient to achieve statistical significance according to Annex H.2 of TS 38.521-1 [8] for NR band, and Annex G.2 of TS 36.521-1 [10] for EUTRA band.

7.3B.2.3.4.2.3 Message contents

Message contents are according to TS 38.508-1 [5] clause 4.6.

7.3B.2.3.5 Test requirement

For inter-band EN-DC configurations, the throughput of each CG shall be $\geq 95\%$ of the maximum throughput for the reference receive power level specified in Table 7.3B.2.3.5-1, Table 7.3B.2.3.5-2, Table 7.3B.2.3.5-3, Table 7.3B.2.3.5-4 and Table 7.3B.2.3.5-5 for MSDs due to uplink harmonic, harmonic mixing, cross band isolation, dual uplinks for PC3 EN-DC and dual uplink operation for PC2 EN-DC, respectively. For a given EN-DC combo, if more than one category of MSD applies, UE shall pass all requirement.

Reference sensitivity test requirements for EN-DC configurations without any reference sensitivity exception are specified in Table 7.3.2.5-1 in TS 38.521-1 [8] for the NR CC with uplink configuration specified in Table 7.3B.2.3.4.2.1-0.

For the UE which supports inter-band EN-DC, the minimum requirement for reference sensitivity in Table 7.3.2.5-1 of TS 38.521-1 [8] for NR band and Table 7.3.5-1 of TS 36.521-1 [10] for EUTRA band, shall be increased by the amount given in $\Delta R_{B,c}$ defined in clause 7.3B.3.3 for the applicable for two, three, four and five bands operation.

Table 7.3B.2.3.5-1: Reference sensitivity due to UL harmonic for EN-DC in NR FR1

UL band	DL band	SCS (kHz)	5 MHz (dBm)	10 MHz (dBm)	15 MHz (dBm)	20 MHz (dBm)	25 MHz (dBm)	30 MHz (dBm)	40 MHz (dBm)	50 MHz (dBm)	60 MHz (dBm)	80 MHz (dBm)	90 MHz (dBm)	
1, 3	n77 ²	15		-71.4 +TT	-71.4 +TT	-71.3 +TT			-71.2 +TT	-71.3 +TT				
		30		-71.7 +TT	-71.5 +TT	-71.5 +TT			-71.3 +TT	-71.4 +TT	-71.4 +TT	-71.3 +TT	-71.4 +TT	
		60		-72.1 +TT	-71.8 +TT	-71.7 +TT			-71.5 +TT	-71.5 +TT	-71.5 +TT	-71.4 +TT	-71.4 +TT	
	n77 ³	15		-94.2 +TT	-92.7 +TT	-91.9 +TT								
		30		-94.5 +TT	-92.8 +TT	-92.1 +TT								
		60		-94.9 +TT	-93.1 +TT	-92.3 +TT								
2	n78 ²	15		-71.9 +TT	-71.9 +TT	-71.8 +TT			-71.7 +TT	-71.8 +TT				
		30		-72.2 +TT	-72.0 +TT	-72.0 +TT			-71.8 +TT	-71.9 +TT	-71.9 +TT	-71.8 +TT	-71.8 +TT	
		60		-72.6 +TT	-72.3 +TT	-72.2 +TT			-72.0 +TT	-72.0 +TT	-72.0 +TT	-71.9 +TT	-71.9 +TT	
2	n78 ³	15		-94.7 +TT	-93.2 +TT	-92.4 +TT								
		30		-94.9 +TT	-93.3 +TT	-92.6 +TT								
		60		-95.4 +TT	-93.6 +TT	-92.8 +TT								
3	n78 ²	15		-71.9 +TT	-71.9 +TT	-71.8 +TT			-71.7 +TT	-71.8 +TT				
		30		-72.2 +TT	-72.0 +TT	-72.0 +TT			-71.8 +TT	-71.9 +TT	-71.9 +TT	-71.8 +TT	-71.8 +TT	
		60		-72.6 +TT	-72.3 +TT	-72.2 +TT			-72.0 +TT	-72.0 +TT	-72.0 +TT	-71.9 +TT	-71.9 +TT	
	n78 ³	15		-94.7 +TT	-93.2 +TT	-92.4 +TT								
		30		-95.0 +TT	-93.3 +TT	-92.6 +TT								
		60		-95.4 +TT	-93.6 +TT	-92.8 +TT								
5	n78	15		-84.2 +TT	-84.4 +TT				-84.2 +TT	-84.4 +TT				
		30		-84.3 +TT	-84.5 +TT	-84.4 +TT			-84.3 +TT	-84.5 +TT	-84.4 +TT	-84.3 +TT	-84.4 +TT	
		60		-84.5 +TT	-84.6 +TT	-84.5 +TT			-84.5 +TT	-84.6 +TT	-84.5 +TT	-84.4 +TT	-84.4 +TT	
8	n77 ^{6,7} n78 ^{6,7}	15		-84.5 +TT	-84.4 +TT	-84.2 +TT			-84.0 +TT	-83.9 +TT				
		30		-84.8 +TT	-84.5 +TT	-84.4 +TT			-84.1 +TT	-84.0 +TT	-83.9 +TT	-83.8 +TT	-83.9 +TT	
		60		-85.2 +TT	-84.8 +TT	-84.6 +TT			-84.3 +TT	-84.1 +TT	-84.0 +TT	-83.9 +TT	-83.9 +TT	
8	n41	15		-81.8 +TT	-81.7 +TT	-81.7 +TT			-81.6 +TT	-81.5 +TT				
		30		-82.1 +TT	-81.8 +TT	-81.9 +TT			-81.7 +TT	-81.6 +TT	-81.4 +TT	-81.3 +TT	-81.3 +TT	
		60		-82.5 +TT	-82.1 +TT	-81.1 +TT			-81.9 +TT	-81.7 +TT	-81.6 +TT	-81.3 +TT	-81.3 +TT	
8	n79 ^{4,5}	15							-82.8 +TT	-82.4 +TT				
		30							-82.9 +TT	-82.5 +TT	-82.3 +TT	-81.7 +TT		
		60							-83.1 +TT	-82.6 +TT	-82.4 +TT	-81.8 +TT		
12	n66	15	-89.5 +TT	-88.8 +TT	-88.3 +TT	-87.8 +TT			-87.7 +TT					
		30		-89.1 +TT	-88.4 +TT	-88.0 +TT			-87.8 +TT					

		60		-89.5 +TT	-88.7 +TT	-88.2 +TT			-87.9 +TT				
12	n78	15		-85.4 +TT	-85.1 +TT	-84.9 +TT			-84.9 +TT	-84.9 +TT			
		30		-85.7 +TT	-85.2 +TT	-85.1 +TT			-85.0 +TT	-85.0 +TT	-84.9 +TT	-84.9 +TT	-84.9 +TT
		60		-86.1 +TT	-85.5 +TT	-85.3 +TT			-85.2 +TT	-85.1 +TT	-85.0 +TT	-85.0 +TT	-85.0 +TT
18, 19	n77 ^{4,5}	15		-84.9 +TT	-84.6 +TT	-84.4 +TT			-84.4 +TT	-84.4 +TT			
		30		-85.2 +TT	-84.7 +TT	-84.6 +TT			-84.5 +TT	-84.5 +TT	-84.4 +TT	-84.4 +TT	-84.4 +TT
		60		-85.6 +TT	-85.0 +TT	-84.8 +TT			-84.7 +TT	-84.6 +TT	-84.5 +TT	-84.5 +TT	-84.5 +TT
28	n51	15	-72.2 +TT										
		30											
		60											
28	n77 ^{4,5} n78 ^{4,5}	15		-84.9 +TT	-84.6 +TT	-84.4 +TT			-84.4 +TT	-84.4 +TT			
		30		-85.2 +TT	-84.7 +TT	-84.6 +TT			-84.5 +TT	-84.5 +TT	-84.4 +TT	-84.4 +TT	-84.4 +TT
		60		-85.6 +TT	-85.0 +TT	-84.8 +TT			-84.7 +TT	-84.6 +TT	-84.5 +TT	-84.5 +TT	-84.5 +TT
20	n77 ^{6,7} n78 ^{6,7}	15		-84.5 +TT	-84.4 +TT	-84.2 +TT			-83.1 +TT				
		30		-84.8 +TT	-84.5 +TT	-84.4 +TT			-83.2 +TT				
		60		-85.2 +TT	-84.8 +TT	-84.6 +TT			-83.4 +TT				
26	n41	15		-84.5 +TT	-84.6 +TT	-84.4 +TT			-83.6 +TT	-83.3 +TT	3.9 +TT	3.1 +TT	2.1 +TT
		30		-84.8 +TT	-84.7 +TT	-84.6 +TT			-83.7 +TT	-83.4 +TT	-83.0 +TT	-82.5 +TT	-82.5 +TT
		60		-85.2 +TT	-85.0 +TT	-84.8 +TT			-83.9 +TT	-83.5 +TT	-83.2 +TT	-82.5 +TT	-82.5 +TT
26	n77 ^{6,7} n78 ^{6,7}	15		-85.0 +TT	-84.9 +TT	-84.7 +TT			-83.6 +TT	-84.6 +TT			
		30		-85.3 +TT	- 85.0+TT	-84.9 +TT			-83.7 +TT	-84.7 +TT	-84.7 +TT	-84.6 +TT	-84.6 +TT
		60		-85.7 +TT	-85.3 +TT	-85.1 +TT			-83.9 +TT	-84.8 +TT	-84.8 +TT	-84.7 +TT	-84.7 +TT
26	n77 ^{4,5}	15		-84.9 +TT	-84.6 +TT	-84.4 +TT			-84.4 +TT	-84.4 +TT			
		30		-85.2 +TT	-84.7 +TT	-84.6 +TT			-84.5 +TT	-84.5 +TT	-84.4 +TT	-84.4 +TT	-84.4 +TT
		60		-85.6 +TT	-85.0 +TT	-84.8 +TT			-84.7 +TT	-84.6 +TT	-84.5 +TT	-84.5 +TT	-84.5 +TT
n28	18,9,10	N/A	-89.1	-88.7	-88.3	-88.0							
n71	2 ¹¹	N/A	-92.7	-93.3	-91.8	-90.7							
n71	2 ¹²	N/A	-95.6	-93.3	-91.8	-90.7							
n71	7	N/A	-82.7	-82.6	-82.4	-82.3							
66	n78 ²	15		-71.9 +TT	-71.9 +TT	-71.8 +TT			-71.7 +TT	-71.8 +TT			
		30		- 72.2+TT	-72.0 +TT	-72.0 +TT			-71.8 +TT	-71.9 +TT	-71.9 +TT	-71.8 +TT	-71.8 +TT
		60		-72.6 +TT	-72.3 +TT	-72.2 +TT			-72.0 +TT	-72.0 +TT	-72.0 +TT	-71.9 +TT	-71.9 +TT
	n78 ³	15		-94.7 +TT	-93.2 +TT	-92.4 +TT							
		30		-95.0 +TT	-93.3 +TT	-92.6 +TT							
		60		-95.4 +TT	-93.6 +TT	-92.8 +TT							

n66	48 ^{2,13}	N/A	-70.7	-70.6	-70.8	-70.8						
n66	48 ³	N/A	-96.1	-93.6	-92.3	-91.6						

- NOTE 1: Void.
- NOTE 2: The requirements should be verified for UL EARFCN or NR ARFCN of the aggressor (lower) band (superscript LB) such that $f_{UL}^{LB} = \lfloor f_{DL}^{HB} / 0.2 \rfloor 0.1$ in MHz and $F_{UL_low}^{LB} + BW_{Channel}^{LB} / 2 \leq f_{UL}^{LB} \leq F_{UL_high}^{LB} - BW_{Channel}^{LB} / 2$ with carrier frequency in the victim (higher) band in MHz and the channel bandwidth configured in the lower band.
- NOTE 3: The requirements are only applicable to channel bandwidths no larger than 20 MHz and with a carrier frequency at $\pm (20 + BW_{Channel}^{HB} / 2)$ MHz offset from $2f_{UL}^{LB}$ in the victim (higher) band with $F_{UL_low}^{LB} + BW_{Channel}^{LB} / 2 \leq f_{UL}^{LB} \leq F_{UL_high}^{LB} - BW_{Channel}^{LB} / 2$ where $BW_{Channel}^{LB}$ and $BW_{Channel}^{HB}$ are the channel bandwidths configured in the aggressor (lower) and victim (higher) bands respectively.
- NOTE 4: These requirements apply when there is at least one individual RE within the uplink transmission bandwidth of the aggressor (lower) band for which the 5th transmitter harmonic is within the downlink transmission bandwidth of a victim (higher) band.
- NOTE 5: The requirements should be verified for UL EARFCN of the aggressor (lower) band (superscript LB) such that $f_{UL}^{LB} = \lfloor f_D^1 / 5 \rfloor$ in MHz and $F_{UL_low}^{LB} + BW_{Channel}^{LB} / 2 \leq f_{UL}^{LB} \leq F_{UL_high}^{LB} - BW_{Channel}^{LB} / 2$ with carrier frequency in the victim (higher) band in MHz and the channel bandwidth configured in the lower band.
- NOTE 6: These requirements apply when there is at least one individual RE within the uplink transmission bandwidth of the aggressor (lower) band for which the 4th transmitter harmonic is within the downlink transmission bandwidth of a victim (higher) band.
- NOTE 7: The requirements should be verified for UL EARFCN of the aggressor (lower) band (superscript LB) such that $f_{UL}^{LB} = \lfloor f_D^1 / 4 \rfloor$ in MHz and $F_{UL_low}^{LB} + BW_{Channel}^{LB} / 2 \leq f_{UL}^{LB} \leq F_{UL_high}^{LB} - BW_{Channel}^{LB} / 2$ with carrier frequency in the victim (higher) band in MHz and the channel bandwidth configured in the lower band.
- NOTE 8: These requirements apply when there is at least one individual RE within the uplink transmission bandwidth of a low band for which the 3rd transmitter harmonic is within the downlink transmission bandwidth of a high band.
- NOTE 9: The requirements should be verified for UL EARFCN of a low band (superscript LB) such that in MHz and $F_{UL_low}^{LB} + BW_{Channel}^{LB} / 2 \leq f_{UL}^{LB} \leq F_{UL_high}^{LB} - BW_{Channel}^{LB} / 2$ with the carrier frequency of a high band in MHz and the channel bandwidth configured in the low band.
- NOTE 10: Applicable for the operations with 2 or 4 antenna ports supported in the band with carrier aggregation configured.
- NOTE 11: These requirements apply when the lower edge frequency of the 5 MHz uplink channel in Band 71 is located at or below 1990 MHz and the downlink channel in Band 2 is located with its upper edge at 1990 MHz.
- NOTE 12: These requirements apply when the lower edge frequency of the 10 MHz, 15 MHz, or 20 MHz uplink channel in Band 71 is located at or below 668 MHz and the downlink channel in Band 2 is located with its upper edge at 1990 MHz.
- NOTE 13: These requirements apply when there is at least one individual RE within the uplink transmission bandwidth of the aggressor (lower) band for which the 2nd transmitter harmonic is within the downlink transmission bandwidth of a victim (higher) band by a range ΔF_{HD} above and below the edge of this downlink transmission bandwidth. The value ΔF_{HD} depends on the EN-DC combination: $\Delta F_{HD} = 10$ MHz for DC_1_n77, DC_2_n77, DC_66_n77, DC_3_n77 and DC_3_n78.
- NOTE 14: TT is the same as defined in Table 7.3B.2.3.5-1a.

Table 7.3B.2.3.5-1a: Test Tolerance (TT) for RX sensitivity level

f ≤ 3.0GHz	3.0GHz < f ≤ 6.0 GHz
0.7 dB	1.0 dB

Reference sensitivity exceptions due to receiver harmonic mixing for EN-DC in NR FR1, are specified in Table 7.3B.2.3.5-2 with uplink configuration specified in Table 7.3B.2.3.4.2.1-3a to Table 7.3B.2.3.4.2.1-3k for each specific EN-DC combination scenario.

Table 7.3B.2.3.5-2: Reference sensitivity due to receiver harmonic mixing for EN-DC in NR FR1

UL band	DL band	SCS (kHz)	5 MHz (dBm)	10 MHz (dBm)	15 MHz (dBm)	20 MHz (dBm)	25 MHz (dBm)	40 MHz (dBm)	50 MHz (dBm)	60 MHz (dBm)	80 MHz (dBm)	90 MHz (dBm)	100 MHz (dBm)
2	n71 ⁴	15	-70.4 +TT	-70.4 +TT	-70.4 +TT	-70.4 +TT							
		30		-70.7 +TT	-70.7 +TT	-71.8 +TT							
		60		-72.4 +TT	-72.7 +TT	-77.0 +TT							
n41	26 ⁴	N/A	-72.5	-69.5	-69.5	N/A							
n77	41 ⁸	N/A	-86.9	-83.9	-82.1	-80.9	N/A	N/A	N/A	N/A	N/A	N/A	
n77	28 ²	N/A	-69.8	-69.8	-69.8	-68.3							
n78	3	N/A	91.3	-89.8	-89.0	-88.1							
n78	40	N/A	-86.9	-83.9	-82.1	-80.9							
n78	41 ⁸	N/A	-86.9	-83.9	-82.1	-80.9	N/A	N/A	N/A	N/A	N/A	N/A	
n79	19 ²	N/A	-69.8	-69.8	-69.8								
n79	26 ²	N/A	-69.8	-69.8	-69.8	N/A	N/A	N/A	N/A	N/A	N/A		N/A

NOTE 1: These requirements apply when there is at least one individual RE within the uplink transmission bandwidth of the aggressor (higher) band for which the mixing product due to harmonic of victim (lower) band LO with leakage of aggressor (higher) band is within the downlink transmission bandwidth of a victim (lower) band.

NOTE 2: The requirements should be verified for DL EARFCN of the victim (lower) band (superscript LB) such that $f_{DL}^{LB} = \lfloor f_{UL}^{HB} / 0.5 \rfloor 0.1$ with f_{DL}^{LB} the DL carrier frequency in the lower band and f_{UL}^{HB} the UL carrier frequency in the higher band, both in MHz.

NOTE 3: Void.

NOTE 4: The requirements should be verified for DL EARFCN or NR-ARFCN of the victim (lower) band (superscript LB) such that $f_{DL}^{LB} = \lfloor f_{UL}^{HB} / 0.3 \rfloor 0.1$ with f_{DL}^{LB} the DL carrier frequency in the lower band and f_{UL}^{HB} the UL carrier frequency in the higher band, both in MHz.

NOTE 5: Void.

NOTE 6: Void.

NOTE 7: The requirements should be verified for DL EARFCN of the victim (higher) band (superscript HB) such that $f_{DL}^{HB} = \lfloor 50 \times f_{UL}^{LB} \rfloor 0.03$ with f_{DL}^{HB} the DL carrier frequency in the higher band and f_{UL}^{LB} the UL carrier frequency in the lower band, both in MHz.

NOTE 8: The requirements should be verified for DL EARFCN of the victim (lower) band (superscript LB) such that $f_{DL}^{LB} = \lfloor a f_{UL}^{HB} / 0.15 \rfloor 0.1$ with f_{DL}^{LB} the DL carrier frequency in the lower band and f_{UL}^{HB} the UL carrier frequency in the higher band, both in MHz.

NOTE 9: TT is the same as defined in Table 7.3B.2.3.5-1a.

Reference sensitivity exceptions due to cross band isolation for EN-DC in NR FR1, are specified in Table 7.3B.2.3.5-3 with uplink configuration specified in Table 7.3B.2.3.4.2.1-4a to Table 7.3B.2.3.4.2.1-4n.

Table 7.3B.2.3.5-3: Reference sensitivity exceptions due to cross band isolation for PC3 EN-DC in NR FR1

E-UTRA or NR Band / Channel bandwidth of the affected DL band													
UL band	DL band	SCS (kHz)	5 MHz (dBm)	10 MHz (dBm)	15 MHz (dBm)	20 MHz (dBm)	25 MHz (dBm)	40 MHz (dBm)	50 MHz (dBm)	60 MHz (dBm)	80 MHz (dBm)	90 MHz (dBm)	100 MHz (dBm)
1	n40	15	-93.4 +TT	-90.2 +TT	-88.4 +TT	-87.2 +TT	-86.1 +TT	-85.3 +TT	-84.0 +TT				
n40	1	NA	-91.0	-88.0	-86.2	-85.0							
n41	2	N/A	-96.7	-93.7	-91.9	-90.7							
n41	25	N/A	-95.2	-92.2	-90.4	-89.2							
n77	41	N/A	-92.8	-89.8	-88.0	-86.8							
n41	66	N/A	-95.3	-92.3	-90.5	-89.3							
41	n77	30		-87.3 +TT	-85.3 +TT	-84.1 +TT		-82.9 +TT	-82.9 +TT	-82.9 +TT	-82.1 +TT	-81.7 +TT	-81.3 +TT
3	n51	15	-93.6 +TT										
30	n66	15	-91.2 +TT	-88.0 +TT	-86.2 +TT	-85.0 +TT			-81.8 +TT				
n78	7 ¹	N/A	-93.5	-90.5	-88.7	-87.5							
n78	38	N/A	-96.7	-93.7	-91.9	-90.7							
n78	41 ¹	N/A	-93.5	-90.5	-88.7	-87.5							
41	n78	30		-87.8 +TT	-85.8 +TT	-84.6 +TT		-83.4 +TT	-83.4 +TT	-83.4 +TT	-82.6 +TT	-82.2 +TT	-81.8 +TT

NOTE 1: Applicable only when harmonic mixing MSD for this combination is not applied.
 NOTE 2: TT is the same as defined in Table 7.3B.2.3.5-1a.

Table 7.3B.2.3.5-3a: Reference sensitivity exceptions due to cross band isolation for PC2 EN-DC in NR FR1

E-UTRA or NR Band / Channel bandwidth of the affected DL band														
UL band	DL band	SCS (kHz)	5 MHz (dBm)	10 MHz (dBm)	15 MHz (dBm)	20 MHz (dBm)	25 MHz (dBm)	30MHz (dBm)	40 MHz (dBm)	50 MHz (dBm)	60 MHz (dBm)	80 MHz (dBm)	90 MHz (dBm)	100 MHz (dBm)
3	n41	30		-94.4 +TT	-92.4 +TT	-91.3 +TT		-90.0 +TT	-88.0 +TT	-87.0 +TT	-86.2 +TT	-84.9 +TT	-84.4 +TT	-84.0 +TT
n41	3	N/A	-94.0	-91.0	-89.2	-88.0								

NOTE 1: Applicable only when harmonic mixing MSD for this combination is not applied.
 NOTE 2: TT is the same as defined in Table 7.3B.2.3.5-1a.

Reference sensitivity exceptions due to dual uplink operation for EN-DC in NR FR1, are specified in Table 7.3B.2.3.5-4 with uplink configuration specified in Table 7.3B.2.3.4.2.1-6.

Table 7.3B.2.3.5-4: Reference sensitivity exceptions due to dual uplink operation for PC3 EN-DC in NR FR1 (two bands)

NR or E-UTRA Band / Channel bandwidth									
EN-DC Configuration	EUTRA or NR band	SCS (kHz)	5 MHz (dBm)	10 MHz (dBm)	15 MHz (dBm)	20 MHz (dBm)	40 MHz (dBm)	IMD order	Duplex mode
DC_1A_n3A	1	N/A	[-76.3]	-	-	-	-	IMD3	FDD
	n3	15	REFSENS	-	-	-	-	N/A	TDD
DC_1A_n5A	1	N/A	-93.3	-	-	-	-	IMD4	FDD
	n5	15	REFSENS	-	-	-	-	N/A	FDD
DC_1A_n77A	1	N/A	-69.5	-	-	-	-	IMD2 ³	FDD
	n77	15	-	REFSENS	-	-	-	N/A	TDD
DC_1A_n77A	1	N/A	-91.3	-	-	-	-	IMD4-	FDD
	n77	15	-	REFSENS	-	-	-	N/A	TDD
DC_1A_n78A	1	N/A	-91.3	-	-	-	-	IMD4	FDD
	n78	15	-	REFSENS	-	-	-	N/A	TDD
DC_2A_n66A	2	N/A	-77.3	-	-	-	-	IMD3	
	n66	15	REFSENS	-	-	-	-	N/A	
DC_2A_n66A	2	N/A	REFSENS	-	-	-	-	N/A	
	n66	15	-95.5 +TT	-	-	-	-	IMD5	
DC_2A_n78A	2	N/A	-71.3	-	-	-	-	IMD2 ³	FDD
	n78	15	-	REFSENS	-	-	-	-	TDD
DC_2A_n78A	2	N/A	-89.3	-	-	-	-	N/A	
	n78	15	-	REFSENS	-	-	-	IMD4 ³	TDD
DC_3A_n1A	3	N/A	REFSENS	-	-	-	-	N/A	FDD
	n1	15	-74.0+TT	-	-	-	-	IMD3	FDD
DC_3A_n5A	3	N/A	-	-89.3	-	-	-	IMD4	FDD
	n5	15	REFSENS	-	-	-	-	N/A	FDD
	3	N/A	-	REFSENS	-	-	-	N/A	FDD
DC_3A_n5A	n5	15	-74.0+TT	-	-	-	-	IMD23	FDD
	3	N/A	REFSENS	-	-	-	-	-	
DC_3A_n7A	n7	15	-	-84.6 +TT ⁵	-	-	-	-	
	3	N/A	-92.3	-	-	-	-	IMD4	FDD
CA_3A-n20A	n20	15	REFSENS	-	-	-	-	N/A	FDD
	3	N/A	REFSENS	-	-	-	-	N/A	FDD
	n20	15	-88.0+TT	-	-	-	-	IMD4	FDD
	3	N/A	-88.1	-	-	-	-	IMD4	FDD
DC_3A_n41A	n41	15	-	REFSENS	-	-	-	IMD4	TDD
DC_3A_n77A, DC_3A_n78A, DC_3A- SUL_n78A-n80A, DC_3C_n78A	3	N/A	-70.3	-	-	-	-	IMD2 ³	
	n77, n78	15	-	REFSENS	-	-	-	-	TDD
DC_3A_n77A, DC_3A_n78A, DC_3A- SUL_n78A-n80A, DC_3C_n78A	3	N/A	-88.3	-	-	-	-	IMD4 ³	
	n77, n78	15	-	REFSENS	-	-	-	N/A	TDD
DC_5A_n78A	5	N/A	-89.0	-	-	-	-	IMD4	FDD
	n78	15	-	REFSENS	-	-	-	N/A	TDD

DC_7A_n3A	7	N/A	-	-81.3	-	-	-	IMD4	FDD
	n3	15	REFSENS	-	-	-	-	N/A	FDD
DC_7A_n5A	7	N/A		REFSEN S	-	-	-	N/A	FDD
	n5	15	-86.0+TT	-	-	-	-	IMD33	FDD
DC_7A_n66A	7	N/A	-	-79.3	-	-	-	IMD4	FDD
	n66	15	REFSENS	-	-	-	-	N/A	TDD
DC_7A_n77A	7	N/A	-90.2	-	-	-	-	IMD4	FDD
	n77	15	-	REFSEN S	-	-	-	N/A	TDD
DC_8A_n1A	8	N/A	REFSENS	-	-	-	-	N/A	FDD
	n1	15	-94.0 + TT	-	-	--	-	IMD4	FDD
DC_8A_n3A	8	N/A	-88.3	-	-	-	-	IMD4 ³	FDD
	n3	15	-	REFSEN S	-	-	-	N/A	FDD
	8	N/A	REFSENS	-	-	-	-	N/A	FDD
	n3	15	-	-87.4+ TT	-	-	-	IMD5	FDD
DC_8A_n41A	8	N/A	-84.2	-	-	-	-	IMD3 ³	FDD
	n41	15	-	REFSEN S	-	-	-	N/A	TDD
DC_8A_n77A	8	N/A	-88.0	-	-	-	-	IMD4	FDD
DC_8A_n78A DC_8A- SUL_n78A-n81A	n77, n78	15	-	REFSEN S	-	-	-	H4	TDD
DC_8A_n79A DC_8A- SUL_n79A-n81A	8	N/A	-91.5	-	-	-	-	IMD5	FDD
	n79	15	-	-	-	-	REFSEN S	N/A	TDD
DC_12_n78	12	N/A	-90.8	-	-	-	-	IMD5	FDD
	n78	15	-	REFSEN S	-	-	-	N/A	TDD
DC_20A_n3A	20	N/A	REFSENS	-	-	-	-	N/A	FDD
	n3	15	-93.0 +TT	-	-	-	-	IMD4	FDD
	20	N/A	-87.3	-	-	-	-	IMD4	FDD
	n3	15	REFSENS	-	-	-	-	N/A	FDD
DC_20A_n77A	20	N/A	-85.3	-	-	-	-	IMD4	FDD
	n77	15	-	REFSEN S	-	-	-	N/A	TDD
	20	N/A	-89.8	-	-	-	-	IMD5	FDD
	n77	15	-	REFSEN S	-	-	-	N/A	TDD
DC_20A_n78A, DC_20A- SUL_n78A-n82A	20	N/A	-74.6	-	-	-	-	IMD4 ⁴	FDD
	n78	15	-	REFSEN S	-	-	-	N/A	TDD
DC_21A_n79A	21	N/A	-80.9	-	-	-	-	IMD3	FDD
	n79	15	-	-	-	-	REFSEN S	N/A	TDD
DC_28A_n41A	28	N/A	-	-82.1	-	-	-	IMD3	FDD
	n41	15	-	REFSEN S	-	-	-	N/A	TDD
DC_28_n50	28	N/A	-	-79.5	-	-	-	IMD 2	FDD
	n50	15	-	REFSEN S	-	-	-	N/A	TDD
	28	N/A	-	-88.8	-	-	-	IMD 4	FDD
	n50	15	-	REFSEN S	-	-	-	N/A	TDD
	28	N/A	-	-94.3	-	-	-	IMD 5	FDD
	n50	15	-	REFSEN S	-	-	-	N/A	TDD
CA_28A_n77A, CA_28A_n78A, DC_28A- SUL_n78A-n83A	28	N/A	-92.3	-	-	-	-	IMD5	FDD
	n77, n78	15	-	REFSEN S	-	-	-	N/A	TDD
DC_48A_n66A	48	N/A	-	REFSEN S	-	-	-	N/A	TDD
	n66	15	-95.5 +TT	-	-	-	-	IMD5	FDD
DC_66A_n2A	66	N/A	REFSENS	-	-	-	-	N/A	FDD

	n2	15	-78.0+TT	-	-	-	-	IMD3	FDD
	66	N/A	-94.8	-	-	-	-	IMD5	FDD
	n2	15	REFSENS	-	-	-	-	N/A	FDD
DC_66A_n5A	66	N/A	-68.8	-	-	-	-	IMD2 ³	FDD
	n5	15	REFSENS	-	-	-	-	N/A	FDD
DC_66A_n25A	66	N/A	REFSENS	-	-	-	-	N/A	FDD
	n25	15	-76.5+TT	-	-	-	-	IMD3	FDD
	66	N/A	-75.8	-	-	-	-	IMD3	FDD
	n25	15	REFSENS	-	-	-	-	N/A	FDD
	66	N/A	-94.8	-	-	-	-	IMD5	FDD
DC_66A_n71A	n25	15	REFSENS	-	-	-	-	N/A	FDD
	66	N/A	-93.8	-	-	-	-	IMD4	FDD
DC_66A_n78A	n71	15	REFSENS	-	-	-	-	N/A	FDD
	66	N/A	-93.8	-	-	-	-	IMD5	FDD
	n78	15	-	REFSENS	-	-	-	N/A	TDD

NOTE 1: Both of the transmitters shall be set min(+20 dBm, P_{CMAX,L,c}) as defined in clause 6.2.5A. In case Single UL is allowed and the UE only indicates support of "Single UL" the output power of the active UL shall be set at P_{CMAX,L,c} or set to the maximum output power according to the UE power scaling capability.

NOTE 2: RB_{START} = 0

NOTE 3: This band is subject to IMD5 also which MSD is not specified.

NOTE 4: The symbol "REFSENS" in this table refers to the reference sensitivity values for single carrier specified in Table 7.3.5-2 of TS 36.521-1 [10] for 2 antenna port E-UTRA band, Table 7.3_1.5-1 of TS 36.521-1 [10] for 4 antenna port E-UTRA band, Table 7.3.2.5-1 for 2 antenna port NR band and Table 7.3.2_1.5-1 for 4 antenna port NR band.

NOTE 5: For UEs only indicating support of Single UL, this requirement is verified with non-simultaneous uplink transmissions on the E-UTRA and NR CGs.

NOTE 6: TT is the same as defined in Table 7.3B.2.3.5-1a.

Table 7.3B.2.3.5-5: Reference sensitivity exceptions due to dual uplink operation for PC2 EN-DC in NR FR1 (two bands)

NR or E-UTRA Band / Channel bandwidth									
EN-DC Configuration	EUTRA or NR band	SCS (kHz)	5 MHz (dBm)	10 MHz (dBm)	15 MHz (dBm)	20 MHz (dBm)	40 MHz (dBm)	IMD order)	Duplex mode
DC_3A_n41A	3	N/A	-77.9	-	-	-	-	IMD4 ³	
	n41	15	-	REFSENS	-	-	-	N/A	TDD
DC_3A_n78A	3	N/A	-64.4	-	-	-	-	IMD2 ³	
	n78	15	-	REFSENS	-	-	-	-	TDD
DC_3A_n78A	3	N/A	-77.8	-	-	-	-	IMD4 ³	
	n78	15	-	REFSENS	-	-	-	N/A	TDD

NOTE 1: Both of the transmitters shall be set min(+20 dBm, P_{CMAX,L,c}) as defined in clause 6.2.5A. In case Single UL is allowed and the UE only indicates support of "Single UL" the output power of the active UL shall be set at P_{CMAX,L,c} or set to the maximum output power according to the UE power scaling capability.

NOTE 2: RB_{START} = 0

NOTE 3: This band is subject to IMD5 also which MSD is not specified.

NOTE 4: The symbol "REFSENS" in this table refers to the reference sensitivity values for single carrier specified in Table 7.3.5-2 of TS 36.521-1 [10] for 2 antenna port E-UTRA band, Table 7.3_1.5-1 of TS 36.521-1 [10] for 4 antenna port E-UTRA band, Table 7.3.2.5-1 for 2 antenna port NR band and Table 7.3.2_1.5-1 for 4 antenna port NR band.

NOTE 5: For UEs only indicating support of Single UL, this requirement is verified with non-simultaneous uplink transmissions on the E-UTRA and NR CGs.

NOTE 6: TT is the same as defined in Table 7.3B.2.3.5-1a.

7.3B.2.3_1 Reference sensitivity for EN-DC within FR1 (>2 CCs)

7.3B.2.3_1.1 Reference sensitivity for EN-DC within FR1 (3 CCs)

Editor's note: The test requirements section of this test case contains some EN-DC configurations that have no test points defined meaning these cannot be tested.

7.3B.2.3_1.1.1 Test purpose

To verify the ability of UE that support EN-DC configurations to receive data with a given average throughput for a specified reference measurement channel, under conditions of low signal level, ideal propagation and no added noise when no CA exceptions are allowed and single carrier requirements apply whenever possible. A UE unable to meet the throughput requirement under these conditions will decrease the effective coverage area.

7.3B.2.3_1.1.2 Test applicability

This test applies to all types of NR UE release 15 and forward supporting 3CC EN-DC.

7.3B.2.3_1.1.3 Minimum conformance requirements

The minimum conformance requirements are defined in clause 7.3B.2.0

Exception requirements for both NR and E-UTRA are defined for this test and therefore LTE anchor agnostic approach is not applied. E-UTRA test point analysis is included and E-UTRA measurements are performed.

7.3B.2.3_1.1.4 Test description

7.3B.2.3_1.1.4.1 Initial conditions

Same initial conditions as in clause 7.3B.2.3.4.1 with following exceptions:

The initial test configurations for E-UTRA band and NR band consist of environmental conditions, test frequencies, and channel bandwidths and RB allocations for exceptional test scenarios are specified in Table 7.3B.2.3_1.1.4.1-0 and 7.3B.2.3_1.1.4.1-1.

Table 7.3B.2.3_1.1.4.1-0: Test Configuration Table for EN-DC configurations not affected by Reference sensitivity exceptions

Initial Conditions												
Test Environment as specified in TS 38.508-1 [6] clause 4.1						Normal, TL/VL, TL/VH, TH/VL, TH/VH						
NR Test Frequencies as specified in TS 38.508-1 [6] clause 4.3.1, E-UTRA Test Frequencies as specified in TS 36.508 [11] clause 4.3.1						DC_XA_nYA_nZA and DC_XA-YA_nZA: Mid range for MCG and SCG DC_XA_nYC: Mid range for XA Low range, High Range for nXC DC_(n)XCA: Low range, High Range For non-contiguous carriers: TBD						
Test DC Combination setting (NRB_agg) as specified in clause [TBD] for the DC Configuration across bandwidth combination sets supported by the UE.						Refer to "NR NRB" and "E-UTRA NRB" columns						
Network signalling value						NS_01 by default, exceptions listed in Table 7.3.3-3, dependent on PCC Band						
Test SCS for the NR cell as specified in TS 38.521-1 [8] Table 5.3.5-1						Lowest SCS per Channel Bandwidth						
Test Parameters for DC Configurations												
ID	PCC – E-UTRA				SCC1 – EUTRA/NR				CG -NR			
	Band	Range	NRB		Band	Range	NRB		Band	Range	NRB	
	UL MOD	DL MOD	CH BW	DL alloc/UL alloc	UL MOD	DL MOD	UL/DL Ch BW	DL alloc/UL alloc	UL MOD	DL MOD	UL/DL Ch BW	DL alloc/UL alloc
Test Settings for a DC_(n)XCA Configuration (Intra-band contiguous EN-DC with LTE CA)– Note 2												
1	X	default	Highest	All RBs / REFSENS	X	default	Highest	All RBs / 0	nX	default	Highest	All RBs / REFSENS
	QPSK	REFSENS			N/A	QPSK			CP-OFDM QPSK	QPSK		
Test Settings for a DC_XC_nXA Configuration (Intra-band non-contiguous EN-DC with LTE CA)– Note 3												
							No test required, LTE 1CC fallback is tested in 7.3B.2.2)					
Test Settings for a DC_XA-XA_nXA Configuration (Intra-band non-contiguous EN-DC with LTE CA)– Note 3												

							No test required, LTE 1CC fallback is tested in 7.3B.2.2)						
Test Settings for a DC_XA_nYC Configuration (Inter-band EN-DC with NR CA, 2 bands) – Note 1													
1	X	default	5 MHz	0/0	nY	default	Highest	All RBs / 0	nY	default	Highest	All RBs / REFSSENS	
	N/A	N/A			N/A	QPSK /CP-OFDM QPSK			CP-OFDM QPSK	QPSK			
Test Settings for a DC_XA_nY(2A) Configuration (Inter-band EN-DC with NR CA, 2 bands) – Note 1													
1	X	default	5 MHz	0/0	nY	default	Highest	All RBs / 0	nY	default	Highest	All RBs / REFSSENS	
	N/A	N/A			N/A	QPSK /CP-OFDM QPSK			CP-OFDM QPSK	QPSK			
Test Settings for a DC_XC_nYA, DC_XA-XA_nYA Configuration (Inter-band EN-DC with LTE CA, 2 bands) – Note 3													
							No test required, LTE 1CC fallback is tested in 7.3B.2.3)						
Default Test Settings for a DC_XA-YA_nZA Configuration (Inter-band EN-DC with LTE CA, 3 bands) – Note 3													
							No test required, LTE 1CC fallback is tested in 7.3B.2.3)						
Default Test Settings for a DC_XA_nYA_nZA Configuration (Inter-band EN-DC with NR CA, 3 bands) – Note 1													
1	X	Mid	5 MHz	0/0	nY	default	Highest	All RBs / 0	nZ	default	Highest	All RBs / REFSSENS	
	N/A	N/A			N/A	QPSK /CP-OFDM QPSK			CP-OFDM QPSK	QPSK			
2	X	Mid	5 MHz	0/0	nY	default	Highest	All RBs / REFSSENS	nZ	default	Highest	All RBs / 0	
	N/A	N/A			CP-OFDM QPSK	QPSK /CP-OFDM QPSK			N/A	QPSK			

- | | |
|---------|---|
| Note 1: | LTE anchor agnostic configuration |
| Note 2: | Not LTE anchor agnostic configuration due to exception requirement for intra-band contiguous CA in clause 7.4B, 7.5B, 7.6B.2, 7.6B.3, 7.6B.4, 7.7B, 7.8B, 7.9B test cases |
| Note 3: | LTE anchor agnostic configuration with LTE CA where LTE CA fallback to 1CC is sufficient to test |
| Note 4: | In a FR1 band where UE supports 4Rx, the test shall be performed only with 4Rx antennas ports connected. |

Table 7.3B.2.3_1.1.4.1-1: Test Configuration Table for EN-DC configurations affected by Reference sensitivity exceptions

Initial Conditions												
Test Environment as specified in TS 38.508-1 [6] clause 4.1					Normal, TL/VL, TL/VH, TH/VL, TH/VH							
NR Test Frequencies as specified in TS 38.508-1 [6] clause 4.3.1, E-UTRA Test Frequencies as specified in TS 36.508 [11] clause 4.3.1					EN-DC configurations containing the following band combinations: 20-n78: Mid in band 20 and Mid in band 78.							
Test DC Combination setting (NRB_agg) as specified in clause [TBD] for the DC Configuration across bandwidth combination sets supported by the UE.					Refer to "NR NRB" and "E-UTRA NRB " columns							
Network signalling value					NS_01 by default, exceptions listed in Table 7.3.3-3, dependent on PCC Band							
Test SCS for the NR cell as specified in TS 38.521-1 [8] Table 5.3.5-1					Lowest SCS per Channel Bandwidth							
Test Parameters for DC Configurations												
ID	PCC – E-UTRA				SCC1 – EUTRA/NR				CG -NR			
	Band	Range	NRB		Band	Range	NRB		Band	Range	NRB	
	UL MOD	DL MOD	CH BW	DLalloc/UL alloc	UL MOD	DL MOD	UL/DL Ch BW	DLalloc/ULalloc	UL MOD	DL MOD	UL/DL Ch BW	DLalloc/UL alloc
Default Test Settings for a DC_(n)XAC Configuration (Intra-band contiguous EN-DC with NR CA) – Note 1												
							N/A					
Default Test Settings for a DC_(n)XCA Configuration (Intra-band contiguous EN-DC with LTE CA)– Note 1												
							N/A					
Default Test Settings for a DC_XC_nXA Configuration (Intra-band non-contiguous EN-DC with LTE CA)– Note 1												
							N/A					
Default Test Settings for a DC_XA-XA_nXA Configuration (Intra-band non-contiguous EN-DC with LTE CA)– Note 1												
							N/A					
Default Test Settings for a DC_XA_nYC Configuration (Inter-band EN-DC with NR CA, 2 bands) – Note 2, 7												
1	X	default	Highest	All RBs / REFSENS	nY	default	Highest	All RBs / 0	nY	default	Highest	All RBs / 0
	QPSK	REFSENS			N/A	CP-OFDM QPSK			N/A	CP-OFDM QPSK		
2	X	default	Highest	All RBs / 0	nY	default	Highest	All RBs / 0	nY	default	Highest	All RBs / REFSENS
	N/A	REFSENS			N/A	CP-OFDM QPSK			CP-OFDM QPSK			
Default Test Settings for a DC_XC_nYA, DC_XA-XA_nYA Configuration (Inter-band EN-DC with LTE CA, 2 bands) – Note 4												

								No test required, LTE 1CC fallback is tested in 7.3B.2.3)					
Default Test Settings for a DC_XA-YA_nZA Configuration (Inter-band EN-DC with LTE CA, 3 bands) – Note 4													
								No test required, LTE 1CC fallback is tested in 7.3B.2.3					
Default Test Settings for a DC_XA_nYA_nZA Configuration (Inter-band EN-DC with NR CA, 3 bands) – Note 2, 7													
1	X	Mid	5 MHz	0/0	nY	default	Highest	All RBs / 0	nZ	default	Highest	All RBs / REFSSENS	
	N/A	N/A			N/A	CP-OFDM QPSK			CP-OFDM QPSK				
2	X	Mid	5 MHz	0/0	nY	default	Highest	All RBs / REFSSENS	nZ	default	Highest	All RBs / 0	
	N/A	N/A			CP-OFDM QPSK	CP-OFDM QPSK			N/A	CP-OFDM QPSK			
Test Settings for DC_1A-3A_n78A Configuration – Note 3													
1	1	DL 2140 MHz	5 MHz	All RBs / All RBs	3	DL 1807.5 MHz	5 MHz	All RBs / 0	n78	3757.5 MHz	10 MHz	All RBs / All RBs	
	QPSK	QPSK			N/A	QPSK			CP-OFDM QPSK	CP-OFDM QPSK			
2	1	DL 2125 MHz	5 MHz	All RBs / 0	3	DL 1870 MHz	5 MHz	All RBs / All RBs	n78	3725.5 MHz	10 MHz	All RBs / All RBs	
	N/A	QPSK			QPSK	QPSK			CP-OFDM QPSK	CP-OFDM QPSK			
Test Settings for DC_1A-5A_n78A Configuration – Note 3													
1	1	DL 2122 MHz	5 MHz	All RBs / 0	5	DL 874 MHz	5 MHz	All RBs / All RBs	n78	3780 MHz	10 MHz	All RBs / All RBs	
	N/A	QPSK			QPSK	QPSK			CP-OFDM QPSK	CP-OFDM QPSK			
2	1	DL 2165 MHz	5 MHz	All RBs / All RBs	5	DL 885 MHz	5 MHz	All RBs / 0	n78	3405 MHz	10 MHz	All RBs / All RBs	
	QPSK	QPSK			N/A	QPSK			CP-OFDM QPSK	CP-OFDM QPSK			
Test Settings for DC_1A-7A_n78A Configuration – Note 3													

1	1	UL 1977.5 / DL 2167.5 MHz			7	DL 2627.5 MHz			n78	3305 MHz		
	QPSK	QPSK	5 MHz	All RBs / All RBs	N/A	QPSK	5 MHz	All RBs / 0	CP-OFDM QPSK	CP-OFDM QPSK	10 MHz	All RBs / All RBs
2	1	DL 2140 MHz			7	UL 2510 / DL 2630 MHz			n78	3580 MHz		
	N/A	QPSK	5 MHz	All RBs / 0	QPSK	QPSK	10MHz	All RBs / All RBs	CP-OFDM QPSK	CP-OFDM QPSK	10 MHz	All RBs / All RBs
Test Settings for DC_1A-20A_n78A Configuration – Note 3												
1	1	UL 1930 / DL 2120 MHz			20	DL 794 MHz			n78	3790 MHz		
	N/A	QPSK	5 MHz	All RBs / 0	QPSK	QPSK	5 MHz	All RBs / All RBs	CP-OFDM QPSK	CP-OFDM QPSK	10 MHz	All RBs / All RBs
2	1	DL 2140 MHz			20	DL 810 MHz			n78	3330 MHz		
	QPSK	QPSK	5 MHz	All RBs / All RBs	N/A	QPSK	5 MHz	All RBs / 0	CP-OFDM QPSK	CP-OFDM QPSK	10 MHz	All RBs / All RBs
Test Settings for DC_1A-28A_n3A – Note 3												
1	1	DL 1875 MHz			28	DL 765.5 MHz			n3	1875 MHz		
	QPSK	QPSK	5 MHz	All RBs / All RBs	N/A	QPSK	5 MHz	All RBs / 0	CP-OFDM QPSK	CP-OFDM QPSK	5 MHz	All RBs / All RBs
Test Settings for DC_3A-7A_n78A Configuration – Note 3												
1	3	DL 1820 MHz			7	DL 2685 MHz			n78	3310 MHz		
	N/A	QPSK	5 MHz	All RBs / 0	QPSK	QPSK	5 MHz	All RBs / All RBs	CP-OFDM QPSK	CP-OFDM QPSK	10 MHz	All RBs / All RBs
2	3	DL 1820 MHz			7	DL 2685 MHz			n78	3475 MHz		
	QPSK	QPSK	5 MHz	All RBs / All RBs	N/A	QPSK	5 MHz	All RBs / 0	CP-OFDM QPSK	CP-OFDM QPSK	10 MHz	All RBs / All RBs
Test Settings for DC_3A-8A_n78A Configuration – Note 3												

1	3	DL 1820 MHz			8	DL 955 MHz			n78	3640 MHz		
	N/A	QPSK	5 MHz	All RBs / 0	QPSK	QPSK	5 MHz	All RBs / All RBs	CP-OFDM QPSK	CP-OFDM QPSK	10 MHz	All RBs / All RBs
Test Settings for DC_3A-20A_n78A Configuration – Note 3												
1	3	DL 1820 MHz			20	UL 845 / DL 804 MHz			n78	3510 MHz		
	N/A	QPSK	5 MHz	All RBs / 0	QPSK	QPSK	5 MHz	All RBs / All RBs	CP-OFDM QPSK	CP-OFDM QPSK	10 MHz	All RBs / All RBs
Test Settings for DC_3A-40A_n1A Configuration – Note 3, 6												
1	3	UL 1735 / DL 1830 MHz			40	DL 2380 MHz			n1A	UL 1950 / 2140 MHz		
	QPSK	QPSK	5 MHz	All RBs / All RBs	N/A	QPSK	5 MHz	All RBs / 0	CP-OFDM QPSK	CP-OFDM QPSK	5 MHz	All RBs / All RBs
Test Settings for DC_5A-7A_n78A Configuration – Note 3												
1	5	DL 889 MHz			7	DL 2645 MHz			n78	3489 MHz		
	QPSK	QPSK	5 MHz	All RBs / All RBs	N/A	QPSK	5 MHz	All RBs / 0	CP-OFDM QPSK	CP-OFDM QPSK	10 MHz	All RBs / All RBs
2	5	DL 879 MHz			7	DL 2670 MHz			n78	3429 MHz		
	N/A	QPSK	5 MHz	All RBs / 0	QPSK	QPSK	5 MHz	All RBs / All RBs	CP-OFDM QPSK	CP-OFDM QPSK	10 MHz	All RBs / All RBs
3	5	DL 875 MHz			7	DL 2645 MHz			n78	3350 MHz		
	N/A	QPSK	5 MHz	All RBs / 0	QPSK	QPSK	5 MHz	All RBs / All RBs	CP-OFDM QPSK	CP-OFDM QPSK	10 MHz	All RBs / All RBs
Test Settings for DC_7A-20A_n1A Configuration – Note 3												
1	7	2630 MHz			20	800 MHz			n1	2130 MHz		
	N/A	QPSK	10 MHz	All RBs / 0	QPSK	QPSK	10 MHz	All RBs / All RBs	CP-OFDM QPSK	CP-OFDM QPSK	5 MHz	All RBs / All RBs
Test Settings for DC_7A-20A_n3A Configuration – Note 3												
1	7	DL 2663 MHz			20	DL 806 MHz			n3	DL 1832 MHz		

	QPSK	QPSK	10 MHz	All RBs / All RBs	N/A	QPSK	10 MHz	All RBs / 0	CP- OFDM QPSK	CP-OFDM QPSK	5 MHz	All RBs / All RBs
2	7	DL 2630 MHz			20	DL 896 MHz			n3	DL 1870 MHz		
	QPSK	QPSK	10 MHz	All RBs / All RBs	N/A	QPSK	5 MHz	All RBs / 0	CP- OFDM QPSK	CP-OFDM QPSK	10 MHz	All RBs / All RBs
Test Settings for DC_7A-20A_n78A Configuration – Note 3												
1	7	UL 2560 / DL 2680 MHz			20	DL 810 MHz			n78	3370 MHz		
	QPSK	QPSK	5 MHz	All RBs / All RBs	N/A	QPSK	5 MHz	All RBs / 0	CP- OFDM QPSK	CP-OFDM QPSK	10 MHz	All RBs / All RBs
2	7	UL 2560 / DL 2680 MHz			20	DL 810 MHz			n78	3435 MHz		
	QPSK	QPSK	5 MHz	All RBs / All RBs	N/A	QPSK	5 MHz	All RBs / 0	CP- OFDM QPSK	CP-OFDM QPSK	10 MHz	All RBs / All RBs
3	7	DL 2675 MHz			20	UL 845 / DL 804 MHz			n78	3520 MHz		
	N/A	QPSK	5 MHz	All RBs / 0	QPSK	QPSK	5 MHz	All RBs / All RBs	CP- OFDM QPSK	CP-OFDM QPSK	10 MHz	All RBs / All RBs
Test Settings for DC_7A-28A_n3A Configuration – Note 3												
1	7	DL 2663 MHz			28	DL 769 MHz			n3	1842 MHz		
	N/A	QPSK	5 MHz	All RBs / 0	QPSK	QPSK	5 MHz	All RBs / 0	CP- OFDM QPSK	CP-OFDM QPSK	5 MHz	All RBs / All RBs
2	7	DL 2685 MHz			28	DL 800 MHz			n3	1810 MHz		
	QPSK	QPSK	5 MHz	All RBs / All RBs	N/A	QPSK	5 MHz	All RBs / 0	CP- OFDM QPSK	CP-OFDM QPSK	5 MHz	All RBs / All RBs
Test Settings for DC_7A-28A_n78A Configuration – Note 3												
1	7	DL 2687.5 MHz			20	DL 782.5 MHz			n78	3350 MHz		
	QPSK	QPSK	5 MHz	All RBs / All RBs	N/A	QPSK	5 MHz	All RBs / 0	CP- OFDM QPSK	CP-OFDM QPSK	10 MHz	All RBs / All RBs

2	7	DL 2687.5 MHz			20	DL 782.5 MHz			n78	3460 MHz		
	QPSK	QPSK	5 MHz	All RBs / All RBs	N/A	QPSK	5 MHz	All RBs / 0	CP-OFDM QPSK	CP-OFDM QPSK	10 MHz	All RBs / All RBs
3	7	DL 2650 MHz			20	DL 795 MHz			n78	3390 MHz		
	N/A	QPSK	5 MHz	All RBs / 0	QPSK	QPSK	5 MHz	All RBs / All RBs	CP-OFDM QPSK	CP-OFDM QPSK	10 MHz	All RBs / All RBs
Test Settings for DC_2A-14A_n66A Configuration – Note 3												
1	2	DL 1954 MHz			14	DL 763 MHz			n66	DL 2170 MHz		
	N/A	QPSK	5 MHz	All RBs / 0	QPSK	QPSK	5 MHz	All RBs / All RBs	CP-OFDM QPSK	CP-OFDM QPSK	5 MHz	All RBs / All RBs
Test Settings for DC_14A-66A_n2A Configuration – Note 3												
1	14	DL 763 MHz			66	DL 2162 MHz			n2	DL 1954 MHz		
	QPSK	QPSK	5 MHz	All RBs / All RBs	N/A	QPSK	5 MHz	All RBs / 0	CP-OFDM QPSK	CP-OFDM QPSK	5 MHz	All RBs / All RBs
Test Settings for DC_20A_n28A-n75A Configuration												
1	20	Mid			n28	High			n75	DL 1476MHz		
	QPSK	QPSK	20MHz	All RBs / 0	DFT-s-OFDM QPSK	CP-OFDM QPSK	20MHz	All RBs / REFSEN S_ENDC_1	N/A	CP-OFDM QPSK	20MHz	All RBs / N/A
2 ⁸	20	Mid			n28	Low			n75	High		
	QPSK	QPSK	20MHz	All RBs / 0	DFT-s-OFDM QPSK	CP-OFDM QPSK	20MHz	All RBs / REFSEN S_ENDC_1	N/A	CP-OFDM QPSK	20MHz	All RBs / N/A
<p>Note 1: No refsens exceptions with this EN-DC configuration exist in TS38.101-3</p> <p>Note 2: This test setting is valid for EN-DC configurations affected by UL harmonics, harmonic mixing exceptions when the exception is avoided by selecting specific test frequency. Test only one of the test points. UL to be active on the cell that form the aggressor of the exception</p> <p>Note 3: EN-DC configuration affected by 2UL intermodulation exception. The exceptions always apply for a certain UL configuration.</p> <p>Note 4: LTE CA fallback to 1CC is sufficient to test, unless both LTE cells are part of the exception requirement in which case the configuration need to be tested (using configuration specific test settings and not default).</p> <p>Note 5: In an E-UTRA band or FR1 band where UE supports 4Rx, the test shall be performed only with 4Rx antennas ports connected.</p> <p>Note 6: Test only applicable for 2UL UE.</p> <p>Note 7: NR CA fallback to 1CC is sufficient to test, unless both NR cells are part of the exception requirement in which case the configuration need to be tested (using configuration specific test settings and not default).</p> <p>Note 8: Test ID with UL harmonic exception avoided.</p>												

7.3B.2.3_1.1.4.2 Test procedure

Same as in clause 7.3B.2.3.4.2.

7.3B.2.3_1.1.4.3 Message contents

Message contents are according to TS 38.508-1 [5] clause 4.6.

7.3B.2.3_1.1.5 Test requirement

Reference sensitivity test requirements for EN-DC configurations affected by 2UL intermodulation interference in NR FR1, are specified in Table 7.3B.2.3_1.1.5-1 and Table 7.3B.2.3_1.1.5-2 with uplink configuration specified in Table 7.3B.2.3_1.1.4.1-1.

Reference sensitivity test requirements for EN-DC configurations not affected by 2UL intermodulation interference in NR FR1, are specified in Table 7.3.5-1 in TS 36.521-1 [10] for the LTE CC, and Table 7.3.2.5-1 in TS 38.521-1 [8] for the NR CC.

Table 7.3B.2.3_1.1.5-1: Reference sensitivity exceptions for SCell due to dual uplink operation for EN-DC in NR FR1 (three bands)

EN-DC Configuration	Test ID	EUTRA/ NR band	SCS (kHz)	5 MHz (dBm)	10 MHz (dBm)	20 MHz (dBm)	40 MHz (dBm)	Duplex mode	IMD order
DC_1A-3A_n77A	1	1	N/A	REFSENS	-	-	-	FDD	N/A
		3	N/A	-64.8	-	-	-		IMD2
		n77	15	-	REFSENS	-	-		TDD
	2	1	N/A	REFSENS	-	-	-	FDD	N/A
		3	N/A	-87.8	-	-	-		IMD4
		n77	15	-	REFSENS	-	-		TDD
	3	1	N/A	-68.3	-	-	-	FDD	IMD2
		3	N/A	REFSENS	-	-	-		N/A
		n77	15	-	REFSENS	-	-		TDD
DC_1A-3A_n78A DC_1A-3C_n78A	1	1	N/A	-91.0	-	-	-	FDD	IMD4
		3	N/A	REFSENS	-	-	-		N/A
		n78	15	-	REFSENS	-	-		TDD
	2	1	N/A	REFSENS	-	-	-	FDD	N/A
		3	N/A	-65.1	-	-	-		IMD2
		n78	15	-	REFSENS	-	-		TDD
	3	1	N/A	-96.5	-	-	-	FDD	IMD5
		3	N/A	REFSENS	-	-	-		N/A
		n78	15	-	REFSENS	-	-		TDD
DC_1A-5A_n78A	1	1	N/A	-91.0	-	-	-	FDD	IMD4
		5	N/A	REFSENS	-	-	-		N/A
		n78	15	-	REFSENS	-	-		TDD
	2	1	N/A	REFSENS	-	-	-	FDD	N/A
		5	N/A	-89.0	-	-	-		IMD4
		n78	15	-	REFSENS	-	-		TDD
	3	1	N/A	-81.2	-	-	-	FDD	IMD3
		5	N/A	REFSENS	-	-	-		N/A
		n78	15	-	REFSENS	-	-		TDD
	4	1	N/A	REFSENS	-	-	-	FDD	N/A
		5	N/A	-94.2	-	-	-		IMD5
		n78	15	-	REFSENS	-	-		TDD
DC_1A-7A_n78A	1	1	N/A	REFSENS	-	-	-	FDD	N/A
		7	N/A	-88.2	-	-	-		IMD4
		n78	15	-	REFSENS	-	-		TDD
	2	1	N/A	-90.6	-	-	-	FDD	IMD4
		7	N/A	-	REFSENS	-	-		N/A
		n78	15	-	REFSENS	-	-		TDD
DC_1A-20A_n78A	1	1	N/A	-79.0	-	-	-	FDD	IMD3
		20	N/A	REFSENS	-	-	-		N/A
		n78	15	-	REFSENS	-	-		TDD
DC_1A-20A_n78A	2	1	N/A	REFSENS	-	-	-	FDD	N/A
		20	N/A	-93.3	-	-	-		IMD5
		n78	15	-	REFSENS	-	-		TDD
DC_1A-28A_n3A	1	28	N/A	REFSENS	-	-	-	FDD	N/A
		n3	15	REFSENS	-	-	-		N/A
		1	N/A	-88.3	-	-	-		IMD4
DC_2A-14A_n66A	1	2	N/A	-90.1	-	-	-	FDD	IMD4
		14	N/A	REFSENS	-	-	-		N/A
		n66	15	REFSENS	-	-	-		FDD
DC_3A-5A_n78A	1	3	N/A	REFSENS	-	-	-	FDD	N/A
		5	N/A	-89.0	-	-	-		IMD4
		n78	15	-	REFSENS	-	-		TDD
	2	3	N/A	-70.3	-	-	-	FDD	IMD2
		5	N/A	REFSENS	-	-	-		N/A
		n78	15	-	REFSENS	-	-		TDD
3	n78	15	-	REFSENS	-	-	TDD	N/A	
	3	N/A	-88.3	-	-	-			FDD

EN-DC Configuration	Test ID	EUTRA/ NR band	SCS (kHz)	5 MHz (dBm)	10 MHz (dBm)	20 MHz (dBm)	40 MHz (dBm)	Duplex mode	IMD order	a
				[TBD]			10.7 ⁵			
DC_3C-7C_n78A	1	3	N/A	-78.7	-	-	-	FDD	IMD3	
		7	N/A	REFSENS	-	-	-	FDD	N/A	
		n78	15	-	REFSENS	-	-	TDD	N/A	
	2	3	N/A	-87.7	-	-	-	FDD	IMD4	
		7	N/A	REFSENS	-	-	-	FDD	N/A	
		n78	15	-	REFSENS	-	-	TDD	N/A	
DC_3A-7A_n78A DC_3C-7A_n78A	1	3	N/A	-78.7	-	-	-	FDD	IMD3	
		7	N/A	REFSENS	-	-	-	FDD	N/A	
		n78	15	-	REFSENS	-	-	TDD	N/A	
DC_3A-7A_n78A DC_3C-7A_n78A	2	3	N/A	-87.7	-	-	-	FDD	IMD4	
		7	N/A	REFSENS	-	-	-	FDD	N/A	
		n78	15	-	REFSENS	-	-	TDD	N/A	
DC_3A-8A_n78A	1	3	N/A	-79.8	-	-	-	FDD	IMD3	
		8	N/A	REFSENS	-	-	-	FDD	N/A	
		n78	15	-	REFSENS	-	-	TDD	N/A	
DC_3A-20A_n78A DC_3C-20A_n78A	1	3	N/A	-79.0	-	-	-	FDD	IMD3	
		20	N/A	REFSENS	-	-	-	FDD	N/A	
		n78	15	-	REFSENS	-	-	TDD	N/A	
DC_3A-40A_n1A	1	n1	15	REFSENS	-	-	-	FDD	N/A	
		3	N/A	REFSENS	-	-	-	FDD	N/A	
		40	N/A	-91.3	-	-	-	TDD	IMD5	
DC_5A-7A_n78A	1	5	N/A	-89.0	-	-	-	FDD	IMD4	
		7	N/A	REFSENS	-	-	-	FDD	N/A	
		n78	15	-	REFSENS	-	-	TDD	N/A	
	2	5	N/A	REFSENS	-	-	-	FDD	N/A	
		7	N/A	-67.2	-	-	-	FDD	N/A	
		n78	15	-	REFSENS	-	-	TDD	N/A	
	3	5	N/A	-67.1	-	-	-	FDD	IMD2	
		7	N/A	REFSENS	-	-	-	FDD	N/A	
		n78	15	-	REFSENS	-	-	TDD	N/A	
	4	5	N/A	-94.0	-	-	-	FDD	IMD5	
		7	N/A	REFSENS	-	-	-	FDD	N/A	
		n78	15	-	REFSENS	-	-	TDD	N/A	
DC_7A-20A_n1A	1	7						FDD	N/A	
		20		-88.8				FDD	IMD5	
		n1		REFSENS				FDD	N/A	
DC_7A-20A_n3A	1	7	N/A	-	REFSENS	-	-	FDD	N/A	
		20	N/A	-	-82.8	-	-	FDD	IMD2	
		n3	15	REFSENS	-	-	-	FDD	N/A	
	2	7	N/A	-	-68.3	-	-	FDD	IMD2	
		20	N/A	REFSENS	-	-	-	FDD	N/A	
DC_7A-20A_n78A	1	n3	15	-	REFSENS	-	-	FDD	N/A	
		7	N/A	REFSENS	-	-	-	FDD	N/A	
		20	N/A	-65.8	-	-	-	FDD	IMD2	
DC_7A-20A_n78A	2	n78	15	-	REFSENS	-	-	TDD	N/A	
		7	N/A	REFSENS	-	-	-	FDD	N/A	
		20	N/A	-93.3	-	-	-	FDD	IMD5	
DC_7A-20A_n78A	3	n78	15	-	REFSENS	-	-	TDD	N/A	
		7	N/A	-66.5	-	-	-	FDD	IMD2	
		20	N/A	REFSENS	-	-	-	FDD	N/A	
DC_7A-28A_n3A	1	n78	15	-	REFSENS	-	-	TDD	N/A	
		7	N/A	REFSENS				FDD	N/A	
		28	N/A	-77.8				FDD	IMD2	
	2	n3	15	REFSENS				FDD	N/A	
		7	N/A	-79.3				FDD	IMD3	
2	28	N/A	REFSENS				FDD	N/A		
	n3	15	REFSENS				FDD	N/A		

EN-DC Configuration	Test ID	EUTRA/ NR band	SCS (kHz)	5 MHz (dBm)	10 MHz (dBm)	20 MHz (dBm)	40 MHz (dBm)	Duplex mode	IMD order
DC_7A-28A_n78A	1	7	N/A	REFSENS	-	-	-	FDD	N/A
		28	N/A	-89.5	-	-	-		IMD2
		n78	15	-	REFSENS	-	-	TDD	N/A
	2	7	N/A	REFSENS	-	-	-	FDD	N/A
		28	N/A	-94.8	-	-	-		IMD5
		n78	15	-	REFSENS	-	-	TDD	N/A
	3	7	N/A	-66.8	-	-	-	FDD	IMD2
		28	N/A	REFSENS	-	-	-		N/A
		n78	15	-	REFSENS	-	-	TDD	N/A
DC_14A-66A_n2A	1	14	N/A	REFSENS	-	-	-	FDD	N/A
		66	N/A	-91.2	-	-	-	FDD	IMD4
		n2	15	REFSENS	-	-	-	FDD	N/A

NOTE 1: Both of the transmitters shall be set min (+20 dBm, P_{CMAX,L,c}) as defined in clause 6.2.5A. In case Single UL is allowed a UE only indicates support of "Single UL" the output power of the active UL shall be set at P_{CMAX,L,c} or set to the maximum power according to the UE power scaling capability.

NOTE 2: RB_{START} = 0

NOTE 3: For UEs only indicating support of Single UL, this requirement is verified with non-simultaneous uplink transmissions on 1 UTRA and NR CGs.

NOTE 4: This band is subject to IMD5 also which MSD is not specified.

NOTE 5: The symbol "REFSENS" in this table refers to the reference sensitivity values for single carrier specified in Table 7.3.5-1 TS 36.521-1 [10] for 2 antenna port E-UTRA band, Table 7.3.1.5-1 of TS 36.521-1 [10] for 4 antenna port E-UTRA band 7.3.2.5-1 for 2 antenna port NR band and Table 7.3.2.5-2 for 4 antenna port NR band.

NOTE 6: No requirements apply when there is at least one individual RE within the intermodulation generated by the dual uplink is the downlink transmission bandwidth of the Band 46. The reference sensitivity should only be verified when this is not the (the requirements for Band 46 specified in the CA_7A-46A in clause 7.3.1 of TS 36.101 [5] apply).

Table 7.3B.2.3_1.1.5-2: Reference sensitivity exceptions for Scell due to dual uplink operation for EN-DC in NR FR1 (two bands)

EN-DC Configuration	EUTRA/ NR band	SCS (kHz)	5 MHz (dBm)	10 MHz (dBm)	20 MHz (dBm)	40 MHz (dBm)	Duplex mode	IMD order	Single UL allowed
DC_1A_n78C	1	N/A	-92.0+T T	-	-	-	FDD	IMD4	
	n78	15	-	REFSENS	-	-	TDD	N/A	
	n78	15	-	REFSENS	-	-		N/A	

NOTE 1: Both of the transmitters shall be set min (+20 dBm, P_{CMAX,L,c}) as defined in clause 6.2.5A. In case Single UL is allowed and the UE only indicates support of "Single UL" the output power of the active UL shall be set at P_{CMAX,L,c} or set to the maximum output power according to the UE power scaling capability.

NOTE 2: RB_{START} = 0

Test tolerance is the same as given in Table 7.3B.2.3.5-2.

7.3B.2.3_1.2 Reference sensitivity for EN-DC within FR1 (4 CCs)

7.3B.2.3_1.2.1 Test purpose

Same as in clause 7.3B.2.3.1.

7.3B.2.3_1.2.2 Test applicability

This test applies to all types of NR UE release 15 and forward supporting 4 CCs EN-DC.

7.3B.2.3_1.2.3 Minimum conformance requirements

The minimum conformance requirements are defined in clause 7.3B.2.0.

For EN-DC combinations with no exception requirements applicable to NR or LTE, LTE anchor agnostic approach is applied.

For EN-DC combinations with exceptional requirements, LTE anchor agnostic approach is not applied.

7.3B.2.3_1.2.4 Test description

7.3B.2.3_1.2.4.1 Initial conditions

Initial conditions are a set of test configurations the UE needs to be tested in and the steps for the SS to take with the UE to reach the correct measurement state.

The initial test configurations for E-UTRA consist of the test frequency based on E-UTRA operating band and test channel bandwidth as specified in Table 4.6-1, with the exception that the E-UTRA channel bandwidth is the lowest supported value in Table 5.3B.1.3-1 for the EN-DC non-contiguous configuration under test.

The initial test configurations consist of environmental conditions, test frequencies, test channel bandwidths and sub-carrier spacing based on NR operating bands specified in table 5.2B.2.1-1. The 4CC EN-DC configurations listed in table 7.3B.2.3_1.2.4.1-0 shall not be tested according to TR 38.905 test point analysis. The other 4CC configurations shall be tested with applicable test parameters for each combination of test channel bandwidth and sub-carrier spacing are shown in Tables 7.3B.2.3.4.2.1-0 to 7.3B.2.3.4.2.1-1 for NR band. The details of the uplink reference measurement channels (RMCs) are specified in Annex A.2. Configurations of PDSCH and PDCCH before measurement are specified in TS 38.521-1 [8] Annex C2.

Table 7.3B.2.3_1.2.4.1-0: 4CC EN-DC configurations that shall not be tested

EN-DC type	E-UTRA CA	NR CA	Notation
Intra-band non-contiguous EN-DC (1 band)	Yes (cont)	No	DC_XD_nXA
Inter-band EN-DC	Yes (non-cont)	No	DC_XA-XC_nXA
	Yes (all types)	No	DC_XD-nYA, DC_XA-YC_nZA, DC_XA-XA-YA-nZA, DC_XA-YA-ZA_nRA
	Yes (all types)	Yes (cont)	DC_XC_nYC, DC_XA-XA_nYC, DC_XA-YA_nYC
		Yes (cont)	DC_XC_nY(2A), DC_XC_nY(2A), DC_XA-YA_nY(2A)
		Yes (inter)	DC_XC-nYA-nZA, DC_XA-XA_nYA-nZA, DC_XA-YA_nZA-nRA
Intra-band contiguous EN-DC (2-3 band)	Yes	No	DC_XA-YA_(n)ZAA, DC_XC_(n)YAA
	Yes	Yes	DC_(n)XCA-nYA
Intra-band non contiguous EN-DC (2-3 band)	Yes	No	DC_XA-YA-ZA_nZA
	Yes	Yes	DC_XA-YA_nYA-nZA
NOTE 1: X, Y and Z in this table correspond to different bands i.e. X != Y != Z.			
NOTE 2: The table apply to all band numbers, i.e. all values of X, Y and Z defined in TS38.101-3			
NOTE 3: The band combinations with difference appearance order of bands/sub-blocks in the band combination string are not distinguished. E.g. DC_YA-(n)XAA represents the set of DC_YA-(n)XAA and DC_(n)XAA-YA.			

Table 7.3B.2.3_1.2.4.1-1: Test Configuration Table for EN-DC configurations not affected by Reference sensitivity exceptions

Initial Conditions									
Test Environment as specified in TS 38.508-1 [6] clause 4.1					Normal, TL/VL, TL/VH, TH/VL, TH/VH				
Test Frequencies as specified in TS 38.508-1 [6] clause 4.3.1 for different EN-DC bandwidth classes					For test frequencies refer to "Range" columns. For mapping within Band refer to "CC" columns				
Test EN-DC bandwidth combination as specified in Table 5.3B.1.2-1 across bandwidth combination sets supported by the UE					DC_(n)XDA: Low range, High Range DC_XA-nYA-nZC: Mid range for X Low range, High Range for nY and nZ DC_XA-nY(2A)-nZA: Mid range for X TBD for nY Mid range for nZ				
NR Test SCS as specified in Table 5.3.5-1 in TS 38.521-1 [8]					Lowest SCS per Channel Bandwidth				
Network signalling value					NS_01 by default, exceptions listed in Table 7.3.3-3, dependent on PCC Band				
Test Parameters for EN-DC Configurations									
ID	CC (NOTE1)	Band	SCS	NRB	Range/Wgap	UL MOD	DL MOD	UL Alloc	DL Alloc
Default Test Settings for a DC_(n)XDA Configuration – Note 5									
1 (Note 6)	PCC(M)	X		Highest N _{RB}	default	QPSK	QPSK	REFSENS	All RBs
	SCC1(M)	X		Highest N _{RB}	Default	N/A	QPSK	N/A	All RBs
	SCC2(M)	X		Highest N _{RB}	Default	N/A	QPSK	N/A	All RBs
	PCC(S)	X		Highest N _{RB}	default	DFT-s-OFDM QPSK	CP-OFDM QPSK	REFSENS	All RBs
2 (Note 7)	PCC(M)	X		Highest N _{RB}	default	N/A	QPSK	0	All RBs
	SCC1(M)	X		Highest N _{RB}	Default	N/A	QPSK	N/A	All RBs
	SCC2(M)	X		Highest N _{RB}	Default	N/A	QPSK	N/A	All RBs
	PCC(S)	X		Highest N _{RB}	default	DFT-s-OFDM QPSK	CP-OFDM QPSK	REFSENS	All RBs
Default Test Settings for a DC_XA-nY(2A)-nZA Configuration – Note 4									
1	PCC(M)	X		5 MHz	default	N/A	QPSK	0	All RBs
	SCC1(S)	Y		Highest N _{RB}	default	N/A	QPSK	N/A	All RBs
	SCC2(S)	Z		Highest N _{RB}	default	N/A	QPSK	N/A	All RBs
	PCC(S)	Y		Highest N _{RB}	default	DFT-s-OFDM QPSK	CP-OFDM QPSK	REFSENS	All RBs
2	PCC(M)	X		5 MHz	default	N/A	QPSK	0	All RBs
	SCC1(S)	Y		Highest N _{RB}	default	N/A	QPSK	N/A	All RBs
	SCC2(S)	Y		Highest N _{RB}	default	N/A	QPSK	N/A	All RBs
	PCC(S)	Z		Highest N _{RB}	default	DFT-s-OFDM QPSK	CP-OFDM QPSK	REFSENS	All RBs
Default Test Settings for a DC_XA-nYA-nZC Configuration– Note 4									
1	PCC(M)	X		5 MHz	default	N/A	QPSK	0	All RBs
	SCC1(S)	Z		Highest N _{RB}	default	N/A	QPSK	N/A	All RBs
	SCC2(S)	Z		Highest N _{RB}	default	N/A	QPSK	N/A	All RBs
	PCC(S)	Y		Highest N _{RB}	default	DFT-s-OFDM QPSK	CP-OFDM QPSK	REFSENS	All RBs
2	PCC(M)	X		5 MHz	default	N/A	QPSK	0	All RBs

	SCC1(S)	Z		Highest N _{RB}	default	N/A	QPSK	N/A	All RBs
	SCC2(S)	Y		Highest N _{RB}	default	N/A	QPSK	N/A	All RBs
	PCC(S)	Z		Highest N _{RB}	default	DFT-s-OFDM QPSK	CP-OFDM QPSK	REFSENS	All RBs

NOTE 1: (M) and (S) indicate MCG and SCG respectively.

NOTE 2: X, Y and Z in this table correspond to different bands i.e. X != Y != Z.

NOTE 3: The band combinations with difference appearance order of bands/sub-blocks in the band combination string are not distinguished. E.g. DC_YA-(n)XAA represents the set of DC_YA-(n)XAA and DC_(n)XAA-YA.

NOTE 4: LTE anchor agnostic configuration

NOTE 5: Not LTE anchor agnostic configuration due to exception requirement for intra-band contiguous CA in clause 7.4B, 7.5B, 7.6B.2, 7.6B.3, 7.6B.4, 7.7B, 7.8B, 7.9B test cases

NOTE 6: Test point for UE supporting dual UL

NOTE 7: Test point for UE supporting single UL

NOTE 8: In a FR1 band where UE supports 4Rx, the test shall be performed only with 4Rx antennas ports connected.

Table 7.3B.2.3_1.2.4.1-2: Test Configuration Table for EN-DC configurations affected by Reference sensitivity exceptions

Initial Conditions									
Test Environment as specified in TS 38.508-1 [6] clause 4.1					Normal, TL/VL, TL/VH, TH/VL, TH/VH				
Test Frequencies as specified in TS 38.508-1 [6] clause 4.3.1 for different EN-DC bandwidth classes					For test frequencies refer to "Range" columns. For mapping within Band refer to "CC" columns				
Test EN-DC bandwidth combination as specified in Table 5.3B.1.2-1 across bandwidth combination sets supported by the UE					DC_XA-nYA-nZC: Mid range for X Mid Range for nY and nZ DC_XA-nY(2A)-nZA: Mid range for X TBD for nY Mid range for nZ				
NR Test SCS as specified in Table 5.3.5-1 in TS 38.521-1 [8]					Lowest SCS per Channel Bandwidth				
Network signalling value					NS_01 by default, exceptions listed in Table 7.3.3-3, dependent on PCC Band				
Test Parameters for EN-DC Configurations									
ID	CC (NOTE1)	Band	SCS	NRB	Range/Wgap	UL MOD	DL MOD	UL Alloc	DL Alloc
Default Test Settings for a DC_(n)XDA Configuration – Note 4									
					N/A				
Default Test Settings for a DC_XA-nY(2A)-nZA Configuration – Note 5									
1	PCC(M)	X		Highest N _{RB}	default	QPSK	QPSK	REFSENS	All RBs
	SCC1(S)	Y		Highest N _{RB}	default	N/A	QPSK	N/A	All RBs
	SCC2(S)	Z		Highest N _{RB}	default	N/A	QPSK	N/A	All RBs
	PCC(S)	Y		Highest N _{RB}	default	DFT-s-OFDM QPSK	CP-OFDM QPSK	REFSENS	All RBs
2	PCC(M)	X		Highest N _{RB}	default	QPSK	QPSK	REFSENS	All RBs
	SCC1(S)	Y		Highest N _{RB}	default	N/A	QPSK	N/A	All RBs
	SCC2(S)	Y		Highest N _{RB}	default	N/A	QPSK	N/A	All RBs
	PCC(S)	Z		Highest N _{RB}	default	DFT-s-OFDM QPSK	CP-OFDM QPSK	REFSENS	All RBs
Default Test Settings for a DC_XA-nYA-nZC Configuration – Note 5									
1	PCC(M)	X		Highest N _{RB}	default	QPSK	QPSK	REFSENS	All RBs
	SCC1(S)	Z		Highest N _{RB}	default	N/A	QPSK	N/A	All RBs
	SCC2(S)	Z		Highest N _{RB}	default	N/A	QPSK	N/A	All RBs
	PCC(S)	Y		Highest N _{RB}	default	DFT-s-OFDM QPSK	CP-OFDM QPSK	REFSENS	All RBs
2	PCC(M)	X		Highest N _{RB}	default	QPSK	QPSK	REFSENS	All RBs
	SCC1(S)	Z		Highest N _{RB}	default	N/A	QPSK	N/A	All RBs
	SCC2(S)	Y		Highest N _{RB}	default	N/A	QPSK	N/A	All RBs
	PCC(S)	Z		Highest N _{RB}	default	DFT-s-OFDM QPSK	CP-OFDM QPSK	REFSENS	All RBs

NOTE 1: (M) and (S) indicate MCG and SCG respectively.
 NOTE 2: X, Y and Z in this table correspond to different bands i.e. X != Y != Z.
 NOTE 3: The band combinations with difference appearance order of bands/sub-blocks in the band combination string are not distinguished. E.g. DC_YA-(n)XAA represents the set of DC_YA-(n)XAA and DC_(n)XAA-YA.
 NOTE 4: No refsens exceptions with this EN-DC configuration exist in TS38.101-3
 NOTE 5: This test setting is valid for EN-DC configurations affected by UL harmonics, harmonic mixing or cross band isolation exceptions when the exception is avoided by selecting specific test frequency. Test only one of the test points. UL to be active on the cell that form the aggressor of the exception
 NOTE 6: EN-DC configuration affected by 2UL intermodulation exception. The exceptions always apply for a certain UL configuration.
 NOTE 7: LTE CA fallback to 1CC is sufficient to test, unless both LTE cells are part of the exception requirement in which case the configuration need to be tested (using configuration specific test settings and not default).
 NOTE 8: In an E-UTRA band or FR1 band where UE supports 4Rx, the test shall be performed only with 4Rx antennas ports connected.

Table 7.3B.2.3_1.2.4.1-3: Void

7.3B.2.3_1.2.4.2 Test procedure

Same as in clause 7.3B.2.3.4.2

7.3B.2.3_1.2.4.3 Message contents

Message contents are according to TS 38.508-1 [5] clause 4.6.

7.3B.2.3_1.2.5 Test Requirement

Reference sensitivity test requirements for EN-DC configurations affected by 2UL intermodulation interference in NR FR1, are specified in Table 7.3B.2.3_1.2.5-1 and Table 7.3B.2.3_1.2.5-2 with uplink configuration specified in Table 7.3B.2.3_1.1.4.1-2.

Reference sensitivity test requirements for EN-DC configurations not affected by 2UL intermodulation interference in NR FR1, are specified in Table 7.3.5-1 in TS 36.521-1 [10] for the LTE CC, and Table 7.3.2.5-1 in TS 38.521-1 [8] for the NR CC.

Table 7.3B.2.3_1.2.5-1: Reference sensitivity exceptions for Scell due to dual uplink operation for EN-DC in NR FR1 (two bands)

FFS

Table 7.3B.2.3_1.2.5-2: Reference sensitivity exceptions for Scell due to dual uplink operation for EN-DC in NR FR1 (three bands)

FFS

Test tolerance is the same as given in Table 7.3B.2.3.5-2.

7.3B.2.3_1.3 Reference sensitivity for EN-DC within FR1 (5 CCs)

7.3B.2.3_1.3.1 Test purpose

Same as in clause 7.3B.2.3.1.

7.3B.2.3_1.3.2 Test applicability

This test applies to all types of NR UE release 15 and forward supporting 5 CCs inter-band EN-DC.

7.3B.2.3_1.3.3 Minimum conformance requirements

The minimum conformance requirements are defined in clause 7.3B.2.0

Exception requirements for both NR and E-UTRA are defined for this test and therefore LTE anchor agnostic approach is not applied. E-UTRA test point analysis is included and E-UTRA measurements are performed.

7.3B.2.3_1.3.4 Test description

7.3B.2.3_1.3.4.1 Initial conditions

Same initial conditions as in clause 7.3B.2.3.4.1 with following exceptions:

The initial test configurations for E-UTRA band and NR band consist of environmental conditions, test frequencies, and channel bandwidths and RB allocations for exceptional test scenarios are specified in Table 7.3B.2.3_1.3.4.1-1 and Table 7.3B.2.3_1.3.4.1-2

Table 7.3B.2.3_1.3.4.1-1: Test Configuration Table Reference sensitivity exceptions due to dual uplink operation for EN-DC in NR FR1 (four bands)

Initial Conditions									
Test Environment as specified in TS 38.508-1 [6] clause 4.1				Normal, TL/VL, TL/VH, TH/VL, TH/VH					
Test Frequencies as specified in TS 38.508-1 [6] clause 4.3.1 for different EN-DC bandwidth classes				For test frequencies refer to "Range" columns. For mapping within Band refer to "CC" columns					
Test EN-DC bandwidth combination as specified in Table 5.3B.1.2-1 across bandwidth combination sets supported by the UE				Refer to "NRB" column					
NR Test SCS as specified in Table 5.3.5-1 in TS 38.521-1 [8]				Refer to "SCS" column					
Network signalling value				NS_01 by default, exceptions listed in Table 7.3.3-3, dependent on PCC Band					
Test Parameters for EN-DC Configurations									
ID	CC (NOTE1)	Band	SCS	NRB	Range/Wgap	UL MOD	DL MOD	UL Alloc	DL Alloc
Default Test Settings for a DC_XA-YA_ZC_nRA Configuration									
1	PCC(M)	X	N/A	Highest N _{RB}	Mid	QPSK	QPSK	REFSENS	All RBs
	SCC1(M)	Y	N/A	Highest N _{RB}	Mid	N/A	QPSK	N/A	All RBs
	SCC2(M)	Z	N/A	Highest N _{RB}	Mid	N/A	QPSK	N/A	All RBs
	SCC3(M)	Z	N/A	Highest N _{RB}	Mid	N/A	QPSK	N/A	All RBs
	PCC(S)	R	15 kHz	Highest N _{RB}	Mid	DFT-s-OFDM QPSK	CP-OFDM QPSK	REFSENS	All RBs
NOTE 1: (M) and (S) indicate MCG and SCG respectively.									
NOTE 2: X, Y and Z in this table correspond to different bands i.e. X != Y != Z									
NOTE 3: The band combinations with difference appearance order of bands/sub-blocks in the band combination string are not distinguished. E.g. DC_YA-(n)XAA represents the set of DC_YA-(n)XAA and DC_(n)XAA-YA									

Table 7.3B.2.3_1.3.4.1-2: Test Configuration Table Reference sensitivity exceptions due to dual uplink operation for EN-DC in NR FR1 (five bands)

Initial Conditions									
Test Environment as specified in TS 38.508-1 [6] clause 4.1				Normal, TL/VL, TL/VH, TH/VL, TH/VH					
Test Frequencies as specified in TS 38.508-1 [6] clause 4.3.1 for different EN-DC bandwidth classes				For test frequencies refer to "Range" columns. For mapping within Band refer to "CC" columns					
Test EN-DC bandwidth combination as specified in Table 5.3B.1.2-1 across bandwidth combination sets supported by the UE				Refer to "NRB" column					
NR Test SCS as specified in Table 5.3.5-1 in TS 38.521-1 [8]				Refer to "SCS" column					
Network signalling value				NS_01 by default, exceptions listed in Table 7.3.3-3, dependent on PCC Band					
Test Parameters for EN-DC Configurations									
ID	CC (NOTE1)	Band	SCS	NRB	Range/Wgap	UL MOD	DL MOD	UL Alloc	DL Alloc
Default Test Settings for a DC_XA-YA-ZA-SA_nRA Configuration									
1	PCC(M)	X	N/A	Highest N _{RB}	Mid	QPSK	QPSK	REFSENS	All RBs
	SCC1(M)	Y	N/A	Highest N _{RB}	Mid	N/A	QPSK	N/A	All RBs
	SCC2(M)	Z	N/A	Highest N _{RB}	Mid	N/A	QPSK	N/A	All RBs
	SCC3(M)	S	N/A	Highest N _{RB}	Mid	N/A	QPSK	N/A	All RBs
	PCC(S)	R	15 kHz	Highest N _{RB}	Mid	DFT-s-OFDM QPSK	CP-OFDM QPSK	REFSENS	All RBs
NOTE 1: (M) and (S) indicate MCG and SCG respectively.									
NOTE 2: X, Y and Z in this table correspond to different E-UTRA bands i.e. X != Y != Z, R corresponds to NR band.									
NOTE 3: For inter-band EN-DC 4CCs configuration with four bands, if there is no additional exceptional test point is defined besides the requirement for default uplink EN-DC configurations defined in Table 5.5B.4.3-1, testing for 4CC with four band can be skipped.									

7.3B.2.3_1.3.4.2 Test procedure

Same as in clause 7.3B.2.3.4.2.

7.3B.2.3_1.3.4.3 Message contents

Message contents are according to TS 38.508-1 [5] clause 4.6.

7.3B.2.3_1.3.5 Test requirement

For inter-band EN-DC configurations, the throughput of each CG shall be $\geq 95\%$ of the maximum throughput of the reference measurement channels as specified in Annex A.3.2 with reference receive power level specified in Tables Table 7.3.2.5-1 in TS 38.521-1 [8] and parameters specified Tables 7.3.2.4.1-1, Tables 7.3.2.4.1-2 and Tables 7.3.2.4.1-3 in TS 38.521-1 [8] for NR band.

Each EN-DC combination defined in Table 5.5B.4.3-1 shall be tested in anchor-agnostic anchor-agnostic mode as described in this clause. If a test point is overlapped with uplink EN-DC combo MSD test points, the requirement with MSD shall apply.

For the UE which supports inter-band EN-DC, the minimum requirement for reference sensitivity in Table 7.3.2.5-1 of TS 38.521-1 [8] for NR band and Table 7.3.5-1 of TS 36.521-1 [10] for EUTRA band, shall be increased by the amount given in $\Delta R_{B,c}$ defined in clause 7.3B.3.3 for the applicable for two, three, four and five bands operation.

Reference sensitivity exceptions for intermodulation interference due to dual uplink operation for EN-DC in NR FR1, are specified in Table 7.3B.2.3_1.3.5-1 for four bands and Table 7.3B.2.3_1.3.5-2 for five bands with uplink configuration specified in Table 7.3B.2.3_1.3.4.1-1 for four bands and 7.3B.2.3_1.3.4.1-2 for five bands, respectively.

For a given inter-band EN-DC 5CCs configuration defined in Table 5.5B.4.3-1 and Table 5.5B.4.4-1, if there is no additional exceptional test point is defined besides the requirement for default uplink EN-DC configurations defined in

Table 5.5B.4.3-1 and Table 5.5B.4.4-1, the test requirement for default fallback uplink EN-DC configurations defined in Table 5.5B.4.3-1 applies.

Table 7.3B.2.3_1.3.5-1 Reference sensitivity exceptions for Scell due to dual uplink operation for EN-DC in NR FR1 (four bands)

TBD

Table 7.3B.2.3_1.3.5-2 Reference sensitivity exceptions for Scell due to dual uplink operation for EN-DC in NR FR1 (five bands)

TBD

7.3B.2.3_1.4 Reference sensitivity for EN-DC within FR1 (6 CCs)

TBD

7.3B.2.4 Reference sensitivity for Inter-band EN-DC including FR2

7.3B.2.4.1 Test purpose

Same test purpose as in clause 7.3.2.1 in TS 38.521-2 [9] for the NR carrier.

7.3B.2.4.2 Test applicability

This test case applies to all types of E-UTRA UE release 15 and forward, supporting inter-band EN-DC including FR2 with 2 DL CCs.

7.3B.2.4.3 Minimum conformance requirements

Same minimum conformance requirements as in clause 7.3B.2.0.4 TS 3.

No exception requirements applicable to NR or LTE. LTE anchor agnostic approach is applied.

The normative reference for this requirement is TS 38.101-3 [4] clause 7.3B.2.4.

7.3B.2.4.4 Test description

7.3B.2.4.4.1 Initial conditions

Same test description as in clause 7.3.2.4 in TS 38.521-2 [9] for the NR carrier with the following exception:

The initial test configurations for E-UTRA band consist of environmental conditions, test frequencies, and channel bandwidths based on E-UTRA bands specified in Table 4.6-1. For Initial conditions as in clause 7.3.2.4.1 in TS 38.521-2 [9], the following steps will be added to configure E-UTRA component:

- 2.1. The parameter settings for E-UTRA cell are set up according to TS 36.508 [11] clause 4.4.3.
- 3.1. The E-UTRA downlink signal level, uplink signal level are set according to Table 4.7-1 and propagation conditions are set according to Annex B.0 of TS 36.521-1 [10].

Step 6 of Initial conditions as in clause 7.3.2.4.1 in TS 38.521-2 [9] is replaced by:

6. Ensure the UE is in state RRC_CONNECTED with generic procedure parameters Connectivity EN-DC, DC bearer MCG and SCG, Connected without release On according to TS 38.508-1 [6] clause 4.5.

Same test procedure as in clause 7.3.2.4.2 in TS 38.521-2 [9] with the following steps added for E-UTRA component:

- 1.1 On the E-UTRA carrier, disable periodic and aperiodic CQI reports, disable SRS, set *TimeAlignmentTimerDedicated* IE to infinity and disable downlink and uplink scheduling, all as per Table 4.7-1 under clause 4.7.

7.3B.2.4.5 Test requirement

Same test requirement as in clause 7.3.2.5 in TS 38.521-2 [9] for the NR carrier.

7.3B.2.4_1 Reference sensitivity for Inter-band EN-DC including FR2 (>2 CCs)

7.3B.2.4_1.1 Reference sensitivity for Inter-band EN-DC including FR2 (3 CCs)

7.3B.2.4_1.1.1 Test purpose

Same test purpose as in clause 7.3B.2.4.1.

7.3B.2.4_1.1.2 Test applicability

This test case applies to all types of E-UTRA UE release 15 and forward, supporting inter-band EN-DC including FR2 with 3 DL CCs (2NR DL CCs).

7.3B.2.4_1.1.3 Minimum conformance requirements

Same minimum conformance requirements as in clause 7.3B.2.0.4.

7.3B.2.4_1.1.4 Test description

The FR2 reference sensitivity test description for all 3CC EN-DC CA combinations (1LTE+2FR2, 2LTE+1FR2), is the same as in corresponding clause of clause 7.5A or clause 7.5 (if only 1 FR2 carrier) in TS 38.521-2 [9] with the exceptions described below.

7.3B.2.4_1.1.4.1 Initial conditions

Initial conditions are a set of test configurations the UE needs to be tested in and the steps for the SS to take with the UE to reach the correct measurement state.

The initial test configurations consist of environmental conditions, test frequencies and channel bandwidths based on EN-DC operating bands specified in clause 5.2B.1, channel bandwidths and sub-carrier spacings for the NR cell specified in TS 38.521-2 [9] clause 5.3 or clause 5.3A and channel bandwidth for the E-UTRA cell are specified in TS 36.521-1 [10] clause 5.4.2 or clause 5.4.2A. All valid configurations shall be tested with applicable test parameters for inter-band EN-DC including FR2 configuration specified in clause 5.5B.5, and the configuration for NR carrier are shown in TS 38.521-2 [9] Table 7.3.2.4.1-1 or Table 7.3A.2.1.4.1-1.

For Initial conditions as in clause 7.3.2.4.1 or clause 7.3A.2.1.4.1 in TS 38.521-2 [9], the following steps will be added to configure E-UTRA component:

- 2.1. The parameter settings for E-UTRA cell are set up according to TS 36.508 [11] clause 4.4.3.
- 3.1. The E-UTRA downlink signal level, uplink signal level are configured as per clause 4.7 with parameters set according to Table 4.7-1 and propagation conditions set according to Annex B.0 of TS 36.521-1 [10].

Step 6 of Initial conditions as in clause 7.3.2.4.1 or clause 7.3A.2.1.4.1 in TS 38.521-2 [9] is replaced by:

6. Ensure the UE is in state RRC_CONNECTED with generic procedure parameters Connectivity EN-DC, DC bearer MCG and SCG, Connected without release On according to TS 38.508-1 [6] clause 4.5.

7.3B.2.4_1.1.4.2 Test Procedure

Same test procedure as in clause 7.3.2.4.2 or clause 7.3A.2.1.4.2 in TS 38.521-2 [9] with the following steps added for E-UTRA component:

1.1 On the E-UTRA carrier, disable periodic and aperiodic CQI reports, disable SRS, set *TimeAlignmentTimerDedicated* IE to infinity and disable downlink and uplink scheduling, all as per Table 4.7-1 under clause 4.7.

7.3B.2.4_1.1.4.3 Message contents

Message contents are according to TS 38.508-1 [6] clause 4.6.1.

7.3B.2.4_1.1.5 Test requirement

For each NR component carrier, the test requirement is the same as in clause 7.3.2.5 or clause 7.3A.2.1.5 in TS 38.521-2 [9].

7.3B.2.4_1.2 Reference sensitivity for Inter-band EN-DC including FR2 (4 CCs)

7.3B.2.4_1.2.1 Test purpose

Same test purpose as in clause 7.3B.2.4_1.1.1.

7.3B.2.4_1.2.2 Test applicability

This test case applies to all types of E-UTRA UE release 15 and forward, supporting inter-band EN-DC including FR2 with 4 DL CCs (3NR DL CCs).

7.3B.2.4_1.2.3 Minimum conformance requirements

Same minimum conformance requirements as in clause 7.3B.2.4_1.1.3.

7.3B.2.4_1.2.4 Test description

The FR2 reference sensitivity test description for all 4CC EN-DC CA combinations (1LTE+3FR2, 2LTE+2FR2, 3LTE+1FR2), is the same as in corresponding clause of clause 7.5A or clause 7.5 (if only 1 FR2 carrier) in TS 38.521-2 [9], with the exceptions described in clause 7.3B.2.4_1.1.4.1 and clause 7.3B.2.4_1.1.4.2.

7.3B.2.4_1.2.5 Test requirement

For each NR component carrier, the test requirement is the same as in clause 7.3.2.5 or clause 7.3A.2.1.5 in TS 38.521-2 [9].

7.3B.2.4_1.3 Reference sensitivity for Inter-band EN-DC including FR2 (5 CCs)

7.3B.2.4_1.3.1 Test purpose

Same test purpose as in clause 7.3B.2.4_1.1.1.

7.3B.2.4_1.3.2 Test applicability

This test case applies to all types of E-UTRA UE release 15 and forward, supporting inter-band EN-DC including FR2 with 5 DL CCs (4NR DL CCs).

7.3B.2.4_1.3.3 Minimum conformance requirements

Same minimum conformance requirements as in clause 7.3B.2.4_1.1.3.

7.3B.2.4_1.3.4 Test description

The FR2 reference sensitivity test description for all 5CC EN-DC CA combinations (1LTE+4FR2, 2LTE+3FR2, 3LTE+2FR2, 4LTE+1FR2), is the same as in corresponding clause of clause 7.5A or clause 7.5 (if only 1 FR2 carrier) in TS 38.521-2 [9], with the exceptions described in clause 7.3B.2.4_1.1.4.1 and clause 7.3B.2.4_1.1.4.2.

7.3B.2.4_1.3.5 Test requirement

For each NR component carrier, the test requirement is the same as in clause 7.3.2.5 or clause 7.3A.2.1.5 in TS 38.521-2 [9].

7.3B.2.4_1.4 Reference sensitivity for Inter-band EN-DC including FR2 (6 CCs)

7.3B.2.4_1.4.1 Test purpose

Same test purpose as in clause 7.3B.2.4_1.1.1.

7.3B.2.4_1.4.2 Test applicability

This test case applies to all types of E-UTRA UE release 15 and forward, supporting inter-band EN-DC including FR2 with 6 DL CCs (5NR DL CCs).

7.3B.2.4_1.4.3 Minimum conformance requirements

Same minimum conformance requirements as in clause 7.3B.2.4_1.1.3.

7.3B.2.4_1.4.4 Test description

The FR2 reference sensitivity test description for all 6CC EN-DC CA combinations (1LTE+5FR2, 2LTE+4FR2, 3LTE+3FR2, 4LTE+2FR2, 5LTE+1FR2), is the same as in corresponding clause of clause 7.5A or clause 7.5 (if only 1 FR2 carrier) in TS 38.521-2 [9], with the exceptions described in clause 7.3B.2.4_1.1.4.1 and clause 7.3B.2.4_1.1.4.2.

7.3B.2.4_1.4.5 Test requirement

For each NR component carrier, the test requirement is the same as in clause 7.3.2.5 or clause 7.3A.2.1.5 in TS 38.521-2 [9].

7.3B.2.4D Reference sensitivity for inter-band EN-DC including FR2 for UL-MIMO

No exception requirements applicable to NR or LTE. LTE anchor agnostic approach can be applied and only NR carriers need to be tested.

No test case details are specified. Given UE's Rx performance would not be impacted by the Tx configuration in NR FR2 TDD bands, the requirements in this test case can be well covered in 7.3B.2.4 and 7.3B.2.4_1 and don't need to be tested again.

7.3B.2.5 Reference sensitivity for Inter-band EN-DC including FR1 and FR2 (3 CCs)

7.3B.2.5.1 Test purpose

Same test purpose as in 7.3B.2 in TS 38.521-1 [8] for NR FR1 carrier(s) and 7.3.2 in TS 38.521-2 [9] for NR FR2 carrier(s).

7.3B.2.5.2 Test applicability

The requirements in this test are not testable due to issues with combined testing of NR FR1 and E-UTRA in conducted mode with NR FR2 in radiated mode. Therefore, the conducted and radiated requirements are tested separately.

No test case details are specified. The NSA requirements for reference sensitivity apply and are tested as part of the EN-DC within FR1 and EN-DC including FR2 test cases in clause 7.3B.

7.3B.2.5D Reference sensitivity for inter-band EN-DC including FR1 and FR2 for UL-MIMO

7.3B.2.5D.1 Test purpose

Same test purpose as in clause 7.3D in TS 38.521-1 [8] for NR FR1 carrier and 7.3D in TS 38.521-2 [9] for NR FR2 carrier.

7.3B.2.5D.2 Test applicability

The requirements in this test are not testable due to issues with combined testing of NR FR1 and E-UTRA in conducted mode with NR FR2 in radiated mode. Therefore, the conducted and radiated requirements are tested separately.

No test case details are specified. The NSA requirements for reference sensitivity apply and are tested as part of the EN-DC within FR1 as in clause 7.3 in TS 38.521-1 [8] and EN-DC within FR2 as in clause 7.3 in TS 38.521-2 [9].

7.3B.2.6 Void

7.3B.3 $\Delta R_{IB,c}$ ΔR_{IBNC} for EN-DC

7.3B.3.0 General

For the UE which supports inter-band EN-DC or NE-DC configuration, the minimum requirement for reference sensitivity in Table 7.3.1-1 and Table 7.3.1-1a in TS.36101 [5], clause 7.3.2, 7.3A.2, 7.3C.2 in TS 38.101-1 [2] and clause 7.3.2, 7.3A.2 in TS 38.101-2 [3] shall be increased by the amount given in $\Delta R_{IB,c}$ ΔR_{IBNC} in Tables below where unless otherwise stated, the same $\Delta R_{IB,c}$, ΔR_{IBNC} are applicable to NR band(s) part for DC configurations which have the same NR operating band combination. Unless otherwise stated, $\Delta R_{IB,c}$ or ΔR_{IBNC} is set to zero.

In case the UE supports more than one of band combinations for CA, SUL or DC, and an operating band belongs to more than one band combinations then

- When the operating band frequency range is ≤ 1 GHz, the applicable additional $\Delta R_{IB,c}$ shall be the average value for all band combinations defined in clause 7.3A, 7.3B, 7.3C in this specification and 7.3A, 7.3B in TS 38.101-3 [4], truncated to one decimal place that apply for that operating band among the supported band combinations. In case there is a harmonic relation between low band UL and high band DL, then the maximum $\Delta R_{IB,c}$ among the different supported band combinations involving such band shall be applied.
- When the operating band frequency range is > 1 GHz, the applicable additional $\Delta R_{IB,c}$ shall be the maximum value for all band combinations defined in clause 7.3A, 7.3B, 7.3C in this specification and 7.3A, 7.3B in TS 38.101-3 [4] for the applicable operating bands.

Unless $\Delta R_{IB,c}$ is specified for the NE-DC configuration, the specified $\Delta R_{IB,c}$ for the EN-DC configuration including same bands as the corresponding NE-DC configuration is applicable for the NE-DC configuration.

The normative reference for this requirement is TS 38.101-3 [4] clause 7.3B.3.

7.3B.3.1 Reference sensitivity $\Delta R_{IB,c}$ for Intra-band Contiguous EN-DC

FFS

7.3B.3.2 Reference sensitivity $\Delta R_{IB,C}$ for Intra-band non-contiguous EN-DC

Table 7.3B.3.2-1: Intra-band non-contiguous EN-DC with one uplink configuration on E-UTRA for reference sensitivity

DC configuration	Aggregated channel bandwidth (LTE+NR)		W_{gap} / (MHz)	UL E-UTRA allocation	ΔR_{IBNC} (dB)	Duplex mode
	E-UTRA	NR				
DC_3A_n3A	5MHz	5MHz	$45.0 < W_{gap} \leq 65.0$	12 ¹	4.7	FDD
			$0.0 < W_{gap} \leq 45.0$	25 ¹	0	
	5MHz	10MHz	$40.0 < W_{gap} \leq 60.0$	12 ¹	3.8	
			$0.0 < W_{gap} \leq 40.0$	25 ¹	0	
	5MHz	15MHz	$35.0 < W_{gap} \leq 55.0$	12 ¹	3.6	
			$0.0 < W_{gap} \leq 35.0$	25 ¹	0	
	5MHz	20MHz	$30.0 < W_{gap} \leq 50.0$	12 ¹	3.4	
			$0.0 < W_{gap} \leq 30.0$	25 ¹	0	
	5MHz	25MHz	$25.0 < W_{gap} \leq 45.0$	12 ¹	3.2	
			$0.0 < W_{gap} \leq 25.0$	25 ¹	0	
	5MHz	30MHz	$20.0 < W_{gap} \leq 40.0$	12 ¹	3.0	
			$0.0 < W_{gap} \leq 20.0$	25 ¹	0	
	10MHz	5MHz	$30.0 < W_{gap} \leq 60.0$	12 ⁵	5.1	
			$0.0 < W_{gap} \leq 30.0$	32 ¹	0	
	10MHz	10MHz	$25.0 < W_{gap} \leq 55.0$	12 ⁵	4.3	
			$0.0 < W_{gap} \leq 25.0$	32 ¹	0	
	10MHz	15MHz	$20.0 < W_{gap} \leq 50.0$	12 ⁵	3.8	
			$0.0 < W_{gap} \leq 20.0$	32 ¹	0	
	10MHz	20MHz	$15.0 < W_{gap} \leq 45.0$	12 ⁵	3.5	
			$0.0 < W_{gap} \leq 15.0$	32 ¹	0	
	10MHz	25MHz	$10.0 < W_{gap} \leq 40.0$	12 ⁵	3.2	
			$0.0 < W_{gap} \leq 10.0$	32 ¹	0	
	10MHz	30MHz	$5.0 < W_{gap} \leq 35.0$	12 ⁵	2.8	
			$0.0 < W_{gap} \leq 5.0$	32 ¹	0	
	15MHz	5MHz	$25.0 < W_{gap} \leq 55.0$	12 ⁶	6.0	
			$0.0 < W_{gap} \leq 25.0$	32 ¹	0	
	15MHz	10MHz	$20.0 < W_{gap} \leq 50.0$	12 ⁶	4.7	
			$0.0 < W_{gap} \leq 20.0$	32 ¹	0	
	15MHz	15MHz	$15.0 < W_{gap} \leq 45.0$	12 ⁶	4.2	
			$0.0 < W_{gap} \leq 15.0$	32 ¹	0	
	15MHz	20MHz	$10.0 < W_{gap} \leq 40.0$	12 ⁶	3.8	
			$0.0 < W_{gap} \leq 10.0$	32 ¹	0	
15MHz	25MHz	$5.0 < W_{gap} \leq 35.0$	12 ⁶	3.5		
		$0.0 < W_{gap} \leq 5.0$	32 ¹	0		
15MHz	30MHz	$0.0 < W_{gap} \leq 30.0$	12 ⁶	3.3		
20MHz	5MHz	$15.0 < W_{gap} \leq 50.0$	16 ⁷	6.5		
		$0.0 < W_{gap} \leq 15.0$	32 ¹	0		
20MHz	10MHz	$10.0 < W_{gap} \leq 45.0$	16 ⁷	5.1		
		$0.0 < W_{gap} \leq 10.0$	32 ¹	0		
20MHz	15MHz	$5.0 < W_{gap} \leq 40.0$	16 ⁷	4.5		
		$0.0 < W_{gap} \leq 5.0$	32 ¹	0		
20MHz	20MHz	$0.0 < W_{gap} \leq 35.0$	16 ⁷	4.1		
20MHz	25MHz	$0.0 < W_{gap} \leq 30.0$	16 ⁷	3.8		
20MHz	30MHz	$0.0 < W_{gap} \leq 25.0$	16 ⁷	3.6		

NOTE 1: UL resource blocks shall be located as close as possible to the downlink operating band but confined within the transmission.

NOTE 2: W_{gap} is the sub-block gap between the two sub-blocks.

NOTE 3: The table only applies when the centre frequency of E-UTRA carrier is higher than the NR carrier, and the ΔR_{IBNC} applies to the NR DL carrier only.

NOTE 4: All combinations of channel bandwidths defined in Table 5.3B.1.3-1.

NOTE 5: UL resource blocks shall be located at $RB_{start}=25$.

NOTE 6: UL resource blocks shall be located at $RB_{start}=35$.

NOTE 7: UL resource blocks shall be located at $RB_{start}=50$.

7.3B.3.3 $\Delta R_{IB,c}$ for Inter-band EN-DC within FR1

7.3B.3.3.1 $\Delta R_{IB,c}$ for EN-DC in two bands

Table 7.3B.3.3.1-1: $\Delta R_{IB,c}$ due to EN-DC(two bands)

Inter-band EN-DC configuration	E-UTRA or NR Band	$\Delta R_{B,c}$ (dB)
DC_1_n28	n28	0.2
DC_1_n51	n51	0.1
DC_1_n77	1	0.2
	n77	0.5
DC_1_n78	n78	0.5
DC_2_n66	2	0.3
	n66	0.3
DC_2_n78	2	0.2
	n78	0.5
DC_3_n41	n41	0 ³
		0.5 ⁴
DC_3_n51	3	0.2
	n51	0.2
DC_3_n77, DC_3-3_n77	3	0.2
	n77	0.5
DC_3_n78, DC_3-3_n78	3	0.2
	n78	0.5
DC_5_n78	5	0.2
	n78	0.5
DC_7_n51	n51	0.2
DC_7_n71	n71	0.2
DC_7_n77, DC_7-7_n77	n77	0.5
DC_7_n78, DC_7-7_n78	n78	0.5
DC_8_n77	8	0.2
	n77	0.5
DC_8_n78	8	0.2
	n78	0.5
DC_11_n77	n77	0.5
DC_11_n78	n78	0.5
DC_12_n5	12	0.3
	n5	0.5
DC_12_n66	12	0.5
DC_12_n78	12	0.2
	n78	0.5
DC_18_n77	n77	0.5
DC_19_n77	n77	0.5
DC_19_n78	n78	0.5
DC_20_n51	n51	0.2
DC_20_n77	n77	0.5
DC_20_n78	n78	0.5
DC_21_n77	n77	0.5
DC_21_n78	n78	0.5
DC_25_n41, DC_25-25_n41	n41	0 ¹
		0.5 ²
DC_26_n77	n77	0.5
DC_26_n78	n78	0.5
DC_28_n8	28	0.1
	n8	0.2
DC_28_n51	n51	0.2
DC_28_n77	28	0.2
	n77	0.5
DC_28_n78	28	0.2
	n78	0.5
DC_30_n66	30	0.5
	n66	0.4
DC_38_n78	38	0.4
	n78	0.5
DC_39-n41	39	0.2
	n41	0.2
DC_39_n78	n78	0.5
DC_39_n79	n79	0.5
DC_40_n77	40	0.4
	n77	0.5

DC_40_n78	40	0.4 ⁵
	n78	0.5 ⁵
DC_40_n79	n79	0.5
DC_41_n77	n77	0.5
DC_41_n78	n78	0.5
DC_41_n79	n79	0.5
DC_42_n51	n51	0.2
DC_66_n2	66	0.3
	n2	0.3
DC_66_n25	66	0.3
	n25	0.3
DC_66_n41	66	0.5
	n41	0.5 ¹
		1 ²
DC_66_n78	66	0.2
	n78	0.5

NOTE 1: The requirement is applied for UE transmitting on the frequency range of 2545-2690MHz.
NOTE 2: The requirement is applied for UE transmitting on the frequency range of 2496-2545MHz.
NOTE 3: Applicable for the frequency range of 2515-2690 MHz.
NOTE 4: Applicable for the frequency range of 2496-2515 MHz.
NOTE 5: Only applicable for UE supporting inter-band carrier aggregation with uplink in one E-UTRA band and without simultaneous Rx/Tx.

7.3B.3.3.2 $\Delta R_{IB,c}$ for EN-DC in three bands

Table 7.3B.3.3.2-1: $\Delta R_{IB,c}$ due to EN-DC (three bands)

Inter-band EN-DC configuration	E-UTRA or NR Band	$\Delta R_{IB,c}$ (dB)
DC_1-3_n28	n28	0.2
DC_1-3_n77	1	0.2
	3	0.2
	n77	0.5
DC_1-3_n78	1	0.2
	3	0.2
	n78	0.5
DC_1_n3-n78	1	0.2
	n3	0.2
	n78	0.5
DC_1-5_n78	1	0.2
	5	0.2
	n78	0.5
DC_1-7_n28	n28	0.2
DC_1-7_n78 DC_1-7-7_n78 DC_1_n7-n78	1	0.2
	7 or n7	0.2
	n78	0.5
	8	0.2
DC_1-8_n78	n77	0.5
	8	0.2
DC_1-11_n77	n78	0.5
	1	0.2
	n77	0.5
DC_1-18_n77	n77	0.5
DC_1-18_n78	n78	0.5
DC_1-19_n77	n77	0.5
DC_1-19_n78	n78	0.5
DC_1-19_n79	1	0.3
	19	0.3
DC_1-20_n28	20	0.2
	n28	0.2
DC_1-20_n78	n78	0.5
DC_1-21_n77	n77	0.5
DC_1-21_n78	1	0.2
	n78	0.5
DC_1-28_n77	28	0.2
	n77	0.5
DC_1-28_n78	28 or n28	0.2
DC_1_n28-n78	n78	0.5
DC_1_n28-n79	1	0.3
	28	0.3
DC_1_n40-n78	n78	0.5
DC_1-41_n28	n28	0.2
DC_1-41_n77	n77	0.5
DC_1-41_n78	n78	0.5
DC_1-42_n77	1	0.2
	42	0.5
	n77	0.5
DC_1-42_n78	1	0.2
	42	0.5
	n78	0.5
DC_1-42_n79	42	0.5
DC_1_n77-n79	1	0.2
	n77	0.5
DC_1_SUL_n77-n80	1	0.2
	n77	0.5
DC_1_SUL_n77-n84	1	0.2
	n77	0.5
DC_1_n78-n79	n78	0.5
DC_1_SUL_n78-n80	1	0.2
	n78	0.5
DC_1-SUL_n78-n84	n78	0.5

DC_2-5_n66	2	0.3			
	n66	0.3			
	n71	0.2			
DC_2-13_n66	2	0.3			
DC_2-2-13_n66	n66	0.3			
DC_2-29_n260	2	0			
DC_2-14_n66	2	0.3			
DC_2-2-14_n66	n66	0.3			
DC_2-30_n5, DC_2-2-30_n5	2	0.4			
	30	0.5			
DC_2_30_n66	2	0.4			
	30	0.5			
	n66	0.4			
DC_2-66_n5 DC_2A-2A-66A_n5A DC_2-66-66_n5 DC_2A-2A-66A-66A_n5A DC_2-66-66-66_n5	2	0.3			
	66	0.3			
			DC_2-66_n41	2	0.3
				66	0.5
				n41	0.5 ¹
	1 ²				
DC_2-66_n71B	2	0.3			
	66	0.3			
DC_2-66_n78 DC_2-66-66_n78	2	0.3			
	66	0.3			
	n78	0.5			
DC_3_n1-n77	3	0.2			
	n1	0.2			
	n77	0.5			
DC_3_n1-n78	3	0.2			
	n1	0.2			
	n78	0.5			
DC_3_n3-n77	3	0.2			
	n3	0.2			
	n77	0.5			
DC_3_n3-n78	3	0.2			
	n3	0.2			
	n78	0.5			
DC_3-5_n78	3	0.2			
	5	0.2			
	n78	0.5			
DC_3-7_n78 DC_3-7-7_n78 DC_3-3-7_n78 DC_3-3-7-7_n78 DC_3_n7-n78	3	0.2			
	7 or n7	0.2			
	n78	0.5			
			DC_3-8_n77	3	0.2
	8	0.2			
	n77	0.5			
DC_3-8_n78	3	0.2			
	8	0.2			
	n78	0.5			
DC_3-18-n77	3	0.2			
	n77	0.5			
DC_3-18-n78	3	0.2			
	n78	0.5			
DC_3-19_n77	3	0.2			
	n77	0.5			
DC_3-19_n78	3	0.2			
	n78	0.5			
DC_3-20_n28	20	0.1			
	n28	0.1			
DC_3-20_n78	3	0.2			
	n78	0.5			

DC_3_n20-n78	3	0.2
	n78	0.5
DC_3-21_n77	3	0.3
	21	0.5
	n77	0.5
DC_3-21_n78	3	0.3
	21	0.5
	n78	0.5
DC_3-21_n79	3	0.3
	21	0.5
	28	0.1
	n5	0.1
	n41	0 ¹ /0.5 ²
DC_3-28_n78	3	0.2
DC_3_n28-n78	n78	0.5
DC_3-38_n78	3	0.2
	38	0.4
	n78	0.5
DC_3-41_n28	3	0
	41	0 ¹ /0.5 ²
	n28	0
DC_3-41-n77	3	0.2
	41	0 ¹
	n77	0.5 ²
DC_3-41_n78	3	0.5
	41	0.2
	n78	0.1
DC_3-41-n79	3	0.5 ²
	41	0.2
	n79	0 ¹
DC_3_SUL_n41-n80	n41	0.5 ³
DC_3-42_n77	3	0.2
	42	0.5
	n77	0.5
DC_3-42_n78	3	0.2
	42	0.5
	n78	0.5
DC_3-42_n79	3	0.2
	42	0.5
DC_3_n77-n79	3	0.2
	n77	0.5
DC_3_SUL_n77-n80	3	0.2
	n77	0.5
DC_3_SUL_n77-n84	3	0.2
	n77	0.5
DC_3_n78-n79	3	0.2
	n78	0.5
DC_3-SUL_n78-n80	3	0.2
	n78	0.5
DC_3-SUL_n78-n82	3	0.2
	n78	0.5
DC_3_SUL_n78-n84	3	0.2
	n78	0.5
	n71	0.2
DC_5-7_n78	5	0.2
	7	0.2
	n78	0.5 ²
DC_5_30_n66	30	0.5
	n66	0.4
DC_7_n1-n78	7	0.2
	n1	0.2
	n78	0.5
DC_7-8_n77	7	0

	8	0.2
	n77	0.5
DC_7-8_n78	7	0
	8	0.2
DC_7-20_n28	n78	0.5
	20	0.2
DC_7-20_n78	n28	0.2
	n78	0.5
DC_7-28_n78	n78	0.5
DC_7_n28-n78	n78	0.5
DC_7-46_n78	n78	0.5
DC_7_SUL_n78-n80	7	0.2
	n78	0.5
DC_8-11_n77	8	0.2
	n77	0.5
DC_8-11_n78	8	0.2
	n78	0.2
DC_8-20_n78	8	0.2
	n78	0.5
DC_8_SUL_n78-n80	8	0.2
	n78	0.5
DC_8-SUL_n78-n81	8	0.2
	n78	0.2
DC_14-66_n2	66	0.3
DC_14-66-66_n2	n2	0.3
DC_18-28_n77	n77	0.5
DC_18-28_n78	n78	0.5
DC_18-41_n77	n77	0.5
DC_18-41_n78	n78	0.5
	42	0.5
	n77	0.5
	42	0.5
	n78	0.5
	42	0.5
DC_19-21_n77	n77	0.5
DC_19-21_n78	n78	0.5
DC_19-42_n77	42	0.5
	n77	0.5
DC_19-42_n78	42	0.5
	n78	0.5
DC_19-42_n79	42	0.5
DC_19_n77-n79	n77	0.5
DC_19_n78-n79	n78	0.5
DC_20_n1-n78	n78	0.5
DC_20_n3-n78	n3	0.2
	n78	0.5
DC_20_n28-n75	n28	0.2
DC_20_n28-n78	20	0.2
	n28	0.2
	n78	0.5
DC_20-38_n78	38	0.4
	n78	0.5
DC_20_n75-n78	n78	0.5
DC_20_n76-n78	n78	0.5
DC_20_SUL_n78-n80	n78	0.5
DC_20-SUL_n78-n82	n78	0.5
DC_20-SUL_n78-n83	20	0.2
	n78	0.5
DC_21-42_n77	42	0.5
	n77	0.5
DC_21-42_n78	42	0.5
	n78	0.5
DC_21-42_n79	42	0.5
DC_21_n77-n79	n77	0.5
DC_21_n78-n79	n78	0.5

DC_28-SUL_n78-n83	28	0.2
	n78	0.5
	n83	0.2
DC_28_n8-n258	28	0.1
	n8	0.2
DC_28-41_n77	28	0.2
	n77	0.5
DC_28-41_n78	28	0.2
	n78	0.5
	n79	0.5
DC_28-42_n77	28	0.2
	42	0.5
	n77	0.5
DC_28-42_n78	28	0.2
	42	0.5
	n78	0.5
DC_28-42_n79	28	0.2
	42	0.5
	66	0.4
	n5	0.5
DC_41-42_n77	42	0.5
	n77	0.5
DC_41-42_n78	42	0.5
	n78	0.5
DC_41-42_n79	42	0.5
DC_66-SUL_n78-n86	66	0.2
	n78	0.5
<p>NOTE 1: The requirement is applied for UE transmitting on the frequency range of 2545-2690MHz.</p> <p>NOTE 2: The requirement is applied for UE transmitting on the frequency range of 2496-2545MHz.</p> <p>NOTE 3: The requirement is applied for UE transmitting on the frequency range of 2515 – 2690 MHz.</p> <p>NOTE 4: The requirement is applied for UE transmitting on the frequency range of 2496 – 2515 MHz.</p> <p>NOTE 5: Only applicable for UE supporting inter-band carrier aggregation with uplink in one NR band and without simultaneous Rx/Tx.</p>		

7.3B.3.3.3 $\Delta R_{IB,c}$ for EN-DC in four bandsTable 7.3B.3.3.3-1: $\Delta R_{IB,c}$ due to EN-DC (four bands)

Inter-band EN-DC configuration	E-UTRA or NR Band	$\Delta R_{IB,c}$ (dB)
DC_1-3-5_n78	1	0.2
	3	0.2
	n78	0.5
DC_1-3-7_n28	n28	0.2
DC_1-3-7_n78 DC_1-3-7-7_n78 DC_1-3_n7-n78	1	0.3
	3	0.3
	7 or n7	0.3
	n78	0.5
DC_1-3-8_n77	1	0.2
	3	0.2
	8	0.2
	n77	0.5
DC_1-3-8_n78	1	0.2
	3	0.2
	8	0.2
	n78	0.5
DC_1-3-28_n5	28	0.2
	n5	0.2
DC_1-3-18_n77	1	0.2
	3	0.2
	n77	0.5
DC_1-3-18_n78	1	0.2
	3	0.2
	n78	0.5
DC_1-3-19_n78	1	0.2
	3	0.2
	n78	0.5
DC_1-3-20_n28	20	0.2
	n28	0.2
DC_1-3-20_n78	1	0.2
	3	0.2
	n78	0.5
DC_1-3-21_n77	1	0.2
	3	0.3
	21	0.5
	n77	0.5
DC_1-3-21_n78	1	0.2
	3	0.3
	21	0.5
	n78	0.5
DC_1-3-21_n79	3	0.3
	21	0.5
DC_1-3-28_n77	1	0.2
	3	0.2
	28	0.2
	n77	0.5
DC_1-3-28_n78 DC_1-3_n28-n78	1	0.2
	3	0.2
	28 or n28	0.2
	n78	0.5
DC_1-3-28_n79	1	0.2
	3	0.2
	28	0.2

DC_1-3-41_n77	1	0.2
	3	0.2
	n77	0.5
DC_1-3-41_n78	1	0.2
	3	0.2
	n78	0.5
DC_1-3-41_n79	41	$0^3/0.5^4$
DC_1-3-42_n77	1	0.2
	3	0.2
	42	0.5
	n77	0.5
DC_1-3-42_n78	1	0.2
	3	0.2
	42	0.5
	n78	0.5
DC_1-3-42_n79	1	0.2
	3	0.2
	42	0.5
DC_1-3_n77-n79	1	0.2
	3	0.2
	n77	0.5
DC_1-3_n78-n79	1	0.2
	3	0.2
	n78	0.5
DC_1-3_SUL_n78-n80	1	0.2
	3	0.2
	n78	0.5
DC_1-5-7_n78 DC_1-5-7-7_n78	1	0.2
	5	0.2
	7	0.2
	n78	0.5
DC_1-7-20_n28	20	0.2
	n28	0.2
DC_1-7-20_n78	1	0.2
	7	0.2
	20	0.2
	n78	0.5
DC_1-7-28_n5	28	0.2
	n5	0.2
DC_1-7-28_n78	1	0.2
	7	0.2
	28	0.2
	n78	0.5
DC_1-7_n28-n78	1	0.2
	7	0.2
	n28	0.2
	n78	0.5
DC_1-8-11_n77	1	0.2
	8	0.2
	n77	0.5
DC_1-8-11_n78	8	0.2
	n78	0.5
DC_1-8-20_n78A	8	0.2
	n78	0.5
DC_1-18-28_n77	n77	0.5
DC_1-18-28_n78	n78	0.5
DC_1-18-42_n77	42	0.5
	n77	0.5
DC_1-18-42_n78	42	0.5
	n78	0.5
DC_1-18-42_n79	42	0.5
DC_1-19-42_n77	1	0.2
	42	0.5
	n77	0.5
DC_1-19-42_n78	42	0.5

	n78	0.5
DC_1-19-42_n79	42	0.5
DC_1-19_n77-n79	1	0.3
	19	0.3
	n77	0.5
DC_1-19_n78-n79	1	0.3
	19	0.3
	n78	0.5
DC_1-20_n28-n78	20	0.2
	n28	0.2
	n78	0.5
DC_1-21-42_n77	1	0.2
	42	0.5
	n77	0.5
DC_1-21-42_n78	42	0.5
	n78	0.5
DC_1-21-42_n79	42	0.5
DC_1-21_n77-n79	n77	0.5
DC_1-21_n78-n79	n78	0.5
DC_1-28-42_n77	1	0.2
	28	0.2
	42	0.5
	n77	0.5
DC_1-28-42_n78	28	0.2
	42	0.5
	n78	0.5
DC_1-28-42_n79	28	0.2
	42	0.5
DC_1-41-42_n78	42	0.5
	n78	0.5
DC_1-41-42_n79	42	0.5
DC_1-41-42_n79	42	0.5
DC_1-42_n77-n79	1	0.2
	42	0.5
	n77	0.5
DC_1-42_n78-n79	1	0.2
	42	0.5
	n78	0.5
DC_2-7-13_n66	2	0.3
	7	0.5
	n66	0.5
DC_2-7-66_n66 DC_2-7-7-66_n66	2	0.3
	7	0.5
	66	0.5
	n66	0.5
DC_2-7-66_n78 DC_2-7-7-66_n78	2	0.6
	7	0.5
	66	0.6
	n78	0.8
DC_2-14-66_n2 DC_2-14-66-66_n2	2	0.3
	66	0.3
	n2	0.3
DC_2-14-66_n66 DC_2-2-14-66_n66	2	0.3
	66	0.3
	n66	0.3
DC_2-30-66_n5	2	0.4
	30	0.5
	66	0.4
DC_2-66-(n)71	2	0.3
	66	0.3
DC_3-5-7_n78 DC_3-5-7-7_n78	3	0.2
	5	0.2
	7	0.2
	n78	0.5
DC_3-5-41_n79	41	0 ¹ /0.5 ²

DC_3-7_n1-n78	3	0.3
	7	0.3
	n1	0.3
	n78	0.5
DC_3-7-7_n78	3	0.2
	7	0.2
	n78	0.5
DC_3-7-8_n78	3	0.2
	7	0.2
	8	0.2
	n78	0.5
DC_3-7-20_n28	20	0.2
	n28	0.1
DC_3-7-20_n78	3	0.2
	7	0.2
	n78	0.5
DC_3-7-28_n78 DC_3-7_n28-n78	3	0.2
	7	0.2
	28 or n28	0.2
	n78	0.5
DC_3-7_SUL_n78-n80	7	0.2
	3	0.2
	n78	0.5
DC_3-8-20_n78A	3	0.2
	8	0.2
	n78	0.5
DC_3-8_SUL_n78-n80	3	0.2
	8	0.2
	n78	0.5
DC_3-18-42_n77	42	0.5
	n77	0.5
DC_3-18-42_n78	42	0.5
	n78	0.5
DC_3-18-42_n79	3	0.2
	42	0.5
DC_3-19-21_n77	3	0.3
	21	0.5
	n77	0.5
DC_3-19-21_n78	3	0.3
	21	0.5
	n78	0.5
DC_3-19-21_n79	3	0.3
	21	0.5
DC_3-19-42_n77	3	0.2
	42	0.5
	n77	0.5
DC_3-19-42_n78	3	0.2
	42	0.5
	n78	0.5
DC_3-19-42_n79	3	0.2
	42	0.5
DC_3-19_n77-n79	3	0.2
	n77	0.5
DC_3-19_n78-n79	3	0.2
	n78	0.5
DC_3-20_n28-n78	3	0.2
	20	0.2
	n28	0.2
	n78	0.5
DC_3_20_SUL_n78-n80	3	0.2
	n78	0.5
DC_3-21-42_n77	3	0.3
	21	0.5
	42	0.5
	n77	0.5

DC_3-21-42_n78	3	0.3
	21	0.5
	42	0.5
	n78	0.5
DC_3-21-42_n79	3	0.3
	21	0.5
	42	0.5
DC_3-21_n77-n79	3	0.3
	21	0.5
	n77	0.5
DC_3-21_n78-n79	3	0.3
	21	0.5
	n78	0.5
DC_3-28-42_n77	3	0.2
	28	0.2
	42	0.5
	n77	0.5
DC_3-28-42_n78	3	0.2
	28	0.2
	42	0.5
	n78	0.5
DC_3-28-42_n79	3	0.2
	28	0.2
	42	0.5
DC_3-41-42_n77	3	0.5
	41	0 ¹ /0.5 ²
	42	0.5
	n77	0.5
DC_3-41-42_n78	3	0.5
	41	0 ¹ /0.5 ²
	42	0.5
	n78	0.5
DC_3-41-42_n79	3	0.5
	41	0 ¹ /0.5 ²
	42	0.5
DC_3-42_n77-n79	3	0.2
	42	0.5
	n77	0.5
DC_3-42_n78-n79	3	0.2
	42	0.5
	n78	0.5
DC_5-7-7_n78	5	0.2
	7	0.2
	n78	0.5
DC_7-20_n28-n78	20	0.2
	n28	0.2
	n78	0.5
DC_12-30-66_n260	12	0.5
	30	0.5
	66	0.4
DC_19-21-42_n77	42	0.5
	n77	0.5
DC_19-21-42_n78	42	0.5
	n78	0.5
DC_19-21-42_n79	42	0.5
DC_19-21_n77-n79	n77	0.5
DC_19-21_n78-n79	n78	0.5
DC_19-42_n77-n79	42	0.5
	n77	0.5
DC_19-42_n78-n79	42	0.5
	n78	0.5
DC_21-28-42_n77	28	0.2
	42	0.5
	n77	0.5
DC_21-28-42_n78	28	0.2

	42	0.5
	n78	0.5
DC_21-28-42_n79	28	0.2
	42	0.5
DC_21-42_n77-n79	42	0.5
	n77	0.5
DC_21-42_n78-n79	42	0.5
	n78	0.5
NOTE 1: The requirement is applied for UE transmitting on the frequency range of 2545 - 2690 MHz.		
NOTE 2: The requirement is applied for UE transmitting on the frequency range of 2496 - 2545 MHz.		
NOTE 3: The requirement is applied for UE transmitting on the frequency range of 2515 - 2690 MHz.		
NOTE 4: The requirement is applied for UE transmitting on the frequency range of 2496 - 2515 MHz.		

7.3B.3.3.4 $\Delta R_{IB,c}$ for EN-DC in five bands**Table 7.3B.3.3.4-1: $\Delta R_{IB,c}$ due to EN-DC (five bands)**

Inter-band EN-DC configuration	E-UTRA or NR Band	$\Delta R_{IB,c}$ (dB)
DC_1-3-5-7_n78, DC_1-3-5-7-7_n78	1	0.2
	3	0.2
	5	0.2
	7	0.2
	n78	0.5
DC_1-3-5-41_n79	41	0 ¹
		0.5 ²
DC_1-3-7-20_n28	20	0.2
	n28	0.2
DC_1-3-7-20_n78	1	0.2
	3	0.2
	7	0.2
	n78	0.5
DC_1-3-7-28_n78	1	0.2
	3	0.2
	7	0.2
	28	0.2
	n78	0.5
DC_1-3-7_n28-n78	1	0.2
	3	0.2
	7	0.2
	n28	0.2
	n78	0.5
DC_1-3-18-42_n77	1	0.2
	3	0.2
	42	0.5
	n77	0.5
DC_1-3-18-42_n78	1	0.2
	3	0.2
	42	0.5
	n78	0.5
DC_1-3-18-42_n79	1	0.2
	3	0.2
	42	0.5
DC_1-3-19-21-n77	1	0.2
	3	0.3
	21	0.5
	n77	0.5
DC_1-3-19-21_n78	1	0.2
	3	0.3
	21	0.5
	n78	0.5
DC_1-3-19-21_n79	3	0.3
	21	0.5
DC_1-3-19-42_n77	1	0.2
	3	0.2
	42	0.5
	n77	0.5
DC_1-3-19-42_n79	1	0.2
	3	0.2
	42	0.5
DC_1-3-20_n28-n78	1	0.2
	3	0.2
	20	0.2
	n28	0.2
	n78	0.5
DC_1-3-21-42_n77	1	0.2
	3	0.3
	21	0.5
	42	0.5
	n77	0.2
DC_1-3-21-42_n78	1	0.2
	3	0.3
	21	0.5

	42	0.5
	n78	0.2
DC_1-3-21-42_n79	1	0.2
	3	0.3
	21	0.5
	42	0.5
	n79	0.0
DC_1-3-21_n77-n79	1	0.2
	3	0.3
	21	0.5
	n77	0.5
DC_1-3-21_n78-n79	1	0.2
	3	0.3
	21	0.5
	n78	0.5
DC_1-3-28-42_n77	1	0.2
	3	0.2
	28	0.2
	42	0.5
	n77	0.5
DC_1-3-28-42_n78	1	0.2
	3	0.2
	28	0.2
	42	0.5
	n78	0.5
DC_1-3-28-42_n79	1	0.2
	3	0.2
	28	0.2
	42	0.5
DC_1-3-41-42_n77	1	0.2
	3	0.2
	42	0.5
	n77	0.5
DC_1-3-41-42_n78	1	0.2
	3	0.2
	42	0.5
	n78	0.5
DC_1-3-41-42_n79	1	0.2
	3	0.2
	42	0.5
DC_1-7-20_n28-n78	1	0.2
	7	0.2
	20	0.2
	n28	0.2
	n78	0.5
DC_1-19-21-42_n77	1	0.2
	42	0.5
	n77	0.5
DC_1-19-21-42_n78	42	0.5
	n78	0.5
DC_1-19-21-42_n79	42	0.5
DC_1-19-42_n77-n79	1	0.2
	42	0.5
	n77	0.5
DC_1-19-42_n78-n79	42	0.5
	n78	0.5
DC_1-21-28-42_n77	1	0.2
	28	0.2
	42	0.5
DC_1-21-28-42_n78	n77	0.5
	28	0.2
	42	0.5
DC_1-21-28-42_n79	n78	0.5
	28	0.2
	42	0.5

DC_1-21-42_n77-n79	1	0.2
	21	0.2
	42	0.5
	n77	0.5
DC_1-21-42_n78-n79	21	0.2
	42	0.5
	n78	0.5
DC_3-7-20_n28-n78	3	0.2
	7	0.2
	20	0.2
	n28	0.2
DC_3-19-21-42_n77	3	0.3
	21	0.5
	42	0.5
	n77	0.5
DC_3-19-21-42_n78	3	0.3
	21	0.5
	42	0.5
DC_3-19-21-42_n79	3	0.3
	21	0.5
	42	0.5
DC_19-21-42_n77-n79	42	0.5
	n77	0.5
DC_19-21-42_n78-n79	42	0.5
	n78	0.5

NOTE 1: The requirement is applied for UE transmitting on the frequency range of 2545 – 2690 MHz.
NOTE 2: The requirement is applied for UE transmitting on the frequency range of 2496 – 2545 MHz.

7.3B.3.3.5 $\Delta R_{IB,c}$ for EN-DC six bands

Table 7.3B.3.3.5-1: $\Delta R_{IB,c}$ due to EN-DC (six bands)

Inter-band EN-DC configuration	E-UTRA or NR Band	$\Delta R_{IB,c}$ (dB)
DC_1-3-7-20_n28-n78	1	0.2
	3	0.2
	7	0.2
	20	0.2
	n28	0.2
	n78	0.5

7.3B.3.4 Reference sensitivity for $\Delta R_{IB,c}$ Inter-band EN-DC including FR2

The $\Delta R_{IB,c}$ for NR FR2 band of inter-band CA defined in tables 5.5B.5.1-1 to 5.5B.5.5-1 is set to zero.

7.3B.4 EIS Spherical Coverage for Inter-band EN-DC including FR2

7.3B.4.1 Test purpose

Same test purpose as in clause 7.3.4.1 in TS 38.521-2 [9] for the NR carrier.

7.3B.4.2 Test applicability

This test case applies to all types of E-UTRA UE release 15 and forward, supporting inter-band EN-DC including FR2 with 2 DL CCs.

7.3B.4.3 Minimum conformance requirements

Same minimum conformance requirements as in clause 7.3.4.3 in TS 38.521-2 [9] for the NR carrier.

No exception requirements applicable to NR or LTE. LTE anchor agnostic approach is applied.

The normative reference for this requirement is TS 38.101-2 [9] clause 7.3.4.

7.3B.4.4 Test description

7.3B.4.4.1 Initial conditions

Same test description as in clause 7.3.4.4 in TS 38.521-2 [9] for the NR carrier with the following exception:

The initial test configurations for E-UTRA band consist of environmental conditions, test frequencies, and channel bandwidths based on E-UTRA bands specified in Table 4.6-1. For Initial conditions as in clause 7.3.4.4.1 in TS 38.521-2 [9], the following steps will be added to configure E-UTRA component:

- 2.1. The parameter settings for E-UTRA cell are set up according to TS 36.508 [11] clause 4.4.3.
- 3.1. The E-UTRA downlink signal level, uplink signal level are set according to Table 4.7-1 and propagation conditions are set according to Annex B.0 of TS 36.521-1 [10].

Step 6 of Initial conditions as in clause 7.3.4.4.1 in TS 38.521-2 [9] is replaced by:

6. Ensure the UE is in state RRC_CONNECTED with generic procedure parameters Connectivity EN-DC, DC bearer MCG and SCG, Connected without release On according to TS 38.508-1 [6] clause 4.5.

Same test procedure as in clause 7.3.4.4.2 in TS 38.521-2 [9] with the following steps added for E-UTRA component:

- 1.1 On the E-UTRA carrier, disable periodic and aperiodic CQI reports, disable SRS, set *TimeAlignmentTimerDedicated* IE to infinity and disable downlink and uplink scheduling, all as per Table 4.7-1 under clause 4.7.

7.3B.4.5 Test requirement

Same test requirement as in clause 7.3.4.5 in TS 38.521-2 [9] for the NR carrier.

7.4 Void

7.4A Maximum Input Level for CA

7.4A.1 Test purpose

Same test purpose as in clause 7.4 in TS 38.521-1 [8] for NR FR1 carrier(s) and clause 7.4 in TS 38.521-2 [9] for NR FR2 carrier(s).

7.4A.2 Test applicability

The requirements in this test are not testable due to issues with combined testing of NR FR1 conducted mode with NR FR2 in radiated mode. Therefore, the conducted and radiated requirements are tested separately.

No test case details are specified. The SA requirements for maximum input level apply and are tested in TS 38.521-1 [8] clause 7.4 and 7.4A and TS 38.521-2 [9] clauses 7.4 and 7.4A.

7.4B Maximum Input Level for DC

7.4B.0 Minimum conformance requirement

7.4B.0.1 Intra-band contiguous EN-DC in FR1

Intra-band contiguous EN-DC maximum input level requirement and parameters are defined in Table 7.4B.0.1-1.

Table 7.4B.0.1-1: Maximum Input

Power in Largest CC, E-UTRA or NR, dBm	X^1
Power in each other CC, dBm	$X^1 - 10 \cdot \log_{10}(N_x \cdot SCS_x / N_y \cdot SCS_y)$
NOTE 1: Power in Largest E-UTRA or NR bandwidth CC, listed in Table 7.4-1 [2]	
NOTE 2: N_x, SCS_x is the number of RB's and Sub carrier spacing in the largest carrier bandwidth and could be LTE or NR carrier	
NOTE 3: N_y, SCS_y is the number of RB's in any other carrier.	
NOTE 4: For NR carrier, the transmitter shall be set to 4dB below P_{CMAX_L} at the minimum uplink configuration specified in Table 7.3.2-3 [2] with P_{CMAX_L} as defined in clause 6.2B.4.	
NOTE 5: For E-UTRA carrier, the transmitter shall be set to 4dB below P_{CMAX_L} at the minimum uplink configuration specified in Table 7.3.1-2 [5] with P_{CMAX_L} as defined in clause 6.2B.4.	

7.4B.0.2 Intra-band non-contiguous EN-DC in FR1

For the E-UTRA sub-block containing one or multiple CC's, the requirement is defined in clause 7.4.1 for single carrier operation and in clause 7.4.1A for CA in TS 36.101 [5].

For the NR sub-block, the requirement is defined in clause 7.4 in TS 38.101-1 [2].

7.4B.0.3 Inter-band EN-DC within FR1

Maximum input level requirement for E-UTRA single carrier and CA operation specified in clauses 7.4.1 and 7.4.1A of TS 36.101 [5] and for NR single carrier and CA operation specified in clauses 7.4 and 7.4A of TS 38.101-1 [2] apply.

7.4B.0.4 Inter-band EN-DC including FR2

Maximum input level requirement for E-UTRA single carrier and CA operation specified in clauses 7.4.1 and 7.4.1A of TS 36.101 [5] and for NR single carrier and CA operation specified in clauses 7.4 and 7.4A of TS 38.101-2 [3] apply.

7.4B.0.5 Inter-band EN-DC including both FR1 and FR2

Maximum input level requirement for E-UTRA single carrier and CA operation specified in clauses 7.4.1 and 7.4.1A of TS 36.101 [5] and for NR single carrier and CA operation specified in clauses 7.4 and 7.4A of TS 38.101-1 [2] and TS 38.101-2 [3] apply.

The normative reference for this requirement is TS 38.101-3 [4] clause 7.4B.

7.4B.1 Maximum Input Level for Intra-Band Contiguous EN-DC (2 CCs)

7.4B.1.1 Test purpose

Maximum input level for intra-band contiguous EN-DC tests the UE's ability to receive data with a given average throughput for a specified reference measurement channel, under conditions of high signal level, ideal propagation and no added noise.

A UE unable to meet the throughput requirement under these conditions will decrease the coverage area near to an e-NodeB or a gNB.

7.4B.1.2 Test applicability

This test applies to all types of E-UTRA UE release 15 and forward, supporting intra-band contiguous EN-DC operating in FR1.

7.4B.1.3 Minimum conformance requirements

Refer to Clause 7.4B.0.1 for the intra-band contiguous EN-DC maximum input level requirement.

Exception requirements are defined for this test, therefore LTE agnostic approach is not applied, E-UTRA test point analysis is included and E-UTRA measurements are performed.

The normative reference for this requirement is TS 38.101-3 [4] Clause 7.4B.1.

7.4B.1.4 Test Description

7.4B.1.4.1 Initial Condition

Initial conditions are a set of test configurations the UE needs to be tested in and the steps for the SS to take with the UE to reach the correct measurement state.

The initial test configurations consist of environmental conditions, test frequencies and channel bandwidths based on EN-DC operating bands specified in clause 5.2B.2, channel bandwidths and sub-carrier spacings for the NR cell specified in TS 38.521-1 [8] clause 5.3 and channel bandwidth for the E-UTRA cell are specified in TS 36.521-1 [10] clause 5.4.2. All of these configurations shall be tested with applicable test parameters for each intra-band contiguous EN-DC configuration specified in clause 5.3B.1.2, and are shown in table 7.4B.3.4.1-1. The details of the uplink reference measurement channels (RMCs) are specified in Annex A.2 for E-UTRA RMC for TDD, TS 36.521-1 [10] Annex A.2 for E-UTRA RMC for FDD, and TS 38.521-1 [8] Annex A.2 for NR RMC Configurations of PDSCH and PDCCH before measurement are specified in TS 36.521-1 [10] Annex C.2 and in TS 38.521-1 [8] Annex C.2 for E-UTRA CG and NR CG respectively.

Table 7.4B.1.4.1-1: Test configuration table

Initial Conditions								
Test Environment as specified in TS 38.508-1 [6] clause 4.1					Normal			
Test Frequencies as specified in TS 38.508-1 [6] clause 4.3.1					Mid range			
Test EN-DC bandwidth combination as specified in Table 5.3B.1.2-1 across bandwidth combination sets supported by the UE					Lowest N_{RB_agg} , Highest N_{RB_agg} (NOTE 5)			
Test SCS for the NR cell as specified in TS 38.521-1 [8] Table 5.3.5-1					Lowest			
Test Parameters for Intra-band Contiguous EN-DC Configuration								
Downlink Configuration					Uplink Configuration			
Test ID	NR Modulation	NR RB allocation	E-UTRA Modulation	E-UTRA RB allocation	NR Modulation	NR RB allocation	E-UTRA Modulation	E-UTRA RB allocation
1	CP-OFDM 64QAM	Full RB (NOTE 1)	CP-OFDM 64QAM	Full RB	DFT-s-OFDM QPSK	NOTE 2	QPSK	NOTE 3
2	CP-OFDM 256QAM	Full RB (NOTE 1)	CP-OFDM 256QAM	Full RB	DFT-s-OFDM QPSK	NOTE 2	QPSK	NOTE 3
NOTE 1: Full RB allocation shall be used per each SCS and channel BW as specified in Table 7.3.2.4.1-2 of TS 38.521-1 [8].								
NOTE 2: Same RB allocation shall be used per each SCS and channel BW as specified in Table 7.3.2.4.1-2 of TS 38.521-1 [8].								
NOTE 3: Same RB allocation shall be used per the E-UTRA band and channel BW as specified in Table 7.3.3-2 of TS 36.521 [10].								
NOTE 4: In an E-UTRA band or FR1 band where UE supports 4Rx, the test shall be performed only with 4Rx antennas ports connected.								
NOTE5: If the UE supports multiple CC combinations in the EN-DC configuration with the same N_{RB_agg} , select the combination to test as follows: - Lowest ENBW: NR component with lowest NRB is tested. - Highest ENBW: NR component with highest NRB is tested.								

1. Connect the SS to the UE antenna connectors as shown in [6] TS 38.508-1 A.3.1.1 for SS diagram and A.3.2 for UE diagram.
2. The parameter settings for the E-UTRA cell are set up according to TS 36.508 [11] clause 4.4.3, and the parameter settings for the NR cell are set up according to TS 38.508-1 [6] clause 4.4.3.

3. Downlink signals are initially set up according to TS 36.521-1 [10] Annex C.0, C.1,C.2,C3.1 and TS 38.521-1 [8] Annex C.0,C.1,C.2,C3.1 for E-UTRA CG and NR CG respectively, and uplink signals according to TS 36.521-1 [10] Annex H.0,H.1,H.2,H.3.1 and TS 38.521-1 [8] Annex G.0,G.1,G.2,G.3.1 for E-UTRA CG and NR CG respectively.
4. The UL Reference Measurement channels are TS 36.521-1 [10] Annex A.2 and TS 38.521-1 [8] Annex A.2 for E-UTRA CG and NR CG respectively.
5. Propagation conditions are set according to TS 36.521-1 [10] Annex B.0 and TS 38.521-1 [8] Annex B.0 for E-UTRA CG and NR CG respectively.
6. Ensure the UE is in state RRC_CONNECTED with generic procedure parameters Connectivity EN-DC, DC bearer *MCG* and *SCG*, Connected without release *On* according to TS 38.508-1 [6] clause 4.5. Message contents are defined in clause 7.4B.1.4.3.

7.4B.1.4.2 Test Procedure

1. SS transmits PDSCH via PDCCH DCI format 1A and PDCCH DCI format 1_1 for C_RNTI to transmit the DL RMC according to Tables 7.4B.1.4.1 on the E-UTRA CC and NR CC, The SS sends downlink MAC padding bits on the DL RMC.
2. SS sends uplink scheduling information for each UL HARQ process via PDCCH DCI format 0 and PDCCH DCI format 0_1 for C_RNTI to schedule the UL RMC according to Table 7.4B.1.4.1-1 on the E-UTRA CC and NR CC. Since the UL has no payload and no loopback data to send the UE sends uplink MAC padding bits on the UL RMC.
3. SS sets the Downlink signal level for the E-UTRA CC and NR CC to the value defined in Table 7.4B.1.5-1. For NR CC and E-UTRA CC, send uplink power control commands to the UE using 1dB power step size to ensure that the UE output power measured by the test system is within the Uplink power control window, defined as -MU to -(MU + Uplink power control window size) dB of the target power level in Table 7.4B.1.5-1 for at least the duration of the Throughput measurement, where:
 - MU is the test system uplink power measurement uncertainty and is specified in Table F.1.3-1 for the carrier frequency f and the channel bandwidth BW
 - For NR CC, Uplink power control window size = 1dB (UE power step size) + 0.7dB (UE power step tolerance) + (Test system relative power measurement uncertainty), where, the UE power step tolerance is specified in TS 38.101-1 [2], Table 6.3.4.3-1 and is 0.7dB for 1dB power step size, and the Test system relative power measurement uncertainty is specified in Table F.1.2-1.
 - For E-UTRA CC, Uplink power control window size = 1dB (UE power step size) + 1.0dB (UE power step tolerance) + (Test system relative power measurement uncertainty), where, the UE power step tolerance is specified in TS 36.101 [5], Table 6.3.5.2.1-1 and is 1.0dB for 1dB power step size, and the Test system relative power measurement uncertainty is specified in Table F.1.2-1 of TS 36.521-1 [10].
4. Measure the average throughput for each component carrier for duration sufficient to achieve statistical significance according to Annex H in TS 38.521-1 [8].

NOTE: The purpose of the Uplink power control window is to ensure that the actual UE output power is no greater than the target power level, and as close as possible to the target power level. The relationship between the Uplink power control window, the target power level and the corresponding possible actual UE Uplink power window is illustrated in Annex F, clause F.4.

Table 7.4B.1.4.2-1: Void

7.4B.1.4.3 Message Contents

Message contents are according to TS 36.508-1 [11] clause 4.6.1 and TS 38.508-1 [6] clause 4.6.1.

7.4B.1.5 Test Requirement

For the NR CC, the throughput measurement of the carrier derived in test procedure shall be $\geq 95\%$ of the maximum throughput of the reference measurement channels with parameters specified in Table 7.4B.1.5-1

Table 7.4B.1.5-1: Maximum input level requirement for each CC

Channel bandwidth of Largest BW CC	Rx Parameter			
	Power in the Largest CC	Power in the other CC	Power in the Largest CC	Power in the other CC
5 MHz	-25^2 -TT	$-25^2 - 10 \cdot \log_{10}(N_x SCS_x / N_y SCS_y)$ -TT	-27^3 -TT	$-27^3 - 10 \cdot \log_{10}(N_x SCS_x / N_y SCS_y)$ -TT
10 MHz	-25^2 -TT	$-25^2 - 10 \cdot \log_{10}(N_x SCS_x / N_y SCS_y)$ -TT	-27^3 -TT	$-27^3 - 10 \cdot \log_{10}(N_x SCS_x / N_y SCS_y)$ -TT
15 MHz	-25^2 -TT	$-25^2 - 10 \cdot \log_{10}(N_x SCS_x / N_y SCS_y)$ -TT	-27^3 -TT	$-27^3 - 10 \cdot \log_{10}(N_x SCS_x / N_y SCS_y)$ -TT
20 MHz	-25^2 -TT	$-25^2 - 10 \cdot \log_{10}(N_x SCS_x / N_y SCS_y)$ -TT	-27^3 -TT	$-27^3 - 10 \cdot \log_{10}(N_x SCS_x / N_y SCS_y)$ -TT
25 MHz	-24^2 -TT	$-24^2 - 10 \cdot \log_{10}(N_x SCS_x / N_y SCS_y)$ -TT	-26^3 -TT	$-26^3 - 10 \cdot \log_{10}(N_x SCS_x / N_y SCS_y)$ -TT
30 MHz	-23^2 -TT	$-23^2 - 10 \cdot \log_{10}(N_x SCS_x / N_y SCS_y)$ -TT	-25^3 -TT	$-25^3 - 10 \cdot \log_{10}(N_x SCS_x / N_y SCS_y)$ -TT
40 MHz	-22^2 -TT	$-22^2 - 10 \cdot \log_{10}(N_x SCS_x / N_y SCS_y)$ -TT	-24^3 -TT	$-24^3 - 10 \cdot \log_{10}(N_x SCS_x / N_y SCS_y)$ -TT
50 MHz	-21^2 -TT	$-21^2 - 10 \cdot \log_{10}(N_x SCS_x / N_y SCS_y)$ -TT	-23^3 -TT	$-23^3 - 10 \cdot \log_{10}(N_x SCS_x / N_y SCS_y)$ -TT
60 MHz	-20^2 -TT	$-20^2 - 10 \cdot \log_{10}(N_x SCS_x / N_y SCS_y)$ -TT	-22^3 -TT	$-22^3 - 10 \cdot \log_{10}(N_x SCS_x / N_y SCS_y)$ -TT
80 MHz	-20^2 -TT	$-20^2 - 10 \cdot \log_{10}(N_x SCS_x / N_y SCS_y)$ -TT	-22^3 -TT	$-22^3 - 10 \cdot \log_{10}(N_x SCS_x / N_y SCS_y)$ -TT
90 MHz	-20^2 -TT	$-20^2 - 10 \cdot \log_{10}(N_x SCS_x / N_y SCS_y)$ -TT	-22^3 -TT	$-22^3 - 10 \cdot \log_{10}(N_x SCS_x / N_y SCS_y)$ -TT
100 MHz	-20^2 -TT	$-20^2 - 10 \cdot \log_{10}(N_x SCS_x / N_y SCS_y)$ -TT	-22^3 -TT	$-22^3 - 10 \cdot \log_{10}(N_x SCS_x / N_y SCS_y)$ -TT

NOTE 1: N_x, SCS_x is the number of RB's and Sub carrier spacing in the largest carrier bandwidth and could be LTE or NR carrier.
 NOTE 2: Reference measurement channel refers to Clauses A.3.2.3 or A.3.3.3 in TS 38.521-1 [8] for 64-QAM NR Carrier, and to Tables A.3.2-3, A.3.2-4 for 64QAM in TS 36.521-1 [10] for E-UTRA Carrier.
 NOTE 3: Reference measurement channel refers to Clauses A.3.2.4 or A.3.3.4 in TS 38.521-1 [8] for 256QAM NR Carrier, and Tables A.3.2-5, A.3.2-6 in TS 36.521-1 [10] for 256QAM E-UTRA Carrier.
 NOTE 4: N_y, SCS_y is the number of RB's in any other carrier
 NOTE 5: For NR carrier, the transmitter shall be set to 4dB below PC_{MAX_L} at the minimum uplink configuration specified in Table 7.3.2-3 in TS 38.101-1 [2] with PC_{MAX_L} as defined in clause 6.2B.4.
 NOTE 6: For E-UTRA carrier, the transmitter shall be set to 4dB below $P_{C_{MAX_L}}$ at the minimum uplink configuration specified in Table 7.3.1-2 in TS 38.101-3 [4] with $P_{C_{MAX_L}}$ as defined in clause 6.2B.4 for single carrier.
 NOTE 7: TT for each frequency is specified in Table 7.4B.1.5-2

Table 7.4B.1.5-2: Test Tolerance (Maximum input level)

$f \leq 3.0\text{GHz}$	$3.0\text{GHz} < f \leq 6.0\text{GHz}$
0.7 dB	1.0 dB

7.4B.2 Maximum Input Level for Intra-Band Non-Contiguous EN-DC (2 CCs)

7.4B.2.1 Test purpose

Maximum input level for intra-band non-contiguous EN-DC tests the UE's ability to receive data with a given average throughput for a specified reference measurement channel, under conditions of high signal level, ideal propagation and no added noise.

A UE unable to meet the throughput requirement under these conditions will decrease the coverage area near to an e-NodeB or a gNB.

7.4B.2.2 Test applicability

This test applies to all types of E-UTRA UE release 15 and forward, supporting intra-band non-contiguous EN-DC.

7.4B.2.3 Minimum conformance requirements

Refer to Clause 7.4B.0.2 for the intra-band non-contiguous EN-DC maximum input level requirement.

The normative reference for this requirement is TS 38.101-3 [4] clause 7.4B.2, and TS 38.101-1 [2] clause 7.4, and TS 38.101-2 [3] clauses 7.4 and 7.4A

No exception requirements for E-UTRA CG and NR CG, LTE agnostic approach applies.

7.4B.2.4 Test Description

Same test description as in clause 7.4.4 in TS 38.521-1 [8] for the NR carrier with the following exceptions in the initial test configuration.

- The initial test configurations consist of environmental conditions, test frequencies and channel bandwidths based on EN-DC operating bands specified in clause 5.2B.3, all of these configurations shall be tested with applicable test parameters for each intra-band non-contiguous EN-DC configuration specified in clause 5.3B.1.3, and are shown in table 7.4B.2.4.1-1.

Table 7.4B.2.4.1-1: Test configuration table

Initial Conditions								
Test Environment as specified in TS 38.508-1 [6] clause 4.1					Normal			
Test Frequencies as specified in TS 38.508-1 [6] clause 4.3.1					MaxWGap for intra-band non-contiguous EN-DC			
Test EN-DC bandwidth combination as specified in Table 5.3B.1.3-1 across bandwidth combination sets supported by the UE					Lowest, Mid, Highest of Channel BW for NR CC			
Test SCS for the NR cell as specified in TS 38.521-1 [8] Table 5.3.5-1					Lowest			
Test Parameters for EN-DC Configuration								
Downlink Configuration					Uplink Configuration			
Test ID	NR Modulation	NR RB allocation	E-UTRA Modulation	E-UTRA RB allocation	NR Modulation	NR RB allocation	E-UTRA Modulation	E-UTRA RB allocation
1	CP-OFDM 64QAM	NOTE 1	NOTE 2	NOTE 2	DFT-s-OFDM QPSK	NOTE 1	NOTE 2	NOTE 2
2	CP-OFDM 256QAM	NOTE 1	NOTE 2	NOTE 2	DFT-s-OFDM QPSK	NOTE 1	NOTE 2	NOTE 2
NOTE 1: Same RB allocation shall be used per modulation as specified in Table 7.4.4.1-1 of TS 38.521-1 [8].								
NOTE 2: Modulation and RB allocation for E-UTRA CC refers to the Table 4.6-2.								
NOTE 3: In a FR1 band where UE supports 4Rx, the test shall be performed only with 4Rx antennas ports connected.								

The initial test configurations for E-UTRA band consist of environmental conditions, test frequencies, and channel bandwidths based on E-UTRA bands specified in Table 4.6-1 with the exception that

- E-UTRA test frequency are specified in Table 7.4B.2.4.1-1 based on intra-band non-contiguous EN-DC configuration specified in clause 5.3B.1.3.

For Initial conditions as in clause 7.4.4.1 in TS 38.521-1 [8] with the following steps will be added to configure E-UTRA component:

- 2.1. The parameter settings for E-UTRA cell are set up according to TS 36.508 [11] clause 4.4.3.
- 3.1. The E-UTRA downlink signal level, uplink signal level are set according to Table 4.6-1 and propagation conditions are set according to Annex B.0 of TS 36.521-1 [10].

Step 6 of Initial conditions as in clause 6.4.1.4.1 in TS 38.521-1 [8] is replaced by:

6. Ensure the UE is in state RRC_CONNECTED with generic procedure parameters Connectivity EN-DC, DC bearer MCG and SCG according to TS 38.508 [6] clause 4.5.
7. On the E-UTRA carrier, disable periodic and aperiodic CQI reports, disable SRS, set *TimeAlignmentTimerDedicated* IE to infinity and disable downlink and uplink scheduling, all as per Table 4.6-1 under clause 4.6.

7.4B.2.5 Test Requirement

Same test requirement as in clause 7.4.5 in TS 38.521-1 [8] for NR carrier.

7.4B.3 Maximum Input Level for Inter-band EN-DC within FR1

7.4B.3.1 Test purpose

Same test purpose as in clause 7.4.1 in TS 38.521-1 [8] for the NR carrier.

7.4B.3.2 Test applicability

This test applies to all types of E-UTRA UE release 15 and forward, supporting inter-band EN-DC.

7.4B.3.3 Minimum conformance requirements

Same minimum conformance requirements as in clause 7.4.3 in TS 38.521-1 [8] for the NR carrier.

The normative reference for this requirement is TS 38.101-3 [4] clause 7.4B.3.

No exception requirements applicable to NR or LTE. LTE anchor agnostic approach is applied.

7.4B.3.4 Test Description

Same test description as in clause 7.4.4 in TS 38.521-1 [8] for the NR carrier with the following exceptions:

The initial test configurations for E-UTRA consist of test frequency based on E-UTRA operating band and test channel bandwidth as specified in Table 4.6-1.

For Initial conditions as in clause 7.4.4.1 in TS 38.521-1 [8], the following steps will be added to configure E-UTRA component:

- 2.1. The parameter settings for the cell are set up according to TS 36.508 [11] clause 4.4.3.
- 3.1. The E-UTRA downlink signal level, uplink signal level are set according to Table 4.6-1 and propagation conditions are set according to Annex B, clause B.0 of TS 36.521-1 [10].

Step 6 of Initial conditions as in clause 7.4.4.1 in TS 38.521-1 [8] is replaced by:

6. Ensure the UE is in state RRC_CONNECTED with generic procedure parameters Connectivity EN-DC, DC bearer MCG and SCG, Connected without release On according to TS 38.508 [6] clause 4.5.
7. On the E-UTRA carrier, disable periodic and aperiodic CQI reports, disable SRS, set *TimeAlignmentTimerDedicated* IE to infinity and disable downlink and uplink scheduling, all as per Table 4.6-1 under clause 4.6.

7.4B.3.5 Test Requirement

Same test requirement as in clause 7.4.5 in TS 38.521-1 [8] for the NR carrier.

7.4B.3_1 Maximum Input Level for EN-DC within FR1 (>2 CCs)

Editor's note: The test cases in this clause are incomplete, the following aspects are either missing or not yet determined:

- Only inter-band EN-DC within FR1 is considered. Testing of intra-band contiguous/non-contiguous EN-DC are FFS.
- The referred test cases 7.4A.2, 7.4A.3 and 7.4A.4 in TS 38.521-1 [8] are incomplete.
- Test applicability, test configuration and test procedure details need further discussion and refinement to accurately to test the applicable set of EN-DC combinations in this test.

7.4B.3_1.1 Maximum Input Level for EN-DC within FR1 (3 CCs)

7.4B.3_1.1.1 Test purpose

Same test purpose as in clause 7.4B.3.1.

7.4B.3_1.1.2 Test applicability

This test applies to all types of E-UTRA UE release 15 and forward, supporting EN-DC within FR1 with 3CCs.

7.4B.3_1.1.3 Minimum conformance requirements

Refer to Clause 7.4B.0.3 for the inter-band EN-DC within FR1 maximum input level requirement.

No exception requirements applicable to NR or LTE. LTE anchor agnostic approach is applied.

7.4B.3_1.1.4 Test Description

Same test description as in clause 7.4.4 or 7.4A.1.4 in TS 38.521-1 [8] for the NR carrier with the following exceptions:

The initial test configurations for E-UTRA consist of test frequency based on E-UTRA operating band and test channel bandwidth as specified in Table 4.6-1.

For Initial conditions as in clause 7.4.4.1 or 7.4A.1.4.1 in TS 38.521-1 [8], the following steps will be added to configure E-UTRA component:

- 2.1. The parameter settings for the cell are set up according to TS 36.508 [11] subclause 4.4.3.
- 3.1. The E-UTRA downlink signal level, uplink signal level are set according to Table 4.6-1 and propagation conditions are set according to Annex B.0 of TS 36.521-1 [10].

Step 6 of Initial conditions as in clause 7.4.4.1 or 7.4A.1.4.1 in TS 38.521-1 [8] is replaced by:

6. Ensure the UE is in state RRC_CONNECTED with generic procedure parameters Connectivity EN-DC, DC bearer MCG and SCG, Connected without release *On* according to TS 38.508 [6] clause 4.5.
7. On the E-UTRA carrier, disable periodic and aperiodic CQI reports, disable SRS, set TimeAlignmentTimerDedicated IE to infinity and disable downlink and uplink scheduling, all as per Table 4.6-1 under clause 4.6.

7.4B.3_1.1.5 Test Requirement

Same test requirement as specified in TS 38.521-1 [8] clause 7.4.5 or 7.4A.1.5 for the NR carrier(s).

7.4B.3_1.2 Maximum Input Level for EN-DC within FR1 (4 CCs)

7.4B.3_1.2.1 Test purpose

Same test purpose as in clause 7.4B.3.1.

7.4B.3_1.2.2 Test applicability

This test applies to all types of E-UTRA UE release 15 and forward, supporting EN-DC within FR1 with 4CCs.

7.4B.3_1.2.3 Minimum conformance requirements

Refer to Clause 7.4B.0.3 for the inter-band EN-DC within FR1 maximum input level requirement.

No exception requirements applicable to NR or LTE. LTE anchor agnostic approach is applied.

7.4B.3_1.2.4 Test Description

Same test description as in clause 7.4.4, 7.4A.1.4 or 7.4A.2.4 in TS 38.521-1 [8] for the NR carrier with the following exceptions:

The initial test configurations for E-UTRA consist of test frequency based on E-UTRA operating band and test channel bandwidth as specified in Table 4.6-1.

For Initial conditions as in clause 7.4.4.1, 7.4A.1.4.1 or 7.4A.2.4.1 in TS 38.521-1 [8], the following steps will be added to configure E-UTRA component:

2.1. The parameter settings for the cell are set up according to TS 36.508 [11] subclause 4.4.3.

3.1. The E-UTRA downlink signal level, uplink signal level are set according to Table 4.6-1 and propagation conditions are set according to Annex B.0 of TS 36.521-1 [10].

Step 6 of Initial conditions as in clause 7.4.4.1, 7.4A.1.4.1 or 7.4A.2.4.1 in TS 38.521-1 [8] is replaced by:

6. Ensure the UE is in state RRC_CONNECTED with generic procedure parameters Connectivity EN-DC, DC bearer MCG and SCG, Connected without release *On* according to TS 38.508 [6] clause 4.5.

7. On the E-UTRA carrier, disable periodic and aperiodic CQI reports, disable SRS, set TimeAlignmentTimerDedicated IE to infinity and disable downlink and uplink scheduling, all as per Table 4.6-1 under clause 4.6.

7.4B.3_1.2.5 Test Requirement

Same test requirement as specified in TS 38.521-1 [8] clause 7.4.5, 7.4A.1.5 or 7.4A.2.5 for the NR carrier(s).

7.4B.3_1.3 Maximum Input Level for EN-DC within FR1 (5 CCs)

7.4B.3_1.3.1 Test purpose

Same test purpose as in clause 7.4B.3.1.

7.4B.3_1.3.2 Test applicability

This test applies to all types of E-UTRA UE release 15 and forward, supporting EN-DC within FR1 with 5CCs.

7.4B.3_1.3.3 Minimum conformance requirements

Refer to Clause 7.4B.0.3 for the inter-band EN-DC within FR1 maximum input level requirement.

No exception requirements applicable to NR or LTE. LTE anchor agnostic approach is applied.

7.4B.3_1.3.4 Test Description

Same test description as in clause 7.4.4, 7.4A.1.4, 7.4A.2.4 or 7.4A.3.4 in TS 38.521-1 [8] for the NR carrier with the following exceptions:

The initial test configurations for E-UTRA consist of test frequency based on E-UTRA operating band and test channel bandwidth as specified in Table 4.6-1.

For Initial conditions as in clause 7.4.4.1, 7.4A.1.4.1, 7.4A.2.4.1 or 7.4A.3.4.1 in TS 38.521-1 [8], the following steps will be added to configure E-UTRA component:

2.1. The parameter settings for the cell are set up according to TS 36.508 [11] subclause 4.4.3.

3.1. The E-UTRA downlink signal level, uplink signal level are set according to Table 4.6-1 and propagation conditions are set according to Annex B.0 of TS 36.521-1 [10].

Step 6 of Initial conditions as in clause 7.4.4.1, 7.4A.1.4.1, 7.4A.2.4.1 or 7.4A.3.4.1 in TS 38.521-1 [8] is replaced by:

6. Ensure the UE is in state RRC_CONNECTED with generic procedure parameters Connectivity EN-DC, DC bearer MCG and SCG, Connected without release *On* according to TS 38.508 [6] clause 4.5.

7. On the E-UTRA carrier, disable periodic and aperiodic CQI reports, disable SRS, set TimeAlignmentTimerDedicated IE to infinity and disable downlink and uplink scheduling, all as per Table 4.6-1 under clause 4.6.

7.4B.3_1.3.5 Test Requirement

Same test requirement as specified in TS 38.521-1 [8] clause 7.4.5, 7.4A.1.5, 7.4A.2.5 or 7.4A.3.5 for the NR carrier(s).

7.4B.3_1.4 Maximum Input Level for EN-DC within FR1 (6 CCs)

7.4B.3_1.4.1 Test purpose

Same test purpose as in clause 7.4B.3.1.

7.4B.3_1.4.2 Test applicability

This test applies to all types of E-UTRA UE release 15 and forward, supporting EN-DC within FR1 with 6CCs.

7.4B.3_1.4.3 Minimum conformance requirements

Refer to Clause 7.4B.0.3 for the inter-band EN-DC within FR1 maximum input level requirement.

No exception requirements applicable to NR or LTE. LTE anchor agnostic approach is applied.

7.4B.3_1.4.4 Test Description

Same test description as in clause 7.4.4, 7.4A.1.4, 7.4A.2.4, 7.4A.3.4 or 7.4A.4.4 in TS 38.521-1 [8] for the NR carrier with the following exceptions:

The initial test configurations for E-UTRA consist of test frequency based on E-UTRA operating band and test channel bandwidth as specified in Table 4.6-1.

For Initial conditions as in clause 7.4.4.1, 7.4A.1.4.1, 7.4A.2.4.1, 7.4A.3.4.1 or 7.4A.4.4.1 in TS 38.521-1 [8], the following steps will be added to configure E-UTRA component:

2.1. The parameter settings for the cell are set up according to TS 36.508 [11] subclause 4.4.3.

3.1. The E-UTRA downlink signal level, uplink signal level are set according to Table 4.6-1 and propagation conditions are set according to Annex B.0 of TS 36.521-1 [10].

Step 6 of Initial conditions as in clause 7.4.4.1, 7.4A.1.4.1, 7.4A.2.4.1, 7.4A.3.4.1 or 7.4A.4.4.1 in TS 38.521-1 [8] is replaced by:

6. Ensure the UE is in state RRC_CONNECTED with generic procedure parameters Connectivity EN-DC, DC bearer MCG and SCG, Connected without release *On* according to TS 38.508 [6] clause 4.5.

7. On the E-UTRA carrier, disable periodic and aperiodic CQI reports, disable SRS, set TimeAlignmentTimerDedicated IE to infinity and disable downlink and uplink scheduling, all as per Table 4.6-1 under clause 4.6.

7.4B.3_1.4.5 Test Requirement

Same test requirement as specified in TS 38.521-1 [8] clause 7.4.5, 7.4A.1.5, 7.4A.2.5, 7.4A.3.5 or 7.4A.4.5 for the NR carrier(s).

7.4B.4 Maximum Input Level for inter-band EN-DC including FR2 (2CCs)

Editor's note: The following aspects are either missing or not yet determined:

- The referred test case 7.4 in TS 38.521-2 is incomplete.

7.4B.4.1 Test purpose

Same test purpose as in clause 7.4 in TS 38.521-2 [9] for the NR carrier.

7.4B.4.2 Test applicability

This test case applies to all types of E-UTRA UE release 15 and forward, supporting inter-band EN-DC including FR2 with 2CCs.

The minimum conformance requirements of NR FR2 carrier in this test case are not testable due to maximum input level unachievable in IFF OTA test setup. Other test setups have not been analysed. Thus the test case will not be tested as part of UE conformance testing.

NOTE: As a result TC 7.4B.4 has not been included in the test case applicability table 4.1.3-1, TS 38.522. This does not preclude the test from being used for R&D or other purposes if deemed useful to all types of NR UE release 15 and forward.

7.4B.4.3 Minimum conformance requirements

Refer to Clause 7.4B.0.4 for the inter-band EN-DC including FR2 maximum input level requirement.

No exception requirements applicable to NR or LTE. LTE anchor agnostic approach is applied.

7.4B.4.4 Test description

Same test description as in clause 7.4.4 in TS 38.521-2 [9] for the NR carrier with the following exception:

The initial test configurations for E-UTRA band consist of environmental conditions, test frequencies, and channel bandwidths based on E-UTRA bands specified in Table 4.7-1.

For initial conditions as in clause 7.4.4.1 in TS 38.521-2 [9], the following steps will be added to configure E-UTRA component:

2.1 The parameter settings for E-UTRA cell are set up according to TS 36.508 [11] subclause 4.4.3.

3.1 The E-UTRA downlink signal level, uplink signal level are set according to Table 4.7-1 and propagation conditions are set according to Annex B.0 of TS36.521-1 [10].

Step 6 of Initial conditions as in clause 7.4.4.1 in TS 38.521-2 [9] is replaced by:

6. Ensure the UE is in state RRC_CONNECTED with generic procedure parameters Connectivity EN-DC, DC bearer MCG and SCG, Connected without release On according to TS 38.508-1 [6] clause 4.5.

Same test procedure as in clause 7.4.4.2 in TS 38.521-2 [9] with the following steps added for E-UTRA component:

1.1 On the E-UTRA carrier, disable periodic and aperiodic CQI reports, disable SRS, set TimeAlignmentTimerDedicated IE to infinity and disable downlink and uplink scheduling, all as per Table 4.7-1 under clause 4.7.

7.4B.4.5 Test requirement

Same test requirement as in clause 7.4.5 in TS 38.521-2 [9] for the NR carrier.

7.4B.4_1 Maximum Input Level for inter-band EN-DC including FR2 (>2CCs)

7.4B.4_1.1 Maximum Input Level for Inter-Band EN-DC including FR2 (3 CCs)

Editor's note: This clause is incomplete. The following aspects are either missing or not yet determined:

- The referred test case 7.4A.1 in TS 38.521-2 is incomplete.

7.4B.4_1.1.1 Test purpose

Same test purpose as in clause 7.4 in TS 38.521-2 [9] for the NR carrier.

7.4B.4_1.1.2 Test applicability

This test case applies to all types of E-UTRA UE release 15 and forward, supporting inter-band EN-DC including FR2 with 3 DL CCs (2NR DL CCs).

The minimum conformance requirements of NR FR2 carrier in this test case are not testable due to maximum input level unachievable in IFF OTA test setup. Other test setups have not been analysed. Thus the test case will not be tested as part of UE conformance testing.

NOTE: As a result TC 7.4B.4_1.1 has not been included in the test case applicability table 4.1.3-1, TS 38.522. This does not preclude the test from being used for R&D or other purposes if deemed useful to all types of NR UE release 15 and forward.

7.4B.4_1.1.3 Minimum conformance requirements

Same minimum conformance requirements as in clause 7.4B.4.3.

7.4B.4_1.1.4 Test description

Same test description as in clause 7.4.4 or 7.4A.1.4 in TS 38.521-2 [9] for the NR carrier with the following exception:

The initial test configurations for E-UTRA band consist of environmental conditions, test frequencies, and channel bandwidths based on E-UTRA bands specified in Table 4.7-1.

For initial conditions as in clause 7.4.4.1 or 7.4A.1.4.1 in TS 38.521-2 [9], the following steps will be added to configure E-UTRA component:

2.1 The parameter settings for E-UTRA cell are set up according to TS 36.508 [11] subclause 4.4.3.

3.1 The E-UTRA downlink signal level, uplink signal level are set according to Table 4.7-1 and propagation conditions are set according to Annex B.0 of TS36.521-1 [10].

Step 6 of Initial conditions as in clause 7.4.4.1 or 7.4A.1.4.1 in TS 38.521-2 [9] is replaced by:

6. Ensure the UE is in state RRC_CONNECTED with generic procedure parameters Connectivity EN-DC, DC bearer MCG and SCG, Connected without release On according to TS 38.508-1 [6] clause 4.5.

Same test procedure as in clause 7.4.4.2 or 7.4A.1.4.2 in TS 38.521-2 [9] with the following steps added for E-UTRA component:

1.1 On the E-UTRA carrier, disable periodic and aperiodic CQI reports, disable SRS, set TimeAlignmentTimerDedicated IE to infinity and disable downlink and uplink scheduling, all as per Table 4.7-1 under clause 4.7.

7.4B.4_1.1.5 Test Requirements

Same test requirement as in clause 7.4.5 or 7.4A.1.5 in TS 38.521-2 [9] for the NR carrier(s).

7.4B.4_1.2 Maximum Input Level for Inter-Band EN-DC including FR2 (4 CCs)

Editor's note: This clause is incomplete. The following aspects are either missing or not yet determined:

- The referred test case 7.4A.1 and 7.4A.2 in TS 38.521-2 is incomplete.

7.4B.4_1.2.1 Test purpose

Same test purpose as in clause 7.4 in TS 38.521-2 [9] for the NR carrier.

7.4B.4_1.2.2 Test applicability

This test case applies to all types of E-UTRA UE release 15 and forward, supporting inter-band EN-DC including FR2 with 4 DL CCs (3NR DL CCs).

The minimum conformance requirements of NR FR2 carrier in this test case are not testable due to maximum input level unachievable in IFF OTA test setup. Other test setups have not been analysed. Thus the test case will not be tested as part of UE conformance testing.

NOTE: As a result TC 7.4B.4_1.2 has not been included in the test case applicability table 4.1.3-1, TS 38.522. This does not preclude the test from being used for R&D or other purposes if deemed useful to all types of NR UE release 15 and forward.

7.4B.4_1.2.3 Minimum conformance requirements

Same minimum conformance requirements as in clause 7.4B.4.3.

7.4B.4_1.2.4 Test description

Same test description as in clause 7.4.4, 7.4A.1.4 or 7.4A.2.4 in TS 38.521-2 [9] for the NR carrier with the following exception:

The initial test configurations for E-UTRA band consist of environmental conditions, test frequencies, and channel bandwidths based on E-UTRA bands specified in Table 4.7-1.

For initial conditions as in clause 7.4.4.1, 7.4A.1.4.1 or 7.4A.2.4.1 in TS 38.521-2 [9], the following steps will be added to configure E-UTRA component:

- 2.1 The parameter settings for E-UTRA cell are set up according to TS 36.508 [11] subclause 4.4.3.
- 3.1 The E-UTRA downlink signal level, uplink signal level are set according to Table 4.7-1 and propagation conditions are set according to Annex B.0 of TS36.521-1 [10].

Step 6 of Initial conditions as in clause 7.4.4.1, 7.4A.1.4.1 or 7.4A.2.4.1 in TS 38.521-2 [9] is replaced by:

6. Ensure the UE is in state RRC_CONNECTED with generic procedure parameters Connectivity EN-DC, DC bearer MCG and SCG, Connected without release On according to TS 38.508-1 [6] clause 4.5.

Same test procedure as in clause 7.4.4.2, 7.4A.1.4.2 or 7.4A.2.4.2 in TS 38.521-2 [9] with the following steps added for E-UTRA component:

- 1.1 On the E-UTRA carrier, disable periodic and aperiodic CQI reports, disable SRS, set TimeAlignmentTimerDedicated IE to infinity and disable downlink and uplink scheduling, all as per Table 4.7-1 under clause 4.7.

7.4B.4_1.2.5 Test Requirements

Same test requirement as in clause 7.4.5, 7.4A.1.5 or 7.4A.2.5 in TS 38.521-2 [9] for the NR carrier(s).

7.4B.4_1.3 Maximum Input Level for Inter-Band EN-DC including FR2 (5 CCs)

Editor's note: This clause is incomplete. The following aspects are either missing or not yet determined:

- The referred test case 7.4A.1, 7.4A.2 and 7.4A.3 in TS 38.521-2 is incomplete.

7.4B.4_1.3.1 Test purpose

Same test purpose as in clause 7.4 in TS 38.521-2 [9] for the NR carrier.

7.4B.4_1.3.2 Test applicability

This test case applies to all types of E-UTRA UE release 15 and forward, supporting inter-band EN-DC including FR2 with 5 DL CCs (4NR DL CCs).

The minimum conformance requirements of NR FR2 carrier in this test case are not testable due to maximum input level unachievable in IFF OTA test setup. Other test setups have not been analysed. Thus the test case will not be tested as part of UE conformance testing.

NOTE: As a result TC 7.4B.4_1.3 has not been included in the test case applicability table 4.1.3-1, TS 38.522. This does not preclude the test from being used for R&D or other purposes if deemed useful to all types of NR UE release 15 and forward.

7.4B.4_1.3.3 Minimum conformance requirements

Same minimum conformance requirements as in clause 7.4B.4.3.

7.4B.4_1.3.4 Test description

Same test description as in clause 7.4.4, 7.4A.1.4, 7.4A.2.4 or 7.4A.3.4 in TS 38.521-2 [9] for the NR carrier with the following exception:

The initial test configurations for E-UTRA band consist of environmental conditions, test frequencies, and channel bandwidths based on E-UTRA bands specified in Table 4.7-1.

For initial conditions as in clause 7.4.4.1, 7.4A.1.4.1, 7.4A.2.4.1 or 7.4A.3.4.1 in TS 38.521-2 [9], the following steps will be added to configure E-UTRA component:

2.1 The parameter settings for E-UTRA cell are set up according to TS 36.508 [11] subclause 4.4.3.

3.1 The E-UTRA downlink signal level, uplink signal level are set according to Table 4.7-1 and propagation conditions are set according to Annex B.0 of TS36.521-1 [10].

Step 6 of Initial conditions as in clause 7.4.4.1, 7.4A.1.4.1, 7.4A.2.4.1 or 7.4A.3.4.1 in TS 38.521-2 [9] is replaced by:

6. Ensure the UE is in state RRC_CONNECTED with generic procedure parameters Connectivity EN-DC, DC bearer MCG and SCG, Connected without release On according to TS 38.508-1 [6] clause 4.5.

Same test procedure as in clause 7.4.4.2, 7.4A.1.4.2, 7.4A.2.4.2 or 7.4A.3.4.2 in TS 38.521-2 [9] with the following steps added for E-UTRA component:

1.1 On the E-UTRA carrier, disable periodic and aperiodic CQI reports, disable SRS, set TimeAlignmentTimerDedicated IE to infinity and disable downlink and uplink scheduling, all as per Table 4.7-1 under clause 4.7.

7.4B.4_1.2.5 Test Requirements

Same test requirement as in clause 7.4.5, 7.4A.1.5, 7.4A.2.5 or 7.4A.3.5 in TS 38.521-2 [9] for the NR carrier(s).

7.4B.4_1.4 Maximum Input Level for Inter-Band EN-DC including FR2 (6 CCs)

Editor's note: This clause is incomplete. The following aspects are either missing or not yet determined:

- The referred test case 7.4A.1, 7.4A.2, 7.4A.3 and 7.4A.4 in TS 38.521-2 is incomplete.

7.4B.4_1.4.1 Test purpose

Same test purpose as in clause 7.4 in TS 38.521-2 [9] for the NR carrier.

7.4B.4_1.4.2 Test applicability

This test case applies to all types of E-UTRA UE release 15 and forward, supporting inter-band EN-DC including FR2 with 6 DL CCs (5NR DL CCs).

The minimum conformance requirements of NR FR2 carrier in this test case are not testable due to maximum input level unachievable in IFF OTA test setup. Other test setups have not been analysed. Thus the test case will not be tested as part of UE conformance testing.

NOTE: As a result TC 7.4B.4_1.4 has not been included in the test case applicability table 4.1.3-1, TS 38.522. This does not preclude the test from being used for R&D or other purposes if deemed useful to all types of NR UE release 15 and forward.

7.4B.4_1.4.3 Minimum conformance requirements

Same minimum conformance requirements as in clause 7.4B.4.3.

7.4B.4_1.4.4 Test description

Same test description as in clause 7.4.4, 7.4A.1.4, 7.4A.2.4, 7.4A.3.4 or 7.4A.4.4 in TS 38.521-2 [9] for the NR carrier with the following exception:

The initial test configurations for E-UTRA band consist of environmental conditions, test frequencies, and channel bandwidths based on E-UTRA bands specified in Table 4.7-1.

For initial conditions as in clause 7.4.4.1, 7.4A.1.4.1, 7.4A.2.4.1, 7.4A.3.4.1 or 7.4A.4.4.1 in TS 38.521-2 [9], the following steps will be added to configure E-UTRA component:

2.1 The parameter settings for E-UTRA cell are set up according to TS 36.508 [11] subclause 4.4.3.

3.1 The E-UTRA downlink signal level, uplink signal level are set according to Table 4.7-1 and propagation conditions are set according to Annex B.0 of TS36.521-1 [10].

Step 6 of Initial conditions as in clause 7.4.4.1, 7.4A.1.4.1, 7.4A.2.4.1, 7.4A.3.4.1 or 7.4A.4.4.1 in TS 38.521-2 [9] is replaced by:

6. Ensure the UE is in state RRC_CONNECTED with generic procedure parameters Connectivity EN-DC, DC bearer MCG and SCG, Connected without release On according to TS 38.508-1 [6] clause 4.5.

Same test procedure as in clause 7.4.4.2, 7.4A.1.4.2, 7.4A.2.4.2, 7.4A.3.4.2 or 7.4A.4.4.2 in TS 38.521-2 [9] with the following steps added for E-UTRA component:

1.1 On the E-UTRA carrier, disable periodic and aperiodic CQI reports, disable SRS, set TimeAlignmentTimerDedicated IE to infinity and disable downlink and uplink scheduling, all as per Table 4.7-1 under clause 4.7.

7.4B.4_1.4.5 Test Requirements

Same test requirement as in clause 7.4.5, 7.4A.1.5, 7.4A.2.5, 7.4A.3.5 or 7.4A.4.5 in TS 38.521-2 [9] for the NR carrier(s).

7.4B.4D Maximum Input Level for inter-band EN-DC including FR2 for UL-MIMO

No exception requirements applicable to NR or LTE. LTE anchor agnostic approach can be applied and only NR carriers need to be tested.

No test case details are specified. Given UE's Rx performance would not be impacted by the Tx configuration in NR FR2 TDD bands, the requirements in this test case can be well covered in 7.4B.4 and 7.4B.4_1 and don't need to be tested again.

7.4B.5 Maximum Input Level for inter-band EN-DC including both FR1 and FR2

7.4B.5.1 Test purpose

Same test purpose as in clause 7.4.1 in TS 38.521-1 [8] for NR FR1 carrier and 7.4.1 in TS 38.521-2 [9] for NR FR2 carrier.

7.4B.5.2 Test applicability

The requirements in this test are not testable due to issues with combined testing of NR FR1 and E-UTRA in conducted mode with NR FR2 in radiated mode. Therefore, the conducted and radiated requirements are tested separately.

No test case details are specified. The NSA requirements for maximum input level apply and are tested as part of the EN-DC within FR1 and EN-DC including FR2 test cases in clause 7.4B.

7.4B.5D Maximum Input Level for inter-band EN-DC including FR1 and FR2 for UL-MIMO

7.4B.5D.1 Test purpose

Same test purpose as in clause 7.4D.1 in TS 38.521-1 [8] for NR FR1 carrier and 7.4D.1 in TS 38.521-2 [9] for NR FR2 carrier.

7.4B.5D.2 Test applicability

The requirements in this test are not testable due to issues with combined testing of NR FR1 and E-UTRA in conducted mode with NR FR2 in radiated mode. Therefore, the conducted and radiated requirements are tested separately.

No test case details are specified. The NSA requirements for maximum input level apply and are tested as part of the EN-DC within FR1 and EN-DC including FR2 test cases in clause 7.4B.

7.5 Void

7.5A Adjacent Channel Selectivity for CA

7.5A.0 Test purpose

Same test purpose as in clauses 7.5 and 7.5A in TS 38.521-1 [8] for NR FR1 carrier(s) and clauses 7.5 and 7.5A in TS 38.521-2 [9] for NR FR2 carrier(s).

7.5A.1 Test applicability

The requirements in this test are not testable due to issues with combined testing of NR FR1 conducted mode with NR FR2 in radiated mode. Therefore, the conducted and radiated requirements are tested separately.

No test case details are specified. The SA requirements for adjacent channel selectivity apply and are tested in clauses 7.5 and 7.5A in TS 38.521-1 [8] and clauses 7.5 and 7.5A in TS 38.521-2 [9].

7.5B Adjacent channel selectivity for DC

7.5B.0 Minimum Conformance Requirements

7.5B.0.1 Intra-band contiguous EN-DC in FR1

Intra-band contiguous EN-DC ACS requirement and parameters are defined for test case 1 in Table 7.5B.0.1-1 and for test case 2 in Table 7.5B.0.1-2.

Table 7.5B.0.1-1: ACS test case 1

EN-DC Aggregated Bandwidth, MHz	≤100	>100, ≤120	>120, ≤140	>140, ≤160
ACS, dB	X ¹	19.2	18.5	17.9
P _{interferer} , dBm	P _i ²	Aggregated power + 17.7 dB	Aggregated power + 17 dB	Aggregated power + 16.4dB
P _w in Transmission BW configuration, per CC, dBm	REFSENS +14dB			
NOTE 1: X is ACS level at the specified EN-DC aggregated Bandwidth from Table 7.5.1A-1 in TS 36.101 [5]				
NOTE 2: P _i is from Table 7.5.1A-2 in TS 36.101 [5]				
NOTE 3: Jammer BW and offset is from Table 7.5.1A-2 in TS 36.101 [5] and is applied from the lowest edge of the lowest carrier and the highest edge of the highest carrier				
NOTE 4: For NR carrier, the transmitter shall be set to 4dB below P _{CMAX_L,f,c,NR} at the minimum uplink configuration specified in Table 7.3.2-3 in TS 38.101-1 [2] with P _{CMAX_L,f,c,NR} as defined in clause 6.2B.4 from TS 38.101-3 [4].				
NOTE 5: For E-UTRA carrier, the transmitter shall be set to 4dB below P _{CMAX_L,E-UTRA,c} at the minimum uplink configuration specified in Table 7.3.1-2 in TS 36.101 [5] with P _{CMAX_L,E-UTRA,c} as defined in clause 6.2B.4 from TS 38.101-3 [4] for single carrier.				

Table 7.5B.0.1-2: ACS test case 2

EN-DC Aggregated Bandwidth, ENBW, MHz	≤100	>100, ≤120	>120, ≤140	>140, ≤160
P _w in Transmission Bandwidth Configuration, perCC, dBm	P _w ¹	-42.7 +10log ₁₀ (N _{RB,c} /N _{NRB_agg})	-42 +10log ₁₀ (N _{RB,c} /N _{NRB_agg})	-41.4 +10log ₁₀ (N _{RB,c} /N _{NRB_agg})
P _{interferer} , dBm	-25			
NOTE 1: P _w is wanted signal power level at the specified EN-DC aggregated Bandwidth from Table 7.5.1A-3 in TS 36.101 [5]				
NOTE 2: Jammer BW and offset is from Table 7.5.1A-3 in TS 36.101 [5] and is applied from the lowest edge of the lowest carrier and the highest edge of the highest carrier				
NOTE 3: For NR carrier, the transmitter shall be set to 4dB below P _{CMAX_L,f,c,NR} at the minimum uplink configuration specified in Table 7.3.2-3 in TS 38.101-1 [2] with P _{CMAX_L,f,c,NR} as defined in clause 6.2B.4 from TS 38.101-3 [4].				
NOTE 4: For E-UTRA carrier, the transmitter shall be set to 4dB below P _{CMAX_L,E-UTRA,c} at the minimum uplink configuration specified in Table 7.3.1-2 in TS 36.101 [5] with P _{CMAX_L,E-UTRA,c} as defined in clause 6.2B.4 from TS 38.101-3 [4] for single carrier.				

7.5B.0.2 Intra-band non-contiguous EN-DC in FR1

For the E-UTRA sub-block containing one or multiple CC's, the requirement is defined in clause 7.5.1 for single carrier operation and in clause 7.5.1A for CA in TS 36.101 [5].

For the NR sub-block, the requirement is defined in clause 7.5 in TS 38.101-1 [2].

The blocker configuration is defined in the general clause 7.1 in TS 38.101-3 [4].

7.5B.0.3 Inter-band EN-DC within FR1

Adjacent channel selectivity requirement for E-UTRA single carrier and CA operation specified in clauses 7.5.1 and 7.5.1A of TS 36.101 [5] and for NR single carrier and CA operation specified in clauses 7.5 and 7.5A of TS 38.101-1 [2] apply.

7.5B.0.3a Inter-band NE-DC within FR1

Adjacent channel selectivity requirement for E-UTRA single carrier and CA operation specified in subclauses 7.5.1 and 7.5.1A of TS 36.101 [5] and for NR single carrier and CA operation specified in subclauses 7.5 and 7.5A of TS 38.101-1 [2] apply.

7.5B.0.4 Inter-band EN-DC including FR2

Adjacent channel selectivity requirement for E-UTRA single carrier and CA operation specified in clauses 7.5.1 and 7.5.1A of TS 36.101 [5] and for NR single carrier and CA operation specified in clauses 7.5 and 7.5A of TS 38.101-2 [3] apply.

7.5B.0.5 Inter-band EN-DC including both FR1 and FR2

Adjacent channel selectivity requirement for E-UTRA single carrier and CA operation specified in clauses 7.5.1 and 7.5.1A of TS 36.101 [5] and for NR single carrier and CA operation specified in clauses 7.5 and 7.5A of TS 38.101-1 [2] and TS 38.101-2 [3] apply.

The normative reference for this requirement is TS 38.101-3 [4] clause 7.5B.1, 7.5B.2, 7.5B.3, 7.5B.4 and 7.5B.5.

7.5B.1 Adjacent Channel Selectivity for intra-band contiguous EN-DC (2 CCs)

Editor's note: this clause is incomplete. The following aspects are either missing or not yet determined:

- **Maximum Test System Uncertainty analysis is incomplete**

7.5B.1.1 Test purpose

Adjacent channel selectivity (ACS) is a measure of a receiver's ability to receive an NR and E-UTRA signal at its assigned channel frequency in the presence of an adjacent channel signal at a given frequency offset from the centre frequency of the assigned channel. ACS is the ratio of the receive filter attenuation on the assigned channel frequency to the receive filter attenuation on the adjacent channel(s).

7.5B.1.2 Test applicability

This test case applies to all types of E-UTRA UE release 15 and forward, supporting intra-band contiguous EN-DC operating in FR1.

7.5B.1.3 Minimum conformance requirements

Refer to Clause 7.5B.0.1 for the intra-band contiguous EN-DC in FR1.

Exception requirements are applicable for NR but not for E-UTRA within this test. LTE anchor agnostic approach is not applied. E-UTRA test points are defined and measurements performed over the aggregated EN-DC bandwidth.

7.5B.1.4 Test description

7.5B.1.4.1 Initial Condition

Initial conditions are a set of test configurations the UE needs to be tested in and the steps for the SS to take with the UE to reach the correct measurement state.

The initial test configurations consist of environmental conditions, test frequencies and channel bandwidths based on EN-DC operating bands specified in clause 5.2B.2, channel bandwidths and sub-carrier spacings for the NR cell specified in TS 38.521-1 [8] clause 5.3 and channel bandwidth for the E-UTRA cell are specified in TS 36.521-1 [10] clause 5.4.2. All of these configurations shall be tested with applicable test parameters for each intra-band contiguous EN-DC configuration specified in clause 5.5B.2, and are shown in table 7.3B.2.1.4.1-1 for intra-band DC_(n)71AA.

In an E-UTRA band or FR1 band where UE supports 4Rx, the test shall be performed only with 4Rx antennas ports connected and 4Rx REFSSENS requirement (TS 38.521-1 [8] Table 7.3.2.5-2) is used in the test requirements.

The details of the uplink reference measurement channels (RMCs) are specified in Annex A.2 for E-UTRA RMC for TDD, TS 36.521-1 [10] Annex A.2 for E-UTRA RMC for FDD, TS 38.521-1 [8] Annex A.2 for NR UL RMC and TS 38.521-1 [8] Annex A.3 for NR DL RMC. Configurations of PDSCH and PDCCH before measurement are specified in TS 36.521-1 [10] Annex C.2 and in TS 38.521-1 [8] Annex C.2 for E-UTRA CG and NR CG respectively.

1. Connect the SS to the UE antenna connectors as shown in A.3.1.1 for SS diagram and A.3.2 for UE diagram in TS 38.508-1 [6].
2. The parameter settings for the E-UTRA cell are set up according to TS 36.508 [11] clause 4.4.3, and parameter settings for the NR cell are set up according to TS 38.508-1 [6] clause 4.4.3.
3. Downlink signals are initially set up according to TS 36.521-1 [10] Annex C.0 and TS 38.521-1 [8] Annex C.0 for E-UTRA CG and NR CG respectively, and uplink signals according to TS 36.521-1 [10] Annex H and TS 38.521-1 [8] Annex G for E-UTRA CG and NR CG respectively.
4. The UL Reference Measurement channels are TS 36.521-1 [10] Annex A.2 and TS 38.521-1 [8] Annex A.2 for E-UTRA CG and NR CG respectively.
5. Propagation conditions are set according to TS 36.521-1 [10] Annex B.0 and TS 38.521-1 [8] Annex B.0 for E-UTRA CG and NR CG respectively.
6. Ensure the UE is in state RRC_CONNECTED with generic procedure parameters Connectivity EN-DC, DC bearer *MCG* and *SCG*, Connected without release *On* according to TS 38.508-1 [6] clause 4.5. Message contents are defined in clause 7.5B.1.4.3.

7.5B.1.4.2 Test Procedure

1. SS transmits PDSCH via PDCCH DCI format 1_1 for C_RNTI to transmit the DL RMC on the NR CC according to Table 7.5B.1.4.1-1. SS transmits PDSCH via PDCCH DCI format 1A for C_RNTI to transmit the DL RMC on the E-UTRA CC according to Table 7.5.4.1-1 in TS 36.521-1 [10]. The SS sends downlink MAC padding bits on the DL RMC.
2. SS sends uplink scheduling information for each UL HARQ process via PDCCH DCI format 0_1 for C_RNTI to schedule the UL RMC on the NR CC according to Table 7.5B.1.4.1-1. SS sends uplink scheduling information for each UL HARQ process via PDCCH DCI format 0 for C_RNTI to schedule the UL RMC on the E-UTRA CC according to Table 7.5.4.1-1 in TS 36.21-1 [10]. Since the UE has no payload data to send, the UE transmits uplink MAC padding bits on the UL RMC.
3. Set the Downlink signal level on the NR CC to the value as defined in Table 7.5.5-2 or Table 7.5.5-5 as appropriate in TS 38.521-1 [8] (Case 1). For NR CC and E-UTRA CC, send uplink power control commands to the UE using 1dB power step size to ensure that the UE output power measured by the test system is within the Uplink power control window, defined as $-MU$ to $-(MU + \text{Uplink power control window size})$ dB of the target power level in Table 7.5B.0.1-1 for at least the duration of the Throughput measurement, where:
 - MU is the test system uplink power measurement uncertainty and is specified in Table F.1.3-1 for the carrier frequency f and the channel bandwidth BW .
 - For NR CC, Uplink power control window size = 1dB (UE power step size) + 0.7dB (UE power step tolerance) + (Test system relative power measurement uncertainty), where, the UE power step tolerance is specified in TS 38.101-1 [2], Table 6.3.4.3-1 and is 0.7dB for 1dB power step size, and the Test system relative power measurement uncertainty is specified in Table F.1.2-1.
 - For E-UTRA CC, Uplink power control window size = 1dB (UE power step size) + 1.0dB (UE power step tolerance) + (Test system relative power measurement uncertainty), where, the UE power step tolerance

is specified in TS 36.101 [5], Table 6.3.5.2.1-1 and is 1.0dB for 1dB power step size, and the Test system relative power measurement uncertainty is specified in Table F.1.2-1 of TS 36.521-1 [10].

4. Set the Interferer signal level to the value as defined in Table 7.5B.0.1-1 (Case 1) and frequency below the wanted signal on the NR CC and E-UTRA CC, using a modulated interferer bandwidth as defined in Annex D.
5. Measure the average throughput for a duration sufficient to achieve statistical significance according to Annex H.
6. Repeat steps from 3 to 5, using an interfering signal above the wanted signal in Case 1 at step 4.
7. Set the Downlink signal level on the NR CC to the value as defined in Table 7.5.5-3 or Table 7.5.5-6 as appropriate in TS 38.521-1 [8] (Case 2). Set the Downlink signal level on the E-UTRA CC to the value as defined in Table 7.5.5-3 in TS 36.521-1 [10] (Case 2). For NR CC and E-UTRA CC, send uplink power control commands to the UE using 1dB power step size to ensure that the UE output power measured by the test system is within the Uplink power control window, defined as $-(MU)$ to $-(MU + \text{Uplink power control window size})$ dB of the target power level in Table 7.5B.0.1-2 for at least the duration of the Throughput measurement, where MU and Uplink power control window size are defined above.
8. Set the Interferer signal level to the value as defined in Table 7.5B.0.1-2 (Case 2) and frequency below the wanted signal on the NR CC and E-UTRA CC, using a modulated interferer bandwidth as defined in Annex D.
9. Measure the average throughput for a duration sufficient to achieve statistical significance according to Annex H
10. Repeat steps from 7 to 9, using an interfering signal above the wanted signal in Case 2 at step 8.
11. Repeat for applicable channel bandwidths and operating band combinations in both Case 1 and Case 2.

NOTE: The purpose of the Uplink power control window is to ensure that the actual UE output power is no greater than the target power level, and as close as possible to the target power level. The relationship between the Uplink power control window, the target power level and the corresponding possible actual UE Uplink power window is illustrated in Annex F, clause F.4.

7.5B.1.4.3 Message Contents

Message contents are according to TS 38.508-1 [6] clause 4.6.1.

7.5B.1.5 Test requirement

For the NR CC, the throughput measurement of the carrier derived in test procedure shall be $\geq 95\%$ of the maximum throughput of the reference measurement channels as specified in Annex A.3 under the conditions specified in Table 7.5B.0.1-1, and also under the conditions specified in Table 7.5B.0.1-2.

7.5B.2 Adjacent Channel Selectivity for intra-band non-contiguous EN-DC (2 CCs)

Editor's note: this clause is incomplete. The following aspects are either missing or not yet determined:

- **The test point selection analysis is incomplete**
- **Maximum Test System Uncertainty analysis is incomplete**

7.5B.2.1 Test purpose

Same test purpose as clause 7.5B.1.1

7.5B.2.2 Test applicability

This test case applies to all types of E-UTRA UE release 15 and forward, supporting intra-band non-contiguous EN-DC.

7.5B.2.3 Minimum conformance requirements

The minimum conformance requirements are defined in clause 7.5B.0.2.

No exception requirements applicable to NR or LTE. LTE anchor agnostic approach is applied.

7.5B.2.4 Test description

Same test description as in subclause 7.5.4 in TS 38.521-1 [8] for the NR carrier with the following exceptions:

Table 7.5B.2.4.1-1: Test Configuration Table

Initial Conditions	
Test Frequencies as specified in TS 38.508-1 [6] clause 4.3.1 for different DC bandwidth classes	Low with maxWgap, High with maxWgap
Test EN-DC bandwidth combination as specified in Table 5.3B.1.3-1 across bandwidth combination sets supported by the UE	Highest N_{RB_agg} (NOTE 1)
NOTE 1: If the UE supports multiple CC Combinations in the EN-DC Configuration with the same NRB_agg , only the combination with the highest NRB_SCG is tested.	

The initial test configurations for E-UTRA as specified in Table 4.6-1 except for the parameters specified in Table 7.5B.2.4.1-1.

For initial conditions as in clause 7.5.4.1 in TS 38.521-1 [8], the following steps are added to configure E-UTRA component:

- 2.1. The parameter settings for E-UTRA cell are set up according to TS 36.508 [11] clause 4.4.3. The E-UTRA downlink signal level, uplink signal level are set according to Table 4.6-1 and propagation conditions are set according to Annex B.0 of TS 36.521-1 [10].
7. On the E-UTRA carrier, disable periodic and aperiodic CQI reports, disable SRS, set *TimeAlignmentTimerDedicated* IE to infinity and disable downlink and uplink scheduling, all as per Table 4.6-1 under clause 4.6.

Step 6 of Initial conditions as in clause 7.5.4.1 in TS 38.521-1 [8] is replaced by:

6. Ensure the UE is in state RRC_CONNECTED with generic procedure parameters Connectivity EN-DC, DC bearer MCG and SCG, Connected without release *On* according to TS 38.508-1 [6] clause 4.5.

Step 3 of Test procedure as in clause 7.6.2.4.2 in TS 38.521-1 [8] shall treat the in-gap tests as below: For intra-band non-contiguous EN-DC of two sub-blocks with channel bandwidth larger than or equal to 5 MHz, the existing requirements apply for in-gap tests only if the corresponding interferer frequency offsets satisfy the following condition in relation to the sub-block gap size W_{gap} , so that the interferer frequency position does not change the nature of the core requirement tested:

$$W_{gap} \geq 2 \cdot |F_{Interferer}(\text{offset})| - BW_{Channel}$$

Same test procedure as specified in clause 7.5.4.2 in TS 38.521-1 [8].

7.5B.2.5 Test requirement

Same test requirement as specified in TS 38.521-1 [8] Clause 7.5.5.

7.5B.3 Adjacent Channel Selectivity for inter-band EN-DC within FR1 (2 CCs)

7.5B.3.1 Test purpose

Same test purpose as in clause 7.5B.1.1.

7.5B.3.2 Test applicability

This test case applies to all types of E-UTRA UE release 15 and forward, supporting inter-band EN-DC within FR1.

7.5B.3.3 Minimum conformance requirements

The minimum conformance requirements are defined in clause 7.5B.0.3.

No exception requirements applicable to NR or LTE. LTE anchor agnostic approach is applied.

7.5B.3.4 Test description

Same test description as in clause 7.5.4.2 in TS 38.521-1 [8] for the NR carrier with the following exceptions:

The initial test configurations for E-UTRA consist of test frequency based on E-UTRA operating band and test channel bandwidth as specified in Table 4.6-1.

For Initial conditions as in clause 7.5.4.1 in TS 38.521-1 [8], add step 2.1 and step 3.1 as follows:

- 2.1. The parameter settings for E-UTRA cell are set up according to TS 36.508 [11] clause 4.4.3.
- 3.1. The E-UTRA downlink signal level, uplink signal level are set according to Table 4.6-1 and propagation conditions are set according to Annex B.0 of TS 36.521-1 [10].

Step 6 of Initial conditions as in clause 7.5.4.1 in TS 38.521-1 [8] is replaced by:

6. Ensure the UE is in state RRC_CONNECTED with generic procedure parameters Connectivity EN-DC, DC bearer MCG and SCG, Connected without release *On* according to TS 38.508 [6] clause 4.5.

Add step 7 to Initial conditions in clause 7.5.4.1 in TS 38.521-1 [8] as follows:

7. On the E-UTRA carrier, disable periodic and aperiodic CQI reports, disable SRS, set *TimeAlignmentTimerDedicated* IE to infinity and disable downlink and uplink scheduling, all as per Table 4.6-1 under clause 4.6.

7.5B.3.5 Test requirement

Same test requirement as specified in TS 38.521-1 [8] Clause 7.5.5.

7.5B.3_1 Adjacent Channel Selectivity for EN-DC within FR1 (>2 CCs)

7.5B.3_1.1 Adjacent Channel Selectivity for EN-DC within FR1 (3 CCs)

7.5B.3_1.1.1 Test purpose

Same test purpose as in clause 7.5B.1.1.

7.5B.3_1.1.2 Test applicability

This test applies to all types of E-UTRA UE release 15 and forward, supporting EN-DC within FR1 with 3CCs.

7.5B.3_1.1.3 Minimum conformance requirements

The minimum conformance requirements are defined in clause 7.5B.0.3.

No exception requirements applicable to NR or LTE. LTE anchor agnostic approach is applied.

7.5B.3_1.1.4 Test description

Same test description as in clause 7.5.4.2 or 7.5A.1.4 in TS 38.521-1 [8] for the NR carrier with the following exceptions:

The initial test configurations for E-UTRA consist of test frequency based on E-UTRA operating band and test channel bandwidth as specified in Table 4.6-1.

For Initial conditions as in clause 7.5.4.1 or 7.5A.1.4.1 in TS 38.521-1 [8], add step 2.1 and step 3.1 as follows:

- 2.1. The parameter settings for E-UTRA cell are set up according to TS 36.508 [11] clause 4.4.3.
- 3.1. The E-UTRA downlink signal level, uplink signal level are set according to Table 4.6-1 and propagation conditions are set according to Annex B.0 of TS 36.521-1 [10].

Step 6 of Initial conditions as in clause 7.5.4.1 or 7.5A.1.4.1 in TS 38.521-1 [8] is replaced by:

6. Ensure the UE is in state RRC_CONNECTED with generic procedure parameters Connectivity EN-DC, DC bearer MCG and SCG, Connected without release *On* according to TS 38.508 [6] clause 4.5.

Add step 7 to Initial conditions in clause 7.5.4.1 or 7.5A.1.4.1 in TS 38.521-1 [8] as follows:

7. On the E-UTRA carrier, disable periodic and aperiodic CQI reports, disable SRS, set *TimeAlignmentTimerDedicated* IE to infinity and disable downlink and uplink scheduling, all as per Table 4.6-1 under clause 4.6.

7.5B.3_1.1.5 Test requirement

Same test requirement as specified in TS 38.521-1 [8] Clause 7.5.5 or 7.5A.1.5 for the NR carrier(s).

7.5B.3_1.2 Adjacent Channel Selectivity for EN-DC within FR1 (4 CCs)

Editor's note: The ACS for EN-DC within FR1 (4 CCs) test cases below cover only inter-band EN-DC.

7.5B.3_1.2.1 Test purpose

Same test purpose as in clause 7.5B.1.1.

7.5B.3_1.2.2 Test applicability

This test applies to all types of E-UTRA UE release 15 and forward, supporting EN-DC within FR1 with 4CCs.

7.5B.3_1.2.3 Minimum conformance requirements

The minimum conformance requirements are defined in clause 7.5B.0.3.

No exception requirements applicable to NR or LTE. LTE anchor agnostic approach is applied.

7.5B.3_1.2.4 Test description

Same test description as in clause 7.5.4.2 or 7.5A.1.4 or 7.5A.2.4 in TS 38.521-1 [8] for the NR carrier with the following exceptions:

The initial test configurations for E-UTRA consist of test frequency based on E-UTRA operating band and test channel bandwidth as specified in Table 4.6-1.

For Initial conditions as in clause 7.5.4.1 or 7.5A.1.4.1 or 7.5A.2.4.1 in TS 38.521-1 [8], add step 2.1 and step 3.1 as follows:

- 2.1. The parameter settings for E-UTRA cell are set up according to TS 36.508 [11] clause 4.4.3.
- 3.1. The E-UTRA downlink signal level, uplink signal level are set according to Table 4.6-1 and propagation conditions are set according to Annex B.0 of TS 36.521-1 [10].

Step 6 of Initial conditions as in clause 7.5.4.1 or 7.5A.1.4.1 or 7.5A.2.4.1 in TS 38.521-1 [8] is replaced by:

6. Ensure the UE is in state RRC_CONNECTED with generic procedure parameters Connectivity EN-DC, DC bearer MCG and SCG, Connected without release *On* according to TS 38.508 [6] clause 4.5.

Add step 7 to Initial conditions in clause 7.5.4.1 or 7.5A.1.4.1 or 7.5A.2.4.1 in TS 38.521-1 [8] as follows:

7. On the E-UTRA carrier, disable periodic and aperiodic CQI reports, disable SRS, set *TimeAlignmentTimerDedicated* IE to infinity and disable downlink and uplink scheduling, all as per Table 4.6-1 under clause 4.6.

7.5B.3_1.2.5 Test requirement

Same test requirement as specified in TS 38.521-1 [8] Clause 7.5.5 or 7.5A.1.5 or 7.5A.2.5 for the NR carrier(s).

7.5B.4 Adjacent Channel Selectivity for inter-band EN-DC including FR2 (2CCs)

Editor's note: This test case is not complete. Following aspects are either missing or not yet determined:

- MU is FFS in referred test case 7.5 in TS 38.521-2 [9].
- Testability issue due to high PSD interferer has been identified.

7.5B.4.1 Test purpose

Same test purpose as in clause 7.5B.1.1.

7.5B.4.2 Test applicability

This test case applies to all types of E-UTRA UE release 15 and forward, supporting inter-band EN-DC including FR2 with 2 DL CCs.

7.5B.4.3 Minimum conformance requirements

The minimum conformance requirements are defined in clause 7.5B.0.4.

No exception requirements applicable to NR or LTE. LTE anchor agnostic approach is applied.

7.5B.4.4 Test description

7.5B.4.4.1 Initial Condition

Initial conditions are a set of test configurations the UE needs to be tested in and the steps for the SS to take with the UE to reach the correct measurement state.

The initial test configurations consist of environmental conditions, test frequencies and channel bandwidths based on EN-DC operating bands specified in clause 5.2B.5.1, channel bandwidths and sub-carrier spacings for the NR cell specified in TS 38.521-2 [9] clause 5.3 and channel bandwidth for the E-UTRA cell are specified in TS 36.521-1 [10] clause 5.4.2. All of these configurations shall be tested with applicable test parameters for each inter-band EN-DC including FR2 configuration specified in clause 5.5B.5.1, and the configuration for NR carrier are shown in TS 38.521-2 [9] Table 7.5.4.1-1.

For initial conditions as in clause 7.5.4.1 in TS 38.521-2 [9], the following steps are added to configure E-UTRA component:

- 2.1. The parameter settings for E-UTRA cell are set up according to TS 36.508 [11] clause 4.4.3. The E-UTRA downlink signal level, uplink signal level are set according to Table 4.6-1 and propagation conditions are set according to Annex B.0 of TS 36.521-1 [10].
7. On the E-UTRA carrier, disable periodic and aperiodic CQI reports, disable SRS, set *TimeAlignmentTimerDedicated* IE to infinity and disable downlink and uplink scheduling, all as per Table 4.6-1 under clause 4.6.

Step 6 of initial conditions as in clause 7.5.4.1 in TS 38.521-2 [9] is replaced by:

6. Ensure the UE is in state RRC_CONNECTED with generic procedure parameters Connectivity EN-DC, DC bearer MCG and SCG, Connected without release On according to TS 38.508-1 [6] clause 4.5.

7.5B.4.4.2 Test Procedure

Same test procedure as specified in clause 7.5.4.2 in TS 38.521-2 [9] with the following exceptions for E-UTRA anchor
On the E-UTRA carrier, disable periodic and aperiodic CQI reports, disable SRS, set *TimeAlignmentTimerDedicated* IE to infinity and disable downlink and uplink scheduling, all as per Table 4.6-1 under clause 4.6.

7.5B.4.4.3 Message contents

Message contents are according to TS 38.508-1 [6] clause 4.6.1.

7.5B.4.5 Test requirement

Same test requirement as specified in TS 38.521-2 [9] Clause 7.5.5.

7.5B.4_1 Adjacent Channel Selectivity for inter-band EN-DC including FR2 (>2 CCs)

7.5B.4_1.1 Adjacent Channel Selectivity for inter-band EN-DC including FR2 (3 CCs)

Editor's note: This test case is not complete. Following aspects are either missing or not yet determined:

- Working assumption: to avoid LTE CA testing in inter-band EN-DC including FR2 and only PCC band is configured.
- MU and TT are FFS.
- [Table 7.5A.4.1-1] in TS 38.521-2 [9] where the configuration for NR CA carriers are shown is FFS.
- [clause 7.5A.4.1] in TS 38.521-2 [9] where the initial conditions for NR CA is FFS.
- [clause 7.5A.4.2] in TS 38.521-2 [9] where the test procedure for NR CA is FFS.
- [Clause 7.5A.5] in TS 38.521-2 [9] where the test requirements for NR CA is FFS.
- [Clause 7.5A] in TS 38.521-2 [9] where the test description for NR CA is FFS.
- How to choose the LTE anchor when LTE CA is implemented is FFS.

7.5B.4_1.1.1 Test purpose

Same test purpose as in clause 7.5B.1.1.

7.5B.4_1.1.2 Test applicability

This test case applies to all types of E-UTRA UE release 15 and forward, supporting inter-band EN-DC including FR2 with 3 DL CCs (2NR DL CCs).

7.5B.4_1.1.3 Minimum conformance requirements

The minimum conformance requirements are defined in clause 7.5B.0.4.

No exception requirements applicable to NR or LTE. LTE anchor agnostic approach is applied.

7.5B.4_1.1.4 Test description

- For inter-band of "single carrier LTE + 2DL FR2 CA", the test description of 2DL FR2 CA for adjacent channel selectivity is the same as in corresponding clause 7.5A in TS 38.521-2 [9] for FR2 with the exceptions described below.

- For inter-band of "2DL LTE CA + single carrier FR2", the test description of single carrier FR2 for adjacent channel selectivity is the same as in corresponding clause 7.5 in TS 38.521-2 [9] for FR2 with the exceptions described below.

7.5B.4_1.1.4.1 Initial Condition

Initial conditions are a set of test configurations the UE needs to be tested in and the steps for the SS to take with the UE to reach the correct measurement state.

The initial test configurations consist of environmental conditions, test frequencies and channel bandwidths based on EN-DC operating bands specified in clause 5.2B.5.2, channel bandwidths and sub-carrier spacings for the NR cell specified in TS 38.521-2 [9] clause 5.3 or clause 5.3A and channel bandwidth for the E-UTRA cell are specified in TS 36.521-1 [10] clause 5.4.2 or clause 5.4.2A. All of these configurations shall be tested with applicable test parameters for each inter-band EN-DC including FR2 configuration specified in clause 5.5B.5.2, and the configuration for NR carrier are shown in TS 38.521-2 [9] Table 7.5.4.1-1 or [Table 7.5A.4.1-1].

For initial conditions as in clause 7.5.4.1 or [clause 7.5A.4.1] in TS 38.521-2 [9], the following steps are added to configure E-UTRA component:

- 2.1. The parameter settings for E-UTRA cell are set up according to TS 36.508 [11] clause 4.4.3. The E-UTRA downlink signal level, uplink signal level are set according to Table 4.6-1 and propagation conditions are set according to Annex B.0 of TS 36.521-1 [10].
7. On the E-UTRA carrier, disable periodic and aperiodic CQI reports, disable SRS, set *TimeAlignmentTimerDedicated* IE to infinity and disable downlink and uplink scheduling, all as per Table 4.6-1 under clause 4.6.

Step 6 of initial conditions as in clause 7.5.4.1 or [clause 7.5A.4.1] in TS 38.521-2 [9] is replaced by:

6. Ensure the UE is in state RRC_CONNECTED with generic procedure parameters Connectivity EN-DC, DC bearer MCG and SCG, Connected without release On according to TS 38.508-1 [6] clause 4.5.

7.5B.4_1.1.4.2 Test Procedure

Same test procedure as specified in clause 7.5.4.2 or [clause 7.5A.4.2] in TS 38.521-2 [9] with the following exceptions for E-UTRA anchor

On the E-UTRA carrier, disable periodic and aperiodic CQI reports, disable SRS, set *TimeAlignmentTimerDedicated* IE to infinity and disable downlink and uplink scheduling, all as per Table 4.6-1 under clause 4.6.

7.5B.4_1.1.4.3 Message contents

Message contents are according to TS 38.508-1 [6] clause 4.6.1.

7.5B.4_1.1.5 Test requirement

Same test requirement as specified in TS 38.521-2 [9] Clause 7.5.5 or [Clause 7.5A.5].

7.5B.4_1.2 Adjacent Channel Selectivity for inter-band EN-DC including FR2 (4 CCs)

Editor's note: This test case is not complete. Following aspects are either missing or not yet determined:

- Working assumption: to avoid LTE CA testing in inter-band EN-DC including FR2 and only PCC band is configured.
- MU and TT are FFS.
- [Table 7.5A.4.1-1] in TS 38.521-2 [9] where the configuration for NR CA carriers are shown in FFS.
- [clause 7.5A.4.1] in TS 38.521-2 [9] where the initial conditions for NR CA in FFS.
- [clause 7.5A.4.2] in TS 38.521-2 [9] where the test procedure for NR CA in FFS.
- [Clause 7.5A.5] in TS 38.521-2 [9] where the test requirements for NR CA in FFS.

- [Clause 7.5A] in TS 38.521-2 [9] where the test description for NR CA is FFS.
- How to choose the LTE anchor when LTE CA is implemented is FFS.

7.5B.4_1.2.1 Test purpose

Same test purpose as in clause 7.5B.1.1.

7.5B.4_1.2.2 Test applicability

This test case applies to all types of E-UTRA UE release 15 and forward, supporting inter-band EN-DC including FR2 with 4 DL CCs (3NR DL CCs).

7.5B.4_1.2.3 Minimum conformance requirements

The minimum conformance requirements are defined in clause 7.5B.0.4.

No exception requirements applicable to NR or LTE. LTE anchor agnostic approach is applied.

7.5B.4_1.2.4 Test description

- For inter-band of "single carrier LTE + 3DL FR2 CA", the test description of 3DL FR2 CA for adjacent channel selectivity is the same as in corresponding part of clause 7.5A in TS 38.521-2 [9] for FR2 with the exceptions described below.
- For inter-band of "2DL LTE CA + 2DL FR2 CA", the test description of 2DL FR2 CA for adjacent channel selectivity is the same as in corresponding part of clause 7.5A in TS 38.521-2 [9] for FR2 with the exceptions described below.
- For inter-band of "3DL LTE CA + single carrier FR2", the test description of single carrier FR2 for adjacent channel selectivity is the same as in corresponding part of clause 7.5 in TS 38.521-2 [9] for FR2 with the exceptions described below.

7.5B.4_1.2.4.1 Initial Condition

Initial conditions are a set of test configurations the UE needs to be tested in and the steps for the SS to take with the UE to reach the correct measurement state.

The initial test configurations consist of environmental conditions, test frequencies and channel bandwidths based on EN-DC operating bands specified in clause 5.2B.5.3, channel bandwidths and sub-carrier spacings for the NR cell specified in TS 38.521-2 [9] clause 5.3 or clause 5.3A and channel bandwidth for the E-UTRA cell are specified in TS 36.521-1 [10] clause 5.4.2 or clause 5.4.2A. All of these configurations shall be tested with applicable test parameters for each inter-band EN-DC including FR2 configuration specified in clause 5.5B.5.3, and the configuration for NR carrier are shown in TS 38.521-2 [9] Table 7.5.4.1-1 or [Table 7.5A.4.1-1].

For initial conditions as in clause 7.5.4.1 or [clause 7.5A.4.1] in TS 38.521-2 [9], the following steps are added to configure E-UTRA component:

- 2.1. The parameter settings for E-UTRA cell are set up according to TS 36.508 [11] clause 4.4.3. The E-UTRA downlink signal level, uplink signal level are set according to Table 4.6-1 and propagation conditions are set according to Annex B.0 of TS 36.521-1 [10].
7. On the E-UTRA carrier, disable periodic and aperiodic CQI reports, disable SRS, set *TimeAlignmentTimerDedicated* IE to infinity and disable downlink and uplink scheduling, all as per Table 4.6-1 under clause 4.6.

Step 6 of initial conditions as in clause 7.5.4.1 or [clause 7.5A.4.1] in TS 38.521-2 [9] is replaced by:

6. Ensure the UE is in state RRC_CONNECTED with generic procedure parameters Connectivity EN-DC, DC bearer MCG and SCG, Connected without release On according to TS 38.508-1 [6] clause 4.5.

7.5B.4_1.2.4.2 Test Procedure

Same test procedure as specified in clause 7.5B.4.2.4.2.

7.5B.4_1.2.4.3 Message contents

Same message contents as specified in clause 7.5B.4.2.4.3.

7.5B.4_1.2.5 Test requirement

Same test requirement as specified in clause 7.5B.4.2.5.

7.5B.4_1.3 Adjacent Channel Selectivity for inter-band EN-DC including FR2 (5 CCs)

Editor's note: This test case is not complete. Following aspects are either missing or not yet determined:

- Working assumption: to avoid LTE CA testing in inter-band EN-DC including FR2 and only PCC band is configured.
- MU and TT are FFS.
- [Table 7.5A.4.1-1] in TS 38.521-2 [9] where the configuration for NR CA carriers are shown is FFS.
- [clause 7.5A.4.1] in TS 38.521-2 [9] where the initial conditions for NR CA is FFS.
- [clause 7.5A.4.2] in TS 38.521-2 [9] where the test procedure for NR CA is FFS.
- [Clause 7.5A.5] in TS 38.521-2 [9] where the test requirements for NR CA is FFS.
- [Clause 7.5A] in TS 38.521-2 [9] where the test description for NR CA is FFS.
- How to choose the LTE anchor when LTE CA is implemented is FFS.

7.5B.4_1.3.1 Test purpose

Same test purpose as in clause 7.5B.1.1.

7.5B.4_1.3.2 Test applicability

This test case applies to all types of E-UTRA UE release 15 and forward, supporting inter-band EN-DC including FR2 with 5 DL CCs (4NR DL CCs).

7.5B.4_1.3.3 Minimum conformance requirements

The minimum conformance requirements are defined in clause 7.5B.0.4.

No exception requirements applicable to NR or LTE. LTE anchor agnostic approach is applied.

7.5B.4_1.3.4 Test description

- For inter-band of "single carrier LTE + 4DL FR2 CA", the test description of 4DL FR2 CA for adjacent channel selectivity is the same as in corresponding part of clause 7.5A in TS 38.521-2 [9] for FR2 with the exceptions described below.
- For inter-band of "2DL LTE CA + 3DL FR2 CA", the test description of 3DL FR2 CA for adjacent channel selectivity is the same as in corresponding part of clause 7.5A in TS 38.521-2 [9] for FR2 with the exceptions described below.
- For inter-band of "3DL LTE CA + 2DL FR2 CA", the test description of 2DL FR2 CA for adjacent channel selectivity is the same as in corresponding part of clause 7.5A in TS 38.521-2 [9] for FR2 with the exceptions described below.

- For inter-band of "4DL LTE CA + single carrier FR2", the test description of single carrier FR2 for adjacent channel selectivity is the same as in corresponding part of clause 7.5 in TS 38.521-2 [9] for FR2 with the exceptions described below.

7.5B.4_1.3.4.1 Initial Condition

Initial conditions are a set of test configurations the UE needs to be tested in and the steps for the SS to take with the UE to reach the correct measurement state.

The initial test configurations consist of environmental conditions, test frequencies and channel bandwidths based on EN-DC operating bands specified in clause 5.2B.5.4, channel bandwidths and sub-carrier spacings for the NR cell specified in TS 38.521-2 [9] clause 5.3 or clause 5.3A and channel bandwidth for the E-UTRA cell are specified in TS 36.521-1 [10] clause 5.4.2 or clause 5.4.2A. All of these configurations shall be tested with applicable test parameters for each inter-band EN-DC including FR2 configuration specified in clause 5.5B.5.4, and the configuration for NR carrier are shown in TS 38.521-2 [9] Table 7.5.4.1-1 or [Table 7.5A.4.1-1].

For initial conditions as in clause 7.5.4.1 or [clause 7.5A.4.1] in TS 38.521-2 [9], the following steps are added to configure E-UTRA component:

- 2.1. The parameter settings for E-UTRA cell are set up according to TS 36.508 [11] clause 4.4.3. The E-UTRA downlink signal level, uplink signal level are set according to Table 4.6-1 and propagation conditions are set according to Annex B.0 of TS 36.521-1 [10].
7. On the E-UTRA carrier, disable periodic and aperiodic CQI reports, disable SRS, set *TimeAlignmentTimerDedicated* IE to infinity and disable downlink and uplink scheduling, all as per Table 4.6-1 under clause 4.6.

Step 6 of initial conditions as in clause 7.5.4.1 or [clause 7.5A.4.1] in TS 38.521-2 [9] is replaced by:

6. Ensure the UE is in state RRC_CONNECTED with generic procedure parameters Connectivity EN-DC, DC bearer MCG and SCG, Connected without release On according to TS 38.508-1 [6] clause 4.5.

7.5B.4_1.3.4.2 Test Procedure

Same test procedure as specified in clause 7.5B.4.2.4.2.

7.5B.4_1.3.4.3 Message contents

Same message contents as specified in clause 7.5B.4.2.4.3.

7.5B.4_1.3.5 Test requirement

Same test requirement as specified in clause 7.5B.4.2.5.

7.5B.4_1.4 Adjacent Channel Selectivity for inter-band EN-DC including FR2 (6 CCs)

Editor's note: This test case is not complete. Following aspects are either missing or not yet determined:

- Working assumption: to avoid LTE CA testing in inter-band EN-DC including FR2 and only PCC band is configured.
- MU and TT are FFS.
- [Table 7.5A.4.1-1] in TS 38.521-2 [9] where the configuration for NR CA carriers are shown is FFS.
- [clause 7.5A.4.1] in TS 38.521-2 [9] where the initial conditions for NR CA is FFS.
- [clause 7.5A.4.2] in TS 38.521-2 [9] where the test procedure for NR CA is FFS.
- [Clause 7.5A.5] in TS 38.521-2 [9] where the test requirements for NR CA is FFS.
- [clause 5.2B.5.5] where EN-DC operating bands have been specified is FFS.
- [Clause 7.5A] in TS 38.521-2 [9] where the test description for NR CA is FFS.

- How to choose the LTE anchor when LTE CA is implemented is FFS.

7.5B.4_1.4.1 Test purpose

Same test purpose as in clause 7.5B.1.1.

7.5B.4_1.4.2 Test applicability

This test case applies to all types of E-UTRA UE release 15 and forward, supporting inter-band EN-DC including FR2 with 6 DL CCs (5NR DL CCs).

7.5B.4_1.4.3 Minimum conformance requirements

The minimum conformance requirements are defined in clause 7.5B.0.4.

No exception requirements applicable to NR or LTE. LTE anchor agnostic approach is applied.

7.5B.4_1.4.4 Test description

- For inter-band of "single carrier LTE + 5DL FR2 CA", the test description of 5DL FR2 CA for adjacent channel selectivity is the same as in corresponding part of clause 7.5A in TS 38.521-2 [9] for FR2 with the exceptions described below.
- For inter-band of "2DL LTE CA + 4DL FR2 CA", the test description of 4DL FR2 CA for adjacent channel selectivity is the same as in corresponding part of clause 7.5A in TS 38.521-2 [9] for FR2 with the exceptions described below.
- For inter-band of "3DL LTE CA + 3DL FR2 CA", the test description of 3DL FR2 CA for adjacent channel selectivity is the same as in corresponding part of clause 7.5A in TS 38.521-2 [9] for FR2 with the exceptions described below.
- For inter-band of "4DL LTE CA + 2DL FR2 CA", the test description of 2DL FR2 CA for adjacent channel selectivity is the same as in corresponding part of clause 7.5A in TS 38.521-2 [9] for FR2 with the exceptions described below.
- For inter-band of "5DL LTE CA + single carrier FR2", the test description of single carrier FR2 for adjacent channel selectivity is the same as in corresponding part of clause 7.5 in TS 38.521-2 [9] for FR2 with the exceptions described below.

7.5B.4_1.4.4.1 Initial Condition

Initial conditions are a set of test configurations the UE needs to be tested in and the steps for the SS to take with the UE to reach the correct measurement state.

The initial test configurations consist of environmental conditions, test frequencies and channel bandwidths based on EN-DC operating bands specified in [clause 5.2B.5.5], channel bandwidths and sub-carrier spacings for the NR cell specified in TS 38.521-2 [9] clause 5.3 or clause 5.3A and channel bandwidth for the E-UTRA cell are specified in TS 36.521-1 [10] clause 5.4.2 or clause 5.4.2A. All of these configurations shall be tested with applicable test parameters for each inter-band EN-DC including FR2 configuration specified in clause 5.5B.5.5, and the configuration for NR carrier are shown in TS 38.521-2 [9] Table 7.5.4.1-1 or [Table 7.5A.4.1-1].

For initial conditions as in clause 7.5.4.1 or [clause 7.5A.4.1] in TS 38.521-2 [9], the following steps are added to configure E-UTRA component:

- 2.1. The parameter settings for E-UTRA cell are set up according to TS 36.508 [11] clause 4.4.3. The E-UTRA downlink signal level, uplink signal level are set according to Table 4.6-1 and propagation conditions are set according to Annex B.0 of TS 36.521-1 [10].
7. On the E-UTRA carrier, disable periodic and aperiodic CQI reports, disable SRS, set *TimeAlignmentTimerDedicated* IE to infinity and disable downlink and uplink scheduling, all as per Table 4.6-1 under clause 4.6.

Step 6 of initial conditions as in clause 7.5.4.1 or [clause 7.5A.4.1] in TS 38.521-2 [9] is replaced by:

6. Ensure the UE is in state RRC_CONNECTED with generic procedure parameters Connectivity EN-DC, DC bearer MCG and SCG, Connected without release On according to TS 38.508-1 [6] clause 4.5.

7.5B.4_1.4.4.2 Test Procedure

Same test procedure as specified in clause 7.5B.4.2.4.2.

7.5B.4_1.4.4.3 Message contents

Same message contents as specified in clause 7.5B.4.2.4.3.

7.5B.4_1.4.5 Test requirement

Same test requirement as specified in clause 7.5B.4.2.5.

7.5B.4D Adjacent Channel Selectivity for inter-band EN-DC including FR2 for UL-MIMO

No exception requirements applicable to NR or LTE. LTE anchor agnostic approach can be applied and only NR carriers need to be tested.

No test case details are specified. Given UE's Rx performance would not be impacted by the Tx configuration in NR FR2 TDD bands, the requirements in this test case can be well covered in 7.5B.4 and 7.5B.4_1 and don't need to be tested again.

7.5B.5 Adjacent Channel Selectivity for inter-band EN-DC including both FR1 and FR2

7.5B.5.1 Test purpose

Same test purpose as in 7.5.1 in TS 38.521-1 [8] for NR FR1 carrier and 7.5.1 in TS 38.521-2 [9] for NR FR2 carrier.

7.5B.5.2 Test applicability

The requirements in this test are not testable due to issues with combined testing of NR FR1 and E-UTRA in conducted mode with NR FR2 in radiated mode. Therefore, the conducted and radiated requirements are tested separately.

No test case details are specified. The NSA requirements for adjacent channel selectivity apply and are tested as part of the EN-DC within FR1 and EN-DC including FR2 test cases in clause 7.5B.

7.5B.5D Adjacent Channel Selectivity for inter-band EN-DC including FR1 and FR2 for UL-MIMO

7.5B.5D.1 Test purpose

Same test purpose as in 7.5D in TS 38.521-1 [8] for NR FR1 carrier and 7.5D in TS 38.521-2 [9] for NR FR2 carrier.

7.5B.5D.2 Test applicability

The requirements in this test are not testable due to issues with combined testing of NR FR1 and E-UTRA in conducted mode with NR FR2 in radiated mode. Therefore, the conducted and radiated requirements are tested separately.

No test case details are specified. The NSA requirements for adjacent channel selectivity apply and are tested as part of the EN-DC within FR1 and EN-DC including FR2 test cases in clause 7.5B.

7.6 Void

7.6A Blocking characteristics for CA

7.6A.1 Test purpose

Same test purpose as in clause 7.6 in TS 38.521-1 [8] for NR FR1 carrier(s) and clause 7.6 in TS 38.521-2 [9] for NR FR2 carrier(s).

7.6A.2 Test applicability

The requirements in this test are not testable due to issues with combined testing of NR FR1 conducted mode with NR FR2 in radiated mode. Therefore, the conducted and radiated requirements are tested separately.

No test case details are specified. The SA requirements for blocking characteristics apply and are tested in TS 38.521-1 [8] clause 7.6 and 7.6A and TS 38.521-2 [9] clauses 7.6 and 7.6A.

7.6B Blocking characteristics for DC

7.6B.1 General

The blocking characteristic for EN-DC in FR1 is a measure of the receiver's ability of an UE that support EN-DC in FR1 to receive a wanted signal at its assigned channel frequency in the presence of an unwanted interferer on frequencies other than those of the spurious response or the adjacent channels, without this unwanted input signal causing a degradation of the performance of the receiver beyond a specified limit. The blocking performance shall apply at all frequencies except those at which a spurious response occur.

7.6B.2 Inband blocking for DC

7.6B.2.0 Minimum Conformance Requirements

7.6B.2.0.1 Intra-band contiguous EN-DC in FR1

Intra-band contiguous EN-DC in-band blocking requirement and parameters are defined in Table 7.6B.2.0.1-1.

Table 7.6B.2.0.1-1: In-band blocking for intra-band contiguous EN-DC

EN-DC Aggregated Bandwidth, MHz	≤100	>100, ≤120	>120, ≤140	>140, ≤160
P _w in Transmission Bandwidth Configuration, perCC, dBm	REFSENS + Aggregated BW specific value below			
	P _w ¹	16.8	17.5	18
NOTE 1: P _w is wanted signal power level at the specified EN-DC aggregated Bandwidth from Table 7.6.1.1A-1 in TS 36.101 [5].				
NOTE 2: Interferer values are specified from Table 7.6.1.1A-2 in TS 36.101 [5].				
NOTE 3: Jammer BW and offset is from Table 7.6.1.1A-1 in TS 36.101 [5] and is applied from the lowest edge of the lowest carrier and the highest edge of the highest carrier.				
NOTE 4: For NR carrier, the transmitter shall be set to 4dB below P _{C_{MAX}_L_{f,c},NR} at the minimum uplink configuration specified in Table 7.3.2-3 [2] with P _{C_{MAX}_L_{f,c},NR} as defined in clause 6.2B.4.				
NOTE 5: For E-UTRA carrier, the transmitter shall be set to 4dB below P _{C_{MAX}_L_{E-UTRA,c}} at the minimum uplink configuration specified in Table 7.3.1-2 in TS 36.101 [5] with P _{C_{MAX}_L_{E-UTRA,c}} as defined in clause 6.2B.4 for single carrier.				

The normative reference for this requirement is TS 38.101-3 [4] clause 7.6B.2.1.

7.6B.2.0.2 Intra-band non-contiguous EN-DC in FR1

For the E-TRA sub-block containing one or multiple CC's, the requirement is defined in clause 7.6.1.1 for single carrier operation and in clause 7.6.1.1A for CA in TS 36.101 [5].

For the NR sub-block, the requirement is defined in clause 7.6.2 in TS 38.101-1 [2].

The blocker configuration is defined in the general clause 7.1.

The normative reference for this requirement is TS 38.101-3 [4] clause 7.6B.2.2.

7.6B.2.0.3 Inter-band EN-DC within FR1

Inband blocking requirement for E-UTRA single carrier and CA operation specified in clauses 7.6.1.1 and 7.6.1.1A of TS 36.101 [5] and for NR single carrier and CA operation specified in clauses 7.6.2 and 7.6A.2 of TS 38.101-1 [2] apply.

The normative reference for this requirement is TS 38.101-3 [4] clause 7.6B.2.3.

7.6B.2.0.3A Inter-band NE-DC within FR1

Inband blocking requirement for E-UTRA single carrier and CA operation specified in clauses 7.6.1.1 and 7.6.1.1A of TS 36.101 [5] and for NR single carrier and CA operation specified in clauses 7.6.2 and 7.6A.2 of TS 38.101-1 [2] apply.

The normative reference for this requirement is TS 38.101-3 [4] clause 7.6B.2.3a.

7.6B.2.0.4 Inter-band EN-DC including FR2

Inband blocking requirement for E-UTRA single carrier and CA operation specified in clauses 7.6.1.1 and 7.6.1.1A of TS 36.101 [5] and for NR single carrier and CA operation specified in clauses 7.6.2 and 7.6A.2 of TS 38.101-2 [3] apply.

The normative reference for this requirement is TS 38.101-3 [4] clause 7.6B.2.4.

7.6B.2.0.5 Inter-band EN-DC including both FR1 and FR2

Inband blocking requirement for E-UTRA single carrier and CA operation specified in clauses 7.6.1.1 and 7.6.1.1A of TS 36.101 [5] and for NR single carrier and CA operation specified in clauses 7.6.2 and 7.6A.2 of TS 38.101-1 [2] and TS 38.101-2 [3] apply.

The normative reference for this requirement is TS 38.101-3 [4] clause 7.6B.2.5.

7.6B.2.1 Inband blocking for intra-band contiguous EN-DC in FR1 (2 CCs)

7.6B.2.1.1 Test Purpose

In-band blocking is defined for an unwanted interfering signal falling into the range from 15MHz below to 15MHz above the UE receive band, at which the relative throughput shall meet or exceed the requirement for the specified measurement channels. The lack of in-band blocking ability will decrease the coverage area when other NodeB transmitters exist (except in the adjacent channels and spurious response).

7.6B.2.1.2 Test Applicability

This test case applies to all types of E-UTRA UE release 15 and forward, supporting intra-band contiguous EN-DC in FR1 with 2CCs.

7.6B.2.1.3 Minimum Conformance Requirements

The minimum conformance requirements are defined in clause 7.6 B.2.0.1.

Exception requirements for both NR and E-UTRA are defined for this test and therefore LTE anchor agnostic approach is not applied. E-UTRA test point analysis is included and E-UTRA measurements are performed.

7.6B.2.1.4 Test Description

7.6 B.2.1.4.1 Initial condition

Initial conditions are a set of test configurations the UE needs to be tested in and the steps for the SS to take with the UE to reach the correct measurement state.

The initial test configurations consist of environmental conditions, test frequencies and channel bandwidths based on EN-DC operating bands specified in clause 5.3B.1.2, channel bandwidths and sub-carrier spacings for the NR cell specified in TS 38.521-1 [8] clause 5.3 and channel bandwidth for the E-UTRA cell are specified in TS 36.521-1 [10] clause 5.4.2. All of these configurations shall be tested with applicable test parameters for each EN-DC configuration specified in clause 5.3B.1.2 and are shown in Table 7.6B.2.1.4.1-1. The details of the uplink and downlink reference measurement channels (RMCs) are specified in Annex A.2 and A.3 respectively. The details of the OCNG patterns used are specified in TS 36.521-1 [10] Annex A.5 and in TS 38.521-1 [8] Annex A.5 for E-UTRA CG and NR CG respectively. Configurations of PDSCH and PDCCH before measurement are specified in TS 36.521-1 [10] Annex C.2 and in TS 38.521-1 [8] Annex C.2 for E-UTRA CG and NR CG respectively.

Table 7.6B.2.1.4.1-1: Test configuration table

Initial Conditions							
Test Environment as specified in TS 38.508-1 [6] clause 4.1				Normal			
Test Frequencies as specified in TS 38.508-1 [6] clause 4.3.1 for different EN-DC bandwidth classes				Mid range			
Test EN-DC bandwidth combination as specified in Table 5.3B.1.2-1 across bandwidth combination sets supported by the UE				Lowest N_{RB_agg} , Highest N_{RB_agg} (NOTE 3)			
NR Test SCS as specified in Table 5.3.5-1 in TS 38.521-1 [8]				Lowest			
NR/E-UTRA Test Parameters							
Downlink Configuration				Uplink Configuration			
NR Modulation	NR RB allocation	E-UTRA Modulation	E-UTRA RB allocation	NR Modulation	NR RB allocation	E-UTRA Modulation	E-UTRA RB allocation
CP-OFDM QPSK	Full RB (NOTE 1)	QPSK	Full RB	DFT-s-OFDM QPSK	REFSENS	QPSK	REFSENS
NOTE 1: Full RB allocation shall be used per each SCS and channel BW as specified in Table 7.3.2.4.1-2 of TS 38.521-1 [8].							
NOTE 2: Test Channel Bandwidths are checked separately for each EN-DC band, which applicable channel bandwidths are specified in Table 5.3B.1.2-1.							
NOTE 3: If the UE supports multiple CC Combinations in the EN-DC Configuration with the same N_{RB_agg} , only the combination with the highest N_{RB_SCG} is tested.							
NOTE 4: REFSENS refers to Uplink configuration in Table 7.3.2.3-3 in [8] and Table 7.3.3-2 in [10] for NR and E-UTRA CC respectively.							
NOTE 5: In an E-UTRA band or FR1 band where UE supports 4Rx, the test shall be performed only with 4Rx antennas ports connected and 4Rx REFSENS requirement (TS 38.521-1 [8] Table 7.3.2.5-2) is used in the test requirements.							

1. Connect the SS to the UE antenna connectors as shown in [6] TS 38.508-1 Annex A, in Figure A.3.1.4.1 for SS diagram and clause A.3.2 for UE diagram.
2. The parameter settings for the E-UTRA cell are set up according to TS 36.508 [11] clause 4.4.3, and the parameter settings for the NR cell are set up according to TS 38.508-1 [6] clause 4.4.3.
3. Downlink signals are initially set up according to TS 36.521-1 [10] Annex C and TS 38.521-1 [8] Annex C for E-UTRA CG and NR CG respectively, and uplink signals according to TS 36.521-1 [10] Annex H and TS 38.521-1 [8] Annex G for E-UTRA CG and NR CG respectively.

4. The UL and DL Reference Measurement channels are TS 36.521-1 [10] Annex A.2, A.3 and TS 38.521-1 [8] Annex A.2 , A.3 for E-UTRA CG and NR CG respectively.
5. Propagation conditions are set according to TS 36.521-1 [10] Annex B.0 and TS 38.521-1 [8] Annex B.0 for E-UTRA CG and NR CG respectively.
6. Ensure the UE is in state RRC_CONNECTED with generic procedure parameters Connectivity EN-DC, DC bearer *MCG* and *SCG*, Connected without release *On* according to TS 38.508-1 [6] clause 4.5. Message contents are defined in clause 7.6B.2.1.4.3.

7.6B.2.1.4.2 Test procedure

1. SS transmits PDSCH via PDCCH DCI format 1A and PDCCH DCI format 1_1 for C_RNTI to transmit the DL RMC according to Table 7.6B.2.1.4.1-1 on E-UTRA CC and NR CC respectively. The SS sends downlink MAC padding bits on the DL RMC.
2. SS sends uplink scheduling information for each UL HARQ process via PDCCH DCI format 0 and DCI format 0_1 for C_RNTI to schedule the UL RMC according to Table 7.6B.2.1.4.1-1 on E-UTRA CC and NR CC respectively. Since the UL has no payload and no loopback data to send the UE sends uplink MAC padding bits on the UL RMC.
3. Set the Downlink signal level to the value as defined in Table 7.6B.2.1.5-1. For NR CC and E-UTRA CC, send uplink power control commands to the UE using 1dB power step size to ensure that the UE output power measured by the test system is within the Uplink power control window, defined as $-(\text{MU} + \text{Uplink power control window size})$ dB of the target power level in Table 7.6B.2.1.5-1 $+([10\log(S_{\text{L}_{\text{CRB}}/N_{\text{RB_alloc}})]$ for NR CC, $[10\log(P_{\text{L}_{\text{CRB}}/N_{\text{RB_alloc}})]$ for E-UTRA CC) for at least the duration of the Throughput measurement, where:
 - MU is the test system uplink power measurement uncertainty and is specified in Table F.1.3-1 for the carrier frequency f and the channel bandwidth BW
 - For NR CC, Uplink power control window size = 1dB (UE power step size) + 0.7dB (UE power step tolerance) + (Test system relative power measurement uncertainty), where, the UE power step tolerance is specified in TS 38.101-1 [2], Table 6.3.4.3-1 and is 0.7dB for 1dB power step size, and the Test system relative power measurement uncertainty is specified in Table F.1.2-1.
 - For E-UTRA CC, Uplink power control window size = 1dB (UE power step size) + 1.0dB (UE power step tolerance) + (Test system relative power measurement uncertainty), where, the UE power step tolerance is specified in TS 36.101 [5], Table 6.3.5.2.1-1 and is 1.0dB for 1dB power step size, and the Test system relative power measurement uncertainty is specified in Table F.1.2-1 of TS 36.521-1 [10].
4. Set the parameters of the signal generator for an interfering signal below the aggregated component carriers in Case 1 according to Table 7.6B.2.1.5-1.
5. Measure the average throughput for a duration sufficient to achieve statistical significance according to Annex H.2.
6. Repeat steps from 4 to 5, using an interfering signal above the aggregated component carriers in Case 1 at step 4.
7. Repeat steps from 4 to 6, using interfering signals in Case 2 at steps 4 and 6.

NOTE: The purpose of the Uplink power control window is to ensure that the actual UE output power is no greater than the target power level, and as close as possible to the target power level. The relationship between the Uplink power control window, the target power level and the corresponding possible actual UE Uplink power window is illustrated in Annex F, clause F.4.

7.6B.2.1.4.3 Message contents

Message contents are according to TS 38.508-1 [6] clause 4.6 Table 4.6.3-118 with condition TRANSFORM_PRECODER_ENABLED.

7.6B.2.1.5 Test Requirement

The throughput shall be $\geq 95\%$ of the maximum throughput of the reference measurement channels as specified in TS 36.521-1 [10] Annex A.3 and TS 38.521-1 [8] Annex A.3 for E-UTRA CG and NR CG respectively with parameters specified in Table 7.6B.2.1.5-1 for the specified wanted signal mean power in the presence of interfering signals.

Table 7.6B.2.1.5-1: In-band blocking for intra-band contiguous EN-DC

EN-DC Aggregated Bandwidth, MHz	≤ 100	$>100, \leq 120$	$>120, \leq 140$	$>140, \leq 160$
Pw in Transmission Bandwidth Configuration, perCC, dBm	REFSENS + Aggregated BW specific value below			
	P_w^1	16.8	17.5	18
NOTE 1: P_w is wanted signal power level at the specified EN-DC aggregated Bandwidth from Table 7.6.1.1A-1 in TS 36.101 [5].				
NOTE 2: Interferer values are specified from Table 7.6.1.1A-2 in TS 36.101 [5].				
NOTE 3: Jammer BW and offset is from Table 7.6.1.1A-1 in TS 36.101 [5] and is applied from the lowest edge of the lowest carrier and the highest edge of the highest carrier.				
NOTE 4: For NR carrier, the transmitter shall be set to 4dB below $P_{\text{CMAX_L,f,c,NR}}$ at the minimum uplink configuration specified in TS 38.101-1 [2], Table 7.3.2-3 with $P_{\text{CMAX_L,f,c,NR}}$ as defined in clause 6.2B.4.				
NOTE 5: For E-UTRA carrier, the transmitter shall be set to 4dB below $P_{\text{CMAX_L,E-UTRA,c}}$ at the minimum uplink configuration specified in TS 36.101 [5], Table 7.3.1-2 with $P_{\text{CMAX_L,E-UTRA,c}}$ as defined in clause 6.2B.4 for single carrier.				

Table 7.6B.2.1.5-2: Void**Table 7.6B.2.1.5-3: Void**

7.6B.2.2 Inband blocking for intra-band non-contiguous EN-DC in FR1 (2 CCs)

7.6B.2.2.1 Test Purpose

Same test purpose as in clause 7.6.2.1 in TS 38.521-1 [8] for the NR carrier.

7.6B.2.2.2 Test Applicability

This test case applies to all types of E-UTRA UE release 15 and forward, supporting intra-band non-contiguous EN-DC in FR1 with 2CCs.

7.6B.2.2.3 Minimum Conformance Requirements

The minimum conformance requirements are defined in clause 7.6B.2.0.2.

No exception requirements applicable to NR or LTE. LTE anchor agnostic approach is applied.

7.6B.2.2.4 Test Description

Same test description as in clause 7.6.2.4 in TS 38.521-1 [8] for the NR carrier with the following exceptions:

Table 7.6B.2.2.4-1: Test Configuration Table

Initial Conditions	
Test Frequencies as specified in TS 38.508-1 [6] clause 4.3.1 for different EN-DC bandwidth classes	High range with maxWGap
Test EN-DC bandwidth combination as specified in Table 5.3B.1.2-1 across bandwidth combination sets supported by the UE	Highest N _{RB_agg} (NOTE1)
NOTE 1: If the UE supports multiple CC Combinations in the EN-DC Configuration with the same N _{RB_agg} , only the combination with the highest N _{RB_SCG} is tested.	

The initial test configurations for E-UTRA consist of test frequency based on E-UTRA operating band and test channel bandwidth as specified in Table 4.6-1 except for the parameters specified in Table 7.6B.2.2.4-1.

For Initial conditions as in clause 7.6.2.4.1 in TS 38.521-1 [8], add step 2.1 and step 3.1 as follows:

- 2.1. The parameter settings for E-UTRA cell are set up according to TS 36.508 [11] clause 4.4.3.
- 3.1. The E-UTRA downlink signal level, uplink signal level are set according to Table 4.6-1 and propagation conditions are set according to Annex B.0 of TS 36.521-1 [10].

Step 6 of Initial conditions as in clause 7.6.2.4.1 in TS 38.521-1 [8] is replaced by:

6. Ensure the UE is in state RRC_CONNECTED with generic procedure parameters Connectivity EN-DC, DC bearer MCG and SCG, Connected without release *On* according to TS 38.508 [6] clause 4.5.

Add step 7 to Initial conditions in clause 7.6.2.4.1 in TS 38.521-1 [8] as follows:

7. On the E-UTRA carrier, disable periodic and aperiodic CQI reports, disable SRS, set *TimeAlignmentTimerDedicated* IE to infinity and disable downlink and uplink scheduling, all as per Table 4.6-1 under clause 4.6.

Step 3 of Test procedure as in clause 7.6.2.4.2 in TS 38.521-1 [8] shall treat the in-gap tests as below: For intra-band non-contiguous EN-DC of two sub-blocks with channel bandwidth larger than or equal to 5 MHz, the existing requirements apply for in-gap tests only if the corresponding interferer frequency offsets satisfy the following condition in relation to the sub-block gap size W_{gap} , so that the interferer frequency position does not change the nature of the core requirement tested:

$$W_{\text{gap}} \geq 2 \cdot |F_{\text{Interferer}}(\text{offset})| - BW_{\text{Channel}}$$

Step 4 of Test procedure as in clause 7.6.2.4.2 in TS 38.521-1 [8] is replaced by:

4. Set the downlink signal level for NR CC according to the Table 7.6.2.5-1 or 7.6.2.5-3 in TS 38.521-1 [8] as appropriate. For NR CC and E-UTRA CC, send uplink power control commands to the UE using 1dB power step size to ensure that the UE output power measured by the test system is within the Uplink power control window, defined as $-MU$ to $-(MU + \text{Uplink power control window size})$ dB of $(P_{\text{CMAX_L,c}} - 29\text{dB})$ for E-UTRA CC, and of 4dB below $P_{\text{CMAX_L,f,c}}$ for NR CC for at least the duration of the Throughput measurement, where:
 - MU is the test system uplink power measurement uncertainty and is specified in Table F.1.3-1 for the carrier frequency f and the channel bandwidth BW
 - For NR CC, Uplink power control window size = 1dB (UE power step size) + 0.7dB (UE power step tolerance) + (Test system relative power measurement uncertainty), where, the UE power step tolerance is specified in TS 38.101-1 [2], Table 6.3.4.3-1 and is 0.7dB for 1dB power step size, and the Test system relative power measurement uncertainty is specified in Table F.1.2-1.
 - For E-UTRA CC, Uplink power control window size = 1dB (UE power step size) + 1.0dB (UE power step tolerance) + (Test system relative power measurement uncertainty), where, the UE power step tolerance is specified in TS 36.101 [5], Table 6.3.5.2.1-1 and is 1.0dB for 1dB power step size, and the Test system relative power measurement uncertainty is specified in Table F.1.2-1 of TS 36.521-1 [10].

7.6B.2.2.5 Test Requirement

Same test requirement as in clause 7.6.2.5 in TS 38.521-1 [8].

7.6B.2.3 Inband blocking for inter-band EN-DC within FR1 (2 CCs)

7.6B.2.3.1 Test Purpose

Same test purpose as in clause 7.6.2.1 in TS 38.521-1 [8] for the NR carrier.

7.6B.2.3.2 Test Applicability

This test case applies to all types of E-UTRA UE release 15 and forward, supporting inter-band EN-DC within FR1 with 2CCs.

7.6B.2.3.3 Minimum Conformance Requirements

The minimum conformance requirements are defined in clause 7.6B.2.0.3.

No exception requirements applicable to NR or LTE. LTE anchor agnostic approach is applied.

7.6B.2.3.4 Test Description

Same test description as in clause 7.6.2.4 in TS 38.521-1 [8] for the NR carrier with the following exceptions:

The initial test configurations for E-UTRA consist of test frequency based on E-UTRA operating band and test channel bandwidth as specified in Table 4.6-1.

For Initial conditions as in clause 7.6.2.4.1 in TS 38.521-1 [8], add step 2.1 and step 3.1 as follows:

- 2.1. The parameter settings for E-UTRA cell are set up according to TS 36.508 [11] clause 4.4.3.
- 3.1. The E-UTRA downlink signal level, uplink signal level are set according to Table 4.6-1 and propagation conditions are set according to Annex B.0 of TS 36.521-1 [10].

Step 6 of Initial conditions as in clause 7.6.2.4.1 in TS 38.521-1 [8] is replaced by:

6. Ensure the UE is in state RRC_CONNECTED with generic procedure parameters Connectivity EN-DC, DC bearer MCG and SCG, Connected without release *On* according to TS 38.508 [6] clause 4.5.

Add step 7 to Initial conditions in clause 7.6.2.4.1 in TS 38.521-1 [8] as follows:

7. On the E-UTRA carrier, disable periodic and aperiodic CQI reports, disable SRS, set *TimeAlignmentTimerDedicated* IE to infinity and disable downlink and uplink scheduling, all as per Table 4.6-1 under clause 4.6.

7.6B.2.3.5 Test Requirement

Same test requirement as in clause 7.6.2.5 in TS 38.521-1 [8].

7.6B.2.3_1 Inband blocking for EN-DC within FR1 (>2 CCs)

7.6B.2.3_1.1 Inband blocking for EN-DC within FR1 (3 CCs)

7.6B.2.3_1.1.1 Test Purpose

For intra-band contiguous EN-DC within FR1 with 3 DL CCs: In-band blocking is defined for an unwanted interfering signal falling into the range from 15MHz below to 15MHz above the UE receive band, at which the relative throughput shall meet or exceed the requirement for the specified measurement channels. The lack of in-band blocking ability will decrease the coverage area when other NodeB transmitters exist (except in the adjacent channels and spurious response).

For inter-band EN-DC within FR1 with 3 DL CCs (2NR DL CCs): Same test purpose as in clause 7.6A.2.1.1 in TS 38.521-1 [8].

7.6B.2.3_1.1.2 Test Applicability

This test case applies to all types of E-UTRA UE release 15 and forward, supporting intra-band contiguous EN-DC within FR1 with 3 DL CCs or inter-band EN-DC within FR1 with 3 DL CCs (2NR DL CCs).

7.6B.2.3_1.1.3 Minimum Conformance Requirements

For intra-band contiguous EN-DC within FR1 with 3 DL CCs: The minimum conformance requirements are defined in clause 7.6 B.2.0.1. Exception requirements for both NR and E-UTRA are defined and therefore LTE anchor agnostic approach is not applied. E-UTRA test point analysis is included and E-UTRA measurements are performed.

For inter-band EN-DC within FR1 with 3 DL CCs (2NR DL CCs): The minimum conformance requirements are defined in clause 7.6B.2.0.3.

No exception requirements applicable to NR or LTE. LTE anchor agnostic approach is applied.

7.6B.2.3_1.1.4 Test Description

7.6B.2.3_1.1.4.1 Intra-band contiguous EN-DC within FR1 with 3 DL CCs

7.6B.2.3_1.1.4.1.1 Initial condition

Initial conditions are a set of test configurations the UE needs to be tested in and the steps for the SS to take with the UE to reach the correct measurement state.

The initial test configurations consist of environmental conditions, test frequencies and channel bandwidths based on EN-DC operating bands specified in clause 5.3B.1.2, channel bandwidths and sub-carrier spacings for the NR cell specified in TS 38.521-1 [8] clause 5.3 and channel bandwidth for the E-UTRA cell are specified in TS 36.521-1 [10] clause 5.4.2. All of these configurations shall be tested with applicable test parameters for each EN-DC configuration specified in clause 5.3B.1.2 and are shown in Table 7.6B.2.3_1.1.4.1.1-1. The details of the uplink and downlink reference measurement channels (RMCs) are specified in Annex A.2 and A.3 respectively. The details of the OCNG patterns used are specified in TS 36.521-1 [10] Annex A.5 and in TS 38.521-1 [8] Annex A.5 for E-UTRA CG and NR CG respectively. Configurations of PDSCH and PDCCH before measurement are specified in TS 36.521-1 [10] Annex C.2 and in TS 38.521-1 [8] Annex C.2 for E-UTRA CG and NR CG respectively.

Table 7.6B.2.3_1.1.4.1.1-1: Test configuration table

Initial Conditions					
Test Environment as specified in TS 38.508-1 [6] clause 4.1			Normal		
Test Frequencies as specified in TS 38.508-1 [6] clause 4.3.1 for different EN-DC bandwidth classes			Mid range		
Test EN-DC bandwidth combination as specified in Table 5.3B.1.2-1 across bandwidth combination sets supported by the UE			Lowest N_{RB_agg} , Highest N_{RB_agg} (NOTE 3)		
NR Test SCS as specified in Table 5.3.5-1 in TS 38.521-1 [8]			Lowest		
NR/E-UTRA Test Parameters					
PCC – E-UTRA		SCC – EUTRA		NR	
UL/DL Modulation	UL/DL allocation	UL/DL Modulation	UL/DL allocation	UL/DL Modulation	UL/DL allocation
QPSK/QPSK	REFSENS/Full RB	NA/QPSK	NA/Full RB	DFT-s-OFDM QPSK/CP-OFDM QPSK	REFSENS/Full RB (NOTE 1)
NOTE 1: Full RB allocation shall be used per each SCS and channel BW as specified in Table 7.3.2.4.1-2 of TS 38.521-1 [8].					
NOTE 2: Test Channel Bandwidths are checked separately for each EN-DC band, which applicable channel bandwidths are specified in Table 5.3B.1.2-1.					
NOTE 3: If the UE supports multiple CC Combinations in the EN-DC Configuration with the same N_{RB_agg} , only the combination with the highest N_{RB_SCG} is tested.					
NOTE 4: REFSENS refers to Uplink configuration in Table 7.3.2.3-3 in [8] and Table 7.3.3-2 in [10] for NR and E-UTRA CC respectively.					
NOTE 5: In a FR1 band where UE supports 4Rx, the test shall be performed only with 4Rx antennas ports connected and 4Rx REFSENS requirement (TS 38.521-1 [8] Table 7.3.2.5-2) is used in the test requirements.					

1. Connect the SS to the UE antenna connectors as shown in [6] TS 38.508-1 Annex A, in Figure A.3.1.4.1 for SS diagram and clause A.3.2 for UE diagram.
2. The parameter settings for the E-UTRA cell are set up according to TS 36.508 [11] clause 4.4.3, and the parameter settings for the NR cell are set up according to TS 38.508-1 [6] clause 4.4.3.
3. Downlink signals are initially set up according to TS 36.521-1 [10] Annex C and TS 38.521-1 [8] Annex C for E-UTRA CG and NR CG respectively, and uplink signals according to TS 36.521-1 [10] Annex H and TS 38.521-1 [8] Annex G for E-UTRA CG and NR CG respectively.
4. The UL and DL Reference Measurement channels are TS 36.521-1 [10] Annex A.2, A.3 and TS 38.521-1 [8] Annex A.2, A.3 for E-UTRA CG and NR CG respectively.
5. Propagation conditions are set according to TS 36.521-1 [10] Annex B.0 and TS 38.521-1 [8] Annex B.0 for E-UTRA CG and NR CG respectively.
6. Ensure the UE is in state RRC_CONNECTED with generic procedure parameters Connectivity EN-DC, DC bearer *MCG* and *SCG*, Connected without release *On* according to TS 38.508-1 [6] clause 4.5. Message contents are defined in clause 7.6B.2.3_1.1.4.1.3.

7.6B.2.3_1.1.4.1.2 Test procedure

1. SS transmits PDSCH via PDCCH DCI format 1A and PDCCH DCI format 1_1 for C_RNTI to transmit the DL RMC according to Table 7.6B.2.3_1.1.4.1.1-1 on E-UTRA CC and NR CC respectively. The SS sends downlink MAC padding bits on the DL RMC.
2. SS sends uplink scheduling information for each UL HARQ process via PDCCH DCI format 0 and DCI format 0_1 for C_RNTI to schedule the UL RMC according to Table 7.6B.2.3_1.1.4.1.1-1 on E-UTRA CC and NR CC respectively. Since the UL has no payload and no loopback data to send the UE sends uplink MAC padding bits on the UL RMC.

3. Set the Downlink signal level to the value as defined in Table 7.6B.2.1.5-1. For NR CC and E-UTRA CC, send uplink power control commands to the UE using 1dB power step size to ensure that the UE output power measured by the test system is within the Uplink power control window, defined as $-(\text{MU} + \text{Uplink power control window size})$ dB of the target power level in Table 7.6B.2.1.5-1 + $(10\log(S_{\text{LCRB}}/N_{\text{RB_alloc}}))$ for NR CC, $(10\log(P_{\text{LCRB}}/N_{\text{RB_alloc}}))$ for E-UTRA CC) for at least the duration of the Throughput measurement, where:
 - MU is the test system uplink power measurement uncertainty and is specified in Table F.1.3-1 for the carrier frequency f and the channel bandwidth BW
 - For NR CC, Uplink power control window size = 1dB (UE power step size) + 0.7dB (UE power step tolerance) + (Test system relative power measurement uncertainty), where, the UE power step tolerance is specified in TS 38.101-1 [2], Table 6.3.4.3-1 and is 0.7dB for 1dB power step size, and the Test system relative power measurement uncertainty is specified in Table F.1.2-1.
 - For E-UTRA CC, Uplink power control window size = 1dB (UE power step size) + 1.0dB (UE power step tolerance) + (Test system relative power measurement uncertainty), where, the UE power step tolerance is specified in TS 36.101 [5], Table 6.3.5.2.1-1 and is 1.0dB for 1dB power step size, and the Test system relative power measurement uncertainty is specified in Table F.1.2-1 of TS 36.521-1 [10].
4. Set the parameters of the signal generator for an interfering signal below the aggregated component carriers in Case 1 according to Table 7.6B.2.1.5-1.
5. Measure the average throughput for a duration sufficient to achieve statistical significance according to Annex H.2.
6. Repeat steps from 4 to 5, using an interfering signal above the aggregated component carriers in Case 1 at step 4.
7. Repeat steps from 4 to 6, using interfering signals in Case 2 at steps 4 and 6.

NOTE: The purpose of the Uplink power control window is to ensure that the actual UE output power is no greater than the target power level, and as close as possible to the target power level. The relationship between the Uplink power control window, the target power level and the corresponding possible actual UE Uplink power window is illustrated in Annex F, clause F.4.

7.6B.2.3_1.1.4.1.3 Message contents

Message contents are according to TS 38.508-1 [6] clause 4.6 Table 4.6.3-118 with condition TRANSFORM_PRECODER_ENABLED.

7.6B.2.3_1.1.4.2 Inter-band EN-DC within FR1 with 3 DL CCs (2NR DL CCs)

Same test description as in clause 7.6A.2.1.4 in TS 38.521-1 [8] for the NR carrier with the following exceptions:

The initial test configurations for E-UTRA consist of test frequency based on E-UTRA operating band and test channel bandwidth as specified in Table 4.6-1.

For Initial conditions as in clause 7.6A.2.1.4.1 in TS 38.521-1 [8], add step 2.1 and step 3.1 as follows:

- 2.1. The parameter settings for E-UTRA cell are set up according to TS 36.508 [11] clause 4.4.3.
- 3.1. The E-UTRA downlink signal level, uplink signal level are set according to Table 4.6-1 and propagation conditions are set according to Annex B.0 of TS 36.521-1 [10].

Step 6 of Initial conditions as in clause 7.6A.2.1.4.1 in TS 38.521-1 [8] is replaced by:

6. Ensure the UE is in state RRC_CONNECTED with generic procedure parameters Connectivity EN-DC, DC bearer MCG and SCG, Connected without release *On* according to TS 38.508 [6] clause 4.5.

Add step 7 to Initial conditions in clause 7.6A.2.1.4.1 in TS 38.521-1 [8] as follows:

7. On the E-UTRA carrier, disable periodic and aperiodic CQI reports, disable SRS, set *TimeAlignmentTimerDedicated* IE to infinity and disable downlink and uplink scheduling, all as per Table 4.6-1 under clause 4.6.

7.6B.2.3_1.1.5 Test Requirement

For intra-band contiguous EN-DC within FR1 with 3 DL CCs: Same test requirement as in clause 7.6B.2.1.5.

For inter-band EN-DC within FR1 with 3 DL CCs (2NR DL CCs): Same test requirement as in clause 7.6A.2.1.5 in TS 38.521-1 [8].

7.6B.2.3_1.2 Inband blocking for EN-DC within FR1 (4 CCs)

7.6B.2.3_1.2.1 Test Purpose

For intra-band contiguous EN-DC within FR1 with 4 DL CCs: In-band blocking is defined for an unwanted interfering signal falling into the range from 15MHz below to 15MHz above the UE receive band, at which the relative throughput shall meet or exceed the requirement for the specified measurement channels. The lack of in-band blocking ability will decrease the coverage area when other NodeB transmitters exist (except in the adjacent channels and spurious response).

For inter-band EN-DC within FR1 with 4 DL CCs (3NR DL CCs): Same test purpose as in clause 7.6A.2.2.1 in TS 38.521-1 [8].

7.6B.2.3_1.2.2 Test Applicability

This test case applies to all types of E-UTRA UE release 15 and forward, supporting intra-band contiguous EN-DC within FR1 with 4 DL CCs or inter-band EN-DC within FR1 with 4 DL CCs (3NR DL CCs).

7.6B.2.3_1.2.3 Minimum Conformance Requirements

For intra-band contiguous EN-DC within FR1 with 4 DL CCs: The minimum conformance requirements are defined in clause 7.6 B.2.0.1. Exception requirements for both NR and E-UTRA are defined and therefore LTE anchor agnostic approach is not applied. E-UTRA test point analysis is included and E-UTRA measurements are performed.

For inter-band EN-DC within FR1 with 4 DL CCs (3NR DL CCs): The minimum conformance requirements are defined in clause 7.6B.2.0.3.

No exception requirements applicable to NR or LTE. LTE anchor agnostic approach is applied.

7.6B.2.3_1.2.4 Test Description

7.6B.2.3_1.2.4.1 Intra-band contiguous EN-DC within FR1 with 4 DL CCs

7.6B.2.3_1.2.4.1.1 Initial condition

Initial conditions are a set of test configurations the UE needs to be tested in and the steps for the SS to take with the UE to reach the correct measurement state.

The initial test configurations consist of environmental conditions, test frequencies and channel bandwidths based on EN-DC operating bands specified in clause 5.3B.1.2, channel bandwidths and sub-carrier spacings for the NR cell specified in TS 38.521-1 [8] clause 5.3 and channel bandwidth for the E-UTRA cell are specified in TS 36.521-1 [10] clause 5.4.2. All of these configurations shall be tested with applicable test parameters for each EN-DC configuration specified in clause 5.3B.1.2 and are shown in Table 7.6B.2.3_1.2.4.1.1-1. The details of the uplink and downlink reference measurement channels (RMCs) are specified in Annex A.2 and A.3 respectively. The details of the OCN patterns used are specified in TS 36.521-1 [10] Annex A.5 and in TS 38.521-1 [8] Annex A.5 for E-UTRA CG and NR CG respectively. Configurations of PDSCH and PDCCH before measurement are specified in TS 36.521-1 [10] Annex C.2 and in TS 38.521-1 [8] Annex C.2 for E-UTRA CG and NR CG respectively.

Table 7.6B.2.3_1.2.4.1.1-1: Test configuration table

Initial Conditions					
Test Environment as specified in TS 38.508-1 [6] clause 4.1			Normal		
Test Frequencies as specified in TS 38.508-1 [6] clause 4.3.1 for different EN-DC bandwidth classes			Mid range		
Test EN-DC bandwidth combination as specified in Table 5.3B.1.2-1 across bandwidth combination sets supported by the UE			Lowest N_{RB_agg} , Highest N_{RB_agg} (NOTE 3)		
NR Test SCS as specified in Table 5.3.5-1 in TS 38.521-1 [8]			Lowest		
NR/E-UTRA Test Parameters					
PCC – E-UTRA		SCC1 – EUTRA and SCC2 – EUTRA		NR	
UL/DL Modulation	UL/DL allocation	UL/DL Modulation	UL/DL allocation	UL/DL Modulation	UL/DL allocation
QPSK/QPSK	REFSENS/Full RB	NA/QPSK	NA/Full RB	DFT-s-OFDM QPSK/CP-OFDM QPSK	REFSENS/Full RB (NOTE 1)
NOTE 1: Full RB allocation shall be used per each SCS and channel BW as specified in Table 7.3.2.4.1-2 of TS 38.521-1 [8].					
NOTE 2: Test Channel Bandwidths are checked separately for each EN-DC band, which applicable channel bandwidths are specified in Table 5.3B.1.2-1.					
NOTE 3: If the UE supports multiple CC Combinations in the EN-DC Configuration with the same N_{RB_agg} , only the combination with the highest N_{RB_SCG} is tested.					
NOTE 4: REFSENS refers to Uplink configuration in Table 7.3.2.3-3 in [8] and Table 7.3.3-2 in [10] for NR and E-UTRA CC respectively.					
NOTE 5: In a FR1 band where UE supports 4Rx, the test shall be performed only with 4Rx antennas ports connected and 4Rx REFSENS requirement (TS 38.521-1 [8] Table 7.3.2.5-2) is used in the test requirements.					

1. Connect the SS to the UE antenna connectors as shown in [6] TS 38.508-1 Annex A, in Figure A.3.1.4.1 for SS diagram and clause A.3.2 for UE diagram.
2. The parameter settings for the E-UTRA cell are set up according to TS 36.508 [11] clause 4.4.3, and the parameter settings for the NR cell are set up according to TS 38.508-1 [6] clause 4.4.3.
3. Downlink signals are initially set up according to TS 36.521-1 [10] Annex C and TS 38.521-1 [8] Annex C for E-UTRA CG and NR CG respectively, and uplink signals according to TS 36.521-1 [10] Annex H and TS 38.521-1 [8] Annex G for E-UTRA CG and NR CG respectively.
4. The UL and DL Reference Measurement channels are TS 36.521-1 [10] Annex A.2, A.3 and TS 38.521-1 [8] Annex A.2, A.3 for E-UTRA CG and NR CG respectively.
5. Propagation conditions are set according to TS 36.521-1 [10] Annex B.0 and TS 38.521-1 [8] Annex B.0 for E-UTRA CG and NR CG respectively.
6. Ensure the UE is in state RRC_CONNECTED with generic procedure parameters Connectivity EN-DC, DC bearer *MCG* and *SCG*, Connected without release *On* according to TS 38.508-1 [6] clause 4.5. Message contents are defined in clause 7.6B.2.3_1.2.4.1.3.

7.6B.2.3_1.2.4.1.2 Test procedure

1. SS transmits PDSCH via PDCCH DCI format 1A and PDCCH DCI format 1_1 for C_RNTI to transmit the DL RMC according to Table 7.6B.2.3_1.2.4.1.1-1 on E-UTRA CC and NR CC respectively. The SS sends downlink MAC padding bits on the DL RMC.
2. SS sends uplink scheduling information for each UL HARQ process via PDCCH DCI format 0 and DCI format 0_1 for C_RNTI to schedule the UL RMC according to Table 7.6B.2.3_1.2.4.1.1-1 on E-UTRA CC and NR CC respectively. Since the UL has no payload and no loopback data to send the UE sends uplink MAC padding bits on the UL RMC.

3. Set the Downlink signal level to the value as defined in Table 7.6B.2.1.5-1. For NR CC and E-UTRA CC, send uplink power control commands to the UE using 1dB power step size to ensure that the UE output power measured by the test system is within the Uplink power control window, defined as $-\text{MU}$ to $-(\text{MU} + \text{Uplink power control window size})$ dB of the target power level in Table 7.6B.2.1.5-1 + $(10\log(S_{\text{LCRB}}/N_{\text{RB_alloc}}))$ for NR CC, $(10\log(P_{\text{LCRB}}/N_{\text{RB_alloc}}))$ for E-UTRA CC) for at least the duration of the Throughput measurement, where:
 - MU is the test system uplink power measurement uncertainty and is specified in Table F.1.3-1 for the carrier frequency f and the channel bandwidth BW
 - For NR CC, Uplink power control window size = 1dB (UE power step size) + 0.7dB (UE power step tolerance) + (Test system relative power measurement uncertainty), where, the UE power step tolerance is specified in TS 38.101-1 [2], Table 6.3.4.3-1 and is 0.7dB for 1dB power step size, and the Test system relative power measurement uncertainty is specified in Table F.1.2-1.
 - For E-UTRA CC, Uplink power control window size = 1dB (UE power step size) + 1.0dB (UE power step tolerance) + (Test system relative power measurement uncertainty), where, the UE power step tolerance is specified in TS 36.101 [5], Table 6.3.5.2.1-1 and is 1.0dB for 1dB power step size, and the Test system relative power measurement uncertainty is specified in Table F.1.2-1 of TS 36.521-1 [10].
4. Set the parameters of the signal generator for an interfering signal below the aggregated component carriers in Case 1 according to Table 7.6B.2.1.5-1.
5. Measure the average throughput for a duration sufficient to achieve statistical significance according to Annex H.2.
6. Repeat steps from 4 to 5, using an interfering signal above the aggregated component carriers in Case 1 at step 4.
7. Repeat steps from 4 to 6, using interfering signals in Case 2 at steps 4 and 6.

NOTE: The purpose of the Uplink power control window is to ensure that the actual UE output power is no greater than the target power level, and as close as possible to the target power level. The relationship between the Uplink power control window, the target power level and the corresponding possible actual UE Uplink power window is illustrated in Annex F, clause F.4.

7.6B.2.3_1.2.4.1.3 Message contents

Message contents are according to TS 38.508-1 [6] clause 4.6 Table 4.6.3-118 with condition TRANSFORM_PRECODER_ENABLED.

7.6B.2.3_1.2.4.2 Inter-band EN-DC within FR1 with 4 DL CCs (3NR DL CCs)

Same test description as in clause 7.6A.2.2.4 in TS 38.521-1 [8] for the NR carrier with the following exceptions:

The initial test configurations for E-UTRA consist of test frequency based on E-UTRA operating band and test channel bandwidth as specified in Table 4.6-1.

For Initial conditions as in clause 7.6A.2.2.4.1 in TS 38.521-1 [8], add step 2.1 and step 3.1 as follows:

- 2.1. The parameter settings for E-UTRA cell are set up according to TS 36.508 [11] clause 4.4.3.
- 3.1. The E-UTRA downlink signal level, uplink signal level are set according to Table 4.6-1 and propagation conditions are set according to Annex B.0 of TS 36.521-1 [10].

Step 6 of Initial conditions as in clause 7.6A.2.2.4.1 in TS 38.521-1 [8] is replaced by:

6. Ensure the UE is in state RRC_CONNECTED with generic procedure parameters Connectivity EN-DC, DC bearer MCG and SCG, Connected without release *On* according to TS 38.508 [6] clause 4.5.

Add step 7 to Initial conditions in clause 7.6A.2.2.4.1 in TS 38.521-1 [8] as follows:

7. On the E-UTRA carrier, disable periodic and aperiodic CQI reports, disable SRS, set *TimeAlignmentTimerDedicated* IE to infinity and disable downlink and uplink scheduling, all as per Table 4.6-1 under clause 4.6.

7.6B.2.3_1.2.5 Test Requirement

For intra-band contiguous EN-DC within FR1 with 4 DL CCs: Same test requirement as in clause 7.6B.2.1.5.

For inter-band EN-DC within FR1 with 4 DL CCs (3NR DL CCs): Same test requirement as in clause 7.6A.2.2.5 in TS 38.521-1 [8].

7.6B.2.3_1.3 Inband blocking for EN-DC within FR1 (5 CCs)

7.6B.2.3_1.3.1 Test Purpose

Same test purpose as in clause 7.6B.2.3.1.

7.6B.2.3_1.3.2 Test Applicability

This test case applies to all types of E-UTRA UE release 16 and forward, supporting inter-band EN-DC within FR1 with 5 DL CCs (4 NR DL CCs).

7.6B.2.3_1.3.3 Minimum Conformance Requirements

The minimum conformance requirements are defined in clause 7.6B.2.0.3.

No exception requirements applicable to NR or LTE. LTE anchor agnostic approach is applied.

7.6B.2.3_1.3.4 Test Description

Same test description as in clause 7.6A.2.3.4 in TS 38.521-1 [8] for the NR carrier with the following exceptions:

The initial test configurations for E-UTRA consist of test frequency based on E-UTRA operating band and test channel bandwidth as specified in Table 4.6-1.

For Initial conditions as in clause 7.6A.2.3.4.1 in TS 38.521-1 [8], add step 2.1 and step 3.1 as follows:

- 2.1. The parameter settings for E-UTRA cell are set up according to TS 36.508 [11] clause 4.4.3.
- 3.1. The E-UTRA downlink signal level, uplink signal level are set according to Table 4.6-1 and propagation conditions are set according to Annex B.0 of TS 36.521-1 [10].

Step 6 of Initial conditions as in clause 7.6A.2.3.4.1 in TS 38.521-1 [8] is replaced by:

6. Ensure the UE is in state RRC_CONNECTED with generic procedure parameters Connectivity EN-DC, DC bearer MCG and SCG, Connected without release *On* according to TS 38.508 [6] clause 4.5.

Add step 7 to Initial conditions in clause 7.6A.2.3.4.1 in TS 38.521-1 [8] as follows:

7. On the E-UTRA carrier, disable periodic and aperiodic CQI reports, disable SRS, set *TimeAlignmentTimerDedicated* IE to infinity and disable downlink and uplink scheduling, all as per Table 4.6-1 under clause 4.6.

7.6B.2.3_1.3.5 Test Requirement

Same test requirement as in clause 7.6A.2.3.5 in TS 38.521-1 [8].

7.6B.2.3_1.4 Void

7.6B.2.4 Inband blocking for inter-band EN-DC including FR2 (2 CCs)

Editor's note: This clause is incomplete. The following aspects are either missing or not yet determined:

- **MU is FFS in referred test case 7.6.2 in TS 38.521-2 [9].**

7.6B.2.4.1 Test Purpose

Same test purpose as in clause 7.6.2.1 in TS 38.521-2 [9] for the NR carrier.

7.6B.2.4.2 Test Applicability

This test case applies to all types of E-UTRA UE release 15 and forward, supporting inter-band EN-DC including FR2 with 2 DL CCs.

7.6B.2.4.3 Minimum Conformance Requirements

The minimum conformance requirements are defined in clause 7.6B.2.0.4.

No exception requirements applicable to NR or LTE. LTE anchor agnostic approach is applied.

7.6B.2.4.4 Test Description

Same test description as in clause 7.6.2.4 in TS 38.521-2 [9] for the NR carrier with the following exceptions:

The initial test configurations for E-UTRA consist of test frequency based on E-UTRA operating band and test channel bandwidth as specified in Table 4.6-1.

For Initial conditions as in clause 7.6.2.4.1 in TS 38.521-2 [9], add step 2.1 and step 3.1 as follows:

- 2.1. The parameter settings for E-UTRA cell are set up according to TS 36.508 [11] clause 4.4.3.
- 3.1. The E-UTRA downlink signal level, uplink signal level are set according to Table 4.6-1 and propagation conditions are set according to Annex B.0 of TS 36.521-1 [10].

Step 6 of Initial conditions as in clause 7.6.2.4.1 in TS 38.521-2 [9] is replaced by:

6. Ensure the UE is in state RRC_CONNECTED with generic procedure parameters Connectivity EN-DC, DC bearer MCG and SCG, Connected without release *On* according to TS 38.508 [6] clause 4.5.

Add step 7 to Initial conditions in clause 7.6.2.4.1 in TS 38.521-2 [9] as follows:

7. On the E-UTRA carrier, disable periodic and aperiodic CQI reports, disable SRS, set *TimeAlignmentTimerDedicated* IE to infinity and disable downlink and uplink scheduling, all as per Table 4.6-1 under clause 4.6.

7.6B.2.4.5 Test Requirement

Same test requirement as in clause 7.6.2.5 in TS 38.521-2 [9].

7.6B.2.4_1 Inband blocking for inter-band EN-DC including FR2 (>2 CCs)

7.6B.2.4_1.1 Inband blocking for inter-band EN-DC including FR2 (3 CCs)

Editor's note: This clause is incomplete. The following aspects are either missing or not yet determined:

- **The referred test case 7.6A.2.1 in TS 38.521-2 is incomplete.**

7.6B.2.4_1.1.1 Test Purpose

Same test purpose as in clause 7.6B.2.4.1.

7.6B.2.4_1.1.2 Test Applicability

This test case applies to all types of E-UTRA UE release 15 and forward, supporting inter-band EN-DC including FR2 with 3CCs (2NR CCs).

7.6B.2.4_1.1.3 Minimum Conformance Requirements

Same minimum conformance requirements as in clause 7.4B.2.4.3

7.6B.2.4_1.1.4 Test Description

Same test description as in clause 7.6A.2.1.4 in TS 38.521-2 [9] for the NR carrier with the following exceptions:

The initial test configurations for E-UTRA consist of test frequency based on E-UTRA operating band and test channel bandwidth as specified in Table 4.6-1.

For Initial conditions as in clause 7.6A.2.1.4.1 in TS 38.521-2 [9], add step 2.1 and step 3.1 as follows:

- 2.1. The parameter settings for E-UTRA cell are set up according to TS 36.508 [11] clause 4.4.3.
- 3.1. The E-UTRA downlink signal level, uplink signal level are set according to Table 4.6-1 and propagation conditions are set according to Annex B.0 of TS 36.521-1 [10].

Step 6 of Initial conditions as in clause 7.6A.2.1.4.1 in TS 38.521-2 [9] is replaced by:

6. Ensure the UE is in state RRC_CONNECTED with generic procedure parameters Connectivity EN-DC, DC bearer MCG and SCG, Connected without release *On* according to TS 38.508 [6] clause 4.5.

Add step 7 to Initial conditions in clause 7.6A.2.1.4.1 in TS 38.521-2 [9] as follows:

7. On the E-UTRA carrier, disable periodic and aperiodic CQI reports, disable SRS, set *TimeAlignmentTimerDedicated* IE to infinity and disable downlink and uplink scheduling, all as per Table 4.6-1 under clause 4.6.

7.6B.2.4_1.1.5 Test Requirement

Same test requirement as in clause 7.6A.2.1.5 in TS 38.521-2 [9].

7.6B.2.4_1.2 Inband blocking for inter-band EN-DC including FR2 (4 CCs)

Editor's note: This clause is incomplete. The following aspects are either missing or not yet determined:

- The referred test case 7.6A.2.2 in TS 38.521-2 is incomplete.

7.6B.2.4_1.2.1 Test Purpose

Same test purpose as in clause 7.6B.2.4.1.

7.6B.2.4_1.2.2 Test Applicability

This test case applies to all types of E-UTRA UE release 15 and forward, supporting inter-band EN-DC including FR2 with 4CCs (3NR CCs).

7.6B.2.4_1.2.3 Minimum Conformance Requirements

Same minimum conformance requirements as in clause 7.4B.2.4.3

7.6B.2.4_1.2.4 Test Description

Same test description as in clause 7.6A.2.2.4 in TS 38.521-2 [9] for the NR carrier with the following exceptions:

The initial test configurations for E-UTRA consist of test frequency based on E-UTRA operating band and test channel bandwidth as specified in Table 4.6-1.

For Initial conditions as in clause 7.6A.2.2.4.1 in TS 38.521-2 [9], add step 2.1 and step 3.1 as follows:

- 2.1. The parameter settings for E-UTRA cell are set up according to TS 36.508 [11] clause 4.4.3.

- 3.1. The E-UTRA downlink signal level, uplink signal level are set according to Table 4.6-1 and propagation conditions are set according to Annex B.0 of TS 36.521-1 [10].

Step 6 of Initial conditions as in clause 7.6A.2.2.4.1 in TS 38.521-2 [9] is replaced by:

6. Ensure the UE is in state RRC_CONNECTED with generic procedure parameters Connectivity EN-DC, DC bearer MCG and SCG, Connected without release *On* according to TS 38.508 [6] clause 4.5.

Add step 7 to Initial conditions in clause 7.6A.2.2.4.1 in TS 38.521-2 [9] as follows:

7. On the E-UTRA carrier, disable periodic and aperiodic CQI reports, disable SRS, set *TimeAlignmentTimerDedicated* IE to infinity and disable downlink and uplink scheduling, all as per Table 4.6-1 under clause 4.6.

7.6B.2.4_1.2.5 Test Requirement

Same test requirement as in clause 7.6A.2.2.5 in TS 38.521-2 [9].

7.6B.2.4_1.3 Inband blocking for inter-band EN-DC including FR2 (5 CCs)

Editor's note: This clause is incomplete. The following aspects are either missing or not yet determined:

- The referred test case 7.6A.2.3 in TS 38.521-2 is incomplete.

7.6B.2.4_1.3.1 Test Purpose

Same test purpose as in clause 7.6B.2.4.1.

7.6B.2.4_1.3.2 Test Applicability

This test case applies to all types of E-UTRA UE release 15 and forward, supporting inter-band EN-DC including FR2 with 5CCs (4NR CCs).

7.6B.2.4_1.3.3 Minimum Conformance Requirements

Same minimum conformance requirements as in clause 7.4B.2.4.3

7.6B.2.4_1.3.4 Test Description

Same test description as in clause 7.6A.2.3.4 in TS 38.521-2 [9] for the NR carrier with the following exceptions:

The initial test configurations for E-UTRA consist of test frequency based on E-UTRA operating band and test channel bandwidth as specified in Table 4.6-1.

For Initial conditions as in clause 7.6A.2.3.4.1 in TS 38.521-2 [9], add step 2.1 and step 3.1 as follows:

- 2.1. The parameter settings for E-UTRA cell are set up according to TS 36.508 [11] clause 4.4.3.
- 3.1. The E-UTRA downlink signal level, uplink signal level are set according to Table 4.6-1 and propagation conditions are set according to Annex B.0 of TS 36.521-1 [10].

Step 6 of Initial conditions as in clause 7.6A.2.3.4.1 in TS 38.521-2 [9] is replaced by:

6. Ensure the UE is in state RRC_CONNECTED with generic procedure parameters Connectivity EN-DC, DC bearer MCG and SCG, Connected without release *On* according to TS 38.508 [6] clause 4.5.

Add step 7 to Initial conditions in clause 7.6A.2.3.4.1 in TS 38.521-2 [9] as follows:

7. On the E-UTRA carrier, disable periodic and aperiodic CQI reports, disable SRS, set *TimeAlignmentTimerDedicated* IE to infinity and disable downlink and uplink scheduling, all as per Table 4.6-1 under clause 4.6.

7.6B.2.4_1.3.5 Test Requirement

Same test requirement as in clause 7.6A.2.3.5 in TS 38.521-2 [9].

7.6B.2.4_1.4 Inband blocking for inter-band EN-DC including FR2 (6 CCs)

Editor's note: This clause is incomplete. The following aspects are either missing or not yet determined:

- **The referred test case 7.6A.2.4 in TS 38.521-2 is incomplete.**

7.6B.2.4_1.4.1 Test Purpose

Same test purpose as in clause 7.6B.2.4.1.

7.6B.2.4_1.4.2 Test Applicability

This test case applies to all types of E-UTRA UE release 15 and forward, supporting inter-band EN-DC including FR2 with 6CCs (5NR CCs).

7.6B.2.4_1.4.3 Minimum Conformance Requirements

Same minimum conformance requirements as in clause 7.4B.2.4.3

7.6B.2.4_1.4.4 Test Description

Same test description as in clause 7.6A.2.4.4 in TS 38.521-2 [9] for the NR carrier with the following exceptions:

The initial test configurations for E-UTRA consist of test frequency based on E-UTRA operating band and test channel bandwidth as specified in Table 4.6-1.

For Initial conditions as in clause 7.6A.2.4.4.1 in TS 38.521-2 [9], add step 2.1 and step 3.1 as follows:

- 2.1. The parameter settings for E-UTRA cell are set up according to TS 36.508 [11] clause 4.4.3.
- 3.1. The E-UTRA downlink signal level, uplink signal level are set according to Table 4.6-1 and propagation conditions are set according to Annex B.0 of TS 36.521-1 [10].

Step 6 of Initial conditions as in clause 7.6A.2.4.4.1 in TS 38.521-2 [9] is replaced by:

6. Ensure the UE is in state RRC_CONNECTED with generic procedure parameters Connectivity EN-DC, DC bearer MCG and SCG, Connected without release *On* according to TS 38.508 [6] clause 4.5.

Add step 7 to Initial conditions in clause 7.6A.2.4.4.1 in TS 38.521-2 [9] as follows:

7. On the E-UTRA carrier, disable periodic and aperiodic CQI reports, disable SRS, set *TimeAlignmentTimerDedicated* IE to infinity and disable downlink and uplink scheduling, all as per Table 4.6-1 under clause 4.6.

7.6B.2.4_1.4.5 Test Requirement

Same test requirement as in clause 7.6A.2.4.5 in TS 38.521-2 [9].

7.6B.2.4D Inband blocking for inter-band EN-DC including FR2 for UL-MIMO

No exception requirements applicable to NR or LTE. LTE anchor agnostic approach can be applied and only NR carriers need to be tested.

No test case details are specified. Given UE's Rx performance would not be impacted by the Tx configuration in NR FR2 TDD bands, the requirements in this test case can be well covered in 7.6B.2.4 and 7.6B.2.4_1 and don't

7.6B.2.5 Inband blocking for inter-band EN-DC including both FR1 and FR2

7.6B.2.5.1 Test purpose

Same test purpose as in clause 7.6.2.1 in TS 38.521-1 [8] for NR FR1 carrier and clause 7.6.2.1 in TS 38.521-2 [9] for NR FR2 carrier.

7.6B.2.5.2 Test applicability

The requirements in this test are not testable due to issues with combined testing of NR FR1 and E-UTRA in conducted mode with NR FR2 in radiated mode. Therefore, the conducted and radiated requirements are tested separately.

No test case details are specified. The NSA requirements for Inband blocking apply and are tested as part of the EN-DC within FR1 and EN-DC including FR2 test cases in clause 7.6B.2.

7.6B.2.5D Inband blocking for inter-band EN-DC including FR1 and FR2 for UL-MIMO

7.6B.2.5D.1 Test purpose

Same test purpose as in clause 7.6D.2 in TS 38.521-1 [8] for NR FR1 carrier and clause 7.6D in TS 38.521-2 [9] for NR FR2 carrier.

7.6B.2.5D.2 Test applicability

The requirements in this test are not testable due to issues with combined testing of NR FR1 and E-UTRA in conducted mode with NR FR2 in radiated mode. Therefore, the conducted and radiated requirements are tested separately.

No test case details are specified. The NSA requirements for Inband blocking apply and are tested as part of the EN-DC within FR1 and EN-DC including FR2 test cases in clause 7.6B.2.

7.6B.3 Out-of-band blocking for DC

7.6B.3.0 Minimum Conformance Requirements

7.6B.3.0.1 Intra-band contiguous EN-DC in FR1

Intra-band contiguous EN-DC out-of-band requirement and parameters are defined in Table 7.6B.3.0.1-1.

Table 7.6B.3.0.1-1: Out-of-band blocking for intra-band contiguous EN-DC

EN-DC Aggregated Bandwidth, MHz	≤100	>100, ≤120	>120, ≤140	>140, ≤160
Pw in Transmission Bandwidth Configuration, perCC, dBm	REFSENS + Aggregated BW specific value below			
	9			
NOTE 1: Interferer values and offsets are specified from Table 7.6.2.1A-2 in TS 36.101 [5]. For inter-band combinations where the intra-band requirements are applicable, in which the E-UTRA band is a subset of an NR-only band, the NR band interferer values and offsets specified from Table 7.6A.3-2 in TS 38.101-1 [2] apply to both E-UTRA and NR carriers.				
NOTE 2: For NR carrier, the transmitter shall be set to 4dB below $P_{\text{CMAX_L,f,c,NR}}$ at the minimum uplink configuration specified in Table 7.3.2-3 [2] with $P_{\text{CMAX_L,f,c,NR}}$ as defined in clause 6.2B.4.				
NOTE 3: For E-UTRA carrier, the transmitter shall be set to 4dB below $P_{\text{CMAX_L,E-UTRA,c}}$ at the minimum uplink configuration specified in Table 7.3.1-2 [5] with $P_{\text{CMAX_L,E-UTRA,c}}$ as defined in clause 6.2B.4 for single carrier.				

The normative reference for this requirement is TS 38.101-3 [4] clause 7.6B.3.1.

7.6B.3.0.2 Intra-band non-contiguous EN-DC in FR1

For the E-UTRA sub-block containing one or multiple CC's, the requirement is defined in clause 7.6.2.1 for single carrier operation and in clause 7.6.2.1A for CA in TS 36.101 [5].

For the NR sub-block, the requirement is defined in clause 7.6.3 in TS 38.101-1 [2].

The normative reference for this requirement is TS 38.101-3 [4] clause 7.6B.3.2.

7.6B.3.0.3 Inter-band EN-DC within FR1

Out-of-band blocking requirements for E-UTRA single carrier and CA operation specified in clauses 7.6.2.1 and 7.6.2.1A of TS 36.101 [5] and for NR single carrier and CA operation specified in clauses 7.6.3 and 7.6A.3 of TS 38.101-1 [2] apply for lowest level EN-DC fallbacks (two bands) in clause 5.5B.4.1 with following conditions:

- one E-UTRA uplink carrier with the output power set to 4dB below $P_{\text{CMAX_L,c}}$ and the NR band whose downlink is being tested has its uplink carrier output power set to 29 dB below $P_{\text{CMAX_L,f,c}}$.
- one NR uplink carrier with the output power set to 4dB below $P_{\text{CMAX_L,f,c}}$ on the NR band with both E-UTRA and NR downlinks being tested with E-UTRA output power set to 29 dB below $P_{\text{CMAX_L,c}}$.

If CW interferer falls in a gap between $F_{\text{DL_high}}$ of the E-UTRA or NR band and $F_{\text{DL_low}}$ of the NR or EUTRA band, where the corresponding OOB ranges 1 and 2 overlap, then the lower level interferer limit of the overlapping OOB ranges applies.

If $F_{\text{DL_high}}$ of the lower E-UTRA or NR band is greater than or equal to the $F_{\text{DL_low}}$ of the upper NR or E-UTRA band as in overlapping RX frequency ranges, then the OOB range shall start from the $F_{\text{DL_low}}$ of the lower E-UTRA or NR band, and from the $F_{\text{DL_high}}$ of the upper NR or E-UTRA band.

For EN-DC combination listed in Table 7.6B.3.0.3-1 under the first test condition above, exceptions to the requirement specified in Table 7.6B.3.0.3-2 are allowed when the second order intermodulation product of the lower frequency band UL carrier and the CW interfering signal fully or partially overlaps with the higher frequency band DL carrier.

Table 7.6B.3.0.3-1: EN-DC combination with exceptions allowed

EN-DC combination
DC_5_n78
DC_8_n77
DC_8_n78
DC_8_n79
DC_11_n77
DC_18_n77
DC_18_n78
DC_18_n79
DC_19_n77
DC_19_n78
DC_19_n79
DC_20_n77
DC_20_n78
DC_21_n77
DC_26_n77
DC_26_n78
DC_26_n79
DC_28_n77
DC_28_n78
DC_28_n79

Table 7.6B.3.0.3-2: Exceptions allowed

Parameter	Unit	Level
$P_{\text{Interferer}} \text{ (CW)}$	dBm	-44 ¹
NOTE 1: The requirement applies when $ f_{\text{Interferer}} \pm f_{\text{UL}}^{\text{LB}} - f_{\text{DL}}^{\text{HB}} \leq (BW_{\text{UL}}^{\text{LB}} + BW_{\text{DL}}^{\text{HB}})/2$, where $f_{\text{UL}}^{\text{LB}}$ and $f_{\text{DL}}^{\text{HB}}$ are the carrier frequencies for lower frequency band UL and higher frequency band DL, respectively. $BW_{\text{UL}}^{\text{LB}}$ and $BW_{\text{DL}}^{\text{HB}}$ are the channel bandwidths configured for lower frequency band UL carrier and higher frequency band DL carrier in MHz, respectively.		

For each of the two test cases in clauses 7.6.2.1 and 7.6.2.1A of [5] and for NR single carrier and CA operation specified in clauses 7.6.3 and 7.6A.3 of TS 38.101-1 [2] for all interferer frequency ranges a maximum of

$$\lfloor \max \{24, 6 \cdot \lceil n \cdot N_{\text{RB}} / 6 \rceil \} / \min \{ \lfloor n \cdot N_{\text{RB}} / 10 \rfloor, 5 \} \rfloor$$

exceptions are allowed for spurious response frequencies in each assigned frequency channel when measured using a step size of $\min(\lfloor CBW / 2 \rfloor, 5)$ MHz with N_{RB} the number of resource blocks in the downlink transmission bandwidth configuration, CBW the bandwidth of the frequency channel in MHz and $n = 1, 2, 3$ for SCS = 15, 30, 60 kHz, respectively. For these exceptions, the requirements in clause 7.7 apply.

The normative reference for this requirement is TS 38.101-3 [4] clause 7.6B.3.3.

7.6B.3.0.3A Inter-band NE-DC within FR1

Out-of-band blocking requirements for E-UTRA single carrier and CA operation specified in clauses 7.6.2.1 and 7.6.2.1A of TS 36.101 [5] and for NR single carrier and CA operation specified in clauses 7.6.3 and 7.6A.3 of TS 38.101-1 [2] apply for lowest level NE-DC fallbacks (two bands) in clause 5.5B.4a.1 with following conditions:

- one E-UTRA uplink carrier with the output power set to 4 dB below $P_{\text{CMAX,L,c}}$ and the NR band whose downlink is being tested has its uplink carrier output power set to 29 dB below $P_{\text{CMAX,L,f,c}}$.
- one NR uplink carrier with the output power set to 4 dB below $P_{\text{CMAX,L,f,c}}$ on the NR band with both E-UTRA and NR downlinks being tested with E-UTRA output power set to 29 dB below $P_{\text{CMAX,L,c}}$.

The normative reference for this requirement is TS 38.101-3 [4] clause 7.6B.3.3a.

7.6B.3.0.4 Inter-band EN-DC including FR2

Out-of-band blocking requirements specified for E-UTRA single carrier and CA operation specified in clauses 7.6.2.1 and 7.6.2.1A of TS 36.101 [5] apply for lowest level EN-DC fallbacks (two bands) in clause 5.5B.5.1 with only E-UTRA UL with output power as in TS 36.101 [5] (4dB below $P_{\text{CMAX,L}}$).

The normative reference for this requirement is TS 38.101-3 [4] clause 7.6B.3.4.

7.6B.3.0.5 Inter-band EN-DC including both FR1 and FR2

Out-of-band blocking requirements specified for E-UTRA single carrier and CA operation specified in clauses 7.6.2.1 and 7.6.2.1A of TS 36.101 [5] and for NR single carrier and CA operation specified in clauses 7.6.3 and 7.6A.3 of TS 38.101-1 [2] apply for lowest level EN-DC fallbacks (three bands) in clause 5.5B.6.2 with only E-UTRA UL with output power as in TS 36.101 [5] (4dB below $P_{\text{CMAX,L}}$).

The normative reference for this requirement is TS 38.101-3 [4] clause 7.6B.3.5.

7.6B.3.1 Out-of-band blocking for intra-band contiguous EN-DC in FR1 (2 CCs)

7.6B.3.1.1 Test Purpose

Out-of-band band blocking is defined for an unwanted CW interfering signal falling more than 15 MHz below or above the UE receive band, at which a given average throughput shall meet or exceed the requirement for the specified measurement channels.

For the first 15 MHz below or above the UE receive band the appropriate in-band blocking or adjacent channel selectivity in clause 7.6B.2.1 and clause 7.5B.1 shall be applied.

The lack of out-of-band blocking ability will decrease the coverage area when other NodeB transmitters exist (except in the adjacent channels and spurious response).

7.6B.3.1.2 Test Applicability

This test case applies to all types of E-UTRA UE release 15 and forward, supporting intra-band contiguous EN-DC in FR1 with 2CCs.

7.6B.3.1.3 Minimum Conformance Requirements

The minimum conformance requirements are defined in clause 7.6B.3.0.1.

Exception requirements for both NR and E-UTRA are defined for this test and therefore LTE anchor agnostic approach is not applied. E-UTRA test point analysis is included and E-UTRA measurements are performed.

7.6B.3.1.4 Test Description

7.6B.3.1.4.1 Initial condition

Initial conditions are a set of test configurations the UE needs to be tested in and the steps for the SS to take with the UE to reach the correct measurement state.

The initial test configurations consist of environmental conditions, test frequencies and channel bandwidths based on EN-DC operating bands specified in clause 5.3B.1.2, channel bandwidths and sub-carrier spacings for the NR cell specified in TS 38.521-1 [8] clause 5.3 and channel bandwidth for the E-UTRA cell are specified in TS 36.521-1 [10] clause 5.4.2. All of these configurations shall be tested with applicable test parameters for each EN-DC configuration specified in clause 5.3B.1.2 and are shown in Table 7.6B.3.1.4.1-1. The details of the uplink and downlink reference measurement channels (RMCs) are specified in Annex A.2 and A.3 respectively. The details of the OCNG patterns used are specified in TS 36.521-1 [10] Annex A.5 and in TS 38.521-1 [8] Annex A.5 for E-UTRA CG and NR CG respectively. Configurations of PDSCH and PDCCH before measurement are specified in TS 36.521-1 [10] Annex C.2 and in TS 38.521-1 [8] Annex C.2 for E-UTRA CG and NR CG respectively.

Table 7.6B.3.1.4.1-1: Test configuration table

Initial Conditions							
Test Environment as specified in TS 38.508-1 [6] clause 4.1				Normal			
Test Frequencies as specified in TS 38.508-1 [6] clause 4.3.1 for different EN-DC bandwidth classes				Mid range			
Test EN-DC bandwidth combination as specified in Table 5.3B.1.2-1 across bandwidth combination sets supported by the UE				Highest N_{RB_agg} (NOTE 3)			
NR Test SCS as specified in Table 5.3.5-1 in TS 38.521-1 [8]				Lowest			
NR/E-UTRA Test Parameters							
Downlink Configuration				Uplink Configuration			
NR Modulation	NR RB allocation	E-UTRA Modulation	E-UTRA RB allocation	NR Modulation	NR RB allocation	E-UTRA Modulation	E-UTRA RB allocation
CP-OFDM QPSK	Full RB (NOTE 1)	QPSK	Full RB	DFT-s-OFDM QPSK	REFSENS	QPSK	REFSENS
NOTE 1: Full RB allocation shall be used per each SCS and channel BW as specified in Table 7.3.2.4.1-2 of TS 38.521-1 [8].							
NOTE 2: Test Channel Bandwidths are checked separately for each EN-DC band, which applicable channel bandwidths are specified in Table 5.3B.1.2-1.							
NOTE 3: If the UE supports multiple CC Combinations in the EN-DC Configuration with the same N_{RB_agg} , only the combination with the highest N_{RB_SCG} is tested.							
NOTE 4: REFSENS refers to Uplink configuration in Table 7.3.2.3-3 in [8] and Table 7.3.3-2 in [10] for NR and E-UTRA CC respectively.							
NOTE 5: In an E-UTRA band or FR1 band where UE supports 4Rx, the test shall be performed only with 4Rx antennas ports connected and 4Rx REFSENS requirement (TS 38.521-1 [8] Table 7.3.2.5-2) is used in the test requirements.							

1. Connect the SS to the UE antenna connectors as shown in [6] TS 38.508-1 Annex A, in Figure A.3.1.4.2 for SS diagram and clause A.3.2 for UE diagram.
2. The parameter settings for the cell are set up according to TS 38.508-1 [6] clause 4.4.3.
3. Downlink signals are initially set up according to TS 36.521-1 [10] Annex C and TS 38.521-1 [8] Annex C for E-UTRA CG and NR CG respectively, and uplink signals according to TS 36.521-1 [10] Annex H and TS 38.521-1 [8] Annex G for E-UTRA CG and NR CG respectively.
4. The UL and DL Reference Measurement channels are TS 36.521-1 [10] Annex A.2, A.3 and TS 38.521-1 [8] Annex A.2, A.3 for E-UTRA CG and NR CG respectively.
5. Propagation conditions are set according to TS 36.521-1 [10] Annex B.0 and TS 38.521-1 [8] Annex B.0 for E-UTRA CG and NR CG respectively.
6. Ensure the UE is in state RRC_CONNECTED with generic procedure parameters Connectivity EN-DC, DC bearer *MCG* and *SCG*, Connected without release *On* according to TS 38.508-1 [6] clause 4.5. Message contents are defined in clause 7.6B.3.1.4.3.

7.6B.3.1.4.2 Test procedure

1. SS transmits PDSCH via PDCCH DCI format 1A and PDCCH DCI format 1_1 for C_RNTI to transmit the DL RMC according to Table 7.6B.3.1.4.1-1 on E-UTRA CC and NR CC respectively. The SS sends downlink MAC padding bits on the DL RMC.
2. SS sends uplink scheduling information for each UL HARQ process via PDCCH DCI format 0 and DCI format 0_1 for C_RNTI to schedule the UL RMC according to Table 7.6B.3.1.4.1-1 on E-UTRA CC and NR CC respectively. Since the UL has no payload and no loopback data to send the UE sends uplink MAC padding bits on the UL RMC.
3. Set the Downlink signal level to the value as defined in Table 7.6B.3.1.5-1. For NR CC and E-UTRA CC, send uplink power control commands to the UE using 1dB power step size to ensure that the UE output power

measured by the test system is within the Uplink power control window, defined as $-(\text{MU} + \text{Uplink power control window size})$ dB of the target power level in Table 7.6B.3.1.5-1 + $([10\log(S_{\text{LCRB}}/N_{\text{RB_alloc}})]$ for NR CC, $[10\log(P_{\text{LCRB}}/N_{\text{RB_alloc}})]$ for E-UTRA CC) for at least the duration of the Throughput measurement, where:

- MU is the test system uplink power measurement uncertainty and is specified in Table F.1.3-1 for the carrier frequency f and the channel bandwidth BW
 - For NR CC, Uplink power control window size = 1dB (UE power step size) + 0.7dB (UE power step tolerance) + (Test system relative power measurement uncertainty), where, the UE power step tolerance is specified in TS 38.101-1 [2], Table 6.3.4.3-1 and is 0.7dB for 1dB power step size, and the Test system relative power measurement uncertainty is specified in Table F.1.2-1.
 - For E-UTRA CC, Uplink power control window size = 1dB (UE power step size) + 1.0dB (UE power step tolerance) + (Test system relative power measurement uncertainty), where, the UE power step tolerance is specified in TS 36.101 [5], Table 6.3.5.2.1-1 and is 1.0dB for 1dB power step size, and the Test system relative power measurement uncertainty is specified in Table F.1.2-1 of TS 36.521-1 [10].
4. Set the parameters of the CW signal generator for an interfering signal below the aggregated component carriers according to Table 7.6B.3.1.5-1. The frequency step size is 1MHz.
 5. Measure the average throughput for a duration sufficient to achieve statistical significance according to Annex H.2.
 6. Repeat steps from 4 to 5, using an interfering signal above the aggregated component carriers at step 4.

NOTE: The purpose of the Uplink power control window is to ensure that the actual UE output power is no greater than the target power level, and as close as possible to the target power level. The relationship between the Uplink power control window, the target power level and the corresponding possible actual UE Uplink power window is illustrated in Annex F, clause F.4.

7.6B.3.1.4.3 Message contents

Message contents are according to TS 38.508-1 [6] clause 4.6 Table 4.6.3-118 with condition TRANSFORM_PRECODER_ENABLED.

7.6B.3.1.5 Test Requirement

The throughput shall be $\geq 95\%$ of the maximum throughput of the reference measurement channels as specified in TS 36.521-1 [10] Annex A.3 and TS 38.521-1 [8] Annex A.3 for E-UTRA CG and NR CG respectively with parameters specified in Table 7.6B.3.1.5-1 for the specified wanted signal mean power in the presence of interfering signals.

Table 7.6B.3.1.5-1: Out-of-band blocking for intra-band contiguous EN-DC

EN-DC Aggregated Bandwidth, MHz	≤ 100	$>100, \leq 120$	$>120, \leq 140$	$>140, \leq 160$
Pw in Transmission Bandwidth Configuration, perCC, dBm	REFSENS + Aggregated BW specific value below			
	9			
NOTE 1: Interferer values and offsets are specified from Table 7.6.2.1A-2 in TS 36.101 [5]. For inter-band combinations where the intra-band requirements are applicable, in which the E-UTRA band is a subset of an NR-only band, the NR band interferer values and offsets specified from Table 7.6A.3-2 in TS 38.101-1 [2] apply to both E-UTRA and NR carriers. NOTE 2: For NR carrier, the transmitter shall be set to 4dB below $P_{\text{CMAX_L,f,c,NR}}$ at the minimum uplink configuration specified in Table 7.3.2-3 in TS 8.101-1 [2] with $P_{\text{CMAX_L,f,c,NR}}$ as defined in clause 6.2B.4. NOTE 3: For E-UTRA carrier, the transmitter shall be set to 4dB below $P_{\text{CMAX_L,E-UTRA,c}}$ at the minimum uplink configuration specified in Table 7.3.1-2 in TS 36.101 [5] with $P_{\text{CMAX_L,E-UTRA,c}}$ as defined in clause 6.2B.4 for single carrier.				

Table 7.6B.3.1.5-2: Void**Table 7.6B.3.1.5-3: Void****7.6B.3.2 Out-of-band blocking for intra-band non-contiguous EN-DC in FR1 (2 CCs)****7.6B.3.2.1 Test Purpose**

Same test purpose as in clause 7.6.3.1 in TS 38.521-1 [8] for the NR carrier.

7.6B.3.2.2 Test Applicability

This test case applies to all types of E-UTRA UE release 15 and forward, supporting intra-band non-contiguous EN-DC in FR1 with 2CCs.

7.6B.3.2.3 Minimum Conformance Requirements

The minimum conformance requirements are defined in clause 7.6B.3.0.2.

No exception requirements applicable to NR or LTE. LTE anchor agnostic approach is applied.

7.6B.3.2.4 Test Description

Same test description as in clause 7.6.3.4 in TS 38.521-1 [8] for the NR carrier with the following exceptions:

Table 7.6B.3.2.4-1: Test Configuration Table

Initial Conditions	
Test Frequencies as specified in TS 38.508-1 [6] clause 4.3.1 for different EN-DC bandwidth classes	High range with maxWGap
Test EN-DC bandwidth combination as specified in Table 5.3B.1.2-1 across bandwidth combination sets supported by the UE	Highest N_{RB_agg} (NOTE1)
NOTE 1: If the UE supports multiple CC Combinations in the EN-DC Configuration with the same NRB_agg , only the combination with the highest NRB_SCG is tested.	

The initial test configurations for E-UTRA consist of test frequency based on E-UTRA operating band and test channel bandwidth as specified in Table 4.6-1 except for the parameters specified in Table 7.6B.3.2.4-1.

For Initial conditions as in clause 7.6.3.4.1 in TS 38.521-1 [8], add step 2.1 and step 3.1 as follows:

- 2.1. The parameter settings for E-UTRA cell are set up according to TS 36.508 [11] clause 4.4.3.
- 3.1. The E-UTRA downlink signal level, uplink signal level are set according to Table 4.6-1 and propagation conditions are set according to Annex B.0 of TS 36.521-1 [10].

Step 6 of Initial conditions as in clause 7.6.3.4.1 in TS 38.521-1 [8] is replaced by:

6. Ensure the UE is in state RRC_CONNECTED with generic procedure parameters Connectivity EN-DC, DC bearer MCG and SCG, Connected without release *On* according to TS 38.508 [6] clause 4.5.

Add step 7 to Initial conditions in clause 7.6.3.4.1 in TS 38.521-1 [8] as follows:

7. On the E-UTRA carrier, disable periodic and aperiodic CQI reports, disable SRS, set *TimeAlignmentTimerDedicated* IE to infinity and disable downlink and uplink scheduling, all as per Table 4.6-1 under clause 4.6.

Step 4 of Test procedure as in clause 7.6.3.4.2 in TS 38.521-1 [8] is replaced by:

4. Set the downlink signal level for NR CC according to the Table 7.6.3.5-1 or 7.6.3.5-3 in TS 38.521-1 [8] as appropriate. For NR CC and E-UTRA CC, send uplink power control commands to the UE using 1dB power

step size to ensure that the UE output power measured by the test system is within the Uplink power control window, defined as $-(\text{MU} + \text{Uplink power control window size})$ dB of $(P_{\text{CMAX_L,c}} - 29\text{dB})$ for E-UTRA CC, and of 4dB below $P_{\text{CMAX_L,f,c}}$ for NR CC for at least the duration of the Throughput measurement, where:

- MU is the test system uplink power measurement uncertainty and is specified in Table F.1.3-1 for the carrier frequency f and the channel bandwidth BW
- For NR CC, Uplink power control window size = 1dB (UE power step size) + 0.7dB (UE power step tolerance) + (Test system relative power measurement uncertainty), where, the UE power step tolerance is specified in TS 38.101-1 [2], Table 6.3.4.3-1 and is 0.7dB for 1dB power step size, and the Test system relative power measurement uncertainty is specified in Table F.1.2-1.
- For E-UTRA CC, Uplink power control window size = 1dB (UE power step size) + 1.0dB (UE power step tolerance) + (Test system relative power measurement uncertainty), where, the UE power step tolerance is specified in TS 36.101 [5], Table 6.3.5.2.1-1 and is 1.0dB for 1dB power step size, and the Test system relative power measurement uncertainty is specified in Table F.1.2-1 of TS 36.521-1 [10].

7.6B.3.2.5 Test Requirement

Same test requirement as in clause 7.6.3.5 in TS 38.521-1 [8].

7.6B.3.3 Out-of-band blocking for inter-band EN-DC within FR1 (2 CCs)

7.6B.3.3.1 Test Purpose

Out-of-band band blocking is defined for an unwanted CW interfering signal falling more than 15 MHz or $3 \cdot \text{CBW}$ below or above the UE receive band, at which a given average throughput shall meet or exceed the requirement for the specified measurement channels.

For the first 15 MHz or $3 \cdot \text{CBW}$ below or above the UE receive band the appropriate in-band blocking or adjacent channel selectivity in clause 7.6B.2.3 and clause 7.5B.3 shall be applied.

The lack of out-of-band blocking ability will decrease the coverage area when other NodeB transmitters exist (except in the adjacent channels and spurious response).

7.6B.3.3.2 Test Applicability

This test case applies to all types of E-UTRA UE release 15 and forward, supporting inter-band EN-DC within FR1 with 2CCs.

7.6B.3.3.3 Minimum Conformance Requirements

The minimum conformance requirements are defined in clause 7.6B.3.0.3.

Exception requirements for both NR and E-UTRA are defined for this test and therefore LTE anchor agnostic approach is not applied. E-UTRA test point analysis is included and E-UTRA measurements are performed.

7.6B.3.3.4 Test Description

7.6B.3.3.4.1 Initial Conditions

Initial conditions are a set of test configurations the UE needs to be tested in and the steps for the SS to take with the UE to reach the correct measurement state.

The initial test configurations consist of environmental conditions, test frequencies, DC configuration specified in clause 5.5B.4 and test channel bandwidths specified in TS 36.508 [11] clause 4.3.1 and TS 38.508-1 [6] clause 4.3.1, and sub-carrier spacing based on NR operating bands specified in TS 38.521-1 [8] clause 5.3. All of these configurations shall be tested with applicable test parameters for each EN-DC configuration, and are shown in Table 7.6B.3.3.4.1-1. The details of the uplink and downlink reference measurement channels (RMCs) and OCNG patterns are specified in TS 36.521-1 [10] Annex A for E-UTRA, and TS 38.521-1 [8] Annex A for NR. Configurations of PDSCH and PDCCH before measurement are specified in TS 36.521-1 [10] Annex C and in TS 38.521-1 [8] Annex C for E-UTRA CG and NR CG respectively.

Table 7.6B.3.3.4.1-1: Test configuration table

Initial Conditions							
Test Environment as specified in TS 38.508-1 [6] clause 4.1				Normal			
NR Test Frequencies as specified in TS 38.508-1 [6] clause 4.3.1				Mid range for E-UTRA and Mid range for NR (NOTE 3)			
E-UTRA Test Frequencies as specified in TS 36.508-1 [11] clause 4.3.1							
NR Test Channel Bandwidths as specified in TS 38.508-1 [6] clause 4.3.1				Highest for E-UTRA and Highest for NR			
E-UTRA Test Channel Bandwidths as specified in TS 36.508 [11] clause 4.3.1							
NR Test SCS as specified in TS 38.508-1 [6] Table 5.3.5-1				Lowest			
Test Parameters							
Downlink Configuration				Uplink Configuration			
E-UTRA Cell		NR Cell		E-UTRA Cell		NR Cell	
Modulation	RB allocation	Modulation	RB allocation	Modulation	RB allocation	Modulation	RB allocation
QPSK	NOTE 1	CP-OFDM QPSK	NOTE 1	QPSK	NOTE 1	DFT-s-OFDM QPSK	NOTE 1
NOTE 1: The specific configuration of uplink and downlink are defined in Table 7.3B.2.3.4.2.1-1.							
NOTE 2: In an E-UTRA band or FR1 band where UE supports 4Rx, the test shall be performed only with 4Rx antennas ports connected and 4Rx REFSENS requirement (TS 38.521-1 [8] Table 7.3.2.5-2) is used in the test requirements.							
NOTE 3: For NR band n28, 30MHz test channel bandwidth is tested with High range test frequency.							

1. Connect the SS to the UE antenna connectors as shown in [6] TS 38.508-1 Annex A, in Figure A.3.1.4.2 for SS diagram and clause A.3.2 for UE diagram.
2. The parameter settings for the cell are set up according to TS 38.508-1 [6] clause 4.4.3.
3. Downlink signals are initially set up according to TS 36.521-1 [10] Annex C and TS 38.521-1 [8] Annex C for E-UTRA CG and NR CG respectively, and uplink signals according to TS 36.521-1 [10] Annex H and TS 38.521-1 [8] Annex G for E-UTRA CG and NR CG respectively.
4. The UL and DL Reference Measurement channels are TS 36.521-1 [10] Annex A.2, A.3 and TS 38.521-1 [8] Annex A.2, A.3 for E-UTRA CG and NR CG respectively.
5. Propagation conditions are set according to TS 36.521-1 [10] Annex B.0 and TS 38.521-1 [8] Annex B.0 for E-UTRA CG and NR CG respectively.
6. Ensure the UE is in state RRC_CONNECTED with generic procedure parameters Connectivity EN-DC, DC bearer MCG and SCG, Connected without release *On* according to TS 38.508-1 [6] clause 4.5. Message contents are defined in clause 7.6B.3.3.4.3.

7.6B.3.3.4.2 Test procedure

1. SS transmits PDSCH via PDCCH DCI format 1A and PDCCH DCI format 1_1 for C_RNTI to transmit the DL RMC according to Table 7.6B.3.3.4.1-1 on E-UTRA CC and NR CC respectively. The SS sends downlink MAC padding bits on the DL RMC.
2. SS sends uplink scheduling information for each UL HARQ process via PDCCH DCI format 0 and DCI format 0_1 for C_RNTI to schedule the UL RMC according to Table 7.6B.3.3.4.1-1 on E-UTRA CC and NR CC respectively. Since the UL has no payload and no loopback data to send the UE sends uplink MAC padding bits on the UL RMC.
3. Set the Downlink signal level to the value as defined in Table 7.6B.3.3.5-1, Table 7.6B.3.3.5-3, or Table 7.6B.3.3.5-5 for E-UTRA CC and NR CC respectively. For NR CC and E-UTRA CC, send uplink power control commands to the UE using 1dB power step size to ensure that the UE output power measured by the test system is within the Uplink power control window, defined as -MU to -(MU + Uplink power control window size) dB

of ($P_{\text{CMAX_L,c}} - 4\text{dB}$) for E-UTRA CC, and of 29 dB below $P_{\text{CMAX_L,f,c}}$ for NR CC for at least the duration of the Throughput measurement, where:

- MU is the test system uplink power measurement uncertainty and is specified in Table F.1.3-1 for the carrier frequency f and the channel bandwidth BW
- For NR CC, Uplink power control window size = 1dB (UE power step size) + 0.7dB (UE power step tolerance) + (Test system relative power measurement uncertainty), where, the UE power step tolerance is specified in TS 38.101-1 [2], Table 6.3.4.3-1 and is 0.7dB for 1dB power step size, and the Test system relative power measurement uncertainty is specified in Table F.1.2-1.
- For E-UTRA CC, Uplink power control window size = 1dB (UE power step size) + 1.0dB (UE power step tolerance) + (Test system relative power measurement uncertainty), where, the UE power step tolerance is specified in TS 36.101 [5], Table 6.3.5.2.1-1 and is 1.0dB for 1dB power step size, and the Test system relative power measurement uncertainty is specified in Table F.1.2-1 of TS 36.521-1 [10].

4. Set the parameters of the CW signal generator for an interfering signal below the aggregated component carriers according to Table 7.6B.3.3.5-4 or Table 7.6B.3.3.5-6. The frequency step size is $\min(\lfloor CBW / 2 \rfloor, 5)$ MHz.

If CW interferer falls in a gap between $F_{\text{DL_high}}$ of the E-UTRA or NR band and $F_{\text{DL_low}}$ of the NR or EUTRA band, where the corresponding OOB ranges 1 and 2 in Table 7.6B.3.3.5-2 and Table 7.6B.3.3.5-4 or Table 7.6B.3.3.5-6 overlap, then the lower level interferer limit of the overlapping OOB ranges applies. CW interferer is eliminated from $F_{\text{DL_low}} - 15\text{MHz}$ to $F_{\text{DL_high}} + 15\text{MHz}$ of E-UTRA carrier.

If $F_{\text{DL_high}}$ of the lower E-UTRA or NR band is greater than or equal to the $F_{\text{DL_low}}$ of the upper NR or E-UTRA band as in overlapping RX frequency ranges, then the OOB range shall start from the $F_{\text{DL_low}}$ of the lower E-UTRA or NR band, and from the $F_{\text{DL_high}}$ of the upper NR or E-UTRA band.

For EN-DC combination listed in Table 7.6B.3.3.5-7, exceptions to the requirement specified in Table 7.6B.3.3.5-8 are allowed when the second order intermodulation product of the lower frequency band UL carrier and the CW interfering signal fully or partially overlaps with the higher frequency band DL carrier.

5. Measure the average throughput of NR CC for a duration sufficient to achieve statistical significance according to Annex H.2. Record the frequencies for which the throughput doesn't meet the requirements.
6. Repeat steps from 4 to 5, using an interfering signal above the aggregated component carriers at step 4.
7. Set the Downlink signal level to the value as defined in Table 7.6B.3.3.5-1, Table 7.6B.3.3.5-3, or Table 7.6B.3.3.5-5 for E-UTRA CC and NR CC respectively. For NR CC and E-UTRA CC, send uplink power control commands to the UE using 1dB power step size to ensure that the UE output power measured by the test system is within the Uplink power control window, defined as $-(\text{MU} + \text{Uplink power control window size})$ dB of ($P_{\text{CMAX_L,f,c}} - 4\text{dB}$) for NR CC, and of 29 dB below $P_{\text{CMAX_L,c}}$ for E-UTRA CC for at least the duration of the Throughput measurement, where:

- MU is the test system uplink power measurement uncertainty and is specified in Table F.1.3-1 for the carrier frequency f and the channel bandwidth BW
- For NR CC, Uplink power control window size = 1dB (UE power step size) + 0.7dB (UE power step tolerance) + (Test system relative power measurement uncertainty), where, the UE power step tolerance is specified in TS 38.101-1 [2], Table 6.3.4.3-1 and is 0.7dB for 1dB power step size, and the Test system relative power measurement uncertainty is specified in Table F.1.2-1.
- For E-UTRA CC, Uplink power control window size = 1dB (UE power step size) + 1.0dB (UE power step tolerance) + (Test system relative power measurement uncertainty), where, the UE power step tolerance is specified in TS 36.101 [5], Table 6.3.5.2.1-1 and is 1.0dB for 1dB power step size, and the Test system relative power measurement uncertainty is specified in Table F.1.2-1 of TS 36.521-1 [10].

8. Set the parameters of the CW signal generator for an interfering signal below the aggregated component carriers according to Table 7.6B.3.3.5-2, Table 7.6B.3.3.5-4 or Table 7.6B.3.3.5-6 for E-UTRA CC and NR CC testing respectively. The frequency step size is $\min(\lfloor CBW / 2 \rfloor, 5)$ MHz.

If CW interferer falls in a gap between $F_{\text{DL_high}}$ of the E-UTRA or NR band and $F_{\text{DL_low}}$ of the NR or EUTRA band, where the corresponding OOB ranges 1 and 2 in Table 7.6B.3.3.5-2 and Table 7.6B.3.3.5-4 or Table

7.6B.3.3.5-6 overlap, then the lower level interferer limit of the overlapping OOB ranges applies. CW interferer is eliminated from $F_{DL_low} - 15\text{MHz}$ to $F_{DL_high} + 15\text{MHz}$ of E-UTRA and NR carriers.

If F_{DL_high} of the lower E-UTRA or NR band is greater than or equal to the F_{DL_low} of the upper NR or E-UTRA band as in overlapping RX frequency ranges, then the OOB range shall start from the F_{DL_low} of the lower E-UTRA or NR band, and from the F_{DL_high} of the upper NR or E-UTRA band.

9. Measure the average throughput of E-UTRA CC and NR CC respectively for a duration sufficient to achieve statistical significance according to Annex H.2. Record the frequencies for which the throughput doesn't meet the requirements.

10. Repeat steps from 8 to 9, using an interfering signal above the aggregated component carriers at step 8.

NOTE: The purpose of the Uplink power control window is to ensure that the actual UE output power is no greater than the target power level, and as close as possible to the target power level. The relationship between the Uplink power control window, the target power level and the corresponding possible actual UE Uplink power window is illustrated in Annex F, clause F.4.

7.6B.3.3.4.3 Message contents

Message contents are according to TS 38.508-1 [6] clause 4.6.

7.6B.3.3.5 Test Requirement

For E-UTRA bands, except for the spurious response frequencies recorded in test procedure, the throughput measurement derived in test procedure shall be $\geq 95\%$ of the maximum throughput of the reference measurement channels as specified in Annex A.3.2 of TS 36.521-1 [10] with parameters specified in Tables 7.6B.3.3.5-1 and 7.6B.3.3.5-2.

For NR bands with $F_{DL_high} < 2700\text{ MHz}$ and $F_{UL_high} < 2700\text{ MHz}$, except for the spurious response frequencies recorded in test procedure, the throughput measurement derived in test procedure shall be $\geq 95\%$ of the maximum throughput of the reference measurement channels as specified in Annex A.3.2 and A.3.3 of TS 38.521-1 [8] with parameters specified in Tables 7.6B.3.3.5-3 and 7.6B.3.3.5-4.

For NR bands with $F_{DL_low} \geq 3300\text{ MHz}$ and $F_{UL_low} \geq 3300\text{ MHz}$, except for the spurious response frequencies recorded in test procedure, the throughput measurement derived in test procedure shall be $\geq 95\%$ of the maximum throughput of the reference measurement channels as specified in Annex A.3.2 and A.3.3 of TS 38.521-1 [8] with parameters specified in Tables 7.6B.3.3.5-5 and 7.6B.3.3.5-6.

If CW interferer falls in a gap between F_{DL_high} of the E-UTRA or NR band and F_{DL_low} of the NR or EUTRA band, where the corresponding OOB ranges 1 and 2 in Table 7.6B.3.3.5-2 and Table 7.6B.3.3.5-4 or Table 7.6B.3.3.5-6 overlap, then the lower level interferer limit of the overlapping OOB ranges applies.

If F_{DL_high} of the lower E-UTRA or NR band is greater than or equal to the F_{DL_low} of the upper NR or E-UTRA band as in overlapping RX frequency ranges, then the OOB range shall start from the F_{DL_low} of the lower E-UTRA or NR band, and from the F_{DL_high} of the upper NR or E-UTRA band.

For EN-DC combination listed in Table 7.6B.3.3.5-7 under the first test condition above, exceptions to the requirement specified in Table 7.6B.3.3.5-8 are allowed when the second order intermodulation product of the lower frequency band UL carrier and the CW interfering signal fully or partially overlaps with the higher frequency band DL carrier.

For all interferer frequency ranges a maximum of

$$\lfloor \max \{ 24, 6 \cdot \lceil n \cdot N_{RB} / 6 \rceil \} / \min \{ \lfloor n \cdot N_{RB} / 10 \rfloor, 5 \} \rfloor$$

exceptions are allowed for spurious response frequencies in each assigned frequency channel when measured using a step size of $\min(\lfloor CBW / 2 \rfloor, 5)$ MHz with N_{RB} the number of resource blocks in the downlink transmission bandwidth configuration, CBW the bandwidth of the frequency channel in MHz and $n = 1, 2, 3$ for SCS = 15, 30, 60 kHz, respectively. For these exceptions, the requirements in clause 7.7B.3 apply.

Table 7.6B.3.3.5-1: Out-of-band blocking parameters for E-UTRA bands

Rx Parameter	Units	Channel bandwidth					
		1.4 MHz	3 MHz	5 MHz	10 MHz	15 MHz	20 MHz
Power in Transmission Bandwidth Configuration	dBm	REFSENS + channel bandwidth specific value below					
		6	6	6	6	7	9
Note 1: The reference measurement channel is specified in Annex A.3.2 of TS 36.521-1 [10] with one sided dynamic OCNB Pattern OP.1 FDD/TDD as described in Annex A.5.1.1/A.5.2.1 of TS 36.521-1 [10]. Note 2: The REFSENS power level is specified in Table 7.3.3-1 of TS 36.521-1 [10] for two and four antenna ports, respectively.							

Table 7.6B.3.3.5-2: Out of band blocking for E-UTRA bands

E-UTRA band	Parameter	Units	Frequency			
			range 1	range 2	range 3	range 4
	$P_{Interferer}$	dBm	-44	-30	-15	-15
1, 2, 3, 4, 5, 6, 7, 8, 9, 10, 11, 12, 13, 14, 17, 18, 19, 20, 21, 22, 23, 24, 25, 26, 27, 28, 30, 31, 33, 34, 35, 36, 37, 38, 39, 40, 41, 42 (Note 3), 43 (Note 3), 44, 45, 53, 65, 66, 68, 70, 71, 72, 73, 74	$F_{Interferer}$ (CW)	MHz	$F_{DL_low} -15$ to $F_{DL_low} -60$	$F_{DL_low} -60$ to $F_{DL_low} -85$	$F_{DL_low} -85$ to 1 MHz	-
			$F_{DL_high} +15$ to $F_{DL_high} +60$	$F_{DL_high} +60$ to $F_{DL_high} +85$	$F_{DL_high} +85$ to +12750 MHz	-
2, 5, 12, 17	$F_{Interferer}$	MHz	-	-	-	$F_{UL_low} - F_{UL_high}$
Note 1: Range 3 shall be tested only with the highest channel bandwidth. Note 2: For the UE which supports both Band 11 and Band 21 the out of blocking is FFS. Note 3: The power level of the interferer ($P_{Interferer}$) for Range 3 shall be modified to -20 dBm for $F_{Interferer} > 2800$ MHz and $F_{Interferer} < 4400$ MHz. Note 4: For the UE that supports both Band 4 and Band 66, the out-of-blocking frequency range for Band 4 is defined relative to F_{DL_low} and F_{DL_high} of Band 66.						

Table 7.6B.3.3.5-3: Out-of-band blocking parameters for NR bands with $F_{DL_high} < 2700$ MHz and $F_{UL_high} < 2700$ MHz

RX parameter	Units	Channel bandwidth				
		5 MHz	10 MHz	15 MHz	20 MHz	25 MHz
Power in transmission bandwidth configuration	dBm	REFSENS + channel bandwidth specific value below				
	dB	6	6	7	9	10
RX parameter	Units	Channel bandwidth				
		30 MHz	40 MHz	50 MHz	60 MHz	80 MHz
Power in transmission bandwidth configuration	dBm	REFSENS + channel bandwidth specific value below				
	dB	11	12	13	14	15
RX parameter	Units	Channel bandwidth				
		90 MHz	100 MHz			
Power in transmission bandwidth configuration	dBm	REFSENS + channel bandwidth specific value below				
	dB	15.5	16			
NOTE: The transmitter shall be at the minimum UL configuration specified in Table 7.3.2.3-3 of TS 38.521-1 [8].						

Table 7.6B.3.3.5-4: Out of-band blocking for NR bands with $F_{DL_high} < 2700$ MHz and $F_{UL_high} < 2700$ MHz

NR band	Parameter	Unit	Range 1	Range 2	Range 3
n1, n2, n3, n5, n7, n8, n12, n20, n25, n28, n34, n38, n39, n40, n41, n50, n51, n65, n66, n70, n71, n74, n75, n76	$P_{interferer}$	dBm	-44	-30	-15
	$F_{interferer}$ (CW)	MHz	$-60 < f - F_{DL_low} < -15$ or $15 < f - F_{DL_high} < 60$	$-85 < f - F_{DL_low} \leq -60$ or $60 \leq f - F_{DL_high} < 85$	$1 \leq f \leq F_{DL_low} - 85$ or $F_{DL_high} + 85 \leq f \leq 12750$
NOTE 1: The power level of the interferer ($P_{interferer}$) for Range 3 shall be modified to -20 dBm for $F_{interferer} > 6000$ MHz.					
NOTE 2: For band 51 the F_{DL_high} of band 50 is applied as F_{DL_high} for band 51. For band 50, the F_{DL_low} of band 51 is applied as F_{DL_low} for band 50.					
NOTE 3: For band 76 the F_{DL_high} of band 75 is applied as F_{DL_high} for band 76. For band 75, the F_{DL_low} of band 76 is applied as F_{DL_low} for band 75.					
NOTE 4: For UEs supporting both bands 38 and 41, the F_{DL_high} and F_{DL_low} of band 41 is applied as F_{DL_high} and F_{DL_low} for band 38.					

Table 7.6B.3.3.5-5: Out-of-band blocking parameters for NR bands with $F_{DL_low} \geq 3300$ MHz and $F_{UL_low} \geq 3300$ MHz

RX parameter	Units	Channel bandwidth				
		10 MHz	15 MHz	20 MHz	40 MHz	50 MHz
Power in transmission bandwidth configuration	dBm	REFSENS + channel bandwidth specific value below				
	dB	6	7	9	9	9
RX parameter	Units	Channel bandwidth				
		60 MHz	80 MHz	90 MHz	100 MHz	
Power in transmission bandwidth configuration	dBm	REFSENS + channel bandwidth specific value below				
	dB	9	9	9	9	
NOTE: The transmitter shall be at the minimum UL configuration specified in Table 7.3.2.3-3 of TS 38.521-1 [8].						

Table 7.6B.3.3.5-6: Out of-band blocking for NR bands with $F_{DL_low} \geq 3300$ MHz and $F_{UL_low} \geq 3300$ MHz

NR band	Parameter	Unit	Range1	Range 2	Range 3
n77, n78 (NOTE 3)	$P_{interferer}$	dBm	-44	-30	-15
	$F_{interferer}$ (CW)	MHz	$-60 < f - F_{DL_low} \leq -3CBW$ or $3CBW \leq f - F_{DL_high} < 60$	$-200 < f - F_{DL_low} \leq -MAX(60,3CBW)$ or $MAX(60,3CBW) \leq f - F_{DL_high} < 200$	$1 \leq f \leq F_{DL_low} - MAX(200,3CBW)$ or $F_{DL_high} + MAX(200,3CBW) \leq f \leq 12750$
n79 (NOTE 4)	$F_{interferer}$ (CW)	MHz	N/A	$-150 < f - F_{DL_low} \leq -MAX(60,3CBW)$ or $MAX(60,3CBW) \leq f - F_{DL_high} < 150$	$1 \leq f \leq F_{DL_low} - MAX(150,3CBW)$ or $F_{DL_high} + MAX(150,3CBW) \leq f \leq 12750$
<p>NOTE 1: The power level of the interferer ($P_{interferer}$) for Range 3 shall be modified to -20 dBm for $F_{interferer} > 6000$ MHz.</p> <p>NOTE 2: CBW denotes the channel bandwidth of the wanted signal</p> <p>NOTE 3: The power level of the interferer ($P_{interferer}$) for Range 3 shall be modified to -20 dBm, for $F_{interferer} > 2700$ MHz and $F_{interferer} < 4800$ MHz. For $CBW > 15$ MHz, the requirement for Range 1 is not applicable and Range 2 applies from the frequency offset of 3CBW from the band edge. For CBW larger than 60 MHz, the requirement for Range 2 is not applicable and Range 3 applies from the frequency offset of 3CBW from the band edge.</p> <p>NOTE 4: The power level of the interferer ($P_{interferer}$) for Range 3 shall be modified to -20 dBm, for $F_{interferer} > 3650$ MHz and $F_{interferer} < 5750$ MHz. For $CBW \geq 40$ MHz, the requirement for Range 2 is not applicable and Range 3 applies from the frequency offset of 3CBW from the band edge.</p>					

Table 7.6B.3.3.5-7: EN-DC combination with exceptions allowed

EN-DC combination
DC_5_n78
DC_8_n77
DC_8_n78
DC_8_n79
DC_11_n77
DC_18_n77
DC_18_n78
DC_18_n79
DC_19_n77
DC_19_n78
DC_19_n79
DC_20_n77
DC_20_n78
DC_21_n77
DC_26_n77
DC_26_n78
DC_26_n79
DC_28_n77
DC_28_n78
DC_28_n79

Table 7.6B.3.3.5-8: Exceptions allowed

Parameter	Unit	Level
$P_{\text{Interferer}}$ (CW)	dBm	-44 ¹
NOTE 1: The requirement applies when $ f_{\text{Interferer}} \pm f_{\text{UL}}^{\text{UL}} - f_{\text{DL}}^{\text{DL}} \leq (BW_{\text{UL}}^{\text{UL}} + BW_{\text{DL}}^{\text{DL}})/2$, where $f_{\text{UL}}^{\text{UL}}$ and $f_{\text{DL}}^{\text{DL}}$ are the carrier frequencies for lower frequency band UL and higher frequency band DL, respectively. $BW_{\text{UL}}^{\text{UL}}$ and $BW_{\text{DL}}^{\text{DL}}$ are the channel bandwidths configured for lower frequency band UL carrier and higher frequency band DL carrier in MHz, respectively.		

7.6B.3.3_1 Out-of-band blocking for EN-DC within FR1 (>2 CCs)

7.6B.3.3_1.1 Out-of-band blocking for EN-DC within FR1 (3 CCs)

7.6B.3.3_1.1.1 Test Purpose

Out-of-band band blocking is defined for an unwanted CW interfering signal falling more than 15 MHz below or above the UE receive band, at which a given average throughput shall meet or exceed the requirement for the specified measurement channels.

For the first 15 MHz below or above the UE receive band the appropriate in-band blocking or adjacent channel selectivity in clause 7.6B.2.1 and clause 7.5B.1 shall be applied.

The lack of out-of-band blocking ability will decrease the coverage area when other NodeB transmitters exist (except in the adjacent channels and spurious response).

7.6B.3.3_1.1.2 Test Applicability

This test case applies to all types of E-UTRA UE release 15 and forward, supporting intra-band contiguous EN-DC in FR1 with 3 DL CCs.

7.6B.3.3_1.1.3 Minimum Conformance Requirements

The minimum conformance requirements are defined in clause 7.6B.3.0.1.

Exception requirements for both NR and E-UTRA are defined for this test and therefore LTE anchor agnostic approach is not applied. E-UTRA test point analysis is included and E-UTRA measurements are performed.

7.6B.3.3_1.1.4 Test Description

7.6B.3.3_1.1.4.1 Initial condition

Initial conditions are a set of test configurations the UE needs to be tested in and the steps for the SS to take with the UE to reach the correct measurement state.

The initial test configurations consist of environmental conditions, test frequencies and channel bandwidths based on EN-DC operating bands specified in clause 5.3B.1.2, channel bandwidths and sub-carrier spacings for the NR cell specified in TS 38.521-1 [8] clause 5.3 and channel bandwidth for the E-UTRA cell are specified in TS 36.521-1 [10] clause 5.4.2. All of these configurations shall be tested with applicable test parameters for each EN-DC configuration specified in clause 5.3B.1.2 and are shown in Table 7.6B.3.3_1.1.4.1-1. The details of the uplink and downlink reference measurement channels (RMCs) are specified in Annex A.2 and A.3 respectively. The details of the OCN patterns used are specified in TS 36.521-1 [10] Annex A.5 and in TS 38.521-1 [8] Annex A.5 for E-UTRA CG and NR CG respectively. Configurations of PDSCH and PDCCH before measurement are specified in TS 36.521-1 [10] Annex C.2 and in TS 38.521-1 [8] Annex C.2 for E-UTRA CG and NR CG respectively.

Table 7.6B.3.3_1.1.4.1-1: Test configuration table

Initial Conditions					
Test Environment as specified in TS 38.508-1 [6] clause 4.1			Normal		
Test Frequencies as specified in TS 38.508-1 [6] clause 4.3.1 for different EN-DC bandwidth classes			Mid range		
Test EN-DC bandwidth combination as specified in Table 5.3B.1.2-1 across bandwidth combination sets supported by the UE			Highest N_{RB_agg} (NOTE 3)		
NR Test SCS as specified in Table 5.3.5-1 in TS 38.521-1 [8]			Lowest		
NR/E-UTRA Test Parameters					
PCC – E-UTRA		SCC – EUTRA		NR	
UL/DL Modulation	UL/DL allocation	UL/DL Modulation	UL/DL allocation	UL/DL Modulation	UL/DL allocation
QPSK/QPSK	REFSENS/Full RB	NA/QPSK	NA/Full RB	DFT-s-OFDM QPSK/CP-OFDM QPSK	REFSENS/Full RB (NOTE 1)
NOTE 1: Full RB allocation shall be used per each SCS and channel BW as specified in Table 7.3.2.4.1-2 of TS 38.521-1 [8].					
NOTE 2: Test Channel Bandwidths are checked separately for each EN-DC band, which applicable channel bandwidths are specified in Table 5.3B.1.2-1.					
NOTE 3: If the UE supports multiple CC Combinations in the EN-DC Configuration with the same N_{RB_agg} , only the combination with the highest N_{RB_SCG} is tested.					
NOTE 4: REFSENS refers to Uplink configuration in Table 7.3.2.3-3 in [8] and Table 7.3.3-2 in [10] for NR and E-UTRA CC respectively.					
NOTE 5: In an E-UTRA band or FR1 band where UE supports 4Rx, the test shall be performed only with 4Rx antennas ports connected and 4Rx REFSENS requirement (TS 38.521-1 [8] Table 7.3.2.5-2) is used in the test requirements.					

1. Connect the SS to the UE antenna connectors as shown in [6] TS 38.508-1 Annex A, in Figure A.3.1.4.2 for SS diagram and clause A.3.2 for UE diagram.
2. The parameter settings for the cell are set up according to TS 38.508-1 [6] clause 4.4.3.
3. Downlink signals are initially set up according to TS 36.521-1 [10] Annex C and TS 38.521-1 [8] Annex C for E-UTRA CG and NR CG respectively, and uplink signals according to TS 36.521-1 [10] Annex H and TS 38.521-1 [8] Annex G for E-UTRA CG and NR CG respectively.
4. The UL and DL Reference Measurement channels are TS 36.521-1 [10] Annex A.2, A.3 and TS 38.521-1 [8] Annex A.2, A.3 for E-UTRA CG and NR CG respectively.
5. Propagation conditions are set according to TS 36.521-1 [10] Annex B.0 and TS 38.521-1 [8] Annex B.0 for E-UTRA CG and NR CG respectively.
6. Ensure the UE is in state RRC_CONNECTED with generic procedure parameters Connectivity EN-DC, DC bearer MCG and SCG, Connected without release *On* according to TS 38.508-1 [6] clause 4.5. Message contents are defined in clause 7.6B.3.3_1.1.4.3.

7.6B.3.3_1.1.4.2 Test procedure

1. SS transmits PDSCH via PDCCH DCI format 1A and PDCCH DCI format 1_1 for C_RNTI to transmit the DL RMC according to Table 7.6B.3.3_1.1.4.1-1 on E-UTRA CC and NR CC respectively. The SS sends downlink MAC padding bits on the DL RMC.
2. SS sends uplink scheduling information for each UL HARQ process via PDCCH DCI format 0 and DCI format 0_1 for C_RNTI to schedule the UL RMC according to Table 7.6B.3.3_1.1.4.1-1 on E-UTRA CC and NR CC respectively. Since the UL has no payload and no loopback data to send the UE sends uplink MAC padding bits on the UL RMC.

3. Set the Downlink signal level to the value as defined in Table 7.6B.3.3_1.1.5-1. For NR CC and E-UTRA CC, send uplink power control commands to the UE using 1dB power step size to ensure that the UE output power measured by the test system is within the Uplink power control window, defined as $-(\text{MU} + \text{Uplink power control window size})$ dB of the target power level in Table 7.6B.3.3_1.1.5-1 $+([10\log(S_{L_{\text{CRB}}/N_{\text{RB_alloc}}}]$ for NR CC, $[10\log(P_{L_{\text{CRB}}/N_{\text{RB_alloc}}}]$ for E-UTRA CC) for at least the duration of the Throughput measurement, where:
 - MU is the test system uplink power measurement uncertainty and is specified in Table F.1.3-1 for the carrier frequency f and the channel bandwidth BW
 - For NR CC, Uplink power control window size = 1dB (UE power step size) + 0.7dB (UE power step tolerance) + (Test system relative power measurement uncertainty), where, the UE power step tolerance is specified in TS 38.101-1 [2], Table 6.3.4.3-1 and is 0.7dB for 1dB power step size, and the Test system relative power measurement uncertainty is specified in Table F.1.2-1.
 - For E-UTRA CC, Uplink power control window size = 1dB (UE power step size) + 1.0dB (UE power step tolerance) + (Test system relative power measurement uncertainty), where, the UE power step tolerance is specified in TS 36.101 [5], Table 6.3.5.2.1-1 and is 1.0dB for 1dB power step size, and the Test system relative power measurement uncertainty is specified in Table F.1.2-1 of TS 36.521-1 [10].
4. Set the parameters of the CW signal generator for an interfering signal below the aggregated component carriers according to Table 7.6B.3.3_1.1.5-1. The frequency step size is 1MHz.
5. Measure the average throughput for a duration sufficient to achieve statistical significance according to Annex H.2.
6. Repeat steps from 4 to 5, using an interfering signal above the aggregated component carriers at step 4.

NOTE: The purpose of the Uplink power control window is to ensure that the actual UE output power is no greater than the target power level, and as close as possible to the target power level. The relationship between the Uplink power control window, the target power level and the corresponding possible actual UE Uplink power window is illustrated in Annex F, clause F.4.

7.6B.3.3_1.1.4.3 Message contents

Message contents are according to TS 38.508-1 [6] clause 4.6 Table 4.6.3-118 with condition TRANSFORM_PRECODER_ENABLED.

7.6B.3.3_1.1.5 Test Requirement

The throughput shall be $\geq 95\%$ of the maximum throughput of the reference measurement channels as specified in TS 36.521-1 [10] Annex A.3 and TS 38.521-1 [8] Annex A.3 for E-UTRA CG and NR CG respectively with parameters specified in Table 7.6B.3.3_1.1.5-1 for the specified wanted signal mean power in the presence of interfering signals.

Table 7.6B.3.3_1.1.5-1: Out-of-band blocking for intra-band contiguous EN-DC

EN-DC Aggregated Bandwidth, MHz	≤ 100	$>100, \leq 120$	$>120, \leq 140$	$>140, \leq 160$
Pw in Transmission Bandwidth Configuration, perCC, dBm	REFSENS + Aggregated BW specific value below			
	9			
NOTE 1: Interferer values and offsets are specified from Table 7.6.2.1A-2 in TS 36.101 [5]. For inter-band combinations where the intra-band requirements are applicable, in which the E-UTRA band is a subset of an NR-only band, the NR band interferer values and offsets specified from Table 7.6A.3-2 in TS 38.101-1 [2] apply to both E-UTRA and NR carriers. NOTE 2: For NR carrier, the transmitter shall be set to 4dB below $P_{\text{CMAX_L,f,c,NR}}$ at the minimum uplink configuration specified in Table 7.3.2-3 in TS 8.101-1 [2] with $P_{\text{CMAX_L,f,c,NR}}$ as defined in clause 6.2B.4. NOTE 3: For E-UTRA carrier, the transmitter shall be set to 4dB below $P_{\text{CMAX_L,E-UTRA,c}}$ at the minimum uplink configuration specified in Table 7.3.1-2 in TS 36.101 [5] with $P_{\text{CMAX_L,E-UTRA,c}}$ as defined in clause 6.2B.4 for single carrier.				

7.6B.3.3_1.2 Out-of-band blocking for EN-DC within FR1 (4 CCs)

7.6B.3.3_1.2.1 Test Purpose

Out-of-band band blocking is defined for an unwanted CW interfering signal falling more than 15 MHz below or above the UE receive band, at which a given average throughput shall meet or exceed the requirement for the specified measurement channels.

For the first 15 MHz below or above the UE receive band the appropriate in-band blocking or adjacent channel selectivity in clause 7.6B.2.1 and clause 7.5B.1 shall be applied.

The lack of out-of-band blocking ability will decrease the coverage area when other NodeB transmitters exist (except in the adjacent channels and spurious response).

7.6B.3.3_1.2.2 Test Applicability

This test case applies to all types of E-UTRA UE release 15 and forward, supporting intra-band contiguous EN-DC in FR1 with 4 DL CCs.

7.6B.3.3_1.2.3 Minimum Conformance Requirements

The minimum conformance requirements are defined in clause 7.6B.3.0.1.

Exception requirements for both NR and E-UTRA are defined for this test and therefore LTE anchor agnostic approach is not applied. E-UTRA test point analysis is included and E-UTRA measurements are performed.

7.6B.3.3_1.2.4 Test Description

7.6B.3.3_1.2.4.1 Initial condition

Initial conditions are a set of test configurations the UE needs to be tested in and the steps for the SS to take with the UE to reach the correct measurement state.

The initial test configurations consist of environmental conditions, test frequencies and channel bandwidths based on EN-DC operating bands specified in clause 5.3B.1.2, channel bandwidths and sub-carrier spacings for the NR cell specified in TS 38.521-1 [8] clause 5.3 and channel bandwidth for the E-UTRA cell are specified in TS 36.521-1 [10] clause 5.4.2. All of these configurations shall be tested with applicable test parameters for each EN-DC configuration specified in clause 5.3B.1.2 and are shown in Table 7.6B.3.3_1.2.4.1-1. The details of the uplink and downlink reference measurement channels (RMCs) are specified in Annex A.2 and A.3 respectively. The details of the OCN patterns used are specified in TS 36.521-1 [10] Annex A.5 and in TS 38.521-1 [8] Annex A.5 for E-UTRA CG and NR CG respectively. Configurations of PDSCH and PDCCH before measurement are specified in TS 36.521-1 [10] Annex C.2 and in TS 38.521-1 [8] Annex C.2 for E-UTRA CG and NR CG respectively.

Table 7.6B.3.3_1.2.4.1-1: Test configuration table

Initial Conditions					
Test Environment as specified in TS 38.508-1 [6] clause 4.1			Normal		
Test Frequencies as specified in TS 38.508-1 [6] clause 4.3.1 for different EN-DC bandwidth classes			Mid range		
Test EN-DC bandwidth combination as specified in Table 5.3B.1.2-1 across bandwidth combination sets supported by the UE			Highest N_{RB_agg} (NOTE 3)		
NR Test SCS as specified in Table 5.3.5-1 in TS 38.521-1 [8]			Lowest		
NR/E-UTRA Test Parameters					
PCC – E-UTRA		SCC1 – EUTRA and SCC2 – EUTRA		NR	
UL/DL Modulation	UL/DL allocation	UL/DL Modulation	UL/DL allocation	UL/DL Modulation	UL/DL allocation
QPSK/QPSK	REFSENS/Full RB	NA/QPSK	NA/Full RB	DFT-s-OFDM QPSK/CP-OFDM QPSK	REFSENS/Full RB (NOTE 1)
NOTE 1: Full RB allocation shall be used per each SCS and channel BW as specified in Table 7.3.2.4.1-2 of TS 38.521-1 [8].					
NOTE 2: Test Channel Bandwidths are checked separately for each EN-DC band, which applicable channel bandwidths are specified in Table 5.3B.1.2-1.					
NOTE 3: If the UE supports multiple CC Combinations in the EN-DC Configuration with the same N_{RB_agg} , only the combination with the highest N_{RB_SCG} is tested.					
NOTE 4: REFSENS refers to Uplink configuration in Table 7.3.2.3-3 in [8] and Table 7.3.3-2 in [10] for NR and E-UTRA CC respectively.					
NOTE 5: In an E-UTRA band or FR1 band where UE supports 4Rx, the test shall be performed only with 4Rx antennas ports connected and 4Rx REFSENS requirement (TS 38.521-1 [8] Table 7.3.2.5-2) is used in the test requirements.					

1. Connect the SS to the UE antenna connectors as shown in [6] TS 38.508-1 Annex A, in Figure A.3.1.4.2 for SS diagram and clause A.3.2 for UE diagram.
2. The parameter settings for the cell are set up according to TS 38.508-1 [6] clause 4.4.3.
3. Downlink signals are initially set up according to TS 36.521-1 [10] Annex C and TS 38.521-1 [8] Annex C for E-UTRA CG and NR CG respectively, and uplink signals according to TS 36.521-1 [10] Annex H and TS 38.521-1 [8] Annex G for E-UTRA CG and NR CG respectively.
4. The UL and DL Reference Measurement channels are TS 36.521-1 [10] Annex A.2, A.3 and TS 38.521-1 [8] Annex A.2, A.3 for E-UTRA CG and NR CG respectively.
5. Propagation conditions are set according to TS 36.521-1 [10] Annex B.0 and TS 38.521-1 [8] Annex B.0 for E-UTRA CG and NR CG respectively.
6. Ensure the UE is in state RRC_CONNECTED with generic procedure parameters Connectivity EN-DC, DC bearer *MCG* and *SCG*, Connected without release *On* according to TS 38.508-1 [6] clause 4.5. Message contents are defined in clause 7.6B.3.3_1.2.4.3.

7.6B.3.3_1.2.4.2 Test procedure

1. SS transmits PDSCH via PDCCH DCI format 1A and PDCCH DCI format 1_1 for C_RNTI to transmit the DL RMC according to Table 7.6B.3.3_1.2.4.1-1 on E-UTRA CC and NR CC respectively. The SS sends downlink MAC padding bits on the DL RMC.
2. SS sends uplink scheduling information for each UL HARQ process via PDCCH DCI format 0 and DCI format 0_1 for C_RNTI to schedule the UL RMC according to Table 7.6B.3.3_1.2.4.1-1 on E-UTRA CC and NR CC respectively. Since the UL has no payload and no loopback data to send the UE sends uplink MAC padding bits on the UL RMC.
3. Set the Downlink signal level to the value as defined in Table 7.6B.3.3_1.2.5-1. For NR CC and E-UTRA CC, send uplink power control commands to the UE using 1dB power step size to ensure that the UE output power

measured by the test system is within the Uplink power control window, defined as $-(\text{MU} + \text{Uplink power control window size})$ dB of the target power level in Table 7.6B.3.3_1.2.5-1 $+([10\log(S_{\text{LCRB}}/N_{\text{RB_alloc}})]$ for NR CC, $[10\log(P_{\text{LCRB}}/N_{\text{RB_alloc}})]$ for E-UTRA CC) for at least the duration of the Throughput measurement, where:

- MU is the test system uplink power measurement uncertainty and is specified in Table F.1.3-1 for the carrier frequency f and the channel bandwidth BW
 - For NR CC, Uplink power control window size = 1dB (UE power step size) + 0.7dB (UE power step tolerance) + (Test system relative power measurement uncertainty), where, the UE power step tolerance is specified in TS 38.101-1 [2], Table 6.3.4.3-1 and is 0.7dB for 1dB power step size, and the Test system relative power measurement uncertainty is specified in Table F.1.2-1.
 - For E-UTRA CC, Uplink power control window size = 1dB (UE power step size) + 1.0dB (UE power step tolerance) + (Test system relative power measurement uncertainty), where, the UE power step tolerance is specified in TS 36.101 [5], Table 6.3.5.2.1-1 and is 1.0dB for 1dB power step size, and the Test system relative power measurement uncertainty is specified in Table F.1.2-1 of TS 36.521-1 [10].
4. Set the parameters of the CW signal generator for an interfering signal below the aggregated component carriers according to Table 7.6B.3.3_1.2.5-1. The frequency step size is 1MHz.
 5. Measure the average throughput for a duration sufficient to achieve statistical significance according to Annex H.2.
 6. Repeat steps from 4 to 5, using an interfering signal above the aggregated component carriers at step 4.

NOTE: The purpose of the Uplink power control window is to ensure that the actual UE output power is no greater than the target power level, and as close as possible to the target power level. The relationship between the Uplink power control window, the target power level and the corresponding possible actual UE Uplink power window is illustrated in Annex F, clause F.4.

7.6B.3.3_1.2.4.3 Message contents

Message contents are according to TS 38.508-1 [6] clause 4.6 Table 4.6.3-118 with condition TRANSFORM_PRECODER_ENABLED.

7.6B.3.3_1.2.5 Test Requirement

The throughput shall be $\geq 95\%$ of the maximum throughput of the reference measurement channels as specified in TS 36.521-1 [10] Annex A.3 and TS 38.521-1 [8] Annex A.3 for E-UTRA CG and NR CG respectively with parameters specified in Table 7.6B.3.3_1.2.5-1 for the specified wanted signal mean power in the presence of interfering signals.

Table 7.6B.3.3_1.2.5-1: Out-of-band blocking for intra-band contiguous EN-DC

EN-DC Aggregated Bandwidth, MHz	≤ 100	$>100, \leq 120$	$>120, \leq 140$	$>140, \leq 160$
Pw in Transmission Bandwidth Configuration, perCC, dBm	REFSENS + Aggregated BW specific value below			
	9			
NOTE 1: Interferer values and offsets are specified from Table 7.6.2.1A-2 in TS 36.101 [5]. For inter-band combinations where the intra-band requirements are applicable, in which the E-UTRA band is a subset of an NR-only band, the NR band interferer values and offsets specified from Table 7.6A.3-2 in TS 38.101-1 [2] apply to both E-UTRA and NR carriers.				
NOTE 2: For NR carrier, the transmitter shall be set to 4dB below $P_{\text{CMAX_L,f,c,NR}}$ at the minimum uplink configuration specified in Table 7.3.2-3 in TS 8.101-1 [2] with $P_{\text{CMAX_L,f,c,NR}}$ as defined in clause 6.2B.4.				
NOTE 3: For E-UTRA carrier, the transmitter shall be set to 4dB below $P_{\text{CMAX_L,E-UTRA,c}}$ at the minimum uplink configuration specified in Table 7.3.1-2 in TS 36.101 [5] with $P_{\text{CMAX_L,E-UTRA,c}}$ as defined in clause 6.2B.4 for single carrier.				

7.6B.4 Narrow band blocking for DC

7.6B.4.0 Minimum Conformance Requirements

7.6B.4.0.1 Intra-band contiguous EN-DC in FR1

Intra-band contiguous EN-DC narrow band blocking requirement and parameters are defined in Table 7.6B.4.0.1-1.

Table 7.6B.4.0.1-1: Narrow band blocking parameters for intra-band contiguous EN-DC

EN-DC Aggregated Bandwidth, MHz	≤100	>100, ≤120	>120, ≤140	>140, ≤160
P _w in Transmission Bandwidth Configuration, perCC, dBm	REFSENS + Aggregated BW specific value below			
P _{uw} , dBm (CW)	16			
	-55			
NOTE 1: Jammer offset is from Table 7.6.3.1A-1 in TS 36.101 [5] and is applied from the lowest edge of the lowest carrier and the highest edge of the highest carrier.				
NOTE 2: For NR carrier, the transmitter shall be set to 4dB below P _{CMAX_L,f,c,NR} at the minimum uplink configuration specified in Table 7.3.2-3 [2] with P _{CMAX_L,f,c,NR} as defined in clause 6.2B.4.				
NOTE 3: For E-UTRA carrier, the transmitter shall be set to 4dB below P _{CMAX_L,E-UTRA,c} at the minimum uplink configuration specified in Table 7.3.1-2 [5] with P _{CMAX_L,E-UTRA,c} as defined in clause 6.2B.4 for single carrier.				
NOTE 4: If NR carrier BW > 40 MHz, no narrow band blocking requirements apply when blocker is applied at the edge of the NR carrier.				

The normative reference for this requirement is TS 38.101-3 [4] clause 7.6B.4.1.

7.6B.4.0.2 Intra-band non-contiguous EN-DC in FR1

For the E-TRA sub-block containing one or multiple CC's, the requirement is defined in clause 7.6.3.1 for single carrier operation and in clause 7.6.3.1A for CA in TS 36.101 [5].

For the NR sub-block, the requirement is defined in clause 7.6.4 in TS 38.101-1 [2].

The blocker configuration is defined in the general clause 7.1.

The normative reference for this requirement is TS 38.101-3 [4] clause 7.6B.4.2.

7.6B.4.0.3 Inter-band EN-DC within FR1

Narrow band blocking requirement for E-UTRA single carrier and CA operation specified in clauses 7.6.3.1 and 7.6.3.1A of TS 36.101 [5] and for NR single carrier and CA operation specified in clauses 7.6.4 and 7.6A.4 of TS 38.101-1 [2] apply.

The normative reference for this requirement is TS 38.101-3 [4] clause 7.6B.4.3.

7.6B.4.0.3A Inter-band NE-DC within FR1

Narrow band blocking requirement for E-UTRA single carrier and CA operation specified in clauses 7.6.3.1 and 7.6.3.1A of TS 36.101 [5] and for NR single carrier and CA operation specified in clauses 7.6.4 and 7.6A.4 of TS 38.101-1 [2] apply.

The normative reference for this requirement is TS 38.101-3 [4] clause 7.6B.4.3a.

7.6B.4.0.4 Inter-band EN-DC including FR2

Narrow band blocking requirement for E-UTRA single carrier and CA operation specified in clauses 7.6.3.1 and 7.6.3.1A of TS 36.101 [5] apply.

The normative reference for this requirement is TS 38.101-3 [4] clause 7.6B.4.4.

7.6B.4.0.5 Inter-band EN-DC including both FR1 and FR2

Narrow band blocking requirement for E-UTRA single carrier and CA operation specified in clauses 7.6.3.1 and 7.6.3.1A of TS 36.101 [5] and for NR single carrier and CA operation specified in clauses 7.6.4 and 7.6A.4 of TS 38.101-1 [2] apply.

The normative reference for this requirement is TS 38.101-3 [4] clause 7.6B.4.5.

7.6B.4.1 Narrow band blocking for intra-band contiguous EN-DC in FR1 (2 CCs)

7.6B.4.1.1 Test Purpose

Verifies a receiver's ability to receive EN-DC signals at its assigned channel frequencies in the presence of an unwanted narrow band CW interferer at a frequency, which is less than the nominal channel spacing.

The lack of narrow-band blocking ability will decrease the coverage area when other NodeB transmitters exist (except in the adjacent channels and spurious response).

7.6B.4.1.2 Test Applicability

This test case applies to all types of E-UTRA UE release 15 and forward, supporting intra-band contiguous EN-DC in FR1 with 2CCs.

7.6B.4.1.3 Minimum Conformance Requirements

The minimum conformance requirements are defined in clause 7.6B.4.0.1.

Exception requirements for both NR and E-UTRA are defined for this test and therefore LTE anchor agnostic approach is not applied. E-UTRA test point analysis is included and E-UTRA measurements are performed.

7.6B.4.1.4 Test Description

7.6B.4.1.4.1 Initial condition

Initial conditions are a set of test configurations the UE needs to be tested in and the steps for the SS to take with the UE to reach the correct measurement state.

The initial test configurations consist of environmental conditions, test frequencies and channel bandwidths based on EN-DC operating bands specified in clause 5.3B.1.2, channel bandwidths and sub-carrier spacings for the NR cell specified in TS 38.521-1 [8] clause 5.3 and channel bandwidth for the E-UTRA cell are specified in TS 36.521-1 [10] clause 5.4.2. All of these configurations shall be tested with applicable test parameters for each EN-DC configuration specified in clause 5.3B.1.2 and are shown in Table 7.6B.4.1.4.1-1. The details of the uplink and downlink reference measurement channels (RMCs) are specified in Annex A.2 and A.3 respectively. The details of the OCNG patterns used are specified in TS 36.521-1 [10] Annex A.5 and in TS 38.521-1 [8] Annex A.5 for E-UTRA CG and NR CG respectively. Configurations of PDSCH and PDCCH before measurement are specified in TS 36.521-1 [10] Annex C.2 and in TS 38.521-1 [8] Annex C.2 for E-UTRA CG and NR CG respectively.

Table 7.6B.4.1.4.1-1: Test configuration table

Initial Conditions							
Test Environment as specified in TS 38.508-1 [6] clause 4.1				Normal			
Test Frequencies as specified in TS 38.508-1 [6] clause 4.3.1 for different EN-DC bandwidth classes				Mid range			
Test EN-DC bandwidth combination as specified in Table 5.3B.1.2-1 across bandwidth combination sets supported by the UE				Lowest N_{RB_agg} , Highest N_{RB_agg} (NOTE 3)			
NR Test SCS as specified in Table 5.3.5-1 in TS 38.521-1 [8]				Lowest			
NR/E-UTRA Test Parameters							
Downlink Configuration				Uplink Configuration			
NR Modulation	NR RB allocation	E-UTRA Modulation	E-UTRA RB allocation	NR Modulation	NR RB allocation	E-UTRA Modulation	E-UTRA RB allocation
CP-OFDM QPSK	Full RB (NOTE 1)	QPSK	Full RB	DFT-s-OFDM QPSK	REFSENS	QPSK	REFSENS
NOTE 1: Full RB allocation shall be used per each SCS and channel BW as specified in Table 7.3.2.4.1-2 of TS 38.521-1 [8].							
NOTE 2: Test Channel Bandwidths are checked separately for each EN-DC band, which applicable channel bandwidths are specified in Table 5.3B.1.2-1.							
NOTE 3: If the UE supports multiple CC Combinations in the EN-DC Configuration with the same N_{RB_agg} , only the combination with the highest N_{RB_SCG} is tested.							
NOTE 4: REFSENS refers to Uplink configuration in Table 7.3.2.3-3 in [8] and Table 7.3.3-2 in [10] for NR and E-UTRA CC respectively.							
NOTE 5: In an E-UTRA band or FR1 band where UE supports 4Rx, the test shall be performed only with 4Rx antennas ports connected and 4Rx REFSENS requirement (TS 38.521-1 [8] Table 7.3.2.5-2) is used in the test requirements.							

1. Connect the SS to the UE antenna connectors as shown in [6] TS 38.508-1 Annex A, in Figure A.3.1.4.2 for SS diagram and clause A.3.2 for UE diagram.
2. The parameter settings for the E-UTRA cell are set up according to TS 36.508 [11] clause 4.4.3, and the parameter settings for the NR cell are set up according to TS 38.508-1 [6] clause 4.4.3.
3. Downlink signals are initially set up according to TS 36.521-1 [10] Annex C and TS 38.521-1 [8] Annex C for E-UTRA CG and NR CG respectively, and uplink signals according to TS 36.521-1 [10] Annex H and TS 38.521-1 [8] Annex G for E-UTRA CG and NR CG respectively.
4. The UL and DL Reference Measurement channels are TS 36.521-1 [10] Annex A.2, A.3 and TS 38.521-1 [8] Annex A.2, A.3 for E-UTRA CG and NR CG respectively.
5. Propagation conditions are set according to TS 36.521-1 [10] Annex B.0 and TS 38.521-1 [8] Annex B.0 for E-UTRA CG and NR CG respectively.
6. Ensure the UE is in state RRC_CONNECTED with generic procedure parameters Connectivity EN-DC, DC bearer *MCG* and *SCG*, Connected without release *On* according to TS 38.508-1 [6] clause 4.5. Message contents are defined in clause 7.6B.4.1.4.3.

7.6B.4.1.4.2 Test procedure

1. SS transmits PDSCH via PDCCH DCI format 1A and PDCCH DCI format 1_1 for C_RNTI to transmit the DL RMC according to Table 7.6B.4.1.4.1-1 on E-UTRA CC and NR CC respectively. The SS sends downlink MAC padding bits on the DL RMC.
2. SS sends uplink scheduling information for each UL HARQ process via PDCCH DCI format 0 and DCI format 0_1 for C_RNTI to schedule the UL RMC according to Table 7.6B.4.1.4.1-1 on E-UTRA CC and NR CC respectively. Since the UL has no payload and no loopback data to send the UE sends uplink MAC padding bits on the UL RMC.

3. Set the Downlink signal level to the value as defined in Table 7.6B.4.1.5-1. For NR CC and E-UTRA CC, send uplink power control commands to the UE using 1dB power step size to ensure that the UE output power measured by the test system is within the Uplink power control window, defined as $-(\text{MU} + \text{Uplink power control window size})$ dB of the target power level in Table 7.6B.4.1.5-1 + $([10\log(S_{\text{LCRB}}/N_{\text{RB_alloc}})]$ for NR CC, $[10\log(P_{\text{LCRB}}/N_{\text{RB_alloc}})]$ for E-UTRA CC) for at least the duration of the Throughput measurement, where:
 - MU is the test system uplink power measurement uncertainty and is specified in Table F.1.3-1 for the carrier frequency f and the channel bandwidth BW
 - For NR CC, Uplink power control window size = 1dB (UE power step size) + 0.7dB (UE power step tolerance) = 1.7dB, where, the UE power step tolerance is specified in TS 38.101-1 [2], Table 6.3.4.3-1 and is 0.7dB for 1dB power step size.
 - For E-UTRA CC, Uplink power control window size = 1dB (UE power step size) + 1.0dB (UE power step tolerance) = 2.0dB, where, the UE power step tolerance is specified in TS 36.101 [5], Table 6.3.5.2.1-1 and is 1.0dB for 1dB power step size.
4. Set the parameters of the CW signal generator for an interfering signal below the aggregated component carriers according to Table 7.6B.4.1.5-1.
5. Measure the average throughput for a duration sufficient to achieve statistical significance according to Annex H.2.
6. Repeat steps from 4 to 5, using an interfering signal above the aggregated component carriers at step 4.

NOTE: The purpose of the Uplink power control window is to ensure that the actual UE output power is no greater than the target power level, and as close as possible to the target power level. The relationship between the Uplink power control window, the target power level and the corresponding possible actual UE Uplink power window is illustrated in Annex F, clause F.4.

7.6B.4.1.4.3 Message contents

Message contents are according to TS 38.508-1 [6] clause 4.6 Table 4.6.3-118 with condition TRANSFORM_PRECODER_ENABLED.

7.6B.4.1.5 Test Requirement

The throughput shall be $\geq 95\%$ of the maximum throughput of the reference measurement channels as specified in TS 36.521-1 [10] Annex A.3 and TS 38.521-1 [8] Annex A.3 for E-UTRA CG and NR CG respectively with parameters specified in Table 7.6B.4.1.5-1 for the specified wanted signal mean power in the presence of interfering signals.

Table 7.6B.4.1.5-1: Narrow band blocking for intra-band contiguous EN-DC

EN-DC Aggregated Bandwidth, MHz	≤ 100	$>100, \leq 120$	$>120, \leq 140$	$>140, \leq 160$
Pw in Transmission Bandwidth Configuration, perCC, dBm	REFSENS + Aggregated BW specific value below			
P _{uw} , dBm (CW)	16			
	-55			
NOTE 1: Jammer offset is from Table 7.6.3.1A-1 in TS 36.101 [5] and is applied from the lowest edge of the lowest carrier and the highest edge of the highest carrier.				
NOTE 2: For NR carrier, the transmitter shall be set to 4dB below P _{C_{MAX}_L,f,c,NR} at the minimum uplink configuration specified in Table 7.3.2-3 in TS 38.101-1 [2] with P _{C_{MAX}_L,f,c,NR} as defined in clause 6.2B.				
NOTE 3: For E-UTRA carrier, the transmitter shall be set to 4dB below P _{C_{MAX}_L,E-UTRA,c} at the minimum uplink configuration specified in Table 7.3.1-2 in TS 36.101 [5] with P _{C_{MAX}_L,E-UTRA,c} as defined in clause 6.2B.4 for single carrier.				
NOTE 4: If NR carrier BW > 40 MHz, no narrow band blocking requirements apply when blocker is applied at the edge of the NR carrier.				

Table 7.6B.4.1.5-2: Void**Table 7.6B.4.1.5-3: Void****7.6B.4.2 Narrow band blocking for intra-band non-contiguous EN-DC in FR1 (2 CCs)****7.6B.4.2.1 Test Purpose**

Same test purpose as in clause 7.6.4.1 in TS 38.521-1 [8] for the NR carrier.

7.6B.4.2.2 Test Applicability

This test case applies to all types of E-UTRA UE release 15 and forward, supporting intra-band non-contiguous EN-DC in FR1 with 2CCs.

7.6B.4.2.3 Minimum Conformance Requirements

The minimum conformance requirements are defined in clause 7.6B.4.0.2.

No exception requirements applicable to NR or LTE. LTE anchor agnostic approach is applied.

7.6B.4.2.4 Test Description

Same test description as in clause 7.6.4.4 in TS 38.521-1 [8] for the NR carrier with the following exceptions:

Table 7.6B.4.2.4-1: Test Configuration Table

Initial Conditions	
Test Frequencies as specified in TS 38.508-1 [6] clause 4.3.1 for different EN-DC bandwidth classes	High range with maxWGap
Test EN-DC bandwidth combination as specified in Table 5.3B.1.2-1 across bandwidth combination sets supported by the UE	Highest N _{RB_agg} (NOTE1)
NOTE 1: If the UE supports multiple CC Combinations in the EN-DC Configuration with the same N _{RB_agg} , only the combination with the highest N _{RB_SCG} is tested.	

The initial test configurations for E-UTRA consist of test frequency based on E-UTRA operating band and test channel bandwidth as specified in Table 4.6-1 except for the parameters specified in Table 7.6B.4.2.4-1.

For Initial conditions as in clause 7.6.4.4.1 in TS 38.521-1 [8], add step 2.1 and step 3.1 as follows:

- 2.1. The parameter settings for E-UTRA cell are set up according to TS 36.508 [11] clause 4.4.3.
- 3.1. The E-UTRA downlink signal level, uplink signal level are set according to Table 4.6-1 and propagation conditions are set according to Annex B.0 of TS 36.521-1 [10].

Step 6 of Initial conditions as in clause 7.6.4.4.1 in TS 38.521-1 [8] is replaced by:

6. Ensure the UE is in state RRC_CONNECTED with generic procedure parameters Connectivity EN-DC, DC bearer MCG and SCG, Connected without release *On* according to TS 38.508 [6] clause 4.5.

Add step 7 to Initial conditions in clause 7.6.4.4.1 in TS 38.521-1 [8] as follows:

7. On the E-UTRA carrier, disable periodic and aperiodic CQI reports, disable SRS, set *TimeAlignmentTimerDedicated* IE to infinity and disable downlink and uplink scheduling, all as per Table 4.6-1 under clause 4.6.

Step 3 of Test procedure as in clause 7.6.4.4.2 in TS 38.521-1 [8] shall treat the in-gap tests as below: For intra-band non-contiguous EN-DC of two sub-blocks with channel bandwidth larger than or equal to 5 MHz, the existing requirements apply for in-gap tests only if the corresponding interferer frequency offsets satisfy the following condition

in relation to the sub-block gap size W_{gap} , so that the interferer frequency position does not change the nature of the core requirement tested:

$$W_{\text{gap}} \geq 2 \cdot |F_{\text{Interferer (offset)}}| - BW_{\text{Channel}}$$

Step 4 of Test procedure as in clause 7.6.4.4.2 in TS 38.521-1 [8] is replaced by:

4. Set the downlink signal level for NR CC according to the Table 7.6.4.5-1 in TS 38.521-1 [8] as appropriate. For NR CC and E-UTRA CC, send uplink power control commands to the UE using 1dB power step size to ensure that the UE output power measured by the test system is within the Uplink power control window, defined as -MU to -(MU + Uplink power control window size) dB of ($P_{\text{CMAX,L,c}} - 29\text{dB}$) for E-UTRA CC, and of 4dB below $P_{\text{CMAX,L,f,c}}$ for NR CC for at least the duration of the Throughput measurement, where:
 - MU is the test system uplink power measurement uncertainty and is specified in Table F.1.3-1 for the carrier frequency f and the channel bandwidth BW
 - For NR CC, Uplink power control window size = 1dB (UE power step size) + 0.7dB (UE power step tolerance) + (Test system relative power measurement uncertainty), where, the UE power step tolerance is specified in TS 38.101-1 [2], Table 6.3.4.3-1 and is 0.7dB for 1dB power step size, and the Test system relative power measurement uncertainty is specified in Table F.1.2-1.
 - For E-UTRA CC, Uplink power control window size = 1dB (UE power step size) + 1.0dB (UE power step tolerance) + (Test system relative power measurement uncertainty), where, the UE power step tolerance is specified in TS 36.101 [5], Table 6.3.5.2.1-1 and is 1.0dB for 1dB power step size, and the Test system relative power measurement uncertainty is specified in Table F.1.2-1 of TS 36.521-1 [10].

7.6B.4.2.5 Test Requirement

Same test requirement as in clause 7.6.4.5 in TS 38.521-1 [8].

7.6B.4.3 Narrow band blocking for inter-band EN-DC within FR1 (2 CCs)

7.6B.4.3.1 Test Purpose

Same test purpose as in clause 7.6.4.1 in TS 38.521-1 [8] for the NR carrier.

7.6B.4.3.2 Test Applicability

This test case applies to all types of E-UTRA UE release 15 and forward, supporting inter-band EN-DC within FR1 with 2CCs.

7.6B.4.3.3 Minimum Conformance Requirements

The minimum conformance requirements are defined in clause 7.6B.4.0.3.

No exception requirements applicable to NR or LTE. LTE anchor agnostic approach is applied.

7.6B.4.3.4 Test Description

Same test description as in clause 7.6.4.4 in TS 38.521-1 [8] for the NR carrier with the following exceptions:

The initial test configurations for E-UTRA consist of test frequency based on E-UTRA operating band and test channel bandwidth as specified in Table 4.6-1.

For Initial conditions as in clause 7.6.4.4.1 in TS 38.521-1 [8], add step 2.1 and step 3.1 as follows:

- 2.1. The parameter settings for E-UTRA cell are set up according to TS 36.508 [11] clause 4.4.3.
- 3.1. The E-UTRA downlink signal level, uplink signal level are set according to Table 4.6-1 and propagation conditions are set according to Annex B.0 of TS 36.521-1 [10].

Step 6 of Initial conditions as in clause 7.6.4.4.1 in TS 38.521-1 [8] is replaced by:

6. Ensure the UE is in state RRC_CONNECTED with generic procedure parameters Connectivity EN-DC, DC bearer MCG and SCG, Connected without release *On* according to TS 38.508 [6] clause 4.5.

Add step 7 to Initial conditions in clause 7.6.4.4.1 in TS 38.521-1 [8] as follows:

7. On the E-UTRA carrier, disable periodic and aperiodic CQI reports, disable SRS, set *TimeAlignmentTimerDedicated* IE to infinity and disable downlink and uplink scheduling, all as per Table 4.6-1 under clause 4.6.

7.6B.4.3.5 Test Requirement

Same test requirement as in clause 7.6.4.5 in TS 38.521-1 [8].

7.6B.4.3_1 Narrow band blocking for EN-DC within FR1 (>2 CCs)

7.6B.4.3_1.1 Narrow band blocking for EN-DC within FR1 (3 CCs)

7.6B.4.3_1.1.1 Test Purpose

Verifies a receiver's ability to receive EN-DC signals at its assigned channel frequencies in the presence of an unwanted narrow band CW interferer at a frequency, which is less than the nominal channel spacing.

The lack of narrow-band blocking ability will decrease the coverage area when other NodeB transmitters exist (except in the adjacent channels and spurious response).

7.6B.4.3_1.1.2 Test Applicability

This test case applies to all types of E-UTRA UE release 15 and forward, supporting intra-band contiguous EN-DC within FR1 with 3 DL CCs or inter-band EN-DC within FR1 with 3 DL CCs (2NR DL CCs).

7.6B.4.3_1.1.3 Minimum Conformance Requirements

For intra-band contiguous EN-DC within FR1 with 3 DL CCs: The minimum conformance requirements are defined in clause 7.6B.4.0.1. Exception requirements for both NR and E-UTRA are defined for this test and therefore LTE anchor agnostic approach is not applied. E-UTRA test point analysis is included and E-UTRA measurements are performed.

For inter-band EN-DC within FR1 with 3 DL CCs (2NR DL CCs): The minimum conformance requirements are defined in clause 7.6B.4.0.3. No exception requirements applicable to NR or LTE. LTE anchor agnostic approach is applied.

7.6B.4.3_1.1.4 Test Description

7.6B.4.3_1.1.4.1 Intra-band contiguous EN-DC within FR1 with 3 DL CCs

7.6B.4.3_1.1.4.1.1 Initial condition

Initial conditions are a set of test configurations the UE needs to be tested in and the steps for the SS to take with the UE to reach the correct measurement state.

The initial test configurations consist of environmental conditions, test frequencies and channel bandwidths based on EN-DC operating bands specified in clause 5.3B.1.2, channel bandwidths and sub-carrier spacings for the NR cell specified in TS 38.521-1 [8] clause 5.3 and channel bandwidth for the E-UTRA cell are specified in TS 36.521-1 [10] clause 5.4.2. All of these configurations shall be tested with applicable test parameters for each EN-DC configuration specified in clause 5.3B.1.2 and are shown in Table 7.6B.4.3_1.1.4.1.1-1. The details of the uplink and downlink reference measurement channels (RMCs) are specified in Annex A.2 and A.3 respectively. The details of the OCN patterns used are specified in TS 36.521-1 [10] Annex A.5 and in TS 38.521-1 [8] Annex A.5 for E-UTRA CG and NR CG respectively. Configurations of PDSCH and PDCCH before measurement are specified in TS 36.521-1 [10] Annex C.2 and in TS 38.521-1 [8] Annex C.2 for E-UTRA CG and NR CG respectively.

Table 7.6B.4.3_1.1.4.1.1-1: Test configuration table

Initial Conditions					
Test Environment as specified in TS 38.508-1 [6] clause 4.1			Normal		
Test Frequencies as specified in TS 38.508-1 [6] clause 4.3.1 for different EN-DC bandwidth classes			Mid range		
Test EN-DC bandwidth combination as specified in Table 5.3B.1.2-1 across bandwidth combination sets supported by the UE			Lowest N_{RB_agg} , Highest N_{RB_agg} (NOTE 3)		
NR Test SCS as specified in Table 5.3.5-1 in TS 38.521-1 [8]			Lowest		
NR/E-UTRA Test Parameters					
PCC – E-UTRA		SCC – EUTRA		NR	
UL/DL Modulation	UL/DL allocation	UL/DL Modulation	UL/DL allocation	UL/DL Modulation	UL/DL allocation
QPSK/QPSK	REFSENS/Full RB	NA/QPSK	NA/Full RB	DFT-s-OFDM QPSK/CP-OFDM QPSK	REFSENS/Full RB (NOTE 1)
NOTE 1: Full RB allocation shall be used per each SCS and channel BW as specified in Table 7.3.2.4.1-2 of TS 38.521-1 [8].					
NOTE 2: Test Channel Bandwidths are checked separately for each EN-DC band, which applicable channel bandwidths are specified in Table 5.3B.1.2-1.					
NOTE 3: If the UE supports multiple CC Combinations in the EN-DC Configuration with the same N_{RB_agg} , only the combination with the highest N_{RB_SCG} is tested.					
NOTE 4: REFSENS refers to Uplink configuration in Table 7.3.2.3-3 in [8] and Table 7.3.3-2 in [10] for NR and E-UTRA CC respectively.					
NOTE 5: In a FR1 band where UE supports 4Rx, the test shall be performed only with 4Rx antennas ports connected and 4Rx REFSENS requirement (TS 38.521-1 [8] Table 7.3.2.5-2) is used in the test requirements.					

1. Connect the SS to the UE antenna connectors as shown in [6] TS 38.508-1 Annex A, in Figure A.3.1.4.2 for SS diagram and clause A.3.2 for UE diagram.
2. The parameter settings for the E-UTRA cell are set up according to TS 36.508 [11] clause 4.4.3, and the parameter settings for the NR cell are set up according to TS 38.508-1 [6] clause 4.4.3.
3. Downlink signals are initially set up according to TS 36.521-1 [10] Annex C and TS 38.521-1 [8] Annex C for E-UTRA CG and NR CG respectively, and uplink signals according to TS 36.521-1 [10] Annex H and TS 38.521-1 [8] Annex G for E-UTRA CG and NR CG respectively.
4. The UL and DL Reference Measurement channels are TS 36.521-1 [10] Annex A.2, A.3 and TS 38.521-1 [8] Annex A.2, A.3 for E-UTRA CG and NR CG respectively.
5. Propagation conditions are set according to TS 36.521-1 [10] Annex B.0 and TS 38.521-1 [8] Annex B.0 for E-UTRA CG and NR CG respectively.
6. Ensure the UE is in state RRC_CONNECTED with generic procedure parameters Connectivity EN-DC, DC bearer *MCG* and *SCG*, Connected without release *On* according to TS 38.508-1 [6] clause 4.5. Message contents are defined in clause 7.6B.4.3_1.1.4.1.3.

7.6B.4.3_1.1.4.1.2 Test procedure

1. SS transmits PDSCH via PDCCH DCI format 1A and PDCCH DCI format 1_1 for C_RNTI to transmit the DL RMC according to Table 7.6B.4.3_1.1.4.1.1-1 on E-UTRA CC and NR CC respectively. The SS sends downlink MAC padding bits on the DL RMC.
2. SS sends uplink scheduling information for each UL HARQ process via PDCCH DCI format 0 and DCI format 0_1 for C_RNTI to schedule the UL RMC according to Table 7.6B.4.3_1.1.4.1.1-1 on E-UTRA CC and NR CC respectively. Since the UL has no payload and no loopback data to send the UE sends uplink MAC padding bits on the UL RMC.

3. Set the Downlink signal level to the value as defined in Table 7.6B.4.1.5-1. For NR CC and E-UTRA CC, send uplink power control commands to the UE using 1dB power step size to ensure that the UE output power measured by the test system is within the Uplink power control window, defined as $-\text{MU}$ to $-(\text{MU} + \text{Uplink power control window size})$ dB of the target power level in Table 7.6B.4.1.5-1 + $(10\log(S_{\text{LCRB}}/N_{\text{RB_alloc}}))$ for NR CC, $(10\log(P_{\text{LCRB}}/N_{\text{RB_alloc}}))$ for E-UTRA CC) for at least the duration of the Throughput measurement, where:
 - MU is the test system uplink power measurement uncertainty and is specified in Table F.1.3-1 for the carrier frequency f and the channel bandwidth BW
 - For NR CC, Uplink power control window size = 1dB (UE power step size) + 0.7dB (UE power step tolerance) + (Test system relative power measurement uncertainty), where, the UE power step tolerance is specified in TS 38.101-1 [2], Table 6.3.4.3-1 and is 0.7dB for 1dB power step size, and the Test system relative power measurement uncertainty is specified in Table F.1.2-1.
 - For E-UTRA CC, Uplink power control window size = 1dB (UE power step size) + 1.0dB (UE power step tolerance) + (Test system relative power measurement uncertainty), where, the UE power step tolerance is specified in TS 36.101 [5], Table 6.3.5.2.1-1 and is 1.0dB for 1dB power step size, and the Test system relative power measurement uncertainty is specified in Table F.1.2-1 of TS 36.521-1 [10].
4. Set the parameters of the CW signal generator for an interfering signal below the aggregated component carriers according to Table 7.6B.4.1.5-1.
5. Measure the average throughput for a duration sufficient to achieve statistical significance according to Annex H.2.
6. Repeat steps from 4 to 5, using an interfering signal above the aggregated component carriers at step 4.

NOTE: The purpose of the Uplink power control window is to ensure that the actual UE output power is no greater than the target power level, and as close as possible to the target power level. The relationship between the Uplink power control window, the target power level and the corresponding possible actual UE Uplink power window is illustrated in Annex F, clause F.4.

7.6B.4.3_1.1.4.1.3 Message contents

Message contents are according to TS 38.508-1 [6] clause 4.6 Table 4.6.3-118 with condition TRANSFORM_PRECODER_ENABLED.

7.6B.4.3_1.1.4.2 Inter-band EN-DC within FR1 with 3 DL CCs (2NR DL CCs)

Same test description as in clause 7.6.4.4 or 7.6A.4.1.4 in TS 38.521-1 [8] for the NR carrier with the following exceptions:

The initial test configurations for E-UTRA consist of test frequency based on E-UTRA operating band and test channel bandwidth as specified in Table 4.6-1.

For Initial conditions as in clause 7.6A.4.1.4.1 in TS 38.521-1 [8], add step 2.1 and step 3.1 as follows:

- 2.1. The parameter settings for E-UTRA cell are set up according to TS 36.508 [11] clause 4.4.3.
- 3.1. The E-UTRA downlink signal level, uplink signal level are set according to Table 4.6-1 and propagation conditions are set according to Annex B.0 of TS 36.521-1 [10].

Step 6 of Initial conditions as in clause 7.6A.4.1.4.1 in TS 38.521-1 [8] is replaced by:

6. Ensure the UE is in state RRC_CONNECTED with generic procedure parameters Connectivity EN-DC, DC bearer MCG and SCG, Connected without release On according to TS 38.508 [6] clause 4.5.

Add step 7 to Initial conditions in clause 7.6A.4.1.4.1 in TS 38.521-1 [8] as follows:

7. On the E-UTRA carrier, disable periodic and aperiodic CQI reports, disable SRS, set *TimeAlignmentTimerDedicated* IE to infinity and disable downlink and uplink scheduling, all as per Table 4.6-1 under clause 4.6.

7.6B.4.3_1.1.5 Test Requirement

For intra-band contiguous EN-DC within FR1 with 3 DL CCs: Same test requirement as in clause 7.6B.4.1.5.

For inter-band EN-DC within FR1 with 3 DL CCs (2NR DL CCs): Same test requirement as in clause 7.6A.4.1.5 in TS 38.521-1 [8].

7.6B.4.3_1.2 Narrow band blocking for EN-DC within FR1 (4 CCs)

7.6B.4.3_1.2.1 Test Purpose

Verifies a receiver's ability to receive EN-DC signals at its assigned channel frequencies in the presence of an unwanted narrow band CW interferer at a frequency, which is less than the nominal channel spacing.

The lack of narrow-band blocking ability will decrease the coverage area when other NodeB transmitters exist (except in the adjacent channels and spurious response).

7.6B.4.3_1.2.2 Test Applicability

This test case applies to all types of E-UTRA UE release 15 and forward, supporting intra-band contiguous EN-DC within FR1 with 4 DL CCs or inter-band EN-DC within FR1 with 4 DL CCs (3NR DL CCs).

7.6B.4.3_1.2.3 Minimum Conformance Requirements

For intra-band contiguous EN-DC within FR1 with 4 DL CCs: The minimum conformance requirements are defined in clause 7.6B.4.0.1. Exception requirements for both NR and E-UTRA are defined for this test and therefore LTE anchor agnostic approach is not applied. E-UTRA test point analysis is included and E-UTRA measurements are performed.

For inter-band EN-DC within FR1 with 4 DL CCs (3NR DL CCs): The minimum conformance requirements are defined in clause 7.6B.4.0.3. No exception requirements applicable to NR or LTE. LTE anchor agnostic approach is applied.

7.6B.4.3_1.2.4 Test Description

7.6B.4.3_1.2.4.1 Intra-band contiguous EN-DC within FR1 with 4 DL CCs

7.6B.4.3_1.2.4.1.1 Initial condition

Initial conditions are a set of test configurations the UE needs to be tested in and the steps for the SS to take with the UE to reach the correct measurement state.

The initial test configurations consist of environmental conditions, test frequencies and channel bandwidths based on EN-DC operating bands specified in clause 5.3B.1.2, channel bandwidths and sub-carrier spacings for the NR cell specified in TS 38.521-1 [8] clause 5.3 and channel bandwidth for the E-UTRA cell are specified in TS 36.521-1 [10] clause 5.4.2. All of these configurations shall be tested with applicable test parameters for each EN-DC configuration specified in clause 5.3B.1.2 and are shown in Table 7.6B.4.3_1.2.4.1.1-1. The details of the uplink and downlink reference measurement channels (RMCs) are specified in Annex A.2 and A.3 respectively. The details of the OCN patterns used are specified in TS 36.521-1 [10] Annex A.5 and in TS 38.521-1 [8] Annex A.5 for E-UTRA CG and NR CG respectively. Configurations of PDSCH and PDCCH before measurement are specified in TS 36.521-1 [10] Annex C.2 and in TS 38.521-1 [8] Annex C.2 for E-UTRA CG and NR CG respectively.

Table 7.6B.4.3_1.2.4.1.1-1: Test configuration table

Initial Conditions					
Test Environment as specified in TS 38.508-1 [6] clause 4.1			Normal		
Test Frequencies as specified in TS 38.508-1 [6] clause 4.3.1 for different EN-DC bandwidth classes			Mid range		
Test EN-DC bandwidth combination as specified in Table 5.3B.1.2-1 across bandwidth combination sets supported by the UE			Lowest N_{RB_agg} , Highest N_{RB_agg} (NOTE 3)		
NR Test SCS as specified in Table 5.3.5-1 in TS 38.521-1 [8]			Lowest		
NR/E-UTRA Test Parameters					
PCC – E-UTRA		SCC1 – EUTRA and SCC2 – EUTRA		NR	
UL/DL Modulation	UL/DL allocation	UL/DL Modulation	UL/DL allocation	UL/DL Modulation	UL/DL allocation
QPSK/QPSK	REFSENS/Full RB	NA/QPSK	NA/Full RB	DFT-s-OFDM QPSK/CP-OFDM QPSK	REFSENS/Full RB (NOTE 1)
NOTE 1: Full RB allocation shall be used per each SCS and channel BW as specified in Table 7.3.2.4.1-2 of TS 38.521-1 [8].					
NOTE 2: Test Channel Bandwidths are checked separately for each EN-DC band, which applicable channel bandwidths are specified in Table 5.3B.1.2-1.					
NOTE 3: If the UE supports multiple CC Combinations in the EN-DC Configuration with the same N_{RB_agg} , only the combination with the highest N_{RB_SCG} is tested.					
NOTE 4: REFSENS refers to Uplink configuration in Table 7.3.2.3-3 in [8] and Table 7.3.3-2 in [10] for NR and E-UTRA CC respectively.					
NOTE 5: In a FR1 band where UE supports 4Rx, the test shall be performed only with 4Rx antennas ports connected and 4Rx REFSENS requirement (TS 38.521-1 [8] Table 7.3.2.5-2) is used in the test requirements.					

1. Connect the SS to the UE antenna connectors as shown in [6] TS 38.508-1 Annex A, in Figure A.3.1.4.2 for SS diagram and clause A.3.2 for UE diagram.
2. The parameter settings for the E-UTRA cell are set up according to TS 36.508 [11] clause 4.4.3, and the parameter settings for the NR cell are set up according to TS 38.508-1 [6] clause 4.4.3.
3. Downlink signals are initially set up according to TS 36.521-1 [10] Annex C and TS 38.521-1 [8] Annex C for E-UTRA CG and NR CG respectively, and uplink signals according to TS 36.521-1 [10] Annex H and TS 38.521-1 [8] Annex G for E-UTRA CG and NR CG respectively.
4. The UL and DL Reference Measurement channels are TS 36.521-1 [10] Annex A.2, A.3 and TS 38.521-1 [8] Annex A.2, A.3 for E-UTRA CG and NR CG respectively.
5. Propagation conditions are set according to TS 36.521-1 [10] Annex B.0 and TS 38.521-1 [8] Annex B.0 for E-UTRA CG and NR CG respectively.
6. Ensure the UE is in state RRC_CONNECTED with generic procedure parameters Connectivity EN-DC, DC bearer *MCG* and *SCG*, Connected without release *On* according to TS 38.508-1 [6] clause 4.5. Message contents are defined in clause 7.6B.4.3_1.2.4.1.3.

7.6B.4.3_1.2.4.1.2 Test procedure

1. SS transmits PDSCH via PDCCH DCI format 1A and PDCCH DCI format 1_1 for C_RNTI to transmit the DL RMC according to Table 7.6B.4.3_1.2.4.1.1-1 on E-UTRA CC and NR CC respectively. The SS sends downlink MAC padding bits on the DL RMC.
2. SS sends uplink scheduling information for each UL HARQ process via PDCCH DCI format 0 and DCI format 0_1 for C_RNTI to schedule the UL RMC according to Table 7.6B.4.3_1.2.4.1.1-1 on E-UTRA CC and NR CC respectively. Since the UL has no payload and no loopback data to send the UE sends uplink MAC padding bits on the UL RMC.

3. Set the Downlink signal level to the value as defined in Table 7.6B.4.1.5-1. For NR CC and E-UTRA CC, send uplink power control commands to the UE using 1dB power step size to ensure that the UE output power measured by the test system is within the Uplink power control window, defined as $-(\text{MU} + \text{Uplink power control window size})$ dB of the target power level in Table 7.6B.4.1.5-1 + $([10\log(S_{\text{LCRB}}/N_{\text{RB_alloc}})]$ for NR CC, $[10\log(P_{\text{LCRB}}/N_{\text{RB_alloc}})]$ for E-UTRA CC) for at least the duration of the Throughput measurement, where:
 - MU is the test system uplink power measurement uncertainty and is specified in Table F.1.3-1 for the carrier frequency f and the channel bandwidth BW
 - For NR CC, Uplink power control window size = 1dB (UE power step size) + 0.7dB (UE power step tolerance) + (Test system relative power measurement uncertainty), where, the UE power step tolerance is specified in TS 38.101-1 [2], Table 6.3.4.3-1 and is 0.7dB for 1dB power step size, and the Test system relative power measurement uncertainty is specified in Table F.1.2-1.
 - For E-UTRA CC, Uplink power control window size = 1dB (UE power step size) + 1.0dB (UE power step tolerance) + (Test system relative power measurement uncertainty), where, the UE power step tolerance is specified in TS 36.101 [5], Table 6.3.5.2.1-1 and is 1.0dB for 1dB power step size, and the Test system relative power measurement uncertainty is specified in Table F.1.2-1 of TS 36.521-1 [10].
4. Set the parameters of the CW signal generator for an interfering signal below the aggregated component carriers according to Table 7.6B.4.1.5-1.
5. Measure the average throughput for a duration sufficient to achieve statistical significance according to Annex H.2.
6. Repeat steps from 4 to 5, using an interfering signal above the aggregated component carriers at step 4.

NOTE: The purpose of the Uplink power control window is to ensure that the actual UE output power is no greater than the target power level, and as close as possible to the target power level. The relationship between the Uplink power control window, the target power level and the corresponding possible actual UE Uplink power window is illustrated in Annex F, clause F.4.

7.6B.4.3_1.2.4.1.3 Message contents

Message contents are according to TS 38.508-1 [6] clause 4.6 Table 4.6.3-118 with condition TRANSFORM_PRECODER_ENABLED.

7.6B.4.3_1.2.4.2 Inter-band EN-DC within FR1 with 4 DL CCs (3NR DL CCs)

Same test description as in clause 7.6A.4.2.4 in TS 38.521-1 [8] for the NR carrier with the following exceptions:

The initial test configurations for E-UTRA consist of test frequency based on E-UTRA operating band and test channel bandwidth as specified in Table 4.6-1.

For Initial conditions as in clause 7.6A.4.2.4.1 in TS 38.521-1 [8], add step 2.1 and step 3.1 as follows:

- 2.1. The parameter settings for E-UTRA cell are set up according to TS 36.508 [11] clause 4.4.3.
- 3.1. The E-UTRA downlink signal level, uplink signal level are set according to Table 4.6-1 and propagation conditions are set according to Annex B.0 of TS 36.521-1 [10].

Step 6 of Initial conditions as in clause 7.6A.4.2.4.1 in TS 38.521-1 [8] is replaced by:

6. Ensure the UE is in state RRC_CONNECTED with generic procedure parameters Connectivity EN-DC, DC bearer MCG and SCG, Connected without release On according to TS 38.508 [6] clause 4.5.

Add step 7 to Initial conditions in clause 7.6A.4.2.4.1 in TS 38.521-1 [8] as follows:

7. On the E-UTRA carrier, disable periodic and aperiodic CQI reports, disable SRS, set *TimeAlignmentTimerDedicated* IE to infinity and disable downlink and uplink scheduling, all as per Table 4.6-1 under clause 4.6.

7.6B.4.3_1.2.5 Test Requirement

For intra-band contiguous EN-DC within FR1 with 4 DL CCs: Same test requirement as in clause 7.6B.4.1.5.

For inter-band EN-DC within FR1 with 4 DL CCs (3NR DL CCs): Same test requirement as in clause 7.6A.4.2.5 in TS 38.521-1 [8].

7.6B.4.3_1.3 Narrow band blocking for EN-DC within FR1 (5 CCs)

7.6B.4.3_1.3.1 Test Purpose

Same test purpose as in clause 7.6B.4.3.1.

7.6B.4.3_1.3.2 Test Applicability

This test case applies to all types of E-UTRA UE release 16 and forward, supporting inter-band EN-DC within FR1 with 5 DL CCs (4 NR DL CCs).

7.6B.4.3_1.3.3 Minimum Conformance Requirements

The minimum conformance requirements are defined in clause 7.6B.4.0.3.

No exception requirements applicable to NR or LTE. LTE anchor agnostic approach is applied.

7.6B.4.3_1.3.4 Test Description

Same test description as in clause 7.6A.4.3.4 in TS 38.521-1 [8] for the NR carrier with the following exceptions:

The initial test configurations for E-UTRA consist of test frequency based on E-UTRA operating band and test channel bandwidth as specified in Table 4.6-1.

For Initial conditions as in clause 7.6A.4.3.4.1 in TS 38.521-1 [8], add step 2.1 and step 3.1 as follows:

- 2.1. The parameter settings for E-UTRA cell are set up according to TS 36.508 [11] clause 4.4.3.
- 3.1. The E-UTRA downlink signal level, uplink signal level are set according to Table 4.6-1 and propagation conditions are set according to Annex B.0 of TS 36.521-1 [10].

Step 6 of Initial conditions as in clause 7.6A.4.3.4.1 in TS 38.521-1 [8] is replaced by:

6. Ensure the UE is in state RRC_CONNECTED with generic procedure parameters Connectivity EN-DC, DC bearer MCG and SCG, Connected without release *On* according to TS 38.508 [6] clause 4.5.

Add step 7 to Initial conditions in clause 7.6A.4.3.4.1 in TS 38.521-1 [8] as follows:

7. On the E-UTRA carrier, disable periodic and aperiodic CQI reports, disable SRS, set *TimeAlignmentTimerDedicated* IE to infinity and disable downlink and uplink scheduling, all as per Table 4.6-1 under clause 4.6.

7.6B.4.3_1.3.5 Test Requirement

Same test requirement as in clause 7.6A.4.3.5 in TS 38.521-1 [8].

7.6B.4.3_1.4 Void

7.7 Void

7.7A Spurious response for CA

7.7A.1 Test purpose

Same test purpose as in clause 7.7 in TS 38.521-1 [8] for NR FR1 carrier(s).

7.7A.2 Test applicability

The requirements are only for FR1. Therefore, only the conducted requirements are tested.

No test case details are specified. The SA requirements for Spurious response apply and are tested in TS 38.521-1 [8] clause 7.7 and 7.7A.

7.7B Spurious response for DC

7.7B.0 Minimum Conformance Requirements

7.7B.0.1 Intra-band contiguous EN-DC in FR1

Intra-band contiguous EN-DC spurious response requirement and parameters are defined in Table 7.7B.0.1-1.

Table 7.7B.0.1-1: Spurious Response Parameters for intra-band contiguous EN-DC

EN-DC Aggregated Bandwidth, MHz	≤100	>100, ≤120	>120, ≤140	>140, ≤160
P _w in Transmission Bandwidth Configuration, perCC, dBm	REFSENS + Aggregated BW specific value below			
	9			
P _{interferer} , dBm (CW)	-44			
NOTE 1: For NR carrier, the transmitter shall be set to 4dB below P _{C_{MAX}L,f,c,NR} at the minimum uplink configuration specified in Table 7.3.2-3 in TS 38.101-1 [2] with P _{C_{MAX}L,f,c,NR} as defined in clause 6.2B.4.				
NOTE 2: For E-UTRA carrier, the transmitter shall be set to 4dB below P _{C_{MAX}L,E-UTRA,c} at the minimum uplink configuration specified in Table 7.3.1-2 in TS 36.101 [5] with P _{C_{MAX}L,E-UTRA,c} as defined in clause 6.2B.4 for single carrier.				

The normative reference for this requirement is TS 38.101-3 [4] clause 7.7B.1.

7.7B.0.2 Intra-band non-contiguous EN-DC in FR1

For the E-UTRA sub-block containing one or multiple CC's, the requirement is defined in clause 7.7.1 for single carrier operation and in clause 7.7.1A for CA in TS 36.101 [5].

For the NR sub-block, the requirement is defined in clause 7.7 in TS 38.101-1 [2].

The normative reference for this requirement is TS 38.101-3 [4] clause 7.7B.2.

7.7B.0.3 Inter-band EN-DC within FR1

Spurious response requirement for E-UTRA single carrier and CA operation specified in clauses 7.7.1 and 7.7.1A of TS 36.101 [5] and for NR single carrier and CA operation specified in clauses 7.7 and 7.7A of TS 38.101-1 [2] apply for lowest level EN-DC fallbacks (two bands) in clause 5.5B.4.1 with following conditions:

- one E-UTRA uplink carrier with the output power set to 4 dB below $P_{\text{CMAX_L,c}}$ and the NR band whose downlink is being tested has its uplink carrier output power set to 29 dB below $P_{\text{CMAX_L,f,c}}$.
- one NR uplink carrier with the output power set to 4 dB below $P_{\text{CMAX_L,f,c}}$ on the NR band with both E-UTRA and NR downlinks being tested with E-UTRA output power set to 29 dB below $P_{\text{CMAX_L,c}}$.

The normative reference for this requirement is TS 38.101-3 [4] clause 7.7B.3.

7.7B.0.3A Inter-band NE-DC within FR1

Spurious response requirement for E-UTRA single carrier and CA operation specified in clauses 7.7.1 and 7.7.1A of TS 36.101 [5] and for NR single carrier and CA operation specified in clauses 7.7 and 7.7A of TS 38.101-1 [2] apply for lowest level NE-DC fallbacks (two bands) in clause 5.5B.4a.1 with following conditions:

- one E-UTRA uplink carrier with the output power set to 4 dB below $P_{\text{CMAX_L,c}}$ and the NR band whose downlink is being tested has its uplink carrier output power set to 29 dB below $P_{\text{CMAX_L,f,c}}$.
- one NR uplink carrier with the output power set to 4 dB below $P_{\text{CMAX_L,f,c}}$ on the NR band with both E-UTRA and NR downlinks being tested with E-UTRA output power set to 29 dB below $P_{\text{CMAX_L,c}}$.

The normative reference for this requirement is TS 38.101-3 [4] clause 7.7B.3a.

7.7B.0.4 Inter-band EN-DC including FR2

Spurious response requirement for E-UTRA single carrier and CA operation specified in clauses 7.7.1 and 7.7.1A of TS 36.101 [5] apply for lowest level EN-DC fallbacks (two bands) in clause 5.5B.5.1 with only E-UTRA UL with output power as in TS 36.101 [5] (4 dB below $P_{\text{CMAX_L}}$).

The normative reference for this requirement is TS 38.101-3 [4] clause 7.7B.4.

7.7B.0.5 Inter-band EN-DC including both FR1 and FR2

Spurious response requirement for E-UTRA single carrier and CA operation specified in clauses 7.7.1 and 7.7.1A of TS 36.101 [5] and for NR single carrier and CA operation specified in clauses 7.7 and 7.7A of TS 38.101-1 [2] apply for lowest level EN-DC fallbacks (three bands) in clause 5.5B.6.2 with only E-UTRA UL with output power as in TS 36.101 [5] (4 dB below $P_{\text{CMAX_L}}$).

The normative reference for this requirement is TS 38.101-3 [4] clause 7.7B.5.

7.7B.1 Spurious Response for intra-band contiguous EN-DC in FR1 (2 CCs)

7.7B.1.1 Test Purpose

Spurious response for EN-DC verifies the receiver's ability to receive a wanted aggregated signal on its assigned channel frequency without exceeding a given degradation due to the presence of an unwanted CW interfering signal at any other frequency at which a response is obtained i.e. for which the out of band blocking limit as specified in clause 7.6B.3.1 is not met.

The lack of the spurious response ability decreases the coverage area when other unwanted interfering signal exists at any other frequency.

7.7B.1.2 Test Applicability

This test case applies to all types of E-UTRA UE release 15 and forward, supporting intra-band contiguous EN-DC in FR1 with 2CCs.

7.7B.1.3 Minimum Conformance Requirements

The minimum conformance requirements are defined in clause 7.7B.0.1.

Exception requirements for both NR and E-UTRA are defined for this test and therefore LTE anchor agnostic approach is not applied. E-UTRA test point analysis is included and E-UTRA measurements are performed.

7.7B.1.4 Test Description

7.7B.1.4.1 Initial condition

The initial conditions shall be the same as in clause 7.6B.3.1.4.1 in order to test spurious responses obtained in clause 7.6B.3.1 under the same conditions.

7.7B.1.4.2 Test procedure

1. SS transmits PDSCH via PDCCH DCI format 1A and PDCCH DCI format 1_1 for C_RNTI to transmit the DL RMC according to Table 7.6B.3.1.4.1-1 on E-UTRA CC and NR CC respectively. The SS sends downlink MAC padding bits on the DL RMC.
2. SS sends uplink scheduling information for each UL HARQ process via PDCCH DCI format 0 and DCI format 0_1 for C_RNTI to schedule the UL RMC according to Table 7.6B.3.1.4.1-1 on E-UTRA CC and NR CC respectively. Since the UL has no payload and no loopback data to send the UE sends uplink MAC padding bits on the UL RMC.
3. Set the Downlink signal level to the value as defined in Table 7.7B.1.5-1. For NR CC and E-UTRA CC, send uplink power control commands to the UE using 1dB power step size to ensure that the UE output power measured by the test system is within the Uplink power control window, defined as $-(\text{MU} + \text{Uplink power control window size})$ dB of the target power level in Table 7.7B.1.5-1 $+([10\log(S_{\text{LCRB}}/N_{\text{RB_alloc}})]$ for NR CC, $[10\log(P_{\text{LCRB}}/N_{\text{RB_alloc}})]$ for E-UTRA CC) for at least the duration of the Throughput measurement, where:
 - MU is the test system uplink power measurement uncertainty and is specified in Table F.1.3-1 for the carrier frequency f and the channel bandwidth BW.
 - For NR CC, Uplink power control window size = 1dB (UE power step size) + 0.7dB (UE power step tolerance) + (Test system relative power measurement uncertainty), where, the UE power step tolerance is specified in TS 38.101-1 [2], Table 6.3.4.3-1 and is 0.7dB for 1dB power step size, and the Test system relative power measurement uncertainty is specified in Table F.1.2-1.
 - For E-UTRA CC, Uplink power control window size = 1dB (UE power step size) + 1.0dB (UE power step tolerance) + (Test system relative power measurement uncertainty), where, the UE power step tolerance is specified in TS 36.101 [5], Table 6.3.5.2.1-1 and is 1.0dB for 1dB power step size, and the Test system relative power measurement uncertainty is specified in Table F.1.2-1 of TS 36.521-1 [10].
4. Set the parameters of the CW signal generator for an interfering signal according to Table 7.7B.1.5-1. The spurious frequencies are taken from records in the final step of test procedures in clause 7.6B.3.1.4.2.
5. For each spurious frequency, Measure the average throughput for a duration sufficient to achieve statistical significance according to Annex H.2.

NOTE: The purpose of the Uplink power control window is to ensure that the actual UE output power is no greater than the target power level, and as close as possible to the target power level. The relationship between the Uplink power control window, the target power level and the corresponding possible actual UE Uplink power window is illustrated in Annex F, clause F.4.

7.7B.1.4.3 Message contents

Message contents are according to TS 38.508-1 [6] clause 4.6 Table 4.6.3-118 with condition TRANSFORM_PRECODER_ENABLED.

7.7B.1.5 Test Requirement

The throughput shall be $\geq 95\%$ of the maximum throughput of the reference measurement channels as specified in TS 36.521-1 [10] Annex A.3 and TS 38.521-1 [8] Annex A.3 for E-UTRA CG and NR CG respectively with parameters specified in Table 7.7B.1.5-1 for the specified wanted signal mean power in the presence of interfering signals.

Table 7.7B.1.5-1: Spurious Response for intra-band contiguous EN-DC

EN-DC Aggregated Bandwidth, MHz	≤100	>100, ≤120	>120, ≤140	>140, ≤160
P _w in Transmission Bandwidth Configuration, perCC, dBm	REFSENS + Aggregated BW specific value below			
P _{interferer} , dBm (CW)	9			
P _{interferer} , dBm (CW)	-44			
NOTE 1: For NR carrier, the transmitter shall be set to 4dB below P _{C_{MAX}_L,f,c,NR} at the minimum uplink configuration specified in Table 7.3.2-3 in TS 38.101-1 [2] with P _{C_{MAX}_L,f,c,NR} as defined in clause 6.2B.4.				
NOTE 2: For E-UTRA carrier, the transmitter shall be set to 4dB below P _{C_{MAX}_L,E-UTRA,c} at the minimum uplink configuration specified in Table 7.3.1-2 in TS 36.101 [5] with P _{C_{MAX}_L,E-UTRA,c} as defined in clause 6.2B.4 for single carrier.				

Table 7.7B.1.5-2: Void**Table 7.7B.1.5-3: Void**

7.7B.2 Spurious Response for intra-band non-contiguous EN-DC in FR1 (2 CCs)

7.7B.2.1 Test Purpose

Same test purpose as in clause 7.7.1 in TS 38.521-1 [8] for the NR carrier.

7.7B.2.2 Test Applicability

This test case applies to all types of E-UTRA UE release 15 and forward, supporting intra-band non-contiguous EN-DC in FR1 with 2CCs.

7.7B.2.3 Minimum Conformance Requirements

The minimum conformance requirements are defined in clause 7.7B.0.2.

No exception requirements applicable to NR or LTE. LTE anchor agnostic approach is applied.

7.7B.2.4 Test Description

Same test description as in clause 7.7.4 in TS 38.521-1 [8] for the NR carrier with the following exceptions:

The initial conditions shall be the same as the initial conditions in clause 7.6B.3.2.4 in order to test spurious responses obtained in clause 7.6B.3.2 under the same conditions.

Step 4 of Test procedure as in clause 7.7.4.2 in TS 38.521-1 [8] is replaced by:

4. Set the downlink signal level for NR CC according to the Table 7.7.5-1 or 7.7.5-1a in TS 38.521-1 [8] as appropriate. For NR CC and E-UTRA CC, send uplink power control commands to the UE using 1dB power step size to ensure that the UE output power measured by the test system is within the Uplink power control window, defined as $-(MU)$ to $-(MU + \text{Uplink power control window size})$ dB of $(P_{C_{MAX_L,c}} - 29\text{dB})$ for E-UTRA CC, and of 4dB below $P_{C_{MAX_L,f,c}}$ for NR CC for at least the duration of the Throughput measurement, where:
 - MU is the test system uplink power measurement uncertainty and is specified in Table F.1.3-1 for the carrier frequency f and the channel bandwidth BW
 - For NR CC, Uplink power control window size = 1dB (UE power step size) + 0.7dB (UE power step tolerance) + (Test system relative power measurement uncertainty), where, the UE power step tolerance is specified in TS 38.101-1 [2], Table 6.3.4.3-1 and is 0.7dB for 1dB power step size, and the Test system relative power measurement uncertainty is specified in Table F.1.2-1.

- For E-UTRA CC, Uplink power control window size = 1dB (UE power step size) + 1.0dB (UE power step tolerance) + (Test system relative power measurement uncertainty), where, the UE power step tolerance is specified in TS 36.101 [5], Table 6.3.5.2.1-1 and is 1.0dB for 1dB power step size, and the Test system relative power measurement uncertainty is specified in Table F.1.2-1 of TS 36.521-1 [10].

7.7B.2.5 Test Requirement

Same test requirement as in clause 7.7.5 in TS 38.521-1 [8].

7.7B.3 Spurious Response for inter-band EN-DC within FR1 (2 CCs)

7.7B.3.1 Test Purpose

Spurious response is a measure of the ability of the receiver to receive a wanted signal on its assigned channel frequency without exceeding a given degradation due to the presence of an unwanted CW interfering signal at any other frequency for which a response is obtained, i.e. for which the out-of-band blocking limit as specified in subclause 7.6B.3.3 is not met.

The lack of the spurious response ability decreases the coverage area when other unwanted interfering signal exists at any other frequency.

7.7B.3.2 Test Applicability

This test case applies to all types of E-UTRA UE release 15 and forward, supporting inter-band EN-DC within FR1 with 2CCs.

7.7B.3.3 Minimum Conformance Requirements

The minimum conformance requirements are defined in clause 7.7B.0.3.

Exception requirements for both NR and E-UTRA are defined for this test and therefore LTE anchor agnostic approach is not applied. E-UTRA test point analysis is included and E-UTRA measurements are performed.

7.7B.3.4 Test Description

7.7B.3.4.1 Initial Conditions

The initial conditions shall be the same as in clause 7.6B.3.3.4.1 in order to test spurious responses obtained in clause 7.6B.3.3 under the same conditions.

7.7B.3.4.2 Test procedure

1. SS transmits PDSCH via PDCCH DCI format 1A and PDCCH DCI format 1_1 for C_RNTI to transmit the DL RMC according to Table 7.6B.3.3.4.1-1 on E-UTRA CC and NR CC respectively. The SS sends downlink MAC padding bits on the DL RMC.
2. SS sends uplink scheduling information for each UL HARQ process via PDCCH DCI format 0 and DCI format 0_1 for C_RNTI to schedule the UL RMC according to Table 7.6B.3.3.4.1-1 on E-UTRA CC and NR CC respectively. Since the UL has no payload and no loopback data to send the UE sends uplink MAC padding bits on the UL RMC.
3. Set the Downlink signal level to the value as defined in Table 7.7B.3.5-1, Table 7.7B.3.5-3, or Table 7.7B.3.5-4 for E-UTRA CC and NR CC respectively. For NR CC and E-UTRA CC, send uplink power control commands to the UE using 1dB power step size to ensure that the UE output power measured by the test system is within the Uplink power control window, defined as $-MU$ to $-(MU + \text{Uplink power control window size})$ dB of $(P_{\text{CMAX,L,c}} - 4\text{dB})$ for E-UTRA CC, and of 29 dB below $P_{\text{CMAX,L,f,c}}$ for NR CC for at least the duration of the Throughput measurement, where:
 - MU is the test system uplink power measurement uncertainty and is specified in Table F.1.3-1 for the carrier frequency f and the channel bandwidth BW

- For NR CC, Uplink power control window size = 1dB (UE power step size) + 0.7dB (UE power step tolerance) + (Test system relative power measurement uncertainty), where, the UE power step tolerance is specified in TS 38.101-1 [2], Table 6.3.4.3-1 and is 0.7dB for 1dB power step size, and the Test system relative power measurement uncertainty is specified in Table F.1.2-1.
 - For E-UTRA CC, Uplink power control window size = 1dB (UE power step size) + 1.0dB (UE power step tolerance) + (Test system relative power measurement uncertainty), where, the UE power step tolerance is specified in TS 36.101 [5], Table 6.3.5.2.1-1 and is 1.0dB for 1dB power step size, and the Test system relative power measurement uncertainty is specified in Table F.1.2-1 of TS 36.521-1 [10].
4. Set the parameters of the CW signal generator for an interfering signal according to Table 7.7B.3.5-2. The spurious frequencies are taken from records in test procedures in clause 7.6B.3.3.4.2.
 5. For the spurious frequency, measure the average throughput of NR CC for a duration sufficient to achieve statistical significance according to Annex H.2.
 6. Set the Downlink signal level to the value as defined in Table 7.7B.3.5-1, Table 7.7B.3.5-3, or Table 7.7B.3.5-4 for E-UTRA CC and NR CC respectively. For NR CC and E-UTRA CC, send uplink power control commands to the UE using 1dB power step size to ensure that the UE output power measured by the test system is within the Uplink power control window, defined as $-MU$ to $-(MU + \text{Uplink power control window size})$ dB of $(P_{\text{CMAX_L,f,c}} - 4\text{dB})$ for NR CC, and of 29 dB below $P_{\text{CMAX_L,c}}$ for E-UTRA CC for at least the duration of the Throughput measurement, where:
 - MU is the test system uplink power measurement uncertainty and is specified in Table F.1.3-1 for the carrier frequency f and the channel bandwidth BW
 - For NR CC, Uplink power control window size = 1dB (UE power step size) + 0.7dB (UE power step tolerance) + (Test system relative power measurement uncertainty), where, the UE power step tolerance is specified in TS 38.101-1 [2], Table 6.3.4.3-1 and is 0.7dB for 1dB power step size, and the Test system relative power measurement uncertainty is specified in Table F.1.2-1.
 - For E-UTRA CC, Uplink power control window size = 1dB (UE power step size) + 1.0dB (UE power step tolerance) + (Test system relative power measurement uncertainty), where, the UE power step tolerance is specified in TS 36.101 [5], Table 6.3.5.2.1-1 and is 1.0dB for 1dB power step size, and the Test system relative power measurement uncertainty is specified in Table F.1.2-1 of TS 36.521-1 [10].
 7. Set the parameters of the CW signal generator for an interfering signal according to Table 7.7B.3.5-2. The spurious frequencies are taken from records in test procedures in clause 7.6B.3.3.4.2 for E-UTRA CC and NR CC testing respectively..
 8. For the spurious frequency, measure the average throughput of E-UTRA CC and NR CC respectively for a duration sufficient to achieve statistical significance according to Annex H.2.

NOTE: The purpose of the Uplink power control window is to ensure that the actual UE output power is no greater than the target power level, and as close as possible to the target power level. The relationship between the Uplink power control window, the target power level and the corresponding possible actual UE Uplink power window is illustrated in Annex F, clause F.4.

7.7B.3.4.3 Message contents

Message contents are according to TS 38.508-1 [6] clause 4.6.

7.7B.3.5 Test Requirement

For E-UTRA bands, the throughput measurement derived in test procedure shall be $\geq 95\%$ of the maximum throughput of the reference measurement channels as specified in Annex A.3.2 of TS 36.521-1 [10] with parameters specified in Tables 7.7B.3.5-1 and 7.7B.3.5-2.

For NR bands with $F_{\text{DL_high}} < 2700$ MHz and $F_{\text{UL_high}} < 2700$ MHz, the throughput measurement derived in test procedure shall be $\geq 95\%$ of the maximum throughput of the reference measurement channels as specified in Annex A.3.2 and A.3.3 of TS 38.521-1 [8] with parameters specified in Tables 7.7B.3.5-3 and 7.7B.3.5-2.

For NR bands with $F_{DL_low} \geq 3300$ MHz and $F_{UL_low} \geq 3300$ MHz, the throughput measurement derived in test procedure shall be $\geq 95\%$ of the maximum throughput of the reference measurement channels as specified in Annex A.3.2 and A.3.3 of TS 38.521-1 [8] with parameters specified in Tables 7.7B.3.5-4 and 7.7B.3.5-2.

Table 7.7B.3.5-1: Spurious response parameters for E-UTRA bands

Rx Parameter	Units	Channel bandwidth					
		1.4 MHz	3 MHz	5 MHz	10 MHz	15 MHz	20 MHz
Power in Transmission Bandwidth Configuration	dBm	REFSENS + channel bandwidth specific value below					
		6	6	6	6	7	9
Note 1: The reference measurement channel is specified in Annex A.3.2 of TS 36.521-1 [10] with one sided dynamic OCNG Pattern OP.1 FDD/TDD as described in Annex A.5.1.1/A.5.2.1 of TS 36.521-1 [10]. Note 2: The REFSENS power level is specified in Table 7.3.3-1 of TS 36.521-1 [10] for two and four antenna ports, respectively.							

Table 7.7B.3.5-2: Spurious Response for E-UTRA bands and NR bands

Parameter	Unit	Level
$P_{Interferer}$ (CW)	dBm	-44
$F_{Interferer}$	MHz	Spurious response frequencies

Table 7.7B.3.5-3: Spurious response parameters for NR bands with $F_{DL_high} < 2700$ MHz and $F_{UL_high} < 2700$ MHz

RX parameter	Units	Channel bandwidth				
		5 MHz	10 MHz	15 MHz	20 MHz	25 MHz
Power in transmission bandwidth configuration	dBm	REFSENS + channel bandwidth specific value below				
	dB	6	6	7	9	10
RX parameter	Units	Channel bandwidth				
		30 MHz	40 MHz	50 MHz	60 MHz	80 MHz
Power in transmission bandwidth configuration	dBm	REFSENS + channel bandwidth specific value below				
	dB	11	12	13	14	15
RX parameter	Units	Channel bandwidth				
		90 MHz	100 MHz			
Power in transmission bandwidth configuration	dBm	REFSENS + channel bandwidth specific value below				
	dB	15.5	16			
NOTE: The transmitter shall be at the minimum UL configuration specified in Table 7.3.2.3-3 of TS 38.521-1 [8].						

Table 7.7B.3.5-4: Spurious response parameters for NR bands with $F_{DL_low} \geq 3300$ MHz and $F_{UL_low} \geq 3300$ MHz

RX parameter	Units	Channel bandwidth				
		10 MHz	15 MHz	20 MHz	40 MHz	50 MHz
Power in transmission bandwidth configuration	dBm	REFSENS + channel bandwidth specific value below				
	dB	6	7	9	9	9
RX parameter	Units	Channel bandwidth				
		60 MHz	80 MHz	90 MHz	100 MHz	
Power in transmission bandwidth configuration	dBm	REFSENS + channel bandwidth specific value below				
	dB	9	9	9	9	
NOTE: The transmitter shall be at the minimum UL configuration specified in Table 7.3.2.3-3 of TS 38.521-1 [8].						

7.7B.3_1 Spurious Response for EN-DC within FR1 (>2 CCs)

7.7B.3_1.1 Spurious Response for EN-DC within FR1 (3 CCs)

7.7B.3_1.1.1 Test Purpose

Spurious response for EN-DC verifies the receiver's ability to receive a wanted aggregated signal on its assigned channel frequency without exceeding a given degradation due to the presence of an unwanted CW interfering signal at any other frequency at which a response is obtained i.e. for which the out of band blocking limit as specified in clause 7.6B.3.3_1.1 is not met.

The lack of the spurious response ability decreases the coverage area when other unwanted interfering signal exists at any other frequency.

7.7B.3_1.1.2 Test Applicability

This test case applies to all types of E-UTRA UE release 15 and forward, supporting intra-band contiguous EN-DC in FR1 with 3 DL CCs.

7.7B.3_1.1.3 Minimum Conformance Requirements

The minimum conformance requirements are defined in clause 7.7B.0.1.

Exception requirements for both NR and E-UTRA are defined for this test and therefore LTE anchor agnostic approach is not applied. E-UTRA test point analysis is included and E-UTRA measurements are performed.

7.7B.3_1.1.4 Test Description

7.7B.3_1.1.4.1 Initial condition

The initial conditions shall be the same as in clause 7.6B.3.3_1.1.4.1 in order to test spurious responses obtained in clause 7.6B.3.3_1.1 under the same conditions.

7.7B.3_1.1.4.2 Test procedure

1. SS transmits PDSCH via PDCCH DCI format 1A and PDCCH DCI format 1_1 for C_RNTI to transmit the DL RMC according to Table 7.6B.3.3_1.1.4.1-1 on E-UTRA CC and NR CC respectively. The SS sends downlink MAC padding bits on the DL RMC.
2. SS sends uplink scheduling information for each UL HARQ process via PDCCH DCI format 0 and DCI format 0_1 for C_RNTI to schedule the UL RMC according to Table 7.6B.3.3_1.1.4.1-1 on E-UTRA CC and NR CC respectively. Since the UL has no payload and no loopback data to send the UE sends uplink MAC padding bits on the UL RMC.

3. Set the Downlink signal level to the value as defined in Table 7.7B.3_1.1.5-1. For NR CC and E-UTRA CC, send uplink power control commands to the UE using 1dB power step size to ensure that the UE output power measured by the test system is within the Uplink power control window, defined as $-(\text{MU} + \text{Uplink power control window size})$ dB of the target power level in Table 7.7B.3_1.1.5-1 + $([10\log(S_{\text{L_CRB}}/N_{\text{RB_alloc}})])$ for NR CC, $[10\log(P_{\text{L_CRB}}/N_{\text{RB_alloc}})]$ for E-UTRA CC) for at least the duration of the Throughput measurement, where:
- MU is the test system uplink power measurement uncertainty and is specified in Table F.1.3-1 for the carrier frequency f and the channel bandwidth BW.
 - For NR CC, Uplink power control window size = 1dB (UE power step size) + 0.7dB (UE power step tolerance) + (Test system relative power measurement uncertainty), where, the UE power step tolerance is specified in TS 38.101-1 [2], Table 6.3.4.3-1 and is 0.7dB for 1dB power step size, and the Test system relative power measurement uncertainty is specified in Table F.1.2-1.
 - For E-UTRA CC, Uplink power control window size = 1dB (UE power step size) + 1.0dB (UE power step tolerance) + (Test system relative power measurement uncertainty), where, the UE power step tolerance is specified in TS 36.101 [5], Table 6.3.5.2.1-1 and is 1.0dB for 1dB power step size, and the Test system relative power measurement uncertainty is specified in Table F.1.2-1 of TS 36.521-1 [10].
4. Set the parameters of the CW signal generator for an interfering signal according to Table 7.7B.3_1.1.5-1. The spurious frequencies are taken from records in the final step of test procedures in clause 7.6B.3.3_1.1.4.2.
5. For each spurious frequency, Measure the average throughput for a duration sufficient to achieve statistical significance according to Annex H.2.

NOTE: The purpose of the Uplink power control window is to ensure that the actual UE output power is no greater than the target power level, and as close as possible to the target power level. The relationship between the Uplink power control window, the target power level and the corresponding possible actual UE Uplink power window is illustrated in Annex F, clause F.4.

7.7B.3_1.1.4.3 Message contents

Message contents are according to TS 38.508-1 [6] clause 4.6 Table 4.6.3-118 with condition TRANSFORM_PRECODER_ENABLED.

7.7B.3_1.1.5 Test Requirement

The throughput shall be $\geq 95\%$ of the maximum throughput of the reference measurement channels as specified in TS 36.521-1 [10] Annex A.3 and TS 38.521-1 [8] Annex A.3 for E-UTRA CG and NR CG respectively with parameters specified in Table 7.7B.3_1.1.5-1 for the specified wanted signal mean power in the presence of interfering signals.

Table 7.7B.3_1.1.5-1: Spurious Response for intra-band contiguous EN-DC

EN-DC Aggregated Bandwidth, MHz	≤ 100	$>100, \leq 120$	$>120, \leq 140$	$>140, \leq 160$
Pw in Transmission Bandwidth Configuration, perCC, dBm	REFSENS + Aggregated BW specific value below			
	9			
$P_{\text{interferer}}$, dBm (CW)	-44			
NOTE 1: For NR carrier, the transmitter shall be set to 4dB below $P_{\text{CMAX_L_f,c,NR}}$ at the minimum uplink configuration specified in Table 7.3.2-3 in TS 38.101-1 [2] with $P_{\text{CMAX_L_f,c,NR}}$ as defined in clause 6.2B.4.				
NOTE 2: For E-UTRA carrier, the transmitter shall be set to 4dB below $P_{\text{CMAX_L_E-UTRA,c}}$ at the minimum uplink configuration specified in Table 7.3.1-2 in TS 36.101 [5] with $P_{\text{CMAX_L_E-UTRA,c}}$ as defined in clause 6.2B.4 for single carrier.				

7.7B.3_1.2 Spurious Response for EN-DC within FR1 (4 CCs)

7.7B.3_1.2.1 Test Purpose

Spurious response for EN-DC verifies the receiver's ability to receive a wanted aggregated signal on its assigned channel frequency without exceeding a given degradation due to the presence of an unwanted CW interfering signal at any other frequency at which a response is obtained i.e. for which the out of band blocking limit as specified in clause 7.6B.3.3_1.2 is not met.

The lack of the spurious response ability decreases the coverage area when other unwanted interfering signal exists at any other frequency.

7.7B.3_1.2.2 Test Applicability

This test case applies to all types of E-UTRA UE release 15 and forward, supporting intra-band contiguous EN-DC in FR1 with 4 DL CCs.

7.7B.3_1.2.3 Minimum Conformance Requirements

The minimum conformance requirements are defined in clause 7.7B.0.1.

Exception requirements for both NR and E-UTRA are defined for this test and therefore LTE anchor agnostic approach is not applied. E-UTRA test point analysis is included and E-UTRA measurements are performed.

7.7B.3_1.2.4 Test Description

7.7B.3_1.2.4.1 Initial condition

The initial conditions shall be the same as in clause 7.6B.3.3_1.2.4.1 in order to test spurious responses obtained in clause 7.6B.3.3_1.2 under the same conditions.

7.7B.3_1.2.4.2 Test procedure

1. SS transmits PDSCH via PDCCH DCI format 1A and PDCCH DCI format 1_1 for C_RNTI to transmit the DL RMC according to Table 7.6B.3.3_1.2.4.1-1 on E-UTRA CC and NR CC respectively. The SS sends downlink MAC padding bits on the DL RMC.
2. SS sends uplink scheduling information for each UL HARQ process via PDCCH DCI format 0 and DCI format 0_1 for C_RNTI to schedule the UL RMC according to Table 7.6B.3.3_1.2.4.1-1 on E-UTRA CC and NR CC respectively. Since the UL has no payload and no loopback data to send the UE sends uplink MAC padding bits on the UL RMC.
3. Set the Downlink signal level to the value as defined in Table 7.7B.3_1.2.5-1. For NR CC and E-UTRA CC, send uplink power control commands to the UE using 1dB power step size to ensure that the UE output power measured by the test system is within the Uplink power control window, defined as $-(\text{MU} + \text{Uplink power control window size})$ dB of the target power level in Table 7.7B.3_1.2.5-1 $+([10\log(S_{\text{LCRB}}/N_{\text{RB_alloc}})]$ for NR CC, $[10\log(P_{\text{LCRB}}/N_{\text{RB_alloc}})]$ for E-UTRA CC) for at least the duration of the Throughput measurement, where:
 - MU is the test system uplink power measurement uncertainty and is specified in Table F.1.3-1 for the carrier frequency f and the channel bandwidth BW.
 - For NR CC, Uplink power control window size = 1dB (UE power step size) + 0.7dB (UE power step tolerance) + (Test system relative power measurement uncertainty), where, the UE power step tolerance is specified in TS 38.101-1 [2], Table 6.3.4.3-1 and is 0.7dB for 1dB power step size, and the Test system relative power measurement uncertainty is specified in Table F.1.2-1.
 - For E-UTRA CC, Uplink power control window size = 1dB (UE power step size) + 1.0dB (UE power step tolerance) + (Test system relative power measurement uncertainty), where, the UE power step tolerance is specified in TS 36.101 [5], Table 6.3.5.2.1-1 and is 1.0dB for 1dB power step size, and the Test system relative power measurement uncertainty is specified in Table F.1.2-1 of TS 36.521-1 [10].

4. Set the parameters of the CW signal generator for an interfering signal according to Table 7.7B.3_1.2.5-1. The spurious frequencies are taken from records in the final step of test procedures in clause 7.6B.3.3_1.2.4.2.
5. For each spurious frequency, Measure the average throughput for a duration sufficient to achieve statistical significance according to Annex H.2.

NOTE: The purpose of the Uplink power control window is to ensure that the actual UE output power is no greater than the target power level, and as close as possible to the target power level. The relationship between the Uplink power control window, the target power level and the corresponding possible actual UE Uplink power window is illustrated in Annex F, clause F.4.

7.7B.3_1.2.4.3 Message contents

Message contents are according to TS 38.508-1 [6] clause 4.6 Table 4.6.3-118 with condition TRANSFORM_PRECODER_ENABLED.

7.7B.3_1.2.5 Test Requirement

The throughput shall be $\geq 95\%$ of the maximum throughput of the reference measurement channels as specified in TS 36.521-1 [10] Annex A.3 and TS 38.521-1 [8] Annex A.3 for E-UTRA CG and NR CG respectively with parameters specified in Table 7.7B.3_1.2.5-1 for the specified wanted signal mean power in the presence of interfering signals.

Table 7.7B.3_1.2.5-1: Spurious Response for intra-band contiguous EN-DC

EN-DC Aggregated Bandwidth, MHz	≤ 100	$>100, \leq 120$	$>120, \leq 140$	$>140, \leq 160$
Pw in Transmission Bandwidth Configuration, perCC, dBm	REFSENS + Aggregated BW specific value below			
P _{interferer} , dBm (CW)	-44			
NOTE 1: For NR carrier, the transmitter shall be set to 4dB below P _{CMAX_L,f,c,NR} at the minimum uplink configuration specified in Table 7.3.2-3 in TS 38.101-1 [2] with P _{CMAX_L,f,c,NR} as defined in clause 6.2B.4.				
NOTE 2: For E-UTRA carrier, the transmitter shall be set to 4dB below P _{CMAX_L,E-UTRA,c} at the minimum uplink configuration specified in Table 7.3.1-2 in TS 36.101 [5] with P _{CMAX_L,E-UTRA,c} as defined in clause 6.2B.4 for single carrier.				

7.8 Void

7.8B Intermodulation characteristics for DC in FR1

7.8B.1 General

7.8B.2 Wide band Intermodulation

7.8B.2.0 Minimum Conformance Requirements

7.8B.2.0.1 Intra-band contiguous EN-DC in FR1

Intra-band contiguous EN-DC wide band intermodulation requirement and parameters are defined in Table 7.8B.2.0.1-1.

Table 7.8B.2.0.1-1: Wide band intermodulation

EN-DC Aggregated Bandwidth, MHz	≤100	>100, ≤120	>120, ≤140	>140, ≤160
P _w in Transmission Bandwidth Configuration, perCC, dBm	P _w ¹	16.8	17.5	18.0
P _{interferer 1} , dBm (CW) ²	-46			
P _{interferer 2} , dBm (Modulated) ²	-46			
NOTE 1: P _w is wanted signal power level from Table 7.8.1A-1 in TS 36.101 [5]				
NOTE 2: Jammer BW and offsets is from Table 7.8.1A-1 [5] and is applied from the lowest edge of the lowest carrier and the highest edge of the highest carrier				
NOTE 3: For NR carrier, the transmitter shall be set to 4dB below P _{C_{MAX}L,f,c} at the minimum uplink configuration specified in Table 7.3-3 with P _{C_{MAX}L,f,c} as defined in clause 6.2B.4.				
NOTE 4: For E-UTRA carrier, the transmitter shall be set to 4dB below P _{C_{MAX}L,c} at the minimum uplink configuration specified in Table 7.3-1-2 with P _{C_{MAX}L,c} as defined in clause 6.2B.4 for single carrier.				

The normative reference for this requirement is TS 38.101-3 [4] clause 7.8B.2.1.

7.8B.2.0.2 Intra-band non-contiguous EN-DC in FR1

For the E-UTRA sub-block containing one or multiple CC's, the requirement is defined in clause 7.8.1 for single carrier operation and in clause 7.8.1A for CA in TS 36.101 [5].

For the NR sub-block, the requirement is defined in clause 7.8.2 in TS 38.101-1 [2].

The blocker configuration is defined in the general clause 7.1 and the requirement only apply for out of gap interferers.

The normative reference for this requirement is TS 38.101-3 [4] clause 7.8B.2.2.

7.8B.2.0.3 Inter-band EN-DC within FR1

Wide band Intermodulation requirement for E-UTRA single carrier and CA operation specified in clauses 7.8.1 and 7.8.1A of TS 36.101 [5] and for NR single carrier and CA operation specified in clauses 7.8.2 and 7.8A.2 of TS 38.101-1 [2] apply.

The normative reference for this requirement is TS 38.101-3 [4] clause 7.8B.2.3.

7.8B.2.0.4 Inter-band EN-DC including FR2

Wide band Intermodulation requirement for E-UTRA single carrier and CA operation specified in clauses 7.8.1 and 7.8.1A of TS 36.101 [5] apply.

The normative reference for this requirement is TS 38.101-3 [4] clause 7.8B.2.4.

7.8B.2.0.5 Inter-band EN-DC including both FR1 and FR2

Wide band Intermodulation requirement for E-UTRA single carrier and CA operation specified in clauses 7.8.1 and 7.8.1A of TS 36.101 [5] and for NR single carrier and CA operation specified in clauses 7.8.2 and 7.8A.2 of TS 38.101-1 [2] apply.

The normative reference for this requirement is TS 38.101-3 [4] clause 7.8B.2.5.

7.8B.2.1 Wideband Intermodulation for intra-band contiguous EN-DC in FR1

Editor's note: This clause is incomplete. The following aspects are either missing or not yet determined:

- **UL Power configuration is TBD**

7.8B.2.1.1 Test Purpose

Intermodulation response tests the UE's ability to receive data with a given average throughput for a specified reference measurement channel, in the presence of two or more interfering signals which have a specific frequency relationship to the wanted signal, under conditions of ideal propagation and no added noise.

A UE unable to meet the throughput requirement under these conditions will decrease the coverage area when two or more interfering signals exist which have a specific frequency relationship to the wanted signal.

7.8B.2.1.2 Test Applicability

This test case applies to all types of E-UTRA UE release 15 and forward, supporting intra-band contiguous EN-DC within FR1.

7.8B.2.1.3 Minimum Conformance Requirements

The minimum conformance requirements are defined in clause 7.8B.2.0.1.

Exception requirements for both NR and E-UTRA are defined for this test and therefore LTE anchor agnostic approach is not applied. E-UTRA test point analysis is included and E-UTRA measurements are performed.

7.8B.2.1.4 Test Description

7.8B.2.1.4.1 Initial condition

Initial conditions are a set of test configurations the UE needs to be tested in and the steps for the SS to take with the UE to reach the correct measurement state.

The initial test configurations consist of environmental conditions, test frequencies and channel bandwidths based on EN-DC operating bands specified in clause 5.3B.1.2, channel bandwidths and sub-carrier spacings for the NR cell specified in TS 38.521-1 [8] clause 5.3 and channel bandwidth for the E-UTRA cell are specified in TS 36.521-1 [10] clause 5.4.2. All of these configurations shall be tested with applicable test parameters for each EN-DC configuration specified in clause 5.3B.1.2 and are shown in table 7.8B.2.1.4.1-1. The details of the uplink reference measurement channels (RMCs) are specified in Annex A.2. Configurations of PDSCH and PDCCH before measurement are specified in TS 36.521-1 [10] Annex C.2 and in TS 38.521-1 [8] Annex C.2 for E-UTRA CG and NR CG respectively.

Table 7.8B.2.1.4.1-1: Test configuration table

Initial Conditions							
Test Environment as specified in TS 38.508-1 [6] clause 4.1				Normal			
Test Frequencies as specified in TS 38.508-1 [6] clause 4.3.1 for different EN-DC bandwidth classes				Mid range			
Test EN-DC bandwidth combination as specified in Table 5.3B.1.2-1 across bandwidth combination sets supported by the UE				Lowest N_{RB_agg} , Highest N_{RB_agg} (NOTE 3)			
NR Test SCS as specified in Table 5.3.5-1 in TS 38.521-1 [8]				Highest			
NR/E-UTRA Test Parameters							
Downlink Configuration				Uplink Configuration			
NR Modulation	NR RB allocation	E-UTRA Modulation	E-UTRA RB allocation	NR Modulation	NR RB allocation	E-UTRA Modulation	E-UTRA RB allocation
CP-OFDM QPSK	Full RB (NOTE 1)	QPSK	Full RB	DFT-s-OFDM QPSK	REFSENS	QPSK	REFSENS
NOTE 1: Full RB allocation shall be used per each SCS and channel BW as specified in Table 7.3.2.4.1-2 of TS 38.521-1 [8].							
NOTE 2: Test Channel Bandwidths are checked separately for each E-UTRA band, which applicable channel bandwidths are specified in Table 5.3B.1.2-1.							
NOTE 3: If the UE supports multiple CC Combinations in the EN-DC Configuration with the same N_{RB_agg} , only the combination with the highest N_{RB_SCG} is tested.							
NOTE 4: REFSENS refers to Uplink configuration in Table 7.3.2-3 in [8] and Table 7.3.3-2 in [10] for NR and E-UTRA CC respectively.							
NOTE 5: In an E-UTRA band or NR FR1 band where UE supports 4Rx, the test shall be performed only with 4Rx antennas ports connected and 4Rx REFSENS requirement (TS 38.521-1 [8] Table 7.3.2.5-2) is used in the test requirements.							

1. Connect the SS to the UE antenna connectors as shown in [6] TS 38.508-1 A.3.1.2.1 for SS diagram and A.3.2 for UE diagram.
2. The parameter settings for the E-UTRA cell are set up according to TS 36.508 [11] clause 4.4.3, and the parameter settings for the NR cell are set up according to TS 38.508-1 [6] clause 4.4.3.
3. Downlink signals are initially set up according to TS 36.521-1 [10] Annex C.0 and TS 38.521-1 [8] Annex C.0 for E-UTRA CG and NR CG respectively, and uplink signals according to TS 36.521-1 [10] Annex H and TS 38.521-1 [8] Annex G for E-UTRA CG and NR CG respectively.
4. The UL Reference Measurement channels are TS 36.521-1 [10] Annex A.2 and TS 38.521-1 [8] Annex A.2 for E-UTRA CG and NR CG respectively.
5. Propagation conditions are set according to TS 36.521-1 [10] Annex B.0 and TS 38.521-1 [8] Annex B.0 for E-UTRA CG and NR CG respectively.
6. Ensure the UE is in state RRC_CONNECTED with generic procedure parameters Connectivity EN-DC, DC bearer *MCG* and *SCG*, Connected without release *On* according to TS 38.508-1 [6] clause 4.5. Message contents are defined in clause 6.2B.1.1.4.3.

7.8B.2.1.4.2 Test procedure

1. SS sends uplink scheduling information for each UL HARQ process via PDCCH DCI format 0 and DCI format 0_1 for C_RNTI to schedule the UL RMC according to table 7.8B.2.1.4.1-1 on E-UTRA CC and NR CC respectively. Since the UL has no payload and no loopback data to send the UE sends uplink MAC padding bits on the UL RMC.
2. Set the Downlink signal level to the value as defined in Table 7.8B.2.1.5-1. For NR CC and E-UTRA CC, send uplink power control commands to the UE using 1dB power step size to ensure that the UE output power measured by the test system is within the Uplink power control window, defined as $-(\text{MU} + \text{Uplink power control window size})$ dB of the target power level in Table 7.8B.2.1.5-1 $+ (10\log(S_L_{CRB}/N_{RB_alloc}))$ for

NR CC, $[10\log(P_{L_{CRB}}/N_{RB_alloc})]$ for E-UTRA CC) for at least the duration of the Throughput measurement, where:

- MU is the test system uplink power measurement uncertainty and is specified in Table F.1.3-1 for the carrier frequency f and the channel bandwidth BW.
 - For NR CC, Uplink power control window size = 1dB (UE power step size) + 0.7dB (UE power step tolerance) + (Test system relative power measurement uncertainty), where, the UE power step tolerance is specified in TS 38.101-1 [2], Table 6.3.4.3-1 and is 0.7dB for 1dB power step size. and the Test system relative power measurement uncertainty is specified in Table F.1.2-1.
 - For E-UTRA CC, Uplink power control window size = 1dB (UE power step size) + 1.0dB (UE power step tolerance) + (Test system relative power measurement uncertainty), where, the UE power step tolerance is specified in TS 36.101 [5], Table 6.3.5.2.1-1 and is 1.0dB for 1dB power step size, and the Test system relative power measurement uncertainty is specified in Table F.1.2-1 of TS 36.521-1 [10].
3. Set the Interfering signal levels to the values as defined in Table 7.8B.2.1.5-1 and frequency below the wanted signal
 4. Measure the average throughput for a duration sufficient to achieve statistical significance according to Annex G.2.
 5. Repeat steps from 2 to 4, using an interfering signal above the wanted signal at step 3.

NOTE: The purpose of the Uplink power control window is to ensure that the actual UE output power is no greater than the target power level, and as close as possible to the target power level. The relationship between the Uplink power control window, the target power level and the corresponding possible actual UE Uplink power window is illustrated in Annex F, clause F.4.

7.8B.2.1.4.3 Message contents

Message contents are according to TS 38.508-1 [5] clause 4.6 with DFT-s-OFDM condition in Table 4.6.3-118 PUSCH-Config.

7.8B.2.1.5 Test Requirement

The throughput shall be $\geq 95\%$ of the maximum throughput of the reference measurement channels as specified in Annex A.3.2 with parameters specified in Table 7.8B.2.1.5-1 for the specified wanted signal mean power in the presence of two interfering signals.

Table 7.8B.2.1.5-1: Wide band intermodulation

EN-DC Aggregated Bandwidth, MHz	≤ 100	$>100, \leq 120$	$>120, \leq 140$	$>140, \leq 160$
Pw in Transmission Bandwidth Configuration, perCC, dBm	P_w^1	16.8	17.5	18.0
$P_{interferer\ 1}$, dBm (CW) ²	-46			
$P_{interferer\ 2}$, dBm (Modulated) ²	-46			
NOTE 1: P_w is wanted signal power level from Table 7.8.1A-1 in TS 36.101 [5]				
NOTE 2: Jammer BW and offsets is from Table 7.8.1A-1 in TS 36.101 [5] and is applied from the lowest edge of the lowest carrier and the highest edge of the highest carrier				
NOTE 3: For NR carrier, the transmitter shall be set to 4dB below $P_{CMAX_L,f,c}$ at the minimum uplink configuration specified in Table 7.3-3 with $P_{CMAX_L,f,c}$ as defined in clause 6.2.4 from [2].				
NOTE 4: For E-UTRA carrier, the transmitter shall be set to 4dB below $P_{CMAX_L,c}$ at the minimum uplink configuration specified in Table 7.3-1-2 with $P_{CMAX_L,c}$ as defined in clause 6.2.5 for single carrier and in Table 7.3-1A-1 with P_{CMAX_L} as defined in clause 6.2.5A for LTE-CA from TS 36.101 [5].				

Table 7.8B.2.1.5-2: Void**7.8B.2.2 Wideband Intermodulation for intra-band non-contiguous EN-DC in FR1****7.8B.2.2.1 Test Purpose**

Same test purpose as in clause 7.8.2.1 in TS 38.521-1 [8] for the NR carrier.

7.8B.2.2.2 Test Applicability

This test case applies to all types of E-UTRA UE release 15 and forward, supporting intra-band non-contiguous EN-DC within FR1.

7.8B.2.2.3 Minimum Conformance Requirements

The minimum conformance requirements are defined in clause 7.8B.2.0.2.

No exception requirements applicable to NR or LTE. LTE anchor agnostic approach is applied.

7.8B.2.2.4 Test Description

Same test description as in clause 7.8.2.4 in TS 38.521-1 [8] with the following exceptions:

Table 7.8B.2.2.4-1: Test Configuration Table

Initial Conditions	
Test Frequencies as specified in TS 38.508-1 [6] clause 4.3.1 for different EN-DC bandwidth classes	High range with maxWGap
Test EN-DC bandwidth combination as specified in Table 5.3B.1.2-1 across bandwidth combination sets supported by the UE	Highest N_{RB_agg} (NOTE1)
NOTE 1: If the UE supports multiple CC Combinations in the EN-DC Configuration with the same N_{RB_agg} , only the combination with the highest N_{RB_SCG} is tested.	

The initial test configurations for E-UTRA as specified in Table 4.6-1 except for the parameters specified in Table 7.9B.2.4-1.

For Initial conditions as in clause 7.8.2.4.1 in TS 38.521-1 [8], the following steps are added to configure E-UTRA component:

- 2.1. The parameter settings for E-UTRA cell are set up according to TS 36.508 [11] clause 4.4.3. The E-UTRA downlink signal level, uplink signal level are set according to Table 4.6-1 and propagation conditions are set according to Annex B.0 of TS 36.521-1 [10].7. On the E-UTRA carrier, disable periodic and aperiodic CQI reports, disable SRS, set *TimeAlignmentTimerDedicated* IE to infinity and disable downlink and uplink scheduling, all as per Table 4.6-1 under clause 4.6.

Step 6 of Initial conditions as in clause 7.8.2.4.2 in TS 38.521-1 [8] is replaced by:

6. Ensure the UE is in state RRC_CONNECTED with generic procedure parameters Connectivity EN-DC, DC bearer MCG and SCG, Connected without release *On* according to TS 38.508 [6] clause 4.5.

Step 4 of Test procedure is replaced by:

4. Set the Interfering signal levels to the values as defined in Table 7.8.2.5-1 and frequency at the out-of-gap of the sub-blocks.

Step 6 of Test procedure is removed.

7.8B.2.2.5 Test Requirement

Same test requirement as in clause 7.8.2.5 in TS 38.521-1 [8].

7.8B.2.3 Wideband Intermodulation for inter-band EN-DC in FR1 (2 CCs)

7.8B.2.3.1 Test Purpose

Same test purpose as in clause 7.8.2.1 in TS 38.521-1 [8] for the NR carrier.

7.8B.2.3.2 Test Applicability

This test case applies to all types of E-UTRA UE release 15 and forward, supporting inter-band EN-DC within FR1.

7.8B.2.3.3 Minimum Conformance Requirements

The minimum conformance requirements are defined in clause 7.8B.2.0.3.

No exception requirements applicable to NR or LTE. LTE anchor agnostic approach is applied.

7.8B.2.3.4 Test Description

Same test description as in clause 7.8.2.4 in TS 38.521-1 [8] for the NR carrier with the following exceptions:

The initial test configurations for E-UTRA consist of test frequency based on E-UTRA operating band and test channel bandwidth as specified in Table 4.6-1.

For Initial conditions as in clause 7.8.2.4.1 in TS 38.521-1 [8], the following steps are added to configure E-UTRA component:

- 2.1. The parameter settings for E-UTRA cell are set up according to TS 36.508 [11] clause 4.4.3. The E-UTRA downlink signal level, uplink signal level are set according to Table 4.6-1 and propagation conditions are set according to Annex B.0 of TS 36.521-1 [10].
7. On the E-UTRA carrier, disable periodic and aperiodic CQI reports, disable SRS, set *TimeAlignmentTimerDedicated* IE to infinity and disable downlink and uplink scheduling, all as per Table 4.6-1 under clause 4.6.

Step 6 of Initial conditions as in clause 7.8.2.4.2 in TS 38.521-1 [8] is replaced by:

6. Ensure the UE is in state RRC_CONNECTED with generic procedure parameters Connectivity EN-DC, DC bearer MCG and SCG, Connected without release *On* according to TS 38.508 [6] clause 4.5.

7.8B.2.3.5 Test Requirement

Same test requirement as in clause 7.8.2.5 in TS 38.521-1 [8].

7.8B.2.3_1 Wideband Intermodulation for EN-DC within FR1 (>2 CCs)

7.8B.2.3_1.1 Wideband Intermodulation for EN-DC within FR1 (3 CCs)

Editor's note: The following aspects are either missing or not yet determined:

- Test repetition and measurement configuration for DC_XA-nYA-nZA, DC_XA-nYC and DC_XA-nXA-nYA still TBD.

7.8B.2.3_1.1.1 Test Purpose

Intermodulation response tests the UE's ability to receive data with a given average throughput for a specified reference measurement channel, in the presence of two or more interfering signals which have a specific frequency relationship to the wanted signal, under conditions of ideal propagation and no added noise.

A UE unable to meet the throughput requirement under these conditions will decrease the coverage area when two or more interfering signals exist which have a specific frequency relationship to the wanted signal.

7.8B.2.3_1.1.2 Test Applicability

This test case applies to all types of E-UTRA UE release 15 and forward, supporting EN-DC within FR1 (3 CCs).

7.8B.2.3_1.1.3 Minimum Conformance Requirements

The minimum conformance requirements are defined in clause 7.8B.2.0.

7.8B.2.3_1.1.4 Test Description

7.8B.2.3_1.1.4.1 Initial condition

Initial conditions are a set of test configurations the UE needs to be tested in and the steps for the SS to take with the UE to reach the correct measurement state.

The initial test configurations consist of environmental conditions, test frequencies and channel bandwidths based on EN-DC operating bands specified in clause 5.3B.1.2, channel bandwidths and sub-carrier spacings for the NR cell specified in TS 38.521-1 [8] clause 5.3 and channel bandwidth for the E-UTRA cell are specified in TS 36.521-1 [10] clause 5.4.2. All of these configurations shall be tested with applicable test parameters for each EN-DC configuration specified in clause 5.3B.1.2 and are shown in table 7.8B.2.3_1.1.4.1-1. The details of the uplink reference measurement channels (RMCs) are specified in Annex A.2. Configurations of PDSCH and PDCCH before measurement are specified in TS 36.521-1 [10] Annex C.2 and in TS 38.521-1 [8] Annex C.2 for E-UTRA CG and NR CG respectively.

Table 7.8B.2.3_1.1.4.1-1: Test configuration table

Initial Conditions					
Test Environment as specified in TS 38.508-1 [6] clause 4.1					Normal
Test Frequencies as specified in TS 38.508-1 [6] clause 4.3.1 for different EN-DC bandwidth classes					Mid range
Test EN-DC bandwidth combination as specified in Table 5.3B.1.2-1 across bandwidth combination sets supported by the UE					Highest N_{RB_agg}
NR Test SCS as specified in Table 5.3.5-1 in TS 38.521-1 [8]					Highest
Network signalling value					NS_01 by default
Test Parameters for EN-DC Configurations					
EN-DC Configurations	Environment	Frequency	Bandwidth Combination	SCS	Other Parameter Settings
DC_(n)XCA	Default	Default	Default	Default	As per DC_(n)XCA in Table 7.3B.2.3_1.1.4.1-0
DC_XC-nXA	-	-	-	-	No test required (LTE 1CC fallback is tested in 7.8B.2.2)
DC_XA-XA-nXA	-	-	-	-	No test required (LTE 1CC fallback is tested in 7.8B.2.2)
DC_XA-nYC	Default	Default	Default	Default	As per DC_XA-nYC in Table 7.3B.2.3_1.14.1-0
DC_XA-nY(2A)	Default	Default	Default	Default	As per DC_XA-nY(2A) in Table 7.3B.2.3_1.14.1-0
DC_XA-nYA-nZA	Default	Default	Default	Default	As per DC_XA-nYA-nZA in Table 7.3B.2.3_1.14.1-0
DC_XC-nYA	-	-	-	-	No test required (LTE 1CC fallback is tested in 7.8B.2.3)
DC_XA-XA-nYA	-	-	-	-	No test required (LTE 1CC fallback is tested in 7.8B.2.3)
DC_XA-YA-nZA	-	-	-	-	No test required (LTE 1CC fallback is tested in 7.8B.2.3)
NOTE 1: Void					
NOTE 2: Void					
NOTE 3: Void					
NOTE 4: X, Y and Z in this table correspond to different bands i.e. X != Y != Z					
NOTE 5: The band combinations with difference appearance order of bands/sub-blocks in the band combination string are not distinguished. E.g. DC_YA-(n)XAA represents the set of DC_YA-(n)XAA and DC_(n)XAA-YA					
NOTE 6: In a FR1 band where UE supports 4Rx, the test shall be performed only with 4Rx antennas ports connected and 4Rx REFSENS requirement (TS 38.521-1 [8] Table 7.3.2.5-2) is used in the test requirements.					

1. Connect the SS to the UE antenna connectors as shown in [6] TS 38.508-1 A.3.1.2.1 for SS diagram and A.3.2 for UE diagram.
2. The parameter settings for the E-UTRA cell are set up according to TS 36.508 [11] clause 4.4.3, and the parameter settings for the NR cell are set up according to TS 38.508-1 [6] clause 4.4.3.
3. Downlink signals are initially set up according to TS 36.521-1 [10] Annex C.0 and TS 38.521-1 [8] Annex C.0 for E-UTRA CG and NR CG respectively, and uplink signals according to TS 36.521-1 [10] Annex H and TS 38.521-1 [8] Annex G for E-UTRA CG and NR CG respectively.
4. The UL Reference Measurement channels are TS 36.521-1 [10] Annex A.2 and TS 38.521-1 [8] Annex A.2 for E-UTRA CG and NR CG respectively.
5. Propagation conditions are set according to TS 36.521-1 [10] Annex B.0 and TS 38.521-1 [8] Annex B.0 for E-UTRA CG and NR CG respectively.
6. Ensure the UE is in state RRC_CONNECTED with generic procedure parameters Connectivity EN-DC, DC bearer MCG and SCG, Connected without release *On* according to TS 38.508-1 [6] clause 4.5. Message contents are defined in clause 6.2B.1.1.4.3.
7. For the E-UTRA CC(s) where anchor agnostic apply according to NOTE 2 in Table 7.8B.2.3_1.1.4.1-1, downlink signal level and uplink signal level are set according to Table 4.6-1 and propagation conditions are set according to Annex B, clause B.0 of TS 36.521-1 [10]. Disable periodic and aperiodic CQI reports, disable SRS, set *TimeAlignmentTimerDedicated* IE to infinity and disable downlink and uplink scheduling, all as per Table 4.6-1 under clause 4.6.

7.8B.2.3_1.1.4.2 Test procedure

1. SS sends uplink scheduling information for each UL HARQ process via PDCCH DCI format 0 and DCI format 0_1 for C_RNTI to schedule the UL RMC according to table 7.8B.2.3_1.1.4.2-1 on E-UTRA CC and NR CC respectively. Since the UL has no payload and no loopback data to send the UE sends uplink MAC padding bits on the UL RMC.
2. Set the Downlink signal level to the value as defined in Table 7.8B.2.3_1.1.4.2-1. For E-UTRA CC and NR CC where uplink is allocated according to Table 7.8B.2.3_1.1.4.1-1, send uplink power control commands to the UE using 1dB power step size to ensure that the UE output power measured by the test system is within the Uplink power control window, defined as $-MU$ to $-(MU + \text{Uplink power control window size})$ dB of the 4dB below PCMAX_L with PCMAX_L as defined in clause 6.2B.4 for at least the duration of the Throughput measurement.
 - MU is the test system uplink power measurement uncertainty and is specified in Table F.1.3-1 for the carrier frequency f and the channel bandwidth BW.
 - For NR CC, Uplink power control window size = 1dB (UE power step size) + 0.7dB (UE power step tolerance) + (Test system relative power measurement uncertainty), where, the UE power step tolerance is specified in TS 38.101-1 [2], Table 6.3.4.3-1 and is 0.7dB for 1dB power step size, and the Test system relative power measurement uncertainty is specified in Table F.1.2-1.
 - For E-UTRA CC, Uplink power control window size = 1dB (UE power step size) + 1.0dB (UE power step tolerance) + (Test system relative power measurement uncertainty), where, the UE power step tolerance is specified in TS 36.101 [5], Table 6.3.5.2.1-1 and is 1.0dB for 1dB power step size, and the Test system relative power measurement uncertainty is specified in Table F.1.2-1 of TS 36.521-1 [10].

NOTE: The purpose of the Uplink power control window is to ensure that the actual UE output power is no greater than, or no less than the target power level, and as close as possible to the target power level. The relationship between the Uplink power control window, the target power level and the corresponding possible actual UE Uplink power window is illustrated in Annex F, clause F.4.

3. Set the Interfering signal levels to the values as defined in Table 7.8B.2.3_1.1.4.2-1 and frequency below the wanted signal.
4. Measure the average throughput for a duration sufficient to achieve statistical significance according to Annex G, clause G.2.
5. Repeat steps from 2 to 4, using an interfering signal above the wanted signal at step 3.
6. Repeat steps 2 to 5 for component carriers listed in Table 7.8B.2.3_1.1.4.2-1.

Table 7.8B.2.3_1.1.4.2-1: Test repetition and measurement configuration

DC configuration	Throughput measured on (NOTE 3)	Test parameters to select (NOTE 2)
DC_(n)XCA	DL allocated CC	7.8B.2.1.5
DC_XC-nXA		7.8B.2.2.5
DC_XA-XA-nXA		
DC_XA-nYC		7.8B.2.3.5
DC_XA-nY(2A)		
DC_XA-nYA-nZA		
DC_XC-nYA		
DC_XA-XA-nYA		
DC_XA-YA-nZA		
NOTE 1: Void		
NOTE 2: The reference for the placement of the interferer signals is the centre frequency of the carrier closest to the interferer among the carriers throughput is measured on.		
NOTE 3: Where there are multiple rows for a single Test point ID, the test is repeated for each row.		

7.8B.2.3_1.1.4.3 Message contents

Message contents are according to TS 38.508-1 [5] clause 4.6 with DFT-s-OFDM condition in Table 4.6.3-118 PUSCH-Config.

7.8B.2.3_1.1.5 Test Requirement

The throughput shall be $\geq 95\%$ of the maximum throughput of the reference measurement channels as specified in Annex A, clause A.3.2 with parameters specified in Table 7.8B.2.3_1.1.4.2-1 for the specified wanted signal mean power in the presence of two interfering signals.

7.8B.2.3_1.2 Wideband Intermodulation for EN-DC within FR1 (4 CCs)

TBD

7.8B.2.3_1.3 Wideband Intermodulation for EN-DC within FR1 (5 CCs)

TBD

7.8B.2.3_1.4 Wideband Intermodulation for EN-DC within FR1 (6 CCs)

TBD

7.8B.2.3A Wideband Intermodulation for inter-band NE-DC within FR1 (2 CCs)

TBD

7.8B.2.4 Void

7.8B.2.5 Void

7.8B.2.6 Void

7.8B.2.7 Void

7.8B.2.8 Void

7.8B.2.9 Void

7.9 Void

7.9B Spurious emissions for DC in FR1

7.9B.0 Minimum Conformance Requirements

7.9B.0.1 Intra-band contiguous EN-DC in FR1

The requirement is defined in clause 7.9A.1 in TS 38.101-1 [2].

The normative reference for this requirement is TS 38.101-3 [4] clause 7.9B.1.

7.9B.0.2 Intra-band non-contiguous EN-DC in FR1

Spurious emissions requirement for E-UTRA single carrier and CA operation specified in clauses 7.9.1 and 7.9.1A of TS 36.101 [5] and for NR single carrier and CA operation specified in clauses 7.9 and 7.9A of TS 38.101-1 [2] apply.

The normative reference for this requirement is TS 38.101-3 [4] clause 7.9B.2.

7.9B.0.3 Inter-band EN-DC within FR1

E-UTRA requirements from TS 36.101 [5] and NR requirements from TS 38.101-1 [2] apply.

The normative reference for this requirement is TS 38.101-3 [4] clause 7.9B.3.

7.9B.0.4 Inter-band EN-DC including FR2

Spurious emissions requirement for E-UTRA single carrier and CA operation specified in clauses 7.9.1 and 7.9.1A of TS 36.101 [5] and for NR single carrier and CA operation specified in clause 7.9 of TS 38.101-2 [3] apply.

The normative reference for this requirement is TS 38.101-3 [4] clause 7.9B.4.

7.9B.0.5 Inter-band EN-DC including both FR1 and FR2

Spurious emissions requirement for E-UTRA single carrier and CA operation specified in clauses 7.9.1 and 7.9.1A of TS 36.101 [5] and for NR single carrier and CA operation specified in clauses 7.9 and 7.9A of TS 38.101-1 [2] and TS 38.101-2 [3] apply.

The normative reference for this requirement is TS 38.101-3 [4] clause 7.9B.5.

7.9B.1 Spurious Emissions for intra-band contiguous EN-DC in FR1(2 CCs)

7.9B.1.1 Test purpose

Same test purpose as in clause 7.9.1 in TS 38.521-1 [8] for the NR carrier.

7.9B.1.2 Test applicability

This test case applies to all types of E-UTRA UE release 15 and forward, supporting intra-band contiguous EN-DC within FR1.

7.9B.1.3 Minimum conformance requirements

The minimum conformance requirements are defined in clause 7.9B.0.3.

No exception requirements applicable to NR or LTE. LTE anchor agnostic approach is applied.

7.9B.1.4 Test description

Same test description as in clause 7.9.4 in TS 38.521-1 [8] with the following exceptions:

Table 7.9B.1.4-1: Test Configuration Table

Initial Conditions	
Test Frequencies as specified in TS 38.508-1 [6] clause 4.3.1 for different DC bandwidth classes.	Mid range
Test EN-DC bandwidth combination as specified in Table 5.3B.1.2-1 across bandwidth combination sets supported by the UE	Highest NRB_{agg} (NOTE 1)
NOTE 1: If the UE supports multiple CC Combinations in the EN-DC Configuration with the same NRB_{agg} , only the combination with the highest NRB_{SCG} is tested.	

The initial test configurations for E-UTRA as specified in Table 4.6-1 except for the parameters specified in Table 7.9B.1.4-1.

For Initial conditions as in clause 7.9.4.1 in TS 38.521-1 [8], the following steps are added to configure E-UTRA component:

2.1. The parameter settings for E-UTRA cell are set up according to TS 36.508 [11] clause 4.4.3. The E-UTRA downlink signal level, uplink signal level are set according to Table 4.6-1 and propagation conditions are set according to Annex B.0 of TS 36.521-1 [10].

7. On the E-UTRA carrier, disable periodic and aperiodic CQI reports, disable SRS, set *TimeAlignmentTimerDedicated* IE to infinity and disable downlink and uplink scheduling, all as per Table 4.6-1 under clause 4.6.

Step 6 of Initial conditions as in clause 7.9.4.1 in TS 38.521-1 [8] is replaced by:

6. Ensure the UE is in state RRC_CONNECTED with generic procedure parameters Connectivity EN-DC, DC bearer MCG and SCG, Connected without release *On* according to TS 38.508 [6] clause 4.5.

7.9B.1.5 Test requirement

Same test requirement as in clause 7.9.5 in TS 38.521-1 [8].

7.9B.2 Spurious Emissions for intra-band non-contiguous EN-DC in FR1(2 CCs)

7.9B.2.1 Test purpose

Same test purpose as in clause 7.9.1 in TS 38.521-1 [8] for the NR carrier.

7.9B.2.2 Test applicability

This test case applies to all types of E-UTRA UE release 15 and forward, supporting inter-band EN-DC within FR1.

7.9B.2.3 Minimum conformance requirements

The minimum conformance requirements are defined in clause 7.9B.0.3.

No exception requirements applicable to NR or LTE. LTE anchor agnostic approach is applied.

7.9B.2.4 Test description

Same test description as in clause 7.9.4 in TS 38.521-1 [8] with the following exceptions:

Table 7.9B.2.4-1: Test Configuration Table

Initial Conditions	
Test Frequencies as specified in TS 38.508-1 [6] clause 4.3.1 for different DC bandwidth classes	MaxWGap
Test EN-DC bandwidth combination as specified in Table 5.3B.1.2-1 across bandwidth combination sets supported by the UE	Highest N_{RB_agg} (NOTE 1)
NOTE 1: If the UE supports multiple CC Combinations in the EN-DC Configuration with the same N_{RB_agg} , only the combination with the highest N_{RB_SCG} is tested.	

The initial test configurations for E-UTRA as specified in Table 4.6-1 except for the parameters specified in Table 7.9B.2.4-1.

For Initial conditions as in clause 7.9.4.1 in TS 38.521-1 [8], the following steps are added to configure E-UTRA component:

2.1. The parameter settings for E-UTRA cell are set up according to TS 36.508 [11] clause 4.4.3. The E-UTRA downlink signal level, uplink signal level are set according to Table 4.6-1 and propagation conditions are set according to Annex B.0 of TS 36.521-1 [10].

7. On the E-UTRA carrier, disable periodic and aperiodic CQI reports, disable SRS, set *TimeAlignmentTimerDedicated* IE to infinity and disable downlink and uplink scheduling, all as per Table 4.6-1 under clause 4.6.

Step 6 of Initial conditions as in clause 7.9.4.1 in TS 38.521-1 [8] is replaced by:

6. Ensure the UE is in state RRC_CONNECTED with generic procedure parameters Connectivity EN-DC, DC bearer MCG and SCG, Connected without release *On* according to TS 38.508 [6] clause 4.5.

7.9B.2.5 Test requirement

Same test requirement as in clause 7.9.5 in TS 38.521-1 [8].

7.9B.3 Spurious Emissions for inter-band EN-DC within FR1(2 CCs)

7.9B.3.1 Test purpose

Same test purpose as in clause 7.9.1 in TS 38.521-1 [8] for the NR carrier.

7.9B.3.2 Test applicability

This test case applies to all types of E-UTRA UE release 15 and forward, supporting inter-band EN-DC within FR1.

7.9B.3.3 Minimum conformance requirements

The minimum conformance requirements are defined in clause 7.9B.0.3.

No exception requirements applicable to NR or LTE. LTE anchor agnostic approach is applied.

7.9B.3.4 Test description

Same test description as in clause 7.9.4 in TS 38.521-1 [8] for the NR carrier with the following exceptions:

The initial test configurations for E-UTRA consist of test frequency based on E-UTRA operating band and test channel bandwidth as specified in Table 4.6-1.

For Initial conditions as in clause 7.9.4.1 in TS 38.521-1 [8], the following steps are added to configure E-UTRA component:

- 2.1. The parameter settings for E-UTRA cell are set up according to TS 36.508 [11] clause 4.4.3. The E-UTRA downlink signal level, uplink signal level are set according to Table 4.6-1 and propagation conditions are set according to Annex B.0 of TS 36.521-1 [10].
7. On the E-UTRA carrier, disable periodic and aperiodic CQI reports, disable SRS, set *TimeAlignmentTimerDedicated* IE to infinity and disable downlink and uplink scheduling, all as per Table 4.6-1 under clause 4.6.

Step 6 of Initial conditions as in clause 7.9.4.1 in TS 38.521-1 [8] is replaced by:

6. Ensure the UE is in state RRC_CONNECTED with generic procedure parameters Connectivity EN-DC, DC bearer MCG and SCG, Connected without release *On* according to TS 38.508 [6] clause 4.5.

7.9B.3.5 Test requirement

Same test requirement as in clause 7.9.5 in TS 38.521-1 [8].

7.9B.4 Spurious Emissions for inter-band EN-DC including FR2 (2 CCs)

Editor's note: The following aspects are either missing or not yet determined:

- The testability of this test case is pending further analysis on relaxation of the requirement for band other than n257, n258, n260 and n261.

- **Measurement Uncertainties and Test Tolerances are FFS for power class 1, 2, and 4.**

7.9B.4.1 Test purpose

Same test purpose as in clause 7.9.1 in TS 38.521-2 [9] for the *NR* carrier.

7.9B.4.2 Test applicability

This test applies to all types of E-UTRA UE release 15 and forward, supporting inter-band EN-DC including FR2 with 2 DL CCs.

7.9B.4.3 Minimum conformance requirements

Same minimum conformance requirements as in clause 7.9.3 in TS 38.521-2 [9] for the *NR* carrier.

No exception requirements applicable to NR or LTE. LTE anchor agnostic approach is applied.

The normative reference for this requirement is TS 38.101-3 [4] clause 7.9B.4.

7.9B.4.4 Test description

Same test description as in clause 7.9.4 in TS 38.521-2 [9] for the *NR* carrier with the following exception:

The initial test configurations for E-UTRA band consist of environmental conditions, test frequencies, and channel bandwidths based on E-UTRA bands specified in Table 4.7-1.

For initial conditions as in clause 7.9.4.1 in TS 38.521-2 [9], the following steps will be added to configure E-UTRA component:

- 2.1. The parameter settings for E-UTRA cell are set up according to TS 36.508 [11] clause 4.4.3.
- 3.1. The E-UTRA downlink signal level, uplink signal level are set according to Table 4.7-1 and propagation conditions are set according to Annex B.0 of TS 36.521-1 [10].

Step 6 of Initial conditions as in clause 7.9.4.1 in TS 38.521-2 [9] is replaced by:

6. Ensure the UE is in state RRC_CONNECTED with generic procedure parameters Connectivity EN-DC, DC bearer MCG and SCG, Connected without release On according to TS 38.508-1 [6] clause 4.5.

Same test procedure as in clause 7.9.4.1 in TS 38.521-2 [9] with the following steps added for E-UTRA component:

- 1.1 On the E-UTRA carrier, disable periodic and aperiodic CQI reports, disable SRS, set *TimeAlignmentTimerDedicated* IE to infinity and disable downlink and uplink scheduling, all as per Table 4.7-1 under clause 4.7.

7.9B.4.5 Test requirements

Same test requirement as in clause 7.9.5 in TS 38.521-2 [9] for the *NR* carrier.

7.9B.4_1 Spurious Emissions for inter-band EN-DC including FR2 (>2 CCs)

7.9B.4_1.1 Spurious Emissions for inter-band EN-DC including FR2 (3 CCs)

TBD

7.9B.4_1.2 Spurious Emissions for inter-band EN-DC including FR2 (4 CCs)

TBD

7.9B.4_1.3 Spurious Emissions for inter-band EN-DC including FR2 (5 CCs)

TBD

7.9B.4_1.4 Spurious Emissions for inter-band EN-DC including FR2 (5 CCs)

TBD

7.9B.5 Spurious Emissions for inter-band EN-DC including both FR1 and FR2 (3 CCs)

TBD

7.9B.3_1 Spurious Emissions for EN-DC within FR1 (>2 CCs)

7.9B.3_1.1 Spurious Emissions for EN-DC within FR1 (3 CCs)

7.9B.3_1.1.1 Test purpose

Same test purpose as in clause 7.9B.1.

7.9B.3_1.1.2 Test applicability

This test applies to all types of E-UTRA UE release 15 and forward, supporting EN-DC within FR1 with 3CCs.

7.9B.3_1.1.3 Minimum conformance requirements

The minimum conformance requirements are defined in clause 7.9B.0.3.

No exception requirements applicable to NR or LTE. LTE anchor agnostic approach is applied.

7.9B.3_1.1.4 Test description

Same test description as in clause 7.9.4 or 7.9.A.1.4 in TS 38.521-1 [8] with the following exceptions:

Table 7.9B.1.4-1: Test Configuration Table

Initial Conditions	
Test Frequencies as specified in TS 38.508-1 [6] clause 4.3.1 for different DC bandwidth classes.	Mid range
Test EN-DC bandwidth combination as specified in Table 5.3B.1.2-1 across bandwidth combination sets supported by the UE	Highest N_{RB_agg} (NOTE 1)
NOTE 1: If the UE supports multiple CC Combinations in the EN-DC Configuration with the same N_{RB_agg} , only the combination with the highest N_{RB_SCG} is tested.	

The initial test configurations for E-UTRA as specified in Table 4.6-1 except for the parameters specified in Table 7.9B.1.4-1.

For Initial conditions as in clause 7.9.4.1 or 7.9A.1.4.1 in TS 38.521-1 [8], the following steps are added to configure E-UTRA component:

- 2.1. The parameter settings for E-UTRA cell are set up according to TS 36.508 [11] clause 4.4.3. The E-UTRA downlink signal level, uplink signal level are set according to Table 4.6-1 and propagation conditions are set according to Annex B.0 of TS 36.521-1 [10].
7. On the E-UTRA carrier, disable periodic and aperiodic CQI reports, disable SRS, set *TimeAlignmentTimerDedicated* IE to infinity and disable downlink and uplink scheduling, all as per Table 4.6-1 under clause 4.6.

Step 6 of Initial conditions as in clause 7.9.4.1 or 7.9A.1.4.1 in TS 38.521-1 [8] is replaced by:

6. Ensure the UE is in state RRC_CONNECTED with generic procedure parameters Connectivity EN-DC, DC bearer MCG and SCG, Connected without release *On* according to TS 38.508 [6] clause 4.5.

7.9B.3_1.1.5 Test requirement

Same test requirement as in clause 7.9.5 in TS 38.521-1 [8].

Annex A (normative): Measurement Channels

Please refer to Annex A in TS 38.521-1 [8] and 38.521-2 [9] for appropriate details as needed for test cases in this test specification. EN-DC exceptions will be added.

A.1 General

The throughput values defined in the measurement channels specified in Annex A, are calculated and are valid per datastream (codeword). For multi-stream (more than one codeword) transmissions, the throughput referenced in the minimum requirements is the sum of throughputs of all datastreams (codewords).

The UE category entry in the definition of the reference measurement channel in Annex A is only informative and reveals the UE categories, which can support the corresponding measurement channel. Whether the measurement channel is used for testing a certain UE category or not is specified in the individual minimum requirements.

A.2 UL reference measurement channels for E-UTRA TDD Config 2

A.2.1 General

The measurement channels in the following clauses are defined to derive the requirements in clause 6 (Transmitter Characteristics) and clause 7 (Receiver Characteristics). The measurement channels represent example configurations of physical channels for different data rates.

A.2.2 Reference measurement channels for E-UTRA

A.2.2.1 Full RB allocation

A.2.2.1.1 QPSK

Table A.2.2.1.1-1: Reference Channels for QPSK with full RB allocation

Parameter	Unit	Value					
		1.4	3	5	10	15	20
Channel bandwidth	MHz	1.4	3	5	10	15	20
Allocated resource blocks		6	15	25	50	75	100
Uplink-Downlink Configuration (Note 2)		2	2	2	2	2	2
Special subframe configuration (Note 3)		7	7	7	7	7	7
DFT-OFDM Symbols per Sub-Frame		12	12	12	12	12	12
Modulation		QPSK	QPSK	QPSK	QPSK	QPSK	QPSK
Target Coding rate		1/3	1/3	1/3	1/3	1/5	1/6
Payload size							
For Sub-Frame 2,7	Bits	600	1544	2216	5160	4392	4584
Transport block CRC	Bits	24	24	24	24	24	24
Number of code blocks per Sub-Frame (Note 1)							
For Sub-Frame 2,7		1	1	1	1	1	1
Total number of bits per Sub-Frame							
For Sub-Frame 2,7	Bits	1728	4320	7200	14400	21600	28800
Total symbols per Sub-Frame							
For Sub-Frame 2,7		864	2160	3600	7200	10800	14400
UE Category		≥ 1	≥ 1	≥ 1	≥ 1	≥ 1	≥ 1
Note 1:	If more than one Code Block is present, an additional CRC sequence of L = 24 Bits is attached to each Code Block (otherwise L = 0 Bit)						
Note 2:	As per Table 4.2-2 in TS 36.211 [13]						
Note 3:	As per Table 4.2-1 in TS 36.211 [13]						

A.2.2.1.2 16-QAM

Table A.2.2.1.2-1: Reference Channels for 16-QAM with full RB allocation

Parameter	Unit	Value					
		1.4	3	5	10	15	20
Channel bandwidth	MHz	1.4	3	5	10	15	20
Allocated resource blocks		6	15	25	50	75	100
Uplink-Downlink Configuration (Note 2)		2	2	2	2	2	2
Special subframe configuration (Note 3)		7	7	7	7	7	7
DFT-OFDM Symbols per Sub-Frame		12	12	12	12	12	12
Modulation		16QAM	16QAM	16QAM	16QAM	16QAM	16QAM
Target Coding rate		3/4	1/2	1/3	3/4	1/2	1/3
Payload size							
For Sub-Frame 2,7	Bits	2600	4264	4968	21384	21384	19848
Transport block CRC	Bits	24	24	24	24	24	24
Number of code blocks per Sub-Frame (Note 1)							
For Sub-Frame 2,7		1	1	1	4	4	4
Total number of bits per Sub-Frame							
For Sub-Frame 2,7	Bits	3456	8640	14400	28800	43200	57600
Total symbols per Sub-Frame							
For Sub-Frame 2,7		864	2160	3600	7200	10800	14400
UE Category		≥ 1	≥ 1	≥ 1	≥ 2	≥ 2	≥ 2
Note 1:	If more than one Code Block is present, an additional CRC sequence of L = 24 Bits is attached to each Code Block (otherwise L = 0 Bit)						
Note 2:	As per Table 4.2-2 in TS 36.211 [13]						
Note 3:	As per Table 4.2-1 in TS 36.211 [13]						

A.2.2.1.3 64-QAM

Table A.2.2.1.3-1: Reference Channels for 64-QAM with full RB allocation

Parameter	Unit	Value					
		1.4	3	5	10	15	20
Channel bandwidth	MHz	1.4	3	5	10	15	20
Allocated resource blocks		6	15	25	50	75	100
Uplink-Downlink Configuration (Note 2)		2	2	2	2	2	2
Special subframe configuration (Note 3)		7	7	7	7	7	7
DFT-OFDM Symbols per Sub-Frame		12	12	12	12	12	12
Modulation		64QAM	64QAM	64QAM	64QAM	64QAM	64QAM
Target Coding rate		3/4	3/4	3/4	3/4	3/4	3/4
Payload size							
For Sub-Frame 2,7	Bits	3752	9528	15840	31704	46888	63776
Transport block CRC	Bits	24	24	24	24	24	24
Number of code blocks per Sub-Frame (Note 1)							
For Sub-Frame 2,7		1	2	3	6	8	11
Total number of bits per Sub-Frame							
For Sub-Frame 2,7	Bits	5184	12960	21600	43200	64800	86400
Total symbols per Sub-Frame							
For Sub-Frame 2,7		864	2160	3600	7200	10800	14400
UE Category (Note 4)		5, 8	5, 8	5, 8	5, 8	5, 8	5, 8
UE UL Category (Note 4)		5, 8, 13, 14	5, 8, 13, 14	5, 8, 13, 14	5, 8, 13, 14	5, 8, 13, 14	5, 8, 13, 14
Note 1:	If more than one Code Block is present, an additional CRC sequence of L = 24 Bits is attached to each Code Block (otherwise L = 0 Bit)						
Note 2:	As per Table 4.2-2 in TS 36.211 [13]						
Note 3:	As per Table 4.2-1 in TS 36.211 [13]						
Note 4:	If UE does not report UE UL category, then the applicability of reference channel is determined by UE category. If UE reports UE UL category, then the applicability of reference channel is determined by UE UL category.						

A.2.2.1.4 256 QAM

Table A.2.2.1.4-1: Reference Channels for 256 QAM with full RB allocation

Parameter	Unit	Value					
		1.4	3	5	10	15	20
Channel bandwidth	MHz	1.4	3	5	10	15	20
Allocated resource blocks		6	15	25	50	75	100
Uplink-Downlink Configuration (Note 2)		2	2	2	2	2	2
Special subframe configuration (Note 3)		7	7	7	7	7	7
DFT-OFDM Symbols per Sub-Frame		12	12	12	12	12	12
Modulation		256QAM	256QAM	256QAM	256QAM	256QAM	256QAM
Target Coding rate		3/4	3/4	3/4	3/4	3/4	3/4
Payload size							
For Sub-Frame 2,7	Bits	5160	12960	21384	42368	63776	84760
Transport block CRC	Bits	24	24	24	24	24	24
Number of code blocks per Sub-Frame (Note 1)							
For Sub-Frame 2,7		1	3	4	8	11	15
Total number of bits per Sub-Frame							
For Sub-Frame 2,7	Bits	6912	17280	28800	57600	86400	115200
Total symbols per Sub-Frame							
For Sub-Frame 2,7		864	2160	3600	7200	10800	14400
UE UL Category		≥ 15	≥ 15	≥ 15	≥ 15	≥ 15	≥ 15
Note 1: If more than one Code Block is present, an additional CRC sequence of L = 24 Bits is attached to each Code Block (otherwise L = 0 Bit)							
Note 2: As per Table 4.2-2 in TS 36.211 [13]							
Note 3: As per Table 4.2-1 in TS 36.211 [13]							

A.2.2.2 Partial RB allocation

A.2.2.2.1 QPSK

Table A.2.2.2.1-1: Reference Channels for QPSK with partial RB allocation

Parameter	Ch BW	Allocated RBs	UL-DL Configuration (Note 2)	Special subframe configuration (Note 3)	DFT-OFDM Symbols per Sub-Frame	Mod'n	Target Coding rate	Payload size for Sub-Frame 2, 7	Transport block CRC	Number of code blocks per Sub-Frame (Note 1)	Total number of bits per Sub-Frame for Sub-Frame 2, 7	Total symbols per Sub-Frame for Sub-Frame 2, 7	UE Category
Unit	MHz							Bits	Bits		Bits		
	1.4 - 20	1	2	7	12	QPSK	1/3	72	24	1	288	144	≥ 1
	1.4 - 20	2	2	7	12	QPSK	1/3	176	24	1	576	288	≥ 1
	1.4 - 20	3	2	7	12	QPSK	1/3	256	24	1	864	432	≥ 1
	1.4 - 20	4	2	7	12	QPSK	1/3	392	24	1	1152	576	≥ 1
	1.4 - 20	5	2	7	12	QPSK	1/3	424	24	1	1440	720	≥ 1
	3-20	6	2	7	12	QPSK	1/3	600	24	1	1728	864	≥ 1
	3-20	8	2	7	12	QPSK	1/3	808	24	1	2304	1152	≥ 1
	3-20	9	2	7	12	QPSK	1/3	776	24	1	2592	1296	≥ 1
	3-20	10	2	7	12	QPSK	1/3	872	24	1	2880	1440	≥ 1
	3-20	12	2	7	12	QPSK	1/3	1224	24	1	3456	1728	≥ 1
	5-20	15	2	7	12	QPSK	1/3	1320	24	1	4320	2160	≥ 1
	5-20	16	2	7	12	QPSK	1/3	1384	24	1	4608	2304	≥ 1
	5-20	18	2	7	12	QPSK	1/3	1864	24	1	5184	2592	≥ 1
	5-20	20	2	7	12	QPSK	1/3	1736	24	1	5760	2880	≥ 1
	5-20	24	2	7	12	QPSK	1/3	2472	24	1	6912	3456	≥ 1
	10-20	25	2	7	12	QPSK	1/3	2216	24	1	7200	3600	≥ 1
	10-20	27	2	7	12	QPSK	1/3	2792	24	1	7776	3888	≥ 1
	10-20	30	2	7	12	QPSK	1/3	2664	24	1	8640	4320	≥ 1
	10-20	32	2	7	12	QPSK	1/3	2792	24	1	9216	4608	≥ 1
	10-20	36	2	7	12	QPSK	1/3	3752	24	1	10368	5184	≥ 1
	10-20	40	2	7	12	QPSK	1/3	4136	24	1	11520	5760	≥ 1
	10-20	45	2	7	12	QPSK	1/3	4008	24	1	12960	6480	≥ 1
	10-20	48	2	7	12	QPSK	1/3	4264	24	1	13824	6912	≥ 1
	15 - 20	50	2	7	12	QPSK	1/3	5160	24	1	14400	7200	≥ 1
	15 - 20	54	2	7	12	QPSK	1/3	4776	24	1	15552	7776	≥ 1
	15 - 20	60	2	7	12	QPSK	1/4	4264	24	1	17280	8640	≥ 1
	15 - 20	64	2	7	12	QPSK	1/4	4584	24	1	18432	9216	≥ 1
	15 - 20	72	2	7	12	QPSK	1/4	5160	24	1	20736	10368	≥ 1
	20	75	2	7	12	QPSK	1/5	4392	24	1	21600	10800	≥ 1
	20	80	2	7	12	QPSK	1/5	4776	24	1	23040	11520	≥ 1
	20	81	2	7	12	QPSK	1/5	4776	24	1	23328	11664	≥ 1
	20	90	2	7	12	QPSK	1/6	4008	24	1	25920	12960	≥ 1
	20	96	2	7	12	QPSK	1/6	4264	24	1	27648	13824	≥ 1
Note 1:	If more than one Code Block is present, an additional CRC sequence of L = 24 Bits is attached to each Code Block (otherwise L = 0 Bit)												
Note 2:	As per Table 4.2-2 in TS 36.211 [13]												
Note 3:	As per Table 4.2-1 in TS 36.211 [13]												

A.2.2.2.2 16-QAM

Table A.2.2.2.2-1: Reference Channels for 16QAM with partial RB allocation

Parameter	Ch BW	Allocated RBs	UL-DL Configuration (Note 2)	Special subframe configuration (Note 3)	DFT-OFDM Symbols per Sub-Frame	Mod'n	Target Coding rate	Payload size for Sub-Frame 2, 7	Transport block CRC	Number of code blocks per Sub-Frame (Note 1)	Total number of bits per Sub-Frame for Sub-Frame 2, 7	Total symbols per Sub-Frame for Sub-Frame 2, 7	UE Category
Unit	MHz							Bits	Bits		Bits		
	1.4 - 20	1	2	7	12	16QAM	3/4	408	24	1	576	144	≥ 1
	1.4 - 20	2	2	7	12	16QAM	3/4	840	24	1	1152	288	≥ 1
	1.4 - 20	3	2	7	12	16QAM	3/4	1288	24	1	1728	432	≥ 1
	1.4 - 20	4	2	7	12	16QAM	3/4	1736	24	1	2304	576	≥ 1
	1.4 - 20	5	2	7	12	16QAM	3/4	2152	24	1	2880	720	≥ 1
	3-20	6	2	7	12	16QAM	3/4	2600	24	1	3456	864	≥ 1
	3-20	8	2	7	12	16QAM	3/4	3496	24	1	4608	1152	≥ 1
	3-20	9	2	7	12	16QAM	3/4	3880	24	1	5184	1296	≥ 1
	3-20	10	2	7	12	16QAM	3/4	4264	24	1	5760	1440	≥ 1
	3-20	12	2	7	12	16QAM	3/4	5160	24	1	6912	1728	≥ 1
	5-20	15	2	7	12	16QAM	1/2	4264	24	1	8640	2160	≥ 1
	5-20	16	2	7	12	16QAM	1/2	4584	24	1	9216	2304	≥ 1
	5-20	18	2	7	12	16QAM	1/2	5160	24	1	10368	2592	≥ 1
	5-20	20	2	7	12	16QAM	1/3	4008	24	1	11520	2880	≥ 1
	5-20	24	2	7	12	16QAM	1/3	4776	24	1	13824	3456	≥ 1
	10-20	25	2	7	12	16QAM	1/3	4968	24	1	14400	3600	≥ 1
	10-20	27	2	7	12	16QAM	1/3	4776	24	1	15552	3888	≥ 1
	10-20	30	2	7	12	16QAM	3/4	12960	24	3	17280	4320	≥ 2
	10-20	32	2	7	12	16QAM	3/4	13536	24	3	18432	4608	≥ 2
	10-20	36	2	7	12	16QAM	3/4	15264	24	3	20736	5184	≥ 2
	10-20	40	2	7	12	16QAM	3/4	16992	24	3	23040	5760	≥ 2
	10-20	45	2	7	12	16QAM	3/4	19080	24	4	25920	6480	≥ 2
	10-20	48	2	7	12	16QAM	3/4	20616	24	4	27648	6912	≥ 2
	15 - 20	50	2	7	12	16QAM	3/4	21384	24	4	28800	7200	≥ 2
	15 - 20	54	2	7	12	16QAM	3/4	22920	24	4	31104	7776	≥ 2
	15 - 20	60	2	7	12	16QAM	2/3	23688	24	4	34560	8640	≥ 2
	15 - 20	64	2	7	12	16QAM	2/3	25456	24	4	36864	9216	≥ 2

	15 - 20	72	2	7	12	16QA M	1/2	20616	24	4	41472	10368	≥ 2
	20	75	2	7	12	16QA M	1/2	21384	24	4	43200	10800	≥ 2
	20	80	2	7	12	16QA M	1/2	22920	24	4	46080	11520	≥ 2
	20	81	2	7	12	16QA M	1/2	22920	24	4	46656	11664	≥ 2
	20	90	2	7	12	16QA M	2/5	20616	24	4	51840	12960	≥ 2
	20	96	2	7	12	16QA M	2/5	22152	24	4	55296	13824	≥ 2
Note 1:	If more than one Code Block is present, an additional CRC sequence of L = 24 Bits is attached to each Code Block (otherwise L = 0 Bit)												
Note 2:	As per Table 4.2-2 in TS 36.211 [13]												
Note 3:	As per Table 4.2-1 in TS 36.211 [13]												

A.2.2.2.3 64-QAM

Table A.2.2.2.3-1: Reference Channels for 64-QAM with partial RB allocation

Parameter	ChBW	Allocated RBs	UL-DL Configuration (Note 2)	Special subframe configuration (Note 3)	DFT-OFDM Symbols per Sub-Frame	Mod'n	Target Coding rate	Payload size for Sub-Frame 2, 7	Transport block CRC	Number of code blocks per Sub-Frame (Note 1)	Total number of bits per Sub-Frame for Sub-Frame 2, 7	Total symbols per Sub-Frame for Sub-Frame 2, 7	UE Category (Note 4)	UE UL Category (Note 4)
Unit	MHz							Bits	Bits		Bits			
	1.4-20	1	2	7	12	64QAM	3/4	616	24	1	864	144	5,8	5, 8, 13, 14
	1.4-20	2	2	7	12	64QAM	3/4	1256	24	1	1728	288	5,8	5, 8, 13, 14
	1.4-20	3	2	7	12	64QAM	3/4	1864	24	1	2592	432	5,8	5, 8, 13, 14
	1.4-20	4	2	7	12	64QAM	3/4	2536	24	1	3456	576	5,8	5, 8, 13, 14
	1.4-20	5	2	7	12	64QAM	3/4	3112	24	1	4320	720	5,8	5, 8, 13, 14
	3-20	6	2	7	12	64QAM	3/4	3752	24	1	5184	864	5,8	5, 8, 13, 14
	3-20	8	2	7	12	64QAM	3/4	5160	24	1	6912	1152	5,8	5, 8, 13, 14
	3-20	9	2	7	12	64QAM	3/4	5736	24	1	7776	1296	5,8	5, 8, 13, 14
	3-20	10	2	7	12	64QAM	3/4	6200	24	2	8640	1440	5,8	5, 8, 13, 14
	3-20	12	2	7	12	64QAM	3/4	7480	24	2	10368	1728	5,8	5, 8, 13, 14
	5-20	15	2	7	12	64QAM	3/4	9528	24	2	12960	2160	5,8	5, 8, 13, 14
	5-20	16	2	7	12	64QAM	3/4	10296	24	2	13824	2304	5,8	5, 8, 13, 14
	5-20	18	2	7	12	64QAM	3/4	11448	24	2	15552	2592	5,8	5, 8, 13, 14
	5-20	20	2	7	12	64QAM	3/4	12576	24	3	17280	2880	5,8	5, 8, 13, 14
	5-20	24	2	7	12	64QAM	3/4	15264	24	3	20736	3456	5,8	5, 8, 13, 14
	10-20	25	2	7	12	64QAM	3/4	15840	24	3	21600	3600	5,8	5, 8, 13, 14

	10 - 20	27	2	7	12	64Q AM	3/4	169 92	24	3	233 28	3888	5,8	5, 8, 13, 14
	10 - 20	30	2	7	12	64Q AM	3/4	190 80	24	4	259 20	4320	5,8	5, 8, 13, 14
	10 - 20	32	2	7	12	64Q AM	3/4	206 16	24	4	276 48	4608	5,8	5, 8, 13, 14
	10 - 20	36	2	7	12	64Q AM	3/4	229 20	24	4	311 04	5184	5,8	5, 8, 13, 14
	10 - 20	40	2	7	12	64Q AM	3/4	254 56	24	5	345 60	5760	5,8	5, 8, 13, 14
	10 - 20	45	2	7	12	64Q AM	3/4	283 36	24	5	388 80	6480	5,8	5, 8, 13, 14
	10 - 20	48	2	7	12	64Q AM	3/4	305 76	24	5	414 72	6912	5,8	5, 8, 13, 14
	15 - 20	50	2	7	12	64Q AM	3/4	317 04	24	6	432 00	7200	5,8	5, 8, 13, 14
	15 - 20	54	2	7	12	64Q AM	3/4	340 08	24	6	466 56	7776	5,8	5, 8, 13, 14
	15 - 20	60	2	7	12	64Q AM	3/4	378 88	24	7	518 40	8640	5,8	5, 8, 13, 14
	15 - 20	64	2	7	12	64Q AM	3/4	405 76	24	7	552 96	9216	5,8	5, 8, 13, 14
	15 - 20	72	2	7	12	64Q AM	3/4	453 52	24	8	622 08	1036 8	5,8	5, 8, 13, 14
	20	75	2	7	12	64Q AM	3/4	468 88	24	8	648 00	1080 0	5,8	5, 8, 13, 14
	20	80	2	7	12	64Q AM	3/4	510 24	24	9	691 20	1152 0	5,8	5, 8, 13, 14
	20	81	2	7	12	64Q AM	3/4	510 24	24	9	699 84	1166 4	5,8	5, 8, 13, 14
	20	90	2	7	12	64Q AM	3/4	510 24	24	9	777 60	1296 0	5,8	5, 8, 13, 14
	20	96	2	7	12	64Q AM	3/4	616 64	24	11	829 44	1382 4	5,8	5, 8, 13, 14

Note 1: If more than one Code Block is present, an additional CRC sequence of L = 24 Bits is attached to each Code Block (otherwise L = 0 Bit)

Note 2: As per Table 4.2-2 in TS 36.211 [13]

Note 3: As per Table 4.2-1 in TS 36.211 [13]

Note 4: If UE does not report UE UL category, then the applicability of reference channel is determined by UE category. If UE reports UE UL category, then the applicability of reference channel is determined by UE UL category

A.2.2.2.4 256 QAM

Table A.2.2.2.4-1: Reference Channels for 256 QAM with partial RB allocation

Parameter	Ch BW	Allocated RBs	UL-DL Configuration (Note 2)	Special Slot Configuration (Note 3)	DFT-OFDM Symbols per Sub-Frame	Mod'n	Target Coding rate	Payload size for Sub-Frame 2, 7	Transport block CRC	Number of code blocks per Sub-Frame (Note 1)	Total number of bits per Sub-Frame for Sub-Frame 2, 7	Total symbols per Sub-Frame for Sub-Frame 2, 7	UE Category
Unit	MHz							Bits	Bits		Bits		
	1.4 - 20	1	2	7	12	256QAM	3/4	840	24	1	1152	144	≥ 14
	1.4 - 20	2	2	7	12	256QAM	3/4	1672	24	1	2304	288	≥ 14
	1.4 - 20	3	2	7	12	256QAM	3/4	2536	24	1	3456	432	≥ 14
	1.4 - 20	4	2	7	12	256QAM	3/4	3368	24	1	4608	576	≥ 14
	1.4 - 20	5	2	7	12	256QAM	3/4	4264	24	1	5760	720	≥ 14
	3-20	6	2	7	12	256QAM	3/4	5160	24	1	6912	864	≥ 14
	3-20	8	2	7	12	256QAM	3/4	6712	24	2	9216	1152	≥ 14
	3-20	9	2	7	12	256QAM	3/4	7736	24	2	10368	1296	≥ 14
	3-20	10	2	7	12	256QAM	3/4	8504	24	2	11520	1440	≥ 14
	3-20	12	2	7	12	256QAM	3/4	10296	24	2	13824	1728	≥ 14
	5-20	15	2	7	12	256QAM	3/4	12960	24	3	17280	2160	≥ 14
	5-20	16	2	7	12	256QAM	3/4	13536	24	3	18432	2304	≥ 14
	5-20	18	2	7	12	256QAM	3/4	15264	24	3	20736	2592	≥ 14
	5-20	20	2	7	12	256QAM	3/4	16992	24	3	23040	2880	≥ 14
	5-20	24	2	7	12	256QAM	3/4	20616	24	4	27648	3456	≥ 14
	10-20	25	2	7	12	256QAM	3/4	21384	24	4	28800	3600	≥ 14
	10-20	27	2	7	12	256QAM	3/4	22920	24	4	31104	3888	≥ 14
	10-20	30	2	7	12	256QAM	3/4	25456	24	5	34560	4320	≥ 14
	10-20	32	2	7	12	256QAM	3/4	27376	24	5	36864	4608	≥ 14
	10-20	36	2	7	12	256QAM	3/4	30576	24	6	41472	5184	≥ 14
	10-20	40	2	7	12	256QAM	3/4	34008	24	6	46080	5760	≥ 14
	10-20	45	2	7	12	256QAM	3/4	37888	24	7	51840	6480	≥ 14
	10-20	48	2	7	12	256QAM	3/4	40576	24	8	55296	6912	≥ 14
	15 - 20	50	2	7	12	256QAM	3/4	42368	24	8	57600	7200	≥ 14
	15 - 20	54	2	7	12	256QAM	3/4	46888	24	8	62208	7776	≥ 14
	15 - 20	60	2	7	12	256QAM	3/4	51024	24	9	69120	8640	≥ 14
	15 - 20	64	2	7	12	256QAM	3/4	55056	24	9	73728	9216	≥ 14
	15 - 20	72	2	7	12	256QAM	3/4	61664	24	11	82944	10368	≥ 14
	20	75	2	7	12	256QAM	3/4	63776	24	11	86400	10800	≥ 14
	20	80	2	7	12	256QAM	3/4	68808	24	12	92160	11520	≥ 14
	20	81	2	7	12	256QAM	3/4	68808	24	12	93312	11664	≥ 14
	20	90	2	7	12	256QAM	3/4	76208	24	13	103680	12960	≥ 14
	20	96	2	7	12	256QAM	3/4	81176	24	14	110592	13824	≥ 14

Note 1: If more than one Code Block is present, an additional CRC sequence of L = 24 Bits is attached to each Code Block (otherwise L = 0 Bit)

Note 2: As per Table 4.2-2 in TS 36.211 [13]

Note 3: As per Table 4.2-1 in TS 36.211 [13]

A.3 DL reference measurement channels for E-UTRA

A.3.1 General

The number of available channel bits varies across the sub-frames due to PBCH and PSS/SSS overhead. The payload size per sub-frame is varied in order to keep the code rate constant throughout a frame.

Unless otherwise stated, no user data is scheduled on subframes #5 in order to facilitate the transmission of system information blocks (SIB).

The algorithm for determining the payload size A is as follows; given a desired coding rate R and radio block allocation N_{RB}

1. Calculate the number of channel bits N_{ch} that can be transmitted during the first transmission of a given sub-frame.
2. Find A such that the resulting coding rate is as close to R as possible, that is,

$$\min \left| R - (A + 24 * (N_{CB} + 1)) / N_{ch} \right|, \text{ where } N_{CB} = \begin{cases} 0, & \text{if } C = 1 \\ C, & \text{if } C > 1 \end{cases},$$

subject to

- a) A is a valid TB size according to clause 7.1.7 of TS 36.213 [6] assuming an allocation of N_{RB} resource blocks.
- b) C is the number of Code Blocks calculated according to clause 5.1.2 of TS 36.212 [5].
3. If there is more than one A that minimizes the equation above, then the larger value is chosen per default and the chosen code rate should not exceed 0.93.
4. For TDD, the measurement channel is based on DL/UL configuration ratio of 3DL+DwPTS (10 OFDM symbol SSF7): 1UL.

A.3.1.1 QPSK

Table A.3.1.1-1: Fixed Reference Channel for Receiver Requirements (TDD)

Parameter	Unit	Value					
		1.4	3	5	10	15	20
Channel Bandwidth	MHz	1.4	3	5	10	15	20
Allocated resource blocks		6	15	25	50	75	100
Uplink-Downlink Configuration (NOTE 5)		2	2	2	2	2	2
Special subframe configuration (NOTE 6)		7	7	7	7	7	7
Allocated subframes per Radio Frame (D+S)		3	3+2	3+2	3+2	3+2	3+2
Number of HARQ Processes	Processes	7	7	7	7	7	7
Maximum number of HARQ transmission		1	1	1	1	1	1
Modulation		QPSK	QPSK	QPSK	QPSK	QPSK	QPSK
Target coding rate		1/3	1/3	1/3	1/3	1/3	1/3
Information Bit Payload per Sub-Frame	Bits						
For Sub-Frame 3, 4, 8, 9		408	1320	2216	4392	6712	8760
For Sub-Frame 1, 6		N/A	776	1288	2664	4008	5352
For Sub-Frame 5		N/A	N/A	N/A	N/A	N/A	N/A
For Sub-Frame 0		208	1064	1800	4392	6712	8760
Transport block CRC	Bits	24	24	24	24	24	24
Number of Code Blocks per Sub-Frame (NOTE 4)							
For Sub-Frame 3, 4, 8, 9		1	1	1	1	2	2
For Sub-Frame 1, 6		N/A	1	1	1	1	1
For Sub-Frame 5		N/A	N/A	N/A	N/A	N/A	N/A
For Sub-Frame 0		1	1	1	1	2	2
Binary Channel Bits Per Sub-Frame	Bits						
For Sub-Frame 3, 4, 8, 9		1368	3780	6300	13800	20700	27600
For Sub-Frame 1, 6		N/A	2616	4456	9056	13656	18256
For Sub-Frame 5		N/A	N/A	N/A	N/A	N/A	N/A
For Sub-Frame 0		672	3084	5604	13104	20004	26904
Max. Throughput averaged over 1 frame	kbps	102.4	564	932	1965.6	3007.2	3970.4
UE Category		≥ 1	≥ 1	≥ 1	≥ 1	≥ 1	≥ 1
NOTE 1: For normal subframes(0,3,4,5,8,9), 2 symbols allocated to PDCCH for 20 MHz, 15 MHz and 10 MHz channel BW; 3 symbols allocated to PDCCH for 5 MHz and 3 MHz; 4 symbols allocated to PDCCH for 1.4 MHz. For special subframe (1&6), only 2 OFDM symbols are allocated to PDCCH for all BWs.							
NOTE 2: For 1.4MHz, no data shall be scheduled on special subframes(1&6) to avoid problems with insufficient PDCCH performance							
NOTE 3: Reference signal, Synchronization signals and PBCH allocated as per TS 36.211 [7]							
NOTE 4: If more than one Code Block is present, an additional CRC sequence of L = 24 Bits is attached to each Code Block (otherwise L = 0 Bit).							
NOTE 5: As per Table 4.2-2 in TS 36.211 [7]							
NOTE 6: As per Table 4.2-1 in TS 36.211 [7]							

A.3.1.2 64-QAM

Table A.3.1.2-1: Fixed Reference Channel for Maximum input level for UE Categories ≥ 3 (TDD)

Parameter	Unit	Value					
Channel bandwidth	MHz	1.4	3	5	10	15	20
Allocated resource blocks		6	15	25	50	75	100
Subcarriers per resource block		12	12	12	12	12	12
Uplink-Downlink Configuration (NOTE 5)		2	2	2	2	2	2
Special subframe configuration (NOTE 6)		7	7	7	7	7	7
Allocated subframes per Radio Frame		2	3+2	3+2	3+2	3+2	3+2
Modulation		64QAM	64QAM	64QAM	64QAM	64QAM	64QAM
Target Coding Rate		$\frac{3}{4}$	$\frac{3}{4}$	$\frac{3}{4}$	$\frac{3}{4}$	$\frac{3}{4}$	$\frac{3}{4}$
Number of HARQ Processes	Processes	7	7	7	7	7	7
Maximum number of HARQ transmissions		1	1	1	1	1	1
Information Bit Payload per Sub-Frame							
For Sub-Frames 3, 4, 8, 9	Bits	2984	8504	14112	30576	46888	61664
For Sub-Frames 1,6	Bits	N/A	5544	9528	19848	30576	40576
For Sub-Frame 5	Bits	N/A	N/A	N/A	N/A	N/A	N/A
For Sub-Frame 0	Bits	N/A	6968	12576	30576	45352	61664
Transport block CRC	Bits	24	24	24	24	24	24
Number of Code Blocks per Sub-Frame (NOTE 4)							
For Sub-Frames 3, 4, 8, 9		1	2	3	5	8	11
For Sub-Frames 1,6		N/A	2	2	4	6	8
For Sub-Frame 5		N/A	N/A	N/A	N/A	N/A	N/A
For Sub-Frame 0		N/A	2	3	5	8	11
Binary Channel Bits per Sub-Frame							
For Sub-Frames 3, 4, 8, 9	Bits	4104	11340	18900	41400	62100	82800
For Sub-Frames 1,6		N/A	7848	13368	27168	40968	54768
For Sub-Frame 5	Bits	N/A	N/A	N/A	N/A	N/A	N/A
For Sub-Frame 0	Bits	N/A	9252	16812	39312	60012	80712
Max. Throughput averaged over 1 frame	kbps	596.8	3791.2	6369.6	13910	20945	27877
NOTE 1: For normal subframes(0,3,4,5,8,9), 2 symbols allocated to PDCCH for 20 MHz, 15 MHz and 10 MHz channel BW; 3 symbols allocated to PDCCH for 5 MHz and 3 MHz; 4 symbols allocated to PDCCH for 1.4 MHz. For special subframe (1&6), only 2 OFDM symbols are allocated to PDCCH for all BWs.							
NOTE 2: For 1.4MHz, no data shall be scheduled on special subframes(1&6) to avoid problems with insufficient PDCCH performance.							
NOTE 3: Reference signal, Synchronization signals and PBCH allocated as per TS 36.211 [7].							
NOTE 4: If more than one Code Block is present, an additional CRC sequence of L = 24 Bits is attached to each Code Block (otherwise L = 0 Bit).							
NOTE 5: As per Table 4.2-2 in TS 36.211 [7].							
NOTE 6: As per Table 4.2-1 in TS 36.211 [7]							

A.3.1.3 256-QAM

Table A.3.1.3-1: Fixed Reference Channel for Maximum input level for UE Categories 11/12 and UE DL categories ≥ 11 (TDD)

Parameter	Unit	Value					
		1.4	3	5	10	15	20
Channel bandwidth	MHz	1.4	3	5	10	15	20
Allocated resource blocks		6	15	25	50	75	100
Subcarriers per resource block		12	12	12	12	12	12
Uplink-Downlink Configuration (NOTE 5)		2	2	2	2	2	2
Special subframe configuration (NOTE 6)		7	7	7	7	7	7
Allocated subframes per Radio Frame		2	3+2	3+2	3+2	3+2	3+2
Modulation		256QAM	256QAM	256QAM	256QAM	256QAM	256QAM
Target Coding Rate		4/5	4/5	4/5	4/5	4/5	4/5
Number of HARQ Processes	Processes	7	7	7	7	7	7
Maximum number of HARQ transmissions		1	1	1	1	1	1
Information Bit Payload per Sub-Frame							
For Sub-Frames 3,4,8,9	Bits	4392	12216	19848	42368	63776	84760
For Sub-Frames 1,6	Bits	N/A	10464	17824	36224	54624	73024
For Sub-Frame 5	Bits	N/A	N/A	N/A	N/A	N/A	N/A
For Sub-Frame 0	Bits	N/A	9912	17568	42368	63776	84760
Transport block CRC	Bits	24	24	24	24	24	24
Number of Code Blocks per Sub-Frame (NOTE 4)							
For Sub-Frames 3,4,8,9		1	2	4	7	11	14
For Sub-Frames 1,6		N/A	2	3	6	9	13
For Sub-Frame 5		N/A	N/A	N/A	N/A	N/A	N/A
For Sub-Frame 0		N/A	2	3	7	11	14
Binary Channel Bits per Sub-Frame							
For Sub-Frames 3,4,8,9	Bits	5472	15120	25200	55200	82800	110400
For Sub-Frames 1,6		N/A	8248	13536	27376	40576	55056
For Sub-Frame 5	Bits	N/A	N/A	N/A	N/A	N/A	N/A
For Sub-Frame 0	Bits	N/A	12336	22416	52416	80016	107616
Max. Throughput averaged over 1 frame	kbps	878.4	5570.4	9240	20049.6	30144	40503.2
NOTE 1: For normal subframes(0,3,4,5,8,9), 2 symbols allocated to PDCCH for 20 MHz, 15 MHz and 10 MHz channel BW; 3 symbols allocated to PDCCH for 5 MHz and 3 MHz; 4 symbols allocated to PDCCH for 1.4 MHz. For special subframe (1&6), only 2 OFDM symbols are allocated to PDCCH for all BWs.							
NOTE 2: For 1.4MHz, no data shall be scheduled on special subframes(1&6) to avoid problems with insufficient PDCCH performance.							
NOTE 3: Reference signal, Synchronization signals and PBCH allocated as per TS 36.211 [7].							
NOTE 4: If more than one Code Block is present, an additional CRC sequence of L = 24 Bits is attached to each Code Block (otherwise L = 0 Bit).							
NOTE 5: As per Table 4.2-2 in TS 36.211 [7].							
NOTE 6: As per Table 4.2-1 in TS 36.211 [7]							

Annex B (normative): Propagation Conditions

Please refer to Annex B in TS 38.521-1 [8] and 38.521-2 [9] for appropriate details as needed for test cases in this test specification. EN-DC exceptions will be added,

Annex C (normative): Downlink Physical Channels

Please refer to Annex C in TS 38.521-1 [8] and 38.521-2 [9] for appropriate details as needed for test cases in this test specification. EN-DC exceptions will be added,

Annex D (normative): Characteristics of the Interfering Signal

Please refer to Annex D in TS 38.521-1 [8] and 38.521-2 [9] for appropriate details as needed for test cases in this test specification. EN-DC exceptions will be added,

Annex E (normative): Global In-Channel Tx Test

Please refer to Annex E in TS 38.521-1 [8] and 38.521-2 [9] for appropriate details as needed for test cases in this test specification. EN-DC exceptions will be added,

Annex F (informative): Measurement uncertainties and Test Tolerances

F.1 Acceptable uncertainty of Test System (normative)

TBD

F.1.1 Measurement of test environments

TBD

F.1.2 Measurement of transmitter

Table F.1.2-1: Maximum Test System Uncertainty for transmitter tests

Clause	Maximum Test System Uncertainty	Derivation of Test System Uncertainty
6.2B.1.1 UE Maximum Output Power for Intra-Band Contiguous EN-DC	$f \leq 3.0\text{GHz}$ $\pm 0.7 \text{ dB}, \text{BW} \leq 40\text{MHz}$ $\pm 1.4 \text{ dB}, 40\text{MHz} < \text{BW} \leq 100\text{MHz}$ $3.0\text{GHz} < f \leq 4.2\text{GHz}$ $\pm 1.0 \text{ dB}, \text{BW} \leq 40\text{MHz}$ $\pm 1.6 \text{ dB}, 40\text{MHz} < \text{BW} \leq 100\text{MHz}$ $4.2\text{GHz} < f \leq 6.0\text{GHz}$ $\pm 1.3 \text{ dB}, \text{BW} \leq 20\text{MHz}$ $\pm 1.5 \text{ dB}, 20\text{MHz} < \text{BW} \leq 40\text{MHz}$ $\pm 1.6 \text{ dB}, 40\text{MHz} < \text{BW} \leq 100\text{MHz}$	
6.2B.1.2 UE Maximum Output Power for Intra-Band Non-Contiguous EN-DC	MAX ($\text{MU}_{\text{LTE}}, \text{MU}_{\text{SA}}$) MU_{LTE} $\pm 0.7 \text{ dB}, f \leq 3.0\text{GHz}$ $\pm 1.0 \text{ dB}, 3.0\text{GHz} < f \leq 4.2\text{GHz}$ MU_{SA} $f \leq 3.0\text{GHz}$ $\pm 0.7 \text{ dB}, \text{BW} \leq 40\text{MHz}$ $\pm 1.4 \text{ dB}, 40\text{MHz} < \text{BW} \leq 100\text{MHz}$ $3.0\text{GHz} < f \leq 4.2\text{GHz}$ $\pm 1.0 \text{ dB}, \text{BW} \leq 40\text{MHz}$ $\pm 1.6 \text{ dB}, 40\text{MHz} < \text{BW} \leq 100\text{MHz}$ $4.2\text{GHz} < f \leq 6.0\text{GHz}$ $\pm 1.3 \text{ dB}, \text{BW} \leq 20\text{MHz}$ $\pm 1.5 \text{ dB}, 20\text{MHz} < \text{BW} \leq 40\text{MHz}$ $\pm 1.6 \text{ dB}, 40\text{MHz} < \text{BW} \leq 100\text{MHz}$	MU_{LTE} is MU of LTE specified in clause 6.2.2 in TS 36.521-1 [10]. MU_{SA} is MU of FR1 SA specified in clause 6.2.1 in TS 38.521-1 [8].
6.2B.1.3 UE Maximum Output Power for Inter-Band EN-DC within FR1	MAX ($\text{MU}_{\text{LTE}}, \text{MU}_{\text{SA}}$) MU_{LTE} $\pm 0.7 \text{ dB}, f \leq 3.0\text{GHz}$ $\pm 1.0 \text{ dB}, 3.0\text{GHz} < f \leq 4.2\text{GHz}$ MU_{SA} $f \leq 3.0\text{GHz}$ $\pm 0.7 \text{ dB}, \text{BW} \leq 40\text{MHz}$ $\pm 1.4 \text{ dB}, 40\text{MHz} < \text{BW} \leq 100\text{MHz}$ $3.0\text{GHz} < f \leq 4.2\text{GHz}$ $\pm 1.0 \text{ dB}, \text{BW} \leq 40\text{MHz}$ $\pm 1.6 \text{ dB}, 40\text{MHz} < \text{BW} \leq 100\text{MHz}$ $4.2\text{GHz} < f \leq 6.0\text{GHz}$ $\pm 1.3 \text{ dB}, \text{BW} \leq 20\text{MHz}$ $\pm 1.5 \text{ dB}, 20\text{MHz} < \text{BW} \leq 40\text{MHz}$ $\pm 1.6 \text{ dB}, 40\text{MHz} < \text{BW} \leq 100\text{MHz}$	MU_{LTE} is MU of LTE specified in clause 6.2.2 in TS 36.521-1 [10]. MU_{SA} is MU of FR1 SA specified in clause 6.2.1 in TS 38.521-1 [8].
6.2B.1.4.1 UE Maximum Output Power for Inter-Band EN-DC including FR2 (2 CCs) - EIRP and TRP	Same as clause 6.2.1.1 in TS 38.521-2	
6.2B.1.4_1.1.1 UE Maximum Output Power for Inter-Band EN-DC including FR2 (3 CCs) - EIRP and TRP	Same as clause 6.2A.1.1.1 in TS 38.521-2	
6.2B.1.4_1.1.2 UE Maximum Output Power for Inter-Band EN-DC including FR2 (3 CCs) - Spherical Coverage	Same as clause 6.2A.1.2.1 in TS 38.521-2	

6.2B.1.4.2 UE Maximum Output Power for Inter-Band EN-DC including FR2 (2 CCs) - Spherical Coverage	Same as clause 6.2.1.2 in TS 38.521-2	
6.2B.2.1 UE Maximum Output Power reduction for Intra-Band Contiguous EN-DC	Same as clause 6.2B.1.1	
6.2B.2.2 UE Maximum Output Power reduction for Intra-Band Non-Contiguous EN-DC	Same as clause 6.2B.1.2	
6.2B.2.3 UE Maximum Output Power reduction for Inter-Band EN-DC within FR1	Same as clause 6.2B.1.3	
6.2B.2.4 UE Maximum Output Power reduction for Inter-Band EN-DC including FR2	Same as clause 6.2.2 in TS 38.521-2 [9]	
6.2B.3.1 UE Additional Maximum Output Power reduction for Intra-band contiguous EN-DC	Same as clause 6.2B.1.1	
6.2B.3.2 UE Additional Maximum Output Power reduction for Intra-Band Non-Contiguous EN-DC	Same as clause 6.2B.1.2	
6.2B.3.3 UE Additional Maximum Output Power reduction for Inter-Band EN-DC within FR1	Same as clause 6.2B.1.3	
6.2B.4.1.1 Configured Output Power Level for Intra-Band Contiguous EN-DC	Same as clause 6.2B.1.1	
6.2B.4.1.2 Configured Output Power for Intra-Band Non-Contiguous EN-DC	Same as clause 6.2B.1.2	
6.2B.4.1.3 Configured Output Power for Inter-Band EN-DC within FR1	Same as clause 6.2B.1.3	
6.3B.1.1 Minimum Output Power for intra-band contiguous EN-DC	Same as clause 6.3.1 in TS 38.521-1 [8]	
6.3B.1.2 Minimum output power for intra-band non-contiguous EN-DC	Same as clause 6.3.1 in TS 38.521-1 [8]	
6.3B.1.3 Minimum output power for inter-band EN-DC within FR1	Same as clause 6.3.1 in TS 38.521-1 [8]	
6.3B.1.4 Minimum Output Power for EN-DC Interband including FR2	Same as clause 6.3.1 in TS 38.521-1 [8]	
6.3B.2.1 Transmit OFF Power for intra-band contiguous EN-DC	Same as clause 6.3.2 in TS 38.521-1 [8]	
6.3B.2.2 Transmit OFF Power for intra-band non-contiguous EN-DC	Same as clause 6.3.2 in TS 38.521-1 [8]	
6.3B.2.3 Transmit OFF Power for inter-band EN-DC within FR1	Same as clause 6.3.2 in TS 38.521-1 [8]	
6.3B.2.4 Transmit OFF Power for inter-band EN-DC including FR2	Same as clause 6.3.2 in TS 38.521-2 [9]	

6.3B.3.1 Tx ON/OFF time mask for intra-band contiguous EN-DC	Same as clause 6.3.3.2 in TS 38.521-1 [8]	
6.3B.3.2 Tx ON/OFF time mask for intra-band non-contiguous EN-DC	Same as clause 6.3.3.2 in TS 38.521-1 [8]	
6.3B.3.3 Tx ON/OFF time mask for inter-band EN-DC within FR1	Same as clause 6.3.3.2 in TS 38.521-1 [8]	
6.3B.4.3 PRACH Time Mask for inter-band EN-DC within FR1	Same as clause 6.3.3.4 in TS 38.521-1 [8]	
6.3B.8.1.1 Absolute power tolerance for intra-band contiguous EN-DC	Same as clause 6.3.4.2 in TS 38.521-1 [8]	
6.3B.8.1.2 Absolute power tolerance for intra-band non-contiguous EN-DC	Same as clause 6.3.4.2 in TS 38.521-1 [8]	
6.3B.8.1.3 Absolute power tolerance for inter-band EN-DC within FR1	Same as clause 6.3.4.2 in TS 38.521-1 [8]	
6.3B.8.1.4 Absolute power tolerance for inter-band EN-DC including FR2	Same as clause 6.3.4.2 in TS 38.521-2 [9]	
6.3B.8.2.1 Relative power tolerance for intra-band contiguous EN-DC	Same as clause 6.3.4.3 in TS 38.521-1 [8]	
6.3B.8.2.2 Relative power tolerance for intra-band non-contiguous EN-DC	Same as clause 6.3.4.3 in TS 38.521-1 [8]	
6.3B.8.2.3 Relative power tolerance for inter-band EN-DC within FR1	Same as clause 6.3.4.3 in TS 38.521-1 [8]	
6.3B.8.2.4 Relative power tolerance for inter-band EN-DC including FR2	Same as clause 6.3.4.3 in TS 38.521-2 [9]	
6.3B.8.3.1 Aggregate power tolerance for intra-band contiguous EN-DC	Same as clause 6.3.4.4 in TS 38.521-1 [8]	
6.3B.8.3.2 Aggregate power tolerance for intra-band non-contiguous EN-DC	Same as clause 6.3.4.4 in TS 38.521-1 [8]	
6.3B.8.3.3 Aggregate power tolerance for inter-band EN-DC within FR1	Same as clause 6.3.4.4 in TS 38.521-1 [8]	
6.3B.8.3.4 Aggregate power tolerance for inter-band EN-DC including FR2	Same as clause 6.3.4.4 in TS 38.521-2 [9]	
6.4B.1.1 Frequency Error for intra-band contiguous EN-DC	TBD	
6.4B.1.2 Frequency Error for intra-band non-contiguous EN-DC	TBD	
6.4B.1.3 Frequency Error for inter-band EN-DC within FR1	Same as clause 6.4.1 in TS 38.521-1 [8]	
6.4B.1.4 Frequency Error for inter-band EN-DC including FR2	Same as clause 6.4.1 in TS 38.521-2 [9]	
6.4B.1.4_1.1 Frequency Error for Inter-band EN-DC including FR2 (3 CCs)	Same as clause 6.4A.1.1 in TS 38.521-2 [9]	
6.4B.1.4_1.2 Frequency Error for Inter-band EN-DC including FR2 (4 CCs)	Same as clause 6.4A.1.2 in TS 38.521-2 [9]	

6.4B.1.4_1.3 Frequency Error for Inter-band EN-DC including FR2 (5 CCs)	Same as clause 6.4A.1.3 in TS 38.521-2 [9]	
6.4B.2.1.1 Error Vector Magnitude for intra-band contiguous EN-DC	Same as clause 6.4.2.1 in TS 38.521-1 [8] Uplink power measurement same as 6.3B.1.1.	
6.4B.2.1.2 Carrier Leakage for intra-band contiguous EN-DC	Same as clause 6.4.2.2 in TS 38.521-1 [8]	
6.4B.2.1.3 In-band Emissions for intra-band contiguous EN-DC	TBD Uplink power measurement for steps 2 and 8 same as 6.2B.1.1. Uplink power measurement for steps 4, 6, 10, and 12 same as 6.3B.1.1.	
6.4B.2.1.4 EVM Equalizer Flatness for intra-band contiguous EN-DC	TBD	
6.4B.2.2.1 Error Vector Magnitude for intra-band non-contiguous EN-DC	Same as clause 6.4.2.1 in TS 38.521-1 [8] Uplink power measurement same as 6.3B.1.2.	
6.4B.2.2.2 Carrier Leakage for intra-band non-contiguous EN-DC	Same as clause 6.4.2.2 in TS 38.521-1 [8] Uplink power measurement for step 2 and step 4 same as 6.2B.1.2. Uplink power measurement for step 6 and step 8 same as 6.3B.1.2.	
6.4B.2.2.3 In-band Emissions for intra-band non-contiguous EN-DC	Same as clause 6.4.2.3 in TS 38.521-1 [8] Uplink power measurement for steps 2 and 8 same as 6.2B.1.2. Uplink power measurement for steps 4, 6, 10, and 12 same as 6.3B.1.2.	
6.4B.2.2.4 EVM Equalizer Flatness for intra-band non-contiguous EN-DC	Same as clause 6.4.2.4 in TS 38.521-1 [8]	
6.4B.2.3.1 Error Vector Magnitude for inter-band EN-DC within FR1	Same as clause 6.4.2.1 in TS 38.521-1 [8] Uplink power measurement same as 6.3B.1.3.	
6.4B.2.3.2 Carrier Leakage for inter-band EN-DC within FR1	Same as clause 6.4.2.2 in TS 38.521-1 [8] Uplink power measurement for step 2 and step 4 same as 6.2B.1.3. Uplink power measurement for step 6 and step 8 same as 6.3B.1.3.	
6.4B.2.3.3 In-band Emissions for inter-band EN-DC within FR1	Same as clause 6.4.2.3 in TS 38.521-1 [8] Uplink power measurement for steps 1.2, 1.4, 2.2, and 2.4 same as 6.2B.1.3. Uplink power measurement for steps 1.6, 1.8, 2.6, and 2.8 same as 6.3B.1.3.	
6.4B.2.3.4 EVM Equalizer Flatness for inter-band EN-DC within FR1	Same as clause 6.4.2.4 in TS 38.521-1 [8]	
6.4B.2.4.1 Error Vector Magnitude for inter-band EN-DC including FR2	Same as clause 6.4.2.1 in TS 38.521-2 [9]	
6.4B.2.4.2 Carrier Leakage for inter-band EN-DC including FR2	Same as clause 6.4.2.2 in TS 38.521-2 [9]	
6.4B.2.4.3 In-band Emissions for inter-band EN-DC including FR2	Same as clause 6.4.2.3 in TS 38.521-2 [9]	
6.4B.2.4.4 EVM Equalizer Flatness for inter-band EN-DC including FR2	Same as clause 6.4.2.4 in TS 38.521-2 [9]	
6.5B.1.1 Occupied bandwidth for Intra-Band Contiguous EN-DC	1.5% of aggregated channel bandwidth	
6.5B.1.2 Occupied bandwidth for Intra-Band Non-Contiguous EN-DC	Same as clause 6.5.1 in TS 38.521-1 [8]	

6.5B.1.3 Occupied bandwidth for Inter-Band EN-DC within FR1	Same as clause 6.5.1 in TS 38.521-1 [8]	
6.5B.1.4 Occupied bandwidth for Inter-Band EN-DC including FR2	Same as clause 6.5.1 in TS 38.521-2 [9]	
6.5B.1.4_1.1 Occupied bandwidth for Inter-band EN-DC including FR2 (3 CCs)	TBD	
6.5B.1.4_1.2 Occupied bandwidth for Inter-band EN-DC including FR2 (4 CCs)	TBD	
6.5B.1.4_1.3 Occupied bandwidth for Inter-band EN-DC including FR2 (5 CCs)	TBD	
6.5B.1.4D Occupied bandwidth for inter-band EN-DC including FR2 for UL-MIMO	Same as clause 6.5D.1 in TS 38.521-2 [9]	
6.5B.2.1.1 Spectrum emissions mask for intra-band contiguous EN-DC	Same as clause 6.5.2.2 in TS 38.521-1 [8]	
6.5B.2.1.2 Additional spectrum emissions mask for intra-band contiguous EN-DC	Same as clause 6.5.2.3 in TS 38.521-1 [8]	
6.5B.2.1.3 Adjacent channel leakage ratio for intra-band contiguous EN-DC	Same as clause 6.5.2.4.1 in TS 38.521-1 [8]	
6.5B.2.2.1 Spectrum emissions mask for intra-band non-contiguous EN-DC	Same as clause 6.5.2.2 in TS 38.521-1 [8]	
6.5B.2.2.2 Additional Spectrum emissions mask for intra-band non-contiguous EN-DC	Same as clause 6.5.2.3 in TS 38.521-1 [8]	
6.5B.2.2.3 Adjacent channel leakage ratio for intra-band non-contiguous EN-DC	TBD	
6.5B.2.3.1 Spectrum emissions mask for Inter-band EN-DC within FR1	Same as clause 6.5.2.2 in TS 38.521-1 [8]	
6.5B.2.3.2 Additional Spectrum emissions mask for Inter-band EN-DC within FR1	Same as clause 6.5.2.3 in TS 38.521-1 [8]	
6.5B.2.3.3 Adjacent channel leakage ratio for inter-band EN-DC within FR1	Same as clause 6.5.2.4.1 in TS 38.521-1 [8]	
6.5B.2.4.1 Spectrum emissions mask for Inter-band EN-DC including FR2	Same as clause 6.5.2.1 in TS 38.521-2 [9]	
6.5B.2.4.3 Adjacent channel leakage ratio for Inter-band EN-DC including FR2	Same as clause 6.5.2.3 in TS 38.521-2 [9]	
6.5B.2.4.3_1.1 Adjacent channel leakage ratio for Inter-band EN-DC including FR2 (3 CCs)	Same as clause 6.5A.2.2.1 in TS 38.521-2 [9]	
6.5B.2.4.3_1.2 Adjacent channel leakage ratio for Inter-band EN-DC including FR2 (4 CCs)	Same as clause 6.5A.2.2.2 in TS 38.521-2 [9]	

6.5B.2.4.3_1.3 Adjacent channel leakage ratio for Inter-band EN-DC including FR2 (5 CCs)	Same as clause 6.5A.2.2.3 in TS 38.521-2 [9]	
6.5B.3.1.1 General spurious emissions for intra-band contiguous EN-DC	Same as clause 6.5.3.1 in TS 38.521-1 [8]	
6.5B.3.1.2 Spurious emission band UE co-existence for intra-band contiguous EN-DC	Same as clause 6.5.3.1 in TS 38.521-1 [8]	
6.5B.3.2.1 General spurious emissions for Intra-band non-contiguous EN-DC	Same as clause 6.5.3.1 in TS 38.521-1 [8]	
6.5B.3.2.2 Spurious Emission band UE co-existence for intra-band non-contiguous EN-DC	Same as clause 6.5.3.1 in TS 38.521-1 [8]	
6.5B.3.3.1 General spurious emissions for Inter-band EN-DC within FR1	Same as clause 6.5.3.1 in TS 38.521-1 [8]	
6.5B.3.3.2 Spurious emission band UE co-existence for Inter-band within FR1	Same as clause 6.5.3.1 in TS 38.521-1 [8]	
6.5B.3.4.1 General Spurious Emissions for Inter-band including FR2 (2 CCs)	Same as clause 6.5.3.1 in TS 38.521-2 [9]	
6.5B.3.4.2 Spurious emission band UE co-existence for Inter-band including FR2	Same as clause 6.5.3.2 in TS 38.521-2 [9]	
6.5B.4.3 Additional Spurious Emissions for Inter-band EN-DC within FR1	Same as clause 6.5.3.3 in TS 38.521-1 [8]	
6.5B.5.3 Transmit intermodulation for Inter-band EN-DC within FR1	Same as clause 6.5.4.3 in TS 38.521-1 [8]	

F.1.3 Measurement of receiver

Table F.1.3-1: Maximum Test System Uncertainty for receiver tests

Clause	Maximum Test System Uncertainty	Derivation of Test System Uncertainty
7.3B.2.1 Reference sensitivity for Intra-band Contiguous EN-DC (2 CCs)	Same as clause 7.3.2 in TS 38.521-1 [8]	
7.3B.2.2 Reference sensitivity for Intra-band non-contiguous EN-DC (2 CCs)	Same as clause 7.3.2 in TS 38.521-1 [8]	
7.3B.2.3 Reference sensitivity for Inter-band EN-DC within FR1 (2 CCs)	Same as clause 7.3.2 in TS 38.521-1 [8]	
7.3B.2.3_1.1 Reference sensitivity for Inter-band EN-DC within FR1 (3 CCs)	Same as clause 7.3A.1 in TS 38.521-1 [8]	
7.3B.2.4 Reference sensitivity for Inter-band EN-DC including FR2	Same as clause 7.3.2 in TS 38.521-2 [9]	
7.3B.2.4_1.1 Reference sensitivity for Inter-band EN-DC including FR2 (3 CCs)	Same as clause 7.3A.2.1 in TS 38.521-2 [9]	
7.3B.2.4_1.2 Reference sensitivity for Inter-band EN-DC including FR2 (4 CCs)	Same as clause 7.3A.2.2 in TS 38.521-2 [9]	
7.3B.2.4_1.3 Reference sensitivity for Inter-band EN-DC including FR2 (5 CCs)	Same as clause 7.3A.2.3 in TS 38.521-2 [9]	
7.3B.2.4_1.4 Reference sensitivity for Inter-band EN-DC including FR2 (6 CCs)	Same as clause 7.3A.2.4 in TS 38.521-2 [9]	
7.3B.4 EIS Spherical Coverage for Inter-band EN-DC including FR2	Same as clause 7.3.4 in TS 38.521-2 [9]	
7.4B.1 Maximum Input Level for Intra-Band Contiguous EN-DC (2 CCs)	MU for NR CC downlink power same as clause 7.4 in TS 38.521-1 [8]. Uplink power measurement same as 6.2B.1.1.	
7.4B.2 Maximum Input Level for Intra-Band Non-Contiguous EN-DC (2 CCs)	Same as clause 7.4 in TS 38.521-1 [8] Uplink power measurement same as 6.2B.1.2.	
7.4B.3 Maximum Input Level for Inter-band EN-DC within FR1 (2 CCs)	Same as clause 7.4 in TS 38.521-1 [8] Uplink power measurement same as 6.2B.1.3.	
7.4B.3_1.1 Maximum Input Level for Inter-band EN-DC within FR1 (3 CCs)	Same as clause 7.4A.1 in TS 38.521-1 [8] Uplink power measurement same as 6.2B.1.3.	
7.5B.1 Adjacent Channel Selectivity for intra-band contiguous EN-DC (2 CCs)	TBD Uplink power measurement same as 6.2B.1.1.	
7.5B.2 Adjacent Channel Selectivity for intra-band non-contiguous EN-DC (2 CCs)	TBD Uplink power measurement same as 6.2B.1.2.	
7.5B.3 Adjacent Channel Selectivity for inter-band EN-DC within FR1 (2 CCs)	Same as clause 7.5 in TS 38.521-1 [8] Uplink power measurement same as 6.2B.1.3.	
7.5B.3_1.1 Adjacent Channel Selectivity for EN-DC within FR1 (3 CCs)	Same as clause 7.5 in TS 38.521-1 [8] Uplink power measurement same as 6.2B.1.3.	
7.5B.3_1.2 Adjacent Channel Selectivity for EN-DC within FR1 (4 CCs)	Same as clause 7.5 in TS 38.521-1 [8] Uplink power measurement same as 6.2B.1.3.	The wanted signal level uncertainty applies for each CC
7.5B.4 Adjacent Channel Selectivity for inter-band EN-DC including FR2 (2CCs)	Same as clause 7.5 in TS 38.521-2 [9]	

7.5B.4_1.1 Adjacent Channel Selectivity for inter-band EN-DC including FR2 (3 CCs)	Same as clause 7.5A in TS 38.521-2 [9]	
7.5B.4_1.2 Adjacent Channel Selectivity for inter-band EN-DC including FR2 (4 CCs)	Same as clause 7.5A in TS 38.521-2 [9]	
7.5B.4_1.3 Adjacent Channel Selectivity for inter-band EN-DC including FR2 (5 CCs)	Same as clause 7.5A in TS 38.521-2 [9]	
7.5B.4_1.4 Adjacent Channel Selectivity for inter-band EN-DC including FR2 (6 CCs)	Same as clause 7.5A in TS 38.521-2 [9]	
7.6B.2.1 Inband blocking for intra-band contiguous EN-DC in FR1 (2 CCs)	MU for NR CC downlink power same as clause 7.6.2 in TS 38.521-1 [8]. Uplink power measurement same as 6.2B.1.1.	
7.6B.2.2 Inband blocking for intra-band non-contiguous EN-DC in FR1 (2 CCs)	Same as clause 7.6.2 in TS 38.521-1 [8] Uplink power measurement same as 6.2B.1.2.	
7.6B.2.3 Inband blocking for inter-band EN-DC within FR1 (2 CCs)	Same as clause 7.6.2 in TS 38.521-1 [8] Uplink power measurement same as 6.2B.1.3.	
7.6B.2.3_1.1 Inband blocking for EN-DC within FR1 (3 CCs)	Same as clause 7.6A.2.1 in TS 38.521-1 [8] Uplink power measurement same as 6.2B.1.3.	
7.6B.2.3_1.2 Inband blocking for EN-DC within FR1 (4 CCs)	Same as clause 7.6.2 in TS 38.521-1 [8] for each component carrier. Uplink power measurement same as 6.2B.1.3.	
7.6B.2.3_1.3 Inband blocking for EN-DC within FR1 (5 CCs)	Same as clause 7.6.2 in TS 38.521-1 [8] for each component carrier. Uplink power measurement same as 6.2B.1.3.	
7.6B.2.4 Inband blocking for inter-band EN-DC including FR2 (2 CCs)	Same as 7.6.2 in TS 38.521-2 [9]	
7.6B.2.4_1.1 Inband blocking for inter-band EN-DC including FR2 (3 CCs)	TBD	
7.6B.2.4_1.2 Inband blocking for inter-band EN-DC including FR2 (4 CCs)	TBD	
7.6B.2.4_1.3 Inband blocking for inter-band EN-DC including FR2 (5 CCs)	TBD	
7.6B.2.4_1.4 Inband blocking for inter-band EN-DC including FR2 (6 CCs)	TBD	
7.6B.3.1 Out-of-band blocking for intra-band contiguous EN-DC in FR1 (2 CCs)	MU for NR CC downlink power same as clause 7.6.3 in TS 38.521-1 [8]. Uplink power measurement same as 6.2B.1.1.	
7.6B.3.2 Out-of-band blocking for intra-band non-contiguous EN-DC in FR1 (2 CCs)	Same as clause 7.6.3 in TS 38.521-1 [8] Uplink power measurement same as 6.2B.1.2.	
7.6B.3.3 Out-of-band blocking for inter-band EN-DC within FR1 (2 CCs)	Same as clause 7.6.3 in TS 38.521-1 [8]. Uplink power measurement same as 6.2B.1.3.	
7.6B.4.1 Narrow band blocking for intra-band contiguous EN-DC in FR1 (2 CCs)	MU for NR CC downlink power same as clause 7.6.4 in TS 38.521-1 [8]. Uplink power measurement same as 6.2B.1.1.	
7.6B.4.2 Narrow band blocking for intra-band non-contiguous EN-DC in FR1 (2 CCs)	Same as clause 7.6.4 in TS 38.521-1 [8] Uplink power measurement same as 6.2B.1.2.	

7.6B.4.3 Narrow band blocking for inter-band EN-DC within FR1 (2 CCs)	Same as clause 7.6.4 in TS 38.521-1 [8] Uplink power measurement same as 6.2B.1.3.	
7.6B.4.3_1.1 Narrow band blocking for EN-DC within FR1 (3 CCs)	Same as clause 7.6A.4.1 in TS 38.521-1 [8] Uplink power measurement same as 6.2B.1.3.	
7.6B.4.3_1.2 Narrow band blocking for EN-DC within FR1 (4 CCs)	Same as clause 7.6.4 in TS 38.521-1 [8] for each component carrier. Uplink power measurement same as 6.2B.1.3.	
7.6B.4.3_1.3 Narrow band blocking for EN-DC within FR1 (5 CCs)	Same as clause 7.6.4 in TS 38.521-1 [8] for each component carrier. Uplink power measurement same as 6.2B.1.3.	
7.7B.1 Spurious Response for intra-band contiguous EN-DC in FR1 (2 CCs)	MU for NR CC downlink power same as clause 7.7 in TS 38.521-1 [8]. Uplink power measurement same as 6.2B.1.1.	
7.7B.2 Spurious Response for intra-band non-contiguous EN-DC in FR1 (2 CCs)	Same as clause 7.7 in TS 38.521-1 [8] Uplink power measurement same as 6.2B.1.2.	
7.7B.3 Spurious Response for inter-band EN-DC within FR1 (2 CCs)	Same as clause 7.7 in TS 38.521-1 [8]. Uplink power measurement same as 6.2B.1.3.	
7.7B.3_1.1 Spurious Response for EN-DC within FR1 (3 CCs)	Same as clause 7.7 in TS 38.521-1 [8] for each component carrier. Uplink power measurement same as 6.2B.1.2.	
7.7B.3_1.2 Spurious Response for EN-DC within FR1 (4 CCs)	Same as clause 7.7 in TS 38.521-1 [8] for each component carrier. Uplink power measurement same as 6.2B.1.2.	
7.8B.2.1 Wideband Intermodulation for intra-band contiguous EN-DC in FR1 (2 CCs)	MU for NR CC downlink power same as clause 7.8.2 in TS 38.521-1 [8]. Uplink power measurement same as 6.2B.1.1.	
7.8B.2.2 Wideband Intermodulation for intra-band non-contiguous EN-DC in FR1 (2 CCs)	Same as clause 7.8.2 in TS 38.521-1 [8] Uplink power measurement for same as 6.2B.1.2.	
7.8B.2.3 Wideband Intermodulation for inter-band EN-DC within FR1 (2 CCs)	Same as clause 7.8.2 in TS 38.521-1 [8] Uplink power measurement for same as 6.2B.1.3.	
7.8B.2.6 Wideband Intermodulation for EN-DC within FR1 (3 CCs) (2 CCs)	Same as clause 7.8A.2.1 in TS 38.521-1 [8] Uplink power measurement for same as 6.2B.1.3.	
7.9B.1 Spurious Emissions for intra-band contiguous EN-DC within FR1 (2 CCs)	Same as clause 7.9 in TS 38.521-1 [8]	
7.9B.2 Spurious Emissions for intra-band non-contiguous EN-DC within FR1 (2 CCs)	Same as clause 7.9 in TS 38.521-1 [8]	
7.9B.3 Spurious Emissions for inter-band EN-DC within FR1 (2 CCs)	Same as clause 7.9 in TS 38.521-1 [8]	
7.9B.4 Spurious Emissions for inter-band EN-DC including FR2 (2 CCs)	Same as clause 7.9 in TS 38.521-2 [9]	

F.2 Interpretation of measurement results (normative)

TBD

F.3 Test Tolerance and Derivation of Test Requirements (informative)

TBD

F.3.1 Measurement of test environments

TBD

F.3.2 Measurement of transmitter

Table F.3.2-1: Derivation of Test Requirements (Transmitter tests)

Sub clause	Test Tolerance (TT)	Formula for test requirement
6.2B.1.1 UE Maximum Output Power for Intra-Band Contiguous EN-DC	Same as 6.2.1 in TS 38.521-1 [8]	
6.2B.1.2 UE Maximum Output Power for Intra-Band Non-Contiguous EN-DC	<p>MAX (TT_{LTE}, TT_{SA})</p> <p>TT_{LTE} 0.7 dB, $f \leq 3.0\text{GHz}$ 1.0 dB, $3.0\text{GHz} < f \leq 4.2\text{GHz}$</p> <p>TT_{SA} $f \leq 3.0\text{GHz}$ 0.7 dB, $\text{BW} \leq 40\text{MHz}$ 1.0 dB, $40\text{MHz} < \text{BW} \leq 100\text{MHz}$ $3.0\text{GHz} < f \leq 6.0\text{GHz}$ 1.0 dB, $\text{BW} \leq 100\text{MHz}$</p>	<p>TT_{LTE} is TT of LTE specified in 6.2.2 in TS 36.521-1 [10].</p> <p>TT_{SA} is TT of FR1 SA specified in 6.2.1 in TS 38.521-1 [8].</p>
6.2B.1.3 UE Maximum Output Power for Inter-Band EN-DC within FR1	<p>MAX (TT_{LTE}, TT_{SA})</p> <p>TT_{LTE} 0.7 dB, $f \leq 3.0\text{GHz}$ 1.0 dB, $3.0\text{GHz} < f \leq 4.2\text{GHz}$</p> <p>TT_{SA} $f \leq 3.0\text{GHz}$ 0.7 dB, $\text{BW} \leq 40\text{MHz}$ 1.0 dB, $40\text{MHz} < \text{BW} \leq 100\text{MHz}$ $3.0\text{GHz} < f \leq 6.0\text{GHz}$ 1.0 dB, $\text{BW} \leq 100\text{MHz}$</p>	<p>TT_{LTE} is TT of LTE specified in 6.2.3 in TS 36.521-1 [10].</p> <p>TT_{SA} is TT of FR1 SA specified in 6.2.2 in TS 38.521-1 [8].</p>
6.2B.1.4 UE Maximum Output Power for Inter-Band EN-DC including FR2	Same as 6.2.1 in TS 38.521-2 [9]	
6.2B.1.4.1 UE Maximum Output Power for Inter-Band EN-DC including FR2 (2 CCs) - EIRP and TR	Same as 6.2.1.1 in TS 38.521-2	
6.2B.1.4_1.1.1 UE Maximum Output Power for Inter-Band EN-DC including FR2 (3 CCs) - EIRP and TRP	Same as 6.2A.1.1.1 in TS 38.521-2	
6.2B.1.4_1.1.2 UE Maximum Output Power for Inter-Band EN-DC including FR2 (3 CCs) - Spherical Coverage	Same as 6.2A.1.2.1 in TS 38.521-2	
6.2B.1.4.2 UE Maximum Output Power for Inter-Band EN-DC including FR2 (2 CCs) - Spherical Coverage	Same as 6.2.1.2 in TS 38.521-2	
6.2B.2.2 UE Maximum Output Power reduction for Intra-Band Non-Contiguous EN-DC	Same as 6.2B.1.2	
6.2B.2.3 UE Maximum Output Power reduction for Inter-Band EN-DC within FR1	Same as 6.2B.1.3	
6.2B.2.4 UE Maximum Output Power reduction for Inter-Band EN-DC including FR2	Same as clause 6.2.2 and 6.2A.2.1 in TS 38.521-2 [9]	
6.2B.3.1 UE Additional Maximum Output Power reduction for Intra-band contiguous EN-DC	Same as 6.2.3 in TS 38.521-1 [8]	
6.2B.3.2 UE Additional Maximum Output Power reduction for Intra-Band Non-Contiguous EN-DC	Same as 6.2B.1.2	

6.2B.3.3 UE Additional Maximum Output Power reduction for Inter-Band EN-DC within FR1	Same as 6.2B.1.3	
6.2B.4.1.1 Configured Output Power Level for Intra-Band Contiguous EN-DC	Same as 6.2.4 in TS 38.521-1 [8]	
6.2B.4.1.2 Configured Output Power for Intra-Band Non-Contiguous EN-DC	Same as 6.2B.1.2	
6.2B.4.1.3 Configured Output Power for Inter-Band EN-DC within FR1	Same as 6.2B.1.3	
6.3B.1.1 Minimum Output Power for intra-band contiguous EN-DC	Same as 6.3.1 in TS 38.521-1 [8]	
6.3B.1.2 Minimum output power for intra-band non-contiguous EN-DC	Same as 6.3.1 in TS 38.521-1 [8]	
6.3B.1.3 Minimum output power for inter-band EN-DC within FR1	Same as 6.3.1 in TS 38.521-1 [8]	
6.3B.1.4 Minimum Output Power for EN-DC Interband including FR2	Same as 6.3.1 in TS 38.521-2 [9]	
6.3B.2.1 Transmit OFF Power for intra-band contiguous EN-DC	Same as 6.3.2 in TS 38.521-1 [8]	
6.3B.2.2 Transmit OFF Power for intra-band non-contiguous EN-DC	Same as 6.3.2 in TS 38.521-1 [8]	
6.3B.2.3 Transmit OFF Power for inter-band EN-DC within FR1	Same as 6.3.2 in TS 38.521-1 [8]	
6.3B.2.4 Transmit OFF Power for inter-band EN-DC including FR2	Same as 6.3.2 in TS 38.521-2 [9]	
6.3B.3.1 Tx ON/OFF time mask for intra-band contiguous EN-DC	Same as 6.3.3.2 in TS 38.521-1 [8]	
6.3B.3.2 Tx ON/OFF time mask for intra-band non-contiguous EN-DC	Same as 6.3.3.2 in TS 38.521-1 [8]	
6.3B.3.3 Tx ON/OFF time mask for inter-band EN-DC within FR1	Same as 6.3.3.2 in TS 38.521-1 [8]	
6.3B.4.3 PRACH Time Mask for inter-band EN-DC within FR1	Same as 6.3.3.4 in TS 38.521-1 [8]	
6.3B.8.1.1 Absolute power tolerance for intra-band contiguous EN-DC	Same as 6.3.4.2 in TS 38.521-1 [8]	
6.3B.8.1.2 Absolute power tolerance for intra-band non-contiguous EN-DC	Same as 6.3.4.2 in TS 38.521-1 [8]	
6.3B.8.1.3 Absolute power tolerance for inter-band EN-DC within FR1	Same as 6.3.4.2 in TS 38.521-1 [8]	
6.3B.8.1.4 Absolute power tolerance for inter-band EN-DC including FR2	Same as 6.3.4.2 in TS 38.521-2 [9]	
6.3B.8.2.1 Relative power tolerance for intra-band contiguous EN-DC	Same as 6.3.4.3 in TS 38.521-1 [8]	
6.3B.8.2.2 Relative power tolerance for intra-band non-contiguous EN-DC	Same as 6.3.4.3 in TS 38.521-1 [8]	

6.3B.8.2.3 Relative power tolerance for inter-band EN-DC within FR1	Same as 6.3.4.3 in TS 38.521-1 [8]	
6.3B.8.2.4 Relative power tolerance for inter-band EN-DC including FR2	Same as 6.3.4.3 in TS 38.521-2 [9]	
6.3B.8.3.1 Aggregate power tolerance for intra-band contiguous EN-DC	Same as 6.3.4.4 in TS 38.521-1 [8]	
6.3B.8.3.2 Aggregate power tolerance for intra-band non-contiguous EN-DC	Same as 6.3.4.4 in TS 38.521-1 [8]	
6.3B.8.3.3 Aggregate power tolerance for inter-band EN-DC within FR1	Same as 6.3.4.4 in TS 38.521-1 [8]	
6.3B.8.3.4 Aggregate power tolerance for inter-band EN-DC including FR2	Same as 6.3.4.4 in TS 38.521-2 [9]	
6.4B.1.1 Frequency Error for intra-band contiguous EN-DC	Same as 6.4.1 in TS 38.521-1 [8]	
6.4B.1.2 Frequency Error for intra-band non-contiguous EN-DC	Same as 6.4.1 in TS 38.521-1 [8]	
6.4B.1.3 Frequency Error for inter-band EN-DC within FR1	Same as 6.4.1 in TS 38.521-1 [8]	
6.4B.1.4 Frequency Error for inter-band EN-DC including FR2	Same as 6.4.1 in TS 38.521-2 [9]	
6.4B.1.4_1.1 Frequency Error for Inter-band EN-DC including FR2 (3 CCs)	Same as 6.4A.1.1 in TS 38.521-2 [9]	
6.4B.1.4_1.2 Frequency Error for Inter-band EN-DC including FR2 (4 CCs)	Same as 6.4A.1.2 in TS 38.521-2 [9]	
6.4B.1.4_1.3 Frequency Error for Inter-band EN-DC including FR2 (5 CCs)	Same as 6.4A.1.3 in TS 38.521-2 [9]	
6.4B.2.1.1 Error Vector Magnitude for intra-band contiguous EN-DC	Same as 6.4.2.1 in TS 38.521-1 [8]	
6.4B.2.1.2 Carrier Leakage for intra-band contiguous EN-DC	Same as 6.4.2.2 in TS 38.521-1 [8]	
6.4B.2.1.3 In-band Emissions for intra-band contiguous EN-DC	Same as 6.4.2.3 in TS 38.521-1 [8]	
6.4B.2.1.4 EVM Equalizer Flatness for intra-band contiguous EN-DC	Same as 6.4.2.4 in TS 38.521-1 [8]	
6.4B.2.2.1 Error Vector Magnitude for intra-band non-contiguous EN-DC	Same as 6.4.2.1 in TS 38.521-1 [8]	
6.4B.2.2.2 Carrier Leakage for intra-band non-contiguous EN-DC	Same as 6.4.2.2 in TS 38.521-1 [8]	
6.4B.2.2.3 In-band Emissions for intra-band non-contiguous EN-DC	Same as 6.4.2.3 in TS 38.521-1 [8]	
6.4B.2.2.4 EVM Equalizer Flatness for intra-band non-contiguous EN-DC	Same as 6.4.2.4 in TS 38.521-1 [8]	
6.4B.2.3.1 Error Vector Magnitude for inter-band EN-DC within FR1	Same as 6.4.2.1 in TS 38.521-1 [8]	
6.4B.2.3.2 Carrier Leakage for inter-band EN-DC within FR1	Same as 6.4.2.2 in TS 38.521-1 [8]	

6.4B.2.3.3 In-band Emissions for inter-band EN-DC within FR1	Same as 6.4.2.3 in TS 38.521-1 [8]	
6.4B.2.3.4 EVM Equalizer Flatness for inter-band EN-DC within FR1	Same as 6.4.2.4 in TS 38.521-1 [8]	
6.4B.2.4.1 Error Vector Magnitude for inter-band EN-DC including FR2	Same as 6.4.2.1 in TS 38.521-2 [9]	
6.4B.2.4.2 Carrier Leakage for inter-band EN-DC including FR2	Same as 6.4.2.2 in TS 38.521-2 [9]	
6.4B.2.4.3 In-band Emissions for inter-band EN-DC including FR2	Same as 6.4.2.3 in TS 38.521-2 [9]	
6.4B.2.4.4 EVM Equalizer Flatness for inter-band EN-DC including FR2	Same as 6.4.2.4 in TS 38.521-2 [9]	
6.5B.1.1 Occupied bandwidth for Intra-Band Contiguous EN-DC	Same as 6.5.1 in TS 38.521-1 [8]	
6.5B.1.2 Occupied bandwidth for Intra-Band Non-Contiguous EN-DC	Same as 6.5.1 in TS 38.521-1 [8]	
6.5B.1.3 Occupied bandwidth for Inter-Band EN-DC within FR1	Same as 6.5.1 in TS 38.521-1 [8]	
6.5B.1.4 Occupied bandwidth for Inter-Band EN-DC including FR2	Same as 6.5.1 in TS 38.521-2 [9]	
6.5B.1.4_1.1 Occupied bandwidth for Inter-band EN-DC including FR2 (3 CCs)	TBD	
6.5B.1.4_1.2 Occupied bandwidth for Inter-band EN-DC including FR2 (4 CCs)	TBD	
6.5B.1.4_1.3 Occupied bandwidth for Inter-band EN-DC including FR2 (5 CCs)	TBD	
6.5B.1.4D Occupied bandwidth for inter-band EN-DC including FR2 for UL-MIMO	Same as 6.5D.1 in TS 38.521-2 [9]	
6.5B.2.1.1 Spectrum emissions mask for intra-band contiguous EN-DC	Same as 6.5.2.2 in TS 38.521-1 [8]	
6.5B.2.1.2 Additional spectrum emissions mask for intra-band contiguous EN-DC	Same as 6.5.2.3 in TS 38.521-1 [8]	
6.5B.2.1.3 Adjacent channel leakage ratio for intra-band contiguous EN-DC	Same as 6.5.2.4.1 in TS 38.521-1 [8]	
6.5B.2.2.1 Spectrum emissions mask for intra-band non-contiguous EN-DC	Same as 6.5.2.2 in TS 38.521-1 [8]	
6.5B.2.2.2 Additional Spectrum emissions mask for intra-band non-contiguous EN-DC	Same as 6.5.2.3 in TS 38.521-1 [8]	
6.5B.2.2.3 Adjacent channel leakage ratio for intra-band non-contiguous EN-DC	Same as 6.5.2.4.1 in TS 38.521-1 [8]	
6.5B.2.3.1 Spectrum emissions mask for Inter-band EN-DC within FR1	Same as 6.5.2.2 in TS 38.521-1 [8]	

6.5B.2.3.2 Additional Spectrum emissions mask for Inter-band EN-DC within FR1	Same as 6.5.2.3 in TS 38.521-1 [8]	
6.5B.2.3.3 Adjacent channel leakage ratio for inter-band EN-DC within FR1	Same as 6.5.2.4.1 in TS 38.521-1 [8]	
6.5B.2.4.1 Spectrum emissions mask for Inter-band EN-DC including FR2	Same as 6.5.2.1 in TS 38.521-2 [9]	
6.5B.2.4.3 Adjacent channel leakage ratio for Inter-band EN-DC including FR2	Same as 6.5.2.3 in TS 38.521-2 [9]	
6.5B.2.4.3_1.1 Adjacent channel leakage ratio for Inter-band EN-DC including FR2 (3 CCs)	Same as clause 6.5A.2.2.1 in TS 38.521-2 [9]	
6.5B.2.4.3_1.2 Adjacent channel leakage ratio for Inter-band EN-DC including FR2 (4 CCs)	Same as clause 6.5A.2.2.2 in TS 38.521-2 [9]	
6.5B.2.4.3_1.3 Adjacent channel leakage ratio for Inter-band EN-DC including FR2 (5 CCs)	Same as clause 6.5A.2.2.3 in TS 38.521-2 [9]	
6.5B.3.1.1 General spurious emissions for intra-band contiguous EN-DC	Same as 6.5.3.1 in TS 38.521-1 [8]	
6.5B.3.1.2 Spurious emission band UE co-existence for intra-band contiguous EN-DC	Same as 6.5.3.2 in TS 38.521-1 [8]	
6.5B.3.2.1 General spurious emissions for Intra-band non-contiguous EN-DC	Same as 6.5.3.1 in TS 38.521-1 [8]	
6.5B.3.2.2 Spurious Emission band UE co-existence for intra-band non-contiguous EN-DC	Same as 6.5.3.2 in TS 38.521-1 [8]	
6.5B.3.3.1 General spurious emissions for Inter-band EN-DC within FR1	Same as 6.5.3.1 in TS 38.521-1 [8]	
6.5B.3.3.2 Spurious emission band UE co-existence for Inter-band within FR1	Same as 6.5.3.2 in TS 38.521-1 [8]	
6.5B.3.4.1 General Spurious Emissions for Inter-band including FR2 (2 CCs)	Same as 6.5.3.1 in TS 38.521-2 [9]	
6.5B.3.4.2 Spurious emission band UE co-existence for Inter-band including FR2	Same as 6.5.3.2 in TS 38.521-2 [9]	
6.5B.4.3 Additional Spurious Emissions for Inter-band EN-DC within FR1	Same as clause 6.5.3.3 in TS 38.521-1 [8]	
6.5B.5.3 Transmit intermodulation for Inter-band EN-DC within FR1	Same as 6.5.4 in TS 38.521-1 [8]	

F.3.3 Measurement of receiver

Table F.3.3-1: Derivation of Test Requirements (Receiver tests)

Sub clause	Test Tolerance (TT)	Formula for test requirement
7.3B.2.1 Reference sensitivity for Intra-band Contiguous EN-DC (2 CCs)	Same as 7.3.2 in TS 38.521-1 [8]	
7.3B.2.2 Reference sensitivity for Intra-band non-contiguous EN-DC (2 CCs)	Same as 7.3.2 in TS 38.521-1 [8]	
7.3B.2.3 Reference sensitivity for Inter-band EN-DC within FR1 (2 CCs)	Same as 7.3.2 in TS 38.521-1 [8]	
7.3B.2.3_1.1 Reference sensitivity for Inter-band EN-DC within FR1 (3 CCs)	Same as 7.3A.1 in TS 38.521-1 [8]	
7.3B.2.4 Reference sensitivity for Inter-band EN-DC including FR2	Same as 7.3.2 in TS 38.521-2 [9]	
7.3B.2.4_1.1 Reference sensitivity for Inter-band EN-DC including FR2 (3 CCs)	Same as 7.3A.2.1 in TS 38.521-2 [9]	
7.3B.2.4_1.2 Reference sensitivity for Inter-band EN-DC including FR2 (4 CCs)	Same as 7.3A.2.2 in TS 38.521-2 [9]	
7.3B.2.4_1.3 Reference sensitivity for Inter-band EN-DC including FR2 (5 CCs)	Same as 7.3A.2.3 in TS 38.521-2 [9]	
7.3B.2.4_1.4 Reference sensitivity for Inter-band EN-DC including FR2 (6 CCs)	Same as 7.3A.2.4 in TS 38.521-2 [9]	
7.3B.4 EIS Spherical Coverage for Inter-band EN-DC including FR2	Same as 7.3.4 in TS 38.521-2 [9]	
7.4B.1 Maximum Input Level for Intra-Band Contiguous EN-DC (2 CCs)	Same as 7.4 in TS 38.521-1 [8]	
7.4B.2 Maximum Input Level for Intra-Band Non-Contiguous EN-DC (2 CCs)	Same as 7.4 in TS 38.521-1 [8]	
7.4B.3 Maximum Input Level for Inter-band EN-DC within FR1 (2 CCs)	Same as 7.4 in TS 38.521-1 [8]	
7.4B.3_1.1 Maximum Input Level for Inter-band EN-DC within FR1 (3 CCs)	Same as 7.4A.1 in TS 38.521-1 [8]	
7.5B.1 Adjacent Channel Selectivity for intra-band contiguous EN-DC (2 CCs)	Same as 7.5 in TS 38.521-1 [8]	
7.5B.2 Adjacent Channel Selectivity for intra-band non-contiguous EN-DC (2 CCs)	Same as 7.5 in TS 38.521-1 [8]	
7.5B.3 Adjacent Channel Selectivity for inter-band EN-DC within FR1 (2 CCs)	Same as 7.5 in TS 38.521-1 [8]	
7.5B.3_1.1 Adjacent Channel Selectivity for EN-DC within FR1 (3 CCs)	Same as 7.5A.1 in TS 38.521-1 [8]	
7.5B.3_1.2 Adjacent Channel Selectivity for EN-DC within FR1 (4 CCs)	Same as 7.5 in TS 38.521-1 [8]	
7.5B.4 Adjacent Channel Selectivity for inter-band EN-DC including FR2 (2CCs)	Same as clause 7.5 in TS 38.521-2 [9]	
7.6B.2.1 Inband blocking for intra-band contiguous EN-DC in FR1 (2 CCs)	Same as 7.6.2 in TS 38.521-1 [8]	
7.6B.2.2 Inband blocking for intra-band non-contiguous EN-DC in FR1 (2 CCs)	Same as 7.6.2 in TS 38.521-1 [8]	

7.6B.2.3 Inband blocking for inter-band EN-DC within FR1 (2 CCs)	Same as 7.6.2 in TS 38.521-1 [8]	
7.6B.2.3_1.1 Inband blocking for EN-DC within FR1 (3 CCs)	<u>0 dB</u>	Wanted signal power + TT Interferer signal power unchanged T-put limit unchanged
7.6B.2.3_1.2 Inband blocking for EN-DC within FR1 (4 CCs)	<u>0 dB</u>	Wanted signal power + TT Interferer signal power unchanged T-put limit unchanged
7.6B.2.3_1.3 Inband blocking for EN-DC within FR1 (5 CCs)	<u>0 dB</u>	Wanted signal power + TT Interferer signal power unchanged T-put limit unchanged
7.6B.2.4 Inband blocking for inter-band EN-DC including FR2 (2 CCs)	Same as 7.6.2 in TS 38.521-2 [9]	
7.6B.2.4_1.1 Inband blocking for inter-band EN-DC including FR2 (3 CCs)	<u>0 dB</u>	Wanted signal power + TT T-put limit unchanged
7.6B.2.4_1.2 Inband blocking for inter-band EN-DC including FR2 (4 CCs)	<u>0 dB</u>	Wanted signal power + TT T-put limit unchanged
7.6B.2.4_1.3 Inband blocking for inter-band EN-DC including FR2 (5 CCs)	<u>0 dB</u>	Wanted signal power + TT T-put limit unchanged
7.6B.2.4_1.4 Inband blocking for inter-band EN-DC including FR2 (6 CCs)	<u>0 dB</u>	Wanted signal power + TT T-put limit unchanged
7.6B.3.1 Out-of-band blocking for intra-band contiguous EN-DC in FR1 (2 CCs)	Same as 7.6.3 in TS 38.521-1 [8]	
7.6B.3.2 Out-of-band blocking for intra-band non-contiguous EN-DC in FR1 (2 CCs)	Same as 7.6.3 in TS 38.521-1 [8]	
7.6B.3.3 Out-of-band blocking for inter-band EN-DC within FR1 (2 CCs)	Same as 7.6.3 in TS 38.521-1 [8]	
7.6B.3.3_1.1 Out-of-band blocking for EN-DC within FR1 (3 CCs)	0 dB	Wanted signal power + TT Interferer signal power unchanged T-put limit unchanged
7.6B.3.3_1.2 Out-of-band blocking for EN-DC within FR1 (4 CCs)	0 dB	Wanted signal power + TT Interferer signal power unchanged T-put limit unchanged
7.6B.4.1 Narrow band blocking for intra-band contiguous EN-DC in FR1 (2 CCs)	Same as 7.6.4 in TS 38.521-1 [8]	
7.6B.4.2 Narrow band blocking for intra-band non-contiguous EN-DC in FR1 (2 CCs)	Same as 7.6.4 in TS 38.521-1 [8]	
7.6B.4.3 Narrow band blocking for inter-band EN-DC within FR1 (2 CCs)	Same as 7.6.4 in TS 38.521-1 [8]	
7.6B.4.3_1.1 Narrow band blocking for EN-DC within FR1 (3 CCs)	<u>0 dB</u>	Wanted signal power + TT Interferer signal power unchanged T-put limit unchanged
7.6B.4.3_1.2 Narrow band blocking for EN-DC within FR1 (4 CCs)	<u>0 dB</u>	Wanted signal power + TT Interferer signal power unchanged T-put limit unchanged
7.6B.4.3_1.3 Narrow band blocking for EN-DC within FR1 (5 CCs)	<u>0 dB</u>	Wanted signal power + TT Interferer signal power unchanged T-put limit unchanged
7.7B.1 Spurious Response for intra-band contiguous EN-DC in FR1 (2 CCs)	Same as 7.7 in TS 38.521-1 [8]	

7.7B.2 Spurious Response for intra-band non-contiguous EN-DC in FR1 (2 CCs)	Same as 7.7 in TS 38.521-1 [8]	
7.7B.3 Spurious Response for inter-band EN-DC within FR1 (2 CCs)	Same as 7.7 in TS 38.521-1 [8]	
7.6B.3.3_1.1 Out-of-band blocking for EN-DC within FR1 (3 CCs)	0 dB	Wanted signal power + TT Interferer signal power unchanged T-put limit unchanged
7.6B.3.3_1.2 Out-of-band blocking for EN-DC within FR1 (4 CCs)	0 dB	Wanted signal power + TT Interferer signal power unchanged T-put limit unchanged
7.8B.2.1 Wideband Intermodulation for intra-band contiguous EN-DC in FR1 (2 CCs)	Same as 7.8.2 in TS 38.521-1 [8]	
7.8B.2.2 Wideband Intermodulation for intra-band non-contiguous EN-DC in FR1 (2 CCs)	Same as 7.8.2 in TS 38.521-1 [8]	
7.8B.2.3 Wideband Intermodulation for inter-band EN-DC within FR1 (2 CCs)	Same as 7.8.2 in TS 38.521-1 [8]	
7.8B.2.6 Wideband Intermodulation for EN-DC within FR1 (3 CCs) (2 CCs)	Same as 7.8A.2.1 in TS 38.521-1 [8]	
7.9B.1 Spurious Emissions for intra-band contiguous EN-DC within FR1 (2 CCs)	Same as 7.9 in TS 38.521-1 [8]	
7.9B.2 Spurious Emissions for intra-band non-contiguous EN-DC within FR1 (2 CCs)	Same as 7.9 in TS 38.521-1 [8]	
7.9B.3 Spurious Emissions for inter-band EN-DC within FR1 (2 CCs)	Same as 7.9 in TS 38.521-1 [8]	
7.9B.4 Spurious Emissions for inter-band EN-DC including FR2 (2 CCs)	Same as 7.9 in TS 38.521-2 [9]	

F.4 Uplink power window

F.4.1 Introduction

A number of Tx and Rx Test cases set the UE uplink power to be within a defined window to ensure the test is carried out in the intended conditions. This clause gives the method for calculating the uplink power window used in Tx test cases and Rx Test cases.

F.4.2 Setting the power window above a requirement

F.4.2.1 NR FR1

Information from the core requirements in TS 38.101-1 [2], TS 38.213 [19] and the uncertainties in Annex F applicable to the Test case are used to derive the uplink power window. There are 4 stages:

- Find the uplink power target value.
- Determine how closely the uplink power can be set to the target value.
- Include the effect of test system uncertainty.

- Position the Uplink power window to ensure UE is not tested outside Core requirements.

This process is shown in the diagram below, using values for $f \leq 3\text{GHz}$ and $\text{BW} \leq 40\text{MHz}$ and taking an example where the target value is 0dBm (lower end of a UE Core requirement side condition range of $0\text{dBm} \leq \text{Output power} \leq 10\text{dBm}$):

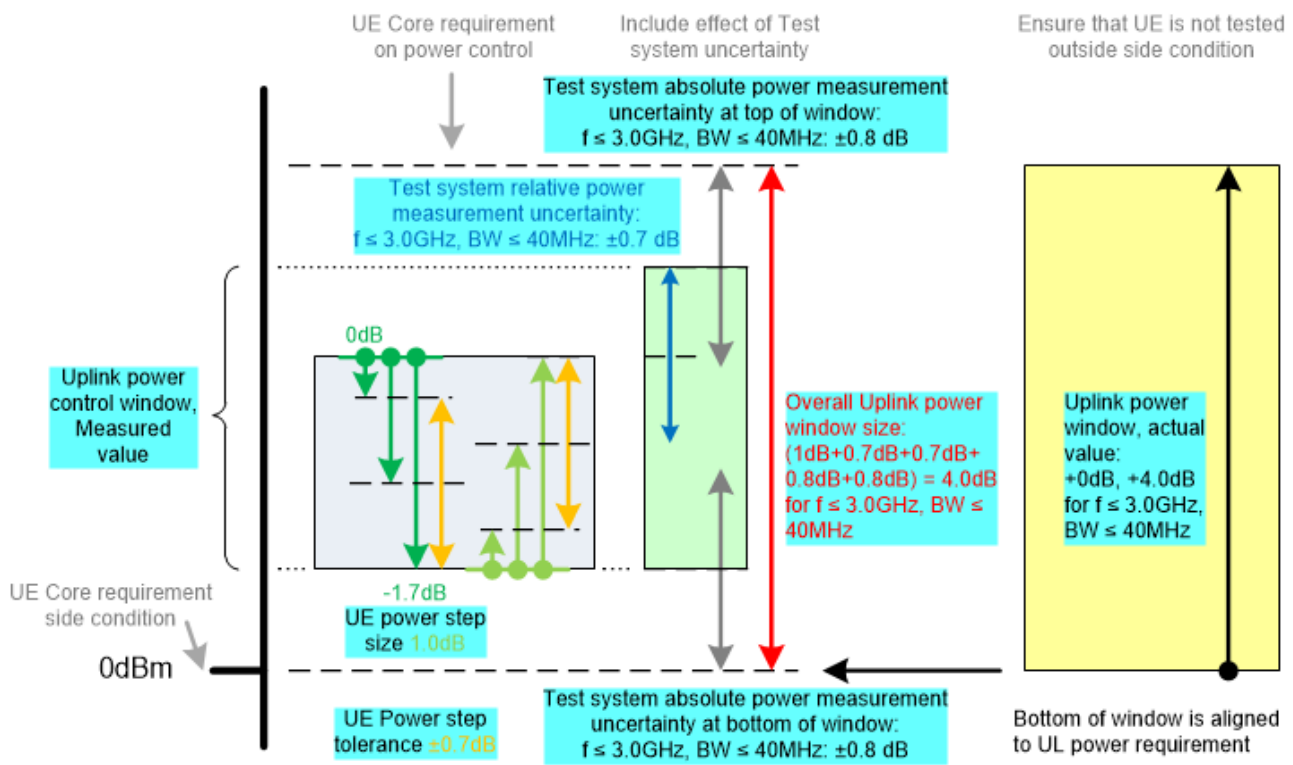

UE Uplink power

Figure F.4.2.1-1: Example NR FR1 uplink power setting to be above a requirement

The smallest UE Power step size is defined in TS 38.213 [9] Table 7.1.1-1, for absolute $\delta_{\text{PUSCH},f,c}$.

The UE Power step size tolerance is defined in TS 38.101-1 [2] Table 6.3.4.3-1, for PUSCH to PUSCH transitions with the allocated resource blocks fixed in frequency and no transmission gaps other than those generated by downlink subframes, DwPTS fields or Guard Periods, and for a power step $\Delta P \leq 1\text{ dB}$.

The Test system uncertainties are defined in Annex F of the present document.

To ensure that the actual UE uplink power is within the Uplink power window, UE uplink power measured by the test system should remain within the smaller Uplink power control window shown in Figure F.4.2.1-1.

F.4.2.2 NR FR2

[FFS]

F.4.2.3 E-UTRA

Information from the core requirements in TS 36.101 [5], TS 36.213 [20] and the uncertainties in Annex F applicable to the Test case are used to derive the uplink power window. There are 4 stages:

- Find the uplink power target value.

- Determine how closely the uplink power can be set to the target value.
- Include the effect of test system uncertainty.
- Position the Uplink power window to ensure UE is not tested outside Core requirements.

This process is shown in the diagram below, using values for $f \leq 3\text{GHz}$ and $\text{BW} \leq 40\text{MHz}$ and taking an example where the target value is 0dBm (lower end of a UE Core requirement side condition range of $0\text{dBm} \leq \text{Output power} \leq 10\text{dBm}$):

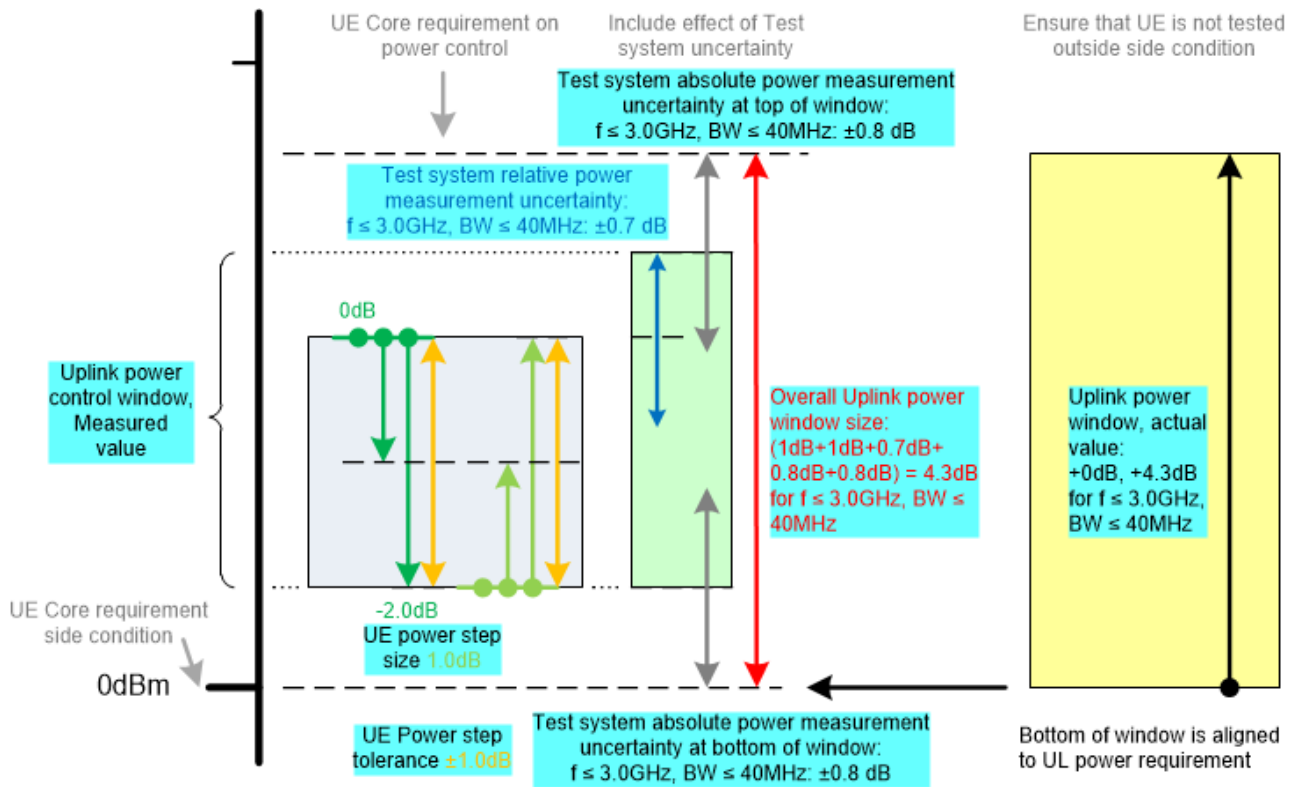

UE Uplink power

Figure F.4.2.3-1: Example E-UTRA uplink power setting to be above a requirement

The smallest UE Power step size is defined in TS 36.213 [20] Table 5.1.1.1-2, for absolute δ_{PUSCH} .

The UE Power step size tolerance is defined in TS 36.101 [5] Table 6.3.5.2.1-1, for PUSCH to PUSCH transitions with the allocated resource blocks fixed in frequency and no transmission gaps other than those generated by downlink subframes, DwPTS fields or Guard Periods, and for a power step $\Delta P \leq 1\text{ dB}$.

The Test system uncertainties are defined in Annex F of the present document.

To ensure that the actual UE uplink power is within the Uplink power window, UE uplink power measured by the test system should remain within the smaller Uplink power control window shown in Figure F.4.2.3-1.

F.4.3 Setting the power window below a requirement

F.4.3.1 NR FR1

Information from the core requirements in TS 38.101-1 [2], TS 38.213 [19] and the uncertainties in Annex F applicable to the Test case are used to derive the uplink power window. There are 4 stages:

- Find the uplink power target value.
- Determine how closely the uplink power can be set to the target value.
- Include the effect of test system uncertainty.
- Position the Uplink power window to ensure UE is not tested outside Core requirements.

This process is shown in the diagram below, using values for $f \leq 3\text{GHz}$ and $\text{BW} \leq 40\text{MHz}$ and taking an example where the target value is 4dB below PCMAX_L (UE Core requirement side condition):

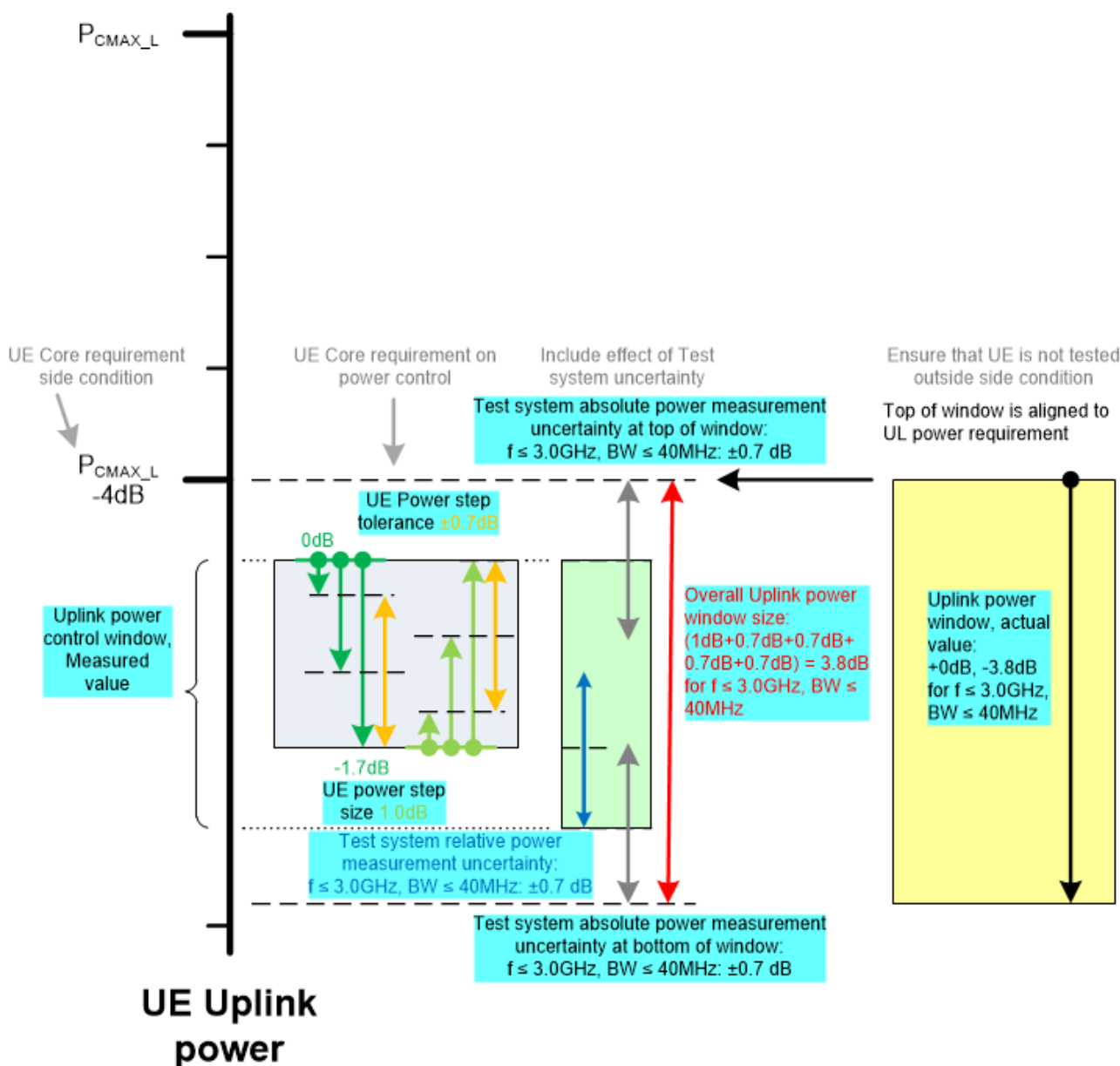

Figure F.4.3.1-1: Example NR FR1 uplink power setting to be below a requirement

The smallest UE Power step size is defined in TS 38.213 [19] Table 7.1.1-1, for absolute $\delta_{\text{PUSCH},f,c}$.

The UE Power step size tolerance is defined in TS 38.101-1 [5] Table 6.3.4.3-1, for PUSCH to PUSCH transitions with the allocated resource blocks fixed in frequency and no transmission gaps other than those generated by downlink subframes, DwPTS fields or Guard Periods, and for a power step $\Delta P \leq 1$ dB.

The Test system uncertainties are defined in Annex F of the present document.

To ensure that the actual UE uplink power is within the Uplink power window, UE uplink power measured by the test system should remain within the smaller Uplink power control window shown in Figure F.4.3.1-1.

F.4.3.2 NR FR2

[FFS]

F.4.3.3 E-UTRA

Information from the core requirements in TS 36.101 [5], TS 36.213 [20] and the uncertainties in Annex F applicable to the Test case are used to derive the uplink power window. There are 4 stages:

- Find the uplink power target value.
- Determine how closely the uplink power can be set to the target value.
- Include the effect of test system uncertainty.
- Position the Uplink power window to ensure UE is not tested outside Core requirements.

This process is shown in the diagram below, using values for $f \leq 3\text{GHz}$ and $\text{BW} \leq 40\text{MHz}$ and taking an example where the target value is 4dB below PCMAX_L (UE Core requirement side condition):

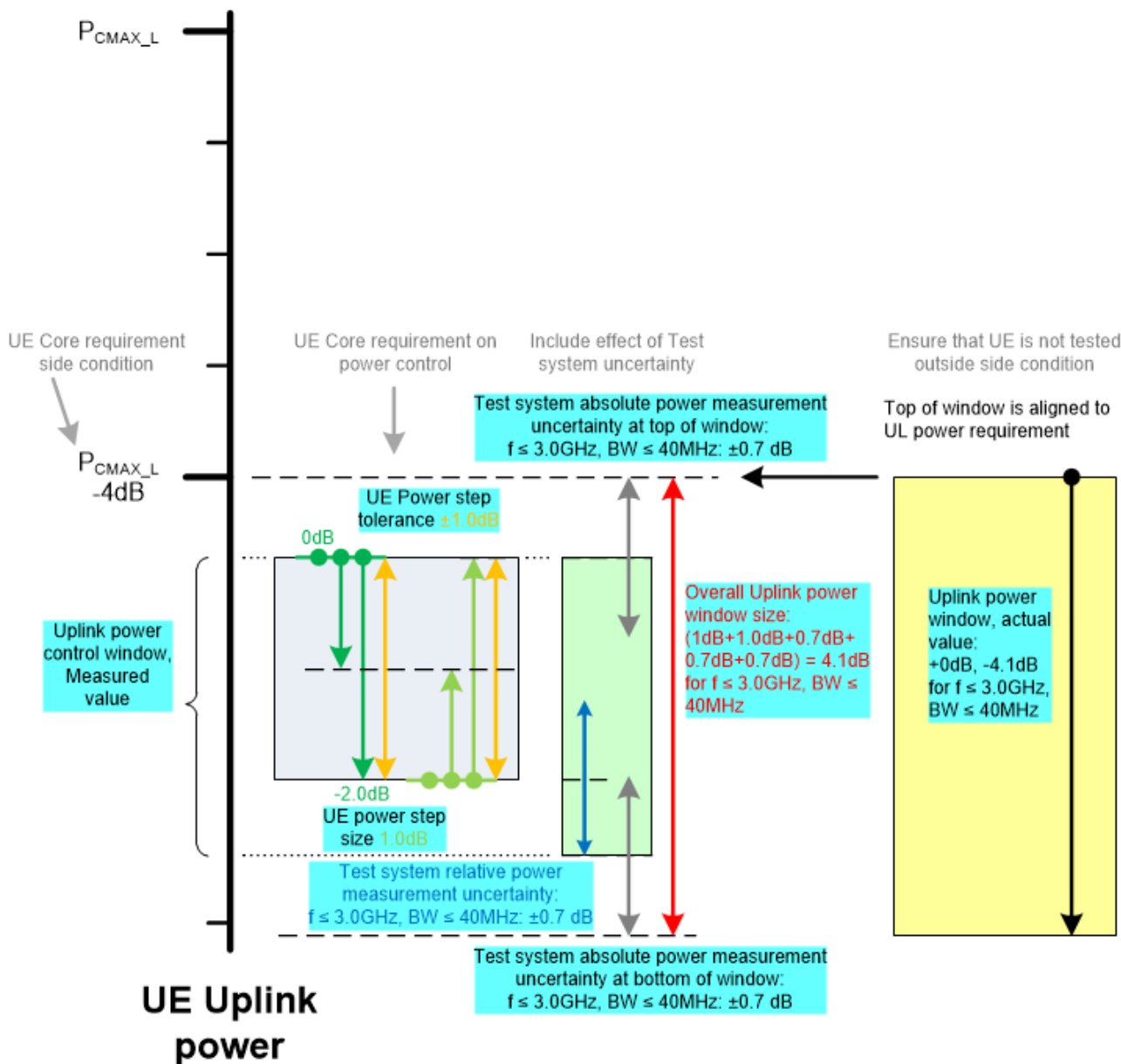

Figure F.4.3.3-1: Example E-UTRA uplink power setting to be below a requirement

The smallest UE Power step size is defined in TS 36.213 [20] Table 5.1.1.1-2, for absolute δ_{PUSCH} .

The UE Power step size tolerance is defined in TS 36.101 [5] Table 6.3.5.2.1-1, for PUSCH to PUSCH transitions with the allocated resource blocks fixed in frequency and no transmission gaps other than those generated by downlink subframes, DwPTS fields or Guard Periods, and for a power step $\Delta P \leq 1\text{ dB}$.

The Test system uncertainties are defined in Annex F of the present document.

To ensure that the actual UE uplink power is within the Uplink power window, UE uplink power measured by the test system should remain within the smaller Uplink power control window shown in Figure F.4.3.3-1.

F.4.4 Setting the power window centred on a target value

F.4.4.1 NR FR1

Information from the core requirements in TS 38.101-1 [2], TS 38.213 [19] and the uncertainties in Annex F applicable to the Test case are used to derive the uplink power window. There are 4 stages:

- Find the uplink power target value.
- Determine how closely the uplink power can be set to the target value.
- Include the effect of test system uncertainty.
- Position the Uplink power window centred on the target value.

This process is shown in the diagram below, using values for $f \leq 3\text{GHz}$ and $\text{BW} \leq 40\text{MHz}$ and taking an example where the target value is $+10\text{dBm}$:

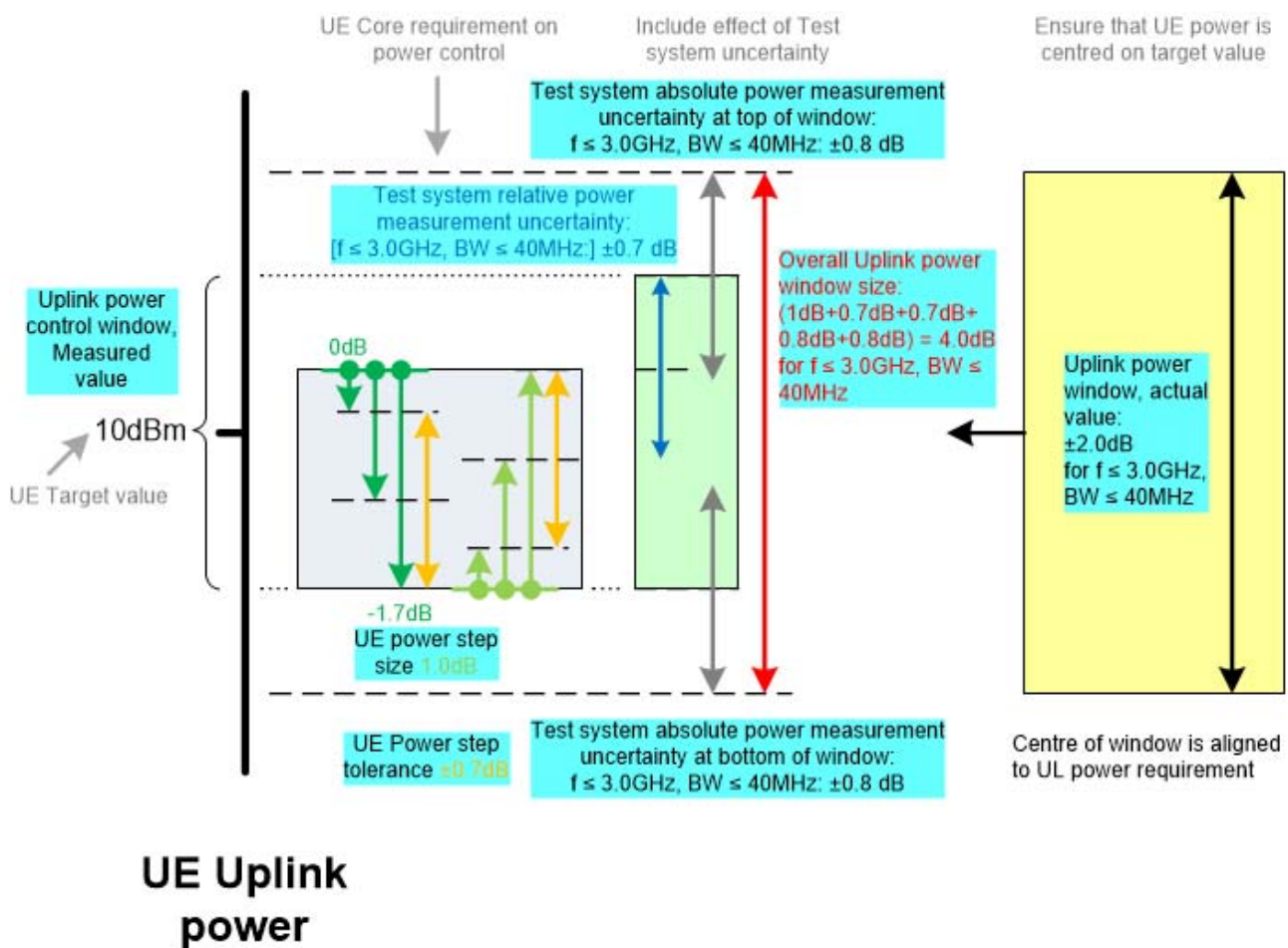

Figure F.4.4.1-1: Example NR FR1 uplink power setting centred on a target value

The smallest UE Power step size is defined in TS 38.213 [9] Table 7.1.1-1, for absolute $\delta_{\text{PUSCH},f,c}$.

The UE Power step size tolerance is defined in TS 38.101-1 [2] Table 6.3.4.3-1, for PUSCH to PUSCH transitions with the allocated resource blocks fixed in frequency and no transmission gaps other than those generated by downlink subframes, DwPTS fields or Guard Periods, and for a power step $\Delta P \leq 1$ dB.

The Test system uncertainties are defined in Annex F of the present document.

To ensure that the actual UE uplink power is centred on the target value, UE uplink power measured by the test system should remain within the smaller Uplink power control window shown in Figure F.4.4.1-1.

F.4.4.2 NR FR2

[FFS]

F.4.4.3 E-UTRA

Information from the core requirements in TS 36.101 [5], TS 36.213 [20] and the uncertainties in Annex F applicable to the Test case are used to derive the uplink power window. There are 4 stages:

- Find the uplink power target value.
- Determine how closely the uplink power can be set to the target value.
- Include the effect of test system uncertainty.
- Position the Uplink power window centred on the target value.

This process is shown in the diagram below, using values for $f \leq 3\text{GHz}$ and $\text{BW} \leq 40\text{MHz}$ and taking an example where the target value is -10dBm :

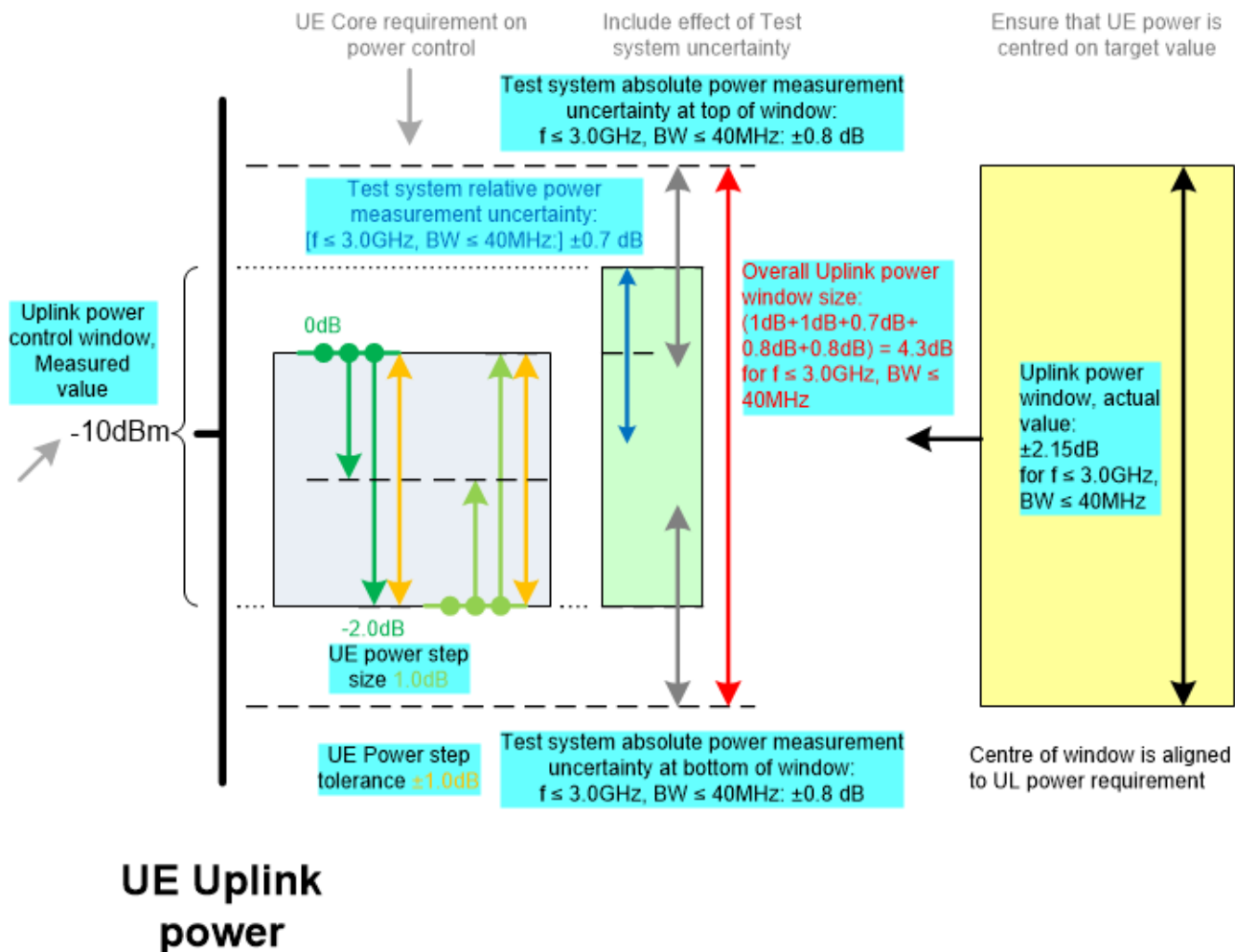

Figure F.4.4.3-1: Example E-UTRA uplink power setting centred on a target value

The smallest UE Power step size is defined in TS 36.213 [20] Table 5.1.1.1-2, for absolute δ_{PUSCH} .

The UE Power step size tolerance is defined in TS 36.101 [5] Table 6.3.5.2.1-1, for PUSCH to PUSCH transitions with the allocated resource blocks fixed in frequency and no transmission gaps other than those generated by downlink subframes, DwPTS fields or Guard Periods, and for a power step $\Delta P \leq 1$ dB.

The Test system uncertainties are defined in Annex F of the present document.

To ensure that the actual UE uplink power is centred on the target value, UE uplink power measured by the test system should remain within the smaller Uplink power control window shown in Figure F.4.4.3-1.

Annex G (normative): Uplink Physical Channels

Please refer to Annex G in TS 38.521-1 [8] and TS 38.521-2 [9] for appropriate details as needed for test cases in this test specification. EN-DC exceptions will be added,

Annex H (normative): Statistical Testing

Editor's Note:

- Further investigate the technical details behind this statistical method to ensure that this is applicable for FR2 radiated test cases.

H.1 General

This annex specifies mapping throughput to error ratio, pass fail limits and pass fail decision rules that are needed for measuring average throughput for a duration sufficient to achieve statistical significance for testing receiver characteristics.

H.2 Statistical testing of receiver characteristics

H.2.1 General

The test of receiver characteristics is twofold.

1. A signal or a combination of signals is offered to the RX port(s) of the receiver.
2. The ability of the receiver to demodulate /decode this signal is verified by measuring the throughput.

In (2) is the statistical aspect of the test and is treated here.

The minimum requirement for all receiver tests is >95% of the maximum throughput.

All receiver tests are performed in static propagation conditions. No fading conditions are applied.

H.2.2 Mapping throughput to error ratio

- a) The measured information bit throughput R is defined as the sum (in kilobits) of the information bit payloads successfully received during the test interval, divided by the duration of the test interval (in seconds).
- b) In measurement practice the UE indicates successfully received information bit payload by signalling an ACK to the SS.
If payload is received, but damaged and cannot be decoded, the UE signals a NACK.
- c) Only the ACK and NACK signals, not the data bits received, are accessible to the SS.
The number of bits is known in the SS from knowledge of what payload was sent.
- d) For the reference measurement channel, applied for testing, the number of bits is different in different subframes, however in a radio frame it is fixed during one test.
- e) The time in the measurement interval is composed of successfully received subframes (ACK), unsuccessfully received subframes (NACK) and no reception at all (DTX-subframes).
- f) DTX-subframes may occur regularly according the applicable reference measurement channel (regDTX).
In real live networks this is the time when other UEs are served. In TDD these are the UL and special subframes. regDTX vary from test to test but are fixed within the test.
- g) Additional DTX-subframes occur statistically when the UE is not responding ACK or NACK where it should. (statDTX)
This may happen when the UE was not expecting data or decided that the data were not intended for it.

The pass / fail decision is done by observing the:

- number of NACKs

- number of ACKs and
- number of statDTXs (regDTX is implicitly known to the SS)

The ratio $(NACK + statDTX) / (NACK + statDTX + ACK)$ is the Error Ratio (ER). Taking into account the time consumed by the ACK, NACK, and DTX-TTIs (regular and statistical), ER can be mapped unambiguously to throughput for any single reference measurement channel test.

H.2.3 Design of the test

The test is defined by the following design principles (see clause H.x, Theory...):

1. The early decision concept is applied.
2. A second limit is introduced: Bad DUT factor $M > 1$
3. To decide the test pass:
 - Supplier risk is applied based on the Bad DUT quality
 - To decide the test fail
 - Customer Risk is applied based on the specified DUT quality

The test is defined by the following parameters:

1. Limit ER = 0.05 (Throughput limit = 95%)
2. Bad DUT factor $M = 1.5$ (selectivity)
3. Confidence level CL = 95% (for specified DUT and Bad DUT-quality)

H.2.4 Numerical definition of the pass fail limits

Table H.2.4-1: pass fail limits

ne	ns _p	ns _f	ne	ns _p	ns _f	ne	ns _p	ns _f	ne	ns _p	ns _f
0	67	NA	39	763	500	78	1366	1148	117	1951	1828
1	95	NA	40	778	516	79	1381	1166	118	1965	1845
2	119	NA	41	794	532	80	1396	1183	119	1980	1863
3	141	NA	42	810	548	81	1412	1200	120	1995	1881
4	162	NA	43	826	564	82	1427	1217	121	2010	1899
5	183	NA	44	842	580	83	1442	1234	122	2025	1916
6	202	NA	45	858	596	84	1457	1252	123	2039	1934
7	222	NA	46	873	612	85	1472	1269	124	2054	1952
8	241	NA	47	889	629	86	1487	1286	125	2069	1969
9	259	NA	48	905	645	87	1502	1303	126	2084	1987
10	278	76	49	920	661	88	1517	1321	127	2099	2005
11	296	88	50	936	678	89	1532	1338	128	2113	2023
12	314	100	51	952	694	90	1547	1355	129	2128	2040
13	332	113	52	967	711	91	1562	1373	130	2143	2058
14	349	126	53	983	727	92	1577	1390	131	2158	2076
15	367	140	54	998	744	93	1592	1407	132	2172	2094
16	384	153	55	1014	760	94	1607	1425	133	2187	2111
17	401	167	56	1029	777	95	1623	1442	134	2202	2129
18	418	181	57	1045	793	96	1637	1459	135	2217	2147
19	435	195	58	1060	810	97	1652	1477	136	2231	2165
20	452	209	59	1076	827	98	1667	1494	137	2246	2183
21	469	224	60	1091	844	99	1682	1512	138	2261	2201
22	486	238	61	1106	860	100	1697	1529	139	2275	2218
23	503	253	62	1122	877	101	1712	1547	140	2290	2236
24	519	268	63	1137	894	102	1727	1564	141	2305	2254
25	536	283	64	1153	911	103	1742	1582	142	2320	2272
26	552	298	65	1168	928	104	1757	1599	143	2334	2290
27	569	313	66	1183	944	105	1772	1617	144	2349	2308
28	585	328	67	1199	961	106	1787	1634	145	2364	2326
29	602	343	68	1214	978	107	1802	1652	146	2378	2344
30	618	359	69	1229	995	108	1817	1669	147	2393	2361
31	634	374	70	1244	1012	109	1832	1687	148	2408	2379
32	650	389	71	1260	1029	110	1847	1704	149	2422	2397
33	667	405	72	1275	1046	111	1861	1722	150	2437	2415
34	683	421	73	1290	1063	112	1876	1740	151	2452	2433
35	699	436	74	1305	1080	113	1891	1757	152	2466	2451
36	715	452	75	1321	1097	114	1906	1775	153*)	NA	2469
37	731	468	76	1336	1114	115	1921	1793			
38	747	484	77	1351	1131	116	1936	1810	*) note 2 in H.2.5		

NOTE 1: The first column is the number of errors (ne = number of NACK + statDTX)

NOTE 2: The second column is the number of samples for the pass limit (ns_p, ns=Number of Samples= number of NACK + statDTX + ACK)

NOTE 3: The third column is the number of samples for the fail limit (ns_f)

H.2.5 Pass fail decision rules

The pass fail decision rules apply for a single test, comprising one component in the test vector. The over all Pass /Fail conditions are defined in clause H.2.6 and H.2A.6

Having observed 0 errors, pass the test at 67+ samples, otherwise continue

Having observed 1 error, pass the test at 95+ otherwise continue

Having observed 2 errors, pass the test at 119+ samples, fail the test at 2- samples, otherwise continue

Etc. etc.

Having observed 151 errors, pass the test at 2452+ samples, fail the test at 2433- samples, otherwise continue

Having observed 152 errors, pass the test at 2466+ samples, fail the test at 2451- samples.

Where x+ means: x or more, x- means x or less

NOTE 1: an ideal DUT passes after 67 samples. The maximum test time is 2466 samples.

NOTE 2: It is allowed to deviate from the early decision concept by postponing the decision (pass/fail or continue). Postponing the decision to or beyond the end of Table H.2.4-1 requires a pass fail decision against the test limit: pass the DUT for $ER < 0.0618$, otherwise fail.

Annex I (normative):
Void

Annex J (normative): Test applicability per permitted test method

Please refer to Annex J in TS 38.521-1 [8] and 38.521-2 [9] for appropriate details as needed for test cases in this test specification. Exceptions for EN-DC may be added as needed.

Annex K (normative): EIRP, TRP, and EIS measurement procedures

Please refer to Annex K in 38.521-2 [9] for appropriate details as needed for test cases in this test specification. Exceptions for EN-DC may be added as needed.

Annex L (normative):
Void

Annex M (normative): Dual uplink interferer

UE is mandated to support operation in dual and triple uplink mode for EN-DC configuration in NR FR1 listed in Table 5.5B.2-1, Table 5.5B.3-1, and Table 5.5B.4.1-1 and indicated by column single uplink allowed, Table 7.3B.2.0.3.5.1-1, Table 7.3B.2.0.3.5.2-0, Table 7.3B.2.0.3.5.2-1 or NE-DC configuration in NR FR1 listed in Table 5.5B.4a.1-1 and indicated by column single uplink allowed if the intermodulation products caused by the dual uplink operation do not interfere with its own primary downlink transmission channel bandwidth. For intermodulation products falling into LTE secondary downlink channel bandwidth, UE single UL capability is not considered.

Formula for determining if the EN-DC in NR FR1 configuration with dual uplink operation interferes with its own downlink reception.

Interference bandwidth: $IBW = |a| * CBW1 + |b| * CBW2$

- $|a| + |b| = 2$ (or 3)
- CBW1 and CBW2 are the transmission bandwidth configurations of the UL channels

Center frequency of IBW: $f_{IBW} = |a * f1 + b * f2|$

- f1 and f2 are center frequency of the transmission bandwidth configurations of each UL channel

The range of IMD 2 (or 3): $[f_{IBW} - IBW/2, f_{IBW} + IBW/2]$

NOTE 1: UE shall be able to apply operations which are configured by RRC reconfiguration and corresponding HARQ timing on the transmission bandwidth.

NOTE 2: For identified difficult band combination, during two adjacent RRC reconfiguration, the changing of transmission bandwidth should not introduce IM2 and IM3, which will result in UE changing from 2Tx to 1Tx. Otherwise, UE behavior is not specified.

For DC_3A_n3A intra-band non-contiguous EN-DC combination, only single switched UL is supported in Rel-15.

For DC_2A_n2A, DC_66A_n66A intra-band non-contiguous EN-DC combination, only single switched UL is supported.

Annex N (normative): Modified MPR behaviour

Editor's note: The *modifiedMPRbehavior* is given in the Annex H.1 of TS 38.101-3.

N.1 Indication of modified MPR behaviour

This annex contains the definitions of the bits in the field *modifiedMPRbehavior* indicated in the IE RF-Parameters [13] by a UE supporting an MPR or A-MPR modified in a later release of this specification. *modifiedMPRbehavior* is indicated in TS 36.211 [13] by an 8-bit bitmap per NR band.

Table N.1-1: Definitions of the bits in the field *modifiedMPRbehavior*

NR Band	Index of field (bit number)	Definition (description of the supported functionality if indicator set to one)	Notes
n41	0 (leftmost bit)	- EN-DC contiguous intraband MPR as defined in clause 6.2B.2.1 of 38.101-3 v15.5.0	- This bit may be set to 1 by a UE supporting DC_(n)41AA UE EN-DC
	1	- EN-DC non-contiguous intraband MPR as defined in clause 6.2B.2.2 of 38.101-3 v15.5.0	- This bit may be set to 1 by a UE supporting DC_41A_n41A EN-DC
n71	0 (leftmost bit)	- EN-DC contiguous intraband MPR as defined in clause 6.2B.2.1 of 38.101-3 v15.5.0	- This bit may be set to 1 by a UE supporting DC_(n)71AA UE EN-DC

Annex O (informative): Change history

Change history							
Date	Meeting	TDoc	CR	R ev	Cat	Subject/Comment	New version
2017-08	RAN5#76	R5-174710	-	-	-	Draft skeleton	0.0.1
2018-01	RAN5#1-5G-NR Adhoc	R5-180086	-	-	-	TP to add clause 6.2B.3.3 UE A-MPR intra-band EN-DC to 38.521-3	0.1.0
2018-01	RAN5#1-5G-NR Adhoc	R5-180087	-	-	-	TP to add clause 6.5B.2.1.2 Additional Spectrum emissions mask (contiguous sub-blocks) for intra-band EN-DC to 38.521-3	0.1.0
2018-02	RAN5#78	R5-181509	-	-	-	Updated 38.521-3 for new Annex A Dual uplink interferer information	0.2.0
2018-02	RAN5#78	R5-181690	-	-	-	Updated 38.521-3 for channel bandwidth information	0.2.0
2018-03	RAN5#2-5G-NR Adhoc	R5-181760	-	-	-	Draft TS 38.521-3 0.3.0	0.3.0
2018-04	RAN5#2-5G-NR Adhoc	R5-182035	-	-	-	5G-NR Text Proposal to add spurious emissions test case to 38.521-3	0.4.0
2018-04	RAN5#2-5G-NR Adhoc	R5-182016	-	-	-	TP for new test case: 6.5B.2.1.3, Adjacent channel leakage ratio for intra-band contiguous EN-DC	0.4.0
2018-04	RAN5#2-5G-NR Adhoc	R5-182017	-	-	-	TP to update clause 6.2B.3.1 UE A-MPR intra-band EN-DC to 38.521-3	0.4.0
2018-04	RAN5#2-5G-NR Adhoc	R5-182018	-	-	-	TP to update clause 6.5B.2.1.2 Additional spectrum emission mask to 38.521-3	0.4.0
2018-04	RAN5#2-5G-NR Adhoc	R5-181807	-	-	-	Update to Operating bands of 38.521-3	0.4.0
2018-04	RAN5#2-5G-NR Adhoc	R5-181808	-	-	-	Update to clause 3 and clause 4 of 38.521-3	0.4.0
2018-04	RAN5#2-5G-NR Adhoc	R5-181828	-	-	-	Updated 38.521-3 for channel bandwidth information with new structure	0.4.0
2018-07	RAN5#79	R5-183961	-	-	-	5G_FR1_EN_DC_RF_sensitivity_for_DC	0.5.0
2018-07	RAN5#79	R5-183962	-	-	-	Introduction of TC 6.2B.1.3 for EN-DC	0.5.0
2018-07	RAN5#79	R5-183949	-	-	-	Statistical Testing Annex for 38.521-3	0.5.0
2018-07	RAN5#79	R5-182995	-	-	-	Corrections annex for EIRP and TRP metric definition in TS 38.521-3	0.5.0
2018-07	RAN5#79	R5-183707	-	-	-	TP for updating test case 6.2B.2.1, UE Maximum Output Power reduction for Intra-Band Contiguous EN-DC	0.5.0
2018-07	RAN5#79	R5-183708	-	-	-	Updated clause 5.5B Configuration for DC to 38.521-3	0.5.0
2018-07	RAN5#79	R5-183709	-	-	-	TP to add Occupied BW EN-DC test case	0.5.0
2018-07	RAN5#79	R5-183710	-	-	-	TP to add SEM EN-DC test case	0.5.0
2018-07	RAN5#79	R5-183711	-	-	-	TP to add ACLR EN-DC test case	0.5.0
2018-09	RAN5#80	R5-185563	-	-	-	FR2_StoreTxRxBeamPeakCoordinates_38.521-3	1.0.0
2018-09	RAN5#80	R5-185520	-	-	-	Addition of TRx MU and TT in TS 38.521-3 Annex	1.0.0
2018-09	RAN5#80	R5-185503	-	-	-	Add Clause 7.5B.1 into TS 38.521-3	1.0.0
2018-09	RAN5#80	R5-185504	-	-	-	Add Clause 7.5B.2 into TS 38.521-3	1.0.0
2018-09	RAN5#80	R5-185505	-	-	-	Add Clause 7.5B.3 into TS 38.521-3	1.0.0
2018-09	RAN5#80	R5-184579	-	-	-	Updated EN-DC configuration information in clause 5	1.0.0
2018-09	RAN5#80	R5-184580	-	-	-	TIB value add for EN-DC band in 38.521-3	1.0.0
2018-09	RAN5#80	R5-184671	-	-	-	Update of References in clause 2 of 38.521-3 spec	1.0.0
2018-09	RAN5#80	R5-184672	-	-	-	Updates to Operating Bands in clause 5.2	1.0.0
2018-09	RAN5#80	R5-184737	-	-	-	Dual uplink interferer updated to 38.521-3	1.0.0
2018-09	RAN5#80	R5-184737	-	-	-	Dual uplink interferer updated to 38.521-3	1.0.0
2018-09	RAN5#80	R5-185332	-	-	-	Addition of 6.2B.4.1.1 Configured OP for Intra-Band Contiguous EN-DC	1.0.0
2018-09	RAN5#80	R5-185333	-	-	-	Addition of 6.2B.4.1.2 Configured OP for Intra-Band Non-Contiguous EN-DC	1.0.0
2018-09	RAN5#80	R5-185507	-	-	-	Addition of 6.2B.4.1.3 Configured OP for Inter-Band within FR1	1.0.0
2018-09	RAN5#80	R5-185198	-	-	-	Addition of 6.2B.4.1.4 Configured OP for Inter-Band EN-DC including FR2	1.0.0
2018-09	RAN5#80	R5-185199	-	-	-	Addition of 6.2B.4.1.5 Configured OP for Inter-Band EN-DC including both FR1 and FR2	1.0.0
2018-09	RAN5#80	R5-185469	-	-	-	TP for updating test case 6.2B.3.1 UE AMPR for Intra-band contiguous EN-DC	1.0.0
2018-09	RAN5#80	R5-185470	-	-	-	TP for updating test case 6.2B.3.2 UE AMPR for Intra-band non-contiguous EN-DC	1.0.0
2018-09	RAN5#80	R5-185200	-	-	-	TP for updating test case 6.5B.2.1.2 Additional spectrum emission mask for intra-band contiguous EN-DC	1.0.0

2018-09	RAN5#80	R5-185556	-	-	-	FR2_UE_BeamlockInvoke_38.521-3	1.0.0
2018-09	RAN5#80	R5-185472	-	-	-	Update of TC 6.2B.1.1	1.0.0
2018-09	RAN5#80	R5-185473	-	-	-	Introduction of TC 6.2B.1.2	1.0.0
2018-09	RAN5#80	R5-185474	-	-	-	Update of 6.2B.1.3	1.0.0
2018-09	RAN5#80	R5-185201	-	-	-	Introduction of TC 7.4B.1	1.0.0
2018-09	RAN5#80	R5-185202	-	-	-	Introduction of 7.4B.2	1.0.0
2018-09	RAN5#80	R5-185203	-	-	-	Introduction of 7.4B.3	1.0.0
2018-09	RAN5#80	R5-185479	-	-	-	Update Occupied Bandwidth for interband EN-DC within FR1	1.0.0
2018-09	RAN5#80	R5-185480	-	-	-	Update SEM interband EN-DC within FR1	1.0.0
2018-09	RAN5#80	R5-185481	-	-	-	Update ACLR for interband EN-DC within FR1	1.0.0
2018-09	RAN5#80	R5-185204	-	-	-	5G NR_EN_DC with FR1_Text update for RX sensitivity	1.0.0
2018-09	RAN5#80	R5-185205	-	-	-	5G NR_EN_DC with FR1_Text_proposal for_TX_Spurious_emission	1.0.0
2018-09	RAN5#80	R5-185422	-	-	-	Alignment of Annex numbering with core spec	1.0.0
2018-09	RAN5#80	R5-184897	-	-	-	Updates to Channel Arrangement clause in 38.521-3	1.0.0
2018-09	RAN5#80	R5-185206	-	-	-	Addition of TC6.3B.1.1 Minimum Output power for intra-band contiguous EN-DC	1.0.0
2018-09	RAN5#80	R5-185207	-	-	-	Addition of TC6.3B.1.2 Minimum output power for intra-band non-contiguous EN-DC	1.0.0
2018-09	RAN5#80	R5-185208	-	-	-	Addition of TC6.3B.1.3 Minimum output power for inter-band EN-DC within FR1	1.0.0
2018-09	RAN5#80	R5-185351	-	-	-	Update across EN-DC RF test cases in TS 38.521-3	1.0.0
2018-09	RAN#81	-	-	-	-	raised to v15.0.0 with editorial changes only	15.0.0
2018-12	RAN#82	R5-186503	0033	-	F	FR2 Spurious Emission test case updates	15.1.0
2018-12	RAN#82	R5-186506	0034	-	F	Update Text on Store Beam Peak Coordinate	15.1.0
2018-12	RAN#82	R5-186507	0035	-	F	38.521-3 Applicability Rules	15.1.0
2018-12	RAN#82	R5-186601	0039	-	F	5G NR_EN_DC with FR1_Text update for Intra-Band Contiguous RX sensitivity	15.1.0
2018-12	RAN#82	R5-186602	0040	-	F	5G NR_Text update for TX spurious emission intra-band contiguous EN-DC	15.1.0
2018-12	RAN#82	R5-186608	0042	-	F	Spurious emission band UE co-existence for Inter-band EN-DC within FR1	15.1.0
2018-12	RAN#82	R5-186672	0044	-	F	Updating test case 6.2B.3.1 Additional Maximum Output Power reduction for Intra-band contiguous EN-DC	15.1.0
2018-12	RAN#82	R5-186673	0045	-	F	Updating test case 6.5B.2.1.2 Additional spectrum emissions mask for intra-band contiguous EN-DC	15.1.0
2018-12	RAN#82	R5-186681	0046	-	F	Updates to EN-DC test case 6.2B.2.1, UE Maximum Output Power reduction for Intra-Band Contiguous EN-DC	15.1.0
2018-12	RAN#82	R5-186684	0047	-	F	Updates to test case 6.2B.2.3, UE Maximum Output Power reduction for Inter-Band EN-DC within FR1	15.1.0
2018-12	RAN#82	R5-186788	0049	-	F	Minor update OBW, SEM and ACLR inter-band FR1 test cases	15.1.0
2018-12	RAN#82	R5-187153	0061	-	F	Updated EN-DC configuration information in clause 5	15.1.0
2018-12	RAN#82	R5-187371	0076	-	F	Addition of TC6.3B.2.1 Transmit OFF Power for intra-band contiguous EN-DC	15.1.0
2018-12	RAN#82	R5-187372	0077	-	F	Addition of TC6.3B.2.3 Transmit OFF Power for inter-band EN-DC within FR1	15.1.0
2018-12	RAN#82	R5-187373	0078	-	F	Addition of TC6.3B.2.2 Transmit OFF Power for intra-band non-contiguous EN-DC	15.1.0
2018-12	RAN#82	R5-187552	0083	-	F	Updates to TS 38.521-3 common sections 1-4 to align with core spec	15.1.0
2018-12	RAN#82	R5-187559	0084	-	F	Updates to TS 38.521-3 clause 5 to align with core spec	15.1.0
2018-12	RAN#82	R5-187562	0085	-	F	Update to TC6.5B.3.2.1 - General Spurious Emissions for intra-band non-contiguous EN-DC	15.1.0
2018-12	RAN#82	R5-187563	0086	-	F	Update to 7.3B.2.2 - REFSENS for Intra-band Non-Contiguous EN-DC	15.1.0
2018-12	RAN#82	R5-187565	0087	-	F	Updates to TS 38.521-3 clause 4 with LTE anchor details	15.1.0
2018-12	RAN#82	R5-187614	0094	-	F	Updates to EN-DC test case 6.2B.2.2, UE Maximum Output Power reduction for Intra-Band Non-Contiguous EN-DC	15.1.0
2018-12	RAN#82	R5-187816	0048	1	F	Adding test case 6.2B.2.4, UE Maximum Output Power reduction for Inter-Band EN-DC including FR2	15.1.0
2018-12	RAN#82	R5-187819	0053	1	F	Update general parameter Connection without release in initial conditions in TS 38.521-3	15.1.0
2018-12	RAN#82	R5-187820	0043	1	F	Updates to test case 6.5B.2.1.3, Adjacent channel leakage ratio for intra-band contiguous EN-DC	15.1.0
2018-12	RAN#82	R5-187821	0052	1	F	Addition OBW intraband non contiguous EN-DC	15.1.0
2018-12	RAN#82	R5-187822	0055	1	F	Introduction of New test case 6.4B.2.2.1 Error Vector Magnitude for intra-band non-contiguous EN-DC	15.1.0
2018-12	RAN#82	R5-187823	0056	1	F	Introduction of New test case 6.4B.2.2.2 Carrier Leakage for intra-band non-contiguous EN-DC	15.1.0
2018-12	RAN#82	R5-187825	0058	1	F	Introduction of New test case 6.4B.2.3.1 Error Vector Magnitude for inter-band EN-DC within FR1	15.1.0
2018-12	RAN#82	R5-187826	0059	1	F	Introduction of New test case 6.4B.2.3.2 Carrier Leakage for inter-band EN-DC within FR1	15.1.0

2018-12	RAN#82	R5-187827	0060	1	F	Introduction of New test case 6.4B.2.3.3 In-band Emissions for inter-band EN-DC within FR1	15.1.0
2018-12	RAN#82	R5-187828	0070	1	F	Introduction of Error Vector Magnitude for intra-band contiguous EN-DC	15.1.0
2018-12	RAN#82	R5-187829	0071	1	F	Introduction of Carrier Leakage for intra-band contiguous EN-DC	15.1.0
2018-12	RAN#82	R5-187831	0088	1	F	FR2 General Spurious Emission test case update	15.1.0
2018-12	RAN#82	R5-187832	0089	1	F	FR2 Reference Sensitivity test case update	15.1.0
2018-12	RAN#82	R5-187833	0092	1	F	Updates to clause 7.3B.3.4 in TS 38.521-3	15.1.0
2018-12	RAN#82	R5-187834	0090	1	F	Updates to sections 1-4 in TS 38.521-3 to align with core spec	15.1.0
2018-12	RAN#82	R5-187835	0091	1	F	Updates to Clause 5 in TS 38.521-3	15.1.0
2018-12	RAN#82	R5-187913	0067	1	F	Addition of notes to clarify test point selection into general clause of TS 38.521-3	15.1.0
2018-12	RAN#82	R5-188012	0057	1	F	Introduction of New test case 6.4B.2.2.3 In-band Emissions for intra-band non-contiguous EN-DC	15.1.0
2018-12	RAN#82	R5-188013	0050	1	F	Addition OBW intra-band contiguous EN-DC	15.1.0
2018-12	RAN#82	R5-188014	0051	1	F	Addition SEM intra-band contiguous EN-DC	15.1.0
2018-12	RAN#82	R5-188015	0064	1	F	Additional Spurious Emissions for Intra-band contiguous EN-DC	15.1.0
2018-12	RAN#82	R5-188016	0065	1	F	Additional Spurious Emissions for Intra-band non-contiguous EN-DC	15.1.0
2018-12	RAN#82	R5-188017	0066	1	F	Additional Spurious emission for inter-band EN-DC	15.1.0
2018-12	RAN#82	R5-188018	0068	1	F	Spurious emission band UE co-existence for intra-band non-contiguous EN-DC	15.1.0
2018-12	RAN#82	R5-188019	0072	1	F	Introduction of In-band Emissions for intra-band contiguous EN-DC	15.1.0
2018-12	RAN#82	R5-188020	0073	1	F	Addition of TC6.3B.3.1 Tx ON/OFF time mask for intra-band contiguous EN-DC	15.1.0
2018-12	RAN#82	R5-188021	0074	1	F	Addition of TC6.3B.3.2 Tx ON/OFF time mask for intra-band non-contiguous EN-DC	15.1.0
2018-12	RAN#82	R5-188022	0075	1	F	Addition of TC6.3B.3.3 Tx ON/OFF time mask for inter-band EN-DC within FR1	15.1.0
2018-12	RAN#82	R5-188023	0080	1	F	Update of test case 6.5B.2.1.2 Additional spectrum emission mask for intra-band contiguous EN-DC for NS_04	15.1.0
2018-12	RAN#82	R5-188024	0081	1	F	Update of test case 6.2B.3.1 UE A-MPR for Intra-band contiguous EN-DC for NS_04	15.1.0
2018-12	RAN#82	R5-188025	0038	1	F	Update Clause 7.5B.3 in TS 38.521-3	15.1.0
2018-12	RAN#82	R5-188026	0041	1	F	5G NR_EN_DC with FR1_Text update for Inter-Band RX sensitivity	15.1.0
2018-12	RAN#82	R5-188027	0082	1	F	Update TC 7.4B.3	15.1.0
2018-12	RAN#82	R5-188028	0036	1	F	Updates of MU in TS 38.521-3 Annex F during RAN5#81	15.1.0
2018-12	RAN#82	R5-188029	0037	1	F	Updates of TT in TS 38.521-3 Annex F during RAN5#81	15.1.0
2018-12	RAN#82	R5-188039	0093	1	F	LTE Anchor Link configuration for FR2	15.1.0
2018-12	RAN#82	R5-188219	0062	1	F	Introduction of receiver spurious emission tests for FR1 inter-band EN-DC	15.1.0
2018-12	RAN#82	R5-188220	0063	1	F	Introduction of wideband intermodulation tests for FR1 inter-band EN-DC	15.1.0
2018-12	RAN#82	R5-188221	0054	1	F	LTE TDD configuration for UE Tx test in EN-DC	15.1.0
2018-12	RAN#82	R5-188222	0069	1	F	Core alignment CR to capture TS 38.101-3 updates during RAN4#89	15.1.0
2019-03	RAN#83	R5-191057	0165	-	F	Introduction of TC 7.5B.0	15.2.0
2019-03	RAN#83	R5-191157	0174	-	F	Updated EN-DC configuration information in clause 5	15.2.0
2019-03	RAN#83	R5-191231	0175	-	F	Adding missing reference to 38.521-3	15.2.0
2019-03	RAN#83	R5-191336	0176	-	F	Updates to EN-DC test case 6.2B.2.1, UE Maximum Output Power reduction for Intra-Band Contiguous EN-DC	15.2.0
2019-03	RAN#83	R5-191339	0177	-	F	Updates to EN-DC test case 6.2B.2.2, UE Maximum Output Power reduction for Intra-Band Non-Contiguous EN-DC	15.2.0
2019-03	RAN#83	R5-191340	0178	-	F	Adding test case 6.5A.2.3, Adjacent channel leakage ratio for CA without EN-DC	15.2.0
2019-03	RAN#83	R5-191510	0183	-	F	Shared Risk clarification in TS 38.521-3	15.2.0
2019-03	RAN#83	R5-191637	0193	-	F	Updates of TT in TS 38.521-3 Annex F during RAN5#NR4	15.2.0
2019-03	RAN#83	R5-191845	0200	-	F	Text update for 7.3B.3 deltaRIB,c deltaRIBNC for EN-DC	15.2.0
2019-03	RAN#83	R5-191867	0205	-	F	Addition of 7.3B.2.0 Reference sensitivity Minimum Conformance Requirements for EN-DC	15.2.0
2019-03	RAN#83	R5-192004	0215	-	F	Update of TC 6.2B.1.1	15.2.0
2019-03	RAN#83	R5-192005	0216	-	F	Update of TC 6.2B.1.2	15.2.0
2019-03	RAN#83	R5-192006	0217	-	F	Update of TC 6.2B.1.3	15.2.0
2019-03	RAN#83	R5-192176	0224	-	F	TIB,c updated for CA and EN-DC cases	15.2.0
2019-03	RAN#83	R5-192177	0225	-	F	Updated to Annex M Dual uplink interferer	15.2.0
2019-03	RAN#83	R5-192206	0228	-	F	38.521-3 Common clause updates to clarify leverage across architecture options	15.2.0
2019-03	RAN#83	R5-192207	0229	-	F	Formatting updates and index correction in TS 38.521-3	15.2.0
2019-03	RAN#83	R5-192208	0230	-	F	38.521-1 Common clause updates to clarify leverage across architecture options	15.2.0
2019-03	RAN#83	R5-192209	0231	-	F	38.521-2 Common clause updates to clarify leverage across architecture options	15.2.0

2019-03	RAN#83	R5-192242	0237	-	F	Update of test case 6.2B.3.1 UE A-MPR for Intra-band contiguous EN-DC	15.2.0
2019-03	RAN#83	R5-192243	0238	-	F	Update of test case 6.2B.3.4 UE A-MPR for Inter-Band EN-DC including FR2	15.2.0
2019-03	RAN#83	R5-192244	0239	-	F	Update of test case 6.5B.2.1.2 UE Additional spectrum emissions mask for intra-band contiguous EN-DC	15.2.0
2019-03	RAN#83	R5-192423	0157	1	F	Update of TC 7.5B.1	15.2.0
2019-03	RAN#83	R5-192424	0159	1	F	Introduction of TC 7.5B.4	15.2.0
2019-03	RAN#83	R5-192425	0166	1	F	Update of TC 7.5B.3	15.2.0
2019-03	RAN#83	R5-192427	0180	1	F	Introduction of NSA FR1 7.6B.2.1 Inband blocking for intra-band contiguous EN-DC in FR1	15.2.0
2019-03	RAN#83	R5-192428	0182	1	F	Introduction of NSA FR1 7.6B.2.3 Inband blocking for inter-band EN-DC within FR1	15.2.0
2019-03	RAN#83	R5-192429	0184	1	F	Introduction of NSA FR1 7.6B.3.1 Out-of-band blocking for intra-band contiguous EN-DC in FR1	15.2.0
2019-03	RAN#83	R5-192430	0185	1	F	Introduction of NSA FR1 7.6B.3.2 Out-of-band blocking for intra-band non-contiguous EN-DC in FR1	15.2.0
2019-03	RAN#83	R5-192431	0186	1	F	Introduction of NSA FR1 7.6B.3.3 Out-of-band blocking for inter-band EN-DC within FR1	15.2.0
2019-03	RAN#83	R5-192432	0187	1	F	Introduction of NSA FR1 7.6B.4.1 Narrow band blocking for intra-band contiguous EN-DC in FR1	15.2.0
2019-03	RAN#83	R5-192433	0188	1	F	Introduction of NSA FR1 7.6B.4.2 Narrow band blocking for intra-band non-contiguous EN-DC in FR1	15.2.0
2019-03	RAN#83	R5-192434	0189	1	F	Introduction of NSA FR1 7.6B.4.3 Narrow band blocking for inter-band EN-DC within FR1	15.2.0
2019-03	RAN#83	R5-192435	0190	1	F	Introduction of NSA FR1 7.7B.1 Spurious Response for intra-band contiguous EN-DC in FR1	15.2.0
2019-03	RAN#83	R5-192436	0191	1	F	Introduction of NSA FR1 7.7B.2 Spurious Response for intra-band non-contiguous EN-DC in FR1	15.2.0
2019-03	RAN#83	R5-192437	0192	1	F	Introduction of NSA FR1 7.7B.3 Spurious Response for inter-band EN-DC within FR1	15.2.0
2019-03	RAN#83	R5-192438	0207	1	F	Text Update for 7.3B.2.2 Reference sensitivity for Intra-band non-contiguous EN-DC	15.2.0
2019-03	RAN#83	R5-192439	0234	1	F	TS 38.521-3 corrections and clean-up to TC categories within Clause 7	15.2.0
2019-03	RAN#83	R5-192440	0179	1	F	Editorial: Band combinations for Inter-band CA between FR1 and FR2	15.2.0
2019-03	RAN#83	R5-192441	0232	1	F	TS 38.521-3 clause 5 updates to align with core specification	15.2.0
2019-03	RAN#83	R5-192442	0195	1	F	Addition of TC6.3B.4.3 PRACH Time Mask for inter-band EN-DC within FR1	15.2.0
2019-03	RAN#83	R5-192443	0220	1	F	Update of EN-DC 6.2B.4.1.3 Configured transmitted power inter-band within FR1	15.2.0
2019-03	RAN#83	R5-192445	0233	1	F	TS 38.521-3 corrections and clean-up to TC categories within Clause 6	15.2.0
2019-03	RAN#83	R5-192453	0198	1	F	FR2 NSA Spurious Emission Coexistence test case	15.2.0
2019-03	RAN#83	R5-192454	0199	1	F	FR2 NSA Frequency Error test case	15.2.0
2019-03	RAN#83	R5-192455	0221	1	F	Addition of transmit modulation quality test cases for inter-band EN-DC including FR2	15.2.0
2019-03	RAN#83	R5-192456	0222	1	F	Introduction 6.5B.1.4 OBW interband EN-DC including FR2	15.2.0
2019-03	RAN#83	R5-192457	0223	1	F	Introduction 6.5B.2.4.1 SEM interband EN-DC including FR2	15.2.0
2019-03	RAN#83	R5-192458	0226	1	F	Introduction 6.5B.2.4.3 ACLR interband EN-DC including FR2	15.2.0
2019-03	RAN#83	R5-192459	0236	1	F	Addition of TC6.3B.1.4 - Minimum Output Power for EN-DC Interband including FR2	15.2.0
2019-03	RAN#83	R5-192535	0194	1	F	Clean up of occupied bandwidth for EN-DC within FR1	15.2.0
2019-03	RAN#83	R5-192600	0196	1	F	Addition of TC6.3B.4.1 PRACH Time Mask for intra-band contiguous EN-DC	15.2.0
2019-03	RAN#83	R5-192601	0197	1	F	Addition of TC6.3B.4.2 PRACH Time Mask for intra-band non-contiguous EN-DC	15.2.0
2019-03	RAN#83	R5-192603	0201	1	F	Text Update for 6.5B.3.2 Spurious Emissions for intra-band non-contiguous EN-DC	15.2.0
2019-03	RAN#83	R5-192604	0202	1	F	Text Update for 6.5B.3.1 Spurious Emissions for intra-band contiguous EN-DC	15.2.0
2019-03	RAN#83	R5-192605	0203	1	F	Text Update for 6.5B.3.3 Spurious Emissions for Inter-band EN-DC within FR1	15.2.0
2019-03	RAN#83	R5-192606	0204	1	F	Text Update for 6.5B.4 Additional Spurious Emissions for EN-DC	15.2.0
2019-03	RAN#83	R5-192607	0209	1	F	Update to Carrier Leakage for intra-band contiguous EN-DC	15.2.0
2019-03	RAN#83	R5-192608	0210	1	F	Introduction of Error Vector Magnitude for intra-band contiguous EN-DC	15.2.0
2019-03	RAN#83	R5-192609	0211	1	F	Update to In-band Emissions for intra-band contiguous EN-DC	15.2.0
2019-03	RAN#83	R5-192610	0227	1	F	Clarification on UL slots in OBW, SEM and ACLR in TS 38.521-3	15.2.0
2019-03	RAN#83	R5-192611	0158	1	F	Update of TC 7.5B.2	15.2.0
2019-03	RAN#83	R5-192617	0167	1	F	Introducing Wideband Intermodulation for intra-band EN-DC in FR1	15.2.0
2019-03	RAN#83	R5-192618	0168	1	F	Introducing receiver spurious emission for intra-band EN-DC in FR1	15.2.0

2019-03	RAN#83	R5-192619	0181	1	F	Introduction of NSA FR1 7.6B.2.2 Inband blocking for intra-band non-contiguous EN-DC in FR1	15.2.0
2019-03	RAN#83	R5-192620	0206	1	F	Text Update for 7.3B.2.1 Reference sensitivity for Intra-band Contiguous EN-DC	15.2.0
2019-03	RAN#83	R5-192622	0170	1	F	Updates of MU in TS 38.521-3 Annex F during RAN5#82	15.2.0
2019-03	RAN#83	R5-192623	0171	1	F	Updates of TT in TS 38.521-3 Annex F during RAN5#82	15.2.0
2019-03	RAN#83	R5-192626	0214	1	F	Update of TC 7.4B.2	15.2.0
2019-03	RAN#83	R5-192681	0235	1	F	Addition of TC6.2B.1.4 - Max Output Power for EN-DC Interband including FR2	15.2.0
2019-03	RAN#83	R5-192689	0218	1	F	Update of 6.2B.4.1.1 Configured output power Intra-band contiguous EN-DC	15.2.0
2019-03	RAN#83	R5-192690	0219	1	F	Update of EN-DC 6.2B.4.1.2 Configured transmitted power Intra-band non-contiguous	15.2.0
2019-03	RAN#83	R5-192844	0213	2	F	Update of TC 7.4B.1	15.2.0
2019-03	RAN#83	R5-192847	0212	1	F	Addition of 7.4B.0	15.2.0
2019-03	RAN#83	R5-192863	0172	1	F	Introduction of TxIM (inter-band EN-DC within FR1)	15.2.0
2019-03	RAN#83	-	-	-	-	Editorial correction of references to TS 38.508-1 clause 4.6 tables	15.2.0
2019-06	RAN#84	R5-193539	0294	-	F	Adding missing reference in 38.521-3	15.3.0
2019-06	RAN#84	R5-193546	0295	-	F	Updates to 6.2B.2.3, UE Maximum Output power reduction for inter-band EN-DC within FR1	15.3.0
2019-06	RAN#84	R5-193547	0296	-	F	Adding test case 6.2B.2.5, UE Maximum Output power reduction for inter-band EN-DC including both FR1 and FR2	15.3.0
2019-06	RAN#84	R5-193548	0297	-	F	Update of test case 6.2B.2.1, UE Maximum Output Power reduction for Intra-Band Contiguous EN-DC	15.3.0
2019-06	RAN#84	R5-193714	0309	-	F	Update of Clause 5.5B Configuration for DC	15.3.0
2019-06	RAN#84	R5-193719	0311	-	F	Update of TC 7.5B.2 ACS for intra-band non-contiguous 2CC	15.3.0
2019-06	RAN#84	R5-193720	0312	-	F	Update of TC 7.5B.3 ACS for inter-band FR1 2CC	15.3.0
2019-06	RAN#84	R5-193722	0314	-	F	Update of TC 7.5B.4.1 ACS for inter-band FR2 2CC	15.3.0
2019-06	RAN#84	R5-193724	0316	-	F	Introduction of TC 7.5B.4.3 ACS for inter-band FR2 4CC	15.3.0
2019-06	RAN#84	R5-193725	0317	-	F	Introduction of TC 7.5B.4.4 ACS for inter-band FR2 5CC	15.3.0
2019-06	RAN#84	R5-193726	0318	-	F	Introduction of TC 7.5B.4.5 ACS for inter-band FR2 6CC	15.3.0
2019-06	RAN#84	R5-193727	0319	-	F	Introduction of TC 7.5B.5 inter-band FR1 FR2 3CC	15.3.0
2019-06	RAN#84	R5-193886	0320	-	F	Introduction of NSA FR2 7.6B.2.4.1	15.3.0
2019-06	RAN#84	R5-193888	0322	-	F	Update of NSA FR1 7.6B.2.0	15.3.0
2019-06	RAN#84	R5-193896	0324	-	F	Update of NSA FR1 7.6B.2.2	15.3.0
2019-06	RAN#84	R5-193899	0326	-	F	Update of NSA FR1 7.6B.3.1	15.3.0
2019-06	RAN#84	R5-193900	0327	-	F	Update of NSA FR1 7.6B.3.2	15.3.0
2019-06	RAN#84	R5-193901	0328	-	F	Update of NSA FR1 7.6B.4.0	15.3.0
2019-06	RAN#84	R5-193902	0329	-	F	Update of NSA FR1 7.6B.4.1	15.3.0
2019-06	RAN#84	R5-193903	0330	-	F	Update of NSA FR1 7.6B.4.2	15.3.0
2019-06	RAN#84	R5-193904	0331	-	F	Update of NSA FR1 7.7B.0	15.3.0
2019-06	RAN#84	R5-193905	0332	-	F	Update of NSA FR1 7.7B.1	15.3.0
2019-06	RAN#84	R5-193906	0333	-	F	Update of NSA FR1 7.7B.2	15.3.0
2019-06	RAN#84	R5-193947	0343	-	F	Removing invalid test IDs from test case 6.5B.2.1.3	15.3.0
2019-06	RAN#84	R5-194016	0344	-	F	38.521-3 Annex re-alignment	15.3.0
2019-06	RAN#84	R5-194128	0347	-	F	Addition SEM intraband non-contiguous EN-DC in TS 38.521-3	15.3.0
2019-06	RAN#84	R5-194129	0348	-	F	Addition ACLR intraband non-contiguous EN-DC in TS 38.521-3	15.3.0
2019-06	RAN#84	R5-194164	0351	-	F	Update of test case 6.2B.3.1 UE A-MPR for Intra-band contiguous EN-DC	15.3.0
2019-06	RAN#84	R5-194166	0353	-	F	Update of test case 6.2B.3.3 UE A-MPR for Inter-Band EN-DC within FR1	15.3.0
2019-06	RAN#84	R5-194317	0359	-	F	Text Update for 7.3B.2.3 Reference sensitivity for Inter-band EN-DC within FR1	15.3.0
2019-06	RAN#84	R5-194318	0360	-	F	Text Update for 7.3B.2.1 Ref sensitivity for Intra-band Contiguous EN-DC	15.3.0
2019-06	RAN#84	R5-194319	0361	-	F	Text Update for 6.5B.4 Additional Spurious Emissions for EN-DC	15.3.0
2019-06	RAN#84	R5-194320	0362	-	F	Text Update for 7.3B.3	15.3.0
2019-06	RAN#84	R5-194374	0366	-	F	Text Update for 6.5B.3.3.2 Spurious emission band UE co-existence for Inter-band EN-DC within FR1	15.3.0
2019-06	RAN#84	R5-194375	0367	-	F	Text Update for 7.3B.2.2 Ref sensitivity for Intra-band Non-Contiguous EN-DC	15.3.0
2019-06	RAN#84	R5-194376	0368	-	F	Text Update for 7.3B.2.0 Min Requirements of Ref sensitivity for EN-DC	15.3.0
2019-06	RAN#84	R5-194400	0372	-	F	Update to Carrier Leakage and In-band Emissions for intra-band contiguous EN-DC	15.3.0
2019-06	RAN#84	R5-194463	0378	-	F	Update to 6.2.3 A-MPR FR2 NSA	15.3.0
2019-06	RAN#84	R5-194484	0380	-	F	Update EN-DC Transmit modulation quality test cases	15.3.0
2019-06	RAN#84	R5-194621	0381	-	F	Update of transmit modulation quality test cases for inter-band EN-DC including FR2	15.3.0

2019-06	RAN#84	R5-194706	0382	-	F	TS 38.521-3 clause 5 updates to align with core specification	15.3.0
2019-06	RAN#84	R5-194707	0383	-	F	TS 38.521-3 updates across clause 6 test cases	15.3.0
2019-06	RAN#84	R5-194708	0384	-	F	TS 38.521-3 updates across clause 7 test cases	15.3.0
2019-06	RAN#84	R5-194725	0388	-	F	Update to clarify number of LTE CCs config for anchor agnostic EN-DC RF tests	15.3.0
2019-06	RAN#84	R5-194934	0334	1	F	Update of NSA FR1 RF 6.2B.1.1 MOP	15.3.0
2019-06	RAN#84	R5-194935	0335	1	F	Update of NSA FR1 RF 6.2B.1.2 MOP	15.3.0
2019-06	RAN#84	R5-194936	0337	1	F	Update of NSA FR1 RF 7.4B.1	15.3.0
2019-06	RAN#84	R5-194937	0338	1	F	Update of NSA FR1 RF 7.4B.2	15.3.0
2019-06	RAN#84	R5-194938	0298	1	F	Adding test case 6.5A.2.2, Additional Spectrum emissions mask for CA without EN-DC	15.3.0
2019-06	RAN#84	R5-194941	0350	1	F	Introduction of New test case 6.4B.2.3.4 EVM Equalizer Flatness for inter-band EN-DC within FR1	15.3.0
2019-06	RAN#84	R5-194942	0373	1	F	Update of test case 6.2A.2.1, UE maximum output power reduction for inter-band NR CA between FR1 and FR2 without EN-DC	15.3.0
2019-06	RAN#84	R5-194943	0374	1	F	Update of 6.2B.3.1 A-MPR Intra-band contiguous for NS_35	15.3.0
2019-06	RAN#84	R5-194944	0375	1	F	Update of 6.2B.3.2 A-MPR for Intra-band non-contiguous with additional test frequencies	15.3.0
2019-06	RAN#84	R5-194945	0376	1	F	Correction of editorial note in 6.5B.2.1.2	15.3.0
2019-06	RAN#84	R5-194946	0377	1	F	Update to 6.2.3 A-MPR FR1 and FR2	15.3.0
2019-06	RAN#84	R5-194947	0389	1	F	Updates to E-UTRA, FR1,FR2 IW tests in line with agreed way forward	15.3.0
2019-06	RAN#84	R5-194948	0369	1	F	Addition of msg content in TC 6.3B.4.1	15.3.0
2019-06	RAN#84	R5-194949	0370	1	F	Addition of msg content in TC 6.3B.4.2	15.3.0
2019-06	RAN#84	R5-194950	0371	1	F	Addition of msg content in TC 6.3B.4.3	15.3.0
2019-06	RAN#84	R5-194951	0310	1	F	Update of TC 7.5B.0 ACS for EN-DC	15.3.0
2019-06	RAN#84	R5-194952	0321	1	F	Introduction of NSA FR2 7.6B.2.5	15.3.0
2019-06	RAN#84	R5-194953	0323	1	F	Update of NSA FR1 7.6B.2.1	15.3.0
2019-06	RAN#84	R5-194954	0363	1	F	Updated to EN-DC band and TIB information	15.3.0
2019-06	RAN#84	R5-194955	0385	1	F	TS 38.521-3 clause 5 updates to align with core specification	15.3.0
2019-06	RAN#84	R5-194975	0315	1	F	Introduction of TC 7.5B.4.2 ACS for inter-band FR2 3CC	15.3.0
2019-06	RAN#84	R5-195046	0356	1	F	Update to Wideband Intermodulation for EN-DC in FR1- 2CCs	15.3.0
2019-06	RAN#84	R5-195047	0379	1	F	Update to 6.2.3 A-MPR FR1 and FR2 NSA	15.3.0
2019-06	RAN#84	R5-195049	0357	1	F	Correction to 6.5B.3.3.2 Spurious emission band UE co-existence for Inter-band within FR1	15.3.0
2019-06	RAN#84	R5-195050	0358	1	F	Introducing Wideband Intermodulation for EN-DC including FR1 - 3 CCs	15.3.0
2019-06	RAN#84	R5-195051	0391	-	F	Update of 6.5B.3.3.2 spurious co-existence inter-band EN-DC FR1	15.3.0
2019-06	RAN#84	R5-195091	0392	1	F	Update of EN-DC ON_ON time mask test cases	15.3.0
2019-06	RAN#84	R5-195162	0349	1	F	Introduction of New test case 6.4B.2.2.4 EVM Equalizer Flatness for intra-band non-contiguous EN-DC	15.3.0
2019-06	RAN#84	R5-195163	0364	1	F	Clean up FR2 Inter-band EN-DC test cases	15.3.0
2019-06	RAN#84	R5-195164	0390	1	F	Update to UE Maximum Output Power for Inter-Band EN-DC within FR1	15.3.0
2019-06	RAN#84	R5-195165	0325	1	F	Update of NSA FR1 7.6B.3.0	15.3.0
2019-06	RAN#84	R5-195411	0386	1	F	TS 38.521-3 updates across clause 6 test cases	15.3.0
2019-06	RAN#84	R5-195412	0387	1	F	TS 38.521-3 updates across clause 7 test cases	15.3.0
2019-06	RAN#84	R5-195419	0393	1	F	EN-DC implementation of FR2 UL demod OTA tests using single pol Rx TE	15.3.0
2019-06	RAN#84	R5-195436	0336	1	F	Update of NSA FR1 RF 6.2B.1.3 MOP	15.3.0
2019-06	RAN#84	R5-195437	0299	1	F	Updates of MU and TT in TS 38.521-3	15.3.0
2019-06	RAN#84	R5-195446	0394	1	F	Introduction of Tx test cases for FR2 NSA UL CA	15.3.0
2019-06	RAN#84	R5-193922	0340	-	F	Update of 6.2B.1.3 MOP inter-band adding Rel-16 EN-DC configurations	16.0.0
2019-06	RAN#84	R5-193923	0341	-	F	Update of 7.3B.2.3 REFSENS inter-band adding Rel-16 EN-DC configurations	16.0.0
2019-06	RAN#84	R5-194059	0345	-	F	Update of general sections adding Rel-16 EN-DC configurations, Editorial	16.0.0
2019-06	RAN#84	R5-195054	0342	1	F	Update of 6.5B.3.3.2 spurious co-existence inter-band adding Rel-16 EN-DC configurations	16.0.0
2019-09	RAN#85	R5-197441	0397	1	F	Correction of test case numbering for UL CA	16.1.0
2019-09	RAN#85	R5-197346	0398	1	F	Update of UE A_MPR intra band contiguous EN DC test case in 6.2B.3.1	16.1.0
2019-09	RAN#85	R5-197347	0399	1	F	Update of UE A_MPR intra band non contiguous EN DC test case in 6.2B.3.2	16.1.0
2019-09	RAN#85	R5-197348	0401	1	F	Addition of test case 6.5B.2.1.2 Additional Spectrum emissions mask for intra band contiguous EN DC	16.1.0
2019-09	RAN#85	R5-197349	0402	1	F	Addition of test case 6.5B.2.2.2 Additional Spectrum emissions mask for intra band non contiguous EN DC	16.1.0
2019-09	RAN#85	R5-197350	0403	1	F	Addition of test case 6.5B.2.3.2 Additional Spectrum emissions mask for Inter band EN DC within FR1	16.1.0
2019-09	RAN#85	R5-197561	0404	1	F	Refsens test case updates	16.1.0

2019-09	RAN#85	R5-197351	0405	1	F	Spurious test case updates	16.1.0
2019-09	RAN#85	R5-197331	0406	1	F	Correction to ACLR inter-band EN-DC FR1 test case	16.1.0
2019-09	RAN#85	R5-196160	0407	-	F	Clean up test cases 6.4B.2.2 Transmit Modulation Quality	16.1.0
2019-09	RAN#85	R5-196161	0408	-	F	Update to Annex F for Tx modulation quality test cases	16.1.0
2019-09	RAN#85	R5-196200	0409	-	F	Correction of uplink power setting for NSA transmitter test cases	16.1.0
2019-09	RAN#85	R5-197516	0410	1	F	Correction of uplink power setting for NSA receiver test cases	16.1.0
2019-09	RAN#85	R5-196241	0411	-	F	Correction to FR1 Transmit OFF Power	16.1.0
2019-09	RAN#85	R5-197646	0412	1	F	Correction to NR power control in FR1 Out-of-band blocking	16.1.0
2019-09	RAN#85	R5-197352	0414	1	F	Correction to FR1 PRACH time mask for EN-DC	16.1.0
2019-09	RAN#85	R5-197353	0415	1	F	Correction of NR uplink RB allocation for FR1 Inter-Band EN-DC MOP	16.1.0
2019-09	RAN#85	R5-196290	0416	-	F	Add Annex F.4 Uplink Power window explanation for interworking test cases	16.1.0
2019-09	RAN#85	R5-196296	0417	-	F	Addition of Clause 7.5A in TS 38.521-3	16.1.0
2019-09	RAN#85	R5-197549	0418	1	F	Update of 6.2B.1.1 MOP for Intra-band contiguous EN-DC	16.1.0
2019-09	RAN#85	R5-197550	0419	1	F	Update of 6.2B.1.2 MOP for Intra-band non-contiguous EN-DC	16.1.0
2019-09	RAN#85	R5-196446	0421	-	F	Editorial update of general sections adding Rel-16 EN-DC configurations	16.1.0
2019-09	RAN#85	R5-196449	0422	-	F	Correction to description of Table 4.5.1-2	16.1.0
2019-09	RAN#85	R5-197354	0423	1	F	Update for 6.5B.3.1.2 Spurious emission band UE co-existence for intra-band contiguous EN-DC	16.1.0
2019-09	RAN#85	R5-197553	0424	1	F	Update for 6.5B.3.3.2 Spurious emission band UE co-existence for Inter-band within FR1	16.1.0
2019-09	RAN#85	R5-197333	0425	1	F	Update for 7.3B.2.0 Minimum Conformance Requirements of Reference sensitivity for EN-DC	16.1.0
2019-09	RAN#85	R5-197636	0426	2	F	Update for 7.3B.2.3 Ref sensitivity for Inter-band EN-DC within FR1	16.1.0
2019-09	RAN#85	R5-197359	0427	1	F	Update for 7.3B.2.1 Reference sensitivity for Intra-band Contiguous EN-DC	16.1.0
2019-09	RAN#85	R5-197334	0428	1	F	Update for 7.3B.3.2	16.1.0
2019-09	RAN#85	R5-197335	0429	1	F	Update for 7.3B.3	16.1.0
2019-09	RAN#85	R5-197337	0430	1	F	Update for 7.3B.3.3	16.1.0
2019-09	RAN#85	R5-197338	0431	1	F	Updated to EN-DC band information	16.1.0
2019-09	RAN#85	R5-197336	0433	1	F	Update of TCs in 7.6B and 7.7B	16.1.0
2019-09	RAN#85	R5-197554	0434	1	F	Updates to 6.2B.2.1, UE Maximum Output Power reduction for Intra-Band Contiguous EN-DC	16.1.0
2019-09	RAN#85	R5-197555	0435	1	F	Update of TC 6.3B.1.1 Minimum Output Power for intra-band contiguous EN-DC	16.1.0
2019-09	RAN#85	R5-197556	0436	1	F	Update of TC 6.3B.1.2 Minimum output power for intra-band non-contiguous EN-DC	16.1.0
2019-09	RAN#85	R5-197340	0437	1	F	Update of TC 6.3B.2.1 Transmit OFF Power for intra-band contiguous EN-DC	16.1.0
2019-09	RAN#85	R5-197341	0438	1	F	Update of TC 6.3B.2.2 Transmit OFF Power for intra-band non-contiguous EN-DC	16.1.0
2019-09	RAN#85	R5-197342	0440	1	F	Update of TC 6.4B.1.1 Frequency error for Intra-band contiguous EN-DC	16.1.0
2019-09	RAN#85	R5-197557	0441	1	F	Update of TC 6.4B.1.2 Frequency error for Intra-band non-contiguous EN-DC	16.1.0
2019-09	RAN#85	R5-197343	0442	1	F	Update of TC 6.4B.1.3 Frequency error for Inter-band EN-DC within FR1	16.1.0
2019-09	RAN#85	R5-197647	0443	1	F	Correction to 7.8B.2.6 Wideband Intermodulation for EN-DC including FR1 - 3 CCs	16.1.0
2019-09	RAN#85	R5-197562	0448	1	F	Corrections to Reference sensitivity for EN-DC	16.1.0
2019-09	RAN#85	R5-196842	0449	-	F	Editorial corrections to Additional Spurious Emission test case	16.1.0
2019-09	RAN#85	R5-197360	0450	1	F	Correction to test case 7.4B.3	16.1.0
2019-09	RAN#85	R5-197558	0452	1	F	Correction to EN-DC Spurious Emissions	16.1.0
2019-09	RAN#85	R5-197345	0456	1	F	Update OBW EN-DC FR2 test case	16.1.0
2019-09	RAN#85	R5-197339	0457	1	F	TS 38.521-3 Section 5 updates to align with core specification (Covered by CR0431R1)	16.1.0
2019-09	RAN#85	R5-197542	0458	1	F	TS 38.521-3 updates across section 6 test cases	16.1.0
2019-09	RAN#85	R5-197563	0459	1	F	TS 38.521-3 updates across section 7 test cases	16.1.0
2019-09	RAN#85	R5-197559	0460	1	F	Updates to 6.2B.2.4, UE Maximum Output Power reduction for Inter-Band EN-DC including FR2	16.1.0
2019-09	RAN#85	R5-196946	0461	-	F	Corrections on UE maximum output power for DC in 38.521-3	16.1.0
2019-09	RAN#85	R5-197332	0462	1	F	Corrections on Minimum conformance requirements of A-MPR in 38.521-3	16.1.0
2019-09	RAN#85	R5-196948	0463	-	F	Corrections on clause 5 in 38.521-3	16.1.0
2019-09	RAN#85	R5-196949	0464	-	F	Corrections on clause 2-4 in 38.521-3	16.1.0
2019-09	RAN#85	R5-197633	0465	-	F	Removing test points for CP-OFDM PI/2 BPSK in test case 6.5B.2.1.1	16.1.0
2019-12	RAN#86	R5-197940	0472	-	F	Addition of 6.2B.1.5 MOP for Inter-Band EN-DC including FR1 and FR2	16.2.0

2019-12	RAN#86	R5-197944	0475	-	F	Update of 6.2B.4.1.4 configured transmitted power for Inter-Band EN-DC including FR2	16.2.0
2019-12	RAN#86	R5-197945	0476	-	F	Update of 6.2B.4.1.5 configured transmitted power for Inter-Band EN-DC including FR1 and FR2	16.2.0
2019-12	RAN#86	R5-197946	0477	-	F	Addition of 7.4A Maximum Input Level for FR1-FR2 CA	16.2.0
2019-12	RAN#86	R5-197949	0480	-	F	Addition of 7.4B.5 Maximum Input Level for inter-band EN-DC including FR1 and FR2	16.2.0
2019-12	RAN#86	R5-198045	0485	-	F	Update of TC 7.5B.0 ACS for EN-DC	16.2.0
2019-12	RAN#86	R5-198046	0486	-	F	Update of TC 7.5B.1 ACS for intra-band contiguous EN-DC 2CCs	16.2.0
2019-12	RAN#86	R5-198172	0488	-	F	Updating incorrect note in test procedure	16.2.0
2019-12	RAN#86	R5-198280	0490	-	F	Introduction of New TC 6.4B.2.1.4 EVM Equalizer Flatness for intra-band contiguous EN-DC	16.2.0
2019-12	RAN#86	R5-198403	0501	-	F	Correction to TC 6.4B.1.3 test description	16.2.0
2019-12	RAN#86	R5-198404	0502	-	F	Correction to Additional Spurious Emissions for Inter-band EN-DC within FR1	16.2.0
2019-12	RAN#86	R5-198406	0504	-	F	Correction to Spurious emission band UE co-existence for Inter-band within FR1	16.2.0
2019-12	RAN#86	R5-198537	0509	-	F	Updates to 6.2B.3.1, UE A-MPR for Intra-band Contig EN-DC	16.2.0
2019-12	RAN#86	R5-198538	0510	-	F	Updates to 6.2B.3.2, UE A-MPR for Intra-band Non-Contig EN-DC	16.2.0
2019-12	RAN#86	R5-198539	0511	-	F	Updates to 6.5B.2.1.2, Additional spectrum emission mask for intra-band Contig EN-DC	16.2.0
2019-12	RAN#86	R5-198559	0512	-	F	Updated to EN-DC band information Rel-16	16.2.0
2019-12	RAN#86	R5-198637	0513	-	F	Updated to EN-DC General clause and band information Rel-15	16.2.0
2019-12	RAN#86	R5-198685	0515	-	F	Update single allowed info and MPR test description to EN-DC configuration in 38.521-3	16.2.0
2019-12	RAN#86	R5-198686	0516	-	F	Corrections on delta TIB for EN-DC configurations in 38.521-3	16.2.0
2019-12	RAN#86	R5-198722	0519	-	F	Update for 7.3B.1 General	16.2.0
2019-12	RAN#86	R5-198734	0523	-	F	Update for 6.5B.3.3.1 General spurious emissions for Inter-band EN-DC within FR1	16.2.0
2019-12	RAN#86	R5-198735	0524	-	F	Update for 6.5B.3.3.2 Spurious emission band UE co-existence for Inter-band within FR1	16.2.0
2019-12	RAN#86	R5-199088	0466	1	F	Updates of MU and TT in TS 38.521-3	16.2.0
2019-12	RAN#86	R5-199342	0483	1	F	Updates to test case 6.2B.2.1, UE Maximum Output Power reduction for Intra-Band Contiguous EN-DC	16.2.0
2019-12	RAN#86	R5-199343	0487	1	F	Editorial correction of test description in TC 6.4B.2.3.3	16.2.0
2019-12	RAN#86	R5-199344	0478	1	F	Addition of 7.4B.3 Maximum Input Level for inter-band EN-DC within FR1	16.2.0
2019-12	RAN#86	R5-199345	0491	1	F	Update of minimum conformance requirements of 7.6B.3 and editorial correction in 7.6B and 7.7B	16.2.0
2019-12	RAN#86	R5-199346	0492	1	F	Addition of 7.6A Blocking Characteristics for CA	16.2.0
2019-12	RAN#86	R5-199347	0493	1	F	Addition of 7.6B.2.3_1 Inband blocking for EN-DC within FR1 (>2 CCs)	16.2.0
2019-12	RAN#86	R5-199348	0495	1	F	Addition of 7.6B.4.3_1 Narrow band blocking for EN-DC within FR1 (>2 CCs)	16.2.0
2019-12	RAN#86	R5-199349	0468	1	F	Add Uplink Power window explanation when centred on a target	16.2.0

2019-12	RAN#86	R5-199350	0489	1	F	Correction and addition of uplink power measurement MUs for NSA FR1 TCs	16.2.0
2019-12	RAN#86	R5-199351	0508	1	F	Addition of MU and TT for NSA 7.6B.2.3_1, 7.6B.2.4, 7.6B.2.4_1 and 7.6B.4.3_1 TCs in F.1.3 and F.3.3	16.2.0
2019-12	RAN#86	R5-199352	0529	1	F	TS 38.521-3 Section 1-5 and Annex updates to align with core specification	16.2.0
2019-12	RAN#86	R5-199377	0471	1	F	Update of 6.2B.1.4 MOP for Inter-Band EN-DC including FR2	16.2.0
2019-12	RAN#86	R5-199378	0479	1	F	Addition of 7.4B.4 Maximum Input Level for inter-band EN-DC including FR2	16.2.0
2019-12	RAN#86	R5-199413	0482	1	F	Addition of 2A-7A-7A-66A_n66A	16.2.0
2019-12	RAN#86	R5-199498	0500	1	F	Correction to minimum output power for intra-band EN-DC	16.2.0
2019-12	RAN#86	R5-199506	0496	1	F	Removal of 7.7A Spurious Response for CA	16.2.0
2019-12	RAN#86	R5-199508	0484	1	F	Updates to test case 6.2B.2.2, UE Maximum Output Power reduction for Intra-Band Non-Contiguous EN-DC	16.2.0
2019-12	RAN#86	R5-199514	0469	1	F	Update of 6.2B.1.1 MOP for Intra-Band contiguous EN-DC	16.2.0
2019-12	RAN#86	R5-199518	0467	1	F	Updates of test procedure for MOP and co-existence tests	16.2.0
2019-12	RAN#86	R5-199519	0517	1	F	Update for 6.5B.3.1.1 General spurious emissions for intra-band contiguous EN-DC	16.2.0
2019-12	RAN#86	R5-199520	0518	1	F	Update for 6.5B.3.2.1 General spurious emissions for Intra-band non-contiguous EN-DC	16.2.0
2019-12	RAN#86	R5-199521	0527	1	F	Update for Additional Spurious Emissions for Intra-band contiguous EN-DC	16.2.0
2019-12	RAN#86	R5-199522	0530	1	F	TS 38.521-3 updates across section 6 test cases	16.2.0
2019-12	RAN#86	R5-199523	0526	1	F	Update for 7.3B.2.0 Minimum Conformance Requirements of Reference sensitivity for EN-DC	16.2.0
2019-12	RAN#86	R5-199524	0531	1	F	TS 38.521-3 updates across section 7 test cases	16.2.0
2019-12	RAN#86	R5-199543	0520	1	F	Correction of E-UTRA Mid channel bandwidth	16.2.0
2019-12	RAN#86	R5-199546	0498	1	F	Corrections to DC Config and dual UL interferer	16.2.0
2019-12	RAN#86	R5-199547	0499	1	F	Corrections to EN-DC and NE-DC Configurations	16.2.0
2019-12	RAN#86	R5-199566	0494	1	F	Addition of 7.6B.2.4_1 Inband blocking for inter-band EN-DC including FR2 (>2 CCs)	16.2.0
2019-12	RAN#86	R5-199567	0522	1	F	Update to test case 7.3B.2.3	16.2.0
2019-12	RAN#86	R5-199568	0525	1	F	Update for 7.3B.2.3 Reference sensitivity for Inter-band EN-DC within FR1	16.2.0
2019-12	RAN#86	R5-199569	0528	1	F	Update 4.5 Applicability and test coverage rules	16.2.0
2020-03	RAN#87	R5-200351	0538	-	F	Updated to EN-DC band information Rel-16	16.3.0
2020-03	RAN#87	R5-200446	0549	-	F	Correction to FR1 EN-DC Spurious Test Case	16.3.0
2020-03	RAN#87	R5-200448	0551	-	F	Correction to LTE specialSubframePatterns in Maximum Output Power Test Case	16.3.0
2020-03	RAN#87	R5-200449	0552	-	F	Correction to tdm-PatternConfig in FR1 EN-DC Maximum Output Power Test Case	16.3.0
2020-03	RAN#87	R5-200599	0553	-	F	Update of 6.2B.1.3 on inter-band EN-DC MOP in 38.521-3	16.3.0
2020-03	RAN#87	R5-200651	0558	-	F	Updates to 6.2B.2.1, UE Maximum Output Power reduction for Intra-Band Contiguous EN-DC	16.3.0

2020-03	RAN#87	R5-200653	0559	-	F	Updates to 6.2B.2.2, UE Maximum Output Power reduction for Intra-Band Non-Contiguous EN-DC	16.3.0
2020-03	RAN#87	R5-200657	0560	-	F	Updates to 6.2B.2.3 and 6.2B.3.3	16.3.0
2020-03	RAN#87	R5-200668	0561	-	F	Correction of reference clause for 7.3B.2.3 Reference Sensitivity Test Procedure	16.3.0
2020-03	RAN#87	R5-200670	0563	-	F	Update reference in Test Requirement section of 6.5B.4.3.5	16.3.0
2020-03	RAN#87	R5-200728	0568	-	F	Correction of test cases in 7.6B.2 Inband blocking for DC	16.3.0
2020-03	RAN#87	R5-200730	0569	-	F	Correction to reference table number for TC 6.2B.2.3 and TC 6.2B.2.4	16.3.0
2020-03	RAN#87	R5-200731	0570	-	F	Correction of test cases in 7.6B.3 Out-of-band blocking for DC	16.3.0
2020-03	RAN#87	R5-200732	0571	-	F	Correction of test cases in 7.6B.4 Narrow band blocking for DC	16.3.0
2020-03	RAN#87	R5-200733	0572	-	F	Correction of test cases in 7.7B Spurious response for DC	16.3.0
2020-03	RAN#87	R5-200776	0576	-	F	TS 38.521-3 Section 1-5 and Annex updates to align with core specification	16.3.0
2020-03	RAN#87	R5-200801	0577	-	F	Update of Non-Standalone FR2 A-MPR test case	16.3.0
2020-03	RAN#87	R5-200814	0579	-	F	Correction to Test Case 6.5B.3.3.2	16.3.0
2020-03	RAN#87	R5-200913	0534	1	F	Update of Clause 4 in TS 38.521-3	16.3.0
2020-03	RAN#87	R5-200925	0541	1	F	Adding common uplink configuration of E-UTRA carrier for EN-DC testing	16.3.0
2020-03	RAN#87	R5-200926	0543	1	F	Updating configured output power for inter-band EN-DC	16.3.0
2020-03	RAN#87	R5-200927	0545	1	F	Updating configured output power for intra-band contiguous EN-DC	16.3.0
2020-03	RAN#87	R5-200928	0547	1	F	Updating configured output power for intra-band non-contiguous EN-DC	16.3.0
2020-03	RAN#87	R5-200929	0567	1	F	Core spec alignment of EN-DC MOP and configured output power	16.3.0
2020-03	RAN#87	R5-200963	0536	1	F	Update of TC 7.5B.2 ACS for intra-band non-contiguous EN-DC 2CCs	16.3.0
2020-03	RAN#87	R5-200964	0535	1	F	Update of TC 7.5B.1 ACS for intra-band contiguous EN-DC 2CCs	16.3.0
2020-03	RAN#87	R5-200982	0557	1	F	Updates to 6.5B.2.1.3, Adjacent channel leakage ratio for intra-band contiguous EN-DC	16.3.0
2020-03	RAN#87	R5-200983	0575	1	F	Corrections to 6.2B.3.1, UE A_MPR for Intra-band Contig EN_DC	16.3.0
2020-03	RAN#87	R5-200984	0533	1	F	Addition of Clause 7.5B.0.3a	16.3.0
2020-03	RAN#87	R5-200995	0578	1	F	Correction of Reference Sensitivity Test Case 7.3B.2.3	16.3.0
2020-03	RAN#87	R5-201019	0555	1	F	Update of general sections on EN-DC configurations in 38.521-3	16.3.0
2020-03	RAN#87	R5-201055	0542	1	F	Updating MOP for inter-band EN-DC	16.3.0
2020-03	RAN#87	R5-201066	0564	1	F	Add TX test for Rel16_DC_2_n41 and 66_n41	16.3.0
2020-03	RAN#87	R5-201067	0565	1	F	Add RX test for Rel16_DC_2_n41 and 66_n41	16.3.0
2020-03	RAN#87	R5-201165	0574	1	F	Correction of REFSSENS for inter-band EN-DC	16.3.0
2020-03	RAN#87	R5-201187	0548	1	F	Addition of a few R16 EN-DC configurations	16.3.0
2020-03	RAN#87	R5-201193	0532	1	F	Updates of MU and TT in TS 38.521-3	16.3.0
2020-03	RAN#87	R5-201198	0556	1	F	Correcting usage of modifiedMPR-Behaviour	16.3.0
2020-06	RAN#88	R5-201721	0587	-	F	Update Annex F.4 Uplink Power window explanation	16.4.0

2020-06	RAN#88	R5-201855	0594	-	F	Update of 6.2B.1.3 MOP for inter-band EN-DC	16.4.0
2020-06	RAN#88	R5-201859	0596	-	F	Updating A-SE to align test points with A-MPR	16.4.0
2020-06	RAN#88	R5-201870	0598	-	F	Update of test configuration in 6.5B.3.3.2 for UE co-existence	16.4.0
2020-06	RAN#88	R5-201942	0605	-	F	Updated to EN-DC Rel-16 band information in clause 5	16.4.0
2020-06	RAN#88	R5-202032	0611	-	F	Correction of Initial condition for OOB intra-band contiguous EN-DC 2 CCs in FR1 in TC 7.6B.3.1 R15	16.4.0
2020-06	RAN#88	R5-202293	0626	-	F	Correction to 7.3B.2.3 test configuration for EN-DC 26_n79	16.4.0
2020-06	RAN#88	R5-202294	0627	-	F	Correction to Frequency error for Intra-band contiguous EN-DC	16.4.0
2020-06	RAN#88	R5-202295	0628	-	F	Correction to PRACH configuration for intra-band EN-DC tests	16.4.0
2020-06	RAN#88	R5-202393	0630	-	F	Addition of Intra-band non-contiguous EN-DC combination	16.4.0
2020-06	RAN#88	R5-202421	0633	-	F	Update Uplink power control window size for NSA TX TCs	16.4.0
2020-06	RAN#88	R5-202429	0637	-	F	Update for 7.3A.3 for CA without EN-DC	16.4.0
2020-06	RAN#88	R5-202475	0638	-	F	TS 38.521-3 Section 1-5 and Annex updates to align with core specification	16.4.0
2020-06	RAN#88	R5-202725	0585	1	F	Correction on the channel bandwidth to use in section 6.5B.3.3	16.4.0
2020-06	RAN#88	R5-202726	0586	1	F	Setting p-MaxEUTRA to avoid limiting NR power in section 6.5B	16.4.0
2020-06	RAN#88	R5-202727	0590	1	F	Correction to TC 6.2B.4.1.3	16.4.0
2020-06	RAN#88	R5-202728	0595	1	F	Updating 6.2B.4.x configured output power test cases for FR1 EN-DC	16.4.0
2020-06	RAN#88	R5-202729	0614	1	F	correction 6.3B.1.3 to include anchor agnostic approach applies	16.4.0
2020-06	RAN#88	R5-202730	0616	1	F	Clarification of disabling Tx diversity for FR2 UE for NSA FR2 testing	16.4.0
2020-06	RAN#88	R5-202731	0618	1	F	Updation of 6.5B.3.3.1	16.4.0
2020-06	RAN#88	R5-202732	0639	1	F	Addition of UL-MIMO EN-DC tests in Clause 6	16.4.0
2020-06	RAN#88	R5-202733	0641	1	F	Common updates across tests in Clause 6	16.4.0
2020-06	RAN#88	R5-202734	0640	1	F	Addition of UL-MIMO EN-DC tests in Clause 7	16.4.0
2020-06	RAN#88	R5-202735	0642	1	F	Common updates across tests in Clause 7	16.4.0
2020-06	RAN#88	R5-202782	0635	1	F	Update Rx TC for 5 Rel_16_DC_combos	16.4.0
2020-06	RAN#88	R5-202809	0632	1	F	Receiver characteristics testing update to 38.521-3	16.4.0
2020-06	RAN#88	R5-202829	0601	1	F	Addition of 6.2B.1.5D UE Maximum Output Power for Inter-Band EN-DC including both FR1 and FR2 for UL-MIMO	16.4.0
2020-06	RAN#88	R5-202830	0602	1	F	Addition of 6.2B.5.1.1 Configured Output Power Level for Inter-band NR-DC between FR1 and FR2	16.4.0
2020-06	RAN#88	R5-202901	0631	1	F	Power control for EN-DC	16.4.0
2020-06	RAN#88	R5-202902	0588	1	F	Updated structure for RefSens for EN-DC within FR1 more than 2CCs	16.4.0
2020-06	RAN#88	R5-202903	0597	1	F	Updating REFSSENS for 1A_n78A and 3A_n78A	16.4.0
2020-06	RAN#88	R5-202904	0613	1	F	Introduction of Rx test cases for EN-DC within FR1 3CCs	16.4.0
2020-06	RAN#88	R5-202905	0629	1	F	Update to NSA FR2 Receiver Spurious Emission Test Case	16.4.0
2020-06	RAN#88	R5-202906	0636	1	F	Add 7.3B.2.3_1.2 Reference sensitivity for EN-DC within FR1v - 4 CCs	16.4.0
2020-06	RAN#88	R5-202907	0624	1	F	Updates of FR2 MU and TT in TS 38.521-3	16.4.0

2020-06	RAN#88	R5-202925	0634	1	F	Update Tx TC for 5 Rel_16_DC_combos	16.4.0
2020-06	RAN#88	R5-202934	0604	1	F	Addition of TDD-TDD PC2 inter-band EN-DC	16.4.0
2020-06	RAN#88	R5-202945	0592	1	F	Updating 6.2B.1.1 MOP for intra-band contiguous EN-DC	16.4.0
2020-06	RAN#88	R5-202946	0593	1	F	Updating 6.2B.1.2 MOP for intra-band non-contiguous EN-DC	16.4.0
2020-06	RAN#88	R5-202947	0606	1	F	Updates to 6.2B.2.1, UE Maximum Output Power reduction for Intra-Band Contiguous EN-DC	16.4.0
2020-06	RAN#88	R5-202948	0607	1	F	Updates to 6.5B.2.1.1, Spectrum emissions mask for intra-band contiguous EN-DC	16.4.0
2020-06	RAN#88	R5-202949	0608	1	F	Updates to 6.5B.2.1.3, Adjacent channel leakage ratio for intra-band contiguous EN-DC	16.4.0
2020-06	RAN#88	R5-202959	0620	1	F	Updates of Tx test cases for EN-DC including FR2	16.4.0
2020-06	RAN#88	R5-202964	0622	1	F	Update to configured output power relaxation due to inter-band EN-DC in 38.521-3	16.4.0
2020-06	RAN#88	R5-202965	0623	1	F	Update to REFSENS relaxation due to inter-band EN-DC in 38.521-3	16.4.0
2020-06	RAN#88	R5-202991	0609	1	F	Completion of TC 7.6B.3.3 OOB Inter-band EN-DC 2CCs within FR1 R15	16.4.0
2020-06	RAN#88	R5-202992	0610	1	F	Completion of TC 7.7B.3 Spurious Response Inter-band EN-DC 2CCs within FR1 R15	16.4.0
2020-06	RAN#88	R5-202993	0612	1	F	Alignment of requirements in 7.6B and 7.7B with core spec for Intra-band contiguous EN-DC in FR1 R15	16.4.0
2020-09	RAN#89	R5-203227	0644	-	F	Adding receiver requirements for Rel-16 inter-band EN-DC FR1 band combinations	16.5.0
2020-09	RAN#89	R5-203294	0645	-	F	Correction of MU definition for test case 6.5B.2.1.3	16.5.0
2020-09	RAN#89	R5-203295	0646	-	F	definition of MU and TT for test case 6.3B.4.3	16.5.0
2020-09	RAN#89	R5-203296	0647	-	F	definition of MU and TT for test case 6.5B.4.3	16.5.0
2020-09	RAN#89	R5-203297	0648	-	F	Definition of MU and TT for test case 7.3B.2.4	16.5.0
2020-09	RAN#89	R5-203492	0650	-	F	In-band Blocking FR2 MU updates in 38.521-3	16.5.0
2020-09	RAN#89	R5-203515	0651	-	F	Editorial correction of test case 6.5B.3.3.1	16.5.0
2020-09	RAN#89	R5-203637	0655	-	F	Introduction of additional Rel-16 EN-DC inter-band configurations to EN-DC MOP test case 6.2B.1.3	16.5.0
2020-09	RAN#89	R5-203753	0660	-	F	Update test procedure to 6.5B.3.3.1	16.5.0
2020-09	RAN#89	R5-203763	0661	-	F	Editorial correction of referenced clause (6.2.3) in test case 6.2B.2.1.2	16.5.0
2020-09	RAN#89	R5-203872	0668	-	F	Adding RRCCOnnectionReconfiguration Table for E-UTRA on FDD band and UE does not support dynamic power sharing in 6.5B.3.3.1 and 6.5B.3.3.2	16.5.0
2020-09	RAN#89	R5-203907	0669	-	F	Corrections on delta RIB due to Rel-16 EN-DC configurations	16.5.0
2020-09	RAN#89	R5-203941	0674	-	F	Addition of the test description to apply LTE agnostic approach in 7.4B.2 MIL	16.5.0
2020-09	RAN#89	R5-203960	0680	-	F	Correction to additional test points for spurious emission UE co-existence for a few Rel-15 inter-band EN-DC	16.5.0
2020-09	RAN#89	R5-203973	0684	-	F	Cleaning up of delta_TIB	16.5.0
2020-09	RAN#89	R5-204154	0693	-	F	Updated to Annex M for EN-DC Rel-16 configuration requirement	16.5.0

2020-09	RAN#89	R5-204170	0697	-	F	Update for TC 7.5B.0 Minimum Conformance Requirements of ACS for DC	16.5.0
2020-09	RAN#89	R5-204176	0703	-	F	Update for TC 7.5B.4 ACS for inter-band EN-DC including FR2 2CCs	16.5.0
2020-09	RAN#89	R5-204177	0704	-	F	Update for TC 7.5B.4_1.1 ACS for inter-band EN-DC including FR2 3CCs	16.5.0
2020-09	RAN#89	R5-204178	0705	-	F	Update for TC 7.5B.4_1.2 ACS for inter-band EN-DC including FR2 4CCs	16.5.0
2020-09	RAN#89	R5-204179	0706	-	F	Update for TC 7.5B.4_1.3 ACS for inter-band EN-DC including FR2 5CCs	16.5.0
2020-09	RAN#89	R5-204180	0707	-	F	Update for TC 7.5B.4_1.4 ACS for inter-band EN-DC including FR2 6CCs	16.5.0
2020-09	RAN#89	R5-204198	0713	-	F	Update for 7.3B.2.0	16.5.0
2020-09	RAN#89	R5-204199	0714	-	F	Update for Spurious Emissions for intra-band EN-DC	16.5.0
2020-09	RAN#89	R5-204209	0717	-	F	Update Uplink power control window size for NSA RX TCs	16.5.0
2020-09	RAN#89	R5-204210	0718	-	F	Update Tx TC for Rel-16 DC combos	16.5.0
2020-09	RAN#89	R5-204250	0721	-	F	FR2 Minimum output power measurement period definition	16.5.0
2020-09	RAN#89	R5-204296	0726	-	F	Addition of test case 6.4B.2.4.1D	16.5.0
2020-09	RAN#89	R5-204297	0727	-	F	Addition of test case 6.4B.2.4.2D	16.5.0
2020-09	RAN#89	R5-204298	0728	-	F	Addition of test case 6.4B.2.4.3D	16.5.0
2020-09	RAN#89	R5-204299	0729	-	F	Addition of test case 6.4B.2.4.4D	16.5.0
2020-09	RAN#89	R5-204310	0730	-	F	Update of test case 6.2B.3.1 UE Additional Maximum Output Power reduction for Intra-band contiguous EN-DC	16.5.0
2020-09	RAN#89	R5-204313	0733	-	F	TS 38.521-3 Section 1-5 and Annex updates to align with core specification	16.5.0
2020-09	RAN#89	R5-204322	0736	-	F	Update for TC 7.5B.5 ACS for inter-band EN-DC including both FR1 and FR2	16.5.0
2020-09	RAN#89	R5-204349	0738	-	F	Editorial correction of Rx spurious emissions for FR1 EN-DC	16.5.0
2020-09	RAN#89	R5-204705	0739	-	F	Addition of test configuration for 71AA in 6.2B.1.1 MOP	16.5.0
2020-09	RAN#89	R5-204707	0740	-	F	Addition of MOP testing for DC_28A_n3A in 6.2B.1.3	16.5.0
2020-09	RAN#89	R5-204719	0715	1	F	Update for 7.3B.2.3_1.3 Reference sensitivity for EN-DC within FR1 5CCs	16.5.0
2020-09	RAN#89	R5-204724	0662	1	F	Updated to clause 6 for EN-DC Rel-16 band requirement	16.5.0
2020-09	RAN#89	R5-204766	0665	1	F	Spurious inter-band EN-DC FR2 UL MIMO test cases	16.5.0
2020-09	RAN#89	R5-204767	0673	1	F	Addition of test requirement of dropped NR carrier for non-DPS UE in 6.2B.4.x	16.5.0
2020-09	RAN#89	R5-204768	0678	1	F	Addition of additional test points for spurious emission UE co-existence for a few Rel-15 inter-band EN-DC	16.5.0
2020-09	RAN#89	R5-204769	0723	1	F	Editorial correction to EN-DC co-existence requirements	16.5.0
2020-09	RAN#89	R5-204770	0664	1	F	FR2 RefSens inter-band EN-DC UL MIMO test cases	16.5.0
2020-09	RAN#89	R5-204771	0670	1	F	Update of 7.3B.3.3 for REFSSENS relaxation due to inter-band EN-DC within FR1	16.5.0
2020-09	RAN#89	R5-204772	0676	1	F	Addition of new test case 7.4B.5D MIL for inter-band EN-DC including FR1 and FR2 for UL-MIMO	16.5.0

2020-09	RAN#89	R5-204773	0709	1	F	Addition of TC 7.5B.5D ACS for inter-band EN-DC including FR1 and FR2 for UL-MIMO	16.5.0
2020-09	RAN#89	R5-204809	0643	1	F	Adding transmitter requirements for Rel-16 inter-band EN-DC FR1 band combinations	16.5.0
2020-09	RAN#89	R5-204810	0654	1	F	Editorial correction to spurious emission test case 6.5B.3.3.2	16.5.0
2020-09	RAN#89	R5-204811	0656	1	F	Introduction of dTIBc for additional Rel-16 EN-DC inter-band configurations	16.5.0
2020-09	RAN#89	R5-204812	0657	1	F	Introduction of Rel-16 EN-DC configuration DC_40A_n1A to spurious emission test case 6.5B.3.3.2	16.5.0
2020-09	RAN#89	R5-204813	0658	1	F	Introduction of Rel-16 EN-DC configuration DC_40A_n78A to spurious emission test case 6.5B.3.3.2	16.5.0
2020-09	RAN#89	R5-204814	0679	1	F	Addition of additional test points for spurious emission UE co-existence for a few Rel-16 inter-band EN-DC	16.5.0
2020-09	RAN#89	R5-204815	0694	1	F	Updated to clause 6 for EN-DC Rel-16 configuration test requirement	16.5.0
2020-09	RAN#89	R5-204816	0692	1	F	Updated to EN-DC Rel-16 Configuration information in clause 5	16.5.0
2020-09	RAN#89	R5-204840	0696	1	F	Updated to EN-DC general clauses for NRSL eV2X	16.5.0
2020-09	RAN#89	R5-204866	0689	1	F	CR to update MU and TT in 38.521-3	16.5.0
2020-09	RAN#89	R5-204867	0716	1	F	Update for 6.5B.3.3.2 Spurious emission band UE co-existence	16.5.0
2020-09	RAN#89	R5-204869	0649	1	F	Adjacent Channel Selectivity FR2 MU and TT updates in 38.521-3	16.5.0
2020-09	RAN#89	R5-204924	0666	1	F	Update of Test applicability for some Inter-Band EN-DC including FR2 TCs	16.5.0
2020-09	RAN#89	R5-204925	0687	1	F	Clean up complete status for EN-DC test cases	16.5.0
2020-09	RAN#89	R5-204926	0731	1	F	Addition of pending UL-MIMO tests (FR2) in Clause 6	16.5.0
2020-09	RAN#89	R5-204928	0681	1	F	Update of NSA Rx test cases for 4Rx UEs	16.5.0
2020-09	RAN#89	R5-204929	0700	1	F	Addition of TC 7.5B.3_1.2 ACS for EN-DC within FR1 4CC	16.5.0
2020-09	RAN#89	R5-204930	0711	1	F	Addition of TC 7.6B.2.5D Inband blocking for inter-band EN-DC including FR1 and FR2 for UL-MIMO	16.5.0
2020-09	RAN#89	R5-204931	0712	1	F	Update for 7.3B.2.3 Ref sense for Inter-band EN-DC within FR1-2 CCs	16.5.0
2020-09	RAN#89	R5-204932	0719	1	F	Re-organization of EN-DC refsens test cases	16.5.0
2020-09	RAN#89	R5-204957	0695	1	F	Updated to clause 7 for EN-DC Rel-16 configuration test requirement	16.5.0
2020-09	RAN#89	R5-204958	0737	1	F	Add Rx TC for 2Rel 16 DC combos	16.5.0
2020-09	RAN#89	R5-205005	0741	-	F	Update of OOB and Spurious Response of Inter-band EN-DC within FR1	16.5.0
2020-09	RAN#89	R5-205006	0690	1	F	Update Refsense exceptions for EN-DC including n78	16.5.0
2020-12	RAN#90	R5-205489	0749	-	F	Correction to Reference Sensitivity for Inter-band EN-DC	16.6.0
2020-12	RAN#90	R5-205500	0750	-	F	Minor correction of section 6.1	16.6.0
2020-12	RAN#90	R5-205501	0751	-	F	Correction of spec style in section 7.6B and 7.7B and correction of table number in 7.6B.3.3.4.1	16.6.0
2020-12	RAN#90	R5-205502	0752	-	F	Addition of intra-band contiguous EN-DC testing and update of inter-band EN-DC testing for 7.6B.2.3_1.1 Inband blocking for EN-DC within FR1 3 CCs	16.6.0

2020-12	RAN#90	R5-205503	0753	-	F	Addition of intra-band contiguous EN-DC testing and update of inter-band EN-DC testing for 7.6B.2.3_1.2 Inband blocking for EN-DC within FR1 4 CCs	16.6.0
2020-12	RAN#90	R5-205505	0755	-	F	Addition of new test case 7.6B.3.3_1.1 Out-of-band blocking for EN-DC within FR1 3 CCs	16.6.0
2020-12	RAN#90	R5-205506	0756	-	F	Addition of new test case 7.6B.3.3_1.2 Out-of-band blocking for EN-DC within FR1 4 CCs	16.6.0
2020-12	RAN#90	R5-205507	0757	-	F	Addition of intra-band contiguous EN-DC testing and update of inter-band EN-DC testing for 7.6B.4.3_1.1 Narrow band blocking for EN-DC within FR1 3 CCs	16.6.0
2020-12	RAN#90	R5-205508	0758	-	F	Addition of intra-band contiguous EN-DC testing and update of inter-band EN-DC testing for 7.6B.4.3_1.2 Narrow band blocking for EN-DC within FR1 4 CCs	16.6.0
2020-12	RAN#90	R5-205510	0760	-	F	Addition of new test case 7.7B.3_1.1 Spurious Response for EN-DC within FR1 3 CCs	16.6.0
2020-12	RAN#90	R5-205511	0761	-	F	Addition of new test case 7.7B.3_1.2 Spurious Response for EN-DC within FR1 4 CCs	16.6.0
2020-12	RAN#90	R5-205515	0763	-	F	Correction of section 7.1 and update of 7.6B.3.0.3A and 7.7B.0.3A as per RAN4 spec	16.6.0
2020-12	RAN#90	R5-205516	0764	-	F	Correction of uplink power and in gap test requirement for 7.6B.2.2, 7.6B.3.2, 7.6B.4.2 and 7.7B.2	16.6.0
2020-12	RAN#90	R5-205534	0768	-	F	Editorial, removing duplication of text in test case	16.6.0
2020-12	RAN#90	R5-205568	0776	-	F	Introduction of DC_3A-40A_n1A to reference sensitivity test	16.6.0
2020-12	RAN#90	R5-205678	0778	-	F	Addition of Clause 7.5B.4D ACS for inter-band EN-DC including FR2 for UL-MIMO	16.6.0
2020-12	RAN#90	R5-205679	0779	-	F	Addition of Clause 7.6B.2.4D Inband blocking for inter-band EN-DC including FR2 for UL-MIMO	16.6.0
2020-12	RAN#90	R5-205696	0782	-	F	Editorial correction to EN-DC test cases 6.5B.2.3	16.6.0
2020-12	RAN#90	R5-205775	0785	-	F	Adding delta TIB for a few Rel-16 inter-band EN-DC configurations within FR1	16.6.0
2020-12	RAN#90	R5-205776	0786	-	F	Adding refsens exceptions for DC_3_n78 due to receiver harmonic mixing	16.6.0
2020-12	RAN#90	R5-205778	0788	-	F	Adding delta RIB for DC_2-7-66_n78	16.6.0
2020-12	RAN#90	R5-205784	0790	-	F	Update of UE co-existence spurious emissions for Rel-16 inter-band EN-DC DC_13_n66	16.6.0
2020-12	RAN#90	R5-205788	0792	-	F	Correction to UE co-existence spurious emissions for inter-band EN-DC within FR1	16.6.0
2020-12	RAN#90	R5-205803	0793	-	F	Introduction of New TC 6.4B.2.4.2_1.1 Carrier Leakage for inter-band EN-DC including FR2 with 3 CCs	16.6.0
2020-12	RAN#90	R5-205804	0794	-	F	Introduction of New TC 6.4B.2.4.2_1.2 Carrier Leakage for inter-band EN-DC including FR2 with 4 CCs	16.6.0
2020-12	RAN#90	R5-205806	0795	-	F	Introduction of New TC 6.4B.2.4.2_1.3 Carrier Leakage for inter-band EN-DC including FR2 with 5 CCs	16.6.0
2020-12	RAN#90	R5-205855	0798	-	F	Correction of channel bandwidth for EN-DC MOP TC 6.2B.1.3	16.6.0
2020-12	RAN#90	R5-205911	0803	-	F	Introduction of DC_3A-20A_n78A to reference sensitivity test	16.6.0
2020-12	RAN#90	R5-205934	0805	-	F	Update of DC_1A-7A_n78A to reference sensitivity test	16.6.0
2020-12	RAN#90	R5-205935	0806	-	F	Update DC_7A-20A_n78A to reference sensitivity test	16.6.0
2020-12	RAN#90	R5-205994	0808	-	F	Updates to Reference sensitivity for EN-DC within FR1 3CC	16.6.0

2020-12	RAN#90	R5-206018	0811	-	F	Correction of 7.3B.3.3 for delta RIB with inter-band EN-DC configurations	16.6.0
2020-12	RAN#90	R5-206029	0813	-	F	Update spurious emission band UE co-existence for DC_2_n41 and DC_66_n41	16.6.0
2020-12	RAN#90	R5-206236	0832	-	F	Correction to Rel-16 EN-DC configuration DC_40A_n1A and DC_40A_n78 in spurious emission test case 6.5B.3.3.2	16.6.0
2020-12	RAN#90	R5-206237	0833	-	F	Introduction of Rel-16 EN-DC configuration DC_1A_n3A to spurious emission test case 6.5B.3.3.2	16.6.0
2020-12	RAN#90	R5-206238	0834	-	F	Introduction of Rel-16 EN-DC configuration DC_20A_n3A to spurious emission test case 6.5B.3.3.2	16.6.0
2020-12	RAN#90	R5-206255	0835	-	F	Update for 6.5B.3.2.2 Spurious emission band UE co-existence for intra-band non-contiguous EN-DC	16.6.0
2020-12	RAN#90	R5-206648	0766	1	F	Addition of TC6.3B.1.4D Minimum output power for inter-band EN-DC including FR2 for UL-MIMO	16.6.0
2020-12	RAN#90	R5-206649	0767	1	F	Addition of TC6.3B.3.4 Transmit ON/OFF time mask for inter-band EN-DC including FR2	16.6.0
2020-12	RAN#90	R5-206650	0777	1	F	Update on Transmit OFF power for EN-DC including FR2	16.6.0
2020-12	RAN#90	R5-206651	0789	1	F	Update of UE co-existence spurious emissions for a few Rel-15 inter-band EN-DC configurations	16.6.0
2020-12	RAN#90	R5-206652	0796	1	F	Addition of 6.5B.2.4D.3 Adjacent channel leakage ratio for inter-band EN-DC including FR2 for UL-MIMO	16.6.0
2020-12	RAN#90	R5-206653	0799	1	F	Update of 6.2B.1.4_1 MOP for Inter-Band EN-DC including FR2	16.6.0
2020-12	RAN#90	R5-206654	0821	1	F	Update for 6.5B.3.1.2 Spurious emission band UE co-existence for intra-band contiguous EN-DC	16.6.0
2020-12	RAN#90	R5-206655	0822	1	F	Update for 6.5B.3.3.2 Spurious emission band UE co-existence for Inter-band within FR1	16.6.0
2020-12	RAN#90	R5-206656	0780	1	F	Update for Clause F.1.3 Measurement of receiver	16.6.0
2020-12	RAN#90	R5-206657	0810	1	F	Correction of 7.3B.3.3 for allowed reference sensitivity relaxation	16.6.0
2020-12	RAN#90	R5-206658	0819	1	F	Update the interferer range for OOB and Spurious Response of Inter-band EN-DC within FR1	16.6.0
2020-12	RAN#90	R5-206659	0823	1	F	Update for 7.3B.2.0 Minimum Conformance Requirements of Reference sensitivity for EN-DC	16.6.0
2020-12	RAN#90	R5-206660	0826	1	F	Editor's notes updates for FR1 inter-band 3CC DL CA	16.6.0
2020-12	RAN#90	R5-206661	0762	1	F	Addition of measurement uncertainties and test tolerance for blocking test cases for EN-DC within FR1 with 3CCs, 4CCs and 5CCs and correction of some spec styles	16.6.0
2020-12	RAN#90	R5-206662	0817	1	F	6.4B.2.1.1 Error Vector Magnitude for intra-band contiguous EN DC Measurement Uncertainty update	16.6.0
2020-12	RAN#90	R5-206663	0818	1	F	6.4B.2.1.2 Carrier Leakage for intra-band contiguous EN-DC Measurement Uncertainty update	16.6.0
2020-12	RAN#90	R5-206664	0820	1	F	FR1 Intra-band CA General Tx ON OFF time mask measurement uncertainties and test tolerances corrections	16.6.0
2020-12	RAN#90	R5-206665	0836	1	F	TS 38.521-3 Section 1-5 and Annex updates to align with core specification	16.6.0
2020-12	RAN#90	R5-206720	0742	1	F	Introduction of New test case 6.3B.1.4_1.1 Minimum output power for inter-band EN-DC including FR2 - 3 CCs	16.6.0
2020-12	RAN#90	R5-206721	0743	1	F	Introduction of New test case 6.3B.1.4_1.2 Minimum output power for inter-band EN-DC including FR2 - 4 CCs	16.6.0

2020-12	RAN#90	R5-206722	0744	1	F	Introduction of New test case 6.3B.1.4_1.3 Minimum output power for inter-band EN-DC including FR2 - 5 CCs	16.6.0
2020-12	RAN#90	R5-206723	0745	1	F	Introduction of New test case 6.4B.2.4.1_1.1 Error Vector Magnitude for inter-band EN-DC including FR2 - 3 CCs	16.6.0
2020-12	RAN#90	R5-206724	0746	1	F	Introduction of New test case 6.4B.2.4.1_1.2 Error Vector Magnitude for inter-band EN-DC including FR2 - 4 CCs	16.6.0
2020-12	RAN#90	R5-206725	0747	1	F	Introduction of New test case 6.4B.2.4.1_1.3 Error Vector Magnitude for inter-band EN-DC including FR2 - 5 CCs	16.6.0
2020-12	RAN#90	R5-206727	0787	1	F	Adding refsens exceptions for DC_3_n1 due to cross band isolation	16.6.0
2020-12	RAN#90	R5-206728	0783	1	F	Update to EN-DC R16 Configuration information in clause 5	16.6.0
2020-12	RAN#90	R5-206772	0781	1	F	Addition of PC2 Tx requirements for DC_3A_n41A	16.6.0
2020-12	RAN#90	R5-206773	0801	1	F	Addition of PC2 Tx requirements for DC_3A_n78A	16.6.0
2020-12	RAN#90	R5-206784	0802	1	F	Updating Rel-16 EN-DC PC2 MOP to add UE power class capability for NR part	16.6.0
2020-12	RAN#90	R5-206827	0829	1	F	Minimum output power editor's notes	16.6.0
2020-12	RAN#90	R5-206828	0828	1	F	Update FR2 TRx MU and TT in 38.521-3	16.6.0
2020-12	RAN#90	R5-206869	0809	1	F	Updates to Reference sensitivity for EN-DC within FR1 4CC restructuring test configuration tables	16.6.0
2020-12	RAN#90	R5-206870	0825	1	F	Measurement uncertainties and test tolerances updates for FR1 inter-band 3CC DL CA	16.6.0
2020-12	RAN#90	R5-206883	0772	1	F	Introduction of DC_3A_n1A to reference sensitivity test	16.6.0
2020-12	RAN#90	R5-206884	0773	1	F	Introduction of DC_1A_n3A to reference sensitivity test	16.6.0
2020-12	RAN#90	R5-206885	0774	1	F	Introduction of DC_20A_n3A to reference sensitivity test	16.6.0
2020-12	RAN#90	R5-206886	0775	1	F	Introduction of DC_40A_n78A to reference sensitivity test	16.6.0
2020-12	RAN#90	R5-206902	0769	1	F	Moving test configurations table for EN-DC 20_n78 to a general test configuration table for 2CC reference sensitivity exceptions	16.6.0
2020-12	RAN#90	R5-206903	0770	1	F	Introduction of DC_1A_n78A to reference sensitivity test	16.6.0
2020-12	RAN#90	R5-206904	0771	1	F	Introduction of DC_3A_n78A to reference sensitivity test	16.6.0
2020-12	RAN#90	R5-206913	0754	1	F	Update of 7.6B.2.3_1.3 Inband blocking for EN-DC within FR1 5 CCs and removal of 7.6B.2.3_1.4 Inband blocking for EN-DC within FR1 6 CCs	16.6.0
2020-12	RAN#90	R5-206914	0759	1	F	Update of 7.6B.4.3_1.3 Narrow band blocking for EN-DC within FR1 5 CCs and removal of 7.6B.4.3_1.4 Narrow band blocking for EN-DC within FR1 6 CCs	16.6.0
2020-12	RAN#90	R5-206915	0807	1	F	Updates to Reference sensitivity for EN-DC within FR1 2CC for UE supporting single UL	16.6.0
2020-12	RAN#90	R5-206916	0827	1	F	Update for 7.3B.3.2	16.6.0
2020-12	RAN#90	R5-206918	0804	1	F	Addition of PC2 Rx requirements for DC_3A_n41A	16.6.0
2020-12	RAN#90	R5-206919	0814	1	F	Addition of PC2 ENDC DC_3A-n78A into TC7.3B.2.3	16.6.0
2021-03	RAN#91	R5-210093	0842	-	F	Introduction of DC_7A-20A_n3A to reference sensitivity test	16.7.0
2021-03	RAN#91	R5-210301	0847	-	F	Completion of OBW intra-band non-contiguous test 6.5B.1.2	16.7.0
2021-03	RAN#91	R5-210302	0848	-	B	Addition of new test case 6.5B.1.4D OBW for inter-band EN-DC FR2 UL MIMO	16.7.0
2021-03	RAN#91	R5-210387	0857	-	F	Correction to EN-DC OoB emissions	16.7.0

2021-03	RAN#91	R5-210415	0858	-	F	Addition of new test case 6.4B.2.4.3_1.1 In-band Emissions for inter-band EN-DC including FR2 with 3 CCs	16.7.0
2021-03	RAN#91	R5-210416	0859	-	F	Addition of new test case 6.4B.2.4.3_1.2 In-band Emissions for inter-band EN-DC including FR2 with 4 CCs	16.7.0
2021-03	RAN#91	R5-210417	0860	-	F	Addition of new test case 6.4B.2.4.3_1.3 In-band Emissions for inter-band EN-DC including FR2 with 5 CCs	16.7.0
2021-03	RAN#91	R5-210497	0861	-	F	Correction of test frequencies for NR band n28 30MHz test channel bandwidth of 6.2B.1.3	16.7.0
2021-03	RAN#91	R5-210498	0862	-	F	Addition of editor note to the incomplete test cases	16.7.0
2021-03	RAN#91	R5-210499	0863	-	F	Correction of test applicability of 6.5B.5.3	16.7.0
2021-03	RAN#91	R5-210500	0864	-	F	Correction of test configuration tables in section 6	16.7.0
2021-03	RAN#91	R5-210501	0865	-	F	Completion of 7.6B.2.3_1.3 Inband blocking for EN-DC within FR1 5 CCs	16.7.0
2021-03	RAN#91	R5-210502	0866	-	F	Correction of test frequencies for NR band n28 30MHz test channel bandwidth of 7.6B.3.3	16.7.0
2021-03	RAN#91	R5-210548	0872	-	F	Default message exceptions for LTE carriers in EN-DC	16.7.0
2021-03	RAN#91	R5-210725	0874	-	F	Omitting of NSA Rx cases with UL-MIMO on TDD bands	16.7.0
2021-03	RAN#91	R5-210909	0882	-	F	Editorial correction to test case 6.2B.4.1.3	16.7.0
2021-03	RAN#91	R5-210943	0883	-	F	Adding delta TIB and delta RIB for DC_2-7-7-66_n78	16.7.0
2021-03	RAN#91	R5-210989	0889	-	F	Update for 7.3B.2.0 Minimum Conformance Requirements of Reference sensitivity for EN-DC	16.7.0
2021-03	RAN#91	R5-211005	0893	-	F	Update to EN-DC R16 Configuration information in clause 5	16.7.0
2021-03	RAN#91	R5-211010	0895	-	F	Update of reference sensitivity for intra-band contiguous EN-DC	16.7.0
2021-03	RAN#91	R5-211014	0899	-	F	Adding in-gap tests to ACS for intra-band non-contiguous EN-DC	16.7.0
2021-03	RAN#91	R5-211017	0901	-	F	Update of test coverage for reference sensitivity for 3CC EN-DC	16.7.0
2021-03	RAN#91	R5-211020	0902	-	F	Adding EN-DC configurations DC_1A-28A_n3A and DC_7A-28A_n3A to clause 5.5B.4.2	16.7.0
2021-03	RAN#91	R5-211099	0917	-	F	Correction to editors note about number of E-UTRA carriers	16.7.0
2021-03	RAN#91	R5-211111	0921	-	F	Corrections to subclauses in 38.521-3 with appropriate subclause level and heading styles	16.7.0
2021-03	RAN#91	R5-211125	0922	-	F	Update of 5.3B for UE channel bandwidth for EN-DC	16.7.0
2021-03	RAN#91	R5-211240	0934	-	F	Introduction of DC_7A-20A_n1A to reference sensitivity test	16.7.0
2021-03	RAN#91	R5-211241	0935	-	F	Introduction of DC_7A- 28A_n3A to referce sensitivity test	16.7.0
2021-03	RAN#91	R5-211694	0844	1	F	Spectrum emissions mask for intra-band non-contiguous EN-DC Test Definition	16.7.0
2021-03	RAN#91	R5-211695	0849	1	F	ACLR for intra-band non-contiguous EN-DC Test Definition	16.7.0
2021-03	RAN#91	R5-211696	0856	1	F	Update Test description of 6.5B.1.1	16.7.0
2021-03	RAN#91	R5-211697	0871	1	F	EN-DC FR2 UL CA Frequency error test cases update	16.7.0
2021-03	RAN#91	R5-211698	0876	1	F	Correction of test requirements for EN-DC configured output power	16.7.0
2021-03	RAN#91	R5-211699	0906	1	F	Introduction of Rel-15 EN-DC configuration DC_8A_n77A to spurious emission test case 6.5B.3.3.2	16.7.0
2021-03	RAN#91	R5-211700	0907	1	F	Introduction of Rel-15 EN-DC configuration DC_11A_n77A to spurious emission test case 6.5B.3.3.2	16.7.0

2021-03	RAN#91	R5-211701	0908	1	F	Introduction of Rel-15 EN-DC configuration DC_11A_n78A to spurious emission test case 6.5B.3.3.2	16.7.0
2021-03	RAN#91	R5-211702	0909	1	F	Introduction of Rel-15 EN-DC configuration DC_11A_n79A to spurious emission test case 6.5B.3.3.2	16.7.0
2021-03	RAN#91	R5-211703	0910	1	F	Introduction of Rel-15 EN-DC configuration DC_25A_n41A to spurious emission test case 6.5B.3.3.2	16.7.0
2021-03	RAN#91	R5-211704	0911	1	F	Introduction of Rel-15 EN-DC configuration DC_26A_n41A to spurious emission test case 6.5B.3.3.2	16.7.0
2021-03	RAN#91	R5-211705	0912	1	F	Introduction of Rel-15 EN-DC configuration DC_26A_n77A to spurious emission test case 6.5B.3.3.2	16.7.0
2021-03	RAN#91	R5-211706	0913	1	F	Introduction of Rel-15 EN-DC configuration DC_26A_n78A to spurious emission test case 6.5B.3.3.2	16.7.0
2021-03	RAN#91	R5-211707	0914	1	F	Introduction of Rel-15 EN-DC configuration DC_26A_n79A to spurious emission test case 6.5B.3.3.2	16.7.0
2021-03	RAN#91	R5-211708	0915	1	F	Introduction of Rel-15 EN-DC configuration DC_41A_n77A to spurious emission test case 6.5B.3.3.2	16.7.0
2021-03	RAN#91	R5-211709	0916	1	F	Introduction of Rel-15 EN-DC configuration DC_41A_n78A to spurious emission test case 6.5B.3.3.2	16.7.0
2021-03	RAN#91	R5-211710	0853	1	F	Correction of MSD test point on Table 7.3B.2.0.3.5.2-1 DC_1A-8A_n78A	16.7.0
2021-03	RAN#91	R5-211711	0854	1	F	Update of 7.3B.2.3_1.1 RefSens DC_3A-8A_n78A	16.7.0
2021-03	RAN#91	R5-211712	0855	1	F	Addition of new test case 7.3B.4 for EIS Spherical Coverage	16.7.0
2021-03	RAN#91	R5-211713	0867	1	F	Editorial correction for errors in 7.6B.4.3_1	16.7.0
2021-03	RAN#91	R5-211714	0868	1	F	Correction of test configuration tables in section 7	16.7.0
2021-03	RAN#91	R5-211715	0877	1	F	Clarification of tested Rx antenna numbers on E-UTRA band	16.7.0
2021-03	RAN#91	R5-211766	0837	1	F	Introduction of Rel-16 EN-DC configuration DC_7A_n3A to spurious emission test case 6.5B.3.3.2	16.7.0
2021-03	RAN#91	R5-211767	0838	1	F	Introduction of Rel-16 EN-DC configuration DC_8A_n3A to spurious emission test case 6.5B.3.3.2	16.7.0
2021-03	RAN#91	R5-211768	0839	1	F	Introduction of Rel-16 EN-DC configuration DC_20A_n1A to spurious emission test case 6.5B.3.3.2	16.7.0
2021-03	RAN#91	R5-211769	0887	1	F	Update for 6.5B.3.3.2 Spurious emission band UE co-existence_Rel16	16.7.0
2021-03	RAN#91	R5-211770	0903	1	F	Adding Delta TIB,c for DC_1A-28A_n3A, DC_7A-20A_n1A and DC_7A-28A_n3A to clause 6.2B.4.2.3.3	16.7.0
2021-03	RAN#91	R5-211771	0840	1	F	Introduction of DC_7A_n3A to reference sensitivity test	16.7.0
2021-03	RAN#91	R5-211772	0841	1	F	Introduction of DC_8A_n1A and DC_8A_n3A to reference sensitivity test	16.7.0
2021-03	RAN#91	R5-211773	0869	1	F	Adding Inter-band EN-DC combination within FR1	16.7.0
2021-03	RAN#91	R5-211840	0878	1	F	Updating Rel-16 EN-DC PC2 MOP to include powerClassNRPart-r16	16.7.0
2021-03	RAN#91	R5-211841	0879	1	F	Updating Rel-16 EN-DC PC2 MPR to include powerClassNRPart-r16	16.7.0
2021-03	RAN#91	R5-211842	0880	1	F	Updating Rel-16 EN-DC PC2 A-MPR to include powerClassNRPart-r16	16.7.0
2021-03	RAN#91	R5-211843	0881	1	F	Updating Rel-16 EN-DC PC2 configured output power to include powerClassNRPart-r16	16.7.0
2021-03	RAN#91	R5-211852	0888	1	F	Update for 6.5B.3.3.2 Spurious emission band UE co-existence	16.7.0

2021-03	RAN#91	R5-211854	0890	1	F	Correction to EN-DC Wideband Intermodulation tests	16.7.0
2021-03	RAN#91	R5-211870	0843	1	F	Editorial addition of editors notes in 6.3B.8.1.4, 6.3B.8.2.4 and 6.3B.8.3.4	16.7.0
2021-03	RAN#91	R5-211871	0875	1	F	Correcting EN-DC A-MPR test requirements for non-overlapping test points	16.7.0
2021-03	RAN#91	R5-211872	0886	1	F	Correction to the TDM pattern configuration for EN-DC Tx test cases	16.7.0
2021-03	RAN#91	R5-211873	0918	1	F	Correction to MOP and MPR test procedures for PC2 in TC 6.2B.1.3 and 6.2B.2.1	16.7.0
2021-03	RAN#91	R5-211874	0845	1	F	Correction of LTE frequency for 19-n79 combo in 7.3B.2.3	16.7.0
2021-03	RAN#91	R5-211875	0870	1	F	Update to EN-DC Reference Sensitivity	16.7.0
2021-03	RAN#91	R5-211876	0896	1	F	Update of reference sensitivity for intra-band non-contiguous EN-DC	16.7.0
2021-03	RAN#91	R5-211877	0897	1	F	Update of reference sensitivity for inter-band 2CC EN-DC	16.7.0
2021-03	RAN#91	R5-211878	0898	1	F	Correction to refsens test requirements for DC_1A-7A_n78A	16.7.0
2021-03	RAN#91	R5-211879	0900	1	F	Update of test configuration for inter-band 2CC EN-DC configurations affected by reference sensitivity exceptions	16.7.0
2021-03	RAN#91	R5-211880	0924	1	F	Update of 2CC refsens test case 7.3B.2.3	16.7.0
2021-03	RAN#91	R5-211881	0925	1	F	Update of 3CC refsens test case 7.3B.2.3_1.1	16.7.0
2021-03	RAN#91	R5-211882	0926	1	F	Correction of configurations not to be tested in 4CC refsens test case 7.3B.2.3_1.2	16.7.0
2021-03	RAN#91	R5-211883	0927	1	F	Addition of DC_8A_n77A in test case 7.3B.2.3	16.7.0
2021-03	RAN#91	R5-211884	0928	1	F	Addition of DC_11A_n79A in test case 7.3B.2.3	16.7.0
2021-03	RAN#91	R5-211885	0929	1	F	Addition of DC_26A_n41A in test case 7.3B.2.3	16.7.0
2021-03	RAN#91	R5-211886	0930	1	F	Addition of DC_26A_n77A and DC_26A_n78A in test case 7.3B.2.3	16.7.0
2021-03	RAN#91	R5-211887	0931	1	F	Addition of DC_26A_n79A in test case 7.3B.2.3	16.7.0
2021-03	RAN#91	R5-211888	0932	1	F	Addition of DC_41A_n77A and DC_41A_n78A in test case 7.3B.2.3	16.7.0
2021-03	RAN#91	R5-211905	0933	1	F	Introduction of DC_1A-28A_n3A to reference sensitivity test	16.7.0
2021-03	RAN#91	R5-211926	0851	1	F	MU definition for UE MOP for Inter-Band EN-DC including FR2 (3CCs)	16.7.0
2021-03	RAN#91	R5-211927	0852	1	F	MU and TT definition for REFSENS EN-DC including FR2 up to 5CCs	16.7.0
2021-03	RAN#91	R5-211928	0920	1	F	Update FR2 MU and TT in 38.521-3	16.7.0

History

Document history		
V16.4.0	July 2020	Publication
V16.5.0	November 2020	Publication
V16.6.0	January 2021	Publication
V16.7.0	May 2021	Publication